

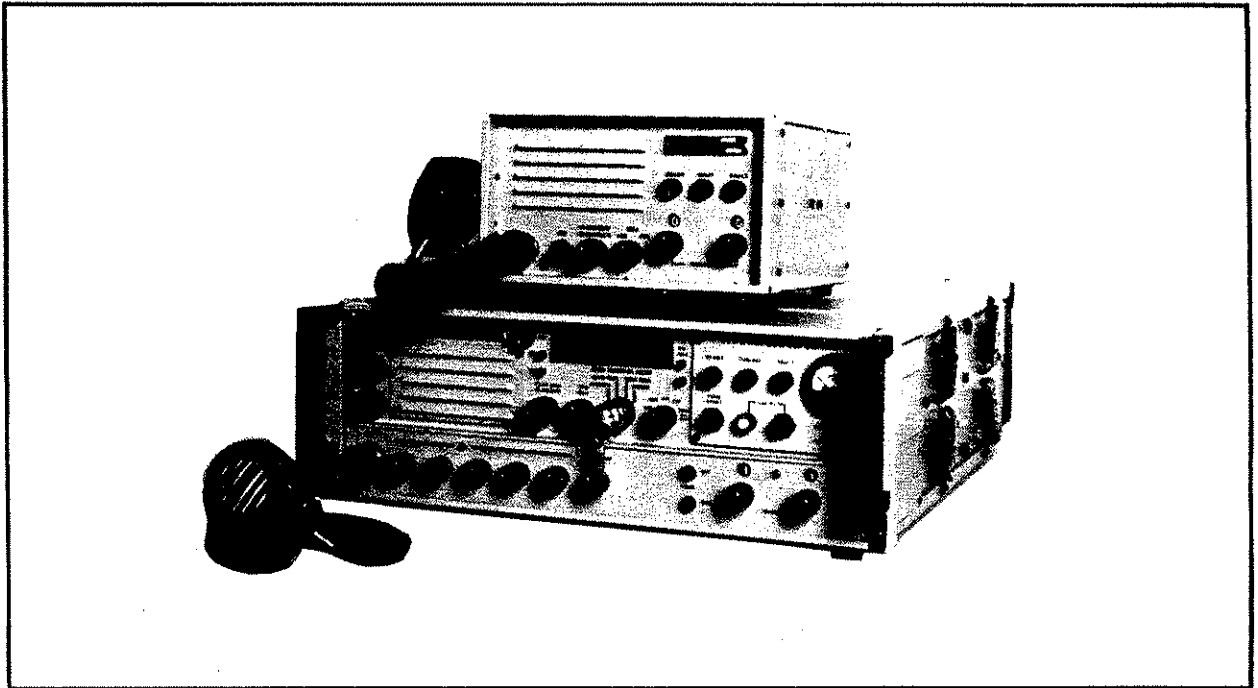

**sunair electronics, inc.**

3101 S. W. 3rd Avenue, Ft. Lauderdale, Florida 33315 USA



**OPERATION AND  
MAINTENANCE MANUAL**

**REMOTE CONTROLLED  
HF TRANSCEIVER**

**GSB-900 SC/R**

FIRST EDITION, 1 MARCH 1984  
MANUAL PART NUMBER 8070000503

## PRODUCT SERVICE:

In case of difficulty please contact the Sunair Product Service Department, between the hours of 8:00 AM and 5:00 PM or write to:

Product Service Dept.  
Sunair Electronics, Inc.  
3101 SW Third Avenue  
Ft. Lauderdale, FL 33315-3389  
U.S.A.

Telephone: (954) 525-1505  
Fax: (954) 765-1322

## TRAINING:

Sunair offers training programs of varying lengths covering operation, service, and maintenance of all Sunair manufactured equipment. For details please contact the Product Service Department.

# TABLE OF CONTENTS

Section	Page	Section	Page
<b>I GENERAL INFORMATION</b>			
1.1	Scope .....	3.7	Operating with the GCU-935 or DCU-100 Antenna Couplers .....
1.2	General .....	3.8	Operating with the GSL-1900A Kilowatt Linear Power Amplifier .....
1.3	Technical Specifications: GRC-901.....		
1.4	Equipment Supplied .....		
1.5	Optional Equipment .....		
1.6	Fuse Complement .....		
<b>II INSTALLATION</b>			
2.1	General .....		
2.2	Unpacking and Inspection .....		
2.3	Reshipping .....		
2.4	General Installation and Mounting Information GRC-901.....		
2.4.1	Base Station Installation .....		
2.4.2	Rack Mounted Installation .....		
2.4.3	System Configuration .....		
2.5	External Connections .....		
2.5.1	Primary Power .....		
2.5.2	Two-Wire Remote .....		
2.5.3	Line Level Adjustments .....		
2.5.4	Coupler Control Configurations .....		
2.5.5	Optional External Modem 1A3J2 .....		
<b>III OPERATION</b>			
3.1	General .....		
3.2	Operating Controls .....		
3.3	Rear Apron Fuses and Connections .....		
3.4	Coupler Control Panel GCU-935/DCU-100.....		
3.5	KW Coupler Control Panel .....		
3.6	Loading Frequencies .....		
3.6.1	Simplex Operation .....		
3.6.2	Half-Duplex Operation .....		
3.6.3	Half-Duplex Limitations .....		
3.6.4	Master Clear Operation .....		
3.6.5	Secure Operation .....		
<b>IV THEORY OF OPERATION</b>			
4.1	General .....		
4.1.1	Overall Block Diagram .....		
4.2	Introduction to DTMF Signaling .....		
4.2.1	DTMF Signaling .....		
4.3	DTMF Signaling Matrix .....		
4.4	Digital Assembly 1A5 .....		
4.4.1	Encoder Functions .....		
4.4.2	Decoder Functions .....		
4.4.3	KW Filament On .....		
4.4.4	Switch Pulse Detector .....		
4.4.5	Power Up .....		
4.5	Analog Assembly 1A6 .....		
4.5.1	Receive Hybrid .....		
4.5.2	DTMF Receive .....		
4.5.3	HF Receive Audio .....		
4.5.4	External Modem HF Receive Audio .....		
4.5.5	Keyline Tone .....		
4.5.6	Speech and Keyline Tone .....		
4.5.7	Modem Audio and Keyline Tone .....		
4.5.8	DTMF Transmit .....		
4.5.9	Squelch .....		
4.5.10	Speaker Driver Board 1A7 .....		
4.5.11	Power Supply .....		
4.6	Transceiver Board 1A9 .....		
4.6.1	Transceiver Board Analog Section .....		
4.6.2	Digital Functions .....		
4.7	Pilot Supply 1A10 .....		
4.8	Kilowatt Control Panel 1A2 .....		
4.8.1	KW Fil On .....		
4.8.2	Plate On .....		
4.8.3	KW Tune .....		
4.8.4	Fault .....		
4.8.5	Ready .....		
4.8.6	Local Control .....		
4.9	Mother Board 1A1A5 .....		
4.10	Front Panel 1A1 .....		

## TABLE OF CONTENTS (Cont.)

Section	Page	Section	Page
V MAINTENANCE AND REPAIR			
5.1. General . . . . .	5-1	5.9 Transceiver Line Level Adjustment Procedure . . . . .	5-11
5.2 Disassembly . . . . .	5-1	5.9.1 Receive Level Procedure . . . . .	5-11
5.2.1 Transceiver Top or Bottom Cover Removal . . . . .	5-1	5.9.2 Transmit Level Adjustment . . . . .	5-12
5.2.2 Remote Control Head Cover Removal . . . . .	5-1	5.10 GRC-901 Control Head Line Level Adjustment Procedure . . . . .	5-12
5.2.3 Disassembly of the GRC-901 . . . . .	5-1	5.10.1 Receive Level Procedure . . . . .	5-12
5.3 Performance Tests . . . . .	5-1	5.10.2 Transmit Level Procedures . . . . .	5-12
5.3.1 Test Equipment . . . . .	5-1	5.11 Transceiver Depot Alignment Procedure . . . . .	5-12
5.3.2 Preliminary . . . . .	5-2	5.11.1 HF Receive and DTMF Transmit Audio . . . . .	5-12
5.4 Fault Analysis and Performance Chart . . . . .	5-3	5.11.2 Transmit and DTMF Receive Audio . . . . .	5-13
5.5 Channel Encoding Chart . . . . .	5-5	5.12 GRC-901 Control Head Depot Alignment Procedure . . . . .	5-13
5.6 Transceiver Board 1A9 . . . . .	5-6	5.12.1 Equipment Required . . . . .	5-13
5.7 KW Control Panel 1A2 . . . . .	5-9	5.12.2 Receive Audio Alignment . . . . .	5-14
5.8 Troubleshooting Chart . . . . .	5-10	5.12.3 Transmit Audio Alignment . . . . .	5-14

## LIST OF ILLUSTRATIONS

Figure		Page	Figure	Page	
2.1	Outline Dimensions GRC-901 . . . . .	2-3	5.1	GRC-901 with Cover Removed . . . . .	5-15
2.2	Panel Mounting Dimensions GRC-901 . . . . .	2-4	5.2	GRC-901 with PCB's Extended . . . . .	5-16
2.3	100 Watt Mobile Installation . . . . .	2-5	5.3	GRC-901 Chassis Assembly Schematic 1A1, 1A2, 1A3, 1A4 . . . . .	5-17
2.4	1 KW Fixed Station Installation . . . . .	2-6	5.4	GRC-901 Digital Board Schematic 1A5 . . . . .	5-22
2.5	100 Watt Fixed Station Installation . . . . .	2-7	5.5	GRC-901 Analog Board Schematic 1A6 . . . . .	5-28
2.6	GRC-901 AC Power Cable . . . . .	2-9	5.6	GRC-901 Speaker Driver Board Schematic 1A7 . . . . .	5-31
2.7	GSB-900SC/R - GRC-901 Cable . . . . .	2-10	5.7	GRC-901 Squelch Board Schematic 1A8 . . . . .	5-33
2.8	GSB-900SC/R - GRC-901 Two-Wire . . . . .	2-10	5.8	GSB-900SC/R Transceiver Board Schematic 1A9 . . . . .	5-35
3.1	GRC-901 Front Panel . . . . .	3-2	5.9	GSB-900SC/R Pilot Supply Board Schematic 1A10 . . . . .	5-39
3.2	GRC-901 Rear Apron . . . . .	3-3	5.10	GSB-900SC/R Front Panel Assembly Schematic 1A1 . . . . .	5-42
3.3	GSB-900SC/R Antenna Coupler Control Panel . . . . .	3-5	5.11	GSB-900SC/R Mother Board Schematic 1A1A5 . . . . .	5-48
3.4	GSB-900SC/R 1 KW Coupler Control Panel . . . . .	3-5	5.12	GSB-900SC/R Coupler Control Panel Schematic 1A2 . . . . .	5-51
3.5	GSB-900SC/R Front Panel . . . . .	3-7	5.13	GSB-900SC/R KW Coupler Con- trol Panel Schematic 1A2 . . . . .	5-53
4.1	GSB-900SC/R Block Diagram . . . . .	4-3	5.14	GSB-900SC/R Main Frame Schematic . . . . .	5-56
4.2	GRC-901 Block Diagram . . . . .	4-4			
4.3	DTMF Remote Control Simplified . . . . .	4-5			
4.4	GSB-900SC/R System Signaling Diagram . . . . .	4-6			
4.5	GSB-900SC/R DC Power Switching Simplified . . . . .	4-9			
4.6	GSB-900SC/R Top View . . . . .	4-12			
4.7	GSB-900SC/R Keyline Tone Simplified . . . . .	4-13			

THIS PAGE INTENTIONALLY LEFT BLANK.

## IN CASE OF DIFFICULTY

If your Sunair Electronics, Inc. equipment, develops a malfunction, please follow the steps outlined below to expedite your equipment repair.

1. Note all of the symptoms of the problem, i.e, when does it occur; how often; which modes of operation work, which do not; and anything else which might assist in problem solving.
2. Note model number and serial number.
3. When and from whom (dealer, representative or factory) equipment was acquired.
4. Note peripheral equipment being used in conjunction with the Sunair equipment. Is the peripheral equipment working properly?

After determining the answers to the above, contact your dealer or representative and discuss the problem with him, he may be able to fix the problem locally, avoiding shipping delays. If it becomes necessary to return the equipment to the factory, please follow the procedures outlined in Section II of this manual.

THIS PAGE INTENTIONALLY LEFT BLANK.

## SECTION 1

### GENERAL INFORMATION

#### 1.1 SCOPE

This instruction manual is a supplement to the GSB-900SC manual p/n 1004190000. The manual describes the GSB-900SC/R Transceiver interface section and the GRC-901 Remote Control Head. It includes Installation details, Operating instructions, Theory of Operation and Maintenance and Repair. For information concerning the transceiver, refer to the GSB-900SC manual.

#### 1.2 GENERAL

The GSB-900SC/R is a modified GSB-900SC containing a remote control interface card. The single sideband transceiver has a programmable memory system, providing storage capacity for 100 transmit and receive frequencies. The GRC-901 Remote Control Head utilized with the GSB-900SC/R provides the capability of accessing the stored frequencies by channel number, selecting the desired operating mode, and controlling the transceiver AC Power Supply remotely. Operation occurs over a two-wire path using Dual-Tone Multifrequency (DTMF) signaling. Termination at both the Remote Control Head and Transceiver is 600 ohms.

The Remote Control Head provides basic control functions such as Receive Volume, Squelch, Channel Select, and Automatic Antenna Coupler or Kilowatt lamps (READY, WAIT, and FAULT).

Where AC power is not available, such as mobile installations, a six conductor DC control cable (maximum 150 feet) may be used.

#### 1.3 TECHNICAL SPECIFICATIONS: GRC-901

Refer to the GSB-900SC manual for GSB-900SC/R specifications.

**FREQUENCY RANGE:** Access to 100 stored channels in the GSB-900SC/R.

**FREQUENCY SELECTION:** 2 Digit mechanical, back illuminated.

**OPERATING MODES:** USB, LSB, AM (FSK or FAX with optional external modem).

**ENVIRONMENTAL:** -30°C to +50°C

**HUMIDITY:** 100% at 50°C

**SHOCK:** Per MIL-STD-810B, method 516.1 Procedure I, Fig. 516.1.2 Amplitude a Duration C.

**VIBRATION:** Per MIL-STD-810B, method 514.1, Procedure VIII, Curve V.

**ENCLOSURE:** Per MIL-STD-108, Table II. (Splashproof)

**POWER INPUT:** AC: 115/230 Volts +10% 50-60 Hz 35 Watts (two wire)  
DC: +28VDC power supplied by GSB-900SC/R (six wire)

**CONTROL CABLE:** Fixed Station, two-wire operation, 600 ohm balanced screw type terminal block.

Mobile, 6 conductor shielded, 150 feet maximum MS type connector.

**DIMENSIONS:** (INCHES) 5.22H x 9.0W x 10.00D  
(CM) 13.26H, 22.86W, 25.4D.

**WEIGHT:** 7.5 lbs., 3.4 KG

**AUDIO OUTPUT:** 5 watts into 8 ohms (speaker) @ less than 10% distortion.

# SUNAIR GSB-900SC/R

AUDIO INPUT: Front panel microphone 5k input impedance.

TWO-WIRE AUDIO: 600 ohm twisted pair.

CONTROL TONES: Dual tone multi-frequency (DTMF) channel and power switching tones, tone range from 683 Hz to 1666 Hz.

KEYLINE TONE: 304 Hz single tone 10 db below voice or external data modem.

XMT VOICE OR DATA: 450 Hz - 3000 Hz line level adjustable, +3 DBM maximum.

RCV VOICE DATA: 300-3000Hz Level Adjustable to -10DBM

EXTERNAL MODEM: 600 ohms unbalanced 0 DBM in, 0 DBM out.

EXTERNAL KEYLINE: Switch to ground.

## 1.4 EQUIPMENT SUPPLIED

Refer to GSB-900SC manual for equipment supplied with transceiver.

	Sunair Part No.	
GSB-900SC/R Transceiver	8070000058	Grey
	8070000091	Green
GRC-901 Remote Control Head	8070100052	Grey
	8070100095	Green
Operation and Maintenance Manual	8070000503	
Cable, primary power 115/230 VAC	8070002093	115V
	8070002091	230V
Microphone	50240000609	

## 1.5 OPTIONAL EQUIPMENT

Control Cable (DC)	5024002296
Mobile Mounting Bracket	8070005092

Rack Mounting Kit	8070004053	Grey
	8070004096	Green
Depot Spares Kit for GSB-900SC/R	8070907096	
Depot Spares Kit for GRC-901	8070900091	
Field Module Kit for GSB-900SC/R	8070906791	
Field Module Kit for GRC-901	8070905794	
Connector Kit Modem	8070102292	
Running Spares Kit for GRC-901	8070906090	

**1.6 FUSE COMPLEMENT**

1A3F1 - ½ amp AC Power	0841310009
1A3F2 - ½ amp AC Power	0841310009
1A3F3 - 1 amp DC Power	0841100004

THIS PAGE INTENTIONALLY LEFT BLANK.

**CAUTION**

TO INSURE THAT CABLE HAS NOT BEEN DAMAGED DURING SHIPMENT, ALL CABLE ASSEMBLIES MUST BE CHECKED FOR CONTINUITY OR SHORTS, FROM PIN TO PIN, BETWEEN CONNECTORS BEFORE INITIAL RADIO OR SYSTEM POWER UP.

**WARNING**

CONNECTORS INSTALLED BY THE CUSTOMER MUST BE WIRED IN ACCORDANCE WITH INSTALLATION INSTRUCTIONS PROVIDED IN THE OPERATION AND MAINTENANCE MANUAL. THE CABLE MUST BE CONTINUITY CHECKED AFTER INSTALLATION AND PRIOR TO RADIO OR SYSTEM POWER UP.

THIS PAGE INTENTIONALLY LEFT BLANK.

## SECTION 2

# INSTALLATION

### 2.1 GENERAL

Section II contains all necessary instructions for the unpacking, inspection, and if necessary, re-shipping of damaged equipment or parts. In addition, information regarding location mounting considerations and power requirements is also provided. Instructions for antenna and ground system hook-ups are provided in Section 2.5 of the GSB-900SC manual p/n 1004190000.

### 2.2 UNPACKING AND INSPECTION

Unpack and inspect all parts and equipment as soon as received.

#### NOTE

*Be sure to retain the carton and its associated packing materials should it be necessary to reship damaged equipment.*

Do not accept a shipment when there are visible signs of damage to the cartons until a complete inspection is made. If there is a shortage of items or any evidence of damage is noted, insist on a notation to that effect on the shipping papers before signing the receipt from the carrier.

If concealed damage is discovered after a shipment has been accepted, notify the carrier immediately in writing and await his inspection before making any disposition of the shipment. A full report of the damage should also be forwarded to Sunair. Include the following:

- (a) Order Number
- (b) Model and serial number
- (c) Name of transportation agency.

When Sunair receives this information, arrangements will be made for repair or replacement.

When necessary to return equipment to Sunair for warranty or non-warranty repair, an Authorization Number is required. This number can be obtained from the Product Support Department. Telephone: 305-525-1505, Telex: 51-4443, or Cable: SUNAIR.

### 2.3 RESHIPPING

The shipping carton for the equipment has been carefully designed to protect the transceiver and its accessories during shipment.

This carton and its associated packing materials should be used to reship the transceiver.

If the original shipping carton is not available, be sure to carefully pack each unit separately, using suitable cushioning material where necessary. Very special attention should be given to providing enough packing material around controls, connectors, and other protrusions from the transceiver. Rigid cardboard should be placed at the corners of the equipment to protect against denting.

When returning one or more subassemblies for repair, please ship AIR PARCEL POST consigned to:

SUNAIR ELECTRONICS, INC.  
3101 SW 3rd Avenue  
Ft. Lauderdale, Florida 33315-3389  
U.S.A.

ATTN: PRODUCT SUPPORT DEPARTMENT

Plainly mark with indelible ink all mailing documents as follows:

U.S. GOODS RETURNED FOR REPAIR VALUE  
FOR CUSTOMS (\$100.00)

and be sure to mark all sides of the package

"FRAGILE - ELECTRONIC EQUIPMENT".

**NOTE**

*Before shipping, carefully inspect the package to be sure it is marked properly and is securely wrapped.*

**2.4 GENERAL INSTALLATION AND MOUNTING INFORMATION GRC-901**

Refer to the GSB-900SC manual p/n 1004190000 Section 2.4 for information concerning the GSB-900SC/R Transceiver.

**NOTE**

*If the GSB-900SC/R is used without the GRC-901 Remote Control Unit, a 600 ohm 1/4 watt resistor must be placed between pins E and F of the audio connector 1A8J2 at the rear of the GSB-900SC/R Transceiver.*

**2.4.1 Base Station Installation - GRC-901**

The Remote Control Head is equipped with rubber feet so that it can be set directly on a table, desk or similar flat surface. The front feet are taller than the rear feet in order to tilt the unit at a convenient operating angle. Minimum clearances of 1 inch at the side, rear, and top should be allowed to provide adequate cooling. Figure 2.1 shows the outline configuration for the GRC-901.

**2.4.2 Rack Mounted Installation**

The GRC-901 may be conveniently mounted in a standard 19" rack using the optional rack mount kit p/n 8070004053/96. The kit includes rack mount ears and hardware. The GRC-901 in the rack mount configuration, requires a standard panel space of 5 1/4". Refer to Figure 2.2 for assembly details.

**2.4.3 System Configuration**

The following are recommended configurations for the GSB-900SC/R, GRC-901 with optional 100 Watt Antenna Coupler or Kilowatt Power Amplifier. Figure 2.3 is a block diagram of the Mobile Station GRC-901 Remote Control Unit, GSB-900SC/R Transceiver, and GCU-935 100 Watt Coupler. Figure 2.4 is a block diagram of a fixed station GRC-901, GSB-900SC/R, and GCU-935. The GSL-1900A Kilowatt Amplifier with companion GCU-1935 Coupler is shown in Figure 2.5. The GSL-1900A may also be operated with broad-band antennas.

**2.5 EXTERNAL CONNECTIONS**

**2.5.1 Primary Power**

**2.5.1.1 Operation from AC Power Source**

- a. GSB-900SC/R: Switch the AC/DC switch on the Transceiver Board in the GSB-900SC/R to the AC position. For GSB-900SC/R primary power source information refer to Section 2.6.1, of the GSB-900SC manual.
- b. GRC-901: See Figure 2.6. The selection of 115 or 230 volt nominal line voltage is made by the appropriate wiring in the connector of the AC power cord assembly. The line voltage to the unit may be changed by changing the power cord. Since each leg of the power supply transformer is individually fused, there is no requirement to change fuses when changing line voltage.

**2.5.1.2 Operation from DC Power Source**

- a. GSB-900SC/R: Switch the AC/DC switch on the Transceiver Board in the GSB-900SC/R to the DC position. For GSB-900SC/R Primary Power Source information, refer to Section 2.6.3, of the GSB-900SC manual.
- b. GRC-901: See Figure 2.7. Connect the DC control cable from 1A3P1 power to GSB-900SC/R 1A8J2 Audio.

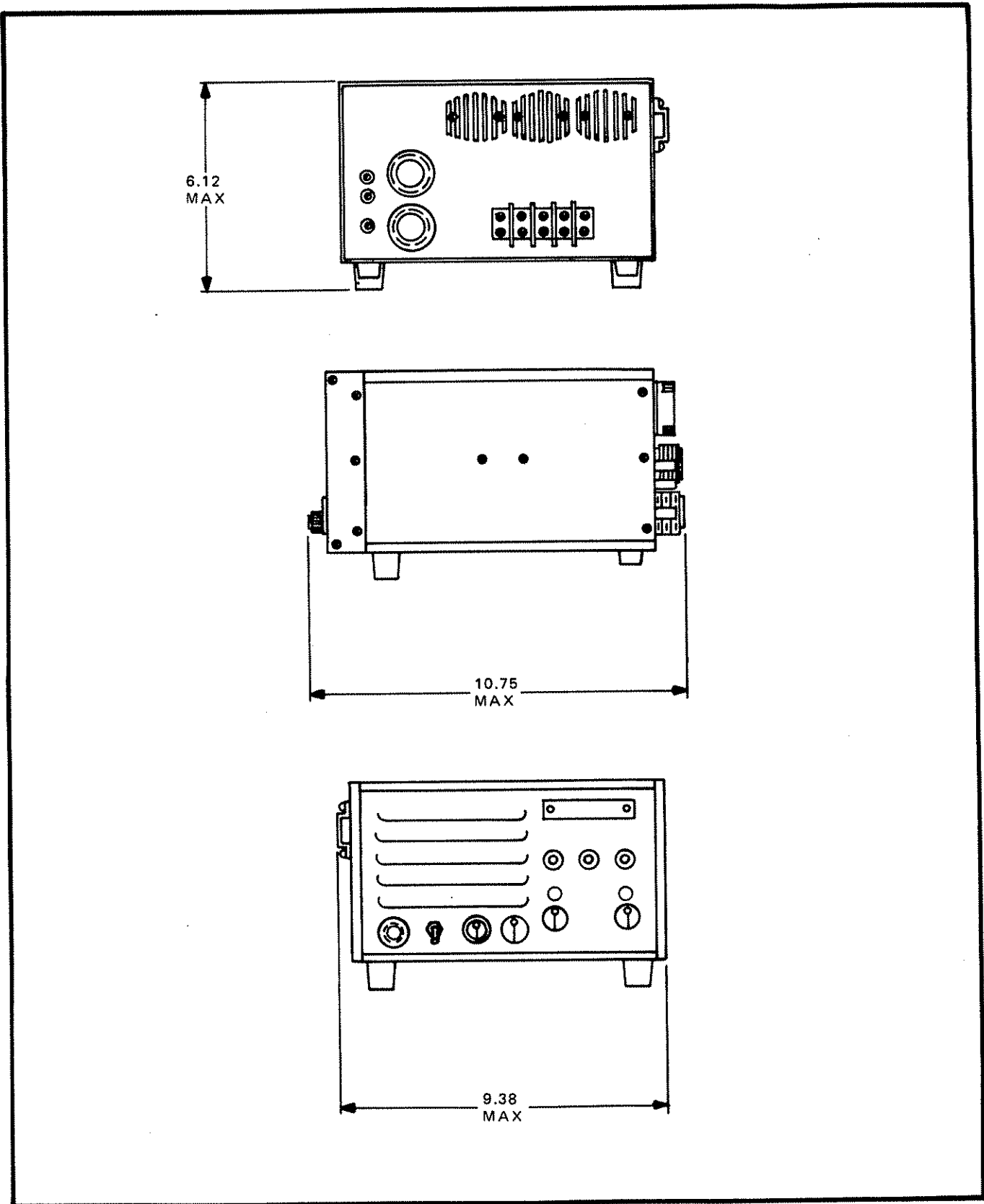

Figure 2.1 Outline Dimensions For GRC-901 Control Head

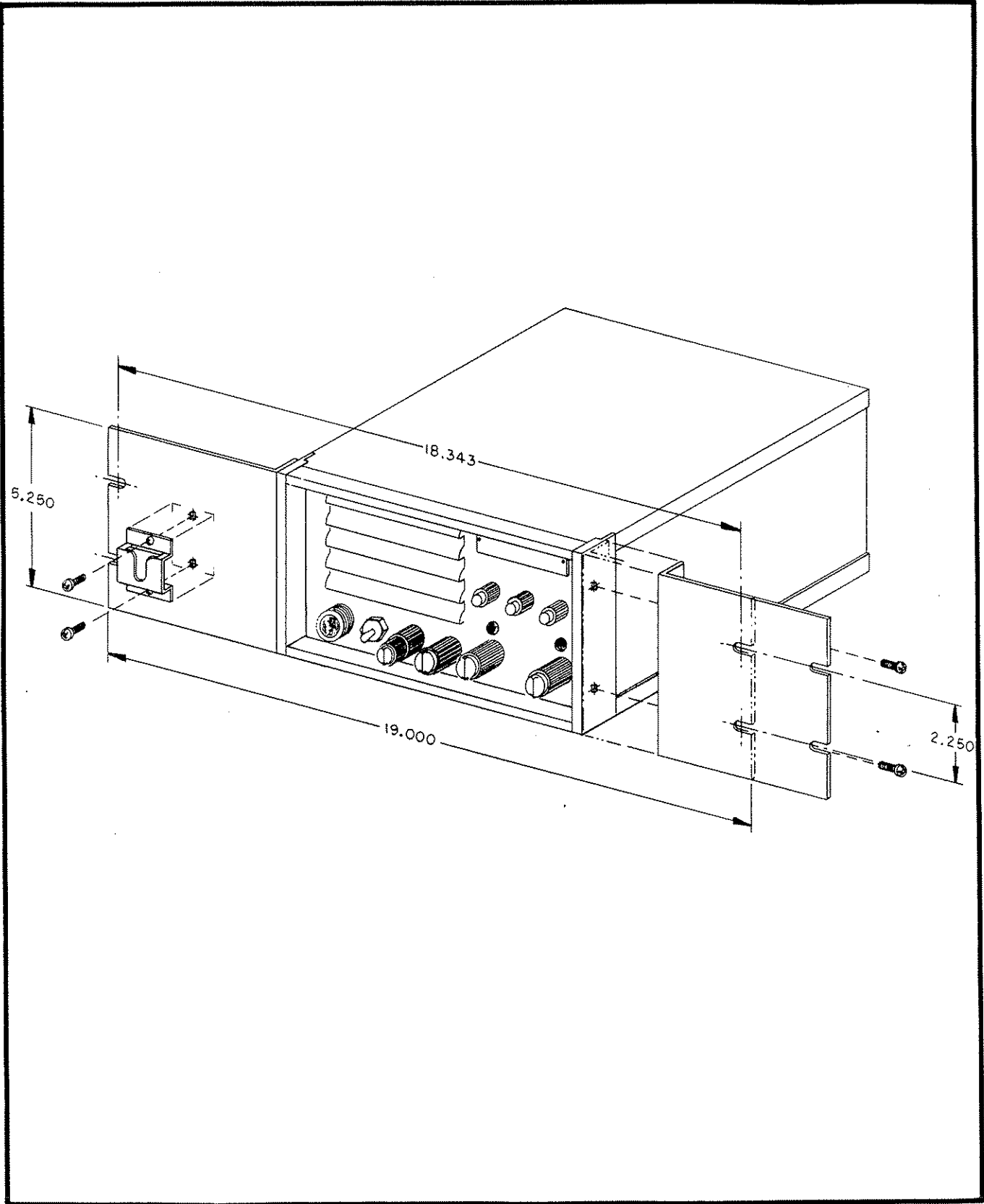

Figure 2.2 Panel Mounting Dimensions For GRC-901

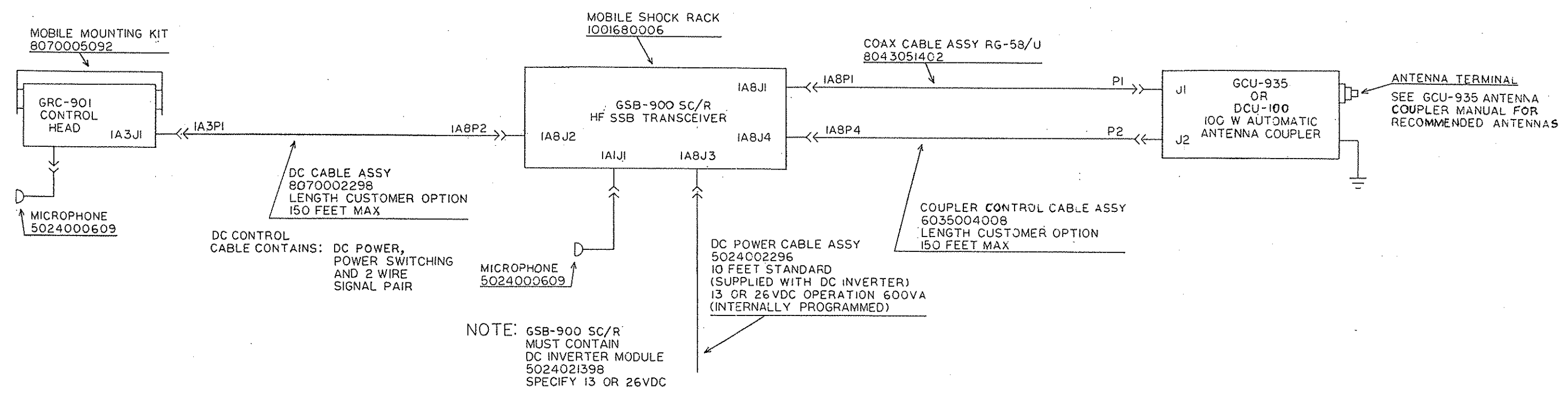

Figure 2.3 100 Watt Mobile Installation

SUNAIR GSB-900SC/R

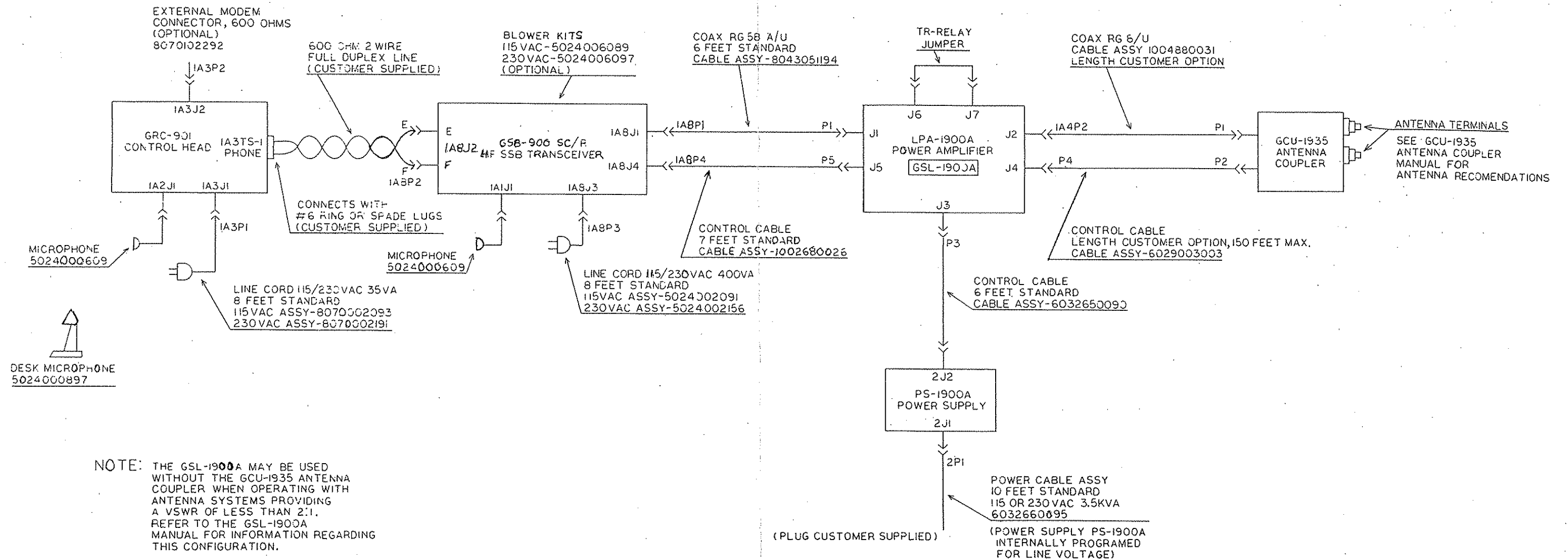

Figure 2.4 1 KW Fixed Station Installation

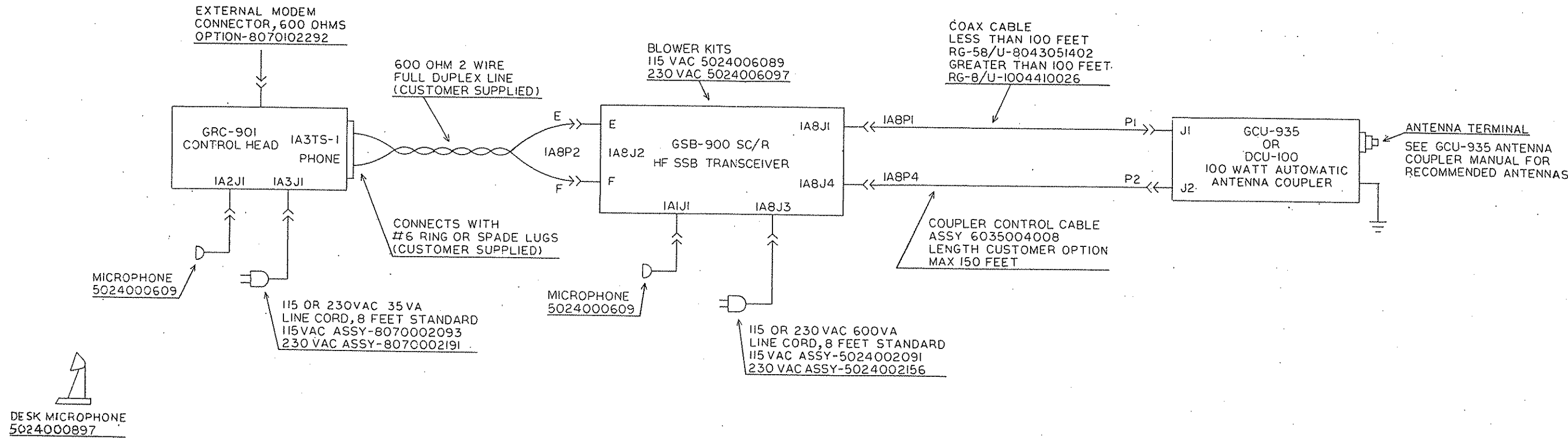

Figure 2.5 100 Watt Fixed Station Installation

THIS PAGE INTENTIONALLY LEFT BLANK.

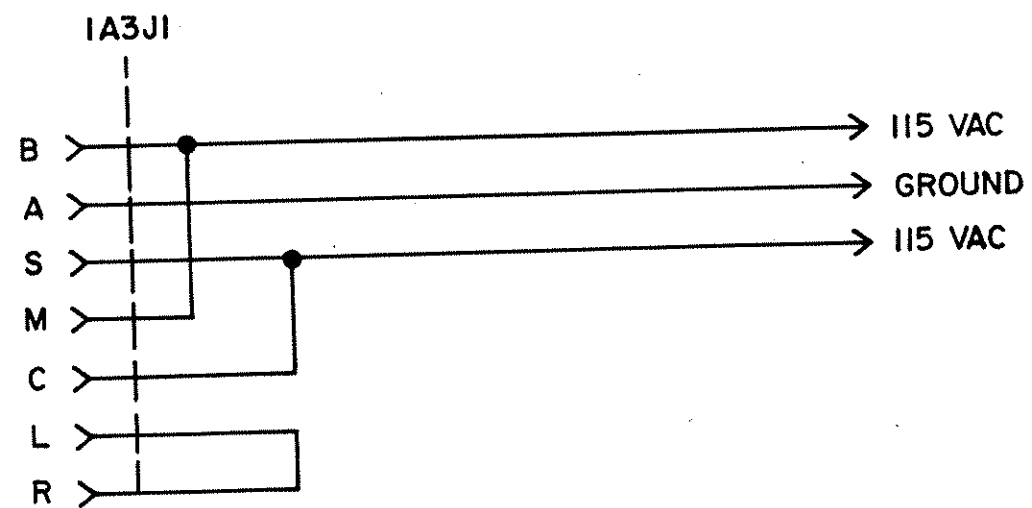
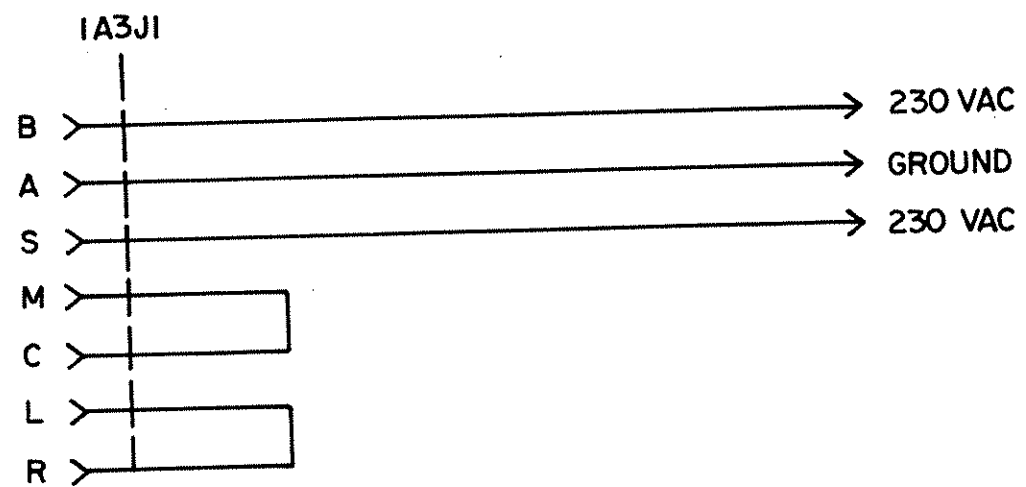

Figure 2.6 GRC-901 AC Power Cable

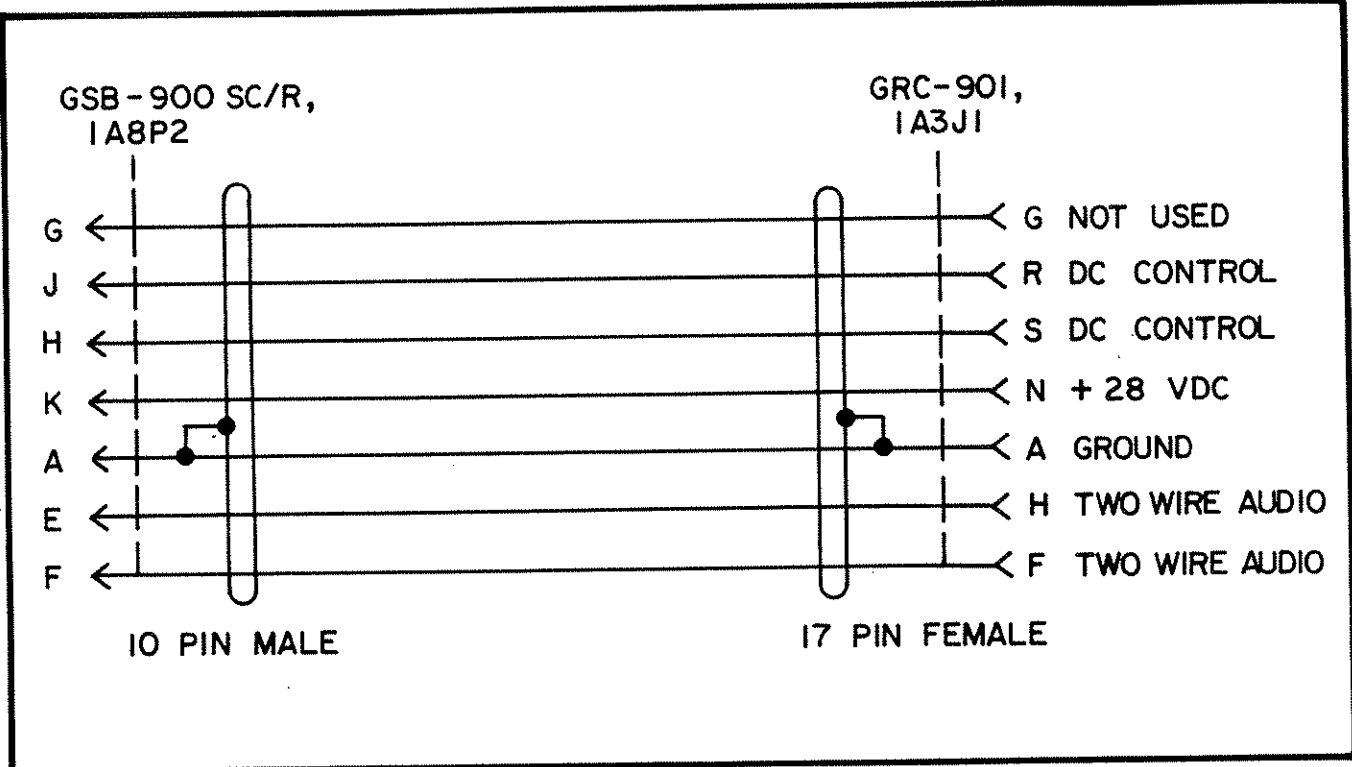

Figure 2.7 GSB-900SC/R DC Cable

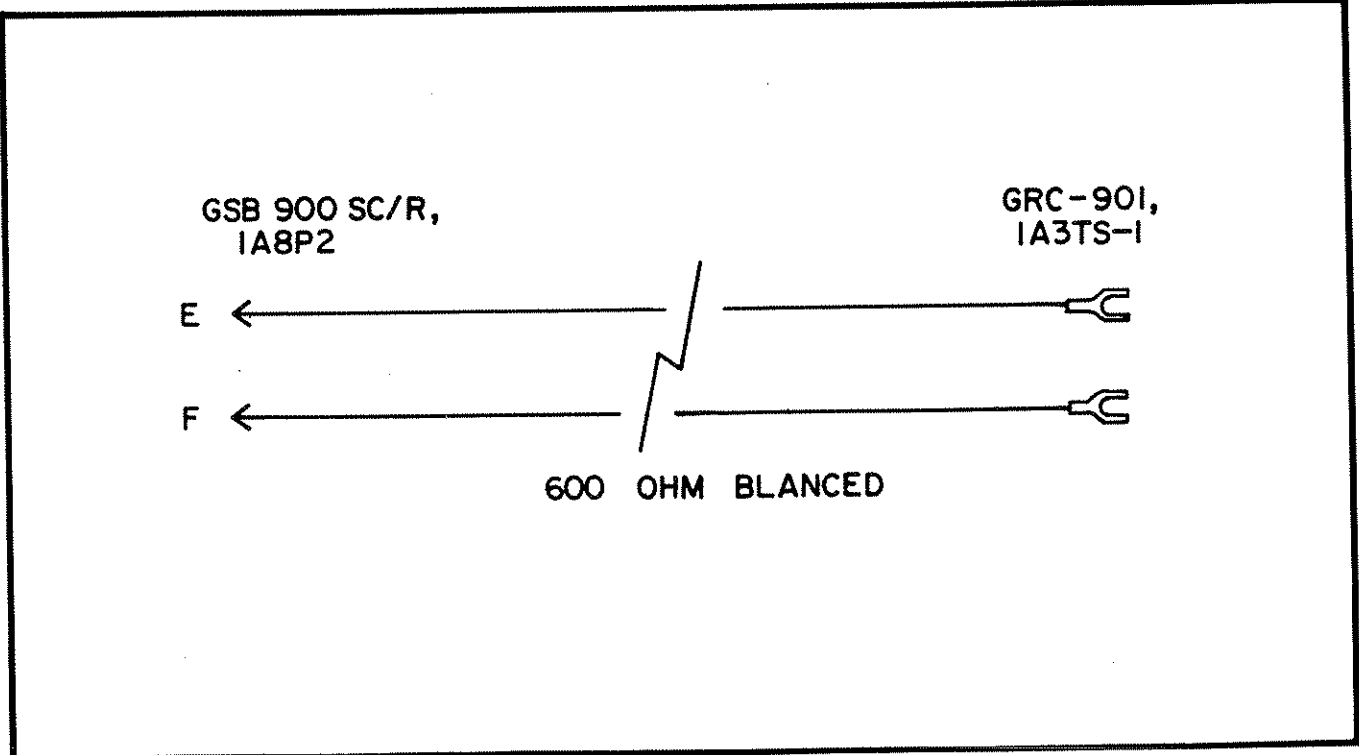

Figure 2.8 GSB-900SC/R-GRC-901 Two Wire

### 2.5.2 Two-Wire Remote Cable

See Figure 2.8

When using an AC power source, connect the two-wire line between the GRC-901 1A3TS-1 and the GSB-900SC/R 1A8J2 Audio pins E and F. In DC operation, the two-wire line is part of the DC Control Cable. **DO NOT** connect a two-wire line to the phone terminals during DC operation.

### 2.5.3 Line Level Adjustments

If it is necessary to adjust the Line Levels on the two-wire line, refer to the Line Level Adjustment Procedures outlined in Section V, paragraphs 5.9 through 5.12.

### 2.5.4 Coupler Control Configurations

The following are Coupler Control Panel Configurations for the GSB-900SC/R Transceiver Front Panel.

- a. If the GSB-900SC/R is ordered for use with the GCU-935 Coupler, the Antenna Coupler Control Panel p/n 8070048051 is factory installed in the GSB-900SC/R Front Panel.
- b. If the GSB-900SC/R is ordered for use with the GSL-1900A Linear Amplifier, the Special KW Control Panel p/n 8070050098 is factory installed in the GSB-900SC/R Front Panel.
- c. If a GSB-900SC/R is currently in use with a GCU-935 and containing the Antenna Coupler

Control Panel is to be used with the GSL-1900A, a Special KW Control Panel p/n 8070050098 must be ordered from the factory and installed in the GSB-900SC/R Front Panel.

#### NOTE

*The GSB-900SC/R will not operate with the GSL-1900A unless a special KW control panel has been installed.*

### 2.5.5 Optional External Modem 1A3J2 (Connector Kit Required)

1A3J2 provides an interconnect between the GRC-901 and external Modems. The pin outs on the 1A3J2 connector are as follows:

- a. Modem Power ground.
- b. Modem Transmit Audio - 600 ohms Odbm, single end.
- c. Modem Transmit Audio ground.
- d. +24 VDC (max 100ma).
- e. Modem Receive Audio - 600 ohms Odbm, single end.
- f. Modem Receive ground.
- g. Remote Keyline (switch to ground).
- h. +12VDC (max 100ma).

THIS PAGE INTENTIONALLY LEFT BLANK.

## SECTION 3 OPERATION

### 3.1 GENERAL

This section provides instructions required for proper operation of the GRC-901 Remote Control Head. Also included in this section are instructions for loading frequencies into the GSB-900SC/R. Refer to Section 3.2, page 3-1, of the GSB-900SC manual p/n 1004190000 for Transceiver operating instructions.

### 3.2 OPERATING CONTROLS

Listed on the following pages are descriptions of all controls, indicators and connectors located on the GRC-901 Remote Control Head Front Panel. They are illustrated in Figure 3.1.

CONTROLS OR INDICATORS	FUNCTION
ON/OFF .....	Controls primary power.
SQUELCH .....	Controls receive audio squelch.
VOLUME .....	Controls receive audio signal to the speaker.
<u>Channel Selector Switches</u>	
CHANNEL TENS SWITCH.....	Selects frequency control memory locations containing the required transmit and receive frequencies.
CHANNEL ONES SWITCH .....	
MODE.....	Selects operating modes; USB, LSB, or AM.
READY LAMP (Green).....	Indicates GCU-935/DCU-100 Antenna Coupler, or GSL-1900A Kilowatt Amplifier is ready.
WAIT LAMP (Amber).....	Indicates GCU-935/DCU-100 Antenna Coupler, or GSL-1900A Kilowatt Amplifier is tuning. When flashing, indicates GSL-1900A filament warm up. (3 Min. typical)
FAULT LAMP (Red) .....	Indicates GCU-935/DCU-100 Antenna Coupler, or GSL-1900A Kilowatt Amplifier fault.

### 3.3 REAR APRON FUSES AND CONNECTIONS

See Figure 3.2

**3.4 COUPLER CONTROL PANEL GCU-935/DCU  
100**

Refer to Figure 3.3

CONTROLS AND INDICATORS	FUNCTION
STATUS LIGHTS:	
READY.....	This light is illuminated after a tuning cycle has been successfully completed.
TUNING.....	This light is illuminated only during a tune cycle.
FAULT.....	This light is illuminated when one of the following conditions exists: <ul style="list-style-type: none"> <li>a. When the transceiver is initially turned on.</li> <li>b. When the MODE switch is switched from any position to TUNE KW or CPLR.</li> <li>c. When the time delay runs out and the GCU-935/DCU-100 coupler has not properly tuned.</li> <li>d. Anytime the reflected power exceeds the predetermined threshold.</li> </ul>

**3.5 KW CONTROL PANEL**

Refer to Figure 3.4

CONTROLS AND INDICATORS	FUNCTION
TUNE START.....	Initiates a tune cycle. This is the only action required to tune after MODE switch is placed in TUNE KW or CPLR.
LOCAL.....	When depressed, control of the system functions are returned to the transceiver front panel. When the GRC-901 is not connected, this button must be depressed after the transceiver's MODE switch is turned from OFF to any other position, to give control of the system to the transceiver front panel.
POWER MONITOR.....	a. Switches meter input when in transmit: <ul style="list-style-type: none"> <li>1) FWD: Indicates relative forward RF power at the output of the Transceiver.</li> </ul>

POWER MONITOR ( Cont. ) ..... 2) REFL: Indicates relative reflected RF power at the input to the coupler. A null in this reading indicates that the antenna is correctly matched to the transceiver.

b. Indicates strength of received signals at the antenna.

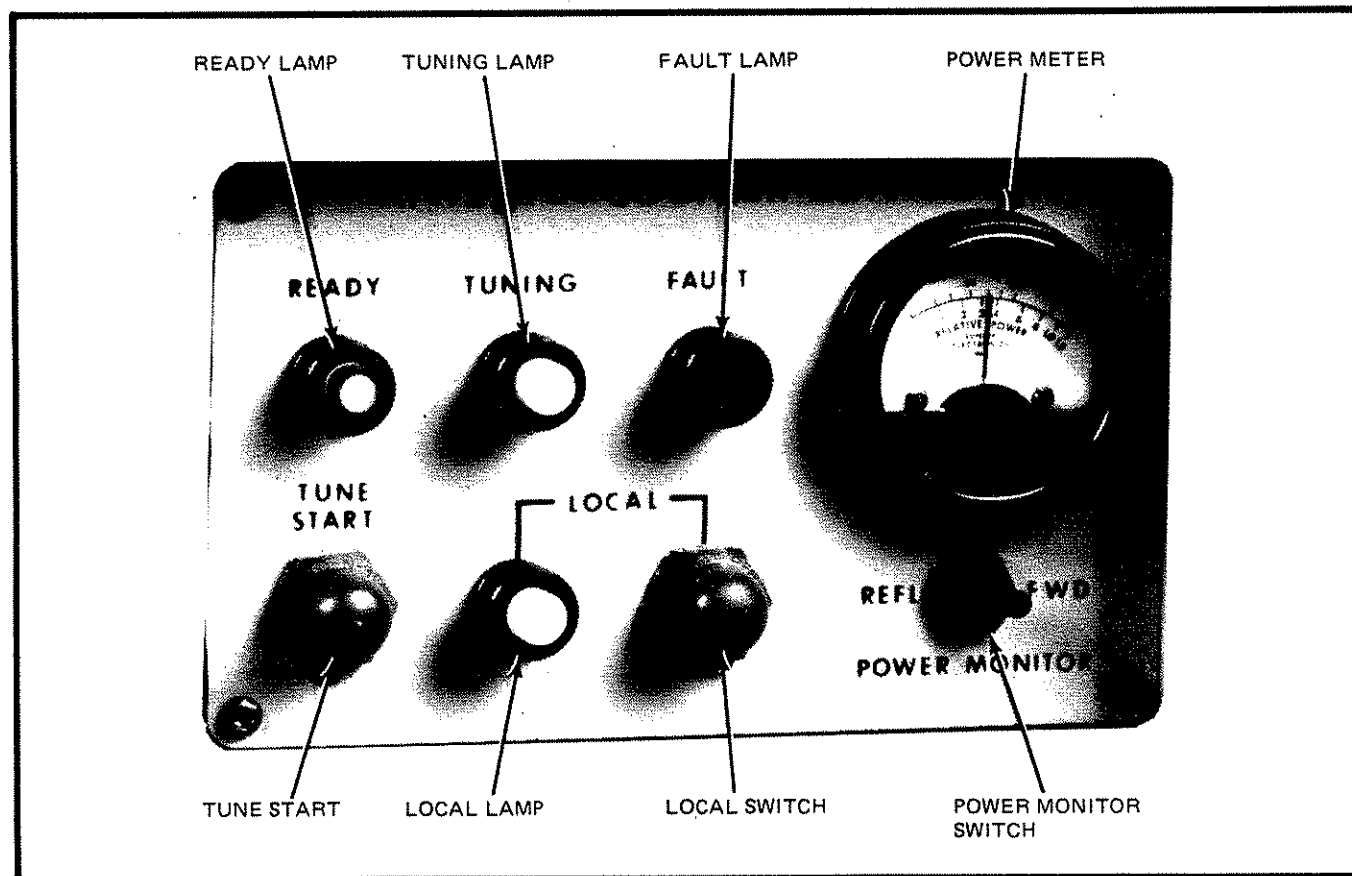

Figure 3.3 Antenna Coupler Control Panel



Figure 3.4 1 KW Coupler Control Panel

**3.6 LOADING FREQUENCIES****3.6.1 Simplex Operation**

Refer to Figure 3.5

Any desired channel may be loaded with a desired frequency and tested for simplex operation as above. Any channel from 00 through 99 may be selected and programmed with the same receive and transmit frequency without regard for its former contents. Any previous frequency stored in a channel will be erased if a new frequency is loaded into that channel.

**3.6.2 Half-Duplex Operation**

**3.6.2.1** Turn the Freq Control Mode switch to the Load Freq position. The Disable Lamp will turn on indicating that the transceiver is disabled.

**3.6.2.2** Set the two Channel Selector switches to the desired storage channel (00 to 99). Set the six Frequency Selector switches so that the display contains the desired receive frequency. Depress and release the Load REC pushbutton.

**3.6.2.3** Set the six frequency selector switches so that the display contains the desired transmit frequency. Depress and release the Load XMT pushbutton. The REC Lamp will turn off and the XMT Lamp will turn on while the Load XMT pushbutton is depressed.

**3.6.1.1** Turn the Freq Control Mode Key switch to the Load Freq position. The Disable Lamp will turn on indicating that the transceiver is disabled. The REC Lamp

will be on. **NOTE:** The GRC-901 does not have to be connected to load frequencies into the GSB-900SC/R.

**3.6.1.2** Set the two Channel Selector switches to the desired storage channel (00 to 99). Set the six Frequency Selector switches to the desired receive and transmit frequency.

**3.6.1.3** Press and release the Load REC pushbutton. Next press and release the Load XMT pushbutton. The XMT Lamp will turn on and the REC Lamp will turn off while the Load XMT pushbutton is pressed. The channel now contains the desired frequency in both the receive memory location and in the transmit memory location.

**CHANNEL VERIFICATION:**

**3.6.1.4** Turn the Freq Control Mode switch to the Read Freq position. The Disable Lamp will turn off, the REC Lamp will turn on, and the display will contain the frequency loaded above.

**3.6.1.5** Press and hold the Load XMT pushbutton. The XMT Lamp will turn on, and the REC Lamp will turn off. The display will continue to display the frequency loaded above. Release the XMT Load pushbutton. The REC Lamp will turn on and the XMT Lamp will turn off. Leave the Freq Control Mode switch in the Read Freq position. **NOTE:** When in remote operation using the GRC-901, the Freq Control Mode switch must be in either the Read Freq or Secure position.

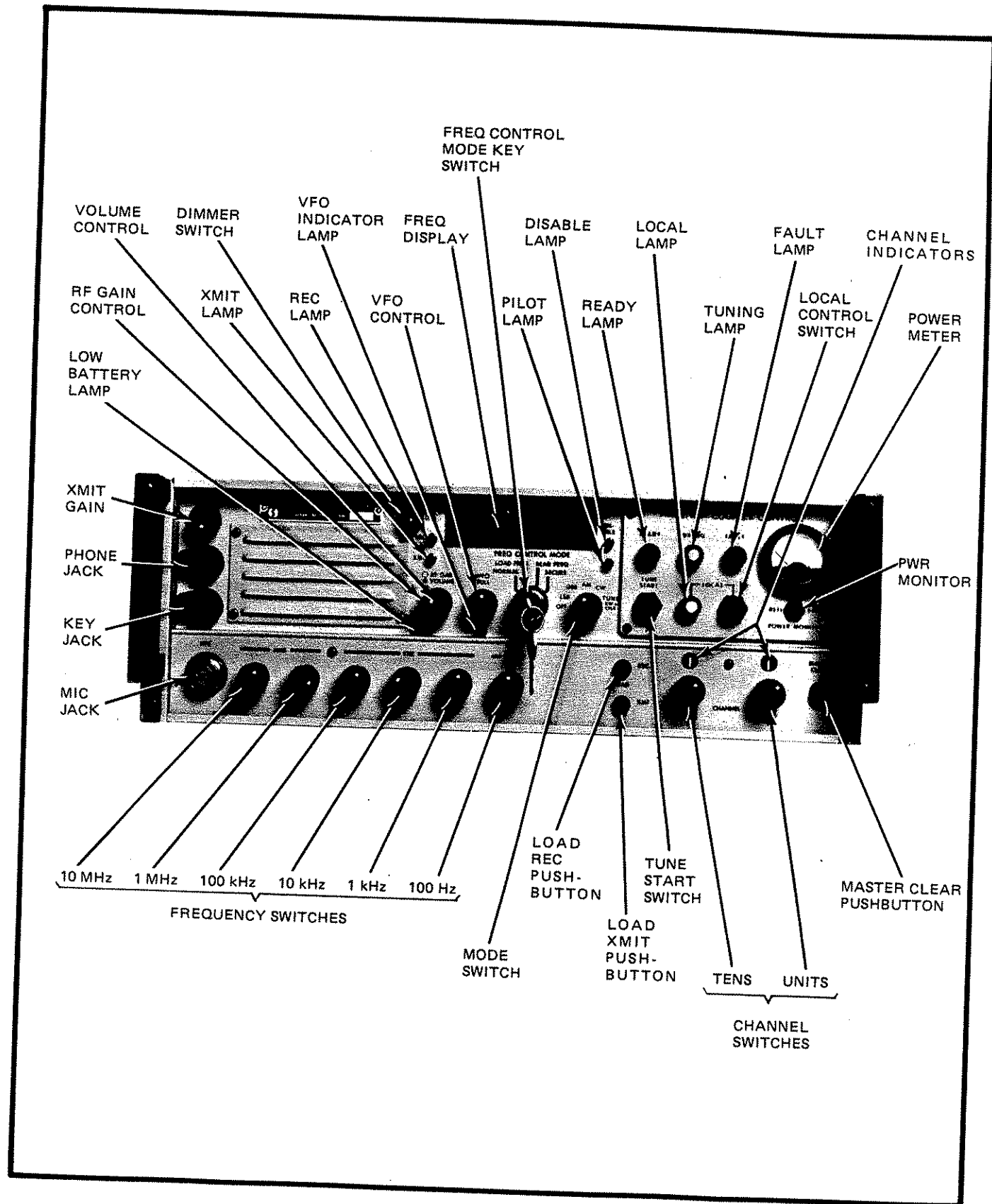

Figure 3.5 GSB-900SC/R Front Panel

CHANNEL VERIFICATION:

- 3.6.2.4. Turn the Freq Control Mode switch to the Read Freq position. The Disable Lamp will turn off and the display will contain the receive frequency loaded above.
- 3.6.2.5 Press and hold the Load XMT push-button. The XMT Lamp will turn on and the REC Lamp will turn off. The display will contain the transmit frequency loaded above. Release the Load XMT push-button. Leave the Freq Control Mode switch in the Read Freq position. **NOTE:** When in remote operation using the GRC-901, the Freq Control Mode switch must be in either the Read Freq or Secure position. Note that the receive frequency is displayed while the transceiver is receiving and the transmit frequency is displayed while transmitting. As in simplex operation, any desired channel may be loaded with a desired receive and a desired transmit frequency and tested for Half-Duplex operation as above. Any channel may be selected and programmed with a required receive frequency and a different required transmit frequency without regard for the former contents of the channel. Any previous information stored in a channel will be erased if a new transmit and a new receive frequency are loaded into that channel.

3.6.3 Half-Duplex Limitations

Half-Duplex operation requires one frequency for reception and a separate, discrete frequency for transmission. These two frequencies are normally separated from one another by less than 500 khz. This is required primarily by the selectivity characteristics of the antenna coupler. The coupler is tuned to the transmit frequency, so received signal strength degrades as the separation between the two frequencies is increased. However, the two frequencies are normally close to each other also because of the propagation characteristic of the two frequencies. The propagation characteristic

of two frequencies is such that the greater the separation of the two frequencies, the more variation in path length and the more fading will be noticed. (Typical Marine public correspondence stations have 300 to 400 khz separation between transmit and receive frequencies.) Consequently, for best Half-Duplex operation, never store in a Half-Duplex channel a transmit and a receive frequency that are more than 500 khz apart.

The GSB-900SC/R input and output filter networks, used to reduce harmonics and cross channel interference, are banded for the following frequency ranges:

Band 1	1.6 - 1.9999 Mhz
Band 2	2.0 - 2.9999 Mhz
Band 3	3.0 - 3.9999 Mhz
Band 4	4.0 - 5.9999 Mhz
Band 5	6.0 - 8.9999 Mhz
Band 6	9.0 - 12.9999 Mhz
Band 7	13.0 - 19.9999 Mhz
Band 8	20.0 - 29.9999 Mhz

In receive mode, these filters are bandpass networks, attenuating the received signal at frequencies above and below the band limits given above. In transmit mode, these filters are low pass networks, attenuating any transmit frequency above its upper band limit given above. If in a Half-Duplex mode the receive frequency is widely separated from the transmit frequency so that both are not in the same filter band, severe degradation of a received or transmitted signal may result if either the transmit or the receive frequency permanently selects the filter band for any Half-Duplex channel. Further since the memory system of the GSB-900SC/R is comprised of Random Access Memory capable of producing only one frequency output at a time, any Half-Duplex channel with the transmit frequency in a different band than the receive frequency will select the transmit band filters when transmitting and the receive band filters when receiving. Consequently any Half-Duplex channel with the transmit frequency in a different band than the receive frequency will require several seconds for the transceiver to select the correct filter network in making the transition from either transmit mode to receive mode or

receive mode to transmit mode. Therefore, in a Half-Duplex channel avoid storing, if possible, a transmit and a receive frequency that are in different bands because the transceiver will always be ineffective for several seconds during the transition from transmit mode to receive mode or receive mode to transmit mode as it selects the correct filter network.

### 3.6.4 Master Clear Operation

Rotate the Freq Control Mode keylock switch to the Load Freq position. Depress and release the Master Clear pushbutton using the eraser end of a pencil or some other similar shaped object that will fit inside the pushbutton guard.

When the Master Clear pushbutton is released, the frequency display will briefly contain all zeroes before again displaying the number selected by the frequency switches. Both the XMT Lamp and the REC Lamp should be dimly illuminated briefly before the REC Lamp again turns on at full brightness. The above activity clears to zero the entire contents of the GSB-900SC/R memory system. The purpose of this feature is to remove from the memory system all obsolete or forgotten frequencies so that only new and useful frequencies may be added with the knowledge that any unused channel is clean and empty of anything but zero. In this manner, a new record of the contents of the memory system may be made in the event that the old record is lost or incomplete. A second purpose of this feature is to provide a means of instantaneously erasing all frequencies in memory in the event that all records of operating frequencies require quick destruction. In this event, once the Master Clear pushbutton clears all of the memory system, the Freq Control Mode keylock switch may be rotated to the Freq Read or Secure position and the key removed from the keylock switch. This action will lock the transceiver into a position where it will be useless to anyone who uses it without permission since with every channel containing zero and no way to select the Load Freq or the Normal modes to change that fact, the transceiver will be permanently disabled.

### 3.6.5 Secure Operation

3.6.5.1 Rotate the Freq Control Mode keylock switch to the Secure position. The frequency display will Blank with the exception of the decimal point, which stays illuminated to indicate the memory system is functioning.

3.6.5.2 Remove the key from the Freq Control Mode keylock switch. The transceiver is now locked into a mode that both restricts knowledge of its operating frequency and prevents change of any frequencies set in any channel.

## 3.7 OPERATING WITH THE GCU-935 OR DCU-100 ANTENNA COUPLERS

- a. Turn the GRC-901 Remote Control Head Power switch to the ON position. (NOTE: The GSB-900SC/R must be in the LSB, USB, or AM position.) The WAIT Lamp will illuminate for approximately 1 second then go off. A constant WAIT Lamp may indicate a transceiver failure or a two-wire line failure.
- b. Select the desired operating channel and mode on the front panel of the GRC-901.
- c. Press the push-to-talk (PTT) button on the microphone. The WAIT Lamp will illuminate. When the Tune cycle is terminated, (approximately 3 to 45 seconds) the WAIT Lamp will extinguish and the READY Lamp will illuminate. Receipt of a FAULT Lamp may indicate the following:
  1. GCU-935 or DCU-100 Antenna Coupler failure.
  2. Antenna Failure
  3. Invalid frequency has been loaded into the GSB 900SC/R.

The system may be retuned by pushing the PTT button on the microphone.

**3.8 OPERATING WITH THE GSL-1900A KILO-WATT LINEAR POWER AMPLIFIER**

- a. Turn the GRC-901 Remote Control Head power switch to the ON position. (NOTE: The GSB-900SC/R must be in the LSB, USB or AM position.) The WAIT Lamp will illuminate for approximately 5 seconds, then begin to flash, indicating the GSL-1900A filaments are on. Approximately 3 minutes later the WAIT Lamp will extinguish and the FAULT Lamp will illuminate indicating the GSL-1900A filament timer has expired and the plate voltage has automatically turned on.
- b. Select the desired operating channel and mode on the front panel of the GRC-901.
- c. Push the PTT button on the microphone. The WAIT Lamp will illuminate. When the Tune cycle has terminated (approximately 4 to 10 seconds) the WAIT Lamp will extinguish and the READY Lamp will illuminate. Receipt of a FAULT Lamp may indicate one of the following:

1. GSL-1900A failure  
DC Overload  
VSWR Fault  
TUNE Fault
2. Antenna failure
3. Invalid frequency has been loaded into the GSB-900SC/R.

The system may be retuned by pushing the PTT button on the microphone.

**NOTE**

*Speaker audio and the keyline are inoperative when the FAULT Lamp is illuminated. The FAULT Lamp will also be displayed when changing channels or modes.*

- d. Receive: Turn the Squelch Control full CW. Adjust the Volume control for a comfortable listening level. Adjust the Squelch CCW without a receive signal to quiet background noise.
- e. Transmit: Push the microphone PTT button and speak into the microphone.

## SECTION 4

### THEORY OF OPERATION

#### 4.1 GENERAL

The Theory of Operation will pertain to DTMF Signaling, GRC-901 Remote Control Head, GSB-900SC/R Transceiver Encoder/Decoder Functions, and GSB-900SC/R control of the GCU-935/DCU-100/GSL-1900A. For the Theory of Operation of the GSB-900SC/R Transceiver, other than that which is covered in this supplement, refer to the GSB-900SC Manual p/n 1004190000.

##### 4.1.1 Overall Block Diagram

Figure 4.1 shows an overall block diagram of the GSB-900SC/R. Figure 4.2 shows the block diagram of the GRC-901. Discussion of the various circuits are presented in the following sections.

#### 4.2 INTRODUCTION TO DTMF SIGNALING

Refer to Figure 4.3

Dual-Tone Multi-Frequency (DTMF) signaling is a widely used method for telephone switching, and the remote controlling of equipment over a voice-grade path. DTMF utilizes a two tone signal to represent digits and special functions. The signal tones are divided into two groups; the Low group containing 697 Hz, 770 Hz, 852 Hz, 941 Hz and the High group containing 1209 Hz, 1336 Hz, 1477Hz, and 1633 Hz. The Low and High tone groups have been selected to minimize duplication by normal voice frequencies and are not harmonically related. Figure 4.3 illustrates a simple DTMF Remote Control. The DTMF Encoder uses a Row-Column 4 x 4 matrix providing 10 digits and 6 special codes. When Row 1 is connected to Column 1, a 701 Hz and a 1216 Hz signal appear on the output of the encoder. The tones are equal in amplitude and will remain for the duration of the matrix connection. The DTMF signal is amplified and transmitted over a two wire path

to the receiver. The receiver splits the two tones by using Low and High tone group filters. Each tone is processed and detected in the DTMF decoder. The result is displayed at the output of the decoder as BCD.

##### 4.2.1 DTMF Signaling

Refer to Figure 4.4

The GRC-901 Control Head utilizes four DTMF signals in a serial format to select the operating channel and Mode of the GSB-900SC/R Transceiver. The DTMF sequence is generated each time the FAULT Lamp is illuminated and the PTT line is switched to ground. Each DTMF signal is sent for 250 ms with a 250 ms Quiet Period between signals. The first DTMF signal "RESET" sets the transceiver counter circuits to 0. The second and third DTMF signals select the operating Channel and the fourth the operating Mode.

The GSB-900SC/R transceiver decodes the four DTMF signals, selects the operating frequency, Mode and initiates Antenna Coupler or 1 KW Amplifier tuning. Antenna Coupler or 1 KW Amplifier status at the completion of a Tune Cycle is provided to the GRC-901 Control Head by READY or FAULT DTMF signals. The 1 KW Amplifier also sends "KW FILAMENT ON" DTMF signal (flashing WAIT Lamp) to alert the Control Head operator the 3 minute KW Filament warm up cycle is in progress.

#### 4.3 DTMF SIGNALING MATRIX (GRC-901 1A5 DIGITAL BOARD)

Refer to Figure 5.4, Sheet 1. The DTMF Signaling Matrix is comprised of switches U1, U2, U3, and U4. Each device permits 1 of 4 possible Row-Column connections by placing a High on the control point. By placing a High on control

point 2 for instance, column 2 is connected to row 1, and DTMF "2" is sent.

#### 4.4 DIGITAL ASSEMBLY 1A5

##### 4.4.1 Encoder Functions (Tune Start)

Refer to Figure 5.4

When the PTT line is depressed a transition from High (1) to Low (0) appears on the TUNE line. It is inverted by U15A. This High appears on the clock input pin 11 of U10B. If the Data on U10B pin 9 is High, which indicates that a fault condition does exist, U10B will clock and the Q output, pin 13, will go High. This High is coupled through C2 and R4 as a positive going pulse. The pulse is squared by U15C and U15B to the clock input of U10A pin 3. U10A clocks, placing the Q output, pin 1, High and the  $\bar{Q}$  output, pin 2, Low. The Q output enables astable U12. Astable U12 pin 3 output drives U9 Decade counter clock input. On every positive clock pulse one of the decimal counter outputs will go High.

##### 4.4.1.1 DTMF-Reset

On the first positive clock pulse to U9, the first decimal output, "1" goes High and is coupled to U19B. From U19B pin 1 the High appears on U13B pin 6, U13B pin 4 and U6 pin 23. This inhibits U6 placing its outputs to zero. The High on U9 pin 2 turns on U4 in the encoder matrix enabling DTMF "C" RESET.

The second positive clock pulse generated by U12 places a High on U19B pin 2. This High is provided to U13B pin 6 and the resulting High on pin 23 of U6 inhibits the Decoder providing a 250ms Quiet Period between data tones.

##### 4.4.1.2 DTMF-MSD

The third positive clock pulse generated by U12 places U9 pin 7 High which is fed to U15F pin 13 and is inverted Low. This enables Tri-State-Buffer U7A which enables the Most Significant Digit (MSD) and disables the Least Significant Digit (LSD) and the Mode function. U7A provides

the MSD BCD switch data to U6 Decimal Decoder, turning on the appropriate Matrix switch U1 through U4.

The fourth positive clock pulse is a Quiet Period.

##### 4.4.1.3 DTMF-LSD

The fifth positive clock pulse enables the LSD via U9 and U15 as in the MSD operation. The MSD and the MODE selectors are disabled.

The sixth Positive clock pulse is a Quiet Period.

##### 4.4.1.4 DTMF MODE

The seventh positive clock pulse enables the MODE selector via U9 and U22 which reads the MODE and disables the MSD and LSD.

The eighth positive clock pulse places U9 pin 8 High which places U13D pin 13 and U14A pin 3 High. This Resets U10B and U10A. When U10A is Reset, U10B and U9 are reset to zero, and U12 is disabled.

#### 4.4.2 Decoder Functions

Refer to Figure 5.4 Sheet 2

U18 is the DTMF Crystal Control Bandsplit Filter. It separates the High and Low frequency tones for use by Decoder U17. X1 is a 3.5795 MHz crystal which provides the frequency standard for the Encoder/Decoder and Bandsplit Filter.

U18 separates and squares the High and Low tones. The conditioned tones are provided to DTMF Decoder U17 pins 11 and 12. The DTMF Decoder converts the two tones to a BCD value, based on the frequency of each of the two tones. A valid DTMF signal places pin 4 of U17 DTMF Decoder High after 30 ms. A pulse formed by C19, R17 and U22F, U22E latches the data in U16 on the negative edge. The BCD is decoded as READY, WAIT, FAULT, or KW Filament On signal which places a High on Lamp Driver Q1, 2, or 3 which illuminates the appropriate Front Panel Lamp.

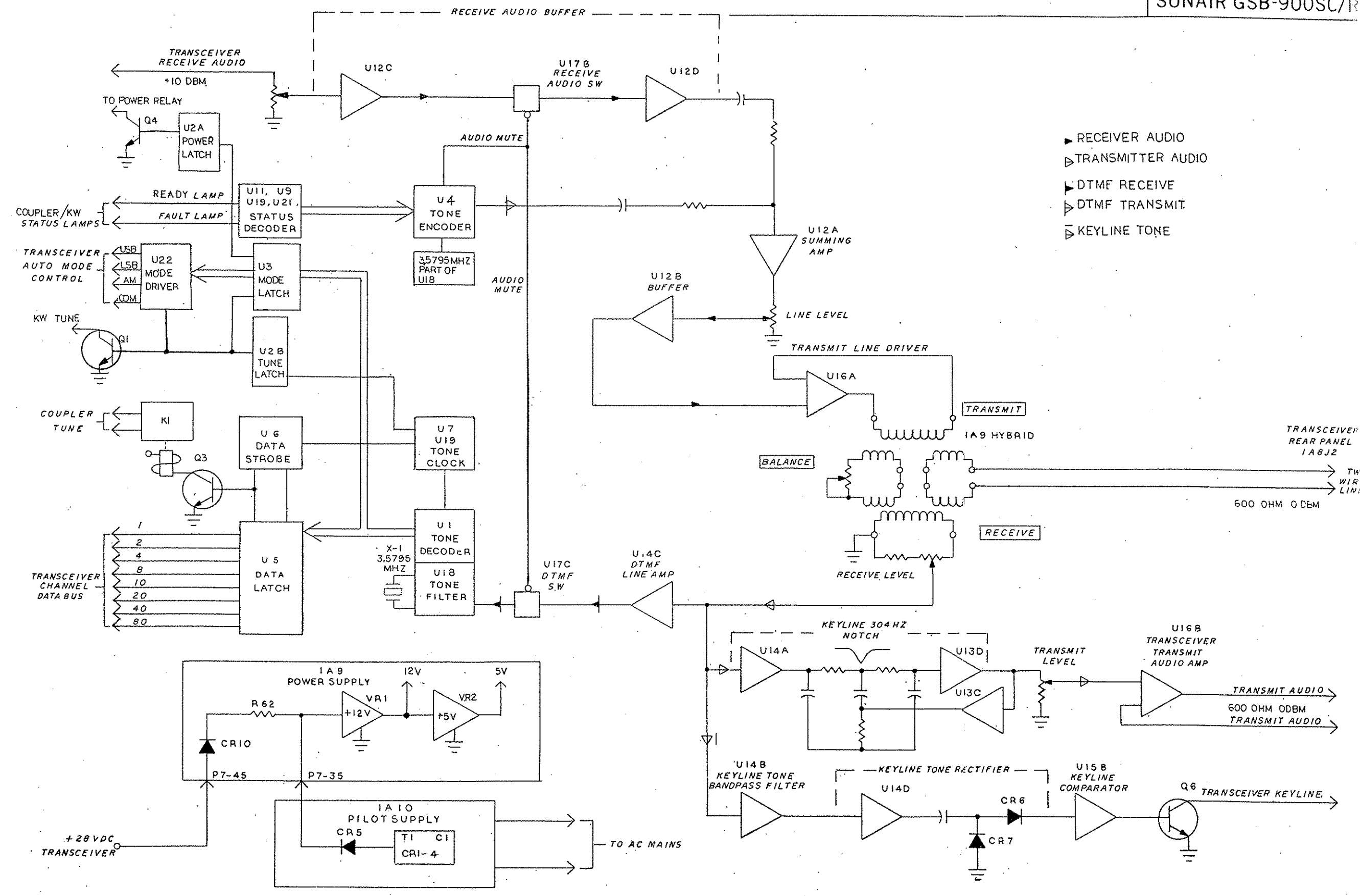

Figure 4.1 GSB-900SC/R Block Diagram

SUNAIR GSB-900SC/R

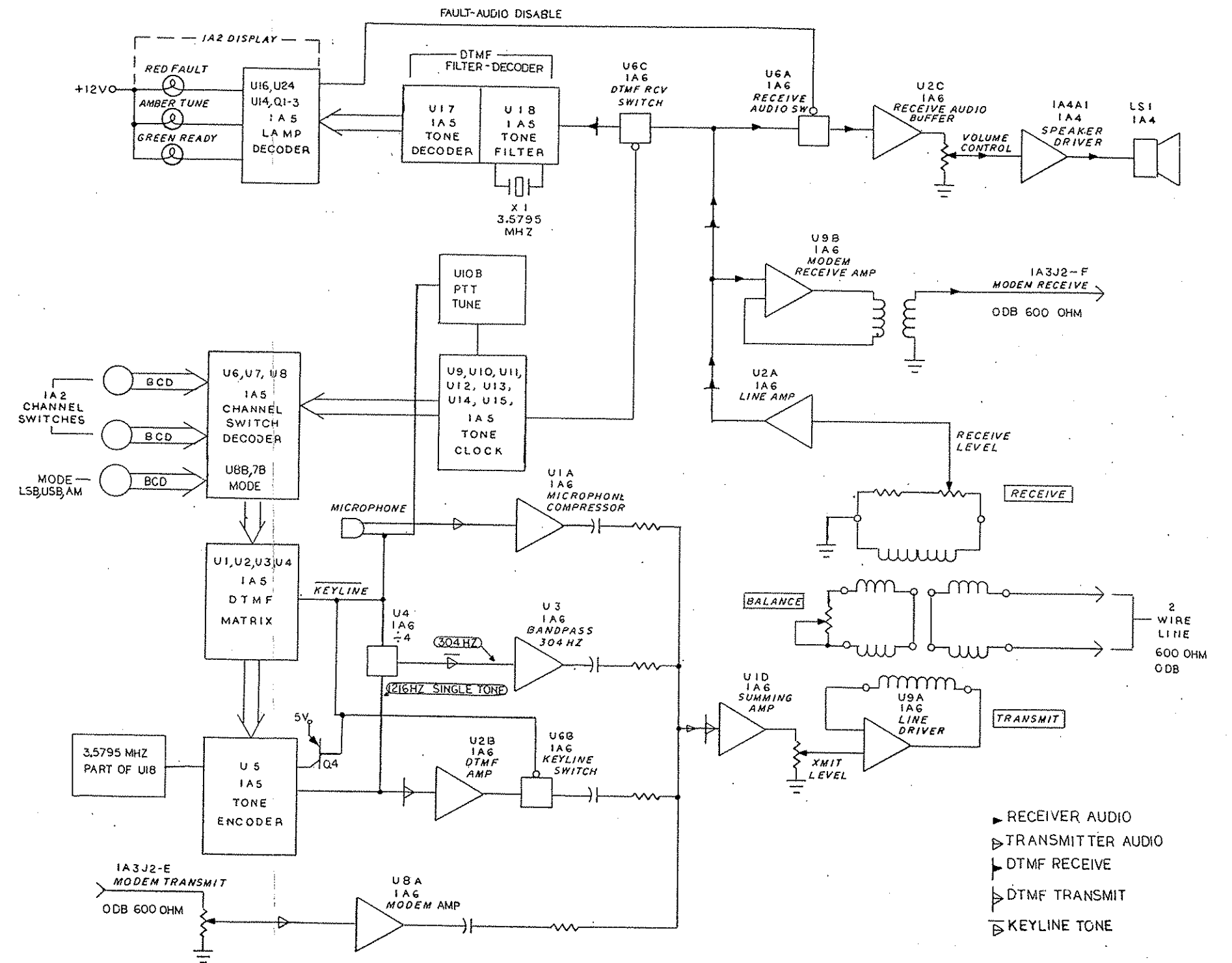

Figure 4.2 GRC-901 Block Diagram

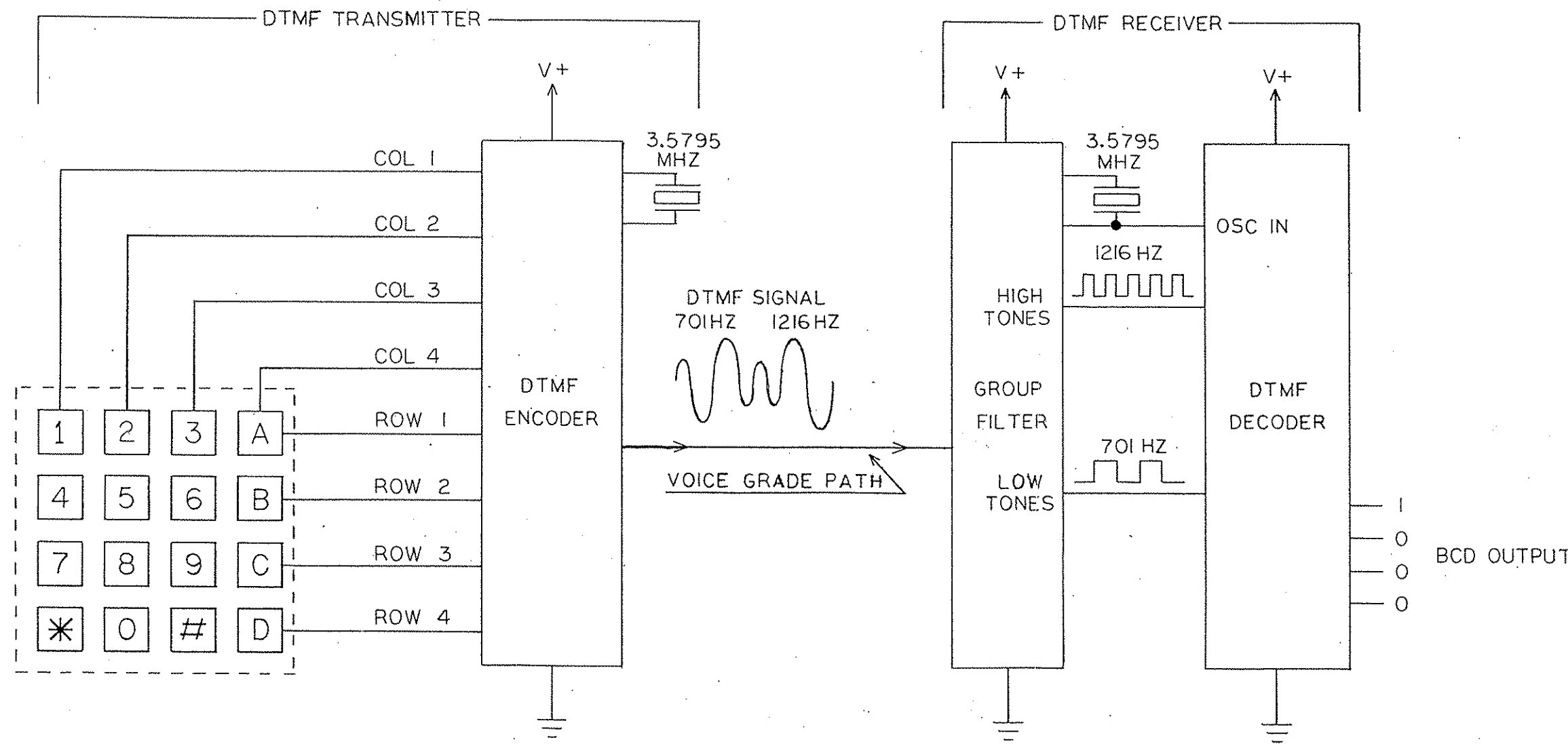
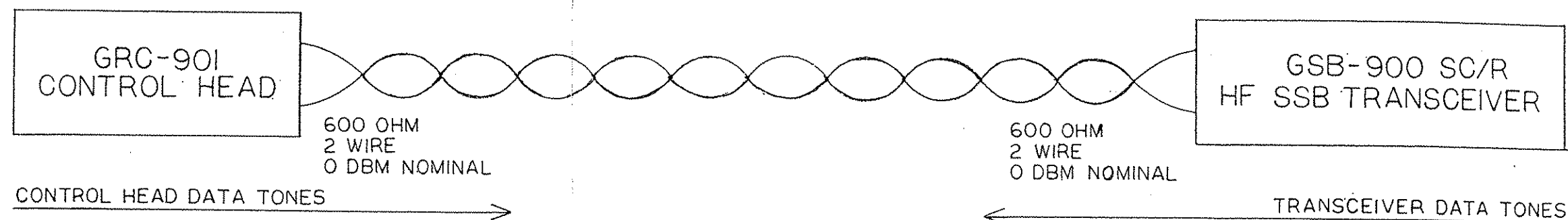

Figure 4.3 DTMF Remote Control Simplified



	<u>DTMF KEY</u>	
① RESET	C	
② CHANNEL TENS	0-9	}
③ CHANNEL ONES	0-9	
		SELECTED BY CHANNEL DIGITS
④ MODE: LSB	0	
USB	1	
AM	2	
NO MODE	3	

	<u>DTMF KEY</u>
① READY	#
② FAULT	*
③ KW FILAMENT ON (USED ONLY WITH GSL-1900A)	4

KEYLINE TONE: 304 HZ 10 DB BELOW  
SPEECH OR DATA

POWER ON - B  
POWER OFF - A

Figure 4.4 GSB-900SC/R System Signaling Diagram

#### 4.4.3 KW Filament On

Refer to Figure 5.4 Sheet 2

When a KW FIL ON signal is received, U16 Decoder places a High on the KW FIL ON output, pin 7. It is inverted by U22B inhibiting U24D. The High at U16 pin 7 also enables astable U23 pin 4. The clock High output at U23 pin 3 goes to U13A pin 1 which is fed to lamp driver Q2. As U23 clocks, Q2 flashes the WAIT Lamp indicating a KW FIL ON condition. This lamp continues to flash until a Fault tone is received indicating the plate supply has turned on. The KW FIL ON, pin 7 goes Low disabling U23 and places a High on U14C pin 6 which drives the lamp driver Q3 and lights the FAULT Lamp.

#### 4.4.4 Switch Pulse Detector

Refer to Figure 5.4 Sheet 2

The Switch Pulse Detector illuminates the FAULT Lamp each time the LSD, MSD, or MODE switch is rotated. The Least Significant Bit (LSB) of the MSD, LSD and MODE switches are connected to the pulse generator U21 and associated circuitry. Each switch rotation provides a positive pulse. Example: Inverter U21F, C15, and R26 generate a pulse on the negative transition of the LSB of the MSD switch. The pulse clocks U20A Q output High and  $\bar{Q}$  Low, placing U14C pin 5 High which turns on Q3 and illuminates the FAULT Lamp. The  $\bar{Q}$  disables the READY and WAIT Lamps through U24A and B. The High from U11B also appears on U13D pin 12, and U14A pin 2 resetting U10B via U13C pin 8. This terminates the DTMF send sequence, extinguishes the READY Lamp, and turns the receiver audio off. The Switch Pulse Detector is reset from the TUNE command.

#### 4.4.5 Power Up

Refer to Figure 5.4 Sheet 1

When the power is turned on, +5VDC is applied to all digital circuitry. Power Up conditioning circuit U15D pin 9 is Low until time constant R3, C3 expires. While pin 9 is Low the output of

U15D pin 8 is High. This High appears on U14A resetting U10A. U10A resets U9. The power up High is slightly delayed by R7 and C24 appearing on U14D and B. This High is inverted by U22D and places the Tone Decoder U17 in the Tri-State position which allows U16 to read Lows on pins 2, 3, 21, and 22 through resistor network RN4.

The rising output of U14B pin 11 is integrated by C19 and R17 producing a 1ms pulse. This pulse is conditioned by U22F, and U22E. The output of U22E pin 11 loads U16 on the negative side of the pulse. U16 pin 11, U24B, pin 4, and U13A pin 2 go High turning on Q2 and illuminating the WAIT Lamp.

#### 4.4.5.1 DTMF Power ON/OFF GRC-901

DTMF ON: When Front Panel Power switch S1 is placed in the "ON" position, +12VDC is supplied to the emitter of Q2 through 16AJ1-14. Q2 is disabled during the Power up period. When the Power up period expires, 1A6J1-28 goes Low. Inverter U5 switches open collector driver U11F Low. The Output of U11F goes Low turning on Q2. The collector of Q2 supplies +12VDC to Power On One Shot U12. U12 pin 7 goes High for 375ms. This High is provided to the Digital Board 1A5 on 1A5J1-16, enabling DTMF "B".

DTMF OFF: When Front Panel Power switch S1 is placed in the "OFF" position, +12VDC is supplied to Power Off one shot U11. U11 pin 7 goes High for 375ms. This High is provided to the Digital Board 1A5 on 1A5J1-17, enabling DTMF "A".

### 4.5 ANALOG ASSEMBLY 1A6

#### 4.5.1 Receive Hybrid

Refer to Figure 5.5 GRC-901 Analog Board 1A6

The HF Transceiver Audio appears on the two-wire line J2-7 and J2-8 of the Analog Board 1A6. The audio appears on pin 6 of hybrid T2. The audio is adjustable through variable attenuator assembly R34, R33 which presents a 600 ohm termination to the transformer. The audio is then

passed through R60 and C34, low pass filter. The Audio is amplified by U2A. The output of U2A pin 14, is distributed to External Modem Receive, Receive Audio, and DTMF Receive.

#### 4.5.2 DTMF Receive

Refer to Figure 5.5

DTMF Receive Audio is controlled by U6C. U6C control pin 6 is driven by open collector driver U11A. When the DTMF Off Line is High, the output of U11A, pin 16, places a Low on pin 6 of U6C inhibiting the audio. When a Low appears on U11A pin 1, the output, pin 16, goes High turning U6C on and passing the audio to the DTMF Receiver.

#### 4.5.3 HF Receive Audio

Refer to Figure 5.5

The HF Receive Audio is controlled by U6A. U6A control pin 13 is driven by an open collector driver U11G. When the Receive Audio Mute is High, the output of U11G, pin 10, goes Low, feeding a Low to pin 13 of U6A. U6A turns off inhibiting the Audio. This occurs whenever the READY Lamp is NOT illuminated. If U6A is on, the audio appears at U6A pin 1 and buffered by U2C. The output of U2C, pin 8, drives the Squelch Assembly 1A8.

#### 4.5.4 External Modem HF Receive Audio

Refer to Figure 5.5

The Modem Level audio is controlled by potentiometer R57, "Receive Modem Level" and coupled by C77, R63 to amplifier U1C pin 9. The output at pin 8, is fed to line driver U9B pin 5. The output U9B pin 7, is coupled through 600 ohm transformer T3, supplying audio to an external modem at 0dbm. (2.2V PPK)

#### 4.5.5 Keyline Tone

Refer to Figure 4.7

Figure 4.7 is a simplified version of the Keyline Tone circuitry contained in Figure 5. Assume that the Keyline Inhibit at J-11 is Low. Pin 9 of U7C is connected through blocking diode CR3 to the front panel PTT microphone switch. When the PTT is pressed, J1-6 is grounded and places a Low on pin 9 of U7C. With Low inputs on pins 8 and 9 of U7C the output pin 10 is Low and is fed to U7B pin 5. The output of U7B pin 4 will be Low provided that the on/off shots are Low. This Low is connected to the Digital Board 1A5 pin J1-7 and turns on Q4 placing +5V on the collector of Q4, which places a High on Column 1 U5 pin 3. A 1216 Hz tone is generated by U5 at pin 16. This tone is connected to J1-13 of the Analog Board 1A6, coupled through C6, and R26 to pin 6 of amplifier U2B. The 1216 Hz tone is coupled by C10, and R36 to pin 9 of Squaring Amplifier U3C. The tone appears on the output of U3C pin 8 as a square wave, and is coupled through voltage divider R38, and R39. A 1216 5V ppk square wave appears on the input of Schmitt Trigger U5B pin 3. U5B provides a CMOS compatible signal to Divider U4. Pin 15, ENABLE, of U4 is connected to U7B pin 4 output which is Low. The 1216 Hz square wave is divided by 4 and the output pin 12 appears as a 304 Hz square wave. This square wave is coupled by C12, and R40 to the 304 Hz bandpass filters U3A, B and D. The result of filter U3A, B and D is a 304 Hz sinewave, and appears on the Keyline Tone Level potentiometer R49. The Keyline tone is coupled through C33, and R32 to pin 13 of U10 summing amplifier.

#### 4.5.6 Speech and Keyline Tone

Refer to Figure 5.5

Microphone audio appears on the Analog Board J1-5 and is coupled through C4 to R12 and R9 which combine with Q1 to make up a Variable Attenuator Network. The Audio is amplified by audio amplifier U1A. Diodes CR4, CR5 and C35 rectify the Audio and provide a smooth DC voltage to Q1. This DC voltage is relative to the magnitude of the input signal. As it increases, Q1 turns on, increasing the input attenuation.



THIS PAGE INTENTIONALLY LEFT BLANK.

The circuitry prevents the microphone Audio from overdriving the two-wire line. Potentiometer R13 adjusts the output level Control. The adjusted Audio is coupled through C7 and R15 to pin 13 of U1D Summing Amplifier. Summing Amplifier U1D combines the 304 Hz Keyline Tone and Speech Audio. The combined output is provided to line drivers U1B and U9A through XMT Level Control R18.

#### 4.5.7 Modem Audio and Keyline Tone

Refer to Figure 5.5

The Modem Audio appears on the Analog Board 1A6J2-6 and is coupled through C2 to the 600 ohm termination network R3 and R4. R4 is the XMT Modem Level Control. The Audio is coupled through C3 and R5 to pin 2 of Buffer Amplifier U8A. The output of U8A is fed to pin 11 U6D. When J2-5 Modem Keyline is switched Low, the output of U11B goes High turning on U6D enabling the Audio. Audio on U6D pin 10 is fed to pin 5 of Buffer U8B. From U8B the Audio is passed to the Summing Amplifier U1D.

When an ON or OFF Power signal is received on J1-14 or J1-16 from the Front Panel Power switch, U10 or U12 is turned on. U10 and U12 are ORed in U7D. A High on pin 7 of U10 or pin 7 of U12 will result in a High on pin 11 of U7D. This High is connected to pin 5 of U11E. U11E inverts the signal and places a Low on pin 12 of U6D, turning U6D off, inhibiting Modem Audio to pass while the ON/OFF DTMF signals are being sent.

#### 4.5.8 DTMF Transmit

The DTMF signal is amplified by U2B. The output of U2B is controlled by switch U6B. When the Keyline is disabled, a High is placed on the input of inverter U5C. U5C turns open collector driver U11C Off. The output of U11C turns switch U6B On, enabling the DTMF Audio. Buffer U2D and Level Control R31 provide the DTMF signal Audio to the input of Summing Amplifier U1D.

#### 4.5.9 Squelch

Refer to Figure 5.7

The Receiver Audio from the Analog Board 1A6 is applied to the Squelch Board at 1A1P2-M. This Audio is fed to U1A pin 4 through level control R23 and C1. It is amplified by U1A and U1C then detected by CR1 and CR2. The resulting DC voltage turns on U1D which in turn opens the Audio gate Q1, unsquelching the receiver. U1B is an emitter follower which matches the impedance and drives the Audio gate Q1. Squelch sensitivity at maximum Squelch position is adjustable by R23. The adjustment is set at the factory to ensure a 100uv signal will break Squelch when the GRC-901 Squelch Control (1A1R29) on the Front Panel is set to maximum.

#### 4.5.10 Speaker Driver Board 1A7

Refer to Figure 5.6

The Speaker Driver is a hybrid integrated assembly capable of delivering five watts of Audio to an eight ohm speaker. The GRC-901 power supply furnishes regulated 24VDC. Output to the speaker is taken through a 470uf capacitor to provide good fidelity. When the PTT Line goes Low, Q1 and Q2 mute the Audio.

#### 4.5.11 Power Supply

AC Operation: The AC Power Supply consists of Power Transformer 1A1T1, Bridge Rectifier CR1 and filter capacitor C7. The unregulated DC voltage is supplied to the input of voltage regulators VR1 +24VDC, VR2 +12VDC and VR3 +5VDC. VR1 supplies +24VDC to the Speaker Driver Board 1A7. VR2 supplies +12VDC to the Front Panel Lamps, Analog and Digital Boards. VR3 supplies +5VDC to the Analog and Digital Boards.

DC Operation: Refer to Figure 4.5. The Transceiver Board 1A9 AC/DC switch (in DC position) connects power relay 1A10K1 pin 1 to the + battery. When power switch S1 is placed in the On position, battery is connected to pin 4 of

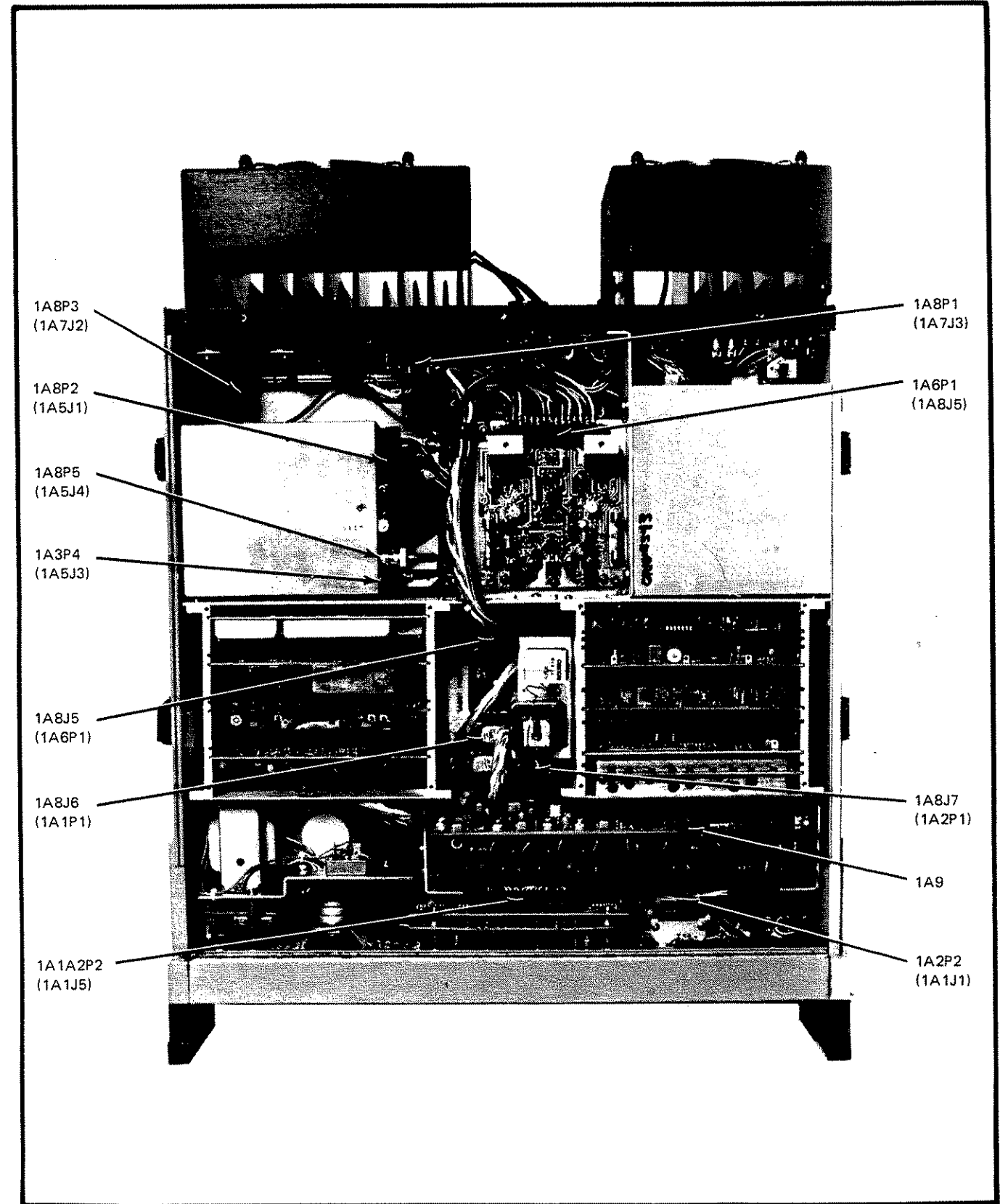

Figure 4.6 GSB-900SC/R Top View

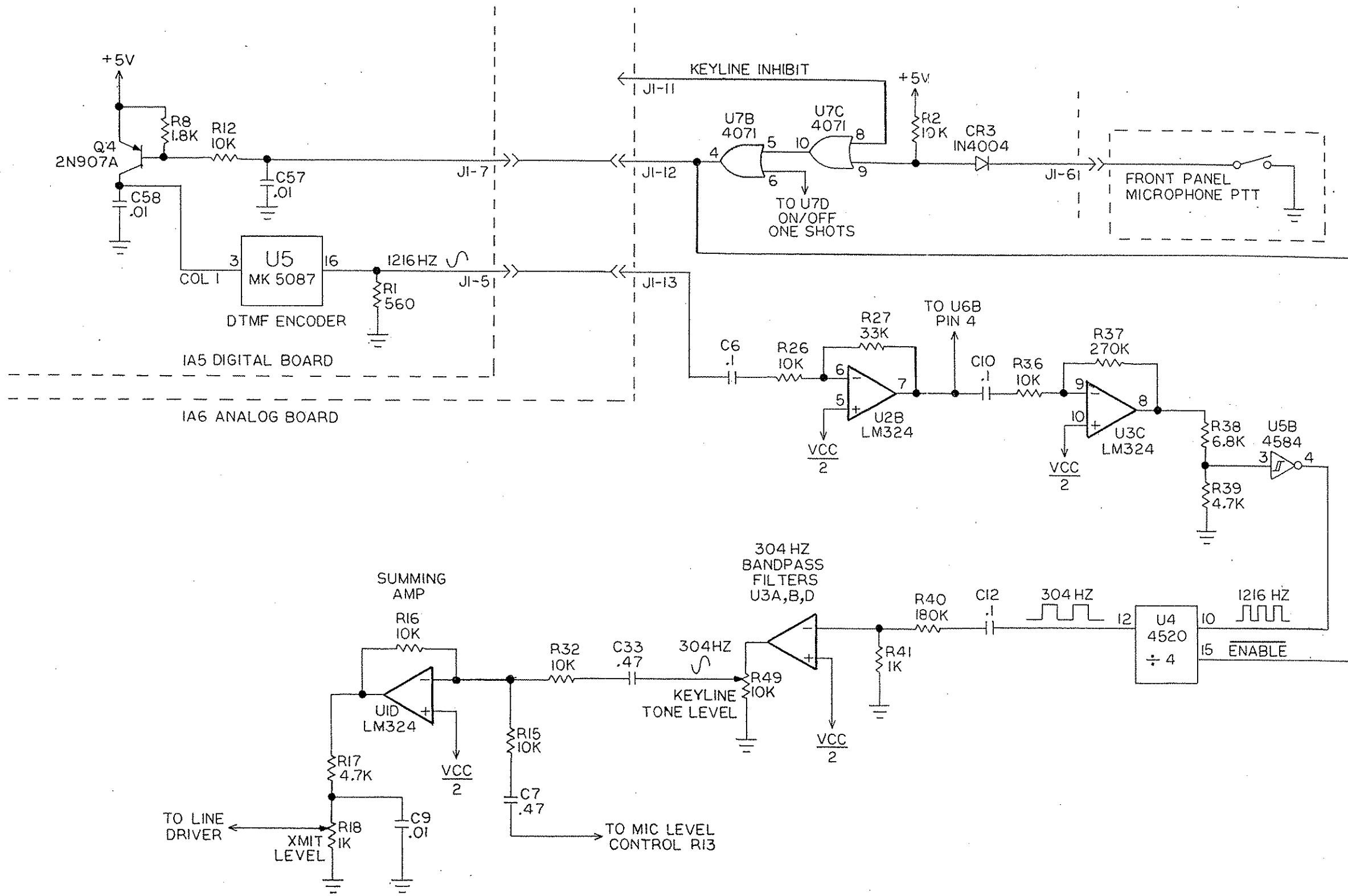

Figure 4.7 GSB-900SC/R Keyline Tone Simplified

THIS PAGE INTENTIONALLY LEFT BLANK.

1A10K1, engaging the relay. Relay contacts 12 and 13 turn the Transceiver's DC power supply On. Unregulated DC voltage is supplied by the GSB-900SC/R power supply to the Control Head DC input. R1 reduces Power dissipation at VR1. Voltage regulators VR1-VR3 operate as specified in AC Operation. The seven conductor DC control cable provides: Power Control, Audio Signal Pair, Unregulated DC Voltage, and one spare.

#### 4.6 TRANSCEIVER BOARD 1A9

The Transceiver Board 1A9 is located in the GSB-900SC/R Transceiver. See Figure 4.6 for board location. The Transceiver Board performs DTMF Encoder and Decoder functions for the GSB-900SC/R. The Transceiver Board is divided into a Analog and Digital section.

##### 4.6.1 Transceiver Board Analog Section

Refer to Figure 5.8 Sheet 2

The Analog section of the Transceiver Board is responsible for processing the Audio from the Two-Wire Line.

##### 4.6.1.1 304 Hz Notch Filter

Refer to Figure 5.8 Sheet 2

Control Head Transmit Audio appears on receive transformer T2. R83 Receive Level Adjustment and R82 provide the 600 ohm termination. The signal is coupled through R81, C47 and R80 to pin 9 of Buffer Amplifier U14A. The output of U14A, pin 8, is fed to the 304 Hz Notch Filter. The 304 Hz Notch Filter is comprised of R72 through R77 and C44, C45 and C46. The Notch Filter removes the 304 Hz Keyline tone passing speech or data from 450 Hz to 3000 Hz. Buffer Amplifier U13A provides XMT Level control by potentiometer R64 to Transmit Line Driver U16B. The output of U16B is connected by pins P7-41 and P7-39 to the 600 ohm transmit Audio transformer located on 1A3A4 Audio Board in the Transceiver.

##### 4.6.1.2 304 Hz Keyline Bandpass Filter

Refer to Figure 5.8 Sheet 2

Control Head Transmit Audio appearing on Level Control R83 is also coupled by C49 and R84 to the 304 Hz Keyline Bandpass Filter. This filter consists of C50, C51, R86, and U14B. The Bandpass Filter is centered on the 304 Hz Keyline Tone. The 304 Hz Tone appears at the output of the Bandpass Filter on pin 7 of U14B, and is coupled by C52 and R89 to pin 2 of amplifier U14D. The output of U14B is fed to Germanium diodes CR6 and CR7, which rectify the 304 Hz tone. The rectified voltage is fed to Comparator U15B. Voltage Divider R98 and R99 set the inverting input to 1.2VDC. When pin 7 of U15B is greater than 1.2 volts, indicating the presence of 304 Hz, the comparator output will go High, turning on Q6 and switching the Keyline Low. Zener Diode CR13 suppresses Keyline transients.

##### 4.6.1.3 DTMF Audio Amplifier

Refer to Figure 5.8 Sheet 2

Control Head DTMF Audio appears on Level Control R83 and is coupled by C58, R100 to pin 13 of Audio Amplifier U14C. The output of U14C, pin 14 is fed to pin 8 of switch U17C. When pin 6 of U17C is High, the switch enables DTMF Audio to coupling capacitor C1. C1 couples DTMF Audio to the Bandsplit Filter U18.

##### 4.6.1.4 HF Receive Audio

Refer to Figure 5.8 Sheet 2

The HF Receive Audio Level is adjusted by potentiometer R39. The wiper of R39 provides Audio to buffer U12C. The output of U12C is controlled by switch U17B. When the Receive Audio mute or DTMF encoder mute outputs are High, or Gate UD8 turns Q5 on, Q5 provides a Low on U17B pin 5. This disables the Audio to buffer U12D. When both mutes are Low, U17B is disabled supplying Audio to Summing Amplifier U12A.

#### 4.6.1.5 DTMF Status Signal

Refer to Figure 5.8 Sheet 2

DTMF Status Signal Audio, generated by DTMF encoder U4 is provided to Summing Amplifier U12A. The output of U12A through Line Level potentiometer R50 supplies DTMF signal or HF Receive Audio to Line Drivers U12B and U16A. The output of U16A drives the Transmit side of the Two-Wire hybrid.

#### 4.6.2 Digital Functions

Refer to Figure 5.8 Sheet 3

The Digital portion of the Transceiver Board decodes control DTMF signals from the GRC-901 Remote Control Head, and encodes status DTMF signals to the Remote Control Head.

##### 4.6.2.1 Decoder Functions

Refer to Figure 5.8 Sheet 3

DTMF Tones (Reset, Channel 1's, Channel 10's, Mode, and Power ON/OFF) are decoded by the Digital portion of the Transceiver Board. Band-split Filter U18 separates the two tone signal into the High tone group and the Low tone group. The two tones are fed to the DTMF Decoder U1. U1 decodes the tones, and presents a BCD output on pins 7, 8, 9 and 10. Pin 4 of U1, the Strobe Out validates the DTMF signal by placing pin 4 High after 30ms.

##### DTMF-RESET

DTMF RESET is fed to the input of BCD to decimal decoder U3. U3 pin 15 goes High, resetting counter U7 to zero and setting U2C Q output High disabling one shots U6A, and B. U2C Q output also disables the Status Encoder through U10B. 30ms later the Strobe output of U1 RESETS Local - Remote Latch U2D. U2D Q output goes Low and enables Tri-State-Data-Latches U2A and U2B. U2D Q output also turns off Q8 enabling the Remote Channel selection on the Transceiver's Memory Board 1A1A7.

##### DTMF-Channel Tens

Any digit 0-9 sets U3 pin 15 Low enabling Counter U7. 30ms later U1 strobe out of U1 goes High clocking U7 on the positive going edge of the pulse. U7 output pin 2 (Q1) goes High. Pin 2 triggers one shot U6A and places a High on the output pin 6 for 5ms. This pulse is connected to the Strobe input of U5A a TRI-STATE-LATCH. U5A loads the channel Tens information on the Memory Data Line.

##### DTMF-Channel Ones

Channel Ones places U7 pin 4 (Q2) output High. Pin 4 triggers one shot U6B placing a High on the output pin 10 for 100ms. This pulse is connected to the Strobe input of U5B a TRI-STATE-LATCH. U5B loads Channel Ones information on the Memory Data Line. U6B Q output also turns on Q3. Q3 enables Coupler Tune relay K1. The relay SPST contacts are paralleled with TUNE START pushbutton 1A2S2. Closing the contacts initiates GCU-935/DCU-100 Antenna Coupler Tuning.

##### DTMF-Mode

The output of U1, pins 7, 8, 9 and 10 feed the BCD information for the Mode via the Data Line to U3. U3 output supplies the BCD mode to Source Driver U22 which provides +12 Volts to the MODE selector switch position LSB, USB, or AM.

##### 4.6.2.2 Tune Command

Refer to Figure 5.8 Sheet 3

Channel Ones clocks the output of U7 Q2 High. This High places U2B output High turning on Q1. Q1 enables KW Tune. At the same time, pin 9 of U2B feeds a High to pin 5 of U22. Pin 14 of U22 goes high turning on the AM Mode. When the Antenna Coupler or KW Amplifier Tune Cycle is complete a Low is placed on the appropriate Fault or Ready Line. Both of these lines are connected to inverting voltage comparators, U15C and U15A, respectively. The High outputs feed

the Fault/Ready Decoder comprised of U19A, U10B, U11C, U9C, and U11D. If U10B inputs 5 and 6 are Low, indicating DTMF is not being received, a High will be placed on the input of U11C pin 8 by inverter U9F. A High from OR gate U19A, indicating READY or FAULT, will place AND gate U11C High. The High appears on the input of U11D pin 12. Combined with the High provided by inverter U9C, it places the output of the AND gate U11D High for the time constant R25, C14. U11D High output AND with the READY or FAULT High turning on the DTMF Encoder Matrix switch. When time constant R25, C14 reaches a High, inverter U9C goes Low placing U11D output Low terminating the DTMF signal. The output of the Fault/Ready Decoder U11D is also fed to U8B pin 5 and U8A pin 2 which resets U2B. U2B turns Q1 off and places a Low on Pin 5 of U22 taking Pin 14 Low and the Transceiver out of the AM Mode.

#### 4.6.2.3 Local Control

Refer to Figure 5.8

When the LOCAL pushbutton on the Coupler Control Panel is depressed, +5VDC appears on the set input pin 14 of U2D. U2D pin 1 Q output goes High:

1. Setting binary to decimal decoder U3 outputs to zero and disabling the Remote Mode Data.
2. Placing U5A and B Tri-State-Data-Latches in the Tri-State mode (outputs High Impedance).
3. Enabling U22 pin 18 Mode common, returning Mode control to the Transceiver Front Panel Mode Switch.
4. Turning Q9 on and illuminating the Coupler Control Panel LOCAL Lamp.
5. Turning Q4 on, enabling Pilot Supply relay 1A10K1. K1 turns the GSB-900SC/R Transceiver power supplies on.
6. Activating the FAULT/READY decoder thru U19C and sending a FAULT DTMF signal to the GRC-901 Control Head.
7. Turning Q8 on inhibiting the READY Line from sending a READY DTMF signal. Q8 also enables the GSB-900SC/R Memory Board, returning channel selection to the Transceiver's Front Panel Channel switches.

#### 4.7 PILOT SUPPLY 1A10

Refer to Figure 5.9

The Pilot Supply 1A10 powers Transceiver Board 1A9, when the GSB-900SC/R power supplies are off. This allows the Transceiver Board to monitor the two-wire line for a DTMF "ON" signal. The Pilot Power Supply consists of transformer T1, full wave bridge rectifier CR2 through CR5 and filter capacitor C1. The unregulated DC output voltage is supplied through CR6 to 1A9P7-35. The DC voltage drives regulator 1A9VR1 and VR2. When the Transceiver's power supply is turned on, +28 VDC regulated drives 1A9VR1 through CR10 and R62. The higher DC voltage provided at the input of 1A9VR1 back biases 1A10CR6 relaxing the Pilot Supply.

Power relay K1 controls the Transceiver's AC power through two parallel SPST contacts. The DC Power is controlled through a single SPST contact. K1 also provides a Low to the KW Control Panel 1A2J1-2.

#### NOTE

*See the GSB-900SC Manual Paragraph 4.2.9.3 and Figure 3.3 for Power Supply Battery Assembly 1A1A4.*

#### 4.8 KILOWATT CONTROL PANEL 1A2

Refer to Figure 5.13

Due to the Remote Control Operation of the GSB-900SC/R, it is necessary for all functions

on the Control Panel of the GSL-1900A to be performed through the GRC-901 Remote Control Head and the GSB-900SC/R Transceiver. The following discussion explains the circuitry within the Kilowatt Control Panel which makes this remote operation possible.

#### 4.8.1 KW FIL ON

Refer to Figure 5.13

When the GSB-900SC/R is turned on at the GRC-901 Remote Control Head, the Transceiver supplies 28VDC to 1A2J1-13 on the Kilowatt Control Panel Board 1A2A1. 28VDC is supplied to pins 5 and 6 of U4. A switch Low provided from the Pilot Supply Board 1A1A4 turns on relay K2. U4 timer operates as a Low for a period of 5 seconds before going High. The High from pin 7 of U4 is fed to pins 1 and 5 of timer U5. The output of U5 remains Low for a period of 225 msec. This Low turns on Darlington Power transistor Q2. Q2 provides a 225 msec 28 VDC pulse current limited through R12 to Plate Off Line 1A2J2-12, turning on the KW Filaments. The 225 msec Low pulse from U5 is also passed to pin 3 of U7B. Pin 4 of U7B goes High, and is fed to pin 8 of U9C. The Plate Ready Line is also Low at this time. This Low is connected to pins 1 and 2 of U9A. A High appears at the output of U9A, pin 3, which is fed to pin 9 of U9C. Pin 10 of U9C goes Low placing Lows on pins 5 and 6 of U9B. Pin 4 of U9B goes High and supplies the KW FIL ON switch signal to the Transceiver Board.

#### 4.8.2 PLATE ON

Refer to Figure 5.13

When the Plate Ready Line 1A2J2-8 goes High, a High is placed on pin 5 of Timer U2. U2 operates as a Low for 225 msec before going High. The High is fed to pins 5 and 1 of Timer U3. The output of U3, pin 6 remains Low for a period of 225 ms. This Low turns on Darlington Power transistor Q1. A 225 ms 28VDC Pulse is current

limited through R9 to the PLATE ON Line 1A2J2-7, turning on the KW PLATE supply. The output of U3 is also supplied to inverter U7C. U7C provides a High to U6B turning on U8F, illuminating the FAULT Lamp and sending a FAULT signal to the Transceiver Board.

#### 4.8.3 KW TUNE

Refer to Figure 5.13

When the KW TUNE line, 1A2J1-1 goes Low, a Low is placed on pin 1 of U7A. The output of U7A, pin 2, is coupled by C8 and R21 creating a positive pulse, which is fed to pin 1 of U6A. Pin 3 of U6A goes High resetting FAULT latch U1A. The positive output pulse from U7A also resets READY latch U1B through U6C and D.

#### 4.8.4 FAULT

Tune Fault, VSWR, or DC O/L are ORed by diodes CR9-11 as a Low. This Low is inverted by U7E, placing a High on pin 3, the clock input of Fault latch U1A. U1A pin 1 Q output goes High. This High turns on U8F through U6B. U8F illuminates the FAULT Lamp and turns on the Transceiver's FAULT encoder. U1A  $\bar{Q}$  output pin 2 disables the plate supply through relay K1.

#### 4.8.5 READY

A Low on READY Line 1A2J2-2 is inverted by U7F, placing a High on pin 11 clock input of READY latch U1B. U1B pin 13, Q output goes High. This High turns on U8G illuminating the READY Lamp and turning on the Transceiver's READY encoder 1A5U3.

#### 4.8.6 LOCAL Control

When the LCL-REM line 1A2J1-3 goes Low, U8A turns on U8E and U8D. This disables Filament On and Plate On timers U4 and U2 respectively. U8A also turns on U8B which illuminates the LOCAL Lamp 1A2DS4 and enables Plate Off relay K1.

#### 4.9 MOTHERBOARD 1A1A5

Figure 5.11 is the schematic of the GSB-900SC/R Motherboard. In addition to the Motherboard functions covered in the GSB-900SC manual, 1A1A5J2 and 1A1A5J8 contain connections for Two-Wire Line functions A10 through A15, Mode functions A18, A19 and A23 through A25, and Coupler TUNE, FAULT, and READY functions A26 through A30.

#### 4.10 FRONT PANEL 1A1

Figure 5.10 is the schematic for the GSB-900SC/R Front Panel. In addition to the Front Panel functions covered in the GSB-900SC manual, connections for the Pilot Supply 1A10 and the KW Control Panel are shown.

- c. 600 ohm resistor.
- d. Oscilloscope 150 MHz Bandwidth, Tektronix 2445.
- e. VOM, Simpson 260
- f. Frequency Counter, Systron Donner Model 6242A/Option 10

5.3.2 Preliminary

Set the Front Panel Controls on the GRC-901 as follows:

Channel	00
Mode	USB
Volume	Full Counter Clockwise (CCW)
Squelch	Full Clockwise (CW)
Power	ON

5.3.2.1 Unregulated Voltage

Set the VOM to the 50 Volt range and check the following points for a +36VDC  $\pm$ 10%.

- a. Filter Capacitor C1
- b. Diode CR1
- c. Base of VR1

5.3.2.2 24VDC Voltage Check

Set the VOM to the 50 volt range and test the following points for +24VDC  $\pm$ 10%.

- a. Emitter of VR1
- b. Base of VR2
- c. E1 1A4A1 Speaker Driver Board 1A7
- d. Pin D 1A3J2 Modem

5.3.2.3 12VDC Voltage Check

Set the VOM to the 50 volt range and test the following points for +12VDC  $\pm$ 10%.

- a. Emitter of VR2
- b. Base of VR3
- c. Pin K of 1A3J2 Modem
- d. 1A5P1-22
- e. 1A5J1-23
- f. 1A6P1-22
- g. 1A6J1-23
- h. Lamps DS1, DS2, DS3, and DS4
- i. E1 - 1A4A2 Squelch Board 1A8
- j. 1A2R1B Squelch Control
- k. 1A2S1-2 Power Switch

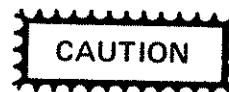

*115 VAC or 230 VAC present on switch*

5.3.2.4 5VDC Voltage Check

Set the VOM to the 5 volt range and test the following points for +5VDC  $\pm$ 10%.

- a. Emitter of VR3
- b. 1A5P1-3
- c. 1AJJ1-4
- d. 1A6P1-4

## 5.4 FAULT ANALYSIS AND PERFORMANCE CHART

<u>TEST</u>	<u>PROCEDURE</u>	<u>PERFORMANCE</u>
1. WAIT LAMP	POWER ON	<p><u>NORMAL</u>: WAIT Lamp illuminates.</p> <p><u>ABNORMAL</u>: Check pin 11, U16 on the Digital Board (1A5) for Logic "1". Pin 3, U13 of Digital Board (1A5) should be a Logic "1". The collector of Q2 Digital Board should be a Logic "0".</p>
2. FAULT LAMP	Set Least Significant digit channel switch (S4) to "1".	<p><u>NORMAL</u>: WAIT Lamp will extinguish and FAULT Lamp will illuminate.</p> <p><u>ABNORMAL</u>: Check the collector of Q3 Digital Board (1A5). Should be at Logic "0". Pin 4, U14 at Logic "1". Pin 5, of U14 Digital Board (1A5) @ Logic "1". Pin 1, U20 @ Logic "1". Check for 650ms pulse at pin 3, U20 Digital Board (1A5) when Channel Switch (S4) is operated. Check U21 and associated circuitry.</p>
3. PTT/DTMF Send	Press PTT On Microphone.	<p><u>NORMAL</u>: FAULT Lamp extinguishes and WAIT Lamp illuminates.</p> <p><u>ABNORMAL</u>: Monitor 2-wire line, (terminated with 600 ohms) with oscilloscope for four bursts of DTMF signal. If no DTMF signal check the following on the Digital Board (1A5). Pin 16, U5 for DTMF. If no DTMF check pin 3, U12 for 230ms clock pulse, and Pin 1, U19 for clock pulse. If DTMF present on pin 16, U5 check the following on the Analog Board (1A6) for DTMF signal. Pin 7, U2; pin 3, U6; pin 1, U2; TP1; pin 7, U1; pin 1, U9; and T1.</p>
4. DTMF/Receive	Connect two Audio Generators to the two-wire line. One set at 941 Hz 0dbm, and one set at 1477 Hz 0dbm equal amplitude on both.	<p><u>NORMAL</u>: WAIT Lamp extinguishes and READY Lamp illuminates.</p> <p><u>ABNORMAL</u>: Check Analog Board (1A6) pin 14, U2 and pin 9, U6 for 941 Hz and 1477 Hz, respectively. Check Digital Board (1A5) pin 12, U17 for 1477 Hz and pin 11, U17 for</p>

<u>TEST</u>	<u>PROCEDURE</u>	<u>PERFORMANCE</u>
4. DTMF Receive (Con't)		941 Hz. Pin 14, U16 should be @ Logic "1". Pin 3, U24 should be @ Logic "1". The collector of Q1 should be at ground (Logic "0").
5. Key Line Tone	Monitor 2-Wire line with Oscilloscope and key Microphone.	<p><u>NORMAL:</u> 304 Hz tone appears on the Two-Wire line.</p> <p><u>ABNORMAL:</u> On the Digital Board (1A5) check pin 16, U5 for 1216 Hz single tone. If 1216 Hz not present check Q4 for Logic 1 on the collector. On the Analog Board (1A6) check pin 8, U3 for 1216 Hz square wave, and pin 12, U4 for 304 Hz square wave. Check pin 14, U3; pin 1, U3; and pin 7, U3 for 304 Hz sine wave.</p>
6. Microphone Transmit	Same as Test No. 5	<p><u>NORMAL:</u> Audio should appear on Two-Wire Line.</p> <p><u>ABNORMAL:</u> On Analog Board (1A6) check pin 1, U1 and associated circuitry (CR4, CR5, and Q1) for Speech Audio.</p>
7. Receive Audio	Connect Audio Generator set at 1477 Hz 0dbm to Two-Wire Line.	<p><u>NORMAL:</u> Audio should be heard on Speaker.</p> <p><u>ABNORMAL:</u> Check Analog Board (1A6) pin 14, U2; pin 1, U6; and pin 8, U2 for 1477 Hz. On Digital Board (1A5) pin 10, U11 should be at "0".</p>

5.5 The following is a table for Channel Encoding on the Digital Board (1A5).

LSD ON DIAL	1A5J1				1A5U8			
	PIN 12	PIN 13	PIN 14	PIN 15	PIN 2	PIN 4	PIN 6	PIN 10
0	0	0	0	0	0	0	0	0
1	1	0	0	0	1	0	0	0
2	0	0	1	0	0	1	0	0
3	1	0	1	0	1	1	0	0
4	0	1	0	0	0	0	1	0
5	1	1	0	0	1	0	1	0
6	0	1	1	0	0	1	1	0
7	1	1	1	0	1	1	1	0
8	0	0	0	1	0	0	0	1
9	1	0	0	1	1	0	0	1

MSD ON DIAL	1A5J1				1A5U7			
	PIN 8	PIN 9	PIN 10	PIN 11	PIN 2	PIN 4	PIN 6	PIN 10
0	0	0	0	0	0	0	0	0
1	1	0	0	0	1	0	0	0
2	0	0	1	0	0	1	0	0
3	1	0	1	0	1	1	0	0
4	0	1	0	0	0	0	1	0
5	1	1	0	0	1	0	1	0
6	0	1	1	0	0	1	1	0
7	1	1	1	0	1	1	1	0
8	0	0	0	1	0	0	0	1
9	1	0	0	1	1	0	0	1

5.5 Table for Channel Encoding on the Digital Board (1A5) (Con't)

MODE SWITCH	1A5J1		1A5U8		1A5U7	
	PIN 18	PIN 19	PIN 12	PIN 14	PIN 14	PIN 14
LSB	0	0	0	0	0	0
USB	1	0	1	0	0	0
AM	0	1	0	1	0	0

**5.6 TRANSCEIVER BOARD (1A9)**

To conduct tests on the Transceiver Board (1A9), it is first necessary to make the following connections and jumpers to the GSB-900SC/R:

- a. Connect the AC Power Cable to the Rear Panel Connector J3.
- b. Connect the Two-Wire line to the Audio Connector J2 pins E and F on the Rear Panel.
- c. Jumper pins H & p and N & h in accessory connector J4 on Rear Panel.
- d. Set the Front Panel Control switches to the following positions:

SWITCH OR CONTROL

POSITION

- |                        |            |
|------------------------|------------|
| Frequency Switches     | 1.6000 MHz |
| Frequency Control Mode | Read Freq  |
| MODE Switch            | OFF        |
| RF Gain Control        | Full CW    |
| XMIT Gain Control      | Full CCW   |
| Dimmer Control         | Full CW    |
| VFO Control            | Pushed IN  |
| Volume Control         | Full CCW   |

- e. Remove the Transceiver Board (1A9) from the PCB holder in the GSB-900SC/R, and plug in an extender PCB. Plug the Transceiver Board into the extender card with the component side facing the Rear Panel.

<u>TEST</u>	<u>PROCEDURE</u>	<u>PERFORMANCE</u>
1. PILOT SUPPLY	Place MODE switch in the USB position. Set VOM to 50 Volt range.	Pin 35, P7 should read +19VDC, ±10%.
2. +12 VDC Supply	Set VOM to 50 Volt range.	Emitter of VR1 should read +12VDC ± 10%.
3. +5 VDC Supply	Set VOM to 10 Volt range.	Emitter of VR2 should read +5VDC ± 10%.
4. Power UP READY Lamp	Turn on unit at GRC-901 Remote Control Unit.	

**NORMAL:** GSB-900SC/R Powers Up, READY Lamps on both Coupler Control Panel and Remote Control Unit (GRC-901) illuminate.

**ABNORMAL:** If GSB-900SC/R Powers Up, but READY Lamp on GRC-901 fails to illuminate, check the following on the Transceiver Board (1A9): Pin 16, U4 for 250ms burst of DTMF. If DTMF not present check pin 7, U12; pin 8, U12; pin 7, U16 and associated circuitry for DTMF. Also check pin 2, U15 should be at Logic "1". Pin 4, U11 should have a 250ms positive pulse at Power Up. If not, check U11C, U8C, U11D, U9F, and associated circuitry. GSB-900SC/R does not Power Up. When the GRC-901 Remote Control Unit is turned on, a DTMF signal of approx. 1 volt p/p should be observed on pin 14, U14. If DTMF signal is present at this point, check pin 16, U3 for a Logic "1". If Logic "1" present pin 2, U2 should also be at Logic "1". If this high is also present check Q4 and associated circuitry. If DTMF not present at pin 16, U3 check U18, U1, U3, and associated circuitry for DTMF.

<u>TEST</u>	<u>PROCEDURE</u>	<u>PERFORMANCE</u>
5. CHANNELING	Select a Channel and MODE on the GRC-901 and push the PTT on the Microphone.	<u>NORMAL</u> : Frequency stored in Memory for selected Channel should be displayed on GSB-900SC/R. If not, check pin 4, U1 on the Transceiver Board (1A9) for a 500ms pulse upon receipt of the DTMF information. Check U5, U6 and U7 and associated circuitry.
6. Transmit Audio	With READY Lamp illuminated on GRC-901, push PTT and speak into Microphone.	<u>NORMAL</u> : Power monitor meter on Front Panel of GSB-900SC/R will indicate forward power. <u>ABNORMAL</u> : If no forward power indicated check U14A the 304 Hz Notch Filter, U13A, U13B, U16B, and associated circuitry.
7. KEYLINE	With READY Lamp illuminated, push PTT on Microphone.	<u>NORMAL</u> : GSB-900SC/R will key, Power meter on Front Panel of GSB-900SC/R will indicate forward power. <u>ABNORMAL</u> : If Transceiver does not key, check U14B, U14D, C54, CR6, and CR7 on the Transceiver Board (1A9). Also check Q6 and associated circuitry.
8. LOCAL CONTROL	Set Front Panel Control Switches as in Para 5.5.d Press LOCAL Pushbutton on GSB-900SC/R.	<u>NORMAL</u> : GSB-900SC/R should Power up and 1.6000 MHz should be displayed on the Front Panel. Full Control of the GSB-900SC/R should now be with the Transceiver. <u>ABNORMAL</u> : If not, check pin 1, 1A9U2 this point should be at a Logic "1". Pin 4, 1A9U20, and pin 2 1A9U2 both should be at a Logic "1". Also check Q4, Q8, and associated circuitry.
9. Transmit FAULT Tone		<u>NORMAL</u> : The GSB-900SC/R Transceiver should transmit a 250ms burst of DTMF signal upon receipt of a FAULT Lamp. <u>ABNORMAL</u> : If not check comparator 1A9U15A and associated circuitry, U19C, U11A, U19B, and U21B.

5.7 Performance test for the GSB-900SC/R  
 Kilowatt Control Panel with GSL-1900A  
 Linear Amplifier.

<u>TEST</u>	<u>PROCEDURE</u>	<u>PERFORMANCE</u>
Filament Turn-on	Place MODE switch on GSB-900SC/R in USB. Turn Power on at GRC-901.	<p><u>NORMAL:</u> WAIT Lamp illuminates on the GRC-901, and approx. 5 seconds later WAIT Lamp begins to Flash. At the same time, the GSL-1900A filaments turn on.</p> <p><u>ABNORMAL:</u> Check the base of VR1 for +28VDC <math>\pm</math>10%. Check the Emitter of VR1 for +5VDC <math>\pm</math>10%. At power up, 1A2A1U4 pin 3 should be at a Logic 0 for approx. 5 seconds. After 5 seconds, 1A2A1U4 pin 3 should go to a Logic "1", and 1A2A1U5 pin 6 should go to a Logic "0" for approx. 250ms. Also check 1A2A1U9, 1A2A1U7, Q2, and associated circuitry.</p>
Plate Turn-on		<p><u>NORMAL:</u> Approx. 3 minutes after the GSL-1900A filaments turn on, the KW PLATE Lamp will illuminate. At the same time the GRC-901 WAIT Lamp extinguishes and the FAULT Lamp illuminates.</p> <p><u>ABNORMAL:</u> When the PLATE READY Lamp illuminates, 1A2U2 pin 7 should go to a Logic "0" for a period of 225 ms. When 1A2U2 pin 7 returns to a Logic "1", 1A2A1U3 pin 6 should go to a Logic "0" for a period of approx. 225ms. Also check 1A2A1U6, 1A2A1U8, 1A2A1 Q1 and associated circuitry.</p>
TUNE CYCLE	Select a Channel and MODE on the GRC-901. Push the PTT button.	<p><u>NORMAL:</u> WAIT Lamp will illuminate on GRC-901. TUNING Lamp will illuminate on GSB-900SC/R. GSL-1900A will tune during this period.</p> <p><u>ABNORMAL:</u> 1A2A1U1 pin 1 should be at a Logic "0". If not, check 1A2A1U6, 1A2A1U7, and associated circuitry. 1A2A1U1 pin 13 should be at a Logic "0". If not, check 1A2A1U6 and associated circuitry.</p>

## 5.8 TROUBLESHOOTING CHART

The following is a chart which lists some possible problems and the associated symptom displayed by the GSB-900SC/R.

<u>SYMPTOM</u>	<u>POSSIBLE TROUBLE</u>
GRC-901 Remote Control Head Displays a FAULT on all Channels.	<ul style="list-style-type: none"> <li>a. Keyswitch not in READ FREQ.</li> <li>b. All channels cleared from Memory.</li> <li>c. Faulty GCU-935/DCU-100.</li> </ul>
No Audio at GRC-901 Remote Control Head.	<ul style="list-style-type: none"> <li>a. Two-Wire line not connected or broken.</li> <li>b. GSB-900SC/R Transceiver in TUNE Position.</li> <li>c. Squelch fully CCW.</li> </ul>
No Lamps illuminated on GRC-901 Remote Control Head.	<ul style="list-style-type: none"> <li>a. GRC-901 in receipt of invalid DTMF signal.</li> </ul>
No Lamps illuminated on GSB-900SC/R Transceiver	<ul style="list-style-type: none"> <li>a. Dimmer control on Front Panel fully CCW.</li> </ul>
No Audio at GRC-901 Remote Control Head or GSB-900SC/R Transceiver Power Meter fully deflected to the Right.	<ul style="list-style-type: none"> <li>a. RF Gain Control on the GSB-900SC/R turned fully CCW.</li> </ul>
GRC-901 Remote Control Unit Inoperative Channel indicators not illuminated.	<ul style="list-style-type: none"> <li>a. Power Cord defective or not connected.</li> <li>b. Primary Power fuses F1 or F2 (F3 for DC operation) not installed or open.</li> <li>c. Intermittent or loose PCB connections.</li> </ul>
GSB-900SC/R Transceiver does not power up when GRC-901 is turned on.	<ul style="list-style-type: none"> <li>a. GSB-900SC/R Power cord defective or not connected.</li> <li>b. GSB-900SC/R MODE switch in the OFF position.</li> <li>c. Two-Wire line not connected to either the GRC-901 or the GSB-900SC/R.</li> <li>d. Primary Power fuses F1 or F2 not installed or open.</li> </ul>
GRC-901 Remote Control Unit WAIT Lamp remains illuminated at all times.	<ul style="list-style-type: none"> <li>a. Two-Wire line not connected.</li> <li>b. GCU-935/DCU-100 not connected to GSB-900SC/R.</li> </ul>
GRC-901 Remote Control Unit WAIT Lamp Flashes.	<ul style="list-style-type: none"> <li>a. GSB-900SC/R configured with a KW Control Panel and no GSL-1900A installed.</li> </ul>

5.8 TROUBLESHOOTING CHART (Con't)

SYMPTOM

POSSIBLE TROUBLE

When GRC-901 Channel is changed and PTT switch is pressed, GSB-900SC/R does not change Channel.

- a. Two-Wire line not connected.
- b. Modem Keyline Keyed (This will result in a constant XMIT Lamp illuminated on the GSB-900SC/R.)

GRC-901 Remote Control Unit displays FAULT on some Channels.

- a. Invalid frequency stored in memory for that particular channel. Check both Transmit and Receive frequencies stored in memory.

**5.9 GSB-900SC/R TRANSCEIVER LINE LEVEL ADJUSTMENT PROCEDURE**

The GSB-900SC/R Transceiver may be set to operate at any line level in the range of 0db to -10db with two adjustments on the Transceiver Board 1A9, R83 (Rcv Line Level Potentiometer) is used to adjust the receive input, and R50 (Xmit Line Level Potentiometer) is used to set the level of the signal transmitted over the Two-Wire Line.

- 1. 600 ohm Audio generator or any 600 ohm single tone audio source.
- 2. VTVM
- 3. Oscilloscope

5.9.1.1 Set Up

Connect the 600 ohm Audio source to pins E and F of the Audio connector on the rear of the GSB-900SC/R and monitor with the VTVM. Adjust the Audio source output to the desired Line Level. Remove the Tranceiver Board, 1A9, insert an extender card, and insert the Transceiver Board into the extender card.

5.9.1.2 Adjustment

Monitor pin 14 of 1A9U14 with the Oscilloscope and adjust R83 (Rcv Line Level Potentiometer) for a reading of 1.0 VPP. This completes the Receive Line Level Adjustment.

**NOTE**

*If line levels need to be adjusted beyond the limits discussed in these procedures, consult the Product Support Department at Sunair for instructions.*

5.9.1 Receive Level Procedure

The following equipment is required to perform this procedure:

### 5.9.2 Transmit Level Adjustment

The following equipment is required to perform this procedure:

1. Oscilloscope

#### 5.9.2.1 Set Up

Terminate pins E and F of the Audio connector on the rear panel of the GSB-900SC/R with 600 ohms and monitor with the oscilloscope. Connect a clip-lead from pin 10 1A9U15 on the Transceiver Board to ground.

#### 5.9.2.2 Adjustment

Observing the Oscilloscope, adjust R50 (Xmit Line Level Potentiometer) to obtain the desired peak Line Level. Disconnect the clip-lead. This completes the Transmit Line Level Adjustment.

### 5.10 GRC-901 CONTROL HEAD LINE LEVEL ADJUSTMENT PROCEDURE

The GRC-901 may be set to operate at any Line Level in the range of 0db to -10db with two adjustments on the Analog Board 1A6. R34 (Rcv Level) is used to adjust the receive input and R18 (Xmit Level) is used to set the level of the signal transmitted over the two-wire line.

#### 5.10.1 Receive Level Procedure

The following is a list of equipment necessary to perform this procedure:

1. 600 Ohm Audio generator or any 600 Ohm single tone audio source.
2. VTVM
3. Oscilloscope

##### 5.10.1.1 Set Up

Turn the GRC-901 power on. Connect the 600 ohm audio source to the "Phone Line" terminals on the rear panel of the GRC-901 and monitor with the VTVM. Adjust the Audio source to the desired line level.

#### 5.10.1.2 Adjustment

Monitor pin 14 of 1A6U2 on the Analog Board 1A6 with the Oscilloscope. Adjust R34 (Rcv Level Potentiometer) for a 1 VPP reading. This completes the Receive Level Adjustment.

#### 5.10.2 Transmit Level Procedures

The following is the equipment necessary to perform this procedure:

1. Oscilloscope.

##### 5.10.2.1 Set Up

Terminate the "Phone Line" terminals on the rear of the GRC-901 with 600 Ohms and monitor with the oscilloscope. Connect a clip-lead from the + side of C38 on the Analog Board 1A6 to any point that is at ground potential.

##### 5.10.2.2 Adjustment

Observing the oscilloscope, adjust R18 (Xmit Level Potentiometer) on the Analog Board 1A6 to obtain the desired peak to peak Line Level. Disconnect the clip-lead. This completes the Transmit Level Adjustment.

This completes the Control Head Line Level Adjustment.

### 5.11 GSB-900SC/R TRANSCEIVER DEPOT ALIGNMENT PROCEDURE

The following is the Depot Alignment Procedure for the GSB-900SC/R Transceiver.

#### 5.11.1 HF Receiver and DTMF Transmit Audio

The following is a list of equipment necessary to perform this procedure

1. 600 ohm 1/2 watt resistor
2. VTVM
3. RF Signal Generator

### 5.11.1.1 Set Up

Place the MODE selector on the front panel of the Transceiver in the USB position. Push the Local button. Terminate pins E and F on 1A8J2 Audio connector (600 Ohm Line) with a 600 Ohm 1/2 watt resistor.

### 5.11.1.2 Adjustment

1. Place a ground on pin 10 1A9U15D and adjust 1A9R50 (Xmit Line Level) for 2.2 VPP (-3dbm two tone) on the 600 Ohm Line.
2. Monitor pin 6 of 1A9T1 and adjust 1A9R56 for less than 50 mv PP. Remove the ground from 1A9U15-D.
3. Place an RF signal generator at the Transceiver's antenna terminals. Set the generator for 100 microvolts at 12.001 MHz and set the receiver frequency for 12.000 MHz USB.
4. Adjust 1A9R39 (Rec Audio) for 0dbm @ 1 KHz on the 600 Ohm Line.

### 5.11.2 Transmitter and DTMF Receive Audio

The following equipment is necessary to perform this procedure.

1. AF Signal Generator
2. VTVM

#### 5.11.2.1 Set Up

1. Remove the 600 Ohm terminating resistor.
2. Connect jumpers from pin N to pin h and from pins H to pin p on 1A8J4 (Accessory) plug on the rear of the GSB-900SC/R.
3. Place an AF generator (600 Ohm output impedance ) set for -13dbm @ 1.5 KHz on pins E and F of 1A8J2 Audio connector (600 Ohm line).

#### 5.11.2.2 Adjustment

1. Set 1A9R83 (Rcv Line Level) to maximum (Fully CW). Monitor 1A9P7-41 and adjust 1A9R64 (Xmit Level) for 0dbm (2.2 VPP). **NOTE:** 1A9P7-41 is the 21st pin counted from the left edge of the board on the left group of pins.
2. Reset the AF generator for -10dbm. Adjust 1A9R101 (DTMF Rcv) for 1 VPP on 1A9U14 pin 14.
3. Reset AF generator for -27dbm @ 304 Hz and adjust 1A9R90 (Keyline) for transmit key.
4. Reset the AF generator for -3dbm @ 1.5 KHz and adjust 1A9R83 (Rcv Line Level) for 0dbm (2.2 VPP) at 1A9P7-41. (See note in Step 1 above for location).
5. Remove the Audio generator and connect the GRC-901 Control Head to 1A8J2 on the GSB-900SC/R Transceiver. Connect a 50 Ohm Load to the antenna terminals.
6. Load channel 00 with 2.6 MHz per instructions in Section 3.6. Select channel 00 on the GRC-901 and tune system. The GRC-901 should display a green lamp upon completion of tune. With a microphone shorting plug, (pins A to E and B to D jumpered), Key the system. Observe the Transceiver's antenna terminals and adjust the Keyline Notch Filter Pots 1A9R77, 75, and 72 for less than .6 VPP.

This completes the Depot Alignment Procedure for the GSB-900SC/R Transceiver.

### 5.12 GRC-901 CONTROL HEAD DEPOT ALIGNMENT PROCEDURE

The following is the DEPOT Alignment procedure for the GRC-901.

#### 5.12.1 Equipment Required

1. Two 600 Ohm Audio Generators

2. VTVM
3. Oscilloscope

#### 5.12.2 Receive Audio Alignment

1. Connect 600 Ohm Audio Generator to the "Phone Line" Terminals on the rear panel of the GRC-901.
2. Set the Audio Generator to 1200 Hz @-10dbm.
3. Set R34 (Rcv Level) on the Analog Board 1A6 to maximum (full CW).
4. Monitor pin 14 1A6U2 with the oscilloscope and adjust R56 ( Rcv Amp Level) on the Analog Board 1A6 for 1 VPP.

Monitor pin E of the Modem connector on the rear panel of the GRC-901 with the oscilloscope and adjust R57 (Rcv Modem Level) on the Analog Board 1A6 for 2.2 VPP.

This completes the Receive Audio Alignment.

#### 5.12.3 Transmit Audio Alignment

1. Terminate the "Phone Line" terminals on the rear of the GRC-901 with 600 Ohms and monitor with the oscilloscope.
2. Set R18 (Xmit Level) on the Analog Board 1A6 fully CW.
3. Connect a clip-lead from the + side of C38 to ground, and adjust R31 (DTMF Xmit) on the Analog Board 1A6 for 3.5 VPP on the Two-Wire Line. Monitor R60 (lead towards the 100 ohm resistor) and adjust R25 balance for less than 50 mv ppk. Remove the clip-lead.
4. Jumper pins B to D of the microphone connector on the front panel of the GRC-901.

#### NOTE

*The READY Lamp must be illuminated in order to perform the following steps. Use two 600 Ohm Audio Generators connected in parallel one set at 941 Hz and the other set at 1477 Hz, equal in amplitude and the combined output should be set at 0dbm (-3dbm on VTVM; 2.2 VPP on oscilloscope) to simulate a DTMF signal. Turn the GRC-901 OFF, and then turn it back On again. Turn the channel one's switch one position CW. The FAULT Lamp will illuminate. Press the PTT button on the microphone connected to the front panel of the GRC-901. Connect the Two-Wire line to the output of the combined Audio Generators. The Green READY Lamp should now be illuminated. Remove the audio generators.*

Set R49 (Keyline Tone) on the Analog Board 1A6 for 1.1 VPP on the Two-Wire Line. Remove Jumper.

5. Connect 600 Ohm Audio Generator to pins B (high) and C (low) of the Modem Connector on the rear panel of the GRC-901. Set the Audio Generator to 2.2 KHz @0dbm.
6. Jumper pins G to A of the Modem Connector on the rear panel. Adjust R4 (Xmit Modem Level) on the Analog Board 1A6 for 3.5 VPP on the Two-Wire Line.
7. Connect the Audio Generator set at 1.5 KHz @ -20db to pins A (high) and E (low) of the front panel microphone connector. Adjust R13 (Mic Level) on the Analog Board 1A6 for 3.5 VPP on the Two-Wire Line.

This completes the Transmit Audio Alignment Procedure for the GRC-901.

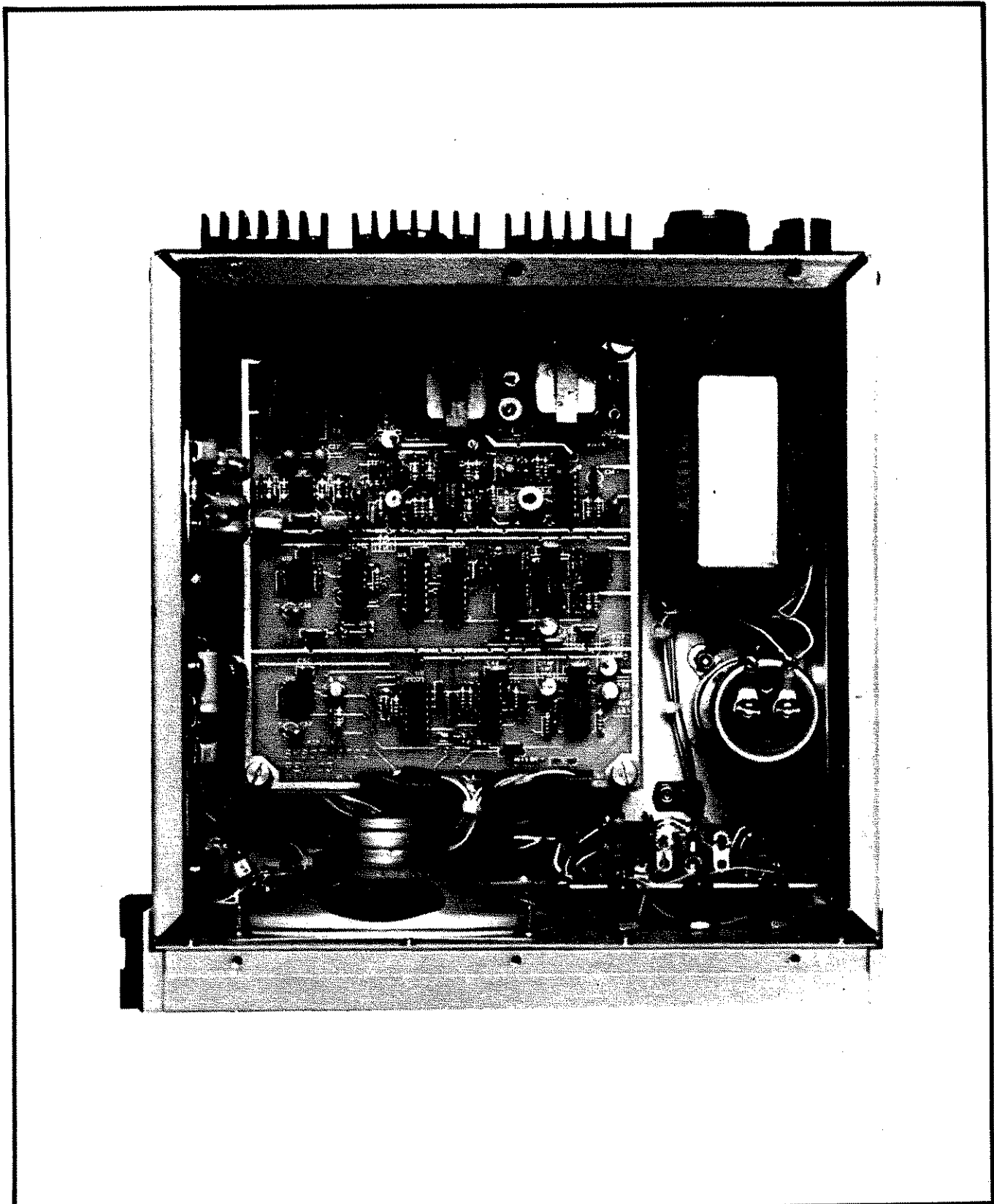

Figure 5.1 GRC-901 With Top Cover Removed

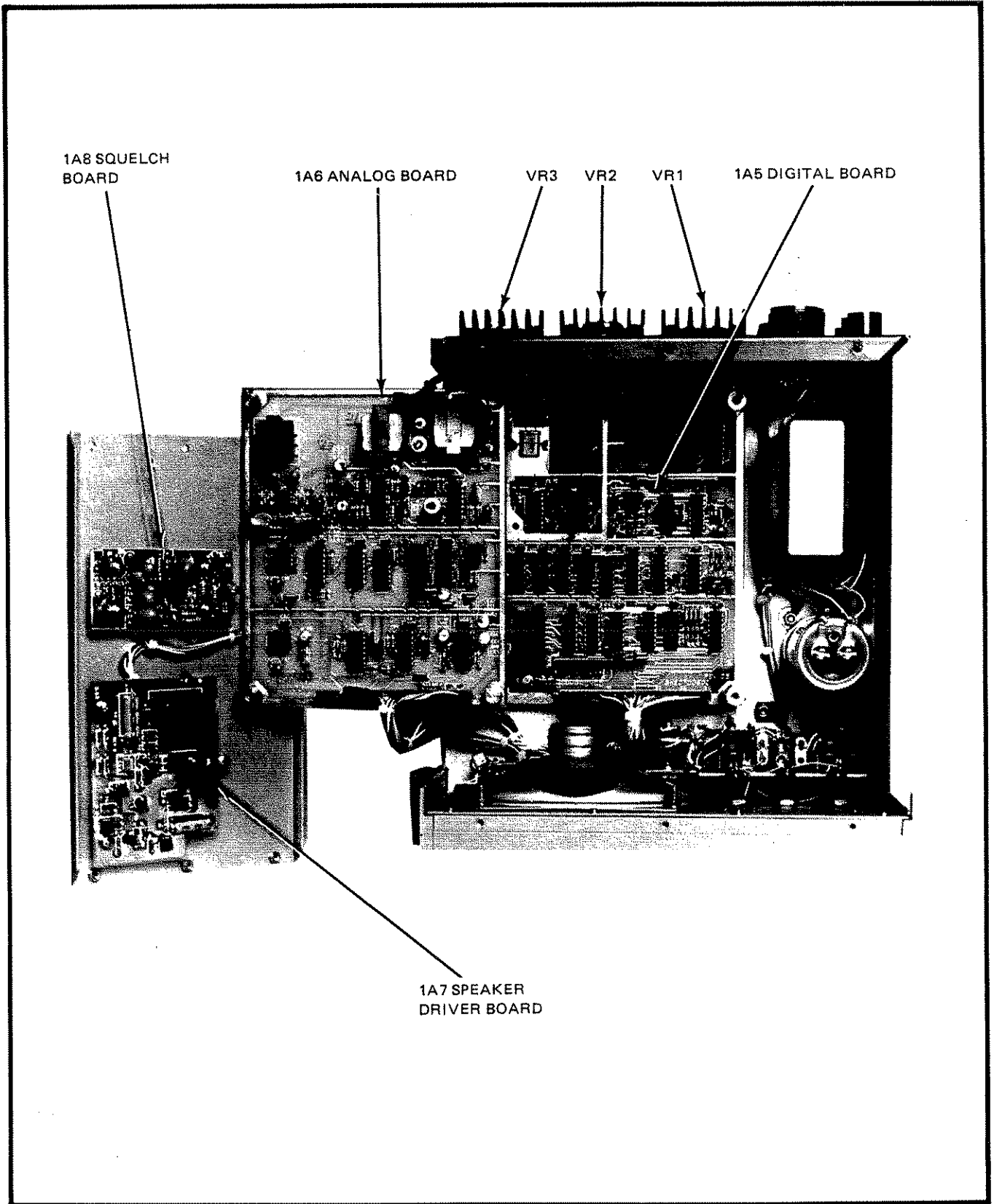

Figure 5.2 GRC-901 With PCB'S Extended

8070120070A

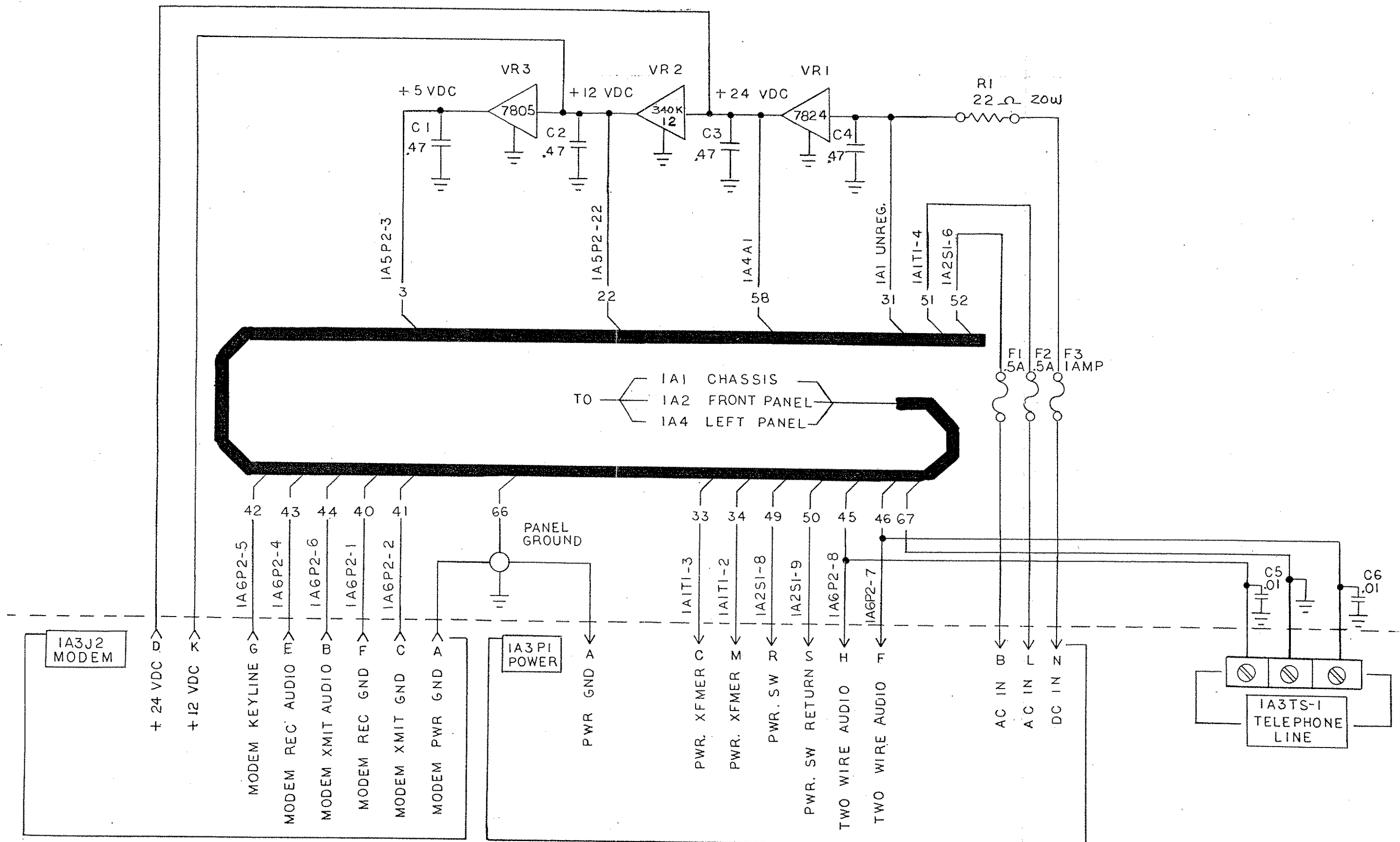

Figure 5.3 GRC-901 Chassis Assy. 1A1, 1A2, 1A3, 1A4 (Sheet 1)

SUNAIR GSB-900SC/R

8070120070A

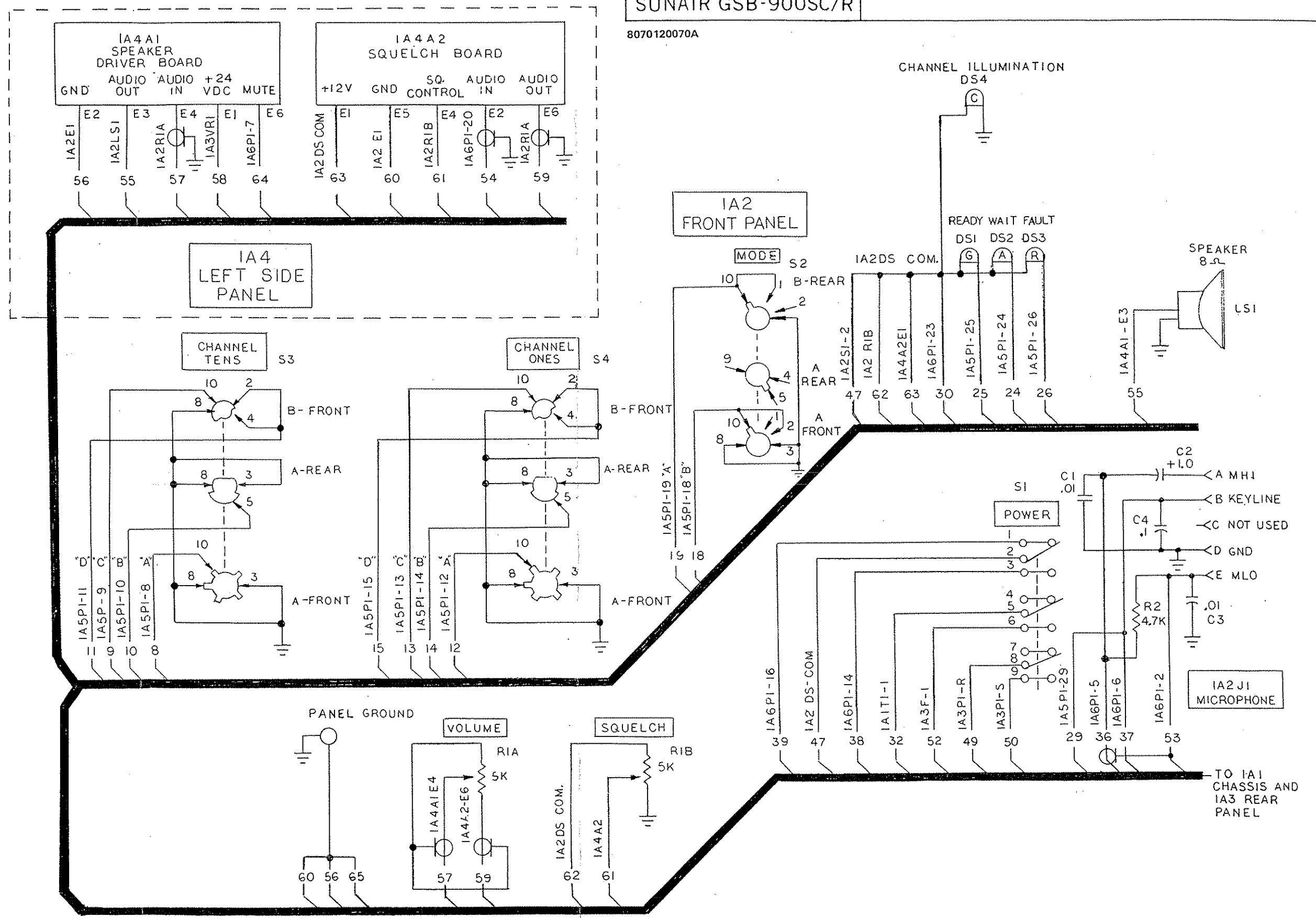

Figure 5.3 GRC-901 Chassis Assy, 1A1, 1A2, 1A3, 1A4 (Sheet 2)

8070060093 PC ASSY, DIGITAL GRC-901

REF SYMBOL	DESCRIPTION	SUNAIR PART NO.
	PC ASSY DIGITAL GRC-901	8070060093
C1	Capacitor, 0.01 UF, 50 V, X7 R, 20%	0281610002
C2	Capacitor, .47 UF, 50 V, X7 R, 20%	0283377771
C3	Capacitor, 6.8 UF, 20 V, T368	0296780006
C4	Capacitor, 2.2 UF, 35 V, T368	0273950092
C5	Capacitor, .01 UF, 50 V, X7 R, 20%	0281730008
C6	Capacitor, .01 UF, 50 V, X7 R, 20%	0281730008
C7	Capacitor, .01 UF, 50 V, X7 R, 20%	0281730008
C8	Capacitor, .01 UF, 50 V, X7 R, 20%	0281730008
C9	Capacitor, .01 UF, 50 V, X7 R, 20%	0281730008
C10	Capacitor, .01 UF, 50 V, X7 R, 20%	0281730008
C11	Capacitor, .01 UF, 50 V, X7 R, 20%	0281730008
C12	Capacitor, .01 UF, 50 V, X7 R, 20%	0281730008
C13	Capacitor, .01 UF, 50 V, X7 R, 20%	0281730008
C14	Capacitor, .01 UF, 50 V, X7 R, 20%	0281730008
C15	Capacitor, 0.1 UF, 50 V, X7 R, 20%	0281610002
C16	Capacitor, 0.1 UF, 50 V, X7 R, 20%	0281610002
C17	Capacitor, 0.1 UF, 50 V, X7 R, 20%	0281610002
C18	Capacitor, 0.1 UF, 50 V, X7 R, 20%	0281610002
C19	Capacitor, .01 UF, 50 V, X7 R, 20%	0281730008
C20	Capacitor, 1 UF, 35 V, T368	0283630001
C21	Capacitor, 1 UF, 35 V, T368	0283630001
C22	Capacitor, .05 UF, 25 V, Y5 U/Y5P	0273577778
C23	Capacitor, 0.1 UF, 50 V, X7 R, 20%	0281610002
C24	Capacitor, 1 UF, 35 V, T368	0283630001
C25	Capacitor, 0.1 UF, 50 V, X7 R, 20%	0281610002
C26	Capacitor, 0.1 UF, 50 V, X7 R, 20%	0281610002
C27	Capacitor, .05 UF, 25 V, Y5 U/Y5P	0273577778
C28	Capacitor, .01 UF, 50 V, X7 R, 20%	0281730008
C29	Capacitor, .01 UF, 50 V, X7 R, 20%	0281730008
C30	Capacitor, .01 UF, 50 V, X7 R, 20%	0281730008
C31	Capacitor, .01 UF, 50 V, X7 R, 20%	0281730008
C32	Capacitor, .01 UF, 50 V, X7 R, 20%	0281730008
C33	Capacitor, .01 UF, 50 V, X7 R, 20%	0281730008
C34	Capacitor, .01 UF, 50 V, X7 R, 20%	0281730008
C35	Capacitor, .01 UF, 50 V, X7 R, 20%	0281730008
C36	Capacitor, .01 UF, 50 V, X7 R, 20%	0281730008
C37	Capacitor, .01 UF, 50 V, X7 R, 20%	0281730008
C38	Capacitor, .01 UF, 50 V, X7 R, 20%	0281730008
C39	Capacitor, .01 UF, 50 V, X7 R, 20%	0281730008
C40	Capacitor, .01 UF, 50 V, X7 R, 20%	0281730008
C41	Capacitor, .01 UF, 50 V, X7 R, 20%	0281730008
C42	Capacitor, .01 UF, 50 V, X7 R, 20%	0281730008
C43	Capacitor, .01 UF, 50 V, X7 R, 20%	0281730008
C44	Capacitor, .01 UF, 50 V, X7 R, 20%	0281730008
C45	Capacitor, .01 UF, 50 V, X7 R, 20%	0281730008
C46	Capacitor, .01 UF, 50 V, X7 R, 20%	0281730008
C47	Capacitor, .01 UF, 50 V, X7 R, 20%	0281730008
C48	Capacitor, .01 UF, 50 V, X7 R, 20%	0281730008
C49	Capacitor, .01 UF, 50 V, X7 R, 20%	0281730008
C50	Capacitor, .01 UF, 50 V, X7 R, 20%	0281730008
C51	Capacitor, .01 UF, 50 V, X7 R, 20%	0281730008
C52	Capacitor, 3.3 UF, 35 V, 196 D	0281680001
C53	Capacitor, .01 UF, 50 V, X7 R, 20%	0281730008
C54	Capacitor, .01 UF, 50 V, X7 R, 20%	0281730008
C55	Capacitor, 0.1 UF, 50 V, X7 R, 20%	0281610002
C56	Capacitor, 0.1 UF, 50 V, X7 R, 20%	0281610002
C57	Capacitor, .01 UF, 50 V, X7 R, 20%	0281730008
C58	Capacitor, .01 UF, 50 V, X7 R, 20%	0281730008
C59	Capacitor, .05 UF, 25 V, Y5 U/Y5P	0273577778
C60	Capacitor, .05 UF, 25 V, Y5 U/Y5P	0273577778
CR1	Diode, Rectifier 1N4004	0405180004
CR2	Diode, Rectifier 1N4004	0405180004
CR3	Diode, Rectifier 1N4004	0405180004
CR4	Diode, Rectifier 1N4004	0405180004
Q1	Transistor, NPN SI MPS-A13	1003323502

REF SYMBOL	DESCRIPTION	SUNAIR PART NO.
Q2	Transistor, NPN SI MPS-A13	1003323502
Q3	Transistor, NPN SI MPS-A13	1003323502
Q4	Transistor, PNP, SI 2N2907A	0448390001
R1	Resistor, 560, 5%, 1/4 W	0183200004
R2	Resistor, 100 K, 10%, 1/4 W	0170390004
R3	Resistor, 100 K, 10%, 1/4 W	0170390004
R4	Resistor, 10 K, 10%, 1/4 W	0170410005
R5	Resistor, 180 K, 10%, 1/4 W	0177280000
R6	Resistor, 100 K, 10%, 1/4 W	0170390004
R7	Resistor, 10 K, 10%, 1/4 W	0170410005
R8	Resistor, 1.8 K, 10%, 1/4 W	0178190004
R9	Resistor, 22 K, 5%, 1/4 W	0172230004
R10	Resistor, 22 K, 5%, 1/4 W	0172230004
R11	Resistor, 22 K, 5%, 1/4 W	0172230004
R12	Resistor, 10 K, 10%, 1/4 W	0170410005
R13	Resistor, 10 K, 10%, 1/4 W	0170410005
R14	Resistor, 10 K, 10%, 1/4 W	0170410005
R15	Resistor, 180 K, 10%, 1/4 W	0177280000
R16	Resistor, 100 K, 10%, 1/4 W	0170390004
R17	Resistor, 22 K, 5%, 1/4 W	0172230004
R18	Resistor, 22 K, 5%, 1/4 W	0172280000
R19	Resistor, 180 K, 10%, 1/4 W	0172280000
R20	Resistor, 22 K, 5%, 1/4 W	0172230004
R21	Resistor, 680 K, 10%, 1/4 W	0181480000
R22	Resistor, 22 K, 5%, 1/4 W	0172230004
R23	Resistor, 22 K, 5%, 1/4 W	0172230004
R24	Resistor, 180 K, 10%, 1/4 W	0172280000
R25	Resistor, 3.9 K, 10%, 1/4 W	0178830003
R26	Resistor, 10 K, 10%, 1/4 W	0170410005
R27	Resistor, 10 K, 10%, 1/4 W	0170410005
R28	Resistor, 10 K, 10%, 1/4 W	0170410005
R29	Resistor, 10 K, 10%, 1/4 W	0170410005
R30	Resistor, 39 K, 10%, 1/4 W	0177800003
R31	Resistor, 39 K, 10%, 1/4 W	0177800003
R32	Resistor, 1 M, 10%, 1/4 W	0170650006
R33	Resistor, 3.9 K, 10%, 1/4 W	0178830003
R34	Resistor, 680 K, 10%, 1/4 W	0181480000
RN1	Res Ntwk 10 Pin Sip 10 K COM	1006130021
RN2	Res Ntwk 6 Pin Sip 10 K COM	1006130004
RN3	Res Ntwk 6 Pin Sip 10 K COM	1006130004
RN4	Res Ntwk 6 Pin Sip 10 K COM	1006130004
U1	IC, Digital CD4016 B	1006250026
U2	IC, Digital CD4016 B	1006250026
U3	IC, Digital CD4016 B	1006250026
U4	IC, Digital CD4016 B	1006250026
U5	IC, Digital MK5087 N	1006250034
U6	IC, Digital CD4514 B	1006260005
U7	IC Digital MC14503 BCP	1005180032
U8	IC Digital MC14503 BCP	1005180032
U9	IC, Digital CD4017 B	1006260013
U10	IC, Digital MC14013 B	1005150028
U11	IC, Digital MC14071 B	1005160023
U12	IC, Linear Timer LM555	8043095329
U13	IC, Digital MC14071 B	1005160023
U14	IC, Digital MC14071 B	1005160023
U15	IC, Digital MC14584 BCP	1005190011
U16	IC, Digital CD4514 B	1006260005
U17	IC, Digital MK5103 N	1006260021
U18	IC, Digital S3525 A	1006260030
U19	IC, Digital MC14072 B	1005160031
U20	IC Digital MC14013 B	1005150028
U21	IC, Digital MC14584 BCP	1005190011
U22	IC, Digital MC14584 BCP	1005190011
U23	IC, Linear Timer LM555	8043095329
U24	IC, Digital CD4081 B	1006280031
X1	Crystal, 3.579545 MHz Connector, PC, 30 Pin Male	1006270001 1006510036

# SUNAIR GSB-900SC/R

8070060077C

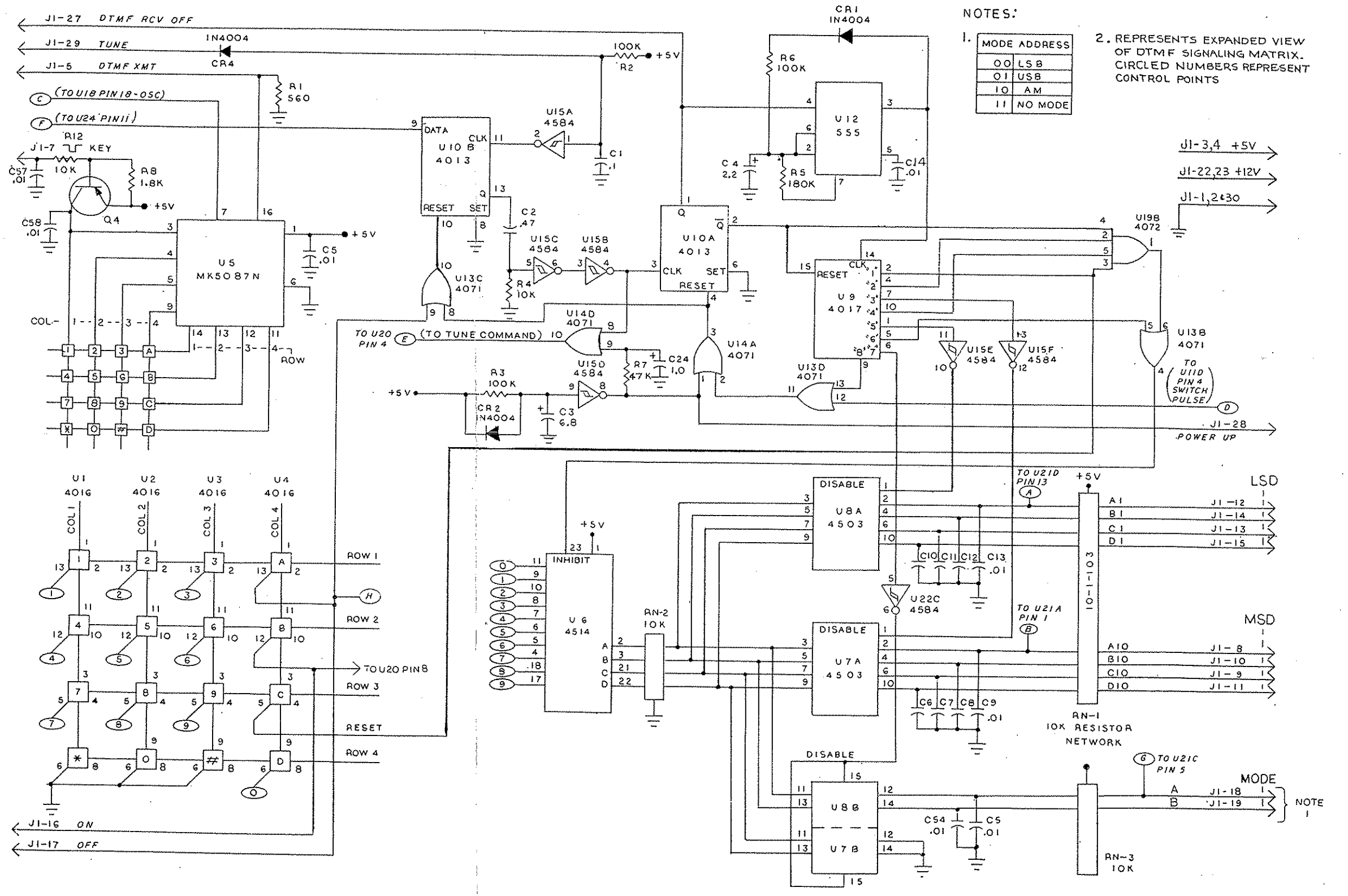

Figure 5.4 Digital Board 1A5 Schematic (Sheet 1)

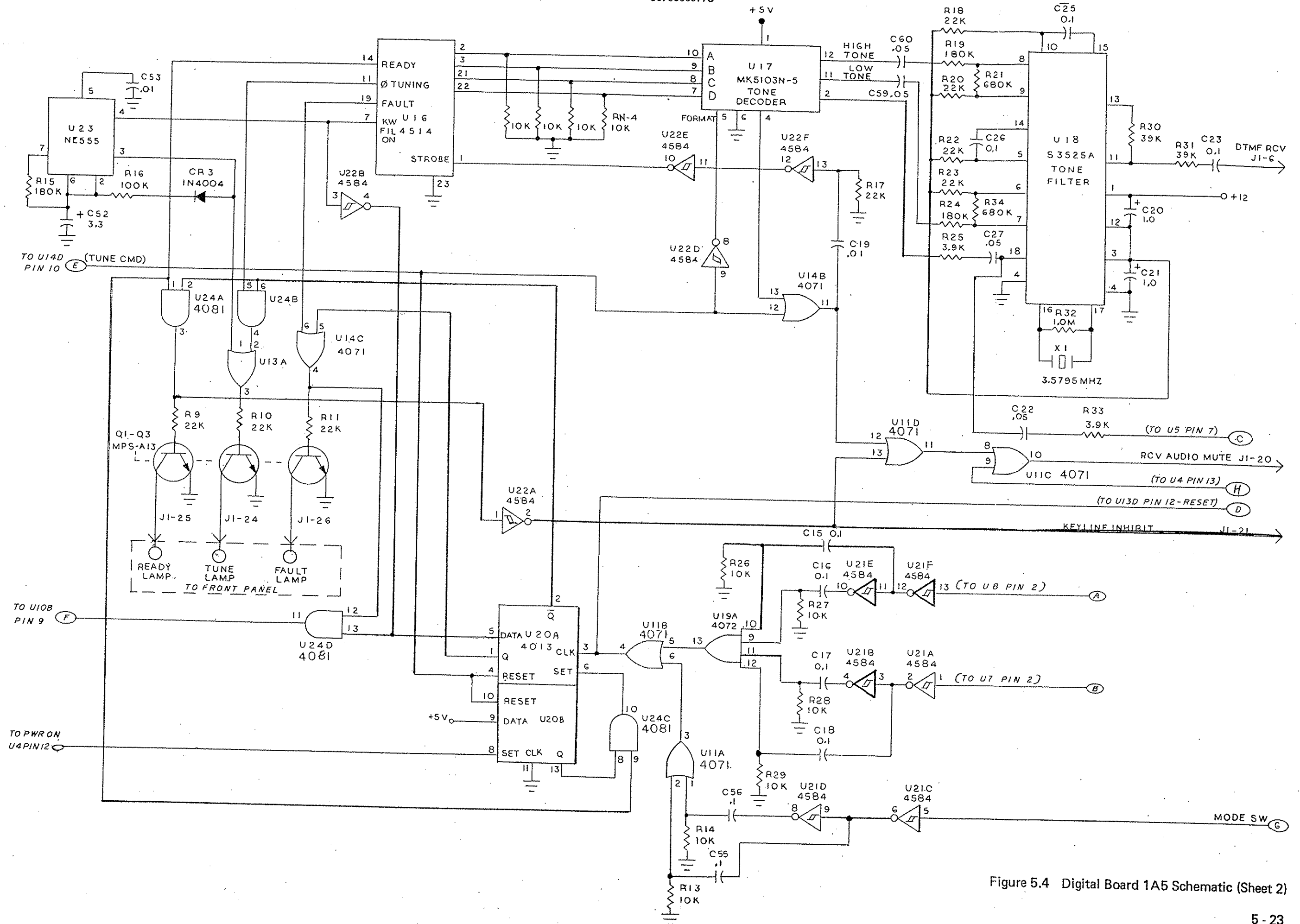

Figure 5.4 Digital Board 1A5 Schematic (Sheet 2)

THIS PAGE INTENTIONALLY LEFT BLANK.

8070060077C

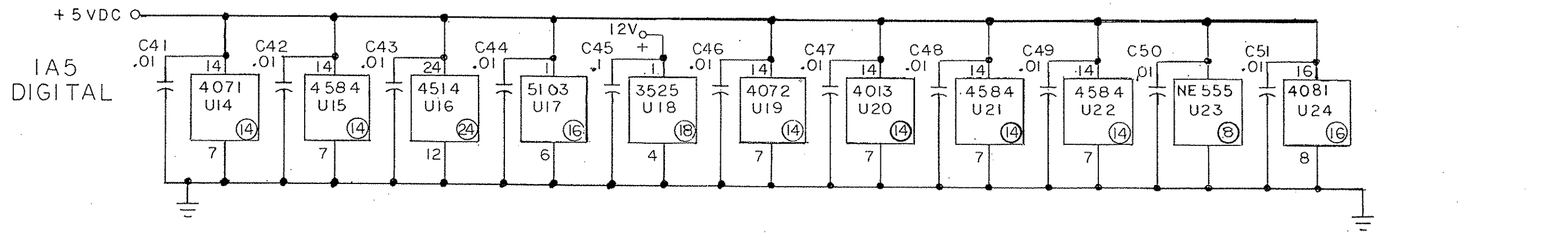
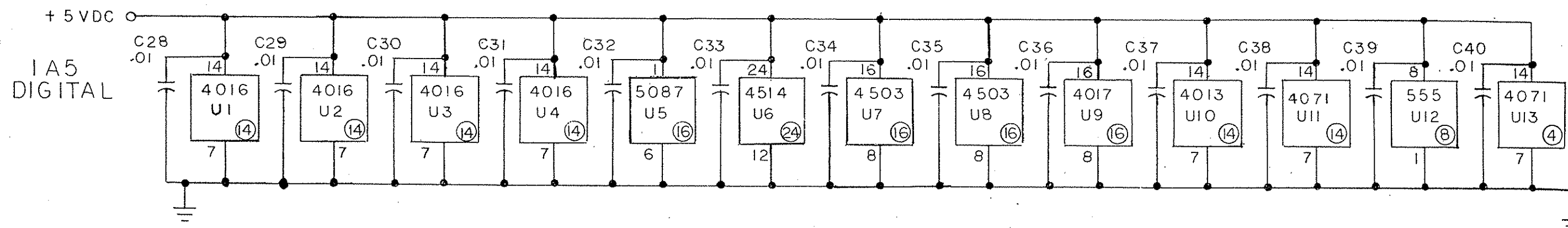
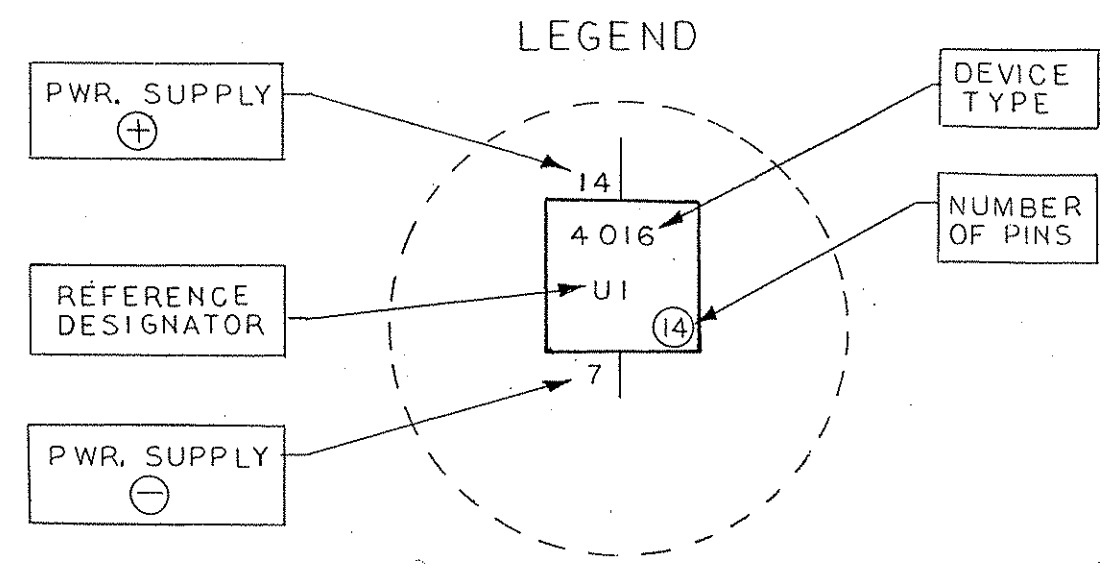
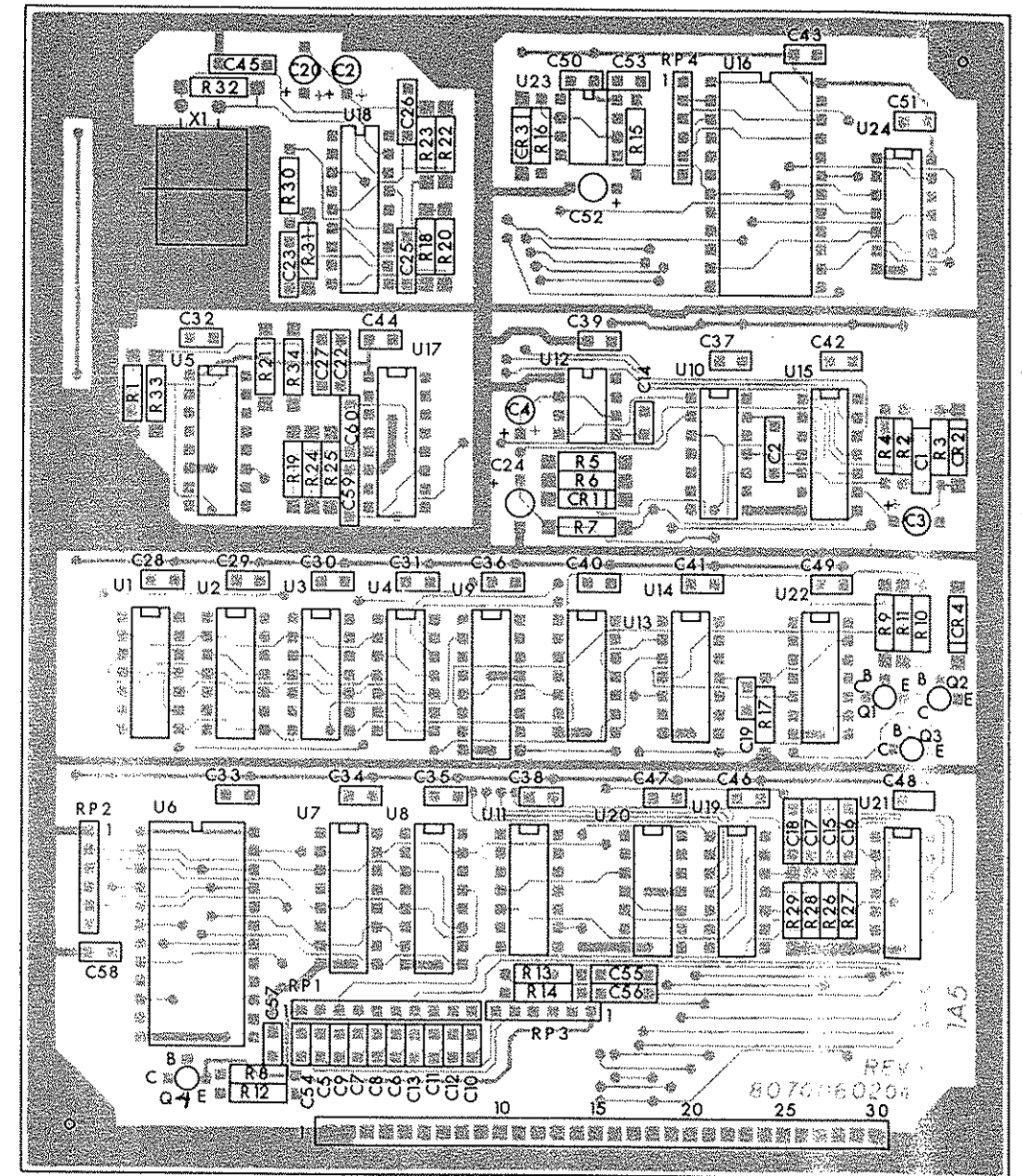
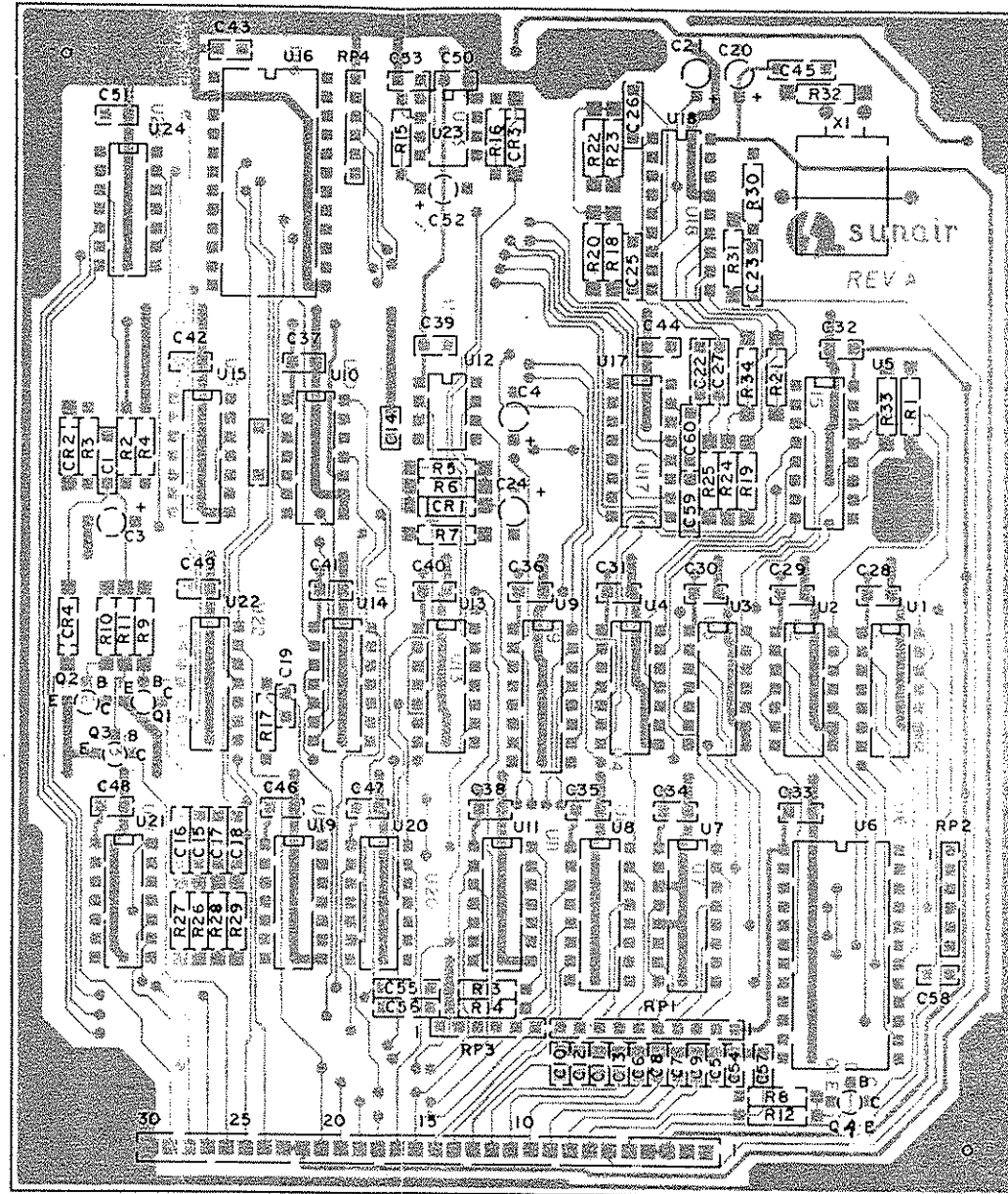

Figure 5.4 Digital Board 1A5 Schematic (Sheet 3)

SUNAIR GSB-900SC/R





# SUNAIR GSB-900SC/R

8070070072A

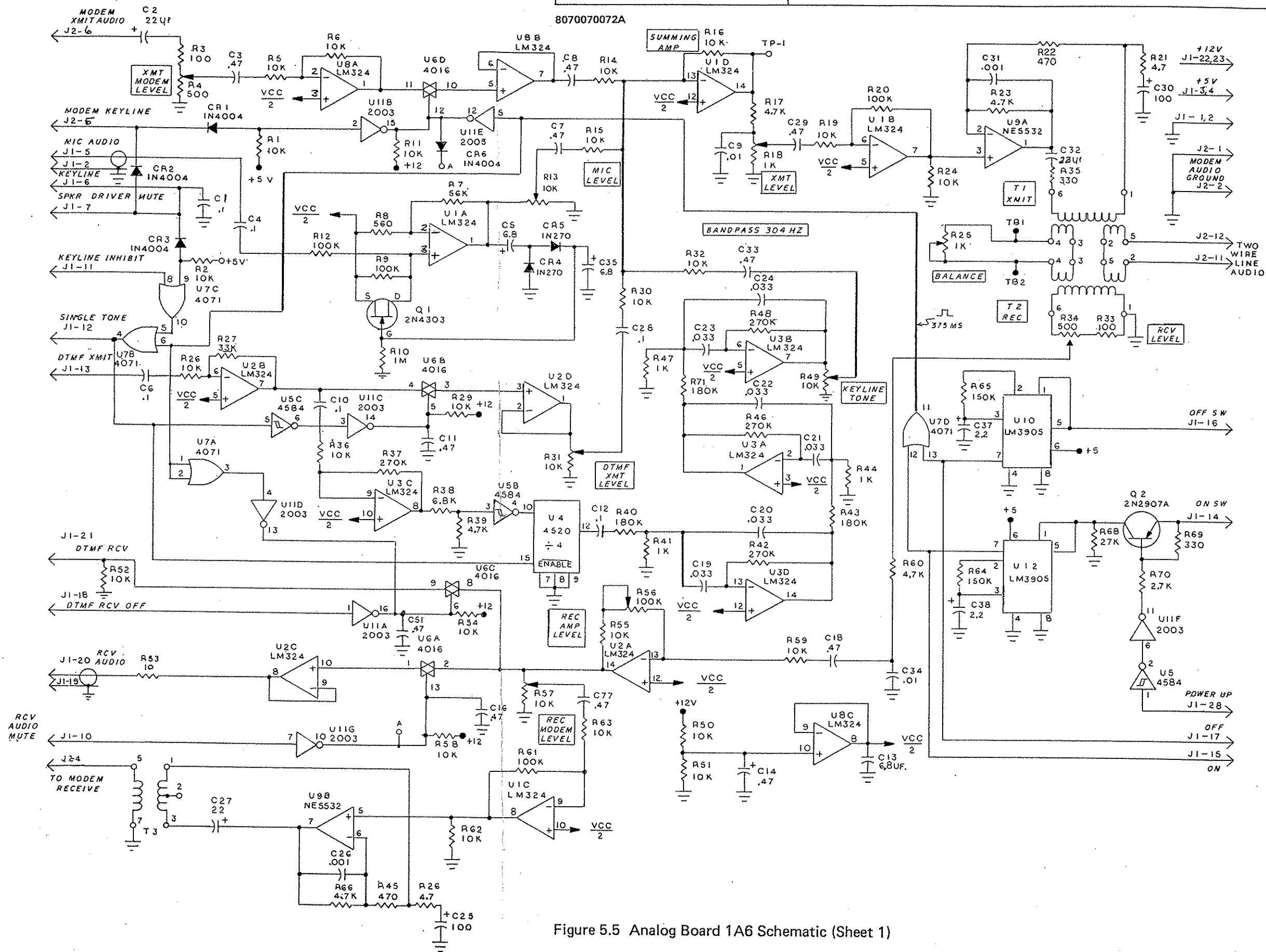
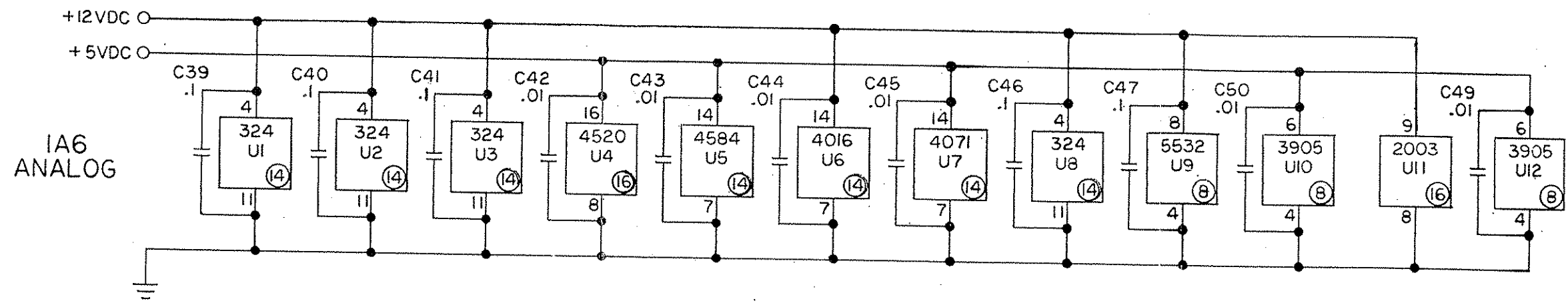

Figure 5.5 Analog Board 1A6 Schematic (Sheet 1)



LEGEND

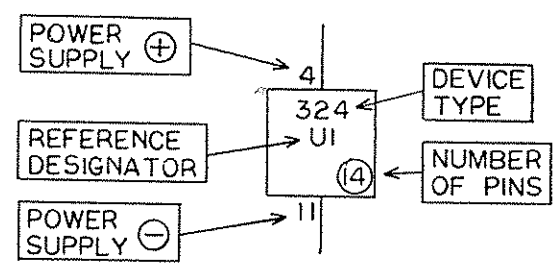

Figure 5.5 Analog Board 1A6 Schematic (Sheet 2)

SUNAIR GSB-900SC/R

8070070099 PC ASSY, ANALOG GRC-901

REF SYMBOL	DESCRIPTION	SUNAIR PART NO.
	PC ASSY, ANALOG GRC-901	8070070099
C1	Capacitor, 0.1 UF, 50 V, X7 R, 20%	0281610002
C2	Capacitor, 22 UF, 15 V, 196 D	0281690006
C3	Capacitor, .47 UF, 50 V, X7 R	0283377771
C4	Capacitor, 0.1 UF, 50 V, X7 R, 20%	0281610002
C5	Capacitor, 6.8 UF, 20 V	0296780006
C6	Capacitor, 0.1 UF, 50 V, X7 R, 20%	0281610002
C7	Capacitor, .47 UF, 50 V, X7 R	0283377771
C8	Capacitor, .47 UF, 50 V, X7 R	0283377771
C9	Capacitor, .01 UF, 50 V, X7 R, 20%	0281730008
C10	Capacitor, 0.1 UF, 50 V, X7 R, 20%	0281610002
C11	Capacitor, .47 UF, 50 V, X7 R	0283377771
C12	Capacitor, 0.1 UF, 50 V, X7 R, 20%	0121610002
C13	Capacitor, 6.8 UF, 20 V	0296780006
C14	Capacitor, .47 UF, 50 V, X7 R	0283377771
C16	Capacitor, .47 UF, 50 V, X7 R	0283377771
C18	Capacitor, .47 UF, 50 V, X7 R	0283377771
C19	Capacitor, .033 UF, 50 V, 10/20%	0281770000
C20	Capacitor, .033 UF, 50 V, 10/20%	0281770000
C21	Capacitor, .033 UF, 50 V, 10/20%	0281770000
C22	Capacitor, .033 UF, 50 V, 10/20%	0281770000
C23	Capacitor, .033 UF, 50 V, 10/20%	0281770000
C24	Capacitor, .033 UF, 50 V, 10/20%	0281770000
C25	Capacitor, 100 UF, 20 V, 20%	1005120030
C26	Capacitor, 0.001 UF, 100 V, X7 R, 20%	0281630003
C27	Capacitor, 22 UF, 15 V, 196 D	0281690006
C28	Capacitor, 0.1 UF, 50 V, X7 R, 20%	0281610002
C29	Capacitor, .47 UF, 50 V, X7 R	0283377771
C30	Capacitor, 100 UF, 20 V, 20%	1005120030
C31	Capacitor, 0.001 UF, 100 V, X7 R, 20%	0281630003
C32	Capacitor, 22 UF, 15 V, 196 D	0121690006
C33	Capacitor, .47 UF, 50 V, X7 R	0283377771
C34	Capacitor, .01 UF, 50 V, X7 R, 20%	0281730008
C35	Capacitor, 6.8 UF, 20 V	0296780006
C37	Capacitor, 2.2 UF, 15 V	0296420000
C38	Capacitor, 2.2 UF, 15 V	0296420000
C39	Capacitor, 0.1 UF, 50 V, X7 R, 20%	0281610002
C40	Capacitor, 0.1 UF, 50 V, X7 R, 20%	0281610002
C41	Capacitor, 0.1 UF, 50 V, X7 R, 20%	0281610002
C42	Capacitor, .01 UF, 50 V, X7 R, 20%	0281730008
C43	Capacitor, .01 UF, 50 V, X7 R, 20%	0281730008
C44	Capacitor, 0.1 UF, 50 V, X7 R, 20%	0281610002
C45	Capacitor, .01 UF, 50 V, X7 R, 20%	0281730008
C46	Capacitor, .01 UF, 50 V, X7 R, 20%	0281730008
C47	Capacitor, 0.1 UF, X7 R, 20%	0281610002
C49	Capacitor, .01 UF, 50 V, X7 R, 20%	0281730008
C50	Capacitor, .01 UF, 50 V, X7 R, 20%	0281730008
C51	Capacitor, .47 UF, 50 V, X7 R,	0283377771
C77	Capacitor, .47 UF, 50 V, X7 R	0283377771
CR1	Diode, Rectifier 1N4004	0405180004
CR2	Diode, Rectifier 1N4004	0405180004
CR3	Diode, Rectifier 1N4004	0405180004
CR4	Diode, Signal, Germ. 1N270	0405510004
CR5	Diode, Signal, Germ. 1N270	0405510004
CR6	Diode, Rectifier 1N4004	0405180004
Q1	Transistor, N-CH. FET J4303	0443930007
Q2	Transistor, PNP, Si. 2N2907A	0448390001
R1	Resistor, 10 K, 10%, 1/4 W	0170410005
R2	Resistor, 10 K, 10%, 1/4 W	0170410005
R3	Resistor, 100, 5%, 1/4 W	0171180003
R4	Resistor, 500, 20%, 1/2 W	0345980000
R5	Resistor, 10 K, 10%, 1/4 W	0170410005
R6	Resistor, 10 K, 10%, 1/4 W	0170410005

REF SYMBOL	DESCRIPTION	SUNAIR PART NO.
R7	Resistor, 56 K, 10%, 1/4 W	0171440005
R8	Resistor, 560, 5%, 1/4 W	0183200004
R9	Resistor, 100 K, 10%, 1/4 W	0170390004
R10	Resistor, 1 M, 10%, 1/4 W	0170650006
R11	Resistor, 10 K, 10%, 1/4 W	0170410005
R12	Resistor, 100 K, 10%, 1/4 W	0170390004
R13	Potentiometer, 10 K, 10%, 1/2 W	0346630002
R14	Resistor, 10 K, 10%, 1/4 W	0170410005
R15	Resistor, 10 K, 10%, 1/4 W	0170410005
R16	Resistor, 10 K, 10%, 1/4 W	0170410005
R17	Resistor, 4.7 K, 5%, 1/4 W	0170770001
R18	Potentiometer, 1 K, 10%, 1/2 W	1004680007
R19	Resistor, 10 K, 10%, 1/4 W	0170410005
R20	Resistor, 100 K, 10%, 1/4 W	0170390004
R21	Resistor, 4.7 K, 5%, 1/4 W	1001060024
R22	Resistor, 470, 5%, 1/4 W	0184110009
R23	Resistor, 4.7 K, 5%, 1/4 W	0170770001
R24	Resistor, 10 K, 10%, 1/4 W	0170410005
R25	Potentiometer, 1 K, 10%, 1/2 W	1004680007
R26	Resistor, 10 K, 10%, 1/4 W	0170410005
R27	Resistor, 3.3 K, 5%, 1/4 W	0195820002
R28	Resistor, 4.7 K, 5%, 1/4 W	1001060024
R29	Resistor, 10 K, 10%, 1/4 W	0170410005
R30	Resistor, 10 K, 10%, 1/4 W	0170410005
R31	Pot., 10 K, 10%, 1/2 W	0346630002
R32	Resistor, 10 K, 10%, 1/4 W	0170410005
R33	Resistor, 100, 5%, 1/4 W	0171180033
R34	Pot. 500, 20%, 1/2 W	0345980000
R35	Resistor, 330, 5%, 1/4 W	0170910008
R36	Resistor, 10 K, 10%, 1/4 W	0170410005
R37	Resistor, 270 K, 10%, 1/4 W	0172110009
R38	Resistor, 6.8 K, 5%, 1/4 W	0174810008
R39	Resistor, 4.7 K, 5%, 1/4 W	0170770001
R40	Resistor, 180 K, 10%, 1/4 W	0177280000
R41	Resistor, 1 K, 10%, 1/4 W	0171560001
R42	Resistor, 270 K, 10%, 1/4 W	0172110009
R43	Resistor, 180 K, 10%, 1/4 W	0177280000
R44	Resistor, 1 K, 10%, 1/4 W	0171560001
R45	Resistor, 470 K, 5%, 1/4 W	0184110009
R46	Resistor, 270 K, 10%, 1/4 W	0172110009
R47	Resistor, 1 K, 10%, 1/4 W	0171560001
R48	Resistor, 270 K, 10%, 1/4 W	0172110009
R49	Pot., 10 K, 10%, 1/2 W	0346630002
R50	Resistor, 10 K, 10%, 1/4 W	0170410005
R51	Resistor, 10 K, 10%, 1/4 W	0170410005
R52	Resistor, 10 K, 10%, 1/4 W	0170410005
R53	Resistor, 10, 5%, 1/4 W	0177160004
R54	Resistor, 10 K, 10%, 1/4 W	0170410005
R55	Resistor, 10 K, 10%, 1/4 W	0170410005
R56	Pot., 100 K, 10%, 1/2 W	0345320000
R57	Pot., 10 K, 10%, 1/2 W	0346630002
R58	Resistor, 10 K, 10%, 1/4 W	0170410005
R59	Resistor, 10 K, 10%, 1/4 W	0170410005
R60	Resistor, 4.7 K, 5%, 1/4 W	0170770001
R61	Resistor, 100 K, 10%, 1/4 W	0170390004
R62	Resistor, 10 K, 10%, 1/4 W	0170410005
R63	Resistor, 10 K, 10%, 1/4 W	0170410005
R64	Resistor, 150 K, 10%, 1/4 W	0176750002
R65	Resistor, 150 K, 10%, 1/4 W	0176750002
R66	Resistor, 4.7 K, 5%, 1/4 W	0170770001
R68	Resistor, 27 K, 10%, 1/4 W	0171200004
R69	Resistor, 330, 5%, 1/4 W	0170910008
R70	Resistor, 2.7 K, 10%, 1/4 W	0186670001

REF SYMBOL	DESCRIPTION	SUNAIR PART NO.
R71	Resistor, 180 K, 10%, 1/4 W	0177280000
R76	Resistor, 180 K, 10%, 1/4 W	0177280000
T1	Transformer, Hybrid	1006270035
T2	Transformer, Hybrid	1006270035
T3	Transformer, Audio	0491650001
U1	IC. Linear LM324 N	1003970001
U2	IC. Linear LM324 N	1003910001
U3	IC. Linear LM324 N	1003970001
U4	IC. Digital	1006270027
U5	IC. Digital	1005190011
U6	IC. Digital	1006250026
U7	IC. Digital	1005160023
U8	IC. Linear LM324 N	1003970001
U9	IC. Linear	1006270019
U10	IC. Linear LM3905 N	0448470004
U11	IC. Digital	1005630038
U12	IC. Linear LM3905 N	0448470004
	Connector, Strip, 10 Pin	1006010033
	Connector, PC, 30 Pin Male	1006510036

5024047079A

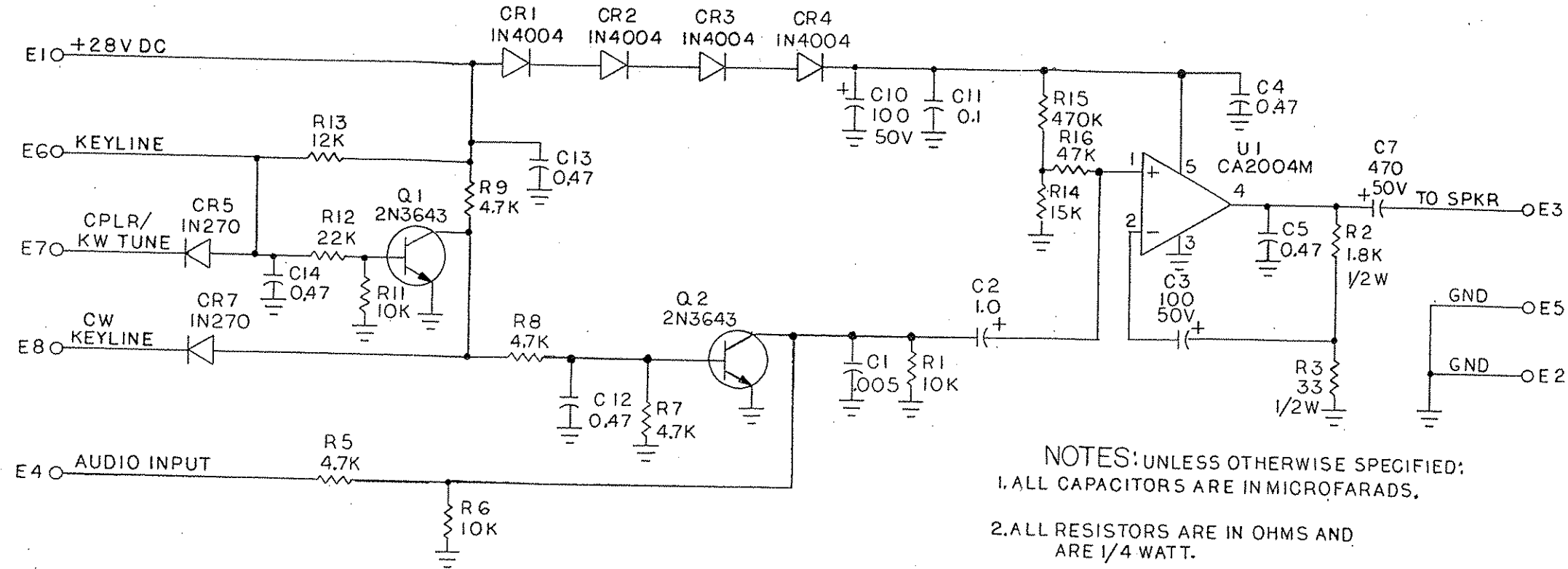

NOTES: UNLESS OTHERWISE SPECIFIED:  
 1. ALL CAPACITORS ARE IN MICROFARADS.  
 2. ALL RESISTORS ARE IN OHMS AND ARE 1/4 WATT.

5024047095 PC ASSY, SPEAKER DRIVER

REF SYMBOL	DESCRIPTION	SUNAIR PART NO.
	PC ASSY, SPEAKER DRIVER	5024047095
C1	Capacitor, 0.005 UF, 100 V, Z5 V	0273330004
C2	Capacitor, 1 UF, 35 V	0283630001
C3	Capacitor, 1000 UF, 50 V	1004260016
C4	Capacitor, .47 UF, 50 V, X7 R, 20%	0283377771
C5	Capacitor, .47 UF, 50 V, X7 R, 20%	0283377771
C7	Capacitor, 4700 UF, 50 V	0280890001
C10	Capacitor, 100 UF, 50 V	1004260016
C11	Capacitor, 0.1 UF, 50 V, X7 R, 20%	0281610002
C12	Capacitor, .47 UF, 50 V, X7 R, 20%	0283377771
C13	Capacitor, .47 UF, 50 V, X7 R, 20%	0283377771
C14	Capacitor, .47 UF, 50 V, X7 R, 20%	0283377771
CR1	Diode, Rectifier 1N4004	0405180004
CR2	Diode, Rectifier 1N4004	0405180004
CR3	Diode, Rectifier 1N4004	0405180004
CR4	Diode, Rectifier 1N4004	0405180004
CR5	Diode, Signal, Germ. 1N270	0405510004
CR7	Diode, Signal, Germ. 1N270	0405510004
R1	Resistor, 10 K, 10%, 1/4 W	0170410005
R2	Resistor, 1.8 K, 5%, 1/2 W	0184970008
R3	Resistor, 33, 10%, 1/2 W	0171700007
R5	Resistor, 4.7 K, 5%, 1/4 W	0170770001
R6	Resistor, 10 K, 10%, 1/4 W	0170410005
R7	Resistor, 4.7 K, 5%, 1/4 W	0170770001
R8	Resistor, 4.7 K, 5%, 1/4 W	0170770001
R9	Resistor, 4.7 K, 5%, 1/4 W	0170770001
R11	Resistor, 10 K, 10%, 1/4 W	0170410005
R12	Resistor, 22 K, 5%, 1/4 W	0172230004
R13	Resistor, 12 K, 10%, 1/4 W	0183180003
R14	Resistor, 15 K, 10%, 1/4 W	0172350000
R15	Resistor, 470 K, 10%, 1/4 W	0180570005
R16	Resistor, 47 K, 10%, 1/4 W	0171060008
U1	IC Linear	1003140025

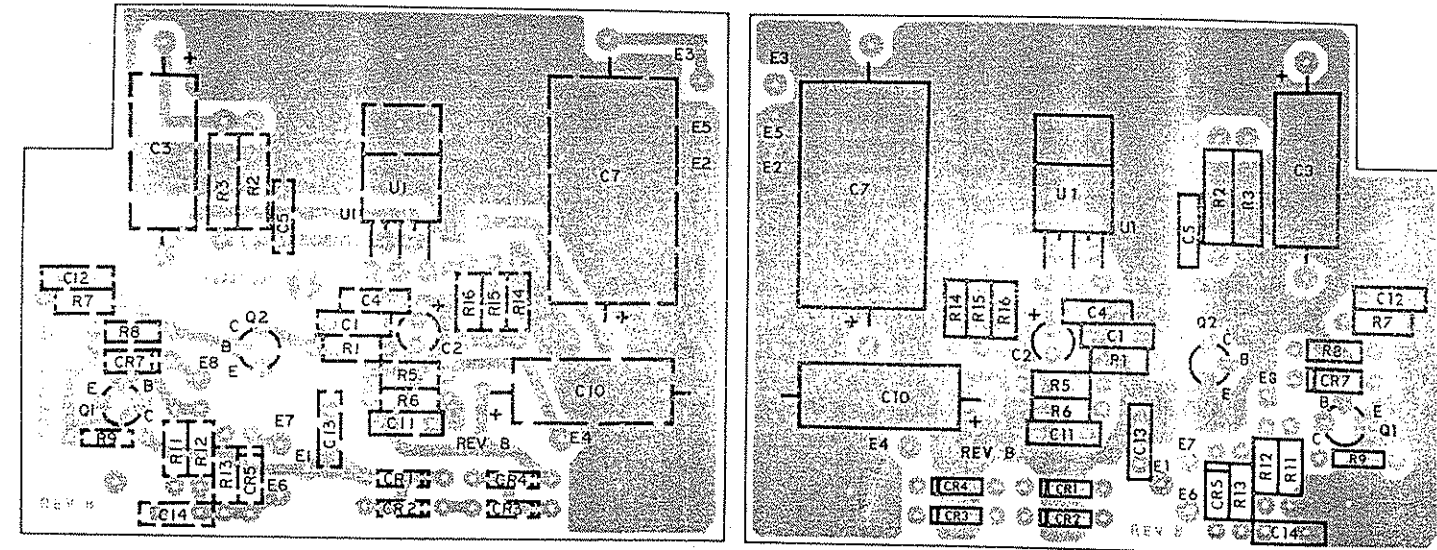
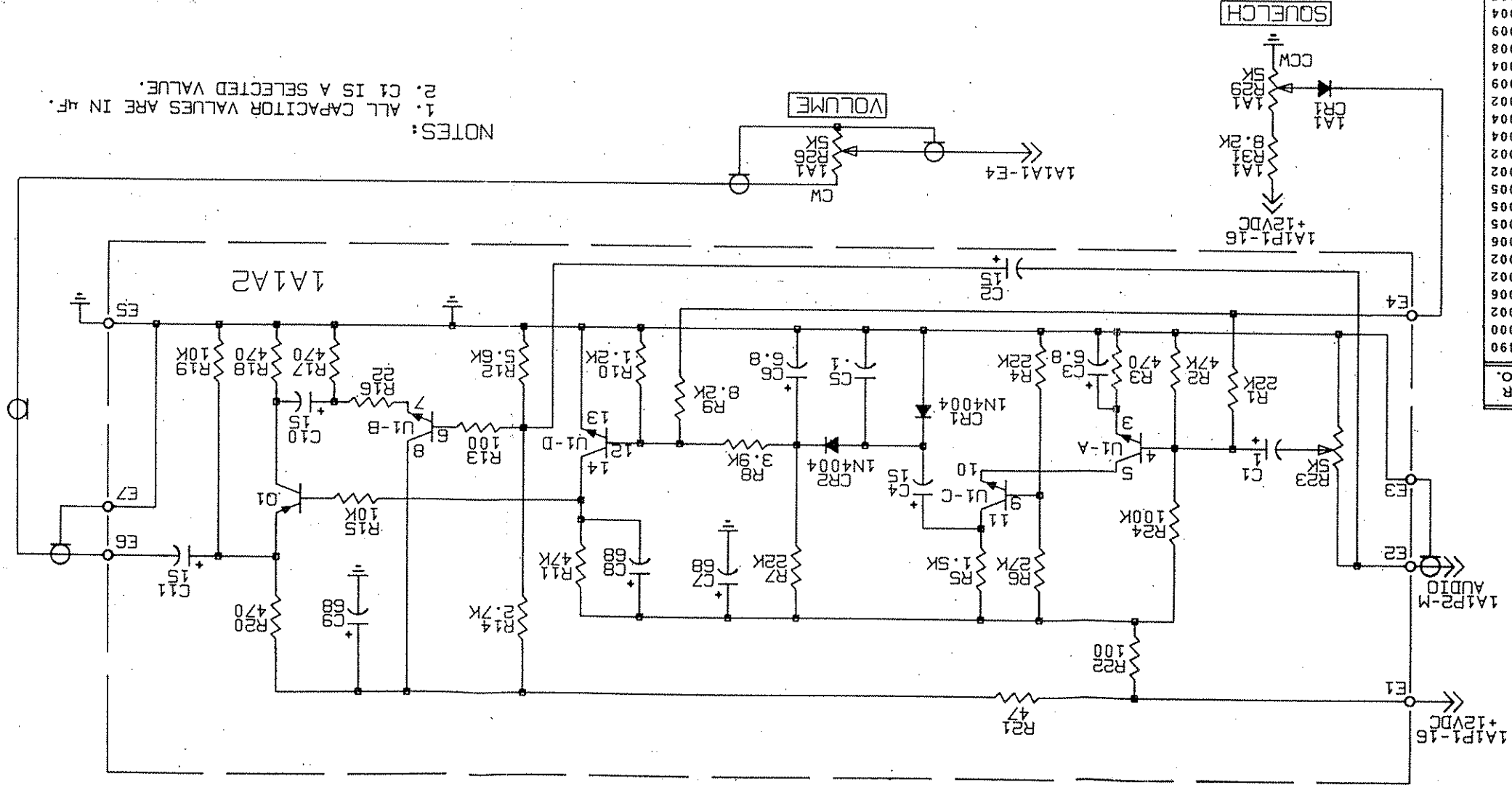
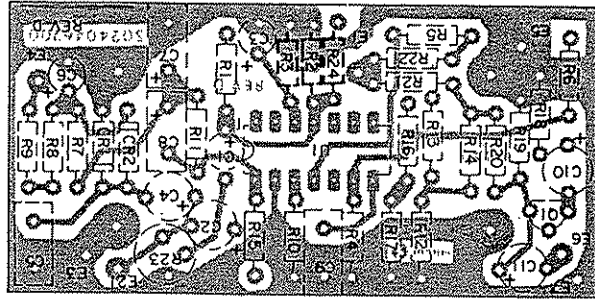
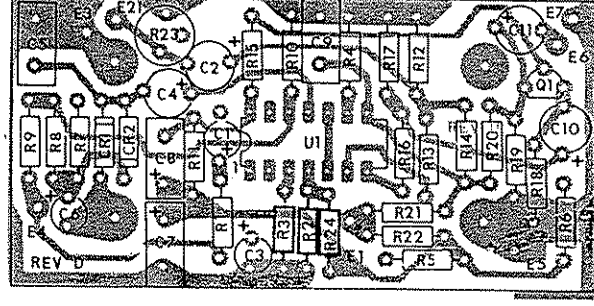

Figure 5.6 Speaker Driver Board 1A7 Schematic

THIS PAGE INTENTIONALLY LEFT BLANK.



NOTES:  
 1. ALL CAPACITOR VALUES ARE IN  $\mu$ F.  
 2. C1 IS A SELECTED VALUE.



REF	DESCRIPTION	SUNAIR PART NO.
C1	Capacitor, 1 $\mu$ F, 35V	8070110490
C2	Capacitor, 15 $\mu$ F, 15V	0281666000
C3	Capacitor, 6.8 $\mu$ F, 20V	0296780006
C4	Capacitor, 15 $\mu$ F, 15V	0281720002
C5	Capacitor, 0.1 $\mu$ F, 50V, X7 R, 20%	0281610002
C6	Capacitor, 6.8 $\mu$ F, 20V	0296780006
C7	Capacitor, 68 $\mu$ F, 25V	0282150005
C8	Capacitor, 68 $\mu$ F, 25V	0282150005
C9	Capacitor, 68 $\mu$ F, 25V	0282150005
C10	Capacitor, 15 $\mu$ F, 15V	0281720002
C11	Capacitor, 15 $\mu$ F, 15V	0271720002
CR1	Diode, Rectifier 1N4004	0405180004
CR2	Diode, Rectifier 1N4004	0405180004
JC1	IC, Linear	0447950002
Q1	Transistor, PNP, S12N4126	0448020009
R1	Resistor, 22K, 5%, 1/4W	0172230004
R2	Resistor, 47K, 10%, 1/4W	0171060008
R3	Resistor, 470, 5%, 1/4W	0184110009
R4	Resistor, 22K, 5%, 1/4W	0172230004
R5	Resistor, 1.5K, 10%, 1/4W	0172470005
R6	Resistor, 27K, 10%, 1/4W	0171200004
R7	Resistor, 22K, 5%, 1/4W	0172230004
R8	Resistor, 3.9K, 10%, 1/4W	0172230004
R9	Resistor, 8.2K, 10%, 1/4W	0181620006
R10	Resistor, 1.2K, 10%, 1/4W	0181860007
R11	Resistor, 47K, 10%, 1/4W	0171060008
R12	Resistor, 5.6K, 10%, 1/4W	0183060008
R13	Resistor, 100, 5%, 1/4W	0171180003
R14	Resistor, 2.7K, 10%, 1/4W	0186670001
R15	Resistor, 10K, 10%, 1/4W	0170410005
R16	Resistor, 22, 10%, 1/4W	0192690001
R17	Resistor, 470, 5%, 1/4W	0184410009
R18	Resistor, 470, 5%, 1/4W	0184410009
R19	Resistor, 10K, 10%, 1/4W	0170410005
R20	Resistor, 470, 5%, 1/4W	0184110009
R21	Resistor, 47, 10%, 1/4W	0179360001
R22	Resistor, 100, 5%, 1/4W	0171800003
R23	Pot, 5K, 10%, 1/2W	0197510001
R24	Resistor, 100K, 10%, 1/4W	0170390004

Figure 5.7 Squelch Board Assy 1A8

REF	SYMBOL	DESCRIPTION	SUNAIR PART NO.
C1		Capacitor, 0.1 uF, 50V, X7R, 20%	0286100002
C2		Capacitor, 1 uF, 35V, T368	0283630001
C3		Capacitor, 1 uF, 35V, T368	0283630001
C4		Capacitor, 0.1 uF, 50V, X7R, 20%	0281610002
C5		Capacitor, 0.1 uF, 50V, X7R, 20%	0281610002
C6		Capacitor, 0.47 uF, 25V, Y5U/Y5P	0273577778
C7		Capacitor, 0.47 uF, 25V, Y5U/Y5P	0273577778
C8		Capacitor, 47 uF, 50V, X7R, 20%	0283337771
C9		Capacitor, 47 uF, 50V, X7R, 20%	0283337771
C10		Capacitor, 47 uF, 50V, X7R, 20%	0283337771
C11		Capacitor, 0.1 uF, 50V, X7R, 20%	0281610002
C12		Capacitor, 2.2 uF, 15V	0296420000
C13		Capacitor, 2.2 uF, 15V	0296420000
C14		Capacitor, 1 uF, 35V, T368	0283630001
C15		Capacitor, 15 uF, 15V	0296800007
C16		Capacitor, 47 uF, 50V, X7R, 20%	0283337771
C17		Capacitor, 47 uF, 50V, X7R, 20%	0283337771
C18		Capacitor, 47 uF, 50V, X7R, 20%	0283337771
C19		Capacitor, 47 uF, 50V, X7R, 20%	0283337771
C20		Capacitor, 47 uF, 50V, X7R, 20%	0283337771
C21		Capacitor, 0.1 uF, 50V, X7R, 20%	0281730008
C22		Capacitor, 0.1 uF, 50V, X7R, 20%	0281730008
C23		Capacitor, 47 uF, 50V, X7R, 20%	0283337771
C24		Capacitor, 47 uF, 50V, X7R, 20%	0283337771
C25		Capacitor, 47 uF, 50V, X7R, 20%	0283337771
C26		Capacitor, 47 uF, 50V, X7R, 20%	0283337771
C27		Capacitor, 47 uF, 50V, X7R, 20%	0283337771
C28		Capacitor, 0.1 uF, 50V, X7R, 20%	0281610002
C29		Capacitor, 47 uF, 50V, X7R, 20%	0283337771
C30		Capacitor, 47 uF, 50V, X7R, 20%	0283337771
C31		Capacitor, 47 uF, 50V, X7R, 20%	0283337771
C32		Capacitor, 0.1 uF, 50V, X7R, 20%	0281730008
C33		Capacitor, 47 uF, 50V, X7R, 20%	0283337771
C34		Capacitor, 47 uF, 50V, X7R, 20%	0283337771
C35		Capacitor, 0.01 uF, 100V, X7R, 20%	0281630003
C36		Capacitor, 22 uF, 15V, 196D	0281690006
C37		Capacitor, 100 uF, 20V	1005120030
C38		Capacitor, 2.2 uF, 15V	0296420000
C39		Capacitor, 47 uF, 50V, X7R, 20%	0283337771
C40		Capacitor, 47 uF, 50V, X7R, 20%	0283337771
C41		Capacitor, 47 uF, 50V, X7R, 20%	0283337771
C42		Capacitor, 15 uF, 15V	0296800007
C43		Capacitor, 0.1 uF, 50V, X7R, 20%	0281610002
C44		Capacitor, 500 pF, 500V, DM15, 5%	0286120003
C45		Capacitor, 500 pF, 500V, DM15, 5%	0286120003
C46		Capacitor, 1000 pF, 500V, CM19, 2%	0281210004
C47		Capacitor, 47 uF, 50V, X7R, 20%	0283337771
C48		Capacitor, 0.1 uF, 50V, X7R, 20%	0281730008
C49		Capacitor, 47 uF, 50V, X7R, 20%	0283337771
C50		Capacitor, 0.33 uF, 50V, 10/20%	0281770000
C51		Capacitor, 0.33 uF, 50V, 10/20%	0281770000
C52		Capacitor, 47 uF, 50V, X7R, 20%	0283337771
C53		Capacitor, 0.1 uF, 50V, X7R, 20%	0281730008
C54		Capacitor, 6.8 uF, 20V	0296780006
C55		Capacitor, 47 uF, 50V, X7R, 20%	0283337771
C56		Capacitor, 47 uF, 50V, X7R, 20%	0283337771
C57		Capacitor, 47 uF, 50V, X7R, 20%	0283337771
C58		Capacitor, 47 uF, 50V, X7R, 20%	0283337771
C59		Capacitor, 47 uF, 50V, X7R, 20%	0283337771
C60		Capacitor, 0.1 uF, 50V, X7R, 20%	0281610002
C61		Capacitor, 22 uF, 15V, 196D	0281690006
C62		Capacitor, 0.001 uF, 100V, X7R, 20%	1005120030
C63		Capacitor, 100 uF, 20V	1005120030
C64		Capacitor, 0.1 uF, 50V, X7R, 20%	0281730008
C65		Capacitor, 0.1 uF, 50V, X7R, 20%	0281730008
C66		Capacitor, 0.1 uF, 50V, X7R, 20%	0281730008
C67		Capacitor, 0.1 uF, 50V, X7R, 20%	0281730008
C68		Capacitor, 0.1 uF, 50V, X7R, 20%	0281730008
C69		Capacitor, 0.1 uF, 50V, X7R, 20%	0281730008
C70		Capacitor, 0.1 uF, 50V, X7R, 20%	0281730008
C71		Capacitor, 0.1 uF, 50V, X7R, 20%	0281730008
C72		Capacitor, 0.1 uF, 50V, X7R, 20%	0281730008
C73		Capacitor, 0.1 uF, 50V, X7R, 20%	0281730008
C74		Capacitor, 0.1 uF, 50V, X7R, 20%	0281730008
C75		Capacitor, 0.1 uF, 50V, X7R, 20%	0281610002
C76		Capacitor, 0.1 uF, 50V, X7R, 20%	0281610002
C77		Capacitor, 0.1 uF, 50V, X7R, 20%	0281610002
C78		Capacitor, 0.1 uF, 50V, X7R, 20%	0281610002
C79		Capacitor, 0.1 uF, 50V, X7R, 20%	0281610002
C80		Capacitor, 0.1 uF, 50V, X7R, 20%	0281730008

REF	SYMBOL	DESCRIPTION	SUNAIR PART NO.
C81		Capacitor, 0.1 uF, 50V, X7R, 20%	0281610002
C82		Capacitor, 0.1 uF, 50V, X7R, 20%	0281730008
C83		Capacitor, 1 uF, 35V, T368	0296800007
C84		Capacitor, 15 uF, 15V	0283630001
C85		Capacitor, 1 uF, 35V, T368	0283630001
C86		Capacitor, 47 uF, 50V, X7R, 20%	0283337771
C87		Capacitor, 0.47 uF, 25V, Y5U/Y5P	0273577778
C88		Capacitor, 0.47 uF, 25V, Y5U/Y5P	0273577778
C89		Capacitor, 0.1 uF, 50V, X7R, 20%	0281730008
C90		Capacitor, 47 uF, 50V, X7R, 20%	0283337771
CP1		Capacitor, Network, 0.1 uF	1006160001
CR2		Diode, Rectifier	0405180004
CR3		Diode, Rectifier	0405180004
CR4		Diode, Rectifier	0405180004
CR5		Diode, Rectifier	0405180004
CR6		Diode, Signal, Germ. 1N270	0405180004
CR7		Diode, Signal, Germ. 1N270	0405180004
CR8		Diode, Rectifier	0405180004
CR9		Diode, Rectifier	0405180004
CR10		Diode, Rectifier	0405180004
CR11		Diode, Rectifier	0405180004
CR12		Diode, Rectifier	0405180004
CR13		Diode, Zener	0405210001
CR14		Diode, Signal, Sil. 1N4454	0405270003
K1		Relay, SPST, 12V, DIP, 1/2A	1003332804
Q1		Transistor, NPN SI	1003332352
Q2		Transistor, NPN SI	1003332352
Q3		Transistor, NPN SI	1003332352
Q4		Transistor, NPN SI	1003332352
Q5		Transistor, NPN SI	1003332352
Q6		Transistor, NPN	0448570009
Q7		Transistor, NPN SI	1003332352
Q8		Transistor, NPN SI	1003332352
Q9		Transistor, NPN SI	1003332352
R1		Resistor, 39K, 10%, 1/4W	0177800003
R2		Resistor, 39K, 10%, 1/4W	0177800003
R3		Resistor, 3.9K, 10%, 1/4W	0178830003
R4		Resistor, 22K, 5%, 1/4W	0178830003
R5		Resistor, 680K, 10%, 1/4W	0181480000
R6		Resistor, 180K, 10%, 1/4W	0172280000
R7		Resistor, 180K, 10%, 1/4W	0172280000
R8		Resistor, 22K, 5%, 1/4W	0172230004
R9		Resistor, 680K, 10%, 1/4W	0172230004
R10		Resistor, 22K, 5%, 1/4W	0177330004
R11		Resistor, 22K, 5%, 1/4W	0177330004
R12		Resistor, 1M, 10%, 1/4W	0170650006
R13		Resistor, 22K, 5%, 1/4W	0172230004
R14		Resistor, 3.9K, 10%, 1/4W	0178830003
R15		Resistor, 22K, 5%, 1/4W	0172230004
R16		Resistor, 100K, 10%, 1/4W	0170390004
R17		Resistor, 100K, 10%, 1/4W	0170390004
R18		Resistor, 100K, 10%, 1/4W	0170390004
R19		Resistor, 100K, 10%, 1/4W	0170390004
R20		Resistor, 22K, 5%, 1/4W	0172230004
R21		Resistor, 22K, 5%, 1/4W	0172230004
R22		Resistor, 22K, 5%, 1/4W	0172230004
R23		Resistor, 22K, 5%, 1/4W	0172230004
R24		Resistor, 22K, 5%, 1/4W	0172230004
R25		Resistor, 270K, 10%, 1/4W	0175260001
R26		Resistor, 10K, 10%, 1/4W	0172110009
R27		Resistor, 1M, 10%, 1/4W	0170410005
R28		Resistor, 10K, 10%, 1/4W	0170410005
R29		Resistor, 10K, 10%, 1/4W	0170410005
R30		Resistor, 10K, 10%, 1/4W	0170410005
R31		Resistor, 10K, 10%, 1/4W	0170410005
R32		Resistor, 10K, 10%, 1/4W	0170410005
R33		Resistor, 10K, 10%, 1/4W	0170410005
R34		Resistor, 10K, 10%, 1/4W	0170410005
R35		Resistor, 1M, 10%, 1/4W	0170650006
R36		Resistor, 10K, 10%, 1/4W	0170410005
R37		Resistor, 8.2K, 5%, 1/4W	0192070002
R38		Pot., 500, 20%, 1/2W	0183180003
R39		Pot., 500, 20%, 1/2W	0345980000
R40		Resistor, 560, 5%, 1/4W	0183200004
R41		Resistor, 10K, 10%, 1/4W	0170410005

SUNAIR GSB-9005C/R

REF	SYMBOL	DESCRIPTION	SUNAIR PART NO.
R42		Resistor, 10K, 10%, 1/4W	0170410005
R43		Resistor, 10K, 10%, 1/4W	0170410005
R44		Resistor, 10K, 10%, 1/4W	0170410005
R45		Resistor, 10K, 10%, 1/4W	0170410005
R46		Resistor, 6.8K, 5%, 1/4W	0174810008
R47		Resistor, 6.8K, 5%, 1/4W	0174810008
R48		Resistor, 10K, 10%, 1/4W	0170410005
R49		Resistor, 4.7K, 5%, 1/4W	0170410005
R50		Pot., 1K, 10%, 1/2W	1004680007
R51		Resistor, 10K, 10%, 1/4W	0170410005
R52		Resistor, 10K, 10%, 1/4W	0170390004
R53		Resistor, 10K, 10%, 1/4W	0170410005
R54		Resistor, 470, 5%, 1/4W	0184110009
R55		Resistor, 470, 5%, 1/4W	0170410005
R56		Pot., 1K, 10%, 1/2W	1004680007
R57		Resistor, 4.7K, 5%, 1/4W	1001060024
R58		Resistor, 10K, 10%, 1/4W	0170410005
R59		Resistor, 10K, 10%, 1/4W	0170410005
R60		Resistor, 150, 5%, 3W	0160110009
R61		Resistor, 150, 5%, 3W	0160110009
R62		Resistor, 150, 5%, 3W	0160110009
R63		Resistor, 10K, 10%, 1/4W	0346630002
R64		Pot., 10K, 1/2W	0346630002
R65		Resistor, 10K, 10%, 1/4W	0170410005
R66		Resistor, 10K, 10%, 1/4W	0170410005
R67		Resistor, 47K, 10%, 1/4W	0171060008
R68		Resistor, 6.8K, 5%, 1/4W	0174810008
R69		Resistor, 3.9K, 10%, 1/4W	0178830003
R70		Resistor, 10K, 10%, 1/4W	0170410005
R71		Resistor, 10K, 10%, 1/4W	0170410005
R72		Pot., 100K, 10%, 1/2W	1004820011
R73		Resistor, 1M, 10%, 1/4W	0170650006
R74		Resistor, 1M, 10%, 1/4W	0170650006
R75		Pot., 100K, 10%, 1/2W	1004820011
R76		Resistor, 470K, 10%, 1/4W	0180570005
R77		Pot., 100K, 10%, 1/2W	1004820011
R78		Resistor, 6.8K, 5%, 1/4W	0174810008
R79		Resistor, 10K, 10%, 1/4W	0170410005
R80		Resistor, 10K, 10%, 1/4W	0170410005
R81		Resistor, 4.7K, 5%, 1/4W	0170410005
R82		Resistor, 100, 5%, 1/4W	0171180003
R83		Pot., 500, 20%, 1/2W	0345980000
R84		Resistor, 13K, 1%, 1/8W	1004070004
R85		Resistor, 1.8K, 10%, 1/4W	1004070004
R86		Resistor, 150K, 10%, 1/4W	0178190004
R87		Resistor, 6.8K, 5%, 1/4W	0174810008
R88		Resistor, 10K, 10%, 1/4W	0170410005
R89		Resistor, 10K, 10%, 1/4W	0170410005
R90		Pot., 100K, 10%, 1/2W	0345320000
R91		Resistor, 47K, 10%, 1/4W	0171060008
R92		Resistor, 6.8K, 5%, 1/4W	0174810008
R93		Resistor, 47K, 10%, 1/4W	0171060008
R94		Resistor, 2.2K, 5%, 1/4W	0178070009
R95		Resistor, 1M, 10%, 1/4W	0178070009
R96		Resistor, 1K, 10%, 1/4W	0176050006
R97		Resistor, 10K, 10%, 1/4W	0170410005
R98		Resistor, 10K, 10%, 1/4W	0170410005
R99		Resistor, 1K, 10%, 1/4W	0171560001
R100		Resistor, 10K, 10%, 1/4W	0170410005
R101		Resistor, 10K, 10%, 1/4W	0170410005
R102		Resistor, 10K, 10%, 1/4W	0170410005
R103		Resistor, 6.8K, 5%, 1/4W	0174810008
R104		Resistor, 10K, 10%, 1/4W	0170410005
R105		Resistor, 10K, 10%, 1/4W	0170410005
R106		Resistor, 470, 5%, 1/4W	0170770001
R107		Resistor, 470, 5%, 1/4W	0184110009
R108		Resistor, 4.7K, 5%, 1/4W	1001060024
R109		Resistor, 10K, 10%, 1/4W	0170410005
R111		Resistor, 27K, 10%, 1/4W	0171200004

8070047071B

LEGEND

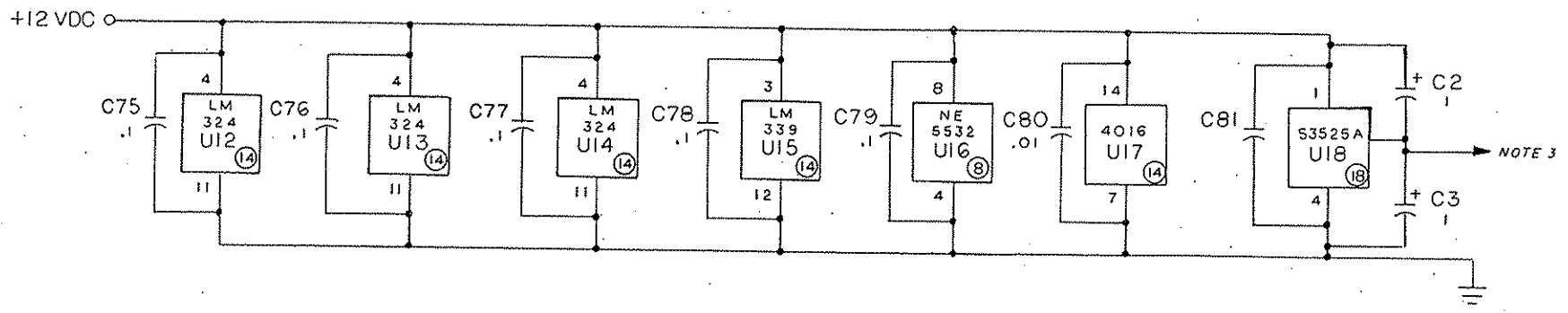
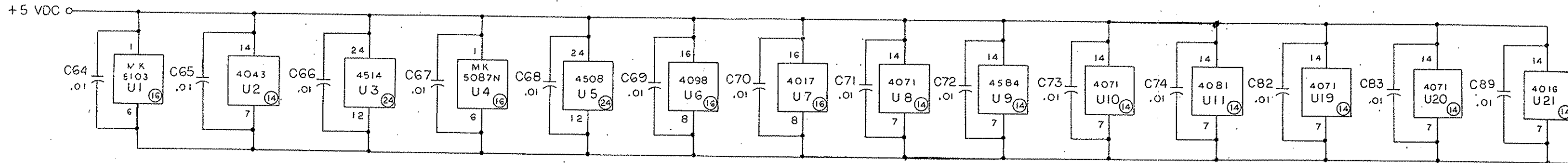
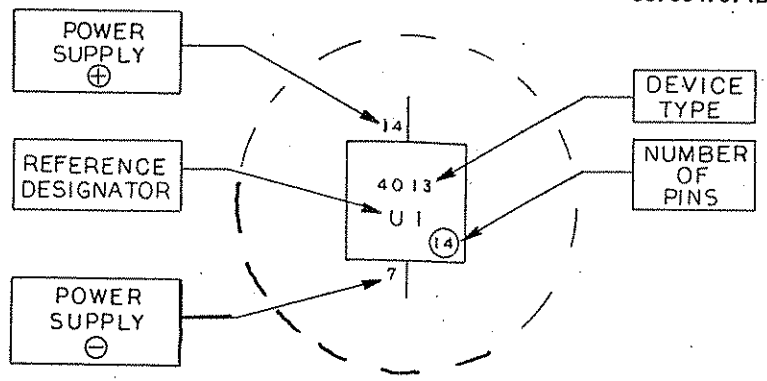

UNUSED

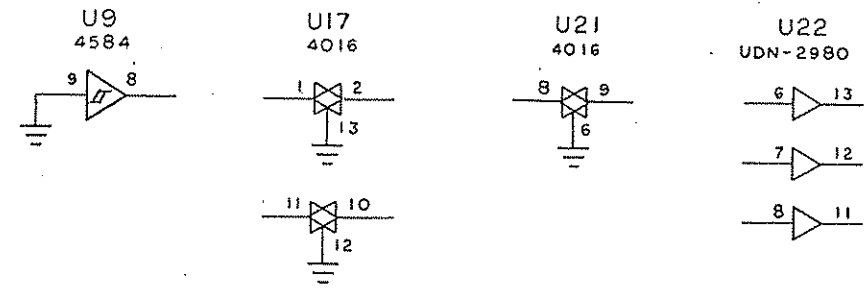

- NOTES:  
 1. ALL CAPACITORS ARE IN MICROFARADS UNLESS OTHERWISE SPECIFIED.  
 2. ALL RESISTORS ARE IN OHMS AND ARE 1/4 WATT UNLESS OTHERWISE SPECIFIED.  
 3. REFERENCE VOLTAGE FOR U18.

Figure 5.8 Transceiver Board 1A9 Schematic (Sheet 1)

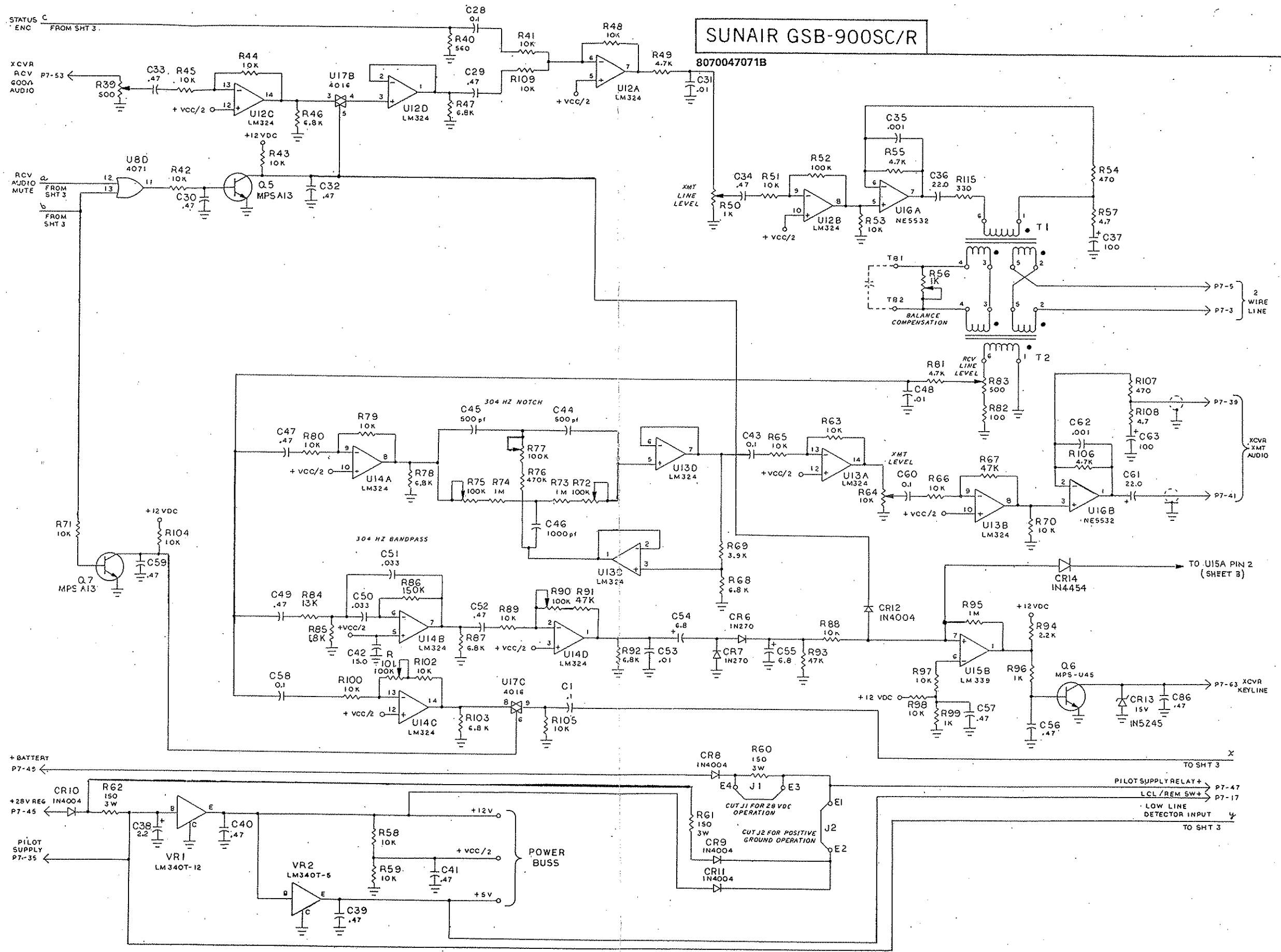
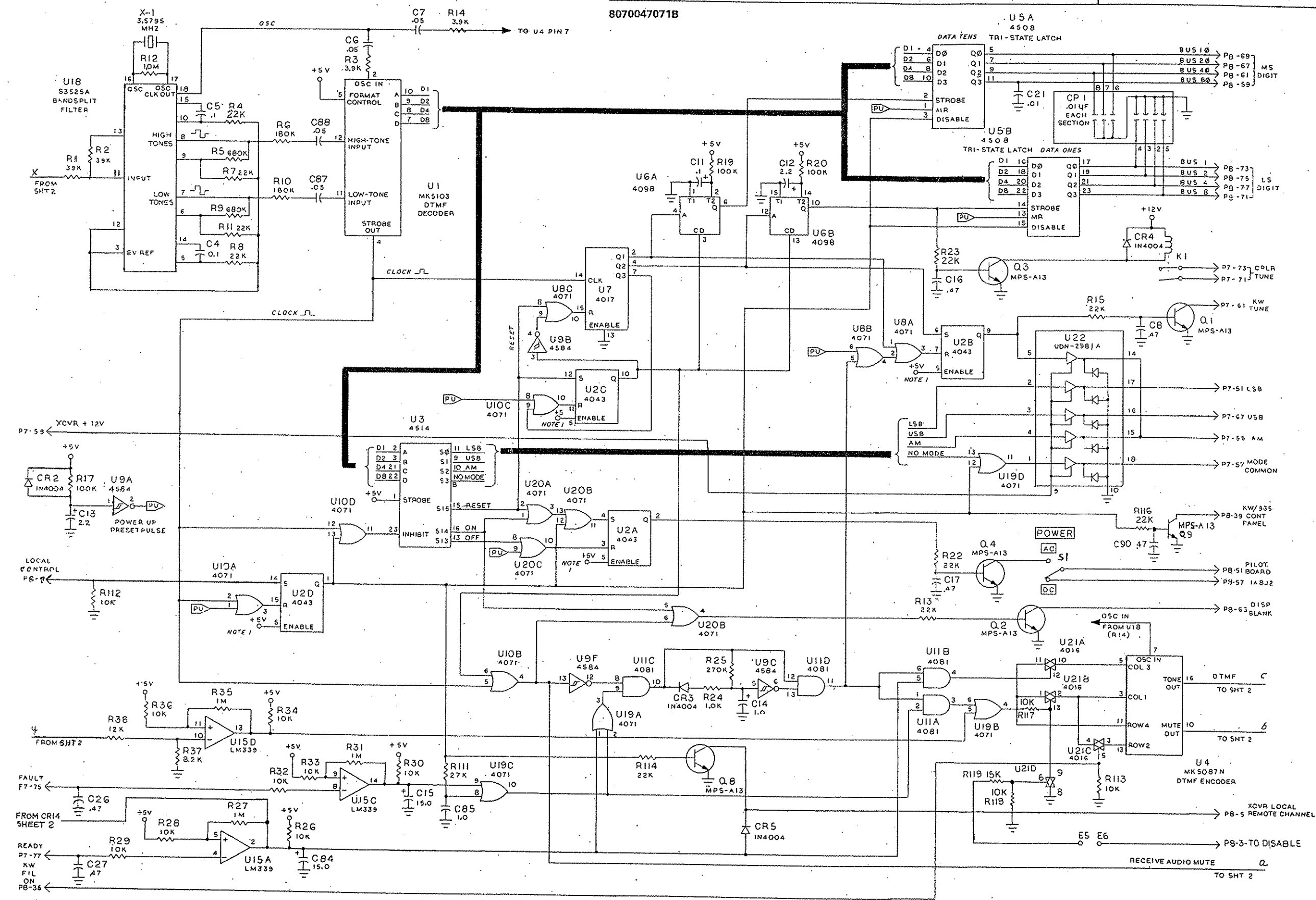

Figure 5.8 Transceiver Board 1A9 Schematic (Sheet 2)

8070047071B



NOTES:  
 1. ENABLE FUNCTION U2 - PIN 5 IS A COMMON P/N CONNECTION TO U2A, U2B, U2C, AND U2D.  
 2. S1 NOT USED.

Figure 5.8 Transceiver Board 1A9 Schematic (Sheet 3)

SUNAIR GSB-900SC/R

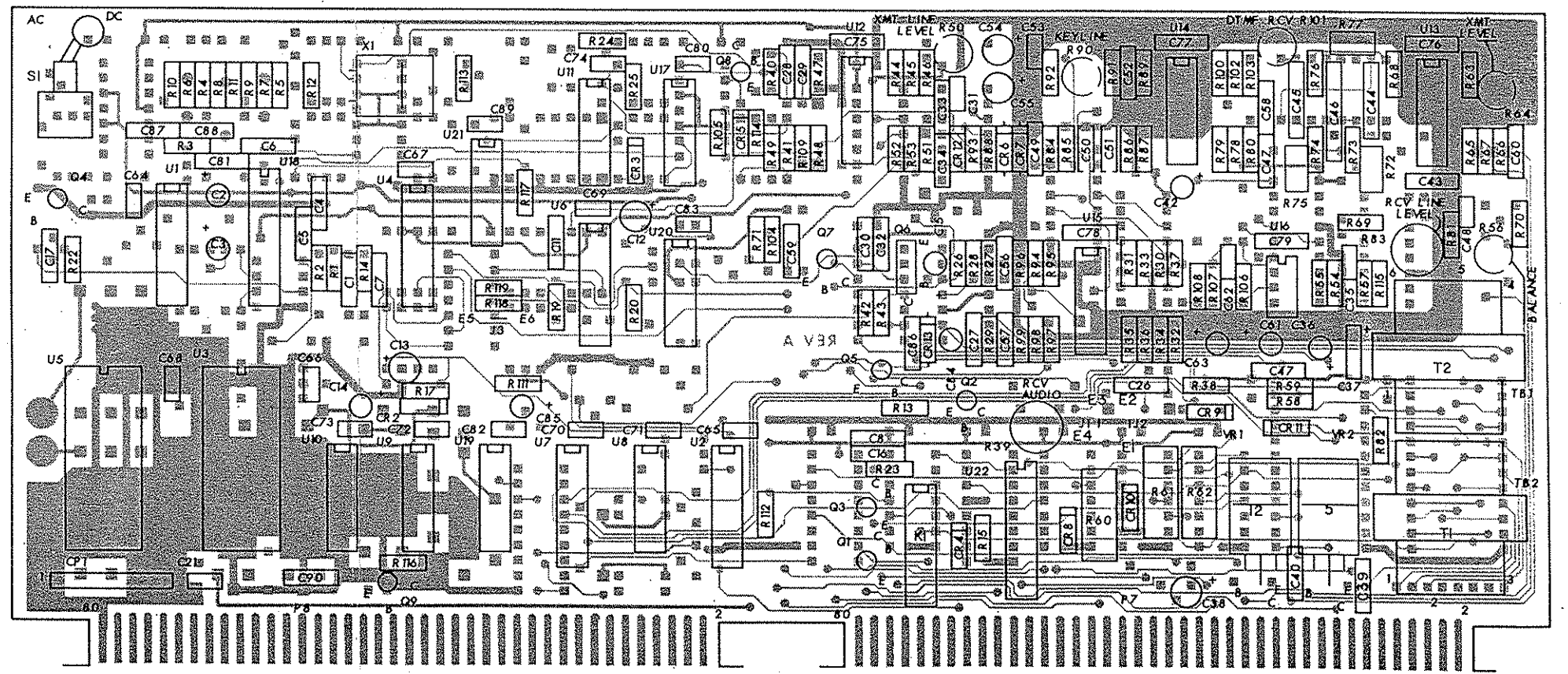
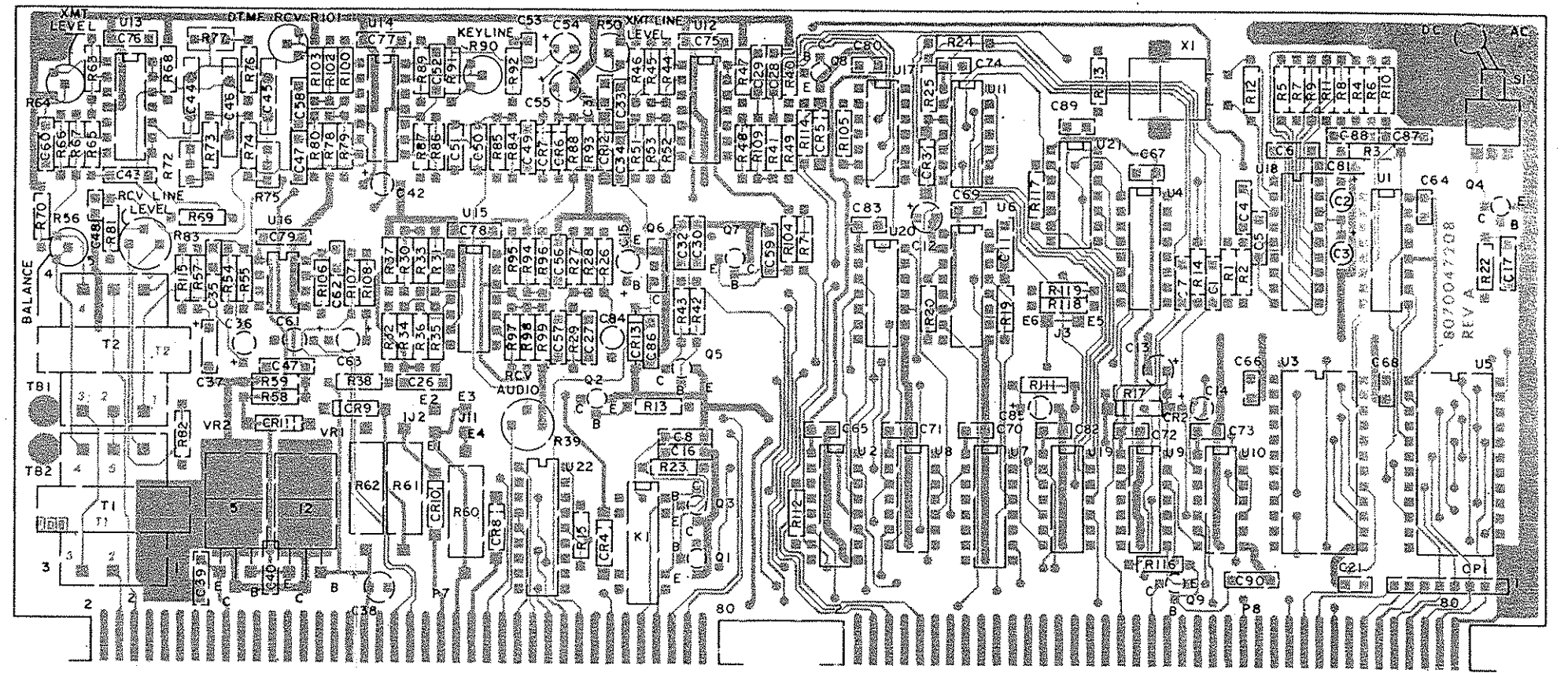

8070046074A

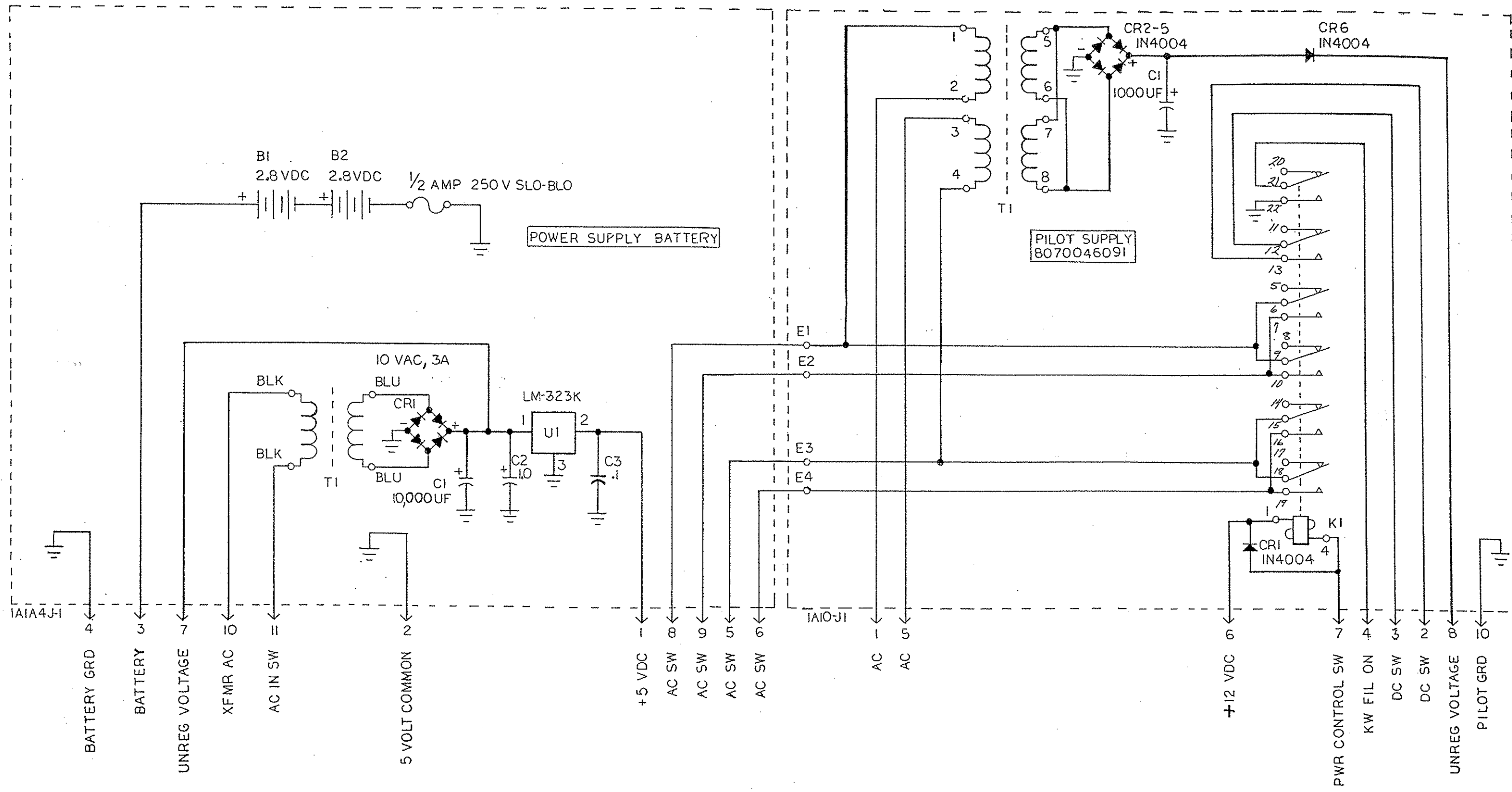

IAIA4J1 MATES WITH IAIP6

IAIOJ1 MATES WITH IAIP11

Figure 5.9 Pilot Supply Board 1A10 Schematic

SUNAIR GSB-900SC/R

8070040076A

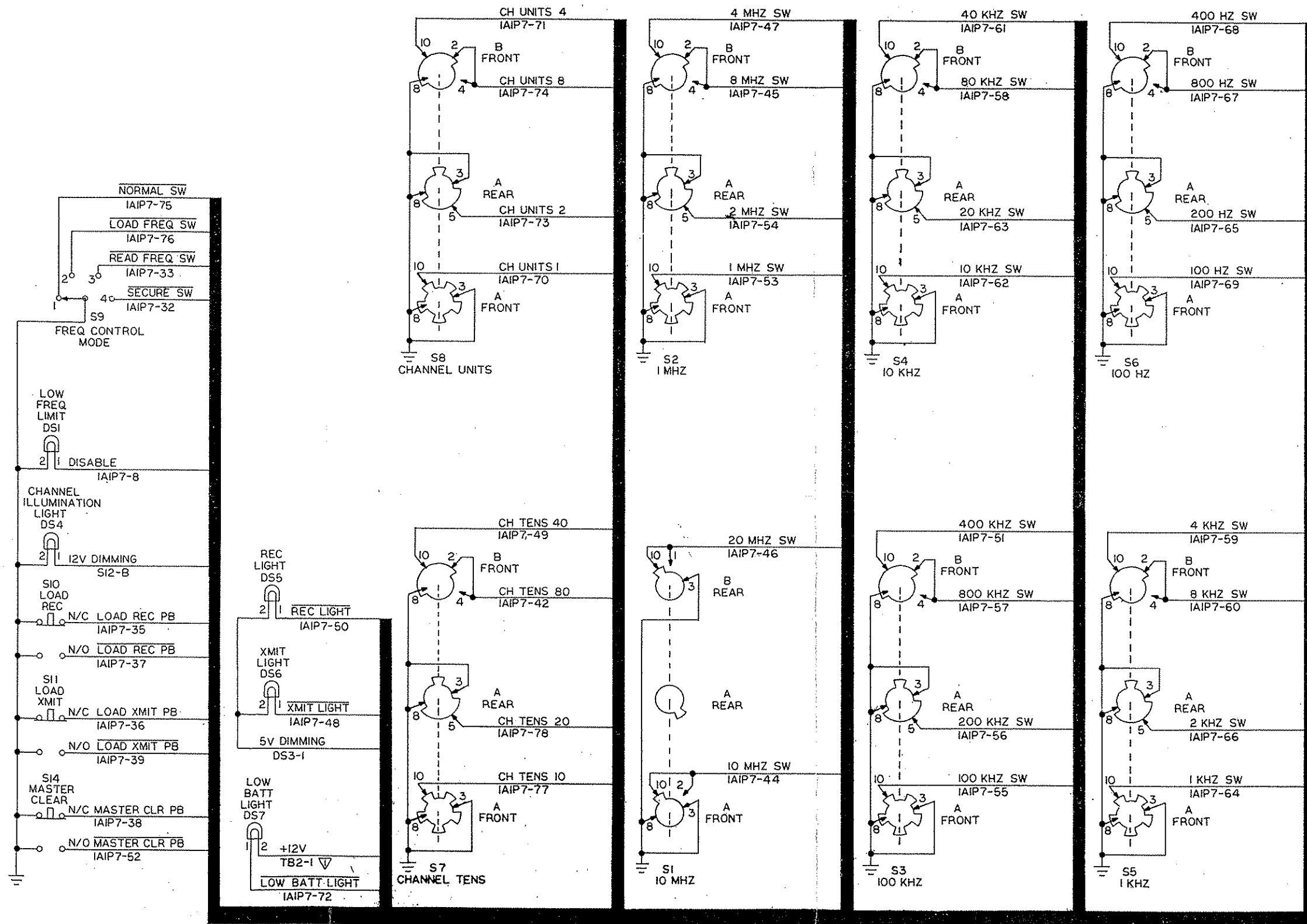

NOTES: UNLESS OTHERWISE SPECIFIED  
 ▽ COMMON CONNECTION FOR +12VDC  
 2 ALL RESISTORS ARE IN OHMS, 1/2 WATT  
 3 ALL CAPACITORS ARE IN MICROFARADS

Figure 5.10 GSB-900SC/R Front Panel 1A1 (Sheet 1)



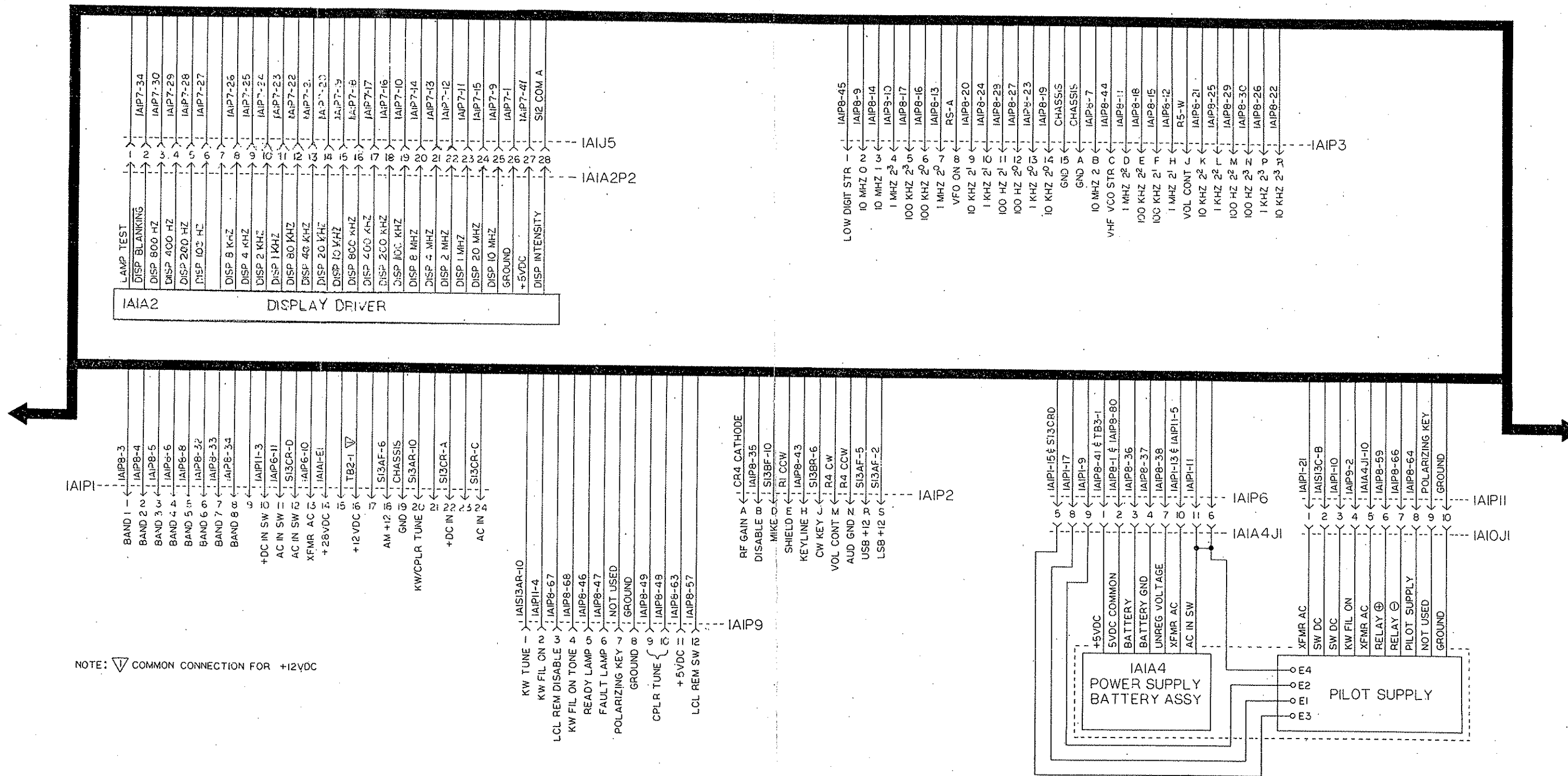

Figure 5.10 GSB-900SC/R Front Panel 1A1 (Sheet 3)

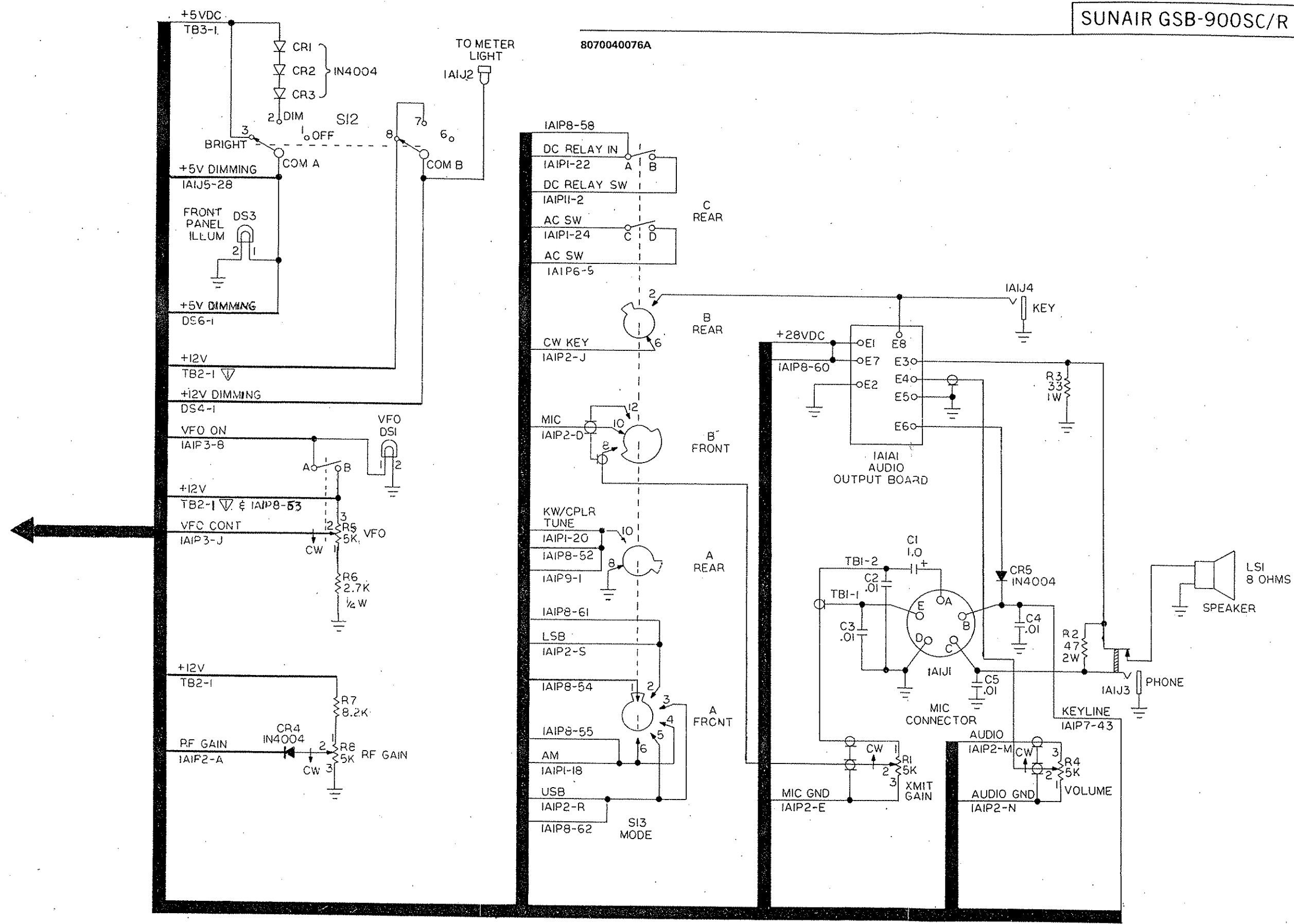
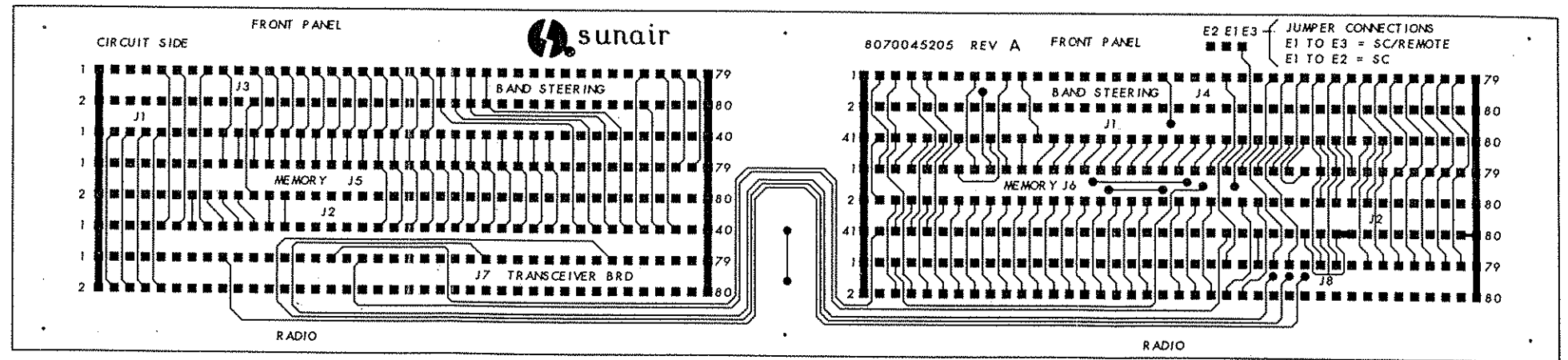
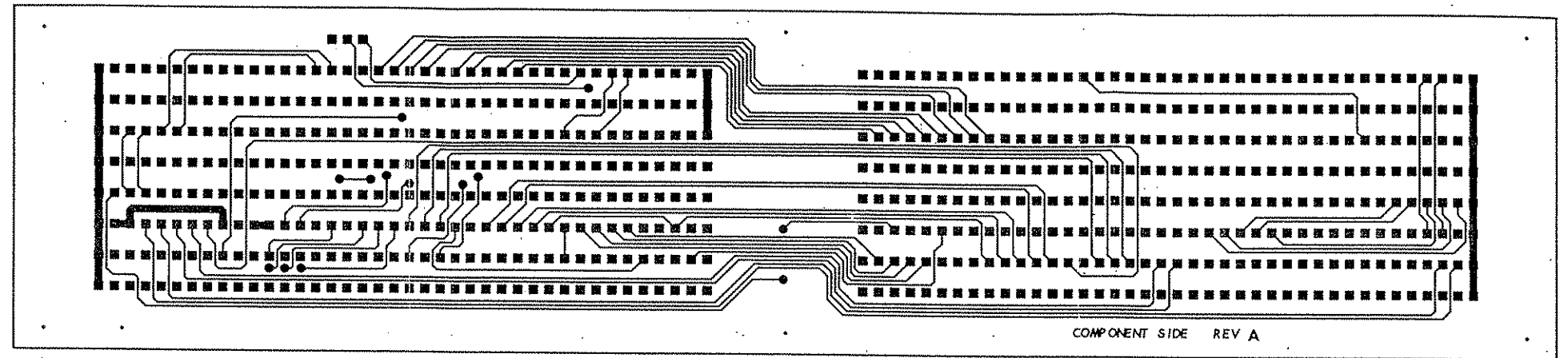

Figure 5.10 GSB-900SC/R Front Panel 1A1 (Sheet 4)

THIS PAGE INTENTIONALLY LEFT BLANK.



SUNAIR GSB-900SC/R

8070045078A

IAIA5J4 MATES WITH  
PC EDGE IAIA6PI ON  
BAND STEER BOARD

IAIA5J1 MATES  
WITH IAIP7  
TO FRONT PANEL

IAIA5J6 MATES WITH  
PC EDGE IAIA7PI ON  
BOARD

IAIA5J2 MATES  
WITH IAIP8  
TO RADIO

IAIA5J8 MATES WITH  
PC EDGE IAIA9PI  
ON REMOTE BOARD

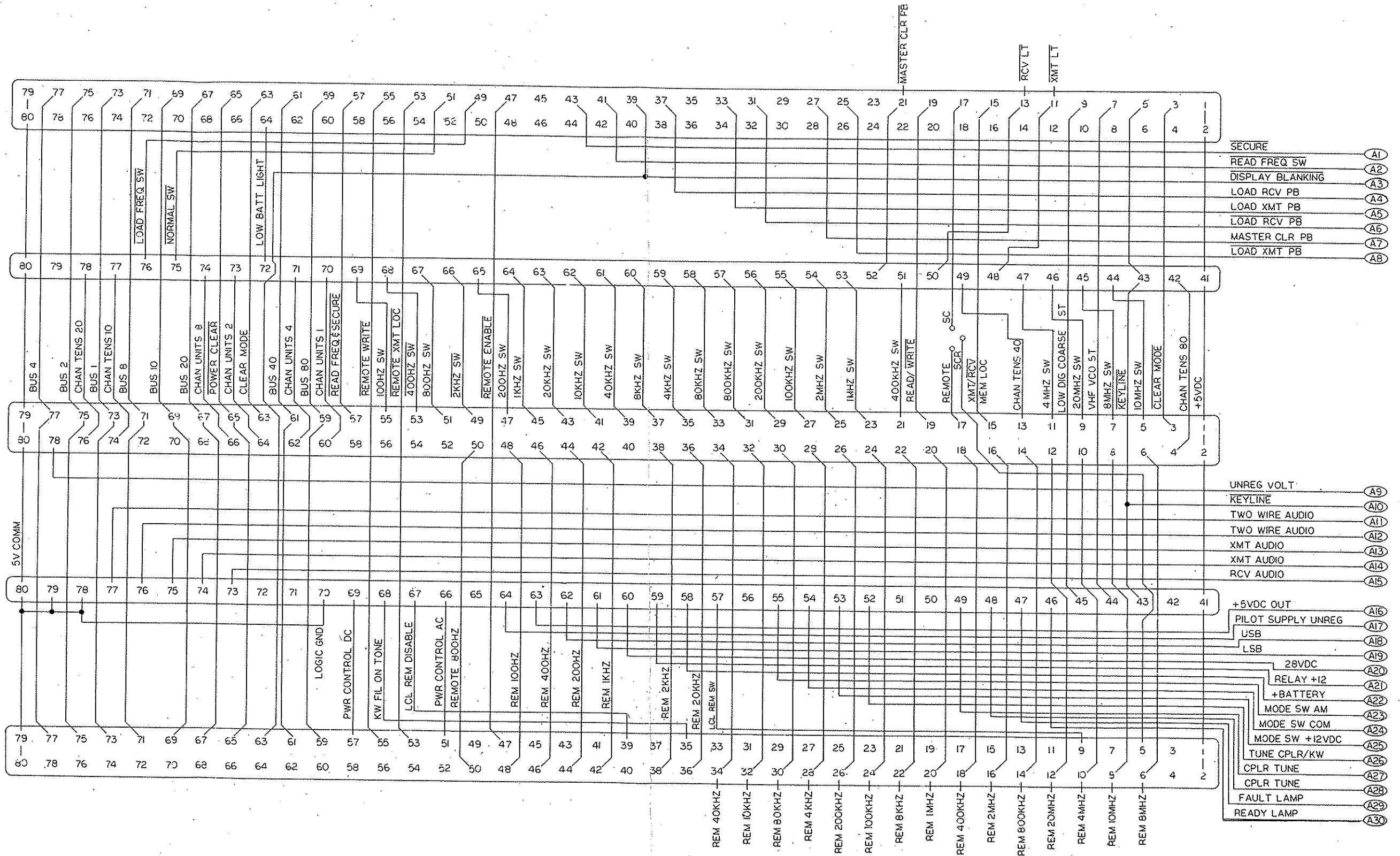

Figure 5.11 GSB-900SC/R Motherboard 1A1A5 (Sheet 1)

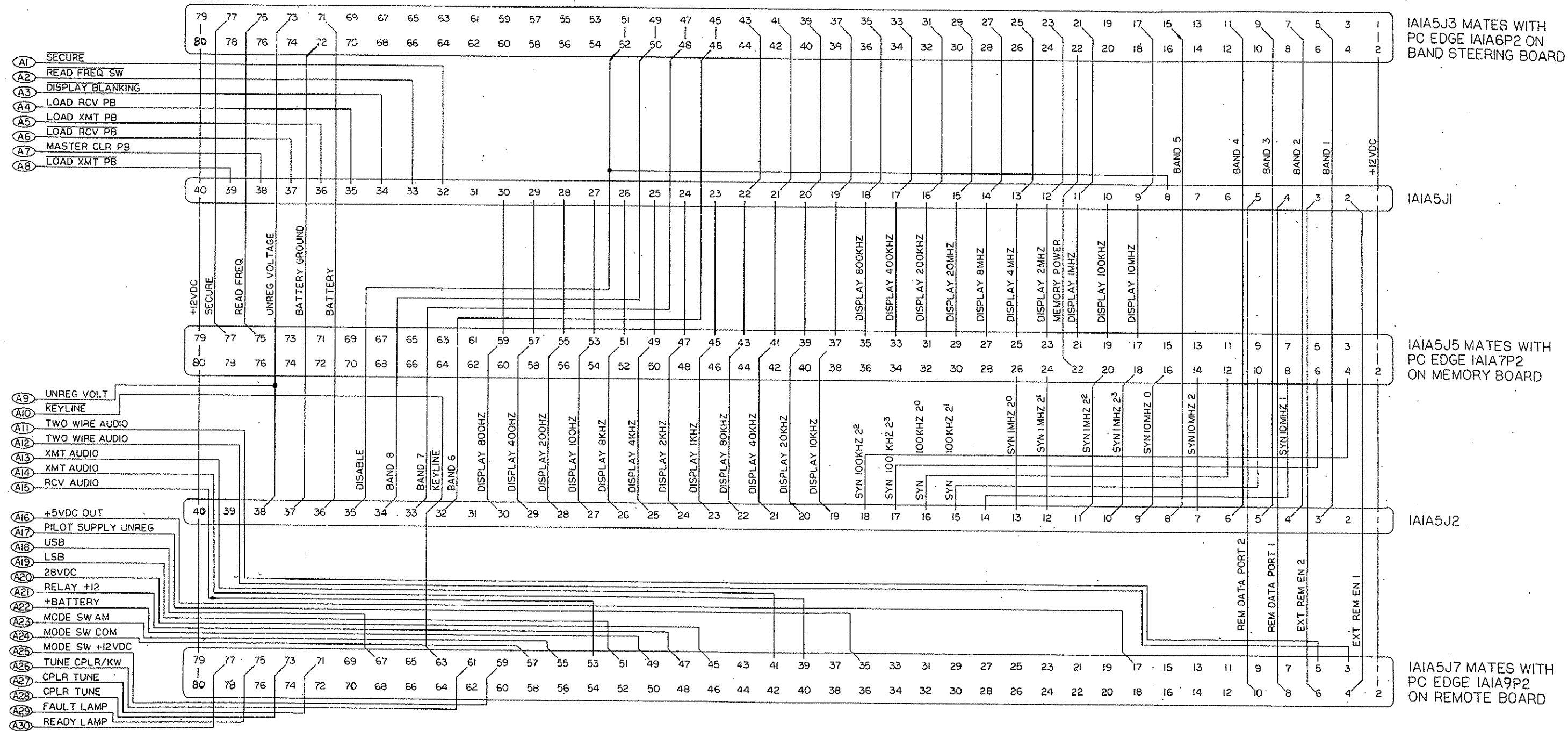
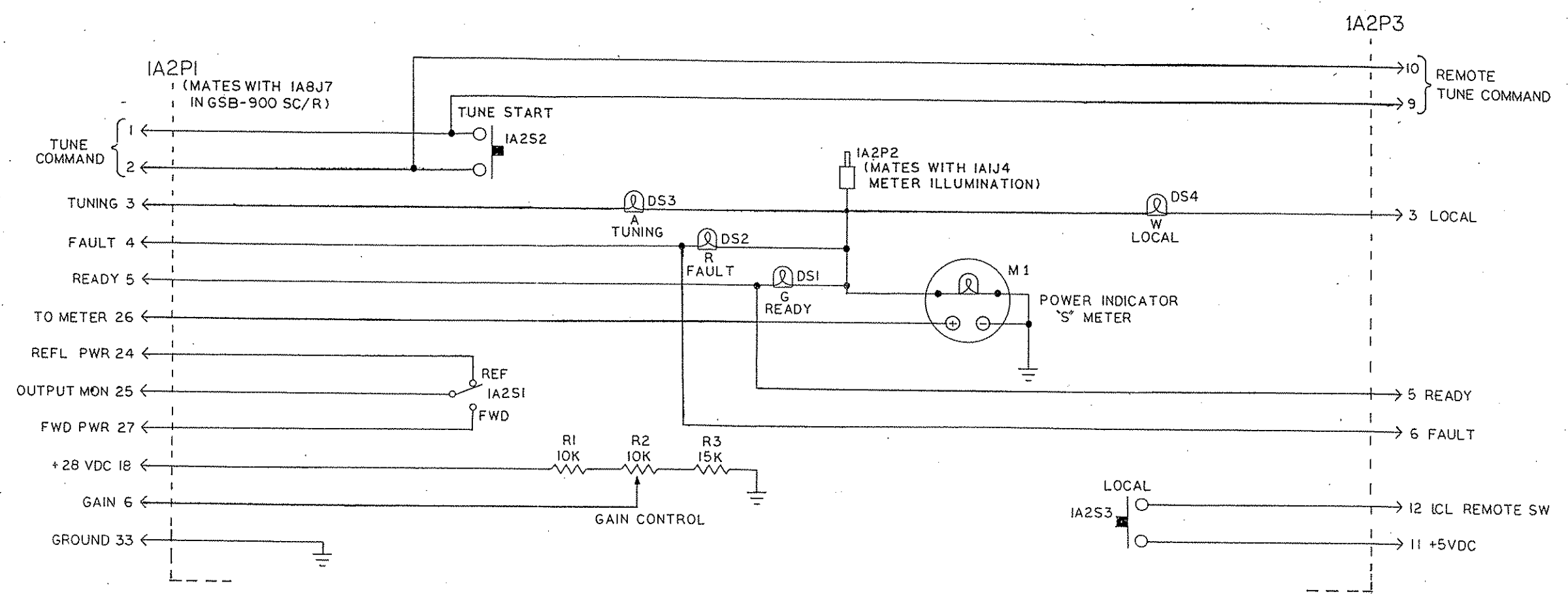

Figure 5.11 GSB-900SC/R Motherboard 1A1A5 (Sheet 2)

THIS PAGE INTENTIONALLY LEFT BLANK.

8070048093D



8070048051 CPLR. CONT. ASSY, 935, GRY SC/R

REF SYMBOL	DESCRIPTION	SUNAIR PART NO.
	CPLR. CONT. ASSY, 935, GRY SC/R	8070048051
R1	Resistor, 10K, 10%, 1/4 W	0170410005
R2	Pot. 10 K, 10%, 3/4 W, 1/8	0335900003
R3	Resistor, 15K, 10%, 1/4 W	0172350000
IA2S1	Switch, Toggle, DPDT	0334610001
IA2S3	Switch, Pushbutton, SPST Local	0346520002
IA2P1	Connector, Power, 36 Pin Rect.	0754070000
DS1	Lamp Assy, Green, Ready	0841480001
DS2	Lamp Assy, Red, Fault	0841490007
DS3	Lamp Assy, Amber, Tuning	0841500002
	Connector, PC, 12 Pin Female	1003321402
	Pin, Connector, Male Gold FL	1003322409
DS4	Lamp Assy, White	1003324703
	Meter	5024042204
	Panel, 935 Control 900 SC/R	8070048514

Figure 5.12 GSB-900SC/R Coupler Control Panel 1A2

THIS PAGE INTENTIONALLY LEFT BLANK.

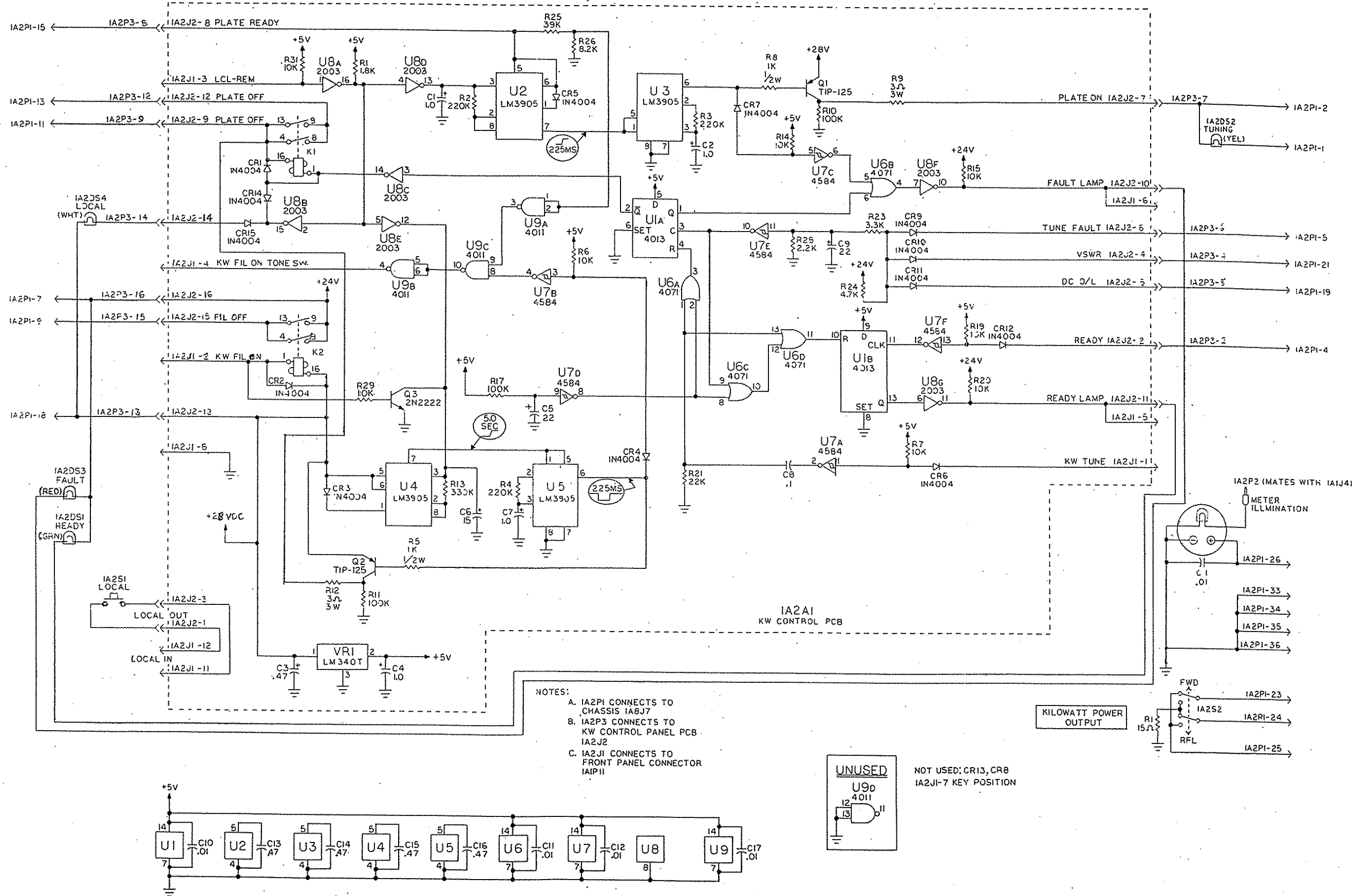
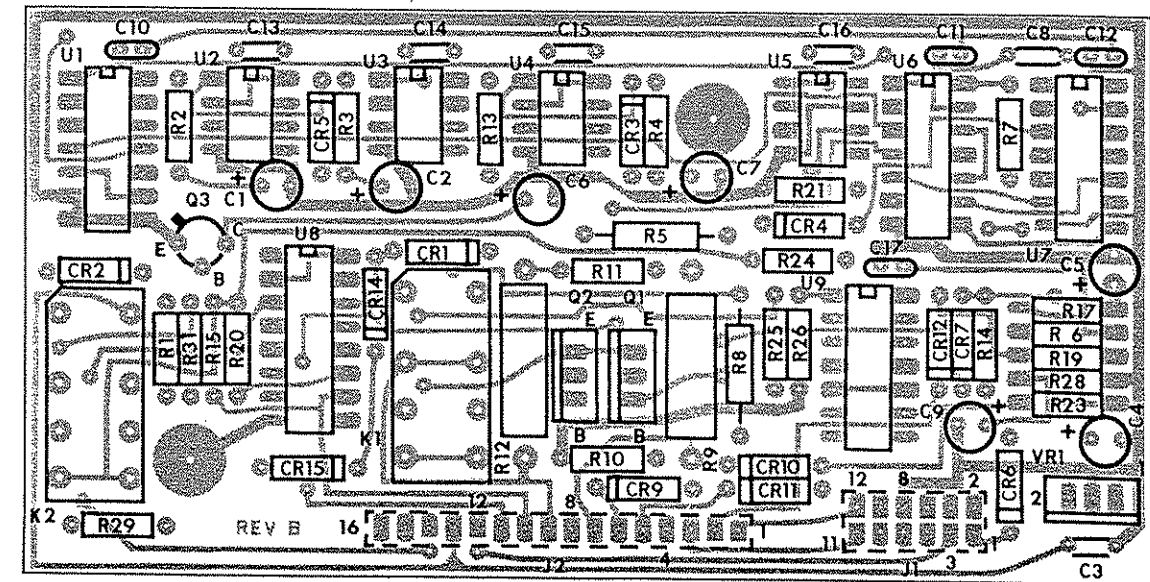
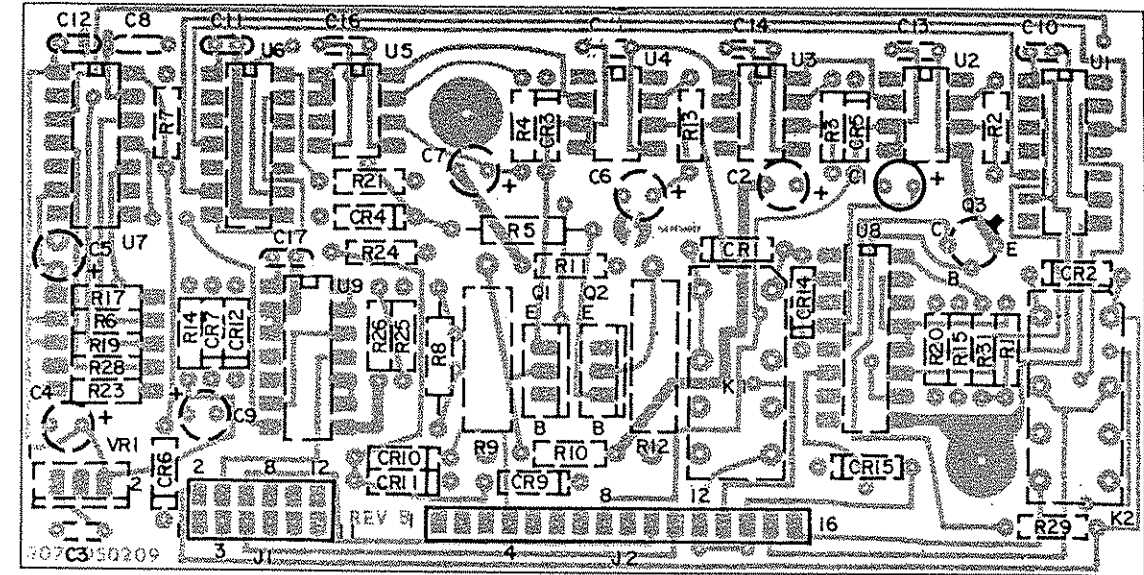

Figure 5.13 GSB-900SC/R KW Control Panel 1A2

8070051094 PC ASSY. KW CONTROL 900SC/R

REF SYMBOL	DESCRIPTION	SUNAIR PART NO.
	PC ASSY, KW CONTROL 900SC/R	8070051094
C1	Capacitor, 1UF, 35V	0283630001
C2	Capacitor, 2UF, 35V	0283610001
C3	Capacitor, 0.47UF, 50V, X5V, 20%	0283370009
C4	Capacitor, 1UF, 35V	0283630001
C5	Capacitor, 22UF, 15V	0296660001
C6	Capacitor, 15UF, 15V	0296800007
C7	Capacitor, 1UF, 35V	0283630001
C8	Capacitor, 0.1UF, 50V, X7R	0281610002
C9	Capacitor, 22UF, 15V	0296660001
C10	Capacitor, .01UF, 50V, X7R, 20%	0281730008
C11	Capacitor, .01UF, 50V, X7R, 20%	0281730008
C12	Capacitor, .01UF, 50V, X7R, 20%	0281730008
C13	Capacitor, 0.47UF, 50V, X5V, 20%	0283370009
C14	Capacitor, 0.47UF, 50V, X5V, 20%	0283370009
C15	Capacitor, 0.47UF, 50V, X5V, 20%	0283370009
C16	Capacitor, 0.47UF, 50V, X5V, 20%	0283370009
C17	Capacitor, .01UF, 50V, X7R, 20%	0281730008
CR1	Diode, Rectifier 1N4004	0405180004
CR2	Diode, Rectifier 1N4004	0405180004
CR3	Diode, Rectifier 1N4004	0405180004
CR4	Diode, Rectifier 1N4004	0405180004
CR5	Diode, Rectifier 1N4004	0405180004
CR6	Diode, Rectifier 1N4004	0405180004
CR7	Diode, Rectifier 1N4004	0405180004
CR9	Diode, Rectifier 1N4004	0405180004
CR10	Diode, Rectifier 1N4004	0405180004
CR11	Diode, Rectifier 1N4004	0405180004
CR12	Diode, Rectifier 1N4004	0405180004
CR14	Diode, Rectifier 1N4004	0405180004
CR15	Diode, Rectifier 1N4004	0405180004
K1	Relay, DPDT, 24 VDC	1005250022
K2	Relay, DPDT, 24 VDC	1005250022
Q1	Transistor, PNP, Si.	1005760012
Q2	Transistor, PNP, Si.	1005760012
Q3	Transistor, NPN, Si 2N2222A	0448580004
R1	Resistor, 1.8K, 10%, 1/4W	0178190004
R2	Resistor, 220K, 10%, 1/4W	0177780002
R3	Resistor, 220K, 10%, 1/4W	0177780002
R4	Resistor, 220K, 10%, 1/4W	0177780002
R5	Resistor, 1K, 10%, 1/2W	0167480006
R6	Resistor, 10K, 10%, 1/4W	0170410005
R7	Resistor, 10K, 10%, 1/4W	0170410005
R8	Resistor, 1K, 10%, 1/2W	0167480006
R9	Resistor 3, 5%, 3W	1004600003
R10	Resistor, 100K, 10%, 1/4W	0170390004
R11	Resistor, 100K, 10%, 1/4W	0170390004
R12	Resistor 3, 5%, 3W	1004600003
R13	Resistor, 330K, 10%, 1/4W	0174670001
R14	Resistor, 10K, 10%, 1/4W	0170410005
R15	Resistor, 10K, 10%, 1/4W	0170410005
R17	Resistor 100K, 10%, 1/4W	0170390004
R19	Resistor, 10K, 10%, 1/4W	0170410005
R20	Resistor, 10K, 10%, 1/4W	0170410005
R21	Resistor, 22K, 5%, 1/4W	0172230004
R23	Resistor, 3.3K, 10%, 1/4W	0170890007
R24	Resistor, 4.7K, 5%, 1/4W	0170770001
R25	Resistor, 39K, 10%, 1/4W	0177800003
R26	Resistor, 8.2K, 5%, 1/4W	0192070002
R29	Resistor, 10K, 1/4W	0170410005
R31	Resistor, 10K, 10%, 1/4W	0170410005
U1	IC, Digital	1005150028
U2	IC, Linear	0448470004
U3	IC, Linear	0448470004
U4	IC, Linear	0448470004
U5	IC, Linear	0448470004
U6	IC, Digital	1005160023
U7	IC, Digital	1005190011
U8	IC, Digital	1005630038
U9	IC, Digital	1005150010
VR1	IC, Linear	0448600005
	Connector, PC, 6 Pin Dual	1006660003

SUNAIR GSB-900SC/R



## 50240xxxxx CHASSIS ASSY

REF SYMBOL	DESCRIPTION	SUNAIR PART NO.
	CHASSIS ASSY.	50240xxxxx
1 A3 P1	Connector, RF, Subminiature	0753700000
1 A3 P2	Connector, RF, Subminiature	0753700000
1 A3 P3	Connector, RF, Miniature	0753720001
1 A3 P4	Connector, RF, Miniature	0753720001
1 A8 P5	Connector, RF, BNC	0753710005
1 A8 U1	TCXO, 5 MHz Ground Eqpt.	5024012704
C1	Capacitor, 0.01 UF, 15 V, X5S	0281620008
C2	Capacitor, 0.01 UF, 25 V, X5S	0281620008
C3	Capacitor, 2 UF, 100 V, Mylar	0272420000
C5	Capacitor, 0.01 UF, 1000 V, Z5 U, 20%	0243550006
C6	Capacitor, 0.01 UF, 1000 V, Z5 U, 20	0243550006
C7	Capacitor, 0.01 UF, 25 V, X5S	0281620008
C8	Capacitor, 0.01 UF, 25 V, X5S	0281620008
C9	Capacitor, 0.01 UF, 25 V, X5S	0281620008
C10	Capacitor, 0.01 UF, 25 V, X5S	0281620008
C11	Capacitor, 0.01 UF, 25 V, X5S	0281620008
C12	Capacitor, 15 UF, 35 V	0282240004
CR1	Diode, Rectifier 1N4004	0405180004
CR2	Diode, Rectifier 1N4004	0405180004
CR3	Diode, Signal, Sil. 1N4454	0405270003
CR4	Diode, Signal, Sil. 1N4454	0405270003
CR5	Diode, Rectifier 1N4004	0405180004
CR6	Diode, Rectifier 1N4004	0405180004
J1	Connector, RF, UHF	0753300001
J2	Connector, Power, 10 Pin Round	0753990008
J3	Connector, Power, 9 Pin Round	0753440008
J4	Connector, Power, 37 Pin Round	0753430002
J5	Connector, Power, 11 Pin Rect.	0753460009
J6	Connector, Power, 24 Pin Rect.	0753510006
J7	Connector, Power, 36 Pin Rect.	0753520001
K1	Relay, 4 PDT, 12 V, Sensitive	0666640009
K2	Relay, 3 PDT, 12 V, Plug-In 10 A	0666760004
L1	Inductor, Molded, 47 UH, 5%	0652680003
P1	Connector, Power, 7 Pin Rect.	0753530007
P2	Connector, Power, 20 Pin Rect.	0753550008
Q1	Transistor, PNP, Sil. TIP-32 A	0448200007
Q101	Transistor, NPN, Si.	0448210002
R1	Resistor, 3.9, 5%, 1/2W	0168270005
R2	Resistor, 2.2K, 10%, 1W	0164510001
	Socket, Tube 7 Pin	0764370006
	Connector, RF, Coax Feedthru	0753690004
	Coax Cable Assy.	5024003799

# SUNAIR GSB-900SC/R

8070001381

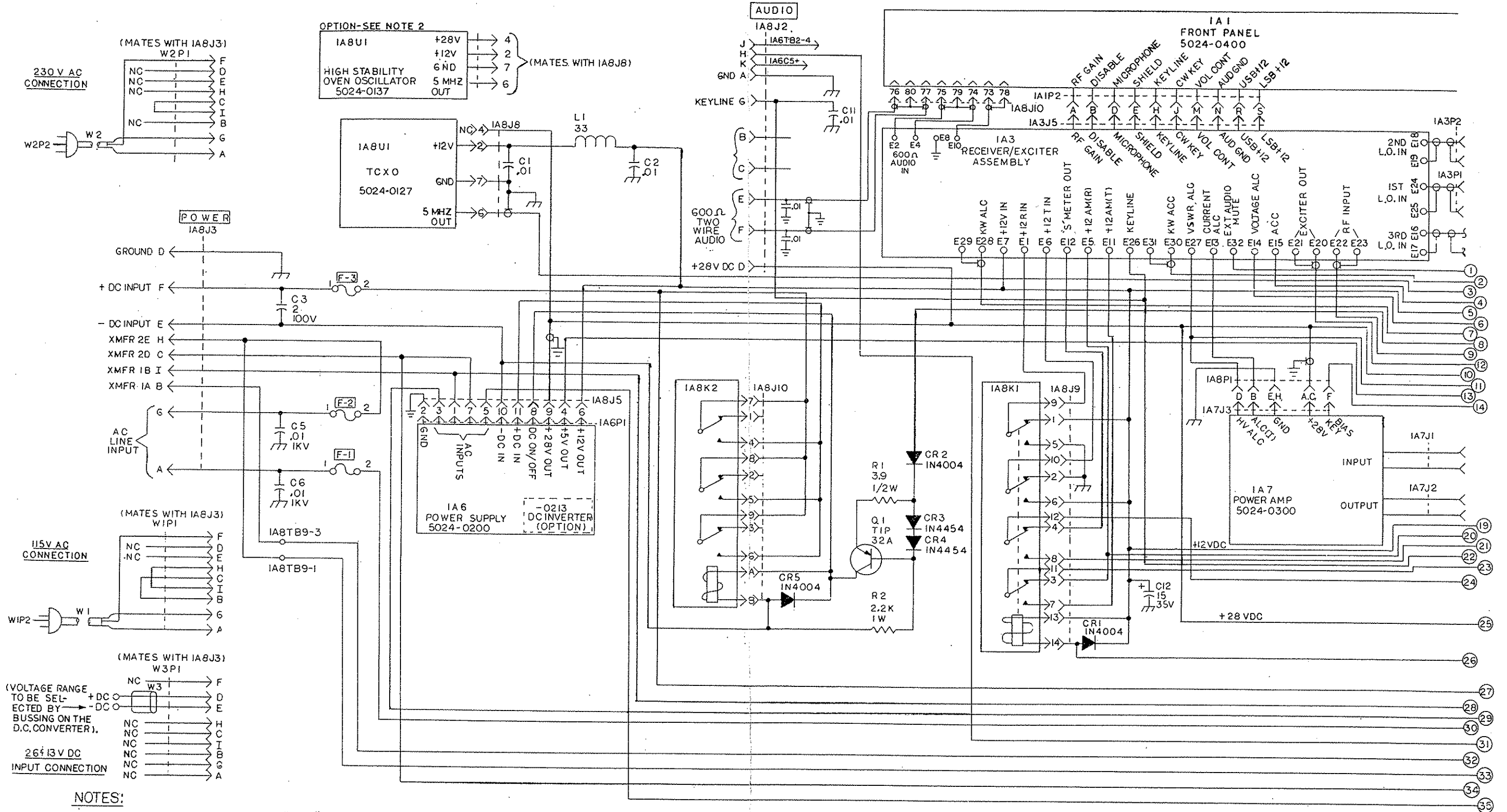

**NOTES:**

1. PREFIX ALL PARTIAL DESIGNATORS WITH "IA8-".
2. IN THE STANDARD GSB-900, IA8UI IS "TCXO PART #5024-0127, WHEN DELIVERED WITH OPTIONAL PART #5024-0137, IA8UI IS "HIGH STABILITY OVEN OSCILLATOR,"
3. UNLESS OTHERWISE DESIGNATED: — ALL CAPACITORS ARE IN MICROFARADS (μF), — ALL INDUCTORS ARE IN MICROHENRIES (μH).
4. FUSE RATINGS: F1; F2: 5A FOR 115V AC INPUT, OR 3A FOR 230 V AC INPUT.  
F3: 30A SLO BLO FOR 13V DC INPUT, OR 15A SLO BLO FOR 26V DC INPUT.

Figure 5.14 GSB-900SC/R Main Frame Schematic (Sheet 1)

8070001381

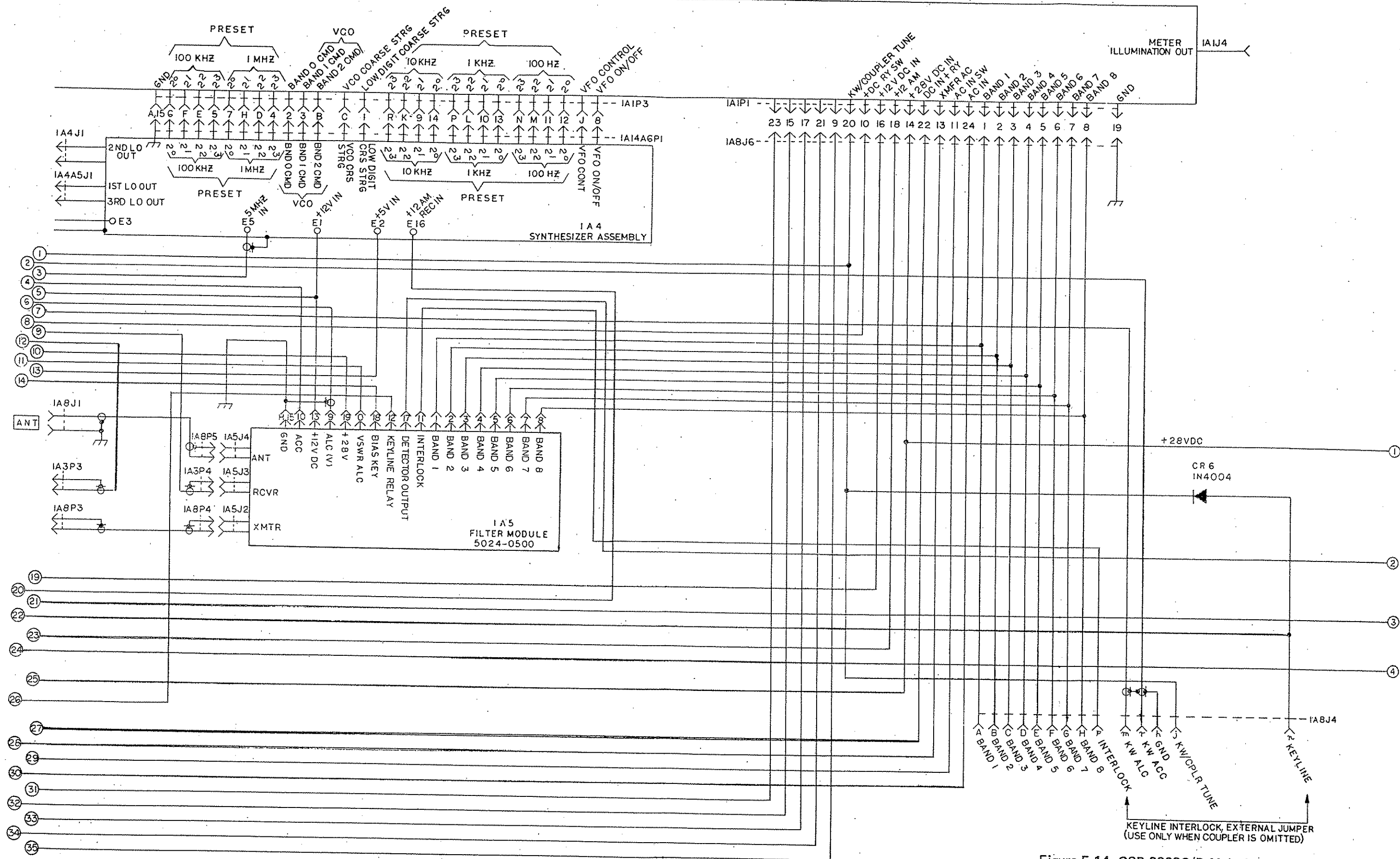

Figure 5.14 GSB-900SC/R Main Frame Schematic (Sheet 2)

THIS PAGE INTENTIONALLY LEFT BLANK.

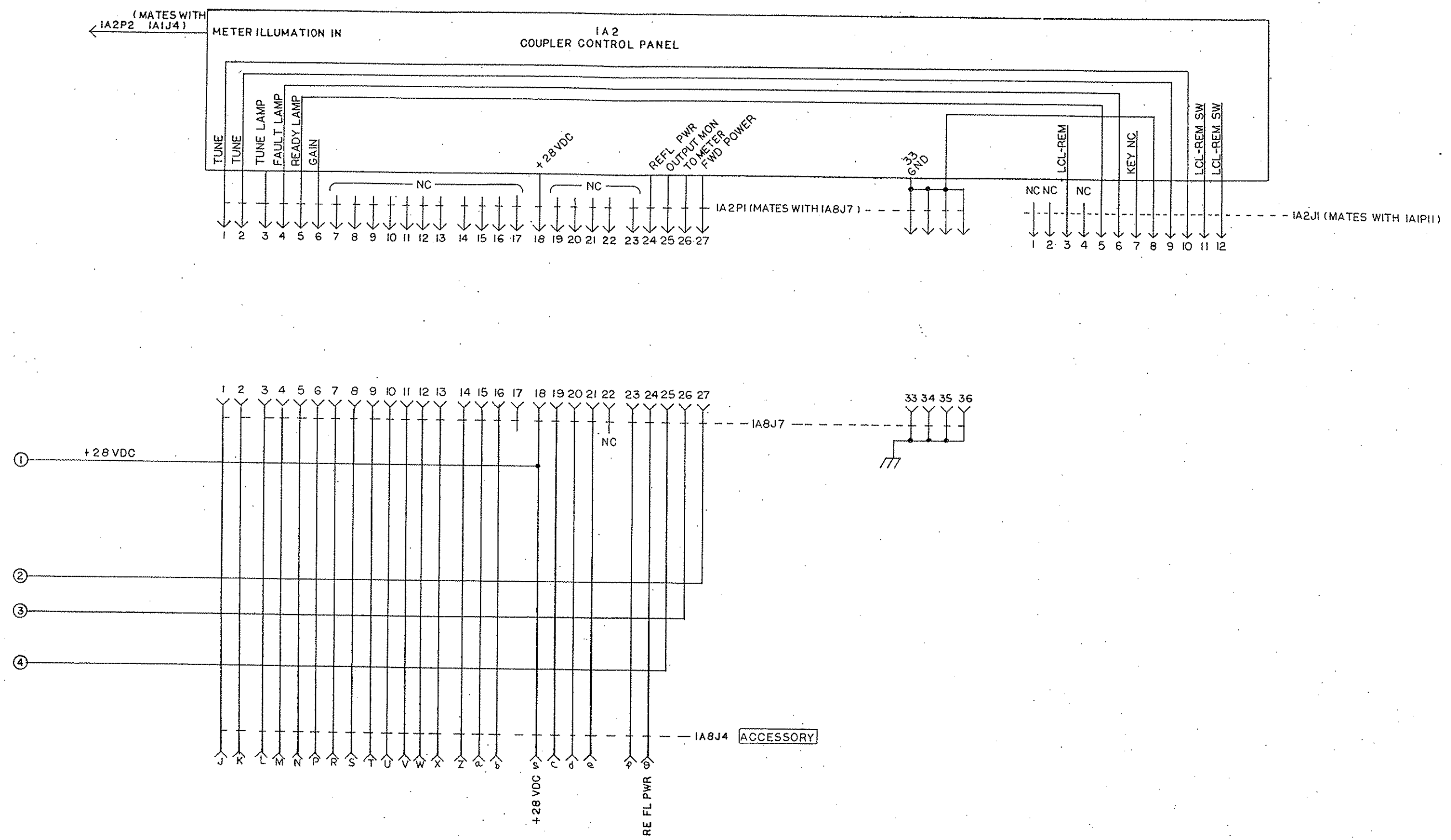

Figure 5.14 GSB-900SC/R Main Frame Schematic (Sheet 3)

THIS PAGE INTENTIONALLY LEFT BLANK.