



Single RAN BTS Site Solutions, Rel. 23R1, Operating Documentation, Issue 01

Nokia AirScale System Module Product Description

DN09231912

Issue 30

Approved on 2022-10-18

Nokia is committed to diversity and inclusion. We are continuously reviewing our customer documentation and consulting with standards bodies to ensure that terminology is inclusive and aligned with the industry. Our future customer documentation will be updated accordingly.

This document includes Nokia proprietary and confidential information, which may not be distributed or disclosed to any third parties without the prior written consent of Nokia. This document is intended for use by Nokia's customers ("You"/"Your") in connection with a product purchased or licensed from any company within Nokia Group of Companies. Use this document as agreed. You agree to notify Nokia of any errors you may find in this document; however, should you elect to use this document for any purpose(s) for which it is not intended, You understand and warrant that any determinations You may make or actions You may take will be based upon Your independent judgment and analysis of the content of this document.

Nokia reserves the right to make changes to this document without notice. At all times, the controlling version is the one available on Nokia's site.

No part of this document may be modified.

NO WARRANTY OF ANY KIND, EITHER EXPRESS OR IMPLIED, INCLUDING BUT NOT LIMITED TO ANY WARRANTY OF AVAILABILITY, ACCURACY, RELIABILITY, TITLE, NON-INFRINGEMENT, MERCHANTABILITY OR FITNESS FOR A PARTICULAR PURPOSE, IS MADE IN RELATION TO THE CONTENT OF THIS DOCUMENT. IN NO EVENT WILL NOKIA BE LIABLE FOR ANY DAMAGES, INCLUDING BUT NOT LIMITED TO SPECIAL, DIRECT, INDIRECT, INCIDENTAL OR CONSEQUENTIAL OR ANY LOSSES, SUCH AS BUT NOT LIMITED TO LOSS OF PROFIT, REVENUE, BUSINESS INTERRUPTION, BUSINESS OPPORTUNITY OR DATA THAT MAY ARISE FROM THE USE OF THIS DOCUMENT OR THE INFORMATION IN IT, EVEN IN THE CASE OF ERRORS IN OR OMISSIONS FROM THIS DOCUMENT OR ITS CONTENT.

Copyright and trademark: Nokia is a registered trademark of Nokia Corporation. Other product names mentioned in this document may be trademarks of their respective owners.

© 2022 Nokia.

Table of Contents

Summary of changes	8
1 AirScale SM compliances	11
1.1 EU compliance	11
1.2 FCC Part 15 compliance	12
2 Changes in AirScale product naming	14
3 List of AirScale SM units and compatibility	15
4 AirScale SM overview	20
4.1 AirScale SM compatibility with Flexi Multiradio 10 BTS	21
4.2 AirScale SM chaining	21
5 AirScale subracks description	23
5.1 AirScale subracks specifications	27
5.2 AirScale subracks PDUs specifications	32
6 AirScale common plug-in units	37
6.1 AirScale SM synchronization	43
6.2 AirScale SM holdover performance	44
6.3 AirScale common plug-in units reset and service buttons	45
7 AirScale capacity plug-in units	48
8 AirScale SM environmental requirements	53
9 NEBS requirements for AirScale SM	56
10 AirScale SM sound power levels	58
11 AirScale SM power supply solutions	59
12 AirScale SM power requirements and consumption	63
13 AirScale SM LED indicators	66
13.1 Common plug-in units LED indicators	66
13.2 Capacity plug-in units LED indicators	71
14 AirScale naming convention	77
15 Appendix: AirScale SM connectors pin maps	81
15.1 DC input connectors pin map	81
15.2 AirScale common plug-in units grounding connectors	82
15.3 External alarm connection connector pin map	82
15.4 External synchronization input connector pin map	84
15.5 External synchronization output connector pin map	86

List of Figures

Figure 1	CE marking (EU R&TTE Directive 1999/5/EC)	11
Figure 2	CE marking	11
Figure 3	RED Article 10.10-marking	12
Figure 4	AirScale SM architecture	21
Figure 5	Subracks slot numbering	23
Figure 6	AMIA overview	25
Figure 7	AMOB overview	25
Figure 8	AMOD overview	26
Figure 9	AMID overview	26
Figure 10	AMID with cable support bars	27
Figure 11	AirScale subrack dimensions orientation	29
Figure 12	AMOB PDU front panel	33
Figure 13	AMOD PDU front panel	34
Figure 14	Common plug-in unit dimensions orientation	37
Figure 15	ASIA AirScale common plug-in unit interfaces	38
Figure 16	ASIB AirScale common plug-in unit interfaces	39
Figure 17	ASIK AirScale common plug-in unit interfaces	39
Figure 18	ASIL AirScale common plug-in unit interfaces	39
Figure 19	ASIA Reset and Service buttons locations	46
Figure 20	ASIB Reset and Service buttons locations	47
Figure 21	ASIK Reset and Service buttons locations	47
Figure 22	ASIL Reset and Service buttons locations	47
Figure 23	Capacity plug-in unit dimensions orientation	48
Figure 24	ABIA interfaces	49
Figure 25	ABIC interfaces	50
Figure 26	ABIL interfaces	51
Figure 27	ABIN and ABIO interfaces	51
Figure 28	Power option 1	61
Figure 29	Power option 2	61
Figure 30	Power option 3	62
Figure 31	ASIA LED indicators location	66
Figure 32	ASIB LED indicators location	67
Figure 33	ASIK LED indicator locations	68
Figure 34	ASIL LED indicator locations	70
Figure 35	ABIA LED indicators location	71
Figure 36	ABIC LED indicators location	72
Figure 37	ABIL LED indicators location	74
Figure 38	ABIO/ABIN LED indicators location	75
Figure 39	DC input (ASIA, ASIB, ASIK, ASIL)	81
Figure 40	DC input (ASIAA, ASIBA, ASIKA)	81

Figure 41	ASIA A.101 grounding connector	82
Figure 42	ASIA A.202, ASIAA, ASIB, ASIBA, ASIK, ASIKA, ASIL grounding connector	82
Figure 43	EAC pins order	83
Figure 44	SIN pins order	85
Figure 45	SOUT pins order	86

List of Tables

Table 1	Releases covered by the document	8
Table 2	List of AirScale subracks	15
Table 3	List of AirScale common plug-in units	16
Table 4	List of AirScale capacity plug-in units	16
Table 5	AirScale subracks and plug-in units compatibility	17
Table 6	AirScale common and capacity plug-in units compatibility	18
Table 7	AirScale common plug-in units compatibility	18
Table 8	AirScale subracks dimensions and weight	28
Table 9	AirScale subracks installation specification	29
Table 10	AMOB cold start time	31
Table 11	BTS faults related to subracks	31
Table 12	AMOB PDU interfaces	33
Table 13	AMOB PDU LED indicators	34
Table 14	AMOD PDU interfaces	35
Table 15	AMOD PDU LED indicators	36
Table 16	Common plug-in units overview	37
Table 17	Common plug-in units basic comparison	38
Table 18	Common plug-in units interfaces	40
Table 19	Reset and Service buttons usage effects	46
Table 20	Capacity plug-in units overview	48
Table 21	Capacity plug-in units basic comparison	49
Table 22	ABIA interfaces	50
Table 23	ABIC interfaces	50
Table 24	ABIL interfaces	51
Table 25	ABIN and ABIO interfaces	52
Table 26	AirScale SM temperature and humidity requirements	53
Table 27	Operating temperature requirements for common plug-in units	54
Table 28	Operating temperature requirements for capacity plug-in units	54
Table 29	Required climatic conditions	55
Table 30	Typical sound power levels (LwAd [dBA]) for indoor subracks at 25°C (77°F)	58
Table 31	Maximum sound power levels (LwAd [dBA]) for outdoor subracks at 23°C and 45°C (based on ETS 300 753)	58
Table 32	Power supply options supported by subracks	59
Table 33	Max power loads and amps values with 48.0 V DC for AirScale SM	60
Table 34	Input voltage of the indoor AirScale SM	63
Table 35	Power consumption of the AirScale plug-in units	64
Table 36	Power consumption of the AirScale subracks	65
Table 37	ASIA and ASIB LED indicators	67
Table 38	ASIK LED indicators	69

Table 39	ASIL LED indicators	70
Table 40	ABIA LED indicators	72
Table 41	ABIC LED indicators	73
Table 42	ABIL LED indicators	74
Table 43	ABIO/ABIN LED indicators	76
Table 44	AirScale naming convention	77
Table 45	Radio bands naming convention	80
Table 46	Common plug-in unit DC input connectors	81
Table 47	Common plug-in unit grounding connectors	82
Table 48	EAC pin map	84
Table 49	External synchronization input connector pin map	85
Table 50	External synchronization output connector pin map	87

Summary of changes

A list of changes between document issues. You can navigate through the respective changed topics.

Changes between document issues are cumulative. Therefore, the latest document issue contains all changes made to previous issues.

This document is common for various radio access technologies (RATs). You may find here information about solutions that are not available or supported in a specific software release or RAT. For features supported in your software release, see respective feature documentation chapter in the system library.

Note:

For more details on Nokia AirScale compliance, see *Operating Documentation/Single RAN BTS Site Solutions/Nokia AirScale BTS/Nokia AirScale BTS legal, safety and environmental information/Nokia AirScale BTS Environmental Product Declaration*.

Table 1: Releases covered by the document

Product	Release
Single RAN	SRAN 21B, 22R1-SR, 22R2, 22R3, 22R4, 23R1
5G	5G21A, 5G21B, 22R1-5G

Changes between issues 29 (2022-07-21, 22R3) and 30 (2022-10-18, 23R1)

List of AirScale SM units and compatibility

- Table: AirScale common plug-in units compatibility has been added.

AirScale subracks description

- The maximum configurations with ABIO and ABIL in AMOB have been updated.

AirScale subracks specifications

- Table: BTS faults related to subracks - the 4080 Cooling fan is over speeding fault has been added.

Changes between issues 28 (2022-05-20, 22R3) and 29 (2022-07-21, 22R3)

Changes in AirScale product naming

- Section has been added

Changes between issues 27 (2022-03-02, 22R2) and 28 (2022-05-20, 22R3)

List of AirScale SM units and compatibility

- Table: List of AirScale capacity plug-in units - 22R3 release and *CB007358: AirScale Capacity Unit ABIN* feature have been added to ABIN.
- Table: AirScale subracks and plug-in units compatibility - has been added.
- Table: AirScale common and capacity plug-in units compatibility - has been added.
- References to the following documents have been added: *SRAN Compatibility*, *SBTS Supported Configurations*, *Nokia AirScale System Module Core Unit (ASOE) Product Description*, and *Nokia Liquid-Cooled AirScale System Module Product Description*.

AirScale SM overview

- Reference to the *SBTS Supported Configurations* document has been added.

AirScale SM chaining

- OBSAI, CPRI, and SEI have been removed as these interfaces aren't used in SM chaining.
- SM backplane connection between plug-in units has been removed as it isn't SM chaining.

AirScale subracks specifications

- Table: BTS faults related to subracks has been added, it replaced the *Cloud BTS faults and alarms related to AMOB - NR* and *BTS faults and alarms related to AMOD - NR* tables.
- Table: AirScale subracks installation specification - FMAB has been added to AMIA, AMID optional items
- Table: AirScale subracks installation specification - AYGD and FPKC have been added to AMOB optional items
- Table: AirScale subracks installation specification - AMFW, AMGW, and AYGD have been

added to AMOD optional items

AirScale common plug-in units

- Table: Common plug-in units basic comparison - capacity plug-in unit compatibility has been moved to Table: AirScale common and capacity plug-in units compatibility.
- Table: Common plug-in units basic comparison - subrack compatibility has been moved to Table: AirScale subracks and plug-in units compatibility.

AirScale capacity plug-in units

- Table: Capacity plug-in units basic comparison - NR RAT has been added to ABIN.
- Table: ABIN and ABIO interfaces - *CB008885: ABIN OBSAI Support* feature has been added.
- Table: ABIN and ABIO interfaces - reference to *List of Supported Nokia BTS SFPs* document has been added.

AirScale SM environmental requirements

- Table: AirScale SM temperature and humidity requirements - operating temperature requirements have been updated by adding Table: Operating temperature requirements for common plug-in units and Table: Operating temperature requirements for capacity plug-in units.

AirScale SM sound power levels

- Table: Typical sound power levels (LwAd [dBA]) for indoor subracks at 25°C (77°F) - has been added.
- Table: Maximum sound power levels (LwAd [dBA]) for outdoor subracks at 23°C and 45°C (based on ETS 300 753) - has been added, the values for 23°C and 45°C have been included in one table.

AirScale SM power requirements and consumption

- Table: Power consumption of the AirScale plug-in units - power consumption of ASIL has been updated.

AirScale naming convention

- Table: AirScale naming convention - fifth letter L has been added.

1. AirScale SM compliances

EU and FCC compliances for AirScale system module (SM)

1.1 EU compliance

EU RoHS statement, CE marking, Directive 2014/53/EU (RED) Article 10.10 compliance.

EU RoHS statement

This equipment complies with the European Union RoHS Directive 2011/65/EU on the restriction of the use of certain hazardous substances in electrical and electronic equipment. The directive applies to the use of lead, mercury, cadmium, hexavalent chromium, Polybrominated Biphenyls (PBB), and Polybrominated Diphenyl Ethers (PBDE) in electrical and electronic equipment.

CE marking

The equipment described in this document complies with either:

- The relevant provisions of the European Union R&TTE Directive 1999/5/EC for some products shipped prior to June 30, 2017

Figure 1: CE marking (EU R&TTE Directive 1999/5/EC)



Hereby, Nokia declares that one or more of these base stations is compliant with the essential requirements and other relevant provisions of Directive: 1999/5/EC.

or

- European Union Radio Equipment Directive (RED) 2014/53/EU for some current products and all products shipped after June 30, 2017.

Figure 2: CE marking



Hereby, Nokia declares that radio equipment type Flexi Multiradio BTS, Flexi Multiradio 10 BTS and Nokia AirScale BTS is compliant with Directive 2014/53/EC. The full text of the EU declaration of conformity is available at the following internet address: <https://online.networks.nokia.com>

These declarations are only valid for configurations (combinations of software, firmware, and hardware) provided and/or supported by Nokia.

Directive 2014/53/EU (RED) Article 10.10 compliance

The radio frequency usage in EU is restricted and before you use the radio equipment in the commercial network you must apply for the band license from the local regulator.

As an evidence for the restriction, the packaging is to have the RED Article 10.10-marking describing the impacted countries.

Figure 3: RED Article 10.10-marking

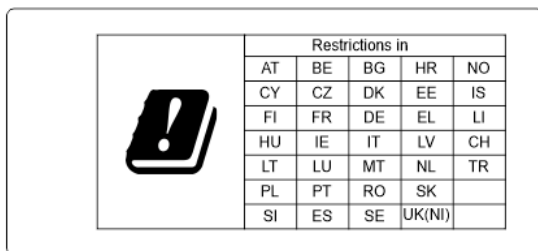

1.2 FCC Part 15 compliance

i Note:

This equipment has been tested and is compliant with the limits for a Class B digital device, pursuant to Part 15 of the FCC Rules. These limits are designed to provide reasonable protection against harmful interference in a residential installation. This equipment generates, uses, and can radiate radio frequency energy and, if not installed and used in accordance with the instruction, may cause harmful interference to radio communications. However, there is no guarantee that interference will not occur in a particular installation. If this equipment causes harmful interference to radio or television reception, which can be determined by turning the equipment off and on, try to correct the interference by one or more of the following measures:

- Reorient or relocate the receiving antenna.
- Increase the separation between the equipment and receiver.
- Connect the equipment into an outlet on a circuit different from the one to which the receiver is connected.
- Consult the dealer or an experienced radio/TV technician for help.

Changes or modifications not expressly approved by the party responsible for compliance could void the user's authority to operate the equipment.

i Note:

This compliance statement is not applicable to all hardware units described in this document.

2. Changes in AirScale product naming

Nokia has introduced product names for its new generation AirScale plug-in units and radio units. The names, featuring names of winds and birds, will be used in marketing materials and initial interactions. The use of product specific identification codes continues in operating and release documentation as well as for ordering purposes.

The new naming convention will:

- simplify discussions.
- make it easier to remember products and names.
- differentiate products when launching new versions.

AirScale plug-in units

Each new type of common or capacity plug-in unit is named after a wind, for example:

- AirScale Chinook – ASIL common plug-in unit
- AirScale Fremantle – ABIO capacity plug-in unit
- AirScale Ostro – ABIN capacity plug-in unit

AirScale radio units

Each new generation of sub-6 GHz radio units or Massive MIMO Adaptive Antennas (MAAs) is named after a bird of prey. The current generation of radio unit products is known as AirScale Osprey:

- AirScale Osprey 4 – 4T4R micro remote radio head (RRH) or macro RRH
For example: AirScale Micro RRH 4T4R n77 80 W AWHQN
- AirScale Osprey 8 – 8T8R RRH
For example: AirScale RRH 8T8R n78 320 W AKQZ
- AirScale Osprey 32 – 32T32R MAA
For example: AirScale MAA 32T32R 128 AE n78 240 W AQQQ
- AirScale Osprey 64 – 64T64R MAA
For example: AirScale MAA 64T64R 192 AE n78 320 W AQQE

3. List of AirScale SM units and compatibility

Feature numbers, product codes, supported radio access technology (RAT) releases, compatibility of the subracks and the plug-in units

List of AirScale SM units

Table 2: List of AirScale subracks

Name	Supported from RAT release	Feature numbers	Product code
AMIA	LTE 16A SRAN 17A 5G19	LTE2262 SR001120, SR001160, SR001258 5GC000623	473098A
AMID	22R2	CB007575	475773A
AMOB	LTE 17A SRAN 17A 5G19	LTE3359 SR001722 5GC000418	473952A
AMOD	LTE 19 SRAN 19 5G19A	LTE4525 SR002002 5GC001121	474930A

Table 3: List of AirScale common plug-in units

Name	Supported from RAT release	Feature numbers	Product code
ASIA	LTE 16A SRAN 17A	LTE2114 SR001120, SR001160, SR001258	473095A
ASIAA	SRAN 16A	-	474403A
ASIB	LTE 19 SRAN 19A 5G20A	LTE3178 SR001682 5GC000470	473764A
ASIBA	SRAN 19	-	474408A
ASIK	5G19	5GC000275	474021A
ASIKA	5G18A	-	474424A
ASIL	5G21A SRAN 21B	CB005979	474767A

Table 4: List of AirScale capacity plug-in units

Name	Supported from RAT release	Feature numbers	Product code
ABIA	LTE 16A SRAN 17A	LTE2261 SR001120, SR001160, SR001258	473096A
ABIC	LTE 19B	LTE4032	474723A
ABIL	5G19A	5GC000276	474020A 474020B
ABIN	SRAN 21A 22R3	SR002410 CB007358	474824A 474824B
ABIO	SRAN 21A 5G21A	SR002605 5GC002176	475266A 475266B

Note:

In SRAN, the plug-in units may be mixed within a subrack. For software-supported mixing options, see *Operating Documentation/Single RAN Features/BTS Site Solution Features/General BTS Site Solution Features/Mixing Plug-In Units in AirScale System Module* .

For the ASOE system module, see *Operating Documentation/Single RAN BTS Site Solutions/Nokia AirScale BTS/Nokia AirScale BTS Descriptions/Nokia AirScale System Module Core Unit (ASOE) Product Description*.

For the liquid-cooled AirScale subracks and plug-in units, see *Operating Documentation/Single RAN BTS Site Solutions/Nokia AirScale BTS/Nokia AirScale BTS Descriptions/Nokia Liquid-Cooled AirScale System Module Product Description*.

AirScale SM compatibility

Table 5: AirScale subracks and plug-in units compatibility

Subrack	Supported common plug-in unit	Supported capacity plug-in unit
AMIA	ASIA ASIB ASIK ASIL	ABIA ABIC ABIL ABIN ABIO
AMID	ASIB ASIL	ABIA ABIN ABIO
AMOB	ASIA ASIB ASIK ASIL	ABIA ABIC ABIL ABIN ABIO
AMOD	ASIA ASIB ASIK ASIL	ABIA ABIC ABIL ABIN ABIO

Table 6: AirScale common and capacity plug-in units compatibility

Common plug-in unit	Supported capacity plug-in unit
ASIA	ABIA
ASIB	ABIA ABIC ABIL ABIN ABIO
ASIK	ABIL
ASIL	ABIA ABIL ABIN ABIO

Compatible common plug-in units can operate in the same subrack. The possible combinations are listed in the table below.

Table 7: AirScale common plug-in units compatibility

Common plug-in unit	Supported common plug-in unit
ASIA	ASIA ASIB ASIL
ASIB	ASIA ASIB ASIK ASIL
ASIK	ASIB ASIK ASIL
ASIL	ASIA ASIB ASIK ASIL

For more information on AirScale system module compatibility, see *Reference Documentation/Compatibility/SRAN Compatibility*.

For the supported plug-in units in RATs, see [Table: Common plug-in units basic comparison](#), [Table: Capacity plug-in units basic comparison](#), and *Reference Documentation/5G and SRAN Supported Configurations/SBTS and gNB Supported Configurations/SBTS Supported Configurations/Site Composition*.

4. AirScale SM overview

The AirScale system module (SM) offers high capacity, high scalability, rich fronthaul and backhaul connectivity, and optimized power consumption. It supports Single RAN technologies and can be used with legacy Flexi Multiradio 10 BTS product family.

AirScale SM provides control and baseband functions for the supported radio access technologies (RATs). The basic functionalities of AirScale SM are:

- Baseband processing and decentralized control
- Transport control, integrated Ethernet ports, and IPv4/IPv6 and IPsec transport
- BTS clock and timing generation and distribution
- BTS operation and maintenance
- Central radio interface control
- OBSAI, CPRI-N, CPRI-A, and eCPRI-compatible interfaces to radio units (for details, see *Reference Documentation/5G and SRAN Supported Configurations/SBTS and gNB Supported Configurations/SBTS Supported Configurations/Site Composition*)
- Web Element Manager (WebEM) compatibility
- Modular construction, consists of common and capacity plug-in units inside a subrack

Note:

For mean time between failures (MTBF) values, check with your local Nokia support.

Figure 4: AirScale SM architecture

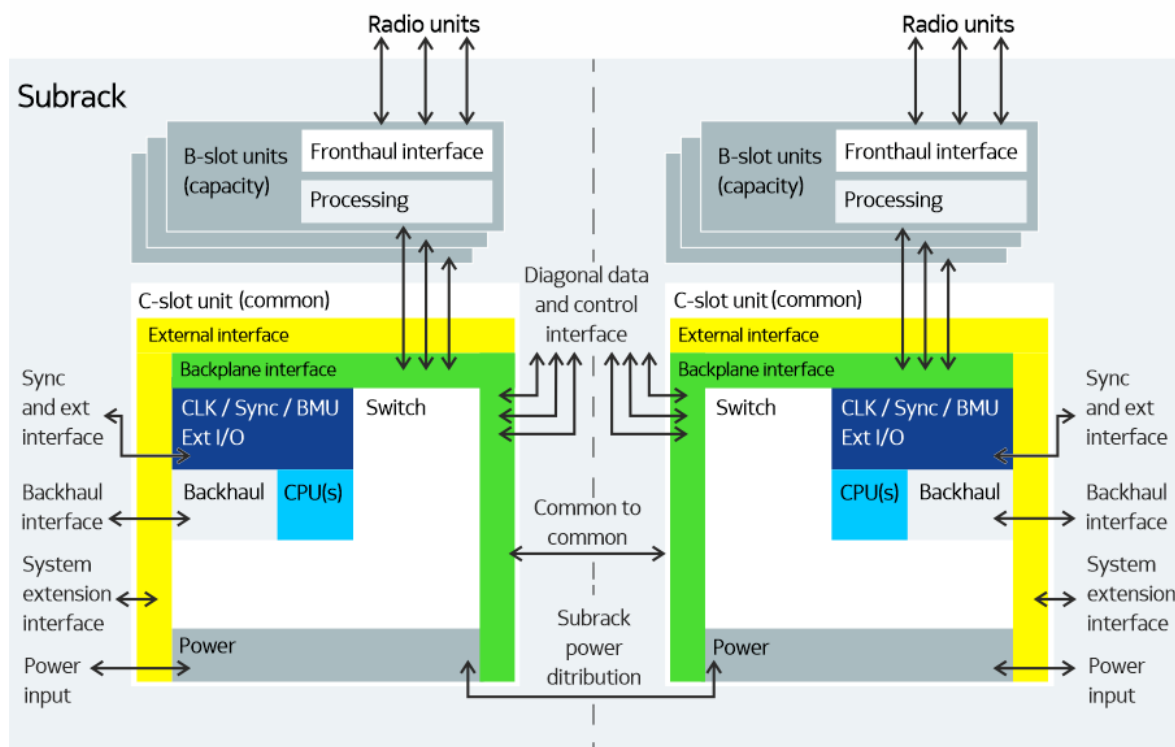

4.1 AirScale SM compatibility with Flexi Multiradio 10 BTS

AirScale system module (SM) supports legacy hardware and interconnectivity. Also, you can use all the installation options that are applicable to the previous generation of BTS.

AirScale SM is backwards compatible with the following Flexi Multiradio 10 BTS solutions:

- SyncIn, SyncOut, SFP-SRIO, and EAC interfaces
- RF modules, remote radio heads, and related optional items
- Most of the cables and SFPs
- Floor, wall, pole, rack, and cabinet installation
- Stacking with Flexi units

4.2 AirScale SM chaining

AirScale system module (SM) supports SM chaining with Flexi Multiradio 10 BTS SM and AirScale subracks equipped with ASIA or ASIB common plug-in units.

Use the following interfaces to connect SMs:

- SRIO (only with Flexi Multiradio 10 BTS SM)
- Synchronization input/output (SIN, SOUT)

The following SM connectivity and chaining combinations are supported:

- AirScale SM with Flexi Multiradio 10 BTS SM interconnection
- Chaining of two or more AirScale subracks

5. AirScale subracks description

Indoor and outdoor subracks accommodate plug-in units, provide interconnectivity, power distribution, and temperature management.

General features and functionalities

AirScale subracks accommodate the common and capacity plug-in units and provide:

- Power distribution through the backplane
- Interconnections between the plug-in units through the backplane
- Cooling systems
- Heaters for cold start from -40°C (-40°F) in outdoor subracks
 - One hour cold start time for AMOB with two heaters in full configuration
 - AMOB in non-full configurations and various temperatures: see [Table: AMOB cold start time](#)
 - AMOD: one hour cold start time, regardless of the configuration
- Ingress protection:
 - Indoor subracks: IP20
 - Outdoor subracks: IP55

Common and capacity plug-in units are accommodated in two subrack halves, in specific slots and in a specific order:

- C-slots accommodate common plug-in units.
- B-slots accommodate capacity plug-in units.

Figure 5: Subracks slot numbering

B3	B6
B2	B5
B1	B4
C1	C2

The plug-in units need to be inserted in a specific order:

- Left half:
 1. C1
 2. B1
 3. B2
 4. B3
- Right half:

1. C2
2. B4
3. B5
4. B6

You can equip the subrack halves independently from each other which means you can first equip the left half, then the right half or the other way round. Depending on the given radio access technology (RAT) software, both subrack halves may be configured as a single BTS or as two separate, independent entities, for example: eNB in one subrack half and gNB in the other subrack half.

For details on the AirScale SM architecture and interfaces between the subracks and plug-in units, see [Figure: AirScale SM architecture](#).

i Note:

For NR-ready capacity plug-in units we recommend that outdoor subrack AMOD and outdoor cabinet ACOC be used. Due to AMOB thermal load limitation, the maximum configurations with ABIO/ABIN/ABIL are:

- 2 x ASIL/2 x ASIB + 3 x ABIN + 3 x ABIA - maximum ambient operating temperature is 50°C (122°F)
- 2 x ASIL/2 x ASIB + 3 x ABIO/2 x ABIL + 2 x ABIA - maximum ambient operating temperature is 45°C (113°F)
- 2 x ASIL/2 x ASIB + 2 x ABIO/1 x ABIL + 3 x ABIA - maximum ambient operating temperature is 45°C (113°F)

AMIA AirScale subrack

Figure 6: AMIA overview



AMOB AirScale subrack

Figure 7: AMOB overview



AMOD AirScale subrack

Figure 8: AMOD overview



AMID AirScale subrack

Figure 9: AMID overview



The figure below presents the AMID subrack with cable support bars. Installation of the cable support bars is optional depending on the cable layout at the site.

Figure 10: AMID with cable support bars



5.1 AirScale subracks specifications

Dimensions, weight, installation options and reference data

Dimensions and weight

Table 8: AirScale subracks dimensions and weight

Subrack	Dimensions		Weight	
	Height x width x depth (see: Figure: AirScale subrack dimensions orientation)	U-height	Empty	Full*
AMIA	129 mm x 447 mm x 400 mm (5.08 in. x 17.60 in. x 15.75 in.)	3U	5.1 kg (11.2 lb)	23.9 kg (52.7 lb)
AMID	129 mm x 447 mm x 400 mm (5.08 in. x 17.60 in. x 15.75 in.)	3U	5.2 kg (11.4 lb)	24 kg (52.9 lb)
AMOB	355 mm x 487 mm x 605 mm (13.98 in. x 19.17 in. x 23.82 in.)	8U	23 kg (50.7 lb)	41.8 kg (92.2 lb)
AMOD	488 mm x 487 mm x 665 mm (19.21 in. x 19.17 in. x 26.18 in.)	11U	37.5 kg (82.7 lb)	56.3 kg (124.1 lb)

*With 2 x ASIA and 6 x ABIA, without any additional items, such as SFPs or cables.

Figure 11: AirScale subrack dimensions orientation



Installation options

Table 9: AirScale subracks installation specification

Subrack	Installation options	Related optional items	Cable entries	Airflow direction
AMIA, AMID	Wall, floor, stack, 19-inch rack or cabinet	<ul style="list-style-type: none"> • AYGD GNSS module • AYGM GNSS module • AMHB GNSS bracket assembly • FMAB GNSS bracket assembly • FMFA Flexi mounting kit • FYGM GNSS module 	-	Front-to-back (default) Back-to-front

Subrack	Installation options	Related optional items	Cable entries	Airflow direction
AMOB	Pole, wall, floor, stack, 19-inch rack or cabinet	<ul style="list-style-type: none"> • AMFF blind panel assembly • AMFG FCOA installation kit • AMFH stack, wall, pole installation kit • AMFI heater assembly • AMFJ conduit fittings • AMFK cable glands • AMFL GNSS bracket assembly • AMFO stacking kit • AMFR door sensor kit • AMFS cable gland 12x8 • AMFT front cover • AYGD GNSS module • AYGM GNSS module • FMFA Flexi mounting kit • FPKA Flexi pole kit (30-120 mm) • FPKC Flexi pole kit (60-295 mm) • FYGM GNSS module 	Side holes (left and right): 3 x 35 mm (0.12 x 1.38 in.) on each side 2 x 50 mm (0.08 x 1.97 in.) on each side	Back-to-front (default) Front-to-back
AMOD	Pole, wall, floor, stack	<ul style="list-style-type: none"> • AMFF blind panel assembly • AMFV 3U plinth kit • AMFW FCOA installation kit • AMFX wall/pole mount kit • AMFY mufflers kit • AMGS 8U plinth kit • AMGT cable gland kit • AMGU wall/pole mount kit (standard) • AMGW Earthquake Zone 4 top stacking kit • AMHB GNSS bracket assembly • AYGD GNSS module • AYGM GNSS module • FPKA Flexi pole kit (30-120 mm) • FPKC Flexi pole kit (60-295 mm) • FYGM GNSS module 	Bottom entries for around 88 cables (standard installation) Side holes: 2 x 50 mm (0.08 x 1.97 in.) (in diameter) on each side (optional, on customer's demand)	Bottom-to-back

AMOB cold start time

Table 10: AMOB cold start time

Configuration	Ambient temperature	Required number of heaters*	Left vertical	Horizontal	Right vertical
1 x common + 1 x capacity	-40°C (-40°F)	2	~90 min	~70 min	~60 min
1 x common + 1 x capacity	-25°C (-13°F)	1	~90 min	~70 min	~60 min
1 x common + 1 x capacity	-25°C (-13°F)	2	~25 min	~25 min	~25 min
1 x common + 1 x capacity	-10°C (14°F)	1	~10 min	~10 min	~10 min
1 x common + 3 x capacity	-25°C (-13°F)	1	~35 min	~35 min	~35 min
2 x common + 2 x capacity	-25°C (-13°F)	1	~35 min	~35 min	~35 min

*Two heaters are required for all configurations when ambient temperature is between -40°C (-40°F) and -25°C (-13°F).

Reference data

For reference data descriptions, see *Reference Documentation/Reference document*.

Table 11: BTS faults related to subracks

Fault ID	Fault name	Reported alarms
94	Unknown HW resource	7112 BASE STATION CONFIGURATION PROBLEM 7115 BASE STATION INFORMATION 7650 BASE STATION FAULTY 7651 BASE STATION OPERATION DEGRADED 7652 BASE STATION NOTIFICATION 7653 CELL FAULTY

Fault ID	Fault name	Reported alarms
238	Filter clogged	7115 BASE STATION INFORMATION 7652 BASE STATION NOTIFICATION
239	Heater defective	7115 BASE STATION INFORMATION 7652 BASE STATION NOTIFICATION
240	Subrack Control Board Unit defective	7115 BASE STATION INFORMATION 7652 BASE STATION NOTIFICATION
241	Subrack Control Board Sensor board defective	7115 BASE STATION INFORMATION 7652 BASE STATION NOTIFICATION
1300	Cabinet door open	7115 BASE STATION INFORMATION 7652 BASE STATION NOTIFICATION
2078	Eeprom read error	7100 BASE STATION HARDWARE PROBLEM 7115 BASE STATION INFORMATION 7650 BASE STATION FAULTY 7651 BASE STATION OPERATION DEGRADED 7652 BASE STATION NOTIFICATION 7653 CELL FAULTY
4073	Fan vendor not detected	7115 BASE STATION INFORMATION 7652 BASE STATION NOTIFICATION
4078	Cooling fan broken	7115 BASE STATION INFORMATION 7652 BASE STATION NOTIFICATION
4080*	Cooling fan is over speeding	7115 BASE STATION INFORMATION 7652 BASE STATION NOTIFICATION

* To raise the fault 4080 for the subrack, set the `FMCADM Enable fan overspeed alarm (enableFanOverspeedAlarm)` parameter to `true`.

5.2 AirScale subracks PDUs specifications

Outdoor AirScale subracks are equipped with a power distribution unit (PDU). The PDU provides control functions and feeds the power to the plug-in units, fans, and heaters.

AMOB internal PDU

Figure 12: AMOB PDU front panel

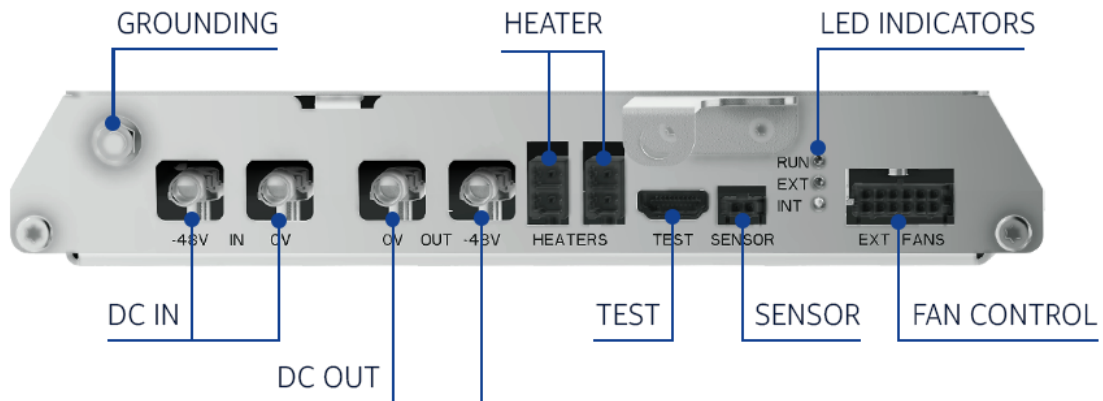

Table 12: AMOB PDU interfaces

Label	Function	Connector type
⏏	Grounding	M5 screw
IN	DC power input (50 A) with OVP	2 x M4 spacer nut
OUT	DC power output (42 A)	2 x M4 spacer nut
HEATERS	Heater port	Nokia-specific
TEST	Test access port	19PIN
SENSOR	Temperature sensor	Nokia-specific
EXT FANS	Fan control	Nokia-specific

Table 13: AMOB PDU LED indicators

Label	LED color	
	RED	GREEN
RUN	PDU malfunction	PDU works correctly
EXT	External fan speed decreased at least 30%	External fan works correctly
INT	Internal fan speed decreased at least 30%	Internal fan works correctly

AMOD internal PDU

Figure 13: AMOD PDU front panel

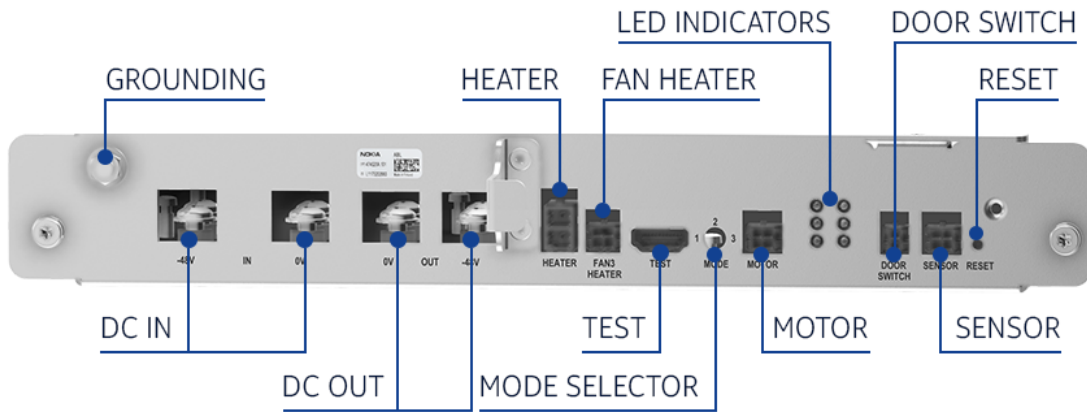

Table 14: AMOD PDU interfaces

Label	Function	Connector type
	Grounding	M5 lug
IN	DC power input (80 A) with OVP	4 x M5 spacer nut
OUT	DC power output (60 A)	4 x M5 spacer nut
HEATER	Power output for the heaters	Nokia-specific
FAN3 HEATER	Power and control of the internal fan	Nokia-specific
TEST	Service port for maintenance and troubleshooting	19PIN
MODE	Acoustic mode selection: 1 - standard (default; ETSI-compliant) 2 - Japan-specific (do not use in other regions) 3, 4 - not used	4-mode selector
MOTOR	For the stepper motor	Nokia-specific
DOOR SWITCH	Interface to a door switch	Nokia-specific
SENSOR	For temperature, humidity, and pressure sensors	Nokia-specific
RESET	Button to reset the PDU control board after maintenance activities, for example filter replacement. The system module power is kept on during the reset, so there is no interruption of BTS service.	N/A

Table 15: AMOD PDU LED indicators

Label	LED color		
	RED	GREEN	ORANGE
HEATER	Heater fan is faulty.	Heater works correctly.	Heater fan alarm is reported.
SENSOR 1	Temperature and humidity sensor is faulty.	Temperature and humidity sensor works correctly.	Not applicable
SENSOR 2	Pressure sensor is faulty.	Pressure sensor works correctly.	Not applicable
FAN - IN	Inlet fan is faulty and needs to be replaced.	Inlet fan works correctly.	Inlet fan is not stable, alarm is reported.
FAN - OUT	Outlet fan is faulty and needs to be replaced.	Outlet fan works correctly.	Outlet fan is not stable, alarm is reported.
FILTER	Filter is clogged (pressure dropped below the threshold).	Filter works correctly.	Not applicable

6. AirScale common plug-in units

The AirScale common plug-in units provide transport, central antenna data routing, and centralized control for supported radio access technologies (RATs). They occupy one or two C-slots inside a subrack.

Table 16: Common plug-in units overview

Property	ASIA	ASIB	ASIK	ASIL
Nokia product code	473095A	473764A	474021A	474767A
Ingress protection class	IP 20			
Dimensions (height x width x depth) see: Figure: Common plug-in unit dimensions orientation	48 mm x 219 mm x 377 mm (1.89 in. x 8.62 in. x 14.84 in.)			
Weight (without packaging)	3.1 kg (6.83 lb)	2.9 kg (6.39 lb)	3.2 kg (7.05 lb)	3.1 kg (6.83 lb)

Figure 14: Common plug-in unit dimensions orientation

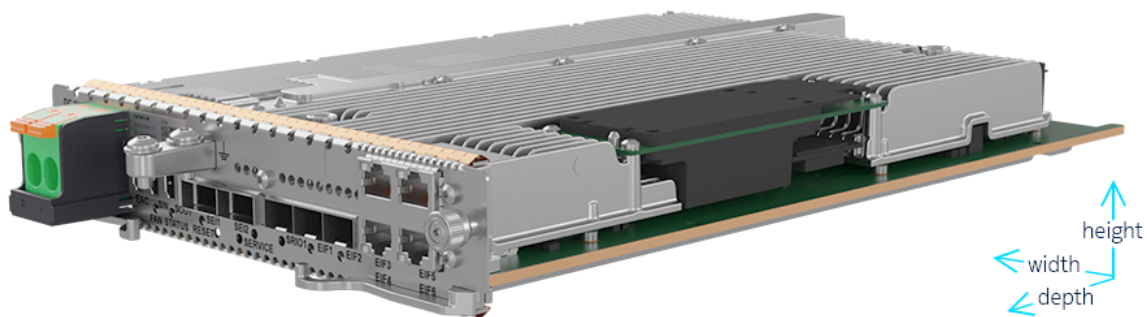

Table 17: Common plug-in units basic comparison

Property	ASIA	ASIB	ASIK	ASIL
RAT standards	GSM WCDMA LTE	GSM WCDMA LTE NR	NR	GSM WCDMA LTE NR
Backhaul/transport interfaces	3 x RJ45 (1GE) 2 x SFP+ (1GE/10GE)	3 x RJ45 (1GE) 2 x SFP+ (1GE/10GE)	2 x SFP28 (1GE/10GE/25GE)	1 x RJ45 (1GE/10GE) 3 x SFP28 (1GE/10GE/25GE)
Typical power consumption at 25°C (77°F) according to ETSI ES202 706	65 W	73 W	82 W	112 W

Note:

AirScale system module common plug-in units exist in various versions. Refer to Technical Notes (part of system software release documentation) for functionality details of each version.

Figure 15: ASIA AirScale common plug-in unit interfaces

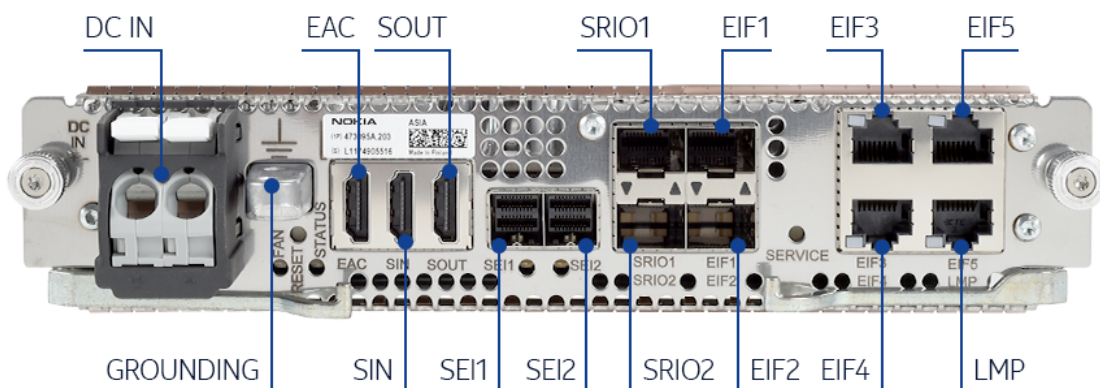

Figure 16: ASIB AirScale common plug-in unit interfaces

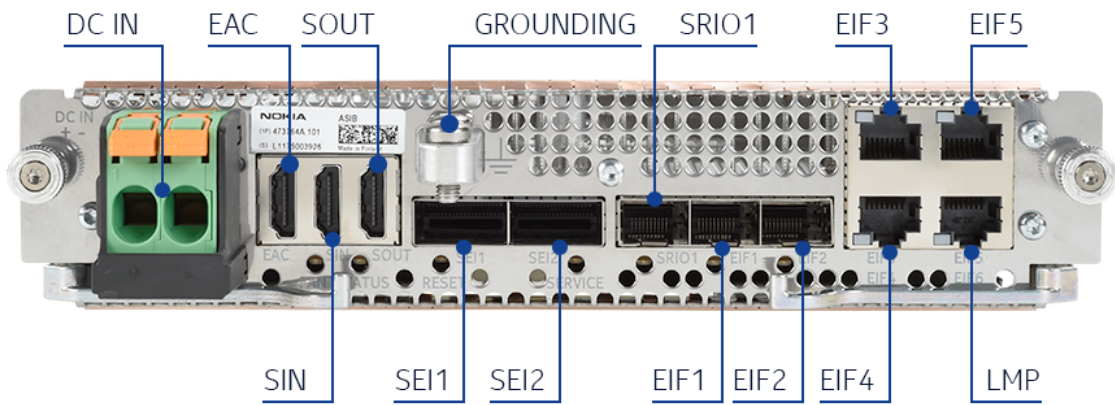

Figure 17: ASIK AirScale common plug-in unit interfaces

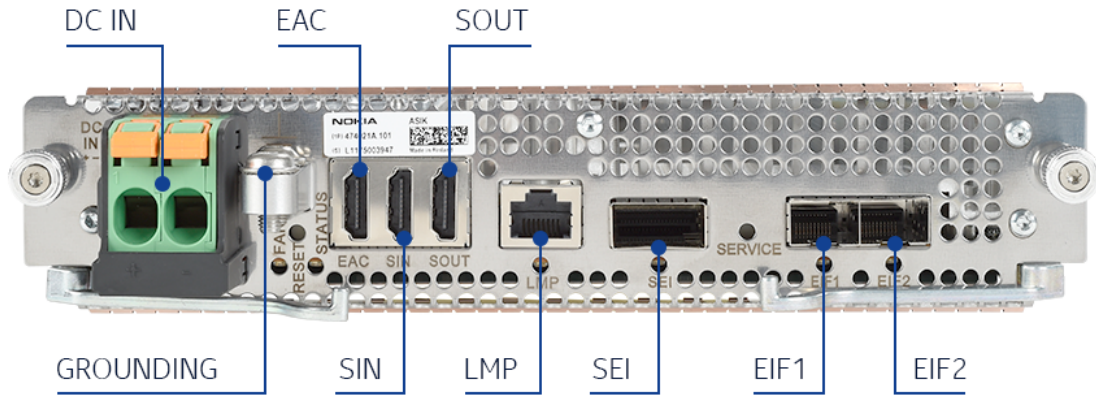
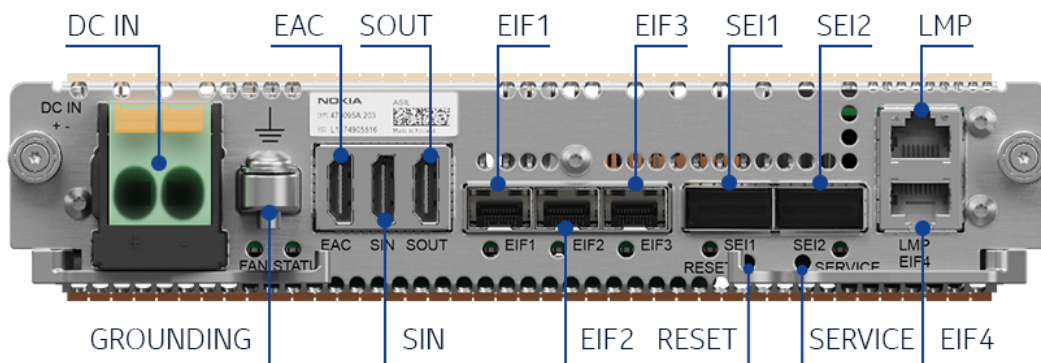



Figure 18: ASIL AirScale common plug-in unit interfaces



Note:

The common plug-in units have a variant with a lug connector (see [DC input connectors pin map](#)), these units are ASIAA, ASIBA, and ASIKA. All the other interfaces are the same as in ASIA, ASIB, and ASIK.

Table 18: Common plug-in units interfaces

Label	Name	Function	Connector type				Additional information
			ASIA	ASIB	ASIK	ASIL	
DC IN	Power supply interface	48 V input for the system module	clamps				Cables: <ul style="list-style-type: none"> • conductor cross section, solid - 0.75 mm² to 16 mm² • conductor cross section, stranded - 0.75 mm² to 25 mm²
	Grounding	Grounding	A.101: single-hole M5 A.202: dual-hole 2 x M5	dual-hole 2 x M5			-
EAC	External alarm connection interface	Set of control and alarm signals as well as an interface for alarm extension	19PIN				<ul style="list-style-type: none"> • Six software-assignable signals for either alarm input or control output signals • Alarm extension interface compatible with FSEB and FSEE Flexi System External Alarm Module

Label	Name	Function	Connector type				Additional information
			ASIA	ASIB	ASIK	ASIL	
SIN	Synchronization input	External synchronization inputs, GNSS equipment powering and control	19PIN				Signals in: <ul style="list-style-type: none"> • GNSS synchronization • GSM frame flock and frame number • ITU G.703 2.048 MHz or 10 MHz GNSS control and power supply (15 V, GND)
SOUT	Synchronization output	Interface for external synchronization outputs	19PIN				Signals out: <ul style="list-style-type: none"> • GNSS synchronization • GSM frame flock and frame number • ITU G.703 2.048 MHz or 10 MHz
SEI1	System module extension interface	Interface for traffic between system modules, additional synchronization source	MiniSA S-HD 2 x 10GE 2 x SRIO, 6.25 Gbit/s	QSFP+ 4 x 10G or 1 x 40G Ethernet			Synchronization signals: SyncE, ToP (IEEE 1588v2)
SEI2	System module extension interface	Interface for traffic between system modules, additional synchronization source	MiniSA S-HD 2 x 10GE 2 x SRIO, 6.25 Gbit/s	QSFP+ 4 x 10G or 1 x 40G Ethernet	N/A	QSFP+ 4 x 10G or 1 x 40G Ethernet	Synchronization signals: SyncE, ToP (IEEE 1588v2)
SRIO1	Interconnection interface	Interface for Flexi Multiradio 10 BTS system modules	SFP+		N/A	N/A	-

Label	Name	Function	Connector type				Additional information
			ASIA	ASIB	ASIK	ASIL	
SRIO2	Interconnection interface	Interface for Flexi Multiradio 10 BTS system modules	SFP+	N/A	N/A	N/A	-
EIF1	Transport interface	Backhaul/higher layer fronthaul interface	1GE/10GE SFP/SFP+		1GE/10GE/25GE SFP28		ASIA/ASIB: 10GBase-SR/LR, 1000Base-SX/LX/BX/ZX ASIK/ASIL : 1GE, 10GE, 25GE
EIF2	Transport interface	Backhaul/higher layer fronthaul interface	1GE/10GE SFP/SFP+		1GE/10GE/25GE SFP28		ASIA/ASIB: 10GBase-SR/LR, 1000Base-SX/LX/BX/ZX ASIK/ASIL : 1GE, 10GE, 25GE
EIF3	Transport interface	Backhaul/higher layer fronthaul interface	1GE RJ45	N/A	1GE/25GE SFP28	ASIA/ASIB: 100/1000Base-T ASIL: 1GE, 25GE	
EIF4	Transport interface	Backhaul/higher layer fronthaul interface	1GE RJ45	N/A	1GE/10GE RJ45	ASIA/ASIB: 100/1000Base-T ASIL: 1000Base-T/10GBase-T	
EIF5	Transport interface	Backhaul/higher layer fronthaul interface	1GE RJ45	N/A	N/A	100/1000Base-T	
LMP	Local Management Port	Ethernet interface for Element Manager, site support equipment, or diagnostic	1GE RJ45				100/1000Base-T

The transport interfaces can be used for:

- Backhaul connectivity (tail sites)

- Aggregation (chain or tree sites)
- Redundancy (link load sharing, fast IP rerouting)
- Centralized RAN site solutions
- Ethernet-based chaining and switching across up to five interfaces

Note:

Adding the second common plug-in unit to the right half of the subrack does not increase transport capacity. Plan the transport configuration accordingly.

6.1 AirScale SM synchronization

AirScale system module (SM) synchronization is handled by common plug-in units.

To ensure proper operation, accurate synchronization within a single AirScale BTS and between different AirScale BTSs is implemented. The control and timing block in the BTS is responsible for implementing these functions.

The AirScale SM has the following synchronization sources:

- Synchronous Ethernet recovered clock; through the transport interface
- Timing over Packet (ToP) (IEEE 1588v2); through the transport interface
- Pulse per second and time of day (1PPS & ToD)
 - Through GNSS (for example GPS)
 - From another BTS through synchronization input (SIN)
- ITU G.703 2.048 MHz /10 MHz through synchronization input (SIN)
- GSM frame clock and frame number
- SM–SM synchronization (between subracks)
- SM–SM synchronization (between the common plug-in units in one subrack)
- Fronthaul interfaces on the capacity plug-in units; through RP3-01/CPRI

Synchronization requirements can be classified into three different types:

- Frequency synchronization
- Phase synchronization
- Time synchronization

Frequency synchronization

Synchronization in the frequency domain refers to the frequency accuracy measured by comparing the actual frequency generated by the BTS in the air interface (carrier frequency) to a stable reference clock. This frequency accuracy is measured in units of ppb (parts per billion) or ppm (parts per million). 3GPP requires that the modulated carrier frequency of the BTS (all radio access technologies) is accurate within ± 50 ppb.

Frequency synchronization can be provided through Synchronous Ethernet, ToP (IEEE1588v2), 2.048 MHz signal, or GNSS.

Phase synchronization

Synchronization in the phase domain refers to the frame alignment of the radio frame transmitted into the air interface by different BTSs that are aligned to each other with the required accuracy (in the unit of microseconds or even nanoseconds). Time duplex technology, such as LTE TDD, requires phase synchronization for its basic operation to align downlink and uplink transmission. Phase synchronization implicitly includes frequency synchronization but not the other way around.

Phase synchronization can be provided through ToP with phase synchronization or GNSS receiver.

Time synchronization

Synchronization in the absolute time domain means that different network elements are aligned to the required ToD – in the unit of years, months, days, hours, and so on. The requirements span from very mild requirements to the most stringent depending on the applications. For example, time synchronization is required for Operations, Administration, and Maintenance (OAM) purposes, such as alarm correlation. In this case, the accuracy requirement is in the range of milliseconds. On the other hand, System Frame Number (SFN) alignment on the radio interface has a very strict accuracy requirement on the level of sub-microseconds. Note that SFN alignment requires phase synchronization.

6.2 AirScale SM holdover performance

AirScale system module (SM) provides internal synchronization for a limited time in case the external synchronization is lost.

The AirScale common plug-in units provide the following holdover capabilities:

- Typical holdover performance of +/- 50 ppb for 60 days
- Typical holdover performance of +/- 3 μ s for 24 hours
- Typical holdover performance of +/- 10 μ s for > 24 hours

i Note:

Conditions: The BTS has been powered on and supplied with accurate phase synchronization sources for a period of no less than seven days. During the overall period (including holdover), BTS has been subject to stable conditions.

6.3 AirScale common plug-in units reset and service buttons

The AirScale common plug-in unit buttons reset the BTS, the configuration, or restart the BTS in a fail-safe mode.

You can use the **Reset** and **Service** buttons on AirScale common plug-in units in case the remote connection is not possible. The hole diameter is 3.4 mm (0.13 in.).

i Note:

Pressing any of the buttons results in the service outage.

Table 19: *Reset* and *Service* buttons usage effects

Button	Pressing time	Effect
Reset	Less than 5 s	Reboot to active partition software (nominal software), no changes in configuration.
	More than 5 s	Reboot to active partition software (nominal software), commissioning data cleared, security certificates maintained - recommissioning is needed.
Service	Less than 5 s	Reboot to fail-safe software losing ASlx logs. Rescue console in fail safe software supports diagnostics and repair functions like nominal software re-installation. After software re-installation recommissioning is needed.
	More than 5 s	Reboot to fail-safe software preserving ASlx logs. Snapshot including ASlx logs from can be collected for troubleshooting purposes. Rescue console in fail-safe software supports diagnostics and repair functions like nominal software re-installation. After software re-installation recommissioning is needed.

Figure 19: ASIA *Reset* and *Service* buttons locations

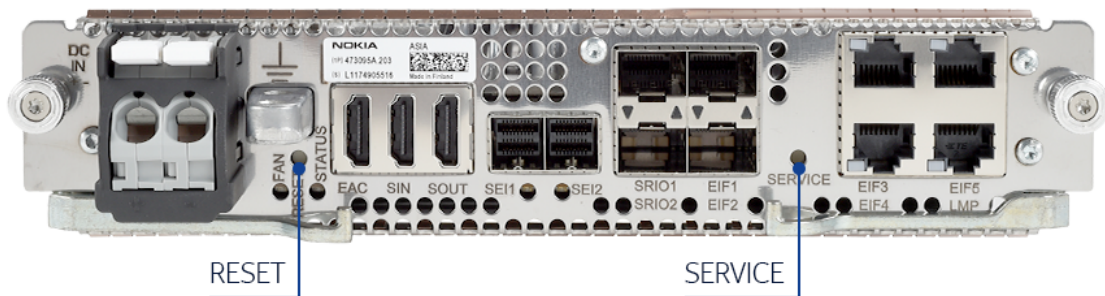

Location of those buttons on ASIAA is the same.

Figure 20: ASIB **Reset** and **Service** buttons locations

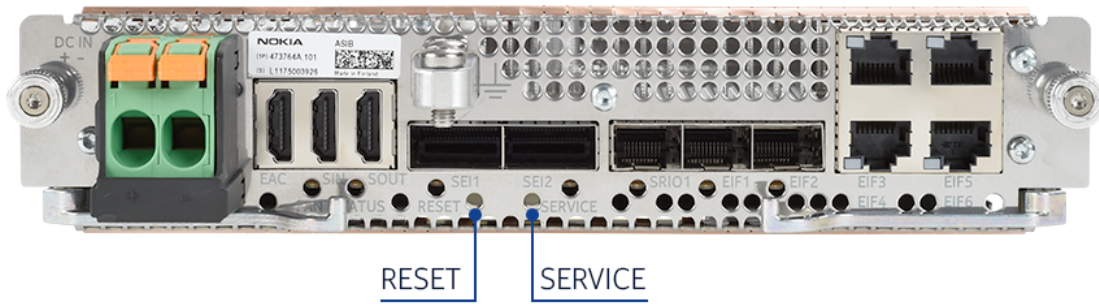

Location of those buttons on ASIBA is the same.

Figure 21: ASIK **Reset** and **Service** buttons locations

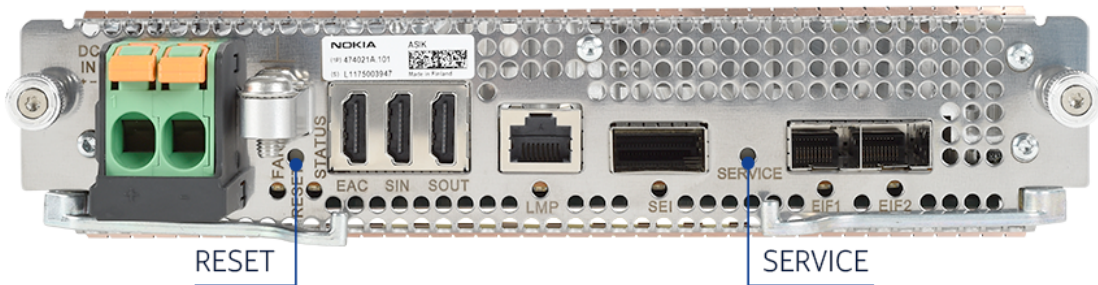

Location of those buttons on ASIKA is the same.

Figure 22: ASIL **Reset** and **Service** buttons locations

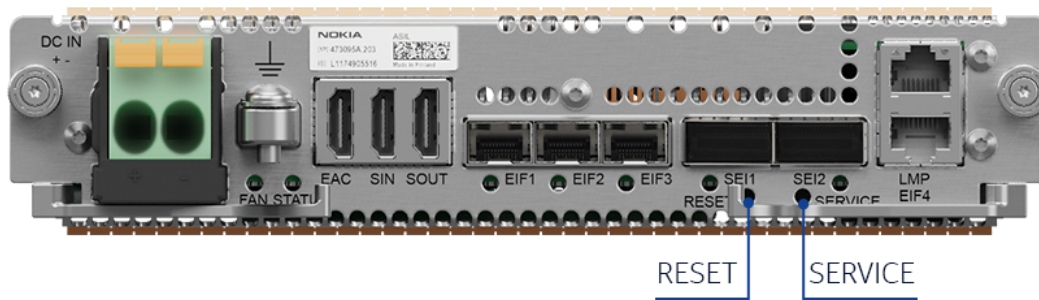

7. AirScale capacity plug-in units

The AirScale capacity plug-in units provide cell-specific baseband processing and optical interfaces to radio units.

Capacity plug-in units overview

Table 20: Capacity plug-in units overview

Property	ABIA	ABIC	ABIL	ABIN	ABIO
Nokia product code	473096A	474723A	474020A 474020B	474824A 474824B	475266A 475266B
Ingress protection class	IP 20				
Dimensions (height x width x depth) See: Figure: Capacity plug-in unit dimensions orientation.	25 mm x 219 mm x 364 mm (0.98 in. x 8.62 in. x 14.33 in.)				
Weight (without packaging)	2.1 kg (4.6 lb)	2.65 kg (5.84 lb)	2.1 kg (4.6 lb)	2.1 kg (4.6 lb)	2.65 kg (5.84 lb)

Figure 23: Capacity plug-in unit dimensions orientation



Table 21: Capacity plug-in units basic comparison

Property	ABIA	ABIC	ABIL	ABIN	ABIO
RAT standards	GSM WCDMA LTE	LTE	NR	LTE NR	LTE NR
Interface connectors	6 x SFP+	6 x SFP28 3 x SFP+	2 x SFP28 2 x QSFP28	9 x SFP28	9 x SFP28
Interface types	OBSAI CPRI	CPRI eCPRI	CPRI eCPRI	OBSAI CPRI eCPRI	OBSAI CPRI eCPRI
Interface type mixing	No	No	No	Yes	Yes
Typical power consumption at 25°C (77°F) according to ETSI ES202 706	96 W	100 W (CPRI) 130 W (eCPRI)	136 W	107 W	149 W

i Note:

- AirScale system module capacity plug-in units exist in various versions. For functionality details of each version, refer to Technical Notes (part of system software release documentation).
- The data in this section is related to hardware capabilities. For software capabilities, see the respective technology features and supported configurations.

ABIA capacity plug-in unit interfaces

Figure 24: ABIA interfaces

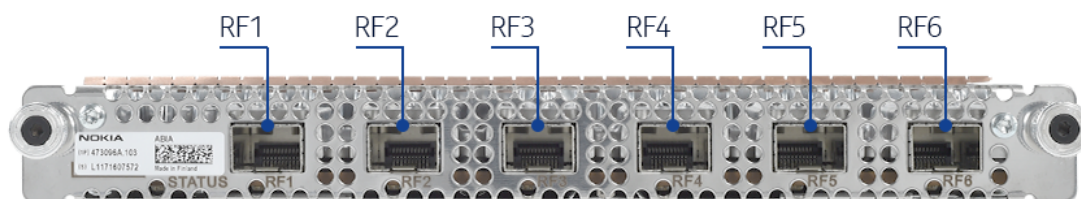

Table 22: ABIA interfaces

Label	Function	Connector type	Additional information
RF1 to RF6	Fronthaul interface RP3-01/CPRI to radio units	SFP+	<ul style="list-style-type: none"> • 1 x OBSAI RP3-01 (3072 Mbps or 6144 Mbps) or CPRI (2.45/4.91/6.14/9.83 Gbps) • Supports IQ compression (IQC) with three CPRI interfaces RF1, RF2 and RF3

ABIC capacity plug-in unit interfaces

Figure 25: ABIC interfaces

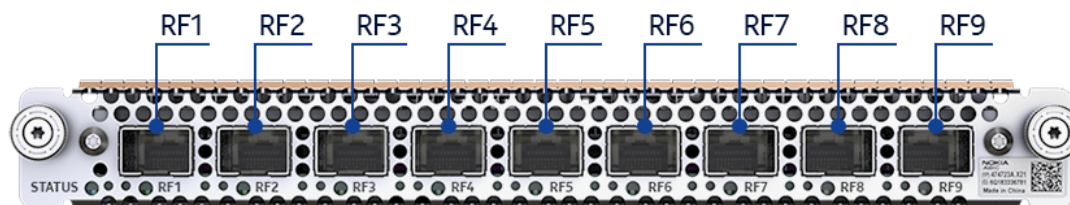

Table 23: ABIC interfaces

Label	Function	Connector type	Additional information
RF1 to RF3	Fronthaul interfaces to radio units	SFP+	<ul style="list-style-type: none"> • 10GE Ethernet (10G BASE-SR/LR/ER) • CPRI line rates: 2.45/4.91/9.83 Gbps with IQC • eCPRI line rate: 10.31 Gbps
RF4 to RF9	Fronthaul interfaces to radio units	SFP28	<ul style="list-style-type: none"> • 10/25GE Ethernet (10/25G BASE-SR/LR/ER) • CPRI line rates: 2.45/4.91/9.83 Gbps with IQC • eCPRI line rates: 10.31 Gbps or 25.78 Gbps

ABIL capacity plug-in unit interfaces

Figure 26: ABIL interfaces

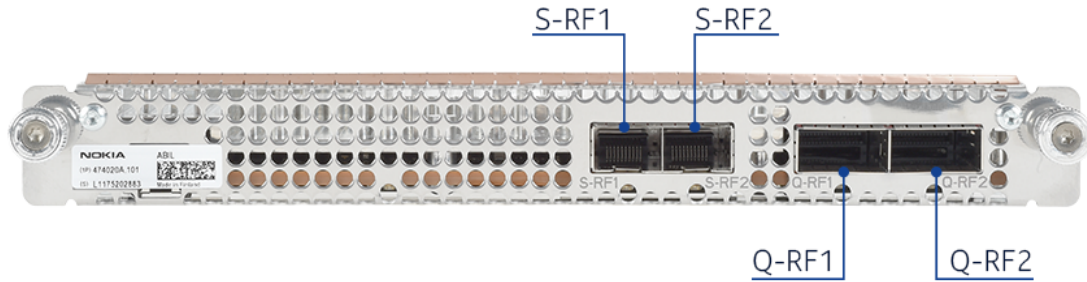

Table 24: ABIL interfaces

Label	Function	Connector type	Additional information
S-RF1, S-RF2	Fronthaul interfaces to radio units	SFP28	<ul style="list-style-type: none"> • CPRI line rate: 9.83 Gbps • eCPRI line rates: 10.31 Gbps or 25.78 Gbps • IQC on CPRI interface for FDD
Q-RF1	Fronthaul interface to radio units	QSFP28	<ul style="list-style-type: none"> • CPRI line rate: 9.83 Gbps • eCPRI line rates: 10.31 Gbps • IQC on CPRI interface for FDD
Q-RF2	Fronthaul interface to radio units	QSFP28	<ul style="list-style-type: none"> • CPRI line rate: 9.83 Gbps • eCPRI line rates: 10.31 Gbps or 25.78 Gbps • IQC on CPRI interface for FDD

ABIN capacity plug-in unit and ABIO capacity plug-in unit interfaces

Figure 27: ABIN and ABIO interfaces

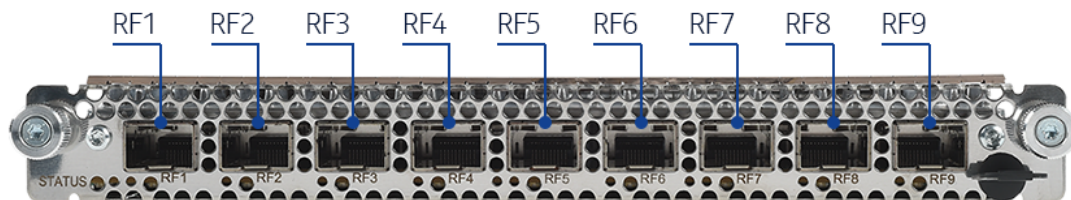

Table 25: ABIN and ABIO interfaces

Label	Function	Connector type	Additional information
RF1 to RF9	Fronthaul interfaces to radio units	SFP28	eCPRI 10/25GE (10/25G BASE-SR/LR/ER) Of these nine ports eight are: <ul style="list-style-type: none"> • CPRI-capable (9.83 Gbps with IQC) • CPRI-A-capable (9.83 Gbps) in NR FDD only. Functionality introduced by the <i>CB007605: CPRI-A Support on ABIO for NR</i> feature. • OBSAI-capable (6.14 Gbps): <ul style="list-style-type: none"> - at ABIN by introducing of the <i>CB008885: ABIN OBSAI Support</i> feature. - at ABIO by introducing of the <i>CB006844: ABIO OBSAI Support</i> feature.

 Note:

For CPRI/eCPRI (9.8G/10G/25G link), it is recommended to use only MN qualified AOxx SFP pluggables. For detailed list of supported SFPs, see *Operating Documentation/Single RAN BTS Site Solutions/Nokia AirScale BTS/Nokia AirScale BTS Descriptions/List of Supported Nokia BTS SFPs*.

8. AirScale SM environmental requirements

Temperature, humidity ranges, transport, storage, and operational requirements for AirScale system module (SM)

Table 26: AirScale SM temperature and humidity requirements

Activity	Temperature ranges		Humidity ranges
	Indoor	Outdoor	
Transportation	-40°C to 70°C (-40°F to 158°F)		Up to 95%
Storage	-33°C to 55°C (-27°F to 131°F)		10% to 100%
Installation	-20°C to 60°C (-4°F to 140°F)		Up to 93%
Operating	For common plug-in units, see Table: Operating temperature requirements for common plug-in units . For capacity plug-in units, see Table: Operating temperature requirements for capacity plug-in units .	-40°C to 55°C (-40°F to 131°F)	
Powering up*	-40°C to 55°C (-40°F to 131°F)		
Cold start-up	-5°C to 55°C (23°F to 131°F)	-40°C to 55°C (-40°F to 131°F)	

* You can power on AirScale SM from -40°C (-40°F), but it doesn't start until -5°C (23°F) is reached.

Table 27: Operating temperature requirements for common plug-in units

Unit name	Front-to-back airflow*	Back-to-front airflow**
ASIA	-5°C to 55°C (23°F to 131°F) for ASIA A.101 unit variant -5°C to 60°C (23°F to 140°F) for ASIA A.202 or newer unit variant	-5°C to 55°C (23°F to 131°F)
ASIB	-5°C to 60°C (23°F to 140°F)	-5°C to 55°C (23°F to 131°F)
ASIK ASIL	-5°C to 55°C (23°F to 131°F)	-5°C to 50°C (23°F to 122°F)

* Front-to-back is a factory default airflow direction and is recommended to use. Hardware-related specifications (for example, power consumption, noise) are delivered for these configurations.

** In special cases you can use the back-to-front airflow but you should monitor SFP temperature in hot conditions.

Table 28: Operating temperature requirements for capacity plug-in units

Unit name	Front-to-back airflow*	Back-to-front airflow**
ABIA	-5°C to 60°C (23°F to 140°F)	-5°C to 55°C (23°F to 131°F)
ABIC ABIL ABIN ABIO	-5°C to 55°C (23°F to 131°F)	-5°C to 50°C (23°F to 122°F)

* Front-to-back is a factory default airflow direction and is recommended to use. Hardware-related specifications (for example, power consumption, noise) are delivered for these configurations.

** In special cases you can use the back-to-front airflow but you should monitor SFP temperature in hot conditions.

Table 29: Required climatic conditions

Installation environment	ETSI norm required for:		
	Transportation	Storage	Operation
Indoor	ETSI EN 300 019-1-2 Class 2.3	ETSI EN 300 019-1-1 Class 1.2	ETSI EN 300 019-1-3, class 3.1E ¹⁾
Outdoor			ETSI EN 300 019-1-4, class 4.1

¹⁾ETSI EN 300 019-1-3, class 3.1 gives general guidance on indoor installation environmental conditions. However, local conditions can change over time (day, season) and it can be impossible to verify if the indoor site requirements are unambiguously met. For example, the amount of humidity and dust can increase to a level which eventually can decrease performance and prevent the normal operation of the module over time. In such a case, when this environmental uncertainty is present, secure the long-term operation of BTS modules by improving the operating conditions, for example, by using proper filtering for dust and humidity. "Indoor" in this context means a controlled environment that has no direct outdoor contact or access (such as open windows or doors). For example, a roof or any other shelter against rain alone does not qualify as an indoor space. Incoming air must be filtered to remove any dust. If the outside air is hotter than the indoor space, make sure there is no moisture that might condense into water. Use a heat exchanger or an air conditioner instead of filter air cooling.

9. NEBS requirements for AirScale SM

Network Equipment-Building System (NEBS) site requirements are a set of common technical requirements of safety, spatial, and environmental design guidelines applied to telecommunications equipment

NEBS (GR-1089 criteria) installation site requirements for the AirScale system module (SM) are:

- AirScale SM needs to be connected to the local grounding system. All grounding system wiring must be installed by appropriately licensed personnel. Installation must be performed in accordance with national and local electrical codes, for example: National Electrical Code (NEC), National Fire Protection Association 70 (NFPA 70) in the United States.
- AirScale SM can be grounded using either Common Bonding Network (CBN) or Isolated Bonding Network (IBN) or both methods.
- AirScale SM needs to be provided with an environmental enclosure in locations where the NEC applies for restricted access, and in outside plant locations.
- AirScale SM needs to be installed using thread-forming type unit mounting screws that remove any point or non-conductive coatings and establish metal-to-metal contact.
- AirScale SM uses an Isolated DC return (DC-I) standard.
- Intra-building ports, such as the Ethernet Interface (EIF) and the Local Management Port (LMP) of the equipment or sub-assembly, are suitable for connection to intra-building, unexposed wiring, or cabling only. The intra-building ports of the equipment or sub-assembly mustn't be metallic connected to interfaces that connect to the Outside Plant (OSP) or its wiring. These interfaces are designed for use as intra-building interfaces only (Type 2 or Type 4 ports as described in GR-1089) and require isolation from the exposed OSP cabling. The addition of primary protectors is not sufficient protection in order to connect these interfaces metallic to OSP wiring.
- Intra-building ports of the equipment or sub-assembly must use shielded intra-building cabling/wiring that is grounded at both ends.
- For NEBS installations, 6 AWG (16 mm²) wire or higher is required.
- External surge protectors used to protect the unit's antenna inputs should not allow a let through voltage greater than 600 V.

 **Note:**

This product is intended to be protected by a surge protector that meets the applicable criteria of GR-974 or GR-3154. Failure to utilize this appropriate surge protector could result in susceptibility to lightning surges or create a potential hazard due to lightning surges or power faults.

10. AirScale SM sound power levels

Acoustic noise levels emitted by AirScale subracks, measured according to ISO 3744

Table 30: Typical sound power levels (L_{wA_d} [dBA]) for indoor subracks at 25°C (77°F)

Fan profile	AMIA half	AMID half	AMIA full	AMID full
Linear	68	60	72	68
Low noise	61	54	63	63

Minimum sound power level for AMIA is 54 dBA and for AMID 49 dBA.

Maximum sound power level at 55°C (131°F) for AMIA is up to 84 dBA* and for AMID up to 88 dBA.

* Maximum values may be reached with **optimized cooling profile**, full ABIO/ASIL subrack depending on configurations, software release, and traffic load.

Table 31: Maximum sound power levels (L_{wA_d} [dBA]) for outdoor subracks at 23°C and 45°C (based on ETS 300 753)

Temperature	Fan profile	AMOB	AMOD
23°C (73°F)	Linear	83	66
	Linear with muffler	Not applicable	61
	Low noise	76	Not applicable
45°C (113°F)	Linear	83	71
	Linear with muffler	Not applicable	67
	Low noise	76	Not applicable

A linear fan profile is default for all subrack types from 22R2 release onwards.

11. AirScale SM power supply solutions

You can provide a single power supply to the entire subrack, supply halves separately, or have a duplicated and fully redundant power supply.

Table 32: Power supply options supported by subracks

Power supply option	AMIA	AMID	AMOB	AMOD
<u>Option 1</u>	Yes	Yes	Yes	Yes
<u>Option 2</u>	Yes	Yes	No	No
<u>Option 3</u>	Yes	Yes	No	Yes*

*requires two power feeding lines:

- One to the PDU and from the PDU to the left side common plug-in unit
- One with a third-party overvoltage protection (OVP) to the right side common plug-in unit

Note:

A separate grounding cable is needed for each connected DC feed.

The table below shows the maximum power loads and amps values for AirScale system module (SM) depending on the subrack type and power supply options.

Table 33: Max power loads and amps values with 48.0 V DC for AirScale SM

Subrack	Max power load	Amps value with 48.0 V at DC input connector*
AMIA	<u>Option 2</u> : ~750 W + ~750 W <u>Option 1 and 3</u> : ~1500 W	<u>Option 2</u> : 16 A + 16 A <u>Option 1 and 3</u> : 32 A
AMID	<u>Option 2</u> : ~1050 W + ~1050 W <u>Option 1 and 3</u> : ~2100 W	<u>Option 2</u> : 22 A + 22 A <u>Option 1 and 3</u> : 44 A
AMOB	<u>Option 1</u> : 1744 W	<u>Option 1</u> : 37 A
AMOD**	<u>Option 1</u> : 1656 W	<u>Option 1</u> : 35 A

*Follow local regulations and planning guidelines for defining right circuit breaker and taking also in account smallest used voltage at SM input.

**If air humidity exceeds 65%, the heaters start working to reduce it, causing current inrush of 23 A.

Use generic site breaker dimensioning per subrack, independent of plug-in unit type (valid for supported combinations). See the table above for recommended values.

Follow local regulations and planning guidelines for possible smaller circuit breaker values if SM configuration allows or the total cost of ownership (TCO) requires that kind of optimization.

For cable and circuit-breaker dimensioning guidelines, see *Operating Documentation/Single RAN BTS Site Solutions/Nokia AirScale BTS/Installing Nokia AirScale System Modules/Nokia AirScale BTS Installation Site Requirements*.

Option 1: A single power supply for the whole AirScale SM

In this option, there is one DC feed from either left or right subrack half's DC input. Power consumption of the whole subrack is measured and reported by the unit with the DC IN.

Figure 28: Power option 1

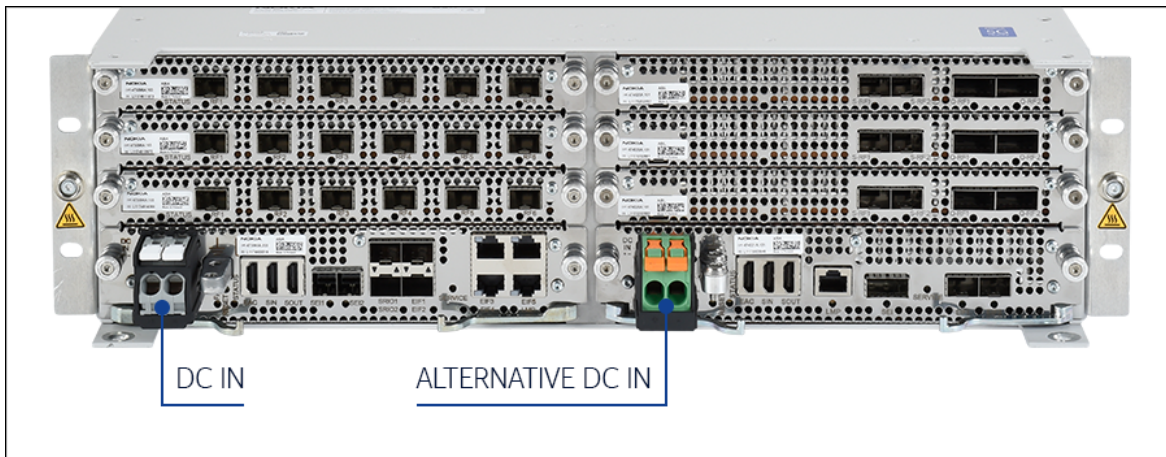

Option 2: Two power supplies, supplying power independently to two BTSs

In this option, the DC bridge in the subrack's rear is removed (in case of AMIA) or disconnected (in case of AMID). Both inputs feed their own subrack half. Power consumption of each subrack half is measured and reported by each of the common plug-in units separately.

Figure 29: Power option 2

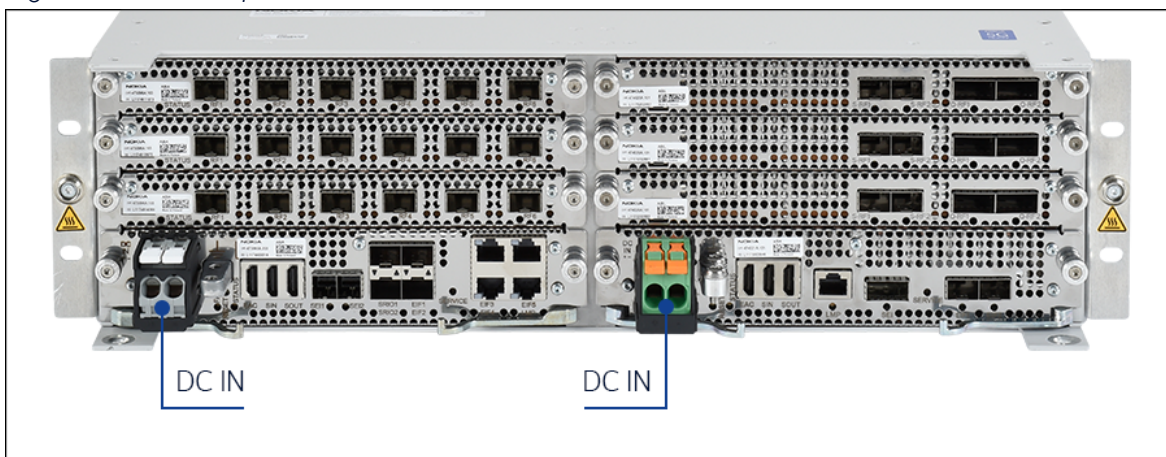

Option 3: Redundant for one BTS

This option provides load balancing between the two inputs through a DC bridge in the subrack rear. Power consumption is measured and reported by both common plug-in units. Total power consumption of the whole subrack is the sum of power reported by each of the common plug-in units.

Figure 30: Power option 3

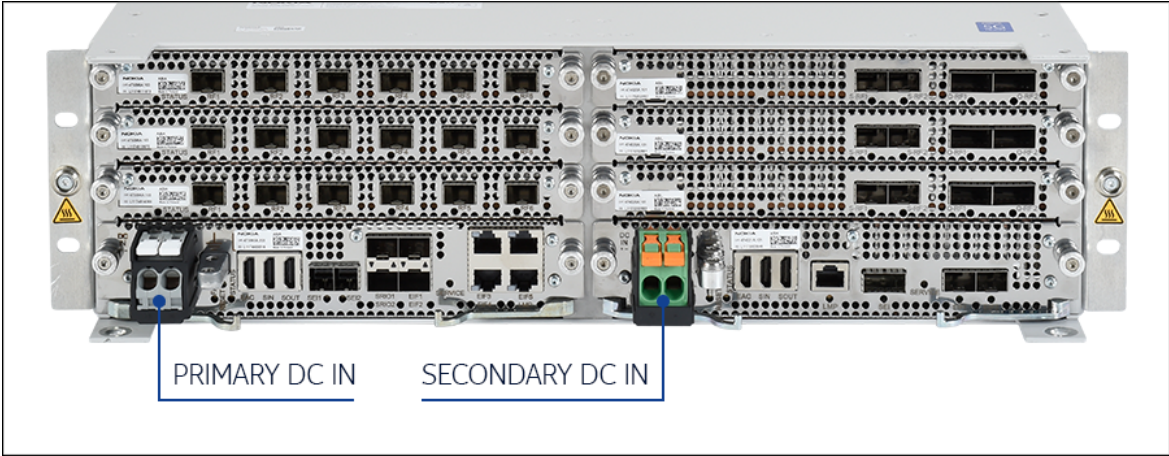

Copyrighted material licensed to imran.khumaeri1@t-mobile.com on 18-01-2023. No further reproduction or networking is permitted. Distributed by Nokia.

12. AirScale SM power requirements and consumption

Supply voltage range and power consumption of AirScale system module (SM) plug-in units and subracks

Table 34: Input voltage of the indoor AirScale SM

Property	Value
Nominal supply voltage	-48 V DC
Nominal input voltage range	-40.5 V DC to -57.0 V DC
Extended input voltage range	-36.0 V DC to -40.5 V DC -57.0 V DC to -60.0 V DC
Minimum startup voltage	-40.5 V DC

Note:

- When the input voltage level is higher than 57.0 V, an overvoltage alarm is raised.
- When the input voltage is lower than 40.5 V, an undervoltage alarm is raised.
- If the input voltage exceeds the extended range, the unit may shut down.

The power consumption values provided below are given for the nominal 48 V input. There is an embedded software feature which allows power consumption measurements during the BTS operation. You can use it to obtain exact values for your configuration.

Table 35: Power consumption of the AirScale plug-in units

Plug-in unit	Typical power consumption at 25°C (77°F) Measured according to ETSI ES 202 706	Typical power consumption at 55°C (131°F)
ASIA	65 W	Not declared
ASIB	73 W	83 W
ASIK	82 W	Not declared
ASIL	112 W	120 W
ABIA	96 W	106 W
ABIA (1/2 capacity)	62 W	68 W
ABIC	CPRI: 100 W eCPRI: 130 W	Not declared
ABIL	136 W*	Not declared
ABIN	107 W	114 W
ABIO	149 W	165 W

* Higher value due to new software features allowing higher capacity.

Table 36: Power consumption of the AirScale subracks

Subrack	Typical power consumption at 25°C (77°F) Measured according to ETSI ES 202 706	Typical power consumption at 55/60°C (131/140°F)	Cold start power consumption AMOB, AMOD: at -40°C (-40°F)
AMIA	5 W to 20 W	40 W	Not applicable
AMID	5 W to 20 W	40 W	Not applicable
AMOB	40 W	225 W	570 W
AMOD*	70 W	130 W	600 W

* If air humidity exceeds 65%, the heaters start working to reduce it, causing current inrush of 23 A.

i Note:

The typical power consumption of the subracks depends on the thermal load. Thermal load increases with the number of the plug-in units in a subrack.

For power consumption of the AirScale SM configurations contact Nokia Technical Support.

13. AirScale SM LED indicators

Each of the plug-in unit LEDs indicates a status of specific ports, fans, plug-in units, or the whole system module (SM).

LEDs indicate operation of the plug-in units (or the whole SM) as follows:

- Unit (SM) status LED.
- All SFP/QSFP and RJ45 interfaces status LED.
- FAN status LED.
- SEI interfaces link status LED (common plug-in units).
- All LEDs are three-color (red, green, yellow) and have three possible states when lit:
 - Stable
 - Blinking
 - Alternating colors

13.1 Common plug-in units LED indicators

Location of common plug-in units LED indicators and LED status description

Figure 31: ASIA LED indicators location

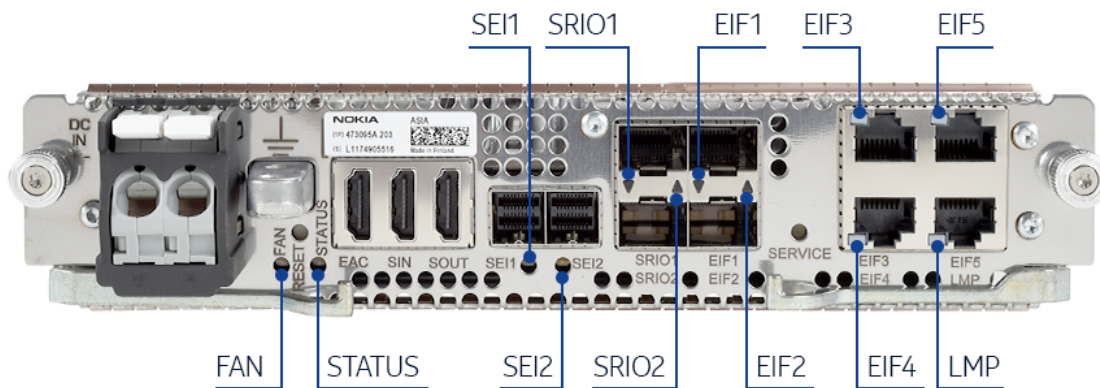

ASIAA LED indicators are located in the same locations.

Figure 32: ASIB LED indicators location

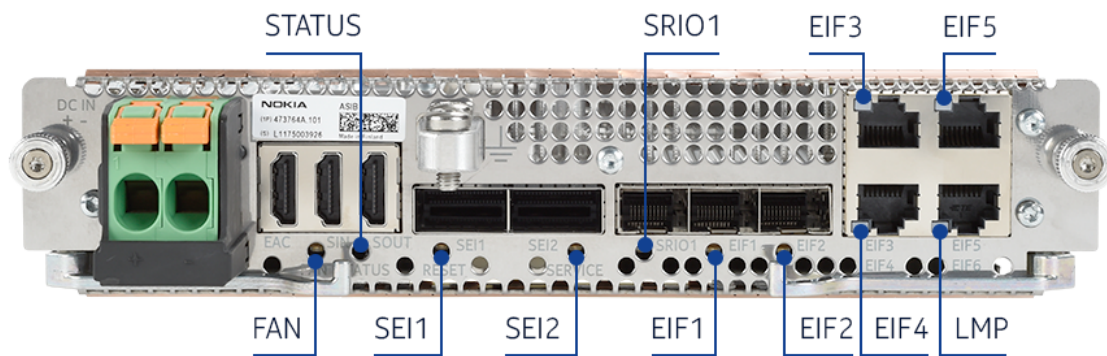

ASIBA LED indicators are in the same locations.

Table 37: ASIA and ASIB LED indicators

LED name	LED description	LED status
FAN	Operational status of fan	<ul style="list-style-type: none"> Stable GREEN: All fans working Stable YELLOW: Some fans faulty Stable RED: All fans faulty
STATUS	Operational status of the whole system module	<ul style="list-style-type: none"> Stable GREEN: Hardware online or commissioning configured Blinking GREEN: Commissioning internal software download while configured Stable YELLOW: Hardware blocked or hardware detected or commissioning unconfigured Blinking YELLOW: Commissioning preparing or commissioning configuring or commissioning prepared Stable RED: Hardware resetting or hardware failed Blinking RED: Hardware degraded
SEI1	Link status of system extension interface SEI1	Available in a future release
SEI2	Link status of system extension interface SEI2	Available in a future release

LED name	LED description	LED status
SRIO1	Link status of SRIO SFP+ interface SRIO1	<ul style="list-style-type: none"> • Stable GREEN: SRIO port online • Stable YELLOW: SRIO port connecting • Stable RED: SRIO port degraded • Off: SRIO port failed or not used
SRIO2 (ASIA only)	Link status of SRIO SFP+ interface SRIO2	
EIF1	Link status of 1/10GE SFP/SFP+ TRS interface EIF1	<ul style="list-style-type: none"> • Stable GREEN: EIF online • Stable YELLOW: SFP disconnected • Stable RED: No link detected • Stable RED: EIF failed • Blinking RED: EIF degraded • Off: EIF port not used
EIF2	Link status of 1/10GE SFP/SFP+ TRS interface EIF2	
EIF3	Link status of 100/1000Base-T TRS interface EIF3	
EIF4	Link status of 100/1000Base-T TRS interface EIF4	
EIF5	Link status of 100/1000Base-T TRS interface EIF5	
LMP	Link status of Local Management Port	<ul style="list-style-type: none"> • Stable GREEN: LMP port online • Stable YELLOW: LMP port offline (LTE) • Off: LMP port not used (LTE) • Off: LMP port offline or not used (SRAN)

Figure 33: ASIK LED indicator locations

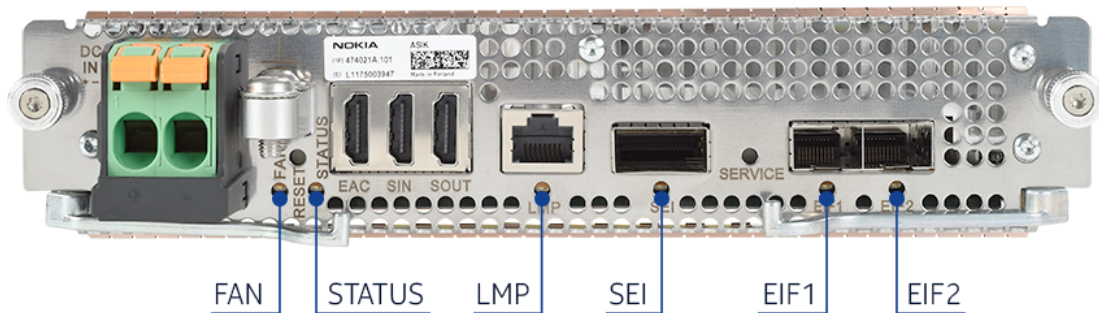

ASIKA LED indicators are in the same locations.

Table 38: ASIK LED indicators

LED name	LED description	LED status
FAN	Operational status of fan	<ul style="list-style-type: none"> • Stable GREEN: All fans working • Stable YELLOW: Some fans faulty • Stable RED: All fans faulty • OFF: Not in use
STATUS	Operational status of the whole system module	<ul style="list-style-type: none"> • Stable GREEN: Hardware online or commissioning configured • Blinking GREEN: Software downloading or commissioning configuring (in runtime) • Stable YELLOW: Commissioning not configured, nor uploaded to the BTS • Blinking YELLOW: Software downloading or commissioning configuring (in start-up) • Stable RED: Hardware resetting or hardware failed, commissioned data was uploaded to the BTS, but is missing/corrupted • Blinking RED: Hardware degraded • Alternating RED/YELLOW: Autoconnection state: Rejected or registered NOK • Alternating GREEN/RED: Autoconnection state: Registered • Alternating GREEN/YELLOW: Autoconnection state: Completed
SEI	Link status of system extension interface SEI1	Available in a future release
EIF1	Link status of 1/10/25GE SFP28 TRS interface EIF1	<ul style="list-style-type: none"> • Stable GREEN: EIF link working • Stable YELLOW: EIF port has a faulty or non-compliant SFP module
EIF2	Link status of 1/10/25GE SFP28 TRS interface EIF2	<ul style="list-style-type: none"> • OFF: In start-up OAM configures both EIF ports as default or SFP plug-in module is missing from EIF port or EIF has a correct SFP module but link is not working
LMP	Link status of Local Management Port	<ul style="list-style-type: none"> • Stable GREEN: LMP connected • OFF: LMP disabled

Figure 34: ASIL LED indicator locations

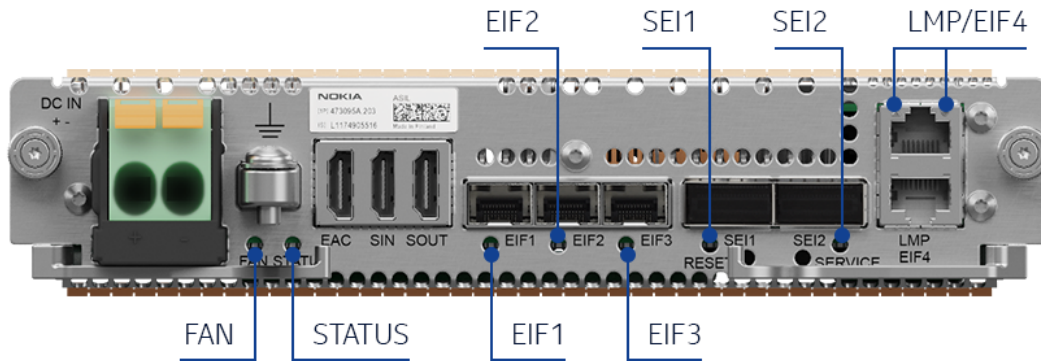

Table 39: ASIL LED indicators

LED name	LED description	LED status
FAN	Operational status of fan	<ul style="list-style-type: none"> • Stable GREEN: All fans working • Stable YELLOW: Some fans faulty • Stable RED: All fans faulty • Blinking RED: Air/liquid cooling configuration mismatch • OFF: Not in use
STATUS	Operational status of the whole system module	<ul style="list-style-type: none"> • Stable GREEN: Hardware online or commissioning configured • Blinking GREEN: Software downloading or commissioning configuring (in runtime) • Stable YELLOW: Commissioning not configured, nor uploaded to the BTS • Blinking YELLOW: Software downloading or commissioning configuring (in start-up) • Stable RED: Hardware resetting or hardware failed, commissioned data was uploaded to the BTS, but is missing/corrupted • Blinking RED: Hardware degraded • Alternating RED/YELLOW: Autoconnection state: Rejected or registered NOK • Alternating GREEN/RED: Autoconnection state: Registered • Alternating GREEN/YELLOW: Autoconnection state: Completed

LED name	LED description	LED status
SEI1	Link status of system extension interface SEI1	<ul style="list-style-type: none"> • Stable GREEN: In use, link detected • Stable YELLOW: In use, no link detected • Stable RED: In use, data link faulty • Blinking RED: In use, data link degraded • OFF: Not in use
SEI2	Link status of system extension interface SEI2	<ul style="list-style-type: none"> • Stable GREEN: In use, link detected • Stable YELLOW: In use, no link detected • Stable RED: In use, data link faulty • Blinking RED: In use, data link degraded • OFF: Not in use
EIF1	Link status of 1/10/25GE SFP28 TRS interface EIF1	<ul style="list-style-type: none"> • Stable GREEN: EIF link working • Stable YELLOW: EIF port has a faulty/non-compliant SFP module or SFP module is missing • Stable RED: EIF link not working • Blinking RED: EIF link degraded • OFF: OAM is not initialized/no declared link
EIF2	Link status of 1/10/25GE SFP28 TRS interface EIF2	
EIF3	Link status of 1/10/25GE SFP28 TRS interface EIF3	
EIF4	Link status of 1/10GE TRS EIF4	
LMP	Link status of Local Management Port	<ul style="list-style-type: none"> • Stable GREEN: LMP connected • OFF: LMP disabled

13.2 Capacity plug-in units LED indicators

Location of capacity plug-in units LED indicators and LED status description

Figure 35: ABIA LED indicators location

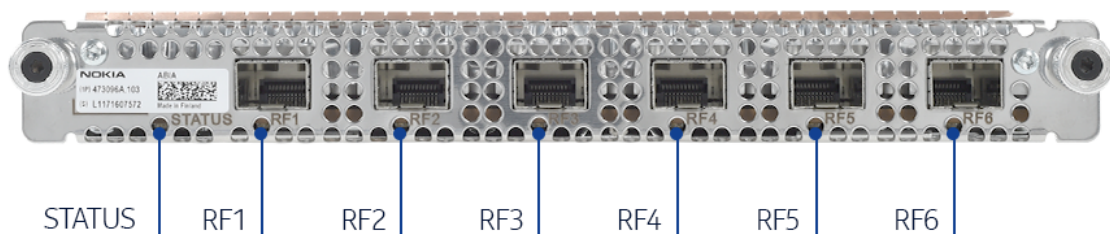

Table 40: ABIA LED indicators

LED name	LED description	LED status
STATUS	Operational status of the ABIA plug-in unit	<ul style="list-style-type: none"> • Stable GREEN: Hardware online or commissioning configured • Blinking GREEN: Commissioning internal software download while configured • Stable YELLOW: Hardware blocked or hardware detected or commissioning unconfigured • Blinking YELLOW: Commissioning preparing or commissioning configuring or commissioning prepared • Stable RED: Hardware resetting or hardware failed • Blinking RED: Hardware degraded
RF1	Link status of RF SFP+ interface RF1	<ul style="list-style-type: none"> • Stable GREEN: Optical cable online • Stable YELLOW: Optical cable disconnected • Stable RED: Optical cable failed • Blinking RED: Optical cable degraded • OFF: Optical cable not used
RF2	Link status of RF SFP+ interface RF2	
RF3	Link status of RF SFP+ interface RF3	
RF4	Link status of RF SFP+ interface RF4	
RF5	Link status of RF SFP+ interface RF5	
RF6	Link status of RF SFP+ interface RF6	

Figure 36: ABIC LED indicators location

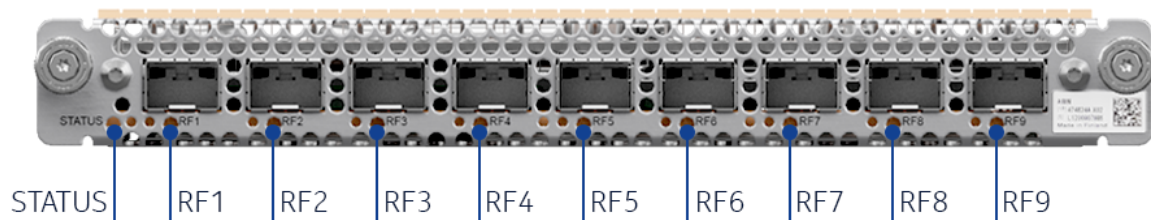

Table 41: ABIC LED indicators

LED name	LED description	LED status
STATUS	Operational status of ABIC	<ul style="list-style-type: none"> • Stable GREEN: Hardware online or commissioning configured • Blinking GREEN: Commissioning internal software download while configured • Stable YELLOW: Hardware blocked or hardware detected or commissioning unconfigured • Blinking YELLOW: Commissioning preparing or commissioning configuring or commissioning prepared • Stable RED: Hardware resetting or hardware failed • Blinking RED: Hardware degraded
RF1	Link status of RF SFP+ interface RF1	<ul style="list-style-type: none"> • Stable GREEN: Optical cable online • Stable YELLOW: Optical cable disconnected • Stable RED: Optical cable failed • Blinking RED: Optical cable degraded • OFF: Optical cable not used
RF2	Link status of RF SFP+ interface RF2	
RF3	Link status of RF SFP+ interface RF3	
RF4	Link status of RF SFP28 interface RF4	
RF5	Link status of RF SFP28 interface RF5	
RF6	Link status of RF SFP28 interface RF6	
RF7	Link status of RF SFP28 interface RF7	
RF8	Link status of RF SFP28 interface RF8	
RF9	Link status of RF SFP28 interface RF9	

Figure 37: ABIL LED indicators location

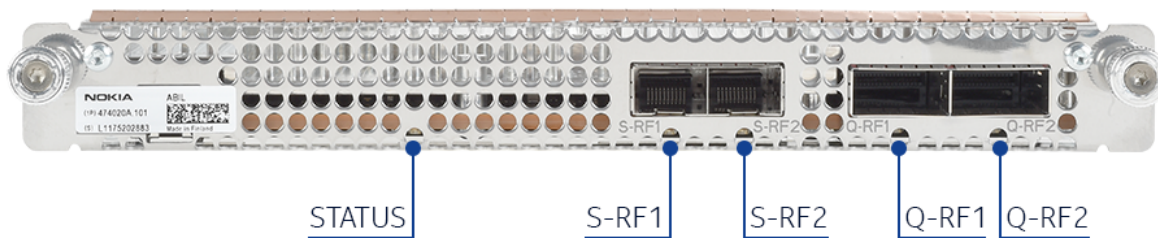

Table 42: ABIL LED indicators

LED name	LED description	LED status
STATUS	Operational status of the ABIL plug-in unit	<ul style="list-style-type: none"> • Stable GREEN: Hardware online or commissioning configured • Blinking YELLOW: Software downloading or commissioning configuring (in start-up) • Stable RED: Hardware failed • Blinking RED: Hardware degraded
S-RF1	Link status of RF SFP+/SFP28 interface S-RF1	<ul style="list-style-type: none"> • Stable GREEN: Link established • Stable YELLOW: Missing SFP module or SFP module hardware error
S-RF2	Link status of RF SFP+/SFP28 interface S-RF2	<ul style="list-style-type: none"> • Stable RED: Link broken • OFF: M-plane is not initialized or the port is not commissioned
Q-RF1	Link status of RF QSFP+/QSFP28 interface Q-RF1	<ul style="list-style-type: none"> • Stable GREEN: All commissioned links established • Stable YELLOW: Missing QSFP module or QSFP module hardware error
Q-RF2	Link status of RF QSFP+/QSFP28 interface Q-RF2	<ul style="list-style-type: none"> • Stable RED: All commissioned links broken • Alternating RED/GREEN: Some commissioned links broken • OFF: M-plane is not initialized or the port is not commissioned

Figure 38: ABIO/ABIN LED indicators location

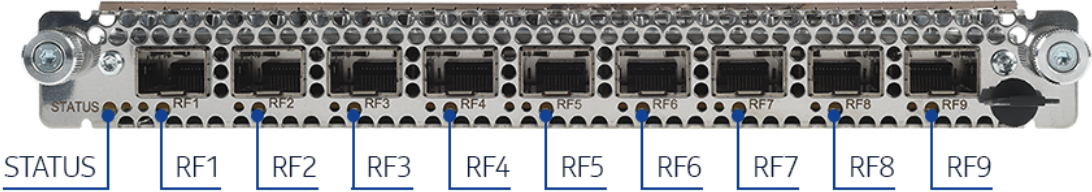

Table 43: ABIO/ABIN LED indicators

LED name	LED description	LED status
STATUS	Operational status of the ABIO/ABIN plug-in unit	<ul style="list-style-type: none"> • Stable GREEN: Hardware online or commissioning configured • Blinking YELLOW: Software downloading or commissioning configuring (in start-up) • Stable RED: Hardware resetting or hardware failed • Blinking RED: Hardware degraded
RF1	Link status of RF SFP28 interface RF1	<ul style="list-style-type: none"> • Stable GREEN: Optical link online • Stable YELLOW: Port has a faulty/non-compliant SFP module or SFP module is missing • Stable RED: Optical link failed • Blinking RED: Optical link degraded • OFF: OAM not initialized/no declared link
RF2	Link status of RF SFP28 interface RF2	
RF3	Link status of RF SFP28 interface RF3	
RF4	Link status of RF SFP28 interface RF4	
RF5	Link status of RF SFP28 interface RF5	
RF6	Link status of RF SFP28 interface RF6	
RF7	Link status of RF SFP28 interface RF7	
RF8	Link status of RF SFP28 interface RF8	
RF9	Link status of RF SFP28 interface RF9	

14. AirScale naming convention

Explanation of consecutive letters of a Nokia AirScale BTS module name

Table 44: AirScale naming convention

Letter	Description
First letter A _ _ _	Nokia AirScale product family
First letter F _ _ _	First generation of Nokia AirScale remote radio head (RRH), Flexi Multiradio 10 BTS product family
Second letter _ A _ _	Antenna equipment, same band combiner, LTE and/or NR mMIMO
Second letter _ B _ _	Capacity plug-in unit
Second letter _ C _ _	Cabinet and cabinet accessories
Second letter _ D _ _	Diplexers
Second letter _ E _ _	NR and LTE mMIMO
Second letter _ H _ _	Nokia AirScale RRHs
Second letter _ J _ _	NR radio access points (RAPs)
Second letter _ L _ _	Low-noise mast head amplifier (MHA)
Second letter _ M _ _	Subracks
Second letter _ N _ _	Compact active antenna (CAA) solution
Second letter _ O _ _	Small form-factor pluggables (SFPs)

Letter	Description
Second letter _ P _ _	Power supply modules
Second letter _ Q _ _	NR mMIMO
Second letter _ R _ _	RF modules
Second letter _ S _ _	Common plug-in units (Nokia AirScale BTS)
Second letter _ T _ _	Transport modules, submodules, and cables
Second letter _ W _ _	Flexi Zone and AirScale small cells
Second letter _ Y _ _	GNSS/GPS equipment and accessories
Second letter _ Z _ _	Nokia AirScale TD-LTE and NR remote radio heads (RRHs)
Third letter _ _ I _	Indoor usage (AirScale system module)
Third letter _ _ O _	Outdoor usage (AirScale system module)
Fourth letter _ _ _ A	Hardware version - A is the first, B - the second, and so on.
Fifth (and consecutive) letter _ _ _ _ A	In case of multi-band radio units, there may be five or more letters, depending on the number of supported bands. The fifth letter is also added in some special cases, when it denotes a market-specific or customer-specific variant. For example, ASIAA is the same as ASIA, but it has a different DC input connector.
Fifth letter AB _ _ L AM _ _ L AS _ _ L	Liquid-cooled variant of AirScale system module (capacity plug-in unit/subrack/common plug-in unit)

For the following radio units, the second letter indicates the unit type:

- AA - Nokia AirScale mMIMO

- AE - Nokia AirScale mMIMO
- AH - Nokia AirScale FDD-LTE RRH
- AQ - Nokia AirScale mMIMO
- AR - Nokia AirScale RF modules
- AZ - Nokia AirScale TD-LTE and NR RRH
- FH - first generation Nokia AirScale RRH

The third letter in those cases indicates the operating 3GPP band for the respective technology (LTE or NR) as in the table below. If a radio unit supports more than one frequency band, the respective letters are given one after another. For example, AHPMDA is a triple-band RRH, where the letters PMD describe the bands it supports - bands 28, 20, and 8.

Table 45: Radio bands naming convention

Letter	Band
A	400 MHz
B	Band 12, band 13, band 14, band 17, band 29 (700 MHz)
C	Band 5 (850 MHz)
D	Band 8 (900 MHz)
E	Band 3 (1700/1800 MHz)
F	Band 25 (1900 MHz)
G	Band 1 (2100 MHz)
H	Band 7 (2600 MHz)
I	Band 66 (1700/2100 MHz)
K	Band 11 (1500 MHz)
L	Band 12 (700 MHz)
M	Band 20 (800 MHz EU)
N	Band 30 (2300 MHz)
O	Band 71 (600 MHz US)
P	Band 28 (700 MHz)
Q	Band 42, band 43 NR bands n77, n78 (3500 MHz – 4200 MHz)
U	NR bands n257, n258 (24 GHz – 28 GHz)
W	NR band n260 (39 GHz)

15. Appendix: AirScale SM connectors pin maps

Pin maps of Nokia-specific connectors

15.1 DC input connectors pin map

There are two different DC input connectors. One for ASIA, ASIB, ASIK, and ASIL uses a clamp terminal, the one for ASIAA, ASIBA, and ASIKA uses a screwed terminal.

Figure 39: DC input (ASIA, ASIB, ASIK, ASIL)

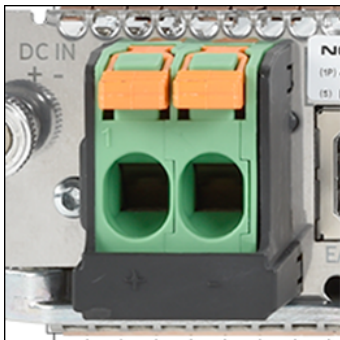

Figure 40: DC input (ASIAA, ASIBA, ASIKA)

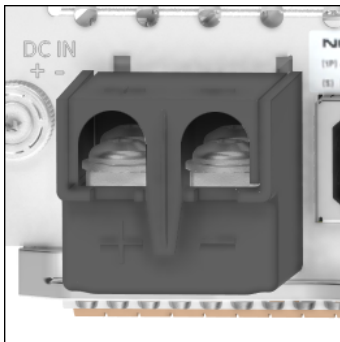

Table 46: Common plug-in unit DC input connectors

Pin	Signal (-48 V DC)	Allowed wire sizes for clamped DC input
Left (+)	V48RTN (+)	From 2 x 6 mm ² (10 AWG) to 2 x 16 mm ² (6 AWG)*
Right (-)	V48N (-)	

* For details on site power system and cable size dimensioning, see *Operating*

Documentation/Single RAN BTS Site Solutions/Nokia AirScale BTS/Installing Nokia AirScale System Modules/Nokia AirScale BTS Installation Site Requirements.

15.2 AirScale common plug-in units grounding connectors

Grounding connectors are two M5 screw holes (on ASIA A.202, ASIAA, ASIB, ASIBA, ASIK, ASIKA, and ASIL unit variants) or one M5 screw hole (on ASIA A.101 unit variant).

Figure 41: ASIA A.101 grounding connector



Figure 42: ASIA A.202, ASIAA, ASIB, ASIBA, ASIK, ASIKA, ASIL grounding connector



Table 47: Common plug-in unit grounding connectors

Common plug-in unit	Grounding connector
ASIA A.101	One M5 screw hole
ASIA A.202, ASIAA, ASIB, ASIBA, ASIK, ASIKA, ASIL	Two M5 screw holes

15.3 External alarm connection connector pin map

External alarm connection (EAC) uses a 19PIN connector port. The connector is marked EAC on the unit.

Figure 43: EAC pins order

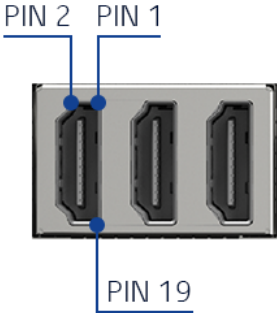

Table 48: EAC pin map

Pin	Signal
case	ground / chassis ground
1	EXT_AL0
2	EXT_AL1
3	EXT_AL2
4	EXT_AL3
5	EXT_AL4
6	EXT_AL5
7	EXT_CTRL0_EXT_AL6
8	EXT_CTRL1_EXT_AL7
9	EXT_CTRL2_EXT_AL8
10	EXT_CTRL3_EXT_AL9
11	EXT_CTRL4_EXT_AL10
12	EXT_CTRL5_EXT_AL11
13	P5V_EAC
14	P5V_EAC
15	PROT_CAN_H_P5V_EAC
16	GND
17	PROT_CAN_L_P5V_EAC
18	GND
19	GND

15.4 External synchronization input connector pin map

Synchronization input uses a 19PIN connector port. The connector is marked SIN on the plug-in unit.

Figure 44: SIN pins order

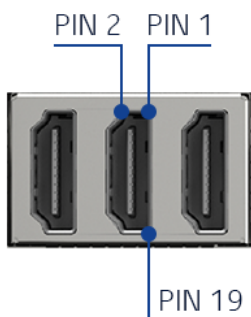

Table 49: External synchronization input connector pin map

Pin	Signal	Pin	Signal
1	GPS_TIME_IN_H GSM_FC_IN_H	2	SingleEndedIn
3	GPS_TIME_IN_L GSM_FC_IN_L	4	GND
5	NC	6	GND
7	GPS_PPS_IN_H GSM_FN_IN_H	8	NC
9	GPS_PPS_IN_L GSM_FN_IN_L	10	GPS_CONTROL_H
11	GND	12	GPS_CONTROL_L
13	GND	14	NC
15	GPS_PWR_RET	16	GND
17	GND	18	GPS_PWR
19	NC	-	-

Signal descriptions:

- GPS_TIME_IN_H, GSM_FC_IN_H, GPS_TIME_IN_L, GSM_FC_IN_L: Serial data from GPS to CPU or GSM Frame Clock input; RS422/485 differential.
- SingleEndedIn: REF2M_IN REF10M_IN Accepts TTL/CMOS and SINE from -6 to +13 dBm. Input impedance is approximately 75 Ohm.

- NC: No connection.
- GPS_PPS_IN_H, GSM_FN_IN_H, GPS_PPS_IN_L, GSM_FN_IN_L: PPS pulse from GPS or GSM Frame Number input; RS422/485 differential.
- GPS_CONTROL_H, GPS_CONTROL_L: Serial data from CPU to GPS; RS422/485 differential.
- GPS_PWR, GPS_PWR_RET: GPS power supply: 50 mA at 15 to >35 V.

15.5 External synchronization output connector pin map

Synchronization output uses a 19PIN connector port. The connector is marked SOUT on the plug-in unit.

Figure 45: SOUT pins order

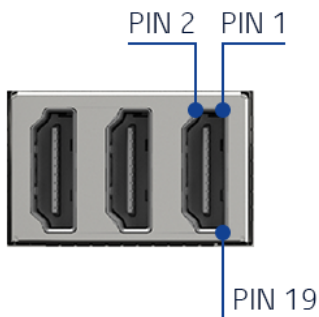

Table 50: External synchronization output connector pin map

Pin	Signal	Pin	Signal
1	GPS_TIME_OUT_H GSM_FC_OUT_H	2	SingleEndedClockOut1
3	GPS_TIME_OUT_L GSM_FC_OUT_L	4	GND
5	NC	6	GND
7	PPS_OUT_H	8	SingleEndedClockOut2
9	PPS_OUT_L	10	DiffClockOut_H or GSM_FN_OUT_H
11	GND	12	DiffClockOut_L or GSM_FN_OUT_L
13	GND	14	NC
15	-	16	GND
17	GND	18	NC
19	TESTCLK_GSM_FN_OUT_H	-	-

Signal descriptions:

- GPS_TIME_OUT_H, GSM_FC_OUT_H, GPS_TIME_OUT_L, GSM_FC_OUT_L: Copy of the serial data from GPS to CPU. The collocated BTS is only interested in the NMEA contents of this data stream or GSM Frame Clock output; RS422/485 differential or frame clock out.
- SingleEndedClockOut1: LVTTTL, which can have 11 sources: 2.048 MHz (from SingleEndedIn), 10 MHz (from SingleEndedIn), 10 MHz (FPGA internally generated), FCLK_IN 250 Hz, SYNC_WFCLK 30.72 MHz, SYNC_SFCLK 100 Hz, SYNC_SFCLK/2 50 Hz, SYNC_SFCLK/4 25 Hz, SYNC_SFCLK/8 12.5 Hz, SFNO 30.72 MHz pulse per 10 ms, Internal PPS_int 1 Hz.
- PPS_OUT_H, PPS_OUT_L: PPS_OUT RS422/485 differential.
- SingleEndedClockOut2: LVTTTL, which can have two sources: 2.048 MHz (from SingleEndedIn), 10 MHz (from SingleEndedIn).
- DiffClockOut_H or GSM_FN_OUT_H, DiffClockOut_L or GSM_FN_OUT_L: Has 12 potential clock sources: 2.048 MHz (from SingleEndedIn), 10 MHz (from SingleEndedIn), 10 MHz (FPGA internally generated), FCLK_IN 250 Hz, SYNC_WFCLK 30.72 MHz, SYNC_SFCLK 100 Hz, SYNC_SFCLK/2 50 Hz, SYNC_SFCLK/4 25 Hz, SYNC_SFCLK/8 12.5 Hz, SFNO 30.72 MHz

pulse per 10 ms, Internal PPS_int 1 Hz, GSM FRAME number.

- TESTCLK_GSM_FN_OUT_H: Single ended copy of pins 10/12.