

# **LTE Radio Access, Rel. RL70, Operating Documentation, Issue 01**

## **Flexi Multiradio BTS RF Module and Remote Radio Head Description**

**DN0951745**

**Issue 08**

**Approval Date 2014-11-27**

The information in this document applies solely to the hardware/software product ("Product") specified herein, and only as specified herein.

This document is intended for use by Nokia Solutions and Networks' customers ("You") only, and it may not be used except for the purposes defined in the agreement between You and Nokia Solutions and Networks ("Agreement") under which this document is distributed. No part of this document may be used, copied, reproduced, modified or transmitted in any form or means without the prior written permission of Nokia Solutions and Networks. If you have not entered into an Agreement applicable to the Product, or if that Agreement has expired or has been terminated, You may not use this document in any manner and You are obliged to return it to Nokia Solutions and Networks and destroy or delete any copies thereof.

The document has been prepared to be used by professional and properly trained personnel, and You assume full responsibility when using it. Nokia Solutions and Networks welcome Your comments as part of the process of continuous development and improvement of the documentation.

This document and its contents are provided as a convenience to You. Any information or statements concerning the suitability, capacity, fitness for purpose or performance of the Product are given solely on an "as is" and "as available" basis in this document, and Nokia Solutions and Networks reserves the right to change any such information and statements without notice. Nokia Solutions and Networks has made all reasonable efforts to ensure that the content of this document is adequate and free of material errors and omissions, and Nokia Solutions and Networks will correct errors that You identify in this document. But, Nokia Solutions and Networks' total liability for any errors in the document is strictly limited to the correction of such error(s). Nokia Solutions and Networks does not warrant that the use of the software in the Product will be uninterrupted or error-free.

NO WARRANTY OF ANY KIND, EITHER EXPRESS OR IMPLIED, INCLUDING BUT NOT LIMITED TO ANY WARRANTY OF AVAILABILITY, ACCURACY, RELIABILITY, TITLE, NON-INFRINGEMENT, MERCHANTABILITY OR FITNESS FOR A PARTICULAR PURPOSE, IS MADE IN RELATION TO THE CONTENT OF THIS DOCUMENT. IN NO EVENT WILL NOKIA SOLUTIONS AND NETWORKS BE LIABLE FOR ANY DAMAGES, INCLUDING BUT NOT LIMITED TO SPECIAL, DIRECT, INDIRECT, INCIDENTAL OR CONSEQUENTIAL OR ANY LOSSES, SUCH AS BUT NOT LIMITED TO LOSS OF PROFIT, REVENUE, BUSINESS INTERRUPTION, BUSINESS OPPORTUNITY OR DATA THAT MAY ARISE FROM THE USE OF THIS DOCUMENT OR THE INFORMATION IN IT, EVEN IN THE CASE OF ERRORS IN OR OMISSIONS FROM THIS DOCUMENT OR ITS CONTENT.

This document is Nokia Solutions and Networks' proprietary and confidential information, which may not be distributed or disclosed to any third parties without the prior written consent of Nokia Solutions and Networks.

Nokia is a registered trademark of Nokia Corporation. Other product names mentioned in this document may be trademarks of their respective owners, and they are mentioned for identification purposes only.

Copyright © 2014 Nokia Solutions and Networks. All rights reserved.



### **Important Notice on Product Safety**

This product may present safety risks due to laser, electricity, heat, and other sources of danger.

Only trained and qualified personnel may install, operate, maintain or otherwise handle this product and only after having carefully read the safety information applicable to this product.

The safety information is provided in the Safety Information section in the "Legal, Safety and Environmental Information" part of this document or documentation set.

Nokia Solutions and Networks is continually striving to reduce the adverse environmental effects of its products and services. We would like to encourage you as our customers and users to join us in working towards a cleaner, safer environment. Please recycle product packaging and follow the recommendations for power use and proper disposal of our products and their components.

If you should have questions regarding our Environmental Policy or any of the environmental services we offer, please contact us at Nokia Solutions and Networks for any additional information.

## Table of Contents

This document has 227 pages

	Summary of changes.....	16
1	RSS-310 compliance.....	17
2	EU RoHS statement.....	18
3	CE marking.....	19
4	FCC Part 15 compliance.....	20
5	Flexi RF Module 3TX 800 (FRMA).....	21
6	Flexi RF Module 3TX 800 (FRMD).....	26
7	Flexi RFM 3-pipe 850 180W (FXCA).....	31
8	Flexi RF Module 3TX 900 (FXDA).....	37
9	Flexi RF Module 3TX 900 (FXDJ).....	42
10	Flexi RF Module 3TX 1800 (FXEA).....	47
11	Flexi RF Module 3TX 1900 (FXFB).....	52
12	Flexi RF Module 3TX 2100 (FRGP).....	58
13	Flexi RF Module 3TX 2600 (FRHA).....	63
14	Flexi RF Module 3TX 1700/2100 (FRIE).....	68
15	Flexi RF Module 3TX 850 (FXCB).....	73
16	Flexi RF Module 3TX 900 (FXDB).....	79
17	Flexi RF Module 3TX 1800 (FXEB).....	84
18	Flexi RF Module 3TX 1900 (FXFC).....	90
19	Flexi RFM 3-pipe 900 240W (FXJB).....	96
20	Flexi RF Module 3TX 2100 (FRGT).....	102
21	Flexi RF Module 3TX 2100 (FRGS).....	108
22	Flexi RF Module 6TX 700 (FRPA).....	114
23	Flexi RF Module 6TX 700 (FRPB).....	119
24	Flexi RF Module 6TX 2600 (FRHC).....	124
25	Flexi RF Module 6TX 2600 (FRHF).....	129

26	Flexi RF Module 6TX 800 (FRMC).....	134
27	Flexi RFM 6-pipe 1800 360W (FXED).....	139
28	Flexi Remote Radio Head 2TX 850 (FHCA).....	145
29	Flexi Remote Radio Head 2TX 730 (FRLB).....	150
30	Flexi RRH 2-pipe 900 80W (FHDA).....	155
31	Flexi Remote Radio Head 2TX 1800 (FHEA).....	160
32	Flexi Remote Radio Head 2TX 2100 (FRGQ).....	165
33	Flexi Remote Radio Head 2TX 2600 (FRHB).....	170
34	Flexi Remote Radio Head 2TX 800EU (FRMB).....	175
35	Flexi Remote Radio Head 2TX 1800 (FHEB).....	180
36	Flexi RRH 2-pipe 1800 120W (FHEF).....	186
37	Flexi Remote Radio Head 2TX 900 (FHDB).....	191
38	Flexi Remote Radio Head 2TX 2100 (FRGY).....	196
39	Flexi Remote Radio Head 4TX 1700/2100 (FRIG).....	201
40	Flexi Remote Radio Head 4TX 2600 (FRHD).....	207
41	Flexi Remote Radio Head 4TX 2600 (FRHE).....	213
42	Flexi RRH 4-pipe 1900 160W (FHFB).....	219
43	Compliance with EMC, RF, and safety.....	225
44	Avoiding Passive Intermodulation during RF Module and RRH operation.....	227

## List of Figures

Figure 1	List of countries respecting EU Directive 1999/5/EC.....	19
Figure 2	FRMA interfaces.....	21
Figure 3	FRMA functional block diagram.....	22
Figure 4	FRMD interfaces.....	26
Figure 5	FRMD functional block diagram.....	27
Figure 6	FXCA interfaces.....	31
Figure 7	FXCA functional block diagram.....	33
Figure 8	FXDA interfaces.....	37
Figure 9	FXDA functional block diagram.....	38
Figure 10	FXDJ interfaces.....	42
Figure 11	FXDJ functional block diagram.....	43
Figure 12	FXEA interfaces.....	47
Figure 13	FXEA functional block diagram.....	48
Figure 14	FXFB interfaces.....	52
Figure 15	FXFB functional block diagram.....	54
Figure 16	FRGP interfaces.....	58
Figure 17	FRGP functional block diagram.....	59
Figure 18	FRHA interfaces.....	63
Figure 19	FRHA functional block diagram.....	64
Figure 20	FRIE interfaces.....	68
Figure 21	FRIE functional block diagram.....	69
Figure 22	FXCB interfaces.....	73
Figure 23	FXCB functional block diagram.....	75
Figure 24	FXDB interfaces.....	79
Figure 25	FXDB functional block diagram.....	80
Figure 26	FXEB interfaces.....	84
Figure 27	FXEB functional block diagram.....	86
Figure 28	FXFC interfaces.....	90
Figure 29	FXFC functional block diagram.....	92
Figure 30	FXJB interfaces.....	96
Figure 31	FXJB functional block diagram.....	98
Figure 32	FRGT interfaces.....	103
Figure 33	FRGT functional block diagram.....	104
Figure 34	FRGS interfaces.....	109
Figure 35	FRGS functional block diagram.....	110
Figure 36	FRPA interfaces.....	114
Figure 37	FRPA functional block diagram.....	115
Figure 38	FRPB interfaces.....	119

Figure 39	FRPB functional block diagram.....	120
Figure 40	FRHC interfaces.....	124
Figure 41	FRHC functional block diagram.....	125
Figure 42	FRHF interfaces.....	129
Figure 43	FRHF functional block diagram.....	130
Figure 44	FRMC interfaces.....	134
Figure 45	FRMC functional block diagram.....	135
Figure 46	FXED interfaces.....	139
Figure 47	FXED functional block diagram.....	141
Figure 48	FHCA interfaces.....	145
Figure 49	FHCA functional block diagram.....	146
Figure 50	FRLB interfaces.....	150
Figure 51	FRLB functional block diagram.....	151
Figure 52	FHDA interfaces.....	155
Figure 53	FHDA functional block diagram.....	156
Figure 54	FHEA interfaces.....	160
Figure 55	FHEA functional block diagram.....	161
Figure 56	FRGQ interfaces.....	165
Figure 57	FRGQ functional block diagram.....	166
Figure 58	FRHB interfaces.....	170
Figure 59	FRHB functional block diagram.....	171
Figure 60	FRMB interfaces.....	175
Figure 61	FRMB functional block diagram.....	176
Figure 62	FHEB interfaces.....	181
Figure 63	FHEB functional block diagram.....	182
Figure 64	FHEF interfaces.....	186
Figure 65	FHEF functional block diagram.....	187
Figure 66	FHDB interfaces.....	191
Figure 67	FHDB functional block diagram.....	192
Figure 68	FRGY interfaces.....	196
Figure 69	FRGY functional block diagram.....	197
Figure 70	FRIG interfaces.....	201
Figure 71	FRIG functional block diagram.....	203
Figure 72	FRHD interfaces.....	207
Figure 73	FRHD functional block diagram.....	209
Figure 74	FRHE interfaces.....	213
Figure 75	FRHE functional block diagram.....	215
Figure 76	FHFB interfaces.....	219
Figure 77	FHFB functional block diagram.....	221

## List of Tables

Table 1	FRMA functional specification.....	21
Table 2	FRMA interfaces.....	21
Table 3	FRMA ALD support.....	22
Table 4	FRMA electrical specifications.....	23
Table 5	FRMA power consumption.....	23
Table 6	FRMA installation and mechanical specifications.....	23
Table 7	FRMA dimensions and weight.....	23
Table 8	FRGS environmental specifications.....	24
Table 9	FRMA LEDs.....	24
Table 10	FRMD functional specification.....	26
Table 11	FRMD interfaces.....	26
Table 12	FRMD ALD support.....	27
Table 13	FRMD electrical specifications.....	28
Table 14	FRMD power consumption.....	28
Table 15	FRMD installation and mechanical specifications.....	28
Table 16	FRMD dimensions and weight.....	28
Table 17	FRMD environmental specifications.....	29
Table 18	FRMD LEDs.....	29
Table 19	FXCA functional specification.....	31
Table 20	FXCA interfaces.....	32
Table 21	FXCA ALD support.....	32
Table 22	FXCA electrical specifications.....	33
Table 23	FXCA power consumption.....	33
Table 24	FXCA installation and mechanical specifications.....	34
Table 25	FXCA dimensions and weight.....	34
Table 26	FXCA environmental specifications.....	34
Table 27	FXCA LEDs.....	34
Table 28	FXDA functional specification.....	37
Table 29	FXDA interfaces.....	37
Table 30	FXDA ALD support.....	38
Table 31	FXDA electrical specifications.....	39
Table 32	FXDA power consumption.....	39
Table 33	FXDA installation and mechanical specifications.....	39
Table 34	FXDA dimensions and weight.....	39
Table 35	FXDA environmental specifications.....	40
Table 36	FXDA LEDs.....	40
Table 37	FXDJ functional specification.....	42
Table 38	FXDJ interfaces.....	42

---

Table 39	FXDJ ALD support.....	43
Table 40	FXDJ electrical specifications.....	44
Table 41	FXDJ power consumption.....	44
Table 42	FXDJ installation and mechanical specifications.....	44
Table 43	FXDJ dimensions and weight.....	44
Table 44	FXDJ environmental specifications.....	45
Table 45	FXDJ LEDs.....	45
Table 46	FXEA functional specification.....	47
Table 47	FXEA interfaces.....	47
Table 48	FXEA ALD support.....	48
Table 49	FXEA electrical specifications.....	49
Table 50	FXEA power consumption.....	49
Table 51	FXEA installation and mechanical specifications.....	49
Table 52	FXEA dimensions and weight.....	49
Table 53	FXEA environmental specifications.....	50
Table 54	FXEA LEDs.....	50
Table 55	FXFB functional specification.....	52
Table 56	FXFB interfaces.....	52
Table 57	FXFB ALD support.....	53
Table 58	FXFB electrical specifications.....	54
Table 59	FXFB power consumption.....	54
Table 60	FXFB installation and mechanical specifications.....	55
Table 61	FXFB dimensions and weight.....	55
Table 62	FXFB environmental specifications.....	55
Table 63	FXFB LEDs.....	55
Table 64	FRGP functional specification.....	58
Table 65	FRGP interfaces.....	58
Table 66	FRGP ALD support.....	59
Table 67	FRGP electrical specifications.....	60
Table 68	FRGP power consumption.....	60
Table 69	FRGP installation and mechanical specifications.....	60
Table 70	FRGP dimensions and weight.....	60
Table 71	FRGP environmental specifications.....	61
Table 72	FRGP LEDs.....	61
Table 73	FRHA functional specification.....	63
Table 74	FRHA interfaces.....	63
Table 75	FRHA ALD support.....	64
Table 76	FRHA electrical specifications.....	65
Table 77	FRHA power consumption.....	65
Table 78	FRHA installation and mechanical specifications.....	65

Table 79	FRHA dimensions and weight.....	65
Table 80	FRHA environmental specifications.....	66
Table 81	FRHA LEDs.....	66
Table 82	FRIE functional specification.....	68
Table 83	FRIE interfaces.....	68
Table 84	FRIE ALD support.....	69
Table 85	FRIE electrical specifications.....	70
Table 86	FRIE power consumption.....	70
Table 87	FRIE installation and mechanical specifications.....	70
Table 88	FRIE dimensions and weight.....	70
Table 89	FRIE environmental specifications.....	71
Table 90	FRIE LEDs.....	71
Table 91	FXCB functional specification.....	73
Table 92	FXCB interfaces.....	73
Table 93	FXCB ALD support.....	74
Table 94	FXCB electrical specifications.....	75
Table 95	FXCB power consumption.....	75
Table 96	FXCB installation and mechanical specifications.....	76
Table 97	FXCB dimensions and weight.....	76
Table 98	FXCB environmental specifications.....	76
Table 99	FXCB LEDs.....	76
Table 100	FXDB functional specification.....	79
Table 101	FXDB interfaces.....	79
Table 102	FXDB ALD support.....	80
Table 103	FXDB electrical specifications.....	81
Table 104	FXDB power consumption.....	81
Table 105	FXDB installation and mechanical specifications.....	81
Table 106	FXDB dimensions and weight.....	81
Table 107	FXDB environmental specifications.....	82
Table 108	FXDB LEDs.....	82
Table 109	FXEB functional specification.....	84
Table 110	FXEB interfaces.....	84
Table 111	FXEB ALD support.....	85
Table 112	FXEB electrical specifications.....	86
Table 113	FXEB power consumption.....	86
Table 114	FXEB installation and mechanical specifications.....	87
Table 115	FXEB dimensions and weight.....	87
Table 116	FXEB environmental specifications.....	87
Table 117	FXEB LEDs.....	87
Table 118	FXFC functional specification.....	90

---

Table 119	FXFC interfaces.....	90
Table 120	FXFC ALD support.....	91
Table 121	FXFC electrical specifications.....	92
Table 122	FXFC power consumption.....	92
Table 123	FXFC installation and mechanical specifications.....	93
Table 124	FXFC dimensions and weight.....	93
Table 125	FXFC environmental specifications.....	93
Table 126	FXFC LEDs.....	93
Table 127	FXJB functional specification.....	96
Table 128	FXJB interfaces.....	96
Table 129	FXJB ALD support.....	97
Table 130	FXJB electrical specifications.....	98
Table 131	FXJB power consumption.....	98
Table 132	FXJB installation and mechanical specifications.....	99
Table 133	FXJB dimensions and weight.....	99
Table 134	FXJB environmental specifications.....	100
Table 135	FXJB LEDs.....	100
Table 136	FRGT functional specification.....	102
Table 137	FRGT output power in RU40.....	102
Table 138	FRGT interfaces.....	103
Table 139	FRGT ALD support.....	103
Table 140	FRGT electrical specifications.....	104
Table 141	FRGT power consumption.....	105
Table 142	FRGT installation and mechanical specifications.....	105
Table 143	FRGT dimensions and weight.....	105
Table 144	FRGT environmental specifications.....	106
Table 145	FRGT LEDs.....	106
Table 146	FRGS functional specification.....	108
Table 147	FRGS output power in RU40.....	108
Table 148	FRGS interfaces.....	109
Table 149	FRGS ALD support.....	109
Table 150	FRGS electrical specifications.....	110
Table 151	FRGS power consumption.....	111
Table 152	FRGS installation and mechanical specifications.....	111
Table 153	FRGS dimensions and weight.....	111
Table 154	FRGS environmental specifications.....	112
Table 155	FRGS LEDs.....	112
Table 156	FRPA functional specification.....	114
Table 157	FRPA interfaces.....	114
Table 158	FRPA ALD support.....	115

Table 159	FRPA electrical specifications.....	116
Table 160	FRPA power consumption.....	116
Table 161	FRPA installation and mechanical specifications.....	116
Table 162	FRPA dimensions and weight.....	116
Table 163	FRPA environmental specifications.....	117
Table 164	FRPA LEDs.....	117
Table 165	FRPB functional specification.....	119
Table 166	FRPB interfaces.....	119
Table 167	FRPB ALD support.....	120
Table 168	FRPB electrical specifications.....	121
Table 169	FRPB power consumption.....	121
Table 170	FRPB installation and mechanical specifications.....	121
Table 171	FRPB dimensions and weight.....	121
Table 172	FRPB environmental specifications.....	122
Table 173	FRPB LEDs.....	122
Table 174	FRHC functional specification.....	124
Table 175	FRHC interfaces.....	124
Table 176	FRHC ALD support.....	125
Table 177	FRHC electrical specifications.....	126
Table 178	FRHC power consumption.....	126
Table 179	FRHC installation and mechanical specifications.....	126
Table 180	FRHC dimensions and weight.....	126
Table 181	FRHC environmental specifications.....	127
Table 182	FRHC LEDs.....	127
Table 183	FRHF functional specification.....	129
Table 184	FRHF interfaces.....	129
Table 185	FRHF ALD support.....	130
Table 186	FRHF electrical specifications.....	131
Table 187	FRHF power consumption.....	131
Table 188	FRHF installation and mechanical specifications.....	131
Table 189	FRHF dimensions and weight.....	131
Table 190	FRHF environmental specifications.....	132
Table 191	FRHF LEDs.....	132
Table 192	FRMC functional specification.....	134
Table 193	FRMC interfaces.....	134
Table 194	FRMC ALD support.....	135
Table 195	FRMC electrical specifications.....	136
Table 196	FRMC power consumption.....	136
Table 197	FRMC installation and mechanical specifications.....	136
Table 198	FRMC dimensions and weight.....	136

---

Table 199	FRMC environmental specifications.....	137
Table 200	FRMC LEDs.....	137
Table 201	FXED functional specification.....	139
Table 202	FXED interfaces.....	139
Table 203	FXED ALD support.....	140
Table 204	FXED electrical specifications.....	141
Table 205	FXED power consumption.....	141
Table 206	FXED installation and mechanical specifications.....	142
Table 207	FXED dimensions and weight.....	142
Table 208	FXED environmental specifications.....	142
Table 209	FXED LEDs.....	143
Table 210	FHCA functional specification.....	145
Table 211	FHCA interfaces.....	146
Table 212	FHCA ALD support.....	146
Table 213	FHCA electrical specifications.....	147
Table 214	FHCA power consumption.....	147
Table 215	FHCA installation and mechanical specifications.....	147
Table 216	FHCA dimensions and weight.....	148
Table 217	FHCA environmental specifications.....	148
Table 218	FHCA LEDs.....	148
Table 219	FRLB functional specification.....	150
Table 220	FRLB interfaces.....	150
Table 221	FRLB ALD support.....	151
Table 222	FRLB electrical specifications.....	152
Table 223	FRLB power consumption.....	152
Table 224	FRLB installation and mechanical specifications.....	152
Table 225	FRLB dimensions and weight.....	153
Table 226	FRLB environmental specifications.....	153
Table 227	FRLB LEDs.....	153
Table 228	FHDA functional specification.....	155
Table 229	FHDA interfaces.....	156
Table 230	FHDA ALD support.....	156
Table 231	FHDA electrical specifications.....	157
Table 232	FHDA power consumption.....	157
Table 233	FHDA installation and mechanical specifications.....	157
Table 234	FHDA dimensions and weight.....	158
Table 235	FHDA environmental specifications.....	158
Table 236	FHDA LEDs.....	158
Table 237	FHEA functional specification.....	160
Table 238	FHEA interfaces.....	161

Table 239	FHEA ALD support.....	161
Table 240	FHEA electrical specifications.....	162
Table 241	FHEA power consumption.....	162
Table 242	FHEA installation and mechanical specifications.....	162
Table 243	FHEA dimensions and weight.....	163
Table 244	FHEA environmental specifications.....	163
Table 245	FHEA LEDs.....	163
Table 246	FRGQ functional specification.....	165
Table 247	FRGQ interfaces.....	166
Table 248	FRGQ ALD support.....	166
Table 249	FRGQ electrical specifications.....	167
Table 250	FRGQ power consumption.....	167
Table 251	FRGQ installation and mechanical specifications.....	167
Table 252	FRGQ dimensions and weight.....	168
Table 253	FRGQ environmental specifications.....	168
Table 254	FRGQ LEDs.....	168
Table 255	FRHB functional specification.....	170
Table 256	FRHB interfaces.....	171
Table 257	FRHB ALD support.....	171
Table 258	FRHB electrical specifications.....	172
Table 259	FRHB power consumption.....	172
Table 260	FRHB installation and mechanical specifications.....	172
Table 261	FRHB dimensions and weight.....	173
Table 262	FRHB environmental specifications.....	173
Table 263	FRHB LEDs.....	173
Table 264	FRMB functional specification.....	175
Table 265	FRMB interfaces.....	176
Table 266	FRMB ALD support.....	176
Table 267	FRMB electrical specifications.....	177
Table 268	FRMB power consumption.....	177
Table 269	FRMB installation and mechanical specifications.....	177
Table 270	FRMB dimensions and weight.....	178
Table 271	FRMB environmental specifications.....	178
Table 272	FRMB LEDs.....	178
Table 273	FHEB functional specification.....	180
Table 274	FHEB interfaces.....	181
Table 275	FHEB ALD support.....	181
Table 276	FHEB electrical specifications.....	182
Table 277	FHEB power consumption.....	182
Table 278	FHEB installation and mechanical specifications.....	183

---

Table 279	FHEB dimensions and weight.....	183
Table 280	FHEB environmental specifications.....	183
Table 281	FHEB LEDs.....	184
Table 282	FHEF functional specification.....	186
Table 283	FHEF interfaces.....	187
Table 284	FHEF ALD support.....	187
Table 285	FHEF electrical specifications.....	188
Table 286	FHEF power consumption.....	188
Table 287	FHEF installation and mechanical specifications.....	188
Table 288	FHEF dimensions and weight.....	189
Table 289	FHEF environmental specifications.....	189
Table 290	FHEF LEDs.....	189
Table 291	FHDB functional specification.....	191
Table 292	FHDB interfaces.....	192
Table 293	FHDB ALD support.....	192
Table 294	FHDB electrical specifications.....	193
Table 295	FHDB power consumption.....	193
Table 296	FHDB installation and mechanical specifications.....	193
Table 297	FHDB dimensions and weight.....	194
Table 298	FHDB environmental specifications.....	194
Table 299	FHDB LEDs.....	194
Table 300	FRGY functional specification.....	196
Table 301	FRGY interfaces.....	197
Table 302	FRGY ALD support.....	197
Table 303	FRGY electrical specifications.....	198
Table 304	FRGY power consumption.....	198
Table 305	FRGY installation and mechanical specifications.....	198
Table 306	FRGY dimensions and weight.....	199
Table 307	FRGY environmental specifications.....	199
Table 308	FRGY LEDs.....	199
Table 309	FRIG functional specification.....	201
Table 310	FRIG interfaces.....	201
Table 311	FRIG ALD support.....	202
Table 312	FRIG electrical specifications.....	203
Table 313	FRIG power consumption.....	204
Table 314	FRIG installation and mechanical specifications.....	204
Table 315	FRIG dimensions and weight.....	204
Table 316	FRIG environmental specifications.....	205
Table 317	FRIG LEDs.....	205
Table 318	FRHD functional specification.....	207

Table 319	FRHD interfaces.....	207
Table 320	FRHD ALD support.....	208
Table 321	FRHD electrical specifications.....	209
Table 322	FRHD power consumption.....	210
Table 323	FRHD installation and mechanical specifications.....	210
Table 324	FRHD dimensions and weight.....	210
Table 325	FRHE environmental specifications.....	211
Table 326	FRHD LEDs.....	211
Table 327	FRHE functional specification.....	213
Table 328	FRHE interfaces.....	213
Table 329	FRHE ALD support.....	214
Table 330	FRHE electrical specifications.....	215
Table 331	FRHE power consumption.....	216
Table 332	FRHE installation and mechanical specifications.....	216
Table 333	FRHE dimensions and weight.....	216
Table 334	FRHE environmental specifications.....	217
Table 335	FRHE LEDs.....	217
Table 336	FHFB functional specification.....	219
Table 337	FHFB interfaces.....	220
Table 338	FHFB ALD support.....	220
Table 339	FHFB electrical specifications.....	221
Table 340	FHFB power consumption.....	222
Table 341	FHFB installation and mechanical specifications.....	222
Table 342	FHFB dimensions and weight.....	222
Table 343	FHFB environmental specifications.....	223
Table 344	FHFB LEDs.....	223
Table 345	Typical reference sensitivity degradation with different Antenna line PIM performance. ....	227

---

## Summary of changes

Changes between document issues are cumulative. Therefore, the latest document issue contains all changes made to previous issues.

### **Changes between issues 07 (2014-11-21) and 08 (2014-11-27)**

Information on the following module has been added: FXJB.

### **Changes between issues 06 (2014-10-16) and 07 (2014-11-21)**

The format of the document has been changed.

Information on the following modules has been added: FXED, FHDA, FHEF, FHFB.

Information on the FXCA has been updated.

### **Changes between issues 05 (2014-05-30) and 06 (2014-10-16)**

#### ***RF Module frequency range and bandwidth***

- Information on FXCA, FXEA and FRGS has been updated.

#### ***Overview of Flexi Multiradio BTS RRH***

- **Table 4: RRH naming convention** has been updated.

#### ***RRH frequency range and bandwidth***

- Information on FRGY has been updated.

#### ***RF Module power requirements and output power***

- Information on *DC cable requirements for 60 W RF Modules* and *DC cable requirements for 6TX 40W RF Modules* has been updated.

#### ***RRH Module power requirements***

- Information on FRGY in **Table 16: RRH power consumption** has been updated.

#### ***RF Module and RRH Module dimensions and weight***

- **Table 18: RRH dimensions and weights** has been updated.

## 1 **RSS-310 compliance**

This equipment complies with RSS-310 of Industry Canada. Operation is subject to the condition that this device does not cause harmful interference.

## 2 EU RoHS statement

This equipment complies with the European Union RoHS Directive 2011/65/EU on the restriction of the use of certain hazardous substances in electrical and electronic equipment. The directive applies to the use of lead, mercury, cadmium, hexavalent chromium, polybrominated biphenyls (PBB), and polybrominated diphenyl ethers (PBDE) in electrical and electronic equipment.

### 3 CE marking

#### Declaration of Conformity with Regard to the EU Directive 1999/5/EC (R&TTE Directive)

Hereby, NSN declares that this equipment is in compliance with the essential requirements and other relevant provisions of Directive: 1999/5/EC. TEST

Figure 1 List of countries respecting EU Directive 1999/5/EC

<b>CE ⓘ R&amp;TTE Directive 1995/5/EC</b>							
AT	✓	FR	✓	LV	✓	LI	✓
BE	✓	DE	✓	LT	✓	RO	✓
BG	✓	GB	✓	LU	✓	SK	✓
CY	✓	GR	✓	MT	✓	SI	✓
CZ	✓	HU	✓	NL	✓	ES	✓
DK	✓	IS	✓	NO	✓	SE	✓
EE	✓	IE	✓	PL	✓	CH	✓
FI	✓	IT	✓	PT	✓	TR	✓

This declaration is only valid for configurations (combinations of software, firmware, and hardware) provided and/or supported by NSN.

---

## 4 FCC Part 15 compliance

This equipment has been tested and found to comply with the limits for a Class A digital device, pursuant to Part 15 of the FCC Rules. These limits are designed to provide reasonable protection against harmful interference, in a commercial environment. This equipment generates, uses, and can radiate radio frequency energy and, if not installed and used in accordance with the instruction manuals, might cause harmful interference to radio communications. Operation of this equipment in a residential area is likely to cause harmful interference in which case the user will be required to correct the interference at his own expense. Changes or modifications not expressly approved by the party responsible for compliance could void the user's authority to operate the equipment.

## 5 Flexi RF Module 3TX 800 (FRMA)

FRMA technical specifications.

### Functional description

Table 1 FRMA functional specification

Property	Value
Output power	3x60 W
MIMO	yes, 2TX
Outdoor installation	yes
SW supported technology	FDD-LTE
TX frequency range	791 - 821 MHz
RX frequency range	832 - 862 MHz
DL instantaneous bandwidth	20 MHz
UL instantaneous bandwidth	20 MHz
DL filter bandwidth	30 MHz
UL filter bandwidth	30 MHz

### Interfaces

Figure 2 FRMA interfaces

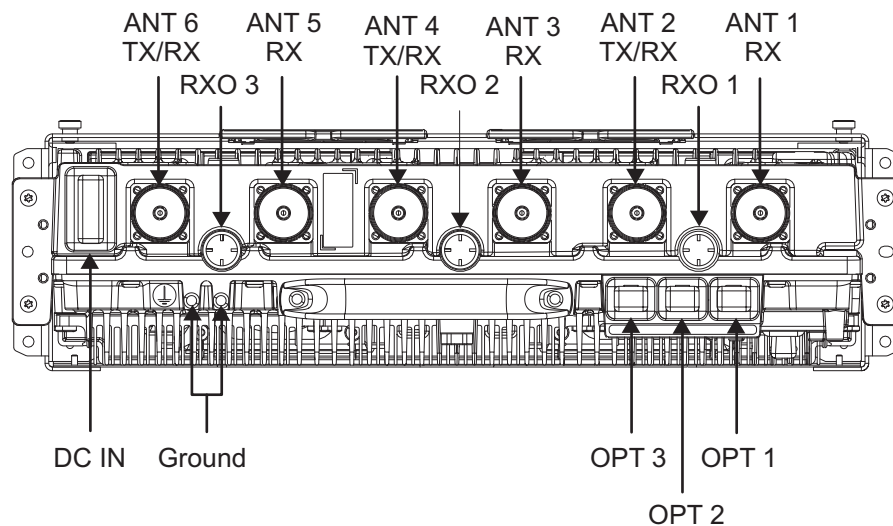

Table 2 FRMA interfaces

Interface	Label on the HW	Number of interfaces	Connector type	Additional info
Power connector	DC IN	1	2-pin multibeam XL	
Antenna connector	ANT	6	7/16	

Table 2 FRMA interfaces (Cont.)

Interface	Label on the HW	Number of interfaces	Connector type	Additional info
RF output connector	RxO	3	QMA	
Optical interface	OPT	3	SFP	3 Gbps

### Antenna Line Devices (ALDs) support

Table 3 FRMA ALD support

ALD support via antenna ports	Value
AISG	2.0 Main only
Legacy Siemens equipment	No
CWA (for non-AISG installations)	No
Voltage	24 V Main only
Power per port	30 W

### Functional block diagram

Figure 3 FRMA functional block diagram

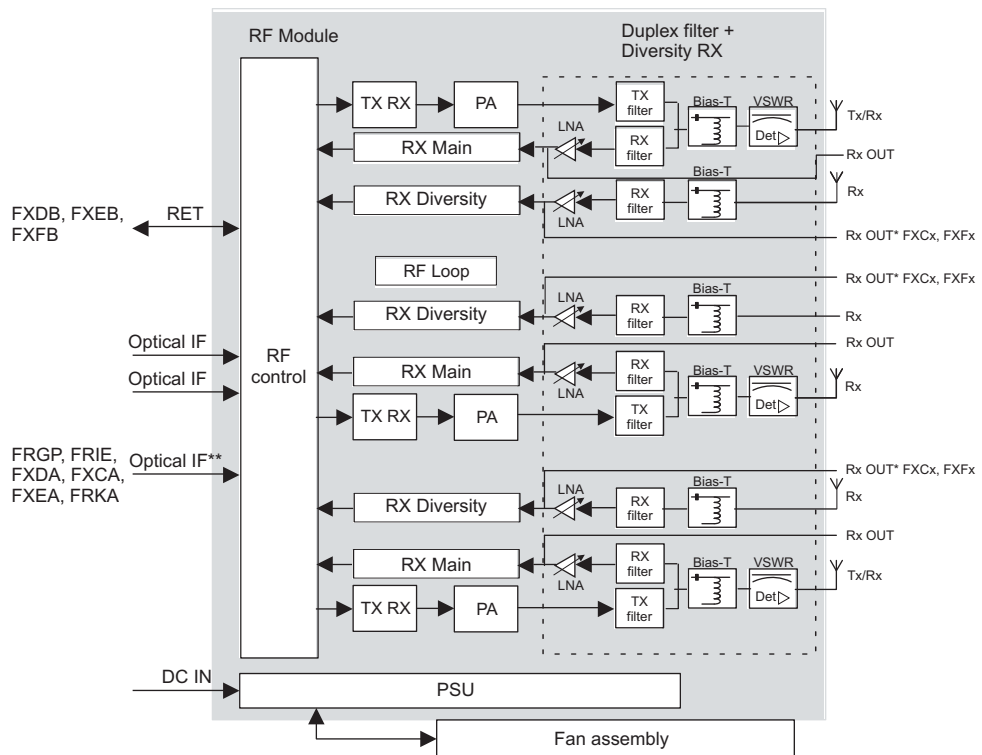

## Electrical specifications

Table 4 FRMA electrical specifications

Property	Value
Nominal supply voltage	-48.0 V DC
Nominal input voltage range	-40.5 V DC to -57.0 V DC
Extended input voltage range	-36.0 V DC to -40.5 V DC -57.0 V DC to -60.0 V DC

## Power consumption

Table 5 FRMA power consumption

Number of TXs	RF output power per TX [W]	Estimated power consumption [W] at 48 VDC input at 23°C. Non-committed estimated values depend on the final product HW and SW optimization with +/- 10% margin.	
		50% RF Load	100% RF Load
3	60	669	943
	40	510	673
	20	374	450

## Installation and mechanical specifications

Table 6 FRMA installation and mechanical specifications

Property	Value
Installation options	<ul style="list-style-type: none"> <li>stack/pole/wall installation</li> <li>directly on the wall installation</li> </ul>
IP rating	IP65
Related optional items	<ul style="list-style-type: none"> <li>Flexi Pole Mounting Kit (FPKA/C)</li> <li>Pole Mounting Kit (VMPB)</li> </ul>

## Dimensions and weight

Table 7 FRMA dimensions and weight

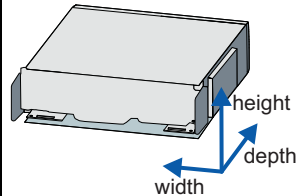
Property	Value	Dimensions orientation
Height	133 mm/ 3U (5.2 in.)	
Depth	Without front covers: 422 mm (16.6 in.) With front covers: 560 mm (22.1 in.)	

**Table 7** FRMA dimensions and weight (Cont.)

Property	Value	Dimensions orientation
Width	Without front covers: 447 mm (17.6 in.) With front covers: 492 mm (19.4 in.)	
Weight	25 kg (55.1 lbs)	

**Environmental specifications**

**Table 8** FRGS environmental specifications

Property	Value
Maximum operational outdoor temperature (at constant high ambient temperature maximum output power might be limited)	+55°C (131°F)
Minimum operational temperature (including cold start)	-35°C (-31°F)

**LEDs**

**Table 9** FRMA LEDs

LED color	Description	Alarm
Red, stable	Critical alarm affecting the whole RF module or all antenna carriers	Fault
Red, blinking	Operation degraded <ul style="list-style-type: none"> <li>Major alarm affecting the whole RF Module</li> <li>Major alarm affecting the whole RF Module</li> <li>Major/Critical alarm affecting a module subcomponent or antenna carrier</li> </ul>	Major/critical alarm
Yellow, stable	<ul style="list-style-type: none"> <li>Until software download begins</li> <li>The carriers are blocked from BTS</li> <li>There is no connection to any System Module</li> </ul>	No alarm
Yellow, blinking	<ul style="list-style-type: none"> <li>Software download in progress</li> <li>Configuration in progress: RF resources are being setup, but not yet activated</li> </ul>	No alarm
Green, stable	<ul style="list-style-type: none"> <li>Software configuration is complete or supervisory:</li> </ul>	No alarm

Table 9 FRMA LEDs (Cont.)

LED color	Description	Alarm
	RF resources activated and transmission is possible <ul style="list-style-type: none"> <li>Working normally, no alarm on the RF Module</li> </ul>	
Green, blinking	Software downloading and updating	No alarm
Stable Red for less than 5 seconds and changes to Stable Yellow	Switched ON, but the next conditions are not reached yet	No alarm
Stable Red for less than 5 seconds	The module is in the process of resetting	No alarm
Periodic Red and Green	Antenna line device faulty/degraded	No alarm
Blinking Colors (Red, Yellow, and Green), each color stable for 0.5 second	Module highlighting (Flexi BTS SM functionality that can help identifying faulty module)	No alarm
RF Module fan/TX status LED: Red	At least one fan is faulty or degraded	
RF Module fan/TX status LED: Green	All fans are working	
RF Module fan/TX status LED: Color set according to fan status, stable	RF transmission is ON	
RF Module fan/TX status LED: Color set according to fan status, blinking	RF transmission is OFF	

**Warnings, cautions or notes related to the product**



**WARNING! Risk of electric shock.**

Before turning RF power on, RF ports have to be terminated by nominal 50Ω load (for example, feeder with antenna). However, if these conditions are not met, the plastic caps that are delivered within the unused RF ports should remain in place. The plastic caps isolate RF power from the environment, and thus provide electric shock security in case RF power is accidentally on.



The minimum startup voltage is 40.5 V DC. If the input voltage is below/beyond extended limits, unit might shut down.

## 6 Flexi RF Module 3TX 800 (FRMD)

FRMD technical specifications.

### Functional description

Table 10 FRMD functional specification

Property	Value
Output power	3x60 W
MIMO	yes, 2TX
Outdoor installation	yes
SW supported technology	FDD-LTE
TX frequency range	791 -806 MHz
RX frequency range	832 - 847 MHz
DL instantaneous bandwidth	15 MHz
UL instantaneous bandwidth	15 MHz
DL filter bandwidth	15 MHz
UL filter bandwidth	15 MHz

### Interfaces

Figure 4 FRMD interfaces

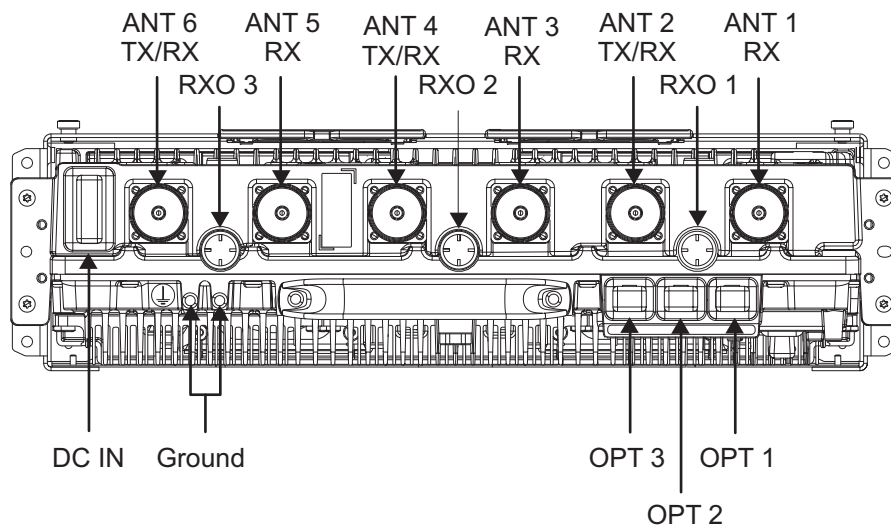

Table 11 FRMD interfaces

Interface	Label on the HW	Number of interfaces	Connector type	Additional info
Power connector	DC IN	1	2-pin multibeam XL	
Antenna connector	ANT	6	6x 7/16	

Table 11 FRMD interfaces (Cont.)

Interface	Label on the HW	Number of interfaces	Connector type	Additional info
RF output connector	RxO	3	QMA	
Optical interface	OPT	3	SFP	3 Gbps

### Antenna Line Devices (ALDs) support

Table 12 FRMD ALD support

ALD support via antenna ports	Value
AISG	2.0 Main only
Legacy Siemens equipment	No
CWA (for non-AISG installations)	No
Voltage	24 V Main only
Power per port	30 W

### Functional block diagram

Figure 5 FRMD functional block diagram

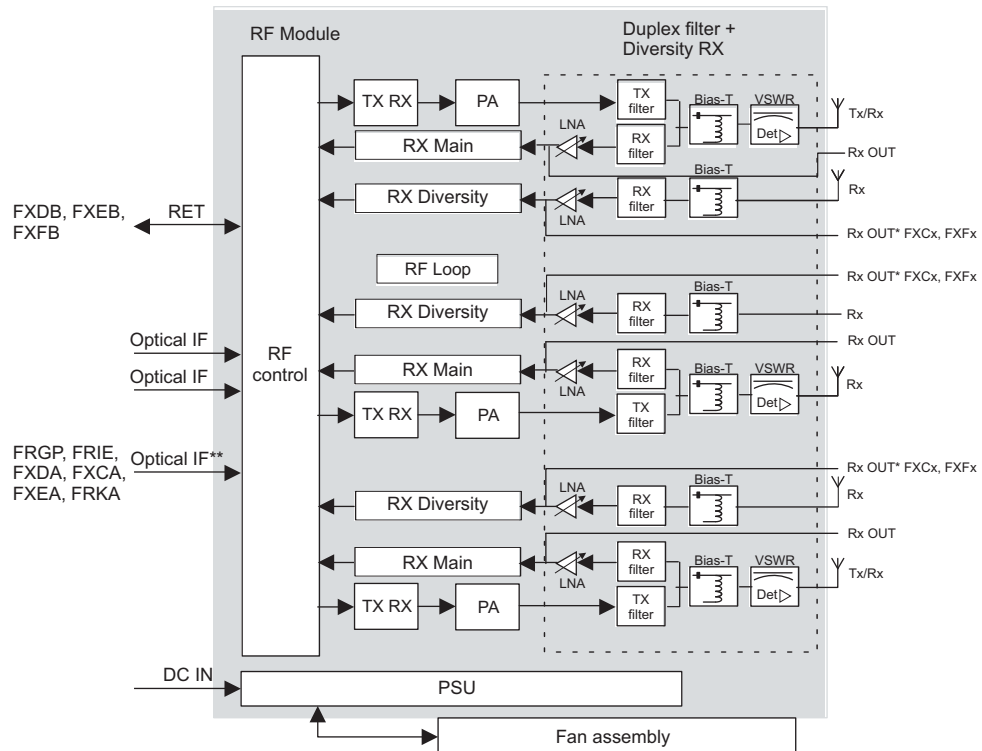

## Electrical specifications

Table 13 FRMD electrical specifications

Property	Value
Nominal supply voltage	-48.0 V DC
Nominal input voltage range	-40.5 V DC to -57.0 V DC
Extended input voltage range	-36.0 V DC to -40.5 V DC -57.0 V DC to -60.0 V DC

## Power consumption

Table 14 FRMD power consumption

Number of TXs	RF output power per TX [W]	Estimated power consumption [W] at 48 VDC input at 23°C. Non-committed estimated values depend on the final product HW and SW optimization with +/- 10% margin.	
		50% RF Load	100% RF Load
3	60	621	826
	40	486	616
	20	369	435

## Installation and mechanical specifications

Table 15 FRMD installation and mechanical specifications

Property	Value
Installation options	<ul style="list-style-type: none"> <li>stack/pole/wall installation</li> <li>directly on the wall installation</li> </ul>
IP rating	IP65
Related optional items	<ul style="list-style-type: none"> <li>Flexi Pole Mounting Kit (FPKA/C)</li> <li>Pole Mounting Kit (VMPB)</li> </ul>

## Dimensions and weight

Table 16 FRMD dimensions and weight

Property	Value	Dimensions orientation
Height	133 mm/ 3U (5.2 in.)	
Depth	Without front covers: 422 mm (16.6 in.) With front covers: 560 mm (22.1 in.)	

Table 16 FRMD dimensions and weight (Cont.)

Property	Value	Dimensions orientation
Width	Without front covers: 447 mm (17.6 in.) With front covers: 492 mm (19.4 in.)	
Weight	25 kg (55.1 lbs)	

## Environmental specifications

Table 17 FRMD environmental specifications

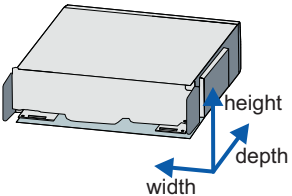
Property	Value
Maximum operational outdoor temperature (at constant high ambient temperature maximum output power might be limited)	+55°C (131°F)
Minimum operational temperature (including cold start)	-35°C (-31°F)

## LEDs

Table 18 FRMD LEDs

LED color	Description	Alarm
Red, stable	Critical alarm affecting the whole RF module or all antenna carriers	Fault
Red, blinking	Operation degraded <ul style="list-style-type: none"> <li>Major alarm affecting the whole RF Module</li> <li>Major alarm affecting the whole RF Module</li> <li>Major/Critical alarm affecting a module subcomponent or antenna carrier</li> </ul>	Major/critical alarm
Yellow, stable	<ul style="list-style-type: none"> <li>Until software download begins</li> <li>The carriers are blocked from BTS</li> <li>There is no connection to any System Module</li> </ul>	No alarm
Yellow, blinking	<ul style="list-style-type: none"> <li>Software download in progress</li> <li>Configuration in progress: RF resources are being setup, but not yet activated</li> </ul>	No alarm
Green, stable	<ul style="list-style-type: none"> <li>Software configuration is complete or supervisory:</li> </ul>	No alarm

Table 18 FRMD LEDs (Cont.)

LED color	Description	Alarm
	RF resources activated and transmission is possible <ul style="list-style-type: none"> <li>Working normally, no alarm on the RF Module</li> </ul>	
Green, blinking	Software downloading and updating	No alarm
Stable Red for less than 5 seconds and changes to Stable Yellow	Switched ON, but the next conditions are not reached yet	No alarm
Stable Red for less than 5 seconds	The module is in the process of resetting	No alarm
Periodic Red and Green	Antenna line device faulty/degraded	No alarm
Blinking Colors (Red, Yellow, and Green), each color stable for 0.5 second	Module highlighting (Flexi BTS SM functionality that can help identifying faulty module)	No alarm
RF Module fan/TX status LED: Red	At least one fan is faulty or degraded	
RF Module fan/TX status LED: Green	All fans are working	
RF Module fan/TX status LED: Color set according to fan status, stable	RF transmission is ON	
RF Module fan/TX status LED: Color set according to fan status, blinking	RF transmission is OFF	

**Warnings, cautions or notes related to the product**



**WARNING! Risk of electric shock.**

Before turning RF power on, RF ports have to be terminated by nominal 50Ω load (for example, feeder with antenna). However, if these conditions are not met, the plastic caps that are delivered within the unused RF ports should remain in place. The plastic caps isolate RF power from the environment, and thus provide electric shock security in case RF power is accidentally on.



The minimum startup voltage is 40.5 V DC. If the input voltage is below/beyond extended limits, unit might shut down.

## 7 Flexi RFM 3-pipe 850 180W (FXCA)

FXCA technical specifications.

### Functional description

Table 19 FXCA functional specification

Property	Value
Output power	3x60 W
MIMO	no
Outdoor installation	yes
SW supported technologies	GSM, WCDMA, FDD-LTE
TX frequency range	869-894 MHz 30x version: 852-894 MHz
RX frequency range	824-849 MHz 30x version: 807-849 MHz
DL instantaneous bandwidth	15 MHz, 18 MHz in GSM dedicated mode
UL instantaneous bandwidth	15 MHz, 18 MHz in GSM dedicated mode
DL filter bandwidth	15 MHz, 18 MHz in GSM dedicated mode
UL filter bandwidth	15 MHz, 18 MHz in GSM dedicated mode

### Interfaces

Figure 6 FXCA interfaces

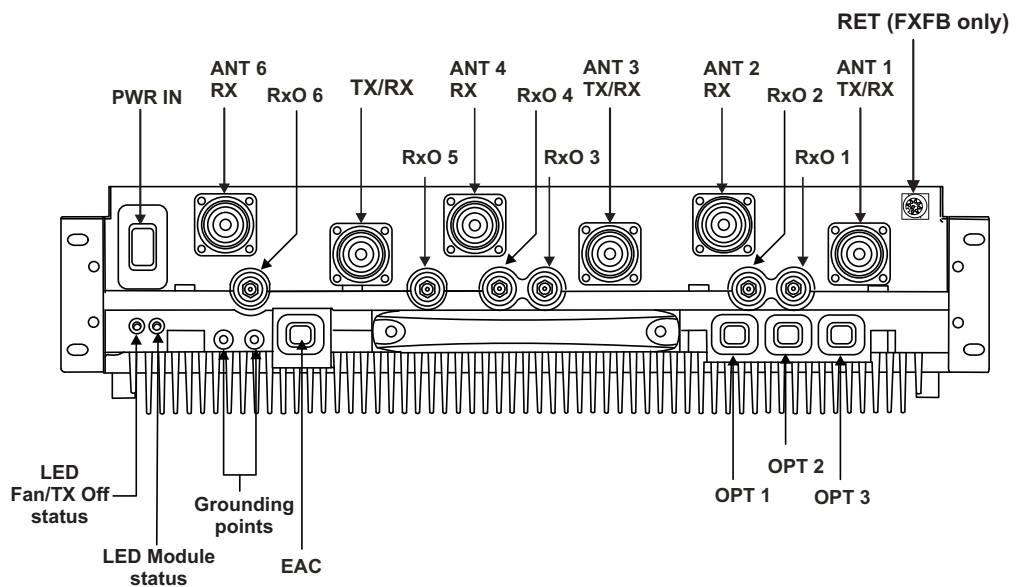

*Table 20* FXCA interfaces

Interface	Label on the HW	Number of interfaces	Connector type	Additional info
Power connector	DC IN	1	2-pin multibeam XL	
Antenna connector	ANT	6	7/16	
RF output connector	RxO	3	QMA	
External Alarm Connection	EAC	1	RJ45	
Optical interface	OPT		SFP	3 Gbps

**Antenna Line Devices (ALDs) support**

*Table 21* FXCA ALD support

ALD support via antenna ports	Value
AISG	2.0 Main only
Legacy Siemens equipment	Yes
CWA (for non-AISG installations)	Yes
Voltage	Main = 12V/1A or 24V/30W
Power per port	Div = 12V/1A

## Functional block diagram

Figure 7 FXCA functional block diagram

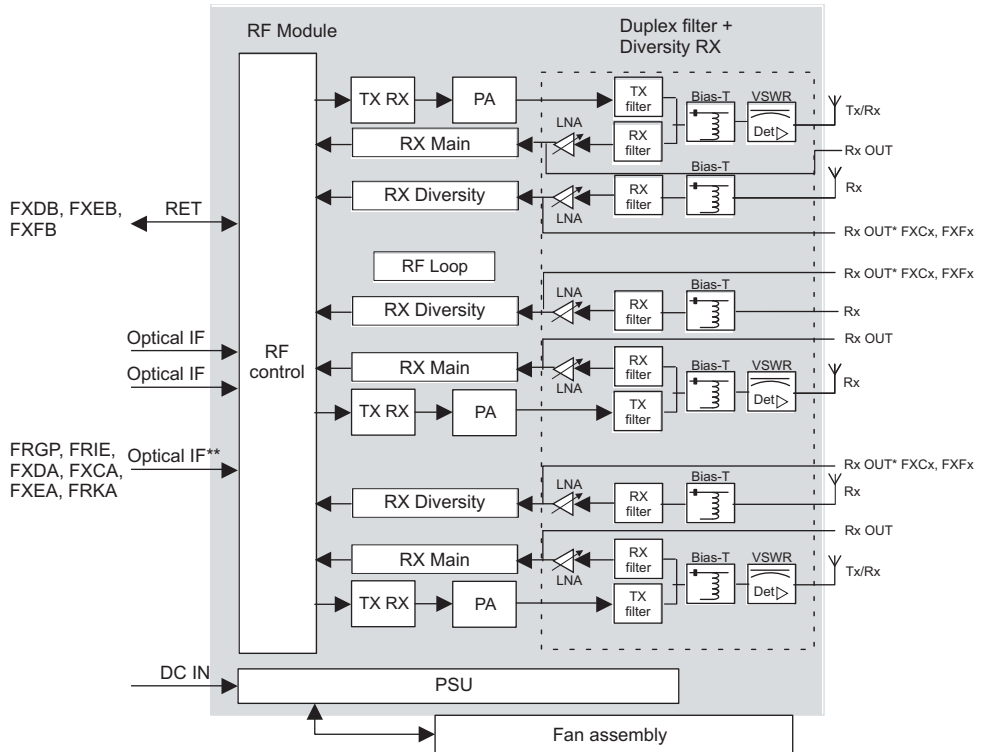

## Electrical specifications

Table 22 FXCA electrical specifications

Property	Value
Nominal supply voltage	-48.0 V DC
Nominal input voltage range	-40.5 V DC to -57.0 V DC
Extended input voltage range	-36.0 V DC to -40.5 V DC -57.0 V DC to -60.0 V DC

## Power consumption

Table 23 FXCA power consumption

Number of TXs	RF output power per TX [W]	Estimated power consumption [W] at 48 VDC input at 23°C. Non-committed estimated values depend on the final product HW and SW optimization with +/- 10% margin.	
		50% RF Load	100% RF Load
3	60	545	794
	40	468	644
	20	393	494

## Installation and mechanical specifications

Table 24 FXCA installation and mechanical specifications

Property	Value
Installation options	<ul style="list-style-type: none"> <li>stack/pole/wall installation</li> <li>directly on the wall installation</li> </ul>
IP rating	IP65
Related optional items	<ul style="list-style-type: none"> <li>Flexi Pole Mounting Kit (FPKA/C)</li> <li>Pole Mounting Kit (VMPB)</li> </ul>

## Dimensions and weight

Table 25 FXCA dimensions and weight

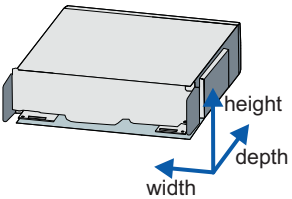
Property	Value	Dimensions orientation
Height	133 mm/ 3U (5.2 in.)	
Depth	Without front covers: 422 mm (16.6 in.) With front covers: 560 mm (22.1 in.)	
Width	Without front covers: 447 mm (17.6 in.) With front covers: 492 mm (19.4 in.)	
Weight	25 kg (55.1 lbs)	

## Environmental specifications

Table 26 FXCA environmental specifications

Property	Value
Maximum operational outdoor temperature (at constant high ambient temperature maximum output power might be limited)	+55°C (131°F)
Minimum operational temperature (including cold start)	-35°C (-31°F)

## LEDs

Table 27 FXCA LEDs

LED color	Description	Alarm
Red, stable	Critical alarm affecting the whole RF module or all antenna carriers	Fault
Red, blinking	Operation degraded	Major/critical alarm

Table 27 FXCA LEDs (Cont.)

LED color	Description	Alarm
	<ul style="list-style-type: none"> <li>Major alarm affecting the whole RF Module</li> <li>Major alarm affecting the whole RF Module</li> <li>Major/Critical alarm affecting a module subcomponent or antenna carrier</li> </ul>	
Yellow, stable	<ul style="list-style-type: none"> <li>Until software download begins</li> <li>The carriers are blocked from BTS</li> <li>There is no connection to any System Module</li> </ul>	No alarm
Yellow, blinking	<ul style="list-style-type: none"> <li>Software download in progress</li> <li>Configuration in progress: RF resources are being setup, but not yet activated</li> </ul>	No alarm
Green, stable	<ul style="list-style-type: none"> <li>Software configuration is complete or supervisory: RF resources activated and transmission is possible</li> <li>Working normally, no alarm on the RF Module</li> </ul>	No alarm
Green, blinking	Software downloading and updating	No alarm
Stable Red for less than 5 seconds and changes to Stable Yellow	Switched ON, but the next conditions are not reached yet	No alarm
Stable Red for less than 5 seconds	The module is in the process of resetting	No alarm
Periodic Red and Green	Antenna line device faulty/degraded	No alarm
Blinking Colors (Red, Yellow, and Green), each color stable for 0.5 second	Module highlighting (Flexi BTS SM functionality that can help identifying faulty module)	No alarm
RF Module fan/TX status LED: Red	At least one fan is faulty or degraded	
RF Module fan/TX status LED: Green	All fans are working	
RF Module fan/TX status LED: Color set according to fan status, stable	RF transmission is ON	
RF Module fan/TX status LED: Color set according to fan status, blinking	RF transmission is OFF	

---

## Warnings, cautions or notes related to the product

**WARNING! Risk of electric shock.**

Before turning RF power on, RF ports have to be terminated by nominal 50Ω load (for example, feeder with antenna). However, if these conditions are not met, the plastic caps that are delivered within the unused RF ports should remain in place. The plastic caps isolate RF power from the environment, and thus provide electric shock security in case RF power is accidentally on.



The minimum startup voltage is 40.5 V DC. If the input voltage is below/beyond extended limits, unit might shut down.

## 8 Flexi RF Module 3TX 900 (FXDA)

FXDA technical specifications.

### Functional description

Table 28 FXDA functional specification

Property	Value
Output power	3x60 W
MIMO	yes, 2TX
Outdoor installation	yes
SW supported technologies	GDM, WCDMA, FDD-LTE
TX frequency range	925-960 MHz
RX frequency range	880-915 MHz
DL instantaneous bandwidth	20 MHz
UL instantaneous bandwidth	20 MHz
DL filter bandwidth	20 MHz
UL filter bandwidth	20 MHz

### Interfaces

Figure 8 FXDA interfaces

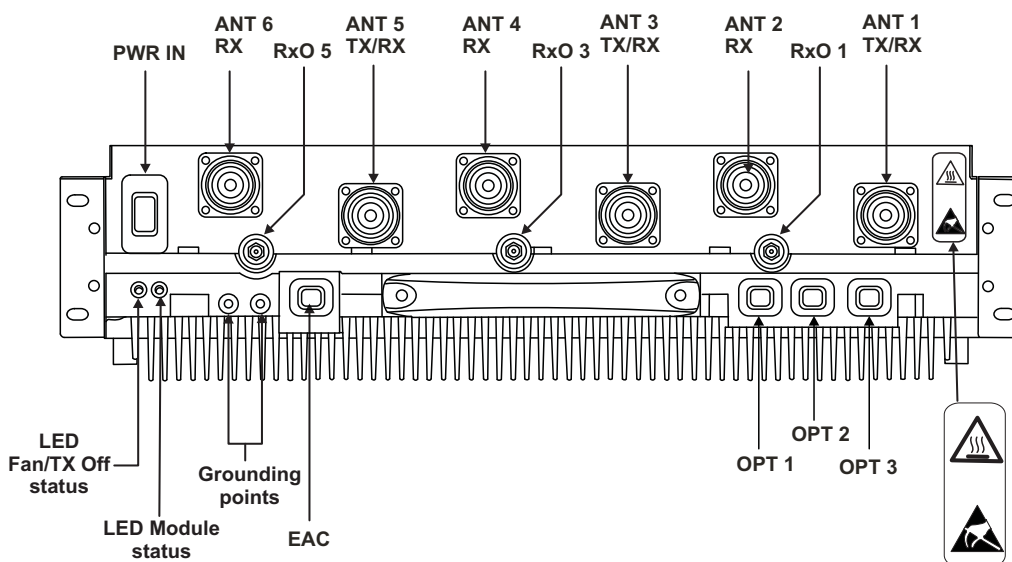

Table 29 FXDA interfaces

Interface	Label on the HW	Number of interfaces	Connector type	Additional info
Power connector	DC IN	1	2-pin multibeam XL	
Antenna connector	ANT	6	7/16	

Table 29 FXDA interfaces (Cont.)

Interface	Label on the HW	Number of interfaces	Connector type	Additional info
RF output connector	RxO	3	QMA	
External Alarm Connection	EAC	1	RJ45	
Optical interface	OPT	3	SFP	3 Gbps

**Antenna Line Devices (ALDs) support**

Table 30 FXDA ALD support

ALD support via antenna ports	Value
AISG	2.0 Main only
Legacy Siemens equipment	Yes
CWA (for non-AISG installations)	Yes
Voltage	Main = 12V/1A or 24V/30W
Power per port	Div = 12V/1A

**Functional block diagram**

Figure 9 FXDA functional block diagram

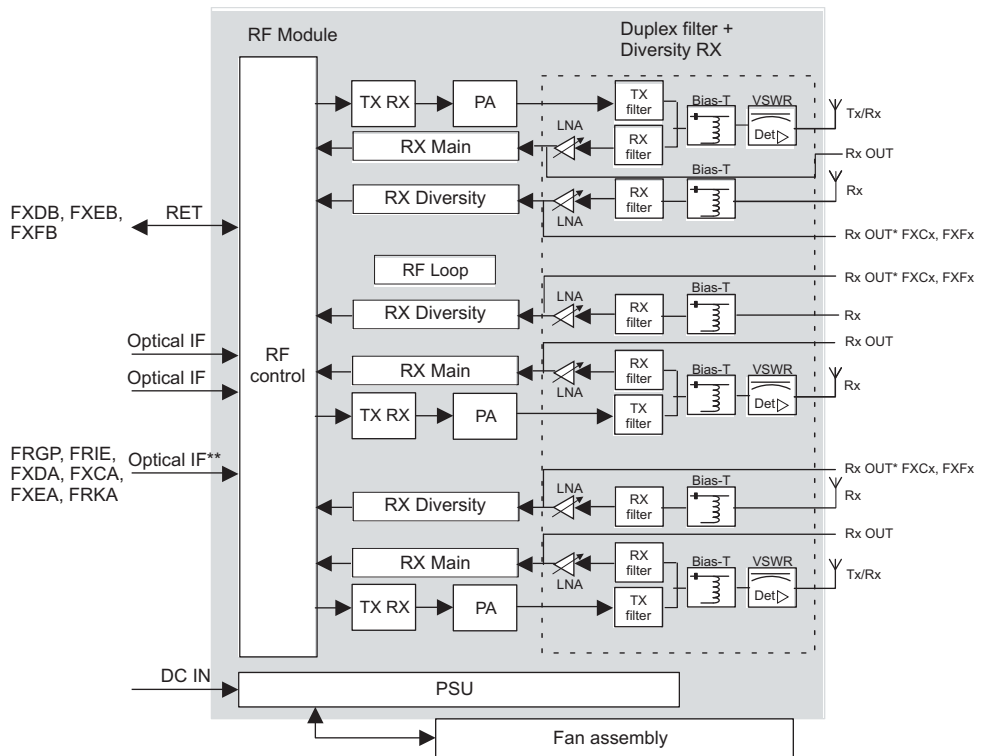

## Electrical specifications

Table 31 FXDA electrical specifications

Property	Value
Nominal supply voltage	-48.0 V DC
Nominal input voltage range	-40.5 V DC to -57.0 V DC
Extended input voltage range	-36.0 V DC to -40.5 V DC -57.0 V DC to -60.0 V DC

## Power consumption

Table 32 FXDA power consumption

Number of TXs	RF output power per TX [W]	Estimated power consumption [W] at 48 VDC input at 23°C. Non-committed estimated values depend on the final product HW and SW optimization with +/- 10% margin.	
		50% RF Load	100% RF Load
3	60	700	932
	40	533	672
	20	447	523

## Installation and mechanical specifications

Table 33 FXDA installation and mechanical specifications

Property	Value
Installation options	<ul style="list-style-type: none"> <li>stack/pole/wall installation</li> <li>directly on the wall installation</li> </ul>
IP rating	IP65
Related optional items	<ul style="list-style-type: none"> <li>Flexi Pole Mounting Kit (FPKA/C)</li> <li>Pole Mounting Kit (VMPB)</li> </ul>

## Dimensions and weight

Table 34 FXDA dimensions and weight

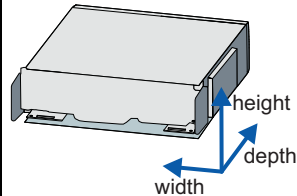
Property	Value	Dimensions orientation
Height	133 mm/ 3U (5.2 in.)	
Depth	Without front covers: 422 mm (16.6 in.) With front covers: 560 mm (22.1 in.)	

**Table 34** FXDA dimensions and weight (Cont.)

Property	Value	Dimensions orientation
Width	Without front covers: 447 mm (17.6 in.) With front covers: 492 mm (19.4 in.)	
Weight	25 kg (55.1 lbs)	

**Environmental specifications**

**Table 35** FXDA environmental specifications

Property	Value
Maximum operational outdoor temperature (at constant high ambient temperature maximum output power might be limited)	+55°C (131°F)
Minimum operational temperature (including cold start)	-35°C (-31°F)

**LEDs**

**Table 36** FXDA LEDs

LED color	Description	Alarm
Red, stable	Critical alarm affecting the whole RF module or all antenna carriers	Fault
Red, blinking	Operation degraded <ul style="list-style-type: none"> <li>Major alarm affecting the whole RF Module</li> <li>Major alarm affecting the whole RF Module</li> <li>Major/Critical alarm affecting a module subcomponent or antenna carrier</li> </ul>	Major/critical alarm
Yellow, stable	<ul style="list-style-type: none"> <li>Until software download begins</li> <li>The carriers are blocked from BTS</li> <li>There is no connection to any System Module</li> </ul>	No alarm
Yellow, blinking	<ul style="list-style-type: none"> <li>Software download in progress</li> <li>Configuration in progress: RF resources are being setup, but not yet activated</li> </ul>	No alarm
Green, stable	<ul style="list-style-type: none"> <li>Software configuration is complete or supervisory:</li> </ul>	No alarm

Table 36 FXDA LEDs (Cont.)

LED color	Description	Alarm
	RF resources activated and transmission is possible <ul style="list-style-type: none"> <li>Working normally, no alarm on the RF Module</li> </ul>	
Green, blinking	Software downloading and updating	No alarm
Stable Red for less than 5 seconds and changes to Stable Yellow	Switched ON, but the next conditions are not reached yet	No alarm
Stable Red for less than 5 seconds	The module is in the process of resetting	No alarm
Periodic Red and Green	Antenna line device faulty/degraded	No alarm
Blinking Colors (Red, Yellow, and Green), each color stable for 0.5 second	Module highlighting (Flexi BTS SM functionality that can help identifying faulty module)	No alarm
RF Module fan/TX status LED: Red	At least one fan is faulty or degraded	
RF Module fan/TX status LED: Green	All fans are working	
RF Module fan/TX status LED: Color set according to fan status, stable	RF transmission is ON	
RF Module fan/TX status LED: Color set according to fan status, blinking	RF transmission is OFF	

**Warnings, cautions or notes related to the product**



**WARNING! Risk of electric shock.**

Before turning RF power on, RF ports have to be terminated by nominal 50Ω load (for example, feeder with antenna). However, if these conditions are not met, the plastic caps that are delivered within the unused RF ports should remain in place. The plastic caps isolate RF power from the environment, and thus provide electric shock security in case RF power is accidentally on.



The minimum startup voltage is 40.5 V DC. If the input voltage is below/beyond extended limits, unit might shut down.

## 9 Flexi RF Module 3TX 900 (FXDJ)

FXDJ technical specifications.

### Functional description

Table 37 FXDJ functional specification

Property	Value
Output power	3x60 W
MIMO	no
Outdoor installation	yes
SW supported technologies	GMS, WCDMA
TX frequency range	935-960 MHz
RX frequency range	890-915 MHz
DL instantaneous bandwidth	12.5 MHz
UL instantaneous bandwidth	12.5 MHz
DL filter bandwidth	12.5 MHz
UL filter bandwidth	12.5 MHz

### Interfaces

Figure 10 FXDJ interfaces

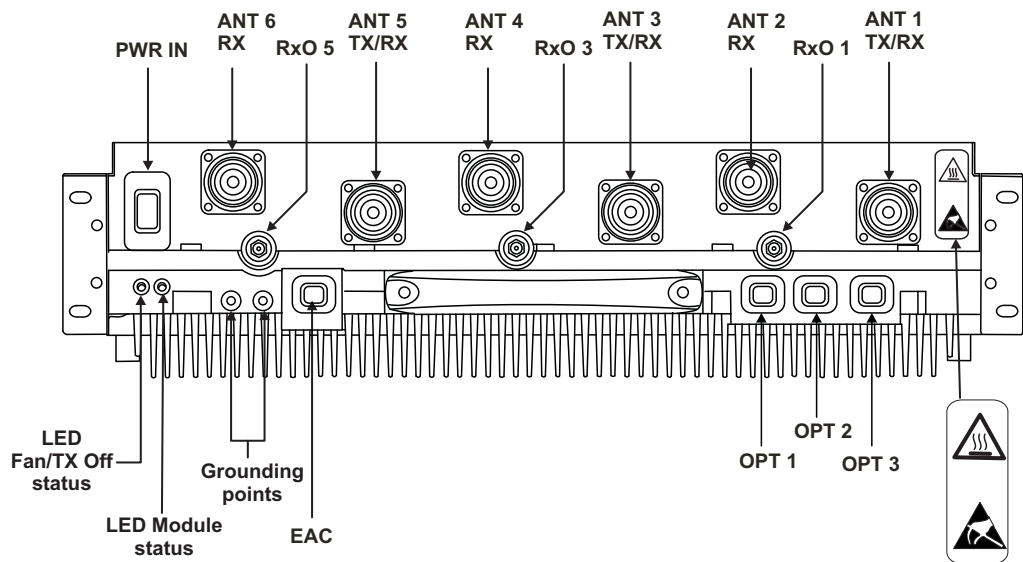

Table 38 FXDJ interfaces

Interface	Label on the HW	Number of interfaces	Connector type	Additional info
Power connector	DC IN	1	2-pin multibeam XL	
Antenna connector	ANT	6	7/16	

Table 38 FXDJ interfaces (Cont.)

Interface	Label on the HW	Number of interfaces	Connector type	Additional info
RF output connector	RxO	3	QMA	
External Alarm Connection	EAC	1	RJ45	
Optical interface	OPT	3	SFP	3 Gbps

### Antenna Line Devices (ALDs) support

Table 39 FXDJ ALD support

ALD support via antenna ports	Value
AISG	2.0 Main only
Legacy Siemens equipment	Yes
CWA (for non-AISG installations)	Yes
Voltage	Main = 12V/1A or 24V/30W
Power per port	Div = 12V/1A

### Functional block diagram

Figure 11 FXDJ functional block diagram

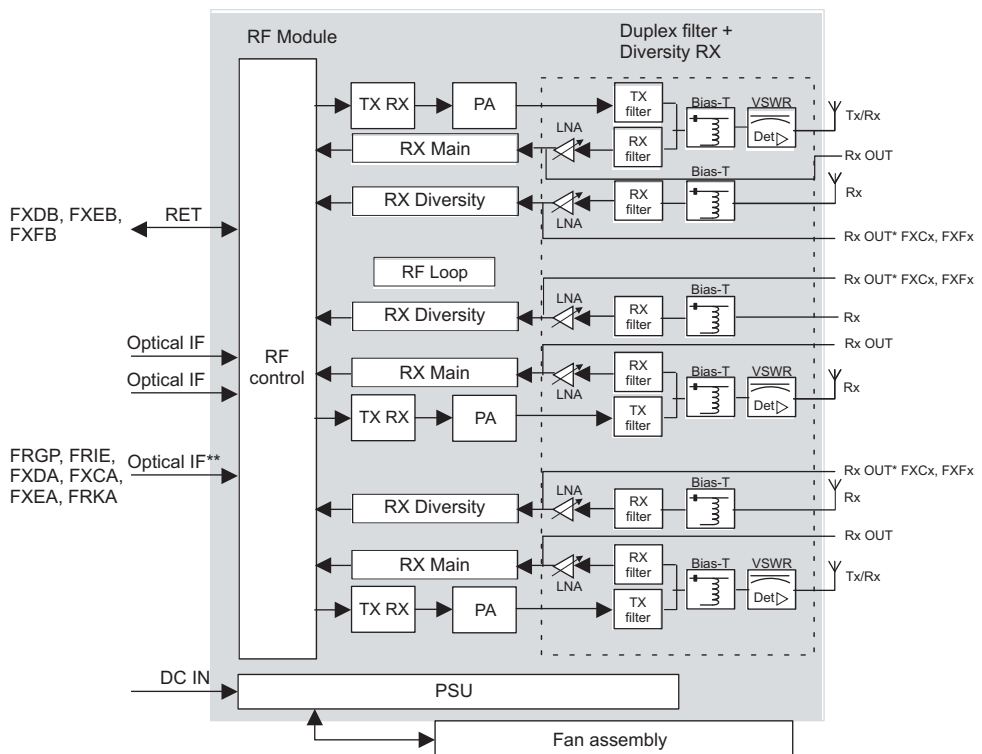

### Electrical specifications

Table 40 FXDJ electrical specifications

Property	Value
Nominal supply voltage	-48.0 V DC
Nominal input voltage range	-40.5 V DC to -57.0 V DC
Extended input voltage range	-36.0 V DC to -40.5 V DC -57.0 V DC to -60.0 V DC

### Power consumption

Table 41 FXDJ power consumption

Number of TXs	RF output power per TX [W]	Estimated power consumption [W] at 48 VDC input at 23°C. Non-committed estimated values depend on the final product HW and SW optimization with +/- 10% margin.	
		50% RF Load	100% RF Load
3	60	700	932
	40	533	672
	20	447	523

### Installation and mechanical specifications

Table 42 FXDJ installation and mechanical specifications

Property	Value
Installation options	<ul style="list-style-type: none"> <li>stack/pole/wall installation</li> <li>directly on the wall installation</li> </ul>
IP rating	IP65
Related optional items	<ul style="list-style-type: none"> <li>Flexi Pole Mounting Kit (FPKA/C)</li> <li>Pole Mounting Kit (VMPB)</li> </ul>

### Dimensions and weight

Table 43 FXDJ dimensions and weight

Property	Value	Dimensions orientation
Height	133 mm/ 3U (5.2 in.)	
Depth	Without front covers: 422 mm (16.6 in.) With front covers: 560 mm (22.1 in.)	

Table 43 FXDJ dimensions and weight (Cont.)

Property	Value	Dimensions orientation
Width	Without front covers: 447 mm (17.6 in.) With front covers: 492 mm (19.4 in.)	
Weight	25 kg (55.1 lbs)	

## Environmental specifications

Table 44 FXDJ environmental specifications

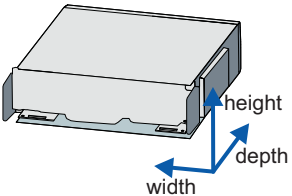
Property	Value
Maximum operational outdoor temperature (at constant high ambient temperature maximum output power might be limited)	+55°C (131°F)
Minimum operational temperature (including cold start)	-35°C (-31°F)

## LEDs

Table 45 FXDJ LEDs

LED color	Description	Alarm
Red, stable	Critical alarm affecting the whole RF module or all antenna carriers	Fault
Red, blinking	Operation degraded <ul style="list-style-type: none"> <li>Major alarm affecting the whole RF Module</li> <li>Major alarm affecting the whole RF Module</li> <li>Major/Critical alarm affecting a module subcomponent or antenna carrier</li> </ul>	Major/critical alarm
Yellow, stable	<ul style="list-style-type: none"> <li>Until software download begins</li> <li>The carriers are blocked from BTS</li> <li>There is no connection to any System Module</li> </ul>	No alarm
Yellow, blinking	<ul style="list-style-type: none"> <li>Software download in progress</li> <li>Configuration in progress: RF resources are being setup, but not yet activated</li> </ul>	No alarm
Green, stable	<ul style="list-style-type: none"> <li>Software configuration is complete or supervisory:</li> </ul>	No alarm

Table 45 FXDJ LEDs (Cont.)

LED color	Description	Alarm
	RF resources activated and transmission is possible <ul style="list-style-type: none"> <li>Working normally, no alarm on the RF Module</li> </ul>	
Green, blinking	Software downloading and updating	No alarm
Stable Red for less than 5 seconds and changes to Stable Yellow	Switched ON, but the next conditions are not reached yet	No alarm
Stable Red for less than 5 seconds	The module is in the process of resetting	No alarm
Periodic Red and Green	Antenna line device faulty/degraded	No alarm
Blinking Colors (Red, Yellow, and Green), each color stable for 0.5 second	Module highlighting (Flexi BTS SM functionality that can help identifying faulty module)	No alarm
RF Module fan/TX status LED: Red	At least one fan is faulty or degraded	
RF Module fan/TX status LED: Green	All fans are working	
RF Module fan/TX status LED: Color set according to fan status, stable	RF transmission is ON	
RF Module fan/TX status LED: Color set according to fan status, blinking	RF transmission is OFF	

**Warnings, cautions or notes related to the product**



**WARNING! Risk of electric shock.**

Before turning RF power on, RF ports have to be terminated by nominal 50Ω load (for example, feeder with antenna). However, if these conditions are not met, the plastic caps that are delivered within the unused RF ports should remain in place. The plastic caps isolate RF power from the environment, and thus provide electric shock security in case RF power is accidentally on.



The minimum startup voltage is 40.5 V DC. If the input voltage is below/beyond extended limits, unit might shut down.

## 10 Flexi RF Module 3TX 1800 (FXEA)

FXEA technical specifications.

### Functional description

Table 46 FXEA functional specification

Property	Value
Output power	3x60 W
MIMO	yes, 2TX
Outdoor installation	yes
SW supported technologies	GSM, WCDMA, FDD-LTE
TX frequency range	1805-1880 MHz
RX frequency range	1710-1785 MHz
DL instantaneous bandwidth	A.10x version: 20 MHz A.20x version: 25 MHz
UL instantaneous bandwidth	30 MHz
DL filter bandwidth	30 MHz
UL filter bandwidth	30 MHz

### Interfaces

Figure 12 FXEA interfaces

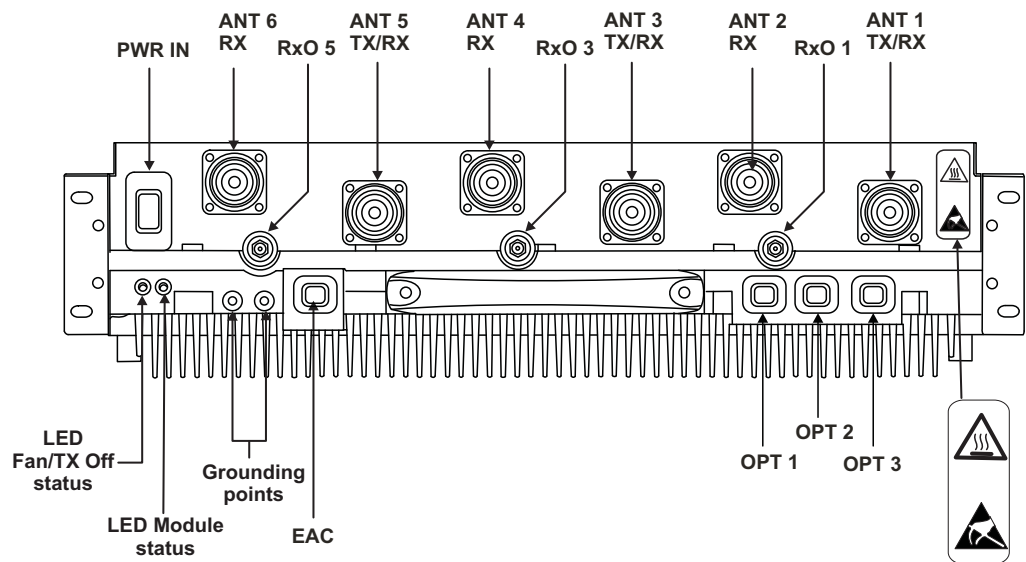

Table 47 FXEA interfaces

Interface	Label on the HW	Number of interfaces	Connector type	Additional info
Power connector	PWR IN	1	2-pin multibeam XL	

Table 47 FXEA interfaces (Cont.)

Interface	Label on the HW	Number of interfaces	Connector type	Additional info
Antenna connector	ANT	6	7/16	
RF output connector	RxO	3	QMA <td></td>	
External Alarm Connection	EAC	1	RJ45	
Optical interface	OPT	3	SFP	3 Gbps

**Antenna Line Devices (ALDs) support**

Table 48 FXEA ALD support

ALD support via antenna ports	Value
AISG	2.0 Main only
Legacy Siemens equipment	Yes
CWA (for non-AISG installations)	Yes
Voltage	Main = 13V/1.3A or 24V/30W
Power per port	Div = 13V/1A

**Functional block diagram**

Figure 13 FXEA functional block diagram

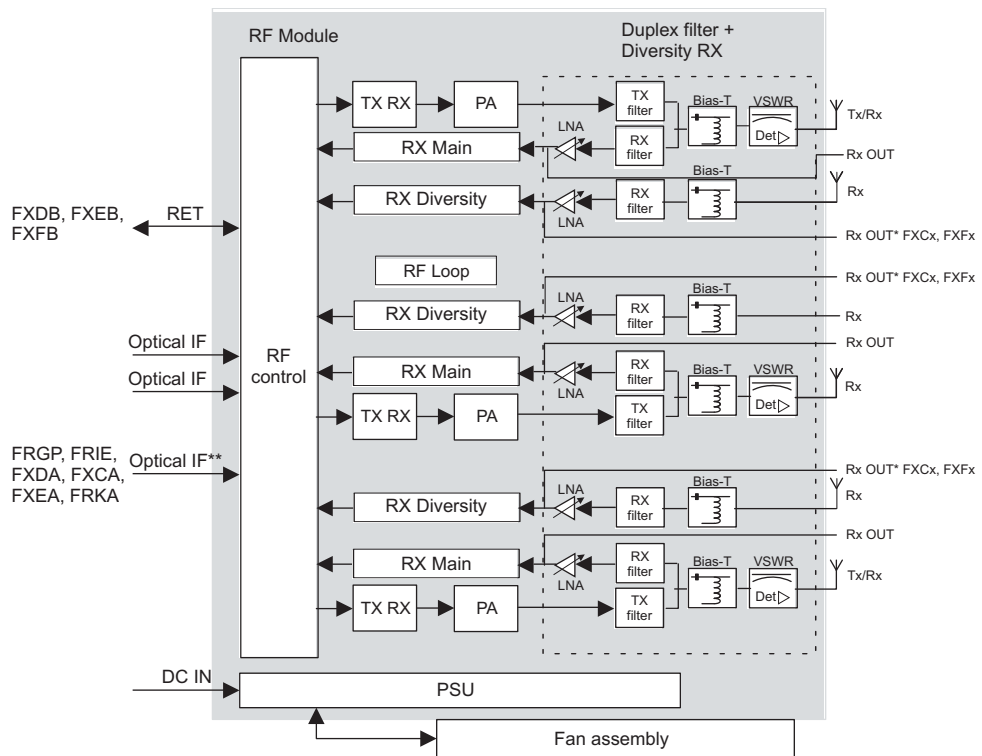

## Electrical specifications

Table 49 FXEA electrical specifications

Property	Value
Nominal supply voltage	-48.0 V DC
Nominal input voltage range	-40.5 V DC to -57.0 V DC
Extended input voltage range	-36.0 V DC to -40.5 V DC -57.0 V DC to -60.0 V DC

## Power consumption

Table 50 FXEA power consumption

Number of TXs	RF output power per TX [W]	Estimated power consumption [W] at 48 VDC input at 23°C. Non-committed estimated values depend on the final product HW and SW optimization with +/- 10% margin.	
		50% RF Load	100% RF Load
3	60	679	909
	40	565	719
	20	466	555

## Installation and mechanical specifications

Table 51 FXEA installation and mechanical specifications

Property	Value
Installation options	<ul style="list-style-type: none"> <li>stack/pole/wall installation</li> <li>directly on the wall installation</li> </ul>
IP rating	IP65
Related optional items	<ul style="list-style-type: none"> <li>Flexi Pole Mounting Kit (FPKA/C)</li> <li>Pole Mounting Kit (VMPB)</li> </ul>

## Dimensions and weight

Table 52 FXEA dimensions and weight

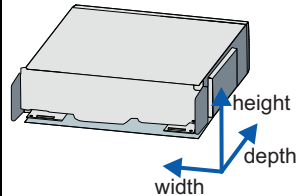
Property	Value	Dimensions orientation
Height	133 mm/ 3U (5.2 in.)	
Depth	Without front covers: 422 mm (16.6 in.) With front covers: 560 mm (22.1 in.)	

**Table 52** FXEA dimensions and weight (Cont.)

Property	Value	Dimensions orientation
Width	Without front covers: 447 mm (17.6 in.) With front covers: 492 mm (19.4 in.)	
Weight	25 kg (55.1 lbs)	

**Environmental specifications**

**Table 53** FXEA environmental specifications

Property	Value
Maximum operational outdoor temperature (at constant high ambient temperature maximum output power might be limited)	+55°C (131°F)
Minimum operational temperature (including cold start)	-35°C (-31°F)

**LEDs**

**Table 54** FXEA LEDs

LED color	Description	Alarm
Red, stable	Critical alarm affecting the whole RF module or all antenna carriers	Fault
Red, blinking	Operation degraded <ul style="list-style-type: none"> <li>Major alarm affecting the whole RF Module</li> <li>Major alarm affecting the whole RF Module</li> <li>Major/Critical alarm affecting a module subcomponent or antenna carrier</li> </ul>	Major/critical alarm
Yellow, stable	<ul style="list-style-type: none"> <li>Until software download begins</li> <li>The carriers are blocked from BTS</li> <li>There is no connection to any System Module</li> </ul>	No alarm
Yellow, blinking	<ul style="list-style-type: none"> <li>Software download in progress</li> <li>Configuration in progress: RF resources are being setup, but not yet activated</li> </ul>	No alarm
Green, stable	<ul style="list-style-type: none"> <li>Software configuration is complete or supervisory:</li> </ul>	No alarm

Table 54 FXEA LEDs (Cont.)

LED color	Description	Alarm
	RF resources activated and transmission is possible <ul style="list-style-type: none"> <li>Working normally, no alarm on the RF Module</li> </ul>	
Green, blinking	Software downloading and updating	No alarm
Stable Red for less than 5 seconds and changes to Stable Yellow	Switched ON, but the next conditions are not reached yet	No alarm
Stable Red for less than 5 seconds	The module is in the process of resetting	No alarm
Periodic Red and Green	Antenna line device faulty/degraded	No alarm
Blinking Colors (Red, Yellow, and Green), each color stable for 0.5 second	Module highlighting (Flexi BTS SM functionality that can help identifying faulty module)	No alarm
RF Module fan/TX status LED: Red	At least one fan is faulty or degraded	
RF Module fan/TX status LED: Green	All fans are working	
RF Module fan/TX status LED: Color set according to fan status, stable	RF transmission is ON	
RF Module fan/TX status LED: Color set according to fan status, blinking	RF transmission is OFF	

### Warnings, cautions or notes related to the product



**WARNING! Risk of electric shock.**

Before turning RF power on, RF ports have to be terminated by nominal 50Ω load (for example, feeder with antenna). However, if these conditions are not met, the plastic caps that are delivered within the unused RF ports should remain in place. The plastic caps isolate RF power from the environment, and thus provide electric shock security in case RF power is accidentally on.



The minimum startup voltage is 40.5 V DC. If the input voltage is below/beyond extended limits, unit might shut down.

# 11 Flexi RF Module 3TX 1900 (FXFB)

FXFB technical specifications.

## Functional description

Table 55 FXFB functional specification

Property	Value
Output power	3x60 W
MIMO	yes, 2TX
Outdoor installation	yes
SW supported technologies	GSM, WCDMA, FDD-LTE
TX frequency range	1930-1990 MHz
RX frequency range	1850-1910 MHz
DL instantaneous bandwidth	20 MHz
UL instantaneous bandwidth	20 MHz
DL filter bandwidth	20 MHz
UL filter bandwidth	20 MHz

## Interfaces

Figure 14 FXFB interfaces

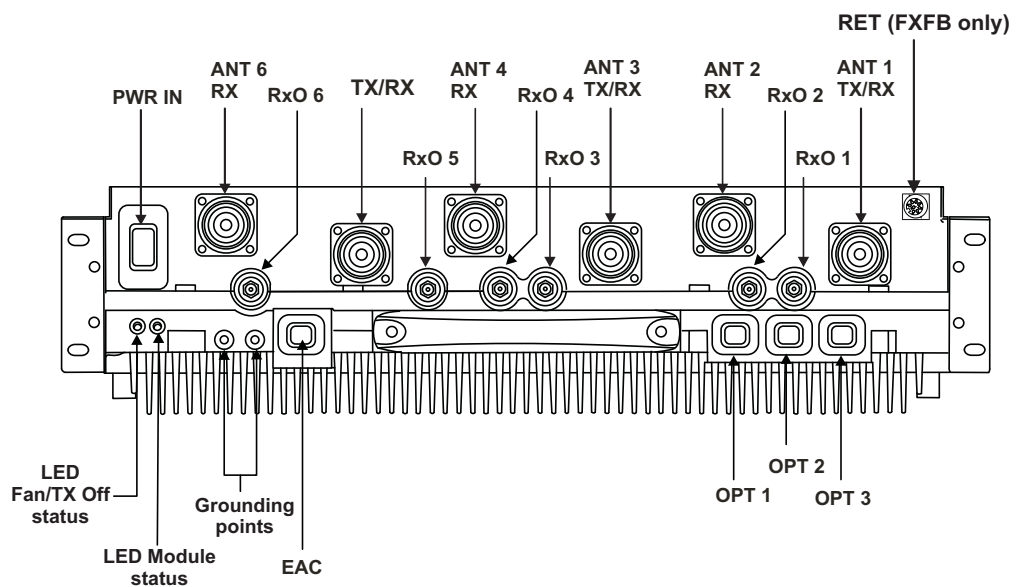

Table 56 FXFB interfaces

Interface	Label on the HW	Number of interfaces	Connector type	Additional info
Power connector	PWR IN	1	2-pin multibeam XL	

*Table 56* FXFB interfaces (Cont.)

Interface	Label on the HW	Number of interfaces	Connector type	Additional info
Antenna connector	ANT	6	7/16	
RF output connector	RxO	6	QMA	
Remote Electrical Tilt	RET	1	8-pin circular	
External Alarm Connection	EAC	1	RJ45	
Optical interface	OPT	3	SFP	3 Gbps

### Antenna Line Devices (ALDs) support

*Table 57* FXFB ALD support

ALD support via antenna ports	Value
AISG	2.0 Main only
Legacy Siemens equipment	No
CWA (for non-AISG installations)	Yes
Voltage	Main = 13V/1.3A or 24V/30W
Power per port	Div = 13V/1A

### Functional block diagram

Figure 15 FXFB functional block diagram

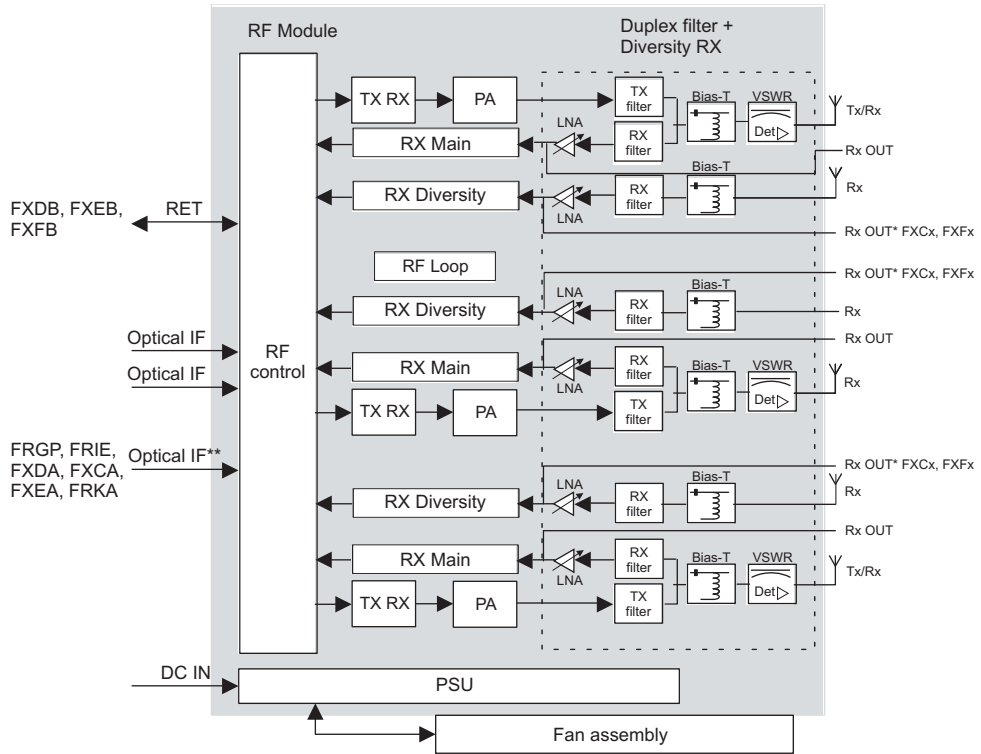

### Electrical specifications

Table 58 FXFB electrical specifications

Property	Value
Nominal supply voltage	-48.0 V DC
Nominal input voltage range	-40.5 V DC to -57.0 V DC
Extended input voltage range	-36.0 V DC to -40.5 V DC -57.0 V DC to -60.0 V DC

### Power consumption

Table 59 FXFB power consumption

Number of TXs	RF output power per TX [W]	Estimated power consumption [W] at 48 VDC input at 23°C. Non-committed estimated values depend on the final product HW and SW optimization with +/- 10% margin.	
		50% RF Load	100% RF Load
3	60	709	977
	40	612	776
	20	508	599

## Installation and mechanical specifications

Table 60 FXFB installation and mechanical specifications

Property	Value
Installation options	<ul style="list-style-type: none"> <li>stack/pole/wall installation</li> <li>directly on the wall installation</li> </ul>
IP rating	IP65
Related optional items	<ul style="list-style-type: none"> <li>Flexi Pole Mounting Kit (FPKA/C)</li> <li>Pole Mounting Kit (VMPB)</li> </ul>

## Dimensions and weight

Table 61 FXFB dimensions and weight

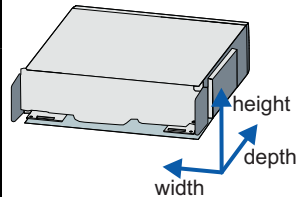
Property	Value	Dimensions orientation
Height	133 mm/ 3U (5.2 in.)	
Depth	Without front covers: 422 mm (16.6 in.) With front covers: 560 mm (22.1 in.)	
Width	Without front covers: 447 mm (17.6 in.) With front covers: 492 mm (19.4 in.)	
Weight	25 kg (55.1 lbs)	

## Environmental specifications

Table 62 FXFB environmental specifications

Property	Value
Maximum operational outdoor temperature (at constant high ambient temperature maximum output power might be limited)	+55°C (131°F)
Minimum operational temperature (including cold start)	-35°C (-31°F)

## LEDs

Table 63 FXFB LEDs

LED color	Description	Alarm
Red, stable	Critical alarm affecting the whole RF module or all antenna carriers	Fault
Red, blinking	Operation degraded	Major/critical alarm

Table 63 FXFB LEDs (Cont.)

LED color	Description	Alarm
	<ul style="list-style-type: none"> <li>Major alarm affecting the whole RF Module</li> <li>Major alarm affecting the whole RF Module</li> <li>Major/Critical alarm affecting a module subcomponent or antenna carrier</li> </ul>	
Yellow, stable	<ul style="list-style-type: none"> <li>Until software download begins</li> <li>The carriers are blocked from BTS</li> <li>There is no connection to any System Module</li> </ul>	No alarm
Yellow, blinking	<ul style="list-style-type: none"> <li>Software download in progress</li> <li>Configuration in progress: RF resources are being setup, but not yet activated</li> </ul>	No alarm
Green, stable	<ul style="list-style-type: none"> <li>Software configuration is complete or supervisory: RF resources activated and transmission is possible</li> <li>Working normally, no alarm on the RF Module</li> </ul>	No alarm
Green, blinking	Software downloading and updating	No alarm
Stable Red for less than 5 seconds and changes to Stable Yellow	Switched ON, but the next conditions are not reached yet	No alarm
Stable Red for less than 5 seconds	The module is in the process of resetting	No alarm
Periodic Red and Green	Antenna line device faulty/degraded	No alarm
Blinking Colors (Red, Yellow, and Green), each color stable for 0.5 second	Module highlighting (Flexi BTS SM functionality that can help identifying faulty module)	No alarm
RF Module fan/TX status LED: Red	At least one fan is faulty or degraded	
RF Module fan/TX status LED: Green	All fans are working	
RF Module fan/TX status LED: Color set according to fan status, stable	RF transmission is ON	
RF Module fan/TX status LED: Color set according to fan status, blinking	RF transmission is OFF	

### Warnings, cautions or notes related to the product



**WARNING! Risk of electric shock.**

Before turning RF power on, RF ports have to be terminated by nominal 50Ω load (for example, feeder with antenna). However, if these conditions are not met, the plastic caps that are delivered within the unused RF ports should remain in place. The plastic caps isolate RF power from the environment, and thus provide electric shock security in case RF power is accidentally on.



The minimum startup voltage is 40.5 V DC. If the input voltage is below/beyond extended limits, unit might shut down.

## 12 Flexi RF Module 3TX 2100 (FRGP)

FRGP technical specifications.

### Functional description

Table 64 FRGP functional specification

Property	Value
Output power	3x60 W
MIMO	yes, 2TX
Outdoor installation	yes
SW supported technologies	WCDMA, FDD-LTE
TX frequency range	2110-2170 MHz
RX frequency range	1920-1980 MHz
DL instantaneous bandwidth	20 MHz
UL instantaneous bandwidth	20 MHz
DL filter bandwidth	20 MHz
UL filter bandwidth	20 MHz

### Interfaces

Figure 16 FRGP interfaces

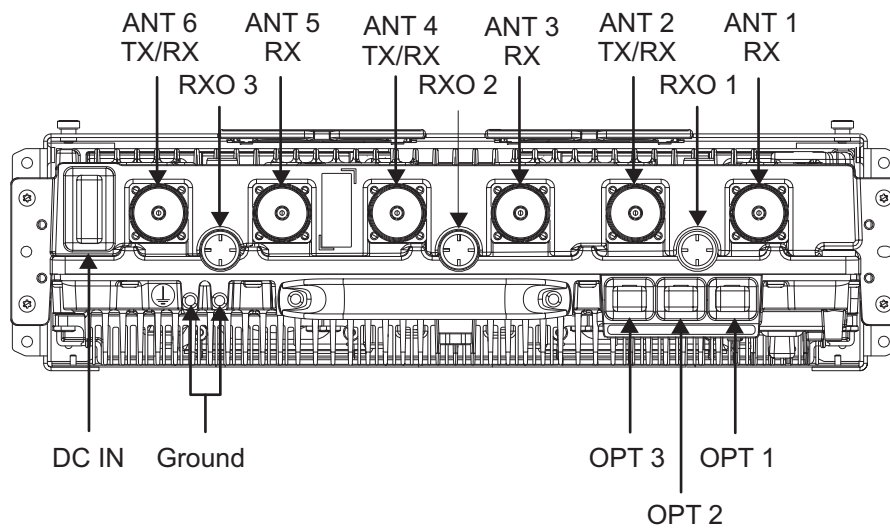

Table 65 FRGP interfaces

Interface	Label on the HW	Number of interfaces	Connector type	Additional info
Power connector	DC IN	1	2-pin multibeam XL	
Antenna connector	ANT	6	7/16	

Table 65 FRGP interfaces (Cont.)

Interface	Label on the HW	Number of interfaces	Connector type	Additional info
RF output connector	RxO	1	QMA	
Optical interface	OPT	3	SFP	3 Gbps

### Antenna Line Devices (ALDs) support

Table 66 FRGP ALD support

ALD support via antenna ports	Value
AISG	2.0 Main only
Legacy Siemens equipment	Yes
CWA (for non-AISG installations)	Yes
Voltage	Main 24V/12V Div 12V
Power per port	30 W

### Functional block diagram

Figure 17 FRGP functional block diagram

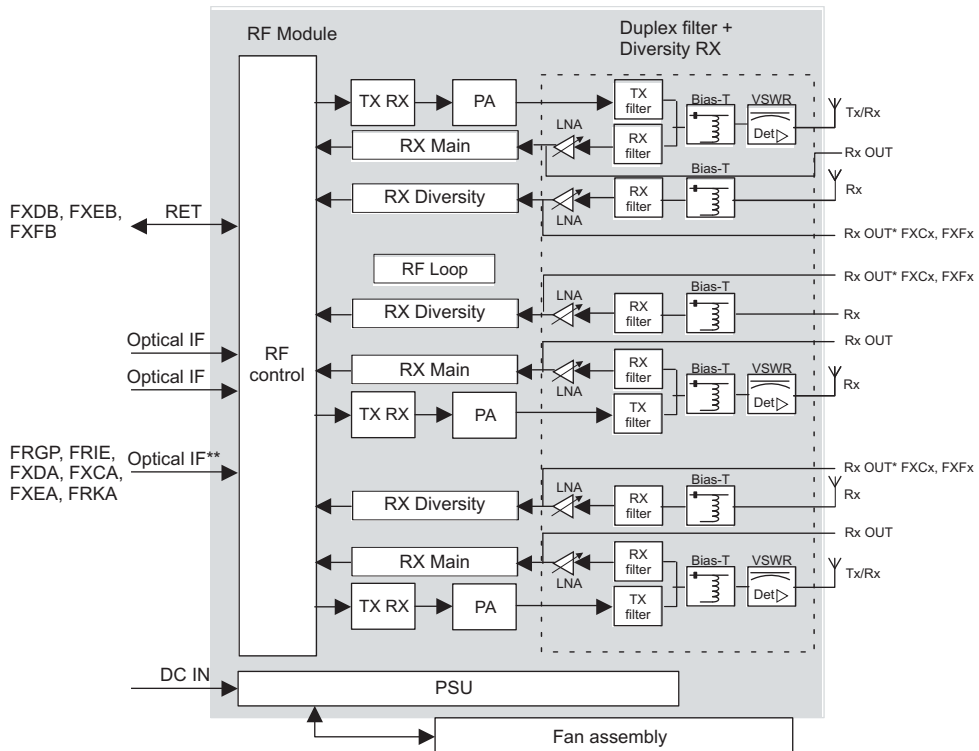

## Electrical specifications

Table 67 FRGP electrical specifications

Property	Value
Nominal supply voltage	-48.0 V DC
Nominal input voltage range	38.0 V DC to 60.0 V DC
Extended input voltage range	-36.0 V DC to -40.5 V DC -57.0 V DC to -60.0 V DC

## Power consumption

Table 68 FRGP power consumption

Number of TXs	RF output power per TX [W]	Estimated power consumption [W] at 48 VDC input at 23°C. Non-committed estimated values depend on the final product HW and SW optimization with +/- 10% margin.	
		50% RF Load	100% RF Load
3	60	584	804
	40	490	647
	20	393	476

## Installation and mechanical specifications

Table 69 FRGP installation and mechanical specifications

Property	Value
Installation options	<ul style="list-style-type: none"> <li>stack/pole/wall installation</li> <li>directly on the wall installation</li> </ul>
IP rating	IP65
Related optional items	<ul style="list-style-type: none"> <li>Flexi Pole Mounting Kit (FPKA/C)</li> <li>Pole Mounting Kit (VMPB)</li> </ul>

## Dimensions and weight

Table 70 FRGP dimensions and weight

Property	Value	Dimensions orientation
Height	133 mm/ 3U (5.2 in.)	
Depth	Without front covers: 422 mm (16.6 in.) With front covers: 560 mm (22.1 in.)	

Table 70 FRGP dimensions and weight (Cont.)

Property	Value	Dimensions orientation
Width	Without front covers: 447 mm (17.6 in.) With front covers: 492 mm (19.4 in.)	
Weight	25 kg (55.1 lbs)	

## Environmental specifications

Table 71 FRGP environmental specifications

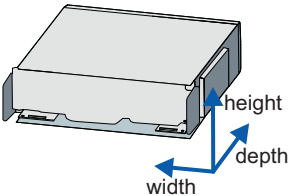
Property	Value
Maximum operational outdoor temperature (at constant high ambient temperature maximum output power might be limited)	+55°C (131°F)
Minimum operational temperature (including cold start)	-35°C (-31°F)

## LEDs

Table 72 FRGP LEDs

LED color	Description	Alarm
Red, stable	Critical alarm affecting the whole RF module or all antenna carriers	Fault
Red, blinking	Operation degraded <ul style="list-style-type: none"> <li>Major alarm affecting the whole RF Module</li> <li>Major alarm affecting the whole RF Module</li> <li>Major/Critical alarm affecting a module subcomponent or antenna carrier</li> </ul>	Major/critical alarm
Yellow, stable	<ul style="list-style-type: none"> <li>Until software download begins</li> <li>The carriers are blocked from BTS</li> <li>There is no connection to any System Module</li> </ul>	No alarm
Yellow, blinking	<ul style="list-style-type: none"> <li>Software download in progress</li> <li>Configuration in progress: RF resources are being setup, but not yet activated</li> </ul>	No alarm
Green, stable	<ul style="list-style-type: none"> <li>Software configuration is complete or supervisory:</li> </ul>	No alarm

Table 72 FRGP LEDs (Cont.)

LED color	Description	Alarm
	RF resources activated and transmission is possible <ul style="list-style-type: none"> <li>Working normally, no alarm on the RF Module</li> </ul>	
Green, blinking	Software downloading and updating	No alarm
Stable Red for less than 5 seconds and changes to Stable Yellow	Switched ON, but the next conditions are not reached yet	No alarm
Stable Red for less than 5 seconds	The module is in the process of resetting	No alarm
Periodic Red and Green	Antenna line device faulty/degraded	No alarm
Blinking Colors (Red, Yellow, and Green), each color stable for 0.5 second	Module highlighting (Flexi BTS SM functionality that can help identifying faulty module)	No alarm
RF Module fan/TX status LED: Red	At least one fan is faulty or degraded	
RF Module fan/TX status LED: Green	All fans are working	
RF Module fan/TX status LED: Color set according to fan status, stable	RF transmission is ON	
RF Module fan/TX status LED: Color set according to fan status, blinking	RF transmission is OFF	

**Warnings, cautions or notes related to the product**



**WARNING! Risk of electric shock.**

Before turning RF power on, RF ports have to be terminated by nominal 50Ω load (for example, feeder with antenna). However, if these conditions are not met, the plastic caps that are delivered within the unused RF ports should remain in place. The plastic caps isolate RF power from the environment, and thus provide electric shock security in case RF power is accidentally on.



The minimum startup voltage is 40.5 V DC. If the input voltage is below/beyond extended limits, unit might shut down.

## 13 Flexi RF Module 3TX 2600 (FRHA)

FRHA technical specifications.

### Functional description

Table 73 FRHA functional specification

Property	Value
Output power	3x60 W
MIMO	yes, 2TX
Outdoor installation	yes
SW supported technology	FDD-LTE
TX frequency range	2620-2690 MHz
RX frequency range	2500-2570 MHz
DL instantaneous bandwidth	20 MHz
UL instantaneous bandwidth	20 MHz
DL filter bandwidth	70 MHz
UL filter bandwidth	70 MHz

### Interfaces

Figure 18 FRHA interfaces

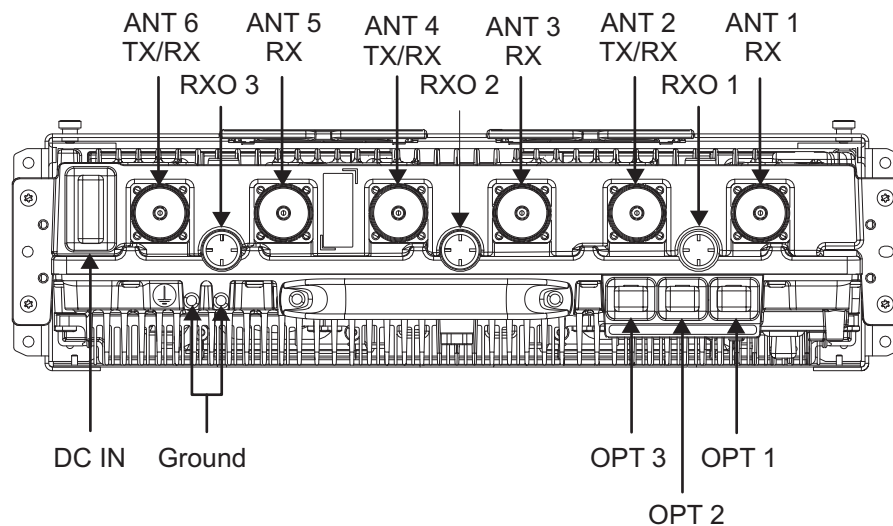

Table 74 FRHA interfaces

Interface	Label on the HW	Number of interfaces	Connector type	Additional info
Power connector	DC IN	1	2-pin multibeam XL	
Antenna connector	ANT	6	7/16	

Table 74 FRHA interfaces (Cont.)

Interface	Label on the HW	Number of interfaces	Connector type	Additional info
RF output connector	RxO	6	QMA	
Optical interface	OPT	3	SFP	3 Gbps

**Antenna Line Devices (ALDs) support**

Table 75 FRHA ALD support

ALD support via antenna ports	Value
AISG	2.0 Main only
Legacy Siemens equipment	No
CWA (for non-AISG installations)	No
Voltage	24 V Main only
Power per port	30 W

**Functional block diagram**

Figure 19 FRHA functional block diagram

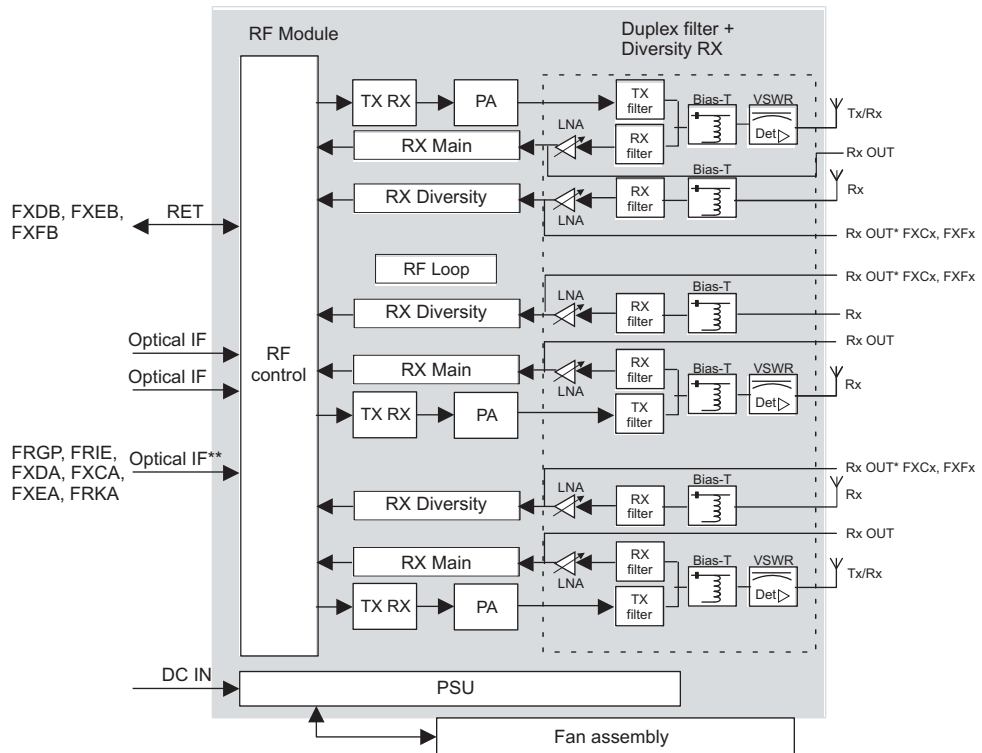

## Electrical specifications

Table 76 FRHA electrical specifications

Property	Value
Nominal supply voltage	-48.0 V DC
Nominal input voltage range	38.0 V DC to 60.0 V DC
Extended input voltage range	-36.0 V DC to -40.5 V DC -57.0 V DC to -60.0 V DC

## Power consumption

Table 77 FRHA power consumption

Number of TXs	RF output power per TX [W]	Estimated power consumption [W] at 48 VDC input at 23°C. Non-committed estimated values depend on the final product HW and SW optimization with +/- 10% margin.	
		50% RF Load	100% RF Load
3	60	806	1130
	40	622	825
	20	462	580

## Installation and mechanical specifications

Table 78 FRHA installation and mechanical specifications

Property	Value
Installation options	<ul style="list-style-type: none"> <li>stack/pole/wall installation</li> <li>directly on the wall installation</li> </ul>
IP rating	IP65
Related optional items	<ul style="list-style-type: none"> <li>Flexi Pole Mounting Kit (FPKA/C)</li> <li>Pole Mounting Kit (VMPB)</li> </ul>

## Dimensions and weight

Table 79 FRHA dimensions and weight

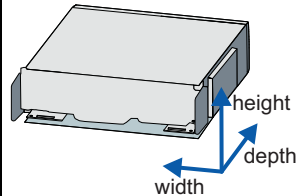
Property	Value	Dimensions orientation
Height	133 mm/ 3U (5.2 in.)	
Depth	Without front covers: 422 mm (16.6 in.) With front covers: 560 mm (22.1 in.)	

**Table 79** FRHA dimensions and weight (Cont.)

Property	Value	Dimensions orientation
Width	Without front covers: 447 mm (17.6 in.) With front covers: 492 mm (19.4 in.)	
Weight	25 kg (55.1 lbs)	

**Environmental specifications**

**Table 80** FRHA environmental specifications

Property	Value
Maximum operational outdoor temperature (at constant high ambient temperature maximum output power might be limited)	+55°C (131°F)
Minimum operational temperature (including cold start)	-35°C (-31°F)

**LEDs**

**Table 81** FRHA LEDs

LED color	Description	Alarm
Red, stable	Critical alarm affecting the whole RF module or all antenna carriers	Fault
Red, blinking	Operation degraded <ul style="list-style-type: none"> <li>Major alarm affecting the whole RF Module</li> <li>Major alarm affecting the whole RF Module</li> <li>Major/Critical alarm affecting a module subcomponent or antenna carrier</li> </ul>	Major/critical alarm
Yellow, stable	<ul style="list-style-type: none"> <li>Until software download begins</li> <li>The carriers are blocked from BTS</li> <li>There is no connection to any System Module</li> </ul>	No alarm
Yellow, blinking	<ul style="list-style-type: none"> <li>Software download in progress</li> <li>Configuration in progress: RF resources are being setup, but not yet activated</li> </ul>	No alarm
Green, stable	<ul style="list-style-type: none"> <li>Software configuration is complete or supervisory:</li> </ul>	No alarm

Table 81 FRHA LEDs (Cont.)

LED color	Description	Alarm
	RF resources activated and transmission is possible <ul style="list-style-type: none"> <li>Working normally, no alarm on the RF Module</li> </ul>	
Green, blinking	Software downloading and updating	No alarm
Stable Red for less than 5 seconds and changes to Stable Yellow	Switched ON, but the next conditions are not reached yet	No alarm
Stable Red for less than 5 seconds	The module is in the process of resetting	No alarm
Periodic Red and Green	Antenna line device faulty/degraded	No alarm
Blinking Colors (Red, Yellow, and Green), each color stable for 0.5 second	Module highlighting (Flexi BTS SM functionality that can help identifying faulty module)	No alarm
RF Module fan/TX status LED: Red	At least one fan is faulty or degraded	
RF Module fan/TX status LED: Green	All fans are working	
RF Module fan/TX status LED: Color set according to fan status, stable	RF transmission is ON	
RF Module fan/TX status LED: Color set according to fan status, blinking	RF transmission is OFF	

**Warnings, cautions or notes related to the product**



**WARNING! Risk of electric shock.**

Before turning RF power on, RF ports have to be terminated by nominal 50Ω load (for example, feeder with antenna). However, if these conditions are not met, the plastic caps that are delivered within the unused RF ports should remain in place. The plastic caps isolate RF power from the environment, and thus provide electric shock security in case RF power is accidentally on.



The minimum startup voltage is 40.5 V DC. If the input voltage is below/beyond extended limits, unit might shut down.

## 14 Flexi RF Module 3TX 1700/2100 (FRIE)

FRIE technical specifications.

### Functional description

Table 82 FRIE functional specification

Property	Value
Output power	3x60 W
MIMO	yes, 2TX
Outdoor installation	yes
SW supported technologies	WCDMA, FDD-LTE
TX frequency range	2110-2170 MHz
RX frequency range	1710-1770 MHz
DL instantaneous bandwidth	20 MHz
UL instantaneous bandwidth	20 MHz
DL filter bandwidth	45 MHz
UL filter bandwidth	45 MHz

### Interfaces

Figure 20 FRIE interfaces

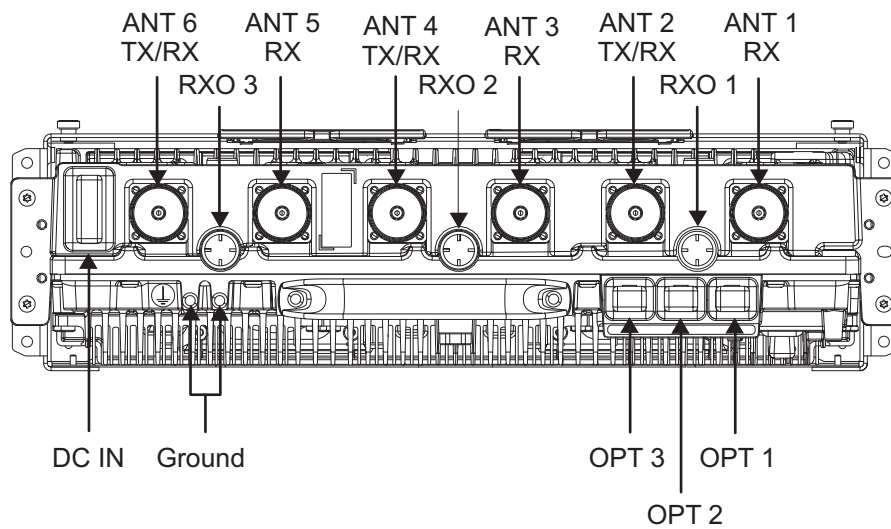

Table 83 FRIE interfaces

Interface	Label on the HW	Number of interfaces	Connector type	Additional info
Power connector	DC IN	1	2-pin multibeam XL	
Antenna connector	ANT	6	7/16	

Table 83 FRIE interfaces (Cont.)

Interface	Label on the HW	Number of interfaces	Connector type	Additional info
RF output connector	RxO	3	QMA	
External Alarm Connection	EAC	1	RJ45	
Optical interface	OPT	3	SFP	3 Gbps

### Antenna Line Devices (ALDs) support

Table 84 FRIE ALD support

ALD support via antenna ports	Value
AISG	2.0 Main only
Legacy Siemens equipment	No
CWA (for non-AISG installations)	Yes
Voltage	Main 24V/12V Div 12V
Power per port	30 W

### Functional block diagram

Figure 21 FRIE functional block diagram

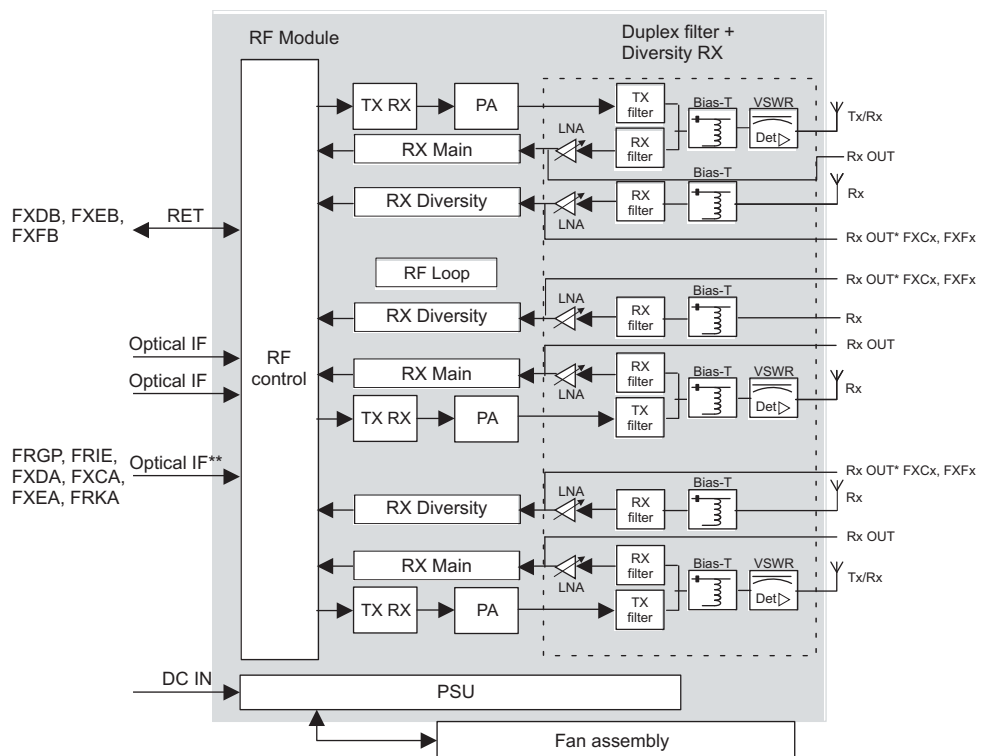

## Electrical specifications

Table 85 FRIE electrical specifications

Property	Value
Nominal supply voltage	-48.0 V DC
Nominal input voltage range	-40.5 V DC to -57.0 V DC
Extended input voltage range	-36.0 V DC to -40.5 V DC -57.0 V DC to -60.0 V DC

## Power consumption

Table 86 FRIE power consumption

Number of TXs	RF output power per TX [W]	Estimated power consumption [W] at 48 VDC input at 23°C. Non-committed estimated values depend on the final product HW and SW optimization with +/- 10% margin.	
		50% RF Load	100% RF Load
3	60	590	805
	40	465	610
	20	345	420

## Installation and mechanical specifications

Table 87 FRIE installation and mechanical specifications

Property	Value
Installation options	<ul style="list-style-type: none"> <li>stack/pole/wall installation</li> <li>directly on the wall installation</li> </ul>
IP rating	IP65
Related optional items	<ul style="list-style-type: none"> <li>Flexi Pole Mounting Kit (FPKA/C)</li> <li>Pole Mounting Kit (VMPB)</li> </ul>

## Dimensions and weight

Table 88 FRIE dimensions and weight

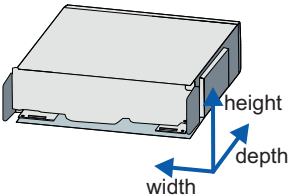
Property	Value	Dimensions orientation
Height	133 mm/ 3U (5.2 in.)	
Depth	Without front covers: 422 mm (16.6 in.) With front covers: 560 mm (22.1 in.)	

**Table 88** FRIE dimensions and weight (Cont.)

Property	Value	Dimensions orientation
Width	Without front covers: 447 mm (17.6 in.) With front covers: 492 mm (19.4 in.)	
Weight	25 kg (55.1 lbs)	

### Environmental specifications

**Table 89** FRIE environmental specifications

Property	Value
Maximum operational outdoor temperature (at constant high ambient temperature maximum output power might be limited)	+55°C (131°F)
Minimum operational temperature (including cold start)	-35°C (-31°F)

### LEDs

**Table 90** FRIE LEDs

LED color	Description	Alarm
Red, stable	Critical alarm affecting the whole RF module or all antenna carriers	Fault
Red, blinking	Operation degraded <ul style="list-style-type: none"> <li>Major alarm affecting the whole RF Module</li> <li>Major alarm affecting the whole RF Module</li> <li>Major/Critical alarm affecting a module subcomponent or antenna carrier</li> </ul>	Major/critical alarm
Yellow, stable	<ul style="list-style-type: none"> <li>Until software download begins</li> <li>The carriers are blocked from BTS</li> <li>There is no connection to any System Module</li> </ul>	No alarm
Yellow, blinking	<ul style="list-style-type: none"> <li>Software download in progress</li> <li>Configuration in progress: RF resources are being setup, but not yet activated</li> </ul>	No alarm
Green, stable	<ul style="list-style-type: none"> <li>Software configuration is complete or supervisory:</li> </ul>	No alarm

Table 90 FRIE LEDs (Cont.)

LED color	Description	Alarm
	RF resources activated and transmission is possible <ul style="list-style-type: none"> <li>Working normally, no alarm on the RF Module</li> </ul>	
Green, blinking	Software downloading and updating	No alarm
Stable Red for less than 5 seconds and changes to Stable Yellow	Switched ON, but the next conditions are not reached yet	No alarm
Stable Red for less than 5 seconds	The module is in the process of resetting	No alarm
Periodic Red and Green	Antenna line device faulty/degraded	No alarm
Blinking Colors (Red, Yellow, and Green), each color stable for 0.5 second	Module highlighting (Flexi BTS SM functionality that can help identifying faulty module)	No alarm
RF Module fan/TX status LED: Red	At least one fan is faulty or degraded	
RF Module fan/TX status LED: Green	All fans are working	
RF Module fan/TX status LED: Color set according to fan status, stable	RF transmission is ON	
RF Module fan/TX status LED: Color set according to fan status, blinking	RF transmission is OFF	

**Warnings, cautions or notes related to the product**



**WARNING! Risk of electric shock.**

Before turning RF power on, RF ports have to be terminated by nominal 50Ω load (for example, feeder with antenna). However, if these conditions are not met, the plastic caps that are delivered within the unused RF ports should remain in place. The plastic caps isolate RF power from the environment, and thus provide electric shock security in case RF power is accidentally on.



The minimum startup voltage is 40.5 V DC. If the input voltage is below/beyond extended limits, unit might shut down.

## 15 Flexi RF Module 3TX 850 (FXCB)

FXCB technical specifications.

### Functional description

Table 91 FXCB functional specification

Property	Value
Output power	3x80 W
MIMO	no
Outdoor installation	yes
SW supported technologies	GSM, WCDMA, FDD-LTE
TX frequency range	869-894 MHz
RX frequency range	824-849 MHz
DL instantaneous bandwidth	35 MHz
UL instantaneous bandwidth	25 MHz
DL filter bandwidth	25 MHz
UL filter bandwidth	25 MHz

### Interfaces

Figure 22 FXCB interfaces

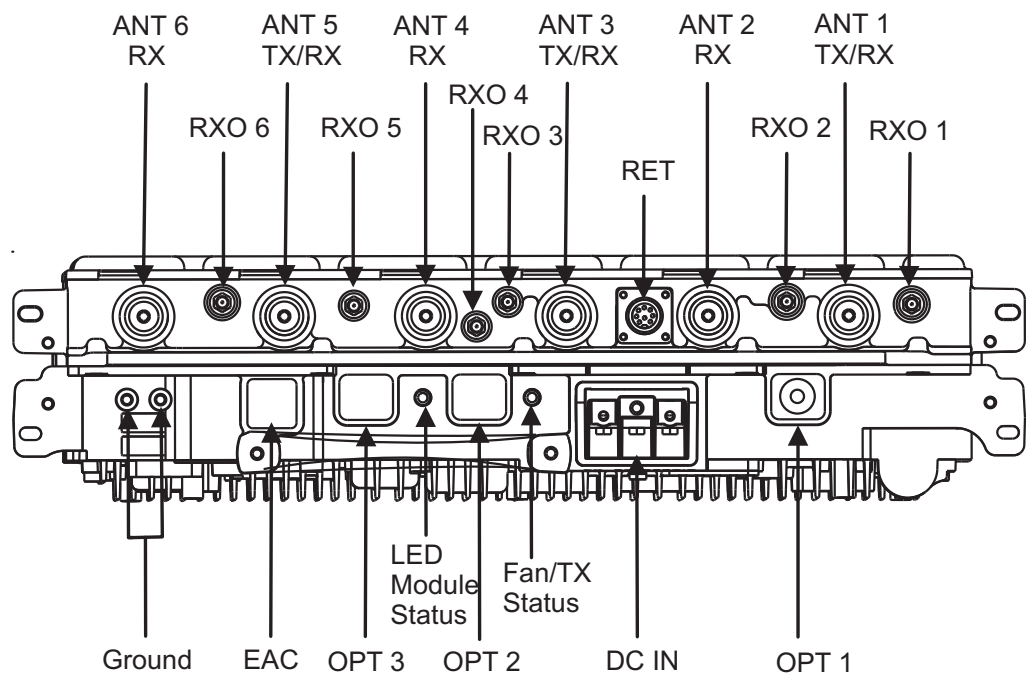

Table 92 FXCB interfaces

Interface	Label on the HW	Number of interfaces	Connector type	Additional info
Power connector	DC IN	1	Screw-terminal	

*Table 92* FXCB interfaces (Cont.)

Interface	Label on the HW	Number of interfaces	Connector type	Additional info
Antenna connector	ANT	6	7/16	
RF output connector	RxO	6	QMA	
Remote Electrical Tilt	RET	1	8-pin circular	
External Alarm Connection	EAC	1	RJ45	
Optical interface	OPT	3	SFP	3 Gbps or 6 Gbps

**Antenna Line Devices (ALDs) support**

*Table 93* FXCB ALD support

ALD support via antenna ports	Value
AISG	2.0 Main only
Legacy Siemens equipment	No
CWA (for non-AISG installations)	Yes
Voltage	Main = 13V/1.3A or 24V/30W
Power per port	Div = 13V/1A

## Functional block diagram

Figure 23 FXCB functional block diagram

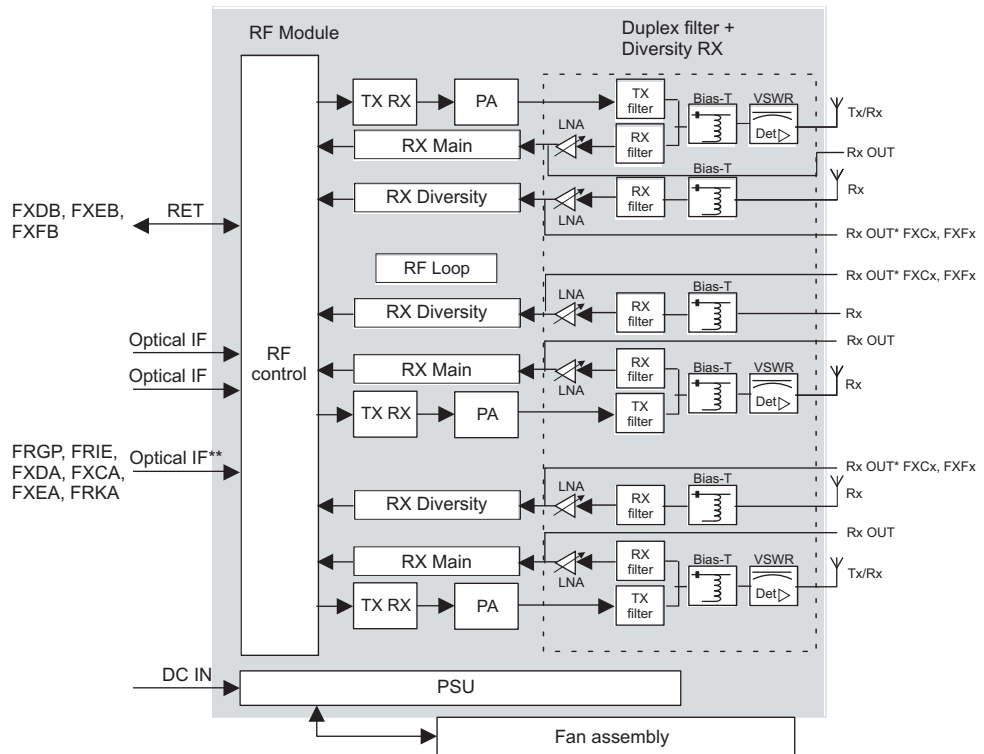

## Electrical specifications

Table 94 FXCB electrical specifications

Property	Value
Nominal supply voltage	-48.0 V DC
Nominal input voltage range	-40.5 V DC to -57.0 V DC
Extended input voltage range	-36.0 V DC to -40.5 V DC -57.0 V DC to -60.0 V DC

## Power consumption

Table 95 FXCB power consumption

Number of TXs	RF output power per TX [W]	Estimated power consumption [W] at 48 VDC input at 23°C. Non-committed estimated values depend on the final product HW and SW optimization with +/- 10% margin.	
		50% RF Load	100% RF Load
3	80	671	935
	60	594	810
	40	444	581
	20	351	428

## Installation and mechanical specifications

Table 96 FXCB installation and mechanical specifications

Property	Value
Installation options	<ul style="list-style-type: none"> <li>• stack/pole/wall installation</li> <li>• directly on the wall installation</li> </ul>
IP rating	IP65
Related optional items	<ul style="list-style-type: none"> <li>• Flexi Pole Mounting Kit (FPKA/C)</li> <li>• Pole Mounting Kit (VMPB)</li> </ul>

## Dimensions and weight

Table 97 FXCB dimensions and weight

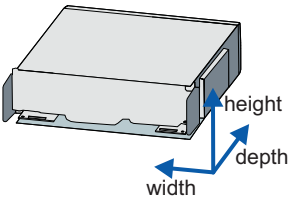
Property	Value	Dimensions orientation
Height	133 mm/ 3U (5.2 in.)	
Depth	Without front covers: 422 mm (16.6 in.) With front covers: 560 mm (22.1 in.)	
Width	Without front covers: 447 mm (17.6 in.) With front covers: 492 mm (19.4 in.)	
Weight	25 kg (55.1 lbs)	

## Environmental specifications

Table 98 FXCB environmental specifications

Property	Value
Maximum operational outdoor temperature (at constant high ambient temperature maximum output power might be limited)	+55°C (131°F)
Minimum operational temperature (including cold start)	-35°C (-31°F)

## LEDs

Table 99 FXCB LEDs

LED color	Description	Alarm
Red, stable	Critical alarm affecting the whole RF module or all antenna carriers	Fault
Red, blinking	Operation degraded	Major/critical alarm

Table 99 FXCB LEDs (Cont.)

LED color	Description	Alarm
	<ul style="list-style-type: none"> <li>Major alarm affecting the whole RF Module</li> <li>Major alarm affecting the whole RF Module</li> <li>Major/Critical alarm affecting a module subcomponent or antenna carrier</li> </ul>	
Yellow, stable	<ul style="list-style-type: none"> <li>Until software download begins</li> <li>The carriers are blocked from BTS</li> <li>There is no connection to any System Module</li> </ul>	No alarm
Yellow, blinking	<ul style="list-style-type: none"> <li>Software download in progress</li> <li>Configuration in progress: RF resources are being setup, but not yet activated</li> </ul>	No alarm
Green, stable	<ul style="list-style-type: none"> <li>Software configuration is complete or supervisory: RF resources activated and transmission is possible</li> <li>Working normally, no alarm on the RF Module</li> </ul>	No alarm
Green, blinking	Software downloading and updating	No alarm
Stable Red for less than 5 seconds and changes to Stable Yellow	Switched ON, but the next conditions are not reached yet	No alarm
Stable Red for less than 5 seconds	The module is in the process of resetting	No alarm
Periodic Red and Green	Antenna line device faulty/degraded	No alarm
Blinking Colors (Red, Yellow, and Green), each color stable for 0.5 second	Module highlighting (Flexi BTS SM functionality that can help identifying faulty module)	No alarm
RF Module fan/TX status LED: Red	At least one fan is faulty or degraded	
RF Module fan/TX status LED: Green	All fans are working	
RF Module fan/TX status LED: Color set according to fan status, stable	RF transmission is ON	
RF Module fan/TX status LED: Color set according to fan status, blinking	RF transmission is OFF	

---

## Warnings, cautions or notes related to the product

**WARNING! Risk of electric shock.**

Before turning RF power on, RF ports have to be terminated by nominal 50Ω load (for example, feeder with antenna). However, if these conditions are not met, the plastic caps that are delivered within the unused RF ports should remain in place. The plastic caps isolate RF power from the environment, and thus provide electric shock security in case RF power is accidentally on.



The minimum startup voltage is 40.5 V DC. If the input voltage is below/beyond extended limits, unit might shut down.

## 16 Flexi RF Module 3TX 900 (FXDB)

FXDB technical specifications.

### Functional description

Table 100 FXDB functional specification

Property	Value
Output power	3x80 W
MIMO	yes, 2TX
Outdoor installation	yes
SW supported technologies	GSM, WCDMA, FDD-LTE
TX frequency range	925-960 MHz
RX frequency range	880-915 MHz
DL instantaneous bandwidth	35 MHz
UL instantaneous bandwidth	35 MHz
DL filter bandwidth	35 MHz
UL filter bandwidth	35 MHz

### Interfaces

Figure 24 FXDB interfaces

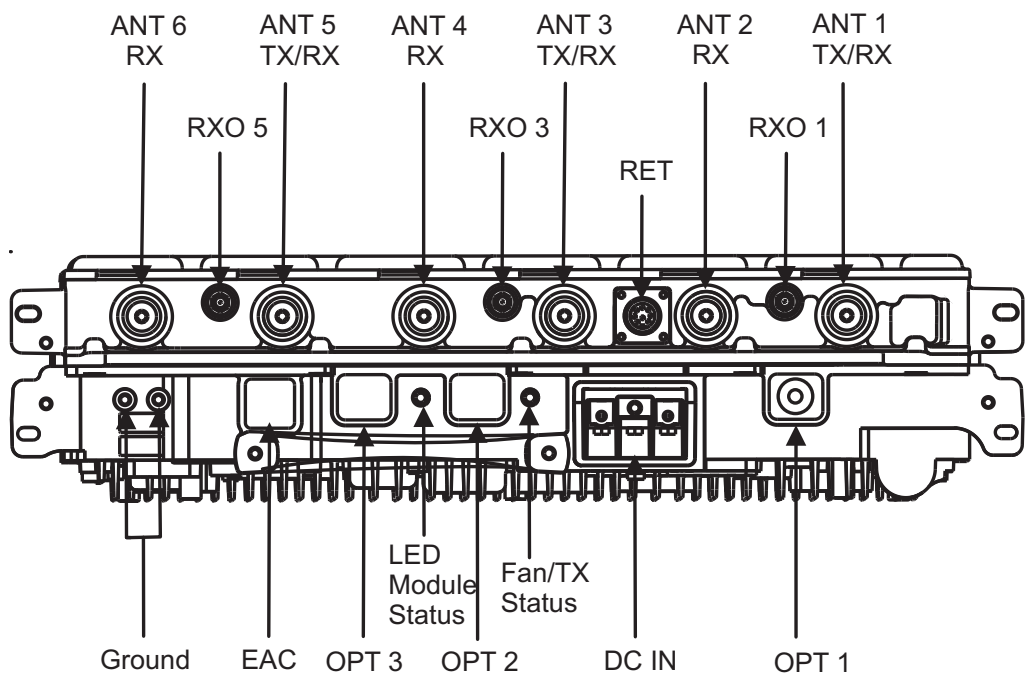

Table 101 FXDB interfaces

Interface	Label on the HW	Number of interfaces	Connector type	Additional info
Power connector	DC IN	1	Screw-terminal	

Table 101 FXDB interfaces (Cont.)

Interface	Label on the HW	Number of interfaces	Connector type	Additional info
Antenna connector	ANT	6	7/16	
RF output connector	RxO	3	QMA <td></td>	
External Alarm Connection	EAC	1	RJ45	
Optical interface	OPT	3	SFP	3 Gbps or 6 Gbps

**Antenna Line Devices (ALDs) support**

Table 102 FXDB ALD support

ALD support via antenna ports	Value
AISG	2.0 Main only
Legacy Siemens equipment	No
CWA (for non-AISG installations)	Yes
Voltage	Main = 13V/1.3A or 24V/30W
Power per port	Div = 13V/1A

**Functional block diagram**

Figure 25 FXDB functional block diagram

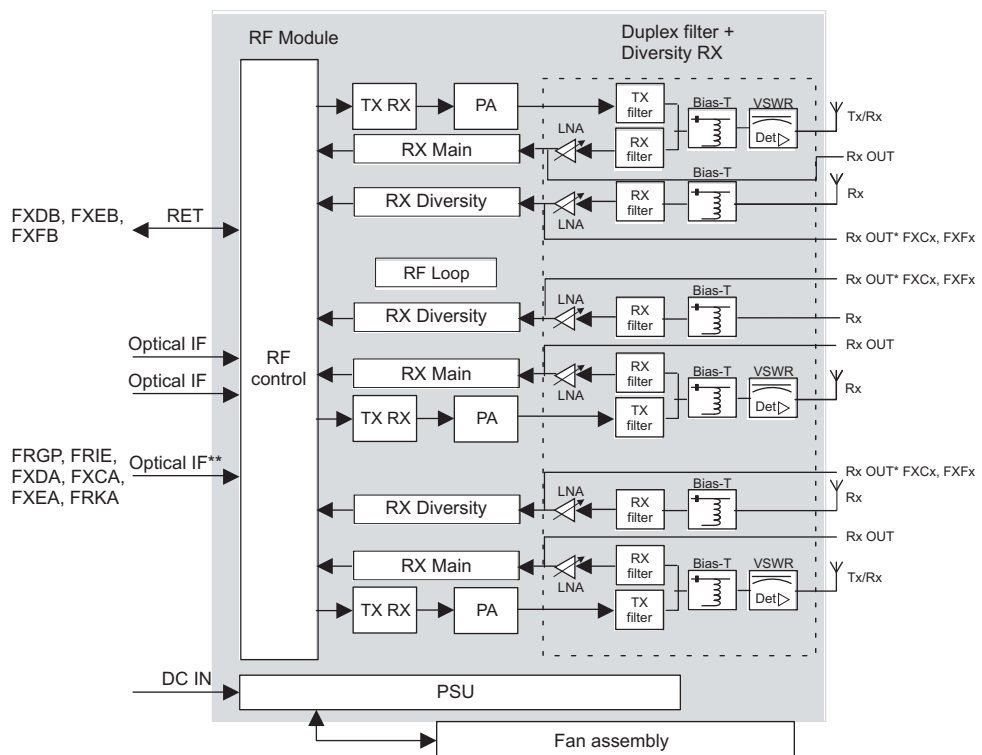

## Electrical specifications

Table 103 FXDB electrical specifications

Property	Value
Nominal supply voltage	-48.0 V DC
Nominal input voltage range	-40.5 V DC to -57.0 V DC
Extended input voltage range	-36.0 V DC to -40.5 V DC -57.0 V DC to -60.0 V DC

## Power consumption

Table 104 FXDB power consumption

Number of TXs	RF output power per TX [W]	Estimated power consumption [W] at 48 VDC input at 23°C for WCDMA mode. Non-committed estimated values depend on the final product HW and SW optimization with +/- 10% margin.	
		50% RF Load	100% RF Load
3	80	643	903
	60	575	776
	40	409	533
	20	327	395

## Installation and mechanical specifications

Table 105 FXDB installation and mechanical specifications

Property	Value
Installation options	<ul style="list-style-type: none"> <li>stack/pole/wall installation</li> <li>directly on the wall installation</li> </ul>
IP rating	IP65
Related optional items	<ul style="list-style-type: none"> <li>Flexi Pole Mounting Kit (FPKA/C)</li> <li>Pole Mounting Kit (VMPB)</li> </ul>

## Dimensions and weight

Table 106 FXDB dimensions and weight

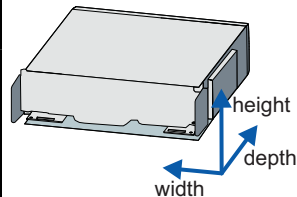
Property	Value	Dimensions orientation
Height	133 mm/ 3U (5.2 in.)	
Depth	Without front covers: 422 mm (16.6 in.) With front covers: 560 mm (22.1 in.)	

**Table 106** FXDB dimensions and weight (Cont.)

Property	Value	Dimensions orientation
Width	Without front covers: 447 mm (17.6 in.) With front covers: 492 mm (19.4 in.)	
Weight	25 kg (55.1 lbs)	

**Environmental specifications**

**Table 107** FXDB environmental specifications

Property	Value
Maximum operational outdoor temperature (at constant high ambient temperature maximum output power might be limited)	+55°C (131°F)
Minimum operational temperature (including cold start)	-35°C (-31°F)

**LEDs**

**Table 108** FXDB LEDs

LED color	Description	Alarm
Red, stable	Critical alarm affecting the whole RF module or all antenna carriers	Fault
Red, blinking	Operation degraded <ul style="list-style-type: none"> <li>Major alarm affecting the whole RF Module</li> <li>Major alarm affecting the whole RF Module</li> <li>Major/Critical alarm affecting a module subcomponent or antenna carrier</li> </ul>	Major/critical alarm
Yellow, stable	<ul style="list-style-type: none"> <li>Until software download begins</li> <li>The carriers are blocked from BTS</li> <li>There is no connection to any System Module</li> </ul>	No alarm
Yellow, blinking	<ul style="list-style-type: none"> <li>Software download in progress</li> <li>Configuration in progress: RF resources are being setup, but not yet activated</li> </ul>	No alarm
Green, stable	<ul style="list-style-type: none"> <li>Software configuration is complete or supervisory:</li> </ul>	No alarm

Table 108 FXDB LEDs (Cont.)

LED color	Description	Alarm
	RF resources activated and transmission is possible <ul style="list-style-type: none"> <li>Working normally, no alarm on the RF Module</li> </ul>	
Green, blinking	Software downloading and updating	No alarm
Stable Red for less than 5 seconds and changes to Stable Yellow	Switched ON, but the next conditions are not reached yet	No alarm
Stable Red for less than 5 seconds	The module is in the process of resetting	No alarm
Periodic Red and Green	Antenna line device faulty/degraded	No alarm
Blinking Colors (Red, Yellow, and Green), each color stable for 0.5 second	Module highlighting (Flexi BTS SM functionality that can help identifying faulty module)	No alarm
RF Module fan/TX status LED: Red	All fans are faulty	
RF Module fan/TX status LED: Green	All fans are working	
RF Module fan/TX status LED: Color set according to fan status, stable	RF transmission is ON	
RF Module fan/TX status LED: Color set according to fan status, blinking	RF transmission is OFF	

**Warnings, cautions or notes related to the product**



**WARNING! Risk of electric shock.**

Before turning RF power on, RF ports have to be terminated by nominal 50Ω load (for example, feeder with antenna). However, if these conditions are not met, the plastic caps that are delivered within the unused RF ports should remain in place. The plastic caps isolate RF power from the environment, and thus provide electric shock security in case RF power is accidentally on.



The minimum startup voltage is 40.5 V DC. If the input voltage is below/beyond extended limits, unit might shut down.

## 17 Flexi RF Module 3TX 1800 (FXEB)

FXEB technical specifications.

### Functional description

Table 109 FXEB functional specification

Property	Value
Output power	3x80 W
MIMO	yes, 2TX
Outdoor installation	yes
SW supported technologies	GSM, FDD-LTE
TX frequency range	1805-1880 MHz
RX frequency range	1710-1785 MHz
DL instantaneous bandwidth	35 MHz
UL instantaneous bandwidth	60 MHz
DL filter bandwidth	75 MHz
UL filter bandwidth	75 MHz

### Interfaces

Figure 26 FXEB interfaces

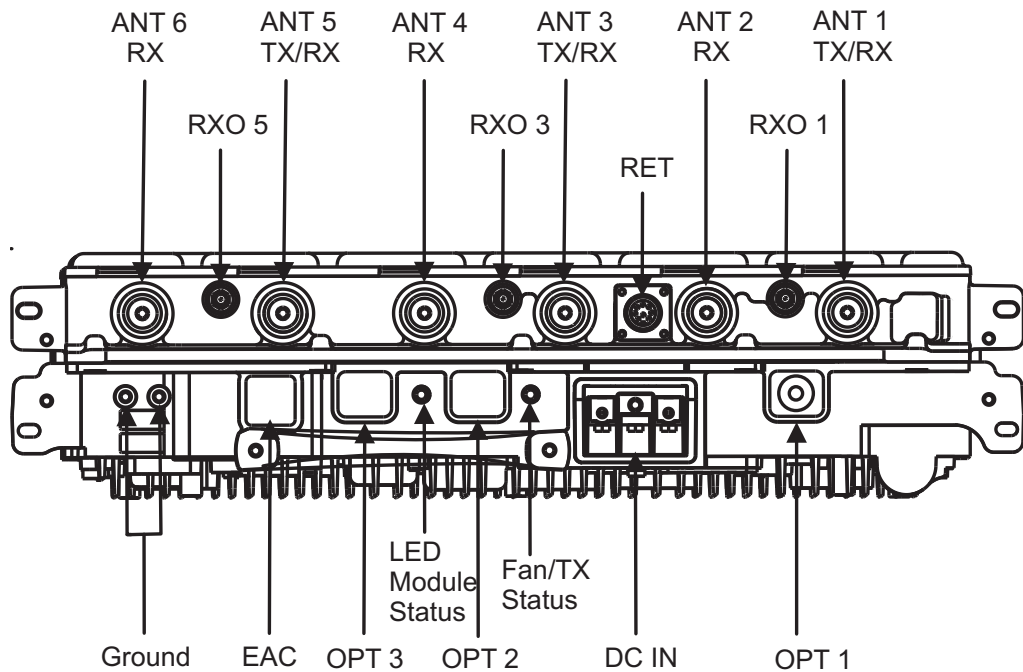

Table 110 FXEB interfaces

Interface	Label on the HW	Number of interfaces	Connector type	Additional info
Power connector	DC IN	1	Screw-interminal	

*Table 110* FXEB interfaces (Cont.)

Interface	Label on the HW	Number of interfaces	Connector type	Additional info
Antenna connector	ANT	6	7/16	
RF output connector	RxO	3	QMA	
Remote Electrical Tilt	RET	1	8-pin circular	
External Alarm Connection	EAC	1	RJ45	
Optical interface	OPT	3	SFP	3 Gbps or 6 Gbps

### Antenna Line Devices (ALDs) support

*Table 111* FXEB ALD support

ALD support via antenna ports	Value
AISG	2.0 Main only
Legacy Siemens equipment	No
CWA (for non-AISG installations)	Yes
Voltage	Main = 13V/1.3A or 24V/30W
Power per port	Div = 13V/1A



## Installation and mechanical specifications

Table 114 FXEB installation and mechanical specifications

Property	Value
Installation options	<ul style="list-style-type: none"> <li>stack/pole/wall installation</li> <li>directly on the wall installation</li> </ul>
IP rating	IP65
Related optional items	<ul style="list-style-type: none"> <li>Flexi Pole Mounting Kit (FPKA/C)</li> <li>Pole Mounting Kit (VMPB)</li> </ul>

## Dimensions and weight

Table 115 FXEB dimensions and weight

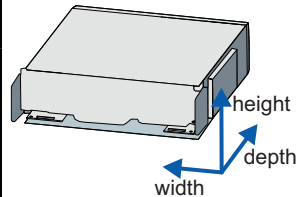
Property	Value	Dimensions orientation
Height	133 mm/ 3U (5.2 in.)	
Depth	Without front covers: 422 mm (16.6 in.) With front covers: 560 mm (22.1 in.)	
Width	Without front covers: 447 mm (17.6 in.) With front covers: 492 mm (19.4 in.)	
Weight	25 kg (55.1 lbs)	

## Environmental specifications

Table 116 FXEB environmental specifications

Property	Value
Maximum operational outdoor temperature (at constant high ambient temperature maximum output power might be limited)	+55°C (131°F)
Minimum operational temperature (including cold start)	-35°C (-31°F)

## LEDs

Table 117 FXEB LEDs

LED color	Description	Alarm
Red, stable	Critical alarm affecting the whole RF module or all antenna carriers	Fault
Red, blinking	Operation degraded	Major/critical alarm

Table 117 FXEB LEDs (Cont.)

LED color	Description	Alarm
	<ul style="list-style-type: none"> <li>Major alarm affecting the whole RF Module</li> <li>Major alarm affecting the whole RF Module</li> <li>Major/Critical alarm affecting a module subcomponent or antenna carrier</li> </ul>	
Yellow, stable	<ul style="list-style-type: none"> <li>Until software download begins</li> <li>The carriers are blocked from BTS</li> <li>There is no connection to any System Module</li> </ul>	No alarm
Yellow, blinking	<ul style="list-style-type: none"> <li>Software download in progress</li> <li>Configuration in progress: RF resources are being setup, but not yet activated</li> </ul>	No alarm
Green, stable	<ul style="list-style-type: none"> <li>Software configuration is complete or supervisory: RF resources activated and transmission is possible</li> <li>Working normally, no alarm on the RF Module</li> </ul>	No alarm
Green, blinking	Software downloading and updating	No alarm
Stable Red for less than 5 seconds and changes to Stable Yellow	Switched ON, but the next conditions are not reached yet	No alarm
Stable Red for less than 5 seconds	The module is in the process of resetting	No alarm
Periodic Red and Green	Antenna line device faulty/degraded	No alarm
Blinking Colors (Red, Yellow, and Green), each color stable for 0.5 second	Module highlighting (Flexi BTS SM functionality that can help identifying faulty module)	No alarm
RF Module fan/TX status LED: Red	At least one fan is faulty or degraded	
RF Module fan/TX status LED: Green	All fans are working	
RF Module fan/TX status LED: Color set according to fan status, stable	RF transmission is ON	
RF Module fan/TX status LED: Color set according to fan status, blinking	RF transmission is OFF	

### Warnings, cautions or notes related to the product



**WARNING! Risk of electric shock.**

Before turning RF power on, RF ports have to be terminated by nominal 50Ω load (for example, feeder with antenna). However, if these conditions are not met, the plastic caps that are delivered within the unused RF ports should remain in place. The plastic caps isolate RF power from the environment, and thus provide electric shock security in case RF power is accidentally on.



The minimum startup voltage is 40.5 V DC. If the input voltage is below/beyond extended limits, unit might shut down.

## 18 Flexi RF Module 3TX 1900 (FXFC)

FXFC technical specifications.

### Functional description

Table 118 FXFC functional specification

Property	Value
Output power	3x80 W
MIMO	yes, 2TX
Outdoor installation	yes
SW supported technologies	GSM, WCDMA, FDD-LTE
TX frequency range	1930-1990 MHz
RX frequency range	1850-1915 MHz
DL instantaneous bandwidth	35 MHz
UL instantaneous bandwidth	60 MHz
DL filter bandwidth	65 MHz
UL filter bandwidth	65 MHz

### Interfaces

Figure 28 FXFC interfaces

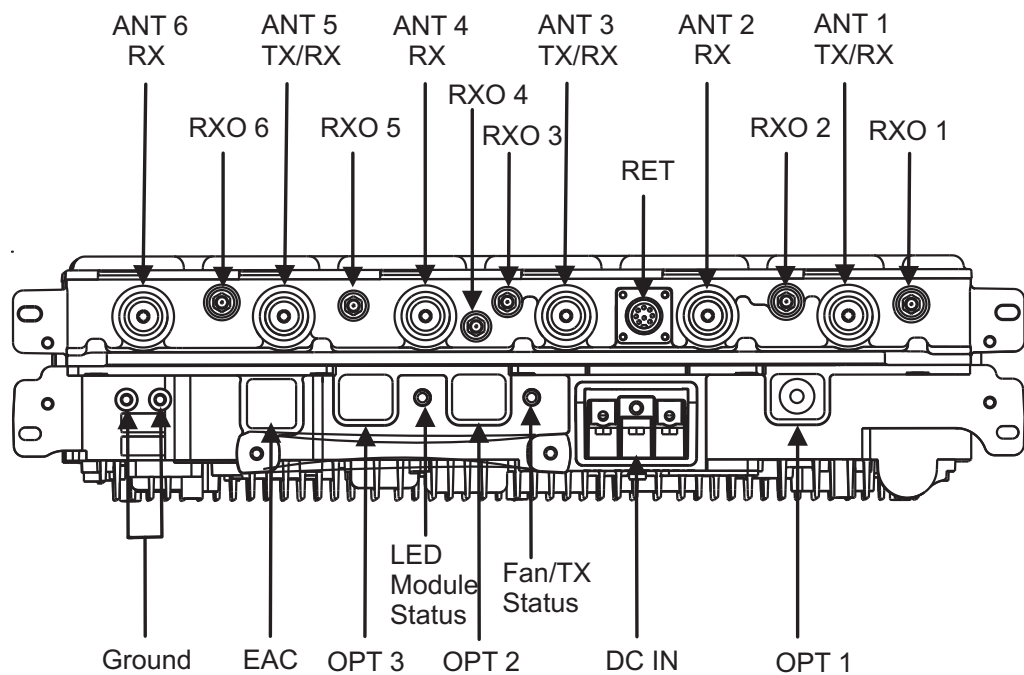

Table 119 FXFC interfaces

Interface	Label on the HW	Number of interfaces	Connector type	Additional info
Power connector	DC IN	1	Screw-interminal	

*Table 119* FXFC interfaces (Cont.)

Interface	Label on the HW	Number of interfaces	Connector type	Additional info
Antenna connector	ANT	6	7/16	
RF output connector	RxO	6	QMA	
Remote Electrical Tilt	RET	1	8-pin circular	
External Alarm Connection	EAC	1	RJ45	
Optical interface	OPT	3	SFP	3 Gbps or 6 Gbps

### Antenna Line Devices (ALDs) support

*Table 120* FXFC ALD support

ALD support via antenna ports	Value
AISG	2.0 Main only
Legacy Siemens equipment	No
CWA (for non-AISG installations)	Yes
Voltage	Main = 13V/1.3A or 24V/30W
Power per port	Div = 13V/1A

### Functional block diagram

Figure 29 FXFC functional block diagram

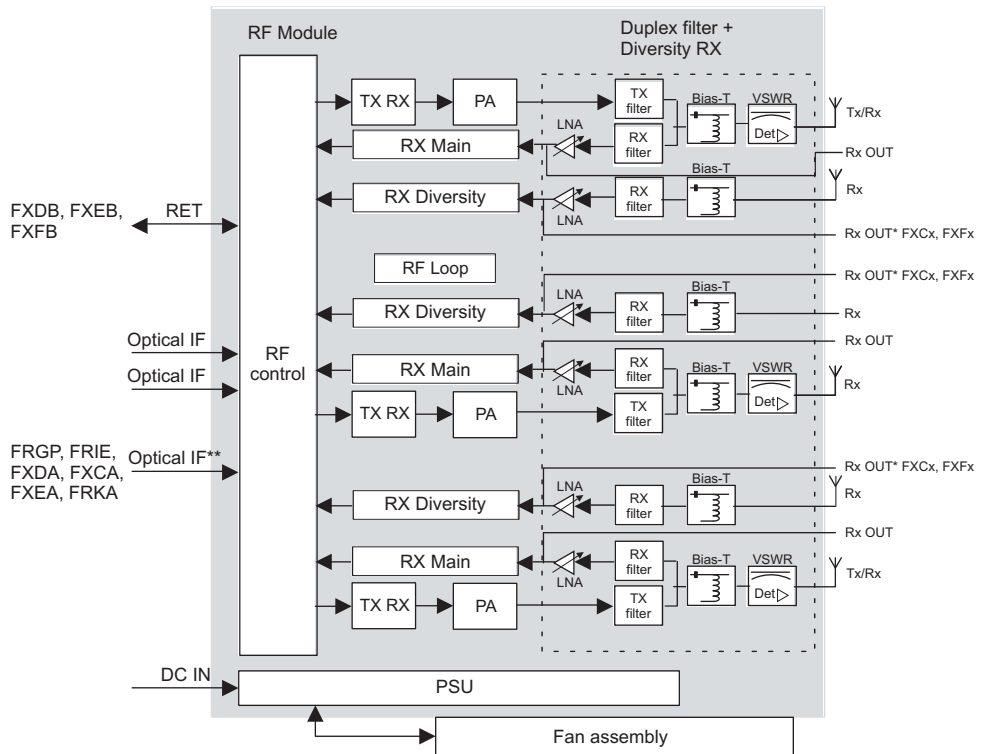

### Electrical specifications

Table 121 FXFC electrical specifications

Property	Value
Nominal supply voltage	-48.0 V DC
Nominal input voltage range	-40.5 V DC to -57.0 V DC
Extended input voltage range	-36.0 V DC to -40.5 V DC -57.0 V DC to -60.0 V DC

### Power consumption

Table 122 FXFC power consumption

Number of TXs	RF output power per TX [W]	Estimated power consumption [W] at 48 VDC input at 23°C for WCDMA mode. Non-committed estimated values depend on the final product HW and SW optimization with +/- 10% margin.	
		50% RF Load	100% RF Load
3	80	641	923
	60	554	778
	40	439	587
	20	353	428

## Installation and mechanical specifications

Table 123 FXFC installation and mechanical specifications

Property	Value
Installation options	<ul style="list-style-type: none"> <li>stack/pole/wall installation</li> <li>directly on the wall installation</li> </ul>
IP rating	IP65
Related optional items	<ul style="list-style-type: none"> <li>Flexi Pole Mounting Kit (FPKA/C)</li> <li>Pole Mounting Kit (VMPB)</li> </ul>

## Dimensions and weight

Table 124 FXFC dimensions and weight

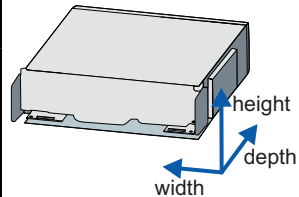
Property	Value	Dimensions orientation
Height	133 mm/ 3U (5.2 in.)	
Depth	Without front covers: 422 mm (16.6 in.) With front covers: 560 mm (22.1 in.)	
Width	Without front covers: 447 mm (17.6 in.) With front covers: 492 mm (19.4 in.)	
Weight	25 kg (55.1 lbs)	

## Environmental specifications

Table 125 FXFC environmental specifications

Property	Value
Maximum operational outdoor temperature (at constant high ambient temperature maximum output power might be limited)	+55°C (131°F)
Minimum operational temperature (including cold start)	-35°C (-31°F)

## LEDs

Table 126 FXFC LEDs

LED color	Description	Alarm
Red, stable	Critical alarm affecting the whole RF module or all antenna carriers	Fault
Red, blinking	Operation degraded	Major/critical alarm

Table 126 FXFC LEDs (Cont.)

LED color	Description	Alarm
	<ul style="list-style-type: none"> <li>Major alarm affecting the whole RF Module</li> <li>Major alarm affecting the whole RF Module</li> <li>Major/Critical alarm affecting a module subcomponent or antenna carrier</li> </ul>	
Yellow, stable	<ul style="list-style-type: none"> <li>Until software download begins</li> <li>The carriers are blocked from BTS</li> <li>There is no connection to any System Module</li> </ul>	No alarm
Yellow, blinking	<ul style="list-style-type: none"> <li>Software download in progress</li> <li>Configuration in progress: RF resources are being setup, but not yet activated</li> </ul>	No alarm
Green, stable	<ul style="list-style-type: none"> <li>Software configuration is complete or supervisory: RF resources activated and transmission is possible</li> <li>Working normally, no alarm on the RF Module</li> </ul>	No alarm
Green, blinking	Software downloading and updating	No alarm
Stable Red for less than 5 seconds and changes to Stable Yellow	Switched ON, but the next conditions are not reached yet	No alarm
Stable Red for less than 5 seconds	The module is in the process of resetting	No alarm
Periodic Red and Green	Antenna line device faulty/degraded	No alarm
Blinking Colors (Red, Yellow, and Green), each color stable for 0.5 second	Module highlighting (Flexi BTS SM functionality that can help identifying faulty module)	No alarm
RF Module fan/TX status LED: Red	At least one fan is faulty or degraded	
RF Module fan/TX status LED: Green	All fans are working	
RF Module fan/TX status LED: Color set according to fan status, stable	RF transmission is ON	
RF Module fan/TX status LED: Color set according to fan status, blinking	RF transmission is OFF	

### Warnings, cautions or notes related to the product



**WARNING! Risk of electric shock.**

Before turning RF power on, RF ports have to be terminated by nominal 50Ω load (for example, feeder with antenna). However, if these conditions are not met, the plastic caps that are delivered within the unused RF ports should remain in place. The plastic caps isolate RF power from the environment, and thus provide electric shock security in case RF power is accidentally on.



The minimum startup voltage is 40.5 V DC. If the input voltage is below/beyond extended limits, unit might shut down.

## 19 Flexi RFM 3-pipe 900 240W (FXJB)

FXJB technical specifications.

### Functional description

Table 127 FXJB functional specification

Property	Value
Output power	3x80 W
MIMO	yes, 2TX
Outdoor installation	yes
SW supported technologies	GSM, WCDMA
TX frequency range	935-960 MHz
RX frequency range	890-915 MHz
DL instantaneous bandwidth	25 MHz
UL instantaneous bandwidth	25 MHz
DL filter bandwidth	25 MHz
UL filter bandwidth	25 MHz

### Interfaces

Figure 30 FXJB interfaces

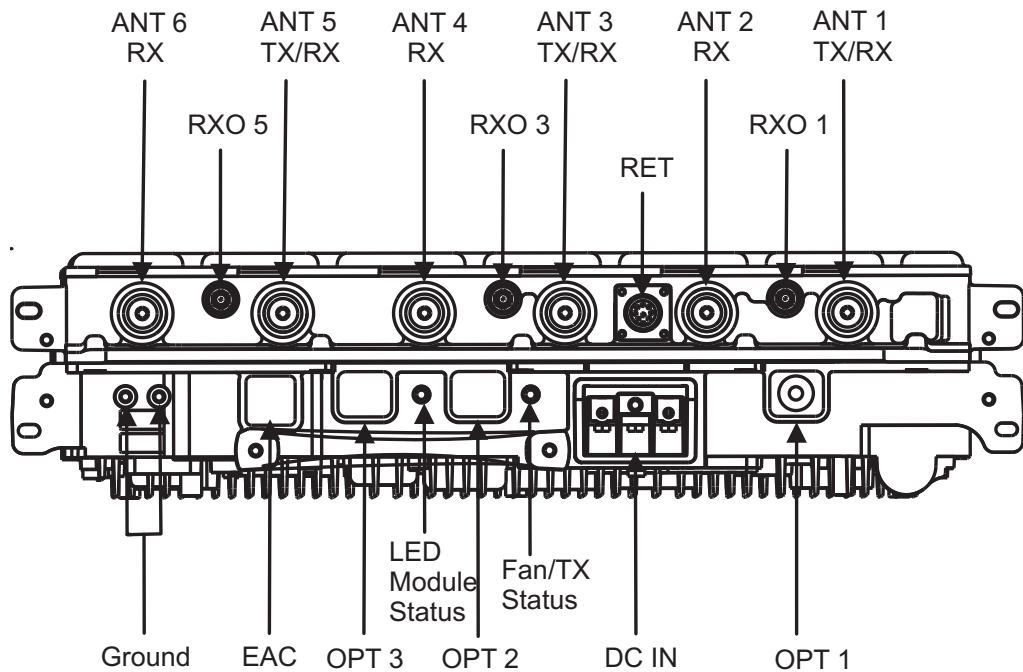

Table 128 FXJB interfaces

Interface	Label on the HW	Number of interfaces	Connector type	Additional info
Power connector	DC IN	1	Screw-interminal	

Table 128 FXJB interfaces (Cont.)

Interface	Label on the HW	Number of interfaces	Connector type	Additional info
Antenna connector	ANT	6	7/16	
RF optical connector	RxO	3	QMA	
External Alarm Connection	EAC	1	RJ45	
Optical interface	OPT	3	SFP	3 Gbps or 6 Gbps, OBSAI

### Antenna Line Devices (ALDs) support

Table 129 FXJB ALD support

ALD support via antenna ports	Value
AISG	2.0 Main only
Legacy Siemens equipment	No
CWA (for non-AISG installations)	No
Voltage	Main 24V Div 12V
Power per port	30 W

### Functional block diagram

Figure 31 FXJB functional block diagram

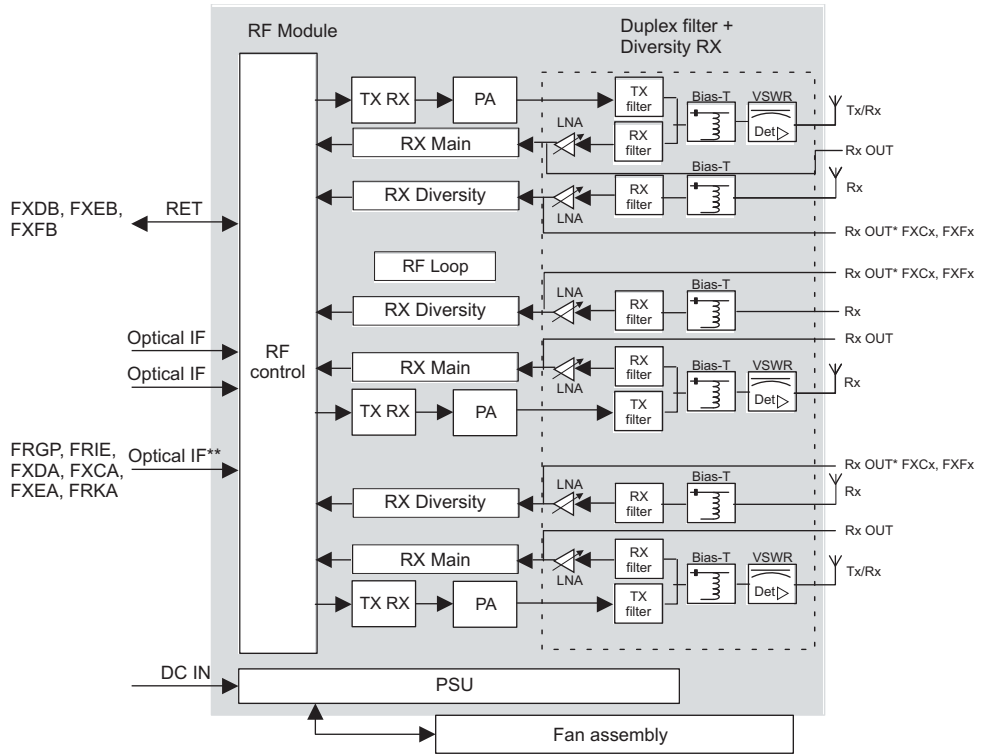

### Electrical specifications

Table 130 FXJB electrical specifications

Property	Value
Nominal supply voltage	-48.0 V DC
Nominal input voltage range	-40.5 V DC to -57.0 V DC
Extended input voltage range	-36.0 V DC to -40.5 V DC -57.0 V DC to -60.0 V DC

### Power consumption

Table 131 FXJB power consumption

Number of TXs	RF output power per TX [W]	Estimated power consumption [W] at 48 VDC input at 23°C for WCDMA mode. Non-committed estimated values depend on the final product HW and SW optimization with +/- 10% margin. Values preliminary estimate.	
		50% RF Load	100% RF Load
3	80	643	903

Table 131 FXJB power consumption (Cont.)

Number of TXs	RF output power per TX [W]	Estimated power consumption [W] at 48 VDC input at 23°C for WCDMA mode. Non-committed estimated values depend on the final product HW and SW optimization with +/- 10% margin. Values preliminary estimate.	
		50% RF Load	100% RF Load
	60	575	776
	40	409	533
	20	327	395

### Installation and mechanical specifications

Table 132 FXJB installation and mechanical specifications

Property	Value
Installation options	<ul style="list-style-type: none"> <li>• pole/wall installation</li> <li>• directly on the wall installation</li> </ul>
IP rating	IP65
Related optional items	<ul style="list-style-type: none"> <li>• Flexi Pole Mounting Kit (FPKA/C)</li> <li>• Pole Mounting Kit (VMPB)</li> </ul>

### Dimensions and weight

Table 133 FXJB dimensions and weight

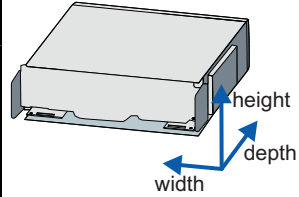
Property	Value	Dimensions orientation
Height	133 mm/ 3U (5.2 in.)	
Depth	Without front covers: 422 mm (16.6 in.)	
	With front covers: 560 mm (22.1 in.)	
Width	Without front covers: 447 mm (17.6 in.)	
	With front covers: 492 mm (19.4 in.)	
Weight	25 kg (55.1 lbs)	

## Environmental specifications

Table 134 FXJB environmental specifications

Property	Value
Maximum operational outdoor temperature (at constant high ambient temperature maximum output power might be limited)	+55°C (131°F)
Minimum operational temperature (including cold start)	-35°C (-31°F)

## LEDs

Table 135 FXJB LEDs

LED color	Description	Alarm
Red, stable	Critical alarm affecting the whole RF module or all antenna carriers	Fault
Red, blinking	Operation degraded <ul style="list-style-type: none"> <li>Major alarm affecting the whole RF Module</li> <li>Major alarm affecting the whole RF Module</li> <li>Major/Critical alarm affecting a module subcomponent or antenna carrier</li> </ul>	Major/critical alarm
Yellow, stable	<ul style="list-style-type: none"> <li>Until software download begins</li> <li>The carriers are blocked from BTS</li> <li>There is no connection to any System Module</li> </ul>	No alarm
Yellow, blinking	<ul style="list-style-type: none"> <li>Software download in progress</li> <li>Configuration in progress: RF resources are being setup, but not yet activated</li> </ul>	No alarm
Green, stable	<ul style="list-style-type: none"> <li>Software configuration is complete or supervisory: RF resources activated and transmission is possible</li> <li>Working normally, no alarm on the RF Module</li> </ul>	No alarm
Green, blinking	Software downloading and updating	No alarm
Stable Red for less than 5 seconds and changes to Stable Yellow	Switched ON, but the next conditions are not reached yet	No alarm

Table 135 FXJB LEDs (Cont.)

LED color	Description	Alarm
Stable Red for less than 5 seconds	The module is in the process of resetting	No alarm
Periodic Red and Green	Antenna line device faulty/degraded	No alarm
Blinking Colors (Red, Yellow, and Green), each color stable for 0.5 second	Module highlighting (Flexi BTS SM functionality that can help identifying faulty module)	No alarm
RF Module fan/TX status LED: Red	At least one fan is faulty or degraded	
RF Module fan/TX status LED: Green	All fans are working	
RF Module fan/TX status LED: Color set according to fan status, stable	RF transmission is ON	
RF Module fan/TX status LED: Color set according to fan status, blinking	RF transmission is OFF	

**Warnings, cautions or notes related to the product**



**WARNING! Risk of electric shock.**

Before turning RF power on, RF ports have to be terminated by nominal 50Ω load (for example, feeder with antenna). However, if these conditions are not met, the plastic caps that are delivered within the unused RF ports should remain in place. The plastic caps isolate RF power from the environment, and thus provide electric shock security in case RF power is accidentally on.



The minimum startup voltage is 40.5 V DC. If the input voltage is below/beyond extended limits, unit might shut down.

## 20 Flexi RF Module 3TX 2100 (FRGT)

FRGT technical specifications.

### Functional description

Table 136 FRGT functional specification

Property	Value
Output power	3x80 W
MIMO	yes, 2TX
Outdoor installation	yes
SW supported technologies	WCDMA, FDD-LTE
TX frequency range	2110-2170 MHz
RX frequency range	1920-1980 MHz
DL instantaneous bandwidth	60 MHz
UL instantaneous bandwidth	60 MHz
DL filter bandwidth	60 MHz
UL filter bandwidth	60 MHz

Table 137 FRGT output power in RU40

DL bandwidth	Output power
0-20 MHz	80 W
20-45 MHz	70 W (BTS can be commissioned as 80 W (for example 4x20 W per pipe) and RFM internal power control limits the total power to 70 W when needed.)
45-60 MHz	60 W

## Interfaces

Figure 32 FRGT interfaces

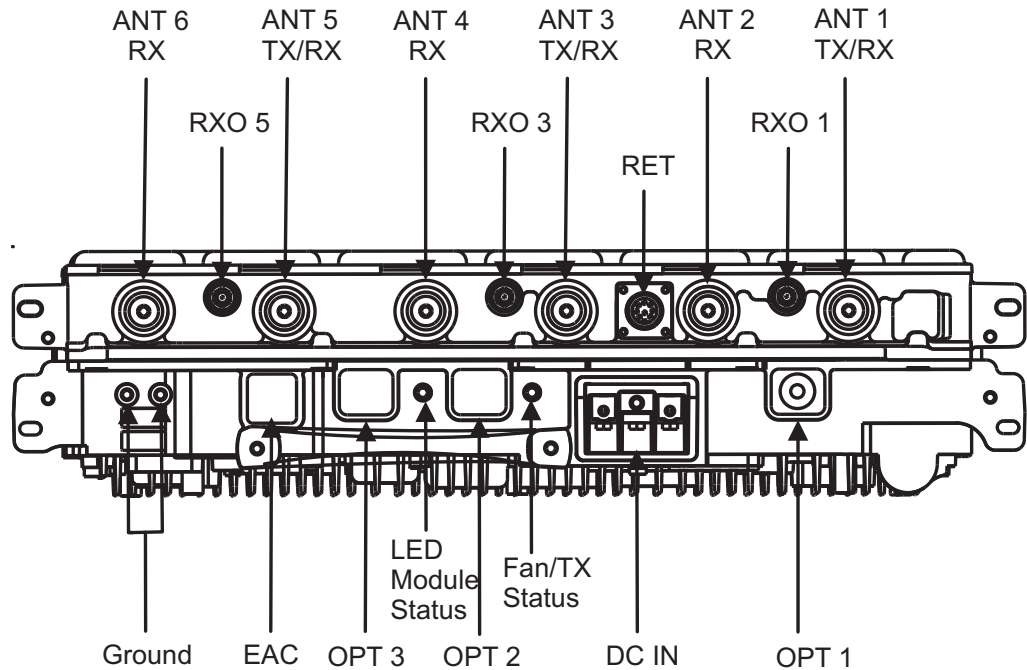

Table 138 FRGT interfaces

Interface	Label on the HW	Number of interfaces	Connector type	Additional info
Power connector	DC IN	1	Screw-interminal	
Antenna connector	ANT	6	7/16	
RF output connector	RxO	3	QMA	
Remote Electrical Tilt	RET	1	8-pin circular	
External Alarm Connection	EAC	1	RJ45	
Optical interface	OPT	3	SFP	3 Gbps or 6 Gbps

## Antenna Line Devices (ALDs) support

Table 139 FRGT ALD support

ALD support via antenna ports	Value
AISG	2.0 Main only
Legacy Siemens equipment	No
CWA (for non-AISG installations)	Yes
Voltage	Main = 12V/1A or 24V/30W Div = 12V/1A

Table 139 FRGT ALD support (Cont.)

ALD support via antenna ports	Value
Power per port	30 W

Functional block diagram

Figure 33 FRGT functional block diagram

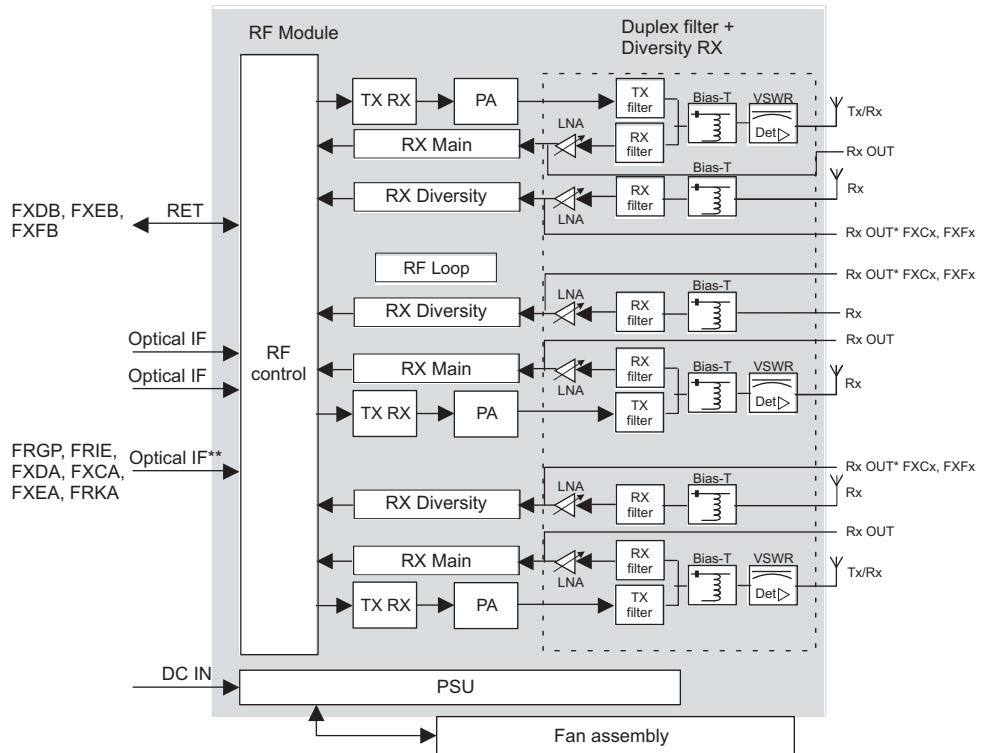

Electrical specifications

Table 140 FRGT electrical specifications

Property	Value
Nominal supply voltage	-48.0 V DC
Nominal input voltage range	-40.5 V DC to -57.0 V DC
Extended input voltage range	-36.0 V DC to -40.5 V DC -57.0 V DC to -60.0 V DC

## Power consumption

Table 141 FRGT power consumption

Number of TXs	RF output power per TX [W]	Estimated power consumption [W] at 48 VDC input at 23°C. Non-committed estimated values depend on the final product HW and SW optimization with +/- 10% margin.	
		50% RF Load	100% RF Load
3	80	560	884
	60	522	729
	40	407	544
	20	316	386

## Installation and mechanical specifications

Table 142 FRGT installation and mechanical specifications

Property	Value
Installation options	<ul style="list-style-type: none"> <li>stack/pole/wall installation</li> <li>directly on the wall installation</li> </ul>
IP rating	IP65
Related optional items	<ul style="list-style-type: none"> <li>Flexi Pole Mounting Kit (FPKA/C)</li> <li>Pole Mounting Kit (VMPB)</li> </ul>

## Dimensions and weight

Table 143 FRGT dimensions and weight

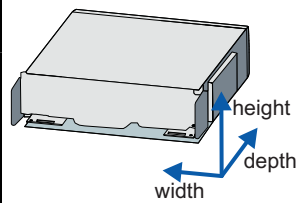
Property	Value	Dimensions orientation
Height	133 mm/ 3U (5.2 in.)	
Depth	Without front covers: 422 mm (16.6 in.) With front covers: 560 mm (22.1 in.)	
Width	Without front covers: 447 mm (17.6 in.) With front covers: 492 mm (19.4 in.)	
Weight	25 kg (55.1 lbs)	

## Environmental specifications

Table 144 FRGT environmental specifications

Property	Value
Maximum operational outdoor temperature (at constant high ambient temperature maximum output power might be limited)	+55°C (131°F)
Minimum operational temperature (including cold start)	-35°C (-31°F)

## LEDs

Table 145 FRGT LEDs

LED color	Description	Alarm
Red, stable	Critical alarm affecting the whole RF module or all antenna carriers	Fault
Red, blinking	Operation degraded <ul style="list-style-type: none"> <li>Major alarm affecting the whole RF Module</li> <li>Major alarm affecting the whole RF Module</li> <li>Major/Critical alarm affecting a module subcomponent or antenna carrier</li> </ul>	Major/critical alarm
Yellow, stable	<ul style="list-style-type: none"> <li>Until software download begins</li> <li>The carriers are blocked from BTS</li> <li>There is no connection to any System Module</li> </ul>	No alarm
Yellow, blinking	<ul style="list-style-type: none"> <li>Software download in progress</li> <li>Configuration in progress: RF resources are being setup, but not yet activated</li> </ul>	No alarm
Green, stable	<ul style="list-style-type: none"> <li>Software configuration is complete or supervisory: RF resources activated and transmission is possible</li> <li>Working normally, no alarm on the RF Module</li> </ul>	No alarm
Green, blinking	Software downloading and updating	No alarm
Stable Red for less than 5 seconds and changes to Stable Yellow	Switched ON, but the next conditions are not reached yet	No alarm

Table 145 FRGT LEDs (Cont.)

LED color	Description	Alarm
Stable Red for less than 5 seconds	The module is in the process of resetting	No alarm
Periodic Red and Green	Antenna line device faulty/degraded	No alarm
Blinking Colors (Red, Yellow, and Green), each color stable for 0.5 second	Module highlighting (Flexi BTS SM functionality that can help identifying faulty module)	No alarm
RF Module fan/TX status LED: Red	At least one fan is faulty or degraded	
RF Module fan/TX status LED: Green	All fans are working	
RF Module fan/TX status LED: Color set according to fan status, stable	RF transmission is ON	
RF Module fan/TX status LED: Color set according to fan status, blinking	RF transmission is OFF	

### Warnings, cautions or notes related to the product



**WARNING! Risk of electric shock.**

Before turning RF power on, RF ports have to be terminated by nominal 50Ω load (for example, feeder with antenna). However, if these conditions are not met, the plastic caps that are delivered within the unused RF ports should remain in place. The plastic caps isolate RF power from the environment, and thus provide electric shock security in case RF power is accidentally on.



The minimum startup voltage is 40.5 V DC. If the input voltage is below/beyond extended limits, unit might shut down.

## 21 Flexi RF Module 3TX 2100 (FRGS)

FRGS technical specifications.

### Functional description

Table 146 FRGS functional specification

Property	Value
Output power	3x80 W
MIMO	yes, 2TX
Outdoor installation	yes
SW supported technologies	WCDMA, FDD-LTE
TX frequency range	2130-2170 MHz
RX frequency range	1940-1980 MHz
DL instantaneous bandwidth	40 MHz
UL instantaneous bandwidth	40 MHz
DL filter bandwidth	40 MHz
UL filter bandwidth	40 MHz

Table 147 FRGS output power in RU40

DL bandwidth	Output power
0-20 MHz	80 W
20-40 MHz	70 W (BTS can be commissioned as 80 W (for example 4x20 W per pipe) and RFM internal power control limits the total power to 70 W when needed.)

## Interfaces

Figure 34 FRGS interfaces

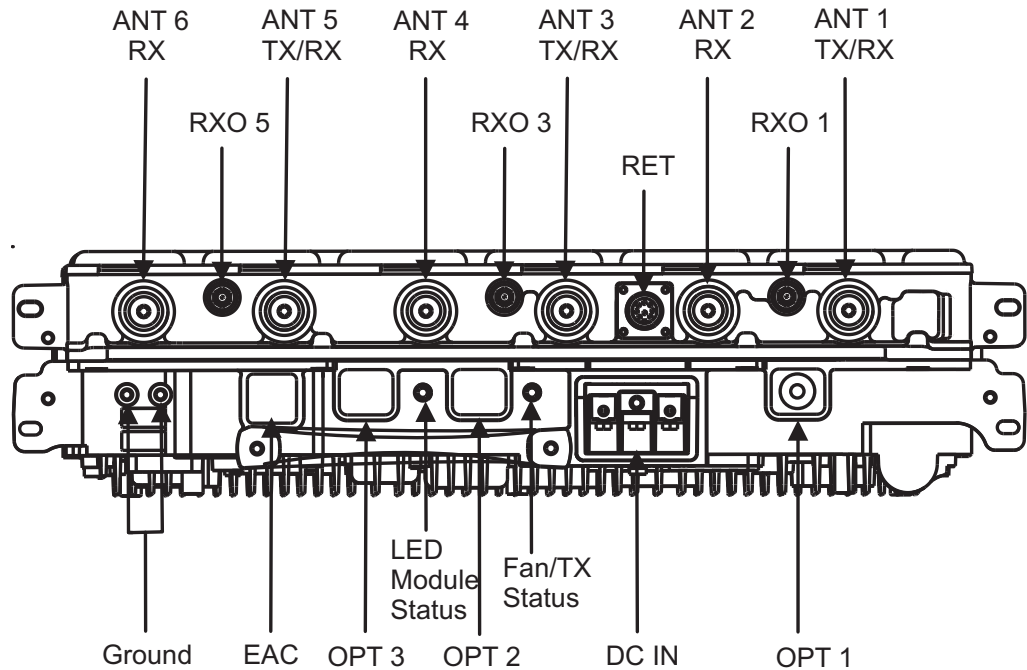

Table 148 FRGS interfaces

Interface	Label on the HW	Number of interfaces	Connector type	Additional info
Power connector	DC IN	1	Screw-interminal	
Antenna connector	ANT	6	7/16	
RF output connector	RxO	3	QMA	
Remote Electrical Tilt	RET	1	8-pin circular	
External Alarm Connection	EAC	1	RJ45	
Optical interface	OPT	3	SFP	3 Gbps or 6 Gbps

## Antenna Line Devices (ALDs) support

Table 149 FRGS ALD support

ALD support via antenna ports	Value
AISG	2.0 Main only
Legacy Siemens equipment	No
CWA (for non-AISG installations)	Yes
Voltage	Main = 12V/1A or 24V/30W Div = 12V/1A

Table 149 FRGS ALD support (Cont.)

ALD support via antenna ports	Value
Power per port	30 W

**Functional block diagram**

Figure 35 FRGS functional block diagram

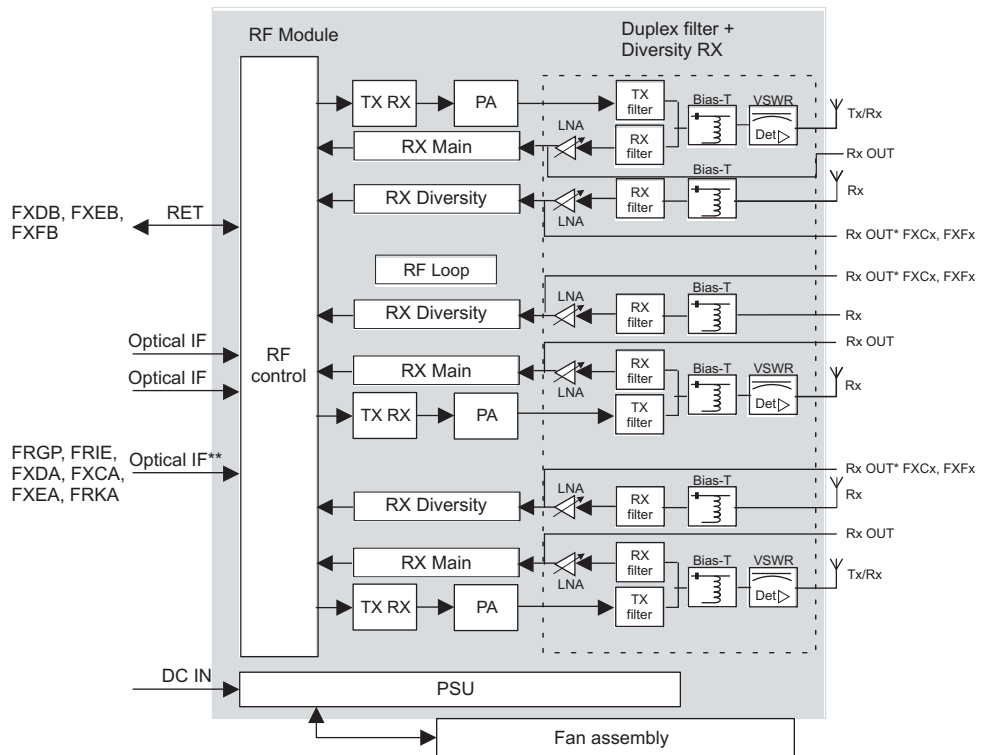

**Electrical specifications**

Table 150 FRGS electrical specifications

Property	Value
Nominal supply voltage	-48.0 V DC
Nominal input voltage range	-40.5 V DC to -57.0 V DC
Extended input voltage range	-36.0 V DC to -40.5 V DC -57.0 V DC to -60.0 V DC

## Power consumption

Table 151 FRGS power consumption

Number of TXs	RF output power per TX [W]	Estimated power consumption [W] at 48 VDC input at 23°C. Non-committed estimated values depend on the final product HW and SW optimization with +/- 10% margin.	
		50% RF Load	100% RF Load
3	80	595	892
	60	524	738
	40	405	541
	20	314	381

## Installation and mechanical specifications

Table 152 FRGS installation and mechanical specifications

Property	Value
Installation options	<ul style="list-style-type: none"> <li>stack/pole/wall installation</li> <li>directly on the wall installation</li> </ul>
IP rating	IP65
Related optional items	<ul style="list-style-type: none"> <li>Flexi Pole Mounting Kit (FPKA/C)</li> <li>Pole Mounting Kit (VMPB)</li> </ul>

## Dimensions and weight

Table 153 FRGS dimensions and weight

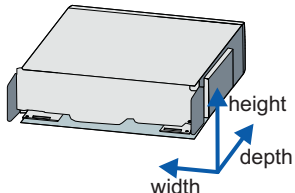
Property	Value	Dimensions orientation
Height	133 mm/ 3U (5.2 in.)	
Depth	Without front covers: 422 mm (16.6 in.)	
	With front covers: 560 mm (22.1 in.)	
Width	Without front covers: 447 mm (17.6 in.)	
	With front covers: 492 mm (19.4 in.)	
Weight	25 kg (55.1 lbs)	

## Environmental specifications

Table 154 FRGS environmental specifications

Property	Value
Maximum operational outdoor temperature (at constant high ambient temperature maximum output power might be limited)	+55°C (131°F)
Minimum operational temperature (including cold start)	-35°C (-31°F)

## LEDs

Table 155 FRGS LEDs

LED color	Description	Alarm
Red, stable	Critical alarm affecting the whole RF module or all antenna carriers	Fault
Red, blinking	Operation degraded <ul style="list-style-type: none"> <li>Major alarm affecting the whole RF Module</li> <li>Major alarm affecting the whole RF Module</li> <li>Major/Critical alarm affecting a module subcomponent or antenna carrier</li> </ul>	Major/critical alarm
Yellow, stable	<ul style="list-style-type: none"> <li>Until software download begins</li> <li>The carriers are blocked from BTS</li> <li>There is no connection to any System Module</li> </ul>	No alarm
Yellow, blinking	<ul style="list-style-type: none"> <li>Software download in progress</li> <li>Configuration in progress: RF resources are being setup, but not yet activated</li> </ul>	No alarm
Green, stable	<ul style="list-style-type: none"> <li>Software configuration is complete or supervisory: RF resources activated and transmission is possible</li> <li>Working normally, no alarm on the RF Module</li> </ul>	No alarm
Green, blinking	Software downloading and updating	No alarm
Stable Red for less than 5 seconds and changes to Stable Yellow	Switched ON, but the next conditions are not reached yet	No alarm

Table 155 FRGS LEDs (Cont.)

LED color	Description	Alarm
Stable Red for less than 5 seconds	The module is in the process of resetting	No alarm
Periodic Red and Green	Antenna line device faulty/degraded	No alarm
Blinking Colors (Red, Yellow, and Green), each color stable for 0.5 second	Module highlighting (Flexi BTS SM functionality that can help identifying faulty module)	No alarm
RF Module fan/TX status LED: Red	At least one fan is faulty or degraded	
RF Module fan/TX status LED: Green	All fans are working	
RF Module fan/TX status LED: Color set according to fan status, stable	RF transmission is ON	
RF Module fan/TX status LED: Color set according to fan status, blinking	RF transmission is OFF	

**Warnings, cautions or notes related to the product**



**WARNING! Risk of electric shock.**

Before turning RF power on, RF ports have to be terminated by nominal 50Ω load (for example, feeder with antenna). However, if these conditions are not met, the plastic caps that are delivered within the unused RF ports should remain in place. The plastic caps isolate RF power from the environment, and thus provide electric shock security in case RF power is accidentally on.



The minimum startup voltage is 40.5 V DC. If the input voltage is below/beyond extended limits, unit might shut down.

## 22 Flexi RF Module 6TX 700 (FRPA)

FRPA technical specifications.

### Functional description

Table 156 FRPA functional specification

Property	Value
Output power	6x40 W
MIMO	yes, 2TX
Outdoor installation	yes
SW supported technology	FDD-LTE
TX frequency range	758-793 MHz
RX frequency range	703-738 MHz
DL instantaneous bandwidth	35 MHz
UL instantaneous bandwidth	35 MHz
DL filter bandwidth	35 MHz
UL filter bandwidth	35 MHz

### Interfaces

Figure 36 FRPA interfaces

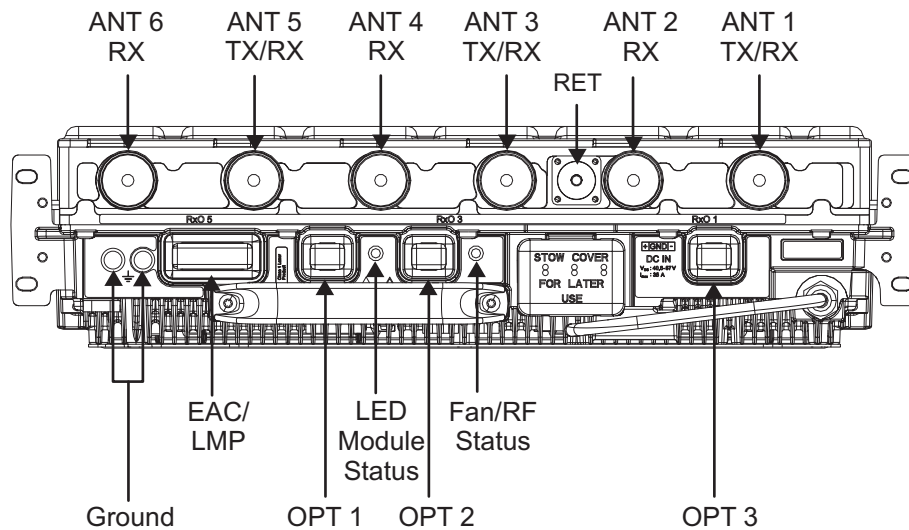

Table 157 FRPA interfaces

Interface	Label on the HW	Number of interfaces	Connector type	Additional info
Power connector	DC IN	1	Screw-interminal	
Antenna connector	ANT	6	7/16	

Table 157 FRPA interfaces (Cont.)

Interface	Label on the HW	Number of interfaces	Connector type	Additional info
Remote Electrical Tilt	RET	1	8-pin circular	
External Alarm Connection	EAC	1	MDR36	
Optical interface	OPT	3	SFP	3 Gbps or 6 Gbps

### Antenna Line Devices (ALDs) support

Table 158 FRPA ALD support

ALD support via antenna ports	Value
AISG	2.0 Main only
Legacy Siemens equipment	No
CWA (for non-AISG installations)	No
Voltage	25 V Main only
Power per port	30 W

### Functional block diagram

Figure 37 FRPA functional block diagram

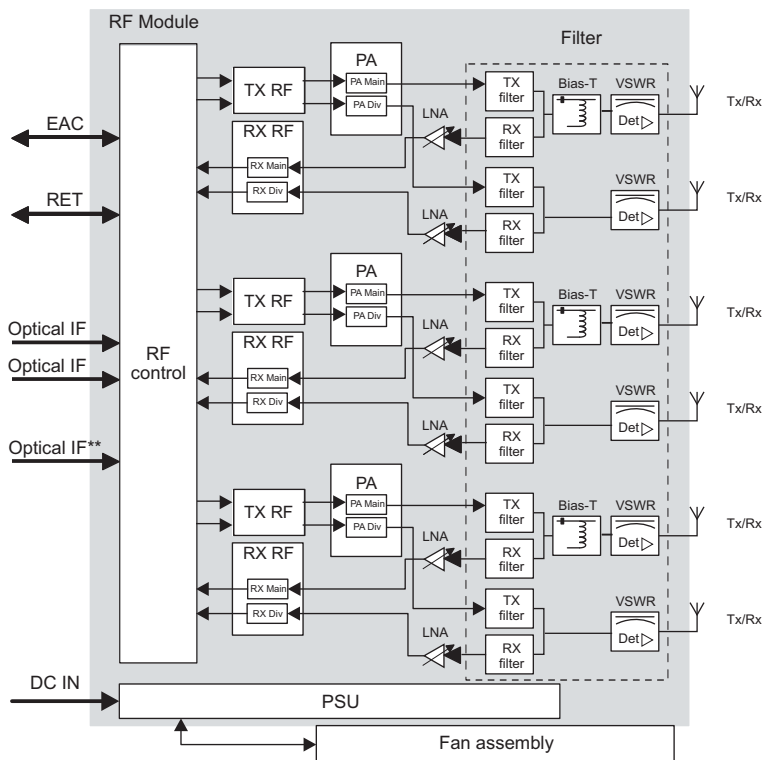

## Electrical specifications

Table 159 FRPA electrical specifications

Property	Value
Nominal supply voltage	-48.0 V DC
Nominal input voltage range	-40.5 V DC to -57.0 V DC
Extended input voltage range	-36.0 V DC to -40.5 V DC -57.0 V DC to -60.0 V DC

## Power consumption

Table 160 FRPA power consumption

Number of TXs	RF output power per TX [W]	Estimated power consumption [W] at 48 VDC input at 23°C. Non-committed estimated values depend on the final product HW and SW optimization with +/- 10% margin.	
		50% RF Load	100% RF Load
6	40	778	1038
	20	514	632

## Installation and mechanical specifications

Table 161 FRPA installation and mechanical specifications

Property	Value
Installation options	<ul style="list-style-type: none"> <li>stack/pole/wall installation</li> <li>directly on the wall installation</li> </ul>
IP rating	IP65
Related optional items	<ul style="list-style-type: none"> <li>Flexi Pole Mounting Kit (FPKA/C)</li> <li>Pole Mounting Kit (VMPB)</li> </ul>

## Dimensions and weight

Table 162 FRPA dimensions and weight

Property	Value	Dimensions orientation
Height	133 mm/ 3U (5.2 in.)	
Depth	Without front covers: 422 mm (16.6 in.)	
	With front covers: 560 mm (22.1 in.)	
Width	Without front covers: 447 mm (17.6 in.)	

Table 162 FRPA dimensions and weight (Cont.)

Property	Value	Dimensions orientation
	With front covers: 492 mm (19.4 in.)	
Weight	25 kg (55.1 lbs)	

## Environmental specifications

Table 163 FRPA environmental specifications

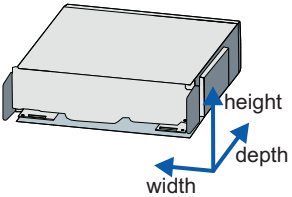
Property	Value
Maximum operational outdoor temperature (at constant high ambient temperature maximum output power might be limited)	+55°C (131°F)
Minimum operational temperature (including cold start)	-35°C (-31°F)

## LEDs

Table 164 FRPA LEDs

LED color	Description	Alarm
Red, stable	Critical alarm affecting the whole RF module or all antenna carriers	Fault
Red, blinking	Operation degraded <ul style="list-style-type: none"> <li>Major alarm affecting the whole RF Module</li> <li>Major alarm affecting the whole RF Module</li> <li>Major/Critical alarm affecting a module subcomponent or antenna carrier</li> </ul>	Major/critical alarm
Yellow, stable	<ul style="list-style-type: none"> <li>Until software download begins</li> <li>The carriers are blocked from BTS</li> <li>There is no connection to any System Module</li> </ul>	No alarm
Yellow, blinking	<ul style="list-style-type: none"> <li>Software download in progress</li> <li>Configuration in progress: RF resources are being setup, but not yet activated</li> </ul>	No alarm
Green, stable	<ul style="list-style-type: none"> <li>Software configuration is complete or supervisory: RF resources activated and transmission is possible</li> </ul>	No alarm

Table 164 FRPA LEDs (Cont.)

LED color	Description	Alarm
	<ul style="list-style-type: none"> <li>Working normally, no alarm on the RF Module</li> </ul>	
Green, blinking	Software downloading and updating	No alarm
Stable Red for less than 5 seconds and changes to Stable Yellow	Switched ON, but the next conditions are not reached yet	No alarm
Stable Red for less than 5 seconds	The module is in the process of resetting	No alarm
Periodic Red and Green	Antenna line device faulty/degraded	No alarm
Blinking Colors (Red, Yellow, and Green), each color stable for 0.5 second	Module highlighting (Flexi BTS SM functionality that can help identifying faulty module)	No alarm
RF Module fan/TX status LED: Red	At least one fan is faulty or degraded	
RF Module fan/TX status LED: Green	All fans are working	
RF Module fan/TX status LED: Color set according to fan status, stable	RF transmission is ON	
RF Module fan/TX status LED: Color set according to fan status, blinking	RF transmission is OFF	

**Warnings, cautions or notes related to the product**



**WARNING! Risk of electric shock.**

Before turning RF power on, RF ports have to be terminated by nominal 50Ω load (for example, feeder with antenna). However, if these conditions are not met, the plastic caps that are delivered within the unused RF ports should remain in place. The plastic caps isolate RF power from the environment, and thus provide electric shock security in case RF power is accidentally on.



The minimum startup voltage is 40.5 V DC. If the input voltage is below/beyond extended limits, unit might shut down.

## 23 Flexi RF Module 6TX 700 (FRPB)

FRPB technical specifications.

### Functional description

Table 165 FRPB functional specification

Property	Value
Output power	6x40 W
MIMO	yes, 2TX
Outdoor installation	yes
SW supported technology	FDD-LTE
TX frequency range	773-803 MHz
RX frequency range	718-748 MHz
DL instantaneous bandwidth	30 MHz
UL instantaneous bandwidth	30 MHz
DL filter bandwidth	30 MHz
UL filter bandwidth	30 MHz

### Interfaces

Figure 38 FRPB interfaces

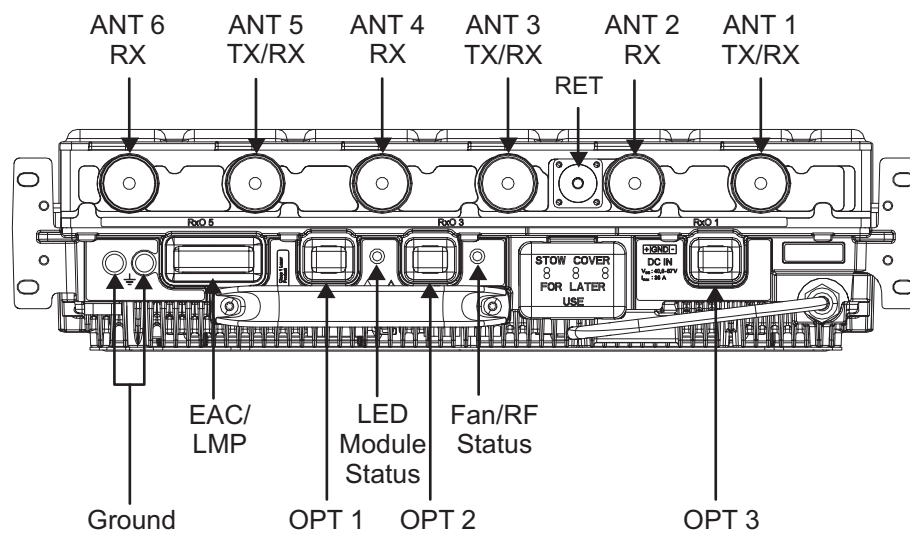

Table 166 FRPB interfaces

Interface	Label on the HW	Number of interfaces	Connector type	Additional info
Power connector	DC IN	1	Screw-interterminal	
Antenna connector	ANT	6	7/16	

Table 166 FRPB interfaces (Cont.)

Interface	Label on the HW	Number of interfaces	Connector type	Additional info
Remote Electrical Tilt	RET	1	8-pin circular	
External Alarm Connection	EAC	1	MDR36	
Optical interface	OPT	3	SFP	3 Gbps or 6 Gbps

**Antenna Line Devices (ALDs) support**

Table 167 FRPB ALD support

ALD support via antenna ports	Value
AISG	2.0 Main only
Legacy Siemens equipment	No
CWA (for non-AISG installations)	No
Voltage	25 V Main only
Power per port	30 W

**Functional block diagram**

Figure 39 FRPB functional block diagram

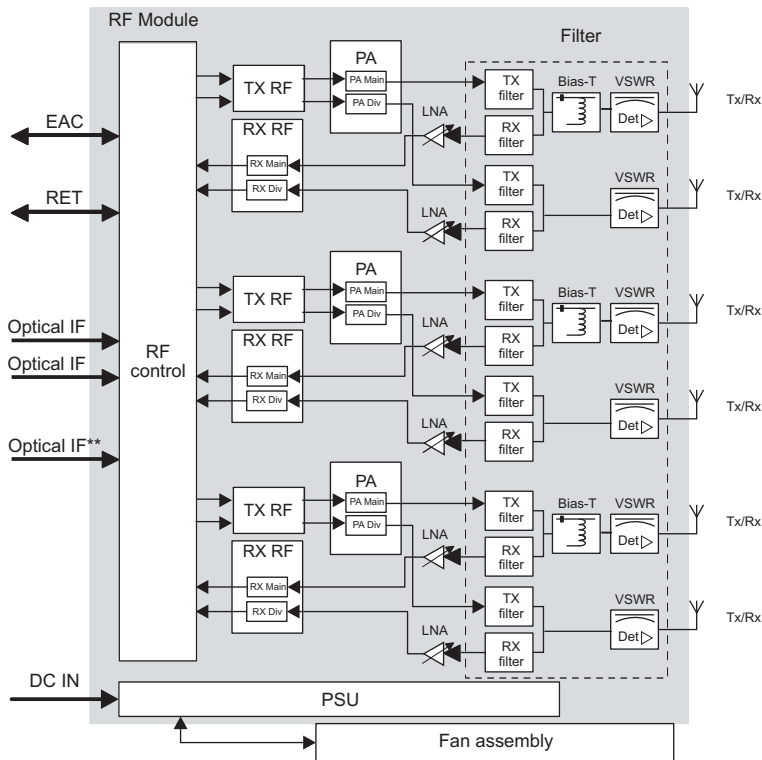

## Electrical specifications

Table 168 FRPB electrical specifications

Property	Value
Nominal supply voltage	-48.0 V DC
Nominal input voltage range	-40.5 V DC to -57.0 V DC
Extended input voltage range	-36.0 V DC to -40.5 V DC -57.0 V DC to -60.0 V DC

## Power consumption

Table 169 FRPB power consumption

Number of TXs	RF output power per TX [W]	Estimated power consumption [W] at 48 VDC input at 23°C. Non-committed estimated values depend on the final product HW and SW optimization with +/- 10% margin.	
		50% RF Load	100% RF Load
6	40	778	1033
	20	517	637

## Installation and mechanical specifications

Table 170 FRPB installation and mechanical specifications

Property	Value
Installation options	<ul style="list-style-type: none"> <li>stack/pole/wall installation</li> <li>directly on the wall installation</li> </ul>
IP rating	IP65
Related optional items	<ul style="list-style-type: none"> <li>Flexi Pole Mounting Kit (FPKA/C)</li> <li>Pole Mounting Kit (VMPB)</li> </ul>

## Dimensions and weight

Table 171 FRPB dimensions and weight

Property	Value	Dimensions orientation
Height	133 mm/ 3U (5.2 in.)	
Depth	Without front covers: 422 mm (16.6 in.)	
	With front covers: 560 mm (22.1 in.)	
Width	Without front covers: 447 mm (17.6 in.)	

Table 171 FRPB dimensions and weight (Cont.)

Property	Value	Dimensions orientation
	With front covers: 492 mm (19.4 in.)	
Weight	25 kg (55.1 lbs)	

### Environmental specifications

Table 172 FRPB environmental specifications

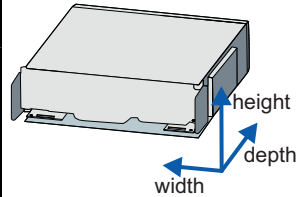
Property	Value
Maximum operational outdoor temperature (at constant high ambient temperature maximum output power might be limited)	+55°C (131°F)
Minimum operational temperature (including cold start)	-35°C (-31°F)

### LEDs

Table 173 FRPB LEDs

LED color	Description	Alarm
Red, stable	Critical alarm affecting the whole RF module or all antenna carriers	Fault
Red, blinking	Operation degraded <ul style="list-style-type: none"> <li>Major alarm affecting the whole RF Module</li> <li>Major alarm affecting the whole RF Module</li> <li>Major/Critical alarm affecting a module subcomponent or antenna carrier</li> </ul>	Major/critical alarm
Yellow, stable	<ul style="list-style-type: none"> <li>Until software download begins</li> <li>The carriers are blocked from BTS</li> <li>There is no connection to any System Module</li> </ul>	No alarm
Yellow, blinking	<ul style="list-style-type: none"> <li>Software download in progress</li> <li>Configuration in progress: RF resources are being setup, but not yet activated</li> </ul>	No alarm
Green, stable	<ul style="list-style-type: none"> <li>Software configuration is complete or supervisory: RF resources activated and transmission is possible</li> </ul>	No alarm

Table 173 FRPB LEDs (Cont.)

LED color	Description	Alarm
	<ul style="list-style-type: none"> <li>Working normally, no alarm on the RF Module</li> </ul>	
Green, blinking	Software downloading and updating	No alarm
Stable Red for less than 5 seconds and changes to Stable Yellow	Switched ON, but the next conditions are not reached yet	No alarm
Stable Red for less than 5 seconds	The module is in the process of resetting	No alarm
Periodic Red and Green	Antenna line device faulty/degraded	No alarm
Blinking Colors (Red, Yellow, and Green), each color stable for 0.5 second	Module highlighting (Flexi BTS SM functionality that can help identifying faulty module)	No alarm
RF Module fan/TX status LED: Red	At least one fan is faulty or degraded	
RF Module fan/TX status LED: Green	All fans are working	
RF Module fan/TX status LED: Color set according to fan status, stable	RF transmission is ON	
RF Module fan/TX status LED: Color set according to fan status, blinking	RF transmission is OFF	

### Warnings, cautions or notes related to the product



**WARNING! Risk of electric shock.**

Before turning RF power on, RF ports have to be terminated by nominal 50Ω load (for example, feeder with antenna). However, if these conditions are not met, the plastic caps that are delivered within the unused RF ports should remain in place. The plastic caps isolate RF power from the environment, and thus provide electric shock security in case RF power is accidentally on.



The minimum startup voltage is 40.5 V DC. If the input voltage is below/beyond extended limits, unit might shut down.

## 24 Flexi RF Module 6TX 2600 (FRHC)

FRHC technical specifications.

### Functional description

Table 174 FRHC functional specification

Property	Value
Output power	6x40 W
MIMO	yes, 2TX
Outdoor installation	yes
SW supported technology	FDD-LTE
TX frequency range	2620-2675 MHz
RX frequency range	2500-2555 MHz
DL instantaneous bandwidth	40 MHz
UL instantaneous bandwidth	40 MHz
DL filter bandwidth	55 MHz
UL filter bandwidth	55 MHz

### Interfaces

Figure 40 FRHC interfaces

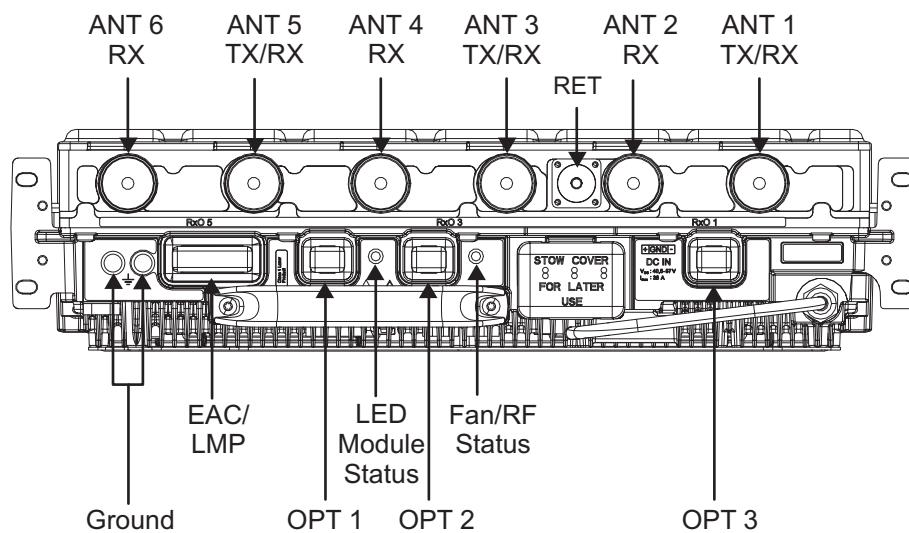

Table 175 FRHC interfaces

Interface	Label on the HW	Number of interfaces	Connector type	Additional info
Power connector	DC IN	1	Screw-interminal	
Antenna connector	ANT	6	7/16	

Table 175 FRHC interfaces (Cont.)

Interface	Label on the HW	Number of interfaces	Connector type	Additional info
Remote Electrical Tilt	RET	1	8-pin circular	
External Alarm Connection	EAC	1	MDR36	
Optical interface	OPT	3	SFP	3 Gbps or 6 Gbps

**Antenna Line Devices (ALDs) support**

Table 176 FRHC ALD support

ALD support via antenna ports	Value
AISG	2.0 Main only
Legacy Siemens equipment	No
CWA (for non-AISG installations)	No
Voltage	25 V Main only
Power per port	30 W

**Functional block diagram**

Figure 41 FRHC functional block diagram

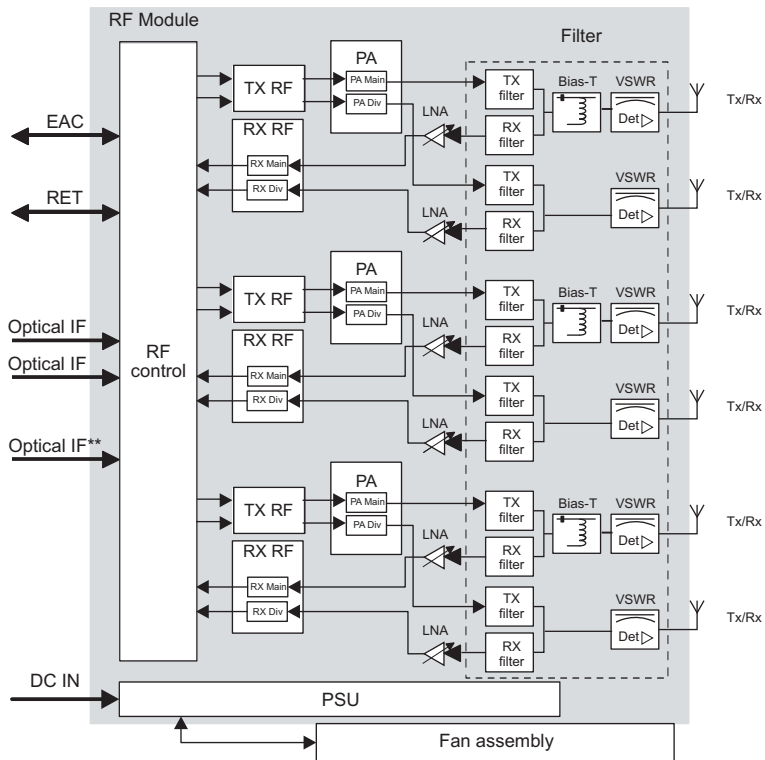

## Electrical specifications

Table 177 FRHC electrical specifications

Property	Value
Nominal supply voltage	-48.0 V DC
Nominal input voltage range	-40.5 V DC to -57.0 V DC
Extended input voltage range	-36.0 V DC to -40.5 V DC -57.0 V DC to -60.0 V DC

## Power consumption

Table 178 FRHC power consumption

Number of TXs	RF output power per TX [W]	Estimated power consumption [W] at 48 VDC input at 23°C. Non-committed estimated values depend on the final product HW and SW optimization with +/- 10% margin.	
		50% RF Load	100% RF Load
6	40	808	1101
	20	548	698

## Installation and mechanical specifications

Table 179 FRHC installation and mechanical specifications

Property	Value
Installation options	<ul style="list-style-type: none"> <li>stack/pole/wall installation</li> <li>directly on the wall installation</li> </ul>
IP rating	IP65
Related optional items	<ul style="list-style-type: none"> <li>Flexi Pole Mounting Kit (FPKA/C)</li> <li>Pole Mounting Kit (VMPB)</li> </ul>

## Dimensions and weight

Table 180 FRHC dimensions and weight

Property	Value	Dimensions orientation
Height	133 mm/ 3U (5.2 in.)	
Depth	Without front covers: 422 mm (16.6 in.)	
	With front covers: 560 mm (22.1 in.)	
Width	Without front covers: 447 mm (17.6 in.)	

Table 180 FRHC dimensions and weight (Cont.)

Property	Value	Dimensions orientation
	With front covers: 492 mm (19.4 in.)	
Weight	25 kg (55.1 lbs)	

## Environmental specifications

Table 181 FRHC environmental specifications

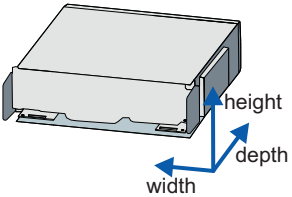
Property	Value
Maximum operational outdoor temperature (at constant high ambient temperature maximum output power might be limited)	+55°C (131°F)
Minimum operational temperature (including cold start)	-35°C (-31°F)

## LEDs

Table 182 FRHC LEDs

LED color	Description	Alarm
Red, stable	Critical alarm affecting the whole RF module or all antenna carriers	Fault
Red, blinking	Operation degraded <ul style="list-style-type: none"> <li>Major alarm affecting the whole RF Module</li> <li>Major alarm affecting the whole RF Module</li> <li>Major/Critical alarm affecting a module subcomponent or antenna carrier</li> </ul>	Major/critical alarm
Yellow, stable	<ul style="list-style-type: none"> <li>Until software download begins</li> <li>The carriers are blocked from BTS</li> <li>There is no connection to any System Module</li> </ul>	No alarm
Yellow, blinking	<ul style="list-style-type: none"> <li>Software download in progress</li> <li>Configuration in progress: RF resources are being setup, but not yet activated</li> </ul>	No alarm
Green, stable	<ul style="list-style-type: none"> <li>Software configuration is complete or supervisory: RF resources activated and transmission is possible</li> </ul>	No alarm

Table 182 FRHC LEDs (Cont.)

LED color	Description	Alarm
	<ul style="list-style-type: none"> <li>Working normally, no alarm on the RF Module</li> </ul>	
Green, blinking	Software downloading and updating	No alarm
Stable Red for less than 5 seconds and changes to Stable Yellow	Switched ON, but the next conditions are not reached yet	No alarm
Stable Red for less than 5 seconds	The module is in the process of resetting	No alarm
Periodic Red and Green	Antenna line device faulty/degraded	No alarm
Blinking Colors (Red, Yellow, and Green), each color stable for 0.5 second	Module highlighting (Flexi BTS SM functionality that can help identifying faulty module)	No alarm
RF Module fan/TX status LED: Red	At least one fan is faulty or degraded	
RF Module fan/TX status LED: Green	All fans are working	
RF Module fan/TX status LED: Color set according to fan status, stable	RF transmission is ON	
RF Module fan/TX status LED: Color set according to fan status, blinking	RF transmission is OFF	

**Warnings, cautions or notes related to the product**



**WARNING! Risk of electric shock.**

Before turning RF power on, RF ports have to be terminated by nominal 50Ω load (for example, feeder with antenna). However, if these conditions are not met, the plastic caps that are delivered within the unused RF ports should remain in place. The plastic caps isolate RF power from the environment, and thus provide electric shock security in case RF power is accidentally on.



The minimum startup voltage is 40.5 V DC. If the input voltage is below/beyond extended limits, unit might shut down.

## 25 Flexi RF Module 6TX 2600 (FRHF)

FRHF technical specifications.

### Functional description

Table 183 FRHF functional specification

Property	Value
Output power	6x40 W
MIMO	yes, 2TX
Outdoor installation	yes
SW supported technology	FDD-LTE
TX frequency range	2640-2690 MHz
RX frequency range	2520-2570 MHz
DL instantaneous bandwidth	40 MHz
UL instantaneous bandwidth	40 MHz
DL filter bandwidth	50 MHz
UL filter bandwidth	50 MHz

### Interfaces

Figure 42 FRHF interfaces

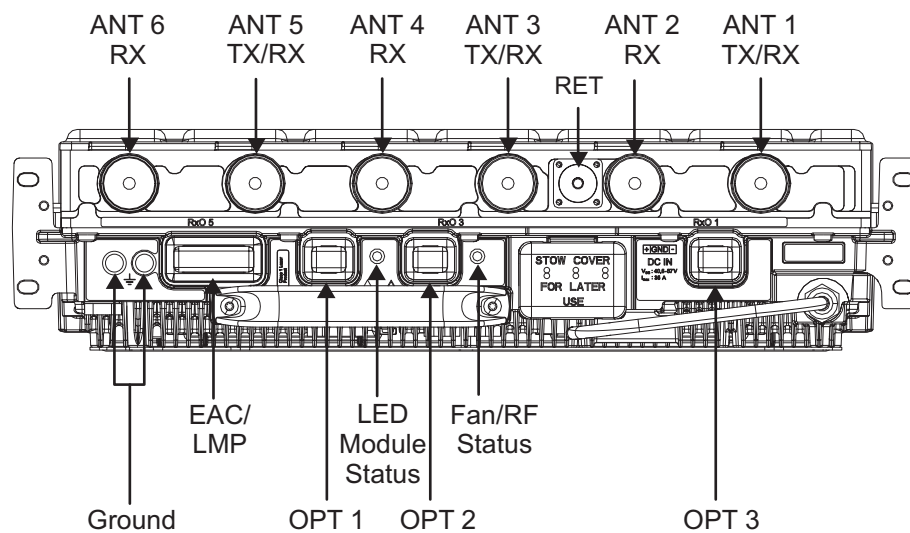

Table 184 FRHF interfaces

Interface	Label on the HW	Number of interfaces	Connector type	Additional info
Power connector	DC IN	1	Screw-interterminal	
Antenna connector	ANT	6	7/16	

Table 184 FRHF interfaces (Cont.)

Interface	Label on the HW	Number of interfaces	Connector type	Additional info
Remote Electrical Tilt	RET	1	8-pin circular	
External Alarm Connection	EAC	1	MDR36	
Optical interface	OPT	3	SFP	3 Gbps or 6 Gbps

**Antenna Line Devices (ALDs) support**

Table 185 FRHF ALD support

ALD support via antenna ports	Value
AISG	2.0 Main only
Legacy Siemens equipment	No
CWA (for non-AISG installations)	No
Voltage	25 V Main only
Power per port	30 W

**Functional block diagram**

Figure 43 FRHF functional block diagram

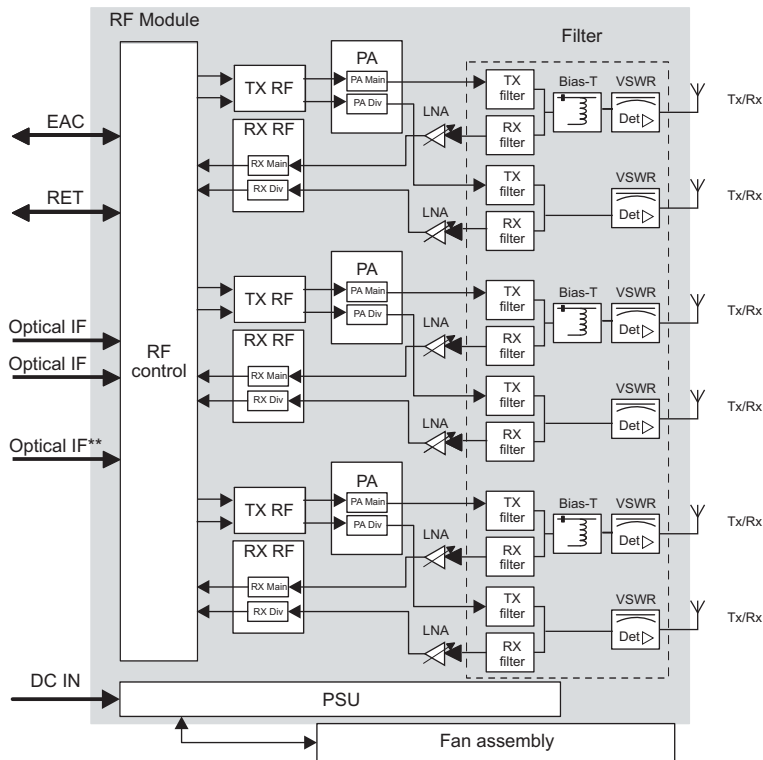

## Electrical specifications

Table 186 FRHF electrical specifications

Property	Value
Nominal supply voltage	-48.0 V DC
Nominal input voltage range	-40.5 V DC to -57.0 V DC
Extended input voltage range	-36.0 V DC to -40.5 V DC -57.0 V DC to -60.0 V DC

## Power consumption

Table 187 FRHF power consumption

Number of TXs	RF output power per TX [W]	Estimated power consumption [W] at 48 VDC input at 23°C. Non-committed estimated values depend on the final product HW and SW optimization with +/- 10% margin.	
		50% RF Load	100% RF Load
6	40	828	1148
	20	574	748

## Installation and mechanical specifications

Table 188 FRHF installation and mechanical specifications

Property	Value
Installation options	<ul style="list-style-type: none"> <li>stack/pole/wall installation</li> <li>directly on the wall installation</li> </ul>
IP rating	IP65
Related optional items	<ul style="list-style-type: none"> <li>Flexi Pole Mounting Kit (FPKA/C)</li> <li>Pole Mounting Kit (VMPB)</li> </ul>

## Dimensions and weight

Table 189 FRHF dimensions and weight

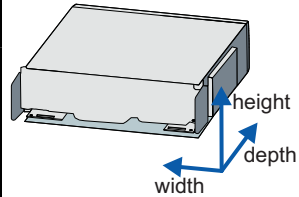
Property	Value	Dimensions orientation
Height	133 mm/ 3U (5.2 in.)	
Depth	Without front covers: 422 mm (16.6 in.)	
	With front covers: 560 mm (22.1 in.)	
Width	Without front covers: 447 mm (17.6 in.)	

*Table 189* FRHF dimensions and weight (Cont.)

Property	Value	Dimensions orientation
	With front covers: 492 mm (19.4 in.)	
Weight	25 kg (55.1 lbs)	

**Environmental specifications**

*Table 190* FRHF environmental specifications

Property	Value
Maximum operational outdoor temperature (at constant high ambient temperature maximum output power might be limited)	+55°C (131°F)
Minimum operational temperature (including cold start)	-35°C (-31°F)

**LEDs**

*Table 191* FRHF LEDs

LED color	Description	Alarm
Red, stable	Critical alarm affecting the whole RF module or all antenna carriers	Fault
Red, blinking	Operation degraded <ul style="list-style-type: none"> <li>Major alarm affecting the whole RF Module</li> <li>Major alarm affecting the whole RF Module</li> <li>Major/Critical alarm affecting a module subcomponent or antenna carrier</li> </ul>	Major/critical alarm
Yellow, stable	<ul style="list-style-type: none"> <li>Until software download begins</li> <li>The carriers are blocked from BTS</li> <li>There is no connection to any System Module</li> </ul>	No alarm
Yellow, blinking	<ul style="list-style-type: none"> <li>Software download in progress</li> <li>Configuration in progress: RF resources are being setup, but not yet activated</li> </ul>	No alarm
Green, stable	<ul style="list-style-type: none"> <li>Software configuration is complete or supervisory: RF resources activated and transmission is possible</li> </ul>	No alarm

Table 191 FRHF LEDs (Cont.)

LED color	Description	Alarm
	<ul style="list-style-type: none"> <li>Working normally, no alarm on the RF Module</li> </ul>	
Green, blinking	Software downloading and updating	No alarm
Stable Red for less than 5 seconds and changes to Stable Yellow	Switched ON, but the next conditions are not reached yet	No alarm
Stable Red for less than 5 seconds	The module is in the process of resetting	No alarm
Periodic Red and Green	Antenna line device faulty/degraded	No alarm
Blinking Colors (Red, Yellow, and Green), each color stable for 0.5 second	Module highlighting (Flexi BTS SM functionality that can help identifying faulty module)	No alarm
RF Module fan/TX status LED: Red	At least one fan is faulty or degraded	
RF Module fan/TX status LED: Green	All fans are working	
RF Module fan/TX status LED: Color set according to fan status, stable	RF transmission is ON	
RF Module fan/TX status LED: Color set according to fan status, blinking	RF transmission is OFF	

**Warnings, cautions or notes related to the product**



**WARNING! Risk of electric shock.**

Before turning RF power on, RF ports have to be terminated by nominal 50Ω load (for example, feeder with antenna). However, if these conditions are not met, the plastic caps that are delivered within the unused RF ports should remain in place. The plastic caps isolate RF power from the environment, and thus provide electric shock security in case RF power is accidentally on.



The minimum startup voltage is 40.5 V DC. If the input voltage is below/beyond extended limits, unit might shut down.

## 26 Flexi RF Module 6TX 800 (FRMC)

FRMC technical specifications.

### Functional description

Table 192 FRMC functional specification

Property	Value
Output power	6x40 W
MIMO	yes, 2TX
Outdoor installation	yes
SW supported technology	FDD-LTE
TX frequency range	801-821 MHz
RX frequency range	832-862 MHz
DL instantaneous bandwidth	20 MHz
UL instantaneous bandwidth	30 MHz
DL filter bandwidth	20 MHz
UL filter bandwidth	20 MHz

### Interfaces

Figure 44 FRMC interfaces

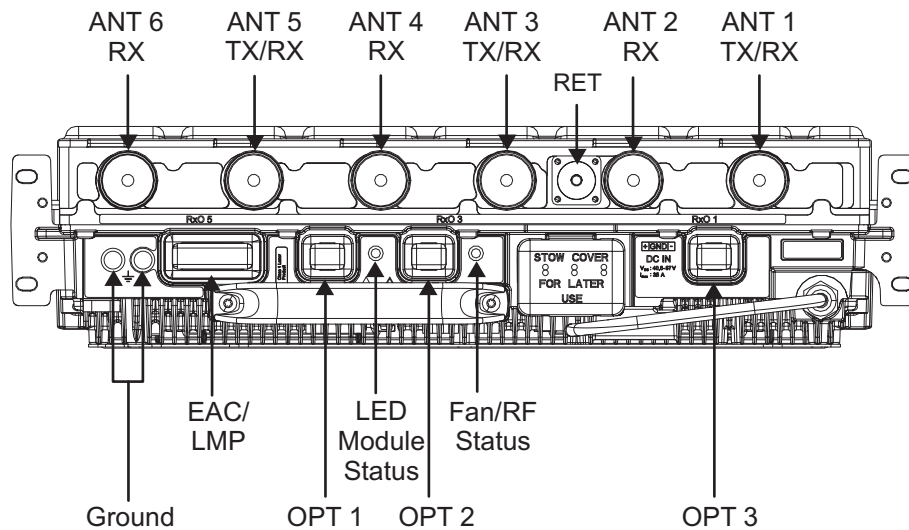

Table 193 FRMC interfaces

Interface	Label on the HW	Number of interfaces	Connector type	Additional info
Power connector	DC IN	1	Screw-interterminal	
Antenna connector	ANT	6	7/16	

Table 193 FRMC interfaces (Cont.)

Interface	Label on the HW	Number of interfaces	Connector type	Additional info
Remote Electrical Tilt	RET	1	8-pin circular	
External Alarm Connection	EAC	1	MDR36	
Optical interface	OPT	3	SFP	3 Gbps or 6 Gbps

### Antenna Line Devices (ALDs) support

Table 194 FRMC ALD support

ALD support via antenna ports	Value
AISG	2.0 Main only
Legacy Siemens equipment	No
CWA (for non-AISG installations)	No
Voltage	25 V Main only
Power per port	30 W

### Functional block diagram

Figure 45 FRMC functional block diagram

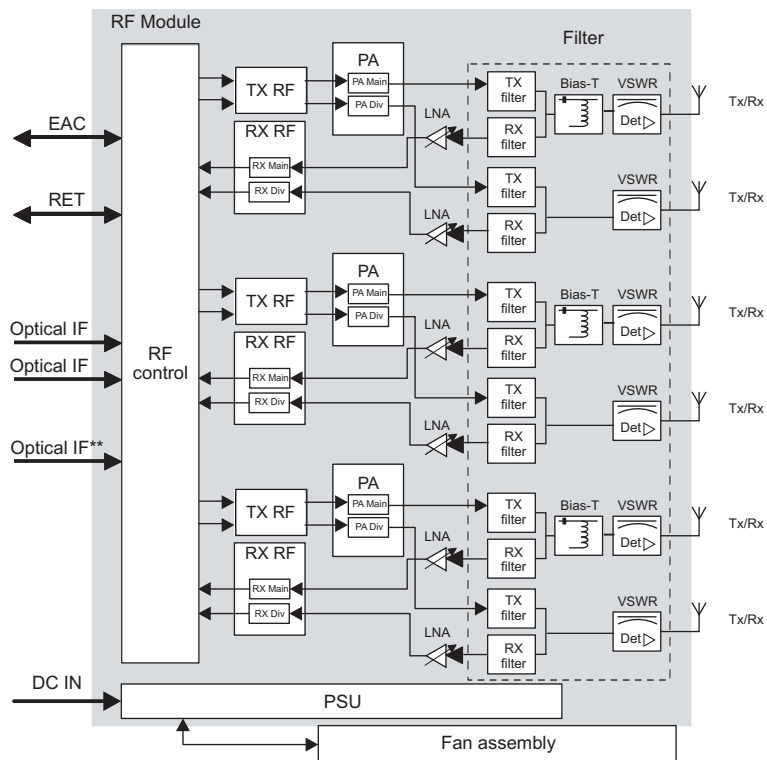

## Electrical specifications

Table 195 FRMC electrical specifications

Property	Value
Nominal supply voltage	-48.0 V DC
Nominal input voltage range	-40.5 V DC to -57.0 V DC
Extended input voltage range	-36.0 V DC to -40.5 V DC -57.0 V DC to -60.0 V DC

## Power consumption

Table 196 FRMC power consumption

Number of TXs	RF output power per TX [W]	Estimated power consumption [W] at 48 VDC input at 23°C. Non-committed estimated values depend on the final product HW and SW optimization with +/- 10% margin.	
		50% RF Load	100% RF Load
6	40	784	1071
	20	510	657

## Installation and mechanical specifications

Table 197 FRMC installation and mechanical specifications

Property	Value
Installation options	<ul style="list-style-type: none"> <li>stack/pole/wall installation</li> <li>directly on the wall installation</li> </ul>
IP rating	IP65
Related optional items	<ul style="list-style-type: none"> <li>Flexi Pole Mounting Kit (FPKA/C)</li> <li>Pole Mounting Kit (VMPB)</li> </ul>

## Dimensions and weight

Table 198 FRMC dimensions and weight

Property	Value	Dimensions orientation
Height	133 mm/ 3U (5.2 in.)	
Depth	Without front covers: 422 mm (16.6 in.)	
	With front covers: 560 mm (22.1 in.)	
Width	Without front covers: 447 mm (17.6 in.)	

Table 198 FRMC dimensions and weight (Cont.)

Property	Value	Dimensions orientation
	With front covers: 492 mm (19.4 in.)	
Weight	25 kg (55.1 lbs)	

### Environmental specifications

Table 199 FRMC environmental specifications

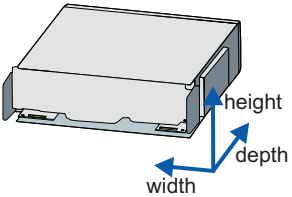
Property	Value
Maximum operational outdoor temperature (at constant high ambient temperature maximum output power might be limited)	+55°C (131°F)
Minimum operational temperature (including cold start)	-35°C (-31°F)

### LEDs

Table 200 FRMC LEDs

LED color	Description	Alarm
Red, stable	Critical alarm affecting the whole RF module or all antenna carriers	Fault
Red, blinking	Operation degraded <ul style="list-style-type: none"> <li>Major alarm affecting the whole RF Module</li> <li>Major alarm affecting the whole RF Module</li> <li>Major/Critical alarm affecting a module subcomponent or antenna carrier</li> </ul>	Major/critical alarm
Yellow, stable	<ul style="list-style-type: none"> <li>Until software download begins</li> <li>The carriers are blocked from BTS</li> <li>There is no connection to any System Module</li> </ul>	No alarm
Yellow, blinking	<ul style="list-style-type: none"> <li>Software download in progress</li> <li>Configuration in progress: RF resources are being setup, but not yet activated</li> </ul>	No alarm
Green, stable	<ul style="list-style-type: none"> <li>Software configuration is complete or supervisory: RF resources activated and transmission is possible</li> </ul>	No alarm

Table 200 FRMC LEDs (Cont.)

LED color	Description	Alarm
	<ul style="list-style-type: none"> <li>Working normally, no alarm on the RF Module</li> </ul>	
Green, blinking	Software downloading and updating	No alarm
Stable Red for less than 5 seconds and changes to Stable Yellow	Switched ON, but the next conditions are not reached yet	No alarm
Stable Red for less than 5 seconds	The module is in the process of resetting	No alarm
Periodic Red and Green	Antenna line device faulty/degraded	No alarm
Blinking Colors (Red, Yellow, and Green), each color stable for 0.5 second	Module highlighting (Flexi BTS SM functionality that can help identifying faulty module)	No alarm
RF Module fan/TX status LED: Red	All fans are faulty	
RF Module fan/TX status LED: Green	All fans are working	
RF Module fan/TX status LED: Color set according to fan status, stable	RF transmission is ON	
RF Module fan/TX status LED: Color set according to fan status, blinking	RF transmission is OFF	

**Warnings, cautions or notes related to the product**



**WARNING! Risk of electric shock.**

Before turning RF power on, RF ports have to be terminated by nominal 50Ω load (for example, feeder with antenna). However, if these conditions are not met, the plastic caps that are delivered within the unused RF ports should remain in place. The plastic caps isolate RF power from the environment, and thus provide electric shock security in case RF power is accidentally on.



The minimum startup voltage is 40.5 V DC. If the input voltage is below/beyond extended limits, unit might shut down.

## 27 Flexi RFM 6-pipe 1800 360W (FXED)

FXED technical specifications.

### Functional description

Table 201 FXED functional specification

Property	Value
Output power	6x60 W
MIMO	yes, 2TX
Outdoor installation	yes
SW supported technology	FDD-LTE
TX frequency range	1805 - 1880 MHz
RX frequency range	1710 - 1785 MHz
DL instantaneous bandwidth	60 MHz 45 MHz in GSM/multimode
UL instantaneous bandwidth	60 MHz
DL filter bandwidth	75 MHz
UL filter bandwidth	75 MHz

### Interfaces

Figure 46 FXED interfaces

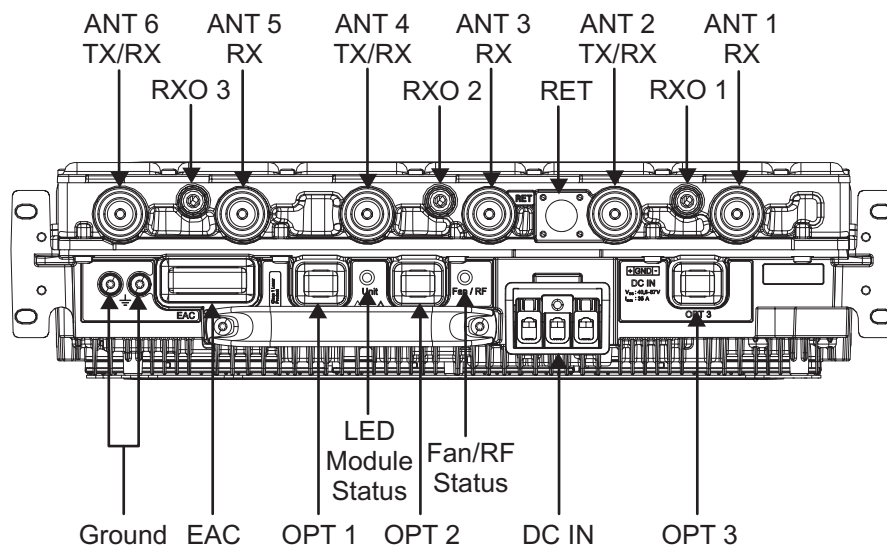

Table 202 FXED interfaces

Interface	Label on the HW	Number of interfaces	Connector type	Additional info
Power connector	DC IN	1	3-pole screw terminal	

*Table 202* FXED interfaces (Cont.)

Interface	Label on the HW	Number of interfaces	Connector type	Additional info
Antenna connector	ANT	6	7/16	
RF output connector	RxO	3	QMA	
Remote Electrical Tilt	RET	1	8-pin circular	
External Alarm Connection	EAC	1	MDR36	
Optical interface	OPT	3	SFP	3 Gbps or 6 Gbps

**Antenna Line Devices (ALDs) support**

*Table 203* FXED ALD support

ALD support via antenna ports	Value
AISG	2.0 Main only
Legacy Siemens equipment	No
CWA (for non-AISG installations)	No
Voltage	Main 25V/12V Div 12V
Power per port	30 W

## Functional block diagram

Figure 47 FXED functional block diagram

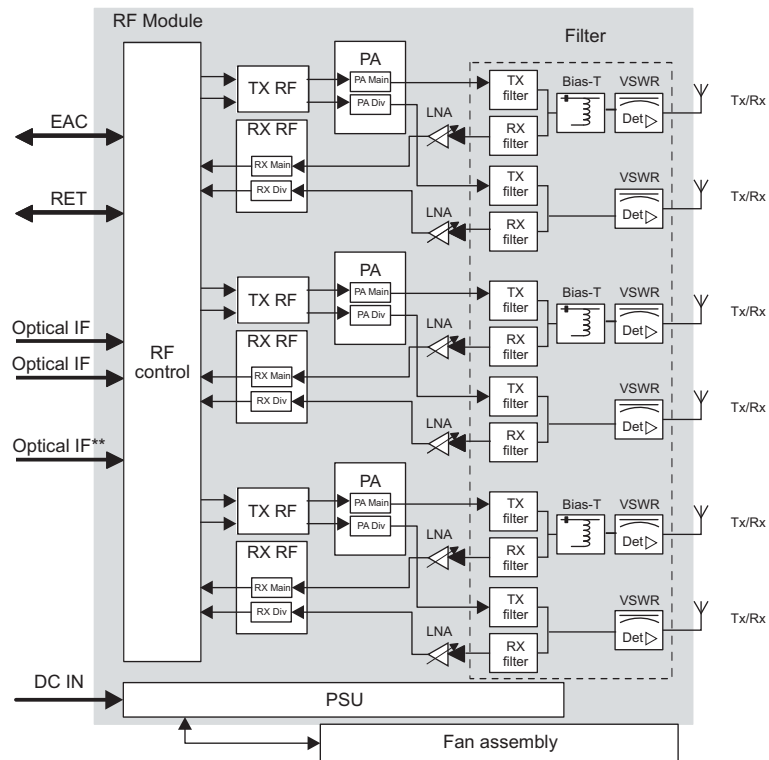

## Electrical specifications

Table 204 FXED electrical specifications

Property	Value
Nominal supply voltage	-48.0 V DC
Nominal input voltage range	-40.5 V DC to -57.0 V DC
Extended input voltage range	-36.0 V DC to -40.5 V DC -57.0 V DC to -60.0 V DC

## Power consumption

Table 205 FXED power consumption

Number of TXs	RF output power per TX [W]	Estimated power consumption [W] at 48 VDC input at 23°C. Non-committed estimated values depend on the final product HW and SW optimization with +/- 10% margin. Values preliminary estimated.	
		50% RF Load	100% RF Load
6	60	1100	1547
	40	812	1140

Table 205 FXED power consumption (Cont.)

Number of TXs	RF output power per TX [W]	Estimated power consumption [W] at 48 VDC input at 23°C. Non-committed estimated values depend on the final product HW and SW optimization with +/- 10% margin. Values preliminary estimated.	
		50% RF Load	100% RF Load
	20	499	667

### Installation and mechanical specifications

Table 206 FXED installation and mechanical specifications

Property	Value
Installation options	<ul style="list-style-type: none"> <li>stack/pole/wall installation</li> <li>directly on the wall installation</li> </ul>
IP rating	IP65
Related optional items	<ul style="list-style-type: none"> <li>Flexi Pole Mounting Kit (FPKA/C)</li> <li>Pole Mounting Kit (VMPB)</li> </ul>

### Dimensions and weight

Table 207 FXED dimensions and weight

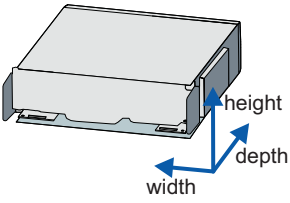
Property	Value	Dimensions orientation
Height	133 mm/ 3U (5.2 in.)	
Depth	Without front covers: 422 mm (16.6 in.)	
	With front covers: 560 mm (22.1 in.)	
Width	Without front covers: 447 mm (17.6 in.)	
	With front covers: 492 mm (19.4 in.)	
Weight	25 kg (55.1 lbs)	

### Environmental specifications

Table 208 FXED environmental specifications

Property	Value
Maximum operational outdoor temperature (at constant high ambient temperature maximum output power might be limited)	+55°C (131°F)

Table 208 FXED environmental specifications (Cont.)

Property	Value
Minimum operational temperature (including cold start)	-35°C (-31°F)

## LEDs

Table 209 FXED LEDs

LED color	Description	Alarm
Red, stable	Critical alarm affecting the whole RF module or all antenna carriers	Fault
Red, blinking	Operation degraded <ul style="list-style-type: none"> <li>Major alarm affecting the whole RF Module</li> <li>Major alarm affecting the whole RF Module</li> <li>Major/Critical alarm affecting a module subcomponent or antenna carrier</li> </ul>	Major/critical alarm
Yellow, stable	<ul style="list-style-type: none"> <li>Until software download begins</li> <li>The carriers are blocked from BTS</li> <li>There is no connection to any System Module</li> </ul>	No alarm
Yellow, blinking	<ul style="list-style-type: none"> <li>Software download in progress</li> <li>Configuration in progress: RF resources are being setup, but not yet activated</li> </ul>	No alarm
Green, stable	<ul style="list-style-type: none"> <li>Software configuration is complete or supervisory: RF resources activated and transmission is possible</li> <li>Working normally, no alarm on the RF Module</li> </ul>	No alarm
Green, blinking	Software downloading and updating	No alarm
Stable Red for less than 5 seconds and changes to Stable Yellow	Switched ON, but the next conditions are not reached yet	No alarm
Stable Red for less than 5 seconds	The module is in the process of resetting	No alarm
Periodic Red and Green	Antenna line device faulty/degraded	No alarm

Table 209 FXED LEDs (Cont.)

LED color	Description	Alarm
Blinking Colors (Red, Yellow, and Green), each color stable for 0.5 second	Module highlighting (Flexi BTS SM functionality that can help identifying faulty module)	No alarm
RF Module fan/TX status LED: Red	At least one fan is faulty or degraded	
RF Module fan/TX status LED: Green	All fans are working	
RF Module fan/TX status LED: Color set according to fan status, stable	RF transmission is ON	
RF Module fan/TX status LED: Color set according to fan status, blinking	RF transmission is OFF	

**Warnings, cautions or notes related to the product**



**WARNING! Risk of electric shock.**

Before turning RF power on, RF ports have to be terminated by nominal 50Ω load (for example, feeder with antenna). However, if these conditions are not met, the plastic caps that are delivered within the unused RF ports should remain in place. The plastic caps isolate RF power from the environment, and thus provide electric shock security in case RF power is accidentally on.



The minimum startup voltage is 40.5 V DC. If the input voltage is below/beyond extended limits, unit might shut down.

## 28 Flexi Remote Radio Head 2TX 850 (FHCA)

FHCA technical specifications.

### Functional description

Table 210 FHCA functional specification

Property	Value
Output power	2x20 W
MIMO	yes, 2TX
Outdoor installation	yes
SW supported technology	FDD-LTE
TX frequency range	869-894 MHz
RX frequency range	824-849 MHz
DL instantaneous bandwidth	15 MHz
UL instantaneous bandwidth	15 MHz
DL filter bandwidth	25 MHz
UL filter bandwidth	25 MHz

### Interfaces

Figure 48 FHCA interfaces

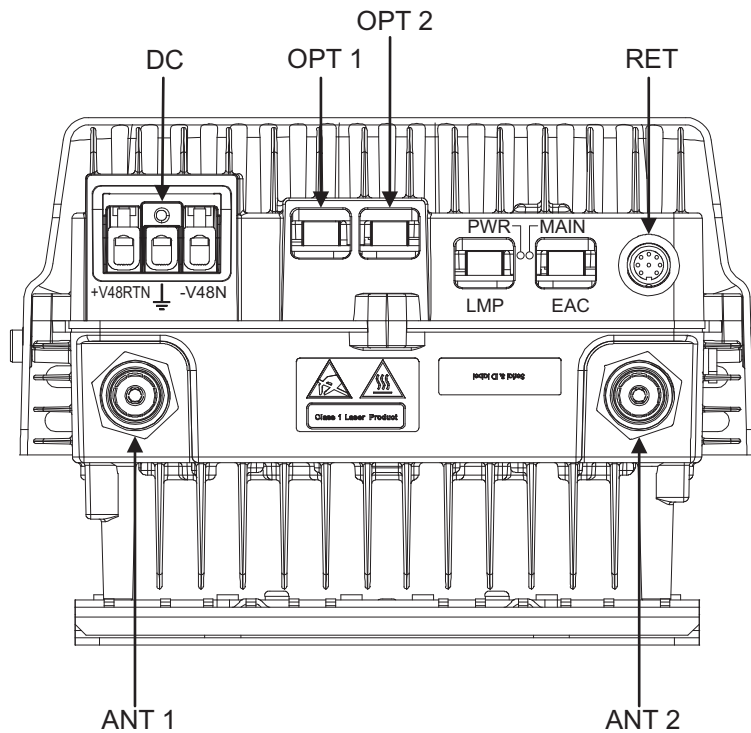

Table 211 FHCA interfaces

Interface	Label on the HW	Number of interfaces	Connector type	Additional info
Power connector	DC IN	1	3-pole screw terminal	
Antenna connector	ANT	2	7/16	
Remote Electrical Tilt	RET	1	8-pin circular	
External Alarm Connection	EAC	1	D-sub MDR14	
Optical interface	OPT	2	SFP	6 Gbps

**Antenna Line Devices (ALDs) support**

Table 212 FHCA ALD support

ALD support via antenna ports	Value
AISG	2.0 Main only
Legacy Siemens equipment	No
CWA (for non-AISG installations)	No
Voltage	14.5 V
Power per port	17 W

**Functional block diagram**

Figure 49 FHCA functional block diagram

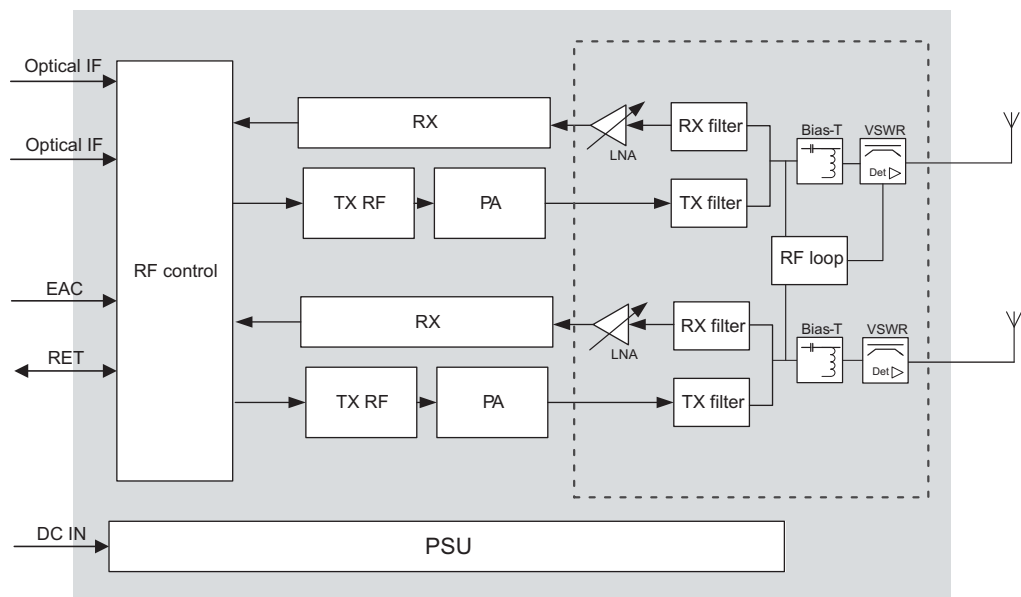

## Electrical specifications

Table 213 FHCA electrical specifications

Property	Value
Nominal supply voltage	-48.0 V DC
Nominal input voltage range	-40.5 V DC to -57.0 V DC
Extended input voltage range	-36.0 V DC to -40.5 V DC -57.0 V DC to -60.0 V DC

## Power consumption

Table 214 FHCA power consumption

Number of TXs	RF output power per TX [W]	Estimated power consumption [W] at 48 VDC input at 23°C. Non-committed estimated values depend on the final product HW and SW optimization with +/- 10% margin.	
		50% RF Load	100% RF Load
2	20	200	240

## Installation and mechanical specifications

Table 215 FHCA installation and mechanical specifications

Property	Value
Installation options	<ul style="list-style-type: none"> <li>pole/wall installation</li> <li>directly on the wall installation</li> </ul>
IP rating	IP65
Related optional items	<ul style="list-style-type: none"> <li>Flexi Pole Mounting Kit (FPKA/C)</li> <li>Pole Mounting Kit (VMPB)</li> </ul>

## Dimensions and weight

Table 216 FHCA dimensions and weight

Property	Value	Dimensions orientation
Height	As delivered, cable tie point recessed: 579 mm (22.7 in.) As installed, cable tie point released due to brackets and solar shields: 733 mm (28.8 in.)	<p>The diagram shows a 3D perspective view of the FHCA unit. Three blue arrows indicate the dimensions: 'height' points to the vertical dimension, 'width' points to the front horizontal dimension, and 'depth' points to the side horizontal dimension.</p>
Depth	215 mm (8.4 in.)	
Width	358 mm (14.1 in.)	
Weight	20 kg (44 lbs)	

## Environmental specifications

Table 217 FHCA environmental specifications

Property	Value
Maximum operational outdoor temperature in the shade (at constant high ambient temperature maximum output power might be limited)	+55°C (131°F)
Maximum operational outdoor temperature in the sun (according to GR-487-Core specification)	+50°C (122°F)
Maximum indoor temperature (this is valid for fanless products)	+45°C (129.2°F)
Minimum operational temperature (including cold start)	-40°C (-40°F)

## LEDs

Table 218 FHCA LEDs

LED color	Description	Alarm
Red, stable	Critical alarm affecting the whole RF module or all antenna carriers	Fault
Red, blinking	Operation degraded <ul style="list-style-type: none"> <li>Major alarm affecting the whole RF Module</li> </ul>	Major/critical alarm

Table 218 FHCA LEDs (Cont.)

LED color	Description	Alarm
	<ul style="list-style-type: none"> <li>Critical alarm affecting fans</li> <li>Major/Critical alarm affecting a module subcomponent or antenna carrier</li> </ul>	
Yellow, stable	<ul style="list-style-type: none"> <li>Until software download begins</li> <li>The carriers are blocked from BTS</li> <li>There is no connection to any System Module</li> </ul>	No alarm
Yellow, blinking	<ul style="list-style-type: none"> <li>Software download in progress</li> <li>Configuration in progress: RF resources are being setup, but not yet activated</li> </ul>	No alarm
Green, stable	<ul style="list-style-type: none"> <li>Software configuration is complete or supervisory: RF resources activated and transmission is possible</li> <li>Working normally, no alarm on the RF Module</li> </ul>	No alarm
Green, blinking	Software downloading and updating	No alarm
Stable Red for less than 5 seconds and changes to Stable Yellow	Switched ON, but the next conditions are not reached yet	No alarm
Stable Red for less than 5 seconds	The module is in the process of resetting	No alarm
Periodic Red and Green	Antenna line device faulty/degraded	No alarm
Blinking Colors (Red, Yellow, and Green), each color stable for 0.5 second	Module highlighting (Flexi BTS SM functionality that can help identifying faulty module)	No alarm

**Warnings, cautions or notes related to the product**



**NOTICE:** The RRH should always be mounted in a vertical orientation with connectors on the bottom side to ensure convection cooling.



The minimum startup voltage is 40.5 V DC. If the input voltage is below/beyond extended limits, unit might shut down.

## 29 Flexi Remote Radio Head 2TX 730 (FRLB)

FRLB technical specifications.

### Functional description

Table 219 FRLB functional specification

Property	Value
Output power	2x30 W
MIMO	yes, 2TX
Outdoor installation	yes
SW supported technology	FDD-LTE
TX frequency range	729-745 MHz
RX frequency range	699-715 MHz
DL instantaneous bandwidth	16 MHz
UL instantaneous bandwidth	16 MHz
DL filter bandwidth	16 MHz
UL filter bandwidth	16 MHz

### Interfaces

Figure 50 FRLB interfaces

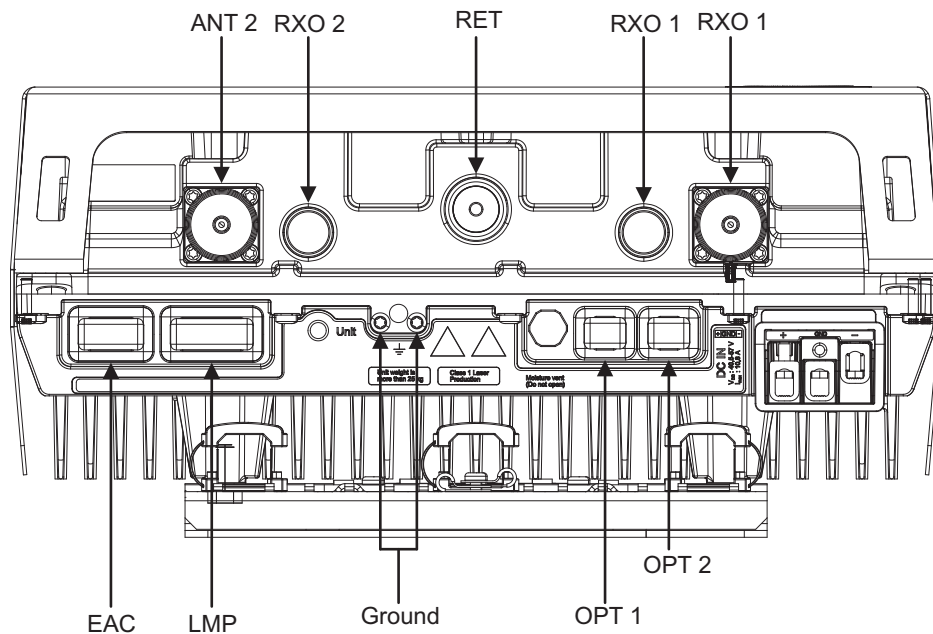

Table 220 FRLB interfaces

Interface	Label on the HW	Number of interfaces	Connector type	Additional info
Power connector	DC IN	1	3-pole screw terminal	

Table 220 FRLB interfaces (Cont.)

Interface	Label on the HW	Number of interfaces	Connector type	Additional info
Antenna connector	ANT	2	7/16	
RF external connector	Rx EXT	2	QMA	
Remote Electrical Tilt	RET	1	8-pin circular	
External Alarm Connection	EAC	1	D-sub MDR14	
Optical interface	OPT	2	SFP	3 Gbps
Local Management Port	LMP	1	2x15 pin header	

### Antenna Line Devices (ALDs) support

Table 221 FRLB ALD support

ALD support via antenna ports	Value
AISG	2.0 Main only
Legacy Siemens equipment	No
CWA (for non-AISG installations)	No
Voltage	24 V
Power per port	30 W

### Functional block diagram

Figure 51 FRLB functional block diagram

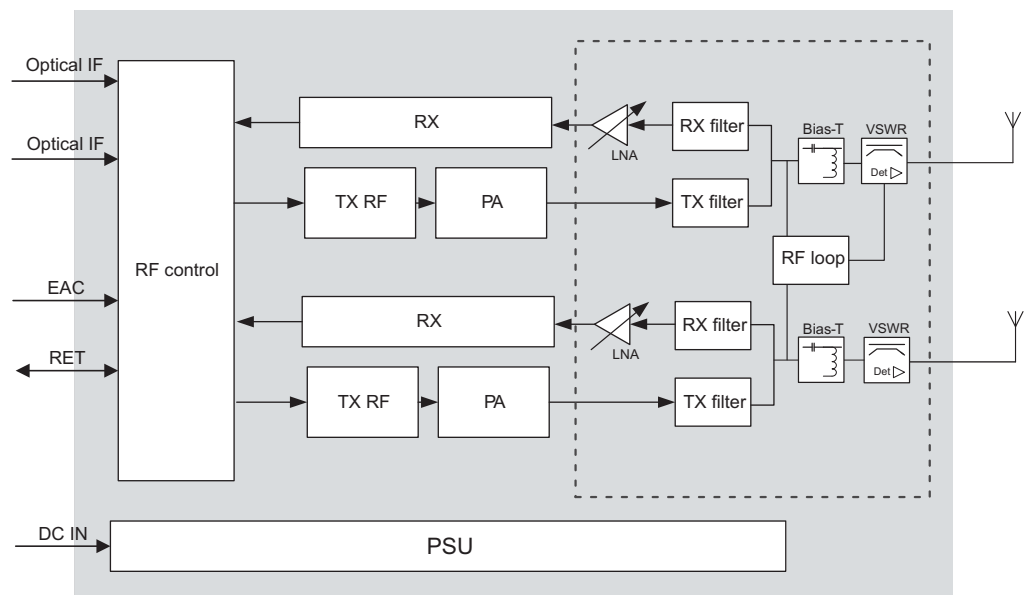

## Electrical specifications

Table 222 FRLB electrical specifications

Property	Value
Nominal supply voltage	-48.0 V DC
Nominal input voltage range	-40.5 V DC to -57.0 V DC
Extended input voltage range	-36.0 V DC to -40.5 V DC -57.0 V DC to -60.0 V DC

## Power consumption

Table 223 FRLB power consumption

Number of TXs	RF output power per TX [W]	Estimated power consumption [W] at 48 VDC input at 23°C. Non-committed estimated values depend on the final product HW and SW optimization with +/- 10% margin.	
		50% RF Load	100% RF Load
2	30	248	321
	20	192	239

## Installation and mechanical specifications

Table 224 FRLB installation and mechanical specifications

Property	Value
Installation options	<ul style="list-style-type: none"> <li>pole/wall installation</li> <li>directly on the wall installation</li> </ul>
IP rating	IP65
Related optional items	<ul style="list-style-type: none"> <li>Flexi Pole Mounting Kit (FPKA/C)</li> <li>Pole Mounting Kit (VMPB)</li> </ul>

## Dimensions and weight

Table 225 FRLB dimensions and weight

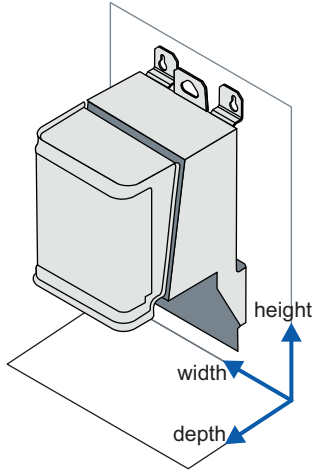
Property	Value	Dimensions orientation
Height	400 mm (15.7 in.)	 <p>The diagram shows a 3D perspective view of the FRLB. Three blue arrows indicate the dimensions: 'height' points vertically upwards from the base to the top edge; 'width' points horizontally across the front face; and 'depth' points horizontally from the front face towards the back of the device.</p>
Depth	150 mm (5.9 in.)	
Width	400 mm (15.7 in.)	
Weight	Without solar shield and mounting shroud: 27 kg (59.5 lbs)	

## Environmental specifications

Table 226 FRLB environmental specifications

Property	Value
Maximum operational outdoor temperature in the shade (at constant high ambient temperature maximum output power might be limited)	+55°C (131°F)
Maximum operational outdoor temperature in the sun (according to GR-487-Core specification)	+50°C (122°F)
Maximum indoor temperature (this is valid for fanless products)	+45°C (129.2°F)
Minimum operational temperature (including cold start)	-40°C (-40°F)

## LEDs

Table 227 FRLB LEDs

LED color	Description	Alarm
Red, stable	Critical alarm affecting the whole RF module or all antenna carriers	Fault
Red, blinking	Operation degraded <ul style="list-style-type: none"> <li>Major alarm affecting the whole RF Module</li> </ul>	Major/critical alarm

Table 227 FRLB LEDs (Cont.)

LED color	Description	Alarm
	<ul style="list-style-type: none"> <li>Critical alarm affecting fans</li> <li>Major/Critical alarm affecting a module subcomponent or antenna carrier</li> </ul>	
Yellow, stable	<ul style="list-style-type: none"> <li>Until software download begins</li> <li>The carriers are blocked from BTS</li> <li>There is no connection to any System Module</li> </ul>	No alarm
Yellow, blinking	<ul style="list-style-type: none"> <li>Software download in progress</li> <li>Configuration in progress: RF resources are being setup, but not yet activated</li> </ul>	No alarm
Green, stable	<ul style="list-style-type: none"> <li>Software configuration is complete or supervisory: RF resources activated and transmission is possible</li> <li>Working normally, no alarm on the RF Module</li> </ul>	No alarm
Green, blinking	Software downloading and updating	No alarm
Stable Red for less than 5 seconds and changes to Stable Yellow	Switched ON, but the next conditions are not reached yet	No alarm
Stable Red for less than 5 seconds	The module is in the process of resetting	No alarm
Periodic Red and Green	Antenna line device faulty/degraded	No alarm
Blinking Colors (Red, Yellow, and Green), each color stable for 0.5 second	Module highlighting (Flexi BTS SM functionality that can help identifying faulty module)	No alarm

**Warnings, cautions or notes related to the product**



**NOTICE:** The RRH should always be mounted in a vertical orientation with connectors on the bottom side to ensure convection cooling.



The minimum startup voltage is 40.5 V DC. If the input voltage is below/beyond extended limits, unit might shut down.

## 30 Flexi RRH 2-pipe 900 80W (FHDA)

FHDA technical specifications.

### Functional description

Table 228 FHDA functional specification

Property	Value
Output power	2x40 W
MIMO	yes, 2TX
Outdoor installation	yes
SW supported technologies	GSM, WCDMA
TX frequency range	925-960 MHz
RX frequency range	880-915 MHz
DL instantaneous bandwidth	A.10x version: 25 MHz A.20x version: 30.2 MHz
UL instantaneous bandwidth	35 MHz
DL filter bandwidth	35 MHz
UL filter bandwidth	35 MHz

### Interfaces

Figure 52 FHDA interfaces

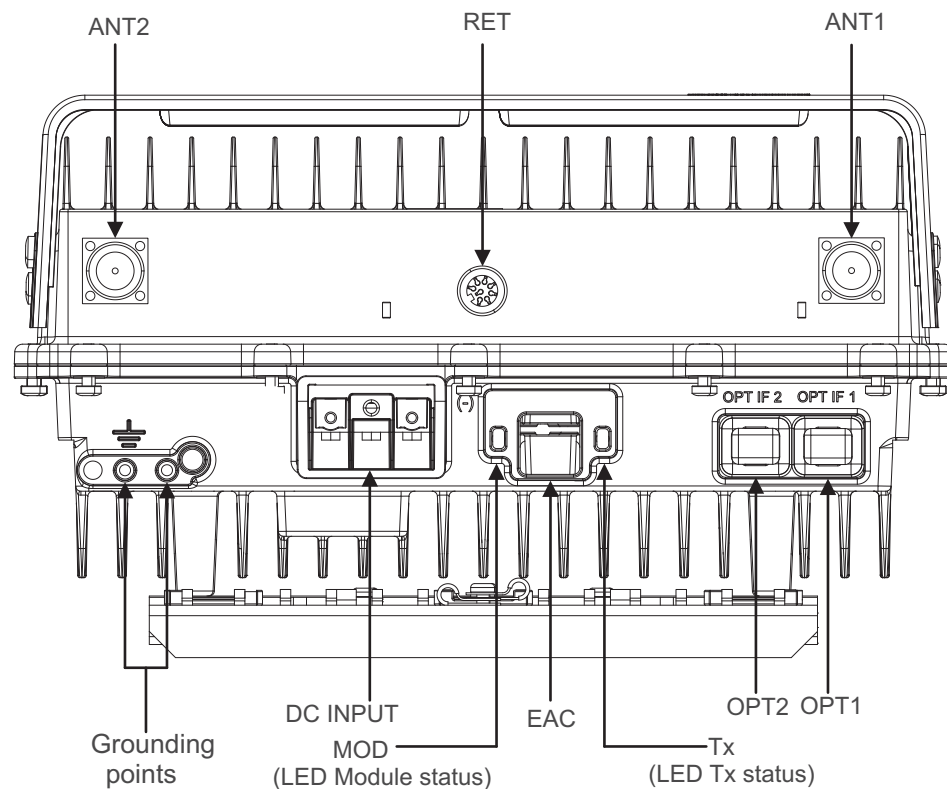

Table 229 FHDA interfaces

Interface	Label on the HW	Number of interfaces	Connector type	Additional info
Power connector	DC IN	1	3-pole screw terminal	
Antenna connector	ANT	2	7/16	
Remote Electrical Tilt	RET	1	8-pin circular	
External Alarm Connection	EAC	1	RJ45	
Optical interface	OPT	2	SFP	3 Gbps
Local Management Port	LMP	1	-	

### Antenna Line Devices (ALDs) support

Table 230 FHDA ALD support

ALD support via antenna ports	Value
AISG	2.0 Main+Div
Legacy Siemens equipment	No
CWA (for non-AISG installations)	No
Voltage	14.5 V
Power per port	30 W

### Functional block diagram

Figure 53 FHDA functional block diagram

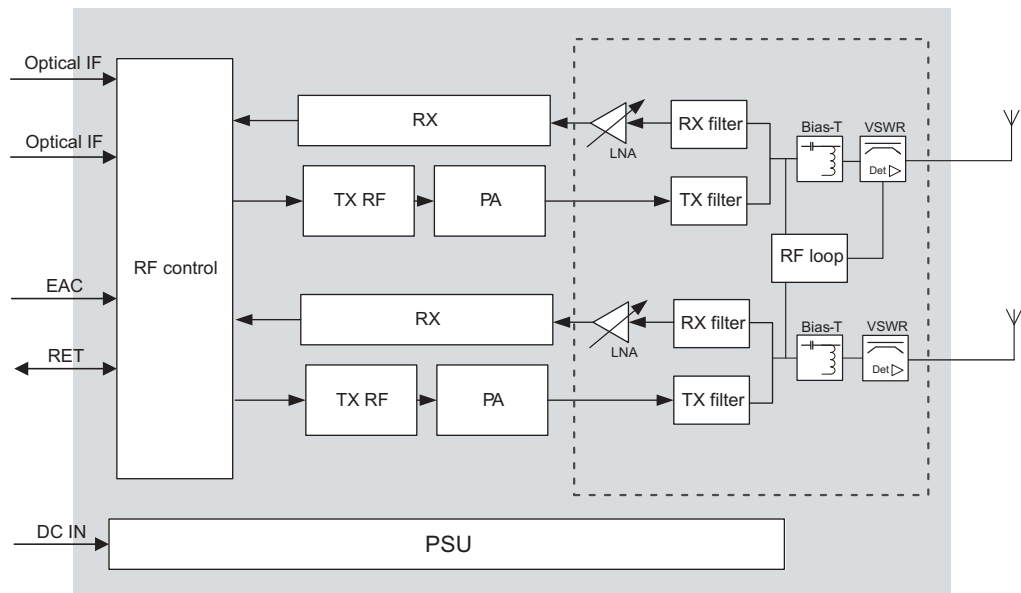

## Electrical specifications

Table 231 FHDA electrical specifications

Property	Value
Nominal supply voltage	-48.0 V DC
Nominal input voltage range	-40.5 V DC to -57.0 V DC
Extended input voltage range	-36.0 V DC to -40.5 V DC -57.0 V DC to -60.0 V DC

## Power consumption

Table 232 FHDA power consumption

Number of TXs	RF output power per TX [W]	Estimated power consumption [W] at 48 VDC input at 23°C. Non-committed estimated values depend on the final product HW and SW optimization with +/- 10% margin.	
		50% RF Load	100% RF Load
2	40	305	344
	20	192	233

## Installation and mechanical specifications

Table 233 FHDA installation and mechanical specifications

Property	Value
Installation options	<ul style="list-style-type: none"> <li>pole/wall installation</li> <li>directly on the wall installation</li> </ul>
IP rating	IP65
Related optional items	<ul style="list-style-type: none"> <li>Flexi Pole Mounting Kit (FPKA/C)</li> <li>Pole Mounting Kit (VMPB)</li> </ul>

## Dimensions and weight

Table 234 FHDA dimensions and weight

Property	Value	Dimensions orientation
Height	As delivered, cable tie point recessed: 579 mm (22.7 in.) As installed, cable tie point released due to brackets and solar shields: 733 mm (28.8 in.)	<p>The diagram shows a 3D perspective view of the Flexi RRH 2-pipe 900 80W (FHDA) module. Three blue arrows indicate the dimensions: 'height' points to the vertical dimension, 'width' points to the front horizontal dimension, and 'depth' points to the side horizontal dimension. The module has a rectangular shape with a slightly protruding top edge and a recessed area for cable tie points.</p>
Depth	215 mm (8.4 in.)	
Width	358 mm (14.1 in.)	
Weight	20 kg (44.0 lbs)	

## Environmental specifications

Table 235 FHDA environmental specifications

Property	Value
Maximum operational outdoor temperature in the shade (at constant high ambient temperature maximum output power might be limited)	+55°C (131°F)
Maximum operational outdoor temperature in the sun (according to GR-487-Core specification)	+50°C (122°F)
Maximum indoor temperature (this is valid for fanless products)	+45°C (129.2°F)
Minimum operational temperature (including cold start)	-40°C (-40°F)

## LEDs

Table 236 FHDA LEDs

LED color	Description	Alarm
Red, stable	Critical alarm affecting the whole RF module or all antenna carriers	Fault
Red, blinking	Operation degraded <ul style="list-style-type: none"> <li>Major alarm affecting the whole RF Module</li> </ul>	Major/critical alarm

Table 236 FHDA LEDs (Cont.)

LED color	Description	Alarm
	<ul style="list-style-type: none"> <li>Critical alarm affecting fans</li> <li>Major/Critical alarm affecting a module subcomponent or antenna carrier</li> </ul>	
Yellow, stable	<ul style="list-style-type: none"> <li>Until software download begins</li> <li>The carriers are blocked from BTS</li> <li>There is no connection to any System Module</li> </ul>	No alarm
Yellow, blinking	<ul style="list-style-type: none"> <li>Software download in progress</li> <li>Configuration in progress: RF resources are being setup, but not yet activated</li> </ul>	No alarm
Green, stable	<ul style="list-style-type: none"> <li>Software configuration is complete or supervisory: RF resources activated and transmission is possible</li> <li>Working normally, no alarm on the RF Module</li> </ul>	No alarm
Green, blinking	Software downloading and updating	No alarm
Stable Red for less than 5 seconds and changes to Stable Yellow	Switched ON, but the next conditions are not reached yet	No alarm
Stable Red for less than 5 seconds	The module is in the process of resetting	No alarm
Periodic Red and Green	Antenna line device faulty/degraded	No alarm
Blinking Colors (Red, Yellow, and Green), each color stable for 0.5 second	Module highlighting (Flexi BTS SM functionality that can help identifying faulty module)	No alarm

**Warnings, cautions or notes related to the product**



**NOTICE:** The RRH should always be mounted in a vertical orientation with connectors on the bottom side to ensure convection cooling.



The minimum startup voltage is 40.5 V DC. If the input voltage is below/beyond extended limits, unit might shut down.

# 31 Flexi Remote Radio Head 2TX 1800 (FHEA)

FHEA technical specifications.

## Functional description

Table 237 FHEA functional specification

Property	Value
Output power	2x40 W
MIMO	yes, 2TX
Outdoor installation	yes
SW supported technologies	GSM, FDD-LTE
TX frequency range	1805-1880 MHz
RX frequency range	1710-1785 MHz
DL instantaneous bandwidth	A.10x version: 23 MHz A.20x version: 25 MHz
UL instantaneous bandwidth	40 MHz
DL filter bandwidth	75 MHz
UL filter bandwidth	75 MHz

## Interfaces

Figure 54 FHEA interfaces

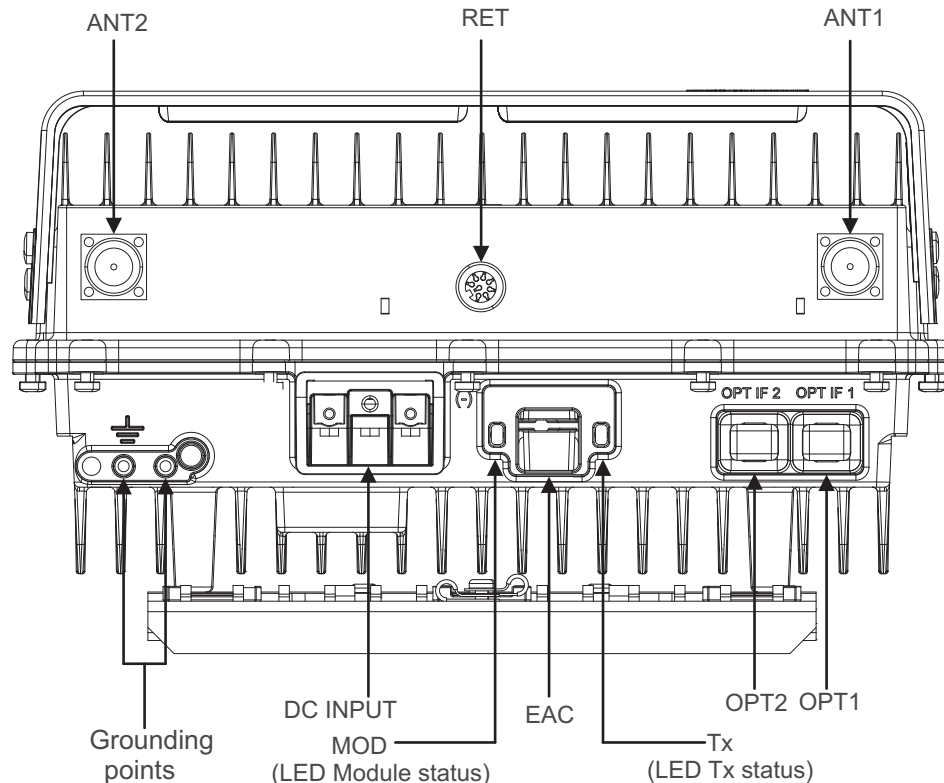

Table 238 FHEA interfaces

Interface	Label on the HW	Number of interfaces	Connector type	Additional info
Power connector	DC IN	1	3-pole screw terminal	
Antenna connector	ANT	2	7/16	
Remote Electrical Tilt	RET	1	8-pin circular	
External Alarm Connection	EAC	1	RJ45	
Optical interface	OPT	2	SFP	3 Gbps

### Antenna Line Devices (ALDs) support

Table 239 FHEA ALD support

ALD support via antenna ports	Value
AISG	2.0 Main+Div
Legacy Siemens equipment	No
CWA (for non-AISG installations)	No
Voltage	14.5 V
Power per port	30 W

### Functional block diagram

Figure 55 FHEA functional block diagram

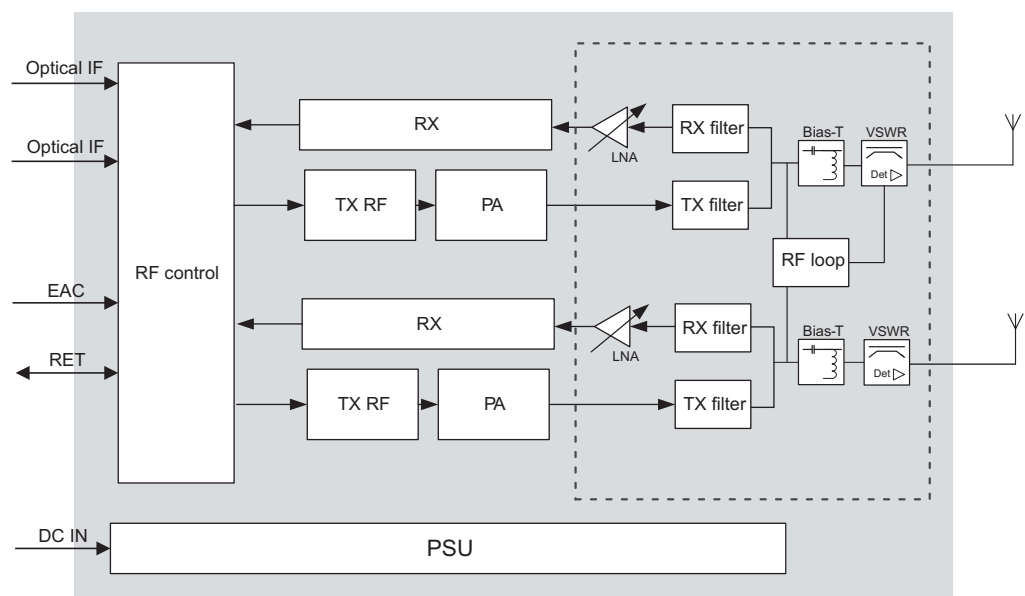

### Electrical specifications

Table 240 FHEA electrical specifications

Property	Value
Nominal supply voltage	-48.0 V DC
Nominal input voltage range	-40.5 V DC to -57.0 V DC
Extended input voltage range	-36.0 V DC to -40.5 V DC -57.0 V DC to -60.0 V DC

### Power consumption

Table 241 FHEA power consumption

Number of TXs	RF output power per TX [W]	Estimated power consumption [W] at 48 VDC input at 23°C. Non-committed estimated values depend on the final product HW and SW optimization with +/- 10% margin.	
		50% RF Load	100% RF Load
2	40	303	397
	20	225	275

### Installation and mechanical specifications

Table 242 FHEA installation and mechanical specifications

Property	Value
Installation options	<ul style="list-style-type: none"> <li>pole/wall installation</li> <li>directly on the wall installation</li> </ul>
IP rating	IP65
Related optional items	<ul style="list-style-type: none"> <li>Flexi Pole Mounting Kit (FPKA/C)</li> <li>Pole Mounting Kit (VMPB)</li> </ul>

## Dimensions and weight

Table 243 FHEA dimensions and weight

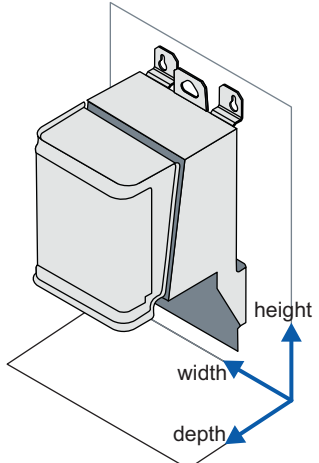
Property	Value	Dimensions orientation
Height	As delivered, cable tie point recessed: 579 mm (22.7 in.) As installed, cable tie point released due to brackets and solar shields: 733 mm (28.8 in.)	
Depth	215 mm (8.4 in.)	
Width	358 mm (14.1 in.)	
Weight	20 (44.0 lbs)	

## Environmental specifications

Table 244 FHEA environmental specifications

Property	Value
Maximum operational outdoor temperature in the shade (at constant high ambient temperature maximum output power might be limited)	+55°C (131°F)
Maximum operational outdoor temperature in the sun (according to GR-487-Core specification)	+50°C (122°F)
Maximum indoor temperature (this is valid for fanless products)	+45°C (129.2°F)
Minimum operational temperature (including cold start)	-40°C (-40°F)

## LEDs

Table 245 FHEA LEDs

LED color	Description	Alarm
Red, stable	Critical alarm affecting the whole RF module or all antenna carriers	Fault
Red, blinking	Operation degraded <ul style="list-style-type: none"> <li>Major alarm affecting the whole RF Module</li> </ul>	Major/critical alarm

Table 245 FHEA LEDs (Cont.)

LED color	Description	Alarm
	<ul style="list-style-type: none"> <li>Critical alarm affecting fans</li> <li>Major/Critical alarm affecting a module subcomponent or antenna carrier</li> </ul>	
Yellow, stable	<ul style="list-style-type: none"> <li>Until software download begins</li> <li>The carriers are blocked from BTS</li> <li>There is no connection to any System Module</li> </ul>	No alarm
Yellow, blinking	<ul style="list-style-type: none"> <li>Software download in progress</li> <li>Configuration in progress: RF resources are being setup, but not yet activated</li> </ul>	No alarm
Green, stable	<ul style="list-style-type: none"> <li>Software configuration is complete or supervisory: RF resources activated and transmission is possible</li> <li>Working normally, no alarm on the RF Module</li> </ul>	No alarm
Green, blinking	Software downloading and updating	No alarm
Stable Red for less than 5 seconds and changes to Stable Yellow	Switched ON, but the next conditions are not reached yet	No alarm
Stable Red for less than 5 seconds	The module is in the process of resetting	No alarm
Periodic Red and Green	Antenna line device faulty/degraded	No alarm
Blinking Colors (Red, Yellow, and Green), each color stable for 0.5 second	Module highlighting (Flexi BTS SM functionality that can help identifying faulty module)	No alarm

**Warnings, cautions or notes related to the product**



**NOTICE:** The RRRH should always be mounted in a vertical orientation with connectors on the bottom side to ensure convection cooling.



The minimum startup voltage is 40.5 V DC. If the input voltage is below/beyond extended limits, unit might shut down.

## 32 Flexi Remote Radio Head 2TX 2100 (FRGQ)

FRGQ technical specifications.

### Functional description

Table 246 FRGQ functional specification

Property	Value
Output power	2x40 W
MIMO	yes, 2TX
Outdoor installation	yes
SW supported technologies	WCDMA, FDD-LTE
TX frequency range	2110-2170 MHz
RX frequency range	1920-1980 MHz
DL instantaneous bandwidth	20 MHz
UL instantaneous bandwidth	60 MHz
DL filter bandwidth	60 MHz
UL filter bandwidth	60 MHz

### Interfaces

Figure 56 FRGQ interfaces

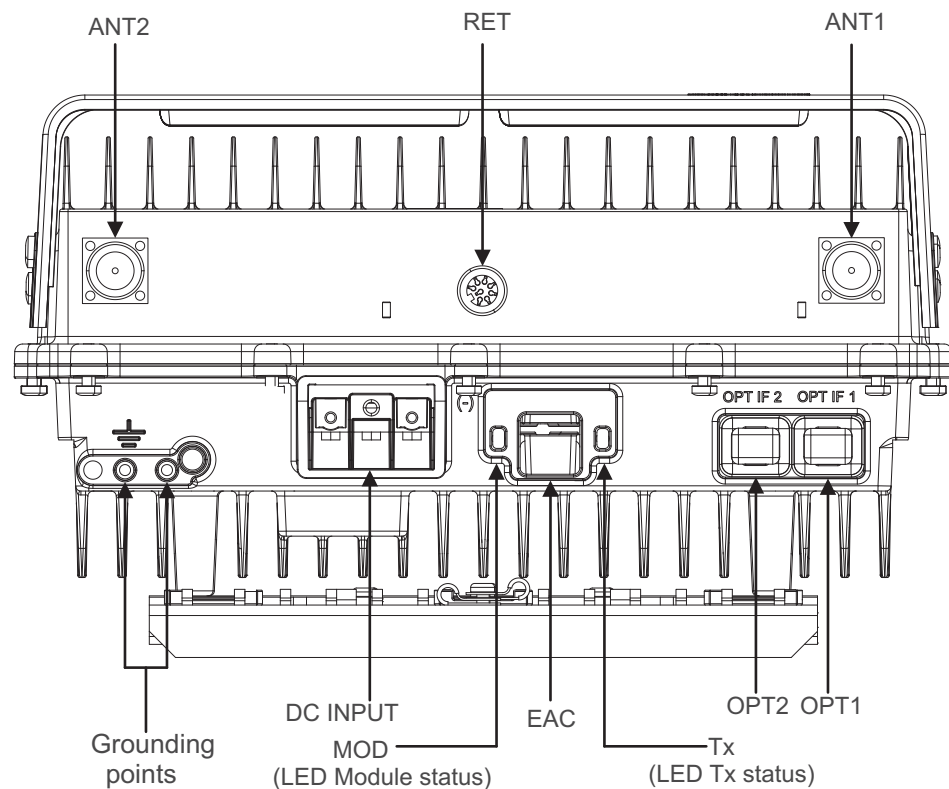

Table 247 FRGQ interfaces

Interface	Label on the HW	Number of interfaces	Connector type	Additional info
Power connector	DC IN	1	3-pole screw terminal	
Antenna connector	ANT	2	7/16	
RF external connector	Rx EXT	2	QMA	
Remote Electrical Tilt	RET	1	8-pin circular	
External Alarm Connection	EAC	1	D-sub MDR14	
Optical interface	OPT	2	SFP	3 Gbps
Local Management Port	LMP	1	2x15 pin header	

### Antenna Line Devices (ALDs) support

Table 248 FRGQ ALD support

ALD support via antenna ports	Value
AISG	2.0 Main only
Legacy Siemens equipment	No
CWA (for non-AISG installations)	No
Voltage	14.5 V
Power per port	30 W

### Functional block diagram

Figure 57 FRGQ functional block diagram

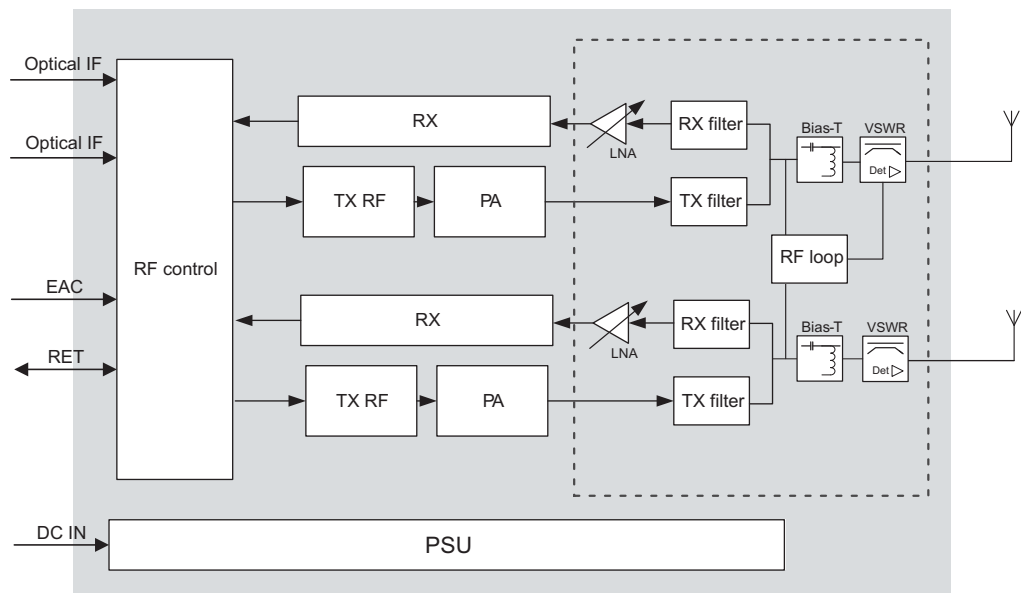

## Electrical specifications

Table 249 FRGQ electrical specifications

Property	Value
Nominal supply voltage	-48.0 V DC
Nominal input voltage range	-40.5 V DC to -57.0 V DC
Extended input voltage range	-36.0 V DC to -40.5 V DC -57.0 V DC to -60.0 V DC

## Power consumption

Table 250 FRGQ power consumption

Number of TXs	RF output power per TX [W]	Estimated power consumption [W] at 48 VDC input at 23°C. Non-committed estimated values depend on the final product HW and SW optimization with +/- 10% margin.	
		50% RF Load	100% RF Load
2	40	292	382
	30	265	334
	20	212	259

## Installation and mechanical specifications

Table 251 FRGQ installation and mechanical specifications

Property	Value
Installation options	<ul style="list-style-type: none"> <li>pole/wall installation</li> <li>directly on the wall installation</li> </ul>
IP rating	IP65
Related optional items	<ul style="list-style-type: none"> <li>Flexi Pole Mounting Kit (FPKA/C)</li> <li>Pole Mounting Kit (VMPB)</li> </ul>

## Dimensions and weight

Table 252 FRGQ dimensions and weight

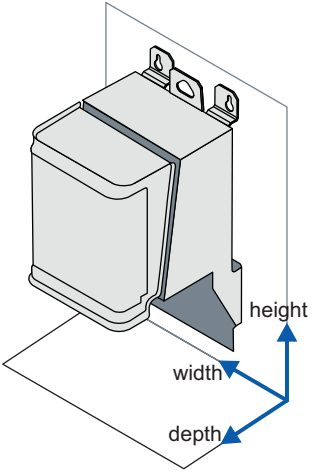
Property	Value	Dimensions orientation
Height	486 mm (19.1 in.)	
Depth	155 mm (6.1 in.)	
Width	324 mm (12.8 in.)	
Weight	17 kg (37.5 lbs)	

## Environmental specifications

Table 253 FRGQ environmental specifications

Property	Value
Maximum operational outdoor temperature in the shade (at constant high ambient temperature maximum output power might be limited)	+55°C (131°F)
Maximum operational outdoor temperature in the sun (according to GR-487-Core specification)	+50°C (122°F)
Maximum indoor temperature (this is valid for fanless products)	+45°C (129.2°F)
Minimum operational temperature (including cold start)	-40°C (-40°F)

## LEDs

Table 254 FRGQ LEDs

LED color	Description	Alarm
Red, stable	Critical alarm affecting the whole RF module or all antenna carriers	Fault
Red, blinking	Operation degraded <ul style="list-style-type: none"> <li>Major alarm affecting the whole RF Module</li> </ul>	Major/critical alarm

Table 254 FRGQ LEDs (Cont.)

LED color	Description	Alarm
	<ul style="list-style-type: none"> <li>Critical alarm affecting fans</li> <li>Major/Critical alarm affecting a module subcomponent or antenna carrier</li> </ul>	
Yellow, stable	<ul style="list-style-type: none"> <li>Until software download begins</li> <li>The carriers are blocked from BTS</li> <li>There is no connection to any System Module</li> </ul>	No alarm
Yellow, blinking	<ul style="list-style-type: none"> <li>Software download in progress</li> <li>Configuration in progress: RF resources are being setup, but not yet activated</li> </ul>	No alarm
Green, stable	<ul style="list-style-type: none"> <li>Software configuration is complete or supervisory: RF resources activated and transmission is possible</li> <li>Working normally, no alarm on the RF Module</li> </ul>	No alarm
Green, blinking	Software downloading and updating	No alarm
Stable Red for less than 5 seconds and changes to Stable Yellow	Switched ON, but the next conditions are not reached yet	No alarm
Stable Red for less than 5 seconds	The module is in the process of resetting	No alarm
Periodic Red and Green	Antenna line device faulty/degraded	No alarm
Blinking Colors (Red, Yellow, and Green), each color stable for 0.5 second	Module highlighting (Flexi BTS SM functionality that can help identifying faulty module)	No alarm

**Warnings, cautions or notes related to the product**



**NOTICE:** The RRH should always be mounted in a vertical orientation with connectors on the bottom side to ensure convection cooling.



The minimum startup voltage is 40.5 V DC. If the input voltage is below/beyond extended limits, unit might shut down.

### 33 Flexi Remote Radio Head 2TX 2600 (FRHB)

FRHB technical specifications.

#### Functional description

Table 255 FRHB functional specification

Property	Value
Output power	2x40 W
MIMO	yes, 2TX
Outdoor installation	yes
SW supported technology	FDD-LTE
TX frequency range	2620-2690 MHz
RX frequency range	2500-2570 MHz
DL instantaneous bandwidth	20 MHz
UL instantaneous bandwidth	20 MHz
DL filter bandwidth	70 MHz
UL filter bandwidth	70 MHz

#### Interfaces

Figure 58 FRHB interfaces

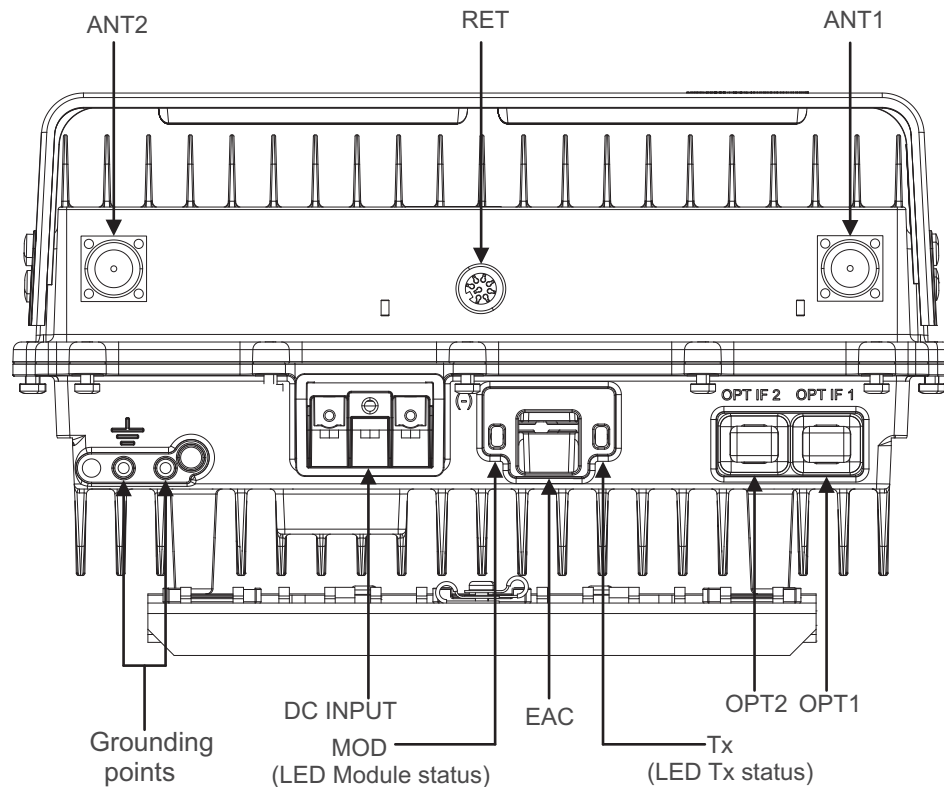

Table 256 FRHB interfaces

Interface	Label on the HW	Number of interfaces	Connector type	Additional info
Power connector	DC IN	1	3-pole screw terminal	
Antenna connector	ANT	2	7/16	
RF external connector	Rx EXT	2	SMA	
Remote Electrical Tilt	RET	1	8-pin circular	
External Alarm Connection	EAC	1	D-sub MDR14	
Optical interface	OPT	2	SFP	3 Gbps
Local Management Port	LMP	1	2x15 pin header	

**Antenna Line Devices (ALDs) support**

Table 257 FRHB ALD support

ALD support via antenna ports	Value
AISG	2.0 Main only
Legacy Siemens equipment	No
CWA (for non-AISG installations)	No
Voltage	14.5 V
Power per port	30 W

**Functional block diagram**

Figure 59 FRHB functional block diagram

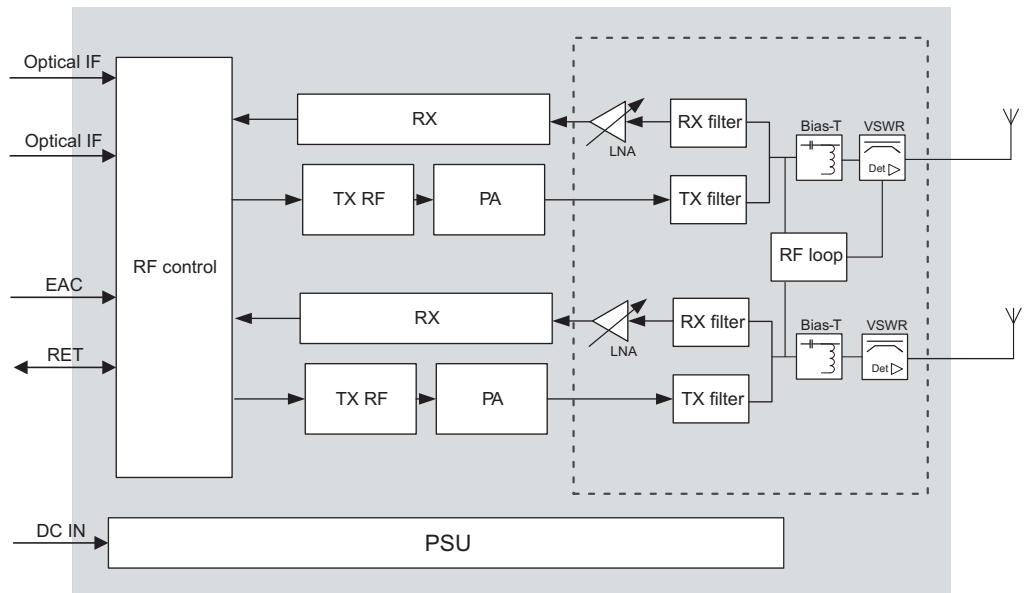

## Electrical specifications

Table 258 FRHB electrical specifications

Property	Value
Nominal supply voltage	-48.0 V DC
Nominal input voltage range	-40.5 V DC to -57.0 V DC
Extended input voltage range	-36.0 V DC to -40.5 V DC -57.0 V DC to -60.0 V DC

## Power consumption

Table 259 FRHB power consumption

Number of TXs	RF output power per TX [W]	Estimated power consumption [W] at 48 VDC input at 23°C. Non-committed estimated values depend on the final product HW and SW optimization with +/- 10% margin.	
		50% RF Load	100% RF Load
2	40	317	439
	30	272	370
	20	227	298

## Installation and mechanical specifications

Table 260 FRHB installation and mechanical specifications

Property	Value
Installation options	<ul style="list-style-type: none"> <li>pole/wall installation</li> <li>directly on the wall installation</li> </ul>
IP rating	IP65
Related optional items	<ul style="list-style-type: none"> <li>Flexi Pole Mounting Kit (FPKA/C)</li> <li>Pole Mounting Kit (VMPB)</li> </ul>

## Dimensions and weight

Table 261 FRHB dimensions and weight

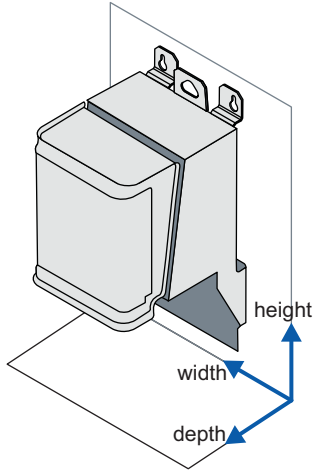
Property	Value	Dimensions orientation
Height	514 mm (20.3 in.)	
Depth	148 mm (5.8 in.)	
Width	326 mm (12.8 in.)	
Weight	Without solar shield and mounting shroud: 17.3 kg (38.1 lbs)	

## Environmental specifications

Table 262 FRHB environmental specifications

Property	Value
Maximum operational outdoor temperature in the shade (at constant high ambient temperature maximum output power might be limited)	+55°C (131°F)
Maximum operational outdoor temperature in the sun (according to GR-487-Core specification)	+50°C (122°F)
Maximum indoor temperature (this is valid for fanless products)	+45°C (129.2°F)
Minimum operational temperature (including cold start)	-40°C (-40°F)

## LEDs

Table 263 FRHB LEDs

LED color	Description	Alarm
Red, stable	Critical alarm affecting the whole RF module or all antenna carriers	Fault
Red, blinking	Operation degraded <ul style="list-style-type: none"> <li>Major alarm affecting the whole RF Module</li> </ul>	Major/critical alarm

Table 263 FRHB LEDs (Cont.)

LED color	Description	Alarm
	<ul style="list-style-type: none"> <li>Critical alarm affecting fans</li> <li>Major/Critical alarm affecting a module subcomponent or antenna carrier</li> </ul>	
Yellow, stable	<ul style="list-style-type: none"> <li>Until software download begins</li> <li>The carriers are blocked from BTS</li> <li>There is no connection to any System Module</li> </ul>	No alarm
Yellow, blinking	<ul style="list-style-type: none"> <li>Software download in progress</li> <li>Configuration in progress: RF resources are being setup, but not yet activated</li> </ul>	No alarm
Green, stable	<ul style="list-style-type: none"> <li>Software configuration is complete or supervisory: RF resources activated and transmission is possible</li> <li>Working normally, no alarm on the RF Module</li> </ul>	No alarm
Green, blinking	Software downloading and updating	No alarm
Stable Red for less than 5 seconds and changes to Stable Yellow	Switched ON, but the next conditions are not reached yet	No alarm
Stable Red for less than 5 seconds	The module is in the process of resetting	No alarm
Periodic Red and Green	Antenna line device faulty/degraded	No alarm
Blinking Colors (Red, Yellow, and Green), each color stable for 0.5 second	Module highlighting (Flexi BTS SM functionality that can help identifying faulty module)	No alarm

**Warnings, cautions or notes related to the product**



**NOTICE:** The RRRH should always be mounted in a vertical orientation with connectors on the bottom side to ensure convection cooling.



The minimum startup voltage is 40.5 V DC. If the input voltage is below/beyond extended limits, unit might shut down.

## 34 Flexi Remote Radio Head 2TX 800EU (FRMB)

FRMB technical specifications.

### Functional description

Table 264 FRMB functional specification

Property	Value
Output power	2x40 W
MIMO	yes, 2TX
Outdoor installation	yes
SW supported technology	FDD-LTE
TX frequency range	791-821 MHz
RX frequency range	832-862 MHz
DL instantaneous bandwidth	20 MHz
UL instantaneous bandwidth	20 MHz
DL filter bandwidth	30 MHz
UL filter bandwidth	30 MHz

### Interfaces

Figure 60 FRMB interfaces

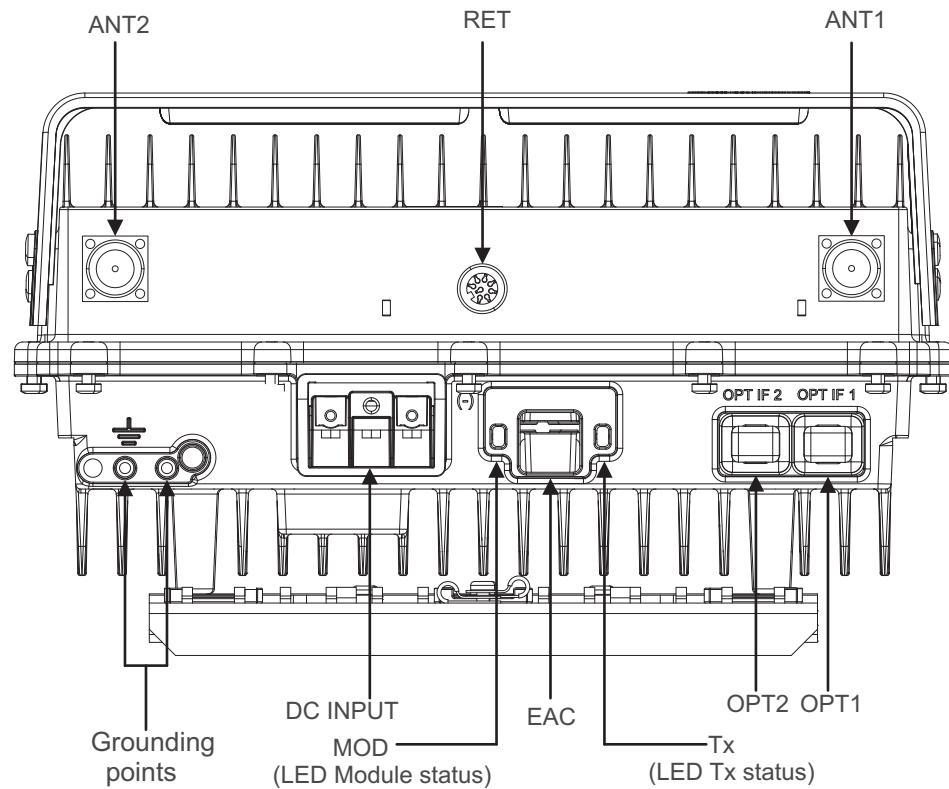

Table 265 FRMB interfaces

Interface	Label on the HW	Number of interfaces	Connector type	Additional info
Power connector	DC IN	1	3-pole screw terminal	
Antenna connector	ANT	2	7/16	
RF external connector	Rx EXT	2	SMA	
Remote Electrical Tilt	RET	1	8-pin circular	
External Alarm Connection	EAC	1	D-sub MDR14	
Optical interface	OPT	2	SFP	3 Gbps
Local Management Port	LMP	1	2x15 pin header	

### Antenna Line Devices (ALDs) support

Table 266 FRMB ALD support

ALD support via antenna ports	Value
AISG	2.0 Main only
Legacy Siemens equipment	No
CWA (for non-AISG installations)	No
Voltage	14.5 V
Power per port	30 W

### Functional block diagram

Figure 61 FRMB functional block diagram

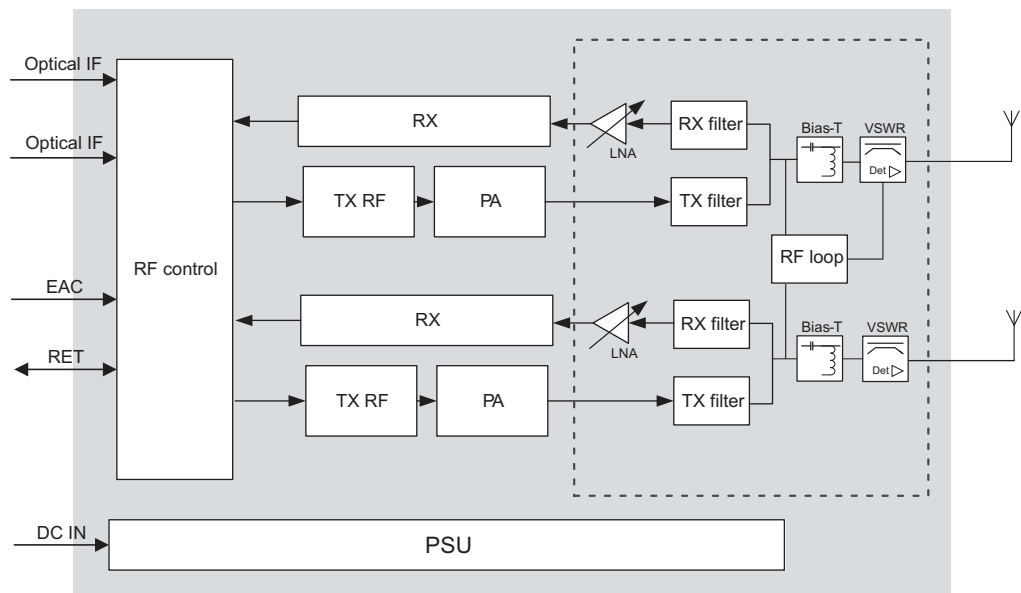

## Electrical specifications

Table 267 FRMB electrical specifications

Property	Value
Nominal supply voltage	-48.0 V DC
Nominal input voltage range	-40.5 V DC to -57.0 V DC
Extended input voltage range	-36.0 V DC to -40.5 V DC -57.0 V DC to -60.0 V DC

## Power consumption

Table 268 FRMB power consumption

Number of TXs	RF output power per TX [W]	Estimated power consumption [W] at 48 VDC input at 23°C. Non-committed estimated values depend on the final product HW and SW optimization with +/- 10% margin.	
		50% RF Load	100% RF Load
2	40	274	373
	20	174	218

## Installation and mechanical specifications

Table 269 FRMB installation and mechanical specifications

Property	Value
Installation options	<ul style="list-style-type: none"> <li>pole/wall installation</li> <li>directly on the wall installation</li> </ul>
IP rating	IP65
Related optional items	<ul style="list-style-type: none"> <li>Flexi Pole Mounting Kit (FPKA/C)</li> <li>Pole Mounting Kit (VMPB)</li> </ul>

## Dimensions and weight

Table 270 FRMB dimensions and weight

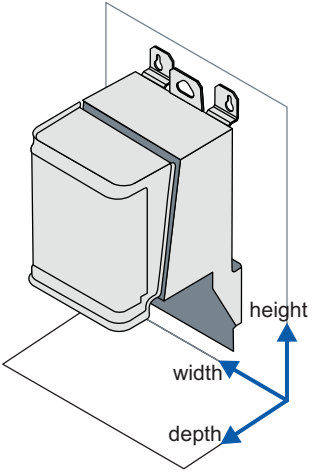
Property	Value	Dimensions orientation
Height	514 mm (20.3 in.)	
Depth	148 mm (5.8 in.)	
Width	326 mm (12.8 in.)	
Weight	Without solar shield and mounting shroud: 17.3 kg (38.1 lbs)	

## Environmental specifications

Table 271 FRMB environmental specifications

Property	Value
Maximum operational outdoor temperature in the shade (at constant high ambient temperature maximum output power might be limited)	+55°C (131°F)
Maximum operational outdoor temperature in the sun (according to GR-487-Core specification)	+50°C (122°F)
Maximum indoor temperature (this is valid for fanless products)	+45°C (129.2°F)
Minimum operational temperature (including cold start)	-40°C (-40°F)

## LEDs

Table 272 FRMB LEDs

LED color	Description	Alarm
Red, stable	Critical alarm affecting the whole RF module or all antenna carriers	Fault
Red, blinking	Operation degraded <ul style="list-style-type: none"> <li>Major alarm affecting the whole RF Module</li> </ul>	Major/critical alarm

Table 272 FRMB LEDs (Cont.)

LED color	Description	Alarm
	<ul style="list-style-type: none"> <li>Critical alarm affecting fans</li> <li>Major/Critical alarm affecting a module subcomponent or antenna carrier</li> </ul>	
Yellow, stable	<ul style="list-style-type: none"> <li>Until software download begins</li> <li>The carriers are blocked from BTS</li> <li>There is no connection to any System Module</li> </ul>	No alarm
Yellow, blinking	<ul style="list-style-type: none"> <li>Software download in progress</li> <li>Configuration in progress: RF resources are being setup, but not yet activated</li> </ul>	No alarm
Green, stable	<ul style="list-style-type: none"> <li>Software configuration is complete or supervisory: RF resources activated and transmission is possible</li> <li>Working normally, no alarm on the RF Module</li> </ul>	No alarm
Green, blinking	Software downloading and updating	No alarm
Stable Red for less than 5 seconds and changes to Stable Yellow	Switched ON, but the next conditions are not reached yet	No alarm
Stable Red for less than 5 seconds	The module is in the process of resetting	No alarm
Periodic Red and Green	Antenna line device faulty/degraded	No alarm
Blinking Colors (Red, Yellow, and Green), each color stable for 0.5 second	Module highlighting (Flexi BTS SM functionality that can help identifying faulty module)	No alarm

**Warnings, cautions or notes related to the product**



**NOTICE:** The RRH should always be mounted in a vertical orientation with connectors on the bottom side to ensure convection cooling.



The minimum startup voltage is 40.5 V DC. If the input voltage is below/beyond extended limits, unit might shut down.

## 35 Flexi Remote Radio Head 2TX 1800 (FHEB)

FHEB technical specifications.

### Functional description

Table 273 FHEB functional specification

Property	Value
Output power	2x60 W
MIMO	yes, 2TX
Outdoor installation	yes
SW supported technologies	GSM, FDD-LTE
TX frequency range	1805-1880 MHz
RX frequency range	1710-1785 MHz
DL instantaneous bandwidth	For WCDMA/LTE when shared with GSM: 35/40 MHz For WCDMA and LTE: 40 MHz
UL instantaneous bandwidth	60 MHz
DL filter bandwidth	75 MHz
UL filter bandwidth	75 MHz

## Interfaces

Figure 62 FHEB interfaces

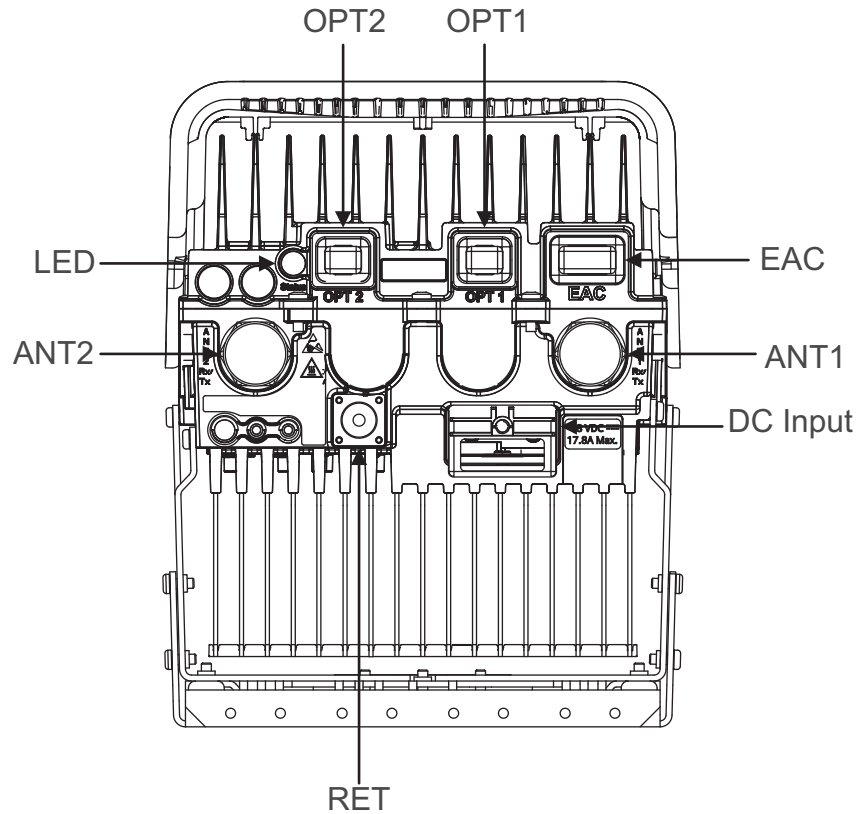

Table 274 FHEB interfaces

Interface	Label on the HW	Number of interfaces	Connector type	Additional info
Power connector	DC IN	1	3-pole screw terminal	
Antenna connector	ANT	2	7/16	
Remote Electrical Tilt	RET	1	8-pin circular	
External Alarm Connection	EAC	1	D-sub MDR14	
Optical interface	OPT	2	SFP	6 Gbps

## Antenna Line Devices (ALDs) support

Table 275 FHEB ALD support

ALD support via antenna ports	Value
AISG	2.0 Main only
Legacy Siemens equipment	No
CWA (for non-AISG installations)	No
Voltage	14.5 V

Table 275 FHEB ALD support (Cont.)

ALD support via antenna ports	Value
Power per port	15 W

### Functional block diagram

Figure 63 FHEB functional block diagram

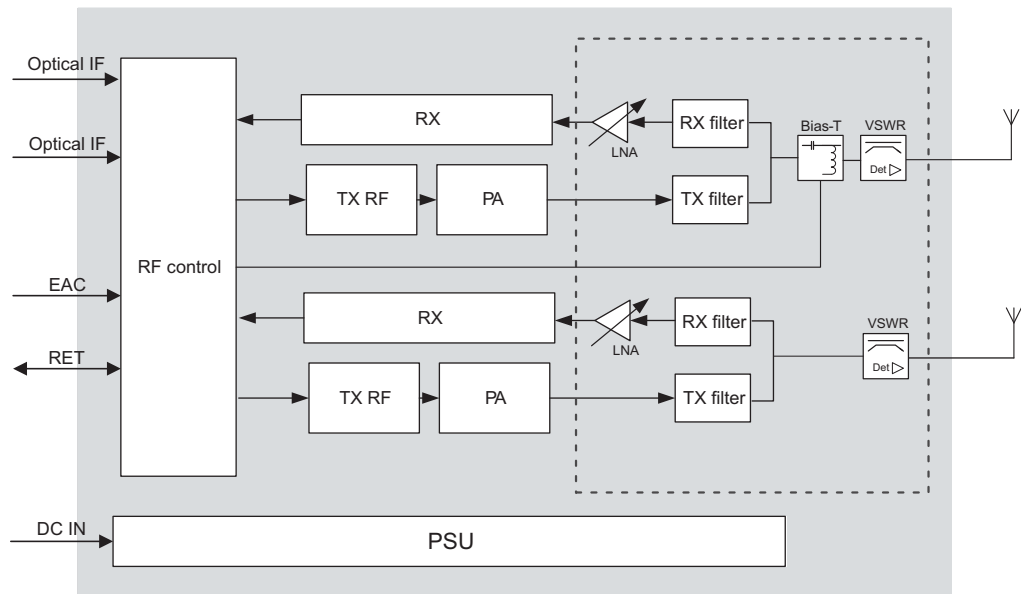

### Electrical specifications

Table 276 FHEB electrical specifications

Property	Value
Nominal supply voltage	-48.0 V DC
Nominal input voltage range	-40.5 V DC to -57.0 V DC
Extended input voltage range	-36.0 V DC to -40.5 V DC -57.0 V DC to -60.0 V DC

### Power consumption

Table 277 FHEB power consumption

Number of TXs	RF output power per TX [W]	Estimated power consumption [W] at 48 VDC input at 23°C for LTE mode. Non-committed estimated values depend on the final product HW and SW optimization with +/- 10% margin.	
		50% RF Load	100% RF Load
2	60	353	486
	40	280	378
	20	213	266

## Installation and mechanical specifications

Table 278 FHEB installation and mechanical specifications

Property	Value
Installation options	<ul style="list-style-type: none"> <li>• pole/wall installation</li> <li>• directly on the wall installation</li> </ul>
IP rating	IP65
Related optional items	<ul style="list-style-type: none"> <li>• Flexi Pole Mounting Kit (FPKA/C)</li> <li>• Pole Mounting Kit (VMPB)</li> </ul>

## Dimensions and weight

Table 279 FHEB dimensions and weight

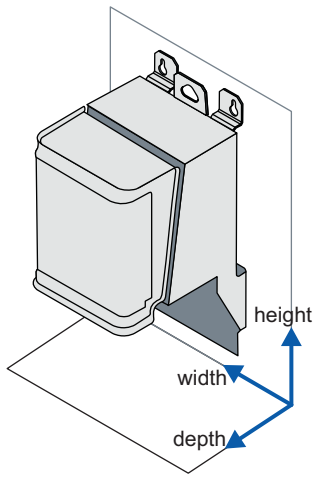
Property	Value	Dimensions orientation
Height	As delivered, cable tie point recessed: 335.2 mm (13.2 in.)  With lower mounting bracket in the "FMFA" position: 571 mm (22.5 in.)  With lower mounting bracket in the alternative "ALT" position: 621 mm (24.4 in.)	 <p>The diagram shows a perspective view of the FHEB unit. Three blue arrows indicate the dimensions: 'height' points to the top edge, 'width' points to the front edge, and 'depth' points to the side edge.</p>
Depth	324 mm (12.8 in.)	
Width	260 mm (10.2 in.)	
Weight	17.3 kg (38.1 lbs)	

## Environmental specifications

Table 280 FHEB environmental specifications

Property	Value
Maximum operational outdoor temperature in the shade (at constant high ambient temperature maximum output power might be limited)	+55°C (131°F)
Maximum operational outdoor temperature in the sun (according to GR-487-Core specification)	+50°C (122°F)
Maximum indoor temperature (this is valid for fanless products)	+45°C (129.2°F)
Minimum operational temperature (including cold start)	-40°C (-40°F)

## LEDs

Table 281 FHEB LEDs

LED color	Description	Alarm
Red, stable	Critical alarm affecting the whole RF module or all antenna carriers	Fault
Red, blinking	Operation degraded <ul style="list-style-type: none"> <li>Major alarm affecting the whole RF Module</li> <li>Critical alarm affecting fans</li> <li>Major/Critical alarm affecting a module subcomponent or antenna carrier</li> </ul>	Major/critical alarm
Yellow, stable	<ul style="list-style-type: none"> <li>Until software download begins</li> <li>The carriers are blocked from BTS</li> <li>There is no connection to any System Module</li> </ul>	No alarm
Yellow, blinking	<ul style="list-style-type: none"> <li>Software download in progress</li> <li>Configuration in progress: RF resources are being setup, but not yet activated</li> </ul>	No alarm
Green, stable	<ul style="list-style-type: none"> <li>Software configuration is complete or supervisory: RF resources activated and transmission is possible</li> <li>Working normally, no alarm on the RF Module</li> </ul>	No alarm
Green, blinking	Software downloading and updating	No alarm
Stable Red for less than 5 seconds and changes to Stable Yellow	Switched ON, but the next conditions are not reached yet	No alarm
Stable Red for less than 5 seconds	The module is in the process of resetting	No alarm
Periodic Red and Green	Antenna line device faulty/degraded	No alarm
Blinking Colors (Red, Yellow, and Green), each color stable for 0.5 second	Module highlighting (Flexi BTS SM functionality that can help identifying faulty module)	No alarm

### Warnings, cautions or notes related to the product



**NOTICE:** The RRH should always be mounted in a vertical orientation with connectors on the bottom side to ensure convection cooling.



The minimum startup voltage is 40.5 V DC. If the input voltage is below/beyond extended limits, unit might shut down.

## 36 Flexi RRH 2-pipe 1800 120W (FHEF)

FHEF technical specifications.

### Functional description

Table 282 FHEF functional specification

Property	Value
Output power	2x60 W
MIMO	yes, 2TX
Outdoor installation	yes
SW supported technologies	GSM, FDD-LTE
TX frequency range	1805 - 1860 MHz
RX frequency range	1710 - 1765 MHz
DL instantaneous bandwidth	40 MHz
UL instantaneous bandwidth	55 MHz
DL filter bandwidth	55 MHz
UL filter bandwidth	55 MHz

### Interfaces

Figure 64 FHEF interfaces

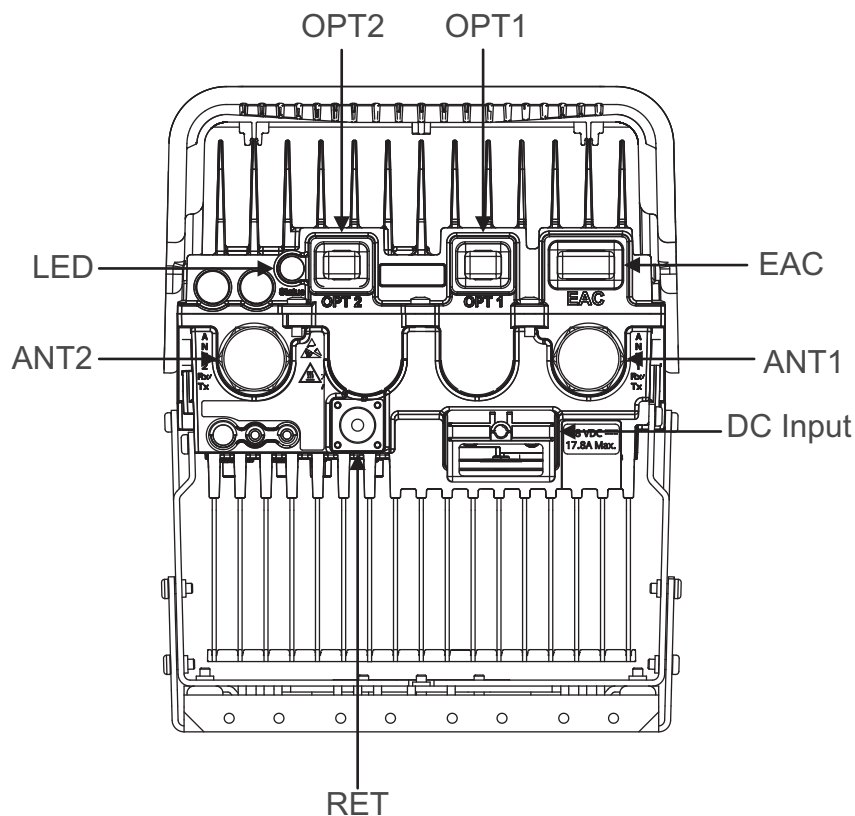

Table 283 FHEF interfaces

Interface	Label on the HW	Number of interfaces	Connector type	Additional info
Power connector	DC IN	1	3-pole screw terminal	
Antenna connector	ANT	4	7/16	
RF external connector	Rx EXT	2	QMA	
Remote Electrical Tilt	RET	1	8-pin circular	
External Alarm Connection	EAC	1	D-sub MDR14	
Optical interface	OPT	3	SFP	6 Gbps, OBSAI
Local Management Port	LMP	1	2x15 pin header	

### Antenna Line Devices (ALDs) support

Table 284 FHEF ALD support

ALD support via antenna ports	Value
AISG	2.0 Main only
Legacy Siemens equipment	No
CWA (for non-AISG installations)	No
Voltage	14.5 V
Power per port	15 W

### Functional block diagram

Figure 65 FHEF functional block diagram

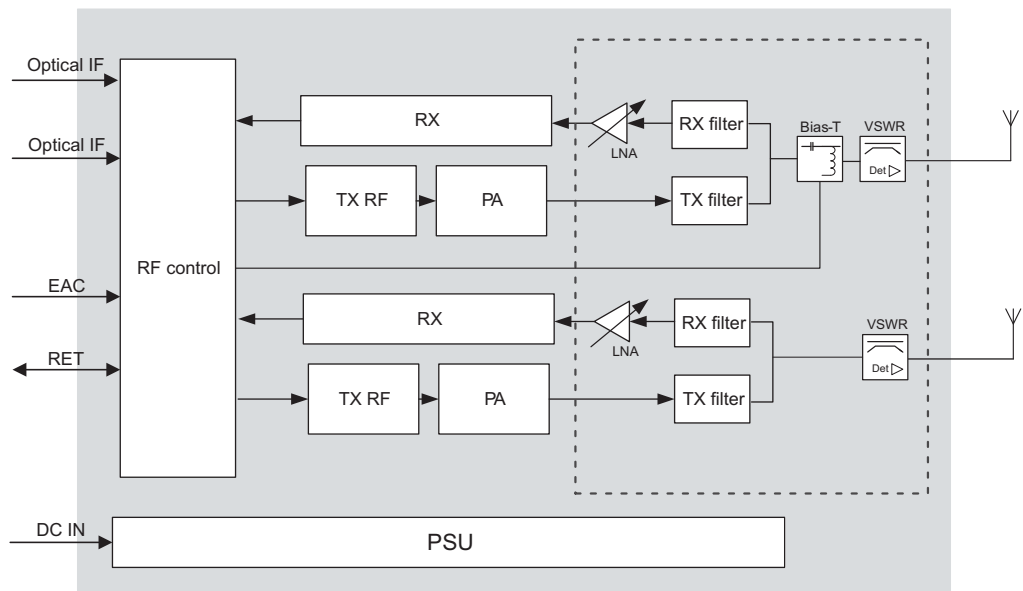

### Electrical specifications

Table 285 FHEF electrical specifications

Property	Value
Nominal supply voltage	-48.0 V DC
Nominal input voltage range	-40.5 V DC to -57.0 V DC
Extended input voltage range	-36.0 V DC to -40.5 V DC -57.0 V DC to -60.0 V DC

### Power consumption

Table 286 FHEF power consumption

Number of TXs	RF output power per TX [W]	Estimated power consumption [W] at 48 VDC input at 23°C. Non-committed estimated values depend on the final product HW and SW optimization with +/- 10% margin.	
		50% RF Load	100%RF Load
2	60	353	487
	40	270	358
	20	207	259

### Installation and mechanical specifications

Table 287 FHEF installation and mechanical specifications

Property	Value
Installation options	<ul style="list-style-type: none"> <li>pole/wall installation</li> <li>directly on the wall installation</li> </ul>
IP rating	IP65
Related optional items	<ul style="list-style-type: none"> <li>Flexi Pole Mounting Kit (FPKA/C)</li> <li>Pole Mounting Kit (VMPB)</li> </ul>

## Dimensions and weight

Table 288 FHEF dimensions and weight

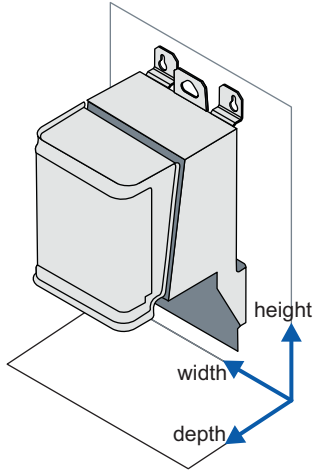
Property	Value	Dimensions orientation
Height	As delivered, cable tie point recessed: 335.2 mm (13.2 in.) With lower mounting bracket in the "FMFA" position: 571 mm (22.5 in.) With lower mounting bracket in the alternative "ALT" position: 621 mm (24.4 in.)	
Depth	324 mm (12.8 in.)	
Width	260 mm (10.2 in.)	
Weight	17.3 kg (38.1 lbs)	

## Environmental specifications

Table 289 FHEF environmental specifications

Property	Value
Maximum operational outdoor temperature in the shade (at constant high ambient temperature maximum output power might be limited)	+55°C (131°F)
Maximum operational outdoor temperature in the sun (according to GR-487-Core specification)	+50°C (122°F)
Maximum indoor temperature (this is valid for fanless products)	+45°C (129.2°F)
Minimum operational temperature (including cold start)	-40°C (-40°F)

## LEDs

Table 290 FHEF LEDs

LED color	Description	Alarm
Red, stable	Critical alarm affecting the whole RF module or all antenna carriers	Fault
Red, blinking	Operation degraded <ul style="list-style-type: none"> <li>Major alarm affecting the whole RF Module</li> </ul>	Major/critical alarm

Table 290 FHEF LEDs (Cont.)

LED color	Description	Alarm
	<ul style="list-style-type: none"> <li>Critical alarm affecting fans</li> <li>Major/Critical alarm affecting a module subcomponent or antenna carrier</li> </ul>	
Yellow, stable	<ul style="list-style-type: none"> <li>Until software download begins</li> <li>The carriers are blocked from BTS</li> <li>There is no connection to any System Module</li> </ul>	No alarm
Yellow, blinking	<ul style="list-style-type: none"> <li>Software download in progress</li> <li>Configuration in progress: RF resources are being setup, but not yet activated</li> </ul>	No alarm
Green, stable	<ul style="list-style-type: none"> <li>Software configuration is complete or supervisory: RF resources activated and transmission is possible</li> <li>Working normally, no alarm on the RF Module</li> </ul>	No alarm
Green, blinking	Software downloading and updating	No alarm
Stable Red for less than 5 seconds and changes to Stable Yellow	Switched ON, but the next conditions are not reached yet	No alarm
Stable Red for less than 5 seconds	The module is in the process of resetting	No alarm
Periodic Red and Green	Antenna line device faulty/degraded	No alarm
Blinking Colors (Red, Yellow, and Green), each color stable for 0.5 second	Module highlighting (Flexi BTS SM functionality that can help identifying faulty module)	No alarm

**Warnings, cautions or notes related to the product**



**NOTICE:** The RRH should always be mounted in a vertical orientation with connectors on the bottom side to ensure convection cooling.



The minimum startup voltage is 40.5 V DC. If the input voltage is below/beyond extended limits, unit might shut down.

## 37 Flexi Remote Radio Head 2TX 900 (FHDB)

FHDB technical specifications.

### Functional description

Table 291 FHDB functional specification

Property	Value
Output power	2x60 W
MIMO	yes, 2TX
Outdoor installation	yes
SW supported technologies	GSM, WCDMA, FDD-LTE
TX frequency range	925-960 MHz
RX frequency range	880-915 MHz
DL instantaneous bandwidth	35 MHz
UL instantaneous bandwidth	35 MHz
DL filter bandwidth	35 MHz
UL filter bandwidth	35 MHz

### Interfaces

Figure 66 FHDB interfaces

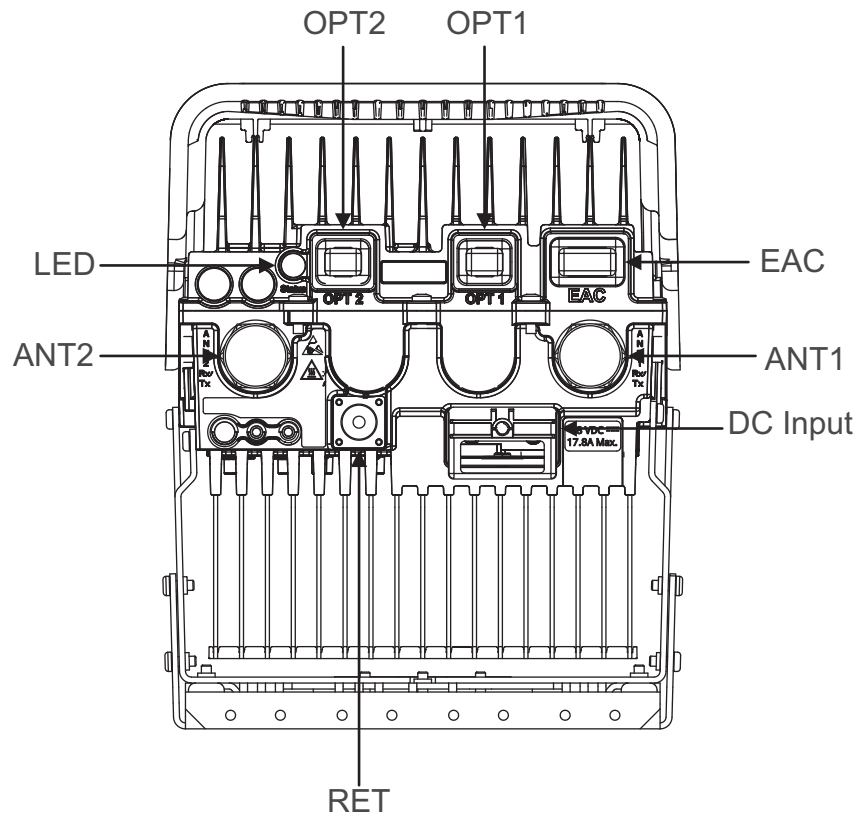

Table 292 FHDB interfaces

Interface	Label on the HW	Number of interfaces	Connector type	Additional info
Power connector	DC IN	1	3-pole screw terminal	
Antenna connector	ANT	2	7/16	
Remote Electrical Tilt	RET	1	8-pin circular	
External Alarm Connection	EAC	1	D-sub MDR14	
Optical interface	OPT	2	SFP	6 Gbps

### Antenna Line Devices (ALDs) support

Table 293 FHDB ALD support

ALD support via antenna ports	Value
AISG	2.0 Main only
Legacy Siemens equipment	No
CWA (for non-AISG installations)	No
Voltage	14.5 V
Power per port	15 W

### Functional block diagram

Figure 67 FHDB functional block diagram

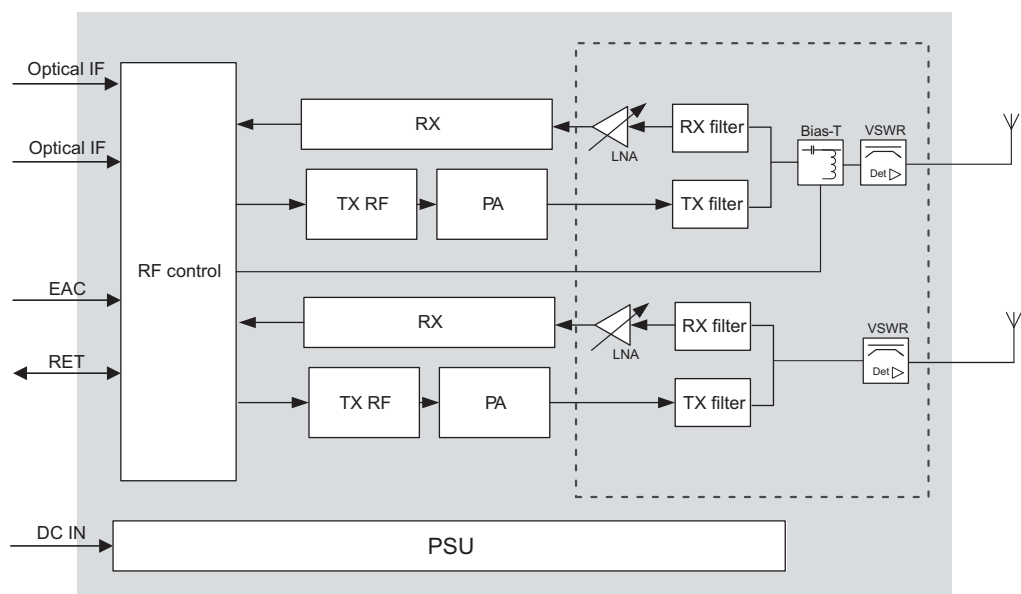

## Electrical specifications

Table 294 FHDB electrical specifications

Property	Value
Nominal supply voltage	-48.0 V DC
Nominal input voltage range	-40.5 V DC to -57.0 V DC
Extended input voltage range	-36.0 V DC to -40.5 V DC -57.0 V DC to -60.0 V DC

## Power consumption

Table 295 FHDB power consumption

Number of TXs	RF output power per TX [W]	Estimated power consumption [W] at 48 VDC input at 23°C for WCDMA mode. Non-committed estimated values depend on the final product HW and SW optimization with +/- 10% margin.	
		50% RF Load	100% RF Load
2	60	335	458
	40	266	351
	20	189	232

## Installation and mechanical specifications

Table 296 FHDB installation and mechanical specifications

Property	Value
Installation options	<ul style="list-style-type: none"> <li>pole/wall installation</li> <li>directly on the wall installation</li> </ul>
IP rating	IP65
Related optional items	<ul style="list-style-type: none"> <li>Flexi Pole Mounting Kit (FPKA/C)</li> <li>Pole Mounting Kit (VMPB)</li> </ul>

## Dimensions and weight

Table 297 FHDB dimensions and weight

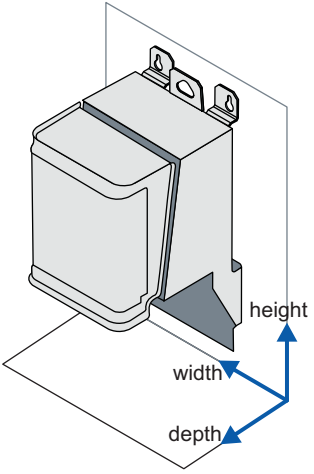
Property	Value	Dimensions orientation
Height	As delivered, cable tie point recessed: 335.2 (13.2 in.) with lower mounting bracket in the "FMFA" position: 571 mm (22.5 in.) with lower mounting bracket in the alternative "ALT" position: 621 mm (24.4 in.)	
Depth	324 mm (12.8 in.)	
Width	260 mm (10.2 in.)	
Weight	17.3 kg (38.1 lbs)	

## Environmental specifications

Table 298 FHDB environmental specifications

Property	Value
Maximum operational outdoor temperature in the shade (at constant high ambient temperature maximum output power might be limited)	+55°C (131°F)
Maximum operational outdoor temperature in the sun (according to GR-487-Core specification)	+50°C (122°F)
Maximum indoor temperature (this is valid for fanless products)	+45°C (129.2°F)
Minimum operational temperature (including cold start)	-40°C (-40°F)

## LEDs

Table 299 FHDB LEDs

LED color	Description	Alarm
Red, stable	Critical alarm affecting the whole RF module or all antenna carriers	Fault
Red, blinking	Operation degraded <ul style="list-style-type: none"> <li>Major alarm affecting the whole RF Module</li> </ul>	Major/critical alarm

Table 299 FHDB LEDs (Cont.)

LED color	Description	Alarm
	<ul style="list-style-type: none"> <li>Critical alarm affecting fans</li> <li>Major/Critical alarm affecting a module subcomponent or antenna carrier</li> </ul>	
Yellow, stable	<ul style="list-style-type: none"> <li>Until software download begins</li> <li>The carriers are blocked from BTS</li> <li>There is no connection to any System Module</li> </ul>	No alarm
Yellow, blinking	<ul style="list-style-type: none"> <li>Software download in progress</li> <li>Configuration in progress: RF resources are being setup, but not yet activated</li> </ul>	No alarm
Green, stable	<ul style="list-style-type: none"> <li>Software configuration is complete or supervisory: RF resources activated and transmission is possible</li> <li>Working normally, no alarm on the RF Module</li> </ul>	No alarm
Green, blinking	Software downloading and updating	No alarm
Stable Red for less than 5 seconds and changes to Stable Yellow	Switched ON, but the next conditions are not reached yet	No alarm
Stable Red for less than 5 seconds	The module is in the process of resetting	No alarm
Periodic Red and Green	Antenna line device faulty/degraded	No alarm
Blinking Colors (Red, Yellow, and Green), each color stable for 0.5 second	Module highlighting (Flexi BTS SM functionality that can help identifying faulty module)	No alarm

**Warnings, cautions or notes related to the product**



**NOTICE:** The RRH should always be mounted in a vertical orientation with connectors on the bottom side to ensure convection cooling.



The minimum startup voltage is 40.5 V DC. If the input voltage is below/beyond extended limits, unit might shut down.

## 38 Flexi Remote Radio Head 2TX 2100 (FRGY)

FRGY technical specifications.

### Functional description

Table 300 FRGY functional specification

Property	Value
Output power	2x60 W
MIMO	yes, 2TX
Outdoor installation	yes
SW supported technology	WCDMA
TX frequency range	2110-2170 MHz
RX frequency range	1920-1980 MHz
DL instantaneous bandwidth	60 MHz
UL instantaneous bandwidth	60 MHz
DL filter bandwidth	60 MHz
UL filter bandwidth	60 MHz

### Interfaces

Figure 68 FRGY interfaces

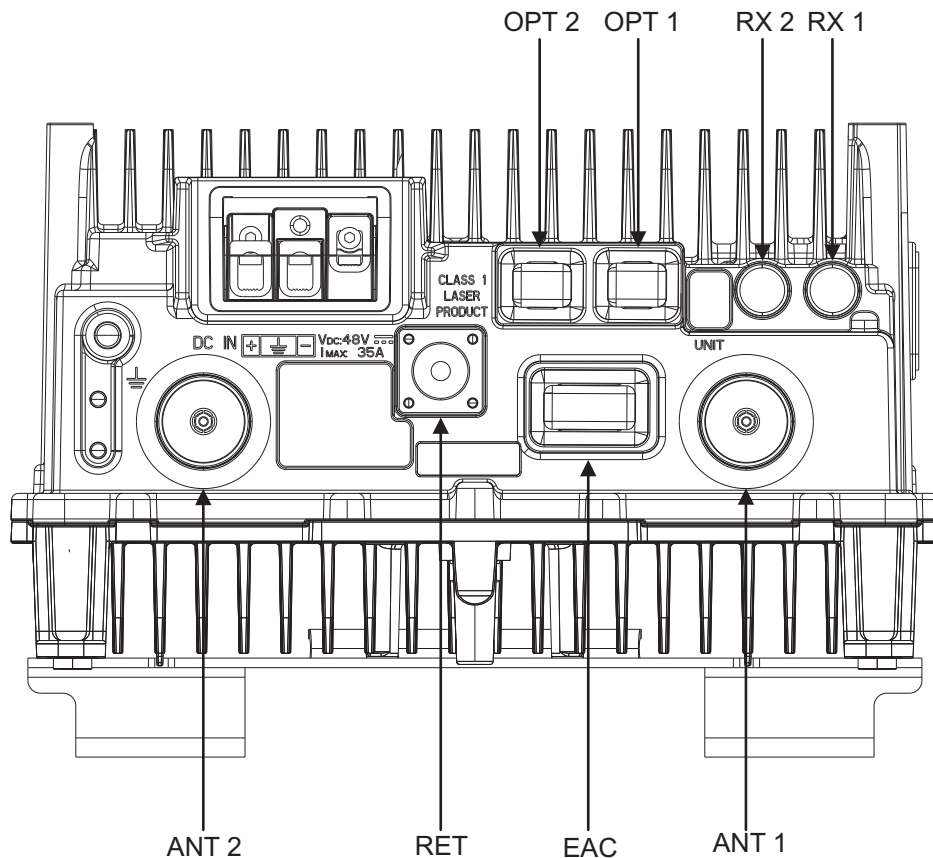

Table 301 FRGY interfaces

Interface	Label on the HW	Number of interfaces	Connector type	Additional info
Power connector	DC IN	1	3-pole screw terminal	
Antenna connector	ANT	2	7/16	
RF external connector	Rx EXT	2	QMA	
Remote Electrical Tilt	RET	1	8-pin circular	
External Alarm Connection	EAC	1	D-sub MDR14	
Optical interface	OPT	2	SFP	6 Gbps, OBSAI

### Antenna Line Devices (ALDs) support

Table 302 FRGY ALD support

ALD support via antenna ports	Value
AISG	2.0 Main only
Legacy Siemens equipment	No
CWA (for non-AISG installations)	No
Voltage	14.5 V
Power per port	30 W

### Functional block diagram

Figure 69 FRGY functional block diagram

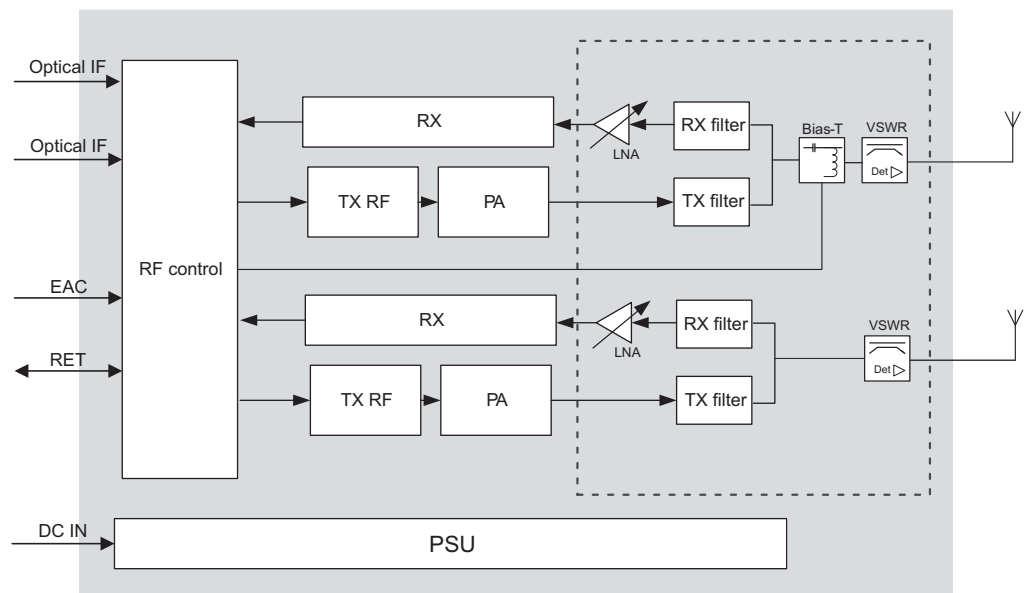

## Electrical specifications

Table 303 FRGY electrical specifications

Property	Value
Nominal supply voltage	-48.0 V DC
Nominal input voltage range	-40.5 V DC to -57.0 V DC
Extended input voltage range	-36.0 V DC to -40.5 V DC -57.0 V DC to -60.0 V DC

## Power consumption

Table 304 FRGY power consumption

Number of TXs	RF output power per TX [W]	Estimated power consumption [W] at 48 VDC input at 23°C. Non-committed estimated values depend on the final product HW and SW optimization with +/- 10% margin.	
		50% RF Load	100% RF Load
2	60	330	522
	40	262	383
	30	217	309
	20	178	240

## Installation and mechanical specifications

Table 305 FRGY installation and mechanical specifications

Property	Value
Installation options	<ul style="list-style-type: none"> <li>pole/wall installation</li> <li>directly on the wall installation</li> </ul>
IP rating	IP65
Related optional items	<ul style="list-style-type: none"> <li>Flexi Pole Mounting Kit (FPKA/C)</li> <li>Pole Mounting Kit (VMPB)</li> </ul>

## Dimensions and weight

Table 306 FRGY dimensions and weight

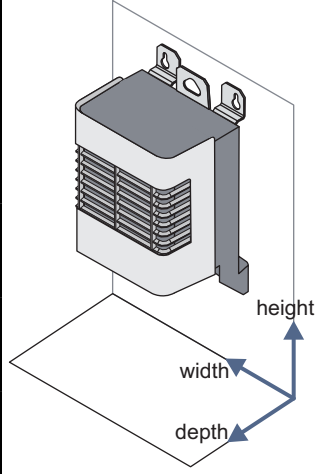
Property	Value	Dimensions orientation
Height	With lower bracket: 702 mm (27.6 in.) Without lower bracket: 437 mm (17.2 in.) Module only: 366 mm (14.4 in.)	 <p>The diagram shows a 3D perspective view of the FRGY Remote Radio Head. It is a rectangular unit with a fan grille on the front and a lower bracket on the bottom. Three arrows indicate the dimensions: 'height' points upwards from the base to the top, 'width' points from the front-left to the front-right, and 'depth' points from the front-right to the back-right.</p>
Depth	206 mm (8.1 in.)	
Width	302 mm (11.9 in.)	
Weight	15 kg (33.1 lbs)	

## Environmental specifications

Table 307 FRGY environmental specifications

Property	Value
Maximum operational outdoor temperature in the shade (at constant high ambient temperature maximum output power might be limited)	+55°C (131°F)
Maximum operational outdoor temperature in the sun (according to GR-487-Core specification)	+50°C (122°F)
Maximum indoor temperature (this is valid for fanless products)	+45°C (129.2°F)
Minimum operational temperature (including cold start)	-40°C (-40°F)

## LEDs

Table 308 FRGY LEDs

LED color	Description	Alarm
Red, stable	Critical alarm affecting the whole RF module or all antenna carriers	Fault
Red, blinking	Operation degraded <ul style="list-style-type: none"> <li>Major alarm affecting the whole RF Module</li> </ul>	Major/critical alarm

Table 308 FRGY LEDs (Cont.)

LED color	Description	Alarm
	<ul style="list-style-type: none"> <li>Critical alarm affecting fans</li> <li>Major/Critical alarm affecting a module subcomponent or antenna carrier</li> </ul>	
Yellow, stable	<ul style="list-style-type: none"> <li>Until software download begins</li> <li>The carriers are blocked from BTS</li> <li>There is no connection to any System Module</li> </ul>	No alarm
Yellow, blinking	<ul style="list-style-type: none"> <li>Software download in progress</li> <li>Configuration in progress: RF resources are being setup, but not yet activated</li> </ul>	No alarm
Green, stable	<ul style="list-style-type: none"> <li>Software configuration is complete or supervisory: RF resources activated and transmission is possible</li> <li>Working normally, no alarm on the RF Module</li> </ul>	No alarm
Green, blinking	Software downloading and updating	No alarm
Stable Red for less than 5 seconds and changes to Stable Yellow	Switched ON, but the next conditions are not reached yet	No alarm
Stable Red for less than 5 seconds	The module is in the process of resetting	No alarm
Periodic Red and Green	Antenna line device faulty/degraded	No alarm
Blinking Colors (Red, Yellow, and Green), each color stable for 0.5 second	Module highlighting (Flexi BTS SM functionality that can help identifying faulty module)	No alarm

**Warnings, cautions or notes related to the product**



**NOTICE:** The RRH should always be mounted in a vertical orientation with connectors on the bottom side to ensure convection cooling.



The minimum startup voltage is 40.5 V DC. If the input voltage is below/beyond extended limits, unit might shut down.

## 39 Flexi Remote Radio Head 4TX 1700/2100 (FRIG)

FRIG technical specifications.

### Functional description

Table 309 FRIG functional specification

Property	Value
Output power	4x30 W/2x60 W
MIMO	yes, 4TX
Outdoor installation	yes
SW supported technology	FDD-LTE
TX frequency range	2110-2155 MHz
RX frequency range	1710-1755 MHz
DL instantaneous bandwidth	45 MHz
UL instantaneous bandwidth	45 MHz
DL filter bandwidth	45 MHz
UL filter bandwidth	45 MHz

### Interfaces

Figure 70 FRIG interfaces

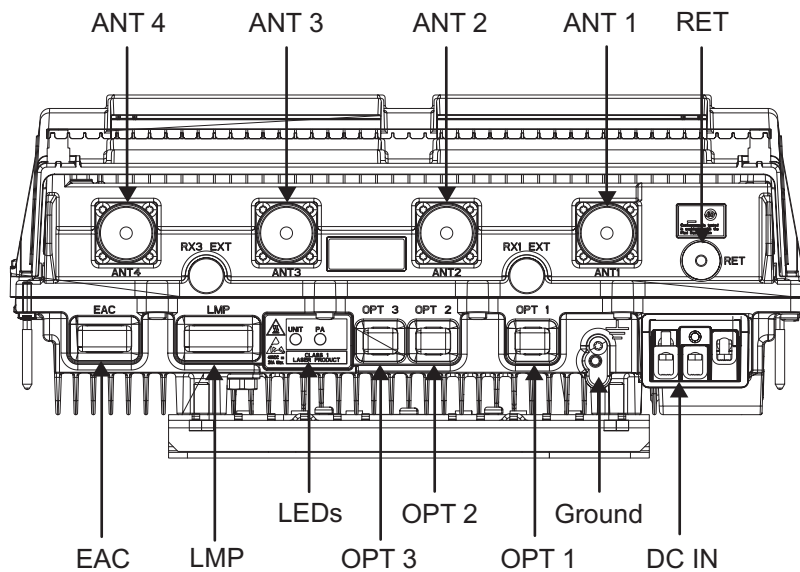

Table 310 FRIG interfaces

Interface	Label on the HW	Number of interfaces	Connector type	Additional info
Power connector	DC IN	1	3-pole screw terminal	

*Table 310* FRIG interfaces (Cont.)

Interface	Label on the HW	Number of interfaces	Connector type	Additional info
Antenna connector	ANT	4	7/16	
RF external connector	Rx EXT	2	QMA	
Remote Electrical Tilt	RET	1	8-pin circular	
External Alarm Connection	EAC	1	D-sub MDR14	
Optical interface	OPT	2	SFP	6 Gbps
Local Management Port	LMP	1	2x15 pin header	

**Antenna Line Devices (ALDs) support**

*Table 311* FRIG ALD support

ALD support via antenna ports	Value
AISG	2.0 Port 1 & 3 only
Legacy Siemens equipment	No
CWA (for non-AISG installations)	No
Voltage	15.5 V
Power per port	30 W (shared 60 W across three ports)

### Functional block diagram

Figure 71 FRIG functional block diagram

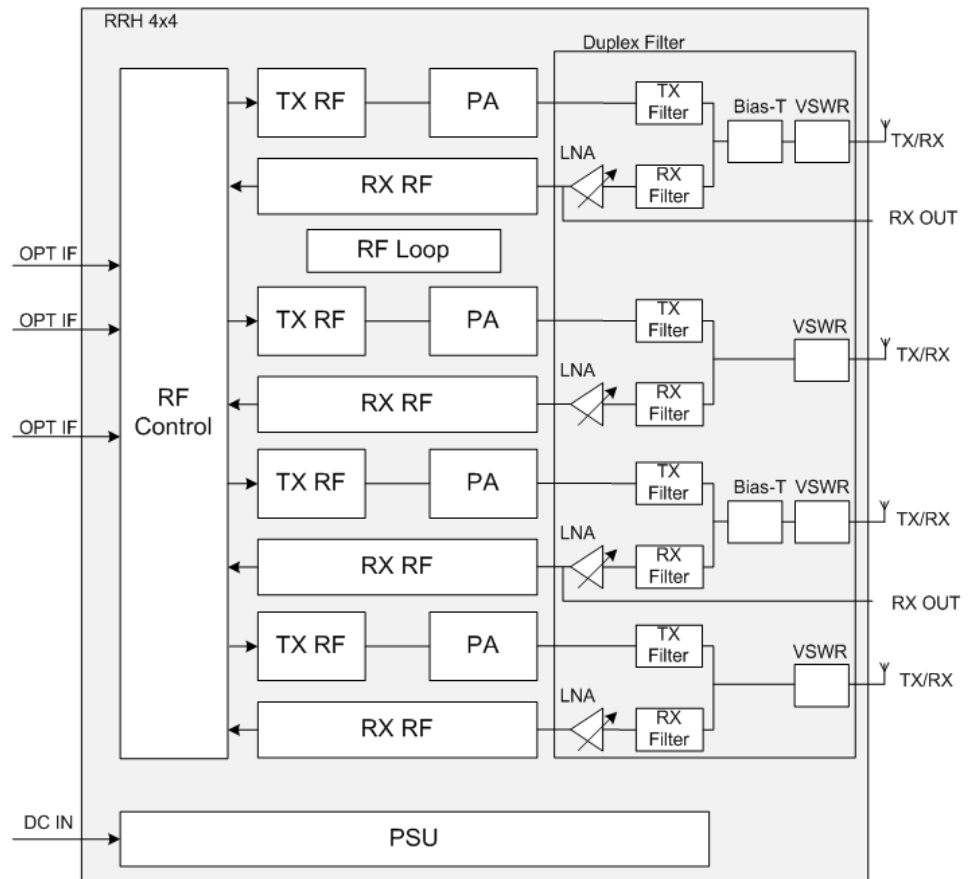

### Electrical specifications

Table 312 FRIG electrical specifications

Property	Value
Nominal supply voltage	-48.0 V DC
Nominal input voltage range	-40.5 V DC to -57.0 V DC
Extended input voltage range	-36.0 V DC to -40.5 V DC -57.0 V DC to -60.0 V DC

### Power consumption

Table 313 FRIG power consumption

Number of TXs	RF output power per TX [W]	Estimated power consumption [W] at 48 VDC input at 23°C. Non-committed estimated values depend on the final product HW and SW optimization with +/- 10% margin.	
		50% RF Load	100% RF Load
4	30	479	673
	20	417	533
	10	355	415
2	60	394	595

### Installation and mechanical specifications

Table 314 FRIG installation and mechanical specifications

Property	Value
Installation options	<ul style="list-style-type: none"> <li>pole/wall installation</li> <li>directly on the wall installation</li> </ul>
IP rating	IP65
Related optional items	<ul style="list-style-type: none"> <li>Flexi Pole Mounting Kit (FPKA/C)</li> <li>Pole Mounting Kit (VMPB)</li> </ul>

### Dimensions and weight

Table 315 FRIG dimensions and weight

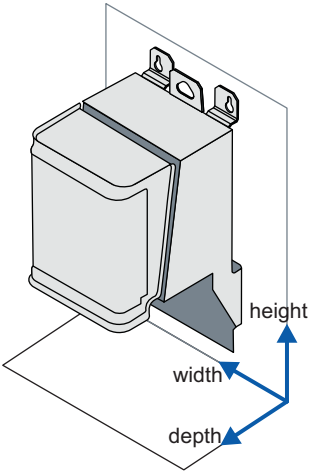
Property	Value	Dimensions orientation
Height	459.5 mm (18.1 in.)	
Depth	2x60 W version: 133.4 mm (5.2 in.) 3x40 W version: 162.3 mm (6.4 in.)	
Width	400 mm (15.7 in.)	
Weight	23.7 kg (52.5 lbs)	

## Environmental specifications

Table 316 FRIG environmental specifications

Property	Value
Maximum operational outdoor temperature in the shade (at constant high ambient temperature maximum output power might be limited)	+55°C (131°F)
Maximum operational outdoor temperature in the sun (according to GR-487-Core specification)	+50°C (122°F)
Maximum indoor temperature (this is valid for fanless products)	+45°C (129.2°F)
Minimum operational temperature (including cold start)	-40°C (-40°F)

## LEDs

Table 317 FRIG LEDs

LED color	Description	Alarm
Red, stable	Critical alarm affecting the whole RF module or all antenna carriers	Fault
Red, blinking	Operation degraded <ul style="list-style-type: none"> <li>Major alarm affecting the whole RF Module</li> <li>Critical alarm affecting fans</li> <li>Major/Critical alarm affecting a module subcomponent or antenna carrier</li> </ul>	Major/critical alarm
Yellow, stable	<ul style="list-style-type: none"> <li>Until software download begins</li> <li>The carriers are blocked from BTS</li> <li>There is no connection to any System Module</li> </ul>	No alarm
Yellow, blinking	<ul style="list-style-type: none"> <li>Software download in progress</li> <li>Configuration in progress: RF resources are being setup, but not yet activated</li> </ul>	No alarm
Green, stable	<ul style="list-style-type: none"> <li>Software configuration is complete or supervisory: RF resources activated</li> </ul>	No alarm

Table 317 FRIG LEDs (Cont.)

LED color	Description	Alarm
	and transmission is possible <ul style="list-style-type: none"> <li>Working normally, no alarm on the RF Module</li> </ul>	
Green, blinking	Software downloading and updating	No alarm
Stable Red for less than 5 seconds and changes to Stable Yellow	Switched ON, but the next conditions are not reached yet	No alarm
Stable Red for less than 5 seconds	The module is in the process of resetting	No alarm
Periodic Red and Green	Antenna line device faulty/degraded	No alarm
Blinking Colors (Red, Yellow, and Green), each color stable for 0.5 second	Module highlighting (Flexi BTS SM functionality that can help identifying faulty module)	No alarm

**Warnings, cautions or notes related to the product**



**NOTICE:** The RRH should always be mounted in a vertical orientation with connectors on the bottom side to ensure convection cooling.



The minimum startup voltage is 40.5 V DC. If the input voltage is below/beyond extended limits, unit might shut down.

## 40 Flexi Remote Radio Head 4TX 2600 (FRHD)

FRHD technical specifications.

### Functional description

Table 318 FRHD functional specification

Property	Value
Output power	4x30 W
MIMO	yes, 4TX
Outdoor installation	yes
SW supported technology	FDD-LTE
TX frequency range	2640 - 2690 MHz
RX frequency range	2520 - 2570 MHz
DL instantaneous bandwidth	40 MHz
UL instantaneous bandwidth	40 MHz
DL filter bandwidth	50 MHz
UL filter bandwidth	50 MHz

### Interfaces

Figure 72 FRHD interfaces

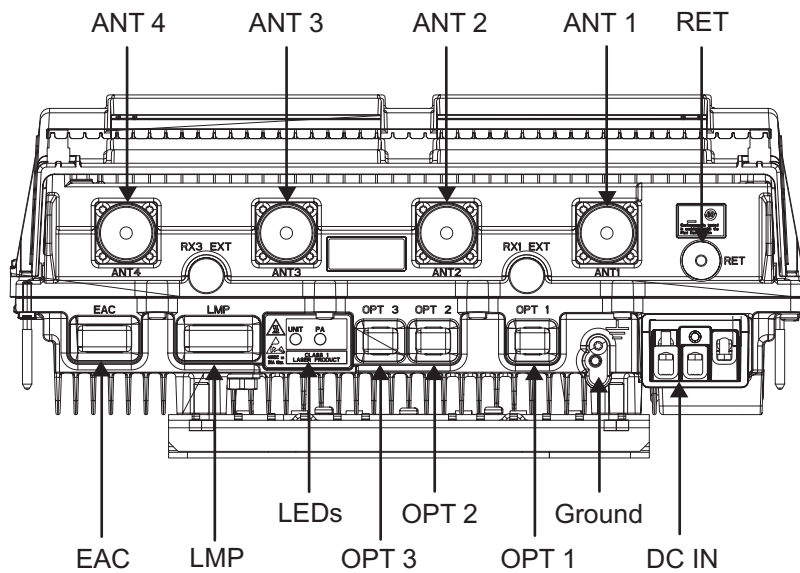

Table 319 FRHD interfaces

Interface	Label on the HW	Number of interfaces	Connector type	Additional info
Power connector	DC IN	1	3-pole screw terminal	

*Table 319* FRHD interfaces (Cont.)

Interface	Label on the HW	Number of interfaces	Connector type	Additional info
Antenna connector	ANT	4	7/16	
RF external connector	Rx EXT	2	QMA	
Remote Electrical Tilt	RET	1	8-pin circular	
External Alarm Connection	EAC	1	D-sub MDR14	
Optical interface	OPT	3	SFP	6 Gbps
Local Management Port	LMP	1	2x15 pin header	

### Antenna Line Devices (ALDs) support

*Table 320* FRHD ALD support

ALD support via antenna ports	Value
AISG	2.0 Port 1 & 3 only
Legacy Siemens equipment	No
CWA (for non-AISG installations)	No
Voltage	15.5 V
Power per port	30 W (shared 60W across three ports)

### Functional block diagram

Figure 73 FRHD functional block diagram

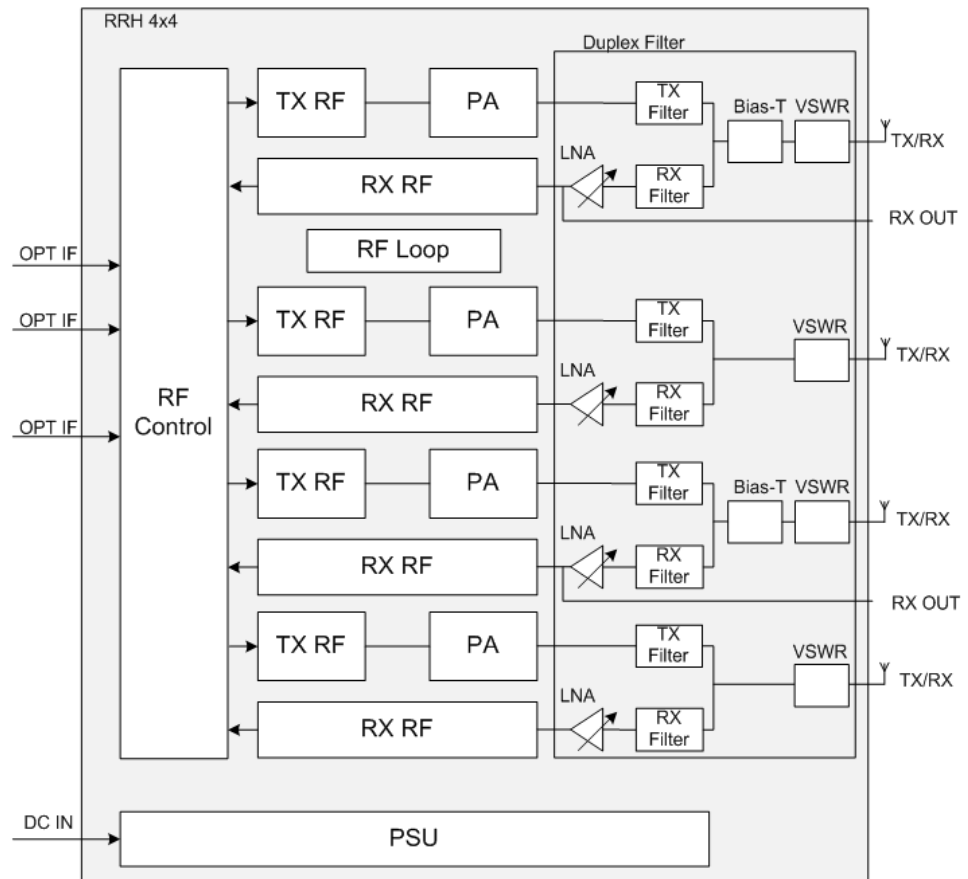

### Electrical specifications

Table 321 FRHD electrical specifications

Property	Value
Nominal supply voltage	-48.0 V DC
Nominal input voltage range	-40.5 V DC to -57.0 V DC
Extended input voltage range	-36.0 V DC to -40.5 V DC -57.0 V DC to -60.0 V DC

### Power consumption

Table 322 FRHD power consumption

Number of TXs	RF output power per TX [W]	Estimated power consumption [W] at 48 VDC input at 23°C. Non-committed estimated values depend on the final product HW and SW optimization with +/- 10% margin.	
		50% RF Load	100% RF Load
4	30	484	664
	20	417	544
	10	346	417

### Installation and mechanical specifications

Table 323 FRHD installation and mechanical specifications

Property	Value
Installation options	<ul style="list-style-type: none"> <li>• pole/wall installation</li> <li>• directly on the wall installation</li> </ul>
IP rating	IP65
Related optional items	<ul style="list-style-type: none"> <li>• Flexi Pole Mounting Kit (FPKA/C)</li> <li>• Pole Mounting Kit (VMPB)</li> </ul>

### Dimensions and weight

Table 324 FRHD dimensions and weight

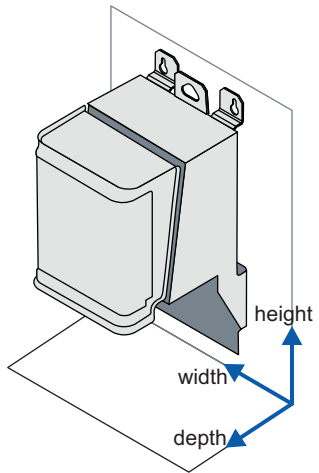
Property	Value	Dimensions orientation
Height	578 mm (22.7 in.)	
Depth	201.5 mm (7.9 in.)	
Width	400 mm (15.7 in.)	
Weight	max. 28.5 kg (62.8 lbs)	

## Environmental specifications

Table 325 FRHE environmental specifications

Property	Value
Maximum operational outdoor temperature in the shade (at constant high ambient temperature maximum output power might be limited)	+55°C (131°F)
Maximum operational outdoor temperature in the sun (according to GR-487-Core specification)	+50°C (122°F)
Maximum indoor temperature (this is valid for fanless products)	+45°C (129.2°F)
Minimum operational temperature (including cold start)	-40°C (-40°F)

## LEDs

Table 326 FRHD LEDs

LED color	Description	Alarm
Red, stable	Critical alarm affecting the whole RF module or all antenna carriers	Fault
Red, blinking	Operation degraded <ul style="list-style-type: none"> <li>Major alarm affecting the whole RF Module</li> <li>Critical alarm affecting fans</li> <li>Major/Critical alarm affecting a module subcomponent or antenna carrier</li> </ul>	Major/critical alarm
Yellow, stable	<ul style="list-style-type: none"> <li>Until software download begins</li> <li>The carriers are blocked from BTS</li> <li>There is no connection to any System Module</li> </ul>	No alarm
Yellow, blinking	<ul style="list-style-type: none"> <li>Software download in progress</li> <li>Configuration in progress: RF resources are being setup, but not yet activated</li> </ul>	No alarm
Green, stable	<ul style="list-style-type: none"> <li>Software configuration is complete or supervisory: RF resources activated</li> </ul>	No alarm

Table 326 FRHD LEDs (Cont.)

LED color	Description	Alarm
	and transmission is possible <ul style="list-style-type: none"> <li>Working normally, no alarm on the RF Module</li> </ul>	
Green, blinking	Software downloading and updating	No alarm
Stable Red for less than 5 seconds and changes to Stable Yellow	Switched ON, but the next conditions are not reached yet	No alarm
Stable Red for less than 5 seconds	The module is in the process of resetting	No alarm
Periodic Red and Green	Antenna line device faulty/degraded	No alarm
Blinking Colors (Red, Yellow, and Green), each color stable for 0.5 second	Module highlighting (Flexi BTS SM functionality that can help identifying faulty module)	No alarm

**Warnings, cautions or notes related to the product**



**NOTICE:** The RRH should always be mounted in a vertical orientation with connectors on the bottom side to ensure convection cooling.



The minimum startup voltage is 40.5 V DC. If the input voltage is below/beyond extended limits, unit might shut down.

# 41 Flexi Remote Radio Head 4TX 2600 (FRHE)

FRHE technical specifications.

## Functional description

Table 327 FRHE functional specification

Property	Value
Output power	4x30 W
MIMO	yes, 4TX
Outdoor installation	yes
SW supported technology	FDD-LTE
TX frequency range	2620-2675 MHz
RX frequency range	2500-2555 MHz
DL instantaneous bandwidth	40 MHz
UL instantaneous bandwidth	40 MHz
DL filter bandwidth	55 MHz
UL filter bandwidth	55 MHz

## Interfaces

Figure 74 FRHE interfaces

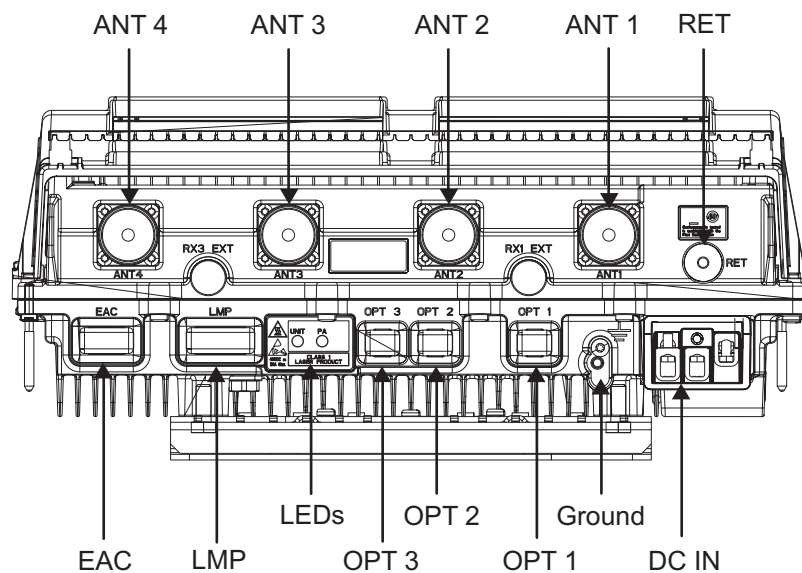

Table 328 FRHE interfaces

Interface	Label on the HW	Number of interfaces	Connector type	Additional info
Power connector	DC IN	1	3-pole screw terminal	

*Table 328* FRHE interfaces (Cont.)

Interface	Label on the HW	Number of interfaces	Connector type	Additional info
Antenna connector	ANT	4	7/16	
RF external connector	Rx EXT	2	QMA	
Remote Electrical Tilt	RET	1	8-pin circular	
External Alarm Connection	EAC	1	D-sub MDR14	
Optical interface	OPT	3	SFP	6 Gbps
Local Management Port	LMP	1	2x15 pin header	

### Antenna Line Devices (ALDs) support

*Table 329* FRHE ALD support

ALD support via antenna ports	Value
AISG	2.0 Port 1 & 3 only
Legacy Siemens equipment	No
CWA (for non-AISG installations)	No
Voltage	15.5 V
Power per port	30 W (shared 60W across three ports)

### Functional block diagram

Figure 75 FRHE functional block diagram

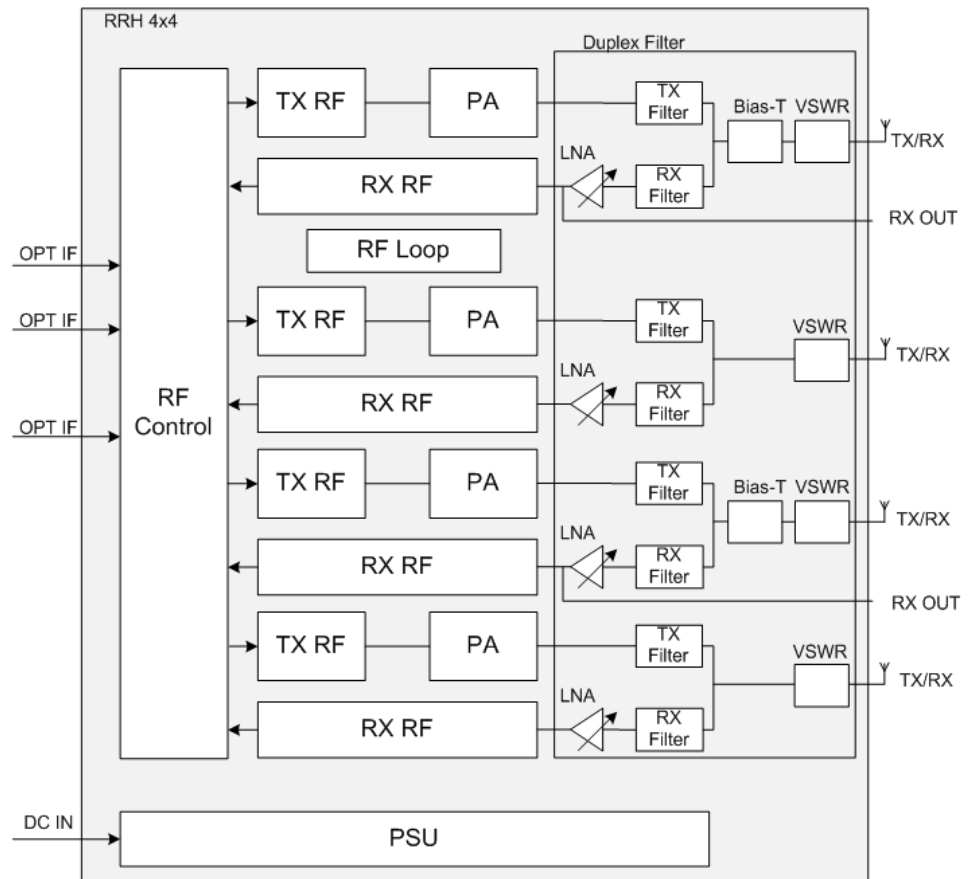

### Electrical specifications

Table 330 FRHE electrical specifications

Property	Value
Nominal supply voltage	-48.0 V DC
Nominal input voltage range	-40.5 V DC to -57.0 V DC
Extended input voltage range	-36.0 V DC to -40.5 V DC -57.0 V DC to -60.0 V DC

### Power consumption

Table 331 FRHE power consumption

Number of TXs	RF output power per TX [W]	Estimated power consumption [W] at 48 VDC input at 23°C. Non-committed estimated values depend on the final product HW and SW optimization with +/- 10% margin.	
		50% RF Load	100% RF Load
4	30	484	664
	20	417	544
	10	346	417

### Installation and mechanical specifications

Table 332 FRHE installation and mechanical specifications

Property	Value
Installation options	<ul style="list-style-type: none"> <li>pole/wall installation</li> <li>directly on the wall installation</li> </ul>
IP rating	IP65
Related optional items	<ul style="list-style-type: none"> <li>Flexi Pole Mounting Kit (FPKA/C)</li> <li>Pole Mounting Kit (VMPB)</li> </ul>

### Dimensions and weight

Table 333 FRHE dimensions and weight

Property	Value	Dimensions orientation
Height	578 mm (22.7 in.)	<p>The diagram shows a 3D perspective view of the FRHE unit. Three blue arrows indicate the dimensions: 'height' points upwards from the base, 'width' points across the front face, and 'depth' points into the unit from the front.</p>
Depth	201.5 mm (7.9 in.)	
Width	400 mm (15.7 in.)	
Weight	max. 28.5 kg (62.8 lbs)	

## Environmental specifications

Table 334 FRHE environmental specifications

Property	Value
Maximum operational outdoor temperature in the shade (at constant high ambient temperature maximum output power might be limited)	+55°C (131°F)
Maximum operational outdoor temperature in the sun (according to GR-487-Core specification)	+50°C (122°F)
Maximum indoor temperature (this is valid for fanless products)	+45°C (129.2°F)
Minimum operational temperature (including cold start)	-40°C (-40°F)

## LEDs

Table 335 FRHE LEDs

LED color	Description	Alarm
Red, stable	Critical alarm affecting the whole RF module or all antenna carriers	Fault
Red, blinking	Operation degraded <ul style="list-style-type: none"> <li>Major alarm affecting the whole RF Module</li> <li>Critical alarm affecting fans</li> <li>Major/Critical alarm affecting a module subcomponent or antenna carrier</li> </ul>	Major/critical alarm
Yellow, stable	<ul style="list-style-type: none"> <li>Until software download begins</li> <li>The carriers are blocked from BTS</li> <li>There is no connection to any System Module</li> </ul>	No alarm
Yellow, blinking	<ul style="list-style-type: none"> <li>Software download in progress</li> <li>Configuration in progress: RF resources are being setup, but not yet activated</li> </ul>	No alarm
Green, stable	<ul style="list-style-type: none"> <li>Software configuration is complete or supervisory: RF resources activated</li> </ul>	No alarm

Table 335 FRHE LEDs (Cont.)

LED color	Description	Alarm
	and transmission is possible <ul style="list-style-type: none"> <li>Working normally, no alarm on the RF Module</li> </ul>	
Green, blinking	Software downloading and updating	No alarm
Stable Red for less than 5 seconds and changes to Stable Yellow	Switched ON, but the next conditions are not reached yet	No alarm
Stable Red for less than 5 seconds	The module is in the process of resetting	No alarm
Periodic Red and Green	Antenna line device faulty/degraded	No alarm
Blinking Colors (Red, Yellow, and Green), each color stable for 0.5 second	Module highlighting (Flexi BTS SM functionality that can help identifying faulty module)	No alarm

**Warnings, cautions or notes related to the product**



**NOTICE:** The RRH should always be mounted in a vertical orientation with connectors on the bottom side to ensure convection cooling.



The minimum startup voltage is 40.5 V DC. If the input voltage is below/beyond extended limits, unit might shut down.

## 42 Flexi RRH 4-pipe 1900 160W (FHFB)

FHFB technical specifications.

### Functional description

Table 336 FHFB functional specification

Property	Value
Output power	4x40 W
MIMO	yes, 4TX
Outdoor installation	yes
SW supported technology	FDD-LTE
TX frequency range	1930-1995 MHz
RX frequency range	1850-1915 MHz
DL instantaneous bandwidth	65 MHz
UL instantaneous bandwidth	65 MHz
DL filter bandwidth	65 MHz
UL filter bandwidth	65 MHz

### Interfaces

Figure 76 FHFB interfaces

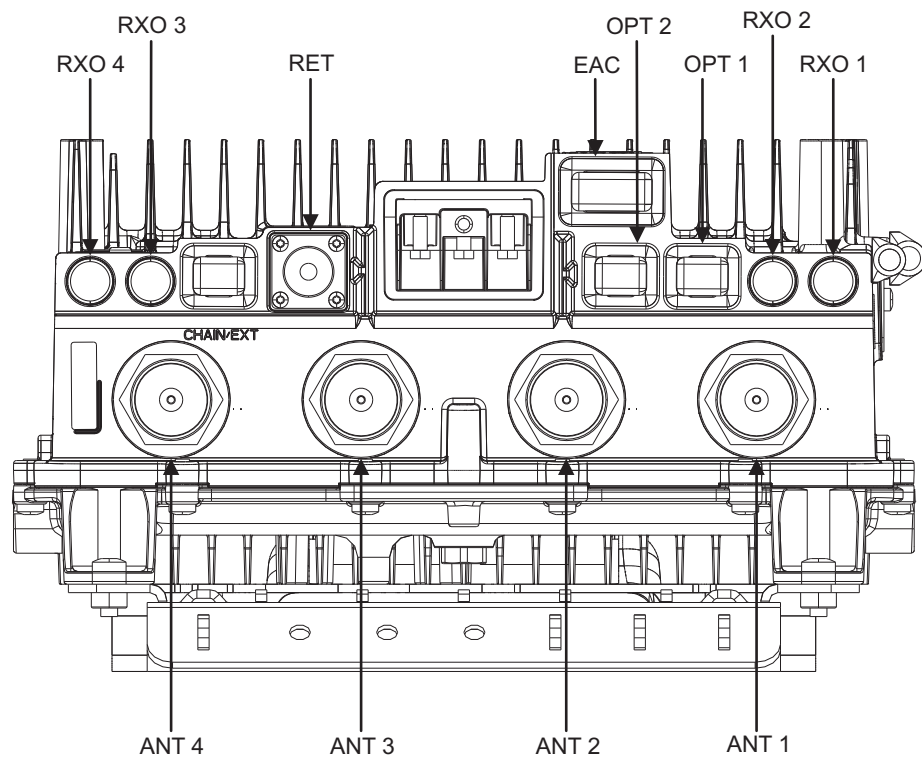

*Table 337* FHFB interfaces

Interface	Label on the HW	Number of interfaces	Connector type	Additional info
Power connector	DC IN	1	3-pole screw terminal	
Antenna connector	ANT	4	7/16	
RF external connector	Rx EXT	4	QMA	
Remote Electrical Tilt	RET	1	8-pin circular	
External Alarm Connection	EAC	1	D-sub MDR14	
Optical interface	OPT	3	SFP	
Local Management Port	LMP	1	2x15 pin header	

**Antenna Line Devices (ALDs) support**

*Table 338* FHFB ALD support

ALD support via antenna ports	Value
AISG	2.0 Main only
Legacy Siemens equipment	No
CWA (for non-AISG installations)	No
Voltage	14.5 V
Power per port	15 W

### Functional block diagram

Figure 77 FHFB functional block diagram

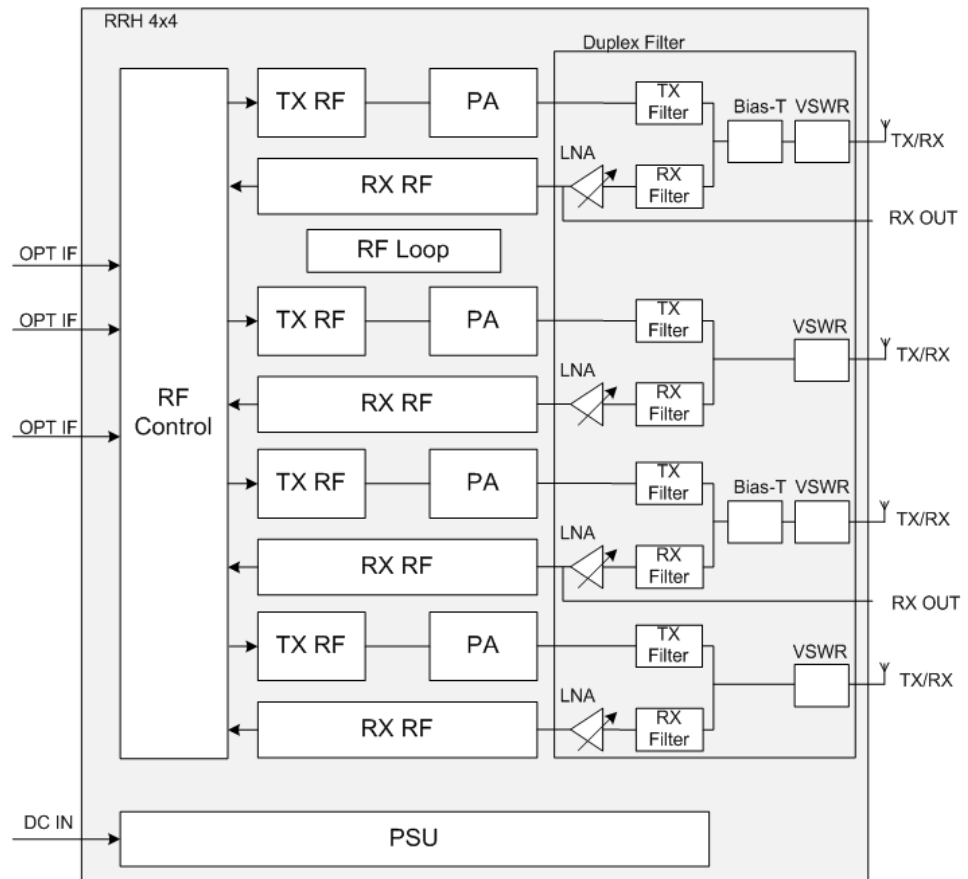

### Electrical specifications

Table 339 FHFB electrical specifications

Property	Value
Nominal supply voltage	-48.0 V DC
Nominal input voltage range	-40.5 V DC to -57.0 V DC
Extended input voltage range	-36.0 V DC to -40.5 V DC -57.0 V DC to -60.0 V DC

### Power consumption

Table 340 FHFB power consumption

Number of TXs	RF output power per TX [W]	Estimated power consumption [W] at 48 VDC input at 23°C. Non-committed estimated values depend on the final product HW and SW optimization with +/- 10% margin. Values preliminary estimate.	
		50% RF Load	100% RF Load
4	40	663	900
	20	520	663

### Installation and mechanical specifications

Table 341 FHFB installation and mechanical specifications

Property	Value
Installation options	<ul style="list-style-type: none"> <li>pole/wall installation</li> <li>directly on the wall installation</li> </ul>
IP rating	IP65
Related optional items	<ul style="list-style-type: none"> <li>Flexi Pole Mounting Kit (FPKA/C)</li> <li>Pole Mounting Kit (VMPB)</li> </ul>

### Dimensions and weight

Table 342 FHFB dimensions and weight

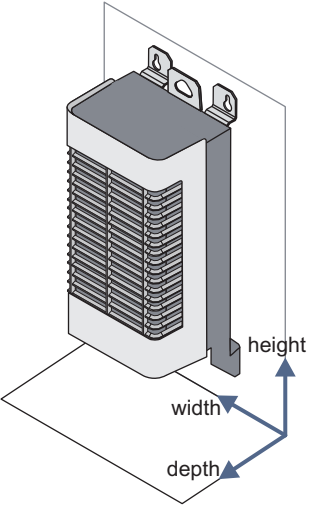
Property	Value	Dimensions orientation
Height	With lower bracket: 872 mm (34.3 in.) Without lower bracket: 637 mm (25.1 in.) Without brackets: 585 mm (23.0 in.)	
Depth	200 mm (7.8 in.)	
Width	Without solar shield: 320 mm (12.6 in.)	
Weight	With lower bracket: 23 kg (51.0 lbs) Without solar shield and mounting shroud: 22 kg (68.5 lbs)	

## Environmental specifications

Table 343 FHFB environmental specifications

Property	Value
Maximum operational outdoor temperature in the shade (at constant high ambient temperature maximum output power might be limited)	+55°C (131°F)
Maximum operational outdoor temperature in the sun (according to GR-487-Core specification)	+50°C (122°F)
Maximum indoor temperature (this is valid for fanless products)	+45°C (129.2°F)
Minimum operational temperature (including cold start)	-40°C (-40°F)

## LEDs

Table 344 FHFB LEDs

LED color	Description	Alarm
Red, stable	Critical alarm affecting the whole RF module or all antenna carriers	Fault
Red, blinking	Operation degraded <ul style="list-style-type: none"> <li>Major alarm affecting the whole RF Module</li> <li>Critical alarm affecting fans</li> <li>Major/Critical alarm affecting a module subcomponent or antenna carrier</li> </ul>	Major/critical alarm
Yellow, stable	<ul style="list-style-type: none"> <li>Until software download begins</li> <li>The carriers are blocked from BTS</li> <li>There is no connection to any System Module</li> </ul>	No alarm
Yellow, blinking	<ul style="list-style-type: none"> <li>Software download in progress</li> <li>Configuration in progress: RF resources are being setup, but not yet activated</li> </ul>	No alarm
Green, stable	<ul style="list-style-type: none"> <li>Software configuration is complete or supervisory: RF resources activated</li> </ul>	No alarm

Table 344 FHFB LEDs (Cont.)

LED color	Description	Alarm
	and transmission is possible <ul style="list-style-type: none"> <li>Working normally, no alarm on the RF Module</li> </ul>	
Green, blinking	Software downloading and updating	No alarm
Stable Red for less than 5 seconds and changes to Stable Yellow	Switched ON, but the next conditions are not reached yet	No alarm
Stable Red for less than 5 seconds	The module is in the process of resetting	No alarm
Periodic Red and Green	Antenna line device faulty/degraded	No alarm
Blinking Colors (Red, Yellow, and Green), each color stable for 0.5 second	Module highlighting (Flexi BTS SM functionality that can help identifying faulty module)	No alarm

**Warnings, cautions or notes related to the product**



**NOTICE:** The RRH should always be mounted in a vertical orientation with connectors on the bottom side to ensure convection cooling.



The minimum startup voltage is 40.5 V DC. If the input voltage is below/beyond extended limits, unit might shut down.

---

## 43 Compliance with EMC, RF, and safety

Short reference description.

In Europe, this means compliance with Directive 1999/5/EC of the European Parliament and of the Council of 9 March 1999 on radio equipment and telecommunications terminal equipment and the mutual recognition of their conformity.

In other market areas additional compliance is fulfilled according to relevant authority requirements.

### EMC emission

- ETSI EN 301 489-1: Electromagnetic compatibility and Radio spectrum Matters (ERM); ElectroMagnetic Compatibility (EMC) standard for radio equipment and services; Part 1: Common technical requirements.
- ETSI EN 301 489-8: Part 8: Specific conditions for GSM base stations.
- EN55022: "Limits and methods of measurement of radio disturbance characteristics of information technology equipment".

### RF

- **GSM:** ETSI EN 301 502: Harmonized EN for Global System for Mobile communications (GSM) - Base Station and Repeater equipment covering essential requirements under article 3.2 of the R&TTE directive.
- **WCDMA:** ETSI EN 301 908-3: IMT cellular networks; Harmonized EN covering the essential requirements of article 3.2 of the R&TTE Directive; Part 3: CDMA Direct Spread (UTRA FDD) Base Stations (BS).
- **LTE:** ETSI EN 301 908-14: IMT cellular networks; Harmonized EN covering the essential requirements of article 3.2 of the R&TTE Directive; Part 14: Evolved Universal Terrestrial Radio Access (E-UTRA) Base Stations (BS)

### Safety

- IEC 60950-1/ EN 60950-1: "Safety of Information Technology equipment including electrical business equipment".
- IEC 60950-22/ EN 60950-22: "Information technology equipment - Safety - Part 22: Equipment to be installed outdoors"
- EN 50383: Basic standard for the calculation and measurement of the electromagnetic field strength and SAR related to human exposure from radio base stations and fixed terminal stations for wireless telecommunications system (110 MHz - 40 GHz).
- EN 50384: Product standard to demonstrate the compliance of radio base stations and fixed terminal stations for wireless telecommunications systems with the basic restrictions or the reference levels related to human exposure to radio frequency electromagnetic fields (110 MHz - 40 GHz) - Occupational.

- 
- EN 50385: Product standard to demonstrate the compliances of radio base stations and fixed terminal stations for wireless telecommunications systems with the basic restrictions or the reference levels related to human exposure to radio frequency electromagnetic fields (110 MHz - 40 GHz) - General public.
  - UL 60950-1: Safety of Information Technology Equipment.
  - CSA C22.2 No. 60950-00: Safety of Information Technology Equipment.

## 44 Avoiding Passive Intermodulation during RF Module and RRH operation

In wideband frequencies when several transmitting and receiving signals are sharing same hardware there could be noted effect called Passive Intermodulation (PIM) Interference. Using RF Modules might cause a potential risk of generating third-order intermodulation that results in distortions in own receiver (RX) channel. Antenna Line Devices (ALD) have important role in preventing Passive Intermodulation generation, even if used RF Module and RRH performance at the antenna connector complies with 3GPP requirements. Poor PIM performance of ALD might degrade significantly the reference sensitivity. ALDs, like MHAs, provided by NSN have high PIM requirements.

The risk might be high in the following cases:

- maximum bandwidth (BW) used for the carriers is more than 0.5 x duplex separation of the band
- carriers in configuration are wideband in nature (for example WCDMA or LTE), or combination of wideband and narrow band carriers (for example RF sharing GSM-WCDMA or GSM-LTE).
- antenna line PIM performance is poor, or not on the required level for the configuration.

*Table 345* Typical reference sensitivity degradation with different Antenna line PIM performance.

PIM performance	Typical degradation	Note
-140 dBc @ 2x43 dBm	~10 dB	High degradation, carrier configuration unusable in many cases
-153 dBc @ 2x43 dBm	~2 dB	Modest degradation, tolerable in many cases
-161 dBc @ 2x43 dBm	~0.2 dB	Minimal degradation, however, difficult to reach on the typical site environment.

When using wideband carrier configurations where PIM products fall into own receiver band, it is recommended that antenna line PIM performance is at least -153 dBc measured with 2 x 43dB test signals.

However, this kind of performance might be very difficult to achieve and maintain over time in outdoor environment due to mechanisms behind the PIM including corrosion, oxidation, material imperfections, and defects in workmanship. Some of these parameters might change, and can degrade performance during operation. Taking that into consideration, it is highly recommended not to use carrier configurations which are generating intermodulation results in landing in own receiver channels.