



Nokia Siemens Networks GSM/EDGE BSS, rel. RG10(BSS), operating documentation, issue 03

Troubleshoot

Trouble Management of UltraSite EDGE BTS

DN05168243

Issue 13-2

Approval Date 2009-10-14

The information in this document is subject to change without notice and describes only the product defined in the introduction of this documentation. This documentation is intended for the use of Nokia Siemens Networks customers only for the purposes of the agreement under which the document is submitted, and no part of it may be used, reproduced, modified or transmitted in any form or means without the prior written permission of Nokia Siemens Networks. The documentation has been prepared to be used by professional and properly trained personnel, and the customer assumes full responsibility when using it. Nokia Siemens Networks welcomes customer comments as part of the process of continuous development and improvement of the documentation.

The information or statements given in this documentation concerning the suitability, capacity, or performance of the mentioned hardware or software products are given "as is" and all liability arising in connection with such hardware or software products shall be defined conclusively and finally in a separate agreement between Nokia Siemens Networks and the customer. However, Nokia Siemens Networks has made all reasonable efforts to ensure that the instructions contained in the document are adequate and free of material errors and omissions. Nokia Siemens Networks will, if deemed necessary by Nokia Siemens Networks, explain issues which may not be covered by the document.

Nokia Siemens Networks will correct errors in this documentation as soon as possible. IN NO EVENT WILL Nokia Siemens Networks BE LIABLE FOR ERRORS IN THIS DOCUMENTATION OR FOR ANY DAMAGES, INCLUDING BUT NOT LIMITED TO SPECIAL, DIRECT, INDIRECT, INCIDENTAL OR CONSEQUENTIAL OR ANY LOSSES, SUCH AS BUT NOT LIMITED TO LOSS OF PROFIT, REVENUE, BUSINESS INTERRUPTION, BUSINESS OPPORTUNITY OR DATA, THAT MAY ARISE FROM THE USE OF THIS DOCUMENT OR THE INFORMATION IN IT.

This documentation and the product it describes are considered protected by copyrights and other intellectual property rights according to the applicable laws.

The wave logo is a trademark of Nokia Siemens Networks Oy. Nokia is a registered trademark of Nokia Corporation. Siemens is a registered trademark of Siemens AG.

Other product names mentioned in this document may be trademarks of their respective owners, and they are mentioned for identification purposes only.

Copyright © Nokia Siemens Networks 2009. All rights reserved



Important Notice on Product Safety

Elevated voltages are inevitably present at specific points in this electrical equipment. Some of the parts may also have elevated operating temperatures.

Non-observance of these conditions and the safety instructions can result in personal injury or in property damage.

Therefore, only trained and qualified personnel may install and maintain the system.

The system complies with the standard EN 60950 / IEC 60950. All equipment connected has to comply with the applicable safety standards.

The same text in German:

Wichtiger Hinweis zur Produktsicherheit

In elektrischen Anlagen stehen zwangsläufig bestimmte Teile der Geräte unter Spannung. Einige Teile können auch eine hohe Betriebstemperatur aufweisen.

Eine Nichtbeachtung dieser Situation und der Warnungshinweise kann zu Körperverletzungen und Sachschäden führen.

Deshalb wird vorausgesetzt, dass nur geschultes und qualifiziertes Personal die Anlagen installiert und wartet.

Das System entspricht den Anforderungen der EN 60950 / IEC 60950. Angeschlossene Geräte müssen die zutreffenden Sicherheitsbestimmungen erfüllen.

Table of Contents

This document has 209 pages.

1	Changes in Trouble Management of UltraSite EDGE BTS	13
2	Statutory statements	15
2.1	CE Marking	15
2.2	FCC Statement	16
3	Warnings and cautions for trouble management	17
4	Trouble management of UltraSite EDGE BTS alarms	18
4.1	UltraSite EDGE Base Station alarm examples	18
4.2	Identifying faulty units	19
4.3	Troubleshooting with the help of alarm tables	21
4.4	UltraSite EDGE Base Station alarm reclassification	23
4.5	Alarms list for UltraSite EDGE BTS	26
4.6	UltraSite EDGE BTS alarms	27
4.6.1	7208 LOCAL BLOCK	27
4.6.2	7401-7424 EXTERNAL ALARM	28
4.6.3	7600 BCF FAULTY	29
4.6.4	7601 BCF OPERATION DEGRADED	30
4.6.5	7602 BCF NOTIFICATION	33
4.6.6	7603 BTS FAULTY	37
4.6.7	7604 BTS OPERATION DEGRADED	38
4.6.8	7605 BTS NOTIFICATION	40
4.6.9	7606 TRX FAULTY	41
4.6.10	7607 TRX OPERATION DEGRADED	48
4.6.11	7608 TRX NOTIFICATION	51
4.6.12	7609 TRE FAULTY	52
4.6.13	7612 SITE POWERING FAULTY	53
4.6.14	7613 SITE POWERING OPERATION DEGRADED	54
4.6.15	7614 SITE POWERING NOTIFICATION	55
4.6.16	7615 RTS IN TEST USE	56
4.6.17	7616 OSCILLATOR ADJUSTMENT TEMPORARILY INTERRUPTED	57
4.6.18	7617 SEVERAL CALLS DROPPED DUE TO PROBLEM WITH TRANSCODER	58
4.6.19	7622 CABINET OPEN	59
4.6.20	7801 MMI CONNECTED TO BASE STATION	60
4.6.21	7995 MAINS BREAKDOWN WITH BATTERY BACKUP	61
5	Trouble management of ITN, LMU and other transmission alarms	62
5.1	Trouble management of ITN alarms	62
5.1.1	Monitoring transmission node alarms	62
5.1.2	Configuring FXC STM-1 alarm monitoring states	68
5.1.3	Common node alarms	71
5.1.3.1	20 Blocked from use	71
5.1.3.2	8062 No connection	72
5.1.3.3	8112 Frequency error	73

5.1.3.4	8122 Synchronizing fault.	74
5.1.3.5	8124 Synchronising fault in clock recovery.	75
5.1.3.6	8125 Loss of synchronisation signals	76
5.1.3.7	8139 Subrack is missing units	77
5.1.3.8	8140 Subrack has excessive units	78
5.1.3.9	8142 Fault in installation of equipment	79
5.1.3.10	8162 Database full	80
5.1.3.11	221 Version mismatch	81
5.1.3.12	8240 Active alarm point	82
5.1.4	Common alarms for FXC transmission units	83
5.1.4.1	8021 Loop to interface	83
5.1.4.2	8022 Loop to equipment	84
5.1.4.3	8025 Test generator on.	85
5.1.4.4	8032 Loss of outgoing signal	86
5.1.4.5	8052 Loss of incoming 34M signal	87
5.1.4.6	8066 AIS 2M	88
5.1.4.7	8081 Loss of frame alignment.	89
5.1.4.8	86 Loss of CRC multiframe alignment	90
5.1.4.9	8099 Error rate > 1 E-3.	91
5.1.4.10	8102 Error rate > 1 E-6.	92
5.1.4.11	8126 Unit function degraded.	93
5.1.4.12	137 Fault in oscillator	94
5.1.4.13	8148 Equipment reset.	95
5.1.4.14	8150 Fault in unit	96
5.1.4.15	8179 Far-end alarm	98
5.1.5	Specific alarms for FXC E1/T1 transmission units	99
5.1.5.1	56 Loss of incoming 1.5M signal.	99
5.1.5.2	8073 AIS 1.5M	100
5.1.5.3	8172 Yellow alarm	101
5.1.6	Specific alarms for FXC RRI transmission units	102
5.1.6.1	8064 Alarm signal received.	102
5.1.6.2	8128 Fault in equipment	103
5.1.6.3	8141 Forced control on.	104
5.1.6.4	8143 Fault in changeover function	105
5.1.7	Specific alarms for FXC STM transmission units	106
5.1.7.1	8124 Synchronisation fault in clock recovery	106
5.1.7.2	8125 Loss of synchronization signal(s).	107
5.1.7.3	8130 Fault in memory	108
5.1.7.4	8139 Subrack is missing units	109
5.1.7.5	8140 Subrack has excessive units	110
5.1.7.6	8141 Forced control on.	111
5.1.7.7	8152 Fault in block	112
5.1.7.8	8162 Database full	113
5.1.7.9	165 Real time lost fault	114
5.1.7.10	184 Real time updated	115
5.1.7.11	8207 Calibration expired.	116
5.1.7.12	8221 Version mismatch	117

5.1.7.13	8223 Protection switch.	118
5.1.8	Specific alarms for FXC STM-1	119
5.1.8.1	8148 Equipment reset	119
5.1.8.2	8149 Forced indication	120
5.1.8.3	8150 Fault in unit	121
5.1.8.4	8162 Database full.	122
5.1.9	Specific alarms for FXC STM-1 Interface x	123
5.1.9.1	23 Test mode active	123
5.1.9.2	48 Loss of incoming signal	124
5.1.9.3	8057 Loss of pointer	125
5.1.9.4	59 Incoming signal level incorrect	126
5.1.9.5	64 Alarm signal is received	127
5.1.9.6	81 Loss of frame alignment	128
5.1.9.7	141 Forced control on	129
5.1.9.8	153 Fault in transmitter	130
5.1.9.9	156 Laser power out of range	131
5.1.9.10	158 Forced laser cut off	132
5.1.9.11	8162 Database full.	133
5.1.9.12	8213 Remote Defect Indication (RDI)	134
5.1.9.13	214 Signal degraded	135
5.1.9.14	215 Trace identifier mismatch	136
5.1.10	Specific alarms for FXC STM-1 Interface S4 x	137
5.1.10.1	47 Payload mismatch	137
5.1.10.2	57 Loss of pointer	138
5.1.10.3	64 Alarm signal is received	139
5.1.10.4	82 Loss of multiframe alignment	140
5.1.10.5	8162 Database full.	141
5.1.10.6	213 Remote Defect Indication (RDI)	142
5.1.10.7	214 Signal degraded	143
5.1.10.8	215 Trace identifier mismatch	144
5.1.10.9	216 Unequipped signal	145
5.1.11	Specific alarms for FXC Bridge PDH	146
5.1.11.1	8022 Loop to equipment	146
5.1.11.2	8032 Loss of outgoing signal	147
5.1.11.3	8126 Unit function degraded	148
5.1.11.4	139 Subrack is missing units	149
5.1.11.5	145 Temperature alarm	150
5.1.11.6	8221 Version mismatch	151
5.1.12	Specific alarms for FXC Bridge SDH	152
5.1.12.1	8022 Loop to equipment	152
5.1.12.2	8047 Payload mismatch	153
5.1.12.3	64 Alarm signal is received	154
5.1.12.4	81 Loss of frame alignment	155
5.1.12.5	96 Excessive error rate	156
5.1.12.6	8148 Equipment reset	157
5.1.12.7	8162 Database full.	158
5.1.12.8	213 Remote defect indication (RDI).	159

5.1.12.9	214 Signal degraded	160
5.1.12.10	215 Trace identifier mismatch	161
5.1.12.11	216 Unequipped signal	162
5.2	Trouble management of LMU alarms	163
5.2.1	8003 Loss of remote power supply	163
5.2.2	8048 Loss of incoming signal (GPS fix lost)	164
5.2.3	8145 Temperature alarm	165
5.2.4	8148 Equipment reset	166
5.2.5	8165 Q1 real time lost	167
5.2.6	8184 Q1 real time update	168
5.2.7	8240 Active alarm point (self test failure)	169
5.2.8	8272 Position not locked	170
5.3	Trouble management of other transmission alarms	171
5.3.1	8202 Loss of supervision connection	171
6	Troubleshooting UltraSite EDGE BTS	172
6.1	Overview of troubleshooting the BTS	172
6.2	Troubleshooting commissioning	173
6.3	Troubleshooting BTS Manager connection	174
6.4	Troubleshooting electrical power	175
6.5	Troubleshooting transmission unit operation	176
6.6	Troubleshooting Transceiver unit (TSxx) operation	177
6.7	Troubleshooting Fan units	178
6.8	Troubleshooting TRX Test failures with BTS Manager	179
6.9	Advanced BTS troubleshooting option	181
7	Troubleshooting BTS Transmission Hub	182
7.1	Using forced indications to test the FXC STM transmission unit LEDs	182
7.2	Using timeslot monitoring to locate faults	183
7.3	Using MCB/LCB bits to locate faults	184
7.4	Using the condition bits of protected cross-connections to locate faults	186
7.5	Using pending cross-connections to locate faults	188
7.6	Using loopbacks to test the transmission node	190
7.6.1	Overview of using loopbacks to test the transmission node	190
7.6.2	Using loopbacks to test the FXC E1(/T1) transmission unit	192
7.6.3	Using loopbacks to test the FXC RRI transmission unit	194
7.6.4	Using loopbacks to test the FXC STM-1 transmission unit	196
7.6.5	An example of loopback usage during a traffic cut	199
7.7	BTS Transmission Hub faults	201
7.7.1	No power to the transmission node	201
7.7.2	Transmission node powered, but a manager connection cannot be established	203
7.7.3	The cross-connections test of a transmission unit fails in the manager	204
8	Troubleshooting software licensing	205
8.1	Change of unit	205
8.2	The software licence key is not available	206
8.3	Typographic errors in the licence key	207

9	Completing troubleshooting	208
	Related information.	209

List of Figures

Figure 1	Examples of active alarms as seen at the BSC	18
Figure 2	Example of an active alarm as seen at the BSC.	18
Figure 3	Rack, shelf, and slot information in UltraSite EDGE BTS	19
Figure 4	BTS Manager desktop showing the alarms in the Alarms window	20
Figure 5	Faulty and degraded object alarm reclassification	24
Figure 6	Alarms window	63
Figure 7	Alarm Options window, View tab	65
Figure 8	Alarm Options window, Monitoring tab	66
Figure 9	FXC STM-1 Alarm Monitoring States, STM-1 Interfaces	68
Figure 10	STM-1 Alarm Monitoring States, SDH-PDH Channels	69
Figure 11	FXC STM-1 or FXC Bridge Forced Indications.	182
Figure 12	Timeslot Monitoring dialogue box	183
Figure 13	MCB/LCB status in the Synchronization dialogue box	184
Figure 14	The Cross-connections window	186
Figure 15	Condition information in the Cross-connection Properties dialogue box	187
Figure 16	Pending cross-connections because of disabled interface 1 of the FXC E1/T1 unit in slot 2	188
Figure 17	Symbols used in the cross-connections window.	189
Figure 18	Loopbacks in FXC E1 unit, FXC RRI unit, FlexiHopper and MetroHopper.	190
Figure 19	Interface Loops dialogue box in the FXC E1/T1 Manager	192
Figure 20	Interface Loops dialogue box in the FXC RRI Manager	194
Figure 21	FXC STM node 2M loops	196
Figure 22	The Loops window, SDH-PDH Channels	197
Figure 23	The Modify dialogue box.	197
Figure 24	Example of loopback usage during a traffic cut	199
Figure 25	Licence not installed	206
Figure 26	The licence installation was not successful	206
Figure 27	Error message: validation error in a file	207

List of Tables

Table 1	Description of the fields in the alarm table	21
Table 2	7208 LOCAL BLOCK	27
Table 3	7401 EXTERNAL ALARM 7401-7424, EXTERNAL ALARM 1-24	28
Table 4	7600 BCF FAULTY	29
Table 5	BCF OPERATION DEGRADED	30
Table 6	7602 BCF NOTIFICATION	33
Table 7	7603 BTS FAULTY	37
Table 8	7604 BTS OPERATION DEGRADED	38
Table 9	7605 BTS NOTIFICATION	40
Table 10	7606 TRX FAULTY	41
Table 11	7607 TRX OPERATION DEGRADED	48
Table 12	7608 TRX NOTIFICATION	51
Table 13	7609 TRE FAULTY	52
Table 14	7612 SITE POWERING FAULTY	53
Table 15	7613 SITE POWERING OPERATION DEGRADED	54
Table 16	7614 SITE POWERING NOTIFICATION	55
Table 17	7615 RTS IN TEST USE	56
Table 18	7616 OSCILLATOR ADJUSTMENT TEMPORARILY INTERRUPTED	57
Table 19	7617 SEVERAL CALLS DROPPED DUE TO PROBLEM WITH TRANSCODER	58
Table 20	7622 CABINET OPEN	59
Table 21	7801 MMI CONNECTED TO BASE STATION	60
Table 22	7995 MAINS BREAKDOWN WITH BATTERY BACKUP	61
Table 23	Colour codes of the alarms	63
Table 24	8062 No connection	72
Table 25	8112 Frequency error	73
Table 26	8122 Synchronizing fault	74
Table 27	8124 Synchronising fault in clock recovery	75
Table 28	8125 Loss of synchronisation signals	76
Table 29	8139 Subrack is missing units	77
Table 30	8140 Subrack has excessive units	78
Table 31	8142 Fault in installation of equipment	79
Table 32	8162 Database full	80
Table 33	8240 Active alarm point	82
Table 34	8021 Loop to interface	83
Table 35	8022 Loop to equipment	84
Table 36	8025 Test generator on	85
Table 37	8032 Loss of outgoing signal	86
Table 38	8052 Loss of incoming 34M signal	87
Table 39	8066 AIS 2M	88
Table 40	8081 Loss of frame alignment	89
Table 41	8099 Error rate > 1 E-3	91
Table 42	8102 Error rate > 1 E-6	92
Table 43	8126 Unit function degraded	93
Table 44	8148 Equipment reset	95
Table 45	8150 Fault in unit	96

Table 46	8179 Far-end alarm	98
Table 47	8073 AIS 1.5M	100
Table 48	8172 Yellow alarm	101
Table 49	8064 Alarm signal received	102
Table 50	8128 Fault in equipment	103
Table 51	8141 Forced control on	104
Table 52	8143 Fault in changeover function	105
Table 53	8124 Synchronisation fault in clock recovery	106
Table 54	8125 Loss of synchronization signal(s)	107
Table 55	8130 Fault in Memory	108
Table 56	8139 Subrack is missing units	109
Table 57	8140 Subrack has excessive units	110
Table 58	8141 Forced control on	111
Table 59	8152 Fault in block	112
Table 60	8162 Database full	113
Table 61	8207 Calibration expired	116
Table 62	8221 Version mismatch	117
Table 63	8223 Protection switch	118
Table 64	8148 Equipment reset	119
Table 65	8149 Forced indication	120
Table 66	8150 Fault in unit	121
Table 67	8162 Database full	122
Table 68	8057 Loss of pointer	125
Table 69	8162 Database full	133
Table 70	8213 Remote Defect Indication (RDI)	134
Table 71	8162 Database full	141
Table 72	8022 Loop to equipment	146
Table 73	8032 Loss of outgoing signal	147
Table 74	8126 Unit function degraded	148
Table 75	8221 Version mismatch	151
Table 76	8022 Loop to equipment	152
Table 77	8047 Payload mismatch	153
Table 78	8148 Equipment reset	157
Table 79	8162 Database full	158
Table 80	8003 Loss of remote power supply	163
Table 81	8048 Loss of incoming signal (GPS fix lost)	164
Table 82	8145 Temperature alarm	165
Table 83	8148 Equipment reset	166
Table 84	8165 Q1 real time lost	167
Table 85	8184 Q1 real time update	168
Table 86	8240 Active alarm point (self test failure)	169
Table 87	8272 Position not locked	170
Table 88	8202 Loss of supervision connection	171
Table 89	Troubleshooting commissioning	173
Table 90	Troubleshooting BTS Manager connection	174
Table 91	Troubleshooting electrical power	175
Table 92	Troubleshooting Transmission unit operation	176

Table 93	Troubleshooting TSxx operation	177
Table 94	Troubleshooting Fan units	178
Table 95	Troubleshooting TRX Test failures	179
Table 96	MCB/LCB bit statuses	184

1 Changes in Trouble Management of UltraSite EDGE BTS

This section describes changes in the *Trouble Management of UltraSite EDGE BTS* document.

Changes between CX7 and CX7 MP1.0

For alarm 7606 TRX Faulty, the instructions under the fault reason - Non EDGE TRX device used accidentally in EDGE capable mode, have been updated.

A new TRX Test failure reason has been added in the table for Troubleshooting TRX Test failures.

Changes between CX6 CD2.0 and CX7

The note under alarm 7208 LOCAL BLOCK has been updated.

For alarm 7600 BCF FAULTY, the instructions under the fault reason - Base station synchronisation failed, have been updated.

A new note has been added for alarm 7602 BCF NOTIFICATION under the fault reason - External synchronisation signals disabled.

A new note has been added for alarm 7606 TRX FAULTY under the fault reason - Fault in VSWR antenna monitoring.

Changes between CX6 CD1.0 and CX6 CD2.0

The alarm 7601 BCF OPERATION DEGRADED has been updated.

The following new fault reasons have been added to the table *BCF OPERATION DEGRADED*:

- Loss of BSS Sync while on Abis clock
- Irrecoverable Loss of BSS Synch
- BTS on own internal clock for more than 10 mins during BSS Synchronisation

Changes between CX5 CD4.0/CX6 and CX6 CD1.0

A minor note has been added in section *Warnings and cautions for trouble management*.

Changes between CX5 CD3.0 and CX5 CD4.0/CX6

A new fault reason, Incompatible unit presence detected in the BTS, has been added to the following table:

- 7602 BCF NOTIFICATION

New sections *Trouble management of LMU alarms* and *Trouble management of other transmission alarms* have been created.

The following alarms have been added:

- 8003 Loss of remote power supply
- 8048 Loss of incoming signal
- 8145 Temperature alarm
- 8148 Equipment reset
- 8165 Q1 Real time lost
- 8184 Q1 Real time update

- 8202 Loss of supervision connection
- 8240 Active alarm point (self test failure)
- 8272 Position not locked
- 8130 Fault in memory

The following alarms have been updated and new fault reasons added:

- 8126 Unit function degraded. This alarm was moved into section *Common alarms for FXC transmission units*.
- 8150 Fault in unit

2 Statutory statements

2.1 CE Marking

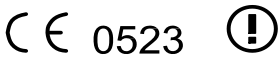
Standard	Description
	<p>Hereby, Nokia Siemens Networks, declares that this UltraSite EDGE Base Station is in compliance with the essential requirements and other relevant provisions of Directive: 1999/5/EC.</p> <p>The product is marked with the CE marking and Notified Body number according to the Directive 1999/5/EC.</p>

2.2 FCC Statement

Standard	Description
FCC Statement	<p>This equipment has been tested and found to comply with the limits for a Class B digital device, pursuant to part 15 of the FCC Rules. These limits are designed to provide reasonable protection against harmful interference in a residential installation. This equipment generates, uses and can radiate radio frequency energy and, if not installed and used in accordance with the instructions, may cause harmful interference to radio communications. However, there is no guarantee that interference will not occur in a particular installation. Changes or modifications not expressly approved by the party responsible for compliance could void the user's authority to operate the equipment. The term "IC:" before the radio certification number only signifies that Industry Canada technical specifications were met.</p>

3 Warnings and cautions for trouble management



Avoid setting the alarm monitoring delay to a very small value when monitoring a network element remotely. This places a strain on the Q1 bus resources and causes delays for other activities.



Setting a Flexbus loop cuts the connection to the outdoor unit until the loop is cancelled or it expires. This includes all data and management information. The interface loopback in FlexiHopper stays active until the loopback timeout expires.

Note that if the OMU signaling link between the BSC and BTS is blocked, no alarms will be reported by the BTS. De-block the link to enable the sending of the alarms.

For a complete list of warnings and cautions for UltraSite EDGE BTS, please refer to the document *Legal and Safety Statements for UltraSite EDGE BTS* in the latest Product Documentation set.

4 Trouble management of UltraSite EDGE BTS alarms

4.1 UltraSite EDGE Base Station alarm examples

UltraSite EDGE Base Station alarms issued at the BSC or NMS/NetAct have a four-digit alarm number and an alarm name, and an optional fault reason (see the figure below). For other fields in the below figure, please refer to BSC documentation.

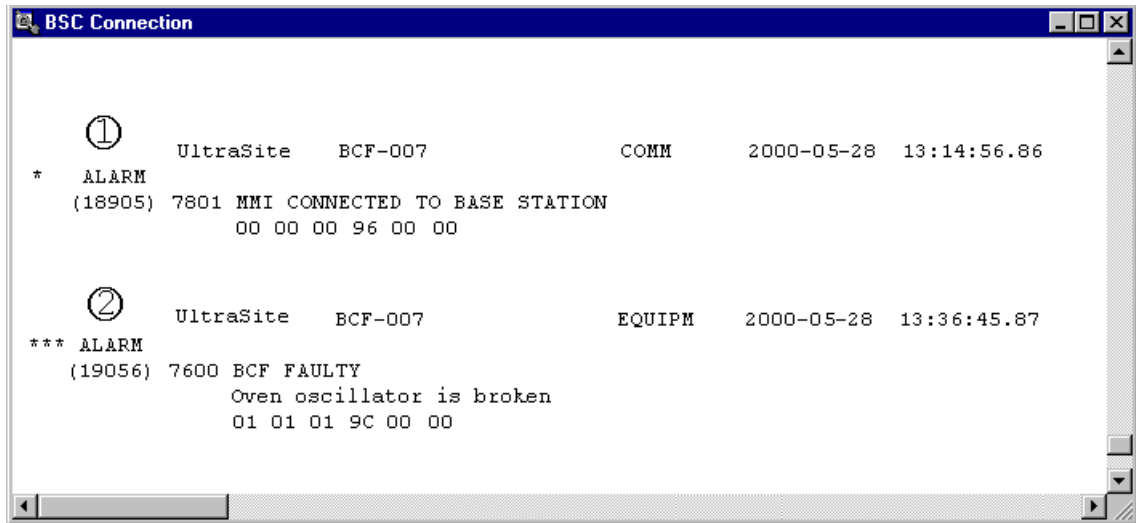

Figure 1 Examples of active alarms as seen at the BSC

The text under the alarm name gives the fault reason that has caused the alarm, for example see 2. in the figure above: `Oven oscillator is broken`.

i One alarm can have many different fault reasons:

The fault reason 2. displayed in the above figure is different from what is displayed in the figure below, although the alarm number remains the same. Different faults may have the same effect on the operation of a base station object, therefore they have the same alarm number and name. The fault reason specifies the fault and helps in troubleshooting.

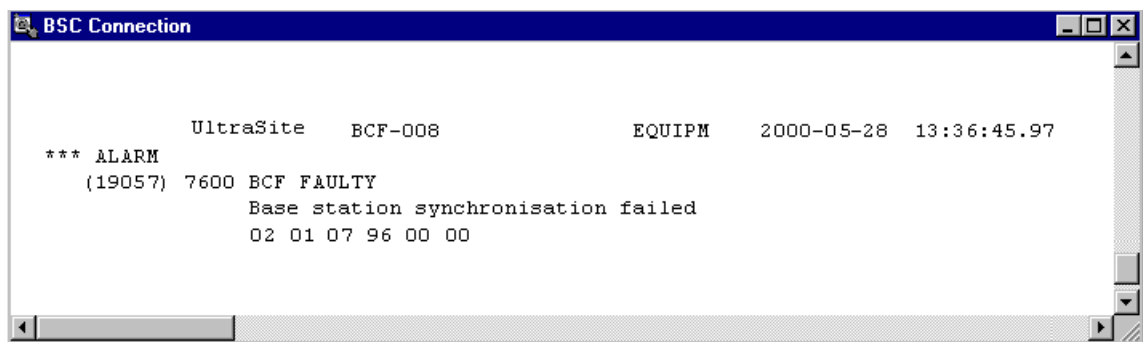

Figure 2 Example of an active alarm as seen at the BSC

4.2 Identifying faulty units

Faulty units can be identified on the BTS Manager desktop. The BTS Manager shows an Alarms window with an Object column giving the object (for example BCF), that the alarm refers to, and also specifying the unit, rack, shelf, and slot. The Severity column in the Alarms window indicates the level of the alarm (for example critical, minor). The Equipment view in the Supervision window shows the location of the units in the cabinet.

Unit location numbers are used in alarm information to locate a failed unit. The main principle for numbering locations is from top to bottom and from left to right (see the figure below). Location numbers are defined with the following parameters:

- RACK specifies the rack of the cabinet
- SHELF specifies the shelf in the cabinet
- SLOT specifies the location on the shelf

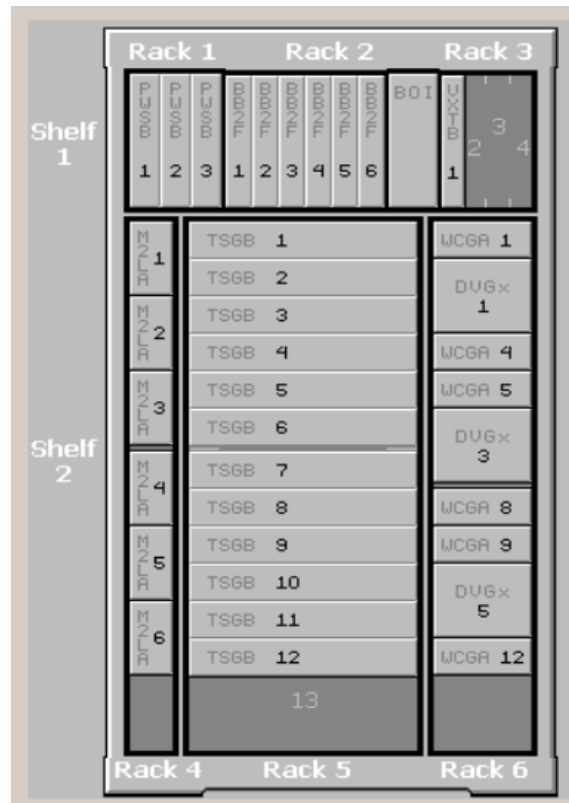

Figure 3 Rack, shelf, and slot information in UltraSite EDGE BTS

The figure below shows how alarms (number, name, and fault reason) are seen in the Alarms window on BTS Manager desktop. See for example BB2's location (location number 2/1/1) in rack 2, shelf 1, slot 1.

For identifying a faulty transmission unit and for checking transmission related alarms, use the UltraSite BTS Hub Manager.

For location of the fan units, refer to the UltraSite EDGE BTS Product Documentation: *UltraSite EDGE BTS, Unit Descriptions*.

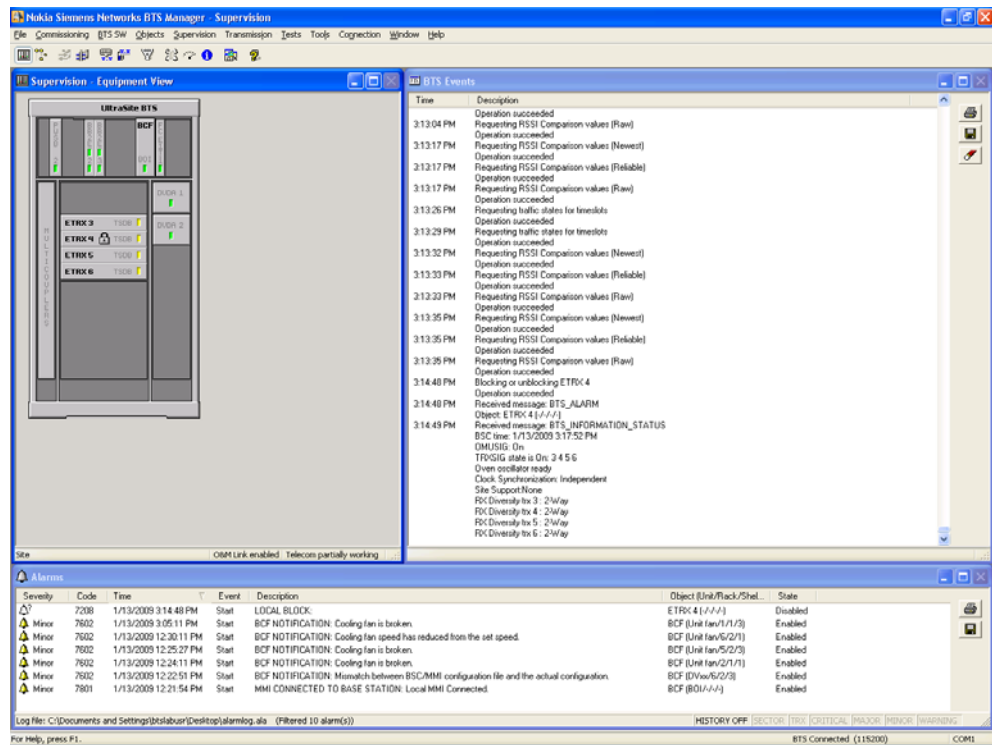

Figure 4 BTS Manager desktop showing the alarms in the Alarms window

4.3 Troubleshooting with the help of alarm tables

Purpose

The fault reason can be used for troubleshooting. The faults and instructions on how to correct the faults are presented in table format (see example of alarm table below):

1234 ALARM NAME			
Severity:	Object affected:	Object state:	Unit:
Shows the alarm severity as displayed at the BSC or NMS/NetAct. The options are: <ul style="list-style-type: none"> • * = minor • ** = major • *** = critical • User definition 	The logical object affected by the fault. The options are: BCF, BTS, TRX, TRE, RTS	The state of the affected object at the time the alarm is issued. The options are: <ul style="list-style-type: none"> • Enabled • Disabled 	The alarm origin(s). The unit is given an acronym, for example: BOI, RTxx, TSxx, BB2x
Fault reason:	Instruction:	Alarm cancelling:	
This field describes the cause of the alarm, for example: Power unit temperature is dangerously high.	This field gives instructions for the operator (at the NMS/NetAct or at the BSC) how to correct the fault reason causing the alarm, for example: <ol style="list-style-type: none"> 1. Ensure that the ambient temperature of the base station is within specified limits. 2. Check the cabinet fans. 3. Replace the faulty power unit(s). 	This field describes how the alarm is cancelled. The options are: <ul style="list-style-type: none"> • Automatic • Manual 	

Table 1 Description of the fields in the alarm table

- i** When baseband hopping is used, alarms do not cancel automatically when a fault is corrected. Sector reset from BTS Manager or BTS lock/unlock from the BSC is required to clear the active alarms.
- i** If the fault reason cannot be found in the *Fault reason* field, the instructions given for *Other faults* apply for the current fault.
- i** For instructions on how to replace units, refer to the latest *UltraSite EDGE BTS Product Documentation set*.

Steps

-
- 1 Check the alarm number and alarm name.**
To find the correct alarm description table, refer to [Alarm list for Ultrasite EDGE BTS](#)

 - 2 Find the fault reason in the *Fault reason* field in the alarm description table.**
See 2. in Figure 'Examples of active alarms as seen at the BSC', or the Alarms window in Figure 'BTS Manager desktop showing the alarms in the Alarms window'.

 - 3 Follow the instructions in the proposed order given in the *Instruction* field.**
See also alarm cancelling information in the *Cancelling* field.

-
- 4 If the fault reason cannot be found in the *Fault reason* field, follow the instructions given for *Other faults*.
-
- 5 If there is no fault reason text with the alarm (see 1. in Figure '*Examples of active alarms as seen at the BSC*'), refer to the correct alarm description table and follow the possible instructions given in the *Instruction* field.

4.4 UltraSite EDGE Base Station alarm reclassification

In fault situations, UltraSite EDGE Base Station runs an automatic reclassification procedure for major (**) and critical (***) alarms before it sends an alarm to the BSC. When an object becomes faulty, only one critical (***) alarm from the object can be active at a time.

In reclassification, the alarm handling detects which logical base station object is affected by a unit level fault. After reclassification, an object level alarm is issued according to a certain hierarchy, as described in the figure below.

i After reclassification, only one object level alarm with only one fault reason is sent to the BSC. However, the same alarm can be caused by several different fault reasons.

Alarm Output in the figure below shows the number and the name of the alarm(s) issued at the BSC in such a fault situation. Also, the object that is the alarm origin is given in brackets.

① Alarm Output:

7606 TRX FAULTY (TRX 1)

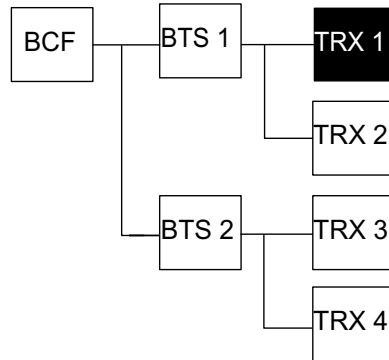

② Alarm Output, in this order:

7606 TRX FAULTY (TRX 1)
7606 TRX FAULTY (TRX 2)
7603 BTS FAULTY (BTS 1)

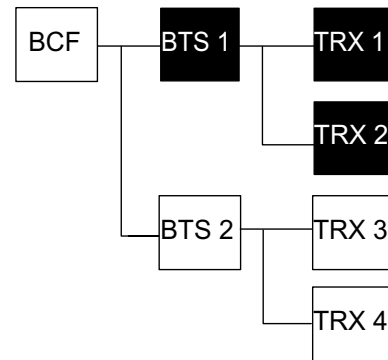

③ Alarm Output, in this order:

7606 TRX FAULTY (TRX 1)
7606 TRX FAULTY (TRX 2)
7603 BTS FAULTY (BTS 1)
7606 TRX FAULTY (TRX 3)
7606 TRX FAULTY (TRX 4)
7600 BCF FAULTY (BCF)

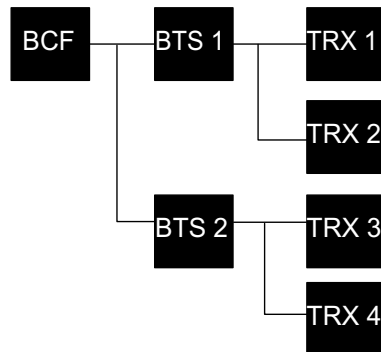

④ Alarm Output, in this order:

7606 TRX FAULTY (TRX 1)
7607 TRX DEGRADED (TRX 2)
7604 BTS OPERATION DEGRADED (BTS 1)

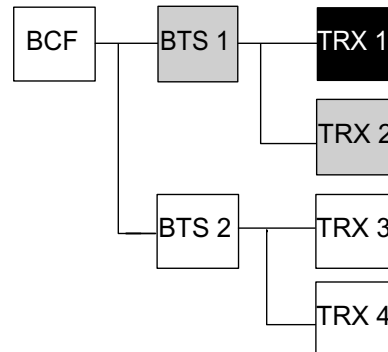

- Functioning object
- Degraded object
- Faulty object

Figure 5 Faulty and degraded object alarm reclassification

Fault situation 1:

1. TRX 1 becomes faulty and ceases to operate. 7606 TRX FAULTY alarm is issued.

Fault situation 2:

1. TRX 1 becomes faulty and ceases to operate. 7606 TRX FAULTY alarm is issued.
2. TRX 2 becomes faulty and ceases to operate. 7606 TRX FAULTY alarm is issued.

3. Now both TRXs are not operating, which causes BTS 1 cease to operate. A BTS alarm, 7603 BTS FAULTY, is issued.

Fault situation 3:

1. TRX 1 becomes faulty and ceases to operate. 7606 TRX FAULTY alarm is issued.
2. TRX 2 becomes faulty and ceases to operate. 7606 TRX FAULTY alarm is issued.
3. Now both TRXs are not operating, which causes BTS 1 cease to operate. A BTS alarm, 7603 BTS FAULTY, is issued.
4. TRX 3 becomes faulty, and another 7606 TRX FAULTY alarm is issued.
5. TRX 4 becomes faulty, and another 7606 TRX FAULTY alarm is issued. BTS 2 ceases to operate.
6. Now both sectors in the BCF are not operating, and a BCF alarm, 7600 BCF FAULTY, is issued.

Fault situation 4:

1. TRX 1 becomes faulty and ceases to operate. 7606 TRX FAULTY alarm is issued.
2. TRX 2 becomes partially faulty but calls are getting through. 7607 TRX DEGRADED alarm is issued.
3. Now the sector is partially faulty, and a BTS alarm, 7604 BTS OPERATION DEGRADED, is issued.

4.5 Alarms list for UltraSite EDGE BTS

The UltraSite EDGE BTS alarms are:

Alarm 7208 / LOCAL BLOCK

Alarm 7401-7424 / EXTERNAL ALARM

Alarm 7600 / BCF FAULTY

Alarm 7601 / BCF OPERATION DEGRADED

Alarm 7602 / BCF NOTIFICATION

Alarm 7603 / BTS FAULTY

Alarm 7604 / BTS OPERATION DEGRADED

Alarm 7605 / BTS NOTIFICATION

Alarm 7606 / TRX FAULTY

Alarm 7607 / TRX OPERATION DEGRADED

Alarm 7608 / TRX NOTIFICATION

Alarm 7609 / TRE FAULTY

Alarm 7612 / SITE POWERING FAULTY

Alarm 7613 / SITE POWERING OPERATION DEGRADED

Alarm 7614 / SITE POWERING NOTIFICATION

Alarm 7615 / RTS IN TEST USE

Alarm 7616 / OSCILLATOR ADJUSTMENT TEMPORARILY INTERRUPTED

Alarm 7617 / SEVERAL CALLS DROPPED DUE TO PROBLEM WITH TRANSCODER

Alarm 7622 / CABINET OPEN

Alarm 7801 / MMI CONNECTED TO BASE STATION

Alarm 7995 / MAINS BREAKDOWN WITH BATTERY BACKUP

4.6 UltraSite EDGE BTS alarms

4.6.1 7208 LOCAL BLOCK

7208 LOCAL BLOCK			
Severity:	Object affected:	Object state:	Unit:
*	BCF, or BTS, or TRX	Disabled	—
Fault reason:	Instruction:	Alarm cancelling:	
No fault reason text with the alarm. UltraSite EDGE Base Station BTS object is blocked with BTS Manager.	1. No actions required.	Alarm is cancelled when the Local Deblock command is given from the BTS Manager. The object state changes to Enabled.	

Table 2 7208 LOCAL BLOCK

i Do not give OMU Restart either locally or remotely when Local Block is used. This will cause unexpected behaviour of locally blocked sector or alarm handling. In such event, BCF restart may be required.

See also [Alarms list for UltraSite EDGE BTS](#) and [Troubleshooting with the help of alarm tables](#).

4.6.2 7401-7424 EXTERNAL ALARM

7401 EXTERNAL ALARM 7401 - 7424, EXTERNAL ALARM 1 - 24			
Severity:	Object affected:	Object state:	Unit:
User definition	BCF	Enabled	BOI
Fault reason:	Instruction:		Alarm cancelling:
No fault reason text with the alarm. This is an external user-definable alarm.	<ol style="list-style-type: none"> 1. Check the settings at the BSC. 2. Check the cable connected to the Interface Module on the top side of the cabinet. 3. Check the unit connected to the external alarm line. 4. If all of the above are OK, check the Interface Module and replace it if faulty. 		Automatic.

Table 3 7401 EXTERNAL ALARM 7401-7424, EXTERNAL ALARM 1-24

See also [Alarms list for UltraSite EDGE BTS](#) and [Troubleshooting with the help of alarm tables](#).

4.6.3 7600 BCF FAULTY

7600 BCF FAULTY			
Severity:	Object affected:	Object state:	Unit:
***	BCF	Disabled	BB2x, BOI, DVxx, PWSx, RTxx, TSxx, MHA Note: Prior to CX5 CD2 SW, the unit description shall be MNxx.
Fault reason:	Instruction:	Alarm cancelling:	
Oven oscillator is broken.	1. Replace the BOI.	Automatic.	
Base station synchronisation failed.	1. Check that the synchronisation source is up and alive. 2. Check that the transmission settings are OK. 3. Check the synchronisation cabling. 4. Reset Site. 5. If steps 1 - 4 fail, replace the BOI.	Automatic.	
Other faults.	1. Check whether either of the following alarms is active: 7606 TRX FAULTY 7603 BTS FAULTY and follow the instructions given for the active alarm(s).	Automatic.	

Table 4 7600 BCF FAULTY

See also [Alarms list for UltraSite EDGE BTS](#) and [Troubleshooting with the help of alarm tables](#).

4.6.4 7601 BCF OPERATION DEGRADED

7601 BCF OPERATION DEGRADED			
Severity:	Object affected:	Object state:	Unit:
**	BCF	Enabled	BB2x, BOI, DVxx, MHA, PWSx, RTxx, SISU, TSxx Note: Prior to CX5 CD2 SW, the unit description shall be MNxx.
Fault reason:	Instruction:		Alarm cancelling:
Power unit output voltage fault.	1. Replace all faulty power units.		Automatic.
Power unit input voltage fault.	1. Ensure that the input voltage is correct. 2. Replace all faulty power units.		Automatic.
No connection to power unit.	1. Replace all faulty power units.		Automatic.
Power unit temperature is dangerously high.	1. Ensure that the ambient temperature of the base station is within specified limits. 2. Check the cabinet fans. 3. Replace the faulty power unit(s). Note: An alarm is activated when the PWSx internal temperature exceeds +85°C.		Automatic.
Transmission unit temperature is dangerously high.	1. Ensure that the ambient temperature of the base station is within specified limits. 2. Check the cabinet fans. 3. Replace the faulty transmission unit. Note: An alarm is activated when the transmission unit internal temperature exceeds +85°C.		Automatic.
Difference between PCM and base station frequency reference.	1. Check the network synchronisation between the BSC and the base station. 2. Check the transmission synchronisation settings on the transmission card. 3. Check the transmission cabling at the site. 4. Replace the BOI. Note: After corrective actions, it may take several hours to adjust the clock and the alarm to disappear. Note: With BTS SW CX5 and the implementation of the Fast Tune feature, you may set the DAC clock control word via BTS Manager. This will initiate a Fast Tune procedure, in which the 26 MHz oven oscillator is quickly (within minutes) set very close to the correct frequency.		Automatic.
Flash operation failed in BOI or TRX.	1. Replace the BOI.		Automatic.
BOI detected that the site support is dumb.	1. Check the SISU cabinet and the connections.		Automatic.

Table 5 BCF OPERATION DEGRADED

7601 BCF OPERATION DEGRADED		
Rx levels differ too much between main and diversity antennas.	<ol style="list-style-type: none"> 1. Check the RSSI measurements by BTS Manager. Note: From BTS Manager, open the RSSI Comparison Values dialog box or Site Information dialog box to pinpoint the alarming RSSI value and antenna. From CX5 CD1.0 onwards the history of last active RSSI alarms will provide the information of which antenna line was detected faulty. Note: There is a hysteresis of 2 dB in the cancellation of the alarm. The alarm is cancelled when the RSSI measurement result is less than RXDL -2 dB. 2. Check and measure the antenna lines. 3. Check the BTS RF cables and connections. 4. Replace the combiner unit. Check that the RXDL parameter at the BSC is set to a reasonable value, taking into account the site conditions to prevent unnecessary alarms. 5. Replace the TSxx unit. Note: With BTS SW CX4.1 to CX4.1 CD2.0, the alarm may be generated unnecessarily when the Relative Difference is less than the set difference from the BSC. Check the alarm reason from the RSSI measurements by BTS Manager. If the reason is Relative Difference, increase the RSSI alarm threshold value at the BSC. 	Automatic.
Power supply unable to read MHA current.	<ol style="list-style-type: none"> 1. Replace all faulty power units. 	Automatic.
Loss of BSS Synch while on Abis clock.	<ol style="list-style-type: none"> 1. No corrective actions required. Note: Alarm start/cancel is based on the alignment of the BTS clock to the external clock reference after external clock reference has recovered from fault condition. Alarm start will equate to degradation in DFCA performance. A site reset will reduce alignment time. 	Automatic. Note: BTS clock will align with external clock reference over a period of several hours.
Irrecoverable Loss of BSS Synch.	<ol style="list-style-type: none"> 1. Site reset is required. Note that the alarm start is based on the following: <ol style="list-style-type: none"> a) Large alignment problems between Abis clock and external clock reference, after external clock reference has recovered from fault condition. b) Fluctuation in the DAC word. Alarm start will equate to significant degradation in DFCA performance. 	Manual. Note: BTS clock will align with external clock immediately after reset completes.
BTS on own internal clock for more than 10 mins during BSS Synchronisation.	<ol style="list-style-type: none"> 1. No actions required. Note: In case the alarm remains active, a BCF reset can be triggered. However, reset should not be needed as the synchronisation for each site is managed by BSC. 	Automatic.

Table 5 BCF OPERATION DEGRADED (Cont.)

7601 BCF OPERATION DEGRADED		
Other faults.	<ol style="list-style-type: none"> 1. Check whether one or several of the following alarms are active: 7606 TRX FAULTY 7603 BTS FAULTY 7607 TRX OPERATION DEGRADED 7604 BTS OPERATION DEGRADED 7602 BCF NOTIFICATION and follow the instructions given for the active alarm(s). 	Automatic.

Table 5 BCF OPERATION DEGRADED (Cont.)

See also [Alarms list for UltraSite EDGE BTS](#) and [Troubleshooting with the help of alarm tables](#).

4.6.5 7602 BCF NOTIFICATION

7602 BCF NOTIFICATION			
Severity:	Object affected:	Object state:	Unit:
*	BCF	Enabled	BB2x, BOI, Cabinet, Cabinet fan, DVxx, HETx, PWSx, RTxx, SISU, TRE, TSxx, Unit fan
Fault reason:	Instruction:	Alarm cancelling:	
Power unit temperature is low.	<ol style="list-style-type: none"> 1. Ensure that the ambient temperature of the base station is within specified limits. 2. Check that the heater is working properly if equipped. 3. Replace the PWSx. <p>Note: An alarm is activated when the PWSx internal temperature is below -10°C.</p>	Automatic.	
Transmission unit temperature is low.	<ol style="list-style-type: none"> 1. Ensure that the ambient temperature of the base station is within specified limits. 2. Check that the heater is working properly if equipped. 3. Replace the transmission unit. <p>Note: An alarm is activated when the transmission unit's internal temperature is below -10°C.</p>	Automatic.	
Power unit has lost connection to temperature sensor.	<ol style="list-style-type: none"> 1. If another slot in the cabinet is empty, move the power unit into the empty slot. 2. The temperature sensor is probably broken. Temperature changes cannot be measured. Replace the power unit. 	Automatic.	
Transmission unit has lost connection to temperature sensor.	<ol style="list-style-type: none"> 1. Temperature sensor is probably broken. Temperature changes cannot be measured. Replace the transmission unit. 	Automatic.	
BOI detected that connection to transmission unit is lost.	<ol style="list-style-type: none"> 1. Open the UltraSite BTS Hub Manager and check the active alarms. If this base station or other base stations beyond it otherwise operate properly, there is no need for an immediate repair. However, the transmission alarms for the faulty unit are not reported to the BSC nor the BTS Manager. 2. Reset the faulty transmission unit. Note: Resetting the unit affects the traffic routed through it. 3. If the alarm reappears after the transmission unit reset, switch the cabinet power off and on. 4. If the alarm reappears after the recovery actions above, replace the faulty transmission plug-in unit. 	Automatic.	

Table 6 7602 BCF NOTIFICATION

7602 BCF NOTIFICATION		
Cooling fan is broken.	<ol style="list-style-type: none"> 1. Check which fan is giving the alarm from the supplementary information (rack/shelf/slot). 2. If something has jammed the cooling fan unit, remove the jamming object. 3. If the TSxx fan is alarming: <ul style="list-style-type: none"> • Replace the TSxx in front of the fan. If the fan starts working, the removed TSxx is broken. • If the fan still does not rotate after the first TSxx was replaced, reinsert the original TRX and replace the second TSxx in front of the same fan unit. If the fan starts rotating, the second TSxx is broken. • If the fan does not work after the TSxx removal test, the fan is broken and must be replaced. 4. For other fan alarms, replace the corresponding fan unit. 5. Otherwise, replace the BOI. <p>Note: This alarm is related to fans located in the back of the cabinet.</p>	Automatic.
Cabinet fan is broken.	<ol style="list-style-type: none"> 1. Check that the fan cable is connected to the door switch box. 2. If something has jammed the cabinet fan unit, remove the jamming object. Otherwise, replace the fan unit. 3. Replace the door switch box. 4. Otherwise, replace the BOI. <p>Note: This alarm is related to door fan (Outdoor BTS only).</p>	Automatic.
Cooling fan speed has reduced from the set speed.	<ol style="list-style-type: none"> 1. If the fan is dirty, clean the fan unit. 2. If something has jammed the cooling fan unit, remove the jamming object. Otherwise, replace the fan unit. <p>Note: This alarm is related to fans located in the back of the cabinet.</p>	Automatic.
Cabinet fan speed has reduced from the set speed.	<ol style="list-style-type: none"> 1. If the fan is dirty, clean the fan unit. 2. If something has jammed the cabinet fan unit, remove the jamming object. Otherwise, replace the fan unit. <p>Note: This alarm is related to door fan.</p>	Automatic.
Heater is broken.	<ol style="list-style-type: none"> 1. Check that the heater cable is connected to the door switch box. 2. Check that the AC power supply is OK by measuring AC from the cabinet connection box (the heater always requires AC power). 3. Replace the faulty heater, or the heater is not installed although it is defined in the configuration file, therefore an alarm is issued. Install the heater. 	Automatic.
Power unit output voltage fault.	<ol style="list-style-type: none"> 1. Replace the faulty power unit. The cabinet has more than one power supply unit. The other power units are still functioning. 	Automatic.

Table 6 7602 BCF NOTIFICATION (Cont.)

7602 BCF NOTIFICATION		
Power unit input voltage fault.	<ol style="list-style-type: none"> 1. Ensure that the input voltage is correct. 2. Replace the faulty power unit. The cabinet has more than one power supply unit. The other power units are still functioning. 	Automatic.
Common rack PWS I2C bus is jammed.	<ol style="list-style-type: none"> 1. Give a one-minute power reset to the whole BTS cabinet. 2. Check the power unit(s) and power backplane connectors, and replace if faulty. 	Automatic.
Common rack EAC I2C bus is jammed.	<ol style="list-style-type: none"> 1. Give a one-minute power reset to the whole BTS cabinet. 2. Reset the BCF. 3. If the cabling between the BOI and the Interface board on the top side of the cabinet is OK, replace the Interface board. 4. Replace the BOI. 5. Replace the common backplane. 	Automatic.
TSxx rack I2C bus is jammed.	<ol style="list-style-type: none"> 1. Reset the TRX/sector. 2. If the TRX does not come to working state, swap the unit with another working (non-alarming) TSxx unit in the cabinet. 3. Replace the alarming TSxx. <p>Note: The alarm might appear unnecessarily, when BTS SW earlier than CX4.1 CD1.0 is being used.</p> <p>Workaround for SW, used earlier than CX4.1 CD1.0</p> <ol style="list-style-type: none"> 1. TRX in an RF/Non-hopping sector: remove the TSxx from the slot and re-insert it after a few seconds. 2. TRX in a BB/Antenna hopping sector: lock the sector first, then remove the TSxx from the slot and re-insert it after a few seconds. Unlock the sector. 	Automatic.
No connection to power unit.	<ol style="list-style-type: none"> 1. Check if the power unit is switched off. 2. If the power unit is on, replace the faulty power unit. The cabinet has more than one power supply unit. The other power units are still functioning. 	Automatic.
Mismatch between BSC/MMI configuration file and the actual configuration.	<ol style="list-style-type: none"> 1. Check that all units are installed and working OK. 2. Check that the actual base station configuration, HW configuration file and BSC configuration match. Make necessary corrections. 	Automatic.
BSS synchronisation failed.	<ol style="list-style-type: none"> 1. Check the clock cabling between the external clock source and the BCF. 	Automatic.
External synchronisation signals disabled.	<ol style="list-style-type: none"> 1. Check that the master clock source is OK. 2. Check the clock cabling between the LMU and the BCF. 3. Check that the GPS signal cable is connected to the LMU. <p>Note: If this alarm is activated by connection problem in LMU Q1/clock or cable/connector while the LMU is still powered; you need to restart the LMU after the problem is cleared and the cables are reconnected.</p>	Automatic.

Table 6 7602 BCF NOTIFICATION (Cont.)

7602 BCF NOTIFICATION		
Incompatible unit presence detected in the BTS	<ol style="list-style-type: none"> 1. Ensure that the ratio TRXs:PSUs in the cabinet is less than or equal to 6:1. Note that a ratio TRXs:PSUs greater than 6:1 in the cabinet is not recommended; it may result in alarms on the Power Supply Units, TRXs or duplexers, or other spurious alarms, and it may result in the site going into an unstable state. 	Automatic.
Power supply unable to read MHA current.	<ol style="list-style-type: none"> 1. Replace the faulty power unit. 	Automatic.

Table 6 7602 BCF NOTIFICATION (Cont.)

See also [Alarms list for UltraSite EDGE BTS](#) and [Troubleshooting with the help of alarm tables](#).

4.6.6 7603 BTS FAULTY

7603 BTS FAULTY			
Severity:	Object affected:	Object state:	Unit:
***	BTS	Disabled	BB2x, DVxx, RTxx, TSxx, MHA Note: Prior to CX5 CD2 SW, the unit description shall be MNxx.
Fault reason:	Instruction:		Alarm cancelling:
Other faults.	1. Check whether either of the following alarms is active: 7606 TRX FAULTY 7607 TRX OPERATION DEGRADED and follow the instructions given for the active alarm(s).		Automatic.

Table 7 7603 BTS FAULTY

See also [Alarms list for UltraSite EDGE BTS](#) and [Troubleshooting with the help of alarm tables](#).

4.6.7 7604 BTS OPERATION DEGRADED

7604 BTS OPERATION DEGRADED			
Severity:	Object affected:	Object state:	Unit:
**	BTS	Enabled	BB2x, BOI, DVxx, MHA, RTxx, TSxx Note: Prior to CX5 CD2 SW, the unit description shall be MNxx.
Fault reason:	Instruction:		Alarm cancelling:
Remote tune combiner temperature is dangerously high.	<ol style="list-style-type: none"> 1. Ensure that the ambient temperature of the base station is within specified limits. 2. Check the cabinet fans. 3. Replace the RTxx. Note: An alarm is activated when the RTxx unit internal temperature exceeds +70°C. 		Automatic.
Remote tune combiner temperature is low.	<ol style="list-style-type: none"> 1. Ensure that the ambient temperature of the base station is within specified limits. 2. Check that the heater is working properly if equipped. 3. Replace the RTxx. Note: An alarm is activated when the RTxx unit internal temperature is below -10°C. 		Automatic.

Table 8 7604 BTS OPERATION DEGRADED

7604 BTS OPERATION DEGRADED		
<p>Rx levels differ too much between main and diversity antennas.</p>	<ol style="list-style-type: none"> 1. Check the RSSI measurements by BTS Manager. Note: From BTS Manager, open the RSSI Comparison Values dialog box or Site Information dialog box to pinpoint the alarming RSSI value and antenna. From CX5 CD1.0 onwards the history of last active RSSI alarms will provide the information of which antenna line was detected faulty. Note: There is a hysteresis of 2 dB in the cancellation of the alarm. The alarm is cancelled when the RSSI measurement result is less than RXDL -2 dB. 2. Check and measure the antenna lines. 3. Check the BTS RF cables and connections. 4. Replace the combiner unit. Check that the RXDL parameter at the BSC is set to a reasonable value, taking into account the site conditions in order to prevent unnecessary alarms. 5. Replace the TSxx unit. Note: With BTS SW CX4.1 to CX4.1 CD2.0, the alarm may be generated unnecessarily when the Relative Difference is less than the set difference from the BSC. Check the alarm reason from the RSSI measurements by BTS Manager. If the reason is Relative Difference, increase the RSSI alarm threshold value at the BSC. 	<p>Automatic.</p>
<p>Other faults.</p>	<ol style="list-style-type: none"> 1. Check whether either of the following alarms is active: 7606 TRX FAULTY 7607 TRX OPERATION DEGRADED and follow the instructions given for the active alarm(s). 	<p>Automatic.</p>

Table 8 7604 BTS OPERATION DEGRADED (Cont.)

See also [Alarms list for UltraSite EDGE BTS](#) and [Troubleshooting with the help of alarm tables](#).

4.6.8 7605 BTS NOTIFICATION

7605 BTS NOTIFICATION			
Severity:	Object affected:	Object state:	Unit:
*	BTS	Enabled	BOI, RTxx
Fault reason:	Instruction:		Alarm cancelling:
Remote tune combiner flash checksum is invalid and the code is corrupted.	<ol style="list-style-type: none"> 1. Reset the sector. 2. If the fault reappears, replace the RTxx. 		Automatic.
Cavity stepper motor cannot tune the remote tune combiner.	<ol style="list-style-type: none"> 1. Reset the sector. 2. If the fault reappears, replace the RTxx. 		Automatic.
Remote tune combiner has lost connection to temperature sensor.	<ol style="list-style-type: none"> 1. Reset the the sector. 2. Replace the RTxx. 		Automatic.

Table 9 7605 BTS NOTIFICATION

See also [Alarms list for UltraSite EDGE BTS](#) and [Troubleshooting with the help of alarm tables](#).

4.6.9 7606 TRX FAULTY

7606 TRX FAULTY			
Severity:	Object affected:	Object state:	Unit:
**	TRX	Disabled	BB2x, DVxx, RTxx, TSxx, MHA Note: Prior to CX5 CD2 SW, the unit description shall be MNxx.
Fault reason:	Instruction:		Alarm cancelling:
Antenna connection faulty.	<ol style="list-style-type: none"> 1. Check the TSxx TX cable. Replace if faulty and reset TRX to cancel the alarm. 2. If the TX cable is OK, the TSxx is faulty. Replace the TSxx. <p>Note: The alarm can be activated only when the highest BTS TX power levels are used (P_{MAX} 0...2 in BSC). If a sector configured with an RTxx is reset, while the TSxx TX cable is disconnected, and if there is no traffic in the current TRX, alarm 7606 TRX FAULTY with a fault reason 'Tuning carrier is not detected in remote tune combiner' is issued.</p>		Manual.
Fault in VSWR antenna monitoring.	<ol style="list-style-type: none"> 1. Check the antenna line and Bias-T cabling. 2. Reset the sector. 3. Check all RF cabling between the TSxx's TX output connector and top of the cabinet (including WCDx and DVxx or RTxx units). 4. Replace the Bias-T. 5. Replace TSxx. <p>Note: If this alarm is active in Antenna Hopping configuration, disable the VSWR Monitoring from HW Configuration file or use the latest BTS SW (CX7 or newer).</p>		Manual (sector lock/unlock).
Fault in the chain between power unit and MHA.	<ol style="list-style-type: none"> 1. Check the voltage supply chain between the PWSx unit(s) and the MHA. 2. Replace the PWSx. 3. Replace the Bias-T. 4. Replace the MHA. 		Automatic.
Failure detected during TRX configuring.	<ol style="list-style-type: none"> 1. Check whether the TSxx/DVxx/RTxx frequency is compatible with the BSC network parameters. 2. Reset the TRX/sector. 3. Replace the TSxx. <p>Note: The alarm may appear unnecessarily, when BTS SW earlier than CX4.1 CD3.0 is being used.</p>		Automatic.

Table 10 7606 TRX FAULTY

7606 TRX FAULTY		
BOI detected that connection to TRX is lost.	<ol style="list-style-type: none"> 1. Check the BTS configuration and install the BB2x if it is missing. 2. Replace the BB2x. Reset the TRX/sector. <p>Note: This alarm refers to the connection between BOIA and BB2x. Do not replace TSxx in this case.</p> <p>Note: The alarm may appear unnecessarily, when BTS SW earlier than CX4.1 CD3.0 is being used.</p>	Automatic.
Failure in 26 MHz clock input.	<ol style="list-style-type: none"> 1. If all TRXs indicate this fault, replace the BOI. 2. If only one TRX indicates this fault, replace the BB2x. 	Automatic.
BOI or TRX has detected a failure in the incoming frame clock signal.	<ol style="list-style-type: none"> 1. If all TRXs indicate this fault, replace the BOI. 2. If only one TRX indicates this fault, replace the BB2x. 	Automatic.
Interface problems between O&M and DSP SW.	<ol style="list-style-type: none"> 1. Reset the TRX/sector. 2. If the fault reappears, replace the BB2x. <p>Note: The alarm may appear unnecessarily, when BTS SW earlier than CX5 CD3.0 is being used.</p> <p>Note: With CX4.1 or newer releases, this alarm is included in the Runtime Diagnostics feature (BB hopping is not supported).</p>	Manual.
Failure in internal DSP monitoring loop.	<ol style="list-style-type: none"> 1. Reset the TRX/sector. 2. If the fault reappears, replace the BB2x. 	Automatic.
The synthesizer in remote tune combiner is faulty.	<ol style="list-style-type: none"> 1. Replace the RTxx that is connected to the alarming TRX. 	Automatic.
The controller is out of order in remote tune combiner.	<ol style="list-style-type: none"> 1. Replace the RTxx that is connected to the alarming TRX. 	Automatic.
The tuning of a cavity has failed in remote tune combiner.	<ol style="list-style-type: none"> 1. Reset the TRX. 2. If the TSxx is faulty, replace it. 3. Check the RTxx cabling. 4. If cabling is OK, replace the RTxx connected to the alarming TRX. 	Automatic.
Cavity reset has failed, cavity is not available in remote tune combiner.	<ol style="list-style-type: none"> 1. Reset the sector. 2. If the fault reappears, replace the RTxx connected to the alarming TRX. 	Automatic.
Tuning carrier is not detected in remote tune combiner.	<ol style="list-style-type: none"> 1. Check that the TRX LAPD link is working. 2. Check the TSxx cabling connected to RTxx. 3. If cabling is OK, replace the faulty TSxx. 4. If the fault reappears, replace the RTxx connected to the alarming TSxx. <p>Note: This alarm is activated when a sector is reset while the TSxx TX cable to the RTxx is disconnected.</p>	Automatic.
LNA main branch in remote tune combiner is faulty.	<ol style="list-style-type: none"> 1. The LNA main branch is faulty. Replace the RTxx connected to the alarming TRX. 	Automatic.

Table 10 7606 TRX FAULTY (Cont.)

7606 TRX FAULTY		
LNA diversity branch in remote tune combiner is faulty.	<ol style="list-style-type: none"> 1. The LNA diversity branch is faulty. Replace the RTxx connected to the alarming TRX. 	Automatic.
The reflected power of remote tune combiner is too high.	<ol style="list-style-type: none"> 1. Check the antenna connection to the RTxx . 2. If the antenna connection is OK, replace the RTxx. <p>Note: Prior to CX4.1 CD2.0, this alarm might be false. Reset the sector to clear the alarm. If the alarm reactivates soon after the sector reset, consider it as a real RTC failure.</p>	Automatic.
Software downloading to remote tune combiner failed.	<ol style="list-style-type: none"> 1. Check the cabling from the RTxx to the back-plane. 2. Reset the sector. 3. If the fault reappears, replace the RTxx. 	Automatic.
Remote tune combiner initialisation failed.	<ol style="list-style-type: none"> 1. Check the cabling from the RTxx to the back-plane. 2. Reset the sector. 3. If the fault reappears, replace the RTxx. 	Automatic.
No connection to remote tune combiner.	<ol style="list-style-type: none"> 1. Check the cabling from the RTxx to the back-plane. 2. If the connection is OK, replace the RTxx. 	Automatic.
1st branch LNA in dual variable gain duplex unit is faulty.	<ol style="list-style-type: none"> 1. Replace the DVxx. 	Automatic.
2nd branch LNA in dual variable gain duplex unit is faulty.	<ol style="list-style-type: none"> 1. Replace the DVxx. 	Automatic.
BB2x temperature is dangerously high.	<ol style="list-style-type: none"> 1. Ensure that the ambient temperature of the base station is within specified limits. 2. Check the cabinet fans. 3. Replace the BB2x. <p>Note: An alarm is activated when the BB2x internal temperature exceeds +70°C.</p>	Automatic.

Table 10 7606 TRX FAULTY (Cont.)

7606 TRX FAULTY		
TSxx temperature is dangerously high.	<ol style="list-style-type: none"> 1. Ensure that the ambient temperature of the base station is within specified limits. 2. If air filters are used, check that they are not clogged. 3. If outdoor cabinet is used, check the door fan. 4. Check the cabinet fans. 5. Replace the TSxx. <p>Note: An alarm is activated when the TSxx internal temperature exceeds +85°C.</p> <p>Note: With CX4.1 and CX4.1 CD0.1/1.0, the alarm might be false. The problem may occur when the BOIA card has not been used with BTS SW CX4.1 before, for example, during the first BTS SW CX4.1 activation. Reset the BCF to clear the alarm. If the alarm reactivates, consider it as a real temperature issue.</p> <p>Note: With CX4.0, the alarm might activate with a false TRX id, for example, with 236 which is not under the BCF. In this case the alarm is most likely false and can be cancelled manually from the BSC.</p>	Automatic.
There is disturbance in the serial DL bus or bus is broken.	<ol style="list-style-type: none"> 1. Reset the TRX/sector. 2. Check that the BB2x-TSxx HW configuration is valid. 3. Reset the BCF. 4. Swap the unit with another working (non-alarming) TSxx unit in the cabinet. 5. If the new TSxx raises the same alarm, check the backplane connectors. <p>If alarms follow the original TSxx, replace the unit.</p> <p>Note: The alarm may appear unnecessarily, when BTS SW earlier than CX5 CD3.0 is being used.</p>	Automatic.
No data is received from DIBA Asic traffic channels to CHDSP.	<ol style="list-style-type: none"> 1. Replace the BB2x. 	Automatic.
IDD main/auxiliary TRX frequency band mismatch.	<ol style="list-style-type: none"> 1. Check the IDD configuration (TSxx frequency band) from the HW Configurator. 2. Ensure that the frequency bands of the IDD TSxx units are correct. 	Automatic.

Table 10 7606 TRX FAULTY (Cont.)

7606 TRX FAULTY		
Non EDGE TRX device used accidentally in EDGE capable mode.	<p>When this alarm is related to the STIRC feature (EDGE capable mode requires EDGE BB):</p> <ol style="list-style-type: none"> 1. Replace the non-EDGE base band board BB2A with BB2E/F. <p>When this alarm is related to an EDGE capable feature other than STIRC i.e. Antenna Hopping, Ecell, IDD (EDGE capable mode requires EDGE BB + EDGE RFM (TSxB)):</p> <ol style="list-style-type: none"> 1. Check the BTS HW configuration (BB2x and TSxx unit type) from the HW Configurator. 2. Replace either the non-EDGE BB or the RFM or both with an EDGE capable unit (BB2E/F and TSxB). 	Automatic.
TRX is stuck in waiting for system information state.	<ol style="list-style-type: none"> 1. Reset the TRX/sector. <p>Note: Do not replace the TSxx unit.</p>	Automatic.
FBUS HW failure.	<ol style="list-style-type: none"> 1. Reset the sector. 2. Replace the BB2x units one by one. <p>Note: The alarm may appear unnecessarily, when BTS SW earlier than CX5 CD2.0 (or CX5 CD1.1) is being used.</p>	Automatic.
The transmitter output of TRX is overdriven.	<ol style="list-style-type: none"> 1. Replace the TSxx. <p>Note: With CX4.0 to CX4.0-4, Lock/Unlock the TRX/Sector to clear the alarm.</p> <p>Note: With CX4.1 or newer releases, this alarm is included in the Runtime Diagnostics feature (BB hopping is not supported).</p>	Automatic.
The transmitter output power has dropped at least 3 dB.	<ol style="list-style-type: none"> 1. Reset the TRX/sector. 2. Replace the TSxx. <p>Note: With CX4.1 or newer releases, this alarm is included in the Runtime Diagnostics feature (BB hopping is not supported).</p>	Automatic.
The transmitter output power is too low.	<ol style="list-style-type: none"> 1. Reset the TRX/sector. 2. Replace the TSxx. <p>Note: With CX4.1 or newer releases, this alarm is included in the Runtime Diagnostics feature (BB hopping is not supported).</p>	Automatic.
Fault in RF module transmitter interface.	<ol style="list-style-type: none"> 1. Replace the TSxx. <p>Note: With CX4.1 or newer releases, this alarm is included in the Runtime Diagnostics feature (BB hopping is not supported).</p>	Automatic.
Fault in RF module receiver interface.	<ol style="list-style-type: none"> 1. Replace the TSxx. <p>Note: With CX4.1 or newer releases, this alarm is included in the Runtime Diagnostics feature (BB hopping is not supported).</p>	Automatic.

Table 10 7606 TRX FAULTY (Cont.)

7606 TRX FAULTY		
RF module initialization has failed.	<ol style="list-style-type: none"> 1. Replace the TSxx. <p>Note: With CX4.1 or newer releases, this alarm is included in the Runtime Diagnostics feature (BB hopping is not supported).</p>	Automatic.
Internal DSP and RF module communication failure in TRX.	<ol style="list-style-type: none"> 1. Reset the sector. 2. Replace the BB2x. 3. If the fault still exists, replace the TSxx. <p>Note: With CX4.1 or newer releases, this alarm is included in the Runtime Diagnostics feature (BB hopping is not supported).</p>	Automatic.
The RF transmitter synthesizer is not locked.	<ol style="list-style-type: none"> 1. Reset the TRX/sector. 2. Replace the TSxx. <p>Note: With CX4.1 or newer releases, this alarm is included in the Runtime Diagnostics feature (BB hopping is not supported).</p>	Automatic.
The RF transmitter frequency hopping synthesizer 1 is not locked.	<ol style="list-style-type: none"> 1. Reset the TRX/sector. 2. Replace the TSxx. <p>Note: The alarm may appear unnecessarily, when BTS SW earlier than CX4.1 CD3.0 is being used.</p>	Automatic.
The RF transmitter frequency hopping synthesizer 2 is not locked.	<ol style="list-style-type: none"> 1. Reset the TRX/sector. 2. Replace the TSxx. <p>Note: With CX4.1 or newer releases, this alarm is included in the Runtime Diagnostics feature (BB hopping is not supported).</p>	Automatic.
The RF receiver synthesizer is not locked.	<ol style="list-style-type: none"> 1. Reset the TRX/sector. 2. Replace the TSxx. <p>Note: With CX4.1 or newer releases, this alarm is included in the Runtime Diagnostics feature (BB hopping is not supported).</p>	Automatic.
The RF receiver frequency hopping synthesizer 1 is not locked.	<ol style="list-style-type: none"> 1. Reset the TRX/sector. 2. Replace the TSxx. <p>Note: With CX4.1 or newer releases, this alarm is included in the Runtime Diagnostics feature (BB hopping is not supported).</p>	Automatic.
The RF receiver frequency hopping synthesizer 2 is not locked.	<ol style="list-style-type: none"> 1. Reset the TRX/sector. 2. Replace the TSxx. <p>Note: With CX4.1 or newer releases, this alarm is included in the Runtime Diagnostics feature (BB hopping is not supported).</p>	Automatic.
Invalid BB hopping set-up.	<ol style="list-style-type: none"> 1. Not a supported BB configuration. Check the Technical Note No. 34 for supported BB hopping configurations. <p>Note: Do not send unit(s) to service because of this alarm.</p>	Manual.

Table 10 7606 TRX FAULTY (Cont.)

7606 TRX FAULTY		
Other faults.	1. Replace the TSxx.	Automatic.

Table 10 7606 TRX FAULTY (Cont.)

i For BTS SW CX4.1 and newer versions, the Runtime Diagnostics is done for some of the 7606 TRX FAULTY alarms. The Runtime Diagnostics is activated by an alarm condition generated by HW. The unit will be in BL-DGN state in the BSC while the diagnostics is operational.

If the diagnostics cannot remove the alarm condition, the 7606 TRX FAULTY alarm is sent to the BSC with the alarm description. When the unit is in BL-DGN state, no call drop occurs as the BSC will command handover to all active calls. The Runtime Diagnostics is performed only in non-hopping and RF hopping modes.

i With baseband hopping, the blocking alarm is cancelled when the troubleshooting/recovery actions have been completed. The BB hopping sector needs to be reset to allow the TRX back into the hopping group.

i In case of alarm 7606, if a BCCH TRX is affected, the BSC performs a BCCH reconfiguration if possible.

See also [Alarms list for UltraSite EDGE BTS](#) and [Troubleshooting with the help of alarm tables](#).

4.6.10 7607 TRX OPERATION DEGRADED

7607 TRX OPERATION DEGRADED			
Severity:	Object affected:	Object state:	Unit:
**	TRX	Enabled	BB2x, DVxx, MHA, RTxx, TSxx Note: Prior to CX5 CD2 SW, the unit description shall be MNxx.
Fault reason:	Instruction:	Alarm cancelling:	
Flash operation failed in BOI or TRX.	1. Replace the BB2x.	Automatic.	
The reflected power of remote tune combiner is too high.	1. Check the antenna line from the RTxx onwards. 2. If the antenna connection is OK, replace the RTxx. Diversity branch is still working and calls are getting through. Note: Prior to CX4.1 CD2.0, this alarm might be false. Reset the sector where the alarming RTC is located to clear the alarm. If the alarm reactivates soon after the sector reset, consider it as a real RTC failure.	Automatic.	
LNA main branch in remote tune combiner is faulty.	1. Replace the RTxx. Diversity branch is still working and calls are getting through.	Automatic.	
LNA diversity branch in remote tune combiner is faulty.	1. Replace the RTxx. Main branch is still working and calls are getting through.	Automatic.	
The synthesizer in remote tune combiner is faulty.	1. Replace the RTxx. Diversity branch is still working and calls are getting through.	Automatic.	
The controller is out of order in remote tune combiner.	1. Replace the RTxx. Diversity branch is still working and calls are getting through.	Automatic.	
Performance of the main branch LNA in remote tune combiner is degraded.	1. Replace the RTxx. Diversity branch is still working and calls are getting through.	Automatic.	
Performance of the diversity branch LNA in remote tune combiner is degraded.	1. Replace the RTxx. Main branch is still working and calls are getting through.	Automatic.	
1st branch LNA in dual variable gain duplex unit is faulty.	1. Replace the DVxx. 2nd branch is still working and calls are getting through.	Automatic.	
2nd branch LNA in dual variable gain duplex unit is faulty.	1. Replace the DVxx. 1st branch is still working and calls are getting through.	Automatic.	



Table 11 7607 TRX OPERATION DEGRADED

7607 TRX OPERATION DEGRADED		
Performance is degraded in the 1st branch dual variable gain unit.	<ol style="list-style-type: none"> 1. Replace the DVxx. 2nd branch is still working and calls are getting through. 	Automatic.
Performance is degraded in the 2nd branch dual variable gain unit.	<ol style="list-style-type: none"> 1. Replace the DVxx. 1st branch is still working and calls are getting through. 	Automatic.
No connection to dual variable gain duplex unit.	<ol style="list-style-type: none"> 1. Check the BTS configuration and install the DVxx if it is missing from the configuration. 2. Check the cable connection between the backplane and the DVxx unit. 3. Replace the DVxx. 	Automatic.
Fault in the chain between power unit and MHA.	<ol style="list-style-type: none"> 1. Check the voltage supply chain between the PWSx unit(s) and the MHA. 2. Replace the PWSx. 3. Replace the Bias-T. 4. Replace the MHA. 	Automatic.
Fault in the chain between power unit and high gain MHA with bypass.	<ol style="list-style-type: none"> 1. Check the Antenna Properties in the HW configuration file. 2. Check the antenna cabling. 3. Check the Bias-T and the cabling between the Bias-T and the Interface board on the top side of the cabinet. 4. Check the interface board. 5. Check the PWSx unit. 6. Replace the MHA (here MHA refers to High Gain with Bypass MHA types like MNxx or Dual MHAs). <p>Note: Prior to CX5 CD2 BTS SW, the same alarm has a different alarm description text i.e.: Fault in the chain between power unit and high gain MNxx with bypass.</p>	Automatic.
Fault in VSWR antenna monitoring.	<ol style="list-style-type: none"> 1. Check the antenna line and the Bias-T cabling. Reset the sector. 2. Check all RF cabling between the TSxx's TX output connector and top of the cabinet (including WCDx and DVxx or RTxx units). 3. Replace the Bias-T. 4. Replace the TSxx. <p>Note: Diversity RX branch is still working and calls are getting through.</p>	Manual (sector lock/unlock).
TRX is unable to implement EDGE services.	<ol style="list-style-type: none"> 1. Check the configuration of TRX at the BSC. 2. Upgrade the TSxx/BB2x units to EDGE capability. 	Automatic.

Table 11 7607 TRX OPERATION DEGRADED (Cont.)

7607 TRX OPERATION DEGRADED		
IDD main/auxiliary TRX frequency band mismatch.	<ol style="list-style-type: none"> 1. Check the IDD configuration (TSxx frequency band) from the HW Configurator. 2. Ensure that the frequency band of the IDD TSxx units is correct. 3. Replace the IDD auxiliary TSxx with one of the same frequency as the IDD main TSxx unit. <p>Note: The TSxx units used for an IDD pair must be of the same type.</p>	Automatic.
Mismatch between BSC/MMI configuration and/or IDD TRX.	<ol style="list-style-type: none"> 1. Delete the IDD auxiliary TRX from the BSC configuration. 2. Reset the IDD main TRX. <p>Note: This alarm is related to auxiliary TRX. IDD auxiliary TRXs are not to be defined at the BSC.</p>	Automatic.
Non EDGE TRX device used accidentally in EDGE capable mode.	<ol style="list-style-type: none"> 1. Check the IDD configuration of the BCF. 2. Check the configuration of the TRX. 3. Replace the IDD auxiliary TSxx with an EDGE capable unit. <p>Note: This alarm is related to auxiliary TRX. IDD TRXs must be EDGE capable.</p>	Automatic.
Diversity branch runtime loop failure between CHDSP and EQDSP via Fbus.	<ol style="list-style-type: none"> 1. Reset the TRX (lock/unlock). 2. If the alarm reappears, reset the IDD main TRX. 3. Replace the BB2E unit. <p>Note: This alarm is related to auxiliary TRX. This alarm may appear when the IDD auxiliary TRX is reset.</p>	Automatic.
Diversity branch FBUS HW failure.	<ol style="list-style-type: none"> 1. Reset the IDD main TRX. 2. Replace the BB2E/F unit. <p>Note: This alarm is related to auxiliary TRX. This alarm may appear when the IDD auxiliary TRX is reset.</p>	Automatic.
The transmitter output power has dropped at least 3 dB.	<ol style="list-style-type: none"> 1. Reset the TRX/sector. 2. Replace the TSxx. <p>Note: This is the last partly working TRX in the sector, service has degraded.</p>	Automatic.

Table 11 7607 TRX OPERATION DEGRADED (Cont.)

-  Rack/Shelf/Slot information gives the position of the IDD auxiliary TRX.
-  With baseband hopping, the blocking alarm is cancelled when the troubleshooting/recovery actions have been completed. The BB hopping sector needs to be reset to allow the TRX back into the hopping group.

See also [Alarms list for UltraSite EDGE BTS](#) and [Troubleshooting with the help of alarm tables](#).

4.6.11 7608 TRX NOTIFICATION

7608 TRX NOTIFICATION			
Severity:	Object affected:	Object state:	Unit:
*	TRX	Enabled	BB2x, BOI, DVxx, RTxx, TSxx
Fault reason:	Instruction:		Alarm cancelling:
TSxx internal I2C bus is jammed.	<ol style="list-style-type: none"> 1. Reset the TRX. 2. If the fault reappears, replace the TSxx. 		Automatic.
BB2x temperature is low.	<ol style="list-style-type: none"> 1. Check the ambient temperature. 2. Check that the heater is working properly if equipped. 3. If the temperature is OK, replace the BB2x. <p>Note: An alarm is activated when the BB2x unit internal temperature is below -10°C.</p>		Automatic.
TSxx temperature is low.	<ol style="list-style-type: none"> 1. Check the ambient temperature. 2. Check that the heater is working properly if equipped. 3. If the temperature is OK, replace the TSxx. <p>Note: An alarm is activated when the TSxx unit internal temperature is below -10°C.</p>		Automatic.
BB2x has lost connection to temperature sensor.	<ol style="list-style-type: none"> 1. Reset the TRX/sector. 2. Temperature sensor is probably broken. Temperature changes cannot be measured. Replace the BB2x. 		Automatic.
TSxx has lost connection to temperature sensor.	<ol style="list-style-type: none"> 1. Reset the TRX/sector. 2. Temperature sensor is probably broken. Temperature changes cannot be measured. Replace the TSxx. <p>Note: The alarm might appear unnecessarily, when BTS SW earlier than CX4.1 CD1.0 is being used.</p> <p>Workaround for an earlier SW:</p> <ol style="list-style-type: none"> 1. TRX in an RF/Non-hopping sector: remove the TSxx from the slot and re-insert it after a few seconds. 2. TRX in a BB/Antenna hopping sector: lock the sector first, then remove the TSxx from the slot and re-insert it after a few seconds. Unlock the sector 		Automatic.

Table 12 7608 TRX NOTIFICATION

See also [Alarms list for UltraSite EDGE BTS](#) and [Troubleshooting with the help of alarm tables](#).

4.6.12 7609 TRE FAULTY

7609 TRE FAULTY			
Severity:	Object affected:	Object state:	Unit:
***	BCF	Disabled	TRE
Fault reason:	Instruction:		Alarm cancelling:
BOI detected that connection to transmission unit is lost.	<ol style="list-style-type: none"> 1. If the base station otherwise operates properly, there is no need for an immediate repair. However, the transmission alarms for the node are not reported to the BSC nor the BTS Manager. 2. Reset BCF. 3. If the alarm reappears after the BCF reset, switch the cabinet power off and on. 4. If the alarm reappears after the recovery actions above, replace the faulty transmission plug-in unit located in slot 1. <p>Note: Replacing the unit blocks the base station and cuts off the traffic routed through it.</p>		Automatic.

Table 13 7609 TRE FAULTY

See also [Alarms list for UltraSite EDGE BTS](#) and [Troubleshooting with the help of alarm tables](#).

4.6.13 7612 SITE POWERING FAULTY

7612 SITE POWERING FAULTY			
Severity:	Object affected:	Object state:	Unit:
***	BCF	Enabled	SISU
Fault reason:	Instruction:		Alarm cancelling:
CCUA PSM alarm 1.	1. Use the PSM Manager software to check the active SISU alarms and follow the instructions given in the SISU.		Automatic.

Table 14 7612 SITE POWERING FAULTY

See also [Alarms list for UltraSite EDGE BTS](#) and [Troubleshooting with the help of alarm tables](#).

4.6.14 7613 SITE POWERING OPERATION DEGRADED

7613 SITE POWERING OPERATION DEGRADED			
Severity:	Object affected:	Object state:	Unit:
**	BCF	Enabled	SISU
Fault reason:	Instruction:		Alarm cancelling:
CCUA PSM alarm 2.	1. Use the PSM Manager software to check the active SISU alarms and follow the instructions given in the SISU.		Automatic.

Table 15 7613 SITE POWERING OPERATION DEGRADED

See also [Alarms list for UltraSite EDGE BTS](#) and [Troubleshooting with the help of alarm tables](#).

4.6.15 7614 SITE POWERING NOTIFICATION

7614 SITE POWERING NOTIFICATION			
Severity:	Object affected:	Object state:	Unit:
*	BCF	Enabled	SISU
Fault reason:	Instruction:		Alarm cancelling:
CCUA PSM alarm 3.	1. Use the PSM Manager software to check the active SISU alarms and follow the instructions given in the SISU.		Automatic.

Table 16 7614 SITE POWERING NOTIFICATION

See also [Alarms list for UltraSite EDGE BTS](#) and [Troubleshooting with the help of alarm tables](#).

4.6.16 7615 RTS IN TEST USE

7615 RTS IN TEST USE			
Severity:	Object affected:	Object state:	Unit:
*	RTS	Disabled	TSxx
Fault reason:	Instruction:	Alarm cancelling:	
No fault reason text with the alarm. Internal O&M SW is testing the timeslots during TRX test.	1. No actions required.	Automatic.	

Table 17 7615 RTS IN TEST USE

 Alarm 7615 is sent to the BSC only when the abis loop or TRX test is started from the BTS Manager.

See also [Alarms list for UltraSite EDGE BTS](#) and [Troubleshooting with the help of alarm tables](#).

4.6.17 7616 OSCILLATOR ADJUSTMENT TEMPORARILY INTERRUPTED

7616 OSCILLATOR ADJUSTMENT TEMPORARILY INTERRUPTED			
Severity:	Object affected:	Object state:	Unit:
*	BCF	Enabled	BOI
Fault reason:	Instruction:		Alarm cancelling:
Oven oscillator adjustment function interrupted.	1. Check that the Abis synchronisation is correct. NOTE: The alarm is an indication that the BTS DAC control value is less than 204 steps away from either control range end limit (0 or 4095). The adjusting of the BTS clock still continues. The alarm is automatically canceled when the control value is more than 204 steps away from the control range end limits.		Automatic.

Table 18 7616 OSCILLATOR ADJUSTMENT TEMPORARILY INTERRUPTED

See also [Alarms list for UltraSite EDGE BTS](#) and [Troubleshooting with the help of alarm tables](#).

4.6.18 7617 SEVERAL CALLS DROPPED DUE TO PROBLEM WITH TRANSCODER

7617 SEVERAL CALLS DROPPED DUE TO PROBLEM WITH TRANSCODER			
Severity:	Object affected:	Object state:	Unit:
**	TRX	Enabled	BB2x, TSxx
Fault reason:	Instruction:		Alarm cancelling:
There is an error with the connection between the BTS and the transcoder.	1. Check the transmission path between the base station and the transcoder.		Automatic.

Table 19 7617 SEVERAL CALLS DROPPED DUE TO PROBLEM WITH TRANSCODER

See also [Alarms list for UltraSite EDGE BTS](#) and [Troubleshooting with the help of alarm tables](#).

4.6.19 7622 CABINET OPEN

7622 CABINET OPEN			
Severity:	Object affected:	Object state:	Unit:
*	BCF	Enabled	BOI
Fault reason:	Instruction:		Alarm cancelling:
Cabinet door is open.	<ol style="list-style-type: none"> 1. Ensure the cabinet door is properly closed and secured. 2. Check that the door switch is fitted properly in the cabinet and that all related cabling is OK. <p>Note: In earlier releases than CX4.1 CD2.0 with the UltraSite outdoor cabinet, the alarm may remain active although the door is closed. This can happen if the cabinet door is opened and closed immediately within a few seconds. The alarm is cancelled correctly when you wait at least for 10-20 seconds before closing the door.</p>		Automatic.

Table 20 7622 CABINET OPEN



i Alarm 7622 applies to outdoor cabinets only. Indoor cabinets do not issue alarm 7622.

See also [Alarms list for UltraSite EDGE BTS](#) and [Troubleshooting with the help of alarm tables](#).

4.6.20 7801 MMI CONNECTED TO BASE STATION

7801 MMI CONNECTED TO BASE STATION			
Severity:	Object affected:	Object state:	Unit:
*	BCF	Enabled	BOI
Fault reason:	Instruction:	Alarm cancelling:	
No fault reason text with the alarm. BTS Manager is connected to UltraSite EDGE Base Station.	1. No actions required. The Additional Information field indicates whether MMI is connected to the BTS locally or remotely from NetAct. The text will read <code>Local MMI connected</code> or <code>Remote MMI connected</code> .	Alarm is cancelled automatically when the BTS Manager connection is disconnected.	

Table 21 7801 MMI CONNECTED TO BASE STATION

-  Alarm 7801 applies to both local and remote BTS Manager.
-  Only one BTS Manager connection can be active.
-  If the alarm is cancelled and restarted within 10 seconds (the default alarm cancelling delay time in the BSC), the correct alarm state is not shown in the alarm details in the BSC. The state may change from remote to local or local to remote. The alarm cancelling delay can be changed to no delay to show the correct alarm state. Use the following MML command: `ZEOM:7801:MOD=CDL,TIME=0;`

See also [Alarms list for UltraSite EDGE BTS](#) and [Troubleshooting with the help of alarm tables](#).

4.6.21 7995 MAINS BREAKDOWN WITH BATTERY BACKUP

7995 MAINS BREAKDOWN WITH BATTERY BACKUP			
Severity:	Object affected:	Object state:	Unit:
*	BCF	Enabled	SISU
Fault reason:	Instruction:		Alarm cancelling:
Mains breakdown with battery backup.	<ol style="list-style-type: none"> 1. Check the mains supply. 2. If the mains supply is OK, check the EAC/Q1 cabling between the BTS and the SISU. 3. Repair the SISU. 		Automatic.

Table 22 7995 MAINS BREAKDOWN WITH BATTERY BACKUP

See also [Alarms list for UltraSite EDGE BTS](#) and [Troubleshooting with the help of alarm tables](#).

5 Trouble management of ITN, LMU and other transmission alarms

5.1 Trouble management of ITN alarms

5.1.1 Monitoring transmission node alarms

Purpose

The UltraSite BTS Hub or the MetroHub Manager can monitor a number of different alarms that occur in the node.

Before you start

Before you can see the STM-1 alarms, you must enable/disable alarm monitoring in the **Alarm Monitoring States** window. See Section [Configuring FXC STM-1 alarm monitoring states](#) for details.

Summary

The manager provides the following information about any alarm that has occurred in the node:

- **Severity** - severity class of the alarm
- **Location** - unit the alarm is located in
- **Description** - brief description of the alarm
- **Time stamp** - date and time when the alarm was detected
- **Code** - fault code of the alarm
- **Activation** (in the alarm history view) – indicates if an alarm is active or cancelled

The unit alarm status in **Equipment View** is visible only when the **Alarms** window is open and the alarm polling is on.

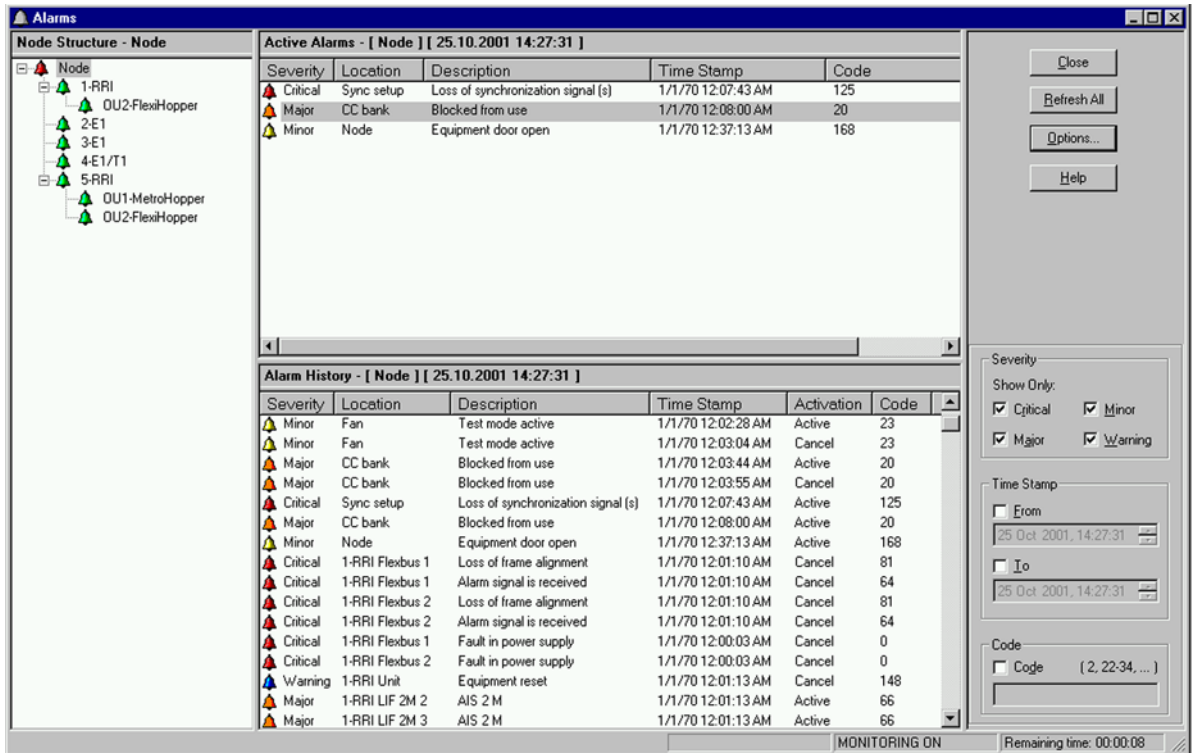

Figure 6 Alarms window

Note that if the alarm(s) and the alarm history of a unit cannot be read, the state is *Missing unit* in the **Equipment** view.

☞ If the alarm history is not displayed, select the option button to enable the alarm history.



A very small alarm-monitoring interval puts a strain on the Q1 bus resources and delays other activities. Do not set the alarm-monitoring delay to a very small value when monitoring a network element remotely.

Severity

Severity shows the severity class of the alarm as it appears in the node manager.

Colour codes of the alarms

The alarms are colour-coded according to the **Severity** of the alarm.

Severity	Symbol	Colour
Critical (***)		Red
Major (**)		Orange
Minor (*)		Yellow
Warning (W)		Blue

Table 23 Colour codes of the alarms

Location

The **Location** field indicates which unit or interface is producing the alarm.

By default, the alarms are listed by **Time stamp**. You can sort the alarms by clicking on the column heading in the window. To sort the alarms in reverse order, click a heading a second time.

Description and code

The alarm descriptions give the following information:

Title row shows the fault code and the alarm name.

Severity shows the default severity class of the alarm as it appears in the node manager.

- *Critical* is used to indicate a fault situation that requires immediate measures. A critical alarm indicates possible service degradation.
- *Major* is used to indicate a fault situation that requires some measures during normal working hours.
- *Minor* is used to indicate a fault situation that does not require any measures. The alarm is cancelled when the fault situation is cleared.
- *Warning* can be used to provide information. A warning is not an alarm, and it does not indicate a fault. Warnings are not cancelled.

 Alarm severity can be modified in the Alarm Properties dialogue box. The modified alarm severity is visible in the local manager alarm window. The alarm is reported to the NMS and BSC with an alarm code. Local alarm severity modification does not override global severity settings in the NMS or BSC.

Fault reason gives the possible cause of the alarm.

Description contains location and consequence information.

Location shows the unit and the block indicating the alarm.

Consequence shows whether an indication signal is sent upstream or downstream.

Instructions gives instructions on how to remedy the fault.

Cancelling gives instructions on how the alarm is cancelled.

 For information on how to replace units or carry out other maintenance tasks, please refer to the instructions in this documentation.

Steps

- 1 **Open the alarms window.**

Steps

- a **Select Alarms → View.**

The **Alarms** window opens and a list of active alarms, the node structure view, and the filter view are shown.

- 2 **Open the alarm history view.**

Steps

- a **Click the Options button in the Alarms window.**

The **Alarm Options** window opens.

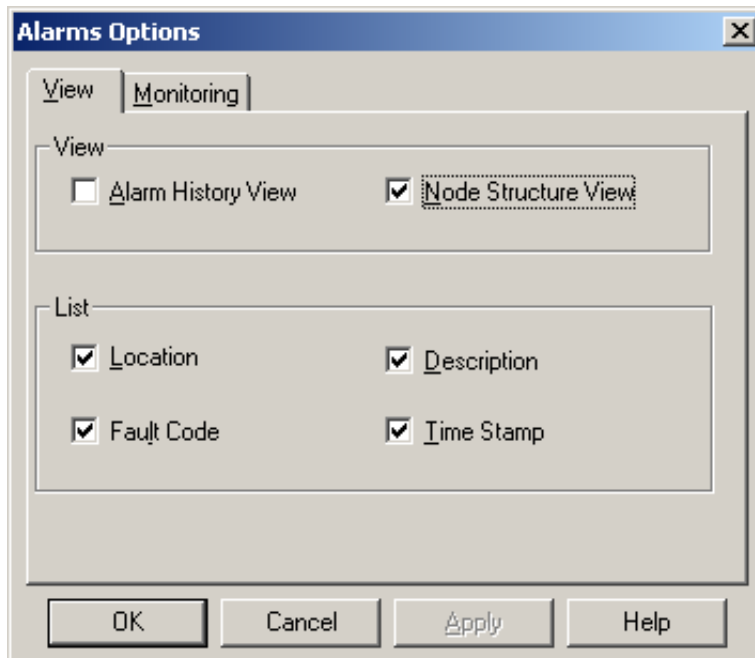

Figure 7 Alarm Options window, View tab

- b **Tick the Alarm History View box in the View tab.**

- c **Click OK.**

The alarm history view opens.

Further information

Past alarms which have occurred in the network element are shown in the **Alarm History** window (that is, the alarm polling history). The alarm history view contains a header that shows the location and time of the last refresh, that is, when the currently shown events were last read.

You can sort the alarm history by clicking the column heading in the window. Every time the column is clicked, the sort order is reversed.

The **Activation** field lists if an alarm is active or if it has been cancelled.

The alarm history is saved as a text file with the extension .alr and must be opened with a text editor.

3 Keep the list of active alarms updated by enabling alarm monitoring.

Steps

- a **Click Options in the Alarms window.**

The **Alarm Options** window opens.

b Click the Monitoring tab.

The **Monitoring** tab of the **Alarm Options** window is displayed.

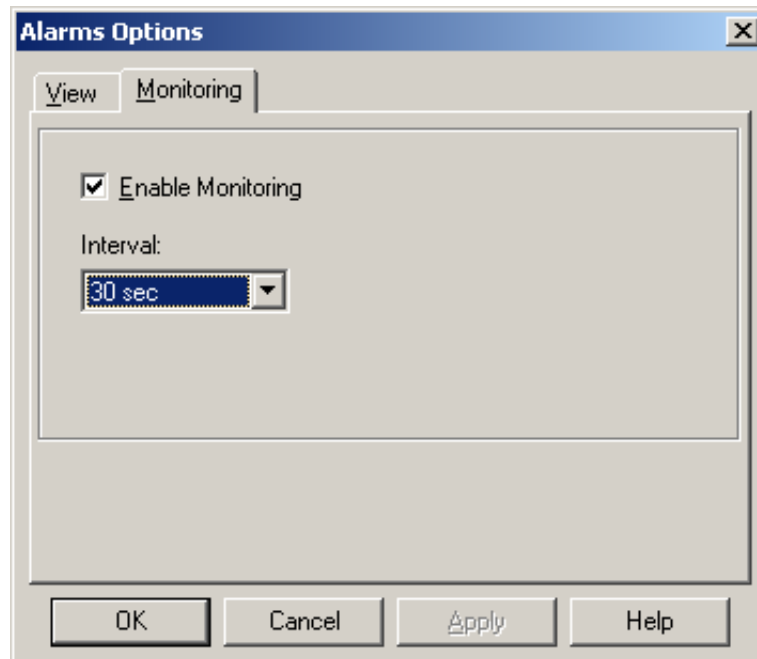

Figure 8 Alarm Options window, Monitoring tab

c Tick the Enable Monitoring box.

d Select the desired interval.

e Click OK.

A remaining time clock indicator in the right bottom corner shows the interval progressing.

Further information

The most critical alarms of the FXC units are shown as bell symbols in the node structure view. The bell symbols show the colour corresponding to the highest severity of the alarms present in the unit in question. For example, if the most severe alarm is a critical alarm, the bell symbol is red.

When monitoring is enabled, the LED states are also updated in the **Equipment** window.

4 Refresh active alarms and alarm history.

Steps

a Click the Refresh All button in the Alarms window.

The information in the **Alarms** window and alarm history view is updated.

5 Select filtering options.

Summary

The filter options are located on the right hand side of the alarms window. You can select the alarms to be displayed according to severity, time stamp, and code.

Steps**a Tick the desired filtering options.**

For example, if you want to be notified about critical and major alarms only, tick those boxes only.

Only the selected alarms are displayed in the alarms window.

6 Change the alarm list options.**Steps****a Click Options in the Alarms window.****b In the View tab, select the columns you want to be displayed in the alarms window.****c Click OK.**

Only the selected columns are displayed in the alarms window.

Further information

By right-clicking the mouse, you can open a pop-up menu for sorting and viewing alarms.

5.1.2 Configuring FXC STM-1 alarm monitoring states

Purpose

You can enable/disable alarm monitoring in the Alarm Monitoring States window.

Note that current alarms are managed under the UltraSite BTS Hub Manager or MetroHub Manager Alarms menu.

Alarm monitoring means checking the status of determined alarm sources at regular intervals. Alarms are not visible if the alarm monitoring is off (the default state is off).

You need to activate alarm monitoring separately for each interface (STM-1 interfaces 1 and 2, payload for interfaces 1 and 2, and the 20 SDH-PDH channels) to receive alarms.

Before you start

In alarm description tables, an asterisk (*) before the alarm name means that the alarm is masked when alarm monitoring is off (for example, *Loss of pointer).

Steps

- 1 Click **FXC STM-1 → Alarm Monitoring States** to open the window (see the following figure).

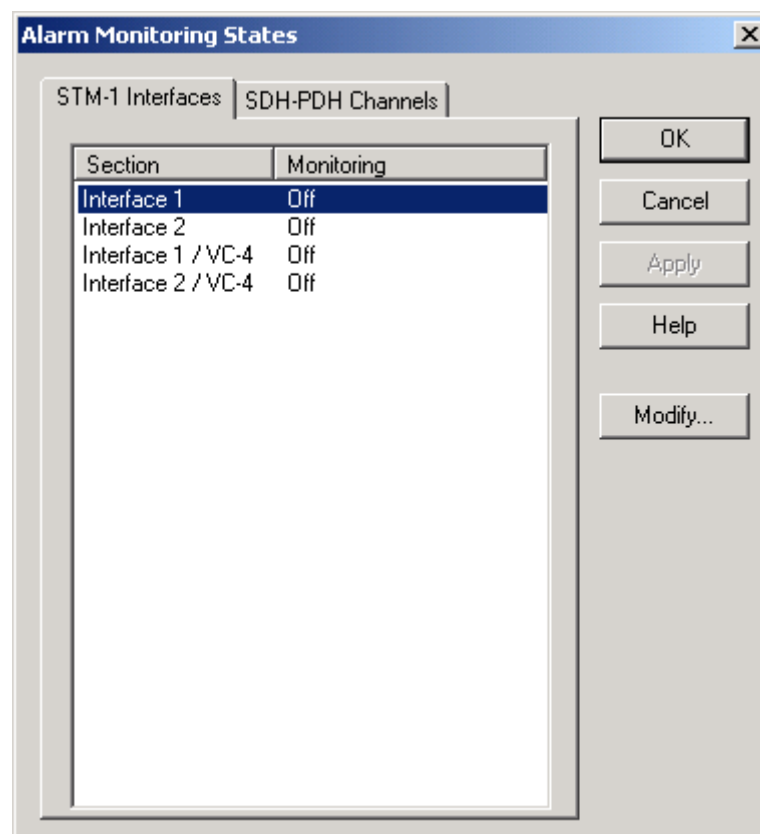

Figure 9 FXC STM-1 Alarm Monitoring States, STM-1 Interfaces

- 2 Click the tabs (**STM-1 Interfaces / SDH-PDH Channels**) to switch between the pages.

- 3 **On the STM-1 Interfaces page, select the section you want to modify by clicking it.**
Select the section/sections you want to modify by clicking. To select multiple sections, hold down the Ctrl key or the Shift key on your PC keyboard while clicking.
- 4 **Click Modify to open the dialogue box.**
- 5 **Switch alarm monitoring on/off by selecting/clearing the Monitoring box.**
- 6 **Click OK.**
- 7 **Send the changes to the node by clicking Apply in the Alarm Monitoring States window.**
- 8 **In the SDH-PDH Channels page, select the channel/s to be modified by clicking them.**

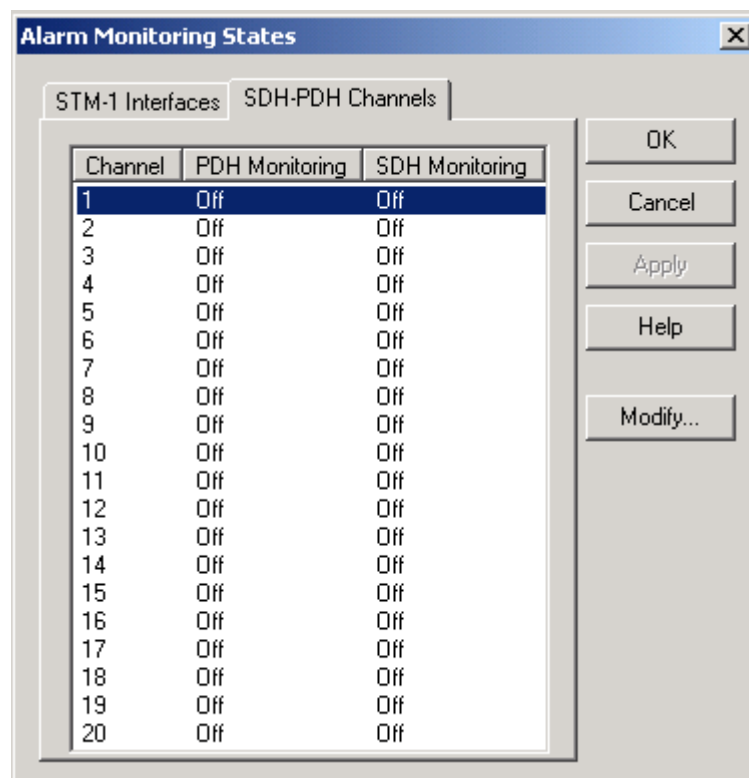

Figure 10 STM-1 Alarm Monitoring States, SDH-PDH Channels

- 9 **Click Modify to open the dialogue box.**
- 10 **Switch alarm monitoring on/off by selecting/clearing the SDH and/or the PDH box.**

11 Click OK.

12 Send the changed settings to the node by clicking Apply in the Alarm Monitoring window.

13 Click OK to close the window.

5.1.3 Common node alarms

5.1.3.1 20 Blocked from use

20 Blocked from use

Severity

Major

Fault reason

When a node has a cross-connection terminated in an interface, which is not in use, the cross-connection bank shows pending cross-connections. The cross-connections are also set to pending state, if a slave unit with cross-connections is removed without uninstalling it first. In these cases the cross-connection remains in the cross-connection bank, but it is not set in the hardware.

Description

Location: Node cross-connection bank

Instructions

Check that all interfaces, in which cross-connections have been created, are in use. Remove cross-connections that are connected to non-existing interfaces. Reinstall the removed unit(s).

Cancelling

Automatically cancelled when there are no blocked cross-connections.

5.1.3.2 8062 No connection

8062 No connection		
Severity:	Description:	
***	Location: Node Trunet	
Fault reason:	Instruction:	Alarm cancelling:
Enabling Trunet has failed, because the cross-connection capacity required is not free.	Disable Trunet and remove the cross-connections that are using the capacity needed for Trunet. After performing this action, re-enable Trunet.	Automatically cancelled when Trunet can create the cross-connections that are needed.

Table 24 8062 No connection

5.1.3.3 8112 Frequency error

8112 Frequency error		
Severity:	Description:	
*	Location: Node synchronisation setup	
Fault reason:	Instruction:	Alarm cancelling:
<ol style="list-style-type: none"> 1. The node is running on the internal clock as configured in the timing priority list, as none of the Rx or external clock sources defined in the timing priority list is valid. 2. The Rx source signal in use has its MCB in state '1'. An Rx source signal with MCB state '1' is selected as the synchronisation source if all other configured synchronisation sources have failed. If there are two synchronisation sources with the MCB state '1', the source with higher priority is selected. 	Check the incoming signals in the synchronisation priority list.	Automatically cancelled when at least one Rx signal in the priority list is valid.

Table 25 8112 Frequency error

5.1.3.4 8122 Synchronizing fault

8122 Synchronizing fault		
Severity:	Description:	
**	Location: Backplane	
Fault reason:	Instruction:	Alarm cancelling:
Synchronisation is stuck to a currently active source. Switching off this source did not succeed.	Reset all units by selecting Maintenance → Resets → HW reset . If the reset does not cancel the alarm, first replace the unit that provides the active synchronisation source. If this does not cancel the alarm, replace the unit in slot 1 (master unit).	If the alarm is caused by internal deadlock of the synchronisation system, the alarm is cancelled after reset. If the alarm is caused by a defect in HW, the alarm is cancelled after the replacement of the defect unit.

Table 26 8122 Synchronizing fault

5.1.3.5 8124 Synchronising fault in clock recovery

8124 Synchronising fault in clock recovery		
Severity:	Description:	
**	Location: Node synchronisation setup	
Fault reason:	Instruction:	Alarm cancelling:
A missing signal from an external synchronisation input clock signal. The signal has been configured as an available synchronisation source in the timing priority list.	Check the external synchronisation input clock signal is present at the synchronisation input interface. If the external synchronisation input clock signal is not needed, remove the related entry in the timing priority list.	Automatic.

Table 27 8124 Synchronising fault in clock recovery

5.1.3.6 8125 Loss of synchronisation signals

8125 Loss of synchronisation signals		
Severity:	Description:	
***	Location: Node synchronisation setup Backplane	
Fault reason:	Instruction:	Alarm cancelling:
All synchronisation sources from the priority list are unavailable. The active synchronisation source does not provide the clock signal on the backplane.	1. Check the incoming signals in the synchronisation priority list. 2. Ensure that location of the alarm is backplane. Reset all units by selecting Maintenance → Resets → HW reset . If the reset does not cancel the alarm, replace first the unit that provides the active synchronisation source. If this does not cancel the alarm, replace the unit in slot 1 (master unit).	Automatically cancelled when at least one synchronisation source in the priority list is available. If the alarm is caused by internal deadlock of the synchronisation system, the alarm is cancelled after reset. If the alarm is caused by a defect in HW, the alarm is cancelled after the replacement of the defect unit.

Table 28 8125 Loss of synchronisation signals

5.1.3.7 8139 Subrack is missing units

8139 Subrack is missing units		
Severity:	Description:	
***	Location: 1. Node HW setup 2. DIU (only MetroHub) 3. FAN (only MetroHub) 4. Power supply 1/2 (only MetroHub) 5. Battery (only MetroHub)	
Fault reason:	Instruction:	Alarm cancelling:
The unit is logically installed, but it has been physically removed, or it is broken.	Uninstall the removed unit logically, or replace the broken unit.	Automatically cancelled.

Table 29 8139 Subrack is missing units

5.1.3.8 8140 Subrack has excessive units

8140 Subrack has excessive units		
Severity:	Description:	
**	Location: 1. Node HW setup 2. FAN (only MetroHub) 3. Power supply 1/2 (only MetroHub) 4. Battery (only MetroHub) 5. DIU (only MetroHub) 6. DIPx (only MetroHub)	
Fault reason:	Instruction:	Alarm cancelling:
A unit which is physically present has not been logically installed with the manager.	Install the unit.	Automatically cancelled when the excessive unit has been installed logically with the manager.

Table 30 8140 Subrack has excessive units

5.1.3.9 8142 Fault in installation of equipment

8142 Fault in installation of equipment		
Severity:	Description:	
***	Location: Node HW setup	
Fault reason:	Instruction:	Alarm cancelling:
The installed FXC or outdoor unit has been changed to a unit of a different type than specified in the installation.	Uninstall the unit that is of the wrong type, or run the "Install all" command. You can also replace the unit with the same type of unit as used earlier.	Automatically cancelled.

Table 31 8142 Fault in installation of equipment

5.1.3.10 8162 Database full

8162 Database full		
Severity:	Description:	
Warning	Location: Node or FXC unit event history	
Fault reason:	Instruction:	Alarm cancelling:
Fault management event history database is full. New events are not recorded in the database. This happens when the poller (NMS/BSC) is unable to poll the unit and thus it clears the alarm history.	Check that the polling is working.	Warnings are not cancelled.

Table 32 8162 Database full

5.1.3.11 221 Version mismatch

221 Version mismatch

Severity

Critical

Fault reason

At least one slave unit is not compatible with the master unit.

Description

Location: Node HW setup

Instructions

Check the SW versions of the units and upgrade them to the wanted level, starting first with the PDH DNCU and the PDH DNAU units, and then continue with FXC STM-1 and the FXC Bridge SDH SW.

The 221 Version mismatch alarm must be cancelled in order to manage the node successfully.

Cancelling

Automatically cancelled when all units are compatible with the master unit.

5.1.3.12 8240 Active alarm point

8240 Active alarm point		
Severity:	Description:	
**	Location: DIUA EAC input 1...10 in MetroHub. VIFA unit in MetroSite EDGE and ConnectSite 10 BTSs. BOI unit in UltraSite EDGE and ConnectSite 100 BTSs.	
Fault reason:	Instruction:	Alarm cancelling:
External alarm is active, user-defined alarm is on, or EAC incorrectly defined.	Check that the definition is correct and that the external circuitry works correctly.	Automatically cancelled.

Table 33 8240 Active alarm point

5.1.4 Common alarms for FXC transmission units

5.1.4.1 8021 Loop to interface

8021 Loop to interface		
Severity:	Description:	
**	Location: 1. FXC RRI Flexbus. 2. FXC RRI Flexbus channel. 3. FXC RRI platform interface. 4. FXC E1/T1 interface. Consequence: 1. AIS is connected to all received Flexbus channels. 2. AIS is connected to the receiving direction of the looped channel. 3. AIS is connected to the receiving direction of the looped interface. 4. AIS to Rx direction (towards the cross-connection field).	
Fault reason:	Instruction:	Alarm cancelling:
1. The Flexbus interface loop is set to active. The whole received Flexbus signal is looped back to the OU (or another IU). The IU - OU communication is cut during the loop. 2. The Flexbus channel loop to interface is set to active. The whole received Flexbus channel signal is looped back to the OU (or another IU). 3. The platform interface loop to interface is set to active. The whole received platform signal is looped back to the OU (or another IU) without regenerating time slot 0. 4. The user has activated an interface loop.		Loopbacks are automatically removed, after the control timeout has expired. A loop can also be removed with the manager by setting the interface, channel or Flexbus back to the normal state.

Table 34 8021 Loop to interface

5.1.4.2 8022 Loop to equipment

8022 Loop to equipment		
Severity:	Description:	
**	Location: 1. FXC RRI Flexbus. 2. FXC RRI platform interface. 3. FXC E1/T1 interface. Consequence: 1. AIS is connected to all transmitted Flexbus channels in the receiving equipment. 2. AIS to Tx direction. 3. AIS to Tx direction.	
Fault reason:	Instruction:	Alarm cancelling:
The user has activated an equipment loop. Tx signal of the interface is looped back to the equipment.		Loopbacks are automatically removed, after the control timeout has expired. A loop can also be removed with the manager by setting the interface or Flexbus back to the normal state.

Table 35 8022 Loop to equipment

5.1.4.3 8025 Test generator on

8025 Test generator on		
Severity:	Description:	
**	Location: FXC unit	
Fault reason:	Instruction:	Alarm cancelling:
User-activated signal test generator of the unit is active.		The alarm is cancelled when the signal test has been completed.

Table 36 8025 Test generator on

5.1.4.4 8032 Loss of outgoing signal

8032 Loss of outgoing signal		
Severity:	Description:	
***	Location: FXC unit	
Fault reason:	Instruction:	Alarm cancelling:
During performing a signal test, the received signal was lost, indicating that some unit is not functioning properly.	Find the broken unit and replace it. The faulty unit can be different to the unit in which the alarm is active. The alarm is activated in the unit where pattern detection is done. After changing the unit, run the test again.	The alarm is cancelled when the signal test has been completed.

Table 37 8032 Loss of outgoing signal

5.1.4.5 8052 Loss of incoming 34M signal

8052 Loss of incoming 34M signal		
Severity:	Description:	
***	Location: 1. FXC RRI platform interface. 2. FXC E1 interface. Consequence: FEA alarm (TS0/B3) is generated to the far-end AIS to Rx direction.	
Fault reason:	Instruction:	Alarm cancelling:
Incoming 34M signal is not received.	1. Replace the unit. 2. Check the interface settings and cabling at both ends.	Automatically cancelled when the signal is received.

Table 38 8052 Loss of incoming 34M signal

5.1.4.6 8066 AIS 2M

8066 AIS 2M		
Severity:	Description:	
**	Location: 1. FXC RRI platform interface. 2. FXC E1 interface. Consequence: FEA alarm (TS0/B3) generated to the far-end.	
Fault reason:	Instruction:	Alarm cancelling:
Alarm signal is received, but the received signal has no framing and it is all ones.	The signal is cut somewhere in the network and AIS replacement has taken place. Follow the 2M signal in the network to find the place where AIS replacement has occurred. The link is usually faulty or it has configuration errors. Other alarms may also cause this alarm, because of AIS switching in the receiving direction, as shown in the consequence field of some alarms.	Automatically cancelled when AIS no longer received.

Table 39 8066 AIS 2M

5.1.4.7 8081 Loss of frame alignment

8081 Loss of frame alignment		
Severity:	Description:	
***	Location: 1. FXC RRI Flexbus. 2. FXC RRI platform interface. 3. FXC E1/T1 interface. Consequence: 1. AIS is connected to all received Flexbus channels. 2. AIS is connected to the receiving direction of the platform interface. FEA alarm (TS0/B3) is generated to the far-end. 3. FEA alarm is generated to the far-end AIS to Rx direction.	
Fault reason:	Instruction:	Alarm cancelling:
The interface does not detect framing from the received signal.	1. Check in the Configuration window that all installed units are present. A faulty outdoor unit may not be present in the view. Try disconnecting the power feed and then connect it back on. If the outdoor unit does not stay present, replace it. <ul style="list-style-type: none"> • Check that the radios are configured correctly (no configuration error or fault in unit alarms). If the receiving level is sufficient, check the following: <ol style="list-style-type: none"> a) Both ends of the hop are set to the same capacity. b) Flexbus interfaces are in use. c) The outdoor unit's interleaving settings are the same at both ends of the hop. • Check with Flexbus loop to equipment that the indoor unit locks to its own signal. If not, replace it. 2. Check in the Cross-connections window that the right signal is connected to this interface at both ends of the hop. <ul style="list-style-type: none"> • Use a platform interface loop to equipment to check that the platform interface locks to its own transmit signal. If not, replace the unit. • Use Flexbus loop to equipment and check that the platform interface locks to its own signal. If not, replace the unit. 3. Check the interface and synchronisation settings at both ends. If the settings are correct, replace the unit. Check the Flexbus cable.	Automatically cancelled, when the frame is received correctly.

Table 40 8081 Loss of frame alignment

5.1.4.8 86 Loss of CRC multiframe alignment

86 Loss of CRC multiframe alignment

Severity

Critical

Fault reason

Platform interface has lost CRC frame alignment.

Description

Location:

1. FXC RRI platform interface.
2. FXC E1 interface.

Consequence:

- AIS is connected to the receiving direction of the platform interface.
- FEA alarm (TS0/B3) generated to the far-end.

Instructions

Check that the other end of the link has CRC in use. Use the same instructions as in the [Loss of frame alignment](#) alarm to locate the fault.

Cancelling

Automatically cancelled.

5.1.4.9 8099 Error rate > 1 E-3

8099 Error rate > 1 E-3		
Severity:	Description:	
***	<p>The bit error ratio is determined by evaluating the CRC checksum and the frame alignment word. As a result, the exact bit error ratio cannot be measured, but rather an approximate value is obtained.</p> <p>Location:</p> <ol style="list-style-type: none"> 1. FXC RRI Flexbus 2. FXC RRI platform interface 3. FXC E1/T1 interface 4. FXC RRI protected hop <p>Consequence:</p> <ol style="list-style-type: none"> 1. AIS is connected to all received Flexbus channels. 2. FEA alarm (TS0/B3) generated to far-end AIS to Rx direction. 3. FEA alarm (TS0/B3) generated to far-end AIS to Rx direction. 4. AIS is connected to all received Flexbus channels. 	
Fault reason:	Instruction:	Alarm cancelling:
<p>Received signal bit error ratio is worse than $1.0 * 10^{-3}$.</p> <p>If the location is FXC RRI protected hop, both links in the HSB hop have a bit error ratio worse than $1.0 * 10^{-3}$.</p>	<ol style="list-style-type: none"> 1. 'Alarm signal received' also causes this alarm. The signal may be faded in the radio path or the antenna alignment has changed. 2. If the Flexbus, to which this interface has been connected, has the same alarm, see its instructions. If the Flexbus does not have this alarm, use loop to equipment for both the platform interface and the Flexbus. If either one of the loops gives this alarm, replace the unit. 3. Check the cabling between the units. 4. 'Alarm signal received' also causes this alarm. The signal may be faded in the radio path or the antenna alignment has changed. 	<p>1 - 4. Automatically cancelled when the received signal BER is better than $1.0 * 10^{-3}$. If the radio signal is faded, it is restored when the fading stops. If the antenna alignment has changed, align the antennas according to the instructions in the radio documentation.</p>

Table 41 8099 Error rate > 1 E-3

5.1.4.10 8102 Error rate > 1 E-6

8102 Error rate > 1 E-6		
Severity:	Description:	
**	The bit error ratio is determined by evaluating the CRC checksum and the frame alignment word. As a result, the exact bit error ratio cannot be measured, but rather an approximate value is obtained. Location: 1. FXC RRI platform interface. 2. FXC E1/T1 interface.	
Fault reason:	Instruction:	Alarm cancelling:
Received signal bit error ratio is worse than 1.0×10^{-6} .	Most commonly caused by radio path fading. If it persists for a long time, use loop to equipment for both the platform interface and Flexbus. If either of the loops gives this alarm, replace the unit.	Automatically cancelled, when the received signal is without errors.

Table 42 8102 Error rate > 1 E-6

5.1.4.11 8126 Unit function degraded

8126 Unit function degraded		
Severity:	Description:	
**	Location: FXC unit or synchronisation database of FXC STM transmission units	
Fault reason:	Instruction:	Alarm cancelling:
Operating voltage -5V has been detected to be out of range.	<p>From ITN C3 CD2 release onwards, this fault reason causes alarm 8126.</p> <p>ITN SW C3 CD1 and later releases can operate in a wider range of reference voltages. The alarm is active if the -5V reference voltage is outside the new supported range. In this case, measure the -5V voltage. This can be done through the Element Manager (FXC unit menu > Measurements). The supported range is: -4.25 V to -6.00 V.</p> <p>A -5V voltage which is out of range, does not affect the normal operation of the BTS. However this reference voltage is used for calibration of the internal oscillator of the FXC unit, which becomes the active synchronisation source during a transmission link break or degradation. Without an accurate reference voltage, the frequency accuracy of the oscillator cannot be guaranteed. Therefore during transmission link degradation or breaks, third party transmission equipment synchronised to the BTS may be affected (e.g. detects the synchronisation degradation and switches to internal until manual reset). The fault does not have any impact on the operation of the BTS or transmission if:</p> <ul style="list-style-type: none"> • there are no other transmission alarms active and • there is no service degradation at the BTS and • there is no third party transmission equipment synchronised to the FXC unit or if the equipment automatically recovers from synchronisation degradation <p>In this case the alarm can be inhibited in the unit alarm properties window of the Element Manager. If in contrast the troubleshooting shows that there is an impact for transmission or the BTS, the transmission backplane should be replaced.</p>	<p>This is a permanent alarm, thus the alarm is not cancelled when the voltage is again inside the limits due to fluctuations. Once the root cause of the alarm has been corrected, the alarm will be cancelled upon reset of the FXC unit. The alarm can be inhibited for the affected site, if the troubleshooting has shown that there is no impact for the BTS or transmission (see instructions).</p>
Defect in the synchronisation HW. Synchronisation of the node might be lost or degraded. Only for FXC Bridge or FXC STM-1.	If the -5V voltage is inside the limits (see above instructions) and the alarm remains active after resetting the unit, then the root cause is a defect in the synchronisation HW. If there are active synchronisation alarms, then the unit should be replaced.	The alarm is permanent. A reset of the FXC unit causes a temporary alarm cancellation. Once the root cause of the alarm has been corrected, the alarm will be cancelled.

Table 43 8126 Unit function degraded

5.1.4.12 137 Fault in oscillator

137 Fault in oscillator

Severity

Major

Fault reason

Unit oscillator is not working correctly.

Description

Location: FXC unit

Instructions

Replace the unit.

Note that the 16 MHz oscillator in the master unit is used as the internal clock of the node. If a slave unit raises the alarm, there is no immediate need to replace the unit.

Cancelling

Reset the unit to cancel the alarm.

5.1.4.13 8148 Equipment reset

8148 Equipment reset		
Severity:	Description:	
Warning	Location: FXC unit	
Fault reason:	Instruction:	Alarm cancelling:
The unit has started up after power-on or reset.		Warnings are not cancelled.

Table 44 8148 Equipment reset

5.1.4.14 8150 Fault in unit

8150 Fault in unit		
Severity:	Description:	
***	Location: FXC unit	
Fault reason:	Instruction:	Alarm cancelling:
Operating voltage +5V has been detected to be out of range. The transmission backplane voltage regulator may be defect.	<p>ITN SW C3 CD1 and later releases can operate in a wider range of reference voltages.</p> <p>Update the SW on the FXC unit to ITN C3 CD1 or newer. The latest ITN SW C3 CD1 can operate in a wider range of voltages.</p> <p>In some cases the alarm may still be active after the SW upgrade if the reference voltage is outside the new supported range. In this case, measure the +5V voltage. This can be done through the Element Manager (FXC unit menu > Measurements). The supported voltage range is: +4.25 V to + 5.58 V.</p> <p>If the deviation of the +5V voltage persists for a long time, the FXC unit can be damaged. For this reason, the transmission backplane should be replaced.</p>	This is a permanent alarm, thus the alarm is not cancelled when the voltage is again inside the limits due to fluctuations. A reset of the FXC unit causes a temporary alarm cancellation. The alarm is cancelled permanently upon reset of the FXC unit If the root cause of the alarm has been corrected.

Table 45 8150 Fault in unit

8150 Fault in unit		
<p>Operating voltage -5V has been detected to be out of range.</p>	<p>This fault reason causes alarm 8150 in ITN C3 CD1 and previous releases. In later releases alarm 8126 is reported, as it matches better the actual effect of the fault.</p> <p>ITN SW C3 CD1 and later releases can operate in a wider range of reference voltages than previous releases. Upgrade the SW on the FXC units accordingly.</p> <p>In some cases the alarm may still be active after the SW upgrade if the reference voltage is outside the new supported range. In this case, measure the -5V voltage. This can be done through the Element Manager (FXC unit menu > Measurements). The supported range is: -4.25 V to -6.00 V.</p> <p>A -5V voltage which is out of range, does not affect the normal operation of the BTS. However this reference voltage is used for calibration of the internal oscillator of the FXC unit, which becomes the active synchronisation source during a transmission link break or degradation. Without an accurate reference voltage, the frequency accuracy of the oscillator cannot be guaranteed. Therefore during transmission link degradation or breaks, third party transmission equipment synchronised to the BTS may be affected (e.g. detects the synchronisation degradation and switches to internal until manual reset). The fault does not have any impact on the operation of the BTS or transmission if:</p> <ul style="list-style-type: none"> • there are no other transmission alarms active and • there is no service degradation at the BTS and • there is no third party transmission equipment synchronised to the FXC unit or if the equipment automatically recovers from synchronisation degradation <p>In this case the alarm can be inhibited in the unit alarm properties window of the Element Manager. If in contrast the troubleshooting shows that there is an impact for transmission or the BTS, the transmission backplane should be replaced.</p>	<p>This is a permanent alarm, thus the alarm is not cancelled when the voltage is again inside the limits due to fluctuations. A reset of the FXC unit causes a temporary alarm cancellation. Once the root cause of the alarm has been corrected, the alarm will be cancelled permanently upon reset of the FXC unit. The alarm can be inhibited for the affected site, if the troubleshooting has shown that there is no impact for the BTS or transmission (see instructions).</p>

Table 45 8150 Fault in unit (Cont.)

5.1.4.15 8179 Far-end alarm

8179 Far-end alarm		
Severity:	Description:	
**	Location: 1. FXC RRI platform interface. 2. FXC E1 interface.	
Fault reason:	Instruction:	Alarm cancelling:
Sent by the equipment in the far-end (TS0/B3); indicates a serious fault in the received signal of the far-end equipment.	Check the signal flow from the transmit direction of the alarming interface to the far-end.	Automatically cancelled, when FEA not detected from the far-end any longer.

Table 46 8179 Far-end alarm

5.1.5 Specific alarms for FXC E1/T1 transmission units

5.1.5.1 56 Loss of incoming 1.5M signal

56 Loss of incoming 1.5M signal

Severity

Critical

Fault reason

Proper 1.5M signal is not received.

Description

Location: FXC T1 interface

Consequence: Yellow alarm generated to far-end and AIS to Rx direction

Instructions

Check the interface cabling.

Cancelling

Automatically cancelled, when the signal is received again.

5.1.5.2 8073 AIS 1.5M

8073 AIS 1.5M		
Severity:	Description:	
**	Location: FXC T1 interface Consequence: Yellow alarm (TS0/B3) generated to the far-end and AIS to Rx direction.	
Fault reason:	Instruction:	Alarm cancelling:
Alarm signal is received, but the received signal has no framing and it is all ones.	The signal is cut somewhere in the network and AIS replacement has taken place. Follow the 1.5M signal in the network to find out the place where AIS replacement has occurred. The link is usually faulty or it has configuration errors. Other alarms may cause this alarm because of AIS switching in the receiving direction as shown in the consequence field of some alarms.	Automatically cancelled, when the signal is acceptable.

Table 47 8073 AIS 1.5M

5.1.5.3 8172 Yellow alarm

8172 Yellow alarm		
Severity:	Description:	
**	Location: FXC T1 interface	
Fault reason:	Instruction:	Alarm cancelling:
The yellow alarm is sent by the equipment in the far-end, it indicates a serious fault in the received signal of the far-end equipment.	Check interface and synchronisation settings at both ends.	Automatically cancelled.

Table 48 8172 Yellow alarm

5.1.6 Specific alarms for FXC RRI transmission units

5.1.6.1 8064 Alarm signal received

8064 Alarm signal received		
Severity:	Description:	
**	Location: FXC RRI Flexbus Consequence: AIS is connected to all received Flexbus channels. This causes an AIS 2 Mbit/s alarm to all used platform interfaces that are connected to the Flexbus interface, which is causing the alarm.	
Fault reason:	Instruction:	Alarm cancelling:
An outdoor unit has lost frame lock and it has replaced the frame with a pseudo-frame to ensure communication between the indoor and outdoor units.		If the radio signal is faded, it recovers when the fading stops. If the outdoor unit is FlexiHopper (Plus), check the maximum Tx power setting. If a stronger Tx power is allowed, it withstands fading better.

Table 49 8064 Alarm signal received

5.1.6.2 8128 Fault in equipment

8128 Fault in equipment		
Severity:	Description:	
**	Location: FXC RRI protection lost.	
Fault reason:	Instruction:	Alarm cancelling:
Protection is lost and a redundant signal path is in use. Reasons: <ol style="list-style-type: none"> 1. OU1 transmitter error. Outdoor unit in Flexbus 1 is faulty or not present. 2. OU2 transmitter error. Outdoor unit in Flexbus 2 is faulty or not present. 3. OU1 receiver error. Outdoor unit in Flexbus 1 is not locked to the Rx signal, or it is faulty or not present. 4. OU2 receiver error. Outdoor unit in Flexbus 2 is not locked to the Rx signal, or it is faulty or not present. 	Check the outdoor unit installation. If the configuration is correct and the signal is valid, change the faulty outdoor unit.	Automatically cancelled, when the protection is in order.

Table 50 8128 Fault in equipment

5.1.6.3 8141 Forced control on

8141 Forced control on		
Severity:	Description:	
***	Location: FXC RRI operation mode	
Fault reason:	Instruction:	Alarm cancelling:
<ol style="list-style-type: none"> 1. The user has started Automatic Fading Margin Measurement (AFMM), and AFMM forced control is on. Protection is disabled until AFMM is completed. 2. Forced controls on OU Tx. The user has selected the active transmitter using forced control. 3. Forced controls on OU Rx. The user has selected the active receiver using forced control. 		Automatically cancelled, when the measurement has finished.

Table 51 8141 Forced control on

5.1.6.4 8143 Fault in changeover function

8143 Fault in changeover function		
Severity:	Description:	
***	Location: FXC RRI operation mode	
Fault reason:	Instruction:	Alarm cancelling:
<ol style="list-style-type: none"> 1. OU configuration is incompatible with the protection mode. 2. OU configuration checksum is missing, or incompatible with the OU software. The outdoor unit SW is incompatible with the protection mode or the outdoor unit is faulty. 	<ol style="list-style-type: none"> 1. Check Tx frequency and interleaving settings. 2. Update the outdoor unit software. 	Automatically cancelled, when the problem has been corrected.

Table 52 8143 Fault in changeover function

5.1.7 Specific alarms for FXC STM transmission units

5.1.7.1 8124 Synchronisation fault in clock recovery

8124 Synchronisation fault in clock recovery		
Severity:	Description:	
**	Location: Synchronisation database	
Fault reason:	Instruction:	Alarm cancelling:
<ol style="list-style-type: none"> 1. A missing synchronisation input clock signal with a priority is present on the synchronisation list. 2. Missing or degraded signals. 	<ol style="list-style-type: none"> 1. Check the settings of interface 1 and/or 2 under SDH priorities in the Synchronisation dialogue box. 2. Check the signal quality statistics. 	Not applicable.

Table 53 8124 Synchronisation fault in clock recovery

5.1.7.2 8125 Loss of synchronization signal(s)

8125 Loss of synchronization signal(s)		
Severity:	Description:	
***	Location: Synchronisation database Consequence: 2M-AIS upstream	
Fault reason:	Instruction:	Alarm cancelling:
<ol style="list-style-type: none"> 1. The transmission node is not receiving synchronisation from the interfaces (SNC protection). 2. Missing or degraded signals. 	<ol style="list-style-type: none"> 1. Check the settings in the synchronisation dialogue box, or the settings at the other side of the link. 2. Check the signal quality statistics. 	Not applicable.

Table 54 8125 Loss of synchronization signal(s)

5.1.7.3 8130 Fault in memory

8130 Fault in Memory		
Severity:	Description:	
Major	Location: Node	
Fault reason:	Instruction:	Alarm cancelling:
The FC Bridge or FC STM-1 unit have a faulty backup.	Reset the node and check if the fault is still displayed. Set FC STM back to factory default settings and reconfigure the settings.	Not applicable.

Table 55 8130 Fault in Memory

5.1.7.4 8139 Subrack is missing units

8139 Subrack is missing units		
Severity:	Description:	
***	Location: Node	
Fault reason:	Instruction:	Alarm cancelling:
The FXC Bridge is logically installed, but it has been either removed physically or it is broken.	Uninstall the removed unit, plug the removed unit back or replace the broken unit.	Not applicable.

Table 56 8139 Subrack is missing units

5.1.7.5 8140 Subrack has excessive units

8140 Subrack has excessive units		
Severity:	Description:	
**	Location: Node	
Fault reason:	Instruction:	Alarm cancelling:
There are two FXC Bridge or FXC STM-1 units installed.	Remove the extra unit. (Only one FXC Bridge or STM-1 unit can be installed in the same cabinet).	Not applicable.

Table 57 8140 Subrack has excessive units

5.1.7.6 8141 Forced control on

8141 Forced control on		
Severity:	Description:	
***	Location: Synchronisation database CC database	
Fault reason:	Instruction:	Alarm cancelling:
STM interface 1 or 2 was forced to be used as the synchronisation source. An SNC protection group status is forced to either the protecting or protected path.	Configure synchronisation to the use priorities mode. Configure the SNC protection group to the automatic protection switch mode.	Not applicable.

Table 58 8141 Forced control on

5.1.7.7 8152 Fault in block

8152 Fault in block		
Severity:	Description:	
***	Location: Synchronisation database	
Fault reason:	Instruction:	Alarm cancelling:
Fault in the FXC STM-1 unit oscillator, which causes also the Fault in unit alarm.	Replace the FXC STM-1 unit.	Not applicable.

Table 59 8152 Fault in block

5.1.7.8 8162 Database full

8162 Database full		
Severity:	Description:	
Warning	Location: Event history	
Fault reason:	Instruction:	Alarm cancelling:
Fault management event history database is full. New events are not recorded in the database. This happens when the poller (NMS/BSC) is unable to poll the unit and thus clears the alarm history.	Make sure that polling is working.	Warnings are not cancelled.

Table 60 8162 Database full

5.1.7.9 165 Real time lost fault

165 Real time lost fault

Severity

Major

Fault reason

Real time clock is not set.

Description

Location: Node

Instructions

Not applicable, see Cancelling.

Cancelling

This alarm is cancelled automatically within 24 hours because the FXC STM node gets an RTC update periodically.

 Automatic cancelling only occurs if FXC STM is connected to the NMS.

5.1.7.10 184 Real time updated

184 Real time updated

Severity

Warning

Fault reason

Real time clock (RTC) time difference between the node (internal) and poller (network). The difference was over 1s and the RTC has been automatically updated.

Description

Location: Node

Instructions

Not applicable.

Cancelling

Warnings are not cancelled.

5.1.7.11 8207 Calibration expired

8207 Calibration expired		
Severity:	Description:	
Warning		
Fault reason:	Instruction:	Alarm cancelling:
The SDH node clock was last calibrated one year ago.	Recalibrate the SDH node clock in the synchronisation window. Check the current synchronisation status before calibration to avoid calibration to a low quality synchronisation source.	Warnings are not cancelled.

Table 61 8207 Calibration expired

5.1.7.12 8221 Version mismatch

8221 Version mismatch		
Severity:	Description:	
***	Location: Node	
Fault reason:	Instruction:	Alarm cancelling:
At least one unit in the subrack is not compatible with the FXC STM-1 unit.	Check the SW versions of the units and upgrade them to the wanted level, starting first with the PDH DNCU and the PDH DNAU units and then continue with FXC STM-1 and the FXC Bridge SDH SW.	Automatically cancelled when all units are compatible with the master unit.

Table 62 8221 Version mismatch

5.1.7.13 8223 Protection switch

8223 Protection switch		
Severity:	Description:	
Warning	Location: CC database	
Fault reason:	Instruction:	Alarm cancelling:
Protection switch of the STM interfaces (SNC-protection) caused by: 1. the connector, the cable, or the link. 2. a fault somewhere in the network (only some of the VC-12s are cut).	1. Check the connector, the fibre, and the link. 2. Check the signal quality statistics.	Warnings are not cancelled.

Table 63 8223 Protection switch

5.1.8 Specific alarms for FXC STM-1

5.1.8.1 8148 Equipment reset

8148 Equipment reset		
Severity:	Description:	
Warning	Location: unit	
Fault reason:	Instruction:	Alarm cancelling:
The unit is starting up again after a power-on or reset.	The unit restarts automatically after power-on or reset.	Not applicable.

Table 64 8148 Equipment reset

5.1.8.2 8149 Forced indication

8149 Forced indication		
Severity:	Description:	
Warning	Location: LED	
Fault reason:	Instruction:	Alarm cancelling:
LED is forced on or off.	Set the LED to normal state in the FXC STM-1 Manager's Forced indications dialogue box.	The forced state is automatically cancelled, after control timeout.

Table 65 8149 Forced indication

5.1.8.3 8150 Fault in unit

8150 Fault in unit		
Severity:	Description:	
***	Location: Unit	
Fault reason:	Instruction:	Alarm cancelling:
Frame alignment hardware fault detected in the unit.	Remove the unit and replace it with new one.	Not applicable.

Table 66 8150 Fault in unit

5.1.8.4 8162 Database full

8162 Database full		
Severity:	Description:	
Warning	Location: Event history	
Fault reason:	Instruction:	Alarm cancelling:
Fault management event history database is full. New events are not recorded in the database. This happens when the poller (NMS/BSC) is unable to poll the unit and clears the alarm history.	Check that polling is working.	Not applicable.

Table 67 8162 Database full

5.1.9 Specific alarms for FXC STM-1 Interface x

5.1.9.1 23 Test mode active

23 Test mode active

Severity

Major

Fault reason

Laser control state is changed to test shutdown for the period of the control timeout.

Description

☞ This alarm is masked if alarm monitoring for the STM-1 interface x is off.

Location: OS

Consequence: Transmit laser is off.

Instructions

The laser switches back on automatically after a control timeout.

Cancelling

Not applicable.

5.1.9.2 48 Loss of incoming signal

48 Loss of incoming signal

Severity

Critical

Fault reason

Optical input power level is too low.

Description

Location: OS

Consequence: MS-RDI upstream

TU AIS for pass through TU12s and 2M AIS for dropped TU12s downstream.

Instructions

- Check if the fibre is connected to the optical connector of the FXC STM unit.
- Check if there is a cut or physical damage on the fibre at some point of the fibre link.
- Check that the far-end of the fibre is connected and the far-end device is operational and sending a signal.
- Check if the attenuation of the fibre is too high. High attenuation is caused by long distances (> 40 km), splices, or fibre adapters.

Cancelling

This alarm is cancelled when a signal is received again (input power level above minimum receive sensitivity of -34 dBm).

5.1.9.3 8057 Loss of pointer

8057 Loss of pointer		
Severity:	Description:	
***	Location: MS/S4 Consequence: S4-RDI upstream TU AIS for pass through TU12s and 2M AIS for dropped TU12s downstream.	
Fault reason:	Instruction:	Alarm cancelling:
The AU-4 pointer was not found.	Check for the correct synchronisation of the signal.	This alarm is cancelled as soon as a valid pointer is detected.

Table 68 8057 Loss of pointer

5.1.9.4 59 Incoming signal level incorrect

59 Incoming signal level incorrect

Severity

Critical

Fault reason

The received power level has dropped to -40dBm or below.

Description

Location: OS

Instructions

Check if it is expected that the receive level is -40dBm or lower. Loss of signal occurs at about -35dBm. If the low signal level is as planned and expected, this alarm should be inhibited. If the low receive level is unexpected, check whether the attenuation of the fibre is too high. High attenuation is caused by long distances (> 40 km), splices, or fibre adapters.

Check whether there is dirt or damage on one of the fibre connector tips. Check the correct fit of the fibre connectors.

Cancelling

The alarm is cancelled if the receive level is -39dB or higher.

5.1.9.5 64 Alarm signal is received

64 Alarm signal is received

Severity

Major

Fault reason

1. MS-AIS inserted.
2. AU-AIS inserted.

Description

 This alarm is masked if alarm monitoring for the STM-1 interface x is off.

Location:

1. MS
2. MS/S4

Consequence:

1. MS-RDI upstream
2. S4-RDI upstream

TU AIS for pass through TU12s and 2M AIS for dropped TU12s downstream.

Instructions

Check the whole MS signal path to find the reason behind the alarm.

Cancelling

Not applicable.

5.1.9.6 81 Loss of frame alignment

81 Loss of frame alignment

Severity

Critical

Fault reason

Frame alignment word of STM signal not found.

Description

☞ This alarm is masked if alarm monitoring for the STM-1 interface x is off.

Location: OS/RS

Consequence: MS-RDI upstream

TU AIS for pass through TU12s and 2M AIS for dropped TU12s downstream.

Instructions

This alarm is either caused by bad quality of the STM signal, or due to the fact that the device at the far-end is not sending an STM-1 signal at all.

- Check for correct synchronisation of the signal.
- Check if the wrong type of fibre is in use (FXC STM L.1.1 laser is defined for type G.652 fibre).
- Check if the far-end device is not sending an STM-1 frame at all.
- Check if there is dirt or damage on one of the fibre connector tips.
- Check if the attenuation of the fibre is too high. High attenuation is caused by long distances (>40 km), splices, or fibre adapters.

Cancelling

The alarm is cancelled when the frame alignment of the STM signal is detected again.

5.1.9.7 141 Forced control on

141 Forced control on

Severity

Critical

Fault reason

1. The laser is forced on.

Description

☞ This alarm is masked if alarm monitoring for the STM-1 interface x is off.

Location: OS

Consequence: Transmit laser is on, even under ALS or Transmitter Fail (TF) conditions.

Instructions

Set the laser control state back to on.

Cancelling

Not applicable.

5.1.9.8 153 Fault in transmitter

153 Fault in transmitter

Severity

Critical

Fault reason

Monitored transmit power is lower than -7dBm or higher than +3dBm from the Begin of Life value.

Description

 This alarm is masked if alarm monitoring for the STM-1 interface x is off.

Location: OS

Consequence: Corresponding optical transmitter is switched off.

Instructions

Replace the unit.

Cancelling

Not applicable.

5.1.9.9 156 Laser power out of range

156 Laser power out of range

Severity

Critical

Fault reason

Monitored transmit power is lower than -3dBm or higher than +3dBm from Begin of Life value.

Description

 This alarm is masked if alarm monitoring for the STM-1 interface x is off.

Location: OS

Instructions

The lifetime of the laser is nearing its end or the power has dropped due to a laser failure. Replace the unit when performing the next maintenance activities. The laser will not be shut down.

Note that the current estimated lifetime of the laser transceiver is about 300 years. In normal operation, this alarm only occurs due to a faulty laser.

Cancelling

Not applicable.

5.1.9.10 158 Forced laser cut off

158 Forced laser cut off

Severity

Critical

Fault reason

The user has changed the laser control state to Forced off.

Description

☞ This alarm is masked if alarm monitoring for the STM-1 interface x is off.

Location: OS

Consequence: Transmit laser is off.

Instructions

Set the laser control state back to on.

Cancelling

Not applicable.

5.1.9.11 8162 Database full

8162 Database full		
Severity:	Description:	
Warning	Location: Event history	
Fault reason:	Instruction:	Alarm cancelling:
Fault management event history database is full. New events are not recorded in the database. This happens when the poller (NMS/BSC) is unable to poll the unit and clears the alarm history.	Make sure that polling is working.	Not applicable.

Table 69 8162 Database full

5.1.9.12 8213 Remote Defect Indication (RDI)

8213 Remote Defect Indication (RDI)		
Severity:	Description:	
**	Location: MS	
Fault reason:	Instruction:	Alarm cancelling:
The far-end device generating the MS overhead has detected a defect on the received signal from FXC STM direction (such as loss of signal or loss of frame alignment) and it has inserted MS-RDI bit in direction to FXC STM.	Check for open alarms at the far-end device and remove the cause of the alarms.	MS-RDI is cancelled at the far-end device, which is generating the MS overhead.

Table 70 8213 Remote Defect Indication (RDI)

5.1.9.13 214 Signal degraded

214 Signal degraded

Severity

Major

Fault reason

The threshold for signal degraded was crossed based on BIP-24 in MSOH B2 bytes.

Description

Location: MS

Instructions

This alarm is caused by bad quality of the STM signal.

- Check if a wrong type of fibre is in use (FXC STM L.1.1 laser is defined for type G.652 fibre).
- Check if there is dirt or damage on one of the fibre connector tips.
- Check if the attenuation of the fibre is too high. High attenuation is caused by long distances (> 40 km), splices, or fibre adapters.

Cancelling

The alarm is cancelled when the number of bit errors falls below the threshold specified in ETSI/ITU standard for the signal degraded alarm.

5.1.9.14 215 Trace identifier mismatch

215 Trace identifier mismatch

Severity

Critical

Fault reason

Received RS-TTI and Expected RS-TTI do not match. (Mismatch monitoring for RS needs to be activated to receive this alarm.)

Description

 This alarm is masked if alarm monitoring for the STM-1 interface x is off.

Location: RS

Consequence: MS-RDI upstream

TU AIS for pass through TU12s and 2M AIS for dropped TU12s downstream.

Instructions

- Check if the correct device is connected at the far-end of the fibre.
- Check if the device at the far-end of the fibre link inserts the transmitted TTI as expected by FXC STM.
- Check if the expected TTI string is configured correctly to the FXC STM device.

Cancelling

The alarm is cancelled when the expected TTI matches the received TTI, or when mismatch monitoring is disabled.

5.1.10 Specific alarms for FXC STM-1 Interface S4 x

5.1.10.1 47 Payload mismatch

47 Payload mismatch

Severity

Critical

Fault reason

Received and expected VC-4 path labels do not match (0x02 TUG structure).

Description

☞ This alarm is masked if alarm monitoring for the STM-1 interface x is off.

Location: S4/TUG

Consequence: TUG-AIS downstream.

Instructions

Check if the correct signal structure is inserted at the far-end of the VC-4 path. FXC STM supports only TUG structure.

Cancelling

The alarm is cancelled when TUG structure is received as the path label.

5.1.10.2 57 Loss of pointer

57 Loss of pointer

Severity

Critical

Fault reason

TU-Pointer is not found.

Description

☞ This alarm is masked if alarm monitoring for the STM-1 interface x is off.

Location: TU12_K.L.M

K.L.M specifies one of the 63 TU-12s within the STM-1 signal according to EN 300 417-1-1 (for example, TU12_3.7.3).

Consequence: TU12-AIS downstream.

Instructions

Check the synchronisation of FXC STM and the SDH network. Check if VC-4 contains TUG structure.

Cancelling

The alarm is cancelled when the pointer is detected again.

5.1.10.3 64 Alarm signal is received

64 Alarm signal is received

Severity

Major

Fault reason

TU-AIS is inserted.

Description

☞ This alarm is masked if alarm monitoring for the STM-1 interface x is off.

Location: TU12_K.L.M

K.L.M specifies one of the 63 TU-12s within the STM-1 signal according to EN 300 417-1-1 (for example, TU12_3.7.3).

Instructions

TU-AIS was received as a consequent action of a defect in the TU-12 path. Check TU-12 path for defects.

Cancelling

The alarm is cancelled when the reason behind TU-AIS insertion at the far-end is removed.

5.1.10.4 82 Loss of multiframe alignment

82 Loss of multiframe alignment

Severity

Critical

Fault reason

TU-Multiframe in H4 byte is not found.

Description

☞ This alarm is masked if alarm monitoring for the STM-1 interface x is off.

Location: S4/TUG

Consequence: TU AIS for pass through TU12s and 2M AIS for dropped TU12s downstream.

Instructions

Check if the VC-4 contains TUG structure.

Cancelling

Not applicable.

5.1.10.5 8162 Database full

8162 Database full		
Severity:	Description:	
Warning	Location: Event history	
Fault reason:	Instruction:	Alarm cancelling:
Fault management event history database is full. New events are not recorded in the database. This happens when the poller (NMS/BSC) is unable to poll the unit and clears the alarm history.	Make sure that polling is working.	Not applicable.

Table 71 8162 Database full

5.1.10.6 213 Remote Defect Indication (RDI)

213 Remote Defect Indication (RDI)

Severity

Major

Fault reason

S4-RDI bit is set.

Description

 This alarm is masked if alarm monitoring for the STM-1 interface x is off.

Location: S4

Instructions

The far-end device generating the VC-4 has detected a defect on the received signal from FXC STM direction and it has inserted S4-RDI in direction to FXC STM. Check for open alarms at the far-end device and remove the reason behind the alarms.

Cancelling

The alarm is cancelled when the RDI bit is no longer received from the far-end.

5.1.10.7 214 Signal degraded

214 Signal degraded

Severity

Major

Fault reason

The number of block errors indicated by the B3 byte has crossed the threshold for the signal degraded alarm.

Description

 This alarm is masked if alarm monitoring for the STM-1 interface x is off.

Location: S4

Instructions

Check the quality of the whole VC-4 path to determine the source of the bit errors and remove the source of the errors.

Cancelling

The alarm is cancelled when the number of block errors falls below the threshold specified in ETSI/ITU standard for the signal degraded alarm.

5.1.10.8 215 Trace identifier mismatch

215 Trace identifier mismatch

Severity

Critical

Fault reason

Received VC-4 path label is 0x00 (C2 byte).

Description

☞ This alarm is masked if alarm monitoring for the STM-1 interface x is off.

Location: S4

Consequence: S4-RDI upstream.

TU AIS for pass through TU12s and 2M AIS for dropped TU12s downstream.

Instructions

The source of the VC-4 path signal is out of service, or the VC-4 was not cross-connected correctly in an intermediate node along the VC-4 path. Check the far-end device, which should generate the VC-4 and intermediate nodes for correct cross-connection settings.

Cancelling

The alarm is cancelled when the expected TTI matches the received TTI or when mismatch monitoring is disabled.

5.1.10.9 216 Unequipped signal

216 Unequipped signal

Severity

Critical

Fault reason

Received VC-4 path label is 0x00.

Description

☞ This alarm is masked if alarm monitoring for the STM-1 interface x is off.

Location: S4

Instructions

The source of the VC-4 path signals is out of service. There is no content inserted to the VC-4 at the far-end VC-4 path.

Cancelling

The alarm is cancelled when the content is inserted into the VC-4 path at the far-end.

5.1.11 Specific alarms for FXC Bridge PDH

5.1.11.1 8022 Loop to equipment

8022 Loop to equipment		
Severity:	Description:	
**	Location: FXC Bridge; C12/D-bus.	
Fault reason:	Instruction:	Alarm cancelling:
2M signal coming back from the backplane bus (D-bus or cross-connection bus), it is looped back to the backplane.	The loop is disabled after the control timeout period expires.	Not applicable.

Table 72 8022 Loop to equipment

5.1.11.2 8032 Loss of outgoing signal

8032 Loss of outgoing signal		
Severity:	Description:	
***	Location: FXC Bridge Unit	
Fault reason:	Instruction:	Alarm cancelling:
The test signal used during a cross-connection test has been lost.	Alarm is active as long as the test is ongoing.	The alarm is automatically cancelled after the test has been completed.

Table 73 8032 Loss of outgoing signal

5.1.11.3 8126 Unit function degraded

8126 Unit function degraded		
Severity:	Description:	
**	Location: FXC Bridge Unit	
Fault reason:	Instruction:	Alarm cancelling:
The heating test of the unit failed.	See Alarm cancelling.	The alarm is automatically cancelled, after the test has been completed.

Table 74 8126 Unit function degraded

5.1.11.4 139 Subrack is missing units

139 Subrack is missing units

Severity

Critical

Fault reason

The FXC STM-1 unit is not present, it might be broken or not logically installed.

Description

Location: FXC Bridge; SPI link

Instructions

Check if an FXC STM-1 unit is present in one of the transmission slots of the subrack.
Check that the unit is logically installed. Replace the unit if it is broken.

Cancelling

Not applicable.

5.1.11.5 145 Temperature alarm

145 Temperature alarm

Severity

Major

Fault reason

The temperature measured directly at the unit (within the mechanical housing) is below -12°C (10°F).

Description

Location: FXC Bridge unit.

Instructions

Check if the temperature outdoors is below -40°C (-40°F). Performing a heating test to check if the heating layer on the FXC Bridge unit is working correctly.

Cancelling

The alarm is cancelled when the temperature measured at the FXC Bridge unit is above -12°C (10°F).

5.1.11.6 8221 Version mismatch

8221 Version mismatch		
Severity:	Description:	
***	Location: Unit	
Fault reason:	Instruction:	Alarm cancelling:
The node contains units that are not compatible. This is generated when there are FXC E1 T1 or RRI units in the node that are not compatible with STM units.	Check the SW versions of the units and upgrade them to the wanted level, starting first with the PDH DNCU and the PDH DNAU units and then continue with FXC STM-1 and the FXC Bridge SDH SW.	Automatically cancelled when all units are compatible with the master unit.

Table 75 8221 Version mismatch

5.1.12 Specific alarms for FXC Bridge SDH

5.1.12.1 8022 Loop to equipment

8022 Loop to equipment		
Severity:	Description:	
**	Location: PDH channel y Consequence: 2M-AIS downstream	
Fault reason:	Instruction:	Alarm cancelling:
2M signal coming from SDH is looped back to SDH.	The loop is disabled after the control timeout period expires.	Not applicable.

Table 76 8022 Loop to equipment

5.1.12.2 8047 Payload mismatch

8047 Payload mismatch		
Severity:	Description:	
***	Location: SDH channel y Consequence: S12-RDI upstream and 2M-AIS downstream.	
Fault reason:	Instruction:	Alarm cancelling:
Received VC-12 path label and expected VC-12 path label do not match.	Check if the correct signal structure is mapped at the far-end of the VC-12 path. FXC STM supports both byte synchronous (2048 kbit/s) and asynchronous mapping.	The alarm is cancelled when a supported signal structure is mapped at the far-end of the VC-12 path.

Table 77 8047 Payload mismatch

5.1.12.3 64 Alarm signal is received

64 Alarm signal is received

Severity

Major

Fault reason

2M AIS is received.

Description

☞ This alarm is masked if alarm monitoring for the STM-1 interface x is off.

Location: PDH channel y

Consequence: A bit stream upstream and 2M-AIS downstream.

Instructions

2M AIS was received as a consequent action of a defect at the far-end of the 2M signal.
Check the source of the 2M signal for defects.

Cancelling

The alarm is cancelled when the reason behind 2M AIS insertion at the far-end is removed.

5.1.12.4 81 Loss of frame alignment

81 Loss of frame alignment

Severity

Critical

Fault reason

Frame alignment is missing.

Description

☞ This alarm is masked if alarm monitoring for the STM-1 interface x is off.

Location: PDH channel y

Consequence: A-Bit set upstream and 2M-AIS downstream.

Instructions

FXC STM could not detect the frame alignment of the 2M signal. Check if the device generating the 2M signal generates the same frame format as FXC STM. This can be either double frame without CRC-4 or multiframe with CRC-4.

Cancelling

The alarm is cancelled when the frame alignment is detected again.

5.1.12.5 96 Excessive error rate

96 Excessive error rate

Severity

Critical

Fault reason

Frame alignment word error rate is high.

Description

☞ This alarm is masked if alarm monitoring for the STM-1 interface x is off.

Location: PDH channel y

Consequence: A-Bit set upstream and 2M-AIS downstream.

Instructions

The number of errored basic frame alignment words has crossed the threshold for this alarm. Check the quality of the whole path of the 2M signal to find the source of the bit errors and remove it.

Cancelling

The alarm is cancelled when the number of errored frame alignment words falls below the threshold of this alarm.

5.1.12.6 8148 Equipment reset

8148 Equipment reset		
Severity:	Description:	
Warning	Location: Unit	
Fault reason:	Instruction:	Alarm cancelling:
The unit is starting up again after a power-on or reset.	The unit restarts automatically after power-on or reset.	Warnings are not cancelled.

Table 78 8148 Equipment reset

5.1.12.7 8162 Database full

8162 Database full		
Severity:	Description:	
Warning	Location: Event history	
Fault reason:	Instruction:	Alarm cancelling:
Fault management event history database is full. New events are not recorded into the database. This happens when the poller (NMS/BSC) is unable to poll the unit and clears the alarm history.	Make sure that polling is working.	Not applicable.

Table 79 8162 Database full

5.1.12.8 213 Remote defect indication (RDI)

213 Remote defect indication (RDI)

Severity

Major

Fault reason

1. S12 RDI bit is set.
2. A-Bit is set.

Description

☞ This alarm is masked if alarm monitoring for the STM-1 interface x is off.

Location:

1. SDH channel y.
2. PDH channel y.

Instructions

The far-end device generating the VC-12 has detected a defect on the receive signal from FXC STM direction and it has inserted S12-RDI in direction to FXC STM. Check for open alarms at the far-end device and remove the cause of the alarms.

Cancelling

The alarm is cancelled when the RDI bit is no longer received from the far-end.

5.1.12.9 214 Signal degraded

214 Signal degraded

Severity

Major

Fault reason

The number of block errors indicated by the V5 byte has crossed the threshold for the signal degraded alarm.

Description

 This alarm is masked if alarm monitoring for the STM-1 interface x is off.

Location:

1. SDH channel y.
2. PDH channel y.

Instructions

Check the quality of the whole VC-12 path to find the source of the bit errors and remove the source of the errors.

Cancelling

The alarm is cancelled when the number of bit errors falls below the alarm threshold.

5.1.12.10 215 Trace identifier mismatch

215 Trace identifier mismatch

Severity

Critical

Fault reason

The expected SDH-PDH channel TTI and the received TTI do not match. Mismatch monitoring for the channel needs to be activated to receive this alarm.

Description

 This alarm is masked if alarm monitoring for the STM-1 interface x is off.

Location: SDH channel y

Consequence: S12-RDI upstream and TU12-AIS downstream.

Instructions

Not applicable.

Cancelling

Not applicable.

5.1.12.11 216 Unequipped signal**216 Unequipped signal****Severity**

Critical

Fault reason

Received VC-12 path label is 0x00.

Description

☞ This alarm is masked if alarm monitoring for the STM-1 interface x is off.

Location: SDH channel y.

Consequence: S12-RDI upstream and TU12-AIS downstream.

Instructions

The source of the VC-12 path signals is out of service, or the VC-12 was not cross-connected correctly in an intermediate node along the VC-12 path. Check if the VC-12 at the far-end is cross-connected to the correct VC-4 and check the location at the far-end.

Cancelling

The alarm is cancelled when the VC-12 path is taken into service at the far-end again.

5.2 Trouble management of LMU alarms

5.2.1 8003 Loss of remote power supply

8003 Loss of remote power supply		
Severity:	Description:	

Fault reason:	Instruction:	Alarm cancelling:
<ol style="list-style-type: none"> 1. Power has either exceeded normal limit or is below normal limit. LMUB will be reset. 2. The fuse-link has blown due to excessive current. 	<ol style="list-style-type: none"> 1. If power has either exceeded normal limit or is below normal limit: <ul style="list-style-type: none"> • Check the mains supply. • Check the external AC/DC power supply (if used). 2. If the fuse-link has blown due to excessive current: <ul style="list-style-type: none"> • Replace the blown fuse-link extension. 	<p>Do not cancel the alarm. The system cancels the alarm automatically.</p> <p>i If the voltage drop is very fast or the fuse-link blows, LMUB does not have enough time to send the 8003 alarm. In that case, alarms 7210/7860 NO CONNECTION TO TRANSMISSION UNIT and 8202 LOSS OF SUPERVISION CONNECTION are raised at the BTS, BSC, or NetAct.</p>

Table 80 8003 Loss of remote power supply

5.2.2 8048 Loss of incoming signal (GPS fix lost)

8048 Loss of incoming signal (GPS fix lost)		
Severity:	Description:	

Fault reason:	Instruction:	Alarm cancelling:
LMUB GPS signal/fix is lost. The clock outputs will stop after a timeout. The default timeout is 1 hour.	<p>See <i>GPS fix is lost occasionally</i>, <i>GPS fix is lost permanently</i>, and <i>Displaying Constellation Log</i> in documents <i>Maintaining and Troubleshooting Location Measurement Unit (LMUB)</i> and <i>Using Location Measurement Unit (LMUB) Manager</i> in Nokia Siemens Networks Location Measurement Unit (LMUB) documentation.</p> <p>i If the GPS fix is recovered and the alarm is cancelled, it may take up to 15 minutes for LMUB to reactivate the clock outputs.</p>	<p>Do not cancel the alarm. The system cancels the alarm automatically.</p>

Table 81 8048 Loss of incoming signal (GPS fix lost)

5.2.3 8145 Temperature alarm

8145 Temperature alarm		
Severity:	Description:	
**		
Fault reason:	Instruction:	Alarm cancelling:
Temperature is outside of normal range.	See <i>Operating temperature in LMUB is too low</i> and <i>Operating temperature in LMUB is too high</i> in document <i>Maintaining and Troubleshooting Location Measurement Unit (LMUB)</i> in Nokia Siemens Networks Location Measurement Unit (LMUB) documentation.	Do not cancel the alarm. The system cancels the alarm automatically.

Table 82 8145 Temperature alarm

5.2.4 8148 Equipment reset

8148 Equipment reset		
Severity:	Description:	
*		
Fault reason:	Instruction:	Alarm cancelling:
Reset occurred. LMUB has just started up after reset.	No actions required.	Not applicable.

Table 83 8148 Equipment reset

5.2.5 8165 Q1 real time lost

8165 Q1 real time lost		
Severity:	Description:	
**		
Fault reason:	Instruction:	Alarm cancelling:
Q1 real time has been lost.	No actions required.	Do not cancel the alarm. The system cancels the alarm automatically after Q1 real time has been updated.

Table 84 8165 Q1 real time lost

5.2.6 8184 Q1 real time update

8184 Q1 real time update		
Severity:	Description:	
*		
Fault reason:	Instruction:	Alarm cancelling:
Q1 real time has been updated to LMUB.	No actions required.	Not applicable.

Table 85 8184 Q1 real time update

5.2.7 8240 Active alarm point (self test failure)

8240 Active alarm point (self test failure)		
Severity:	Description:	
**		
Fault reason:	Instruction:	Alarm cancelling:
When the alarm is raised, LMUB internal self-tests status in LMUB Manager is shown as Not OK. The alarm is raised if: <ul style="list-style-type: none"> • LMUB software is faulty • LMUB is faulty 	<ol style="list-style-type: none"> 1. Reset LMUB. Update the latest software from NOLS. 2. If the LMUB internal self-tests status is still Not OK, replace the unit. See <i>LMUB internal self-tests status is Not OK</i> in document <i>Maintaining and Troubleshooting Location Measurement Unit (LMUB)</i> in Nokia Siemens Networks Location Measurement Unit (LMUB) documentation.	Alarm needs to be cancelled from the BSC.

Table 86 8240 Active alarm point (self test failure)

5.2.8 8272 Position not locked

8272 Position not locked		
Severity:	Description:	
*	The alarm is raised if GPS position is not locked because GPS self survey is ongoing.	
Fault reason:	Instruction:	Alarm cancelling:
LMU GPS position is not locked. Minimum of 4 satellites signals are needed to achieve GPS FIX. GPS position survey takes about 24 hours with good satellite view.	1. If self survey is not completed in reasonable time (may take 1 to 5 days), first check the GPS antenna installation.	Do not cancel the alarm. The system cancels the alarm automatically.

Table 87 8272 Position not locked

5.3 Trouble management of other transmission alarms

5.3.1 8202 Loss of supervision connection

8202 Loss of supervision connection			
Severity:	Object affected:	Object state:	Module/Unit:
***	TRE	Enabled	ESMA
Fault reason:	Instruction:		Alarm cancelling:
Field not used.	<p>Q1 device does not respond to poll command sent by the polling master (BTS/BSC).</p> <ol style="list-style-type: none"> 1. Check that Q1 baud rate and Q1 address of the Q1 device matches with what is configured at the BSC. 2. Check if alarm 7601 "Q1 bus faulty" is active. Check that the cable is correctly mated with the ESMA and Q1 device. Check also condition of the Q1 cable connectors. 3. Check that Q1 switches are set to enable polling master (BTS/BSC) to access the micro-processor (up) of the Q1 device. 4. Replace ESMA. 		Automatic.

Table 88 8202 Loss of supervision connection

6 Troubleshooting UltraSite EDGE BTS

6.1 Overview of troubleshooting the BTS

Before you start, please review chapter **UltraSite EDGE BTS alarms** in this document.

For additional information on the BTS status when troubleshooting, use a mobile phone to contact the Base Station Controller (BSC) personnel.

If a fault occurs during BTS operation, connect the BTS Manager laptop PC to the Base Operations and Interfaces (BOIx) unit. The BTS Manager windows, Supervision, BTS Events, and Alarms, can help you identify the problem.

In the chapters to follow, BTS troubleshooting is divided into eight subcategories:

- [Troubleshooting commissioning](#)
- [Troubleshooting BTS Manager connection](#)
- [Troubleshooting electrical power](#)
- [Troubleshooting transmission unit operation](#)
- [Troubleshooting transceiver unit \(TSxx\) operation](#)
- [Troubleshooting fan units](#)
- [Troubleshooting TRX test failures with BTS Manager](#)
- [Advanced BTS troubleshooting option](#)

All damages, failures, or faults must be reported to Nokia Siemens Networks using the Failure Report Form (FRF) provided by your local Nokia Siemens Networks representative.

 You can save the alarm information to a log file on your laptop with BTS Manager software. Remember to attach the alarm log file with the Failure Report Form (FRF).

For more information on possible faults and appropriate corrective actions, see the **Generic Failure Status Report** document in the SW Release Documentation. For transmission unit failures, see the **Monitoring UltraSite EDGE BTS** document in the latest Product Documentation set.

6.2 Troubleshooting commissioning

Purpose

In the case of a failure in any part of the whole commissioning procedure, an alarm will appear in the alarm window (see figure 'BTS Manager desktop showing the alarms in the Alarms window' in chapter [Identifying faulty units](#)). Also, you may check the state where the failure occurred from the commissioning report. The report only stores whether commissioning was successful or not.

UltraSite Hub Manager may be used for checking the transmission-related alarms.

Summary

Fault - The commissioning of UltraSite EDGE BTS fails.

Steps

1 Determine the cause and corrective action.

Potential cause	Corrective action
The RX and TX cables are not properly connected causing TRX test to fail	Check that the RX and TX cables are properly connected to the failing TRX.
The Abis cables are not properly connected (transmission unit LED is not green)	Connect the Abis cables properly.
The pre-configuration fails at the BSC (for example, the BCF and TRX objects were not created)	Create the BCF, BTS, and TRX objects at the BSC.
The oven oscillator has not yet warmed up causing the BCF to remain in the 'Configuring' state	Wait until the oven oscillator has warmed up.
The TRXs are not unlocked at the BSC (as a result of this the TRXs do not enter the 'Supervisory' state)	Unlock the TRXs at the BSC.
The Lapd links are disabled at the BSC/ET	Ensure that the Lapd links are enabled at the BSC/ET.

Table 89 Troubleshooting commissioning

2 Report damage, failure, or fault.

Further information

-  Before starting to re-commission the BTS, first run the *Undo Commissioning* procedure in the BTS Commissioning Wizard.

6.3 Troubleshooting BTS Manager connection

Summary

Fault - Cannot connect to BTS Manager

Steps

1 Determine the cause and corrective action.

Potential cause	Corrective action
Wrong BTS Manager port setting (COM1, COM2)	Correct the settings.
LMP cable broken or not properly connected	<ul style="list-style-type: none"> • Check the connection. • Replace or repair the cable.
Faulty or damaged BOIx unit	Reset or replace the BOIx.
Old or incorrectly installed BTS Manager software	<ul style="list-style-type: none"> • Use the same or a newer version of BTS Manager SW when compared to BTS SW. • (Re)install BTS Manager SW.

Table 90 Troubleshooting BTS Manager connection

2 Report damage, failure, or fault.

6.4 Troubleshooting electrical power

Summary

Fault - No power to the BTS

Steps

1 Determine the cause and corrective action.

Potential cause	Corrective action
Power supply unit is in STAND BY mode	Turn the switch to the ON position.
Site mains power supply fault (power supply LED is OFF)	<ul style="list-style-type: none"> Replace the power supply unit, if necessary. Check the site mains power source and fuses.
Defective power cable	Replace the power cable. If the AC connector inside the cabinet is faulty, replace the faulty AC connector with spare part 083728A. Replacement instructions are delivered with the connector.
Cold-start function activates (power supply LED is YELLOW)	Close the door to allow the units to warm up to a temperature of -5° C (20° F).
Defective power supply unit (LED is RED may indicate the unit is overheated)	Replace the power supply unit.
Short in one of the plug-in units	<ul style="list-style-type: none"> Pull the units out one by one until the power returns. Return the units one by one and replace the faulty unit(s).
Wrong power supply type	Replace power supply to correct type.

Table 91 Troubleshooting electrical power

2 Report damage, failure, or fault.

6.5 Troubleshooting transmission unit operation

Summary

Fault - No transmission connection to the BSC

Steps

1 Determine the cause and corrective action.

Potential cause	Corrective action
Abis cable not connected (LED is RED)	Check the connection of the Abis cable on the Transmission unit and at the BSC.
Defective Abis cable (LED is RED)	Repair or replace the cable.
Line interface disconnected (LED is RED)	<ul style="list-style-type: none"> Connect a jumper cable from the RX connector of each transmission interface to its RS connector. If the GREEN LED is Steady, the line interface is OK. Otherwise, replace the Transmission unit.
Incorrect transmission card setting (LED is GREEN or YELLOW)	<ul style="list-style-type: none"> Check the alarm with the Transmission Manager software. Check the cross-connection and ensure the interface is enabled. Check the line interface settings.
Master Transmission unit is not in slot 1	Check the location of the transmission units.
Defective Transmission unit (LED is RED)	Replace the Transmission unit.

Table 92 Troubleshooting Transmission unit operation

2 Report damage, failure, or fault.

6.6 Troubleshooting Transceiver unit (TSxx) operation

Summary

Fault – The device status report in the BTS Manager indicates that both the BCCH TRX and the TCH TRXs are in Supervisory state.

i When calls are ongoing, the normal TSxx LED indication is GREEN for both the BCCH and TCH TRXs. The normal TSxx LED indicator with no ongoing calls is GREEN for BCCH TRX and YELLOW for TCH TRX.

Steps

1 Determine the cause and corrective action.

Potential cause	Corrective action
Objects are locked from the BSC, NMS/2000, or NetAct	<ul style="list-style-type: none"> Request the state from the BSC, NMS/2000, or NetAct. Request an unlock from the BSC, NMS/2000, NetAct, or by using the BTS Manager, if necessary.
Unit alarm is active (the front led is red)	<ul style="list-style-type: none"> Check the alarm state from BSC or locally with BTS Manager. Find the alarm and corrective actions in chapter <i>Trouble management of UltraSite EDGE BTS alarms</i> in this document.
Unit is not properly connected, no electric power or led is broken (the front led does not light up)	<ul style="list-style-type: none"> Check that the unit is properly connected and the screws are correctly tightened. Check that the cabinet power is in order. Replace the unit.

Table 93 Troubleshooting TSxx operation

2 Report damage, failure, or fault.

6.7 Troubleshooting Fan units

Summary

Fault – The fan is not rotating.

Steps

1 Determine the cause and corrective action.

Potential cause	Corrective action
Fan cable is not properly connected	Verify the proper cable connection.
The outdoor cabinet electronics module cable is not properly connected to the cabinet fan	Verify the proper cable connection
Fan rotor blocked	Clear rotor.
Door switch is faulty or not engaged (cabinet fan)	<ul style="list-style-type: none"> • Replace switch. • Engage door switch button.
Faulty TSxx unit (if the TRX unit fan stops)	Replace the TSxx(s) in front of the fan.

Table 94 Troubleshooting Fan units

2 Report damage, failure, or fault.

6.8 Troubleshooting TRX Test failures with BTS Manager

Summary

Fault - TRX Test fails when test is executed locally or remotely with UltraSite BTS Manager.

Steps

1 Determine the cause in TRX Test Result column and corrective action.

TRX Test Result	Corrective action
"The transmitted power is too low"	<ul style="list-style-type: none"> Run the TRX Test again. If the test persistently fails, replace TSxx.
"RF receivers are too unbalanced"	Replace faulty TSxx.
"Faulty baseband creates bit error ratio >0%"	<ul style="list-style-type: none"> Run the TRX Test again. Replace faulty BB2x.
"Invalid CH configuration"	<ul style="list-style-type: none"> Run the TRX Test again to non BCCH/SDCCH/GP TS. Replace faulty TSxx and/or BB2x.
"RX cabling is faulty or missing"	<ul style="list-style-type: none"> Check all RX cabling between DVxx/RTxx - MxxA - TSxx. Replace faulty cable and/or TSxx unit.
"High Bit Error in RF loop detected"	<ul style="list-style-type: none"> Run the TRX Test again. Check for high RF interference levels in RX antenna input. Replace faulty TSxx.
"Invalid TRX state"	<ul style="list-style-type: none"> Check the TRX State from the BTS Manager. The TRX state should be CONFIGURING or SUPERVISORY. Run the TRX Test again. <p>Note: TRX test has to be finished before re-run.</p>
"Unable to measure TX power level"	<ul style="list-style-type: none"> Run the TRX Test again. If the test persistently fails, replace TSxx or BB2x unit.
"Too much phase error in RF"	Replace faulty TSxx.
"The standing wave ratio is too high at the antenna"	<ul style="list-style-type: none"> Check the TX cabling between TSxx and WCxx/DVxx/RTxx units. Replace faulty TSxx.
"The timeslot is already in use"	<p>Run the TRX Test again.</p> <p>Note: The tested TS and its offset TS (tested TS minus 3 TSs) both have to be free before the TRX test can be started.</p>

Table 95 Troubleshooting TRX Test failures

TRX Test Result	Corrective action
<p>"Starting TRX Test failed. Invalid HOP Type.."</p> <p>Note: In prior BTS Manager 4.1, the result message was "TRX test failed, can't get response from BTS software".</p>	<p>Check the hopping mode of the TRX.</p> <p>Note: TRX test cannot be done to BB hop or Antenna hopping sector.</p>
<p>"Requested test can not be carried out"</p>	<p>If a BTS has both IDD and RF hopping active then not all RTSL can be tested. Disable one of the features if it is necessary to carry out the test.</p>

Table 95 Troubleshooting TRX Test failures (Cont.)

2 Report damage, failure, or fault.

6.9 Advanced BTS troubleshooting option

The advanced BTS troubleshooting option allows the operator to get detailed diagnostic information from the BTS internal processes. The diagnostic information can be traced with the UltraSite BTS Manager. This option is called BTS Diagnostic Capture in the UltraSite BTS Manager under the Tools menu. This option should only be used in accordance with instructions supplied by Nokia Siemens Networks during possible BTS failure investigation.

 Misuse of the BTS Diagnostic Capture functionality may leave the BTS inoperable.

7 Troubleshooting BTS Transmission Hub

7.1 Using forced indications to test the FXC STM transmission unit LEDs

Purpose

The FXC STM-1 and FXC Bridge cards have three-colour unit status LEDs. In the **Forced Indications** windows, you can test the LEDs by forcing them into different states.

Steps

- 1 Click **FXC STM-1 → Forced Indications** to open the FXC STM window, or **FXC Bridge → Forced Indications** to open the FXC Bridge window.

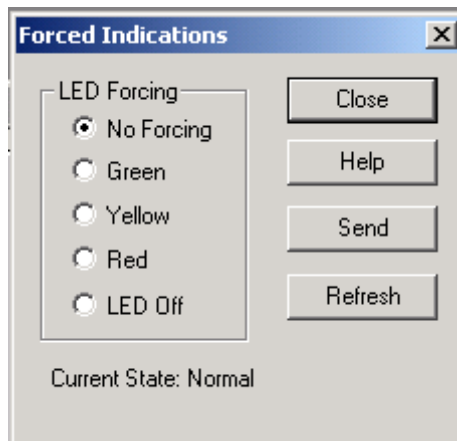

Figure 11 FXC STM-1 or FXC Bridge Forced Indications

- 2 View the **Current State of the LED**. Usually, this is **Normal** or **No Forcing**.
- 3 Select the state you want to force the LED to (**No Forcing**, **Green**, **Yellow**, **Red**, or **LED Off**).
- 4 Click **Send**.
- 5 Click **Refresh** to read the current state of the LED from the unit.

7.2 Using timeslot monitoring to locate faults

Purpose

The **Timeslot Monitoring** page displays monitored timeslot data in bits (1-8). Monitoring timeslots is restricted to those interfaces in which there have been either cross-connections or control bits created. The platform interface connected to the selected channel is also displayed. It is possible to monitor the contents of individual timeslots.

Steps

- 1 **Click Maintenance → Timeslot Monitoring to access the Timeslot Monitoring dialogue box.**

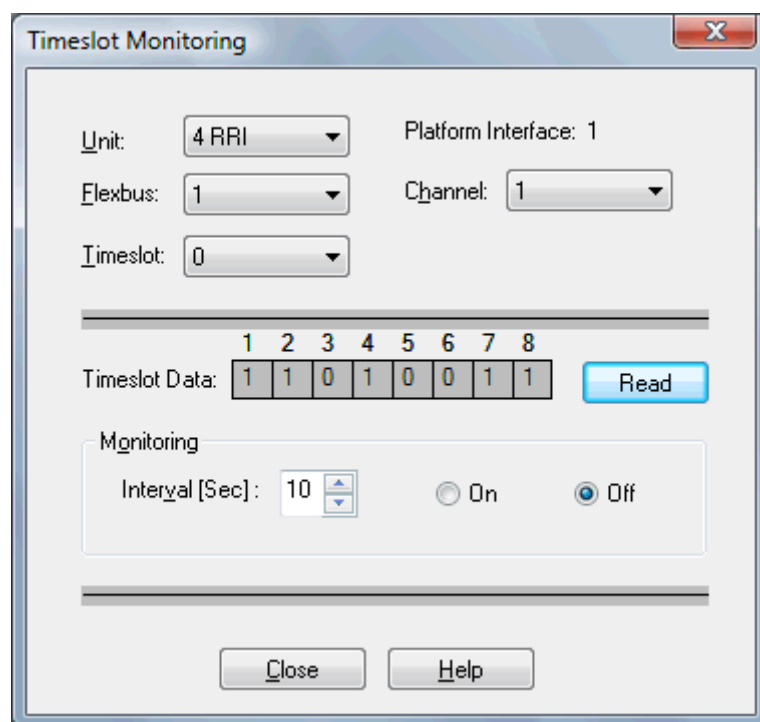

Figure 12 Timeslot Monitoring dialogue box

- 2 **Select the monitored Unit and Interface (or Flexbus and Channel with the FXC RRI unit), and the Timeslot.**

Note that the selected timeslot must be active, that is, have a cross-connection or control bit created.

- 3 **Click Read to read the 8 bits of the monitored timeslot.**

It is also possible to monitor the timeslots automatically at a specified time interval.

Steps:

- a) Select the monitored Unit and Interface (or Flexbus and Channel with the FXC RRI unit), and the Timeslot.
- b) Select the monitoring interval.
- c) Click **On**.

7.3 Using MCB/LCB bits to locate faults

Purpose

The status of MCB/LCB bits gives you information on the synchronisation in the loop network. The status of these bits can be monitored in the **Loop Bits** tab of the **Synchronization** dialogue box. Only the received MCB/LCB bits are shown.

Steps

- 1 **Connect to the node or open a file.**
- 2 **Select Configuration → Synchronization.**
- 3 **Select the Loop Bits tab.**

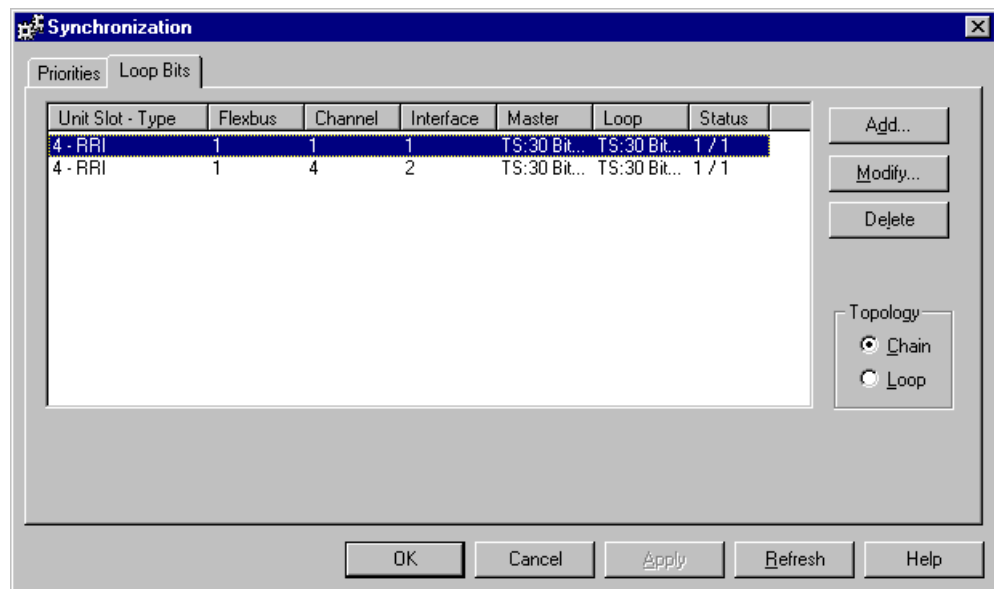

Figure 13 MCB/LCB status in the Synchronization dialogue box

- 4 **Locate any faults using the MCB/LCB bit statuses.**

Locate faults using the MCB/LCB bit statuses. In all good situations, the incoming master bit is 0. If the master bit is 1, it indicates that the incoming signal from that direction is not synchronised from the loop master. The loop bit is used to detect any breaks or loopbacks in the synchronisation chain.

Note that only the received MCB/LCB bits are shown.

MCB	LCB	Conditions in the sending node (B), based on receiving MCB/LCB bits in the receiving node (A)
0	0	The connection from the loop master to node B is acceptable. Node B is getting its synchronisation from the loop master. Node A can use this interface as a synchronisation source.

Table 96 MCB/LCB bit statuses

MCB	LCB	Conditions in the sending node (B), based on receiving MCB/LCB bits in the receiving node (A)
0	1	Node B gets its synchronisation from the loop master. Node A should not use this as its synchronisation source, because the synchronisation is coming from node A direction in order to prevent a synchronisation loop back.
1	0	Not applicable.
1	1	The connection from the loop master to node B is not acceptable. Node A should not use this interface as its synchronisation source.

Table 96 MCB/LCB bit statuses (Cont.)

7.4 Using the condition bits of protected cross-connections to locate faults

Purpose

Condition bits of protected cross-connections give information on the status of the protected/protecting cross-connection directions. If a received pilot bit is '1', the connection is faulty, if '0', the connection is functioning. The status information is shown in the **Condition Information** frame of the **Cross-connection Properties** dialogue box.

Steps

- 1 **Connect to the node.**
- 2 **Select Configuration → Cross Connections.**

The **Cross-connections** window opens.

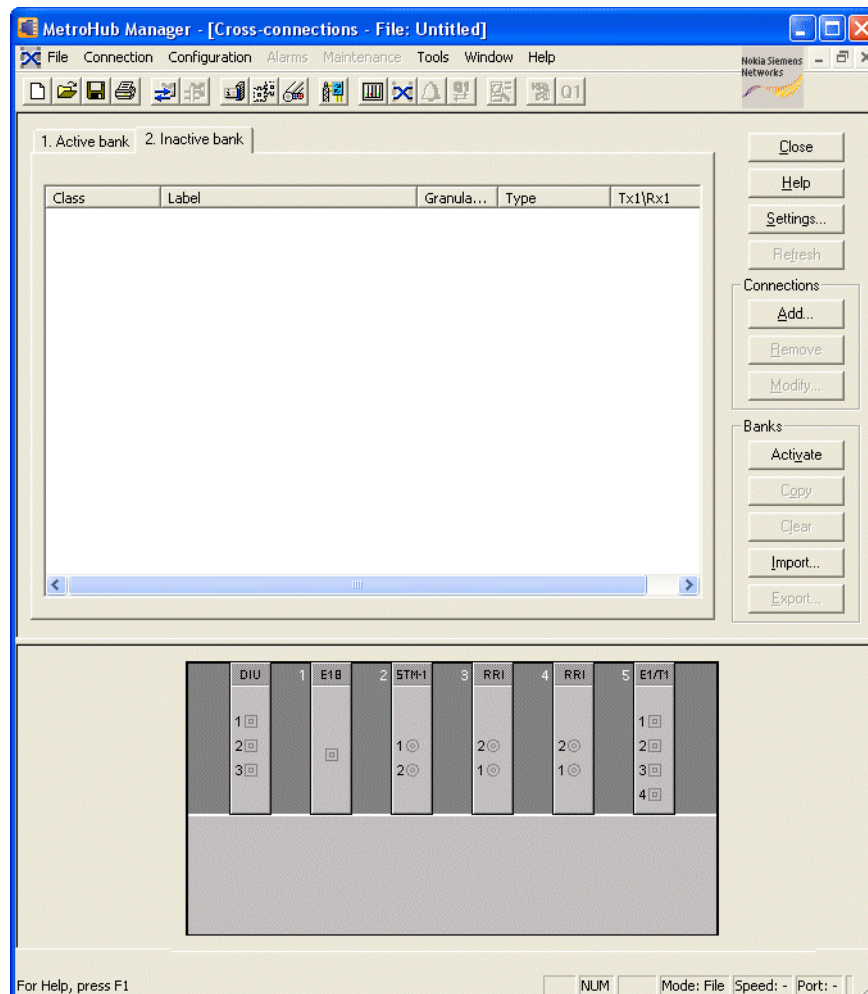

Figure 14 The Cross-connections window

- 3 **Click the Settings button in the Cross-connections window.**

4 Select Condition Type, Condition 1, and Condition 2.

5 Click OK.

6 Select a cross-connection, right click on it, and click Properties to access the Cross-connection Properties dialogue box.

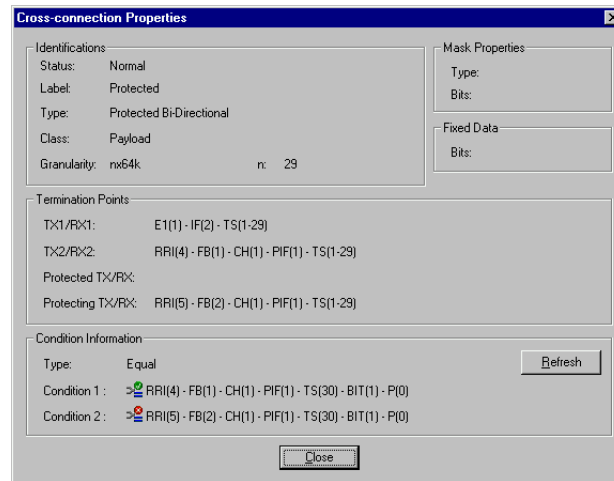

Figure 15 Condition information in the Cross-connection Properties dialogue box

7 Assess if the connection is faulty by viewing the condition bits of the protected cross-connections, in the Condition Information frame.

View the condition bits of the protected cross-connections in the **Condition Information** frame. If a received pilot bit is 1, the connection is faulty. If a received pilot bit is 0, the connection is functioning.

Further information

For more information, see [Technical description of PDH transmission network protection using loop topology](#).

7.5 Using pending cross-connections to locate faults

Purpose

If a traffic cut has occurred, and there is an active pending cross-connections alarm ('20 Blocked from use'), check the status of the cross-connections, especially if the node settings have been changed.

Steps

- 1 **Connect to the node.**
- 2 **Select Configuration → Cross-connections.**
- 3 **View the pending cross-connections.**

Pending cross-connections are displayed in the **Cross-connections** window with the colour red. Cross-connections are in pending state when something is preventing them from working normally. See the following diagram.

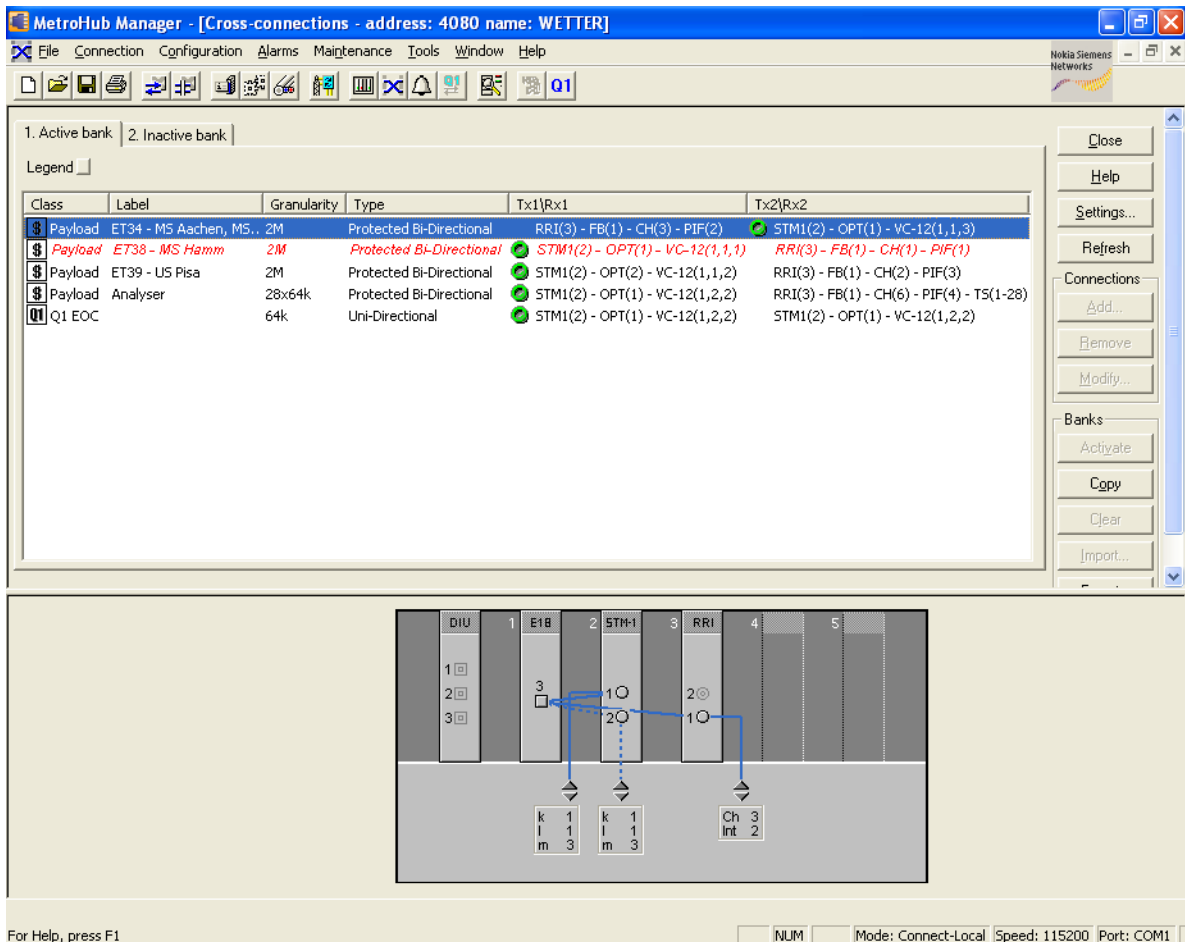

Figure 16 Pending cross-connections because of disabled interface 1 of the FXC E1/T1 unit in slot 2

Reasons for the pending state can be that one end (termination point) of the cross-connection is an interface that is not in use. Another reason is that it is not operational, because of an active alarm. The responsible end (termination point) for each pending cross-connection is shown by the icon next to the termination point. Click the **Legend** button to see an explanation of the symbols, as shown in the figure below.

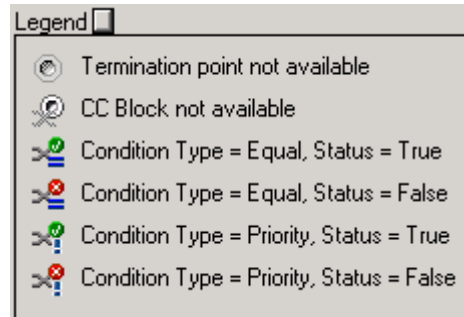

Figure 17 Symbols used in the cross-connections window

Once the reason for the pending state is removed, the cross-connection is reactivated automatically.

☞ To see the actual status of the cross-connections, you need to refresh the **Cross-connections** view.

7.6 Using loopbacks to test the transmission node

7.6.1 Overview of using loopbacks to test the transmission node

Purpose

The units contain several loopback points that you can set to test the node. These loopbacks are accessed through the FXC E1/(T1) Manager, the FXC RRI Manager, or the FXC STM-1 Manager (standalone or embedded in the MetroHub Manager or UltraSite BTS Hub Manager).

The loopback status can change without the user changing it, for example, when the timeout has been reached (alarms [21 Loop to interface](#) and [22 Loop to equipment](#)).

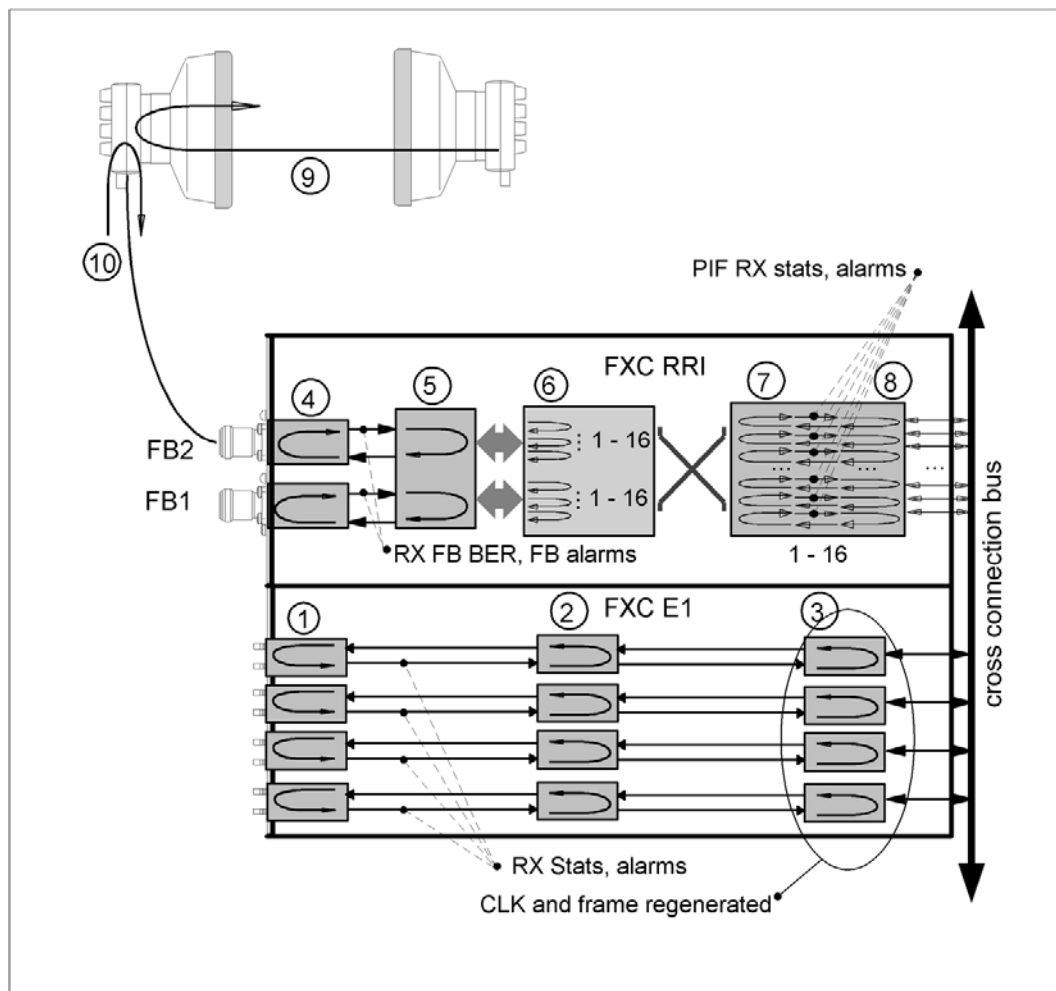

Figure 18 Loopbacks in FXC E1 unit, FXC RRI unit, FlexiHopper and MetroHopper

The following loops are supported by the FXC E1 unit, FXC RRI unit, FlexiHopper, and MetroHopper:

1. Loop to equipment
2. Loop to interface (line)
3. Loop to interface (payload)
4. Flexbus loop to equipment

5. Flexbus loop to interface
6. Flexbus channel loop to interface
7. Platform interface loop to equipment
8. Platform interface loop to interface
9. Outdoor unit loop to interface
10. Outdoor unit loop to equipment

Steps

1 **Configure the unit loopback settings as required.**

Configure the unit loopback settings as required. See the following sections for details:

- [Using loopbacks to test the FXC E1\(T1\) transmission unit](#)
 - [Using loopbacks to test the FXC RRI transmission unit](#)
 - [Using loopbacks to test the FXC STM-1 transmission unit](#)
-

2 **Define the control timeout, which sets how long the loops are active.**

When the defined time has expired, the loops are automatically removed. The control timeout is set in the **Configuration** → **Service Interface** menu in the FXC units and node managers.

7.6.2 Using loopbacks to test the FXC E1(/T1) transmission unit

Purpose

Three integrated loopback tests are available in the FXC E1(/T1) units for testing and diagnostics purposes. You can verify the operation of the signal path with the help of an external BER analyser equipment.

Steps

- 1 Click **FXC E1/T1** → **Interface Loops** to open the **Interface Loops** dialogue box.

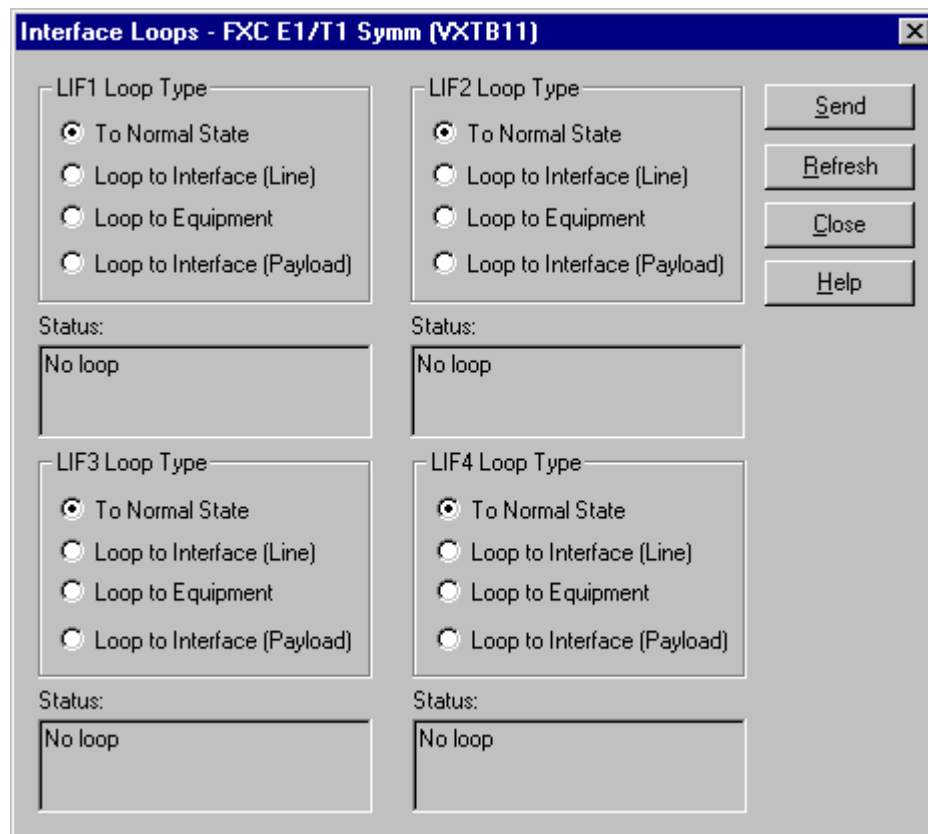

Figure 19 Interface Loops dialogue box in the FXC E1/T1 Manager

- 2 **Select loop types for particular Line Interfaces (LIFs) as required.**

Select loop types for a particular **LIF (1, 2, 3, 4) Loop Type**, as required:

- **Loop to Equipment** is a near-end loop. The signal is looped back from the interface to the node cross-connection section. The **TX** direction is forwarded as **AIS**. This loopback can be used to test the FXC E1 interface framer.
- **Loop to Interface (Line)** is a far-end loop. The signal to the 2M interface from another interface (NE) is looped back. The whole signal in the unit's 2Mbit/s interface is looped back, synchronising it to the incoming signal. The **RX** direction is forwarded as AIS.
- **Loop to Interface (payload)** is a far-end loop. The signal to the 2M interface from another interface (NE) is looped back. The reframed signal in the unit's 2Mbit/s inter-

faces is looped back, synchronising it to the node clock. The RX direction is forwarded as AIS.

3 Click Send to apply the loop(s).



Traffic is cut when you apply loops in the related interfaces, channels, or Flexbuses.

4 Use the Refresh button to view the current information.

7.6.3 Using loopbacks to test the FXC RRI transmission unit

Purpose

Seven integrated loopback tests are available in the FXC RRI units for testing and diagnostics purposes. You can verify the operation of the signal path with the help of an external BER analyser equipment.

Steps

- 1 Click **FXC RRI** → **Interface Loops**.

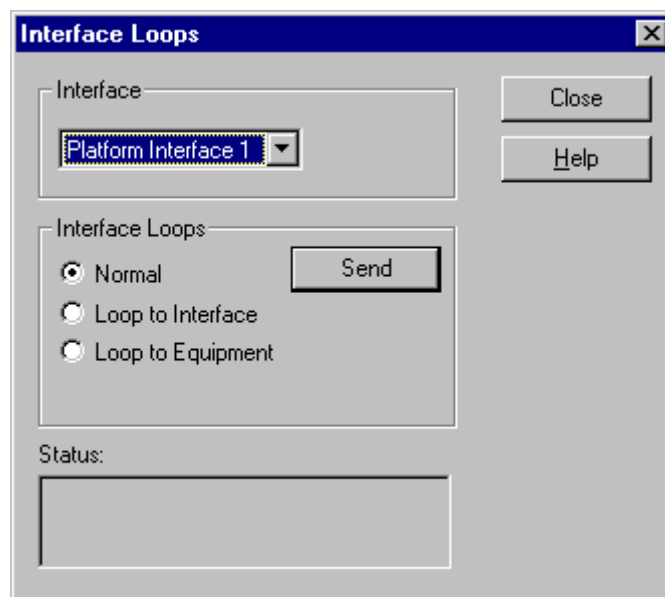



Figure 20 Interface Loops dialogue box in the FXC RRI Manager

- 2 In the **Interface Loops** window, select loop types for particular **Flexbus**, **Flexbus Channel**, **Platform Interface**, or **Outdoor Unit**, as required.

Select loop types for a particular **Flexbus** interface as required:

- The Flexbus **Loop to Equipment** is a near-end loop. The signal is looped back from the Flexbus interface to the cross-connection section. In the TX direction the signal is passed through.
- The Flexbus **Loop to Interface** is a far-end loop. The signal to the 2M Flexbus channel from another interface (NE) is looped back. The whole signal in the Flexbus channel is looped back, synchronising it to the incoming signal. The RX direction is forwarded as AIS. This loop does not work with a direct Flexbus cable connection.

-  Activating 'Flexbus loop to interface' cuts the connection to the outdoor unit. The Flexbus Bit Error Ratio (BER) measurement does not work and this generates the irrelevant Flexbus alarms [99 Error rate E-3](#) and [81 Loss of frame alignment](#).



Setting a Flexbus loop cuts the connection to the outdoor unit until the loop is cancelled or it expires. This includes all data and management information. The interface loopback in FlexiHopper stays active until the loopback timeout expires.

Select loop types for a particular **FB Channel** interface as required:

- The Flexbus channel **Loop to Interface** is a far-end loop. The signal to the 2M Flexbus channel from another interface (NE) is looped back. The whole signal in the Flexbus channel is looped back, synchronising it to the incoming signal. The RX direction is forwarded as AIS.

Select loop types for a particular **Platform Interface** as required:

- The Platform interface **Loop to Equipment** is a near-end loop. The signal from the platform interface to the node cross-connection section is looped back. The TX direction is forwarded as AIS.
- The Platform interface **Loop to Interface** is a far-end loop. The signal to the platform interface from another interface (NE) is looped back. The whole signal in the unit's interfaces is looped back, synchronising it to the incoming signal. The RX direction is forwarded as AIS.

Select loop types for a particular **OU Radio Interface** as required:

- The Outdoor unit **Loop to Interface** is a far-end loop. The incoming radio signal is looped back to the other end of the radio hop. In the RX direction the signal is passed through.
 -  The connection to the outdoor unit is cut, when 'Outdoor unit loop to interface' is activated.
- The Outdoor unit **Loop to Equipment** is a near-end loop. The incoming Flexbus signal is looped back to the indoor unit. In the TX direction the signal is passed through.

Note that this loop may cause an irrelevant alarm: *60 No incoming radio signal* or *59 Incoming signal level incorrect*.

3 Click Send to apply the loop(s).

-  Traffic is cut when you apply loops in the related interfaces, channels, or Flexbuses.

7.6.4 Using loopbacks to test the FXC STM-1 transmission unit

Purpose

You can set interface loops manually to test the FXC STM node interface loops. These are 2M loops to SDH or PDH.

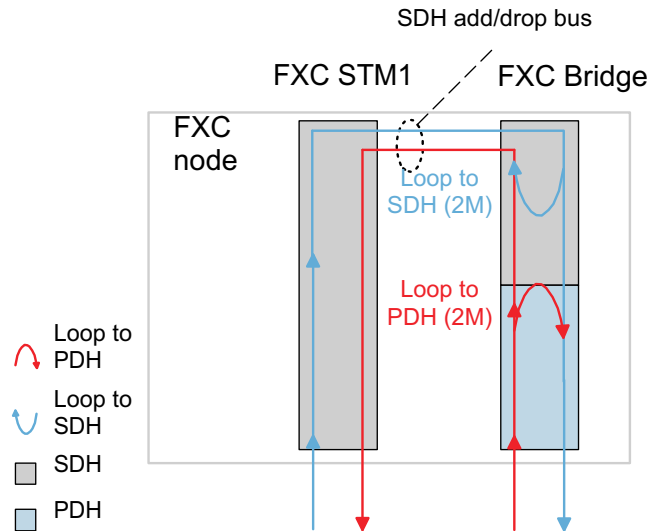

Figure 21 FXC STM node 2M loops

Through the **Loops** window, you can view and modify the FXC STM node interface loops for the SDH-PDH channels. You can modify one or several channels at a time.

Steps

- 1 Click **FXC STM-1** → **Loops** to open the **Loops** window.
The **Loops** window opens, showing the SDH-PDH Channels.

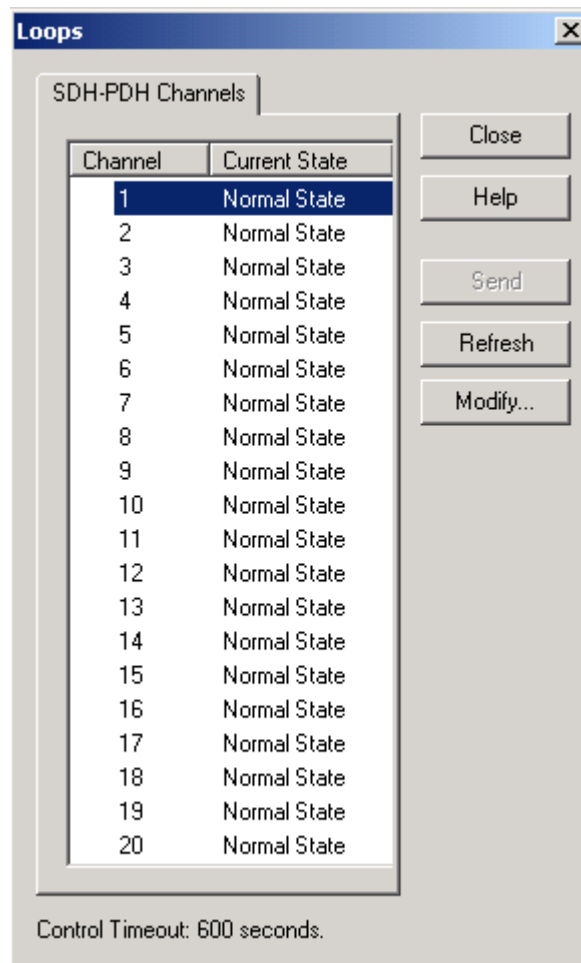

Figure 22 The Loops window, SDH-PDH Channels

2 Select a channel from the list by clicking on it.

3 Click **Modify**.

The **Modify** dialogue box opens.

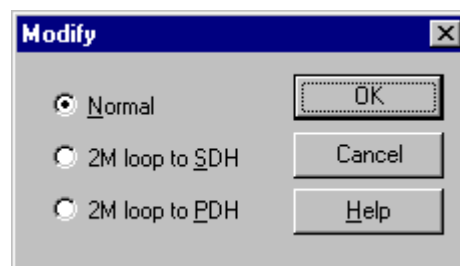

Figure 23 The Modify dialogue box

4 Select/clear the desired states.

Select/clear the desired states. **2M loop to SDH** means that the channel is looped to the SDH part of the STM-1. **2M loop to PDH** means that the channel is looped to the PDH part of the STM-1.

5 Click OK.

Further information

Control Timeout shows the time for which the loops will be sustained unless you set them manually back to normal state. You can change the FXC STM-1 Control Timeout value in the **Service Interface** dialogue box.

7.6.5 An example of loopback usage during a traffic cut

Purpose

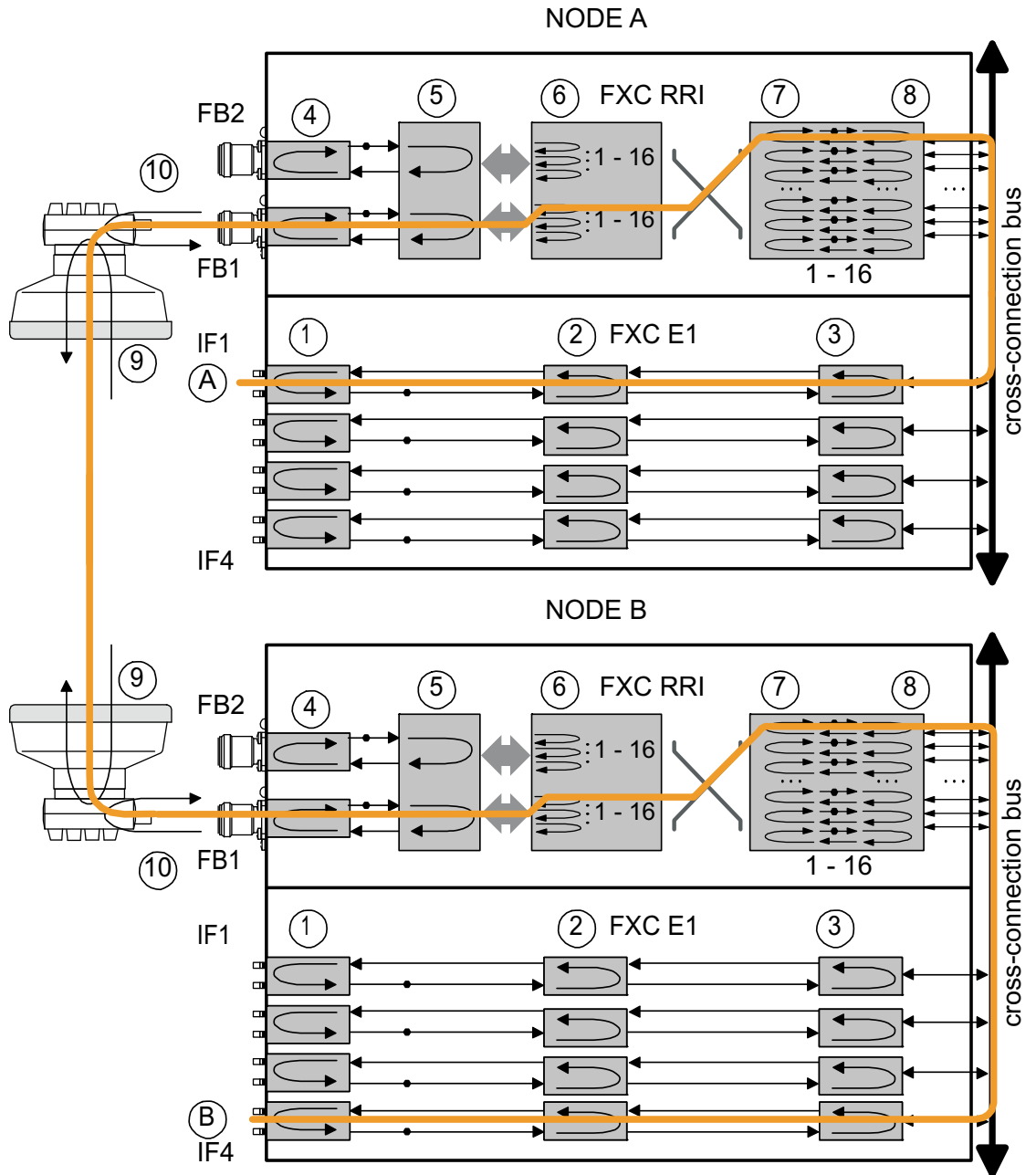

Figure 24 Example of loopback usage during a traffic cut

Let us assume that there is traffic cut between interface (A) in node A and interface (B) in node B. The signal path is presented in Figure *Example of loopback usage during a traffic cut*. Loopbacks can be used to find where the cut is located. There are several approaches to the problem, but the principle is the same in all of them, which is looping the signal back at different positions in the signal path and thus ensuring that the signal is acceptable from the measurement point to the loop position. One possible approach is presented below.

Steps

1 Connect an external BER tester to the IF 4 in node B, FXC E1, denoted here as (B).

2 Activate FlexiHopper loop to equipment in node B (10).

3 Check the value on the BER meter.

If the signal is acceptable, the traffic cut is not located inside node B or in the Flexbus connection between the FXC RRI unit and FlexiHopper in node B. Let us assume here that the signal is acceptable.

4 Remove the loop to equipment in FlexiHopper, in node B.

5 Activate FXC E1 loop to equipment in node A (1).

Let us assume that the signal is not acceptable, which indicates that the break is between FlexiHopper in node B and the FXC E1 in node A.

6 Remove the loop to equipment in FXC E1, in node A.

7 Activate FlexiHopper loop to interface, in node A (9).

Let us assume that the signal is acceptable, which indicates that the signal path up to that point is working.

 Adjust the timeout to a sensible value before activating the FlexiHopper loop to interface, see Section [Adjusting service interface settings](#).

8 Wait for the control timeout to expire, after which the FlexiHopper loop to interface, in node A, is removed.

9 Activate FXC RRI Flexbus loop to interface, in node A (5).

Let us assume that the signal is not acceptable, which indicates that the break is between FlexiHopper in node A and the Flexbus interface of FXC RRI, in node A. This indicates that the failure is in the FXC RRI unit in node A, in the Flexbus cable, or in the FlexiHopper in node A.

7.7 BTS Transmission Hub faults

7.7.1 No power to the transmission node

Description

If there are no LEDs activated in any of the FXC units in the hub, check the hub power system. Start from the mains power supply side and move on to check the MetroHub cabinet (if applicable).

Possible causes are:

- fault in the site mains power supply
- broken power cable
- power supply unit switch in stand-by position
- loose fixing screws in the power interface unit or the power supply unit
- active cold start
- overheated power supply unit

Symptoms

Power supply in stand-by position

Blinking yellow LED in the power supply unit.

Cold start active

Steady yellow LED in the power supply unit.

Overheated power supply unit

Steady yellow LED in the power supply unit.

Power supply unit broken

Alarm 'Fault in power supply' may be activated. No lights in the power supply unit, or the LED is red.

Recovery procedures

Fault in the site mains power supply

Steps

- 1 Check the site mains power source and fuses. Replace if needed.
- 2 Measure with a multimeter that the DIPx has operating voltage.
- 3 Make sure the polarity is correct if using DC mains.

Broken power cable

Steps

- 1 **Replace the power cable.**

Power supply unit switch in stand-by position

Steps

- 1 **Turn the switch ON.**

Power interface unit's or power supply unit's fixing screws are loose

Steps

- 1 **Tighten the loose screws.**

Cold start active

Steps

- 1 **Wait until the units are warmed up to the operational temperature range, and the power supply unit LED switches from yellow to green.**

Overheated power supply unit

Steps

- 1 **Wait for the power supply unit to cool down.**
- 2 **Check that the fan is functioning correctly.**

Power supply unit broken

Steps

- 1 **Replace the power supply unit.**

Power interface unit broken

Steps

- 1 **Replace the unit.**

Short circuit in one of the units

Steps

- 1 **Pull the units out, one by one, until the power comes back on.**
Start from the FXC units, proceed to the fan, and finally replace the interface unit.
- 2 **Re-install the units one by one, and replace the faulty unit(s).**

7.7.2 Transmission node powered, but a manager connection cannot be established

Description

The problem situation when a transmission node is powered, but a connection to the manager cannot be established can be caused by:

1. a bad or poorly connected LMP cable
2. the wrong COM port settings in the UltraSite BTS Hub or MetroHub Manager
3. SW problems in the PC
4. a broken FXC master unit
5. a broken DIUx interface unit

Symptoms

FXC master unit broken

The transmission unit LED is off.

Recovery procedures

Bad or poorly connected LMP cable

Check the cable and verify that it is properly connected.

Check that the pins are not broken in the DIUx and that the sockets are fine in the LMP connector. Replace the DIUx interface unit or the cable if the connections are bad.

Wrong COM port settings in the UltraSite BTS Hub or MetroHub Manager

Select the right COM port settings in the Tools → Options menu. The default settings are: port: COM1, and speed: 9600.

SW problems in the PC

Restart the PC. It might be useful to restart the UltraSite BTS Hub or MetroHub as well by turning the power switch off, and after a few seconds back on when you are setting up a new node.



Risk of traffic and data loss. Do not restart an UltraSite BTS Hub or MetroHub that is already operating in a network, as this may cause severe traffic cuts.

FXC master unit is broken

Replace the FXC master unit.

DIUx interface unit is broken

Check that the DIUx interface unit has been correctly installed. Restart the UltraSite BTS Hub or MetroHub by turning the power switch off. Wait a few seconds, then turn the power switch back on. If the LED is still red, restart the DIUx unit by removing it for a few seconds and putting it back in. If the LED is still red, replace the DIUx interface unit.

7.7.3 The cross-connections test of a transmission unit fails in the manager

Description

Cross-connections test fails in the Commissioning Wizard. This may be caused by a fault in an FXC unit.

Symptoms

The cross-connections test fails

The cross-connections test fails in the Commissioning Wizard.

Recovery procedures

Fault in an FXC unit

Steps

- 1 Remove the unit, starting from the right-hand side.**
- 2 Redo the test until you find the faulty unit.**
- 3 To test the master FXC unit**

Steps

- a Remove the master unit and plug it into slot 2 of the node.**
- b Plug-in an already tested unit in slot 1 acting temporarily as a master unit.**
- c Redo the test.**
- d If the test is not passed, the original master unit now plugged into slot 2 is faulty.**

8 Troubleshooting software licensing

8.1 Change of unit

Description

When replacing an existing FlexiHopper Plus unit, there are two situations related to software licensing if a licensed feature is being used.

- The unit being replaced is still under warranty.
- The warranty period for the unit being replaced has expired.

Symptoms

- The replacement unit has been installed, and is currently using a time-limited licence instead of the previous non-time-limited licence.

Recovery procedures

The replacement unit is using a licensed feature and was replaced under warranty.

Steps

- 1 **The replacement unit should come with the licences that were purchased for the unit being replaced.**
- 2 **If the replacement unit does not contain the correct licence, contact Nokia Siemens Networks. The existing time-limited licence allows the use of the feature for 60 days.**
- 3 **When the correct license is received, install the license using the license manager.**

The replacement unit is using a licensed feature and the warranty has expired.

Steps

- 1 **Purchase the required licence and install them using the licence manager. The existing time limited licence allows the use of the feature for 60 days.**

8.2 The software licence key is not available

Description

If the software licence key is not available, an error dialogue box is displayed.

Symptoms

An error dialogue box is displayed

If the licences to be activated have not been installed or if the licence installation was not successful, an error message is displayed.

Recovery procedures

Installing the software licence

Steps

- 1 *If* the licences to be activated have not been installed,

Then

install the required licence(s) by clicking Yes in the error message dialogue box.

The following error message is displayed if the licences to be activated have not been installed:

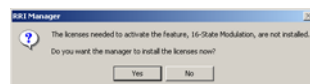

Figure 25 Licence not installed

After you have clicked **Yes**, the required licence is searched in the system and installed if found.

- 2 *If* the licence is not found in the system,

Then

verify and correct the licence file folder through the licence manager.

The following error message is displayed if the licence is not found in the system:

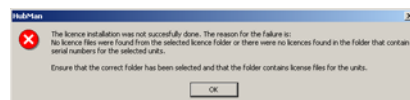

Figure 26 The licence installation was not successful

8.3 Typographic errors in the licence key

Description

If there are typographic errors or other problems with the licences, an error dialogue box is displayed.

Symptoms

An error dialogue box is displayed

Recovery procedures

Checking the licence file folder

Steps

- 1 **Check that the licence file folder path is correct in the licence manager.**

The following error message is displayed if there are typographic errors or other problems with the licences:

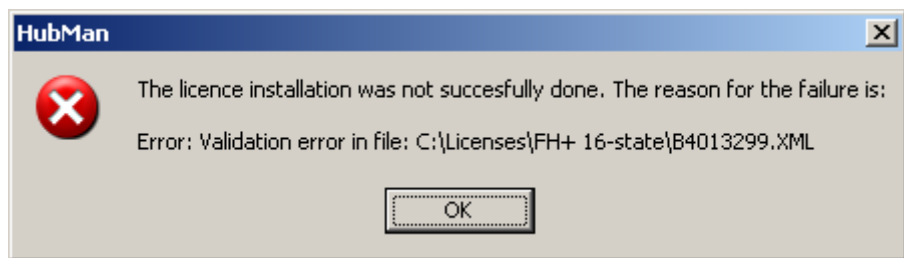

Figure 27 Error message: validation error in a file

The file path displayed in the error message is just an example. It will change with the actual location that the user has specified through the license manager.

9 Completing troubleshooting

Steps

-
- 1 After having replaced the faulty unit, send it to hardware service.
-
- 2 If fault still exists after troubleshooting, contact your local Nokia Siemens Networks representative.

Related information

Using pending cross-connections to locate faults

Reference

[20 Blocked from use](#)

Overview of using loopbacks to test the transmission node

Instructions

[Using loopbacks to test the FXC E1\(T1\) transmission unit](#)

[Using loopbacks to test the FXC RRI transmission unit](#)

[Using loopbacks to test the FXC STM-1 transmission unit](#)

Reference

[21 Loop to interface](#)

[22 Loop to equipment](#)

Using loopbacks to test the FXC RRI transmission unit

Reference

[99 Error rate E-3](#)

[81 Loss of frame alignment](#)

An example of loopback usage during a traffic cut

Instructions

[Adjusting service interface settings](#)