

# Offline Charging

TECHN PRODUCT DESCR

## **Copyright**

© Ericsson AB 2013–2018. All rights reserved. No part of this document may be reproduced in any form without the written permission of the copyright owner.

## **Disclaimer**

The contents of this document are subject to revision without notice due to continued progress in methodology, design and manufacturing. Ericsson shall have no liability for any error or damage of any kind resulting from the use of this document.

## **Trademark List**

All trademarks mentioned herein are the property of their respective owners. These are shown in the document Trademark Information.



# Contents

<b>1</b>	<b>Introduction</b>	<b>1</b>
1.1	Scope	1
1.2	Target Groups	1
<b>2</b>	<b>Overview</b>	<b>1</b>
2.1	Charging Concepts and Transfer	1
2.2	Charging Information	3
<b>3</b>	<b>Charging Characteristics</b>	<b>3</b>
3.1	Charging Profiles	3
3.1.1	RAT-Based Limit Profiles	4
3.2	Charging Characteristics Value	4
3.3	Charging Characteristics Mask	5
3.4	Selection of Charging Characteristics	5
3.4.1	Selection of Charging Characteristics in the GGSN and PGW	6
3.4.2	Selection of Charging Characteristics in the SGW	9
<b>4</b>	<b>CDR-Based Charging</b>	<b>11</b>
4.1	Charging Network and CDR Distribution	11
4.2	Charging Information	11
4.3	CDR Types and Formats	11
4.3.1	CDR Types	11
4.3.2	CDR Formats	12
4.4	CDR Encoding	13
4.4.1	CDR Size	13
4.5	Usage Measurement and Reporting Levels	13
4.5.1	Bearer Level Reporting	14
4.5.2	RG Level Reporting	14
4.5.3	SI Level Reporting	14
4.5.4	URI Level Reporting	14
4.5.5	IP Flow Level Volume Reporting	15
4.6	Backwards Compatibility	16
4.7	CDR Contents and Generation	16
4.7.1	Record Data	17
4.7.2	Bearer Data	21
4.7.3	Service Data	23
4.7.4	Record Extensions	27
4.8	CDR Generation Options	28
4.8.1	Record Data Options	28



4.8.2	Bearer Data Options	29
4.8.3	Service Data Options	30
4.8.4	Limited Support for Duplicate Prevention	31
4.9	NPI Octet as a part of the MSISDN structure	31
<b>5</b>	<b>Rf-Based Charging</b>	<b>31</b>
5.1	Charging Network and Rf ACR Distribution	31
5.2	Charging Information	32
5.3	Rf ACR Format	32
5.4	Usage Measurement and Reporting Levels	32
5.4.1	Bearer Level Reporting	33
5.4.2	RG Level Reporting	33
5.4.3	SI Level Reporting	33
5.4.4	Transaction Level Reporting	33
5.5	Rf Data Collection	33
5.5.1	Record Data	34
5.5.2	Bearer Data (SGW Only)	38
5.5.3	Service Data (PGW Only)	40
5.6	ACR Generation Options	45
5.6.1	Record Data Options	45
5.6.2	Bearer Data Options (SGW Only)	46
5.6.3	Service Data Options (PGW Only)	47
5.7	Credit Control Information Support in Rf	49
5.8	Credit Control Failure Support in Rf	49
<b>6</b>	<b>Failure Handling</b>	<b>51</b>
<b>7</b>	<b>Configuration Planning</b>	<b>51</b>
7.1	Control Plane Process Failures	51
7.2	Control Plane Board Failures	52
7.3	Packet Processing Board Failures	52
7.4	Calculations for Rf Charging Loss	52
<b>8</b>	<b>Counters</b>	<b>54</b>
<b>9</b>	<b>Alarms and Alerts</b>	<b>54</b>



# 1 Introduction

This document describes offline charging in the EPG for GSM, WCDMA, LTE, trusted Non-3GPP network, and untrusted Non-3GPP network.

**Note:** For an overview of related concepts and terminology, refer to [Session Management and SACC Overview](#).

## 1.1 Scope

This document describes Charging Data Record (CDR) based and Rf Accounting-Request (ACR) based charging in the EPG.

For information on configuring charging, refer to [Offline Charging Configuration](#).

## 1.2 Target Groups

This document is intended for personnel supervising or performing configuration of the EPG, and other maintenance personnel. The content assumes a basic knowledge of telecommunications systems.

# 2 Overview

This section presents an overview of offline charging in the EPG.

## 2.1 Charging Concepts and Transfer

The 3GPP defines the following three components that translate service use to payment for services:

<b>Billing</b>	Generating the invoice of the subscriber for services.
<b>Charging</b>	Gathering statistics about service usage for each subscriber.
<b>Rating</b>	Determining how much each service costs each subscriber, based on the services contracted or tariffed.

For offline charging, rating and billing are performed by external charging nodes such as Billing System (BS). Charging information can be transferred directly from the EPG to the following network nodes:



- BS over the Bp interface, by storing CDRs to a file and using FTP-pull
- Charging Gateway Function (CGF) over the Ga interface, by sending CDRs to the CGF over GTP Prime in near real time
- Charging Data Function (CDF) over the Rf interface, by sending Rf ACR messages

Figure 1 shows the EPG and its surrounding nodes related to offline charging.

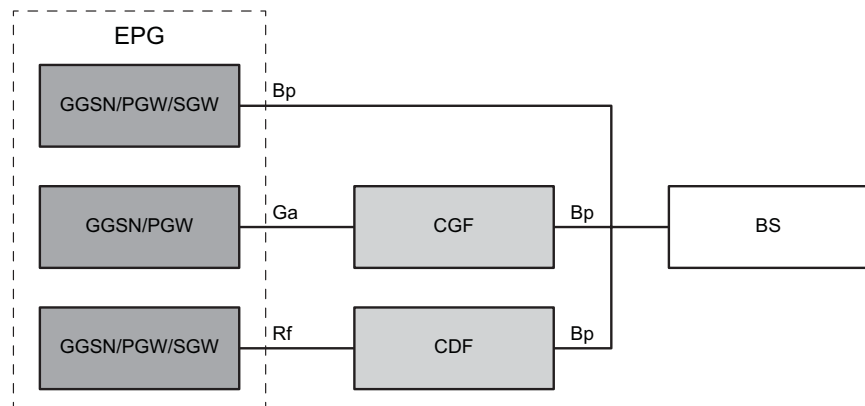

Figure 1 EPG and Surrounding Network Nodes Related to Offline Charging

The following charging concepts are important for offline charging in the EPG:

**CDR** The CDR is a formatted collection of information used to gather mobile data usage information during the lifetime of the bearer. CDRs can be transferred to the BS over the Bp interface or the CGF over the Ga interface. For more information on CDRs, refer to CDR Format for the GGSN and PGW and CDR Format for the SGW.

**Rf ACR** The Rf Accounting-Request (ACR) is a formatted collection of information used to gather mobile data usage information during the lifetime of the user session. Rf ACRs can be transferred to the CDF over the Rf interface. For more information on Rf ACRs, refer to ACR Format.

### Charging Characteristics

Charging Characteristics (CC) is a 3GPP-defined 16-bit attribute which is divided into two parts, charging profile (4 bits) and behavior (12 bits). The EPG uses the 4-bit charging profile part of the CC to identify which charging profile to use for a user session. CC can also be used for user category selection.

**Charging Profile**

A charging profile is a configurable set of parameters determining the charging properties used for a user session. These properties include specific trigger values, such as data volume and time limits, which determine when and how often CDRs and Rf ACRs are generated.

For more information about support of these concepts, refer to SoC with 3GPP TS 32.251 (pre-Rel 8), SoC with 3GPP TS 32.251, SoC with 3GPP TS 32.299 (Offline Charging - PGW), SoC with 3GPP TS 32.299 (Offline Charging - SGW), and the following sections.

## 2.2 Charging Information

For a standalone SGW, the SGW generates the charging records (CDRs or Rf ACRs) containing information needed to charge a subscriber for accessing data. This also applies in a combined SGW and PGW, if a user session is handled by an external PGW.

For the standalone PGW, the PGW generates the charging records containing information needed to charge a subscriber for accessing data.

For a combined SGW and PGW, both the SGW and the PGW can simultaneously generate charging records containing information needed to charge a subscriber for accessing data.

**Note:** By default, only the PGW generates charging records for user sessions handled by the combined SGW and PGW. For information on configuring the SGW to generate CDRs for combined sessions in a combined SGW and PGW, refer to *Offline Charging Configuration*.

## 3 Charging Characteristics

The EPG determines the charging characteristics identified by the charging characteristics value and corresponding charging profile for a user session at default bearer activation. The following sections describe charging profiles and the selection of charging characteristics in the EPG.

### 3.1 Charging Profiles

Charging profiles control the generation and output of charging records in the EPG.



Up to 16 different charging profiles can be configured in the SGW and in the GGSN and PGW. A profile index refers to each profile, (profile0, profile1, ... , profile15).

The behavior of each profile can be configured, and all profiles have the same default values.

If no configured charging profile is matched by the selected CC, the default settings are used according to [Offline Charging Configuration](#). By default, offline charging is enabled for all bearers. To disable offline charging completely, it must be disabled for every charging profile. Therefore, for full flexibility, it is recommended to configure all 16 charging profiles.

For information on configuring charging profiles, refer to [Offline Charging Configuration](#).

### 3.1.1 RAT-Based Limit Profiles

It is possible to configure alternative limits based on Radio Access Type for a charging profile. Different limit-profiles can be configured to have different time and volume limits. A charging profile is then configured with an association of a RAT-type and the limit profile. The values configured under the charging profile are overwritten for the RAT type with the limit profile values

If a limit profile is not configured, the time and volume limits defined under the charging profile are used.

For more information on how to configure RAT-based limit profiles, see [Offline Charging Configuration](#).

## 3.2 Charging Characteristics Value

The Charging Characteristics Value is a 3GPP-defined 16-bit attribute, indicating the charging behavior. It can be configured on the APN level.



Table 1 Structure of the Charging Characteristics Value

Octet	Bit							
	7	6	5	4	3	2	1	0
1 most significant octet	B7	B6	B5	B4	B3	B2	B1	B0
2 least significant octet	B15	B14	B13	B12	B11	B10	B9	B8

The EPG uses the bit B0-B3 to select the charging profile for offline charging.

**Note:** In previous 3GPP specifications, bit B0-B3 was referred as bit P0-P3.

### 3.3 Charging Characteristics Mask

The CC mask indicates the significant bits of the full 16-bit CC value assigned to a user session in the process of selecting a user category based on CC. The mask, configured as four hexadecimal digits, is either a contiguous set of ones with optional heading or trailing zeros, or both. The CC mask is applied according to the following rule:

The first octet of the CC mask is applied to bit B0-B7 of the CC value while the second octet of the CC mask is applied to bit B8-B15.

For example, an initial hexadecimal CC value of 0201 and a CC mask of 0F00 gives the following:

A hexadecimal CC value of 0201 means octet 1 is 01 and octet 2 is 02. A CC mask of 0F00 means that 0F of the CC mask is applied to 01 of the CC value., which gives the value of 1.

### 3.4 Selection of Charging Characteristics

The EPG determines the CC and corresponding profile for a user session during default bearer activation.

The 4-bit charging profile part of the CC value identifies the charging profile to apply for offline charging. The selected charging profile is applied for both CDR-based and Rf-based offline charging.



The following sections describe the selection of CC in the SGW and in the GGSN and PGW.

### 3.4.1 Selection of Charging Characteristics in the GGSN and PGW

When selecting the charging characteristics on the GGSN or PGW for a user session, the EPG uses the priority order shown in Figure 2.

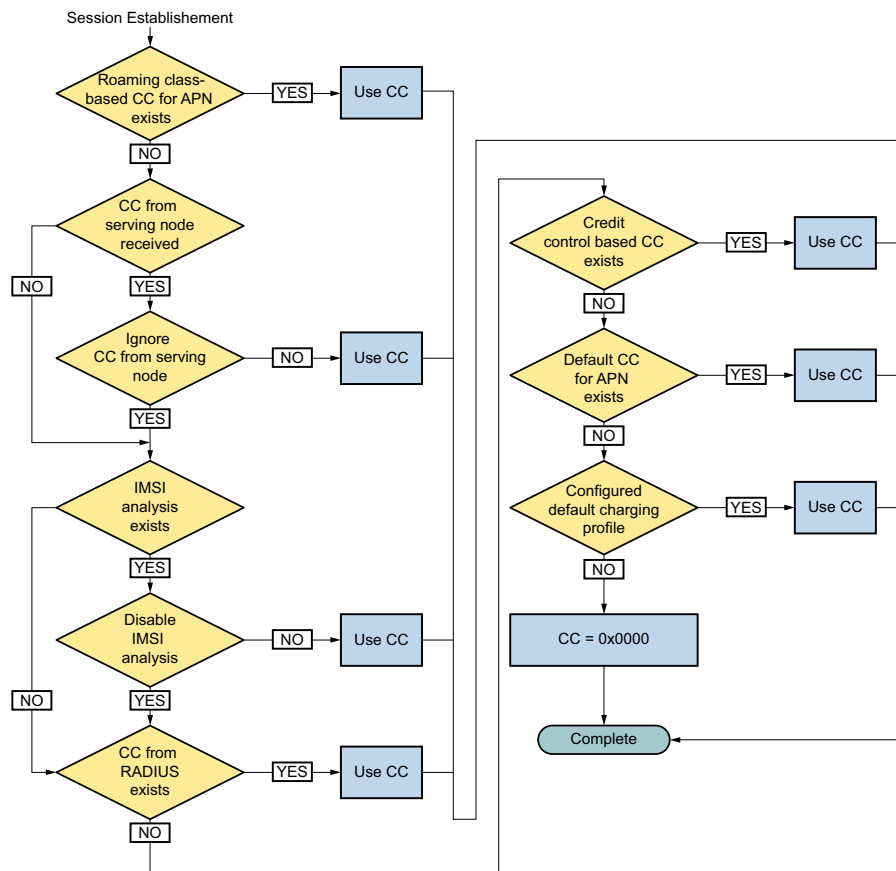

Figure 2 Charging Characteristics Selection Procedure for a User Session for the GGSN and PGW

1. Roaming-based CC:  
CC based on roaming class (if enabled).
2. CC from serving node:  
CC defined in Home Location Register (HLR) and received from SGSN or defined in the Home Subscriber Server (HSS) and received from the Mobility Management Entity (MME) (if provided and not configured to be ignored).
3. Ignore CC value from serving node:  
The CC value that was received from the serving node is configured not to be selected.



4. IMSI analysis:  
Select the CC value based on the configured IMSI analysis. That is, if the CC value received from the serving node are ignored and an IMSI analysis exists.
5. Disable IMSI analysis:  
The CC selection that was based on the IMSI analysis is configured to be disabled.
6. CC from RADIUS:  
CC received from Remote Authentication Dial In User Service (RADIUS) server (if enabled).
7. Credit control-based CC:  
Configured CC based on credit control queries. This is only possible if credit control based on SACC is enabled, and query is configured.  
  
Different CC can be configured depending on credit control being applied or not, or no valid answer received. For further information, refer to [Credit Control Configuration](#).
8. Default CC for APN:  
Configured default CC per APN (if enabled).
9. Use the configured default CC:  
If no CC is found in the previous steps, a default charging profile is chosen, and the selected CC value is the number of the default charging profile, placed in the most significant byte of the CC. For example, if the default charging profile is 8 then the selected CC value is 0x0800. For information on how to configure a default charging profile, refer to [Offline Charging Configuration](#).
10. Internal default CC:  
If the default charging profile number is not configured, the selected CC value is 0x0000.

The selection mode used is documented in the CDRs. For more information, refer to [CDR Format for the GGSN and PGW](#).

The GGSN and PGW can be configured to include the selected CC in the CCR Initial and CCR Update messages sent to the PCRF over the Gx+ interface. For more information, refer to [Policy Control Configuration](#).

#### 3.4.1.1 Charging Profile, User Category, and Credit Control Profile Selection Using Charging Characteristics

The EPG supports configuration of 64 user categories at APN level. The user categories are selected based on the roaming class or the chosen charging characteristics, combined with IMSI and MSISDN analysis. A credit control profile is connected to each user category for which online charging applies. Each credit control profile refers to an Online Charging System (OCS), configured as a Diameter Application System (DAS). For information on how to configure a DAS, refer to [Diameter Configuration](#).



**Note:** The default APN CC is not used for user category selection.

By default, the EPG selects the charging profile that has the same number as the chosen CC value.

Through configuration on APN level, the full 16-bit charging characteristics value, or a limited part of it as defined by a configurable bit-mask, can be used to determine which user category is applicable for the user session.

If no charging characteristics that is either based on roaming class or received from the SGSN or MME, IMSI analysis, or RADIUS is available, the charging characteristics is determined using the following Gy query procedure:

- If no credit control is configured for the user category selected, and no default charging characteristics for the APN exist, the default charging profile and category are used, see Figure 2.
- If credit control is configured, a CCR Initial message is sent to the OCS. The selection is then based on the CCA Initial message and the charging characteristics configured per type of response:
  - Credit control enabled
  - Credit control disabled
  - No valid answer from OCS
- If no charging characteristics is configured for the OCS response and no default charging characteristics for the APN exists, the default charging profile is used, see Figure 2.

The charging characteristics value assigned to the user session is reported over online (Gy) and offline (eG-CDR and PGW-CDR) charging interfaces. The charging characteristics value assigned never changes over the lifetime of the user session.

### 3.4.1.2 Charging Profile Selection Based on Roaming Status

The charging profile based on the selected CC can be overridden for roaming users. The override is performed by configuring a roaming profile for roaming users, which is configured per APN. If configured and the user is roaming, the configured roaming profile overrides the charging profile based on the selected CC. A user is considered to be roaming if its serving network PLMN-ID is different from the EPG PLMN-ID.

The PLMN-ID of the serving node is extracted from the Routing Area Identity (RAI) (GTPv1) and Serving Network (GTPv2) Information Elements (IE). If the PLMN-ID is not included in any of these IEs, the PLMN-ID is derived from the SGSN address and the PLMN-ID configuration. If the PLMN-ID is not configured, the user is considered not to be roaming, and the charging profile based on the selected CC is used.



For information on how to configure roaming profiles, refer to [Offline Charging Configuration](#).

For information on user categories and user category selection, refer to [SACC Overview](#).

### 3.4.1.3 Charging Profile Selection Based on Roaming Class and CC Value Selection

The charging profile based on the selected CC can be overridden by configuring a charging profile based on roaming class and selected CC value.

If the charging profile based on roaming class and CC value is configured, and the user matches the roaming class and CC value, the EPG uses the charging profile.

The EPG uses the charging profile based on the selected CC if the roaming class or CC value is not configured or matched.

For information on how to configure roaming class and CC value profiles, refer to [Offline Charging Configuration](#).

For information on user categories and user category selection, refer to [SACC Overview](#).

## 3.4.2 Selection of Charging Characteristics in the SGW

When selecting the charging characteristics on the SGW for a PDN connection, the EPG first checks if a shared PLMN-ID list exists and if the user is roaming. The EPG then uses the following priority list, as depicted in Figure 3:

1. Charging characteristics based on roaming class (if enabled). Charging-Characteristics-Selection-Mode AVP is set to **4 Roaming-Default**. This is only applicable for roaming users.
2. Charging characteristics received from the serving node (if provided and not configured to be ignored). Charging-Characteristics-Selection-Mode AVP is set to **0 Serving-Node-Supplied**.
3. Since the charging profile is selected based on the charging characteristics value, a default charging profile is chosen if no charging characteristics are found. Charging-Characteristics-Selection-Mode AVP is set to **3 Home-Default**. For information on how to configure a default charging profile, refer to [Offline Charging Configuration](#).

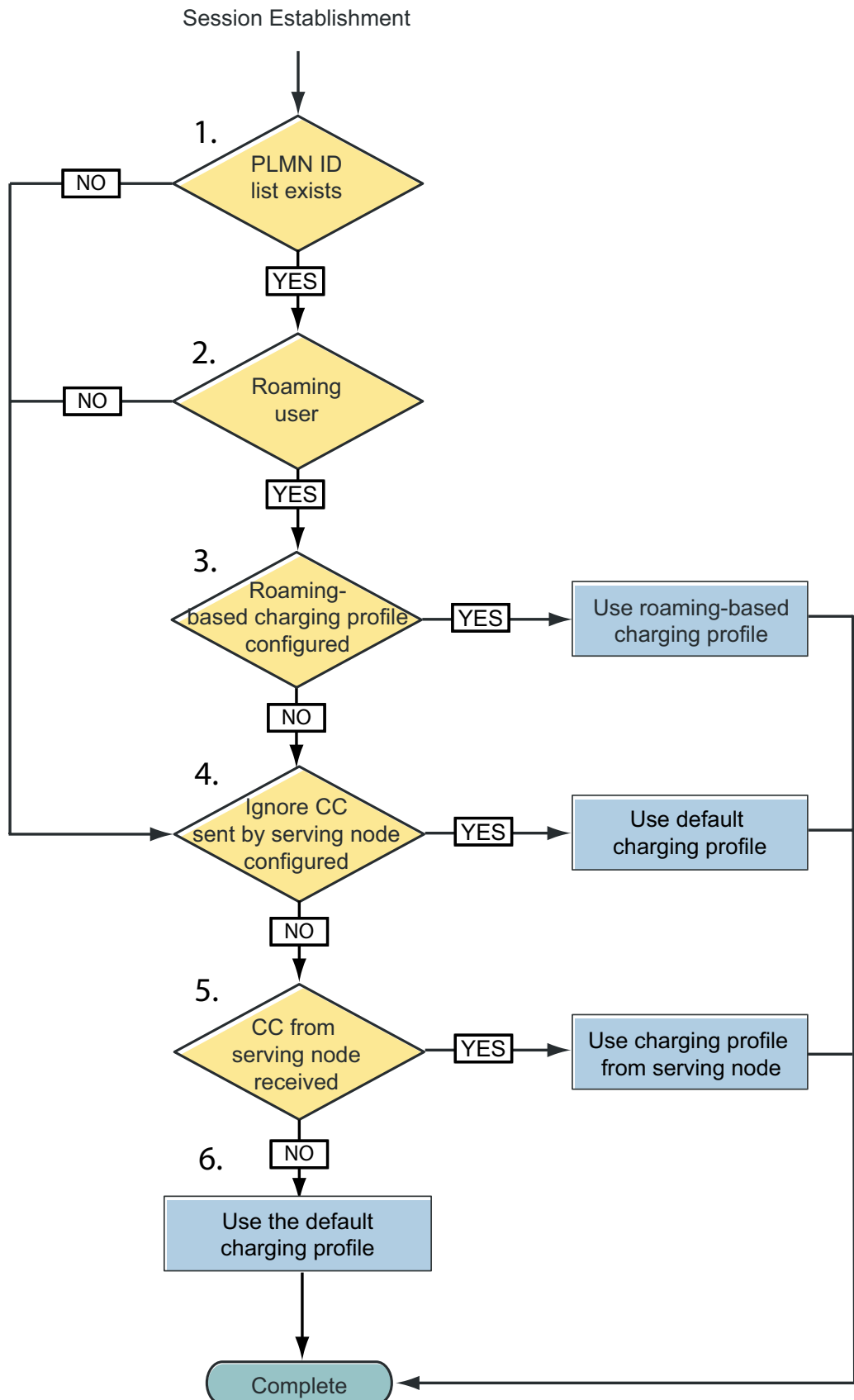

Figure 3 Charging Characteristics Selection Procedure for a PDN Connection for the SGW



## 4 CDR-Based Charging

The following sections describe CDR-based charging in the EPG.

### 4.1 Charging Network and CDR Distribution

The CDRs and ACRs can be sent directly to a BS or through a CGF, for example, the Multi Mediation (MM) product. A CGF handles consolidation of CDRs, preprocessing of CDRs fields, filtering of unused fields, and adding operator-defined fields, which is not supported by EPG.

SFTP is used for file-based transfer of CDRs and GTP Prime is used for near-real-time transfer of CDRs. A description of the charging interfaces can be found in [CDR-Based Charging Interface Description](#).

### 4.2 Charging Information

CDRs contain the information required to charge a subscriber for accessing data from an Access Point Name (APN). The CGF consolidates charges for a particular bearer from the GGSN or PGW and for the SGSN or SGW. Each CDR is marked with a charging ID that identifies the UE and the particular bearer. This charging ID correlates information generated by SGSN or SGW and GGSN or PGW. The BS generates the information shown in the bill that is sent to the subscriber.

### 4.3 CDR Types and Formats

The EPG generates CDRs on a per bearer basis. The CDR format depends on the generating node type and the configured charging format.

#### 4.3.1 CDR Types

During the lifetime of the bearer, the EPG generates one or several partial CDRs, depending on the duration of the user session. The EPG can generate the following partial CDR types:

##### **Fully Qualified Partial CDR**

Partial CDR that contains a complete set of the fields specified in the present document. This set includes all the mandatory and conditional fields, and the fields that are not excluded by configuration. The first partial CDR for a user session is a fully qualified partial CDR.



### Reduced Partial CDR

Partial CDRs that provide only mandatory fields and information regarding changes in the session parameters relative to the previous partial CDR. For example, location information is not repeated in reduced partial CDRs if the subscriber did not change its location. Generation of reduced partial CDRs is enabled by default and can be disabled by configuration.

## 4.3.2 CDR Formats

The generated CDR format depends on the generating node type, the configured charging format, and the APN type of the bearer. The EPG can generate the following CDR formats:

<b>G-CDR</b>	Used for bearer charging data if the EPG is acting as GGSN or PGW. The G-CDR is compliant with 3GPP releases Rel-6 to Rel-7.
<b>eG-CDR</b>	Used for bearer and service charging data if the EPG is acting as GGSN or PGW. The eG-CDR is compliant with 3GPP releases Rel-6 and Rel-7.
<b>PGW-CDR</b>	Used for bearer and service charging data if the EPG is acting as GGSN or PGW. The PGW-CDR is compliant with 3GPP releases Rel-8, Rel-13, and Rel-15.
<b>SGW-CDR</b>	Used for bearer charging data if the EPG is acting as SGW. The SGW-CDR is compliant with 3GPP release Rel-9, Rel-13, and Rel-15.

Table 2 shows the generated CDR format depending on the node type, the APN type, and the charging format.

Table 2 Generated CDR Format Depending on Node Type, APN Type, and Charging Format

Node Type	APN Type						
		Rel-6	Rel-7	Rel-8	Rel-9	Rel-13	Rel-15
GGSN	No SACC	G-CDR	G-CDR	PGW-CDR	n/a	PGW-CDR	PGW-CDR
GGSN	SACC	eG-CDR	eG-CDR	PGW-CDR	n/a	PGW-CDR	PGW-CDR
PGW	No SACC	G-CDR	G-CDR	PGW-CDR	n/a	PGW-CDR	PGW-CDR
PGW	SACC	eG-CDR	eG-CDR	PGW-CDR	n/a	PGW-CDR	PGW-CDR
SGW	n/a	n/a	n/a	n/a	SGW-CDR	SGW-CDR	SGW-CDR



For a detailed description of the CDR fields contained per CDR format, refer to CDR Format for the SGW and CDR Format for the GGSN and PGW.

For instructions on configuring the charging format, refer to Offline Charging Configuration.

## 4.4 CDR Encoding

The CDRs generated in the EPG are specified according to Abstract Syntax Notation One (ASN.1) and ASN.1 Basic Encoding Rules (BER) are used to encode the CDRs into a binary format after they are closed.

### 4.4.1 CDR Size

The default CDR size is 512,000 bytes, but can be limited to 64,000 bytes.

For information on configuring the CDR size, refer to Offline Charging Configuration.

## 4.5 Usage Measurement and Reporting Levels

The EPG supports usage measurement and reporting using different methods at several levels. Measured usage is included in containers as described in Section 4.7.2 on page 21 and Section 4.7.3 on page 23.

Usage can be measured using any of the following charging methods:

- Volume-based measurement
- Time-based measurement
- Event-based measurement

**Note:** Time-based measurement and event-based measurement is not applicable for the SGW.

For detailed information on the available charging methods, refer to Charging Methods.

Measured usage can be reported on the following levels in a CDR:

- Bearer level
- Rating Group (RG) level
- Service Identifier (SI) level
- Uniform Resource Identifier (URI) level



**Note:** Service usage, that is, usage measured and reported on RG level, SI level, and URI level, is not applicable for the SGW.

The usage reported in a container is not cumulative. Each container reports the usage measured during the lifetime of the container, starting from when the first payload arrives, alternatively according to applied time-based measurement method, for the bearer or the service. This applies to all measurement types on all reporting levels.

**Note:** Time usage has a discrete relation to payload, depending on applied measurement method.

#### 4.5.1 Bearer Level Reporting

Volume is measured and reported on bearer level by default in G-CDRs, eG-CDR, and SGW-CDRs, and optionally in PGW-CDRs.

For instructions for configuring bearer level reporting, refer to [Offline Charging Configuration](#).

#### 4.5.2 RG Level Reporting

RG level measurement and reporting provide detailed usage information per RG of a user session. By default, volume is measured and reported on RG level if SACC is applied. Optionally, time and events can be measured and reported on RG level. A specific RG can be configured to be used for reporting if SACC is not applied.

For instructions for configuring RG mapping, refer to [SACC Configuration](#). For detailed instructions for configuring RG level reporting, refer to [Offline Charging Configuration](#).

#### 4.5.3 SI Level Reporting

SI level measurement and reporting provide optional detailed service access and usage information per combination of an RG and an SI of a user session. On SI level, only volume can be measured and reported.

SI level reporting can be enabled on node level or per SI on rule space level. Usage of a packet flow that is not associated with an SI, or is associated with an SI that is not configured for SI level reporting, is reported on RG level.

For instructions for configuring SI mapping, refer to [SACC Configuration](#). For detailed instructions for configuring SI level reporting, refer to [Offline Charging Configuration](#).

#### 4.5.4 URI Level Reporting

**Note:** URI level reporting is resource consuming and can have an impact on the capacity and performance of the EPG.



URI level measurement and reporting provide optional detailed service access and usage information per combination of an RG and a URI of a user session. On URI level, a combination of access, volume, and events can be measured and reported.

URI access in a packet flow can be tracked per Deep Packet Inspection (DPI) rule for the following protocols:

- Hypertext Transfer Protocol (HTTP)
- Multimedia Messaging System (MMS)
- Real Time Streaming Protocol (RTSP)
- Session Initiation Protocol (SIP)
- Wireless Session Protocol (WSP)

URI level reporting of tracked URIs can be enabled on node level. The following URI attributes can be included:

- Textual URI identifier
- Numerical URI identifier
- Volume
- Events

The numerical URI identifier is a generated unique number that is intended to facilitate the correlation of consecutive containers for the charging system. To release resources and to limit the amount of record data, the GGSN or PGW discards the textual URI after the first reported container of URI access in a packet flow. Consecutive access is associated with the numerical URI identifier only.

**Note:** By enabling numerical URI identifier inclusion, the textual URI can be omitted in consequent containers. By disabling numerical URI identifier inclusion, consecutive usage may not be reported.

For URI access reporting purposes, inclusion of the numerical URI identifier can be disabled.

For URI usage reporting purposes, inclusion of the numerical URI identifier must be enabled for usage accuracy.

For detailed instructions for configuring URI tracking and URI level reporting, refer to [Offline Charging Configuration](#).

## 4.5.5 IP Flow Level Volume Reporting

**Note:** IP flow level volume reporting is resource-consuming and can have an impact on the capacity and performance of the EPG. IP flow level volume reporting is not compatible with URI level reporting.



IP flow level volume reporting provides optional detailed service access and usage information per IP flow (5-tuples) of a user session. IP flow level volume reporting is available only in Release 8, Release 13, and Release 15 PGW-CDRs.

On top of RG level reporting, if IP flow level reporting is activated, the information of all IP flows for that RG is reported as an extension in the CDR. Moreover, if SI level reporting is activated, the information for all IP flows for each SI is also reported as an extension. IP flows reported at SI level are not reported at RG level.

Only TCP and UDP IP flows are considered and the following information is reported per IP flow basis:

- UE IP address
- UE port
- Network IP address
- Network port
- Protocol
- Uplink data volume
- Downlink data volume
- URI domain only if IP flow handles HTTP traffic

The maximum number of IP flows reported per CDR can be configured. When this limit is passed, no more IP flows are recorded in ongoing CDR.

For detailed instructions for configuring IP flow level volume reporting, refer to [Offline Charging Configuration](#).

## 4.6 Backwards Compatibility

The GGSN can generate CDRs according to 3GPP Release 8 (refer to [SoC with 3GPP TS 32.251 \(pre-Rel 8\)](#)), and earlier formats (Release 6 and Release 7). The PGW can generate CDRs according to Release 6, Release 7, Release 8, Release 13, and Release 15. The SGW can generate CDRs based on Release 9 and Release 13 (refer to [SoC with 3GPP TS 32.251](#)).

## 4.7 CDR Contents and Generation

The EPG supports the generation of partial CDRs for all bearers. The partial CDRs include both static charging information and dynamic charging information dependent on network usage. If the EPG uses SACC functions, the partial CDRs for the GGSN or PGW contain additional SACC specific charging information, see [Section 4.7.3 on page 23](#) and [Section 4.7.4 on page 27](#). Charging information also depends on charging release and the options configured.



The following subsections give detailed information on the types of information included in CDRs.

#### 4.7.1 Record Data

The record-specific part of a CDR includes information related to the UE, such as IMSI and MSISDN, information related to the user session, such as APN, information related to the bearer, such as charging identifier, and information related to the record, such as the duration of the record and the cause for record closure. If online charging is applied, a PS Furnish Charging Information (FCI) for the credit control session can be included in CDRs for the default bearer.

The EPG opens a record at bearer creation and records charging data until any of the bearer-related or record-related conditions presented in Table 3, Table 4 and Table 5 are met. The EPG uses priority value internally to prioritize among different causes when closing the records. In case several conditions are met at the same time, the priority value is used to determine which cause is to be used.

Table 3 Cause for Record Closing, Bearer-Related Causes in the PGW

Cause	Priority	Description
Abnormal Release	11	The bearer is deactivated because of an error condition in the GGSN, PGW, SGW, or network.
Credit Control Change	1	Credit control is disabled by the PCRF for the user session, as described in Section 4.7.2 on page 21.  Credit control fails for the user session, as described in Section 4.7.2 on page 21.  Credit control recovers after failure for the user session.
Credit Control Initiated Release	12	The user session is deactivated because of credit control.
Management Initiated Release	10	The bearer is deactivated by the management interface.
MS Time Zone Change <sup>(1)</sup>	5	The time zone changes for the bearer.



Cause	Priority	Description
Normal Release	15	The bearer is deactivated because of normal procedures.  The bearer is deleted by CLI command for SGW termination by IMSI.  PDN connection is terminated because of receipt of an incremented GTPv2 recovery indicator from the associated SGW GTPv2 path.
PLMN Change <sup>(1)</sup>	4	The SGSN or MME PLMN-ID changes for the bearer.
Policy Control Initiated Release	13	The bearer is deactivated because of policy control.
RAT Change	3	The RAT changes for the bearer.
SGSN Change or Serving Node Change	6	The SGSN or MME change limit is reached because of an SGSN or MME change for the bearer, as described in Section 4.7.1.1 on page 20.
SGW Change	14	The bearer is deactivated because of SGW relocation.
MO Exception Data Counter Receipt	6.5	The SGW receives the MO Exception Data Counter IE.

(1) Not Applicable for PMIPv6-based S2a access

Table 4 Cause for Record Closing, Record-Related Causes in the PGW

Cause	Priority	Description
Maximum Change Conditions	9	The change condition limit is reached for the record, as described in Section 4.7.3.1 on page 26.  The tracked event limit is reached for the record, as described in Section 4.7.3.3 on page 26.  The tracked URI limit is reached for the record, as described in Section 4.7.3.2 on page 26.  The time envelope limit is reached for the record, as described in Section 4.7.4.4.1 on page 28.



Cause	Priority	Description
Time Limit	7	The time limit is reached for the record, as described in Section 4.7.1.3 on page 21.
Volume Limit	8	The volume limit is reached for the record, as described in Section 4.7.1.4 on page 21.

Table 5 Cause for Record Closing in the SGW

Cause	Priority	Description
Normal Release	15	The bearer is deactivated because of normal procedures.  The bearer is deleted by CLI command for SGW termination by IMSI.  PDN connection is terminated because of receipt of an incremented GTPv2 recovery indicator from the associated SGW GTPv2 path.
Abnormal Release	11	The bearer is deactivated because of an error condition in the GGSN, PGW, SGW, or network.
SGSN Change or Serving Node Change	6	The SGSN or MME change limit is reached because of an SGSN or MME change for the bearer, as described in Section 4.7.1.1 on page 20.
RAT Change	3	The RAT changes for the bearer.
PLMN Change	4	The SGSN or MME PLMN-ID changes for the bearer.
SGW Change	14	The bearer is deactivated because of SGW relocation.
MO Exception Data Counter Receipt	6.5	The SGW receives the MO Exception Data Counter IE.



Maximum Change Conditions	9	The change condition limit is reached for the record, as described in Section 4.7.3.1 on page 26. The tracked event limit is reached for the record, as described in Section 4.7.3.3 on page 26. The tracked URI limit is reached for the record, as described in Section 4.7.3.2 on page 26. The time envelope limit is reached for the record, as described in Section 4.7.4.4.1 on page 28.
Time Limit	7	The time limit is reached for the record, see Section 4.7.1.3 on page 21.
Volume Limit	8	The volume limit is reached for the record, see Section 4.7.1.4 on page 21.

When any of the bearer-related or record-related conditions presented in Table 3 and Table 4 are met, the following actions are taken:

- The EPG includes the cause for record closing in the `causeForRecClosing` field. In case several conditions are met at the same time, the EPG includes the cause with the highest priority, where 1 is the highest and 15 is the lowest priority.
- If applicable, the EPG closes all service data containers, as described in Section 4.7.3 on page 23.
- If applicable, the EPG closes the traffic volume container, as described in Section 4.7.2 on page 21.
- The EPG closes the record.
- The EPG resets all record-related limits.
- If applicable, the EPG opens a new record.

For the configurable options on the EPG for record data, see Section 4.8.1 on page 28.

#### 4.7.1.1 Serving Node Change Limit

The accumulated number of SGSN or SGW changes in a CDR is limited by a configurable serving node change limit. In case the recorded number of SGSN or SGW changes in an open record reaches or exceeds the serving node change limit, the EPG closes the record.



The serving node change limit is configurable on charging profile level, refer to [Offline Charging Configuration](#).

#### 4.7.1.2 Bearer Condition Change Limit

The accumulated number of changes in bearer conditions in a CDR, see Table 6 and Table 9, is limited by a configurable change limit. In case the recorded number of changes in bearer conditions in an open record reaches or exceeds the change limit, the EPG closes the record.

The bearer condition change limit is configurable on charging profile level, refer to [Offline Charging Configuration](#).

**Note:** Record-related limits are not reset in case the record is closed because of the bearer-related condition `Tariff Time` being met.

By default, changes in user location are not considered being bearer condition changes. User location change triggers can be enabled by configuration to count against the bearer condition change limit, see Section 4.8.3.1 on page 30.

#### 4.7.1.3 Time Limit

The duration of a CDR is limited by a configurable time limit. In case the recorded duration of an open record reaches or exceeds the time limit, the EPG closes the record.

The time limit is configurable on charging profile level, refer to [Offline Charging Configuration](#).

For information on optional configurable options related to time limit, see Section 4.8.1.2 on page 28 and Section 4.8.1.3 on page 29.

#### 4.7.1.4 Volume Limit

The accumulated volume usage in a CDR is limited by a configurable volume limit in kilobytes (KB). In case the recorded usage in an open record reaches or exceeds the volume limit, the EPG closes the record.

The volume limit is configurable on charging profile level, refer to [Offline Charging Configuration](#).

#### 4.7.2 Bearer Data

**Note:** Traffic volume containers are, by default, not applicable for PGW-CDRs, see Section 4.8.2.2 on page 29.

A traffic volume container of a CDR includes information related to a bearer such as QoS, usage, and the cause for container closure.



The EPG opens a traffic volume container at bearer creation and records bearer data in the container until any of the bearer-related or record-related conditions presented in Table 6 and Table 7 are met. In case several conditions are met at the same time, the priority value is used to determine which cause is to be used.

Table 6 Change Condition, Bearer-Related Causes

Cause	Priority	Description
Failure Handling Continue Ongoing	1	Credit control is disabled for the user session. Credit control fails for the user session.
Change in User Plane to UE	1	User Plane changes between S1-U and S11-U.
Failure Handling Retry And Terminate Ongoing	2	Credit control fails for the user session.
Failure Handling Terminate Ongoing	3	Credit control fails for the user session.
Tariff Time	4	The tariff period changes for the bearer, as described in Section 4.7.2.1 on page 23.
QoS Change	5	The QoS changes for the bearer.
Serving PLMN Rate Control Change	6	The changes of Serving PLMN Rate Control for the bearer.
User CSG Information Change	13	The User CSG Information Changes for the bearer.

For more information on credit control failure handling, refer to [Credit Control](#).

Table 7 Change Condition, Record-Related Causes

Cause	Priority	Description
Record Closure	7	The record is closed for other reasons, see Section 4.7.1 on page 17.

When any of the bearer-related or record-related conditions presented in Table 6 and Table 7 are met, the following actions are taken:

- The EPG includes the cause for traffic volume container closing in the ChangeCondition subfield of the traffic volume container. In case several conditions are met at the same time, the EPG includes the cause with the highest priority, where 1 is the highest and 7 is the lowest priority.
- If applicable, the EPG closes all service data containers, see Section 4.7.3 on page 23.



- The EPG closes the traffic volume container.
- The EPG resets bearer usage.
- If applicable, the EPG opens a new traffic volume container.

For the configurable options on the EPG for bearer data, see Section 4.8.2 on page 29.

#### 4.7.2.1 Tariff Period

**Note:** Tariff periods are not supported for SGW-CDRs.

Tariff periods provide the ability for the BS to apply different charges at different times of a day. Each time a user session enters a new tariff period, the EPG closes the traffic volume container for all bearers associated with the user session.

For information on how to configure tariff periods, refer to [Offline Charging Configuration](#).

**Note:** Simultaneous tariff period changes for several user sessions can have a momentary impact on the capacity and performance of the EPG.

#### 4.7.3 Service Data

**Note:** Service data containers are not applicable for G-CDRs and SGW-CDRs.

A Service Data Container (SDC) of a CDR includes information related to a service, such as usage, time stamps, and the cause for container closure. If online charging is applied, a PS-FCI for the service can be included, any non-successful result code at CCA MSCC level received for the service from the OCS is included, and whether the service continues without credit control. If policy control is applied, an Application Function (AF) charging identifier for the service can be included. In addition, an SDC includes information related to the bearer, such as QoS, and the user, such as location.

A service is represented by either an RG level SDC, identified per RG-ID, or an SI level SDC, identified per combination of RG-ID and SI-ID, depending on applied reporting level. By default, the EPG reports information at the level of relevance. That is, with SI level reporting enabled for a particular SI, the EPG reports information related to online charging, the bearer, and the user in an associated RG level SDC, and information related to service usage in an SI level SDC. Optionally, the EPG can be configured to include associated information also in SI level SDCs, refer to [Offline Charging Configuration](#). A PS-FCI is only included in the associated RG level SDF. An AF charging identifier is only included at the level specified by the controlling DCR.

URI level information, identified per combination of RG-ID and URI, is included in an associated RG level service data extension container, see Section 4.7.4.3 on page 27.



IP flow information, identified per RG or the combination of RG and SI, is included in an associated RG level, or SI and RG level service data extension container, see Section 4.7.4.3 on page 27.

SDCs are included in CDRs for the bearer that the service is associated to. For information on service and bearer association, refer to [SACC Overview](#).

The EPG opens an SDC at first use of a service and records service data in the container until any of the service-related, bearer-related, or record-related conditions presented in Table 8, Table 9, and Table 10 are met:

Table 8 Service Condition Change, Service-Related Causes

Cause	Description
Continue Ongoing Session	Credit control is not applicable for the service.
Reauthorization Request	The service is reauthorized by the OCS.
Return Requested	The quota for the service is reported to the OCS.
Service Idled Out	The Quota Holding Time (QHT) provided by the OCS expires for the service.
Service Specific Unit Exhausted	The event quota provided by the OCS is exhausted for the service.
Service Specific Unit Threshold Reached	The event quota threshold provided by the OCS is reached for the service.
Service Stop	The service is stopped by the OCS.
Tariff Time Switch	The tariff period provided by the OCS changes for the service.
Time Exhausted	The time quota provided by the OCS is exhausted for the service.
Time-out	The VT provided by the OCS expires for the service.
Time Threshold Reached	The time quota threshold provided by the OCS is reached for the service.
User CSG Information Change	The User CSG Information changes for the bearer.
Volume Exhausted	The volume quota provided by the OCS is exhausted for the service.
Volume Threshold Reached	The volume quota threshold provided by the OCS is reached for the service.

For more information on service-related causes, refer to [Credit Control](#).



Table 9 Service Condition Change, Bearer-Related Causes

Cause	Description
CGI or SAI Change	The CGI or SAI changes for the bearer, as described in Section 4.8.3.1 on page 30.
Continue Ongoing Session	Credit control is disabled for the user session, as described in Section 4.7.2 on page 21. Credit control fails for the user session, as described in Section 4.7.2 on page 21.
ECGI Change	The ECGI changes for the bearer, as described in Section 4.8.3.1 on page 30.
PDP Context Release	The bearer is deactivated.
QoS Change	The QoS changes for the bearer, as described in Section 4.7.2 on page 21.
RAI Change	The RAI changes for the bearer, as described in Section 4.8.3.1 on page 30.
RAT Change	The RAT changes for the bearer, as described in Section 4.7.1 on page 17.
Retry And Terminate Ongoing Session	Credit control fails for the user session, as described in Section 4.7.2 on page 21.
SGSN Change	The SGSN or SGW address changes for the bearer, as described in Section 4.7.1 on page 17.
SGSN PLMN-ID Change	The SGSN or SGW PLMN-ID changes for the bearer, as described in Section 4.7.1 on page 17.
TAI Change	The TAI changes for the bearer, as described in Section 4.8.3.1 on page 30.
Tariff Time Switch	The tariff period changes for the bearer, as described in Section 4.7.2.1 on page 23.
Terminate Ongoing Session	Credit control fails for the user session, as described in Section 4.7.2 on page 21.
User Location Change	The BSID changes for the bearer, as described in Section 4.8.3.1 on page 30.

Table 10 Service Condition Change, Record-Related Causes

Cause	Description
Record Closure	The record is closed for other reasons, as described in Section 4.7.1 on page 17.



When any of the service-related, bearer-related, or record-related conditions presented in Table 8, Table 9, and Table 10 are met, the following actions are taken:

- The EPG includes the cause for SDC closure in the `ServiceConditionChange` subfield of all affected SDCs. In case several conditions are met at the same time, the EPG includes all causes.
- The EPG closes all affected SDCs.
- The EPG resets service usage for all affected services.

For the configurable options on the EPG for service data, see Section 4.8.3.3 on page 30.

#### 4.7.3.1 Service Condition Change Limit

The accumulated number of service-related changes in service conditions in a CDR, see Table 8, is limited by a configurable change limit. In case the recorded number of changes in service conditions in an open record reaches or exceeds the change limit, the EPG closes the record.

The service condition change limit is configurable on charging profile level, refer to *Offline Charging Configuration*.

For information on optional configurable options related to service condition change limit, see Section 4.8.3.3 on page 30.

#### 4.7.3.2 Tracked URI Limit

The accumulated number of tracked URIs in a CDR is limited by a configurable URI limit. In case the recorded number of tracked URIs in an open record reaches or exceeds the tracked URI limit, the EPG closes the record.

The tracked URI limit is configurable on charging profile level, refer to *Offline Charging Configuration*.

#### 4.7.3.3 Tracked Event Limit

The accumulated number of tracked events in a CDR is limited by a configurable event limit. In case the recorded number of tracked events in an open record reaches or exceeds the tracked event limit, the EPG closes the record.

The tracked event limit is configurable on charging profile level, refer to *Offline Charging Configuration*.

#### 4.7.3.4 Local Sequence Numbers

The Local Sequence Number starts with a value of 1 and the value is incremented for each SDC. By default, the EPG restarts the local Sequence Number for each



new partial CDR. Optionally, the EPG can be configured so that the local Sequence Number is incremented throughout the lifetime of a bearer.

For more information, refer to [Offline Charging Configuration](#).

#### 4.7.4 Record Extensions

The optional record extensions part of a CDR contains proprietary fields with additional information related to a user session and its services. The session-related information includes the user category, rule space, policy control information (if applicable), and credit control information (if applicable). The service-related information includes service data extension containers and time envelopes (if applicable).

**Note:** Record extensions are not applicable for G-CDRs and SGW-CDRs.

##### 4.7.4.1 Policy Control Information

Policy control information is included in CDRs for the default bearer of a user session if a policy control session is established, failed or recovered. The policy control information part of a CDR contains information related to the interaction with the PCRF, such as policy control session information and policy control failure reports.

A policy control failure report, describing the type of request, time, and reason for failure, is included in case a CCR message sent to the PCRF fails, or a PCRF restart is detected. The condition for failure report includes failure to send a CCR, any non-successful result code at CCA command level, a CCR time-out, or a PCRF restart. In case multiple CCRs to the PCRF fail, only the first failure is reported.

##### 4.7.4.2 Credit Control Information

Credit control information is included in CDRs for the default bearer of a user session if a credit control session is established, failed or recovered. The credit control information part of a CDR contains information related to the interaction with the OCS, such as credit control session information and credit control failure reports. For information on credit control information, refer to [Credit Control](#)

A credit control failure report, describing the type of request, CCR request number, and reason for failure, is included in case a CCR to the OCS fails. The condition for failure report includes failure to send a CCR, any non-successful result code at CCA command level, or a CCR time-out.

##### 4.7.4.3 Service Data Extensions

A service data extension container of a CDR contains additional information related to an SDC, see Section 4.7.3 on page 23, such as time measurement information, CCR request number, IP flow information, and tracked URIs. The CCR request number of the corresponding request to the OCS is included if an SDC is closed because of credit control, see Table 8. Tracked URI information is



included if URI level reporting is applied. IP flow information is included if IP flow level reporting is applied. Time measurement information is included if time-based charging is applied.

Service data extension containers are included in CDRs for the bearer that the service is associated with. For information on service and bearer association, refer to [SACC Overview](#).

#### **4.7.4.4 Time Envelopes**

Time envelopes related to a service are included if time envelope measurement is applied.

Time envelopes are included in CDRs for the bearer that the service is associated with. For information on service and bearer association, refer to [SACC Overview](#).

##### **4.7.4.4.1 Time Envelope Limit**

The accumulated number of time envelopes in a CDR is limited by an internal time envelope limit of 100. If the recorded number of time envelopes in an open record reaches or exceeds the time envelope limit, the EPG closes the record.

## **4.8 CDR Generation Options**

The following subsections describe the configurable options related to CDR generation.

For instructions for configuring the options, refer to [Offline Charging Configuration](#).

### **4.8.1 Record Data Options**

The following subsections describe the configurable options related to record data. For the default EPG behavior for record data, see Section 4.7.1 on page 17.

#### **4.8.1.1 Suppression of Initial Partial CDR Closure**

By default, the EPG generates an initial partial CDR at bearer creation that only includes static information, and closes the record immediately. Optionally, the EPG can be configured to suppress the record closure of the initial partial CDR and to record data in the record until the record is closed for other reasons.

This option is not applicable for SGW-CDRs.

#### **4.8.1.2 Suppression of Record Closure without Usage**

By default, the EPG closes the record and resets all record-related limits when the time limit of the record is reached regardless of usage. Optionally, the EPG can be



configured to suppress record closure and reset only the time limit when the time limit of the record is reached if there is no reported usage.

The duration for an idle user can exceed the configured time limit if the `no-empty-cdr` option is configured.

This option is not applicable for SGW-CDRs.

#### 4.8.1.3 Incremental Time Limit Measurement

By default, the time limit condition is measured from the opening of the current record. Optionally, the EPG can be configured to measure the time limit condition in increments since the creation of the bearer, that is, not to reset the time limit when a record is closed for another reason.

This option prevents the synchronization of time limit expiry for several user sessions and the resulting periodical impact on the performance and capacity of the EPG, which can result from a global condition for record closure, such as a tariff period change. See Section 4.7.2.1 on page 23.

This option is not applicable for SGW-CDRs.

### 4.8.2 Bearer Data Options

The following subsection describes the configurable options related to bearer data. For the default EPG behavior for bearer data, see Section 4.7.2 on page 21.

#### 4.8.2.1 Change in UP to UE Trigger

If `change-in-up-to-ue-trigger` is configured, the SGW closes the traffic data container if the value of CP CIoT EPS Optimisation Indicator changes. The SGW uses `Change in User plane to UE` as the closure reason in the `Change Condition` subfield.

If `change-in-up-to-ue-trigger` is not configured, the change of CP CIoT EPS Optimisation Indicator does not trigger the container closure.

For information on how to configure `change-in-up-to-ue-trigger`, refer to the section `Change in UP to UE Trigger at Traffic-Data-Volumes Level` in `Offline Charging Configuration`.

#### 4.8.2.2 Inclusion of Traffic Volume Container

By default, traffic volume containers are not applicable for PGW-CDRs. Optionally, the EPG can be configured to include traffic volume containers in PGW-CDRs.

This option is not applicable for G-CDRs, eG-CDRs, or SGW-CDRs.



### 4.8.3 Service Data Options

The following subsections describe the configurable options related to service data. For the default EPG behavior for service data, see Section 4.7.3 on page 23.

#### 4.8.3.1 User Location Change Trigger

By default, the EPG does not close SDCs at user location change. Optionally, the EPG can be configured to close SDCs at specific changes in the user location, among those listed in Table 9.

This option is not applicable for G-CDRs or SGW-CDRs.

#### 4.8.3.2 Inclusion of Service Data Container without Usage

By default, the EPG opens an SDC at first use, that is, volume, time, or event, of a service and records service data until any condition is met. Optionally, the EPG can be configured to open and immediately close an SDC if there is no service usage recorded but a service-related service condition or PDP Context Release condition is met. For information on service usage measurement, see Section 4.5 on page 13.

This option is not applicable for G-CDRs or SGW-CDRs.

#### 4.8.3.3 Suppression of Service Data Container Closure for Service-Related Causes

By default, the EPG records service data in SDCs until a service-related, bearer-related, or record-related condition is met. Optionally, the EPG can be configured to suppress SDC closure when service-related conditions other than Tariff Time Switch are met.

Suppressed service-related conditions are not reported in the SDC and do not count against the service condition change limit.

This option is not applicable for G-CDRs or SGW-CDRs.

#### 4.8.3.4 Inclusion of Bearer Usage in Service Data Container with SACC Disabled

By default, G-CDRs and PGW-CDRs do not contain SDCs if SACC is disabled. Optionally, the EPG can be configured to record bearer usage, that is, volume, and bearer conditions, see Table 9 and Table 10, in SDCs on a specified RG for an APN with SACC disabled.

By default, if SACC is disabled for an APN, the EPG generates G-CDRs for release 6 and 7. Optionally, if an RG is configured for an APN with SACC disabled, eG-CDRs are generated instead.

This option generates eG-CDRs or PGW-CDRs with SDCs but without record extensions.



#### 4.8.4 Limited Support for Duplicate Prevention

By default, if GTP Prime version 2 is used for the transfer of CDRs to CGFs, CDRs resent to secondary CGFs are not marked as possible duplicates. Optionally, the EPG can be configured to mark CDRs resent to secondary CGFs as possible duplicates, which helps the BS notice duplicate CDRs.

This is not applicable for SGW-CDRs.

#### 4.9 NPI Octet as a part of the MSISDN structure

The structure of MSISDN is specified in 3GPP TS 23.003. The MSISDN data type is AddressString and is specified in 3GPP TS 29.002. The maximum length of the AddressString is nine octets, the last eight octets represent the Telephony Binary Coded Decimal (TBCD) and the first octet comprises of the following:

1. Extension Indicator (EI)
2. Nature of Address Indicator (NAI)
3. Numbering Plan Indicator (NPI)

The first octet is referred to as NPI octet.

For more information, refer to [CDR Format for the SGW](#) and [CDR Format for the GGSN and PGW](#)

## 5 Rf-Based Charging

The following sections describe Rf-based offline charging in the EPG. The EPG supports Rf-based offline charging in the SGW and the PGW.

### 5.1 Charging Network and Rf ACR Distribution

In Rf-based offline charging, the Charging Trigger Function (CTF) implemented in the EPG generates charging data and sends Rf ACR messages to the Charging Data Function (CDF), which responds with Accounting-Answer (AC-A) messages. The CDF uses the received Rf ACR messages to create CDRs for EPS services, billing, and statistics. The EPG can be configured to resend the Rf ACRs if it receives a Diameter error. If the EPG does not receive a successful Rf AC-A message, the EPG stores the relevant Rf ACR in an Rf ACR file. For more information about the CDF and detailed information about the structure of Rf messages, and Rf failure handling, refer to the following documents:



- PGW Rf Interface Description
- SGW Rf Interface Description
- SoC with 3GPP TS 32.299 (Offline Charging - PGW)
- SoC with 3GPP TS 32.299 (Offline Charging - SGW)

## 5.2 Charging Information

The EPG generates Rf ACRs containing information needed to charge a subscriber for accessing data. The CDF consolidates charges for each PDN connection from the PGW and the SGW. Each Rf ACR is marked with a charging ID that identifies the UE and the PDN connection. This charging ID together with the PGW address correlates information generated by the PGW and the SGW.

## 5.3 Rf ACR Format

The EPG generates an Rf ACR for each PDN connection. The EPG supports the following message types of Rf ACR:

- Start
- Interim
- Stop

For more information on the Rf ACR format, refer to [ACR Format](#).

For more information on Rf ACR messages, refer to [PGW Rf Interface Description](#) and [SGW Rf Interface Description](#).

## 5.4 Usage Measurement and Reporting Levels

The EPG supports volume-based usage measurement for Rf charging. For detailed information on the available charging methods, refer to [Charging Methods](#).

The EPG measures and reports the volume per bearer or per service (RG, or RG and SI). However, Rf ACRs are created at the PDN connection-level, and include the reported volume for all bearers or services in a PDN connection – whether the charging event is session or record-related, or the charging event is originated by only one bearer or service.

In a PDN connection, measured usage can be reported on the following levels in an Rf ACR:

- Bearer level (SGW only)
- Rating Group (RG) level (PGW only)



— Service Identifier (SI) level (PGW only)

#### 5.4.1 Bearer Level Reporting

Bearer level measurement and reporting provides detailed usage information per bearer of a user session in the SGW.

#### 5.4.2 RG Level Reporting

RG level measurement and reporting provides detailed usage information per RG of a user session. By default, volume is measured and reported on RG level for a user session.

For instructions for configuring RG mapping, refer to [SACC Configuration](#). For detailed instructions for configuring RG level measurement and reporting, refer to [Offline Charging Configuration](#).

#### 5.4.3 SI Level Reporting

SI level reporting provides optional detailed service access and usage information per combination of an RG and an SI for a user session.

For instructions for configuring SI mapping, refer to [SACC Configuration](#). For detailed instructions for configuring SI level reporting, refer to [Offline Charging Configuration](#).

#### 5.4.4 Transaction Level Reporting

Transaction level reporting provides volume information for URI transactions identified by specific classification rules. Transaction reports are provided per RG or SI level for a user session.

For detailed instructions for configuring transaction level reporting, refer to [Offline Charging Configuration](#).

### 5.5 Rf Data Collection

An Rf ACR is a collection of one or more containers that provide session and usage information about a PDN connection. The charging profile selected for the PDN connection determines if and how Rf ACRs are generated.

The EPG establishes a Diameter Rf session for each chargeable PDN connection. The EPG sends Rf ACRs for the PDN connection in the established Diameter Rf session to the CDF. For more information on Diameter sessions, refer to [Diameter Base Protocol](#).



The EPG creates an Rf ACR to monitor the PDN connection by sending an Rf ACR start message to the CDF when a PDN connection is established. The EPG stores the charging data in containers. A container refers to the Service Data Container (SDC) or Traffic Data Volume (TDV) AVPs in an Rf ACR. The PGW uses SDCs while the SGW uses TDVs to report data usage. Events that modify charging attributes cause the EPG to close the current container and open a new container for subsequent charging data. See Table 14, Table 15, and Table 14 for more information.

For each charging event, the EPG reports the subscriber delta volume transferred for each EPS bearer or service within the PDN connection. The delta volume is the traffic volume sent over an EPS bearer between two charging events. The EPG reports the delta volume to the CDF in the Rf ACR Interim and Rf ACR Stop messages.

Charging events can be set as change conditions and trigger the closure of the ACR or the current container. For more information on change condition closing ACRs, see Section 5.5.1 on page 34. For more information on change condition closing containers, see Section 5.5.2 on page 38 and Section 5.5.3 on page 40. For more information on Change-Condition AVP values, refer to PGW Rf Interface Description and SGW Rf Interface Description.

### 5.5.1 Record Data

The record-specific part of an ACR includes the following information:

- UE - such as the IMSI and MSISDN
- User session - such as the APN
- PDN connection - such as charging identifier
- ACR messages - such as the time-stamp for the creation of the ACR messages, and the cause for ACR closure

The EPG opens an ACR if a PDN connection is established and records charging data. The EPG closes the ACR if any of the session-related or record-related conditions described in Table 11, Table 12 and Table 13 are met. The EPG uses priority value internally to prioritize among different causes when closing the ACRs. If several conditions are met at the same time, the EPG uses the priority value to determine which cause is used as the ACR closure cause.

The triggers listed in Table 11, Table 12 and Table 13 can be set as change conditions at the PS-Information level in the PGW and SGW. For more information on the PS-Information level, refer to PGW Rf Interface Description and SGW Rf Interface Description.

Table 11 describes the session-related triggers that close ACRs in the PGW and trigger the EPG to send an Rf ACR Interim or Rf ACR Stop message to the CDF.



The Rf ACR Interim message can also be triggered because of the Accounting Interim Interval (AII) timer in the PGW or in the SGW. However, AII is not a charging event. For information about the AII timer, refer to PGW Rf Interface Description and SGW Rf Interface Description.

Table 11 Session-Related Triggers Closing ACRs in the PGW

Cause	Priority	Description
RAT Change	3	The RAT changes for the PDN connection. Triggers an Rf ACR Interim message.
Serving Node PLMN Change	4	The Serving Node PLMN-ID changes for the PDN connection. Triggers an Rf ACR Interim message.
Serving Node Change without PLMN	4	The change limit for the SGSN or Serving Node is reached for the PDN connection. Triggers an Rf ACR Interim message.
UE Time Zone Change <sup>(1)</sup>	5	The time zone changes for the PDN connection. Triggers an Rf ACR Interim message.
Management Intervention	10	The PDN connection changes to the new active node during an ICR switchover. Triggers an Rf ACR Interim message.
		The default bearer of the PDN connection is deleted by the external server (for example Radius Server). Triggers an Rf ACR Stop message.
Abnormal Release	11	The PDN connection is deactivated because of the following: <ul style="list-style-type: none"> <li>An error condition in the GGSN, PGW, or network.</li> <li>An ICR state becomes unstable during a switchover.</li> </ul> Triggers an Rf ACR Stop message.
Normal Release	15	The PDN connection is deactivated because of the following: <ul style="list-style-type: none"> <li>A session management procedure, for example PDN connection deletion or detach.</li> <li>A credit or policy control procedure.</li> </ul> Triggers an Rf ACR Stop message.

(1) Not Applicable for PMIPv6-based S2a access



Table 12 describes the session-related triggers that close ACRs in the SGW and trigger the EPG to send an Rf ACR Interim or Rf ACR Stop message to the CDF.

Table 12 Session-Related Triggers Closing ACRs in the SGW

Cause	Priority	Description
SGW Change	2	The PDN connection is terminated at the SGW and the PDN connection is handed over to another SGW or to the GRPS network.  Triggers an Rf ACR Stop message.
UE Time Zone Change	4	The time zone changes for the PDN connection.  Triggers an Rf ACR Interim message.
Serving Node PLMN Change	5	The SGSN or MME PLMN-ID changes for the PDN connection.  Triggers an Rf ACR Interim message.
MO Exception Data Counter	6	The SGW receives the MO Exception Data Counter IE.
Management Intervention	10	The PDN connection is deactivated by a CLI command. Example CLIs: Stop SGW application, deactivate session, or deactivate user.  Triggers an Rf ACR Stop message.
		The PDN connection changes to the new active node during an ICR switchover.  Triggers an Rf ACR Interim message.
Normal Release	15	The PDN connection is deactivated because of a session management procedure, for example PDN connection deletion or detach.
		The PDN connection is deleted by CLI command for SGW termination by IMSI.
		PDN connection is terminated because of receipt of an incremented GTPv2 Recovery Indicator from the associated GTPv2 path.  Triggers an Rf ACR Stop message.

Table 13 describes the record-related triggers that close ACRs and trigger the EPG to send an Rf ACR Interim or Rf ACR Stop message to the CDF, if the configured value is reached for the PDN connection. The triggers are applicable for the PGW and the SGW unless otherwise stated.



Table 13 Record-Related Triggers Closing ACRs

Cause	Priority	Description
Time Limit	7	The time duration reaches the configured duration for one of the bearers in the PDN connection. For more information, see Section 5.5.1.3 on page 38.  Triggers an Rf ACR Interim message.
Volume Limit	8	The volume of traffic reaches the configured data volume limit for one of the bearers in the PDN connection. For more information, see Section 5.5.1.4 on page 38.  Triggers an Rf ACR Interim message.
Maximum Bearer Change Conditions	9	The number of bearer change conditions reaches the configured limit for the PDN connection. For more information, see Section 5.5.1.2 on page 38.  Triggers an Rf ACR Interim message.
Maximum Service Change Conditions (PGW only)	9	The number of service change conditions reaches the configured limit for the PDN connection. For more information, see Section 5.5.3.1 on page 45.  The number of completed transactions reaches the tracked transaction limit for the PDN connection. For more information, see Section 5.5.3.2 on page 45.  Triggers an Rf ACR Interim message.

If any of the session-related or record-related conditions described in Table 11, Table 12 and Table 13 are met, the EPG does the following:

- Includes the condition that caused the change in the Change-Condition AVP. If several conditions are met at the same time, the EPG includes the condition with the highest priority, where 1 is the highest and 15 is the lowest priority.
- Closes the containers.
  - The EPG closes SDCs in the PGW, see Section 5.5.3 on page 40.
  - The EPG closes TDVs in the SGW, see Section 5.5.2 on page 38.
- Closes the ACR record.
- Resets all record-related limits, see Table 13.
- Opens a new ACR.
- Opens a new TDV if the session continues. Opens a new SDC if the EPG receives new service data.

For the configurable options, see Section 5.6 on page 45.



### 5.5.1.1 **Serving Node Change Limit (PGW Only)**

The serving node change limit is a configurable value that defines the accumulated number of SGW or Mobile Access Gateway (MAG) changes allowed before the EPG closes an Rf ACR. The PGW sends an Rf ACR Interim message if the number of SGW or MAG changes reaches the configured value. The serving node change limit is configurable on the charging characteristics profile level. For configuration information, refer to [Offline Charging Configuration](#).

### 5.5.1.2 **Bearer Condition Change Limit**

The bearer condition change limit is a configurable value that defines the accumulated number of bearer condition changes allowed before the EPG closes an Rf ACR. The EPG sends an Rf ACR Interim message if the number of bearer condition changes reaches the configured value. The bearer condition change limit is configurable on the charging characteristics profile level. For configuration information, refer to [Offline Charging Configuration](#).

### 5.5.1.3 **Time Limit**

The duration of an ACR is limited by a configurable time limit. The EPG closes the ACR if the duration of an ACR reaches the configured time limit.

The time limit is configurable on charging profile level, refer to [Offline Charging Configuration](#).

### 5.5.1.4 **Volume Limit**

The accumulated volume usage in an ACR is limited by a configurable volume limit, in kilobytes (KB). The EPG closes the open ACR if the recorded volume for one of the bearers in the PDN connection reaches the configured volume limit.

The volume limit is configurable on charging profile level, refer to [Offline Charging Configuration](#).

## 5.5.2 **Bearer Data (SGW Only)**

A TDV container in an ACR includes bearer-related information such as QoS, usage, and the cause for container closure.

The SGW opens a TDV if a bearer is created and records bearer-related data in the TDV. The EPG closes the TDV if any of the session-related or record-related conditions described in Table 14 are met. If several conditions are met at the same time, the EPG uses the priority value to determine which cause is used as the TDV closure cause.

The SGW counts the number of TDVs collected for a PDN connection and checks the number against the maximum bearer condition change.



Table 14 describes charging triggers closing Rf TDVs in the SGW.

Table 14 Charging Triggers Closing Rf TDVs in the SGW

Cause	Description
Serving PLMN Rate Control Change	The changes of Serving PLMN Rate Control for the session.
QoS Change	The QoS changes for the session.
User CSG Information Change	The user CSG information changes for the session. The trigger is configurable and is disabled by default.
User Location Information Change	The User Location Information (ULI) changes for the session. This cause is triggered if more than one of (CGI, SAI, RAI, ECGI, TAI) change is met.
CGI Change	The CGI changes for the session. The cause is configurable and is disabled by default. This cause is triggered if only CGI Change is met.
SAI Change	The SAI changes for the session. The cause is configurable and is disabled by default. This cause is triggered if only SAI Change is met.
RAI Change	The RAI changes for the session. The cause is configurable and is disabled by default. This cause is triggered if only RAI Change is met.
ECGI Change	The ECGI changes for the session. The cause is configurable and is disabled by default. This cause is triggered if only ECGI Change is met.
TAI Change	The TAI changes for the session. The cause is configurable and is disabled by default. This cause is triggered if only TAI Change is met.
Change in UP to UE	Disabled by default. The CP-CIoT-EPS-Optimisation-Indicator value changes for the session.
SGW Change	See Table 12. Triggers an Rf ACR Stop message which closes the TDVs.
Serving Node PLMN Change	See Table 12. Triggers an Rf ACR Interim message which closes the TDVs.
UE Time Zone Change	See Table 12. Triggers an Rf ACR Interim message which closes the TDVs.
Time Limit	See Table 13. Triggers an Rf ACR Interim message which closes the TDVs.
Volume Limit	See Table 13. Triggers an Rf ACR Interim message which closes the TDVs.
Management Intervention	See Table 12. Triggers an Rf ACR Interim or Stop message which closes the TDVs.



Cause	Description
Normal Release	See Table 12. Triggers an Rf ACR Stop message which closes the TDVs.
MO Exception Data Counter	See Table 12. Triggers an Rf ACR Interim message which closes the TDVs.

If some causes happen at the same time when closing TDV, the EPG uses the cause priority (from high to low) internally to determine which cause is used as the TDV closure cause. The priority sequence from high to low is:

- 1 UE Time Zone Change
- 2 Serving Node PLMN Change
- 3 Change in UP to UE
- 4 User Location Information Change
- 5 User CSG Information Change
- 6 Serving PLMN Rate Control Change
- 7 MO Exception Data Counter

If any of the charging conditions described in Table 14 are met, the EPG does the following:

- Includes the condition that closed the TDV in the Change-Condition AVP at thePS-Information level. If several conditions are met at the same time, the EPG includes the condition with the highest priority, where 1 is the highest and 15 is the lowest priority.
- Closes the TDV.
- Opens a new TDV, if the session continues.

For the configurable options, see Section 5.6.2 on page 46.

### 5.5.3 Service Data (PGW Only)

An SDC for an ACR includes the following information:

- Service information, such as usage, time stamps, and the cause for SDC closure
- Bearer information, such as QoS
- User information, such as location

A service is represented by either an RG level SDC, identified by the RG-ID, or an SI level SDC, identified by a combination of the RG-ID and the SI-ID, depending on the applied reporting level. By default, the EPG reports information at the level



of relevance. This means that if SI level reporting is enabled for a particular SI, the EPG reports information relating to online charging, the bearer, and the user in the associated RG level SDC. The EPG also reports information related to service usage in an SI level SDC. For more information, refer to [Offline Charging Configuration](#).

The EPG opens an SDC the first time a service is accessed and records the service data in the SDC. The EPG closes the SDC if any of the record-related, session-related, or service-related conditions described in Table 15, Table 16, or Table 17 are met. If several conditions are met at the same time, the EPG does one of the following:

- (Default) Uses the priority value to determine which cause is used as the SDC closure cause
- Includes all the applicable causes as the SDC closure clause.

The PGW counts the number of SDCs collected for a PDN connection and checks the number against the maximum service change condition and maximum bearer change condition.

The session-related change conditions described in Table 15 close Rf SDCs and increment the bearer change condition described in Table 13.

Table 15 Session-Related Charging Triggers Closing Rf SDCs in the PGW

Cause (Session-Related Charging Trigger)	Priority	Description
QoS Change	8	The QoS changes for the service.
User CSG information change	7	<p>The User CSG information changes for the service.</p> <p>The user has either entered or leaved a CSG cell, or moved between CSG cells.</p> <p>The CSG information change trigger may be provided by PCRF and may optionally be configured.</p> <p>For configuration information, refer to <a href="#">Offline Charging Configuration</a>.</p> <p>For information on PCRF controlled offline reporting of CSG information changes, refer to <a href="#">Policy Control</a>.</p> <p>For information on CSG information change subscription and event reporting, refer to <a href="#">Session Management</a>.</p>



Cause (Session-Related Charging Trigger)	Priority	Description
User Location Information Change	6	The ULI changes for the service. The ULI change trigger is optional to configure and is enabled by default. For configuration information, refer to <a href="#">Offline Charging Configuration</a> .
CGI or SAI Change	5	The CGI or SAI changes for the service.
RAI Change	4	The RAI changes for the service.
ECGI Change	3	The ECGI changes for the service.
TAI Change	2	The TAI changes for the service.

Table 16 describes record-related change conditions that are used to close Rf SDCs when an Rf ACR Interim message or an Rf ACR Stop message is triggered for the PDN connection.

Table 16 Record-Related Charging Triggers Closing Rf SDCs in the PGW

Cause (Record-Related Charging Trigger)	Description
RAT Change	See Table 11. Triggers an Rf ACR Interim message which closes the SDCs.
Serving Node PLMN Change	See Table 11. Triggers an Rf ACR Interim message which closes the SDCs.
Serving Node Change without PLMN	See Table 11. Triggers an Rf ACR Interim message which closes the SDCs.
UE Time Zone Change	See Table 11. Triggers an Rf ACR Interim message which closes the SDCs.
Time Limit	See Table 13. Triggers an Rf ACR Interim message which closes the SDCs.
Volume Limit	See Table 13. Triggers an Rf ACR Interim message which closes the SDCs.
Maximum Bearer Change Condition	See Table 13. Triggers an Rf ACR Interim message which closes the SDCs.
Maximum Service Change Condition	See Table 13. Triggers an Rf ACR Interim message which closes the SDCs.
Management Intervention	See Table 11. Triggers an Rf ACR Interim or Stop message which closes the SDCs.



Cause (Record-Related Charging Trigger)	Description
Abnormal Release	See Table 11. Triggers an Rf ACR Stop message which closes the SDCs.
Normal Release	See Table 11. Triggers an Rf ACR Stop message which closes the SDCs.

Table 17 lists the credit control changes (Gy events) that can be configured as charging triggers to close SDCs for Rf charging in the PGW. The credit control triggers in Table 17 increment the service change condition described in Table 13.

Table 17 Service-Related Triggers Closing SDCs for Credit Control Events (PGW Only)

Cause (Credit Control Trigger)	Description	Value of Change-Condition AVP in Rf SDCs
Tariff Time Change	The tariff time changes for the service.	10 Tariff Time Change
Forced Reauthorization Request	The service is reauthorized by the OCS.	525 Forced Reauthorization (operator specific)
Service Idled Out <sup>(1)</sup>	The QHT, provided by the OCS or configured in the PGW, expires for the service.	11 Service Idled Out
Quota Holding Time		526 Quota Holding Time (operator specific)
Volume Exhausted	The volume quota provided by the OCS is exhausted for the service.	18 Service Data Volume Limit <sup>(2)</sup>
Volume Threshold Reached	The volume quota threshold provided by the OCS is reached for the service.	
Service Stop <sup>(3)</sup>	The service is stopped by the OCS.	21 Service Stop
Final		522 Final (operator specific)
Timeout	The validity time, provided by the OCS, expires for the service.	523 Validity Time (operator specific)
Rating Condition Change	A Trigger-Type event, activated by the OCS is matched.	524 Rating Condition Change (operator specific)



Cause (Credit Control Trigger)	Description	Value of Change-Condition AVP in Rf SDCs
Gy failure <sup>(4)</sup>	When Gy failure is detected, the user session continues and the PGW closes all Rf SDCs.	610 Continue Ongoing Session
Gy session reestablishment <sup>(4)</sup>	When Gy session is reestablished, the PGW closes all Rf SDCs.	13 Max Number of Changes in Charging Condition

(1) Both Service Idled Out and QHT refer to the same Gy event when the QHT timer expires for the service.

(2) Both Volume Exhausted and Volume Threshold Reached cause the same Change - Condition AVP value in Rf SDCs.

(3) Both Service Stop and Final refer to the same Gy event when the service is stopped.

(4) Only if credit control failure support in Rf function is configured.

If any of the record-related, session related, or service-related conditions described in Table 15, Table 16, or Table 17 are met, the EPG does the following:

- Includes the condition that closed the SDC in the Change-Condition AVP for all the applicable SDCs in the PDN connection. If several conditions are met at the same time, the EPG includes the condition with the highest priority, where 1 is the highest priority and 15 is the lowest priority. Alternatively, the EPG can be configured to include all applicable conditions in the Change-Condition AVP.
- Closes all the SDCs in the PDN connection.
- Opens a new SDC for the service, if the session continues and the EPG receives new service data.

For the configurable options, see Section 5.6.3 on page 46.

Table 18 lists the credit control changes (Gy events) that can be configured as charging triggers to close ACRs for Rf charging in the PGW.



Table 18 Credit Control Triggers Closing ACRs for Credit Control Events (PGW Only)

Cause (Online Charging Trigger)	Description	Value of Change-Condition AVP in Rf ACRs
Gy failure <sup>(1)</sup>	When Gy failure is detected, the user session continues and the PGW closes the Rf ACR and sends it to the CDF.	13 Max Number of Changes in Charging Condition
Gy session reestablishment <sup>(1)</sup>	When Gy session is reestablished, the PGW closes the Rf ACR and sends it to the CDF.	13 Max Number of Changes in Charging Condition

(1) Only if credit control failure support in Rf function is configured.

#### 5.5.3.1 Service Condition Change Limit

The service condition change limit is a configurable value, that defines the accumulated number of service-related changes in service conditions allowed before the EPG closes an Rf ACR. The PGW sends an Rf ACR Interim message if the number service condition changes reach the configured value. The service condition change limit is configurable on the charging characteristics profile level. For configuration information, refer to *Offline Charging Configuration*.

#### 5.5.3.2 Tracked Transaction Limit

The accumulated number of tracked transactions in an Rf ACR is limited by a configurable transaction limit. The PGW sends an Rf ACR Interim message if the number of tracked transactions reaches or exceeds the limit. The tracked transaction limit is configurable on the charging profile level. For configuration information, refer to *Offline Charging Configuration*.

### 5.6 ACR Generation Options

The following subsections describe the configurable options for ACR generation. For configuration information, refer to *Offline Charging Configuration*.

#### 5.6.1 Record Data Options

The following subsections describe the configurable options for ACR record data. For the default EPG behavior for record data, see Section 5.5.1 on page 34.



### 5.6.1.1 AII Timer

The AII timer can be configured at the charging characteristics level, and at profile level. The AII timer is disabled by default. The AII timer configured for a profile takes precedence over the AII timer configured at the charging characteristics level. The AII timer at characteristics level is applied if the AII timer is not configured for a profile.

For information about the AII timer, refer to *PGW Rf Interface Description and SGW Rf Interface Description*.

### 5.6.1.2 SGW Change as Closure Reason (SGW Only)

In mobility procedures involving an SGW change, the SGW can be configured to use the following reasons for closure:

- Normal release (default)
- SGW-Change

## 5.6.2 Bearer Data Options (SGW Only)

The following subsections describe the configurable options for bearer data. For the default SGW behavior for bearer data, see Section 5.5.2 on page 38.

### 5.6.2.1 User Location Change Trigger

By default, the SGW does not close TDVs if the user location changes. The SGW can be configured to close TDVs if one or more of the following types of user location changes:

- CGI or SAI
- ECGI
- RAI
- TAI

### 5.6.2.2 Change in UP to UE Trigger

If `change-in-up-to-ue-trigger` is configured, the SGW closes the TDV container if the value in the `CP-CIoT-EPS-Optimisation-Indicator` AVP changes. The SGW uses `Change in UP to UE` as the closure reason in the `Change-Condition` AVP.

If `change-in-up-to-ue-trigger` is not configured, the change of `CP-CIoT-EPS-Optimisation-Indicator` AVP does not trigger the TDV container closure.



### 5.6.3 Service Data Options (PGW Only)

The following subsections describe the configurable options for service data in the PGW.

#### 5.6.3.1 Service Condition Change Triggers

Rf charging works independently of credit control by default. By configuring the credit control changes as triggers to close SDCs, Rf charging operates in a tight interworking with credit control.

The following triggers are configurable:

- Final
- Gy failure or Gy session reestablishment (Continue ongoing session)

**Note:** If `continue-ongoing-session` is configured, a Gy failure or Gy session reestablishment triggers the closing of all Rf SDCs and the Rf ACR.

- Quota holding time
- Rating condition change
- Service idled out
- Service stop
- Tariff time switch
- Time-out
- Volume exhausted
- Volume threshold reached

**Note:** For PGW Rf charging, online triggers in the `Trigger-Type AVP` do not close SDCs. Online triggers in the `Trigger-Type AVP` result in the accumulation of the consumed volume, along with the time of first usage. The accumulated usage along with time of first usage is reported in the next SDC created for the RG or for the combination of SI and RG. For more information on the `Trigger-Type AVP`, refer to [Gy+ Interface Description](#).

#### 5.6.3.2 User Location Change Trigger

By default, the PGW does not close SDCs if the user location changes. The PGW can be configured to close SDCs if one or more of the following types of user location changes:

- BS Id
- CGI or SAI



- ECGI
- RAI
- TAI

### 5.6.3.3 Service Data Container Limit

The PGW can be configured to limit the number of SDCs. If the number of SDCs in an ACR message exceeds the configured limit, the PGW splits the ACR messages into multiple messages. The PGW can be configured to include the PS-Information level Change-Condition AVP in all the ACR messages or only in the last ACR message.

The PGW splits ACR Interim and ACR Stop messages as follows:

- ACR Interim: the PGW splits the message into multiple ACR Interim messages.
- ACR Stop: the PGW splits the message into multiple ACR Interim messages with an ACR Stop message as the last message of the split.

The maximum number of charging changes in Rf SDCs is independent of the SDC limit, and is configured through the service condition change limit. For more information on the service condition change limit, see Section 5.5.3.1 on page 45.

### 5.6.3.4 Multiple Change Conditions for SDC

The Change-Condition AVP contains the reason for closing Rf SDCs. An Rf SDC can include multiple Change-Condition AVPs if multiple charging triggers occur at the time of SDC closure.

It is possible to configure support for multiple Change-Condition values in Rf SDCs. The EPG uses the Change-Condition AVP values specified in Table 17, if support for multiple Change-Condition values in Rf SDCs is enabled, and events that are configured as triggers to close SDCs happen simultaneously.

Multiple service condition changes in one SDC are counted as one service change. If there are several SDCs, a service condition change for each SDC is counted as a service change although the service condition change is the same for all SDCs.

### 5.6.3.5 Charging Identifier

The PGW assigns the charging identifier when the PGW creates a bearer, and stores the value in the 3GPP-charging-ID AVP. The 3GPP-charging-ID AVP can be included in both TDVs for the SGW and SDCs for the PGW. The PGW and SGW report the usage in the containers (TDV or SDC) in an ACR message to the CDF for each PDN connection. The association of the charging identifier and the usage in the containers enables the PGW and SGW to correlate charging records across the nodes, regardless of the charging model used.



In the PGW, the charging identifier provides a unique identifier for the bearer and can be associated with one or many RGs, or RG and SI combinations.

## 5.7 Credit Control Information Support in Rf

The PGW can be configured to include credit control information in Rf ACR messages during normal credit control session (Gy normal behavior) or when a Gy failure occurs. Credit control information is only included for ongoing credit control sessions.

The following RF proprietary AVPs can be included in Rf ACR messages:

- `Credit-Control-Information` under `PS-Information`
  - `Session-Id`
  - `Destination-Realm`
- `CC-Request-Number` under `Service-Data-Container`

The `CC-Request-Number` AVP included in an Rf ACR message containing the report of an SDC corresponds to the CCR message in which the SDC usage has been reported. If the SDC included in the Rf ACR message has not been reported in a CCR message, the Rf ACR does not contain the `CC-Request-Number` AVP. If the Rf ACR message includes several SDCs whose usage has been reported in different CCRs, in the Rf ACR each SDC contains the `CC-Request-Number` AVP of the corresponding CCR.

For information on how to configure the credit control information in Rf, refer to [Offline Charging Configuration](#).

## 5.8 Credit Control Failure Support in Rf

The credit control failure support in Rf function allows the Rf interface to be aware of a credit control failure. The function is activated if the following conditions are met:

- The failure handling option is configured in the PGW at credit control failure to continue the user session.
- The PGW is configured to indicate credit control session failure over the Rf interface.

When Gy failure occurs and the credit control failure support in Rf is configured, the PGW includes Gy failure information in the Rf ACR and sends it to the CDF. When the Rf interface is aware of the credit control session failure, the PGW performs the following actions:

- Closes all Rf ACR SDCs (including the SDC corresponding to the failed Gy service) with a credit control failure action which is indicated by setting



the SDC Change-Condition AVP to the value **ContinueOngoingSession (610)**. Other SDC Change-Condition AVPs can be included if other closure conditions are met.

SDCs that were closed before the Gy failure but have not been sent in an Rf ACR do not have a Change-Condition AVP set to **ContinueOngoingSession (610)**.

- Sends the Rf ACR Start message including the following information:
  - Optionally, the **Credit-Control-Failure-Report** AVP, including the **CC-Request-Number** AVP of the failed CCR message
  - Optionally, the **CC-Request-Number** AVP with value 0.
- Sends the Rf ACR Interim message including the following information:
  - **Change-Condition** AVP under **PS-Information** set to **Max Number of Changes in Charging Conditions (13)**
  - Optionally, the **Credit-Control-Failure-Report** AVP, including the **CC-Request-Number** AVP of the failed CCR message.
  - Optionally, the **CC-Request-Number** AVP of the successful CCR message at PS Information and at SDC level if SDC usage has been reported.
- Sends the Rf ACR Stop message including the following information:
  - Optionally, the **Credit-Control-Failure-Report** AVP, including the **CC-Request-Number** AVP of the failed CCR message.
  - Optionally, the **CC-Request-Number** AVP of the successful CCR message at PS Information and at SDC level if SDC usage has been reported.

Until Gy reestablishment, if credit control failure support in Rf is configured, the PGW indicates continued credit control session failure in Rf ACRs by including the **Credit-Control-Failure-Handling** AVP for each closed SDC in the Rf ACR Interim message.

After Gy reestablishment, if credit control failure support in Rf is configured, the PGW performs the following actions:

- Sends an Rf ACR Interim message to the CDF to indicate Gy reestablishment:
  - Rf SDCs are closed with **Change-Condition** AVP set to **Max Number of Changes in Charging Conditions (13)**.
  - **Change-Condition** AVP under **PS-Information** set to **Max Number of Changes in Charging Conditions (13)**.
  - No **Credit-Control-Information** AVP (including the **Session-Id** and the **Destination-Realm** AVPs) is included.



- Stops sending credit control failure indication (`Credit-Control-Failure-Handling AVP`) in subsequent Rf SDCs, until a new Gy failure occurs.

By default, the credit control failure support in Rf is disabled. To enable it, the following must be configured:

- `Credit-Control-Failure-Handling AVP`
- Value `ContinueOngoingSession (610)` for SDC Change-Condition AVP
- Optionally, `Credit-Control-Failure-Report AVP`

For information on how to configure the credit control failure support in Rf, refer to [Offline Charging Configuration](#).

**Note:** Credit control failure support in Rf is only supported for Gy CCR Initial and Update messages but not for Gy CCR Terminate messages.

## 6 Failure Handling

For information on impacts of charging because of process or board failure or multiple failure, refer to [Resilience](#).

## 7 Configuration Planning

Planning the charging configuration is important to minimize the impact of a board or process failure on offline charging.

The following parameters can be modified to decrease the loss of charging data because of failures. For information on configuring the parameters, refer to [Offline Charging Configuration](#).

**Note:** Configuration of the parameters to minimize data loss might affect the CPU load on the EPG, and in case of Rf charging also impact load on the Diameter network.

### 7.1 Control Plane Process Failures

The volume data loss can be decreased by lowering the value of the following parameters:



- Change limit
- Volume limit
- Time limit

## 7.2 Control Plane Board Failures

The volume data loss can be decreased by lowering the value of the following parameters:

- Change limit
- Volume limit
- Time limit
- Maximum age of the charging data file
- Maximum size of the charging data file

For the GGSN or PGW CDR, the volume data loss can also be decreased by lowering the value of tracked URI limit, or by configuring the `Transfer Type` to `gtp-prime`.

## 7.3 Packet Processing Board Failures

The volume data loss can be decreased by lowering the value of the following parameters:

- Volume limit
- Time limit

## 7.4 Calculations for Rf Charging Loss

The maximum loss of charging information per CPB or PPB failure because of the configured volume limit can be calculated as follows:

$$\frac{C_v * X}{N}$$

Equation 1 Maximum Charging Data Loss Because of Volume Limit Configuration

Table 19 describes the variables in Equation 1.



Table 19 Variables for Maximum Charging Data Loss Because of Volume Limit Configuration

Variable	Description
$C_V$	Configured volume limit For information on how to configure the volume limit, refer to <i>Offline Charging Configuration</i> .
X	Total number of bearers in the SGW or PGW For information on the number of bearers in the SGW or PGW, refer to <i>Action Commands for the SGW</i> or <i>Action Commands for the GGSN and PGW</i> .
N	Number of CPBs or PPB in the SGW or PGW For information on the number of CPBs in the SGW or PGW, refer to <i>EPG Board Configuration</i> .

The maximum loss of charging information per CPB or PPB failure because of the configured time limit can be calculated as follows:

$$\frac{C_T * Y}{N}$$

Equation 2 Maximum Charging Data Loss Because of Time Limit Configuration

Table 20 describes the variables in Equation 2.

Table 20 Variables for Maximum Charging Data Loss Because of Time Limit Configuration

Variable	Description
$C_T$	Configured time limit For information on how to configure the time limit, refer to <i>Offline Charging Configuration</i> .
Y	SGW or PGW uplink throughput and SGW or PGW downlink throughput For information on the uplink and downlink throughput calculation, refer to <i>EPG Characteristics</i> .
N	Number of CPBs in the SGW or PGW For information on the number of CPBs or PPB in the SGW or PGW, refer to <i>EPG Board Configuration</i> .



## 8 Counters

For information on counters related to offline charging, refer to [Counters and Gauges for the GGSN and PGW](#) and [Counters and Gauges for the SGW](#).

## 9 Alarms and Alerts

For information related to offline charging alarms and alerts, refer to [Fault Management Description](#).