

IBM System Storage TS3500 Tape Library



Operator Guide

IBM 3584 Tape Library

IBM System Storage TS3500 Tape Library



Operator Guide

IBM 3584 Tape Library

Note!

Before using this guide and the product it supports, read the information in “Safety and Environmental Notices” on page xiii and Appendix B, “Notices,” on page 371.

Fourth Edition (May 2007)

This edition applies to the *IBM System Storage TS3500 Tape Library Operator Guide* and to all subsequent releases and modifications until otherwise indicated in new editions. This edition replaces GA32-0560-02.

© Copyright International Business Machines Corporation 2006, 2007. All rights reserved.

US Government Users Restricted Rights – Use, duplication or disclosure restricted by GSA ADP Schedule Contract with IBM Corp.

Read This First

This is the fourth edition of the *IBM System Storage TS3500 Tape Library Operator Guide* (May 2007).

What's New In This Edition

May 2007 (GA32-0560-03)

Revision bars (|) appear next to all of the information that has been added or changed since the previous edition (GA32-0560-02).

- | • LTO Ultrium 4 (TS1040) encryption capable drives and cartridges with enhanced data gathering.
- | • Four I/O stations for new D23 or D53 frames add up to 64 additional I/O slots.
- | • Rack mountable TS3000 System Console (TSSC).
- | • Enhanced web user interface includes a view of I/O stations.
- | • Customizable web access.
- | • Single feed bifurcated AC line cord

December 2006 (GA32-0560-02)

- For Models L22, D22, L23, and D23, support for 3592 Tape Cartridge media types JB and JX.
- "Scratch Encryption Policy" on the left hand navigation was changed to "Barcode Encryption Policy" in the latest code level.
- A new address for the U.S. location of tape cartridge bar code label supplier Netc, L.L.C..

Send Us Your Feedback

Send us your comments by e-mail to starpubs@us.ibm.com or use the Readers' Comments form at the back of this publication. Be sure to include the following:

- Exact publication title
- Form number (for example, GA32-1234-02), or part number and EC level (located on the back cover)
- Page numbers to which you are referring

Contents

Read This First	iii
What's New In This Edition	iii
Send Us Your Feedback	iv
Figures	ix
Tables	xi
Safety and Environmental Notices	xiii
Danger Notice	xiii
Caution Notice	xiii
Attention Notice.	xv
Possible Safety Hazards	xv
Laser Safety and Compliance	xv
Class II Laser Product	xv
Class I Laser Product	xvi
End of Life (EOL) Plan	xvi
Product Recycling and Disposal	xvi
Battery Return Program.	xvii
Flat Panel Display	xviii
Preface	xix
Related Information	xx
Publications about the 3584 Tape Library	xx
IBM System i5 and AS/400 Source	xx
IBM System p5 and RS/6000 Source	xx
IBM System z9 Source	xxi
Other Sources	xxii
Authorized Suppliers of Bar Code Labels.	xxiii
Chapter 1. Introduction	1
Overview	1
Structure of Library	3
Dual Accessors and Service Bays	6
Supported Tape Drives	8
LTO Ultrium Tape Drives	8
3592 Tape Drives	11
Supported Tape Cartridges	16
Compatible Servers and Software	17
Supported Device Drivers	18
Using mtlib for Communication	18
Chapter 2. Main Components	19
Overview of Main Components	19
Library Frame	20
Cartridge Storage Slots	24
Tape Drives	25
Doors	29
Door Safety Switch.	30
I/O Stations	30
Operator Panel	34
Chapter 3. Operating Procedures	39
Overview of Operating Procedures	39

Functions of the Operator Panel	45
Functions of the Tape Library Specialist Web Interface	47
Operating the Library from the Operator Panel	47
Operating the Library from the Web	48
Navigating Through the Tape Library Specialist Web Interface.	49
Using the Tape Library Specialist Interface	51
Powering-On	52
Powering-Off.	53
Inserting Data or Scratch Cartridges	54
Removing Data Cartridges from the Library	63
Removing a Data Cartridge from a Drive in the Library	67
Enabling or Disabling Automatic Cleaning	69
Inserting a Cleaning Cartridge into the Library	70
Inserting a Cleaning Cartridge with Automatic Cleaning Enabled	71
Inserting a Cleaning Cartridge with Automatic Cleaning Disabled	72
Performing Manual Cleaning of Drives in the Library	73
Removing a Cleaning Cartridge from the Library.	75
Initializing a Tape's Volume Serial (VOLSER) Number	76
Assigning a Volume Serial (VOLSER) Number to a Tape with an Unknown VOLSER	77
Enabling or Disabling Security for the Operator Panel	77
Locking or Unlocking the Operator Panel	78
Establishing the Administrator's Web Password	79
Changing the Administrator's Web Password	80
Using the Web to Change the Administrator's Web Password	80
Using the Operator Panel to Change the Administrator's Web Password	81
Activating or Deactivating Password Protection for Web Screens	81
Choosing the Timeout Setting for Web Screens.	82
Understanding Roles Defined by the Web Interface	82
Customized Web Access	83
Adding a Customized Role	83
Adding a Customized Role by Copying an Existing Role	84
Modifying a Customized Web Access Role	85
Deleting a Customized Web Access Role.	85
Adding a Web User	86
Modifying the Settings of a Web User	87
Removing a Web User.	87
Changing Your Web Password	87
Viewing Web Users with Active Sessions	88
Assigning Cartridges to a Logical Library	88
Using the Drive Assignment Web Page	89
Adding a Drive to a Physical Library.	90
Adding a Drive to a Logical Library	90
Sharing Drives in a Logical Library	91

Enabling or Disabling a Control Path in a Logical Library	91	Viewing a World Wide Node Name	147
Removing a Drive from a Logical Library	92	Viewing or Changing Fibre Channel Port Speeds and Topologies	148
Removing a Drive from a Physical Library	92	Viewing or Changing Fibre Channel Port Settings	150
Detecting Gaps Between Drive Element Addresses in a Logical Library	93	Displaying Fibre Channel Port Status	151
Working with a Cartridge Assignment Policy	94	Displaying Control Paths	154
Determining the Status of Components in the Library	95	Changing a Control Path	155
Determining the Status of the Cartridge Accessor	95	Enabling or Disabling SNMP Traps	157
Determining Drive Status.	96	Enabling or Disabling SNMP Requests	158
Viewing Drive Displays	97	Setting the Version of SNMP Traps	159
Determining the Status of an I/O Station	98	Enabling or Disabling Authentication Trap Settings	160
Determining the Status of Storage Slots.	100	Viewing or Changing SNMP System Data	161
Determining the Location of Cartridges	102	Viewing or Changing the Destination IP Configuration and Remote Port	161
Viewing the Drive Emulation Mode of 3592 Tape Drives.	104	Sending a Test SNMP Trap	163
Using the Web to View the Drive Emulation Mode of 3592 Tape Drives	104	Viewing or Changing the Trap Community Name	163
Using the Operator Panel to View the Drive Emulation Mode of 3592 Tape Drives	105	Viewing or Changing the Request Community Name	164
Changing the Drive Emulation Mode of 3592 Tape Drives.	105	Viewing Ethernet Settings	165
Using the Web to Change the Drive Emulation Mode of 3592 Tape Drives	106	Changing the Ethernet Address Settings	167
Using the Operator Panel to Change the Drive Emulation Mode of 3592 Tape Drives	106	Changing the Ethernet Address Settings of a Frame with a Single Port	167
Performing an Inventory of the Library.	108	Changing the Ethernet Address Settings of a Frame with Dual Ports	168
Performing an Inventory of a Frame in the Library	109	Changing the Speed of the Ethernet Link	171
Moving a Cartridge	110	Using DHCP Server Settings	172
Displaying the Existing Library Configuration	116	Disabling an Ethernet Connection	173
Configuring the Library without Partitions	119	Changing the Date and Time	174
Configuring the Library with Partitions	123	Enabling or Disabling the Keypress Beep	175
Using Labels to Configure the Library with Partitions.	124	Enabling or Disabling the Reporting of a Six-Character or Eight-Character VOLSER.	176
Using Menus to Configure the Library with Partitions.	131	Enabling or Disabling the Insert Notification Setting.	177
Entering the ALMS License Key	135	Determining Usage of Library Components	178
Enabling or Disabling ALMS	136	Determining Accessor Usage	179
Enabling or Disabling Virtual I/O Slots.	137	Determining Drive Usage	180
Creating or Removing a Logical Library with ALMS.	138	Determining Cleaning Cartridge Usage.	182
Changing the Name of a Logical Library	139	Accessing Vital Product Data for Library Components.	182
Changing the Maximum Allowable Quantity of Cartridges in a Logical Library	139	Accessing Vital Product Data for the Library	182
Changing the Quantity of Virtual I/O Slots in a Logical Library.	140	Accessing Vital Product Data for Drives in the Library	183
Hiding a Host Application's View of Cartridges That Have Been Queued for Export	140	Accessing Vital Product Data for Node Cards in the Library	184
Discovering New Hardware in the Library	140	Resetting the Library Control System	185
Setting or Changing an Accessor's Preferred Zone	141	Accessing Drive Serial Numbers	186
Using the Web to Set or Change an Accessor's Preferred Zone	141	Accessing Logs for the Library	187
Using the Operator Panel to View or Change an Accessor's Preferred Zone	142	Accessing Enhanced Data Gathering and Reporting Files	187
Installing the Intermediate or Full Capacity On Demand Feature	142	Accessing the Mount History of Tape Cartridges	188
Installing the Control Path Failover Feature	143	Accessing Statistics about Drives	191
Displaying the SCSI ID or Loop ID of a Drive	143	Accessing Port Statistics for Drives	192
Changing the SCSI ID or Loop ID of a Drive	144	Accessing Statistics about the Library	193
Viewing a World Wide Port Name	146	Viewing the Library Error Log	194
		Updating Firmware for the Library	195
		Accessing Logs for Drives or Saving a Drive Dump	196
		Viewing a Drive Error Log	197
		Updating Drive Firmware	198
		Adjusting the Scanner Speed	199
		Performing a Remote Drive Power Cycle	200

Configuring the Library to Work with Your SMI-5 Agent for Tape	200
Viewing Licensed Features	201
Setting Up and Using Encryption.	202
Setting or Changing a Drive's Method of Encryption	203
Working with Key Manager Addresses	204
Testing a Key Manager Address	204
Working with a Barcode Encryption Policy	206
Mapping Encrypted Cartridge Key Labels	208
Viewing a Drive's Method of Encryption	209
Determining Whether a Cartridge is Encrypted	210
Rekeying an Encrypted Cartridge	210

Chapter 4. Using Ultrium Media 213

Overview of Ultrium Media	213
WORM Functionality for Ultrium 3 and Ultrium 4 Tape Drives and Media	214
Compatibility Among Ultrium Drives and Cartridges	215
Ultrium Data Cartridge	216
Ultrium Cleaning Cartridge	218
Ultrium Diagnostic Cartridge	219
Ultrium Bar Code Label	220
Guidelines for Using Ultrium Bar Code Labels	221
Setting the Write-Protect Switch on an Ultrium Cartridge.	223
Handling Ultrium Tape Cartridges	224
Provide Training for Using Ultrium Tape Cartridges	224
Ensure Proper Packaging of Ultrium Tape Cartridges	225
Provide Proper Acclimation and Environmental Conditions for Ultrium Tape Cartridges	226
Perform a Thorough Inspection of Ultrium Tape Cartridges	226
Handle the Ultrium Tape Cartridge Carefully	227
Examples of Problems with Ultrium Tape Cartridges	229
Repositioning or Reattaching a Leader Pin in an Ultrium Cartridge	230
Repositioning a Leader Pin in an Ultrium Cartridge.	230
Reattaching a Leader Pin in an Ultrium Cartridge.	233
Environmental and Shipping Specifications for Ultrium Cartridges	237
Disposing of Ultrium Tape Cartridges	238
Ordering Additional Ultrium Cartridges and Media Supplies	239
Ordering Bar Code Labels for Ultrium Cartridges	241

Chapter 5. Using 3592 Tape Drive Media. 243

Overview of 3592 Media	243
WORM Functionality for 3592 Tape Drives and Media	245
Capacity Scaling and Segmentation	246
3592 Data Cartridge	248

Cartridge Memory in 3592 Tape Cartridges	250
3592 Cleaning Cartridge	251
3592 Diagnostic Cartridge	253
3592 Bar Code Label	254
Guidelines for Using 3592 Bar Code Labels	255
Setting the Write-Protect Switch on a 3592 Cartridge.	257
Handling 3592 Tape Cartridges	258
Provide Training for Using 3592 Tape Cartridges	258
Ensure Proper Packaging of 3592 Tape Cartridges	258
Provide Proper Acclimation and Environmental Conditions for 3592 Tape Cartridges.	258
Perform a Thorough Inspection of 3592 Tape Cartridges	259
Handle the 3592 Tape Cartridge Carefully.	259
Repositioning a Leader Pin in a 3592 Cartridge	260
Environmental and Shipping Specifications for 3592 Cartridges.	262
Disposing of 3592 Cartridges	263
Cartridge Quality and Library Maintenance	263
Ordering 3592 Media Supplies.	263
Ordering 3592 Media Supplies by Using the 3599 Tape Media Method	264
Ordering 3592 Media Supplies by Using Part Numbers	266

Chapter 6. Problem Determination 269

Resolving Errors	269
Resolving Errors with the Library and the Installed Tape Drives	269
Resolving Errors with the Ultrium Tape Drives	290
Attaching the Library to Open Systems.	292
Interpreting SNMP Traps	293
Manually Interpreting an SNMP Trap	293
Using SNMP MIBs to Monitor the Library.	298

Chapter 7. TapeAlert Flags. 301

Overview of TapeAlert Flags	301
TapeAlert Flags Supported by the Ultrium Tape Drives.	302
TapeAlert Flags Supported by the 3592 Tape Drives	307
TapeAlert Flags Supported by the Library.	313

Chapter 8. Technical Components of the Library 315

Overview of Technical Components in the Library	315
Rail Assembly	316
Cartridge Accessor	316
Accessor Controller	318
Operator Panel Controller	318
Power Structures	319

Chapter 9. Frame Capacity. 341

Capacity of Model L22, D22, L23, and D23 Frames	341
Capacity of Model L32 and D32 Frames	342
Capacity of Model L52, D52, L53, and D53 Frames	343

Chapter 10. Locations and Addresses of SCSI Elements. 345

Overview of Locations and Addresses of SCSI Elements 345
Location and Quantity of Addressable Storage Elements in Models L22 and L23 347
Location and Quantity of Addressable Storage Elements in Models D22 and D23 349
Location and Quantity of Addressable Storage Elements in Model L32 without Capacity Expansion Feature. 351
Location and Quantity of Addressable Storage Elements in Model L32 with Capacity Expansion Feature 353
Location and Quantity of Addressable Storage Elements in Model D32 355
Location and Quantity of Addressable Storage Elements in Models L52 and L53 357
Location and Quantity of Addressable Storage Elements in Models D52 and D53 359
Determining SCSI Element Addresses with ALMS Disabled 361
 Storage Element Addresses with ALMS Disabled 361
 Import/Export Element Addresses with ALMS Disabled 362
 Data Transfer Element Addresses with ALMS Disabled 363
Determining SCSI Element Addresses with ALMS Enabled 364
 Storage Element Addresses with ALMS Enabled 364
 Import/Export Element Addresses with ALMS Enabled and Virtual I/O Slots Disabled . . . 364

Import/Export Element Addresses with ALMS Enabled and Virtual I/O Slots Enabled 364
Data Transfer Element Addresses with ALMS Enabled 365

Appendix A. Statement of Limited Warranty 367

Appendix B. Notices 371

Regulatory Approvals 372
Trademarks 373
Electronic Emission Notices 375
 Federal Communications Commission (FCC)
 Class A Statement 375
 Avis de conformité à la réglementation d'Industrie Canada 375
 European Union (EU) Electromagnetic Compatibility Directive 375
 Germany Electromagnetic Compatibility Directive 376
 Japan VCCI Class A ITE Electronic Emission Statement 376
 People's Republic of China Class A Electronic Emission Statement 376
 Taiwan Class A Electronic Emission Statement 377
 Korea Class A Electronic Emission Statement 377
Taiwan Contact Information 377

Glossary 379

Index 393

Figures

1. Laser safety caution label.	xvi	29. Removing a cartridge from a 3592 Tape Drive	68
2. The 3584 Tape Library	1	30. Logical library bar code label and holder	128
3. Frames in the IBM System Storage TS3500 Tape Library	5	31. Attaching logical library bar code labels	129
4. Location of service bays in the 3584 Tape Library	6	32. Indicating the boundaries of logical libraries	131
5. Main components of the IBM System Storage TS3500 Tape Library Model L52.	20	33. The IBM System Storage LTO Data Cartridge for Ultrium 3 Tape Drives	213
6. Location of the power structure in a library frame	22	34. The IBM System Storage LTO Data Cartridge	217
7. Cartridge slots in the service bays of the 3584 Tape Library	23	35. Sample bar code label on the LTO Ultrium 3 Tape Cartridge	221
8. Ultrium Tape Drives mounted inside the 3584 Tape Library and loaded with LTO Ultrium Tape Cartridges	27	36. Setting the write-protect switch on an Ultrium Tape Cartridge	223
9. 3592 Tape Drives mounted inside the 3584 Tape Library and loaded with 3592 Tape Cartridges	28	37. Tape cartridges in a Turtlecase	225
10. Front door of the 3584 Tape Library	29	38. Double-boxing tape cartridges for shipping	226
11. Storage slot addresses in the I/O stations of the 3584 Tape Library	32	39. Checking for gaps in the seams of a cartridge	227
12. Storage slot addresses in four I/O station frames in the 3584 Tape Library.	33	40. Leader pin in the incorrect and correct positions in an Ultrium Tape Cartridge	231
13. Sample screen on the operator panel of the IBM System Storage TS3500 Tape Library, Model L22 or L52	34	41. Placing the dislodged leader pin into the correct position.	232
14. Sample Activity screen on the 3584 Tape Library	35	42. Rewinding the tape into the cartridge	232
15. Functions of the operator panel on the 3584 Tape Library	46	43. Leader Pin Reattachment Kit	233
16. Functions of the Tape Library Specialist web interface	47	44. Attaching the leader pin attach tool to an Ultrium Tape Cartridge	234
17. Sample Welcome Page of the Tape Library Specialist web interface (your screen may vary slightly).	48	45. Winding the tape out of the Ultrium Tape Cartridge	235
18. Elements in a typical Tape Library Specialist web screen.	49	46. Removing the C-clip from the leader pin	235
19. Physical Library Summary screen	51	47. Attaching the leader pin to the tape	236
20. Powering-on the 3584 Tape Library	52	48. Components of the IBM TotalStorage 3592 Enterprise Tape Cartridge	243
21. Using an I/O station to insert cartridges	56	49. Components of the IBM TotalStorage 3592 Enterprise Tape Cartridge	249
22. Positioning an LTO Ultrium Tape Cartridge in the I/O station	57	50. Leader pin in proper position in the 3592 Cleaning Cartridge (the cartridge door is manually retracted)	252
23. Scenarios for importing cartridges into the 3584 Tape Library when virtual I/O slots are enabled	60	51. Characteristics that identify the 3592 Cleaning Cartridge	252
24. Activity screen on the front panel of the IBM System Storage TS3500 Tape Library	62	52. Door of the 3592 Cleaning Cartridge	253
25. Proper orientation of LTO Ultrium Tape Cartridges in cartridge storage slots	63	53. Sample bar code label on the IBM TotalStorage 3592 Enterprise Tape Cartridge	255
26. Proper orientation of 3592 Tape Cartridges in cartridge storage slots	63	54. Setting the write-protect switch on the 3592 Tape Cartridge	257
27. Flow of cartridges that are exported from the 3584 Tape Library with virtual I/O slots enabled	66	55. Leader pin in the incorrect and correct positions in a 3592 Tape Cartridge	260
28. Removing a cartridge from an Ultrium Tape Drive	68	56. Placing the dislodged leader pin into the correct position.	261
		57. Rewinding the tape into the cartridge	261
		58. Front view of the 3592 J1A	269
		59. Rear view of the 3592 J1A	270
		60. Front view of the Ultrium 3 Tape Drive	291
		61. Sample SNMP trap	294
		62. Technical components of the 3584 Tape Library that are accessible through the front door	316
		63. Components of the frame control assembly	319
		64. MCP with 10/100 Ethernet port	320

65. Compartment that houses the tape drives and the power supplies in Model L22 or D22 frames	322	74. Medium Changer Assembly.	337
66. Compartment that houses the tape drives and the power supplies in Model L32 or D32 frames	323	75. Compartment that houses the tape drives and the fixed tray assemblies in Model L23 or D23 frames	338
67. Compartment that houses the tape drives and the power supplies in Model L52 or D52 frames	324	76. Compartment that houses the tape drives and the fixed tray assemblies in Model L53 or D53 frames	339
68. Removing and Replacing a Drive Canister Assembly - LTO Fibre Channel Hot Swap	325	77. Location of storage elements in Models L22 or L23	347
69. Removing or Replacing a Drive Canister Assembly - 3592 Fibre Hot Swap	328	78. Location of storage elements in Models D22 or D23	349
70. Removing or Replacing a Redundant Power Supply - Models L32 or D32 Hot Swap	331	79. Location of storage elements in Model L32 without the capacity expansion feature	351
71. Removing or Replacing a Redundant Power Supply - Models L22, D22, L52, or D52 Hot Swap	333	80. Location of storage elements in Model L32 with the capacity expansion feature	353
72. Dual ac power	335	81. Location of storage elements in Model D32	355
73. Components of the enhanced frame control assembly	336	82. Location of storage elements in Models L52 or L53 with 16 or 32 I/O slots	357
		83. Location of storage elements in Models D52 or D53 with 16 or 32 I/O slots	359
		84. Assigning SCSI StE addresses to storage slots	362

Tables

1. Authorized suppliers of custom bar code labels	xxiii	26. FID messages	279
2. Tape drives that are supported by the 3584 Tape Library	1	27. ASC/ASCQ codes that are related to encryption	280
3. Frames that are supported by the 3584 Tape Library	3	28. Errors that are reported by the encryption key manager	286
4. Cartridges that are compatible with Ultrium Tape Drives	9	29. SCD error codes for the Ultrium Tape Drives	291
5. Specifications for the IBM System Storage 3588 Tape Drive Model F3A, F3B, and the IBM System Storage TS1040 Tape Drives Model F4A Ultrium 4 Tape Drives	11	30. Variables sent by library TapeAlerts and for Traps 1 through 32.	294
6. Features of the 3592 Tape Drives	12	31. Variables sent by LTO Ultrium and 3592 Tape TapeAlerts and for Traps 200 through 254	295
7. Location of I/O slots and LED display in frames with four I/O stations	33	32. Variables sent by library for events that are not by TapeAlerts and for Traps 400 through 408	295
8. Presence or absence of the LOCK, UNLOCK, and MENU buttons on the Activity screen of the 3584 Tape Library	36	33. Fields in an SNMP trap	296
9. Operating procedures for setting up the 3584 Tape Library	39	34. TapeAlert Flags that are supported by the Ultrium Tape Drives	302
10. Operating procedures for changing the 3584 Tape Library	41	35. TapeAlert Flags that are supported by the 3592 Tape Drives	307
11. Operating procedures for viewing the 3584 Tape Library	43	36. TapeAlert Flags that are supported by the 3584 Tape Library	313
12. Types of password protection for web screens	81	37. Quantity of storage slots in L22, D22, L23, and D23 frames.	341
13. Range of SCSI Data Transfer Element (DTE) addresses for tape drives in frames 1 through 16	122	38. Quantity of storage slots in Model L32 and D32 frames	342
14. Procedure for attaching and removing logical library bar code labels	128	39. Quantity of storage slots in Model L52, D52, L53, and D53 frames	343
15. Minimum levels of library and drive firmware required for nondisruptive library firmware updates	196	40. Quantity of SCSI-addressable storage slots (per column) in Model L22 or L23 frame with 16 or 32 I/O slots	348
16. Compatibility among Ultrium Tape Drives and tape cartridges	215	41. Quantity of SCSI-addressable storage slots (per column) in Model D22 or D23 frame	350
17. Environment for operating, storing, and shipping the LTO Ultrium Tape Cartridges.	237	42. Quantity of SCSI-addressable storage slots (per column) in Model L32 frame without capacity expansion feature	352
18. Ordering Ultrium cartridges and media supplies	239	43. Quantity of SCSI-addressable storage slots (per column) in Model L32 frame with capacity expansion feature and 10 I/O slots	354
19. Authorized suppliers of custom bar code labels for Ultrium Tape Cartridges	241	44. Quantity of SCSI-addressable storage slots (per column) in Model L32 frame with capacity expansion feature and 26 or 30 I/O slots	354
20. Types of IBM 3592 TotalStorage Enterprise Tape Cartridges	244	45. Quantity of SCSI-addressable storage slots (per column) in Model D32 frame.	356
21. Environment for operating, storing, and shipping the IBM TotalStorage 3592 Enterprise Tape Cartridge	262	46. Quantity of SCSI-addressable storage slots (per column) in Models L52 or L53 frame with 16 or 32 I/O slots	358
22. Descriptions of 3599 tape media features	264	47. Quantity of SCSI-addressable storage slots (per column) in Model D52 or D53 frame	360
23. Ordering 3592 media supplies by using part numbers	266	48. Range of SCSI Data Transfer Element (DTE) addresses for tape drives in frames 1 through 16	363
24. Authorized suppliers of custom bar code labels for 3592 Tape Cartridges.	267		
25. Resolving errors with the IBM System Storage TS3500 Tape Library	270		

Safety and Environmental Notices

When using this product, observe the danger, caution, and attention notices that are contained in this guide. The notices are accompanied by symbols that represent the severity of the safety condition.

Most danger or caution notices contain a reference number (Dxxx or Cxxx). Use the reference number to check the translation in the *@server Safety Notices*, G229-9054.

The sections that follow define each type of safety notice and give examples.

Danger Notice

A danger notice calls attention to a situation that is potentially lethal or extremely hazardous to people. A lightning bolt symbol always accompanies a danger notice to represent a dangerous electrical condition. A sample danger notice follows:







DANGER

An electrical outlet that is not correctly wired could place hazardous voltage on metal parts of the system or the devices that attach to the system. It is the responsibility of the customer to ensure that the outlet is correctly wired and grounded to prevent an electrical shock. (D004)

Caution Notice

A caution notice calls attention to a situation that is potentially hazardous to people because of some existing condition, or to a potentially dangerous situation that might develop because of some unsafe practice. A caution notice can be accompanied by one of several symbols:

If the symbol is...	It means...
	A hazardous electrical condition with less severity than electrical danger.
	A generally hazardous condition not represented by other safety symbols.

If the symbol is...	It means...
 <p data-bbox="548 373 646 394">Class II</p>	<p data-bbox="771 220 1398 365">A hazardous condition due to the use of a laser in the product. Laser symbols are always accompanied by the classification of the laser as defined by the U. S. Department of Health and Human Services (for example, Class I, Class II, and so forth).</p>
	<p data-bbox="771 445 1398 506">A hazardous condition due to mechanical movement in or around the product.</p>
 <p data-bbox="557 798 638 852">> 18 kg (40 lb)</p>	<p data-bbox="771 644 1398 732">A hazardous condition due to the weight of the unit. Weight symbols are accompanied by an approximation of the product's weight.</p>

Sample caution notices follow:



CAUTION:

The battery is a lithium ion battery. To avoid possible explosion, do not burn. Exchange only with the IBM-approved part. Recycle or discard the battery as instructed by local regulations. In the United States, IBM® has a process for the collection of this battery. For information, call 1-800-426-4333. Have the IBM part number for the battery unit available when you call.(C007)



CAUTION:

Energy hazard present. Shorting may result in system outage and possible physical injury. Remove all metallic jewelry before servicing. (C001)



Class II

CAUTION:

This product contains a Class II laser. Do not stare into the beam. (C029)



> 18 kg
(40 lb)

CAUTION:

The weight of this part or unit is between 18 and 32 kilograms (39.7 and 70.5 pounds). It takes two persons to safely lift this part or unit. (C009)



CAUTION:
This assembly contains mechanical moving parts. Use care when servicing this assembly. (C025)

Attention Notice

An attention notice indicates the possibility of damage to a program, device, or system, or to data. An exclamation point symbol may accompany an attention notice, but is not required. Sample attention notices follow:



Attention: If you use a power screwdriver to perform this procedure it could destroy the tape.



Attention: Do not connect an IBM control unit directly to a public optical network. The customer must use an additional connectivity device between an IBM control unit optical adapter (that is, fibre, ESCON[®], or FICON[®]) and an external public network. Use a device such as a patch panel, a router, or a switch. You do not need an additional connectivity device for optical fibre connectivity that does not pass through a public network.

Attention: Do not operate the 3584 Tape Library in a poor air-quality environment.

Possible Safety Hazards

Possible safety hazards to the operation of this product are:

Electrical An electrically charged frame can cause serious electrical shock.

Mechanical Hazards, such as a safety cover missing, are potentially harmful to people.

Chemical Do not use solvents, cleaners, or other chemicals not approved for use on this product.

Repair any of the preceding problems before you use the 3584 Tape Library.

Laser Safety and Compliance

Before using the IBM System Storage TS3500 Tape Library, review the following laser safety information.

Class II Laser Product

The 3584 Tape Library is a Class II laser product. It is important for you to be aware of the laser caution label. See Figure 1 on page xvi for an example of the label.



Figure 1. Laser safety caution label

This product complies with the performance standards set by the U.S. Food and Drug Administration for a Class II Laser product. This product belongs to a class of laser products that requires precautions be taken to avoid prolonged viewing of the laser beam. Under normal working conditions, you must not come in direct contact with the laser beam. This classification was accomplished by providing the necessary protective housings and scanning safeguards to ensure that laser radiation is inaccessible during operation or is within Class II limits. These products have been reviewed by external safety agencies and have obtained approvals to the latest standards as they apply to this product type.

Class I Laser Product

The 3584 Tape Library contains a laser assembly that complies with the performance standards set by the U.S. Food and Drug Administration for a Class I laser product. Class I laser products do not emit hazardous laser radiation. Protective housing and scanning safeguards ensure that laser radiation is inaccessible during operation or is within Class I limits. External safety agencies have reviewed the library and have obtained approvals to the latest standards as they apply.

End of Life (EOL) Plan

This box is a purchased unit. Therefore, it is the sole responsibility of the purchaser to dispose of it in accordance with local laws and regulations at the time of disposal.

This unit contains recyclable materials. The materials should be recycled where facilities are available and according to local regulations. In some areas, IBM may provide a product take-back program that ensures proper handling of the product. Contact your IBM representative for more information.

Product Recycling and Disposal

This unit must be recycled or discarded according to applicable local and national regulations. IBM encourages owners of information technology (IT) equipment to responsibly recycle their equipment when it is no longer needed. IBM offers a variety of product return programs and services in several countries to assist equipment owners in recycling their IT products. Information on IBM product recycling offerings can be found on IBM's Internet site at <http://www.ibm.com/ibm/environment/products/prp.shtml>.

Esta unidad debe reciclarse o desecharse de acuerdo con lo establecido en la normativa nacional o local aplicable. IBM recomienda a los propietarios de equipos de tecnología de la información (TI) que reciclen responsablemente sus equipos cuando éstos ya no les sean útiles. IBM dispone de una serie de programas y servicios de devolución de productos en varios países, a fin de ayudar a los propietarios de equipos a reciclar sus productos de TI. Se puede encontrar información sobre las ofertas de reciclado de productos de IBM en el sitio web de IBM <http://www.ibm.com/ibm/environment/products/prp.shtml>.

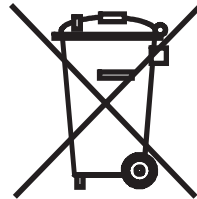

Notice: This mark applies only to countries within the European Union (EU) and Norway.

Appliances are labeled in accordance with European Directive 2002/96/EC concerning waste electrical and electronic equipment (WEEE). The Directive determines the framework for the return and recycling of used appliances as applicable throughout the European Union. This label is applied to various products to indicate that the product is not to be thrown away, but rather reclaimed upon end of life per this Directive.

In accordance with the European WEEE Directive, electrical and electronic equipment (EEE) is to be collected separately and to be reused, recycled, or recovered at end of life. Users of EEE with the WEEE marking per Annex IV of the WEEE Directive, as shown above, must not dispose of end of life EEE as unsorted municipal waste, but use the collection framework available to customers for the return, recycling and recovery of WEEE. Customer participation is important to minimize any potential effects of EEE on the environment and human health due to the potential presence of hazardous substances in EEE. For proper collection and treatment, contact your local IBM representative.

Battery Return Program

This product may contain sealed lead acid, nickel cadmium, nickel metal hydride, lithium, or a lithium ion battery. Consult your user manual or service manual for specific battery information. The battery must be recycled or disposed of properly. Recycling facilities may not be available in your area. For information on disposal of batteries outside the United States, go to <http://www.ibm.com/ibm/environment/products/batteryrecycle.shtml> or contact your local waste disposal facility.

In the United States, IBM has established a return process for reuse, recycling, or proper disposal of used IBM sealed lead acid, nickel cadmium, nickel metal hydride, and other battery packs from IBM Equipment. For information on proper disposal of these batteries, contact IBM at 1-800-426-4333. Please have the IBM part number listed on the battery available prior to your call.

For Taiwan:



Please recycle batteries

廢電池請回收

For the European Union:

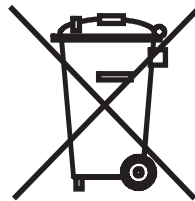

Batteries or packaging for batteries are labeled in accordance with European Directive 2006/66/EC concerning batteries and accumulators and waste batteries and accumulators. The Directive determines the framework for the return and recycling of used batteries and accumulators as applicable throughout the European Union. This label is applied to various batteries to indicate that the battery is not to be thrown away, but rather reclaimed upon end of life per this Directive.

In accordance with the European Directive 2006/66/EC, batteries and accumulators are labeled to indicate that they are to be collected separately and recycled at end of life. The label on the battery may also include a chemical symbol for the metal concerned in the battery (Pb for lead, Hg for mercury and Cd for cadmium). Users of batteries and accumulators must not dispose of batteries and accumulators as unsorted municipal waste, but use the collection framework available to customers for the return, recycling and treatment of batteries and accumulators. Customer participation is important to minimize any potential effects of batteries and accumulators on the environment and human health due to the potential presence of hazardous substances. For proper collection and treatment, contact your local IBM representative.

For California:

Perchlorate Material - special handling may apply. See www.dtsc.ca.gov/hazardouswaste/perchlorate.

The foregoing notice is provided in accordance with California Code of Regulations Title 22, Division 4.5 Chapter 33. Best Management Practices for Perchlorate Materials. This product/part may include a lithium manganese dioxide battery which contains a perchlorate substance.

Flat Panel Display

The fluorescent lamp or lamps in the liquid crystal display contain mercury. Dispose of it as required by local ordinances and regulations.

Preface

This guide contains information about how to operate the IBM® System Storage™™ TS3500 Tape Library, formerly known as the IBM TotalStorage® 3584 Tape Library. It includes the following chapters:

Chapter 1, “Introduction,” provides an overview of the 3584 Tape Library, tells how it can interact in both mainframe and Open Systems environments, lists the models that are available, and describes how the library processes both the Linear Tape-Open (LTO) Ultrium Tape Cartridge and the IBM TotalStorage 3592 Enterprise Tape Cartridge. It also describes the three generations of the Ultrium Tape Drive and the two generations of the 3592 Tape Drive. The chapter introduces the optional second accessor and the accompanying service bays. Information about supported servers, software and device drivers is provided.

Chapter 2, “Main Components,” describes the primary parts of the 3584 Tape Library, including the frames, storage slots, tape drives, door features, and operator panel.

Chapter 3, “Operating Procedures,” includes a table that lists the operating procedures for the 3584 Tape Library. The procedures include how to power the library on or off, insert or remove cartridges, clean a drive, change a configuration, determine the status of components, perform an inventory, move a cartridge, configure logical libraries, and so forth. Instructions are given for operating the library by using its operator panel or the IBM System Storage Tape Library Specialist web interface.

Chapter 4, “Using Ultrium Media,” describes the data, cleaning, and diagnostic cartridges to use in Ultrium Tape Drives. It defines the information that appears on a bar code label, gives requirements for a bar code label, tells how to set the write-protect switch on a tape cartridge, provides tips about storing, shipping, and handling cartridges, and offers information about where to order cartridges and supplies.

Chapter 5, “Using 3592 Tape Drive Media,” describes the data, cleaning, and diagnostic cartridges to use in the IBM TotalStorage 3592 Tape Drive Model J1A and the IBM System Storage TS1120 Tape Drive. It defines the information that appears on a bar code label, gives requirements for a bar code label, tells how to set the write-protect switch on a tape cartridge, provides tips on storing, shipping, and handling cartridges, tells how to clean a tape drive, describes how to inspect a cartridge leader, and offers information about where to order cartridges.

Chapter 6, “Problem Determination,” lists symptoms of possible problems with the 3584 Tape Library and recommends actions to take.

Chapter 7, “TapeAlert Flags,” lists TapeAlert messages that are supported by the Ultrium Tape Drives, 3592 Tape Drives, and 3584 Tape Library. The messages may aid during problem determination.

Chapter 8, “Technical Components,” describes several key components located within the 3584 Tape Library. Included are the rail assembly, cartridge accessor, dual-gripper transport mechanism, accessor controller, operator panel controller,

frame control assembly, Medium Changer card pack, enhanced frame assembly, Medium Changer assembly, drives, and power supplies.

Chapter 9, “Frame Capacity,” provides tables that show the quantity of storage slots that are available in library frames, depending on whether the Capacity On Demand or Capacity Expansion Features are installed, the upper and lower I/O stations are used, and a specified quantity of drives are installed.

Chapter 10, “Locations and Addresses of SCSI Elements,” shows the physical locations of storage slots, I/O slots, and drives in the Model L22, Model D22, Model L23, Model D23, Model L32 without the Capacity Expansion Feature, Model L32 with the Capacity Expansion Feature, Model D32, Model L52, Model D52, Model L53, and Model D53. It gives the rules for mapping these physical locations to their corresponding SCSI element addresses.

Appendix A, “Statement of Limited Warranty,” contains the warranty statement for the 3584 Tape Library.

Appendix B, “Notices,” gives information about the electronic emission regulations that pertain to the 3584 Tape Library in the United States and other countries or regions. It also gives information about the trademarks in this book.

Related Information

Refer to the following publications and sources for additional information about the 3584 Tape Library. To ensure that you have the latest publications, visit the web at:

<http://www.ibm.com/storage/lto>

To view the IBM System Storage TS3500 Tape Library Information Center, go to:

<http://publib.boulder.ibm.com/infocenter/ts3500t1/v1r0/index.jsp>

Publications about the 3584 Tape Library

- *IBM System Storage TS3500 Tape Library Introduction and Planning Guide*, GA32-0559
- *IBM System Storage TS3500 Tape Library Maintenance Information* (provided with the 3584 Tape Library)
- *IBM System Storage TS3500 Tape Library SCSI Reference*, GA32-0561

IBM System i5 and AS/400 Source

For information about the IBM System i5^{™™™} and the AS/400[®] servers, visit the web at <http://publib.boulder.ibm.com/iSeries/>. The IBM System i5 is the follow-on product line to the IBM eServer^{™™™} i5 and iSeries^{™™™} Systems.

IBM System p5 and RS/6000 Source

For information about the IBM System p5^{™™™} and the RS/6000[®] servers, visit the web at <http://www.ibm.com/servers/eserver/pseries>. The IBM System p5 is the follow-on product line to the IBM eServer p5, OpenPower^{™™™}, and pSeries[®] servers.

IBM System z9 Source

For information about the IBM System z9™ server, visit the web at <http://www.ibm.com/servers/eserver/zseries>. The IBM System z9 is the follow-on product line to the IBM eServer zSeries® servers.

Other Sources

- For a list of compatible software, operating systems, and servers for Ultrium Tape Drives, visit the web at <http://www.ibm.com/storage/lto>. Under IBM System Storage TS3500 Tape Library, select Product details. Under Learn more, select Interoperability matrix or select Independent Software Vendor (ISV) matrix for LTO.
- For a list of compatible software, operating systems, and servers for TS1120 Tape Drives, visit the web at <http://www.ibm.com/servers/storage/tape/drives>. Under IBM System Storage TS1120 Tape Drive, select Product details. Under Learn more, select Interoperability matrix or Independent Software Vendor (ISV) matrix.
- For a list of compatible software, operating systems, and servers for 3592 Tape Drives, visit the web at <http://www.ibm.com/servers/storage/tape/drives>. Under IBM TotalStorage 3592 Tape Drive, select Product details. Select Resource library. Select Interoperability, then 3592 Tape Drive. Or select Compatibility information, then Independent Software Vendor (ISV) Matrix for 3592 Tape Drive.
- *IBM Encryption Key Manager component for the Java™ platform Introduction, Planning, and User's Guide*, GA76-0148
- *IBM 3953 Tape System Introduction and Planning Guide*, GA32-0557
- *IBM 3953 Library Manager Model L05 Operator Guide*, GA32-0558
- *IBM 3953 Tape Frame Model F05 Maintenance Information* (provided with the 3953 Tape System)
- *IBM TotalStorage Enterprise Silo Compatible Tape Frame 3592 Introduction, Planning, and User's Guide Model C20*, GA32-0463
- *IBM System Storage TS1120 Tape Drive and Controller Operator Guide*, GA32-0556
- *IBM System Storage TS1120 Tape Drive and Controller Introduction and Planning Guide*, GA32-0555
- *IBM System Storage TS1120 Tape Drive SCSI Reference*, GA32-0466
- *IBM System Storage TS3000 System Console (TSSC) Maintenance Information*.
- *IBM TotalStorage SMI-S Agent for Tape on Linux Systems Installation Guide*, GC35-0512. This book is available through the IBM Publications Center on the web at <http://www.elink.ibm.com/public/applications/publications/cgibin/pbi.cgi>.
- *IBM TotalStorage LTO Ultrium Tape Drive SCSI Reference*, GA32-0450
- *Systems Safety Notices*, G229-9054. This publication is available at <http://www.ibm.com/servers/resourcelink>. To access, register for a userid and password, then select Library in the navigation area.
- *IBM Tape Device Drivers Installation and User's Guide*, GC27-2130
- *IBM Tape Device Drivers Programming Reference*, GA32-0566
- *Implementing IBM Tape in Linux and Windows*, SG24-6268. This book is available on the web at <http://www.redbooks.ibm.com/redpieces/pdfs/sg246268.pdf>.
- *Implementing IBM Tape in Unix Systems*, SG24-6502. This book is available on the web at <http://www.redbooks.ibm.com/redbooks/pdfs/sg246502.pdf>.
- *The IBM TotalStorage Tape Libraries Guide for Open Systems*, SG24-5946
- *The LTO Ultrium Primer for IBM eServer iSeries Customers*, REDP-3580. This book is available on the web at www.redbooks.ibm.com. Search on REDP-3580.
- *IBM System Storage TS3500 Tape Library Data Gathering - Introduction to Library Statistics*, a white paper that is available from your IBM Representative

- *IBM TotalStorage 3584 Tape Library Performance*, a white paper that is available from your IBM Representative
- To access installation instructions for customer-setup units (CSUs) from the web, go to <http://www-03.ibm.com/servers/storage/tape/resource-library.html#publications>. Under the Publications category, select 3584 Tape Library.
- *IBM LTO Ultrium Cartridge Label Specification (Revision 2)*. This document is available on the web at <http://www.ibm.com/servers/storage/support/lto/3584/>. Under Additional resources, select LTO Ultrium media. Under Learn more, select LTO label specifications. Under Abstract, select the .pdf file to access the document.
- *Label Specification for IBM 3592 Cartridges when used in IBM Libraries*. This document is available on the web at www.storage.ibm.com/media/tapecartridges/index.html. Under Enterprise storage media, select 3592 tape cartridges. Under Learn more, select Barcode Label Specification for use with 3592 Tape Media. Under Content, select the .pdf file to access the document. You can also contact your IBM Marketing Representative for this specification.

Authorized Suppliers of Bar Code Labels

You can order bar code labels directly from the authorized label suppliers listed in Table 1.

Attention: The IBM System Storage TS3500 Tape Library is designed to work with bar code labels that meet the specifications and requirements set forth in the *IBM LTO Ultrium Cartridge Label Specification (Revision 2)* and the *Label Specification for IBM 3592 Cartridges when used in IBM Libraries*. The following label providers have demonstrated the ability to produce finished bar code labels that meet the foregoing specifications and requirements. This information is provided for the convenience of 3584 Tape Library users only, and is not an endorsement or recommendation of such providers. IBM is not responsible for the quality of bar code labels procured from sources other than IBM. This information is applicable to bar code labels actually printed by the listed companies. IBM has not reviewed the quality of any labels produced by software or services offered by such companies which allow end users to print labels on their own printing equipment.

Table 1. Authorized suppliers of custom bar code labels

In the Americas	In Europe and Asia
Dataware 7570 Renwick Houston, TX 77081 U. S. A. Telephone: 800-426-4844 http://www.datawarelabels.com/	Not applicable
EDP/Colorflex 2550 West Midway Boulevard Broomfield, CO 80020-1633 U. S. A. Telephone: 800-522-3528 or 303-666-2160 Fax: 303-666-2166 http://www.colorflex.com/colortrax.asp	EDP Europe Limited 43 Redhills Road South Woodham Ferrers Chelmsford, Essex CM3 5UL U. K. Telephone: 44 (0) 1245 322380 Fax: 44 (0)1245 323484 http://www.edpeurope.com/media-labels.html

Table 1. Authorized suppliers of custom bar code labels (continued)

In the Americas	In Europe and Asia
Netc, L. L. C. 100 Corporate Drive Trumbull, CT [®] 06611 U. S. A. Telephone: 203-372-6382 http://www.NetcLabels.com	Netc Europe Ltd Town Farm Bungalow North Curry Taunton Somerset U. K. TA3 6LX Telephone: 44 (0) 1823 491439 http://www.NetcLabels.co.uk
	Netc Asia Pacific Pty Ltd Locked Bag 14 Kenthurst NSW Australia 2156 Telephone: 61 (0) 2 4563 6556 http://www.NetcLabels.com.au

Chapter 1. Introduction

This section introduces the IBM System Storage TS3500 Tape Library (TS3500 Tape Library), machine type 3584, referred to hereafter as the 3584 Tape Library.

Overview

This section describes the 3584 Tape Library. It gives the maximum quantity of frames and drives, describes the data rate and capacity for the IBM LTO Ultrium Tape Drives and the IBM 3592 Tape Drives, describes the library's cartridge capacity, and gives the supported interfaces for each type of drive.

The 3584 Tape Library is a stand-alone device that provides reliable, automated tape handling and storage for both mainframe and Open Systems environments.

Figure 2 shows a 6-frame version of the 3584 Tape Library. The library can expand to 16 frames and can include 192 drives.

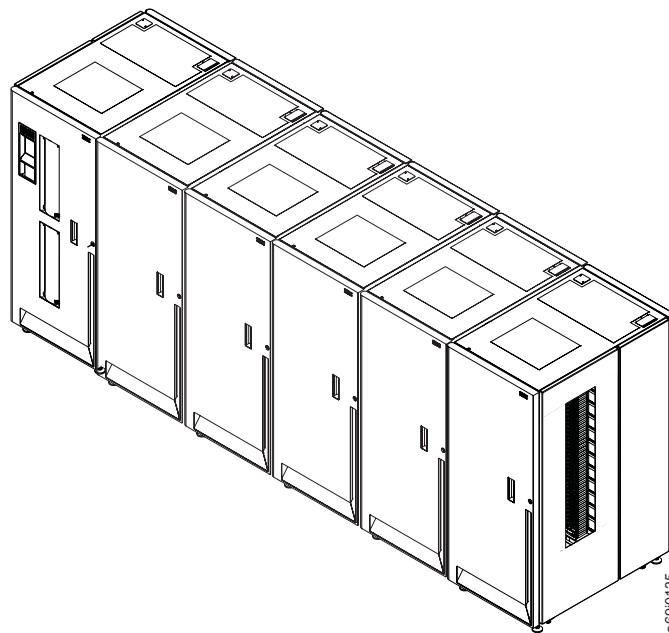

Figure 2. The 3584 Tape Library. The library can contain up to 16 frames.

The 3584 Tape Library comes with several tape drive and frame options to meet your needs. Table 2 provides an overview of supported tape drives. Table 3 on page 3 gives the capacities of the supported frames.

Table 2. Tape drives that are supported by the 3584 Tape Library

Supported Tape Drives				
Type of Drive	Speed of Connectivity	Native Data Rate	Native Capacity	Other Information
IBM System Storage TS1040 Tape Drive Model F4A	4 Gbps Fibre	120 MB/s	800 GB	Known as the Ultrium 4 Tape Drive

Table 2. Tape drives that are supported by the 3584 Tape Library (continued)

Supported Tape Drives				
Type of Drive	Speed of Connectivity	Native Data Rate	Native Capacity	Other Information
IBM System Storage TS1030 Tape Drive Model F3B	4 Gbps Fibre	80 MB/s	400 GB	Both of these drives are known as the Ultrium 3 Tape Drive
IBM System Storage 3588 Tape Drive Model F3A	2 Gbps Fibre	80 MB/s	400 GB	
IBM TotalStorage LTO Ultrium 2 Tape Drive	2 Gbps Fibre 160 MB/s (LVD SCSI) 40 MB/s (HVD SCSI)	35 MB/s	200 GB	Known as the Ultrium 2 Tape Drive
IBM TotalStorage LTO Ultrium 1 Tape Drive	1 Gbps 80 MB/s (LVD SCSI) 40 MB/s (HVD SCSI)	15 MB/s	100 GB	Known as the Ultrium 1 Tape Drive
IBM System Storage TS1120 Tape Drive	4 Gbps Fibre	100 MB/s	500 GB	Formerly known as the IBM TotalStorage 3592 Tape Drive Model E05
IBM TotalStorage 3592 Tape Drive Model J1A	2 Gbps Fibre	40 MB/s	300 GB	

Table 3. Frames that are supported by the 3584 Tape Library

Supported Frames			
A library of these models...	Containing these drives...	Can contain this many cartridges...	And has this maximum capacity...
L52, D52, L53, and D53	Ultrium Tape Drives	6887	5509 TB
L32 and D32	Ultrium Tape Drives	6881	5509 TB
L22, D22, L23, and D23	IBM System Storage TS1120 Tape Drive and IBM TotalStorage 3592 Tape Drive Model J1A	6260	3130 TB (TS1120) 1878 TB (J1A)

Structure of Library

This section defines base and expansion frames, and describes the models of the 3584 Tape Library.

The basic 3584 Tape Library is a single storage unit known as the *base frame* (Models L32, L52, or L53 for LTO Ultrium Tape Drives, or Models L22 or L23 for 3592 Tape Drives). The library's scalability allows you to increase capacity by adding up to fifteen additional storage units, called *expansion frames*. The frames join end to end, with the base frame on the left and the expansion frame on the right. The additional expansion frames are supported by a common cartridge accessor that requires no pass-through mechanism. Each frame may contain up to twelve Ultrium Tape Drives or 3592 Tape Drives, but may not contain a mix of both.

The 3584 Tape Library features an optional second cartridge accessor. If you order dual accessors, two frames that are used as *service bays* are required. Service bay A is known as Model HA1 and service bay B is a Model D23, D22, D52, or D53 frame. For more information, see the section about dual accessors and service bays in the *IBM System Storage TS3500 Tape Library Introduction and Planning Guide*.

For bulk media handling, the TS3500 Tape Library supports four I/O stations in newly purchased Models D23 and D53 frames. The D-frame with I/O installed is comprised of four independently accessible I/O station doors with a total of 64 slots (16 in each I/O station door). Additionally, two LED indicators are provided for each I/O Station in a D-frame in order to indicate if the I/O Station is empty or full and if the I/O Station door is locked or unlocked. This plant feature reduces the frame storage slot capacity by 160 for a Model D23 and by 176 for a Model D53. The I/O stations increase the maximum library I/O slot capacity from 32 to 224. The multiple I/O stations can double the maximum insert/eject throughput since both accessors can be used. The D23 and D53 Models remain compatible with existing Models L22, L32, L52, D22, D32, and D52.

The models of the 3584 Tape Library vary, depending on the type of drives that they contain and whether the frame is a service bay, base frame, or expansion frame. The following is a description of each frame:

Model L22 or L23

A base frame that uses up to twelve 3592 Tape Drives and up to 260 IBM TotalStorage 3592 Enterprise Tape Cartridges. Models L22 and L23 are approximately 307 mm (12 in.) shorter in depth than Model L32. Model L23 is equipped with the enhanced frame control assembly power structure.

Model D22

An expansion frame that uses up to twelve 3592 Tape Drives and up to 400 IBM TotalStorage 3592 Enterprise Tape Cartridges. These frames can optionally be configured as service bay B. Models D22 is approximately 307 mm (12 in.) shorter in depth than Model D32.

Model D23

An expansion frame that optionally includes the Enhanced Frame Control Assembly and optionally offers four I/O stations. The Model D23 uses up to twelve 3592 Tape Drives and up to 400 IBM TotalStorage 3592 Enterprise Tape Cartridges. If not equipped with four I/O stations, this frame can optionally be configured as service bay B. The Model D23 is approximately 307 mm (12 in.) shorter in depth than Model D32. It is optionally equipped with the enhanced frame control assembly power structure.

Model L32

A base frame that uses up to twelve Ultrium Tape Drives and up to 281 IBM LTO Ultrium Tape Cartridges. The Model L32 is approximately 307 mm (12 in.) longer in depth than Model L52.

Model D32

An expansion frame that uses up to twelve Ultrium Tape Drives and up to 440 IBM LTO Ultrium Tape Cartridges. The Model D32 is approximately 307 mm (12 in.) longer in depth than Model D52.

Model L52 or L53

A base frame that uses up to twelve Ultrium Tape Drives and up to 287 IBM LTO Ultrium Tape Cartridges. Models L52 and L53 are approximately 307 mm (12 in.) shorter in depth than Model L32. Model L53 is equipped with the enhanced frame control assembly power structure.

Model D52

An expansion frame that uses up to twelve Ultrium Tape Drives and up to 440 IBM LTO Ultrium Tape Cartridges. These frames can optionally be configured as service bay B. Model D52 is approximately 307 mm (12 in.) shorter in depth than Model D32.

Model D53

An expansion frame that uses up to twelve Ultrium Tape Drives and up to 440 IBM LTO Ultrium Tape Cartridges. Model D53 optionally offers four I/O stations. If not equipped with four I/O stations, this frame can optionally be configured as service bay B. Model D53 is approximately 307 mm (12 in.) shorter in depth than Model D32. Model D53 is optionally equipped with the enhanced frame control assembly power structure.

Model HA1

Required when you order the optional second accessor, a frame that is used as a service bay and that contains no tape drives or data cartridge capacity. Model HA1 contains only slots for diagnostic cartridges. This frame is always configured as service bay A. The Model HA1 is approximately 307 mm (12 in.) shorter in depth than Models L32 and D32.

Models L22, D22, L23, D23, L52, D52, L53, and D53 are compatible with Models L32 and D32, but will require additional features because they use different side and rear covers. If you change from a Model L32 or D32 to a Model D22, D23, D52, or D53 (or from a Model D22, D23, D52, or D53 to a Model L32 or D32) within the same library you may also need the appropriate side covers. If you have a Model D42, it must be removed or converted to a Model D32 before you can add a Model D22, D23, D52, or D53.

The IBM System Storage Tape Library Specialist web interface and 10/100 Ethernet support are included with Models L22, L23, L52, and L53. For Model L32, they are available as feature codes 1662 and 1660, respectively.

Figure 3 shows examples of a base and an expansion frame.

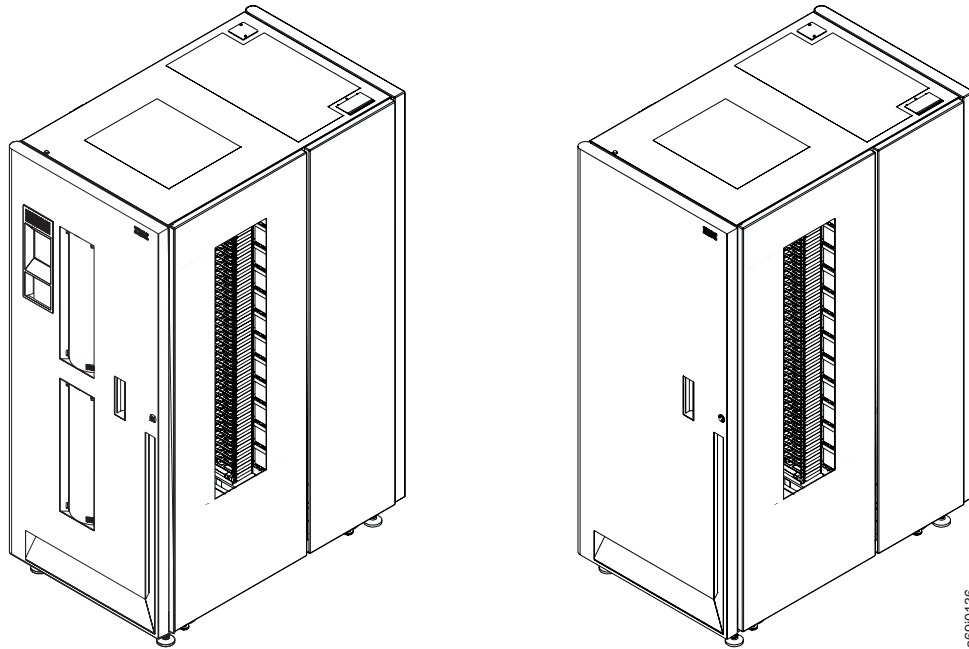

Figure 3. Frames in the IBM System Storage TS3500 Tape Library. A Model L22 or L52 (the base frame) is on the left. A Model D22 or D52 (the expansion frame) is on the right and attaches to the base frame. Models L23, D23, L32, D32, L53, and D53 are not shown. Models L22, D22, L23, and D23 house 3592 Tape Cartridges; Models L32, D32, L52, D52, L53, and D53 house LTO Ultrium Tape Cartridges.

Related concepts

“Supported Tape Drives” on page 8

This section introduces the types of drives that can be installed in the 3584 Tape Library.

Dual Accessors and Service Bays

When an optional second accessor is installed, the 3584 Tape Library features enhanced availability through its ability to use that accessor and to operate without disruption when any component of the working accessor fails.

Note: To use dual accessors and service bays, the 3584 Tape Library must be installed with the Advanced Library Management System (ALMS). For additional information, see the section about the Advanced Library Management System in the *IBM System Storage TS3500 Tape Library Introduction and Planning Guide*.

If the library is installed with the optional second accessor, cartridge mount performance is also optimized. (A *mount* occurs when the accessor removes a cartridge from a drive, returns it to its storage slot, collects another cartridge from a random storage slot, moves it to and loads it into the drive.) The second accessor is part of feature code 1440 (Service Bay B Configuration), which also includes a D23, D22, D52, or D53 frame as service bay B. If you order a second accessor you must also order a 3584 high availability (HA1) frame, which is also known as service bay A. For information about library availability and performance, go to the section about library performance in the *3584 Tape Library Introduction and Planning Guide*.

As you view the library from the front, service bay A is on the far left and service bay B is on the far right. Figure 4 shows the location of service bays in the 3584 Tape Library.

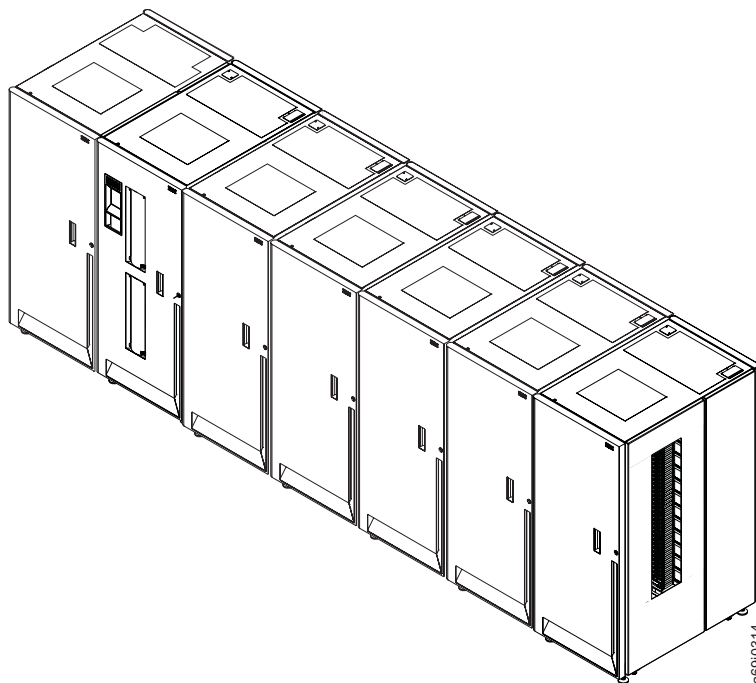

Figure 4. Location of service bays in the 3584 Tape Library. Service bay A (the HA1 frame) is on the far left. Service bay B (the D23, D22, D52, or D53 frame) is on the far right and contains the second accessor.

When dual accessors are installed and an attached host issues a command for cartridge movement, the library automatically determines which accessor can

perform the mount in the most timely manner. If the library's primary accessor fails, the second accessor assumes control and eliminates system outage or the need for operator intervention.

Although the library uses defaults to specify the zones (areas) in which the accessors operate, you can specify particular zones by using the Tape Library Specialist web interface. This process is called setting the preferred zone. For details, see "Using the Web to Set or Change an Accessor's Preferred Zone" on page 141.

Related tasks

"Using the Web to Set or Change an Accessor's Preferred Zone" on page 141

Supported Tape Drives

This section introduces the types of drives that can be installed in the 3584 Tape Library.

The LTO Ultrium Tape Drives and the 3592 Tape Drives are high-performance, high-capacity data-storage units that can be installed in the 3584 Tape Library. Up to 12 drives may be installed in each frame of the library, but the two types of drives may not be mixed in the same frame. You can identify a drive by examining the logo at its front or by inspecting the label at the rear of the drive's canister.

Note: The features and functions of this release are not supported by frames that contain Digital Linear Tape (DLT) drives (called *DLT libraries*). A DLT library can be upgraded to a library that uses all Ultrium Tape Cartridges or a mix of Ultrium and 3592 tape cartridges by converting the D42 frames to D32 frames, or by removing all D42 frames. When this is done, this release will be supported on the 3584 Tape Library. Most field upgrades will require new library firmware that supports all current features of the 3584 Tape Library, except for DLT drives and media.

You or your IBM Service Representative can update firmware for the LTO Ultrium 2 Tape Drive, Ultrium 3 Tape Drives, Ultrium 4 Tape Drives, the 3592 J1A, and the TS1120 Tape Drive without scheduling downtime. This enhancement is called a *nondisruptive drive firmware update*. It is available through the IBM System Storage Tape Library Specialist web interface and (for IBM Service Representatives) through CETool, but is not supported by the SCSI interface. For more information, go to "Updating Drive Firmware" on page 198.

Related concepts

"Updating Drive Firmware" on page 198

This section introduces ways to update firmware for tape drives in the 3584 Tape Library.

LTO Ultrium Tape Drives

The new IBM System Storage TS1040 Tape Drive Model F4A is a Linear Tape-Open (LTO) tape drive that facilitates 4 Gbps Fibre Channel connectivity. Like its predecessors, the IBM System Storage TS1030 Tape Drive Models F3A (which facilitates 2 Gbps Fibre Channel connectivity), and F3B (which facilitates 4 Gbps Fibre Channel connectivity), the drive is also commonly called the Ultrium 4 Tape Drive and is differentiated by its model number.

You can identify Ultrium 4 Tape Drives (Model F4A), Ultrium 3 Tape Drives (Models F3A or F3B), or the Ultrium 2 Tape Drive by the logo at the front of the drive or by the label at the rear of the drive's canister. You can identify the Ultrium 1 Tape Drive by the label at the rear of its canister. An Ultrium 3 WORM-capable drive can be identified by the level of code it contains. If the code level is 54K1 or higher, the Ultrium 3 drive is capable of WORM functionality. Ultrium 3 or Ultrium 4 Tape Drives with WORM capability can recognize WORM-compatible media.

An Ultrium 3 or Ultrium 4 Tape Drive, both with and without WORM-capable firmware, reads and writes non-WORM media. This means that you can load WORM-capable firmware on your Ultrium 3 or Ultrium 4 Tape Drives and use any media that is supported by LTO Ultrium 3 or Ultrium 4 Tape Drives. In this case, only the data that is written on the WORM media is treated as WORM data; data written on other types of media can be overwritten.

Ultrium Tape Drives do not read or write to 3592 Tape Cartridges, and 3592 Tape Drives do not read or write to Ultrium Tape Cartridges.

The 3584 Tape Library supports Ultrium 3 and Ultrium 4 Tape Drives and Ultrium 3 and Ultrium 4 tape cartridges in newly purchased L52, D52, L53, and D53 frames, as well as in installed L32, D32, L52, and D52 frames.

Table 4 gives cartridge compatibility for the Ultrium Tape Drive s.

Table 4. Cartridges that are compatible with Ultrium Tape Drives

Cartridge	Ultrium 4 Tape Drives	Ultrium 3 Tape Drives	Ultrium 2 Tape Drive	Ultrium 1 Tape Drive
IBM System Storage 800 GB LTO Data Cartridge (xxxxxxL4)	Y	N	N ¹	N ¹
IBM System Storage 800 GB LTO WORM Data Cartridge (xxxxxxLU)	Y	Y	N ¹	N ¹
IBM System Storage 400 GB LTO Data Cartridge (xxxxxxL3)	Y	Y	N ¹	N ¹
IBM System Storage 400 GB LTO WORM Data Cartridge (xxxxxxLT)	Y	Y	N ¹	N ¹
IBM System Storage 200 GB LTO Data Cartridge (xxxxxxL2)	Y ²	Y	Y	N ¹
IBM System Storage 100 GB Data Cartridge (xxxxxxL1)	N	Y ²	Y	Y
IBM System Storage Universal LTO Cleaning Cartridge (universal, CLNUxxL1)	Y	Y	Y	Y ³
LTO Ultrium Cleaning Cartridge (IBM only, CLNlxxL1)	Y	Y	Y	Y

Notes:

- Y = supported.
 - N = unsupported.
1. The library rejects any command to move unsupported media to a drive and returns a sense key of 5 and an additional sense code/additional sense code qualifier of 30/00.
 2. Supported for read-only.
 3. Requires drive firmware level 25D4 or higher.

The Ultrium Tape Drives can read tapes that have been written by non-IBM Ultrium drives. They also write to tapes that can be read by non-IBM Ultrium drives.

Ultrium 1, Ultrium 2, Ultrium 3, or Ultrium 4 Tape Drives and cartridges can reside in the same frame.

When a cartridge is labeled according to proper IBM bar code label specifications, the last character of its volume serial (VOLSER) number indicates the generation of the media. For example, a cartridge with a VOLSER of 000764L4 is an Ultrium 4 cartridge; a cartridge with a VOLSER of 000764L3 is an Ultrium 3 cartridge; a cartridge with a VOLSER of 003995L2 is an Ultrium 2 cartridge.

To enhance library performance, Ultrium 2, Ultrium 3, and Ultrium 4 Tape Drives include speed matching, channel calibration, and power management. Speed

matching dynamically adjusts the drive's native (uncompressed) data rate to the slower data rate of a server. Channel calibration customizes each read/write data channel for optimum performance. The customization enables compensation for variations in the recording channel transfer function, media characteristics, and read/write head characteristics. Power management reduces the drive's power consumption during idle power periods.

Encryption

Ultrium 4 tape drives are encryption-capable, which means they can convert data into a cipher that ensures data security. To perform encryption, the drive must be made encryption-enabled by your selection of one of three methods of encryption management. Two of these methods, system-managed and library-managed encryption, require the purchase of FC 1604 (Transparent LTO Encryption). A key is required to encrypt and decrypt the data. How a key is generated, maintained, controlled, and transmitted depends on the operating environment where the TS1040 (Ultrium 4) or TS1120 Tape Drive is installed. Some applications are capable of performing key management. In their absence IBM provides an Encryption Key Manager (EKM) that works in conjunction with the keystore of your choice to perform all necessary key management tasks. There is no recovery for lost encryption keys. For more information about encryption, see the TS1120 Tape Drive encryption overview in the *IBM System Storage TS3500 Tape Library Introduction and Planning Guide*. Also refer to the *IBM Encryption Key Manager component for the Java platform Introduction, Planning, and User's Guide*. To choose a method of encryption management, see "Setting or Changing a Drive's Method of Encryption" on page 203.

The following table gives specifications for the Ultrium 3 and Ultrium 4 Tape Drives.

Table 5. Specifications for the IBM System Storage 3588 Tape Drive Model F3A, F3B, and the IBM System Storage TS1040 Tape Drives Model F4A Ultrium 4 Tape Drives

Specifications for the IBM System Storage 3588 Tape Drive Model F3A, the IBM System Storage TS1030 Tape Drive Model F3B, and the IBM System Storage TS1040 Tape Drive Model F4A	
Specification	Value
Height	93 mm (3.7 in.)
Width	210 mm (8.3 in.) overall
Depth	458 mm (18.0 in.)
Weight	5.7 kg (12.6 lbs)
Heat output	49 watts (0.17 kBTU/hr)
Power requirements (see Note)	5.0 A @ 5 V dc and 2.0 A @ 12 V dc (maximum)
Note: dc voltages are provided by power supplies in the tape library.	

Related concepts

“Ultrium Bar Code Label” on page 220

This section describes the appearance and specifications of the Ultrium bar code label.

3592 Tape Drives

Data encryption is a new feature offered by the TS1120 Tape Drive. You can order the drive with encryption capability or upgrade a Model E05 canister to include encryption capability. Any TS1120 Tape Drive, whether encryption capable, may be installed with the 3592 J1A Tape Drive in Models L22, D22, L23 and D23. For information about encryption-capable drives and media, encryption enablement, and encryption-key management, go to the overview about TS1120 Tape Drive encryption in the *IBM System Storage TS3500 Tape Library Introduction and Planning Guide*.

For minimal upgrade disruption, the features and behaviors of the TS1120 Tape Drive closely resemble those of the 3592 J1A Tape Drive. The TS1120 Tape Drive has dual-port, 4 Gbps, native switch fabric Fibre Channel interfaces, while the 3592 J1A Tape Drive offers the same but at a 2 Gbps rate. These features offer flexibility in an Open Systems environment because the drives can directly attach to Open Systems servers with Fibre Channel attachments.

Both drives include an RS-422 library interface port for communication with the 3584 Tape Library. Both use the Statistical Analysis and Reporting System (SARS) to isolate failures between media and hardware. Like the 3592 J1A Tape Drive, the TS1120 Tape Drive has a service panel port for use by an IBM Service Representative.

A 3592 Tape Drive cannot read or write to a High Performance Cartridge Tape (media type J) or to an Extended High Performance Cartridge Tape (media type K).

Table 6 on page 12 shows the basic features of both the TS1120 Tape Drive and the 3592 J1A Tape Drive.

Table 6. Features of the 3592 Tape Drives

Feature	3592 Tape Drives	
	TS1120 Tape Drive	Model J1A
Native sustained data rate	100 MB/s (using Model E05 format)	40 MB/s (using Model J1A format)
	50 MB/s (using Model J1A format)	
Compressed sustained data rate	200 MB/s (using Model E05 format)	80 MB/s (using Model J1A format)
	100 MB/s (using Model J1A format)	
Native capacity	500 GB (using Model E05 format)	300 GB (using Model J1A format)
	300 GB (using Model J1A format)	
Write once, read many (WORM) capability	Yes	Yes
Capacity scaling and short cartridge	Yes	Yes
Read/write capability	If encryption-enabled, reads and writes Model E05 encrypted format	Cannot read or write to Model E05 encrypted format
	Reads and writes Model E05 format	Cannot read or write to Model E05 format
	Reads and writes Model J1A format	Reads and writes Model J1A format
Host (server) attachment	Supports dual-port, 4 Gbps Fibre Channel interface	Supports dual-port, 2 Gbps Fibre Channel interface
	Maximum interface burst transfer rate of 400 MB/s	Maximum interface burst transfer rate of 200 MB/s
	Supports N and L ports with autoconfigure	Supports N and L ports with autoconfigure
Encryption	With feature code 9592 or 5592	Not supported

The following additional features of the 3592 J1A Tape Drive help to improve performance, capacity, and availability:

- N+1 power supplies when installed in the 3584 frame
- Large 128-MB internal data buffer
- Digital speed matching to adjust the drive’s native data rate to the net host data rate (after data compressibility has been factored out) throughput performance
- Channel calibration which is designed to allow for customization of each read/write data channel for optimum performance
- High resolution tape directory plus enhanced search speed to improve nominal and average access times
- Streaming Lossless Data Compression (SLDC) algorithm which is designed to offer an improvement over previous IBM lossless compression algorithms

The TS1120 Tape Drive offers all of the preceding features of the 3592 J1A Tape Drive, plus the following. For additional information, see Chapter 5, “Using 3592 Tape Drive Media,” on page 243.

Media reuse

The TS1120 Tape Drive and the 3592 J1A Tape Drive can reuse different types of tape and multiple densities (logical formats) across various drive generations. Certain models may only support a subset of densities (such as the 3592 J1A Tape Drive, which can only read and write at a single density), while others (such as the TS1120 Tape Drive) can read and write at multiple densities.

The TS1120 Tape Drive reads and writes at 512 tracks and 8 channels (J1A emulation mode) on the JA, JR, JJ, and JW media types. The JB and JX media types can only be written and read at a density of 896 tracks and 16 channels (TS1120 native mode). 3592 J1A emulation is not supported on the JB and JX media. These logical formats can be divided into multiple sub-format options, such as segmentation and capacity scaling.

Speed matching

When operating in a host environment where the net host data rate is less than the maximum drive native data rate, the TS1120 Tape Drive automatically performs dynamic speed matching to minimize backhitches. Dynamic speed matching adjusts the native data rate of the drive as closely as possible to the net host data rate (after data compressibility has been factored out). A reduction in backhitches improves system performance.

High resolution tape directory (HRTD)

Located in the TS1120 Tape Drive, this directory structure allows the drive to have fast and consistent nominal and average access times for Locate operations.

Channel calibration and on-the-fly adaptive equalization

To gain optimum performance, channel calibration allows the drive to automatically customize each read and write data channel. The customization compensates for variations in the recording channel transfer function, for media characteristics, and for read and write head characteristics. Initial calibration settings are calculated and stored at the time of manufacture. For optimum error rate performance, the TS1120 Tape Drive also uses on-the-fly adaptive equalization hardware on an ongoing basis to adjust the read equalization response.

Recursive accumulating backhitchless flush

The TS1120 Tape Drive uses an algorithm known as recursive accumulating backhitchless flush (or non-volatile caching) to increase effective data rate performance from host servers that force explicit Synchronize operations during Write operations.

Backhitchless backspace

Backhitchless backspacing enables some backspace operations to be virtualized without physical backhitching. If you write and overwrite multiple trailer labels, this firmware feature provides major performance improvements. For more information, refer to the appendix about WORM behavior in the *IBM System Storage TS1120 Tape Drive SCSI Reference*.

Capacity scaling

If you want to exchange capacity for improved access times, the TS1120 Tape Drive supports multiple format options, such as scaling and segmentation modes. The TS1120 Tape Drive can sense and report the scaling state of current medium by using the SCSI Mode Sense command and specifying Mode Page X'23'. Capacity scaling is only offered on the JA

and JB media types. For the exact Mode Select commands and settings necessary to invoke scaling, refer to the *IBM System Storage TS3500 Tape Library SCSI Reference*.

WORM

The TS1120 Tape Drive supports write once, read many (WORM) behaviors and format attributes that are identical to the 3592 J1A Tape Drive, but the support is extended into the WORM logical format of the TS1120 Tape Drive, as well as continuing the support for the WORM logical format of the 3592 J1A Tape Drive. Three WORM cartridge types are supported: JW (full length), JR (short length), and (for TS1120) JX Extended WORM cartridge. WORM cartridges are factory-formatted as WORM cartridges and may not be converted to data cartridges. Both 3592 Tape Drives allow append operations to data already on WORM cartridges, but do not allow data to be overwritten under any circumstances.

Capacity-based and position-based LEOT reporting

The TS1120 Tape Drive uses enhanced logic to report logical end-of-tape (LEOT) data. The drive reports LEOT based on a combination of indicators of capacity-based LEOT and position-based LEOT. The TS1120 Tape Drive monitors the total accumulated physical tape files written to the cartridge and reports the LEOT based on the capacity-based LEOT value, rather than reporting LEOT based on the physical position on the tape (position-based LEOT). To summarize, this technique reports LEOT based on the amount of compressed data that is recorded to the cartridge and reduces the variation in the amount of data recorded before LEOT is issued. For applications that use LEOT to stop the write process, a more consistent capacity is recorded to the media. For a higher percentage of the time, this process allows tape copies to complete without overflow.

Enhanced format for recording error-correction codes (ECCs)

The logical format of the TS1120 Tape Drive offers improved error-correction-code capabilities over the 3592 J1A and LTO formats by increasing the power of one of the two orthogonal Reed-Solomon ECCs that protect the data on tape. The correction power of the inner code is approximately doubled from that of the 3592 J1A and thus offers superior reliability of the data.

Drive mechanical and electrical reliability

The mechanism of the TS1120 Tape Drive is specified at a mean-cycles-between-failure rate of 300,000 cycles, which is the highest reliability rating in the industry. The mechanism contains special mechanical and electrical features to prevent damage to the media on power-down or reset and to prevent the dropping of the leader pin or other thread failures during similar interruptions. It also tolerates extremely high vibration and shock environments without data loss or degraded operation.

Multiple subsystem and automation support

The TS1120 Tape Drive and its cartridge support multiple automation libraries and can be easily transported between environments. The TS1120 Tape Drive supports all automation systems that are supported by the 3592 J1A Tape Drive at identical drive-packaging densities.

Data compression

The TS1120 Tape Drive uses the data-compression method known as streaming lossless data compression (SLDC) algorithm. The method is identical to one used by the 3592 J1A Tape Drive, although the

compression logic for the TS1120 Tape Drive operates at more than twice the overall transfer rates of the 3592 J1A Tape Drive.

512 MB data buffer with read ahead feature

The TS1120 Tape Drive includes a data buffer of 512 MB. Along with enabling performance characteristics in buffered Write and Read commands, the data buffer also supports a Read Ahead feature. When the drive processes a command to locate or read a block, the drive automatically continues to stream down the tape and read ahead until the data buffer is full. This allows subsequent Locate or Read commands to be fulfilled from the data buffer at silicon speeds, rather than requiring access to the tape.

Offboard data string searching

The TS1120 Tape Drive can search the data content of host server records for string matches. The function is called *offboard data string searching* because the data search workload can be performed offboard from the host. The drive can perform a search at the maximum data rate (100 MB/s), which greatly reduces the amount of data transfer and host search times.

Encryption

With IBM feature code 9592 or 5592, TS1120 Tape Drives are encryption-capable, which means they can convert data into a cipher that ensures data security. To perform encryption, the drive must be made encryption-enabled by your selection of one of three methods of encryption management. A key is required to encrypt and decrypt the data. How a key is generated, maintained, controlled, and transmitted depends on the operating environment where the TS1120 Tape Drive is installed. Some applications are capable of performing key management. In their absence IBM provides an Encryption Key Manager (EKM) that works in conjunction with the keystore of your choice to perform all necessary key management tasks. There is no recovery for lost encryption keys.

The LTO Ultrium 4 Tape Drive also supports data encryption on the base drive with Ultrium 4 media, which meets LTO consortium specifications and Application Managed Encryption (see “LTO Ultrium Tape Drives” on page 8).

For more information about encryption, see the TS1120 Tape Drive encryption overview in the *IBM System Storage TS3500 Tape Library Introduction and Planning Guide*. Also refer to the *IBM Encryption Key Manager component for the Java platform Introduction, Planning, and User’s Guide*. To choose a method of encryption management, see “Setting or Changing a Drive’s Method of Encryption” on page 203.

Firmware for the TS1120 Tape Drive will not work in the 3592 J1A Tape Drive, and firmware for the 3592 J1A Tape Drive will not work in the TS1120 Tape Drive.

The 3592 Tape Drive supports four types of the IBM TotalStorage 3592 Enterprise Tape Cartridge. For more information about the supported cartridges, go to section about mixing media in drives in the *IBM System Storage TS3500 Tape Library Operator Guide*.

Related tasks

“Setting or Changing a Drive’s Method of Encryption” on page 203

This section describes how to set or change the encryption method for a TS1120 Tape Drive or LTO Ultrium-4 tape drive.

Supported Tape Cartridges

This section gives information about the tape cartridges that you can use in the 3584 Tape Library.

In the 3584 Tape Library, frames that are installed with Ultrium Tape Drives use Ultrium Tape Cartridges; frames that are installed with 3592 Tape Drives use 3592 Tape Cartridges. A frame cannot house both Ultrium Tape Drives and 3592 Tape Drives. However, in a library that includes both types of frames, you may insert 3592 Tape Cartridges into the lower I/O station of a Model L53, L52, or L32 frame for transport (by the cartridge accessor) to a Model D23 or D22 frame (your library must contain an I/O station that will accept 3592 Tape Cartridges). Similarly, you may insert Ultrium Tape Cartridges into the lower I/O station of a Model L23 or L22 frame for transport (by the cartridge accessor) to a Model D53, D52, or D32 frame (again, your library must contain an I/O station that will accept Ultrium Tape Cartridges).

Certain restrictions apply to the use of tape cartridges with drives. For additional information about compatibility between cartridges and drives, go to the section about mixing media in drives in the *IBM System Storage TS3500 Tape Library Introduction and Planning Guide*.

Cleaning cartridges are identified by a volume serial (VOLSER) number that begins with a prefix of CLNI or CLNU for LTO Ultrium Cleaning Cartridges, and CLN for 3592 Cleaning Cartridges.

Compatible Servers and Software

This section identifies ways to determine the servers and software that support the 3584 Tape Library.

The 3584 Tape Library is supported by a wide variety of servers, operating systems, and adapters. These attachments can change throughout the product's life cycle. To determine the latest attachments, or to get a comprehensive list of compatible software, perform one of the following:

- Visit the web:
 - For a list of compatible software, operating systems, and servers for Ultrium Tape Drives, visit the web at <http://www.ibm.com/storage/lto>. Under IBM System Storage TS3500 Tape Library, select Product details. Under Learn more, select Interoperability matrix or select Independent Software Vendor (ISV) matrix for LTO.
 - For a list of compatible software, operating systems, and servers for TS1120 Tape Drives, visit the web at <http://www.ibm.com/servers/storage/tape/drives>. Under IBM System Storage TS1120 Tape Drive, select Product details. Under Learn more, select Interoperability matrix or Independent Software Vendor (ISV) matrix.
 - For a list of compatible software, operating systems, and servers for 3592 Tape Drives, visit the web at <http://www.ibm.com/servers/storage/tape/drives>. Under IBM TotalStorage 3592 Tape Drive, select Product details. Select Resource library. Select Interoperability, then 3592 Tape Drive. Or select Compatibility information, then Independent Software Vendor (ISV) Matrix for 3592 Tape Drive.
- Contact your IBM Sales Representative.

Notes:

1. IBM does not provide application software with the 3584 Tape Library. To order software, contact your IBM Sales Representative, IBM Business Partner, or an independent software provider.
2. If you attach your library to a non-IBM platform with non-IBM software, IBM recommends that you contact your software vendor to obtain a matrix of compatible hardware, software, firmware revisions, and adapter cards.

Supported Device Drivers

This section identifies ways to determine the latest device drivers for the drives and robotics of the 3584 Tape Library.

IBM provides device driver support for the Ultrium Tape Drives, 3592 Tape Drives, and the robotics in the 3584 Tape Library. The device drivers also provide support for application-managed encryption on all platforms (except for HP-UX), and for system-managed encryption in Open Systems, beginning with the AIX platform.

IBM maintains the latest levels of device drivers and driver documentation on the Internet. To access this material, go to the following URL and select the folder for the platform that you want.

`ftp://ftp.software.ibm.com/storage/devdrv/`

Note: If you do not have Internet access and you need information about device drivers, contact your Sales Representative.

Using mtlb for Communication

This section describes the mtlb program, which facilitates communication between the 3584 Tape Library and the IBM TotalStorage 3494 Tape Library, the IBM TotalStorage Virtual Tape Server (VTS), or the IBM Virtualization Engine™ TS7700 Series.

The mtlb program is a command-line interface that was originally designed to control the 3494 Tape Library. It comes as part of the 3494 device driver, similar to the way the tapeutil utility comes with the SCSI tape device driver.

The mtlb program provides an interface from the server to a 3494 Tape Library, and also to the virtual tape drives and cartridges within an attached VTS or TS7700 Virtualization Engine.

The mtlb program has recently been enhanced to also work with SCSI tape libraries, such as the 3584 Tape Library installed with only 3592 Tape Drives. Some customers have written mtlb scripts to work with the 3494 Tape Library. If a customer with a 3494 Tape Library decides to migrate to the 3584 Tape Library, this mtlb enhancement will ease the migration.

Existing customer scripts that use the mtlb program require no changes or minor changes, depending on the functions of the 3494 Tape Library that are used. For example, there is no *category* concept in SCSI tape libraries, so that any mtlb command that references categories might need to be changed.

For a complete description of the mtlb program and command syntax, see the *IBM TotalStorage and System Storage Tape Device Drivers Installation and User's Guide*.

Chapter 2. Main Components

This section introduces the main components of the IBM System Storage TS3500 Tape Library.

Related information

Chapter 8, “Technical Components of the Library,” on page 315

This section introduces the major technical components of the 3584 Tape Library.

Overview of Main Components

This section provides an illustration of the main components of the 3584 Tape Library.

Figure 5 on page 20 shows the main components of the 3584 Tape Library.

1	Library frame	5	Door safety switch
2	Cartridge storage slots	6	Upper I/O station
3	Tape drive	7	Lower I/O station
4	Front door	8	Operator panel

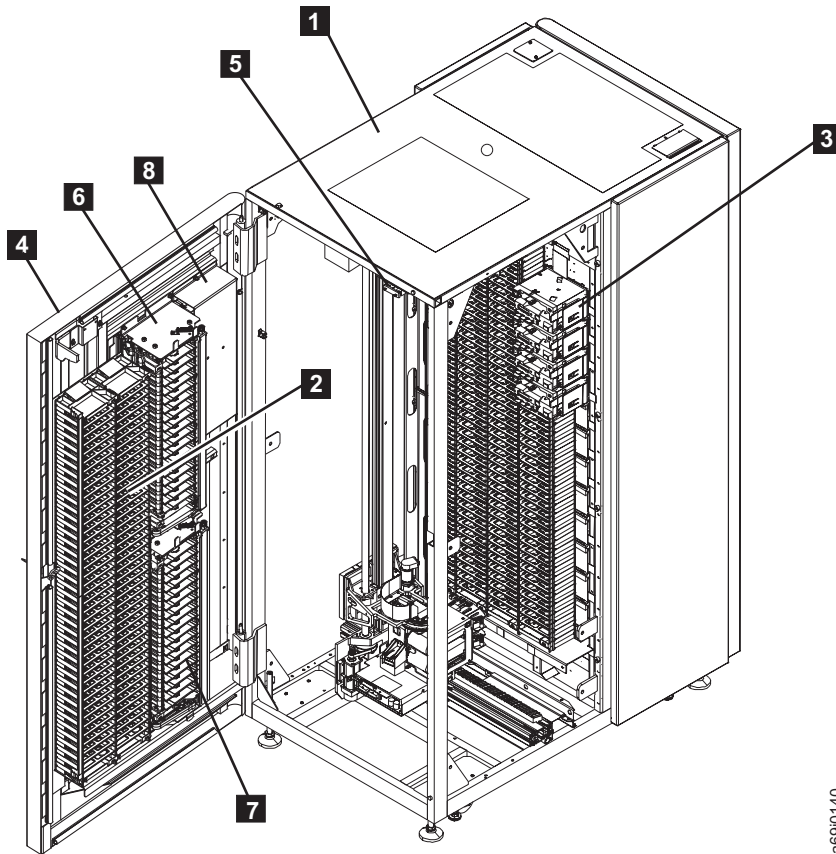

a690140

Figure 5. Main components of the IBM System Storage TS3500 Tape Library Model L52. The front door is open and the side of the library is cut away to show the components.

The sections that follow describe each component.

Library Frame

The library frame is the basic building block for the 3584 Tape Library.

A base frame is:

- Models L32, L52, and L53 for LTO Ultrium Tape Drives
- Models L22 and L23 for 3592 Tape Drives

An expansion frame is:

- Models D32, D52, and D53 for LTO Ultrium Tape Drives
- Models D22 and D23 for 3592 Tape Drives

A high availability frame (contains dual accessor) is:

- Model HA1

All base and expansion frames contain a rail assembly, cartridge storage slots, and 12 drive slots. The base frame includes:

- Cartridge accessor
- Accessor controller
- Two I/O slot option (available for all models):
 - One upper input/output (I/O) station with 16 storage slots for cartridges
 - One Lower I/O station with 16 storage slots for cartridges

Note: The lower I/O station is optional for libraries that use only one type of media and required for libraries that use both 3592 Tape Drives and LTO Ultrium Tape Drives. In a mixed media configuration, the upper I/O station is the media type of the Lxx frame and the lower I/O station is the alternate media type.

- Operator panel
- Operator panel controller

The high availability frame contains a rail assembly and gripper test slots. For additional information about the high availability frame (service bay), see “Dual Accessors and Service Bays” on page 6.

All components of the 3584 Tape Library are contained inside the frames. The tops of the frames have windows that admit ambient lighting. Windows are also located at each end of the library.

Located at the front of each frame is a front door. The door lets you access the cartridge storage slots and allows service personnel to access the rail assembly, cartridge accessor, and accessor controller. The front door of the base frame (Model L22, L23, L32, L52, or L53) includes the operator panel, power switch, I/O stations, handle for opening the door, and keylock. The front doors of the expansion frame (Model D22, D23, D32, D52, or D53) and the high availability frame include a handle and a keylock.

Inside each base and expansion frame, cartridge storage slots are mounted on the interior of the front door. Opposite the front door, cartridge storage slots and drives are mounted on the frame wall. The cartridge accessor accesses these storage slots and drives.

At the rear of each frame is a service access door that lets service personnel access the tape drives and the power structure (see **1** in Figure 6 on page 22). For Models L22, D22, L32, D32, L52, and D52, the power structure is called the *frame control assembly*. It comprises a sheet-metal unit that houses circuit breakers, ac outlets for powering the tape drives and all other components in that frame, and a receptacle for the incoming main ac power. For Models L23, D23, L53, and D53, the power structure is called the *enhanced frame control assembly*. It comprises a separate device called the Medium Changer assembly, as well as a sheet-metal unit that houses power supplies, and incoming main ac power.

Up to 15 expansion frames can be added to the base frame. An additional expansion frame is added as a service bay in a high-availability library. Expansion frames are attached to the right of the base frame (as you face the operator panel), and are numbered consecutively from left to right.

The IBM System Storage Tape Library Specialist web interface and 10/100 Ethernet support are included with Models L22, L23, L52, and L53. For Model L32, they are available as feature codes 1662 and 1660, respectively.

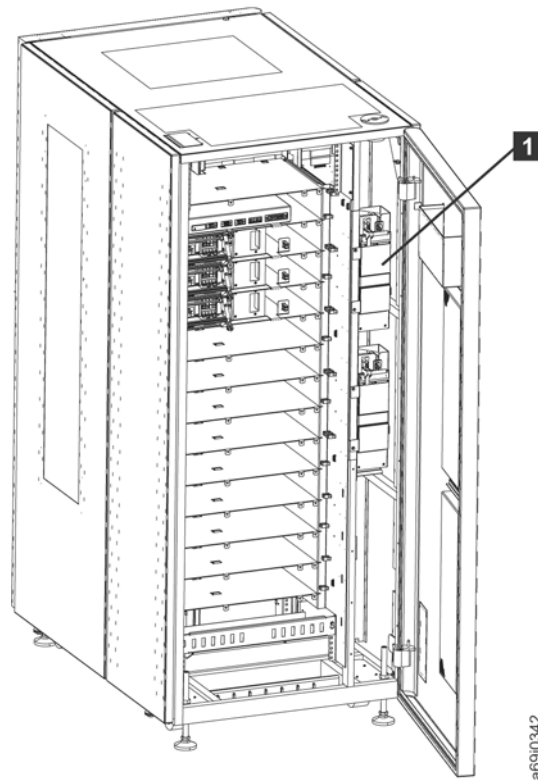

Figure 6. Location of the power structure in a library frame. The picture shows a Model L53 frame, which uses the enhanced frame control assembly.

Related concepts

- “Doors” on page 29
- “Cartridge Storage Slots” on page 24
- “Rail Assembly” on page 316
- “Dual Accessors and Service Bays” on page 6
- “Cartridge Accessor” on page 316
- “Accessor Controller” on page 318
- “Operator Panel” on page 34
- “I/O Stations” on page 30
- “Ultrium Tape Drives” on page 27
- “3592 Tape Drives” on page 28

Frames Used as Service Bays

This section defines how frames can be used as service bays in the 3584 Tape Library.

If you order a second accessor, you must also order a 3584 high availability (HA1) frame (service bay A) and a new D22, D23, D52, or D53 frame (service bay B). As you view the library from the front, service bay A is on the far left and service bay B is on the far right. Service bay B contains the second accessor.

Service bay A (the HA1 frame) contains only gripper test slots (**1** in Figure 7 on page 23) for diagnostic cartridges. Service bay B contains gripper test slots (**2**) for diagnostic cartridges, and also contains unusable storage slots (**3**). The storage slots in service bay B are not used if the frame is configured as a service bay.

Each service bay contains gripper test slots for three Ultrium diagnostic cartridges and three 3592 diagnostic cartridges. Place only diagnostic cartridges in the gripper test slots; do not place data or cleaning cartridges in them. Figure 7 shows the location of slots in the service bays.

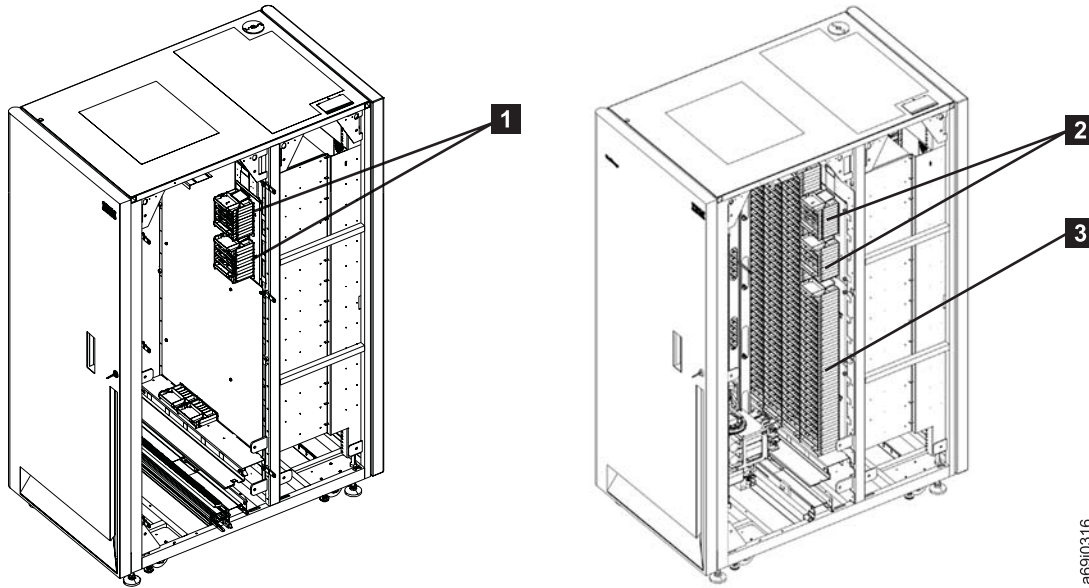

Figure 7. Cartridge slots in the service bays of the 3584 Tape Library. Service bay A (the HA1 frame) is on the left and contains only gripper test slots for diagnostic cartridges. Service bay B (the D22, D23, D52, or D53 frame) is on the right and contains both gripper test slots for diagnostic cartridges and unused storage slots.

Cartridge Storage Slots

Cartridge storage slots are mounted inside the frames of the 3584 Tape Library to store tape cartridges. Each storage slot has a unique address to indicate its physical location. The storage slot's address consists of three values:

Frame number

Represented as Fxx, where F equals the frame and xx equals its number. For the base frame, the frame number is 01; for each adjacent expansion frame, the frame number increments by one.

Column number

Represented as Cyy, where C equals the column and yy equals its number. For each frame, the left frame wall column is column number 1. The column number increments in a zig-zag pattern, alternating between the frame wall and the door wall, and progressing from left to right. Thus, all column numbers on the frame wall are odd numbers, and all column numbers on the door wall are even numbers. The base frame (Models L22, L23, L32, L52, and L53) has eight columns; the expansion frame (Models D22, D23, D32, D52, and D53) has ten columns.

Row number

Represented as Rzz, where R equals the row and zz equals its number. For each column, the row number is 1 for the top storage position in a column and increments by one for each row below the top position. Regardless of whether a storage slot is installed in row number 1, the row numbering is the same for every column.

For example, the storage slot address F02,C03,R22 means:

- F02** Frame 2 (first expansion frame)
- C03** Column 3 (second column from left on drive side)
- R22** Row 22 (twenty-second position down from the top of the column)

Cartridge storage slots vary in color, depending on the type of frame. Storage slots in LTO Ultrium frames are black; storage slots in 3592 frames are gray.

Addressable Cartridge Storage Slots

In the 3584 Tape Library, addressable storage slots have both a physical address, such as F01,C05,R19, and a SCSI element (logical) address, such as 1112(X'458'). They do not include I/O station slots or the non-addressable slots that are reserved for the diagnostic cartridges. A library frame contains a variable number of addressable storage slots, depending on the type of tape cartridge that it uses, the quantity of I/O stations that are installed, and the quantity of drives that are installed on the drive side. To determine the quantity of slots available for each frame, see Chapter 9, "Frame Capacity," on page 341.

The 3584 Tape Library stores cleaning cartridges in addressable cartridge storage slots and as part of the normal inventory. If the automatic cleaning feature is enabled, the cleaning cartridges are not accessible by the host software.

To identify SCSI element addresses for cartridge storage slots, see Chapter 10, "Locations and Addresses of SCSI Elements," on page 345.

Related concepts

"Non-Addressable Cartridge Storage Slot" on page 25

Related information

Chapter 9, “Frame Capacity,” on page 341

This section introduces the quantity of LTO Ultrium Tape Cartridges and 3592 Tape Cartridges that the 3584 Tape Library supports, depending on whether the Capacity On Demand or Capacity Expansion Features are installed, the upper and lower I/O stations are used, and a specified quantity of drives are installed.

Chapter 10, “Locations and Addresses of SCSI Elements,” on page 345

Non-Addressable Cartridge Storage Slot

The base frames of the 3584 Tape Library (Models L22, L23, L32, L52, and L53) each contain one non-addressable cartridge storage slot for a diagnostic cartridge at physical address F01,C01,R01. Additionally, the first expansion frame of a different media type (LTO or 3592) in a mixed media library contains one non-addressable cartridge slot for a diagnostic cartridge at physical address Fxx,C01,R01 (where xx equals the first expansion frame for the second type of media). There are no non-addressable slots in all other expansion frames.

If you purchase a second accessor, the accompanying two service bays will each contain a diagnostic cartridge.

Non-addressable cartridge storage slots do not have SCSI element addresses.

Tape Drives

Each frame in the 3584 Tape Library can contain one of the following types of tape drives:

- IBM LTO Ultrium Tape Drives (Ultrium 4 Tape Drives, Ultrium 3 Tape Drives, Ultrium 2 Tape Drives, or Ultrium 1 Tape Drives)
- IBM 3592 Tape Drives (3592 J1A Tape Drives or TS1120 Tape Drives)

Your commands for library operations and their responses pass through one or more Ultrium Tape Drives or 3592 Tape Drives to the accessor controller circuit board located on each accessor. The accessor controller handles all requests that require motion of the accessor, including calibrations, movement of cartridges, and inventory updates. If your library includes a second accessor, it has two accessor controllers. Because the accessor controller (and other components of the library) has no direct access to a server, the Ultrium Tape Drive or 3592 Tape Drive serves as a conduit for communication between the two and interprets the protocol.

LTO Ultrium Tape Drives and 3592 Tape Drives can be placed into rows 1 through 12. Row 0, if present, is not used.

For information about rear access to the drives, see the section about drive and power supply compartments.

Certain conditions apply to mixing drives and media. To learn about compatible combinations, see the *IBM System Storage TS3500 Tape Library Introduction and Planning Guide*.

The sections that follow describe each type of tape drive in the 3584 Tape Library, and define their physical and logical addresses.

Related concepts

“Accessor Controller” on page 318

Related reference

“Drive and Power Supply Compartment for Models L22 and D22” on page 322

“Drive and Power Supply Compartment for Models L32 and D32” on page 323
“Drive and Power Supply Compartment for Models L52 and D52” on page 324
“Drive and Fixed Tray Assembly Compartment for Models L23 and D23” on
page 338
“Drive and Fixed Tray Assembly Compartment for Models L53 and D53” on
page 339

Ultrium Tape Drives

Ultrium Tape Drives write data to and read data from IBM LTO Ultrium Data Cartridges. The Ultrium 1 and Ultrium 2 Tape Drives communicate with the server by using one of three types of attachment interfaces: Fibre Channel, LVD SCSI, or HVD SCSI. The Ultrium 3 and Ultrium 4 Tape Drives communicate by using only the Fibre Channel interface. Library SCSI commands and SCSI status pass to and from a server through logical unit number 1 (LUN 1) of the first drive of any logical library of the 3584 Tape Library.

Figure 8 shows Ultrium Tape Drives inside the 3584 Tape Library.

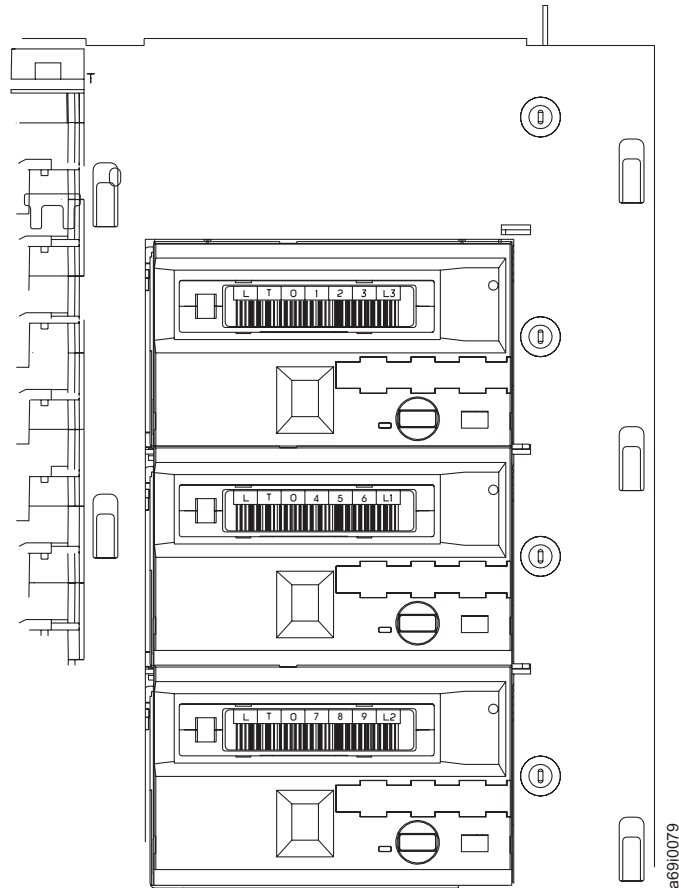

Figure 8. Ultrium Tape Drives mounted inside the 3584 Tape Library and loaded with LTO Ultrium Tape Cartridges

3592 Tape Drives

The 3592 Tape Drives write data to and reads data from the IBM TotalStorage 3592 Enterprise Tape Cartridge. The drives communicate with the server through one of two Fibre Channel ports. The ports can be used as multiple paths of communication or for failover.

Figure 9 shows the 3592 Tape Drives inside the 3584 Tape Library.

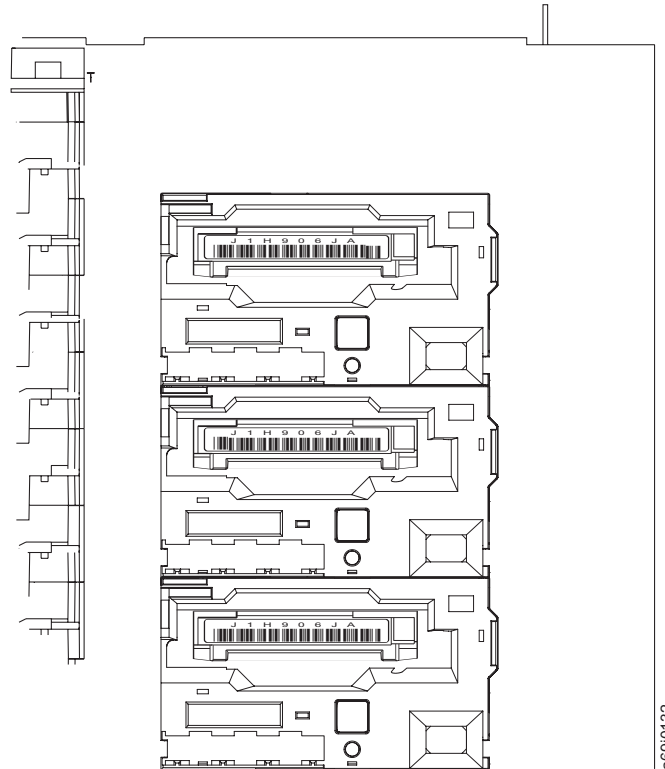

Figure 9. 3592 Tape Drives mounted inside the 3584 Tape Library and loaded with 3592 Tape Cartridges

Physical Addresses of Drives

The 3584 Tape Library assigns each tape drive a unique address to indicate its physical location. You can then use the address whenever you initiate an operation, such as moving a tape cartridge or performing manual cleaning. The drive address consists of two values: a frame number and a row number. The values are defined as follows:

Frame number

Represented as Fxx, where F equals the frame and xx equals its number. Regardless of whether any drives are installed, the frame number for the base frame is 01 and increments by one for each adjacent expansion frame.

Row number

Represented as Rzz, where R equals the row and zz equals its number. Rows 1 through 12 are available for drives. Regardless of whether drives are installed, the row numbering is the same for every frame.

Thus, a drive address of F02,R10 means frame 2 (the first expansion frame), row 10.

Logical Addresses of Drives

Like it does when it assigns a physical address to a tape drive, the 3584 Tape Library also assigns each drive a SCSI element address that consists of a value that defines a logical location in the library to the SCSI interface. This logical address is represented on the operator panel as $xxxx(yyyh)$, where $xxxx$ is a decimal value and $yyyh$ is a hexadecimal value. It is assigned and used by the application when the server processes SCSI commands. The SCSI element address for a drive is unique to the drive's location; it does not vary based on other drives in the library. For a list of the SCSI element addresses for storage slots, I/O slots, and drives, see Chapter 10, "Locations and Addresses of SCSI Elements," on page 345.

Related information

Chapter 10, "Locations and Addresses of SCSI Elements," on page 345

Doors

Located at the front of each frame in the 3584 Tape Library is the front door. The door lets you access the cartridge storage slots that are mounted on the door wall and frame wall (service personnel use the door to access the rail assembly, cartridge accessor, and accessor controller).

The operator panel (**1** in Figure 10) is mounted on the front door of the base frame. Also located on the base frame's door are the power switch **2** and up to two input/output (I/O) stations **3** and **4**. A door handle **5** and a keylock (with key) **6** are included on the front door of all frames (the keys to all front doors are interchangeable). To unlock and open the door of any frame, insert the key into the keylock and turn it counterclockwise approximately 180°.

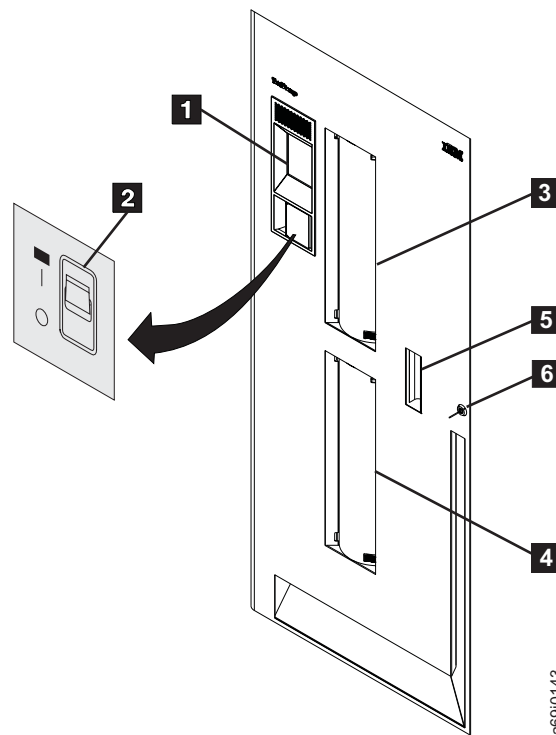

Figure 10. Front door of the 3584 Tape Library. The operator panel is mounted on the front door of the base frame. A Model L22 or L52 is shown.

Each frame of the 3584 Tape Library also includes a rear door with a keylock and key (the keys to all rear doors are interchangeable). To unlock the rear door of any frame, insert the key into the keylock and turn it clockwise.

The keys to the front and rear doors are not interchangeable.

With the exception of the service bays, if you open the front door of any frame during an operation the 3584 Tape Library fails the active operation and rejects new requests for operations until all doors are closed. Note that application processes may fail if you do not halt the application before opening the front door. Approximately 15 seconds after you have closed all doors, the library performs an inventory update for frames whose doors have been opened (a process that determines whether cartridges have been added to or removed from the library, or moved within the library). Following the inventory, the library accepts new requests for operations.

If you need to open the door of a service bay, press the PAUSE key to avoid failing the active operation (the PAUSE key is located on the Activity screen). For more information, see “PAUSE Key” on page 37.

Related concepts

“I/O Stations”

“Operator Panel” on page 34

Door Safety Switch

Each frame in the 3584 Tape Library (excluding the service bays) has a door safety switch that automatically turns off the power to the cartridge accessor (but not the tape drive) whenever you open the front door. The power does not automatically turn off if you open the rear door. The action of automatically turning off the power to the accessor is modified for the service bays if the IBM Service Representative has installed the safety barrier. After you close the front door, the library automatically performs an inventory of the tape cartridges of that frame.

I/O Stations

Note: In the 3584 Tape Library, place only LTO Ultrium Tape Cartridges into Ultrium frames with black, Ultrium-supported I/O slots; place only 3592 Tape Cartridges into 3592 frames with gray-supported I/O slots.

The I/O stations let you insert or remove cartridges while the 3584 Tape Library is performing other operations.

The 3584 Tape Library comes with one 16-cartridge I/O station. To add greater capacity, you can order additional 64 or 16-cartridge LTO I/O or 3592 I/O stations to be installed by your IBM Service Representative.

3584 Tape Library now supports four I/O stations in newly purchased Models D23 or D53 frames. The D-frame with I/O installed is comprised of four independently accessible I/O station doors that have a total of 64 slots (16 in each I/O station). Additionally, two LED indicators are provided for each I/O station in a D-frame in order to indicate if the I/O station is empty or full and if the I/O station door is locked or unlocked. This plant feature reduces the frame storage slot capacity by 160 for a Model D23 and by 176 for a Model D53. The I/O stations increase the maximum library I/O slot capacity from 32 to 224 due to a maximum of three D23 or D53 I/O frames in a 16-frame library. The multiple I/O stations double the

maximum insert/eject throughput. The newly purchased D23 and D53 Models remain compatible with existing Models L22, L32, L52, D22, D32, and D52. For a graphical representation of four I/O station doors and storage slot addresses, see Figure 12 on page 33

To open the door of an upper I/O station, grasp its handle at the bottom right and slide the door to the left. To open the door of a lower I/O station, grasp its handle at the top right and slide the door to the left. When an I/O station door is open, you can access its I/O storage slots. When the door is closed, the cartridge accessor can access the slots. Each I/O station has sensors and a locking mechanism to prevent you and the cartridge accessor from simultaneously accessing it.

If an I/O station door will not close, verify that the orientation of the cartridges is correct. Ensure that you are not attempting to insert an LTO cartridge into a 3592 I/O slot, or a 3592 cartridge into an LTO I/O slot.

Each I/O station slot has a unique address to indicate its physical location. The I/O station slot address consists of two values: a frame number and a row number:

Frame number

Represented as Fxx, where F equals the frame and xx equals its number. The frame number is always 01 in an I/O station in an L-frame.

Row number

Represented as Rzz, where R equals the row and zz equals its number. The row number is 1 for the top cartridge in the upper I/O station in a L-frame or the upper left I/O station in a D-frame, and increments by one for each row below the top slot.

A frame with two I/O stations assigns its I/O slot addresses as if the two stations were one. For example, in an L-frame (which is assigned F01),

- An I/O slot address of F01,R05 means frame 1, slot 5 (fifth row from the top of the upper I/O station; see **1** in Figure 11 on page 32).
- An I/O slot address of F01,R19 means frame 1, slot 19 (third row in the lower I/O station of a Model L22 or L52; see **2**).

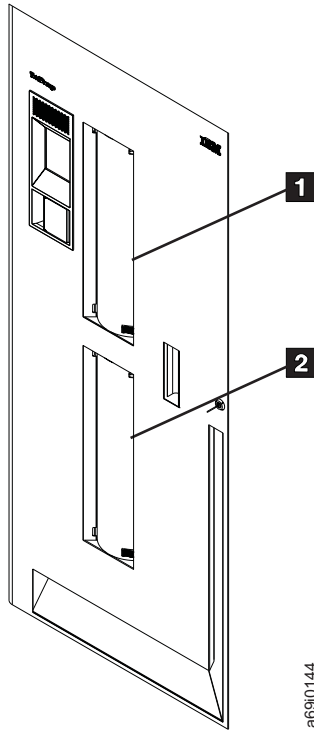

Figure 11. Storage slot addresses in the I/O stations of the 3584 Tape Library. The door of a Model L22 or L52 frame is shown.

A D23 or D53 frame with multiple I/O stations assigns its I/O slot addresses as if the multiple stations were one. For example, in a D-frame:

- An I/O slot address of F02,R05 means frame 1, slot 5 (indicates the fifth row from the top of the upper left I/O station)
- An I/O slot address of F04,R40 means frame 3, slot 8 (indicates the eighth row from the top of the upper right I/O station)

Note: Because the L-frame is always frame number F01, D-frame numbers begin with F02.
(see Figure 12 on page 33)

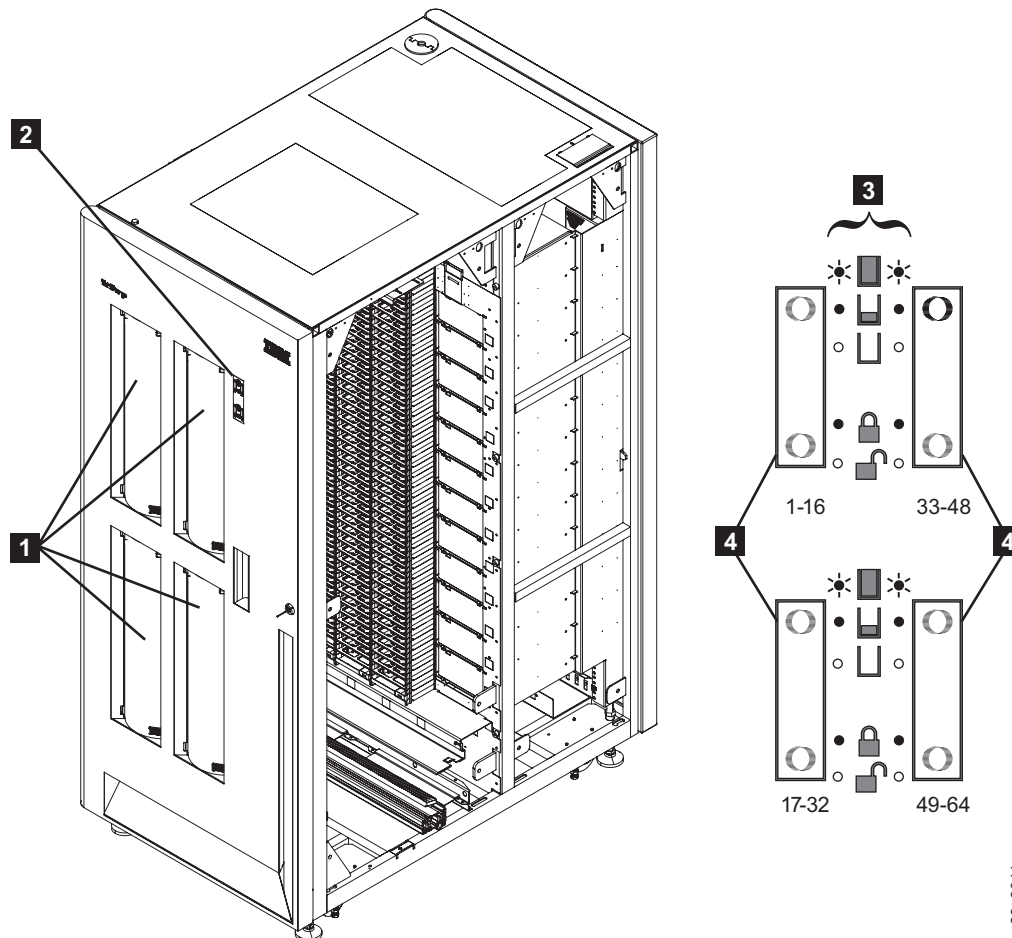

Figure 12. Storage slot addresses in four I/O station frames in the 3584 Tape Library. The door of a Model D23 frame is shown.

Table 7. Location of I/O slots and LED display in frames with four I/O stations

1	Indicates the location of the 4 I/O stations on a D23 frame.
2	Indicates the LED display.
3	Indicates the various on/off and locked/unlocked states of the LED display.
4	Indicates the 4 I/O stations, and below each I/O station, shows the rows assigned to each station: <ul style="list-style-type: none"> • Rows 1-16 are assigned to the upper left I/O station. • Rows 17-32 are assigned to the lower left I/O station. • Rows 33-48 are assigned to the upper right I/O station. • Rows 49-64 are assigned to the lower right I/O station.

Related tasks

“Using the I/O Stations to Insert Data Cartridges When Virtual I/O Slots are Disabled” on page 56

“Removing a Data Cartridge from a Drive in the Library” on page 67

This section describes how to remove a data cartridge from an LTO Ultrium or 3592 Tape Drive in the 3584 Tape Library.

Operator Panel

In the 3584 Tape Library, the operator panel is located on the front door of the base frame. The panel provides an indicator light and controls that let you perform operations and determine the status of the library. It consists of the following components (see Figure 13):

1 Library power switch

A toggle switch that lets you power the 3584 Tape Library on and off.

2 Power-on indicator

A green light that, when lit, indicates that dc power is available within the library.

3 Power switch door

For Models L22, L23, L52, and L53 only (not Model L32), a transparent door that protects the power switch and power-on indicator. To access the power switch, pull the transparent door toward you.

4 Touchscreen LCD

A liquid crystal display (LCD) that, when touched on the touch keys, shows the library's status and menus. Use the display to perform basic and advanced operations (service personnel use the display to run diagnostic tests and observe results). The LCD displays 12 to 15 lines of characters.

5 Touch keys

An array of small, touch-sensitive keypads that lets you select and navigate through menus. For most menus, the keypads are defined as BACK, UP, DOWN, and ENTER. To acknowledge that it has been pressed, a touch key initiates an audible beep when you press it. To disable the keypress beep, refer the section about enabling or disabling the keypress beep.

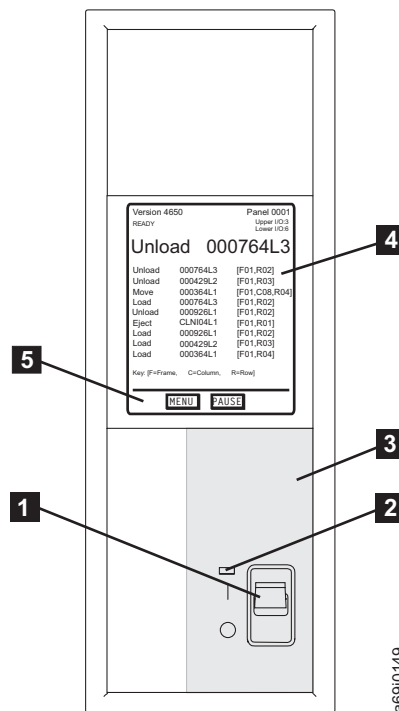

Figure 13. Sample screen on the operator panel of the IBM System Storage TS3500 Tape Library, Model L22 or L52

Related tasks

“Powering-On” on page 52

This section gives the procedure for turning on the power to the 3584 Tape Library.

“Powering-Off” on page 53

This section gives the procedure for turning off the power to the 3584 Tape Library.

“Enabling or Disabling the Keypress Beep” on page 175

This section describes how to enable or disable the beep that sounds when you press a key on the 3584 Tape Library.

Activity Screen

The Activity screen (see Figure 14) displays on the touchscreen LCD when the 3584 Tape Library is ready (that is, when the host applications may interact with the library). The first line on the screen shows the current level of library firmware and the panel (screen) number. The left field on the second line indicates whether the library is ready, not ready (not interacting with host applications), or initializing. The right field indicates the status of one or more I/O stations.

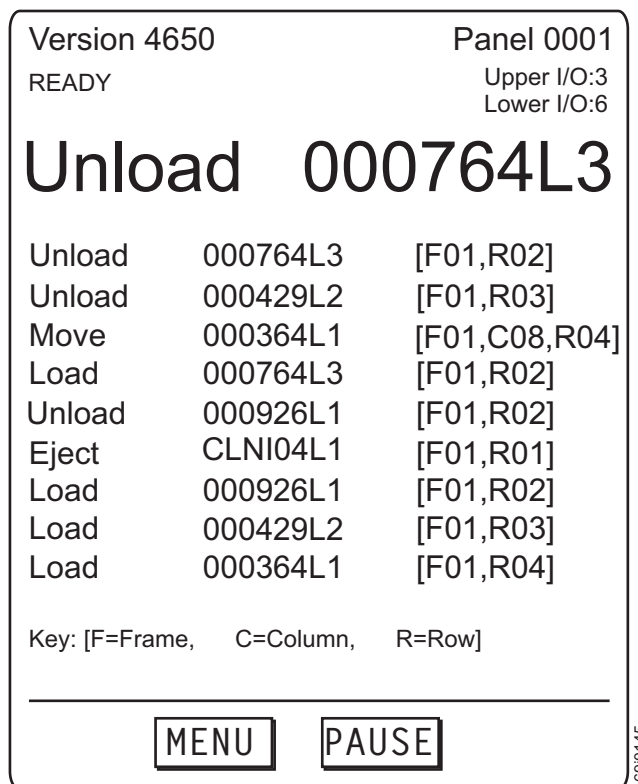

Figure 14. Sample Activity screen on the 3584 Tape Library

The text in the I/O field varies, depending on whether the library has one or two I/O stations:

- If the library contains only one I/O station, I/O: displays.
- If the library contains two I/O stations, Upper I/O: and Lower I/O: display.

The values that can appear in the I/O field are:

- OPEN (when the door of an I/O station is open)

- LOCKED (when the door of an I/O station is closed and locked, and when the library is accessing or scanning cartridges)
- xx (where xx equals the quantity of tape cartridges in an I/O station)

The Activity screen also shows the current activity in a large font type and provides a history of preceding operations in a smaller font type. The operations are listed from top to bottom, with the most recent at the top and the oldest at the bottom. The first line of smaller font type gives a detailed description of the current activity (for example, in the sample Activity screen shown in Figure 14 on page 35, a cartridge with a volume serial (VOLSER) number of 000764L3 was unloaded from the drive in frame 1, row 2). The last character of an LTO VOLSER can be 1, 2, or 3, and indicates the generation of the media.

The information in the Activity screen is automatically replaced by an error message when the 3584 Tape Library detects the following conditions:

- A permanent error has occurred.
- A drive requires cleaning and one of the following conditions exists:
 - Automatic cleaning has been disabled.
 - No cleaning cartridge is present in the library.
 - The cleaning cartridge has expired.

The presence or absence of the LOCK and UNLOCK buttons on the Activity screen depends on whether the frame supports the security feature for the operator panel and whether that feature has been enabled. Models L23 and L53 support the optional security feature; Models L22, L32, and L52 do not. When the operator panel's security feature is both supported and enabled, you can use the LOCK and UNLOCK buttons to control access to the panel. To enable or disable security for the operator panel, use the IBM System Storage Tape Library Specialist web interface (see "Enabling or Disabling Security for the Operator Panel" on page 77).

Table 8 illustrates the conditions under which the LOCK, UNLOCK, and MENU buttons display.

Table 8. Presence or absence of the LOCK, UNLOCK, and MENU buttons on the Activity screen of the 3584 Tape Library

Type of Frame	Presence or Absence of Buttons on the Activity Screen		
	UNLOCK	LOCK	MENU
Models L22, L32, and L52 (security for the operator panel is not supported)	No	No	Yes
Models L23 and L53 when security for the operator panel is disabled	No	No	Yes
Models L23 and L53 when security for the operator panel is enabled and the operator panel is locked	Yes	No	No
Models L23 and L53 when security for the operator panel is enabled and the operator panel is unlocked	No	Yes	Yes

Most screens that are left unattended for more than 5 minutes automatically default to the Activity screen.

Related tasks

“Enabling or Disabling Security for the Operator Panel” on page 77
For Models L23 and L53, this section describes how to provide security for the operator panel of the 3584 Tape Library.

PAUSE Key

The 3584 Tape Library features a PAUSE touch key that you should press before you power off the library or open the front door. Located on the Activity screen on the display, the PAUSE key causes the cartridge accessor to park itself (to quickly resume operation later) and give you clear access to the library’s interior should you need to open the front door.

If you press the PAUSE key by mistake, wait until the end of the 30-second timeout. The library will automatically resume the operation.

Attention: After you open the front door, the library rejects requests for new operations until you close the door and the inventory is completed. IBM recommends that you halt the application (for example, Tivoli^(R) Storage Manager, Legato, or Veritas) prior to pressing the PAUSE Key. Process failures may occur if you do not halt the application before you open the front door.

Chapter 3. Operating Procedures

This section introduces the procedures that you can perform with the 3584 Tape Library.

You can operate the library from its operator panel or by using the IBM System Storage Tape Library Specialist web interface.

Overview of Operating Procedures

This section lists the procedures that you can perform with the 3584 Tape Library.

Not all operating procedures are available from both the operator panel and the web interface of the 3584 Tape Library. To determine whether multiple methods are available to perform a procedure, go to the sections that discuss the functions of the operator panel or the web interface.

If your library uses both LTO Ultrium and 3592 Tape Drive media, certain screens on the operator panel may display a **Media Type** field. This field confirms the type of media that you chose for a particular operation.

Note: This book addresses the level of firmware that was available at the time of publication. If you update your firmware to the latest level, the look and functionality of the interface may be different from what is shown in this book.

Table 9. Operating procedures for setting up the 3584 Tape Library

If You Want to Do This...	Go To...
Activate or deactivate password protection for web screens	"Activating or Deactivating Password Protection for Web Screens" on page 81
Add a drive to a physical or logical library	"Adding a Drive to a Physical Library" on page 90 "Adding a Drive to a Logical Library" on page 90
Adjust the speed of the library's bar code scanner	"Adjusting the Scanner Speed" on page 199
Assign cartridges to a logical library	"Using the I/O Stations to Insert Data Cartridges When Virtual I/O Slots are Disabled" on page 56 "Using the I/O Stations to Insert Data Cartridges When Virtual I/O Slots are Enabled" on page 59 "Enabling or Disabling the Insert Notification Setting" on page 177 "Assigning Cartridges to a Logical Library" on page 88
Assign a range of cartridges to a logical library	"Working with a Cartridge Assignment Policy" on page 94
Configure the library to work with SMI-S	"Configuring the Library to Work with Your SMI-S Agent for Tape" on page 200
Configure the library with partitions (by using labels)	"Using Labels to Configure the Library with Partitions" on page 124
Configure the library with partitions (by using menus)	"Using Menus to Configure the Library with Partitions" on page 131
Configure the library without partitions	"Configuring the Library without Partitions" on page 119
Create a cartridge assignment policy	"Working with a Cartridge Assignment Policy" on page 94

Table 9. Operating procedures for setting up the 3584 Tape Library (continued)

Create a key manager address	"Working with Key Manager Addresses" on page 204
Create a logical library with ALMS	"Creating or Removing a Logical Library with ALMS" on page 138
Create a password for the operator panel (performed by administrator)	"Enabling or Disabling Security for the Operator Panel" on page 77
Create a password for Tape Library Specialist web interface (performed by administrator)	"Modifying the Settings of a Web User" on page 87
Create a scratch encryption policy	"Working with a Barcode Encryption Policy" on page 206
Cycle power to a drive from a remote location (web only)	"Performing a Remote Drive Power Cycle" on page 200
Delete a cartridge assignment policy	"Working with a Cartridge Assignment Policy" on page 94
Delete a key manager address	"Working with Key Manager Addresses" on page 204
Delete a scratch encryption policy	"Working with a Barcode Encryption Policy" on page 206
Determine gaps between drive element addresses in a logical library	"Detecting Gaps Between Drive Element Addresses in a Logical Library" on page 93
Disable Ethernet connection	"Disabling an Ethernet Connection" on page 173
Download a history of cartridges that have been mounted in the library	"Accessing the Mount History of Tape Cartridges" on page 188
Download drive logs	"Accessing Logs for Drives or Saving a Drive Dump" on page 196
Download library logs	"Accessing Logs for the Library" on page 187
Download statistics about drives in the library	"Accessing Statistics about Drives" on page 191
Download statistics about the library	"Accessing Statistics about the Library" on page 193
Download statistics about ports in the drives of the library	"Accessing Port Statistics for Drives" on page 192
Enable or disable security for the operator panel	"Enabling or Disabling Security for the Operator Panel" on page 77 (performed by administrator)
Enable or disable virtual I/O slots	"Enabling or Disabling Virtual I/O Slots" on page 137
Find new hardware in the library	"Discovering New Hardware in the Library" on page 140
Give a user access to the Tape Library Specialist web interface (performed by administrator)	"Adding a Web User" on page 86
Give a web interface user access to specific virtual libraries and pages (performed by administrator)	"Customized Web Access" on page 83
Initialize a tape cartridge's volume serial number (VOLSER)	"Initializing a Tape's Volume Serial (VOLSER) Number" on page 76
Insert a cleaning cartridge into the library	"Inserting a Cleaning Cartridge into the Library" on page 70
Insert a data or scratch cartridge into the library	"Inserting Data or Scratch Cartridges" on page 54
Install the control path failover feature	"Installing the Control Path Failover Feature" on page 143
Install the intermediate or full capacity On Demand feature	"Installing the Intermediate or Full Capacity On Demand Feature" on page 142
Lock or unlock the operator panel (performed by administrator)	"Locking or Unlocking the Operator Panel" on page 78

Table 9. Operating procedures for setting up the 3584 Tape Library (continued)

Manually clean a tape drive	"Performing Manual Cleaning of Drives in the Library" on page 73
Move a specific tape cartridge	"Moving a Cartridge" on page 110
Perform an inventory of a frame	"Performing an Inventory of a Frame in the Library" on page 109
Perform an inventory of the library	"Performing an Inventory of the Library" on page 108
Remove a cleaning cartridge from the library	"Removing a Cleaning Cartridge from the Library" on page 75
Remove a data cartridge from the library	"Removing Data Cartridges from the Library" on page 63
Remove a data cartridge from a drive in the library	"Removing a Data Cartridge from a Drive in the Library" on page 67
Remove a drive from a physical or logical library	"Removing a Drive from a Physical Library" on page 92 "Removing a Drive from a Logical Library" on page 92
Remove a logical library that is enabled with ALMS	"Creating or Removing a Logical Library with ALMS" on page 138
Remove a user's access to the Tape Library Specialist web interface (performed by administrator)	"Removing a Web User" on page 87
Search for a cartridge by its VOLSER	"Determining the Location of Cartridges" on page 102
Send a test SNMP trap	"Sending a Test SNMP Trap" on page 163
Set the encryption method	"Setting or Changing a Drive's Method of Encryption" on page 203
Set the library to automatically clean any tape drive at the drive's request	"Enabling or Disabling Automatic Cleaning" on page 69
Set the library to report to the server a 6- or 8-character cartridge VOLSER	"Enabling or Disabling the Reporting of a Six-Character or Eight-Character VOLSER" on page 176
Set the frames in which dual accessors operate	"Setting or Changing an Accessor's Preferred Zone" on page 141
Share drives in one or more logical libraries	"Sharing Drives in a Logical Library" on page 91
Test a key manager address	"Testing a Key Manager Address" on page 204
Turn off the power to the library	"Powering-Off" on page 53
Turn on the power to the library	"Powering-On" on page 52
Update drive firmware	"Updating Drive Firmware" on page 198
Update library firmware	"Updating Firmware for the Library" on page 195
Use DHCP server settings	"Using DHCP Server Settings" on page 172
Virtualize cartridge locations and let the library dynamically manage cartridges, cartridge storage slots, tape drives, and logical libraries	"Enabling or Disabling ALMS" on page 136

Table 10. Operating procedures for changing the 3584 Tape Library

If You Want to Change This...	Go To...
Accessor's zone	"Setting or Changing an Accessor's Preferred Zone" on page 141
Advanced Library Management System (ALMS)	"Enabling or Disabling ALMS" on page 136
Authentication of SNMP trap settings	"Enabling or Disabling Authentication Trap Settings" on page 160

Table 10. Operating procedures for changing the 3584 Tape Library (continued)

Automatic cleaning of a tape drive	“Enabling or Disabling Automatic Cleaning” on page 69
Cartridge assignment policy	“Working with a Cartridge Assignment Policy” on page 94
Control path	“Changing a Control Path” on page 155 “Enabling or Disabling a Control Path in a Logical Library” on page 91 (when ALMS is enabled)
Customized web access role (performed by administrator or super user)	“Modifying a Customized Web Access Role” on page 85 “Deleting a Customized Web Access Role” on page 85
Date and time	“Changing the Date and Time” on page 174
Destination IP address	“Viewing or Changing the Destination IP Configuration and Remote Port” on page 161
Drive emulation (for TS1120 Tape Drive to emulate 3592 J1A)	“Using the Web to Change the Drive Emulation Mode of 3592 Tape Drives” on page 106
Encryption key	“Rekeying an Encrypted Cartridge” on page 210
Encryption method	“Setting or Changing a Drive’s Method of Encryption” on page 203
Enter the ALMS license key	“Entering the ALMS License Key” on page 135
Ethernet address settings	“Changing the Ethernet Address Settings” on page 167
Ethernet connection	“Disabling an Ethernet Connection” on page 173
Fibre Channel port speeds and topologies	“Viewing or Changing Fibre Channel Port Speeds and Topologies” on page 148
Fibre Channel port settings	“Viewing or Changing Fibre Channel Port Settings” on page 150
Insert notification option	“Enabling or Disabling the Insert Notification Setting” on page 177
Key manager address	“Working with Key Manager Addresses” on page 204
Keypress beep	“Enabling or Disabling the Keypress Beep” on page 175
Location of cartridges in a logical library	“Using the I/O Stations to Insert Data Cartridges When Virtual I/O Slots are Disabled” on page 56 “Using the I/O Stations to Insert Data Cartridges When Virtual I/O Slots are Enabled” on page 59 “Enabling or Disabling the Insert Notification Setting” on page 177
Loop ID	“Changing the SCSI ID or Loop ID of a Drive” on page 144
Maximum cartridges in a logical library	“Changing the Maximum Allowable Quantity of Cartridges in a Logical Library” on page 139
Name of logical library	“Changing the Name of a Logical Library” on page 139
Number of web users	“Adding a Web User” on page 86 “Removing a Web User” on page 87
Password for operator panel (performed by administrator)	“Enabling or Disabling Security for the Operator Panel” on page 77
Password for Tape Library Specialist web interface (performed by administrator)	“Modifying the Settings of a Web User” on page 87
Password for Tape Library Specialist web interface (performed by user)	“Changing Your Web Password” on page 87
Password protection for web screens (activate or deactivate)	“Activating or Deactivating Password Protection for Web Screens” on page 81

Table 10. Operating procedures for changing the 3584 Tape Library (continued)

Quantity of partitions in the library by using labels	“Using Labels to Configure the Library with Partitions” on page 124
Quantity of partitions in the library by using menus	“Using Menus to Configure the Library with Partitions” on page 131
Quantity of virtual I/O slots	“Changing the Quantity of Virtual I/O Slots in a Logical Library” on page 140
Remote port	“Viewing or Changing the Destination IP Configuration and Remote Port” on page 161
Scratch encryption policy	“Working with a Barcode Encryption Policy” on page 206
SCSI ID	“Changing the SCSI ID or Loop ID of a Drive” on page 144
Set the admin password for the first time	“Establishing the Administrator’s Web Password” on page 79 (performed by administrator)
SNMP requests	“Enabling or Disabling SNMP Requests” on page 158
SNMP system data	“Viewing or Changing SNMP System Data” on page 161
SNMP traps	“Enabling or Disabling SNMP Traps” on page 157
Speed of Ethernet cable	“Changing the Speed of the Ethernet Link” on page 171
Timeout for operator panel security	“Enabling or Disabling Security for the Operator Panel” on page 77
User ID or role	“Modifying the Settings of a Web User” on page 87 (performed by administrator)
Version of SNMP traps	“Setting the Version of SNMP Traps” on page 159
Virtual I/O slots	“Enabling or Disabling Virtual I/O Slots” on page 137

Table 11. Operating procedures for viewing the 3584 Tape Library

If You Want to View This...	Go To...
Control paths	“Displaying Control Paths” on page 154
Configuration of the library	“Displaying the Existing Library Configuration” on page 116
Destination IP addresses	“Viewing or Changing the Destination IP Configuration and Remote Port” on page 161
Drive emulation mode of 3592 Tape Drives	“Viewing the Drive Emulation Mode of 3592 Tape Drives” on page 104
Drive error log	“Viewing a Drive Error Log” on page 197
Encrypted cartridge	“Determining Whether a Cartridge is Encrypted” on page 210
Encryption method	“Viewing a Drive’s Method of Encryption” on page 209
Ethernet settings	“Viewing Ethernet Settings” on page 165
Fibre Channel port speeds and topologies	“Viewing or Changing Fibre Channel Port Speeds and Topologies” on page 148
Fibre Channel port settings	“Viewing or Changing Fibre Channel Port Settings” on page 150
Fibre Channel port status	“Displaying Fibre Channel Port Status” on page 151
Library log	“Viewing the Library Error Log” on page 194
Licensed features	“Viewing Licensed Features” on page 201

Table 11. Operating procedures for viewing the 3584 Tape Library (continued)

Location of any cartridge	"Determining the Location of Cartridges" on page 102
Loop ID (AL_PA) of a tape drive	"Displaying the SCSI ID or Loop ID of a Drive" on page 143
Remote port	"Viewing or Changing the Destination IP Configuration and Remote Port" on page 161
Request community name	"Viewing or Changing the Request Community Name" on page 164
SCSI ID of a tape drive	"Displaying the SCSI ID or Loop ID of a Drive" on page 143
SNMP system data	"Viewing or Changing SNMP System Data" on page 161
Status of the cartridge accessor	"Determining the Status of the Cartridge Accessor" on page 95
Status of the I/O stations	"Determining the Status of an I/O Station" on page 98
Status of any storage slot	"Determining the Status of Storage Slots" on page 100
Status of a tape drive	"Determining Drive Status" on page 96
Trap community name	"Viewing or Changing the Trap Community Name" on page 163
Usage of the cartridge accessor	"Determining Accessor Usage" on page 179
Status of the cartridge accessor	"Determining the Status of the Cartridge Accessor" on page 95
Usage of the tape drives	"Determining Drive Usage" on page 180
Users with active web sessions	"Viewing Web Users with Active Sessions" on page 88
Version of an SNMP trap	"Setting the Version of SNMP Traps" on page 159
Vital product data for the library	"Accessing Vital Product Data for the Library" on page 182
Vital product data for the node cards	"Accessing Vital Product Data for Node Cards in the Library" on page 184
Vital product data for Ultrium Tape Drives and 3592 Tape Drives	"Accessing Vital Product Data for Drives in the Library" on page 183
World Wide Node Name of a Fibre Channel tape drive	"Viewing a World Wide Node Name" on page 147
World Wide Port Name of a Fibre Channel tape drive	"Viewing a World Wide Port Name" on page 146

Functions of the Operator Panel

This section contains a flowchart of the procedures that you can perform from the operator panel of the 3584 Tape Library.

Figure 15 on page 46 gives a flowchart of the functions of the operator panel on the 3584 Tape Library. The operator panel also includes a Service category that is not shown in this flowchart. To view the complete set of service functions that are available from the library operator panel, refer to the *IBM System Storage TS3500 Tape Library Maintenance Information* guide.

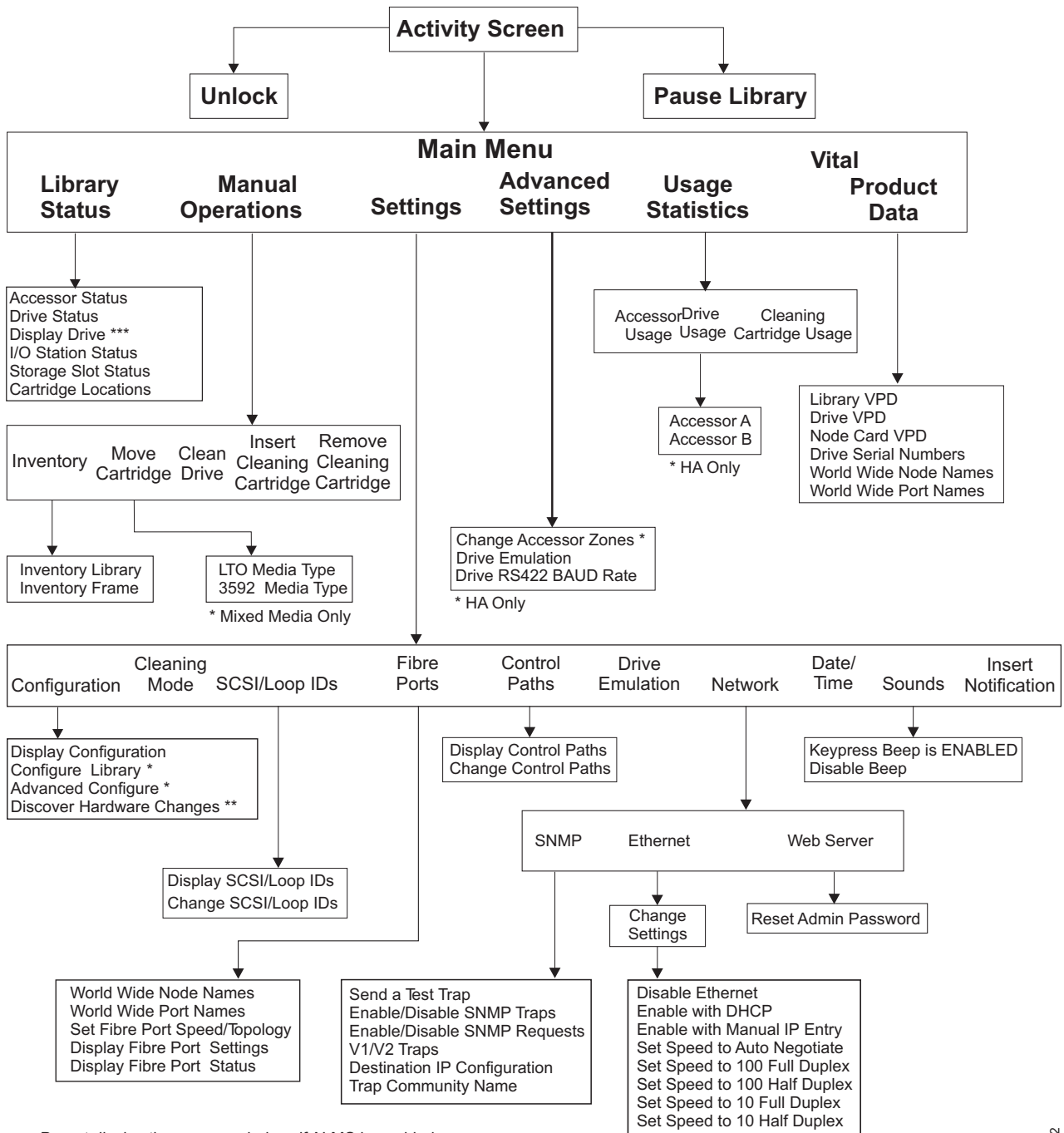

* Do not display these menu choices if ALMS is enabled
 ** Display this menu choice if ALMS is enabled
 *** Display only on later drive code levels

4690302

Figure 15. Functions of the operator panel on the 3584 Tape Library. Items in boldface font mean that subfunctions are available.

Functions of the Tape Library Specialist Web Interface

This section contains a flowchart of the procedures that you can perform from the IBM System Storage Tape Library Specialist web interface of the 3584 Tape Library.

The Tape Library Specialist interface lets you perform many library functions from the web. Figure 16 shows a flowchart of the functions that are available depending on the configuration of your 3584 Tape Library.

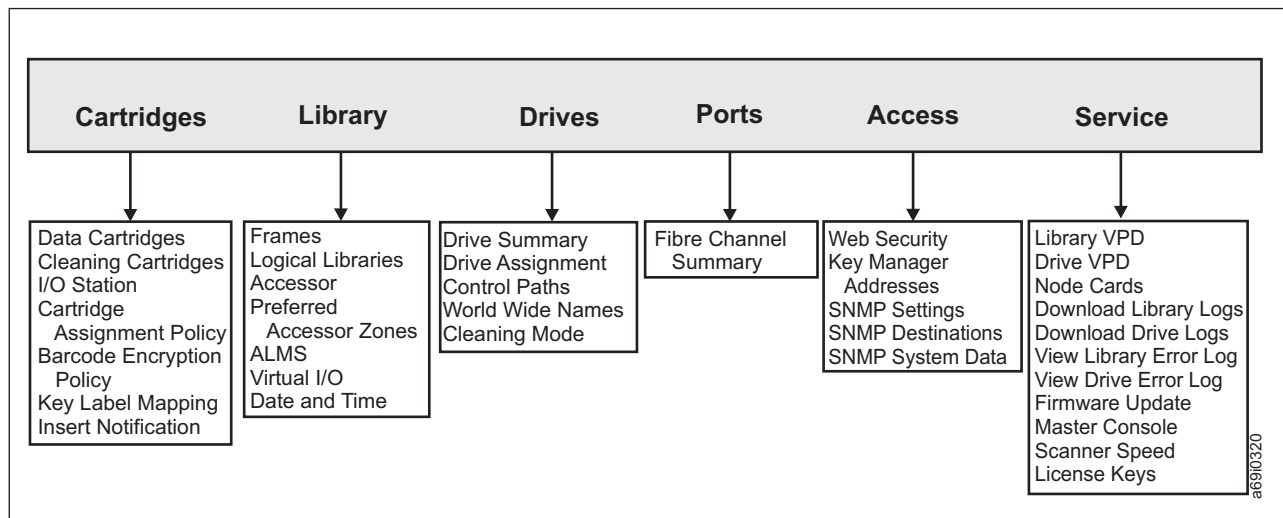

Figure 16. Functions of the Tape Library Specialist web interface

Operating the Library from the Operator Panel

This section describes how to use the operator panel on the 3584 Tape Library.

The operator panel of the 3584 Tape Library allows you make your choices by touching the touchscreen LCD. You begin operation by pressing MENU on the Activity screen. Highlight your choice on any screen by pressing UP or DOWN, then activate it by pressing ENTER. You can return to previous screens by pressing BACK (or where specified, ENTER).

When performing functions, remember to press ENTER after each choice that you have highlighted. For example, if you are setting your initial admin password, the first step reads:

From the library's Activity touchscreen, press MENU → Settings → Network → Web Server → ENTER.

To get to the next screen and ensure that the overall function of setting your initial admin password is successful, you must press ENTER after you highlight **Settings**, **Network**, and **Web Server**.

Throughout this book, it is assumed that you press ENTER after you highlight your choices on the touchscreen LCD.

Related concepts

“Activity Screen” on page 35

Operating the Library from the Web

This section describes how to use the web to operate the 3584 Tape Library.

If you choose to operate the 3584 Tape Library by using a web browser rather than the library's operator panel, read this section. The library features the IBM System Storage Tape Library Specialist web interface. To use the interface, perform the following steps:

1. Make sure that you have available the Ethernet Internet protocol (IP) address of the frame to which you want to connect (for example, **http://10.1.1.1**). To determine the Ethernet IP address, see the section about viewing Ethernet settings.
2. Access Internet Explorer 5.0 (or higher), Firefox 1.0, or Opera 2.5.
3. Type the Ethernet IP address on the URL line of the browser and press Enter.

The Welcome Page of the Tape Library Specialist web interface displays (see Figure 17). The screen lets you access library functions from a newly designed navigation panel or from the original navigation panel.



Figure 17. Sample Welcome Page of the Tape Library Specialist web interface (your screen may vary slightly)

Related tasks

“Viewing Ethernet Settings” on page 165

This section describes how to view the settings for single or dual Ethernet ports in frames of the 3584 Tape Library.

Navigating Through the Tape Library Specialist Web Interface

Navigation through the Tape Library Specialist interface is easy. Figure 18 shows the elements and navigational aids in a typical screen.

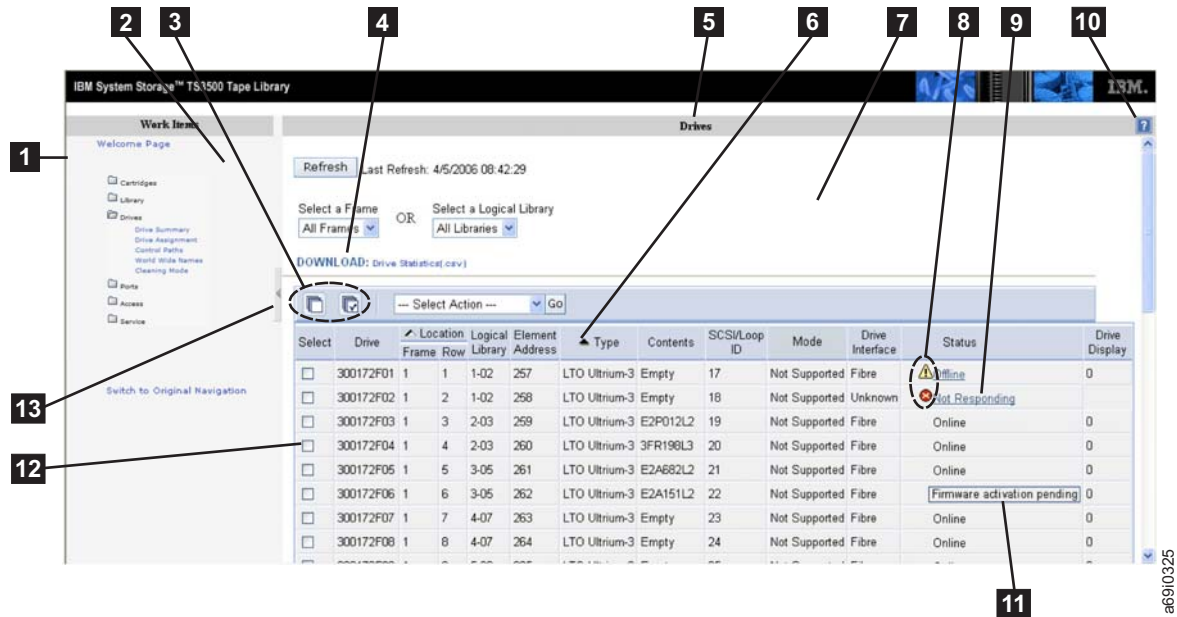

Figure 18. Elements in a typical Tape Library Specialist web screen

1 Expanding or collapsing icons

A closed folder icon (expanding) or an open folder icon (collapsing) at the left of each function in the navigation area. Select the closed folder icon to display a list of subfunctions. Select the open folder icon to collapse the list.

2 Navigation area

A selection of functions that you can perform. When you select a function, subfunctions display. Select the subfunctions to go to related menus. You can select more than one function at a time.

3 Select All or Deselect All icons

Icons that allow you to choose all selectable items or to void your selection of all items. The icons include:



A stack of blank pages. Select this icon to choose all selectable items.



A stack of pages marked with a checkmark. Select this icon to deselect all chosen items.

4 DOWNLOAD: Drive Statistics (.csv)

A link that downloads performance and usage information about the drives in the 3584 Tape Library.

5 Screen title

A navigational tool to help you track your location in the application.

6 Sort indicators

A filled triangle indicates that the field can be sorted. An empty triangle indicates that the field has been sorted.

7 Content area

A collection of information that lends meaning to a query or a function, such as the number of the frame or row, an element address, the type of drive (Ultrium 1, Ultrium 2, Ultrium 3, Ultrium 4, 3592 J1A, or 3592 E05), an indication of whether a drive is occupied or empty, a drive's interface and its SCSI or Loop ID.

8 Error indicators

Icons that indicate a problem. Select the hyperlinked text to the right of the icon to display an error or informational message. The icons include:



A yellow triangle with a black exclamation point indicates a problem of low to medium severity. Action is required, but the problem is not urgent.



A red circle with a white X indicates a problem of severe to fatal severity. Immediate action is required or the function cannot continue.

9 Link

Represented as underscored text, a link is an electronic path that leads to another screen. For example, if a problem exists, select Not Responding to go to another screen that describes the problem and gives possible actions.

10 Help icon on title bar

An icon that, when selected, goes to the Help topics. Help is context-sensitive and includes screen overviews and troubleshooting tips. After you select the Help icon, select the icons at the bottom left of the screen to access a table of contents and an index.

11 Firmware activation pending icon

An icon that displays in the Status column. When you place your mouse over the icon, a message notifies you that firmware has been queued for update.

12 Buttons

Screen entities that indicate selection. Radio buttons (round buttons) signify objects; select buttons (rectangular buttons) signify actions. For example, to download the log of a particular drive, in the Download Drive Log screen select the round button beside that drive. From the Select Action drop-down box, select Download then select Go. You cannot select multiple radio buttons.

13 Collapse or expand arrow

An icon that collapses or expands a navigation heading.

Using the Tape Library Specialist Interface

After you connect to the Tape Library Specialist web interface and display the Welcome Page, select Physical Library. The Physical Library Summary screen displays the main components and physical configuration of the 3584 Tape Library (see Figure 19). To get information about each main component, perform one of the following:

- Select the component in the navigation area
- Select the graphical frame, then the component
- Select the frame from the View drop-down box, then select the component

The screenshot displays the 'Physical Library Summary' screen for the IBM System Storage TS3500 Tape Library. The interface includes a navigation pane on the left with categories like Cartridges, Library, Drives, Ports, Access, and Service. The main area shows a 'View' dropdown set to 'Frame 2' and a table of statistics for Frame 2. A graphical representation of the tape library is shown on the right.

Frame 2	
Total storage slots	211
Empty storage slots	211
Total I/O slots	64
Empty I/O slots	64
Total data cartridges	3
3592	3
3592 Not Labeled	0
Total cleaning cartridges	0
Total drives	3

Figure 19. Physical Library Summary screen

Powering-On

This section gives the procedure for turning on the power to the 3584 Tape Library.

Use the following steps to power-on the 3584 Tape Library:

1. In the section about the operator panel, review the information about the library power switch and power-on indicator.
2. While watching for the green power-on indicator to turn on and stay on (see **1** in Figure 20), move the library power switch (see **2**) to **I**. When you move the switch, the base library and the expansion frame (if attached) power-on at the same time. If the green power-on indicator fails to light, call your IBM Service Representative.

When you power-on the library, it executes a power-on initialization sequence for about 2 minutes. During that time, the menus on the touchscreen display are not available for use. After the power-on initialization sequence, the library performs an inventory of the tape cartridges, which takes less than 60 seconds per frame. The sequence is complete and the library is available for use when the message **READY** displays on the Activity screen.

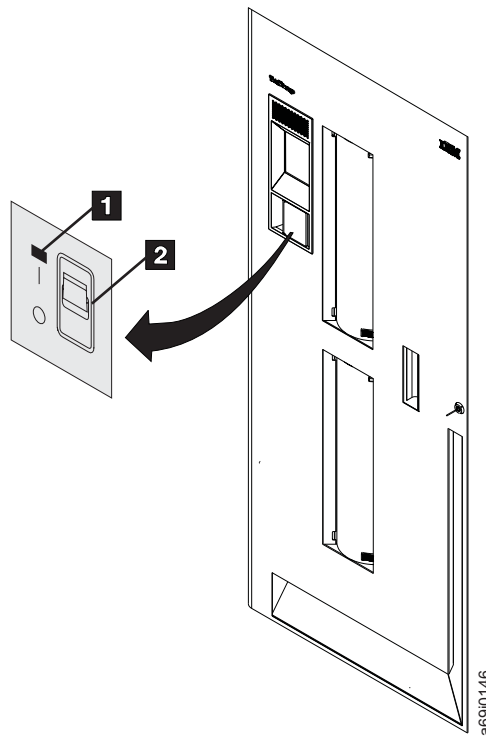

Figure 20. Powering-on the 3584 Tape Library. The library power switch and the power-on indicator are located on the operator panel of the base frame (in this example, a Model L22 or L52 frame).

Related concepts

“Operator Panel” on page 34

Related tasks

“Powering-Off” on page 53

This section gives the procedure for turning off the power to the 3584 Tape Library.

Powering-Off

This section gives the procedure for turning off the power to the 3584 Tape Library.

Note: Always press the PAUSE key before you power-off the 3584 Tape Library. If you power-off before pausing, the library may take longer to go online.

Use the following steps to power-off the 3584 Tape Library after normal operation and not during an emergency:

1. Ensure that the host application has removed cartridges from all drives and that the library is varied offline from the host (if the host is attached).
2. Press the PAUSE key on the display. The library displays the message **If you open the door the library will go Not Ready and any remaining jobs in the work queue may fail. Press ENTER to continue.**
3. Press ENTER. The message **PAUSE in Progress** displays. The library parks the cartridge accessor in the base frame and displays the message **The library is now paused. Normal operations will resume in 30 seconds.**
4. Move the library power switch to **0**. If you do not power-off within 30 seconds, the Activity screen displays again.

Related tasks

“Powering-On” on page 52

This section gives the procedure for turning on the power to the 3584 Tape Library.

Inserting Data or Scratch Cartridges

This section describes the cartridges that are used by the 3584 Tape Library and introduces two ways to insert data and scratch cartridges.

Note: Never insert any type of cartridge into service bays.

After you install the 3584 Tape Library, you can insert cartridges into it. The following types of cartridges can be inserted:

Data or scratch cartridge

A tape cartridge that is designed to receive information recorded to it by a tape drive. A scratch cartridge is a data cartridge whose tape no longer contains useful information and which can be overwritten. To ensure that your tape library conforms to IBM's specifications for reliability, use only the IBM LTO Ultrium Data Cartridge in Ultrium Tape Drives and the IBM TotalStorage 3592 Enterprise Tape Cartridge in 3592 Tape Drives. You can use other LTO- or 3592-certified media, but they may not meet the standards of reliability established by IBM. If you are using mixed drive types, place only LTO Ultrium Tape Cartridges into Ultrium frames with black I/O slots; similarly, place 3592 Tape Cartridges into 3592 frames with gray I/O slots.

Cleaning cartridge

A tape cartridge that is used by the library to clean the heads of its tape drives. Use only the IBM LTO Ultrium Cleaning Cartridge or an IBM-approved cleaning cartridge to clean an Ultrium Tape Drive. Use only the IBM 3592 Cleaning Cartridge or an IBM-approved cleaning cartridge to clean a 3592 Tape Drive. The procedure for inserting and removing cleaning cartridges is different than the procedure for inserting and removing data and scratch cartridges. For more information, see "Using the I/O Stations to Insert Data Cartridges When Virtual I/O Slots are Disabled" on page 56, "Using the I/O Stations to Insert Data Cartridges When Virtual I/O Slots are Enabled" on page 59, "Inserting a Cleaning Cartridge into the Library" on page 70, "Removing Data Cartridges from the Library" on page 63, or "Removing a Cleaning Cartridge from the Library" on page 75.

LTO Diagnostic cartridge or 3592 CE cartridge

A tape cartridge that is used by the IBM Service Representative to service the 3584 Tape Library. The service representative installs the cartridge at the same time that the library is installed. For libraries that use Ultrium and 3592 Tape Drives, the service representative installs a diagnostic cartridge for each type of drive.

The quantity of cartridges that you can add to the 3584 Tape Library is equal to the maximum number of available storage slots (for more information, go to the section about frame capacity). Before you insert data or scratch cartridges, make sure that there are enough available slots. To check, see "Determining the Status of Storage Slots" on page 100.

Conditions apply to mixing drives and media. For more information, see the *IBM System Storage TS3500 Tape Library Introduction and Planning Guide*.

There are two ways to insert data and scratch cartridges:

- Insert the cartridges into an I/O station and let the host application software move the cartridges into the library.

- Open the front door of a frame and bulk load the cartridges directly into empty storage slots (if you use mixed drive types, place LTO Ultrium Tape Cartridges into black slots and place 3592 Tape Cartridges into gray slots). Because this method takes the 3584 Tape Library out of operation, use it only to add or remove large quantities of tape cartridges. Do not remove the LTO diagnostic cartridge or the 3592 CE cartridge from slot F01,C01,R01. This cartridge must be available in that slot for a service representative to use during a service call. Slot F01,C01,R01 is reserved; if you manually place a data cartridge in this slot, the data cartridge will not be accessible.

Attention: Never remove a diagnostic or CE cartridge that is installed in C01,R01 of any frame.

The sections that follow describe each method of inserting data and scratch cartridges.

Related concepts

“Inserting a Cleaning Cartridge into the Library” on page 70

This section introduces methods to insert a cleaning cartridge into the 3584 Tape Library when automatic cleaning is enabled or disabled.

“Removing a Cleaning Cartridge from the Library” on page 75

This section introduces two ways to remove a cleaning cartridge from the 3584 Tape Library.

“Determining the Status of Storage Slots” on page 100

Related reference

“Using SNMP to Determine the Status of Storage Slots” on page 101

Related information

Chapter 9, “Frame Capacity,” on page 341

This section introduces the quantity of LTO Ultrium Tape Cartridges and 3592 Tape Cartridges that the 3584 Tape Library supports, depending on whether the Capacity On Demand or Capacity Expansion Features are installed, the upper and lower I/O stations are used, and a specified quantity of drives are installed.

Using the I/O Stations to Insert Data Cartridges When Virtual I/O Slots are Disabled

Use the following steps to insert the cartridges into the I/O stations and move them into the 3584 Tape Library:

1. On the library's Activity screen, look at the right field on the second line and determine whether the I/O station that you want to use is locked. If the field reads **I/O: LOCKED**, use your application software to unlock the I/O station.
2. Open the door of the intended I/O station and insert the cartridges so that the bar code label faces the interior of the library and the write-protect switch is on the right. For easy insertion, IBM recommends that you grasp the cartridge so that your fingers (and not your thumb) rest comfortably on the top (see Figure 21).

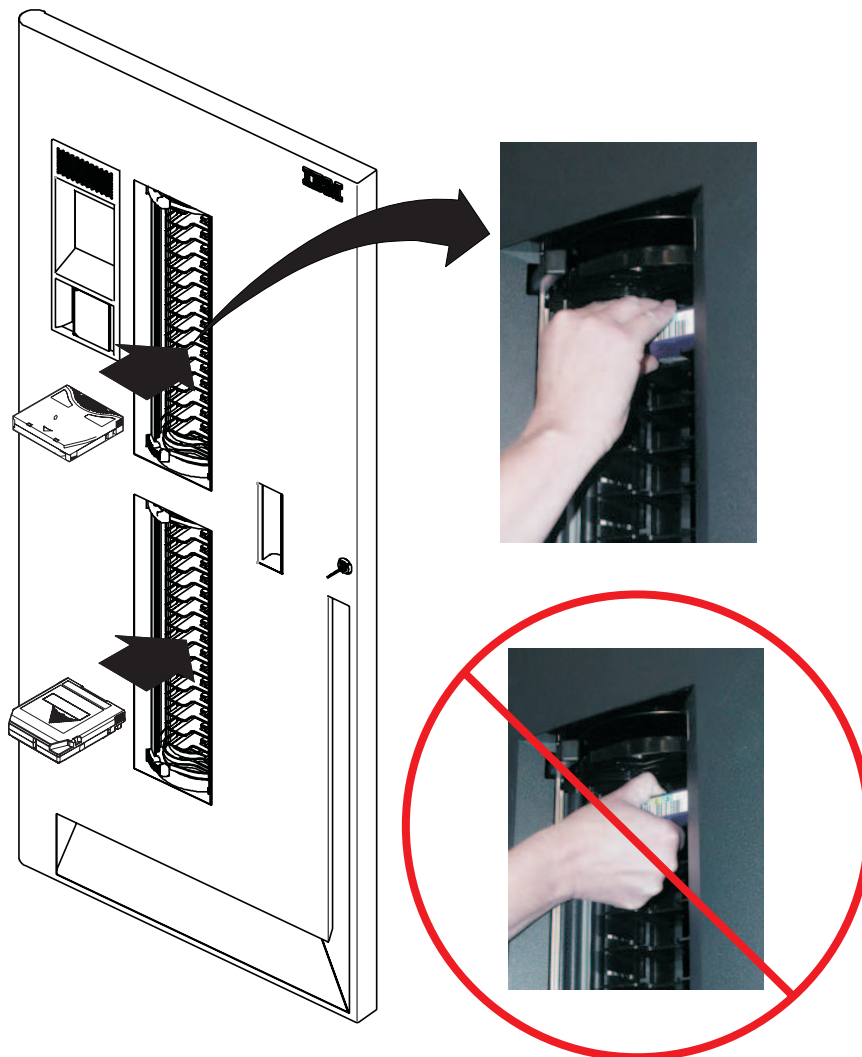

a6910147

Figure 21. Using an I/O station to insert cartridges. Ensure that the bar code label faces the interior of the library and the write-protect switch is on the right. After you insert cartridges, use the host application software to move them to the library's storage slots or drives. The figure shows a library that uses Ultrium and 3592 drives and cartridges.

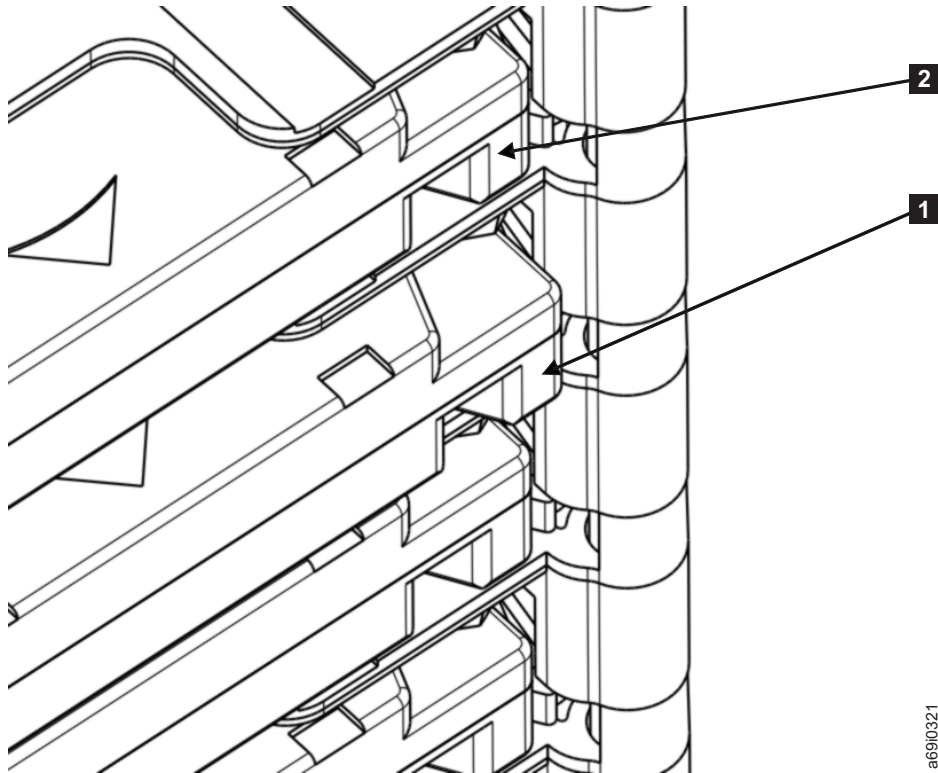

Figure 22. Positioning an LTO Ultrium Tape Cartridge in the I/O station

To correctly seat an LTO Ultrium Tape Cartridge, insert it in the correct orientation and position it as shown in **1** in Figure 22. Continue to push the cartridge until its face is flush **2** with the I/O cell.

One of the following actions occurs:

- If the cartridges are in the Cartridge Assignment Policy, the library will automatically assign them to a specific logical library.
- If the Insert Notification setting is enabled, the Insert Notification screen prompts you for a logical library to which you can assign the cartridges. Press UP or DOWN to select the logical library that you want for that cartridge and press ENTER. (To determine whether Insert Notification is enabled, go to the section about enabling or disabling Insert Notification.)
- If the Insert Notification setting is disabled, the cartridge is made available to any logical library until the cartridge is moved to a storage slot by a host or by the user interface.

Note: In a library that is not partitioned into logical libraries, the Insert Notification screen does not display and the cartridge will be automatically assigned to the first logical library of its media type.

```

Please select a logical          Panel 0191
library to assign the
new cartridges to.

Logical Library:  1

30 seconds until
automatic return to the
Activity Panel

[BACK] [ UP ]      [ENTER]

```

3. Close the door of the I/O station. If the door will not close, check the type and orientation of the tape cartridge that you are using. Ensure that you are not inserting an LTO cartridge into a 3592 I/O slot, or a 3592 cartridge into an LTO I/O slot. If necessary, repeat step 2 on page 56.
4. Perform one of the following to move the cartridges into the library:
 - Use your host's application software to move the cartridges; refer to your application software's documentation.
 - Manually move the cartridges from the I/O station to the library's storage slots or drives. (To manually move the cartridges, see "Moving a Cartridge" on page 110.)

Related concepts

"Enabling or Disabling the Insert Notification Setting" on page 177

This section introduces two ways to enable or disable Insert Notification, which is the setting that monitors and assigns new media to a logical library in the 3584 Tape Library.

Related tasks

"Using the I/O Stations to Insert Data Cartridges When Virtual I/O Slots are Enabled" on page 59

"Enabling or Disabling Virtual I/O Slots" on page 137

This section describes how to enable virtual I/O slots in the 3584 Tape Library so that the host operates as if it has access to more I/O slots than are actually available. It also describes how to disable virtual I/O slots.

"Using the Web to Move a Cartridge" on page 110

"Using the Operator Panel to Move a Cartridge" on page 110

"Working with a Cartridge Assignment Policy" on page 94

This section defines a cartridge assignment policy. It gives procedures for creating, changing, or removing the policy.

Using the I/O Stations to Insert Data Cartridges When Virtual I/O Slots are Enabled

Note: If your library is installed with the Advanced Library Management System (ALMS), you can use the Tape Library Specialist web interface to enable virtual I/O slots and make the host application operate as if the library has more I/O slots than actually exists. For details, see “Enabling or Disabling Virtual I/O Slots” on page 137.

To use I/O stations to insert cartridges into the 3584 Tape Library when virtual I/O slots are enabled, perform the following steps:

1. When virtual I/O slots are enabled, physically seat the cartridges into the I/O station by using the same instructions as when virtual I/O slots are disabled (see “Using the I/O Stations to Insert Data Cartridges When Virtual I/O Slots are Disabled” on page 56).
2. After you have seated the cartridges, the library will automatically move them into storage slots. How each cartridge is assigned to a logical library varies, depending on whether the cartridge assignment policy and insert notification features are set. For additional details, see Figure 23 on page 60.
3. Refer to one of the following to virtually move the cartridges into the logical library:
 - Documentation for your host’s application software.
 - See Figure 23 on page 60, then follow the procedure in “Assigning Cartridges to a Logical Library” on page 88.

Virtual IO Slots - Import Flow

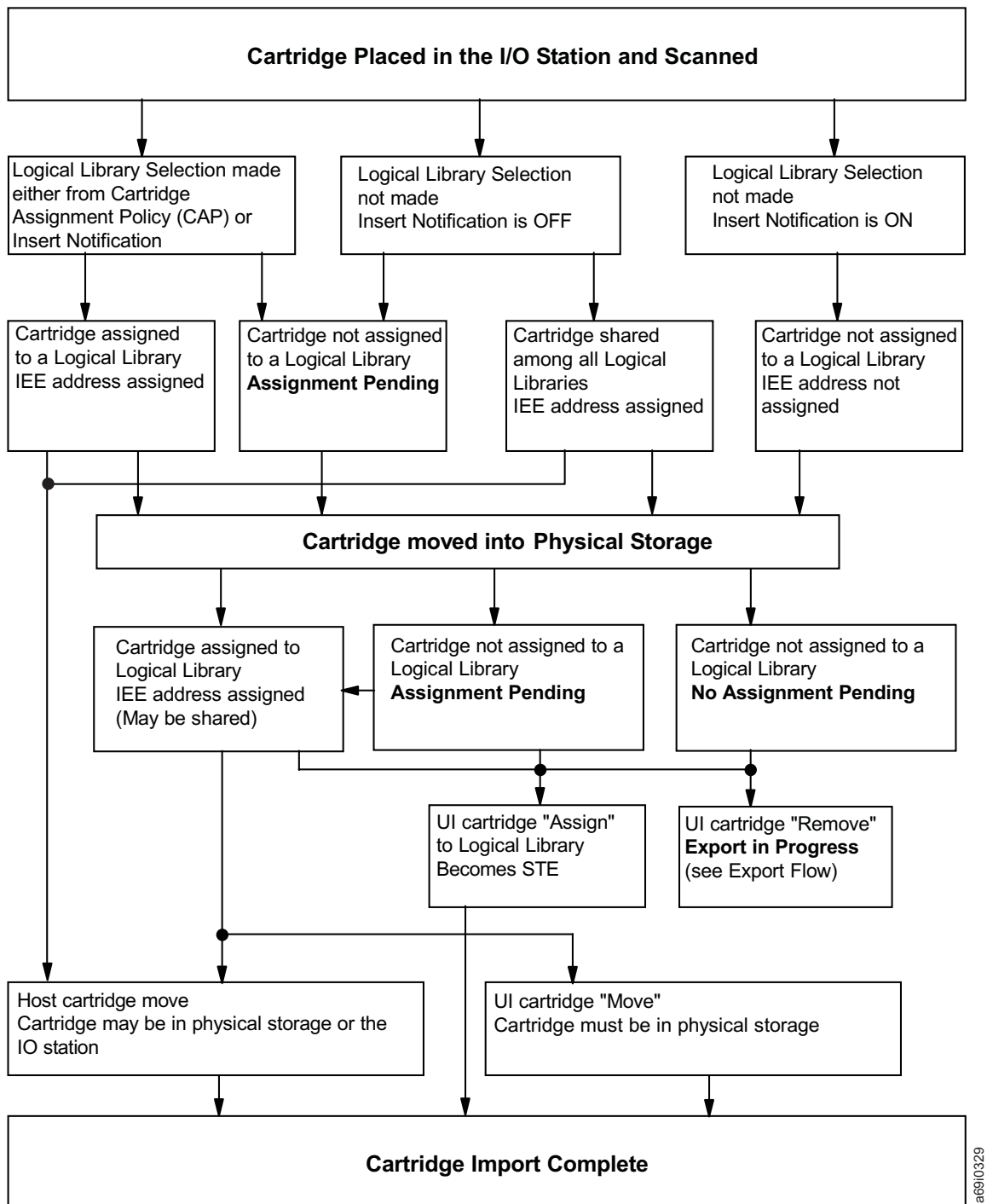

Figure 23. Scenarios for importing cartridges into the 3584 Tape Library when virtual I/O slots are enabled

The following are states that a tape cartridge can be in (after you place it into the I/O station) as an exception to the normal import flow. As the library imports or exports cartridges, the states may display in the Element Address column of the Data Cartridges screen on the Tape Library Specialist web interface.

Assignment Pending

The state that a tape cartridge is in after the operator places it into the I/O station and the library has not yet assigned it an Import/Export Element

(IEE) address. The reason that an address may not yet be assigned could be that there are no IEE addresses available, either for this logical library or, in the case of a shared cartridge, across all logical libraries.

Export in Progress

The state that a tape cartridge is in after the operator selects a remove operation from the Tape Library Specialist web interface and the cartridge is queued to be moved to the I/O station.

No Assignment Pending

The state that a tape cartridge is in when the operator places it in an I/O station, the cartridge accessor moves it into the library, the insert notification feature is enabled, and no logical library selection was made by the operator. When the cartridge is in this state, the operator must make a logical library assignment through the Tape Library Specialist web interface.

Related tasks

“Enabling or Disabling Virtual I/O Slots” on page 137

This section describes how to enable virtual I/O slots in the 3584 Tape Library so that the host operates as if it has access to more I/O slots than are actually available. It also describes how to disable virtual I/O slots.

“Assigning Cartridges to a Logical Library” on page 88

This section describes how to assign data cartridges to a logical library in the 3584 Tape Library.

“Using the I/O Stations to Insert Data Cartridges When Virtual I/O Slots are Disabled” on page 56

Bulk Loading Cartridges into Empty Storage Slots

Note: If the Advanced Library Management System (ALMS) is enabled, cartridges that are not in a cartridge assignment policy will not be added to any logical library.

Use the following steps to bulk load (manually insert) cartridges directly into the storage slots of the 3584 Tape Library.



CAUTION:

Only place cartridges in a frame whose front door is open. Do not add or remove cartridges from an adjacent frame.

1. If you previously used the Advanced Configuration option to partition storage slots into logical libraries (rather than use labels to mark the partitions), determine the boundaries of those partitions by displaying the existing configuration (see “Displaying the Existing Library Configuration” on page 116). Make a note of the boundaries so that you do not place a cartridge outside of a boundary.
2. From the library’s Activity screen (see Figure 24 on page 62), press the PAUSE key. The library displays the message **If you open the door the library will go Not Ready and any remaining jobs in the work queue may fail. Press ENTER to continue.**

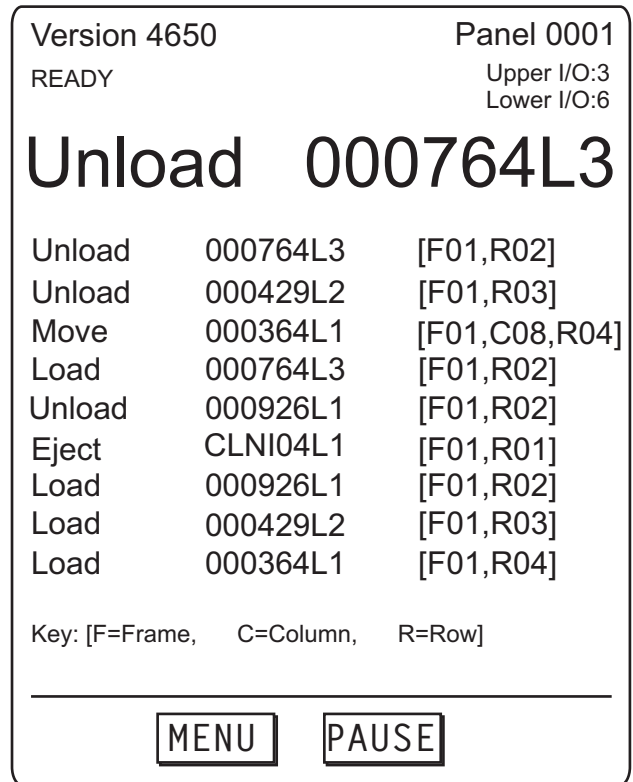

Figure 24. Activity screen on the front panel of the IBM System Storage TS3500 Tape Library. Use the screen to bulk load tape cartridges.

3. Press ENTER. The message **PAUSE in Progress** displays. The library parks the cartridge accessor in the base frame and displays the message **The library is now paused. Normal operations will resume in 30 seconds.**
4. Within 30 seconds, unlock and open the front door on any frame. If you do not open the door within 30 seconds, the Activity screen redisplay.

Note: In the following step, place only Ultrium tape cartridges into black cartridge storage slots; place only 3592 tape cartridges into gray cartridge storage slots.

5. Insert the cartridges into any empty storage slots, except the slots for the diagnostic cartridges (that is, F01,C01,R01, or, if you are using mixed drive types, Fxx,C01,R01 where **xx** equals the first expansion frame for the second type of media). If you previously partitioned logical libraries with labels, insert the cartridges into the appropriate logical library.



CAUTION:

Only place cartridges in a frame whose front door is open. Do not add or remove cartridges from an adjacent frame.

Insert Ultrium and 3592 cartridges into the storage slots so that the write-protect switch is on the right and the volume serial (VOLSER) number label is visible (see Figure 25 on page 63 and Figure 26 on page 63). The orientation differs from the orientation in an I/O slot.

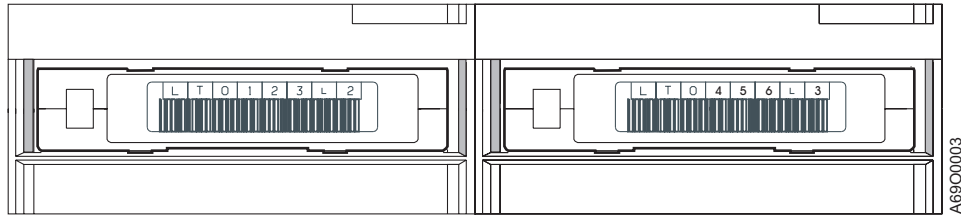

Figure 25. Proper orientation of LTO Ultrium Tape Cartridges in cartridge storage slots

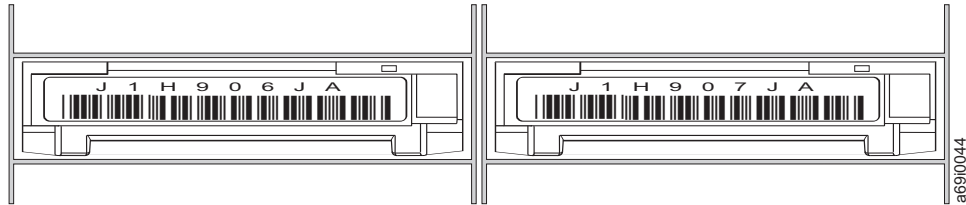

Figure 26. Proper orientation of 3592 Tape Cartridges in cartridge storage slots

6. Gently close and lock the front door.
7. After approximately 15 seconds, the 3584 Tape Library automatically inventories the frame of the door that you opened. During the inventory, the message **INITIALIZING** displays on the Activity screen. When the inventory is complete, **READY** displays.

Note: If you inserted cartridges into an adjacent frame, you must also perform an inventory of that frame or of the entire library. For instructions, see “Performing an Inventory of a Frame in the Library” on page 109 or “Performing an Inventory of the Library” on page 108.

Related concepts

“Using Labels to Configure the Library with Partitions” on page 124

Related tasks

“Using the Web to Display the Existing Library Configuration” on page 116

“Using the Operator Panel to Display the Existing Library Configuration” on page 117

“Using the Web to Perform an Inventory of the Library” on page 108

“Using the Operator Panel to Perform an Inventory of the Library” on page 108

“Working with a Cartridge Assignment Policy” on page 94

This section defines a cartridge assignment policy. It gives procedures for creating, changing, or removing the policy.

Removing Data Cartridges from the Library

In addition to removing data cartridges by using your host application software, you can also use other methods. This section introduces other ways to remove a data cartridge from the 3584 Tape Library.

To remove a data cartridge from the 3584 Tape Library, use one of the following methods.

Using the Web to Remove Data Cartridges

Note: If your library is installed with the Advanced Library Management System (ALMS), you can use the Tape Library Specialist web interface to enable virtual I/O slots and make the host application operate as if the library has more I/O slots than actually exists. If a data cartridge is in a virtual I/O slot, you can export and remove it. When virtual I/O slots are enabled, if you remove a cartridge by using the Tape Library Specialist web interface, the export operation has a higher priority than all server export commands. For details, see “Enabling or Disabling Virtual I/O Slots” on page 137.

To remove data cartridges from the 3584 Tape Library by using the Tape Library Specialist web interface, perform the following steps:

1. Type the Ethernet IP address on the URL line of the browser and press Enter. The Welcome Page displays.
2. Select **Cartridges** → **Data Cartridges**. The Data Cartridges screen displays.
3. Select a Frame (or all frames) or Logical Library (or all libraries), then select Search. A list of cartridges based on the selection criteria you entered is displayed.
4. Select a cartridge, then from the Select Action drop-down list, select Remove, then select Go. The library displays a message that the cartridge has been removed. Close the window.
5. Look at the Activity screen on the operator panel to determine whether the I/O station that you want to use is locked or unlocked. If the station is locked, use your application software to unlock it.
6. Open the door of the I/O station and remove the cartridge.
7. Close the door of the I/O station.

Related tasks

“Enabling or Disabling Virtual I/O Slots” on page 137

This section describes how to enable virtual I/O slots in the 3584 Tape Library so that the host operates as if it has access to more I/O slots than are actually available. It also describes how to disable virtual I/O slots.

Using the Operator Panel to Remove Data Cartridges

To remove data cartridges from the 3584 Tape Library by using the operator panel, perform the following steps:

1. Perform one of the following actions:
 - Use your host’s application software to move the cartridges to an I/O station.
 - Manually move the cartridges to an I/O station (see “Moving a Cartridge” on page 110).
Each time that you move a cartridge from a storage slot to an I/O station, the library updates the display to show the quantity of cartridges in the station.
2. Look at the Activity screen to determine whether the I/O station that you want to use is locked or unlocked. If the station is locked, use your application software to unlock it.
3. Open the door of the I/O station and remove the cartridges.
4. Close the door of the I/O station.

Related tasks

“Using the Web to Move a Cartridge” on page 110

“Using the Operator Panel to Move a Cartridge” on page 110

Removing Data Cartridges When Virtual I/O Slots are Enabled

When the Advanced Library Management System (ALMS) and virtual I/O slots are enabled, and a cartridge is exported to the I/O station, removed from the I/O station, and reinserted into the I/O station in a different slot, that cartridge can become a new importable cartridge and be automatically moved back into the physical library. This requires that the server import and export the cartridge again to move it back to the I/O station for removal. Optionally, you can use the operator panel or the Tape Library Specialist web interface to remove the cartridge to the I/O station (see “Using the Web to Remove Data Cartridges” on page 64 or “Using the Operator Panel to Remove Data Cartridges” on page 64).

Figure 27 on page 66 shows the flow and the status of cartridges when you export them from the library with virtual I/O slots enabled.

Virtual IO Slots - Export Flow

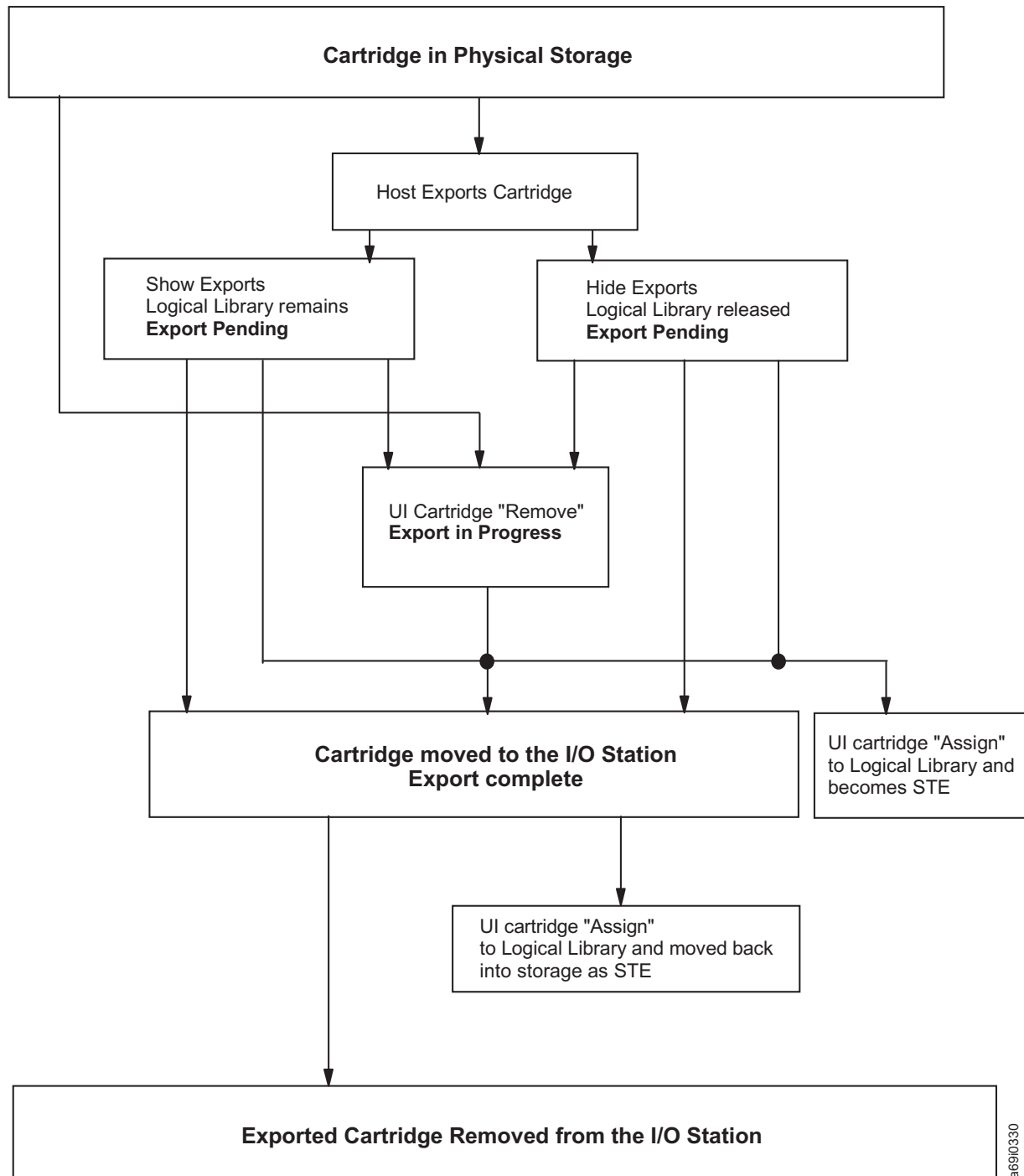

Figure 27. Flow of cartridges that are exported from the 3584 Tape Library with virtual I/O slots enabled

The following are states that a tape cartridge can be in after an administrator issues the command to remove it from the library and place it into the I/O station (see Figure 27). As the library imports or exports cartridges, the states may display in the Element Address column of the Data Cartridges screen on the Tape Library Specialist web interface.

Export Pending

The state that a tape cartridge is in after the server issues a Move

command from the Storage Element to Import/Export Element, and the cartridge is queued to be moved to the I/O station.

Export in Progress

The state that a tape cartridge is in after the operator selects a remove operation from the Tape Library Specialist web interface and the cartridge is queued to be moved to the I/O station.

Export Complete

The state that a tape cartridge is in after the cartridge has been moved to the I/O station. This state is cleared if the cartridge is moved by the operator to any other location, including a different I/O station slot.

Hide Exports

The selection in the library's Tape Library Specialist web interface that prevents a software application from detecting cartridges that are in one of the three export states (Export Pending, Export in Progress, or Export Complete).

Show Exports

The selection in the library's Tape Library Specialist web interface that allows a software application to detect cartridges which are in one of the three export states (Export Pending, Export in Progress, or Export Complete).

Related tasks

"Using the Web to Remove Data Cartridges" on page 64

"Using the Operator Panel to Remove Data Cartridges" on page 64

Removing a Data Cartridge from a Drive in the Library

This section describes how to remove a data cartridge from an LTO Ultrium or 3592 Tape Drive in the 3584 Tape Library.

In a rare situation, you may want to remove a data cartridge directly from a drive in the 3584 Tape Library (that is, without transferring it to an I/O station). To remove a cartridge directly from a drive, perform the following procedure:

1. From the library's Activity screen, press the PAUSE key. The library displays the message **If you open the door the library will go Not Ready and any remaining jobs in the work queue may fail. Press ENTER to continue.**
2. Press ENTER. The message **PAUSE in Progress** displays. The library parks the cartridge accessor in the base frame and displays the message **The library is now paused. Normal operations will resume in 30 seconds.**
3. Within 30 seconds, unlock and open the front door on any frame. If you do not open the door within 30 seconds, the Activity screen redisplay and library operations resume.



CAUTION:

Only remove cartridges from a frame whose front door is open. Do not add or remove cartridges from an adjacent frame.

4. Locate the drive that contains the cartridge that you want to unload and perform the following procedure:
 - For the Ultrium Tape Drive:
 - a. Press the unload button (1 in Figure 28 on page 68).
 - b. Remove the cartridge.

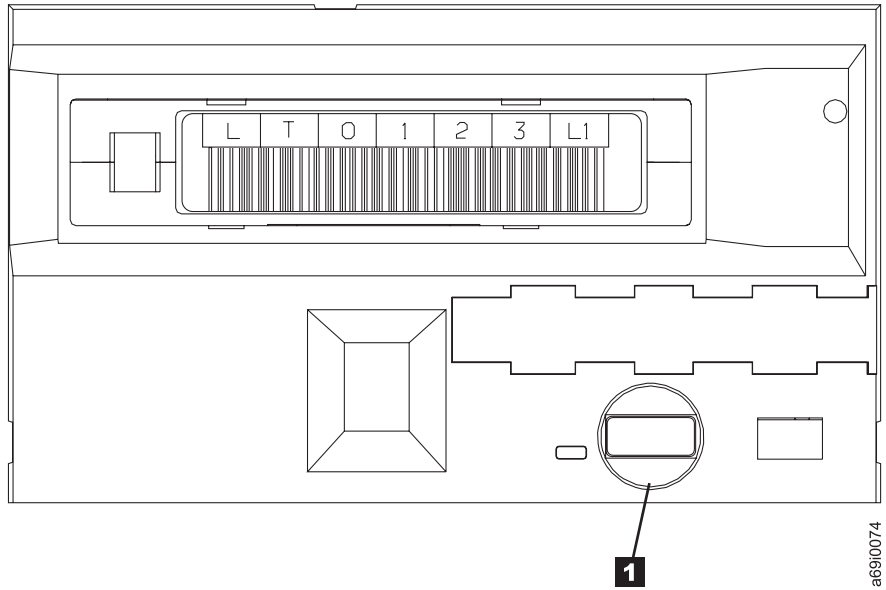

Figure 28. Removing a cartridge from an Ultrium Tape Drive

- For the 3592 Tape Drive:
 - a. Ensure that the green power indicator light is on (see 1 in Figure 29).
 - b. Press the unload button 2, and wait 2 minutes.
 - c. Remove the cartridge.

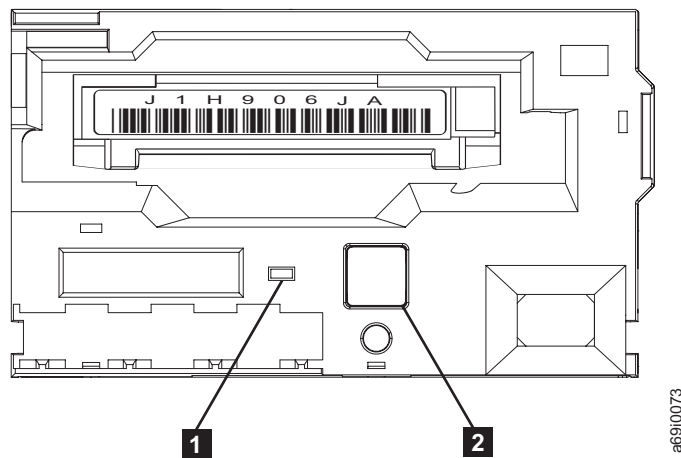

Figure 29. Removing a cartridge from a 3592 Tape Drive

5. Gently close and lock the front door.
6. After approximately 15 seconds, the 3584 Tape Library automatically inventories the frame of the door that you opened. During the inventory, the message **INITIALIZING** displays on the Activity screen. When the inventory is complete, **READY** displays.

Related concepts

“Activity Screen” on page 35

Enabling or Disabling Automatic Cleaning

This section describes how the 3584 Tape Library can automatically clean its tape drives. It introduces two ways to enable or disable automatic cleaning.

Automatic cleaning enables the 3584 Tape Library to automatically respond to any tape drive's request for cleaning and to begin the cleaning process without an operator's intervention. Automatic cleaning applies to all logical libraries that are configured for the 3584 Tape Library. It is required (and cannot be disabled) when the Advanced Library Management System (ALMS) is enabled.

IBM recommends that automatic cleaning always be enabled for the 3584 Tape Library. When automatic cleaning is disabled, the library supports host cleaning (provided the host application software supports host cleaning).

If automatic cleaning is disabled, the library continues to detect the need to clean a tape drive. When the need is detected, the library displays the following message with the physical location of the drive (where **F** equals the frame and **x** equals its number, and where **R** equals the row and **zz** equals its number):

```
Clean Drive  
[F0x,Rzz] - Auto Clean Disabled
```

The message clears after you clean the drive by using any supported cleaning method. For Ultrium Tape Cartridges, the cleaning cycle takes up to 2 minutes; for 3592 Tape Cartridges, the cleaning cycle takes up to 3 minutes.

Whether you enable or disable automatic cleaning, the selected setting is stored in non-volatile memory and becomes the default during later power-on cycles.

To enable or disable automatic cleaning, use one of the following methods.

Using the Web to Enable or Disable Automatic Cleaning

To use the Tape Library Specialist web interface to enable or disable automatic cleaning of the 3584 Tape Library, perform the following steps:

1. Type the Ethernet IP address on the URL line of the browser and press Enter. The Welcome Page displays.
2. Select **Drives** → **Cleaning Mode**. The Cleaning Mode screen displays.
3. Follow the instructions on the screens to enable or disable automatic cleaning.

Note: If you enable automatic cleaning, your cleaning cartridge can cross boundaries and clean multiple logical libraries. If you disable automatic cleaning, your cleaning cartridge cannot cross these boundaries. Therefore, if you disable automatic cleaning, make sure that you have at least one cleaning cartridge in every logical library.

Using the Operator Panel to Enable or Disable Automatic Cleaning

To use the operator panel to enable or disable automatic cleaning of the 3584 Tape Library, perform the following steps:

1. Ensure that a cleaning cartridge is loaded in the library (for help, go to the section about inserting a cleaning cartridge into the library).

- From the library's Activity touchscreen, press **MENU** → **Settings** → **Cleaning Mode** → **ENTER**. The Cleaning Mode screen displays and indicates whether automatic cleaning is currently enabled or disabled.

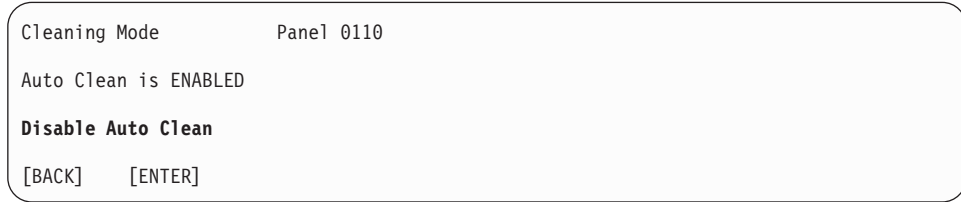

- Press **ENTER** (the **ENTER** key acts as a toggle switch for the two choices).
 - If you chose to enable automatic cleaning, the library displays the message **If you continue you will set the Automatic Cleaning Mode to ENABLED. Do you want to continue?**
 - If you chose to disable automatic cleaning, the library displays the message **If you continue you will set the Automatic Cleaning Mode to DISABLED. Ensure that each logical library has at least one cleaning cartridge. Host-initiated cleaning cannot use cleaning cartridges from another logical library. Do you want to continue?**
- Press **YES** to enable or disable automatic cleaning. The Cleaning Mode screen redisplay with the new setting.
- Press **BACK** until you return to the Activity screen.

Related concepts

“Inserting a Cleaning Cartridge into the Library”

This section introduces methods to insert a cleaning cartridge into the 3584 Tape Library when automatic cleaning is enabled or disabled.

Inserting a Cleaning Cartridge into the Library

This section introduces methods to insert a cleaning cartridge into the 3584 Tape Library when automatic cleaning is enabled or disabled.

Attention: Never insert any type of cartridge into service bays.

To ensure that your 3584 Tape Library conforms to IBM's specifications for reliability, use only one of the following cartridges to clean the heads of the tape drives:

- For LTO Ultrium Tape Drives, use the IBM System Storage Universal LTO Cleaning Cartridge (part number 35L2086) or an IBM-approved cleaning cartridge
- For 3592 Tape Drives, use the IBM TotalStorage 3592 Enterprise Cleaning Cartridge (part number 18P7535) or an IBM-approved cleaning cartridge

The procedure for inserting a cleaning cartridge into the 3584 Tape Library varies, depending on whether automatic cleaning is enabled or disabled. The sections that follow describe each procedure.

Related tasks

“Using the Operator Panel to Enable or Disable Automatic Cleaning” on page 69

“Using the Operator Panel to Perform a Manual Cleaning Operation” on page 74

Inserting a Cleaning Cartridge with Automatic Cleaning Enabled

To insert a cleaning cartridge into the 3584 Tape Library when automatic cleaning is enabled, use one of the following methods. You may insert as many as 100 cartridges.

Using the Web to Insert a Cleaning Cartridge with Automatic Cleaning Enabled

Note: If virtual I/O slots are enabled, your library will automatically import cleaning cartridges.

To use the Tape Library Specialist web interface to insert a cleaning cartridge into the 3584 Tape Library when automatic cleaning is enabled, perform the following steps:

1. Open the door of the I/O station and insert the cartridge so that the bar code label faces the interior of the library and the write-protect switch is on the right.
2. Close the door of the I/O station.
3. Type the Ethernet IP address on the URL line of the browser and press Enter. The Welcome Page displays.
4. Select **Cartridges** → **I/O Station**. The I/O Station screen displays.
5. Follow the instructions on the screen.

Related tasks

“Enabling or Disabling Virtual I/O Slots” on page 137

This section describes how to enable virtual I/O slots in the 3584 Tape Library so that the host operates as if it has access to more I/O slots than are actually available. It also describes how to disable virtual I/O slots.

Using the Operator Panel to Insert a Cleaning Cartridge with Automatic Cleaning Enabled

To use the operator panel to insert a cleaning cartridge into the 3584 Tape Library when automatic cleaning is enabled, perform the following steps:

1. From the library’s Activity touchscreen, press **MENU** → **Manual Operations** → **Insert Cleaning Cartridge** → **ENTER**. The library displays the message **Insert Cleaning Cartridge into I/O station before you continue. Do you want to continue?**
2. Open the door of the I/O station and insert the cartridge so that the bar code label faces the interior of the library and the write-protect switch is on the right.
3. Close the door of the I/O station.
4. Press **YES**. The message **Moving cleaning cartridge** displays while the library scans for one or more cleaning cartridges in the I/O stations:
 - If one or more cleaning cartridges are present, the library moves the cleaning cartridges (one by one) to the lowest empty slots. If the library uses both LTO and 3592 tape cartridges, the accessor moves each cleaning cartridge to a storage location that contains like media (using a separate move operation for each type of media). The library displays the message **Insertion of Cleaning Cartridges has completed**.
 - If no cleaning cartridges are in the I/O stations, the library displays the message **No cleaning cartridge found in the I/O station**.

5. Press ENTER to return to the Manual Operations menu.
6. Press BACK until you return to the Activity screen.

Related tasks

“Using the Operator Panel to Enable or Disable Automatic Cleaning” on page 69

Inserting a Cleaning Cartridge with Automatic Cleaning Disabled

To insert a cleaning cartridge into the 3584 Tape Library when automatic cleaning is disabled, use one of the following methods. You may insert as many as 100 cartridges.

Using the Web to Insert a Cleaning Cartridge with Automatic Cleaning Disabled

To use the Tape Library Specialist web interface to insert a cleaning cartridge into the 3584 Tape Library when automatic cleaning is disabled, perform the following steps:

1. Open the door of the I/O station and insert the cartridge so that the bar code label faces the interior of the library and the write-protect switch is on the right.
2. Close the door of the I/O station.
3. Type the Ethernet IP address on the URL line of the browser and press Enter. The Welcome Page displays.
4. Select **Cartridges** → **I/O Station**. The I/O Station screen displays.
5. Follow the instructions on the screen.

Related tasks

“Enabling or Disabling Virtual I/O Slots” on page 137

This section describes how to enable virtual I/O slots in the 3584 Tape Library so that the host operates as if it has access to more I/O slots than are actually available. It also describes how to disable virtual I/O slots.

“Using the Web to Enable or Disable Automatic Cleaning” on page 69

Using the Operator Panel to Insert a Cleaning Cartridge with Automatic Cleaning Disabled

To use the operator panel to insert a cleaning cartridge into the 3584 Tape Library when automatic cleaning is disabled, perform the following steps:

1. From the library’s Activity touchscreen, press **MENU** → **Manual Operations** → **Insert Cleaning Cartridge** → **ENTER**. The Select Logical Library screen displays with a field for you to specify the name of the logical library that you want to clean.
2. Press UP or DOWN to highlight the name of the logical library into which you want to insert the cleaning cartridge, then press ENTER.

Select Logical Library Panel 0025

Select a logical library:

Logical Library 1
Media Type: LTO

[BACK] [UP] [ENTER]

The library displays the message **Insert Cleaning Cartridges into I/O Station before you continue. Do you want to continue?**

3. Open the door of the I/O station and insert the cartridge so that the bar code label faces the interior of the library and the write-protect switch is on the right. Insert as many cartridges as you want.

Note: If, in step 2 on page 72, you selected a 3592 library and only LTO cartridges are in the I/O station (or if you selected an LTO library and only 3592 cartridges are in the I/O station), the library displays the message **Unable to insert cleaning cartridge, logical library selected is incorrect media type.**

4. Close the door of the I/O station.
5. Press YES. The message **Moving cleaning cartridge** displays while the library scans for one or more cleaning cartridges in the I/O stations.
 - If one or more cleaning cartridges are present, the library moves the cleaning cartridges (one by one) to the lowest empty slots of the logical library that you specified. If the library uses both LTO and 3592 tape cartridges, the accessor moves each cleaning cartridge to a storage location that contains like media (using a separate move operation for each type of media). The library displays the message **Insertion of Cleaning Cartridges has completed.**
 - If no cleaning cartridges are in the I/O stations, the library displays the message **No cleaning cartridge found in the I/O station.**
6. Press ENTER to return to the Manual Operations menu.
7. Press BACK until you return to the Activity screen.

Related tasks

“Using the Operator Panel to Enable or Disable Automatic Cleaning” on page 69

Performing Manual Cleaning of Drives in the Library

If you choose not to use automatic cleaning for drives of the 3584 Tape Library, this section introduces two ways that you can perform manual cleaning.



Attention: Before performing a manual cleaning operation on the 3584 Tape Library, make sure that the tape drive is empty. If a cartridge is in the tape drive, the cleaning operation may hang. To learn whether a drive is empty, go to sections that describe how to use the web, operator panel, or Simple Network Management Protocol (SNMP) to determine drive status.

IBM does not recommend that you clean a drive on a periodic basis; the drive detects when it needs cleaning and the library displays a message that indicates which drive needs to be cleaned. However, if the library does not issue a message and you determine that a specific tape drive needs to be cleaned, perform the manual cleaning operation.

To perform manual cleaning, use one of the methods that follow.

Related tasks

“Using the Web to Determine Drive Status” on page 96

“Using the Operator Panel to Determine Drive Status” on page 96

Related reference

Using the Web to Perform a Manual Cleaning Operation

To use the Tape Library Specialist web interface to perform a manual cleaning operation on the 3584 Tape Library, perform the following steps:

1. Type the Ethernet IP address on the URL line of the browser and press Enter. The Welcome Page displays.
2. Select **Drives** → **Drive Summary**. The Drives screen displays all of the drives in the library.
3. Follow the instructions on the screen.

Using the Operator Panel to Perform a Manual Cleaning Operation

To use the operator panel to perform a manual cleaning operation on the 3584 Tape Library, perform the following steps:

1. From the library’s Activity touchscreen, press **MENU** → **Manual Operations** → **Clean Drive** → **ENTER**. The Select Drive screen displays with a list of tape drives in the library. The drives are listed by their logical SCSI element addresses (in both decimal and hexadecimal format) and their physical frame and row locations (if the Advance Library Management System (ALMS) is enabled, the element addresses are not displayed). The physical locations are listed as **[Fxx,Rzz]** (where **F** equals a frame and **xx** equals its number, and where **R** equals a row and **zz** equals its number).

The screen gives the generation of the drive as **Lx**, where **x** equals 1, 2, 3, or 4 (for the LTO Ultrium 1, Ultrium 2, Ultrium 3, Ultrium 4 Tape Drive, respectively) or **Jx**, where **x** equals 1 (for the 3592 J1A) or 2 (for the TS1120 Tape Drive).

Note: If ALMS is enabled, the element addresses do not display.

```
Select Drive      Panel 0028

Key: F=Frame, R=Row, L=LTO Ultrium,
     J=Enterprise Tape

258  102h  Drive [F01,R02]  L1
259  103h  Drive [F01,R03]  L2
260  104h  Drive [F01,R04]  L2
261  105h  Drive [F01,R05]  L4
262  106h  Drive [F01,R06]  L3
263  107h  Drive [F01,R07]  L1
264  108h  Drive [F01,R08]  L1
269  10Dh  Drive [F02,R02]  J2
269  10Eh  Drive [F02,R10]  L3

[BACK] [ UP ] [DOWN] [ENTER]
```

2. Highlight the drive that you want to clean, then select it. The library locates a cleaning cartridge and moves it to the drive that you specified. The message **Cleaning is queued for drive [Fxx,Rzz]** displays and the cleaning cartridge with the highest usage count cleans the head of the drive. For Ultrium Tape Cartridges, the cleaning cycle takes up to 2 minutes. For 3592 Tape Cartridges, the cleaning cycle takes up to 3 minutes and 30 seconds in the 3592 J1A; the cleaning cycle takes up to 4 minutes and 35 seconds in the TS1120 Tape Drive.

The library then returns the cleaning cartridge to its original slot and displays the message **Drive [Fxx,Rzz] has been cleaned** (see the preceding explanation for **Fxx,Rzz**).

Note: If the message **No cleaning cartridges in the library** displays, press ENTER to return to the Manual Operations menu, then go to “Inserting a Cleaning Cartridge into the Library” on page 70.

3. Press ENTER to return to the Select Drive screen.
4. To clean another drive, repeat step 2 on page 74.
5. Press BACK until you return to the Activity screen.

Related concepts

“Inserting a Cleaning Cartridge into the Library” on page 70

This section introduces methods to insert a cleaning cartridge into the 3584 Tape Library when automatic cleaning is enabled or disabled.

Removing a Cleaning Cartridge from the Library

This section introduces two ways to remove a cleaning cartridge from the 3584 Tape Library.

To remove a cleaning cartridge from the 3584 Tape Library, use one of the following methods.

Using the Web to Remove a Cleaning Cartridge from the Library

To use the Tape Library Specialist web interface to remove a cleaning cartridge from the 3584 Tape Library, perform the following steps:

1. Type the Ethernet IP address on the URL line of the browser and press Enter. The Welcome Page displays.
2. Select **Cartridges** → **Cleaning Cartridges**. The Cleaning Cartridges screen displays.
3. Follow the instructions on the screen to specify the cleaning cartridge and remove it to the I/O station.
4. Look at the Activity screen on the operator panel to determine whether the I/O station that you want to use is locked or unlocked. If the station is locked, use your application software to unlock it.
5. Open the door of the I/O station and remove the cleaning cartridge.
6. Close the door of the I/O station.

Related tasks

“Enabling or Disabling Virtual I/O Slots” on page 137

This section describes how to enable virtual I/O slots in the 3584 Tape Library so that the host operates as if it has access to more I/O slots than are actually available. It also describes how to disable virtual I/O slots.

Using the Operator Panel to Remove a Cleaning Cartridge from the Library

To use the operator panel to remove a cleaning cartridge from the 3584 Tape Library, perform the following steps:

1. From the library's Activity touchscreen, press **MENU** → **Manual Operations** → **Remove Cleaning Cartridge** → **ENTER**. The Cleaning Cartridge Usage screen displays with a list of the cleaning cartridges in the library and a count of how many times they have been used. For libraries that use both LTO and 3592 media, the screen also indicates whether the cartridge is an LTO or 3592 cartridge. To display more cleaning cartridges, press **DOWN**; to return to cartridges that you have viewed, press **UP**.

Cleaning Cartridge Usage		Panel 0220
CLN101JA	025	3592
CLN102L1	020	LTO
CLN103L1	015	LTO
CLN104L1	010	LTO
CLN105JA	005	3592
CLN106JA	000	3592
CLN107L1	000	LTO
CLN108JA	000	3592
CLN109JA	000	3592
CLN110L1	000	LTO

[BACK] [UP] [DOWN]

2. Press **UP** or **DOWN** to highlight the cleaning cartridge that you want to remove, then press **ENTER** to remove the cartridge to an empty slot in an I/O station:
 - If a cleaning cartridge is present, the library begins the removal and displays the message **Move in Progress**. After the library places the cleaning cartridge into an I/O station, **Move Complete** displays.
 - If no empty slot is available in an I/O station, the library displays the message **The Destination Element is Full. Please remove cartridges and restart operation**. Open the door of the I/O station and remove one or more cartridges, then press **ENTER** to resume the operation.
3. Press **ENTER** to return to the Manual Operations menu.
4. Press **BACK** until you return to the Activity screen.
5. Open the door of the I/O station and remove the cleaning cartridge.

Initializing a Tape's Volume Serial (VOLSER) Number

This section provides the procedure to ensure that the volume serial (VOLSER) number on a tape cartridge's bar code label matches the VOLSER written to the tape.

Many tape management applications use Standard Label tape processing. To maintain compatibility with this type of processing in the 3584 Tape Library, the VOLSER number on the bar code label must match the VOLSER written to the tape.

Use the following steps to initialize tape cartridges:

1. Attach a bar code label to the recessed label location on each tape cartridge.
2. Insert the cartridges into the library.
3. Use your software application to write the bar code VOLSER to the tape (for more information, see the documentation for your software application).

Related concepts

"Ultrium Bar Code Label" on page 220

This section describes the appearance and specifications of the Ultrium bar code label.

“3592 Bar Code Label” on page 254

This section describes the appearance and specifications of the 3592 bar code label.

Related reference

“Inserting Data or Scratch Cartridges” on page 54

This section describes the cartridges that are used by the 3584 Tape Library and introduces two ways to insert data and scratch cartridges.

Assigning a Volume Serial (VOLSER) Number to a Tape with an Unknown VOLSER

This section provides the procedure to use the web interface to assign a volume serial number (VOLSER) to a selected cartridge whose volume serial number is unknown.

Many tape management applications use Standard Label tape processing. To maintain compatibility with this type of processing in the 3584 Tape Library, the VOLSER number on the bar code label must match the VOLSER written to the tape. If a tape’s VOLSER is unknown, you will be unable to use it until a VOLSER is established.

Use the following steps to use the web interface to assign a VOLSER number to a tape with an unknown VOLSER:

1. Type the Ethernet IP address or the library URL on the URL line and press Enter. The Welcome Page displays.
2. Make sure that the cartridge is in an I/O station. If the cartridge is not in an I/O station, remove the cartridge to the I/O station (see “Using the Web to Remove Data Cartridges” on page 64).
3. Select **Cartridges** → **Data Cartridges**. The Cartridges screen displays.
4. Select a Frame (or all Frames) or a Logical Library (or all Libraries), then select SEARCH. The Cartridges screen displays a filtered list of data cartridges based on the selection criteria that you entered.
5. Select the cartridge from the list, then from the Select Action drop-down list select Fix Unknown Volume Serial, and select Go. The Fix Unknown Volume Serial Number pop-up window is displayed.
6. Enter a VOLSER by first entering the first six characters of the volume serial number, then selecting the last two characters of the volume serial number (specifying the cartridge type) from the drop-down box.
7. Select Apply. The library displays a message that the volume serial number was successfully assigned.
8. Move the cartridge back to the storage slot (see “Using the Web to Move a Cartridge” on page 110).

Enabling or Disabling Security for the Operator Panel

For Models L23 and L53, this section describes how to provide security for the operator panel of the 3584 Tape Library.

If you are an administrator or superuser, you can enable or disable security for the operator panel. If you enable security, you must create a password. You can also specify a timeout period which, when exceeded, causes the operator panel to lock.

To enable or disable security for the operator panel, establish a timeout period, or create or change a password for the operator panel, perform the following steps:

1. Type the Ethernet IP address or the library URL on the URL line and press Enter. The Welcome Page displays.
2. Select **Access** —> **Operator Panel Security**. The Operator Panel Security screen displays.
3. Select whether to enable or disable operator panel security.
4. If desired, select the timeout period for the operator panel to automatically lock.
5. Perform one of the following (only available when operator panel security is enabled):
 - To create a password for the first time, enter the password twice.
 - To change a password, enter the new password twice.
6. From the Select Action drop-down box, select Apply, then select Go. A confirmation message displays.
7. Select Close.

To lock or unlock the operator panel, see “Locking or Unlocking the Operator Panel.”

Related concepts

“Understanding Roles Defined by the Web Interface” on page 82

This section explains the roles that the administrator of the 3584 Tape Library assigns to users. The roles define the type of access to the library.

Related tasks

“Locking or Unlocking the Operator Panel”

For Models L23 and L53, this section describes how to lock the operator panel on the 3584 Tape Library. It also tells how to unlock the operator panel by entering a password.

Locking or Unlocking the Operator Panel

For Models L23 and L53, this section describes how to lock the operator panel on the 3584 Tape Library. It also tells how to unlock the operator panel by entering a password.

Note: Before you lock or unlock the operator panel, an administrator or superuser must enable security for it (see “Enabling or Disabling Security for the Operator Panel” on page 77).

To lock the operator panel, on the Activity screen, press the LOCK button. The screen refreshes and the UNLOCK button displays.

To unlock the operator panel, perform the following steps:

1. On the Activity screen, press the UNLOCK button. The Password Entry screen displays. The screen initially displays without any asterisks or characters in the line above the keypad.

- If web security is enabled, the Web Server menu displays text that reads **Your 'admin' password has been set to xxxxxxxx** (where xxxxxxxx equals a value that is assigned by the library).
 - If web security is disabled, the Web Server menu displays text that reads **Your 'admin' password has been set to xxxxxxxx but your web security is disabled. To enable web security you must use the web user interface.** To enable web security, see “Activating or Deactivating Password Protection for Web Screens” on page 81.
3. Press BACK until you return to the Activity screen.

Note: To change the password that is assigned by the library, see “Changing the Administrator’s Web Password.”

Related concepts

“Changing the Administrator’s Web Password”

This section introduces two ways to change the administrator’s password to the Tape Library Specialist web interface of the 3584 Tape Library.

“Understanding Roles Defined by the Web Interface” on page 82

This section explains the roles that the administrator of the 3584 Tape Library assigns to users. The roles define the type of access to the library.

Related tasks

“Activating or Deactivating Password Protection for Web Screens” on page 81

This section describes how to add or remove password protection for web screens of the 3584 Tape Library.

Changing the Administrator’s Web Password

This section introduces two ways to change the administrator’s password to the Tape Library Specialist web interface of the 3584 Tape Library.

To change the administrator’s web password, use one of the following methods.

Using the Web to Change the Administrator’s Web Password

This section describes how to use the Tape Library Specialist web interface to change an administrator’s web password.

Only an administrator can use this procedure to change the administrator’s password to the Tape Library Specialist web interface.

To use the Tape Library Specialist web interface to change the administrator’s password, perform the following steps:

1. Type the Ethernet IP address or the library URL on the URL line and press Enter. The Welcome Page displays.
2. Select **Access** —> **Web Security**. The Web Security screen displays.
3. Enter admin for the User ID, then enter the web password that the library assigned in “Establishing the Administrator’s Web Password” on page 79 The screen displays the message Password protection is turned ON.
4. Select **Access** —> **Web Password**. The Change Web Password screen displays.
5. Enter admin for the User ID, the current web password, new web password, and the new web password again for confirmation. Select Apply. A pop-up window displays the message The password change is complete.
6. Select Apply to close the pop-up window.

Related tasks

“Establishing the Administrator’s Web Password” on page 79

This section describes how to initially establish an administrator’s password to the Tape Library Specialist web interface of the 3584 Tape Library.

Using the Operator Panel to Change the Administrator’s Web Password

This section describes how to use the operator panel of the 3584 Tape Library to change an administrator’s password to the Tape Library Specialist web interface.

Only an administrator can use this procedure to change an administrator’s password to the Tape Library Specialist web interface.

1. From the library’s Activity touchscreen, press **MENU** → **Settings** → **Network** → **Web Server** → **ENTER**. The Web Server menu displays.

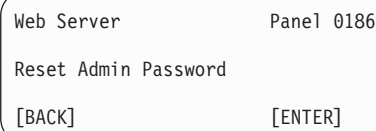

```
Web Server          Panel 0186
Reset Admin Password
[BACK]              [ENTER]
```

2. Press **ENTER**. One of the following occurs. You may want to record the password.
 - If web security is enabled, the Web Server menu displays text that reads **Your 'admin' password has been set to xxxxxxxx** (where xxxxxxxx equals a value that is assigned by the library).
 - If web security is disabled, the Web Server menu displays text that reads **Your 'admin' password has been set to xxxxxxxx but your web security is disabled. To enable web security you must use the web user interface.** To enable web security, see “Activating or Deactivating Password Protection for Web Screens.”
3. Press **BACK** until you return to the Activity screen.

Related tasks

“Activating or Deactivating Password Protection for Web Screens”

This section describes how to add or remove password protection for web screens of the 3584 Tape Library.

Activating or Deactivating Password Protection for Web Screens

This section describes how to add or remove password protection for web screens of the 3584 Tape Library.

For the 3584 Tape Library, the function of choosing password protection for web screens is available only through the Tape Library Specialist web interface; it is not available through the operator panel.

The Tape Library Specialist web interface offers two levels of security access for its screens. Prior to activating password protection, an administrator must choose the type of security access that a user needs to perform library functions. Table 12 describes each level.

Table 12. Types of password protection for web screens

Type of Password Protection	Description
No password protection	You are never prompted to sign on.

Table 12. Types of password protection for web screens (continued)

Type of Password Protection	Description
Password protection	You are prompted to sign on whenever you access the interface.

The factory default for the Tape Library Specialist is no password protection.

To activate or deactivate password protection for web screens, an administrator must perform the following steps:

1. Type the Ethernet IP address or the library URL on the URL line and press Enter. The Welcome Page displays.
2. Select **Access** —> **Web Security**. The Security screen displays the current status of password protection:
 - ON for password protection
 - OFF for no password protection
3. Enter an administrator user ID and password.
4. Select Apply to toggle password protection. The screen redisplay the new setting.

Choosing the Timeout Setting for Web Screens

This section explains how to set the timeout value for the screens in the Tape Library Specialist web interface. The interface is used by the 3584 Tape Library.

1. Type the Ethernet IP address or the library URL on the URL line and press Enter. The Welcome Page displays.
2. Select **Access** —> **Web Security**. The Security screen displays.
3. Under Session Timeout Settings, select one of the following.
 - Number of hours and minutes for the timeout
 - The Do Not Timeout option

Note: The maximum selectable timeout is 24 hours; the minimum selectable timeout is 10 minutes.

4. Select Apply.

If you do not want the web screens to timeout, select Do Not Time Out and select Apply. Although the hours and minutes will default to 24 hours and 00 minutes, the Tape Library Specialist web screens will not time out.

Understanding Roles Defined by the Web Interface

This section explains the roles that the administrator of the 3584 Tape Library assigns to users. The roles define the type of access to the library.

When enabling password protection for users of the 3584 Tape Library, the administrator may want to reserve some functionality for specific users. The Tape Library Specialist web interface uses the concept of roles to restrict or enable specific actions that can be performed by selected users.

Administrators can also create up to 16 of their own roles and define each role's access to libraries and pages. This provides customizable web access.

The pre-defined roles include:

Monitor

Can view all physical and logical library data.

Service

Can perform only service-related functions, such as update firmware, download logs, and view vital product data (VPD).

Superuser

Can perform all tasks of a monitor or service role, plus change library settings and perform library operations. This role cannot change the password of others, or enable or disable security.

Administrator

Can perform all tasks on the web.

Note: Any user can change their own password.

Customized Web Access

This section describes customized web access for the Tape Library Specialist web interface.

Customized web access provides a way for the administrator or super user to add roles with access to specific libraries and specific pages within the libraries for the Tape Library Specialist web interface. Like the standard roles that are delivered with the Tape Library Specialist, these custom roles can be assigned to multiple users. See “Adding a Web User” on page 86.

Customized web access pages are not available unless web security is enabled and password protection is turned on. To enable web security and enable password protection, see “Activating or Deactivating Password Protection for Web Screens” on page 81.

There are two ways to create custom roles:

- Create a new role (see “Adding a Customized Role”).
- Duplicate, then modify an existing role “Adding a Customized Role by Copying an Existing Role” on page 84.

After they are created, customized web access roles can be modified. If a role is assigned to any users, their access will also be modified (see “Modifying a Customized Web Access Role” on page 85). Customized web access roles can also be deleted, however, you cannot delete a role if users are assigned to it (see “Deleting a Customized Web Access Role” on page 85).

Adding a Customized Role

This section describes how to add customized web access by adding a new role to the Tape Library Specialist web interface.

Only an administrator or super user can add a custom role to the Tape Library Specialist web interface. Web security must be enabled, and password protection must be on. A role can be added by either creating a new role, or by copying, then changing an existing role. See “Adding a Customized Role by Copying an Existing Role” on page 84 for instructions on how to add a role by copying an existing role.

To add a customized role, the administrator or super user must perform the following steps:

1. Type the Ethernet IP address or the library URL on the URL line and press Enter. The Welcome Page displays.
2. Select **Access** —> **Roles and Permissions**.
3. From the Select Action drop-down box, select Create, then select Go.
4. On the Define Roles page, enter the Role Name and Description, then select Next.
5. On the Define Pages page, set permissions for each page for a logical library or libraries (which you will select on the next screen), then select Next. Click on the Access header to change the permission for all pages, or an individual cell to change the permission for that page only. Click to toggle thru view-only access, modify access, or no access. White indicates no access, light blue indicates view-only access, and dark blue indicates update access.
6. On the Define Logical Libraries page, select the logical libraries that the role has access to, then select Next. The library displays the message "The Customized Role change is complete." Select Close.

You can now assign users to this role. You can assign only one role to a user, but you can assign multiple users to a role. See "Adding a Web User" on page 86.

Adding a Customized Role by Copying an Existing Role

This section describes how to add a customized web access role by copying an existing role and adding it to the Tape Library Specialist web interface.

Copying an existing role, then changing it, is an efficient method to use to create multiple roles with similar permissions. When a role is duplicated, all the permissions that it has for libraries and pages are also duplicated. You only need to change the specific permissions that differ from the duplicated role. Only an administrator can add a custom role to the Tape Library Specialist web interface. This function is not available unless web security is enabled, and password protection is on.

To add a customized role by copying an existing role, the administrator must perform the following steps:

1. Type the Ethernet IP address or the library URL on the URL line and press Enter. The Welcome Page displays.
2. Select **Access** —> **Roles and Permissions**.
3. On the Roles and Permissions page, select the role you want to copy.
4. From the Select Action drop-down box, select Duplicate, then select Go.
5. On the Define Roles page, enter the new Role Name and Description, then select Next.
6. On the Define Pages page, leave the permissions as they are, or set permissions for each page for a logical library or libraries (which you will select on the next screen), then select Next. Click on the Access header to change the permission for all pages, or an individual cell to change the permission for that page only. Click to toggle thru view-only access, modify access, or no access. White indicates no access, light blue indicates view-only access, and dark blue indicates update access.
7. On the Define Logical Libraries page, select the logical libraries that the role has access to, then select Next. The library displays the message "The Customized Role change is complete." Select Close.

You can now assign users to this role. You can assign only one role to a user, but you can assign multiple users to a role. See “Adding a Web User” on page 86.

Note: You can also copy, then modify an existing role to create a new role.

Modifying a Customized Web Access Role

This section describes how to add a new role to the Tape Library Specialist web interface.

Note: Only an administrator or super user can change a customized web access role to the Tape Library Specialist web interface.

If you change access for a custom role, all web users assigned to that role will have their access modified according to the changes you make.

To change a customized role, the administrator or super user must perform the following steps:

1. Type the Ethernet IP address or the library URL on the URL line and press Enter. The Welcome Page displays.
2. Select **Access** —> **Roles and Permissions**.
3. On the Roles and Permissions page, select a role.
4. From the Select Action drop-down box, select Modify, then select Go.
5. Make any of the following changes:
 - Change the role Description.
 - Change the library page access for the role. Access to each page is determined by toggling through access levels by clicking the box next to the page. White indicates no access, light blue indicates view-only access, and dark blue indicates update access.
 - Change the logical libraries that the role has access to.
6. Select Next. The library displays a message indicating that the role was successfully modified.

The access of all users assigned to role will be changed according to the modifications applied.

Deleting a Customized Web Access Role

This section describes how to delete a customized web access role from the Tape Library Specialist web interface.

Only an administrator or super user can delete a customized web access role from the Tape Library Specialist web interface.

You cannot delete a customized web access role if any web users are assigned to that role. To see a list of which users are assigned to a role, select **Access** —> **Users**. See “Modifying the Settings of a Web User” on page 87 for instructions on how to change a user’s role.

To delete a customized web access role, the administrator must perform the following steps:

1. Type the Ethernet IP address or the library URL on the URL line and press Enter. The Welcome Page displays.
2. Select **Access** —> **Roles and Permissions**.

3. On the Roles and Permissions page, select a role.
4. From the Select Action drop-down box, select Delete, then select Go.
5. A pop-up window asks "Are you sure you want to delete this role?" Select OK. The page refreshes and does not show the user role. If a user is assigned to the role that you want to delete, you will receive the error message "Unable to delete customized web role. At least one user account exists with role." and the role will not be deleted.

The role will be deleted and will no longer display in the list of roles.

Adding a Web User

This section describes how to add a new user ID to the Tape Library Specialist web interface.

Note: Only an administrator can add a new user ID to the Tape Library Specialist web interface. Password protection must be on. To enable password protection, see "Activating or Deactivating Password Protection for Web Screens" on page 81.

An administrator or superuser can create up to nineteen additional web user IDs. To add a web user ID, the administrator or superuser must perform the following steps:

1. Type the Ethernet IP address or the library URL on the URL line and press Enter. The Welcome Page displays.
2. Select **Access** —> **Users**.
3. From the Select Action drop-down box, select Create, then select Go.
4. Enter a user ID in the User ID field (the user ID can be up to fifteen case-sensitive, alphanumeric characters).
5. Using the Role drop-down box, select a role for the new user ID. Both built-in roles and custom roles are listed. Only one role can be selected for a user.
6. Enter any comments, up to 30 characters, about the new user in the Comments field. Suggested comments are the user's full name, job responsibility, or anything that helps associate the user ID with the user.
7. Enter the password in the Password field (the password can be up to fifteen case-sensitive, alphanumeric characters).
8. From the Select Action drop-down box, select Apply, then select Go. The library displays a message indicating that the new user ID was successfully created.

Note: In addition to the four pre-defined roles, an administrator can create up to eighteen custom roles used to access specific libraries and pages. See "Customized Web Access" on page 83.

You can continue to use the preceding web password or you can change the password to a new one. To change your web password, see "Changing Your Web Password" on page 87.

Related tasks

"Activating or Deactivating Password Protection for Web Screens" on page 81
This section describes how to add or remove password protection for web screens of the 3584 Tape Library.

"Changing Your Web Password" on page 87

This section introduces ways to change your password to the Tape Library Specialist web interface of the 3584 Tape Library.

Modifying the Settings of a Web User

This section describes how to change the settings of a user of the Tape Library Specialist web interface.

To modify the settings, an administrator must perform the following steps:

1. Type the Ethernet IP address or the library URL on the URL line and press Enter. The Welcome Page displays.
2. Select **Access** → **Users**.
3. Select the radio button next to the appropriate user ID.
4. From the Select Action drop-down box, select Update, then select Go.
5. Edit the user ID, role, Password field, or Comment field.

Note: For the admin ID, the ID and the role cannot be changed.

6. From The Select Action Drop-down Box, Select Apply, Then Select Go.

Removing a Web User

This section describes how to delete a user ID from the Tape Library Specialist web interface.

To remove a user ID, an administrator must perform the following steps:

1. Type the Ethernet IP address or the library URL on the URL line and press Enter. The Welcome Page displays.
2. Select **Access** → **Users**.
3. Select the radio button next to the appropriate user ID.
4. From the Select Action drop-down box, select Remove, then select Go.

Note: You cannot delete the admin ID.

5. At the prompt **Are you sure?** select the Yes button.

Changing Your Web Password

This section introduces ways to change your password to the Tape Library Specialist web interface of the 3584 Tape Library.

Any user can change their own web password by using the Tape Library Specialist web interface, but not by using the library's operator panel. Only an administrator can change a user's web password by using the operator panel.

Note: This page is only available if Web Security is enabled.

To change your password, perform the following steps:

1. Type the Ethernet IP address or the library URL on the URL line and press Enter. The Welcome Page displays.
2. Select **Access** → **Change Web Password**.
3. Enter the new password.
4. Re-enter the new password.
5. For verification, enter your current password
6. From Select Apply. A confirmation screen displays and indicates that your password has successfully been changed.

Viewing Web Users with Active Sessions

This section describes how an administrator can view the users of the 3584 Tape Library who are connected through the Tape Library Specialist web interface.

Note: This page is only available if Web Security is enabled.

To view active web users of the 3584 Tape Library, perform the following steps:

1. Type the Ethernet IP address or the library URL on the URL line and press Enter. The Welcome Page displays.
2. Select **Access** → **Sessions**. The Active Sessions screen displays a list of users who are currently connected to the Tape Library Specialist web interface. The maximum number of active users is five. The Active Sessions screen displays the following information:

Userid

The user ID of the person who is connected to the Tape Library Specialist.

Role Responsibility that is assigned to the person who is connected to the Tape Library Specialist.

Connect Time

The amount of time the user has been connected to the Tape Library Specialist. Specified in hours (**hh**) and minutes (**mm**).

Assigning Cartridges to a Logical Library

This section describes how to assign data cartridges to a logical library in the 3584 Tape Library.

Note: This function is only valid and available if the Advanced Library Management System (ALMS) is enabled on the 3584 Tape Library. You can assign a data cartridge to a logical library by using the Tape Library Specialist web interface, but not by using the operator panel. Also, if the Advanced Library Management System (ALMS) or cleaning mode is enabled it is normal for a cleaning cartridge to be unassigned. If cleaning mode is disabled, use the operator panel or the Tape Library Specialist web interface to assign the cleaning cartridge as part of an import operation.

To assign a data cartridge to a logical library in the 3584 Tape Library, perform the following steps:

1. Type the Ethernet IP address or the library URL on the URL line and press Enter. The Welcome Page displays.
2. Select **Cartridges** → **Data Cartridges**. The Data Cartridges screen displays.
3. Select the logical library to which the cartridge is currently assigned and select how you want the cartridge range to be sorted. (The library can sort the cartridge by volume serial number, SCSI element address, or frame, column, and row location.) Select Search. The Cartridges screen displays all ranges for the logical library that you specified.
4. Select the range that contains the data cartridge that you want to assign.
5. Select the data cartridge, then from the Select Action drop-down list, select Assign, then select Go.
6. In the Select a Logical Library pop-up window, select the logical library to which you want to assign the data cartridge.

7. Select Next to complete the function.
8. When a message is displayed that the data cartridge is assigned, select Close.

Note: If the cartridges were assigned to a logical library that is attached to a 3953 L05 Library Manager, the operator must initiate an inventory upload from the operator panel or through the web specialist of the 3953 L05 Library Manager. This action is required because the inventory of the Library Manager does not automatically update when data cartridges are assigned to logical libraries through the Tape Library Specialist web interface of the 3584 Tape Library.

Using the Drive Assignment Web Page

This section introduces the drive assignment web page of the 3584 Tape Library, which is available through the Tape Library Specialist web interface. The page enables you to add or remove a drive from a library configuration. It also enables you to add, remove, and share drives in a logical library, and change a control path.

Note: This function is only valid and available if the Advanced Library Management System (ALMS) is enabled on the 3584 Tape Library. You can assign drives to a logical library by using the Tape Library Specialist web interface, but not by using the operator panel.

By using the drive assignment page of the 3584 Tape Library, you can do the following:

- **Add new drives to a logical library.** When you add a new drive to a library, it is marked as unassigned. When you view the Drive Assignment screen, the drive is displayed in the Unassigned column. You can assign the drive to any logical library that is of the same media type.
- **Remove drives.** You can remove any drive to the Unassigned column.
- **View dedicated drives.** You can display dedicated drives (drives that exist in one logical library or that are unassigned). These drives appear with blue table backgrounds.
- **Share drives.** You can share drives in up to ten logical libraries. Drives can only be shared if they are not control paths and they do not contain a cartridge. These drives appear with gold table backgrounds.
- **Determine non-communicating drives.** You can identify drive that is no longer communicating. These drives appear with gray table backgrounds.
- **Change control paths.** All logical libraries must contain at least one control path drive. In a logical library, you can designate any empty, dedicated drive to become a control path drive. A drive that is loaded with a cartridge cannot become a control path until you remove the cartridge. Similarly, any drive that is a control path cannot be disabled until you remove the cartridge that it contains.
- **Detect gaps between drives in logical libraries.** As you reassign drives among logical libraries, you may be creating gaps in the range of drive element addresses. If so, the web screen displays the name of the affected logical library in yellow.

The sections that follow describe how to add and remove a drive to or from physical tape library. For a logical library, they also describe how to add, remove, and share drives, and how to change a control path.

Related tasks

“Enabling or Disabling ALMS” on page 136

This section describes how to enable or disable the Advanced Library Management System (ALMS) in the 3584 Tape Library.

Adding a Drive to a Physical Library

1. Add the tape drive to a physical 3584 Tape Library. For instructions, see the procedure about installing a drive in the *IBM System Storage TS3500 Tape Library Maintenance Information* manual. Then, continue with the following steps.
2. Type the Ethernet IP address or the library URL on the URL line and press Enter. The Welcome Page displays.
3. Select **Drives** —> **Drive Assignment**. The Drive Assignment screen displays.
4. Follow the instructions on the screen to select a drive or logical library, and select Continue.
5. Verify that the drive that you added is displayed in the Unassigned column. If the drive does not display, a communications problem exists. Verify that all cables are properly seated.
6. Select Cancel or select **Settings** —> **Drive Assignment** to refresh the data and display the drive.

Adding a Drive to a Logical Library

When you add a drive to a logical library, note that certain guidelines exist. In a 3584 Tape Library which uses the Advanced Library Management System (ALMS), encryption-enabled drives in a logical library must be all library-managed, all application-managed, or a combination of system-managed and none. A drive can only be shared in homogeneous logical libraries; that is, all drives must be set to the same encryption method. A drive that is not encryption-capable cannot be added to an library-managed or application-managed logical library. Within a frame, encryption-capable drives may reside with non-encryption-capable drives, but encryption-capable drives are not allowed to become encryption-enabled. A non-encryption-capable drive may be added to a system-managed logical library.

To add a tape drive to a logical library, perform the following steps:

1. Type the Ethernet IP address or the library URL on the URL line and press Enter. The Welcome Page displays.
2. Select **Drives** —> **Drive Assignment**. The Drive Assignment Filter screen displays.
3. Follow the instructions on the screen to select a drive or logical library, and select Continue. The Drive Assignment screen displays. The screen includes:
 - **Drive column.** When you select the link to each drive, the Drive Details screen displays the drive’s World Wide Node Name, type (LTO or 3592), physical location (frame and row), type of interface, SCSI or Loop ID, status of contents, and type of encryption method.
 - **Logical Library column.** Up to 192 columns for the logical libraries that you can create.
 - **Totals of dedicated and shared drives.** Located at the bottom of the screen.
 - **Cancel.** When you select Cancel, the firmware erases the changes that you made to the drives and refreshes the Drive Assignment screen with the previous entries (the same occurs if you leave the Drive Assignment screen before you select Assign; all of the changes that you made are lost and the screen restores the previous entries).

4. For each drive that you want to add, select the check box in the Logical Library column.
5. When you have selected the check boxes for all of the drives that you want to assign, from the Select Action drop-down box, select Apply, then select Go. The Drive Assignment Operation in Progress screen displays, followed by a Success screen that indicates that the changes are complete.
6. Select Close. The Drive Assignment screen redisplay with the new assignments.

Related tasks

“Creating or Removing a Logical Library with ALMS” on page 138

This section gives the steps for creating or removing a logical library from a 3584 Tape Library that is enabled with the Advanced Library Management System (ALMS).

Sharing Drives in a Logical Library

After you add one or more drives to a logical library in the 3584 Tape Library, you can share drives with the same media type among multiple logical libraries.

To share drives with the same media type among one or more logical libraries, perform the following steps:

1. Type the Ethernet IP address or the library URL on the URL line and press Enter. The Welcome Page displays.
2. Select **Drives** —> **Drive Assignment**. The Drive Assignment screen displays.
3. Select one or more drives in the Drive column, then select one or more logical libraries to share the drives (you can share a drive in a maximum of ten logical libraries).
4. When you have selected all of the drives that you want to share and all of the logical libraries in which you want to include them, from the Select Action drop-down box, select Apply, then select Go. The Operation in Progress screen displays, followed by a Success screen that indicates that the changes are complete.
5. Select Close. The Drive Assignment screen redisplay with the new assignments.

Enabling or Disabling a Control Path in a Logical Library

Note: This function is only valid and available if ALMS is enabled.

After you add one or more drives to a logical library in the 3584 Tape Library, you can enable or disable a control path. You can use this function to choose multiple control paths for a single library, or multiple pairings of control paths and logical libraries. A logical library must contain at least one control path.

To enable or disable a control path in a logical library, perform the following steps:

1. Type the Ethernet IP address or the library URL on the URL line and press Enter. The Welcome Page displays.
2. Select **Drives** —> **Drive Assignment**. The Drive Assignment screen displays.
3. In the Drive column, select the drive that you want to enable or disable as the control path drive.
4. Locate the intersection of logical library column and drive row that you want, then select the control path icon to the left of the check box.

5. From the Select Action drop-down box, select Apply, then select Go. The Operation in Progress screen displays, followed by a Success screen that indicates that the changes are complete.
6. Select Close. The Drive Assignment screen redisplay with the new assignments.

Related tasks

“Entering the ALMS License Key” on page 135

This section describes how to record your license key for the Advanced Library Management System (ALMS), which is an option of the 3584 Tape Library. The key lets you enable and use ALMS.

“Enabling or Disabling ALMS” on page 136

This section describes how to enable or disable the Advanced Library Management System (ALMS) in the 3584 Tape Library.

Removing a Drive from a Logical Library

Attention: If you remove a drive from the middle of a logical library, this will cause noncontiguous element address ranges and may result in problems with certain Independent Software Vendor (ISV) software.

To remove a tape drive from a logical library in the 3584 Tape Library, perform the following steps:

1. Type the Ethernet IP address or the library URL on the URL line and press Enter. The Welcome Page displays.
2. Select **Drives** → **Drive Assignment**. The Drive Assignment screen displays.
3. Locate the intersection of logical library column and drive row that you want, then perform one of the following:
 - If the drive is a shared drive, select the checkmark to remove it as a shared drive. Then, select the box in the Unassigned column to add a checkmark (this removes the checkmark in the logical library box).
 - If the drive is a dedicated drive, select the checkmark (to delete it) in the logical library box or select the box in the Unassigned column to add a checkmark.
4. When you have selected (deleted) the checkmarks in the Unassigned column for all of the drives that you want to remove, from the Select Action drop-down box, select Apply, then select Go. The Drive Assignment Operation in Progress screen displays. After a short delay, the Success screen displays to indicate that the changes are complete.
5. Select Close. The Drive Assignment screen redisplay. The drives that you selected are checked in the Unassigned column and are no longer available to the logical libraries.

Note: To remove a drive canister from a library, go to the section about removing a drive from a physical library.

Related tasks

“Removing a Drive from a Physical Library”

Removing a Drive from a Physical Library

Note: In the 3584 Tape Library, a drive that has already been assigned but has lost communication will not be removed from the configuration data. It is only removed if it is unassigned.

1. Type the Ethernet IP address or the library URL on the URL line and press Enter. The Welcome Page displays.
2. Select **Drives** → **Drive Assignment**. The Drive Assignment screen displays.
3. For each drive to be removed, select the box in the Unassigned column to add a checkmark (this removes the checkmark in the logical library box).

Note: You cannot move a drive into the Unassigned column if it contains a cartridge. Also, if the drive to be removed is a control path drive, you must ensure that a second drive is designated as the control path drive before you remove the first control path drive.

4. From the Select Action drop-down box, select Apply, then select Go. The Drive Assignment Operation in Progress screen displays. After a short delay, the Success screen displays to indicate that the changes are complete.
5. Select Close. The Drive Assignment screen redisplay. The drives that you selected are checked in the Unassigned column and are no longer available to the logical libraries.
6. Use the appropriate procedure to physically remove an LTO Ultrium Fibre Channel drive or a 3592 Fibre Channel drive from the physical library. For help, see “Removing or Replacing a Drive Canister Assembly - LTO Fibre Channel Hot Swap” on page 325 or “Removing or Replacing a Drive Canister Assembly - 3592 Fibre Channel Hot Swap” on page 328.
7. After you remove the drive from the library, select **Drives** → **Drive Assignment**. After a short delay, the Drive Assignment screen redisplay.
8. Ensure that the drive does not display in the Drive Assignment screen. If it displays, wait a few moments and refresh the screen again (some delay in this procedure is expected).

Note: If you physically remove a drive that is not assigned to a logical library, that drive will not display in the Drive Assignment screen; if you remove a drive that is assigned to a logical library, its background in the Drive Assignment screen becomes gray. This indicates that the drive no longer communicates. The drive remains in its associated logical library until you unassign it by using the procedure to remove a drive from a logical library.

Related tasks

“Removing or Replacing a Drive Canister Assembly - LTO Fibre Channel Hot Swap” on page 325

“Removing or Replacing a Drive Canister Assembly - 3592 Fibre Channel Hot Swap” on page 328

“Removing a Drive from a Logical Library” on page 92

Detecting Gaps Between Drive Element Addresses in a Logical Library

In a 3584 Tape Library, to detect gaps between drive element addresses in a logical library perform the following steps:

1. Type the Ethernet IP address or the library URL on the URL line and press Enter. The Welcome Page displays.
2. Select **Manage Drives** → **Drive Assignment**. The Drive Assignment screen displays. Yellow column headings indicate which logical libraries contain element address gaps.

Working with a Cartridge Assignment Policy

This section defines a cartridge assignment policy. It gives procedures for creating, changing, or removing the policy.

Note: The cartridge assignment policy does not reassign an assigned tape cartridge. To reassign a cartridge, use the procedure for assigning cartridges to a logical library (see “Assigning Cartridges to a Logical Library” on page 88).

When you insert a cartridge into the library and its VOLSER is within a range, the cartridge assignment policy assigns the cartridge to its logical library. The cartridge must be of the same media type as that logical library. For example, if you create for Logical Library 1 (a library of Ultrium drives) a cartridge assignment policy of VOLSERs that range from ABC000 to ABC999 then you insert a cartridge with VOLSER ABC123, the library recognizes that VOLSER as belonging to the range and assigns it to Logical Library 1, provided that the cartridge is an Ultrium Tape Cartridge (and not a different media type, such as a 3592 Tape Cartridge).

Within a physical library, the maximum quantity of ranges that can be created by cartridge policy assignment is 300; for logical libraries, the sum of all cartridge assignment policies must not exceed 300.

To establish a cartridge assignment policy, perform the following steps:

1. Type the Ethernet IP address or the library URL on the URL line and press Enter. The Welcome Page displays.
2. Select **Cartridges**—> **Cartridge Assignment Policy**. The Cartridge Assignment Policy screen displays a list of logical libraries (by number) and the cartridge assignment policies that are currently assigned to them.
3. Perform one of the following:
 - **To create a new cartridge assignment policy**, From the Select Action drop-down box select Create, then select Go. Enter the VOLSERs that begin and end the range that you want (ensure that you type alphabetical characters in uppercase). Select the logical library that you want and select Apply, then Close. The Cartridge Assignment screen redisplay with the new cartridge assignment policy.
 - **To change a cartridge assignment policy**, select the policy that you want to change. From the Select Action drop-down box select Modify, then select Go. The Cartridge Assignment Policy screen displays. You can move the policy to another logical library or edit the existing policy in its current logical library. After you have finished making your changes, select Apply, then Close. The Cartridge Assignment screen redisplay with the changes to the cartridge assignment policy.
 - **To delete a cartridge assignment policy**, select the VOLSER range of that policy. From the Select Action drop-down box select Delete, then select Go. The library displays the message **Are you sure you want to remove the volume serial range?** Select OK. The Cartridge Assignment screen redisplay with the cartridge assignment policy removed.

Related tasks

“Assigning Cartridges to a Logical Library” on page 88

This section describes how to assign data cartridges to a logical library in the 3584 Tape Library.

Determining the Status of Components in the Library

This section introduces procedures for determining the status of the accessor, tape drives, I/O stations, storage slots, and cartridges in the 3584 Tape Library.

Determining the Status of the Cartridge Accessor

To determine whether tape cartridges are present in the cartridge accessor of the 3584 Tape Library, use one of the following methods.

Using the Web to Determine the Status of the Cartridge Accessor

To use the Tape Library Specialist web interface to determine whether tape cartridges are present in the cartridge accessor of the 3584 Tape Library, perform the following steps:

1. Type the Ethernet IP address on the URL line of the browser and press Enter. The Welcome Page displays.
2. Select **Library** → **Accessor**. The Accessor screen displays the state of operation for the accessor and its components (gripper, scanner, and calibration sensor). It also gives usage statistics. If you have a second accessor, the screen also displays status and usage information for this accessor.

Using the Operator Panel to Determine the Status of the Cartridge Accessor

To use the operator panel to determine whether tape cartridges are present in the cartridge accessor of the 3584 Tape Library, perform the following steps:

1. From the library's Activity touchscreen, press **MENU** → **Library Status** → **Accessor Status** → **ENTER**. The Accessor Status screen displays.

```
Accessor Status                Panel 0004
Accessor A - Online Preferred
  Gripper 1 - Operational
                3592/LTO
  Gripper 2 - Failed VOL031L3
                3592/LTO
Accessor B - Online
  Gripper 1 - Failed
                3592/LTO
  Gripper 2 - Operational
                3592/LTO
[BACK]
```

If you have a second accessor, the screen displays status for both accessors. If a cartridge is present in a gripper, the screen displays the cartridge's volume serial (VOLSER) number. If no cartridge is present, the screen indicates that the gripper is **Operational**. If the screen displays **Failed** and a cartridge's VOLSER, a problem has occurred with that cartridge. If the screen simply displays **Failed**, the gripper is empty but broken, and a message about its failed status is reported to the Activity screen. If the library cannot read the VOLSER, the screen displays **Unknown**. For libraries that use both LTO and 3592 media, the Accessor Status screen lists the type of gripper for that media. 3592 media is represented as **3592** and LTO Ultrium media is represented as **LTO**.

To show current status, the Accessor Status screen refreshes every 10 seconds.

2. Press **BACK** until you return to the Activity screen.

Determining Drive Status

To determine whether the tape drives in the 3584 Tape Library are functioning properly and contain tape cartridges, use one of the following methods.

Using the Web to Determine Drive Status

To use the Tape Library Specialist web interface to determine the status of drives in the 3584 Tape Library, perform the following steps:

1. Type the Ethernet IP address on the URL line of the browser and press Enter. The Welcome Page displays.
2. Select **Drives** → **Drive Summary** (presents the drives by frames and logical libraries).
3. (Optional) Select the Frame or Library.
The Drives screen displays the state of operation for all of the drives in the library.

Using the Operator Panel to Determine Drive Status

To use the operator panel to determine the status of drives in the 3584 Tape Library, perform the following steps:

1. From the library's Activity touchscreen, press **MENU** → **Library Status** → **Drive Status** → **ENTER**. The Drive Status screen displays.

```
Drive Status                Panel 0005
Key: L=LTO Ultrium, J = Enterprise Tape

Frame 1  Media type: LTO

Drive 1  L3  Online  VOL110L3
Drive 2  L4  Offline Empty
Drive 3  L2  Online  Empty
Drive 4  J1  Online  VOL111J1
Drive 5  L2  Offline Empty
Drive 6  J1  CommFail
Drive 7  J2  Online  Empty
Drive 8           Not Installed
Drive 9           Not Installed
Drive 10          Not Installed
Drive 11          Not Installed
Drive 12          Not Installed

[BACK] [ UP ] [DOWN]
```

If you have more than one frame, scroll through the frames by pressing UP or DOWN. For libraries that use both LTO and 3592 media, the Drive Status screen lists the type of media in each frame. The screen lists the drives and (if they are LTO Ultrium drives) gives their generation as **Lx**, where **x** equals 1, 2, 3, or 4 (for the LTO Ultrium 1, Ultrium 2, Ultrium 3, or Ultrium 4 Tape Drive, respectively). If the drives are 3592 Tape Drives, the screen lists them as **J1** for Model J1A and **J2** for Model E05. The screen indicates whether each drive is functioning properly (**Online**), is offline for service (**Offline**), has an RS-422 connection to the library that is not functioning (**CommFail**) or is communicating over the RS-422 interface but is not usable (**Failed**). If a cartridge is present in a drive, the screen displays the cartridge's volume serial (VOLSER) number; if no cartridge is present, the screen displays **Empty**.

To show current status, the Drive Status screen refreshes every 10 seconds.

2. Press **BACK** until you return to the Activity screen.

Using SNMP to Determine Drive Status

You can use your management agent for Simple Network Management Protocol (SNMP) to request data about the mediaAccessDeviceGroup. This is an object ID (category) that gives you a list of all drives and their status. For information about how to request the data, see the documentation for your SNMP management agent. The following is sample output.

```
mediaAccessDeviceIndex.1 = 1
mediaAccessDeviceObjectType.1 = tapeDrive(3)
mediaAccessDevice-Name.1 = "IBM 03592J1A 0001300180"
mediaAccessDevice-Status.1 = "deprecated"
mediaAccessDevice-Availability.1 = runningFullPower(3)
mediaAccessDevice-NeedsCleaning.1 = false(2)
mediaAccessDevice-MountCount.1 = Hex: 00 00 00 00 00 00 35 47
mediaAccessDevice-DeviceID.1 = "50 05 07 63 00 01 03 01"
mediaAccessDevice-PowerOnHours.1 = Hex: 00 00 00 00 00 00 0E 59
mediaAccessDevice-TotalPowerOnHours.1 = Hex: 00 00 00 00 00 00 0E 59
mediaAccessDevice-OperationalStatus.1 = ok(2)
mediaAccessDevice-Realizes-StorageLocationIndex.1 = 1
mediaAccessDevice-Realizes-softwareElementIndex.1 = 1
```

For detailed descriptions of these fields, see “Using SNMP MIBs to Monitor the Library” on page 298.

Related reference

“Using SNMP MIBs to Monitor the Library” on page 298

This section describes how to use a Simple Management Network Protocol (SNMP) monitoring station and Management Information Bases (MIBs) to check drive status, give information about the last SNMP trap and about cartridges, and identify supported MIBs and supported SNMP messages. The data gathered from this process originates from the 3584 Tape Library and is displayed on the SNMP monitoring station.

Viewing Drive Displays

This section introduces two ways to view the characters that display on the front of a 3592 Tape Drive or an Ultrium Tape Drive in the 3584 Tape Library.

Using the Web to View Drive Displays

For tape drives that support it, characters on a drive’s display are included in the 3584 Tape Library. To use the Tape Library Specialist web interface to view the characters, perform the following steps:

1. Type the Ethernet IP address on the URL line of the browser and press Enter. The Welcome Page displays.
2. Select **Drives** → **Drive Summary**. The Drives screen displays. For both Ultrium Tape Drives and 3592 Tape Drives, the screen shows the characters that appear on their displays. The display of the Ultrium Tape Drive can show only a single character; the display of the 3592 Tape Drive can show up to 80 characters.

Using the Operator Panel to View Drive Displays

To use the operator panel to view the characters that appear on the displays of Ultrium Tape Drives or 3592 Tape Drives in the 3584 Tape Library, perform the following steps:

1. From the library’s Activity touchscreen, press **MENU** → **Library Status** → **Drive Display** → **ENTER**. The Drive Display screen displays. For both Ultrium Tape Drives and 3592 Tape Drives, the screen shows the characters that appear on their displays. The display of the Ultrium Tape Drive can show only

a single character; the display of the 3592 Tape Drive can show up to 80 characters. The following screens shows an example of the Drive Display screen for each type of drive.

```

Drive Display                Panel 0019
Key: L=LTO Ultrium
Frame n                      Media type: LTO
Drive 1  L1  0
Drive 2  L4  6
Drive 3  L2  0
Drive 4  L3  0
Drive 5  L2  0
Drive 6  L2  0
Drive 7           Not Installed
Drive 8           Not Installed
Drive 9           Not Installed
Drive 10          Not Installed
Drive 11          Not Installed
Drive 12          Not Installed
[BACK]  [ UP ]  [DOWN]

```

```

Drive Display                Panel 0019
Key: J=Enterprise Tape
Frame n                      Media type: 3592
Drive 1  J1  READY*
Drive 2  J1  READ*
Drive 3  J2  @LOAD
Drive 4  J2  READ*
Drive 5  J1  WRITE*
Drive 6  J1  EMPTY*
Drive 7  J1  EMPTY*
Drive 8           Not Installed
Drive 9           Not Installed
Drive 10          Not Installed
Drive 11          Not Installed
Drive 12          Not Installed
[BACK]  [ UP ]  [DOWN]

```

If you have more than one frame, scroll through the frames by pressing UP or DOWN. For libraries that use both LTO and 3592 media, the Drive Display screen lists the type of media in each frame. The screen lists the drives in that frame and (if they are LTO Ultrium drives) gives their generation as Lx, where x equals 1, 2, 3 or 4 (for the LTO Ultrium 1, Ultrium 2, Ultrium 3, Ultrium 4 Tape Drives, respectively). If the drives are 3592 Tape Drives, the screen lists them as J1 for Model J1A or J2 for Model E05. If the drive text area of the screen (the section on the right) is blank, it means that the library could not retrieve information from the drive. This could be because the drive is busy, or, in the case of the 3592 Tape Drive, the code level of the drive does not support the viewing of drive displays. The Drive Display screen does not refresh to show changes.

2. Press BACK until you return to the Activity screen.

Determining the Status of an I/O Station

To determine whether one or more tape cartridges are present in an I/O station of the 3584 Tape Library, use one of the following methods.

Using the Web to Determine the Status of an I/O Station

To use the Tape Library Specialist web interface to determine the status of an I/O station in the 3584 Tape Library, perform the following steps:

1. Type the Ethernet IP address on the URL line of the browser and press Enter. The Welcome Page displays.
2. Select **Cartridges** —> **I/O Station**. The I/O Station screen displays cartridges that are contained in available I/O stations.

Using the Operator Panel to Determine the Status of an I/O Station

To use the operator panel to determine the status of an I/O station in the 3584 Tape Library, perform the following steps:

1. From the library's Activity touchscreen, press **MENU** —> **Library Status** —> **Select I/O Station** —> **ENTER**. The Select I/O Station screen displays. It lists each I/O Station and displays information about whether it is open, locked, and the number of cartridges in the I/O station..

```
Select I/O Station          Panel 0037
KEY: R=Row
Frame 1   R01-R10:   OPEN
Frame 1   R11-R26:    3
Frame 12  R01-R16:  LOCKED
Frame 12  R17-R32:    0
Frame 12  R33-R48:   OPEN
Frame 12  R49-R64:   12
[BACK] [ UP ] [DOWN]
```

OPEN displays next to frames that are open; locked displays next to frames that are locked; the number indicates how many cartridges are in the I/O station.

2. Select an I/O Station and press **ENTER**. The I/O Station Status screen displays. For libraries that use both LTO and 3592 media, the screen shows the type of media used in each I/O station. It lists the storage slots in the I/O station and indicates whether they are occupied by a cartridge or are empty. If occupied, the cartridge is identified by its volume serial (VOLSER) number and logical library name (in the example below, **Admin** and **Finan**).

```
I/O Station Status          Panel 0006
Media Type: LTO
Slot 1   VOL110L3  LL: Admin
Slot 2   Empty
Slot 3   Empty
Slot 4   VOL111L3  LL: Finan
Slot 5   Empty
Slot 6   Empty
Slot 7   Empty
Slot 8   Empty
Slot 9   Empty
Slot 10  Empty
[BACK] [ UP ] [DOWN]
```

To show current status, the I/O Station Status screen refreshes every 10 seconds.

3. Press UP or DOWN to redisplay the next or previous 16 I/O slots.

4. Press BACK until you return to the Activity screen.

Using SNMP to Determine the Status of an I/O Station

You can use your management agent for Simple Network Management Protocol (SNMP) to request data about the limitedAccessPortGroup. This is an object ID (category) that gives you a list of all I/O stations and their status. For information about how to request the data, see the documentation for your SNMP management agent. The following is sample output.

```
limitedAccessPortIndex.1 = 1
limitedAccessPort-DeviceID.1 = "I/O Element Address: 0x301, Frame: 1, Row: 1"
limitedAccessPort-Extended.1 = false(2)
limitedAccessPort-ElementName.1 = "I/O Element Address: 0x301"
limitedAccessPort-Caption.1 = "I/O Element Address: 0x301, Frame: 1, Row: 1"
limitedAccessPort-Description.1 = "I/O Element Address: 0x301, Frame: 1, Row: 1"
limitedAccessPort-Realizes-StorageLocationIndex.1 = 5
```

For detailed descriptions of these fields, see “Using SNMP MIBs to Monitor the Library” on page 298.

Related reference

“Using SNMP MIBs to Monitor the Library” on page 298

This section describes how to use a Simple Management Network Protocol (SNMP) monitoring station and Management Information Bases (MIBs) to check drive status, give information about the last SNMP trap and about cartridges, and identify supported MIBs and supported SNMP messages. The data gathered from this process originates from the 3584 Tape Library and is displayed on the SNMP monitoring station.

Determining the Status of Storage Slots

To determine how many storage slots are occupied in the 3584 Tape Library, use one of the following methods.

Using the Web to Determine the Status of Storage Slots

To use the Tape Library Specialist web interface to determine the status of storage slots in the 3584 Tape Library, perform the following steps:

1. Type the Ethernet IP address on the URL line of the browser and press Enter. The Welcome Page displays.
2. Select **Manage Library** —> **Frames**. The Physical Library Summary page displays with information for the library.
3. To view individual frame information, select a specific frame by clicking the appropriate frame picture or by selecting the frame from the list.

Using the Operator Panel to Determine the Status of Storage Slots

To use the operator panel to determine the status of storage slots in the 3584 Tape Library, perform the following steps:

1. From the library’s Activity touchscreen, press **MENU** —> **Library Status** —> **Storage Slot Status** —> **ENTER**. The Storage Slot Status screen displays.

Storage Slot Status		Panel 0008	
Library Totals	LTO	3592	
Cartridges			
Data:	234	195	
Cleaning:	15	10	
Empty Slots:	375	360	
Total Capacity:	624	565	
Frame 1 Totals			
Cartridges			
Data:	121	0	
Cleaning:	8	0	
Empty Slots:	216	0	
Total Capacity:	345	0	
[BACK] [UP] [DOWN] [DETAIL]			

For both the library and the frame that you specify, the screen lists the quantity of data cartridges and cleaning cartridges, as well as the quantity of empty slots. (If the library contains only one frame, the Frame Totals are redundant and are not displayed.) To specify the number of a frame, press UP or DOWN to increment or decrement the value. To determine which slots are occupied, press DETAIL. The Storage Slot Detail screen displays.

Storage Slot Detail		Panel 0010	
Key: F=Frame, C=Column, R=Row			
Media Type: LTO			
[F01,C01,R02]	VOL012L3		
[F01,C01,R03]	VOL013L1		
[F01,C01,R04]	VOL014L1		
[F01,C01,R05]	CLN101L1		
[F01,C01,R06]	VOL015L1		
[F01,C01,R07]	VOL016L1		
[F01,C01,R08]	VOL017L1		
[F01,C01,R09]	VOL018L2		
[F01,C01,R10]	VOL019L3		
[F01,C01,R11]	VOL020L1		
[BACK] [UP] [DOWN]			

For libraries that use both LTO and 3592 media, the Storage Slot Detail screen shows the type of media used in each frame. The screen lists the location of occupied storage slots in the library as **[Fxx,Cyy,Rzz]** (where **F** equals frame and **xx** equals its number, **C** equals column and **yy** equals its number, and **R** equals row and **zz** equals its number). In addition, the screen identifies the cartridge that occupies the slot by its volume serial (VOLSER) number. To view additional slots, press DOWN; to return to slots that you have viewed, press UP.

2. Press BACK until you return to the Activity screen.

Using SNMP to Determine the Status of Storage Slots

You can use your management agent for the Simple Network Management Protocol (SNMP) to request data about the storageMediaLocationGroup. This is an object ID (category) that gives you a list of all storage slots, drives, and I/O stations and their contents. For information about how to request the data, see the documentation for your SNMP management agent. The following is sample output.

```

storageMediaLocationIndex.263 = 263
storageMediaLocation-Tag.263 = "International Business Machines IBM Total Storage
UltraScalable Tape Library 1340010 Storage Slot located at Frame: 2, Col: 1, Row: 5"
storageMediaLocation-LocationType.263 = slot(2)
storageMediaLocation-LocationCoordinates.263 = "Storage Slot located at
Frame: 2, Col: 1, Row: 5"
storageMediaLocation-MediaTypesSupported.263 = tape(2)
storageMediaLocation-MediaCapacity.273 = 1
storageMediaLocation-Association-ChangerDeviceIndex.263 = 1
physicalMediaEntry.physicalMediaPresent.263 = true(1)
physicalMediaEntry.physicalMedia-Removable.263 = true(1)
physicalMediaEntry.physicalMedia-Replaceable.263 = true(1)
physicalMediaEntry.physicalMedia-HotSwappable.263 = true(1)
physicalMediaEntry.physicalMedia-Capacity.263 = Hex: 00 00 00 45 D9 64 B8 00
physicalMediaEntry.physicalMedia-MediaType.263 = tape(2)
physicalMediaEntry.physicalMedia-MediaDescription.263 = "IBM TotalStorage Enterprise
Tape Cartridge - Data"
physicalMediaEntry.physicalMedia-CleanerMedia.263 = false(2)
physicalMediaEntry.physicalMedia-DualSided.263 = false(2)
physicalMediaEntry.physicalMedia-PhysicalLabel.263 = "J1M174JA"
physicalMediaEntry.physicalMedia-Tag.263 = "J1M174JA"

```

For detailed descriptions of these fields, see “Using SNMP MIBs to Monitor the Library” on page 298.

Related reference

“Using SNMP MIBs to Monitor the Library” on page 298

This section describes how to use a Simple Management Network Protocol (SNMP) monitoring station and Management Information Bases (MIBs) to check drive status, give information about the last SNMP trap and about cartridges, and identify supported MIBs and supported SNMP messages. The data gathered from this process originates from the 3584 Tape Library and is displayed on the SNMP monitoring station.

Determining the Location of Cartridges

To determine the location of any tape cartridge in the 3584 Tape Library, use one of the following methods.

Note: You can locate a data cartridge by specifying its volume serial (VOLSER) number in the Tape Library Specialist web interface. This function is not available, however, from the library’s operator panel.

Using the Web to Determine the Location of Cartridges

To use the Tape Library Specialist web interface to determine the location of cartridges in the 3584 Tape Library, perform the following steps:

1. Type the Ethernet IP address on the URL line of the browser and press Enter. The Welcome Page displays.
2. Select **Cartridges** —> **Data Cartridges** or **Cartridges** —> **Cleaning Cartridges** or **Cartridges** —> **I/O Station** .

Each screen displays a common format, title, and similar display options. For the Data Cartridges screen, you can make selections to view cartridges by library, frame, or logical library. You can also view the cartridge initially sorted by volume serial (VOLSER) number, physical location, or SCSI element address. You can locate a data cartridge by specifying its entire or partial VOLSER. This functionality also exists on the I/O Station page, but not on the Cleaning Cartridge page. On all three pages, you can re-sort the displayed list by VOLSER, physical location, or SCSI element address.

Using the Operator Panel to Determine the Location of Cartridges

To use the operator panel to determine the location of cartridges in the 3584 Tape Library, perform the following steps:

1. From the library's Activity touchscreen, press **MENU** → **Library Status** → **Cartridge Locations** → **ENTER**. For libraries that use both LTO and 3592 media, the Select Media Type screen displays.

```
Select Media Type                Panel 0030

LTO Media Type
3592 Media Type

[BACK] [DOWN] [ENTER]
```

2. Press UP or DOWN to highlight the media type that you want (LTO or 3592), then press ENTER. The Cartridge Locations screen displays.

```
Cartridge Locations              Panel 0009

Key: F=Frame, C=Column, R=Row

Media Type: LTO

VOL001L2 Slot [F01,C03,R01]
VOL002L2 Drive [F02,R03]
VOL003L1 I/O [F01,R03]
VOL004L1 Slot [F01,C03,R01]
VOL005L1 Slot [F01,C03,R02]
VOL006L3 Slot [F01,C03,R03]
VOL007L1 Slot [F01,C03,R04]
VOL008L1 Slot [F01,C03,R05]
VOL009L3 Slot [F01,C03,R06]
VOL010L1 Slot [F01,C03,R07]

[BACK] [ UP ] [DOWN]
```

The screen shows the location of each cartridge in each frame (whether in a storage slot, drive, or I/O station slot). The cartridges are sorted by their volume serial (VOLSER) number and their location is given as **[Fxx,Cyy,Rzz]** or **[Fxx,Rzz]**, (where **F** equals frame and **xx** equals its number, **C** equals column and **yy** equals its number, and **R** equals row and **zz** equals its number). To view additional cartridges, press DOWN; to return to cartridges that you have viewed, press UP.

3. Press BACK until you return to the Activity screen.

Using SNMP to Determine the Location of Cartridges

You can use your management agent for the Simple Network Management Protocol (SNMP) to request data about the storageMediaLocationGroup. This is an object ID (category) that gives you a list of all storage slots, drives, and I/O stations and their contents. For information about how to request the data, see the documentation for your SNMP management agent. The following is sample output.

```

storageMediaLocationIndex.263 = 263
storageMediaLocation-Tag.263 = "International Business Machines IBM Total Storage
UltraScalable Tape Library 1340010 Storage Slot located at Frame: 2, Col: 1, Row: 5"
storageMediaLocation-LocationType.263 = slot(2)
storageMediaLocation-LocationCoordinates.263 = "Storage Slot located at
Frame: 2, Col: 1, Row: 5"
storageMediaLocation-MediaTypesSupported.263 = tape(2)
storageMediaLocation-MediaCapacity.273 = 1
storageMediaLocation-Association-ChangerDeviceIndex.263 = 1
physicalMediaEntry.physicalMediaPresent.263 = true(1)
physicalMediaEntry.physicalMedia-Removable.263 = true(1)
physicalMediaEntry.physicalMedia-Replaceable.263 = true(1)
physicalMediaEntry.physicalMedia-HotSwappable.263 = true(1)
physicalMediaEntry.physicalMedia-Capacity.263 = Hex: 00 00 00 45 D9 64 B8 00
physicalMediaEntry.physicalMedia-MediaType.263 = tape(2)
physicalMediaEntry.physicalMedia-MediaDescription.263 = "IBM TotalStorage Enterprise
Tape Cartridge - Data"
physicalMediaEntry.physicalMedia-CleanerMedia.263 = false(2)
physicalMediaEntry.physicalMedia-DualSided.263 = false(2)
physicalMediaEntry.physicalMedia-PhysicalLabel.263 = "J1M174JA"
physicalMediaEntry.physicalMedia-Tag.263 = "J1M174JA"

```

For detailed descriptions of these fields, see “Using SNMP MIBs to Monitor the Library” on page 298.

Related reference

“Using SNMP MIBs to Monitor the Library” on page 298

This section describes how to use a Simple Management Network Protocol (SNMP) monitoring station and Management Information Bases (MIBs) to check drive status, give information about the last SNMP trap and about cartridges, and identify supported MIBs and supported SNMP messages. The data gathered from this process originates from the 3584 Tape Library and is displayed on the SNMP monitoring station.

Viewing the Drive Emulation Mode of 3592 Tape Drives

This section introduces two ways to view the current drive emulation mode of one or more TS1120 Tape Drives in the 3584 Tape Library.

To view the emulation mode of TS1120 Tape Drives, use one of the following methods:

Using the Web to View the Drive Emulation Mode of 3592 Tape Drives

This section describes how to view the current drive emulation modes of the 3592 Tape Drives in the 3584 Tape Library.

To view the emulation mode of a 3592 Tape Drive, perform the following steps:

1. Type the Ethernet IP address on the URL line of the browser and press Enter. The Welcome Page displays.
2. Select **Drives** —> **Drive Summary**. The Drives screen displays. The Drive Emulation Mode column lists the current emulation mode for each drive. Values are J1A (for the 3592 J1A) or E05 (for the TS1120 Tape Drive).

Using the Operator Panel to View the Drive Emulation Mode of 3592 Tape Drives

To use the operator panel to view the drive emulation mode of one or more TS1120 Tape Drives in the 3584 Tape Library, perform the following steps:

1. From the library's Activity touchscreen, press **MENU** → **Advanced Settings** → **Drive Emulation** → **ENTER**. The Drive Emulation screen displays.

```
Drive Emulation                               Panel 0040
  
Display Emulation Settings
Set Drive Emulation
  
[BACK] [ UP ] [DOWN] [ENTER]
```

2. Press **UP** or **DOWN** to highlight **Display Emulation Settings**, then press **ENTER**. The Display Drive Emulation screen shows the physical location of each type of 3592 Tape Drive and gives its current mode of drive emulation. The physical locations are listed as **[Fxx,Rzz]** (where **F** equals a frame and **xx** equals its number, and where **R** equals a row and **zz** equals its number). The drive emulation for a 3592 J1A is represented as **3592J1A** and the drive emulation for a TS1120 Tape Drive is represented as **3592E05**. Other possible values are **Not Supported** (the drive may require a firmware update) or **CommFail**. If **CommFail** displays, the drive's RS-422 connection to the library is not functioning, the drive firmware image may be corrupted, or the drive may be defective. Unplug and replug the RS-422 cable or cycle power to the drive. If **CommFail** continues to display, contact your IBM Service Representative.

```
Display Drive Emulation                       Panel 0041
  
Key: F=Frame, R=Row
  
[F01,R04] 3592E05
[F01,R05] 3592E05
[F01,R06] 3592J1A
[F02,R01] 3592J1A
[F02,R03] Not Supported
[F02,R04] 3592J1A
[F02,R05] CommFail
  
[BACK] [ UP ] [DOWN]
```

3. Press **BACK** until you return to the Activity screen.

Related concepts

“Updating Drive Firmware” on page 198

This section introduces ways to update firmware for tape drives in the 3584 Tape Library.

Changing the Drive Emulation Mode of 3592 Tape Drives

This section introduces two ways to configure the 3584 Tape Library so that one or more of its TS1120 Tape Drives can emulate a 3592 J1A.

If your library includes 3592 J1A Tape Drives and you want to add a TS1120 Tape Drive but not change your software, you can change the drive emulation mode so that the TS1120 Tape Drive behaves like the 3592 J1A. To change the emulation mode, use one of the following methods:

Using the Web to Change the Drive Emulation Mode of 3592 Tape Drives

This section describes how to configure the 3584 Tape Library so that a TS1120 Tape Drive that is installed in the library can emulate a 3592 J1A.

If your library includes 3592 J1A Tape Drives and you want to add a TS1120 Tape Drive but not change your software, you can change the drive emulation mode so that the TS1120 Tape Drive behaves like the 3592 J1A. To change the emulation mode, perform the following steps:

1. Type the Ethernet IP address on the URL line of the browser and press Enter. The Welcome Page displays.
2. Select **Drives** → **Drive Summary**. The Drives screen displays. The Drive Emulation Mode column lists the current emulation mode for each drive. Values are 3592-J1A (for the 3592 J1A) or 3592-E05 (for the TS1120 Tape Drive).
3. Select the check boxes of the drives whose emulation you want to change.
4. From the Select Action drop-down box, select Change Emulation Mode and select Go. The Change Emulation Mode pop-up window displays.
5. From the drop-down box next to New Emulation Mode, select the type of emulation that you want. Choices are 3592J1A (for the 3592 J1A) or 3592E05 (for the TS1120 Tape Drive).
6. Select Change. A confirmation message displays.

Related concepts

“PAUSE Key” on page 37

Using the Operator Panel to Change the Drive Emulation Mode of 3592 Tape Drives

When you use the operator panel to change the drive emulation of a TS1120 Tape Drive, you can change it for a single drive, for the drives in a logical library, or for all the TS1120 Tape Drives in the 3584 Tape Library.

To use the operator panel to change the drive emulation mode of one or more TS1120 Tape Drives, perform the following steps:

1. From the library’s Activity touchscreen, press **MENU** → **Advanced Settings** → **Drive Emulation** → **ENTER**. The Drive Emulation screen displays.



```
Drive Emulation                               Panel 0040
Display Emulation Settings
Set Drive Emulation
[BACK] [ UP ] [DOWN] [ENTER]
```

2. Press UP or DOWN to highlight Set Drive Emulation, then press ENTER. The Set Drive Emulation screen displays. You can specify to change drive emulation for a single TS1120 Tape Drive, a TS1120 Tape Drive drive in a logical library, or for all the TS1120 Tape Drives.

Set Drive Emulation Panel 0042

Set By Drive
Set by Logical Library
Set All Drives

[BACK] [UP] [DOWN] [ENTER]

- To specify a drive emulation mode for a single TS1120 Tape Drive, highlight **Set by Drive** and press ENTER. The Select Drive screen shows the physical location and media type of only the TS1120 Tape Drives. The physical locations are listed as **[Fxx,Rzz]** (where **F** equals a frame and **xx** equals its number, and where **R** equals a row and **zz** equals its number). The media identifier is represented as J2). Press UP or DOWN to highlight the drive to which you want to apply emulation and press ENTER.

Select Drive Panel 0043

Key: F=Frame, R=Row

[F01,R04] J2
[F01,R05] J2
[F01,R06] J2
[F02,R01] J2
[F02,R03] J2
[F02,R04] J2
[F02,R05] J2

[BACK] [UP] [DOWN] [ENTER]

- To specify a drive emulation mode for the TS1120 Tape Drives in a logical library, highlight **Set by Logical Library** and press ENTER. The Select Logical Library screen displays a logical library that contains TS1120 Tape Drives. Press UP or DOWN to view another logical library that contains TS1120 Tape Drives. Continue this process to view all logical libraries that contain TS1120 Tape Drives. When you identify a logical library to which you want to apply emulation for all drives, press ENTER.

Select Logical Library Panel 0025

Log lib 3 Media Type: 3592

[BACK] [UP] [DOWN] [ENTER]

- To specify a drive emulation mode for TS1120 Tape Drives in the 3584 Tape Library, highlight **Set All Drives** and press ENTER.
3. The Select Emulation Mode screen displays with the two choices of emulation. The emulation mode for a 3592 J1A Tape Drive is represented as 3592J1A; the emulation mode for a TS1120 Tape Drive is represented as 3592E05. Press UP or DOWN to highlight the emulation mode that you want and press ENTER. The message **Completed setting drive emulation mode** displays.

Select Emulation Mode Panel 0044

3592J1A
3592E05

[BACK] [UP] [DOWN] [ENTER]

4. Press BACK until you return to the Activity screen.

Performing an Inventory of the Library

This section introduces two ways to conduct an inventory of the 3584 Tape Library.

To perform an inventory of the entire 3584 Tape Library, use one of the following methods.

Using the Web to Perform an Inventory of the Library

To use the Tape Library Specialist web interface to conduct an inventory of the 3584 Tape Library, perform the following steps:

1. Type the Ethernet IP address on the URL line of the browser and press Enter. The Welcome Page displays.
2. Select **Library** → **Frames**. The Physical Library Summary screen displays with options for performing an inventory on a single frame or on all frames. You can also select a hyperlinks to view more detailed information about the following:
 - Total I/O slots
 - Total data cartridges
 - Total cleaning cartridges
 - Total drives
 - Accessors
 - Node cards
3. Select All Frames or a specific frame, then select the Inventory link. The Confirm Inventory Library pop-up window displays, warning you that if you continue with the inventory, all jobs in the work queue may be delayed while the inventory is performed.
4. If you want to continue, select **Start**. The inventory is performed.

Using the Operator Panel to Perform an Inventory of the Library

To use the operator panel to conduct an inventory of the 3584 Tape Library, perform the following steps:

Note: The host application must request the library inventory to be uploaded. The library does not automatically perform this function.

1. From the library's Activity touchscreen, press **MENU** → **Manual Operations** → **Inventory** → **ENTER**. The Inventory menu displays.

Note: If only one frame exists in the library, the menu displays **Inventory Library**; if more than one frame exists in the library, the menu displays **Inventory Library** and **Inventory Frame**.

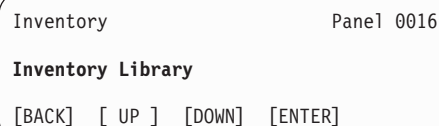

```
Inventory                               Panel 0016
Inventory Library
[BACK] [ UP ] [DOWN] [ENTER]
```

2. If necessary, press UP or DOWN to highlight Inventory Library, then press ENTER. The library displays the warning message **If you continue all jobs in the work queue will be delayed while the inventory is performed. Press ENTER to continue.**

3. Press ENTER. The message **Inventory in Progress** displays, and the inventory of the library begins. When the inventory is finished, **Inventory Complete** displays.
4. Press ENTER to return to the Inventory menu.
5. Press BACK until you return to the Activity screen.

Performing an Inventory of a Frame in the Library

This section introduces two ways to conduct an inventory of a frame in the 3584 Tape Library.

To perform an inventory of a frame in the 3584 Tape Library, use one of the following methods.

Using the Web to Perform an Inventory of a Frame in the Library

To use the Tape Library Specialist web interface to conduct an inventory of a frame in the 3584 Tape Library, perform the following steps:

1. Type the Ethernet IP address on the URL line of the browser and press Enter. The Welcome Page displays.
2. Select **Library** → **Frames**. The Physical Library Summary screen displays with options for performing an inventory on a single frame or on all frames.
3. Select the frame that you want to inventory, then select the Inventory link.

Using the Operator Panel to Perform an Inventory of a Frame in the Library

To use the operator panel to conduct an inventory of a frame in the 3584 Tape Library, perform the following steps:

1. From the library's Activity touchscreen, press **MENU** → **Manual Operations** → **Inventory** → **ENTER**. The Inventory menu displays.

Note: If only one frame exists in the library, the menu displays **Inventory Library**; if more than one frame exists in the library, the menu displays **Inventory Library** and **Inventory Frame**.

Inventory Panel 0016

Inventory Library

Inventory Frame

[BACK] [UP] [ENTER]

2. Press UP or DOWN to highlight **Inventory Frame**, then press ENTER. The library displays the warning message **If you continue all jobs in the work queue will be delayed while the library inventory is performed. Press ENTER to continue.**
3. Press ENTER. The Select Frame screen displays.

Select Frame Panel 0007

Select a frame:

Frame Number **2**
Media Type: 3592

[BACK] [UP] [DOWN] [ENTER]

4. Specify the number of the frame that you want by pressing UP or DOWN to increment or decrement the value. For libraries that use both LTO and 3592 media, the Select Frame screen shows the type of media used in the frame that you selected.
5. When the desired frame number displays, press ENTER. The message **Inventory in Progress** displays, and the inventory of the frame begins. When the inventory is finished, **Inventory Complete** displays.
6. Press ENTER to return to the Inventory menu.
7. Press BACK until you return to the Activity screen.

Moving a Cartridge

This section introduces two ways to move a cartridge in the 3584 Tape Library.

At times, you may want to tell the library to move a specific tape cartridge. For example, if a single host controls the library and the host fails during an operation, you can use menus on the web or operator panel to move cartridges and continue the operation.

To move a specific cartridge in the 3584 Tape Library, use one of the following methods.

Using the Web to Move a Cartridge

To use the Tape Library Specialist web interface to move a cartridge in the 3584 Tape Library, perform the following steps:

1. Type the Ethernet IP address on the URL line of the browser and press Enter. The Welcome Page displays.
2. Select **Cartridges** → **Data Cartridges**. The Data Cartridges screen displays.
3. Select a Frame (or all frames) or Logical Library (or all libraries), then select Search. A list of cartridges based on the selection criteria you entered is displayed.
4. Select a cartridge, then from the Select Action drop-down list, select Move, then select Go. The library displays the Select Move Method pop-up window.
5. Select a move method, then select Next. A warning displays while the cartridge is being moved. When the move is completed, a message displays that the cartridge has been moved. Close the window.

Using the Operator Panel to Move a Cartridge

When you use the operator panel to move a cartridge in the 3584 Tape Library, you can identify that cartridge by its volume serial (VOLSER) number, its SCSI element address, or its frame, column, or row location.

To use the operator panel on the 3584 Tape Library to move a cartridge, perform the following steps:

Note: The operator panel does not allow you to move incompatible media to a storage slot or drive. For example, if you select an Ultrium 3 cartridge, the operator panel does not display Ultrium 1 and Ultrium 2 drives as valid destinations.

1. Vary the library offline at the host.
2. From the library's Activity touchscreen, press **MENU** → **Manual Operations** → **Move Cartridge** → **ENTER**. The Select Source screen displays. You can specify which cartridge to move by its VOLSER, SCSI element address, or frame, column, and row location. Choices are available for LTO Ultrium cartridges and 3592 cartridges.

```
Select Source                Panel 0020
By VOLSER
By SCSI Element Address
By Location (F,C,R)

Key: F=Frame, C=Column, R=Row

[BACK] [ UP ] [DOWN] [ENTER]
```

- To specify the cartridge (in this example, an LTO cartridge) to be moved by its VOLSER, highlight **By VOLSER** and press ENTER. The Select Source Volume screen displays with one of the following:
 - A list of ten or fewer LTO cartridges in the library, identified by their VOLSERs and their physical locations.
 - If the library contains more than ten LTO cartridges, a range of cartridges identified by their VOLSERs and their physical locations.

Cartridge locations are listed as **[Fxx,Cyy,Rzz]** or **[Fxx,Rzz]**, (where **F** equals frame and **xx** equals its number, **C**, equals column and **yy** equals its number, and **R** equals row and **zz** equals its number). Perform one of the following:

- Press UP or DOWN to select the VOLSER of the cartridge that you want, then press ENTER.
- Press UP or DOWN to select the range of VOLSERs that contains the cartridge that you want, then press ENTER (if your library contains a large quantity of cartridges, you may have to repeat this step until you locate the range that contains the cartridge that you want). Press UP or DOWN to select the VOLSER of the cartridge that you want and press ENTER.

```

Select Source Volume          Panel 0022

Key: F=Frame, C=Column, R=Row
    L=LTO Ultrium

Media Type: LTO

VOL011L2  Slot  [F01,C03,R01]
VOL012L2  Drive [F02,R03] L2
VOL013L1  I/O   [F01,R03]
VOL014L1  Slot  [F01,C03,R01]
VOL015L1  Slot  [F01,C03,R02]
VOL016L3  Slot  [F01,C03,R03]
VOL017L1  Slot  [F01,C03,R04]
VOL018L1  Slot  [F01,C03,R05]
VOL019L3  Slot  [F01,C03,R06]
VOL020L1  Slot  [F01,C03,R07]

[BACK] [ UP ] [DOWN] [ENTER]

```

- To specify the cartridge (in this example, an LTO cartridge) to be moved by a specific SCSI element address, highlight **By SCSI Element Address** and press ENTER. The Select Source Element screen displays with one of the following:
 - A list of LTO cartridges in the library, identified by their SCSI element addresses (in both decimal and hexadecimal format) and their VOLSERS.
 - A range of LTO cartridges in the library, identified by their SCSI element addresses (in both decimal and hexadecimal format).

Note: In the following procedures, note that different logical libraries can contain the same element addresses. Because of this, when the Advanced Library Management System (ALMS) is enabled, you must first select which logical library that you want before selecting an element address.

Perform one of the following:

- Press UP or DOWN to select the SCSI element address of the cartridge that you want, then press ENTER.
- Press UP or DOWN to select the range of SCSI element addresses that contains the cartridge that you want, then press ENTER (if your library contains a large quantity of cartridges, you may have to repeat this step until you locate the range that contains the cartridge that you want). Press UP or DOWN to select the SCSI element address of the cartridge that you want and press ENTER.

```

Select Source Element          Panel 0023

Media Type: LTO

1025  401h  VOL011L1
1026  402h  VOL012L3
1027  403h  VOL013L1
1028  404h  VOL014L1
1029  405h  CLNI01L1
1030  406h  VOL015L1
1031  407h  VOL016L1
1032  408h  VOL017L1
1033  409h  VOL018L2
1034  40Ah  VOL019L3

[BACK] [ UP ] [DOWN] [ENTER]

```

- To specify the cartridge (in this example, an LTO cartridge) to be moved by a specific frame, column, or row location, highlight **By Location (F,C,R)** and press ENTER. The Select Source Location screen displays with one of the following:
 - A list of LTO cartridges in the library, identified by their physical frame, column, or row location and their VOLSERS.
 - A range of LTO cartridges in the library, identified by their physical frame, column, or row locations.

The locations are listed as **[Fxx,Cyy,Rzz]** or **[Fxx,Rzz]**, (where **F** equals frame and **xx** equals its number, **C** equals column and **yy** equals its number, and **R** equals row and **zz** equals its number). Perform one of the following:

- Press UP or DOWN to select the physical frame, column, or row location of the cartridge that you want, then press ENTER.
- Press UP or DOWN to select the range of physical frame, column, or row locations that contains the cartridge that you want, then press ENTER (if your library contains a large quantity of cartridges, you may need to repeat this step until you locate the range that contains the cartridge that you want). Press UP or DOWN to select the physical frame, column, or row location of the cartridge that you want and press ENTER.

```

Select Source Location          Panel 0024

Key: F=Frame, C=Column, R=Row

Media Type: LTO

Drive [F02,R12] L1 VOL003L1
I/O   [F01,R01]   VOL004L1
Slot  [F01,C01,R01] VOL005L1
Slot [F01,C01,R02] VOL006L3
Slot  [F01,C02,R01] VOL007L1
Slot  [F02,C01,R02] CLNI01L1
Slot  [F02,C01,R03] CLNI02L1
Slot  [F02,C01,R04] VOL008L1

[BACK] [ UP ] [DOWN] [ENTER]

```

The library locates the cartridge to be moved and performs one of the following:

- If the cartridge is already assigned to a logical library, the library displays the Select Destination screen.

```

Select Destination          Panel 0021

First Empty Storage Slot
By SCSI Element Address
By Location (F,C,R)
To Home Slot

Key: [F=Frame, C=Column, R=Row]

[BACK]          [DOWN] [ENTER]

```

- If the cartridge is not assigned to a logical library, the Select Logical Library screen displays. You must specify the number of the logical library into which you want to move the cartridge by pressing UP or DOWN to increment or decrement the value. When the desired number displays, press ENTER. The library displays the Select Destination screen.

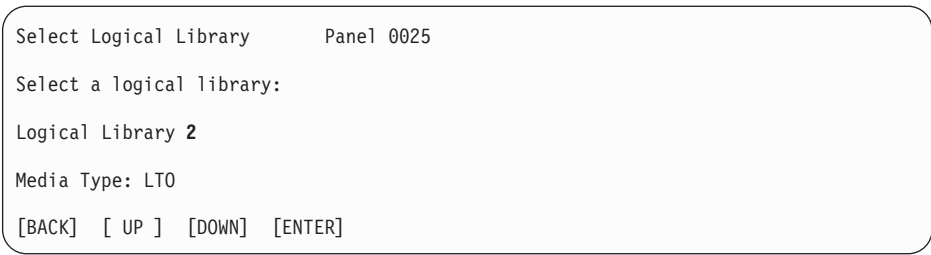

3. In the Select Destination screen, you can specify that the library move the cartridge into the first empty storage slot, a slot with a specific SCSI element address, a slot with a specific frame, column, and row location, or to the home slot (a specific drive).

- To move the cartridge to the first available empty slot, press UP or DOWN to highlight **First Empty Storage Slot** and press ENTER.

Note: If the cartridge was previously loaded in a specific logical library, the move operation is restricted to that logical library.

- To move the cartridge to a location with a specific SCSI element address, press UP or DOWN to highlight **By SCSI Element Address** and press ENTER. The Select Destination Element screen displays with one of the following:
 - A list of the library’s SCSI element addresses for drives, I/O station slots, and storage slots that have been configured and are empty. The SCSI element addresses display in both decimal and hexadecimal format. The screen also lists the physical locations of these SCSI element addresses.
 - A range of the library’s SCSI element addresses for drives, I/O station slots, and storage slots that have been configured and are empty. The SCSI element addresses display in decimal and hexadecimal format.

The physical locations are listed as **[Fxx, Cyy, Rzz]** or **[Fxx, Rzz]**, (where **F** equals frame and **xx** equals its number, **C** equals column and **yy** equals its number, and **R** equals row and **zz** equals its number).

The screen gives the generation of the drive as **Lx**, where **x** equals 1 (the LTO Ultrium 1 drive), 2 (the LTO Ultrium 2 drive), 3 (the LTO Ultrium 3 drive), or 4 (the LTO Ultrium 4 drive).

Perform one of the following:

- Press UP or DOWN to select the SCSI element address of the destination that you want, then press ENTER.
- Press UP or DOWN to select the range of SCSI element addresses that contains the destination that you want, then press ENTER (if your library contains a large quantity of possible destinations, you may need to repeat this step until you locate the range that contains the destination that you want). Press UP or DOWN to select the SCSI element address of the destination that you want and press ENTER.

Note: If ALMS is enabled, the frame, column, and row location is not displayed.

Select Destination Element Panel 0026

Key: [F=Frame, C=Column, R=Row]
L=LTO Ultrium

Media Type: LTO

257	101h	Drive	[F01,R01]	L1
258	102h	Drive	[F01,R02]	L4
769	301h	I/O	[F01,R03]	
1028	404h	Slot	[F01,C01,R04]	
1029	405h	Slot	[F01,C01,R05]	
1030	406h	Slot	[F01,C01,R06]	
1031	407h	Slot	[F01,C01,R07]	
1032	408h	Slot	[F01,C01,R08]	
1033	409h	Slot	[F01,C01,R09]	
1034	40Ah	Slot	[F01,C01,R10]	

[BACK] [UP] [DOWN] [ENTER]

Note: If the cartridge was previously loaded in a specific logical library, the move operation is restricted to that logical library.

- To move the cartridge to a specific frame, column, or row location, press UP or DOWN to highlight **By Location (F,C,R)** and press ENTER. The Select Destination Location screen displays with one of the following:
 - A list of the library's empty storage slots, I/O slots, or drives, identified by their physical frame, column, or row location.
 - A range of the library's empty storage slots, I/O slots, or drives, identified by their physical frame, column, or row location.

The physical locations are listed as **[Fxx,Cyy,Rzz]** or **[Fxx,Rzz]**, (where **F** equals frame and **xx** equals its number, **C** equals column and **yy** equals its number, and **R** equals row and **zz** equals its number). Drives are further identified as **L1** (Ultrium 1), **L2** (Ultrium 2), **L3** (Ultrium 3), or **L4** (Ultrium 4).

Perform one of the following:

- Press UP or DOWN to select the frame, column, and row location of the destination that you want, then press ENTER.
- Press UP or DOWN to select the range of frame, column, and row locations that contains the destination that you want, then press ENTER (if your library contains a large quantity of possible destinations, you may need to repeat this step until you locate the range that contains the destination that you want). Press UP or DOWN to select the frame, column, and row location of the destination that you want and press ENTER.

```

Select Destination Location          Panel 0027

Key: F=Frame, C=Column, R=Row
    L=LTO Ultrium

Media Type: LTO

Drive   [F01,R01]  L1
Drive   [F01,R02]  L2
I/O     [F01,R03]
Slot    [F01,C01,R04]
Slot    [F01,C01,R05]
Slot    [F01,C01,R06]
Slot    [F01,C01,R07]
Slot    [F01,C01,R08]
Slot    [F01,C01,R09]
Slot    [F01,C01,R10]

[BACK] [ UP ] [DOWN] [ENTER]

```

Note: If the cartridge was previously loaded in a specific logical library, the move operation is restricted to that logical library.

- To move the cartridge to the source location that is stored in the element descriptor, press UP or DOWN to highlight **To Home Slot** and press ENTER.

After you press ENTER, the message **Move in Progress** displays and the cartridge accessor moves the cartridge to the home slot. When the move is finished, **Move Complete** displays.

Note: If ALMS is enabled and the cartridge is being moved between cartridge storage slots, it may not physically move. Instead, it may be assigned a new element address.

4. Press ENTER to return to the Manual Operations menu.
5. Press BACK until you return to the Activity screen.

Displaying the Existing Library Configuration

This section introduces two ways to view the existing configuration of the 3584 Tape Library.

To display the current physical and logical configuration of the 3584 Tape Library, use one of the following methods.

Using the Web to Display the Existing Library Configuration

To use the Tape Library Specialist web interface to display the existing configuration of the 3584 Tape Library, perform the following steps:

1. Type the Ethernet IP address on the URL line of the browser and press Enter. The Welcome Page displays.
2. Perform one of the following:
 - Select **Library** —> **Frames** for a physical configuration of the library
 - Select **Library** —> **Logical Libraries** for a logical configuration of the library

Using the Operator Panel to Display the Existing Library Configuration

To use the operator panel to display the existing configuration of the 3584 Tape Library, perform the following steps:

1. From the library's Activity touchscreen, press **MENU** → **Settings** → **Configuration** → **Display Configuration** → **ENTER**. The Physical Configuration screen displays. The screen shows the total quantity of drives, storage slots, and I/O slots in the library's physical configuration. For libraries that use both LTO and 3592 media, the screen provides totals for each media type. The Mode field indicates the menu selection (Configure Library or Advanced Configure) that was used to create the current library configuration.

Note: If the Advanced Library Management System (ALMS) is enabled, the Mode is **ALMS**.

Physical Configuration		Panel 0102
Total Frames:		4
LTO:	1	
3592:	1	
Service Bays:	2	
Total Drives:		7
LTO:	4	
3592:	3	
Total Storage Slots:		280
LTO:	180	
3592:	100	
Total I/O Slots:		26
LTO:	10	
3592:	16	
Configuration Mode: Advanced		
[BACK]	[DETAIL]	[ENTER]

You can view the physical configuration for each frame, or you can view the configuration for each logical library:

- To view the quantity of physical drives, storage slots, and I/O slots in each frame, press **DETAIL**. The Configuration Details screen displays. For libraries that use both LTO and 3592 media, the Media Type field indicates the type of media used in the frame.

Configuration Details		Panel 0104
Frame 1	Media Type: LTO	
Drives:		9
Ultrium-1		3
Ultrium-2		3
Ultrium-3	1	
Ultrium-4	2	
Storage Slots:		280
I/O Slots:		10
*[BACK]	[UP]	[DOWN]

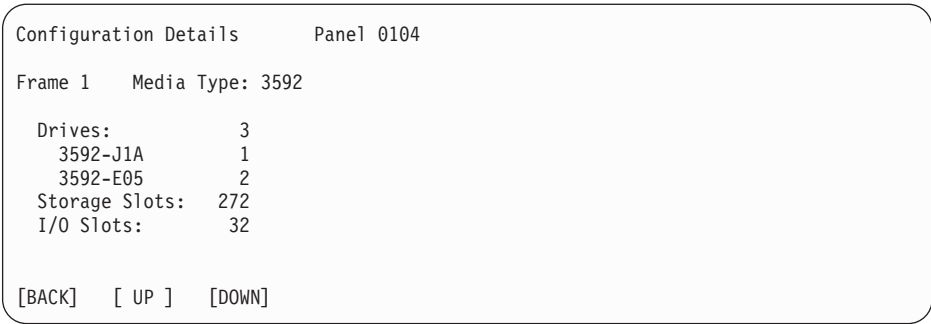

To view the details for additional frames, press UP. The Configuration Details screen displays for the next frame. To return to frames that you have viewed, press DOWN. To return to the Physical Configuration screen, press BACK.

- To view the library's logical configuration, from the Physical Configuration screen press ENTER. The Configuration Summary screen displays. The screen shows the total quantity of storage slots and drives in the logical library configuration. It shows the element address range for the slots and drives, and gives their start and end locations (if the Advanced Library Management System (ALMS) is enabled, the start and end locations do not display). The screen indicates which drives are control paths. It also indicates the quantity of control paths.

Note: If ALMS is enabled, the key, the **Location Start** field, and the **Location End** field do not display.

Note: If ALMS is not enabled, and encryption is enabled, and one or more drives in the displayed frame are not encryption-enabled, the restricted drive count and descriptive text will be displayed.

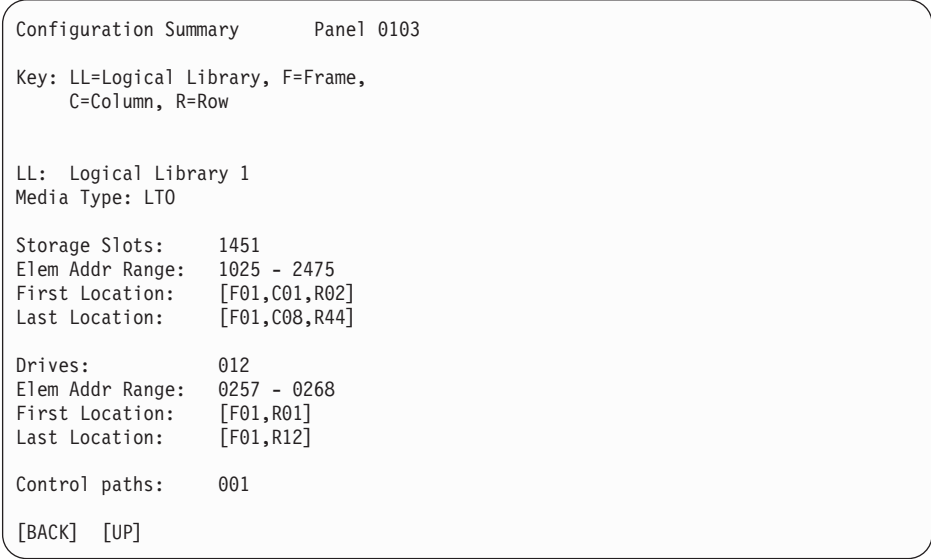

The Element Addr Range field is the range of SCSI element addresses defined for this logical library. To view the summaries for additional logical libraries, press UP. The Configuration Summary screen displays for the next logical library.

```
Configuration Summary      Panel 0103

Key: LL=Logical Library, F=Frame,
     C=Column, R=Row

LL: Logical Library 2
Media Type: 3592

Storage Slots:      0359
Elem Addr Range:   1026 - 1384
First Location:    [F02,C01,R03]
Last Location:     [F02,C10,R36]

Drives:            012
Elem Addr Range:   0305 - 0316
First Location:    [F02,R01]
Last Location:     [F02,R02]

Control paths:     001

[BACK] [DOWN]
```

- To return to summaries that you have viewed, press DOWN.
2. Press BACK until you return to the Activity screen.

Configuring the Library without Partitions

This section introduces two ways to configure the 3584 Tape Library without partitions.

Note: If the Advanced Library Management System (ALMS) is enabled, this function is not valid and is not available.

When you configure the 3584 Tape Library, it performs the following functions:

1. Determines its existing physical configuration by searching for attached physical devices (such as frames, cartridge storage slots, drives, and I/O slots) and displays the physical configuration for your confirmation.
2. Determines its logical configuration by assigning the physical devices to one or more logical libraries:
 - If you configure the library without partitions, it assigns all physical devices to one logical library.
 - If you configure the library with partitions, it divides the physical devices between two or more logical libraries.
3. Automatically assigns default SCSI IDs to new drives, assigns a default control path drive for each logical library, calibrates any new devices, and performs an inventory.

To configure your library without partitions, use one of the following methods.

Related concepts

“Configuring the Library with Partitions” on page 123
This section introduces ways to configure the 3584 Tape Library with partitions.

Using the Web to Configure the Library without Partitions

To use the Tape Library Specialist web interface to configure the 3584 Tape Library without partitions, perform the following steps:

1. Type the Ethernet IP address on the URL line of the browser and press Enter. The Welcome Page displays.
2. Select **Configure Library**. The Configuration Wizard displays.
3. Follow the instructions on the screens until the Select Configuration Method screen displays.
4. Select Automated configuration, then select Finish. The library scans the bar code labels and displays the logical libraries.
5. Follow the instructions on the screens to accept the configuration of the logical library.

Using the Operator Panel to Configure the Library without Partitions

To use the operator panel to configure the 3584 Tape Library without partitions, perform the following steps:

1. Press ENTER to pause the library. The message **PAUSE in Progress** displays. The library parks the cartridge accessor in the base frame and displays the message **The library is now paused. Normal operations will resume in 30 seconds.**
2. Within 30 seconds, unlock and open the front door on any frame. If you do not open the door within 30 seconds, the Activity screen redisplay.
3. On the drive side of the library ensure that there are no logical library bar code labels on any tape drive or on the top of any storage slot column. (To remove logical library bar code labels, see “Attaching and Removing Logical Library Bar Code Labels” on page 127.)
4. Close the front door and from the library’s Activity touchscreen, press **MENU** → **Settings** → **Configuration** → **Configure Library** → **ENTER**. The library reacts with one of the following responses:
 - If you had not previously configured a logical library with the Advanced Configuration Mode option, the library displays the message **If you continue with configuration the library will go offline. Press ENTER to continue.**
 - If you had previously configured a logical library with the Advanced Configuration Mode option, the library displays the message **The configuration was last set with the Advanced Configure Option. If you continue you will lose this information. Press ENTER to continue.** Decide whether you want to lose the Advanced Configure information. If so, press ENTER. The library displays the message **If you continue with configuration the library will go offline. Press ENTER to continue.**
5. Press ENTER. The library displays the message **Ensure that physical configuration changes have been completed before you continue. Press ENTER to continue.** If you want to add or remove drives or frames to your configuration, press BACK until you return to the Activity screen, then contact your IBM Service Representative to add or remove the hardware.
6. Press ENTER. The library displays the message **Searching for installed devices** and may take approximately 2 to 6 minutes to discover the physical configuration, depending on the number of frames. The Physical Configuration screen displays with the library’s existing physical configuration. The screen shows the total quantity of drives, storage slots, and I/O slots in the library’s physical configuration. The Restricted drive count is only displayed if library encryption is enabled and one or more drives are not

encryption capable. For libraries that use both LTO and 3592 media, the screen provides totals for each media type. It also shows what method (mode) was last used to configure the library.

Physical Configuration		Panel 0102
Total Frames:		5
LTO:	2	
3592:	1	
Service Bays:	2	
Total Drives:		34
LTO:	22	
3592:	12	
Restricted:	2*	
Total Storage Slots:		930
LTO:	571	
3592:	359	
Total I/O Slots:		26
LTO:	10	
3592:	16	
* See Detail		
[BACK]	[DETAIL]	[ENTER]

7. Press ENTER. The library displays the message **Do you want to commit the new physical configuration?**
8. Perform one of the following steps:
 - Press YES to accept the new physical configuration and to set up a logical library configuration. The process may take 2 to 4 minutes, depending on the number of frames. The library displays the message **Searching for logical library labels** and then displays the Configuration Summary screen for Logical Library 1 (without partitioning, there is only one logical library). The screen contains the range of SCSI element addresses for the cartridge storage slots and the drives. It also gives the location of the control path (the first drive in each logical library must be a control path).
 - Press NO to reject the new configuration. The library displays the message **The configuration has not been updated.** Press ENTER to return to the Configuration screen.

Note: Your application software may require you to write down the SCSI element addresses of the tape drives that are associated with that application. See Table 13 on page 122 for the range of physical locations of each SCSI element address (referred to as a DTE address).

```

Configuration Summary      Panel 0103

Key: LL=Logical Library, F=Frame,
     C=Column, R=Row

LL: Logical Library 1
Media Type: LTO

Storage Slots:      281
Elem Addr Range:   1025 - 1305
First Location:    [F01,C01,R02]
Last Location:     [F01,C08,R44]

Drives:            6
Elem Addr Range:   257 - 262
First Location:    [F01,R01]
Last Location:     [F01,R06]

Control paths:     2

[BACK]  [UP]  [DOWN]  [ENTER]

```

Table 13. Range of SCSI Data Transfer Element (DTE) addresses for tape drives in frames 1 through 16

Frame	Range of SCSI DTE Addresses for Tape Drives	
	Row 1	Row 12
1	257(X'101')	268(X'10C')
2	269(X'10D')	280(X'118')
3	281(X'119')	292(X'124')
4	293(X'125')	304(X'130')
5	305(X'131')	316(X'13C')
6	317(X'13D')	328(X'148')
7	329(X'149')	340(X'154')
8	341(X'155')	352(X'160')
9	353(X'161')	364(X'16C')
10	365(X'16D')	376(X'178')
11	377(X'179')	388(X'184')
12	389(X'185')	400(X'190')
13	401(X'191')	412(X'19C')
14	413(X'19D')	424(X'1A8')
15	425(X'1A9')	436(X'1B4')
16	437(X'1B5')	448(X'1C0')

Note: Addresses are given in decimal and hexadecimal format.

9. Press ENTER to display the summary for each logical library. If the new logical configuration would move any drives or slots from one logical library to another and if there are cartridges in the library (the library is not empty), the library displays the message **Changes to the logical library configuration may cause some cartridges to become part of a different logical library. Do you want to continue?**
10. Perform one of the following:

- Press YES to accept the new configuration (the library can take several minutes to process). When finished, it displays the message **The Configuration process is complete**.
 - Press NO to reject the new configuration. The library displays the message **The configuration has not been updated**. Press ENTER to return to the Configuration screen.
11. Press BACK until you return to the Activity screen.

Related tasks

“Attaching and Removing Logical Library Bar Code Labels” on page 127

Configuring the Library with Partitions

This section introduces ways to configure the 3584 Tape Library with partitions.

Note: If the Advanced Library Management System (ALMS) is enabled, this function is not valid and is not available.

When you configure the 3584 Tape Library, it performs the following functions:

- Determines its existing physical configuration by searching for attached physical devices (such as frames, cartridge storage slots, drives, and I/O slots) and displays the physical configuration for your confirmation.
- Determines its logical configuration by assigning the physical devices to one or more logical libraries:
 - If you configure the library without partitions, it assigns all physical devices to one logical library.
 - If you configure the library with partitions, it divides the physical devices between two or more logical libraries.
- Automatically assigns default SCSI IDs to new drives, assigns a default control path drive for each logical library, calibrates any new devices, and performs an inventory.

You can partition the 3584 Tape Library into multiple logical libraries by using one of two methods:

- **Configuring the Library by Using Labels** **Note:** This method is no longer supported except by the Request for Price Quotation (RPQ) process. This method requires that you manually label the storage elements (storage slots and drives) that you want in each logical library, then select Configure Library to identify them to the library. If you use this method, you can view the boundaries of your logical library whenever you open the front doors. However, because a logical library bar code label applies to an entire column of storage slots (and not individual slots), this method does not allow you to choose individual slots from that column. To use this method, see “Using Labels to Configure the Library with Partitions” on page 124.
- **Configuring the Library by Using Menus** This method requires that you choose the storage elements that you want by selecting them from the Advanced Configuration menu. If you use this method, it is unnecessary for you to manually label the library elements, and you can choose individual slots from any column. However, you cannot view the boundaries of your logical library whenever you open the front doors. To use this method, see “Using Menus to Configure the Library with Partitions” on page 131.

Related concepts

“Configuring the Library without Partitions” on page 119

This section introduces two ways to configure the 3584 Tape Library without partitions.

Using Labels to Configure the Library with Partitions

This section introduces the process of using labels (rather than menus) to configure the 3584 Tape Library with partitions.

Preparing to Configure the Library with Partitions (by Using Labels)

Note: This method is no longer supported except by the Request for Price Quotation (RPQ) process.

Preparation is necessary when you use labels to configure the 3584 Tape Library with partitions. To prepare for the procedure, perform the following steps:

1. Press ENTER to pause the library. The message **PAUSE in Progress** displays. The library parks the cartridge accessor in the base frame and displays the message **The library is now paused. Normal operations will resume in 30 seconds.**
2. Within 30 seconds, unlock and open the front door on any frame. If you do not open the door within 30 seconds, the Activity screen redisplay.
3. Determine the quantity and location of storage slot columns and tape drives that you want in each logical library (for the quantity of storage slots available in each column, refer to the tables that apply to your frames in Chapter 10, “Locations and Addresses of SCSI Elements,” on page 345).
4. On the drive side of the library, attach a logical library bar code label to each tape drive and storage slot column that you defined in step 3. If you are changing an old partition, remove any labels that defined the old partition. For help, see “Attaching and Removing Logical Library Bar Code Labels” on page 127.

Attention: Ensure that the drives within each logical library are in contiguous locations. If the drives within a logical library span frames, ensure that the logical library label for Drive 12 of Frame n (where n is the number of the frame) matches the logical library label for Drive 1 of Frame n+1.

5. Close all doors of the library.

Related tasks

“Attaching and Removing Logical Library Bar Code Labels” on page 127

Related information

Chapter 10, “Locations and Addresses of SCSI Elements,” on page 345

Choosing the Labeling Method to Configure the Library with Partitions

To configure your 3584 Tape Library with partitions by using logical library bar code labels, use one of the following methods.

Using Labels and the Web to Configure the Library with Partitions:

Note: This method is no longer supported except by the Request for Price Quotation (RPQ) process.

To use labels and the Tape Library Specialist web interface to configure the 3584 Tape Library, perform the following steps:

1. Type the Ethernet IP address on the URL line of the browser and press Enter. The Welcome Page displays.
2. Select **Configure Library**. The Configuration Wizard displays.
3. Follow the instructions on the screens until the Select Configuration Method screen displays.
4. Select Automated configuration, then select Finish. The library scans the bar code labels and displays the logical libraries.
5. Follow the instructions on the screens to accept the configuration of the logical library.

Using Labels and the Operator Panel to Configure the Library with Partitions:

Note: This method is no longer supported except by the Request for Price Quotation (RPQ) process.

To use labels and the operator panel to configure the 3584 Tape Library, perform the following steps:

1. From the library's Activity touchscreen, press **MENU** → **Settings** → **Configuration** → **Configure Library** → **ENTER**. The library displays the message **If you continue with configuration the library will go offline. Press ENTER to continue.**

Note: If you had previously configured a logical library with the Advanced Configuration option, the library displays the message **The current configuration was created by selecting Advanced Configuration. If you continue with Configure Library you will lose all Advanced Configuration information. Press ENTER to continue.**

2. Press **ENTER**. The library displays the message **Ensure that any physical configuration changes have been completed before you continue.** If you want to add or remove drives or frames to your configuration, press **BACK** until you return to the Activity screen, then contact your IBM Service Representative to add or remove the hardware.
3. Press **ENTER**. The library displays the message **Searching for installed devices** and can take approximately 2 minutes to discover the physical configuration. The Physical Configuration screen displays with the library's existing physical configuration. The screen shows the total quantity of drives, storage slots, and I/O slots in the library's physical configuration. The Restricted drive count is only displayed if library encryption is enabled and one or more drives are not encryption capable. For libraries that use both LTO and 3592 media, the screen provides totals for each media type.

```

Physical Configuration          Panel 0102

Total Frames:                  5
  LT0:                         2
  3592:                        1
  Service Bays:                 2

Total Drives:                  34
  LT0:                          22
  3592:                         12
  Restricted:                   2*

Total Storage Slots:          930
  LT0:                          571
  3592:                         359

Total I/O Slots:              26
  LT0:                          10
  3592:                         16

* See Detail

[BACK]                        [DETAIL]  [ENTER]

```

The screen shows the total quantity of drives, storage slots, and I/O slots in the library's physical configuration.

4. Press ENTER. The library displays the message **Do you want to commit the new physical configuration?**
5. Perform one of the following:
 - Press YES to accept the new physical configuration and to set up any logical library configurations. The library displays the message **Searching for logical library labels** as it reads the labels that you previously attached. It then displays the Configuration Summary screen for Logical Library 1. The screen contains the range of SCSI element addresses for the cartridge storage slots and the drives.
 - Press NO to reject the new configuration. The library displays the message **The configuration has not been updated.** Press ENTER to return to the Configuration screen.

Note: Your application software may require you to write down the SCSI element addresses of the tape drives that are attached to that application. To view a table of the physical locations of each SCSI element address (referred to as a DTE address), see Table 13 on page 122.

Configuration Summary Panel 0103

Key: LL=Logical Library, F=Frame,
C=Column, R=Row

LL: Logical Library 1
Media Type: LTO

Storage Slots: 281
Elem Addr Range: 1025 - 1305
First Location: [F01,C01,R02]
Last Location: [F01,C08,R44]

Drives: 6
Elem Addr Range: 257 - 262
First Location: [F01,R01]
Last Location: [F01,R06]

Control paths: 2

[BACK] [UP] [DOWN] [ENTER]

6. Press ENTER to display the Configuration Summary screen for each logical library. After displaying the Configuration Summary screen of the last logical library, the library displays the message **Do you want to commit the new logical configuration?**

Note: If the new logical library configuration moves drives or slots from one logical library to another and if there are cartridges in the library (the library is not empty), the library displays the message **Changes to the logical library configuration may cause some cartridges to become part of a different logical library. This would make them unavailable to the logical library they are in now. Press ENTER to continue.**

7. Perform one of the following:
 - If you want to accept the new configuration, press YES to continue. The library displays the message **Writing new configuration to drives. This may take up to three minutes.** When finished, it displays the message **The configuration process is complete.**
 - If you do not want to move cartridges or drives to a new logical library, press NO to return to the Configuration screen, and move the labels to the storage slots and drives that you want. The library displays the message **The configuration has not been updated.** Press ENTER to return to the Configuration screen.
8. Press BACK until you return to the Activity screen.

Related tasks

“Using the Operator Panel to Configure the Library without Partitions” on page 120

Attaching and Removing Logical Library Bar Code Labels

Note: This method is no longer supported except by the Request for Price Quotation (RPQ) process.

Each frame of the 3584 Tape Library comes with the following supplies:

- Logical library labels that support up to 10 logical libraries
- Six holders for logical library labels

A sample label and holder are shown in Figure 30.

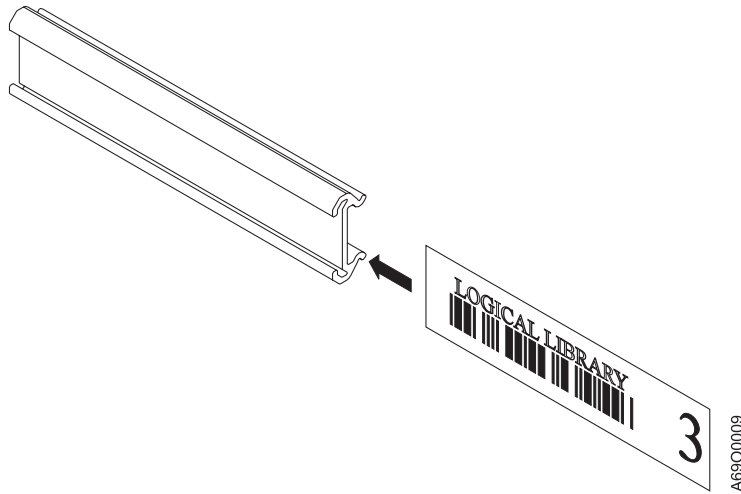

Figure 30. Logical library bar code label and holder

To label the storage slot columns and drives in your logical library, follow the procedures in Table 14.

Table 14. Procedure for attaching and removing logical library bar code labels

Type of Element (see Note)	Procedure for Attaching and Removing Logical Library Bar Code Labels
Storage slot columns	<ol style="list-style-type: none"> 1. Tear a label from its sheet and slide it into a label holder (see Figure 30). 2. On a storage slot column on the drive side of the frame (not on the door), locate the cell top cap (see 1 in Figure 31 on page 129). 3. Slip the top lip of the label holder over the cell top cap, then press the center of the label holder. The holder snaps into place. <p>To remove a label from a storage slot, lift the top lip of the label holder up and away from the cell top cap.</p>
Drive	Tear a label from its sheet and slide it into the bezel of the drive (see 2 in Figure 31 on page 129). To remove the label, simply slide it out of the end of the bezel.
<p>Note: Slide labels in Ultrium drives from right to left; slide labels in 3592 drives from left to right.</p>	

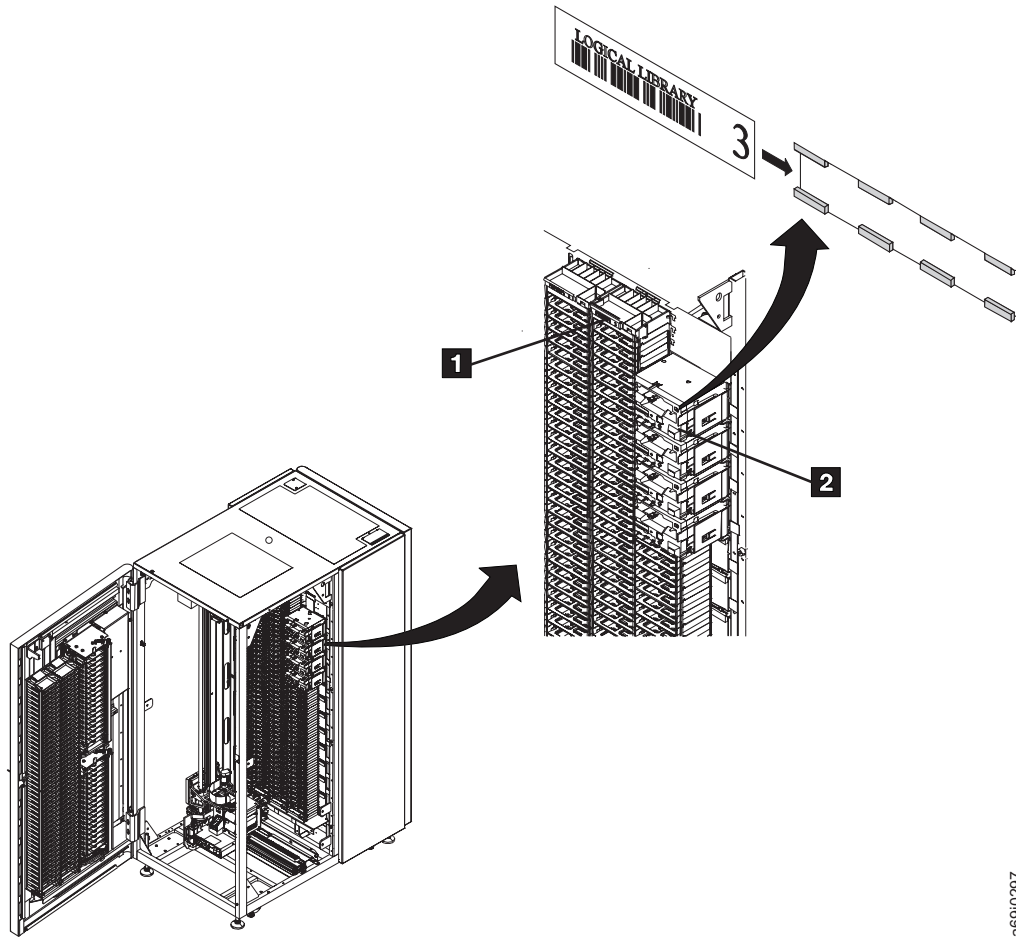

Figure 31. Attaching logical library bar code labels. Place the labels at the top of storage slot columns or drives. Slide labels in L32, D32, L52, and D52 frames from right to left. Slide labels in Model L22 and D22 frames from left to right.

Guidelines for Applying Logical Library Bar Code Labels:

Note: This method is no longer supported except by the Request for Price Quotation (RPQ) process.

Within the 3584 Tape Library, to indicate the boundaries of your logical library with labels refer to Figure 32 on page 131 and use the following guidelines:

- If you mix drive types:
 - Ensure that your software application supports the intermixing of Ultrium 1, Ultrium 2, Ultrium 3, and Ultrium 4 Tape Drives and media in the same logical library. If it does not, configure the drives into separate logical libraries (which can still be within the same frame).
 - Configure LTO and 3592 elements (drives and storage slots) into separate logical libraries.
- Regardless of whether you use mixed drive types, number your logical library labels sequentially and from left to right, beginning with Logical Library 1. Non-sequential labels are ignored for adjacent components. For example, if you label three adjacent columns as Logical Library 1, 4, and 5, all three columns will be in Logical Library 1.
- If you are transitioning from a 3592 frame number **N** to an LTO frame number **N+1**, you must assign the first storage slot and tape drive in the LTO frame to logical library number **L+1** (where **L** is the last logical library number in the 3592

frame). Likewise, when transitioning from an LTO frame number **N** to a 3592 frame number **N+1**, you must assign the first storage slot and tape drive in the 3592 frame to logical library number **L+1** (where **L** is the last logical library number in the LTO frame).

- If you require more than 10 logical libraries, you cannot use labels to partition. Instead, go to the sections about using menus and the web or using menus and the operator panel to configure the library with partitions.
- Label only drive-side (odd-numbered) columns from left to right, beginning with Frame 1, Column 1. Label drives from top to bottom first, and then from left to right, beginning with Frame 1, Row 1.
- Designate the boundaries of your logical libraries. The 3584 Tape Library does not allow non-contiguous labels of the same logical library number. For example, if columns are labeled 1, 2, and 1, the third column will be considered part of Logical Library 2.
- All door-side (even-numbered) columns are not labeled for logical libraries. Instead, each is implicitly assigned to the same logical library as the drive-side (odd-numbered) column that it faces. For example, Column 6 is assigned to the same logical library as Column 5.
- If you use mixed drive types, ensure that the bar code labels for your logical libraries are placed correctly. A mislabeled logical library is assigned to the most recent valid logical library number (including an implicit number forced by a frame type transition). For example, if you label the boundaries of LTO/3592/3592/LTO as 1/1/2/1, the boundaries will be assigned to logical libraries 1/2/2/3, respectively (and the logical configuration process will fail if any of the three resulting logical libraries does not include at least one slot and one drive).

Figure 32 on page 131 shows examples of logical libraries that are properly labeled.

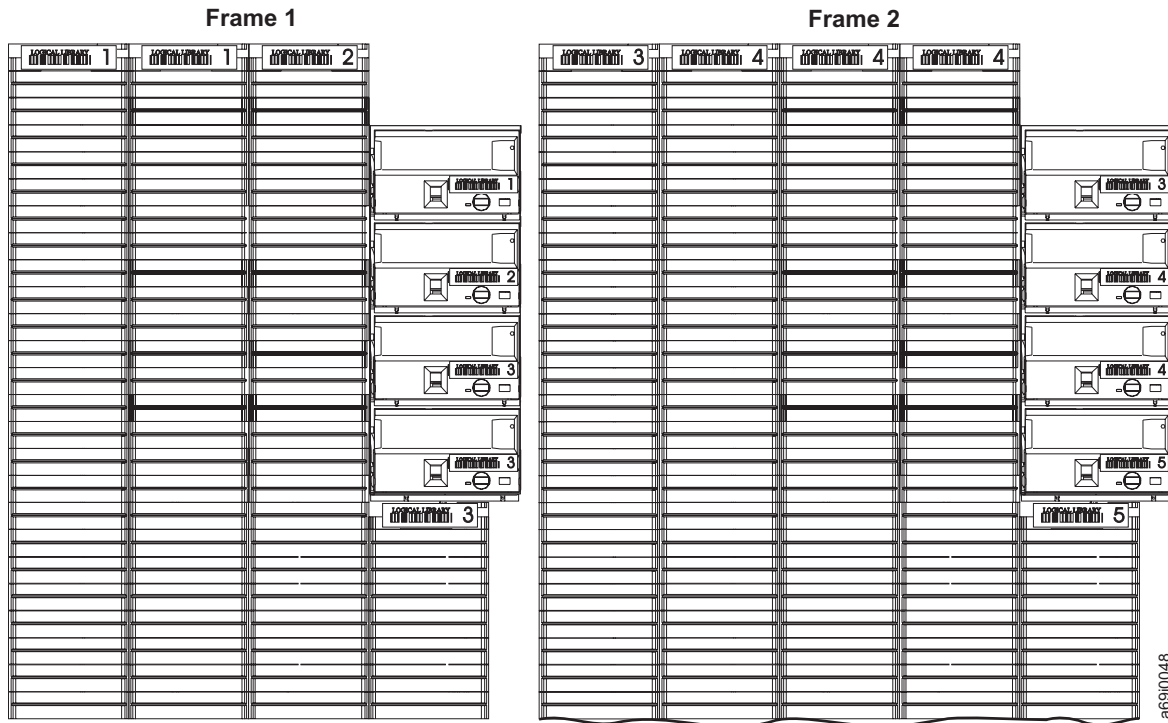

Figure 32. Indicating the boundaries of logical libraries

Related tasks

“Using Menus on the Web to Configure the Library with Partitions” on page 132

“Using Menus on the Operator Panel to Configure the Library with Partitions” on page 132

Using Menus to Configure the Library with Partitions

Note: If the Advanced Library Management System (ALMS) is enabled, this function is not valid and is not available.

This section introduces the process of using menus (rather than labels) to configure the 3584 Tape Library with partitions.

Certain guidelines apply when you configure encryption-capable drives in non-ALMS libraries. The following drive configurations are possible:

- **Encryption-capable drive added to a library that contains non-encryption-capable drives:** You can add a drive that is encryption-capable to a library that previously did not have encryption-capable drives, but you cannot enable encryption.
- **Non-encryption-capable drive added to a library that contains encryption-capable drives which are not encryption-enabled:** You can add a non-encryption-enabled drive to a library that is installed with encryption-capable drives which are not set for encryption. The drives that are encryption-capable are restricted from becoming encryption-enabled.
- **Non-encryption-capable drive added to encryption-capable and encryption-enabled physical library:** A drive that is not encryption-capable cannot be added to a library that has encryption-enabled drives and will be

restricted (not available for use). In the event that you create this configuration, the operator panel or Tape Library Specialist web interface displays the number of restricted drives.

Using Menus on the Web to Configure the Library with Partitions

To use menus on the Tape Library Specialist web interface to configure the 3584 Tape Library with partitions, perform the following steps:

1. Type the Ethernet IP address on the URL line of the browser and press Enter. The Welcome Page displays.
2. Select **Configure Library**. The Configuration Wizard displays.
3. Follow the instructions on the screens until the Select Configuration Method screen displays.
4. Select Advanced configuration and follow the instructions on the screens to specify one or more logical libraries and their attached physical devices (such as cartridge storage slots and drives), and to accept the configuration of the logical libraries.

Note: If you have 3592 and LTO media in your physical library, you will have more than one configuration range and more than one selection in the screens that follow (a configuration range includes all available contiguous drives and a single media type). For example, you can first configure a range of LTO elements, then a range of 3592 elements.

Using Menus on the Operator Panel to Configure the Library with Partitions

To use menus on the operator panel to configure the 3584 Tape Library, perform the following steps:

1. Determine the quantity of storage slots and tape drives that you want in each logical library (for the quantity of storage slots available per quantity of installed drives, see Chapter 9, “Frame Capacity,” on page 341).
2. From the library’s Activity touchscreen, press **MENU** → **Settings** → **Configuration** → **Advanced Configure** → **ENTER**. The library displays the message **If you continue with configuration the library will go offline. Press ENTER to continue.**
3. Press **ENTER**. The library displays the message **Ensure that any physical configuration changes have been completed before you continue.** If you want to add or remove drives or frames to your configuration, press **BACK** until you return to the Activity screen, then contact your IBM Service Representative to add or remove the hardware.
4. Press **ENTER**. The library displays the message **Searching for installed devices** and can take approximately 2 to 6 minutes to discover the physical configuration, depending on the number of frames. The Physical Configuration screen displays with the library’s existing physical configuration. The screen shows the total quantity of drives, storage slots, and I/O slots in the library’s physical configuration. The Restricted drive count is only displayed if library encryption is enabled and one or more drives are not encryption capable. For libraries that use both LTO and 3592 media, the screen provides totals for each media type.

```

Physical Configuration          Panel 0102

Total Frames:                  5
    LTO:                       2
    3592:                      1
    Service Bays:              2

Total Drives:                  34
    LTO:                       22
    3592:                      12
    Restricted:                2*

Total Storage Slots:          930
    LTO:                       571
    3592:                      359

Total I/O Slots:              26
    LTO:                       10
    3592:                      16

* See Detail

[BACK]                        [DETAIL]  [ENTER]

```

5. Press ENTER. The library displays the message **Do you want to commit the new physical configuration?**
6. Press YES to accept the new physical configuration and to set up any logical library configurations. The Set Logical Libraries screen displays with the type of media to be used by the logical library. The screen also gives the numbers of the frames that the logical library spans.

Note: This screen does not appear if the Advanced Library Management System (ALMS) is enabled.

```

Set Logical Libraries          Panel 0105

Media Type: LTO
Frame 1 - 1

Logical Libraries:  1

Select 1 - 12

[CANCEL]  [ UP ]  [ENTER]

```

7. Specify the quantity of logical libraries that you want by pressing UP or DOWN to increment or decrement the value (from 1 to whatever quantity of drives is installed in the library). When the desired quantity of libraries displays, press ENTER. The Set Storage Slots screen displays.

Note: This screen does not appear if ALMS is enabled.

```

Set Storage Slots             Panel 0106

Logical Library 1

Number of Storage Slots:  276

Select 1 - 281

[BACK]  [ UP ]  [DOWN]  [ENTER]

```

- Specify the quantity of storage slots that you want in the logical library by pressing UP or DOWN to increment or decrement the value. When the desired quantity of storage slots displays, press ENTER.

Note: If the quantity of storage slots that you specify changes the quantity of slots in an existing logical library and if this change moves the cartridges from one logical library to another, the library displays the message **Cartridges in the following storage slots will now be part of logical library x**, where **x** is the current logical library when the number is greater than previous, and **x** is the next highest logical library when the number is less than previous. The Set Drives screen displays.

Note: This screen does not appear if ALMS is enabled.

```
Set Drives                Panel 0107
Logical Library 1
Number of Drives: 6
Select 1 - 6
[BACK]  [ UP ]  [DOWN]  [ENTER]
```

- Specify the quantity of drives that you want in the logical library by pressing UP or DOWN to increment or decrement the value. When the desired quantity of drives displays, press ENTER. If applicable, the Set Storage Slots screen displays for you to configure the next logical library.
- For each logical library that you specified in step 7 on page 133, repeat step 8 and step 9 to add the storage slots and drives that you want (for the last logical library of each media type (LTO or 3592), the library automatically calculates the remaining storage slots and drives in the library).
- Press ENTER. The Configuration Summary screen displays for Logical Library 1. The screen contains the range of SCSI element addresses for the cartridge storage slots and the drives. It also gives the location of the control path (the first drive in each logical library must be a control path).

Note: Your application software may require you to write down the SCSI element addresses of the tape drives that are attached to that application. To view a table of the physical locations of each SCSI element address (referred to as a DTE address), see Table 13 on page 122.

```
Configuration Summary      Panel 0103

Key: LL=Logical Library, F=Frame,
     C=Column, R=Row

LL: Logical Library 1
Media Type: LTO

Storage Slots:      281
Elem Addr Range:   1025 - 1305
First Location:    [F01,C01,R02]
Last Location:     [F01,C08,R44]

Drives:            6
Elem Addr Range:   257 - 262
First Location:    [F01,R01]
Last Location:     [F01,R06]

Control paths:     2

[BACK]  [UP]  [DOWN]  [ENTER]
```

- 12. Press ENTER again to display the Configuration Summary screen for each logical library. After you display the Configuration Summary screen of the last logical library, press ENTER. The library displays the message **Do you want to commit the new logical configuration?**
- 13. Press YES. The library displays the message **Writing new configuration to drives. This may take up to three minutes.** When finished, it displays the message **The Configuration process is complete.**
- 14. Press ENTER to return to the Configuration screen.
- 15. Press BACK until you return to the Activity screen.

Related tasks

“Using the Operator Panel to Configure the Library without Partitions” on page 120

Related information

Chapter 9, “Frame Capacity,” on page 341
This section introduces the quantity of LTO Ultrium Tape Cartridges and 3592 Tape Cartridges that the 3584 Tape Library supports, depending on whether the Capacity On Demand or Capacity Expansion Features are installed, the upper and lower I/O stations are used, and a specified quantity of drives are installed.

Entering the ALMS License Key

This section describes how to record your license key for the Advanced Library Management System (ALMS), which is an option of the 3584 Tape Library. The key lets you enable and use ALMS.

Note: You can install ALMS in the 3584 Tape Library by using the operator panel, but not by using the Tape Library Specialist web interface. To use ALMS, you must enable it after you enter the license key (for help, see “Enabling or Disabling ALMS” on page 136). The license key is shipped to you when you order the ALMS feature.

To enter the ALMS license key, perform the following steps:

1. From the library's Activity touchscreen, press **MENU** → **Service Library** → **Firmware Update** → **Features** → **ENTER**. The Features screen displays a list of features, including the Advanced Library Management System.

```

Features                Panel 1400

Intermediate Capacity Expansion
Feature Is Not Installed

Full Capacity Expansion
Feature Is Not Installed

Control Path Failover
Feature Is Installed

Advanced Library Management
Feature Is Not Installed

LTO Transparent Encryption
Feature Is Not Installed

Press ENTER to install or
remove the selected Feature.

[BACK] [ UP ] [DOWN] [ENTER]

```

2. For each character of the license key, press UP or DOWN to increment or decrement to the value that you want.
3. Press ENTER. The Features screen redisplay and indicates that the **Advanced Library Management Feature Is Installed**.
4. Press BACK until you return to the Activity screen.

Related tasks

“Enabling or Disabling ALMS”

This section describes how to enable or disable the Advanced Library Management System (ALMS) in the 3584 Tape Library.

Enabling or Disabling ALMS

This section describes how to enable or disable the Advanced Library Management System (ALMS) in the 3584 Tape Library.

Note: You can enable or disable ALMS in the 3584 Tape Library by using the Tape Library Specialist web interface, but not by using the operator panel. To enable or disable ALMS, you must have previously entered the ALMS license key (to perform this procedure, see “Entering the ALMS License Key” on page 135).

When ALMS is enabled, you can:

- Name, add, and remove logical libraries
- Reassign a cartridge to another logical library
- Change the maximum quantity of cartridges that can be assigned to a logical library
- Add, remove, and edit ranges of volume serial (VOLSER) numbers (also known as cartridge assignment policy)
- Assign shared drives, change control path drives, unassign drives, and assign new drives without using manual configuration methods

CAUTION:

When you disable ALMS, the library returns to an unconfigured state and all cartridge and drive assignments are permanently lost. You must manually reconfigure the library.

Attention: If you manually configure the library, your changes may result in the loss of cartridge or logical library assignments, cartridge assignment policies, maximum cartridge assignments, and logical library names.

To enable or disable ALMS, perform the following steps:

1. Type the Ethernet IP address on the URL line of the browser and press Enter. The Welcome Page displays.
2. Select **Library** → **ALMS**. The Advanced Library Management System Mode screen displays.
3. Follow the instructions on the screens to enable or disable ALMS. When ALMS is enabled, the button displays **Disable ALMS**; when ALMS is disabled, the button displays **Enable ALMS**.

Related concepts

“Configuring the Library without Partitions” on page 119

This section introduces two ways to configure the 3584 Tape Library without partitions.

“Configuring the Library with Partitions” on page 123

This section introduces ways to configure the 3584 Tape Library with partitions.

Related tasks

“Entering the ALMS License Key” on page 135

This section describes how to record your license key for the Advanced Library Management System (ALMS), which is an option of the 3584 Tape Library. The key lets you enable and use ALMS.

Enabling or Disabling Virtual I/O Slots

This section describes how to enable virtual I/O slots in the 3584 Tape Library so that the host operates as if it has access to more I/O slots than are actually available. It also describes how to disable virtual I/O slots.

Note: If your library does not have the virtual I/O slot capability and you want to enable it, you must first enter the license key for the Advanced Library Management System (ALMS). After you enter the ALMS license key, you can enable ALMS and the virtual I/O slot feature through the Tape Library Specialist web interface. ALMS must be enabled and the I/O station must be empty before you can enable or disable virtual I/O slots. For information about entering the license key and enabling or disabling ALMS, see “Entering the ALMS License Key” on page 135 and “Enabling or Disabling ALMS” on page 136.

When the Advanced Library Management System (ALMS) is enabled, you can enable virtual I/O slots in the 3584 Tape Library so that the library automatically queues all cartridge moves between the I/O station and the storage slots. This makes adding and removing cartridges easier and faster.

To enable or disable virtual I/O slots, perform the following steps:

1. Type the Ethernet IP address on the URL line of the browser and press Enter. The Welcome Page displays.

2. Select **Library**—> **Virtual IO**. The Virtual IO screen displays a message that indicates whether virtual I/O slots are enabled or disabled.
3. Select Enable Virtual IO or Disable Virtual IO. The screen automatically refreshes to show the changed setting.

Related tasks

“Entering the ALMS License Key” on page 135

This section describes how to record your license key for the Advanced Library Management System (ALMS), which is an option of the 3584 Tape Library. The key lets you enable and use ALMS.

“Enabling or Disabling ALMS” on page 136

This section describes how to enable or disable the Advanced Library Management System (ALMS) in the 3584 Tape Library.

Creating or Removing a Logical Library with ALMS

This section gives the steps for creating or removing a logical library from a 3584 Tape Library that is enabled with the Advanced Library Management System (ALMS).

Note: This function is only valid and available if ALMS is enabled. You can create or remove a logical library from the 3584 Tape Library by using the Tape Library Specialist web interface, but not by using the operator panel. You can remove a logical library only if you reassign all associated cartridges and only if you remove all associated drives, move them to another logical library or change them to unassigned drives. For help in performing these procedures, see “Assigning Cartridges to a Logical Library” on page 88 or “Using the Drive Assignment Web Page” on page 89.

To create or remove a logical library, perform the following steps:

1. Type the Ethernet IP address on the URL line of the browser and press Enter. The Welcome Page displays.
2. Select **Library** —> **Logical Libraries**. The Manage Logical Libraries screen displays.
3. Perform one of the following:
 - To add a logical library, follow the instructions on the screens to enter a logical library name of up to 15 characters (duplicate names are not allowed). Select the media type for the logical library.
 - To remove a logical library, select it. From the drop-down box select Remove, then select Go. The library displays the message **Are you sure you want to remove this logical library?**
4. Select OK. The Success screen displays.
5. Select Close. The Manage Library screen redisplay with the new data.

Related concepts

“Using the Drive Assignment Web Page” on page 89

This section introduces the drive assignment web page of the 3584 Tape Library, which is available through the Tape Library Specialist web interface. The page enables you to add or remove a drive from a library configuration. It also enables you to add, remove, and share drives in a logical library, and change a control path.

Related tasks

“Assigning Cartridges to a Logical Library” on page 88

This section describes how to assign data cartridges to a logical library in the 3584 Tape Library.

Changing the Name of a Logical Library

This section give the procedure for changing the name of a logical library in the 3584 Tape Library.

Note: This function is only valid and available if the Advanced Library Management System (ALMS) is enabled. You can change the name of a logical library in the 3584 Tape Library by using the Tape Library Specialist web interface, but not by using the operator panel.

To change the name of a logical library, perform the following steps:

1. Type the Ethernet IP address on the URL line of the browser and press Enter. The Welcome Page displays.
2. Select **Library** → **Logical Libraries**. The Manage Logical Libraries screen displays.
3. Select the name of the logical library that you want to change. From the drop-down box select Rename, then select Go.
4. Enter the new name (up to 15 characters) and select Apply. The Success screen displays.

Note: The media type cannot be changed.

5. Select Close. The Manage Library screen redisplay with the new name.

Changing the Maximum Allowable Quantity of Cartridges in a Logical Library

This section describes how to change the maximum number of cartridges that are allowed in a logical library of the 3584 Tape Library.

Note: This function is only valid and available if the Advanced Library Management System (ALMS) is enabled. In the 3584 Tape Library, you can change the quantity of cartridges in a logical library by using the Tape Library Specialist web interface, but not by using the operator panel.

To change the maximum allowable quantity of cartridges in a logical library, perform the following steps:

1. Type the Ethernet IP address on the URL line of the browser and press Enter. The Welcome Page displays.
2. Select **Library** → **Logical Libraries**. The Manage Logical Libraries screen displays.
3. Select the check box next to a logical library.
4. From the Action drop-down list, select Maximum. Cartridges. The library displays a warning about changing the quantity of cartridges.
5. Select Continue. The Change Maximum Number of Cartridges screen displays.
6. Enter the maximum allowable quantity of cartridges that you want and select Apply. The Success screen displays.
7. Select Close. The Manage Library screen redisplay with the new quantity.

Changing the Quantity of Virtual I/O Slots in a Logical Library

This section describes how to increase or decrease the quantity of virtual I/O slots in a logical library.

Note: This function is only valid and available if virtual I/O slots are enabled. In the 3584 Tape Library, you can change the quantity of virtual I/O slots in a logical library by using the Tape Library Specialist web interface, but not by using the operator panel.

To change the quantity of virtual I/O slots in a logical library, perform the following steps:

1. Type the Ethernet IP address on the URL line of the browser and press Enter. The Welcome Page displays.
2. Select **Library** → **Logical Libraries**. The Manage Logical Libraries screen displays.
3. Select a logical library, then from the Select Action drop down list, select Maximum VIO cartridges. The library displays a warning that changing maximum settings for a logical library may require reconfiguration of the host applications for selected logical library
- 4.
5. Select Continue. The Change Number of VIO Slots screen displays.
6. Enter the quantity of virtual I/O slots that you want and select Apply. The Success screen displays.
7. Select Close. The Manage Library screen redisplay with the new quantity.

Hiding a Host Application's View of Cartridges That Have Been Queued for Export

This section describes how to hide a host application's view of a cartridge in the 3584 Tape Library that you have queued for export.

Note: This function is only valid and available if virtual I/O slots are enabled. In the 3584 Tape Library, you can hide an application's view of cartridges that you have queued for export by using the Tape Library Specialist web interface, but not by using the operator panel.

To hide the view, perform the following steps:

1. Type the Ethernet IP address on the URL line of the browser and press Enter. The Welcome Page displays.
2. Select **Library** → **Logical Libraries**. The Manage Logical Libraries screen displays.
3. Select the check box next to a logical library, then from the Select Action drop-down list, select Hide/Show Queued Exports and select Go. A pop-up window displays the message do you want to change the Hid Queued Export flag for this logical library.
4. Select OK to toggle between the Hide or Show setting. The Manage Logical Libraries screen redisplay with the new Hide or Show setting.

Discovering New Hardware in the Library

This section gives the procedure for detecting new hardware in the 3584 Tape Library.

Note: This function is only valid and available if the Advanced Library Management System (ALMS) is enabled. In the 3584 Tape Library, you can identify new hardware (such as frames, cartridges, and changes to the amount of storage for existing frames) by using the library's operator panel, but not by using the Tape Library Specialist web interface.

To determine changes, perform the following steps:

1. From the library's Activity touchscreen, press **MENU** → **Settings** → **Configuration** → **Configure Library** → **Discover New Hardware** → **ENTER**. The library displays the message **If you open the door the library will go Not Ready and any remaining jobs in the work queue may fail**. The library detects any hardware changes.
2. To view the hardware in the library (including hardware changes), from the operator panel press **MENU** → **Settings** → **Configuration** → **Display Configuration** → **ENTER**.
3. Press **BACK** until you return to the Activity screen.

Setting or Changing an Accessor's Preferred Zone

This section applies to the 3584 Tape Library that uses dual cartridge accessors. It introduces two ways to set or change the preferred zone in which each accessor operates.

In the 3584 Tape Library, Accessor A provides default access to the frames in the left half of the library; Accessor B provides default access to the right. The location of the drive that you specify for a mount or demount dictates which accessor will perform the operation. For example, if the drive to be mounted is in frame 1 and a move command is issued for a cartridge in frame 16, the accessor for frame 1 performs the mount (rather than the default accessor for frame 16).

However, to increase the mount performance of one or more logical libraries (by reducing the distance the accessor must travel or the quantity of commands issued to an accessor), you can specify the frames in which the each accessor operates. This specification of frames is called a *preferred zone*. For the example, if frames 1 through 4 contain 3592 Tape Drives and cartridges, and frames 5 through 16 contain Ultrium Tape Drives and cartridges, you can use the web to specify the only 3592 frames as the preferred zone for Accessor A. Accessor B would perform operations for frames 5 through 16.

Note that while the 3584 Tape Library will ordinarily use the accessor of a preferred zone, if that accessor has a problem it will not be used for moves in its preferred zone if the other accessor is functioning properly.

To set or change an accessor's preferred zone, use one of the following methods.

Using the Web to Set or Change an Accessor's Preferred Zone

Note: This procedure is applicable only to libraries with dual accessors.

To use the Tape Library Specialist web interface to set or change an accessor's preferred zone, perform the following steps:

1. Type the Ethernet IP address on the URL line of the browser and press Enter. The Welcome Page displays.

2. Select **Library** —> **Preferred Accessor Zones**. The Accessor Boundaries screen displays.
3. From the drop down box, select the frame that you want to be the boundary for Accessor A.
4. From The Select Action Drop-down Box, Select Apply, Then Select Go. The Accessor Boundaries screen redisplay with an arrow pointing to the frame where the boundary for Accessor A ends and the boundary for Accessor B begins. The end boundary for Accessor B is the final frame in the library. For example, if there are ten frames in the library, the end boundary for Accessor B is the tenth frame; if there are sixteen frames in the library, the end boundary for Accessor B is the sixteenth frame.

Using the Operator Panel to View or Change an Accessor's Preferred Zone

Note: This procedure is applicable only to libraries with dual accessors.

To use the operator panel to set or change an accessor's preferred zone, perform the following steps:

1. From the library's Activity touchscreen, press **MENU** —> **Advanced Settings** —> **Change Accessor Zones** —> **ENTER**. The Set Preferred Zone screen displays. Each pound sign (#) represents a frame in the library.

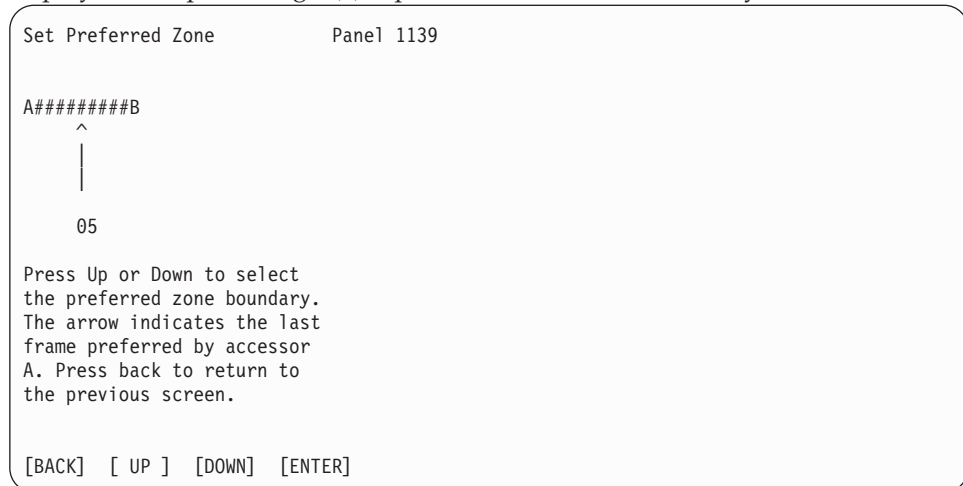

2. Decide the frames in which Accessor A and Accessor B will operate.
3. Press UP or DOWN to move the arrow and set the boundary for Accessor A. The remaining frames will belong to Accessor B. UP moves the arrow right; DOWN moves the arrow left.
4. Press Enter. The library displays the message **Accessor Zone Change Complete** press [ENTER] to return to the previous screen.
5. Press Enter.
6. Press BACK until you return to the Activity screen.

Installing the Intermediate or Full Capacity On Demand Feature

This section gives information about ordering and installing the intermediate or full capacity On Demand feature of the 3584 Tape Library.

By ordering the intermediate or full capacity On Demand feature, you can utilize additional cartridge capacity in the 3584 Tape Library. Installation instructions are included when you order these features. You can order them by using feature code 1643 for the intermediate capacity On Demand feature and 1644 for the full capacity On Demand feature.

Installing the Control Path Failover Feature

This section gives information about ordering and installing the control path failover feature of the 3584 Tape Library.

Installation instructions are included when you order the control path failover feature for the 3584 Tape Library. You can order the feature by using feature code 1680. The feature is activated by a license key, which you enter through the library's operator panel.

Displaying the SCSI ID or Loop ID of a Drive

This section introduces two ways to view the SCSI ID or Loop ID of a tape drive in the 3584 Tape Library.

You can display the IDs of drives in the 3584 Tape Library. For Ultrium 1 or Ultrium 2 Tape Drives, you can display the SCSI IDs of low voltage differential (LVD) or high voltage differential (HVD) interfaces, or the Fibre Channel Loop IDs. For Ultrium 3, Ultrium 4, and 3592 Tape Drives, you can display the Fibre Channel Loop IDs. To display this information, use one of the following methods.

Using the Web to Display the SCSI ID or Loop ID of a Drive

To use the Tape Library Specialist web interface to display the SCSI ID or Loop ID of a drive in the 3584 Tape Library, perform the following steps:

1. Type the Ethernet IP address on the URL line of the browser and press Enter. The Welcome Page displays.
2. Select **Drives** → **Drive Summary**. The Drives screen displays. For Ultrium 1 and Ultrium 2 Tape Drives, the screen shows the SCSI IDs of low voltage differential (LVD) or high voltage differential (HVD) interfaces, or the Fibre Channel Loop IDs. For Ultrium 3 and Ultrium 4 Tape Drives and 3592 Tape Drives, the screen shows the Fibre Channel Loop IDs.

Using the Operator Panel to Display the SCSI ID or Loop ID of a Drive

To use the operator panel to display the SCSI ID or Loop ID of a drive in the 3584 Tape Library, perform the following steps:

1. From the library's Activity touchscreen, press **MENU** → **Settings** → **SCSI/Loop IDs** → **Display SCSI/Loop IDs** → **ENTER**. The Display SCSI/Loop IDs screen displays a list of the tape drives, with their physical locations and SCSI IDs.

Display SCSI/Loop IDs Panel 0121

Key: F=Frame, R=Row

Drive [F01,R01]	SCSI ID	01
Drive [F01,R02]	SCSI ID	02
Drive [F01,R03]	SCSI ID	03
Drive [F01,R04]	SCSI ID	04
Drive [F01,R05]	SCSI ID	05
Drive [F01,R06]	SCSI ID	06
Drive [F02,R01,P0]	Loop ID	26
Drive [F02,R01,P1]	Loop ID	27

[BACK] [UP] [DOWN] [ENTER]

- The locations of the Ultrium Tape Drives are listed as **[Fxx,Rzz]** (where **F** equals frame and **xx** equals its number, and **R** equals row and **zz** equals its number). The locations of the 3592 Tape Drives are listed as **[Fxx,Rzz,Py]** (where the same values apply, but **P** equals port and **y** equals its number). To display more drives, highlight the bottom item and press DOWN. To return to the previous list of drives, highlight the top item and press UP.
- Press BACK until you return to the Activity screen.

Changing the SCSI ID or Loop ID of a Drive

This section introduces two ways to change the SCSI ID or Loop ID of a drive in the 3584 Tape Library.

The 3584 Tape Library assigns a default SCSI ID to each Ultrium Tape Drive that uses a low voltage differential (LVD) or high voltage differential (HVD) interface, and a Loop ID to each Ultrium Tape Drive or 3592 Tape Drive that uses a Fibre Channel interface. To change a SCSI ID or Loop ID, use one of the following methods.

Using the Web to Change the SCSI ID or Loop ID of a Drive

To use the Tape Library Specialist web interface to change the SCSI ID or Loop ID of a drive in the 3584 Tape Library, perform the following steps:

- Type the Ethernet IP address on the URL line of the browser and press Enter. The Welcome Page displays.
- Select **Drives** → **Drive Summary**. The Drives screen displays the SCSI IDs or Loop IDs of the Ultrium Tape Drives or it displays the Loop IDs of the 3592 Tape Drives.
- Select the drive that has the ID that you want to change, then from the Action Menu select Change ID, then select GO. A pop-up window lists the SCSI drives and the selected IDs. Next to each ID, a drop-down box displays the available IDs.
- Select the new ID, then select Change.

Using the Operator Panel to Change the SCSI ID or Loop ID of a Drive

To use the operator panel to change the SCSI ID or Loop ID of a drive in the 3584 Tape Library, perform the following steps:

- From the library's Activity touchscreen, press **MENU** → **Settings** → **SCSI/Loop IDs** → **Change SCSI/Loop IDs** → **ENTER**. The Change SCSI/Loop IDs screen displays a list of the tape drives, with their physical locations and SCSI IDs.

```

Display SCSI/Loop IDs      Panel 0121

Key: F=Frame, R=Row

Drive [F01,R01]   SCSI ID  01
Drive [F01,R02]   SCSI ID  02
Drive [F01,R03]   SCSI ID  03
Drive [F01,R04]   SCSI ID  04
Drive [F01,R05]   SCSI ID  05
Drive [F01,R06]   SCSI ID  06
Drive [F02,R01,P0] Loop ID 26
Drive [F02,R01,P1] Loop ID 27

[BACK] [ UP ] [DOWN] [ENTER]

```

The locations of the Ultrium Tape Drives are listed as **[Fxx,Rzz]** (where **F** equals frame and **xx** equals its number, and **R** equals row and **zz** equals its number). The locations of the 3592 Tape Drives are listed as **[Fxx,Rzz,Py]** (where the same values apply, but **P** equals port and **y** equals its number). To display more drives, highlight the bottom item and press **DOWN**. To return to the previous list of drives, highlight the top item and press **UP**.

- Press **UP** or **DOWN** to highlight the drive that you want to change and press **ENTER**. The library displays the message **Changing SCSI(Loop) IDs will interrupt library and drive activities, and may require reconfiguration of host computers. Press ENTER to continue.**
- Press **ENTER**. The Change SCSI/Loop ID screen displays with one of two types of content:
 - If you selected an LTO Ultrium Tape Drive with a Fibre Channel interface, the screen gives the physical location of the selected drive and its current Loop ID.

```

Change SCSI/Loop ID      Panel 0122

Key: [F=Frame, R=Row]

Drive [F01,R02]   Loop ID [22]
                  AL_PA C6h

Press UP or DOWN to select a new
Loop ID, then press ENTER
to activate the change.

[CANCEL] [ UP ] [DOWN] [ENTER]

```

- If you selected a SCSI drive, the screen gives the physical location of the selected drive and its current SCSI ID.

```

Change SCSI/Loop ID      Panel 0122

Key: F=Frame, R=Row

Drive [F01,R02]   SCSI ID [02]

Press UP or DOWN to select a new
SCSI ID, then press ENTER
to activate the change.

[CANCEL] [ UP ] [DOWN] [ENTER]

```

4. Specify the number of the ID that you want to change by pressing UP or DOWN to increment or decrement the value. When the desired ID number displays, press ENTER. The message **Fibre Loop ID Change Complete** or **SCSI ID Change Complete** displays.

Note: If you press CANCEL, no change will occur.

5. Press ENTER to return to the Display SCSI/Loop IDs screen.
6. Press BACK until you return to the Activity screen.

Viewing a World Wide Port Name

This section introduces two ways to view a World Wide Port Name (WWPN) for each drive slot in the 3584 Tape Library.

The 3584 Tape Library assigns a WWPN to each drive slot in the library. The WWPN does not change whenever a drive is swapped, replaced, or rebooted. Thus, if a drive needs service or replacement, host parameters do not need to be changed or reconfigured. In addition, the library's configuration can easily survive a reboot. To determine the WWPN for a drive, use one of the following methods.

Related concepts

"Viewing a World Wide Node Name" on page 147

This section introduces two ways to view a World Wide Node Name (WWNN) for each drive slot in the 3584 Tape Library.

Using the Web to View a World Wide Port Name

To use the Tape Library Specialist web interface to view a world wide port name in the 3584 Tape Library, perform the following steps:

1. Type the Ethernet IP address on the URL line of the browser and press Enter. The Welcome Page displays.
2. Select **Drives** → **World Wide Names**. The World Wide Names screen displays with the port name of each drive that uses a Fibre Channel interface.

Using the Operator Panel to View a World Wide Port Name

To use the operator panel to view a world wide port name in the 3584 Tape Library, perform the following steps:

1. From the library's Activity touchscreen, press **MENU** → **Settings** → **Fibre Ports** → **View World Wide Port Names** → **ENTER**. The World Wide Port Names screen displays. For each configured Fibre Channel drive in Frame 1, the screen lists its physical location and World Wide Port Name. To display additional drives in Frame 1 or to display the drives in other frames, press **DOWN**. To return to previous screens, press **UP**.

```

World Wide Port Names                               Panel 0125

Key: F=Frame, R=Row, P=Port

[F01,R01]    50050763 00410001
[F01,R02]    50050763 00410002
[F01,R07]    50050763 00410003
[F01,R08]    50050763 00410004
[F01,R09]    50050763 00410005
[F03,R01]    50050763 00410006
[F03,R02,P0] 50050763 00410007
[F03,R03,P1] 50050763 00410008

[BACK]      [ UP ]      [DOWN]

```

2. Press BACK until you return to the Activity screen.

Viewing a World Wide Node Name

This section introduces two ways to view a World Wide Node Name (WWNN) for each drive slot in the 3584 Tape Library.

Like the World Wide Port Name, the WWNN is used as an identifier by the 3584 Tape Library for each Fibre Channel tape drive. To determine the World Wide Node Name for a drive, use one of the following methods.

Related concepts

“Viewing a World Wide Port Name” on page 146

This section introduces two ways to view a World Wide Port Name (WWPN) for each drive slot in the 3584 Tape Library.

Using the Web to View a World Wide Node Name

To use the Tape Library Specialist web interface to view a world wide node name in the 3584 Tape Library, perform the following steps:

1. Type the Ethernet IP address on the URL line of the browser and press Enter. The Welcome Page displays.
2. Select **Drives** —> **World Wide Names**. The World Wide Names screen displays with the node name of each drive that uses a Fibre Channel interface.

Using the Operator Panel to View a World Wide Node Name

To use the operator panel to view a world wide node name in the 3584 Tape Library, perform the following steps:

1. From the library’s Activity touchscreen, press **MENU** —> **Settings** —> **Fibre Ports** —> **View World Wide Node Names** —> **ENTER**. The World Wide Node Names screen displays. For each configured Fibre Channel drive in Frame 1, the screen lists its physical location and World Wide Node Name. To display additional drives in Frame 1 or to display the drives in other frames, press **DOWN**. To return to previous screens, press **UP**.

```

World Wide Node Names                Panel 0126

Key: F=Frame, R=Row, P=Port

[F01,R01]    50050763 00410001
[F01,R02]    50050763 00410002
[F01,R07]    50050763 00410003
[F01,R08]    50050763 00410004
[F01,R09]    50050763 00410005
[F03,R01]    50050763 00410006
[F03,R02]    50050763 00410007
[F03,R03,P0] 50050763 00410008
[F03,R03,P1] 50050763 00410008

[BACK]      [ UP ]      [DOWN]

```

2. Press BACK until you return to the Activity screen.

Viewing or Changing Fibre Channel Port Speeds and Topologies

To view or change the speeds and topologies for the Fibre Channel ports that are located in the tape drives of the 3584 Tape Library, use one of the following methods.

Using the Web to View or Change Fibre Channel Port Speeds and Topologies

To use the Tape Library Specialist web interface to view or change the speeds and topologies for the Fibre Channel ports of drives in the 3584 Tape Library, perform the following steps:

Note: You must have the role of superuser or administrator to perform this procedure.

1. Type the Ethernet IP address on the URL line of the browser and press Enter. The Welcome Page displays.
2. Select **Ports**—> **Fibre Channel Summary**. The Fibre Channel Summary screen displays speed and topology information about each drive port in the 3584 Tape Library.
3. Select one or more drive and port that you want to change.
4. From the Select Action drop-down list, select Set Link Speed/Topology, and select Go. A window displays in which you change the link speed and the topology.
5. Select the link speed and topology that you want and select Change. A confirmation screen displays.
6. Select Close. The Fibre Channel Summary screen redisplay with the change.

Using the Operator Panel to Set or Change Fibre Channel Port Speeds and Topologies

To use the operator panel to set or change the speeds and topologies for the Fibre Channel ports of drives in the 3584 Tape Library, perform the following steps:

1. From the library's Activity touchscreen, press **MENU** —> **Settings** —> **Fibre Ports** —> **Set Fibre Port Speed/Topology** —> **ENTER**. The Fibre Speed/Topology screen displays.

```

Fibre Speed/Topology          Panel 0035

Set by Drive
Set by Logical Library
Set All Fibre Drives

[BACK]          [DOWN] [ENTER]

```

2. To set a drive's speed or topology, press UP or DOWN to select Set by Drive and press ENTER. The library displays the warning **Changing the drive(s) fibre speed and topology will interrupt library and drive activities. Press ENTER to continue.**
3. Press ENTER. The Select Drive screen displays.

```

Select Drive          Panel 0210

Key: F=Frame, R=Row L=LTO Ultrium,
     J = Enterprise Tape

Drive [F01,R01]  L1
Drive [F01,R02]  L1
Drive [F01,R03]  L2
Drive [F01,R04]  L3
Drive [F01,R05]  L4
Drive [F01,R06]  L1
Drive [F01,R07]  L1
Drive [F01,R08]  L2
Drive [F02,R01]  J2
Drive [F02,R02]  J1

[BACK] [ UP ] [DOWN] [ENTER]

```

4. Press UP or DOWN to select the drive that you want, then press ENTER. The Fibre Port Speed/Topology screen displays.

```

Fibre Port Speed/Topology          Panel 0138

Key: F=Frame, R=Row
     Auto (N)=auto but try N Port first,
     Auto (L)=auto but try L Port first
By Drive: [F01,R01]

Port 0 Speed:      [Auto]
Port 1 Speed:      [4Gb/s]
Port 0 Topology:   [Auto]
Port 1 Topology:   [Auto (N)]
Commit Changes

[BACK] [ UP ] [DOWN] [ENTER]

```

- If you press UP or DOWN and ENTER for a speed, the Select Speed screen displays.

```

Select Speed          Panel 2131

Setting Port 1: No Change

Press Up or Down to select the
Fibre speed behavior. Press
back to return to the
previous screen

[BACK] [ UP ] [DOWN]

```

Valid choices are:

No change

Do not change the current setting

Auto Auto-negotiated by drive and fiber switch. Auto is the default.

1 Gb/s Operate at 1 Gigabit per second

2 Gb/s Operate at 2 Gigabits per second

4 Gb/s Operate at 4 Gigabits per second (if your drive supports this speed)

- If you press UP or DOWN and ENTER for a topology, the Select Topology screen displays.

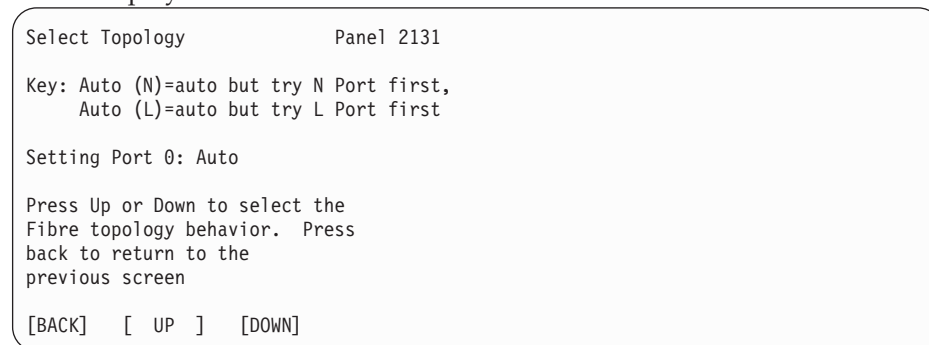

Valid choices are:

No change

Do not change the current setting

Auto (N)

Auto-negotiated; try N-Port first

Auto (L)

Auto-negotiated; try L-Port first. Auto (L) is the default.

All settings are not available on some drives.

5. Press UP or DOWN to indicate the speed or topology that you want, then press ENTER.
6. Press BACK to return to the Fibre Port Speed/Topology screen. Press DOWN to highlight Commit Changes, then press ENTER. The library displays the message **The configuration process is complete.** Press ENTER.
7. Press BACK until you return to the Activity screen.

Viewing or Changing Fibre Channel Port Settings

To display the settings of the Fibre Channel ports that are located in the tape drives of the 3584 Tape Library, use one of the following methods.

Using the Web to View or Change Fibre Channel Port Settings

To use the Tape Library Specialist web interface to view or change the settings of the Fibre Channel ports of drives that are located in the 3584 Tape Library, perform the following steps:

1. Type the Ethernet IP address on the URL line of the browser and press Enter. The Welcome Page displays.
2. Select **Ports**—> **Fibre Channel Summary**. The Fibre Channel Summary screen displays information about each drive port in the 3584 Tape Library.

3. You can change only the configured link speed and topology for each drive. To change these settings, select a drive, then from the Select Action drop-down list, select Set Link Speed/Topology, and select Go. A window displays in which you change the link speed and the topology.
4. Select the link speed and topology that you want and select Change.

Using the Operator Panel to View or Change Fibre Channel Port Settings

To use the operator panel to view or change the Fibre Channel port settings of drives in the 3584 Tape Library, perform the following steps:

1. From the library's Activity touchscreen, press **MENU** → **Settings** → **Fibre Ports** → **Display Fibre Port Settings** → **ENTER**. The Display Fibre Port Settings screen displays with the locations of the drives in the library, their speeds and their topologies.

```

Display Fibre Port Settings                Panel 0136

Key: F=Frame, R=Row, P=Port
     Auto (N)=auto but try N Port first,
     Auto (L)=auto but try L Port first

      Speed  Topology
[F01,R01,P0] 1 Gb/s  Auto (L)
[F01,R01,P1] Auto    Auto (L)
[F01,R02,P0] Auto    N Port
[F01,R02,P1] Auto    Auto (L)
[F02,R01]    4Gb/s  Auto (N)
[F02,R02]    Auto    L Port
[F02,R03]    Auto    Auto (L)
[F02,R04]    Auto    Auto (L)

[BACK] [ UP ] [DOWN]

```

2. Press UP or DOWN to view more drives.
3. Press BACK until you return to the Activity screen.

Displaying Fibre Channel Port Status

To display the status of the Fibre Channel ports that are located in the tape drives of the 3584 Tape Library, use one of the following methods.

Using the Web to Display Fibre Channel Port Status

To use the Tape Library Specialist web interface to display the status of the Fibre Channel ports in drives that are located in the 3584 Tape Library, perform the following steps:

1. Type the Ethernet IP address on the URL line of the browser and press Enter. The Welcome Page displays.
2. Select **Ports** → **Fibre Channel Summary**. The Fibre Channel Summary screen displays a list of Fibre Channel tape drives and the following information for each:

Drive This field requires the drive slot's World Wide Node Name. For information about this topic, go to the section about viewing a World Wide Node Name.

Port This field requires the drive slot's World Wide Port Name. For information about this topic, go to the section about viewing a World Wide Port Name.

Link Status

Indicates the current status of the Fibre Channel port. Values are:

No Light Detected

Means that no light is detected by the drive on this port.

Negotiating Link

Means that a link has been established with the fabric or loop, but has not yet completed.

Configured Link Speed

Speed at which the library has configured this port to run. Values are:

Auto The library has configured this port to automatically negotiate its link speed.

1Gb/s The library has configured this port to run at a speed of 1 gigabit per second (supported by all drives).

2Gb/s The library has configured this port to run at a speed of 2 gigabits per second (supported by all drives except the Ultrium 1 Tape Drive).

4Gb/s The library has configured this port to run at a speed of 4 gigabits per second (supported only by the TS1120 Tape Drive).

Unavailable

The library is unable to communicate with the drive. Check the RS-422 connection between the drive and the library.

Configured Link Topology

Topology at which the library has configured this port to run. Values are:

Auto(L)

The library has configured this port to automatically negotiate its topology and tries L-Port first.

Auto(N)

The library has configured this port to automatically negotiate its topology and tries N-Port first.

Unavailable

The library is unable to communicate with the drive. Check the RS-422 connection between the drive and the library.

Actual Link Speed

The actual speed at which this port is operating. Values are:

1Gb/s A Fibre Channel connection has been established on this port at 1 gigabit per second (supported by all drives).

2Gb/s A Fibre Channel connection has been established on this port at 2 gigabits per second (supported by all drives except the Ultrium 1 Tape Drive).

4Gb/s The library has configured this port to run at a speed of 4 gigabits per second (supported only by the TS1120 Tape Drive).

Unavailable

The library is unable to communicate with the drive. Check the RS-422 connection between the drive and the library.

Not Supported

The level of the drive's firmware does not support the reporting of its current Fibre Channel port connection speed.

Actual Link Topology

Actual topology at which this port is operating. Values are:

L Port A Fibre Channel L Port connection has been established on this port.

N Port

A Fibre Channel N Port connection has been established on this port.

Unavailable

The library is unable to communicate with the drive. Check the RS-422 connection between the drive and the library.

Not Supported

The level of the drive's firmware does not support the reporting of its current Fibre Channel port topology.

3. You can change only the configured link speed and topology for each drive. To change these settings, select a drive, then from the Select Action drop-down list, select Set Link Speed/Topology, and select Go. A window displays in which you change the link speed and the topology.
4. Select the link speed and topology that you want and select Change.

Using the Operator Panel to Display Fibre Channel Port Status

To view the status of Fibre Channel ports that are located in the LTO Ultrium and 3592 Tape Drives in the 3584 Tape Library, perform the following steps:

1. From the library's Activity touchscreen, press **MENU** → **Settings** → **Fibre Ports** → **Display Fibre Port Status** → **ENTER**. The Display Fibre Port Status screen displays with the locations of the drives in the library and their status.

```
Display Fibre Port Status          Panel 0137
Key: F=Frame, R=Row, P=Port
[F01,R01]      No Light Detected
[F01,R02]      Negotiating Link
[F01,R07]      1Gb/s L Port
[F01,R08]      Not Supported
[F01,R09]      1Gb/s N Port
[F03,R01,P0]   Unavailable
[F03,R02,P1]   Unavailable
[F03,R03,P0]   1Gb/s L Port
[F03,R03,P1]   2Gb/s N Port
[BACK]  [ UP ]  [DOWN]
```

The screen includes the following settings.

No Light Detected

No light is detected by the drive on this port.

Negotiating Link

A link has been established with the fabric or loop, but has not yet completed.

1Gb/s L Port

An L Port connection has been established at the rate of 1 gigabit per second.

1Gb/s N Port

An N Port connection has been established at the rate of 1 gigabit per second.

2Gb/s L Port

An L Port connection has been established at the rate of 2 gigabits per second.

2Gb/s N Port

An N Port connection has been established at the rate of 2 gigabits per second.

4Gb/s L Port

An L Port connection has been established at the rate of 4 gigabits per second.

4Gb/s N Port

An N Port connection has been established at the rate of 4 gigabits per second.

Unavailable

The library is unable to communicate with a drive. Check the RS-422 connection between the drive and the library.

Not Supported

The level of the drive's firmware does not support the reporting of its current fibre port status over the library's drive interface.

2. Press UP or DOWN to view more drives.
3. Press BACK until you return to the Activity screen.

Displaying Control Paths

This section introduces two ways to view the control paths of the 3584 Tape Library.

The 3584 Tape Library has no direct SCSI connection to a server. Thus, when a server communicates with the library, it must send the communication through an Ultrium Tape Drive or 3592 Tape Drive that is designated as a control path. A control path is a logical path into the library through which a server sends standard SCSI Medium Changer commands to control a specific logical library. When you add multiple control paths to the 3584 Tape Library, any single, configured logical library can be accessed by multiple servers. Additional control paths also reduce the possibility that failure in one control path will cause a loss in host communication for the entire library.

Note: Microsoft^(R) Windows^(R) 2000 Removable Storage Manager (RSM) does not support multiple control paths within a logical library.

To display control paths, use one of the following methods.

Using the Web to Display Control Paths

To use the Tape Library Specialist web interface to display the control paths of the 3584 Tape Library, perform the following steps:

1. Type the Ethernet IP address on the URL line of the browser and press Enter. The Welcome Page displays.

2. Select **Drives** → **Control Paths**. The Control Paths screen shows where the control path (drive) for each logical library is located (which frame and row), and whether the control path is required, enabled, or disabled.

Using the Operator Panel to Display Control Paths

To use the operator panel to display the control paths of the 3584 Tape Library, perform the following steps:

1. From the library's Activity touchscreen, press **MENU** → **Settings** → **Control Paths** → **Display Control Paths** → **ENTER**. The Control Paths screen displays a list of logical libraries, the drives in the logical libraries (and their physical locations), and whether the control paths for the drives are required, enabled, or disabled. For the first drive in the logical library the setting is always Required. The names of the logical libraries are listed in the first column (in the following example, **Name 1**, **Name 2**, **LogLib**, and so forth). The locations of the drives are listed as **[Fxx,Rzz]**, (where **F** equals frame and **xx** equals its number, and **R** equals row and **zz** equals its number). To display more drives, highlight the bottom item and press **DOWN**. To return to the previous list of drives, highlight the top item and press **UP**.

```
Control Paths                Panel 0131
Key: LL=Logical Library, F=Frame, R=Row
LL: Name 1    [F01,R01]    Required
LL: Name 2    [F01,R02]    Disabled
LL: LogLib    [F01,R03]    Required
LL: Admin     [F01,R04]    Disabled
LL: Engine    [F01,R05]    Required
LL: Engine    [F01,R06]    Disabled
LL: Admin     [F01,R07]    Required
LL: Admin     [F01,R08]    Disabled
LL: LogLib    [F01,R09]    Enabled
LL: LogLib    [F01,R10]    Disabled

[BACK] [ UP ] [DOWN] [ENTER]
```

2. Press **BACK** until you return to the Activity screen.

Changing a Control Path

This section introduces two ways to change a control path in the 3584 Tape Library.

Note: This function is only valid and available if the Advanced Library Management System (ALMS) is not enabled. To enable or disable a control path in the 3584 Tape Library when ALMS is enabled, see “Enabling or Disabling a Control Path in a Logical Library” on page 91.

You can configure any logical library in the 3584 Tape Library to have more than one control path. When you configure additional control paths, additional library sharing configurations and availability options are made possible. Access to a logical library is on a first-come, first-served basis, and each control path for a logical library can accept commands while the library is in use by another control path.

To change a control path, use one of the following methods.

Related tasks

“Enabling or Disabling a Control Path in a Logical Library” on page 91

Using the Web to Change a Control Path

Note: Use this procedure if your library is not enabled with the ALMS option.

To use the Tape Library Specialist web interface to change a control path of the 3584 Tape Library, perform the following steps:

1. Type the Ethernet IP address on the URL line of the browser and press Enter. The Welcome Page displays.
2. Select **Drives** → **Control Paths**. The Control Paths screen shows where the control path (drive) for each logical library is located (which frame and row), and whether the control path is required, enabled, or disabled.
3. Follow the instructions on the screens.

Related tasks

“Entering the ALMS License Key” on page 135

This section describes how to record your license key for the Advanced Library Management System (ALMS), which is an option of the 3584 Tape Library. The key lets you enable and use ALMS.

“Enabling or Disabling ALMS” on page 136

This section describes how to enable or disable the Advanced Library Management System (ALMS) in the 3584 Tape Library.

Using the Operator Panel to Change a Control Path

To use the operator panel to change a control path of the 3584 Tape Library, perform the following steps:

1. From the library’s Activity touchscreen, press **MENU** → **Settings** → **Control Paths** → **Change Control Paths** → **ENTER**. The Control Paths screen displays a list of logical libraries, the drives in the logical libraries (and their physical locations), and whether the control paths for the drives are required, enabled, or disabled. For the first drive in the logical library the setting is always Required. The names of the logical libraries are listed in the first column (in the following example, **Name 1**, **Name 2**, **LogLib2**, and so forth). The locations of the drives are listed as **[Fxx,Rzz]**, (where **F** equals frame and **xx** equals its number, and **R** equals row and **zz** equals its number). To display more drives, highlight the bottom item and press **DOWN**. To return to the previous list of drives, highlight the top item and press **UP**.

Control Paths Panel 0131

Key: F=Frame, R=Row

Name 1	[F01,R01]	Required
Name 2	[F01,R02]	Disabled
LogLib2	[F03,R01]	Required
Admin	[F03,R02]	Disabled
Engineerin	[F03,R03]	Disabled
Engineerin	[F04,R00]	Required
Admin	[F05,R01]	Required
Admin	[F05,R02]	Disabled
LogLib2	[F05,R03]	Enabled
LogLib2	[F01,R10]	Disabled

[BACK] [UP] [DOWN] [ENTER]

2. Press **UP** or **DOWN** to highlight the control path that you want to enable or disable, and press **ENTER**. The Control Path screen displays with the control path that you selected.

Note: If you select a drive that is a required control path, the library displays the message **This drive is a REQUIRED control path and cannot be changed.** Press ENTER to return to the previous screen.

```
Change Control Path      Panel 0132
Key: LL=Logical Library, F=Frame, R=Row
LL: Admin [F01,R02]      ENABLED
Press UP or DOWN key to toggle the
Control Path setting, then press ENTER
to activate the change.
[CANCEL] [ UP ] [DOWN] [ENTER]
```

3. Press UP or DOWN to specify ENABLED or DISABLED for the control path, then press ENTER. The Control Paths screen redisplay with the new setting.

Note: The first time that the Change Control Path screen displays, the library displays the message **Changing Control Path settings will interrupt library and drive activities, and may require reconfiguration of host computers. Do you want to change Control Path settings?** Press YES to continue changing the control path (or press NO to return to the previous screen).

4. Press BACK until you return to the Activity screen.

Enabling or Disabling SNMP Traps

This section introduces two ways to enable or disable informational messages (traps) that are gathered from and transmitted by the 3584 Tape Library through the use of the Simple Network Management Protocol (SNMP).

SNMP is a networking protocol that, when enabled, allows the 3584 Tape Library to automatically gather and transmit information about alerts and status to other entities in the network (such as an SNMP monitoring server). The information is called an SNMP trap.

After you enable SNMP traps, you can set the version that is supported by the SNMP monitoring server, set the destination IP address of the trap, then send the test trap). While setting the parameters for the trap, you can optionally set the remote port and community name.

To enable or disable SNMP traps, use one of the following methods. For help in understanding SNMP traps, see “Interpreting SNMP Traps” on page 293.

Related tasks

“Using the Web to Set the Version of SNMP Traps” on page 160

“Using the Operator Panel to Set the Version of SNMP Traps” on page 160

“Using the Web to View or Change the Destination IP Configuration and Remote Port” on page 162

“Using the Operator Panel to View or Change the Destination IP Configuration and Remote Port” on page 162

“Using the Web to Send a Test SNMP Trap” on page 163

“Using the Operator Panel to Send a Test SNMP Trap” on page 163

“Manually Interpreting an SNMP Trap” on page 293

Related reference

“Interpreting SNMP Traps” on page 293

This section provides information that helps you to understand the meaning of an Simple Network Management Protocol (SNMP) trap that is received by the 3584 Tape Library.

Using the Web to Enable or Disable SNMP Traps

To use the Tape Library Specialist web interface to enable or disable SNMP traps for the 3584 Tape Library, perform the following steps:

1. Type the Ethernet IP address on the URL line of the browser and press Enter. The Welcome Page displays.
2. Select **Access** → **SNMP Settings**. In the SNMP Setting field, view the current setting then select the button to enable or disable SNMP traps.

Using the Operator Panel to Enable to Disable SNMP Traps

To use the operator panel to a enable or disable SNMP traps for the 3584 Tape Library, perform the following steps:

1. From the library’s Activity touchscreen, press **MENU** → **Settings** → **Network** → **SNMP** → **Enable/Disable SNMP Traps** → **ENTER**. The Enable/Disable SNMP screen displays.

Enable/Disable SNMP Panel 0166

SNMP TRAPS are ENABLED

Press UP or DOWN to toggle the
SNMP setting, then press ENTER
to activate the change.

[BACK] [DOWN] [ENTER]

2. Press UP or DOWN to specify ENABLED or DISABLED for SNMP messaging, then press ENTER. The Enable/Disable SNMP screen redisplay the new setting. To accept the new setting and return to the previous screen, press BACK.
3. Press BACK until you return to the Activity screen.

Enabling or Disabling SNMP Requests

This section introduces two ways to enable or disable Simple Network Management Protocol (SNMP) requests to the 3584 Tape Library.

SNMP supports a get and get-response mechanism for an operator to gather more information about a problem or to query the 3584 Tape Library about its current status. A *get* is a request for information about the library that the operator issues through a monitoring server and which is transmitted by SNMP. A *get-response* is the information that is provided in response to the get request. This type of support generally requires an up-to-date library Management Information Base (MIB). The library’s MIB contains units of information that specifically describe an aspect of a system, such as the system name, hardware number, or communications configuration.

To enable or disable SNMP requests, use one of the following methods. For help in understanding how to use SNMP to monitor your library, see “Using SNMP MIBs to Monitor the Library” on page 298.

Related reference

“Using SNMP MIBs to Monitor the Library” on page 298

This section describes how to use a Simple Management Network Protocol (SNMP) monitoring station and Management Information Bases (MIBs) to check drive status, give information about the last SNMP trap and about cartridges, and identify supported MIBs and supported SNMP messages. The data gathered from this process originates from the 3584 Tape Library and is displayed on the SNMP monitoring station.

Using the Web to Enable or Disable SNMP Requests

To use the Tape Library Specialist web interface to enable or disable Simple Network Management Protocol (SNMP) requests for the 3584 Tape Library, perform the following steps:

1. Type the Ethernet IP address on the URL line of the browser and press Enter. The Welcome Page displays.
2. Select **Manage Access** → **SNMP Settings**. In the SNMP Trap Setting field, view the current setting then select the button to enable or disable SNMP requests.

Using the Operator Panel to Enable or Disable SNMP Requests

To use the operator panel to enable or disable Simple Network Management Protocol (SNMP) requests for the 3584 Tape Library, perform the following steps:

1. From the library’s Activity touchscreen, press **MENU** → **Settings** → **Network** → **SNMP** → **Enable/Disable SNMP Requests** → **ENTER**. The Enable/Disable SNMP Requests screen displays the current state of SNMP requests.

Enable/Disable SNMP Requests Panel 0164

SNMP Requests are ENABLED

If SNMP Requests are enabled, an SNMP host will be able to execute SNMP GET, GET-NEXT, and GET-BULK data requests.

Press UP or DOWN to toggle the SNMP Requests setting, then press ENTER to activate the change.

[CANCEL] [UP] [DOWN] [ENTER]

2. Press UP or DOWN to specify ENABLED or DISABLED for SNMP messaging, then press ENTER. The Enable/Disable SNMP Requests screen redisplay the new setting. To accept the new setting and return to the previous screen, press BACK.
3. Press BACK until you return to the Activity screen.

Setting the Version of SNMP Traps

This section introduces two ways of setting the version level of Simple Network Management Protocol (SNMP) traps.

Some SNMP monitoring server's applications only support Version 1 SNMP traps, while others only support Version 2 traps (your SNMP operations staff will know the supported version). The 3584 Tape Library supports both Version 1 and Version 2c.

To set the version of SNMP traps that the library uses to communicate with an SNMP monitoring server's application, use one of the following methods.

Using the Web to Set the Version of SNMP Traps

To use the Tape Library Specialist web interface to set the version of Simple Network Management Protocol (SNMP) traps for the 3584 Tape Library, perform the following steps:

1. Type the Ethernet IP address on the URL line of the browser and press Enter. The Welcome Page displays.
2. Select **Access** → **SNMP Settings**. View the current setting, then select the button to change the version number.

Using the Operator Panel to Set the Version of SNMP Traps

To use the operator panel to set the version of Simple Network Management Protocol (SNMP) traps for the 3584 Tape Library, perform the following steps:

1. From the library's Activity touchscreen, press **MENU** → **Settings** → **Network** → **SNMP** → **V1/V2** → **ENTER**. The V1/V2 Traps screen displays the version of the traps that were last sent by the SNMP agent.

```
V1/V2 Traps                Panel 0161
Trap Version is [V2c]
Version 2 traps are not
supported by some SNMP
management stations.
Press UP or DOWN to toggle the
Trap setting, then press ENTER
to activate the change.
[CANCEL] [ UP ] [DOWN] [ENTER]
```

To send a different version of traps, press UP or DOWN to specify the version of the trap, then press ENTER. The screen redisplay with the new version of the trap.

2. Press **BACK** until you return to the Activity screen.

Enabling or Disabling Authentication Trap Settings

This section defines an authentication trap and describes how to enable or disable its settings.

Note: You can enable or disable authentication trap settings by using the Tape Library Specialist web interface of the 3584 Tape Library, but not by using the operator panel.

An authentication trap is a Simple Network Management Protocol (SNMP) trap that the library sends to a monitoring station when it detects that a device is trying to read the library's SNMP data by using the wrong community name.

To enable or disable authentication trap settings, perform the following steps:

1. Type the Ethernet IP address on the URL line of the browser and press Enter. The Welcome Page displays.
2. Select **Settings** —> **SNMP Settings**. In the Authentication Trap Setting field, view the current authentication trap setting then select the button to enable or disable it.

Viewing or Changing SNMP System Data

This section describes how to view or change the Simple Network Management Protocol (SNMP) configuration and contact information about the 3584 Tape Library.

Note: You can view or change SNMP system data by using the Tape Library Specialist web interface of the 3584 Tape Library, but not by using the operator panel.

SNMP system data is SNMP configuration and contact information about the 3584 Tape Library that you can view or change.

To view or change SNMP system data, perform the following steps:

1. Type the Ethernet IP address on the URL line of the browser and press Enter. The Welcome Page displays.
2. Select **Access** —> **SNMP System Data**. See your system administrator to obtain and enter the information necessary in the Community Names field. In the System Group Information fields, enter information about the library that you want to make available through SNMP. You can assign a text name in the System Name field.

Note: Note that the contact information in the system data is also used by the library when it uses the Call Home capability.

Viewing or Changing the Destination IP Configuration and Remote Port

This section introduces two ways to view the identifier of a Simple Network Management Protocol (SNMP) monitoring server that is used by the 3584 Tape Library. It also provides basic information about the library's remote port.

A destination IP (Internet protocol) configuration is the identifier of an SNMP monitoring server to which SNMP alerts will be sent. The configuration is unique to each monitoring server. It consists of an address that is assigned by your system administrator. The maximum quantity of monitoring servers and IP addresses per library is five.

The 3584 Tape Library defaults to a remote port value of 162. For information about the remote port, see the documentation for your monitoring server.

To view or change the destination IP configuration or remote port that is associated with the IP address, use one of the following methods.

Using the Web to View or Change the Destination IP Configuration and Remote Port

To use the Tape Library Specialist web interface to view or change the destination internet protocol (IP) configuration and remote port of the 3584 Tape Library, perform the following steps:

1. Type the Ethernet IP address on the URL line of the browser and press Enter. The Welcome Page displays.
2. Select **Access** —> **SNMP Destinations**. In the SNMP screen, view or enter the IP addresses and ports of any Simple Network Management Protocol (SNMP) monitoring servers to which you want to send SNMP alerts. Select Apply to accept the information.

Using the Operator Panel to View or Change the Destination IP Configuration and Remote Port

To use the operator panel to view or change the destination internet protocol (IP) configuration and remote port of the 3584 Tape Library, perform the following steps:

1. From the library's Activity touchscreen, press **MENU** —> **Settings** —> **Network** —> **SNMP** —> **Destination IP Configuration** —> **ENTER**. The Destination IP Configuration screen displays with the current destination IP address numbers (in this example, 1 through 5).

```
Destination IP Configuration      Panel 0170

Select the Destination IP
to view/change.

Destination IP : 2

Select 1 - 5

[BACK] [ UP ] [DOWN] [ENTER]
```

2. Press UP or DOWN to specify the destination IP address number that you want to view or change, then press ENTER. The Set Destination Data screen displays the current destination IP address that was assigned by your system administrator. The address is divided into four sets of characters separated by periods. Each set is called an octet.

```
Set Destination Data              Panel 0172

IP Address/Port 2:
10.25.36.1 [162]

Use UP and DOWN to change
highlighted value.

[CANCEL] [ UP ] [DOWN] [ENTER]
```

3. To change the first octet in the address, press UP or DOWN to change the value that you want, then press ENTER. The screen redisplay with the new characters and highlights the second octet. Press UP or DOWN to specify the numbers that you want, then press ENTER. Repeat this procedure for the third and fourth octets. After you modify the fourth octet, the screen redisplay with the entirely new destination IP address and moves to highlight the remote port

setting. Press UP or DOWN to specify the number of the remote port, then press ENTER. To accept the new setting and return to the previous screen, press ENTER.

Note: To disable an address, specify 0 for the first character. The library automatically enters zeroes for all characters and disables the address.

4. Press BACK until you return to the Activity screen.

Sending a Test SNMP Trap

This section introduces two ways to send a Simple Network Management Protocol (SNMP) trap that tests whether the 3584 Tape Library and the application for the SNMP monitoring station are connected.

You can send a test SNMP trap to ensure that the 3584 Tape Library and the SNMP monitoring server's application are properly connected.

To send a test SNMP trap, use one of the following methods.

Using the Web to Send a Test SNMP Trap

To use the Tape Library Specialist web interface to send a test Simple Network Management Protocol (SNMP) trap and ensure proper connection of the 3584 Tape Library, perform the following steps:

1. Type the Ethernet IP address on the URL line of the browser and press Enter. The Welcome Page displays.
2. Select **Access** —> **SNMP Settings**. In the Send a Test Trap field, select the button to send an SNMP test trap.

Using the Operator Panel to Send a Test SNMP Trap

To use the operator panel to send a test Simple Network Management Protocol (SNMP) trap and ensure proper connection of the 3584 Tape Library, perform the following steps:

1. From the library's Activity touchscreen, press **MENU** —> **Settings** —> **Network** —> **SNMP** —> **Send a Test Trap** —> **ENTER**. The library displays the message **A test trap with the text "This is a test SNMP trap." has been sent to all defined target hosts. Press ENTER to continue.**
2. Press ENTER. The library sends an SNMP trap to all SNMP IP addresses at the remote port that you specified. The trap contains the machine type, model number, and serial number of the library, as well as other fields. The SNMP menu displays. For more information about SNMP traps, see the *IBM System Storage TS3500 Tape Library Introduction and Planning Guide*.
3. Press BACK until you return to the Activity screen.

Viewing or Changing the Trap Community Name

This section introduces two ways to view or change the trap community name that is associated with the 3584 Tape Library.

The trap community name is sent with a trap. For information about the trap community name, see the documentation for your monitoring station.

To view or change the community name that is associated with the 3584 Tape Library, use one of the following methods.

Using the Web to View or Change the Trap Community Name

To use the Tape Library Specialist web interface to view or change the community name that is associated with the 3584 Tape Library, perform the following steps:

1. Type the Ethernet IP address on the URL line of the browser and press Enter. The Welcome Page displays.
2. Select **Access** → **SNMP System Data**. See your system administrator to obtain and enter the information necessary in the Community Names field.

Using the Operator Panel to View or Change the Trap Community Name

To use the operator panel to view or change the community name that is associated with the 3584 Tape Library, perform the following steps:

1. From the library's Activity touchscreen, press **MENU** → **Settings** → **Network** → **SNMP** → **Trap Community Name** → **ENTER**. The Trap Community Name screen displays the current setting. The Trap Community Name is a series of characters that both the library and the server must recognize to communicate.

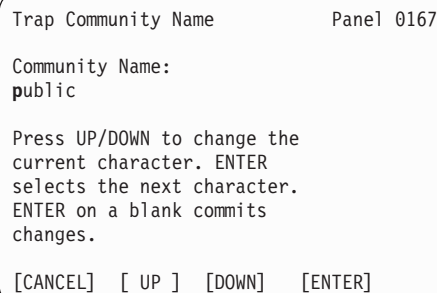

```
Trap Community Name          Panel 0167

Community Name:
public

Press UP/DOWN to change the
current character. ENTER
selects the next character.
ENTER on a blank commits
changes.

[CANCEL] [ UP ] [DOWN] [ENTER]
```

2. To change the password, press UP or DOWN to specify the character that you want and press ENTER. The screen highlights the next character. Continue to press UP or DOWN and ENTER to specify each character until you have typed the password (the maximum quantity of characters is 15). Press ENTER. The library displays the message **Trap Community Name changed**. Press ENTER to return to the new SNMP screen.
3. Press **BACK** until you return to the Activity screen.

Viewing or Changing the Request Community Name

This section defines the request community name for the 3584 Tape Library, and describes how to view or change it.

Note: You can view or change the request community name by using the Tape Library Specialist web interface of the 3584 Tape Library, but not by using the operator panel.

The request community name is data that is required to receive a get-response message.

To view or change the request community name, perform the following steps:

1. Type the Ethernet IP address on the URL line of the browser and press Enter. The Welcome Page displays.
2. Select **Access** → **SNMP Settings**. See your system administrator to obtain and enter the information necessary in the Community Names field.

Viewing Ethernet Settings

This section describes how to view the settings for single or dual Ethernet ports in frames of the 3584 Tape Library.

Note: You can view Ethernet settings for the frames of the 3584 Tape Library by using the operator panel, but not by using the Tape Library Specialist web interface.

To view the settings for single or dual Ethernet ports, use the following method.

1. From the library's Activity touchscreen, press **MENU** → **Settings** → **Network** → **Ethernet** → **Trap Community Name** → **ENTER**. Different screens display, depending on the number of Ethernet ports that a frame has.
 - If the frame has one Ethernet port, the following screen displays.

```

Ethernet                               Panel 0175

Current Settings Frame 1:

MAC Address: 18:36:F3:98:4F:9A
IP Address:  19.117.63.126
Subnet Mask: 255.255.255.0
Gateway:     19.117.63.253

Link State: Connected
Speed: 100 Full duplex (Auto)

Ethernet Mode: Manual IP Entry

Change Settings

[BACK] [ UP ] [DOWN] [ENTER]
```

- If the frame has more than one Ethernet port, the following screen displays.

```

Ethernet                               Panel 0175

Current Settings
Frame 1, Port B:

MAC Address: 18:36:F3:98:4F:9A
IP Address:  19.117.217.67
Subnet Mask: 255.255.255.0
Gateway:     19.117.63.253

Link State: Connected
Speed: 100 Full duplex (Auto)

Ethernet Mode: Manual IP Entry

INITIALIZING

[BACK] [ UP ] [DOWN] [ENTER]
```

The screen includes the following settings (though not all settings may display at the same time).

Current Settings

The Ethernet screen displays Ethernet settings for Frame 1. If the

library contains more than one frame, press UP or DOWN to view the settings for the next or previous frame. If the frame contains more than one Ethernet port, the settings for Port A display. Press UP to view the settings for Port B. Press DOWN to return to the settings for Port A.

MAC Address

The Media Access Control (MAC) address is defined by the manufacturer of the Ethernet chip and cannot be changed.

IP Address

The Internet Protocol (IP) Address is an identifier that is unique to each library and is necessary for communication with the server (it is different from the Simple Network Management Protocol (SNMP) IP address).

Subnet Mask

The Subnet Mask address identifies the library's local area network (LAN).

Gateway

The Gateway Address is the location at which networks attach to each other. The link state indicates whether the Ethernet cable is properly connected to the library.

Link State

The Link State field indicates whether the Ethernet connection has been established between the library and the Ethernet switch. Values are Connected or Not Connected.

Speed The Speed field indicates the speed of data transmission across the Ethernet network. Valid values are:

- Set Speed to Auto Negotiate (the speed was negotiated automatically by the hardware (at 10 half duplex), rather than by a user).
- Set Speed to 100 Full Duplex (the data is communicated at 100 Mb/s with simultaneous sending and receiving capability)
- Set Speed to 100 Half Duplex (the data is communicated at 100 Mb/s with sending or receiving capability)
- Set Speed to 10 Full Duplex (the data is communicated at 10 Mb/s with simultaneous sending and receiving capability)
- Set Speed to 10 Half Duplex (the data is communicated at 10 Mb/s with sending or receiving capability)

Ethernet Mode

The Ethernet Mode field indicates how the IP information was set. Values are Dynamic Host Configuration Protocol (DHCP) or Manual IP Entry.

Setting

The Setting field indicates whether the DHCP lets another machine assign the library a Destination IP Address, or whether you assigned the address manually. Values are DHCP or Manual IP Entry.

2. **Change Settings/INITIALIZING** displays when you cycle power and the Ethernet driver boots. INITIALIZING also displays when you reset the Medium Changer Pack (MCP) card on Models L22, D22, L32, D32, L52, and D52, or when you reset the Medium Changer Assembly (MCA) in Models L23, D23, L53, and D53.
3. Press BACK until you return to the Activity screen.

Changing the Ethernet Address Settings

This section introduces procedures for changing the Ethernet address settings of frames that are part of the 3584 Tape Library and which contain single or dual Ethernet ports.

To change a frame's Ethernet address settings, use one of the following methods.

Related tasks

"Viewing Ethernet Settings" on page 165

This section describes how to view the settings for single or dual Ethernet ports in frames of the 3584 Tape Library.

Changing the Ethernet Address Settings of a Frame with a Single Port

This section describes how to change the Ethernet address settings for a frame that is part of the 3584 Tape Library and contains a single Ethernet port.

Note: You can change Ethernet address settings for the 3584 Tape Library by using its operator panel, but not by using the Tape Library Specialist web interface.

You can disable Ethernet settings, manually enable them, or let another machine enable them by using Dynamic Host Configuration Protocol (DHCP). You can also set a specific speed for the Ethernet port or specify the library to automatically negotiate the speed.

To change the Ethernet address settings for a frame with one port, use the following method.

1. From the library's Activity touchscreen, press **MENU** → **Settings** → **Network** → **Ethernet** → **ENTER**. The Ethernet screen displays Ethernet settings for Frame 1 (for an explanation of the fields in the Ethernet screen, see "Viewing Ethernet Settings" on page 165).

```
Ethernet                Panel 0175
Current Settings Frame 1:
MAC Address: 18:36:F3:98:4F:9A
IP Address:  19.117.63.126
Subnet Mask: 255.255.255.0
Gateway:    19.117.63.253

Link State: Connected
Speed: 100 Full duplex (Auto)

Ethernet Mode: Manual IP Entry

Change Settings

[BACK] [ UP ] [DOWN] [ENTER]
```

2. To change the Ethernet address settings, press **ENTER**. The Ethernet Settings menu displays.

Ethernet Settings Panel 0176

Disable Ethernet
Enable with DHCP
Enable with Manual IP Entry
Set Speed to Auto Negotiate
Set Speed to 100 Full Duplex
Set Speed to 100 Half Duplex
Set Speed to 10 Full Duplex
Set Speed to 10 Half Duplex

[BACK] [UP] [DOWN] [ENTER]

3. Press UP or DOWN to highlight Enable with Manual IP Entry and press ENTER. The Manual Ethernet Settings screen displays.

Manual Ethernet Settings Panel 0177

IP Address: **19.117.217.67**
Subnet Mask: 255.255.255.0
Gateway: 19.117.63.253

Use UP or DOWN to change
highlighted value.

[CANCEL] [UP] [DOWN] [ENTER]

To change the first octet in the IP Address, press UP or DOWN to change the value that you want, then press ENTER. The screen redisplay with the new characters and highlights the second octet. Press UP or DOWN to specify the numbers that you want, then press ENTER. Repeat this procedure for the third and fourth octets. After you modify the fourth octet and press ENTER, the library highlights the first octet of the Subnet Mask. Continue to change numbers as necessary. When you press ENTER after the last octet in Gateway, the library displays the message **Updating. This may take up to four minutes.** followed by **Ethernet Settings updated.**

4. Press ENTER. The Ethernet screen redisplay with the new settings.
5. Press BACK until you return to the Activity screen.

Changing the Ethernet Address Settings of a Frame with Dual Ports

This section describes how to change the Ethernet address settings for a frame that is part of the 3584 Tape Library and contains two Ethernet ports.

Note: You can change Ethernet address settings for the 3584 Tape Library by using its operator panel, but not by using the Tape Library Specialist web interface.

You can disable Ethernet settings, manually enable them, or let another machine enable them by using Dynamic Host Configuration Protocol (DHCP). You can also set a specific speed for the Ethernet port or specify the library to automatically negotiate the speed.

To change the Ethernet address settings for a frame with two ports, use the following method.

1. From the library's Activity touchscreen, press **MENU** → **Settings** → **Network** → **Ethernet** → **ENTER**. The Ethernet screen displays Ethernet settings for Frame 1 (for an explanation of the fields in the Ethernet screen, see "Viewing Ethernet Settings" on page 165).

Ethernet Panel 0175

Current Settings
Frame: 1 Port: A

MAC Address: 18:36:F3:98:4F:9A
IP Address: 19.117.63.126
Subnet Mask: 255.255.255.0
Gateway: 19.117.63.253

Link State: Connected
Speed: 100 Full duplex (Auto)

Ethernet Mode: Manual IP Entry

Change Settings

[BACK] [UP] [DOWN] [ENTER]

2. To change the Ethernet address settings, press ENTER. The Ethernet Settings menu displays.

Ethernet Settings Panel 0176

Disable Ethernet
Enable with DHCP
Enable with Manual IP Entry
Set Speed to Auto Negotiate
Set Speed to 100 Full Duplex
Set Speed to 100 Half Duplex
Set Speed to 10 Full Duplex
Set Speed to 10 Half Duplex

[BACK] [DOWN] [ENTER]

3. Press UP or DOWN to highlight Enable with Manual IP Entry and press ENTER. The Manual Ethernet Settings screen displays.

Manual Ethernet Settings Panel 0177

Frame: 1

IP Address: **19**.117.217.67
Subnet Mask: 255.255.255.0
Gateway: 19.117.63.253

Use UP or DOWN to change
highlighted value.

[CANCEL] [UP] [DOWN] [ENTER]

To change the first octet in the IP Address, press UP or DOWN to change the value that you want, then press ENTER. The screen redisplay with the new characters and highlights the second octet. Press UP or DOWN to specify the numbers that you want, then press ENTER. Repeat this procedure for the third and fourth octets. After you modify the fourth octet and press ENTER, the library highlights the first octet of the Subnet Mask. Continue to change numbers as necessary. When you press ENTER after the last octet in Gateway, the library displays the message **Updating. This may take up to four minutes.** followed by **Ethernet Settings updated.** Press ENTER. The Ethernet screen displays with the new settings for Port A.

Ethernet Panel 0175

Current Settings
Frame: 1 Port: A

MAC Address: 18:36:F3:98:4F:9A
IP Address: 19.117.63.126
Subnet Mask: 255.255.255.0
Gateway: 19.117.63.253

Link State: Connected
Speed: 100 Full duplex (Auto)

Ethernet Mode: Manual IP Entry

Change Settings

[BACK] [UP] [ENTER]

- To optionally change the settings of Port B, press UP. The Ethernet screen redisplay to show Frame 1, Port B.

Ethernet Panel 0175

Current Settings
Frame: 1 Port: B

MAC Address: 18:36:F3:98:4F:9A
IP Address: 19.117.63.126
Subnet Mask: 255.255.255.0
Gateway: 0.0.0.0

Link State: Connected
Speed: 100 Full duplex (Auto)

Ethernet Mode: Manual IP Entry

Change Settings

[BACK] [DOWN] [ENTER]

- Press ENTER. The Ethernet Settings screen displays.

Ethernet Settings Panel 0176

Disable Ethernet
Enable with Manual IP Entry
Set Speed to Auto Negotiate
Set Speed to 100 Full Duplex
Set Speed to 100 Half Duplex
Set Speed to 10 Full Duplex
Set Speed to 10 Half Duplex

[BACK] [UP] [DOWN] [ENTER]

- Press UP or DOWN to highlight Enable with Manual IP Entry and press ENTER. The Manual Ethernet Settings screen displays.

Manual Ethernet Settings Panel 0177

Frame: 1

Port B must only be configured for connection to a Master/System console.

IP Address: 10.1.1.31
Subnet Mask: 255.255.255.0

Use UP or DOWN to change highlighted value.

[CANCEL] [UP] [DOWN] [ENTER]

Refer to step 3 on page 169 for instructions about changing the values of the octets in the IP Address and Subnet Mask. When you have finished, press ENTER. The Ethernet screen displays with the new settings for Port B.

7. Press BACK until you return to the Activity screen.

Changing the Speed of the Ethernet Link

This section describes how to change the speed of the Ethernet link to the 3584 Tape Library.

Note: You can change the speed of the Ethernet link by using the operator panel on the 3584 Tape Library, but not by using the Tape Library Specialist web interface.

You can specify that data be transmitted across the Ethernet network at a specified rate or indicate that the library automatically negotiate that rate. The rates of transmission are 100 Mb/s at full duplex, 100 Mb/s at half duplex, 10 Mb/s at full duplex, and 10 Mb/s at half duplex.

To change the speed of the library's Ethernet port, use the following method.

1. From the library's Activity touchscreen, press **MENU** → **Settings** → **Network** → **Ethernet** → **ENTER**. The Ethernet screen displays Ethernet settings for Frame 1 (for an explanation of the fields in the Ethernet screen, see "Viewing Ethernet Settings" on page 165). If the library contains more than one frame, press UP or DOWN to view the settings for the next or previous frame. If the frame contains more than one Ethernet port, press UP or DOWN to view the settings for each port.

Ethernet Panel 0175

Current Settings Frame 1:

MAC Address: 18:36:F3:98:4F:9A
IP Address: 19.117.63.126
Subnet Mask: 255.255.253.0
Gateway: 19.117.63.253

Link State: Connected
Speed: 100 Full duplex (Auto)

Ethernet Mode: Manual IP Entry

Change Settings

[BACK] [UP] [DOWN] [ENTER]

2. To change the speed of the Ethernet link, press ENTER. The Ethernet Settings menu displays.

```
Ethernet Settings          Panel 0176

Disable Ethernet
Enable with DHCP
Enable with Manual IP Entry
Set Speed to Auto Negotiate
Set Speed to 100 Full Duplex
Set Speed to 100 Half Duplex
Set Speed to 10 Full Duplex
Set Speed to 10 Half Duplex

[BACK] [ UP ] [DOWN] [ENTER]
```

3. Press UP or DOWN to highlight the speed that you want, then press ENTER. The message **Updating Ethernet Settings this may take up to four minutes** displays, and the change begins. When the new setting is in place, **Ethernet Settings Updated** displays.
4. Press ENTER. The Ethernet menu redisplay with the new setting.
5. Press BACK until you return to the Activity screen.

Related tasks

“Viewing Ethernet Settings” on page 165

This section describes how to view the settings for single or dual Ethernet ports in frames of the 3584 Tape Library.

Using DHCP Server Settings

This section describes how to use Dynamic Host Configuration Protocol (DHCP) to assign an internet protocol (IP) address from the operator panel of the 3584 Tape Library.

Note: You can use the DHCP server settings by using the operator panel on the 3584 Tape Library, but not by using the Tape Library Specialist web interface.

The DHCP server acts as an administrator for the network. If you do not assign an internet protocol (IP) address for the library, the DHCP can assign it.

To specify that the DHCP server assign an IP address, use the following method.

1. From the library’s Activity touchscreen, press **MENU** → **Settings** → **Network** → **Ethernet** → **ENTER**. The Ethernet screen displays Ethernet settings for Frame 1 (for an explanation of the fields in the Ethernet screen, see “Viewing Ethernet Settings” on page 165). If the library contains more than one frame, press UP or DOWN to view the settings for the next or previous frame. If the frame contains more than one Ethernet port, press UP or DOWN to view the settings for each port.

```

Ethernet                               Panel 0175

Current Settings Frame 1:

MAC Address: 18:36:F3:98:4F:9A
IP Address:  19.117.63.126
Subnet Mask: 255.255.253.0
Gateway:     19.117.63.253

Link State:  Connected
Speed:      100 Full duplex (Auto)

Ethernet Mode: Manual IP Entry

Change Settings

[BACK] [ UP ] [DOWN] [ENTER]

```

- To change the Ethernet setting, press ENTER. The Ethernet Settings menu displays.

```

Ethernet Settings                       Panel 0176

Disable Ethernet
Enable with DHCP
Enable with Manual IP Entry
Set Speed to Auto Negotiate
Set Speed to 100 Full Duplex
Set Speed to 100 Half Duplex
Set Speed to 10 Full Duplex
Set Speed to 10 Half Duplex

[BACK] [ UP ] [DOWN] [ENTER]

```

- Press UP or DOWN to highlight Enable with DHCP and press ENTER. The library displays the message **If you select ENTER, the Ethernet Settings will be obtained through the DHCP server. Press ENTER to continue.** Press ENTER to obtain the settings. The library displays the message **Enabling DHCP settings. This may take up to four minutes.** followed by **DHCP Enabled.** Press ENTER. The Ethernet menu redisplay with the new setting.
- Press BACK until you return to the Activity screen.

Related tasks

“Viewing Ethernet Settings” on page 165

This section describes how to view the settings for single or dual Ethernet ports in frames of the 3584 Tape Library.

Disabling an Ethernet Connection

This section describes how to disable an Ethernet connection to the 3584 Tape Library.

Note: You can disable Ethernet by using the operator panel on the 3584 Tape Library, but not by using the Tape Library Specialist web interface.

To disable Ethernet, use the following method.

- From the library’s Activity touchscreen, press **MENU** —> **Settings** —> **Network** —> **Ethernet** —> **ENTER**. The Ethernet screen displays Ethernet settings for Frame 1 (for an explanation of the fields in the Ethernet screen, see “Viewing Ethernet Settings” on page 165). If the library contains more than one

frame, press UP or DOWN to view the settings for the next or previous frame. If the frame contains more than one Ethernet port, press UP or DOWN to view the settings for each port.

```
Ethernet                Panel 0175

Current Settings Frame 1:

MAC Address: 18:36:F3:98:4F:9A
IP Address: 19.117.63.126
Subnet Mask: 255.255.253.0
Gateway: 19.117.63.253

Link State: Connected
Speed: 100 Full duplex (Auto)

Ethernet Mode: Manual IP Entry

Change Settings

[BACK] [ UP ] [ENTER]
```

2. To change the Ethernet setting, press ENTER. The Ethernet Settings menu displays.

```
Ethernet Settings      Panel 0176

Disable Ethernet
Enable with DHCP
Enable with Manual IP Entry
Set Speed to Auto Negotiate
Set Speed to 100 Full Duplex
Set Speed to 100 Half Duplex
Set Speed to 10 Full Duplex
Set Speed to 10 Half Duplex

[BACK] [DOWN] [ENTER]
```

3. Press UP or DOWN to highlight Disable Ethernet and press ENTER. The library displays the message **If you select ENTER, the Ethernet Settings will be disabled. Press ENTER to continue.** Press ENTER to disable the settings. The library displays the message **Disabling Ethernet. This may take up to four minutes.** followed by **Ethernet Disabled.**
4. Press ENTER. The Ethernet menu redisplay with the new setting.
5. Press BACK until you return to the Activity screen.

Related tasks

“Viewing Ethernet Settings” on page 165

This section describes how to view the settings for single or dual Ethernet ports in frames of the 3584 Tape Library.

Changing the Date and Time

This section introduces two ways to change the date and time on your 3584 Tape Library.

Errors and internal logs contain a time stamp to indicate when the error occurred or when the log was generated. To change the date and time settings on your 3584 Tape Library, use one of the following methods.

Using the Web to Change the Date and Time

To use the Tape Library Specialist web interface to change the date and time on the 3584 Tape Library, perform the following steps:

1. Type the Ethernet IP address on the URL line of the browser and press Enter. The Welcome Page displays.
2. Select **Library** → **Date and Time**. The Date and Time screen displays.
3. Follow the instructions on the screen.

Using the Operator Panel to Change the Date and Time

To use the operator panel to change the date and time on the 3584 Tape Library, perform the following steps:

1. From the library's Activity touchscreen, press **MENU** → **Settings** → **Date/Time** → **ENTER**. The Date/Time menu displays with the current date and time. It also includes a list of parameters that you can change. They include the minute, hour, day, month, and year.

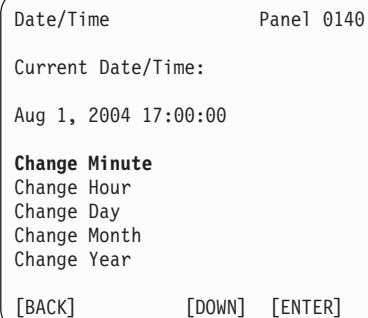

The screenshot shows a menu titled "Date/Time" with "Panel 0140" in the top right corner. Below the title, it says "Current Date/Time:" followed by "Aug 1, 2004 17:00:00". A list of options is shown: "Change Minute", "Change Hour", "Change Day", "Change Month", and "Change Year". At the bottom, there are three buttons: "[BACK]", "[DOWN]", and "[ENTER]".

2. Press UP or DOWN to highlight the parameter that you want to change and press ENTER. Depending on the parameter that you chose, a screen similar to the following displays.



The screenshot shows a screen titled "Set Minute" with "Panel 0141" in the top right corner. Below the title, it says "Aug 1, 2004 17:00:00". At the bottom, there are four buttons: "[BACK]", "[UP]", "[DOWN]", and "[ENTER]".

3. Press UP or DOWN to increment or decrement the minute, hour, day, month, or year setting.
4. Press ENTER to redisplay the screen with the new setting.
5. Press BACK until you return to the Activity screen.

Enabling or Disabling the Keypress Beep

This section describes how to enable or disable the beep that sounds when you press a key on the 3584 Tape Library.

Note: Not implemented in the Tape Library Specialist web interface.

The 3584 Tape Library uses a beep to acknowledge that you pressed a touch key on the touchscreen LCD. Use the following steps to enable or disable the keypress beep:

1. From the library's Activity touchscreen, press **MENU** → **Settings** → **Sounds** → **ENTER**. The Sounds screen displays with the current setting of the beep.

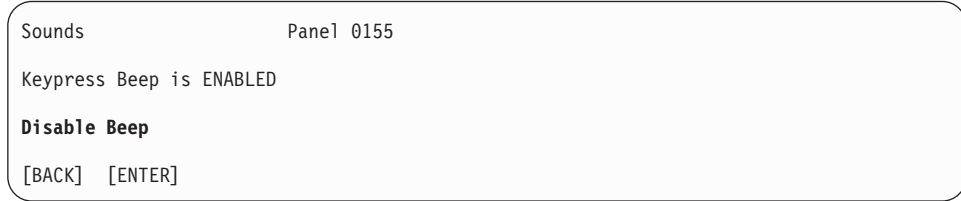

2. Press **ENTER** to change the setting of the beep to **DISABLED** or **ENABLED**. The library displays the message **You are about to set Keypress Beep Mode to x. Do you want to continue?** (where **x** equals **DISABLED** or **ENABLED**).
3. Press **YES**. The Sounds screen redisplay with the new setting.
4. Press **BACK** until you return to the Activity screen.

Enabling or Disabling the Reporting of a Six-Character or Eight-Character VOLSER

This section describes how to configure the 3584 Tape Library so that it reports to the server only the first six characters of the volume serial (VOLSER) number of a tape cartridge's bar code label or it reports the full eight characters of the VOLSER. Reporting eight characters is the default.

The method for enabling or disabling the reporting of the number of VOLSER characters differs depending on whether ALMS is enabled.

Steps for when ALMS is enabled

Notes: When ALMS is enabled:

- You can perform this function by using the Tape Library Specialist web interface, but not by using the operator panel.
- Do not enable the reporting of a six-character VOLSER if your 3584 Tape Library is attached to an IBM 3953 Tape System. If you enable six-character VOLSER reporting, the 3953 Tape System does not recognize the cartridges and sets them to manually eject.
- Enabling or disabling six-character VOLSER can be done on a logical library basis if ALMS is enabled.

If you are migrating cartridges to a 3584 Tape Library from a library that previously reported six-character VOLSERS, it may be necessary to enable the reporting of six-character VOLSERS on the 3584 Tape Library.

To use the Tape Library Specialist web interface to enable or disable the reporting of a six-character VOLSER by the 3584 Tape Library when ALMS is enabled, perform the following steps:

1. Type the Ethernet IP address on the URL line of the browser and press **Enter**. The Welcome Page displays.
2. Select **Library** → **Logical Libraries**. The Manage Logical Libraries screen displays.
3. Select the logical library you want to change to six-character VOLSER reporting.
4. In the **Select Action** drop-down list, select **Modify Volser Reporting** and select **GO**.

5. Under **Volser Reporting** select either **8 (default)** or **6** then click **APPLY** and **CLOSE**. The library displays the message Logical Library Volser reporting change is complete.

The six-character VOLSER is reported to all servers that are attached to this specific logical library; the full six-character or eight-character VOLSER appears on the web interface and library operator panel.

Steps for when ALMS is not enabled

Notes: When ALMS is not enabled:

- You can perform this function by using the Tape Library Specialist web interface, but not by using the operator panel.
- Do not enable the reporting of a six-character VOLSER if your 3584 Tape Library is attached to an IBM 3953 Tape System. If you enable six-character VOLSER reporting, the 3953 Tape System does not recognize the cartridges and sets them to manually eject.

To use the Tape Library Specialist web interface to enable or disable the reporting of a six-character VOLSER by the 3584 Tape Library when ALMS is not enabled, perform the following steps:

1. Type the Ethernet IP address on the URL line of the browser and press Enter. The Welcome Page displays.
2. Select **Library** → **6-Character Volser Reporting**. The 6-character Volser Reporting screen displays.
3. Follow the instructions on the screen.

The six-character VOLSER is reported to all servers that are attached to all logical libraries; the full eight-character VOLSER appears on the web interface and library operator panel.

Enabling or Disabling the Insert Notification Setting

This section introduces two ways to enable or disable Insert Notification, which is the setting that monitors and assigns new media to a logical library in the 3584 Tape Library.

The 3584 Tape Library offers an Insert Notification setting that monitors the library for new media and asks you to assign the media to a logical library. This can occur if you open the door of the I/O station and place a cartridge into an empty I/O slot or move a cartridge from one I/O slot to another.

When the Insert Notification setting is enabled, unassigned cartridges are inaccessible to any logical library, but user interfaces are still able to move cartridges to logical libraries and make them accessible to the host.

Note: The cartridge assignment policy overrides the method of assigning a cartridge to a logical library through the use of the Insert Notification setting. For more information, see “Working with a Cartridge Assignment Policy” on page 94.

To enable or disable the Insert Notification setting, use one of the following methods.

Related tasks

“Working with a Cartridge Assignment Policy” on page 94
This section defines a cartridge assignment policy. It gives procedures for creating, changing, or removing the policy.

Using the Web to Enable or Disable the Insert Notification Setting

To use the Tape Library Specialist web interface to enable or disable insert notification on the 3584 Tape Library, perform the following steps:

To use the library’s Tape Library Specialist web interface, perform the following steps:

1. Type the Ethernet IP address on the URL line of the browser and press Enter. The Welcome Page displays.
2. Select **Cartridges** → **Insert Notification**. The Change Insert Notification screen displays.
3. Follow the instructions on the screen.

Using the Operator Panel to Enable or Disable the Insert Notification Setting

The Insert Notification setting of the 3584 Tape Library allows you to assign a cartridge in the I/O station to a logical library. To use the operator panel to enable or disable the insert notification setting, perform the following steps:

1. From the library’s Activity touchscreen, press **MENU** → **Settings** → **Insert Notification** → **ENTER**. The Change Insert Notification screen displays. If the setting is enabled, the screen prompts you for a logical library and identifies the new cartridges to the server.

Change Insert Notification Panel 0190

Insert Notification: ENABLED

Insert Notification will prompt for a logical library when the I/O station door is opened. New cartridges in the I/O will be assigned to the selected logical library.

Press [UP] or [DOWN] to change the Insert Notification setting, then press [ENTER] to activate the changes.

[BACK] [UP] [DOWN] [ENTER]

2. Press UP or DOWN to specify whether you want to enable or disable the setting, then press ENTER. A confirmation screen displays.
3. If the new setting is correct, press ENTER. The screen redisplay with the new setting.
4. Press BACK until you return to the Activity screen.

Determining Usage of Library Components

This section introduces procedures for determining usage for the accessor, drive, or cleaning cartridge in the 3584 Tape Library.

Determining Accessor Usage

To determine usage information about the cartridge accessor in the 3584 Tape Library, use one of the following methods.

Using the Web to Determine Accessor Usage

To use the Tape Library Specialist web interface to determine usage of the accessor in the 3584 Tape Library, perform the following steps:

1. Type the Ethernet IP address on the URL line of the browser and press Enter. The Welcome Page displays.
2. Select **Library** → **Accessor**. The Accessor screen displays statistics about the accessor's usage.

Using the Operator Panel to Determine Accessor Usage

To use the operator panel to determine usage of the accessor in the 3584 Tape Library, perform the following steps:

1. From the library's Activity touchscreen, press **MENU** → **Usage Statistics** → **Accessor Usage** → **ENTER**. Depending on whether your library has one or two cartridge accessors, different screens display:
 - If your library has only one accessor, the Accessor Usage screen displays. The screen lists how many pivots of the accessor, gets and puts for each gripper, and bar code scans have occurred since the library's first operation. It also lists how many meters the accessor has traveled on the X and Y axes. When you finish viewing the information, go to step 2 on page 180.

```
Accessor Usage          Panel 0201
Accessor A:
  Pivots:                14591
  Gripper 1
    Gets:                30792
    Puts:                30791
  Gripper 2
    Gets:                19036
    Puts:                19036
Scans:                  31879
X Dist. (m)             31879
Y Dist. (m)             40172
[BACK]                 [DOWN]
```

- If your library has two accessors, the Select Accessor screen displays both.

```
Select Accessor        Panel 0031
Accessor A
Accessor B
[BACK]  [UP]  [DOWN]  [ENTER]
```

Press UP or DOWN to select the accessor for which you want usage information (in this example, Accessor A), then press ENTER. The Accessor Usage Cumulative for Life of Library screen displays for the accessor that you selected. For the library's first operation to its most recent operation, the screen lists how many pivots of the accessor, gets and puts for each gripper, and bar code scans have occurred for that library. It also lists how many meters the accessor has traveled on the X and Y axes.

```

Accessor Usage          Panel 0201

Cumulative for Life of Library
Accessor A:
  Pivots:              14591
  Gripper 1
    Gets:              30792
    Puts:              30791
  Gripper 2
    Gets:              19036
    Puts:              19036
Scans:                 31879
X Dist.(m)            31879
Y Dist.(m)            40172

[BACK]      [DOWN]

```

To view usage for each component in the accessor, press DOWN. The Accessor Usage For Life of Component screen displays how many pivots of the accessor, gets and puts for each gripper, and bar code scans have occurred for that particular component. It also lists how many meters that accessor has traveled on the X and Y axes. When you finish viewing the information, go to step 2.

```

Accessor Usage          Panel 0201

Cumulative for Life of Component
Accessor A:
  Pivots:              14591
  Gripper 1
    Gets:              1258
    Puts:              1258
  Gripper 2
    Gets:              19036
    Puts:              19036
Scans:                 31879
X Dist.(m)            31879
Y Dist.(m)            12278

[BACK]      [UP]

```

2. Perform one of the following:
 - To return to a previous menu, press UP.
 - To return to the Activity screen, press BACK until you locate that screen.

Determining Drive Usage

To determine usage information about a drive in the 3584 Tape Library, use one of the following methods.

Using the Web to Determine Drive Usage

To use the Tape Library Specialist web interface to determine usage of a drive in the 3584 Tape Library, perform the following steps:

1. Type the Ethernet IP address on the URL line of the browser and press Enter. The Welcome Page displays.
2. Select **Drives** → **Drive Summary**. The Drives screen displays.
3. Select the drive that you want.
4. From the Select Action drop-down box, select Details, then select Go to display usage statistics.

Using the Operator Panel to Determine Drive Usage

To use the operator panel to determine usage of a drive in the 3584 Tape Library, perform the following steps:

1. From the library's Activity touchscreen, press **MENU** → **Usage Statistics** → **Drive Usage** → **ENTER**. The Select Drive screen displays with a list of drives in the library and their physical locations. The locations are listed as **[Fxx,Rzz]**, (where **F** equals frame and **xx** equals its number, and **R** equals row and **zz** equals its number). To display more drives, highlight the bottom item and press **DOWN**. To return to the previous list of drives, highlight the top item and press **UP**.

```
Select Drive          Panel 0210
Key: F=Frame, R=Row L=LTO Ultrium,
      J = Enterprise Tape

Drive [F01,R01]  L3
Drive [F01,R02]  L1
Drive [F01,R03]  L2
Drive [F01,R04]  L3
Drive [F01,R05]  L2
Drive [F01,R06]  L1
Drive [F01,R07]  L1
Drive [F01,R08]  L2
Drive [F02,R01]  J2
Drive [F02,R02]  J1

[BACK] [ UP ] [DOWN] [ENTER]
```

2. Press **UP** or **DOWN** to highlight the drive that you want to review and press **ENTER**. Another Drive Usage screen displays with data about the drive that you chose. Because the library and the drive each track statistics for the drive independently, the screen contains two sections of statistics. If a drive is exchanged, however, the load and unload statistics tracked by the drive will be different than the statistics tracked by the library. Additional data on the screen includes information about how many times tape cartridges have been loaded into and unloaded from the drive, how many megabytes of data the drive has written and read (represented as **MB Written** and **MB Read**), and how many cleanings the drive has had (**MB Written**, **MB Read**, and **Unloads** are not available for the 3592 Tape Drive). The location of the drive is listed as **[Fxx,Rzz]**, (where **F** equals frame and **xx** equals its number, and **R** equals row and **zz** equals its number).

```
Drive Usage          Panel 0211
Key: F=Frame, R=Row

Drive [F01, R01]  Media Type: LTO

Library Statistics

Loads:              0003024
Unloads:            0003024

Drive Statistics

Loads:              0000001
Unloads:            0000001
MB Written:         0000001
MB Read:            0000002
Cleanings:          0000000

[BACK] [ UP ] [DOWN]
```

Note: If the drive replaced a drive that was removed for service, its load and unload statistics may be lower than those of the library.

3. Press BACK until you return to the Activity screen.

Determining Cleaning Cartridge Usage

To determine how many times the cleaning cartridge has been used in the 3584 Tape Library, use one of the following methods.

Using the Web to Determine Cleaning Cartridge Usage

To use the Tape Library Specialist web interface to determine usage of the cleaning cartridge in the 3584 Tape Library, perform the following steps:

1. Type the Ethernet IP address on the URL line of the browser and press Enter. The Welcome Page displays.
2. Select **Cartridges** → **Cleaning Cartridges**. The Cleaning Cartridges screen displays a list of all cleaning cartridges in the library and their usage statistics.

Using the Operator Panel to Determine Cleaning Cartridge Usage

To use the operator panel to determine usage of the cleaning cartridge in the 3584 Tape Library, perform the following steps:

1. From the library's Activity touchscreen, press **MENU** → **Usage Statistics** → **Cleaning Cartridge Usage** → **ENTER**. The Cleaning Cartridge Usage screen displays with a list of the cleaning cartridges in the 3584 Tape Library and how many times they have been used. For libraries that use both LTO Ultrium and 3592 media, the screen also indicates whether the cartridge is an LTO (Ultrium) or 3592 cartridge. To display more cleaning cartridges, highlight the bottom item and press DOWN. To return to the previous list of cleaning cartridges, highlight the top item and press UP.

Cleaning Cartridge Usage			Panel 0220
CLN101JA	025	3592	
CLN102L1	020	LTO	
CLN103L1	015	LTO	
CLN104L1	010	LTO	
CLN105JA	005	3592	
CLN106JA	000	3592	
CLN107L1	000	LTO	
CLN108JA	000	3592	
CLNU09JA	000	3592	
CLNU10L1	000	LTO	

[BACK] [UP] [DOWN]

2. Press BACK until you return to the Activity screen.

Accessing Vital Product Data for Library Components

This section introduces how to access vital product data (VPD) for the 3584 Tape Library, its drives, or its node cards. It also introduces how to access the serial numbers of drives in the library.

Accessing Vital Product Data for the Library

Vital product data (VPD) for the 3584 Tape Library includes the machine types, model numbers, and serial numbers of its frames, as well as the type of media each frame uses. To determine VPD for the library, use one of the following methods.

Using the Web to Access Vital Product Data for the Library

To use the Tape Library Specialist web interface to access vital product data (VPD) for the 3584 Tape Library, perform the following steps:

1. Type the Ethernet IP address on the URL line of the browser and press Enter. The Welcome Page displays.
2. Select **Service** —> **Library VPD**. The Vital Product Data screen displays the machine type, model number, and serial numbers of each frame, as well as the type of media each frame uses.

Using the Operator Panel to Access Vital Product Data for the Library

To use the operator panel to access vital product data (VPD) for the 3584 Tape Library, perform the following steps:

1. From the library's Activity touchscreen, press **MENU** —> **Vital Product Data** —> **Library VPD** —> **ENTER**. The Library VPD screen displays. The screen lists the machine type, model number, and serial number for Frame 1. For libraries that use both LTO Ultrium and 3592 media, the Media Type field indicates the type of media used in the frame. To display the VPD for additional frames (if applicable), press **DOWN**. To return to a previous screen, press **UP**.

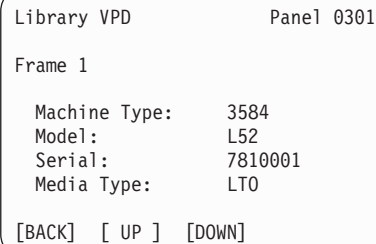

```
Library VPD          Panel 0301
Frame 1
Machine Type:      3584
Model:             L52
Serial:            7810001
Media Type:        LTO
[BACK] [ UP ] [DOWN]
```

2. Press **BACK** until you return to the Activity screen.

Accessing Vital Product Data for Drives in the Library

The vital product data (VPD) for an Ultrium Tape Drive or 3592 Tape Drive in the 3584 Tape Library includes the physical location of the drive, the SCSI Inquiry identification, and the version of firmware loaded. To determine VPD for a drive, use one of the following methods.

Using the Web to Access Vital Product Data for Drives in the Library

To use the Tape Library Specialist web interface to access vital product data (VPD) for drives in the 3584 Tape Library, perform the following steps:

1. Type the Ethernet IP address on the URL line of the browser and press Enter. The Welcome Page displays.
2. Select **Service** —> **Drive VPD**. The Vital Product Data screen displays the location, SCSI Inquiry identification (drive type), version of firmware, and serial number for each drive.

Using the Operator Panel to Access Vital Product Data for Drives in the Library

To use the operator panel to access vital product data (VPD) for drives in the 3584 Tape Library, perform the following steps:

1. From the library's Activity touchscreen, press **MENU** → **Vital Product Data** → **Drive VPD** → **ENTER**. The Drive VPD screen displays. For each configured drive in Frame 1, the screen lists the physical location of the drive and its SCSI Inquiry identification (such as **ULT3580-TD4** for Ultrium 4 Tape Drives, **ULT3580-TD3** for Ultrium 3 Tape Drives, **ULT3580-TD2** for Ultrium 2 Tape Drives, **ULT3580-TD1** for Ultrium 1 Tape Drives, **03592J1A** for the 3592 J1A, and **03592E05** for the TS1120 Tape Drive). It also gives the version of firmware loaded on each drive and whether the drive uses a SCSI LVD, SCSI HVD, or Fibre Channel (FC) interface. To display additional drives for Frame 1 and the VPD for the drives in other frames, press **DOWN**. To return to previous screens, press **UP**.

```
Drive VPD                Panel 0310

Key: F=Frame, R=Row

[F01,R01] ULT3580-TD4 1234 FC
[F01,R02] ULT3580-TD3 1234 FC
[F01,R03] ULT3580-TD1 1234 LVD
[F01,R04] ULT3580-TD1 1234 FC
[F01,R05] ULT3580-TD1 1234 FC
[F01,R06] ULT3580-TD1 1234 FC
[F01,R07] ULT3580-TD2 1234 FC
[F01,R08] ULT3580-TD1 1234 HVD
[F01,R09] ULT3580-TD1 1234 HVD
[F02,R01] 03592J1A    1234 FC
[F02,R02] 03592E05   1234 FC

[BACK] [ UP ] [DOWN]
```

2. Press **BACK** until you return to the Activity screen.

Accessing Vital Product Data for Node Cards in the Library

Node cards are the four circuit boards (accessor controller card, motor driver assembly, and operator panel assembly) that communicate with each other. Depending on the type of frame and power structure that your library has, the fourth circuit board is for the Medium Changer card pack (MCP) or the Medium Changer assembly (MCA). Models L22, D22, L52, and D52 use the node card for the MCP; Models L23, D23, L53, and D53 use the node card for the MCA.

For the 3584 Tape Library the vital product data (VPD) for the node cards includes the part number and serial number of the card, as well as the version of firmware loaded and the number of the frame in which the card is located. To determine VPD for a node card, use one of the following methods.

Using the Web to Access Vital Product Data for Node Cards in the Library

To use the Tape Library Specialist web interface to access vital product data (VPD) for node cards in the 3584 Tape Library, perform the following steps:

1. Type the Ethernet IP address on the URL line of the browser and press Enter. The Welcome Page displays.
2. Select **Service** → **Node Card VPD**. The Vital Product Data screen displays the location of the library's node cards and version of their software.

Using the Operator Panel to Access Vital Product Data for Node Cards in the Library

To use the operator panel to access vital product data (VPD) for node cards in the 3584 Tape Library, perform the following steps:

1. From the library's Activity touchscreen, press **MENU** → **Vital Product Data** → **Node Card VPD** → **ENTER**. The Node Card VPD screen displays for Frame 1. The screen shows the part number and serial number of the accessor controller card, as well as the level of firmware in the library.

```
Node Card VPD          Panel 0320

Frame 1:
Accessor Controller Card

Part Number:          1234567
Serial Number:        YN100002W123
Firmware Version:    4321

[BACK] [ UP ] [DOWN]
```

To view VPD for the motor driver assembly, Medium Changer card pack, and operator panel assembly in Frame 1, press **UP**. Continue to press **UP** to view the VPD for node cards in other frames. To return to previous screens, press **UP**.

Note: If the MCP node card is enabled for web use, the same screen displays but includes the version of the web (see the screen that follows). If **Mismatch** displays in the Web Version field, the web and the code card versions are not the same code versions. To access the web, reload the firmware or contact your IBM Service Representative.

```
Node Card VPD          Panel 0320

Frame 1:
Accessor Controller Card

Part Number:          1234567
Serial Number:        YN100002W123
Firmware Version:    4321
Web Version:          4321

[BACK] [ UP ] [DOWN]
```

2. Press **BACK** until you return to the Activity screen.

Resetting the Library Control System

This section describes how to reset one or more node cards should the 3584 Tape Library experience a hang state.

Attention: If you reset a node card, you could potentially lose data that is necessary for analyzing the problem.

Note: You can reset node cards by using the Tape Library Specialist web interface, but not by using the operator panel.

To use the web to reset node cards in the 3584 Tape Library, perform the following steps:

1. Type the Ethernet IP address on the URL line of the browser and press **Enter**. The Welcome Page displays.

2. Select **Service** —> **Node Cards**. The Node cards screen displays a list of the library's node cards.
3. Select one or more node cards that you want to reset.
4. From the Select Action drop-down box, select Reset Node Cards, then select Go. A confirmation message displays indicating that the cards have been reset.

Note: A node card that is reset could take up to 3 minutes to return to active status on the Node cards screen. To view the new status, select Refresh. If you reset the node card that is serving your web connection, you will need to reconnect to the web server after the card resets.

5. Select **Close**.

Accessing Drive Serial Numbers

You can view the serial numbers of both LTO Ultrium and 3592 Tape Drives without opening the doors of the 3584 Tape Library. This function is particularly useful for 3592 Tape Drives because these drives are tracked as separate machines with their own warranty or maintenance agreement (MA). By using this function and determining a drive's serial number, you can verify whether an MA exists for it. In addition, to save time the IBM Service Representative can use this function to see all of the serial numbers without opening all of the covers and can verify that a serial number was preserved correctly when a drive fails and must be replaced.

To access the drive serial number for an LTO Ultrium or 3592 Tape Drive in the 3584 Tape Library, use one of the following methods.

Using the Web to Access Serial Numbers of Drives

To use the Tape Library Specialist web interface to access the serial numbers of drives in the 3584 Tape Library, perform the following steps:

1. Type the Ethernet IP address on the URL line of the browser and press Enter. The Welcome Page displays.
2. Select **Service** —> **Drive VPD**. The Drive Vital Product Data screen displays the serial numbers (not the world wide names) of the drives in the 3584 Tape Library.

Using the Operator Panel to Access Serial Numbers of Drives

To use the operator panel to access the serial numbers of the drives in the 3584 Tape Library, perform the following steps:

1. From the library's Activity touchscreen, press **MENU** —> **Vital Product Data** —> **Drive Serial Numbers** —> **ENTER**. The Drive Serial Numbers screen displays. The screen gives the location of the LTO and 3592 Tape Drives in the library and their serial numbers.

Drive Serial Numbers Panel 0311

Key: F=Frame, R=Row

[F01,R01] JP002750
[F01,R02] 1310101156
[F01,R03] 1310100797
[F01,R04] JP00001289
[F01,R05] 1310100772
[F02,R01] 0123456789AB0
[F01,R03] 0123456789AB1

[BACK] [UP] [DOWN]

Press UP to view additional drive serial numbers. To return to previous screens, press UP.

2. Press BACK until you return to the Activity screen.

Accessing Logs for the Library

This section describes how to access logs for the 3584 Tape Library.

Note: You can access logs for the 3584 Tape Library by using the Tape Library Specialist web interface but not by using the library's operator panel.

To access logs for the library, use the following method:

1. Type the Ethernet IP address or the library URL on the URL line and press Enter. The Welcome Page displays.
2. Perform one of the following:
 - Select **Service** → **View Library Error Log**. The View Library Error Log screen displays a list of logs that you can view. At the top of the page, the current position in the error log displays. To go to another error log, do one of the following:
 - Enter an error log number in the text box and select Go to skip to that entry.
 - Use the arrows to go forward or back one entry.
 - Select **Service** → **Download Library Logs**. The Download Library Logs screen displays a list of devices and logs that you can download. They include event logs, servo logs, NVRAM event logs, Fatal Exception logs, and so forth.
 - a. Select the log that you want to download
 - b. Select Download. you select NVRAM Backup/Memory Dump, the library attempts to get a snapshot of the current library configuration.
 - c. Specify the directory to which you want to download the log
 - d. Select Save.

Accessing Enhanced Data Gathering and Reporting Files

The section introduces four enhanced methods by which the 3584 Tape Library gathers data and reports files.

The 3584 Tape Library can access physical and logical library statistics, mount history, drive statistics, and port statistics. Data is available from the Ultrium 2 Tape Drive, Ultrium 3 Tape Drive, Ultrium 4 Tape Drive, the 3592 J1A, and the TS1120 Tape Drive 3592 E05. Data is not available from the Ultrium 1 Tape Drive.

The sections that follow describe how to download each category of data.

Accessing the Mount History of Tape Cartridges

This section describes how to obtain the Mount History log, which gives the mount history of one or more cartridges in the 3584 Tape Library. It also describes how to access information from the customer-centric Statistical Analysis and Reporting System (ccSARS) for the TS1120 Tape Drive (formerly the IBM TotalStorage 3592 Tape Drive Model E05). The ccSARS information is only for TS1120 Tape Drives at firmware level 16E4 or later.

The Mount History log displays a list of cartridges in descending order, starting with the most recent unmounted cartridge and going back. Fields in the log are as follows:

Date and Time

The date and time that the cartridge was mounted into the drive. The format is *yyyy mm dd hh:nn. ss*, where *yyyy* equals the year, *mm* equals the month, *dd* equals the day, *hh* equals the hour, *nn* equals the minute, and *ss* equals the second.

VolSer

The volume serial number of the cartridge (also known as *volser*). The volser is a unique identifier. Ignore the underscore that precedes the volser.

Frame The number of the library frame from which the cartridge was demounted. Beginning with the base frame, frames are numbered 1 to 16, from left to right, and excluding the service bays.

Drive The number of the drive from which the cartridge was demounted. Drives are numbered 1 to 12, from top to bottom.

LogLib

The name of the logical library to which the cartridge had been assigned.

EAddr The element address from which the cartridge had been demounted. The element address is a value that defines the cartridge's logical location in the library to the SCSI interface.

Mount Tape Alert Media

The number of the most recent TapeAlert flag that was received by this drive and which pertained to this cartridge. To determine the meaning of the TapeAlert flag, see "TapeAlert Flags Supported by the Ultrium Tape Drives" on page 302 or "TapeAlert Flags Supported by the 3592 Tape Drives" on page 307.

Life Mounts Media

The number of times the cartridge has been mounted to a drive since it was manufactured.

Life WRetries Media

During the life of the cartridge, the number of errors that have occurred when drives retried Write operations.

Life WPerms Media

During the life of the cartridge, the number of permanent, unrecoverable errors that have occurred when drives performed Write operations.

Life RRetries Media

During the life of the cartridge, the number of errors that have occurred when drives retried Read operations.

Life RPerms Media

During the life of the cartridge, the number of permanent, unrecoverable errors that have occurred when drives performed Read operations.

Mount Rating Drive

The overall measure of the drive's condition. X'00' is unknown. The value ranges from X'01' (best) to X'FF' (worst). This is a rating of the drive's efficiency.

Mount Rating Media

The overall measure of the condition of the cartridge that is currently mounted. X'00' is unknown. The value ranges from X'01' (best) to X'FF' (worst). This is a rating of the cartridge's efficiency.

Mount Rating Ports

The overall measure of the condition of the interface to the host server. X'00' is unknown. The value ranges from X'01' (best) to X'FF' (worst). This is a rating of the interface's efficiency.

Mount Rating Port0

The overall measure of the condition of the Port 0 interface to the host server. X'00' is unknown. The value ranges from X'01' (best) to X'FF' (worst). This is a rating of the efficiency of the Port 0 interface.

Mount Rating Port1

The overall measure of the condition of the Port 1 interface to the host server. X'00' is unknown. The value ranges from X'01' (best) to X'FF' (worst). This is a rating of the efficiency of the Port 1 interface.

Mount Rating Rsvd

Reserved for the library interface.

Mount Write Perf

The ratio of performance Write commands with respect to all Write-type commands. This is a measure of the efficiency of write performance. The value is given as a percentage. A high percentage is best; a low percentage is worst.

Mount Write ERPs

The measure of how the data rate performance impacts the error-recovery procedures (ERPs) on Write operations. The value is given as a percentage. A high percentage is best; a low percentage is worst.

Mount Write Burst

For Write operations, the measure of the comparison between the window tape buffer rate to the average rate. The window rate is the amount of data moved divided by the time when ready in the mode (when data could be moved, but is not). The average rate is the amount of data moved divided by the overall time in the mode (including setup, overhead, and so forth). The value is given as a percentage. A high percentage is best; a low percentage is worst.

Mount Write Buffer

The average tape-buffer efficiency on Write operations. This is streaming write efficiency. The value is given as a percentage. A high percentage is best; a low percentage is worst.

Mount Read Perf

The ratio of performance Read-type commands with respect to all Read-type commands. The value is given as a percentage. A high percentage is best; a low percentage is worst.

Mount Read ERPs

The measure of how the data rate performance impacts the error-recovery procedures (ERPs) on Read operations. The value is given as a percentage. A high percentage is best; a low percentage is worst.

Mount Read Burst

For Read operations, the measure of the comparison between the window tape buffer rate to the average rate. The window rate is the amount of data moved divided by the time when ready in the mode (when data could be moved, but is not). The average rate is the amount of data moved divided by the overall time in the mode (including setup, overhead, and so forth). The value is given as a percentage. A high percentage is best; a low percentage is worst.

Mount Read Buffer

The average tape-buffer efficiency on Read operations. This is streaming read efficiency. The value is given as a percentage. A high percentage is best; a low percentage is worst.

Mount Capacity Total

The measure of the efficiency of static capacity. This can be viewed as the percentage of recorded media that fits into the currently recorded area with respect to how much data can ideally fit in that area. The lower the percentage, the less capacity is available (due to recording error recovery, media defects, and so forth).

Mount Capacity Writes

The measure of the efficiency of active capacity on Write commands. This can be viewed as the sum of efficiency for Write operations on this mount. The value is given as a percentage. A high percentage is best; a low percentage is worst.

Mount Capacity Control

The measure of the efficiency of active capacity on all other operations. The value is given as a percentage. A high percentage is best; a low percentage is worst.

Crypto Status

Whether a cartridge is encrypted. Values are 1 (the media contains encrypted data), 0 (the media does not contain encrypted data), or a blank space if the drive was unable to determine whether the media contains encrypted data.

Crypto Rekey

Whether a cartridge has been rekeyed. Values are 1 (the cartridge was rekeyed during the last mount) or 0 (the cartridge was not rekeyed during the last mount).

To access the mount history for one or more cartridges and to access ccSARS data for TS1120 Tape Drives, use the following method:

1. Type the Ethernet IP address or the library URL on the URL line and press Enter. The Welcome Page displays.
2. Select **Cartridges**—> **Data Cartridges**. The Cartridges screen displays.

Note: To capture and download ccSARS data, you may need to flush the cache storage of the TS1120 Tape Drive and turn off caching within your browser.

3. Select the Mount History (.csv) link. The File Download prompt displays.

4. Select Save.
5. Specify the directory to which the log is to download. If you have problems downloading the .csv file, associate it with Microsoft Excel or Lotus 1-2-3 in Windows.
6. Select Save.

Accessing Statistics about Drives

This section describes how to obtain the Drive Statistics file, which contains statistics about drives in the 3584 Tape Library.

The Drive Statistics file displays data about the drives that have resided in the library since the date and time in the first row of the file. The data is captured whenever you reset the library or a node card, or when you update the library's firmware. Fields in the file are as follows:

WWNN

The World Wide Node Name of the drive. Ignore the underscore that precedes each value.

Model The type of drive, as reported by the drive's SCSI string. Ignore the underscore that precedes each value.

S/N The serial number of the drive. Ignore the underscore that precedes each value.

Valid A value of 1 in this column (and 0 in all Write or Read columns) means that commands were run, but there were no errors or activity performed by the drive. A value of 0 in this column means that the entries in all columns are invalid.

Last Volser

The volume serial number of the last cartridge demounted from the drive. Ignore the underscore that precedes each value.

Write MB Host Since

The quantity of megabytes (MB) written by the host to all cartridges since the time stamp at the top of the report.

Write Error Corrected Since

The quantity of write errors that the drive corrected since the time stamp at the top of the report.

Write Error Uncorrected Since

The quantity of write errors that the drive could not correct since the time stamp at the top of the report.

Read MB Host Since

The quantity of megabytes (MB) that the drive read since the time stamp at the top of the report.

Read Error Corrected Since

The quantity of read errors that the drive has corrected since the time stamp at the top of the report.

Read Error Uncorrected Since

The quantity of read errors that the drive could not correct since the time stamp at the top of the report.

To access statistics about the drives, use the following method:

1. Type the Ethernet IP address or the library URL on the URL line and press Enter. The Welcome Page displays.
2. Select **Drives**—> **Drive Summary**. The Drives screen displays.
3. Select the DOWNLOAD: Drive Statistics (.csv) link. The File Download prompt displays.
4. Select Save. If you have problems downloading the .csv file, associate it with Microsoft Excel or Lotus 1-2-3 in Windows.
5. Specify the directory to which the file is to download.
6. Select Save.

Accessing Port Statistics for Drives

This section describes how to obtain the Fibre Port Statistics file, which contains statistics about Fibre Channel drives in the 3584 Tape Library.

The Fibre Port Statistics file displays data about the Fibre Channel drives that have resided in the library since the date and time in the first row of the file. Fields in the file are as follows:

WWNN

The World Wide Node Name of the Fibre Channel drive. Ignore the underscore that precedes each value.

Model The type of Fibre Channel drive, as reported by the drive's SCSI string. Ignore the underscore that precedes each value.

S/N The serial number of the Fibre Channel drive. Ignore the underscore that precedes each value.

Valid A value of 1 in this column (and 0 in all Write or Read columns) means that commands were run, but there were no errors or activity performed by the drive. A value of 0 in this column means that the entries in all columns are invalid.

Host Error Since

The quantity of host Fibre Channel port errors since the date of the time stamp at the top of the report.

Host Abort Since

The quantity of host Fibre Channel port errors ended since the date of the time stamp at the top of the report.

Host Reset Since

The quantity of host Fibre Channel port errors that required a reset since the date in the time stamp at the top of the report.

Host Recoveries Since

The quantity of host Fibre Channel port errors recovered during the error-correction process since the date of the time stamp at the top of the report.

To access statistics about the drives, use the following method:

1. Type the Ethernet IP address or the library URL on the URL line and press Enter. The Welcome Page displays.
2. Select **Ports**—> **Fibre Channel Summary**. The Fibre Channel Summary screen displays.
3. Select the Fibre Port Statistics (.csv) link. The File Download prompt displays.

4. Select Save.
5. Specify the directory to which the file is to download. If you have problems downloading the .csv file, associate it with Microsoft Excel or Lotus 1-2-3 in Windows.
6. Select Save.

Accessing Statistics about the Library

This section describes how to obtain the Library Statistics file, which contains statistics about the physical 3584 Tape Library, as well as its logical libraries.

Note: This function is only available for Models L23 and L53.

Library statistics can help you determine the efficiency of your logical library partitions, particularly if some logical libraries are used more heavily than others. Information from the statistics can help you decide whether to re-partition your library to increase performance. For both the physical library and its logical libraries you can download the Library Statistics file. Fields in the file are as follows:

Date and Time

The date and time that the cartridge was mounted into the drive. The format is *yyyy mm dd hh:nn. ss*, where *yyyy* equals the year, *mm* equals the month, *dd* equals the day, *hh* equals the hour, *nn* equals the minute, and *ss* equals the second.

Log Lib

The name of the logical library for which data has been captured. Ignore the underscore that precedes each name.

Residency Max Time

The amount of time that a cartridge has been mounted in a drive.

Residency Avg Time

The total amount of time that all cartridges have been mounted in drives divided by the number of mounts in the hour.

Mounts Total

The total number of times that a cartridge was mounted to the drive for this logical library.

Mounts Max Time

The time from when a mount command is received until when it is executed.

Mounts Avg Time

The total amount of time that all mount commands have been waiting to be executed divided by the number of mount commands received in the hour.

Ejects Total

The total number of times that a cartridge was moved from the I/O station for this logical library.

Ejects Max Time

The time from when the eject command is received until when it is executed.

Ejects Avg Time

The total amount of time that all eject commands have been waiting to be executed divided by the number of eject commands received in the hour.

Total Inputs

The total number of cartridges moved from the I/O station into the storage slots.

To access statistics about the library, use the following method:

1. Type the Ethernet IP address or the library URL on the URL line and press Enter. The Welcome Page displays.
2. Select **Library**—> **Logical Libraries**. The Manage Logical Libraries screen displays.
3. Select the Library Statistics (.csv) link. The File Download prompt displays.
4. Select Save.
5. Specify the directory to which the file is to download. If you have problems downloading the .csv file, associate it with Microsoft Excel or Lotus 1-2-3 in Windows.
6. Select Save.

Viewing the Library Error Log

This section describes how to view the library error log for the 3584 Tape Library.

To view the library error log for the 3584 Tape Library, use the following method:

1. Type the Ethernet IP address or the library URL on the URL line and press Enter. The Welcome Page displays.
2. Select **Service**—> **View Library Error Log**. The Library Error Log screen displays the current position in the error log.
3. To view another error log, perform one of the following:
 - Enter an error log number in the text box and select Go to skip to that entry.
 - Go forward one entry in the log by selecting the right arrow.
 - Go back one entry by selecting the left arrow.

Fields in the log are as follows:

Date Date that the error occurred. The format is yyyy mm dd, where yyyy equals the year, mm equals the month, and dd equals the day.

Time Time that the error occurred. The format is hh mm ss, where hh equals the hour, mm equals the minute, and ss equals the second.

URC Unit reference code.

Command

SCSI command.

SK Sense key.

ASC/ASCQ

Additional sense code or additional sense code qualifier.

HEC/HECQ

Hardware error code or hardware error code qualifier.

MSB Mechanism state bitmap.

SEB Source element bitmap.

Source

Source location, which can be frame, column, and row, drive, or I/O station slot.

DEB Destination element bitmap.

Destination

Destination location, which can be a frame, column, and row, drive, or I/O station slot.

Object #

Code object that detected the problem.

Object Error

Location in code object.

Frame Frame number.

Drive Drive number.

A trailer record is an addendum to an existing record. The fields in the Trailer Record are as follows:

Logical Library

The logical library in which the error occurred.

Location 1

Source location, which can be frame, column, and row, drive, or I/O station slot.

Location 2

Destination location, which can be frame, column, and row, drive, or I/O station slot.

Location 3

Destination location, which can be frame, column, and row, drive, or I/O station slot. This field is applicable only on Exchange Medium and Inventory requests.

Volser 1

Volume serial (VOLSER) number of the cartridge.

Volser 2

Volume serial number of the cartridge. This field is applicable only on Exchange Medium and Inventory requests.

Updating Firmware for the Library

This section introduces ways to update library firmware for the 3584 Tape Library.

Note: When updating firmware, ensure that the device that you are updating (library or drive) is not in use at the time of the update.

To update firmware for the 3584 Tape Library, use one of the following methods.

Using the Web to Update Library Firmware

In the past, whenever library firmware needed an update it was necessary to schedule downtime for the 3584 Tape Library. Job flow was interrupted and productivity was reduced. The library now offers a nondisruptive library firmware update that the IBM Service Representative can perform by using the CETool software application or that you can perform by using the Tape Library Specialist

web interface. Certain levels of library and drive firmware are required. Table 15 shows the levels of firmware that are necessary for a nondisruptive library firmware update.

Table 15. Minimum levels of library and drive firmware required for nondisruptive library firmware updates

Device (see Note)	Level of Firmware
3584 Tape Library	6050
Ultrium 4 Tape Drive	All Levels
Ultrium 3 Tape Drive	62R0
Ultrium 2 Tape Drive	6750
TS1120 Tape Drive	16E4
3592 J1A Tape Drive	0828
Note: The nondisruptive library firmware update is not applicable when a control path drive is an Ultrium 1 Tape Drive.	

To update library firmware by using the web, perform the following steps:

1. Type the Ethernet IP address on the URL line of the browser and press Enter. The Welcome Page displays.
2. Select **Service** → **Firmware Update**. The Firmware Update screen displays.
3. Follow the instructions on the screen to identify, download (from the Internet), and install the current firmware image for the library.

In addition, you can use another method to update library firmware:

1. Go to <http://www.ibm.com/servers/storage/support>.
2. Under Product family, select Linear Tape Open (LTO).
3. Under Product, select 3584 UltraScalable Tape Library.
4. Select the Download tab.
5. Select Firmware.
6. Select IBM 3584 UltraScalable Tape Library Firmware to download library firmware.

Using a Device Driver to Update Library Firmware from the Host

To update 3584 Tape Library firmware from the host by using a device driver, refer to the instructions in the *IBM Ultrium Device Drivers Installation and User's Guide*.

Using Other Methods to Update Library Firmware

Besides using the web or the host, other methods exist for updating 3584 Tape Library firmware. For more information, contact your IBM Service Representative.

Accessing Logs for Drives or Saving a Drive Dump

This section describes how to access logs for drives in the 3584 Tape Library and how to save a drive dump.

Note: You can access logs for drives in the 3584 Tape Library or save a drive dump by using the Tape Library Specialist web interface but not by using the library's operator panel.

Note: The following procedure only works on 3592 J1A/E05, and 3588 (LTO Ultrium-3 and Ultrium-4) drives. This procedure will NOT work on LTO Ultrium-1 or Ultrium-2 drives.

To access logs for Ultrium Tape Drives and 3592 Tape Drives or to save a drive dump, use the following method:

1. Type the Ethernet IP address or the library URL on the URL line and press Enter. The Introduction screen displays.
2. Ensure that the drive that you want to access is not in operation (that is, no host applications are using the drive). If the drive is operating and you attempt to download its logs, a drive error will occur.
3. Select **Service** —> **Download Drive Logs**. The Download Drive Logs screen displays.
4. Select the drive that you want.
5. Perform one of the following:
 - To obtain a drive log, specify the directory to contain the log, then select Download.
 - To obtain and save a drive dump, select Stop Drive and Preserve Logs.
6. Select Save.

Viewing a Drive Error Log

This section describes how to view one or more error logs for tape drives in the 3584 Tape Library. You can view logs for the 3592 Tape Drives or Ultrium Tape Drives.

To view a drive error log, use the following method:

1. Type the Ethernet IP address or the library URL on the URL line and press Enter. The Welcome Page displays.
2. Select **Service** —> **View Drive Error Log**. The Drive Error Log screen displays.
3. From the Select a Drive drop-down box, select the name of the drive that you want and select Go. The Drive Error Log screen redisplay the current error log.
4. In the <- **Log x of y** -> field (where x equals the number of the current log entry and y equals the number of log entries) specify the number of the log entry that you want to view by selecting an arrow (the left arrow decrements the log entry number; the right arrow increments the log entry number). You may also enter the log entry number in the empty field and select Go. The log entry displays. Depending on the type of drive that you specified (LTO Ultrium Tape Drive or 3592 Tape Drive), fields in the log vary and are as follows:

Fields in an error log from an LTO Ultrium Tape Drive:

- Date** Date that the error occurred. The format is yyyy mm dd, where yyyy equals the year, mm equals the month, and dd equals the day.
- Time** Time that the error occurred. The format is hh mm ss, where hh equals the hour, mm equals the minute, and ss equals the second.

Error Code

Number of the error code.

1st FSC

First fault symptom code.

2nd FSC

Second fault symptom code.

Cartridge

Volume serial (VOLSER) number of the cartridge.

EC Level

Engineering change level.

HW Level

Hardware level.

Fields in an error log from a 3592 Tape Drive:

Date Date that the error occurred. The format is yyyy mm dd, where yyyy equals the year, mm equals the month, and dd equals the day.

Time Time that the error occurred. The format is hh mm ss, where hh equals the year, mm equals the minute, and ss equals the second.

Severity

Severity of the error.

FID Failure identification number.

1st FSC

First fault symptom code.

2nd FSC

Second fault symptom code.

Cartridge

Volume serial (VOLSER) number of the cartridge.

Updating Drive Firmware

This section introduces ways to update firmware for tape drives in the 3584 Tape Library.

For drives in the 3584 Tape Library, you can copy firmware for like drive types from a firmware image. To update firmware for LTO Ultrium or 3592 Tape Drives, use one of the following methods.

Using the Web to Update Drive Firmware

In the past, a firmware update to a drive that was performed through the library was disruptive to the host server; the operator had to stop host jobs that were queued to the drive and take the drive offline. The library now provides two nondisruptive options for updating drive firmware: Activate on Drive Reset and Activate on Drive Unload. These options do not impact the host if they are used when the drive is not busy.

To use the Tape Library Specialist web interface to update firmware for drives in the 3584 Tape Library, perform the following steps:

1. Type the Ethernet IP address on the URL line of the browser and press Enter. The Welcome Page displays.
2. Select **Service Library** → **Firmware Update**. The Firmware Update screen displays.
3. Select the Launch Firmware Update Wizard, then select the choice to update a drive. The Specify Firmware Image File screen displays.
4. Select one or all drives to update, then select one of the following Firmware Activation options.

Note: Only the Activate immediately option is available to the Ultrium 1 Tape Drive. In addition, the Activate when drive is empty option is not supported for control path drives.

Option	Description
Activate immediately	Performs the update as soon as you select Update
Activate when drive is empty	Performs the update only after you have removed the cartridge from each specified drive
Activate when drive is reset	Performs the update after you reset one or more drives

5. Select Update.

Using a Device Driver to Update Drive Firmware from the Host

For the 3584 Tape Library, to update drive firmware from the host by using a device driver refer to the instructions in the *IBM Ultrium Device Drivers Installation and User's Guide*.

Using Other Methods to Update Drive Firmware in the 3584 Tape Library

Besides using the web or the host, other methods exist for updating drive firmware in the 3584 Tape Library. For more information, contact your IBM Service Representative.

Adjusting the Scanner Speed

This section gives instructions for adjusting the speed at which the scanner, a laser device in the 3584 Tape Library, reads bar code labels.

Note: If you suspect that the library is having problems reading the bar code labels, you can slow the scanner speed as part of problem determination. You may choose to slow the scanner speed rather than replace all labels, or you may want to slow the scanner speed while you wait for an opportunity to re-label the media. Depending on the severity of the problem, the error recovery procedure (ERP) for poor labels may greatly exceed the time lost by slowing the scanner. If you have cartridge bar code labels that meet the LTO bar code label specification, there is no need to slow the scanner speed.

To adjust the scanner speed of the 3584 Tape Library, use the following method:

1. Type the Ethernet IP address on the URL line of the browser and press Enter. The Welcome Page displays.
2. Select **Service**—> **Scanner Speed**. The Adjust Scanner Speed screen displays.
3. From the drop-down box, select the percentage of the normal speed that you want.
4. From the Select Action drop-down box, select Apply, then select Go.

Related reference

“Ordering Bar Code Labels for Ultrium Cartridges” on page 241

“Ordering 3592 Bar Code Labels” on page 266

Performing a Remote Drive Power Cycle

This section describes how to conduct a power cycle on the 3584 Tape Library from a remote location.

Note: This function is available only through the Tape Library Specialist web interface; it is not available through the operator panel.

On occasion, a drive in the 3584 Tape Library may experience an error. Errors are represented by the message **Not Responding** and by error indicators in the Status column of the Drives screen. For intermittent, non-hardware problems (such as a drive hang), you can use the Tape Library Specialist web interface to cycle power to the drive (turn it off, then on) from a remote location. The remote power cycle feature resets the drive.

To perform a remote power cycle, use the following steps:

1. Ensure that the drive to which you want to apply the power cycle is not currently operating (if you cycle power to a drive that contains a cartridge, the rewind time may be of extended duration).
2. Type the Ethernet IP address on the URL line of the browser and press Enter. The Welcome Page displays.
3. Select **Drives** —> **Drive Summary**. The Drives screen displays.
4. Select the drive that you want, then from the Select Action drop-down box, select Power Cycle, then select Go. Select Refresh to redisplay the Drives screen and to return the status to Online.

Configuring the Library to Work with Your SMI-S Agent for Tape

This section describes how to set up your 3584 Tape Library so that it uses the Storage Management Initiative - Specification (SMI-S) to communicate in a Storage Area Network (SAN) environment.

Note: This function is available only through the Tape Library Specialist web interface; it is not available through the operator panel.

To configure your 3584 Tape Library to work with your SMI-S Agent for Tape, use the following steps. For the version of SNMP traps, the IP address, the Trap Community Name, and the Request Community Name, refer to the *IBM TotalStorage SMI-S Agent for Tape on Linux Systems Installation Guide*.

1. Go to <http://www-03.ibm.com/servers/storage/support/software/smisagent/> and follow the instructions to download the SMI-S software.
2. Enable SNMP traps. For instructions, see “Enabling or Disabling SNMP Traps” on page 157.

3. Set the version of the SNMP traps to match that of the SMI-Agent for Tape. For instructions, see “Setting the Version of SNMP Traps” on page 159.
4. Set an SNMP Destination IP to match the IP address of the SMI-S Agent for Tape. For instructions, see “Viewing or Changing the Destination IP Configuration and Remote Port” on page 161.
5. Set the Trap Community Name to match the SMI-S Agent for Tape (the default for both is public). For instructions, see “Viewing or Changing the Trap Community Name” on page 163.
6. Enable SNMP Requests. For instructions, see “Enabling or Disabling SNMP Requests” on page 158.
7. Set the Request Community Name to match the SMI-S Agent for Tape (the default for both is public). For instructions, see “Viewing or Changing the Request Community Name” on page 164.
8. Ensure that the 3584 Tape Library is running the most current firmware. To determine the level of the existing firmware, see “Using the Web to Access Vital Product Data for Node Cards in the Library” on page 184. To determine the most current library firmware, see “Using the Web to Update Library Firmware” on page 195.

Related concepts

“Updating Drive Firmware” on page 198

This section introduces ways to update firmware for tape drives in the 3584 Tape Library.

Related tasks

“Using the Web to Enable or Disable SNMP Traps” on page 158

“Using the Web to Set the Version of SNMP Traps” on page 160

“Using the Web to View or Change the Destination IP Configuration and Remote Port” on page 162

“Using the Web to View or Change the Trap Community Name” on page 164

“Using the Web to Enable or Disable SNMP Requests” on page 159

“Viewing or Changing the Request Community Name” on page 164

This section defines the request community name for the 3584 Tape Library, and describes how to view or change it.

“Using the Web to Access Vital Product Data for Node Cards in the Library” on page 184

Viewing Licensed Features

This section describes how to view whether the license keys for the Advanced Library Management System (ALMS), control path failover, or capacity expansion features are installed in Models L22, L23, L32, L52, or L53 of the 3584 Tape Library.

To view installed licensed features, perform the following steps:

1. Type the Ethernet IP address on the URL line of the browser and press Enter. The Welcome Page displays.
2. Select **Service** → **License Keys**. The License Keys screen displays the available features and indicates whether they are Installed or Not Installed.
 - Available features for Models L22, L23, L52, and L53 include ALMS, control path failover, intermediate capacity expansion, and full capacity expansion
 - Available features for Model L32 include ALMS, control path failover, and capacity expansion

Setting Up and Using Encryption

This section introduces how to set up encryption and perform encryption-related tasks.

Attention: There is no recovery for lost encryption keys.

To set up and use encryption in your 3584 Tape Library, perform the following tasks. The sections that follow give instructions for each task.

Note: In the Tape Storage environment, the Encryption function on tape drives (desktop, stand-alone and within libraries) is configured and managed by the customer and not the IBM Systems Services Representative (SSR). In some instances SSRs will be required to enable encryption at a hardware level when service access or service password controlled access is required. Customer setup support is by Field Technical Sales Specialist (FTSS), customer documentation, and software support for encryption software problems. Customer “how to” support is also provided via support line contract.

1. **Set up to four key manager addresses.** (For library-managed encryption only.) A key manager is a software application that manages one or more encryption keys. A key manager address is the IP address of any key manager. For instructions, see “Working with Key Manager Addresses” on page 204.
2. **Test the key manager addresses.** (For library-managed encryption only.) You can ping each key manager IP address to determine if communication is established. For instructions, see “Testing a Key Manager Address” on page 204.
3. **Enable your encryption-capable tape drives.** To do so, select your preferred method of encryption management for the drives that you want to perform encryption. You can choose from among three methods. For instructions, see “Setting or Changing a Drive’s Method of Encryption” on page 203. If you select the application-managed method for your drives, no further steps are necessary. The drives are ready to perform encryption.
4. If you select library-managed encryption, you will need to choose between barcode encryption policy or internal label encryption policy:
 - Note:** ‘Internal Label’ selections are only used for Symantec’s Veritas NetBackup™.
 - **Set up one or more barcode encryption policies.** (Optional and for barcode encryption policy only.) A barcode encryption policy identifies to a TS1120 Tape Drive or LTO Ultrium-4 which range of scratch cartridges will be encrypted. For instructions, see “Working with a Barcode Encryption Policy” on page 206.
 - **Set up internal label encryption policies.** (Optional and for internal label encryption policy only.) When you use one of the Internal Label encryption policy options (Selective Encryption or Encrypt All), you optionally set up key label mapping. For instructions, see “Mapping Encrypted Cartridge Key Labels” on page 208.

Other encryption-related functions are available. To determine a drive’s encryption method, see “Viewing a Drive’s Method of Encryption” on page 209. To learn if the data on a cartridge is encrypted, see “Determining Whether a Cartridge is Encrypted” on page 210. To rekey a cartridge for extra protection or for reuse, see “Rekeying an Encrypted Cartridge” on page 210.

Setting or Changing a Drive's Method of Encryption

This section describes how to set or change the encryption method for a TS1120 Tape Drive or LTO Ultrium-4 tape drive.

Notes:

- You can set or change a drive's method of encryption by using the Tape Library Specialist web interface but not by using the operator panel.
- Before you perform this procedure, ensure that you have installed your Key Manager software.

To set or change the encryption method for each TS1120 Tape Drive or LTO Ultrium-4 tape drive, perform the following steps:

1. Type the Ethernet IP address on the URL line of the browser and press Enter. The Welcome Page displays.
2. Select **Library**—> **Logical Libraries**. The Manage Logical Libraries screen displays. For each logical library, the Encryption Method column indicates whether encryption is Library-Managed, Application-Managed, System-Managed, is assigned no method (None), or is unable to be set to encryption (N/A).
3. To set or change a drive's method of encryption, select the check box of the logical library to which the drive belongs. If you select multiple logical libraries with dissimilar encryption methods, the Encryption Method field displays Mixed and no changes can be made.

Note: If ALMS is not enabled, all logical libraries for a given media type must be selected in order for the Modify Encryption Method to be invoked.

4. From the Select Action drop-down box, select Modify Encryption Method and select Go. The Modify Encryption Method pop-up window displays.
5. In the Encryption Method field, select the type that you want.

Note: If you select the system-managed method when using TS1120 Tape Drives, the screen displays the installed TS1120 Tape Drives and indicates whether they are encryption-capable. Select the encryption-capable drives that you want to become encryption-enabled, then select Apply.

6. If the encryption method is Library Managed Encryption, the Encryption Policy selections are:
 - Barcode (Default)
 - Internal Label - Selective Encryption
 - Internal Label - Encrypt All

Note: 'Internal Label' selections are only used for Symantec's Veritas NetBackup™.

Note: The default setting of the library-managed encryption method is to encrypt all cartridges in a logical partition.

Advanced Encryption Settings: The purpose of Advanced Encryption Settings is to allow only IBM Support personnel (under the direction of the drive development team) to provide a solution to an unforeseen problem or to support a unique configuration. This option is not intended for the customer to use without the guidance of IBM Support.

Working with Key Manager Addresses

This section describes how to set one or more key manager addresses. It also gives procedures for creating, modifying, or deleting a key manager address.

Note: You can create, modify, or delete a key manager address by using the Tape Library Specialist web interface but not by using the operator panel. You can test a key manager address by using both the web and the operator panel.

A key manager is a software application that manages one or more secret encryption keys. A key manager address is the IP address of a server that has one or more encryption key managers.

1. Type the Ethernet IP address on the URL line of the browser and press Enter. The Welcome Page displays.
2. Select **Access—> Key Manager Addresses**. The Key Manager Addresses screen displays.
3. Perform one of the following:
 - **To create a key manager address:** From the Select Action drop-down box select Create, then select Go. The Key Manager Create screen displays. Enter the IP address and port of the key manager. Select Apply.
 - **To change a key manager address:** Select the key manager address that you want to change. From the Select Action drop-down box select Modify, then select Go. The Key Manager Modify screen displays. Enter any necessary changes in the IP Address or Port fields. Select Apply.
 - **To delete a key manager address:** Select the key manager address that you want to delete. From the Select Action drop-down box select Delete, then select Go. The screen displays the message **Are you sure you want to delete this key manager entry?** Select OK. A pop-up window confirms the deletion. Select Close.
 - **To ping a key manager address:** Follow the procedure in “Testing a Key Manager Address.”

Testing a Key Manager Address

This section introduces how to test the address of an encryption key manager. It also introduces a procedure for testing the key path and setup between an encryption-enabled TS1120 Tape Drive or LTO Ultrium-4 tape drive, and the encryption key manager.

A key manager is a software application that manages one or more secret encryption keys. A key manager address is the IP address of a server that has one or more encryption key managers.

On the web, the test of a key manager address is known as a *ping*. To test the address of a key manager or the path between a drive and a key manager, use the following methods.

Using the Web to Ping a Key Manager Address

To use the Tape Library Specialist web interface to ping a key manager address, perform the following steps:

1. Type the Ethernet IP address on the URL line of the browser and press Enter. The Welcome Page displays.
2. Select **Access—> Key Manager Addresses**. The Key Manager Addresses screen displays.

3. Select the key manager address that you want to ping.
4. From the Select Action drop-down box select Ping Address, then select Go. The library performs the ping and the screen displays a status message.
5. Select Close.

Using the Operator Panel to Test the Encryption Key Path and Setup

To test the path and the setup of the TS1120 Tape Drive or LTO Ultrium-4 (second screen below) and the encryption key manager (EKM), perform the following steps:

1. From the library's Activity touchscreen, press **MENU** → **Service** → **Tests/Tools** → **Diagnostics** → **Test Encryption Key Path/Setup** → **ENTER**. The Test Encryption Key Path/Setup screen displays.

Results for a TS1120 Drive

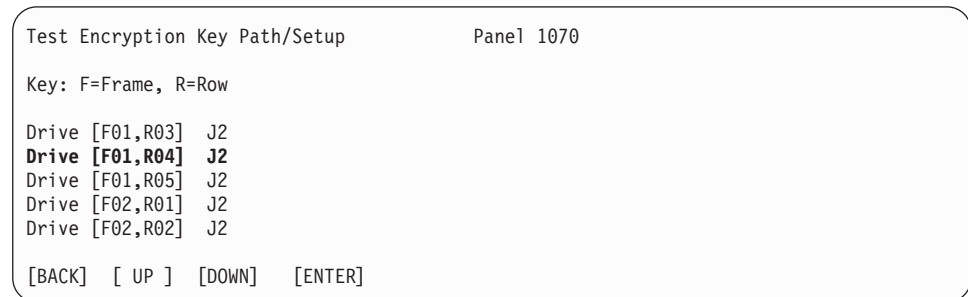

Results for a TS1040 (LTO Ultrium) Drive

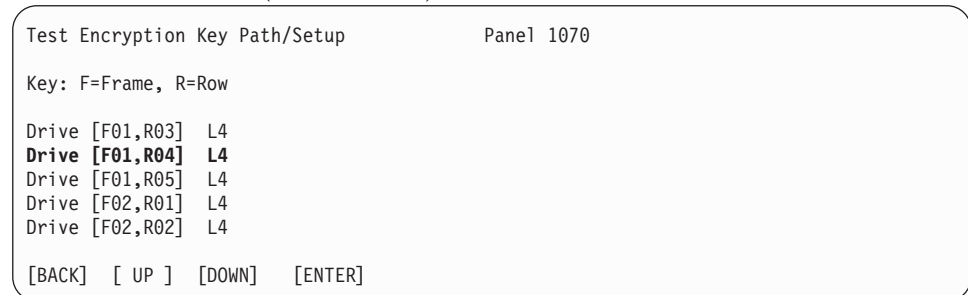

2. Press UP or DOWN to highlight the drive that you want to test, then press ENTER. The Test Encryption Key Path/Setup screen displays and automatically begins the following tests. If a test fails, see "Resolving Errors with the Library and the Installed Tape Drives" on page 269.

Ethernet

A ping of the EKM's IP address where the selected drive is registered. The library can ping up to four IP addresses. If successful, the screen displays Passed which means that the target server can be reached. If unsuccessful, the screen displays Failed. If at least one test passes, the testing continues; if all the tests fail, EKM Path and EKM Configuration will not run and ENTER displays.

EKM Path

A diagnostic that establishes a link to an encryption key manager. The test ensures that the communication path between the drive and the EKM (including the proxy server) is working. If successful, the screen displays Passed; if unsuccessful, it displays Failed. If EKM Path fails, EKM Configuration will not run and ENTER displays.

EKM Configuration

A diagnostic that establishes a link to a encryption key manager and requests a default key which ensures that the drive has been correctly installed and is able to service key requests.

The following screen shows sample results of the three types of tests.

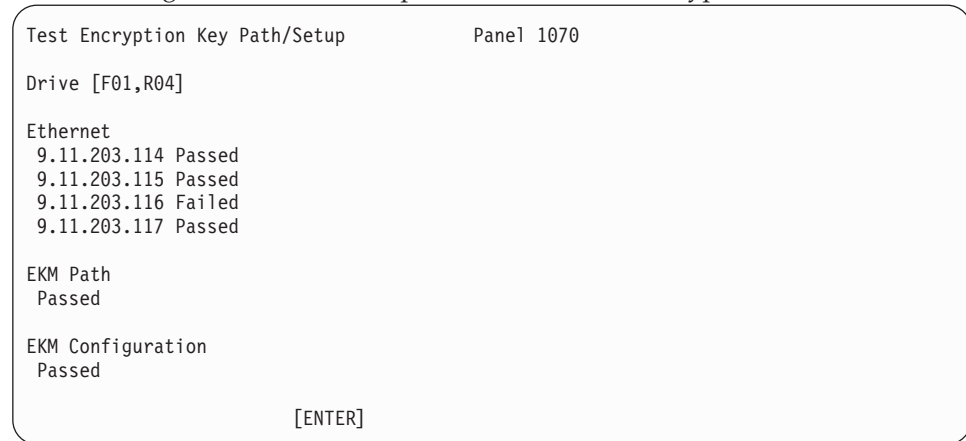

3. Press ENTER to return to the Test Encryption Key Path/Setup screen.

Working with a Barcode Encryption Policy

This section defines a barcode encryption policy. It gives procedures for creating, modifying, or deleting a policy. **Note:** With the latest library firmware level, the left-hand navigation now reads, "Barcode Encryption Policy" instead of "Scratch Encryption Policy."

Note:

- You can create, modify, or delete a barcode encryption policy by using the Tape Library Specialist web interface but not by using the operator panel.
- If your logical libraries are set to library-managed encryption, you use the default All/Other Volsers policy, or you can set the VOLSER ranges that will control encryption in all library-managed logical libraries.
- A Barcode Encryption Policy is only required if you have selected Library Managed Encryption with a Barcode Encryption Policy.

A barcode encryption policy allows the 3584 Tape Library to identify to a TS1120 Tape Drive or TS1040 (LTO Ultrium 4) Tape Drive which scratch cartridges will be encrypted on the next attempt to write from the beginning of the tape. A scratch cartridge is a labeled cartridge that is blank or contains no valid data, that is not currently defined, and that is available for use. A barcode encryption policy specifies what scratch cartridges to encrypt; it does not indicate which cartridges are currently encrypted. The maximum allowed barcode encryption policies is 300 for the entire 3584 Tape Library.

When you create or change a barcode encryption policy, you must specify the following:

Key Label

An alias for the key material managed by the EKM. The label and it's associated key(s) must be pre-generated at the EKM.

- For TS1120 Tape Drives, the key label is an alias for the public/private wrapping key (wrapped key model). TS1120 Tape Drives require two key labels.

- For the TS1040 (LTO Ultrium 4) Tape Drive, the key label is an alias for the symmetric data key (direct key model). TS1040 Tape Drives require one key label.

Key Mode

A key mode is the method by which a key manager identifies the public/private keys that were used to encrypt a data key. For each key label, you are also asked for a key mode.

- Choices for the TS1120 Tape Drive key mode are:
 - Wrapped-Default (The label was configured at the encryption key manager and the key label field is left blank).
 - Wrapped-Clear (The externally encoded data key (EEDK) is referenced by the specified key label. The key label field specifies a wrapping key).
 - Wrapped-Hash (The EEDK is referenced by a computer value which corresponds to the public key that is referenced by the specified key label. The key label field specifies a wrapping key).
- Choices for the TS1040 (LTO Ultrium 4) Tape Drive key mode are:
 - Direct-Default Set (the label was configured at the encryption key manager and the key label field is left blank)
 - Direct-Specific (the key label field specifies a symmetric data key)

To create, change, or delete a barcode encryption policy for a logical library, perform the following steps:

1. Type the Ethernet IP address on the URL line of the browser and press Enter. The Welcome Page displays.
2. Select **Cartridges**—> **Barcode Encryption Policy**. The Barcode Encryption Policy screen displays.
3. Perform one of the following:
 - **To create a barcode encryption policy:**
 - a. From the Select Action drop-down box select Create, then select Go. The Barcode Encryption Policy pop-up window displays.
 - b. Select the Set All/Other Volsers check box or enter the volume serial (VOLSER) numbers that begin and end the range of cartridges to be in the policy.
 - c. Enter the key label(s) and key mode(s) for each.
 - For TS1120 tape drives, enter two key labels. Choices for key mode are Wrapped-Default, Wrapped-Clear, or Wrapped-Hash.
 - For TS1040 (LTO Ultrium 4) tape drives, enter one key label. Choices for key mode are Direct-Default Set or Direct-Specific.
 - **To change a barcode encryption policy:**
 - a. Select the VOLSER range of the policy that you want to change.
 - b. From the Select Action drop-down box select Modify, then select Go. The Barcode Encryption Policy pop-up window displays.
 - c. Enter your changes and select Apply. The screen redisplay with the changes.
 - **To delete a barcode encryption policy:**
 - a. Select All/Other Volsers or select the VOLSER range of the policy that you want to delete.

- b. From the Select Action drop-down box select Delete, then select Go. The library displays the message **Are you sure you want to remove the volume serial range?**
- c. Select OK. The Barcode Encryption Policy screen redisplay with the barcode encryption policy removed. If only one barcode encryption policy exists, the library does not allow you to delete it.

Mapping Encrypted Cartridge Key Labels

This section describes how to create, change, or delete mappings from the cartridge key labels constructed by an encryption-enabled TS1120 or TS1040 (LTO Ultrium-4) tape drive and stored on an encrypted tape cartridge, to the labels for the required key-encrypting keys in the Encryption Key Manager keystore.

The key label is an alias for the key material managed by the EKM. The label and its associated key(s) must be pre-generated at the EKM.

Notes:

- You should only use the Key Label Mapping function for logical libraries using library-managed encryption by one of the two internal label mapping options (Selective Encryption or Encrypt All). Do not use Key Label Mapping for logical libraries using library-managed encryption by cartridge barcode. See “Setting or Changing a Drive’s Method of Encryption” on page 203.
- ‘Internal Label’ selections are only used for Symantec’s Veritas NetBackup™.

To create, modify, or delete encrypted key label mapping, perform the following steps:

1. Type the Ethernet IP address on the URL line of the browser and press Enter. The Welcome Page displays.
2. Select **Cartridges**—> **Key Label Mapping**. The Key Label Mapping screen displays.
3. If you are modifying or deleting an existing key label mapping, select the Key Label Mapping.
4. From the Select Action drop-down box, select one of the following, then select Go.
 - **Create:** to create a new key label mapping (see Step 6.)
 - **Modify:** to change an existing key label mapping (see Step 6.)
 - **Delete:** to remove an existing key label mapping. After you select Go, a window displays asking you to confirm the deletion. Select OK, then, after receiving a confirmation message, close the window.
5. If creating or modifying the key label mapping, specify the mapping by entering values in the following fields:
 - **Map from Key Label** Enter the key label(s) to map from. A key label is an alias for the key (cipher). It is used by the encryption key manager software. You can use the previously selected key labels drop-down list to quickly find a previously selected key label.
 - For TS1120 Drives two key labels are used. Use one of these methods to select the key labels:
 - Enter the two labels in Key Label 1 and Key Label 2.
 - From each of the drop-down boxes titled previously selected key labels, select an existing key label.

- For TS1040 (LTO Ultrium) Drives one key label is used. Use one of these methods to select the key label:
 - Enter the label in Key Label .
 - From the drop-down box titled previously selected key labels, select an existing key label.
 - **Map to Key Mode** From the drop-down boxes beside the Map to Key Mode field(s), select the key mode to map to for each key label.
 - Choices for the TS1120 Tape Drive Key Mode 1 and Key Mode 2 are:
 - Wrapped-Default (The label was configured at the encryption key manager and the key label field is left blank).
 - Wrapped-Clear (The externally encoded data key (EEDK) is referenced by the specified key label. The key label field specifies a wrapping key).
 - Wrapped-Hash (The EEDK is referenced by a computer value which corresponds to the public key that is referenced by the specified key label. The key label field specifies a wrapping key).
 - Choices for the TS1040 (Ultrium) Tape Drive Key Mode are:
 - Direct-Default Set (the label was configured at the encryption key manager and the key label field is left blank)
 - Direct-Specific (the key label field specifies a symmetric data key)
 - **Map to Key Label:** Enter the key label(s) to map to. For TS1120 tape drives, enter two key labels. For TS1040 (LTO Ultrium) tape drives enter one key label.
6. Select Apply. The Library displays a message that the requested policy or mapping change is complete. Select Close.

Viewing a Drive's Method of Encryption

This section describes how to determine the encryption method used by a TS1120 Tape Drive or LTO Ultrium-4 tape drive.

Note: You can view a drive's method of encryption by using the Tape Library Specialist web interface but not by using the operator panel.

To view the encryption method for each TS1120 Tape Drive or LTO Ultrium-4 tape drive, perform the following steps:

1. Type the Ethernet IP address on the URL line of the browser and press Enter. The Welcome Page displays.
2. Select **Library**—> **Logical Libraries**. The Manage Logical Libraries screen displays. For each logical library, the Encryption Method column indicates whether encryption is Library-Managed, Application-Managed, System-Managed, is assigned no method (None), or is unable to be set to encryption (N/A).
3. To view a drive's method of encryption, select the check box of the logical library to which the drive belongs.
4. From the Select Action drop-down box, select View Encryption Method, and select Go. The View Encryption Method pop-up window displays.
5. Locate the entry in the Encryption Method field. To return to the previous screen, select Cancel.
6. If the encryption method is Library Managed Encryption, the Encryption Policy selections are:
 - Barcode (Default)
 - Internal Label - Selective Encryption

- Internal Label - Encrypt All

Note: 'Internal Label' selections are only used for Symantec's Veritas NetBackup™.

Advanced Encryption Settings: The purpose of Advanced Encryption Settings is to allow only IBM Support personnel (under the direction of the drive development team) to provide a solution to an unforeseen problem or to support a unique configuration. This option is not intended for the customer to use without the guidance of IBM Support.

Determining Whether a Cartridge is Encrypted

This section describes how to determine if the data on a 3592 Tape Cartridge or LTO Ultrium-4 tape cartridge is encrypted.

Note: You can find out whether a cartridge contains encrypted data by using the Tape Library Specialist web interface but not by using the operator panel.

To determine whether a cartridge is encrypted, perform the following steps:

1. Type the Ethernet IP address on the URL line of the browser and press Enter. The Welcome Page displays.
2. Select **Cartridges**—> **Data Cartridges**. The Cartridges screen displays.
3. Select whether the cartridges are in a frame or logical library, select how you want the cartridges to be sorted, then select the Search button. The page refreshes and displays a list of volume ranges as links in the upper right. It also displays information about each cartridge in the library. If the library is installed with an encryption-enabled TS1120 Tape Drive or LTO Ultrium-4 tape drive, the screen includes an Encryption column that indicates whether the cartridge is Encrypted, Not Encrypted, or Unknown. An Unknown cartridge is one that has not been previously mounted in a 3592 Tape Drive or LTO Ultrium-4 tape drive.

Rekeying an Encrypted Cartridge

This section describes how to assign a different encryption key (also known as *key label*) to a 3592 Tape Cartridge that has already been encrypted.

Notes:

- You can rekey an encrypted tape cartridge by using the Tape Library Specialist web interface but not by using the operator panel.
- This procedure is applicable only if you have enabled encryption on one or more TS1120 Tape Drives.

The process of rekeying a cartridge is restricted to TS1120 Tape Drives within the cartridge's logical library. Whether a cartridge has been rekeyed is tracked in Mount History logs.

To rekey a cartridge, perform the following steps:

1. Ensure that an encrypted cartridge is mounted in an encryption-enabled TS1120 Tape Drive .
2. Type the Ethernet IP address on the URL line of the browser and press Enter. The Welcome Page displays.
3. Select **Cartridges**—> **Data Cartridges**. The Cartridges screen displays.

4. Select whether the cartridges are in a frame or logical library, select how you want the cartridges to be sorted, then select the Search button. The page refreshes and displays a list of volser ranges as links in the upper right. It also displays information about each cartridge in the library.
5. Select the check box of the encrypted cartridge that you want to rekey.
6. From the Select Action drop-down box, select Rekey Encryption and select Go. The Rekey Encryption pop-up window displays the selected cartridge by volume serial number.
7. Specify the new key label by performing one of the following. A key label is an alias for the key (cipher). It is used by the encryption key manager software.
 - Enter a new label in Key Label 1 and Key Label 2.
 - From each of the drop-down boxes titled previously selected key labels, select an existing key label.
8. From the drop-down boxes beside the Key Mode field(s), select the key mode. A key mode is the method by which a key manager identifies the public/private keys that were used to encrypt a data key. Choices for the TS1120 Tape Drive Key Mode 1 and Key Mode 2 are:
 - Wrapped-Default (The label was configured at the encryption key manager and the key label field is left blank).
 - Wrapped-Clear (The externally encoded data key (EEDK) is referenced by the specified key label. The key label field specifies a wrapping key).
 - Wrapped-Hash (The EEDK is referenced by a computer value which corresponds to the public key that is referenced by the specified key label. The key label field specifies a wrapping key).
9. Select Apply.

Related tasks

“Accessing the Mount History of Tape Cartridges” on page 188

This section describes how to obtain the Mount History log, which gives the mount history of one or more cartridges in the 3584 Tape Library. It also describes how to access information from the customer-centric Statistical Analysis and Reporting System (ccSARS) for the TS1120 Tape Drive (formerly the IBM TotalStorage 3592 Tape Drive Model E05). The ccSARS information is only for TS1120 Tape Drives at firmware level 16E4 or later.

Chapter 4. Using Ultrium Media

The section introduces information about Ultrium Tape Media.

The IBM System Storage TS3500 Tape Library automates the storage and movement of IBM LTO Ultrium Tape Cartridges.

Overview of Ultrium Media

This section describes Ultrium media.

Within the 3584 Tape Library and subject to certain restrictions, the Ultrium Tape Drives use the following cartridge types:

- IBM System Storage 800 GB LTO Data Cartridge (Ultrium 4 cartridge without WORM capability; part number 95P4436)
- IBM System Storage 800 GB LTO WORM Data Cartridge (Ultrium 4 cartridge; part number 95P4450)
- IBM System Storage 400 GB LTO WORM Data Cartridge (Ultrium 3 cartridge; part number 96P1203)
- IBM System Storage 400 GB LTO Data Cartridge (Ultrium 3 cartridge without WORM capability; part number 24R1922)
- IBM System Storage 200 GB LTO Data Cartridge (Ultrium 2 cartridge; part number 08L9870)
- IBM System Storage 100 GB LTO Data Cartridge (Ultrium 1 cartridge; part number 08L9213 or 08L9120)
- IBM System Storage Universal LTO Cleaning Cartridge (part number 35L2086)
- IBM System Storage LTO Cleaning Cartridge
- Diagnostic cartridge

Figure 33 shows the IBM TotalStorage LTO Ultrium Data Cartridge.

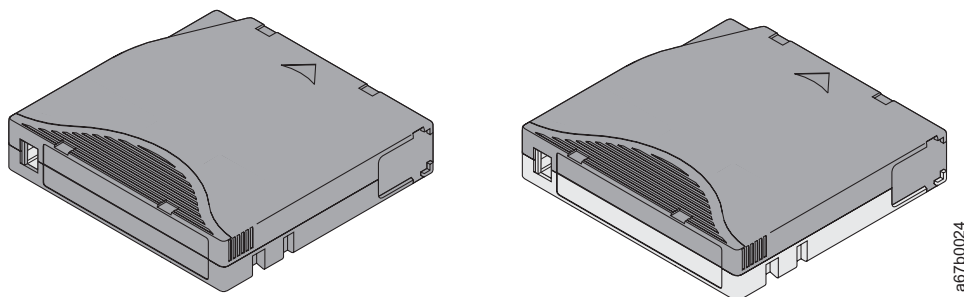

Figure 33. The IBM System Storage LTO Data Cartridge for Ultrium 3 Tape Drives

Related concepts

“WORM Functionality for Ultrium 3 and Ultrium 4 Tape Drives and Media” on page 214

This section describes the write once read many (WORM) functionality that is used by the LTO Ultrium 3 and Ultrium 4 Tape Drives and supported cartridges.

“Ultrium Data Cartridge” on page 216

This section describes the capacity, construction, operation, and components of the IBM LTO Ultrium Data Cartridge.

“Ultrium Cleaning Cartridge” on page 218

This section gives information about the appearance and usage of the IBM TotalStorage LTO Ultrium Cleaning Cartridge.

“Ultrium Diagnostic Cartridge” on page 219

This section gives information about the appearance and usage of the Ultrium diagnostic cartridge.

“Ultrium Bar Code Label” on page 220

This section describes the appearance and specifications of the Ultrium bar code label.

Related reference

“Ordering Additional Ultrium Cartridges and Media Supplies” on page 239

This section tells how to order additional Ultrium Tape Cartridges and other related media supplies.

“Ordering Bar Code Labels for Ultrium Cartridges” on page 241

WORM Functionality for Ultrium 3 and Ultrium 4 Tape Drives and Media

This section describes the write once read many (WORM) functionality that is used by the LTO Ultrium 3 and Ultrium 4 Tape Drives and supported cartridges.

The Ultrium 3 and Ultrium 4 Tape Drives include the write once read many (WORM) feature, which is supported by the IBM System Storage LTO WORM Data Cartridge (formerly the IBM TotalStorage 3589 Ultrium Tape Cartridge Models 028 and 029). All IBM Ultrium 3 Tape Drives with firmware levels of 54K1 or higher and all Ultrium 4 Tape Drives support the WORM function. An Ultrium 3 Tape Drive or Ultrium 4 Tape Drive with WORM capability can recognize WORM-compatible media. Information and the required drive firmware can be found at:

<http://www.ibm.com/servers/storage/support/lto/3584/downloading.html>

The IBM System Storage LTO WORM Data Cartridge is only for use on Ultrium 3 and Ultrium 4 Tape Drives with WORM capable-microcode. The cartridge is designed for applications such as archiving and data retention, and is also suitable for applications that require an audit trail. The cartridge works with the Ultrium 3 and Ultrium 4 Tape Drives to prevent the alteration or deletion of user data.

Additionally, IBM has taken the following steps to reduce tampering with data:

- The bottom of the WORM cartridge is molded in a color (gray) that is different from rewritable cartridges.
- A unique format is factory-written on each WORM cartridge.
- The WORM cartridge’s memory, along with its unique format, protects the WORM character of the media.

Based on LTO technology, the format for the 3589 LTO WORM Data Cartridge provides up to 400 GB native capacity and 800 GB at 2:1 compression for Ultrium 3, and up to 800 GB native capacity and 1600 GB at 2:1 compression for Ultrium 4.

Compatibility Among Ultrium Drives and Cartridges

This section defines compatibility among Ultrium 1, Ultrium 2, Ultrium 3, and Ultrium 4 Tape Drives and cartridges.

Table 16 shows the compatibility among the Ultrium drives and cartridges.

Table 16. Compatibility among Ultrium Tape Drives and tape cartridges

Cartridge Type		Drive Type			
Media Type	Cartridge Capacity	Ultrium 4 (F4A)	Ultrium 3 (F3A, F3B)	Ultrium 2	Ultrium 1
Ultrium 1 Cartridge	100 GB	Not compatible	R	R/W	R/W
Ultrium 2 Cartridge	200 GB	R	R/W	R/W	Not compatible
Ultrium 3 Cartridge	400 GB	R/W	R/W	Not compatible	Not compatible
Ultrium 3 WORM Cartridge	400 GB	R/W	R/W	Not compatible	Not compatible
Ultrium 4 Cartridge	800 GB	R/W	Not compatible	Not compatible	Not compatible
Ultrium 4 WORM Cartridge	800 GB	R/W	Not compatible	Not compatible	Not compatible

Notes:

- R = Read-only capability
- R/W = Read and write capability

If you want to control the capacity of the cartridge (for example, if you want to limit the capacity to obtain a faster seek time) you can do so by issuing the SCSI command SET CAPACITY. For information about this command, refer to the *IBM TotalStorage LTO Ultrium Tape Drive SCSI Reference*.

To ensure that your tape drive conforms to IBM's specifications for reliability, use only IBM LTO Ultrium Tape Cartridges. You may use other LTO-certified data cartridges, but they may not meet the standards of reliability that are established by IBM. The IBM System Storage 400 GB LTO Data Cartridge cannot be interchanged with the media used in other IBM non-LTO Ultrium tape products.

Ultrium Data Cartridge

This section describes the capacity, construction, operation, and components of the IBM LTO Ultrium Data Cartridge.

The IBM Ultrium 4 cartridge is green with a silkscreen label on the top which specifies "Ultrium 4 - 800 GB." The IBM Ultrium 3 WORM Data Cartridge is blue-gray on the top and gray on the bottom. The IBM Ultrium 3 Data Cartridge is blue-gray. The IBM Ultrium 2 Data Cartridge is purple, and the Ultrium 1 Data Cartridge is black. All generations contain 1/2-inch, dual-coat, metal-particle tape. Capacity for the four types of cartridges is as follows:

- Ultrium 4 and IBM Ultrium 4 WORM cartridges have a native data capacity of 800 GB (1600 GB at 2:1 compression)
- Ultrium 3 and Ultrium 3 WORM cartridges have a native data capacity of 400 GB (800 GB at 2:1 compression)
- Ultrium 2 cartridge has a native data capacity of 200 GB (400 GB at 2:1 compression)
- Ultrium 1 cartridge has a native data capacity of 100 GB (200 GB at 2:1 compression)

When processing tape in the cartridges, the Ultrium Tape Drives use a linear, serpentine recording format. The Ultrium 4 drives read and write data on 896 tracks; the Ultrium 3 drives read and write data on 704 tracks; the Ultrium 2 drive, on 512 tracks; and the Ultrium 1 drive, on 384 tracks. Ultrium 1 and Ultrium 2 drives read and write eight tracks at a time. The Ultrium 4 drives read and write 16 tracks at a time by using Ultrium 4 and Ultrium 3 cartridges and read 8 tracks at a time by using Ultrium 2 cartridges. The Ultrium 3 drives read and write 16 tracks at a time by using an Ultrium 3 cartridge and 8 tracks at a time by using Ultrium 1 or 2 cartridges. The first set of tracks is written from near the beginning of the tape to near the end of the tape. The head then repositions to the next set of tracks for the return pass. This process continues until all tracks are written and the tape is full, or until all data is written. Figure 34 on page 217 shows the IBM System Storage LTO Data Cartridge and its components

- | | | | |
|----------|----------------------|----------|----------------------|
| 1 | LTO cartridge memory | 4 | Write-protect switch |
| 2 | Cartridge door | 5 | Label area |
| 3 | Leader pin | 6 | Insertion guide |

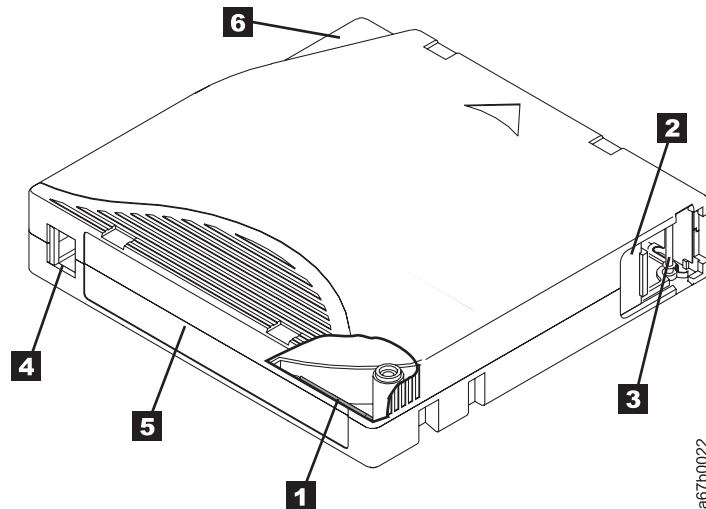

Figure 34. The IBM System Storage LTO Data Cartridge

All generations of the IBM LTO Ultrium Data Cartridge include a Linear Tape-Open Cartridge Memory (LTO-CM) chip (**1** in Figure 34), that contains information about the cartridge and the tape (such as the name of the manufacturer that created the tape), as well as statistical information about the cartridge's use. The LTO-CM enhances the efficiency of the cartridge. For example, the LTO-CM stores the end-of-data location which, when you next insert a cartridge and issue the Write command, enables the drive to quickly locate the recording area and begin recording. The LTO-CM also aids in determining the reliability of the cartridge by storing data about its age, how many times it has been loaded, and how many errors it has accumulated. Whenever you unload a tape cartridge, the tape drive writes any pertinent information to the cartridge memory. The storage capacity of the LTO-CM is 4096 bytes.

The cartridge door **2** protects the tape from contamination when the cartridge is out of the drive. Behind the door, the tape is attached to a leader pin **3**. When you insert the cartridge into the drive, a threading mechanism pulls the pin (and tape) out of the cartridge, across the drive head, and onto a non-removable takeup reel. The head can then read or write data from **1** to the tape.

The write-protect switch **4** prevents data from being written to the tape cartridge. The label area **5** provides a location for you to place a label. Affix only a bar code label. When affixing a label, place it only in the recessed label area. A label that extends outside of the recessed area can cause loading problems in the internal drive or in the 3584 Tape Library. The insertion guide **6** is a large, notched area that prevents you from inserting the cartridge incorrectly. You can order tape cartridges with the bar code labels included, or you can order custom labels.

Generation 3 and 4 of the LTO Ultrium Data Cartridge has a nominal cartridge life of 20,000 load and unload cycles; Generations 1 and 2 of the LTO Ultrium Data Cartridge have a nominal cartridge life of 10,000 load and unload cycles.

Related reference

“Ordering Additional Ultrium Cartridges and Media Supplies” on page 239
 This section tells how to order additional Ultrium Tape Cartridges and other related media supplies.

“Ordering Bar Code Labels for Ultrium Cartridges” on page 241

Ultrium Cleaning Cartridge

This section gives information about the appearance and usage of the IBM TotalStorage LTO Ultrium Cleaning Cartridge.

To maintain the operating efficiency of the drive, IBM supplies a cleaning cartridge with the first frame of each media type. Thus if the 3584 Tape Library contains frames with both LTO Ultrium and 3592 Tape Drives, IBM supplies one LTO Ultrium Cleaning Cartridge and one 3592 Cleaning Cartridge regardless of how many frames of each type are in the library. Each drive determines when it needs to be cleaned and alerts the library. Depending on which cleaning method you choose (automatic, host, or manual), the library uses the cleaning cartridge to automatically clean the drive or you are required to select menus to initiate cleaning (for information about cleaning methods, see the section about drive cleaning in the *IBM System Storage TS3500 Tape Library Introduction and Planning Guide*).

Note: The volume serial (VOLSER) number on the cleaning cartridge's bar code label must begin with **CLNI** or **CLNU**, or the library treats the cleaning cartridge as a data cartridge during an inventory.

The IBM TotalStorage LTO Ultrium Cleaning Cartridge (known as the universal cleaning cartridge) and the LTO Ultrium Cleaning Cartridge are compatible with the Ultrium 1, Ultrium 2, Ultrium 3, and Ultrium 4 Tape Drives. To enable your Ultrium 1 drive to use these cartridges, see "Updating Drive Firmware" on page 198.

Before a drive can be cleaned, ensure that a cleaning cartridge is loaded in the library (to determine whether one or more cleaning cartridges are loaded, see "Removing a Cleaning Cartridge from the Library" on page 75. You can load multiple cleaning cartridges and store them in any cartridge storage slot except the slot that is reserved for the diagnostic cartridge. For additional information, see "Non-Addressable Cartridge Storage Slot" on page 25.

The 3584 Tape Library monitors the use of all cleaning cartridges. The IBM Cleaning Cartridges are valid for 50 uses. When the cartridge expires, the library displays the following sample message on the Activity screen (where xx equals characters of the cartridge's VOLSER):

Remove CLNUxxL1
Cleaning Cartridge Expired

Related concepts

"Removing a Cleaning Cartridge from the Library" on page 75

This section introduces two ways to remove a cleaning cartridge from the 3584 Tape Library.

"Non-Addressable Cartridge Storage Slot" on page 25

"Updating Drive Firmware" on page 198

This section introduces ways to update firmware for tape drives in the 3584 Tape Library.

Ultrium Diagnostic Cartridge

This section gives information about the appearance and usage of the Ultrium diagnostic cartridge.

The Ultrium diagnostic cartridge is a cartridge with known good media that is reserved for diagnostic purposes only. One cartridge slot is reserved in the first Ultrium frame for the Ultrium diagnostic cartridge. The slot is located at Column 1, Row 1. The volume serial (VOLSER) number for a diagnostic cartridge is represented as DG IxxLy, where xx equals alphanumeric characters and y equals the generation of the cartridge type (1 for Ultrium 1, or 2 for Ultrium 2, Ultrium 3, or Ultrium 4). The characters of the VOLSER are white on a black background. During service calls, your IBM Service Representative will use the cartridge to ensure that the tape drives run correctly and to specification.

If your library is installed with a second accessor, service bay A (the HA1 frame) contains only gripper test slots for diagnostic cartridges. Service bay B contains gripper test slots for diagnostic cartridges, and also contains unusable storage slots. The storage slots in service bay B are not usable if the frame is configured as a service bay. Never insert any type of cartridge into service bays. Each service bay contains gripper test slots for three Ultrium diagnostic cartridges and three 3592 diagnostic cartridges.

Because internal diagnostics for the LTO Ultrium Tape Drive will not permit it to write to a WORM cartridge, all diagnostic tests that are selected from the operator panel and performed in maintenance mode will cause the drive to eject a WORM cartridge and issue error code 7 on its single-character display. To run diagnostics, use a non-WORM cartridge.

Ultrium Bar Code Label

This section describes the appearance and specifications of the Ultrium bar code label.

Each Ultrium data, cleaning, and diagnostic cartridge that is processed by the 3584 Tape Library must bear a bar code label. The label contains:

- A volume serial (VOLSER) number that you can read
- A bar code that the library can read

When read by the library's bar code reader, the bar code identifies the cartridge's VOLSER to the tape library. The bar code also tells the library whether the cartridge is a data, cleaning, or diagnostic cartridge. In addition, the bar code includes the two-character media-type identifier Lx, where x equals 1, 2, 3, 4, T, or U. L identifies the cartridge as an LTO cartridge. 1 indicates that the cartridge is the first generation of its type; 2, 3, or 4 indicates that the cartridge is the second, third or fourth generation of its type; T indicates that the cartridge is generation 3 WORM cartridge; and U indicates that the cartridge is generation 4 WORM cartridge. Figure 35 on page 221 shows a sample bar code label for the LTO Ultrium 3 Tape Cartridge.

You can order tape cartridges with the labels included, or you can order custom labels. The bar code must meet predefined specifications. They include (but are not limited to):

- Eight uppercase alphanumeric characters, where the last two characters must be L1, L2, L3, L4, LT, or LU
- Label and printing to be non-glossy
- Nominal narrow line or space width of 0.423 mm (0.017 in.)
- Wide to narrow ratio of 2.75:1
- Minimum bar length of 11.1 mm (0.44 in.)

To determine the complete specifications of the bar code and the bar code label, visit the web at <http://www.ibm.com/servers/storage/support/lto/3584/>. Under *Additional resources*, select LTO Ultrium media. Under *Learn more*, select LTO label specifications. Under *Abstract*, select the .pdf file to view the *IBM LTO Ultrium Cartridge Label Specification (Revision 2)*. You can also contact your IBM Sales Representative for this specification.

When attaching a bar code label to a tape cartridge, place the label only in the recessed label area. A label that extends outside of the recessed area can cause loading problems in the drive or the library.

Attention: Do not place any type of mark on the white space at either end of the bar code. A mark in this area may prevent the 3584 Tape Library from reading the label.

By using the Tape Library Specialist web interface, you can configure the library so that it reports to the server all eight characters of the VOLSER on the bar code label or only the first six characters. For more information, see "Enabling or Disabling the Reporting of a Six-Character or Eight-Character VOLSER" on page 176.

Note: If you suspect that the library is having problems reading the bar code labels, you can slow the scanner speed as part of problem determination. You may choose to slow the scanner speed rather than replace all labels, or

you may want to slow the scanner speed while you wait for an opportunity to re-label the media. Depending on the severity of the problem, the error recovery procedure (ERP) for poor labels may greatly exceed the time lost by slowing the scanner. If you have cartridge bar code labels that meet the LTO bar code label specification, there is no need to slow the scanner speed. For more information, see “Adjusting the Scanner Speed” on page 199.

To order bar code labels, see “Ordering Bar Code Labels for Ultrium Cartridges” on page 241.

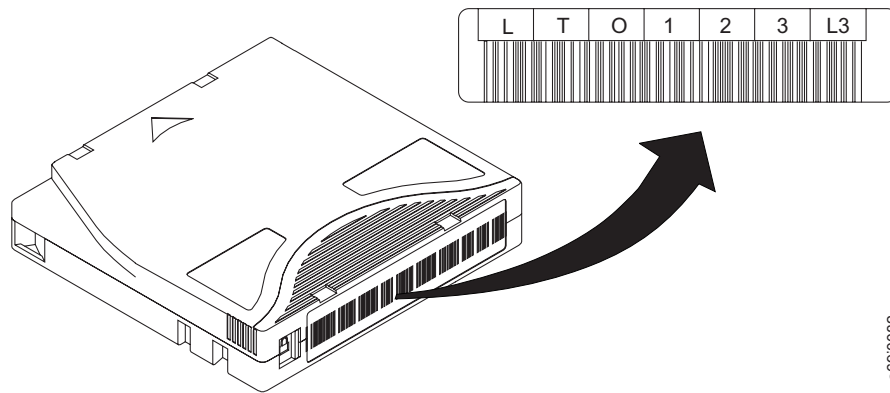

Figure 35. Sample bar code label on the LTO Ultrium 3 Tape Cartridge. The volume serial number (LTO123) and bar code are printed on the label.

Related tasks

“Adjusting the Scanner Speed” on page 199

This section gives instructions for adjusting the speed at which the scanner, a laser device in the 3584 Tape Library, reads bar code labels.

“Enabling or Disabling the Reporting of a Six-Character or Eight-Character VOLSER” on page 176

This section describes how to configure the 3584 Tape Library so that it reports to the server only the first six characters of the volume serial (VOLSER) number of a tape cartridge’s bar code label or it reports the full eight characters of the VOLSER. Reporting eight characters is the default.

Related reference

“Ordering Additional Ultrium Cartridges and Media Supplies” on page 239

This section tells how to order additional Ultrium Tape Cartridges and other related media supplies.

“Ordering Bar Code Labels for Ultrium Cartridges” on page 241

Guidelines for Using Ultrium Bar Code Labels

Apply the following guidelines whenever you use Ultrium bar code labels:

- Use only IBM-approved bar code labels.
- Do not reuse a label or reapply a used label over an existing label.
- Before you apply a new label, remove the old label by slowly pulling it at a right angle to the cartridge case.
- Use peel-clean labels that do not leave a residue after they are removed. If there is glue residue on the cartridge, remove it by gently rubbing it with your finger; do not use a sharp object, water, or a chemical to clean the label area.

- Examine the label before you apply it to the cartridge. Do not use the label if it has voids or smears in the printed characters or bar code (an application's inventory operation will take much longer if the bar code label is not readable).
- Remove the label from the label sheet carefully. Do not stretch the label or cause the edges to curl.
- Position the label within the recessed label area.
- With light finger pressure, smooth the label so that no wrinkles or bubbles exist on its surface.
- Verify that the label is smooth and parallel, and has no roll-up or roll-over. The label must be flat to within 0.5 mm (0.02 in.) over the length of the label and have no folds, missing pieces, or smudges.
- Do not place other machine-readable labels on other surfaces of the cartridge. They may interfere with the ability of the bar code reader to read the bar code.

Setting the Write-Protect Switch on an Ultrium Cartridge

This section gives instructions for setting the write-protect switch on an Ultrium Tape Cartridge.

The position of the write-protect switch on an Ultrium Tape Cartridge (see **1** in Figure 36) determines whether you can write to the tape:

- If the switch is set to  (solid red), data cannot be written to the tape.
- If the switch is set to unlocked (black void), data can be written to the tape.

If possible, use your server's application software to write-protect your cartridges (rather than manually setting the write-protect switch). This allows the server's software to identify a cartridge that no longer contains current data and is eligible to become a scratch cartridge. Do not write-protect scratch (blank) cartridges; the tape drive will not be able to write new data to them.

If you must manually set the write-protect switch, slide it left or right to the desired position.

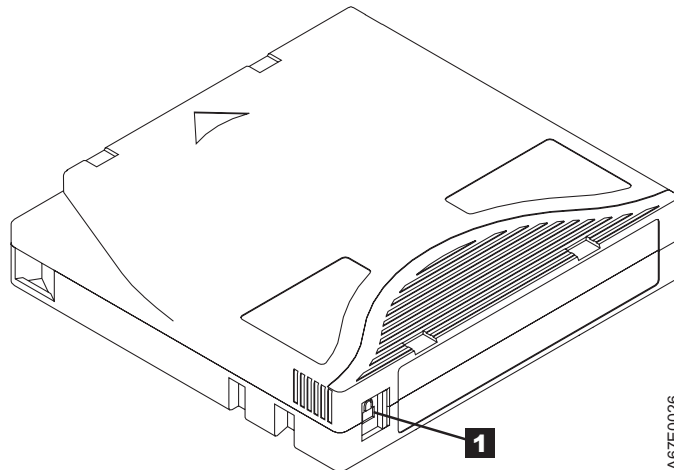

Figure 36. Setting the write-protect switch on an Ultrium Tape Cartridge

Handling Ultrium Tape Cartridges

This section introduces ways to handle Ultrium Tape Cartridges to avoid damage to the cartridge case and the tape.



Attention: Do not insert a damaged tape cartridge into your 3584 Tape Library. A damaged cartridge can interfere with the reliability of a drive and may void the warranties of the drive and the cartridge. Before inserting a tape cartridge, inspect the cartridge case, cartridge door, and write-protect switch for breaks. If you need to recover data from a damaged cartridge, contact your IBM Service Representative.

Incorrect handling or an incorrect environment can damage the IBM LTO Ultrium Tape Cartridges or their magnetic tape. To avoid damage to your tape cartridges and to ensure the continued high reliability of your IBM LTO Ultrium Tape Drives, use the following guidelines:

Provide Training for Using Ultrium Tape Cartridges

- Post procedures that describe proper media handling in places where people gather.
- Ensure that anyone who handles tape has been properly trained in handling and shipping procedures. This includes operators, users, programmers, archival services, and shipping personnel.
- Ensure that any service or contract personnel who perform archiving are properly trained in media-handling procedures.
- Include media-handling procedures as part of any services contract.
- Define and make personnel aware of data recovery procedures.

Ensure Proper Packaging of Ultrium Tape Cartridges

- When you ship a cartridge, ship it in its original or better packaging.
- Always ship or store a cartridge in a jewel case.
- Use only a recommended shipping container that securely holds the cartridge in its jewel case during transportation. Ultrium Turtlecases (by Perm-A-Store) have been tested and found to be satisfactory (see Figure 37). They are available at <http://www.turtlecase.com>.



Figure 37. Tape cartridges in a Turtlecase

- Never ship a cartridge in a commercial shipping envelope. Always place it in a box or package.
- If you ship the cartridge in a cardboard box or a box of a sturdy material, ensure the following:
 - Place the cartridge in polyethylene plastic wrap or bags to protect it from dust, moisture, and other contaminants.
 - Pack the cartridge snugly; do not allow it to move around.
 - Double-box the cartridge (place it inside a box, then place that box inside the shipping box) and add padding between the two boxes (see Figure 38 on page 226).



Figure 38. Double-boxing tape cartridges for shipping

Provide Proper Acclimation and Environmental Conditions for Ultrium Tape Cartridges

- Before you use a cartridge, let it acclimate to the normal operating environment for 1 hour. If you see condensation on the cartridge, wait an additional hour.
- Ensure that all surfaces of a cartridge are dry before inserting it.
- Do not expose the cartridge to moisture or direct sunlight.
- Do not expose recorded or blank cartridges to stray magnetic fields of greater than 100 Oersteds (for example, terminals, motors, video equipment, X-ray equipment, or fields that exist near high-current cables or power supplies). Such exposure can cause the loss of recorded data or make the blank cartridge unusable.
- Maintain the proper conditions for storing and shipping the cartridges.

Related concepts

“Environmental and Shipping Specifications for Ultrium Cartridges” on page 237

This section gives a table of the operating, storage, and shipping requirements for Ultrium Tape Cartridges.

Perform a Thorough Inspection of Ultrium Tape Cartridges

After purchasing a cartridge and before using it, perform the following steps:

- Inspect the cartridge’s packaging to determine potential rough handling.
- When inspecting a cartridge, open only the cartridge door. Do not open any other part of the cartridge case. The upper and lower parts of the case are held together with screws; separating them destroys the usefulness of the cartridge.
- Inspect the cartridge for damage before using or storing it.
- Inspect the rear of the cartridge (the part that you load first into the tape load compartment) and ensure that there are no gaps in the seam of the cartridge case (see **1** in Figure 39 on page 227). If there are gaps in the seam, the leader pin may be dislodged and may need to be repositioned.

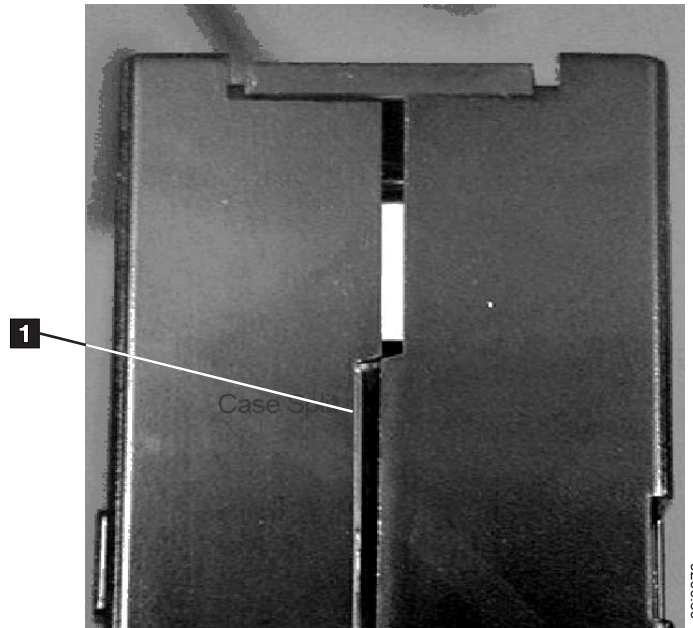

Figure 39. Checking for gaps in the seams of a cartridge

- Check that the leader pin is properly positioned.
- If you suspect that the cartridge has been mishandled but it appears usable, copy any data onto a good cartridge immediately for possible data recovery. Discard the mishandled cartridge.
- If you must recover data from a damaged cartridge, contact your service representative.
- Review handling and shipping procedures.

Related concepts

“Repositioning or Reattaching a Leader Pin in an Ultrium Cartridge” on page 230

This section introduces the procedures to use when you move a leader pin into its proper position in an Ultrium Tape Cartridge, or when you reattach the pin if it has separated from the tape.

Related tasks

“Repositioning a Leader Pin in an Ultrium Cartridge” on page 230

Handle the Ultrium Tape Cartridge Carefully

- Do not drop the Ultrium Tape Cartridge. If the cartridge drops, slide the cartridge door back and ensure that the leader pin is properly positioned in the pin-retaining spring clips. If the leader pin has become dislodged, perform the procedure to reposition it.
- Do not handle tape that is outside the cartridge. Handling the tape can damage the tape’s surface or edges, which may interfere with read or write reliability. Pulling on tape that is outside the cartridge can damage the tape and the brake mechanism in the cartridge.
- Do not stack more than six cartridges.
- Do not degauss a cartridge that you intend to reuse. Degaussing makes the tape unusable.

Related concepts

“Repositioning or Reattaching a Leader Pin in an Ultrium Cartridge” on page 230

This section introduces the procedures to use when you move a leader pin into its proper position in an Ultrium Tape Cartridge, or when you reattach the pin if it has separated from the tape.

Related tasks

“Repositioning a Leader Pin in an Ultrium Cartridge” on page 230

Examples of Problems with Ultrium Tape Cartridges

Example: Split Cartridge Case

The cartridge's case is damaged. There is a high possibility of media damage and potential loss. Perform the following steps:

1. Look for cartridge mishandling.
2. Use the IBM Leader Pin Reattachment Kit (part number 08L9129) to correctly position the pin. Then, immediately use data recovery procedures to minimize chances of data loss.
3. Review media-handling procedures.

Example: Improper Placement of Leader Pin

The leader pin is misaligned. Perform the following steps:

1. Look for cartridge damage.
2. Use the IBM Leader Pin Reattachment Kit (part number 08L9129) to correctly position the pin. Then, immediately use data recovery procedures to minimize chances of data loss.

Related concepts

"Perform a Thorough Inspection of Ultrium Tape Cartridges" on page 226

Related tasks

"Repositioning a Leader Pin in an Ultrium Cartridge" on page 230

Repositioning or Reattaching a Leader Pin in an Ultrium Cartridge

This section introduces the procedures to use when you move a leader pin into its proper position in an Ultrium Tape Cartridge, or when you reattach the pin if it has separated from the tape.



Attention: Use a repaired tape cartridge only to recover data and move it to another cartridge. Continued use of a repaired cartridge may void the warranties of the drive and the cartridge.

If the leader pin in your Ultrium Tape Cartridge becomes dislodged from its pin-retaining spring clips or detaches from the tape, you must use the IBM Leader Pin Reattachment Kit (part number 08L9129) to reposition or reattach it. (Do not reattach the pin if you must remove more than 7 meters (23 feet) of leader tape.)



Attention: Use a repaired tape cartridge only to recover data and move it to another cartridge. Continued use of a repaired cartridge may void the warranties of the drive and the cartridge.

Repositioning a Leader Pin in an Ultrium Cartridge

A leader pin that is improperly positioned inside an Ultrium Tape Cartridge can interfere with the operation of the drive. Figure 40 on page 231 shows a leader pin in the incorrect **1** and correct **2** positions.

To place the leader pin in its proper position, you will need the following tools:

- Plastic or blunt-end tweezers
- Cartridge manual rewind tool (from Leader Pin Reattachment Kit, part number 08L9129)

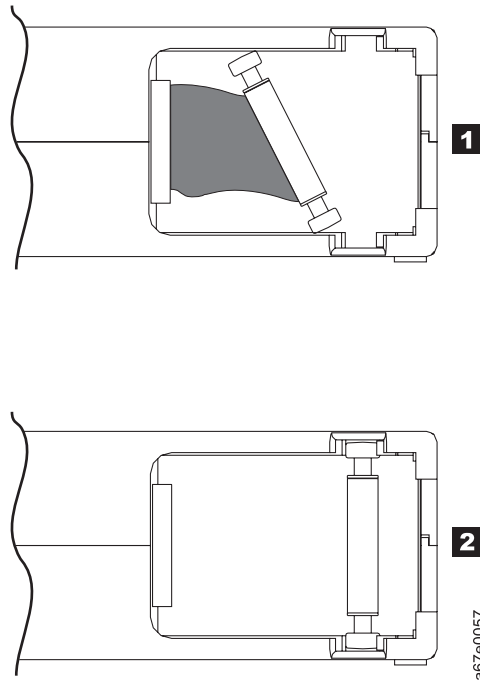

Figure 40. Leader pin in the incorrect and correct positions in an Ultrium Tape Cartridge. The cartridge door is open and the leader pin is visible inside the cartridge.

To reposition the leader pin, perform the following steps.

1. Slide open the cartridge door (**1** in Figure 41 on page 232) and locate the leader pin **2**. You may need to shake the cartridge gently to roll the pin toward the door.
2. With plastic or blunt-end tweezers, grasp the leader pin and position it in the pin-retaining spring clips **3**.
3. Press the leader pin gently into the clips until it snaps into place and is firmly seated. Ensure that there are no gaps in the seam of the cartridge **4**. **Note:** If gaps exist, do not continue with this procedure and do not use the cartridge. Instead, contact your IBM Service Representative.
4. Close the cartridge door.

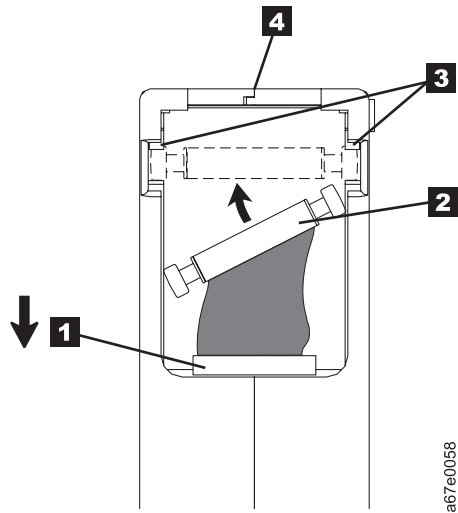

Figure 41. Placing the dislodged leader pin into the correct position.. The cartridge door is open to show the leader pin.

5. To rewind the tape, insert the cartridge manual rewind tool (**1** in Figure 42) into the cartridge's hub (**2**) and turn it clockwise until the tape becomes taut.

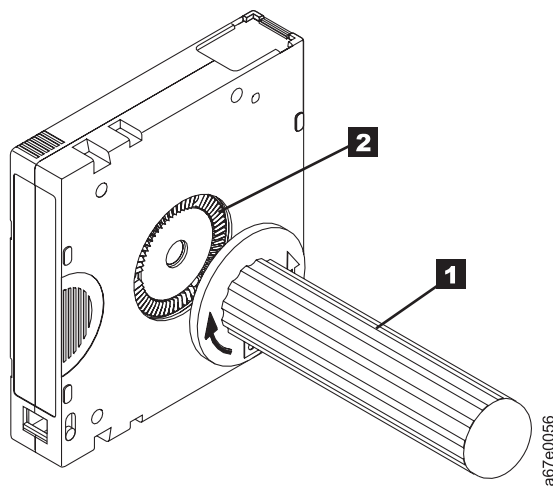

Figure 42. Rewinding the tape into the cartridge

6. Remove the rewind tool by pulling it away from the cartridge.

Reattaching a Leader Pin in an Ultrium Cartridge

The first meter of tape in a Ultrium Tape Cartridge is leader tape. Once the leader tape has been removed there is a possibility of tape breakage. After reattaching the leader pin, transfer data from the defective tape cartridge. **Do not reuse the defective tape cartridge.**

The Leader Pin Reattachment Kit contains three parts:

- **Leader pin attach tool** (see **1** in Figure 43). A plastic brace that holds the cartridge door open.
- **Cartridge manual rewind tool** (see **2** in Figure 43). A device that fits into the cartridge's hub and lets you wind the tape into and out of the cartridge.
- **Pin supplies** (see **3** in Figure 43). Leader pins and C-clips.

Attention:

- Use only the IBM Leader Pin Reattachment Kit to reattach the leader pin to the tape. Other methods of reattaching the pin will damage the tape, the drive, or both.
- Use this procedure on your tape cartridge only when the leader pin detaches from the magnetic tape and you must copy the cartridge's data onto another cartridge. Destroy the damaged cartridge after you copy the data. This procedure may affect the performance of the leader pin during threading and unloading operations.
- Touch only the end of the tape. Touching the tape in an area other than the end can damage the tape's surface or edges, which may interfere with read or write reliability.

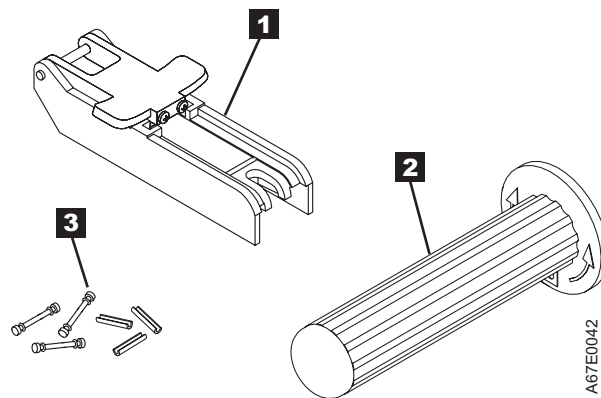
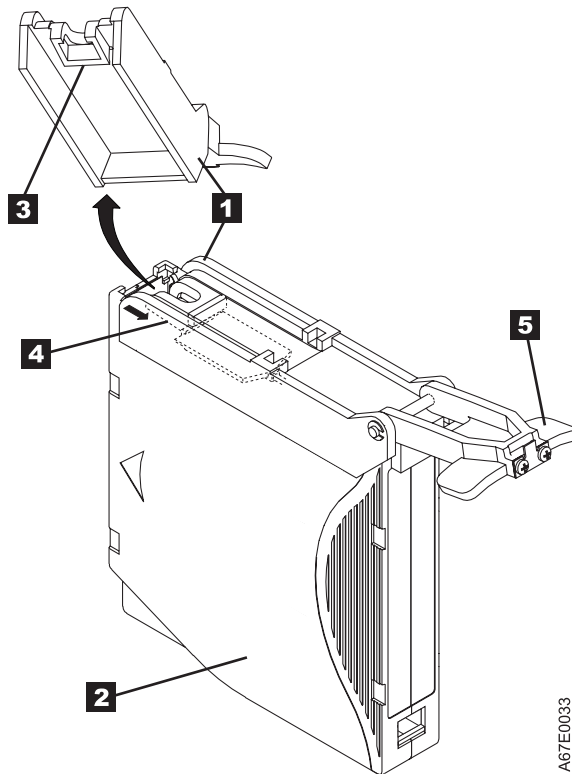

Figure 43. Leader Pin Reattachment Kit

To reattach a leader pin by using the IBM Leader Pin Reattachment Kit, perform the following steps:

1. Attach the leader pin attach tool (**1** in Figure 44 on page 234) to the cartridge **2** so that the tool's hook **3** latches into the cartridge's door **4**. Pull the tool back to hold the door open, then slide the tool onto the cartridge. Open the tool's pivot arm **5**.



A67E0033

Figure 44. Attaching the leader pin attach tool to an Ultrium Tape Cartridge. To hold the cartridge door open, hook the tool into the door and pull the tool back.

2. To find the end of the tape inside the cartridge, attach the cartridge manual rewind tool (**1** in Figure 45 on page 235) to the cartridge's hub **2** by fitting the tool's teeth between the teeth of the hub. Turn the tool clockwise until you see the end of the tape inside the cartridge. Then, slowly turn the rewind tool counterclockwise to bring the tape edge toward the cartridge door **3**.
3. Continue to turn the rewind tool counterclockwise until approximately 13 cm (5 in.) of tape hangs from the cartridge door. If necessary, grasp the tape and pull gently to unwind it from the cartridge.
4. Remove the rewind tool by pulling it away from the cartridge. Set the tool and the cartridge aside.

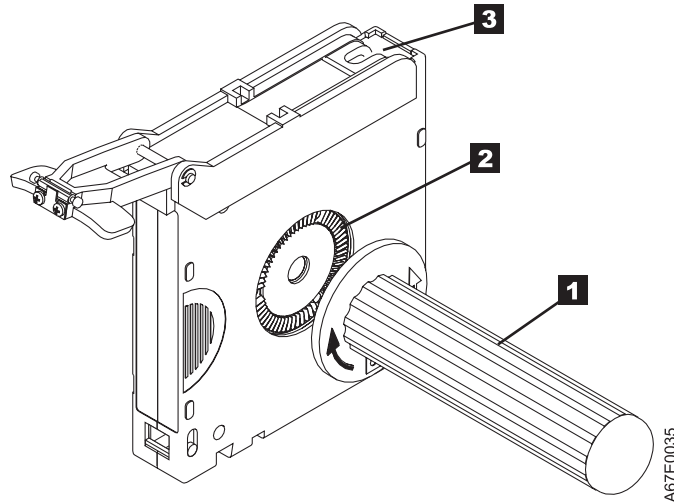

Figure 45. Winding the tape out of the Ultrium Tape Cartridge. Turn the cartridge manual rewind tool clockwise to see the end of the tape, then turn it counterclockwise to bring the tape to the cartridge door.

5. On the leader pin (**1** in Figure 46), locate the open side of the C-clip **2** . The C-clip is a small black part that secures the tape **3** to the pin.
6. Remove the C-clip from the leader pin by using your fingers to push the clip away from the pin. Set the pin aside and discard the clip.

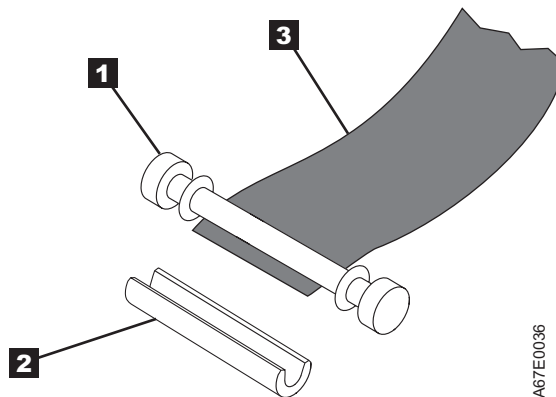
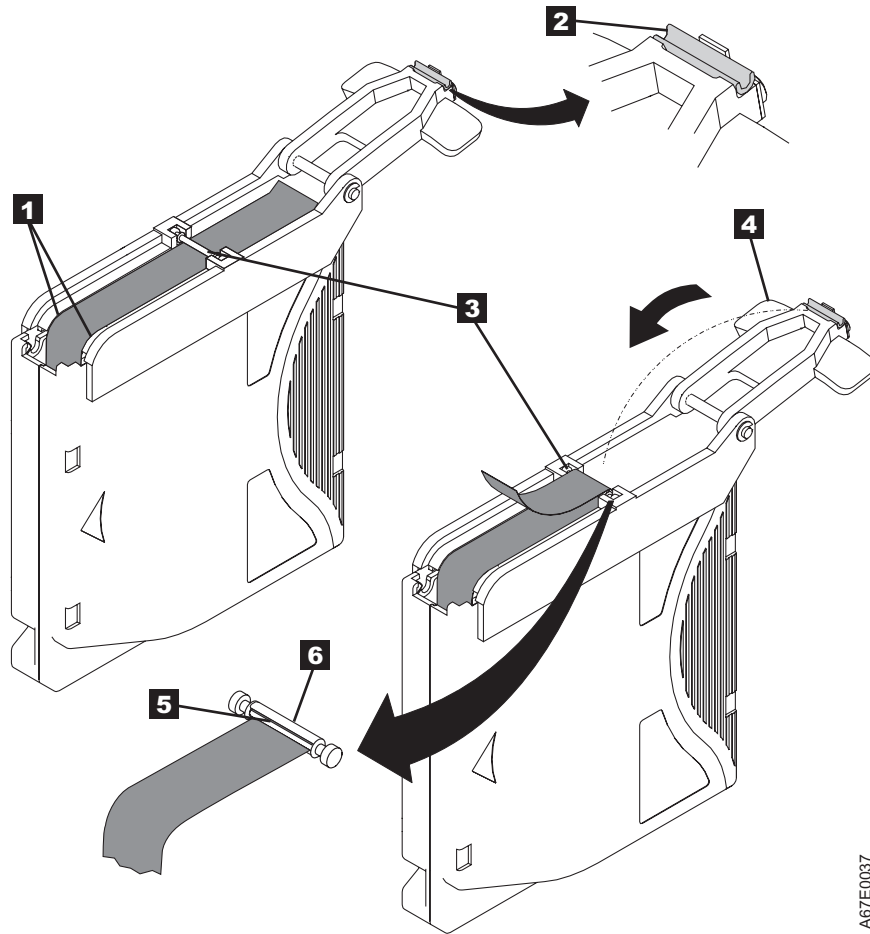

Figure 46. Removing the C-clip from the leader pin. Use your fingers to push the C-clip from the leader pin.

7. Position the tape in the alignment groove of the leader pin attach tool (see **1** in Figure 47 on page 236).
8. Place a new C-clip into the retention groove **2** on the leader pin attachment tool and make sure that the clip's open side faces up.
9. Place the leader pin (from step 6) into the cavity **3** of the leader pin attach tool.
10. **Attention:** To prevent the leader pin from rolling into the cartridge, in the following step use care when folding the tape over the pin.
11. Fold the tape over the leader pin and hold it with your fingers (see Figure 47 on page 236). **Note:** Use care to ensure that the tape is centered over the leader pin. Failure to properly center the tape on the pin will cause the repaired cartridge to fail. When the tape is properly centered, a 0.25-mm (0.01-in.) gap exists on both sides of the pin.



A67E0037

Figure 47. Attaching the leader pin to the tape

12. Close the pivot arm **4** of the leader pin attach tool by swinging it over the leader pin so that the C-clip snaps onto the pin and the tape.
13. Swing the pivot arm open and trim the excess tape **5** so that it is flush with the reattached leader pin **6**.
14. Use your fingers to remove the leader pin from the cavity **3** in the leader pin attach tool.
15. Use the cartridge manual rewind tool to wind the tape back into the cartridge (wind the tape clockwise). Ensure that the leader pin is latched by the pin-retaining spring clips on each end of the leader pin.
16. Remove the rewind tool.
17. Remove the leader pin attach tool by lifting its end up and away from the cartridge.

Environmental and Shipping Specifications for Ultrium Cartridges

This section gives a table of the operating, storage, and shipping requirements for Ultrium Tape Cartridges.

Before you use an Ultrium Tape Cartridge, acclimate it to the operating environment for 24 hours or the time necessary to prevent condensation in the drive (the time will vary, depending on the environmental extremes to which the cartridge was exposed).

The best storage container for the cartridges (until they are opened) is the original shipping container. The plastic wrapping prevents dirt from accumulating on the cartridges and partially protects them from humidity changes.

Attention: Depending on how many drives you have installed in the frame of a 3584 Tape Library, the temperature inside the frame may be as much as 5°C (9°F) above the temperature outside the frame. To ensure continued reliability of your media, be sure to take this temperature difference into account when you set up the environment around your library.

When you ship a cartridge, place it in its jewel case or in a sealed, moisture-proof bag to protect it from moisture, contaminants, and physical damage. Ship the cartridge in a shipping container that has enough packing material to cushion the cartridge and prevent it from moving within the container.

Table 17 gives the environment for operating, storing, and shipping LTO Ultrium Tape Cartridges.

Table 17. Environment for operating, storing, and shipping the LTO Ultrium Tape Cartridges

Environmental Specifications				
Environmental Factor	Operating	Operational Storage ¹	Archival Storage ²	Shipping
Temperature	10 to 45°C (50 to 113°F)	16 to 32°C (61 to 90°F)	16 to 25°C (61 to 77°F)	-23 to 49°C (-9 to 120°F)
Relative humidity (noncondensing)	10 to 80%	20 to 80%	20 to 50%	5 to 80%
Maximum wet bulb temperature	26°C (79°F)	26°C (79°F)	26°C (79°F)	26°C (79°F)
Magnetic field	Stray magnetic field at any point on tape not to exceed 50 Oersteds.			
Notes:				
1. Operational storage equals less than 6 months.				
2. Archival storage equals greater than 6 months.				

Disposing of Ultrium Tape Cartridges

This section describes how to dispose of Ultrium Tape Cartridges according to federal and other regulations.

Under the current rules of the U.S. Environmental Protection Agency (EPA), regulation 40CFR261, the LTO Ultrium Tape Cartridge is classified as non-hazardous waste. As such, it may be disposed of in the same way as normal office trash. These regulations are amended from time to time, and you should review them at the time of disposal.

If your local, state, country (non-U.S.A.), or regional regulations are more restrictive than EPA 40CFR261, you must review them before you dispose of a cartridge. Contact your account representative for information about the materials that are in the cartridge.

If a tape cartridge must be disposed of in a secure manner, you can erase the data on the cartridge by using a high-energy ac degausser (use a minimum of 2800 Oersteds over the entire space that the cartridge occupies). Degaussing makes the cartridge unusable.

If you burn the cartridge and tape, ensure that the incineration complies with all applicable regulations.

Ordering Additional Ultrium Cartridges and Media Supplies

This section tells how to order additional Ultrium Tape Cartridges and other related media supplies.

You can use one of the following methods to order the cartridges and media supplies shown in Table 18:

- Order from your IBM Sales Representative or any authorized IBM Business Partner.
- Order by calling 1-888-IBM-MEDIA.
- Order through an IBM-authorized distributor (for the closest distributor, visit the web at <http://www.ibm.com/storage/media>).

Note: For cartridges with preapplied bar code labels, specify the VOLSER characters that you want.

Table 18. Ordering Ultrium cartridges and media supplies

Supply Item	Method of Ordering
IBM TotalStorage LTO Ultrium 800 GB WORM Data Cartridge Bar code labels are preapplied to cartridges.	Specify Machine Type 3589 Model 032 and the VOLSER characters that you want.
IBM TotalStorage LTO Ultrium 800 GB WORM Data Cartridge Order VOLSER labels separately.	Specify Machine Type 3589 Model 033.
IBM TotalStorage LTO Ultrium 800 GB Data Cartridge Bar code labels are preapplied to cartridges.	Specify Machine Type 3589 Model 010 and the VOLSER characters that you want.
IBM TotalStorage LTO Ultrium 800 GB Data Cartridge Order VOLSER labels separately.	Specify Machine Type 3589 Model 011.
IBM TotalStorage LTO Ultrium 400 GB WORM Data Cartridge Bar code labels are preapplied to cartridges.	Specify Machine Type 3589 Model 028 and the VOLSER characters that you want.
IBM TotalStorage LTO Ultrium 400 GB WORM Data Cartridge Order VOLSER labels separately.	Specify Machine Type 3589 Model 029.
IBM TotalStorage LTO Ultrium 400 GB Data Cartridge Bar code labels are preapplied to cartridges.	Specify Machine Type 3589 Model 008 and the VOLSER characters that you want.
IBM TotalStorage LTO Ultrium 400 GB Data Cartridge Order VOLSER labels separately.	Specify Machine Type 3589 Model 009.
IBM TotalStorage LTO Ultrium 200 GB Data Cartridge Bar code labels are preapplied to cartridges.	Specify Machine Type 3589 Model 006 and the VOLSER characters that you want.
IBM TotalStorage LTO Ultrium 200 GB Data Cartridge Order VOLSER labels separately.	Specify Machine Type 3589 Model 007.
IBM LTO Ultrium 100 GB Data Cartridge Bar code labels are preapplied to cartridges.	Specify Machine Type 3589 Model 002 and the VOLSER characters that you want.

Table 18. Ordering Ultrium cartridges and media supplies (continued)

Supply Item	Method of Ordering
IBM LTO Ultrium 100 GB Data Cartridge Order VOLSER labels separately.	Specify Machine Type 3589 Model 003.
IBM TotalStorage LTO Ultrium Cleaning Cartridge (universal cleaning cartridge for use with Ultrium 1, Ultrium 2, Ultrium 3, and Ultrium 4 drives) VOLSER labels are included.	Specify Machine Type 3589 Model 004 and the VOLSER characters that you want.
Jewel Case for IBM TotalStorage LTO Ultrium 400 GB WORM Data Cartridge	Order the jewel case as feature code 8000. This case can also be used for the Ultrium 2 and Ultrium 1 Tape Cartridges.
Leader Pin Reattachment Kit	Order as part number 08L9129.

Related concepts

“Ultrium Data Cartridge” on page 216

This section describes the capacity, construction, operation, and components of the IBM LTO Ultrium Data Cartridge.

“Ultrium Cleaning Cartridge” on page 218

This section gives information about the appearance and usage of the IBM TotalStorage LTO Ultrium Cleaning Cartridge.

Ordering Bar Code Labels for Ultrium Cartridges

Bar code labels with volume serial (VOLSER) numbers are required for Ultrium Tape Cartridges that are read by the 3584 Tape Library. You can order these labels separately from the IBM Data Cartridges and Cleaning Cartridges.

You can order bar code labels directly from the authorized label suppliers in Table 19.

Attention: The IBM System Storage TS3500 Tape Library is designed to work with bar code labels that meet the specifications and requirements set forth in the *IBM LTO Ultrium Cartridge Label Specification (Revision 2)*. The following label providers have demonstrated the ability to produce finished bar code labels that meet the foregoing specifications and requirements. This information is provided for the convenience of 3584 Tape Library users only, and is not an endorsement or recommendation of such providers. IBM is not responsible for the quality of bar code labels procured from sources other than IBM. This information is applicable to bar code labels actually printed by the listed companies. IBM has not reviewed the quality of any labels produced by software or services offered by such companies which allow end users to print labels on their own printing equipment.

Table 19. Authorized suppliers of custom bar code labels for Ultrium Tape Cartridges

In the Americas	In Europe and Asia
Dataware 7570 Renwick Houston, TX 77081 U. S. A. Telephone: 800-426-4844 http://www.datawarelabels.com/	Not applicable
EDP/Colorflex 2550 West Midway Boulevard Broomfield, CO 80020-1633 U. S. A. Telephone: 800-522-3528 or 303-666-2160 Fax: 303-666-2166 http://www.colorflex.com/colortrax.asp	EDP Europe Limited 43 Redhills Road South Woodham Ferrers Chelmsford, Essex CM3 5UL U. K. Telephone: 44 (0) 1245 322380 Fax: 44 (0)1245 323484 http://www.edpeurope.com/media-labels.html
Netc, L. L. C. 100 Corporate Drive Trumbull, CT 06611 U. S. A. Telephone: 203-372-6382 http://www.NetcLabels.com	Netc Europe Ltd Town Farm Bungalow North Curry Taunton Somerset U. K. TA3 6LX Telephone: 44 (0) 1823 491439 http://www.NetcLabels.co.uk
	Netc Asia Pacific Pty Ltd Locked Bag 14 Kenthurst NSW Australia 2156 Telephone: 61 (0) 2 4563 6556 http://www.NetcLabels.com.au

Chapter 5. Using 3592 Tape Drive Media

The section introduces information about the 3592 Tape Drive media.

In addition to automating the storage and movement of IBM LTO Ultrium Tape Cartridges, the 3584 Tape Library does the same for IBM TotalStorage 3592 Enterprise Tape Cartridges.

Overview of 3592 Media

This section describes the tape cartridges that are used by 3592 Tape Drives in the 3584 Tape Library.

The 3592 Tape Drive uses four different data cartridge types and a cleaning cartridge. Characteristics of these cartridges are summarized in Table 20 on page 244.

Figure 48 shows the IBM TotalStorage 3592 Enterprise Tape Cartridge.

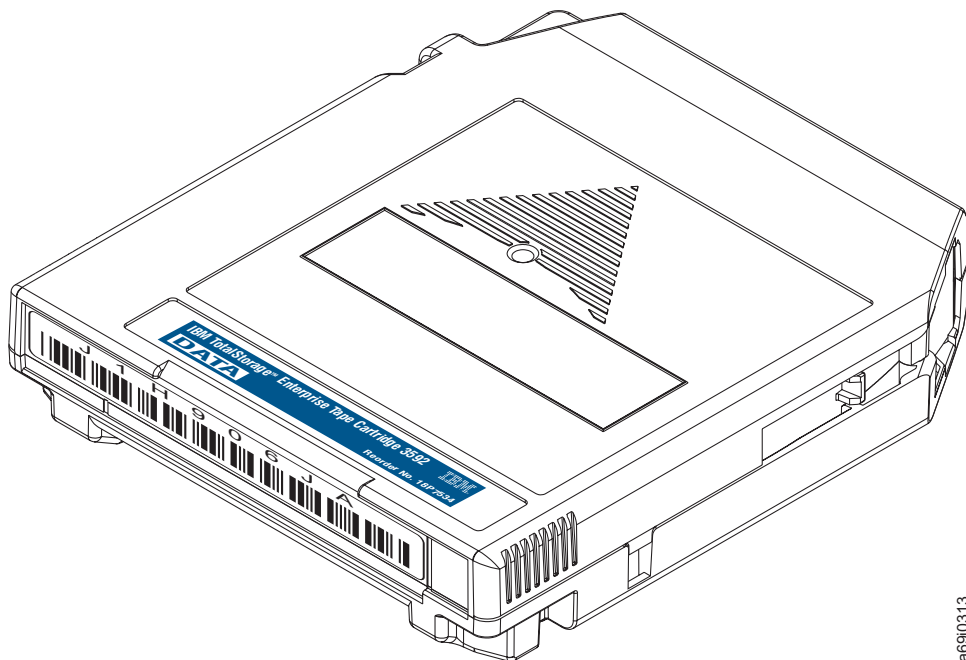

Figure 48. Components of the IBM TotalStorage 3592 Enterprise Tape Cartridge

Cartridges can be distinguished by the text on the product label, as well as by the color of the cartridge case. Table 20 on page 244 gives the differences of the 3592 Tape Cartridges.

Table 20. Types of IBM 3592 TotalStorage Enterprise Tape Cartridges

Text on Product Label and Type of Media ¹	Native Capacity		Color of Case	Color of Label, Door, and Write-Protect Switch	Part Number
	E05	J1A			
Data, JA	500 GB (E05 format)	300 GB ²	Black	Dark Blue	18P7534
	300 GB (J1A format)				
Extended Data, JB	700 GB (E05 format)	Not supported	Black	Dark Green	23R9830
Economy, JJ	100 GB (E05 format)	60 GB	Black	Light Blue	24R0316
	60 GB (J1A format)				
WORM, JW	500 GB (E05 format)	300 GB	Platinum (silvery gray)	Dark Blue	18P7538
	300 GB (J1A format)				
Extended WORM, JX	700 GB (E05 format)	Not supported	Platinum (silvery gray)	Dark Green	23R9831
Economy WORM, JR	100 GB (E05 format)	60 GB	Platinum (silvery gray)	Light Blue	24R0317
	60 GB (J1A format)				
Cleaning, CLNxxxJA ³	N/A ⁴	N/A	Black	Gray	18P7535

Notes:

1. This designation appears as the last two characters on standard bar code labels. In addition, for cleaning cartridges, the first three characters of the volume serial (VOLSER) number are CLN.
2. The Data type cartridge can also be ordered in a 260 GB segmented, capacity scaled format providing 60 GB of high-performance random access, and an additional 200 GB of capacity.
3. Where xxx equals three numerals.
4. N/A = not applicable.

Note: In addition to these cartridges, there is a Customer Engineer (CE) diagnostic cartridge for use by IBM Service Representatives only. The VOLSER for this cartridge is CE xxxJA where a space occurs after CE and xxx equals three numerals.

The 3592 Tape Drive does not support Ultrium formats.

Firmware for the TS1120 Tape Drive will not work in the 3592 J1A Tape Drive, and firmware for the 3592 J1A Tape Drive will not work in the TS1120 Tape Drive.

You can update firmware for the 3592 Tape Drive without scheduling downtime. This enhancement is called a *nondisruptive drive firmware update*. It is available through the IBM System Storage Tape Library Specialist web interface and (for IBM Service Representatives) through CETool, but is not supported by the SCSI interface. For more information, go to "Updating Drive Firmware" on page 198.

Related concepts

“3592 Data Cartridge” on page 248

This section describes the capacity, construction, operation, and components of the IBM TotalStorage 3592 Enterprise Tape Cartridge.

“3592 Cleaning Cartridge” on page 251

This section gives information about the appearance and usage of the IBM TotalStorage 3592 Enterprise Cleaning Cartridge.

“3592 Diagnostic Cartridge” on page 253

This section gives information about the appearance and usage of the 3592 diagnostic cartridge.

“3592 Bar Code Label” on page 254

This section describes the appearance and specifications of the 3592 bar code label.

“Ordering 3592 Media Supplies” on page 263

This section gives an overview of the methods for ordering 3592 Tape Cartridges and other related media supplies.

“Updating Drive Firmware” on page 198

This section introduces ways to update firmware for tape drives in the 3584 Tape Library.

Related reference

“Ordering 3592 Bar Code Labels” on page 266

WORM Functionality for 3592 Tape Drives and Media

This section describes the write once read many (WORM) functionality that is used by the 3592 Tape Drive and supported cartridges.

All 3592 Tape Drives with the appropriate microcode version installed are capable of reading and writing WORM cartridges. The TS1120 Tape Drive supports WORM behaviors and format attributes that are identical to the 3592 J1A, but the support is extended into the TS1120 Tape Drive WORM logical format and continues for the 3592 J1A WORM logical format. The 3592 Tape Drives support three WORM media types, JW (full length), JR (short length), and (for TS1120) JX Extended WORM cartridge.

WORM cartridges are formatted at the factory and may not be converted to data cartridges. The WORM tape media is formatted differently than the standard read/write media. One field in the servo manufacturer’s word (SMW) on the tape designates that the media is WORM. In addition, the cartridge memory (CM) has a WORM indicator byte in the cartridge type field. Both of these conditions must be true for the drive to work with a WORM cartridge. If one condition is true and the other is false, an ATTN DRV - Invalid Cartridge message will post. When the drive senses that a cartridge is a WORM cartridge, the microcode prohibits the changing or altering of user data already written on the tape. The microcode keeps track of the last appendable point on the tape by means of an overwrite-protection pointer stored in the cartridge memory (CM). Statistical Analysis and Reporting System (SARS) data can be written and updated on WORM tapes because the SARS data is not in the user area of the tape.

Each WORM cartridge is identified by using a unique cartridge identifier (UCID) that is permanent and locked, and which provides another level of security for data that must be maintained. This permanent locked information is stored in both the cartridge CM and on the tape itself, and can also be associated with the unique bar code volume serial (VOLSER) number.

Some records retention and data security applications require the WORM function of tape data storage. This WORM function is accomplished on the 3592 Tape Drive by a combination of microcode controls in the drive and a WORM tape cartridge. Special tamper-proofing techniques and checking prevent WORM cartridges from being transported to or from a data cartridge shell or cartridge memory and being inadvertently processed as a read or write (R/W) cartridge. The drive microcode leverages this support by providing an interface and control mechanisms which allow an application or system to manage as needed. The control and status mechanisms for this can be found primarily in mode pages X'23' and X'24'. For more information, see the *IBM System Storage TS1120 Tape Drive and Controller SCSI Reference*.

The 3592 Tape Drives allow append operations to data already on WORM cartridges, and allow overwrite of file marks and other non-data attributes to provide application transparency. However, they do not allow data overwrite under any circumstances. Once full of data, WORM cartridges may not be reused or erased by the drive and must be physically destroyed or bulk degaussed to delete data. For full tape application usage, certain trailer and label record overwrites are allowed.

Capacity Scaling and Segmentation

This section describes how the 3592 Tape Drives use capacity scaling and segmentation to place data in a designated section of tape to speed access and manage efficient capacity.

The 3592 Tape Drive supports capacity scaling for tape cartridges of media types JA and JB over a broad range of capacities. The effect of capacity scaling is to contain data in a specified fraction of the tape. This yields faster locate and read times. Alternatively, you can purchase Economy tapes (the JJ media type) to achieve this faster performance.

The 3592 J1A Tape Drive divides tape into longitudinal segments. Using this capability, it is possible, for example, to segment 300 GB data tapes into two segments: one segment with 60 GB and very fast access, and another 200 GB segment for additional capacity. You can purchase 300 GB data tapes that are pre-formatted in these segments, or you can segment and capacity scale them at a later time. Segmentation is only available within a specified range of capacity scaling settings. Capacity scaling is not supported for Economy (60 GB) or write once read many (WORM) (60 GB or 300 GB) tapes. For information about implementing segmentation and capacity scaling, see the README files in the FTP directory that pertains to your device driver, which you can find by navigating in a web browser to the following URL:

```
ftp://ftp.software.ibm.com/storage/devdrv
```

For more technical information regarding WORM, capacity scaling, and segmentation, see also the *IBM System Storage TS1120 Tape Drive and Controller SCSI Reference*.

Like the 3592 J1A Tape Drive, the TS1120 Tape Drive also supports multiple format options, such as scaling and segmentation modes, to allow you to trade capacity for improved access times. While 256 settings of the Capacity Scaling byte (and resulting fractional capacities) are supported on the TS1120 Tape Drive, three primary settings are recommended for use:

- Full capacity default mode.

- 20% scaled fast access mode (20% capacity scaled, front of tape used). The Capacity Scaling byte is x'35'.
- Performance scaling for 87% capacity and a segmented format with recursive accumulating backhitchless flush (RABF) capability (a non-volatile caching technique) for the full cartridge. For WORM firmware for the 3592 J1A Tape Drive and the 3592 E05 Tape Drive, the Capacity Scaling byte is x'E0'.

These settings are fully certified and are available as labeled and initialized part-numbered cartridges. For the exact Mode Select commands and settings that are necessary to invoke scaling, see the *IBM System Storage TS1120 Tape Drive and Controller SCSI Reference*.

Scaling Support in Drive

Capacity scaling in the TS1120 Tape Drive is controlled by the host program performing a Scaling operation. This is performed using the Capacity Scaling byte and the Capacity Scaling Valid control bit in Mode page X'23'. The TS1120 Tape Drive does not change current cartridge scaling unless a SCSI Mode Select command that specifies Mode Page X'23' (with appropriate non-default parameter settings) is received while the cartridge is positioned at the beginning of the tape. The TS1120 Tape Drive can sense and report the scaling state of the current medium by using a Mode Sense command that specifies Mode Page X'23'. The default unscaled capacity is 300 GB for a JA cartridge in J1A density, 500 GB for a JA cartridge in E05 density, and 700 GB for a JB cartridge (which supports E05 density only).

- The cartridge can be rescaled from any current Capacity Scaling byte value to any supported new value. The tape is logically erased by this (End of Data mark written at beginning of tape), but not physically erased as with the long erase command. Scaling or rescaling one cartridge does not cause rescaling of the next cartridge; an explicit command must be issued for each cartridge to be rescaled.
- The drive provides the option of setting the scaling values of N/256ths of full capacity, where N ranges from X'16' (22 -- equals about 8% capacity) to X'EC' (236 -- equals about 92%)
- For scaling factors N, between X'4B' and X'EB , the drive scales to the specified amount and creates a fast-access 20% capacity segment in the beginning of the scaled region.
- At all scaling factors, the drive supports early warning at the end of the scaled region (with the appropriate unit attention to inform the software that it should flush buffers and close volume) and reports a physical end-of-tape check condition at the end of the scaled region, just as it would if unscaled tape had reached the real physical end of the tape.

Capacity scaling is not offered on either of the short length cartridge types (JJ or JR), or on the WORM cartridges (JW, JX and JR). Capacity scaling is only offered on the JA and JB cartridge types.

Three important attributes are controlled by the setting of the Capacity Scaling byte value:

- The total Medium Capacity.
- The ability to perform the RABF function on an entire cartridge, including last wraps.
- Information about whether the format is segmented. If the format is segmented, a fast-access segment is created on the front part of the tape followed by a larger remainder segment that occupies the remainder of the tape. The fast access segment is always filled (written) first, followed by the filling of the remainder

segment. For some applications that want improved access attributes for partially filled cartridges but still want to use full capacity (if required) without re-scaling, this option is available.

It is important to note that the scaled state and attributes (segmentation, RABF) of the cartridge format is retained when a cartridge is reformatted between the J1A and E05 logical formats, although the exact resulting used capacity as a percentage of full capacity is not identical for all mapped settings.

3592 Data Cartridge

This section describes the capacity, construction, operation, and components of the IBM TotalStorage 3592 Enterprise Tape Cartridge.

The 3592 Tape Drive has a bidirectional read/write head with an Enterprise Tape 3592 format. The 3592 J1A writes or reads eight tracks at a time; the TS1120 Tape Drive writes or reads 16 tracks at a time. The 3592 Data cartridge has a native capacity of 300 GB, while the 3592 Economy cartridge has a native capacity of 60 GB. Capacities of data cartridges can be increased through data compression, with the actual compression and capacity depending upon the specific data. Write once read many (WORM) cartridges are also available in both 60 GB and 300 GB capacities.

TS1120 Tape Drives that are encryption-enabled perform encryption after compression.

Figure 49 on page 249 shows the IBM TotalStorage 3592 Enterprise Tape Cartridge and its components.

- | | | | |
|----------|-------------------------------|----------|----------------------|
| 1 | Cartridge case | 5 | IBM product label |
| 2 | Cartridge bar code label | 6 | Cartridge door |
| 3 | Volume serial (VOLSER) number | 7 | Write-protect switch |
| 4 | Label area | | |

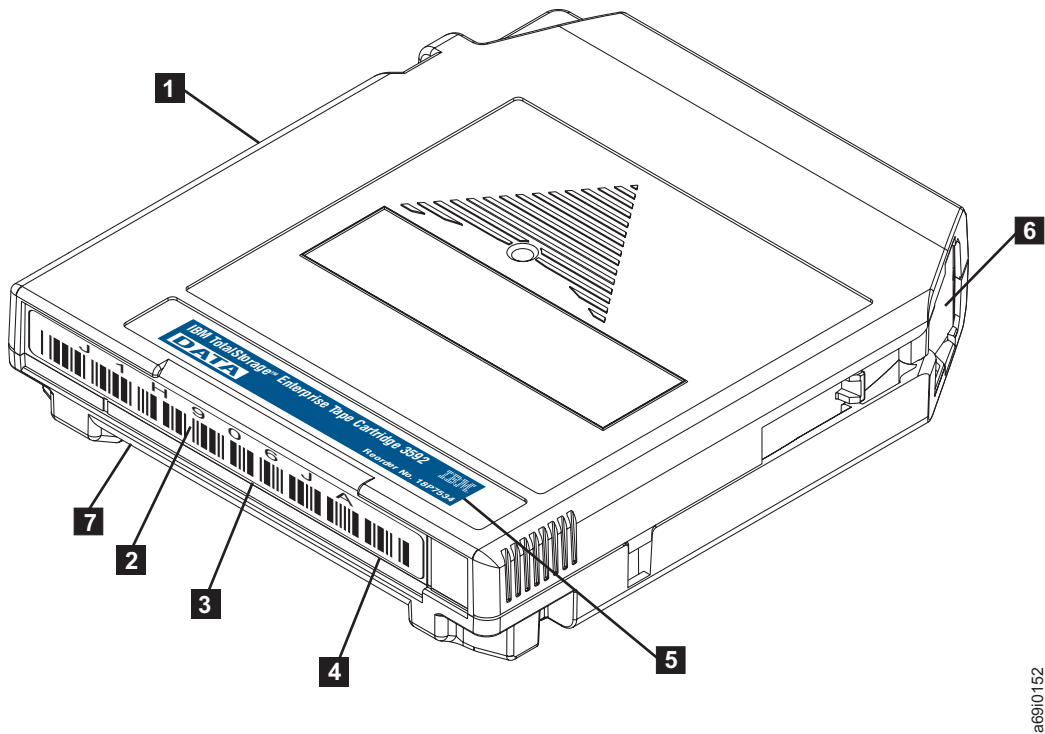

Figure 49. Components of the IBM TotalStorage 3592 Enterprise Tape Cartridge

Through its vision system, the 3584 Tape Library identifies the types of cartridges it contains during an inventory operation. The bar code reader reads the VOLSER (see **3** in Figure 49) of the cartridge bar code label **2** that is in the label area **4** of the cartridge. If your cartridge does not have a pre-attached bar code label and you attach one to it, place it entirely within the recessed label area (see **3** and **4** as an example of proper placement). The label must be flat to within 0.5 mm (0.02 in.) over the length of the label and have no folds, missing pieces, tears, or any extraneous markings. Failure to follow these placement requirements will result in degraded readability.

The IBM product label **5** specifies the type of cartridge: data, Economy, WORM, Economy WORM, or cleaning.

The cartridge door **6** protects the tape from contamination when the cartridge is out of the drive. When you insert the cartridge into the drive, a threading mechanism pulls the tape out of the cartridge, across the drive head, and onto a non-removable takeup reel. The head can then read or write data from or to the tape.

Each data cartridge includes a write-protect switch **7** that you can set to prevent data from being over-written or erased from the tape by the drive.

You can order tape cartridges with the bar code labels included, or you can order custom labels.

The 3592 Data Cartridge has a nominal cartridge life of 20,000 load and unload cycles. The quantity of load and unload cycles to reach this number depends on the environment in which the tape is used.

Related concepts

“Ordering 3592 Media Supplies” on page 263

This section gives an overview of the methods for ordering 3592 Tape Cartridges and other related media supplies.

Cartridge Memory in 3592 Tape Cartridges

Each 3592 data cartridge contains a passive, contactless, silicon storage device called cartridge memory (CM). The CM module holds information about that specific cartridge, the media in the cartridge, and the data on the media. The cartridge and media information is stored in a protected, read-only area of the CM. When the cartridge is loaded into the drive, a CM reader in the drive uses a contactless, radio-frequency interface to read the information. The media's performance statistics are stored in an unprotected, read/write area of the CM module. Prior to when the cartridge is unloaded, these statistics are updated by the CM reader. They are maintained by a portion of the drive's microcode known as the Statistical Analysis and Reporting System (SARS). Each cleaning cartridge also contains a CM module, which tracks the number of cleaning uses and the location of the used cleaning media.

3592 Cleaning Cartridge

This section gives information about the appearance and usage of the IBM TotalStorage 3592 Enterprise Cleaning Cartridge.

To help prevent errors caused by debris, it is important to clean the tape path of the 3592 Tape Drives and to manually clean the outside of its data cartridges, when needed. For each 3584 Tape Library, IBM supplies a specially labeled IBM TotalStorage 3592 Enterprise Cleaning Cartridge with the first 3592 Tape Drive in the library. This cleaning cartridge may be used in both the 3592 J1A and the TS1120 Tape Drive.



Attention: Insert only clean and undamaged cleaning cartridges into a tape system. Before you insert a cartridge into a drive or storage slot, inspect the cartridge for damage or debris. **Damaged or dirty cartridges can reduce system reliability and cause the loss of recorded data.** If debris appears on the cartridge, wipe the outside surfaces with a lint-free cloth lightly moistened with water. Do not allow any liquid to contact the tape. Ensure that all cartridge surfaces are dry and that the leader pin is in place (see **1** in Figure 50 on page 252) before you load the cartridge.

The cleaning of the tape path in the drive is an automatic procedure initiated by the drive when changes in drive performance generates a request for cleaning, when more than 5000 mounts have occurred, when more than 20 full file passes of data have been processed, or when the drive detects a degraded head or channel condition. If you load an expired cleaning cartridge, the drive will eject the cartridge and post a status message to indicate that cleaning was not performed. Failure to clean a drive can result in buildup of debris on the read/write head and malfunction. If no cleaning cartridges are installed in the library, or if the available cleaning cartridges have reached the maximum number of 50 uses, cleaning will not be completed. For information about different cleaning methods (automatic, host, or manual), refer to the section about methods of cleaning drives in the *IBM System Storage TS3500 Tape Library Introduction and Planning Guide*. Also see “Performing Manual Cleaning of Drives in the Library” on page 73 and “Enabling or Disabling Automatic Cleaning” on page 69.

Before you insert a cartridge into a drive or storage cell, inspect the cartridge for damage or debris. **Damaged or dirty cartridges can reduce system reliability and cause the loss of recorded data.** If debris appears on the cartridge, wipe the outside surfaces with a lint-free cloth lightly moistened with water. No visible water residue or droplets should be observable on the cartridge during or after the wiping effort.

Attention: Do not allow any liquid to contact the tape itself. Special care should be made to never allow liquid water to enter the cartridge which can potentially wick into the layers of the tape and cause them to adhere to each other. This creates the risk that the coatings may pull out during unwind.

Ensure that all cartridge surfaces are dry and that the leader pin is in place (see **1** in Figure 50 on page 252) before you load the cartridge.

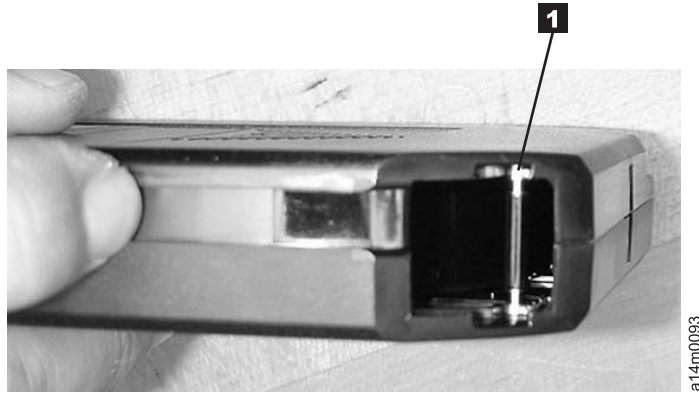

Figure 50. Leader pin in proper position in the 3592 Cleaning Cartridge (the cartridge door is manually retracted)

While the cleaning is in process, the 8-character message display on the drive shows the message, CLEAN*.

The IBM TotalStorage 3592 Enterprise Cleaning Cartridge contains a Cartridge Memory (CM) device that automatically keeps track of the number of times it has been used. Cleaning cartridges need to be replaced after 50 uses. Automatic cleaning is only available if the appropriate cleaning cartridges are installed in the library and have remaining use.

The physical characteristics of the 3592 Cleaning Cartridge distinguish it from the 3592 Data Cartridge. The product label on the top of the cartridge is white, with the word CLEANING printed on it. In place of the write-protect switch, there is a non-moveable light gray block (see **1** in Figure 51). If you order cleaning cartridges with pre-attached labels, the first three characters of the volume serial (VOLSER) number **2** are CLN. The cartridge door (see **1** in Figure 52 on page 253) is also light gray.

- 1** Non-moveable light gray block
- 2** Sample label for cleaning cartridge

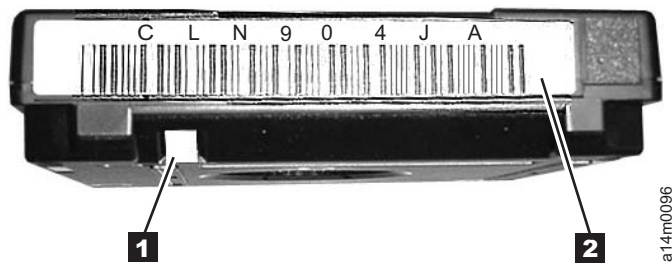

Figure 51. Characteristics that identify the 3592 Cleaning Cartridge



Figure 52. Door of the 3592 Cleaning Cartridge

Before a drive can be cleaned, you must ensure that an IBM TotalStorage 3592 Cleaning Cartridge is loaded in the library. To determine whether one or more cleaning cartridges are loaded, go to the section about inserting a cleaning cartridge into the 3584 Tape Library. You can load multiple cleaning cartridges and store them in any cartridge storage slot except the slot that is reserved for the diagnostic cartridge. For additional information, go to the section about the non-addressable cartridge storage slot.

Related concepts

“Inserting a Cleaning Cartridge into the Library” on page 70

This section introduces methods to insert a cleaning cartridge into the 3584 Tape Library when automatic cleaning is enabled or disabled.

“Non-Addressable Cartridge Storage Slot” on page 25

“Performing Manual Cleaning of Drives in the Library” on page 73

If you choose not to use automatic cleaning for drives of the 3584 Tape Library, this section introduces two ways that you can perform manual cleaning.

“Enabling or Disabling Automatic Cleaning” on page 69

This section describes how the 3584 Tape Library can automatically clean its tape drives. It introduces two ways to enable or disable automatic cleaning.

“Removing a Cleaning Cartridge from the Library” on page 75

This section introduces two ways to remove a cleaning cartridge from the 3584 Tape Library.

“Ordering 3592 Media Supplies” on page 263

This section gives an overview of the methods for ordering 3592 Tape Cartridges and other related media supplies.

3592 Diagnostic Cartridge

This section gives information about the appearance and usage of the 3592 diagnostic cartridge.

The 3592 diagnostic cartridge is a cartridge with verified media that is reserved for diagnostic purposes only. In the 3584 Tape Library, one storage slot is reserved in the first Model L22 or Model D22 frame for the 3592 diagnostic cartridge. The slot is located at Column 1, Row 1. During a service call, your IBM Service Representative uses the cartridge to ensure that the tape drives run correctly and to specification. The volume serial (VOLSER) number for the diagnostic cartridge is CE xxxJJ, where a space occurs after CE and xxx equals three numerals.

Related concepts

“Ordering 3592 Media Supplies” on page 263

This section gives an overview of the methods for ordering 3592 Tape Cartridges and other related media supplies.

3592 Bar Code Label

This section describes the appearance and specifications of the 3592 bar code label.

Each 3592 data, cleaning, and diagnostic cartridge that is processed by the 3584 Tape Library must bear a bar code label. The label contains:

- A volume serial (VOLSER) number that you can read
- A bar code that the library can read

When read by the library's bar code reader, the bar code identifies the cartridge's VOLSER to the tape library. The bar code also tells the library whether the cartridge is a data, Economy, write once read many (WORM), Economy WORM, cleaning, or diagnostic cartridge. In addition, the bar code gives the cartridge type (JA for Data, JB for Extended Data, JJ for Economy, JW for WORM, JX for Extended WORM, JR for Economy WORM, and CLNxxxJA for a cleaning cartridge). Figure 53 on page 255 shows a sample bar code label for the IBM TotalStorage 3592 Enterprise Tape Cartridge.

You can order tape cartridges with the labels included, or you can order custom labels. The labels have a peel-and-stick backing. The bar code must meet predefined specifications. The recommended specifications include (but are not limited to):

- Eight uppercase alphanumeric characters, where the last two characters must be JA, JB, JJ, JW, JX, or JR
- Label and printing to be non-glossy
- Nominal narrow line or space width of 0.500 mm (0.019 in.)
- Wide to narrow ratio of 2.75:1
- Minimum bar length of 7.0 mm (0.27 in.)

To determine the complete specifications of the bar code and the bar code label, visit the web at <http://www.storage.ibm.com/media/tapecartridges/index.html>. Under Enterprise storage media, select 3592 tape cartridges. Under Learn more, select Barcode Label Specification for use with 3592 Tape Media. Under Content, select the .pdf file to view the *Label Specification for IBM 3592 Cartridges when used in IBM Libraries*. You can also contact your IBM Sales Representative for this specification.

When attaching a bar code label to a tape cartridge, place the label only in the recessed label area (see Figure 53 on page 255). A label that extends outside of the recessed area can cause loading problems in the drive or the library.

Attention: Do not place any type of mark on the white space at either end of the bar code. A mark in this area may prevent the 3584 Tape Library from reading the label.

By using the Tape Library Specialist web interface, you can configure the library so that it reports to the server all eight characters of the VOLSER on the bar code label or only the first six characters. For more information, see "Enabling or Disabling the Reporting of a Six-Character or Eight-Character VOLSER" on page 176.

Note: If you suspect that the library is having problems reading the bar code labels, you can slow the scanner speed as part of problem determination. You may choose to slow the scanner speed rather than replace all labels, or you may want to slow the scanner speed while you wait for an opportunity

to re-label the media. Depending on the severity of the problem, the error recovery procedure (ERP) for poor labels may greatly exceed the time lost by slowing the scanner. If you have cartridge bar code labels that meet the LTO bar code label specification, there is no need to slow the scanner speed. For more information, see “Adjusting the Scanner Speed” on page 199.

To order bar code labels, see “Ordering 3592 Bar Code Labels” on page 266.

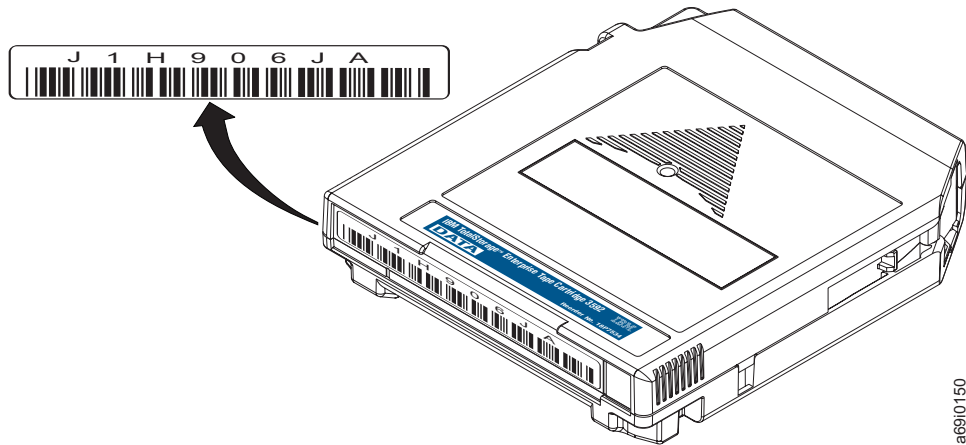

Figure 53. Sample bar code label on the IBM TotalStorage 3592 Enterprise Tape Cartridge. The volume serial number (J1H906JA) and bar code are printed on the label.

Related concepts

“Ordering 3592 Media Supplies” on page 263

This section gives an overview of the methods for ordering 3592 Tape Cartridges and other related media supplies.

Related tasks

“Enabling or Disabling the Reporting of a Six-Character or Eight-Character VOLSER” on page 176

This section describes how to configure the 3584 Tape Library so that it reports to the server only the first six characters of the volume serial (VOLSER) number of a tape cartridge’s bar code label or it reports the full eight characters of the VOLSER. Reporting eight characters is the default.

Related reference

“Ordering 3592 Bar Code Labels” on page 266

Guidelines for Using 3592 Bar Code Labels

Apply the following guidelines whenever you use bar code labels:

- Use only IBM-approved bar code labels.
- Do not reuse a label or reapply a used label over an existing label.
- Examine the label before you apply it to the cartridge. Do not use the label if it has voids or smears in the printed characters or bar code (an application’s inventory operation will take much longer if the bar code label is not readable).
- Position the label within the recessed label area.
- Verify that the label is smooth and parallel, and has no roll-up or roll-over. The label must be flat to within 0.5 mm (0.02 in.) over the length of the label and have no folds, missing pieces, or smudges.

- Do not place other machine readable labels on other surfaces of the cartridge. They may interfere with the ability of the bar code reader to read the bar code.
- Use peel-clean labels that do not leave a residue after they are removed. If there is glue residue on the cartridge, remove it by gently rubbing it with your finger; do not use a sharp object, water, or a chemical to clean the label area.
- Before you apply a new label, remove the old label by slowly pulling it at a right angle to the cartridge case.
- Remove the label from the label sheet carefully. Do not stretch the label or cause the edges to curl.
- With light finger pressure, smooth the label so that no wrinkles or bubbles exist on its surface.

Setting the Write-Protect Switch on a 3592 Cartridge

This section gives instructions for setting the write-protect switch on a 3592 Tape Cartridge.

The position of the write-protect switch on the 3592 Tape Cartridge (see Figure 54) determines whether you can write to the tape.

- To write data to or erase data from the cartridge, set the switch to **1**. This exposes a square hole.
- To prevent data from being overwritten or erased from the cartridge, set the switch to **2**. This covers the hole.

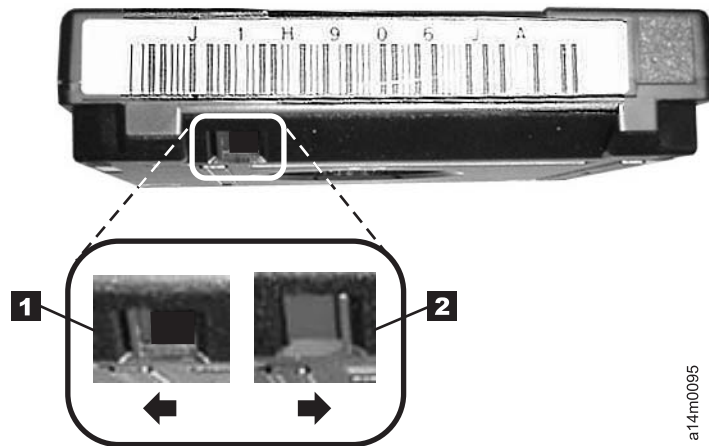

a14m0095

Figure 54. Setting the write-protect switch on the 3592 Tape Cartridge

Handling 3592 Tape Cartridges

This section introduces ways to handle 3592 Tape Cartridges to avoid damage to the cartridge case and the tape.



Attention: Do not insert a damaged tape cartridge into your tape drive. A damaged cartridge can interfere with the reliability of a drive and may void the warranties of the drive and the cartridge. Before inserting a tape cartridge, inspect the cartridge case, cartridge door, and write-protect switch for breaks.

Incorrect handling or an inhospitable environment can damage the IBM TotalStorage 3592 Enterprise Tape Cartridge or its magnetic tape. To avoid damage to your tape cartridges and to ensure the continued high reliability of your 3584 Tape Library, use the following guidelines:

Provide Training for Using 3592 Tape Cartridges

- Post procedures that describe proper media handling in places where people gather.
- Ensure that anyone who handles tape has been properly trained in handling and shipping procedures. This includes operators, users, programmers, archival services, and shipping personnel.
- Ensure that any service or contract personnel who perform archiving are properly trained in media-handling procedures.
- Include media-handling procedures as part of any services contract.
- Define and make personnel aware of data recovery procedures.

Ensure Proper Packaging of 3592 Tape Cartridges

- When you ship a cartridge, ship it in its original or better packaging.
- Use only shipping container that securely hold the cartridge in place during transportation. Such containers can be procured from Perm-A-Store on the web at www.turtlecase.com. The 3592 tape cartridges support racks and storage containers designed for 3590 tape cartridges.
- Never ship a cartridge in a commercial shipping envelope. Always place it in a box or package.
- If you ship the cartridge in a cardboard box or a box of a sturdy material, ensure the following:
 - Place the cartridge in polyethylene plastic wrap or bags to protect it from dust, moisture, and other contaminants.
 - Pack the cartridge snugly; do not allow it to move around.
 - Double-box the cartridge (place it inside a box, then place that box inside the shipping box) and add padding between the two boxes.

Provide Proper Acclimation and Environmental Conditions for 3592 Tape Cartridges

- Before you use a cartridge, let it acclimate to the normal operating environment for a minimum of 24 hours. If you see condensation on the cartridge, wait an additional hour.
- Ensure that all surfaces of a cartridge are dry before inserting it.
- Do not expose the cartridge to moisture or direct sunlight.

- Do not expose recorded or blank cartridges to stray magnetic fields of greater than 100 Oersteds (for example, terminals, motors, video equipment, X-ray equipment, or fields that exist near high-current cables or power supplies). Such exposure can cause the loss of recorded data or make the blank cartridge unusable.
- Maintain the proper conditions for storing and shipping the cartridges.

Related concepts

“Environmental and Shipping Specifications for 3592 Cartridges” on page 262
This section gives a table of the operating, storage, and shipping requirements for 3592 Tape Cartridges.

Perform a Thorough Inspection of 3592 Tape Cartridges

After purchasing a 3592 Tape Cartridge and before using it, perform the following steps:

- Inspect the cartridge’s packaging to determine potential rough handling.
- Ensure that no moisture or condensation exists on or in the cartridge shell or media.
- When inspecting a cartridge, open only the cartridge door. Do not open any other part of the cartridge case. The upper and lower parts of the case are welded and held together with screws; separating them destroys the usefulness of the cartridge.
- Inspect the cartridge for damage before using or storing it.
- Check that the leader pin is properly positioned.
- Ensure that labels are affixed in a manner that does not adversely affect drive operation. Labels must only be affixed in the recessed areas provided on the cartridge.
- If you suspect that the cartridge has been mishandled but it appears usable, copy any data onto a good cartridge immediately for possible data recovery. Discard the mishandled cartridge.

Related tasks

“Repositioning a Leader Pin in a 3592 Cartridge” on page 260
This section gives the procedure to use when you move a leader pin into its proper position in a 3592 Tape Cartridge.

Handle the 3592 Tape Cartridge Carefully

- Do not drop the 3592 Tape Cartridge. If the cartridge drops, slide the cartridge door back and ensure that the leader pin is properly positioned.
- Avoid mechanical loads that would distort the cartridge’s shape.
- Do not handle tape that is outside the cartridge. Handling the tape can damage the tape’s surface or edges, which may interfere with read or write reliability. Pulling on tape that is outside the cartridge can damage the tape and the brake mechanism in the cartridge.
- Do not stack more than six cartridges.
- Do not degauss a cartridge that you intend to reuse. Degaussing the tape erases the servo tracks and makes the tape unusable. An attached host can be used to run a Data Security Erase if the data on the tape needs to be physically erased. This physically overwrites the data on the tape without damaging the servo tracks.

Related tasks

“Repositioning a Leader Pin in a 3592 Cartridge”

This section gives the procedure to use when you move a leader pin into its proper position in a 3592 Tape Cartridge.

Repositioning a Leader Pin in a 3592 Cartridge

This section gives the procedure to use when you move a leader pin into its proper position in a 3592 Tape Cartridge.



Attention: Use a repaired tape cartridge only to recover data and move it to another cartridge. Continued use of a repaired cartridge may void the warranties of the drive and the cartridge.

If the leader pin in your 3592 Tape Cartridge becomes dislodged from its pin-retaining spring clips, you must use the IBM Leader Pin Reattachment Kit (part number 18P8887) to reposition it.

A leader pin that is improperly seated inside a cartridge can interfere with the operation of the drive. Figure 55 shows a leader pin in the incorrect **1** and correct **2** positions.

To place the leader pin in its proper position, you will need the following tools:

- Plastic or blunt-end tweezers
- Cartridge manual rewind tool (from the Leader Pin Reattachment Kit, part number 18P8887)

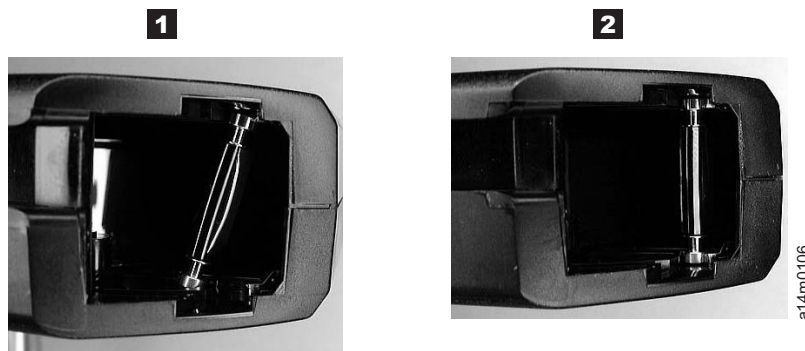

Figure 55. Leader pin in the incorrect and correct positions in a 3592 Tape Cartridge. The cartridge door is open and the leader pin is visible inside the cartridge.

To reposition the leader pin, perform the following steps.

1. Slide open the cartridge door (see **1** in Figure 56 on page 261) and locate the leader pin **2** (you may need to shake the cartridge gently to roll the pin toward the door).
2. With plastic or blunt-end tweezers, grasp the leader pin and position it in the pin-retaining spring clips **3**.
3. Press the leader pin gently into the clips until it snaps into place and is firmly seated.
4. Close the cartridge door.

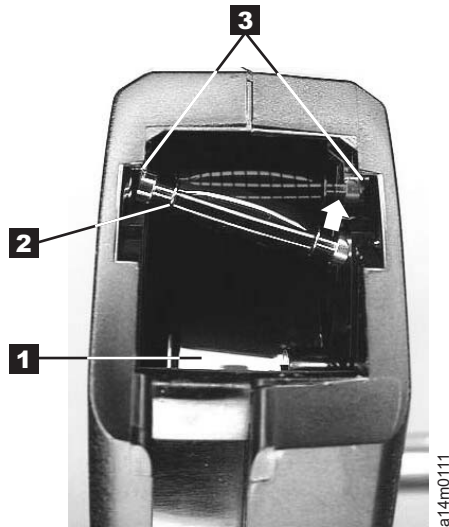

Figure 56. Placing the dislodged leader pin into the correct position.. The cartridge door is open, showing the leader pin out of position

5. To rewind the tape, insert the cartridge manual rewind tool (see **1** in Figure 57) into the cartridge's hub **2** and turn it clockwise until the tape becomes taut.

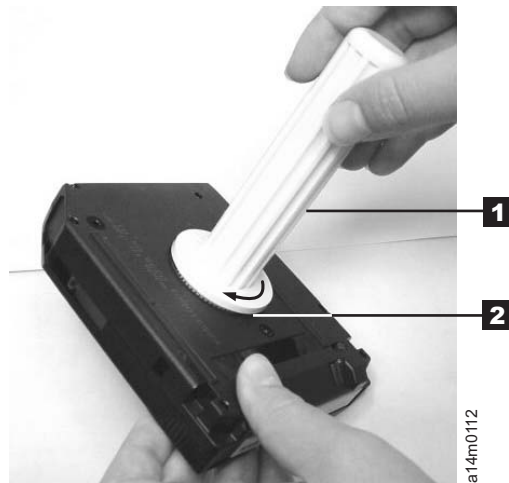

Figure 57. Rewinding the tape into the cartridge

6. Remove the rewind tool by pulling it away from the cartridge.

Environmental and Shipping Specifications for 3592 Cartridges

This section gives a table of the operating, storage, and shipping requirements for 3592 Tape Cartridges.

Before you use a tape cartridge, acclimate it to the operating environment for 24 hours or the time necessary to prevent condensation in the drive (the time will vary, depending on the environmental extremes to which the cartridge was exposed).

The best storage container for the cartridges (until they are opened) is the original shipping container. The plastic wrapping prevents dirt from accumulating on the cartridges and partially protects them from humidity changes.

Attention: Depending on how many drives you have installed in the frame, the temperature inside the frame may be as much as 5°C (9°F) above the temperature outside the frame. To ensure continued reliability of your media, be sure to take this temperature difference into account when you set up the environment around your library.

When you ship a cartridge, place it in a sealed, moisture-proof bag to protect it from moisture, contaminants, and physical damage. Ship the cartridge in a shipping container that has enough packing material to cushion the cartridge and prevent it from moving within the container.

Table 21 lists the environmental conditions for operating, storing, and shipping IBM TotalStorage 3592 Enterprise Tape Cartridges.

Table 21. Environment for operating, storing, and shipping the IBM TotalStorage 3592 Enterprise Tape Cartridge

Environmental Specifications			
Environmental Factor	Operational Storage ^{1,3}	Archival Storage ^{2,4}	Shipping
Temperature	16 to 32°C (61 to 90°F)	16 to 25°C (61 to 77°F)	-23 to 49°C (-9 to 120°F)
Relative humidity (noncondensing)	20 to 80%	20 to 50%	5 to 80%
Wet bulb maximum temperature	26°C (79°F)	26°C (79°F)	26°C (79°F)
Magnetic field	Stray magnetic field at any point on tape not to exceed 50 Oersteds.		
Notes:			
1. Operational storage equals less than 6 months.			
2. Archival storage equals greater than 6 months.			
3. Cartridges shall be stored under these conditions if they will also be used in a drive during storage.			
4. Cartridges shall be stored under these conditions for archiving.			

Disposing of 3592 Cartridges

This section describes how to dispose of 3592 Tape Cartridges according to federal and other regulations.

Under the current rules of the U.S. Environmental Protection Agency (EPA), regulation 40CFR261, the IBM TotalStorage 3592 Enterprise Tape Cartridge is classified as non-hazardous waste. As such, it may be disposed of in the same way as normal office trash. These regulations are amended from time to time, and you should review them at the time of disposal.

If your local, state, country (non-U.S.A.), or regional regulations are more restrictive than EPA 40CFR261, you must review them before you dispose of a cartridge. Contact your account representative for information about the materials that are in the cartridge.

If a tape cartridge must be disposed of in a secure manner, IBM recommends that you use a qualified service provider to degauss and destroy the media.

If you burn the cartridge and tape, ensure that the incineration complies with all applicable regulations.

Cartridge Quality and Library Maintenance

This section describes how to maintain 3592 Tape Cartridges and the 3584 Tape Library to ensure proper operation.

The 3592 Tape Cartridge provides high performance and reliability with IBM magnetic tape cartridge drives when the cartridge is properly handled and stored. As stated previously, repeated handling or inadvertent mishandling can damage the physical parts of the cartridge and make it unusable.

The magnetic tape inside the cartridge is made of highly durable materials. However, the tape wears after repeated cycles in the tape system. Eventually, such wear can cause an increase in tape errors.

Track the error data available by monitoring both the cartridge and cartridge library performance. By monitoring error data, you can identify and replace cartridges that are no longer acceptable for continued use.

Proper maintenance of the 3584 Tape Library helps to keep IBM magnetic tape cartridge systems operating in a reliable and efficient manner.

Ordering 3592 Media Supplies

This section gives an overview of the methods for ordering 3592 Tape Cartridges and other related media supplies.

You can order media supplies in two ways. The 3599 Tape Media method is available for ordering all types of data and cleaning cartridges. This method is typically used for ordering larger quantities and for ordering initialized or pre-labeled cartridges. Media supplies can also be ordered by using part numbers through IBM-authorized distributors.

Related reference

“Ordering Supplies for Repairs” on page 266

Ordering 3592 Media Supplies by Using the 3599 Tape Media Method

If you order media by using the 3599 Tape Media method, IBM TotalStorage Enterprise Tape Media 3599 provides the ability to order unlabeled, pre-labeled, initialized, and bulk-packaged data cartridges in a variety of combinations. You can also order cleaning cartridges. The following data cartridges may be ordered by using the 3599 Tape Media method:

- 300 GB or 500 GB Data cartridges
- 700 GB Extended Data cartridges
- 60 GB or 100 GB Economy cartridges
- 60 GB or 100 GB WORM cartridges
- 300 GB or 500 GB WORM cartridges
- 700 GB Extended WORM cartridges

Segmentation and capacity scaling options are also available for the following:

- 300 GB or 500 GB Data cartridge for a 60 GB or 100 GB Fast Access capability, and a segmented tape with 60 GB or 100 GB of fast access and additional capacity
- 700 GB Extended Data cartridge for a 140 GB Fast Access capability, and a segmented tape with 140 GB of fast access and additional capacity

With the 3599 Tape Media method of ordering, model numbers are used to identify the cartridge types, and feature code combinations are used to specify the quantities, labeling, and initialization options. Table 22 shows a few examples of ordering options for each cartridge type. Note that additional feature codes are required to completely specify all desired characteristics of the cartridges. Orders may be placed by calling 1-800-IBM-CALL (1-800-426-2255).

Table 22. Descriptions of 3599 tape media features

3599 Model	Media ID/ Feature Code	Feature Code for Labeling, Initialization, and Quantity	Format	Individual Cartridge Capacity	Description
011	JA/9030	1020	9081	500 GB	20-pack 3592 Data cartridges, labeled and initialized
			9080	300 GB	
012	JA/9030	2020	9081	500 GB	20-pack 3592 Data cartridges, labeled, not initialized
			9080	300 GB	
013	JA/9030	3020	9081	500 GB	20-pack 3592 Data cartridges, not labeled or initialized
			9080	300 GB	
014	JB/9032	4020	9081	700 GB	20-pack 3592 Extended Data cartridges, labeled and initialized
015	JB/9032	5020	9081	700 GB	20-pack 3592 Extended Data cartridges, labeled, not initialized
016	JB/9032	6020	9081	700 GB	20-pack 3592 Extended Data cartridges, not labeled or initialized

Table 22. Descriptions of 3599 tape media features (continued)

3599 Model	Media ID/ Feature Code	Feature Code for Labeling, Initialization, and Quantity	Format	Individual Cartridge Capacity	Description
E11	JJ/9050	1020	N/A (see Note)	60 GB	20-pack 3592 Economy cartridges, labeled and initialized
E12	JJ/9050	2020	N/A	60 GB	20-pack 3592 Economy cartridges, labeled, not initialized
E13	JJ/9050	3020	N/A	60 GB	20-pack 3592 Economy cartridges, not labeled or initialized
021	JW/9040	1020	9081	500 GB	20-pack 3592 WORM cartridges, labeled and initialized
			9080	300 GB	
022	JW/9040	2020	9081	500 GB	20-pack 3592 WORM cartridges, labeled, not initialized
			9080	300 GB	
023	JW/9040	3020	9081	500 GB	20-pack 3592 WORM cartridges, not labeled or initialized
			9080	300 GB	
024	JX/9044	2420	9081	700 GB	20-pack 3592 Extended WORM cartridges, labeled and initialized
025	JX/9044	2520	9081	700 GB	20-pack 3592 Extended WORM cartridges, labeled, not initialized
026	JX/9044	2620	9081	700 GB	20-pack 3592 Extended WORM cartridges, not labeled or initialized
E21	JR/9042	1020	9081	100 GB	20-pack 3592 Economy WORM cartridges, labeled and initialized
			9080	60 GB	
E22	JR/9042	2020	9081	100 GB	20-pack 3592 Economy WORM cartridges, labeled, not initialized
			9080	60 GB	
E23	JR/9042	3020	9081	100 GB	20-pack 3592 Economy WORM cartridges, not labeled or initialized
			9080	60 GB	
017	JA	7005	N/A	cleaning, 50 uses	5-pack 3592 Cleaning Cartridges, labeled and initialized
017	JA	7006	N/A	cleaning, 50 uses	5-pack 3592 Cleaning Cartridges without media identification labels
Note: N/A = not applicable.					

Ordering 3592 Media Supplies by Using Part Numbers

Table 23 lists the data cartridges and media supplies that you can order for 3592 Tape Drives by using part numbers. The different methods for ordering are listed at the bottom of the table.

Table 23. Ordering 3592 media supplies by using part numbers

Supply Item	Capacity	Part Number
IBM TotalStorage 3592 Enterprise Tape Cartridge - Data	300 GB	18P7534
IBM TotalStorage 3592 Enterprise Tape Cartridge - Extended Data	700 GB	23R9830
IBM TotalStorage 3592 Enterprise Tape Cartridge - Economy	60 GB	24R0316
IBM TotalStorage 3592 Enterprise Tape Cartridge - WORM	300 GB	18P7538
IBM TotalStorage 3592 Enterprise Tape Cartridge - Extended WORM	700 GB	23R9831
IBM TotalStorage 3592 Enterprise Tape Cartridge - Economy WORM	60 GB	24R0317
IBM TotalStorage 3592 Enterprise Tape Cartridge - Cleaning	Cleaning, 50 uses	18P7535
Methods of Ordering		
Use any of the three methods below to order media supplies by part number.		
<ul style="list-style-type: none"> • Order by part number through an IBM-authorized distributor (for the closest distributor, visit the web at http://www.ibm.com/storage/media) • If you do not have Internet access, order the cartridges from any authorized IBM Business Partner or your IBM Sales Representative • Call 1-888-IBM-MEDIA 		
Note: Be sure to order bar code labels for all cleaning and data cartridges. Order volume serial (VOLSER) labels separately.		

Ordering Supplies for Repairs

We recommend that you keep the **Leader Pin Reattachment Kit** to maintain your cartridges. This kit contains the necessary tools to reattach the leader pin to the tape. It includes the rewind tool, which can be used to add tension to a tape if the leader pin is displaced. To order the kit, call 1-888-IBM-MEDIA to order as IBM part number 18P8887.

Ordering 3592 Bar Code Labels

Bar code labels with volume serial (VOLSER) numbers are required for 3592 Tape Cartridges that are used within a library. You can order these labels separately from the IBM data cartridges and cleaning cartridges.

You can order bar code labels directly from the authorized label suppliers in Table 24 on page 267.

Attention: The IBM System Storage TS3500 Tape Library is designed to work with bar code labels that meet the specifications and requirements set forth in the *Label Specification for IBM 3592 Cartridges when used in IBM Libraries*. The following label providers have demonstrated the ability to produce finished bar code labels that meet the foregoing specifications and requirements. This information is provided for the convenience of 3584 Tape Library users only, and is not an endorsement or recommendation of such providers. IBM is not responsible for the quality of bar code labels procured from sources other than IBM. This information is applicable to bar code labels actually printed by the listed companies. IBM has not reviewed the quality of any labels produced by software or services offered by such companies which allow end users to print labels on their own printing equipment.

Table 24. Authorized suppliers of custom bar code labels for 3592 Tape Cartridges

In the Americas	In Europe and Asia
Dataware 7570 Renwick Houston, TX 77081 U. S. A. Telephone: 800-426-4844 http://www.datawarelabels.com/	Not applicable
EDP/Colorflex 2550 West Midway Boulevard Broomfield, CO 80020-1633 U. S. A. Telephone: 800-522-3528 or 303-666-2160 Fax: 303-666-2166 http://www.colorflex.com/colortrax.asp	EDP Europe Limited 43 Redhills Road South Woodham Ferrers Chelmsford, Essex CM3 5UL U. K. Telephone: 44 (0) 1245 322380 Fax: 44 (0)1245 323484 http://www.edpeurope.com/media-labels.html
Netc, L. L. C. 100 Corporate Drive Trumbull, CT 06611 U. S. A. Telephone: 203-372-6382 http://www.NetcLabels.com	Netc Europe Ltd Town Farm Bungalow North Curry Taunton Somerset U. K. TA3 6LX Telephone: 44 (0) 1823 491439 http://www.NetcLabels.co.uk
	Netc Asia Pacific Pty Ltd Locked Bag 14 Kenthurst NSW Australia 2156 Telephone: 61 (0) 2 4563 6556 http://www.NetcLabels.com.au

Chapter 6. Problem Determination

This section introduces ways to help you assess symptoms and resolve possible problems with the 3584 Tape Library. If you are connected to an Simple Network Management Protocol (SNMP) monitoring station, this section also introduces ways to help you analyze problems identified by SNMP traps.

Resolving Errors

This section introduces symptoms and error messages that can help you to resolve problems with the 3584 Tape Library, the 3592 Tape Drives, and the LTO Ultrium Tape Drives.

Resolving Errors with the Library and the Installed Tape Drives

This section contains a table of symptoms or errors that could occur with the 3584 Tape Library and the installed tape drives. The table provides actions to correct the problems.

Table 25 on page 270 lists symptoms or errors that could occur with the 3584 Tape Library and gives the required corrective actions. Figure 58 shows the front and Figure 59 on page 270 shows the rear of the 3592 J1A. Use these figures to resolve errors that are addressed in the table.

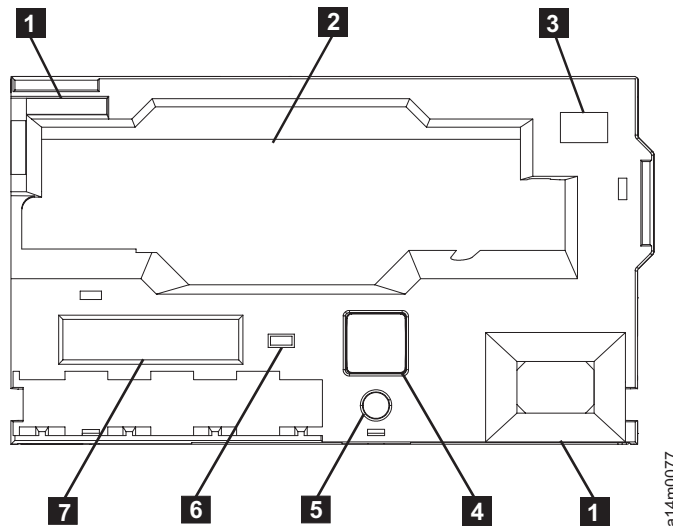
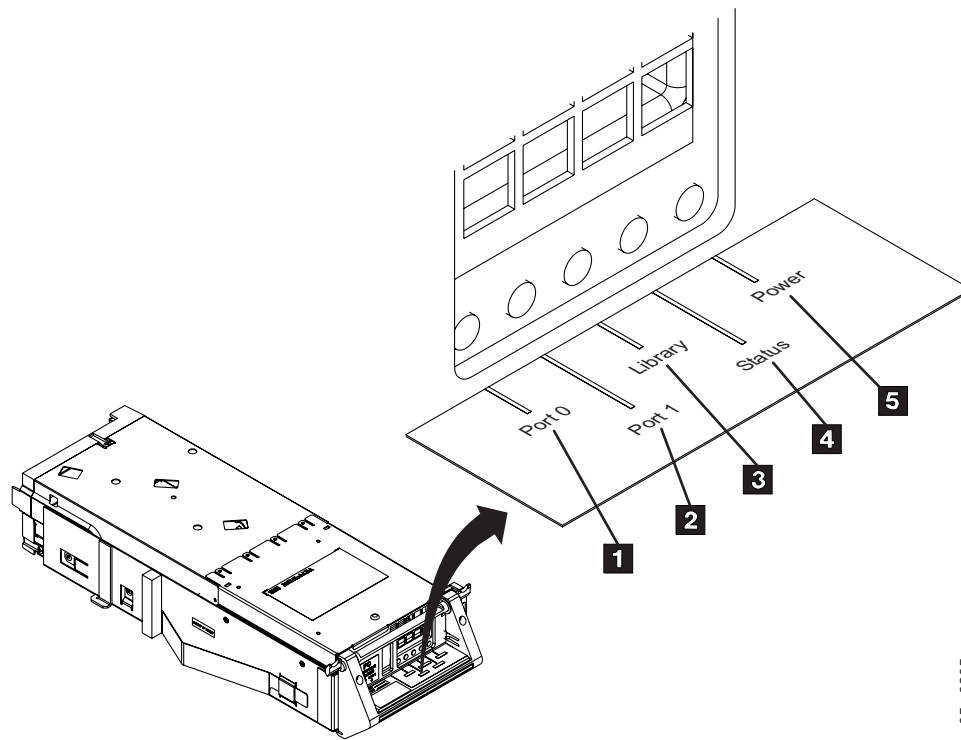

Figure 58. Front view of the 3592 J1A

- | | | | |
|----------|------------------------|----------|---------------------------------|
| 1 | Reflective fiducials | 5 | Reset button |
| 2 | Tape cartridge slot | 6 | LED power indicator |
| 3 | Nonreflective fiducial | 7 | Eight-character message display |
| 4 | Unload area | | |



a05m0205

Figure 59. Rear view of the 3592 J1A

- | | |
|--|---|
| <p>1 LED indicator for Port 0</p> <p>2 LED indicator for Port 1</p> <p>3 LED indicator for library communications</p> | <p>4 LED indicator for drive status</p> <p>5 LED indicator for drive power status</p> |
|--|---|

Table 25. Resolving errors with the IBM System Storage TS3500 Tape Library

Symptom or Error	Action
<p>The library is powered off. All of the following conditions are true:</p> <ul style="list-style-type: none"> • The touchscreen LCD is blank. • The power-on indicator is not lit. • The library and all of the drives do not respond to host commands. 	<ol style="list-style-type: none"> 1. Ensure that the library's power is turned on (the power-on switch is positioned to). 2. Ensure that the library's power cord is plugged into the wall receptacle. Note: Each frame could have a separate power cord. 3. Ensure that the power receptacle (into which the library's power cord is plugged) is active (for example, ensure that a circuit breaker is not tripped or turned off). 4. If the problem still exists, call your IBM Service Representative.
<p>A message displays on the touchscreen and indicates that a front door is open.</p>	<ol style="list-style-type: none"> 1. Ensure that all front doors are closed and properly latched. 2. If the problem still exists, open and close each front door. 3. If the problem still exists, call your IBM Service Representative.
<p>A message displays on the touchscreen and indicates that the door of the I/O station is open or the I/O station is full of cartridges.</p>	<ol style="list-style-type: none"> 1. If the message indicates that the door of the I/O station is open, close the door. 2. If the message indicates that the I/O station is full of cartridges, open the I/O station door, remove the cartridges, and close the door. 3. If the problem still exists, call your IBM Service Representative.

Table 25. Resolving errors with the IBM System Storage TS3500 Tape Library (continued)

Symptom or Error	Action
A message displays on the touchscreen and indicates that a cleaning cartridge has expired.	Usage of the cleaning cartridge has exceeded a specified threshold. To replace the cleaning cartridge, see "Removing a Cleaning Cartridge from the Library" on page 75 or "Inserting a Cleaning Cartridge into the Library" on page 70. To order cleaning cartridges, see "Ordering Additional Ultrium Cartridges and Media Supplies" on page 239 or "Ordering 3592 Media Supplies" on page 263.
A message displays on the touchscreen and indicates that a drive needs to be cleaned.	<ol style="list-style-type: none"> 1. Ensure that a cleaning cartridge is present in the library inventory (see "Performing an Inventory of the Library" on page 108). If no cleaning cartridge is present, see "Inserting a Cleaning Cartridge into the Library" on page 70. 2. Ensure that automatic cleaning is enabled (see "Enabling or Disabling Automatic Cleaning" on page 69). 3. If the host application is responsible for cleaning the drives, ensure that a cleaning cartridge is in the same logical library as the drive to be cleaned. 4. If the problem still exists, manually clean the drive (see "Performing Manual Cleaning of Drives in the Library" on page 73).
An error message displays on the touchscreen.	<ol style="list-style-type: none"> 1. Record the error message, as well as any error codes, locations, and so forth. 2. Press MENU. The library removes the error message from the touchscreen. 3. Call your IBM Service Representative.

Table 25. Resolving errors with the IBM System Storage TS3500 Tape Library (continued)

Symptom or Error	Action
<p>Fibre Channel Communications Problem. The host is unable to communicate with one or more Fibre Channel devices in the library.</p>	<ol style="list-style-type: none"> 1. Ensure that all Fibre Channel cables from the host to the library are securely connected at both ends. 2. If multiple Fibre Channel drives exist on a single loop (as when multiple drives are connected to a hub), ensure that each device on the loop has a unique loop ID (see the section about Fibre Channel Addressing in the <i>IBM System Storage TS3500 Tape Library Introduction and Planning Guide</i>). 3. Ensure that all Fibre Channel host adapters are supported (for a list of supported adapters, visit the web at http://www.ibm.com/servers/storage/tape/drives. Under IBM System Storage TS1120 Tape Drive or IBM TotalStorage 3592 Tape Drive, select Product details, then select Host bus adapter. Or, contact your IBM Sales Representative). 4. Ensure that the appropriate levels of device driver are installed and that any other prerequisites are satisfied (see “Supported Device Drivers” on page 18). 5. If you are connecting through a Storage Area Network (SAN) Data Gateway, ensure that the gateway has the appropriate level of firmware installed (see Note at end of table). 6. Some Fibre Channel devices (such as the SAN Data Gateway, or routers and switches) provide diagnostic routines that show all of the devices that are attached to them. Refer to the device documentation for details about the routines. If a Fibre Channel device that is positioned between the host and the library can see the library’s devices, the problem is probably between the Fibre Channel device and the host. 7. Ensure that the host is configured with the correct World Wide Node Name or World Wide Port Name (see the section about using World Wide Names in the <i>IBM System Storage TS3500 Tape Library Introduction and Planning Guide</i>). If you want to view the World Wide Names for a Fibre Channel Drive, see “Viewing a World Wide Node Name” on page 147 or “Viewing a World Wide Port Name” on page 146. 8. Refer to the documentation for the device driver that you are using. If you are using the IBM Ultrium Device Drivers, refer to <i>IBM Ultrium Device Drivers Installation and User’s Guide</i>. Review the Problem Determination procedures in the device driver documentation. Ensure that the device driver is loaded and that it can communicate with the tape drives: <ul style="list-style-type: none"> • If the device driver is not loaded, install it. • If the device driver is loaded but cannot communicate with the tape drives, call your IBM Service Representative. • If the device driver is loaded and can communicate with the tape drives, but the application software cannot communicate with the tape drives, contact the provider of your application software for assistance. 9. Current Fibre Channel components support various Fibre Channel speeds. Possible speeds are 1 Gb/s, 2 Gb/s, or 4 Gb/s. Refer to the machine configuration and ensure that all drives, switches, and host bus adapters use compatible speed settings.

Table 25. Resolving errors with the IBM System Storage TS3500 Tape Library (continued)

Symptom or Error	Action
Fibre Channel Communications Problem (continued)	<p>Perform the following:</p> <ul style="list-style-type: none"> • For a 3592 Tape Drive, open the rear door of the library, locate the affected drive, and observe the status LEDs on the back of the drive canister. The LEDs have the following meaning: <ul style="list-style-type: none"> - Blank: no light is detected at the drive's Fibre Channel port. This indicates one of the following conditions: <ul style="list-style-type: none"> - A Fibre Channel cable is unplugged at the drive or at the nearest Fibre Channel device (host bus adapter, switch, or hub). - A Fibre Channel cable is broken between the drive and the nearest Fibre Channel device (host bus adapter, switch, or hub). - The drive or the nearest Fibre Channel device (host bus adapter, switch, or hub) is powered off or has a hardware problem. - Blinking Yellow: Fibre Channel connections between the drive and the Fibre Channel device to which it is connected (host bus adapter, switch, or hub) are good, but communication has not been established. - Blinking Green: Fibre Channel connections are good and data is being transferred. - Green (not blinking): Fibre Channel connections are good, but no data is being transferred. Note that the Fibre Channel wrap plug may be installed or that the drive may be offline (in maintenance mode). • For an LTO Ultrium Tape Drive, open the rear door of the library, locate the affected drive, and observe the status LEDs on the back of the drive canister. The LEDs have the following meaning: <ul style="list-style-type: none"> - Blank: no light is detected at the drive's Fibre Channel port. This indicates one of the following conditions: <ul style="list-style-type: none"> - A Fibre Channel cable is unplugged at the drive or at the nearest Fibre Channel device (host bus adapter, switch, or hub). - A Fibre Channel cable is broken between the drive and the nearest Fibre Channel device (host bus adapter, switch, or hub). - The drive or the nearest Fibre Channel device (host bus adapter, switch, or hub) is powered off or has a hardware problem. - Yellow: Fibre Channel connections between the drive and the Fibre Channel device to which it is connected (host bus adapter, switch, or hub) are good, but communication has not been established. - Green: Fibre Channel connections are good and communication has been established.

Table 25. Resolving errors with the IBM System Storage TS3500 Tape Library (continued)

Symptom or Error	Action
<p>SCSI Communications Problem. The host is unable to communicate with one or more SCSI devices in the library.</p>	<ol style="list-style-type: none"> 1. Ensure that all SCSI cables from the host to the library are securely connected at both ends. 2. Ensure that each SCSI bus is properly terminated (the bus is terminated at the SCSI host adapter card and at the last drive on the bus). 3. For each SCSI bus, ensure that all devices on the bus have a unique SCSI address. No two drives can have the same SCSI ID, and no drive can use the SCSI ID that is used by the SCSI host adapter (see the section about using persistent binding to ensure SCSI ID assignments in the <i>IBM System Storage TS3500 Tape Library Introduction and Planning Guide</i>). Note: Unless an RS/6000 High Availability (HA) configuration is used, the SCSI host adapter is typically set to SCSI ID 7. In an HA configuration, one SCSI host adapter is set to SCSI ID 5, the second SCSI host adapter is set to SCSI ID 6, and SCSI ID 7 is reserved. 4. Ensure that all SCSI host adapters, SCSI terminators, and drives on a single SCSI bus are compatible. For example, if a library contains LVD drives, you must use LVD terminators and LVD SCSI host adapters. Similarly, if the library contains HVD drives, you must use HVD terminators and HVD SCSI host adapters. 5. If there is any Fibre Channel equipment between the host and a SCSI tape drive, perform the following tasks: <ol style="list-style-type: none"> a. Follow steps 1 on page 272 through 7 on page 272. b. Ensure that the host is configured with the correct Loop ID or AL_PA (see the section about Fibre Channel Addressing in the <i>IBM System Storage TS3500 Tape Library Introduction and Planning Guide</i>). 6. Refer to the documentation for the device driver that you are using. If you are using the IBM Ultrium Device Drivers, refer to <i>IBM Ultrium Device Drivers Installation and User's Guide</i>. Review the Problem Determination procedures in the device driver documentation. Ensure that the device driver is loaded and that it can communicate with the tape drives: <ul style="list-style-type: none"> • If the device driver is not loaded, install it. • If the device driver is loaded but cannot communicate with the tape drives, call your IBM Service Representative. • If the device driver is loaded and can communicate with the tape drives, but the application software cannot communicate with the tape drives, contact the provider of your application software for assistance. 7. Ensure that the SCSI host adapter settings are correct. The following SCSI host adapter settings are necessary: <ul style="list-style-type: none"> • Wide SCSI must be enabled. • Disconnect must be allowed. • Multiple LUN support must be enabled (for any SCSI host adapter that connects to an Ultrium Tape Drive which serves as a control path). 8. Refer to the documentation for the device driver that you are using. If you are using the IBM Ultrium Device Drivers, refer to <i>IBM Ultrium Device Drivers Installation and User's Guide</i>. Review the Problem Determination procedures in the device driver documentation. Ensure that the device driver is loaded and that it can communicate with the tape drives: <ul style="list-style-type: none"> • If the device driver is not loaded, install it. • If the device driver is loaded but cannot communicate with the tape drives, call your IBM Service Representative. • If the device driver is loaded and can communicate with the tape drives, but the application software cannot communicate with the tape drives, contact the provider of your application software for assistance.

Table 25. Resolving errors with the IBM System Storage TS3500 Tape Library (continued)

Symptom or Error	Action
The host application software indicates that a cartridge is write protected.	<ol style="list-style-type: none"> 1. Record the host message, including any information about which cartridge has the problem. 2. Use the application software to move the cartridge to the I/O station. 3. Open the door of the I/O station and remove the cartridge. 4. Set the write-protect switch on the cartridge to enable writing (see "Setting the Write-Protect Switch on an Ultrium Cartridge" on page 223 or "Setting the Write-Protect Switch on a 3592 Cartridge" on page 257). Insert the cartridge back into the I/O station and close the door. 5. Use the application software to move the cartridge back into the library.
The host application software indicates that there is a problem with the cartridge.	<ol style="list-style-type: none"> 1. Record the host message, including any information about which cartridge has the problem. 2. If possible, use the application software to copy data from the failing cartridge to another cartridge. 3. Use the application software to move the cartridge to the I/O station. Note: If the cartridge is stuck (in a drive, gripper or storage slot) call your IBM Service Representative. 4. Open the door of the I/O station and remove the failing cartridge. 5. Close the door of the I/O station.
The host application software indicates that there is a problem with the bar code on the cartridge.	<ol style="list-style-type: none"> 1. Record the host message, including any information about which cartridge has the problem. 2. Use the application software to move the cartridge to the I/O station. 3. Open the door of the I/O station and remove the cartridge. 4. Check for a loose, damaged, or misaligned bar code label (see "Guidelines for Using Ultrium Bar Code Labels" on page 221 or "Guidelines for Using 3592 Bar Code Labels" on page 255). If there is an obvious problem, correct it. You may need to apply a new bar code label. 5. When the problem is corrected, insert the cartridge back into the I/O station and close the door. 6. Use the application software to move the cartridge back into the library. 7. If the problem still exists, call your IBM Service Representative.
The host application software indicates that there is a problem with the library inventory. For example, a move operation failed because: <ul style="list-style-type: none"> • The cartridge was not found. • The source location was empty. • The destination location was full. 	<ol style="list-style-type: none"> 1. Record the host message, including any information about which cartridges have the problem. 2. Use the host application software to inventory the library. Depending on which application is used, an inventory may be called <i>inventory</i>, <i>initialize element status</i>, <i>audit</i>, <i>remap</i>, or <i>rebuild index</i>. 3. If the problem still exists, perform an inventory of the entire library from the library's operator panel (see "Performing an Inventory of the Library" on page 108). 4. If the problem still exists, call your IBM Service Representative.
The host application software indicates that a drive has failed.	<ol style="list-style-type: none"> 1. Record the error message and any error codes. 2. Retry the job (if possible, use a different cartridge; many problems that are reported as drive failures are caused by media defects). <ul style="list-style-type: none"> • If the retry with a different cartridge is successful, consider the original cartridge defective. If necessary, copy the data from the cartridge and remove it from the library (see "Removing Data Cartridges from the Library" on page 63). • If the retry with a different cartridge fails, call your IBM Service Representative.

Table 25. Resolving errors with the IBM System Storage TS3500 Tape Library (continued)

Symptom or Error	Action
The host application software indicates that the library failed.	<ol style="list-style-type: none"> 1. Record the error message and any error codes. 2. Check the library's touchscreen for any error messages. If an error message is displayed, record it and any error codes. 3. Call your IBM Service Representative.
The library is powered on, but the touchscreen is blurry, unreadable, or blank.	Call your IBM Service Representative.
The touchscreen is readable, but the touch keys do not work.	Call your IBM Service Representative.
You cannot insert a 3592 Tape Cartridge into the library.	<ol style="list-style-type: none"> 1. Ensure that you have the proper cartridge type and that it is oriented correctly (see Figure 21 on page 56). 2. Inspect the cartridge for damage (see "Perform a Thorough Inspection of Ultrium Tape Cartridges" on page 226 or "Perform a Thorough Inspection of 3592 Tape Cartridges" on page 259). 3. Ensure that there is no other cartridge already in the drive. 4. Try to load another cartridge into the tape system. Use a scratch cartridge to avoid possible damage to a data cartridge (see "Inserting Data or Scratch Cartridges" on page 54). If the new cartridge can be inserted into the drive, the original cartridge may be defective. Inspect the cartridge again for damage. If the cartridge is not damaged but it cannot be inserted, contact your IBM Service Representative.
A message similar to FIDx XX alternates with an alphanumeric message on the display of the 3592 Tape Drive.	The code is a failure ID (FID). Record the code and see "Using FID Messages Generated by the 3592 Tape Drives" on page 278.
The message ATTN DRV appears on the display of the 3592 Tape Drive.	The drive has experienced a load error (indicated by the LOAD ERR alternating message) or an unload error (indicated by the UNLOAD E alternating message). If you receive either of these messages, contact your IBM Service Representative.
The 3592 Tape Drive is not ready at load point.	<ol style="list-style-type: none"> 1. Verify that the 3592 Tape Drive is receiving power by ensuring that the LED power indicator at the front of the drive is green (see 6 in Figure 58 on page 269). 2. If the cartridge is not inserted correctly, remove the cartridge and insert it again (see "Removing Data Cartridges from the Library" on page 63 and "Inserting Data or Scratch Cartridges" on page 54). If the cartridge fails to load in the tape system, remove the cartridge and inspect it for correct type or damage. See "Perform a Thorough Inspection of Ultrium Tape Cartridges" on page 226 or "Perform a Thorough Inspection of 3592 Tape Cartridges" on page 259. 3. If a FID or ATTN message appears on the message display, record the code, press the unload button (see 4 in Figure 58 on page 269), and try the operation again. <ul style="list-style-type: none"> • If the drive does not become ready and no messages are displayed, call your IBM Service Representative. • If a FID message appears on the message display, record it and see "Using FID Messages Generated by the 3592 Tape Drives" on page 278. If the code is ATTN DRV, the drive has experienced either a load error (indicated by the LOAD ERR alternating message) or an unload error (indicated by the UNLOAD E alternating message). If you receive either of these messages, contact your IBM Service Representative.

Table 25. Resolving errors with the IBM System Storage TS3500 Tape Library (continued)

Symptom or Error	Action
A power failure occurred and the 3592 Tape Cartridge failed to eject.	<p>If there is a power failure, the normal tape system process will unload a tape cartridge when power is restored to the device. The time required to complete the unload can vary, but may take up to 15 minutes. If the device fails to unload a tape cartridge after this period, you can attempt to unload the cartridge by pressing the unload button on the front of the drive (see 4 in Figure 58 on page 269).</p> <ul style="list-style-type: none"> • If the 3592 Tape Drive unloads the cartridge, remove it by grasping the cartridge, and pulling it towards you. • If, within 15 minutes, the 3592 Tape Drive does not unload the cartridge and a FID or ATTN message appears on the display, report the problem to your IBM Service Representative. See “Using FID Messages Generated by the 3592 Tape Drives” on page 278. If the code is ATTN DRV, the drive has experienced either a load error (indicated by the LOAD ERR alternating message) or an unload error (indicated by the UNLOAD E alternating message). If you receive either of these messages, contact your IBM Service Representative.
The tape cartridge fails to unload from the 3592 Tape Drive.	<ol style="list-style-type: none"> 1. Press the unload button (see 4 in Figure 58 on page 269). 2. If an error code or a FID message appears on the message display, record the error code or FID message and press the unload button again. 3. If the drive does not rewind or unload, call your IBM Service Representative. If a FID or ATTN message appears on the message display, record it and see “Using FID Messages Generated by the 3592 Tape Drives” on page 278. If the code is ATTN DRV, the drive has experienced either a load error (indicated by the LOAD ERR alternating message) or an unload error (indicated by the UNLOAD E alternating message). If you receive either of these messages, contact your IBM Service Representative.
The message display on the front of the 3592 Tape Drive is blank.	<ol style="list-style-type: none"> 1. Verify that the 3592 Tape Drive is receiving power by ensuring that the LED power indicator at the front of the drive is green (see 6 in Figure 58 on page 269). <ul style="list-style-type: none"> • If the light is off, contact your IBM Service Representative. • If the power light is on, verify that a cartridge is in the drive. If not, insert a scratch cartridge (see “Inserting Data or Scratch Cartridges” on page 54). Verify that the message display becomes active. If the panel still does not display a message, contact your IBM Service Representative.
The 3592 Tape Drive has read or write problems.	See “Media and Hardware Problem Isolation for the 3592 Tape Drives” on page 289.
The host application software or tape hardware indicates an encryption-related error, or a backup/restore task to encryption hardware fails.	Check the host application’s error logs, device driver logs, tape library error logs, and tape drive error logs for entries that are related to encryption. See “Viewing the Library Error Log” on page 194, “Viewing a Drive Error Log” on page 197, “Using FID Messages Generated by the 3592 Tape Drives” on page 278, “Encryption-Related ASC/ASCQ Codes” on page 280, and “EKM-Reported Errors” on page 286.

Table 25. Resolving errors with the IBM System Storage TS3500 Tape Library (continued)

Symptom or Error	Action
<p>The host application software or tape hardware indicates a connection problem with the encryption key manager (EKM).</p>	<p>Perform the following:</p> <ul style="list-style-type: none"> • If you are using library-managed encryption, perform the EKM connection test (see “Using the Web to Ping a Key Manager Address” on page 204). <ul style="list-style-type: none"> – If the test fails, a problem could exist with the IP address, the Ethernet cable, or the switches. Perform the following: <ol style="list-style-type: none"> 1. Refer to your network’s documentation. 2. Check the Ethernet connection between the library and the EKM server. 3. Check the TCP/IP configuration of the library and the server. – If the test succeeds, test the encryption key path and setup from the library’s operator panel (see “Using the Operator Panel to Test the Encryption Key Path and Setup” on page 205): <ul style="list-style-type: none"> - If the test succeeds the connection has been properly tested and is good. - If the test fails, perform the following. To obtain instructions for each task, see the documentation for your EKM. <ol style="list-style-type: none"> 1. Check that the EKM is correctly installed and configured, and that the EKM application is properly started. 2. Ensure that TS1120 Tape Drive is registered in the EKM. 3. Ensure that a default key label is defined in the EKM. • If the library does not provide the function of a key proxy server (that is, if you are using the application-managed encryption or system-managed encryption method), check your key proxy server’s documentation for a similar test.
<p>Notes: If your library uses a SAN Data Gateway to connect a Fibre Channel server to a SCSI drive, ensure that the gateway has the appropriate level of firmware installed by performing the following steps:</p> <ol style="list-style-type: none"> 1. Visit the web at http://www-03.ibm.com/servers/storage/support/san/ 2. Select one of the following SAN tape gateways and routers: <ul style="list-style-type: none"> • Model 2108-R03 • Model 2108-G07 3. Select the Download tab. 4. Select Downloadable files. 5. From Product category, select the item for the firmware code. 	

Using FID Messages Generated by the 3592 Tape Drives

This section defines failure ID (FID) messages that are generated by 3592 Tape Drives in the 3584 Tape Library. It includes a table that gives the FID, a short description of the failure, and corrective actions.

Failure ID (FID) messages are short codes that can be used by service technicians to isolate problems with the 3592 Tape Drive. If a FID message appears, you must note the message before contacting your service representative. This message is commonly a two-part, alternating message on the display of the 3592 Tape Drive. A FID error condition message has priority over all other types of messages, and persists until corrected. Technicians use the FID code to identify the failing FRU within the drive subsystem, therefore it is necessary for the operator to make note of the FID message to provide this information to the service representative. An example of the format of these messages is FID1 FF, alternating with an engineering error code, such as 931C9999. In this example, FID indicates to the

operator that a hardware failure occurred and 1 indicates the severity code. FF is the FID number that the service representative uses to enter the Maintenance Package. The alternating display of the engineering error code provides specific support information to the service organization.

Table 26 describes FID messages and the actions that you must take. A FID can be displayed on the message display of the 3592 Tape Drive or obtained from host software or error logs.

Table 26. FID messages

FID	Description	Action
50	Drive canister problem	The encryption configuration that was installed during manufacturing is incorrect. Replace the drive canister. For instructions, see "Removing or Replacing a Drive Canister Assembly - 3592 Fibre Channel Hot Swap" on page 328.
51	Drive canister problem	The encryption hardware's power-on self test failed. Replace the drive canister. For instructions, see "Removing or Replacing a Drive Canister Assembly - 3592 Fibre Channel Hot Swap" on page 328.
52	Hardware or firmware problem	The encryption firmware's power-on self test failed. Call for service.
53	Hardware or firmware problem	A specifically invoked encryption self test failed. Call for service.
54	Encryption diagnostic failure	An automatically invoked encryption diagnostic failed. Call for service.
55	Hardware problem	An unexpected failure of hardware function occurred. Call for service.
58	Encryption error	An error was detected during the encryption of data. Call for service.
59	Decryption error	An error was detected during the decryption of data. Call for service.
5A	Encryption key manager (EKM) failure	An unexpected status was returned by the key manager. Check the library or proxy interface, then check the EKM log. Not a drive or firmware problem. Requires investigation by the customer.
5B	Encryption proxy failure	A failure or timeout occurred on the proxy interface. Check the library or proxy interface, then check the EKM log. Not a drive or firmware problem. Requires investigation by the customer.
5F	Security prohibited function	A function was attempted which is prohibited by the security settings. Requires investigation of the encryption application software by the customer.
81, 82, 8A, 90, AC, AE, AF, BF, C1, D8, E4, F4	Hardware problem	Call for service.
83, E5	Firmware problem	Call for service.
84, E6	Hardware or firmware problem	Call for service.
86, F2	Hardware or media problem	<ol style="list-style-type: none"> 1. Isolate between media and hardware (see "Media and Hardware Problem Isolation for the 3592 Tape Drives" on page 289). 2. This failure may be caused by a damaged cartridge. Inspect the cartridge that was being used when the error occurred for physical defects (see "Perform a Thorough Inspection of 3592 Tape Cartridges" on page 259). Replace the cartridge if it is damaged. 3. Call for service if the problem remains.

Table 26. FID messages (continued)

FID	Description	Action
AA, AD	Configuration problem	Call for service.
85, 87, F5, F6, FE, FF	Cartridge or drive problem	<ol style="list-style-type: none"> 1. Isolate between media and hardware (see “Media and Hardware Problem Isolation for the 3592 Tape Drives” on page 289). 2. Call for service if the problem remains.

Related concepts

“Perform a Thorough Inspection of 3592 Tape Cartridges” on page 259

Related tasks

“Media and Hardware Problem Isolation for the 3592 Tape Drives” on page 289
 This section identifies steps that you can take to determine whether a problem with a 3592 Tape Drive in the 3584 Tape Library is due to faulty media or hardware.

Related reference

“Resolving Errors” on page 269

This section introduces symptoms and error messages that can help you to resolve problems with the 3584 Tape Library, the 3592 Tape Drives, and the LTO Ultrium Tape Drives.

Encryption-Related ASC/ASCQ Codes

Table 27 provides additional sense codes (ASCs) and additional sense code qualifier (ASCQ) for encryption-related messages.

Table 27. ASC/ASCQ codes that are related to encryption

Sense Key	ASC ASCQ	Description	Impact	Explanation ¹	Action
5	EE 00	Encryption - Key Service Not Enabled	N/A ²	N/A	No action required - feature is not enabled (license needed).
5	EE 02	Encryption - Key Service Not Available	N/A	The tape drive has not been configured with an encryption method (application-, system-, or library-managed). Note: This status is only presented by the drive; the EKM cannot see this status.	Configure the tape drive to resolve this error.

Table 27. ASC/ASCQ codes that are related to encryption (continued)

Sense Key	ASC ASCQ	Description	Impact	Explanation ¹	Action
4	EE 0E	Encryption - Key Service Timeout	N/A	Library-managed only. The tape drive sent an encryption-related request to the library proxy server over the RS/422 connection and got an ACK from the library, but never received the full response from the EKM. Potential causes: loss of connection with the library after the ACK (unlikely); loss of Ethernet connection to the EKM server; or EKM not running.	Run the EKM Path Check diagnostic from the library. If the Ethernet connection to the EKM server is bad, verify that the correct IP address is specified and troubleshoot it as if it were a network problem. If the Ethernet connection to the EKM server is good but the EKM is not responding, ask the customer to attempt to start the EKM. If the EKM reports an error, use that error to troubleshoot the problem.
4	EE 0F	Encryption - Key Service Failure	N/A	The tape drive sent an encryption-related request to the EKM and the EKM reported an error back to the tape drive. Potential causes: EKM software problem; problem with the key store (loss of network connection to the key store, hardware problem with the key store); or an undefined key label.	Obtain the flag data from the tape drive sense data for more specific information about the error. Analyze the flag data to determine the reason for the EKM-reported problem.
7	EF 10	Encryption - Key Required	EKM	This is not an error if the tape drive and proxy server are configured correctly. It is sense data that is used to initiate a key request. EE 10 and EF 10 have the same cause, but EE 10 is reported when the tape drive is configured for an application-managed encryption key path, and EF 10 is reported when the tape drive is configured for a system-managed encryption key path.	If this sense is associated with a job failure, verify that the tape drive is set for the correct encryption method (application-, system-, or library-managed) and that the encryption proxy server is configured correctly. If this sense is NOT associated with a job failure, ignore this condition.
5	EE 10	Encryption - Key Required	N/A	This is not an error if the tape drive and proxy server are configured correctly. It is sense data that is used to initiate a key request. EE 10 and EF 10 have the same cause, but EE 10 is reported when the tape drive is configured for an application-managed encryption key path, and EF 10 is reported when the tape drive is configured for a system-managed encryption key path. Note: if the application proactively serves a key you will not see this.	If this sense is associated with a job failure, verify that the tape drive is set for the correct encryption method (application-, system-, or library-managed) and that the encryption proxy server is configured correctly. If this sense is not associated with a job failure, ignore this condition.

Table 27. ASC/ASCQ codes that are related to encryption (continued)

Sense Key	ASC ASCQ	Description	Impact	Explanation ¹	Action
7	EF 11	Encryption - Key Generation	EKM	This is not an error if the tape drive and proxy server are configured correctly. It is sense data that is used to initiate a key generation request. It is similar to EF 10, but this is a key-generation request instead of a request for an existing key.	If this sense is associated with a job failure, verify that the tape drive is set for the correct encryption method (application-, system-, or library-managed) and that the encryption proxy server is configured correctly. If this sense is not associated with a job failure, ignore this condition.
6	EE 12	Encryption - Key Change Detected	N/A	Information only - SCSI Unit Attention – a key has changed.	No action required. Key change detected (notification only) redrive command.
7	EF 13	Encryption - Key Translate	EKM	This is not an error if the tape drive and proxy server are configured correctly. It is sense data that is used to initiate a key translation request to the library key path.	If this sense is associated with a job failure, verify that the tape drive is set for the correct encryption method (application-, system-, or library-managed) and that the encryption proxy server is configured correctly. If this sense is not associated with a job failure, ignore this condition.
0	EF 13	Encryption - Key Translate	EKM	This is not an error if the tape drive and proxy server are configured correctly. It is sense data that is used to initiate a key translation request to the application or system key path.	No action required. Key translation has been requested (in-band).
6	EE 18	Encryption - Changed (Read)	N/A	Information only - SCSI Unit Attention - encryption characteristics (for example, key, method, and so forth) were changed prior to a read operation.	No action required. Retry the command if necessary.
6	EE 19	Encryption - Changed (Write)	N/A	Information only - SCSI Unit Attention - encryption characteristics (for example, key, method, and so forth) were changed prior to a write operation.	No action required. Retry the command if necessary.
5	EE 23	Encryption - Key Conflict	EKM	An attempt was made to reuse a previously used Data Key Index (Dki). This is also known as a <i>key collision</i> . Note: this is expected to be a rare occurrence. It is only used in a multi-key environment.	Retry the command if necessary. If the problem persists, obtain a drive dump and EKM (or application, if no EKM is involved) traces, then contact your next level of support.

Table 27. ASC/ASCQ codes that are related to encryption (continued)

Sense Key	ASC ASCQ	Description	Impact	Explanation ¹	Action
5	EE 25	Encryption - Key Format Not Supported	EKM	The tape drive received a corrupted or unrecognized message from the EKM. The most likely causes are an EKM code bug or incompatible code versions on the drive and EKM. Note: this is expected to be a rare occurrence.	Retry the command if necessary. If the problem persists, verify that the EKM and drive code versions are compatible. As an example, if the EKM code were updated to include a new function but the drive code version does not recognize the new EKM function, then the code versions are incompatible. If the problem still persists, obtain a drive dump and EKM (or application, if no EKM is involved) traces, then contact your next level of support.
5	EE 26	Encryption - Unauthorized Request - dAK	EKM	Key usage error. An invalid Drive Authentication Key (dAK) was used or a valid dAK was used incorrectly. This could be an authorized attempt to access data.	Retry the command if necessary. This sense may be reported after Service replaces a tape drive. If so, then it may be automatically corrected to support the new tape drive. If the problem persists, ensure that the Drive Authentication Keys are correct.
5	EE 27	Encryption - Unauthorized Request - dSK	EKM	Key usage error. An invalid Drive Session Key (dSK) was used or a valid dSK was used incorrectly. This could be an unauthorized attempt to access data.	Retry the command if necessary. This sense may be reported after Service replaces a tape drive. If so, then it may be automatically corrected to support the new tape drive. If the problem persists, ensure that the Drive Session Keys are correct.
5	EE 28	Encryption - Unauthorized Request - eAK	EKM	Key usage error. An invalid External Authentication Key (eAK) was used or a valid eAK was used incorrectly. This could be an unauthorized attempt to access data. Note: a private key is needed for External Authentication.	Retry the command if necessary. If the problem persists, ensure that the External Authentication Keys are correct.

Table 27. ASC/ASCQ codes that are related to encryption (continued)

Sense Key	ASC ASCQ	Description	Impact	Explanation ¹	Action
5	EE 29	Encryption - Authentication Failure	EKM	A corrupted or incorrectly signed message was detected. Potential causes: invalid signature on a message; EKM code bug; tape drive code bug; or drive hardware problem (unlikely). This could be an unauthorized attempt to access data.	Retry the command if necessary. If the problem persists, ensure that the signatures are correct. If the problem still persists, use tape drive diagnostics to ensure that the tape drive encryption hardware is functional.
5	EE 2B	Encryption - Key Incorrect	N/A	An incompatible key was written in a unsupported format. Note: this is expected to be a rare occurrence.	Ensure that the encryption keys are correct, then retry the command. If the problem persists, obtain a drive dump and EKM (or application, if no EKM is involved) traces, then contact your next level of support.
5	EE 2C	Encryption - Key Wrapping Failure	EKM	The EKM has a problem which resulted in building the Session Encrypted Data Key (SEDK) incorrectly. Note: the SEDK is a structure used to wrap a key or keys to send them to the tape drive. This is typically reported with ASC/ASCQ EE 0F, so this sense is typically only found in internal logging.	If a higher version of EKM is available, update the EKM. If the problem persists, obtain a drive dump and EKM (or application, if no EKM is involved) traces, then contact your next level of support.
5	EE 2E	Encryption - Unsupported Type	EKM	The tape drive received a corrupted or unrecognized message from the EKM. The most likely causes are an EKM code bug or incompatible code versions on the drive and EKM. Note: this is expected to be a rare occurrence.	Retry the command if necessary. If the problem persists, verify that the versions of the EKM and drive code are compatible. As an example, if the EKM code were updated to include a new function but the drive code version does not recognize the new EKM function, then the code versions are incompatible. If the problem still persists, obtain a drive dump and EKM (or application, if no EKM is involved) traces, then contact your next level of support. Note: the byte and bit pointers may be used to indicate the first bad field in the message.

Table 27. ASC/ASCQ codes that are related to encryption (continued)

Sense Key	ASC ASCQ	Description	Impact	Explanation ¹	Action
5	EE 30	Encryption - Prohibited Request	N/A	The requested operation was not allowed, due to the current mode or state. As an example, a key path diagnostic was not allowed because there was a cartridge in the tape drive.	Ensure that the requirements for the requested operation have been met. As an example, before running a key path diagnostic ensure that the tape drive is empty. If the problem persists, obtain a drive dump, then contact your next level of support.
5	EE 31	Encryption - Key Unknown	N/A	A key operation was not allowed because the key was not known (not a currently tracked key). The key that was used is not a match for this tape cartridge.	Retry the command by using the correct encryption key for the cartridge.
3	EE 60	Encryption - Proxy Command Error	N/A	A command resulted in a key transition that cannot be handled by the application or system proxy server. The proxy server reports this condition; this sense combination is typically not produced by the tape drive. Note: this is only expected in test environments, not in the field.	If the problem persists, obtain a drive dump and traces from the proxy server, then contact your next level of support.
3	EE D0	Encryption - Data Read Decryption Failure	N/A	The tape drive was unable to decrypt data by using an application-provided key. The probable cause is use of the wrong encryption key. In rare cases this may also be caused by a failure in the tape drive's encryption hardware.	Retry the command by using the encryption key that was used when the cartridge was written. If the problem persists, use the tape drive diagnostics to determine whether there is a problem with the encryption hardware.
3	EE D1	Encryption - Data Read after Write Decryption Failure	N/A	The tape drive wrote encrypted data and was unable to decrypt it after reading it back. The probably cause is a tape drive code or hardware problem.	Obtain a drive dump. Use the tape drive diagnostics to determine whether there is a problem with the encryption hardware. If the diagnostics do not indicate a problem, contact your next level of support.
3	EE E0	Encryption Key Translation Failure	EKM	A permanent error occurred during a key translation operation. The cartridge is in an indeterminate state.	The cartridge may need to be accessed with the old key or with the new key. This tape should be copied and retired.
5	EE E2	Encryption - Key Translation Disallowed	N/A	An encryption key translation was requested, but the encryption proxy server rejected the request. Possible causes: a prior translation is pending and has not yet completed, or the Externally-Encrypted Data Key (EEDK) on the cartridge is persistently unencrypted.	Verify that the tape drive is set for the correct encryption method (application-, system-, or library-managed) and that the encryption proxy server is configured correctly.

Table 27. ASC/ASCQ codes that are related to encryption (continued)

Sense Key	ASC ASCQ	Description	Impact	Explanation ¹	Action
3	EE F1	Encryption - Encryption Fenced (Write)	N/A	The EKM has set an encryption fence condition that prevents further writing. This fence condition is cleared when the cartridge is demounted. Note: this only occurs with the library-managed encryption method. Possible causes: a mismatch between the cartridge's volume serial (VOLSER) number and the VOLSER ranges used for an encryption policy.	Ensure that the cartridge's VOLSER is in the correct VOLSER range (because VOLSER ranges are associated with an encryption policy).

Notes:

1. All ASC EF sense combinations invoke EKM flow at the proxy server.
2. N/A = not applicable.

EKM-Reported Errors

This section defines error messages that are reported by the encryption key manager (EKM) and are related to the TS1120 Tape Drives. The table includes the error number, a short description of the failure, and corrective actions.

Table 28. Errors that are reported by the encryption key manager

Error Number	Description	Action
EE2D	Encryption Read Message Failure: Invalid Message Type	The EKM received a message out of sequence or received a message that it does not know how to handle. Ensure that you are running the latest version of the EKM (to determine the latest version, contact your IBM Representative). Enable debug on the key manager server. Try to recreate the problem and gather debug logs. If the problem persists, contact IBM Support.
EE29	Encryption Read Message Failure: Invalid signature	The message received from the drive or proxy server does not match the signature on it. Ensure that you are running the latest version of the EKM (to determine the latest version, contact your IBM Representative). Enable debug on the key manager server. Try to recreate the problem and gather debug logs. If the problem persists, contact IBM Support.
EE2E	Encryption Read Message Failure: Internal error: Invalid signature type	The message received from the drive or proxy server does not have a valid signature type. Ensure that you are running the latest version of the EKM (to determine the latest version, contact your IBM Representative). Enable debug on the key manager server. Try to recreate the problem and gather debug logs. If the problem persists, contact IBM Support.

Table 28. Errors that are reported by the encryption key manager (continued)

Error Number	Description	Action
EE23	Encryption Read Message Failure: Internal error: "Unexpected error....."	The message received from the drive or proxy server could not be parsed because of general error. Ensure that you are running the latest version of the EKM (to determine the latest version, contact your IBM Representative). Enable debug on the key manager server. Try to recreate the problem and gather debug logs. If the problem persists, contact IBM Support.
EE02	Encryption Read Message Failure: DriverErrorNotifyParameterError: "Bad ASC & ASCQ received. ASC & ASCQ does not match with either of Key Creation/Key Translation/Key Aquisition operation."	The tape drive asked for an unsupported action. Ensure that you are running the latest version of the EKM (to determine the latest version, contact your IBM Representative). Check the versions of drive or proxy server firmware and update them to the latest release, if needed (see "Updating Drive Firmware" on page 198). Enable debug tracing on the key manager server. Try to recreate the problem and gather debug logs. If the problem persists, contact IBM Support.
EE2C	Encryption Read Message Failure: QueryDSKParameterError: "Error parsing a QueryDSKMessage from a device. Unexpected dsk count or unexpected payload."	The tape drive asked the EKM to do an unsupported function. Ensure that you are running the latest version of the EKM (to determine the latest version, contact your IBM Representative). Check the versions of drive or proxy server firmware and update them to the latest release, if needed (see "Updating Drive Firmware" on page 198). Enable debug tracing on the key manager server. Try to recreate the problem and gather debug logs. If the problem persists, contact IBM Support.
EE2B	Encryption Read Message Failure: Internal error: "Either no signature in DSK or signature in DSK can not be verified."	Ensure that you are running the latest version of the EKM (to determine the latest version, contact your IBM Representative). Check the versions of drive or proxy server firmware and update them to the latest release, if needed (see "Updating Drive Firmware" on page 198). Enable debug tracing on the key manager server. Try to recreate the problem and gather debug logs. If the problem persists, contact IBM Support.
EE0F	Encryption logic error: Internal error: "Unexpected error. Internal programming error in EKM."	Ensure that you are running the latest version of the EKM (to determine the latest version, contact your IBM Representative). Check the versions of drive or proxy server firmware and update them to the latest release, if needed (see "Updating Drive Firmware" on page 198). Enable debug tracing on the key manager server. Try to recreate the problem and gather debug logs. If the problem persists, contact IBM Support.

Table 28. Errors that are reported by the encryption key manager (continued)

Error Number	Description	Action
EE01	Encryption Configuration Problem: "Drive not configured."	The drive that is trying to communicate with the EKM is not present in the drive table. Ensure that the config.drivetable.file.url is correct in the KeyManagerConfig.properties file, if that parameter is supplied. Run the listdrives command to check whether the drive is in the list. If not, configure the drive manually by using the adddrive command with the correct drive information or turn "auto-fill" ON by setting "drive.acceptUnknownDrives" to true using the modconfig command. Enable debug tracing and retry the operation. If the problem persists, contact IBM Support.
EE25	Encryption Configuration Problem: Errors that are related to the drive table occurred.	Ensure that the config.drivetable.file.url is correct in the KeyManagerConfig.properties file, if that parameter is supplied. Run the listdrives -drivename <drivename> command on the EKM server to verify whether the drive is correctly configured (for example, the drive serial number, alias, and certifications are correct). Ensure that you are running the latest version of the EKM (to determine the latest version, contact your IBM Representative). Check the versions of drive or proxy server firmware and update them to the latest release, if needed (see "Updating Drive Firmware" on page 198). Enable debug tracing and retry the operation. If the problem persists, contact IBM Support.
EE31	Encryption Configuration Problem: Errors that are related to the key store occurred.	Check the key labels that are used or configured for the defaults. Run the listdrives -drivename <drivename> command on the EKM server to verify whether the drive is correctly configured (for example, the drive serial number, alias, and certifications are correct). Ensure that you are running the latest version of the EKM (to determine the latest version, contact your IBM Representative). Check the versions of drive or proxy server firmware and update them to the latest release, if needed (see "Updating Drive Firmware" on page 198). Enable debug tracing and retry the operation. If the problem persists, contact IBM Support.

Table 28. Errors that are reported by the encryption key manager (continued)

Error Number	Description	Action
EEE1	Encryption logic error: Internal error: "Unexpected error: EK/EEDK flags conflict with subpage."	Ensure that you are running the latest version of the EKM (to determine the latest version, contact your IBM Representative). Check the versions of drive or proxy server firmware and update them to the latest release, if needed (see "Updating Drive Firmware" on page 198). Enable debug on the key manager server. Try to recreate the problem and gather debug logs. If the problem persists, contact IBM Support.

Media and Hardware Problem Isolation for the 3592 Tape Drives

This section identifies steps that you can take to determine whether a problem with a 3592 Tape Drive in the 3584 Tape Library is due to faulty media or hardware.

An error code (FID FE) will be generated when the 3592 Tape Drive experiences an error and cannot determine if the error was caused by the tape cartridge or by a problem in the drive hardware. The FID FE is not displayed on the drive, but is logged in the sense information that is returned to the host system. Follow the procedure in this section if you receive an error when reading or writing to the drive and there is no FID displayed.

Media and drives can affect each other and the indications can be confusing. You must record the symptoms for the drive and the tape to make problem isolation possible. The failing component or tape must be isolated or you will continue to experience problems. Problems can be intermittent, so careful record keeping is necessary. By keeping careful records of transient problems, you will enable problem isolation and resolution.

To determine the cause of the read or write errors, use the steps that follow.

1. Ensure that the 3592 Tape Drive is not overdue for cleaning. If automatic cleaning is enabled, ensure that a cleaning cartridge is installed in the 3584 Tape Library. Ensure that the cartridge maximum usage of 50 cleanings has not been exceeded (see "Determining Cleaning Cartridge Usage" on page 182).
2. Determine which volume serial (VOLSER) numbers or cartridges are potential problems. Note which VOLSERS fail during the operation. (It is possible to have multiple bad cartridges.)
 - Note which VOLSERS fail during the operation. (It is possible to have multiple bad cartridges.)
 - Record the Media Information Message (MIM) MESSAGE CODE at the host and associated VOLSER numbers, if the host supports MIM messages.
 - If you receive a Service Information Message (SIM) at the host, get the VOLSER numbers from the message and record those in your TAPE SERIAL LOG.
3. Determine if the cartridges are bad.
 - Examine the cartridge for damage (see "Perform a Thorough Inspection of 3592 Tape Cartridges" on page 259). Open the door to observe if the pin is in its proper place, and examine the cartridge for cracks. If damaged, repair or replace the cartridge (see "Repositioning a Leader Pin in a 3592 Cartridge" on page 260).

Note: A repaired cartridge may be used long enough to recover data from that cartridge. When the data has been recovered, the cartridge should then be taken out of service and discarded, or returned to the plant of origin.

- If the cartridges appear undamaged and you have access to another 3592 Tape Drive, try the operation with the suspect cartridges in the other drive. If your cartridges fail in the other drive, replace the media.
4. Determine if the drive is bad.
 - Try a new tape on the suspect drive. If it also fails, contact your IBM Service Representative.
 - If tapes show evidence of damage, do not put any more tapes on the drive until your IBM Service Representative has examined the drive.

Related concepts

“Determining Cleaning Cartridge Usage” on page 182

“Perform a Thorough Inspection of 3592 Tape Cartridges” on page 259

Related tasks

“Repositioning a Leader Pin in a 3592 Cartridge” on page 260

This section gives the procedure to use when you move a leader pin into its proper position in a 3592 Tape Cartridge.

Resolving Errors with the Ultrium Tape Drives

This section lists error codes that can appear on the single-character display (SCD) of the Ultrium Tape Drives and describes each error.

The Ultrium Tape Drive has an SCD that displays a code which can aid in servicing the drive. While the 3584 Tape Library is active, it can be difficult to see the SCD without opening the library door. An easier way to obtain information about a drive error is to determine which drive is reporting an error, then access that drive’s error log by using the library’s operator panel or by using the Tape Library Specialist web interface. You can access a drive error log from the operator panel by using the **Service** and **Drive Error Logs** menus. To use the web, see “Accessing Logs for Drives or Saving a Drive Dump” on page 196.

Figure 60 on page 291 shows the front of the Ultrium Tape Drive and the location of the SCD.

- | | | | |
|----------|---------------|----------|--------------------------------|
| 1 | Status light | 3 | Single-character display (SCD) |
| 2 | Unload button | 4 | SCD dot |

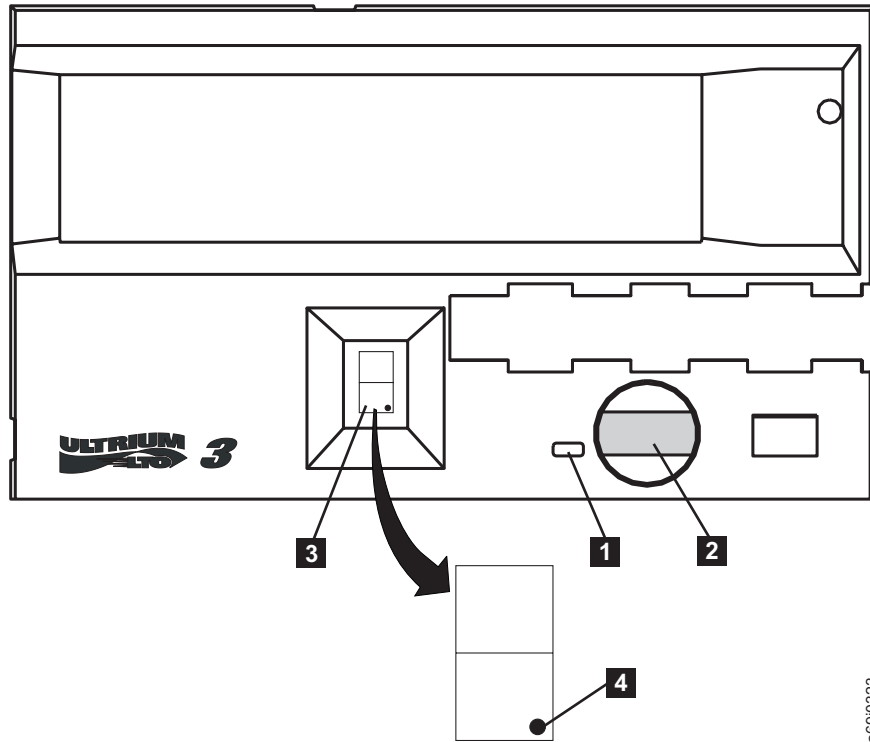

Figure 60. Front view of the Ultrium 3 Tape Drive

Table 29 gives the SCD error codes for the Ultrium Tape Drives. Use this table only if no sense data is available. Whenever possible, use sense data or a drive's Fault Symptom Code (FSC) instead of the SCD code. For information about sense data, see the *IBM TotalStorage LTO Ultrium Tape Drive SCSI Reference*. For information about FSCs, see the *IBM System Storage TS3500 Tape Library Maintenance Information* guide.

Table 29. SCD error codes for the Ultrium Tape Drives

SCD Code	Description
0	No Error. Ran successfully.
1	Cooling problem.
2	5V dc power problem. Tape drive detected that the Drive Power Supply is approaching the specified voltage limit (drive is still operating) or is outside the specified voltage range (drive is not operating).
3	Tape drive determined that a microcode error occurred.
4	Microcode or tape drive problem. Tape drive determined that a microcode or tape drive hardware failure occurred.
5	Tape drive problem. Tape drive determined that a hardware failure occurred.
6	Tape drive or media error. Tape drive determined that an error occurred, but it cannot isolate the error due to faulty hardware or to the tape cartridge.
7	Media error.
8	Tape drive, SCSI bus or fibre channel error.
9	Tape drive or RS-422 error.

Table 29. SCD error codes for the Ultrium Tape Drives (continued)

SCD Code	Description
A	Tape drive hardware problem.
B	No error or message is assigned.
C	Tape drive needs to be cleaned.
D	No error or message is assigned.
=	The Unload button on the drive was pushed in and did not release.

Related tasks

“Accessing Logs for Drives or Saving a Drive Dump” on page 196

This section describes how to access logs for drives in the 3584 Tape Library and how to save a drive dump.

Attaching the Library to Open Systems

This section directs you to information about attaching the 3584 Tape Library to open systems.

For information about attaching the 3584 Tape Library to open systems, refer to the *IBM TotalStorage and System Storage Tape Device Drivers Installation and User's Guide*. To access the most current device driver installation and user guides online, go to: <ftp://ftp.software.ibm.com/storage/devdrv/Doc/>

Interpreting SNMP Traps

This section provides information that helps you to understand the meaning of an Simple Network Management Protocol (SNMP) trap that is received by the 3584 Tape Library.

The 3584 Tape Library can alert you to possible problems by using a TCP/IP LAN network that is connected to an SNMP monitoring station. These alerts are called SNMP traps. The monitoring station must be loaded with systems management software (such as NetView^(R)) that can receive and process the trap, or the trap is discarded. After the trap received, it must be interpreted.

If you have systems management software that includes an SNMP compiler, you may not need to manually interpret SNMP traps but you will need the library's Management Information Base (MIB). The MIB contains units of information that specifically describe an aspect of a system, such as the system name, hardware number, or communications configuration. To obtain the MIBs for the 3584 Tape Library, visit <http://ftp.software.ibm.com/storage/358x/3584/>. Windows users select 3584mib.zip and UNIX^(TM) users select 3584mib.tar. After you obtain the MIB, load it into your management application. When the application next receives an SNMP trap, it will compile it into human-readable form so that you can gather information about the error.

If you do not have systems management software that includes an SNMP compiler, you will need to manually interpret the SNMP traps. The section that follows describes this procedure.

Related reference

"Using SNMP MIBs to Monitor the Library" on page 298

This section describes how to use a Simple Management Network Protocol (SNMP) monitoring station and Management Information Bases (MIBs) to check drive status, give information about the last SNMP trap and about cartridges, and identify supported MIBs and supported SNMP messages. The data gathered from this process originates from the 3584 Tape Library and is displayed on the SNMP monitoring station.

Manually Interpreting an SNMP Trap

To manually interpret a Simple Network Management Protocol (SNMP) trap:

1. Observe the trap when it is received by systems management software and identify its components. Figure 61 on page 294 shows a sample SNMP trap. The trap consists of object identifiers (OIDs) on the left of the equal (=) sign and OID fields on the right.

The characters 182 in the OID indicate that the device is an 3584 Tape Library. The OID fields contain values that will help you to determine the nature of the problem.

Note: Not every trap contains every field.

```

1.3.6.1.4.1.2.6.182.1.2.11.1.0 = 3584 L32 1312345
1.3.6.1.4.1.2.6.182.1.2.21.1.0 = 04 44 00
1.3.6.1.4.1.2.6.182.1.2.31.1.0 = 90 80
1.3.6.1.4.1.2.6.182.1.2.41.1.0 = 24
1.3.6.1.4.1.2.6.182.1.2.51.1.0 = A4D0
1.3.6.1.4.1.2.6.182.1.2.61.1.0 = 01 00
1.3.6.1.4.1.2.6.182.1.2.71.1.0 = The library has detected an error in its inventory
1.3.6.1.4.1.2.6.182.1.2.81.1.0 = 0A1
1.3.6.1.4.1.2.6.182.1.2.91.1.0 = 6
1.3.6.1.4.1.2.6.182.1.2.101.1.0 = 12762L2
1.3.6.1.4.1.2.6.182.1.2.11.1.0 = 1

```

a6910106

Figure 61. Sample SNMP trap. OIDs are on the left of the equal sign; OID fields are on the right. Values in the fields provide information about the problem.

Table 30 shows the variables sent from the 3584 Library TapeAlerts for Traps 1 through 32. Table 31 on page 295 shows the variables sent from the TO Ultrium and 3592 Tape Drive TapeAlerts for Traps 200 through 254. Table 32 on page 295 shows the variables sent from the 3584 Tape Library for events that are not covered by TapeAlerts and for Traps 400 through 408.

Table 30. Variables sent by library TapeAlerts and for Traps 1 through 32

Variable Number	Variables Sent from 3584 Library TapeAlerts	Values	Description
1	ibm3584MIBObjectsMTMNLNSN	Example "3584 L32 1300000"	The Space Delimited string with the machine type, model number, and serial number of the library.
2	ibm3584MIBObjectsSKASCASCQ	Example "04 4400"	The Space Delimited string with the SCSI Sense Key and ASC/ASCQ.
3	ibm3584MIBObjectsHECHECQ	Example "B884"	The string with the hardware error code for the problem.
4	ibm3584MIBObjectsTA	Example "3"	The string with the TapeAlert number of the problem encountered.
5	ibm3584MIBObjectsURC	Example "A428"	The URC error code that is used by the IBM Service Representative to isolate the problem.
6	ibm3584MIBObjectsFFFD	Example "01 05"	The Space Delimited string that indicates the frame and drive location of the problem.
7	ibm3584MIBObjectsTD	A problem with the I/O station exists: <ol style="list-style-type: none"> 1. Ensure that there is no obstruction in the I/O station. 2. Restart the operation. 3. If the problem persists, call your IBM Service Representative. 	The string that describes the problem and a recommended corrective action.
8	ibm3584MIBObjectsSeverity	Example: 1	The string that indicates the severity of the problem, from informational to severe. For exact values, see the IBM 3584 MIB for Version 1 or Version 2c traps.

Table 31. Variables sent by LTO Ultrium and 3592 Tape TapeAlerts and for Traps 200 through 254

Variable Number	Variables Sent from TS3520 Drive TapeAlerts	Values	Description
1	ibm3584MIBObjectsMTMNLNSN	Example "3584 L32 1300000"	The Space Delimited string with the machine type, model number, and serial number of the library.
2	ibm3584MIBObjectsSKASCASCQ	Example "04 4400"	The Space Delimited string with the SCSI Sense Key and ASC/ASCQ.
3	ibm3584MIBObjectsTA	Example "3"	The string with the TapeAlert number of the problem encountered.
4	ibm3584MIBObjectsURC	Example "A428"	The URC error code that is used by the IBM Service Representative to isolate the problem.
5	ibm3584MIBObjectsFSC	Example "0000"	The four-character string with the drive fault symptom code.
6	ibm3584MIBObjectsSCD	Example "6"	The character that is displayed on the front of the drive at the time of the failure.
7	ibm3584MIBObjectsVOLSER	Example "123456L2"	The eight-character volume label on the front of the cartridge in the drive at the time of the event.
8	ibm3584MIBObjectsFFFD	Example "01 05"	The space delimited string that indicates the frame and drive location of the problem.
9	ibm3584MIBObjectsTD	The tape cartridge has reached the end of its calculated useful life: 1. Copy any data that you need to another tape. 2. Discard the old tape.	The space that describes the problem and a recommended corrective action.
10	ibm3584MIBObjectsWWNN	Example "500507630F070641"	The world wide node name that is associated with the drive which reports the trap.
11	ibm3584MIBObjectsDrvSN	Example "0007811157"	The drive serial number that is associated with the drive which is reports the trap.
12	ibm3584MIBObjectsSeverity	Example: 1	The string that indicates the severity of the problem, from informational to severe. For exact values, see the IBM 3584 MIB for Version 1 or Version 2c traps.

Table 32. Variables sent by library for events that are not by TapeAlerts and for Traps 400 through 408

Variable Number	Variables Sent from TS3520 Library for Events that are not Covered by TapeAlerts	Values	Description
1	ibm3584MIBObjectsMTMNLNSN	Example "3584 L32 1300000"	The Space Delimited string with the machine type, model number, and serial number of the library.

Table 32. Variables sent by library for events that are not by TapeAlerts and for Traps 400 through 408 (continued)

Variable Number	Variables Sent from TS3520 Library for Events that are not Covered by TapeAlerts	Values	Description
2	ibm3584MIBObjectsLL	Example "001"	The string that contains the logical library that is associated with this event.
3	ibm3584MIBObjectsVOLSER	Example "123456L2"	The eight-character volume label on the front of the cartridge in the drive at the time of the event.
4	ibm3584MIBObjectsTA	Example "3"	The string with the TapeAlert number of the problem encountered.
5	ibm3584MIBObjectsTD	An Enterprise Tape cleaning cartridge has expired.	The space that describes the problem and a recommended corrective action.
6	ibm3584MIBObjectsSeverity	Example: 1	The string that indicates the severity of the problem, from informational to severe. For exact values, see the IBM 3584 MIB for Version 1 or Version 2c traps.

2. Refer to Table 33 to determine the meaning of the values in the OID fields. Analyze the values to determine the problem.

Table 33. Fields in an SNMP trap. The fields are listed in the order in which they occur in an actual SNMP trap. Use the sample values to interpret the meaning of the example trap in Figure 61 on page 294.

Object Identifier (OID) and Variable Name	Description of OID Field	Maximum Characters	Sample Value in Field
1.3.6.1.4.1.2.6.182.1.2.11.1.0 MTMNLSN	Machine type	4	3584
	Blank character	1	
	Model number	3	L32
	Blank character	1	
	Serial number	7	1312345
1.3.6.1.4.1.2.6.182.1.2.21.1.0 SKASCASCQ	SCSI sense key	2	04
	Blank character	1	
	SCSI additional sense code (ASC)	2	44
	Blank character	1	
	SCSI additional sense code qualifier (ASCQ)	2	00
1.3.6.1.4.1.2.6.182.1.2.31.1.0 HECHECQ	Hardware error code (HEC)	2	90
	Blank character	1	
	Hardware error code qualifier (HECQ)	2	80
1.3.6.1.4.1.2.6.182.1.2.41.1.0 TA	TapeAlert number	2	24
1.3.6.1.4.1.2.6.182.1.2.51.1.0 URC	Unit reference code (URC)	4	A4D0

Table 33. Fields in an SNMP trap (continued). The fields are listed in the order in which they occur in an actual SNMP trap. Use the sample values to interpret the meaning of the example trap in Figure 61 on page 294.

Object Identifier (OID) and Variable Name	Description of OID Field	Maximum Characters	Sample Value in Field
1.3.6.1.4.1.2.6.182.1.2.61.1.0	Failing frame number	2	01
FFED	Blank character	1	
	Failing drive number	2	00
1.3.6.1.4.1.2.6.182.1.2.71.1.0	Text message	255	The library has detected an error in its inventory
TD			
1.3.6.1.4.1.2.6.182.1.2.81.1.0	Drive fault symptom code	4	0A1
FSC			
1.3.6.1.4.1.2.6.182.1.2.91.1.0	Drive single-character display	1	6
SCD			
1.3.6.1.4.1.2.6.182.1.2.101.1.0	Cartridge volume serial number (refers to the volser of the bar code label)	8	127962L2
VOLSER			
1.3.6.1.4.1.2.6.182.1.2.111.1.0	Logical library number	3	1
LL			
1.3.6.1.4.1.2.6.182.1.2.121.1.0	World Wide Node Name	16	500507630F070641
WWNN			
1.3.6.1.4.1.2.6.182.1.2.131.1.0	Element Address	4	1026
EA			
1.3.6.1.4.1.2.6.182.1.2.141.1.0	Serial Number	12	0007811157
SN			
1.3.6.1.4.1.2.6.182.1.2.151.1.0	Severity	1	1
SV			

To determine the meaning of the each OID field, use the following sources:

- For the SCSI sense key, ASC, and ASCQ, see the *IBM System Storage TS3500 Tape Library SCSI Reference*.
- For the TapeAlert flags, see Chapter 7, “TapeAlert Flags,” on page 301.
- For the URC, HEC, and HECQ, drive fault symptom code, and number in the drive’s single-character display, see the *IBM System Storage TS3500 Tape Library Maintenance Information* guide.

In general, the library generates SNMP traps when it detects TapeAlert error conditions. Additionally, the library also generates SNMP traps under certain non-error conditions. These traps are also assigned a unique OID in the MIB. They are generated under the following non-error conditions:

- The I/O station is full for over an hour.
- The logical library is full for over an hour and contains no empty storage slots.
- The I/O station door is open for an extended period of time.
- There are no LTO Ultrium or 3592 Cleaning Cartridges in the library (0 cleanings remain on the LTO Ultrium Cleaning Cartridges in library).

- An LTO Ultrium or 3592 Cleaning Cartridge has expired (the number of cleanings that remain on the cartridge has decreased to 0).

Related concepts

“Overview of TapeAlert Flags” on page 301

This section describes the TapeAlert flags that are used to resolve problems with the 3584 Tape Library and its tape drives.

Using SNMP MIBs to Monitor the Library

This section describes how to use a Simple Management Network Protocol (SNMP) monitoring station and Management Information Bases (MIBs) to check drive status, give information about the last SNMP trap and about cartridges, and identify supported MIBs and supported SNMP messages. The data gathered from this process originates from the 3584 Tape Library and is displayed on the SNMP monitoring station.

Note: When using SNMP to monitor your 3584 Tape Library, make sure that the IBM 3584 Management Information Base (MIB) and Storage Networking Industry Association-Storage Media Library (SNIA-SML) MIB are loaded on your monitoring server (to obtain them visit <http://ftp.software.ibm.com/storage/358x/3584/>; Windows users select 3584mib.zip and UNIX users select 3584mib.tar).

You can use SNMP to monitor the following information in the 3584 Tape Library.

Drive status

To obtain a list of the status of all of the drives in the library:

1. Use your monitoring server to issue an SNMP get request on the object `numberOfMediaAccessDevices.0`. This indicates how many drives are present in the library.
2. Use your monitoring server to issue an SNMP get request on the object `mediaAccessDevice-Availability.1` through `mediaAccessDevice-Availability.n` where `n` is the number returned by `numberOfMediaAccessDevices.0`. This gives a list of the status of all of the drives in the library that are ordered by element address.

Last trap information

To poll the last trap or TapeAlert that was sent by the library, use your SNMP systems management software to issue an SNMP get request on each of the following objects. This returns information about the last trap or TapeAlert.

```
ibm3584MIBObjectsMTMNLSN.0
ibm3584MIBObjectsSKASCASCQ.0
ibm3584MIBObjectsHECCECQ.0
ibm3584MIBObjectsTA.0
ibm3584MIBObjectsURC.0
ibm3584MIBObjectsTD.0
ibm3584MIBObjectsFSC.0
ibm3584MIBObjectsSCD.0
ibm3584MIBObjectsVOLSER.0
ibm3584MIBObjectsLL.0
```

Note that if a value is not valid for a specific TapeAlert, then the library will return an asterisk (*) in each defined character position.

Cartridge information

To obtain a list of all cartridges in the library, perform the following steps:

1. Use your monitoring server to issue an SNMP get request on the object `numberOfPhysicalMedias.0`. This indicates how many cartridges are present in the library.
2. Use your monitoring server to issue an SNMP get request on the object `physicalMedia-PhysicalLabel.1` through `physicalMedia-PhysicalLabel.n` where `n` is the number returned by `numberOfPhysicalMedias.0`. This gives a list of cartridge labels in the library that are ordered by physical location.

Supported MIBs

The 3584 Tape Library now supports the following MIBs:

- IBM 3584 MIB for Version 1 or Version 2c traps
- SNIA SML MIB Version 1.20b
- SNMP MIB-II (comes with your management software and is also available from the web at <http://www.ietf.org/rfc/rfc2011.txt>).

Supported SNMP messages

The following are supported SNMP messages:

- Get (a request for information about the library)
- GetNext (a request for the next sequential piece of information about the library)
- GetBulk (a request for a bundle of get requests)

SNMP Set messages are not supported at this time. Instead, use the Tape Library Specialist web interface to configure your SNMP settings. For more information, see the following:

- “Enabling or Disabling SNMP Traps” on page 157
- “Enabling or Disabling SNMP Requests” on page 158
- “Setting the Version of SNMP Traps” on page 159
- “Enabling or Disabling Authentication Trap Settings” on page 160
- “Viewing or Changing SNMP System Data” on page 161 (note that the contact information in the system data is also used by the library when it uses the Call Home capability)
- “Viewing or Changing the Destination IP Configuration and Remote Port” on page 161
- “Viewing or Changing the Trap Community Name” on page 163
- “Viewing or Changing the Request Community Name” on page 164

Related concepts

“Enabling or Disabling SNMP Traps” on page 157

This section introduces two ways to enable or disable informational messages (traps) that are gathered from and transmitted by the 3584 Tape Library through the use of the Simple Network Management Protocol (SNMP).

“Enabling or Disabling SNMP Requests” on page 158

This section introduces two ways to enable or disable Simple Network Management Protocol (SNMP) requests to the 3584 Tape Library.

“Setting the Version of SNMP Traps” on page 159

This section introduces two ways of setting the version level of Simple Network Management Protocol (SNMP) traps.

“Viewing or Changing the Destination IP Configuration and Remote Port” on page 161

This section introduces two ways to view the identifier of a Simple Network Management Protocol (SNMP) monitoring server that is used by the 3584 Tape Library. It also provides basic information about the library’s remote port.

“Viewing or Changing the Trap Community Name” on page 163

This section introduces two ways to view or change the trap community name that is associated with the 3584 Tape Library.

Related tasks

“Enabling or Disabling Authentication Trap Settings” on page 160

This section defines an authentication trap and describes how to enable or disable its settings.

“Viewing or Changing SNMP System Data” on page 161

This section describes how to view or change the Simple Network Management Protocol (SNMP) configuration and contact information about the 3584 Tape Library.

“Viewing or Changing the Request Community Name” on page 164

This section defines the request community name for the 3584 Tape Library, and describes how to view or change it.

Chapter 7. TapeAlert Flags

This section introduces the TapeAlert flags for the Ultrium Tape Drives, 3592 Tape Drives, and 3584 Tape Library.

Overview of TapeAlert Flags

This section describes the TapeAlert flags that are used to resolve problems with the 3584 Tape Library and its tape drives.

TapeAlert is a standard that defines status conditions and problems experienced by devices such as tape drives, autoloaders, and libraries. The standard enables a server to read TapeAlert messages (called *flags*) from a tape drive or library. The server reads the flags from Log Sense Page 0x2E.

The IBM System Storage TS3500 Tape Library is compatible with TapeAlert technology, which provides error and diagnostic information about the drives and the library to the server.

For specific information, see “TapeAlert Flags Supported by the Ultrium Tape Drives” on page 302, “TapeAlert Flags Supported by the 3592 Tape Drives” on page 307, or “TapeAlert Flags Supported by the Library” on page 313. The sections about the drives indicate whether the drive generates SNMP traps or call home messages based on that flag.

Related reference

“TapeAlert Flags Supported by the Ultrium Tape Drives” on page 302

This section lists the TapeAlert Flags that are supported by the Ultrium Tape Drives.

“TapeAlert Flags Supported by the 3592 Tape Drives” on page 307

This section lists the TapeAlert flags that are supported by the 3592 Tape Drives.

“TapeAlert Flags Supported by the Library” on page 313

This section lists the TapeAlert flags that are supported by the 3584 Tape Library.

TapeAlert Flags Supported by the Ultrium Tape Drives

This section lists the TapeAlert Flags that are supported by the Ultrium Tape Drives.

Table 34 lists the TapeAlert flags that are supported by the Ultrium Tape Drives.

Table 34. TapeAlert Flags that are supported by the Ultrium Tape Drives

TapeAlert Flags Supported by the Ultrium Tape Drives					
Flag Number and Name		Description	Action Required	SNMP Trap	Call Home
3	Hard error	Set for any unrecoverable read, write, or positioning error. (This flag is set in conjunction with flags 4, 5, or 6.)	See the Action Required column for Flag Number 4, 5, or 6 in this table.	Yes	No
4	Media	Set for any unrecoverable read, write, or positioning error that is due to a faulty tape cartridge.	Replace the tape cartridge.	Yes	No
5	Read failure	Set for any unrecoverable read error where isolation is uncertain and failure could be due to a faulty tape cartridge or to faulty drive hardware.	If Flag Number 4 is also set, the cartridge is defective. Replace the tape cartridge. If Flag Number 4 is not set, see Error Code 6 in Table 29 on page 291.	Yes	No
6	Write failure	Set for any unrecoverable write or positioning error where isolation is uncertain and failure could be due to a faulty tape cartridge or to faulty drive hardware.	If Flag Number 9 is also set, make sure that the write-protect switch is set so that data can be written to the tape. See "Setting the Write-Protect Switch on an Ultrium Cartridge" on page 223. If Flag Number 4 is also set, the cartridge is defective. Replace the tape cartridge. If Flag Number 4 is not set, see Error Code 6 in Table 29 on page 291.	Yes	No
7	Media life	Set when the tape cartridge reached its end of life (EOL).	<ol style="list-style-type: none"> 1. Copy the data to another tape cartridge 2. Discard the old (EOL) tape. 	Yes	No
8	Not data grade	Set when the cartridge is not data-grade. Any data that you write to the tape is at risk.	Replace the tape with a data-grade tape.	No	No

Table 34. TapeAlert Flags that are supported by the Ultrium Tape Drives (continued)

TapeAlert Flags Supported by the Ultrium Tape Drives					
Flag Number and Name		Description	Action Required	SNMP Trap	Call Home
9	Write protect	Set when the tape drive detects that the tape cartridge is write-protected.	Make sure that the cartridge's write-protect switch is set so that the tape drive can write data to the tape. See "Setting the Write-Protect Switch on an Ultrium Cartridge" on page 223.	No	No
10	No removal	Set when the tape drive receives an UNLOAD command after the server prevented the tape cartridge from being removed.	Refer to the documentation for your server's operating system.	No	No
11	Cleaning media	Set when you load a cleaning cartridge into the drive.	No action required.	No	No
12	Unsupported format	Set when you load an unsupported cartridge type into the drive or when the cartridge format has been corrupted.	Use a supported tape cartridge.	No	No
14	Unrecoverable snapped tape	Set when the tape split apart.	Do not attempt to extract the old tape cartridge. Call the tape drive supplier's help line.	Yes	Yes
15	Cartridge memory chip failure	Set when a cartridge memory (CM) failure is detected on the loaded tape cartridge.	Replace the tape cartridge. If this error occurs on multiple cartridges, see Error Code 6 in Table 29 on page 291.	Yes	No
16	Forced eject	Set when you manually unload the tape cartridge while the drive was reading or writing.	No action required.	No	No
17	Read Only format	Set when a cartridge marked as read only is loaded into the drive. The flag is cleared when the cartridge is ejected (this flag is supported only for Ultrium 3, not Ultrium 1 or Ultrium 2).	No action required.	No	No
18	Tape directory corrupted in the cartridge memory	Set when the drive detects that the tape directory in the cartridge memory has been corrupted.	Re-read all data from the tape to rebuild the tape directory.	No	No

Table 34. TapeAlert Flags that are supported by the Ultrium Tape Drives (continued)

TapeAlert Flags Supported by the Ultrium Tape Drives					
Flag Number and Name		Description	Action Required	SNMP Trap	Call Home
20	Clean now	Set when the tape drive detects that it needs cleaning.	Clean the tape drive. See the section about the methods for cleaning drives in the <i>IBM System Storage TS3500 Tape Library Introduction and Planning Guide</i> .	No	No
21	Clean periodic	Set when the drive detects that it needs routine cleaning.	Clean the tape drive as soon as possible. The drive can continue to operate, but you should clean the drive soon. See the section about the methods for cleaning drives in the <i>IBM System Storage TS3500 Tape Library Introduction and Planning Guide</i> .	No	No
22	Expired clean	Set when the tape drive detects a cleaning cartridge that has expired.	Replace the cleaning cartridge. See "Removing a Cleaning Cartridge from the Library" on page 75.	Yes	No
23	Invalid cleaning tape	Set when the drive expects a cleaning cartridge and the loaded cartridge is not a cleaning cartridge.	Use a valid cleaning cartridge.	Yes	No
30	Hardware A	Set when a hardware failure occurs that requires that you reset the tape drive to recover.	If resetting the drive does not recover the error, note the error code on the single-character display and see Table 29 on page 291 for the appropriate instructions.	Yes	No
31	Hardware B	Set when the tape drive fails its internal Power-On Self Tests.	Note the error code on the single-character display and see Table 29 on page 291 for the appropriate instructions.	Yes	Yes
32	Interface	Set when the tape drive detects a problem with the SCSI, Fibre Channel, or RS-422 interface.	Locate Error Code 8 or 9 in Table 29 on page 291.	Yes	Yes

Table 34. TapeAlert Flags that are supported by the Ultrium Tape Drives (continued)

TapeAlert Flags Supported by the Ultrium Tape Drives					
Flag Number and Name		Description	Action Required	SNMP Trap	Call Home
33	Eject media	Set when a failure occurs that requires you to unload the cartridge from the drive.	Unload the tape cartridge, then reinsert it and restart the operation.	Yes	No
34	Download fail	Set when an FMR image is unsuccessfully downloaded to the tape drive through the SCSI or Fibre Channel interface.	Ensure that it is the correct FMR image. Download the FMR image again.	No	No
36	Drive temperature	Set when the drive's temperature sensor indicates that the drive's temperature is exceeding the recommended temperature of the library.	See Error Code 1 in Table 29 on page 291.	Yes	No
37	Drive voltage	Set when the drive detects that the externally supplied voltages are either approaching the specified voltage limits or are outside the voltage limits (see the power specifications in the <i>IBM System Storage TS3500 Tape Library Introduction and Planning Guide</i>).	See Error Code 2 in Table 29 on page 291.	Yes	Yes
39	Diagnostics required	Set when the drive detects a failure that requires diagnostics for isolation.	See Error Code 6 in Table 29 on page 291.	No	No
51	Tape directory invalid at unload	Set when the tape directory on the tape cartridge that was previously unloaded is corrupted. The file-search performance is degraded.	Use your backup software to rebuild the tape directory by reading all the data.	No	No
52	Tape system area write failure	Set when the tape cartridge that was previously unloaded could not write its system area successfully.	Copy the data to another tape cartridge, then discard the old cartridge.	Yes	No
53	Tape system area read failure	Set when the tape system area could not be read successfully at load time.	Copy the data to another tape cartridge, then discard the old cartridge.	Yes	No
55	Load failure	The operation failed because the media cannot be loaded and threaded.	Remove the tape and try another. If the problem persists, contact your IBM Service Representative.	Yes	No
56	Unrecoverable unload failure	The operation failed because the media cannot be unloaded.	Contact your IBM Service Representative.	Yes	No

Table 34. TapeAlert Flags that are supported by the Ultrium Tape Drives (continued)

TapeAlert Flags Supported by the Ultrium Tape Drives					
Flag Number and Name		Description	Action Required	SNMP Trap	Call Home
58	Firmware failure	The operation failed because of a problem with the firmware.	Contact your IBM Service Representative.	Yes	Yes

TapeAlert Flags Supported by the 3592 Tape Drives

This section lists the TapeAlert flags that are supported by the 3592 Tape Drives.

Table 35 lists the TapeAlert flags that are supported by the 3592 Tape Drives.

Table 35. TapeAlert Flags that are supported by the 3592 Tape Drives

TapeAlert Flags Supported by the 3592 Tape Drives					
Flag Number and Name		Description	Action Required	SNMP Trap	Call Home
1	Read warning	Set when the tape drive is having problems reading data. No data has been lost, but there has been a reduction in the performance of the tape.	<p>Isolate the fault between drive and media by doing the following:</p> <p>Use a known good tape cartridge in the suspect drive. If the drive fails, contact your IBM Service Representative.</p> <p>Use the suspect tape cartridge in a known good drive. If the test fails, discard the cartridge.</p>	No	No
2	Write warning	Set when the tape drive is having problems writing data. No data has been lost, but there has been a reduction in the capacity of the tape.	<p>Isolate the fault between drive and media by doing the following:</p> <p>Use a known good tape cartridge in the suspect drive. If the drive fails, contact your IBM Service Representative.</p> <p>Use the suspect tape cartridge in a known good drive. If the test fails, discard the cartridge.</p>	No	No
3	Hard error	Set for any unrecoverable read, write, or positioning error. The flag is cleared when the cartridge is removed from the drive (this flag is set in conjunction with flags 4, 5, or 6).	Determine if flags 4, 5, or 6 exist; follow the actions there.	Yes	No
4	Media	Set for any unrecoverable read, write, or positioning error that is due to faulty media. The flag is cleared when the cartridge is removed from the drive.	Discard the media.	Yes	No

Table 35. TapeAlert Flags that are supported by the 3592 Tape Drives (continued)

TapeAlert Flags Supported by the 3592 Tape Drives					
Flag Number and Name		Description	Action Required	SNMP Trap	Call Home
5	Read failure	Set for any unrecoverable read error where the isolation is uncertain and the failure could be faulty media or drive hardware. The flag is cleared when the cartridge is removed from the drive.	Discard the media. If the failure persists, contact your IBM Service Representative.	Yes	Yes
6	Write failure	Set for any unrecoverable write or positioning error where isolation is uncertain and failure could be faulty media or drive hardware. The flag is cleared when the cartridge is removed from the drive.	Discard the media. If the failure persists, contact your IBM Service Representative.	Yes	No
7	Media life	Set when the tape cartridge reached its end of life (EOL).	<ol style="list-style-type: none"> 1. Copy the data to another tape cartridge 2. Discard the old (EOL) tape. 	Yes	No
8	Not data grade	Set when the tape cartridge is not data-grade. Any data that you back up to the tape is at risk. The flag is set when severe servo problems are detected while loading a cartridge.	Discard the media. If the failure persists, contact your IBM Service Representative.	No	No
9	Write protect	Set when the tape drive detects that the tape cartridge is physically write-protected and the device driver sees a write command. The flag is cleared when the cartridge is removed from the drive.	Set the write-protect switch on the cartridge to OFF (see "Setting the Write-Protect Switch on a 3592 Cartridge" on page 257. Ensure that the cartridge is not logically protected. If the problem persists, contact your IBM Service Representative.	No	No
10	No removal	Set when an unload is attempted and SCSI Prevent Media Removal is set to ON. The flag is cleared when the cartridge is removed from the drive.	If the error is an operator error, no action is required; if the error is a customer software error, see the documentation for your server's operating system.	No	No
11	Cleaning media	Set when a cleaning tape is loaded into the drive.	None. Status only.	No	No

Table 35. TapeAlert Flags that are supported by the 3592 Tape Drives (continued)

TapeAlert Flags Supported by the 3592 Tape Drives					
Flag Number and Name		Description	Action Required	SNMP Trap	Call Home
12	Unsupported format	Set when a non-supported cartridge type is loaded into the drive. It is cleared when the cartridge is removed from the drive. Can also be caused by FMR tape loaded for Read/Write or a tape that is formatted for a TS1120 Tape Drive but loaded in an emulated drive.	Remove the invalid cartridge. If the problem persists, contact your IBM Service Representative.	No	No
14	Unrecoverable snapped tape	Set when the tape in the drive snapped. The operator cannot remove the tape.	Contact your IBM Service Representative.	Yes	Yes
15	Memory chip in cartridge	Set when the memory in the tape cartridge failed.	Do not use the cartridge for further backup operation.	Yes	No
16	Forced eject	Set when a tape cartridge was manually removed while reading and writing. It is cleared when a cartridge is loaded into the drive.	None. Status only.	No	No
17	Read-only format	Set when a "read-only," formatted tape is loaded into the drive. The flag is cleared when the cartridge is removed from the drive.	None. Status only.	No	No
18	Tape directory corrupted on load	Set when the tape drive detects that the directory has been corrupted. The flag is cleared when the cartridge is removed from the drive.	Operator action required. Re-read all data from the tape to rebuild the tape directory.	No	No
19	Nearing media life	Set when the tape cartridge is nearing its specified end of life. It is cleared when the cartridge is removed from the drive.	1. Copy the data to another tape cartridge. 2. Replace the tape cartridge.	No	No
20	Clean now	Set when the tape drive detects that it needs cleaning.	Clean the tape drive. See the section about the methods for cleaning drives in the <i>IBM System Storage TS3500 Tape Library Introduction and Planning Guide</i> .	No	No

Table 35. TapeAlert Flags that are supported by the 3592 Tape Drives (continued)

TapeAlert Flags Supported by the 3592 Tape Drives					
Flag Number and Name		Description	Action Required	SNMP Trap	Call Home
21	Clean periodic	Set when the tape drive detects that it needs routine cleaning.	Clean the tape drive as soon as possible. The drive can continue to operate, but you should clean it soon. See the section about drive cleaning in the <i>IBM System Storage TS3500 Tape Library Introduction and Planning Guide</i> .	No	No
22	Expired cleaning media	Set when the tape drive detects a cleaning cartridge that has expired. It is cleared when a valid cleaning cartridge is loaded.	Replace the cleaning cartridge. See "Removing a Cleaning Cartridge from the Library" on page 75.	Yes	No
23	Invalid cleaning cartridge	Set when the drive expects a cleaning cartridge to be loaded and the loaded cartridge is not a cleaning cartridge.	Use a valid cleaning cartridge.	Yes	No
25	Dual-port interface error	Set when a redundant Fibre interface port on the tape drive failed.	Contact your IBM Service Representative.	Yes	Yes
26	Cooling fan failure	Set when a tape drive or power supply cooling fan failed.	Contact your IBM Service Representative.	Yes	Yes
27	Power supply	Set when a power supply failed.	Contact your IBM Service Representative.	Yes	Yes
30	Hardware A	Set when a hardware failure occurred that requires a drive reset to recover.	Contact your IBM Service Representative.	Yes	Yes
31	Hardware B	Set when the tape drive fails its internal Power-On Self-Tests (POSTs), and is not cleared until the drive is powered OFF.	Contact your IBM Service Representative.	Yes	Yes
32	Interface	Set when the tape drive detects a problem with the SCSI, Fibre Channel, or RS-422 interface. It is cleared when the drive is powered OFF.	Contact your IBM Service Representative.	Yes	Yes

Table 35. TapeAlert Flags that are supported by the 3592 Tape Drives (continued)

TapeAlert Flags Supported by the 3592 Tape Drives					
Flag Number and Name		Description	Action Required	SNMP Trap	Call Home
33	Eject media	Set when a failure occurs that requires the tape cartridge to be ejected from the drive and retried. The flag is cleared when the cartridge is removed from the drive.	Try different media. If the problem persists, contact your IBM Service Representative.	Yes	No
34	Download fail	Set when an FMR image is unsuccessfully downloaded to the tape drive via the SCSI, Fibre Channel, or RS-422 interface. It is cleared when the drive is powered OFF or a successful microcode update is performed.	Contact your IBM Service Representative.	No	No
36	Drive temperature	Set when the drive temperature sensor indicates that the drive is too hot.	Contact your IBM Service Representative.	Yes	No
37	Drive voltage	Set when the drive detects power supply voltages outside of the specified voltage limits. It is cleared when the drive is powered OFF.	Contact your IBM Service Representative.	Yes	Yes
38	Predictive failure	Set when a hardware failure of the tape drive is predicted.	Contact your IBM Service Representative.	Yes	Yes
39	Diagnostics required	Set when a tape cartridge or drive FID or ATTN DRV message is posted. The flag is cleared when the drive is powered OFF.	Contact your IBM Service Representative.	No	No
50	Lost statistics	Set when media statistics were lost at some time in the past.	None. Status only.	No	No
51	Tape directory invalid at unload	Set when the tape directory on the tape cartridge that was previously unloaded is corrupted. The file-search performance is degraded.	Use your backup software to rebuild the tape directory by reading all the data.	No	No
52	Tape system area write failure	Set when the tape cartridge that was previously unloaded could not write its system area successfully.	Try another tape.	Yes	No
53	Tape system area read failure	Set when the tape system area could not be read successfully at load time.	Try another tape.	Yes	No
54	No start of data	Set when the start of data could not be found on the tape.	Try another tape.	Yes	No

Table 35. TapeAlert Flags that are supported by the 3592 Tape Drives (continued)

TapeAlert Flags Supported by the 3592 Tape Drives					
Flag Number and Name		Description	Action Required	SNMP Trap	Call Home
55	Load failure	The operation failed because the media cannot be loaded and threaded.	Remove the tape and try another. If the problem persists, contact your IBM Service Representative.	Yes	No
56	Unrecoverable unload failure	The operation failed because the media cannot be unloaded.	Contact your IBM Service Representative.	Yes	No
58	Firmware failure	The operation failed because of a problem with the firmware.	Contact your IBM Service Representative.	Yes	Yes

TapeAlert Flags Supported by the Library

This section lists the TapeAlert flags that are supported by the 3584 Tape Library.

Table 36 lists the TapeAlert flags that are supported by the 3584 Tape Library.

Table 36. TapeAlert Flags that are supported by the 3584 Tape Library

TapeAlert Flags Supported by the 3584 Tape Library					
Flag Number and Name		Description	Action Required	SNMP Trap	Call Home
1	Library hardware A	The library has trouble communicating with the drive.	<ol style="list-style-type: none"> Restart the operation. If the problem persists, call your IBM Service Representative. 	Yes	Yes
2	Library hardware B	The library has a hardware failure.	<ol style="list-style-type: none"> Restart the operation. If the problem persists, call your IBM Service Representative. 	Yes	Yes
4	Library hardware D	The library has a hardware fault that is not mechanically related.	<ol style="list-style-type: none"> Restart the operation. If the problem persists, call your IBM Service Representative. 	Yes	Yes
7	Predictive failure	The library detected that a hardware component is degraded but still operational.	Call your IBM Service Representative.	Yes	No
11	Library voltage limits	A potential failure of a power supply exists.	Call your IBM Service Representative.	Yes	Yes
16	Library door	A library door is open and prevents the library from functioning.	<ol style="list-style-type: none"> Close the library door. If the problem persists, call your IBM Service Representative. 	Yes	No
17	Library I/O station	A problem with an I/O station exists.	<ol style="list-style-type: none"> Ensure that there is no obstruction in the I/O station. Restart the operation. If the problem persists, call your IBM Service Representative. 	Yes	Yes

Table 36. TapeAlert Flags that are supported by the 3584 Tape Library (continued)

TapeAlert Flags Supported by the 3584 Tape Library					
Flag Number and Name		Description	Action Required	SNMP Trap	Call Home
23	Library scan retry	The operation to scan the bar code on a cartridge had to perform an excessive number of retries before succeeding. A potential problem exists with the bar code label or the scanner hardware in the library mechanism.	<ol style="list-style-type: none"> 1. Check for damaged, misaligned, or peeling bar code labels on cartridges. 2. If the problem persists, call your IBM Service Representative. 	Yes	No
24	Library inventory	An inventory of the media was inconsistent.	<ol style="list-style-type: none"> 1. Run a library inventory to correct the inconsistency. 2. Restart the operation. 3. If the problem persists, call your IBM Service Representative. 	Yes	No
25	Library illegal operation	The library detected an illegal operation.	If the problem persists, call your IBM Service Representative.	Yes	No
28	Power supply	A redundant power supply failure exists inside the library.	Call your IBM Service Representative.	Yes	Yes
32	Unreadable bar code label	During an inventory or scan, the library was unable to read a bar code label on a cartridge.	<ol style="list-style-type: none"> 1. Check for damaged, misaligned, or peeling bar code labels on the cartridge. 2. If no problem is found, call your IBM Service Representative. 	Yes	No

Chapter 8. Technical Components of the Library

This section introduces the major technical components of the 3584 Tape Library.

Overview of Technical Components in the Library

This section describes major technical components of the 3584 Tape Library that are accessible from the front or rear door.

Figure 62 on page 316 shows the technical components of the 3584 Tape Library that are accessible through the front door.

1	Rail assembly	4	Accessor controller
2	Cartridge accessor	5	Operator panel controller
3	Dual-gripper transport mechanism		

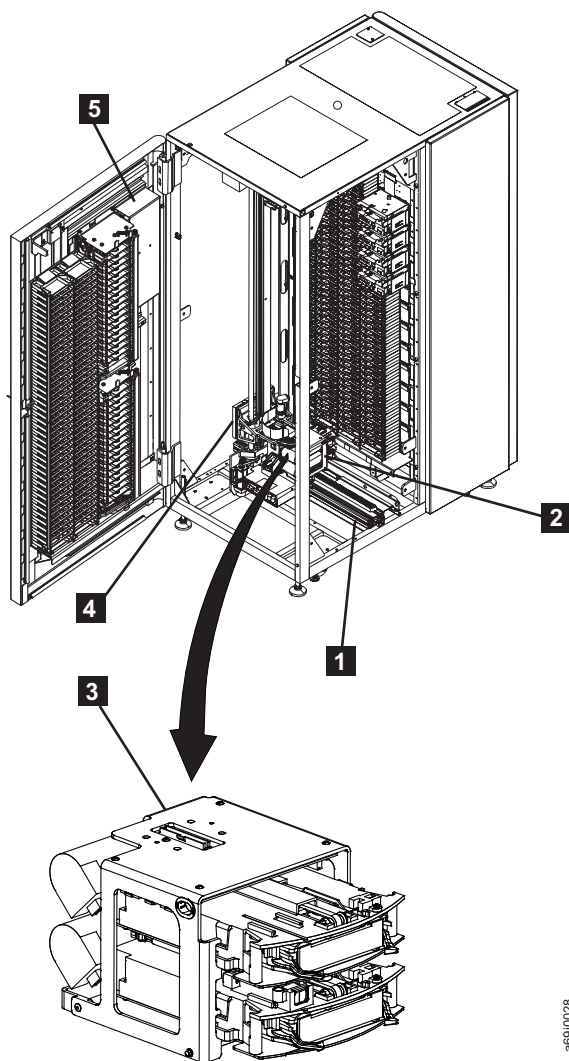

Figure 62. Technical components of the 3584 Tape Library that are accessible through the front door. A Model L52 frame is shown.

The sections that follow describe each component.

Rail Assembly

The cartridge accessor moves through the 3584 Tape Library on a rail assembly. The system consists primarily of a main rail assembly and a support rail, and a trough for the power and control cable. The main rail assembly includes a main bearing way with a rack gear. Its support rail is an L-shaped rail that runs along the top of the frames and provides smooth transport for the cartridge accessor. The power and control cable is kept clear of the accessor in a covered trough located at the bottom rear of the library.

Cartridge Accessor

The cartridge accessor moves cartridges between the storage slots, tape drives, and the I/O station of the 3584 Tape Library. The accessor consists of several components:

X- and Y-axis motion assemblies

A group of parts that includes a controller (circuit board) for the Controller Area Network interface, servo motor, pinion drive gear and lead screw.

These assemblies provide the motive force to move the accessor side to side (on the X-axis) and up and down (on the Y-axis). The controller part of this assembly is referred to as the XY controller.

Pivot assembly

A group of parts that provides a mounting platform for the gripper mechanism and the bar code reader. This assembly is capable of 180° rotation about the vertical axis.

Optimized dual gripper

An electromechanical device (mounted on the pivot assembly) that gets or puts cartridges from or to a storage slot, tape drive, or I/O station. The gripper is independently controlled and can grip a single cartridge. There are two grippers on the pivot assembly (Gripper 1 and Gripper 2). The grippers are located in the dual-gripper transport mechanism.

In libraries that mix drive types, the optimized dual gripper can handle both Ultrium and 3592 Tape Cartridges.

Bar code reader

A component that reads the bar code on a label that is affixed to a cartridge or to the rear of empty storage slots. The bar code reader is mounted on the pivot assembly. It is used during inventories, audits, insertions, and inventory updates (a process that is invoked each time you open a door; the inventory update determines whether cartridges have been added to or removed from the library, or moved within the library).

Calibration sensor

A component that provides a means to locate certain positions within the library very precisely during the calibration operation. The calibration sensor is mounted on the underside of Gripper 1 (for the optimized dual gripper, the sensor is mounted on the top of Gripper 2). All positions are calculated from these locating positions.

Accessor Controller

The accessor controller is the controller (circuit board) for each cartridge accessor in the 3584 Tape Library. If your library includes a second accessor, it has two accessor controllers. The accessor controller handles accessor motion requests, including calibrations, moves, and inventory updates. It also provides centralized management for other aspects of the entire library, including configuration, insert and eject operations, automatic drive cleaning, and determination of element status (for example, whether an element (such as a tape drive) is empty or occupied and the volume serial (VOLSER) number of the tape that occupies it).

The Controller Area Network (CAN) provides communication between the XY controller, accessor controller, Medium Changer card packs or Medium Changer assemblies, and operator panel controller. The Medium Changer card packs and the Medium Changer assemblies use the drives' RS-422 interfaces to communicate between each accessor controller and all drives within any one frame.

Operator Panel Controller

The operator panel controller facilitates communication between the accessor controller and the operator panel of the 3584 Tape Library. It provides input to and output from the LCD, and senses and locks the I/O stations. In addition, the LCD activity and service menus are executed in the operator panel controller, with support from the accessor controller and the drives (via the Medium Changer card packs or Medium Changer assemblies).

The operator panel connects to the accessor controllers, all Medium Changer card packs or Medium Changer assemblies, and the XY controller through the Controller Area Network (CAN).

Power Structures

This section introduces the two types of power structures of the 3584 Tape Library: the *frame control assembly* and the *enhanced frame control assembly*. Models L23, D23, L53, and D53 are equipped with the enhanced frame control assembly. All other models are equipped with the frame control assembly.

Frame Control Assembly

The frame control assembly (FCA) in the Models L22, D22, L32, D32, L52, and D52 of the 3584 Tape Library is a 2N power design with at least two power supplies available to power each load (drive canister). Each drive canister is connected to two associated power supplies, but only one is required. Each canister's power supply is connected to two canisters and is capable of powering both by itself.

Located at the right rear of the 3584 Tape Library, the FCA houses the Medium Changer card pack, which contains the controller logic cards for the logical libraries. Also included in the FCA are a receptacle for the incoming main ac power, three circuit breakers, and ten ac outlets for powering the tape drives (one outlet is required for every two drives).

Figure 63 shows the elements of the FCA.

- | | | | |
|----------|--------------------------------|----------|---|
| 1 | Medium Changer card pack (MCP) | 4 | Circuit breakers |
| 2 | 37 V accessor power supplies | 5 | Incoming main ac power (dual ac line cords) |
| 3 | ac outlets | | |



Figure 63. Components of the frame control assembly. Located at the right rear of the 3584 Tape Library, this power structure comes with Models L22, D22, L32, D32, L52, and D52. A Model L52 frame is shown.

Medium Changer Card Pack: The built-in multiplicity of library control paths via the RS-422 interface gives the 3584 Tape Library the ability to support multiple logical libraries (or Medium Changers, in SCSI terms). Because of this, controllers that are attached via the RS-422 interface are referred to as Medium Changer card packs (MCPs).

For each cartridge storage frame that contains at least one drive, there is one MCP logic card. The electronics of the card pack are located in the frame control assembly.

By using an RS-422 interface for each drive in a frame, the MCP provides a communication path so that library commands can be funneled from the tape drives to the accessor. The MCP also provides management and service interfaces to outside hosts.

On Models L22, 32, and 52, the MCP also includes a port for 10/100 Mbps Ethernet support. MCPs with this capability are characterized by a design that is different from earlier MCP cards. Figure 64 shows an MCP with a 10/100 Mbps Ethernet port.

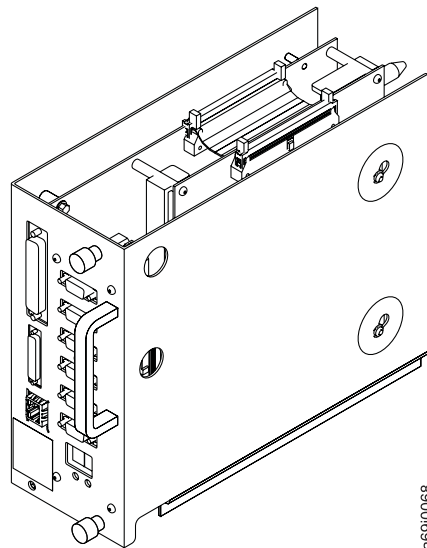

Figure 64. MCP with 10/100 Ethernet port

Drive and Power Supply Compartment for Models L22, D22, L32, D32, L52, and D52: For Models L22, D22, L32, D32, L52, and D52, the 3584 Tape Library is designed so that each Ultrium Tape Drive and 3592 Tape Drive is paired with an associated power supply. Each pairing is packaged side by side on a shelf in a frame. In addition, adjacent power supplies are cabled together such that redundant power becomes a standard function. The design enables a tape drive with a failed power supply to continue operating by using power from an adjacent power supply (also known as redundant drive power).

A frame contains 12 shelves. Each drive is housed in a removable canister, and each power supply is housed in a fixed tray. Both fit side by side on a shelf within the compartment and are identified by the following labels:

E05 IBM System Storage TS1120 Tape Drive

J1A IBM TotalStorage 3592 Tape Drive Model J1A

L1 IBM Ultrium 1 Tape Drive

L2 IBM TotalStorage LTO Ultrium 2 Tape Drive

L3 - 2Gb

IBM System Storage 3588 Tape Drive Model F3A (Ultrium 3 Tape Drive)

L3 - F3B

IBM System Storage TS1030 Tape Drive Model F3B (Ultrium 3 Tape Drive)

FC-AL Fibre Channel Arbitrated Loop

FC-1Gb/s

Fibre Channel - 1 Gigabit per second

FC-2Gb/s

Fibre Channel - 2 Gigabit per second

FC SHORT-WAVE 4Gb/SEC

Fibre Channel - 4 Gigabit per second

HVD SCSI high voltage differential

LVD SCSI low voltage differential

For drives that are equipped with a SCSI host interface, the library uses VHDCI SCSI connectors that connect to ports which are mounted between the power supplies and the drives. The earlier version of the SCSI drive uses HD68 connectors.

You can remove or replace any drive without disconnecting its SCSI cable. When removing and replacing a drive or power supply use the following guidelines.

Drive and Power Supply Compartment for Models L22 and D22:

Figure 65 shows the rear of the 3584 Tape Library and the compartment that contains the tape drives and power supplies for Models L22 and D22.

- | | | | |
|----------|--------------------------------------|----------|---|
| 1 | Drive canister (customer accessible) | 4 | Drive power supply (customer accessible) |
| 2 | Fibre Channel cable connection | 5 | Fixed tray assembly (customer accessible) |
| 3 | Redundant drive dc power cable | | |

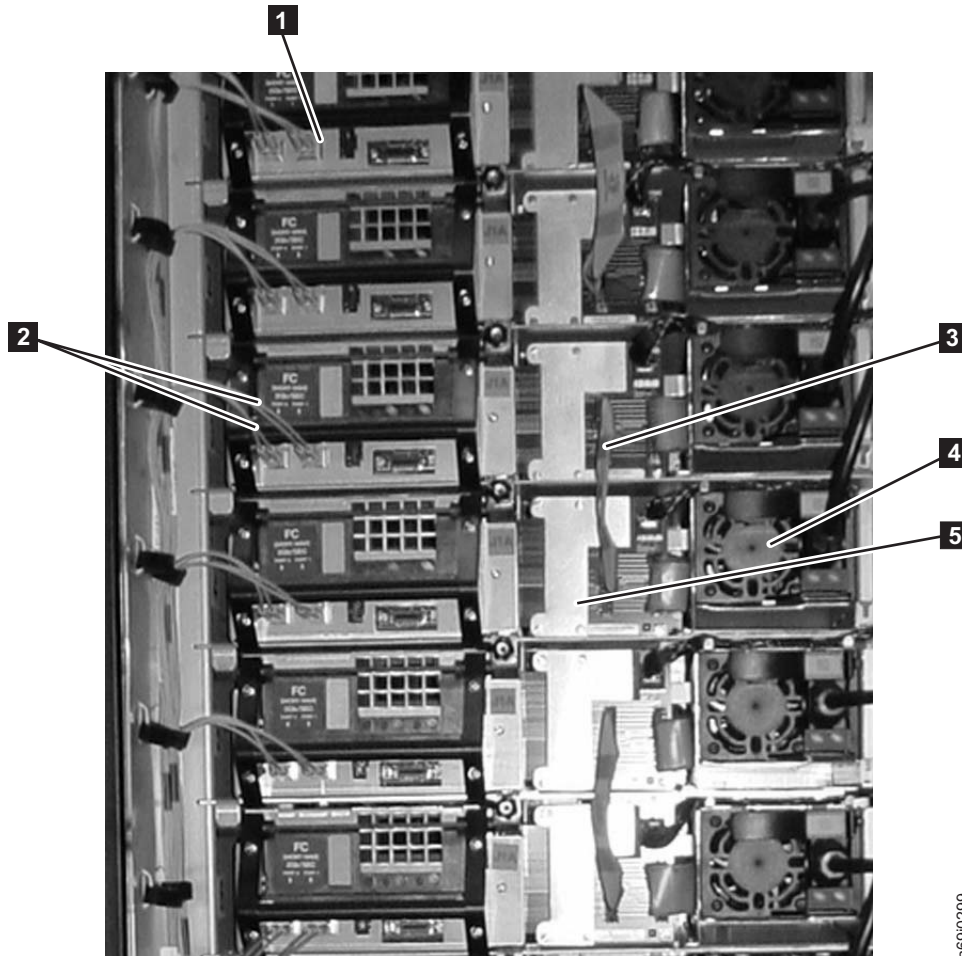

Figure 65. Compartment that houses the tape drives and the power supplies in Model L22 or D22 frames. The view is from the rear of the 3584 Tape Library. The left side of the library has been removed. Only the items designated in the preceding list are customer accessible. All other items are for service personnel.

Drive and Power Supply Compartment for Models L32 and D32:

Figure 66 shows the rear of the 3584 Tape Library and the compartment that contains the tape drives and power supplies for Models L32 and D32.

- | | | | |
|----------|--------------------------------------|----------|---|
| 1 | Drive canister (customer accessible) | 5 | Redundant drive dc power cable |
| 2 | Fibre Channel cable connection | 6 | Drive power supply (customer accessible) |
| 3 | VHDCI SCSI terminator | 7 | Fixed tray assembly (customer accessible) |
| 4 | SCSI cables | | |

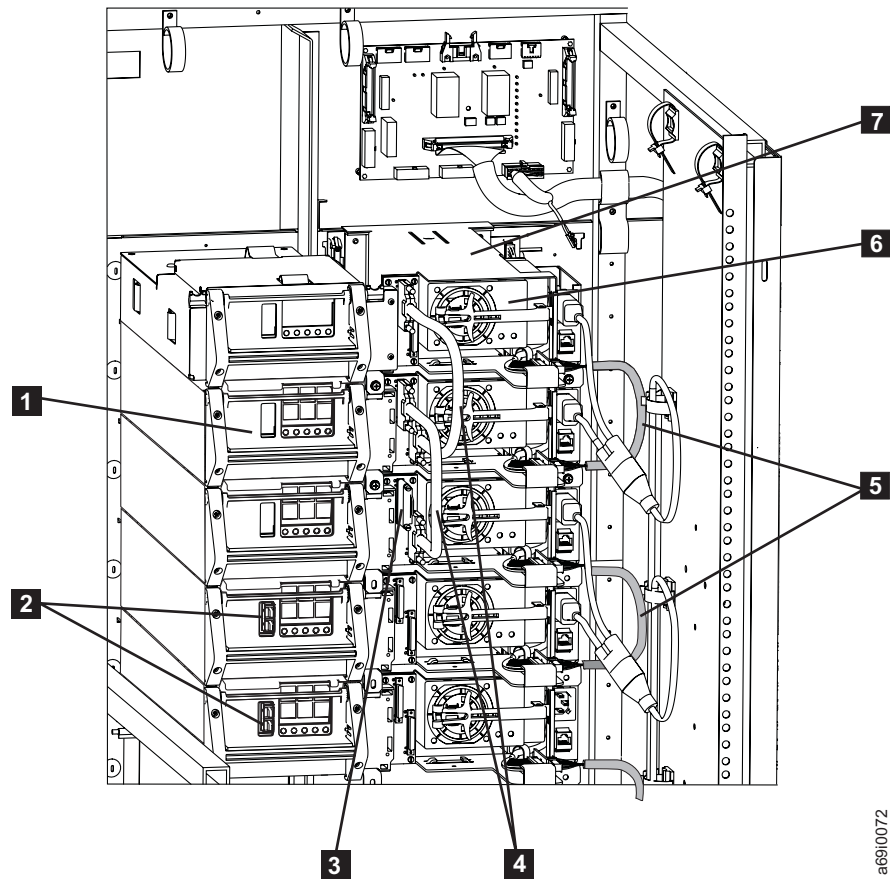
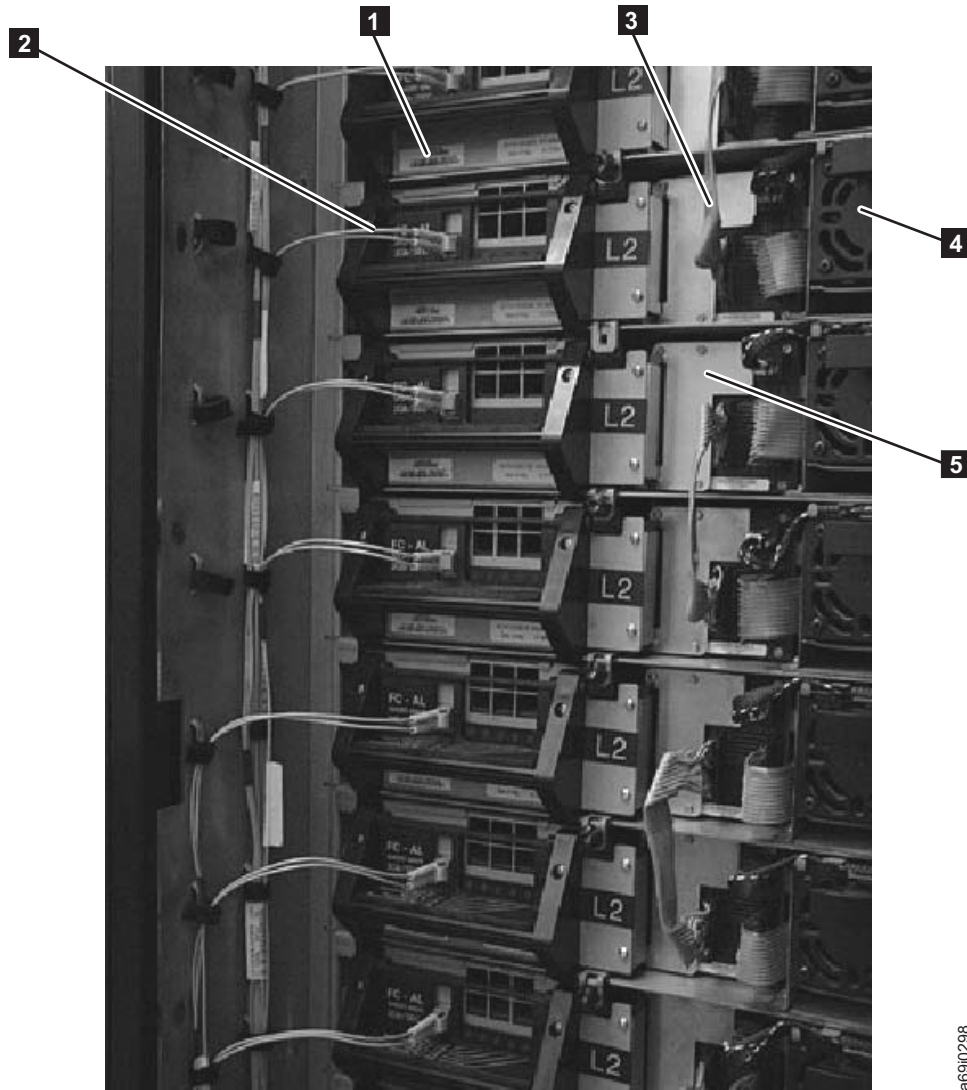

Figure 66. Compartment that houses the tape drives and the power supplies in Model L32 or D32 frames. The view is from the rear of the 3584 Tape Library. The left side of the library has been removed. Only the items designated in the preceding list are customer accessible. All other items are for service personnel.

Drive and Power Supply Compartment for Models L52 and D52:

Figure 67 shows the rear of the 3584 Tape Library and the compartment that contains the tape drives and power supplies for Models L52 and D52.

- | | | | |
|----------|--------------------------------------|----------|---|
| 1 | Drive canister (customer accessible) | 4 | Drive power supply (customer accessible) |
| 2 | Fibre Channel cable connection | 5 | Fixed tray assembly (customer accessible) |
| 3 | Redundant drive dc power cable | | |



a6910298

Figure 67. Compartment that houses the tape drives and the power supplies in Model L52 or D52 frames. The view is from the rear of the 3584 Tape Library. The left side of the library has been removed. Only the items designated in the preceding list are customer accessible. All other items are for service personnel.

Removing or Replacing a Drive Canister Assembly - LTO Fibre Channel Hot Swap:

To remove a drive canister assembly that is an LTO Fibre Channel hot swap from a 3584 Tape Library, perform the following steps:

1. Vary the drive offline.
2. From the library's Activity touchscreen, press **MENU** → **Service** → **FRU Replacement** → **Prepare for Drive Replacement** → **ENTER**.
3. Select the drive that you want to remove and replace, and press **ENTER**.
4. Open the rear door of the frame that contains the drive.
5. Refer to Figure 68. Unplug the fibre cable.
6. While holding up the locking lever **2**, grasp the drive canister's handle **3**. Firmly pull back on the handle to disengage the drive canister.
7. As you remove the drive canister from the fixed tray assembly, use your other hand to support the drive canister from the underside.

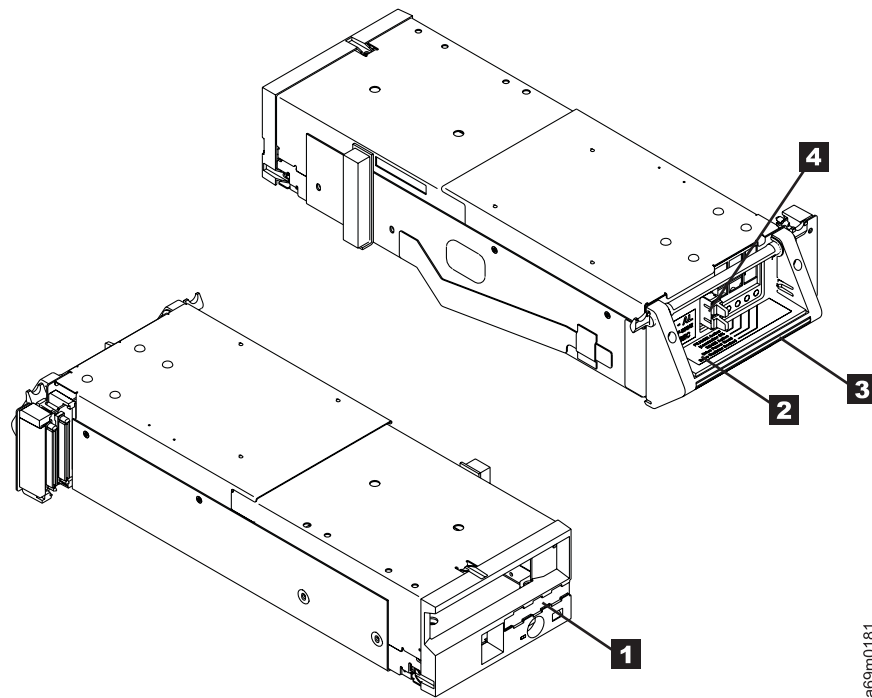

Figure 68. Removing and Replacing a Drive Canister Assembly - LTO Fibre Channel Hot Swap

The replacement procedure is the reverse of the removal procedure. To replace the drive canister assembly in a 3584 Tape Library, perform the following steps.



Notes:

- The removal of the drive canister creates a vacant area in the library. Do not reach through this area.
- If a logical library label (see **4** in Figure 68 on page 325) is attached to the old drive, remove it from the old drive and attach it to the new drive.
- The drive safety flaps in the frame must not be removed when you install the drive. The safety flaps will pivot up and out of the path when the drive is installed.
- If you are copying drive firmware to or from a control path drive, the drive and its entire logical library string of drives will be unavailable to the library until the firmware update is complete.
- Concurrent maintenance of a control path drive may require a logical library to be offline.

CAUTION:

Do not plug in the server's fibre cable until after the drive replacement process is complete and the drive has had its code updated, finished its POST, and Library Verify has completed. If you plug in the cable, a temporary incorrect Loop ID or World Wide Node Name may result.

1. Carefully slide the drive canister into the fixed tray assembly.
2. Hold the locking lever **2** up to ensure the tabs on both sides of the lever will clear the frame.
3. Grasp the drive canister's handle **3**, and carefully but firmly push the drive into position. Ensure that the connectors to the right correctly align and fully engage with the fixed tray connectors.
4. Lower the locking lever **2** until it snaps into place.
5. After you install a replacement drive canister, wait at least 3 minutes before continuing. This ensures that the library has time to automatically configure and calibrate the drive.

Note: The drive firmware update may take as long as 20 minutes. Wait until the screen indicates that the update is complete.

6. From the FRU Replacement screen on the operator panel, press **Prepare for Drive Replacement** → **ENTER**.
7. Select the drive that you replaced and press **ENTER**.
8. Follow the procedure on the screen. The library indicates that the drive is now ready for use.

Notes:

- If the drive that you replaced has a lower version of firmware than other drives of the same type in your library, the library attempts to update the drive firmware by reading code from another drive and writing it to the drive that you replaced. Depending on the drive type, this may take up to 1 hour. Let this process complete before you continue.
- When asked whether you want to perform the Read/Write test, select **Yes** and press **ENTER**. The library attempts to load the diagnostic cartridge into the drive and perform the Read/Write test. This process may take up to 10 minutes. Let this process complete before you continue.

9. From the library's Activity touchscreen, press **MENU** —> **Vital Product Data** —> **Drive VPD** —> **ENTER**. View the drive firmware version for all drives in the library.
10. If the firmware in the drive that you replaced is correct, continue to the next step. If it is downlevel, update the drive firmware (go to the section about updating drive firmware).
11. Replug the fibre cable.

Note: If the drive is connected to an iSeries (AS/400) server, you must perform an initial program load (IPL) on the server input/output processor (IOP) before it recognizes the replacement drive.

12. At the completion of the tests, place the drive online to the server.

Related tasks

“Using the Web to Update Drive Firmware” on page 198

Related reference

“Using a Device Driver to Update Drive Firmware from the Host” on page 199

“Using Other Methods to Update Drive Firmware in the 3584 Tape Library” on page 199

Removing or Replacing a Drive Canister Assembly - 3592 Fibre Channel Hot Swap:

1. Vary the drive offline.
2. From the library's Activity touchscreen, press **MENU** → **Service** → **FRU Replacement** → **Prepare for Drive Replacement** → **ENTER**.
3. Select the drive that you want to remove and replace, and press **ENTER**.
4. Open the rear door of the frame that contains the drive.
5. Refer to Figure 69. Unplug the fibre cable.
6. Push up on the locking lever **2** and grasp the drive canister's handle **3**. Firmly pull back on the handle to disengage the drive canister.
7. As you remove the drive canister from the fixed tray assembly, use your other hand to support the drive canister from the underside.

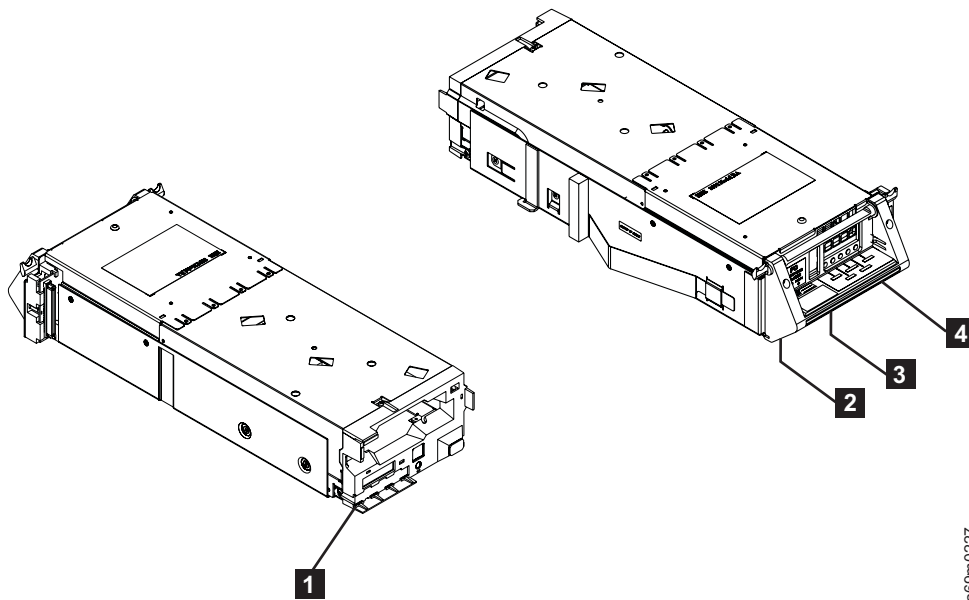

Figure 69. Removing or Replacing a Drive Canister Assembly - 3592 Fibre Hot Swap

The replacement procedure is the reverse of the removal procedure. To replace the drive canister assembly in a 3584 Tape Library, perform the following steps:



Notes:

- The removal of the drive canister creates a vacant area in the library. Do not reach through this area.
- If a logical library label (see **4** in Figure 69) is attached to the old drive, remove it from the old drive and attach it to the new drive.
- The drive safety flaps must not be removed when you install the drive. The safety flaps will pivot up and out of the path when the drive is installed.
- If you are copying drive firmware to or from a control path drive, the drive and its entire logical library string of drives will be unavailable to the library until the firmware update is complete.

CAUTION:

Do not plug in the server's fibre cable until after the drive replacement process is complete and the drive has had its code updated, finished its POST, and Library Verify has completed. If you plug in the cable, a temporary incorrect Loop ID or World Wide Node Name may result.

1. Carefully slide the drive canister into the fixed tray assembly.
2. Hold the locking lever **2** up to ensure that the tabs on both sides of the lever will clear the frame.
3. Grasp the drive canister's handle **3**, and carefully but firmly push the drive into position. Ensure that the connectors on the right correctly align and fully engage with the fixed tray connectors.
4. Lower the locking lever **2** until it snaps into place.
5. After installing a replacement drive canister, wait at least 3 minutes before continuing. This will ensure that the library has time to automatically configure and calibrate the drive.

Note: The drive firmware update may take as long as 20 minutes. Wait until the screen indicates that the update is complete.

6. From the FRU Replacement screen on the operator panel, press **Prepare for Drive Replacement** → **ENTER**.
7. Select the drive that you replaced and press **ENTER**.
8. Follow the procedure on the screen. The library indicates that the drive is now ready for use.

Notes:

- If the drive that you replaced has a lower version of firmware than other drives of the same type in your library, the library attempts to update the drive firmware by reading code from another drive and writing it to the drive that you replaced. Depending on the drive type, this may take up to 1 hour. Let this process complete before you continue.
 - When asked whether you want to perform the Read/Write test, select **Yes** and press **ENTER**. The library attempts to load the diagnostic cartridge into the drive and perform the Read/Write test. This process may take up to 10 minutes. Let this process complete before you continue.
9. From the library's Activity touchscreen, press **MENU** → **Vital Product Data** → **Drive VPD** → **ENTER**. View the drive firmware version for all drives in the library.
 10. If the firmware in the drive that you replaced is correct, continue to the next step. If it is downlevel, update the drive firmware (go to the section about updating drive firmware).
 11. Replug the fibre cables.

Note: If the drive is connected to an iSeries (AS/400) server, you must perform an initial program load (IPL) on the server input/output processor (IOP) before it recognizes the replacement drive.

12. At the completion of the tests, place the drive online to the server.

Related tasks

"Using the Web to Update Drive Firmware" on page 198

Related reference

“Using a Device Driver to Update Drive Firmware from the Host” on page 199
“Using Other Methods to Update Drive Firmware in the 3584 Tape Library” on page 199

Removing or Replacing a Redundant Power Supply - Models L32 or D32 Hot Swap:

To perform a hot swap removal of a redundant power supply in Models L32 or D32, of the 3584 Tape Library, use the following steps:

Note: One redundant power supply provides power to two drives. If the redundant power cable (N+1) is properly installed, you can remove and replace the power supply without affecting drive operation.

1. Open the rear door of the frame that contains the power supply.
2. Use your thumb and index finger to pinch together the locking arms (see **1** in Figure 70) of the power supply.
3. Pivot the locking arm **2** outward to release it from the fixed tray assembly **4**.
4. Grasp the locking arm and firmly pull it back to release it from the fixed tray assembly.
5. As you remove the power supply canister **3** from the fixed tray assembly, use your other hand to support the end of the power supply.

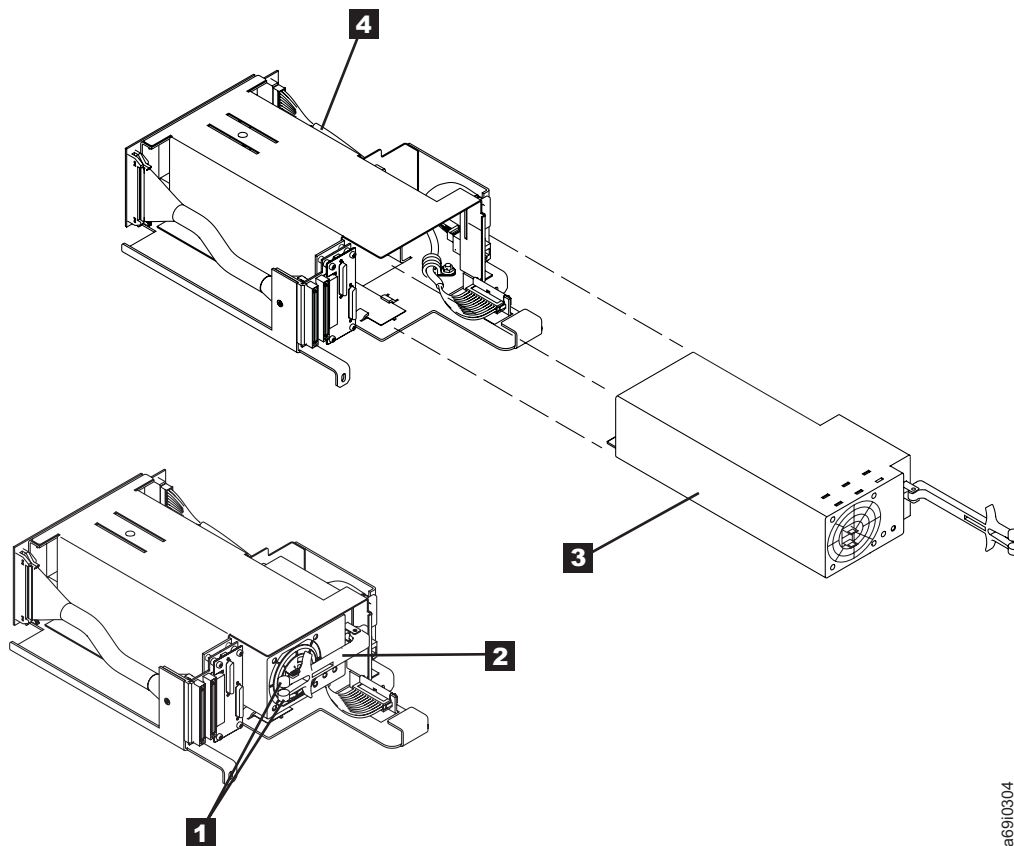

Figure 70. Removing or Replacing a Redundant Power Supply - Models L32 or D32 Hot Swap

6. To perform a hot swap replacement of a redundant power supply in Models L32 or D32 of the 3584 Tape Library, use the following steps. The replacement procedure is the reverse of the removal procedure.
7. Carefully slide the power supply canister (**3** in Figure 70) into the fixed tray assembly **4**.

8. Pinch together the locking arms **1** and slide in the power supply **3**, as you use the locking arm assembly **2** as a lever to move the power supply canister **3** into the locked position.

Removing or Replacing a Redundant Power Supply - Models L22, D22, L52, or D52 Hot Swap:

To perform a hot swap removal of a redundant power supply in Models L22, D22, L52, or D52 of the 3584 Tape Library, use the following steps:

Note: One redundant power supply provides power to two drives. If the redundant power cable (N+1) is properly installed, you can remove and replace the power supply without affecting drive operation.

1. Open the rear door of the frame that contains the power supply canister.
2. Disconnect the power cable (**1** in Figure 71) from the rear of the power supply.
3. Press the colored tab on the side of the locking arm **2** and pivot the arm outward to release the power supply **3** from the fixed tray assembly **5**.
4. Hold the locking arm and firmly pull it back to release it from the fixed tray assembly, while using your other hand to support the end of the power supply as you remove it from the fixed tray assembly.

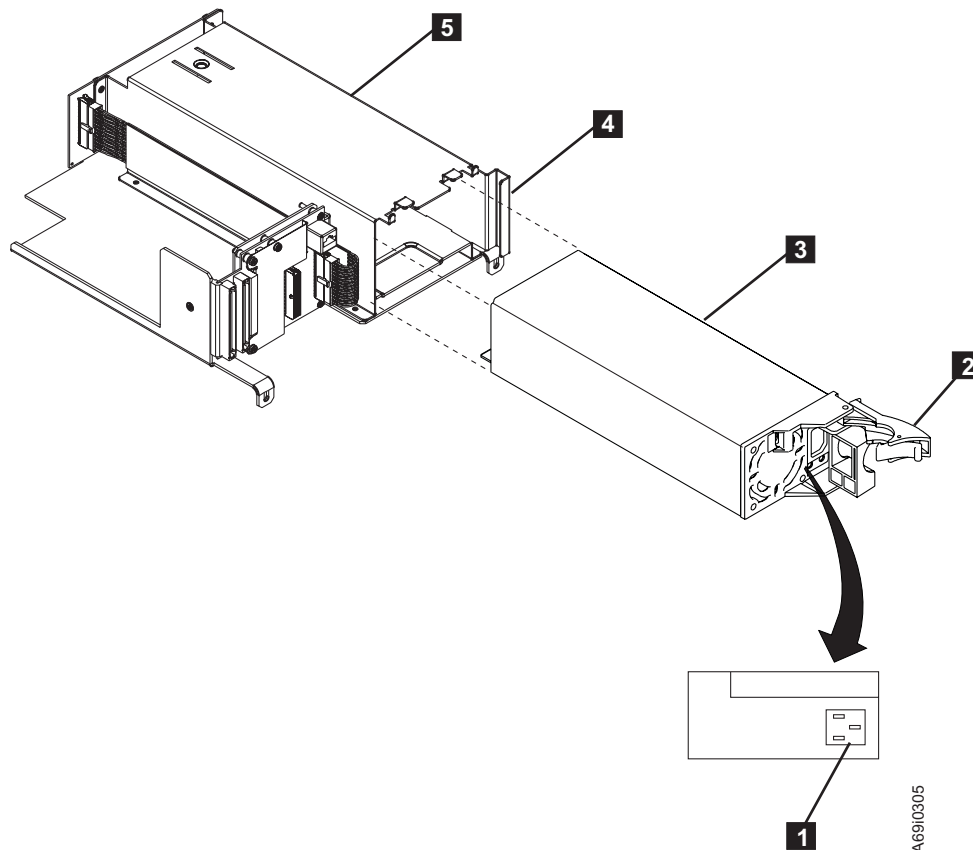

Figure 71. Removing or Replacing a Redundant Power Supply - Models L22, D22, L52, or D52 Hot Swap

5. To perform a hot swap replacement of a redundant power supply in Models L22, D22, L52, or D52 of the 3584 Tape Library, use the following steps. The replacement procedure is the reverse of the removal procedure.
6. With the locking arm **2** in the outward position, carefully slide the power supply canister (see **3** in Figure 71) into the fixed tray assembly **5** as far as it will go.

7. Pivot the locking arm in and make sure that it engages in the power tray frame **4** as you snap the arm into a locked position.
8. Reconnect the power cable **1** to the power supply.

Dual ac Power: Dual ac power enhances availability of the 3584 Tape Library by making another power source available in case of planned or unplanned power grid outages. The dual ac power feature provides a second line cord (110 V ac or 220 V ac) so that a frame can be connected to two independent branch power feeds. The line cords connect to a power switch (**3** in Figure 72) that monitors the ac line voltage on the primary power feed. By default, all power is drawn from the main power feed **1**. If the incoming voltage is lost, the power switch automatically draws power from the backup power feed **2**. When power is restored to the main power feed, the switch automatically returns the power back to the main power feed. Figure 72 shows the dual ac power feature, which you can order as feature code 1901.

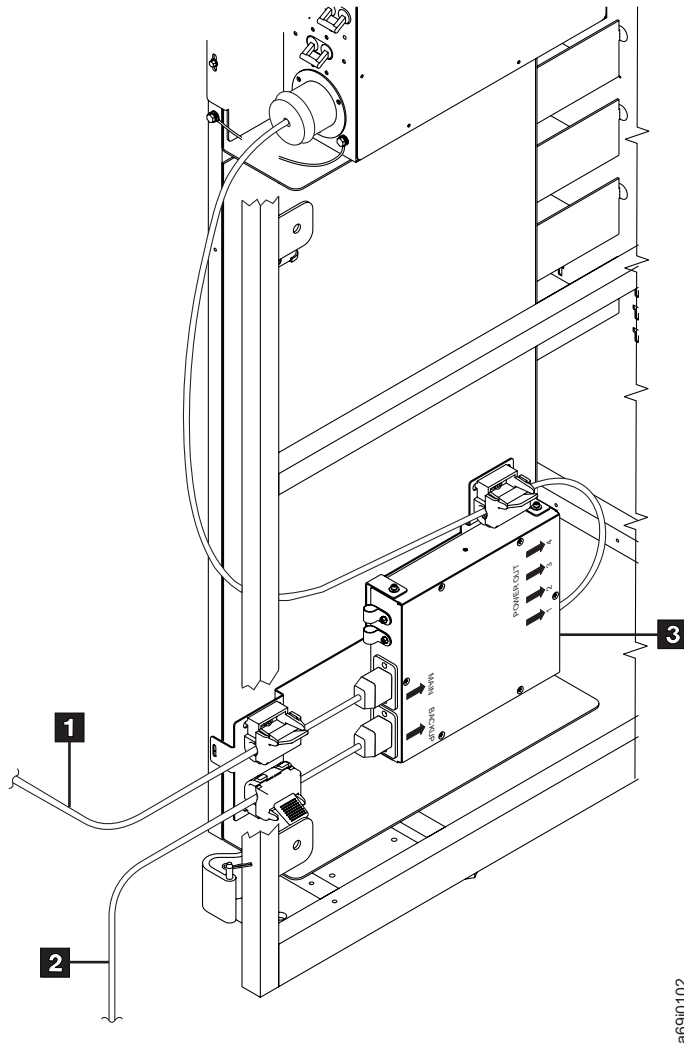

Figure 72. Dual ac power. The view is from the side and rear of a frame. The side panel has been removed to show the placement of the power switch and the two independent ac line cords.

Enhanced Frame Control Assembly

This section describes the enhanced frame control assembly of the 3584 Tape Library.

The enhanced frame control assembly is a 2N power design, but with fewer components than the frame control assembly. The enhanced frame control assembly has only two redundant power supplies which are fed directly by independent dual ac line cords. The assembly is constructed with hot-swappable, redundant parts, which (along with the dual ac line cords) remove the possibility of a single part causing failure. If one power supply fails, the remaining power supply provides all of the power to all of the library's elements.

The enhanced frame control assembly comes standard with Models L23 and L53, and can be ordered as a feature code for Models D23 and D53. The dual ac line cords are standard on Models L23, D23, L53, and D53, and do not have to be ordered separately.

Figure 73 shows the elements of the enhanced frame control assembly.

- 1** Medium Changer assembly (MCA)
- 2** Two 12 V power supplies
- 3** Incoming main ac power (dual ac line cords)

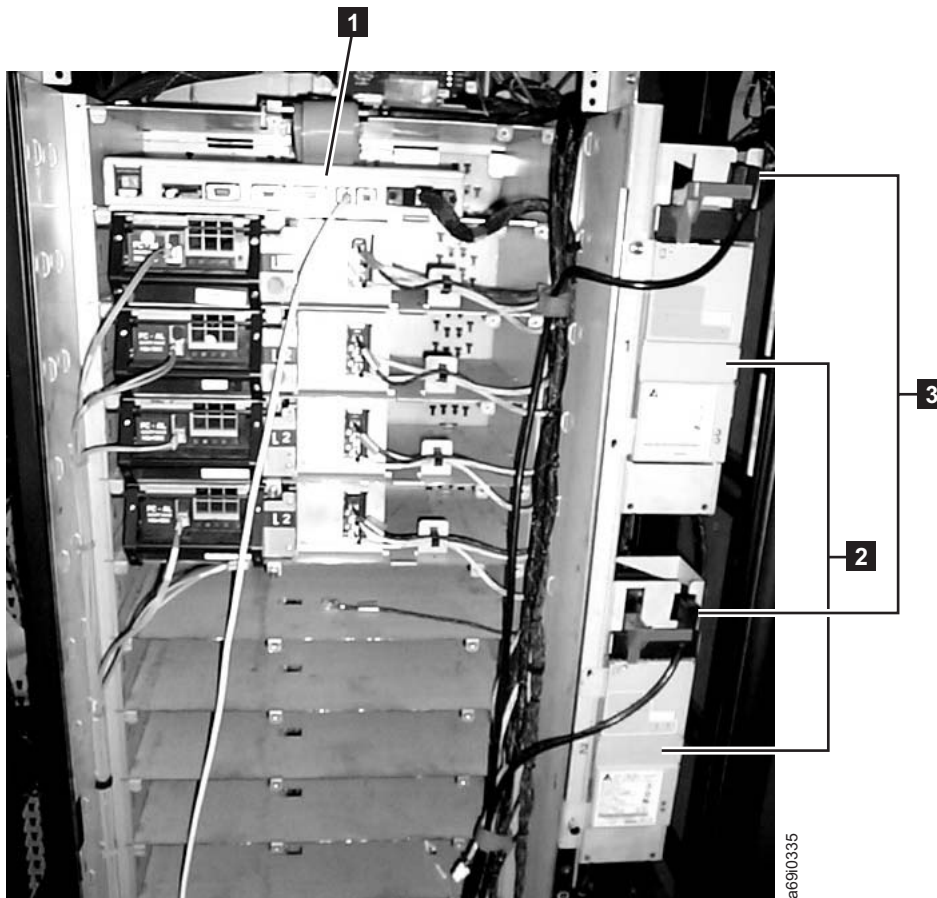

Figure 73. Components of the enhanced frame control assembly. This power structure comes with Models L23, D23, L53, and D53. A Model L53 frame is shown.

Medium Changer Assembly: Integral to the enhanced frame control assembly power structure is the Medium Changer assembly (MCA) unit, a device located above the drives and the fixed power trays in Model L23, D23, L53, and D53 frames. The MCA handles communication between host applications and the library, and houses two Ethernet ports for connection to the IBM System Storage Tape Library Specialist web interface or a master console.

Figure 74 shows the MCA in the 3584 Tape Library.



Figure 74. Medium Changer Assembly. The MCA is located above the drives and the power trays, and is part of the enhanced frame control assembly power structure.

Although the two Ethernet ports in the MCA may be used interchangeably, IBM recommends that you use them as follows:

- Use Port A (**1** in Figure 74) to connect to the Tape Library Specialist web interface.
- Use Port B (**2**) to connect to a TS3000 System Console (TSSC).

You can establish up to five web sessions to the Tape Library Specialist by using one physical Ethernet port. If you have multiple D23 or D53 frames, you can add an additional five connections per frame.

If Port A is connected to the web and Port B is not connected to a TSSC, service personnel may use Port B to connect a laptop to the Tape Library Specialist web interface. A special Ethernet crossover cable is needed to make the connection.

You can also use Port B for the Call Home feature of the 3584 Tape Library. This feature retrieves library and drive logs (as well as other pertinent information) and saves them to the Remote Technical Assistance Information Network (RETAIN) where they can be examined for both failure and maintenance analysis. In the past, this was done by using an analog modem attached to a serial port or by using an Ethernet port in a second frame that was connected to the TS3000 System Console (TSSC). The second frame was necessary because the TSSC required a private network that was separate from the customer network. The dual Ethernet ports of the MCA makes a second frame unnecessary.

Note: A customer rack-mountable TS3000 System Console is available by ordering IBM feature code 2730.

Ethernet cables to the MCA can be routed through the top or bottom of the frame.

Drive and Fixed Tray Assembly Compartment for Models L23 and D23:

Figure 75 shows the rear of the 3584 Tape Library and the compartment that contains the tape drives and fixed tray assemblies for Models L23 and D23.

- | | | | |
|----------|--------------------------------------|----------|---|
| 1 | Drive canister (customer accessible) | 3 | Fixed tray assembly (customer accessible) |
| 2 | Fibre Channel cable connection | | |

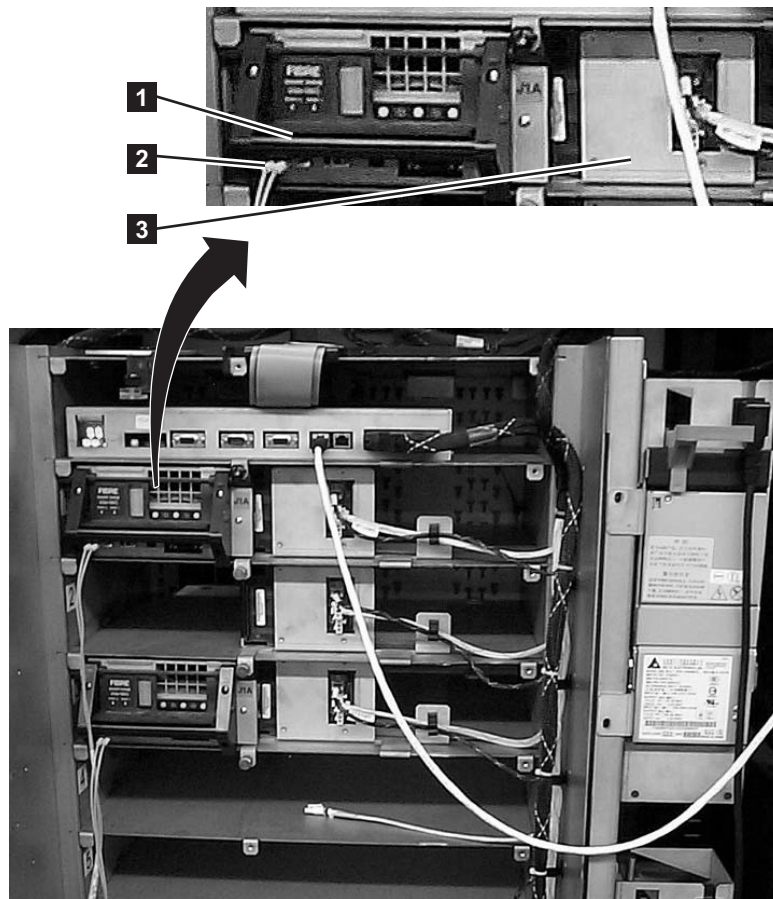

Figure 75. Compartment that houses the tape drives and the fixed tray assemblies in Model L23 or D23 frames. The view is from the rear of the 3584 Tape Library. Only the items designated in the preceding list are customer accessible. All other items are for service personnel.

Drive and Fixed Tray Assembly Compartment for Models L53 and D53:

Figure 76 shows the rear of the 3584 Tape Library and the compartment that contains the tape drives and fixed tray assemblies for Models L53 and D53.

- | | | | |
|----------|--------------------------------------|----------|---|
| 1 | Drive canister (customer accessible) | 3 | Fixed tray assembly (customer accessible) |
| 2 | Fibre Channel cable connection | | |

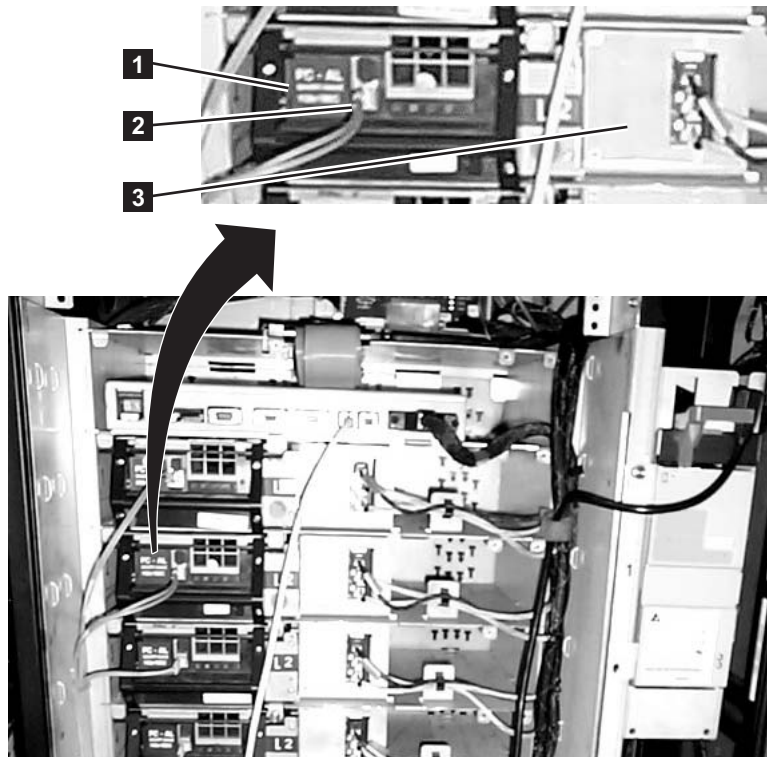

Figure 76. Compartment that houses the tape drives and the fixed tray assemblies in Model L53 or D53 frames. The view is from the rear of the 3584 Tape Library. Only the items designated in the preceding list are customer accessible. All other items are for service personnel.

Chapter 9. Frame Capacity

This section introduces the quantity of LTO Ultrium Tape Cartridges and 3592 Tape Cartridges that the 3584 Tape Library supports, depending on whether the Capacity On Demand or Capacity Expansion Features are installed, the upper and lower I/O stations are used, and a specified quantity of drives are installed.

Capacity of Model L22, D22, L23, and D23 Frames

This section gives the type of eligible Capacity On Demand feature and quantity of drives, I/O slots, and storage slots for L22, D22, L23, and D23 frames.

Table 37. Quantity of storage slots in L22, D22, L23, and D23 frames. The quantity depends on the type of Capacity On Demand feature installed, whether the upper and lower I/O stations are used, and the quantity of drives in a frame.

Type of Frame	Type of Capacity On Demand Feature	Quantity of Drives	Quantity of I/O Slots	Quantity of Storage Slots
L22, L23	Entry	0 to 12	16	58
L22, L23	Intermediate	0 to 12	16	117
L22, L23	Full	0 to 4	16	260
L22, L23	Full	5 to 8	16	248
L22, L23	Full	9 to 12	16	237
L22, L23	Full	0 to 4	32	222
L22, L23	Full	5 to 8	32	210
L22, L23	Full	9 to 12	32	199
D22, D23 ¹	N/A ²	0	N/A	400
D22, D23 ¹	N/A	1 to 4	N/A	383
D22, D23 ¹	N/A	5 to 8	N/A	371
D22, D23 ¹	N/A	9 to 12	N/A	360

Notes:

1. If the L frame is not an L22 or L23, then the first D frame of a mixed media library will have one less storage slot to accommodate a diagnostic cartridge.
2. N/A = not applicable.

Related reference

“Capacity of Model L32 and D32 Frames” on page 342

This section gives the quantity of drives and cartridge storage slots in Model L32 and D32 frames that do not have the Capacity Expansion feature. It also gives the quantity of cartridge storage slots in L32 and D32 frames that have the Capacity Expansion feature and differing numbers of I/O slots.

“Capacity of Model L52, D52, L53, and D53 Frames” on page 343

This section gives the type of eligible Capacity On Demand feature and quantity of drives, I/O slots, and storage slots for Model L52, D52, L53, and D53 frames.

Capacity of Model L32 and D32 Frames

This section gives the quantity of drives and cartridge storage slots in Model L32 and D32 frames that do not have the Capacity Expansion feature. It also gives the quantity of cartridge storage slots in L32 and D32 frames that have the Capacity Expansion feature and differing numbers of I/O slots.

Table 38. Quantity of storage slots in Model L32 and D32 frames. The quantity depends on whether the Capacity Expansion feature is installed, whether the upper and lower I/O stations are used, and the quantity of drives in a frame.

Type of Frame	Quantity of Drives	Quantity of Slots in Frame (without Capacity Expansion Feature)	Quantity of Slots with Capacity Expansion Feature and 26 or 30 I/O Slots	Quantity of Slots with Capacity Expansion Feature and 10 I/O Slots
L32	1 to 4	141	229	281
L32	5 to 8	113	201	253
L32	9 to 12	87	175	227
D32	0	440	N/A (see Note)	N/A
D32	1 to 4	N/A	423	423
D32	5 to 8	N/A	409	409
D32	9 to 12	N/A	396	396

Note: N/A = not applicable.

Related reference

“Capacity of Model L22, D22, L23, and D23 Frames” on page 341

This section gives the type of eligible Capacity On Demand feature and quantity of drives, I/O slots, and storage slots for L22, D22, L23, and D23 frames.

“Capacity of Model L52, D52, L53, and D53 Frames” on page 343

This section gives the type of eligible Capacity On Demand feature and quantity of drives, I/O slots, and storage slots for Model L52, D52, L53, and D53 frames.

Capacity of Model L52, D52, L53, and D53 Frames

This section gives the type of eligible Capacity On Demand feature and quantity of drives, I/O slots, and storage slots for Model L52, D52, L53, and D53 frames.

Table 39. Quantity of storage slots in Model L52, D52, L53, and D53 frames. The quantity depends on the type of Capacity On Demand Expansion feature installed, whether the upper and lower I/O stations are used, and the quantity of drives in a frame.

Type of Frame	Type of Capacity On Demand Feature	Quantity of Drives	Quantity of I/O Slots	Quantity of Storage Slots
L52, L53	Entry	0 to 12	16	64
L52, L53	Intermediate	0 to 12	16	129
L52, L53	Full	0 to 4	16	287
L52, L53	Full	5 to 8	16	273
L52, L53	Full	9 to 12	16	261
L52, L53	Full	0 to 4	32	245
L52, L53	Full	5 to 8	32	231
L52, L53	Full	9 to 12	32	219
D52, D53 ¹	N/A ²	0	N/A	440
D52, D53 ¹	N/A	1 to 4	N/A	422
D52, D53 ¹	N/A	5 to 8	N/A	408
D52, D53 ¹	N/A	9 to 12	N/A	396

Notes:

1. If the L frame is not an L32, L52, or L53, then the first D frame of a mixed media library will have one less storage slot to accommodate a diagnostic cartridge.
2. N/A = not applicable.

Related reference

“Capacity of Model L22, D22, L23, and D23 Frames” on page 341

This section gives the type of eligible Capacity On Demand feature and quantity of drives, I/O slots, and storage slots for L22, D22, L23, and D23 frames.

“Capacity of Model L32 and D32 Frames” on page 342

This section gives the quantity of drives and cartridge storage slots in Model L32 and D32 frames that do not have the Capacity Expansion feature. It also gives the quantity of cartridge storage slots in L32 and D32 frames that have the Capacity Expansion feature and differing numbers of I/O slots.

Chapter 10. Locations and Addresses of SCSI Elements

This section introduces locations and addresses of SCSI elements in the 3584 Tape Library.

Overview of Locations and Addresses of SCSI Elements

This section discusses the SCSI element address that the firmware of the 3584 Tape Library assigns to each storage slot, I/O slot, and drive in the library. It describes how the address is used to indicate the location of an element.

In the IBM System Storage TS3500 Tape Library, each storage slot, I/O slot, and drive is assigned a logical SCSI element address by the library's firmware. When moving a tape cartridge within the library, you can specify its source and destination by SCSI element address (although many operators prefer to specify a volume serial number (VOLSER), or a frame, column, and row address).

For the following frames, this section introduces the physical locations of storage slots and drives. To understand the rules for determining their SCSI element addresses (as well as the element addresses of the I/O slots), go to the sections about determining the SCSI element address with Advanced Library Management System (ALMS) disabled and with ALMS enabled.

- Model L22 (base frame)
- Model D22 (expansion frame)
- Model L23 (base frame)
- Model D23 (expansion frame)
- Model L32 (base frame) without the Capacity Expansion Feature
- Model L32 (base frame) with the Capacity Expansion Feature
- Model D32 (expansion frame)
- Model L52 (base frame)
- Model D52 (expansion frame)
- Model L53 (base frame)
- Model D53 (expansion frame)

Note: If ALMS is enabled, storage element addresses do not vary based on the number of storage slots, drives, or I/O slots in the library. If ALMS is disabled, storage element addresses vary, depending on the quantity of addressable storage slots in the library at the time that the library is configured. In turn, the quantity of addressable storage slots depends on the quantity of drives in the library, on whether a Capacity Expansion Feature is installed, and on whether the lower I/O station is included. As an aid in determining element addresses with ALMS disabled, the section about each model includes quantities of addressable storage slots for each column of the above frames, based on the preceding factors.

Related concepts

“Determining SCSI Element Addresses with ALMS Disabled” on page 361

This section introduces the rules to follow when the Advanced Library Management System (ALMS) is disabled and when you want to determine the

SCSI element addresses of storage elements (storage slots), import/export elements (I/O slots), and data transfer elements (drives) in the 3584 Tape Library.

“Determining SCSI Element Addresses with ALMS Enabled” on page 364
This section introduces the rules to follow when the Advanced Library Management System (ALMS) is enabled and when you want to determine the SCSI element addresses of storage elements (storage slots), import/export elements (I/O slots), and data transfer elements (drives) in the 3584 Tape Library.

Related reference

“Location and Quantity of Addressable Storage Elements in Models L22 and L23” on page 347

“Location and Quantity of Addressable Storage Elements in Models D22 and D23” on page 349

“Location and Quantity of Addressable Storage Elements in Model L32 without Capacity Expansion Feature” on page 351

“Location and Quantity of Addressable Storage Elements in Model L32 with Capacity Expansion Feature” on page 353

“Location and Quantity of Addressable Storage Elements in Model D32” on page 355

“Location and Quantity of Addressable Storage Elements in Models L52 and L53” on page 357

“Location and Quantity of Addressable Storage Elements in Models D52 and D53” on page 359

Location and Quantity of Addressable Storage Elements in Models L22 and L23

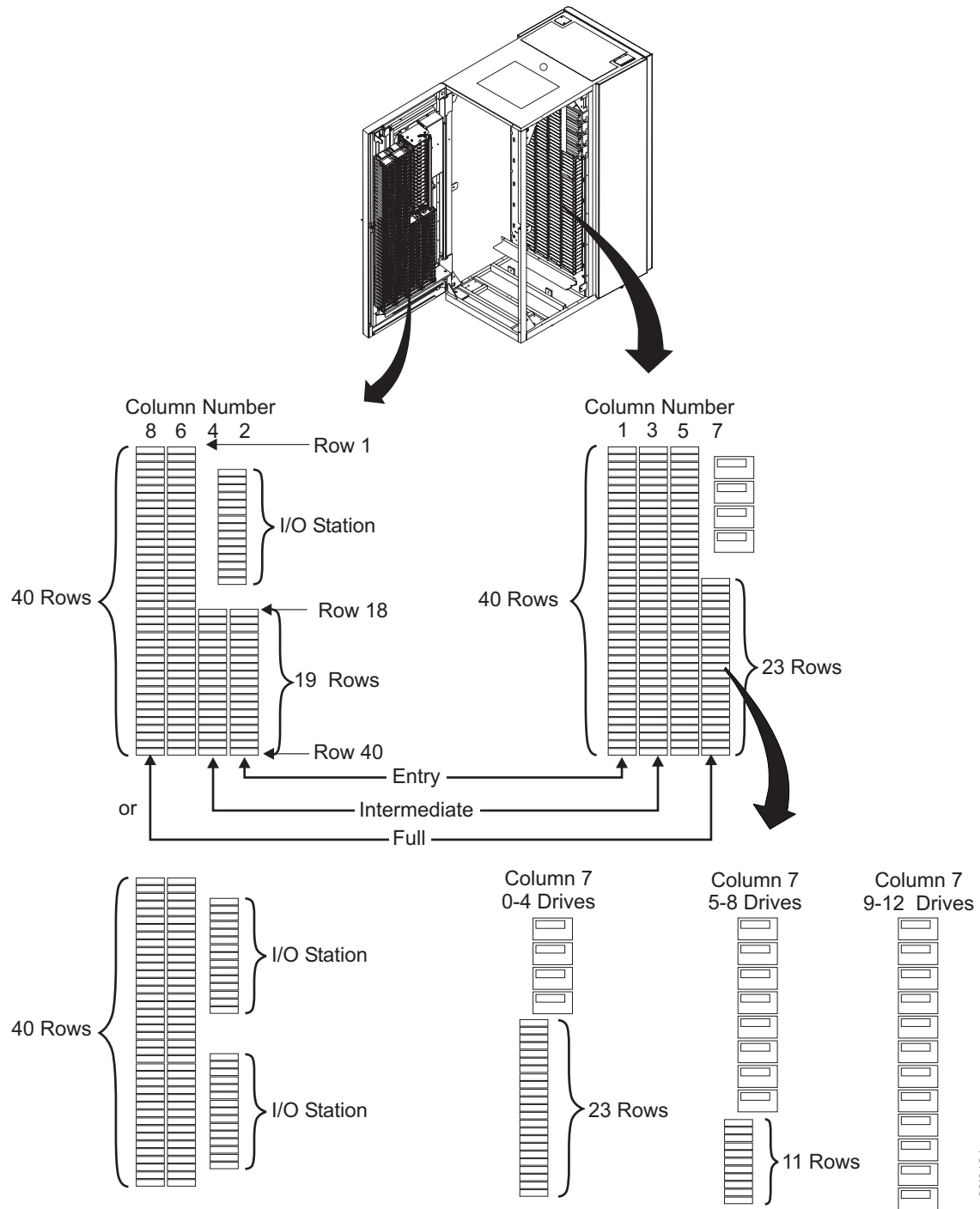

Figure 77. Location of storage elements in Models L22 or L23

Table 40. Quantity of SCSI-addressable storage slots (per column) in Model L22 or L23 frame with 16 or 32 I/O slots

Column Number	Capacity Configuration ¹	Quantity of Storage Slots in Model L22 or L23 Frame with 16 or 32 I/O Slots		
		1-4 Drives	5-8 Drives	9-12 Drives
1 ²	E, I, F	39	39	39
2	E, I, F	19	19	19
3	I, F	40	40	40
4	I, F	19	19	19
5	F	40	40	40
6	F	40	40	40
7	F	23	11	0
8	F	40	40	40
Total		260	248	237

Notes:

1. Abbreviations for capacity configurations are:

- E Entry
- I Intermediate
- F Full

2. Column 1, Row 1 of the Model L22 and L23 is reserved for a diagnostic cartridge.

Location and Quantity of Addressable Storage Elements in Models D22 and D23

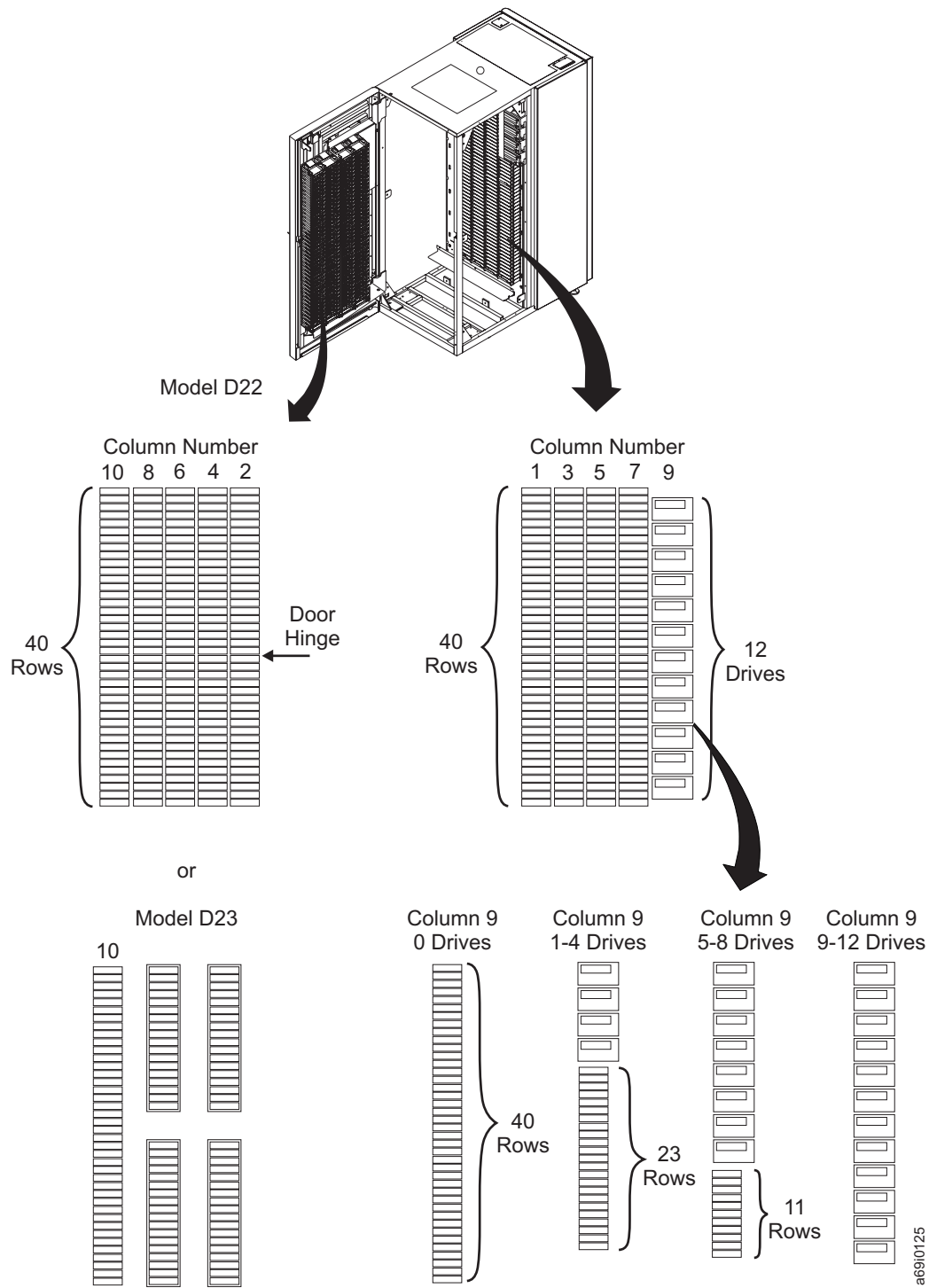

Figure 78. Location of storage elements in Models D22 or D23

Table 41. Quantity of SCSI-addressable storage slots (per column) in Model D22 or D23 frame

Column Number	Quantity of Storage Slots per Drives in Model D22 or D23 Frame			
	0 Drives	1-4 Drives	5-8 Drives	9-12 Drives
1 (see Note)	40	40	40	40
2	40	40	40	40
3	40	40	40	40
4	40	40	40	40
5	40	40	40	40
6	40	40	40	40
7	40	40	40	40
8	40	40	40	40
9	40	23	11	0
10	40	40	40	40
Total	400	383	371	360

Note: For the first Model D22 or D23 frame in a library based on Model L32 or L52, Column 1, Row 1 is reserved for a diagnostic cartridge. In this case, the quantity of slots in Column 1 (and the total) is reduced by one.

Location and Quantity of Addressable Storage Elements in Model L32 without Capacity Expansion Feature

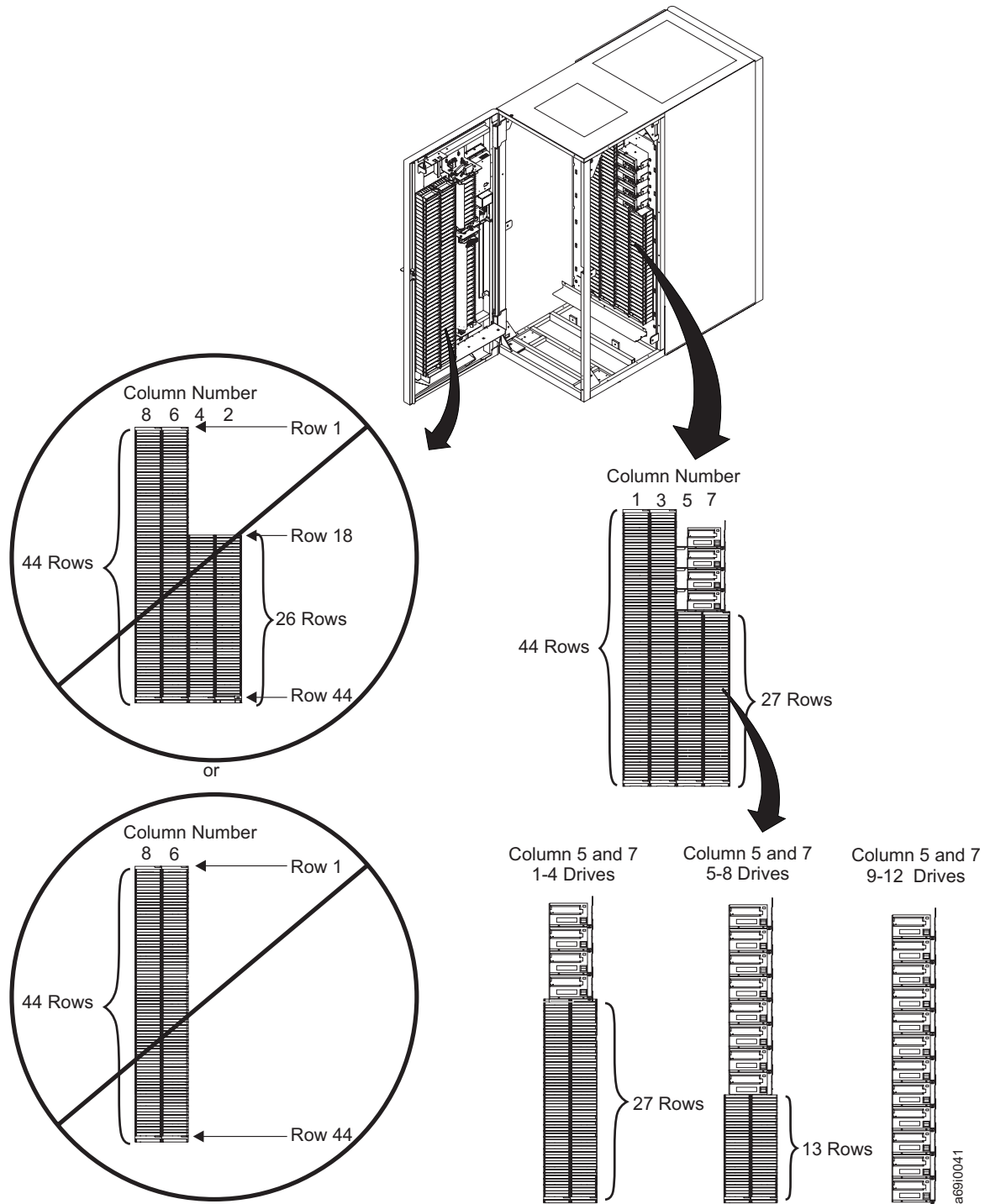

Figure 79. Location of storage elements in Model L32 without the capacity expansion feature. The storage slots on the door are unavailable.

Table 42. Quantity of SCSI-addressable storage slots (per column) in Model L32 frame without capacity expansion feature

Column Number	Quantity of Storage Slots in Model L32 Frame without Capacity Expansion Feature		
	1-4 Drives	5-8 Drives	9-12 Drives
1 (see Note)	43	43	43
2	0	0	0
3	44	44	44
4	0	0	0
5	27	13	0
6	0	0	0
7	27	13	0
8	0	0	0
Total	141	113	87
Note: Column 1, Row 1 of the Model L32 is reserved for a diagnostic cartridge.			

Location and Quantity of Addressable Storage Elements in Model L32 with Capacity Expansion Feature

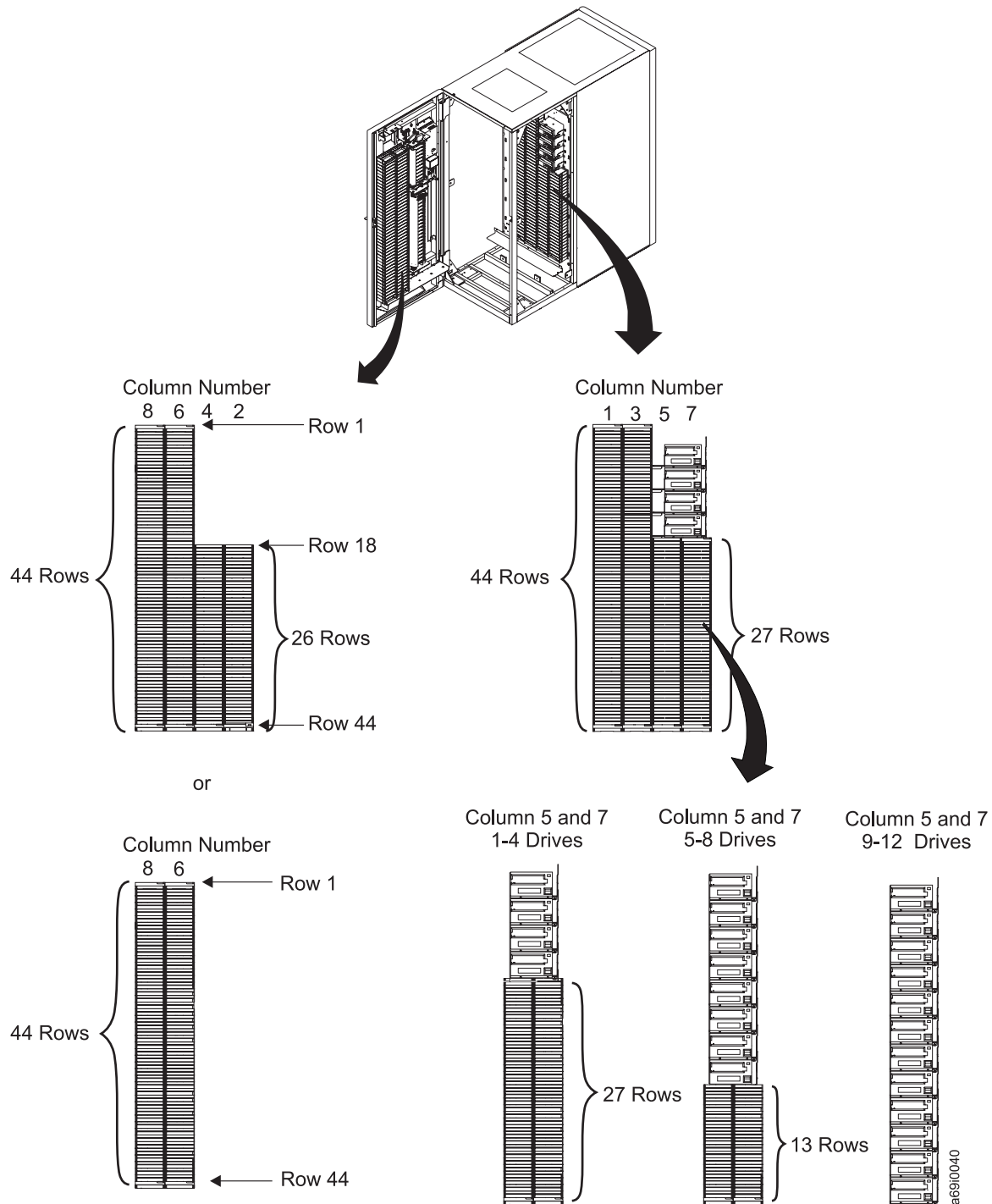

Figure 80. Location of storage elements in Model L32 with the capacity expansion feature. The storage slots on the door are available.

Table 43. Quantity of SCSI-addressable storage slots (per column) in Model L32 frame with capacity expansion feature and 10 I/O slots

Column Number	Quantity of Storage Slots in Model L32 Frame with Capacity Expansion Feature and 10 I/O Slots		
	0-4 Drives	5-8 Drives	9-12 Drives
1 (see Note)	43	43	43
2	26	26	26
3	44	44	44
4	26	26	26
5	27	13	0
6	44	44	44
7	27	13	0
8	44	44	44
Total	281	253	227

Note: Column 1, Row 1 of the Model L32 is reserved for a diagnostic cartridge.

Table 44. Quantity of SCSI-addressable storage slots (per column) in Model L32 frame with capacity expansion feature and 26 or 30 I/O slots

Column Number	Quantity of Storage Slots in Model L32 Frame with Capacity Expansion Feature and 26 or 30 I/O Slots		
	0-4 Drives	5-8 Drives	9-12 Drives
1 (see Note)	43	43	43
2	0	0	0
3	44	44	44
4	0	0	0
5	27	13	0
6	44	44	44
7	27	13	0
8	44	44	44
Total	229	201	175

Note: Column 1, Row 1 of the Model L32 is reserved for a diagnostic cartridge.

Location and Quantity of Addressable Storage Elements in Model D32

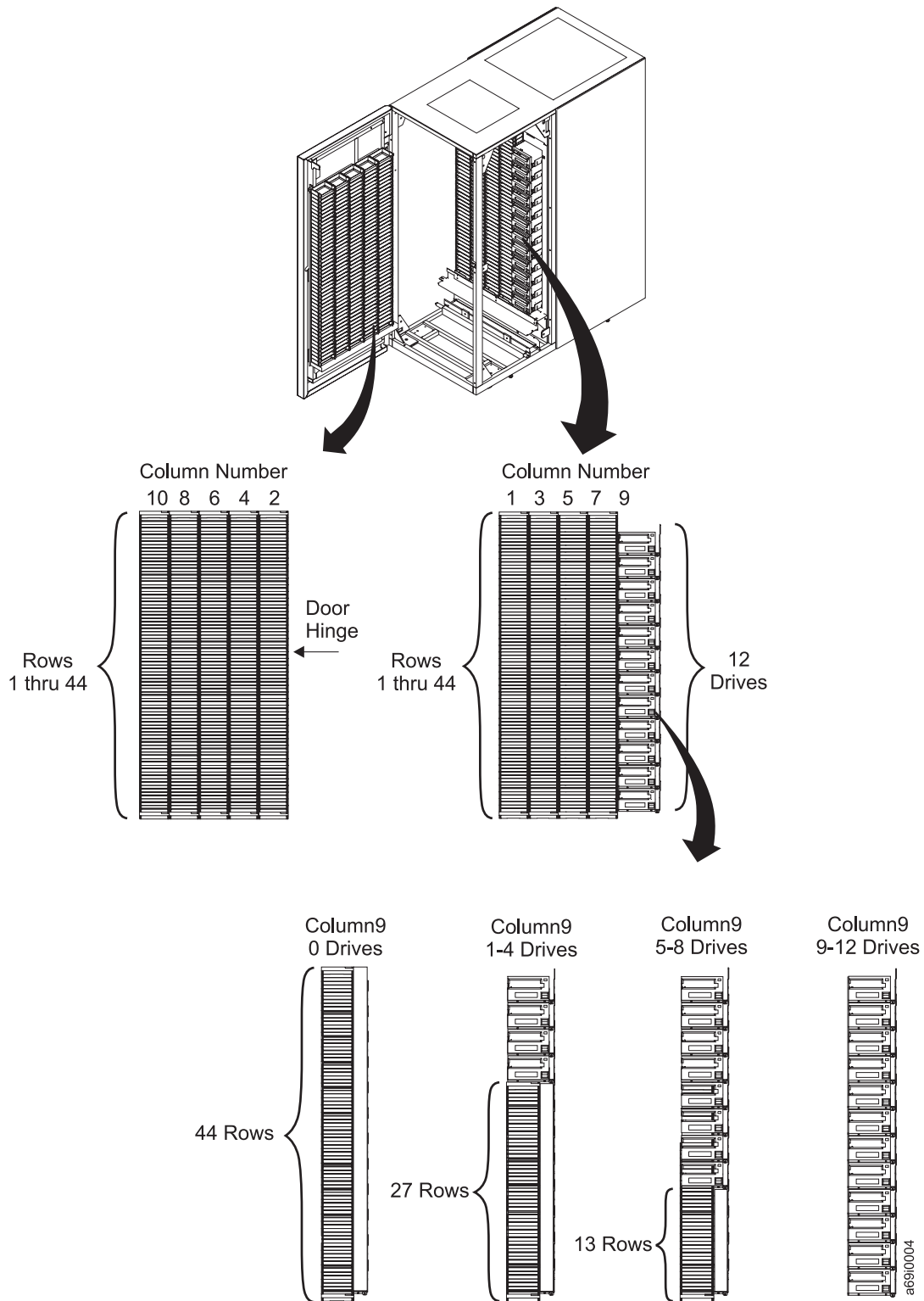

Figure 81. Location of storage elements in Model D32

Table 45. Quantity of SCSI-addressable storage slots (per column) in Model D32 frame

Column Number	Quantity of Storage Slots per Drives in Model D32 Frame			
	0 Drives	1-4 Drives	5-8 Drives	9-12 Drives
1	44	44	44	44
2	44	44	44	44
3	44	44	44	44
4	44	44	44	44
5	44	44	44	44
6	44	44	44	44
7	44	44	44	44
8	44	44	44	44
9	44	27	13	0
10	44	44	44	44
Total	440	423	409	396

Location and Quantity of Addressable Storage Elements in Models L52 and L53

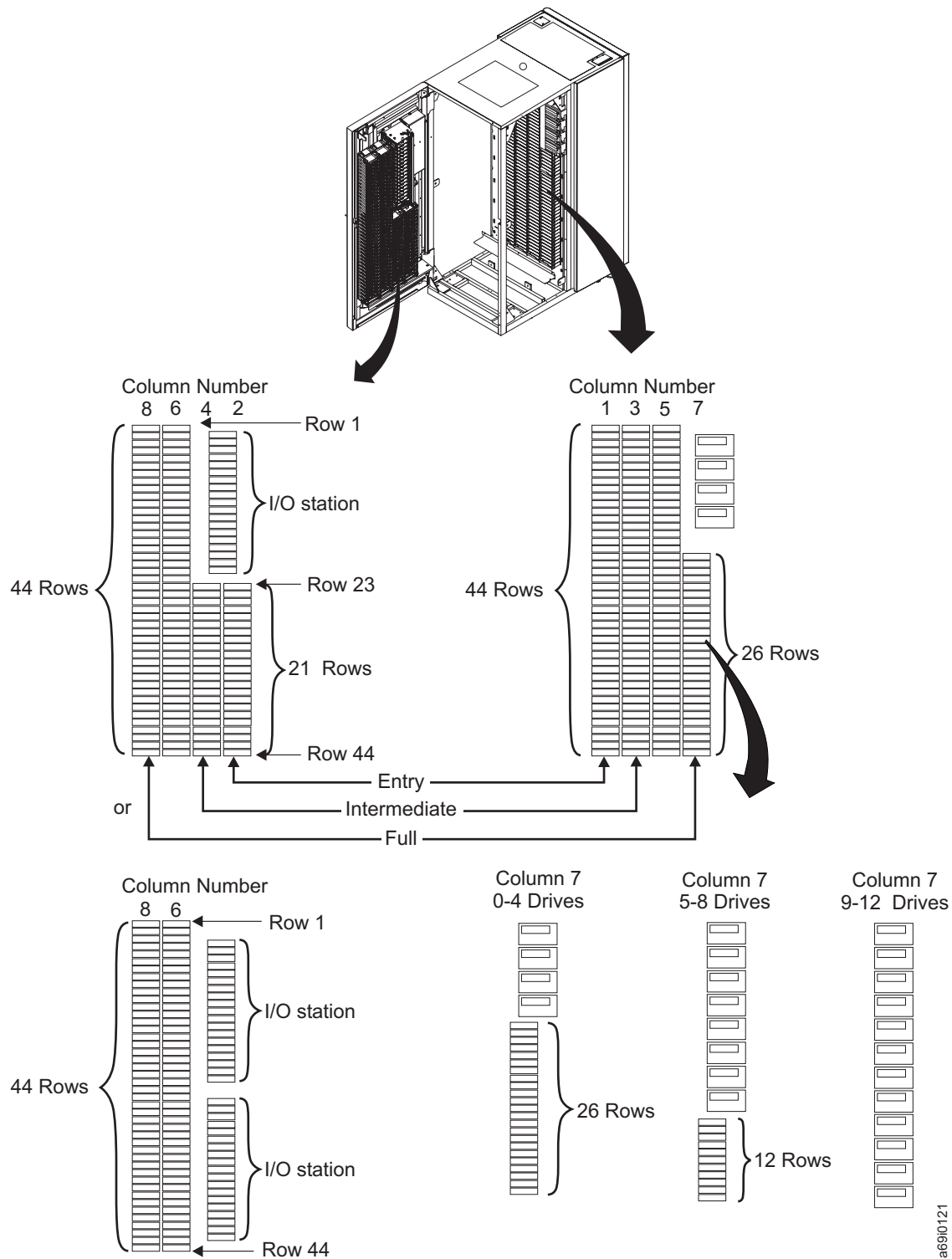

Figure 82. Location of storage elements in Models L52 or L53 with 16 or 32 I/O slots

Table 46. Quantity of SCSI-addressable storage slots (per column) in Models L52 or L53 frame with 16 or 32 I/O slots

Column Number	Capacity Configuration ¹	Quantity of Storage Slots in Model L52 or L53 Frame with Capacity Expansion Feature and 16 or 32 I/O Slots		
		0-4 Drives	5-8 Drives	9-12 Drives
1 ²	E, I, F	43	43	43
2	E, I, F	21	21	21
3	I, F	44	44	44
4	I, F	21	21	21
5	F	44	44	44
6	F	44	44	44
7	F	26	12	0
8	F	44	44	44
Total		287	273	261

Notes:

1. Abbreviations for capacity configurations are:

- E Entry
- I Intermediate
- F Full

2. Column 1, Row 1 of the Model L52 and L53 is reserved for a diagnostic cartridge.

Location and Quantity of Addressable Storage Elements in Models D52 and D53

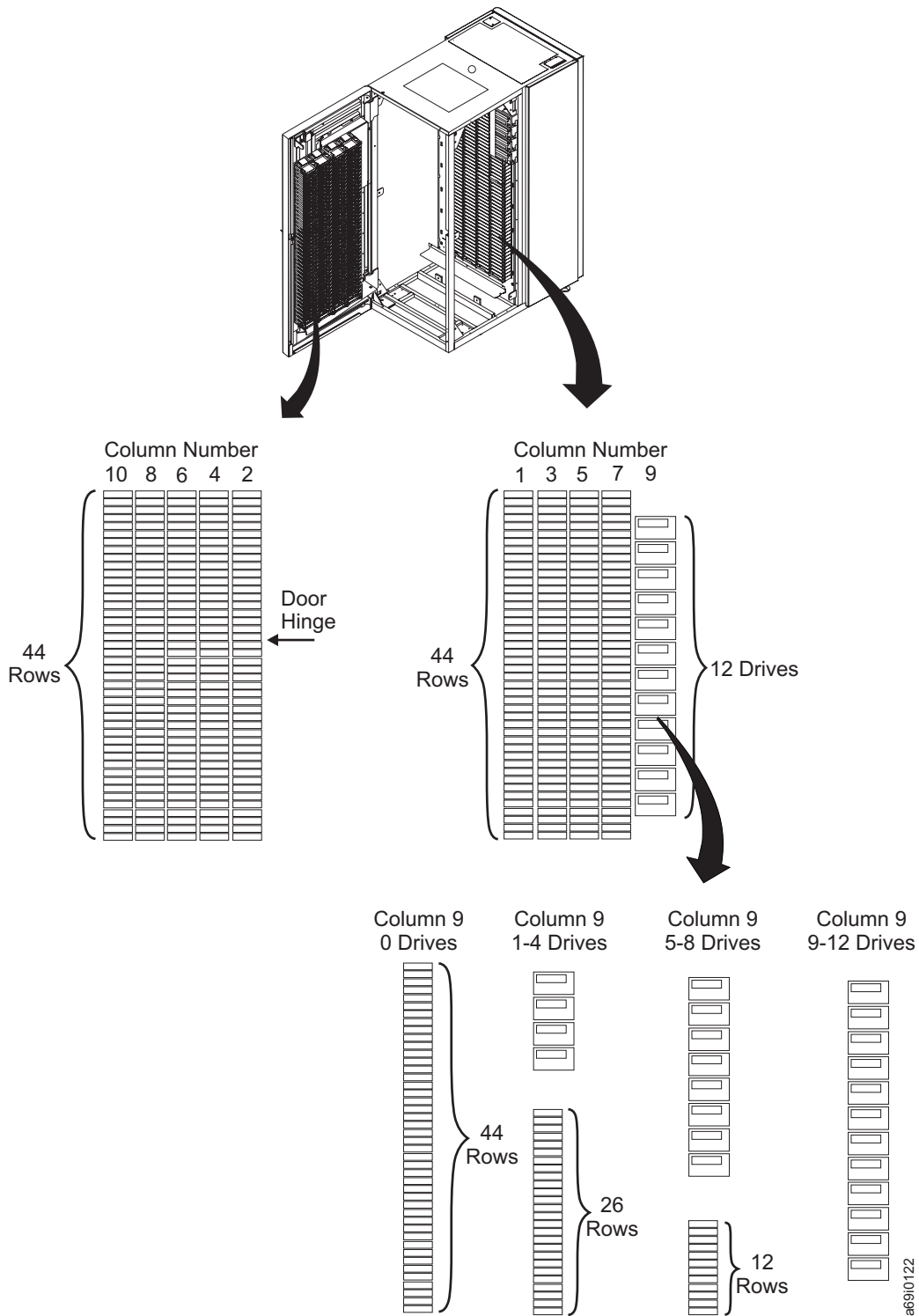

Figure 83. Location of storage elements in Models D52 or D53 with 16 or 32 I/O slots

Table 47. Quantity of SCSI-addressable storage slots (per column) in Model D52 or D53 frame

Column Number	Quantity of Storage Slots per Drives in Model D52 or D53 Frame			
	0 Drives	1-4 Drives	5-8 Drives	9-12 Drives
1 (see Note)	44	44	44	44
2	44	44	44	44
3	44	44	44	44
4	44	44	44	44
5	44	44	44	44
6	44	44	44	44
7	44	44	44	44
8	44	44	44	44
9	44	26	12	0
10	44	44	44	44
Total	440	422	408	396

Note: For the first Model D52 or D53 frame in a library based on Model L22 or L23, Column 1, Row 1 is reserved for a diagnostic cartridge. In this case, the quantity of slots in Column 1 (and the total) is reduced by one.

Determining SCSI Element Addresses with ALMS Disabled

This section introduces the rules to follow when the Advanced Library Management System (ALMS) is disabled and when you want to determine the SCSI element addresses of storage elements (storage slots), import/export elements (I/O slots), and data transfer elements (drives) in the 3584 Tape Library.

Storage Element Addresses with ALMS Disabled

The 3584 Tape Library assigns storage element (StE) addresses sequentially to all storage slots in each frame, regardless of media type. When the Advanced Library Management System (ALMS) is disabled, it uses the following scheme for addressing:

1. Begin with the Model L22, L32, or L52 frame and assign the addresses from top to bottom, starting at Column 1, Row 1 with address 1024 (X'400').

Note: Column 1, Row 1 of the first LTO Ultrium and 3592 frame is reserved for a diagnostic cartridge and is not addressable by the host application.

2. Move to Column 2 and continue the sequence from top to bottom, ignoring the I/O stations.
3. Continue to assign addresses in this manner (ignoring the I/O stations and drives) until each storage slot in the frame has been assigned a SCSI StE address.
4. If the library contains more than one frame, move right to the next frame and repeat this step (continuing with the next number in the sequence).

Figure 84 on page 362 shows one example of how the library assigns the SCSI

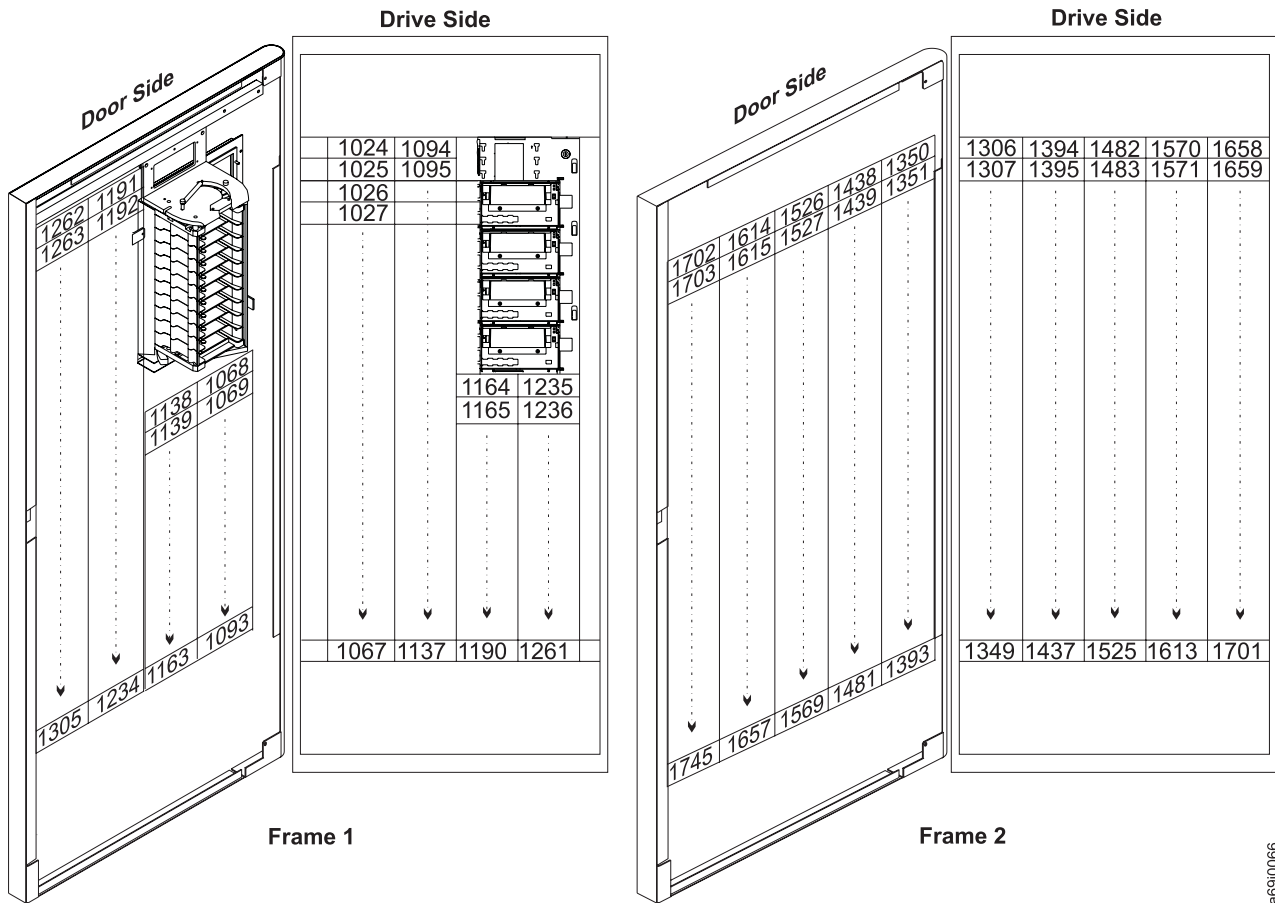

Figure 84. Assigning SCSI StE addresses to storage slots. The example shows a Model L32 and D32 frame, each with their front doors open. When assigning StE addresses, the library ignores the I/O stations and drives, and assigns the addresses to the slots beneath them.

storage element addresses.

Note: When ALMS is enabled, all element addresses in Figure 84 are not used.

Import/Export Element Addresses with ALMS Disabled

When the Advanced Library Management System (ALMS) is disabled, the 3584 Tape Library assigns import/export element (IEE) addresses sequentially to all I/O slots, from top to bottom, and regardless of media type, beginning at I/O slot 1 of the Model L22, L32, or L52, with address 769 (X'301').

Data Transfer Element Addresses with ALMS Disabled

When the Advanced Library Management System (ALMS) is disabled, the 3584 Tape Library assigns data transfer element (DTE) addresses sequentially to all 12 possible drive positions in each frame, regardless of media type. It uses the following scheme for addressing:

1. Begin with the Model L22, L32, or L52 frame and assign the addresses from top to bottom.
2. If the library contains more than one frame, move right to the next frame and continue the sequence from top to bottom.
3. Continue to assign addresses in this manner until each drive in every frame has been assigned a SCSI DTE address

Table 48 lists the SCSI addresses for the DTEs.

Table 48. Range of SCSI Data Transfer Element (DTE) addresses for tape drives in frames 1 through 16

Frame	Range of SCSI DTE Addresses for Tape Drives	
	Row 1	Row 12
1	257(X'101')	268(X'10C')
2	269(X'10D')	280(X'118')
3	281(X'119')	292(X'124')
4	293(X'125')	304(X'130')
5	305(X'131')	316(X'13C')
6	317(X'13D')	328(X'148')
7	329(X'149')	340(X'154')
8	341(X'155')	352(X'160')
9	353(X'161')	364(X'16C')
10	365(X'16D')	376(X'178')
11	377(X'179')	388(X'184')
12	389(X'185')	400(X'190')
13	401(X'191')	412(X'19C')
14	413(X'19D')	424(X'1A8')
15	425(X'1A9')	436(X'1B4')
16	437(X'1B5')	448(X'1C0')

Note: Addresses are given in decimal and hexadecimal format.

Determining SCSI Element Addresses with ALMS Enabled

This section introduces the rules to follow when the Advanced Library Management System (ALMS) is enabled and when you want to determine the SCSI element addresses of storage elements (storage slots), import/export elements (I/O slots), and data transfer elements (drives) in the 3584 Tape Library.

Storage Element Addresses with ALMS Enabled

With the Advanced Library Management System (ALMS) enabled in the 3584 Tape Library, each Storage Element Address is no longer associated with a specific storage slot. Instead, storage slots are virtualized by dynamically associating element addresses to them, as required. An element address is associated with a storage slot that is selected by the library as cartridges are moved and inventoried. In the case of a storage element that is empty due to a move, that source element address will be unassociated. Association of storage element addresses is accomplished in a way that is completely transparent to the application software.

With ALMS enabled, the first Storage Element Address of any logical library is equal to 1024 plus the logical library number. For example, logical library 3 will have a starting Storage Element Address of 1027 (X'403').

You can select the number of Storage Element Addresses for a logical library (as reported to the host application software by the SCSI Mode Page X'1D') by changing the Maximum Number of Cartridges setting for that logical library through the web user interface. For each logical library, the default value for Maximum Number of Cartridges is the number of addressable storage slots that are installed in the library for that cartridge type at the time that ALMS is first enabled or, after ALMS is enabled, at the time that the logical library is created. You can change the Maximum Number of Cartridges setting for each logical library, but the value must always be greater than or equal to the number of actual cartridges that are currently assigned to that logical library. It is possible to set Maximum Number of Cartridges to a value that is higher than the number of addressable storage slots that are installed at the time in order to allow future library capacity expansion to be transparent to the host application software. However, application performance may degrade slightly due to the greater number of addresses. Take care not to exceed the license limitations of the host application software.

Import/Export Element Addresses with ALMS Enabled and Virtual I/O Slots Disabled

When the Advanced Library Management System (ALMS) is enabled on the 3584 Tape Library, the rules for determining Import/Export Element Addresses are the same as when ALMS is disabled. For more information, go to the section about import/export elements with ALMS disabled.

Related concepts

“Import/Export Element Addresses with ALMS Disabled” on page 362

Import/Export Element Addresses with ALMS Enabled and Virtual I/O Slots Enabled

With the Advanced Library Management System (ALMS) and Virtual I/O Slots (VIOS) enabled on the 3584 Tape Library, each Import/Export Element (IEE) address is no longer associated with a specific physical I/O station slot. Instead,

I/O slots are virtualized by dynamically associating element addresses to them as required. Association of IEE addresses is accomplished in a way that is completely transparent to the application software.

By using the IBM System Storage Tape Library Specialist web interface, you can select the number of IEE addresses for a logical library (as reported to the host application software by the SCSI Mode Page X'1D') by changing the Max VIO Slots setting for that logical library up to a value of 255. For each logical library, the default value for the quantity of that logical library's IEE addresses is the quantity of physical I/O slots for that media type at the time that ALMS and VIOS are first enabled. Or, after ALMS and VIOS are enabled, the default will be 255 slots for any newly created logical library.

When you use Virtual Import/Export Element Addressing, the Import/Export Element Address range includes addresses from 769 (X'301') to 1023 (X'3FF'), allowing for a maximum of 255 IEE addresses for each logical library.

Each logical library has a unique Virtual IEE address space that is not accessible by other logical libraries. In previous firmware releases, the IEE space was made up of physical I/O station slots that were shared by all logical libraries. If a cartridge was moved to and remained in the I/O station, all logical libraries had one less IEE address with which to process imports and exports. Virtual IEEs, however, allow each logical library to use all 255 elements without impacting other logical libraries. For example two logical libraries might both have 255 cartridges in Virtual IEEs 769 through 1023, but the cartridges are actually located in different physical storage slots. Thus, competition for IEE space between logical libraries is eliminated and the effective quantity of IEEs is enhanced without physical modifications to the library. The automatic queuing of a cartridge's moves between the I/O station and the virtual storage slots makes it appear to the host application that the library contains more physical I/O slots than actually exists. Thus, instead of sharing a maximum of 32 I/O slot addresses in Frame 1, each logical library can have up to 255 I/O slot addresses that are not shared. For information about configuring virtual I/O slots, see "Configuring the Library without Partitions" on page 119 or "Configuring the Library with Partitions" on page 123.

Related concepts

"Configuring the Library without Partitions" on page 119

This section introduces two ways to configure the 3584 Tape Library without partitions.

"Configuring the Library with Partitions" on page 123

This section introduces ways to configure the 3584 Tape Library with partitions.

Related tasks

"Enabling or Disabling Virtual I/O Slots" on page 137

This section describes how to enable virtual I/O slots in the 3584 Tape Library so that the host operates as if it has access to more I/O slots than are actually available. It also describes how to disable virtual I/O slots.

Data Transfer Element Addresses with ALMS Enabled

When the Advanced Library Management System (ALMS) is enabled for the first time in the 3584 Tape Library, the Data Transfer Element (DTE) addresses of all installed or assigned drives are not changed from how they were set with ALMS disabled. However, after ALMS has been enabled, the DTE addresses for any newly installed or assigned drives are no longer dependent on drive position. Instead, the DTE address for any newly installed or assigned drive is determined by the sequence in which the drive is assigned to each logical library.

After ALMS is enabled, drives are assigned to logical libraries by using the Drive Assignment page of the IBM System Storage Tape Library Specialist web interface. In the web interface, the DTE address for the first drive that is assigned to a new logical library is 257 (X'101'). The DTE address for any other drive that is assigned to the logical library is based on the next available DTE address in that particular logical library. The next available DTE address is the lowest available DTE address after the starting DTE address (this fills any gaps that are created when the assignments for drives are removed or the drives themselves are removed that might exist between previously assigned DTE addresses for that logical library). When a drive assignment is removed from a logical library through the web interface, only that DTE address is made available for future assignment; no other DTE addresses are affected.

The Drive Assignment page also supports the option to share a drive between two or more logical libraries. The drive will be assigned a DTE address in more than one logical library. Note that the DTE addresses that are assigned to a shared drive may differ by logical library.

By using the dynamic Drive Assignment capability of ALMS, any drive in any position within any frame is available to be assigned to any logical library without creating gaps in DTE addresses.

Appendix A. Statement of Limited Warranty

The warranties provided by IBM in this Statement of Limited Warranty apply only to Machines you purchase for your use, and not for resale, from IBM or your reseller. The term "Machine" means an IBM machine, its features, conversions, upgrades, elements, or accessories, or any combination of them. The term "Machine" does not include any software programs, whether pre-loaded with the Machine, installed subsequently or otherwise. Unless IBM specifies otherwise, the following warranties apply only in the country or region where you acquire the Machine. Nothing in this Statement of Warranty affects any statutory rights of consumers that cannot be waived or limited by contract. If you have any questions, contact IBM or your reseller.

Machine: IBM System Storage TS3500 Tape Library, IBM System Storage 3588 Tape Drive Model F3A, and IBM System Storage TS1030 Tape Drive Model F3B

Warranty Period*: 1 year

**Contact your place of purchase for warranty service information. Some IBM Machines are eligible for On-site warranty service, depending on the country or region where service is performed.*

IBM warrants that each Machine 1) is free from defects in materials and workmanship and 2) conforms to IBM's Official Published Specifications ("Specifications"). The warranty period for a Machine is a specified, fixed period commencing on its Date of Installation. The date on your sales receipt is the Date of Installation, unless IBM or your reseller informs you otherwise.

During the warranty period IBM or your reseller, if approved by IBM to provide warranty service, will provide repair and exchange service for the Machine, without charge, under the type of service designated for the Machine and will manage and install engineering changes that apply to the Machine.

If a Machine does not function as warranted during the warranty period, and IBM or your reseller is unable to either 1) make it do so or 2) replace it with one that is at least functionally equivalent, you may return it to your place of purchase and your money will be refunded. The replacement may not be new, but will be in good working order.

Extent of Warranty

The warranty does not cover the repair or exchange of a Machine resulting from misuse, accident, modification, unsuitable physical or operating environment, improper maintenance by you, or failure caused by a product for which IBM is not responsible. The warranty is voided by removal or alteration by Machine or parts identification labels.

THESE WARRANTIES ARE YOUR EXCLUSIVE WARRANTIES AND REPLACE ALL OTHER WARRANTIES OR CONDITIONS, EXPRESS OR IMPLIED, INCLUDING, BUT NOT LIMITED TO, THE IMPLIED WARRANTIES OR CONDITIONS OF MERCHANTABILITY AND FITNESS FOR A PARTICULAR PURPOSE. THESE WARRANTIES GIVE YOU SPECIFIC LEGAL RIGHTS AND YOU MAY ALSO HAVE OTHER RIGHTS WHICH VARY FROM JURISDICTION TO JURISDICTION. SOME JURISDICTIONS DO NOT ALLOW THE EXCLUSION OR LIMITATION OF EXPRESS OR IMPLIED

WARRANTIES, SO THE ABOVE EXCLUSION OR LIMITATION MAY NOT APPLY TO YOU. IN THAT EVENT, SUCH WARRANTIES ARE LIMITED IN DURATION TO THE WARRANTY PERIOD. NO WARRANTIES APPLY AFTER THAT PERIOD.

Items Not Covered by Warranty

IBM does not warrant uninterrupted or error-free operation of a Machine.

Unless specified otherwise, IBM provides non-IBM machines **WITHOUT WARRANTIES OF ANY KIND.**

Any technical or other support provided for a Machine under warranty, such as assistance via telephone with "how-to" questions and those regarding Machine setup and installation, will be provided **WITHOUT WARRANTIES OF ANY KIND.**

To obtain warranty service for the Machine, contact your reseller or IBM. In the United States, call IBM at **1-800-IBM-SERV (426-7378)**. In Canada, call IBM at **1-800-465-6666**. You may be required to present proof of purchase.

IBM or your reseller provides certain types of repair and exchange service, either at your location or at a service center, to keep Machines in, or restore them to, conformance with their Specifications. IBM or your reseller will inform you of the available types of service for a Machine based on its country or region of installation. IBM may repair the failing Machine or exchange it at its discretion.

When warranty service involves the exchange of a Machine or part, the item IBM or your reseller replaces becomes its property and the replacement becomes yours. You represent that all removed items are genuine and unaltered. The replacement may not be new, but will be in good working order and at least functionally equivalent to the item replaced. The replacement assumes the warranty service status of the replaced item.

Any feature, conversion, or upgrade IBM or your reseller services must be installed on a Machine which is 1) for certain Machines, the designated, serial-numbered Machine and 2) at an engineering-change level compatible with the feature, conversion, or upgrade. Many features, conversions, or upgrades involve the removal of parts and their return to IBM. A part that replaces a removed part will assume the warranty service status of the removed part.

Before IBM or your reseller exchanges a Machine or part, you agree to remove all features, parts, options, alterations, and attachments not under warranty service.

You also agree to:

1. ensure that the Machine is free of any legal obligations or restrictions that prevent its exchange;
2. obtain authorization from the owner to have IBM or your reseller service a Machine that you do not own; and
3. where applicable, before service is provided
 - a. follow the problem determination, problem analysis, and service request procedures that IBM or your reseller provides,
 - b. secure all programs, data, and funds contained in a Machine,

- c. provide IBM or your reseller with sufficient, free, and safe access to your facilities to permit them to fulfill their obligations, and
- d. inform IBM or your reseller of changes in a Machine's location.

IBM is responsible for loss of, or damage to, your Machine while it is 1) in IBM's possession or 2) in transit in those cases where IBM is responsible for the transportation charges.

Neither IBM nor your reseller is responsible for any of your confidential, proprietary, or personal information contained in a Machine which you returned to IBM or your reseller for any reason. You should remove all such information from the Machine prior to its return.

Production Status

Each IBM Machine is manufactured from new parts, or new and used parts. In some cases, the Machine may not be new and may have been previously installed. Regardless of the Machine's production status, IBM's appropriate warranty terms apply.

Limitation of Liability

Circumstances may arise where, because of a default on IBM's part or other liability, you are entitled to recover damages from IBM. In each such instance, regardless of the basis on which you were entitled to claim damages from IBM (including fundamental breach, negligence, misrepresentation, or other contract or tort claim), IBM is liable for no more than

1. damages for bodily injury (including death) and damage to real property and tangible personal property; and
2. the amount of any other actual direct damages, up to the greater of US \$100,000 (or equivalent in local currency) or the charges (if recurring, 12 months' charges apply) for the Machine that is the subject of the claim.

This limit also applies to IBM's supplier and your reseller. It is the maximum for which IBM, its suppliers, and your reseller are collectively responsible.

UNDER NO CIRCUMSTANCES IS IBM LIABLE FOR ANY OF THE FOLLOWING: 1) THIRD-PARTY CLAIMS AGAINST YOU FOR DAMAGES (OTHER THAN THOSE UNDER THE FIRST ITEM LISTED ABOVE); 2) LOSS OF, OR DAMAGE TO, YOUR RECORDS OR DATA; OR 3) SPECIAL, INCIDENTAL, OR INDIRECT DAMAGES OR FOR ANY ECONOMIC CONSEQUENTIAL DAMAGES (INCLUDING LOST PROFITS OR SAVINGS), EVEN IF IBM, ITS SUPPLIERS, OR YOUR RESELLER IS INFORMED OF THEIR POSSIBILITY. SOME JURISDICTIONS DO NOT ALLOW THE EXCLUSION OR LIMITATION OF INCIDENTAL OR CONSEQUENTIAL DAMAGES, SO THE ABOVE LIMITATION OR EXCLUSION MAY NOT APPLY TO YOU.

Appendix B. Notices

This information was developed for products and services offered in the U.S.A.

IBM may not offer the products, services, or features discussed in this document in other countries or regions. Consult your local IBM representative for information on the products and services currently available in your area. Any reference to an IBM product, program, or service is not intended to state or imply that only that IBM product, program, or service may be used. Any functionally equivalent product, program, or service that does not infringe any IBM intellectual property right may be used instead. However, it is the user's responsibility to evaluate and verify the operation of any non-IBM product, program, or service.

IBM may have patents or pending patent applications covering subject matter described in this document. The furnishing of this document does not give you any license to these patents. You can send license inquiries, in writing, to:

Director
Intellectual Property and Licensing
IBM Corporation
North Castle Drive
Armonk, NY 10504
U.S.A.

For additional information, visit the web at:

<http://www.ibm.com/ibm/licensing/contact/>

The following paragraph does not apply to the United Kingdom or any other country or region where such provisions are inconsistent with local law:

INTERNATIONAL BUSINESS MACHINES CORPORATION PROVIDES THIS PUBLICATION "AS IS" WITHOUT WARRANTY OF ANY KIND, EITHER EXPRESS OR IMPLIED, INCLUDING, BUT NOT LIMITED TO, THE IMPLIED WARRANTIES OF NON-INFRINGEMENT, MERCHANTABILITY OR FITNESS FOR A PARTICULAR PURPOSE. Some states or regions do not allow disclaimer of express or implied warranties in certain transactions; therefore, this statement may not apply to you.

This information could include technical inaccuracies or typographical errors. Changes are periodically made to the information herein; these changes will be incorporated in new editions of the publication. IBM may make improvements and/or changes in the product(s) and/or the program(s) described in this publication at any time without notice.

Any references in this information to non-IBM web sites are provided for convenience only and do not in any manner serve as an endorsement of those web sites. The materials at those web sites are not part of the materials for this IBM product and use of those web sites is at your own risk.

IBM may use or distribute any of the information you supply in any way it believes appropriate without incurring any obligation to you.

Any performance data contained herein was determined in a controlled environment. Therefore, the results obtained in other operating environments may vary significantly. Some measurements may have been made on development-level systems and there is no guarantee that these measurements will be the same on generally available systems. Furthermore, some measurement may have been estimated through extrapolation. Actual results may vary. Users of this document should verify the applicable data for their specific environment.

Information concerning non-IBM products was obtained from the suppliers of those products, their published announcements, or other publicly available sources. IBM has not tested those products and cannot confirm the accuracy of performance, compatibility, or any other claims related to non-IBM products. Questions on the capabilities of non-IBM products should be addressed to the suppliers of those products.

All statements regarding IBM's future direction or intent are subject to change or withdrawal without notice, and represent goals and objectives only.

All IBM prices shown are IBM's suggested retail prices, are current, and are subject to change without notice. Dealer prices may vary.

This information is for planning purposes only. The information herein is subject to change before the products described become available.

This information contains examples of data and reports used in daily business operations. To illustrate them as completely as possible, the examples include the names of individuals, companies, brands, and products. All of these names are fictitious and any similarity to the names and addresses used by an actual business enterprise is entirely coincidental.

If you are viewing this information in softcopy, the photographs and color illustrations may not appear.

Regulatory Approvals

This product was certified to the following product safety standards at the time of release:

- IEC60950
- EN60950
- IEC60825
- EN60825
- CSA-950
- UL-1950
- IBM Internal Safety Standards

Trademarks

The following terms are trademarks of International Business Machines Corporation in the United States or other countries (or regions) or both:

- 400
- AIX®
- AS/400
- CT
- ESCON
- eServer
- FICON
- IBM
- iSeries
- NetView®
- OpenPower
- OS/400®
- POWER
- pSeries
- RETAIN®
- RS/6000
- System i5
- System p5
- System Storage
- System z™
- Tivoli®
- TotalStorage
- z9
- zSeries

The following are U. S. trademarks of Hewlett-Packard Company, International Business Machines Corporation, and Certance:

- Linear Tape-Open
- LTO
- Ultrium Tape Drive

Java™ and all Java-based trademarks are trademarks of Sun Microsystems, Inc. in the United States, other countries (or regions), or both.

Intel®, Intel logo, Intel Inside®, Intel Inside logo, Intel Centrino™, Intel Centrino logo, Celeron®, Intel Xeon™, Intel SpeedStep®, Itanium®, and Pentium® are trademarks or registered trademarks of Intel Corporation or its subsidiaries in the United States and other countries (or regions).

Microsoft®, Windows®, Windows NT®, and the Windows logo are trademarks of Microsoft Corporation in the United States, other countries (or regions), or both.

Linux® is a trademark of Linus Torvalds in the United States, other countries (or regions), or both.

UNIX® is a registered trademark of The Open Group in the United States and other countries (or regions).

Other company, product, and service names may be trademarks or service marks of others.

Electronic Emission Notices

The following statement applies to this IBM product. The statement for other IBM products intended for use with this product will appear in their accompanying manuals.

IBM System Storage TS3500 Tape Library

Federal Communications Commission (FCC) Class A Statement

Note: This equipment has been tested and found to comply with the limits for a Class A digital device, pursuant to Part 15 of the FCC Rules. These limits are designed to provide reasonable protection against harmful interference when the equipment is operated in a commercial environment. This equipment generates, uses, and can radiate radio frequency energy and, if not installed and used in accordance with the instruction manual, may cause harmful interference to radio communications. Operation of this equipment in a residential area is likely to cause harmful interference, in which case the user will be required to correct the interference at his own expense.

IBM is not responsible for any radio or television interference caused by unauthorized changes or modifications to this equipment. Unauthorized changes or modifications could void the user's authority to operate the equipment.

This device complies with Part 15 of the FCC Rules. Operation is subject to the following two conditions: (1) this device may not cause harmful interference, and (2) this device must accept any interference received, including interference that may cause undesired operation.

Avis de conformité à la réglementation d'Industrie Canada

Cet appareil numérique de la classe A est conforme à la norme NMB-003 du Canada.

European Union (EU) Electromagnetic Compatibility Directive

This product is in conformity with the protection requirements of EU Council Directive 89/336/EEC on the approximation of the laws of the Member States relating to electromagnetic compatibility. IBM cannot accept responsibility for any failure to satisfy the protection requirements resulting from a non-recommended modification of the product, including the fitting of non-IBM option cards.

This product has been tested and found to comply with the limits for Class A Information Technology Equipment according to European Standard EN 55022. The limits for Class A equipment were derived for commercial and industrial environments to provide reasonable protection against interference with licensed communication equipment.

Attention: This is a Class A product. In a domestic environment this product may cause radio interference in which case the user may be required to take adequate measures.

Properly shielded and grounded cables and connectors must be used in order to reduce the potential for causing interference to radio and TV communications and to other electrical or electronic equipment. Such cables and connectors are available

from IBM authorized dealers. IBM cannot accept responsibility for any interference caused by using other than recommended cables and connectors.

Germany Electromagnetic Compatibility Directive

Zulassungsbescheinigung laut dem Deutschen Gesetz über die elektromagnetische Verträglichkeit von Geräten (EMVG) vom 18. September 1998 (bzw. der EMC EG Richtlinie 89/336)

Dieses Gerät ist berechtigt, in Übereinstimmung mit dem Deutschen EMVG das EG-Konformitätszeichen - CE - zu führen.

Verantwortlich für die Konformitätserklärung nach Paragraph 5 des EMVG ist die: IBM Deutschland Informationssysteme GmbH 70548 Stuttgart.

Informationen in Hinsicht EMVG Paragraph 4 Abs. (1) 4:

Das Gerät erfüllt die Schutzanforderungen nach EN 55024 und EN 55022 Klasse A.

EN 55022 Klasse A Geräte müssen mit folgendem Warnhinweis versehen werden: "Warnung: dies ist eine Einrichtung der Klasse A. Diese Einrichtung kann im Wohnbereich Funkstörungen verursachen; in diesem Fall kann vom Betreiber verlangt werden, angemessene Maßnahmen durchzuführen und dafür aufzukommen."

Anmerkung: Um die Einhaltung des EMVG sicherzustellen, sind die Geräte wie in den IBM Handbüchern angegeben zu installieren und zu betreiben.

Japan VCCI Class A ITE Electronic Emission Statement

この装置は、情報処理装置等電波障害自主規制協議会（VCCI）の基準に基づくクラスA情報技術装置です。この装置を家庭環境で使用すると電波妨害を引き起こすことがあります。この場合には使用者が適切な対策を講ずるよう要求されることがあります。

vcci

People's Republic of China Class A Electronic Emission Statement

中华人民共和国“A类”警告声明

声明

此为A级产品，在生活环境中，该产品可能会造成无线电干扰。在这种情况下，可能需要用户对其干扰采取切实可行的措施。

Taiwan Class A Electronic Emission Statement

警告使用者：
這是甲類的資訊產品，在
居住的環境中使用時，可
能會造成射頻干擾，在這
種情況下，使用者會被要
求採取某些適當的對策。^{taitem}

Korea Class A Electronic Emission Statement

이기는 업무용으로 전자파 적합등록을 받은 기기
이오니, 판매자 또는 사용자는 이점을 주의하시기
바라며, 만약 잘못 구입하셨을 때에는 구입한 곳에
서 비업무용으로 교환하시기 바랍니다.

Taiwan Contact Information

IBM Taiwan Product Service Contact Info:
IBM Taiwan Corporation
3F, No 7, Song Ren Rd., Taipei Taiwan
Tel: 0800-016-888

台灣IBM 產品服務聯絡方式：
台灣國際商業機器股份有限公司
台北市松仁路7號3樓
電話：0800-016-888

Glossary

This glossary defines the special terms, abbreviations, and acronyms that are used in this publication.

Numbers

2:1 or 3:1 compression. The relationship between the quantity of data that can be stored with compression as compared to the quantity of data that can be stored without compression. In 2:1 compression, twice as much data can be stored with compression as can be stored without compression. In 3:1 compression, three times as much data can be stored with compression as can be stored without compression.

2N. Twice the amount of a system's electrical power load. If the system has 2N power supplies, then there are two power supplies available for every load, which means greater redundancy and availability of electrical power. The Enhanced Frame Control Assembly of the 3584 Tape Library offers a 2N power design with no single point of failure or single point of repair.

3588 Tape Drive. See *IBM System Storage 3588 Tape Drive Model F3A* or *IBM System Storage TS1030 Tape Drive Model F3B*. Also known as the *Ultrium 3 Tape Drive*.

3592 Tape Drive. See *IBM TotalStorage 3592 Tape Drive Model J1A* or *IBM System Storage TS1120 Tape Drive*.

A

AAP. See *authorized assembler program*.

accessor controller. The logic card for the cartridge accessor. The accessor controller handles accessor motion requests, including calibrations, moves, and inventory updates. It also provides centralized management for other aspects of the entire library, including configuration, insert and eject operations, automatic drive cleaning, and determination of element status.

Activity screen. The primary screen on the touchscreen of the 3584 Tape Library. The Activity screen gives the level of firmware in the library, shows whether the library is ready, not ready, or initializing, and tells the quantity of tape cartridges currently in the I/O stations. The screen also indicates the current activity being performed, the VOLSER of the cartridge associated with the activity, and a history of previous activities. The Activity screen leads to the Main Menu.

adapter. See *adapter card*.

adapter card. A circuit board that adds function to a computer.

addressable cartridge storage slots. Within the 3584 Tape Library, units that can contain tape cartridges and that are recognizable to the library by both a physical address (such as F01,C05,R19) and a SCSI element (logical) address (such as 1112(X'458'). Addressable cartridge storage slots do not include I/O station slots or the non-addressable slots that are reserved for the diagnostic cartridges. The quantity of addressable cartridge storage slots per frame varies, depending on the quantity of drives that are installed in the frame.

Advanced Interactive eXecutive (AIX). A UNIX operating system developed by IBM that is designed and optimized to run on POWER™ microprocessor-based hardware such as servers, workstations, and blades.

Advanced Library Management System (ALMS). An extension of IBM's patented Multi-Path Architecture. ALMS enables logical libraries to consist of unique drives and ranges of VOLSERS, instead of fixed locations. It offers the ability to assign tape drives to any logical library by using the Tape Library Specialist web interface. Logical libraries can also be added, deleted, or easily changed without disruption. ALMS is optional and requires a license key.

AIX. See *Advanced Interactive eXecutive*.

ALMS. See *Advanced Library Management System*.

AL_PA. See *Arbitrated Loop Physical Address*.

alphanumeric. Pertaining to a character set that contains letters, numerals, and usually other characters, such as punctuation marks.

Arbitrated Loop Physical Address (AL_PA). An 8-bit value used to identify a device in an arbitrated loop. Device ports communicate by using AL_PAs.

authorized assembler program (AAP). A training program for selected IBM Business Partners that enables them to purchase incomplete machines and parts, and provides them with the knowledge to assemble the components into a final configured product for sale to customers.

automatic cleaning. A method by which the 3584 Tape Library automatically responds to any tape drive's request for cleaning by beginning the cleaning process. An operator enables or disables automatic cleaning by using the menus on the library's touchscreen or the Tape Library Specialist web interface.

B

backhitch. When the speed of the host server is slower than that of the drive, the action of stopping the tape, rewinding some distance, and restarting.

bar code. A code that represents characters by sets of parallel bars of varying thickness and separation. The bars are read optically by transverse scanning.

bar code label. A slip of paper bearing a bar code and having an adhesive backing. The bar code label must be affixed to a tape cartridge to enable the library to identify the cartridge and its volume serial number.

bar code reader. Located on the dual-gripper transport mechanism of the 3584 Tape Library, a laser device specialized for scanning and reading bar codes and converting them into either the ASCII or EBCDIC digital character code. The bar code reader reads the bar code on the labels of cartridges or at the rear of empty storage slots.

base frame. The primary unit of the 3584 Tape Library (also known as Models L22, L23, L32, L52, or L53). The base frame is distinguished from an expansion frame by its I/O stations and operator panel. The base frame includes a rail assembly for the cartridge accessor, and up to 12 tape drives.

bit. Either of the digits 0 or 1 when used in the binary numbering system.

browser. A client program that initiates requests to a web server and displays the information that the server returns.

bulk load. To manually insert large quantities of tape cartridges into a tape library's empty storage slots.

bus. See *SCSI bus*.

byte. A string consisting of a certain number of bits (usually 8) that are treated as a unit and represent a character. A byte is a fundamental data unit.

C

calibration. Adjustment, tuning.

calibration sensor. Located on the cartridge accessor of the 3584 Tape Library, the component that provides the means to find certain positions within the library very precisely during the calibration operation.

Call Home. A feature that allows the 3584 Tape Library to report failures to a support center by using a modem.

CAN. See *Controller Area Network*.

capacity. The amount of data that can be contained on storage media and expressed in bytes of data.

Capacity Expansion Feature. Applicable only to the base frame (Models L22, L23, L32, L52, or L53) of the 3584 Tape Library, the cartridge storage slots that are located on the interior of the front door and enabled for additional storage. The Capacity Expansion Feature increases the maximum quantity of storage slots in the base frame.

Capacity On Demand. Applicable only to Models L22, L23, L52, and L53, a feature that adds capacity to the library and that is only available through the field.

cartridge. See *tape cartridge*.

cartridge accessor. The mechanism in the 3584 Tape Library that moves cartridges between the storage slots, tape drives, and the I/O stations. The accessor includes the X-axis motion assembly, Y-axis motion assembly, pivot assembly, cartridge gripper, bar code reader, and calibration sensor.

cartridge assignment policy. The method of assigning cartridges to a logical library by using ranges of cartridge labels. When an unassigned cartridge is present in the I/O station, it is automatically assigned to a logical library based on the cartridge label value. If the label does not fall into a policy (a range of labels assigned to a particular logical library) then the library uses a first-come, first-served method of allowing the first host application to move the cartridge from the I/O station to a logical library of that application's choice. The cartridge assignment policy is media-type specific, and two identical labels (except for the media-type indicator) can be assigned to two different logical libraries.

cartridge door. On a tape cartridge, the hinged barrier that can be opened to access, or closed to protect, the magnetic tape within the cartridge.

cartridge gripper. An electromechanical device on the cartridge accessor of the 3584 Tape Library that gets or puts cartridges from or to a storage slot, tape drive, or I/O station. Two grippers (Gripper 1 and Gripper 2) are located on the pivot assembly of the accessor. One gripper can grip a single cartridge.

cartridge manual rewind tool. A device that can be fitted into the reel of a cartridge and used to rewind tape into or out of the cartridge.

cartridge memory. See *LTO cartridge memory*.

cartridge storage slot. One of several containers that are mounted inside the frames of the 3584 Tape Library and are used to store tape cartridges.

cell top cap. Located on each column of storage slots within the 3584 Tape Library, a plastic component to which a bar code label holder can be attached. The

library uses the bar code label to establish the boundary of a logical library.

CETool. CETool is a software program that is used by IBM Service personnel (also known as customer engineers or CEs) to update library and drive firmware, configure the Call Home program for the 3584 Tape Library, collect library and drive logs, backup and restore the configuration for non-volatile random access memory (NVRAM), and perform other service-related tasks.

circuit board. A thin plate on which chips and other electronic components are placed. Computers consist of one or more boards, often called cards or adapters.

cleaning cartridge. A tape cartridge that is used to clean the heads of a tape drive. Contrast with *data cartridge*.

compression. The process of eliminating gaps, empty fields, redundancies, and unnecessary data to shorten the length of records or blocks.

configure. To describe to a system the devices, optional features, and programs installed on the system.

controller. A device that coordinates and controls the operation of one or more input/output devices (such as sensors and actuators), and synchronizes the operation of such devices with the operation of the system as a whole.

Controller Area Network (CAN). A serial bus system that provides a communication path between the XY controller, accessor controller, all Medium Changer card packs (MCPs), and the operator panel controller. The CAN also provides a path between the accessor controller and its X-axis and Y-axis controllers.

control path. (1) Designated by the operator of the 3584 Tape Library, a logical path into the library through which a server sends standard SCSI Medium Changer commands to control a specific logical library. (2) A tape drive that is designated by the operator of the 3584 Tape Library to manage communication to and from a server and the library.

control path failover feature. In response to a break in the active path, a feature that detects redundancy in the path from the application to the library accessor. The feature causes the device driver to transparently fail over to another path.

D

data. Any representations such as characters or analog quantities to which meaning is, or might be, assigned.

data cartridge. A tape cartridge dedicated to storing data. Contrast with *cleaning cartridge*.

data compression. See *compression*.

Data Facility Storage Management Subsystem (DFSMS). An operating environment that helps automate and centralize the management of storage. To manage storage, DFSMS provides the storage administrator with control over data class, storage class, management class, storage group, and automatic class selection routine definitions.

data transfer element (DTE). In SCSI terms, a tape drive.

data transfer element (DTE) address. In SCSI terms, the physical location of a tape drive.

data rate. The average number of bits, characters, or blocks per unit of time that pass between corresponding equipment in a data transmission system. The rate is expressed in bits, characters, or blocks per second, minute, or hour.

decrypt. (1) To decipher data. (2) In Cryptographic Support, to convert ciphertext into plaintext. See also *encrypt*.

degauss. To make a magnetic tape nonmagnetic by means of electrical coils carrying currents that neutralize the magnetism of the tape.

degausser. A device that makes magnetic tape nonmagnetic.

device. Any hardware component or peripheral, such as a tape drive or tape library, that can receive and send data.

device driver. A file that contains the code needed to use an attached device.

DFSMS. See *Data Facility Storage Management Subsystem*.

diagnostic cartridge. A tape cartridge that enables the detection and isolation of errors in programs and faults in equipment.

differential. See *High Voltage Differential*.

disable. To make nonfunctional.

door safety switch. Located on each frame of the 3584 Tape Library, a mechanism that automatically turns off the power to the cartridge accessor whenever you open the front door.

drive. See *IBM TotalStorage LTO Ultrium 1 Tape Drive, IBM TotalStorage LTO Ultrium 2 Tape Drive, IBM System Storage 3588 Tape Drive Model F3A, IBM System Storage TS1030 Tape Drive Model F3B, IBM System Storage TS1120 Tape Drive or IBM TotalStorage 3592 Tape Drive Model J1A*.

drive head. The component that records an electrical signal onto magnetic tape, or reads a signal from tape into an electrical signal.

DTE. See *data transfer element*.

dual-gripper transport mechanism. Located on the cartridge accessor of the 3584 Tape Library and mounted on the pivot assembly, the device that contains the two grippers which get and put cartridges into storage slots, drives, or the I/O stations.

E

eject. To remove or force out from within.

EKM. See *enterprise key manager*.

electronic mail. Correspondence in the form of messages transmitted between user terminals over a computer network.

e-mail. See *electronic mail*.

enable. To make functional.

encrypt. In Cryptographic Support, to systematically scramble information so that it cannot be read without knowing the coding key. See also *decrypt*.

encryption. The conversion of data into a cipher. A key is required to encrypt and decrypt the data. Encryption provides protection from persons or software that attempt to access the data without the key.

enhanced frame control assembly. The power structure for Models L23, D23, L53, and D53. The assembly combines drive power, library power, and dual ac line cord capabilities into a 2N power design with no single point of failure or single point of repair.

encryption key manager (EKM). A Java™ software program that assists IBM-encrypting tape drives in generating, protecting, storing, and maintaining encryption keys, which encrypt information written to and decrypt information read from tape media.

Ethernet. A 10-Mbps baseband local area network that allows multiple stations to access the transmission medium at will without prior coordination, avoids contention by using carrier sense and deference, and resolves contention by using collision detection and delayed retransmission.

Expanded I/O Station. On the front door of the 3584 Tape Library, the lower compartment into which you insert and remove cartridges into and from the library. Both stations are accessed by the cartridge accessor.

expansion frame. A unit that may be added to the base frame of the 3584 Tape Library. Also known as the Model D22, D23, D32, D52, or D53, the expansion

frame includes a rail assembly for the cartridge accessor and up to 12 tape drives.

F

FCA. See *frame control assembly*.

Fibre Channel. A high-speed, full-duplex, serial communications technology that is capable of interconnecting Ultrium Tape Drives and servers which are separated by as much as 11 kilometers (7 miles). Fibre Channel technology combines features of the input/output (I/O) and networking interfaces.

Fibre Channel address. For a tape drive that uses a Fibre Channel interface, an identifier (such as an AL_PA or Loop ID) that enables other device ports to communicate with that drive.

Fibre Channel cable. The cable that connects a Fibre Channel tape drive to another device. The conductive element within the cable is constructed of either copper wires or optical fibers. Generally, copper wires are used for short distances (up to 30 meters or 98 feet); optical fibers are used for longer distances. Fiber-optic cabling is referred to by mode or the frequencies of light waves that are carried by a particular cable type. Multi-mode fiber cables are generally used for distances up to 500 meters (1640 feet) and with short-wave (780 nanometer) laser light. Single-mode fiber cables are used for distances greater than 500 m (1640 feet) and with long-wave (1300 nanometer) laser light.

fiber optics. A branch of optics dealing with the transmission of light through fibers or thin rods of glass or some other transparent material of high refractive index.

file. A named set of records stored or processed as a unit.

file transfer protocol (FTP). In the Internet suite of protocols, an application layer protocol that uses TCP and Telnet services to transfer bulk-data files between machines or hosts.

firmware. Proprietary code that is usually delivered as part of an operating system. Firmware is more efficient than software loaded from an alterable medium and is more adaptable to change than pure hardware circuitry. An example of firmware is the Basic Input/Output System (BIOS) in read-only memory (ROM) on a PC motherboard.

frame. (1) In Fibre Channel technology, a unit of transmission that includes delimiters, control characters, information, and checking characters. (2) See *library frame*.

frame control assembly (FCA). A group of parts that consist of a frame control box (FCB), one or two 37 V power supplies for the cartridge accessor, operator

panel, and I/O stations, and an MCC card pack that runs the firmware that controls the ac and dc power distribution in the 3584 Tape Library. The assembly also provides an RS-422 communication port to each tape drive in a frame. The FCB contains 3 circuit protectors, 10 ac outlets for powering the tape drives and all other components in that frame, and a receptacle for the incoming main ac power.

front door. Located at the front of each frame in the 3584 Tape Library, the swinging barrier by which entry is closed or opened to the frame.

FTP. See *file transfer protocol*.

FTP site. Any electronic repository of information that uses the File Transfer Protocol (FTP) for transferring files to and from servers. Use of an FTP site requires a user ID and possibly a password.

full capacity expansion. A feature that increases the initial capacity of Model L22, L23, L52, and L53 frames. Models L22 and L23 increase from 58 to 199 or 260 cartridge slots for 3592 Tape Cartridges. Models L52 and L53 increase from 64 to 219 or 287 cartridge slots for LTO Ultrium Tape Cartridges.

full duplex. Simultaneous transmission and reception of data between two nodes of a network.

G

Gb. See *gigabit*.

Gbps. Gigabits per second. One gigabit equals 1 000 000 000 bits.

GB. See *gigabyte*.

gigabit (Gb). 1 000 000 000 bits.

gigabyte (GB). 1 000 000 000 bytes.

get. (1) In library operation, the act of a cartridge gripper retrieving a tape cartridge from a storage slot, drive, or I/O station. (2) In Simple Network Management Protocol (SNMP), a request for information about the library that the operator issues through a monitoring server and which is transmitted by SNMP.

get-response. The information that is provided in response to an SNMP get.

gigabyte (GB). 1 000 000 000 bytes.

H

hash. In computer security, a number generated from a string of text that is used to ensure that transmitted messages arrived intact.

head. See *drive head*.

hex, hexadecimal. (1) Pertaining to a selection, choice, or condition that has 16 possible different values or states. (2) Pertaining to a fixed-radix numeration system, with radix of 16. (3) Pertaining to a system of numbers to the base 16; hexadecimal digits range from 0 through 9 and A through F, where A represents 10 and F represents 15.

High Voltage Differential (HVD). A logic signaling system that enables data communication between a supported server and the 3584 Tape Library. HVD signaling uses a paired plus and minus signal level to reduce the effects of noise on the SCSI bus. Any noise injected into the signal is present in both a plus and minus state, and is thereby canceled. Synonymous with *differential*.

homogeneous. Of the same kind.

host. The controlling or highest-level system in a data communication configuration. Synonymous with *server*.

host cleaning. A method that enables the server to detect the need to clean a tape drive and to control the cleaning process. Host cleaning with a cleaning cartridge is only supported when automatic cleaning is disabled, and only for the logical library in which each cleaning cartridge is stored.

hub. A communications device to which nodes on a multi-point bus or loop are physically connected. Hubs are commonly used in Fibre Channel networks to improve the manageability of physical cables. They maintain the logical loop topology of the network of which they are a part, while creating a "hub and spoke" physical star layout. Unlike switches, hubs do not aggregate bandwidth. They typically support the addition or removal of nodes from the bus while it is operating.

HVD. See *High Voltage Differential*.

I

IBM System Storage TS3500 Tape Library. A device that can be attached to one or more supported servers and used to write data to and from magnetic tape. The library, also known as the 3584 Tape Library, can include up to 16 frames and 192 drives, and any combination of Ultrium 3, Ultrium 2, and Ultrium 1 Tape Drives in Ultrium frames, and 3592 Tape Drives in 3592 frames.

IBM System Storage 3588 Tape Drive Model F3A. A data-storage device that controls the movement of the magnetic tape in an IBM LTO Ultrium Tape Cartridge. The drive houses the mechanism (drive head) that reads and writes data to the tape. The drives offer 2

Gbps Fibre Channel connectivity. Its native data capacity is 400[®] GB per cartridge; with 2:1 compression, its capacity is up to 800 GB.

IBM System Storage TS1030 Tape Drive Model F3B.

A data-storage device that controls the movement of the magnetic tape in an IBM LTO Ultrium Tape Cartridge. The drive houses the mechanism (drive head) that reads and writes data to the tape. The drives offer 4 Gbps Fibre Channel connectivity. Its native data capacity is 400 GB per cartridge; with 2:1 compression, its capacity is up to 800 GB.

IBM System Storage TS1120 Tape Drive. Located within the 3584 Tape Library, a high-performance, high-capacity streaming cartridge tape product designed for efficient back-up for mid-range and high-end computing systems. The drive houses the mechanism (drive head) that reads and writes data to the tape. When the media is formatted for a J1A format, the drive's native data capacity is 300 GB and its data rate is 40 MB/s; with 3:1 compression, its capacity is 900 GB. When the media is formatted for a E05 format, the drive's native data capacity is 500 GB and its data rate is 100 MB/s; with 3:1 compression, its capacity is 1.5 TB. Formerly known as the IBM TotalStorage 3592 Tape Drive Model E05.

IBM TotalStorage 3592 Tape Drive Model J1A.

Located within the 3584 Tape Library, a high-performance, high-capacity streaming cartridge tape product designed for efficient back-up for mid-range and high-end computing systems. The drive houses the mechanism (drive head) that reads and writes data to the tape. Its native data capacity is 300 GB; with 3:1 compression, its capacity is 900 GB. The drive has a native data rate of 40 MB/s (80 MB/s at 2:1 compression).

IBM TotalStorage LTO Ultrium 1 Tape Drive.

Located within the 3584 Tape Library, a data-storage device that controls the movement of the magnetic tape in IBM LTO Ultrium Tape Cartridges. The drive houses the mechanism (drive head) that reads and writes data to the tape. Its native data capacity is 100 GB per cartridge; with 2:1 compression, its capacity is up to 200 GB. The drive is also known as the IBM Ultrium Internal Tape Drive.

IBM TotalStorage LTO Ultrium 2 Tape Drive. A data-storage device that controls the movement of the magnetic tape in an IBM LTO Ultrium Tape Cartridge. The drive houses the mechanism (drive head) that reads and writes data to the tape. Its native data capacity is 200 GB per cartridge; with 2:1 compression, its capacity is up to 400 GB.

IBM System Storage 3588 Tape Drive Model F3A. A data-storage device that controls the movement of the magnetic tape in an IBM LTO Ultrium Tape Cartridge. The drive houses the mechanism (drive head) that reads and writes data to the tape. Its native data

capacity is 400 GB per cartridge; with 2:1 compression, its capacity is up to 800 GB. The Model F3A drive provides 2 Gbps Fibre Channel connectivity. Also known as the Ultrium 3 Tape Drive.

IBM System Storage TS1030 Tape Drive Model F3B.

A data-storage device that controls the movement of the magnetic tape in an IBM LTO Ultrium Tape Cartridge. The drive houses the mechanism (drive head) that reads and writes data to the tape. Its native data capacity is 400 GB per cartridge; with 2:1 compression, its capacity is up to 800 GB. The Model F3B drive provides 4 Gbps Fibre Channel connectivity. Also known as the Ultrium 3 Tape Drive.

IBM System Storage TS3500 Tape Library. Formerly known as the IBM TotalStorage 3584 Tape Library, a device that can be attached to a supported server and used to write data to and from magnetic tape. The IBM System Storage TS3500 Tape Library can include up to 16 frames and 192 drives, and any combination of Ultrium 3, Ultrium 2, and Ultrium 1 Tape Drives in Ultrium frames, and 3592 Tape Drives in 3592 frames.

IBM System Storage Tape Library Specialist web interface. A platform-independent, web-based interface that allows a user to configure and monitor the 3584 Tape Library from a remote location.

ID. Identifier.

IEE. See *import/export element*.

IEEA. See *import/export element address*.

import/export element (IEE). In SCSI terms, an I/O slot.

import/export element address (IEEA). In SCSI terms, the location of an I/O slot.

independent software vendor (ISV). A company that makes and sells software products that run on one or more computer hardware or operating system platforms.

initial program load (IPL). (1) The initialization procedure that causes an operating system to commence operation. (2) The process by which a configuration image is loaded into storage at the beginning of a work day or after a system malfunction. (3) The process of loading system programs and preparing a system to run jobs.

initialize. To format a magnetic tape, write a label (VOLSER) on the tape, and leave the tape empty except for the system files containing the structure information. All former contents of the tape are lost.

initializing. The act of performing an inventory on the 3584 Tape Library.

initiator. In SCSI terms, a SCSI device that requests an I/O process to be performed by another SCSI device (a target). In many cases, an initiator can also be a target.

input/output (I/O) station. On the front door of the 3584 Tape Library, one or two compartments into which you insert and remove cartridges into and from the library. Both stations are accessed by the cartridge accessor.

insert. Pertaining to the 3584 Tape Library, a term used to describe the act of putting a tape cartridge into an I/O station.

install. (1) To set up for use or service. (2) The act of adding a product, feature, or function to a system or device either by a singular change or by the addition of multiple components or devices.

interchange. The ability to process (read or write) given tape data on any one of a set of tape devices that support the form factor and recording format of the tape data.

intermediate capacity expansion. A feature that increases the initial capacity of Model L22, L23, L52, and L53 frames. Models L22 and L23 increase from 58 to 117 cartridge slots for 3592 Tape Cartridges. Models L52 and L53 increase from 64 to 129 cartridge slots for LTO Ultrium Tape Cartridges.

Internet. The worldwide collection of interconnected networks that use the Internet suite of protocols and permit public access.

inventory. (1) A survey of tape cartridges in the library and frames. (2) To make an inventory of.

I/O station. See *input/output station*.

IPL. See *Initial program load*.

ISV. See *independent software vendor*.

K

key label. An alias to a encryption key (cipher) used by the encryption key manager.

key manager. In cryptography, a software application that manages one or more secret encryption keys.

key manager address. In cryptography, the IP address of an encryption key manager.

L

label. See *bar code label*.

label area. On the LTO Ultrium Tape Cartridge or 3592 Tape Cartridge, a recessed area next to the write-protect switch where a bar code label must be affixed.

LAN. See *local area network*.

LCD. See *liquid crystal display*.

leader pin. On the LTO Ultrium Tape Cartridge, a small metal column attached to the end of the magnetic tape. During tape processing the leader pin is grasped by a threading mechanism, which pulls the pin and the tape out of the cartridge, across the drive head, and onto a takeup reel. The head can then read or write data from or to the tape.

library frame. The basic unit of the 3584 Tape Library. The frame includes the hardware support structure, covers, mechanisms, and parts. Two types of frames are available: base frame (Models L22, L23, L32, L52, or L53) and expansion frame (Models D22, D23, D32, D52, or D53).

library power switch. Located on the front of the 3584 Tape Library, a toggle switch that enables you to turn the power to the library on and off.

license key. A password or table that is needed to decipher encoded data.

Linear Tape-Open (LTO). A type of tape storage technology developed by the IBM Corporation, Hewlett-Packard, and Certance. LTO technology is an "open format" technology, which means that its users have multiple sources of product and media. The "open" nature of LTO technology enables compatibility between different vendors' offerings by ensuring that vendors comply with verification standards. The LTO technology is implemented in two formats: the Accelis format focuses on fast access; the Ultrium format focuses on high capacity. The Ultrium format is the preferred format when capacity (rather than fast access) is the key storage consideration. An Ultrium cartridge has a compressed data capacity of up to 800 GB (at 2:1 compression) and a native data capacity of up to 400 GB. The Ultrium format is designed with a four-generation road map that provides for up to 1.6 TB per cartridge (2:1 compression) in Generation 4 and a compressed transfer rate of up to 320 MB per second.

link. In Fibre Channel technology, the physical (optical) connection between two nodes of a network, which includes the combination of the link connection (the transmission medium) and two link stations, one at each end of the link connection.

liquid crystal display (LCD). A low-power display technology used in computers and other I/O devices.

load. Pertaining to the 3584 Tape Library and following the insertion of a tape cartridge into a cartridge storage slot, the act (performed by the

cartridge accessor) of transferring the cartridge from the storage slot to the drive and of positioning the tape (performed by the tape drive) for reading or writing by the drive head.

load and unload cycle. The act of inserting a cartridge into a tape drive, loading the tape to load point, rewinding the tape into the cartridge, and ejecting the cartridge from the drive.

load point. The beginning of the recording area on magnetic tape.

local area network (LAN). (1) A computer network located on a user's premises within a limited geographical area. Communication within a local area network is not subject to external regulations; however, communication across the LAN boundary may be subject to some form of regulation. (2) A network in which a set of devices is connected to other sets of devices for communication and that can be connected to a larger network.

logical library. A set of cartridge storage slots and tape drives that are defined as a library by an operator. The operator identifies the slots and drives to the library by their location or count. The ability of the 3584 Tape Library to create logical libraries makes it possible for similar and dissimilar hosts (servers) to share its robotics. As a result, servers can simultaneously run separate applications in separate logical libraries.

logical library bar code label. A specially coded label that can be affixed to the tops of storage slot columns and drives inside the 3584 Tape Library. The tape library reads the labels and uses them to establish the boundaries of one or more logical libraries.

logical library configuration. A way of using the 3584 Tape Library so that its robotics are shared by homogenous (similar) and heterogeneous (dissimilar) servers. The 3584 Tape Library can be partitioned into individual logical libraries that independently communicate with individual servers via individual control paths.

logical unit number (LUN). A number associated with the target address of a drive. The server uses the number to identify the address of the drive.

loop ID. In Fibre Channel technology, the identifier that the 3584 Tape Library assigned to an Ultrium Tape Drive. The ID is based on the drive's physical location within the library and is used by other devices in the topology to communicate.

Low Voltage Differential (LVD). A low-noise, low-power, and low-amplitude electrical signaling system that enables data communication between a supported server and the 3584 Tape Library. LVD

signaling uses two wires to drive one signal over copper wire. The use of wire pairs reduces electrical noise and crosstalk.

LTO. See *Linear Tape-Open*.

LTO cartridge memory (LTO-CM). Within each LTO Ultrium Data Cartridge, an embedded electronics and interface module that can store and retrieve a cartridge's historical usage and other information.

LTO-CM. See *LTO cartridge memory*.

LUN. See *logical unit number*.

LVD. See *Low Voltage Differential*.

M

m. Meter.

magnetic tape. A tape with a magnetizable surface layer on which data can be stored by magnetic recording.

Management Information Base (MIB). Units of managed information that specifically describe an aspect of a system, such as the system name, hardware number, or communications configuration. A collection of related MIB objects is defined as a MIB. The 3584 Tape Library can use the MIB to interpret problem alerts that are transmitted by SNMP traps.

manual cleaning. A method by which an operator selects a menu option from the touchscreen of the 3584 Tape Library or from the Tape Library Specialist web interface to perform cleaning on one or more of the library's tape drives.

MB. See *megabyte*.

Mbps. Megabits per second.

MCP. See *Medium Changer card pack*.

media. The plural of *medium*.

media capacity. See *capacity*.

media-type identifier. Pertaining to the bar code on the bar code label of the IBM LTO Ultrium Tape Cartridge, a 2-character code (Lx), that represents information about the cartridge. L identifies the cartridge as one that can be read by devices that incorporate LTO technology; x indicates the generation of cartridge (1 represents the Ultrium 1 Tape Cartridge, 2 represents the Ultrium 2 Tape Cartridge, and 3 represents the Ultrium 3 Tape Cartridge).

medium. A physical material in or on which data may be represented, such as magnetic tape.

Medium Changer card pack (MCP). In the 3584 Tape Library, a circuit board that provides a communication path to each tape drive (via the RS-422 interface) so that library commands can be funneled from the tape drives to the accessor. It includes one RS-422 interface allotted for each drive in the frame. It also provides management and service interfaces to outside servers. For each library frame that contains at least one drive, there is one MCP. The electronics of the card pack are located in the FCB.

Medium Changer Device. In SCSI terms, an instrument that moves removable storage units from and to storage slots and tape drives. The 3584 Tape Library is a Medium Changer Device.

megabyte (MB). 1 000 000 bytes.

metal particle tape. In the LTO Ultrium Tape Cartridge, tape that uses very small, pure metal particles (rather than oxide coatings) in the magnetic layer.

meter. In the Metric System, the basic unit of length; equal to approximately 39.37 inches.

MIB. See *Management Information Base*.

mid-range systems. A set of multi-user servers with a hard disk capacity of between 50 GB and 250 GB.

mixed drive types. The concept of using both LTO Ultrium Tape Cartridges and 3592 Tape Cartridges in the 3584 Tape Library. A library can consist of frames that house all LTO Ultrium Tape Cartridges or all 3592 Tape Cartridges, but the two types of cartridges cannot be mixed in a single frame. However, both types of cartridges may be inserted or removed from the library through the base frame, provided that a lower I/O station is installed for the 3592 Tape Cartridges.

mixed media configuration. Different media and drive technologies, such as the Ultrium Tape Drive and the TS1120 Tape Drive. Ultrium 1, Ultrium 2, and Ultrium 3 drives and media are not considered mixed media, but are considered different generations of the same type of media.

N

N. A measure of the electrical power load in a system. If there are N loads in the system, N power supplies are required to power all of the loads.

N/A. Not applicable.

native data capacity. The amount of data that can be stored without compression on a tape cartridge.

NetView. (1) Pertaining to an IBM licensed program that is used to monitor a network, manage it, and diagnose its problems. The NetView licensed program can be used to provide network management services

for OSI Communications Subsystem. (2) A network management product that can provide automated operations and rapid notification of events.

network. A configuration of data processing devices and software connected for information interchange.

network server. In a local area network, a personal computer that provides access to files for all of the workstations in the network.

node. In Fibre Channel technology, a communicating device.

node card. Within the 3584 Tape Library, one of four circuit assemblies (accessor controller card, motor driver assembly, Medium Changer card pack, and operator panel assembly) that communicate with each other.

nominal. Approximate.

nominal power. The amount of power (in kilowatts) that the 3584 Tape Library dissipates during normal operation.

non-addressable cartridge storage slot. A cartridge storage slot that is designated for the diagnostic cartridge, which is used during service procedures. The Models L22, L23, L32, L52, and L53 base frames each contain one non-addressable cartridge storage slot for a diagnostic cartridge at physical address F01,C01,R01. Additionally, the first expansion frame of a different media type (3592 or LTO) in a mixed media library contains one non-addressable cartridge slot for a diagnostic cartridge at physical addresses Fxx,C01,R01 (where xx equals the first expansion frame for the second type of media).

nondisruptive firmware update. The ability to update drive or library firmware without scheduling downtime. The 3584 Tape Library provides the ability to perform a nondisruptive update for its library firmware as well as firmware for the 3592 J1A Tape Drive, TS1120 Tape Drive, IBM System Storage 3588 Tape Drive Model F3A, and IBM System Storage TS1030 Tape Drive Model F3B.

not ready. The condition that exists when the 3584 Tape Library is not ready for operation with the host.

non-volatile memory. Types of memory that retain their contents when the power is turned off. ROM is nonvolatile, whereas RAM is volatile.

O

oersted. The unit of magnetic field strength in the unrationalized centimeter-gram-second (cgs) electromagnetic system. The oersted is the magnetic field strength in the interior of an elongated, uniformly

wound solenoid that is excited with a linear current density in its winding of one ampere per 47 centimeters of axial length.

operating environment. The temperature, relative humidity rate, and wet bulb temperature of the room in which the 3584 Tape Library routinely conducts processing.

operating system. The master computer control program that translates the user's commands and allows software application programs to interact with the computer's hardware.

operator panel. A functional unit that controls the tape library. The unit's LCD touchscreen provides information about the operation of the 3584 Tape Library, and one or two I/O stations for inserting and removing cartridges.

operator panel controller. Within the 3584 Tape Library, a circuit board that facilitates communication between the accessor controller and the operator panel. The controller provides input to and output from the LCD, and senses and locks the I/O stations. In addition, the LCD activity and service menus are executed in the operator panel controller with support from the accessor controller and the drives (via the Medium Changer card packs).

P

partition. A fixed-size division of storage.

Pause key. On the touchscreen of the 3584 Tape Library, a touch key that causes the cartridge accessor to park itself and provide clear access to the library's interior when you power-off the library or open the front door. The Pause key enables quick recovery when you power-on the library or close the front door.

ping. (1) A command that calls an IP address. (2) The act of issuing a command that calls an IP address.

pivot assembly. On the cartridge accessor of the 3584 Tape Library, a group of parts that provides a mounting platform for the gripper mechanism and the bar code reader. The pivot assembly is capable of 180° rotation about the vertical axis.

port. (1) A system or network access point for data entry or exit. (2) A connector on a device to which cables for other devices such as display stations and printers are attached. (3) The representation of a physical connection to the link hardware. A port is sometimes referred to as an adapter; however, there can be more than one port on an adapter.

power cord. A cable that connects a device to a source of electrical power.

power-off, powered-off. (1) To remove electrical power from a device. (2) The state of a device when power has been removed from it.

power-on, powered-on. (1) To apply electrical power to a device. (2) The state of a device when power has been applied to it.

power-on indicator. Located beside the library power switch on the operator panel, a green light that, when lit, indicates that dc power is available within the 3584 Tape Library.

power receptacle. The mounted female electrical fitting that contains the live parts of the circuit.

power supply. The electrical component of a computer system that converts standard ac current to the lower voltage dc current used by the computer. The amount of current a power supply can provide is rated in amperes.

power switch. See *library power switch*.

protocol. The meanings of, and the sequencing rules for, requests and responses used for managing a network, transferring data, and synchronizing the states of network components.

put. Pertaining to the 3584 Tape Library, to place, by means of a robotic device, a tape cartridge into a storage slot, drive, or I/O station.

R

RABF. See *recursive accumulating backhitchless flush*.

rail system. Within the 3584 Tape Library, the support structure over which the cartridge accessor moves.

read. To acquire or interpret data from a storage device, from a data medium, or from another source.

ready. The operating condition that the 3584 Tape Library is in when the host applications can interact with it.

recursive accumulating backhitchless flush (RABF). A non-volatile caching technique that is used by the IBM TotalStorage 3592 Tape Drive Model J1A or the IBM System Storage TS1120 Tape Drive.

rekey. In cryptography, the process of encrypting a data key a second time by using the public key of another party to create an additional externally encrypted data key. The cartridge can then be shipped to a business partner that holds the corresponding private key which allows the data key to be unwrapped and the tape decrypted on a different TS1120 Tape Drive.

relative humidity. The ratio of the amount of water vapor actually present in the air to the greatest amount possible at the same temperature.

remote support. See *Call Home*.

Remote Technical Assistance Information Network (RETAIN). Used by IBM Service Representatives, an internal host-based software application that contains records of service problems with IBM hardware and software, as well as tips on how to deal with the problems.

remove. Pertaining to the 3584 Tape Library, a term used to describe the act of taking a tape cartridge out of an I/O station.

RETAIN. See *Remote Technical Assistance Information Network*.

robotics. The cartridge accessor and any associated mechanisms that move a tape cartridge within the 3584 Tape Library.

RS-422 interface. An electrical interface standard approved by the Electronic Industries Association (EIA) for connecting serial devices. The RS-422 standard, which supports higher data rates and greater immunity to electrical interference, is an alternative to the older RS-232 interface and uses individual differential signal pairs for data transmission. Depending on data transmission rates, RS-422 can be used at distances to 1,275 m (4,000 ft). The RS-422 interface also supports multi-point connections.

S

s. Abbreviation for *second*.

SAN. See *Storage Area Network*.

scratch cartridge. A labeled cartridge that is blank or contains no valid data, that is not currently defined, and that is available for use.

scratch encryption policy. A means of identifying to a TS1120 Tape Drive which scratch cartridges will be encrypted on the next attempt to write from the beginning of the tape. A scratch encryption policy specifies what scratch cartridges to encrypt; it does not indicate which cartridges are currently encrypted. When used with library-managed encryption, a policy optionally lets you control cartridge encryption by VOLSER ranges in all logical libraries.

SCSI. See *Small Computer Systems Interface*.

SCSI-2. A variation of the SCSI interface. See *Small Computer Systems Interface*.

SCSI bus. (1) A collection of wires through which data is transmitted from one part of a computer to another. (2) A generic term that refers to the complete

set of signals that define the activity of the Small Computer Systems Interface (SCSI).

SCSI connector. One of the set of all female and male connectors on the SCSI bus.

SCSI device. Anything that can connect into the SCSI bus and actively participate in bus activity.

SCSI element address. A value that defines a logical location in the 3584 Tape Library to the SCSI interface. This logical address is represented on the operator panel or Tape Library Specialist web interface as $xxxx(yyyh)$, where $xxxx$ is a decimal value and $yyyh$ is a hexadecimal value. It is assigned by the library and used by the server when the server processes SCSI commands. The SCSI element address is not unique to a storage slot, drive, or I/O slot; it varies, depending on the quantity of drives in the library, whether the Capacity Expansion feature is installed, and whether an Expanded I/O Station is included.

SCSI ID. The hexadecimal representation of the unique address (0-F) that is assigned to a SCSI device. This identifier would normally be assigned and set in the SCSI device during system installation.

second. The 60th part of a minute of time.

serial number. See *volume serial number*.

server. A functional unit that provides services to one or more clients over a network. Examples include a file server, a print server, and a mail server. The IBM pSeries, IBM iSeries, HP, and Sun are servers. Synonymous with *host*.

shipping environment. The temperature, relative humidity rate, and wet bulb temperature of the environment to which the 3584 Tape Library is exposed when being transferred from one location to another.

Simple Network Management Protocol (SNMP). In the Internet suite of protocols, a network management protocol that is used to monitor routers and attached networks. SNMP is an application layer protocol. Information on devices that are managed is defined and stored in the application's Management Information Base (MIB).

Small Computer Systems Interface (SCSI). A standard used by computer manufacturers for attaching peripheral devices (such as tape drives, hard disks, CD-ROM players, printers, and scanners) to computers (servers). Pronounced "scuzzy." Variations of the SCSI interface provide for faster data transmission rates than standard serial and parallel ports (up to 160 megabytes per second). The variations include:

- Fast/Wide SCSI: Uses a 16-bit bus, and supports data rates of up to 20 MBps.
- SCSI-1: Uses an 8-bit bus, and supports data rates of 4 MBps.

- **SCSI-2:** Same as SCSI-1, but uses a 50-pin connector instead of a 25-pin connector, and supports multiple devices.
- **Ultra SCSI:** Uses an 8- or 16-bit bus, and supports data rates of 20 or 40 MBps.
- **Ultra2 SCSI:** Uses an 8- or 16-bit bus and supports data rates of 40 or 80 MBps.
- **Ultra3 SCSI:** Uses a 16-bit bus and supports data rates of 80 or 160 MBps.
- **Ultra160 SCSI:** Uses a 16-bit bus and supports data rates of 80 or 160 MBps.

SMI-S. See *Storage Management Initiative - Specification*.

SMI-S Agent for Tape. See *Storage Management Initiative - Specification (SMI-S) Agent for Tape*.

soft addressing. A method of creating or changing Loop IDs for drives in the 3584 Tape Library. With soft-addressing, the drives automatically arbitrate the AL_PAs with other Fibre Channel devices on the loop. This method avoids conflicts over the address.

SNMP. See *Simple Network Management Protocol*.

Specialist web interface. See *IBM System Storage Tape Library Specialist*.

speed matching. The ability of Ultrium 3 and Ultrium 2 Tape Drives to adjust their native data rate as closely as possible to the net host data rate (after data compressibility has been factored out).

stand-alone. Pertaining to operation that is independent of any other device, program, or system.

StE. See *storage element*.

Storage Area Network (SAN). A high-speed subnetwork of shared storage devices. A SAN's architecture makes all storage devices available to all servers on a LAN or WAN. As more storage devices are added to a SAN, they too will be accessible from any server in the larger network. Because stored data does not reside directly on any of a network's servers, server power is used for business applications, and network capacity is released to the end user.

storage element (StE). In SCSI terms, a cartridge storage slot.

storage environment. The temperature, relative humidity rate, and wet bulb temperature of the environment in which the 3584 Tape Library is nonoperational and being kept for future use.

Storage Management Initiative - Specification (SMI-S). A design specification of the Storage Management Initiative (SMI) that was launched by the Storage Networking Industry Association (SNIA). The SMI-S specifies a secure and reliable interface that allows storage management systems to identify, classify,

monitor, and control physical and logical resources in a Storage Area Network (SAN).

Storage Management Initiative - Specification (SMI-S) Agent for Tape. Software that is used by management software to communicate with storage devices in a SAN environment. The SMI-S Agent for Tape communicates by using the Web-Based Enterprise Management (WBEM) protocol, which allows management software to communicate with the 3584 Tape Library.

switch. A network infrastructure component to which multiple nodes attach. Unlike hubs, switches typically have the ability to switch node connections from one to another. A typical switch can facilitate several simultaneous bandwidth transmissions between different pairs of nodes.

T

TapeAlert. A patented technology from Hewlett-Packard that monitors the status of a tape device and media, and detects problems as they occur.

TapeAlert flags. Status and error messages that are generated by the TapeAlert utility and display on the host console. The messages indicate the type of problem and tell how to resolve it.

tape cartridge. A removable storage device that consists of a housing containing a belt-driven magnetic tape wound on a supply reel and a takeup reel.

tape drive. See *IBM TotalStorage LTO Ultrium 1 Tape Drive, IBM TotalStorage LTO Ultrium 2 Tape Drive, IBM System Storage 3588 Tape Drive Model F3A, IBM System Storage TS1030 Tape Drive Model F3B, IBM TotalStorage 3592 Tape Drive Model J1A, or IBM System Storage TS1120 Tape Drive*.

target. A SCSI device that performs an operation requested by the initiator. A target can also be an initiator.

TB. Terabyte.

TCP/IP. See *transmission control protocol/Internet protocol*.

terabyte. 1 000 000 000 000 bytes.

terminate, termination. To prevent unwanted electrical signal reflections by applying a device (a terminator) that absorbs the energy from the transmission line.

terminator. (1) A part used to end a SCSI bus. (2) A single-port, 75-Ω device that is used to absorb energy from a transmission line. Terminators prevent energy from reflecting back into a cable plant by absorbing the radio frequency signals. A terminator is usually

shielded, which prevents unwanted signals from entering or valid signals from leaving the cable system.

Tivoli Storage Manager (TSM). An IBM client/server product that provides storage management and data access services in a heterogeneous environment. TSM supports various communication methods, provides administrative facilities to manage the backup and storage of files, and provides facilities for scheduling backups.

topology. In communications, the physical or logical arrangement of nodes in a network, especially the relationships among nodes and the links between them.

touch keys. On the touchscreen of the 3584 Tape Library, an array of small, touch-sensitive keypads that lets you select and navigate through menus. To acknowledge that it has been pressed, a touch key initiates an audible beep (if enabled) whenever you press it. The audible beep is the default.

touchscreen. See *liquid crystal display*.

track. A linear or angled pattern of data written on a tape surface.

transfer rate. See *data transfer rate*.

transmission control protocol/Internet protocol (TCP/IP). (1) The Transmission Control Protocol and the Internet Protocol, which together provide reliable end-to-end connections between applications over interconnected networks of different types. (2) The suite of transport and application protocols that run over the Internet Protocol.

TS1120 (E05) Tape Drive. See *IBM System Storage TS1120 Tape Drive*.

TSM. See *Tivoli Storage Manager*.

3584 Tape Library. See *IBM System Storage TS3500 Tape Library*.

U

Ultra SCSI. See *Small Computer Systems Interface*.

Ultra160 SCSI. See *Small Computer Systems Interface*.

Ultra2 SCSI. See *Small Computer Systems Interface*.

Ultra3 SCSI. See *Small Computer Systems Interface*.

Ultrium Tape Drive. See *IBM TotalStorage LTO Ultrium 1 Tape Drive*, *IBM TotalStorage LTO Ultrium 2 Tape Drive*, *IBM System Storage 3588 Tape Drive Model F3A*, or *IBM System Storage TS1030 Tape Drive Model F3B*.

Ultrium 3 Tape Drive. See *IBM System Storage 3588 Tape Drive Model F3A* or *IBM System Storage TS1030 Tape Drive Model F3B*.

uniform resource locator (URL). The address of an item on the World Wide Web. It includes the protocol followed by the fully qualified domain name (sometimes called the host name) and the request. The web server typically maps the request portion of the URL to a path and file name. For example, if the URL is <http://www.networking.ibm.com/nsg/nsgmain.htm>, the protocol is http; the fully qualified domain name is www.networking.ibm.com; and the request is [/nsg/nsgmain.htm](http://www.networking.ibm.com/nsg/nsgmain.htm).

unload. Pertaining to the 3584 Tape Library, a term used to describe the act of the drive unthreading the tape from the internal tape path and returning the leader block to the tape cartridge.

URL. See *uniform resource locator*.

V

V. Volt.

V ac. Volts ac (alternating current).

vital product data (VPD). Pertaining to the 3584 Tape Library, information about a product such as a library, drive, or node card. The VPD may include a machine type, model number, serial number, part number, or level of firmware.

void. In character recognition, the inadvertent absence of ink within a character outline.

VOLSER. Volume serial number.

volt. The SI (international) unit of potential difference and electromotive force, formally defined to be the difference of electric potential between two points of a conductor carrying a constant current of one ampere, when the power dissipated between these points is equal to one watt.

volume serial number (VOLSER). A number that a computer assigns to a tape cartridge when it prepares (initializes) the cartridge for use.

VPD. Vital product data.

W

web. See *World Wide Web*.

wet bulb temperature. The temperature at which pure water must be evaporated adiabatically at constant pressure into a given sample of air in order to saturate the air under steady-state conditions. Read from a wet-bulb thermometer.

World Wide Node Name. In Fibre Channel technology, the fixed, 64-bit name assigned to a device by its manufacturer and used to identify participants in

a topology. The World Wide Node Name will be unique if the manufacturer has registered a range of addresses with the IEEE.

World Wide Port Name. Within a parent node, a unique 64-bit name that is assigned to a node port. The World Wide Port Name aids the accessibility of the port.

World Wide Web. A network of servers that contain programs and files. Many of the files contain hypertext links to other documents available through the network.

WORM. See *write once read many*.

write. To make a permanent or transient recording of data in a storage device or on a data medium.

write once read many (WORM). A technology that allows data to be written only once to LTO Ultrium 3 and 3592 tape cartridges. After being written, the data cannot be altered, but can be read any number of times.

write protected. A tape cartridge is write protected if some logical or physical mechanism causes the device that is processing the tape to prevent the program from writing on the tape.

write-protect switch. Located on the LTO Ultrium Tape Cartridge or 3592 Tape Cartridge, a switch that prevents accidental erasure of data. Pictures of a locked and unlocked padlock appear on the switch. When you slide the switch to the locked padlock, data cannot be written to the tape. When you slide the switch to the unlocked padlock, data can be written to the tape.

X

X-axis and Y-axis motion assemblies. Within the 3584 Tape Library, a group of parts that includes a controller (circuit board) for the Controller Area Network interface, servo motor, pinion drive gear and lead screw. Provides the motive force to move the accessor side to side (on the X-axis) and up and down (on the Y-axis).

Y

Y-axis motion assembly. See *X-axis and Y-axis motion assemblies*.

Index

Numerics

- 3584 Tape Library, description 1
- 3588 Tape Drives, description 2, 8
- 3592 canister assembly, fibre hot swap 328
- 3592 Model J1A Tape Drive, description 8
- 3592 Tape Cartridges, description 16, 243
- 3592 Tape Drives, description 8, 25, 28
- 512 MB data buffer with read ahead feature, in 3592 Tape Drives 15

A

- ac line cords, dual 319, 335, 336
- accessing
 - logs for drives and library 187, 197
 - mount history of tape cartridges 188
 - statistics for drives 191
 - statistics for ports 192
 - statistics for the library 193
- accessor controller 315, 318
- accessor controller node card 184
- accessor, cartridge
 - changing a preferred zone 141
 - description 316
 - description of dual 6, 22
 - determining status 95
 - determining usage 179
 - setting a preferred zone 141
 - viewing a preferred zone 141
- acclimating the cartridge
 - 3592 Tape Cartridges 258, 262
 - LTO Ultrium Tape Cartridges 226, 237
- activating
 - password for operator panel 77
 - password protection for web screens 81
- Activity screen 35, 36
- adding
 - barcode encryption policy 206
 - cartridge assignment policy 94
 - control path
 - with ALMS enabled 91
 - without ALMS enabled 155
 - drive
 - to a logical library 89, 90
 - to a physical library 90
 - key manager address 204
 - logical library
 - with ALMS enabled 138
 - without ALMS enabled 119
 - scratch encryption policy 207
 - web user 86
- additional sense code (ASC) 280
- additional sense code qualifier (ASCQ) 280

B

- backhitchless backspace, in 3592 Tape Drives 13

- address
 - destination IP, viewing or changing 161
 - Loop ID for Fibre Channel drives
 - changing 144
 - viewing 143
 - physical
 - for cartridge storage slots 24, 28
 - for diagnostic cartridges 25
 - for drives 28
 - for I/O slots 31
 - SCSI element 29, 345
 - SCSI ID for SCSI drives
 - changing 144
 - viewing 143
 - World Wide Node Name 147
 - World Wide Port Name 146
- addressable cartridge storage slots, description 24
- adjusting scanner speed on library 199
- administrator's web password
 - changing 80
 - establishing 79
- Advanced Library Management System (ALMS)
 - enabling or disabling 136
 - entering the license key 135
 - viewing whether installed 201
- ALMS
 - See* Advanced Library Management System (ALMS)
- application-managed encryption 202
- Arbitrated Loop Physical Address (AL_PA) 143
- AS/400
 - requirements for removing 3592 Tape Drives 329
 - requirements for removing LTO Ultrium Tape Drives 327
- ASC/ASCQ codes, encryption-related 280
- assigning
 - data and cleaning cartridges to a logical library 88
 - drives to a logical library 89, 90
 - drives to a physical library 89, 90
- assigning volume serial number to tape cartridge 77
- attaching leader pin to Ultrium tape, procedure 230, 233
- attaching library to servers 17
- attention notice, definition xv
- authentication trap setting, enabling and disabling 160
- automatic cleaning, enabling or disabling 69

bar code label

- description and specifications
 - 3592 Tape Cartridges 254, 255
 - LTO Ultrium Tape Cartridges 220, 221, 241
- for logical library elements 127
- guidelines for using on logical library elements 129
- location
 - 3592 Tape Cartridges 248
 - LTO Ultrium Tape Cartridges 220
- ordering
 - 3592 Tape Cartridges xxiii, 266
 - LTO Ultrium Tape Cartridges xxiii, 241
- suppliers
 - 3592 Tape Cartridges 266
 - LTO Ultrium Tape Cartridges 241
- bar code reader 317
- bar code, description and specifications
 - 3592 Tape Cartridges 254
 - LTO Ultrium Tape Cartridges 220
- barcode encryption policy
 - adding 206
 - changing 206
 - creating 206
 - deleting 206
 - setting up 202
- base frame, description 3
- beep, enabling and disabling 175
- bulk loading cartridges into library 54, 61

C

- calibration sensor 317
- Call Home connection 337
- canister assembly, removing or replacing
 - 3592 fibre hot swap 328
 - LTO fibre hot swap 325
- capacity
 - compressed
 - 3592 Tape Cartridges 243, 248
 - LTO Ultrium Tape Cartridges 216
 - Models L22, D22, L23, and D23 341
 - Models L32 and D32 342
 - Models L52, D52, L53, and D53 343
- native
 - 3592 Tape Cartridges 2, 243, 248
 - LTO Ultrium Tape Cartridges 2, 216
- capacity expansion feature
 - installing intermediate or full 143
 - viewing whether installed 201
- capacity scaling, for 3592 data cartridges 13, 246
- capacity-based LEOT reporting, in 3592 Tape Drives 14
- cartridge accessor 315, 316
- cartridge accessor controller 315, 318
- cartridge assignment policy, using 94

- cartridge door, location
 - 3592 Tape Cartridges 248
 - LTO Ultrium Tape Cartridges 216
- cartridge gripper 315, 317
- cartridge memory
 - for 3592 Tape Cartridges 250
 - for LTO Ultrium Tape Cartridges 217
- cartridge storage slots
 - addressable 24
 - addresses
 - logical 24
 - physical 24
 - description 19, 24
 - logical 361, 364
 - non-addressable 25
- caution notice, definition xiii
- ccSARS, accessing for TS1120 Tape Drives 188
- CE cartridge
 - See* customer engineer (CE) cartridge
- changing
 - accessor's preferred zone 141
 - administrator's web password 80
 - automatic cleaning of tape drive 69
 - barcode encryption policy 206, 207
 - cartridge assignment policy 94
 - control path 89, 155
 - date and time 174
 - destination IP address 161
 - drive emulation mode for 3592 Tape Drives 104, 105, 106
 - encryption method of drive 203
 - Ethernet address settings
 - of frame with dual ports 167, 168
 - of frame with single port 167
 - Fibre Channel port speed 148
 - Fibre Channel topology 148
 - key manager address 204
 - keypress beep 175
 - Loop IDs of drives 144
 - maximum allowable quantity of cartridges in a logical library 139
 - name of logical library 139
 - number of partitions in logical library
 - by using labels 124
 - by using menus 131, 132
 - number of web users 86
 - password for operator panel 77
 - password protection for web screens 81
 - quantity of virtual I/O slots in a logical library 140
 - remote port 161
 - role 83, 84, 85
 - SCSI IDs of drives 144
 - SNMP settings 157, 158, 160, 163
 - SNMP system data 161
 - speed of Ethernet cable 171
 - timeout setting for web interface 82
 - web password 87
 - web user settings 87
- channel calibration
 - 3592 Tape Drives 12, 13
 - LTO Ultrium Tape Drives 9
- circuit breakers 319

- cleaning a drive
 - enabling or disabling automatic cleaning 69
 - performing manual cleaning 73
- cleaning cartridge
 - description
 - 3592 Cleaning Cartridge 16, 244, 251
 - LTO Ultrium Cleaning Cartridges 16, 218
 - determining usage 182
 - inserting into library
 - with automatic cleaning disabled 72
 - with automatic cleaning enabled 71
 - ordering
 - 3592 Cleaning Cartridge 263
 - LTO Ultrium Cleaning Cartridges 239
 - removing from library 75
- CM
 - See* cartridge memory
- compatible tape cartridges
 - 3592 Tape Drives 15, 16
 - LTO Ultrium Tape Drives 8, 16, 215
- compressed capacity
 - 3592 Tape Cartridges 243, 248
 - LTO Ultrium Tape Cartridges 216
- configurations, displaying existing logical and physical 116, 117
- configuring a logical library
 - with ALMS 88, 89, 138
 - with partitions
 - by using labels 123, 124
 - by using menus 131
 - description 123
 - using menus 132
 - without partitions, description 119, 123
- configuring the Tape Library Specialist web interface 48
- connections, master console and web 337
- control path
 - adding 155
 - changing 89, 155
 - displaying 154
 - enabling or disabling in a logical library 91
 - removing 155
- control path failover feature
 - installing 143
 - viewing whether installed 201
- controller
 - accessor 315, 318
 - Medium Changer 318
 - operator panel 315, 318
- Controller Area Network (CAN) 318
- creating
 - barcode encryption policy 206, 207
 - cartridge assignment policy 94
 - key manager address 204
 - creating a logical library 138
 - customer engineer (CE) cartridge
 - 3592 Tape Cartridge 244, 253
 - LTO Ultrium Tape Cartridge 213

- customized role, changing 83, 84
- customized web access 83
 - modifying 85

D

- danger notice, definition xiii
- data capacity
 - 3592 Tape Cartridges 2
 - LTO Ultrium Tape Cartridges 2
- data cartridge
 - description
 - 3592 Tape Cartridges 243, 248
 - LTO Ultrium Tape Cartridges 216
 - load and unload cycles
 - 3592 Tape Cartridges 249
 - LTO Ultrium Tape Cartridges 217
 - ordering
 - 3592 Tape Cartridges 263
 - LTO Ultrium Tape Cartridges 239
- data compression, in 3592 Tape Drives 14
- data transfer rate
 - 3592 Tape Drives 2
 - LTO Ultrium Tape Drives 2
- date, changing 174
- deactivating password protection 81
- degaussing tape cartridges
 - 3592 Tape Cartridges 263
 - LTO Ultrium Tape Cartridges 227, 238
- deleting
 - barcode encryption policy 206, 207
 - cartridge assignment policy 94
 - key manager address 204
- depth, of Ultrium 3 Tape Drives 11
- depth, of Ultrium 4 Tape Drives 11
- description of tape library 1
- destination IP address, viewing or changing 161
- determining and changing SNMP trap version 160
- determining problems
 - with 3584 Tape Library 269
 - with 3592 Tape Drives 269
 - with installed tape drives 269
 - with LTO Ultrium Tape Drives 290
- device drivers, supported 18
- DHCP
 - See* Dynamic Host Configuration Protocol (DHCP)
- diagnostic cartridge
 - 3592 Tape Cartridge 25, 244, 253
 - LTO Ultrium Tape Cartridge 25, 213, 219
- disabling
 - ALMS 136
 - authentication trap settings 160
 - automatic drive cleaning 69
 - control path in a logical library 91
 - Ethernet connection 173
 - Ethernet settings 173
 - insert notification setting 177
 - keypress beep 175
 - security for operator panel 77
 - SNMP requests 158
 - SNMP traps 157, 158

- disabling (*continued*)
 - virtual I/O slots 137
- discovering new hardware 141
- display, touchscreen 34
- disposing of a tape cartridge
 - 3592 Tape Cartridges 263
 - LTO Ultrium Tape Cartridges 238
- disposing of the tape library xvi
- documentation, viewing latest 18
- door
 - front and rear 29, 30
 - safety switch 19, 30
- drive and fixed tray assembly compartment
 - Models L23 and D23 338
 - Models L53 and D53 339
- drive and power supply compartment
 - Models L22 and D22 321, 322
 - Models L32 and D32 321, 323
 - Models L52 and D52 321, 324
- drive dump, saving 197
- drive emulation mode for 3592 Tape Drives
 - changing 105, 106
 - viewing 104, 105
- drive firmware, updating 8, 198
- drive logs
 - accessing 197
 - viewing 197
- drive mechanical and electrical reliability, in 3592 Tape Drives 14
- drive serial numbers, accessing VPD for 186
- drive statistics, accessing 191
- dual ac line cords 319, 335, 336
- dual ac power 335
- dual accessors 6, 22
- dual-gripper transport mechanism 315, 317
- Dynamic Host Configuration Protocol (DHCP)
 - role in enabling Ethernet settings 167, 168
 - settings 172

E

- Economy cartridge 243
- Economy WORM cartridge 243
- EEDK
 - See* externally encrypted data key
- EKM
 - See* Encryption Key Manager
- EKM-reported errors 286
- electronic emission notices 375
- element addresses, SCSI 29, 345
- emission notices 375
- enabling
 - ALMS 136
 - authentication trap settings 160
 - control path in a logical library 91
 - drive cleaning
 - automatic 69
 - manual 73
 - encryption 202
 - insert notification setting 177
 - keypress beep 175

- enabling (*continued*)
 - security for operator panel 77
 - SNMP requests 158
 - SNMP traps 157, 158
 - virtual I/O slots 137
- encryption
 - ASC/ASCQ codes 280
 - changing the method 203
 - description 11, 15
 - determining whether a cartridge is encrypted 210
 - EKM-reported errors 286
 - enabling 202
 - key label mapping 208
 - methods of 202
 - rekeying an encrypted cartridge 210
 - setting the method 202, 203
 - setting up 202
 - setting up barcode encryption policy 202
 - setting up internal label encryption policy 202
 - testing a key manager address 204
 - testing a key path 204
 - using 202
 - viewing the method 209
 - working with key manager addresses 204
- encryption key label mapping 208
- end of life (EOL) plan xvi
- enhanced format for recording error-correction codes, in 3592 Tape Drives 14
- enhanced frame control assembly description 336
- entering ALMS license key 135
- environmental notice xvi
- environmental specifications for media
 - 3592 Tape Cartridges 262
 - LTO Ultrium Tape Cartridges 237
- EOL plan xvi
- erasing, LTO Ultrium Tape Cartridges 238
- error log, viewing library and drive 194, 197
- errors
 - EKM-reported 286
 - interpreting SNMP traps 293
 - resetting node cards 185
 - resolving and clearing 269, 290
 - TapeAlert flags
 - supported by 3584 Tape Library 313
 - supported by 3592 Tape Drives 307
 - supported by Ultrium Tape Drives 302
 - viewing drive error logs 197
 - viewing library error log 194
 - with 3584 Tape Library 269
 - with 3592 Tape Drives 269, 278
 - with LTO Ultrium Tape Drives 290
- establishing a cartridge assignment policy 94
- Ethernet connection, disabling 173
- Ethernet ports
 - in medium changer assembly 337

- Ethernet ports (*continued*)
 - in medium changer card pack 320
- Ethernet settings
 - changing address settings
 - of frames with a single port 167
 - of frames with dual ports 167, 168
 - changing speed of Ethernet link 171
 - role of DHCP in enabling 167, 168
 - viewing 165
- existing configuration, displaying 116, 117
- expansion frames, description 3

F

- failure ID messages 278
- FCA
 - See* frame control assembly (FCA)
- Fibre Channel drive
 - changing Loop ID 144
 - displaying Loop ID 143
- Fibre Channel port
 - changing 150
 - displaying status 151
 - viewing or changing speed or topology 148
 - viewing settings 150
- FID
 - See* failure ID messages (FID)
- firmware version
 - accessor controller card 184
 - Medium Changer assembly 184
 - Medium Changer card pack card 184
 - motor driver assembly card 184
 - operator panel assembly card 184
- firmware, updating library and drive 8, 195, 198
- fixed tray assembly
 - location in Models L23 and D23 338
 - location in Models L53 and D53 339
- fixing an unknown VOLSER for a tape cartridge 77
- frame
 - description 3, 20
 - maximum quantity in library 1, 3
 - performing an inventory on 109
- frame control assembly (FCA) 319
- front door 19, 29
- full capacity expansion feature, viewing whether installed 201
- full capacity On Demand, installing 143
- functions of tape library
 - flowchart of operator panel functions 45
 - flowchart of web functions 47

G

- gaps, detecting between drive element addresses 89, 93
- gateway address, viewing and changing 167, 168
- generation of Ultrium cartridge, determining 9

gets and get-responses, enabling and disabling 158

H

HA1 frame, description 6, 22
handling cartridges
 3592 Tape Cartridges 258
 LTO Ultrium Tape Cartridges 227
hardware
 adding and removing
 to or from multiple logical libraries 125
 to or from one logical library 120
 discovering new 141
hazards, possible safety xv
heat output, of Ultrium 3 Tape Drives 11
heat output, of Ultrium 4 Tape Drives 11
height, of Ultrium 3 Tape Drives 11
height, of Ultrium 4 Tape Drives 11
hiding, host application's view of cartridges for export 140
high availability (HA1) frame, description 6
high availability frame 22
high resolution tape directory, in 3592 Tape Drives 13
High Voltage Differential (HVD) SCSI interface 27
host, supported 17
HVD
 See High Voltage Differential (HVD) SCSI interface

I

I/O slots, enabling or disabling virtual 137
IDs
 drive Loop ID
 changing 144
 displaying 143
 drive SCSI
 changing 144
 displaying 143
incoming main ac power
 in enhanced frame control assembly 336
 in frame control assembly 319
initializing volume serial number of tape cartridge 76
input/output (I/O) station
 addresses of physical I/O slots 31
 description 19, 30
 determining status 98, 99, 100
 logical addresses of storage slots 362
insert notification setting, enabling or disabling 177
inserting data and scratch cartridges into tape library
 manually 54, 61, 177
 using I/O station 54
 when virtual I/O slots are disabled 56

inserting data and scratch cartridges into tape library (*continued*)
 using I/O station (*continued*)
 when virtual I/O slots are enabled 59
insertion guide, on LTO Ultrium Tape Cartridges 216, 217
inspecting
 3592 Tape Cartridges 259
 LTO Ultrium Tape Cartridges 226
installing control path failover feature 143
installing intermediate or full capacity On Demand feature 143
interfaces, supported
 3592 Tape Drives 28
 LTO Ultrium Tape Drives 27
intermediate capacity expansion feature, viewing whether installed 201
intermediate capacity On Demand feature, installing 143
internal label policy for encryption setting up 202
inventory
 performing on frame 109
 performing on library 108
IP address
 viewing and changing destination 161
 viewing and changing Ethernet 165, 167, 168

J

JA cartridge type 243
JB cartridge type 243
jewel case 225
JJ cartridge type 243
JR cartridge type 243
JW cartridge type 243
JX cartridge type 243

K

key manager address
 adding 204
 changing 204
 creating 204
 deleting 204
 testing 202, 204
 use in setting up encryption 202
key path, testing 204
keylock and keys 29, 30
keypress beep, enabling and disabling 175
keys
 in encryption 202
 on touchscreen 34
 Pause key 37

L

label
 for 3592 Tape Cartridges 249
 for logical libraries 123, 124
 for LTO Ultrium Tape Cartridges 217

label area
 on 3592 Tape Cartridges 248, 249
 on LTO Ultrium Tape Cartridges 216, 217
laser safety and compliance notice xv
LCD
 See liquid crystal display (LCD) touchscreen
leader pin
 in 3592 Tape Cartridges 251
 in LTO Ultrium Tape Cartridges 217
 reattaching to Ultrium tape 233
leader pin reattachment kit ordering
 for 3592 Tape Cartridges 266
 for LTO Ultrium Tape Cartridges 239
 using
 for 3592 Tape Cartridges 260
 for LTO Ultrium Tape Cartridges 233
left service bay 22
library
 firmware, updating 8, 195
 frames, description 3, 19, 20
 logs, viewing 187, 194
 power switch 34
 statistics, accessing 193
library-managed encryption 202
license key, entering ALMS 135
lighting, inside the library 21
Linear Tape-Open (LTO) Cartridge Memory (CM) 217
link, changing speed of Ethernet 171
liquid crystal display (LCD) touchscreen 34
loading cartridges into tape library
 cleaning cartridges
 with automatic cleaning disabled 72
 with automatic cleaning enabled 71
 data and scratch cartridges manually 61
 using I/O station when virtual I/O slots are disabled 56
 using I/O station when virtual I/O slots are enabled 59
location of SCSI elements 345
location of tape cartridge, determining 102, 103
locking the operator panel 78
logical and physical addresses 28, 29
logical library
 adding 138
 adding a drive to 89, 90
 bar code labels, attaching and removing 127
 changing
 maximum allowable quantity of cartridges in 139
 name of 139
 quantity of virtual I/O slots in 140
 configuring with partitions
 by using labels 123, 124, 125
 by using menus 131, 132

- logical library (*continued*)
 - configuring without partitions 119, 120
 - creating 138
 - detecting gaps between drive element addresses 89, 93
 - displaying an existing configuration 116, 117
 - enabling or disabling a control path in 91
 - removing 138
 - removing a drive from 89
 - sharing drives 89, 91
 - viewing dedicated drives in 89
- logs, accessing
 - drive 197
 - library 187, 194
- Loop ID
 - changing 144
 - displaying 143
- Low Voltage Differential (LVD) SCSI interface 27
- low-power mode 9
- LTO canister assembly, fibre hot swap 325
- LTO Ultrium Tape Cartridges, description 16, 213
- LTO Ultrium Tape Drives, description 27
- LVD
 - See* Low Voltage Differential (LVD) SCSI interface

M

- mainframe, connection of 3584 Tape Library to 1
- Management Information Base 293
- manual cleaning 73
- master console connection 337
- media
 - mixing in drives and frames 16
 - ordering
 - 3592 Tape Cartridges 263
 - LTO Ultrium Tape Cartridges 239
 - using
 - with 3592 Tape Drives 243
 - with LTO Ultrium Tape Drives 213, 215
- Media Information Message (MIM) 289
- media reuse, in 3592 Tape Drives 13
- media-type identifier for Ultrium cartridges 220
- Medium Changer assembly (MCA) 336, 337
- Medium Changer assembly node card 184
- Medium Changer card pack (MCP) 318, 319, 320
- Medium Changer card pack node card 184
- MIB
 - See* Management Information Base (MIB)
- MIM
 - See* Media Information Message (MIM)

- Model D22
 - description 4
- Model D23
 - description 4
- Model D32
 - description 4
- Model D52
 - description 4
- Model D53
 - description 4
- Model HA1, description 4
- Model L32
 - description 4
- Models L22 and D22
 - capacity 341
 - description 20
 - location and addresses of SCSI elements 345, 347, 349
- Models L22 and L23
 - description 3
- Models L23 and D23
 - capacity 341
 - description 20
 - location and addresses of SCSI elements 345, 347, 349
- Models L32 and D32
 - capacity 342
 - description 20
 - location and addresses of SCSI elements 355
 - with Capacity Expansion feature 345, 353
 - without Capacity Expansion feature 345, 351
- Models L52 and D52
 - capacity 343
 - description 20
 - location and addresses of SCSI elements 345, 357, 359
- Models L52 and L53
 - description 4
- Models L53 and D53
 - capacity 343
 - description 20
 - location and addresses of SCSI elements 345, 357, 359
- motor driver assembly node card 184
- mount history of tape cartridges, accessing 188
- moving a specific tape cartridge 110
- mtlib program, using 18
- multiple subsystem and automation support, in 3592 Tape Drives 14

N

- native capacity
 - 3592 Tape Cartridges 248
 - LTO Ultrium Tape Cartridges 216
- new web user, adding 86
- node card
 - accessing vital product data 184
 - resetting 185
- node names, viewing World Wide 147
- non-addressable cartridge storage slot 25

- non-communicating drives, determining 89
- nondisruptive drive firmware update 8, 198, 244
- notices 371

O

- offboard data string searching, in 3592 Tape Drives 15
- on-the-fly adaptive equalization, in 3592 Tape Drives 13
- operating procedures for tape library
 - flowchart of operator panel functions 45
 - flowchart of web functions 47
- operating systems, supported 17
- operator panel
 - changing password for 77
 - creating password for 77
 - creating timeout period 77
 - description 34
 - enabling or disabling security for 77
 - location 19
 - locking or unlocking 78
 - using 47
- operator panel assembly node card 184
- operator panel controller 315, 318
- ordering tape cartridges and supplies
 - 3592 Tape Cartridges
 - by 3599 Tape Media method 264
 - by part number 266
 - LTO Ultrium Tape Cartridges 239

P

- password
 - changing
 - administrator's web 80
 - operator panel 77
 - web 87
 - creating operator panel 77
 - entering operator panel 78
- password protection
 - activating or deactivating 81
 - choosing type of 82
- Pause key 37
- physical and logical addresses 28, 29
- ping test, for key manager address 202, 204
- pivot assembly 317
- port names, viewing World Wide 146
- port speed, viewing or changing Fibre Channel 148
- port statistics, accessing 192
- position-based LEOT reporting, in 3592 Tape Drives 14
- power cycle, performing remote 200
- power management, in Ultrium Tape Drives 9
- power specifications, Ultrium 3 or 4 Tape Drives 11
- power structure
 - enhanced frame control assembly 336
 - frame control assembly 319

- power supplies
 - in enhanced frame control assembly 336
 - in frame control assembly 319, 336
- power supply compartment
 - Models L22 and D22 321, 322
 - Models L32 and D32 321, 323
 - Models L52 and D52 321, 324
- power switch door 34
- power switch, library 34
- power-on indicator 34
- powering-off the tape library 53
- powering-on the tape library 52
- preferred zone for accessor, setting, viewing, or changing 7, 141
- problems, determining and resolving
 - with 3584 Tape Library 269
 - with 3592 Tape Drives 269
 - with encryption 277, 278, 279, 280, 286
 - with LTO Ultrium Tape Drives 290
- product label, on 3592 Tape Cartridges 248, 249

R

- rail system 315, 316
- rear door 30
- recording method
 - of 3592 Tape Drives 248
 - of Ultrium Tape Drives 216
- recursive accumulating backhitchless flush, in 3592 Tape Drives 13
- recycling of tape library xvi
- redundant drive power
 - Models L22 and D22 321, 322
 - Models L32 and D32 321, 323
 - Models L52 and D52 321, 324
- redundant power supply, removing or replacing
 - Models L22, D22, L52, or D52 hot swap 333
 - Models L32 or D32 hot swap 331
- rekeying an encrypted cartridge 210
- relative humidity specification for media
 - 3592 Tape Cartridges 262
 - LTO Ultrium Tape Cartridges 237
- remote port, viewing and changing 161
- remote power cycle, performing 200
- removing
 - barcode encryption policy 207
 - cartridge assignment policy 94
 - cartridges from a drive 67
 - cartridges from library
 - cleaning cartridges 75
 - data and scratch cartridges 39, 63
 - using I/O station and virtual I/O slots are enabled 65
 - control path 155
 - drive
 - from logical library 89, 92
 - from physical library 92
 - drive canister assembly
 - 3592 Fibre Channel drives 328
 - LTO Fibre Channel 325
 - logical library 138

- removing (*continued*)
 - redundant power supply for Models L22, D22, L52, or D52 333
 - redundant power supply for Models L32 or D32 331
 - scratch encryption policy 206
 - web user 87
- replacing
 - drive canister assembly
 - 3592 Fibre Channel drives 328
 - LTO Fibre Channel drives 325
 - redundant power supply for Models L22, D22, L52, or D52 333
 - redundant power supply for Models L32 or D32 331
- request community name, viewing and changing 164
- resetting node cards 185
- resolving problems
 - with 3584 Tape Library 269
 - with 3592 Tape Drives 269
 - with encryption 277, 278, 279, 280, 286
 - with LTO Ultrium Tape Drives 290
- right service bay 22
- role
 - changing customized web 83, 84
 - changing customized web access 85
 - customized web access 83
- RS-422 interface 320

S

- safety notices xiii
- safety switch, door 19, 30
- safety, possible hazards xv
- SAN
 - See* Storage Area Network (SAN)
- SARS
 - See* Statistical Analysis and Reporting System (SARS)
- scalability of tape library 3
- scanner speed, adjusting library 199
- scratch cartridge, definition 54
- SCSI
 - See* small computer systems interface (SCSI)
- SCSI elements, addresses and locations 345
- SCSI ID, displaying 143
- security
 - changing
 - administrator's web password 80
 - password for operator panel 77
 - user's web password 87
 - choosing type of password protection 82
 - controlling data 238, 263
 - creating password for operator panel 77
 - enabling or disabling for operator panel 77
 - entering password for operator panel 78
 - establishing administrator's web password 79
- segmentation, for 3592 data cartridges 246
- sending SNMP test trap 163
- serial number
 - accessor controller node card 184
 - cartridge
 - for 3592 Tape Cartridges 254
 - for LTO Ultrium Tape Cartridges 220
 - drive 186
 - Medium Changer assembly node card 184
 - Medium Changer card pack node card 184
 - motor driver assembly node card 184
 - operator panel assembly node card 184
- servers, supported 17
- service bays, description 6, 22
- Service Information Message (SIM) 289
- setting
 - accessor's preferred zone 141
 - drive emulation for 3592 Tape Drives 105
 - encryption method of drive 202, 203
 - insert notification 177
 - timeout period for operator panel 77
 - timeout period for web interface 82
 - version of an SNMP trap 160
 - write-protect switch
 - on 3592 Data Cartridges 257
 - on LTO Ultrium Data Cartridges 223
- settings
 - calibration for 3592 Tape Drives 13
 - enabling or disabling authentication trap 160
 - modifying web user's 87
 - using DHCP server 172
 - viewing or changing Ethernet 165
 - viewing or changing Fibre Channel port 150
- sharing drives in a logical library 91
- SIM
 - See* Service Information Message (SIM)
- Simple Network Management Protocol
 - determining and changing trap version 160
 - enabling or disabling SNMP requests 158
 - interpreting a trap 293
 - monitoring server 157
 - sending a test trap 163
 - setting
 - destination IP address 161
 - trap community name 163
 - version of a trap 160
 - traps, enabling and disabling 157
 - viewing or changing
 - request community name 164
 - system data 161
 - viewing the version of a trap 160
- small computer systems interface (SCSI)
 - element addresses 29, 345
 - IDs
 - changing drive 144

- small computer systems interface (SCSI)
 - (*continued*)
 - IDs (*continued*)
 - displaying drive 143
 - storage elements, locations and addresses 345
- SMI-S
 - See Storage Management Initiative - Specification (SMI-S)
- SMI-S support 200
- SNMP
 - See Simple Network Management Protocol (SNMP)
- Specialist web interface, configuring 48
- specifications
 - for bar code and bar code label
 - 3592 Tape Cartridges 254
 - LTO Ultrium Tape Cartridges 220
 - for media
 - 3592 Tape Cartridges 262
 - LTO Ultrium Tape Cartridges 237
- speed matching
 - in 3592 Tape Drives 12, 13
 - in LTO Ultrium Tape Drives 9
- speed of Ethernet link, changing 171
- stacking tape cartridges
 - 3592 Tape Cartridges 259
 - LTO Ultrium Tape Cartridges 227
- Statistical Analysis and Reporting System (SARS) 11
- statistics, accessing
 - cartridge 188
 - drive 191
 - library 193
 - port 192
- status, determining
 - cartridge accessor 95
 - Fibre Channel port 151
 - I/O station 98, 99, 100
 - storage slot 100
 - storage slots 100, 101
 - tape drive 96, 97
- Storage Area Network 272, 278
- storage elements
 - determining addresses with ALMS
 - disabled
 - data transfer elements 363
 - import/export elements 362
 - storage elements 361
 - determining addresses with ALMS
 - enabled
 - data transfer elements 365
 - import/export elements 364
 - storage elements 364
 - effects of ALMS on addresses 345
- storage slot
 - cartridge, description 24
 - changing quantity in logical library 139
 - determining status 100, 101
 - in I/O station 30
- subnet mask address, viewing and changing 167, 168
- supplies, ordering
 - 3592 Tape Cartridges 263
 - LTO Ultrium Tape Cartridges 239

- supported TapeAlert flags
 - for 3584 Tape Library 313
 - for 3592 Tape Drives 307
 - for Ultrium Tape Drives 302
- system data, viewing or changing
 - SNMP 161
- system-managed encryption 202

T

- tape cartridge
 - assigning data and cleaning cartridges to a logical library 88
 - bar code label for 3592 Tape Cartridges
 - description 254
 - guidelines for using 255
 - ordering 254
 - placement 254
 - specifications 249, 254
 - bar code label for logical library 127
 - bar code label for LTO Ultrium Tape Cartridges
 - description 220
 - guidelines for using 221
 - ordering 241
 - placement 220
 - specifications 220
 - bar code, description and specifications
 - 3592 Tape Cartridges 254
 - LTO Ultrium Data Cartridges 220
 - barcode encryption policy
 - adding 206
 - changing 206
 - creating 206
 - deleting 206
 - bulk loading into library 54, 61
 - capacity
 - 3592 Data Cartridges 243, 248
 - LTO Ultrium Data Cartridges 216
 - cartridge door
 - 3592 Data Cartridges 249
 - LTO Ultrium Data Cartridges 217
 - cartridge life
 - 3592 Data Cartridges 249
 - LTO Ultrium Data Cartridges 217
 - cleaning cartridge
 - 3592 Tape Cartridge 243, 251
 - LTO Ultrium Tape Cartridges 213, 218
 - compatible cartridges
 - with 3592 Tape Drives 16, 243
 - with LTO Ultrium Tape Drives 16, 213, 215
 - customer engineer (CE) cartridge
 - 3592 Tape Cartridge 244, 253
 - LTO Ultrium Tape Cartridge 213
 - data cartridge
 - 3592 Data Cartridges 54, 243, 248
 - LTO Ultrium Data Cartridges 54, 216
 - data security
 - for 3592 Tape Cartridges 263
 - for LTO Ultrium Tape Cartridges 238

- tape cartridge (*continued*)
 - degaussing
 - 3592 Tape Cartridges 263
 - LTO Ultrium Tape Cartridges 227, 238
 - determining location in library 102, 103
 - determining whether encrypted 210
 - diagnostic cartridge
 - 3592 Tape Cartridge 25, 244, 253
 - LTO Ultrium Tape Cartridge 25, 213, 219
 - dimension of LTO Ultrium Data Cartridges 216
 - disposal of
 - 3592 Tape Cartridges 263
 - LTO Ultrium Tape Cartridges 238
 - Economy 243
 - Economy WORM 243
 - handling
 - 3592 Tape Cartridges 258
 - LTO Ultrium Tape Cartridges 227
 - hiding host application's view of queued exports 140
 - inserting cleaning cartridges into library
 - with automatic cleaning
 - disabled 72
 - with automatic cleaning
 - enabled 71
 - inserting data and scratch cartridges into library
 - manually 54, 61
 - using I/O station 54
 - using I/O station when virtual
 - I/O slots are disabled 56
 - using I/O station when virtual
 - I/O slots are enabled 59
 - insertion guide on LTO Ultrium Data Cartridges 217
 - inspecting
 - 3592 Tape Cartridges 259
 - LTO Ultrium Tape Cartridges 226
 - key label mapping for encryption 208
 - labels
 - for 3592 Tape Cartridges 249
 - for LTO Ultrium Tape Cartridges 217
 - leader pin
 - description 217
 - location in 3592 Tape Cartridges 251, 259, 260
 - location in LTO Ultrium Tape Cartridges 217
 - reattaching to Ultrium Tape Cartridge 233
 - repositioning in a 3592 Tape Cartridge 260
 - repositioning in an Ultrium Tape Cartridge 230
 - Linear Tape-Open cartridge memory (LTO-CM) 217
 - load and unload cycles
 - 3592 Data Cartridges 249
 - LTO Ultrium Data Cartridges 217

- tape cartridge (*continued*)
 - loading cleaning cartridges into library
 - with automatic cleaning disabled 72
 - with automatic cleaning enabled 71
 - loading data and scratch cartridges into library
 - using I/O station when virtual I/O slots are disabled 56
 - using I/O station when virtual I/O slots are enabled 59
 - moving a specific cartridge 110
 - ordering
 - 3592 Tape Cartridges 263, 266
 - LTO Ultrium Tape Cartridges 239
 - orientation in storage slot 62
 - product label, 3592 Tape Cartridges 249
 - rekeying an encrypted cartridge 210
 - removing data and scratch cartridges from a drive 67
 - removing from library
 - cleaning cartridges 75
 - data and scratch cartridges 39, 63
 - using I/O station when virtual I/O slots are enabled 65
 - scratch cartridge, description 54
 - searching by VOLSER 102, 103
 - specifications for media
 - 3592 Tape Cartridges 262
 - LTO Ultrium Tape Cartridges 237
 - stacking
 - 3592 Tape Cartridges 259
 - LTO Ultrium Tape Cartridges 227
 - tips for handling
 - 3592 Tape Cartridges 258, 259
 - LTO Ultrium Tape Cartridges 224, 227
 - training for handling
 - 3592 Tape Cartridges 258
 - LTO Ultrium Tape Cartridges 224
 - types of
 - 3592 Tape Cartridges 243
 - Ultrium Tape Cartridges 213
 - unloading data and scratch from a drive 67
 - unloading from library
 - cleaning cartridges 75
 - data and scratch cartridges 39, 63
 - volume serial number, assigning 77
 - volume serial number, fixing unknown 77
 - volume serial number, initializing 76
 - WORM
 - 3592 Tape Cartridge 244, 245
 - LTO Ultrium Tape Cartridge 213, 214
 - write-protect switch
 - 3592 Data Cartridges 249, 257
 - LTO Ultrium Data Cartridges 217, 223
- tape drive
 - 1 Gbps drive 2
 - 2 Gbps drive 2
 - 4 Gbps drive 2
- tape drive (*continued*)
 - 512 MB data buffer with read ahead feature in 3592 Tape Drives 15
 - accessing
 - port statistics 192
 - statistics 191
 - adding
 - to a logical library 90
 - to a physical library 90
 - address
 - logical 29
 - physical 28
 - assigning to logical libraries 89
 - backhitchless backspace in 3592 Tape Drives 13
 - capacity scaling in 3592 Tape Drives 13
 - capacity-based LEOT reporting in 3592 Tape Drives 14
 - changing
 - Loop ID 144
 - SCSI IDs 144
 - changing encryption method 203
 - channel calibration in 3592 Tape Drives 13
 - cleaning
 - automatically 69
 - manually 73
 - compatible cartridges and format with 3592 Tape Drives 16, 243
 - with LTO Ultrium Tape Drives 8, 16, 213, 215
 - data compression in 3592 Tape Drives 14
 - depth of Ultrium 3 Tape Drives 11
 - depth of Ultrium 4 Tape Drives 11
 - description
 - 3592 Tape Drives 8, 11, 25
 - LTO Ultrium Tape Drives 8, 25
 - determining gaps between drive element addresses 89, 93
 - determining non-communicating 89
 - determining status 96, 97
 - device drivers, supported 18
 - displaying
 - Loop ID 143
 - SCSI ID 143
 - drive mechanical and electrical reliability in 3592 Tape Drives 14
 - enabling or disabling automatic cleaning 69
 - encryption 11, 15
 - enhanced format for recording error-correction codes in 3592 Tape Drives 14
 - error logs, viewing 197
 - firmware, updating 8
 - heat output of Ultrium 3 Tape Drives 11
 - heat output of Ultrium 4 Tape Drives 11
 - height of Ultrium 3 Tape Drives 11
 - height of Ultrium 4 Tape Drives 11
 - high resolution tape directory in 3592 Tape Drives 13
 - identifying WORM-capable Ultrium drive 8, 214
- tape drive (*continued*)
 - logical address 363
 - Loop ID
 - changing 144
 - displaying 143
 - maximum quantity
 - 3592 Tape Drives 8
 - in library 1
 - LTO Ultrium Tape Drives 8
 - per frame 8
 - media reuse in 3592 Tape Drives 13
 - multiple subsystem and automation support in 3592 Tape Drives 14
 - offboard data string searching in 3592 Tape Drives 15
 - on-the-fly adaptive equalization, in 3592 Tape Drives 13
 - physical address 28
 - position-based LEOT reporting in 3592 Tape Drives 14
 - power specifications of Ultrium 3 or 4 Tape Drives 11
 - recursive accumulating backhitchless flush in 3592 Tape Drives 13
 - removing from logical or physical library 89, 92
 - removing or replacing
 - 3592 Tape Drives 328
 - LTO Ultrium Tape Drives 325
 - saving a drive dump 197
 - SCSI ID
 - changing 144
 - displaying 143
 - setting encryption method 202, 203
 - sharing in a logical library 89, 91
 - speed matching
 - in 3592 Tape Drives 12, 13
 - in LTO Ultrium Tape Drives 9
 - usage, determining 180
 - using a repaired Ultrium cartridge 230
 - viewing
 - displays 97
 - in logical library 89
 - viewing encryption method 209
 - vital product data, accessing 183
 - weight of Ultrium 3 Tape Drives 11
 - weight of Ultrium 4 Tape Drives 11
 - width of Ultrium 3 Tape Drives 11
 - width of Ultrium 4 Tape Drives 11
 - WORM support
 - for 3592 Tape Drives 14, 245
 - for LTO Ultrium Tape Drives 8, 214
 - tape encryption, description 11, 15
 - Tape Library Specialist web interface
 - flowchart of functions 47
 - navigating through 49
 - overview 48
 - using 51
 - TapeAlert flags
 - supported by 3584 Tape Library 313
 - supported by 3592 Tape Drives 307
 - supported by Ultrium Tape Drive 302
 - temperature specification for media
 - 3592 Tape Cartridges 262

- temperature specification for media
(*continued*)
 - LTO Ultrium Tape Cartridges 237
- testing
 - key manager address 204
 - key path 204
 - SNMP trap 163
- time, changing 174
- timeout setting, choosing
 - for operator panel 77
 - for web 82
- topology, viewing or changing Fibre Channel 148
- touch keys 34
- touchscreen display 34
- trademarks 373
- trap community name, viewing and changing 163
- trap settings, enabling or disabling authentication 160
- traps, SNMP
 - determining and changing version 160
 - interpreting 293
 - sending 163
- TS1120 Tape Drive, description 8
- turning off the tape library 53
- turning on the tape library 52
- Turtlecase 225
- types of Ultrium Tape Cartridges 213

U

- Ultrium Tape Cartridges, description 16, 213
- Ultrium Tape Drives, description 8, 25, 27
- universal cleaning cartridge, ordering for LTO Ultrium Drives 239
- unloading cartridges from library
 - cleaning cartridges 75
 - data and scratch cartridges 39, 63
 - using I/O station when virtual I/O slots are enabled 65
- unloading data and scratch cartridges from a drive 67
- unlocking the operator panel 78
- updating library and drive firmware 8, 195, 198
- usage, determining
 - cartridge accessor 179
 - cleaning cartridge 182
 - drive 180
- user ID
 - adding web 86
 - removing web 87

V

- version number
 - firmware, for node cards 184
 - web, for MCC node card 185
- version of SNMP traps, determining and changing 160
- viewing
 - accessor's preferred zone 141

- viewing (*continued*)
 - dedicated drives in logical library 89
 - drive displays 97
 - drive emulation mode for 3592 Tape Drives 104, 105
 - drive error logs 197
 - encryption method of drive 209
 - Ethernet settings 165
 - Fibre Channel port speed 148
 - Fibre Channel topology 148
 - installed licensed features 201
 - IP address 165
 - library error log 194
 - library log 187
- viewing or changing SNMP system data 161
- virtual I/O slots, enabling or disabling 137
- vital product data
 - for library 182
 - for node cards 184
 - for tape drive 183
- VOLSER
 - See volume serial (VOLSER) number
- volume serial (VOLSER) number
 - assigning 77
 - description
 - 3592 Tape Cartridges 254
 - LTO Ultrium Tape Cartridges 220
 - determining generation of Ultrium cartridge 9
 - determining type of 3592 cartridge 254
 - fixing unknown 77
 - initializing 76
 - location
 - 3592 Tape Cartridges 248
 - LTO Ultrium Tape Cartridges 220
 - use in search for cartridge 102, 103

W

- warranty 367
- web connection 337
- web interface
 - adding a user 86
 - changing a customized web access role 85
 - changing a role 83, 84
 - changing administrator's password 80
 - choosing timeout setting 82
 - customized web access 83
 - flowchart of functions 47
 - modifying a user's settings 87
 - navigating through 49
 - overview 48
 - removing a user 87
 - using 51
 - version number for MCC card 185
 - viewing active sessions 88
- weight, of Ultrium 3 Tape Drives 11
- weight, of Ultrium 4 Tape Drives 11
- wet bulb temperature specification for media
 - 3592 Tape Cartridges 262
 - LTO Ultrium Tape Cartridges 237

- width, of Ultrium 3 Tape Drives 11
- width, of Ultrium 4 Tape Drives 11
- World Wide Node Name, description and viewing 147
- World Wide Port Name, description and viewing 146
- WORM
 - See write once read many (WORM)
- write once read many (WORM) cartridge
 - for 3592 Tape Drives 243
 - for Ultrium 3 and 4 Tape Drives 214
 - for 3592 Tape Drives 14
 - functionality
 - for 3592 Tape Drives 245
 - for Ultrium 3 and 4 Tape Drives 214
 - identifying an Ultrium WORM tape drive 8, 214
- write-protect switch
 - location
 - 3592 Tape Cartridges 248, 249
 - LTO Ultrium Tape Cartridges 216
 - setting
 - 3592 Tape Cartridges 257
 - LTO Ultrium Tape Cartridges 223

X

- X-axis motion assembly 316

Y

- Y-axis motion assembly 316

Z

- zone, setting, viewing, or changing preferred accessor 6, 141

Readers' Comments — We'd Like to Hear from You

IBM System Storage TS3500 Tape Library
Operator Guide
IBM 3584 Tape Library

Publication No. GA32-0560-03

We appreciate your comments about this publication. Please comment on specific errors or omissions, accuracy, organization, subject matter, or completeness of this book. The comments you send should pertain to only the information in this manual or product and the way in which the information is presented.

For technical questions and information about products and prices, please contact your IBM branch office, your IBM business partner, or your authorized remarketer.

When you send comments to IBM, you grant IBM a nonexclusive right to use or distribute your comments in any way it believes appropriate without incurring any obligation to you. IBM or any other organizations will only use the personal information that you supply to contact you about the issues that you state on this form.

Comments:

Thank you for your support.

Submit your comments using one of these channels:

- Send your comments to the address on the reverse side of this form.

If you would like a response from IBM, please fill in the following information:

Name

Address

Company or Organization

Phone No.

E-mail address



Fold and Tape

Please do not staple

Fold and Tape



NO POSTAGE
NECESSARY
IF MAILED IN THE
UNITED STATES

BUSINESS REPLY MAIL

FIRST-CLASS MAIL PERMIT NO. 40 ARMONK, NEW YORK

POSTAGE WILL BE PAID BY ADDRESSEE

International Business Machines Corporation
Information Development
Building 9032-2, Department GZW
9000 South Rita Road
Tucson, Arizona U.S.A. 85744-0002

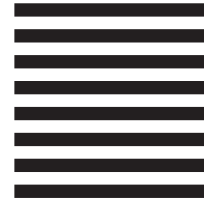

Fold and Tape

Please do not staple

Fold and Tape



Part Number: 95P5558

Printed in USA

H82605

GA32-0560-03



(1P) P/N: 95P5558

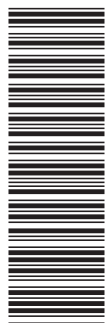

Spine information:



IBM System Storage TS3500 Tape
Library

3584 Tape Library Operator Guide

IBM 3584 Tape Library