

IBM System Storage EXN4000 Storage Expansion Unit



# Hardware and Service Guide



IBM System Storage EXN4000 Storage Expansion Unit



# Hardware and Service Guide

**Note:**

Before using this information and the product it supports, be sure to read the general information in "Notices" on page 57.

The following paragraph does not apply to any country (or region) where such provisions are inconsistent with local law.

INTERNATIONAL BUSINESS MACHINES CORPORATION PROVIDES THIS PUBLICATION "AS IS" WITHOUT WARRANTY OF ANY KIND, EITHER EXPRESS OR IMPLIED, INCLUDING, BUT NOT LIMITED TO, THE IMPLIED WARRANTIES OF MERCHANTABILITY OR FITNESS FOR A PARTICULAR PURPOSE. Some states (or regions) do not allow disclaimer of express or implied warranties in certain transactions; therefore, this statement may not apply to you.

Order publications through your IBM representative or the IBM branch office serving your locality.

© Copyright International Business Machines Corporation 2007. All rights reserved.

US Government Users Restricted Rights – Use, duplication or disclosure restricted by GSA ADP Schedule Contract with IBM Corp.

---

## Safety and environmental notices

This section contains information about:

- “Safety notices and labels”
- “Laser safety” on page vii
- “Rack safety” on page viii
- “Product recycling and disposal” on page xi
- “Battery return program” on page xii
- “Fire suppression systems” on page xiii

---

### Safety notices and labels

When using this product, observe the danger, caution, and attention notices contained in this guide. The notices are accompanied by symbols that represent the severity of the safety condition.

The following sections define each type of safety notice and provide examples.

The following notices and statements are used in IBM® documents. They are listed below in order of increasing severity of potential hazards. Follow the links for more detailed descriptions and examples of the danger, caution, and attention notices in the sections that follow.

- **Note:** These notices provide important tips, guidance, or advice.
- **“Attention notices” on page vii:** These notices indicate potential damage to programs, devices, or data.
- **“Caution notices” on page vi:** These statements indicate situations that can be potentially hazardous to you.
- **“Danger notices”:** These statements indicate situations that can be potentially lethal or extremely hazardous to you. Safety labels are also attached directly to products to warn of these situations.
- In addition to these notices, “Labels” on page vi may be attached to the product to warn of potential hazards.

#### Danger notices

A danger notice calls attention to a situation that is potentially lethal or extremely hazardous to people. A lightning bolt symbol accompanies a danger notice to represent a dangerous electrical condition. A sample danger notice follows.



#### **DANGER**

**An electrical outlet that is not correctly wired could place hazardous voltage on metal parts of the system or the devices that attach to the system. It is the responsibility of the customer to ensure that the outlet is correctly wired and grounded to prevent an electrical shock. (D004)**

A comprehensive danger notice provides instructions on how to avoid shock hazards when servicing equipment. Unless instructed otherwise, follow the procedures in the following danger notice.



## DANGER

When working on or around the system, observe the following precautions:

Electrical voltage and current from power, telephone, and communication cables are hazardous. To avoid a shock hazard:

- Connect power to this unit only with the IBM provided power cord. Do not use the IBM provided power cord for any other product.
- Do not open or service any power supply assembly.
- Do not connect or disconnect any cables or perform installation, maintenance, or reconfiguration of this product during an electrical storm.
- The product might be equipped with multiple power cords. To remove all hazardous voltages, disconnect all power cords.
- Connect all power cords to a properly wired and grounded electrical outlet. Ensure outlet supplies proper voltage and phase rotation according to the system rating plate.
- Connect any equipment that will be attached to this product to properly wired outlets.
- When possible, use one hand only to connect or disconnect signal cables.
- Never turn on any equipment when there is evidence of fire, water, or structural damage.
- Disconnect the attached power cords, telecommunications systems, networks, and modems before you open the device covers, unless instructed otherwise in the installation and configuration procedures.
- Connect and disconnect cables as described below when installing, moving, or opening covers on this product or attached devices.

To Disconnect:

1. Turn off everything (unless instructed otherwise).
2. Remove power cords from the outlet.
3. Remove signal cables from connectors.
4. Remove all cables from devices.

To Connect:

1. Turn off everything (unless instructed otherwise).
2. Attach all cables to devices.
3. Attach signal cables to the connectors.
4. Attach power cords to the outlets.
5. Turn on the devices.

## Labels

As an added precaution, safety labels are often installed directly on products or product components to warn of potential hazards.

The actual product safety labels may differ from these sample safety labels:



(L001)

### DANGER

Hazardous voltage, current, or energy levels are present inside any component that has this label attached. Do not open any cover or barrier that contains this label.

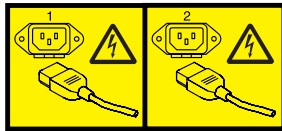



(L003)

### DANGER

Multiple power cords. The product might be equipped with multiple power cords. To remove all hazardous voltages, disconnect all power cords.

## Caution notices

A caution notice calls attention to a situation that is potentially hazardous to people because of some existing condition. A caution notice can be accompanied by different symbols, as in the examples below:

If the symbol is...	It means...
	A hazardous electrical condition with less severity than electrical danger.
	A generally hazardous condition not represented by other safety symbols.
	A hazardous condition due to the use of a laser in the product. Laser symbols are always accompanied by the classification of the laser as defined by the U. S. Department of Health and Human Services (for example, Class I, Class II, and so forth).

## Attention notices

An attention notice indicates the possibility of damage to a program, device, or system, or to data. An exclamation point symbol may accompany an attention notice, but is not required. A sample attention notice follows:



**Attention:** Do not bend a fibre cable to a radius less than 5 cm (2 in.); you can damage the cable. Tie wraps are not recommended for optical cables because they can be easily overtightened, causing damage to the cable.

---

## Laser safety

When using an NVRAM5 or NVRAM6 cluster media converter, the storage system must be installed in a restricted access location.



**CAUTION:**  
This product contains a Class 1M laser. Do not view directly with optical instruments. (C028)

**CAUTION:**  
This product contains a Class 1M laser. Do not view directly with optical instruments. (C0280)

This equipment contains Class 1 laser products, and complies with FDA radiation Performance Standards, 21 CFR Subchapter J and the international laser safety standard IEC 825-2.



**CAUTION:**  
Data processing environments can contain equipment transmitting on system links with laser modules that operate at greater than Class 1 power levels. For this reason, never look into the end of an optical fiber cable or open receptacle. (C027)

**Attention:** In the United States, use only SFP or GBIC optical transceivers that comply with the FDA radiation performance standards, 21 CFR Subchapter J. Internationally, use only SFP or GBIC optical transceivers that comply with IEC standard 825-1. Optical products that do not comply with these standards may produce light that is hazardous to the eyes.

## Usage restrictions

The optical ports of the modules must be terminated with an optical connector or with a dust plug.

## Rack safety

### Rack installation



#### DANGER

Observe the following precautions when working on or around your IT rack system:

- Heavy equipment - personal injury or equipment damage might result if mishandled.
- Always lower the leveling pads on the rack cabinet.
- Always install stabilizer brackets on the rack cabinet.
- To avoid hazardous conditions due to uneven mechanical loading, always install the heaviest devices in the bottom of the rack cabinet. Always install servers and optional devices starting from the bottom of the rack cabinet.
- Rack-mounted devices are not to be used as shelves or work spaces. Do not place objects on top of rack-mounted devices.



- Each rack cabinet might have more than one power cord. Be sure to disconnect all power cords in the rack cabinet when directed to disconnect power during servicing.
- Connect all devices installed in a rack cabinet to power devices installed in the same rack cabinet. Do not plug a power cord from a device installed in one rack cabinet into a power device installed in a different rack cabinet.
- An electrical outlet that is not correctly wired could place hazardous voltage on the metal parts of the system or the devices that attach to the system. It is the responsibility of the customer to ensure that the outlet is correctly wired and grounded to prevent an electrical shock.

**CAUTION:**

- **Do not install a unit in a rack where the internal rack ambient temperatures will exceed the manufacturer's recommended ambient temperature for all your rack-mounted devices.**
- **Do not install a unit in a rack where the air flow is compromised. Ensure that air flow is not blocked or reduced on any side, front, or back of a unit used for air flow through the unit.**
- **Consideration should be given to the connection of the equipment to the supply circuit so that overloading of the circuits does not compromise the supply wiring or overcurrent protection. To provide the correct power connection to a rack, refer to the rating labels located on the equipment in the rack to determine the total power requirement of the supply circuit.**
- *(For sliding drawers.)* **Do not pull out or install any drawer or feature if the rack stabilizer brackets are not attached to the rack. Do not pull out more than one drawer at a time. The rack might become unstable if you pull out more than one drawer at a time.**
- *(For fixed drawers)* **This drawer is a fixed drawer and should not be moved for servicing unless specified by manufacturer. Attempting to move the drawer partially or completely out of the rack may cause the rack to become unstable or cause the drawer to fall out of the rack.**

**(R001 part 2 of 2)**

## Rack relocation (19" rack)

### CAUTION:

Removing components from the upper positions in the rack cabinet improves rack stability during relocation. Follow these general guidelines whenever you relocate a populated rack cabinet within a room or building:

- Reduce the weight of the rack cabinet by removing equipment starting at the top of the rack cabinet. When possible, restore the rack cabinet to the configuration of the rack cabinet as you received it. If this configuration is not known, you must do the following:
  - Remove all devices in the 32U position and above.
  - Ensure that the heaviest devices are installed in the bottom of the rack cabinet.
  - Ensure that there are no empty U-levels between devices installed in the rack cabinet below the 32U level.
  - If the rack cabinet you are relocating is part of a suite of rack cabinets, detach the rack cabinet from the suite.
  - Inspect the route that you plan to take when moving the rack to eliminate potential hazards.
  - Verify that the route that you choose can support the weight of the loaded rack cabinet. Refer to the documentation that came with your rack cabinet for the weight of a loaded rack cabinet.
  - Verify that all door openings are at least 760 x 2030 mm (30 x 80 in.).
  - Ensure that all devices, shelves, drawers, doors, and cables are secure.
  - Ensure that the four leveling pads are raised to their highest position.
  - Ensure that there is no stabilizer bracket installed on the rack cabinet during movement.
  - Do not use a ramp inclined at more than ten degrees.
  - Once the rack cabinet is in the new location, do the following:
    - Lower the four leveling pads.
    - Install stabilizer brackets on the rack cabinet.
    - If you removed any devices from the rack cabinet, repopulate the rack cabinet from the lowest position to the highest position.
  - If a long distance relocation is required, restore the rack cabinet to the configuration of the rack cabinet as you received it. Pack the rack cabinet in the original packaging material, or equivalent. Also, lower the leveling pads to raise the casters off of the pallet and bolt the rack cabinet to the pallet.

(R002)

---

## Product recycling and disposal

This unit must be recycled or discarded according to applicable local and national regulations. IBM encourages owners of information technology (IT) equipment to responsibly recycle their equipment when it is no longer needed. IBM offers a variety of product return programs and services in several countries to assist equipment owners in recycling their IT products. Information on IBM product recycling offerings can be found on IBM's Internet site at:

[www.ibm.com/ibm/environment/products/prp.shtml](http://www.ibm.com/ibm/environment/products/prp.shtml)

Esta unidad debe reciclarse o desecharse de acuerdo con lo establecido en la normativa nacional o local aplicable. IBM recomienda a los propietarios de equipos de tecnología de la información (TI) que reciclen responsablemente sus equipos cuando éstos ya no les sean útiles. IBM dispone de una serie de programas y servicios de devolución de productos en varios países, a fin de ayudar a los propietarios de equipos a reciclar sus productos de TI. Se puede encontrar información sobre las ofertas de reciclado de productos de IBM en el sitio web de IBM [www.ibm.com/ibm/environment/products/prp.shtml](http://www.ibm.com/ibm/environment/products/prp.shtml).

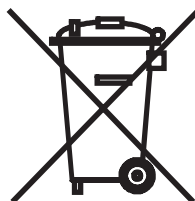

**Notice:** This mark applies only to countries within the European Union (EU) and Norway.

This appliance is labelled in accordance with European Directive 2002/96/EC concerning waste electrical and electronic equipment (WEEE). The Directive determines the framework for the return and recycling of used appliances as applicable throughout the European Union. This label is applied to various products to indicate that the product is not to be thrown away, but rather reclaimed upon end of life per this Directive.

注意：このマークは EU 諸国およびノルウェーにおいてのみ適用されます。

この機器には、EU 諸国に対する廃電気電子機器指令 2002/96/EC(WEEE) のラベルが貼られています。この指令は、EU 諸国に適用する使用済み機器の回収とリサイクルの骨子を定めています。このラベルは、使用済みになった時に指令に従って適正な処理をする必要があることを知らせるために種々の製品に貼られています。

Remarque : Cette marque s'applique uniquement aux pays de l'Union Européenne et à la Norvège.

L'étiquette du système respecte la Directive européenne 2002/96/EC en matière de Déchets des Equipements Electriques et Electroniques (DEEE), qui détermine les dispositions de retour et de recyclage applicables aux systèmes utilisés à travers l'Union européenne. Conformément à la directive, ladite étiquette précise que le produit sur lequel elle est apposée ne doit pas être jeté mais être récupéré en fin de vie.

In accordance with the European WEEE Directive, electrical and electronic equipment (EEE) is to be collected separately and to be reused, recycled, or recovered at end of life. Users of EEE with the WEEE marking per Annex IV of the WEEE Directive, as shown above, must not dispose of end of life EEE as unsorted municipal waste, but use the collection framework available to customers for the return, recycling and recovery of WEEE. Customer participation is important to minimize any potential effects of EEE on the environment and human health due to the potential presence of hazardous substances in EEE. For proper collection and treatment, contact your local IBM representative.

---

## Battery return program

This product may contain sealed lead acid, nickel cadmium, nickel metal hydride, lithium, or lithium ion battery. Consult your user manual or service manual for specific battery information. The battery must be recycled or disposed of properly. Recycling facilities may not be available in your area. For information on disposal of batteries outside the United States, contact your local waste disposal facility or go to the following Web site:

[www.ibm.com/ibm/environment/products/batteryrecycle.shtml](http://www.ibm.com/ibm/environment/products/batteryrecycle.shtml)

In the United States, IBM has established a return process for reuse, recycling, or proper disposal of used IBM sealed lead acid, nickel cadmium, nickel metal hydride, and other battery packs from IBM Equipment. For information on proper disposal of these batteries, contact IBM at 1-800-426-4333. Please have the IBM part number listed on the battery available prior to your call.

For Taiwan:



廢電池請回收

## For the European Union:

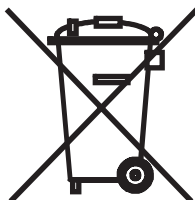

**Note:** This mark applies only to countries within the European Union (EU).

Batteries or packaging for batteries are labeled in accordance with European Directive 2006/66/EC concerning batteries and accumulators and waste batteries and accumulators. The Directive determines the framework for the return and recycling of used batteries and accumulators as applicable throughout the European Union. This label is applied to various batteries to indicate that the battery is not to be thrown away, but rather reclaimed upon end of life per this Directive.

In accordance with the European Directive 2006/66/EC, batteries and accumulators are labeled to indicate that they are to be collected separately and recycled at end of life. The label on the battery may also include a chemical symbol for the metal concerned in the battery (Pb for lead, Hg for mercury and Cd for cadmium). Users of batteries and accumulators must not dispose of batteries and accumulators as unsorted municipal waste, but use the collection framework available to customers for the return, recycling and treatment of batteries and accumulators. Customer participation is important to minimize any potential effects of batteries and accumulators on the environment and human health due to the potential presence of hazardous substances. For proper collection and treatment, contact your local IBM representative.

---

## Fire suppression systems

A fire suppression system is the responsibility of the customer. The customer's own insurance underwriter, local fire marshal, or a local building inspector, or both, should be consulted in selecting a fire suppression system that provides the correct level of coverage and protection. IBM designs and manufactures equipment to internal and external standards that require certain environments for reliable operation. Because IBM does not test any equipment

for compatibility with fire suppression systems, IBM does not make compatibility claims of any kind nor does IBM provide recommendations on fire suppression systems.

---

# Contents

<b>Safety and environmental notices</b> . . . . .	<b>iii</b>
Safety notices and labels . . . . .	iii
Danger notices . . . . .	iii
Labels . . . . .	vi
Caution notices . . . . .	vi
Attention notices . . . . .	vii
Laser safety . . . . .	vii
Usage restrictions . . . . .	vii
Rack safety . . . . .	viii
Rack installation . . . . .	viii
Rack relocation (19" rack). . . . .	x
Product recycling and disposal. . . . .	xi
Battery return program . . . . .	xii
For the European Union: . . . . .	xiii
Fire suppression systems . . . . .	xiii
<b>Figures</b> . . . . .	<b>xix</b>
<b>Tables</b> . . . . .	<b>xxi</b>
<b>About this document.</b> . . . . .	<b>xxiii</b>
Who should read this document . . . . .	xxiii
Supported features . . . . .	xxiii
How this document is organized . . . . .	xxiii
Getting information, help, and service . . . . .	xxiv
Before you call . . . . .	xxiv
Using the documentation . . . . .	xxv
Web sites . . . . .	xxv
Hardware service and support . . . . .	xxv
Supported servers and operating systems . . . . .	xxv
Firmware updates . . . . .	xxv
Conventions and terminology used in this document . . . . .	xxvi
Terminology . . . . .	xxvi
Command conventions . . . . .	xxvii
Formatting conventions . . . . .	xxvii
Keyboard conventions . . . . .	xxvii
How to send your comments . . . . .	xxviii
<b>Chapter 1. Preparing for the installation</b> . . . . .	<b>1</b>
Required manuals, tools and equipment . . . . .	1
Required tools and equipment for installation . . . . .	1
Handling static-sensitive devices . . . . .	1
Planning and organizing the installation. . . . .	2
Hardware specifications . . . . .	3
Checking shipment package contents . . . . .	4

Rules for installing expansion units in a rack . . . . .	4
Guide to the installation process . . . . .	5
Before you begin your installation . . . . .	7
Expansion unit numbering . . . . .	7
Speed setting . . . . .	9
Drive addressing . . . . .	9
Supported disk drives . . . . .	10
Drive bay requirements . . . . .	10
<b>Chapter 2. Connecting an expansion unit . . . . .</b>	<b>13</b>
Handling fiber-optic cables . . . . .	13
Connecting expansion units . . . . .	14
Expansion unit cabling requirements . . . . .	14
Connecting the expansion unit directly to the N series storage system . . . . .	14
Connecting the expansion unit to other expansion units . . . . .	15
Grounding expansion units. . . . .	15
Connecting the expansion unit to a power source . . . . .	15
Hot-adding an expansion unit to an existing loop . . . . .	15
Error messages . . . . .	16
Hot-adding an EXN4000 to an existing loop . . . . .	16
Hot-adding an EXN4000 to an existing adapter in your system. . . . .	17
<b>Chapter 3. Monitoring the expansion unit . . . . .</b>	<b>21</b>
Monitoring the front operation panel . . . . .	21
Location of LEDs . . . . .	22
Monitoring the disk shelf ID . . . . .	22
LED status on the front operation panel . . . . .	22
Front operation panel console error messages. . . . .	23
Monitoring the ESH4 modules. . . . .	24
Location of the module LEDs . . . . .	24
LED status on the ESH4. . . . .	25
ESH4 console error messages . . . . .	25
Monitoring the ESH4. . . . .	27
Sample output . . . . .	27
Description of hub status information . . . . .	27
Shelf state . . . . .	27
ESH4 state . . . . .	28
ESH4 port state. . . . .	28
Hub statistic. . . . .	29
Monitoring the power supply . . . . .	31
Location of LEDs . . . . .	31
Power supply console error messages . . . . .	32
Monitoring the Fibre Channel disk . . . . .	33
Location of LEDs . . . . .	33
LED status on the Fibre Channel disks . . . . .	33
<b>Chapter 4. Replacing expansion unit devices. . . . .</b>	<b>35</b>
Removing an expansion unit . . . . .	35
Removing an expansion unit from a single expansion unit configuration . . . . .	35
Removing an expansion unit from a loop . . . . .	36

Replacing a disk in an expansion unit . . . . .	37
Preparing to replace a disk . . . . .	38
Removing a disk . . . . .	38
Installing a disk . . . . .	39
Replacing a power supply in an expansion unit . . . . .	39
Rules for replacing power supplies . . . . .	39
Removing a power supply . . . . .	40
Installing a power supply . . . . .	40
Replacing an ESH4 module. . . . .	41
Connectors in an ESH4 . . . . .	41
For detailed information. . . . .	41
Removing a module . . . . .	42
Installing a module . . . . .	42
Hot-swapping a module. . . . .	42
<b>Appendix A. Recommended power line sizes. . . . .</b>	<b>45</b>
Recommended AC power line sizes . . . . .	45
<b>Appendix B. FRU/CRU and power cord list for N series products. . . . .</b>	<b>47</b>
FRU/CRU list for N series products . . . . .	47
Power cord list for N series products . . . . .	47
<b>Appendix C. IBM System Storage N series documentation . . . . .</b>	<b>51</b>
N7000 series systems library . . . . .	51
N5000 series systems library . . . . .	51
N3300 and N3600 storage systems library . . . . .	51
N3700 storage system library . . . . .	51
EXN1000, EXN2000 and EXN4000 expansion units library . . . . .	52
Data ONTAP 7.2 filer library . . . . .	52
Data ONTAP 7.1 filer library . . . . .	53
Data ONTAP 7.2 gateway systems library . . . . .	53
Data ONTAP 7.1 gateway systems library . . . . .	54
Other N series and N series-related documents . . . . .	54
<b>Notices . . . . .</b>	<b>57</b>
Trademarks . . . . .	58
Important notes . . . . .	59
Electronic emission notices . . . . .	60
Federal Communications Commission (FCC) Class A Statement . . . . .	60
Industry Canada Class A Emission Compliance Statement . . . . .	61
Avis de conformité à la réglementation d'Industrie Canada . . . . .	61
European Union (EU) Electromagnetic Compatibility Directive . . . . .	61
Australia and New Zealand Class A statement . . . . .	61
Germany Electromagnetic Compatibility Directive . . . . .	62
People's Republic of China Class A Electronic Emission Statement. . . . .	62
Taiwan Class A warning statement . . . . .	63
Japan VCCI Class A ITE Electronic Emission Statement . . . . .	63
Korean Class A Electronic Emission Statement . . . . .	63
Power cords . . . . .	63

**Index . . . . . 65**

---

## Figures

1.	Shelf ID label . . . . .	8
2.	Expansion unit shelf ID and speed switch . . . . .	9
3.	Disk shelf IDs and drive addresses . . . . .	10
4.	Front panel LEDs . . . . .	22
5.	LED indications of normal and fault conditions . . . . .	23
6.	Location of the LEDs for an ESH4. . . . .	24
7.	EXN4000 rear panel quick reference card . . . . .	25
8.	Location of power supply LEDs . . . . .	32
9.	Fibre Channel disk. . . . .	33
10.	Third sheet of the quick reference cards. . . . .	34
11.	Cam mechanism . . . . .	40



---

## Tables

1.	EXN4000 physical characteristics and environmental requirements . . . . .	3
2.	EXN4000 electrical requirements . . . . .	4
3.	Expansion unit installation process . . . . .	6
4.	Stages of enclosure services monitoring . . . . .	11
5.	N series storage system console error messages . . . . .	16
6.	N series storage system error messages . . . . .	23
7.	ESH4 console error messages . . . . .	26
8.	Shelf status responses . . . . .	28
9.	ESH4 status responses . . . . .	28
10.	ESH4 status responses . . . . .	28
11.	Hub statistic responses . . . . .	29
12.	Power supply console error messages . . . . .	32
13.	Recommended conductor size for 2% voltage drop . . . . .	45
14.	American Wire Gauge (AWG) to Harmonized Cordage . . . . .	45



---

## About this document

This guide provides general information about the IBM System Storage™ EXN4000 Storage Expansion Unit (model number 2863-004). This guide also includes a roadmap on the installation, and information on managing the expansion unit that connects to N series storage systems.

Compliance ID 2863-NAS covers the following models: 2863-A10, 2863-A20, 2863-001, and 2863-004.

---

## Who should read this document

This document is for customer use. It addresses setup, operation, and servicing of the EXN4000 Storage Expansion Unit (model number 2863-004). This document is intended to provide information to customers, operators, administrators, installers, and service personnel.

---

## Supported features

IBM N series products are driven by NetApp® Data ONTAP® software. Some features described in the product software documentation are neither offered nor supported by IBM. Please contact your local IBM representative or reseller for further details.

Information about supported features can also be found at the following Web site:

[www.ibm.com/storage/support/nas/](http://www.ibm.com/storage/support/nas/)

A listing of currently available N series products and features can be found at the following Web site:

[www.ibm.com/storage/nas/](http://www.ibm.com/storage/nas/)

---

## How this document is organized

This document contains the following chapters:

- Chapter 1, “Preparing for the installation,” on page 1 describes the preparation requirements for first-time installation of the IBM EXN4000 Storage Expansion Unit (model number 2863-004).
- Chapter 2, “Connecting an expansion unit,” on page 13 describes how to connect a single EXN4000 expansion unit or a loop of EXN4000 expansion

units to a supported N series storage system, how to ground your system, and how to connect your system to power.

- Chapter 3, “Monitoring the expansion unit,” on page 21 describes how to monitor the EXN4000 expansion unit from the error messages displayed on the console that is connected to the N series storage system and identifies the location of the various LEDs on the EXN4000 expansion unit.
- Chapter 4, “Replacing expansion unit devices,” on page 35 describes how to replace EXN4000 expansion units in a rack, disks in an EXN4000 expansion unit, and other devices.
- Appendix A, “Recommended power line sizes,” on page 45 describes the recommended AC power line lengths for the EXN4000.
- Appendix B, “FRU/CRU and power cord list for N series products,” on page 47 lists the feature codes for the power cords for the EXN4000.
- Appendix C, “IBM System Storage N series documentation,” on page 51 lists the publications in the IBM N series documentation library.

---

## Getting information, help, and service

If you need help, service, or technical assistance or just want more information about IBM products, you will find a wide variety of sources available from IBM to assist you. This section contains information about where to go for additional information about IBM and IBM products, what to do if you experience a problem with your IBM N series product, and whom to call for service, if it is necessary.

The following applies in Taiwan:

IBM Taiwan Product Service Contact Info:  
IBM Taiwan Corporation  
3F, No 7, Song Ren Rd., Taipei Taiwan  
Tel: 0800-016-888

台灣IBM 產品服務聯絡方式：  
台灣國際商業機器股份有限公司  
台北市松仁路7號3樓  
電話：0800-016-888

### Before you call

Before you call, make sure that you have taken these steps to try to solve the problem yourself:

- Check all cables to make sure that they are connected.
- Check the power switches to make sure that the system is turned on.

- Use the troubleshooting information in your system documentation and use the diagnostic tools that come with your system.
- Refer to the IBM Support Web site for information on known problems and limitations.

## Using the documentation

Information about the N series product and Data ONTAP software is available in printed documents and a documentation CD that comes with your system. The same documentation is available as PDF files on the IBM NAS support Web site:

[www.ibm.com/storage/support/nas/](http://www.ibm.com/storage/support/nas/)

## Web sites

IBM maintains pages on the World Wide Web where you can get the latest technical information and download device drivers and updates.

- For N series product information, go to the following Web site:  
[www.ibm.com/storage/nas/](http://www.ibm.com/storage/nas/)
- For N series support information, go to the following Web site:  
[www.ibm.com/storage/support/nas/](http://www.ibm.com/storage/support/nas/)
- For AutoSupport information, go to the following Web site:  
[www.ibm.com/storage/support/nas/](http://www.ibm.com/storage/support/nas/)
- You can order publications through the IBM Publications Ordering System at the following Web site:  
[www.elink.ibmmlink.ibm.com/public/applications/publications/cgi-bin/pbi.cgi/](http://www.elink.ibmmlink.ibm.com/public/applications/publications/cgi-bin/pbi.cgi/)

## Hardware service and support

You can receive hardware service through IBM Integrated Technology Services. Visit the following Web site for support telephone numbers:

[www.ibm.com/planetwide/](http://www.ibm.com/planetwide/)

## Supported servers and operating systems

IBM N series products attach to many servers and many operating systems. To determine the latest supported attachments, visit the following Web site and access the IBM System Storage™ N series interoperability matrix:

[www.ibm.com/storage/support/nas/](http://www.ibm.com/storage/support/nas/)

## Firmware updates

As with all devices, it is recommended that you run the latest level of firmware, which is embedded in DataONTAP. If there are changes, they will be posted to the following Web site:

[www.ibm.com/storage/support/nas/](http://www.ibm.com/storage/support/nas/)

**Note:** If you do not see new changes on the Web site, you are running the latest level of firmware.

Verify that the latest level of firmware is installed on your machine before contacting IBM for technical support.

---

## Conventions and terminology used in this document

This guide uses the following terminology, command conventions, format conventions and keyboard conventions:

### Terminology

In this and other IBM N series documents, the term *filer* or *storage system* describes IBM N series models that either contain internal disk storage or attach to the disk storage expansion units specifically designed for the IBM N series storage systems. These models include the N3700, N5000 series (Models A10 and A20), and N7000 series (Models A10 and A20)). There are three disk storage expansion units specifically designed for IBM N series storage systems:

- IBM EXN4000 Fibre-Channel disk storage expansion unit
- IBM EXN2000 Fibre-Channel disk storage expansion unit
- IBM EXN1000 serial advanced technology attachment (SATA) storage expansion unit

**Note:** These expansion units are not intended for attachment to IBM N series gateway systems (Models G10 or G20).

This guide uses the following terms:

- *Device carrier* refers to the container that encases a fan/power supply unit or a disk.
- *Disk* applies to any Fibre Channel disk encased in its device carrier.
- *ESH4* refers to the EXN4000 controller module.
- *Expansion unit* (or *disk shelf*) refers to any shelf or expansion unit containing hard disk drives.
- *Loop* refers to one or more daisy-chained EXN expansion units connected to an N series storage system.
- *Module* refers to the ESH4 module.
- *System* or *storage system* refers to the filer, either by itself or with additional expansion units.
- *SES* refers to SCSI Enclosure Services.

## Command conventions

You can enter filer commands on the system console or from any client that can obtain access to a filer using a Telnet session. In examples that illustrate commands executed on a UNIX<sup>®</sup> workstation, the command syntax and output might differ, depending on your version of UNIX.

## Formatting conventions

The following table lists different character formats used in this guide to set off special information.

Formatting convention	Type of information
<i>Italic type</i>	<ul style="list-style-type: none"><li>• Words or characters that require special attention.</li><li>• Placeholders for information you must supply. For example, if the guide requires you to enter the <code>fctest adaptername</code> command, you enter the characters "fctest" followed by the actual name of the adapter.</li><li>• Book titles in cross-references.</li></ul>
Monospaced font	<ul style="list-style-type: none"><li>• Command and daemon names.</li><li>• Information displayed on the system console or other computer monitors.</li><li>• The contents of files.</li></ul>
Bold monospaced font	Words or characters you type. What you type is always shown in lowercase letters, unless your program is case-sensitive and uppercase letters are necessary for it to work properly.

## Keyboard conventions

This guide uses capitalization and some abbreviations to refer to the keys on the keyboard. The keys on your keyboard might not be labeled exactly as they are in this guide.

What is in this guide...	What it means...
hyphen (-)	Used to separate individual keys. For example, Ctrl-D means holding down the Ctrl key while pressing the D key.
<i>Enter</i>	Used to refer to the key that generates a carriage return, although the key is named Return on some keyboards.
<i>type</i>	Used to mean pressing one or more keys on the keyboard.

What is in this guide...	What it means...
<i>enter</i>	Used to mean pressing one or more keys and then pressing the Enter key.

---

## How to send your comments

Your feedback is important in helping us provide the most accurate and high-quality information. If you have comments or suggestions for improving this document, send us your comments by e-mail to [starpubs@us.ibm.com](mailto:starpubs@us.ibm.com) or use the Readers' Comments form at the back of this publication. Be sure to include the following:

- Exact publication title
- Form number (for example, GC26-1234-02)
- Page numbers to which you are referring

If the Reader Comment Form in the back of this manual is missing, you can direct your mail to:

International Business Machines Corporation  
Information Development  
Department GZW  
9000 South Rita Road  
Tucson, Arizona 85744-0001 U.S.A.

When you send information to IBM, you grant IBM a nonexclusive right to use or distribute the information in any way it believes appropriate without incurring any obligation to you.

---

# Chapter 1. Preparing for the installation

This chapter describes the preparation requirements for first-time installation of the IBM EXN4000 Storage Expansion Unit (model number 2863-004).

This chapter discusses the following topics:

- “Required manuals, tools and equipment”
- “Handling static-sensitive devices”
- “Planning and organizing the installation” on page 2
- “Before you begin your installation” on page 7

---

## Required manuals, tools and equipment

In addition to this document, you need the following manuals:

- *Installation and Setup Instructions* for your filer
- *EXN4000 Installation and Setup Instructions*
- Hardware guide for your expansion unit
- *Data ONTAP Cluster Installation and Management Guide* or *Data ONTAP Active-Active Configuration Guide* for your version of Data ONTAP

## Required tools and equipment for installation

You must supply the following tools and equipment:

- Ethernet LAN cables
- Fibre Channel cables
- Console (for example, a PC or laptop)
- #2 Phillips screwdriver and slotted screwdriver
- Pointed tool for setting switches
- 7-mm nut driver
- Antistatic ESD strap and grounding leash

---

## Handling static-sensitive devices

**Attention:** The expansion unit uses electronic components that are sensitive to static electricity. Static discharge from your clothing or other fixtures around you can damage these components. Put on an antistatic ESD strap and grounding leash to free yourself of static electricity before touching any electronic components.

**Attention:** Static electricity can damage electronic devices and your system. To avoid damage, keep static-sensitive devices in their static-protective packages until you are ready to install them.

To reduce the possibility of electrostatic discharge (ESD), observe the following precautions:

- Limit your movement. Movement can cause static electricity to build up around you.
- Handle the device carefully, holding it by its edges or its frame.
- Do not touch solder joints, pins, or exposed printed circuitry.
- Do not leave the device where others can handle and possibly damage the device.
- While the device is still in its static-protective package, touch it to an unpainted metal part of the system unit for at least two seconds. This drains static electricity from the package and from your body.
- Remove the device from its package and install it directly into your system unit without setting it down. If it is necessary to set the device down, place it in its static-protective package. Do not place the device on your system unit cover or on a metal table. Take additional care when handling devices during cold weather because heating reduces indoor humidity and increases static electricity.

---

## Planning and organizing the installation

This section identifies the shipment contents and the rules and regulations you need to observe for the proper installation of your EXN4000. It also provides an overview of the entire system installation process and the appropriate documentation references for the procedures.

For detailed information, see the following topics:

- “Hardware specifications” on page 3
- “Checking shipment package contents” on page 4
- “Rules for installing expansion units in a rack” on page 4
- “Guide to the installation process” on page 5

## Hardware specifications

The following table lists the characteristics and requirements for your EXN4000.

*Table 1. EXN4000 physical characteristics and environmental requirements*

Physical characteristics			
	Weight	With maximum number of disk drives	77 lbs (35 kg)
		Empty	50.6 lbs (23 kg)
	Rack units		3U
	Height		5.25 in. (13.3 cm)
	Width		17.6 in. (44.8 cm)
	Depth		20 in. (50.9 cm)
Clearance dimensions			
	Front-cooling	All versions	6 in. (15.3 cm)
	Rear-cooling	All versions	12 in. (30.5 cm)
	Rear-maintenance	All versions	12 in. (30.5 cm)
Environmental requirements			
<b>Note:</b> Operating at the extremes of the following environmental requirements might increase the risk of device failure.			
	Operating temperature maximum range		50° F to 104° F (10° C to 40° C)
	Operating temperature recommended range		68° F to 77° F (20° C to 25° C)
	Nonoperating temperature range		-40° F to 149° F (-40° C to 65° C)
	Relative humidity		10 to 90% noncondensing
	Recommended operating temperature relative humidity range		40 to 55%
	Maximum wet bulb temperature		28° C (82° F)
	Maximum altitude		3050 m (10,000 ft.)
	Acoustic level		56.4 dBA @ 23° C 5.64 bels @ 23° C

Table 2. EXN4000 electrical requirements

Input voltage		100 to 120V		200 to 240V	
		Worst-case	Typical single PSU/system	Worst-case	Typical single PSU/system
Input current measured, A	10K drives	2.81	1.51/3.01	1.38	0.76/1.51
	15K drives	3.42	1.83/3.65	1.66	0.91/1.82
Input power measured, W	10K drives	279	148.5/299	272	145/290
	15K drives	342	181.5/363	329	176.5/353
Thermal dissipation, BTU/hr	10K drives	953	510/1020	926	495/990
	15K drives	1167	619/1238	1122	602/1204
Inrush peak, A	10K drives	21	20	12.5	12
	15K drives	21	20	12.5	12
Input power frequency, Hz		50 to 60			
Maximum electrical power		7 A		3.5 A	

**Note:** *Worst-case* indicates a system running with one PSU and high fan speed. *Typical* indicates a system running two PSUs on two circuits.

### Checking shipment package contents

Make sure that your shipment package includes the following items, in addition to the *EXN4000 Hardware and Service Guide*:

- *EXN4000 Installation and Setup Instructions*.
- An expansion unit containing the power supplies and Fibre Channel disks you ordered.
- FC-AL cables and power cords, as ordered.
- A rail kit for mounting the expansion unit in a standard 19-inch rack may also be included.

### Rules for installing expansion units in a rack

You need to observe the following rules and restrictions when installing an expansion unit in a standard 19-inch (48.26 cm) equipment rack with mounting rails:



## DANGER

The weight of this part or unit is between 32 and 55 kg (70.5 and 121.2 lb). It takes three persons to safely lift this part or unit. (C010)

**Attention:** Remove the power supplies and fan units from the chassis before attempting to lift the system.

- With the help of at least two people, remove the expansion unit from the rack.

### CAUTION:

The expansion unit is very heavy when fully loaded and requires at least three people to remove it.

- Install the expansion unit at the bottom of the rack first.

## DANGER

To avoid hazardous conditions due to uneven mechanical loading, always install the heaviest devices in the bottom of the rack cabinet. Always install servers and optional devices starting from the bottom of the rack cabinet. (R001 part 1 of 2)

For additional rack safety notices, refer to “Rack safety” on page viii.

- When installing expansion units in a rack, do not exceed the maximum storage limit for your N series storage system.
- Always install the expansion units fully loaded. Do not remove the disk drives or drive blank covers to reduce the weight.

## Guide to the installation process

The following table provides a guide to the expansion unit installation process.

Refer to *Installation and Setup Instructions* for your filer or the *EXN4000 Installation and Setup Instructions* for complete installation details.

### CAUTION:

Three people are required to lift the expansion unit during installation. Do not remove the disk drives or drive blank covers to reduce the weight.

Table 3. Expansion unit installation process

Stage	Procedure	Is the procedure required?	For instructions, go to...
1	Install the N series storage system in a freestanding rack.	Only if the expansion unit installation is part of a new system installation.	Hardware guide for your N series storage system, or the <i>Installation and Setup Instructions</i> that came with your N series storage system.
2	Install the expansion units in the rack.  <b>Attention:</b> When installing multiple storage expansion units that share a drive loop, always install them sequentially as they will appear in the loop.	Yes, if the expansion unit is an addition to your existing system or if your new system was not shipped in a rack.	See the <i>EXN4000 Installation and Setup Instructions</i> .
3	Connect the expansion unit to the N series storage system.	Only in the following scenarios: <ul style="list-style-type: none"> <li>• If the expansion unit installation is part of a new system installation.</li> <li>• If the expansion unit is the first in an additional loop to your existing system.</li> </ul>	See the <i>EXN4000 Installation and Setup Instructions</i> , or, if applicable, see “Hot-adding an expansion unit to an existing loop” on page 15.
4	Connect the expansion units.	Only in the following scenarios: <ul style="list-style-type: none"> <li>• If the new system installation has multiple expansion units.</li> <li>• If the expansion unit is an addition to your existing system.</li> </ul>	See the <i>EXN4000 Installation and Setup Instructions</i> , or, if applicable, see “Hot-adding an expansion unit to an existing loop” on page 15..
5	Ground the expansion units and N series storage system.	Yes.	“Grounding expansion units” on page 15, or the <i>EXN4000 Installation and Setup Instructions</i> .

Table 3. Expansion unit installation process (continued)

Stage	Procedure	Is the procedure required?	For instructions, go to...
6	Connect the expansion units to a power source.	Yes.	"Connecting the expansion unit to a power source" on page 15
		If the system was shipped in a rack, you must connect the rack to a power source.	See the documentation that shipped with your cabinet.
7	Configure the system.	Yes, if the expansion unit installation is part of a new system installation.	See the <i>Data ONTAP Software Setup Guide</i> for your version of Data ONTAP.

---

## Before you begin your installation

Before you install one or more expansion units in a rack, you need to understand the following information:

- Expansion unit numbering
- Speed setting
- Drive addressing
- Supported disk drives
- Drive bay requirements

**Attention:** Verify that all shelf IDs are correct and sequential in the individual loop(s). If this system was configured by manufacturing, there are labels on the outside of the packaging carton and on the side of the expansion unit chassis to indicate which loop on which node (Filer 1 or 2) that shelf should be located. Make certain the expansion units are placed and cabled according to these labels. The filer nodes may also have a label on the packaging carton and chassis side to clearly distinguish the nodes (Filer 1 and Filer 2).

### Expansion unit numbering

Each expansion unit in a loop must have a unique ID. A valid shelf ID is from 1 through 7. ID 1 is used for the first expansion unit in a new loop, or if the filer also contains disks, then ID 2 is used for the expansion unit closest to the N series storage system controller (which uses ID 1). Shelf IDs for additional expansion units are incremented sequentially from the number of the first expansion unit (either 1 or 2).

Each expansion unit shipped with an N series storage system has its assigned ID already set on its back panel and has a shelf ID label already placed on its front bezel.

You must ensure that the expansion unit has the correct ID number on the label. If you change the shelf ID of the expansion unit by changing the ID switch at the rear of the unit, replace the shelf ID label on the expansion unit to match the new shelf ID.

**Note:** Additional shelf ID labels are supplied with your unit.

The ID label is on the right side of the unit, as shown in the following illustration.

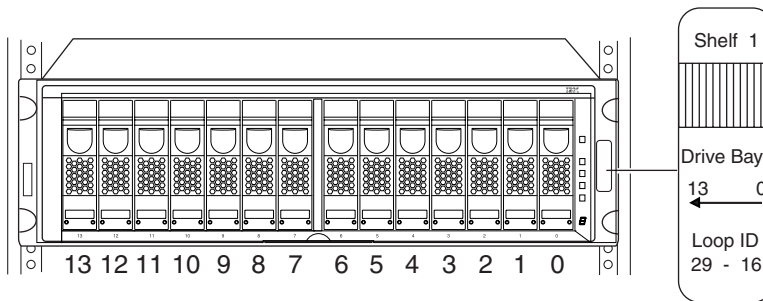

*Figure 1. Shelf ID label*

IBM sets the disk shelf IDs at the factory on configured systems, using an ID switch on the back panel. If you order additional expansion units, you must set the disk shelf ID and apply the correct labels provided with the expansion unit.

**Note:** If you enter a shelf ID that is not from 1 through 7, the drive addresses default to those of a shelf with the ID switch set to 7 even though the shelf ID indicator in the front operation panel displays a dash (-).

The example in Figure 2 on page 9 shows an expansion unit with the disk shelf ID set to 2.

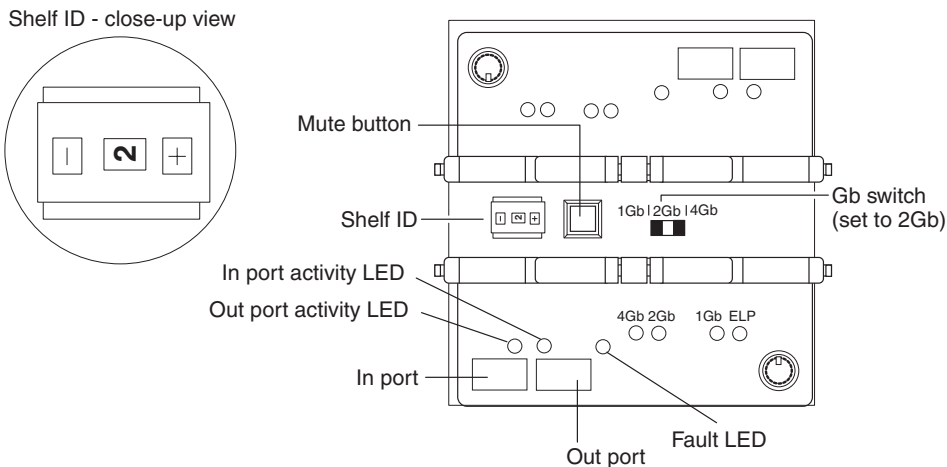

Figure 2. Expansion unit shelf ID and speed switch

## Speed setting

Make sure that all expansion unit speed switches are set to the correct position for your application.

- If connecting to an N3700 storage system, the speed switch must be set to the 1Gb position.
- If connecting to any other N series storage system, the speed switch must be set to the 2Gb or 4Gb (if supported) position.

**Note:** For information about whether your N series storage system supports the 4Gb speed setting on connected EXN4000s, refer to the *Hardware and Service Guide* for your storage system.

See Figure 2 for the location of the speed switch on the rear of the expansion unit.

## Drive addressing

In addition to identifying the disk shelf ID and the direction of the drive bays, the ID label on the right side of the expansion unit includes the drive address. The drive address identifies the disks in the expansion unit. The last sheet of the quick reference cards that come with your expansion unit shows the seven disk shelf IDs and their corresponding drive addresses.

**Note:** For ESH4 module A, drive addressing is in descending order, and for ESH4 module B, drive addressing is in ascending order. ESH4 A is the top controller module in the expansion unit. ESH4 B is the bottom controller module.

**EXN4000** 4 of 4  
 Drive Addressing

### Drive Addressing

Drive Bay #														
13	12	11	10	9	8	7	6	5	4	3	2	1	0	
S E L I D														
126	124	123	122	121	120	119	118	117	116	115	114	113	112	7
106	106	107	108	106	104	103	102	101	100	99	98	97	96	6
83	82	81	80	80	80	87	86	85	84	83	82	81	80	5
77	76	75	74	73	72	71	70	69	68	67	66	65	64	4
61	60	59	58	57	56	55	54	53	52	51	50	49	48	3
45	44	43	42	41	40	39	38	37	36	35	34	33	32	2
29	28	27	26	25	24	23	22	21	20	19	18	17	16	1
126	124	123	122	121	120	119	118	117	116	115	114	113	112	-

Shelf # settings 0, 8, and 9 are displayed as a "-" on the OPS panel display. SEL IDs below # 16 are reserved. Select shelf ID before powering on.

How to contact IBM Service and Support  
<http://www.ibm.com/servers/storage/nas/>  
 or  
**1-800-IBM-SERV**

exn4000d4

Figure 3. Disk shelf IDs and drive addresses

## Supported disk drives

For the types of disks the expansion unit supports, visit the following Web site:

[www.ibm.com/storage/nas/](http://www.ibm.com/storage/nas/)

**Note:** Do not mix different drive types in the same expansion unit.

## Drive bay requirements

For enclosure services monitoring to work, drive bays 0 and 1 must contain a disk. This requirement is posted on the label on the left flange of the expansion unit. In addition, the expansion unit must be populated with at least four hard disk drives to ensure proper operation.

**Attention:** All drive bays in the expansion must contain either a hard disk drive or a drive blank cover to maintain proper air flow and cooling.

The 14 drive bays in the expansion unit are numbered 0 through 13 from right to left, as shown in Figure 1 on page 8. Hard disk drives should be populated in adjacent drive bays in the expansion unit in this sequence, beginning with drive bay 0.

The N series storage system uses the enclosure services monitoring method to monitor environmental conditions of the expansion unit. Enclosure services conditions are communicated to the N series storage system through the ESH4 module.

The following table describes the three stages of enclosure services monitoring.

*Table 4. Stages of enclosure services monitoring*

Stage	Device	What it does...
1	N series storage system	Uses a subset of SCSI-3 commands to monitor the expansion unit for data related to disk presence, temperature, power supply units, and fan status.
2	N series storage system	Sends the commands through its Fibre Channel interface to drive bays 0 and 1 on the expansion unit.
3	Drive bays 0 and 1	Communicate the request to the ESH4 module and send the data to the N series storage system.
	ESH4 module	Collects the requested data and sends it to drive bays 0 and 1.



---

## Chapter 2. Connecting an expansion unit

This chapter describes how to connect a single expansion unit or a loop of expansion units to a supported N series storage system or to other expansion units. This chapter also describes how to ground your system, and how to connect your system to power.

This chapter discusses the following topics:

- “Handling fiber-optic cables”
- “Connecting expansion units” on page 14
- “Grounding expansion units” on page 15
- “Connecting the expansion unit to a power source” on page 15
- “Hot-adding an expansion unit to an existing loop” on page 15

---

### Handling fiber-optic cables

Before you use fiber-optic cables, read the following precautions.

**Attention:** To avoid damage to the fiber-optic cables, follow these guidelines:

- Do not route the cable along a folding cable-management arm.
- When attaching to a device on slide rails, leave enough slack in the cable so that it does not bend to a radius of less than 38 mm (1.5 in.) when extended or become pinched when retracted.
- Route the cable away from places where it can be snagged by other devices in the rack cabinet.
- Do not overtighten the cable straps or bend the cables to a radius of less than 38 mm (1.5 in.).
- Do not put excess weight on the cable at the connection point. Be sure that the cable is well supported.



**CAUTION:**

Data processing environments can contain equipment transmitting on system links with laser modules that operate at greater than Class 1 power levels. For this reason, never look into the end of an optical fiber cable or open receptacle. (C027)

---

## Connecting expansion units

This section describes the requirements for connecting an expansion unit to N series storage systems and other expansion units. For detailed instructions about how to install and connect one or more expansion units in a rack, or to connect an expansion unit to your storage system, refer to the *Installation and Setup Instructions* for your storage system.

- IBM strongly recommends using optical (fibre channel) cabling whenever possible.
- Refer to the *IBM System Storage N series Introduction and Planning Guide* for details about the maximum number of drive loops, maximum number of expansion units or hard disk drives per loop, maximum total storage capacity, and maximum total number of hard disk drives for configurations using your N series storage system. (For example, you can connect a maximum of one loop of three fully populated expansion units to an N3700.)
- Multipath looping is recommended for all configurations to provide additional redundancy. This includes single or dual controller and single or multiple expansion units.
- Do not mix Fibre Channel and SATA expansion units in the same loop.
- EXN4000 and EXN2000 expansion units can be mixed within the same loop, but the speed switches on all EXN4000s and EXN2000s must be set to the same speed (either 1 Gbps or 2 Gbps).

### Expansion unit cabling requirements

You must meet the cabling requirements discussed in the following sections when connecting the ESH4 module to an N series storage system or to other expansion units.

For the latest information on cabling requirements, see *Installation and Setup Instructions* and the *Hardware and Service Guide* for your storage system.

### Connecting the expansion unit directly to the N series storage system

When connecting the expansion unit to an N series storage system, you must use appropriate cables and connectors according to the following guidelines:

- **For direct connections to N3700 storage systems with system serial numbers between 13-00032 and 13-01000 (in general, these are N3700 systems shipped prior to January 31, 2006):** Use a NAS-to-EXP fibre channel copper cable (#2020 or 2022). For attachment to an N3700 Model A10, one NAS-to-EXP fibre channel copper cable is required. For attachment to an N3700 Model A20, two NAS-to-EXP fibre channel copper cables are required.
- **For direct connections to N3700 storage systems with system serial numbers 13-01001 or higher (in general, these are N3700 systems shipped after January 31, 2006):** Use an LC-to-LC fibre channel optical cable and 2

SFPs for attachment to an N3700 Model A10. Use 2 LC-to-LC fibre channel optical cables and 4 SFPs for attachment to an N3700 Model A20.

- **For direct connections to all other N series storage systems:** Use an LC-to-LC fibre channel optical cable and one SFP.

### **Connecting the expansion unit to other expansion units**

When connecting the expansion unit to other expansion units, IBM strongly recommends using LC-to-LC fibre channel optical cables. You must use 2 SFPs per LC-to-LC fibre channel optical cable.

**Note:** SFP-to-SFP fibre channel copper cables may also be used for connections (to a maximum of three meters) between expansion units.

---

## **Grounding expansion units**

For proper grounding, you must daisy-chain the expansion units together with the provided braided copper cables and screws. If possible, you should ground the N series storage system to the expansion unit.

Each expansion unit is shipped with a 0.25m (~6 inch) braided copper cable and an M5 x 0.5 inch Phillips head screw. The copper cable has a hole on each end for grounding filer-to-shelf or shelf-to-shelf.

For detailed instructions about how to ground connected expansion units in a rack, refer to the *Installation and Setup Instructions* for your storage system.

---

## **Connecting the expansion unit to a power source**

The expansion unit is shipped with two power supplies, installed in bay PSU1 and bay PSU2, respectively and an AC power cord for each power supply. You must have separate circuit breakers for each power supply.

For detailed instructions about how to connect expansion units to a power source, refer to the *EXN4000 Installation and Setup Instructions*.

---

## **Hot-adding an expansion unit to an existing loop**

This section provides information about how to hot-add an expansion unit to an existing loop. It also tabulates the error messages that appear on your N series storage system console if the attempt at hot-adding was unsuccessful.

**Note:** To hot-add disk shelves to a cluster, see the *Data ONTAP Cluster Installation and Management Guide* or *Data ONTAP Active/Active Configuration Guide* for your version of Data ONTAP.

**Attention:** It is recommended that you stop all I/O processes before hot-adding an expansion unit to an existing loop. Perform a hot-add only during off-peak times. IBM recommends that you hot-add one disk shelf at a time.

**CAUTION:**

**Failure to follow this recommendation may cause the loop to crash.**

This section contains information on the following topics:

- “Error messages”
- “Hot-adding an EXN4000 to an existing loop”
- “Hot-adding an EXN4000 to an existing adapter in your system” on page 17

**Error messages**

The following error messages appear on your N series storage system console if your attempt at hot-adding the expansion unit is unsuccessful.

*Table 5. N series storage system console error messages*

Error message	Explanation
Open loop panic	One of two reasons cause this error message to appear: <ul style="list-style-type: none"> <li>• The shelf-to-shelf cable between the now second-to-last unit and the newly added expansion unit is defective or is not securely fastened.</li> <li>• The speed of the newly added expansion unit is incorrectly set.</li> </ul>
Soft address panic	One of two reasons cause this error message to appear: <ul style="list-style-type: none"> <li>• There is an invalid disk shelf ID.</li> <li>• The power was turned on before the disk shelf ID was changed and the expansion unit was not power-cycled after the disk shelf ID was changed.</li> </ul>
Speed mismatch termination	The ESH4 modules on the expansion unit detected a speed mismatch between the preceding unit and this expansion unit and is reporting them as automatic terminate errors.

**Hot-adding an EXN4000 to an existing loop**

To hot-add an expansion unit to an existing loop, complete the following steps:

1. Verify that your N series storage unit meets the minimum software requirements to support the disk shelf. See the following Web site for more information.  
[www.ibm.com/storage/support/nas/](http://www.ibm.com/storage/support/nas/)
2. Verify that you received the envelope with the disk shelf ID labels.

3. Put on the antistatic ESD strap and grounding leash.
4. Install the new expansion unit in the rack, cable and ground the expansion unit, and connect the power cables to the expansion unit, as described in the *Installation and Setup Instructions* you received with your N series product.

**Attention:** Do not turn on the power to the expansion unit yet.

After you have completed the installation steps described in the *Installation and Setup Instructions*, continue with Step 4.

5. Verify that all the cables are securely fastened.

**Attention:** Poorly secured cables cause the N series storage system to panic over an open loop.

6. If you have not done so, give the expansion unit a unique disk shelf ID. It is recommended that you choose a number which is one higher than the previous shelf or storage system if the storage system contains disks.
  - a. Using the switch on the rear of the expansion unit, press the + button to raise the number and the - button to lower the number to a valid ID from 1 through 7. Refer to Figure 2 on page 9 for an illustration.

**Note:** Only use disk shelf ID 7 if it is the last ID available. If you change a disk shelf ID, you must power-cycle the expansion unit for the new ID to take effect. The disk shelf ID display on the front of the expansion unit blinks until you power-cycle the expansion unit.

- b. Verify that the disk shelf ID is not being used in the loop by entering the following command at the console:

```
fcstat device_map adaptername
```

- c. Select the correct matching shelf ID label identified in Figure 1 on page 8 and attach it to the right flange of the new expansion unit.

**Attention:** An invalid disk shelf ID causes the N series storage system to panic.

7. Set the loop speed for the new expansion unit to the correct speed setting for your N series storage system. See “Speed setting” on page 9.
8. Turn on the power to the expansion unit. You must wait 30 seconds for the shelf electronics to finish initializing.
9. In 60 seconds, the N series storage system recognizes the hot-added expansion unit.

### Hot-adding an EXN4000 to an existing adapter in your system

The following requirements must be met for this procedure:

- Your system must have Data ONTAP 7.2 or later.
- There must be an available but unused adapter on your N series storage unit to do this procedure.

- If you have an available dual-port and an available quad-port adapter, the dual-port adapter should be used first.
- If you only have an available quad-port adapter and you are hot-adding a single loop of disk shelves, then Ports A and B are defined as a port pair and Ports C and D are defined as a port pair. For the purposes of incorporating redundancy, Module A connects to Port A or Port B and Module B connects to Port C or Port D.

To hot-add an expansion unit to an existing adapter in your system, complete the following steps:

1. Verify that your N series storage unit meets the minimum software requirements to support the disk shelf. See the following Web site for more information.

[www.ibm.com/storage/support/nas/](http://www.ibm.com/storage/support/nas/)

2. Verify that you received the envelope with the disk shelf ID labels.
3. Put on the antistatic ESD strap and grounding leash.
4. Install the new expansion unit in the rack, cable and ground the expansion unit, and connect the power cables to the expansion unit, as described in the *Installation and Setup Instructions* you received with your N series product.

**Attention:** Do not turn on the power to the expansion unit yet.

After you have completed the installation steps described in the *Installation and Setup Instructions*, continue with Step 4.

5. Verify that all the cables are securely fastened.

**Attention:** Poorly secured cables cause the N series storage system to panic over an open loop.

6. If you have not done so, give the expansion unit a unique disk shelf ID. It is recommended that you choose a number which is one higher than the previous shelf or storage system if the storage system contains disks.

- a. Using the switch on the rear of the expansion unit, press the + button to raise the number and the - button to lower the number to a valid ID from 1 through 7. Refer to Figure 2 on page 9 for an illustration.

**Note:** Only use disk shelf ID 7 if it is the last ID available. If you change a disk shelf ID, you must power-cycle the expansion unit for the new ID to take effect. The disk shelf ID display on the front of the expansion unit blinks until you power-cycle the expansion unit.

- b. Verify that the disk shelf ID is not being used in the loop by entering the following command at the console:

```
fcstat device_map adaptername
```

- c. Select the correct matching shelf ID label identified in Figure 1 on page 8 and attach it to the right flange of the new expansion unit.

**Attention:** An invalid disk shelf ID causes the N series storage system to panic.

7. Set the loop speed for the new expansion unit to the correct speed setting for your N series storage system. See “Speed setting” on page 9.
8. Turn on the power to the expansion unit. You must wait 30 seconds for the shelf electronics to finish initializing.
9. In 60 seconds, the N series storage system recognizes the hot-added expansion unit.



---

## Chapter 3. Monitoring the expansion unit

This chapter describes how to monitor the expansion unit from the error messages displayed on the console that is connected to the N series storage system and identifies the location of the various LEDs on the expansion unit.

**Note:** The quick reference cards in the slide-out tray at the base of the expansion unit describe the functions of each LED on the expansion unit and the suggested course of action.

This chapter discusses the following topics:

- “Monitoring the front operation panel”
- “Monitoring the ESH4 modules” on page 24
- “Monitoring the power supply” on page 31
- “Monitoring the Fibre Channel disk” on page 33

---

### Monitoring the front operation panel

The front operation panel has five LEDs and a disk shelf ID display. The LEDs indicate whether your expansion unit is functioning normally or there are problems with the hardware. You can also identify any hardware failure associated with the front operation panel of the expansion unit from the error messages displayed on your N series storage system console.

## Location of LEDs

The following illustration shows the location of the disk shelf ID display and the front panel LEDs.

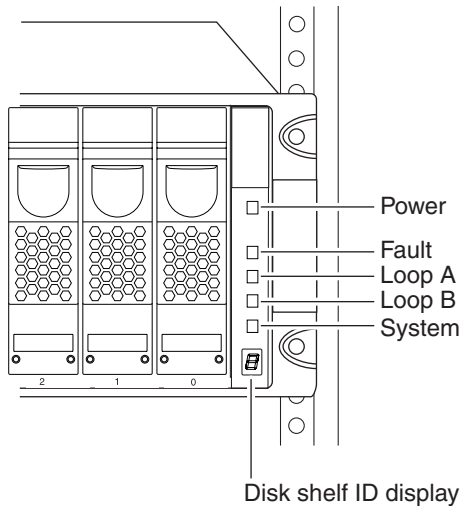

Figure 4. Front panel LEDs

**Note:** The Fault and System LEDs are amber. The other three LEDs are green. See “LED status on the front operation panel” for an illustrated explanation of how the LEDs function.

## Monitoring the disk shelf ID

When you use the switch on the back of the expansion unit to change the disk shelf ID, the disk shelf ID display on the front panel blinks until you power-cycle the expansion unit to make the change take effect.

## LED status on the front operation panel

The following illustration is of the first sheet of the quick reference cards that come with your expansion unit. It shows the normal and fault conditions that the LEDs indicate and recommends a corrective action.

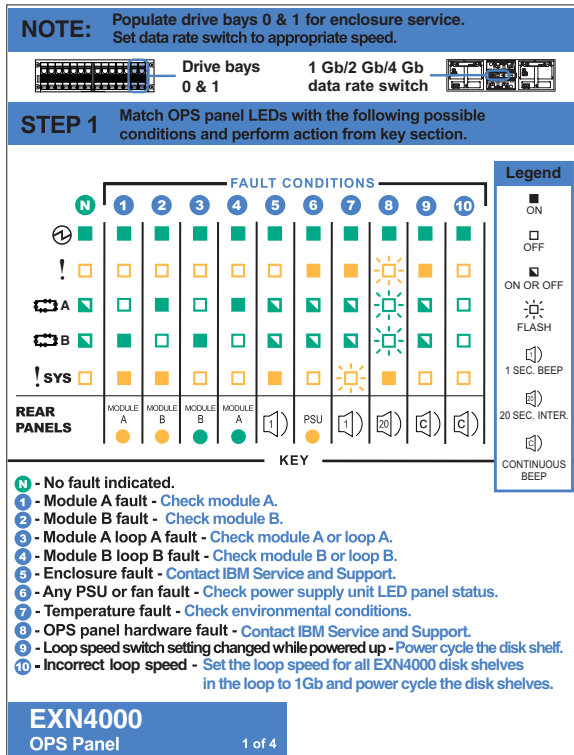

Figure 5. LED indications of normal and fault conditions

## Front operation panel console error messages

The following error messages appear on your N series storage system console if an SES element on the front operation panel fails. For information about replacing an expansion unit, see “Removing an expansion unit” on page 35.

Table 6. N series storage system error messages

Error message	Action required
Temperature sensor Element 1: failed	The temperature sensor on the front operation panel failed. Contact IBM customer service to replace the expansion unit.
Alarm Element 1: failed	The alarm on the front operation panel failed. Contact IBM customer service to replace the expansion unit.
Display Element 1: failed	The display on the front operation panel failed. Contact IBM customer service to replace the expansion unit.

## Monitoring the ESH4 modules

The ESH4 has LEDs that indicate whether the module is functioning normally, whether there are any problems with the hardware, and the loop speed operation of the EXN4000. You can also identify any hardware failure associated with the module from the error messages displayed on your N series storage system console.

This section also describes the different types of messages that appear on the N series storage system console in response to a command monitoring the ESH4.

### Location of the module LEDs

The modules are in the middle of the back of the expansion unit. The following illustration shows the location of the LEDs for an ESH4. See “LED status on the ESH4” on page 25 for an illustrated explanation of the LED functions.

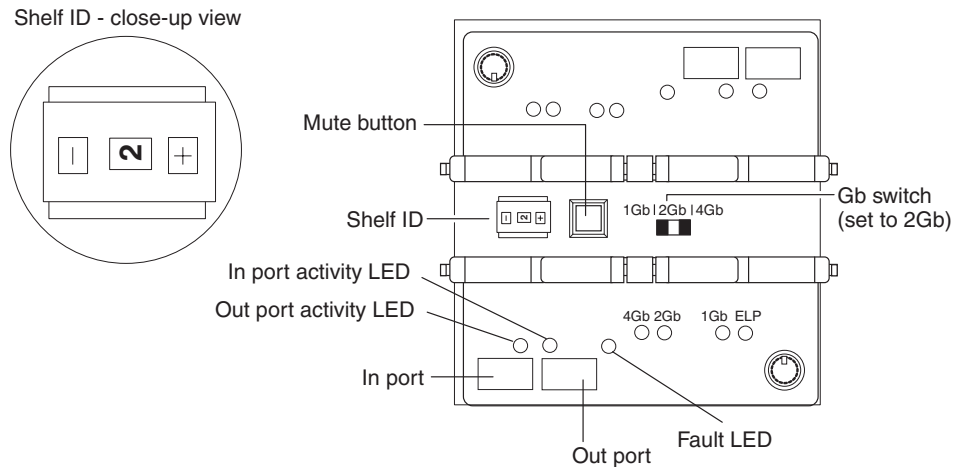

Figure 6. Location of the LEDs for an ESH4

#### Notes:

1. Because module A on the expansion unit is inverted, the location of the module A LEDs is the inverse of what is shown in the preceding illustrations.
2. The LED marked ELP is not currently supported.

## LED status on the ESH4

The following illustration is of the second sheet of the quick reference cards that come with your expansion unit.

**EXN4000**  
 Rear Panel

2 of 4

**STEP 2** Match FC module LEDs with the following possible conditions and perform action from key section.

FAULT CONDITIONS

	<b>N</b>	<b>11</b>	<b>12</b>	<b>13</b>	<b>14</b>	<b>15</b>	<b>16</b>
<b>IN PORT</b>	●	●	●	●	●	●	●
<b>OUT PORT</b>	●	●	●	●	●	●	●
<b>ALARM</b>	!	!	!	!	!	!	!

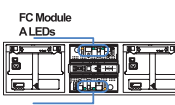

FC Module  
A LEDs

FC Module  
B LEDs

Legend

- ON
- OFF
- ON OR OFF
- ☀ FLASH

KEY

- N** - No fault indicated.
- 11** - FC module fault - [Replace module.](#)
- 12** - No signal - [Check cables.](#)
- 13** - No signal - [Check cables.](#)
- 14** - Invalid termination - [Check "TERM" switch.](#)
- 15** - Data rate mismatch - [Check data rate switch settings.](#)
- 16** - Data rate mismatch - [Check data rate switch settings.](#)

**STEP 3** Match power supply LEDs with the following possible conditions and perform action from key section.

FAULT CONDITIONS

	<b>N</b>	<b>17</b>	<b>18</b>	<b>19</b>
●	●	●	●	●
○	○	○	○	○
○	○	○	○	○
○	○	○	○	○

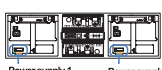

Power supply 1    Power supply 2

Legend

- ON
- OFF

KEY

- N** - No fault indicated.
- 17** - No AC to this PSU - [Check power cord and switch.](#)
- 18** - Fan fault - [Replace PSU.](#)
- 19** - PSU fault - [Replace PSU.](#)

exn4000r2

Figure 7. EXN4000 rear panel quick reference card

**Note:** The rest of the second sheet of the quick reference card identifies the LED status conditions for the power supply and the integrated fan module.

## ESH4 console error messages

The following error messages appear on your N series storage system console if an SES element on the ESH4 fails. For information about replacing the ESH4, see “Replacing an ESH4 module” on page 41.

Table 7. ESH4 console error messages

Error message	Action required
SES electronics Element 1: component is from a different product family	Module A was replaced and the expansion unit has the following unsupported configurations: ESH2 and ESH4  This error message occurs during the process of hot-upgrading.
SES electronics Element 2: component is from a different product family	Module B was replaced and the expansion unit has the following unsupported configurations: ESH2 and ESH4  This error message occurs during the process of hot-upgrading.
SES electronics Element 1: failed	ESH4 module A on the top back of the expansion unit failed. Contact IBM customer service to replace the module.
SES electronics Element 2: failed	ESH4 module B on the bottom back of the expansion unit failed. Contact IBM customer service to replace the module.
Temperature sensor Element 2: not installed or failed	Communication was possible with the temperature sensor on ESH4 module A at one point, but it is not possible now. Even if traffic is flowing through the Fibre Channel loop, contact IBM customer service to replace the ESH4.
Temperature sensor Element 3: not installed or failed	Communication was possible with the temperature sensor on ESH4 module B at one point, but it is not possible now. Even if traffic is flowing through the Fibre Channel loop, contact IBM customer service to replace the ESH4.
SES electronics Element 1: not installed or failed	Communication was possible with ESH4 module A at one point, but it is not possible now. Even if traffic is flowing through the Fibre Channel loop, contact IBM customer service to replace the ESH4.
Vendor-specific Element 1: not installed or failed	
SES electronics Element 2: not installed or failed	Communication was possible with ESH4 module B at one point, but it is not possible now. Even if traffic is flowing through the Fibre Channel loop, contact IBM customer service to replace the ESH4.
Vendor-specific Element 2: not installed or failed	

## Monitoring the ESH4

The **storage show hub** and **environ shelf** commands enable you to monitor the ESH4 module.

### Sample output

The following is an example of the output from the **storage show hub** command. The exact messages that appear on your system console depend on your system configuration.

**Note:** For the ESH4 module, the following output shows the Term switch status as N/A or not applicable because the ESH4 module does not have a terminate switch.

```
Hub name: 9.shelf2
Channel: 9
Loop: B
Shelf id: 2
Shelf UID: 50:05:0c:c0:02:00:24:02
Term switch: N/A
Shelf state: ONLINE
ESH state: OK
```

Disk ID	Disk Bay	Port State	Loop up Count	Invalid CRC Count	Invalid Word Count	Clock Delta	Insert Count	Stall Count	Util %
[IN]		OK	8	0	0	0	20	0	0
[OUT]		TERM	8	0	0	-8	6	0	0
[32]	0	OK	10	0	0	0	6	0	0
[33]	1	OK	8	0	0	-8	9	0	0
[34]	2	OK	10	0	0	-8	6	0	0
[35]	3	OK	10	0	0	0	8	0	0
[36]	4	OK	10	0	0	0	9	0	0
[37]	5	OK	10	0	0	-16	7	0	0
[38]	6	OK	10	0	0	0	6	0	0
[39]	7	OK	10	0	0	16	16	0	0
[40]	8	BYP/TBI	10	0	0	0	8	0	0
[41]	9	OK	8	0	0	-8	6	0	0
[42]	10	OK	8	0	0	0	6	0	0
[43]	11	EMPTY	8	0	0	0	15	0	0
[44]	12	OK	8	0	0	8	4	0	0
[45]	13	OK	10	0	0	16	8	0	0

## Description of hub status information

You might receive some of the following status reports in response to the **storage show hub** command.

### Shelf state

The following table lists and describes the shelf status responses.

*Table 8. Shelf status responses*

<b>Shelf state</b>	<b>Description</b>
<i>ONLINE</i>	Shelf is fully configured and operational.
<i>INIT REQD</i>	Shelf needs to configure one or both ESH4 modules.
<i>OFFLINE</i>	Contact was lost with shelf (SES drive access is down).
<i>MISSING</i>	Shelf was removed from the system entirely (all paths).
<i>FAILED</i>	Failure occurred on the shelf.

### **ESH4 state**

The following table lists and describes the ESH4 status responses.

*Table 9. ESH4 status responses*

<b>Shelf state</b>	<b>Description</b>
<i>OK</i>	ESH4 is fully operational.
<i>MISSING</i>	ESH4 is missing from the specified slot.
<i>XPORT ERROR</i>	Communication with the ESH4 is not possible.

### **ESH4 port state**

The following table lists and describes the ESH4 status responses.

*Table 10. ESH4 status responses*

<b>Shelf state</b>	<b>Description</b>
<i>OK</i>	Port is functioning normally.
<i>EMPTY</i>	No drive is present in bay.
<i>BYP/TBI</i>	Port failed loop test before insert and was not allowed into loop.
<i>BYP/XMIT</i>	Port bypassed due to transmitter default.
<i>BYP/LIPF8</i>	Port bypassed due to drive generating LIP F8s.
<i>BYP/DTO</i>	Port bypassed due to data timeout errors.
<i>BYP/RLOS</i>	Port bypassed due to receiver loss of signal.
<i>BYP/CLOS</i>	Port bypassed due to comma loss of signal.

Table 10. ESH4 status responses (continued)

Shelf state	Description
BYP/RPRT	Port bypassed due to redundant port connection.
BYP/STALL	Port bypassed due to excessive stall errors.
BYP/WRD	Port bypassed due to excessive word errors.
BYP/CRC	Port bypassed due to excessive CRC errors.
BYP/CLK	Port bypassed due to excessive clock delta.
BYP/MIR	Port bypassed due to cluster mirror bit being set (check partner).
BYP/LIPF7	Port bypassed due to drive transmitting LIP F7s.
BYP/GEN	Port bypassed due to a <i>generic</i> error.
BYP/MAN	Port was manually bypassed (Manufacturing test only).
BYP/LIP	Port bypassed due to drive generating excessive LIP requests.
BYP/OSC	Port bypassed due to excessive port state changes.
BYP/INIT	Port bypassed as part of ESH Power-On Self-Test.
/// <i>:0xXX</i>	ESH Admin unable to decode port state <i>XX</i> .

### Hub statistic

The following table lists and describes the hub statistic responses.

Table 11. Hub statistic responses

Hub statistic	Description	Common values	Failure?
<i>Loop up Count</i>	Number of times this port saw the loop come up or transition to up.	Depends on the number of insertions and removals of disks and LIPs that occur in the loop.	No

Table 11. Hub statistic responses (continued)

Hub statistic	Description	Common values	Failure?
<i>Invalid CRC Count</i>	Number of times this port saw a CRC error.	Is zero under normal operation. Removal and addition of disks, and a reset of the adapter, might generate some CRC errors. CRC errors on a port pinpoint the failure location. Excessive CRC errors for a continuous time period causes the ESH4 firmware to bypass this port.	Yes, if drive was bypassed.
<i>Invalid Word Count</i>	Number of times this port saw invalid FC-AL words transmitted.	Is zero under normal operation. Removal and addition of disks, and a reset of the adapter, might generate some word errors. Word errors on a port pinpoint the failure location. Excessive word errors for a continuous time period causes the ESH4 firmware to bypass this port.	Yes, if drive was bypassed.
<i>Clock Delta</i>	The clock delta between this port in respect to the ESH4 clock and seven other ports.	It is normal for the FC-AL sync clocks to drift with respect to each other. This is a signed drift value. A value exceeding 6,400 PPM causes the ESH4 firmware to bypass this port.	Yes, if drive was bypassed.
<i>Insert Count</i>	Number of times this port was inserted into the loop.	Depends on the number of insertions and removals of disks and LIPs that occur in the loop.	No
<i>Stall Count</i>	Number of times this port exceeded the open/close (OPN/CLS) maximum threshold.	Is zero under normal operation. Removal and addition of disks, and a reset of the adapter, might generate some stall errors. Excessive stall errors for a continuous time period causes the ESH4 firmware to bypass this port.	Yes, if drive was bypassed.

Table 11. Hub statistic responses (continued)

Hub statistic	Description	Common values	Failure?
<i>Utilization %</i>	Relative use of this port versus other ports in the ESH4 module.	This value does not reflect the real-time use of what the ports are currently achieving and is only obtained when extended status is available from the ESH4 module. It indicates the relative use from the last time extended status was available.	No

---

## Monitoring the power supply

The power supply has four LEDs. The LEDs indicate whether the power supply or the integrated fan module is functioning normally or there are problems with the hardware. You can also identify any hardware failure associated with the power supplies from the error messages displayed on your N series storage system console.

### Location of LEDs

Each power supply, which contains four LEDs, is encased in a device carrier and housed at the rear of the expansion unit. The following illustration shows the location of the power supply LEDs.

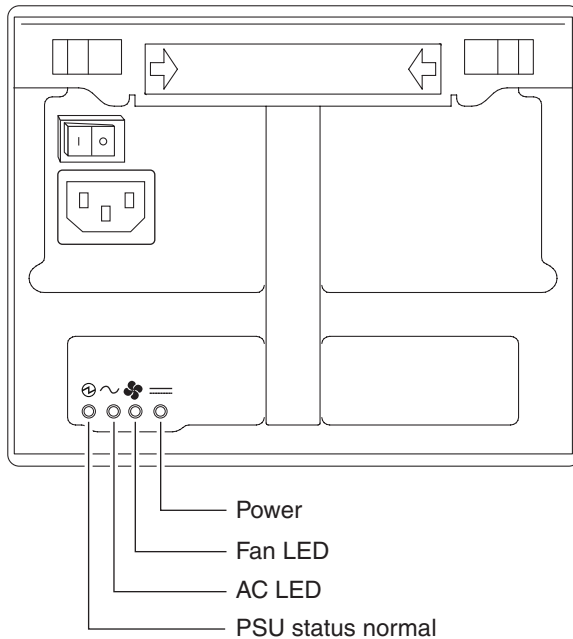

Figure 8. Location of power supply LEDs

**Note:** The PSU status LED is green. The other three LEDs are amber. See Figure 7 on page 25 for an illustrated explanation of how the LEDs function.

## Power supply console error messages

The following error messages appear on your N series storage system console if an SES element on the power supply fails. For information about replacing the power supply, see “Replacing a power supply in an expansion unit” on page 39.

Table 12. Power supply console error messages

Error message	Action required
Power supply Element 1: failed	The power supply unit on the left at the back of the expansion unit failed. Contact IBM customer service to replace the power supply.
Power supply Element 2: failed	The power supply unit on the right at the back of the expansion unit failed. Contact IBM customer service to replace the power supply.

Table 12. Power supply console error messages (continued)

Error message	Action required
Cooling element Element 1: failed	The integrated fan module in the power supply unit on the left at the back of the expansion unit failed. Contact IBM customer service to replace the power supply.
Cooling element Element 2: failed	The integrated fan module in the power supply unit on the right at the back of the expansion unit failed. Contact IBM customer service to replace the power supply.

## Monitoring the Fibre Channel disk

The Fibre Channel disk has two LEDs. The LEDs indicate whether the disk is functioning normally or there are problems with the hardware.

### Location of LEDs

The following illustration shows the Fibre Channel disk, which has two LED indicators on the front.

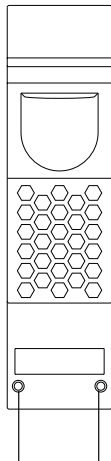

Amber Green

Figure 9. Fibre Channel disk

### LED status on the Fibre Channel disks

The following figure shows the third sheet of the quick reference cards that come with your EXN4000 expansion unit.



---

## Chapter 4. Replacing expansion unit devices

This chapter describes how to replace expansion units in a rack, disks in an expansion unit, and other devices, in the following sections:

- “Removing an expansion unit”
- “Replacing a disk in an expansion unit” on page 37
- “Replacing a power supply in an expansion unit” on page 39
- “Replacing an ESH4 module” on page 41

**Attention:** Return failed parts to IBM. Contact IBM Service and Support at 1-800-IBM-SERV (1-800-426-7378) for more information on the return procedure.

---

### Removing an expansion unit

This section discusses how to disconnect an expansion unit from an N series storage system and how to remove an expansion unit from a daisy-chain configuration. It does not discuss how to install an expansion unit or how to hot-add an expansion unit.

For information about installing an expansion unit in a rack, see “Guide to the installation process” on page 5.

For information about hot-adding an expansion unit, see “Hot-adding an expansion unit to an existing loop” on page 15.

**Attention:** Hot removal or hot-swapping of an expansion unit is not supported.

For detailed information about removing an expansion unit from a rack, see the following topics:

- “Removing an expansion unit from a single expansion unit configuration”
- “Removing an expansion unit from a loop” on page 36

#### Removing an expansion unit from a single expansion unit configuration

To remove an expansion unit from a single expansion unit configuration, complete the following steps:

1. Put on the antistatic ESD strap and grounding leash.
2. Shut down the N series storage system by entering the following command at the console:

```
halt
```

**Attention:** Disable the cluster first and then use the `halt` command to shut down all controllers to which the loop is connected.

3. Turn off the power switches on the expansion unit.
4. Disconnect the two expansion unit power cords from the expansion unit.
5. Disconnect the Fibre Channel cable connecting the expansion unit and N series storage system.
6. Disconnect the grounding strap connecting the expansion unit and N series storage system.
7. Use a flat-blade screwdriver to remove the tie-down screws securing the rear of the expansion unit to the rack. Use a 7mm nut driver to remove the screws securing the front of the expansion unit to the rack.

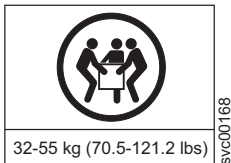

## DANGER

**The weight of this part or unit is between 32 and 55 kg (70.5 and 121.2 lb). It takes three persons to safely lift this part or unit. (C010)**

**Attention:** Remove the power supplies and fan units from the chassis before attempting to lift the system.

8. With the help of at least two people, remove the expansion unit from the rack.

### CAUTION:

**The expansion unit is very heavy when fully loaded and requires at least three people to remove it.**

## Removing an expansion unit from a loop

To remove an expansion unit from a loop of expansion units, complete the following steps:

1. Put on the antistatic ESD strap and grounding leash.
2. Shut down the N series storage system by entering the following command at the console:

```
halt
```

**Attention:** Disable the cluster first and then use the `halt` command to shut down all controllers to which the loop is connected.

3. Turn off the power switches on the expansion unit.

4. Disconnect the two expansion unit power cords from the expansion unit that you are going to remove.
5. Disconnect the Fibre Channel cables connecting the expansion unit to the other expansion units and/or the N series storage system.
6. Disconnect the grounding strap connecting the expansion unit to the other expansion units and/or the N series storage system.
7. Use a flat-blade screwdriver to remove the tie-down screws securing the rear of the expansion unit to the rack. Use a 7mm nut driver to remove the screws securing the front of the expansion unit to the rack.

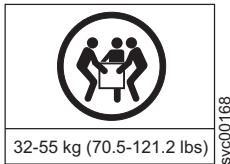

## DANGER

**The weight of this part or unit is between 32 and 55 kg (70.5 and 121.2 lb). It takes three persons to safely lift this part or unit. (C010)**

**Attention:** Remove the power supplies and fan units from the chassis before attempting to lift the system.

8. With the help of at least two people, remove the expansion unit from the rack.

### CAUTION:

**The expansion unit is very heavy when fully loaded and requires at least three people to remove it.**

9. Do one of the following:
  - If you are not installing a replacement expansion unit, then reestablish the loop by connecting the disconnected expansion units or by connecting the unconnected expansion unit to the N series storage system.
  - If you are installing a replacement expansion unit, then see “Guide to the installation process” on page 5.

---

## Replacing a disk in an expansion unit

You can replace a disk in an expansion unit for any reason. However, the most common reason is disk failure. If a disk fails, the N series storage system logs a warning message to the system console indicating which disk on which loop failed.

In addition, an expansion unit with an ESH4 module identifies any one of the following situations as disk failure:

- A disk is bypassed.
- The filer system boots with the presence of bypassed disks.
- The filer system detects an eminent threshold bypass.

The following AutoSupport warning message is then sent:

```
DISK FAIL!! - Bypassed by ESH
```

## Preparing to replace a disk

Before you replace a disk in an expansion unit, you must first check the expansion unit to ensure that after you remove the disk you still have enough disks installed to meet the enclosure services requirements. For information about these requirements, see “Drive bay requirements” on page 10.

Replacing a disk in an expansion unit consists of the following procedures:

- “Removing a disk”
- “Installing a disk” on page 39

**Note:** If you are replacing several disks in an expansion unit or if you are installing several disks into a half-empty expansion unit, replace or install the disks one at a time to allow your storage unit to recognize the existence of each new disk.

## Removing a disk

To remove a disk, complete the following steps:

1. Do one of the following:
  - If you are removing a disk that is a member of a volume, then enter:  
`disk fail disk_name`
  - If you are removing a disk that is a spare disk, then enter:  
`disk remove disk_name`

**Note:** Either command causes the amber fault LED on the disk to illuminate. For more information about LEDs, see “Monitoring the Fibre Channel disk” on page 33.

For more information about disk commands, see the *Data ONTAP System Administrator’s Guide* for your version of Data ONTAP.

2. Put on the antistatic ESD strap and grounding leash.
3. To remove the disk, press down on its release mechanism with one hand while grasping the top flange of the expansion unit with the other hand.

4. Gently slide the disk until it disengages. Wait 30 seconds for the disk to stop spinning; then continue removing the disk from the chassis.  
**Attention:** When removing a disk, always use two hands to support its weight.
5. If you are replacing another disk, repeat steps 1 through 4.

### Installing a disk

To install a disk in an expansion unit, complete the following steps:

1. Put on the antistatic ESD strap and grounding leash.
2. Orient the device carrier so that the release mechanism is at the top.
3. Insert the device carrier into the guide slot in the expansion unit and firmly push it in until it engages the backplane and you see the release mechanism click into place.

**Note:** If the device carrier does not fully seat in the drive bay, you may be trying to install an unsupported disk drive in the expansion unit.

**Attention:** Do not slam the device carrier into place.

4. If you are replacing another disk, repeat steps 1 through 3.
5. Make sure that disks are installed in drive bays 0 and 1 for Enclosure Services to work.

---

## Replacing a power supply in an expansion unit

Replacing a power supply in an expansion unit consists of the following procedures:

- “Removing a power supply” on page 40
- “Installing a power supply” on page 40

### Rules for replacing power supplies

When replacing a power supply on your expansion unit, observe the following rules:

- You do not need to turn off the power to the expansion unit when you replace one power supply, only the power supply being replaced.
- If you are replacing both power supplies in the same expansion unit, replace them one at a time to avoid powering down the expansion unit.
- Although a single fan failure in one of the power supplies is not a critical event, it is recommended that you install a new power supply when one of the two fans in either power supply stops working.
- When hot-swapping power supplies, remove and install the power supplies within two minutes.

**Attention:** You can run with one power supply removed for a maximum of two minutes. The airflow through your is degraded when only one power supply is present and operating. Therefore, if the power supplies are not replaced within two minutes, the system halts and no data is accessible.

- Have the replacement power supply close by and ready to install before removing the old one.



**CAUTION:**

Never remove the cover on a power supply fan unit. There are no serviceable parts inside these components. If you suspect a problem with one of these parts, contact a service technician.

## Removing a power supply

To remove a power supply, complete the following steps:

1. Put on the antistatic ESD strap and grounding leash.
2. Turn off the switch on the power supply that you are replacing.
3. Lift up the clip lock and unplug the power cord from the N series storage system power supply.
4. Using your thumb and index finger, press the cam mechanism levers toward each other to release the power supply handle. The following figure shows how to press the levers on the cam mechanism and release the power supply handle.

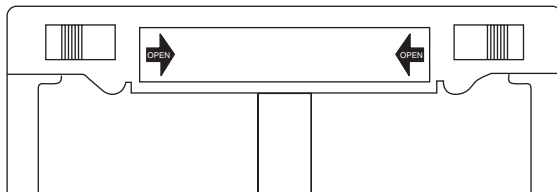

Figure 11. Cam mechanism

5. Use the handle to pull the power supply out of the expansion unit.

**Attention:** When removing a power supply, always use two hands to support its weight.

## Installing a power supply

To install a power supply in an expansion unit, complete the following steps:

**Attention:** Do not use excessive force when sliding the power supply into the expansion unit. You can damage the connector.

1. Put on the antistatic ESD strap and grounding leash.

2. Slide the power supply in the power supply bay until you hear the power supply connect with the connector inside the expansion unit chassis.
3. Raise the handle and push it into place.
4. Using your thumb and index finger, press the cam mechanism levers toward each other to engage the power supply into place.
5. Plug the power cord into the power receptacle and fasten it with the clamp.
6. Plug the other end of the power cord into a grounded AC power source.
7. Turn on the power switch.

---

## Replacing an ESH4 module

The ESH4 module in an expansion unit includes a SCSI-3 Enclosure Services Processor. It maintains the integrity of the loop when disks are swapped and provides signal retiming for enhanced loop stability. There are two ESH4 modules in the middle of the rear of the expansion unit, one for Channel A and one for Channel B.

**Note:** The Input and Output ports on module A on the expansion unit are inverted from module B.

The procedures in this section are based on the assumption that the expansion unit is in a configuration that fulfils one or all of the following requirements:

- It has a single-path connection.
- It is not in a cluster.
- It does not use synchronous mirroring.

### Connectors in an ESH4

The ESH4 module has the following connectors:

**Input** Provides the interface between the expansion unit and the N series storage system.

**Output**

Provides the interface between two expansion units to create a loop of daisy-chained expansion units.

### For detailed information

This section provides information about the following topics:

- “Removing a module” on page 42
- “Installing a module” on page 42
- “Hot-swapping a module” on page 42

## Removing a module

To remove a module that is connected to the Fibre Channel loop, complete the following steps:

1. Put on the antistatic ESD strap and grounding leash.
2. Shut down the N series storage system by entering the following command at the console:

```
halt
```

**Attention:** Disable the cluster first and then use the `halt` command to shut down all controllers to which the loop is connected.

3. Disconnect the Fibre Channel cables from the ESH4 module. If you are using optical cables, remove the associated SFPs from the input and output ports of the ESH4 module.
4. Using the thumb and index finger of both hands, press the levers on the cam mechanism on the module to release it.
5. Pull the module out of the expansion unit.
6. Go to “Installing a module.”

## Installing a module

To install a module into the expansion unit, complete the following steps:

**Attention:** Observe the “Expansion unit cabling requirements” on page 14. Do not mix ESH2 and ESH4 modules within a single expansion unit.

1. Put on the antistatic ESD strap and grounding leash.
2. Push apart the levers on the cam mechanism and slide the module into the slot at the rear of the expansion unit, then push the levers of the cam mechanism into place.

**Attention:** Do not use excessive force when sliding the module into the expansion unit; you might damage the connector.

3. If you are using optical cables, insert SFPs into the input and output ports of the ESH4 module.
4. Reconnect the Fibre Channel cabling.
5. Verify that the speed setting for the ESH4 module meets the requirements for your N series storage system. See “Speed setting” on page 9.
6. Turn on the power to the expansion units.
7. Reboot the N series storage system.

## Hot-swapping a module

**Note:** This procedure assumes that ESH4 modules on the expansion unit have multipath connections to any N series storage system.

**Attention:** If you attempt to hot-swap the ESH4 on an expansion unit that does not have multipath connections, you lose all access to the drives on this expansion unit as well as those below it.

To hot-swap a module, complete the following steps:

**Note:** To hot-swap a module on an expansion unit in a cluster, see the *Data ONTAP Cluster Installation and Management Guide* or *Data ONTAP Active/Active Configuration Guide* for your version of Data ONTAP.

1. Put on the antistatic ESD strap and grounding leash.
2. From the console of the N series storage system, enter the following command to disable the loop in which the failed module is a connection:  
`storage disable adapter adaptername`  
The *Data ONTAP System Administrator's Guide* or your version of Data ONTAP provides more information about these commands.
3. Disconnect the module that you are removing from the Fibre Channel cabling.
4. Using the thumb and index finger of both hands, press the levers on the cam mechanism on the module to release it and pull it out of the EXN4000 expansion unit.
5. Wait for the following console message:  
Module x is not installed.
6. If you are using optical cables, remove the SFPs from the input and output ports of the ESH4 module you have removed. Plug the SFPs into the input and output ports of the replacement ESH4.
7. Slide the replacement module into the slot at the rear of the expansion unit and push the levers of the cam into place.  
**Attention:** Do not use excessive force when sliding the ESH4 into the expansion unit; you might damage the connector.
8. Reconnect the Fibre Channel cabling.
9. Verify that the speed setting for the replacement ESH4 module meets the requirements for your N series storage system. See "Speed setting" on page 9.
10. From the console of the filer, enter the following command to enable the loop in which the replacement ESH4 is a connection:  
`storage enable adapter adaptername`
11. From the N series storage system unit console, enter the following command to verify that the module reports good status.  
`environ shelf`



---

## Appendix A. Recommended power line sizes

This appendix describes the recommended AC power line lengths running from the N series storage system to the power source.

---

### Recommended AC power line sizes

Longer AC power feeds need to be properly designed to preserve voltage levels to the equipment. The wiring from the breaker panel to the power strip, which supplies power to the N series storage system and expansion units, can often exceed 50 feet.

**Note:** Total AC wire length = breaker to wall or ceiling outlet + extension cable or ceiling drop.

The following table lists the recommended conductor size for 2% voltage drop for a particular distance in feet (taken from the *Radio Engineer's Handbook*).

*Table 13. Recommended conductor size for 2% voltage drop*

110V, single-phase	20A circuit	30A circuit	40A circuit	50A circuit
25 feet	12 AWG	10 AWG	8 AWG	8 AWG
50 feet	8 AWG	6 AWG	6 AWG	4 AWG
75 feet	6 AWG	4 AWG	4 AWG	2 AWG

220V, single-phase	20A circuit	30A circuit	40A circuit	50A circuit
25 feet	14 AWG	12 AWG	12 AWG	10 AWG
50 feet	12 AWG	10 AWG	8 AWG	8 AWG
75 feet	10 AWG	8 AWG	6 AWG	6 AWG

The following table lists the approximate equivalent wire gauge (American Wire Gauge (AWG) to Harmonized Cordage).

*Table 14. American Wire Gauge (AWG) to Harmonized Cordage*

AWG	8	10	12
Harmonized, mm-mm	4.0	2.5	1.5
mm-mm = millimeter squared			



---

## Appendix B. FRU/CRU and power cord list for N series products

This appendix contains information about FRU/CRUs and power cords for N series products.

---

### FRU/CRU list for N series products

For the most current FRU/CRU list for your N series product, see the following Web site:

[www.ibm.com/storage/support/nas/](http://www.ibm.com/storage/support/nas/)

---

### Power cord list for N series products

The following list details the power cord feature codes (FCs) for N series products.

#### **FC 9000 (All countries)**

Power cord, Rack PDU

- 27 inches
- Rated 250 V/15 A
- Product end uses C14; PDU end uses C13.

#### **FC 9001 Europe and others**

Provides power cords for Austria, Belgium, Bolivia, Bulgaria, Chile, Croatia, Czech Republic, Egypt, Estonia, European Union, Finland, France, Germany, Greece, Hungary, Iceland, Indonesia, Latvia, Lebanon, Lithuania, Luxemburg, Morocco, Netherlands, Norway, Peru, Poland, Portugal, Romania, Russia, Slovakia, Slovenia, Spain, Suriname, Sweden, Turkey

- 2.5 m (9 feet), unshielded, rated 250 V/10 A.
- Attached plug EL 211 (CEE 7-VII) designed for 200-240 V ac input.

#### **FC 9002 United Kingdom and others**

Provides power cords for United Kingdom, Costa Rica, Cyprus, Guyana, Hong Kong, Ireland, Kuwait, Malta, Oman, Singapore, Sri Lanka

- 2.5 m (9 feet), unshielded, rated 250 V/10 A.
- Attached plug EL 210 (13A fuse) designed for 200-240 V ac input.

#### **FC 9003 Japan**

Provides power cords for Japan

- 1.83 m (6 feet), unshielded, rated 125 V/15 A.
- Attached plug EL 302 (JIS C3306) designed for 100-110 V ac input.

**FC 9004 U.S., Six Feet (2 m)**

Provides power cords for U.S., Canada, Mexico, Belize, Columbia, Ecuador, El Salvador, Guatemala, Honduras, Korea, Nicaragua, Panama, Philippines, Puerto Rico, Saudi Arabia, Thailand, Venezuela

- 1.83 m (6 feet), unshielded, rated 125 V/15 A.
- Attached plug EL 302 (Nema 5-15P) designed for 100-120 V ac input.

**FC 9005 Australia, New Zealand**

Provides power cords for Australia, New Zealand, Uruguay

- 2.5 m (9 feet), unshielded, rated 250 V/10 A.
- Attached plug EL 206 (AS 3112) designed for 200-240 V ac input.

**FC 9006 Switzerland, Liechtenstein**

Provides power cords for Switzerland, Liechtenstein

- 2.5 m (9 feet), unshielded, rated 250 V/10 A.
- Attached plug EL 203 (SEV 1011) designed for 200-240 V ac input.

**FC 9007 Argentina**

Provides power cords for Argentina

- 2.5 m (9 feet), unshielded, rated 250 V/10 A.
- Attached plug EL 219 (IRAM 2073) designed for 200-240 V ac input.

**FC 9008 China**

Provides power cords for China

- 2.5 m (9 feet), unshielded, rated 250 V/10 A.
- Attached plug EL 602 (GB 2099/GB 1002) designed for 200-240 V ac input.

**FC 9009 Denmark**

Provides power cords for Denmark

- 2.5 m (9 feet), unshielded, rated 250 V/10 A.
- Attached plug EL 213 (DHCR 107-2-D1) designed for 200-240 V ac input.

**FC 9010 India, Pakistan, South Africa**

Provides power cords for India, Macau, Pakistan, South Africa

- 2.5 m (9 feet), unshielded, rated 250 V/10 A.
- Attached plug EL 208 (BS 164-1, BS 546) designed for 200-240 V ac input.

**FC 9011 Israel**

Provides power cords for Israel

- 2.5 m (9 feet), unshielded, rated 250 V/10 A.
- Attached plug EL 212 (SI 32) designed for 200-240 V ac input.

**FC 9012 Italy**

Provides power cords for Italy

- 2.5 m (9 feet), unshielded, rated 250 V/10 A.
- Attached plug EL 502 (CEI 23-16) designed for 200-240 V ac input.

**FC 9013 North America (250 V)**

Provides power cords for U.S.

- 1.83 m (6 feet), unshielded, rated 250 V/15 A.
- Attached plug EL 309 (NEMA 6-15P) designed for 200-240 V ac input.

**FC 9014 Brazil**

Provides power cords for Brazil

- 2.5 m (9 feet), unshielded, rated 250 V/10 A.
- Attached plug EL 211 (NBR 6147/2000) designed for 200-240 V ac input

**FC 9015 Taiwan**

Provides 125 V power cords for Taiwan

- 2.5 m (9 feet), unshielded, rated 125 V/15 A.
- Attached plug EL 302 (CNS 10917-3) designed for 100-120 V ac input.

**FC 9016 Taiwan (250 V)**

Provides 250 V power cords for Taiwan

- 1.83 m (6 feet), unshielded, rated 250 V/10 A.
- Attached plug EL 610 (CNS 10917, CNS 690) designed for 250 V ac input.



---

## Appendix C. IBM System Storage N series documentation

The following lists present an overview of the IBM System Storage N series hardware and Data ONTAP product libraries, as well as other related documents.

You can access the documents listed in these tables at the following Web site:

[www.ibm.com/storage/support/nas/](http://www.ibm.com/storage/support/nas/)

---

### **N7000 series systems library**

- *IBM System Storage N7000 Series Hardware and Service Guide, GC26-7953*
- *IBM System Storage N7000 Series Filer Installation and Setup Instructions, GC26-7954*
- *IBM System Storage N7000 Series Gateway Installation and Setup Instructions, GC26-7956*

---

### **N5000 series systems library**

- *IBM System Storage N5000 Series Hardware and Service Guide, GC26-7785*
- *IBM System Storage N5000 Series Filer Installation and Setup Instructions, GC26-7784*
- *IBM System Storage N5000 Series Gateway Installation and Setup Instructions, GC26-7838*

---

### **N3300 and N3600 storage systems library**

- *IBM System Storage N3300 and N3600 Hardware and Service Guide, GC27-2087*
- *IBM System Storage N3300 Installation and Setup Instructions, GC27-2086*
- *IBM System Storage N3600 Installation and Setup Instructions, GC27-2089*

---

### **N3700 storage system library**

- *IBM System Storage N3700 Hardware and Service Guide, GA32-0515*
- *IBM System Storage N3700 Installation and Setup Instructions, GA32-0517*

---

## **EXN1000, EXN2000 and EXN4000 expansion units library**

- *IBM System Storage EXN1000 Storage Expansion Unit Hardware and Service Guide, GC26-7802*
- *IBM System Storage EXN1000 Installation and Setup Instructions, GC26-7786*
- *IBM System Storage EXN2000 Storage Expansion Unit Hardware and Service Guide, GA32-0516*
- *IBM System Storage EXN2000 Installation and Setup Instructions, GC27-2064*
- *IBM System Storage EXN4000 Storage Expansion Unit Hardware and Service Guide, GC27-2080*
- *IBM System Storage EXN4000 Installation and Setup Instructions, GC27-2079*

---

## **Data ONTAP 7.2 filer library**

- *IBM System Storage N series Data ONTAP 7.2 Release Notes, GC26-7963*
- *IBM System Storage N series Data ONTAP 7.2 Active-Active Configuration Guide, GC26-7964*
- *IBM System Storage N series Data ONTAP 7.2 File Access and Protocols Management Guide, GC26-7965*
- *IBM System Storage N series Data ONTAP 7.2 Storage Management Guide, GC26-7966*
- *IBM System Storage N series Data ONTAP 7.2 Data Protection Online Backup and Recovery Guide, GC26-7967*
- *IBM System Storage N series Data ONTAP 7.2 Data Protection Tape Backup and Recovery Guide, GC26-7968*
- *IBM System Storage N series Data ONTAP 7.2 MultiStore Management Guide, GC26-7969*
- *IBM System Storage N series Data ONTAP 7.2 Network Management Guide, GC26-7970*
- *IBM System Storage N series Data ONTAP 7.2 Commands: Manual Page Reference, Volume 1, GC26-7971*
- *IBM System Storage N series Data ONTAP 7.2 Commands: Manual Page Reference, Volume 2, GC26-7972*
- *IBM System Storage N series Data ONTAP 7.2 Upgrade Guide, GC26-7976*
- *IBM System Storage N series Data ONTAP 7.2 Block Access Management Guide for iSCSI & FCP, GC26-7973*
- *IBM System Storage N series Data ONTAP 7.2 System Administration Guide, GC26-7974*
- *IBM System Storage N series Data ONTAP 7.2 Software Setup Guide, GC26-7975*
- *IBM System Storage N series Data ONTAP 7.2 Core Commands Quick Reference, GC26-7977*

---

## Data ONTAP 7.1 filer library

- *IBM System Storage N series Data ONTAP Release Notes, GC26-7862*
- *IBM System Storage N series Data ONTAP 7.1 Cluster Installation and Management Guide, GC26-7790*
- *IBM System Storage N series Data ONTAP 7.1 File Access and Protocols Management Guide, GA32-0520*
- *IBM System Storage N series Data ONTAP 7.1 Storage Management Guide, GA32-0521*
- *IBM System Storage N series Data ONTAP 7.1 Data Protection Online Backup and Recovery Guide, GA32-0522*
- *IBM System Storage N series Data ONTAP 7.1 Data Protection Tape Backup and Recovery Guide, GA32-0523*
- *IBM System Storage N series Data ONTAP 7.1 MultiStore Management Guide, GA32-0524*
- *IBM System Storage N series Data ONTAP 7.1 Network Management Guide, GA32-0525*
- *IBM System Storage N series Data ONTAP 7.1 Commands: Manual Page Reference, Volume 1, GA32-0526*
- *IBM System Storage N series Data ONTAP 7.1 Commands: Manual Page Reference, Volume 2, GA32-0527*
- *IBM System Storage N series Data ONTAP 7.1 Upgrade Guide, GC26-7791*
- *IBM System Storage N series Data ONTAP 7.1 Block Access Management Guide for iSCSI & FCP, GA32-0528*
- *IBM System Storage N series Data ONTAP 7.1 System Administration Guide, GA32-0529*
- *IBM System Storage N series Data ONTAP 7.1 Software Setup Guide, GA32-0530*
- *IBM System Storage N series Data ONTAP 7.1 Core Commands Quick Reference, GA32-0531*

---

## Data ONTAP 7.2 gateway systems library

- *IBM System Storage N series Data ONTAP 7.2 Gateway Release Notes, GC26-7955*
- *IBM System Storage N series Data ONTAP 7.2 Gateway Software Setup, Installation, and Management Guide, GC26-7962*
- *IBM System Storage N series Data ONTAP 7.2 Gateway Connecting Your System, GC26-7990*
- *IBM System Storage N series Data ONTAP 7.2 Gateway Planning Guide, GC26-7957*

- *IBM System Storage N series Data ONTAP 7.2 Gateway Software Upgrade Guide, GC26-7958*
- *IBM System Storage N series Data ONTAP 7.2 Gateway Integration Guide for IBM Storage, GC26-7959*
- *IBM System Storage N series Data ONTAP 7.2 Gateway Integration Guide for Hitachi Storage, GC26-7960*
- *IBM System Storage N series Data ONTAP 7.2 Gateway Integration Guide for HP XP Storage, GC26-7961*
- *IBM System Storage N series Data ONTAP 7.2 Gateway Integration Guide for EMC CLARiiON Storage, GC27-2081*
- *IBM System Storage N series Data ONTAP 7.2 Gateway Integration Guide for Fujitsu ETERNUS Storage, GC27-2082*
- *IBM N series Gateway Data ONTAP 7.2 Integration Guide for IBM SAN Volume Controller Storage, GC27-2061*
- *IBM Gateway Data ONTAP 7.2 3PAR Implementation Guide, GC27-2090*
- *IBM Gateway Data ONTAP 7.2 MetroCluster Guide, GC27-2091*
- *IBM Gateway Data ONTAP 7.2 Installation Requirements, Quick Start, & Reference Guide, GC27-2092*

---

## **Data ONTAP 7.1 gateway systems library**

- *IBM System Storage N series Gateway Planning Guide, GC26-7839*
- *IBM System Storage N series Gateway Integration Guide for IBM Storage, GC26-7840*
- *IBM System Storage N series Gateway Integration Guide for Hitachi Storage, GC26-7841*
- *IBM System Storage N series Gateway Integration Guide for HP Storage, GC26-7858*
- *IBM System Storage N series Gateway Software Upgrade Guide, GC26-7859*
- *IBM System Storage N series Gateway Software Setup, Installation, and Management Guide, GC26-7886*
- *IBM System Storage N series Gateway Release Notes, GC26-7837*

---

## **Other N series and N series-related documents**

- *IBM System Storage N series Platform Monitoring Guide, GC27-2088*
- *IBM System Storage N series Diagnostics Guide, GC26-7789*
- *IBM System Storage N series Introduction and Planning Guide, GA32-0543*
- *IBM System Storage N series Autosupport Overview, GC26-7854*
- *IBM System Storage N series: Changing the cluster cfmnode Setting in Fibre Channel SAN Configurations, GC26-7876*

- *IBM System Storage N series Fibre Channel Configuration Guide, GC26-7835*
- *IBM System Storage N series Metrocluster Redbook, REDP-4243-00*
- *IBM System Storage Systems Safety Notices, G229-9054*
- *IBM Storage Solution Rack 2101 Rack Installation and Service Guide: Models 200 and N00, GC26-7993*



---

## Notices

This information was developed for products and services offered in the U.S.A.

IBM may not offer the products, services, or features discussed in this document in other countries. Consult your local IBM representative for information on the products and services currently available in your area. Any reference to an IBM product, program, or service is not intended to state or imply that only that IBM product, program, or service may be used. Any functionally equivalent product, program, or service that does not infringe on any IBM intellectual property right may be used instead. However, it is the user's responsibility to evaluate and verify the operation of any non-IBM product, program, or service.

IBM may have patents or pending patent applications covering subject matter described in this document. The furnishing of this document does not give you any license to these patents. You can send license inquiries, in writing to:

*IBM Director of Licensing  
IBM Corporation  
North Castle Drive  
Armonk, N.Y. 10504-1785  
U.S.A.*

For additional information, visit the web at:  
<http://www.ibm.com/ibm/licensing/contact/>

**The following paragraph does not apply to the United Kingdom or any other country where such provisions are inconsistent with local law:**  
INTERNATIONAL BUSINESS MACHINES CORPORATION PROVIDES THIS PUBLICATION "AS IS" WITHOUT WARRANTY OF ANY KIND, EITHER EXPRESS OR IMPLIED, INCLUDING, BUT NOT LIMITED TO, THE IMPLIED WARRANTIES OF NON-INFRINGEMENT, MERCHANTABILITY OR FITNESS FOR A PARTICULAR PURPOSE. Some states do not allow disclaimer of express or implied warranties in certain transactions, therefore, this statement may not apply to you.

This information could include technical inaccuracies or typographical errors. Changes are periodically made to the information herein; these changes will be incorporated in new editions of the publication. IBM may make improvements and/or changes in the product(s) and/or the program(s) described in this publication at any time without notice.

Any references in this information to non-IBM web sites are provided for convenience only and do not in any manner serve as an endorsement of those web sites. The materials at those web sites are not part of the materials for this IBM product and use of those web sites is at your own risk.

IBM may use or distribute any of the information you supply in any way it believes appropriate without incurring any obligation to you.

Any performance data contained herein was determined in a controlled environment. Therefore, the results obtained in other operating environments may vary significantly. Some measurements may have been made on development-level systems and there is no guarantee that these measurements will be the same on generally available systems. Furthermore, some measurement may have been estimated through extrapolation. Actual results may vary. Users of this document should verify the applicable data for their specific environment.

Information concerning non-IBM products was obtained from the suppliers of those products, their published announcements or other publicly available sources. IBM has not tested those products and cannot confirm the accuracy of performance, compatibility or any other claims related to non-IBM products. Questions on the capabilities of non-IBM products should be addressed to the suppliers of those products.

If you are viewing this information in softcopy, the photographs and color illustrations may not appear.

---

## Trademarks

The following terms are trademarks of International Business Machines Corporation in the United States, other countries, or both:

IBM  
IBM logo

ServerProven™  
System Storage

NetApp, the Network Appliance logo, the bolt design, NetApp—the Network Appliance Company, Data ONTAP, DataFabric, FAServer, FilerView, MultiStore, NearStore, NetCache, SecureShare, SnapManager, SnapMirror, SnapMover, SnapRestore, SnapVault, SyncMirror, and WAFL are registered trademarks of Network Appliance, Inc. in the United States, and/or other countries. gFiler, Network Appliance, SnapCopy, Snapshot, and The Evolution of Storage are trademarks of Network Appliance, Inc. in the United States and/or other countries and registered trademarks in some other countries. ApplianceWatch, BareMetal, Camera-to-Viewer, ComplianceClock, ComplianceJournal, ContentDirector, ContentFabric, EdgeFiler, FlexClone,

FlexVol, FPolicy, HyperSAN, InfoFabric, LockVault, Manage ONTAP, NOW, NetApp on the Web, ONTAPI, RAID-DP, RoboCache, RoboFiler, SecureAdmin, Serving Data by Design, SharedStorage, Simulate ONTAP, Smart SAN, SnapCache, SnapDirector, SnapDrive, SnapFilter, SnapLock, SnapMigrator, SnapSuite, SnapValidator, SohoFiler, vFiler, VFM, Virtual File Manager, VPolicy, and Web Filer are trademarks of Network Appliance, Inc. in the United States and other countries. NetApp Availability Assurance and NetApp ProTech Expert are service marks of Network Appliance, Inc. in the United States. Spinnaker Networks, the Spinnaker Networks logo, SpinAccess, SpinCluster, SpinFS, SpinHA, SpinMove, and SpinServer are registered trademarks of Spinnaker Networks, LLC in the United States and/or other countries. SpinAV, SpinManager, SpinMirror, SpinRestore, SpinShot, and SpinStor are trademarks of Spinnaker Networks, LLC in the United States and/or other countries.

Network Appliance is a licensee of the CompactFlash and CF Logo trademarks.

Network Appliance NetCache is certified RealSystem compatible.

Microsoft<sup>®</sup>, Windows<sup>®</sup>, and Windows NT<sup>®</sup> are trademarks of Microsoft Corporation in the United States, other countries, or both.

UNIX is a registered trademark of The Open Group in the United States and other countries.

Other company, product, or service names may be trademarks or service marks of others.

---

## Important notes

Processor speeds indicate the internal clock speed of the microprocessor; other factors also affect application performance.

CD-ROM drive speeds list the variable read rate. Actual speeds vary and are often less than the maximum possible.

When referring to processor storage, real and virtual storage, or channel volume, KB stands for approximately 1000 bytes, MB stands for approximately 1 000 000 bytes, and GB stands for approximately 1 000 000 000 bytes.

When referring to hard disk drive capacity or communications volume, MB stands for 1 000 000 bytes, and GB stands for 1 000 000 000 bytes. Total user-accessible capacity may vary depending on operating environments.

Maximum internal hard disk drive capacities assume the replacement of any standard hard disk drives and population of all hard disk drive bays with the largest currently supported drives available from IBM.

Maximum memory may require replacement of the standard memory with an optional memory module.

IBM makes no representation or warranties regarding non-IBM products and services that are ServerProven<sup>®</sup>, including but not limited to the implied warranties of merchantability and fitness for a particular purpose. These products are offered and warranted solely by third parties.

IBM makes no representations or warranties with respect to non-IBM products. Support (if any) for the non-IBM products is provided by the third party, not IBM.

Some software may differ from its retail version (if available), and may not include user manuals or all program functionality.

---

## Electronic emission notices

The following statements apply to this product. The statements for other products intended for use with this product will appear in their accompanying manuals.

### **Federal Communications Commission (FCC) Class A Statement**

**Note:** This equipment has been tested and found to comply with the limits for a Class A digital device, pursuant to Part 15 of the FCC Rules. These limits are designed to provide reasonable protection against harmful interference when the equipment is operated in a commercial environment. This equipment generates, uses, and can radiate radio frequency energy and, if not installed and used in accordance with the instruction manual, may cause harmful interference to radio communications. Operation of this equipment in a residential area is likely to cause harmful interference, in which case the user will be required to correct the interference at his own expense.

Properly shielded and grounded cables and connectors must be used in order to meet FCC emission limits. IBM is not responsible for any radio or television interference caused by using other than recommended cables and connectors or by unauthorized changes or modifications to this equipment. Unauthorized changes or modifications could void the user's authority to operate the equipment.

This device complies with Part 15 of the FCC Rules. Operation is subject to the following two conditions: (1) this device may not cause harmful

interference, and (2) this device must accept any interference received, including interference that may cause undesired operation.

### **Industry Canada Class A Emission Compliance Statement**

This Class A digital apparatus complies with Canadian ICES-003.

### **Avis de conformité à la réglementation d'Industrie Canada**

Cet appareil numérique de la classe A est conforme à la norme NMB-003 du Canada.

### **European Union (EU) Electromagnetic Compatibility Directive**

This product is in conformity with the protection requirements of EU Council Directive 2004/108/EC on the approximation of the laws of the Member States relating to electromagnetic compatibility. IBM cannot accept responsibility for any failure to satisfy the protection requirements resulting from a non-recommended modification of the product, including the fitting of non-IBM option cards.

This product has been tested and found to comply with the limits for Class A Information Technology Equipment according to European Standard EN 55022. The limits for Class A equipment were derived for commercial and industrial environments to provide reasonable protection against interference with licensed communication equipment.

**Attention:** This is a Class A product. In a domestic environment this product may cause radio interference in which case the user may be required to take adequate measures.

Properly shielded and grounded cables and connectors must be used in order to reduce the potential for causing interference to radio and TV communications and to other electrical or electronic equipment. Such cables and connectors are available from IBM authorized dealers. IBM cannot accept responsibility for any interference caused by using other than recommended cables and connectors.

#### **European Community contact:**

IBM Technical Regulations  
Pascalstr. 100, Stuttgart, Germany 70569  
Tele: 0049 (0)711 7851176  
Fax: 0049 (0)711 785 1283  
e-mail: tjahn@de.ibm.com

### **Australia and New Zealand Class A statement**

**Attention:** This is a Class A product. In a domestic environment this product may cause radio interference in which case the user may be required to take adequate measures.

## Germany Electromagnetic Compatibility Directive

Zulassungsbescheinigung laut dem Deutschen Gesetz über die elektromagnetische Verträglichkeit von Geräten (EMVG) vom 18. September 1998 (bzw. der EMC EG Richtlinie 89/336)

Dieses Gerät ist berechtigt, in Übereinstimmung mit dem Deutschen EMVG das EG-Konformitätszeichen - CE - zu führen.

Verantwortlich für die Konformitätserklärung nach Paragraph 5 des EMVG ist die: IBM Deutschland Informationssysteme GmbH 70548 Stuttgart.

Informationen in Hinsicht EMVG Paragraph 4 Abs. (1) 4:

**Das Gerät erfüllt die Schutzanforderungen nach EN 55024 und EN 55022 Klasse A.**

EN 55022 Klasse A Geräte müssen mit folgendem Warnhinweis versehen werden: "Warnung: dies ist eine Einrichtung der Klasse A. Diese Einrichtung kann im Wohnbereich Funkstörungen verursachen; in diesem Fall kann vom Betreiber verlangt werden, angemessene Maßnahmen durchzuführen und dafür aufzukommen."

Anmerkung: Um die Einhaltung des EMVG sicherzustellen, sind die Geräte wie in den IBM Handbüchern angegeben zu installieren und zu betreiben.

## People's Republic of China Class A Electronic Emission Statement

中华人民共和国“A类”警告声明

声明

此为A级产品，在生活环境中，该产品可能会造成无线电干扰。在这种情况下，可能需要用户对其干扰采取切实可行的措施。

## Taiwan Class A warning statement

警告使用者：  
這是甲類的資訊產品，在居住的環境中使用時，可能會造成射頻干擾，在這種情況下，使用者會被要求採取某些適當的對策。

## Japan VCCI Class A ITE Electronic Emission Statement

この装置は、情報処理装置等電波障害自主規制協議会（VCCI）の基準に基づくクラスA情報技術装置です。この装置を家庭環境で使用すると電波妨害を引き起こすことがあります。この場合には使用者が適切な対策を講ずるよう要求されることがあります。

## Korean Class A Electronic Emission Statement

이 기기는 업무용으로 전자파 적합등록을 받은 기기 이오니, 판매자 또는 사용자는 이점을 주의하시기 바라며, 만약 잘못 구입하셨을 때에는 구입한 곳에서 비업무용으로 교환하시기 바랍니다.

---

## Power cords

For your safety, IBM provides a power cord with a grounded attachment plug to use with this IBM product. To avoid electrical shock, always use the power cord and plug with a properly grounded outlet.

IBM power cords used in the United States and Canada are listed by Underwriter's Laboratories (UL) and certified by the Canadian Standards Association (CSA).

For units intended to be operated at 115 volts: Use a UL-listed and CSA-certified cord set consisting of a minimum 18 AWG, Type SVT or SJT,

three-conductor cord, a maximum of 15 feet in length and a parallel blade, grounding-type attachment plug rated 15 amperes, 125 volts.

For units intended to be operated at 230 volts (U.S. use): Use a UL-listed and CSA-certified cord set consisting of a minimum 18 AWG, Type SVT or SJT, three-conductor cord, a maximum of 15 feet in length and a tandem blade, grounding-type attachment plug rated 15 amperes, 250 volts.

For units intended to be operated at 230 volts (outside the U.S.): Use a cord set with a grounding-type attachment plug. The cord set should have the appropriate safety approvals for the country in which the equipment will be installed.

IBM power cords for a specific country or region are usually available only in that country or region.

---

# Index

## A

- about this document
  - how to send your comments xxviii
- AC power line sizes 45
- address, IBM xxviii
- attention notice vii

## C

- caution notices vi
- Class A electronic emission notice 60
- clearance dimensions 3
- command
  - environ shelf 43
  - fcstat device\_map 17, 18
  - halt 35, 36, 42
  - storage disable 43
  - storage enable 43
- comments, how to send xxviii
- connecting to a power source 15
- connections of
  - expansion units to an N series storage system 14
  - expansion units to power source 15
  - grounded expansion units to an N series storage system 15
- console error messages
  - Alarm element 1 23
  - cooling element, element 1 and 2 33
  - Display element 1 23
  - ESH4 module 25
  - front operation panel 23
  - Open loop panic 16
  - power supply 32
  - power supply element 1 and 2 32
  - SES electronics element 1 and 2 26
  - Soft address panic 16
  - Speed mismatch termination 16
  - Temperature sensor element 1, 2, and 3 23, 26
  - Vendor-specific element 1 and 2 26
- conventions
  - command xxvii

- conventions (*continued*)
  - formatting xxvii
  - keyboard xxvii

## D

- danger notices iii
- Data ONTAP 7.1 filer
  - documentation 53
- Data ONTAP 7.1 gateway systems
  - library 54
- Data ONTAP 7.2 filer
  - documentation 52
- Data ONTAP 7.2 gateway systems
  - library 53
- disks
  - location of LEDs 33
  - replacing 38
- documentation
  - Data ONTAP 7.1 filer 53
  - Data ONTAP 7.1 gateway 54
  - Data ONTAP 7.2 filer 52
  - Data ONTAP 7.2 gateway 53
  - EXN1000, EXN2000 and EXN4000 expansion units 52
  - IBM System Storage N series 51
  - N series-related documents 54
  - N3300 and N3600 storage system 51
  - N3700 storage system 51
  - N5000 series systems 51
  - N7000 series systems 51
- drive addressing 9
- drive bay requirements 10

## E

- edition notice ii
- electrical requirements 4
- electronic emission Class A notice 60
- electronic emission notices 60
- Electronic emission notices
  - Australia and New Zealand Class A statement 61
  - European Union EMC Directive conformance statement 61
  - Federal Communications Commission (FCC) statement 60

- Electronic emission notices (*continued*)

- Industry Canada Class A emission compliance statement 61
  - Japanese Voluntary Control Council for Interference (VCCI) statement 63
  - Korean Class A warning statement 63
  - Taiwanese Class A warning statement 63
  - enclosure services, drive bays required for 10
  - environmental notices iii
  - environmental requirements 3
  - ESH4 error messages
    - SES electronics element 1 and 2 26
    - Temperature sensor element 2 and 3 26
    - Vendor-specific element 1 and 2 26
  - ESH4 module
    - console error messages 25
    - installing 42
    - interpreting LEDs 25
    - removing 42
    - replacing 41
  - ESH4 state messages
    - MISSING 28
    - OK 28
    - XPORT ERROR 28
  - EXN1000, EXN2000 and EXN4000 expansion units library 52
  - expansion units
    - connecting to an N series storage system 14
    - removing from a single configuration 35
    - replacing 35
- ## F
- FCC Class A notice 60
  - fiber-optic cable
    - handling 13
  - fire suppression xiii
  - form, reader comment xxviii

front operation panel  
  Alarm element 1 23  
  console error messages 23  
  Display element 1 23  
  interpreting LEDs 27  
  location of LEDs 22  
  monitoring the disk shelf ID 22  
  Temperature sensor element  
    1 23  
FRU/CRU list  
  feature codes 47

**G**  
ground, connecting expansion units  
  to an N series storage system 15

**H**  
handling static-sensitive devices 2  
hardware service and support xxv  
hot-adding an expansion unit to an  
  existing loop 15  
hot-adding error message  
  Open loop panic 16  
  Soft address panic 16  
how to send your comments xxviii

**I**  
IBM  
  address xxviii  
IBM safety information 54  
IDs, shelf 7  
installation  
  before you begin 7  
  ESH4 modules 42  
  power supply 40  
  rack viii  
  site requirements for 1  
  tools 1  
intellectual property 57

**L**  
labels  
  drive bay population 8  
  on the expansion unit 11  
labels on the expansion unit 16, 18  
labels, safety vi  
laser safety vii  
LED interpretation  
  ESH4 module 25  
  front operation panel 27  
  power supplies 25  
LED locations  
  disks 33  
  front operation panel 22  
  power supply 31  
license, patents 57

licensing  
  address 57  
  Web address 57

## **N**

N series  
  related documents 54  
N series documentation 51  
N3300 and N3600 storage system  
  library 51  
N3700 storage system library 51  
N5000 series systems library 51  
N7000 series systems library 51  
notes, important 59  
notice, edition ii  
notices  
  attention vii  
  caution vi  
  danger iii  
  electronic emission 60  
  FCC, Class A 60  
  safety and environmental iii  
  types iii

## **O**

optical port terminators vii

## **P**

patents 57  
physical characteristics 3  
port state messages  
  ///*:0xXX* 29  
  BYP/CLK 29  
  BYP/CLOS 28  
  BYP/CRC 29  
  BYP/DTO 28  
  BYP/GEN 29  
  BYP/INIT 29  
  BYP/LIP 29  
  BYP/LIPF7 29  
  BYP/LIPF8 28  
  BYP/MAN 29  
  BYP/MIR 29  
  BYP/OSC 29  
  BYP/RLOS 28  
  BYP/RPRT 29  
  BYP/STALL 29  
  BYP/TBI 28  
  BYP/WRD 29  
  BYP/XMIT 28  
  EMPTY 28  
  OK 28  
power  
  grounded electrical outlet 41  
  receptacles 41  
power cords 63

power cords (*continued*)  
  feature codes 47  
power supplies  
  installing in an expansion unit 40  
  interpreting LEDs power  
    supply 25  
  location of LEDs 31  
  power switch for 41  
  removing from an expansion  
    unit 40  
  replacing 39  
power supply error messages  
  cooling element, element 1 and  
    2 33  
  power supply element 1 and  
    2 32

## **R**

rack installation  
  safety viii  
rack relocation x  
  safety x  
rack safety viii  
reader comment form  
  processing xxviii  
removal of  
  ESH4 modules 42  
  expansion unit from  
    daisy-chain 36  
  expansion units 35  
  power supplies 40  
replacement of  
  disks 38  
  ESH4 modules 41  
  power supplies 39  
replacing  
  expansion units 35  
requirements  
  drive bay 10  
restrictions, usage vii  
rules  
  for drive bays 10

## **S**

safety  
  environmental notices iii  
  labels iii  
  laser vii  
  notices iii  
  rack viii  
  rack installation viii  
  rack relocation x  
safety labels vi  
shelf ID 7

- shelf state messages
  - FAILED 28
  - INIT REQD 28
  - MISSING 28
  - OFFLINE 28
  - ONLINE 28
- static-sensitive devices, handling 2
- storage show hub command output
  - Clock Delta 30
  - Insert Count 30
  - Invalid CRC Count 30
  - Invalid Word Count 30
  - Loop up Count 29
  - Stall Count 30
  - Utilization % 31
- storage show hub output
  - Port state 28
  - shelf state 27

## T

- tasks by document title 51
- terminators
  - optical ports vii
- terminology xxvi
- trademarks 58

## U

- United States electronic emission
  - Class A notice 60
- United States FCC Class A
  - notice 60
- usage restrictions vii

## W

- web sites, related xxv



---

# Readers' Comments — We'd Like to Hear from You

IBM System Storage EXN4000 Storage Expansion Unit  
Hardware and Service Guide

Publication No. GC27-2080-01

We appreciate your comments about this publication. Please comment on specific errors or omissions, accuracy, organization, subject matter, or completeness of this book. The comments you send should pertain to only the information in this manual or product and the way in which the information is presented.

For technical questions and information about products and prices, please contact your IBM branch office, your IBM business partner, or your authorized remarketer.

When you send comments to IBM, you grant IBM a nonexclusive right to use or distribute your comments in any way it believes appropriate without incurring any obligation to you. IBM or any other organizations will only use the personal information that you supply to contact you about the issues that you state on this form.

Comments:

Thank you for your support.

Submit your comments using one of these channels:

- Send your comments to the address on the reverse side of this form.

If you would like a response from IBM, please fill in the following information:

---

Name

---

Address

---

Company or Organization

---

Phone No.

---

E-mail address



Cut or Fold  
Along Line

Fold and Tape

Please do not staple

Fold and Tape



NO POSTAGE  
NECESSARY  
IF MAILED IN THE  
UNITED STATES

# BUSINESS REPLY MAIL

FIRST-CLASS MAIL PERMIT NO. 40 ARMONK, NEW YORK

POSTAGE WILL BE PAID BY ADDRESSEE

International Business Machines Corporation  
Information Development  
Dept. GZW  
9000 South Rita Road  
Tuscon, AZ  
U.S.A. 85744-0001

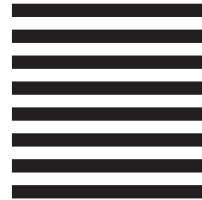

Fold and Tape

Please do not staple

Fold and Tape

Cut or Fold  
Along Line





Printed in USA

GC27-2080-01

