



System i and System p  
Managing the control panel functions







System i and System p

Managing the control panel functions

**Note**

Before using this information and the product it supports, read the information in “Notices” on page 49 and the *IBM Systems Safety Information* manual, G229-9054.

**Seventh Edition (September 2007)**

**© Copyright International Business Machines Corporation 2004, 2007. All rights reserved.**

US Government Users Restricted Rights – Use, duplication or disclosure restricted by GSA ADP Schedule Contract with IBM Corp.

---

# Contents

<b>Safety and environmental notices</b> . . . . .	<b>v</b>
---	----------

<b>About this topic</b> . . . . .	<b>ix</b>
-----------------------------------	-----------

<b>Managing the control panel functions</b> . . . . .	<b>1</b>
---	----------

What's new for Managing the control panel functions . . . . .	1
PDF file for Managing the control panel functions . . . . .	1
Control panel concepts . . . . .	2
Physical control panel . . . . .	2
Remote control panel . . . . .	6
Planning for the remote control panel . . . . .	7
Virtual control panel. . . . .	8
Differences between the virtual control panel and remote control panel . . . . .	10
Control panel function codes . . . . .	10
Control panel function codes on the HMC . . . . .	11
Control panel function codes on the 7037-A50 and 7047-185 models . . . . .	13
Control panel function code comparison for the RCP, VCP, and HMC . . . . .	14
Values for IPL types, system operating modes, and speeds . . . . .	16
Setting up the remote control panel . . . . .	18
Setting up the virtual control panel . . . . .	18
Creating a service tools device ID for the console VCP . . . . .	19
Setting user ID permissions for the VCP. . . . .	20
Accessing the control panel functions. . . . .	20
Accessing the control panel functions using the physical control panel . . . . .	20
Using the control panel power button to power off . . . . .	20
Initiating a delayed power off (DPO). . . . .	21
Initiating a fast power off (FPO) . . . . .	21
Putting the physical control panel in manual operating mode . . . . .	21
Accessing the control panel functions using the remote control panel . . . . .	22
Accessing the control panel functions using the virtual control panel . . . . .	22
Accessing the control panel functions using the HMC . . . . .	23
Primary control panel functions . . . . .	28
Function 01: Display selected IPL type, system operating mode, and IPL speed. . . . .	28
Function 02: Select IPL type, IPL speed override, system operating mode, and firmware mode . . . . .	29
Function 03: Start IPL . . . . .	31
Function 04: Lamp test . . . . .	31
Function 05: Reserved . . . . .	32
Function 06: Reserved . . . . .	32
Function 07: SPCN functions . . . . .	32
Function 08: Fast power off . . . . .	34
Functions 09 to 10: Reserved. . . . .	35
Functions 11 to 19: System reference code (SRC) . . . . .	35
Function 20: System type, model, feature code, and IPL type . . . . .	35
Control panel functions on the 7037-A50 and 7047-185 models . . . . .	35
Function 01: Display selected system operating mode, IPL speed, and firmware IPL mode . . . . .	36
Function 02: Select firmware IPL mode . . . . .	36
Function 04: Lamp test on the 7037-A50 and 7047-185 models . . . . .	37
Function 05: Remind mode for the 7037-A50 and 7047-185 models . . . . .	37
Function 06: Display the BMC version on the 7037-A50 and 7047-185 models . . . . .	38
Function 09: Display the BMC fan speed on the 7037-A50 and 7047-185 models . . . . .	39
Function 10: Display the temperature on the 7037-A50 and 7047-185 models. . . . .	39
Function 20: System type and model . . . . .	40
Function 22: Partition dump on the 7037-A50 and 7047-185 models. . . . .	40
Customer-extended panel functions . . . . .	41
Function 21: Service tool initiation. . . . .	41

Function 22: Partition dump . . . . .	41
Functions 23 to 24: Reserved. . . . .	42
Functions 25 and 26: Service switches 1 and 2. . . . .	42
Functions 27 to 29: Reserved. . . . .	42
Function 30: Service processor IP address and port location . . . . .	42
Functions 31 to 33: Reserved. . . . .	42
Function 34: Retry partition dump. . . . .	42
Functions 35 to 41: Reserved. . . . .	43
Function 42: Platform dump. . . . .	43
Function 43: Service processor dump . . . . .	43
Functions 44 to 54: Reserved. . . . .	44
Troubleshooting remote and virtual control panel problems . . . . .	44
Remote control panel fails to start . . . . .	44
Virtual control panel fails to start . . . . .	44
Unable to use the mode function . . . . .	44
Virtual control panel authentication errors . . . . .	45
Related information . . . . .	45
<b>Appendix. Accessibility features. . . . .</b>	<b>47</b>
<b>Notices . . . . .</b>	<b>49</b>
Trademarks . . . . .	50
Electronic emission notices . . . . .	50
Class A Notices . . . . .	50
Class B Notices . . . . .	54

---

## Safety and environmental notices

Safety notices may be printed throughout this guide:

- **DANGER** notices call attention to a situation that is potentially lethal or extremely hazardous to people.
- **CAUTION** notices call attention to a situation that is potentially hazardous to people because of some existing condition.
- **Attention** notices call attention to the possibility of damage to a program, device, system, or data.

### World Trade safety information

Several countries require the safety information contained in product publications to be presented in their national languages. If this requirement applies to your country, a safety information booklet is included in the publications package shipped with the product. The booklet contains the safety information in your national language with references to the U.S. English source. Before using a U.S. English publication to install, operate, or service this product, you must first become familiar with the related safety information in the booklet. You should also refer to the booklet any time you do not clearly understand any safety information in the U.S. English publications.

### Laser safety information

IBM® System i™ models and System p™ servers can use I/O cards or features that are fiber-optic based and that utilize lasers or LEDs.

#### Laser compliance

All lasers are certified in the U.S. to conform to the requirements of DHHS 21 CFR Subchapter J for class 1 laser products. Outside the U.S., they are certified to be in compliance with IEC 60825 as a class 1 laser product. Consult the label on each part for laser certification numbers and approval information.

#### CAUTION:

**This product might contain one or more of the following devices: CD-ROM drive, DVD-ROM drive, DVD-RAM drive, or laser module, which are Class 1 laser products. Note the following information:**

- **Do not remove the covers. Removing the covers of the laser product could result in exposure to hazardous laser radiation. There are no serviceable parts inside the device.**
- **Use of the controls or adjustments or performance of procedures other than those specified herein might result in hazardous radiation exposure.**

(C026)

#### CAUTION:

**Data processing environments can contain equipment transmitting on system links with laser modules that operate at greater than Class 1 power levels. For this reason, never look into the end of an optical fiber cable or open receptacle. (C027)**

#### CAUTION:

**This product contains a Class 1M laser. Do not view directly with optical instruments. (C028)**

#### CAUTION:

**Some laser products contain an embedded Class 3A or Class 3B laser diode. Note the following information: laser radiation when open. Do not stare into the beam, do not view directly with optical instruments, and avoid direct exposure to the beam. (C030)**

## Power and cabling information for NEBS (Network Equipment-Building System) GR-1089-CORE

The following comments apply to the IBM System i models and IBM System p servers that have been designated as conforming to NEBS (Network Equipment-Building System) GR-1089-CORE:

The equipment is suitable for installation in the following:

- Network telecommunications facilities
- Locations where the NEC (National Electrical Code) applies

The intrabuilding ports of this equipment are suitable for connection to intrabuilding or unexposed wiring or cabling only. The intrabuilding ports of this equipment *must not* be metallically connected to the interfaces that connect to the OSP (outside plant) or its wiring. These interfaces are designed for use as intrabuilding interfaces only (Type 2 or Type 4 ports as described in GR-1089-CORE) and require isolation from the exposed OSP cabling. The addition of primary protectors is not sufficient protection to connect these interfaces metallically to OSP wiring.

**Note:** All Ethernet cables must be shielded and grounded at both ends.

The ac-powered system does not require the use of an external surge protection device (SPD).

The dc-powered system employs an isolated DC return (DC-I) design. The DC battery return terminal *shall not* be connected to the chassis or frame ground.

### Product recycling and disposal

This unit must be recycled or discarded according to applicable local and national regulations. IBM encourages owners of information technology (IT) equipment to responsibly recycle their equipment when it is no longer needed. IBM offers a variety of product return programs and services in several countries to assist equipment owners in recycling their IT products. Information on IBM product recycling offerings can be found on IBM's Internet site at <http://www.ibm.com/ibm/environment/products/prp.shtml>.

Esta unidad debe reciclarse o desecharse de acuerdo con lo establecido en la normativa nacional o local aplicable. IBM recomienda a los propietarios de equipos de tecnología de la información (TI) que reciclen responsablemente sus equipos cuando éstos ya no les sean útiles. IBM dispone de una serie de programas y servicios de devolución de productos en varios países, a fin de ayudar a los propietarios de equipos a reciclar sus productos de TI. Se puede encontrar información sobre las ofertas de reciclado de productos de IBM en el sitio web de IBM <http://www.ibm.com/ibm/environment/products/prp.shtml>.



EU Only

**Note:** This mark applies only to countries within the European Union (EU) and Norway.

Appliances are labeled in accordance with European Directive 2002/96/EC concerning waste electrical and electronic equipment (WEEE). The Directive determines the framework for the return and recycling of used appliances as applicable throughout the European Union. This label is applied to various products to indicate that the product is not to be thrown away, but rather reclaimed upon end of life per this Directive.

In accordance with the European WEEE Directive, electrical and electronic equipment (EEE) is to be collected separately and to be reused, recycled, or recovered at end of life. Users of EEE with the WEEE marking per Annex IV of the WEEE Directive, as shown above, must not dispose of end of life EEE as unsorted municipal waste, but use the collection framework available to customers for the return, recycling, and recovery of WEEE. Customer participation is important to minimize any potential effects of EEE on the environment and human health due to the potential presence of hazardous substances in EEE. For proper collection and treatment, contact your local IBM representative.

## Battery return program

This product may contain sealed lead acid, nickel cadmium, nickel metal hydride, lithium, or lithium ion battery. Consult your user manual or service manual for specific battery information. The battery must be recycled or disposed of properly. Recycling facilities may not be available in your area. For information on disposal of batteries outside the United States, go to <http://www.ibm.com/ibm/environment/products/batteryrecycle.shtml> or contact your local waste disposal facility.

In the United States, IBM has established a return process for reuse, recycling, or proper disposal of used IBM sealed lead acid, nickel cadmium, nickel metal hydride, and other battery packs from IBM Equipment. For information on proper disposal of these batteries, contact IBM at 1-800-426-4333. Please have the IBM part number listed on the battery available prior to your call.

For Taiwan: Please recycle batteries.



For the European Union:



**Note:** This mark applies only to countries within the European Union (EU).

Batteries or packaging for batteries are labeled in accordance with European Directive 2006/66/EC concerning batteries and accumulators and waste batteries and accumulators. The Directive determines the framework for the return and recycling of used batteries and accumulators as applicable throughout the European Union. This label is applied to various batteries to indicate that the battery is not to be thrown away, but rather reclaimed upon end of life per this Directive.

In accordance with the European Directive 2006/66/EC, batteries and accumulators are labeled to indicate that they are to be collected separately and recycled at end of life. The label on the battery may also include a chemical symbol for the metal concerned in the battery (Pb for lead, Hg for mercury and Cd for cadmium). Users of batteries and accumulators must not dispose of batteries and accumulators as unsorted municipal waste, but use the collection framework available to customers for the return, recycling, and treatment of batteries and accumulators. Customer participation is important to minimize any potential effects of batteries and accumulators on the environment and human health due to the potential presence of hazardous substances. For proper collection and treatment, contact your local IBM representative.

For California: Perchlorate Material - special handling may apply. See [www.dtsc.ca.gov/hazardouswaste/perchlorate](http://www.dtsc.ca.gov/hazardouswaste/perchlorate).

The foregoing notice is provided in accordance with California Code of Regulations Title 22, Division 4.5 Chapter 33. Best Management Practices for Perchlorate Materials. This product/part may include a lithium manganese dioxide battery which contains a perchlorate substance.

### **IBM Cryptographic Coprocessor Card Return Program**

The following information applies only for systems originally sold prior to July 1, 2006:

This machine may contain an optional feature, the cryptographic coprocessor card, which includes a polyurethane material that contains mercury. Please follow local ordinances or regulations for disposal of this card. IBM has established a return program for certain IBM Cryptographic Coprocessor Cards. More information can be found at <http://www.ibm.com/ibm/environment/products/prp.shtml>.

---

## About this topic

The control panel functions allow you to interface with the server. Control panel functions range in complexity from functions that display status (such as IPL speed) to low-level service functions that only service representatives must access.

For information about the accessibility features of this product, for users who have a physical disability, see "Accessibility features," on page 47.



---

## Managing the control panel functions

The control panel functions allow you to interface with the server. Control panel functions range in complexity from functions that display status (such as IPL speed) to low-level service functions that only service representatives must access. You can perform control panel functions by using one of the following methods:

- Physical control panel
- IBM i5/OS® remote control panel
- IBM i5/OS virtual control panel
- Hardware Management Console (HMC) if the system is managed by the HMC
- 7037-A50 server and the 7047-185 workstation control panel

---

## What's new for Managing the control panel functions

Learn about new or updated information for Managing the control panel functions.

The following topic is new:

- "Virtual control panel fails to start" on page 44

The following topics are updated:

- "Function 07: SPCN functions" on page 32
- "Control panel function codes" on page 10
- "Control panel function codes on the HMC" on page 11
- "Control panel function codes on the 7037-A50 and 7047-185 models" on page 13
- "Remote control panel fails to start" on page 44

The following topics have been added or updated to provide control panel information for the 7037-A50 server and the 7047-185 workstation:

- "Physical control panel" on page 2
- "Control panel function codes on the 7037-A50 and 7047-185 models" on page 13
- "Control panel functions on the 7037-A50 and 7047-185 models" on page 35
  - "Function 01: Display selected system operating mode, IPL speed, and firmware IPL mode" on page 36
  - "Function 02: Select firmware IPL mode" on page 36
  - "Function 04: Lamp test on the 7037-A50 and 7047-185 models" on page 37
  - "Function 05: Remind mode for the 7037-A50 and 7047-185 models" on page 37
  - "Function 06: Display the BMC version on the 7037-A50 and 7047-185 models" on page 38
  - "Function 09: Display the BMC fan speed on the 7037-A50 and 7047-185 models" on page 39
  - "Function 10: Display the temperature on the 7037-A50 and 7047-185 models" on page 39
  - "Function 20: System type and model" on page 40
  - "Function 22: Partition dump on the 7037-A50 and 7047-185 models" on page 40

---

## PDF file for Managing the control panel functions

You can view and print a PDF file of this information.

To view or download the PDF version of this document, select [Managing the control panel functions](#)  (about 1,366 KB).

## Saving PDF files

To save a PDF on your workstation for viewing or printing:

1. Right-click the PDF link in your browser.
2. Click the option that saves the PDF locally.
3. Navigate to the directory in which you want to save the PDF.
4. Click **Save**.

## Downloading Adobe Reader

You need Adobe Reader installed on your system to view or print these PDFs. You can download a free copy from the Adobe Web site ([www.adobe.com/products/acrobat/readstep2.html](http://www.adobe.com/products/acrobat/readstep2.html)) .

---

## Control panel concepts

Learn about the control panel functions, IPL modes and values, and other concepts.

### Physical control panel

The *physical control panel* is your initial interface with the server or workstation. You can use the physical control panel to perform functions such as IPL, power on, and power off.

Control panel functions range in complexity from functions that display status (such as IPL speed) to low-level service functions that only service representatives access.

The following table lists the control panel figures and descriptions for server and workstation models.

*Table 1. Physical control panels*

Title of figure	Describes the control panel for the following models
Figure 1 on page 3	7037-A50 server model and the 7047-185 workstation
Figure 2 on page 4	505 server model
Figure 3 on page 5	510 and 710 server models
Figure 4 on page 5 for other server models, including the following: <ul style="list-style-type: none"><li>• 520</li><li>• 550</li><li>• 570</li><li>• 720</li></ul>	Other server models, with the following exceptions: <ul style="list-style-type: none"><li>• The system attention light does not appear on the control panel on the model 570. It is located to the right side of the control panel.</li><li>• The 590, 595, and 575 server models do not have physical control panels. Instead, they use the Hardware Management Console (HMC) to perform control panel functions. For information about using the HMC to perform control panel functions, see <a href="#">Accessing the control panel functions using the HMC</a>.</li></ul> The system attention light for the 590, 595, and 575 models is located on the power switch assembly.

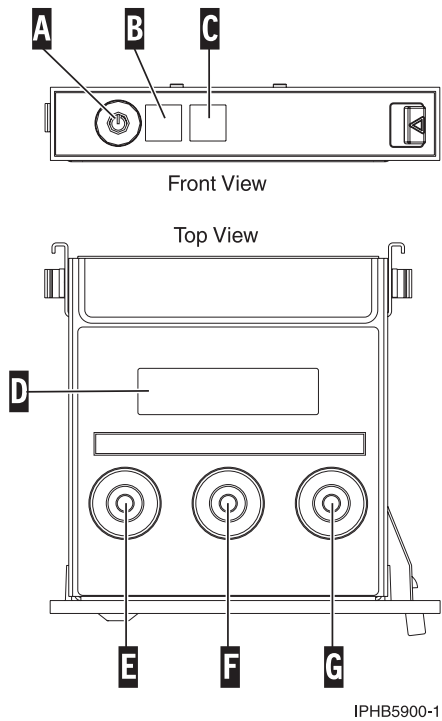
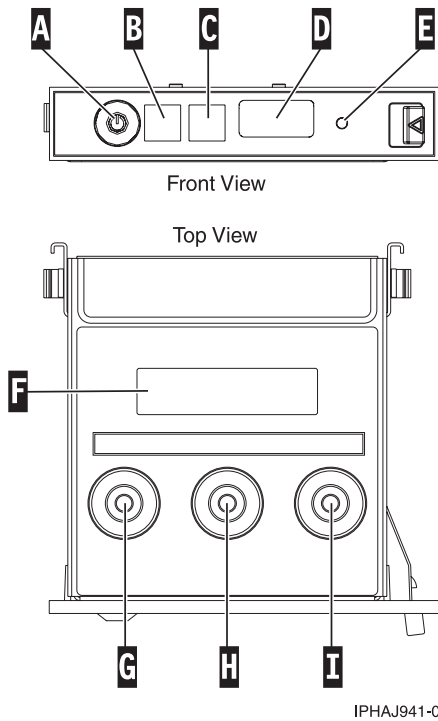

Figure 1. 7037-A50 and 7047-185 control panel

Typically, this control panel is seated inside the chassis so that only the end is showing. To read the Function/Data display, you must pull the control panel out from the front of the system. This illustration shows the control panel pulled out.

- A** Power button
- B** Power on light
  - A slow blinking light indicates standby power to the unit.
  - A fast blinking light indicates that the system is booting.
  - A constant light indicates full system power to the unit.
- C** System attention light
- D** Function/Data display (2 × 16 LCD display)
- E** Decrement button
- F** Enter button
- G** Increment button



IPHAJ941-0

Figure 2. 505 control panel

Typically, this control panel is seated inside the server chassis so that only the end is showing. To read the Function/Data display, you must pull the control panel out from the front of the server. This illustration shows the control panel pulled out.

- A Power button
- B Power on light
  - A blinking light indicates standby power to the unit.
  - A constant light indicates full system power to the unit.
- C System attention light
- D USB port
- E Reset button
- F Function/Data display
- G Decrement button
- H Enter button
- I Increment button

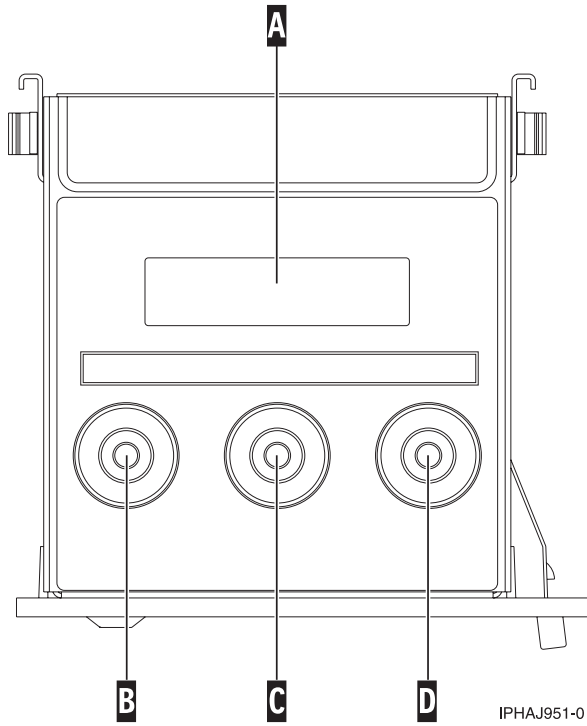

Figure 3. 510 and 710 control panel

- A LCD screen
- B Decrement button
- C Enter button
- D Increment button

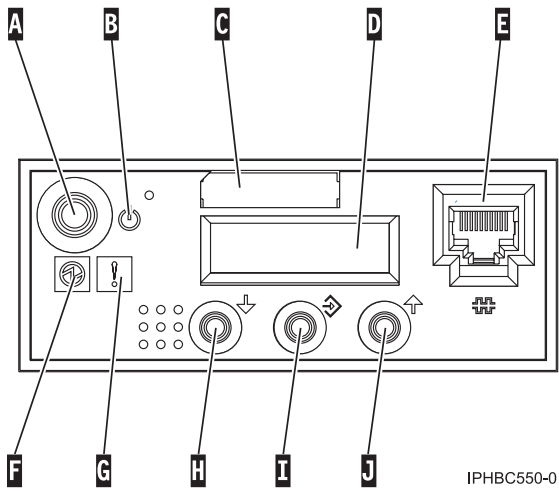

Figure 4. 520, 550, 570, and 720 control panel

- A Power button
- B On/off power symbol

- C Type and serial number label
- D Function/Data display
- E Ethernet connector
- F Power on light
  - A blinking light indicates standby power to the unit.
  - A constant light indicates full system power to the unit.
- G System attention light
- H Decrement button
- I Enter button
- J Increment button

## Remote control panel

The IBM i5/OS *remote control panel* lets you use control panel functions through a PC.

The graphical user interface of the remote control panel looks similar to the physical control panel. The remote control panel has the following characteristics:

- The remote control panel installs through the Operations Console.
- You can use the interface for the remote control panel to restart and power off the server. It cannot power up the server. You can use the remote control panel to perform most of the same functions as the physical control panel.
- POWER5™ server models do not support a directly connected remote control panel. Remote control panel connectivity is supported through a local console on a local area network (LAN-connected RCP) or using the virtual control panel (VCP).

For information about deciding whether the remote control panel or the virtual control panel will best meet your needs, see “Differences between the virtual control panel and remote control panel” on page 10.

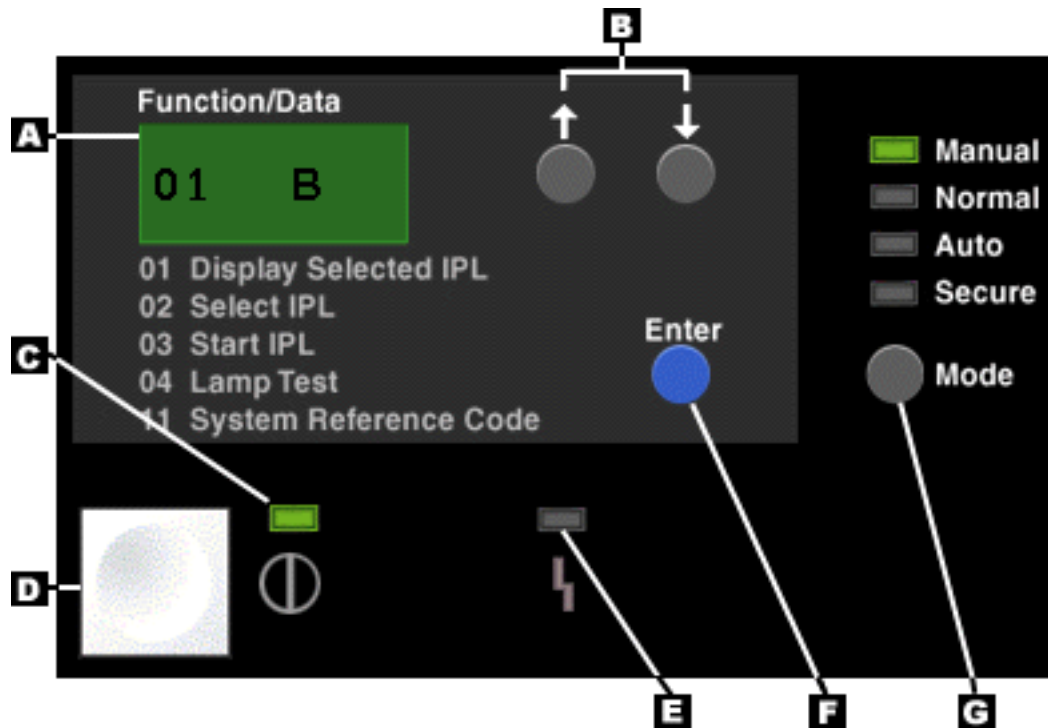

Figure 5. Remote control panel

- A Function/Data display
- B Increment and Decrement buttons
- C Power on indicator
- D Power button
- E System Attention light
- F Enter button
- G Mode button

## Planning for the remote control panel

Determine which remote control panel (RCP) configuration is best for your environment.

The following information can help you determine which IBM i5/OS remote control panel (RCP) configuration is best for your environment:

- The local console on a network (LAN) selects the RCP by default. If you do not want to use the RCP, use **Properties** to deselect the function.
- For IBM eServer™ hardware, you must use a Hardware Management Console (HMC) to manage logical partitions. This means that you cannot use the RCP to activate a logical partition, and you cannot directly connect an RCP cable to 5xx servers. To work with logical partitions remotely, you can use the Web-based System Manager Remote Client or the Advanced System Management Interface (ASMI).
- Any configuration where the device ID is not authorized after the first connection will be unavailable or missing.
  - An unavailable configuration was selected but not authorized.
  - A missing configuration was not selected and was not authorized.

After the configuration is authorized, it reappears in **Properties** the next time you connect.

- You must be granted access to a logical partition's RCP and functions to use the RCP. If a local console on a network (LAN) is being used, then the service tools device ID must also be granted access to that

logical partition's RCP to use this feature. Users and service tools device IDs default values will automatically grant access to the RCP for the logical partition but can be revoked by an administrator for the user ID, device ID, or both. The user that authenticates a connection must also have authority to the respective logical partition's keylock to change the mode.

## Virtual control panel

The IBM i5/OS virtual control panel is an alternative to the remote control panel on servers that do not support a directly connected remote control panel and do not have a network adapter. Like the remote control panel, the *virtual control panel* is a way to use control panel functions through a PC.

The graphical user interface for the virtual control panel is identical to the remote control panel. Also, the virtual control panel can perform most of the same functions as the remote control panel.

For information about deciding whether the remote control panel or the virtual control panel best meets your needs, see "Differences between the virtual control panel and remote control panel" on page 10.

## Considerations for the virtual control panel

The following table lists requirements and restrictions for the virtual control panel.

Table 2. Virtual control panel requirements and restrictions

Requirements	Restrictions
<ul style="list-style-type: none"> <li>The virtual control panel must have a direct connection to the server from the Operations Console using the serial console cable.</li> <li>A unique service tools device profile must exist for each virtual control panel connection.</li> <li>If you want to use the mode function provided by the virtual control panel, the service tools user profile used to authenticate the connection must have the <b>Partition remote panel key</b> privilege. To verify that your service tools user ID has this privilege, see "Setting user ID permissions for the VCP" on page 20.</li> <li>A VCP requires the console to be directly connected over a serial cable, and the console must be connected to use the control panel functions. However, the VCP cannot power on the server. The VCP also requires a service tools device ID on the server.</li> <li>You must be granted access to a logical partition's RCP and functions to use the RCP or VCP. Because the VCP setup uses the Operations Console on a network configuration path and characteristics, the service tools device ID must also be granted access to that logical partition's RCP to use this feature. Users and service tools device IDs default values automatically grant access to the RCP for the logical partition but can be revoked by an administrator for the user ID, device ID, or both. The user that authenticates a connection must also have authority to the respective logical partition's keylock to change the mode.</li> </ul>	<ul style="list-style-type: none"> <li>The virtual control panel is available only while the Operations Console is connected.</li> <li>You cannot use the virtual control panel remotely through a dial-up connection.</li> <li>You cannot use an existing network name or duplicate a name that is already configured on the PC. You might need to verify if a name is used by looking in the hosts file on the PC. The hosts file can be viewed by any standard text editor.</li> <li>More than one LAN-connected remote control panel can be active at the same time. In addition, LAN-connected remote control panels can coexist with a virtual control panel.</li> </ul>

## Connectivity and usage considerations

Ensure that you understand the following connectivity and usage requirements and restrictions before you install the Operations Console virtual control panel (VCP). For information about installing the VCP,

see "Setting up the virtual control panel" on page 18.

Table 3. Connectivity requirements and restrictions

Requirements	Restrictions
<ul style="list-style-type: none"> <li>The VCP requires the serial cable and connection of a local console (directly attached).</li> <li>The VCP requires a unique service tools device ID for connection authentication. If no local console on a local area network (LAN) configuration exists, then you can use the QCONSOLE service tools device ID.</li> </ul>	<ul style="list-style-type: none"> <li>You cannot use a name that already exists on the network or duplicate a name that is already configured on the PC.</li> <li>VCP functions are not supported at a remote console.</li> <li>The hosts file on the PC might need manual cleanup. Each time you create a network configuration on the PC, data is saved in a file named hosts. This file may be used each time the PC attempts to connect to the network, and each entry is unique to any others by the connection name. Be aware that if you delete a VCP configuration, then the corresponding hosts entry is not deleted. You must manually delete the appropriate line from this text-based file using any text editor.</li> </ul>

Table 4. Usage requirements and restrictions

Requirements	Restrictions
<ul style="list-style-type: none"> <li>To control power, you must use the Hardware Management Console (HMC) or the Advanced System Management Interface (ASMI).</li> </ul>	<ul style="list-style-type: none"> <li>The VCP is available only while the console is connected.</li> <li>All VCPs and RCPs are active at the same time. Use care when working with control panel functions when multiple PCs have access to the functions.</li> </ul>

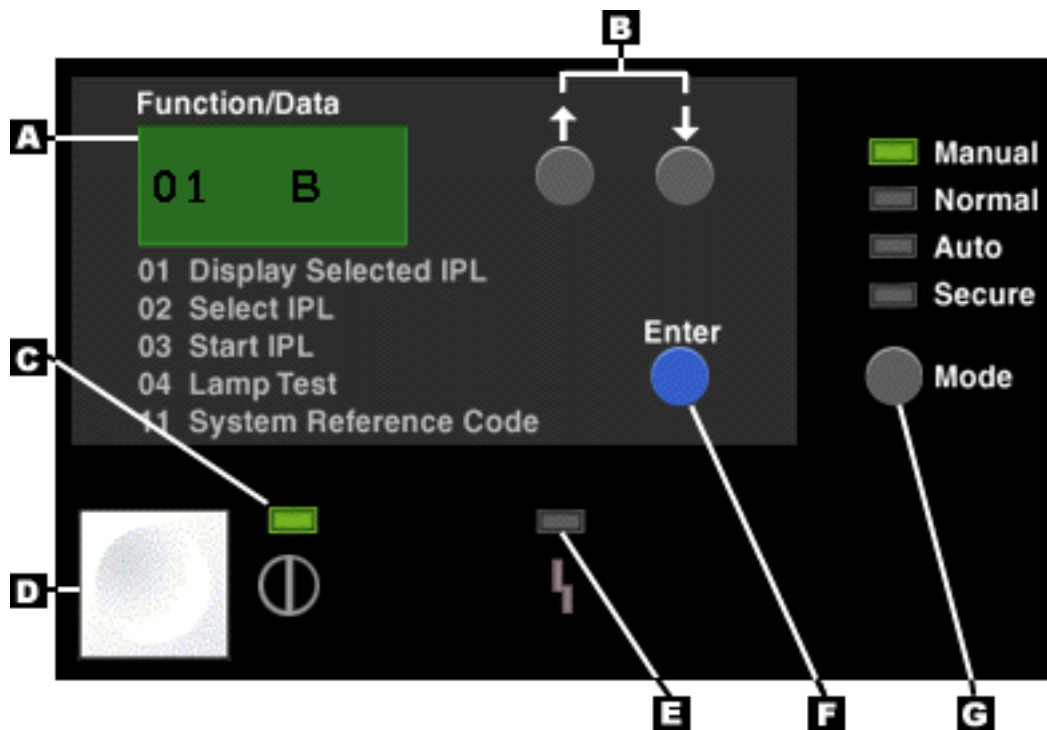

Figure 6. Virtual control panel

A Function/Data display

- B** Increment and Decrement buttons
- C** Power on indicator
- D** Power button
- E** System Attention light
- F** Enter button
- G** Mode button

## Differences between the virtual control panel and remote control panel

The major functional difference between the directly connected remote control panel (RCP) and the virtual control panel (VCP) is that the virtual control panel cannot power on the server.

If you need to power on the system at a later time, you can use the IPL scheduling function in Operational Assistant by pressing the Attention key. You can also use the GO POWER command, and select option 2 (Change power on and off schedule). You can also use the Hardware Management Console (HMC), if installed, or the Advanced System Management interface (ASMI) to control power on a partition.

The following POWER5 server models work with the virtual control panel (VCP) and the LAN-connected remote control panel (RCP):

- 505
- 520
- 550
- 570
- 595

## Control panel function codes

Learn about function codes that are displayed on the control panel to indicate status and function options.

To display all functions, put the control panel in manual operating mode. See “Putting the physical control panel in manual operating mode” on page 21.

The following table includes descriptions of the primary and customer-extended control panel function codes.

*Table 5. Primary and customer-extended control panel (32-character) function codes*

Function code	Function selected
01	<ol style="list-style-type: none"> <li>1. Displays the current IPL parameters.</li> <li>2. Displays an indicator indicating the system is managed by a Hardware Management Console (HMC).</li> </ol> <p>This function is available in both normal and manual operating mode.</p>
02	Used to select the IPL type, system operating mode, IPL speed, and firmware IPL mode. This function is available in both normal and manual operating mode.
03	Starts an IPL to load the system. The IPL uses the selected IPL options. This function is available only in manual operating mode and when the system power is on.
04	Performs a lamp test; all displays and indicators are lit. This function is available in both normal and manual operating mode.
05 and 06	Reserved.

Table 5. Primary and customer-extended control panel (32-character) function codes (continued)

Function code	Function selected
07	Allows you to perform SPCN service functions. This function is available only in the manual operating mode and from power on standby.
08	Causes a fast power off. This function is available only when the system is in manual operating mode and the system power is on. For more information, see the following: <ul style="list-style-type: none"> <li>• Powering off the system.</li> <li>• Powering off the partition.</li> </ul>
09 and 10	Reserved.
11 through 19	Displays a system reference code (SRC) on the control panel. These functions are available in both normal and manual operating mode when an SRC is available.
20	Displays the machine type and model, VPD card CCIN, and IPL types. This function is available in both normal and manual operating mode.
21	Causes the <b>Use Dedicated Service Tool (DST)</b> display to appear on the system console. To exit the DST, select the <b>Resume operating system display</b> option. This function is available only in the manual operating mode and when activated by the operating system.
22	Forces a partition dump. First, see “Function 34: Retry partition dump” on page 42. To perform a system main storage dump, see Performing dumps. This function is available only in the manual operating mode and when activated by the operating system.
23 and 24	Reserved.
25 and 26	Use service switches 1 and 2 to enable or disable functions 50 through 99. These functions are available only in the manual operating mode.
27 through 29	Reserved.
30	Displays the service processor IP address and port location. This function is available only in the manual operating mode and from power on standby.
31 through 33	Reserved.
34	Retries the partition dump. This function is available only in the manual operating mode and when activated by the operating system.
35 through 41	Reserved.
42	Performs a platform dump. This function is available only in the manual operating mode and when activated by the operating system or the service processor.
43	Performs a service processor dump. This function is available only in the manual operating mode.
44 through 54	Reserved.

If you cannot find the function code in this chart, added features or devices might not have been available when this information was produced. Look on the control panel for supplemental unit function code information for the function code that you displayed.

## Control panel function codes on the HMC

Learn about the control panel function codes used to indicate status and function options for a system that is managed by a Hardware Management Console (HMC).

If you are managing the system with the Hardware Management Console (HMC), use the HMC to perform control panel functions. Servers without physical panels (for example, 9406-595, 9119, 590, or 9118-575) require the HMC to perform the equivalent control panel functions. The HMC affects the physical control panel in the following ways:

- Except for some limited auto-platform override function, such as Auto Power On Restart and Timed Power On, the system operating mode value no longer has meaning.
- The operating system IPL-type value is disabled in functions 01 and 02.
- Functions 11-19 do not display partition system reference codes (SRCs). They continue to display SRCs from the platform Licensed Internal Code (LIC).
- Functions 21, 22, 34, and 65-70 are not selectable on the physical control panel.

The following table lists the control panel functions that you can perform on the HMC.

Function	Description
01	1. Displays the currently selected IPL type (and logical key mode on some system types). 2. Displays the currently selected IPL speed override for the next IPL.  This function is available in both normal and manual operating mode.
02	Performs a slow boot. This function is available in both normal and manual operating mode.
03	Performs a re-IPL. The IPL uses the selected IPL options. This function is available only in manual operating mode and when the system power is on.
04	Performs a lamp test; all displays and indicators are switched on. This function is available in both normal and manual operating mode.
05-06	Reserved.
07	Allows you to set SPCN configuration IDs. This function is available only in manual operating mode when the system is in standby.
08	Causes a fast power off. This function is available only when the system is in manual operating mode and the system power is on.
09-10	Reserved.
11-19	Displays a system reference code (SRC) on the control panel. These functions are available in both normal and manual operating mode when an SRC is available.
20	Displays the machine type, model, processor feature code, processor class indicator, and IPL path description. This function is available in both normal and manual operating mode.
21	Causes the <b>Use Dedicated Service Tool</b> (DST) display to appear on the system console. This function is available only in the manual operating mode and when activated by the operating system.
22	Forces a partition dump. This function is available only in the manual operating mode and when activated by the operating system.
23-24	Reserved.
25-26	Not applicable.
27-29	Reserved.
30	Displays CEC FSP IP address and location. This function is available only in the manual operating mode and when activated by the FSP.
31-33	Reserved.
34	Retries the partition dump. This function is available only in the manual operating mode and when activated by the operating system.
35-41	Reserved.
42-43	Not applicable.
44-49	Reserved.

Function	Description
50-52	Reserved.
53	Unconfigures an intermittently failing processor (repeat GARD function). This function is available only in the manual operating mode.
54	Reserved.
55	Platform dump override. This function is available only in the manual operating mode when activated by the FSP and when CE scroll ranges are enabled.
56-62	Reserved.
63	Progress indicator history. This function is available only in the manual operating mode.
64	Diagnostic status SRC trace. This function is available only in the manual operating mode.
65	Deactivates remote service. This function is available only in the manual operating mode when activated by the operating system and when CE scroll ranges are enabled.
66	Activates remote service. This function is available only in the manual operating mode when activated by the operating system and when CE scroll ranges are enabled.
67	Disk unit I/O processor (IOP) reset/reload is enabled only by specific disk unit SRCs. This function is available only in the manual operating mode when activated by the operating system and when CE scroll ranges are enabled.
68	Turns off power domains during concurrent maintenance of IOPs and IOAs. This function is available only in the manual operating mode when activated by the operating system and when CE scroll ranges are enabled.
69	Turns on power domains during concurrent maintenance of IOPs and IOAs. This function is available only in the manual operating mode when activated by the operating system and when CE scroll ranges are enabled.
70	Dump service processor control storage. Initiates an I/O processor (IOP) dump; enabled by specific error conditions. This function is available only in the manual operating mode when activated by the operating system and when CE scroll ranges are enabled.

#### Related reference

“Accessing the control panel functions using the HMC” on page 23

If you are managing the system with the Hardware Management Console (HMC), you can perform control panel functions with the HMC instead of using the physical control panel.

## Control panel function codes on the 7037-A50 and 7047-185 models

Learn about the control panel function codes used to indicate status and function options for the 7037-A50 server and the 7047-185 workstation.

The following table includes descriptions of the control panel function codes.

*Table 6. Control panel (32-character) function codes*

Function code	Function selected
01	Displays the current IPL parameters. This function is available in both normal and manual operating mode.
02	Used to select the firmware IPL mode.
03	Not applicable.
04	Lamp test; all displays and indicators are lit. This function is available in both normal and manual operating mode.
05	Used for Remind mode. This function is available in both normal and manual operating mode.

Table 6. Control panel (32-character) function codes (continued)

Function code	Function selected
06	Displays the base motherboard controller (BMC) version. This function is available in both normal and manual operating mode.
07 through 08	Not applicable.
09	Displays the base motherboard controller (BMC) fan speed. This function is available in both normal and manual operating mode.
10	Displays the temperature. This function is available in both normal and manual operating mode.
11 through 19	Not applicable.
20	Displays the machine type and model. This function is available in both normal and manual operating mode.
21	Not supported.
22	Forces a partition dump. To perform a system main storage dump, see Performing dumps.
23 through 49	Not applicable.

If you cannot find the function code in this chart, added features or devices might not have been available when this information was produced. Look on the control panel for supplemental unit function code information for the function code that you displayed.

## Control panel function code comparison for the RCP, VCP, and HMC

Learn about which function codes are supported by the remote control panel (RCP), virtual control panel (VCP), or HMC .

There are few functional differences among the remote control panel (RCP), virtual control panel (VCP), and physical control panel. The main difference is in how they can or cannot be used to power up the server. For example, consider the following:

- The physical control panel can be used to power up the server.
- The virtual control panel and the LAN-connected remote control panel cannot be used to power up the server.

If you are managing the system with the Hardware Management Console (HMC), use the HMC to perform control panel functions. The HMC affects the physical control panel in the following ways:

- Except for some limited auto-platform override function, such as Auto Power On Restart and Timed Power On, the system operating mode value no longer has meaning.
- The OS IPL type value is disabled in functions 01 and 02.
- Functions 11-19 do not display partition system reference codes (SRCs). They continue to display SRCs from the platform LIC.
- Functions 21, 22, 34, and 65-70 are not selectable on the physical control panel.

The following table describes the control panel function codes and whether the virtual control panel, remote control panel, and HMC support them.

### Notes:

1. Some control panel functions might not be available on all system types.
2. The x can be any number 0 through 9, any letter A through F, or a blank.
3. If you cannot change the Function/Data display or complete the selected function, see Beginning problem analysis.

Table 7. Control panel function code comparison for the RCP, VCP, and HMC

Function code	Virtual control panel function and LAN-connected remote control panel	HMC	Function description
01	Yes	Yes	1. Displays the current IPL parameters. 2. Displays an HMC-managed indicator.
02	Yes	Yes. Initiates a slow boot.	Used to select the IPL type, system operating mode, IPL speed, and firmware IPL mode.
03	Yes	Yes	Starts an IPL to load the system. The IPL uses the selected IPL options.
04	Yes	Yes	Lamp test; all displays and indicators are lit.
05 through 06	No	Not applicable	Reserved.
07	Not applicable	Yes	Allows you to perform SPCN service functions.
08	Yes	Yes	Fast power off. For more information, see the following: <ul style="list-style-type: none"> <li>• Powering off the system.</li> <li>• Powering off the partition.</li> </ul>
09 through 10	Not applicable	Reserved	Reserved.
11 through 19	Yes	Yes	Displays a system reference code (SRC) on the control panel.
20	Yes	Yes	Displays the machine type, model, processor feature code, processor class indicator, and IPL path description.
21	Yes	Yes	Causes the <b>Use Dedicated Service Tool (DST)</b> display to appear on the system console. To exit the DST, select the <i>Resume operating system display</i> option.
22	Yes	Yes	Forces a partition dump. First, see “Function 34: Retry partition dump” on page 42. To perform a system main storage dump, see <i>Performing dumps</i> .
23	Not applicable	Reserved	Reserved.
24	Not applicable	Reserved	Reserved.
25	Yes	Yes	Uses service switches 1 and 2 to enable or disable functions 50 through 70.
26	Yes	Not applicable	Uses service switches 1 and 2 to enable or disable functions 50 through 70.
27 through 29	Not applicable	Reserved	Reserved.
30	Not applicable	No. This function is intended to be used from the physical control panel when no HMC is available.	Displays CEC FSP IP address and location.
31 through 33	Not applicable	Reserved	Reserved.
34	Yes	Yes	Retries the partition dump.
35 through 41	Not applicable	Reserved	Reserved.
42	Not applicable	No	Performs a platform dump.

Table 7. Control panel function code comparison for the RCP, VCP, and HMC (continued)

Function code	Virtual control panel function and LAN-connected remote control panel	HMC	Function description
43	Not applicable	No	Performs a service processor dump.
44 through 49	Not applicable	Reserved	Reserved.
50 through 53	Not applicable	Reserved	Reserved.
54	Not applicable	Reserved	Reserved.
55	Not applicable	Not applicable	Platform dump override.
56 through 62	Not applicable	Reserved	Reserved.
63	Not applicable	Yes	System status SRC trace.
64	Not applicable	Yes	Service processor diagnostic status SRC trace.
65	Yes	Yes	Deactivates remote service.
66	Yes	Yes	Activates remote service.
67	Yes	Yes	Disk unit I/O processor (IOP) reset/reload is enabled only by specific disk unit SRCs.
68	Yes	Yes	Concurrent maintenance power domain power off.
69	Yes	Yes	Concurrent maintenance power domain power on.
70	No	Initiated by specific error conditions.	IOP dump.
Power button	Power button in graphical interface for powering off the server only.	For information about using the HMC to power on the server, see Powering on the managed system.	OFF = Delayed power off ON = Immediate power on (can be timed power on)
Attention light	Yes	Not applicable	Attention state LED.
Power indicator	Power indicator in graphical interface.	Not applicable	Lit when power is fully operational.

## Values for IPL types, system operating modes, and speeds

Learn about the valid initial program load (IPL) types, system operating modes, speeds, and firmware IPL modes that are used in control panel functions.

Refer to the following tables:

- Table 8 on page 17
- Table 9 on page 17
- Table 10 on page 17
- Table 11 on page 17

Table 12 on page 17 describes whether the Hardware Management Console (HMC) is active for HMC-managed systems.

### Notes:

- Systems managed by the HMC can use the HMC to perform control panel functions. For information about performing control panel functions using the HMC, see “Accessing the control panel functions using the HMC” on page 23.
- OS IPL types are displayed only when the OS IPL mode has been enabled from the operating system.

Table 8. Operating system IPL types

Initial program load (IPL) type	Action or description
A	IPL from disk using copy A of the system Licensed Internal Code.
B	IPL from disk using copy B of the system Licensed Internal Code.
C	Reserved for hardware service use only.  <b>Attention:</b> Severe data loss can occur with improper use of this function.
D	IPL from media other than load-source disk. Alternate IPL for code installation support.

Table 9. System operating mode values

System operating mode	Action or description
Manual (M)	Allows you to access the Dedicated Service Tool (DST) and perform an attended IPL.
Normal (N)	Allows you to access the operating system and perform an unattended IPL.

Table 10. IPL speeds

IPL speed	Action or description	Details
F	Fast override for one IPL.	Fast IPL run. Some hardware diagnostics are skipped.
S	Slow override for one IPL.	Full hardware diagnostics run. Use this speed whenever hardware is changed, for intermittent hardware failure, or on the first installation IPL. The following diagnostics are run: <ul style="list-style-type: none"> <li>• Main storage tests.</li> <li>• CEC Inter-chip interface tests (wire test).</li> <li>• Extended Logical Built-in Self Tests.</li> </ul>
V=F	Use system-defined speed.	Fast IPL set by the system value (displayed at function 01).
V=S	Use system-defined speed.	Slow IPL set by the system value (displayed at function 01).
V	Fast IPL or slow IPL set by the system value (selected at function 02).	Function 02 selection, or the system default at each IPL.

Table 11. Firmware IPL types

IPL type	Action or description
P	IPL from disk using copy P of the system Licensed Internal Code.
T	IPL from disk using copy T of the system Licensed Internal Code.

Table 12. HMC indicators

HMC indicator	Action or description
HMC=1	The HMC is connected.
HMC=0	The HMC is disconnected.

---

## Setting up the remote control panel

You can set up the remote control panel (RCP) through an Operations Console configuration.

To receive control panel functions with the RCP, you must install the Operations Console and configure a remote control panel.

### Related information

Troubleshooting Operations Console connections

---

## Setting up the virtual control panel

You can set up the virtual control panel (VCP) through an Operations Console configuration.

To receive control panel functions with the VCP, you must install the Operations Console and configure a virtual control panel. The configuration path to create the VCP connection uses the Operations Console on a network path but does not require a network or network adapter.

You must have a local console directly attached to the server configured in order for the virtual control panel to function. To set up a local console directly attached to the server configuration, follow the setup instructions in the Operations Console. The virtual control panel functions have some limitations and restrictions.

To install the virtual control panel (VCP), do the following:

1. Ensure that you understand and meet the VCP requirements.
2. Install the latest service pack for System i Access for Windows®.
3. Review Changing the console mode in i5/OS, and then complete one of the following steps, depending on the current console value:
  - a. If the console value is **Operations Console (LAN)**, then create a service tools device ID, and set user ID permissions.
  - b. If the console value is not **Operations Console (LAN)**, then you can use the existing service tools device ID of QCONSOLE for the VCP. You do not need to create a service tools device ID. If you are uncertain about whether the Operations Console (LAN) console option was ever used, perform a reset of the QCONSOLE service tools device ID before using the VCP. See the create a service tools device ID topic to access the service tools device ID and perform the **Reset password** task for QCONSOLE.
4. Create a new configuration for the VCP:
  - a. From the **Connection** menu, click **New Connection**.
  - b. Click **Next**. (If the window asking about prerequisites is displayed, click **Yes**.)
  - c. Leave the option **Local Area Network (LAN)** selected, and click **Next**.
  - d. Enter a name to refer to the VCP connection. If the PC that you are working with is connected to a network, do not use a name that can be found on that network or defined on the PC.
  - e. Select the correct logical partition, and click **Next**. POWER5 server models 5xx begin counting logical partitions at 1, while all other server models start counting at 0.
  - f. In the **Service TCP/IP Address** field, type 192.168.0.2.

**Note:** In some cases, the address 192.168.0.*n* might have been previously used for something other than the Operations Console. In those cases, you might have had to use a different base address for the Operations Console, such as 192.168.1.*n*. If so, use the base address currently assigned to the Operations Console, but make the last value 2. For example, use 192.168.1.2.

- 1) To check the current base address, use the regedit or another registry editing program. Navigate to the following: **HKEY\_LOCAL\_MACHINE** → **Software** → **IBM** → **Client Access** → **CurrentVersion** → **AS400 Operations Console** → **LCS**.
  - 2) Expand **LCS**, and select the appropriate configuration.
  - 3) Check the key **IP Address**. Use the IP address reported on your PC to validate the VCP address. You might also need to check the entries in the hosts file on your PC for a matching name or address.
- g. In the **Service gateway address 1** field, enter 0.0.0.0.
  - h. In the **serial number** field, enter a serial number, and click **Next**. This number does not have to be the real system serial number.
  - i. Enter the service tools device ID and password that you are going to use for the VCP connection authentication, and click **Next**. If you are using the default service tools device ID QCONSOLE, then enter its name and password. If you created a device ID, then enter its name and password. Beginning with System i Access for Windows, Version 5 Release 4 (V5R4), you are not prompted for the service tools device ID password. Instead, you are prompted for the service tools device ID name only.
  - j. Enter the password that you want to use to connect this console configuration. This password is only used by the PC for the VCP connection and is not known at the server. For example, if you entered access as the password, then use access later to sign on.
  - k. Enter the password for confirmation and, click **Next**.
  - l. Click **Finish**.
  - m. Select the configured connection you just created, and then select **Properties**.
  - n. Click the **Configuration** tab.
  - o. Unselect the **Use console with this connection** option, and click **OK**.
5. You can now connect the console, if needed, and the VCP configuration to access the control panel functions. To find out how to make the connection, see Connecting a local console directly attached without remote access allowed.

## Creating a service tools device ID for the console VCP

The Operations Console virtual control panel (VCP) requires an available, unused service tools device ID.

If the console value in IBM i5/OS is not set for **Operations Console (LAN attachment)**, you can use the existing service tools device ID of QCONSOLE for the VCP.

To create a service tools device ID for the Operations Console VCP, do the following:

1. Access Dedicated Service Tools (DST) or System Service Tools (SST).
2. Did you access DST or SST?

Option	Description
DST	<ol style="list-style-type: none"> <li>1. Select <b>Work with DST environment</b> (option 5).</li> <li>2. Select <b>Service tools device IDs</b> (option 5).</li> </ol>
SST	<ol style="list-style-type: none"> <li>1. Select <b>Work with service tools user IDs and devices</b> (option 8).</li> <li>2. Select <b>Service tools device IDs</b> (option 2). You may need to unlock the Service Tools Device IDs menu option.</li> </ol>

3. Enter 1 next to the empty **device ID** field.
4. Enter the name you want for the device ID, and press **Enter**.
5. Enter a password into both password fields.

6. Optional: Enter a description.
7. Press Enter.
8. Select **Change attributes** (option 7) to set the service tools device ID attributes for the logical partition remote panel key.
9. Press F3 to return to the DST or SST main menu.

## Setting user ID permissions for the VCP

If you are using a service tools user ID other than QSECOFR, QSRV, 22222222, or 11111111 for use with the Operations Console virtual control panel (VCP), you must set the service tools user privileges for the partition remote panel key to allow access to the mode function.

To verify or set the service tools user privilege, do the following:

1. Access Dedicated Service Tools (DST).
2. Did you access DST or SST?

Option	Description
DST	<ol style="list-style-type: none"> <li>1. Select <b>Work with DST environment</b> (option 5).</li> <li>2. Select <b>Service tools user IDs</b> (option 3).</li> </ol>
SST	<ol style="list-style-type: none"> <li>1. Select <b>Work with service tools user IDs and devices</b> (option 8).</li> <li>2. Select <b>Service tools user IDs</b> (option 1).</li> </ol>

3. Move the cursor to the user for whom you want to verify or set the privileges, enter 7 on the same line, and press Enter.
4. Enter 2 on the line for the partition, and press Enter to grant permission to the mode functions. You only need to verify or set the privilege for the **Partition remote panel key** entry, which is the partition currently being used.
5. Exit DST or SST.

---

## Accessing the control panel functions

You can access the control panel functions by using the physical control panel, the remote control panel (RCP), the virtual control panel (VCP), or the Hardware Management Console (HMC).

If you are not using the HMC to manage your system, you can use a physical, virtual, or remote control panel to access the control panel functions. Systems managed by the HMC should use the HMC to perform the control panel functions.

## Accessing the control panel functions using the physical control panel

Activating a control panel function with the physical control panel is a two-step procedure.

To activate a control panel function, do the following:

1. Select a function number by pressing the Increment (↑) or Decrement (↓) button on the control panel.
2. To activate the function, press Enter on the control panel.

## Using the control panel power button to power off

By using the control panel power button to power off the server, you can initiate a delayed power off (DPO) or a fast power off (FPO).

**Attention:** Using the control panel power button to power off the system might cause unpredictable results in the data files, and the next IPL will take longer to complete.

**Note:** Some servers do not respond to the power-off sequence unless the system is in manual operating mode. If necessary, set the system operating mode to **manual** mode. See “Putting the physical control panel in manual operating mode.”

### **Initiating a delayed power off (DPO):**

You can use the power button on the control panel to initiate the delayed power off (DPO) feature.

Some servers do not respond to the power-off sequence unless the system is in manual operating mode. If necessary, set the system operating mode to **manual** mode. See “Putting the physical control panel in manual operating mode.”

To initiate a delayed power off (DPO), do the following:

1. Press and hold the power button on the control panel for four seconds. After one second, a countdown time is displayed. The default countdown time is four seconds.
2. Continue to press and hold the power button until the countdown time reaches zero, and then release the power button. The DPO is initiated.

To cancel the DPO before it starts, release the power button before the countdown reaches zero. If the power button is depressed for less than one second, no countdown time is displayed, and the power-off function is not initiated.

### **Initiating a fast power off (FPO):**

You can use the power button on the control panel to initiate the fast power off (FPO) feature.

Some servers do not respond to the power-off sequence unless the system is in manual operating mode. If necessary, set the system to manual operating mode. See “Putting the physical control panel in manual operating mode.”

To initiate a fast power off (FPO), do the following:

1. Press and hold the power button on the control panel for four seconds. After one second a countdown time is displayed. The default countdown time is four seconds.
2. Continue to press and hold the power button until the countdown time reaches zero and until after the delayed power off (DPO) is initiated. A new DPO-FPO separation count of 10 seconds is started. The separation count is used to distinguish a DPO from an FPO. During this interval, D10E0FF0 SCR is displayed, followed by the countdown time.
3. Continue to press and hold the power button for 10 seconds until the DPO-FPO separation count reaches zero, and then release the power button. When the FPO count expires, D10E0FF1 SCR is displayed, and the FPO is initiated.

If you release the power button during the DPO-FPO separation count, the FPO is canceled, and the DPO continues.

If you continue to press the power button after the DPO-FPO separation interval has expired, or if you press and hold the power button while a DPO is in progress, the FPO countdown begins again with a D10E0FF0 SRC displayed.

## **Putting the physical control panel in manual operating mode**

You must first put the physical control panel in manual operating mode before you can select or activate certain functions.

To put the physical control panel in manual operating mode, do the following:

1. Use the Increment button to scroll to function 02.

```
0 2 _ _ _ _ _ _ _ _ _ _  
_ _ _ _ _ _ _ _ _ _
```

2. Press Enter to start function 02.
3. Press Enter again to move to the second character on the function 02 menu. The current system operating mode is displayed with a pointer, as shown in the following example:

```
0 2 _ _ B _ _ N < _ _ _ _ P _ _ _ _  
_ _ _ _ _ _ _ _ _ _
```

4. Use the Increment button to scroll through the system operating modes, and select M for manual, as shown in the following example:

```
0 2 _ _ B _ _ M < _ _ _ _ P _ _ _ _  
_ _ _ _ _ _ _ _ _ _
```

5. Press Enter to select the system operating mode.
6. Press Enter again to exit function 02.

The control panel is in manual operating mode. For information about other options in function 02, see “Function 02: Select IPL type, IPL speed override, system operating mode, and firmware mode” on page 29.

## Accessing the control panel functions using the remote control panel

To use a remote control panel (RCP) to select and activate functions on the control panel, you must have the Operations Console configured to use a remote control panel and you must establish a connection to the remote control panel.

If you do not have the Operations Console configured to use a remote control panel, see Setting up the remote control panel.

To connect to the remote control panel (RCP), do the following:

1. Start a connection to the console.
2. Sign in, and wait for the emulator window to be displayed, except with a remote control panel-only configured connection.

If the console configuration includes the remote control panel, the remote control panel automatically starts. If the console configuration does not include the remote control panel, you can add it by clicking **Properties** → **Configuration** and selecting the appropriate settings.

## Accessing the control panel functions using the virtual control panel

To use a virtual control panel (VCP) to select and activate functions on the control panel, you must install and establish a connection between the virtual control panel configuration and the server.

If you have not installed a virtual control panel, see “Setting up the virtual control panel” on page 18.

To connect to the virtual control panel (VCP), do the following steps:

1. Start a connection to the console.
2. Sign in, and wait for the emulator window to be displayed.
3. Start a connection for the VCP.
4. In the Service Device Sign-on window, enter your password in the **Access password** field. This password is the same password used in step 4j on page 19 of the procedure to set up the virtual control panel.
5. Enter any service tools user ID and password.

## Accessing the control panel functions using the HMC

If you are managing the system with the Hardware Management Console (HMC), you can perform control panel functions with the HMC instead of using the physical control panel.

For details about which control panel functions are available on the HMC, see “Control panel function codes on the HMC” on page 11. For information about how to perform control panel actions on the HMC, see the following table:

Function	HMC action
01	To view the power-on parameters or settings on the HMC, do the following: <ol style="list-style-type: none"> <li>1. In the navigation area, expand the <b>Server and Partition</b> folder.</li> <li>2. Select <b>Server Management</b>.</li> <li>3. In the contents area, open the server on which the logical partition is located.</li> <li>4. Choose from the following options:               <ul style="list-style-type: none"> <li>• To view a server’s power-on parameters, right-click the server, and select <b>Properties</b>. Select the <b>Power-on Parameters</b> tab. The parameters are displayed.</li> <li>• To view a logical partition’s power-on parameters, right-click the partition, and select <b>Properties</b>. Click the <b>Settings</b> tab.</li> </ul> </li> </ol>
02	To perform a slow boot on the HMC, do the following: <ol style="list-style-type: none"> <li>1. In the navigation area, click <b>Server and Partition</b> → <b>Server Management</b></li> <li>2. In the contents area, select the server on which you want to perform a slow boot.</li> <li>3. Click <b>Selected</b> → <b>Properties</b>.</li> <li>4. Click the <b>Power-On Parameters</b> tab.</li> <li>5. In the Advanced Options section of the screen click <b>show details</b>.</li> <li>6. Click <b>slow</b> in the Power-on speed override drop-down list.</li> <li>7. Click <b>OK</b>.</li> </ol>
03	To re-IPL using the HMC, do the following: <ol style="list-style-type: none"> <li>1. In the navigation area, expand the <b>Server and Partition</b> folder.</li> <li>2. Select <b>Server Management</b>.</li> <li>3. In the contents area, open the server on which the logical partition is located.</li> <li>4. Open <b>Partitions</b>.</li> <li>5. Right-click the logical partition profile, and select <b>Restart Partition</b>.</li> <li>6. In the Restart Partition window, click the <b>Immediate</b> restart option.</li> </ol>
04	To perform the lamp test using the Service Utilities in Service Focal Point, do the following: <ol style="list-style-type: none"> <li>1. In the navigation area, expand the <b>Service Applications</b> folder.</li> <li>2. Select <b>Service Focal Point</b>.</li> <li>3. In the contents area, click <b>Service Utilities</b>.</li> <li>4. In the Service Utilities window, select the system.</li> <li>5. Click <b>Selected</b> → <b>Lamp test</b>.</li> </ol>
05-06	View the serviceable event log. For more information about viewing serviceable events, see Viewing serviceable events.

Function	HMC action
07	<p>Use the Advanced System Management interface (ASMI) to configure I/O enclosures. To access the ASMI, do the following:</p> <ol style="list-style-type: none"> <li>1. In the navigation area, open the <b>Service Applications</b> folder.</li> <li>2. Select <b>Service Focal Point</b>.</li> <li>3. In the contents area, click <b>Service Utilities</b>.</li> <li>4. In the Service Utilities window, select the system.</li> <li>5. In the <b>Selected</b> menu, click <b>Launch ASM Menu....</b> The ASMI interface opens.</li> </ol> <p>For more information about configuring I/O enclosures, see Configuring I/O Enclosures.</p>
08	<p>Power off the logical partition.</p> <p>To power off a logical partition, do the following:</p> <ol style="list-style-type: none"> <li>1. In the navigation area, expand the <b>Server and Partition</b> folder.</li> <li>2. Select <b>Server Management</b>.</li> <li>3. In the contents area, open the server on which the logical partition is located.</li> <li>4. Open <b>Partitions</b>.</li> <li>5. Right-click the logical partition, and click <b>Shut Down Partition</b>.</li> <li>6. Click a shutdown option, and click <b>OK</b>.</li> </ol> <p>The <b>immediate</b> option is equivalent to the fast power off. The <b>delayed</b> option is equivalent to the white button power off.</p>
09-10	Reserved.
11-19	<p>To view reference code information on the HMC, do the following:</p> <ol style="list-style-type: none"> <li>1. In the navigation area, expand the <b>Server and Partition</b> folder.</li> <li>2. Select <b>Server Management</b>.</li> <li>3. Choose from the following options: <ul style="list-style-type: none"> <li>• To view reference code (function 11), in the right pane, select the system or partition, and view the associated value in the <b>Operator Panel Value</b> column.</li> <li>• To view reference codes (function 12-19), do the following: <ol style="list-style-type: none"> <li>a. In the right pane, expand the system.</li> <li>b. Select the system or partition.</li> <li>c. Right-click the system or partition, and select <b>Properties</b>.</li> <li>d. Click the <b>Reference Code</b> tab.</li> <li>e. Select the entry that corresponds to the time stamp you want to view.</li> <li>f. Click <b>Details</b>.</li> <li>g. View the values that correspond to words 2-9 and FRU Callout. These numbers correspond to functions 12-19 on the control panel.</li> <li>h. When finished, click <b>OK</b> twice.</li> </ol> </li> </ul> </li> </ol>

Function	HMC action
20	<p>To display the machine type, model, and processor feature code on the HMC, do the following:</p> <ol style="list-style-type: none"> <li>1. In the navigation area, expand the <b>Service Applications</b> folder.</li> <li>2. Select <b>Service Focal Point</b>.</li> <li>3. In the contents area, select <b>Service Utilities</b>.</li> <li>4. In the Service Utilities window, select the system.</li> <li>5. Click <b>Selected</b> → <b>Operator Panel Service Functions</b>.</li> <li>6. Choose from the following options: <ul style="list-style-type: none"> <li>• To view function 20 for the selected system, click <b>System Function</b> → <b>System Type, Model, and Feature Code (20)</b>.</li> <li>• To view function 20 for a logical partition, select the logical partition from the list, and click <b>System Function</b> → <b>System Type, Model, and Feature Code (20)</b>.</li> </ul> </li> </ol>
21	<p>Use the Service Utilities in Service Focal Point. To use the Service Utilities, do the following:</p> <ol style="list-style-type: none"> <li>1. In the navigation area, open the <b>Service Applications</b> folder.</li> <li>2. Select <b>Service Focal Point</b>.</li> <li>3. In the contents area, select <b>Service Utilities</b>.</li> <li>4. In the Service Utilities window, select the system.</li> <li>5. Click <b>Selected</b> → <b>Operator Panel Service Functions</b>.</li> <li>6. Select the logical partition, and then select <b>Partition Functions</b>.</li> <li>7. Click <b>DST</b>.</li> </ol>
22	<p>Dump the logical partition. To dump a partition, do the following:</p> <ol style="list-style-type: none"> <li>1. In the navigation area, expand the <b>Server and Partition</b> folder.</li> <li>2. Select <b>Server Management</b>.</li> <li>3. In the contents area, open the server on which the logical partition is located.</li> <li>4. Open <b>Partitions</b>.</li> <li>5. Right-click the logical partition profile, and click <b>Restart Partition</b>.</li> <li>6. In the Restart Partition window, click the <b>Dump</b> restart option.</li> </ol>
23-24	Reserved.
25-26	No longer needed to access functions equivalent to 50-70.
27-32	Reserved.
33	This function is no longer needed.
34	<p>Retry partition dump. To retry a partition dump, do the following:</p> <ol style="list-style-type: none"> <li>1. In the navigation area, expand the <b>Server and Partition</b> folder.</li> <li>2. Select <b>Server Management</b>.</li> <li>3. In the contents area, open the server on which the logical partition is located.</li> <li>4. Open <b>Partitions</b>.</li> <li>5. Right-click the logical partition profile, and click <b>Restart Partition</b>.</li> <li>6. In the Restart Partition window, click the <b>Dump Retry</b> restart option.</li> </ol>
35-41	Reserved.

Function	HMC action
42-43	<p>These functions are performed on the physical operator panel on the managed system. Use the following procedure to work with dump information.</p> <p>Use the Service Utilities in Service Focal Point. To use the Service Utilities, do the following:</p> <ol style="list-style-type: none"> <li>1. In the navigation area, expand the <b>Service Applications</b> folder.</li> <li>2. Select <b>Service Focal Point</b>.</li> <li>3. In the contents area, select <b>Service Utilities</b>.</li> <li>4. In the Service Utilities window, select the system.</li> <li>5. Click <b>Selected</b> → <b>Manage Dumps....</b> The Service Utilities... Manage Dumps window is displayed.</li> <li>6. Use the <b>Selected</b> and <b>Menu</b> options to perform your task.</li> </ol>
44-49	Reserved.
50	No longer used.
51	No longer used.
52	No longer used.
53	<p>Use the Advanced System Management interface (ASMI). To access the ASMI, do the following:</p> <ol style="list-style-type: none"> <li>1. In the navigation area, expand the <b>Service Applications</b> folder.</li> <li>2. Select <b>Service Focal Point</b>.</li> <li>3. In the contents area, select <b>Service Utilities</b>.</li> <li>4. In the Service Utilities window, select the system.</li> <li>5. In the <b>Selected</b> menu, select <b>Launch ASM Menu....</b> The ASMI interface opens.</li> </ol> <p>For more information about deconfiguring a processor using the ASMI interface, see Changing processor configuration.</p>
54	Reserved.
55	<p>Use the Advanced System Management interface (ASMI) to initiate a platform dump. To access the ASMI interface, do the following:</p> <ol style="list-style-type: none"> <li>1. In the navigation area, expand the <b>Service Applications</b> folder.</li> <li>2. Select <b>Service Focal Point</b>.</li> <li>3. In the contents area, select <b>Service Utilities</b>.</li> <li>4. In the Service Utilities window, select the system.</li> <li>5. In the <b>Selected</b> menu, select <b>Launch ASM Menu....</b> The ASMI interface opens.</li> </ol> <p>For more information about initiating a platform dump using ASMI, see Initiating a platform dump.</p>
56-62	Reserved .
63	<p>View either your managed system's properties or the logical partition properties.</p> <p>To view your managed system's properties, see Viewing information about a managed system. On the managed system properties window, click the <b>Reference Code</b> tab, and then click <b>DETAILS</b>.</p> <p>To view logical partition properties, do the following:</p> <ol style="list-style-type: none"> <li>1. In the navigation area, expand the <b>Server and Partition</b> folder.</li> <li>2. Select <b>Server Management</b>.</li> <li>3. In the contents area, open the server on which the logical partition is located.</li> <li>4. Open <b>Partitions</b>.</li> <li>5. Right-click the logical partition, and click <b>Properties</b>.</li> </ol>

Function	HMC action
64	<p>Use the Advanced System Management interface (ASMI). To access the ASMI, do the following:</p> <ol style="list-style-type: none"> <li>1. In the navigation area, expand the <b>Service Applications</b> folder.</li> <li>2. Select <b>Service Focal Point</b>.</li> <li>3. In the contents area, select <b>Service Utilities</b>.</li> <li>4. In the Service Utilities window, select the system.</li> <li>5. In the <b>Selected</b> menu, select <b>Launch ASM Menu....</b> The ASMI interface opens.</li> </ol>
65	<p>Use the Service Utilities in Service Focal Point. To use the Service Utilities, do the following:</p> <ol style="list-style-type: none"> <li>1. In the navigation area, expand the <b>Service Applications</b> folder.</li> <li>2. Select <b>Service Focal Point</b>.</li> <li>3. In the contents area, select <b>Service Utilities</b>.</li> <li>4. In the Service Utilities window, select the system.</li> <li>5. Click <b>Selected</b> → <b>Operator Panel Service Functions</b>.</li> <li>6. Select the logical partition, and then select <b>Partition Functions</b>.</li> <li>7. Choose the associated control panel function.</li> </ol>
66	<p>Use the Service Utilities in Service Focal Point. To use the Service Utilities, do the following:</p> <ol style="list-style-type: none"> <li>1. In the navigation area, expand the <b>Service Applications</b> folder.</li> <li>2. Select <b>Service Focal Point</b>.</li> <li>3. In the contents area, select <b>Service Utilities</b>.</li> <li>4. In the Service Utilities window, select the system.</li> <li>5. Click <b>Selected</b> → <b>Operator Panel Service Functions</b>.</li> <li>6. Select the logical partition, and then select <b>Partition Functions</b>.</li> <li>7. Choose the associated control panel function.</li> </ol>
67	<p>Use the Service Utilities in Service Focal Point, and . To use the Service Utilities, do the following:</p> <ol style="list-style-type: none"> <li>1. In the navigation area, expand the <b>Service Applications</b> folder.</li> <li>2. Select <b>Service Focal Point</b>.</li> <li>3. In the contents area, select <b>Service Utilities</b>.</li> <li>4. In the Service Utilities window, select the system.</li> <li>5. Click <b>Selected</b> → <b>Operator Panel Service Functions</b>.</li> <li>6. Select the logical partition, and then click <b>Partition Functions</b>.</li> <li>7. Choose the associated control panel function.</li> </ol>
68	<p>Use the Service Utilities in Service Focal Point. To use the Service Utilities, do the following:</p> <ol style="list-style-type: none"> <li>1. In the navigation area, expand the <b>Service Applications</b> folder.</li> <li>2. Select <b>Service Focal Point</b>.</li> <li>3. In the contents area, select <b>Service Utilities</b>.</li> <li>4. In the Service Utilities window, select the system.</li> <li>5. Click <b>Selected</b> → <b>Operator Panel Service Functions</b>.</li> <li>6. Select the logical partition, and then click <b>Partition Functions</b>.</li> <li>7. Choose the associated control panel function.</li> </ol>

Function	HMC action
69	Use the Service Utilities in Service Focal Point. To use the Service Utilities, do the following: <ol style="list-style-type: none"> <li>1. In the navigation area, expand the <b>Service Applications</b> folder.</li> <li>2. Select <b>Service Focal Point</b>.</li> <li>3. In the contents area, select <b>Service Utilities</b>.</li> <li>4. In the Service Utilities window, select the system.</li> <li>5. Click <b>Selected</b> → <b>Operator Panel Service Functions</b>.</li> <li>6. Select the logical partition, and then click <b>Partition Functions</b>.</li> <li>7. Choose the associated control panel function.</li> </ol>
70	Use the Service Utilities in Service Focal Point. To use the Service Utilities, do the following: <ol style="list-style-type: none"> <li>1. In the navigation area, expand the <b>Service Applications</b> folder.</li> <li>2. Select <b>Service Focal Point</b>.</li> <li>3. In the contents area, select <b>Service Utilities</b>.</li> <li>4. In the Service Utilities window, select the system.</li> <li>5. Click <b>Selected</b> → <b>Operator Panel Service Functions</b>.</li> <li>6. Select the logical partition, and then Click <b>Partition Functions</b>.</li> <li>7. Choose the associated control panel function.</li> </ol>

## Primary control panel functions

Learn about the primary control panel functions that are available.

### Function 01: Display selected IPL type, system operating mode, and IPL speed

This function allows you to display the selected IPL type, system operating mode, speed, and firmware mode for the next IPL whether or not the system is managed by the Hardware Management Console (HMC).

This function is available in both normal and manual operating mode. It also indicates the status of systems managed by the HMC.

This function displays the following information:

- The operating system (OS) IPL types (A, B, C, or D).
- The valid logical key modes (M or N).
- The IPL speed (F, S, V=F, or V=S).
- The firmware mode (P or T).
- The status of HMC-managed system:

HMC=1

HMC=0

Table 13. Function 01 on systems not managed with an HMC without OS IPL enabled

Function/Data	Action or description
0 1 _	Use the Increment or Decrement buttons to scroll to function 01.
0 1 _ _ _ _ M _ _ V = F _ _ _ _ _ _ _ _ _ _ _ _ P _ _ _ _	Valid system operating modes are M and N. Valid IPL speed displays are F, S, V=F, or V=S. Valid firmware IPL modes are P and T.

Table 13. Function 01 on systems not managed with an HMC without OS IPL enabled (continued)

Function/Data	Action or description
0 1 _ _ _ _ _ _ _ _ _ _	Use the Increment or Decrement buttons to scroll through the control panel functions.

Table 14. Function 01 on HMC-managed systems with OS IPL enabled

Function/data	Action or description
0 1 _ _ _ _ _ _ _ _ _ _	Use the Increment or Decrement buttons to scroll to function 01.
0 1 _ A _ M _ V = F _ _ _ HMC=1 _ _ _ _ _ P _ _ _	Valid OS IPL types are A, B, C, and D.  Valid system operating modes are M and N.  Valid IPL speed displays are F, S, V=F, or V=S.  Valid firmware IPL modes are P and T.  HMC indicators are 1, 0, or HMC.
0 1 _ _ _ _ _ _ _ _ _ _	Use the Increment or Decrement buttons to scroll through the control panel functions.

## Function 02: Select IPL type, IPL speed override, system operating mode, and firmware mode

This function allows you to select the IPL type and logical key mode when the system is either powered on or off.

This function is available in both normal and manual operating mode.

Before you can select the IPL speed, the system must be at power on standby.

For powered-on systems, function 02 is used to select the operating system (OS) IPL type, system operation mode, or firmware IPL mode. The following table shows an example of the function 02 IPL type, system operating mode, and firmware IPL mode selection sequence for a powered-on system.

Table 15. Function 02: Select IPL type, system operating mode, and firmware IPL mode on powered-on systems

Function/Data	Action or description
0 2 _ _ _ _ _ _ _ _ _ _	Use the Increment or Decrement buttons to scroll to function 02.
0 2 _ A < _ M _ _ _ _ P _ _ _ _ _ _ _ _ P _ _ _	Press Enter to start function 02. <ul style="list-style-type: none"> <li>The current OS IPL type is displayed with a pointer.</li> <li>The current system operating mode is displayed.</li> <li>The current firmware mode is displayed.</li> </ul>
0 2 _ B < _ M _ _ _ _ P _ _ _ _ _ _ _ _ P _ _ _	Use the Increment or Decrement buttons to scroll through the OS IPL types.
0 2 _ B _ M < _ _ _ _ P _ _ _ _ _ _ _ _ P _ _ _	Press Enter to select the OS IPL type. <ul style="list-style-type: none"> <li>The current OS IPL type is displayed.</li> <li>The current system operating mode is displayed with a pointer.</li> <li>The current firmware mode is displayed.</li> </ul>

Table 15. Function 02: Select IPL type, system operating mode, and firmware IPL mode on powered-on systems (continued)

Function/Data	Action or description
0 2 _ _ B _ _ N < _ _ _ _ P _	Use the Increment or Decrement buttons to scroll through the system operating modes.
0 2 _ _ B _ _ N _ _ _ _ _ P < _	Press Enter to select the system operating mode. <ul style="list-style-type: none"> <li>The current OS IPL type is displayed.</li> <li>The current system operating mode is displayed.</li> <li>The current firmware mode is displayed with a pointer.</li> </ul>
0 2 _ _ B _ _ N _ _ _ _ _ T < _	Use the Increment or Decrement buttons to scroll through the firmware IPL modes.
0 2 _	Press Enter to select the firmware IPL mode and exit function 02.
0 1 _	Use the Increment or Decrement buttons to scroll through the control panel functions.

For powered-off systems, function 02 is used to select the OS IPL type, system operating mode, system IPL speed, and firmware IPL mode. The following table shows an example of the function 02 OS IPL type, system operating mode, system IPL speed, and firmware IPL mode selection sequence for a powered-off system.

Table 16. Function 02: Select IPL type, system operating mode, system IPL speed, and firmware IPL mode on powered-off systems

Function/Data	Action or description
0 2 _	Use the Increment or Decrement buttons to scroll to function 02.
0 2 _ _ A < _ M _ _ _ _ V _	Press Enter to start function 02. <ul style="list-style-type: none"> <li>The current OS IPL type is displayed with a pointer.</li> <li>The current system operating mode is displayed.</li> <li>The current IPL speed is displayed.</li> <li>The current firmware IPL mode is displayed.</li> </ul>
0 2 _ _ B < _ M _ _ _ _ V _	Use the Increment or Decrement buttons to scroll through the OS IPL types.
0 2 _ _ B _ _ M < _ _ _ _ V _	Press Enter to select the IPL type. <ul style="list-style-type: none"> <li>The current IPL type is displayed.</li> <li>The current system operating mode is displayed with a pointer.</li> <li>The current IPL speed is displayed.</li> <li>The current firmware IPL mode is displayed.</li> </ul>
0 2 _ _ B _ _ N < _ _ _ _ V _	Use the Increment or Decrement buttons to scroll through the system operating modes.
0 2 _ _ B _ _ N _ _ _ _ V < _	Press Enter to select the system operating mode. <ul style="list-style-type: none"> <li>The current IPL type is displayed.</li> <li>The current system operation mode is displayed.</li> <li>The current IPL speed is displayed with a pointer.</li> <li>The current firmware IPL mode is displayed.</li> </ul>

Table 16. Function 02: Select IPL type, system operating mode, system IPL speed, and firmware IPL mode on powered-off systems (continued)

Function/Data	Action or description
0 2 _ _ B _ _ N _ _ _ _ S < _ _ _ _ _ _ _ _ _ _ _ _ T < _ _	Use the Increment or Decrement buttons to scroll through the IPL speeds.
0 2 _ _ B _ _ N _ _ _ _ S _ _ _ _ _ _ _ _ _ _ _ _ T < _ _	Press Enter to select the IPL speed. <ul style="list-style-type: none"> <li>The current IPL type is displayed.</li> <li>The current system operation mode is displayed.</li> <li>The current IPL speed is displayed.</li> <li>The current firmware IPL mode is displayed with a pointer.</li> </ul>
0 2 _ _ B _ _ N _ _ _ _ S _ _ _ _ _ _ _ _ _ _ _ _ P < _ _	Use the Increment or Decrement buttons to scroll through the firmware IPL modes.
0 2 _	Press Enter to select the firmware IPL mode and exit function 02.
0 1 _	Use the Increment or Decrement buttons to scroll through the control panel functions.

### Function 03: Start IPL

This function starts an IPL of the selected IPL type.

This function is available only in manual operating mode and when the system power is on.

After you select an IPL type, and then press the Enter button, all the Licensed Internal Code is loaded.

**Attention:** Do not perform a system shutdown before the IPL. Using this function can cause loss of data.

### Function 04: Lamp test

This function shows whether any control panel indicators are burned out and whether characters that are displayed in the Function/Data display on the control panel are valid.

This function is available in both normal and manual operating mode.

When you activate the lamp test, all of the control panel lights and indicators are lit. The lamp test continues on the system control panel for four minutes.

Use the following procedure to verify that the lights on the system control panel are working correctly. If you cannot complete these steps, see “Starting Point for All Problems” in the Problem Analysis information for your system to start problem analysis.

1. Power on the system.
2. Press the Increment (↑) or Decrement (↓) buttons on the control panel to display function 04. Press Enter on the control panel.

3. Do all of the lights and indicators on the system control panel come on?

Yes	No
↓	Exchange the control panel or the replaceable unit that contains the control panel function [system unit backplane (MB1) or tower card (CB1)]. See "Removal and Installation Procedures" in the Problem Analysis information for your system.

4. Do the expansion unit control panel lights all come on?

**Note:** The expansion unit control panel lights will be lit for only about 25 seconds after function 04 is entered.

Yes	No
↓	Exchange the control panel on the expansion unit.

The lights on the system control panel are working correctly.

## Function 05: Reserved

This function is reserved.

## Function 06: Reserved

This function is reserved.

## Function 07: SPCN functions

This function allows you to perform a System Power Control Network (SPCN) operation.

This function is available only in the manual operating mode and from power on standby.

### Notes:

- The system that will display the ID must be powered off with ac power applied.
- If you have just restored power to the system, the service processor must return to standby mode before the control panel functions will work correctly. Returning the service processor to standby mode takes a few minutes *after* the panel appears to be operational.
- The control panel must be in manual operating mode to access function 07 options.

To perform an SPCN operation that is controlled by function 07, do the following:

1. Select function 07, and then press Enter. 07\*\* is displayed.
2. Select the function that you want to perform (see Table 17). Use the Increment or Decrement buttons (↑↓) to scroll to the appropriate function. Press Enter to display 07nn00, where *nn* is the function that you selected.

Table 17. SPCN functions in function 07

Function	Description	For more information
A1	Broadcasts a power-on command.	Go to step 5.
A6	Displays frame address on all I/O enclosures.	Go to step 5.
A8	Displays the SPCN configuration ID number for a selected frame.	07A8 is displayed. Go to step 3.
A9	Sets the SPCN configuration ID for a selected frame.	07A9 is displayed. Go to step 4.

3. If you selected function A8 in step 2, do the following:
  - a. To display the configuration of the I/O enclosure, do the following:
    - 1) Use the Increment (↑) or Decrement (↓) buttons to select the first two characters of the frame address of the I/O enclosure, and then press Enter. 07nn00 is displayed, where nn is the first byte of the frame address.
    - 2) Use the Increment (↑) or Decrement (↓) buttons to select the second two characters of the frame address of the I/O enclosure, and then press Enter. 07nn00 is displayed on the selected I/O enclosure, where nn is the second byte of the frame address.

**Note:** The display on an addressed I/O enclosure is blinking on and off while displaying the processing unit ID as the last two characters of the bottom line.

- b. To display the configuration of the processing unit, do the following:
    - 1) Use the (↑) or Decrement (↓) buttons to select the first two characters of the frame address of the processing unit, and then press Enter. 07\*\* is displayed.
    - 2) Use the Increment (↑) or Decrement (↓) buttons to select the second two characters of the frame address of the processing unit, and then press Enter. The configuration ID is displayed on the processing unit. 07nn00 is displayed, where nn is the processing unit ID). For example, for a model 505, 07C0 is displayed.
  - c. Use the table at the end of these procedures to check the processing unit ID.

4. If you selected function A9 in step 2, do the following:

- a. To set the configuration of the selected I/O enclosure, do the following:
  - 1) Ensure that the system power of the selected I/O enclosure is in standby mode. If the system power of the selected I/O enclosure is not in standby mode, complete the procedure in Powering off an expansion unit. Then return to step 1.
  - 2) Use the (↑) or Decrement (↓) buttons to select the first two characters of the frame address of the I/O enclosure to configure, and then press Enter. 07nn00 is displayed, where nn is the first byte of the unit address.

**Note:** For nonsystem unit frames only, the display on the addressed frame is blinking on and off.

- 3) Use the Increment (↑) or Decrement (↓) buttons to select the second two characters of the frame address of the I/O enclosure, and then press Enter. 07nn00 is displayed, where nn is the second byte of the frame address.

**Note:** The display on the addressed I/O enclosure is blinking on and off.

- 4) Use the (↑) or Decrement (↓) buttons to select the correct processing unit ID, and then press Enter. Use the table at the end of these procedures to check the processing unit ID. 07nn is displayed, where nn is the processing unit ID). The processing unit ID is accepted and displayed on the I/O enclosure.
  - b. To set the configuration of the selected processing unit, do the following:
    - 1) Ensure that the system power is in standby mode. If the system power of the selected processing unit is not in standby mode, complete the procedure in Stop the system. Then return to step 1.
    - 2) Use the Increment (↑) or Decrement (↓) buttons to select the frame address of the processing unit to configure.
    - 3) Use the (↑) or Decrement (↓) buttons to select the correct processing unit ID, and then press Enter. Use the table at the end of these procedures to check the processing unit ID. 07nn00 is displayed, where nn is the processing unit ID.

The processing unit ID is accepted and displayed on the processing unit.

After 20 to 30 seconds, the display on the addressed I/O enclosure stops blinking and returns to the normal display format. On a system unit, the display shows the series of bring-up reference codes and then displays function 01.

5. Scroll to 07\*\* using the Increment (↑) or Decrement (↓) buttons, and then press Enter. This returns the control panel to the normal display.

*Table 18. Configuration IDs*

Model or I/O enclosure	Processing unit identifier
OpenPower™ 710	BA
285	B4
OpenPower 720	BB
505	C0
510 and 9110-51A	BA
520 and 52A	B4
550 and 55A	B5
9116-561	B2
570	B2
570 (with one or more secondary units)	B3
575	B9
590 and 595	B1
5074 and 5079	81
5088 and 0588	89
5094 and 5294	8A
0595 and 5095	8B
5790	88
7311-D10	88
7311-D11	88
7311-D20	8C

**Note:** Processing unit IDs are not applicable for the 7047-185, 7037-A50, and the 7031-D24 and 7031-T24 enclosure models.

**Related tasks**

PWR1917: Displaying and setting the SPCN configuration ID

Changing the processing unit identifier using the Advanced System Management Interface (ASMI)

## Function 08: Fast power off

This function allows you to power off the system when it is suspended.

This function is available only when the system is in manual operating mode and the system power is on.

The first time that you select function 08 and press Enter, the system displays an attention system reference code (SRC), 11 A1xx 8008. This SRC indicates that you selected function 08. The second time that you select function 08 and press Enter, you confirm the request to power off.

**Attention:**

1. Because of the potential for causing a loss of data, do not use this function if you can shut down the system from the operating system.
2. If you changed the system password at the most recent IPL, performing a fast power off might cause that new password information to be lost.

## Functions 09 to 10: Reserved

These functions are reserved.

## Functions 11 to 19: System reference code (SRC)

These functions display a system reference code (SRC) on the control panel to serve as a diagnostic aid that helps you determine the source of a hardware or operating system problem.

These functions are available in both normal and manual operating mode when an SRC is available.

Functions 11 through 19, if enabled, represent the words of the system reference code (SRC).

Record SRC information for error reporting. For more information, see [Collecting reference codes and system information](#).

For more information about interpreting SRCs, go to [Reference code list for customers](#).

To use an SRC for problem analysis, see [Beginning problem analysis](#).

## Function 20: System type, model, feature code, and IPL type

This function displays the machine type and model, VPD card CCIN, and IPL types.

This function is available in both normal and manual operating mode.

The machine type, model, VPD card CCIN, and IPL type are displayed in the following format:

```
p p p p - m m m _ _ _ c c c c
T T T T T T T t t t t t t t
```

The values are indicated as follows:

- Values for *p* indicate the machine type.
- Values for *m* indicate the machine model.
- Values for *c* indicate the system VPD card CCIN.
- Values for *T* indicate the CEC IPL type.
- Values for *t* indicate the FSP IPL type.

Record this information with the system reference code (SRC).

If you select this function and it has not been activated, the command is rejected.

---

## Control panel functions on the 7037-A50 and 7047-185 models

Learn about the control panel functions that are available on the 7037-A50 server and 7047-185 workstation models.

## Function 01: Display selected system operating mode, IPL speed, and firmware IPL mode

This function displays the selected system operating mode, speed, and firmware mode for the next IPL on the 7037-A50 server and the 7047-185 workstation.

This function is available in both normal and manual operating mode.

This function displays the following information:

- The valid logical key modes (N).
- The IPL speed (F).
- The firmware mode (P or T).

Table 19. Function 01 on systems without OS IPL enabled

Function/Data	Action or description
0 1 _	Use the Increment or Decrement buttons to scroll to function 01.
0 1 _ _ _ _ N _ _ _ F _ _ _ _ _ _ _ _ _ _ _ P _ _ _	Valid system operating mode is N.  Valid IPL speed display is F.  Valid firmware IPL modes are P and T. <ul style="list-style-type: none"> <li>• P = permanent side boot</li> <li>• T = temporary side boot</li> </ul>
0 1 _	Use the Increment or Decrement buttons to scroll through the control panel functions.

## Function 02: Select firmware IPL mode

This function allows you to select the firmware IPL mode on the 7037-A50 server and the 7047-185 workstation.

This function is available in both normal and manual operating mode.

Table 20. Function 02: Select the firmware IPL mode

Function/Data	Action or description
0 2 _	Use the Increment or Decrement buttons to scroll to function 02.
0 2 _ _ _ _ _ _ _ _ P _ _ _ _ _ _ _ _ _ _ _ _ _	Press Enter to start function 02. The current firmware mode is displayed.
0 2 _ _ _ _ _ _ _ _ T < _ _ _ _ _ _ _ _ _ _ _ _ _	Use the Increment or Decrement buttons to scroll through the firmware IPL modes.  Valid firmware IPL modes are P and T. <ul style="list-style-type: none"> <li>• P = permanent side boot</li> <li>• T = temporary side boot</li> </ul>
0 2 _	Press Enter to select the firmware IPL mode and exit function 02.
0 2 _	Use the Increment or Decrement buttons to scroll through the control panel functions.

## Function 04: Lamp test on the 7037-A50 and 7047-185 models

This function performs a lamp test on the 7037-A50 server and the 7047-185 workstation.

This function is available in both normal and manual operating mode.

This function shows whether any control panel indicators are burned out and whether characters that are displayed in the Function/Data display on the control panel are valid. When you activate this test, all the control panel lights and indicators are lit.

The lamp test continues on the system control panel for four minutes.

Use this procedure to verify that the lights on the system control panel are working correctly. If you cannot complete these steps, see “Starting Point for All Problems” in the Problem Analysis information for your system to start problem analysis.

1. Power on the system.
2. Press the Increment (↑) or Decrement (↓) buttons on the control panel to display function 04.  
Press Enter on the control panel.
3. Do all of the lights and indicators on the system control panel come on?

Yes	No
↓	Exchange the control panel or the replaceable unit that contains the control panel function [system unit backplane (MB1) or tower card (CB1)]. See “Removal and Installation Procedures” in the Problem Analysis information for your system.

4. Do the expansion unit control panel lights all come on?

Yes	No
↓	Exchange the control panel on the expansion unit.

The lights on the system control panel are working correctly.

This ends the procedure.

## Function 05: Remind mode for the 7037-A50 and 7047-185 models

This function allows you to place the system fault-indicator LED in *remind* mode on the 7037-A50 server and the 7047-185 workstation.

This function is available in both normal and manual operating mode.

When the system fault-indicator LED is on solid, an error condition exists on the system. If you want to defer the repair of the error, you can place the system fault-indicator LED in *remind* mode. Placing the system in remind mode causes the system fault-indicator LED to flash instead of being on solid. The remind mode lets you know that a system fault that you have deferred still exists on the system. If any other serviceable event occurs on the system, the remind mode is changed back to system fault mode, where the LED is on solid.

Table 21. Function 05 on the 7037-A50 and 7047-185 models

Function/Data	Action or description
0 5 _	Use the Increment or Decrement buttons to scroll to function 05.

Table 21. Function 05 on the 7037-A50 and 7047-185 models (continued)

Function/Data	Action or description
R E M I N D M O D E O N _ -----	Press Enter to start function 05. Valid options are: <ul style="list-style-type: none"> <li>• Remind mode ON</li> <li>• Remind mode OFF</li> </ul>
R E M I N D M O D E O F F _ -----	Press Enter to toggle the option on or off.
0 5 _ -----	Use the Increment or Decrement buttons to scroll through the control panel functions.

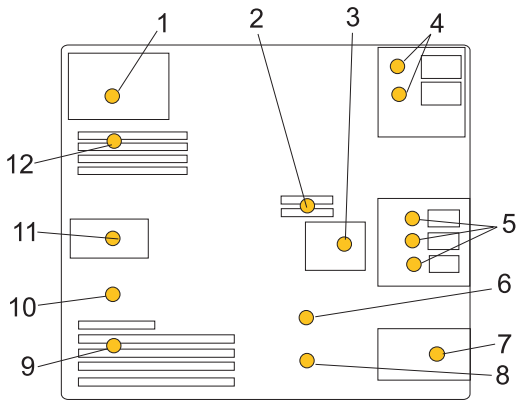

Figure 7. Light path diagnostic card indicator LED layout for the 7037-A50 and 7047-185 models

Table 22. 7037-A50 and 7047-185 fault-indicator LEDs

1 Power supply fault-indicator LED	7 Front fan fault-indicator LED
2 Voltage-regulator module fault-indicator LED	8 Battery fault-indicator LED
3 Disk-drive bay fan fault-indicator LED	9 PCI adapter fault-indicator LED
4 Optical-media bay fault-indicator LEDs	10 Thermal fault-indicator LED
5 Disk-drive bay fault-indicator LEDs	11 Rear fan fault-indicator LED
6 System backplane fault-indicator LED	12 Memory fault-indicator LED

## Function 06: Display the BMC version on the 7037-A50 and 7047-185 models

This function displays the base motherboard controller (BMC) version on the 7037-A50 server and the 7047-185 workstation.

This function is available in both normal and manual operating mode.

Table 23. Function 06 on the 7037-A50 and 7047-185 models

Function/Data	Action or description
0 6 _ -----	Use the Increment or Decrement buttons to scroll to function 06.

Table 23. Function 06 on the 7037-A50 and 7047-185 models (continued)

Function/Data	Action or description
B M C: A W 8 T x x A _ _ _ _ -----	Press Enter to start function 06. An example of the BMC version is AW8T23A.
0 6 _ _ _ _ _ _ _ _ _ _ -----	Use the Increment or Decrement buttons to scroll through the control panel functions.

## Function 09: Display the BMC fan speed on the 7037-A50 and 7047-185 models

This function displays the base motherboard controller (BMC) fan speed on the 7037-A50 server and the 7047-185 workstation.

This function is available in both normal and manual operating mode.

The display alternates every two seconds between MAIN, DASD, and PCI fan speed.

The following table provides details about this function.

Table 24. Function 09 on the 7037-A50 and 7047-185 models

Function/Data	Action or description
0 9 _ _ _ _ _ _ _ _ _ _ -----	Use the Increment or Decrement buttons to scroll to function 09.
M A I N: 7 b 0 _ _ _ _ _ _ -----	Press Enter to start function 09. The main fan speed is listed in hexadecimal (rpm).
D A S D: 7 0 0 _ _ _ _ _ _ -----	Press Enter to start function 09. The DASD fan speed is listed in hexadecimal (rpm).
P C I: 7 b 0 _ _ _ _ _ _ _ _ -----	Press Enter to start function 09. The PCI (I/O) fan speed is listed in hexadecimal (rpm).
0 9 _ _ _ _ _ _ _ _ _ _ -----	Use the Increment or Decrement buttons to scroll through the control panel functions.

## Function 10: Display the temperature on the 7037-A50 and 7047-185 models

This function displays the temperature on the 7037-A50 server and the 7047-185 workstation.

This function is available in both normal and manual operating mode.

The display alternates every two seconds between ambient, CPU1, and CPU2 temperature.

The following table provides details about this function.

Table 25. Function 10 on the 7037-A50 and 7047-185 models

Function/Data	Action or description
1 0 _ _ _ _ _ _ _ _ _ _ -----	Use the Increment or Decrement buttons to scroll to function 10.

Table 25. Function 10 on the 7037-A50 and 7047-185 models (continued)

Function/Data	Action or description
A m b i e n t : 3 e , 3 e _ _ -----	Press Enter to start function 10. The ambient temperature is listed in hexadecimal (degrees Celsius). <ul style="list-style-type: none"> <li>The first value is the average temperature over a time span.</li> <li>The last value is the most recent temperature reading.</li> </ul>
C P U 1 : 5 0 , 6 f _ _ _ _ _ -----	Press Enter to start function 10. The CPU1 temperature is listed in hexadecimal (degrees Celsius). <ul style="list-style-type: none"> <li>The first value is the average temperature over a time span.</li> <li>The last value is the most recent temperature reading.</li> </ul>
C P U 2 : 0 , 0 _ _ _ _ _ -----	Press Enter to start function 10. The CPU2 temperature is listed in hexadecimal (degrees Celsius). <ul style="list-style-type: none"> <li>The first value is the average temperature over a time span.</li> <li>The last value is the most recent temperature reading.</li> <li>The reading is 0 if the system is one-way.</li> </ul>
1 0 _ _ _ _ _ -----	Use the Increment or Decrement buttons to scroll through the control panel functions.

## Function 20: System type and model

This function displays the machine type and model on the 7037-A50 server and the 7047-185 workstation.

This function is available in both normal and manual operating mode.

The machine type and model is displayed in the following format:

p p p p - m m m \_ \_ \_ \_ \_

The values are indicated as follows:

- Values for *p* indicate the machine type.
- Values for *m* indicate the machine model.

## Function 22: Partition dump on the 7037-A50 and 7047-185 models

This function initiates a dump of a partition's operating system data on the 7037-A50 server and the 7047-185 workstation.

This function is available in both normal and manual operating mode.

You must perform two consecutive function 22 selections to initiate a partition dump. The following table shows an example of function 22.

Table 26. Function 22: Initiate a partition dump

Function/Data	Action or description
2 2 _ _ _ _ _ -----	Use the Increment or Decrement buttons to scroll to function 22.
2 2 _ _ _ 0 0 _ _ _ _ _ -----	Press Enter to start function 22.

Table 26. Function 22: Initiate a partition dump (continued)

Function/Data	Action or description
A 1 0 0 3 0 2 2 _ _ _ _ _ _ _ _ _ _	Displays the partition dump verification system reference code (SRC).
2 2 _ _ _ _ _ _ _ _ _ _	Use the Increment or Decrement buttons to scroll to function 22.
2 2 _ _ _ 0 0 _ _ _ _ _ _ _ _ _ _	Press Enter to start function 22.

## Customer-extended panel functions

Learn about the customer-extended panel functions that are available.

### Function 21: Service tool initiation

This function makes Dedicated Service Tools (DST) available on the system console display.

This function is available only in the manual operating mode and when activated by the operating system.

The **Use Dedicated Service Tools (DST)** display is available on the primary or alternative console.

To exit the DST and return to the operating system, select the **Resume operating system display** option on the **Use Dedicated Service Tools (DST)** display.

For more information, see Overview of service and support.

### Function 22: Partition dump

This function initiates a dump of a partition's operating system data.

This function is available only in the manual operating mode and when activated by the operating system.

You must perform two consecutive function 22 selections to initiate a partition dump. The following table shows an example of function 22.

Table 27. Function 22: Initiate a partition dump

Function/Data	Action or description
2 2 _ _ _ _ _ _ _ _ _ _	Use the Increment or Decrement buttons to scroll to function 22.
2 2 _ _ _ 0 0 _ _ _ _ _ _ _ _ _ _	Press Enter to start function 22.
A 1 0 0 3 0 2 2 _ _ _ _ _ _ _ _ _ _	Displays the partition dump verification system reference code (SRC).
2 2 _ _ _ _ _ _ _ _ _ _	Use the Increment or Decrement buttons to scroll to function 22.
2 2 _ _ _ 0 0 _ _ _ _ _ _ _ _ _ _	Press Enter to start function 22.

## Functions 23 to 24: Reserved

These functions are reserved.

## Functions 25 and 26: Service switches 1 and 2

These functions are used to set the service function range (50 to 99).

These functions are available only in the manual operating mode.

To set the service function range (50 to 99), use function 25 to set the service representative switch 1, and then use function 26 to set the service representative switch 2.

## Functions 27 to 29: Reserved

These functions are reserved.

## Function 30: Service processor IP address and port location

This function displays the service processor IP address and port location.

This function is available only in the manual operating mode and from power on standby.

The following table shows an example of function 30.

Table 28. Function 30: Service processor IP address and port location

Function/Data	Action or description
3 0 _	Use the Increment or Decrement buttons to scroll to function 30.
3 0 * * _ _ _ _ _ _ _ _ _ _ _ _ _ _ _ _ _ _	Press Enter to enter sub-function mode.
3 0 0 0 _ _ _ _ _ _ _ _ _ _ _ _ _ _ _ _ _ _	Use the Increment or Decrement buttons to select an IP address 00 = SP A: ETH0 (primary enclosure) 01 = SP A: ETH1 (primary enclosure) 02 = SP B: ETH0 (secondary enclosure) 03 = SP B: ETH1 (secondary enclosure)
S P _ A : _ E T H 0 : _ _ _ T 5 9 . 5 . 1 0 5 . 2 4 3 _ _ _ _ _	Press Enter to display the selected IP address.
3 0 * * _ _ _ _ _ _ _ _ _ _ _ _ _ _ _ _ _ _	Use the Increment or Decrement buttons to select sub-function exit.
3 0 _	Press Enter to exit sub-function mode.

## Functions 31 to 33: Reserved

These functions are reserved.

## Function 34: Retry partition dump

This function is enabled only for partition dump IPLs.

This function is available only in the manual operating mode and when activated by the operating system.

You can use this function when the system is stopped during the partition IPL to retry the IPL without losing the original dump information.

## Functions 35 to 41: Reserved

These functions are reserved.

## Function 42: Platform dump

This function initiates a platform dump.

This function is available only in the manual operating mode and when activated by the operating system or the service processor.

You can use function 42 to dump IBM POWER™ hypervisor main storage and hardware data. You must perform two consecutive function 42 selections to initiate a platform dump. The following table shows an example of function 42:

Table 29. Function 42: Initiate a platform dump

Function/Data	Action or description
4 2 _	Use the Increment or Decrement buttons to scroll to function 42.
4 2 _ _ _ _ 0 0 _ _ _ _ _ _ _ _ _ _ _ _ _ _	Press Enter to start function 42.
A 1 0 0 3 0 4 2 _ _ _ _ _ _ _ _ _ _ _ _ _ _	Displays the confirmation SRC.
4 2 _	Use the Increment or Decrement buttons to scroll to function 42.
4 2 _ _ _ _ 0 0 _ _ _ _ _ _ _ _ _ _ _ _ _ _	Press Enter to start function 42.

## Function 43: Service processor dump

This function initiates a service processor dump.

This function is available only in the manual operating mode.

You must perform two consecutive function 43 selections to initiate a service processor dump. The following table shows an example of function 43.

Table 30. Function 43: Initiate a service processor dump

Function/Data	Action or description
4 3 _	Use the Increment or Decrement buttons to scroll to function 43.
4 3 0 0 _ _ _ _ _ _ _ _ _ _ _ _ _ _ _ _ _ _	Press Enter to confirm.
A 1 0 0 3 0 4 3 _ _ _ _ _ _ _ _ _ _ _ _ _ _	Displays the confirmation system reference code (SRC).
4 3 _	Use the Increment or Decrement buttons to scroll to function 43.
4 3 0 0 _ _ _ _ _ _ _ _ _ _ _ _ _ _ _ _ _ _	Press Enter to confirm.

## Functions 44 to 54: Reserved

These functions are reserved.

---

## Troubleshooting remote and virtual control panel problems

Learn about problems that might occur when accessing the remote control panel (RCP) or virtual control panel (VCP).

When setting up your initial connection, you might encounter problems accessing your remote control panel (RCP) or virtual control panel (VCP). The following sections describe some of the control panel problems that might occur:

### Remote control panel fails to start

Learn why the remote control panel (RCP) might fail to start.

If you are connecting over a network, the RCP might fail to start when either the user ID or service tools device ID being used does not have permission to use the RCP.

### Virtual control panel fails to start

Learn why the virtual control panel (VCP) might fail to start.

If the virtual control panel (VCP) fails to start, do the following:

1. Verify that the cables are properly connected. For more information, see *Installing a console cable*.
2. Verify that the resources of the PC are free of address or interrupt request (IRQ) conflicts. The Operations Console uses addresses in the range of 192.168.0.0 to 192.168.0.255. If you run any software that makes your PC SOCKS-enabled, check your SOCKS configuration, and make sure that the entry is as follows:

```
Direct 192.168.0.0 255.255.255.0
```

A SOCKS-enabled PC accesses the Internet through a firewall, such as Microsoft® Proxy Client, Hummingbird SOCKS Client, or others.

### Unable to use the mode function

Learn about why you might be unable to use the mode function on a remote control panel (RCP) or virtual control panel (VCP).

If you are unable to use the mode function on a remote control panel (RCP) or virtual control panel (VCP), check that the user that authenticated the connection (Service Device Sign-on) has the **Partition remote panel key** privilege for the logical partition to which they are connected. To verify the privilege setting, do the following:

1. Access Dedicated Service Tools (DST).
2. Did you access DST or SST?

Option	Description
DST	<ol style="list-style-type: none"><li>1. Select <b>Work with DST environment</b> (option 5).</li><li>2. Select <b>Service tools user IDs</b> (option 3).</li></ol>
SST	<ol style="list-style-type: none"><li>1. Select <b>Work with service tools user IDs and devices</b> (option 8).</li><li>2. Select <b>Service tools user IDs</b> (option 1).</li></ol>

3. Select **Change privileges** (option 7).

That user must be granted this privilege, by logical partition, in order to use the mode function. Also, if the system supports the keystick, the keystick must be inserted before the mode function is active.

## Virtual control panel authentication errors

Learn about virtual control panel (VCP) authentication errors and solutions.

See the following table for Operations Console virtual control panel (VCP) authentication errors and solutions.

*Table 31. VCP authentication errors and solutions*

Error message	Solution
The current access password entered is not valid. Please enter the valid access password.	This message typically means that the access password that you entered in the Service Device Sign-on window is not the same as the password that you entered in the Specify Access Password window during the configuration wizard. Ensure that the Caps Lock key is not active, and then re-enter the access password using the password that you assigned. Passwords are case sensitive.
The PC service tools device password and the service tools device password do not match. Either the service tools device ID <i>&lt;name&gt;</i> is already in use or the passwords must be RESET on this PC and the server.	This is an indication that the Service Tools Device ID password might be incorrect. If this is the case, then the Service Device ID password stored on the PC no longer matches the value stored on the server. The password assigned to the Service Device ID during the configuration wizard on the PC must match the password assigned to the service device ID on server. If you used the QCONSOLE device ID, then both the PC and server must have the password set to QCONSOLE. Each time that you authenticate successfully, this password is re-encrypted to a new value and stored on both sides of the connection. In rare situations, this password does not synchronize, so you need to reset the value back to the original default values on both the PC and the server. For instructions, see Resynchronize the PC's and the server's service tools device ID passwords.

---

## Related information

Information center topics contain information related to the Managing the control panel functions topic.

- Managing the Hardware Management Console (HMC)
- Managing the Advanced System Management Interface (ASMI)
- Managing your server using the Hardware Management Console (HMC)
- Managing your server using the Advanced System Management Interface (ASMI)
- Managing Operations Console
- Troubleshooting Operations Console connections



---

## Appendix. Accessibility features

Accessibility features help users who have a physical disability, such as restricted mobility or limited vision, to use information technology products successfully.

The following list includes the major accessibility features:

- Keyboard-only operation
- Interfaces that are commonly used by screen readers
- Keys that are tactilely discernible and do not activate just by touching them
- Industry-standard devices for ports and connectors
- The attachment of alternative input and output devices

### IBM and accessibility

See the IBM Accessibility Center at <http://www.ibm.com/able/> for more information about the commitment that IBM has to accessibility.



---

## Notices

This information was developed for products and services offered in the U.S.A.

The manufacturer may not offer the products, services, or features discussed in this document in other countries. Consult the manufacturer's representative for information on the products and services currently available in your area. Any reference to the manufacturer's product, program, or service is not intended to state or imply that only that product, program, or service may be used. Any functionally equivalent product, program, or service that does not infringe any intellectual property right of the manufacturer may be used instead. However, it is the user's responsibility to evaluate and verify the operation of any product, program, or service.

The manufacturer may have patents or pending patent applications covering subject matter described in this document. The furnishing of this document does not give you any license to these patents. You can send license inquiries, in writing, to the manufacturer.

**The following paragraph does not apply to the United Kingdom or any other country where such provisions are inconsistent with local law:** THIS INFORMATION IS PROVIDED "AS IS" WITHOUT WARRANTY OF ANY KIND, EITHER EXPRESS OR IMPLIED, INCLUDING, BUT NOT LIMITED TO, THE IMPLIED WARRANTIES OF NON-INFRINGEMENT, MERCHANTABILITY OR FITNESS FOR A PARTICULAR PURPOSE. Some states do not allow disclaimer of express or implied warranties in certain transactions, therefore, this statement may not apply to you.

This information could include technical inaccuracies or typographical errors. Changes are periodically made to the information herein; these changes will be incorporated in new editions of the publication. The manufacturer may make improvements and/or changes in the product(s) and/or the program(s) described in this publication at any time without notice.

Any references in this information to Web sites not owned by the manufacturer are provided for convenience only and do not in any manner serve as an endorsement of those Web sites. The materials at those Web sites are not part of the materials for this product and use of those Web sites is at your own risk.

The manufacturer may use or distribute any of the information you supply in any way it believes appropriate without incurring any obligation to you.

Any performance data contained herein was determined in a controlled environment. Therefore, the results obtained in other operating environments may vary significantly. Some measurements may have been made on development-level systems and there is no guarantee that these measurements will be the same on generally available systems. Furthermore, some measurements may have been estimated through extrapolation. Actual results may vary. Users of this document should verify the applicable data for their specific environment.

Information concerning products not produced by this manufacturer was obtained from the suppliers of those products, their published announcements or other publicly available sources. This manufacturer has not tested those products and cannot confirm the accuracy of performance, compatibility or any other claims related to products not produced by this manufacturer. Questions on the capabilities of products not produced by this manufacturer should be addressed to the suppliers of those products.

All statements regarding the manufacturer's future direction or intent are subject to change or withdrawal without notice, and represent goals and objectives only.

The manufacturer's prices shown are the manufacturer's suggested retail prices, are current and are subject to change without notice. Dealer prices may vary.

This information is for planning purposes only. The information herein is subject to change before the products described become available.

This information contains examples of data and reports used in daily business operations. To illustrate them as completely as possible, the examples include the names of individuals, companies, brands, and products. All of these names are fictitious and any similarity to the names and addresses used by an actual business enterprise is entirely coincidental.

If you are viewing this information in softcopy, the photographs and color illustrations may not appear.

The drawings and specifications contained herein shall not be reproduced in whole or in part without the written permission of the manufacturer.

The manufacturer has prepared this information for use with the specific machines indicated. The manufacturer makes no representations that it is suitable for any other purpose.

The manufacturer's computer systems contain mechanisms designed to reduce the possibility of undetected data corruption or loss. This risk, however, cannot be eliminated. Users who experience unplanned outages, system failures, power fluctuations or outages, or component failures must verify the accuracy of operations performed and data saved or transmitted by the system at or near the time of the outage or failure. In addition, users must establish procedures to ensure that there is independent data verification before relying on such data in sensitive or critical operations. Users should periodically check the manufacturer's support websites for updated information and fixes applicable to the system and related software.

---

## Trademarks

The following terms are trademarks of International Business Machines Corporation in the United States, other countries, or both:

eServer  
i5/OS  
IBM  
OpenPower  
POWER  
POWER5  
System i  
System i5  
System p

Linux<sup>®</sup> is a registered trademark of Linus Torvalds in the United States, other countries, or both.

Other company, product or service names may be trademarks or service marks of others.

---

## Electronic emission notices

### Class A Notices

The following Class A statements apply to the IBM System i models and IBM System p servers with the exception of those that are specifically identified as Class B.

## **Federal Communications Commission (FCC) statement**

**Note:** This equipment has been tested and found to comply with the limits for a Class A digital device, pursuant to Part 15 of the FCC Rules. These limits are designed to provide reasonable protection against harmful interference when the equipment is operated in a commercial environment. This equipment generates, uses, and can radiate radio frequency energy and, if not installed and used in accordance with the instruction manual, may cause harmful interference to radio communications. Operation of this equipment in a residential area is likely to cause harmful interference, in which case the user will be required to correct the interference at his own expense.

Properly shielded and grounded cables and connectors must be used in order to meet FCC emission limits. IBM is not responsible for any radio or television interference caused by using other than recommended cables and connectors or by unauthorized changes or modifications to this equipment. Unauthorized changes or modifications could void the user's authority to operate the equipment.

This device complies with Part 15 of the FCC rules. Operation is subject to the following two conditions: (1) this device may not cause harmful interference, and (2) this device must accept any interference received, including interference that may cause undesired operation.

## **Industry Canada Compliance Statement**

This Class A digital apparatus complies with Canadian ICES-003.

## **Avis de conformité à la réglementation d'Industrie Canada**

Cet appareil numérique de la classe A respecte est conforme à la norme NMB-003 du Canada.

## **European Community Compliance Statement**

This product is in conformity with the protection requirements of EU Council Directive 2004/108/EC on the approximation of the laws of the Member States relating to electromagnetic compatibility. IBM cannot accept responsibility for any failure to satisfy the protection requirements resulting from a non-recommended modification of the product, including the fitting of non-IBM option cards.

This product has been tested and found to comply with the limits for Class A Information Technology Equipment according to European Standard EN 55022. The limits for Class A equipment were derived for commercial and industrial environments to provide reasonable protection against interference with licensed communication equipment.

European Community contact:  
IBM Technical Regulations  
Pascalstr. 100, Stuttgart, Germany 70569  
Tele: 0049 (0)711 785 1176  
Fax: 0049 (0)711 785 1283  
E-mail: tjahn@de.ibm.com

**Warning:** This is a Class A product. In a domestic environment, this product may cause radio interference in which case the user may be required to take adequate measures.

## VCCI Statement - Japan

この装置は、情報処理装置等電波障害自主規制協議会（VCCI）の基準に基づくクラスA情報技術装置です。この装置を家庭環境で使用すると電波妨害を引き起こすことがあります。この場合には使用者が適切な対策を講ずるよう要求されることがあります。

The following is a summary of the VCCI Japanese statement in the box above.

This product is a Class A Information Technology Equipment and conforms to the standards set by the Voluntary Control Council for Interference by Information Technology Equipment (VCCI). In a domestic environment, this product may cause radio interference, in which case the user may be required to take adequate measures.

## Electromagnetic Interference (EMI) Statement - People's Republic of China

### 声 明

此为A级产品,在生活环境中,该产品可能会造成无线电干扰。在这种情况下,可能需要用户对其干扰采取切实可行的措施。

Declaration: This is a Class A product. In a domestic environment this product may cause radio interference in which case the user may need to perform practical action.

## Electromagnetic Interference (EMI) Statement - Taiwan

### 警告使用者：

這是甲類的資訊產品，在居住的環境中使用時，可能會造成射頻干擾，在這種情況下，使用者會被要求採取某些適當的對策。

The following is a summary of the EMI Taiwan statement above.

Warning: This is a Class A product. In a domestic environment this product may cause radio interference in which case the user will be required to take adequate measures.

**IBM Taiwan Contact Information:**

台灣IBM 產品服務聯絡方式：  
台灣國際商業機器股份有限公司  
台北市松仁路7號3樓  
電話：0800-016-888

## Electromagnetic Interference (EMI) Statement - Korea

이 기기는 업무용으로 전자파적합등록을 한 기기이오니 판매자 또는 사용자는 이점을 주의하시기 바라며, 만약 잘못 판매 또는 구입하였을 때에는 가정용으로 교환하시기 바랍니다.

Please note that this equipment has obtained EMC registration for commercial use. In the event that it has been mistakenly sold or purchased, please exchange it for equipment certified for home use.

## Germany Compliance Statement

### Deutschsprachiger EU Hinweis: Hinweis für Geräte der Klasse A EU-Richtlinie zur Elektromagnetischen Verträglichkeit

Dieses Produkt entspricht den Schutzanforderungen der EU-Richtlinie 2004/108/EG zur Angleichung der Rechtsvorschriften über die elektromagnetische Verträglichkeit in den EU-Mitgliedsstaaten und hält die Grenzwerte der EN 55022 Klasse A ein.

Um dieses sicherzustellen, sind die Geräte wie in den Handbüchern beschrieben zu installieren und zu betreiben. Des Weiteren dürfen auch nur von der IBM empfohlene Kabel angeschlossen werden. IBM übernimmt keine Verantwortung für die Einhaltung der Schutzanforderungen, wenn das Produkt ohne Zustimmung der IBM verändert bzw. wenn Erweiterungskomponenten von Fremdherstellern ohne Empfehlung der IBM gesteckt/eingebaut werden.

EN 55022 Klasse A Geräte müssen mit folgendem Warnhinweis versehen werden:

"Warnung: Dieses ist eine Einrichtung der Klasse A. Diese Einrichtung kann im Wohnbereich Funk-Störungen verursachen; in diesem Fall kann vom Betreiber verlangt werden, angemessene Maßnahmen zu ergreifen und dafür aufzukommen."

### Deutschland: Einhaltung des Gesetzes über die elektromagnetische Verträglichkeit von Geräten

Dieses Produkt entspricht dem "Gesetz über die elektromagnetische Verträglichkeit von Geräten (EMVG)". Dies ist die Umsetzung der EU-Richtlinie 2004/108/EG in der Bundesrepublik Deutschland.

### Zulassungsbescheinigung laut dem Deutschen Gesetz über die elektromagnetische Verträglichkeit von Geräten (EMVG) (bzw. der EMC EG Richtlinie 2004/108/EG) für Geräte der Klasse A.

Dieses Gerät ist berechtigt, in Übereinstimmung mit dem Deutschen EMVG das EG-Konformitätszeichen - CE - zu führen.

Verantwortlich für die Konformitätserklärung nach des EMVG ist die IBM Deutschland GmbH, 70548 Stuttgart.

Generelle Informationen:

Das Gerät erfüllt die Schutzanforderungen nach EN 55024 und EN 55022 Klasse A.

### **Electromagnetic Interference (EMI) Statement - Russia**

**ВНИМАНИЕ!** Настоящее изделие относится к классу А.  
В жилых помещениях оно может создавать радиопомехи, для снижения которых необходимы дополнительные меры

### **Class B Notices**

The following Class B statements apply to model 9111-520 (stand-alone version), 9131-52A (stand-alone version), 7047-185 and the 9111-285.

### **Federal Communications Commission (FCC) statement**

**Note:** This equipment has been tested and found to comply with the limits for a class B digital device, pursuant to Part 15 of the FCC Rules. These limits are designed to provide reasonable protection against harmful interference in a residential installation. This equipment generates, uses, and can radiate radio frequency energy and, if not installed and used in accordance with the instructions, may cause harmful interference to radio communications. However, there is no guarantee that interference will not occur in a particular installation. If this equipment does cause harmful interference to radio or television reception, which can be determined by turning the equipment off and on, the user is encouraged to try to correct the interference by one or more of the following measures:

- Reorient or relocate the receiving antenna.
- Increase the separation between the equipment and receiver.
- Connect the equipment into an outlet on a circuit different from that to which the receiver is connected.
- Consult an IBM authorized dealer or service representative for help.

Properly shielded and grounded cables and connectors must be used in order to meet FCC emission limits. Proper cables and connectors are available from IBM authorized dealers. IBM is not responsible for any radio or television interference caused by using other than recommended cables or connectors or by unauthorized changes or modifications to this equipment. Unauthorized changes or modifications could void the user's authority to operate the equipment.

This device complies with Part 15 of the FCC Rules. Operation is subject to the following two conditions: (1) this device may not cause harmful interferences, and (2) this device must accept any interferences received, including interference that may cause undesired operation.

### **Industry Canada Compliance Statement**

This Class B digital apparatus complies with Canadian ICES-003.

### **Avis de conformité à la réglementation d'Industrie Canada**

Cet appareil numérique de la classe B respecte est conforme à la norme NMB-003 du Canada.

## European Community Compliance Statement

This product is in conformity with the protection requirements of EC Council Directive 2004/108/EC on the approximation of the laws of the Member States relating to electromagnetic compatibility. IBM cannot accept responsibility for any failure to satisfy the protection requirements resulting from a non-recommended modification of the product, including the fitting of non-IBM option cards.

This product has been tested and found to comply with the limits for Class B Information Technology Equipment according to CISPR 22 / European Standard EN 55022. The limits for Class B equipment were derived for typical residential environments to provide reasonable protection against interference with licensed communication devices.

Properly shielded and grounded cables and connectors must be used in order to reduce the potential for causing interference to radio and TV communications and to other electrical or electronic equipment. Such cables and connectors are available from IBM authorized dealers. IBM cannot accept responsibility for an interference caused by using other than recommended cables and connectors.

European Community contact:  
IBM Technical Regulations  
Pascalstr. 100, Stuttgart, Germany 70569  
Tele: 0049 (0)711 785 1176  
Fax: 0049 (0)711 785 1283  
E-mail: tjahn@de.ibm.com

## VCCI Statement - Japan

この装置は、情報処理装置等電波障害自主規制協議会（VCCI）の基準に基づくクラスB情報技術装置です。この装置は、家庭環境で使用することを目的としていますが、この装置がラジオやテレビジョン受信機に近接して使用されると、受信障害を引き起こすことがあります。  
取扱説明書に従って正しい取り扱いをして下さい。

The following is a summary of the VCCI Japanese statement in the box above.

This is a Class B product based on the standard of the Voluntary Control Council for Interference by Information Technology Equipment (VCCI). If this equipment is used in a domestic environment, radio disturbance may arise. When such trouble occurs, the user may be required to take corrective actions.

## IBM Taiwan Product Service Contact Information

台灣IBM 產品服務聯絡方式：  
台灣國際商業機器股份有限公司  
台北市松仁路7號3樓  
電話：0800-016-888

## Electromagnetic Interference (EMI) Statement - Korea

이 기기는 가정용으로 전자파적합등록을 한 기기로서 주거 지역에서는 물론 모든 지역에서 사용할 수 있습니다.

### Radio Protection for Germany

#### Deutschsprachiger EU Hinweis: Hinweis für Geräte der Klasse B EU-Richtlinie zur Elektromagnetischen Verträglichkeit

Dieses Produkt entspricht den Schutzanforderungen der EU-Richtlinie 2004/108/EG zur Angleichung der Rechtsvorschriften über die elektromagnetische Verträglichkeit in den EU-Mitgliedsstaaten und hält die Grenzwerte der EN 55022 Klasse B ein.

Um dieses sicherzustellen, sind die Geräte wie in den Handbüchern beschrieben zu installieren und zu betreiben. Des Weiteren dürfen auch nur von der IBM empfohlene Kabel angeschlossen werden. IBM übernimmt keine Verantwortung für die Einhaltung der Schutzanforderungen, wenn das Produkt ohne Zustimmung der IBM verändert bzw. wenn Erweiterungskomponenten von Fremdherstellern ohne Empfehlung der IBM gesteckt/eingebaut werden.

#### Deutschland: Einhaltung des Gesetzes über die elektromagnetische Verträglichkeit von Geräten

Dieses Produkt entspricht dem "Gesetz über die elektromagnetische Verträglichkeit von Geräten (EMVG)". Dies ist die Umsetzung der EU-Richtlinie 2004/108/EG in der Bundesrepublik Deutschland.

#### Zulassungsbescheinigung laut dem Deutschen Gesetz über die elektromagnetische Verträglichkeit von Geräten (EMVG) (bzw. der EMC EG Richtlinie 2004/108/EG) für Geräte der Klasse B.

Dieses Gerät ist berechtigt, in Übereinstimmung mit dem Deutschen EMVG das EG-Konformitätszeichen - CE - zu führen.

Verantwortlich für die Konformitätserklärung nach des EMVG ist die IBM Deutschland GmbH, 70548 Stuttgart.

Generelle Informationen:

**Das Gerät erfüllt die Schutzanforderungen nach EN 55024 und EN 55022 Klasse B.**





Printed in USA