

SVP SECTION

Contents

SVP01-10	1. How to Operate the SVP (PC)
SVP01-10	1.1 How to use Windows
SVP01-40	1.2 Running the SVP by Specifying a File Name
SVP01-50	1.3 Executing SVP Connect Utility
SVP01-51	1.4 Before using the remote desktop exclusion function
SVP01-51	1.4.1 Version check of Internet Explorer (IE) in the Console PC
SVP01-52	1.4.2 Checking Internet Explorer (IE) options in the Console PC
SVP01-53	1.4.3 Checking SVP connecting person by the remote desktop exclusion function
SVP01-60	1.5 Connecting the PC to the SVP
SVP01-60	1.5.1 Connection to the SVP
SVP01-70	1.5.2 Restoring the previous connection
SVP01-71	1.5.3 Checking the connected subsystems
SVP01-72	1.6 User registration at the time of SVP connection
SVP01-80	1.7 Disconnecting the SVP
SVP01-90	1.8 Windows Screen Component Nomenclature
SVP01-100	1.9 Power On
SVP01-110	1.10 Power Off
SVP01-120	1.11 SVP LED display specification
SVP01-140	1.12 Mode
SVP01-150	1.13 How to reference the manual on CDR
SVP01-150	1.13.1 Preface
SVP01-160	1.13.2 How to reference the manual
SVP02-10	2. Function of the SVP
SVP02-10	2.1 TOD (Time Or Date) setting
SVP02-30	2.2 Log indication
SVP02-180	2.3 Log delete
SVP02-200	2.4 Monitoring
SVP02-200	2.4.1 Monitoring
SVP02-250	2.4.2 Processing Information Monitoring Function
SVP02-260	2.5 Online read margin (ORM)
SVP02-430	2.6 SIM Reporting Specification
SVP02-450	2.7 Management of drive threshold values
SVP02-520	2.8 SIM Log Complete
SVP02-540	2.9 Dump/AutoDump
SVP02-750	2.10 Logical Device Maintenance
SVP02-750	2.10.1 Logical Device
SVP02-970	2.11 Pin Data indication
SVP02-990	2.12 Multi PCB Replace
SVP02-1050	2.13 System Option

SVP02-1110	2.14 Blocking of Cluster
SVP02-1140	2.15 Recovering of Cluster
SVP02-1180	2.16 PCB/SFP Revision Display
SVP02-1200	2.17 Setting Battery Life
SVP02-1220	2.18 Setting Machine Install Data
SVP02-1250	2.19 SFP type change operation
SVP02-1250	2.19.1 Batch type change
SVP02-1260	2.19.2 Changing type specification
SVP02-1290	2.20 Setting Synchronization Information
SVP02-1290	2.20.1 Setting Synchronization Information
SVP02-1311	2.20.2 Confirm Setting Synchronization Information
SVP02-1320	2.21 CHA/MIX PCB type change operation
SVP02-1370	2.22 Fixed time SVP reboot setting
SVP02-1370	2.22.1 Fixed time SVP reboot the setting method
SVP02-1390	2.22.2 Fixed time SVP reboot the setting release method
SVP02-1400	2.23 Received Windows Security Patch Display
SVP02-1410	2.24 Received Windows Security Patch Application
SVP02-1420	2.25 SVP Switching
SVP02-1450	2.26 Configuration Information Transfer
SVP02-1470	2.27 Change CM Module group size
SVP02-1540	2.28 Setting IP address
SVP03-10	3. Activating and Terminating STATUS
SVP03-10	3.1 Activating STATUS
SVP03-40	3.2 Terminating STATUS
SVP03-50	3.3 Updating the STATUS display
SVP03-60	3.4 Main screen
SVP03-100	3.5 DKC screen
SVP03-120	3.6 Logic Box screen
SVP03-140	3.7 Base PCB screen
SVP03-150	3.8 CHA/Base/MIX PCB screen
SVP03-170	3.9 DKU screen
SVP03-180	3.10 HDU screen
SVP03-190	3.11 HDD screen
SVP03-210	3.12 Copy status
SVP03-220	3.13 Logical Device
SVP03-260	3.14 Version of Microprogram
SVP03-320	3.15 Path of LCP/HTP
SVP03-360	3.16 Pin
SVP03-380	3.17 LUN Management
SVP03-460	3.18 CM/SM Path
SVP03-480	3.19 OS Install Status
SVP03-490	3.20 Error or Failure Status Action

1. How to Operate the SVP (PC)

Notice: The device does not have the installation location and power resource for a terminal PC. The maintenance personnel needs to prepare an operation place and a power resource for his PC.
Connect the LAN cable of the terminal PC to the Console PC connector in the rear side of the SVP. (Refer to [LOC04-40](#).)

1.1 How to use Windows

(1) Notation

In this manual, “select” has the following three meanings, and (CL), (DC), or (DR) is added to the word for each meaning.

(CL) Click: Quickly press and release the left side button of mouse.

(DC) Double-click: Click the left side button of mouse twice in rapid succession.

(DR) Drag: To hold down the left side button of mouse while you trace the mouse to move the pointer to a desired position. Then release the button.

example: Select (DC) the [Install] icon in the ‘SVP’ window.

Move the pointer to [Install] with the mouse. Then click the button the Move the pointer to [Install] with the left side button of mouse twice in rapid succession.

(2) Close

“Close” means to close the application window.

(Double-click the control menu box of the window or click the close button for window.)

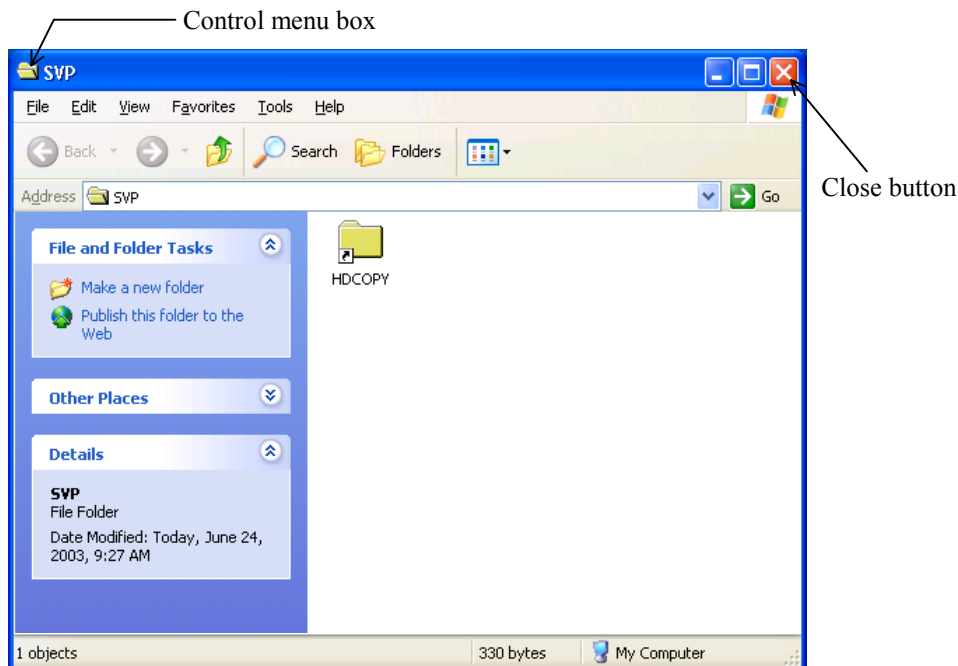

(3) Moving the Window

Move the pointer to the title bar with the trackball.

While pressing the button, move the window with the trackball or touchpad (DR) to a desired position and release the button.

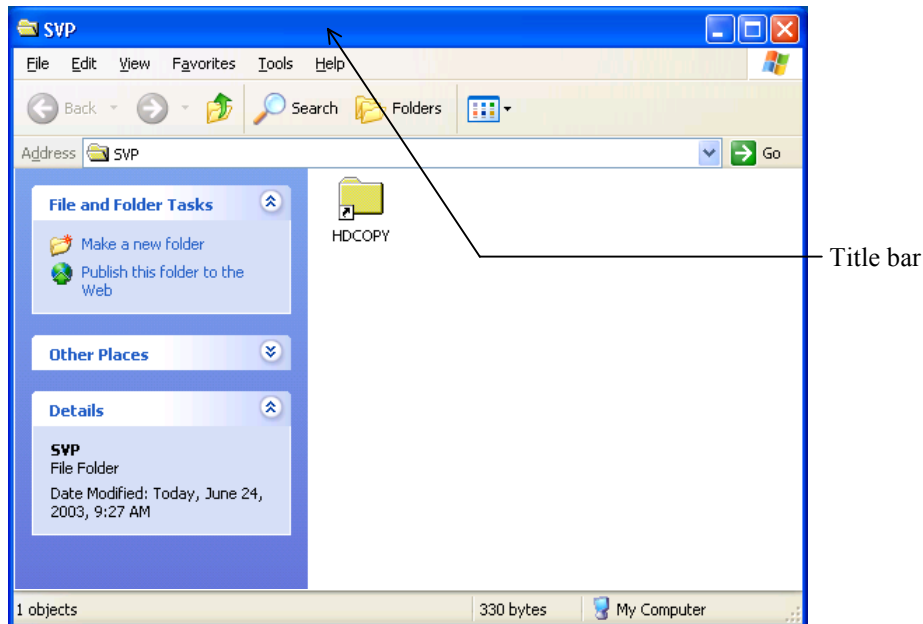

(4) Changing the window size

Move the pointer to the window border (frame) (the pointer changes to the double-headed arrow). While pressing the button, move the border (the border changes to the broken line) until the window becomes a desired size, and release the button.

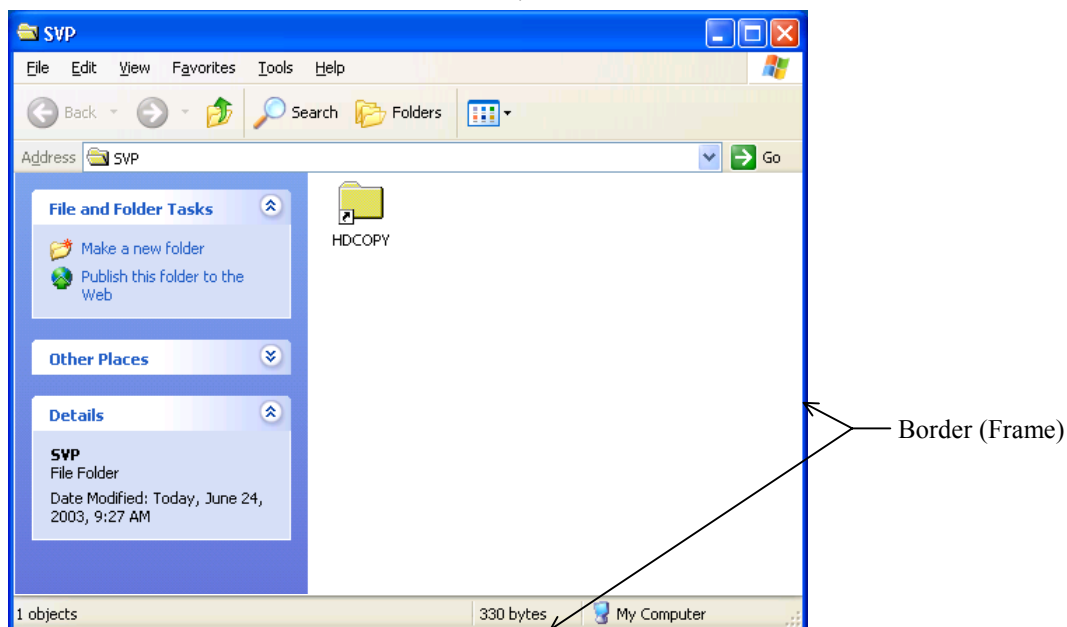

- (5) Switching the screen (when two or more screens are opened)
While pressing the [ALT] key , press [TAB] key (or [ESC] key) until your desired window title is displayed, and release the [ALT] key.

1.2 Running the SVP by Specifying a File Name

- (1) <Select [Run]>
Select (CL) [Run...] from the [Start] menu.



- (2) <Entering a file name>
Enter a file name in the “Open” box and select (CL) the [OK] button.

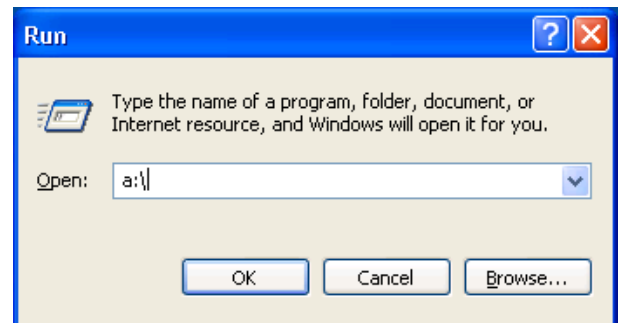

1.3 Executing SVP Connect Utility

Execute SVP Connect Utility through a Console PC. Execute the following procedure through the Console PC.

(1) Installing SVP Connect Utility

Insert the PP medium to the CD-R drive in the Console PC, and select (CL) [Run...] from the [Start] menu.

Enter “e:\Program\Svputl\Cputl.bat e:” in the “Open” box. Select (CL) the [OK] button.

Note: In the step above, the CD-R drive in the Console PC is assigned a drive letter E.

If the CD-R drive is assigned a drive letter D, enter “d:\Program\Svputl\Cputl.bat d:”.

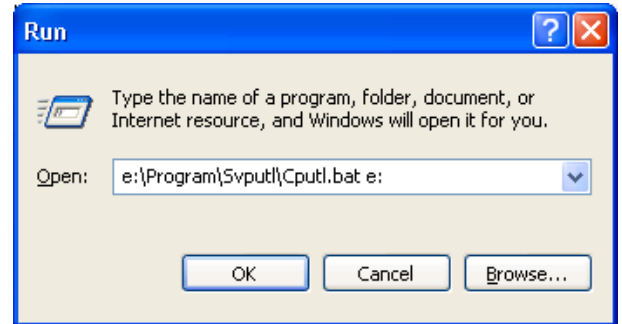

(2) Executing SVP Connect Utility

Double-click “RDPEXE.exe” in the desktop to execute the SVP Connect Utility.

1.4 Before using the remote desktop exclusion function

Note: The version corresponding to the Console PC is as shown in the following table.

OS version of the corresponding Console PC	Windows 2000 / XP / 2003 server
--	---------------------------------

Check that the conditions of Sections 1.4.1 and 1.4.2 are satisfied.

1.4.1 Version check of Internet Explorer (IE) in the Console PC

Check the version of Internet Explorer (IE) in the Console PC.

(1)

Select (DR) the Internet Explorer icon from the desktop, and start IE.

(2)

Select (CL) the system menu [HELP] of IE, and select (CL) the version information from the popup menu.

(3)

Check the section of version in the dialog of the figure.

Check that the version is 6.0.1YYY.YYY.– (Y is a numeric value) and 6.0.2ZZZ.ZZZ.– (Z is a numeric value) or later.

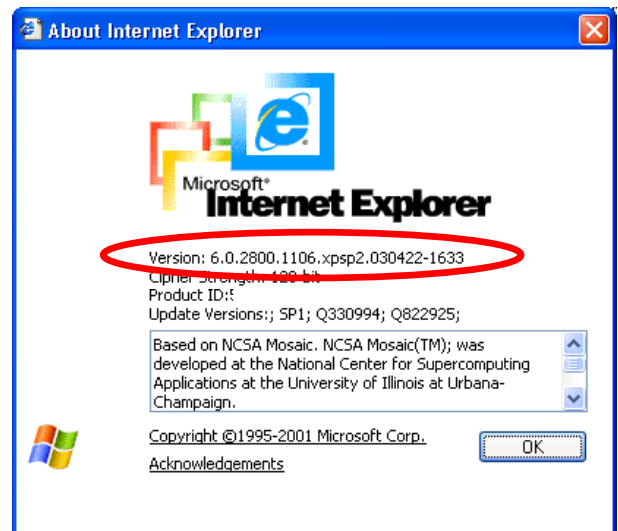

1.4.2 Checking Internet Explorer (IE) options in the Console PC

Check the Internet Explorer (IE) options.

- (1)
Select (CL) the system menu [TOOL] of IE.

- (2)
Select (CL) [Internet Options] from the popup menu.

- (3)
Open the dialog, and select (CL) [Privacy] Tab.

- (4)
Check that the policy is [Medium], [Medium High] or [High] in the section of Setting (or check that cookie of the first party is not blocked).

If Cookie is blocked, change it to the above-mentioned setting.

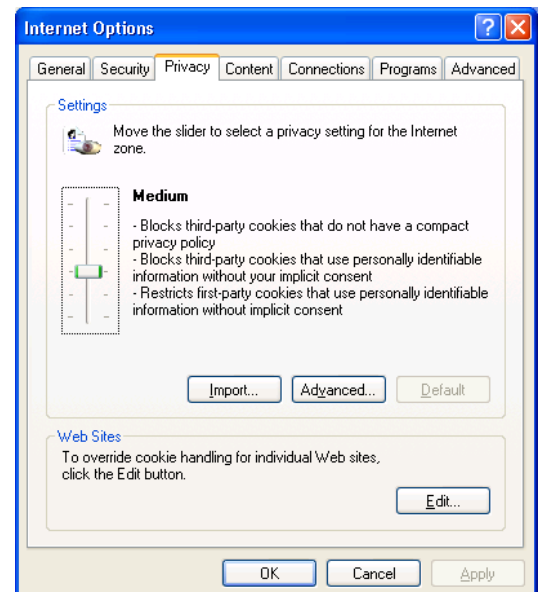

1.4.3 Checking SVP connecting person by the remote desktop exclusion function

Check the usage status of SVP in the Console PC according to the following procedure.

(1)

Enter the following URL in the address bar from IE (Internet Explorer) in the Console PC and display the authentication dialog window. If the connection environment to SVP by WebConsole is SSL, connect from https://... In other cases, connect from http://...

`http[s]://<IP address of SVP>/cgi-bin/rdpCheck/rdp001.cgi`

Note: Enter C of rdpCheck of URL with a capital letter.

(2)

If connected, a dialog of the BASIC authentication is displayed on IE, so that enter the user name and the password, and select (CL) the [OK] button. Contact the Hitachi Technical Support Center for the user name and the password.



Window of the authentication dialog

(3)

CGI starts and the usage status of SVP is displayed on IE. There are two types of the statuses of SVP such as connection enabled and connection disabled (others are using or busy as rebooting, etc.). If it is displayed as connection enabled, two-minute priority is given.

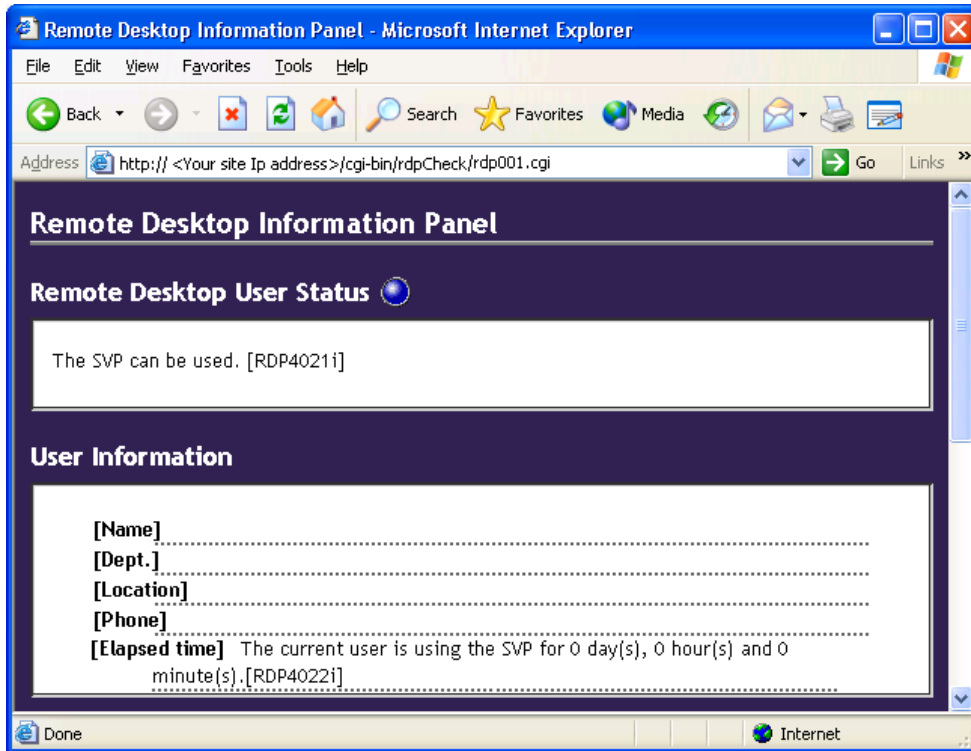

Window of the connection enabled status

Connect it to SVP according to the procedure in Section 1.5 because the status is the connection enabled to SVP.

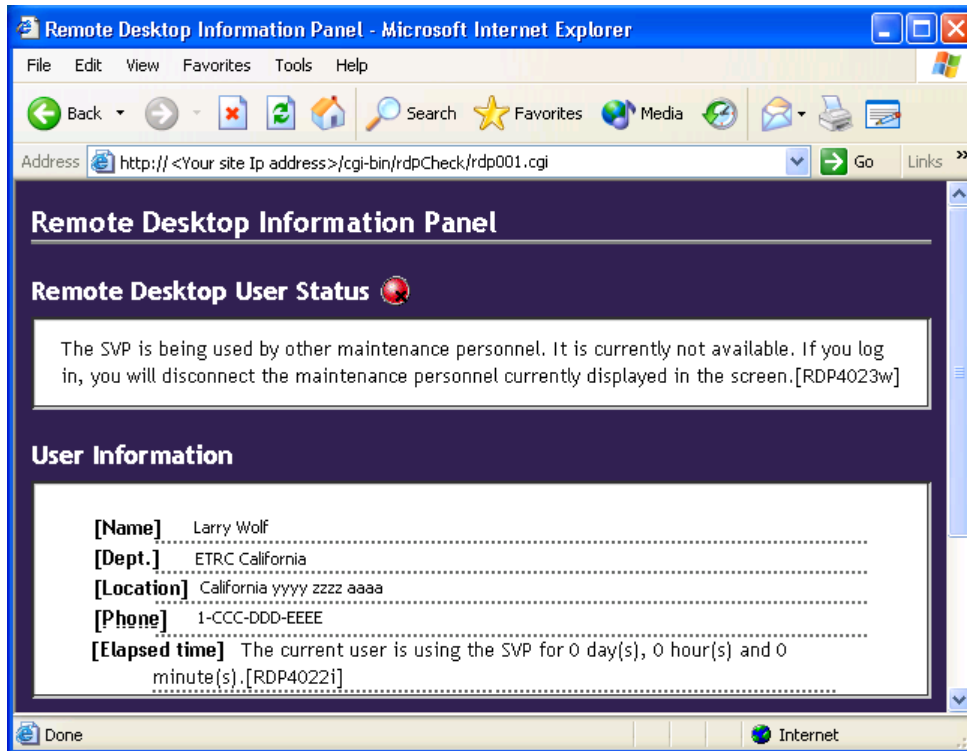

Window of the connection disabled status

Note: Perform the SVP connection within two minutes after the window of IE is displayed. If it is not connected within two minutes, other service personnel may automatically be able to connect SVP. Also, in the status where the priority is given, the priority time cannot be extended by reloading CGI in IE.

If the connection is disabled when the status is checked by IE, contact the service personnel who is indicated in the window and who connects it at present, or wait until the SVP becomes available. In the case of the connection disabled status, the window checks the status of SVP every three minutes, and updates the status display automatically. If you keep IE opened, it is possible to check if SVP becomes usable after the service personnel at present disconnects SVP (at this time, if it becomes usable, the priority is given for two minutes).

In either case, check that the usable status is displayed and then connect it to SVP.

1.5 Connecting the PC to the SVP

Connect the PC for connection to the SVP using SVP Connect Utility.

When connect the same SVP again, carry out “1.5.2 Restoring the previous connection”.

1.5.1 Connection to the SVP

(1) Searching the SVP

Select (CL) [Search] in the ‘SVP Connect Utility’ window.

IP addresses and product serial numbers of the connectable SVPs are displayed in the list.

(2) Performing the connection

Select an SVP to be connected from the SVPs in the list and select (CL) [Connect]. A connection to the selected SVP is done.

Note: Please check that automatic connection of a local disk drive is set up in the case of connection.

(At the time of SvpConnectUtility use, it is set up automatically.)

Go to “1.5.3 Checking the connected subsystems”.

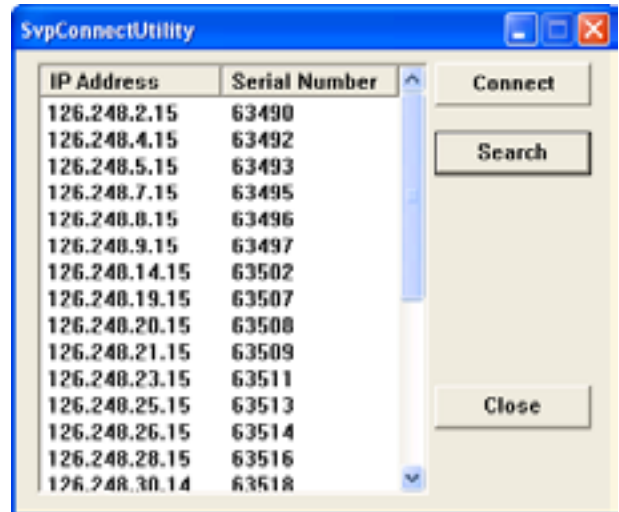

1.5.2 Restoring the previous connection

After the certain SVP is disconnected, connect the same SVP again.

(1) Displaying the dialog box for entering an IP address

Select (CL) [Connect] in a state in which the SVP is not selected from the list. The “Input IP Address” dialog box is displayed.

(2) Restoring the previous connection

Select (CL) the pull down button of the entry box. Select the top one of the displayed IP addresses.

Select (CL) the [Connect] button.

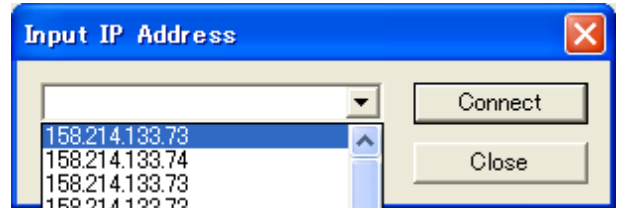

Note: When you reconnect it after a SVP reboot, please leave time more than five minutes.

Go to “1.5.3 Checking the connected subsystems”.

1.5.3 Checking the connected subsystems

After the SVP is connected, the serial number of subsystem is displayed on the left of the mode button in the SVP screen. Please check whether the connected subsystem is correct.

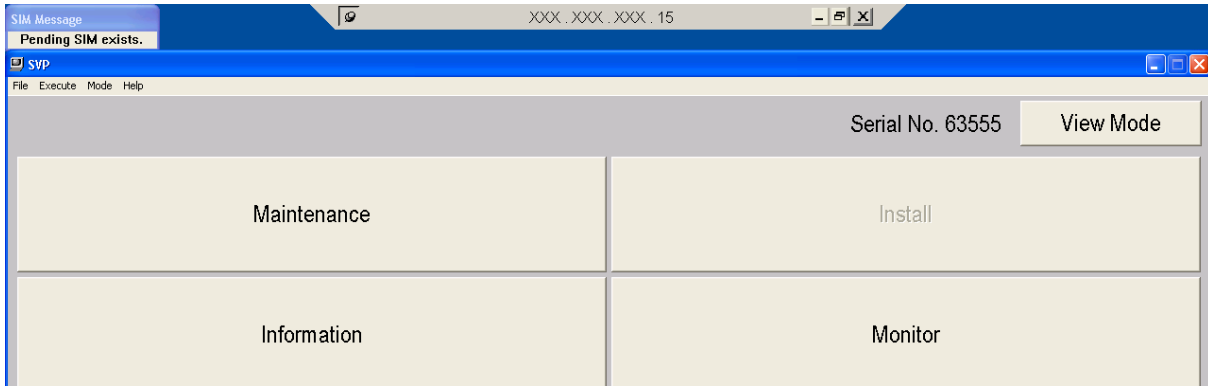

Note: If it connects with a wrong subsystem, maintenance operation is performed, a serious obstacle may occur.

1.6 User registration at the time of SVP connection

(1)

If connected to SVP, the user registration window for the service personnel is displayed on the front of the desktop as shown in the following figure.

Note: The window cannot be deleted or minimized without going through this procedure.

SVP User Registration

Name
NOT IN USE BY ANYONE

Post

Connected origin

Phone Number

History

Register

(2)

Fill in necessary items in the text edit box of the user registration window, and then select (CL) the registration button.

Note: If the registration is completed, the user registration window is minimized (it cannot be terminated).

(3)

The information that the user registration is done by connecting to SVP once is stored up to 20 latest cases of the history.

If the history button is selected (CL) several times, the information entered in the past is displayed in the text edit box, so that select (CL) the registration button when your own information is displayed.

Note: Refer to the following table for the restriction of the entry field.

Entry field	Name	Describe the name of the connecting person	Up to 255 characters
	Post	Describe the division of the connecting person	Up to 127 characters
	Connected Origin	Describe the place of the connection source of the connecting person	Up to 127 characters
	Phone Number	Fill in the contact address of the connecting person	Up to 63 characters
Characters which can be entered	Alphabetical characters	ABCDEFGHIJKLMNOPQRSTUVWXYZ abcdefghijklmnopqrstuvwxyz	
	Numeric characters	0123456789	
	Signals	()-#\$%&+/*!"'~@.,:;<^_ and 0x5c(ASCII)	
	Empty characters	Space characters 0x20(ASCII)	

1.7 Disconnecting the SVP

Disconnect the Console PC from the SVP.

(1) Disconnection

Move the pointer to the upper central portion of the window. Select (CL) the mark “×” on the bar displayed.

The SVP window on the Console PC is closed.

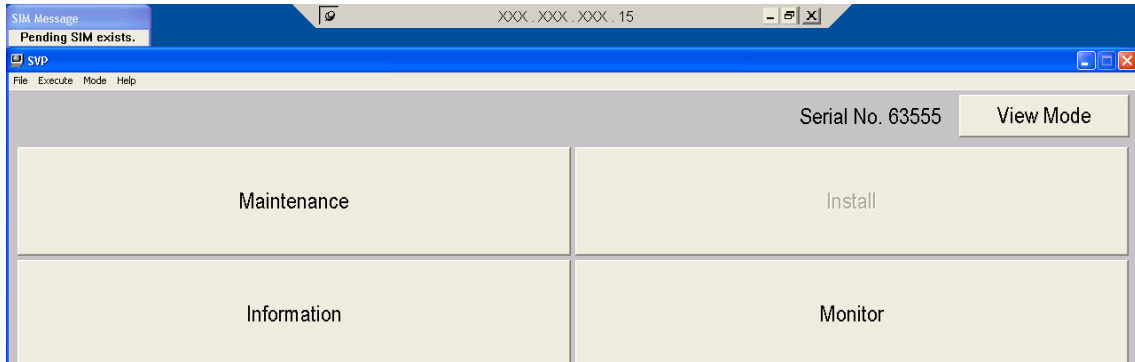

Note: When you want to terminate the connection to the SVP, perform it after verifying that the WebConsole window is not opened. If you have turned off the SVP connection accidentally during using WebConsole, connect the SVP again, and reopen WebConsole window after closing it.

1.8 Windows Screen Component Nomenclature

Either of the following windows is displayed.

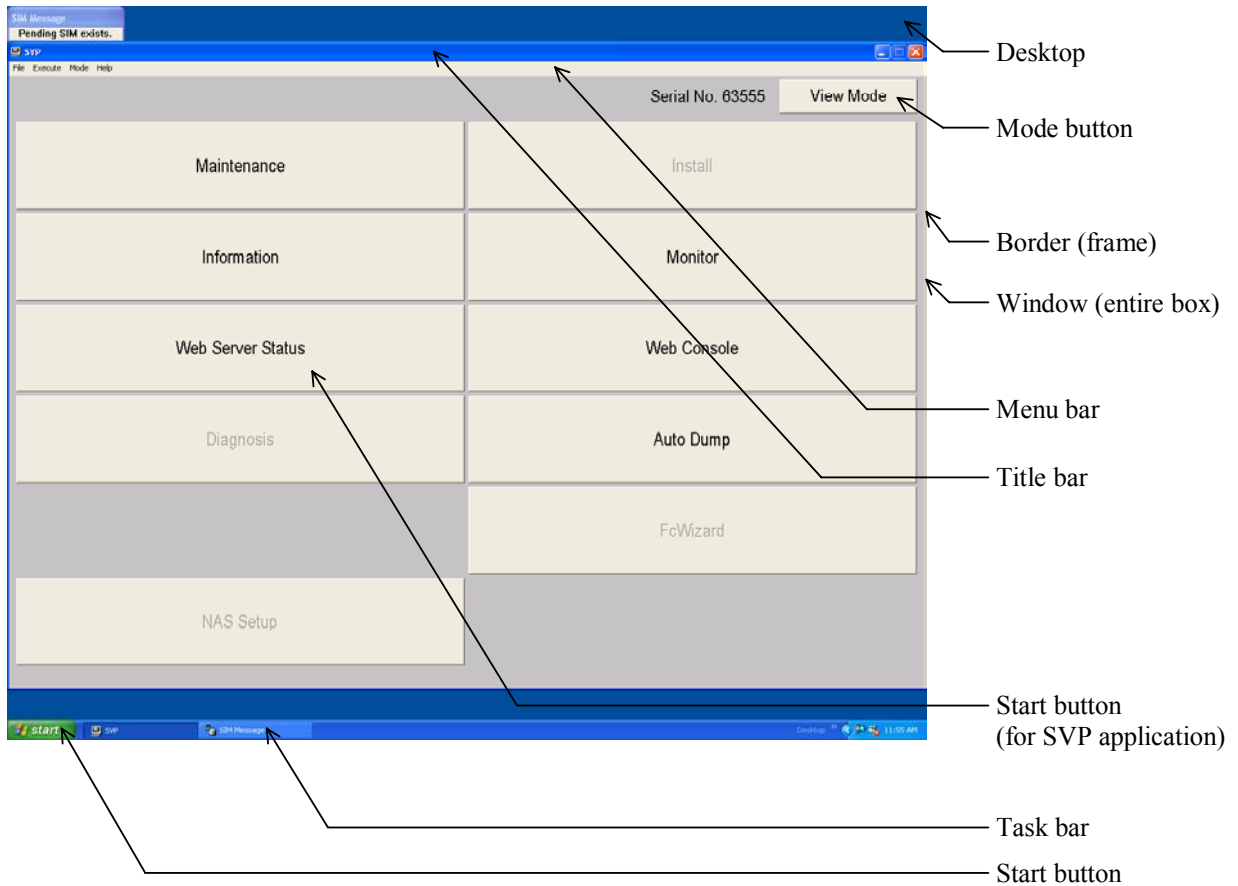

Note: Each SVP screen on this maintenance manual is a sample, and it may not be the same as the actual screen.

1.9 Power On

Usually, SVP starts automatically at the breakers-ON.

If some problems occurred (and you must start SVP), follow the procedures below (to start SVP).

(1) Power On SVP

- a. Press the Power Switch on the front side of the SVP main body.
- b. Make sure that the PWR LED on the front side of the SVP main body comes on.
If not, re-execute Step a in (1).
If the LED does not come on though the Step a in (1) is re-executed twice, replace the SVP.

(2) Windows Start (SVP Start)

- a. Wait for a few minutes until the Windows system starts up.
- b. Select (CL) [Search] of the SVP Connect Utility through the Console PC. Make sure that the SVP concerned is displayed in the list. If it is not displayed, re-execute Step a in (1).
If the Windows system does not start up though the Step a in (1) is re-executed twice, replace the SVP.

Notice: If Windows doesn't start, check the following items.

- (1) Is the DKC "CE mode" ?
- (2) Are the two LEDs at the LAN cable socket always on?

If above two conditions are satisfied, pull out the LAN cable until Windows starts.

1.10 Power Off

(1) Is the Console PC connected ?

a. See what is displayed on the Console PC.

When the PC is not connected to the SVP concerned, connect the Console PC to the SVP.
(See “1.5 Connecting the PC to the SVP” (SVP01-60).)

(2)

Click the right button of a mouse on a taskbar.

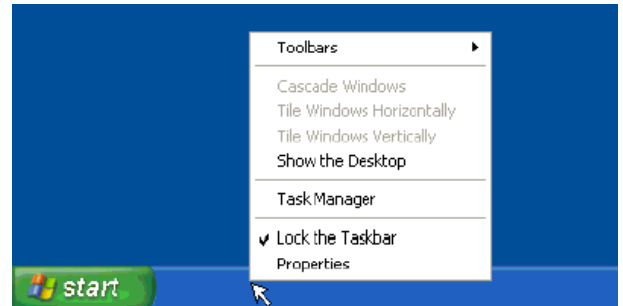

(3)

Select (CL) the [Task Manager].

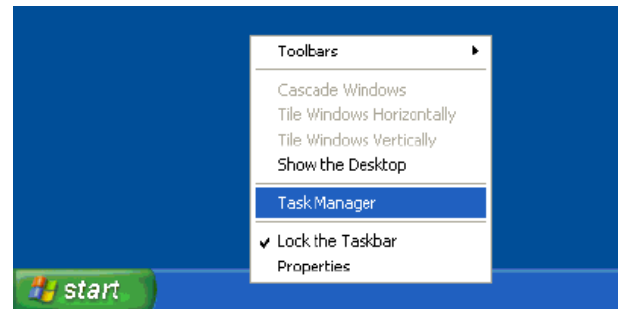

(4)

Select (CL) [Shut Down], and then select (CL) the [Turn Off].

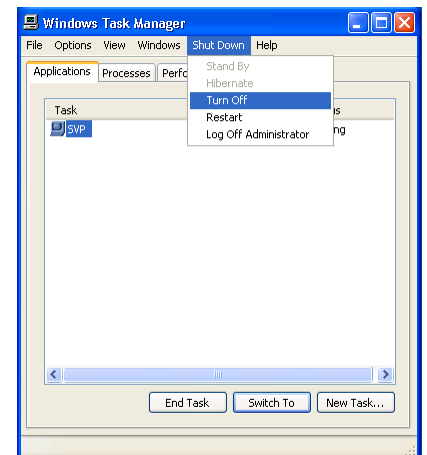

- (5) Select (CL) the [Yes] button.

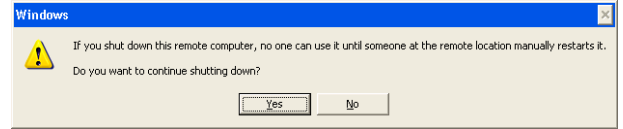

- (6) It waits until SVP POWER LED puts out the light.

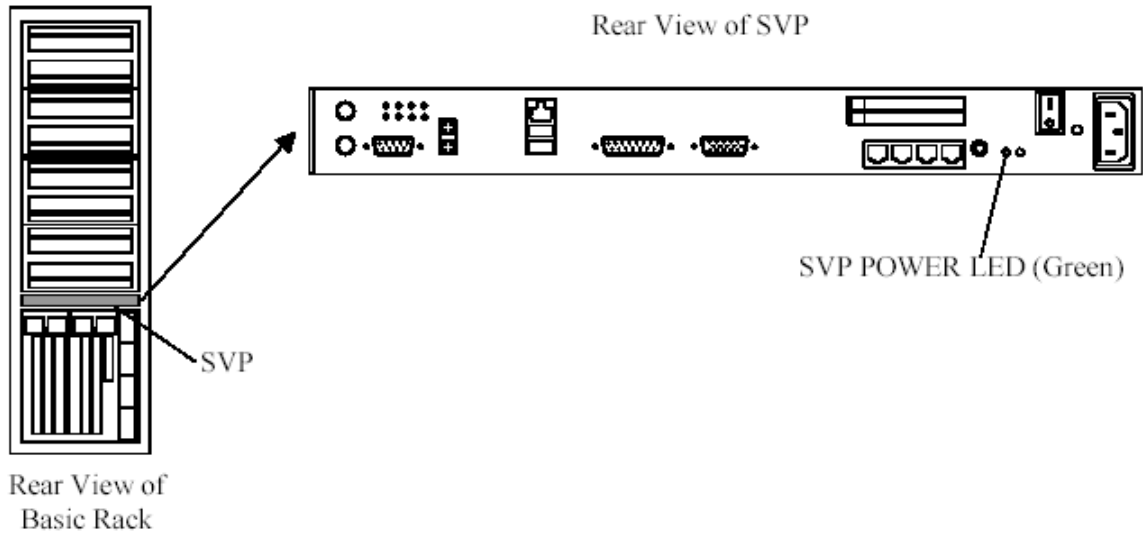

1.11 SVP LED display specification

(1) LED arrangement

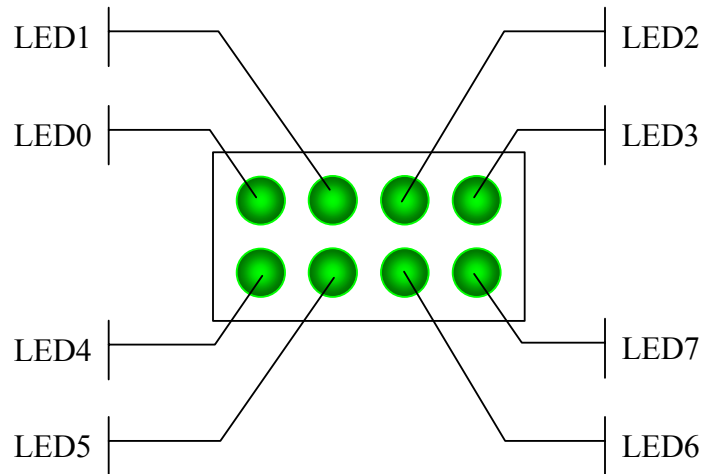

(2) The meaning of LED

LED0 : Lighting at the time of Master SVP

LED7 : It blinks at intervals of 1 second at the time of SVP action.

(3) Lighting at the time of Master SVP

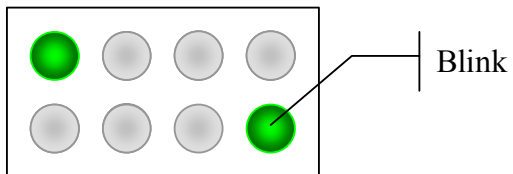

(5) The action at the time of JP3 insertion

Insertion of JP3 switches on LED by the following sequences.

- ① All LED putting out lights (for 1 second)
- ② All LED lighting (for 1 second)
- ③ All LED putting out lights (for 1 second)
- ④ All LED lighting (for 1 second)
- ⑤ The first octet display of an IP address (for 3 seconds)
- ⑥ The second octet display of an IP address (for 3 seconds)
- ⑦ The third octet display of an IP address (for 3 seconds)
- ⑧ The fourth octet display of an IP address (for 3 seconds)
- ⑨ All LED putting out lights (for 10 second)
- ⑩ JP3 insertion check. If still inserted, the sequence continuation. If it has not inserted, sequence is end.
- ⑪ Initialize Password
- ⑫ Initialize IP Address
- ⑬ All LED lighting (for 10 second)
- ⑭ SVP Reboot

(6) IP address display

The data for 1Byte is displayed using eight LED.

When it is 0x00

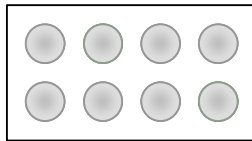

When it is 0xFF

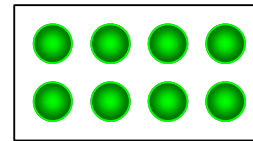

When it is 0x12

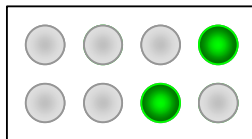

When it is 0x88

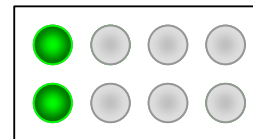

When it is 0x34

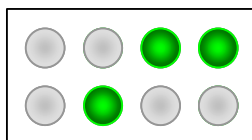

When it is 0x11

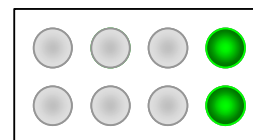

1.12 Mode

(1) <View Mode>

In view mode, only referring the subsystem status is allowed.

Note: In view mode, pending SIMs (if exist) are reported to host.



(2) <Modify Mode>

In modify mode, referring and changing the subsystem status are allowed.

For example, log/pin data indication and status display on MAINTENANCE are available in any mode, but hardware replacement is available in only modify mode.



(3) <Change Mode>

If you push (CL) [View Mode] button, the mode changes from [View Mode] to [Modify Mode], and SVP changes to Modify Mode.

If you push (CL) [Modify Mode] button, the mode changes from [Modify Mode] to [View Mode], and SVP changes to View Mode.



SAFETY SUMMARY

Observe the following cautionary notices after using the SVP.

- Exit the window opened.
- Change the operation mode to “View.”

If the above operation is not performed, a failure may not be notified because the SVP is judged to be under maintenance.

1.13 How to reference the manual on CDR

1.13.1 Preface

The Maintenance Manual, which is provided being contained in a CDR, is written in the format of the HTML (Hyper Text Markup Language) file. To read the manual, it is required to install the special reader software beforehand.

1.13.2 How to reference the manual

To reference this manual.

- (1) Insert the CDR into the drive of your PC.
- (2) Use Explorer to locate the CDR drive.
- (3) Double-click a desired file.

The content of the selected file will be displayed on another window.

2. Function of the SVP

2.1 TOD (Time Or Date) setting

- Note:
- Please do not execute the TOD setting during the P/S ON procedure.
 - Please do not execute the TOD setting during collecting the LCP Dump.
 - Please do not execute the TOD setting during the port error recovery operation using the restart switch function.

Note: In the case that there is MVOL of HRC asynchronous in this DKC and the amount of Sidefiles reach to the threshold, Async pair may be suspended.

Note: In the case that there is PVOL of XRC Replication in this DKC and the amount of Sidefiles reach to the threshold, XRC Replication pair may be suspended.

(1)

Change the mode to [Modify Mode] from [View Mode] (CL).

(2)

Select (CL) [Install].

(3)

Select (CL) [Set Subsystem Time] in the 'Install' window.

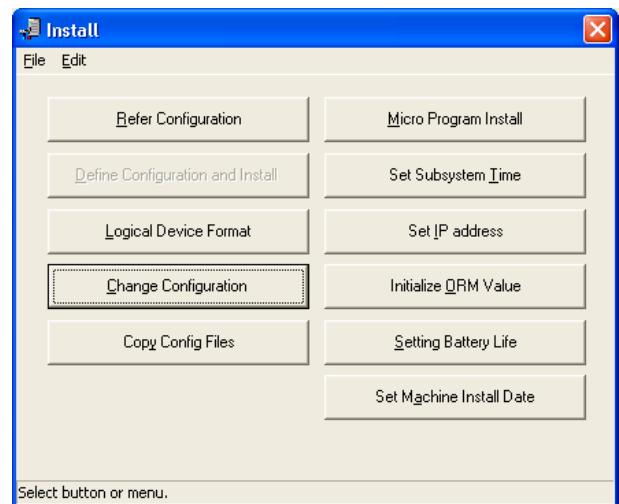

(4)

Select (CL) [TOD Change] in the 'Set Subsystem Time' window, and then select (CL) [OK].

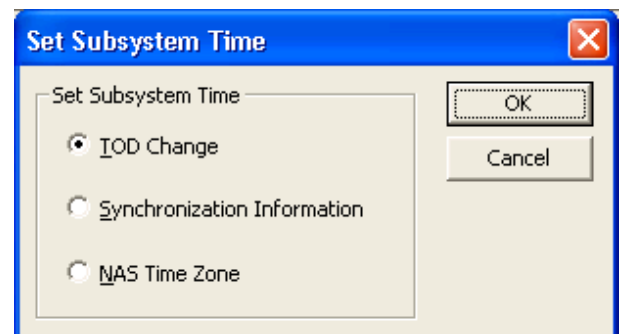

- (5) Specify the date (year, month and day) and time (hour, minute and second) and select (CL) [OK].

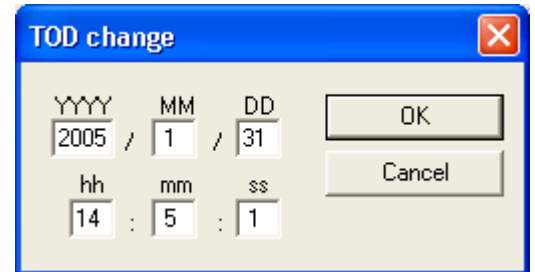

- (6) Close the 'Install' window.

Note: If you execute the performance measurement by Performance Monitor, don't push back the TOD.

2.2 Log indication

[1] SSB Log -----	SVP02-40
[2] SIM Log -----	SVP02-60
[3] Detail Log -----	SVP02-80
[4] Reset Log -----	SVP02-90
[5] Power Event Log -----	SVP02-100
[6] Incident Log -----	SVP02-110
[7] LCP Log -----	SVP02-130
[8] Diagnosis Log -----	SVP02-140
[9] Copy History Log -----	SVP02-150
[10] MP# - Location correspondence table -----	SVP02-160

Prerequisite Operation:

- (1) Select (CL) [Information].

- (2) Select (CL) [Log...].

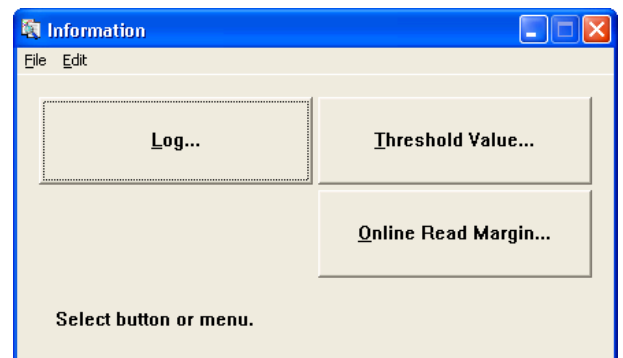

- (3) 'Log' dialog box is displayed.

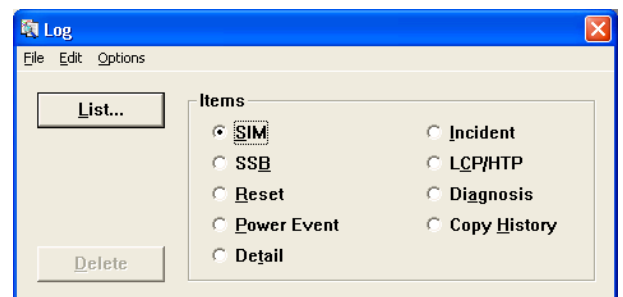

[1] SSB Log

(1)

Select (CL) [SSB] in the 'Log'.

Select (CL) [List...].

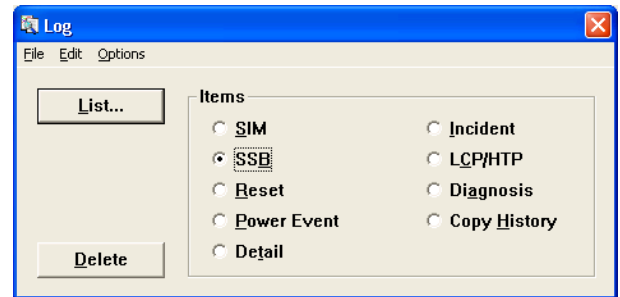

(2)

Select (CL) data to be indicated in the 'List-SSB' dialog box and select (CL) [Content...].

Note: To sort and list items, select (CL) [Sort...] first.

Then select (CL) the desired item in the [Items] and [Order] options in the 'Sort' dialog box, and select (CL) [OK].

Note: To search for the desired log, select (CL) [Search...]. Then set the log for which you want to search individual List in the 'SSB Search Condition' dialog box and select (CL) [OK].

Note: Please do not change an application's window until search function finish.

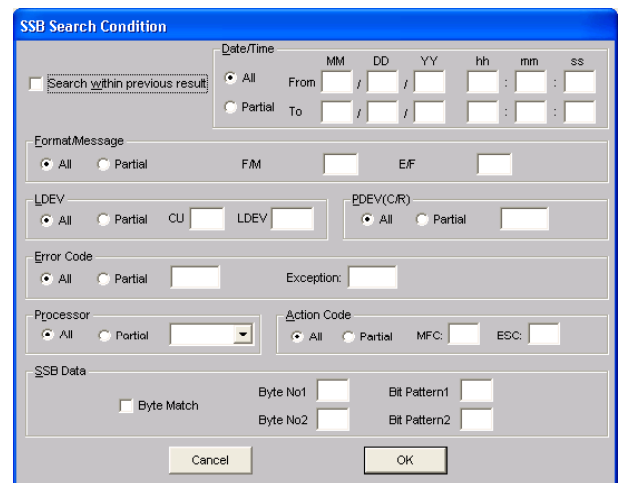
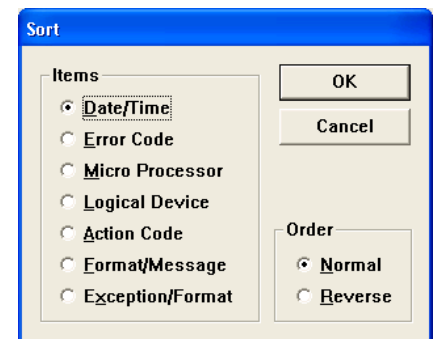
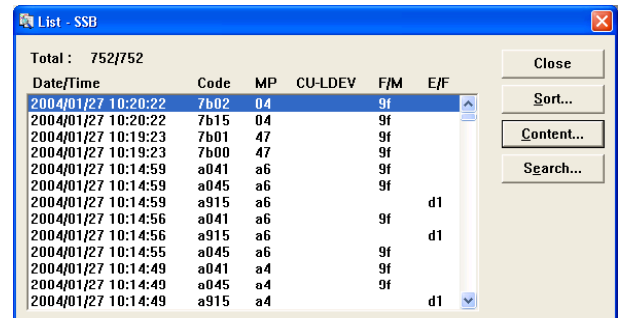

(3)

The detailed data is displayed in the 'Content-SSB' dialog box.

Select (CL) [Refer...] in the 'Content-SSB' dialog box to display the relative log.

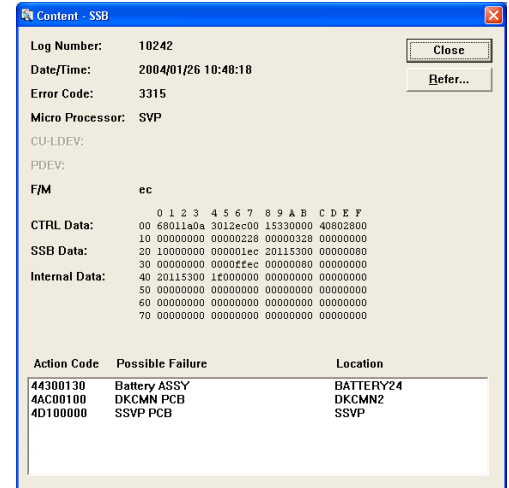

(4)

Select (CL) the log to be displayed in the 'Refer' dialog box.

([SIM] is selected in this example.)

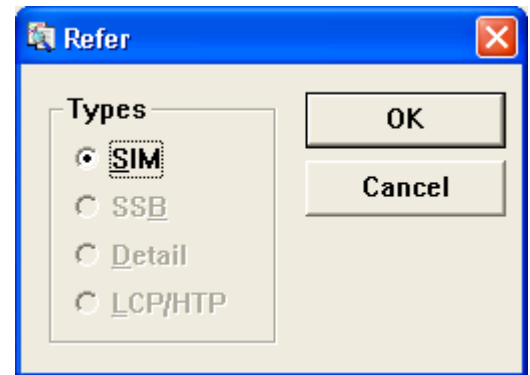

(5)

Display the log to be selected.

('Content-SIM' is displayed in this example.)

See SIM LOG Section

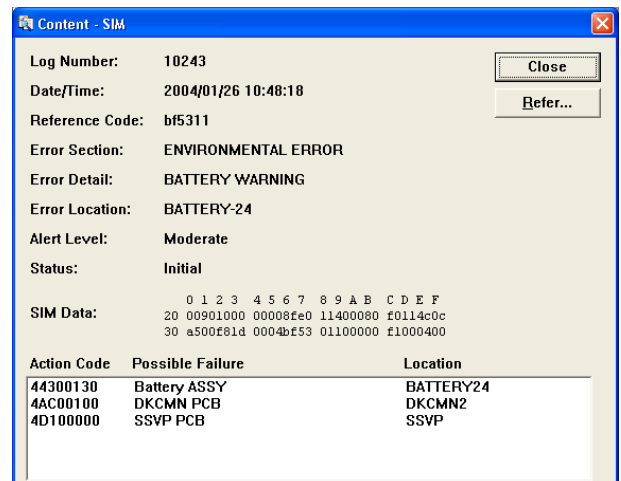

(6)

Close the relative log when it is referred to.

Select (CL) [Close] in the 'Content-SSB' dialog box.

Select (CL) [Close] in the 'List-SSB' dialog box.

Close the 'Log' dialog box and close the 'Information' window.

[2] SIM Log

Note: When SIM log exists after SVP is started up, the 'SIM Message' window is displayed.

(1)

Select (CL) [SIM] in the 'Log' dialog box.
Select (CL) [List...].

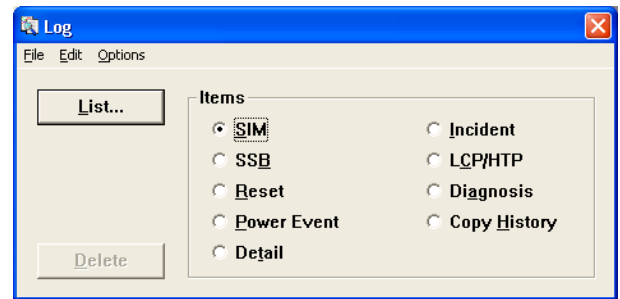

(2)

Select (CL) data to be indicated in the 'List-SIM' dialog box and select (CL) [Content...].

Note: To sort and list items, select (CL) [Sort...] first.
Then select (CL) the desired item in the [Items] and [Order] options in the 'Sort' dialog box, and select (CL) [OK].

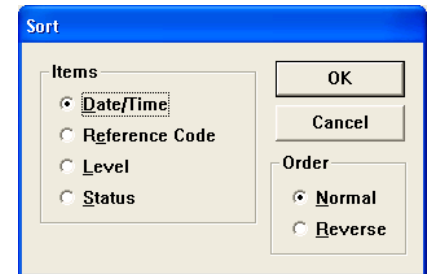
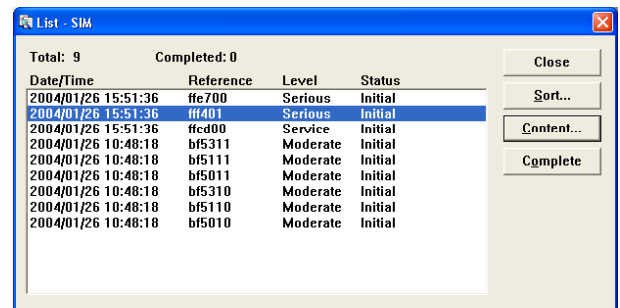

(3)

The 'Content-SIM' dialog box is displayed. Select (CL) [Refer...] in the 'Content-SIM' dialog box, when the relative log is displayed.

Note: In WCHK1 dump and ABEND dump received SIM (RC = 3080X0, 3081X0), the system error code is indicated in the format [YYYY] as in Reference Code 3080X0[YYYY].

Note: If Reference Code is 73XX00 or 1400X0, perform the recovery procedure for LAN error. (See [TRBL05-90](#).)

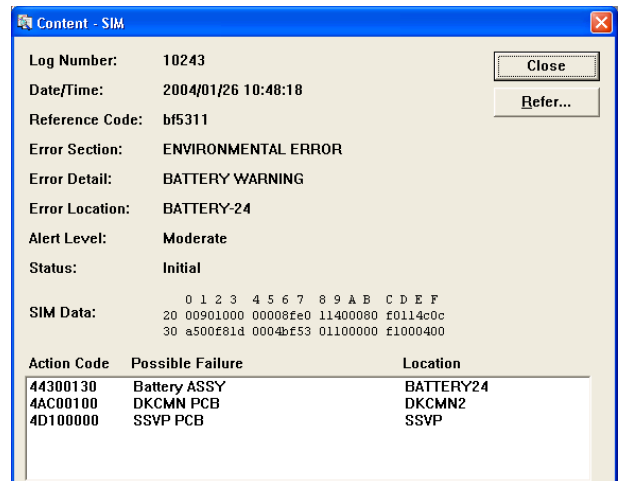

(4)

Select (CL) the log to be displayed in the 'Refer' dialog box.

([SSB] is selected in this example.)

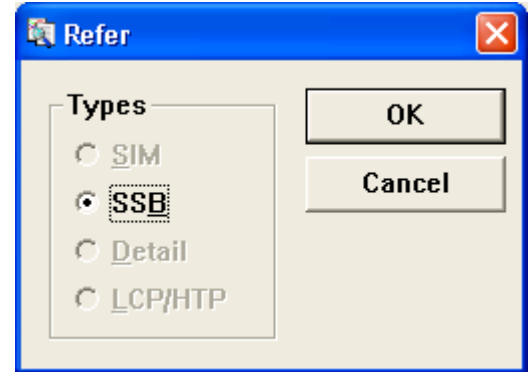

(5)

The selected log is displayed.

('Content-SSB' is displayed in this example.)

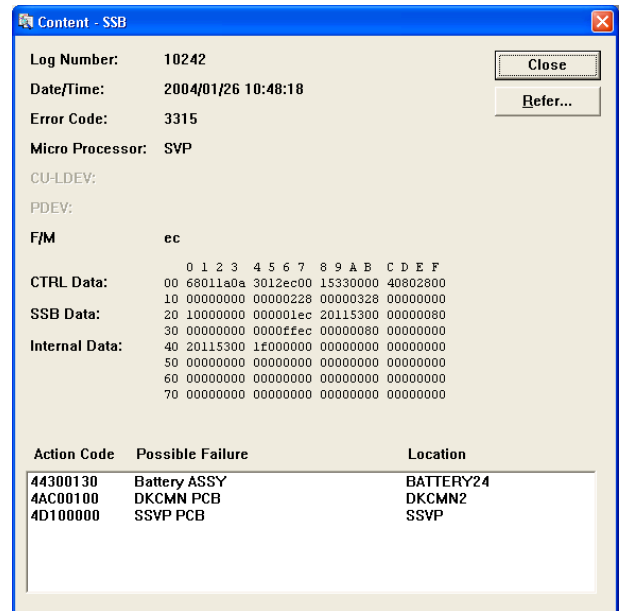

(6)

Close the relative log when it is referred to.

Select (CL) [Close] in the 'Content-SIM' dialog box.

Select (CL) [Close] in the 'List-SIM' dialog box.

Close the 'Log' dialog box and close the 'Information' window.

[3] Detail Log

(1)

Select (CL) [Detail] in the 'Log' dialog box.
Select (CL) [List...].

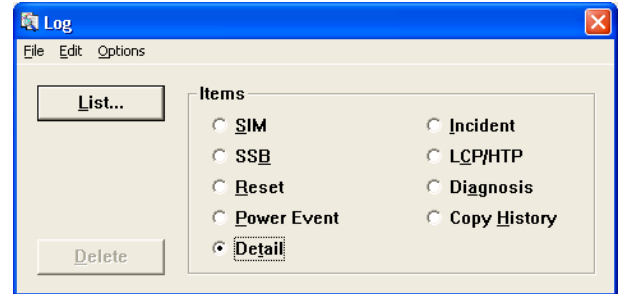

(2)

Select (CL) data to be indicated in the 'List-Detail' dialog box and select (CL) [Content...].

Note: To sort and list items, select (CL) [Sort...] first.

Then select (CL) the desired item in the [Items] and [Order] options in the 'Sort' dialog box, and select (CL) [OK].

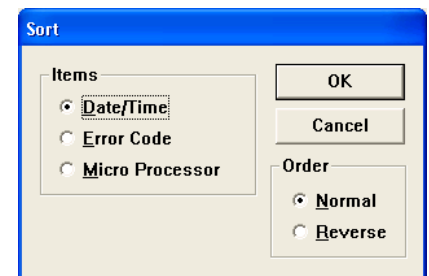
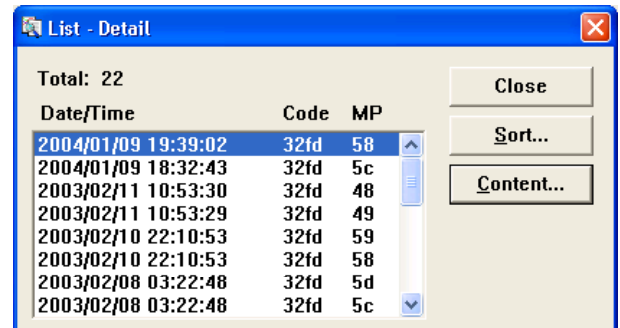

(3)

The 'Content-Detail' dialog box is displayed.

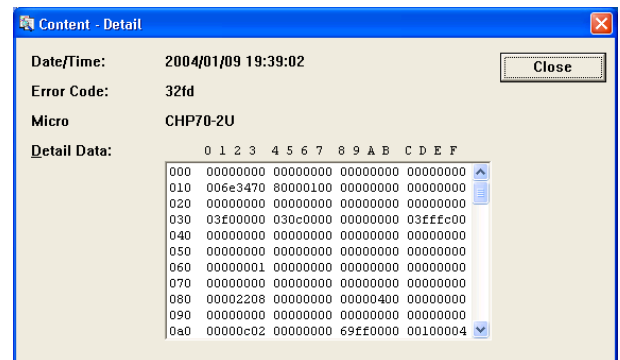

(4)

Select (CL) [Close] in the 'Content-Detail' dialog box.
Select (CL) [Close] in the 'List-Detail' dialog box.
Close the 'Log' dialog box and close the 'Information' window.

[4] Reset Log

(1)

Select (CL) [Reset] in the 'Log' dialog box.
Select (CL) [List...].

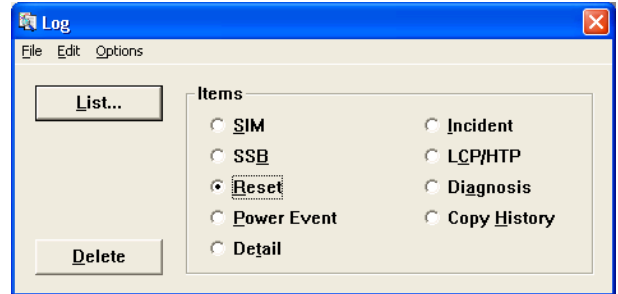

(2)

Select (CL) data to be indicated in the 'List-Reset' dialog box and select (CL) [Content...].

Note: To sort and list items, select (CL) [Sort...] first.

Then select (CL) the desired item in the [Items] and [Order] options in the 'Reset Log Sort' dialog box, and select (CL) [OK].

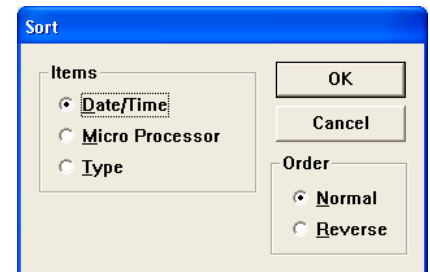
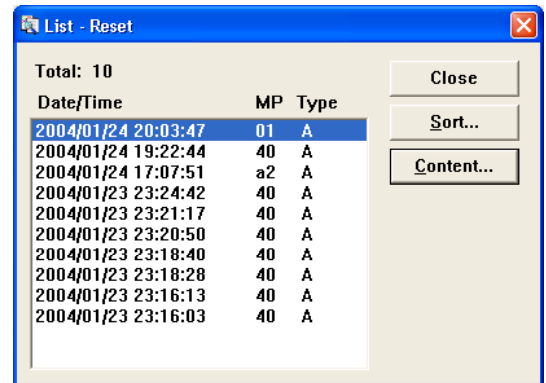

(3)

The 'Content-Reset' dialog box is displayed.

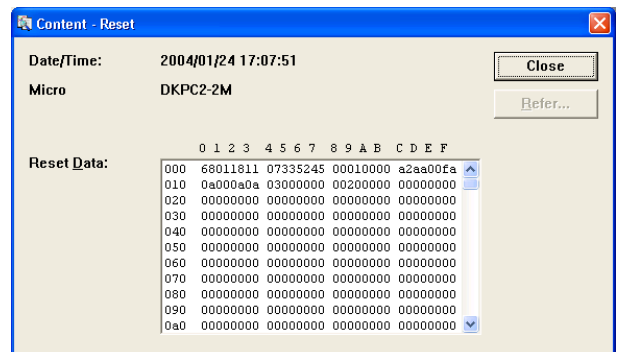

(4)

Select (CL) [Close] in the 'Content-Reset' dialog box.

Select (CL) [Close] in the 'List-Reset' dialog box.

Close the 'Log' dialog box and close the 'Information' window.

[5] Power Event Log

(1)

Select (CL) [Power Event] in the 'Log' dialog box.

Select (CL) [List...].

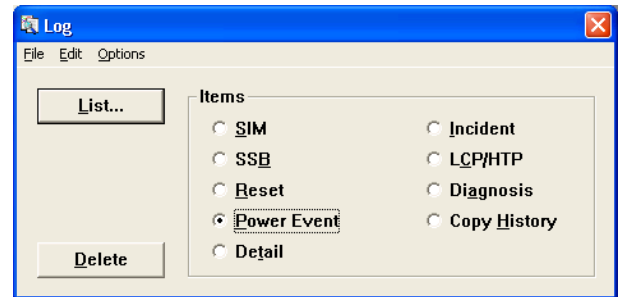

(2)

The 'List-Power Event' dialog box is displayed.

Note: To sort and list items, select (CL) [Sort...] first.

Then select (CL) the desired item in the [Items] and [Order] options in the 'Sort' dialog box, and select (CL) [OK].

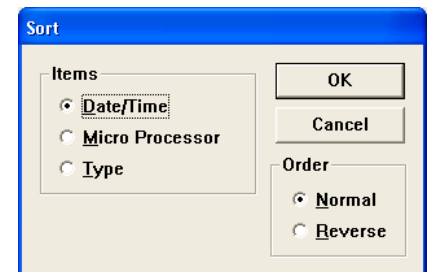
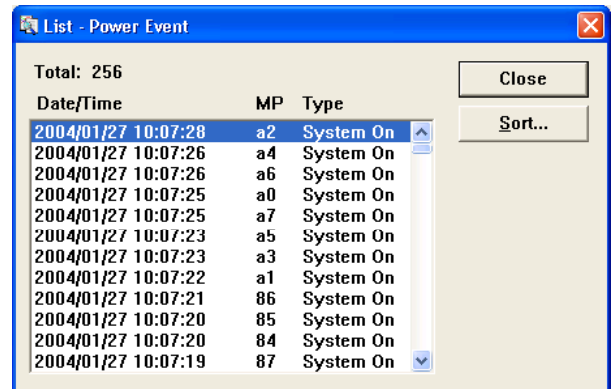

(3)

Select (CL) [Close] in the 'List-Power Event' dialog box.

Close the 'Log' dialog box and close the 'Information' window.

[6] Incident Log

(1)

Select (CL) [Incident] in the 'Log' dialog box.
Select (CL) [List...].

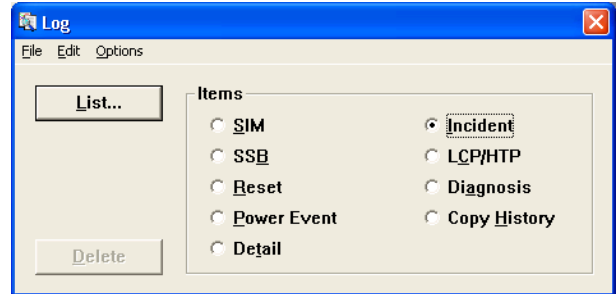

(2)

Select (CL) data to be indicated in the 'List-Incident' dialog box and select (CL) [Content...].

Note: To sort and list items, select (CL) [Sort...] first.

Then select (CL) the desired item in the [Items] and [Order] options in the 'Sort' dialog box, and select (CL) [OK].

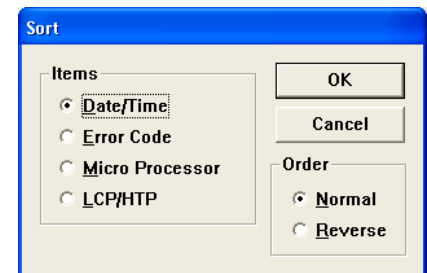
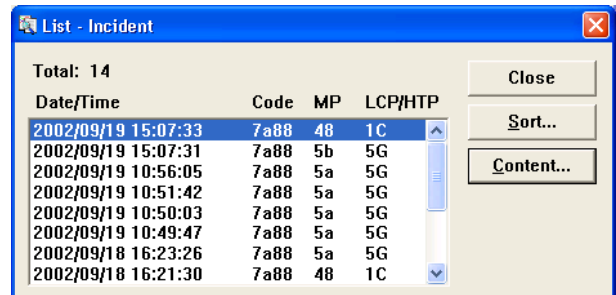

(3)

The 'Content-Incident' dialog box is displayed.

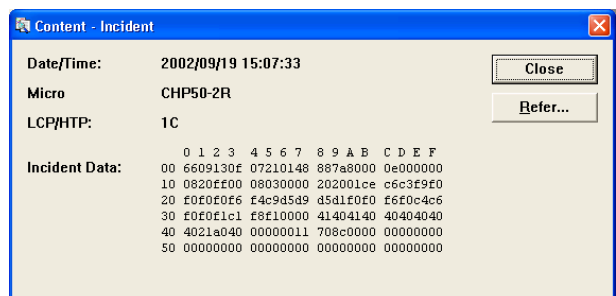

(4)

To display the relative log, select (CL) [Refer...] in the 'Content-Incident' dialog box.

Select (CL) the log type to be displayed in the 'Refer' dialog box and then select (CL) [OK].

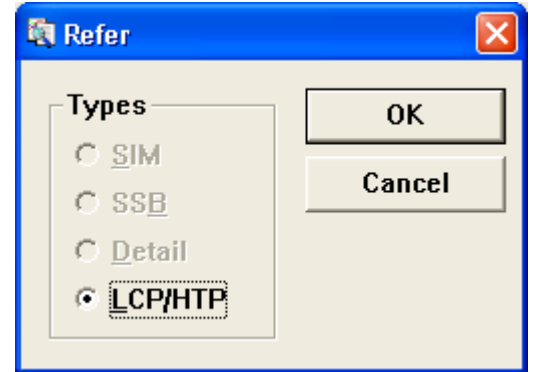

(5)

Select (CL) [Close] in the 'Content-Incident' dialog box.

Select (CL) [Close] in the 'List-Incident' dialog box.

Close the 'Log' dialog box and close the 'Information' window.

[7] LCP Log

(1)

Select (CL) [LCP] in the 'Log' dialog box.
Select (CL) [List...].

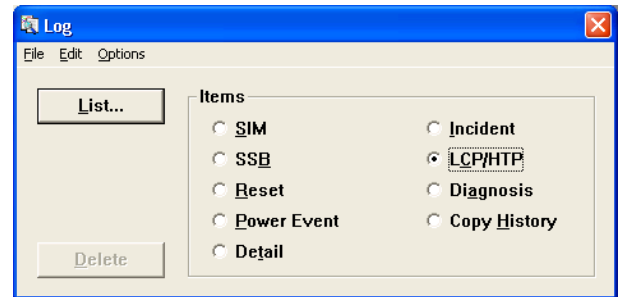

(2)

Select (CL) data to be indicated in the 'List-LCP/HTP' dialog box and select (CL) [Content...].

Note: To sort and list items, select (CL) [Sort...] first.

Then select (CL) the desired item in the [Items] and [Order] options in the 'Sort' dialog box, and select (CL) [OK].

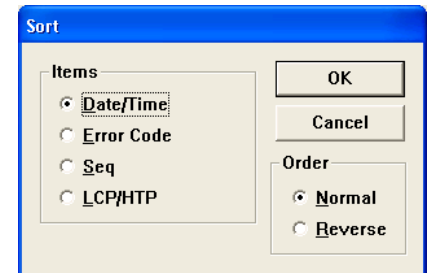
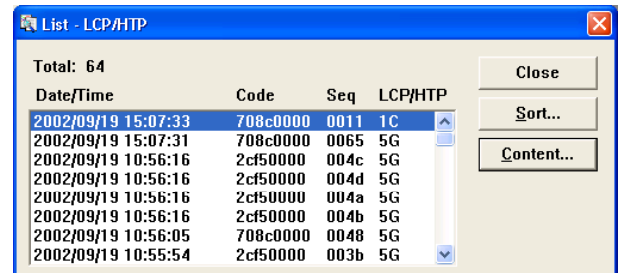

(3)

The 'Content-LCP/HTP' dialog box is displayed.

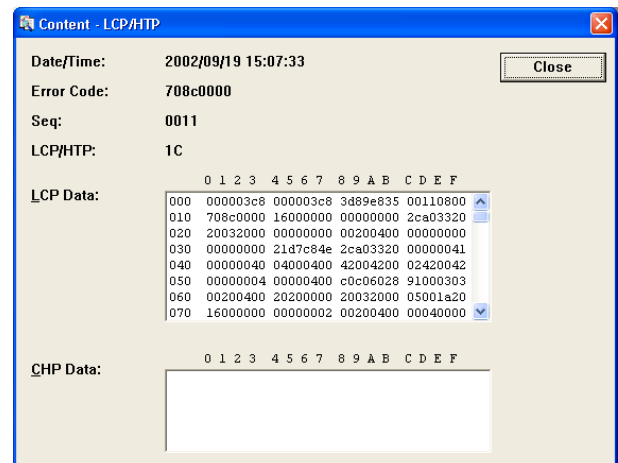

(4)

Select (CL) [Close] in the 'Content-LCP' dialog box.
Select (CL) [Close] in the 'List-LCP' dialog box.
Close the 'Log' dialog box and close the 'Information' window.

[8] Diagnosis Log

(1)

Select (CL) [Diagnosis] in the 'Log' dialog box.

Select (CL) [List...].

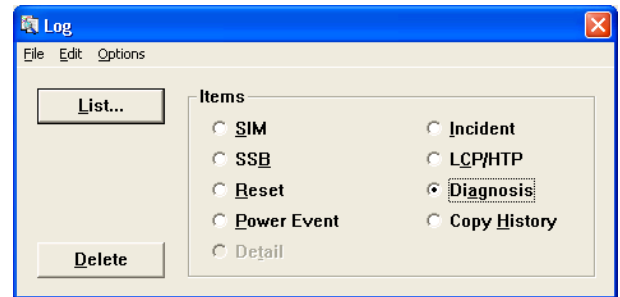

(2)

Select (CL) data to be indicated in the 'List-Diagnosis' dialog box and select (CL) [Content...].

Note: To sort and list items, select (CL) [Sort...] first.

Then select (CL) the desired item in the [Items] and [Order] options in the 'Sort' dialog box, and select (CL) [OK].

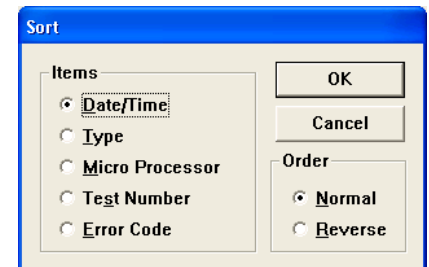
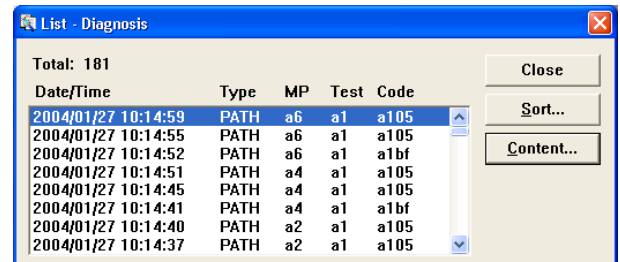

(3)

The 'Content-Diagnosis' dialog box is displayed.

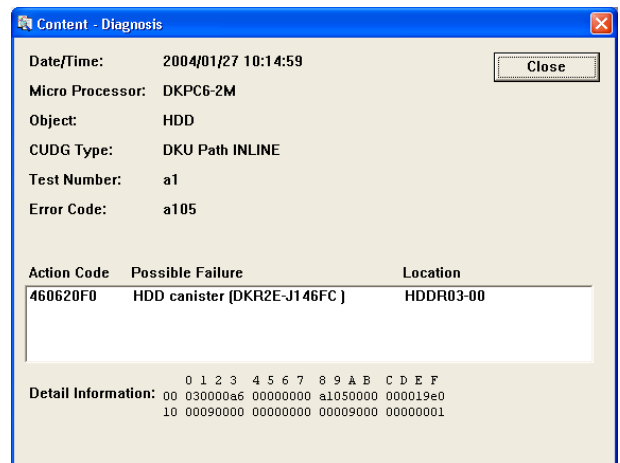

(4)

Select (CL) [Close] in the 'Content-Diagnosis' dialog box.

Select (CL) [Close] in the 'List-Diagnosis' dialog box.

Close the 'Log' dialog box and close the 'Information' window.

[9] Copy History Log

(1)

Select (CL) [Copy history] in the 'Log' dialog box.

Select (CL) [List...].

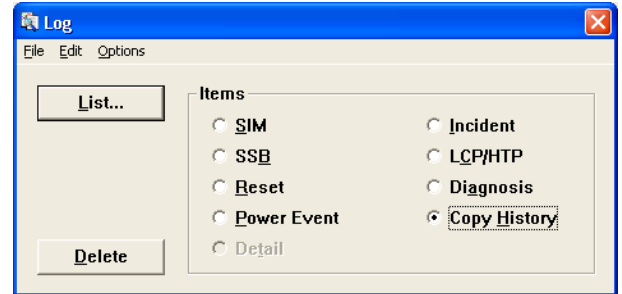

(2)

Select (CL) data to be indicated in the 'List-Copy history' dialog box and select (CL) [Content...].

Note: To sort and list items, select (CL) [Sort...] first.

Then select (CL) the desired item in the [Items] and [Order] options in the 'Sort' dialog box, and select (CL) [OK].

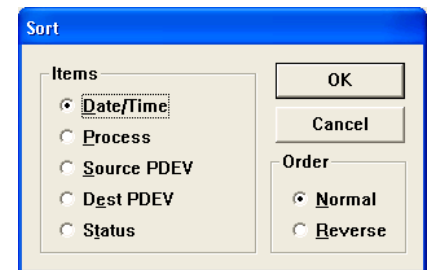
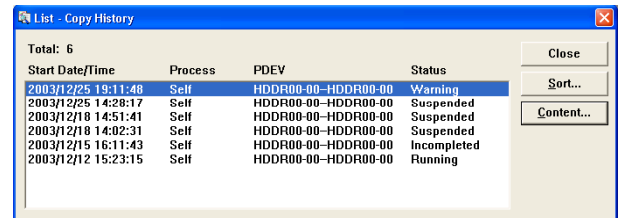

(3)

The 'Content-Copy History' dialog box is displayed.

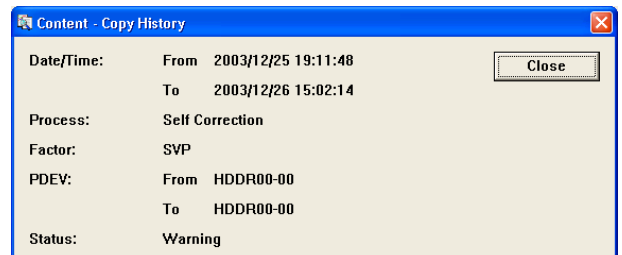

(4)

Select (CL) [Close] in the 'Content-Copy History' dialog box.

Select (CL) [Close] in the 'List-Copy History' dialog box.

Close the 'Log' dialog box and close the 'Information' window.

[10] MP# - Location correspondence table

Location			MP#	Location			MP#		
MIX	Cluster1	MIX-1A	CHP80-1A	20	MIX	Cluster2	MIX-2F	CHPC0-2F	60
			CHP81-1A	21			CHPC1-2F	61	
			CHP82-1A	22			CHPC2-2F	62	
			CHP83-1A	23			CHPC3-2F	63	
			DKP84-1A	84			DKPC4-2F	A4	
			DKP85-1A	85			DKPC5-2F	A5	
			DKP86-1A	86			DKPC6-2F	A6	
			DKP87-1A	87			DKPC7-2F	A7	

Location			MP#	Location			MP#		
CHA	Cluster1	CHA-1B	CHP90-1B	28	CHA	Cluster2	CHA-2E	CHPD0-2E	68
			CHP91-1B	29				CHPD1-2E	69
			CHP92-1B	2a				CHPD2-2E	6a
			CHP93-1B	2b				CHPD3-2E	6b
			CHP94-1B	2c				CHPD4-2E	6c
			CHP95-1B	2d				CHPD5-2E	6d
			CHP96-1B	2e				CHPD6-2E	6e
			CHP97-1B	2f				CHPD7-2E	6f

2.3 Log delete

- [1] SSB Log
- [2] SIM Log
- [3] Detail Log
- [4] Reset Log
- [5] Power Event Log
- [6] Incident Log
- [7] LCP/MCP Log
- [8] Diagnosis Log
- [9] Copy History Log

- (1)
Change the mode from [View Mode] to [Modify Mode].
Select (CL) [Information] in 'SVP' window.

- (2)
Select (CL) [Log...] in the 'Information' dialog box.

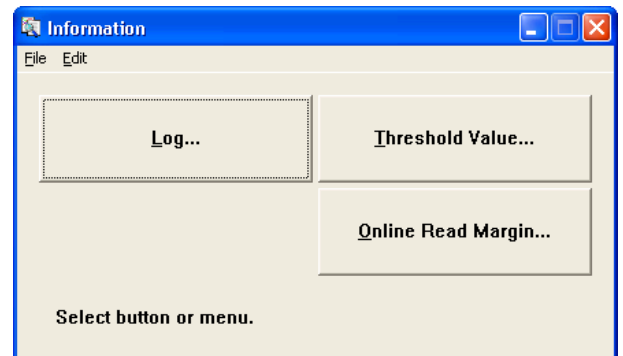

(3)

In the 'Log' dialog box, select (CL) a log to be deleted and select (CL) [Delete].
(For example, select [SIM].)

If the SIM log is deleted, SIM Log Complete ([SVP02-520](#)) should be executed beforehand.

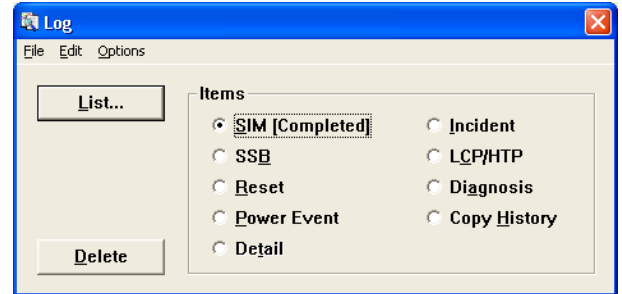

(4)

Select (CL) [Yes] in the 'Delete' dialog box.

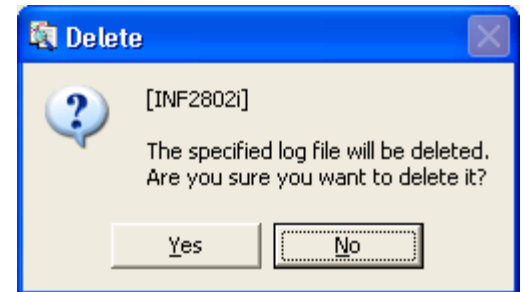

(5)

Close the 'Log' dialog box and close the 'Information' window.
Change the mode from [Modify Mode] to [View Mode].

2.4 Monitoring

2.4.1 Monitoring

<Description of the Select Monitor Item dialog>

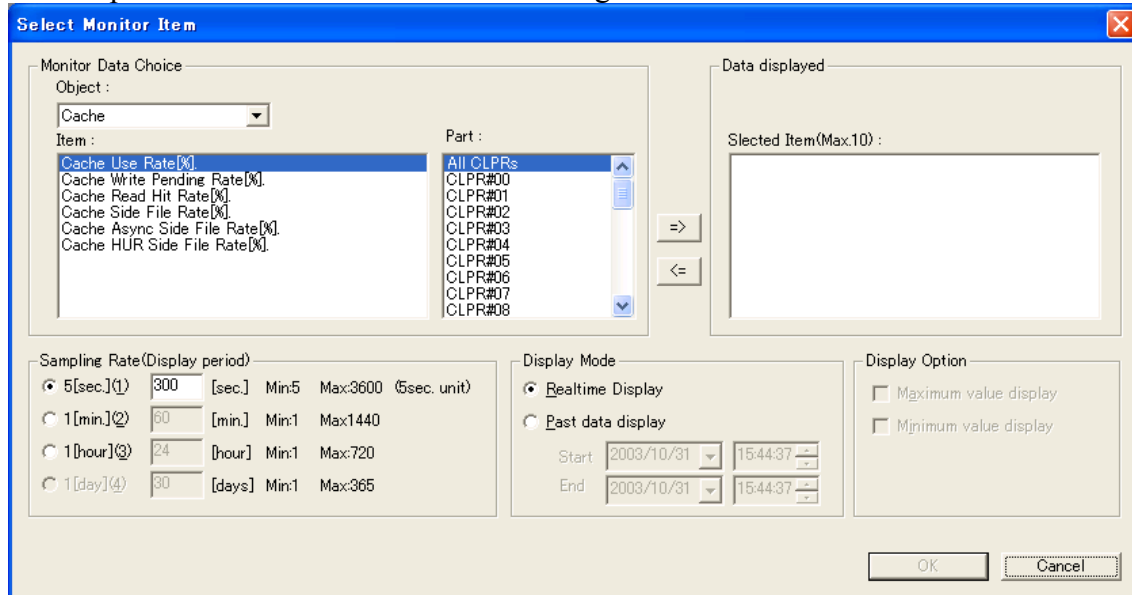

■ Monitor Data Choice

Object.....Select the desirable object. You can select “Cache”, “Processor”, “Port”, “LDEV” (Logical Device), or “Program Product”.

ItemItems corresponding to the selected object are displayed. You can select multiple items.

Part.....Parts corresponding to the selected object are displayed. You can select only one part.

■ Data Displayed

Selected Item.....The selected items are displayed. You can select up to 10 items in one panel.

[=>] button.....This button adds the displayed items. The selected data is added as data that is already selected as the displayed data.

[<=] button.....The selected items are removed from the list of displayed data.

■ Sampling Rate (Display Period)

Specify the time interval of updating data and the period that data is displayed.

You can specify the display period depending on the selected time interval.

	“Object”		Display period
	Select “Cache”, “Processor”, “Port”, or “LDEV”	Select “Program Product”	
5[sec.]	<input type="radio"/>	—	5 seconds to 3600 seconds (1 hour) (units of 5 seconds)
1[min.]	<input type="radio"/>	—	1 minute to 1440 minutes (24 hours)
1[hour]	<input type="radio"/>	<input type="radio"/>	1 hour to 720 hours (30 days)
1[day]	—	<input type="radio"/>	1 day to 365 days

*1: If you specify 1440 minutes, the data may not be displayed depending on the window size.

■ Display Mode

Select the display mode. There are two modes. “Real time Display” displays the current status.

“Past data display” displays the data in the past.

“Real time Display” The data will be updated in the specified time interval.

“Past data display” You can specify the range of the displayed data.

Specify the start time of the display in Start, and specify the end time of the display in End.

The period you have specified in Sampling Rate (Display Period) is ignored.

■ Display Option

You can select either to display or not to display the maximum/minimum values when you specify 1[min.] or 1[hour] in the Sampling Rate (Display Period). When you select this option, the maximum/minimum values are indicated by the dotted lines in the graph.

If you place a check mark in Maximum Value Display, the maximum value will be displayed. If you place a check mark in Minimum Value Display, the minimum value will be displayed.

- (1) Display the Monitor panel
Press the “Monitor” button in the SVP main panel to start the monitoring feature.

- (2) Display the Select Monitor Item panel
Select (CL) [Monitor]–[Open...] from the menu in the Monitor panel.

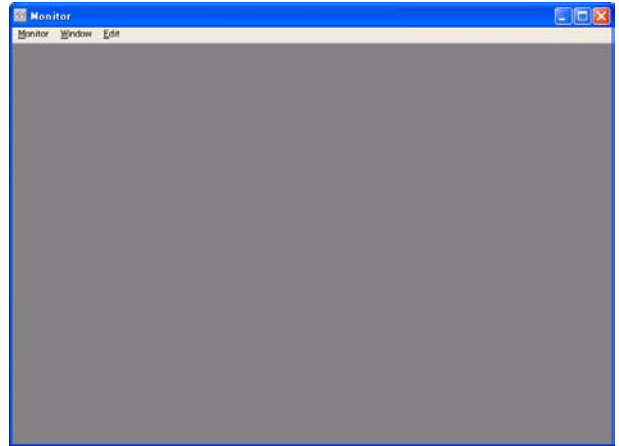

(3) Select data to be displayed

① Select the data you want to display

Select the category whose data you want to display in [Object] in Monitor Data Choice. Available data will appear in [Item]. Select the data you want to display (You can select multiple items). The parts relevant to the selected item will be displayed in [Part]. Choose the desirable part (You can select only one part). After selecting [Object], [Item], and [Part], select [=>] button to add the selected items to [Selected Item]. You can display data on up to 10 items. If there is no data in [Selected Item], the [OK] button will not be activated.

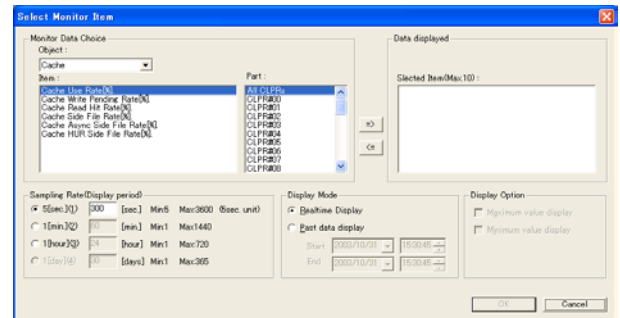

② Select the display interval and period

In [Sampling Rate (Display period)], specify the time interval of updating data and the period that data is displayed. Select 5[sec.], 1[min.], 1[hour], or 1[day] for the time interval of updating data. The interval depends on the data you have selected. You can change the period that the data is displayed.

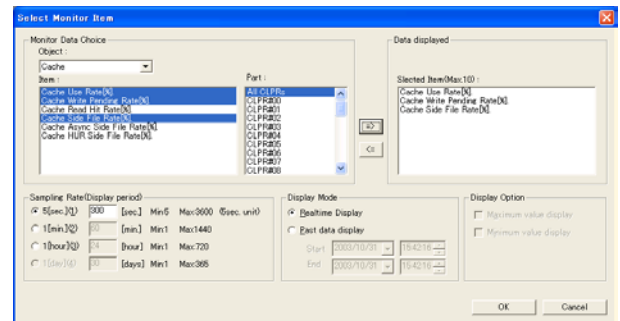

③ Specify the display mode

In [Display Mode], select either [Real Time Display] or [Past data display]. When you select [Past data display], specify Start and End of the display. If you select [Past data display], the period you have specified in ② will be ignored.

④ Specify the display option

When you select 1[min.] or 1[hour] in Display period, you can choose either to display or not to display the maximum/minimum value within the time interval.

After selecting all the necessary items, select (CL) [OK] to display the Statistics information panel.

(4) Description of the Statistics information (Real Time) panel

The specified data obtained during the specified display period is displayed in the panel, and it is updated in the specified time interval. The data on the left is older data, and that on the right is newer data.

The legends are displayed under the graph (Selected data and colors of lines in the graph). The solid lines indicate the data. The thin dotted lines of the same color as the solid lines indicate the maximum/minimum values of the data. The dot-dot-dash lines of the same color as the solid lines show the threshold (if set).

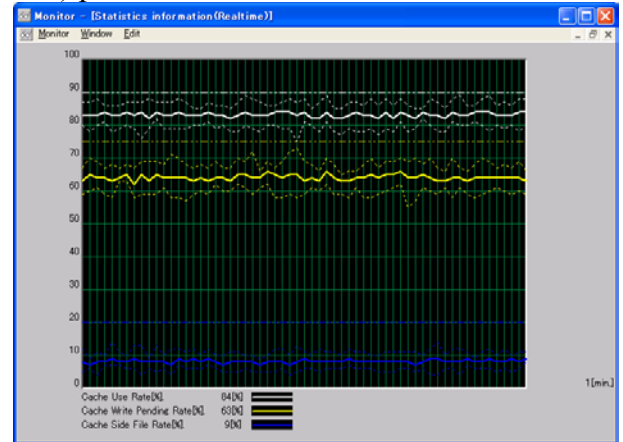

(5) Description of Statistics information (Past data) panel

The specified data obtained during the specified period is displayed in the panel. The data is displayed in the same way as Real Time, but the data is not updated. The dates and times of the oldest/latest available data in the specified period and the number of effective data are shown on the right of the legends.

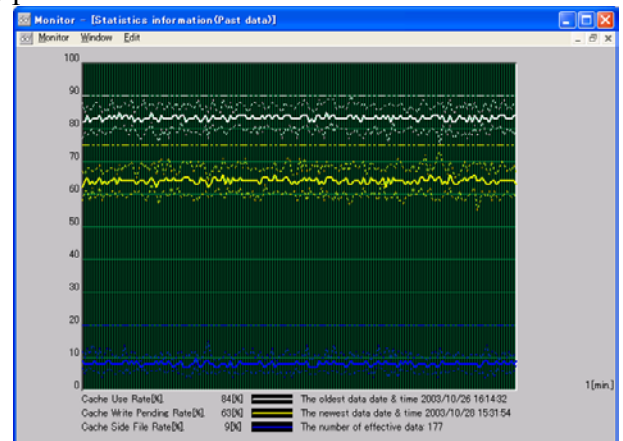

- (6) Align the displayed windows
 You can align the windows from the [Window] menu. To cascade the windows, select (CL) [Window]–[Cascade]. To tile them, select (CL) [Window]–[Tile]. To arrange the minimized windows, select (CL) [Window]–[Icon]. To close all windows, select (CL) [Window]–[All Close].

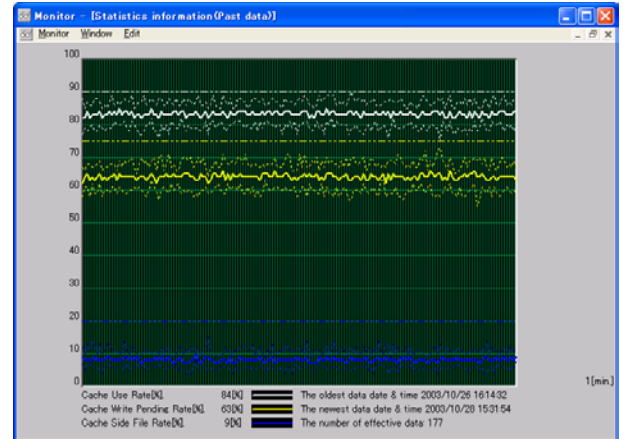

A list of available windows is displayed under the menu. You can select one window to display it in the foreground.

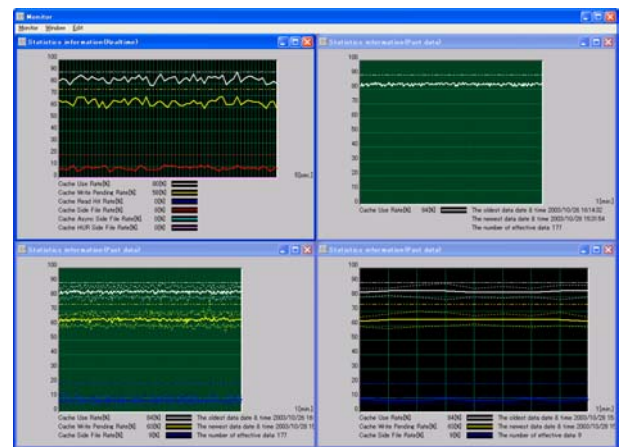

- (7) Exit the Monitor window
 Select (CL) [Monitor]–[Exit] from the menu.

2.4.2 Processing Information Monitoring Function

■ Overview

The threshold monitoring is performed using the monitoring function. A threshold and a term are set for each item, and if the threshold is exceeded continuously in the set term, SIM is reported remotely.

<Threshold setting dialog>

The screenshot shows a 'Threshold' dialog box with the following settings:

Section	Item	Threshold	Direction	Term
Cache	<input checked="" type="checkbox"/> Cache Use Rate	70 %	Over	30 sec.
	<input checked="" type="checkbox"/> Cache Write Pending Rate	70 %	Over	30 sec.
	<input checked="" type="checkbox"/> Cache Read Hit Rate	70 %	Under	30 sec.
	<input checked="" type="checkbox"/> Cache Side File Rate	70 %	Over	30 sec.
	<input checked="" type="checkbox"/> Cache Async Side File Rate	70 %	Over	30 sec.
	<input checked="" type="checkbox"/> Cache HUR JNL Cache Rate	70 %	Over	30 sec.
MP	<input checked="" type="checkbox"/> MP Processing Rate	70 %	Over	30 sec.
Port	<input checked="" type="checkbox"/> Loss Of Signal Count	10 Cnt./sec.	Over	30 sec.
	<input checked="" type="checkbox"/> Bad Received Character Count	10 Cnt./sec.	Over	30 sec.
	<input checked="" type="checkbox"/> Loss of Synchronization Count	10 Cnt./sec.	Over	30 sec.
	<input checked="" type="checkbox"/> Link Failure Count	10 Cnt./sec.	Over	30 sec.
	<input checked="" type="checkbox"/> Received EOFa Count	10 Cnt./sec.	Over	30 sec.
	<input checked="" type="checkbox"/> Discarded Frame Count	10 Cnt./sec.	Over	30 sec.
	<input checked="" type="checkbox"/> Bad CRC Count	10 Cnt./sec.	Over	30 sec.
	<input checked="" type="checkbox"/> Protocol Error Count	10 Cnt./sec.	Over	30 sec.
	<input checked="" type="checkbox"/> Invalid Frame Count	10 Cnt./sec.	Over	30 sec.
	<input checked="" type="checkbox"/> HTP Ex Multiple	10 Cnt./sec.	Over	30 sec.
	<input checked="" type="checkbox"/> HTP Interrupt Count	10 Cnt./sec.	Over	30 sec.
	<input checked="" type="checkbox"/> HTP Delay Time	10 Cnt./sec.	Over	30 sec.
	<input checked="" type="checkbox"/> HTP Read Data Transfer Rate	10 Cnt./sec.	Over	30 sec.
	<input checked="" type="checkbox"/> HTP Write Data Transfer Rate	10 Cnt./sec.	Over	30 sec.
<input checked="" type="checkbox"/> HTP Processing Rate	10 Cnt./sec.	Over	30 sec.	

Buttons: OK, Cancel

■ List of items to be able to set the threshold

#	Part	Item	Description	Remarks	
1	Cache	Cache Use Rate	Cache Use Rate		
2		Cache Write Pending Rate	Cache Write Pending Rate		
3		Cache Read Hit Rate	Cache Read Hit Rate		(*1)
4		Cache Side File Rate	Cache Side File Rate		
5		Cache Async Side File Rate	Cache Async Side File Rate		
6		Cache HUR JNL Cache Rate	Cache HUR JNL Cache Rate		
7	MP	MP Processing Rate	MP Processing Rate		
8	Port (Fibre)	Lost of Signal Count	Lost of Signal Count	Monitoring only with Fibre PCB	
9		Bad Received Character Count	Bad Received Character Count		
10		Loss of Synchronization Count	Loss of Synchronization Count		
11		Link Failure Count	Link Failure Count		
12		Received EOFa Count	Received EOFa Count		
13		Discarded Frame Count	Discarded Frame Count		
14		Bad CRC Count	Bad CRC Count		
15		Protocol Error Count	Protocol Error Count		
16		Invalid Frame Count	Invalid Frame Count		
17	Port (HTP)	HTP Ex Multiple	HTP Ex Multiple	Monitoring only with FICON PCB	
18		HTP Interrupt Count	HTP Interrupt Count		
19		HTP Delay Time	HTP Delay Time		
20		HTP Read Date Transfer Rate	HTP Read Date Transfer Rate		
21		HTP Write Date Transfer Rate	HTP Write Date Transfer Rate		
22		HTP Processing Rate	HTP Processing Rate		

- *1: • The threshold is bottom judgment.
 • When Read I/O of Host is less than 5 I/O between 5 seconds, SIM is restrained.

(1) Start of monitor window

Select (CL) the [Monitor] button on the SVP main window, and start the monitoring function.

(2) Starting threshold setting window

Select [Edit]–[Threshold] from the menu on the ‘Monitor’ window.

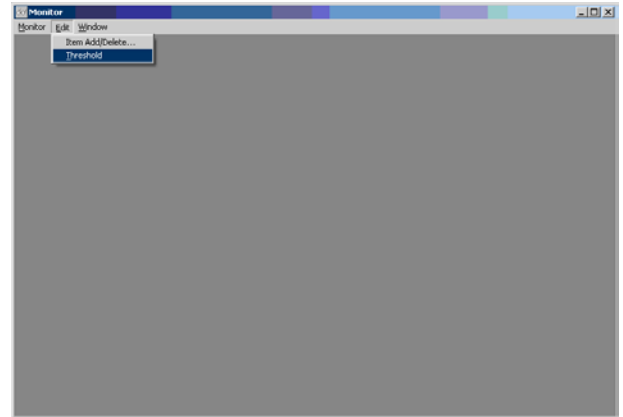

(3) Setting threshold

① Monitoring items

Select (CL) items that you want to perform the threshold monitoring in the ‘Threshold’ window.

② Threshold and term

Enter the threshold and the consecutive exceeding term of each selected item.

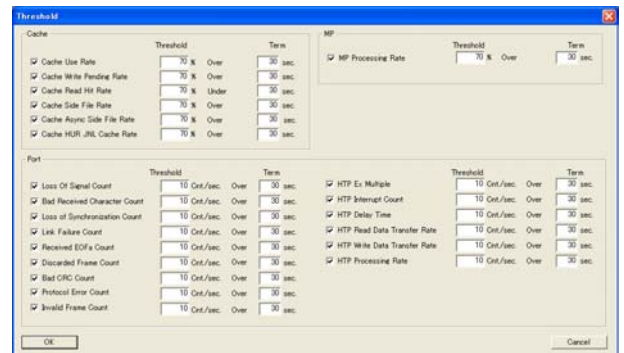

When the selection and the input of all items are completed, select (CL) [OK] and close the window.

(4) Exiting the monitor window

Select (CL) [Monitor]–[Exit] from the menu.

2.5 Online read margin (ORM)

[Overview]

The on-line read margin test (ORM) function is a read diagnostic function provided for preventive maintenance of disk drives. The diagnostic is automatically executed in each drive. The DKC reads the diagnostic result at specified intervals and reports it to the SVP.

The SVP calculates the error ratio to the threshold value which is set in advance, and indicates it in the OVER RATE Display (see [1], (2)). When the Rate in the display exceeds 100%, it means the error count is exceeding the threshold, the SVP creates the warning SIM. It is, however, not reported to the Host. The disk drive reporting the SIM should be exchanged with higher priority than other normal drives.

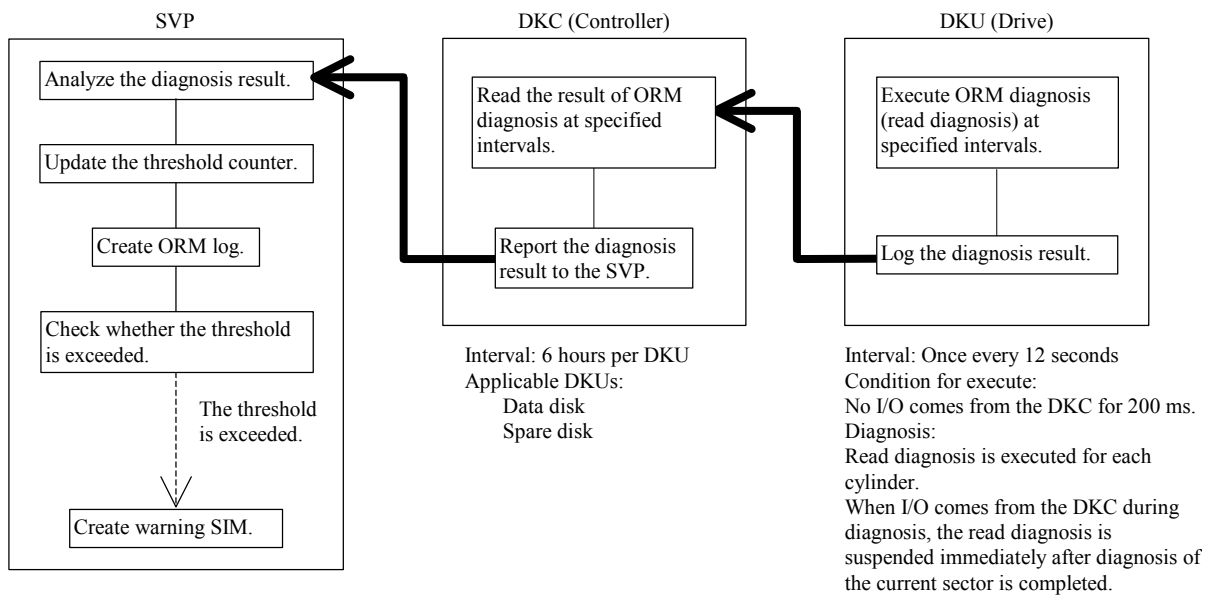

The SVP classifies the errors into six types in the Over Rate Counter Display. They are Unrecovered Read Error, Recovered Read Error, Unrecovered Seek error, Recovered Seek Error, Not Ready and Other Errors. Each has three types of counters indicated as Today, 7 days and Total. Refer to [1], (4) for the Over Rate Counter Display. In the Over Rate Counter Display, the error ratio which has the largest number among those classified types is displayed for each drive to represent each error.

The warning SIMs to be reported in the ORM are shown below.

Table 2.5-1 ORM SIM and Reference Code

No.	Error Type	Reference Code	Meaning
1	Unrecovered Read Error	503X (X = 0 ~ F)	Drive Media Error
2	Recovered Read Error		
3	Unrecovered Seek Error	502X (X = 0 ~ F)	Drive Unit Error
4	Recovered Seek Error		
5	Not Ready		
6	Other Errors		

[1] Displaying an error count, thresholds, and log -----	SVP02-290
[2] Resetting an error count -----	SVP02-340
[3] Displaying thresholds -----	SVP02-370
[4] Altering a threshold -----	SVP02-380
[5] Displaying the ORM running status -----	SVP02-400
[6] Resetting thresholds -----	SVP02-410

(1)

Check SVP Mode.

The Following operation needs SVP Mode to be 'Modify'. (See [SVP01-140](#))

[2] Resetting an error count

[4] Altering a threshold

[6] Resetting thresholds

(2)

Select (CL) the [Information] in the 'SVP' window.

(3)

Select (CL) [Online Read Margin...] in the 'Information' window.

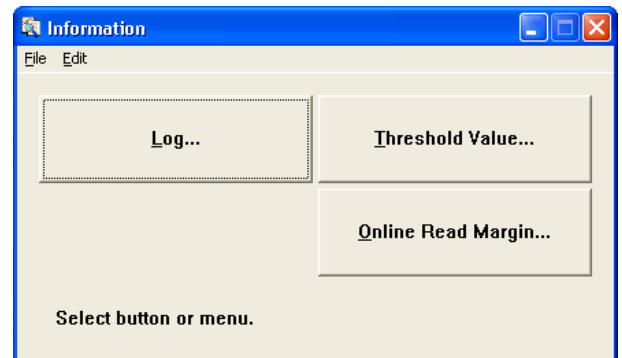

[1] Displaying an error count, thresholds, and log

(1)

Select (CL) [Display Over Rate...] in the 'Online Read margin' window.

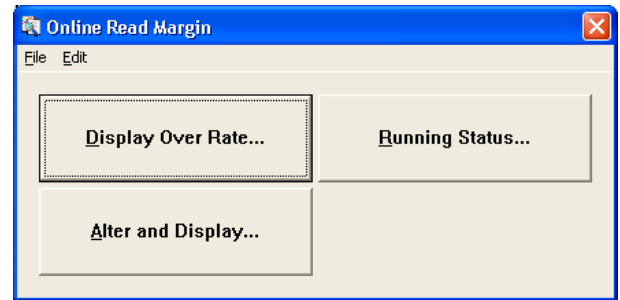

(2)

Enter a number from 0 to 100 at "Rate" in the 'ORM Over Rate HDD# Display' dialog box. Select (CL) [Display].

Then only the HDDs which have the rate of equal to or greater than the input number at "Rate" will appear in the display.

Rate : ratio of the number of errors for the threshold value.

Grp# : the parity group.

SPARE : spare HDD

RSRVD : reserved HDD with sparing

* : spare HDD in use.

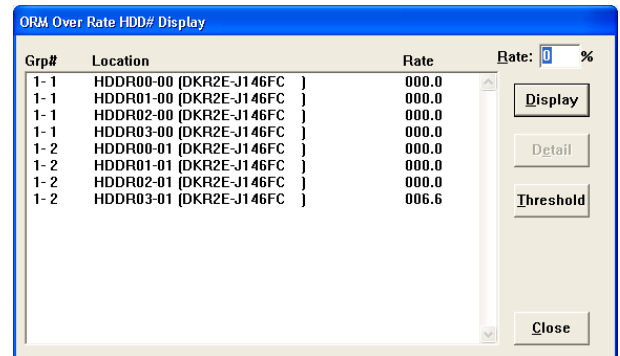

(3)

When more detailed information is needed for the particular drive, select (CL) the HDD from the HDD Location list box.
Select (CL) [Detail].

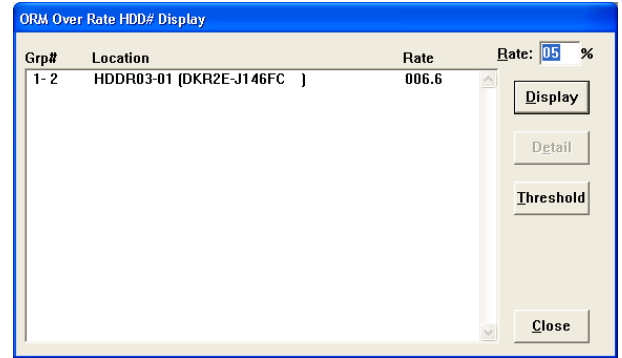

(4)

In the 'Over Rate Counter Display' dialog box, select (CL) the error for which detailed log is to be displayed from the "ID" list box.
Select (CL) [ORM Log].

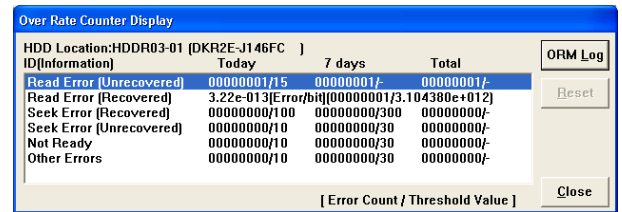

The errors detected in the ORM are classified into six types of error category. Each error has the following definition.

- Read Error (Unrecovered) : A disk media error was detected. After ten times retries, the error was judged that it might become a serious media error which could not be recovered with ECC or retries.
- Read Error (Recovered) : A disk media error was detected. After ten times retries, the error was judged that it was an intermittent read error and recoverable, and included in the error rate management for the preventive maintenance.
- Seek Error (Recovered) : A seek error was detected. After ten times retries, the error was judged to be recoverable.
- Seek Error (Unrecovered) : A seek error was detected. After ten times retries, the error was judged to be unrecoverable.
- Not Ready : Not Ready status of the drive was detected.
- Other Errors : Any error which does not belong to the above classification was detected.

They are also managed with different time periods. "Today" is for one day count and cleared at AM 0:00 every day. "7 days" is for the cumulative value in the latest 7 days. "Total" shows the total cumulative count.

In this Over Rate Counter Display, each error category indicates the Error Count and the Threshold value except for the Read Error [Recovered]. The "-" for the Threshold value means no threshold is set.

Only the Read Error [Recovered] has an error rate expression. It is not managed with error count per day, per 7 days or Total. The error rate of the Read Error [Recovered] is calculated in the following formula:

$$\text{Error rate} = \text{Number of error sectors} / \text{Number of ORM scan bits}$$

Note: Only the result from approximately the latest one volume scan in ORM is used for the calculation.

In the example display, "4.13e-011" means the error rate is " 4.13×10^{-11} ". This is corresponding to the raw error count and scan bits shown as "00000001/2.422270e+010", where the error count is one sector and the scan bits is 2.422270×10^{10} .

- (5) The nature of the error selected in step (4) is displayed.

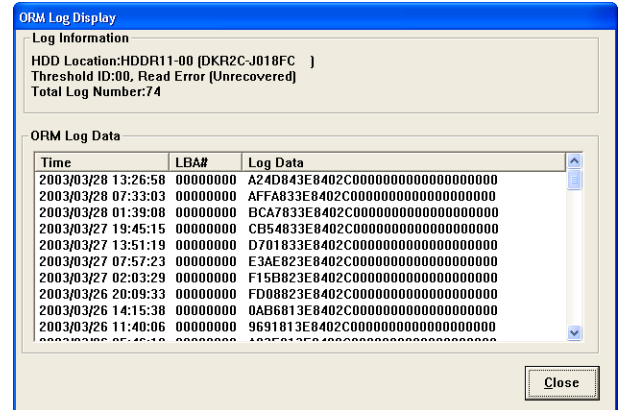

Byte	Bit	Name	Explanation
0-3		UCT	Time when the diagnostic result was reported from the DKC to the SVP.
4	7	Log Valid	When this bit is 1, it indicates that this log is valid.
	6	Address Valid	When this bit is 1, it indicates that the address information in bytes 8 to F is valid.
	5-4	(Reserved)	Reserved
	3-0	Sense Key	Error sense key in the SCSI drive report. (*1)
5		Additional Sense Code	Additional sense code in the SCSI drive report. (*1)
6		Sense Code Qualifier	Additional sense code qualifier in the SCSI drive report. (*1)
7		Seek Error Count	Number of seek errors within 10 seek error retries.
8-9		CC	Address of the cylinder where the error occurred.
A		H	Address of the head where the error occurred.
B		S	Address of the sector where the error occurred.
C-F		LBA	LBA where the error occurred.

*1: Definition and contents of the error codes are same as those of the SSB for ordinary DKU errors.

-
- (6) Select (CL) [Close] in the 'ORM Log Display' dialog box.
-
- (7) Select (CL) [Close] in the 'Over Rate Counter Display' dialog box.
-
- (8) Select (CL) [Close] in the 'ORM Over Rate HDD# Display' dialog box.
-
- (9) Close the 'Information' window.

[2] Resetting an error count

(1)

Select (CL) [Display Over Rate...] in the 'Online Read Margin' window.

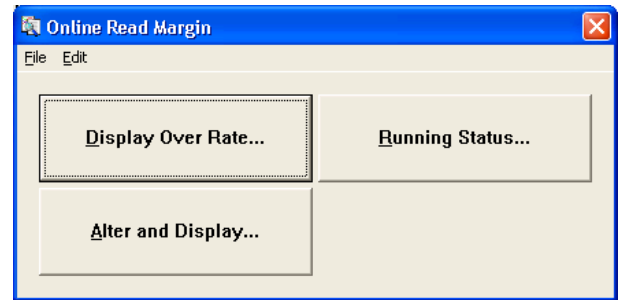

(2)

Enter a number from 0 to 100 at 'Rate' in the 'ORM Over Rate HDD# Display' dialog box. Select (CL) [Display].

Then only the HDDs which have the rate of equal to or greater than the input number at "Rate" will appear in the display.

Rate : ratio of the number of errors for the threshold value.

Grp# : the parity group.

SPARE : spare HDD

RSRVD : reserved HDD with sparing

* : spare HDD in use.

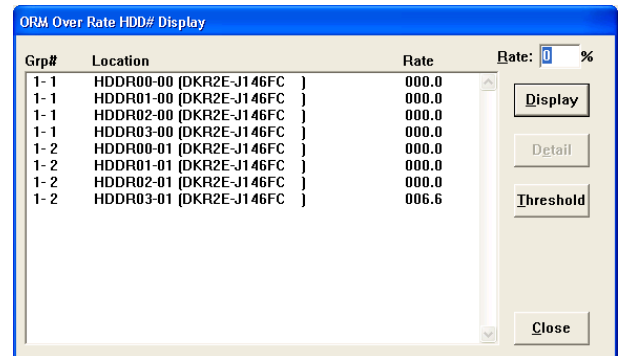

(3)

In the 'ORM Over Rate HDD# Display' dialog box, select (CL) the HDD for which an error count and thresholds are to be reset from the HDD Location list box. Select (CL) [Detail].

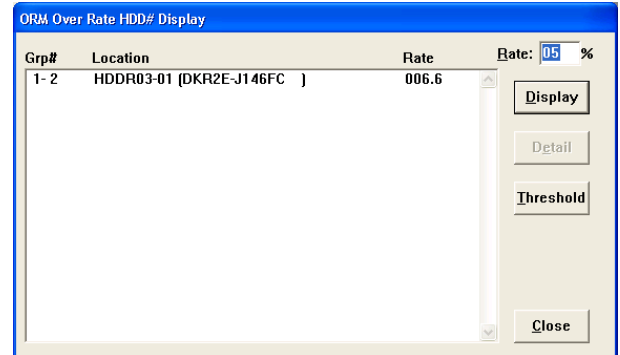

(4)

In the 'Over Rate Counter Display' dialog box, select (CL) [Reset] button.

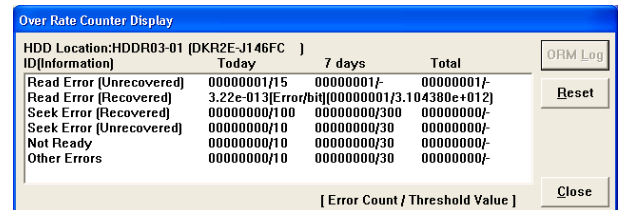

- (5) Select (CL) [OK] in the 'Threshold Counter Reset' dialog box.



- (6) Select (CL) [Close] in the 'Over Rate Counter Display' dialog box.

- (7) Select (CL) [Close] in the 'ORM Over Rate HDD# Display' dialog box.

- (8) Close the 'Information' window.

[3] Displaying thresholds

(1)

Select (CL) [Alter and Display...] in the 'Online Read Margin' window.

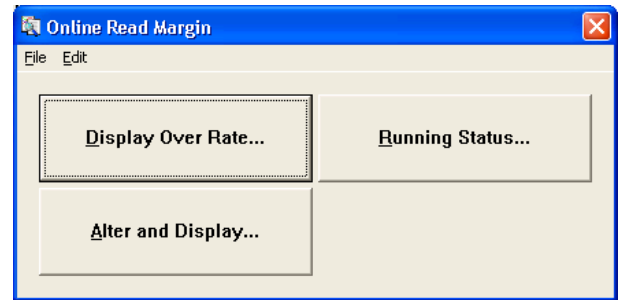

(2)

In the 'ORM Threshold Alter/Display' dialog box, select (CL) an HDD from the "HDD#" list box and select (CL) [Display]. In order to display threshold of another interval, select (CL) the interval from the "Type" list box.

Note: Multiple HDDs can be selected (CL) from the "HDD#" list box while the control key is being held down. In this case, each "Threshold" field in the "Threshold Value" list box shows the threshold for the HDD that is highlighted in the "HDD#" list box.

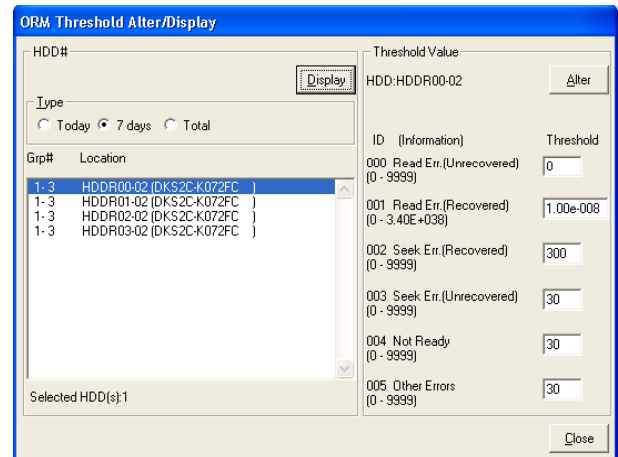

(Multiple Selected)

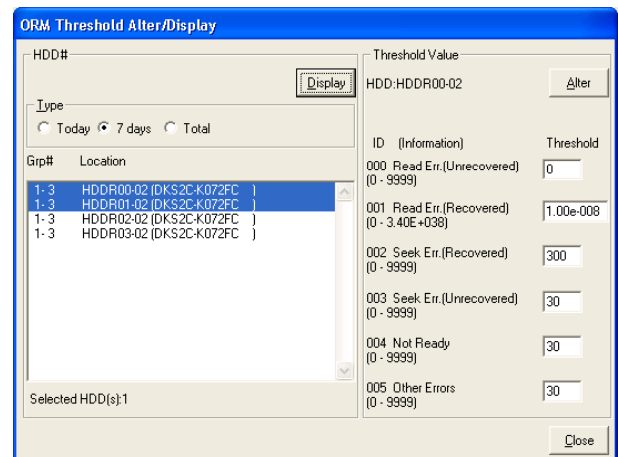

Grp# : the parity group.

SPARE : spare HDD

RSRVD : reserved HDD with sparing

* : spare HDD in use.

(3)

Select (CL) [Close] in the 'ORM Threshold Alter/Display' dialog box and close the 'Information' window.

[4] Altering a threshold

(1)

Select (CL) [Alter and Display...] in the 'Online Read Margin' window.

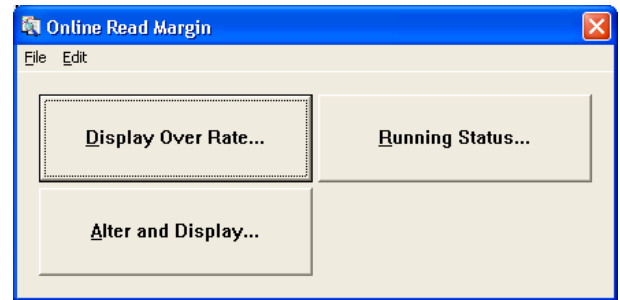

(2)

In the 'ORM Threshold Alter/Display' dialog box, select (CL) an HDD from the "HDD#" list box and select (CL) [Display]. In order to display threshold of another interval, select (CL) the interval from the "Type" list box.

Grp# : the parity group.

SPARE : spare HDD

RSRVD : reserved HDD with sparing

* : spare HDD in use.

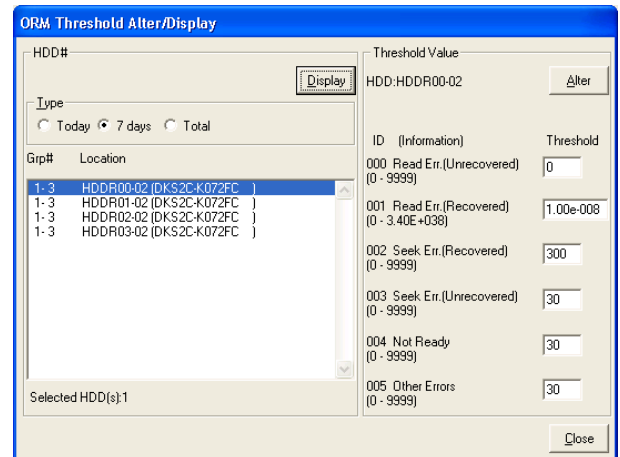

(3)

In the 'ORM Threshold Alter/Display' dialog box, alter the threshold in the "Threshold" field in the "Threshold Value" list box. Then select (CL) [Alter].

Note: When multiple HDDs are selected in the "HDD#" list box, the thresholds of all HDDs are altered to the same value.

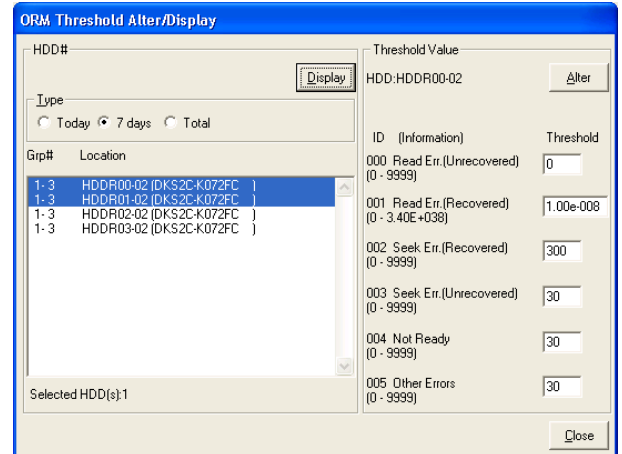

(4)

Select (CL) [OK] in the 'Alter Threshold Value' dialog box.

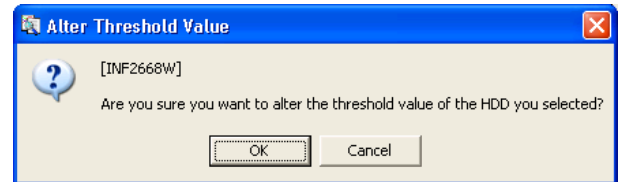

(5)

Select (CL) [Close] in the 'ORM Threshold Alter/Display' dialog box and close the 'Information' window.

[5] Displaying the ORM running status

(1)

Select (CL) [Running Status...].

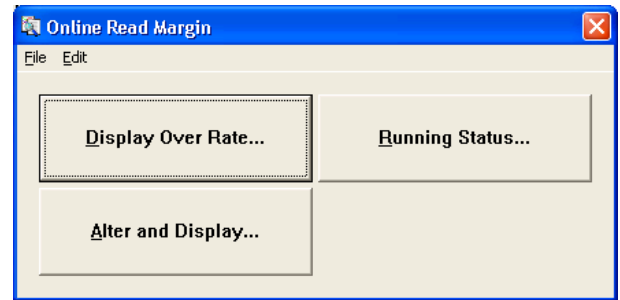

(2)

In the 'ORM Running Status Display' dialog box, the ORM running status is displayed as the number of sectors.

Note: The "HDD#" list box shows the location numbers of HDDs. "Scan" shows the number of scanned sectors. "Total" shows the total number of sectors in the drive. "Times" shows the number of times the entire drive was scanned.

Grp#	Location	Scan	Total	Times
1-1	HDDR00-00 [DKR2E-J146FC]	7.436472e+008	2.807902e+008	[2.6]
1-1	HDDR01-00 [DKR2E-J146FC]	7.423130e+008	2.807902e+008	[2.6]
1-1	HDDR02-00 [DKR2E-J146FC]	7.455069e+008	2.807902e+008	[2.7]
1-1	HDDR03-00 [DKR2E-J146FC]	7.459174e+008	2.807902e+008	[2.7]
1-2	HDDR00-01 [DKR2E-J146FC]	7.457782e+008	2.807902e+008	[2.7]
1-2	HDDR01-01 [DKR2E-J146FC]	7.482194e+008	2.807902e+008	[2.7]
1-2	HDDR02-01 [DKR2E-J146FC]	7.455324e+008	2.807902e+008	[2.7]
1-2	HDDR03-01 [DKR2E-J146FC]	7.462451e+008	2.807902e+008	[2.7]

Grp# : shows the parity group.
 SPARE : spare HDD
 RSRVD : reserved HDD with sparing
 * : spare HDD in use.

(3)

Select (CL) [Close] in the 'ORM Running Status Display' dialog box and close the 'Information' window.

[6] Resetting thresholds

(1)

Select (CL) [File]-[Exit] in the 'Information' window.

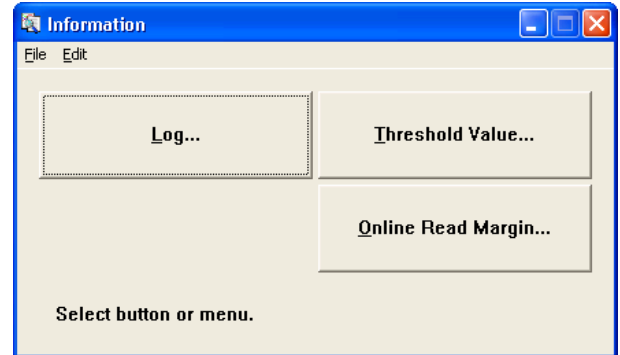

(2)

Select (CL) [Install] in the 'SVP'.

(3)

Select (CL) [Initialize ORM Value] in the 'Install' window.

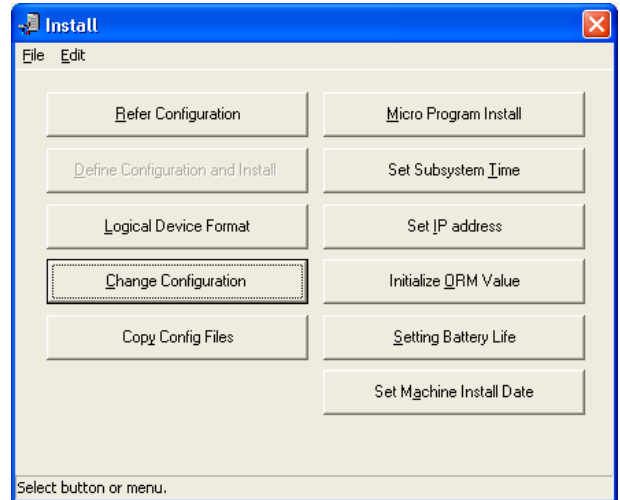

- (4) Select (CL) [Yes] in the 'Initialize ORM Value' dialog box.

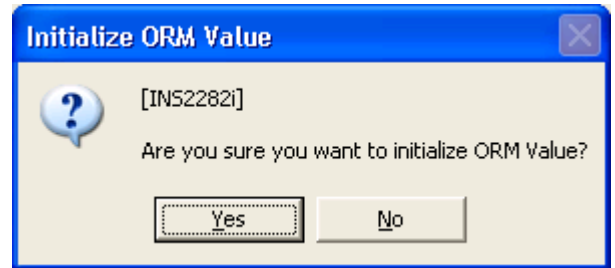

- (5) Select (CL) [OK] in the 'Initialize ORM Value' dialog box.



2.6 SIM Reporting Specification

- [1] DKC SIM
- [2] Cache SIM
- [3] Media SIM
- [4] Device SIM

(1)

Change the mode from [View Mode] to [Modify Mode].
Select (CL) [Information].

(2)

Select (CL) [Log...] in the 'Information window'.

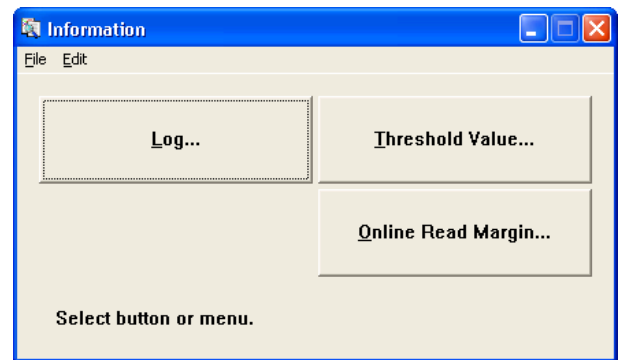

(3)

Select (DR) [SIM Report...] from the [Options] menu in the 'Log' dialog box.

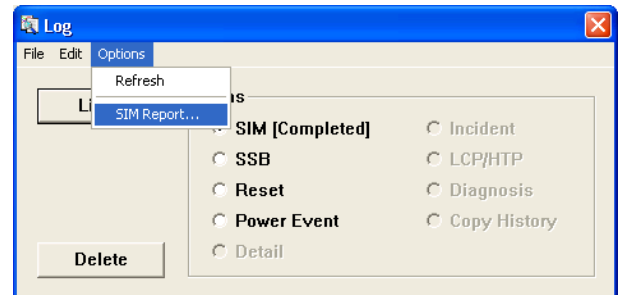

- (4) Select (CL) SIM report type from the 'Type' list box.

Type : DKC SIM
Cache SIM
Media SIM
Device SIM

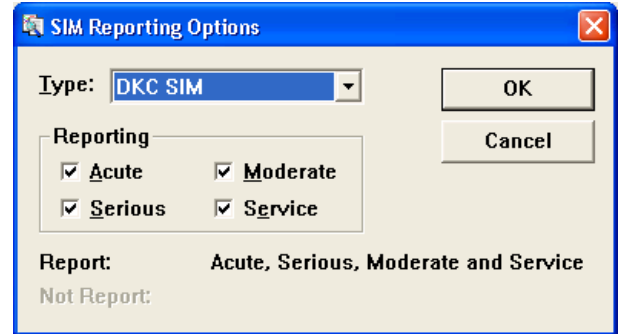

Select (CL) the level to be reported in the 'SIM Reporting Option' dialog box, and also select (CL) [OK].

SIM message report level are arranged as follows in order of the higher level.

Acute > Serious > Moderate > Service

Selecting level, means all higher levels are to be reported.

-
- (5) Close the 'Log' dialog box and also close the 'Information' window.
Change the mode from [Modify Mode] to [View Mode].

2.7 Management of drive threshold values

[1] Displaying threshold values -----	SVP02-460
[2] Altering threshold value -----	SVP02-470
[3] Displaying an error count -----	SVP02-490
[4] Resetting an error count -----	SVP02-500

(1)

Check SVP Mode.

The Following operation needs SVP Mode to be 'Modify'. (See [SVP01-140](#))

[2] Altering threshold value

[4] Resetting an error count

(2)

Select (CL) the [Information] window in the 'SVP' window.

(3)

Select (CL) [Threshold Value...] in the 'Information' window.

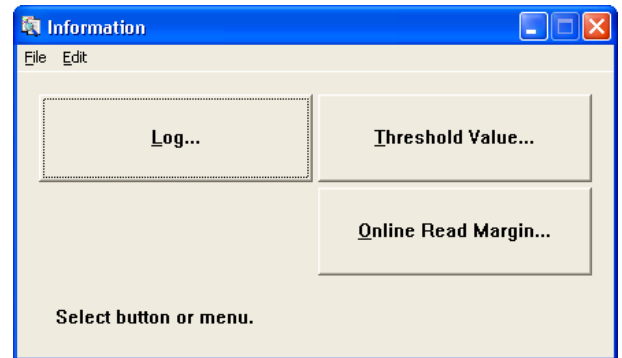

[1] Displaying threshold values

(1)

Select (CL) [Alter and Display...] in the 'Threshold Value' window.

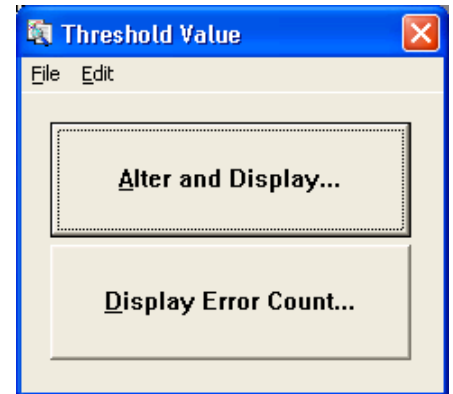

(2)

Select (CL) an HDD location from the "HDD#" list box in the 'Threshold Alter/Display' dialog box and select (CL) [Display].

In order to display threshold of another interval, select (CL) the interval from the "Type" list box.

Note: Multiple HDD locations can be selected (CL) from the "HDD#" list box while the control key being held down. The threshold value in the "Threshold Value" list box shows the threshold value for the HDD location that is highlighted in the "HDD#" list box.

Recovered: Threshold of errors recoverable by retry.

Unrecd: Threshold of errors not recoverable by retry.

Grp# : the parity group.

SPARE : spare HDD

RSRVD : reserved HDD with sparing

* : spare HDD in use.

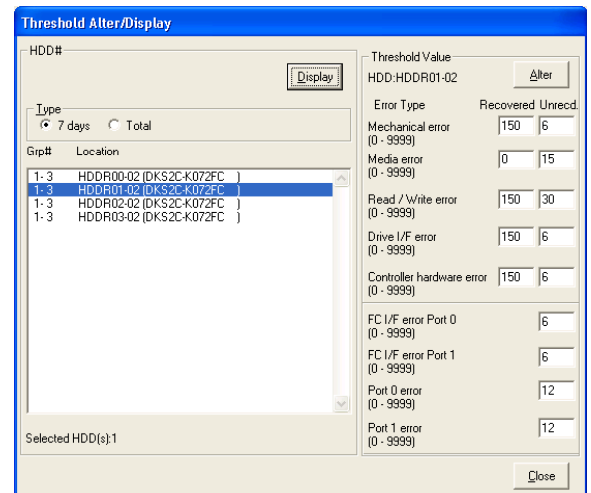

(Multiple Selected)

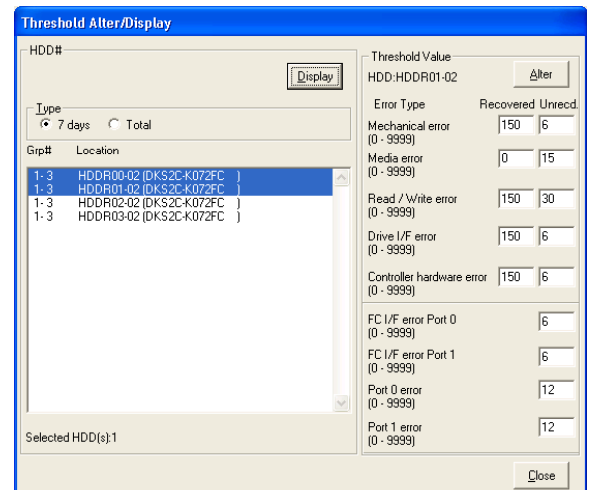

(3)

Select (CL) [Close] in the 'Threshold Alter/Display' dialog box and close the 'Information' window.

[2] Altering threshold value

(1)

Select (CL) [Alter and Display...] in the 'Threshold Value' window.

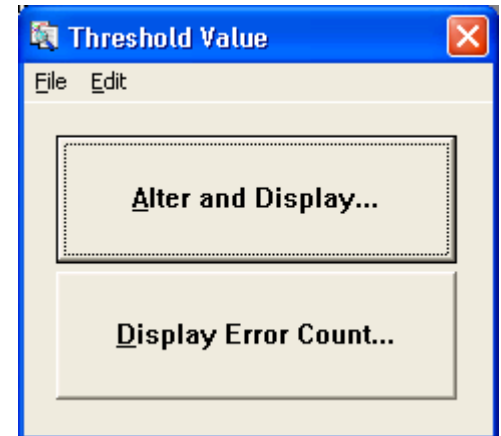

(2)

Select (CL) an HDD location from the "HDD#" list box in the 'Threshold Alter/Display' dialog box and select (CL) [Display]. In order to display threshold of another interval, select (CL) the interval from the "Type" list box.

Grp# : the parity group.

SPARE : spare HDD

RSRVD : reserved HDD with sparing

* : spare HDD in use.

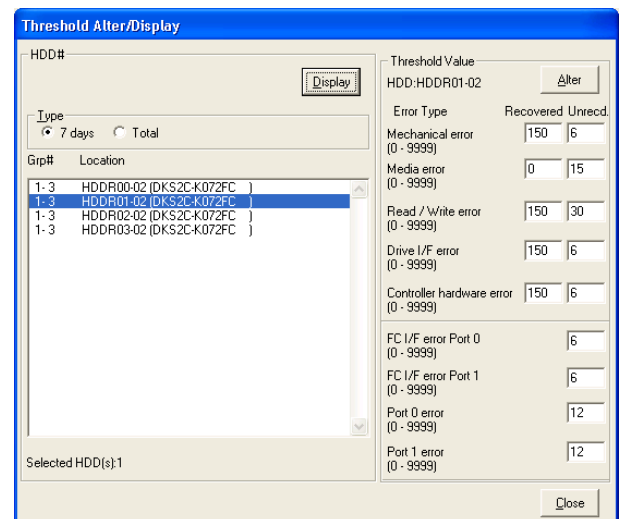

(3)

Alter a threshold value in the “Threshold Value” list box in the ‘Threshold Alter/Display’ dialog box.
Then select (CL) [Alter].

Note: When multiple HDD locations are selected (CL) from the “HDD#” list box with the control key being hold down, the thresholds for all the selected HDDs are modified to the same value.

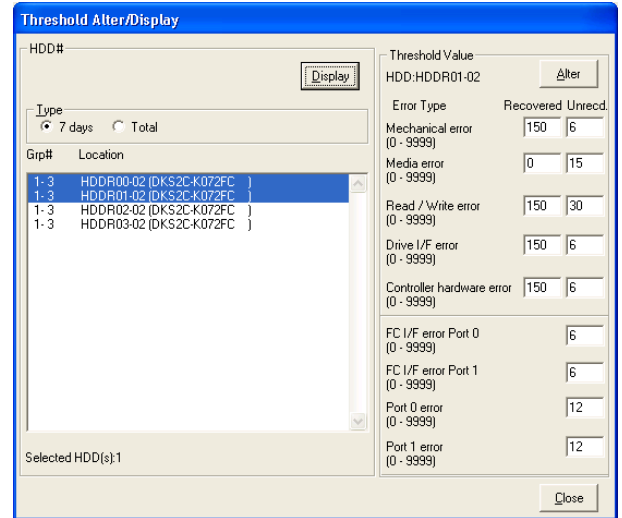

(4)

Select (CL) [OK] in the ‘Alter Threshold Value’ dialog box.

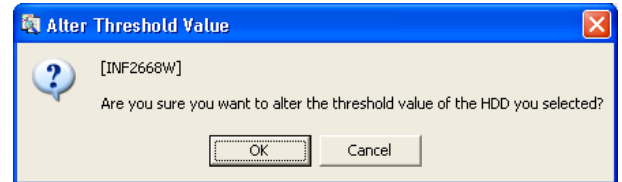

(5)

Select (CL) [Close] in the ‘Threshold Alter/Display’ dialog box and close the ‘Information’ window.

[3] Displaying an error count

(1)

Select (CL) [Display Error Count...] in the 'Threshold Value' Window.

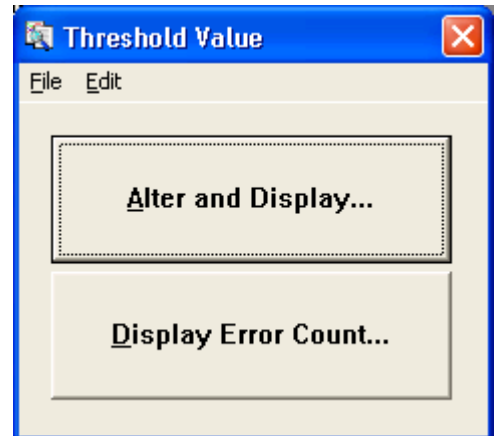

(2)

Select (CL) an HDD location from the HDD Location drop-down list in the 'Threshold Counter Display' dialog box to display the error count for the HDD.

Grp# : the parity group.

SPARE : spare HDD

RSRVD : reserved HDD with sparing

* : spare HDD in use.

ID(Information)	Today	7 days	Total
Mechanical error (recovered)	0000000[5,50],[2000,500]	0000000[150]	-
Media error (recovered)	00000000-	-	-
Read / Write error (recovered)	0000000[2,50],[000,200]	0000000[150]	-
Drive I/F error (recovered)	0000000[5,50],[2000,500]	0000000[150]	-
Controller hardware error (recovered)	0000000[5,50],[2000,500]	0000000[150]	-
Mechanical error (unrecovered)	0000000[1,2],[40,10]	0000000[6]	-
Media error (unrecovered)	0000000[1,5],[200,50]	0000000[15]	0000000[1000]
Read / Write error (unrecovered)	0000000[1,10],[00,20]	0000000[30]	-
Drive I/F error (unrecovered)	0000000[1,2],[40,10]	0000000[6]	-
Controller hardware error (unrecovered)	0000000[1,2],[40,10]	0000000[6]	-
FC I/F error Port 0	0000000[4,10],[400,20]	0000000[6]	-
FC I/F error Port 1	0000000[4,10],[400,20]	0000000[6]	-
Port 0 error	0000000[4],[8]	0000000[12]	-
Port 1 error	0000000[4],[8]	0000000[12]	-

Today:[Error Count / Threshold Value;Warning[Level1,Level2],Blockade[Level1,Level2]]
7 days,Total:[Error Count / Threshold Value]

(3)

Select (CL) [Close] in the 'Threshold Counter Display' dialog box and close the 'Information' window.

[4] Resetting an error count

(1)

Select (CL) [Display Error Count...] in the ‘Threshold Value’ window.

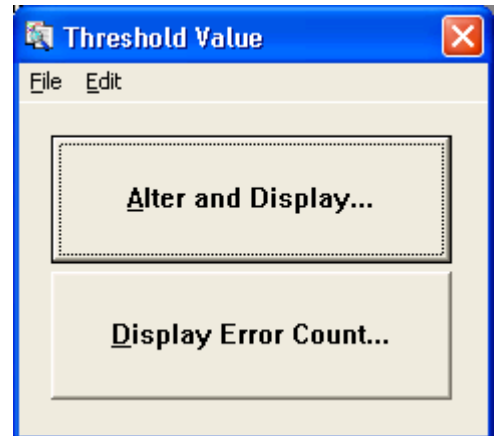

(2)

Select (CL) the HDD location, for which you want to reset the error count, from the ‘HDD Location’ drop-down list in the ‘Threshold Counter Display’ dialog box and also select (CL) [Reset].

Grp# : the parity group.

SPARE : spare HDD

RSRVD : reserved HDD with sparing

* : spare HDD in use.

ID(Information)	Today	7 days	Total
Mechanical error (recovered)	00000000(5,50)(2000,500)	00000000(150)	-
Media error (recovered)	00000000	-	-
Read / Write error (recovered)	00000000(2,50)(800,200)	00000000(150)	-
Drive I/F error (recovered)	00000000(5,50)(2000,500)	00000000(150)	-
Controller hardware error (recovered)	00000000(5,50)(2000,500)	00000000(150)	-
Mechanical error (unrecovered)	00000000(1,2)(40,10)	00000000(6)	-
Media error (unrecovered)	00000000(1,5)(200,50)	00000000(15)	00000000(1000)
Read / Write error (unrecovered)	00000000(1,10)(80,20)	00000000(30)	-
Drive I/F error (unrecovered)	00000000(1,2)(40,10)	00000000(6)	-
Controller hardware error (unrecovered)	00000000(1,2)(40,10)	00000000(6)	-
FC I/F error Port 0	00000000(4,10)(400,20)	00000000(6)	-
FC I/F error Port 1	00000000(4,10)(400,20)	00000000(6)	-
Port 0 error	00000000(4)(8)	00000000(12)	-
Port 1 error	00000000(4)(8)	00000000(12)	-

Today:[Error Count / Threshold Value;Warning[Level1,Level2],Blockade[Level1,Level2]]
7 days,Total:[Error Count / Threshold Value]

(3)

Select (CL) [OK] in the ‘Threshold Counter Reset’ dialog box.

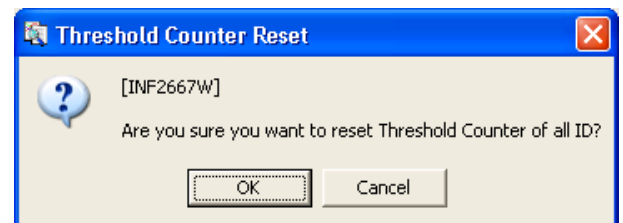

(4)

After confirming that the error count has been reset in the 'Threshold Counter Display' dialog box select (CL) [Close] and close the 'Information' window.

ID[Information]	Today	7 days	Total
Mechanical error [recovered]	0000000[5,50],[2000,500]	0000000[150]	-
Media error [recovered]	0000000[0]	-	-
Read / Write error [recovered]	0000000[2,50],[800,200]	0000000[150]	-
Drive I/F error [recovered]	0000000[5,50],[2000,500]	0000000[150]	-
Controller hardware error [recovered]	0000000[5,50],[2000,500]	0000000[150]	-
Mechanical error [unrecovered]	0000000[1,2],[40,10]	0000000[6]	-
Media error [unrecovered]	0000000[1,5],[200,50]	0000000[15]	0000000[1000]
Read / Write error [unrecovered]	0000000[1,10],[80,20]	0000000[30]	-
Drive I/F error [unrecovered]	0000000[1,2],[40,10]	0000000[6]	-
Controller hardware error [unrecovered]	0000000[1,2],[40,10]	0000000[6]	-
FC I/F error Port 0	0000000[4,10],[400,20]	0000000[6]	-
FC I/F error Port 1	0000000[4,10],[400,20]	0000000[6]	-
Port 0 error	0000000[4],[8]	0000000[12]	-
Port 1 error	0000000[4],[8]	0000000[12]	-

Today:[Error Count / Threshold Value,Warning[Level1,Level2],Blockade[Level1,Level2]]
7 days,Total:[Error Count / Threshold Value]

2.8 SIM Log Complete

- (1) Change the mode from [View Mode] to [Modify Mode].
Select (CL) [Information].

- (2) Select (CL) [Log...] in the 'Information' dialog box.

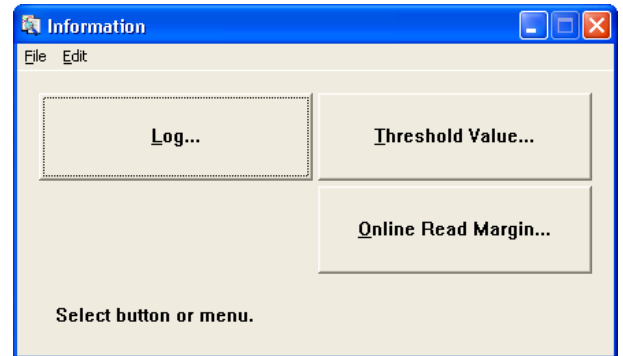

- (3) Select (CL) [SIM] and [List...] in the 'Log'.

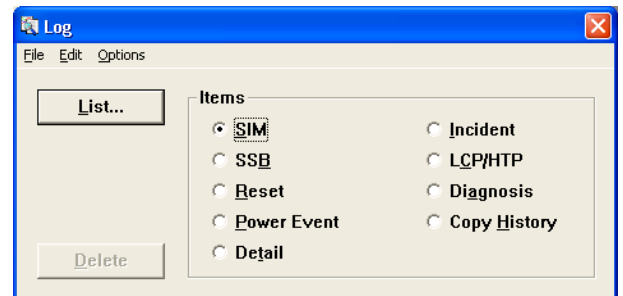

- (4) Select (CL) data to be completed in the 'List-SIM' dialog box and select (CL) [Complete].

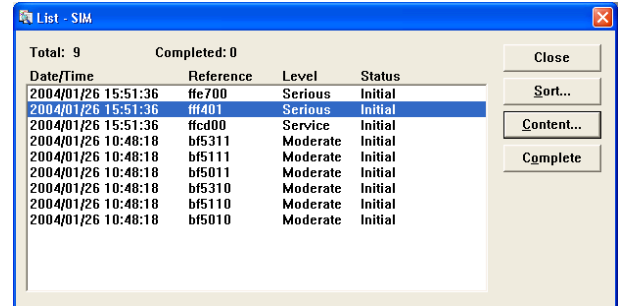

- (5) Select (CL) [Yes] in the 'Complete' dialog box.

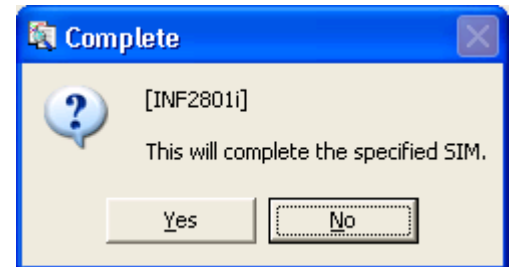

- (6) In the 'List-SIM' dialog box, make sure that "Completed" is displayed in the status.

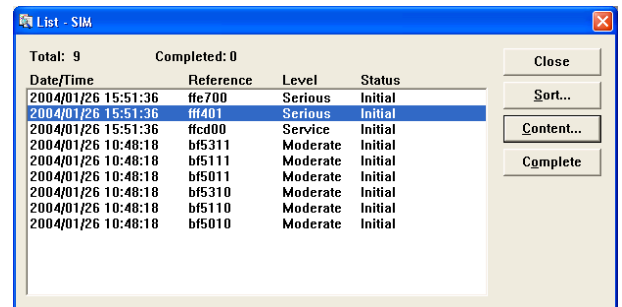

- (7) Select (CL) [Close] in the 'List-SIM' dialog box.
Close the 'Log' dialog box and close the 'Information' window.
Change the mode from [Modify Mode] to [View Mode].

Note: When the Message of an Operator Panel is on, even if it is performed complete of all SIMs, please check SIM Complete carried out by displaying SIM.
When not Complete carried out, please wait for 5 minutes and operate SIM Log Complete again.

2.9 Dump/AutoDump

Auto Dump is a useful function to provide the user with free selection of the dump data type and the output media so that the user can collect dump information.

[1] Auto Dump

- (1) Connect the external USB memory.

When information is collected to the external USB memory, connect the USB memory.

When information is not collected to the external USB memory, go to Step 2.

① Insert the USB Memory in USB port on the SVP.

(a) When connecting to the SVP

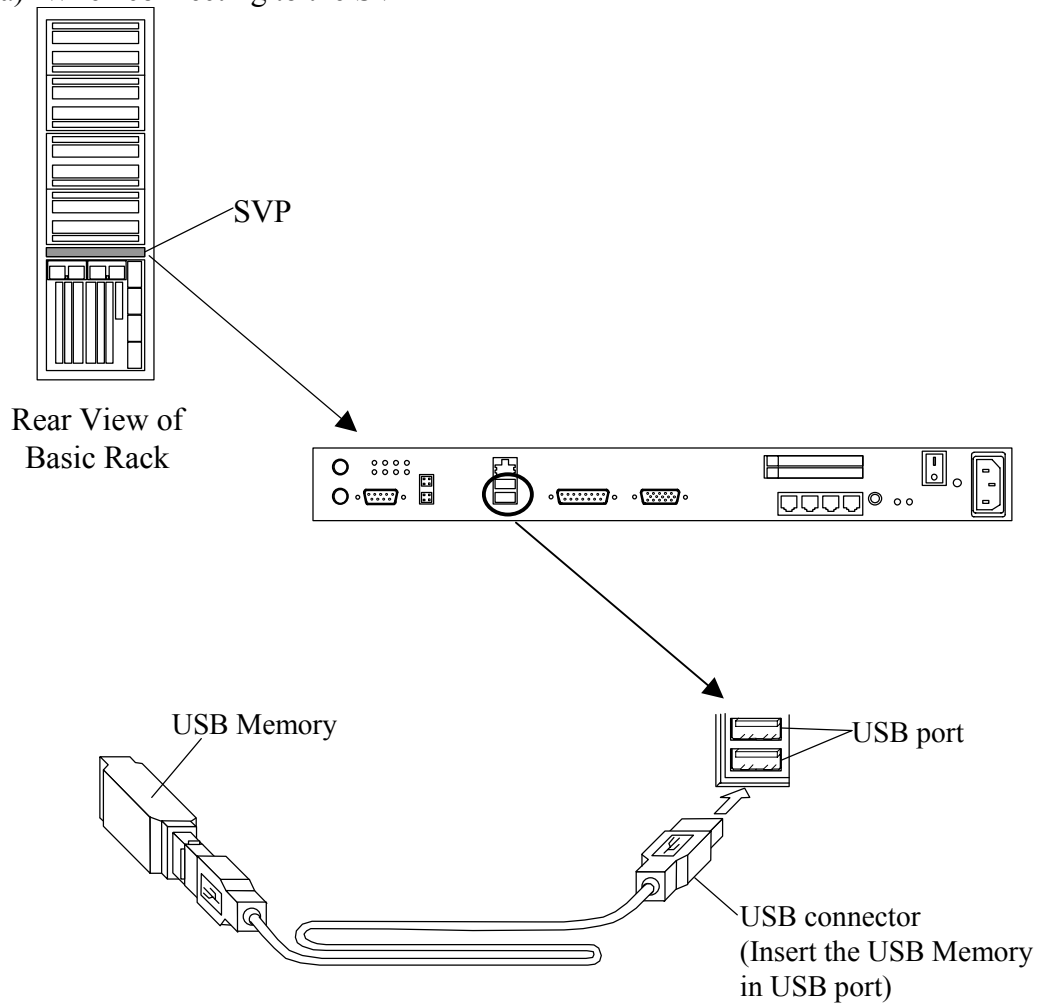

(b) When connecting to the Client PC

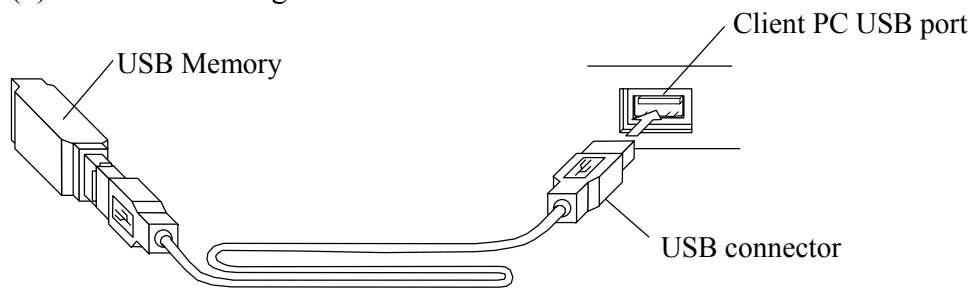

Blank Sheet

Blank Sheet

Blank Sheet

Blank Sheet

- (2)
Select (CL) [AutoDump] button.

- (3)
Select a dump type and a medium for output and make settings of the FTP transfer detail and the Client PC output detail, etc., and then select (CL) the [OK] button.

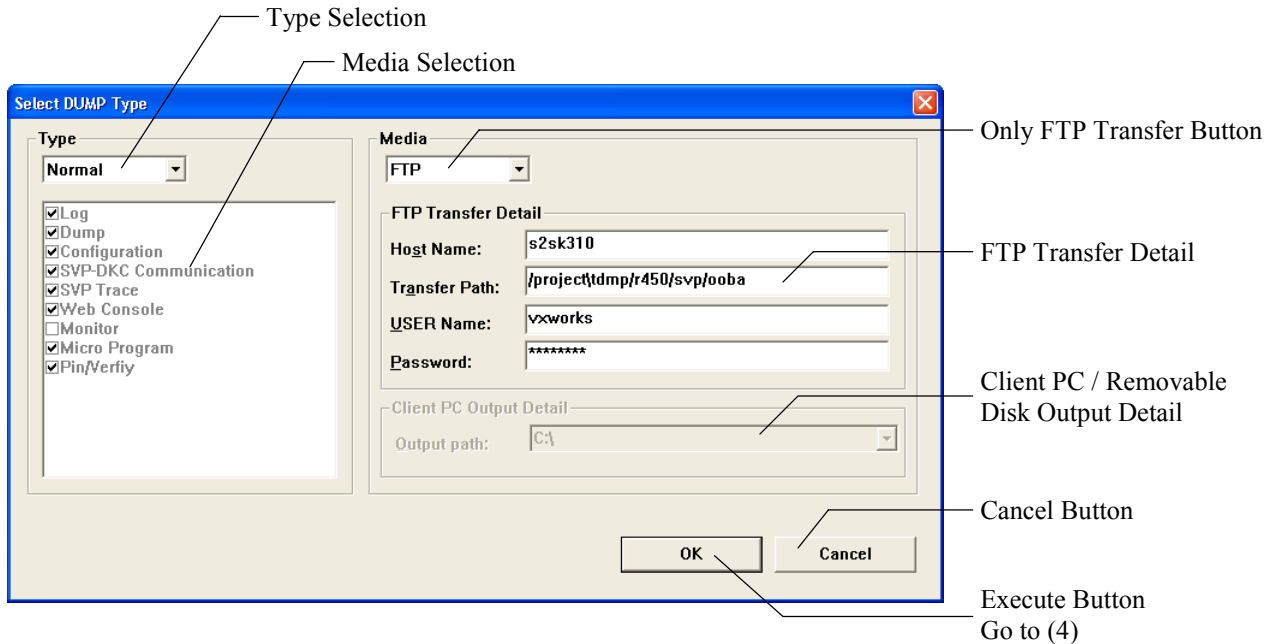

Note1: Please check that automatic connection of a local disk drive is set up in the case of connection to SVP. (At the time of Svp Connect Utility use, it is set up automatically.)

Note2: If you execute the TOD setting during collecting the LCP Dump, the collecting the LCP Dump may fail. Then, please execute collecting the LCP Dump again.
And if you execute collecting LCP Dump at about the time set by Synchronization Information function, the collecting the LCP Dump may fail. Then, please execute collecting the LCP Dump again.

<<Dump Type>>

Rapid:

This dump type is to get log information, SVP operation history, or configuration information. SVP will compress these files automatically. The compressed files will be stored in a few FDs.

This dump type will be used when the initial analysis of error is needed. In this case, you should gather the files used by this type and send it to the Center. After sending this files, you should gather dump data by selecting “Normal” type and send it to the Center to analyze more details.

Normal:

This dump type is to get dump data (you can get DUMP information of all adapters) adding to the log files used by “Rapid” type. SVP will compress these dump files automatically. You should get dump data by using this dump type after sending the “Rapid” type of data to Center.

Detail:

This type is to get monitor information adding to the dump files used by “Normal” type. (You can not get performance monitor information.) This data will be needed when the performance of the DKC wants to be checked. If there is no order to get these data, you do not need to use this type.

DUMP:

The dump of this type selects the processors and gets dumps from them individually.

Log:

The dump of this type collects log information only. The dump is used when it is required to send only the log information immediately to the Technical Support Division before making the initial analysis.

Monitor:

The dump of this type collects all monitor information and configuration information.

Config Backup:

The dump of this type collects the configuration information backup data stored in a hard disk of the SVP.

Custom:

The dump of this type selects source items from the detailed information items and collects information from them.

When none of the detailed information items is checked off, the function of the dump of this type becomes the same as that of the dump whose type is No Gather.

No Gather:

The dump of this type only outputs “c:\dkc200\tmp\hdcg.tgz”, which has already been got, to a selected medium without compressing the data.

The dump of this type cannot collect information when the “c:\dkc200\tmp\hdcg.tgz” does not exist or an HDD is selected as a medium for the output.

<<Media>>

FDD:

SVP will store the compressed files to FD. If the data could not be stored in one FD, SVP will divide the compressed files into smaller files and store them into several FDs. If you cannot transfer the compressed files to your center from the SVP, you could use this media type to save files into several FDs and transfer them by using other PC which can connect to the center.

HDD:

SVP will store the compressed files to HDD. The file name is “c:\dkc200\tmp\hdcp.tgz”. If you can transfer the files to your center directly, this type will be useful.

(Notice: When operating the maintenance, SVP will sometimes delete the files. Do not use the maintenance operation before sending the files to your center.)

FTP:

SVP will store the compressed files to HDD. The file name is “c:\dkc200\tmp\hdcp.tgz”. After the compression processing end, Transfer processing of compression data is performed to the transfer place directory of a specification server inputted into FTP Transfer Detail.

Client PC:

The compressed data is output to the directory which has been entered in the Client PC Output Detail box of the PC remotely connected to the SVP.

When information is collected to the external USB memory of the Client PC, please select “Client PC” as a medium and specify the drive of the USB memory into Client PC Output Detail.

Removable Disk:

The compressed data is output to the directory which has been entered in the Removable Disk of SVP PC.

When information is collected to the external USB memory of the SVP PC, please select “Removable Disk” as a medium and specify the drive of the USB memory into Removable Disk Output Detail.

<<FTP Transfer Detail>>

Host Name: The host name of a FTP transfer place or an IP address is inputted.

Transfer Path: The directory of a FTP transfer place is inputted.

USER Name: The user name which login to a FTP server is inputted.

Password: The password which login to a FTP server is inputted.

<<Client PC Output Detail>>

Output path: Enter a directory, to which data of the PC remotely connected to the SVP is output, into this box. (A list of HDD / USB memory drives of the PC concerned is displayed as an initial display.)

<<Removable Disk>>

Output path: Enter a directory, to which data of the Removable Disk of the SVP PC is output, into this box. (A list of Removable Disk drives of the SVP PC is displayed as an initial display.)

(4) Doing the dump and data compression

A dump is done when a dump type is selected out of “Normal”, “Detail”, “DUMP”, and “Custom” (in the case where “Dump” has been selected from the detailed information items).

Go to Step (4-1-1).

When “No Gather” is selected as a dump type, a message, “Do you want to output what has already been got without collecting dump, log, and operation information and SVP operation history?” is displayed. A selection (CL) of the [OK] button in response to the message makes an output to the selected medium.

Go to Step (5).

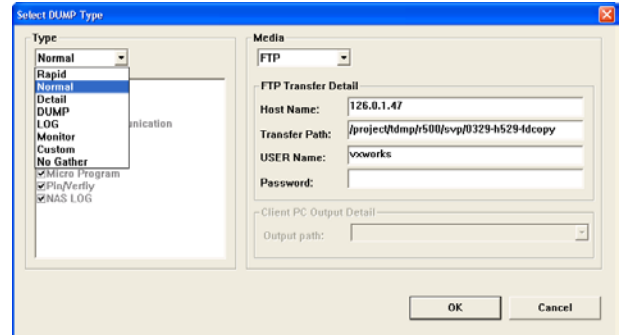

When a dump type other than the above is selected, a data compression is done.

Go to Step (4-2).

(4-1-1)

When “DUMP” is selected as a dump type, select (CL) “Location No.” of the processor in the ‘Dump’ dialog box and select (CL) the [DUMP] button.

When [All Adapter] is selected, dumps are got from all the processors.

When a dump type other than the above is selected, go to Step (4-1-2).

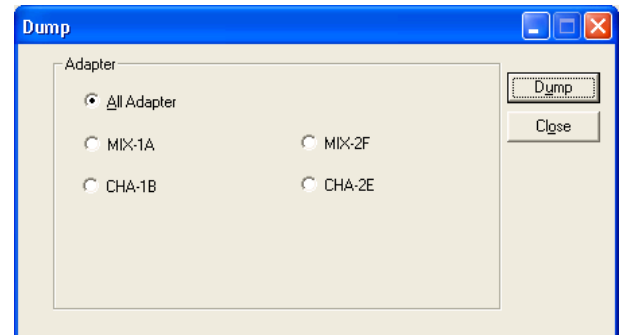

(4-1-2)

A box indicating progress of the dump is displayed.

When the dump terminates normally, go to step (4-1-4).

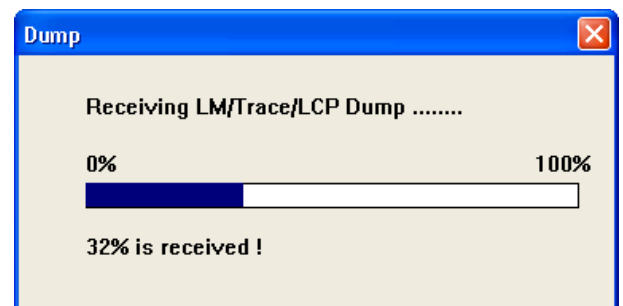

(4-1-3)

When an error occurs, the following dialog box is displayed.

Perform the following procedure and retry the dump.

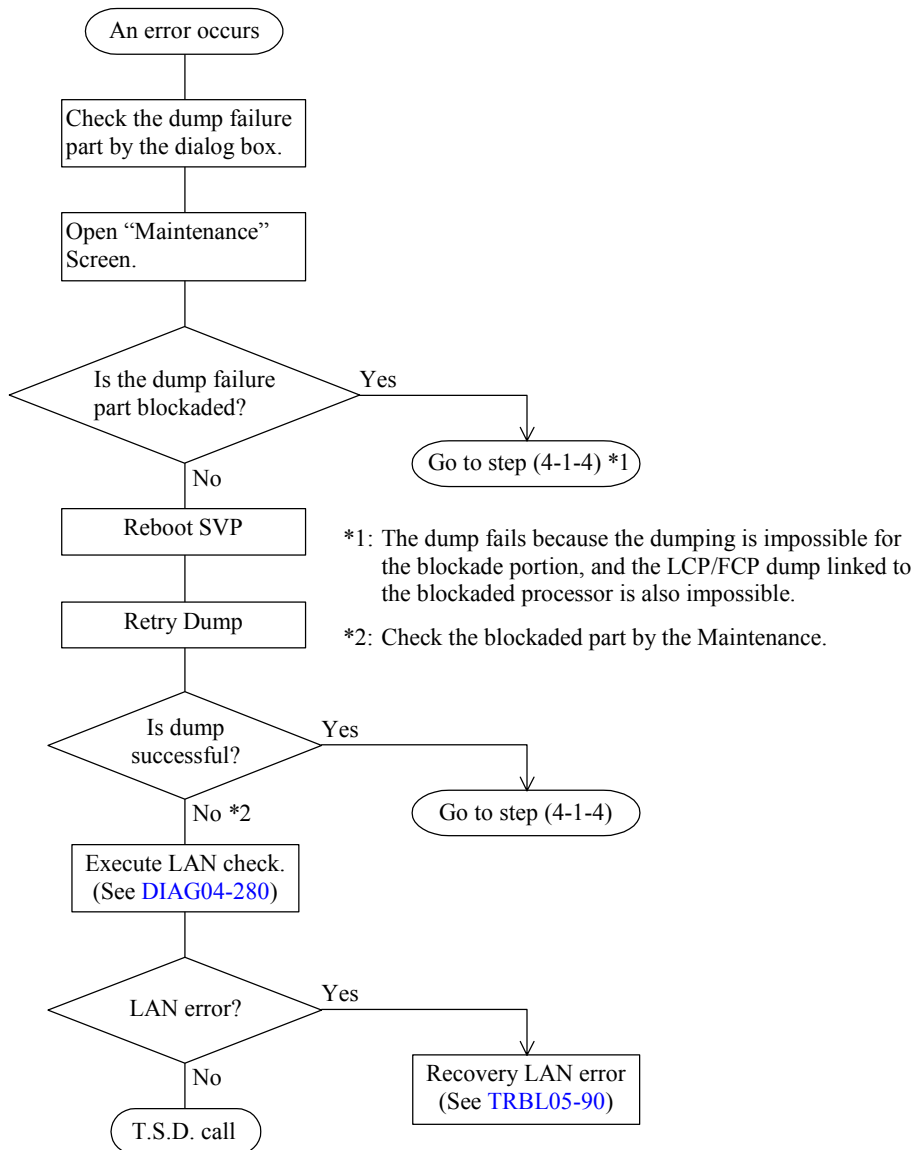
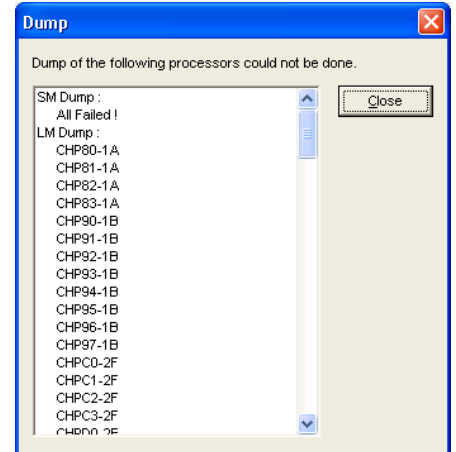

(4-1-4)

A data compression is done.
Go to Step (4-2).

(4-2) Data compression

The 'FD Copy' window is displayed and a data compression is done.

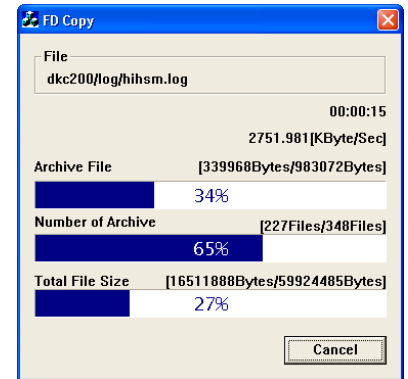

(5) Output to a selected medium.

An output is done to a selected medium

When an FDD was selected, go to Step (5-1-1).

When an HDD was selected, go to Step (5-2-1).

When an FTP was selected, go to Step (5-3-1).

When a Client PC was selected, go to Step (5-4-1).

When a Removable Disk was selected, go to Step (5-5-1).

(5-1-1) When an FDD is selected as a medium for the output

When a message, "Please insert a DOS formatted FD (No.1)." is displayed in the 'SVP' dialog box, insert the FD and select (CL) the [OK] button.

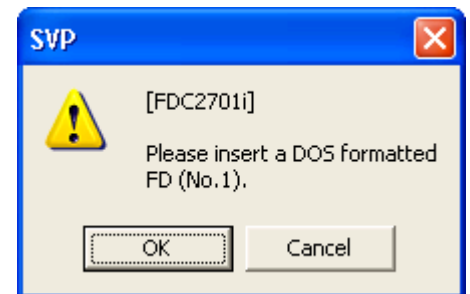

(5-1-2)

If the file is not contained in the FD when the FD is checked through the 'FD Status' dialog box, go to Step (5-1-3). When the file is contained in the FD, a message, "The following files and directories are in FD. Do you want to remove them?" is displayed. When you want to delete the files, select (CL) the [Yes] button and go to Step (5-1-3). If you want to leave the files, select (CL) the [No] button and go to Step (5-1-3).

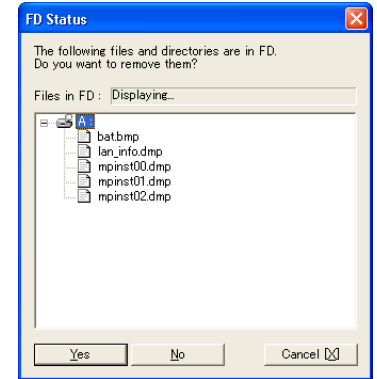

When an error occurs, a message, "Could not access FD. FD is not DOS formatted. FD is not inserted. FD is write protected." is displayed.

Check the matters displayed and then select (CL) the [Retry] button. Return to Step (5-1-2).



(5-1-3)

"Copying to FD..." is displayed and the copying is done. (If a capacity of the FD becomes insufficient, return to Step (5-1-2) and replace the FD with a new one.)

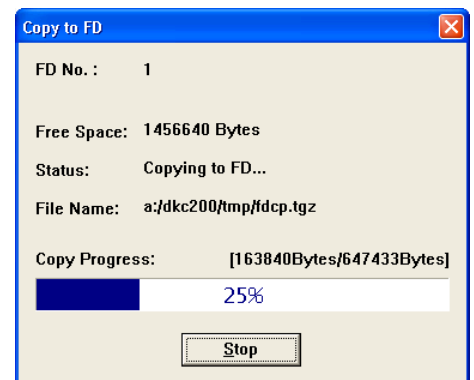

(5-1-4)

A message, "Gathering information data was completed." is displayed. Select (CL) the [OK] button.

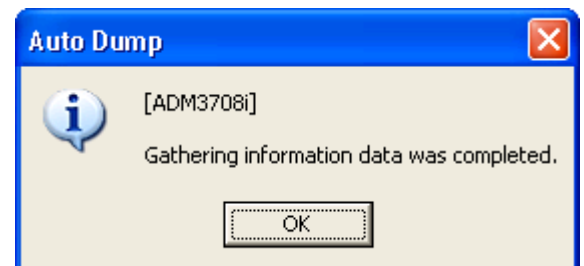

(5-2-1) When the HDD is selected as a medium for the output

A message, “Gathering information data was completed.” is displayed. Select (CL) the [OK] button.

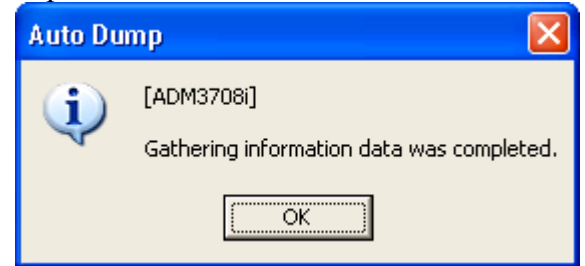

(5-3-1) When the FTP is selected as a medium for the output

When the [FTP] was selected as the media for the output, a transfer of the compressed data is started.

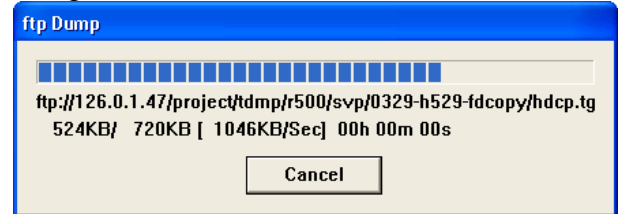

(5-3-2)

After the data transfer is completed, a message, “FTP transfer has ended successfully.” is displayed. Select (CL) the [OK] button.

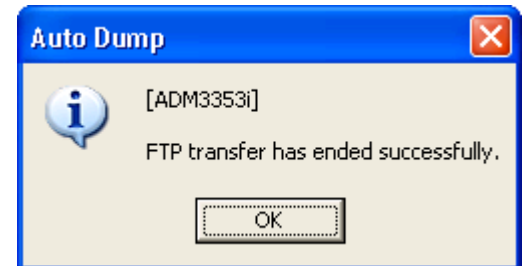

- (5-4-1) When the Client PC is selected as an medium for the output
“Copying to Client PC.” is displayed and a copying
to the Client PC is done.

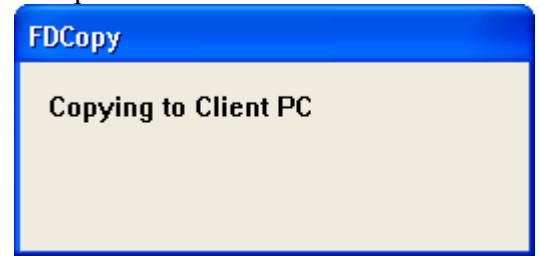

When the copying fails, a message, “Output
to the client PC is failed. Do you want to
specify the output destination in the client PC
again?” is displayed.

Select (CL) the [Yes] button and reset the
directory for the output in the ‘Client PC’
window.

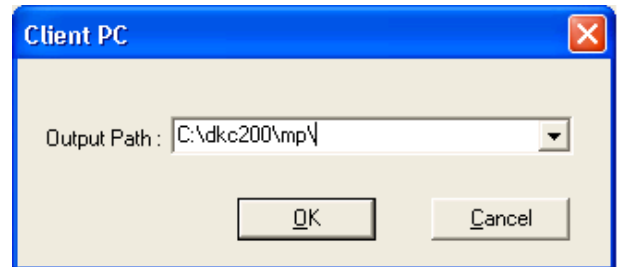
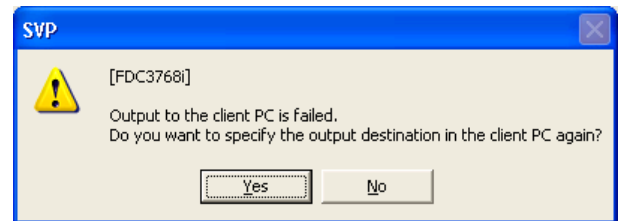

- (5-4-2)

A message, “Gathering information data was
completed.” is displayed. Select (CL) the [OK]
button.

When information is collected to the USB
memory of Client PC, go to Step (6-2).

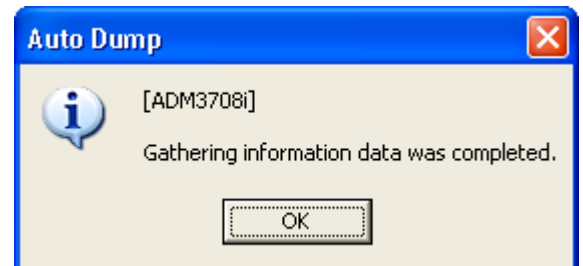

(5-5-1) When the Removable Disk is selected as an medium for the output

“Copying to Removable Disk” is displayed and a copying to the Removable Disk is done.

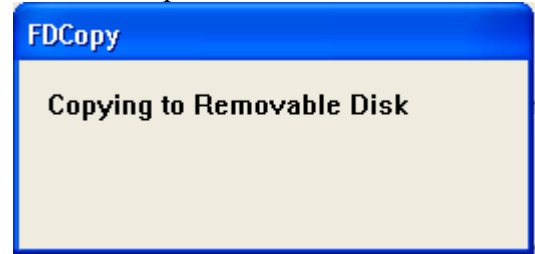

(5-5-2)

A message, “Gathering information data was completed.” is displayed. Select (CL) the [OK] button.

When information is collected to the USB memory of the SVP PC, go to Step (6-1).

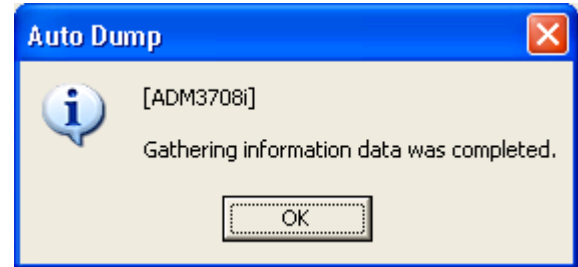

(6-1) Remove the USB memory from SVP PC

Select (CL) the “Safely Remove Hardware” icon in the task tray.



Since the menu bar is displayed, select (CL) “Safely remove USB Mass Storage Device - Drive (X:).”

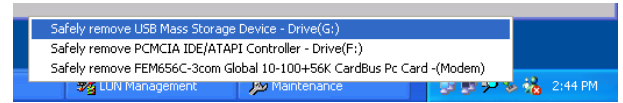

*1: “X:” is a drive letter of the USB memory.

*2: When a device other than the USB memory is selected, the other devices will stop. If a wrong selection is made, insert the device that has been selected by mistake again.

Remove the USB memory from the USB port of the SVP.

(6-2) Remove the USB memory from Client PC

When the collection of information using AutoDump is completed, remove the USB memory from the Client PC.

How to remove the USB memory from Client PC changes with Client PCs to be used.

Please perform removal processing suitable at each Client PC.

example: In the case of Client PC which sets Windows XP (the English version) or Windows 2000 (the English version) to OS

1. When the collection of information using AutoDump is completed, select (CL) the (Windows XP)
“Safely Remove Hardware”
(Windows 2000)
“Unplug or Eject Hardware”
icon in the task tray.

(Windows XP)



(Windows 2000)

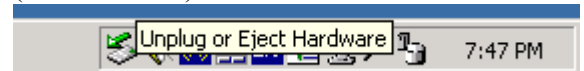

2. Since the menu bar is displayed, select(CL) the (Windows XP)
“Safely remove USB Mass Storage Device– Drive(X:)”
(Windows 2000)
“Stop USB Mass Storage Device– Drive(X:)”.

(Windows XP)

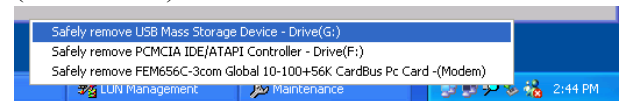

(Windows 2000)

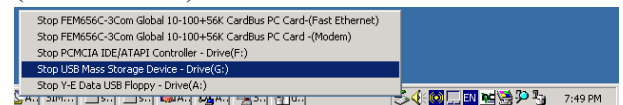

*1: “X:” is a drive letter of the USB memory.

*2: When a device other than the USB memory is selected, the other devices will stop. If a wrong selection is made, insert the device, which has been selected by mistake again.

3. (In the case of Client PC which sets Windows 2000 to OS)

Confirm that the following message appears, and then select(CL) [OK].



4. Remove the USB memory from the USB port of the Client PC.

[2] SSVP DUMP

(1)

Push the SSVP DUMP switch.
(Refer to [LOC03-50](#), [LOC03-90](#).)

(2)

Open the Maintenance window (see SVP section).
Check that the message “SSVP Dump is being performed (XXXX). Environment status can't be read.” is displayed and select (CL) [OK].

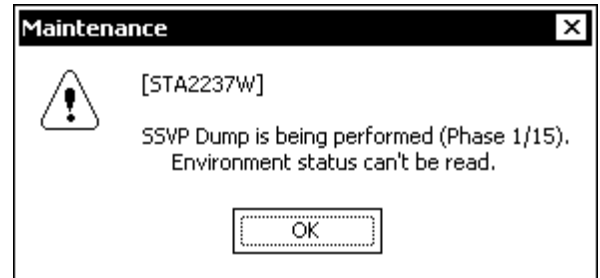

If the message “Connection error occurred. SVP-SSVP” is displayed, check the wiring connection and select (CL) [OK] to start from step (1) again.
If step (1) is performed three times and the same message “Connection error occurred. SVP-SSVP” is displayed, replace SSVP (See [REP01-290](#)).

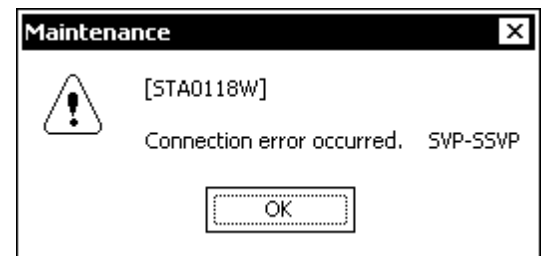

(3)

The SSVP ALARM lamp blinks after completion of dump.
(For about 10 minutes after performing step (1))

(4)

Copy the dump file to FD.
(Refer to [SVP02-540](#) [1] Auto Dump)

- (5) Push the SSVP Alarm Reset switch.
(Refer to [LOC03-50](#), [LOC03-90](#).)

- (6) Open the Maintenance window.
If the message “Connection error occurred. SVP-SSVP” is displayed, select (CL) [OK] to perform step (5) again.
If step (5) is performed three times and the same message “Connection error occurred. SVP-SSVP” is displayed, replace SSVP (See [REP01-290](#)).

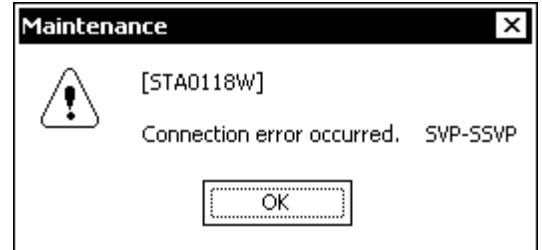

- (7) If the message shown at step (6) is not displayed, the SSVP IMPL is completed.

2.10 Logical Device Maintenance

2.10.1 Logical Device

[1] Physical Device List -----	SVP02-770
[2] FORMAT Logical Device -----	SVP02-780
[3] Block Logical Device -----	SVP02-810
[4] Restore the Logical Device -----	SVP02-840
[5] Verify Logical Device -----	SVP02-870
[6] LDEV recovery for multiple PDEV failures -----	SVP02-930
[7] Format all blocked Logical Devices together -----	SVP02-950

Prerequisite Operation

(1)

- [1] ----- Select (CL) [Maintenance] in the 'SVP' window. -----Go to (2)
- [2] ~ [6] --- Change the Mode from [View Mode] to [Modify Mode].
Select (CL) [Maintenance] in the 'SVP' window. -----Go to (2)
- [7] ----- Change the Mode from [View Mode] to [Modify Mode].
Select (CL) [Install] in the 'SVP' window. -----Go to [7]

(2)

Select (CL) [Logical Device...] in the 'Maintenance' window.

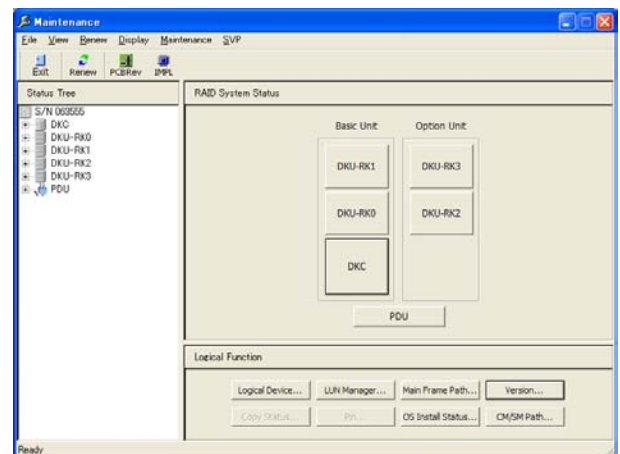

- (3) 'Logical Device' is displayed.

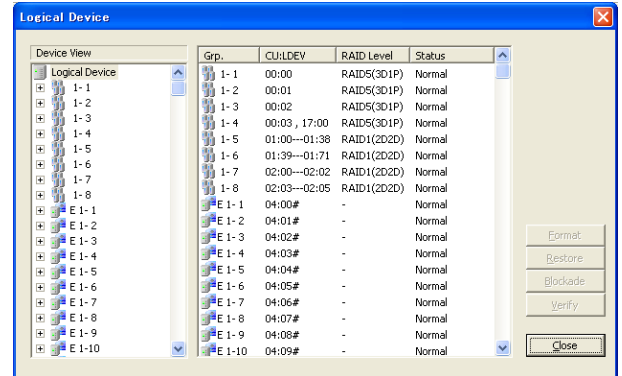

Prerequisite Operation: [7]

- (1) Change the mode to [MODIFY Mode], select (CL) [Install].

[1] Physical Device List

(1)

Select (CL) an LDEV from the Device View in the 'Logical Device Status' dialog box.

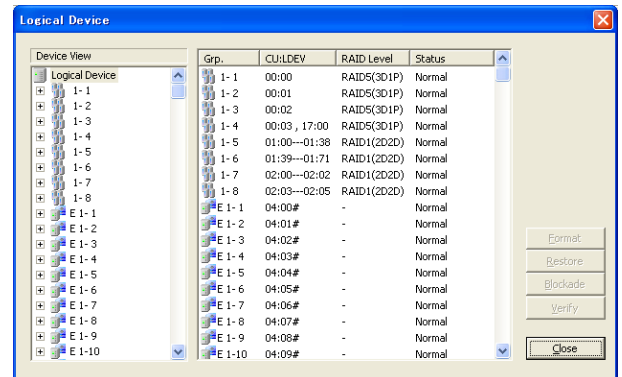

(2)

'Logical Device and Detail List' is displayed. Select (CL) [Close] and close the 'Maintenance' window.

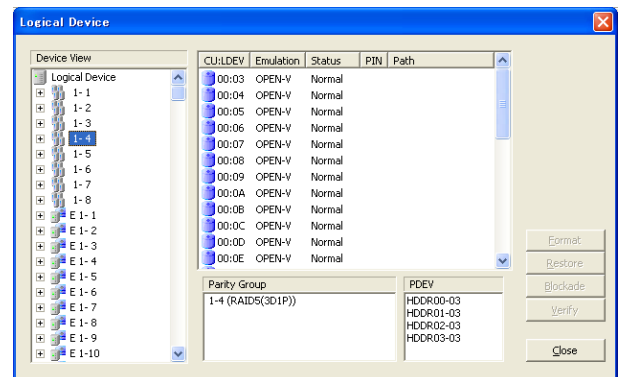

[2] FORMAT Logical Device

Notice:

Executing this operation may cause a serious error such as a system down or a data loss. Accordingly, confirmation of the appropriateness of the operation and input of a password on the succeeding password input screen is required.

(1)

Select (CL) ECC group from the LDEV list box in the 'Logical Device' dialog box.

Format by Ldev unit:

Select (DC) the targeted ECC group.

----- Go to (2-1)

Format by ECC group:

Select (CL) [Format]----- Go to (2-2)

(It can select multiple items at once)

Note: Execute Format Logical Device after you confirm the target Logical Device is blocked.

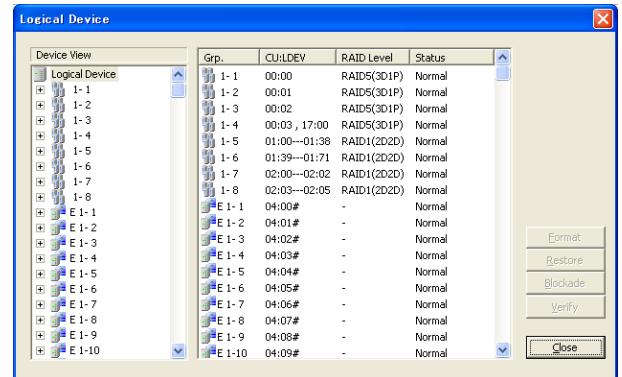

(2-1)

Select (CL) LDEVs which you want to format from "Logical Device Status Detail", and select (CL) [Format]. Go to (2-2). (It can select multiple items at once.)

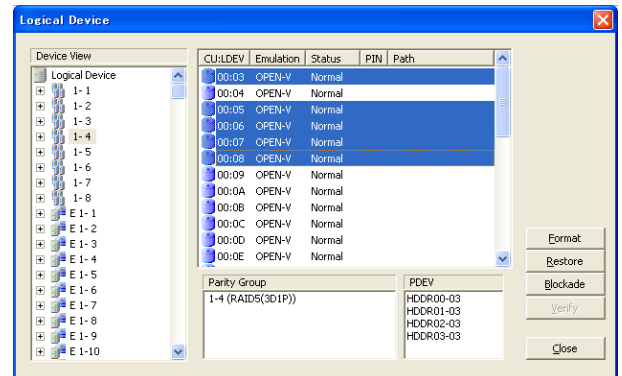

(2-2)

Select (CL) the corresponding LDEV from the LDEV ID list in the 'Logical Device' dialog box and select (CL) [OK].

If the target LDEV was not blocked, return to step (1) the 'Logical Device' dialog box.

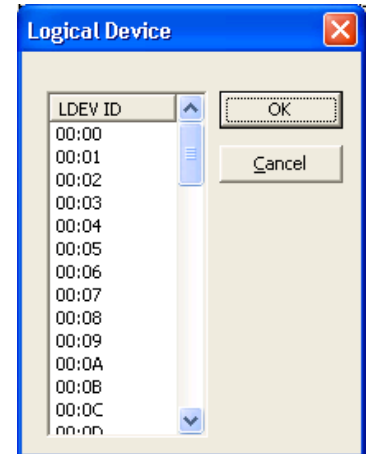

(3)

Notice:

This is a special (exceptional) operation that can cause a serious failure such as a system down or a data loss and requires an input of a password. Ask the technical support division about the appropriateness of the operation, and input the password after getting an approval of executing the operation.

“Data in the specified logical device may be lost due to this operation. You need the password to continue.” is displayed.

Enter the password and select (CL) [OK].

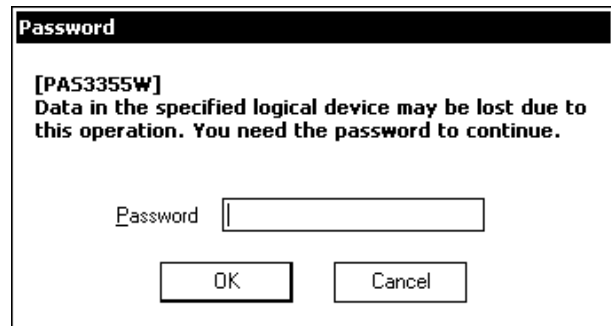

- (4) “Formatting the logical device...” is displayed.

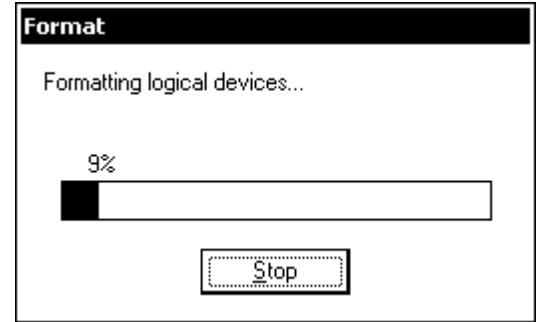

Notice:

When REFER CONFIG etc. is executed during LDEV FORMAT of open volume, there is the rare case that MAINTENANCE WINDOW may disappear. Then please reboot SVP and execute LDEV FORMAT again.

For your information, even while rebooting SVP, LDEV FORMAT is executed without intermission. When you open LDEV FORMAT WINDOW again, you can see the current status of LDEV FORMAT.

- (5) Select (CL) [OK] in response to “Formatting was finished.”.

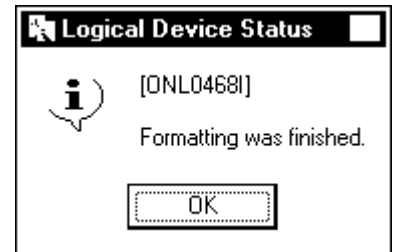

- (6) Select (CL) [Close] in the ‘Logical Device’ dialog box.
Close the ‘Maintenance’ window.

[3] Block Logical Device

Notice:

Executing this operation may cause a serious error such as a system down or a data loss. Accordingly, confirmation of the appropriateness of the operation and input of a password on the succeeding password input screen is required.

(1)

Select (CL) ECC group from the LDEV list box in the 'Logical Device' dialog box.

Blockade by Ldev unit:

Select (DC) the targeted ECC group.

----- Go to (2-1)

Blockade by ECC group:

Select (CL) [Blockade] ----- Go to (2-2)

(It can select multiple items at once)

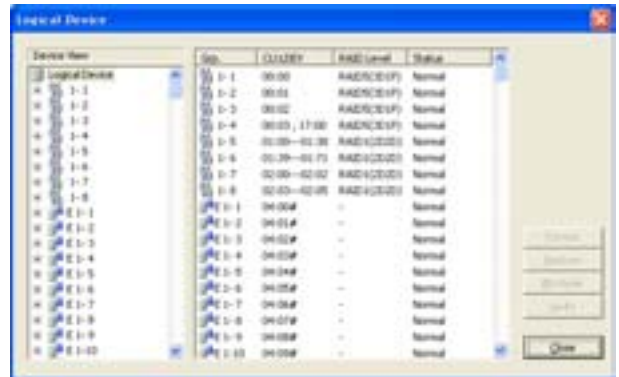
**Notice:**

Execute Format Logical Device after you confirm the target Logical Device is blocked.

(2-1)

Select (CL) LDEVs which you want to block from "Logical Device Status Detail", and select (CL) [Blockade]. Go to (2-2). (It can select multiple items at once.)

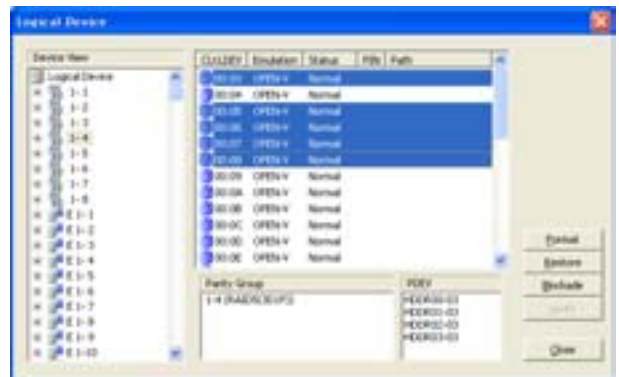

(2-2)

Select the corresponding LDEV from the LDEV ID list in the 'Logical Device' dialog box and select (CL) [OK].

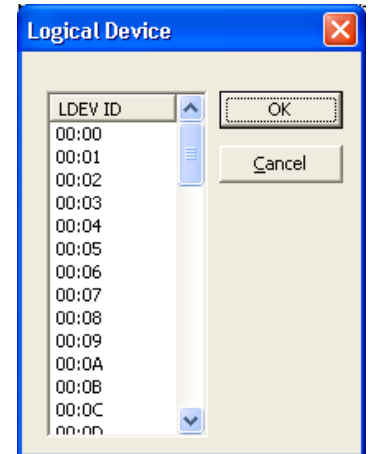

(3)

Notice:

This is a special (exceptional) operation that can cause a serious failure such as a system down or a data loss and requires an input of a password. Ask the technical support division about the appropriateness of the operation, and input the password after getting an approval of executing the operation.

“Data in the specified logical device may be lost due to this operation. You need the password to continue.” is displayed.
Enter the password and select (CL) [OK].

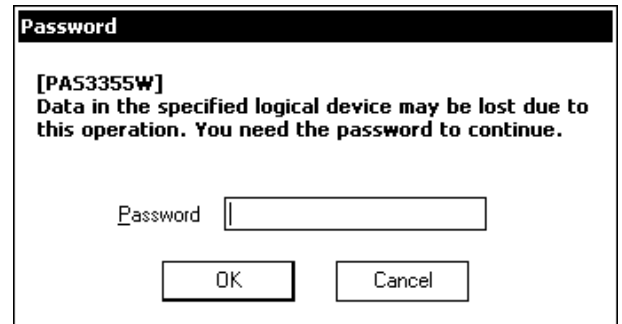

(4)

“Blocking the logical device...” is displayed.

- (5) Select (CL) [OK] in response to “Blocking the logical device is completed.”



- (6) Select (CL) [Close] in the ‘Logical Device’ dialog box.
Close the ‘Maintenance’ window.

[4] Restore the Logical Device

Notice:

Executing this operation may cause a serious error such as a system down or a data loss. Accordingly, confirmation of the appropriateness of the operation and input of a password on the succeeding password input screen is required.

(1)

Select (CL) ECC group from the LDEV list box in the 'Logical Device' dialog box.

Restore by Ldev unit:

Select (DC) the targeted ECC group.

----- Go to (2-1)

Restore by ECC group:

Select (CL) [Restore] ----- Go to (2-2)

(It can select multiple items at once)

Note: Execute Restore Logical Device after you confirm the target Logical Device is blocked.

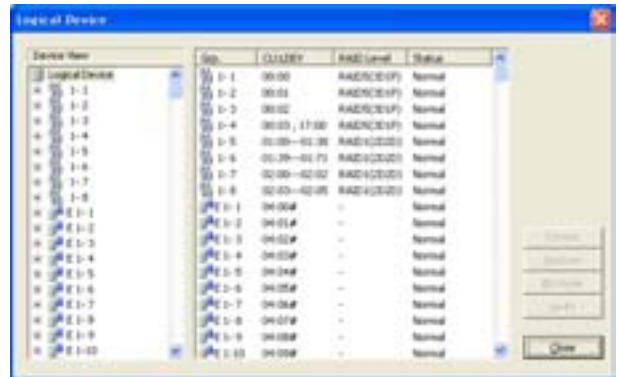

(2-1)

Select (CL) LDEVs which you want to restore from "Logical Device Status Detail", and select (CL) [Restore]. Go to (2-2). (It can select multiple items at once.)

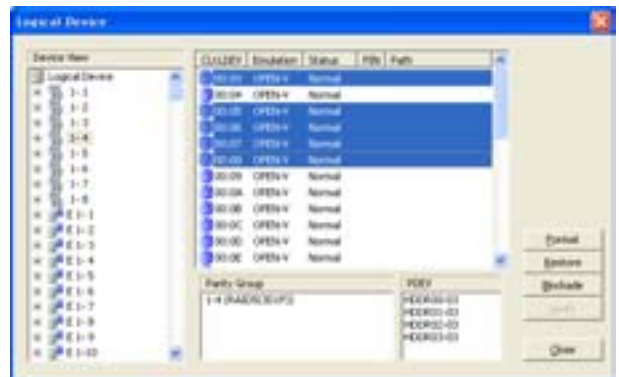

(2-2)

Select (CL) the corresponding LDEV from the LDEV ID list in the 'Logical Device' dialog box and select (CL) [OK].

If the target LDEV was not blocked, return to step (1) the 'Logical Device' dialog box.

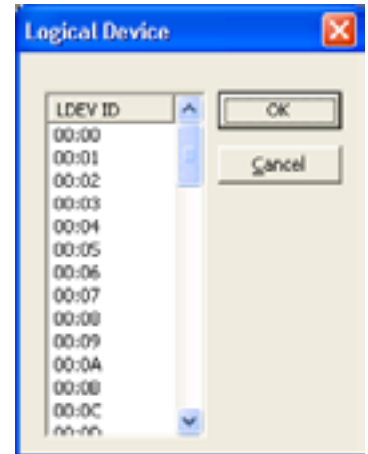

(3)

Notice:

This is a special (exceptional) operation that can cause a serious failure such as a system down or a data loss and requires an input of a password. Ask the technical support division about the appropriateness of the operation, and input the password after getting an approval of executing the operation.

Select (CL) the corresponding item from the Restore Type in the 'Restore Logical Devices' dialog box and select (CL) [OK].

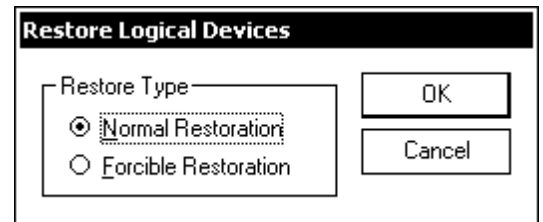

■ Normal Restoration

Explanation:

In case LDEV(s) is (are) blocked due to multiple PDEV failures in one parity group, this option spins up the PDEV which was blocked last to restore the LDEV(s).

When to choose this option?

Use this option when you would like to restore the LDEV(s) that is (are) blocked due to multiple PDEV failures in one parity group.

Notice:

The purpose of this action is to restore the PDEV blocked last and restore the parity group status to "correction access". Therefore do not replace or self-replace any failed HDD in the parity group before performing this action.

■Forcible Restoration

Explanation:

This option restores only the LDEV status forcibly without considering data consistency etc.

When all PDEV status in the parity group is “normal”, the LDEV status is changed from “blocked” to “normal”.

When to choose this option?

In case “Normal Restoration” cannot restore LDEV, use this option by following the instructions of the technical support division.

After PDEV is manually restored, the LDEV status is changed to “normal” forcibly.

Notice:

The data consistency may not be guaranteed. Contact the technical support division to ask for instructions.

If “Forcible Restoration” is selected, the message “Ask the Technical Support Division about the appropriateness of this operation, and enter the password.” is displayed. Enter the password and select (CL) [OK].

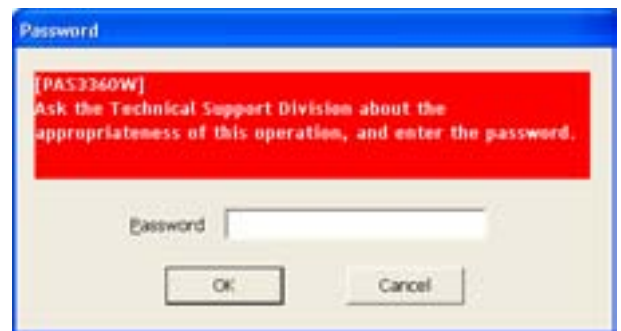

(4)

“Restoring...” is displayed.

In case that, “Normal Restoration” is selected in Step (3).

If multiple PDEV failures, the restoration processing of the recoverable PDEV is performed here.

This processing cannot recover it when the following message is displayed.

“The replaced physical devices could not spin up.”

Perform the procedure RDK7 refer to [REP01-250](#).



- (5) Select (CL) [OK] in response to “Restoring the logical device is completed.”.



- (6) <Check of Device Status>
Check the target device status in the ‘Logical Device’ window.

- (7) Select (CL) [Close] in the ‘Logical Device’ dialog box.
Close the ‘Maintenance’ window.

[5] Verify Logical Device

Notice:

Executing this operation may cause a serious error such as a system down or a data loss. Accordingly, confirmation of the appropriateness of the operation and input of a password on the succeeding password input screen is required.

(1)

Select (CL) ECC Group from the LDEV list box in the 'Logical Device' dialog box.

Verify by Ldev unit:

Select (DC) the targeted ECC group.

----- Go to (2-1)

Verify by ECC group:

Select (CL) [Verify] ----- Go to (2-2)

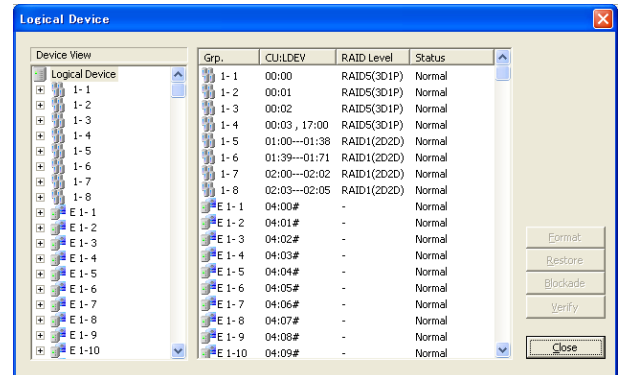

(2-1)

Select (CL) LDEVs which you want to verify from 'Logical Device', and select (CL) [Verify].

Go to (2-2). (It can select multiple items at once.)

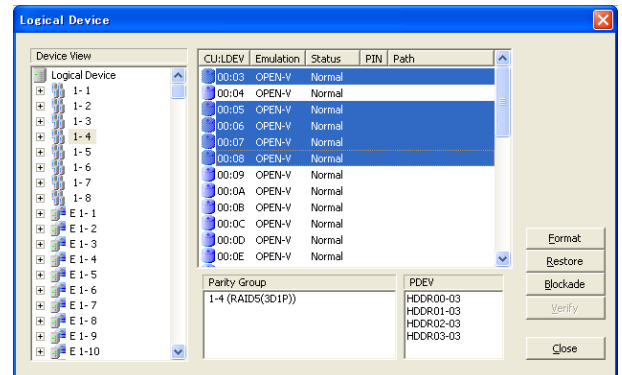

(2-2)

Select (CL) the corresponding LDEV from the LDEV ID list in the 'Logical Device' dialog box and select (CL) [OK].

If the target LDEV was not Normal, return to the 'Logical Device Status' dialog box.

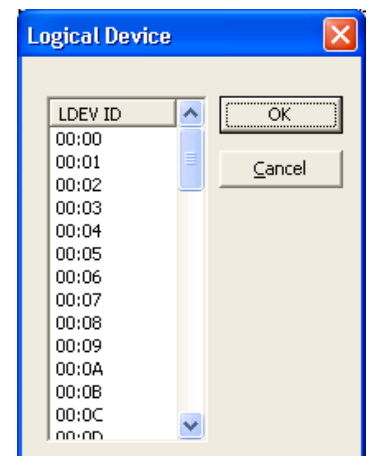

(3)

Notice:

This is a special (exceptional) operation that can cause a serious failure such as a system down or a data loss and requires an input of a password. Ask the technical support division about the appropriateness of the operation, and input the password after getting an approval of executing the operation.

Enter the password and select (CL) [OK].

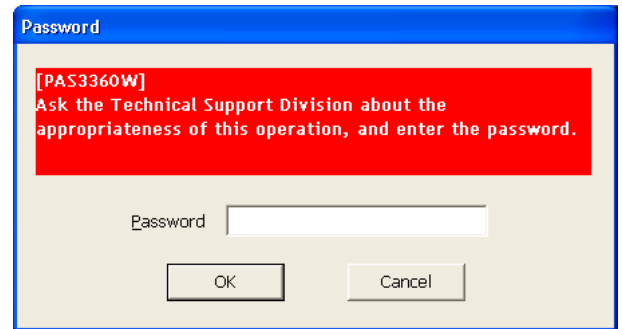

Select (CL) “Auto Correct” or input the value of “Error Stop”, and select (CL) [OK].

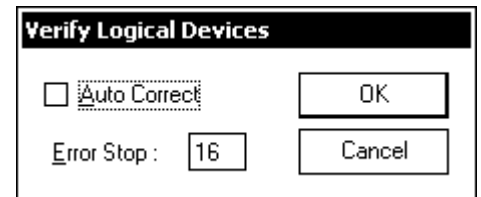

(4)

“Verifying logical devices...” is displayed and the parity synchronization check is started.

When you want to interrupt the check, select (CL) the [Stop] button.

The routine goes to Step (5).

When the parity synchronization check is completed, if a PDEV that could not be checked exists, the routine goes to Step (6), or if an LDEV whose parity is not synchronized exist, the routine goes to Step (7), or if neither of the above exists, the routine goes to Step (13).

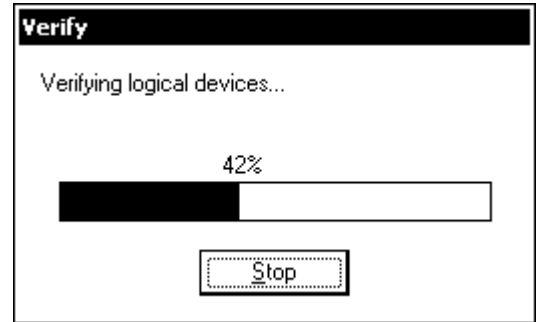

When the check is started on condition that a parity group or an HDEV is specified



When the check is started on condition that two or more parity groups are specified

(5)

When you select (CL) the [Stop] button in the “Verify” window that shows progress of the check and select (CL) the [OK] button in response to a message, “Verifying the logical devices is stopped.”, that asks whether or not to interrupt the check, the parity synchronization check is interrupted immediately.

When a PDEV that could not be checked exists, the routine goes to Step (6).

When an LDEV whose parity is not synchronized exist, the routine goes to Step (7).

When neither of the above exists, the routine goes to Step (13).

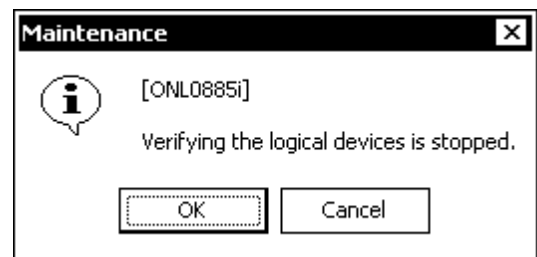

(6)

The PDEV that could not be checked is displayed.
The PDEV concerned may have not been checked because it was detached or the synchronization check was interrupted.
Check the status of the PDEV concerned after the synchronization check is terminated.

When you close the “Skip PDEV” window, select (CL) the [OK] button.

When an LDEV whose parity is not synchronized exists, if Step (9) is not displayed yet, the routine goes to Step (7), or if Step (9) has already been displayed, the routine goes to Step (9).

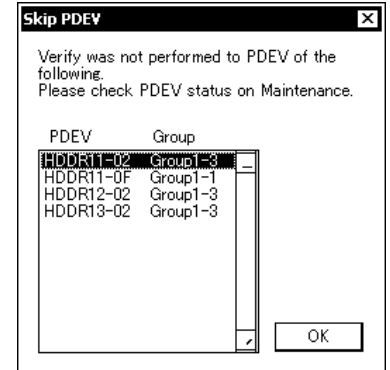

(7)

“Do you want to output the result of Verify to a file?(MAX : ***) A result file is output and compressed when “FD Copy” or “Auto Dump” is performed.” is displayed.
(Time required for processing is displayed on ***)

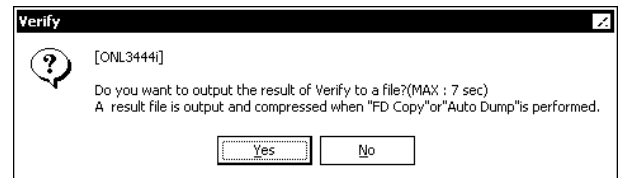

If you want to output the result to a file, select (CL) [Yes] and go to (8).

If you want to not output the result to a file, select (CL) [No] and go to (9).

(8)

“Receiving the Verify result...” is displayed.
“Compressing the Verify result...” is displayed.
“The output of a result file was completed.” is displayed.

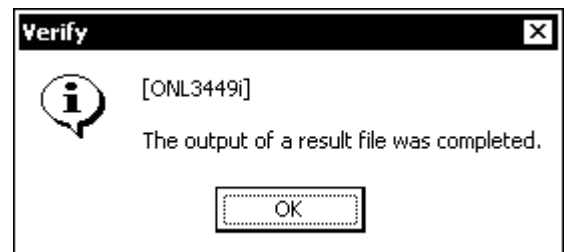

(9)

An LDEV having parity errors is displayed.
 Select (CL) an LDEV to be indicated in the 'Parity Error' dialog box and select (CL) [Detail].
 Go to (10).

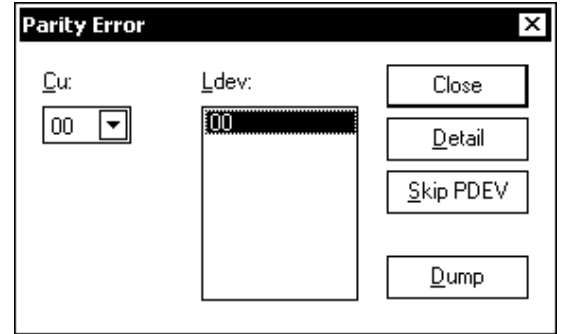

If you want close the 'Parity Error' dialog box,
 select (CL) [Close].

When select (CL) [Yes] by (7), go to (13).

When select (CL) [No] by (7), go to (12).

If you want to output the result to a file, select (CL) [Dump] and go to (7).

When you want to display the "Skip PDEV" window again, select (CL) the [Skip PDEV] button. The routine is returned to Step (6).

(10)

Detail of parity errors.
 (When "No." exist more than 17, select (CL) [Next].)

Note: For OPEN-LDEV, only LBA's are displayed. If LBA of the error slot can not be displayed, "----" is displayed in both CCHH and LBA columns.

As for "Logical Device:", LDEV#:

"XXX" of the error slot and LDEV#: "(YYY)" at the head of extension LU are displayed.

But, the LDEV at the head of extension LU doesn't display "(YYY)".

No	CCHH	Reason	PDEV#	CCHH	Stripe	CCHH	LBA	Stripe	LBA
1	053A 00	Uncheckable	HDD-R102	053A 00	053A 00	-----	-----	-----	-----
2	053A 01	Uncheckable	HDD-R102	053A 01	053A 01	-----	-----	-----	-----
3	053A 0A	Uncheckable	HDD-R102	053A 0A	053A 0A	-----	-----	-----	-----
4	053A 0B	Uncheckable	HDD-R102	053A 0B	053A 0B	-----	-----	-----	-----
5	053A 0C	Uncheckable	HDD-R102	053A 0C	053A 0C	-----	-----	-----	-----
6	053A 0D	Uncheckable	HDD-R102	053A 0D	053A 0D	-----	-----	-----	-----
7	053A 0E	Uncheckable	HDD-R102	053A 0E	053A 0E	-----	-----	-----	-----
8	053B 00	Uncheckable	HDD-R102	053B 00	053B 00	-----	-----	-----	-----
9	053B 01	Uncheckable	HDD-R102	053B 01	053B 01	-----	-----	-----	-----
10	053B 02	Uncheckable	HDD-R102	053B 02	053B 02	-----	-----	-----	-----
11	053B 0B	Uncheckable	HDD-R102	053B 0B	053B 0B	-----	-----	-----	-----
12	053B 0C	Uncheckable	HDD-R102	053B 0C	053B 0C	-----	-----	-----	-----
13	053B 0D	Uncheckable	HDD-R102	053B 0D	053B 0D	-----	-----	-----	-----
14	053B 0E	Uncheckable	HDD-R102	053B 0E	053B 0E	-----	-----	-----	-----
15	053C 0E	Uncheckable	HDD-R102	053C 0E	053C 0E	-----	-----	-----	-----
16	053C 01	Uncheckable	HDD-R102	053C 01	053C 01	-----	-----	-----	-----

* : This parity check information are separately displayed in the next/before page.

(11)

Select (CL) [Close] in the 'Detail' dialog box.
 Go to (9).

(12)

“The result of Verify is not outputted to a file. Are you sure you want to terminate processing? If you want to output the result to a file, select NO, and then select Dump button.” is displayed.

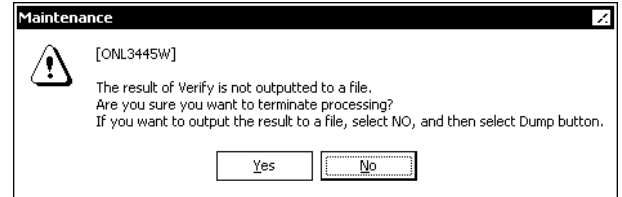

If you want to terminate processing, select (CL) [Yes] and go to (13).

If you want to output the result to a file, select (CL) [No] and go to (9).

(13)

When the parity synchronization check is not interrupted, a message, “Verifying the logical devices is finished.”, is displayed.

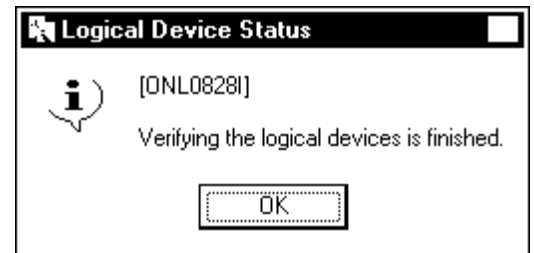

When the parity synchronization check is interrupted, a message, “Verifying the logical devices was interrupted by SVP.”, is displayed.

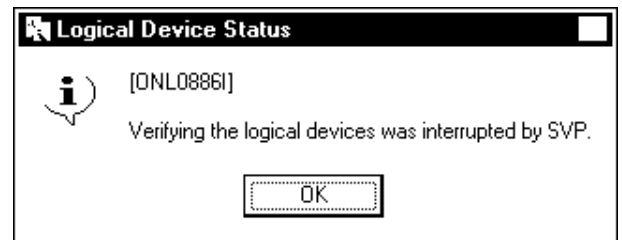

(14)

Select (CL) [close] in the ‘Logical Device Status’ dialog box.

Close the ‘Maintenance’ window.

[6] LDEV recovery for multiple PDEV failures

Refer to [SVP02-840](#).

Blank Sheet

[7] Format all blocked Logical Devices together

Notice:

Executing this operation may cause a serious error such as a system down or a data loss. Accordingly, confirmation of the appropriateness of the operation and input of a password on the succeeding password input screen is required.

(1)

Select (CL) [Logical Device Format].

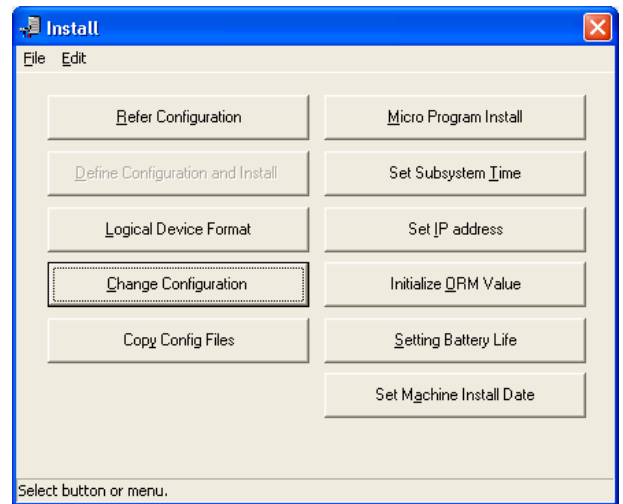

(2)

Select (CL) [Yes] in response to “This process will format blocked logical devices only. Are you sure you want to continue this process?”.

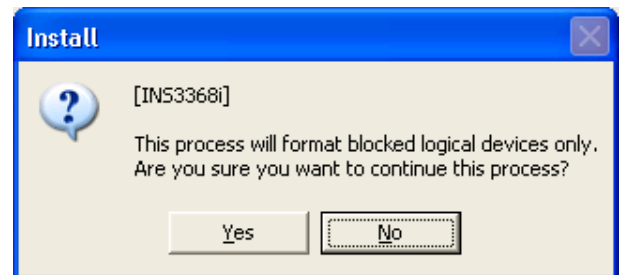

(3)

Select (CL) [OK] in response to “This process will format logical devices at low speed. When you want to format all logical devices, change the current mode to INTIAL SETUP MODE, and then retry the “Logical Device Format” operation.”.

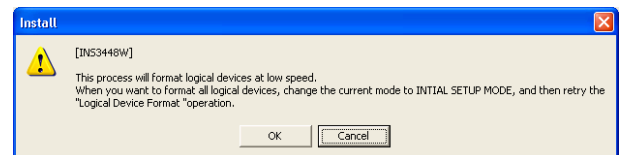

(4)

Notice:

This is a special (exceptional) operation that can cause a serious failure such as a system down or a data loss and requires an input of a password. Ask the technical support division about the appropriateness of the operation, and input the password after getting an approval of executing the operation.

“Data in the specified device may be lost due to this operation. You need the password to continue.” is displayed.

Enter the password and select (CL) [OK].

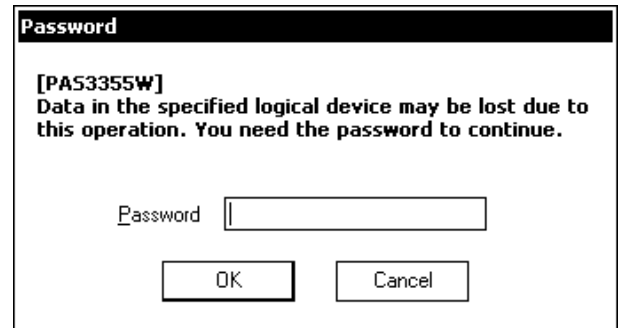

(5)

“Formatting logical devices...” is displayed.

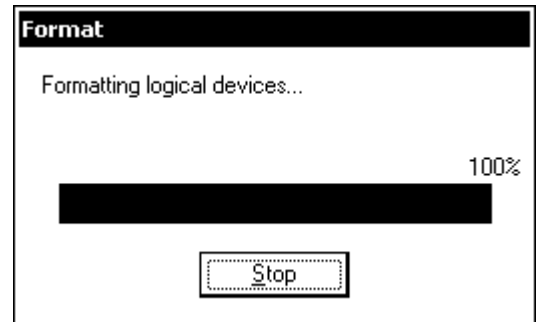

(6)

Select (CL) [OK] in response to “Formatting was finished.”.

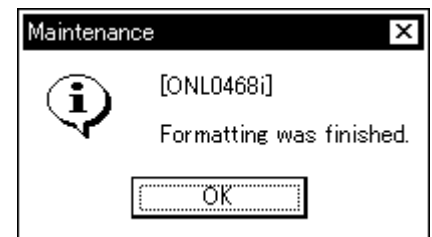

(7)

Close the 'Install' window.

2.11 Pin Data indication

Prerequisite operation

(1)

Select (CL) [Maintenance].

(2)

Select (CL) [PIN...] in the ‘Maintenance’ dialog box.

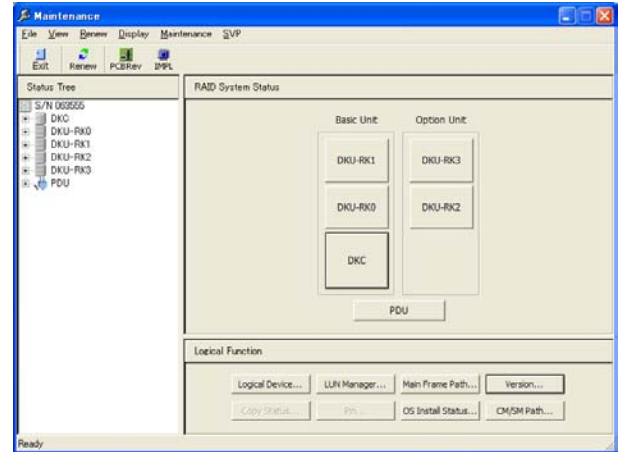

(3)

Display an LDEV with a pinned slot. Select (CL) the LDEV, details of which you want to display, in “Ldev:” and select (CL) [Detail].
----- Go to Step (4).

Note: When the pinned slot is gone, the LDEV, an occurrence of the pinned slot in which was reported by a SIM, is not displayed.

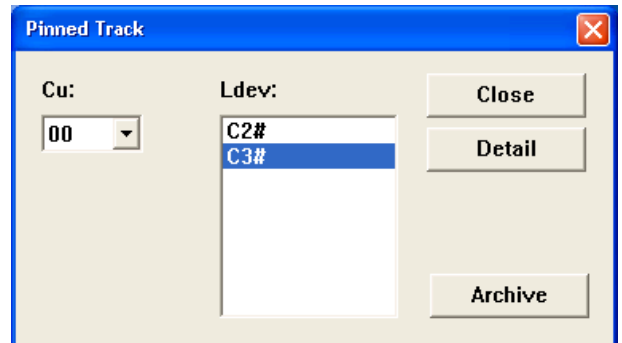

When you want to output pinned data to a file, select (CL) the [Archive] button.

----- Go to Step (5).

When you close the “Pinned Track” window, select (CL) the [Close] button.

----- Go to Step (7).

(4)

Display the detail of a Pin Slot.
(If there are more than 17 Pin Slots, the [Next] button will display other Pin Slots.)

Note: If a Pin Slot has some recoverable trouble, the detail of the Pin Slot will not be displayed. In case of OPEN-LDEV, only LBA's Pin Slots are displayed. But, if the Pin Slot of LBA's can't be displayed, "-----" is displayed in both CCHH and LBA columns.

No	CCHH	Slot	Reason	FDEV#	Strip# CCHH	Strip# LBA	LBA
1	-----	DATA	ECC/LBC error	HD002-00	-----	0000000000000000	0000000000000000
2	-----	DATA	ECC/LBC error	HD002-00	-----	0000000000000000	0000000000000011
3	-----	DATA	ECC/LBC error	HD002-00	-----	0000000000000010	0000000000000017
4	-----	DATA	ECC/LBC error	HD002-00	-----	0000000000000010	0000000000000023
5	-----	DATA	ECC/LBC error	HD002-00	-----	0000000000000010	0000000000000033
6	-----	DATA	ECC/LBC error	HD002-00	-----	0000000000000040	0000000000000039
7	-----	DATA	ECC/LBC error	HD002-00	-----	0000000000000040	0000000000000045
8	-----	DATA	ECC/LBC error	HD002-00	-----	0000000000000030	0000000000000055
9	-----	DATA	ECC/LBC error	HD003-00	-----	0000000000000030	0000000000000061
10	-----	DATA	ECC/LBC error	HD003-00	-----	0000000000000030	0000000000000067
11	-----	DATA	ECC/LBC error	HD003-00	-----	0000000000000040	0000000000000073
12	-----	DATA	ECC/LBC error	HD003-00	-----	0000000000000040	0000000000000079
13	-----	DATA	ECC/LBC error	HD003-00	-----	0000000000000040	0000000000000085
14	-----	PHY	ECC/LBC error	HD001-00	-----	0000000000000060	0000000000000091
14	-----	-----	-----	-----	-----	0000000000000060	0000000000000097
14	-----	-----	-----	-----	-----	0000000000001200	0000000000000103

Vendor Name : ----
DHC Name : ----
Serial No. : ----

Close Before Next

When you want to close the 'Detail' window, select (CL) [Close] button.

----- Return to Step (3).

(5)

"Do you want to output pinned data to a file? You can get the pinned data file by executing the FD Copy or Auto Dump," is displayed.

When you want to output the result to a file, select (CL) [Yes].

----- Go to Step (6).

When you do not want to output the result to a file, select (CL) [No].

----- Return to Step (3).

(6)

"Output of the pinned data file was completed", is displayed.

----- Return to Step (3).

(7)

Select (CL) [Close] in the 'Detail' dialog box.

Select (CL) [Close] in the 'Pin Volume' dialog box.

Close the 'Maintenance' window.

2.12 Multi PCB Replace

(1) <Set path offline>

Set the path offline from HOST when replacing CHA.

[Notes for the case where DKN-200-NGW1 (NAS Unit) is connected to this device]

[Points to be checked in advance]

Prior to this operation, if all of the following three cases applies to this device, execute [Correspondence when connecting the NAS Unit].

1. NAS Unit is connected to this device. (*1)

2. NAS Unit is in operation. (*2)

3. A failure has not occurred on the NAS Unit. (*3)

*1: Confirm with the disk array device administrator to check whether the NAS Unit is connected or not.

*2: Confirm with the NAS Unit administrator to check whether the NAS service is operating or not.

*3: Ask the NAS Unit administrator to check whether failure has occurred or not by checking with the NAS administration software, NAS Manager GUI, List of RAS Information, etc. In case of failure, execute the maintenance operation together with the NAS maintenance personnel.

[Correspondence when connecting the NAS Unit]

Confirm with the NAS Unit administrator whether it is possible to terminate the NAS service. Determine how to react according to the confirmation result.

1. If the NAS service can be terminated:

Before starting this operation, ask the NAS Unit administrator for the planned shutdown of the NAS Unit.

After completing this operation, ask the NAS Unit administrator to reboot the NAS Unit.

2. If the NAS service cannot be terminated:

When the replacement operation of CHA used by the NAS Unit is completed, the Fibre Channel path (FC path) of the NAS Unit might go into the Failure status.

Before starting the operation of the next CHA replacement, contact the NAS Unit administrator, refer to "Recovering from FC path errors" of "Hitachi NAS Manager User's Guide", confirm the FC path status and, if the status is Failure, ask for the recovery of the FC path.

In addition, if there are any personnel for the NAS Unit maintenance, ask the NAS Unit maintenance personnel to refer to "NAS IMS 2.9.8 Displaying LU Path Setting Screen (NAS IMS 02-0490)" in "DKN-200-NGW1 NAS Unit Maintenance Manual", and ask to check the status of the FC path and to recover the FC path if it is in a failure status after completing the replacement operation of CHA used by the NAS Unit.

(2) <Mode Change>

Change the mode from [View Mode] to [Modify Mode].

Select (CL) [Maintenance].

(3) <Maintenance>

The 'Maintenance' window is displayed.

Select (CL) the [Maintenance]-[Multi PCB Replace]-[Cluster n] on the menu.

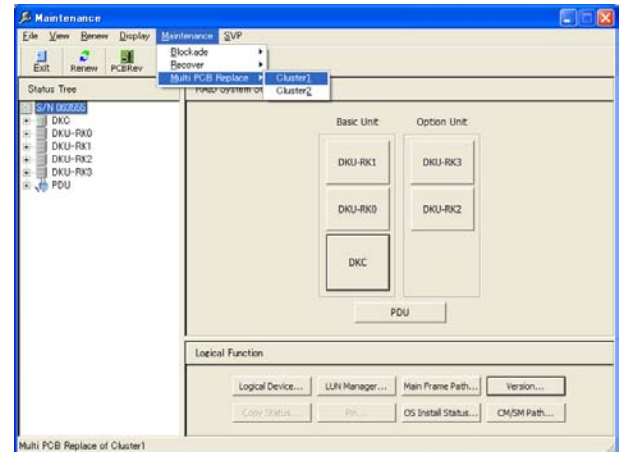

(4) <Select CHA/MIX>

Notice:

- When the subsystem is placed online, ask the customer to place it offline.
- The CUIR function is effective, and Multi PCB Replace of PCB other than Mainframe Fibre CHA and Mainframe Fibre CHA are not enforceable.
- When the screen prompting an operator to input a password in order to prevent multiple maintenance, contact the technical support division to ask for instructions.

Select (CL) CHA/MIX PCB.

Select (CL) [Replace].

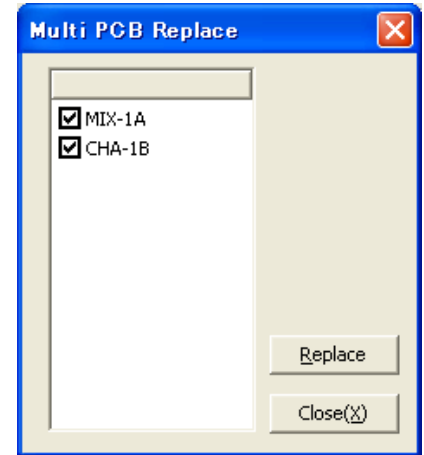

(5) <Confirm the PCB replace>

After you confirm that the PCB to be replaced is correct, select (CL) the [Yes] button in response to “Do you want to replace the PCB (MIX-1A CHA-1B)? If [Yes] is selected, the PCB needs to be removed and inserted again.”.

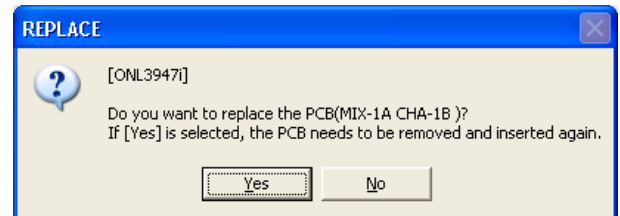

(6) <Confirm Channel Path offline>

Select (CL) [OK] in response to “Please confirm you have already varied off the concerned Channel paths. If OK, please press OK.”

If a Fibre channel adapter is installed:

After you confirm that you have stopped concerned SCSI Channel paths, select (CL) [Yes].

If a NAS adapter is installed:

After you confirm that you have stopped concerned service, select (CL) [Yes].

CHA and CHA (SCSI) exist:

After you confirm that you have stopped concerned Channel paths and SCSI channel paths, select (CL) [Yes].

CHA and CHA (NAS) exist:

After you confirm that you have stopped concerned Channel paths and service, select (CL) [Yes].

CHA (SCSI) and CHA (NAS) exist:

After you confirm that you have stopped concerned SCSI Channel and service, select (CL) [Yes].

CHA, CHA (SCSI) and CHA (NAS) exist:

After you confirm that you have stopped concerned Channel paths, SCSI Channel and service, select (CL) [Yes].

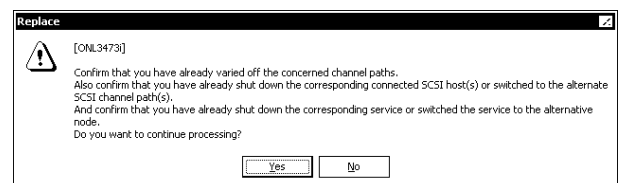
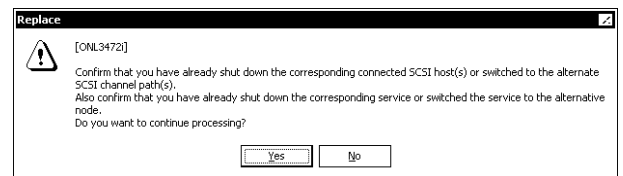
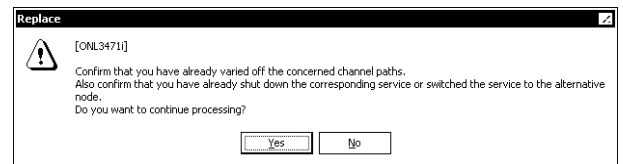
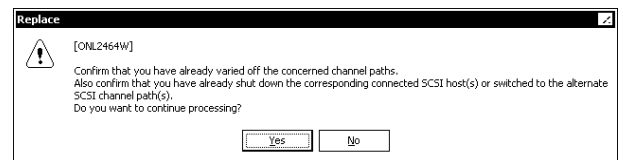
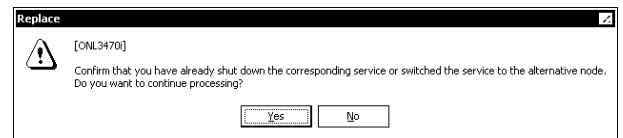
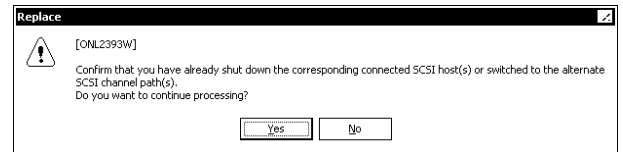
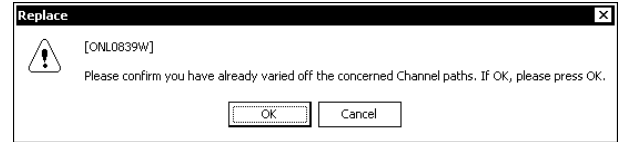

*For Mainframe Fibre CHA

The channel path offline confirmation message is not displayed when the CUIR function is effective, and the following messages are displayed.

Select (CL) [Yes] in response to:

“Do you want to execute CUIR? Do not change the path configuration of mainframe when executing CUIR”.

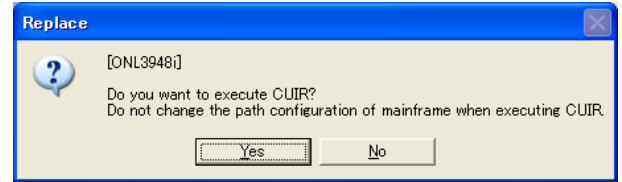

“CUIR blockade processing...” is displayed.

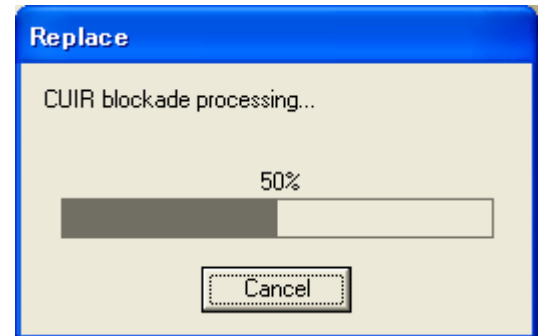

(7) <Caution message for system down>

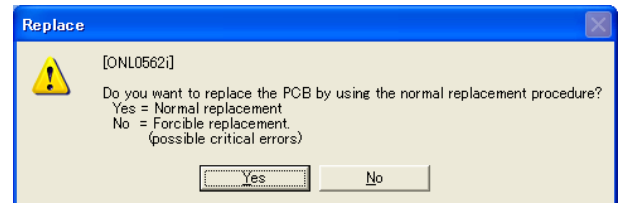

Notice:

Select (CL) [Yes] in response to the message below.

“Do you want to replace the PCB by using the normal replacement procedure?”

Yes = Normal replacement

No = Forcible replacement.

(possible critical errors)”

(8) <CHA/MIX blocking>

* For CHA

“The CHA-xx is being blocked... Usually, several minutes (maximum 15 minutes)”

* For MIX

“The MIX-xx is being blocked...”

(9) <Check to see if shut down LED is lit>

Select (CL)

* [Yes] if LED is on

* [No] if LED is off

in response to “Is the LED of the target PCB(s) lit?”.

If [No] is selected:

Select in response to “Is the LED of the target PCB(s) lit?” again.

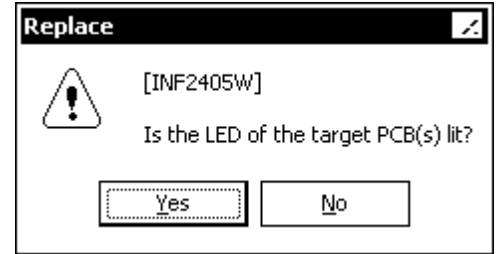
**Notice:**

If the jumper is inserted in the wrong PCB, a system down may occur.

<Forcing shut down LED on>

If [No] is selected twice:

Insert a jumper in response to “Please insert jumper into the target PCB, then pull it out without considering the status of the LED”.

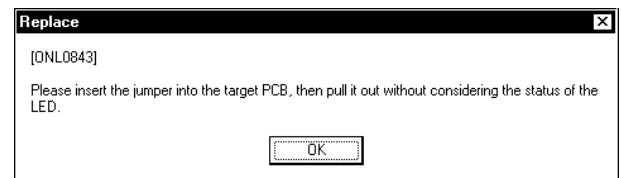

For MIX ----- HARDWARE C ([REP03-140](#))

For CHA (Serial) ----- HARDWARE D ([REP03-180](#))

For CHA (Fiber) ----- HARDWARE E ([REP03-220](#))

For CHA (MF Fibre) ----- HARDWARE F ([REP03-260](#))

For CHA (NAS) ----- HARDWARE G ([REP03-300](#))

For CHA (iSCSI) ----- HARDWARE H ([REP03-340](#))

(10) <Beginning of CHA/MIX Replacement>

“Please replace the PCB(MIX-1A CHA-1B).

After replacement, please select OK.” is displayed.

Select (CL) [OK] after replacing the PCBs.

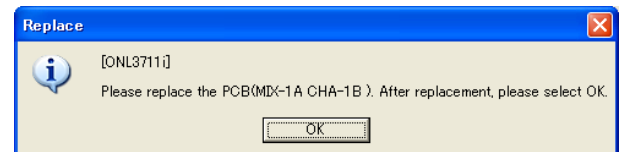

For MIX ----- HARDWARE C ([REP03-140](#))

For CHA (Serial) ----- HARDWARE D ([REP03-180](#))

For CHA (Fiber) ----- HARDWARE E ([REP03-220](#))

For CHA (MF Fibre) ----- HARDWARE F ([REP03-260](#))

For CHA (NAS) ----- HARDWARE G ([REP03-300](#))

For CHA (iSCSI) ----- HARDWARE H ([REP03-340](#))

(11)

Select (CL) [OK] in response to “Please replace the PCB(s). After replacement, please press OK.”.

“Waiting for Power Event... Usually, several minutes (maximum 15 minutes)” is displayed.

(12) <CUIR recovering when Mainframe Fibre CHA is replaced>

When the CUIR function is effective, and the following messages are displayed.

Select (CL) [Yes] in response to:

“CUIR recovery processing is executed.
Connect the cable as it was before the
blockade processing. Please select [OK] after
you finish connecting the cable.”

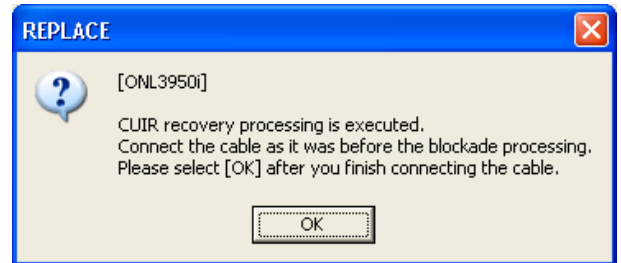

“CUIR recovery processing...” is displayed.

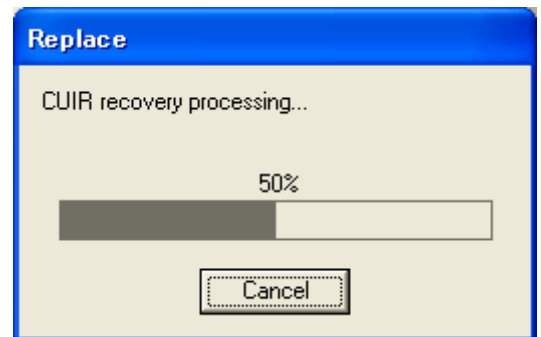

(13) <Check the recovery processing>

The following message is displayed:

* For DKA

“Restoring the DKA-xx...”

“DKA-xx is being path recovered...”

(14) <Check the end of CHA/DKA recovery>

Select (CL) [OK] in response to “Replace finished.”.

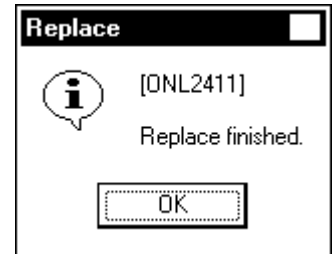

[Notes for the case where DKN-200-NGW1 (NAS Unit) has been connected to this device]

If the NAS Unit is connected to this device, ask the NAS Unit administrator to confirm the following points.

[Points to be checked after completing this operation]

1. If the NAS service is terminated:

After completing this operation, ask the NAS Unit administrator to reboot the NAS Unit.

2. If the NAS service is not terminated:

When the replacement operation of CHA used by the NAS Unit is completed, the Fibre Channel path (FC path) of the NAS Unit might go into the Failure status. Before starting the operation of the next CHA replacement, contact the NAS Unit administrator, refer to “Recovering from FC path errors” of “Hitachi NAS Manager User’s Guide”, confirm the FC path status and, if the status is Failure, ask for the recovery of the FC path.

In addition, if there are any personnel for the NAS Unit maintenance, ask the NAS Unit maintenance personnel to refer to “NAS IMS 2.9.8 Displaying LU Path Setting Screen (NAS IMS 02-0490)” in “DKN-200-NGW1 NAS Unit Maintenance Manual”, and ask to check the status of the FC path and to recover the FC path if it is in a failure status after completing the replacement operation of CHA used by the NAS Unit.

Notice:

When one or more PCBs are replaced normally, “Replace finished.” will be displayed. So please confirm PCBs’ status.

(15) <Path on-line when CHA is replaced>

When a CHA is replaced, set the path (from the host) on the replaced CHA to ONLINE by your customer.

*: (12) When <CUIR recovering when Mainframe Fibre CHA is replaced> is executed, processing concerned is unnecessary.

(16) <SIM Complete>

Go to [SVP02-520](#).

(17)

Close the 'Maintenance' window.

Change the mode from [Modify Mode] to [View Mode].

2.13 System Option

[Overview]

Change the following system option when the system operates.

- ① Spare Disk Recovering ----- Select the performance density when data is copied to a spare disk. (correction copy and drive copy)
- Interleave : Everytime 4-slot copy is completed, copy job sleeps for the time dependent on load of HOST I/O.
 - Full Speed : No sleep. (No considering HOST job)



CAUTION

Please do not use if no channel paths is varied offline.

- ② Disk Copy Pace ----- Specification of copy pace is supported with the “Interleave” mode at Spare Disk Recovering. Three modes are supported.
- Medium : Optimization mode. The copy time depends on load of HOST I/O.
 - Faster : Copy job is prior to HOST job.
 - Slower : HOST job is prior to copy job.
- ③ Copy Operation -----
- Dynamic Sparing : Copy automatically to a spare disk if disk failure exceeded the threshold value.
 - Correction Copy : Execute correction copy to a spare disk automatically when one drive has blocked.
- ④ Read Configuration Data Mode
----- To change the method of adding S/N which DKC reports by the Read Configuration Data command.
- OFF : Compatible method
 - ON : 4096 support method (default)
- ⑤ Power Lost Mode ----- Define the operation during the power supply shut down.
- Memory Backup Mode: Change to the Memory Backup Mode.
- ⑥ Cache Segment Size ----- Define the Cache Segment Size.
- ⑦ Link Fail Threshold ----- Define the threshold value to report the link failure.

- ③ WR Through----- This option sets the write through operation of each LDEV to be performed when a failure occurs in the Cache Memory PCB of one of the duplicated systems.
- Destage : ON : The write through operation is performed.
(default)
 - OFF : The write through operation is not performed.

When ON is selected (default) :

When a failure occurs in the Cache Memory PCB of one of the duplicated systems during a writing of data sent from a host, what is called the write through operation is performed in which completion of a writing is reported to the host after waiting for completion of a writing to a disk drive. Normally, select ON from the viewpoint of usability of data.

When OFF is selected :

When a failure occurs in the Cache Memory PCB of one of the duplicated systems during a writing of data sent from a host, what is called the write after operation is performed in which completion of a writing is reported to a host when the data has been written to the cache memory and it is made possible to reduce lowering of writing performance caused by the Cache Memory PCB failure. However, when the Cache Memory PCB of the other one of the duplicated systems is detached while the subsystem is operating with one of the duplicated systems, write pending data that exists in the operation mode above will be lost. Therefore, set this system option only when the LDEV concerned is duplicated to another DKC by means of the duplicated writing instructed by a host.

- (1) Change the Mode from [View Mode] to [Modify Mode].
Select (CL) [Install].

- (2) Select (CL) the [Change Configuration] menu in the 'Install' window and select (CL) [OK].

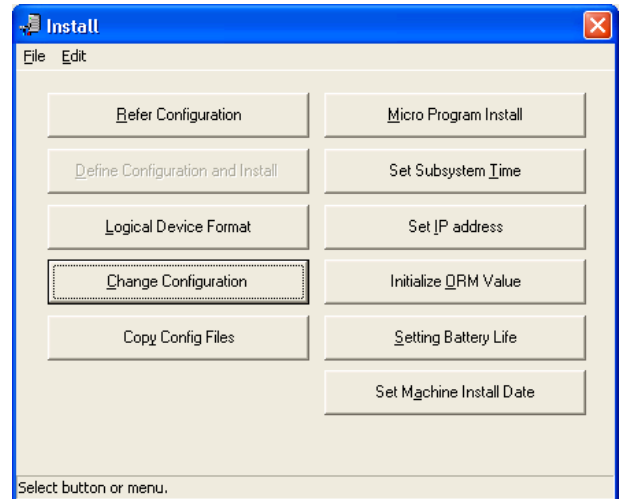

- (3) Select (CL) the [System Option] menu in the 'Menu Dialog' window and select (CL) [OK].

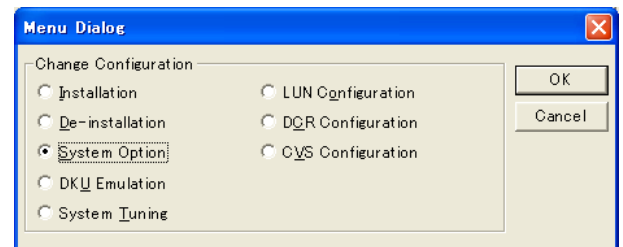

- (4) Select (CL) the desired item in the 'System Option' dialog box, and select (CL) [OK]. Go to step (5).

When [Power...] is selected (CL), the 'Power Supply' window is displayed. Go to step (4-1).

When [WR.Through] is selected (CL), the 'Synchronous Destage Mode Define' window is displayed. Go to step (4-2).

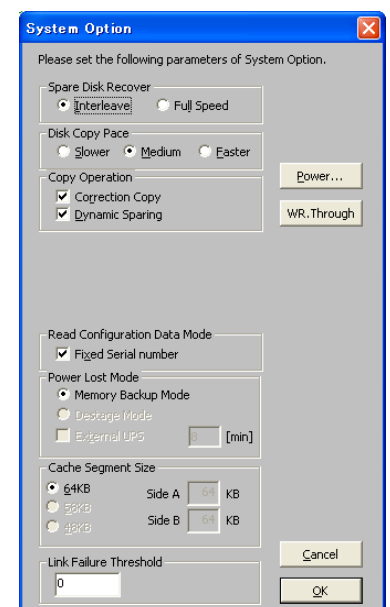

(4-1)

Set the type of PDU in 'Power Supply'.

After setting, select (CL) [OK]. Return to Step (4).

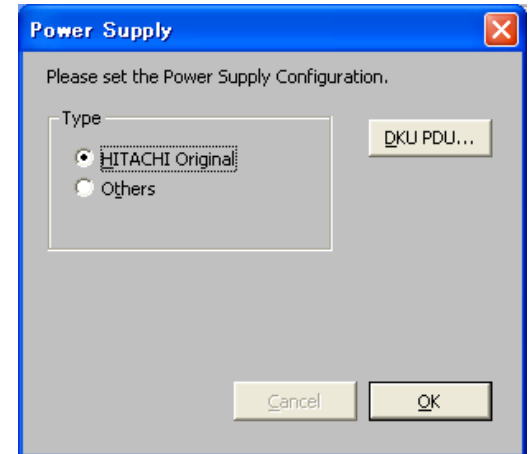

(4-2)

Set the configuration information in 'Synchronous Destage Mode Define'.

After setting all the items, select (CL) [OK]. Return to Step (4).

If you do not want to reflect the setting, select (CL) [Cancel]. Return to Step (4).

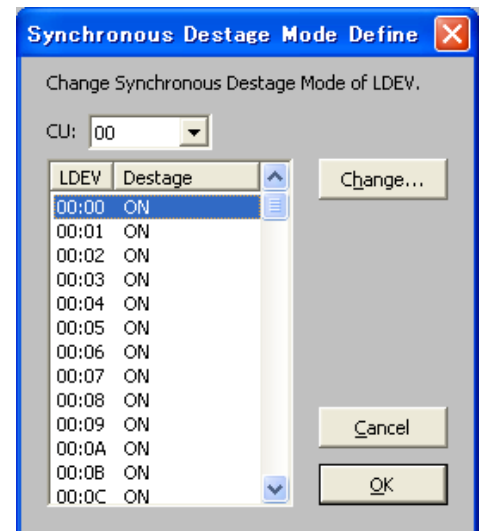

- (5) “Loading configuration...” is displayed.

- (6) “Change Configuration was completed.” is displayed.
Select (CL) [OK].

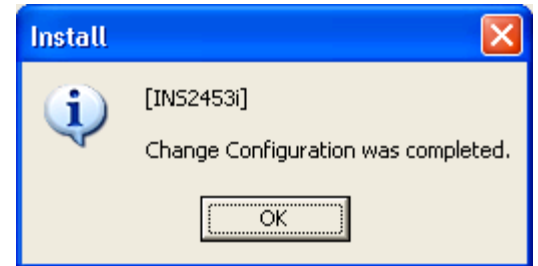

- (7) “Reading subsystem configuration data...” is displayed.
“Backup processing of configuration information will start. Please select the SVP or a client PC and insert a media.” is displayed.
Insert the Config FD into FDD of selected PC.

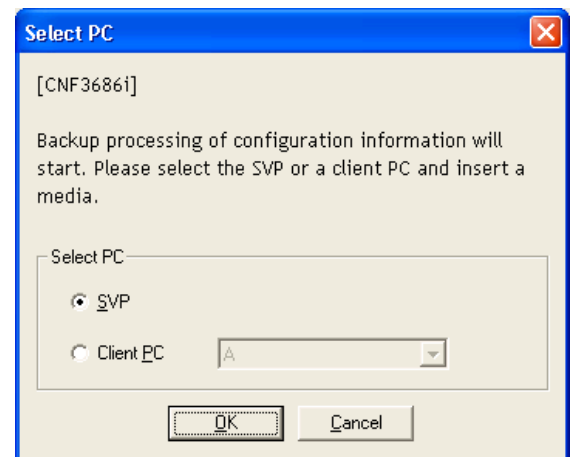

- (8) When this procedure is completed, the message “Please remove the configuration information media.” is displayed.
Remove the FD, select (CL) [OK].

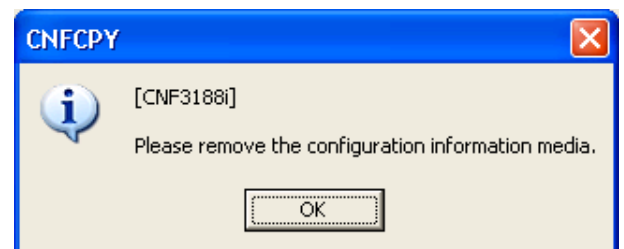

(9)

Close the 'Install' window.
Select (CL) [File]-[Exit].

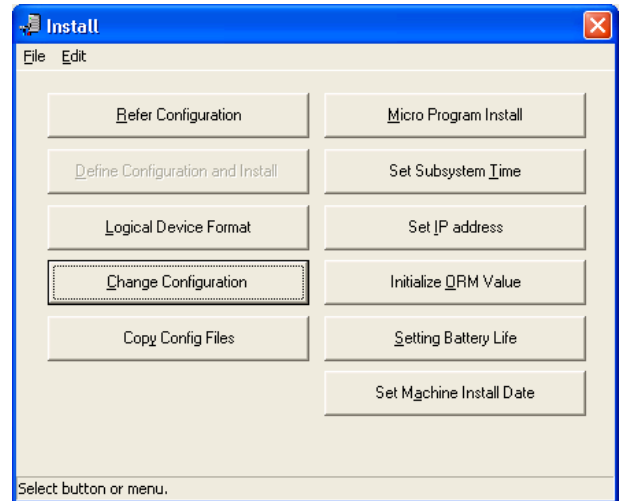

(10)

Change the Mode from [Modify Mode] to [View Mode].

2.14 Blocking of Cluster



This is a special operation. Ask the technical support division about the appropriateness of the operation.

[Notes for the case where DKN-200-NGW1 (NAS Unit) is connected to this device]

[Points to be checked in advance]

Prior to this operation, if all of the following three cases applies to this device, execute [Correspondence when connecting the NAS Unit].

1. NAS Unit is connected to this device. (*1)
2. NAS Unit is in operation. (*2)
3. A failure has not occurred on the NAS Unit. (*3)

*1: Confirm with the disk array device administrator to check whether the NAS Unit is connected or not.

*2: Confirm with the NAS Unit administrator to check whether the NAS service is operating or not.

*3: Ask the NAS Unit administrator to check whether failure has occurred or not by checking with the NAS administration software, NAS Manager GUI, List of RAS Information, etc. In case of failure, execute the maintenance operation together with the NAS maintenance personnel.

[Correspondence when connecting the NAS Unit]

Confirm with the NAS Unit administrator whether it is possible to terminate the NAS service. Determine how to react according to the confirmation result.

1. If the NAS service can be terminated:

Before starting this operation, ask the NAS Unit administrator for the planned shutdown of the NAS Unit.

After completing this operation, ask the NAS Unit administrator to reboot the NAS Unit.

2. If the NAS service cannot be terminated:

When the replacement operation of blocking of Cluster used by the NAS Unit is completed, the Fibre Channel path (FC path) of the NAS Unit might go into the Failure status. Before starting the operation of the next blocking of Cluster replacement, contact the NAS Unit administrator, refer to "Recovering from FC path errors" of "Hitachi NAS Manager User's Guide", confirm the FC path status and, if the status is Failure, ask for the recovery of the FC path.

In addition, if there are any personnel for the NAS Unit maintenance, ask the NAS Unit maintenance personnel to refer to "NAS IMS 2.9.8 Displaying LU Path Setting Screen (NAS IMS 02-0490)" in "DKN-200-NGW1 NAS Unit Maintenance Manual", and ask to check the status of the FC path and to recover the FC path if it is in a failure status after completing the replacement operation of blocking of Cluster used by the NAS Unit.

The following is an example procedure for blocking of Cluster-1.

(1)

Change the Mode from [View Mode] to [Modify Mode].
Select (CL) [Maintenance] in the 'SVP' window.

(2)

Select (CL) [Maintenance]–[Blockade]–
[Cluster n] from the menu.

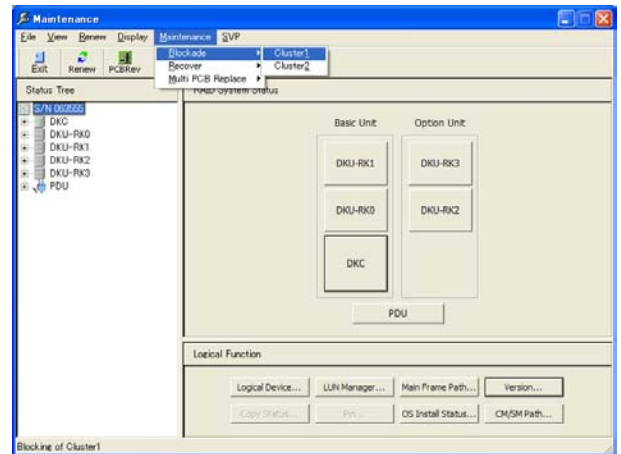

(3) <Beginning of Blocking>

Select [Yes] (CL) in response to "Please confirm the concerned channel path(s) is(are) not used. Do you want to block xxxxx?".



Valid xxxxx values are listed below.

- Cluster-1
- Cluster-2

(4)

Processing to Cluster block.

“Reading configuration...”

“Blocking cache memory...”

“Blocking shared memory...”

“Blocking CHA...”

“Blocking CHP...”

“Blocking DKA...”

“Blocking DKP...”

“Blocking CSW...”

“Blocking Cluster failure report...”

“Processing to disable the environment check...”

(5)

End of Cluster block

Select [OK] (CL) in response to “The blockade has finished. Cluster is blocked.”.



(6)

Close the ‘Maintenance’ window.

2.15 Recovering of Cluster

[Notes for the case where DKN-200-NGW1 (NAS Unit) is connected to this device]

[Points to be checked in advance]

Prior to this operation, if all of the following three cases applies to this device, execute [Correspondence when connecting the NAS Unit].

1. NAS Unit is connected to this device. (*1)
2. NAS Unit is in operation. (*2)
3. A failure has not occurred on the NAS Unit. (*3)

*1: Confirm with the disk array device administrator to check whether the NAS Unit is connected or not.

*2: Confirm with the NAS Unit administrator to check whether the NAS service is operating or not.

*3: Ask the NAS Unit administrator to check whether failure has occurred or not by checking with the NAS administration software, NAS Manager GUI, List of RAS Information, etc. In case of failure, execute the maintenance operation together with the NAS maintenance personnel.

[Correspondence when connecting the NAS Unit]

Confirm with the NAS Unit administrator whether it is possible to terminate the NAS service. Determine how to react according to the confirmation result.

1. If the NAS service can be terminated:

Before starting this operation, ask the NAS Unit administrator for the planned shutdown of the NAS Unit.

After completing this operation, ask the NAS Unit administrator to reboot the NAS Unit.

2. If the NAS service cannot be terminated:

When the replacement operation of recovering of Cluster used by the NAS Unit is completed, the Fibre Channel path (FC path) of the NAS Unit might go into the Failure status. Before starting the operation of the next recovering of Cluster replacement, contact the NAS Unit administrator, refer to "Recovering from FC path errors" of "Hitachi NAS Manager User's Guide", confirm the FC path status and, if the status is Failure, ask for the recovery of the FC path.

In addition, if there are any personnel for the NAS Unit maintenance, ask the NAS Unit maintenance personnel to refer to "NAS IMS 2.9.8 Displaying LU Path Setting Screen (NAS IMS 02-0490)" in "DKN-200-NGW1 NAS Unit Maintenance Manual", and ask to check the status of the FC path and to recover the FC path if it is in a failure status after completing the replacement operation of recovering of Cluster used by the NAS Unit.

Note: Before recovering of Cluster, please reboot SVP.

The following is an example procedure for blocking of Cluster-1.

(1)

Change the Mode from [View Mode] to [Modify Mode].
Select (CL) [Maintenance] in the 'SVP' window.

(2)

Select (CL) [Maintenance]–[Recover]–
[Cluster n] from the menu.

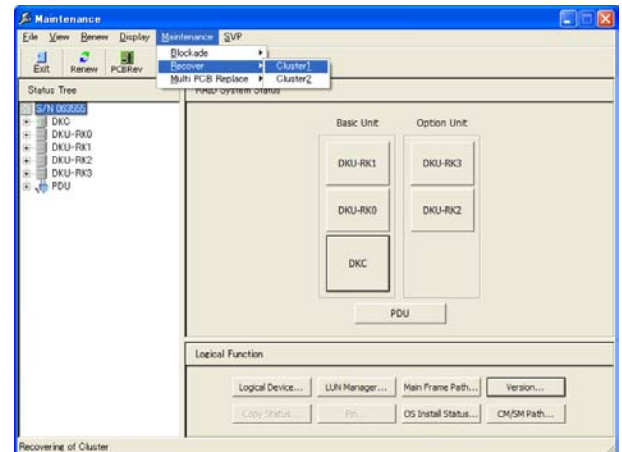

(3) <Beginning of Recovery>

Select [Yes] (CL) in response to “Do you want to recover xxxx?”.

Valid xxxx values are listed below.

- Cluster-1
- Cluster-2

If Cluster 1/2 is fail. Go to 4

If Cluster 1/2 is blockade. Go to 8

If Cluster 1/2 is normal. Go to 9

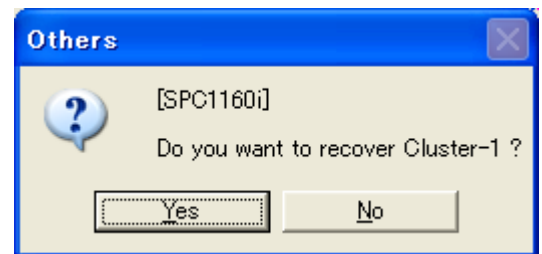

(4)

Confirm varied Off-line.

Select [OK] (CL) in response to “This operation will block xxxxx before recovery.

Please confirm the concerned channel path(s) is(are) not used. Do you want to continue?”.

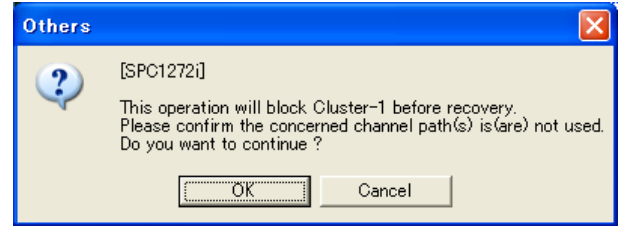

Valid xxxxx values are listed below.

- Cluster-1
- Cluster-2

(5)

Processing to Cluster block.

“Reading configuration...”

“Checking status of Cluster...”

“Blocking Cluster...”

“Blocking cache memory...”

“Blocking shared memory...”

“Blocking CHA...”

“Blocking CHP...”

“Blocking DKA...”

“Blocking DKP...”

“Blocking CSW...”

“Blocking Cluster failure report...”

“Processing to disable the environment check...”

(6)

 CAUTION

- In this section, operate only DKCPSxx and DKC BATTERY-xx in the appropriate cluster.
- Do not operate other PSs and BATTERY. Otherwise, a system down or a part failure way occur.
- This operation Lights up the SUBSYSTEM ALARM LED. Ignore the Light because it goes out with the operation of the LED TEST/CHK RST switch.

Select [OK] (CL) response to “Please perform the following operation.

“Please take the following steps.

1. Set all DKC BATTERYs in Cluster-X to OFF.
2. Set all DKC PSs in Cluster-X to OFF.
3. Set all DKC PSs in Cluster-X to ON.
4. Set all DKC BATTERYs in Cluster-X to ON.
5. Push the CHK RST switch on SSVp/MN.
6. Select [OK].”

Valid X values are listed below.

- Cluster-1: 1
- Cluster-2: 2



- (7) The SVP automatically checks the power supplies to determine if cluster is recoverable.

- (8) Processing to Cluster recover.

“Reading configuration...”

“Checking status of Cluster...”

“Restoring Cluster...”

“Checking Power on...”

“Waiting for Power Event... Usually, several minutes (maximum 15 minutes)”

“Reading configuration...”

“Restoring DKA (PDEV Spin up)...”

“Restoring DKP Path...”

“Restoring Cluster failure report...”

“Setting C-Port register...”

“Running INLINE CUDG...”

“Running CM/SM Path test...”

“Restoring shared memory...”

“Restoring cache memory...”

“Processing to enable the environment check...”

- (9) <End of Cluster Recover>
Select (CL) [OK] in response to “Recovery has finished. The cluster is enabled. The concerned channel path(s) are available. Vary the concerned channel path(s) online.”.

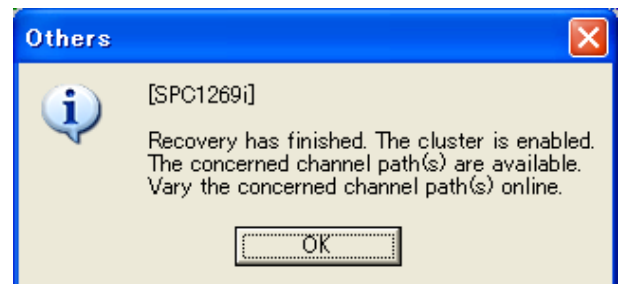

- (10) Close the ‘Maintenance’ window.

[Notes for the case where DKN-200-NGW1 (NAS Unit) has been connected to this device]

If the NAS Unit is connected to this device, ask the NAS Unit administrator to confirm the following points.

[Points to be checked after completing this operation]

1. If the NAS service is terminated:

After completing this operation, ask the NAS Unit administrator to reboot the NAS Unit.

2. If the NAS service is not terminated:

When the replacement operation of recovering of Cluster used by the NAS Unit is completed, the Fibre Channel path (FC path) of the NAS Unit might go into the Failure status. Before starting the operation of the next recovering of Cluster replacement, contact the NAS Unit administrator, refer to "Recovering from FC path errors" of "Hitachi NAS Manager User's Guide", confirm the FC path status and, if the status is Failure, ask for the recovery of the FC path.

In addition, if there are any personnel for the NAS Unit maintenance, ask the NAS Unit maintenance personnel to refer to "NAS IMS 2.9.8 Displaying LU Path Setting Screen (NAS IMS 02-0490)" in "DKN-200-NGW1 NAS Unit Maintenance Manual", and ask to check the status of the FC path and to recover the FC path if it is in a failure status after completing the replacement operation of recovering of Cluster used by the NAS Unit.

2.16 PCB/SFP Revision Display

- (1) Select (CL) [Maintenance] in the 'SVP' window.

- (2) Select (CL) [PCBRev] in the 'Maintenance' window.

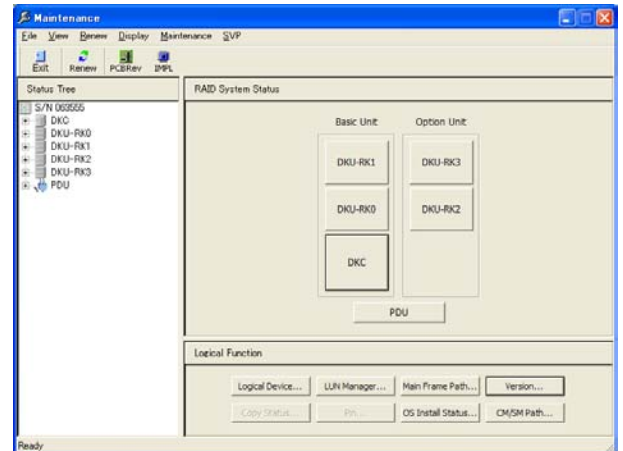

- (3) 'Reading or Writing PCB revision informations...' is displayed.

(4)

Select a PCB/MP/PORT whose revision you want to display in the 'PCB Revision Display' window.

- When [Write] is selected (CL) in the 'PCB Revision Display' window, the revision will be displayed again after the processing is completed.

(When [Write] is selected, perform (1) after changing the mode from [View Mode] to [Modify Mode].)

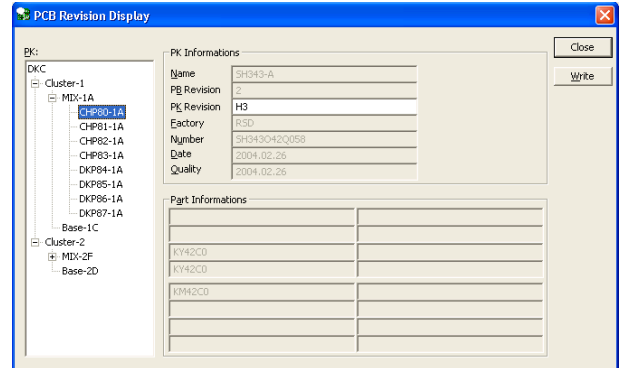

(5)

Select (CL) [Close] in the 'PCB Revision Display' dialog box.

(6)

Close the 'Maintenance' window.

2.17 Setting Battery Life

Set the Battery Life warning SIM to prompt to prepare the periodical exchange maintenance of a battery before the lifetime of the battery (3 years) equipped in the Subsystem.

Set the number of days remained until you generate [Battery Life Warning SIM] based on your maintenance plan.

(1)

Change the mode from [View Mode] to [Modify Mode].

Select (CL) [Install].

Select (CL) the [Setting Battery Life] menu in the 'Install' window.

(2)

Select (CL) [Set...] applying the check to 'Battery Life Warning SIM'. Go to step (3).

Select (CL) [Exit] button and go to Step (4).



(3)

Select (CL) [OK] after inputting the remainder days until Warning SIM is reported.

Return to step (2).

Note: After executing the periodical exchange of a battery, set 33 month (990 days).

Note: Default value is 27 month (810 days), which is 9 month earlier than the lifetime of a battery (3 years).

Determine the number of days remained based on your maintenance plan.

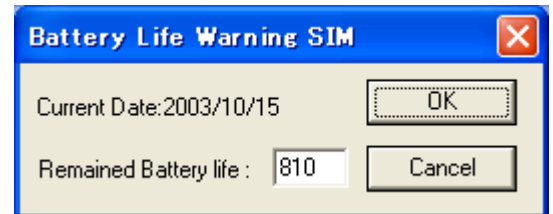

(4)

“Backup processing of configuration information will start. Please select the SVP or a client PC and insert a media.” is displayed. Insert the configuration FD into FDD of selected PC, select (CL) [OK].

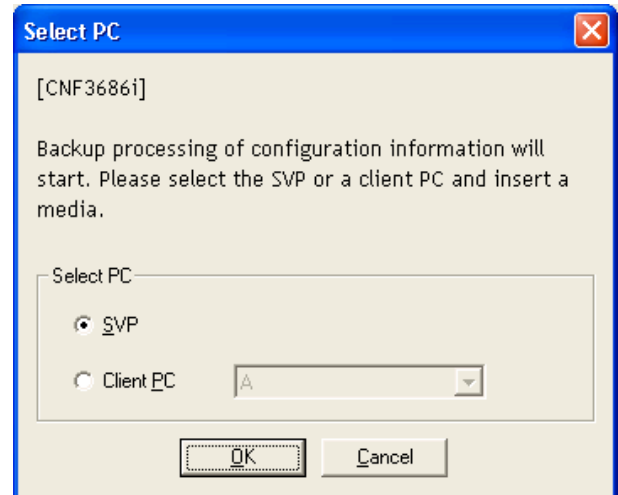

(5)

“Data in the Config FD will be overwritten due to this operation. Are you sure you want to continue?” is displayed. Select (CL) [Yes].

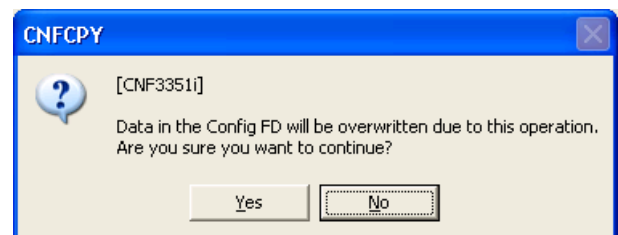

(6)

When this procedure is completed, message “Please remove the configuration information media.” is displayed. Remove the FD, select (CL) [OK].

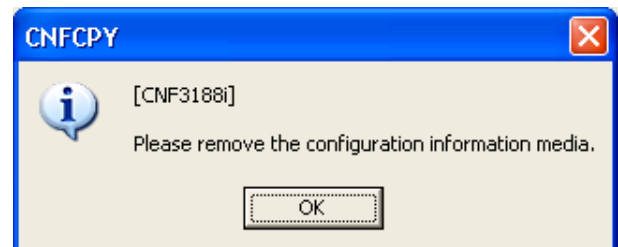

(7)

“Backup Configuration...” is displayed.

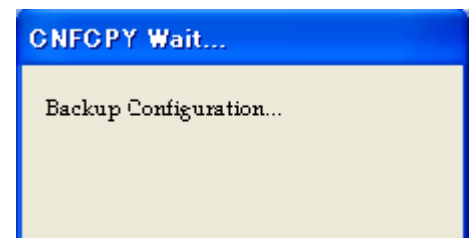

(8)

Close the 'Install' window.

2.18 Setting Machine Install Data

- (1)
Change Mode from [View Mode] to [Modify Mode].
-

- (2)
Select (CL) the [Install] in the [Modify Mode].
-

- (3)
Select (CL) the [Set Machine Install Data] menu in the 'Install' window.

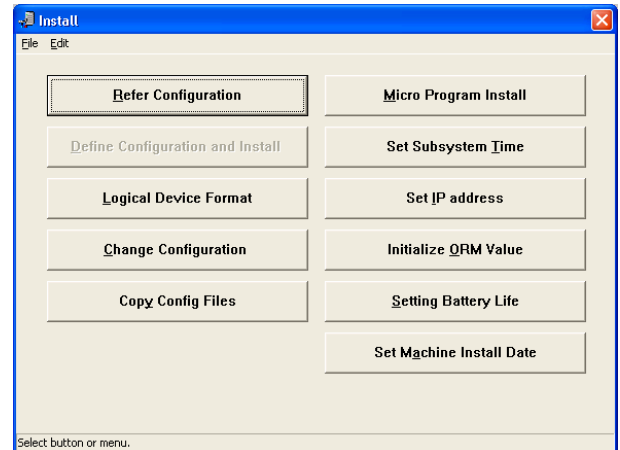

- (4)
Input the Date and Time.
Select (CL) the [OK] button.

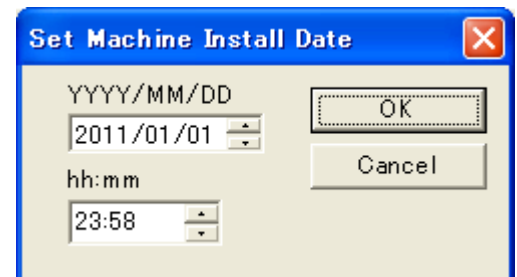

- (5) “Backup Configuration...” is displayed.

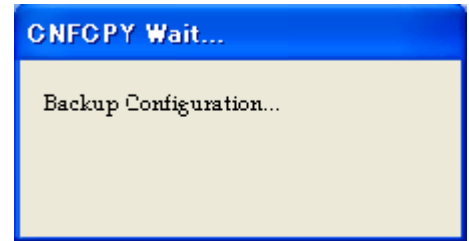

- (6) “A setting of a machine installation data has ended successfully.” is displayed.
Select (CL) the [OK] button.

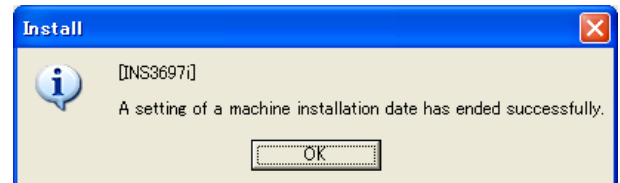

- (7) “Backup processing of configuration information will start. Please select the SVP or a client PC and insert a media.” is displayed.
Insert the Config FD into FDD of selected PC, select (CL) [OK] button.

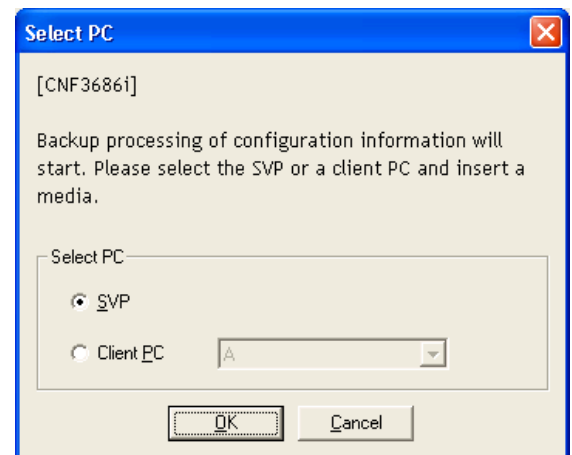

- (8) “Data in the Config FD will be overwritten due to this operation. Are you sure you want to continue?” is displayed. Select (CL) [Yes].

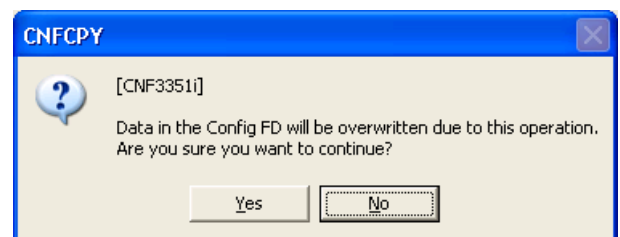

- (9) When this procedure is completed, message “Please remove the configuration information media.” is displayed. Remove the FD from FDD, select (CL) [OK] button.

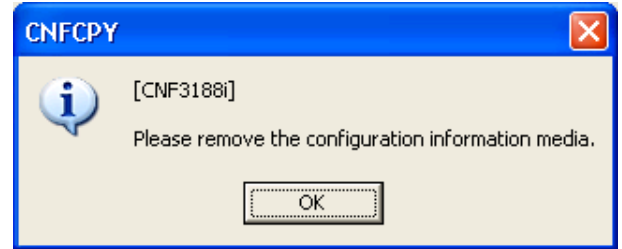

- (10) Close the 'Install' window.

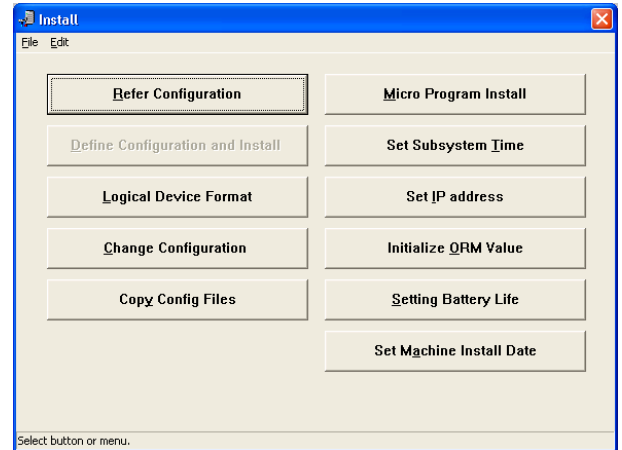

2.19 SFP type change operation

2.19.1 Batch type change

- (1) <Set path offline>

CAUTION

The path to be placed offline is that connected with the SFP concerned.

[Notes for the case where DKN-200-NGW1 (NAS Unit) is connected to this device]

[Points to be checked in advance]

Prior to this operation, if all of the following three cases applies to this device, execute [Correspondence when connecting the NAS Unit].

1. NAS Unit is connected to this device. (*1)
2. NAS Unit is in operation. (*2)
3. A failure has not occurred on the NAS Unit. (*3)

*1: Confirm with the disk array device administrator to check whether the NAS Unit is connected or not.

*2: Confirm with the NAS Unit administrator to check whether the NAS service is operating or not.

*3: Ask the NAS Unit administrator to check whether failure has occurred or not by checking with the NAS administration software, NAS Manager GUI, List of RAS Information, etc. In case of failure, execute the maintenance operation together with the NAS maintenance personnel.

[Correspondence when connecting the NAS Unit]

Confirm with the NAS Unit administrator whether it is possible to terminate the NAS service. Determine how to react according to the confirmation result.

1. If the NAS service can be terminated:

Before starting this operation, ask the NAS Unit administrator for the planned shutdown of the NAS Unit.

After completing this operation, ask the NAS Unit administrator to reboot the NAS Unit.

2. If the NAS service cannot be terminated:

When the replacement operation of SFP used by the NAS Unit is completed, the Fibre Channel path (FC path) of the NAS Unit might go into the Failure status. Before starting the operation of the next SFP replacement, contact the NAS Unit administrator, refer to "Recovering from FC path errors" of "Hitachi NAS Manager User's Guide", confirm the FC path status and, if the status is Failure, ask for the recovery of the FC path.

In addition, if there are any personnel for the NAS Unit maintenance, ask the NAS Unit maintenance personnel to refer to "NAS IMS 2.9.8 Displaying LU Path Setting Screen (NAS IMS 02-0490)" in "DKN-200-NGW1 NAS Unit Maintenance Manual", and ask to check the status of the FC path and to recover the FC path if it is in a failure status after completing the replacement operation of SFP used by the NAS Unit.

- (2) <Preparation>
Close the all SVP menu.
-

- (3) <Input password>
Select “Shift” + “Ctrl” + “F” on the SVP window.
Enter the password “RAID-SFP” and select (CL) [OK].



- (4) <Check the mode>
The ‘SFP Mode’ is Displayed.

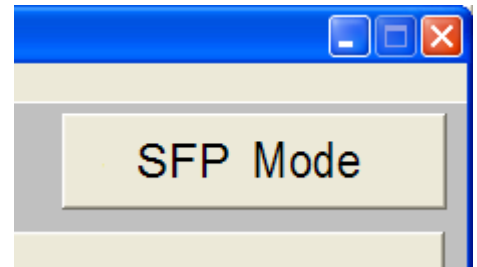

- (5) <Replace SFP>
Refer [HARDWARE T11\(REP03-760\)](#).

(6) <Set path online>

**CAUTION**

The path to be placed online is that connected with the SFP concerned.

[Notes for the case where DKN-200-NGW1 (NAS Unit) has been connected to this device]

If the NAS Unit is connected to this device, ask the NAS Unit administrator to confirm the following points.

[Points to be checked after completing this operation]

1. If the NAS service is terminated:

After completing this operation, ask the NAS Unit administrator to reboot the NAS Unit.

2. If the NAS service is not terminated:

When the replacement operation of SFP used by the NAS Unit is completed, the Fibre Channel path (FC path) of the NAS Unit might go into the Failure status. Before starting the operation of the next SFP replacement, contact the NAS Unit administrator, refer to "Recovering from FC path errors" of "Hitachi NAS Manager User's Guide", confirm the FC path status and, if the status is Failure, ask for the recovery of the FC path.

In addition, if there are any personnel for the NAS Unit maintenance, ask the NAS Unit maintenance personnel to refer to "NAS IMS 2.9.8 Displaying LU Path Setting Screen (NAS IMS 02-0490)" in "DKN-200-NGW1 NAS Unit Maintenance Manual", and ask to check the status of the FC path and to recover the FC path if it is in a failure status after completing the replacement operation of SFP used by the NAS Unit.

2.19.2 Changing type specification

(1) <Set path offline>



The path to be placed offline is that connected with the SFP concerned.

[Notes for the case where DKN-200-NGW1 (NAS Unit) is connected to this device]

[Points to be checked in advance]

Prior to this operation, if all of the following three cases applies to this device, execute [Correspondence when connecting the NAS Unit].

1. NAS Unit is connected to this device. (*1)
2. NAS Unit is in operation. (*2)
3. A failure has not occurred on the NAS Unit. (*3)
 - *1: Confirm with the disk array device administrator to check whether the NAS Unit is connected or not.
 - *2: Confirm with the NAS Unit administrator to check whether the NAS service is operating or not.
 - *3: Ask the NAS Unit administrator to check whether failure has occurred or not by checking with the NAS administration software, NAS Manager GUI, List of RAS Information, etc. In case of failure, execute the maintenance operation together with the NAS maintenance personnel.

[Correspondence when connecting the NAS Unit]

Confirm with the NAS Unit administrator whether it is possible to terminate the NAS service. Determine how to react according to the confirmation result.

1. If the NAS service can be terminated:

Before starting this operation, ask the NAS Unit administrator for the planned shutdown of the NAS Unit.
After completing this operation, ask the NAS Unit administrator to reboot the NAS Unit.
2. If the NAS service cannot be terminated:

When the replacement operation of SFP used by the NAS Unit is completed, the Fibre Channel path (FC path) of the NAS Unit might go into the Failure status.
Before starting the operation of the next SFP replacement, contact the NAS Unit administrator, refer to “Recovering from FC path errors” of “Hitachi NAS Manager User’s Guide”, confirm the FC path status and, if the status is Failure, ask for the recovery of the FC path.

In addition, if there are any personnel for the NAS Unit maintenance, ask the NAS Unit maintenance personnel to refer to “NAS IMS 2.9.8 Displaying LU Path Setting Screen (NAS IMS 02-0490)” in “DKN-200-NGW1 NAS Unit Maintenance Manual”, and ask to check the status of the FC path and to recover the FC path if it is in a failure status after completing the replacement operation of SFP used by the NAS Unit.

- (2) <Preparation>
Change the mode to [Modify Mode].
Select (CL) the [Maintenance] button.

- (3) <Maintenance window>
Select (CL) the [DKC] button in the
'Maintenance' window.

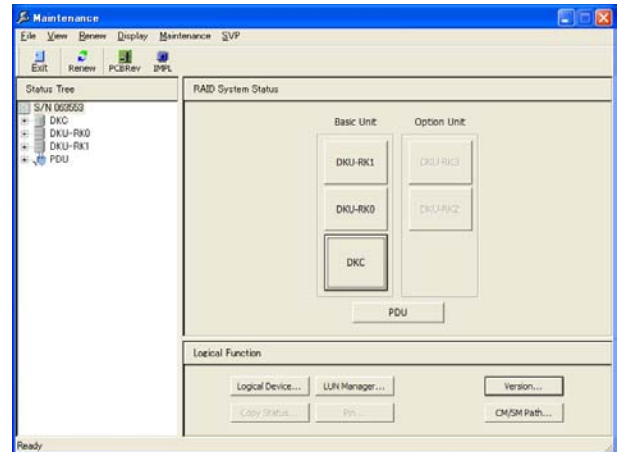

- (4) <DKC window>
Select (CL) the [Logic-Box] button in the
'DKC' window.

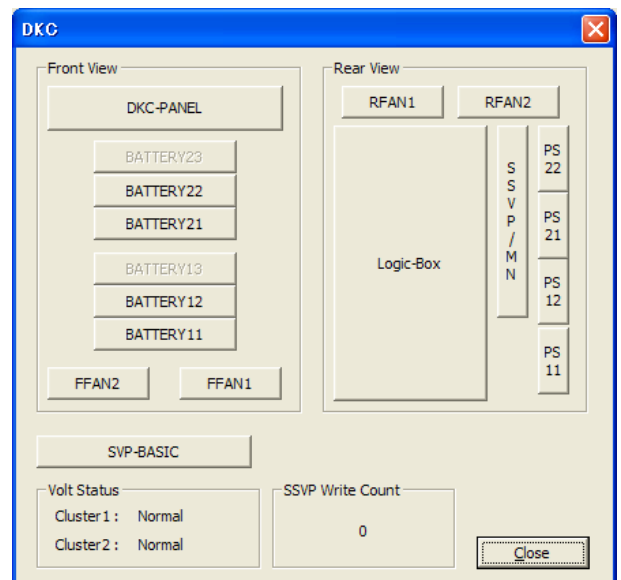

(5) <Selecting CHA/MIX>

Select (CL) the CHA/MIX for which the type change is to be made.

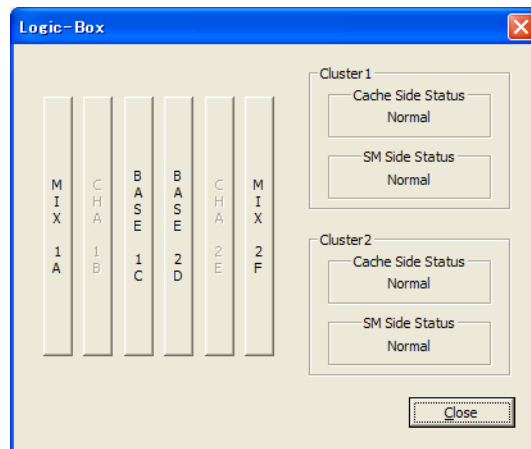

(6) <CHA/MIX window>

Select (CL) the [SFP Maintenance] button in the 'CHA'/'MIX' window.

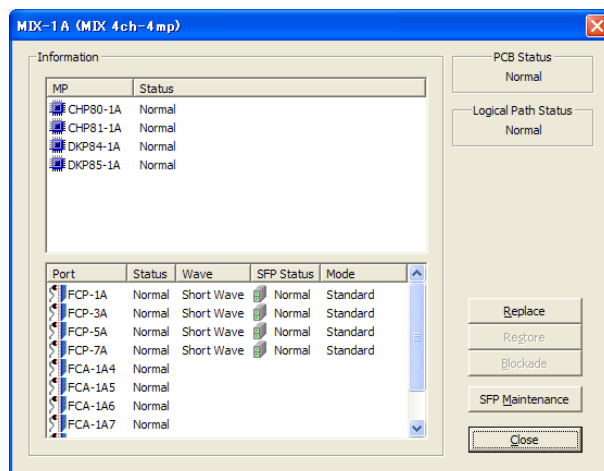

(7) <SFP type change instruction>

Select the button of the port for which the type is to be changed and select (CL) the [Type Change] button.

(The plural can be selected.)

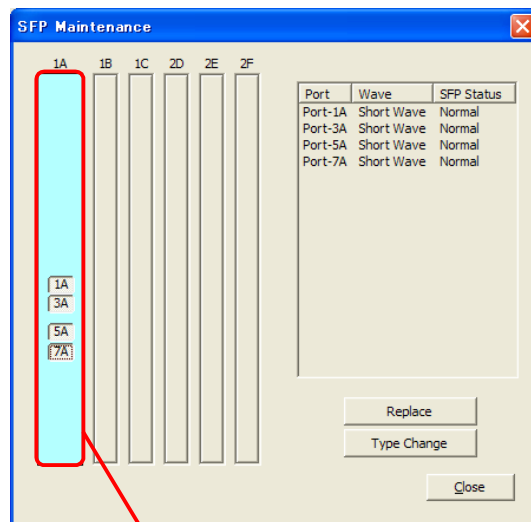

port button

(8) <Enter the password>

Notice:

This is a special (exceptional) operation that can cause a serious failure such as a system down or a data loss and requires an input of a password. Ask the technical support division about the appropriateness of the operation, and input the password after getting an approval of executing the operation.

Enter the password and select (CL) [OK].

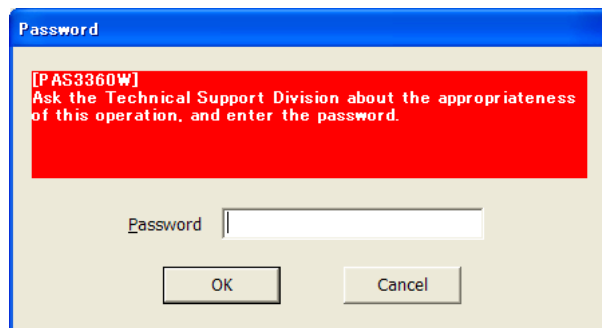

(9) <Confirming execution of the change>

After making sure that the port for which the type change is to be executed, select (CL) the [Yes] button in response to the message, “Do you replace SFP(Port-nn, ...) ?”.

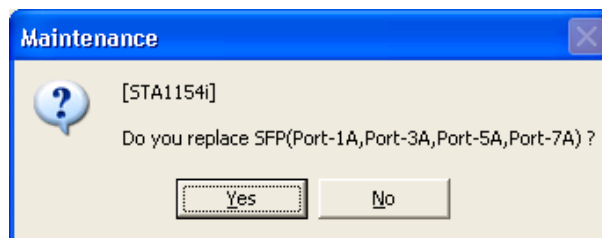

(10) <Replacing the SFP>

A message, “Please replace the “SFP(Port-nn, ...)” After replacement, press OK.” is displayed.

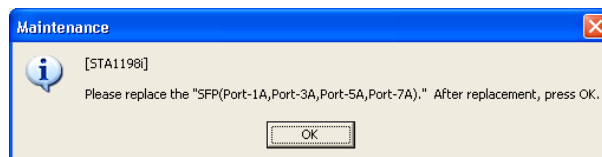

(Select (CL) [OK] after replacing the SFP.)

Refer to the hardware part replacement procedure T11 (on page [REP03-760](#)).

(11) <Set path online>

**CAUTION**

The path to be placed online is that connected with the SFP concerned.

[Notes for the case where DKN-200-NGW1 (NAS Unit) has been connected to this device]

If the NAS Unit is connected to this device, ask the NAS Unit administrator to confirm the following points.

[Points to be checked after completing this operation]

1. If the NAS service is terminated:

After completing this operation, ask the NAS Unit administrator to reboot the NAS Unit.

2. If the NAS service is not terminated:

When the replacement operation of SFP used by the NAS Unit is completed, the Fibre Channel path (FC path) of the NAS Unit might go into the Failure status. Before starting the operation of the next SFP replacement, contact the NAS Unit administrator, refer to "Recovering from FC path errors" of "Hitachi NAS Manager User's Guide", confirm the FC path status and, if the status is Failure, ask for the recovery of the FC path.

In addition, if there are any personnel for the NAS Unit maintenance, ask the NAS Unit maintenance personnel to refer to "NAS IMS 2.9.8 Displaying LU Path Setting Screen (NAS IMS 02-0490)" in "DKN-200-NGW1 NAS Unit Maintenance Manual", and ask to check the status of the FC path and to recover the FC path if it is in a failure status after completing the replacement operation of SFP used by the NAS Unit.

2.20 Setting Synchronization Information

2.20.1 Setting Synchronization Information

[Outline]

This function sets the SVP's time automatically using the SNTP protocol. To use this function, it is required that an SNTP server exists in the same LAN in which the SVP exists. After the setting is made, the SVP resets the time by referring to the specified IP address for the current time once a day at the specified time. When the setting is not made, the SVP does not make the reference.

Note: To use this function, it is required that an SNTP server exists in the same LAN in which the SVP exists.

The SVP's Time Zone is the G.M.T. (Greenwich mean time). If the other Time Zone is used, the SVP's time may not be set correctly.

This function does not work when the SVP is being maintained or the setting is being made through Storage Navigator. In such a case, the setting is postponed until the next day.

In case time set goes wrong, check a setup of a SNTP server's IP address, and a use port, and give the mode as View mode after a setup again. Moreover, the cause by the side of a SNTP server can be considered as other factors.

Note:

- Please do not execute the P/S ON procedure at the synchronization check time.
- Please do not execute collecting the LCP Dump at the synchronization check time.
- Please do not execute the port error recovery operation using the restart switch function at the synchronization check time.

Note: When an M-VOL of an HRC ASYNC pair has been created in this subsystem, if the Recordset amount reaches the Pending Update Data Rate of the ASYNC DKC option, and if the SVP's time is changed to a value exceeding the Offloading Timer of the ASYNC DKC option, the ASYNC pair may suspend.

Note: When a primary volume of an XRC Replication pair has been created in this subsystem, if the Recordset amount reaches the Level 2 threshold of the XRC Replication option, and if the SVP's time is changed to a value exceeding the Timeout of the TSO XSET command, the XRC Replication pair may suspend.

Note: When NAS is installed, it is necessary to set the same time zone for NAS Time Zone. For details, see "3.2.4 Set up the NAS Time Zone" in NAS Software Section. The setting value of NAS Time Zone needs to be the same as the time zone that is specified in NAS Manager. For the time zone setting in NAS Manager, ask SE or the customer.

- (1)
Change the mode from [View Mode] to [Modify Mode].
-

- (2)
Select (CL) [Install] in the [Modify Mode] panel.
-

- (3)
Select (CL) [Set Subsystem Time] in the
'Install' window.

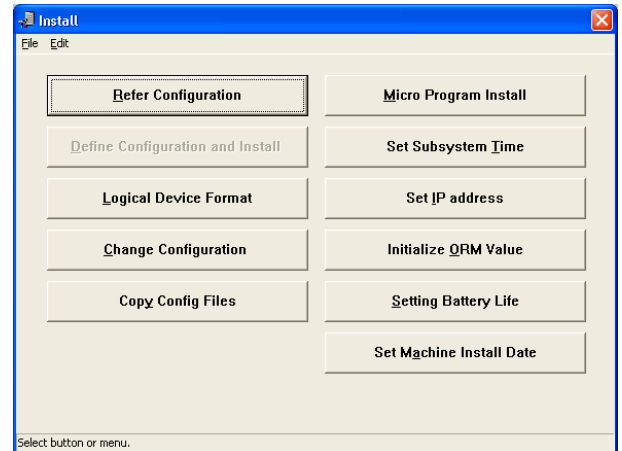

(4)

Select (CL) [Synchronization Information] in the 'Set Subsystem Time' window, and then select (CL) [OK].

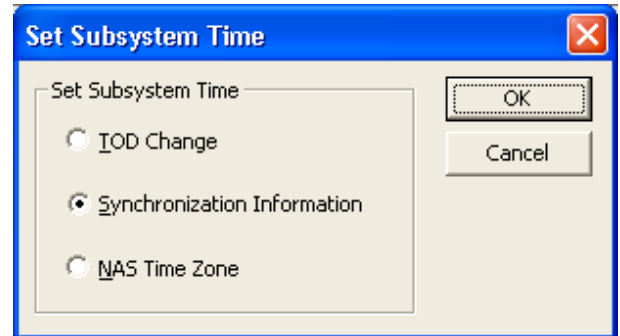

(5)

A window for specifying information for compensating the SVP's time is displayed. Set the necessary information and select (CL) [OK].

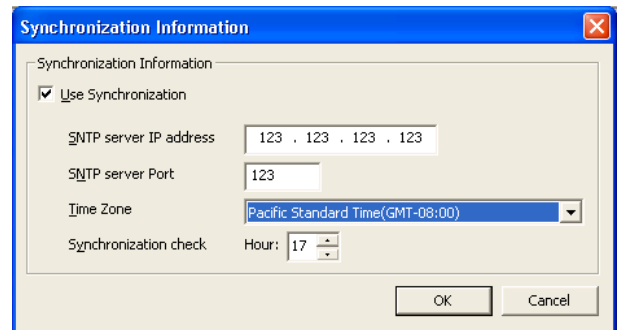

(Example: In the case of U.S. West Coast standard time)

Use Synchronization : In case of checking it, this function is valid.

In case of no checking it, this function is invalid.

SNTP server IP address : IP address of the SNTP server

SNTP server Port : Port (0 to 65535) used by the SNTP server

Time Zone : Time zone of local time

Synchronization check : Time to reset the SVP's time (0 to 23, time of 24-hour clock)

Note: The SVP TOD Set up need to be adjusted to local time until the SNTP time synchronization occurs at the hour set up in "Synchronization Check hour".

Note: Localities with Daylight savings changes will have an offset of one hour when the day time savings starts. Please not that Windows Automatic Daylight savings is not to be set on the SVP PC.

(6)

"Back up Configuration..." is displayed.

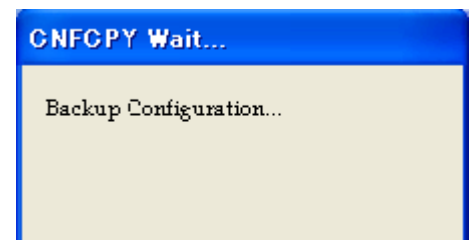

- (7) “The setting of Synchronization Information is completed.” is displayed.
Select (CL) [OK].

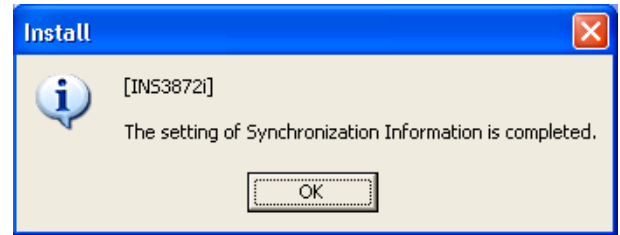

- (8) “Backup processing of configuration information will start. Please select the SVP or a client PC and insert a media.” is displayed. Set the Config FD in the FDD of the specified PC and select (CL) the [OK] button.

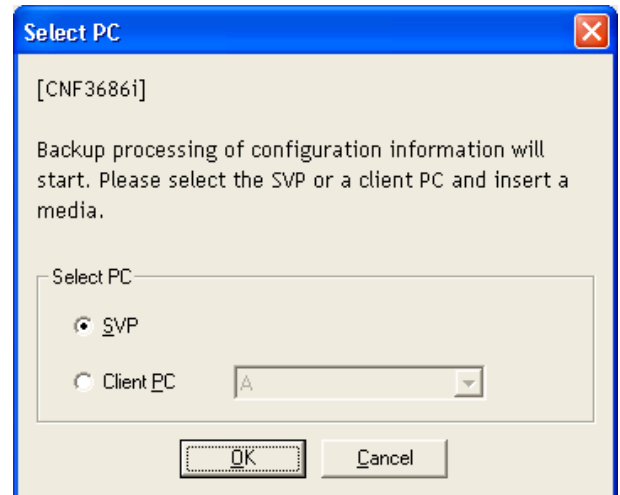

- (9) Since “Please remove the configuration information media.” is displayed when the backup of the FD is completed, pull out the FD from the FDD and select (CL) the [OK] button.

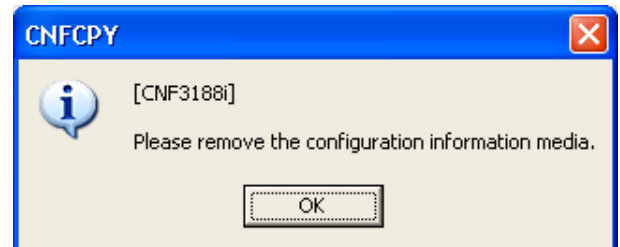

- (10) Close the ‘Install’ window.

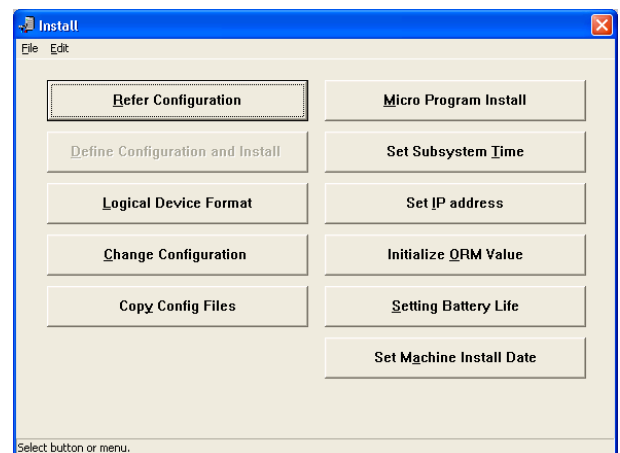

2.20.2 Confirm Setting Synchronization Information

- (1)
Select (CL) [Programs]-[Accessories]-[Command Prompt] from the [Start] menu.

- (2)
Execute command “Ping X.X.X.X” (X.X.X.X is SNTP server IP address).
Confirm it is displayed with “Reply from X.X.X.X: bytes=32 time<Xms TTL=XXX”.

When it was displayed with “Request timed out.”, stop confirmation work.

Confirm network connection with SNTP server, and please set Synchronization Information again.

- (3)
For confirmation, set temporary Synchronization check in now time of SVP, following the procedure “2.20.1 Setting Synchronization Information”.
(An example: If the existing time of SVP is 13:XX, set 13 to Synchronization check.)

- (4)
Change the mode to [View Mode] from [Modify Mode] (CL).
(SVP carry out synchronization at the time by changing in View Mode.)

- (5)
Wait for one minute, confirm that there are not the following SSB LOG. If there is not it, SVP can communicate normally.

Code=3348 : Setting failure of the SNTP time.(Connection failure to a server)
Code=3349 : Setting failure of the SNTP time.(Server does not reply)
Code=334A : Setting failure of the SNTP time.(Practice error)

When SSB LOG is created, please confirm it about setting of a use port, the Synchronization check time. If there setting are right, please confirm to a manager of an SNTP server. Please set Synchronization Information again.

- (6)
Following the procedure “2.20.1 Setting Synchronization Information”, set the setting.
Set Synchronization check following the subsystem worksheet.

2.21 CHA/MIX PCB type change operation

(1) <Combination of options whose types can be changed>

When the types of CHA and MIX PCB are changed, the combination of the options which can be changed is shown in the table below.

No.	Type Change	
	CHA before the change	CHA after the change
1	8 port adapter (8HSR)	8 port adapter (8FS2R)
2	16 port adapter (16HS/16HSR)	16 port adapter (16FS2R)
3	32 port adapter (32HS/32HSR)	32 port adapter (32FSR/32FS2R)
4	8 port adapter (8FS2R)	8 port adapter (8HSR)
5	16 port adapter (16FS2R)	16 port adapter (16HS/16HSR)
6	32 port adapter (32FSR/32FS2R)	32 port adapter (32HS/32HSR)
7	8 port adapter (8MS/8MSR/8ML/8MLR)	16 port adapter (16MSR/16MLR)
8	8 port adapter (8MS/8MSR/8ML/8MLR)	16 port adapter (16MFSR/16MFLR/16MFL4R)
9	16 port adapter (16MSR/16MLR)	16 port adapter (16MFSR/16MFLR/16MFL4R)
10	16 port adapter (16MFSR/16MFLR/16MFL4R)	16 port adapter (16MSR/16MLR)
11	16 port adapter (16MSR/16MLR) *	8 port adapter (8MS/8MSR/8ML/8MLR)
12	16 port adapter (16MFSR/16MFLR/16MFL4R) *	8 port adapter (8MS/8MSR/8ML/8MLR)
13	MIX adapter (MIX2R)	MIX adapter (MIX4R)
14	MIX adapter (MIX4R)	MIX adapter (MIX2R)

*: The emulation type of CHA should not be mixed.

(2) <Check PCB>

 CAUTION

Check whether the CHA/MIX PCB is blocked. When the CHA/MIX PCB is blocked, refer to replace section and recover the CHA.

(3) <Set path offline>

 CAUTION

The path to be placed offline is that connected with the CHA/MIX PCB concerned.

(4)

Close the all SVP menu.

(5) <Input password>

 CAUTION

This is a special (exceptional) operation that requires an input of a password. Ask the technical support division and input the password.

Select [Shift] + [Ctrl] + [B] on the 'SVP' window.
Enter the password and select (CL) [OK].



(6) <CHA Replace Mode>

The 'CHA Mode' is displayed.
And select (CL) [Maintenance].

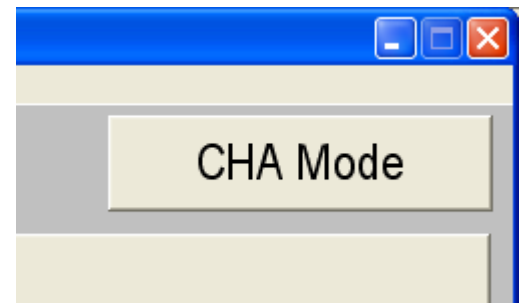

(7) <Maintenance window>

The 'Maintenance' window is displayed.
In the 'Maintenance' window, check and select (CL) [DKC] to be replaced.

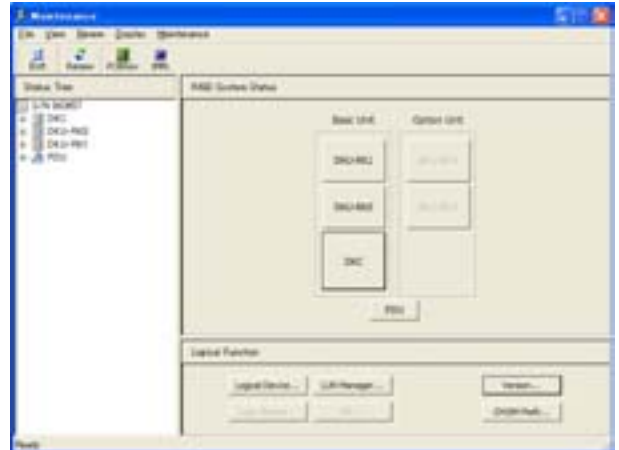

(8) <DKC window>

Select (CL) [Logic-Box] in the 'DKC'.

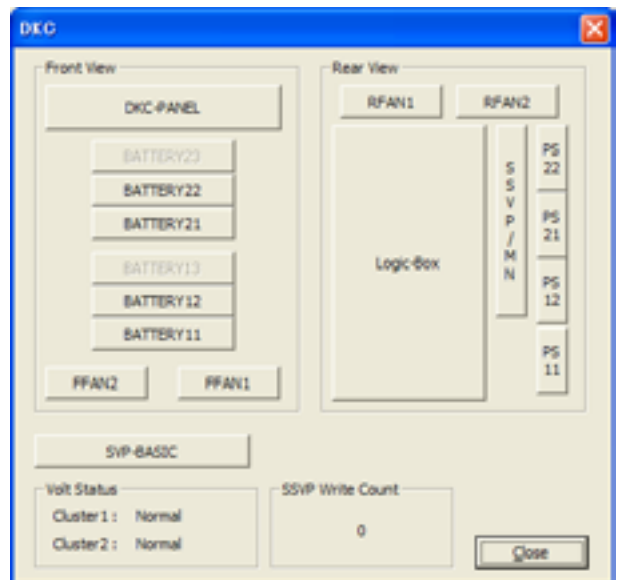

(9) <Select CHA/MIX>

CAUTION

Please execute both Clusters to the CHA/MIX PCB type change without omission.

Select (CL) CHA/MIX.

Select (CL) [Close] returns you to step (8).



(10) <Specify Replacement of CHA/MIX PCB>

 CAUTION

- When the path to the PCB to be replaced is online, ask the customer to place it offline.
- When the screen requests an operator to input a password in order to prevent multiple maintenance contact the technical support division to ask for instructions.

Select (CL) [Replace].



(11) <CHA/MIX PCB replace>

Select (CL) [Yes] in response to:

“Do you want to replace the PCB(XXX-NN)?

If [Yes] is selected, the PCB needs to be removed and inserted again.”

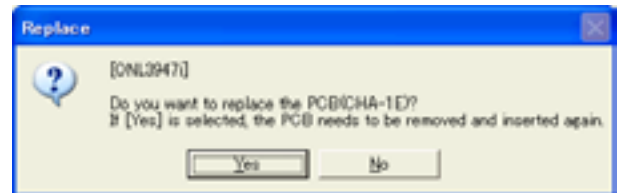

(12) <The check of CHA/MIX PCB type change>

Select (CL) [OK] in response to:

For Fibre CHA:

“This process is changing the CHA type to xxx. If you want to continue this process, please select [OK].”

(xxx is the CHA type after change.)

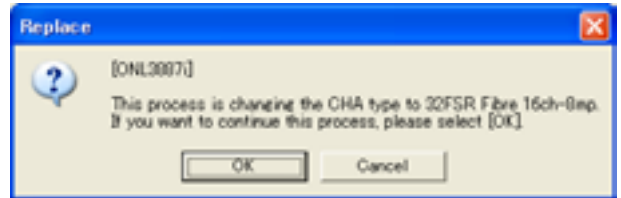

For MF Fibre CHA:

“This process changes the CHA type. If you want to continue this process, choose the PCB type after the change and select [OK].”

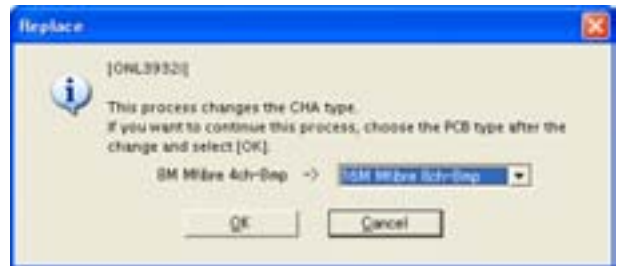

For MIX PCB:

“This process is changing the PCB type to xxx. If you want to continue this process, please select [OK].”

(xxx is the MIX PCB type after change.)

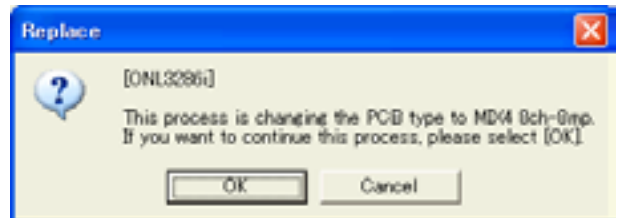

(13) <Confirm Channel Path offline>

Select (CL) [Yes] or [OK] in response to:

For Fibre CHA:

“Confirm that you have already shut down the corresponding connected host(s) or switched to the alternate channel path(s).

Do you want to continue processing?”

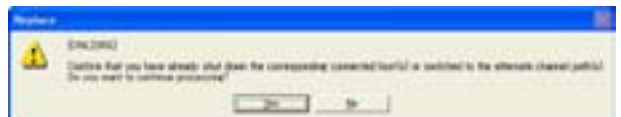

For MF Fibre CHA:

“Please confirm you have already varied off the concerned Channel paths. If OK, please press OK.”

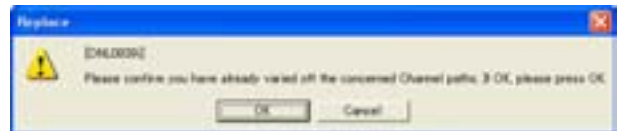

For MIX PCB:

“Confirm that you have already shut down the corresponding connected host(s) or switched to the alternate channel path(s).

Do you want to continue processing?”

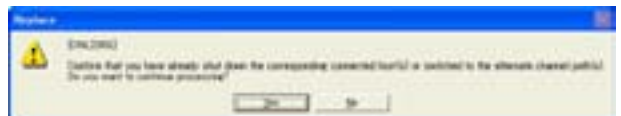

(14) <Caution message for system down>



CAUTION

Select (CL) [Yes] in response to the message below.

“Do you want to replace the PCB by using the normal replacement procedure?

Yes = Normal replacement

No = Forcible replacement.

(Possible critical errors)”



(15) <Check to see if the shut down LED is lit>

Select (CL)

* [Yes] if LED is on

* [No] if LED is off

in response to “Is the LED of the target PCB(s) lit?”.

If [No] is selected:

Select in response to “Is the LED of the target PCB(s) lit?” again.

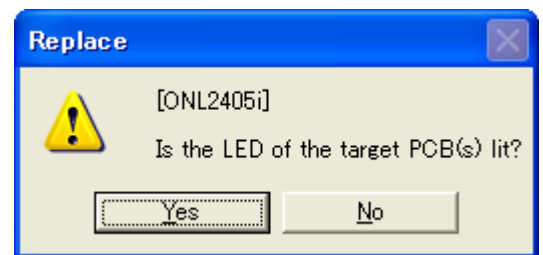

<Forcing shut down LED on>



CAUTION

If the jumper is inserted in the wrong PCB, a system down may occur.

If [No] is selected twice:

Insert a jumper in response to “Please insert the jumper into the target PCB(XXX-NN), then pull out the PCB without considering the status of the LED”.



For CHA (Fibre)----- HARDWARE E ([REP03-220](#))

For CHA (MF Fibre)----- HARDWARE F ([REP03-260](#))

For MIX PCB ----- HARDWARE C ([REP03-140](#))

(16) <Beginning of CHA/MIX PCB Replacement>

“Please replace the PCB(XXX-nn). After replacement, please select OK.” is displayed.
Select (CL) [OK] after replacing the PCBs.



(17) <Waiting for Power Event>

“Waiting for Power Event...”

Usually several minutes (maximum 15 minutes).” is displayed.

 CAUTION

When the type change operation of both clusters is not completed, a warning message is displayed, so that perform the type change operation of the other PCB.

For CHA:

“The CHA types the Cluster 1 and Cluster 2 are different. Change the CHA types, and make sure that the Cluster 1 and Cluster 2 have the same CHA type.”

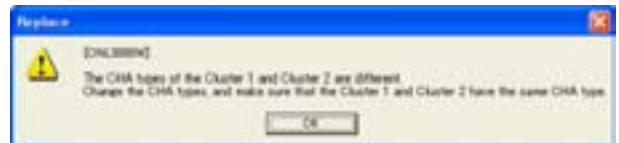

For MIX PCB:

“The MIX PCB types of the Cluster 1 and Cluster 2 are different. Change the MIX PCB types, and make sure that the Cluster 1 and Cluster 2 have the same MIX PCB type.”



(18) <Check the end of CHA/MIX PCB recovery>

Select (CL) [OK] in response to “Replace finished.”.

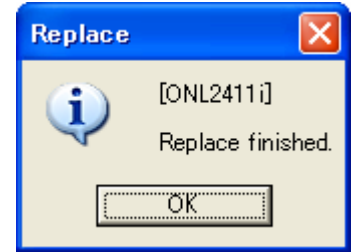

CAUTION

Confirm the version of the exchanged CHA/MIX PCB microprogram on the “STATUS” screen.

Recover according to the following flow when failing in the CHA/MIX PCB type change operation.

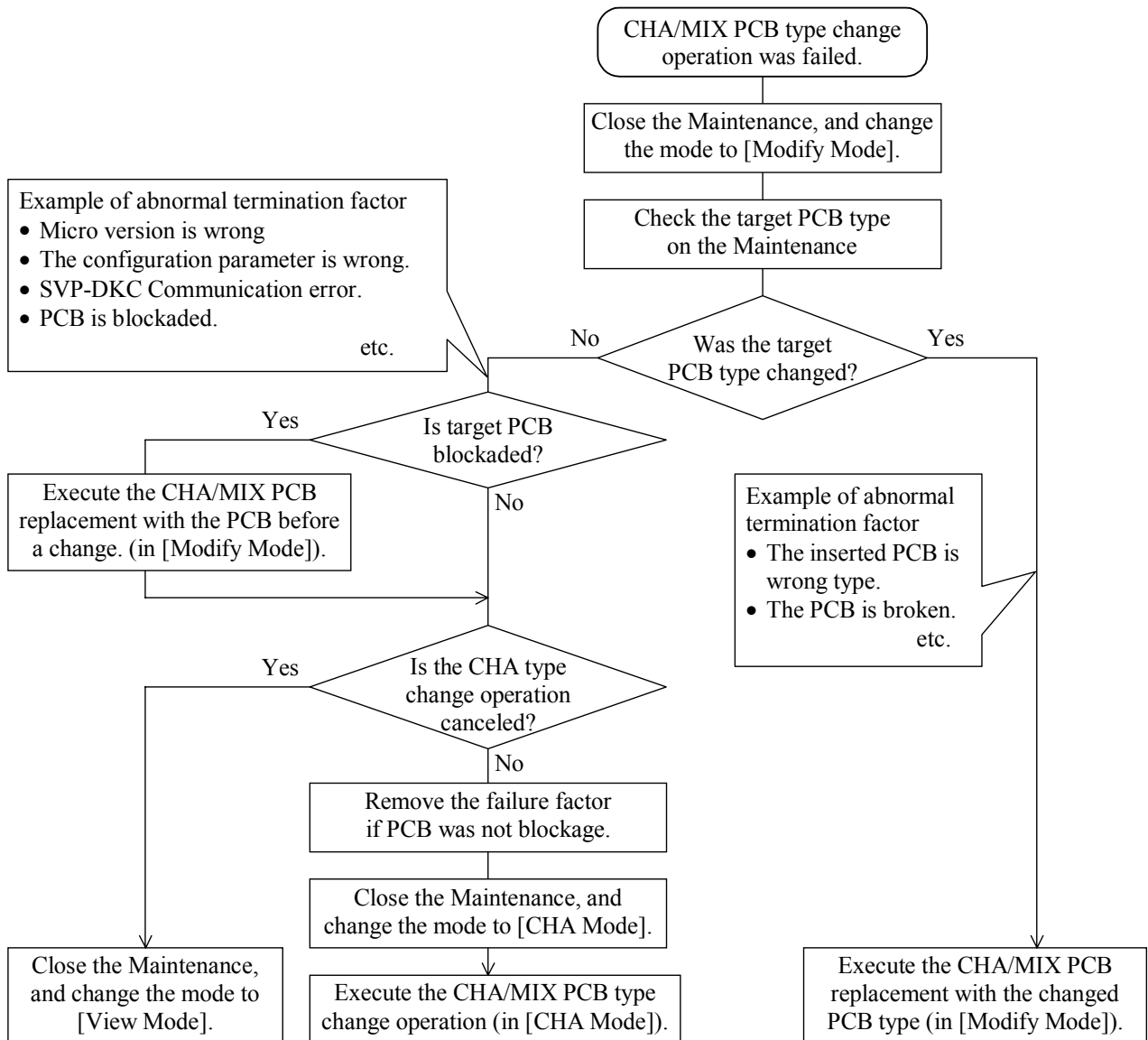

(19) <Path on-line when CHA/MIX PCB is replaced>

Whenever a CHA/MIX PCB is replaced, set the path (from the host) on the replaced CHA/MIX PCB to ONLINE by your customer.

(20)

Close the 'CHA-xx' window.

Close the 'Logic CL-n' window.

Close the 'DKC' window.

Change the mode to [View Mode].

2.22 Fixed time SVP reboot setting

2.22.1 Fixed time SVP reboot the setting method

[OverView]

Reboot of SVP is automatically performed at the time specified once per day by confirming this setup. Moreover, reboot is not performed when SVP is in the following states. In that case, reboot is postponed till the next day.

- When SVP is in Modify mode
- When StorageNavigator is used
- When RemoteConsole is used
- When FD is inserted

(1)

Select (CL) [Run...] from the [Start] menu. Enter “c:\dkc200\mp\pc\RbtSet.exe” in the “Open” box. Select (CL) the [OK] button.

(2)

Since the screen which sets up reboot time is displayed, reboot time is inputted and a check is attached to [Reboot]. Select (CL) the [OK] button.

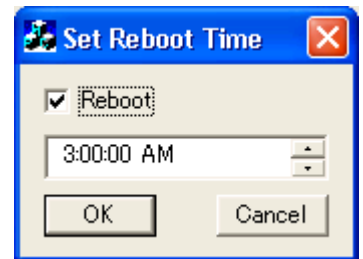

(3)

“Backup processing of configuration information will start. Please select the SVP or a client PC and insert a media.” is displayed. Set the Config FD in the FDD of the specified PC and select (CL) the [OK] button.

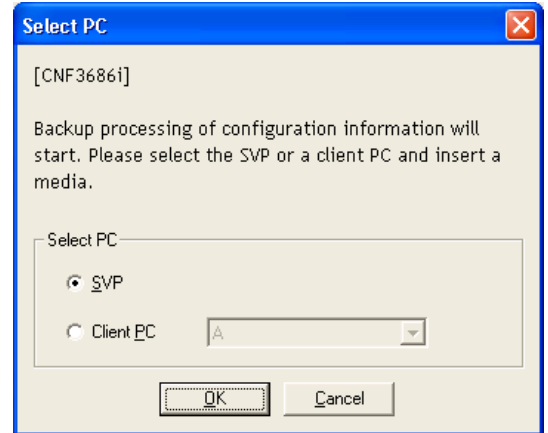

(4)

Since “Please remove the configuration information media.” is displayed when the backup of the FD is completed, pull out the FD from the FDD and select (CL) the [OK] button.

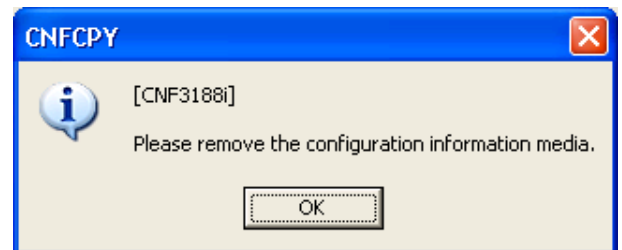

2.22.2 Fixed time SVP reboot the setting release method

(1)

Select (CL) [Run...] from the [Start] menu. Enter “c:\dkc200\mp\pc\RbtSet.exe” in the “Open” box. Select (CL) the [OK] button.

(2)

Since the screen which sets up reboot time is displayed, The check of [Reboot] is removed. Select (CL) the [OK] button.

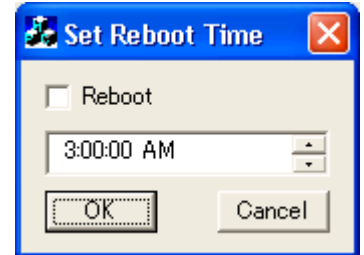

(3)

“Backup processing of configuration information will start. Please select the SVP or a client PC and insert a media.” is displayed. Set the Config FD in the FDD of the specified PC and select (CL) the [OK] button.

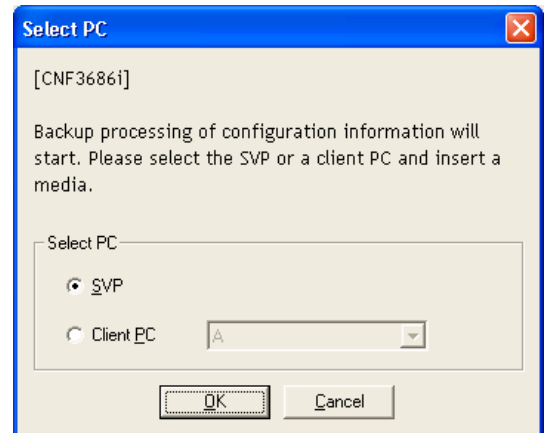

(4)

Since “Please remove the configuration information media.” is displayed when the backup of the FD is completed, pull out the FD from the FDD and select (CL) the [OK] button.

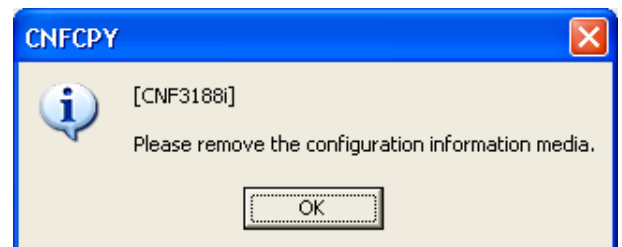

2.23 Received Windows Security Patch Display

When the Windows security patch data is delivered and it is applicable, the warning message at the right is displayed on the upper right of the window of SVP.

Windows(R) Patch(s) is Delivered.

- (1) Select (CL) the warning message displayed on the upper right of the window of SVP.

- (2) 'Delivered Windows Security Patch List' is displayed.

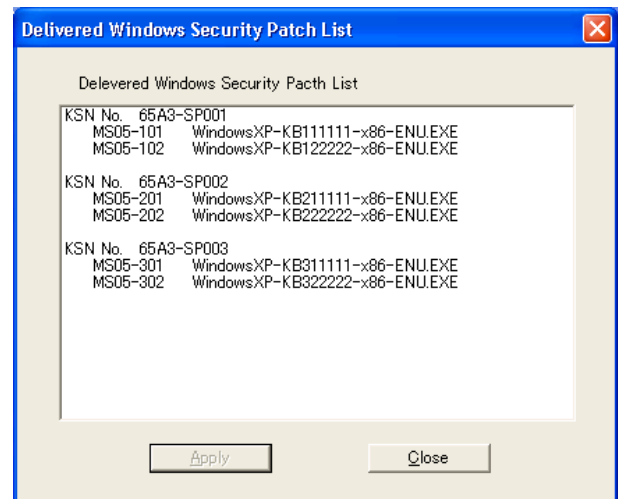

- (3) Select (CL) the [Close] button to end it.

2.24 Received Windows Security Patch Application

- (1) Change the SVP mode from [View Mode] to [Modify Mode].

- (2) Select (CL) the warning message displayed on the upper right of the window of SVP.

- (3) 'Delivered Windows Security Patch List' is displayed.

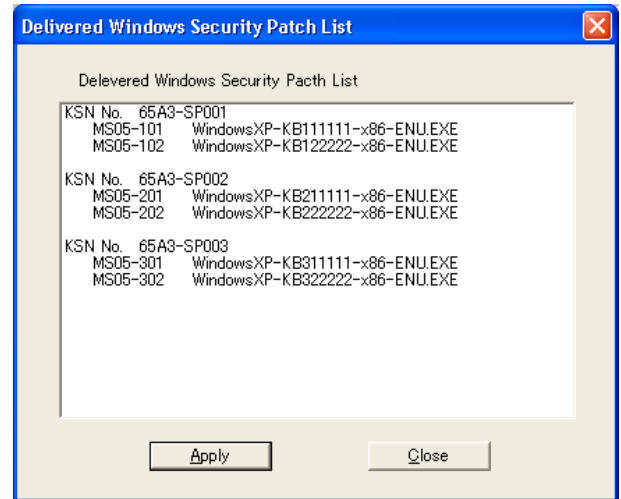

- (4) Select (CL) the [Apply] button in 'Delivered Windows Security Patch List'.

- (5) If Windows reboots and normal SVP is started normally, application is completed.

2.25 SVP Switching

This function is valid when the SVP High Reliability Kit is installed.

Notice: This operation needs that Standby SVP is a View mode.

(1) <Operation Mode Change>

Change the mode to [Modify Mode].
Select (CL) the [Maintenance] button.

(2)

Select (CL) [SVP] in the 'Maintenance' window and select (CL) [Switch SVP].

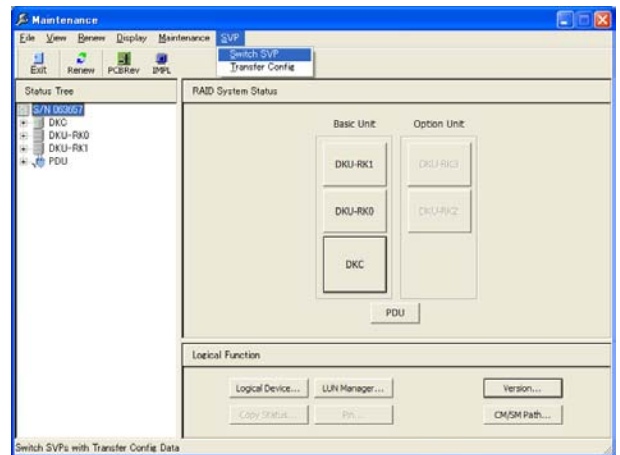

(3) <Execution>

Execute switching.
Select (CL) [Yes].

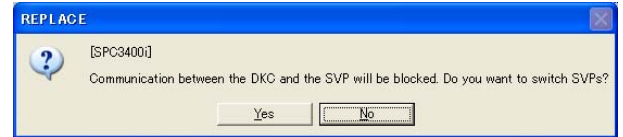

* Switching takes about 20 minutes.

(4) <Configuration Information Transfer>

The message “Transferring subsystem configuration data...” is displayed.

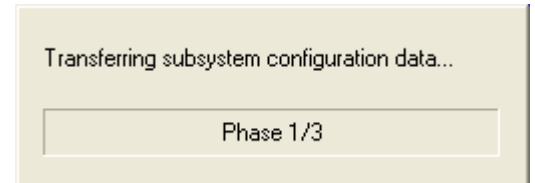

(5) <SVP Switching Start Check>

The message “Switching SVPs has started.” is displayed.
The subsystem is automatically restarted and in the Standby status by SVP switching.
(SVP and Console PC are disconnected.)

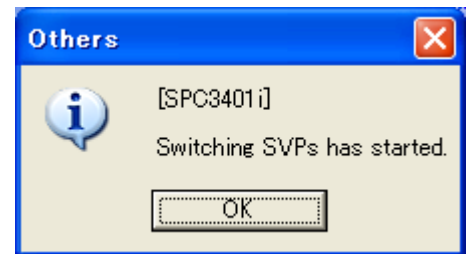

(6) <Connection to SVP after Switching Operation>

It waits for about 3 minutes until a change is completed.

After Standby SVP starts as Master SVP by the switching indication, use the connection utility connect Console PC and the switched SVP.

Select (CL) IP Address of SVP in the 'SvpConnectUtility' window and select (CL) [Connect].
(IP Address is the same with that of SVP at the time of the SVP switching indication.)

(7) <Initial Window>

Press the [Web Server Status] button.

(8) <Web Server Status Window>

If Status displays Ready, switching is completed.

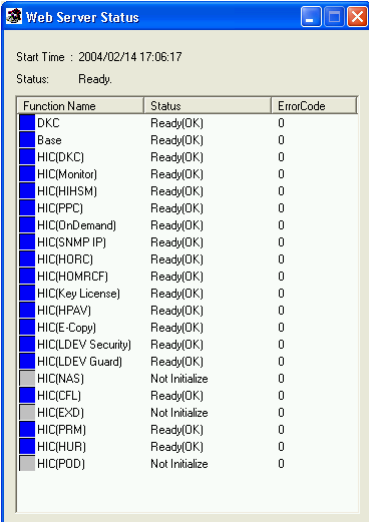

Function Name	Status	ErrorCode
DKC	Ready(OK)	0
Base	Ready(OK)	0
HIC(DKC)	Ready(OK)	0
HIC(Monitor)	Ready(OK)	0
HIC(HIHSM)	Ready(OK)	0
HIC(PPC)	Ready(OK)	0
HIC(OnDemand)	Ready(OK)	0
HIC(SNMP IP)	Ready(OK)	0
HIC(HORC)	Ready(OK)	0
HIC(HOMRCF)	Ready(OK)	0
HIC(Key License)	Ready(OK)	0
HIC(HPAV)	Ready(OK)	0
HIC(E-Copy)	Ready(OK)	0
HIC(LDEV Security)	Ready(OK)	0
HIC(LDEV Guard)	Ready(OK)	0
HIC(NAS)	Not Initialize	0
HIC(CFL)	Ready(OK)	0
HIC(EXD)	Not Initialize	0
HIC(PRM)	Ready(OK)	0
HIC(HUR)	Ready(OK)	0
HIC(POD)	Not Initialize	0

Note: The “A duplicate name exists on the network.” message may be displayed by network environment after a change. Although the message may be displayed, there is especially no problem.

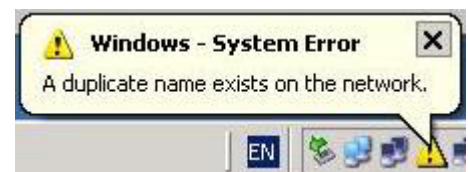

2.26 Configuration Information Transfer

This function is valid when the SVP High Reliability Kit is installed.

Notice: This operation needs that Standby SVP is a View mode.

Execute the following operation for Master SVP.

(1) <Operation Mode Change>

Change the mode to [Modify Mode].

Select (CL) the [Maintenance] button.

(2)

Select (CL) [SVP] in the 'Maintenance' window, and select (CL) [Transfer Config].

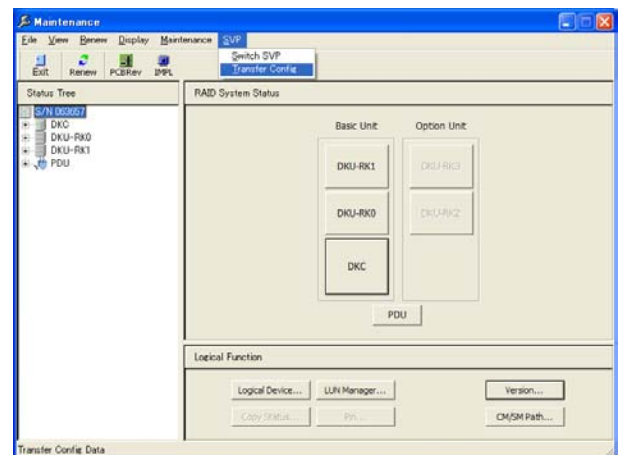

(3)

Select (CL) [Yes] for the message "Do you want to transfer configuration data?".

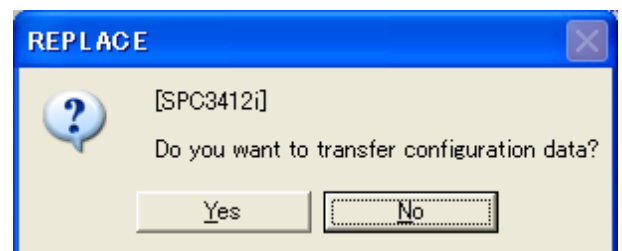

- (4) The message “Transferring subsystem configuration data...” is displayed.

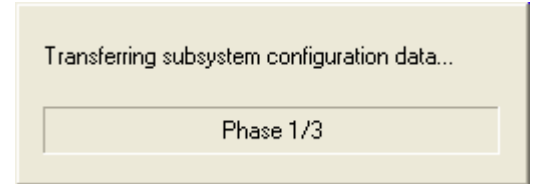

- (5) When configuration data has been transferred, the message “Configuration data has been transferred.” is displayed.
Select (CL) [OK].
If errors occur on the way, check the problems of connection and setting of the replaced SVP (Standby).

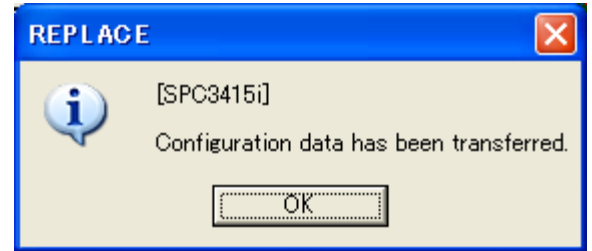

- (6) Close the 'Maintenance' window.

- (7) Change the SVP mode to [View Mode].

2.27 Change CM Module group size

- (1) Close the all SVP menu.

- (2) <Enter the password>

 **CAUTION**

This is a special (exceptional) operation that requires an input of a password. Ask the technical support division and input the password.

Press [Shift] + [Ctrl] + [C] in the 'SVP' window.
Enter the password, and select (CL) [OK].
(Please call Technical Support Division for asking it.)



- (3) <CM Replace Mode>
'CM Replace' is displayed.
Select (CL) [Maintenance].

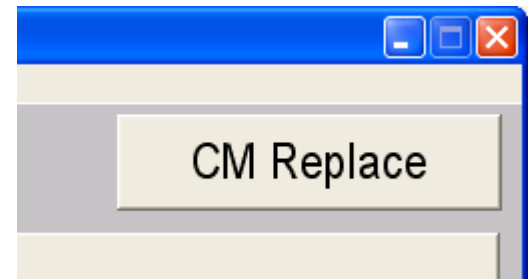

- (4) <Maintenance window>
 'Maintenance' window is displayed.
 In the 'Maintenance' window, check and select (CL) [DKC] to be replaced.

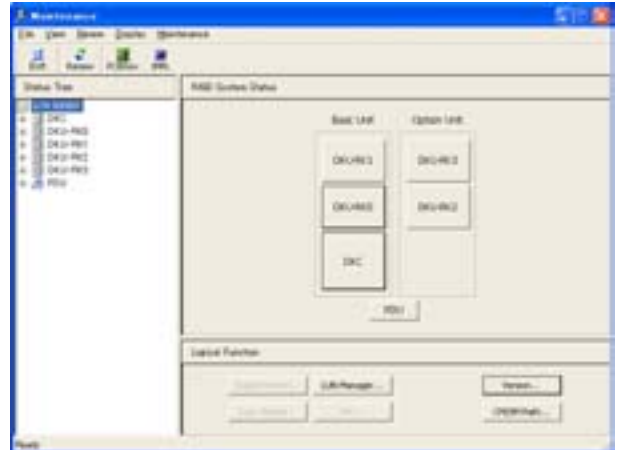

- (5) <DKC window>
 Select (CL) [Logic-Box] in the 'DKC'.

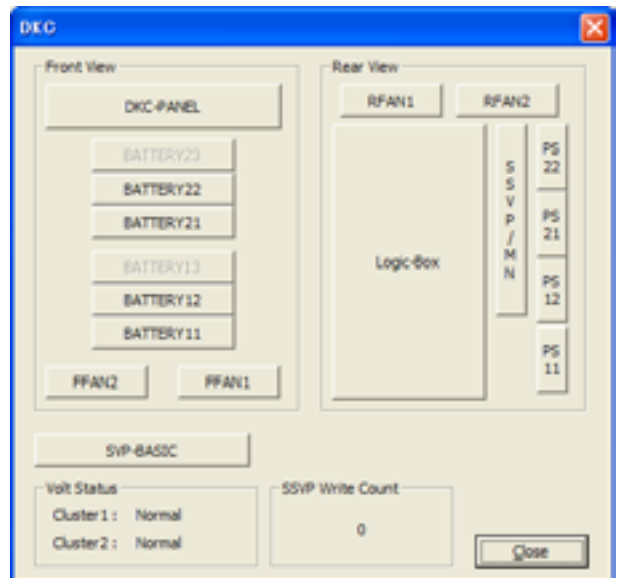

- (6) <Select BASE PCB>
 Select (CL) part.



(7) <Replace>

**CAUTION**

When the screen appears prompting the operator to input a password to prevent multiple maintenance or for executing a pin check, contact the technical support division to ask for instructions.

Check status display.
Select (CL) [Replace].

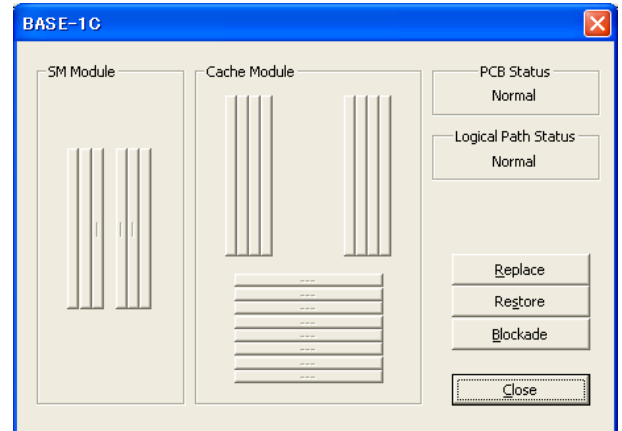

If any other message than the list is displayed, see the SVP Message Section (SVPMSG00-00).

(8) <Check beginning of cache replacement>

Select (CL) [Yes] after making sure that the package to be replaced is correct in response to:

“Do you want to replace the PCB(BASE-nn)?

If [Yes] is selected, the PCB needs to be removed and inserted again.”

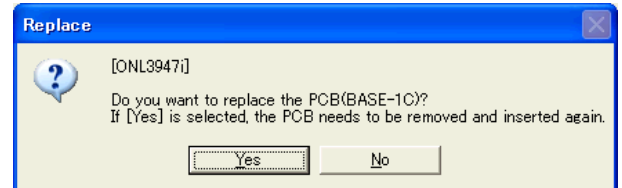

(9) <Change the Cache Memory Module Size>

Check module size, and select (CL) [OK] in response to:

“The CMG size will be changed.

xxxxMB -> xxxxMB

The shared memory will be blocked in this processing.”

(xxxx is CMG of before and after size.)

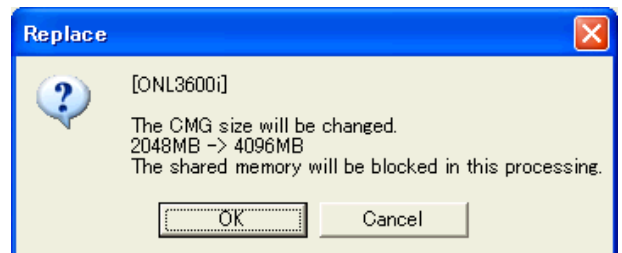

(10) <Addition of the battery>

Do not press the [OK] button at this time yet.
When addition of the battery is required, a message, “Insert the battery assembly (BATTERYnn BATTERYnn), and then select OK.” is displayed.

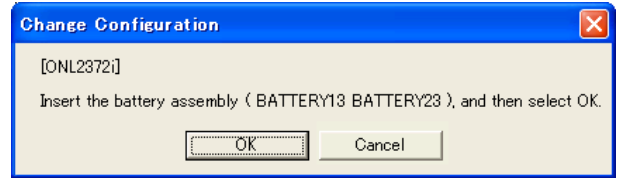

When the message is displayed, install the hardware component following “3. Install the Additional Battery” on page [INST03-09A-50](#).

When the message is not displayed, go to step (11).

(11) <Cache blocking>

“The Shared Memory PCB(BASE-nn) is being blocked.” is displayed.

“The Cache Memory PCB(BASE-nn) is being blocked.” is displayed.

(12) <Check shut down LED>

Select (CL)

* [Yes] if LED is on

* [No] if LED is off

in response to “Is the LED of the target PCB(s) lit?”.

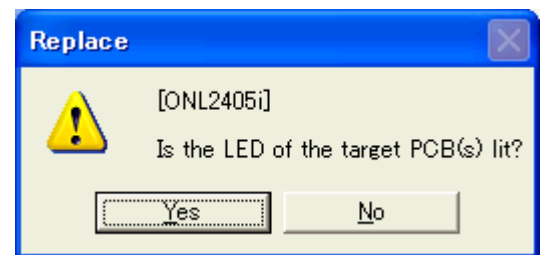

When [No] is selected, the same message is displayed again. Check the LED and then reply to a message.

<Forcing shut down LED on>

 CAUTION

If the jumper is inserted in the wrong PCB, a system down may be caused.

If [No] is selected:

Insert a jumper in response to “Please insert the jumper into target PCB(BASE -nn), then pull out the PCB without considering the status of the LED”. (Refer [REP03-90](#))

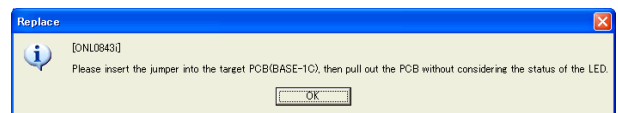

(13) <Cache Replacement>

At this point refrain from pressing the [OK] button.

“Replace the Cache Memory PCB. When you finish replacing the PCB, please select OK.” is displayed.

Make sure of the installation location and size of the module to be added and insert the correct module in the correct location.

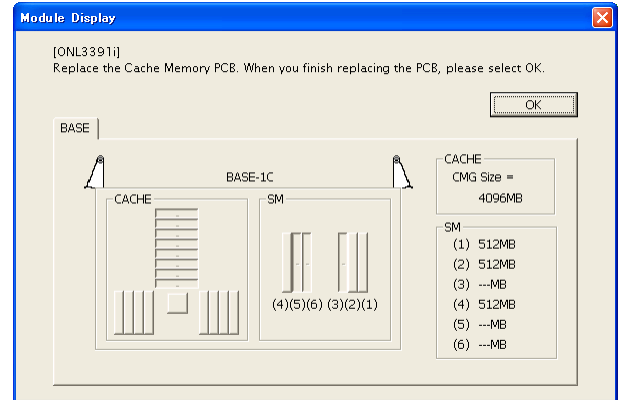

(Uninstalled module is displayed as looks depressed.)

(14) <Replace Cache module>

Replace cache module.

And select (CL) [OK].

See HARDWARE B ([REP03-80](#))

(15) <Restoring the Cache Memory>

“Restoring the Cache Memory PCB(BASE-nn)...” is displayed.

(16) <Restoring the Shared Memory>

“Restoring the Shared Memory PCB(BASE-nn)... ” is displayed.

(17) <De-installation of the battery>

Do not press the [OK] button at this time yet.
When de-installation of the battery is required, a message, “Pull out the battery assembly (BATTERYnn BATTERYnn), and then select OK.” is displayed.

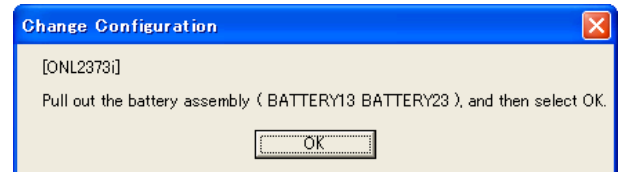

When the message is displayed, remove the hardware component following the procedure for removing the battery.

When the message is not displayed, go to step (18).

- (18) <Check the end of Cache/Shared Memory recovery>
Select (CL) [OK] in response to “Replace finished.”.

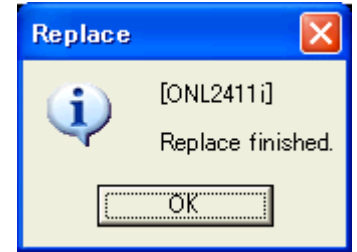

- (19)
Close 'BASE-nn' window.
If finishing in the Cluster-2 side, go to (21).

- (20) <Change the Cache Memory module size in Cluster-2 side>
Perform steps (5) to (16).
Select [BASE-2D].

- (21)
Close 'DKC' window.
Close 'Maintenance' window.
Change the mode to [View Mode].

2.28 Setting IP address

- [1] In case of SVP and DKC ----- SVP02-1540
 [2] In case of SVP ----- SVP02-1570

[1] In case of SVP and DKC

(1)

Change the mode from [View Mode] to [Modify Mode].

(2)

Select (CL) [Install] from the 'SVP' window.

(3)

Select (CL) [Set IP address] from the 'Install' window.

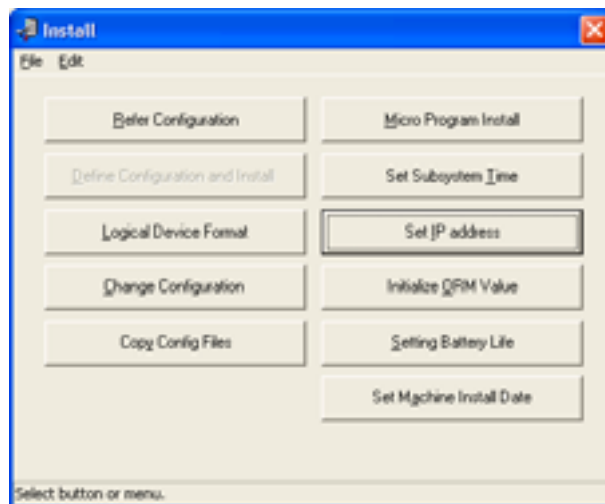

(4) <Changing IP address>

Select (CL) "SVP and DKC" in the "Target" of the "Internal IP Address", and select (CL) [OK] after setting the IP Address and Subnet Mask of "Internal IP Address" and the "External IP Address".



Note: When the Subnet Mask of Internal IP Address is set with a value different from the DKC, the previous value of the Subnet Mask might be displayed after setting. When the value that has been set is not displayed, set the value that corresponds with the DKC again.

(5) <Rebooting SVP>

Select (CL) [OK] to the message “This will reboot SVP.”.

When the message “Failed to change IP address.” is displayed, changing the IP address ended as an abnormal end. Identify the cause of the error according to the procedure ([TRBL05-600](#)) described in the troubleshooting section.

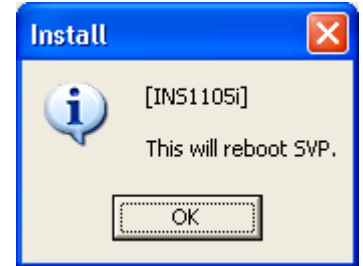
**⚠ CAUTION**

When remote connection of the Client PC is disconnected during this operation, reconnect with the changed IP address and continue this operation. Perform the reconnection by waiting for 5 minutes or more after clicking the [OK] of the [INS1105i] message. (Refer to [SVP01-60](#) regarding the operation for connecting to the SVP)

(6) <IP address setting completed>

Select (CL) [OK] for “The IP address setting has completed”.

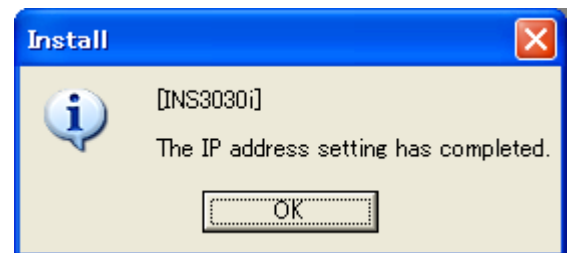

- (7) <Backup for configuration information>
- ① The message “Backup processing of configuration information will start. Please select the SVP or a client PC and insert a media.” is displayed. Set the Config media to the selected drive and select (CL) [OK].

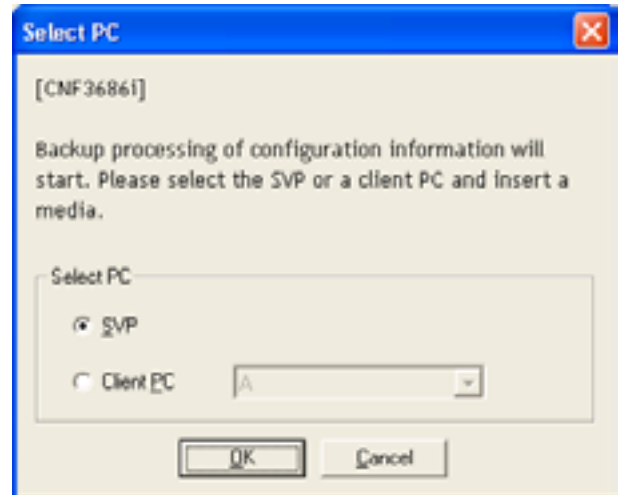

- ② When backup of configuration information is completed, the message “Please remove the configuration information media.” is displayed. Remove the configuration information media and select (CL) [OK].

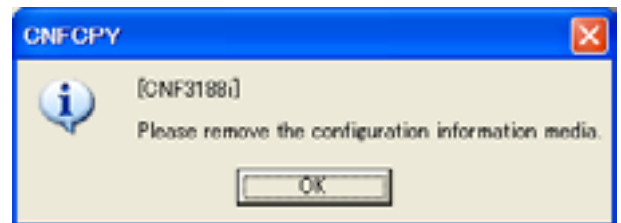

[2] In case of SVP

(1)

Change the mode from [View Mode] to [Modify Mode].

(2)

Select (CL) [Install] from the ‘SVP’ window.

(3)

Select (CL) [Set IP address] from the ‘Install’ window.

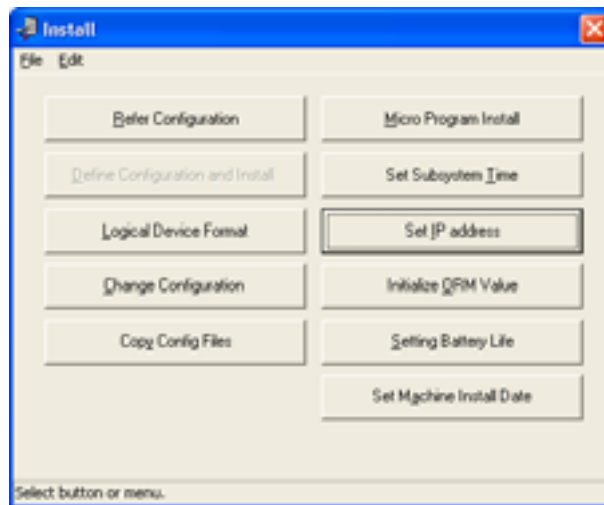

(4) <Changing IP address>

Select (CL) “SVP” in the “Target” of the “Internal IP Address”, and select (CL) [OK] after setting the IP Address and Subnet Mask of “Internal IP Address” and the “External IP Address”.



Note: When the Subnet Mask of Internal IP Address is set with a value different from the DKC, the previous value of the Subnet Mask might be displayed after setting. When the value that has been set is not displayed, set the value that corresponds with the DKC again.

(5) <Backup for configuration information>

- ① The message “Backup processing of configuration information will start. Please select the SVP or a client PC and insert a media.” is displayed. Set the Config media to the selected drive and select (CL) [OK].

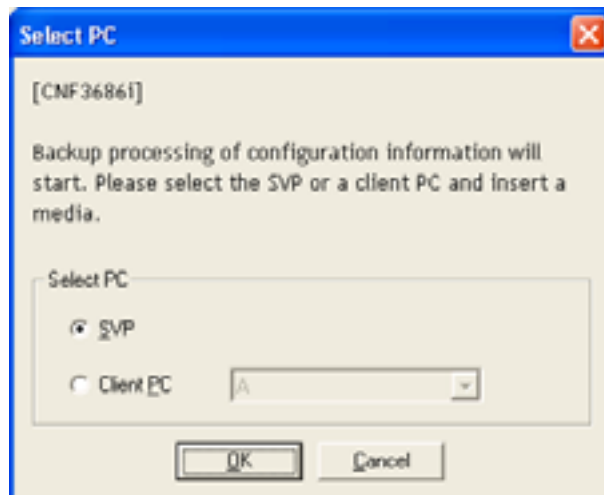

- ② When backup of configuration information is completed, the message “Please remove the configuration information media.” is displayed. Remove the configuration information media and select (CL) [OK].

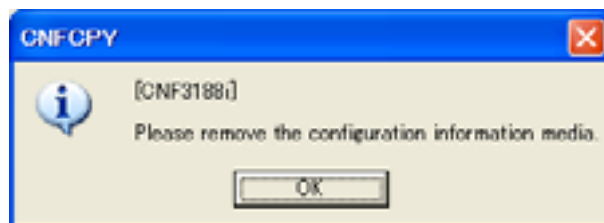

③ <Rebooting SVP>

Select (CL) [OK] to the message “This will reboot SVP.”.

When the message “Failed to change IP address.” is displayed, changing the IP address ended as an abnormal end. Identify the cause of the error according to the procedure (TRBL05-600) described in the troubleshooting section.

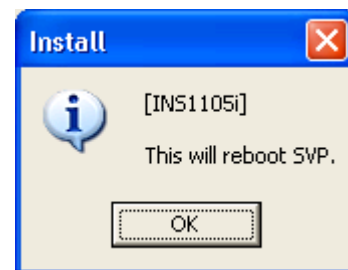

3. Activating and Terminating STATUS

3.1 Activating STATUS

- (1) Select (CL) the [Maintenance] in the 'SVP' window.

- (2) The 'Maintenance' window will appear, on which the message "Reading the Subsystem Configuration. Please wait..." is displayed. Upon completion of reading the system configuration information, go to step (3). If a read error occurs, go to step (4) or (5).

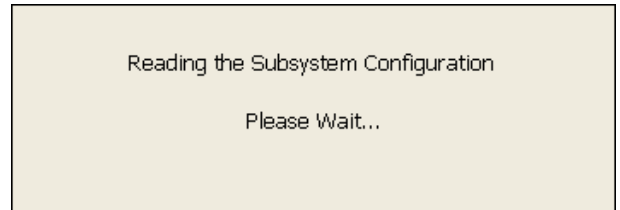

* : Please do not change an application's window until SVP-DKC communication finishes.

- (3) The main screen on the right will appear the 'Maintenance' window, and the status activates.

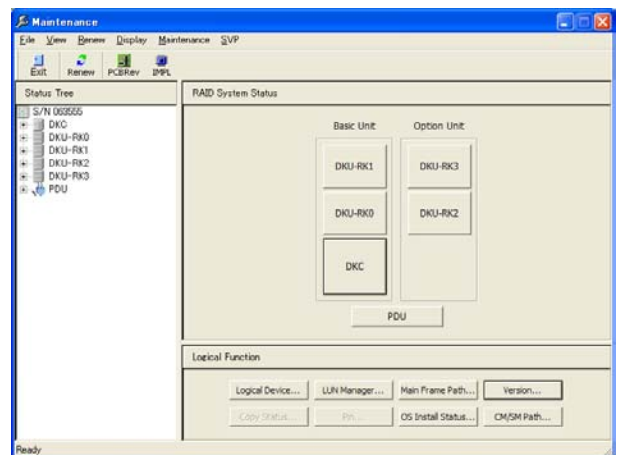

(4)

If an error occurs, the details of error is displayed.

“Cluster X is failed!”

X : 1 or 2

Select (CL) [OK].

If the status is power supply fault (refer to step [SVP03-100](#)), see TROUBLE SHOOTING SECTION (refer to step 3.2.7 ([TRBL03-210](#))).

If the status is normal power supply (refer to step [SVP03-100](#)), see SVP SECTION (refer to step 2.15 ([SVP02-1140](#))).



(5)

If an error occurs, the details of the error is displayed.

① “Connection error occurred. SVP-XXX” is displayed.

XXX : DKC or SSVP

② “Initializing SSVP (Phase X/16) Please Wait”

X : 1~16

③ “SSVP Dump is being performed (Phase X/15). Environment Status cannot be read.”

X : 1~15

Select (CL) [OK].

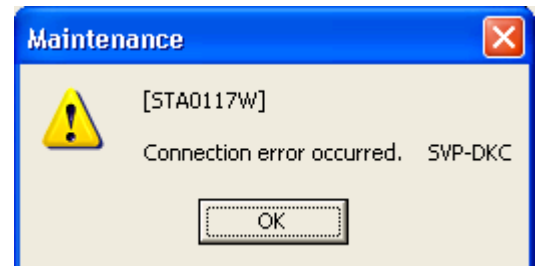

(6)

The similar screen as in step (3) will appear, but “-----” on the button shows that it has an error.

Terminate the STATUS and remove the cause of the error, and then reactivate STATUS.

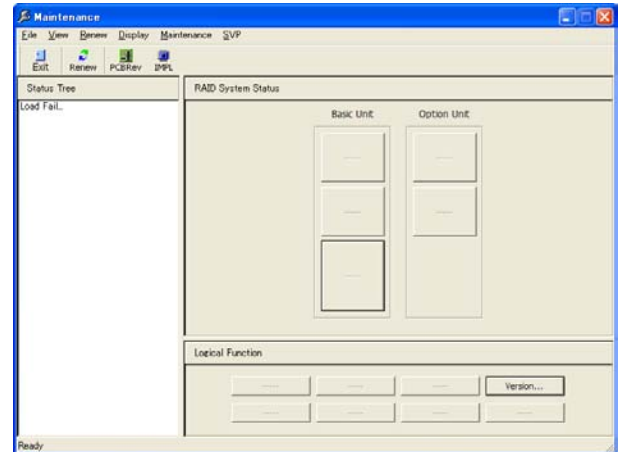

Note: When a communication error occurred on either the SVP-DKC or the SVP-SSVP, the status that was taken through communication is displayed.

The example on the right is the screen displayed when a communication error occurs in SVP-DKC.

* When a communication error occurred on either SVP-DKC or SVP-SSVP, refer to “5.3 Recovery Procedure for LAN Error ([TRBL05-90](#))”.

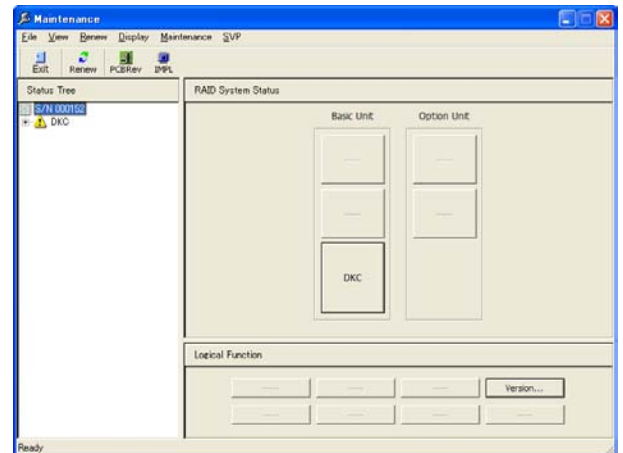

3.2 Terminating STATUS

(1)

Close the 'Maintenance' window.

Select (CL) [File]–[Exit] in menu bar on 'Maintenance'.

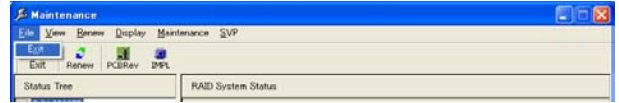

3.3 Updating the STATUS display

The STATUS display remains unchanged while the screen is displayed or being switched.
To display the latest status, follow the procedure below.

- (1) Select (CL) [Renew]--[Renew Status] in the menu bar on the main screen. (Screen on the right)



or

- (2) Terminate STATUS and activate it again.

3.4 Main screen

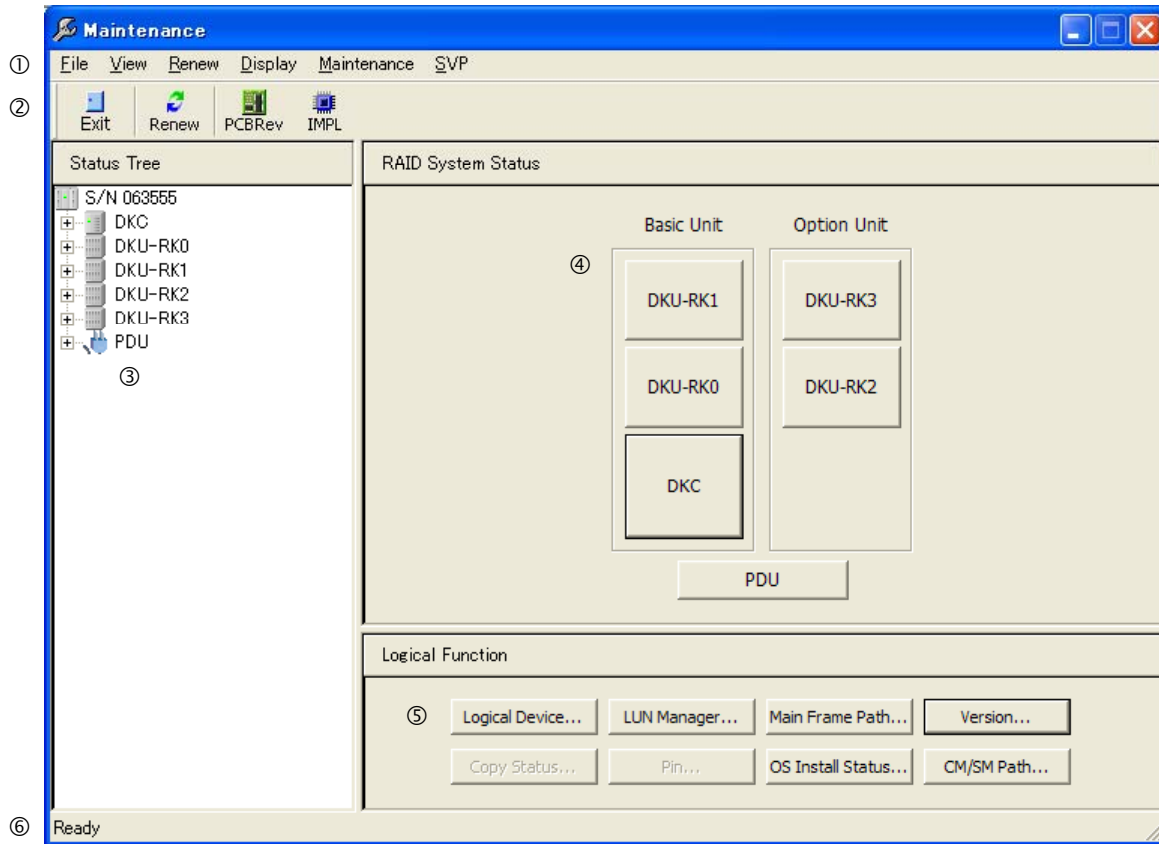

The main window consists of the following parts.





Table 3.4-1 Outline of Each Part in the Main Window

#	Part	Description
①	Menu	Menu items that can be operate using this function
②	Tool bar	Consists of buttons for operating some of the functions in the menu.
③	Tree	Displays statuses of parts in hierarchical order conscious of hardware configuration
④	Button panel (upper)	DKC and DKU statuses are displayed. Or, it starts the detail window with each button pressed.
⑤	Button panel (lower)	The logical part status is displayed. Or, it starts the function window with each button pressed.
⑥	Status bar	When a mouse points each item on the menu and the tool bar, the outline of the function is displayed.

① Menu

② Tool bar

Table 3.4-2 Menu List

Menu	Sub menu		Description	Toolbar
File	Exit		Closes the window.	
View	Toolbar		Displays/does not display the tool bar.	None
	Status Bar		Displays/does not display the status bar.	None
Renew	RenewStatus		Updates information being displayed.	
Display	PCB Revision		Displays the 'PCB Revision Display.'	
	IMPL Status		Displays the 'IMPL Status.'	
Maintenance	Blockade	Cluster1	Blocks the Cluster 1.	None
		Cluster2	Blocks the Cluster 2.	None
	Recover	Cluster1	Recovers the Cluster 1 from the blockade.	None
		Cluster2	Recovers the Cluster 2 from the blockade.	None
	Multi PCB Replace	Cluster1	Replaces all PCBs of the Cluster 1 together.	None
		Cluster2	Replaces all PCBs of the Cluster 2 together.	None

③ Tree

Display of a RAID subsystem serial number.

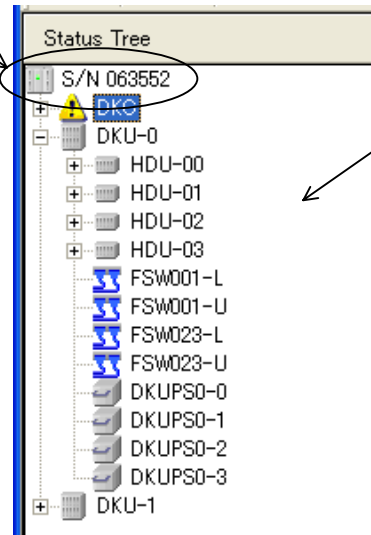

When the each item is double clicked, a related window is opened.

When the status of each part is other than normal, the blockade icon is displayed.

 : Blockade icon

Parts of a RAID system which are objects of maintenance are displayed hierarchically according to hardware configuration.

④ Button panel (upper)

Displays statuses of the DKC and each DKU. Besides, displays a window of lower stratum when the each button is pressed.

Table 3.4-3 Button List

Button	Information displayed	Detailed information displayed
[DKC]	DKC status	Steady lighting of the button: Normal Blinking of the button: Failed or under maintenance
[DKU-X] X: 0,1,2	DKU status	Steady lighting of the button: Normal Blinking of the button: Failed, under maintenance, or copying Extinction of the button: Not installed
[PDU UXn]	PDB location	The button always lighting Not displayed when using the PDB out of the support target.

⑤ Button panel (lower)

Displays statuses of the logical parts. Besides, displays a window of each function when the each button is pressed.

Table 3.4-4 Button List

Button	Information displayed	Detailed information displayed
[Copy Status]	Status of copying	Steady lighting of the button: Copying is in progress. Blinking of the button: No copying is done.
[Logical Device]	Status of the logical device	Steady lighting of the button: Normal Blinking of the button: Failed or under maintenance
[Version]	Display of version information	This button lights always.
[Pin]	Display of Pin information	Steady lighting of the button: Pin information is present. Blinking of the button: No Pin information is present.
[LUN Manager]	Display of information on the open system path	Steady lighting of the button: The open system PCB exists. No display: No open system PCB exists.
[Main Frame Path]	Display of information on the MF system path	Steady lighting of the button: The MF system PCB exists. No display: No MF system PCB exists.
[CM/SM Path]	Display of information on the CM/SM path	Steady lighting of the button: Normal Blinking of the button: Failed
[OS Install Status]	Display of the CHN OS installation status	Steady lighting of the button: Normal Blinking of the button: Being installed or partially installed Extinction of the button: No CHN PCBA is installed.

3.5 DKC screen

This window is displayed when the [DKC] in the main window is selected (CL).

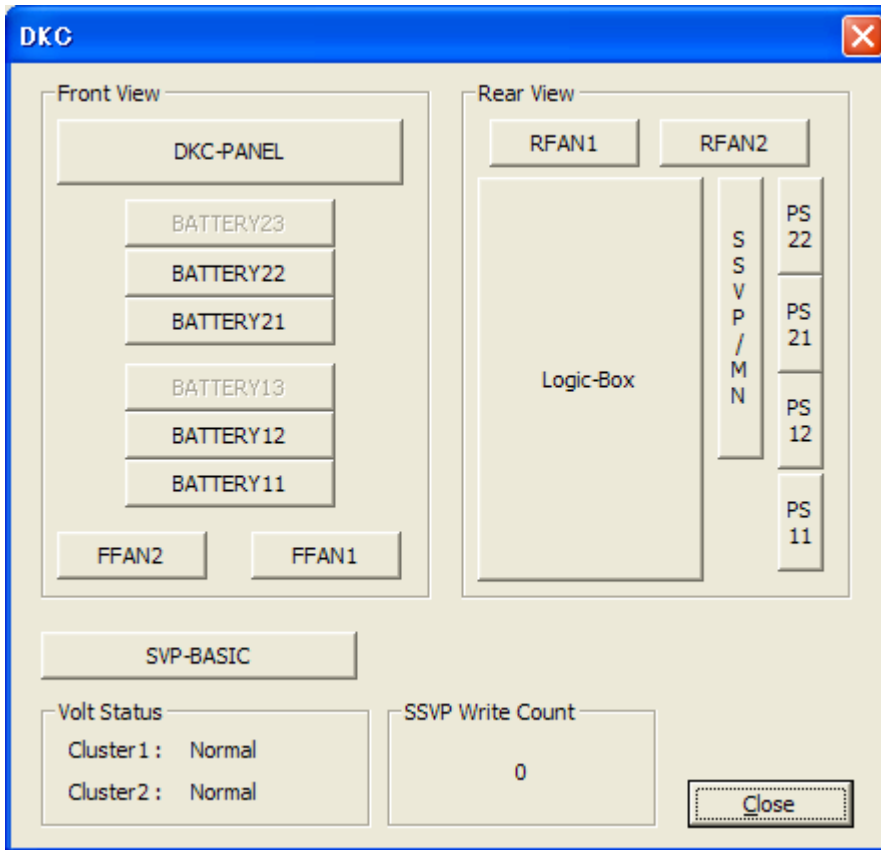

Table 3.5-1 Button List

Button	Information displayed	Detailed information displayed
[SVP-BASIC]	SVP information	
[BATTn]	DKC Battery Box status	Steady lighting of the button : Normal Blinking of the button : Failed Extinction of the button : Not installed
[DKCPANEL]	DKCPANEL information	This button lights always.
[XFANn]	FAN status	Steady lighting of the button : Normal Blinking of the button : Failed
[Logic-Box]	Logic PCB status	Steady lighting of the button : Normal Blinking of the button : Failed
[SSVP/MN]	SSVP/MN information	Steady lighting of the button : Normal Blinking of the button : Failed
[PSn]	PS status	Steady lighting of the button : Normal Blinking of the button : Failed Extinction of the button : Not installed

Table 3.5-2 Text List

Button	Information displayed	Detailed information displayed
[SSVP Write Count]	SSVP memory count	Displays a value of the memory count with an integer.
[Volt Status] Cluster 1	The voltage state of a cluster 1	“Normal” : Normal “Warning” : Abnormal
[Volt Status] Cluster 2	The voltage state of a cluster 2	“Normal” : Normal “Warning” : Abnormal

3.6 Logic Box screen

This window is displayed when the [Logic-Box] in the DKC window is selected (CL).

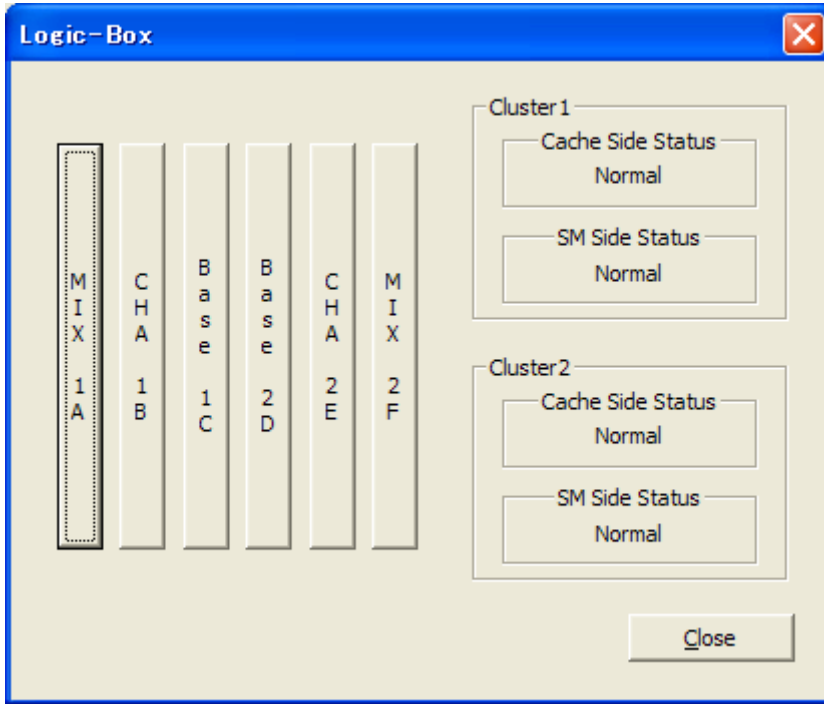

Table 3.6-1 Button List

Button	Information displayed	Detailed information displayed
[CHA XX]	CHA status	Steady lighting of the button : Normal Blinking of the button : Failed Extinction of the button : Not installed
[MIX XXX]	MIX PCB status	Steady lighting of the button : Normal Blinking of the button : Failed Extinction of the button : Not installed
[Base XXX]	Base PCB status	Steady lighting of the button : Normal Blinking of the button : Failed Extinction of the button : Not installed

Table 3.6-2 Text List

Text	Information displayed	Detailed information displayed
[Cache Side Status]	Cache Side Status	“Normal” : Normal “Warning” : Abnormal “Failed” : Blockade owing to a failure “Blocked” : Blockade for the purpose of maintenance
[SM Side Status]	Shared Memory Side Status	“Normal” : Normal “Warning” : Abnormal “Failed” : Blockade owing to a failure “Blocked” : Blockade for the purpose of maintenance

3.7 Base PCB screen

This window is displayed when the [Base XX] in the Logic Box window is selected (CL).

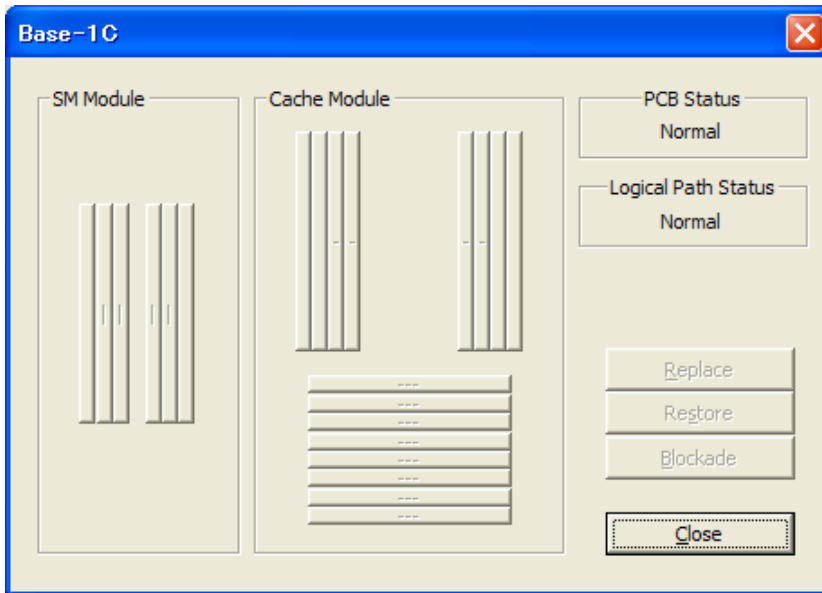

Table 3.7-1 Button List

Button	Information displayed	Detailed information displayed
Cache Module	Cache Memory Module status	Steady lighting of the button : Normal Blinking of the button '*' : Failed Extinction of the button '--' : Not installed
SM Module	SM Module status	Steady lighting of the button : Normal Blinking of the button '*' : Failed Extinction of the button ' ' : Not installed

Table 3.7-2 Text List

Text	Information displayed	Detailed information displayed
[PCB Status]	PCB Status	"Normal" : Normal "Warning" : Abnormal "Failed" : Blockade owing to a failure "Blocked" : Blockade for the purpose of maintenance "Cache Access Error" : Cache Access Error (PCB Blockade, CMG Blockade)
[Logical Path Status]	Logical Path Status	"Normal" : Normal "Warning" : Abnormal "Failed" : Blockade owing to a failure "Blocked" : Blockade for the purpose of maintenance

3.8 CHA/Base/MIX PCB screen

This window is displayed when the [CHA XX], [Base XX], [MIX XX] in the Logic Box window is selected (CL).

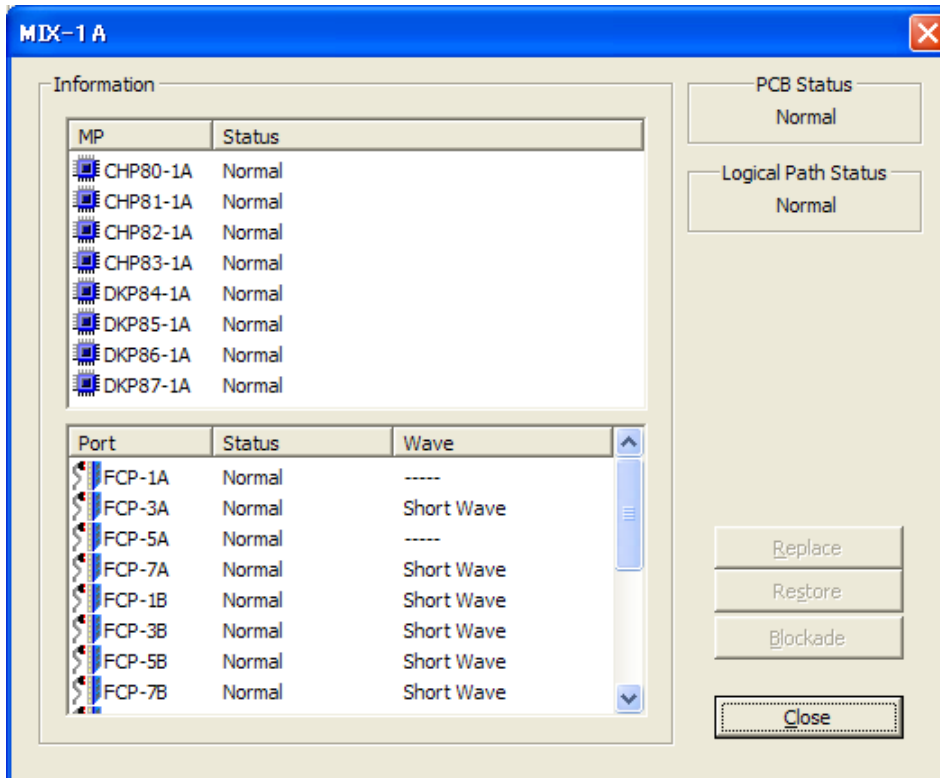

Table 3.8-1 MP information List

Button	Information displayed	Detailed information displayed
MP	Location of MP	
Status	The state of object MP	“Normal” : Normal “Warning” : Abnormal “Failed” : Blockade owing to a failure “Blocked” : Blockade for the purpose of maintenance

Table 3.8-2 Port information List

Button	Information displayed	Detailed information displayed
Port	Location of Port	
Status	Port processor status	“Normal” : Normal “Warning” : Abnormal “Failed” : Blockade owing to a failure “Blocked” : Blockade for the purpose of maintenance “On-Demand” : On-Demand definition.
Wave	Port Wave information	“Short Wave” : Short Wave “Long Wave” : Long Wave “Long Wave-4” : Long Wave (4km) “-----” : Unknown
SFP Status	SFP status	“Normal” : Normal “Failed” : Abnormal “Not Fix” : Uncertainty
Mode	Port mode information	“Standard” : Standard mode “High Speed/MIX” : High-speed/MIX

Table 3.8-3 Text List

Button	Information displayed	Detailed information displayed
[PCB Status]	PCB Status	“Normal” : Normal “Warning” : Abnormal “Failed” : Blockade owing to a failure “Blocked” : Blockade for the purpose of maintenance
[Logical Path Status]	Logical Path Status	“Normal” : Normal “Warning” : Abnormal “Failed” : Blockade owing to a failure “Blocked” : Blockade for the purpose of maintenance

3.9 DKU screen

This window is displayed when the [DKU-X] in the main window is selected (CL).

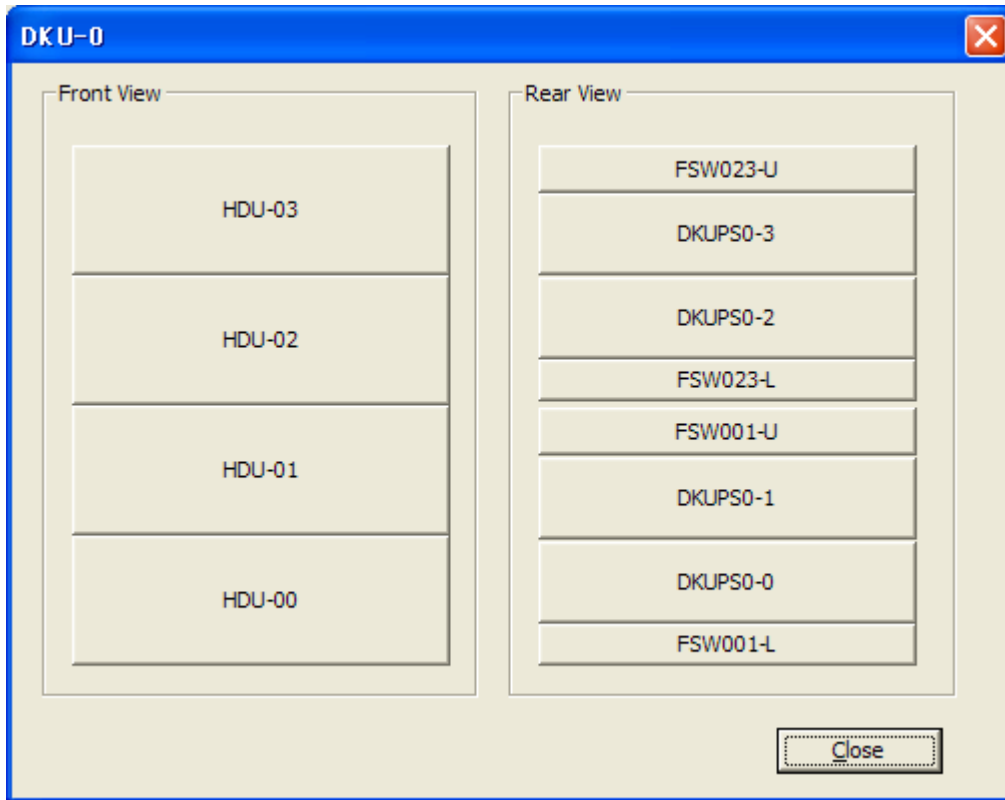

Table 3.9-1 Button List

Button	Information displayed	Detailed information displayed
[HDU-Xn]	HDU status	Steady lighting of the button : Normal Blinking of the button : Failed, under maintenance, or copying Extinction of the button : Not installed
[DKUPSX-n]	DKUPS status	Steady lighting of the button : Normal Blinking of the button : Failed Extinction of the button : Not installed
[FSWXnn-Y]	FSW status	Steady lighting of the button : Normal Blinking of the button : Failed Extinction of the button : Not installed

3.10 HDU screen

This window is displayed when the [HDU-Xn] in the 'DKU-X' window is selected (CL).

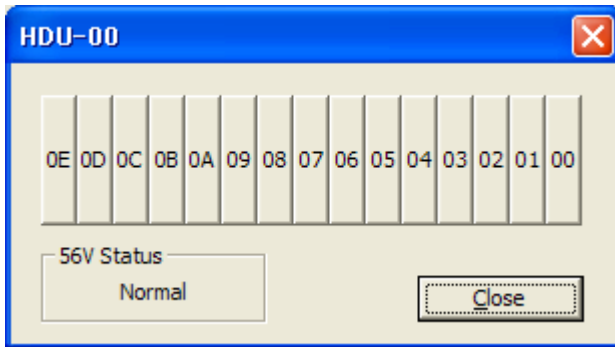

Table 3.10-1 Button List

Button	Information displayed	Detailed information displayed
[XX](HDD)	HDD status	Steady lighting of the button : Normal Blinking of the button : Failed, under maintenance, or copying Extinction of the button : Not installed

Table 3.10-2 Text List

Text	Information displayed	Detailed information displayed
[56V Status]	The voltage state	“Normal” : Normal “Warning”: Abnormal

3.11 HDD screen

This window is displayed when the [XX] (HDD) in the 'HDU-Xn' window is selected (CL).

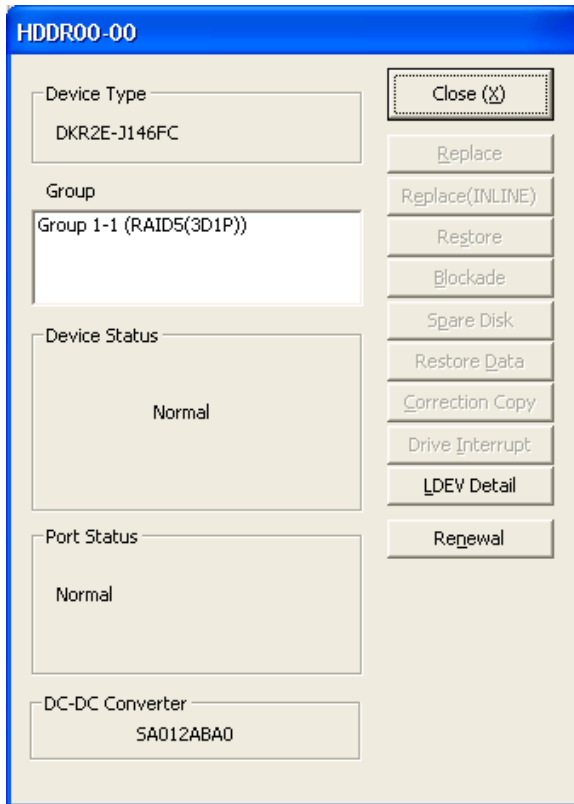

Table 3.11-1 Button List

Button	Information displayed	Detailed information displayed
[LDEV Detail]	Displays a list of logical devices included in the HDD concerned.	This button is displayed always.

Table 3.11-2 Text List

Text	Information displayed	Detailed information displayed	
[Device Status]	HDD model name	Name of each model	
[Group]	Information on the group which the HDD belongs to	A name of the group to which the HDD belongs and a RAID level of the group are displayed.	
[Device Status]	HDD status	Normal	Normal status
		Correction Copy(xx%)	Correction copy is in progress (Rate of progress)
		Copy Back(xx%)	Restoration using spare disk data is in progress (Rate of progress)
		Drive Copy(xx%)	Data copying to the spare disk is in progress (Rate of progress)
		Dynamic Sparing(xx%)	Dynamic sparing is in progress (Rate of progress)
		Blocked	Blocked for the purpose of maintenance
		Failed	Blocked owing to a failure
		Warning	One of the port is blocked.
		Free	The spare disk is usable.
		Reserved	The spare disk is not usable because it is reserved.
		to HDD-XX	Data is copied to the HDD-XX.
		from HDD-XX	Data is copied from the HDD-XX.
[Port Status]	Port status	Normal	Normal
		Warning (Port 0 failed)	Port 0 is blocked.
		Warning (Port 1 failed)	Port 1 is blocked.
		Failed	Both ports are blocked.
[DC-DC Converter]	DC-DC converter serial number	The DC-DC converter serial number is displayed.	

3.13 Logical Device

Select (CL) [Logical Function] and [Logical Device] in the main window in this order.
The 'Logical Device Status' window is displayed.

If the shredding process is running for some logical devices from Storage Navigator, "Shredding" window is displayed.

If the Shredding process is not running, go to ①.

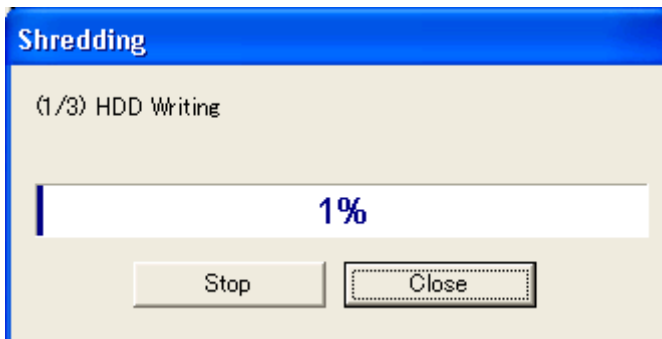

If processing is finished. ----- Go to ①.

If you want to close the Window, select (CL) [Close]. ----- Main screen

If you want to interrupt this process, select (CL) [Stop].

Note: Confirm to user that the process is interrupted. ----- Go to ①.

The 'Logical Device Status' window displays the following pieces of information when one of them is selected (CL or DC) from the tree or list.

- ① Status of each group (initial status)
- ② Status of each logical device
- ③ Information on LU extension

① Displaying status of each group (initial status)

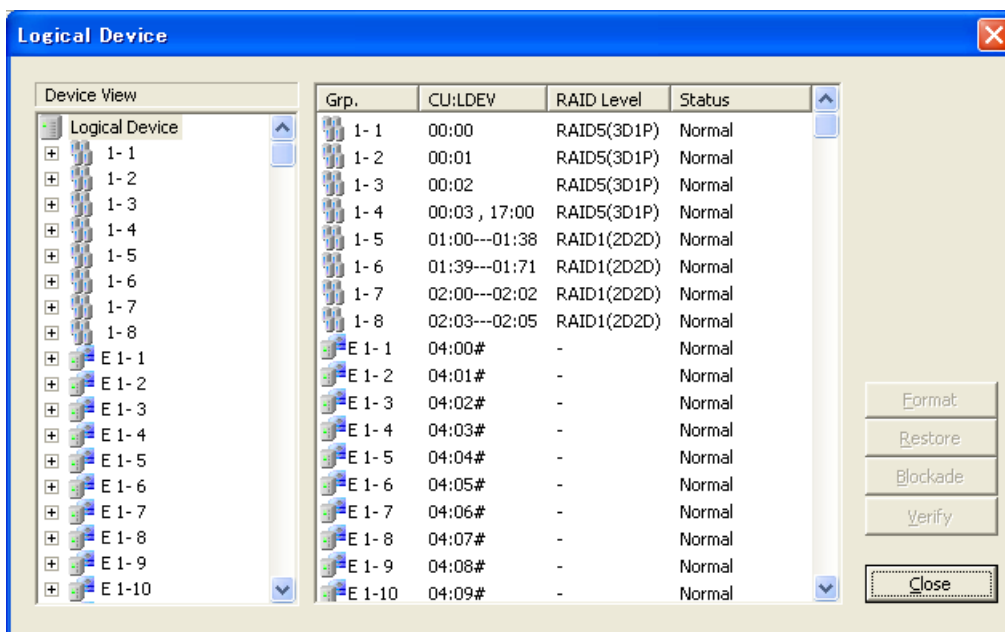

Method for displaying the window concerned: The window is automatically displayed when the 'Logical Device Status' window is activated or it is manually displayed when "Logical Device" is selected (CL) from the tree.

Table 3.13-1 Information Displayed

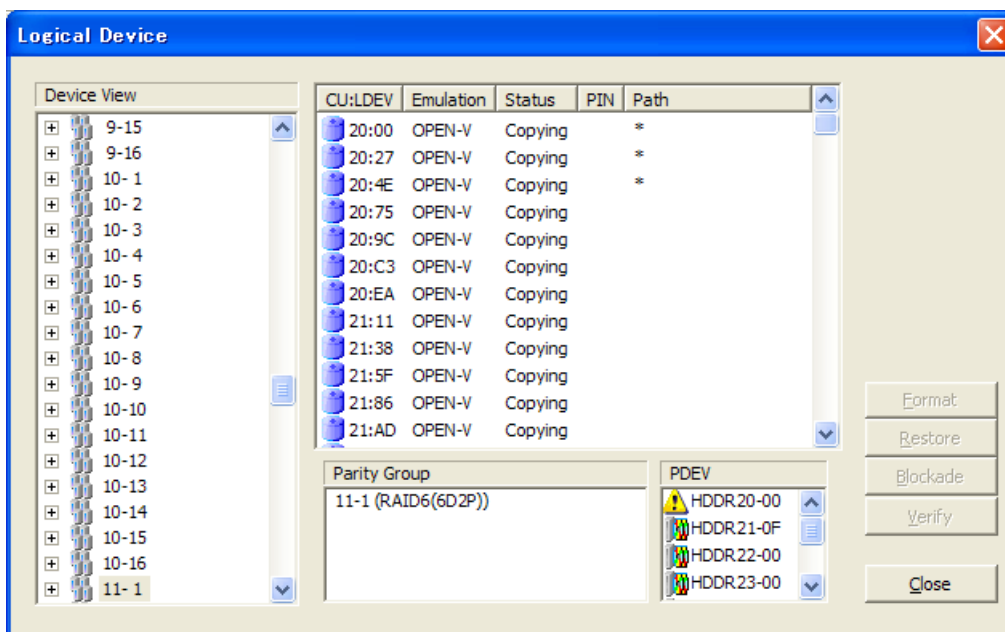

Item	Description
Grp.	Group ID "E" : External Volume Group "V" : Virtual Volume Group "P" : Pool Volume exists in group "*" : RAID Concatenation
CU:LDEV#	List of installed logical devices in a group "#" : External Volume "V" : Virtual Volume
RAID Level	RAID level
Status	Status of each logical device

② Displaying status of each logical device



Method for displaying the window concerned: Select (DC) the list you want to displayed from the display of each group status or select (CL) the group item from the tree.

Table 3.13-2 Information Displayed

Item	Description
CU:LDEV#	List of installed logical devices “#” : External Volume “V” : Virtual Volume
Emulation	Emulation type
Status	Status of each logical device
PIN	Pin data exists : The mark “*” is displayed. No Pin data exists : No mark is displayed.
Path	Path information is present : The mark “*” is displayed. No path information is present : No mark is displayed.
Pool ID	ID number of Pool Volume “---“ : Not Pool Volume
Parity Group	Information on the group which the logical device concerned belongs to is displayed.
PDEV	Information on the PDEV in which the group including the logical device concerned is installed.  : Normal  : Failed

③ Displaying information on LU extension

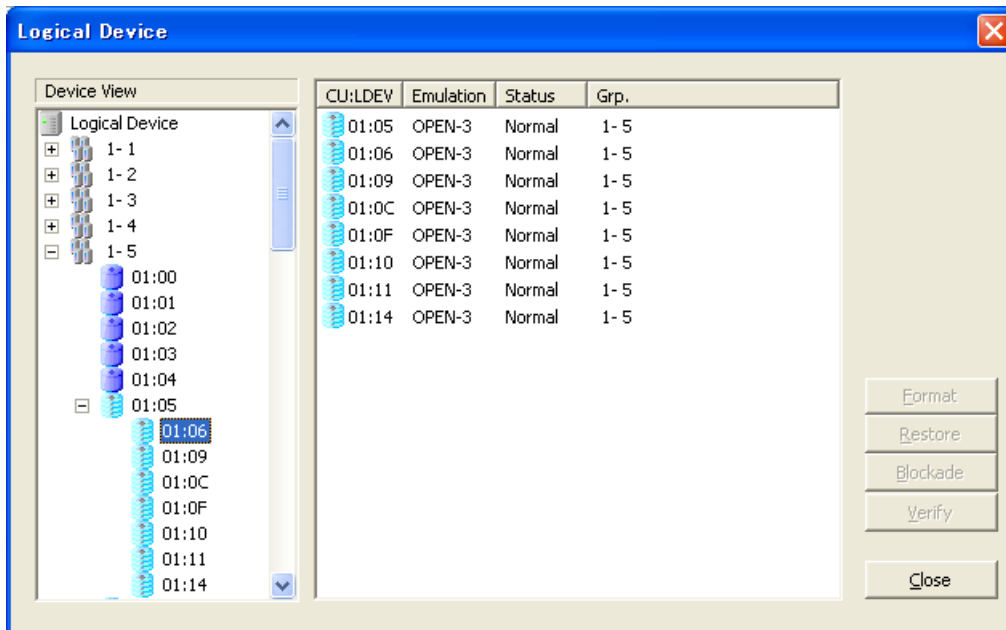

Method for displaying the window concerned: Select (DC) the list you want to display from the display of each logical device status or select (CL) the logical device item from the tree.

Table 3.13-3 Information Displayed

Item	Description
CU:LDEV#	List of installed logical devices “#” : External Volume “V” : Virtual Volume
Emulation	Emulation type
Status	Status of each logical device
Grp.	The group to the LDEV.

3.14 Version of Microprogram

Select (CL) [Logical Function] and [Version] in this order in the main window.
The 'Version' window is displayed.

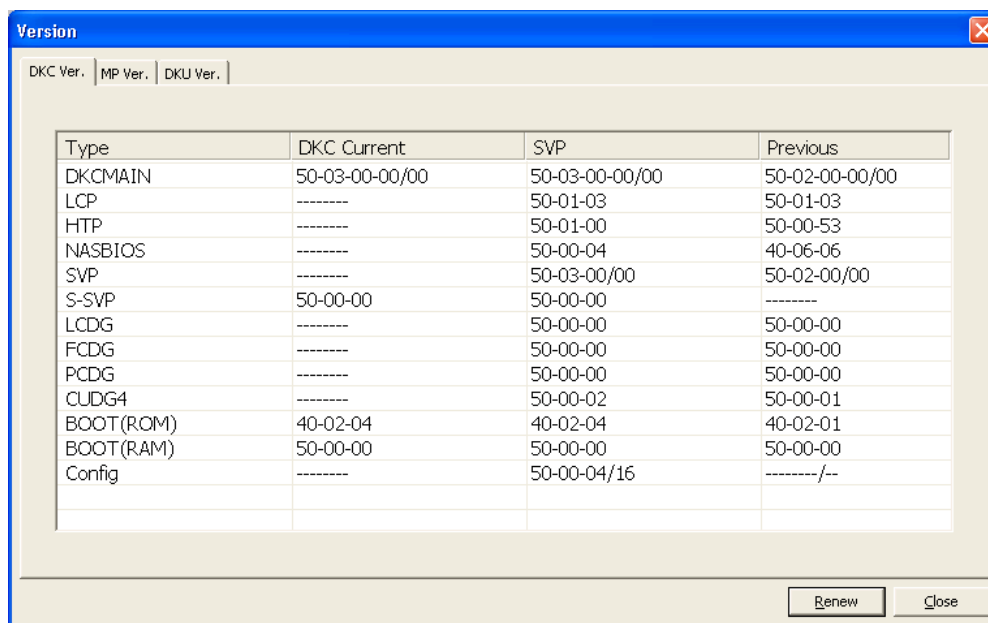

When the each tab is selected (CL), information on the corresponding version is displayed.

- ① [DKC Ver.] : A representative version is displayed. (Initial display)
- ② [MP Ver.] : A version of each processor is displayed.
- ③ [DKU Ver.] : A version of a drive is displayed.

<About the display>

When a version of the microprogram concerned cannot be displayed for some reason, the following is displayed.

- “-” (Hyphen) : The microprogram is not installed.
- “?” (Question mark) : Getting of the version information failed.
- “x” : The data that has been got is outside the range of application.

<Update of the information>

To update the information, which is displayed through the selection of 'Version', to the latest one, select (CL) the [Renew] button.

① The representative version

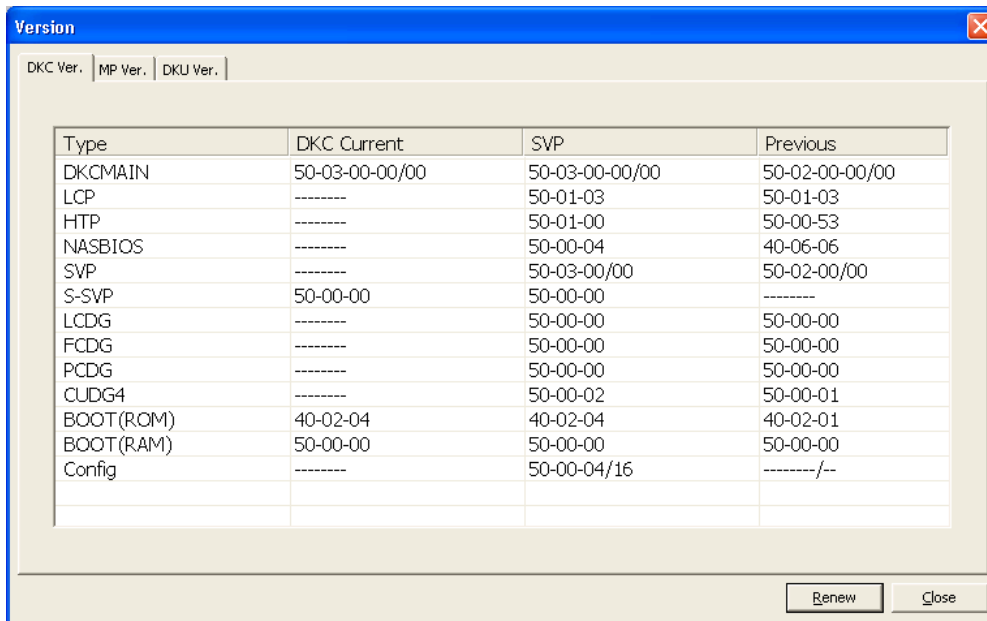

The screenshot shows a window titled "Version" with a close button in the top right corner. Below the title bar, there are three tabs: "DKC Ver.", "MP Ver.", and "DKU Ver.". The main area contains a table with four columns: "Type", "DKC Current", "SVP", and "Previous". The table lists various components and their version numbers. At the bottom right of the window, there are two buttons: "Renew" and "Close".

Type	DKC Current	SVP	Previous
DKCMAIN	50-03-00-00/00	50-03-00-00/00	50-02-00-00/00
LCP	-----	50-01-03	50-01-03
HTP	-----	50-01-00	50-00-53
NASBIOS	-----	50-00-04	40-06-06
SVP	-----	50-03-00/00	50-02-00/00
S-SVP	50-00-00	50-00-00	-----
LCDG	-----	50-00-00	50-00-00
FCDG	-----	50-00-00	50-00-00
PCDG	-----	50-00-00	50-00-00
CUDG4	-----	50-00-02	50-00-01
BOOT(ROM)	40-02-04	40-02-04	40-02-01
BOOT(RAM)	50-00-00	50-00-00	50-00-00
Config	-----	50-00-04/16	-----/--

Table 3.14-1 Information to Be Displayed

Item	Description
DKC Current	Major version of the microprogram currently running
SVP	Latest version of the microprogram stored in the SVP
Previous	Former version of the microprogram stored in the SVP

② Version of each processor

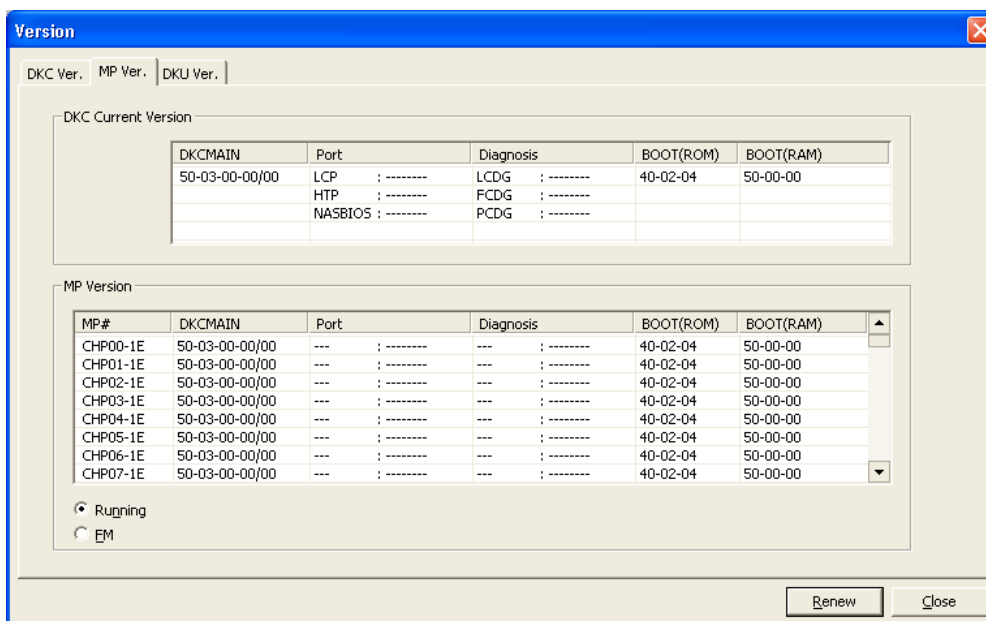



Table 3.14-2 Information to Be Displayed

Item	Description
DKC Current Version area	Major version of the microprogram currently running In regard to a version inconsistent with a corresponding version in the MP Version area, the area concerned is displayed in red-white-reversal with an asterisk (“*”).
MP Version area	Version of the microprogram of each processor currently running A version, which is displayed in red-white-reversal, is inconsistent with the DKC Current Version. A version displayed with an asterisk (“*”) at the end of it is the inconsistent one. However, the microprogram of the “FM” is not displayed in red-white-reversal even if it is inconsistent. Besides, in regard to this area, information to be displayed can be changed with the radio button at the lower left part of the window. When “Running” is selected, a version of the microprogram that is running on the SM is displayed. When “FM” is selected, a version of the microprogram on the FM is displayed.

Concerning this item, when even a single piece of information is inconsistent, an icon “,” which shows an error, is displayed in the tab portion.

<Display of patch status>

Select (DC) a line from the list in the MP Version area.

The 'Patch Map' dialog box is displayed and the patch status of the processor concerned is shown.

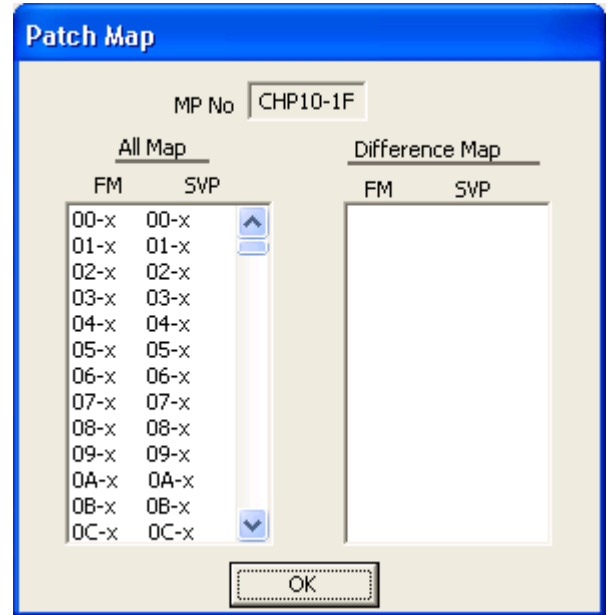

Table 3.14-3 Information to Be Displayed

Item	Description
MP No	ID of the processor
All Map	List of all the maps All the maps of the FM and SVP are displayed. If the FM map is inconsistent with the corresponding SVP map, an asterisk (“*”) is displayed between them.
Difference Map	Only the inconsistent map(s) among all the maps is(are) displayed.

③ Version of the drive

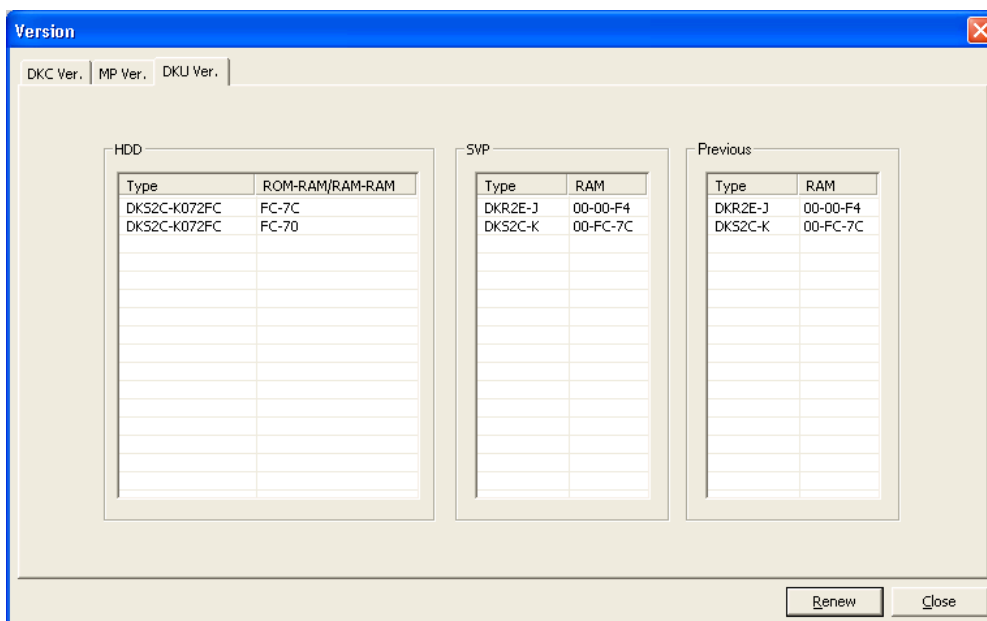

Table 3.14-4 Information to Be Displayed

Item	Description
Display of "HDD"	Version of the drive microprogram currently running "Type" : Drive type "ROM-RAM/RAM-RAM" : Version of the drive (RAM version-RAM version in the case of the OEM drive, or ROM version-RAM version in the other cases)
Display of "SVP"	Latest version of the drive microprogram stored in the SVP
Display of "Previous"	Former version of the drive microprogram stored in the SVP

<Display of the drive name>

Select (DC) a line from the HDD area.

The 'DKU List' dialog box is displayed and a list of drives that are consistent with the version is shown.

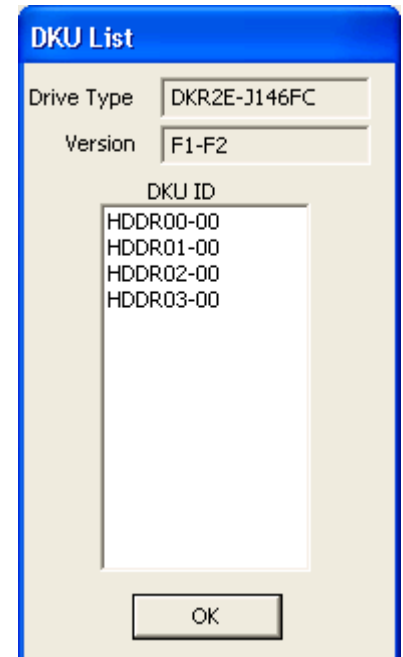

Table 3.14-5 Information to Be Displayed

Item	Description
Drive Type	Type of the drive consistent with the selected version
Version	Selected version
DKU ID	ID list of the drive consistent with the selected version

3.15 Path of LCP/HTP

When [Main Frame Path...] is selected (CL) in the 'Maintenance' window, the 'Main Frame Path Information' window is displayed.

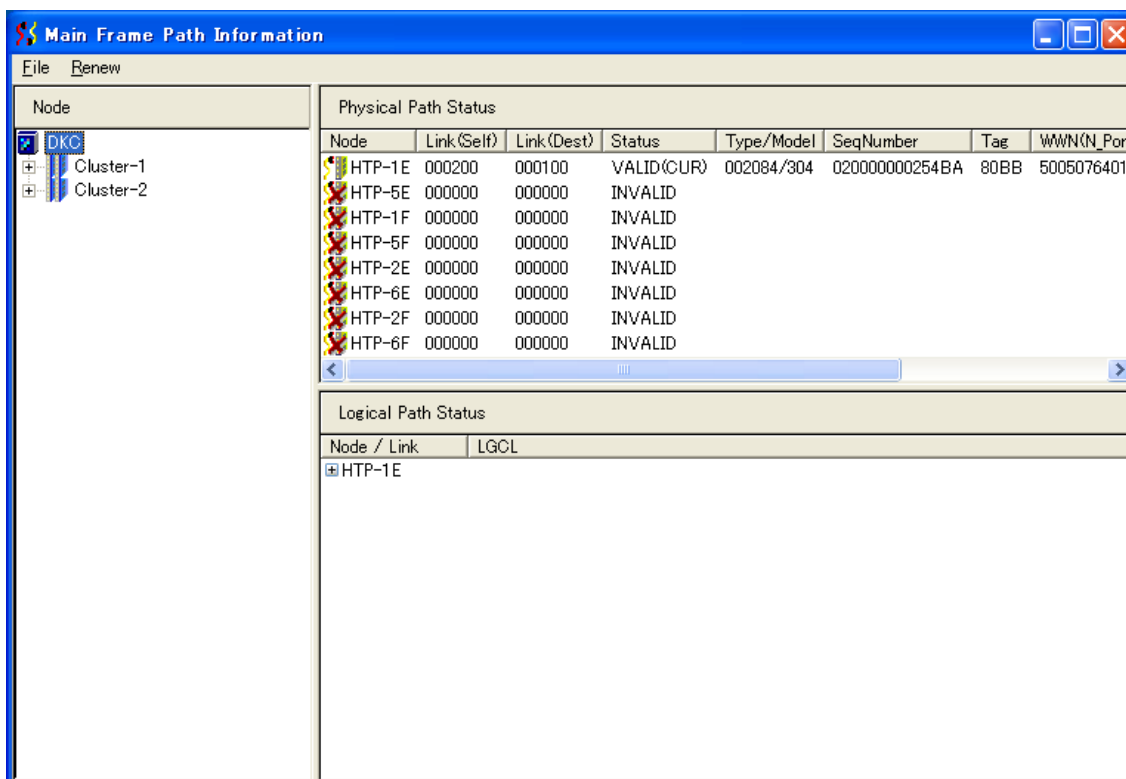

Table 3.15-1 Outline of Each Part

Item	Description
Menu	Menu items that can be operated by this function.
Tree	Installed ports are displayed hierarchically taking hardware configuration in consideration.
Upper list	Physical path information concerning the item selected from the tree is displayed.
Lower list	Logical path information concerning the item selected from the tree is displayed.

Table 3.15-2 List of Menus

Menu	Sub-menu	Description
File	Exit	Closes a window.
Renew	Renewal	Updates displayed information.

To exit the display, press [Close].

(1) Physical path

When a scope wanted to be referred to (subsystem, each cluster, each CHA, or port concerned) is selected (CL) from the tree, the related physical path information is displayed in a list at the upper right part of the window. (In the example shown in the figure below, CHA has been selected (CL) and the physical path information on the port installed in the CHA is displayed.)

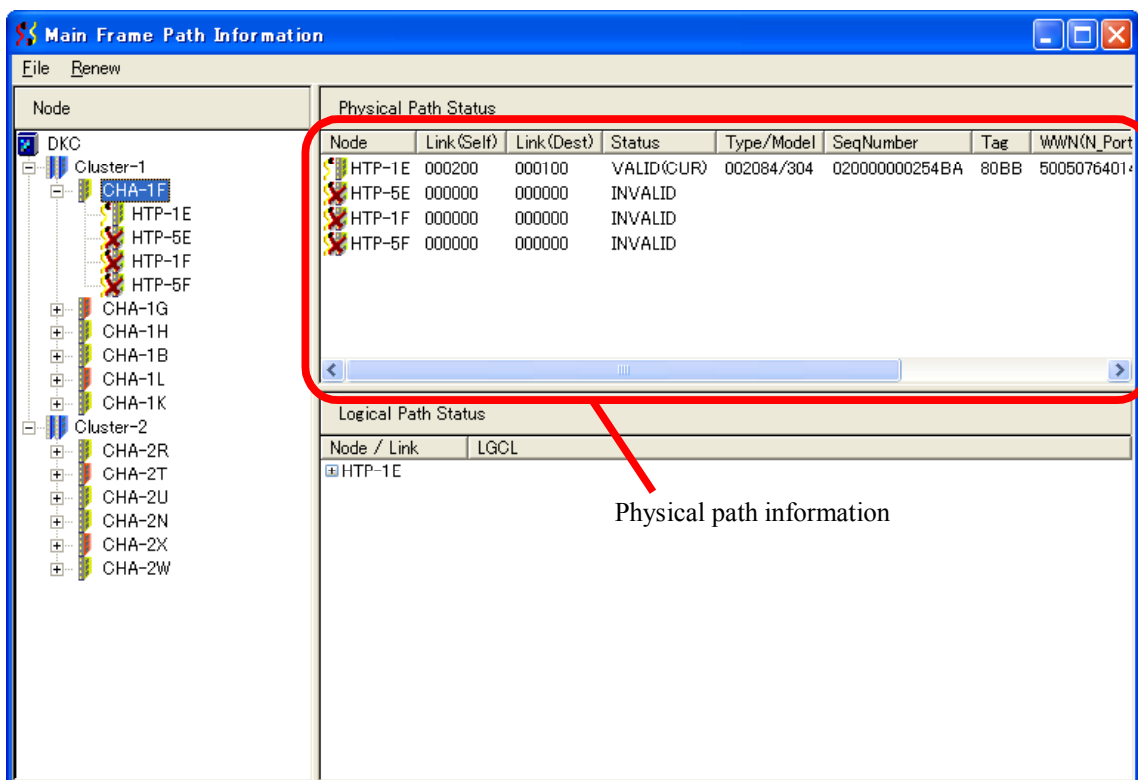

Table 3.15-3 Items Displayed in the Physical Path Information List

Item	Description
Node	Location where the LCP/RCP/HTP is installed.
Link(Self)	Link address of the LCP/RCP/HTP.
Link(Dest)	Link address of a host connected.
Status	Status in which a node ID is acquired.
Type/Model	Type/model name of a host connected.
SeqNumber	Product serial number of a host connected.
Tag	Tag of a host connected.
WWN(N_Port_Name)	N_port name of a host connected.
WWN(Node_Name)	Node name of a host connected.
Speed	Bandwidth of link transfer.

(2) Logical path

When a scope wanted to be referred to (subsystem, each cluster, each CHA, or port concerned) is selected (CL) from the tree, the related logical path information is displayed in a list at the lower right part of the window. (In the example shown in the figure below, CHA has been selected (CL) and the logical path information on the port installed in the CHA is displayed.)

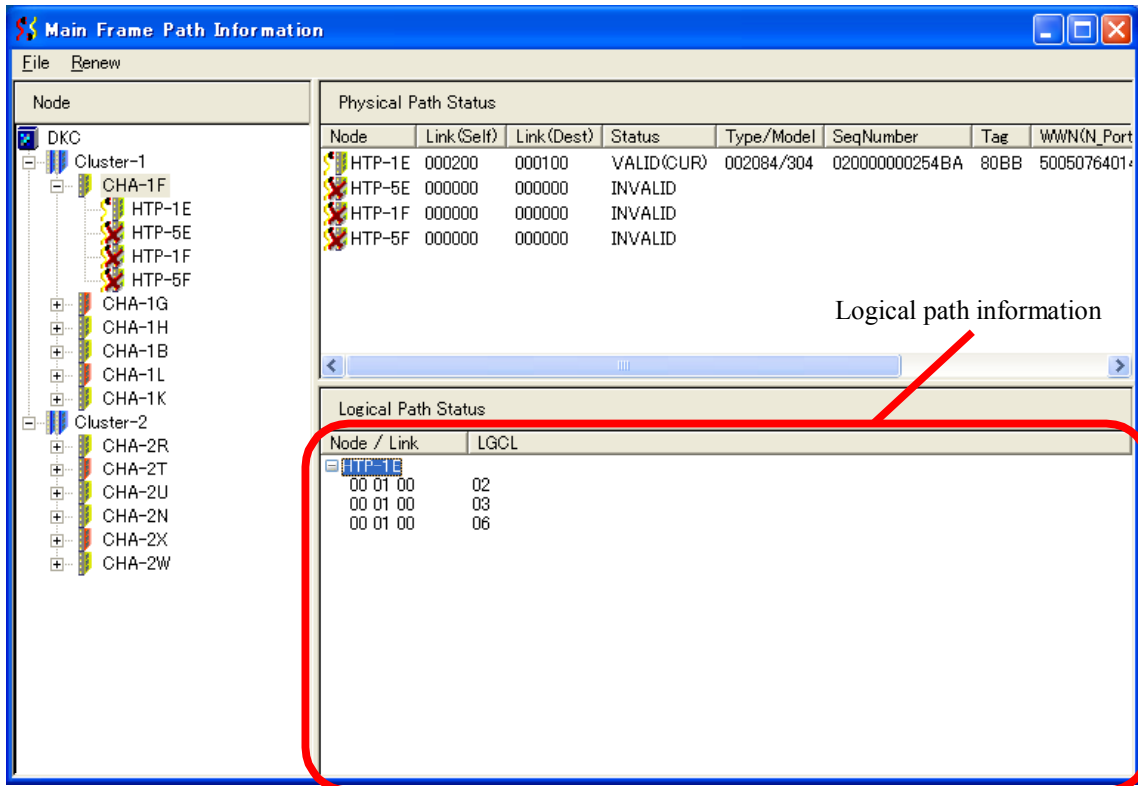
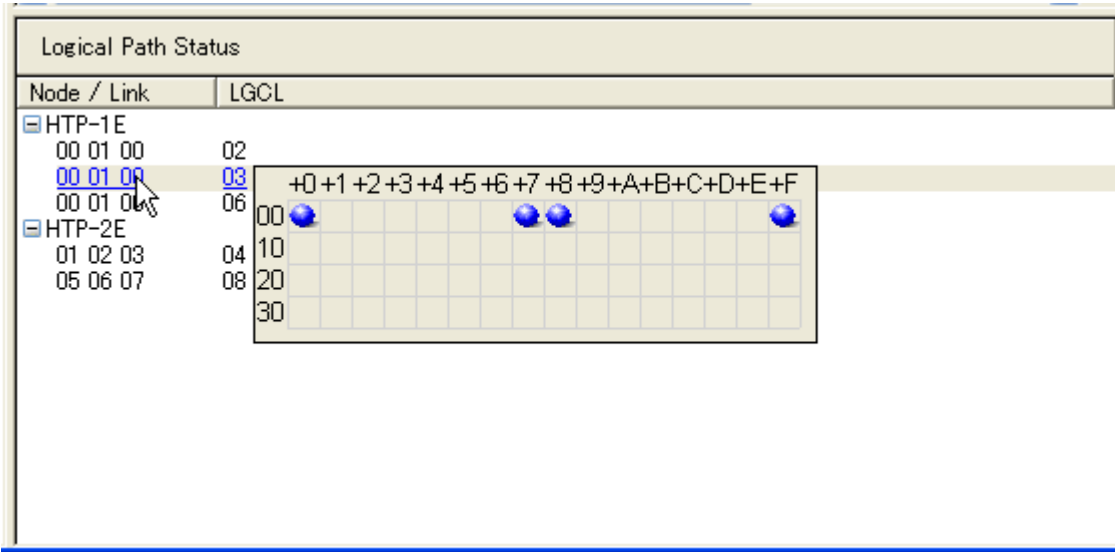

Table 3.15-4 Items Displayed in the Logical Path Information List

Item	Description
Node	Location where the LCP/RCP/HTP, in which the logical path exists, is installed.
Link	Link address of a host connected. When the RCP is used, "NA" is displayed.
LGCL	Logical address of a host connected.

■ Seeing a CU# of the controller connected

To see a CU# (control unit address) of the controller connected, position the mouse pointer on the displayed LINK/LGCL information concerned and select (CL) the information after making sure that it is highlighted (underlined in blue).



<Window displaying CU# of the controller connected>

The CU# (control unit address) of the controller connected is displayed. In the example shown in the figure below, CU#00, CU#07, CU#08, and CU#0F are the CU#'s of the controllers connected.

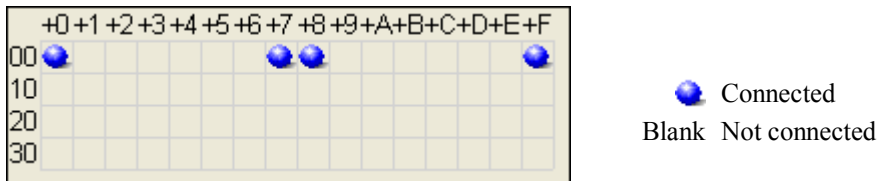

When the mouse pointer is positioned at the place displayed as the CU# of the controller connected, the corresponding LPN (logical path number) is displayed.

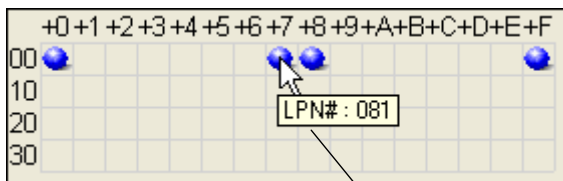

LPN (logical path number)

3.16 Pin

When [Pin...] is selected (CL) in the 'Maintenance' window, the 'Pinned Track' window is displayed.

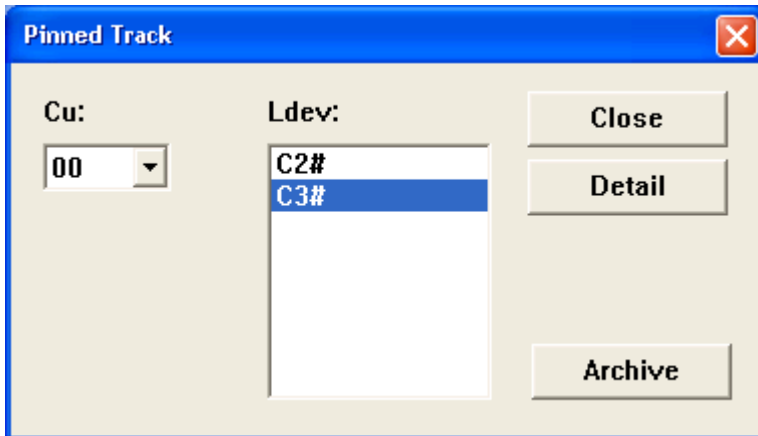

Table 3.16-1 List of Items

Item	Description
Cu	ID number of a Cu
Ldev	Number of a logical device in which pinned data exists

When a logical device is selected (CL) from the list in the 'Pinned Track' window and the [Detail] button is selected (CL), the 'Detail' window is displayed.

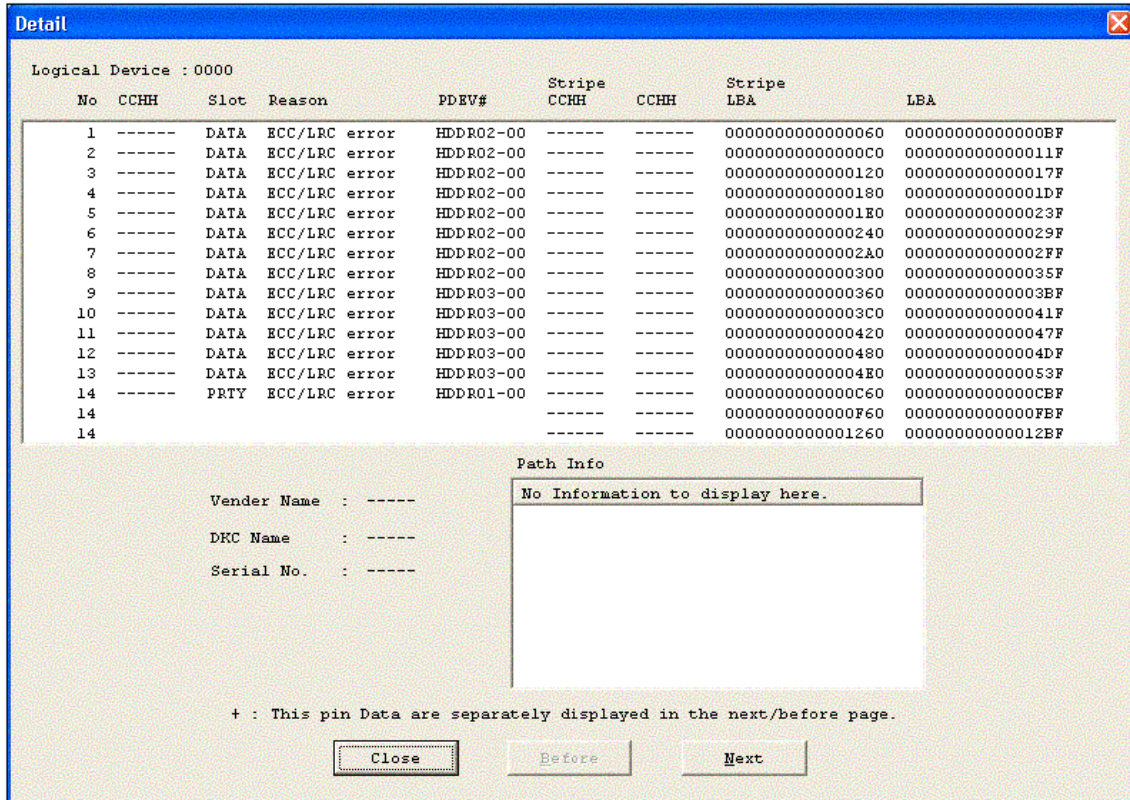

Table 3.16-2 List of Items

Item	Description
CCHH	Number of an assembly of a cylinder and head in which pinned data exists
Slot	Type of a track on which pinned data exists DATA : Data track PRTY : Parity track
Reason	Cause of pinned data ELC/LRC error : See page TRBL04-20 . WRITE error : See page TRBL04-30 .
PDEV#	Number of an HDD of a logical device in which pinned data exists
Stripe	CCHHs/LBAs at the top and end of a parity stripe
Vender Name	Name of a vender of a external Device
DKC Name	Name of a DKC of a external Device
Serial No.	Serial number of a external Device
Path Info	Path information of a external Device

3.17 LUN Management

(1) Outline

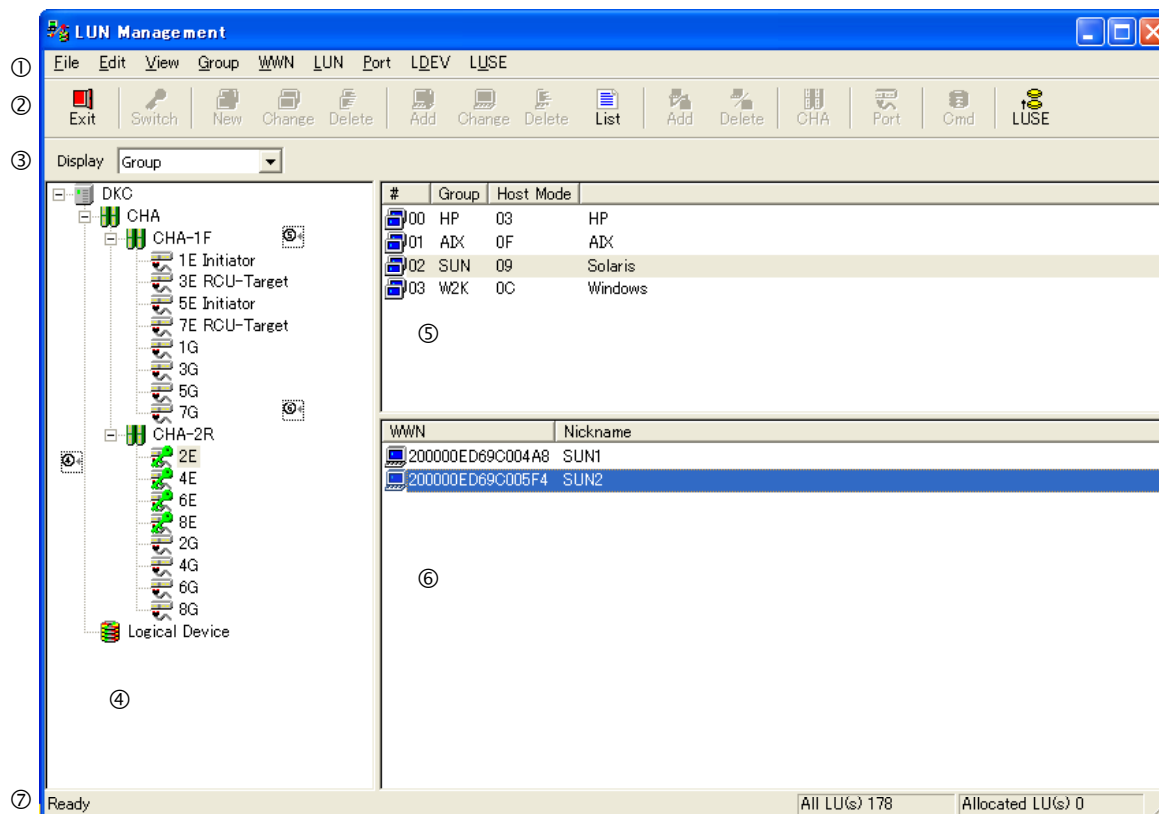

Fig. 3.17-1 Main Window

















The Main window consists of the following elements.

Table 3.17-1 Outline of Main Window Elements

#	Item	Description
①	Menu	Menu of items operable by this function.
②	Tool bar	Part of the menu enabled to be operable by buttons.
③	Switch	When “Switch” displayed in the tree view is selected (Port), the status of the switch is selectable. The setting of the groups or LUN is selectable.
④	Tree	The structure that it is conscious of the hardware construction.(A port type is attached to a port.)
⑤	Upper list	Displays the details of an item selected from the tree.
⑥	Lower list	Displays the details of an item selected from the upper list, if any.
⑦	Status bar	Displays outlined function of each item on the menu and tool bar when the mouse is positioned on it. Also it displays the all of the LU figures and the LU figures with the pass definition.

Menu items and their details are shown below.

Table 3.17-2 List of Menu Items

Menu	Submenu	Description	Tool bar
File	Exit	• Closes the window.	 (Exit)
Edit	Copy	• Not selectable.	None
	Paste	• Not selectable.	None
View	Toolbar	• Makes the tool bar displayed or not.	None
	Status Bar	• Makes the status bar displayed or not.	None
	LDEV Size	• Changes the unit of LDEV size to be displayed to MB or GB.	None
	Host Mode Option	• Displays/does not display the Host Mode Option for the group list.	None
	LUN Status	• Displays/does not display the LUN status (including the Host reserve status) in the LUN list.	None
Group	New	• Not selectable.	 (New)
	Change	• Not selectable.	 (Change)
	Delete	• Not selectable.	 (Delete)
WWN/ iSCSI (Note)	Add	• Not selectable.	 (Add)
	Change...	• Not selectable.	 (Change)
	Delete	• Not selectable.	 (Delete)
	Login List	• The hosts identified by the following WWN/iSCSI Name login to the DKC. (Only WWN has the deletion function.)	 "List"
LUN	Add	• Not selectable.	 (Add)
	Delete	• Not selectable.	 (Delete)
	Command Device...	• Not selectable.	 (Cmd)
	Force Reset	• Cannot be selected. (When the [View]–[LUN Status] menu cannot be selected, this menu does not exist.)	None
Port	Parameter...	• Not selectable.	 (Port)
	Security Switch	• Not selectable	 (Switch)
	CHA PCM Mode...	• Not selectable.	 (CHA)
Device	Command Device...	• Not selectable.	 (Cmd)
	Alternate	• Refers to LUN information from LDEV.	None
LUSE	LU Size Expansion	• Activates the LU Size Expansion window.	 (LUSE)

Note: When the iSCSI port is selected from the tree, it is changed to WWN → iSCSI.

(2) CHA Window

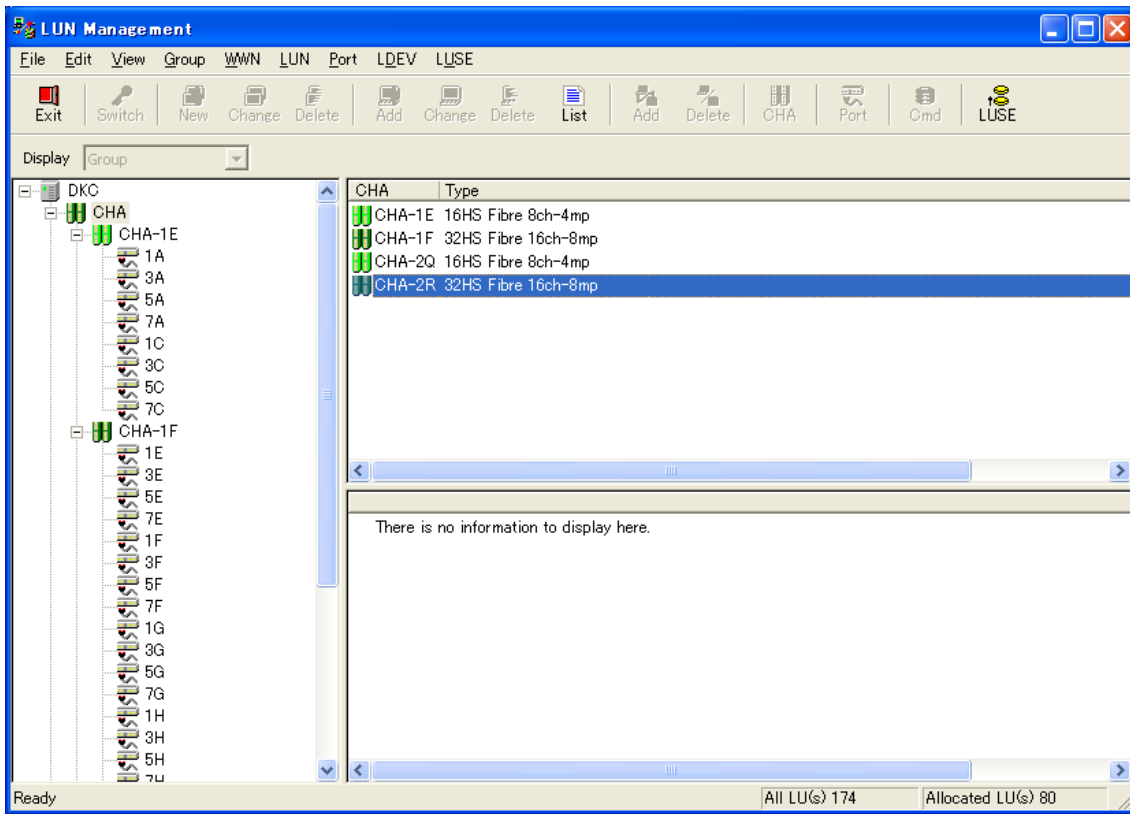

Fig. 3.17-2 CHA Window

When “CHA” in the tree view is selected (CL), installed CHA PCB’s supported by this function are displayed in the upper right list.

Table 3.17-3 Details of CHA Window

Item	Description
Upper list	Displays installed CHA PCB’s supported by this function. Displayed items: PCB name, Host Interface Type
	Provided with a sorting function.
Lower list	Displays nothing.

(3) Port Window

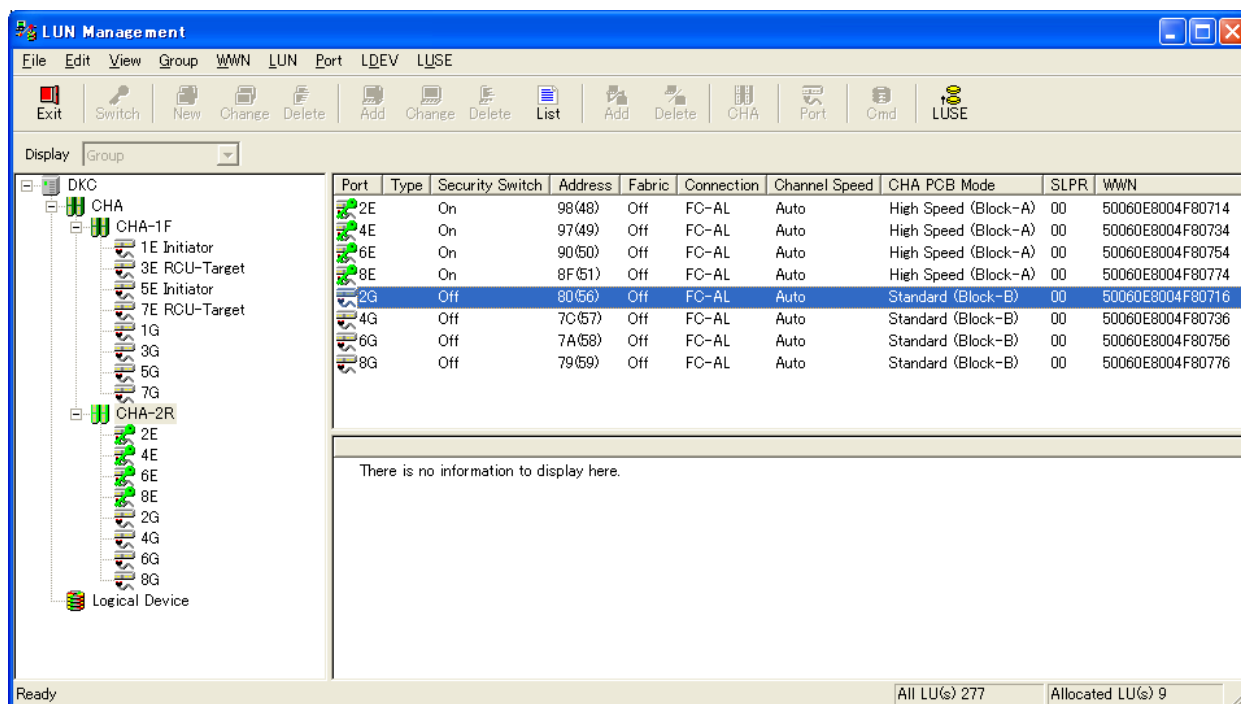

Fig. 3.17-3 Port Window

When “CHA locations” in the tree view is selected (CL), installed ports information supported by this function are displayed in the upper right list.

Table 3.17-4 Details of Port Window

Item	Description
Upper list	<p>Displays installed ports supported by this function.</p> <p>Displayed items: Port name, type (Initiator, RCU target, External, or none:Target), AL-PA, Security Switch, fabric, connection type, and channel speed, Operate mode (Standard mode: Standard / High Speed mode: High Speed / MIX mode: MIX), SLPR number, WWN,</p> <p>In case of iSCSI (IP Address, Subnet Mask, Gateway, Port Number, Keep Alive time, MAC Address, iSNS, iSNS Port Number, iSNS IP Address)</p> <p>Provided with a sorting function.</p>
Lower list	Displays no item.

(4) Group Window

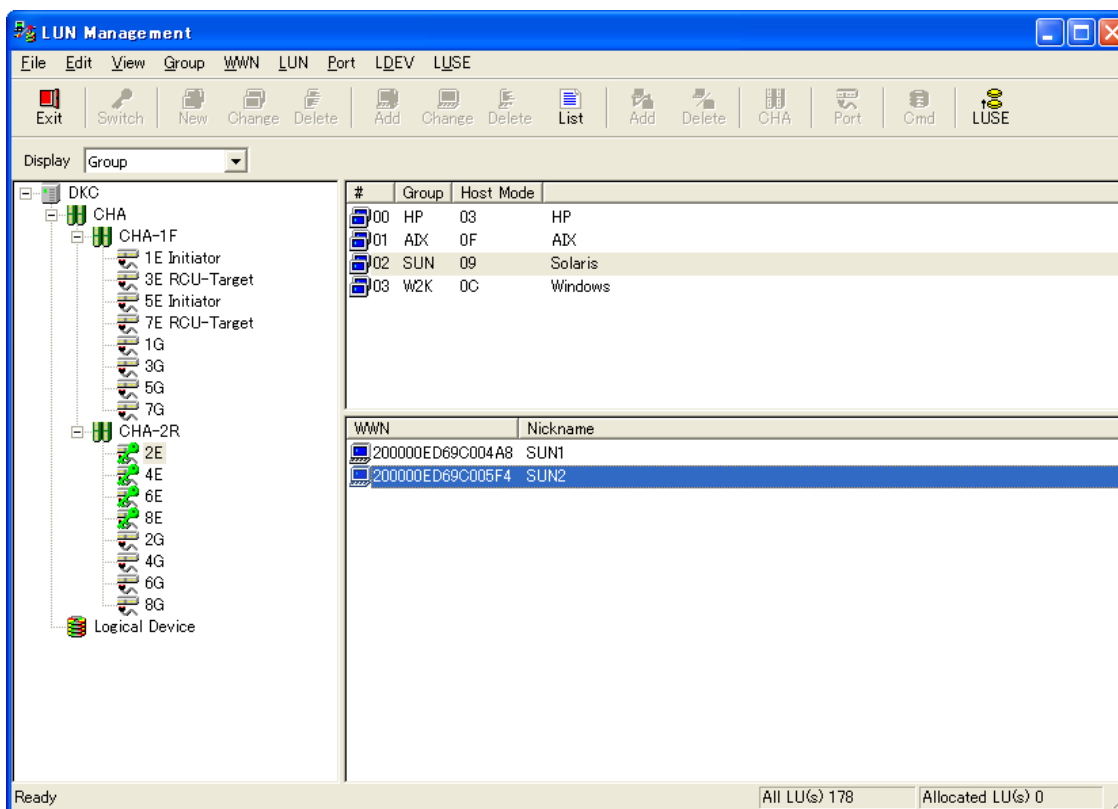

Fig. 3.17-4 Group Window

When “Port” in the tree view is selected, “Group” is set on the Display. Displays the group setting in the port that has been selected in the upper right list. In the lower right list, details of a group that has been selected from the upper right list are displayed.

Table 3.17-5 Details of Group Window

Item	Description
Upper list	Displays groups connected with the port that has been selected from the tree. Displayed items: Group number, group name, and host mode (setting) Target name, Alias name and Host Mode (setting) in case of iSCSI When the [View]–[Host Mode Option] menu is turned on, information on the Host Mode option is displayed.
	Provided with a sorting function.
Lower list	Displays details of a group that has been selected from the upper list. Displayed items: WWN (16 hexadecimal digits) and nickname iSCSI Name and nickname in case of iSCSI (Displays nothing when no item to be selected exists in the upper list or more than one item has been selected.)
	Provided with a sorting function.

(5) LUN Window

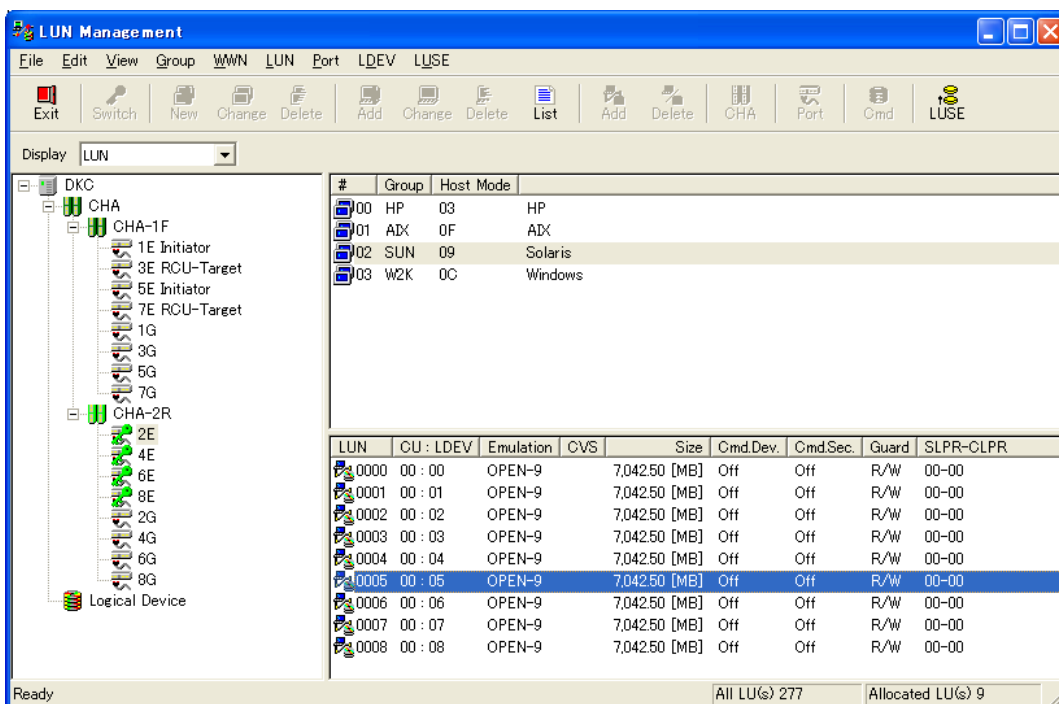

Fig. 3.17-5 LUN Window

When “Port” in the tree view is selected, “LUN” is set on the Display. Displays the group setting in the port that has been selected in the upper right list. In the lower right list, details of a group that has been selected from the upper right list are displayed

Table 3.17-6 Details of LUN Window

Item	Description
Upper list	<p>Displays groups connected with the port that has been selected from the tree. Displayed items: Group number, group name, and host mode(setting) When the [View]–[Host Mode Option] menu is turned on, information on the Host Mode option is displayed.</p> <p>Provided with a sorting function.</p>
Lower list	<p>Displays LUN’s defined as being contained in the group that has been selected from the upper list. Displayed items: LUN (two hexadecimal digits), CU: LDEV number, emulation type (number of connectable in decimal), size (in Mbytes/Gbytes), and Cmd.Dev. (“On*” shows the remote command device), Cmd.Sec, and guard attribute, SLPR number – CLPR number. (Displays nothing when no item to be selected exists in the upper list or more than one item has been selected.)</p> <p>(Note) The following symbols may be added to CU:LDEV #. Each meaning is shown. ‘+’ : One LUN is set in other host groups. ‘++’ : Two or more LUNs are set in other host groups. ‘#’ : An external volume is shown. ‘V’ : A virtual volume is shown.</p> <p>Provided with a sorting function.</p>

(5-1) LUN Status Window

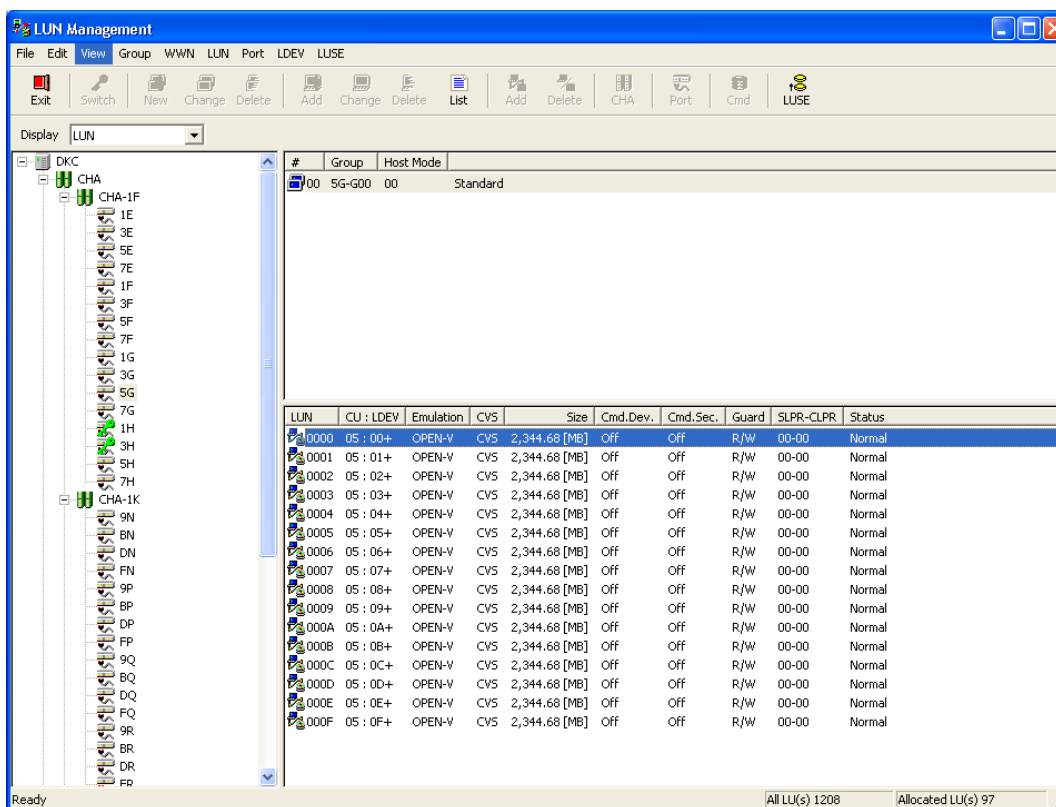

Fig.3.19-5.1 LUN Status Window

If you select LUN Status from View in the LUN Management panel, the LUN status will be displayed in the LUN list in the panel.

The following statuses are displayed in the list (Multiple statuses may be displayed).

By selecting LUN Status from View again, you can obtain the information again.

Table 3.19-6-1 LUN Status List

Status	Explanation
Normal	Normal device
BLK	It is not ready due to blockade.
OPR	It is reserved by the normal Open Reserve command.
KEY	Persistent Group Reserve key is set.
PGR	It is reserved by the Persistent Group Reserve command.
MFR	It is reserved by Mainframe.
H35R	It is reserved from the H3500 server.
ACA	It is in the ACA ACTIVE status.

(6) Logical Device Window

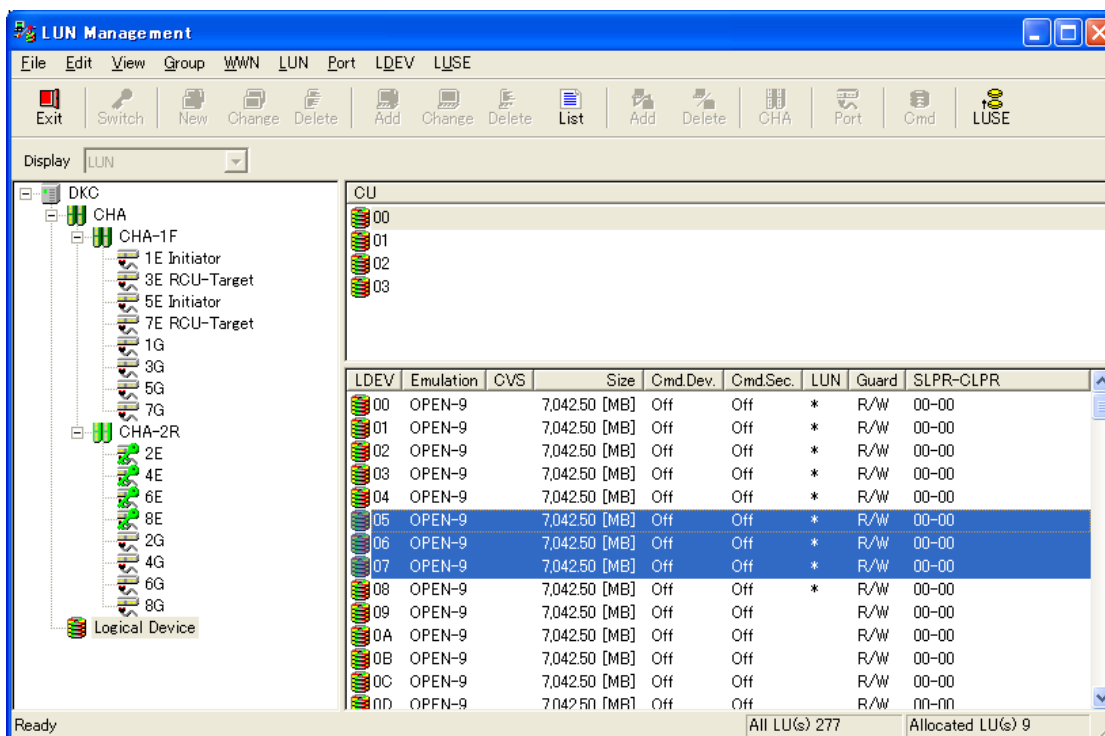

Fig. 3.17-6 Logical Device Window

When “Logical Device” in the tree view is selected (CL), CU numbers of installed LDEV’s supported by this function are displayed in the upper right list. In the lower right list, details of a CU selected from the upper right list are displayed.

Table 3.17-7 Details of Logical Device Window

Item	Description
Upper list	Displays CU numbers of installed LDEV’s supported by this function. Displayed items: CU number (two hexadecimal digits) Provided with a sorting function.
Lower list	Displays details of a CU selected from the upper list. Displayed items: LDEV number (two hexadecimal digits), emulation type (number of connectable in decimal), CVS, size(in Mbytes/Gbytes), Cmd.Dev. (‘On*’ shows the remote command device), Cmd.Sec., definition of LUN (Defined: “*”, Not defined: No indication), and guard attribute, SLPR number – CLPR number. (Displays nothing when no item to be selected exists in the upper list or more than one item has been selected. (Note) The following symbols may be added to LDEV #. Each meaning is shown. ‘#’ : An external volume is shown. ‘V’ : A virtual volume is shown. Provide with a sorting function.

(7) The host's WWN list windows linked to DKC

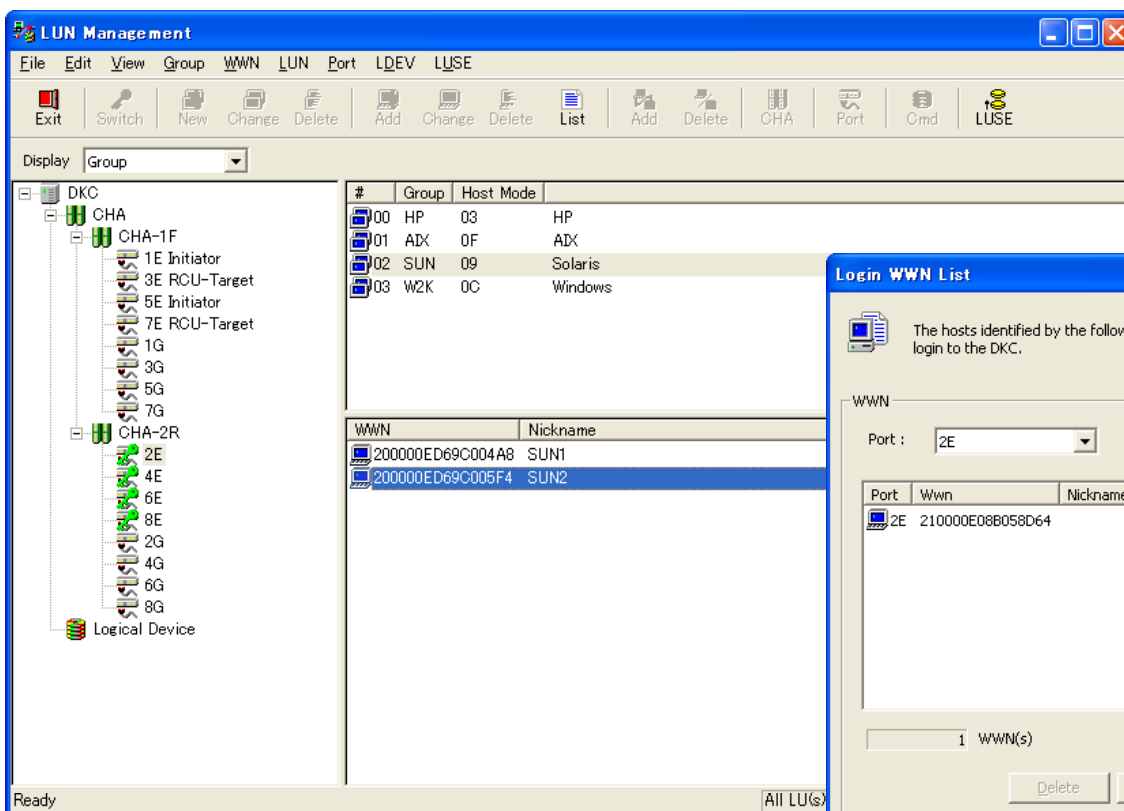

Fig. 3.17-7 Main Window

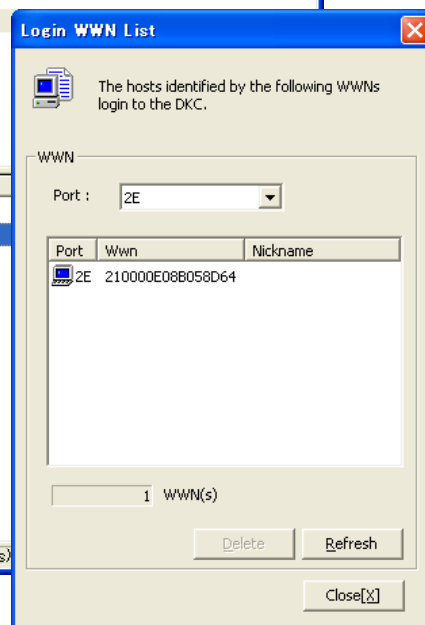

Fig. 3.17-8 Login WWN List Window

Select (DR) [Login List] from the [WWN] menu in the Main Window (Fig. 3.17-7), Login WWN List Window (Fig. 3.17-8) is displayed.

Table 3.17-8 Details Login WWN List window

Item	Description
Port	Specifies a port concerning the WWN to be displayed in the list. When "All Port" is selected, all WWNs in the list are displayed.
List	Displays a WWN list.
Delete button	Not selectable.
Refresh button	Not selectable.
Close button	Returns you the Main window.

(8) The host's Login iSCSI Name list windows linked to DKC

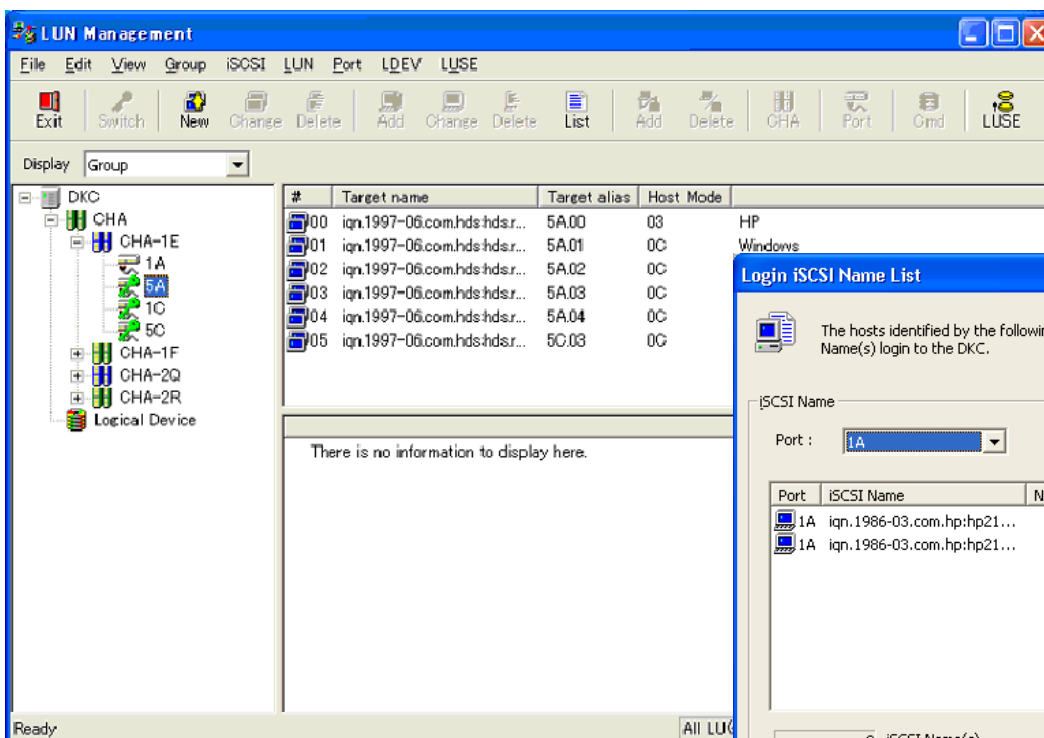

Fig. 3.19-9 Main Window

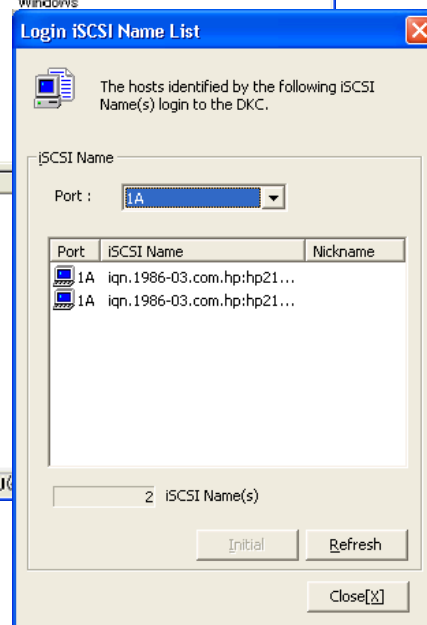

Fig. 3.19-10 Login iSCSI Name List Window

When iSCSI Port  in the tree view is selected, the [WWN] menu changes to the [iSCSI] menu. When [Login List] is selected (DR) from the [iSCSI] menu in the Main window (Figure 3.19-9), the Login iSCSI Name List window (Figure 3.19-10) is displayed.

Table 3.19-9 Details Login iSCSI Name List window

Item	Description
Port	Specifies a port concerning the iSCSI to be displayed in the list. When “All Port” is selected, all iSCSI Name in the list are displayed.
List	Displays a iSCSI Name list.
Initial button	Not selectable.
Refresh button	Redraws the list.
Close button	Returns you the Main window.

Notes: Only iSCSI name by which Initiator issued the login command to Target is displayed in the list. Latest 64 careers of iSCSI name which accepts the login command of each port are displayed in the list regardless of session (Discovery, Normal) or result (Accept, Reject). However, iSCSI name that the acceptance of the command overlaps is not displayed. It is time when it registers iSCSI name, and register to Target by using this career, please before registered target iSCSI Name is deleted from the list when registering bringing two or more clients together in one port. Please execute the login command from Initiator again when registered target iSCSI Name it is time when has been deleted, and wants to display corresponding iSCSI name from the list again. At this time, please do not add iSCSI name that registration is unnecessary to the list by operating only Initiator for which login is necessary for a target port.

3.18 CM/SM Path

- (1) The window for displaying a path status of each PCB

CHA/MIX (Button) - Location names are displayed under this button. When this button is pressed, the path statuses in the list are sorted using the CHA/MIX location name as a key word.

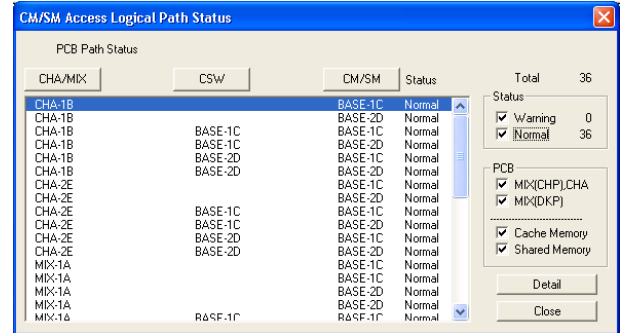

CSW (Button)----- Location names are displayed under this button. When this button is pressed, the path statuses in the list are sorted using the BASE location name as a key word.

CM/SM (Button) ---- Location names are displayed under this button. When this button is pressed, the path statuses in the list are sorted using the BASE location name as a key word.

Status ----- A status of each path is displayed.

Normal : A status in which a path concerned is normal

Warning : A status in which a failure occurred in a path concerned

Total ----- Total number of paths that can be displayed

Status (Check box) --

Warning : Specifies display of failed paths and displays number of the failed paths.

Normal : Specifies display of normal paths and displays number of normal paths.

PCB (Check box)----

MIX (CHP), CHA : Specifies display of paths connected to the CHP.

MIX (DKP) : Specifies display of paths connected to the DKP.

Cache Memory : Specifies display of paths connected to the cache memory in the BASE PCB.

Shared Memory : Specifies display of paths connected to the shared memory in the BASE PCB.

Detail (Button) ----- Displays detailed path status.

Close (Button) ----- Terminates the display.

(2) Detailed path status display window

CHP/DKP ----- Location names are displayed in this column.

CSW ----- Location names are displayed in this column.

CM/SM ----- Location names are displayed in this column.

Status ----- Status of each path is displayed.
 Normal : Status in which a path concerned is normal
 Blockade : Status in which a path concerned is blocked

Total ----- Total number of paths that can be displayed

Status (Check box) --

Blockade : Specifies display of blocked paths and displays number of the blocked paths.

Normal : Specifies display of normal paths and displays number of the normal paths.

Close (Button) ----- Terminates the display.

The screenshot shows a window titled "CM/SM Access Logical Path Status" with a sub-header "Detail Path Status". It contains a table with columns: CHP/DKP, Master, CSW, Port, CM/SM, Status, Total, and a "Status" section with checkboxes for "Blockade" and "Normal".

CHP/DKP	Master	CSW	Port	CM/SM	Status	Total
CHP90-1B			0	BASE-1C	Normal	16
CHP90-1B			1	BASE-1C	Normal	
CHP91-1B			0	BASE-1C	Normal	
CHP91-1B			1	BASE-1C	Normal	
CHP92-1B			0	BASE-1C	Normal	
CHP92-1B			1	BASE-1C	Normal	
CHP93-1B			0	BASE-1C	Normal	
CHP93-1B			1	BASE-1C	Normal	
CHP94-1B			0	BASE-1C	Normal	
CHP94-1B			1	BASE-1C	Normal	
CHP95-1B			0	BASE-1C	Normal	
CHP95-1B			1	BASE-1C	Normal	
CHP96-1B			0	BASE-1C	Normal	
CHP96-1B			1	BASE-1C	Normal	
CHP97-1B			0	BASE-1C	Normal	
CHP97-1B			1	BASE-1C	Normal	

On the right side of the window, there is a "Status" section with two checked checkboxes: "Blockade" (0) and "Normal" (16). A "Close" button is located at the bottom right of the window.

3.19 OS Install Status

When the [OS Install Status] is selected (CL) in the main window, the 'OS Install Status' window is displayed.

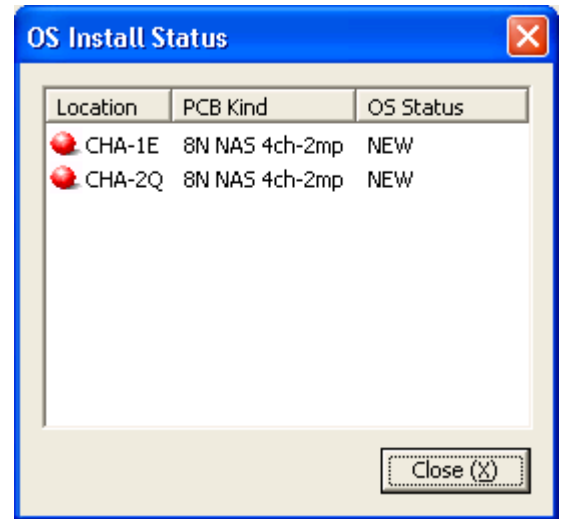

Location ----- Name of the CHA location

PCB Kind ----- Name of the PCBA kind

OS Status ----- Installation status of the CHN OS

Display	Status	Icon
NEW	Not installed	Red
UP	In operation	Blue
DOWN	Shut down deliberately	Blue
DOWN(Failure)	Shut down owing to a failure	Blue
BUSY(Boot)	Being booted	Blue
BUSY(Shutdown)	Being shut down	Blue
ERROR	Being recovered from a crash	Blue
DUMP	Under hibernation operation	Blue
DUMP SKIP	Hibernation skip	Blue
HANG UP	Hung up	Blue

Close ----- Closes the window

3.20 Error or Failure Status Action

When an error status of, Warning, Failure, or other is displayed on the screen and any action is required, locate the part in error and follow the instructions according to the action code (ACC). The ACC can be obtained by executing the SSB log or the SIM log displayed function of the SVP.