

DIAGNOSIS SECTION

Contents

DIAG01-10	1. Types of Diagnosis
DIAG02-10	2. DIAG Details
DIAG02-10	2.1 CUDG3 (Control Unit Diagnosis 3)/ LCDG3 (Link Control module Diagnosis 3)/ FCDG3 (Fiber Channel module Diagnosis 3)/ PCDG3 (Processor Diagnosis 3)
DIAG02-20	2.2 CUDG4 (Control Unit Diagnosis 4)/ CDG4 (Link Control module Diagnosis 4)/ FCDG4 (Fiber Channel module Diagnosis 4)/ PCDG4 (Processor Diagnosis 4)
DIAG02-30	2.2.1 CUDG4
DIAG02-40	2.2.2 LCDG4
DIAG02-50	2.2.3 FCDG4
DIAG02-60	2.2.4 PCDG4
DIAG02-70	2.3 INLINE CUDG (INLINE Control Unit Diagnosis)
DIAG02-80	2.4 DKU INLINE
DIAG02-90	2.5 DKU PATH INLINE
DIAG02-100	2.6 LAN Checker
DIAG03-10	3. DIAG Parts
DIAG04-10	4. DIAG Test Procedures (SVP Operations)
DIAG04-10	4.1 CUDG4 Test Procedures
DIAG04-60	4.2 LCDG4/FCDG4/PCDG4 Test Procedures
DIAG04-110	4.3 DKU INLINE Test Procedures
DIAG04-150	4.4 DKU PATH INLINE Test Procedures
DIAG04-150	4.4.1 A0 routine Test Procedures
DIAG04-190	4.4.2 A6 routine Test Procedures
DIAG04-240	4.4.3 A3 routine Test Procedures
DIAG04-280	4.4.4 A2 (A8) routine Test Procedures
DIAG04-360	4.5 LAN Check Procedure
DIAG05-10	5. DIAG Trouble shooting
DIAG05-10	5.1 CUDG Trouble shooting
DIAG05-20	5.1.1 CUDG3 Trouble shooting
DIAG05-30	5.1.2 CUDG4 Trouble shooting
DIAG05-40	5.1.3 INLINE CUDG Trouble shooting
DIAG05-60	5.1.4 BASE PCB, Cache Memory Module, Shared Memory Module Trouble shooting
DIAG05-70	5.2 DKU INLINE Trouble shooting
DIAG05-80	5.3 DKU PATH INLINE Trouble shooting

- [DIAG06-10](#) 6. DIAG Errors
- [DIAG06-10](#) 6.1 DKU INLINE Error Code List
- [DIAG06-60](#) 6.2 PATH INLINE Error Code List
- [DIAG06-250](#) 6.3 CUDG error code list

1. Types of Diagnosis

This subsystem's diagnostics consist of the five types of test routines listed below. They are selected according to the purpose and the part to be tested.

Table 1-1 Diagnostics Test Routines

Item No.	Type	Diagnosis	Part	Timing
1	CUDG3/ LCDG3/ FCDG3/ PCDG3	Initial diagnoses	CHA, MIX, Cache/Shared Memory	When DKC is powered on or CHA or MIX is replaced or installed (automatic)
2	CUDG4/ LCDG4/ FCDG4/ PCDG4	Functional diagnoses executed when the unit is offline	CHA, MIX, Cache/Shared Memory	During installation (as specified by service personnel)
3	INLINE CUDG	Functional diagnoses executed when the unit is online	Cache/Shared Memory	When Cache or Shared memory is replaced or installed (automatic)
4	DKU INLINE	MIX (DKA)-HDU functional (connection) check	MIX (DKA), FSW, HDD	When an HDD is replaced (automatic) or during installation (as specified by service personnel)
5	DKU PATH INLINE	↑	MIX (DKA), FSW, DKUPS	↑
6	LAN	LAN check between MIX/CHA and SVP	SVP, SSVP, MIX, CHA	When LAN communication error or communication time-out error is occurred.

2. DIAG Details

2.1 CUDG3 (Control Unit Diagnosis 3)/LCDG3 (Link Control module Diagnosis 3)/ FCDG3 (Fiber Channel module Diagnosis 3)/PCDG3 (Processor Diagnosis 3)

CUDG3/LCDG3/FCDG3/PCDG3 is a collection of test routines that are started at system start time (when the unit power is turned on), prior to the execution of the main program and automatically checks the basic functions of the unit to ensure the normal hardware operation of the system. The CUDG3/LCDG3/FCDG3/PCDG3 routines are listed in Table 2.1-1.

Table 2.1-1 CUDG3/LCDG3/FCDG3/PCDG3 Test Routines

Item No.	Routine Name	Function
1	CUDG3B	Local memory/ Processor diagnosis
2	CUDG3C1	CHA/MIX (CHA) self-diagnosis
3	CUDG3C2	MIX (DKA) self-diagnosis
4	CUDG3C3	Shared resource diagnosis by all processors (SMC)
5	CUDG3C4	Shared resource diagnosis by all processors (CACHE)
6	CUDG3C5	Shared resource diagnosis by a delegated processor (SMC)
7	CUDG3C6	Shared resource diagnosis by a delegated processor (CACHE)
8	LCDG3/FCDG3/ PCDG3	CS, for Serial/Parallel port, read/write test, internal diagnostic test, communication diagnostic test

2.2 CUDG4 (Control Unit Diagnosis 4)/LCDG4 (Link Control module Diagnosis 4)/ FCDG4 (Fiber Channel module Diagnosis 4)/PCDG4 (Processor Diagnosis 4)

CUDG4/LCDG4/FCDG4/PCDG4 supports Cache memory/Shared memory read after full write tests and other tests that cannot be covered by CUDG3/LCDG3/FCDG3/PCDG3. It is executed by the service personnel when the unit is offline. After CUDG4/LCDG4/FCDG4/PCDG4, the subsystem PS OFF/ON is mandatory in order to return to ONLINE status of the subsystem.

2.2.1 CUDG4

⚠ CAUTION

If CUDG4 is executed, it may become impossible to guarantee the data on Cache Memory/Shared Memory.

- ① Execute PS OFF and ON before CUDG Test. The data on CACHE is stored to HDD.
- ② Be sure the check the validity of CUDG Test to Technical Support Division before CUDG Test.

The CUDG4 test routines are listed in Table 2.2.1-1.

The CUDG4 run option are listed in Table 2.2.1-2.

Table 2.2.1-1 CUDG4 Test Routines

Item No.	Routine Name	Function
1	P/K test Group	CHA/MIX diagnosis
2	SMC Normal test Group	SMC, Shared Memory diagnosis (Normal test)
3	Cache Normal test Group	CMC, Cache Memory diagnosis (Normal test)
4	SMC test Group	SMC, Shared Memory diagnosis
5	Cache test Group	CMC, Cache Memory diagnosis
6	Heatrun test Group	All the above tests are included. (*1)

*1: When 'Heatrun test Group' is selected, 'Run Option' settings are invalidated and diagnosis is executed under Heatrun mode. Heatrun mode : Even if an error is detected, the CUDG test continues. And Diag log is mode.

Table 2.2.1-2 CUDG Run Option

Item No.	Run Option	If an error is not detected	If an error is detected
1	Normal	CUDG test will be executed only once.	CUDG test will be terminated when an error is detected. And the error detail will be displayed on the SVP screen. After finishing the CUDG function, please refer to Diag log.
2	Loop	CUDG test will be executed continuously.	CUDG test will be terminated when an error is detected. And the error detail will be displayed on the SVP screen. After finishing the CUDG function, please refer to Diag log.
3	Error Loop	CUDG test will be executed continuously.	CUDG test continues. And an error detail is displayed on the SVP screen. But the CUDG will continues testing.
4	Error Log	CUDG test will be executed continuously.	CUDG test continuous. And an error detail will be displayed on the SVP screen. After finishing the CUDG function, refer to Diag log.

2.2.2 LCDG4

⚠ CAUTION

If LCDG4 is executed, it may become impossible to guarantee the data on Cache Memory/Shared Memory.

- ① Execute PS OFF and ON before LCDG4 Test. The data on CACHE is stored to HDD.
- ② Be sure to check the validity of LCDG4 Test to Technical Support Division before LCDG4 Test.

The LCDG4 test routines are listed in Table 2.2.2-1.

The LCDG4 run options are listed in Table 2.2.2-2.

Table 2.2.2-1 LCDG4 Test Routines

Item No.	Routine No.	Parameter	Contents of Test
1	10	—	(1) LCP Operation (2) LCP Register Test (3) Data Buffer Read/Write (4) SPS Function
2	20	—	(1) LCP-MP Communication Test (2) Data Transfer Test
3	30	cb750f	(1) Serial Channel Wraparound Test (*1)
4	40	—	(1) Optical Signal Defect Test (*2) (*3)
5	50	—	(1) Optical Signal Error Rate Check (*2) (*3)

*1: Routine 30 is used for running a serial channel wraparound test. To execute Routine 30, the wraparound test connector is required.

*2: Routine 40 and Routine 50 are used for checking optical signals for the serial channel.

*3: If Routine 40 or Routine 50 is selected, RUN option can select only Normal.

Table 2.2.2-2 LCDG4 Run Option

Item No.	Run Option	Action against Error
1	Normal	LCDG test will be executed only once. LCDG test will be terminated when an error is detected. And the error detail will be displayed on the SVP screen. After finishing the LCDG function, please refer to Diag log.
2	Error Loop	LCDG test continues. And an error detail will be displayed on the SVP screen. But the LCDG test will continue testing.
3	Loop	LCDG test continues. LCDG test will be terminated when an error is detected. And an error detail will be displayed on the SVP screen. After terminated the LCDG function, please refer to Diag log.

2.2.3 FCDG4

CAUTION

If FCDG4 is executed, it may become impossible to guarantee the data on Cache Memory/Shared Memory.

- ① Execute PS OFF and ON before FCDG4 Test. The data on CACHE is stored to HDD.
- ② Be sure to check the validity of FCDG4 Test to Technical Support Division before FCDG4 Test.

The FCDG4 test routines are listed in Table 2.2.3-1.

The FCDG4 run options are listed in Table 2.2.3-2.

Table 2.2.3-1 FCDG4 Test Routines

Item No.	Routine No.	Parameter	Contents of Test
1	10	—	(1) Processor Test (2) Register Test (3) Internal LINK Test
2	20	—	(1) HTP-MP Communication Test (2) Data Transfer Test
3	30	cb750f	(1) Single Channel Wraparound Test (*1)

*1: Routine 30 is used for running Fibre Channel wraparound test. To execute Routine 30, the wraparound test connector is required.

Table 2.2.3-2 FCDG4 Run Option

Item No.	RUN Option	Meaning
1	Normal	FCDG test will be executed once. If an error is detected, error detail will be displayed on the screen. And Diag log is created.
2	Error Loop	Continuous execution of FCDG test. The test is continued even when an error is detected. The error detail will be displayed on the screen.
3	Loop	Continuous execution of FCDG test. The test will be terminated when an error is detected. And an error detail will be displayed on the screen.

2.2.4 PCDG4

⚠ CAUTION

If PCDG4 is executed, it may become impossible to guarantee the data on Cache Memory / Shared Memory.

- ① Execute PS OFF and ON before PCDG4 Test. The data on CACHE is stored to HDD.
- ② Be sure to check the validity of PCDG4 Test to Technical Support Division before PCDG4 Test.

The PCDG4 Test Routines are listed in Table 2.2.4-1.

The PCDG4 Run Options are listed in Table 2.2.4-2.

Table 2.2.4-1 PCDG4 Test Routines

Item No.	Routine No.	Parameter	Contents of Test
1	10	—	(1) Communication Memory Test (2) Door Bell Registers Access Test (3) Direct Mapping Area Memory Test (4) DMA Test
2	20	—	(1) NIC Test (2) Memory Test
3	30	cb750f	(1) Loop Back Test (*1)

*1: Routine 30 is used for running Loop Back Test. To execute Routine 30, Loop Back Connector is required.

Table 2.2.4-2 PCDG4 Run Options

Item No.	RUN Option	Meaning
1	Normal	PCDG Test will be executed once. If an error is detected, The error detail will be displayed on the screen. And Diag log is created.
2	Error Loop	Continuous execution of PCDG Test. The Test is continued even when an error is detected, The error detail will be displayed on the screen.
3	Loop	Continuous execution of PCDG Test. The Test will be terminated when an error is detected. And an error detail will be displayed on the screen.

2.3 INLINE CUDG (INLINE Control Unit Diagnosis)

INLINE CUDG checks the validity of Cache memory and Shared memory when the entire disk subsystem is running normally. The INLINE CUDG test routines are listed in Table 2.3-1.

Table 2.3-1 INLINE CUDG Test Routines

Item No.	Routine Name	Function
1	Cache memory system	Cache Memory and CMA (Cache Memory Adapter) diagnosis
2	Shared memory system	Shared Memory and SMA (Shared Memory Adapter) diagnosis

2.4 DKU INLINE

The DKU INLINE of test routines are used to ensure that the HDD is accessible to the Disk Controller when one is installed (a new or as an additional unit). This INLINE facility is also executed when a HDD is replaced during online processing as part of the recovery procedure to ensure that the HDD is normal. In this case, this INLINE facility runs automatically (with no SVP manipulation). The test routines are listed in Table 2.4-1.

Table 2.4-1 DKU INLINE Test Routines

Routine ID	Test Name	Function
C1	TEST UNIT READY & REQ.SENSE	Issues the TEST UNIT READY to the HDD and verifies that the status is GOOD or CHECK.
C2	INQUIRY	Checks the HDU-specific information.
C3	START/STOP TEST	Issues the STOP command to the HDD and verifies that the command terminates normally. In 10 seconds, the test routine issues the START command and verifies that normal status is returned.
C4	HDU SELF TEST	Issues the SEND DIAG(Self Test) command to the HDD and verifies that the terminates normally.

Notes:

- All logical devices must be in the “BLOCKED” state. If not, the test routine will error-terminate. Refer to from [SVP02-810](#) of SVP SECTION for all logical devices blocked.
- The previous test routines must have been terminated normally before the pertinent test routine is started.
- The Disk Controller should have been powered on normally.

2.5 DKU PATH INLINE

The DKU Path Inline is used to check that the connection between the MIX (DKA) and the HDU is correct. The DKU path inline test routines are shown in Table 2.5-1.

Moreover, the thing for which only the diagnostic routine shown in diagnostic order at the time of introduction is performed at the time of equipment introduction. It is not performing manually, since diagnosis is automatically performed in extension processing when extending DKU to an established subsystem. (It will become a serious error if it performs manually.)

Table 2.5-1 DKU PATH INLINE Test Routine

Introduction diagnostic order	Routine ID	Execution propriety under ONLINE	Test Name	Function	Maximum execution time (1 PORT) (*5)			
					12HDD	24HDD	32HDD	64HDD
1	A0	○	Path Address TEST1	Checks whether the selected MIX (DKA) and HDU are correctly connected.	50 sec.	50 sec.	50 sec.	50 sec.
—	A2	×	Failed HDD detection test	Detects the failed HDD and recovers it by using the reset function when an A0 10 or A0 20 error occurs. (*4) (*9)	1 min.	2 min.	2 min. 40 sec.	5 min. 20 sec.
3 (*1)	A3	×	HDD READ TEST	Executes the read test of the mounted HDD is executed. (*6) (*9)	2 min.	4 min.	5 min. 20 sec.	10 min. 40 sec.
2 (*1)	A6	× (*3)	Path Address TEST EX	Extension of A0 routine. (*8) (*9)	1 min. 20 sec.	1 min. 20 sec.	1 min. 20 sec.	1 min. 20 sec.
—	A8	× (*2)	Failed HDD detection test 2	Extension of A2 routine. (*4) (*7) (*9)	4 min. 50 sec.	9 min. 40 sec.	12 min. 50 sec.	25 min. 40 sec.

Notes:

- *1: Don't perform among ONLINE at the time of HDD extension and DKU extension. Newly, DKC and only when DKC and DKU are introduced by the set, it performs.
- *2: It performs with directions of its Technical Support Division.
- *3: A password input is required.
- *4: The routine A2 (A8) forcibly blocks the port of the HDD by using the individual SCSI RESET function for the HDD connected to the designated port of the selected MIX (DKA). Therefore, you must not do this operation expect for finding the factor of A010/A020 error.
- *5: The maximum execution times here is the time when communication is normal. Communication time-out, is 3 minutes plus the above time.
- *6: The routine A3 executes Read Test to all equipped HDD. Therefore, you must not execute this operation during ONLINE.
- *7: If the target Port (MP) is not blocked, the routine A8 cannot be executed.
- *8: The routine A6 executes Bypass Process for the HDD connected to the designated port of the selected MIX (DKA). Therefore, you must not execute this operation during ONLINE.
- *9: While the NAS OS is running diagnosis cannot be performed. To perform diagnosis, shut down the NAS OS.

2.6 LAN Checker

LAN checker analyses the LAN connection between DKC and SVP to determine whether the LAN error is caused by the physical connection or the communication software.

Table 2.6-1 LAN Checker Test

#	Test Name	Function	Maximum execution time
1	Hardware check	Checker executes “Ping” to all MPs. If the result is “no-response”, for an MP, the physical connection error has occurred between the MP and SVP.	2 min. (1 MP)
2	Software check	Checker executes the communication between SVP and MPs whose result of #1 is “responded”.	

3. DIAG Parts

The parts that are diagnosed by the DIAG test routines are shown in Figs. 3-1 through 3-8.

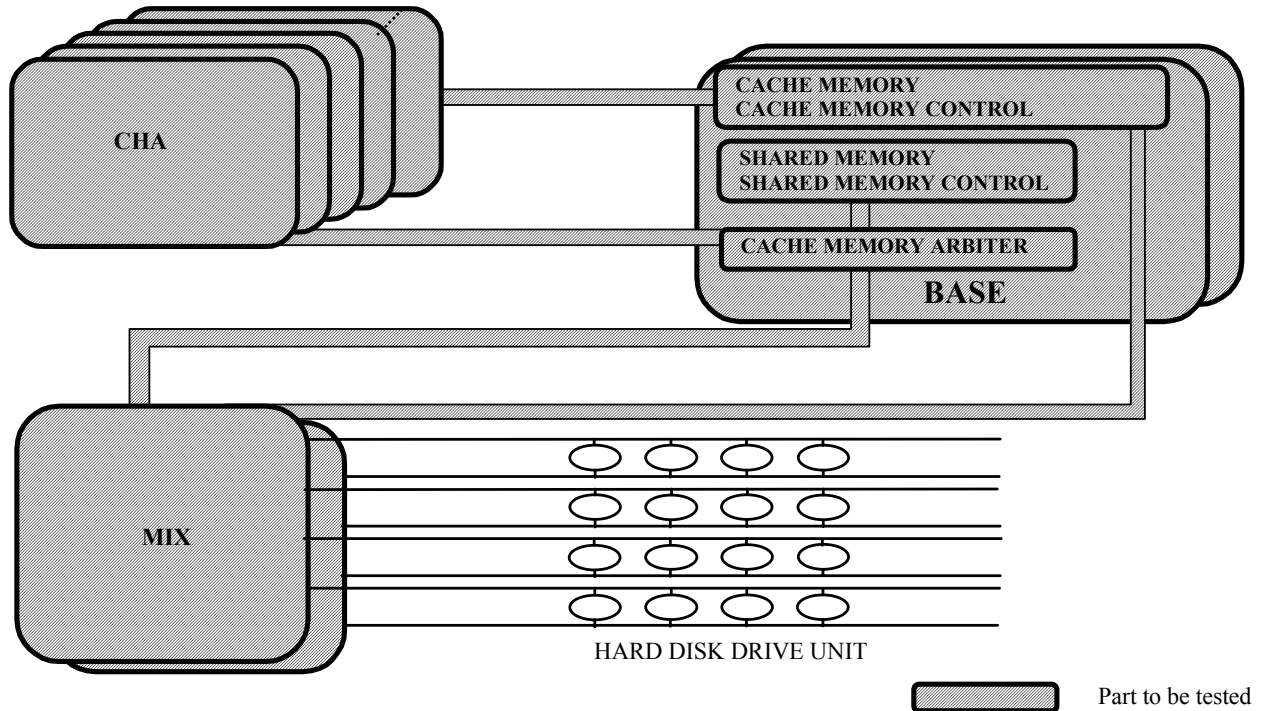

Fig. 3-1 Parts Subject to CUDG3/CUDG4 Tests

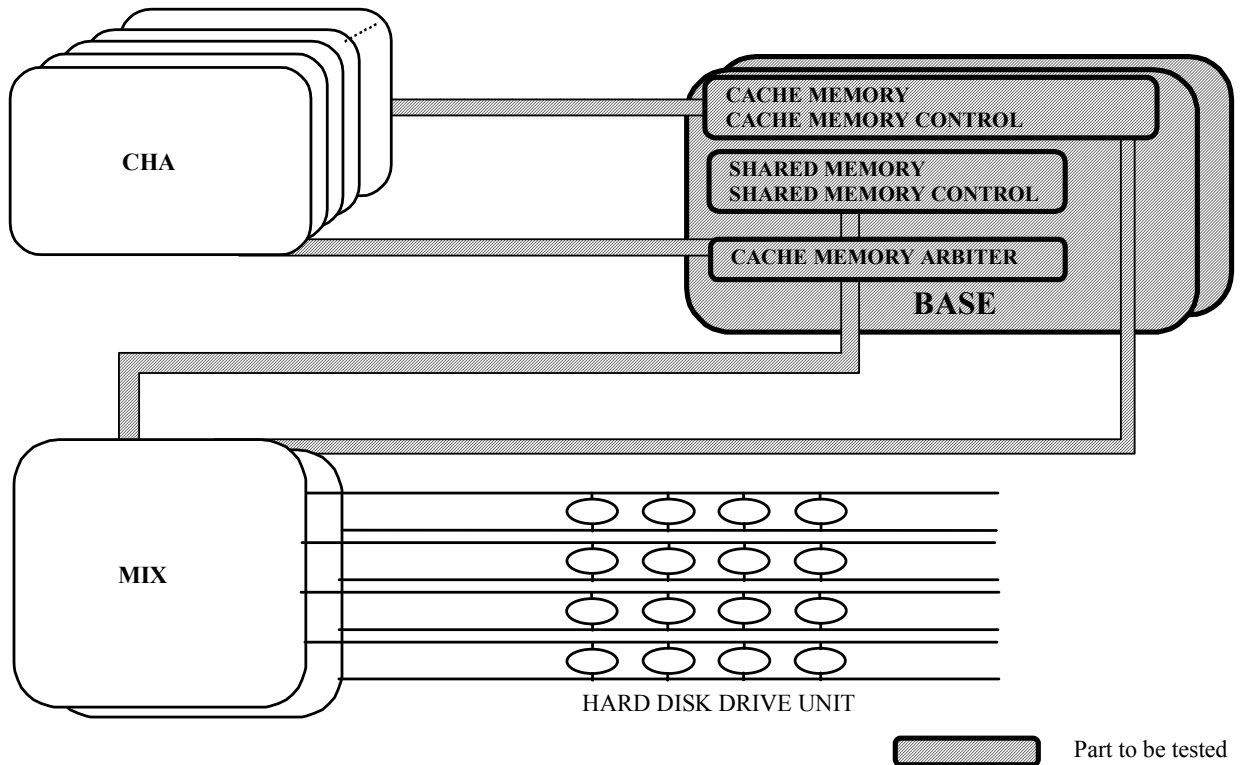

Fig. 3-2 Parts Subject to INLINE CUDG Tests

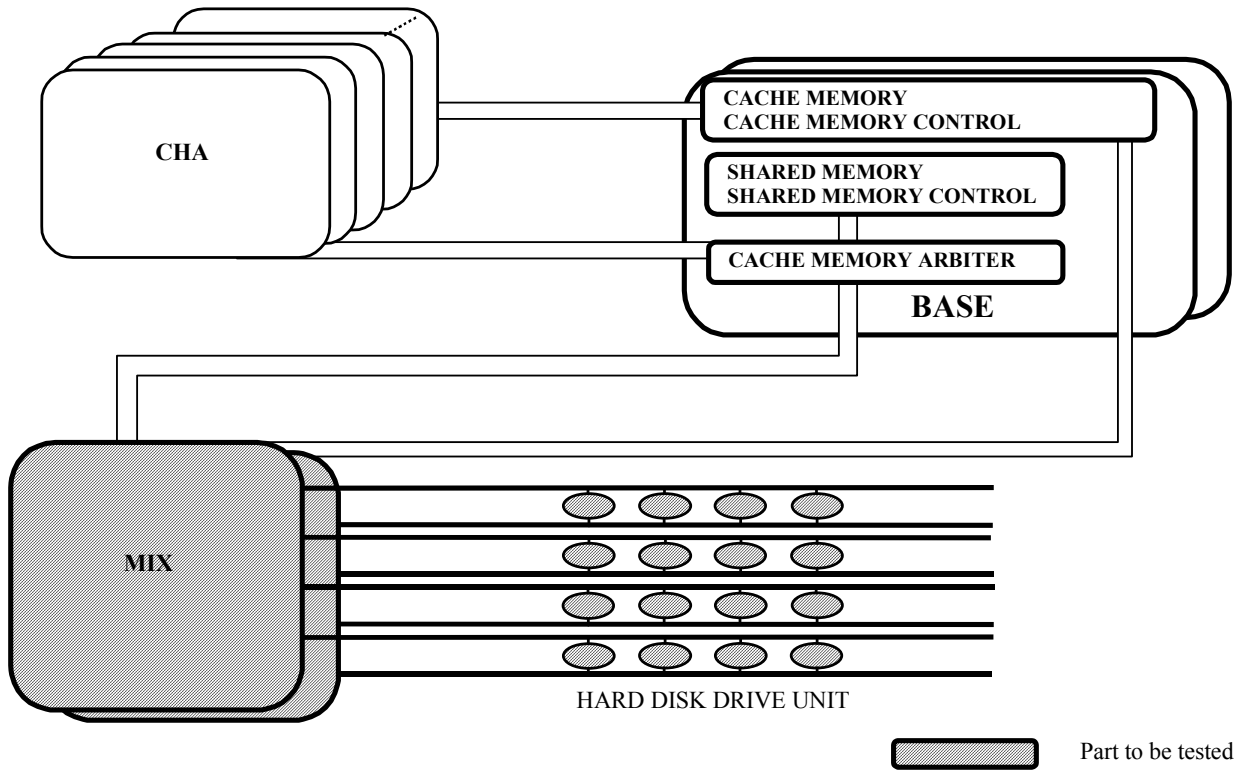

Fig. 3-3 Parts Subject to DKU INLINE Tests

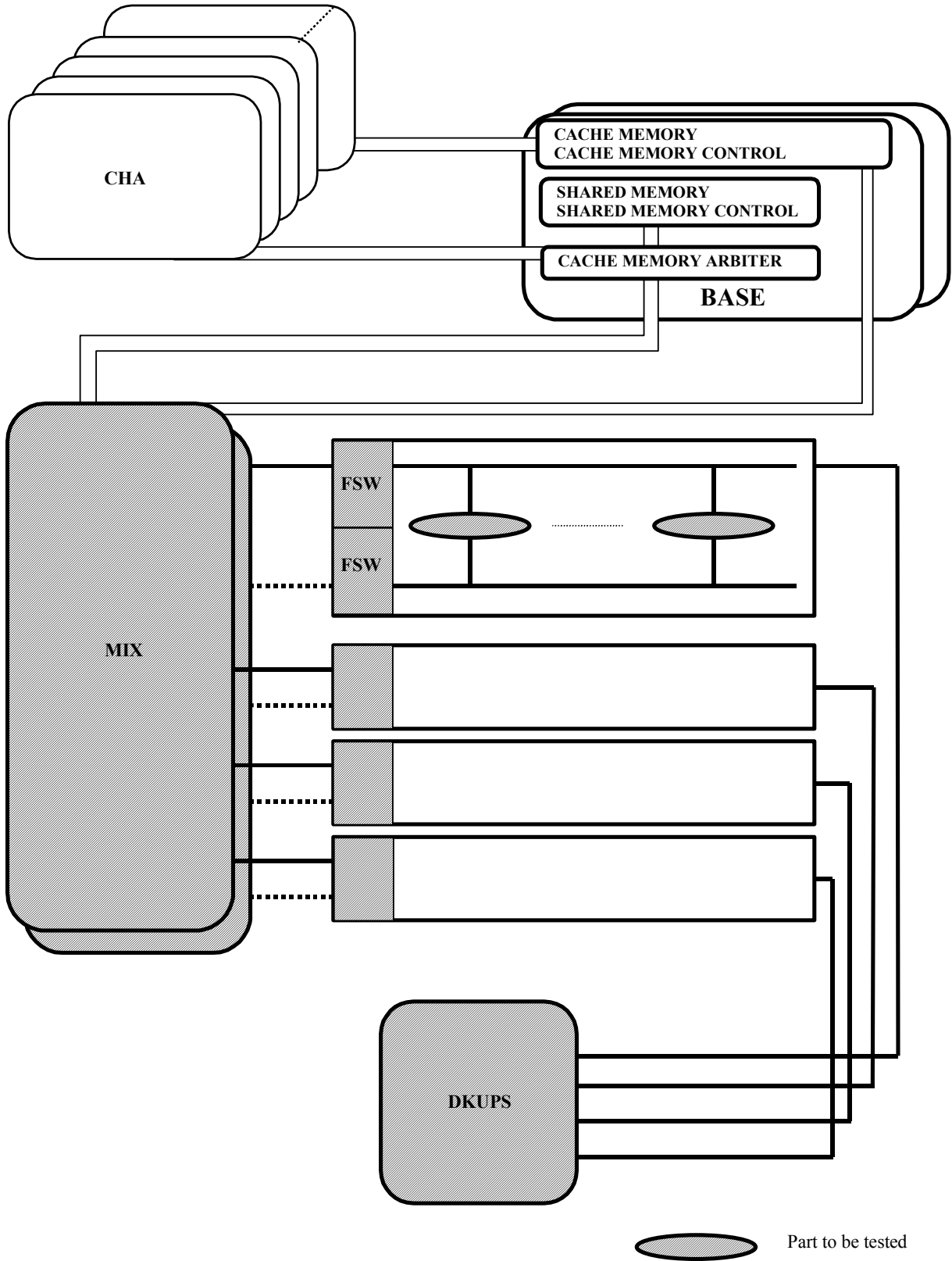

Fig. 3-4 Parts Subject to DKU PATH INLINE Tests

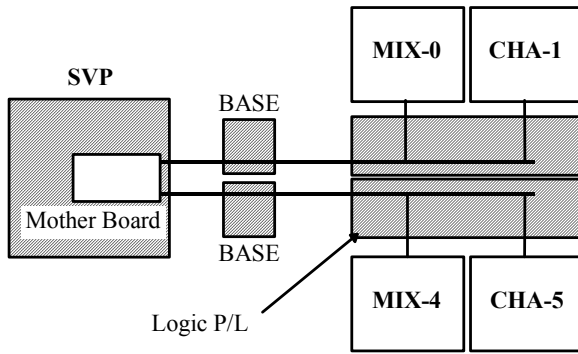

Fig. 3-5 Parts Subjects to LAN check

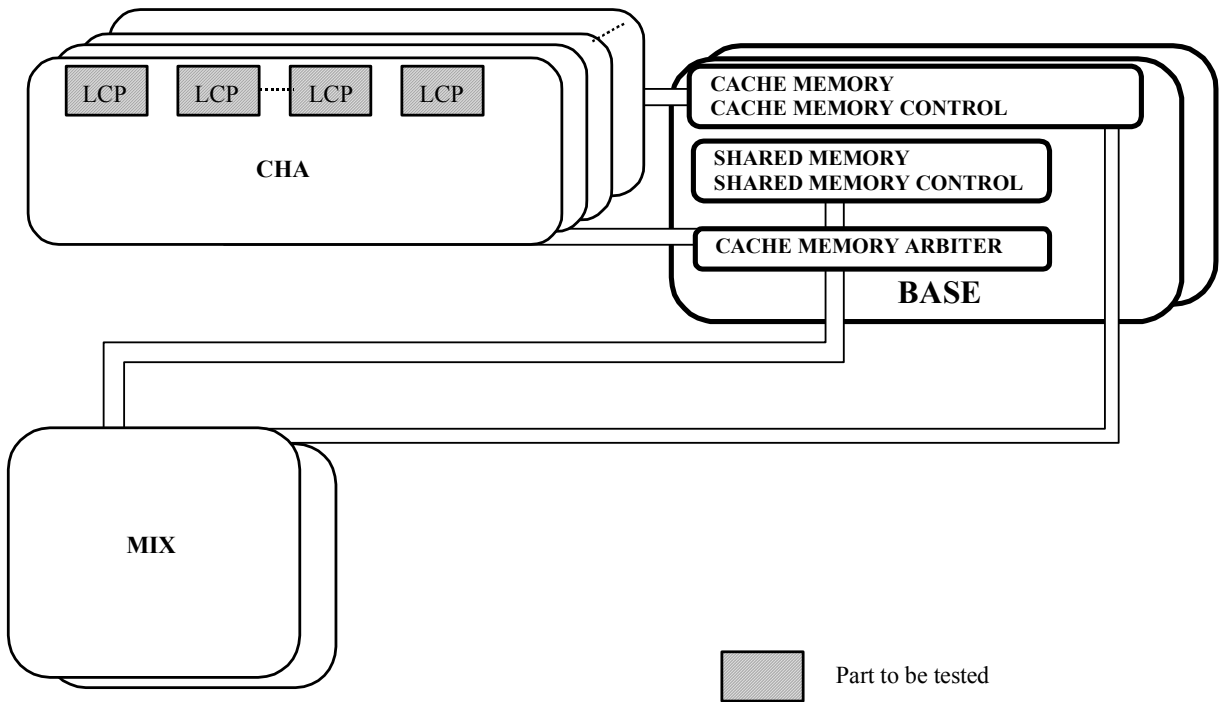

Fig. 3-6 Parts Subject to LCDG4 Tests

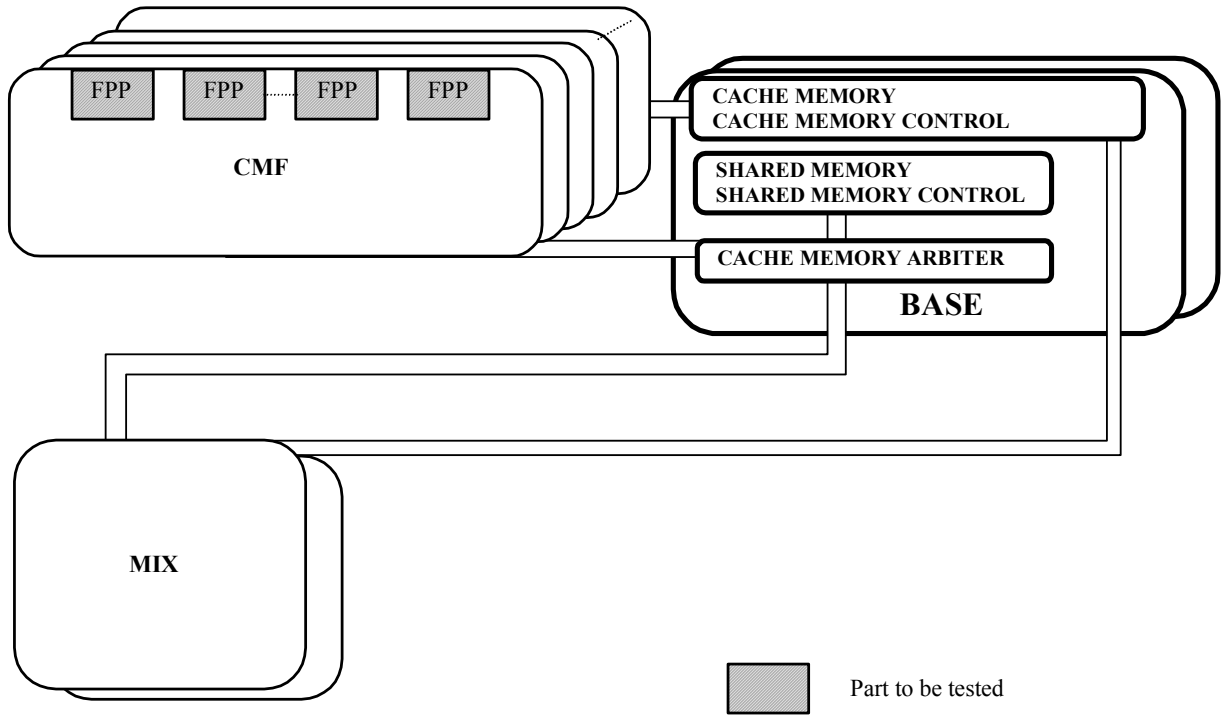

Fig. 3-7 Parts Subject to FCDG4 Tests

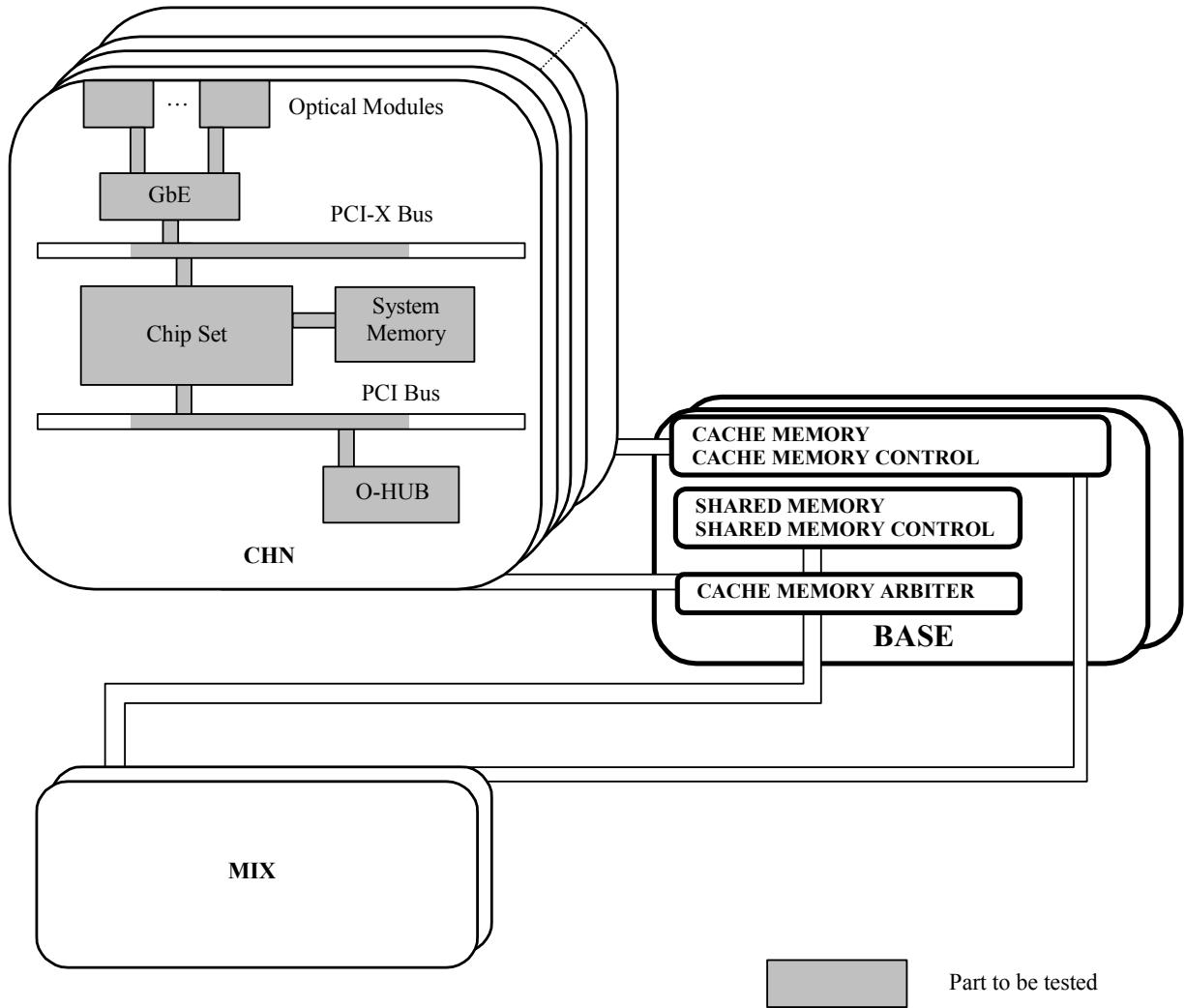

Fig. 3-8 Parts Subject to PCDG4 Tests

4. DIAG Test Procedures (SVP Operations)

4.1 CUDG4 Test Procedures

CAUTION

- ① If CUDG4 is executed, it may become impossible to guarantee the data on Cache Memory/Shared Memory.
 - Execute PS OFF and ON before CUDG Test. The data on CACHE is stored to HDD.
 - Be sure to check the validity of CUDG Test to Technical Support Division before CUDG Test.
- ② Powering off/on is required owing to the performance of this operation.
- ③ The SIM RC = FFEF00 occurs during this operation. But that is not a problem. Erase this SIM.

1. <Initial screen>

2. <Operation mode change>
Change the mode to [Modify Mode].
Select (CL) [Diagnosis].

3. <Activating CUDG>
Select (CL) [CUDG4].

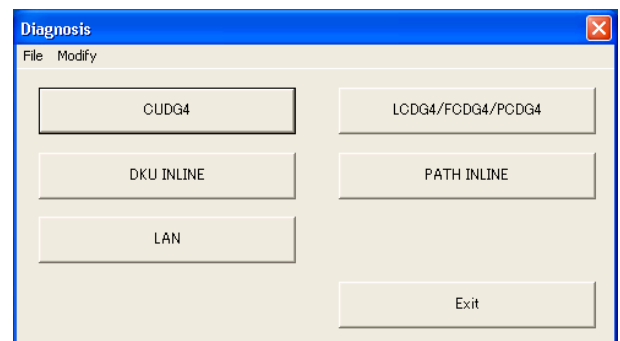

4. <Password>

CAUTION

Ask the technical support division about the appropriateness of the operation, and input a password after getting an approval of executing the operation.

If you want to continue this process, enter the password, and select (CL) [OK].

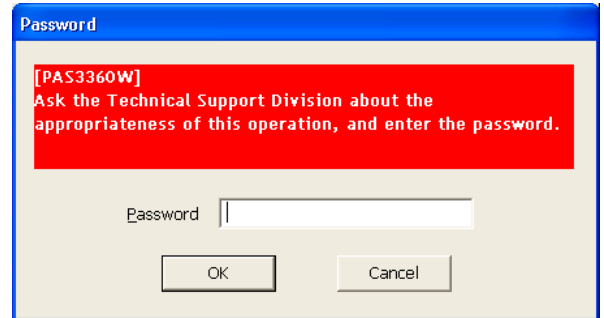

5. <Confirming that the channel path has been varied off>

An inquiry “Have you already varied off all the paths?” is displayed.

Vary off the channel path, then select (CL) the [Yes] button.

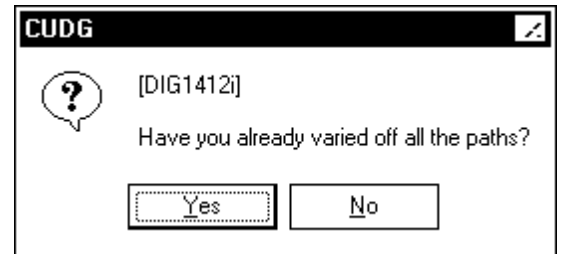

6. <Start of CUDG4 test>

Select (CL) [Start].

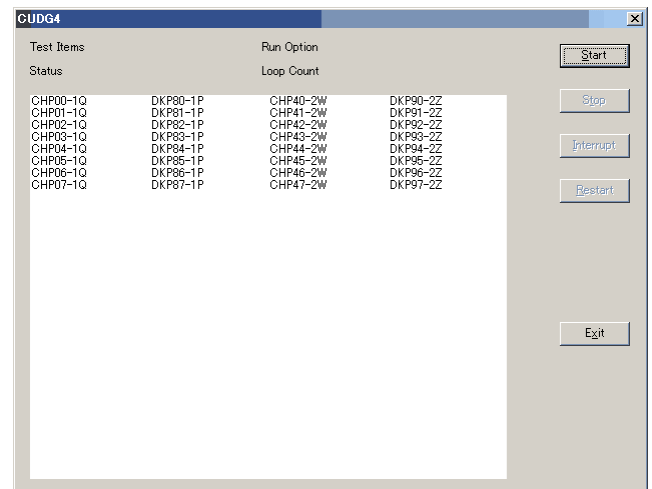

7. <Setting test parameters>

Select a test item, a test execution type, and a test object processor from Test Item, Run Option, and Processor respectively.

Select (CL) the [OK] button after all the above selections are made.

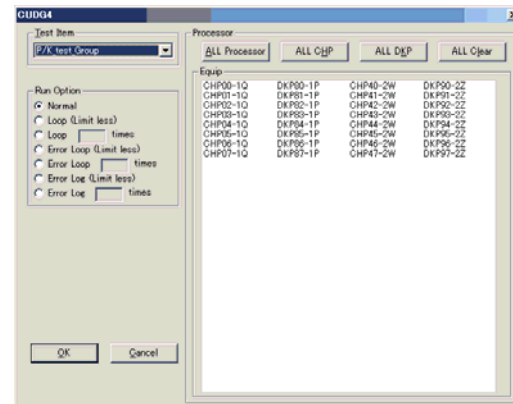

[Test items]

- P/K test Group : Diagnosis on the CHA PCBs or MIX PCBs
- SMC Normal test Group : Diagnosis on the SMC (Shared Memory Control), Shared Memory (test on the normal system)
- Cache Normal test Group : Diagnosis on the CMC (Cache Memory Control), Cache Memory (test on the normal system)
- SMC test Group : Diagnosis on the SMC (shared memory control), Shared Memory
- Cache test Group : Diagnosis on the CMC (Cache Memory Control), Cache Memory
- Heatrun test Group : All the above tests are included

Note: When 'Heatrun test Group' is selected, 'Run Option' settings are invalidated and diagnosis is executed under Heatrun mode.

[Run option (test execution types)]

Refer to [DIAG02-30](#).

[Test object processors]

- ALL Processor : The test is executed on all the processors in the configuration.
- ALL CHP : The test is executed on all the CHPs in the configuration.
- ALL DKP : The test is executed on all the DKPs in the configuration.
- ALL Clear : Release of processor selection.

The mounted processor is displayed on Equip.

Selected processor is displayed in reverse video.

When you want to select a specified processor in the configuration, Select a processor directly.

8. <Linux shutdown>

When CHN PCB is equipped, Linux shutdown processing is executed.

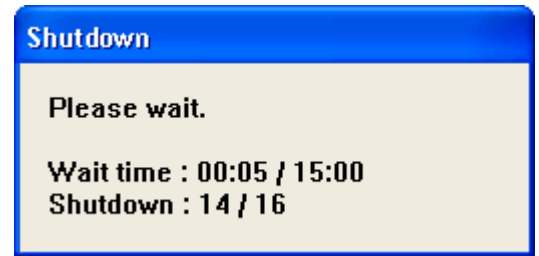

9. <Displaying CUDG4 loading>

Statuses of Init, Load, and Wait are displayed on the 'CUDG4' screen.

The illustration on the right shows the screen when the CUDG4 is being loaded.

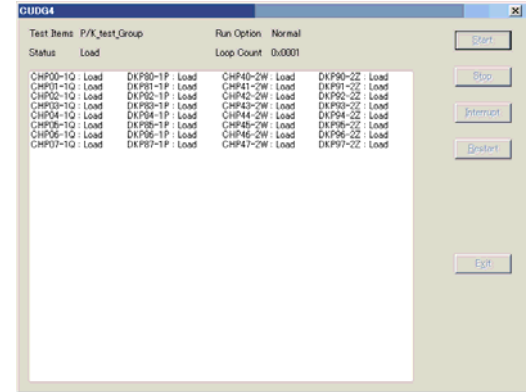

10. <Displaying Run>

State of the run is displayed on the 'CUDG4' screen.

The illustration on the right shows the screen when the CUDG4 test is being executed.

Normal end ----- Go to step 12.

Abnormal end ----- Go to step 11.

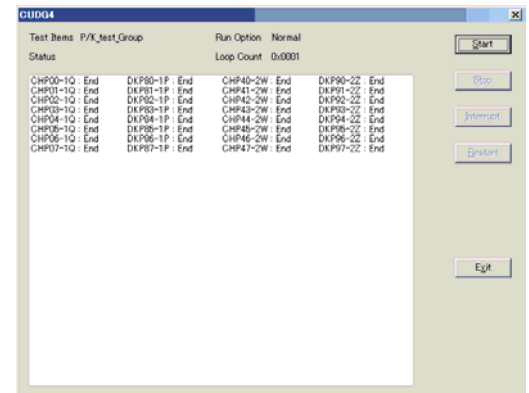

11. <Displaying error>

If an error occurs in CUDG4 test, the CUDG Error window is displayed.

To execute CUDG4 again, go to step 6.

To terminate CUDG4, go to step 13.

To display DIAG LOG, see [SVP02-140](#).

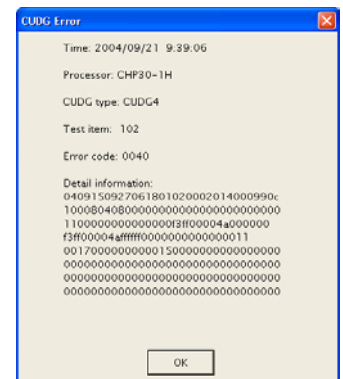

12. <Displaying End>

Status 'End' is displayed for the processor that CUDG4 test ends.

To continue CUDG4, go to step 6.

To terminate CUDG4, go to step 13.

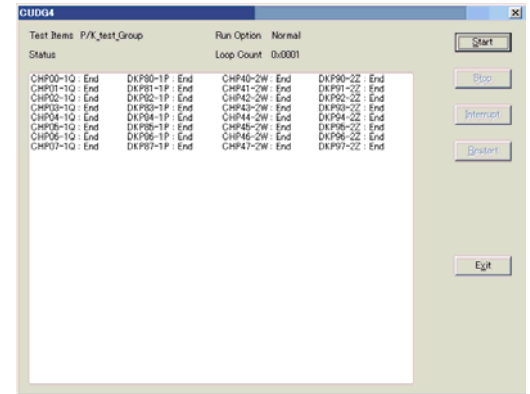

13. <Displaying Exit>

Select (CL) [Exit].

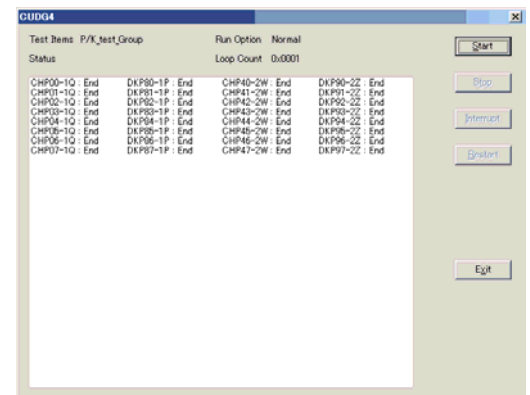

14. <PS-OFF>

Turn off the DKC subsystem by performing the PS-OFF operation following the displayed instruction "Turn off the DKC subsystem", then select (CL) the [OK] button.

If the power is not turned off after PS-OFF operation, immediately turn off the breaker.

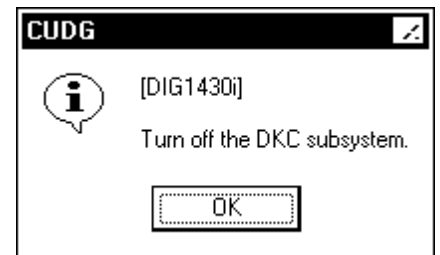

15. <Reboot the PC and PS-ON>

[Diagnosis] window is displayed.

- Close the window
- Reboot the PC
- PS-ON

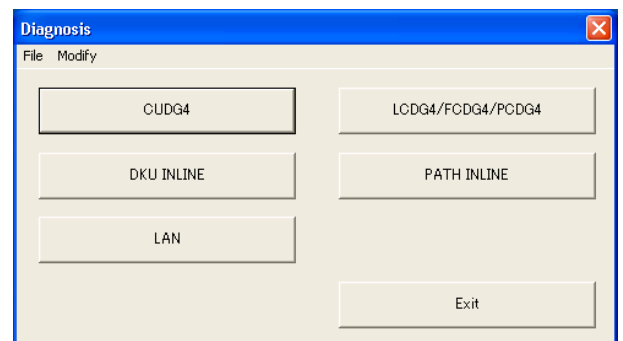

End of CUDG4 operation.

4.2 LCDG4/FCDG4/PCDG4 Test Procedures

CAUTION

- ① If LCDG4/FCDG4/PCDG4 is executed, it may become impossible to guarantee the data on Cache Memory/Shared Memory.
 - Execute PS OFF and ON before LCDG4/FCDG4/PCDG4 Test. The data on CACHE is stored to HDD.
 - Be sure to check the validity of LCDG4/FCDG4/PCDG4 Test to Technical Support Division before LCDG4/FCDG4/PCDG4 Test.
- ② Powering off/on is required owing to the performance of this operation.
- ③ The SIM RC = FFEF00 occurs during this operation. But that is not a problem. Erase this SIM.

1. <Initial screen>

2. <Operation mode change>
Change the mode to [Modify Mode].
Select (CL) [Diagnosis].

3. <Activating LCDG4/FCDG4/PCDG4>
Select (CL) [LCDG4/FCDG4/PCDG4].

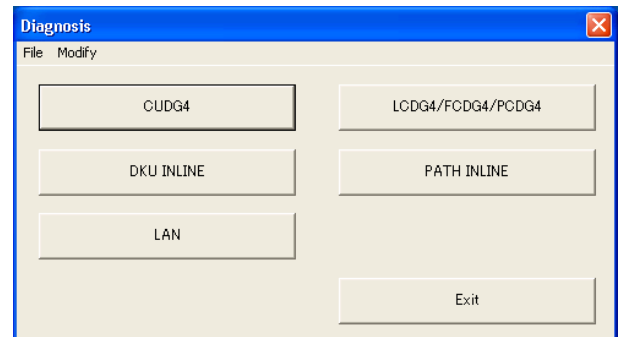

4. <Password>

**CAUTION**

Ask the technical support division about the appropriateness of the operation, and input a password after getting an approval of executing the operation.

If you want to continue this process, enter the password, and select (CL) [OK].

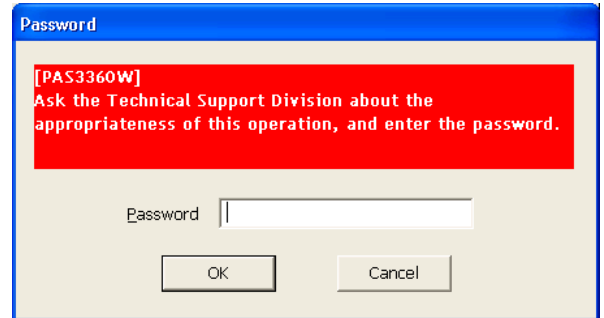

5. <Confirming that the channel path has been varied off>

An inquiry “Have you already varied off all the paths?” is displayed.

Vary off the channel path, then select (CL) the [Yes] button.

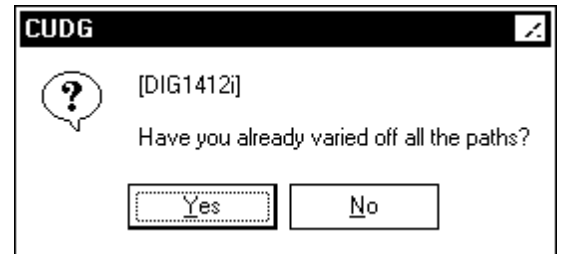

6. <Start of Diagnosis >

Select (CL) [Start].

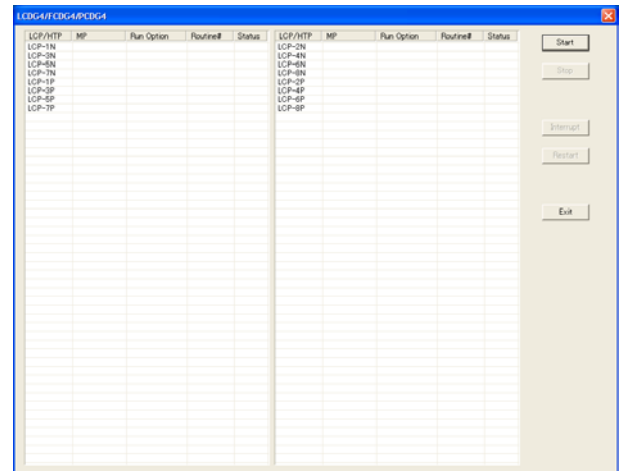

7. <Select [Processor], [LCP/HTP], [Run Option] and [Routine No.]>

Select (CL) [Processor], [LCP/HTP], [Run Option] and [Routine No.] in the 'LCDG4/FCDG4/PCDG4' dialog box.

Select (CL) the [OK] button.

Refer to [DIAG02-40](#).

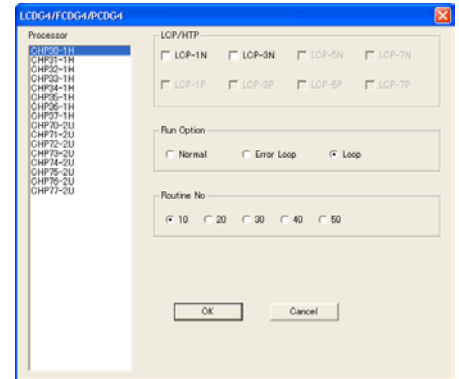

8. <Linux shutdown>

When CHN PCB is equipped, Linux shutdown processing is executed.

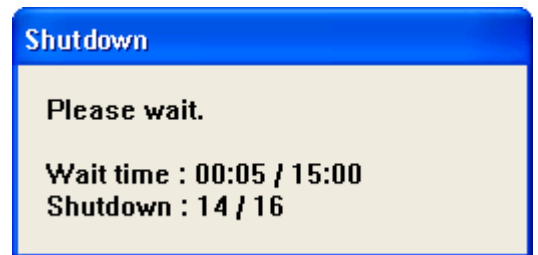

9. <Display of [LOAD]>

Status [Init], [Load], and [Wait] are displayed in the 'LCDG4/FCDG4/PCDG4' dialog box.

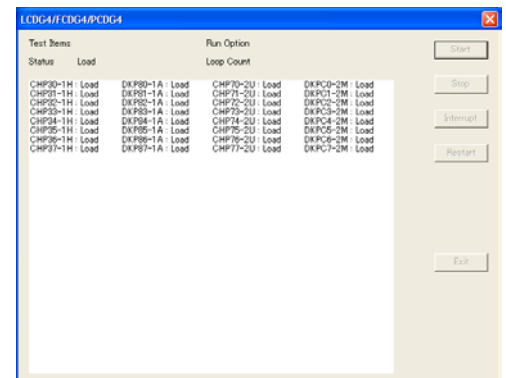

10. <Display of [Run]>

Status [Run] is displayed in the 'Status' dialog box.

Go to 11 in the case of Normal End.

Go to 12 in the case of Abnormal End.

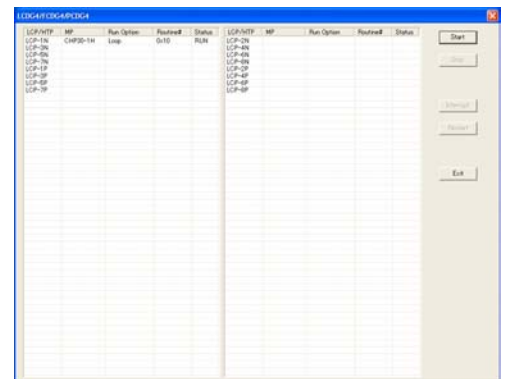

11. <Display of [End]>

Status [End] is displayed in the 'Status' dialog box.

When the routine number is 40, 'Optical Power' is displayed. Select (CL) [OK]. When the routine number is 50, 'Bit Error Rate' is displayed. Select (CL) [OK].

Go to 13.

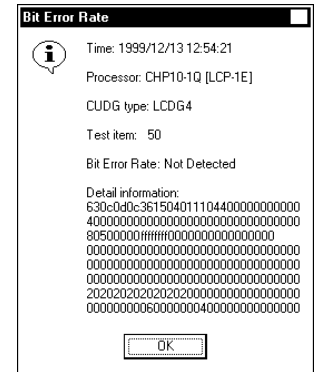
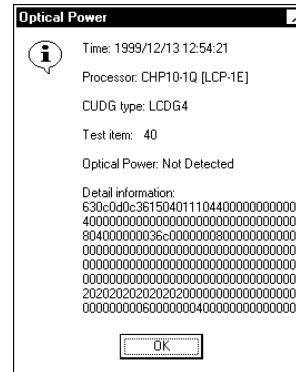
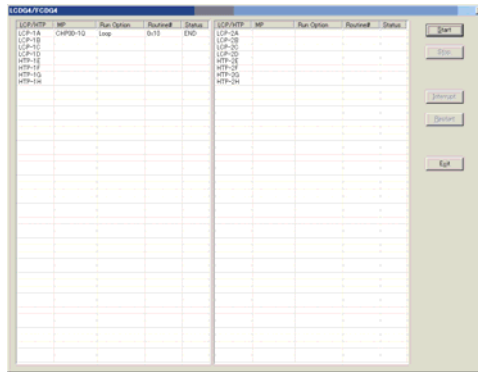

12. <Display of 'CUDG Error'>

After 'CUDG Error' is displayed, select (CL) [OK].

To display DIAG LOG, see [SVP02-140](#).

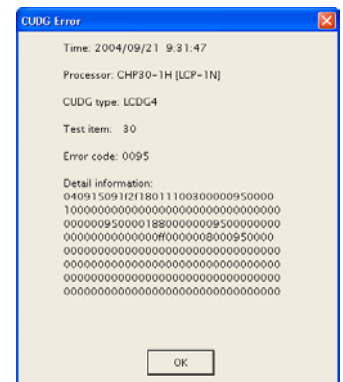

13. <Selection of continuation/termination>

To continue Diagnosis, select (CL) [Start] in the 'Status' dialog box and go to step 7.

To terminate Diagnosis, select (CL) [Exit] in the 'Status' dialog box and go to step 14.

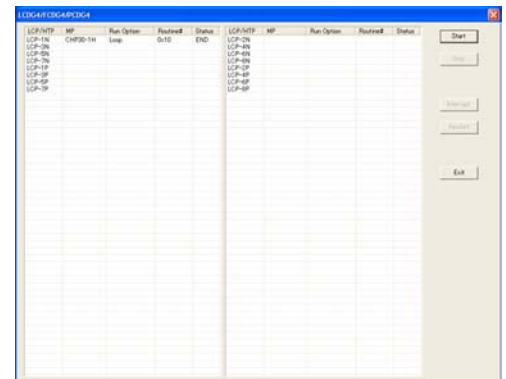

14. <End of Diagnosis >

“Are you sure you want to terminate the LCDG4, FCDG4 and PCDG4?” is displayed.
Select (CL) [OK].

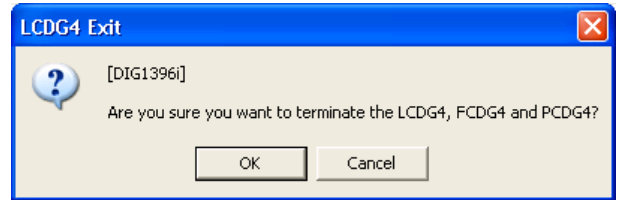

15. <Select [Exit]>

Select (CL) [Exit].

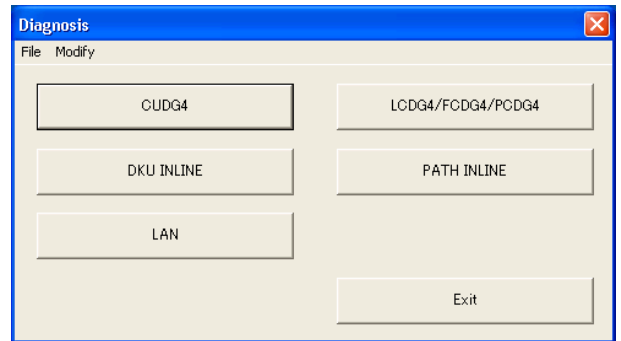

16. <PS-OFF and Reboot the PC>

- PS-OFF

17. < Reboot the PC and PS-ON>

- Reboot the PC
- PS-ON

End of LCDG4/FCDG4/PCDG4 operation.

4.3 DKU INLINE Test Procedures

1. <Initial screen>

2. <Operation mode change>
Change the mode to [Modify Mode].
Select (CL) [Diagnosis].

3. <Select 'DKU INLINE'>
The 'Diagnosis' window is displayed.
And select (CL) [DKU INLINE].

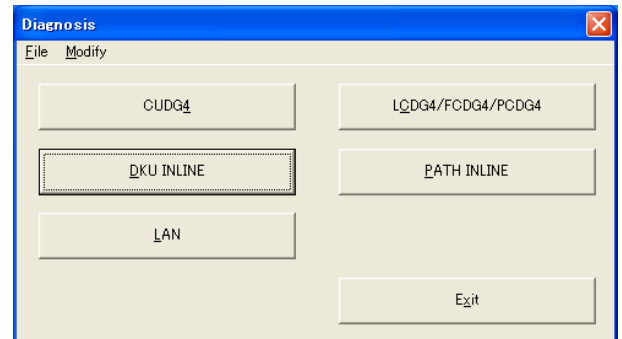

4. <Select [Start]>
Select (CL) [Start].

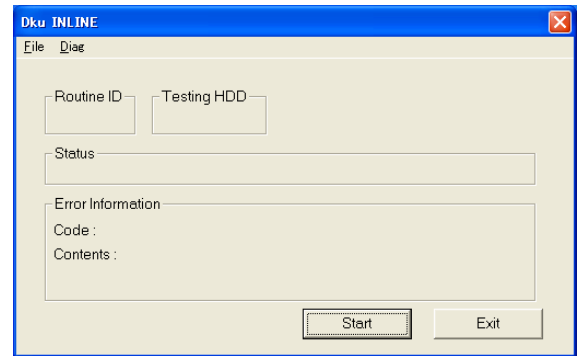

5. <Select UNIT to be tested>
Select (CL) the UNIT for which the test routine is to be executed from 'Select Unit'.

When selecting each 'UNIT', go to 6.
If 'ALL HDD' is selected, go to 9.

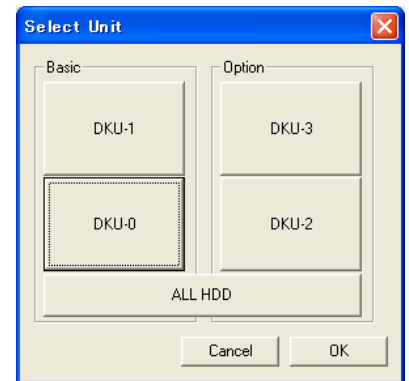

6. <Select HDU Group to be tested>
Select (CL) the HDU Group for which the test routine is to be executed from 'UNIT'.

If [Select UNIT] is selected, go to 5.

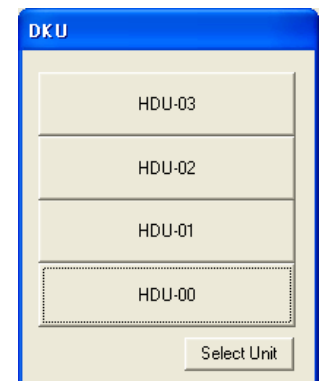

7. <Select HDD to be tested>

Select (CL) HDD for which the test routine is to be executed from selected HDU Group. Then select (CL) the [OK] button.

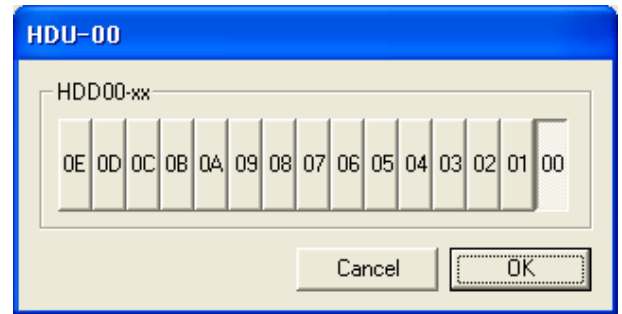

8. <Select [OK]>

Select (CL) the [OK] button.

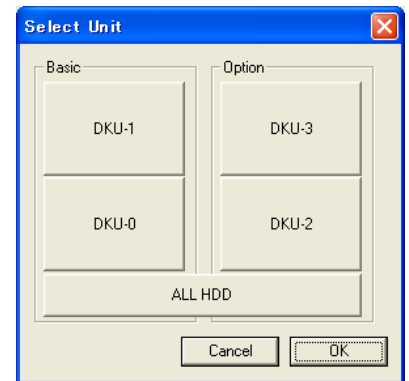

9. <Confirm HDD to be tested>

Confirm HDD to be tested in the 'Select HDD List'. Then select (CL) [OK].

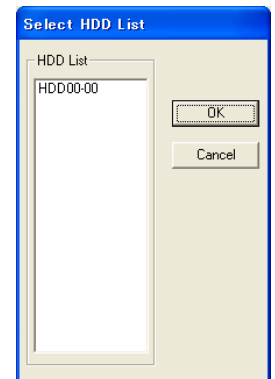

10. <Status Window>

The Status Window is displayed.

Normal end : Go to 11

Abnormal end : Go to 13

In case you abort the diagnosis, select (CL) the [Stop] button.



11. <DKU INLINE end>

After “Dku INLINE Normal END” is displayed in the Status field, select (CL) [Exit].

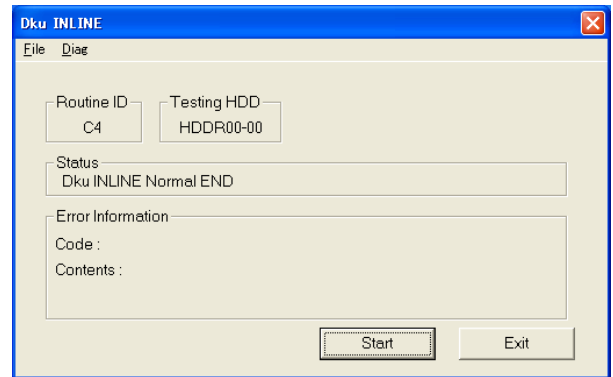

12. <Diagnosis end>

Select (CL) [Exit].

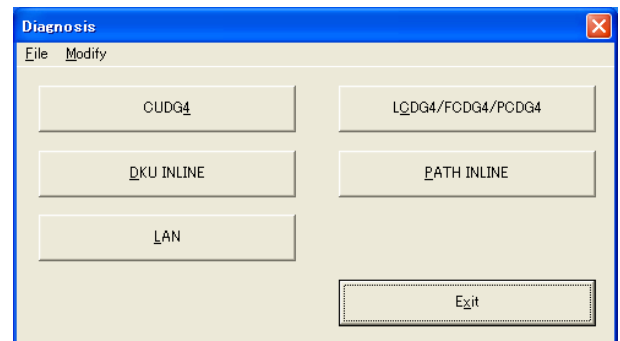

13. <Displaying 'Error HDD'>

Error HDD List is displayed.
Select (CL) [OK].

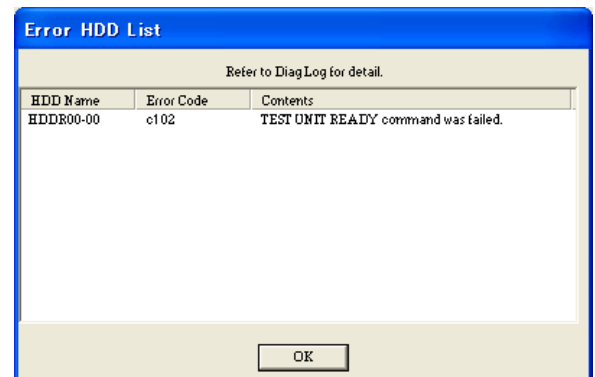

14. <Error End>

“Dku INLINE Abnormal END” is displayed in the Status field.
Refer to Diag Log for the detailed information.
Select (CL) [Exit].
Go to 12.

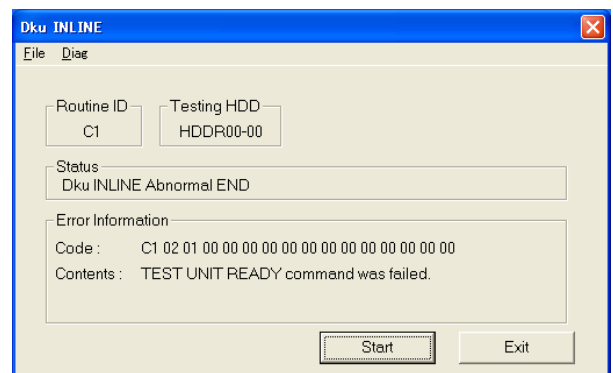

4.4 DKU PATH INLINE Test Procedures

4.4.1 A0 routine Test Procedures

1. <Initial screen>

2. <Operation mode change>
Change the mode to [Modify Mode].
Select (CL) [Diagnosis].

3. <Select 'PATH INLINE'>
The 'Diagnosis' window is displayed.
And select (CL) [PATH INLINE].

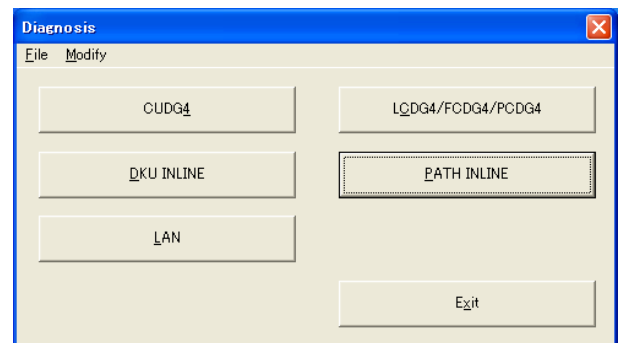

4. <Selecting [Start]>
Select (CL) [Start].

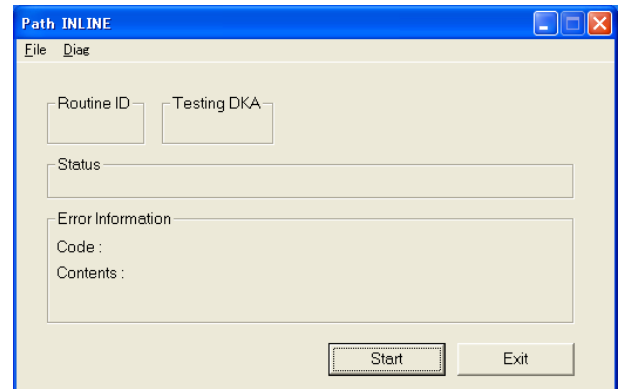

5. <Selecting Routine and the MIX>

Select the routine (A0) which is to be tested from “Select Routine”, Select (CL) the MIX for which the test routine is to be executed.

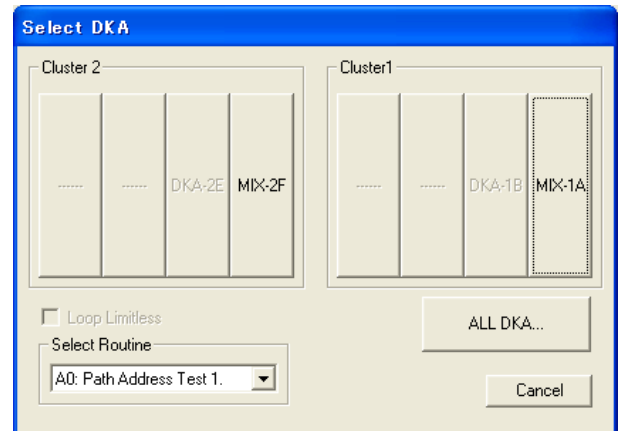

6. <Selecting the PORT to be diagnosed>

Select (CL) the PORT for which the test routine is to be executed.

And select (CL) the [OK] button.

PORT#, MP# mapping (): 4MP

PORT#	MP#
PORT#0	MP#0 (MP#0)
PORT#1	MP#2 (MP#1 or 2)
PORT#2	MP#1 (MP#0)
PORT#3	MP#3 (MP#1 or 2)
PORT#4	MP#4 (MP#4)
PORT#5	MP#6 (MP#5 or 6)
PORT#6	MP#5 (MP#4)
PORT#7	MP#7 (MP#5 or 6)

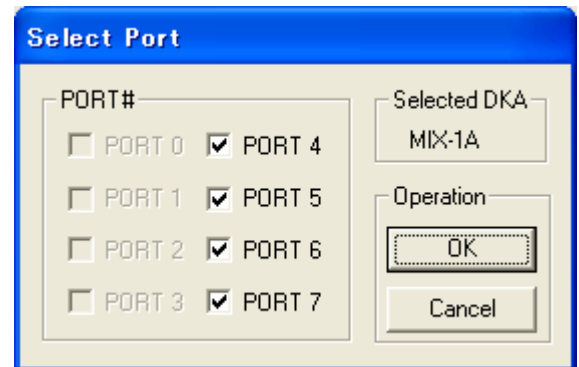

7. <Status Window>

The Status Window is displayed.

Normal end : Go to 8

Abnormal end : Go to 9

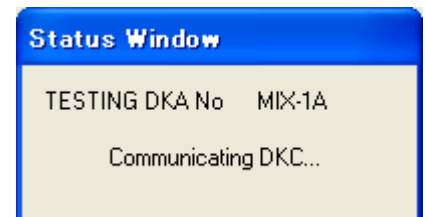

8. <Completing diagnosis>

After “Path INLINE Normal END” is displayed in the Status field, select (CL) [Exit].
Go to 13.

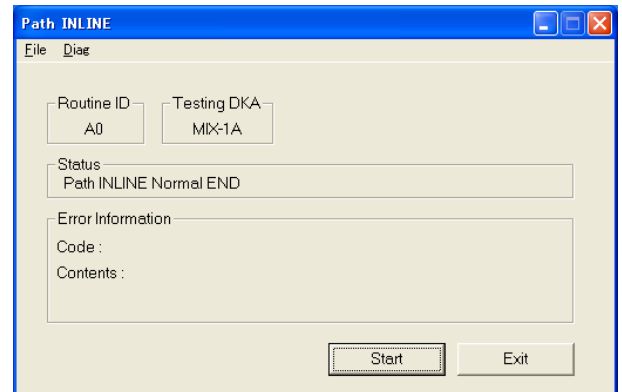

9. <Displaying the error detail>

Select (DR) [List] from [Diag].

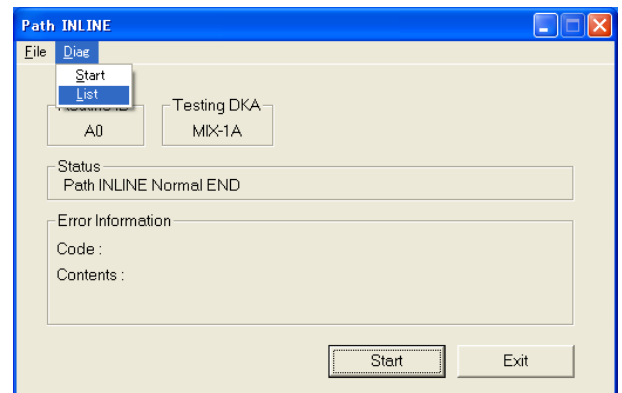

10. <Verification the incorrect part>

Select (CL) the incorrect part from [PORT].

When [PORT] is selected, go to 11.

When [OK] is selected, go to 12.

If you want to display other UNIT, select (CL) [Unit Tab].

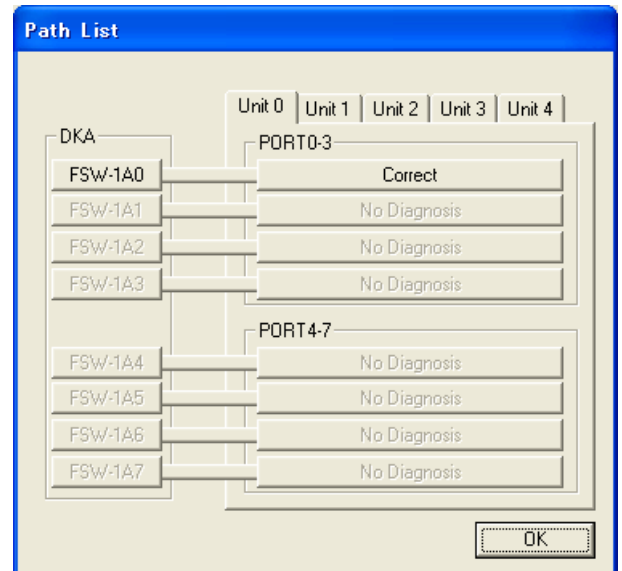

11. <Displaying 'Result'>

'Result' is selected.

Select (CL) the [OK] button.

Go to 10.

Result	HBC	Address
DKA :		MIX-1A
Port No. :		FSW-1A4
Expected HBC Address :		00e6
Location :		FSW001-L
Received HBC Address :		00e6
Location :		FSW001-L
FC Cable :	OK	
AL-PA :	OK	

12. <DKU Path inline end>

After "Path INLINE Abnormal END" is displayed in the Status field, select (CL) [Exit].

Path INLINE	
Routine ID	Testing DKA
A0	MIX-1A
Status	Path INLINE Abnormal END
Error Information	
Code :	A0 10 00 FF FF FF FF 00 FF FF FF 00 00 00 00
Contents :	There was N.G. error to a part of PATH.
<input type="button" value="Start"/> <input type="button" value="Exit"/>	

13. <End of [Diagnosis]>

Select (CL) [Exit].

Diagnosis	
CUDG4	LQDG4/FCDG4/PCDG4
DKU INLINE	PATH INLINE
LAN	
<input type="button" value="Exit"/>	

4.4.2 A6 routine Test Procedures

1. <Initial screen>

2. <Operation mode change>
Change the mode to [Modify Mode].
Select (CL) [Diagnosis].

3. <Select 'PATH INLINE'>
The 'Diagnosis' window is displayed.
And select (CL) [PATH INLINE].

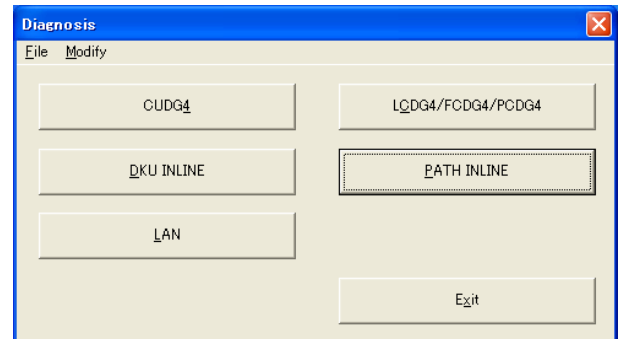

4. <Selecting [Start]>
Select (CL) [Start].

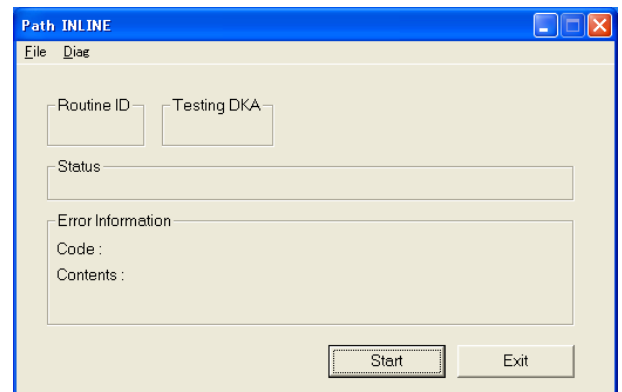

5. <Selecting Routine and the MIX>

Select the routine (A6) which is to be tested from “Select Routine”, Select (CL) the MIX for which the test routine is to be executed.

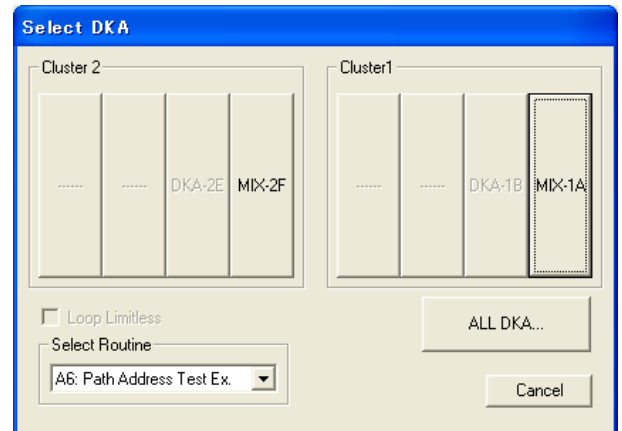

6. <Selecting the PORT to be diagnosed>

Select (CL) the PORT for which the test routine is to be executed.

And select (CL) the [OK] button.

PORT#, MP# mapping (): 4MP

PORT#	MP#
PORT#0	MP#0 (MP#0)
PORT#1	MP#2 (MP#1 or 2)
PORT#2	MP#1 (MP#0)
PORT#3	MP#3 (MP#1 or 2)
PORT#4	MP#4 (MP#4)
PORT#5	MP#6 (MP#5 or 6)
PORT#6	MP#5 (MP#4)
PORT#7	MP#7 (MP#5 or 6)

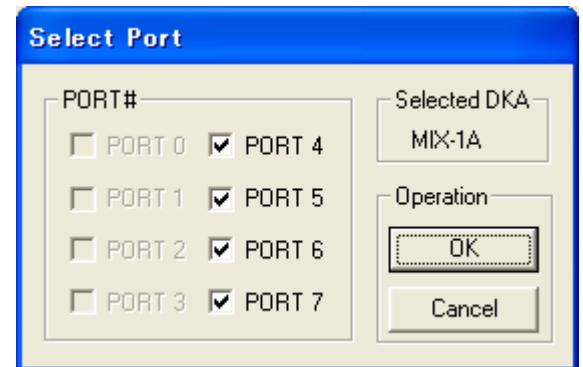

7. <Password>

If you want to continue this process, enter the password, and select (CL) [OK].

Note: Please call Technical Support Division for asking how to Password.

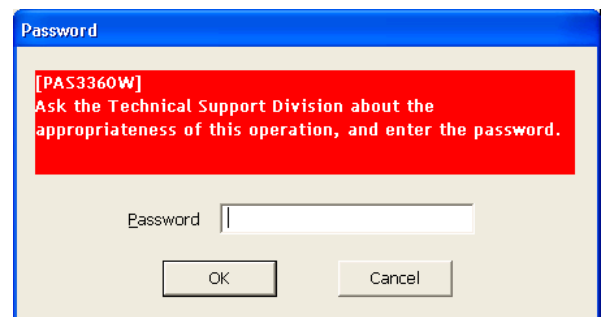

8. <Status Window>

The Status Window is displayed.

Normal end : Go to 9

Abnormal end : Go to 10

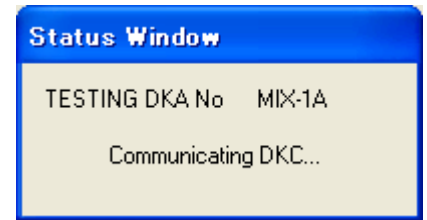

9. <Completing diagnosis>

After "Path INLINE Normal END" is displayed in the Status field, select (CL) [Exit].

Go to 14.

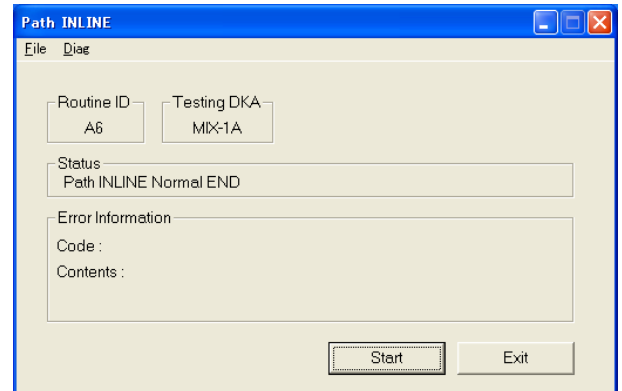

10. <Displaying the error detail>

Select (DR) [List] from [Diag].

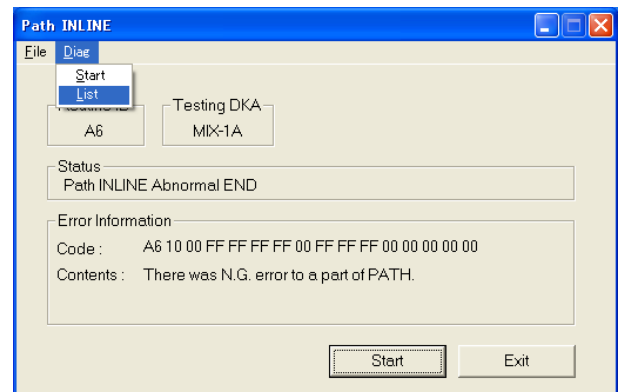

11. <Verification the incorrect part>

Select (CL) the incorrect part from [PORT].

When [PORT] is selected, go to 12.

When [OK] is selected, go to 13.

If you want to display other UNIT, select (CL) [Unit Tab].

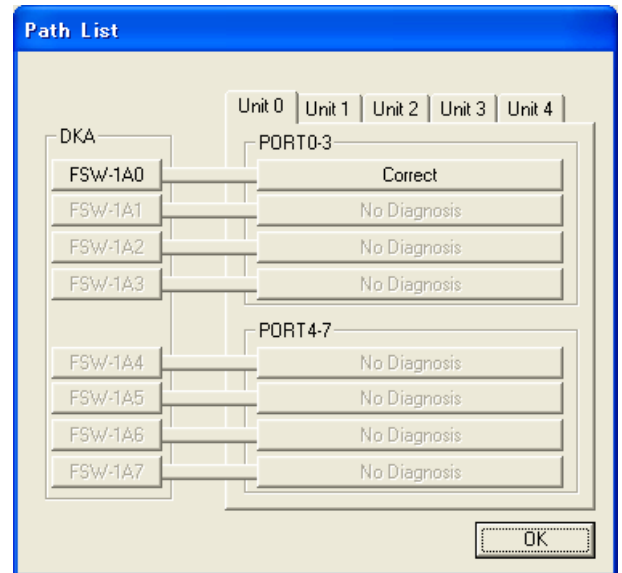

12. <Displaying 'Result'>

'Result' is selected.

Select (CL) the [OK] button.

Go to 11.



13. <DKU Path inline end>

After "Path INLINE Abnormal END" is displayed in the Status field, select (CL) [Exit].

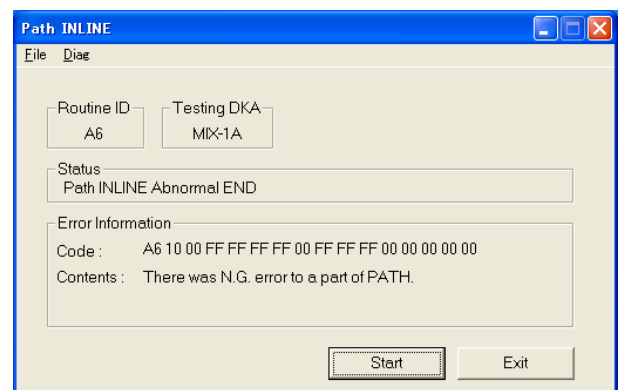

14. <End of [Diagnosis]>
Select (CL) [Exit].

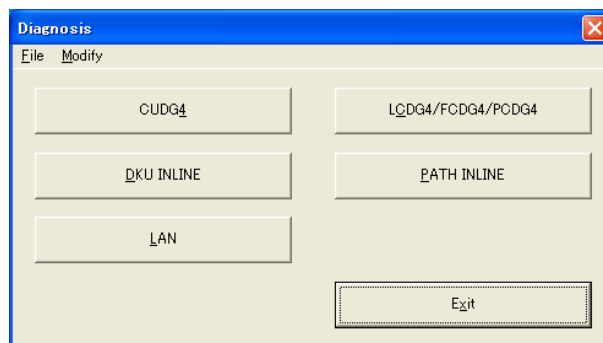

4.4.3 A3 routine Test Procedures

1. <Initial screen>

2. <Operation mode change>
Change the mode to [Modify Mode].
Select (CL) [Diagnosis].

3. <Select 'PATH INLINE'>
The 'Diagnosis' window is displayed.
And select (CL) [PATH INLINE].

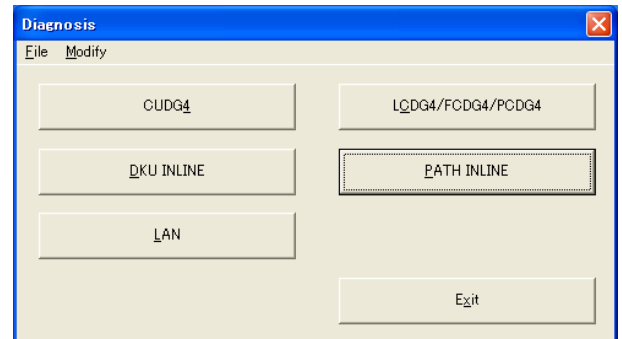

4. <Selecting [Start]>
Select (CL) [Start].

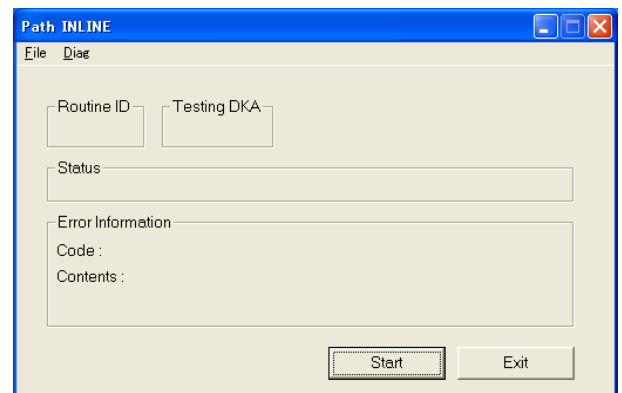

5. <Selecting the DKA >

Select the routine (A3) which is to be tested from “Select Routine”, Select (CL) the [ALL DKA].

In case you loop the diagnosis, check the “Loop Limitless” Check-Box.

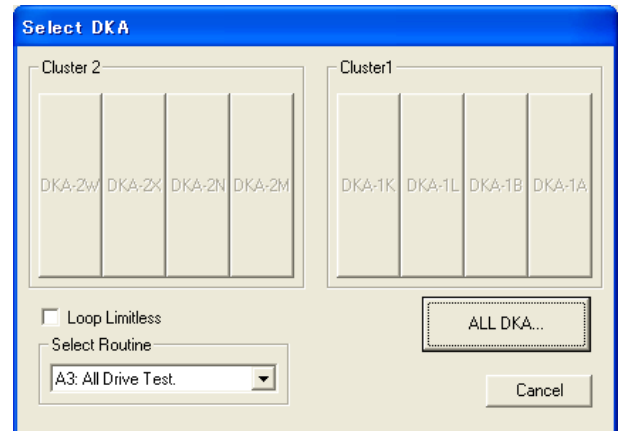

6. <I/O check>

An inquiry “You cannot perform execution when I/O operations are performed from hosts. Are you sure I/O operations are stopped?” is displayed.

It checks that I/O has stopped, then select (CL) the [Yes] button.

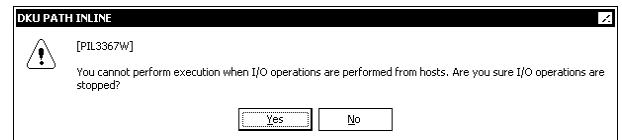

7. <Execution check>

An inquiry “If you do not stop I/Os before continuing execution, a problem may occur. Do you want to continue processing?” is displayed.

In case you perform the diagnosis, select (CL) the [Yes] button.

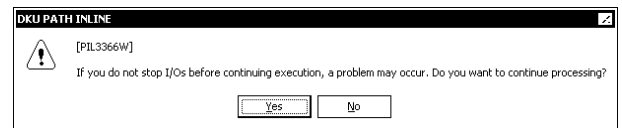

8. <Status Window>

The Status Window is displayed.

Normal end ----- Go to 9

Abnormal end ----- Go to 10

In case you abort the diagnosis, select (CL) the [Stop] button.



9. <DKU Path inline normal end>

After “Path INLINE NORMAL END” is displayed in the Status field, select (CL) [Exit].

Go to 14.

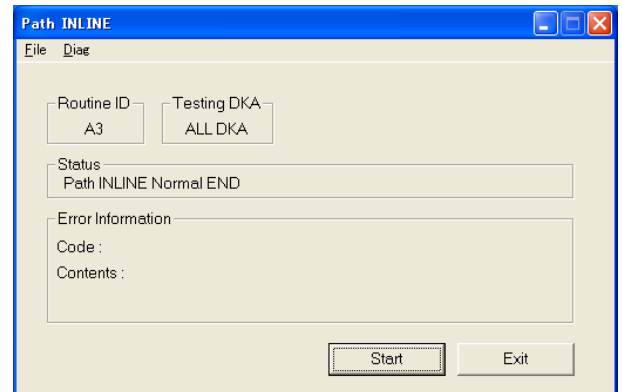

10. <Displaying the error detail>

Select (DR) [List] from [Diag].

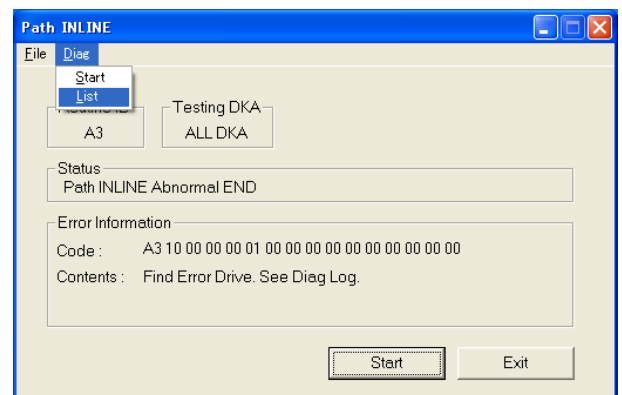

11. <Displaying the Error Devices>

“NG” is displayed in the PDEV installing position viewed in the RK0-Unit.

If you want to display other Unit, select (CL) [Unit Tab].

If you want to refer to more detailed information about the “NG” PDEV, select the [NG] button.

Go to 13.

“EQ” is displayed when the diagnosis ends on the way, and shows that equipped PDEV is undiagnosis.

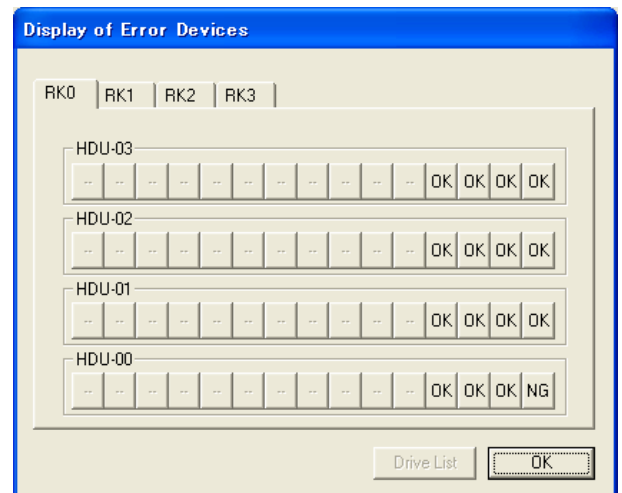

12. <Displaying the Error detail>

Select (CL) the [OK] button after 'Result' is displayed.

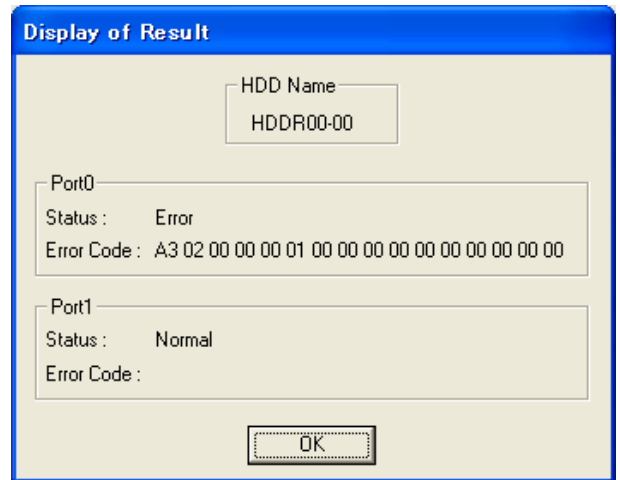

13. <DKU Path inline end>

Select (CL) [Exit].

Refer to Diag Log for detailed information.

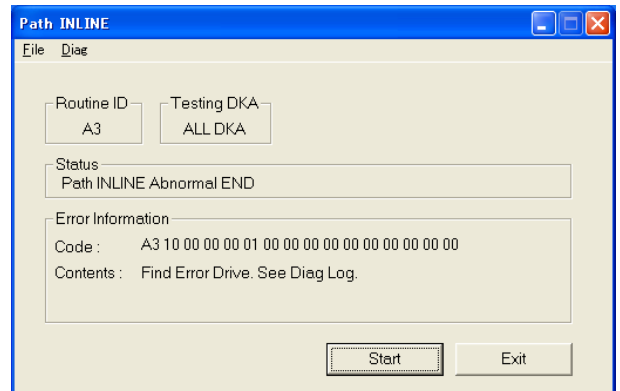

14. <End of [Diagnosis]>

Select (CL) [Exit].

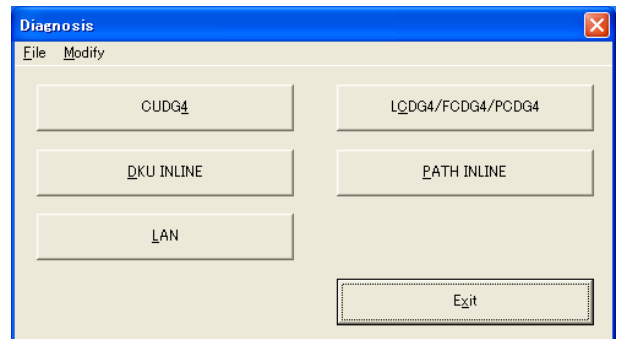

4.4.4 A2 (A8) routine Test Procedures

1. <Initial screen>

2. <Operation mode change>

Change the mode to [Test Mode].

Select (CL) [Diagnosis].

Note: Please call Technical Support Division for asking how to change the mode to Test Mode.

3. <Select 'PATH INLINE'>

The 'Diagnosis' window is displayed.

And select (CL) [PATH INLINE].

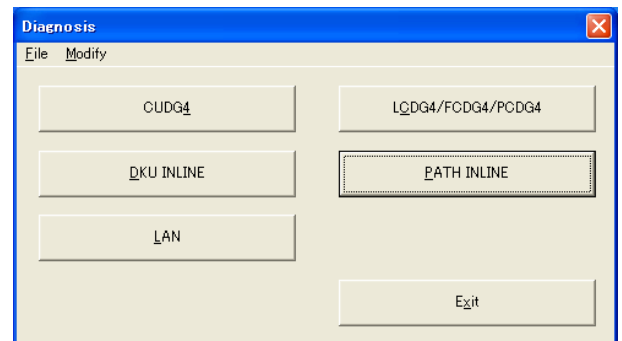

4. <Selecting [Start]>

Select (CL) [Start].

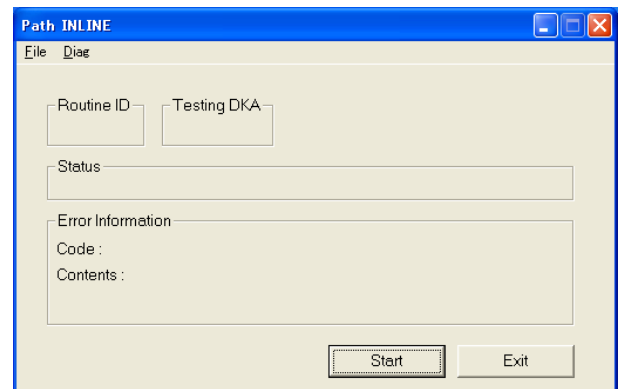

5. <Selecting Routine and the DKA>

Select the routine (A2) which is to be tested from “Select Routine”, Select (CL) the MIX for which the test routine is to be executed.

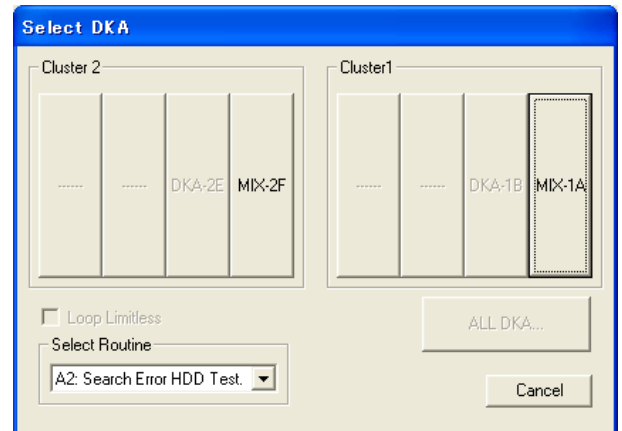

6. <Selecting the PORT to be diagnosed>

Selecting the PORT and the routine to be executed.

Select (CL) the PORT for which the test routine is to be executed.

And select (CL) the [OK] button.

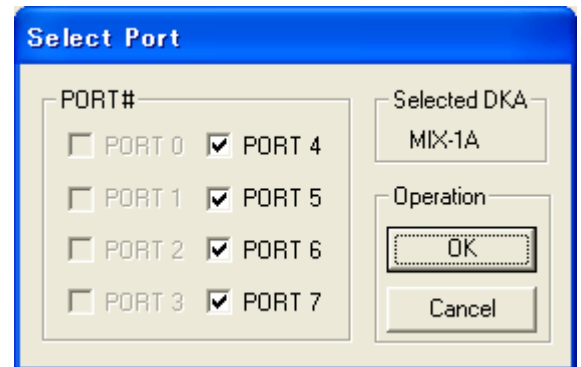

PORT#, MP# mapping (): 4MP

PORT#	MP#
PORT#0	MP#0 (MP#0)
PORT#1	MP#2 (MP#1 or 2)
PORT#2	MP#1 (MP#0)
PORT#3	MP#3 (MP#1 or 2)
PORT#4	MP#4 (MP#4)
PORT#5	MP#6 (MP#5 or 6)
PORT#6	MP#5 (MP#4)
PORT#7	MP#7 (MP#5 or 6)

7. <Status Window>

The Status Window is displayed.

Normal end ----- Go to 8

Abnormal end ----- Go to 9

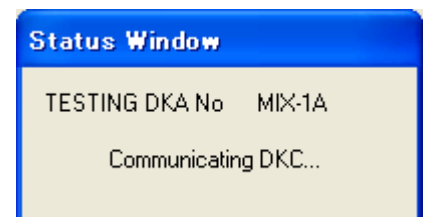

8. <DKU Path INLINE normal end>
After “Path INLINE Normal END” is displayed in the Status field, select (CL) [Exit].
Go to 13.

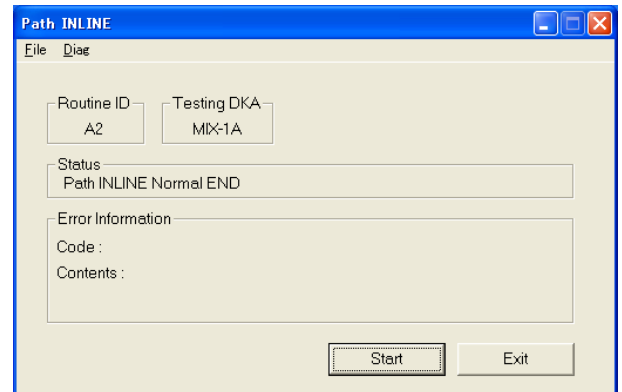

9. <Displaying the error detail>
Select (DR) [List] from [Diag].

In case of A8 routine, go to 14.

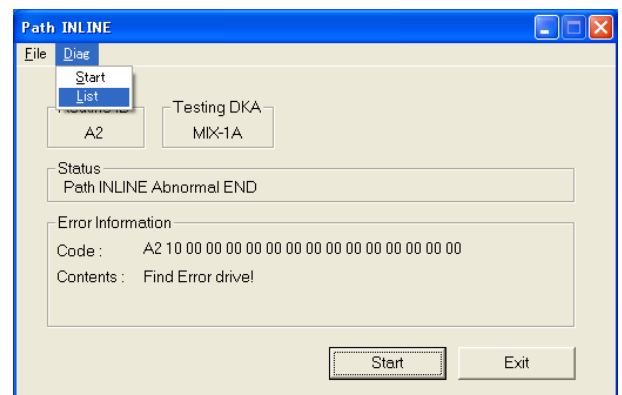

10. <Displaying the Error Devices>
“NG” is displayed in the PDEV installing position viewed in the RK0-Unit.

If you want to display other Unit, select (CL) [Unit Tab].

If you want to refer to more detailed information about the “NG” PDEV, select the “NG” button. Go to 11.

“EQ” is displayed when the diagnosis ends on the way, and shows that equipped PDEV is undiagnosis.

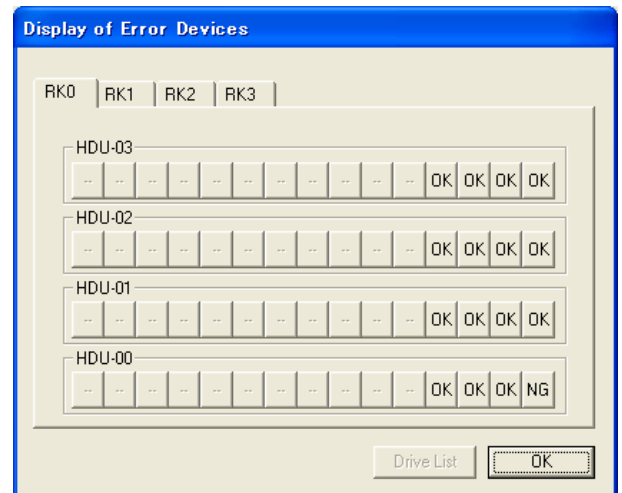

11. <Displaying the Error detail>

Select (CL) the [OK] button after 'Result' is displayed.

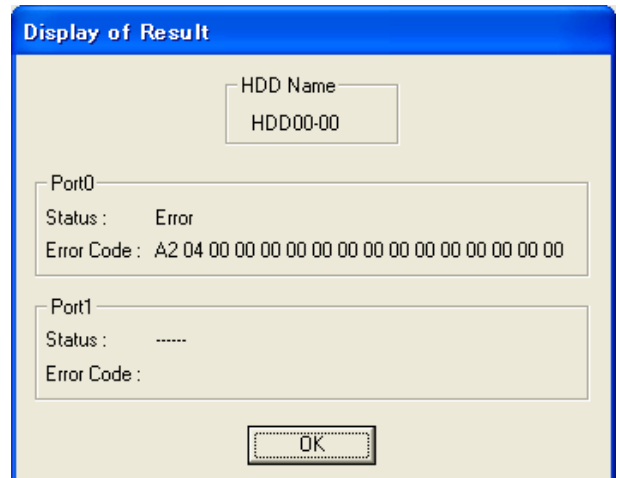

12. <DKU Path inline end>

Select (CL) [Exit].

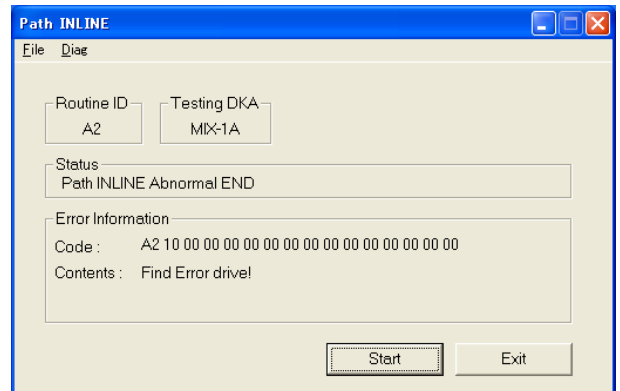

13. <End of [Diagnosis]>

Select (CL) [Exit].

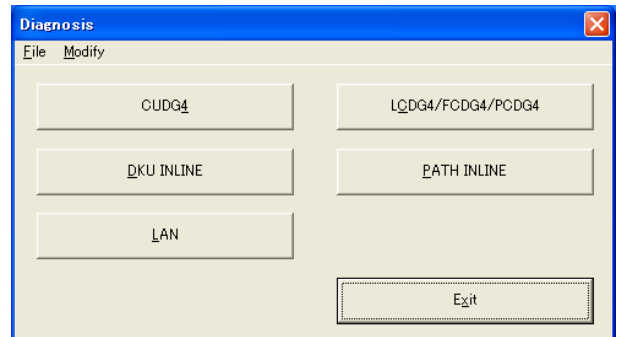

14. <Displaying the Error Devices (A8)>

“NG” is displayed in the PDEV installing position viewed in the RK0-Unit.

If you want to display other Unit, select (CL) [Unit Tab].

If you want to refer to more detailed information about the “NG” PDEV, select the [NG] button.

Go to 15.

If you want to refer to Drive List, select the [Drive List] button.

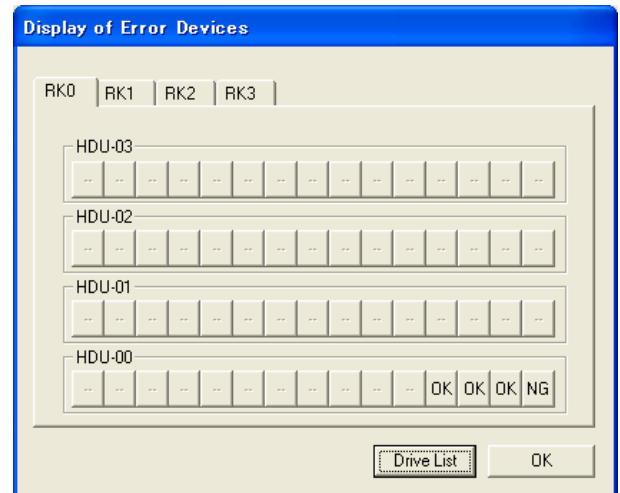

“EQ” is displayed when the diagnosis ends on the way, and shows that equipped PDEV is undiagnosis.

15. <Displaying the Drive List>

Select (CL) the [OK] button after ‘Drive List’ is displayed.

Go to 14.

[HDD Name (C/R#)]

HDD Name, CDEV Number, RDEV Number

[STATUS]

NORMAL : No Error.

ERROR : Drive Read Error.

TP_ERR : Through Path Error.

[Read Cnt.]

Issue count of Drive Read Command.

[TOV]

Occurrence count of Time over.

[Check Condition 0-F]

Occurrence count of each Check Condition.

(Definition of Check Condition see Sense Key in [SSB04-40.](#))

[Fibre]

Occurrence count of Fibre Error.

HDD(C/R#)	Status	Cnt.	TOV	0	1	2	3	4	5	6	7	8	9	A	B	C	D	E	F	Fibre
HDDR00-00(0000)	NORMAL	0	0	0	0	0	0	0	0	0	0	0	0	0	0	0	0	0	0	0
HDDR00-01(0001)	NORMAL	0	0	0	0	0	0	0	0	0	0	0	0	0	0	0	0	0	0	0
HDDR00-02(0002)	NORMAL	0	0	0	0	0	0	0	0	0	0	0	0	0	0	0	0	0	0	0
HDDR00-03(0003)	NORMAL	0	0	0	0	0	0	0	0	0	0	0	0	0	0	0	0	0	0	0
HDDR00-04(0004)	NORMAL	0	0	0	0	0	0	0	0	0	0	0	0	0	0	0	0	0	0	0
HDDR00-05(0005)	NORMAL	0	0	0	0	0	0	0	0	0	0	0	0	0	0	0	0	0	0	0
HDDR00-06(0006)	NORMAL	0	0	0	0	0	0	0	0	0	0	0	0	0	0	0	0	0	0	0
HDDR00-07(0007)	NORMAL	0	0	0	0	0	0	0	0	0	0	0	0	0	0	0	0	0	0	0
HDDR00-08(0008)	NORMAL	0	0	0	0	0	0	0	0	0	0	0	0	0	0	0	0	0	0	0
HDDR00-09(0009)	NORMAL	0	0	0	0	0	0	0	0	0	0	0	0	0	0	0	0	0	0	0
HDDR00-0A(000a)	NORMAL	0	0	0	0	0	0	0	0	0	0	0	0	0	0	0	0	0	0	0
HDDR00-0B(000b)	NORMAL	0	0	0	0	0	0	0	0	0	0	0	0	0	0	0	0	0	0	0
HDDR00-0C(000c)	NORMAL	0	0	0	0	0	0	0	0	0	0	0	0	0	0	0	0	0	0	0
HDDR00-0D(000d)	NORMAL	0	0	0	0	0	0	0	0	0	0	0	0	0	0	0	0	0	0	0
HDDR00-0E(000e)	NORMAL	0	0	0	0	0	0	0	0	0	0	0	0	0	0	0	0	0	0	0

Blank Sheet

Blank Sheet

Blank Sheet

4.5 LAN Check Procedure

1. <Initial screen>

2. <Operation mode change>
Change the mode to [Modify mode].
Select (CL) [Diagnosis].

3. <Activating LAN>
Select (CL) [LAN].
(The screen is changed to the LAN Check menu screen.)

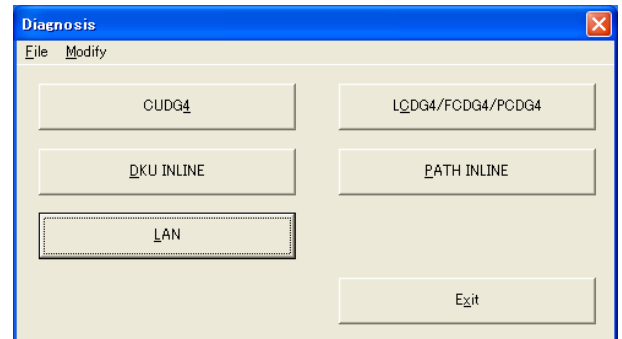

4. <Starting LAN Check>

Select (CL) [Start] in the 'LAN Check' window.

<Supplementary explanation>

Although an installed processor is set to be default to execute a hardware diagnosis, all processors can be selected.

Installed processor : Select (CL) [Target MP] and then select (DR) [Equipped MP].

All processors : Select (CL) [Target MP] and then select (DR) [All MP].

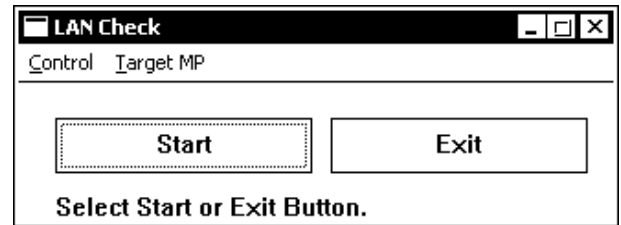

5. <Displaying Wait message>

The Wait message is displayed. The screen will change to the result display screen in a few minutes.

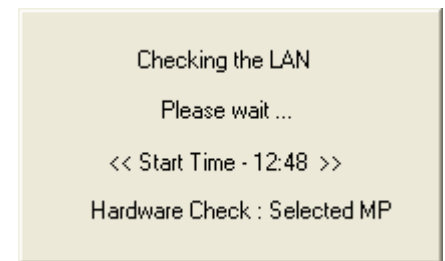

6. <Displaying result>

① Adapter status display

When the Adapter button is selected, the screen is changed to the MP status screen. The screen is returned to the LAN Check menu screen by selecting (CL) [OK].

[Explanation on statuses]

The status is shown by the appearance of the button as follows:

Black : The test object is normal.

Blinking : The test object is abnormal.

Gray : The test object is not installed.

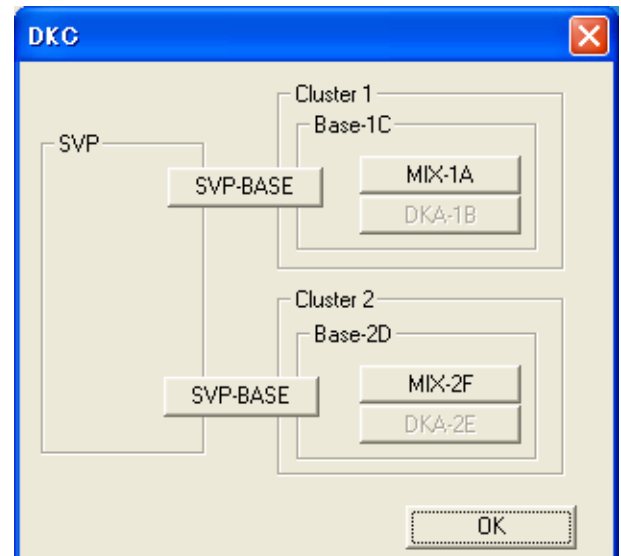

② MP status display

When the MP button is selected, the screen is changed to the detailed status screen.

The screen is returned to the adapter status screen by selecting (CL) [OK].

[Explanation on statuses]

The status is shown by the appearance of the MP button as follows:

Black : The concerning MP is normal.

Blinking : The test object is abnormal. However, for the MP which was normal at the time of an FF-Ping, “#” is indicated in front of the MP name.

Gray : The test object is not installed.

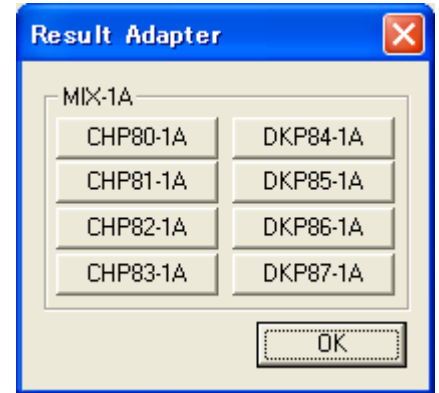

[Supplemental explanation]

When the test object is not installed in the state that the hardware is abnormal:

The concerning MP is indicated in gray.

When the test object is not installed in the state that the hardware is normal:

The indication of the concerning MP is grayed and blinks.

When the test object is installed by an FF-Ping:

A character “#” is indicated in front of the MP name, and the name indication blinks.

When the test object is connected by an FF-Ping but not installed:

A character “#” is indicated in front of the MP name, and the name indication is grayed and blinks.

③ Detailed status display

Detailed information on the concerning MP is displayed.

The screen is returned to the MP status screen by selecting (CL) [OK].

[Explanation on statuses]

The test result is shown by the appearance of the Task button as follows:

Black : The MP is normal from the viewpoint of software.

Blinking : The blinking part has a problem.

Gray : Not diagnosed yet.

[Supplemental explanation]

There are five types of status as shown below:

When the hardware is abnormal : Rcv., I/F-JOB, and R-JOB are indicated in gray.

When the software is normal : Rcv., I/F-JOB, and R-JOB are indicated in black.

When the Rcv. is abnormal : Rcv. indication blinks, and I/F-JOB and R-JOB are indicated in gray.

When the I/F-JOB is abnormal : Rcv. is indicated in black, I/F-JOB indication blinks, and R-JOB is indicated in gray.

When the R-JOB is abnormal : Rcv. and I/F JOB are indicated in black and R-JOB indication blinks.

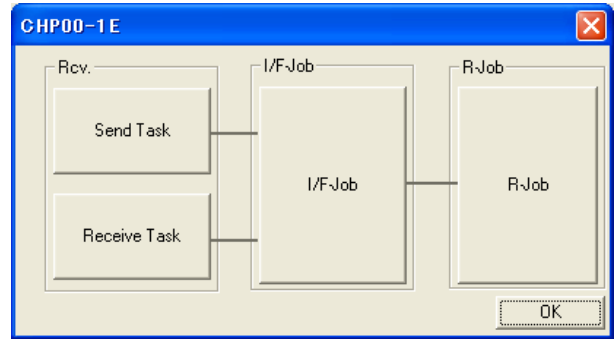

7. <Exiting from LAN Check>

Select (CL) [Exit] in the 'LAN Check' window.

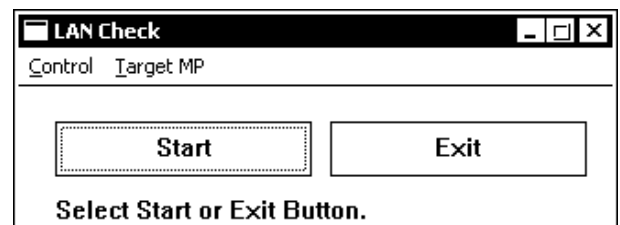

5. DIAG Trouble shooting

5.1 CUDG Trouble shooting

Procedures of CUDG Trouble Shooting depend on CUDG Error Opportunity.

The procedures are listed in Table 5.1-1 CUDG Trouble shooting Types.

Table 5.1-1 CUDG Trouble shooting Types

CUDG Error Opportunity	CUDG Trouble shooting Types	Procedure
IMPL, CHA/MIX Replace, CHA/MIX Install	CUDG3 Trouble shooting	Following Subsection 5.1.1
CUDG4	CUDG4 Trouble shooting	Following Subsection 5.1.2
BASE Replace, BASE Install	INLINE CUDG Trouble shooting	Following Subsection 5.1.3

Note: If FPC is BASE PCB or Cache Memory Module, Shared Memory Module see Subsection 5.1.4 ([DIAG05-60](#)).

5.1.1 CUDG3 Trouble shooting

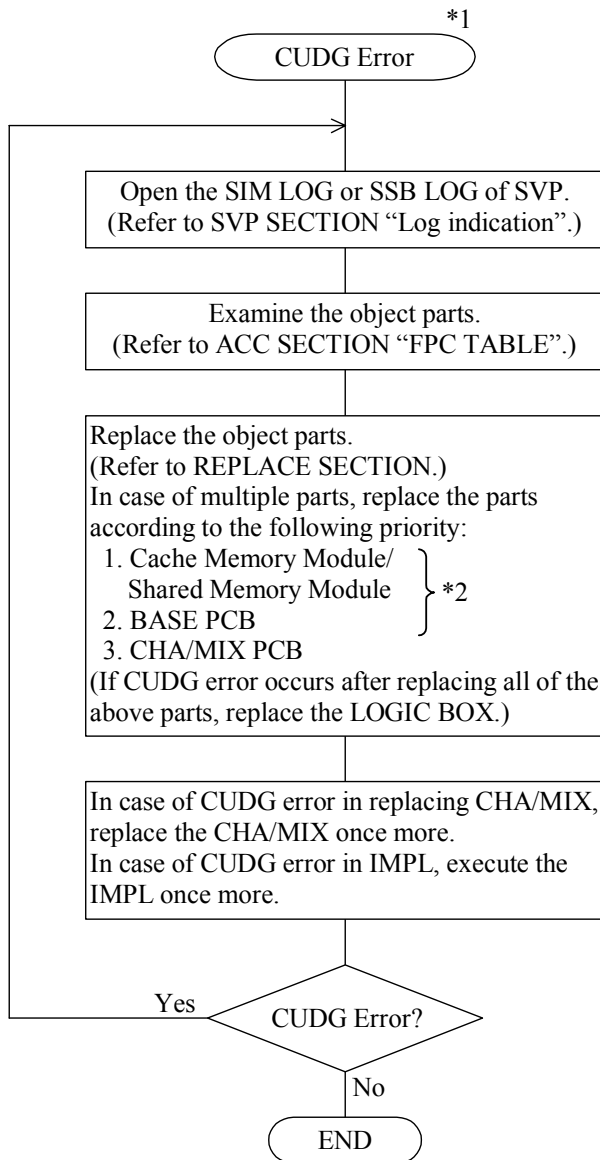

*1: CUDG Error Code is SIM REFERENCE CODE = (760xxx) or SSB ERROR CODE = (3306).

*2: See Subsection 5.1.4 ([DIAG05-60](#)).

5.1.2 CUDG4 Trouble shooting

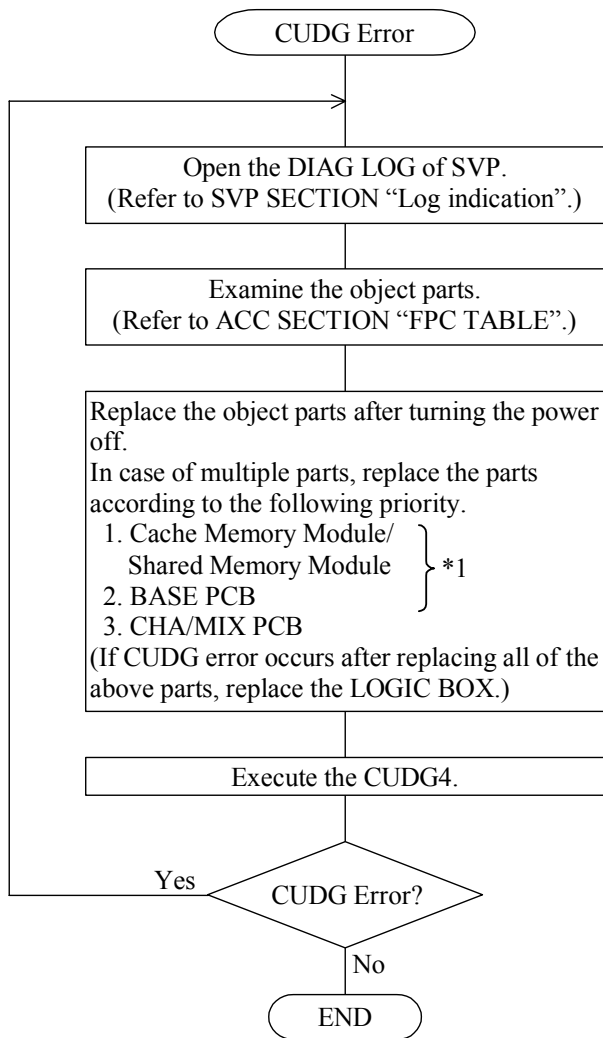

*1: See Subsection 5.1.4 ([DIAG05-60](#)).

5.1.3 INLINE CUDG Trouble shooting

(1) Installation

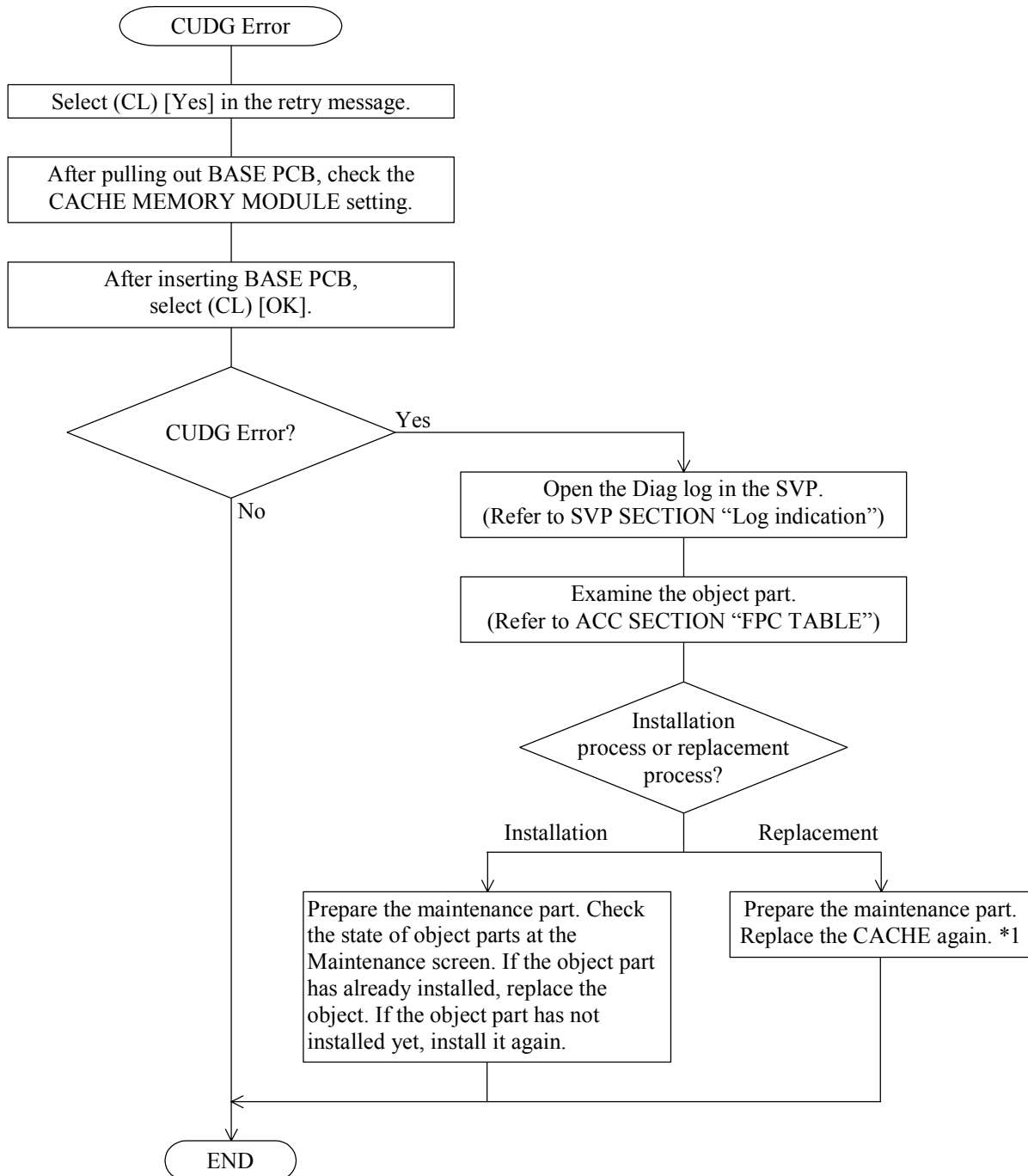

*1: In case of multiple parts, replace the parts according to the following priority:

- ① Cache Memory Module/Shared Memory Module
- ② BASE PCB
- ③ CHA/MIX PCB

(If a CUDG error occurred after replacing all of the above parts, replace LOGIC BOX.)

If the error part is Cache Memory Module/Shared Memory Module/BASE PCB, refer to Subsection 5.1.4 ([DIAG05-60](#)).

(2) De-Installation

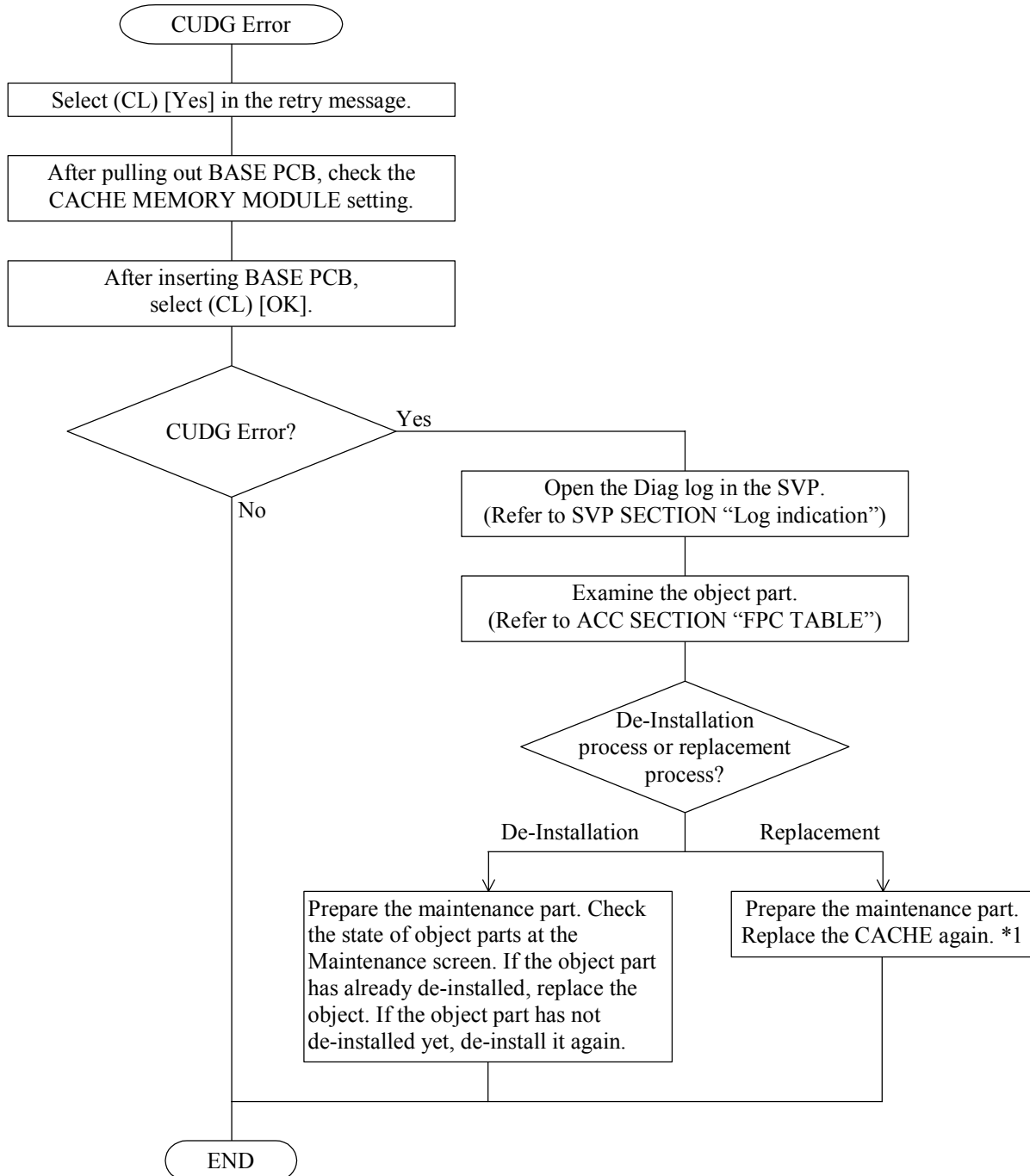

*1: In case of multiple parts, replace the parts according to the following priority:

- ① Cache Memory Module/Shared Memory Module
- ② BASE PCB
- ③ CHA/MIX PCB

(If a CUDG error occurred after replacing all of the above parts, replace LOGIC BOX.)

If the error part is Cache Memory Module/Shared Memory Module/BASE PCB, refer to Subsection 5.1.4 ([DIAG05-60](#)).

5.1.4 BASE PCB, Cache Memory Module, Shared Memory Module Trouble shooting

If FPC is BASE PCB, Cache Memory Module, Shared Memory Module execute the following process.

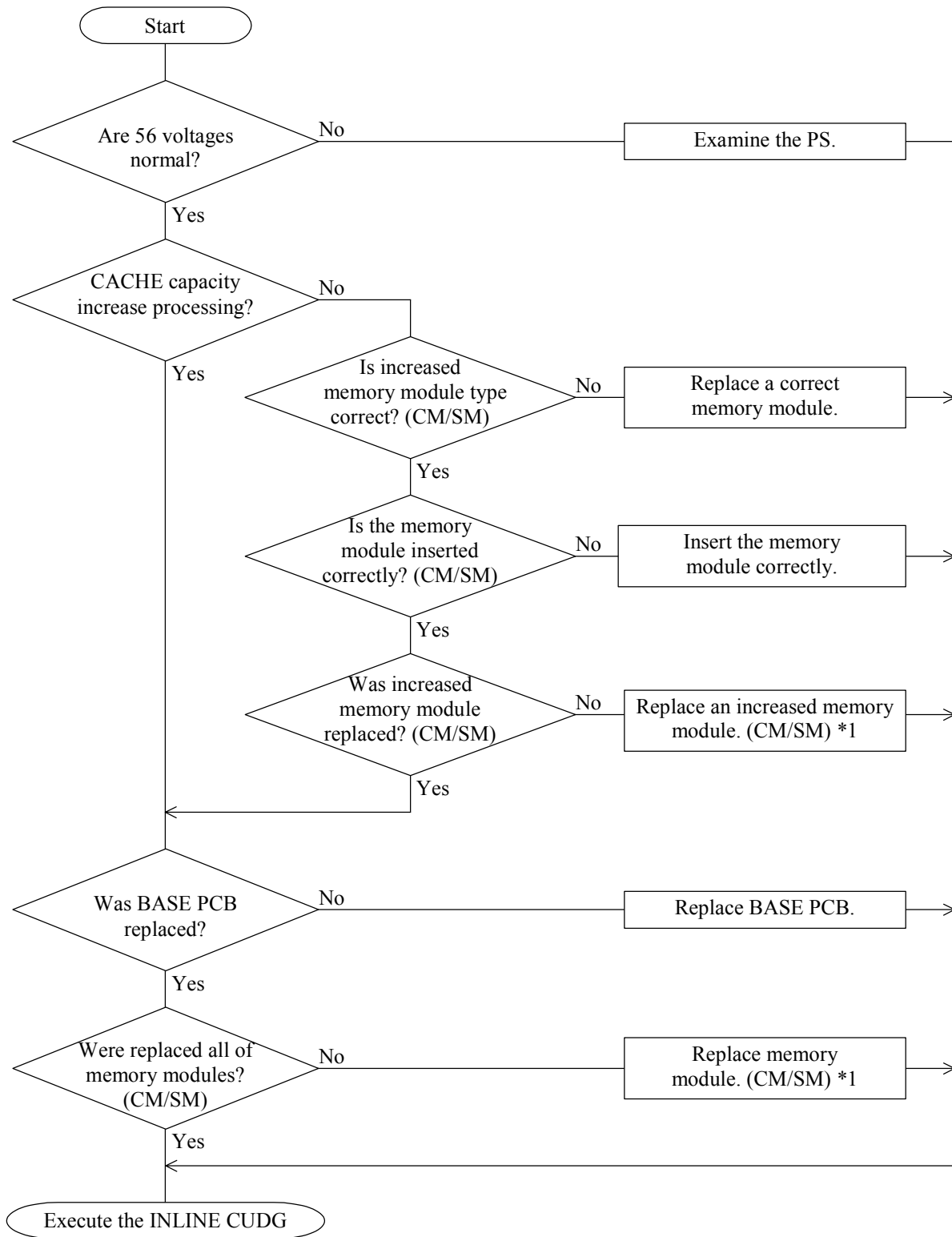

*1: In case of multiple module groups, replace the module groups one by one.
If a CUDG error occurs after replacing the group, put them to original position.

5.2 DKU INLINE Trouble shooting

Trouble shoot procedures (Except Error Code = "xx e3")

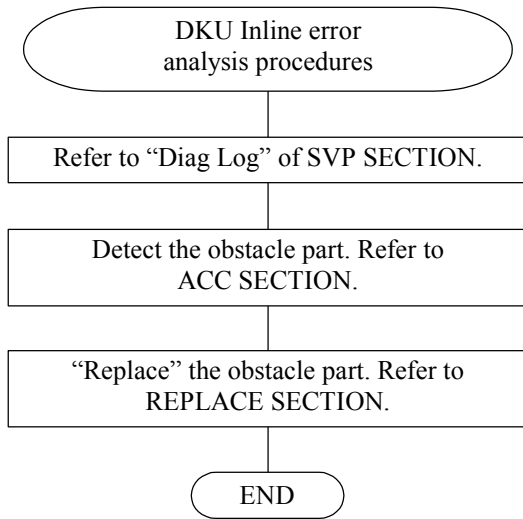

Trouble shoot procedures (In case of Error Code = "xx e3")

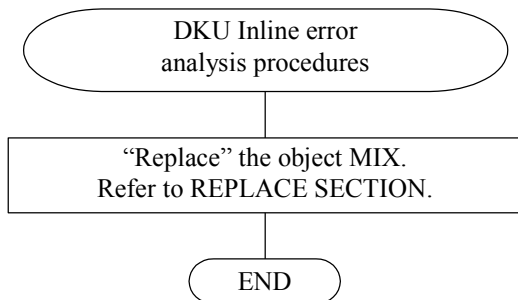

5.3 DKU PATH INLINE Trouble shooting

Trouble shoot procedures (Error Code = "ax ad", "ax ae", "ax 07")

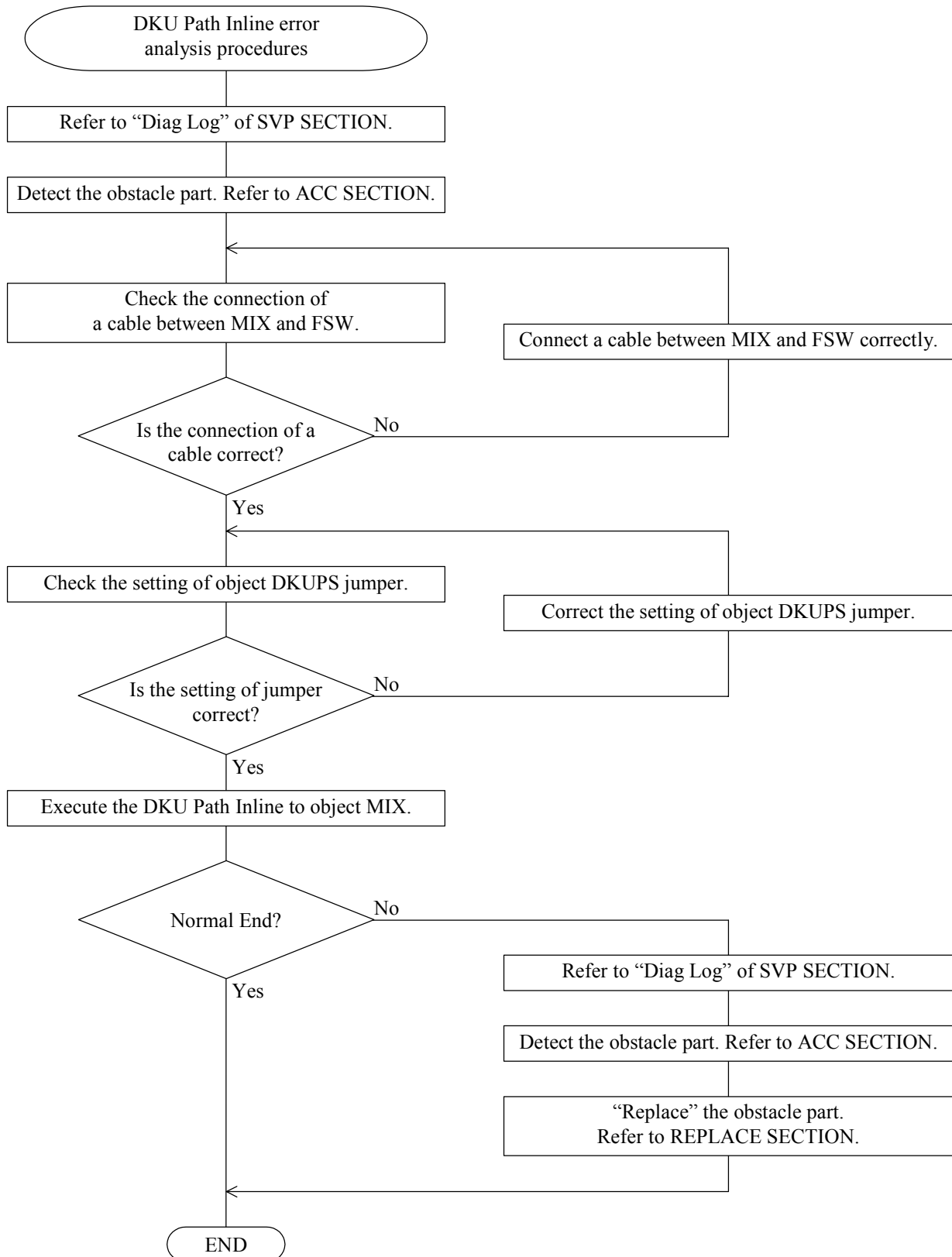

Trouble shoot procedures (Except Error Code = "ax ad", "ax ae", "ax 07")

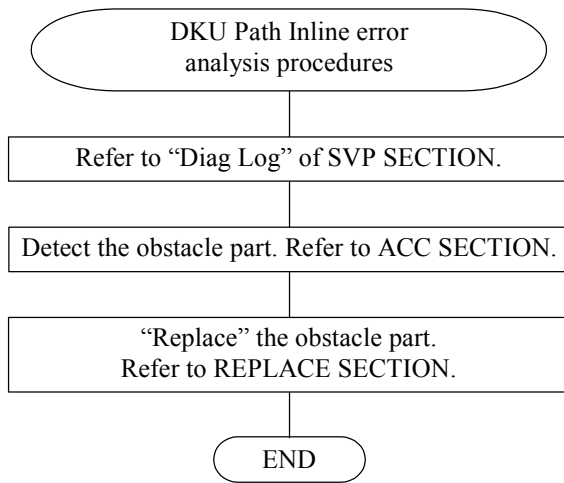

6. DIAG Errors

6.1 DKU INLINE Error Code List

Notes: Replace Error Code on Diagnosis Log of SVP Information since the 8th Byte and after of the Detail Information Byte correspond to Byte 01 and after of Error Byte.

Error Byte										Contents
01	02	03	04	05	06	07	08	09	10	
XX	E0									The TEST UNIT READY command failed.
XX	E1									The Bypass Check command failed.
XX	E2									The Reset Bypass command failed.
XX	E3									Communication of between DKC and SVP was TIME OUT.
XX	E4									Invalid SENSE KEY in TEST UNIT READY. Ev : 0x00
XX	E5									The LIP command failed.
XX	E6									The Set Bypass command failed.
XX	E8									The Start INLINE command was failed.
XX	E9									The End INLINE command failed.
XX	EA									The specified HDD does not exist.
XX	EB									SVP error (Program Error)
XX	EC									Windows error
XX	ED									SVP error (DKC-SVP Communication)

Notes: Replace Error Code on Diagnosis Log of SVP Information since the 8th Byte and after of the Detail Information Byte correspond to Byte 01 and after of Error Byte. Refer to [DIAG06-10](#), when there is nothing to the following error code tables.

Error Byte										Contents
01	02	03	04	05	06	07	08	09	10	
C1	01									Communication of the TEST UNIT READY command failed.
C1	02									The TEST UNIT READY command failed.
C1	03									Communication of the REQUEST SENSE command failed.
C1	04									The REQUEST SENSE command failed.
C1	05									The SENSE KEY is abnormal.
C1	06									The SENSE CODE is abnormal.
C1	07									The ADDITIONAL CODE is abnormal.

Notes: Replace Error Code on Diagnosis Log of SVP Information since the 8th Byte and after of the Detail Information Byte correspond to Byte 01 and after of Error Byte. Refer to [DIAG06-10](#), when there is nothing to the following error code tables.

Error Byte										Contents
01	02	03	04	05	06	07	08	09	10	
C2	01									Communication of the INQUIRY command failed.
C2	02									The INQUIRY command failed.
C2	03									The Vendor ID is abnormal.

Notes: Replace Error Code on Diagnosis Log of SVP Information since the 8th Byte and after of the Detail Information Byte correspond to Byte 01 and after of Error Byte. Refer to [DIAG06-10](#), when there is nothing to the following error code tables.

Error Byte										Contents
01	02	03	04	05	06	07	08	09	10	
C3	01									Communication of the STOP UNIT command failed.
C3	02									The STOP UNIT command failed.
C3	03									The Delay function failed.
C3	04									Communication of the START UNIT command failed.
C3	05									The START UNIT command failed.
C3	06									Communication of the TEST UNIT READY command failed.
C3	07									The TEST UNIT READY command failed.
C3	08									Communication of the REQUEST SENSE command failed.
C3	09									The REQUEST SENSE command failed.
C3	0A									The SENSE KEY is abnormal.
C3	0B									The SENSE CODE is abnormal.
C3	0C									The ADDITIONAL CODE is abnormal.

Notes: Replace Error Code on Diagnosis Log of SVP Information since the 8th Byte and after of the Detail Information Byte correspond to Byte 01 and after of Error Byte. Refer to [DIAG06-10](#), when there is nothing to the following error code tables.

Error Byte										Contents
01	02	03	04	05	06	07	08	09	10	
C4	01									Communication of the SELF TEST command failed.
C4	02									The SELF TEST command failed.
C4	03									The SELF TEST failed.

6.2 PATH INLINE Error Code List

Notes: Replace Error Code on Diagnosis Log of SVP Information since the 8th Byte and after of the Detail Information Byte correspond to Byte 01 and after of Error Byte.

Error Byte										Contents
01	02	03	04	05	06	07	08	09	10	
XX	51									GEN_IO0 register read failed. (TERM check)
XX	52									GEN_IO0 register write failed. (TERM check)
XX	53									PKCTRL register read failed. (TERM check)
XX	54									GEN_IO0 register write failed. (TERM check)
XX	55									HDCCNT register write failed. (Bypass test)
XX	56									H_PRSNNT register read failed. (DCDC check)
XX	57									HDCWARN register read failed. (DCDC check)
XX	58									GEN_IO0 register read failed. (DCDC check)
XX	59									GEN_IO0 register write failed. (DCDC check)
XX	5A									HDCSENS register read failed. (DCDC check)
XX	5B									GEN_IO0 register write failed. (DCDC check)
XX	5C									HDCSENS error. FSW error. (DCDC check)
XX	5D									HDCCNT register read failed. (DCDC check)
XX	5E									FSW that doesn't exist in configuration information is equipped. Please confirm equipping FSW.
XX	FC	D#	P#	U#						FC cable connection error. There is the possibility of a FC cable connection mistake.
XX	FD									DCDC converter error. (DCDC check)
XX	FE									FC Check error. There is the possibility of a FC cable connection mistake.

D# : MIX# P# : PORT# U# : UNIT#
(*1)

*1: MIX#, PORT#, UNIT# mapping

MIX# : 0, 4	PORT# : 4-7	UNIT# : 0-3
0 : MIX-1A	4 : HDU-00, 10, 20, 30 5 : HDU-01, 11, 21, 31	0 : DKU-RK0 1 : DKU-RK1
4 : MIX-2F	6 : HDU-02, 12, 22, 32 7 : HDU-03, 13, 23, 33	2 : DKU-RK2 3 : DKU-RK3

Notes: Replace Error Code on Diagnosis Log of SVP Information since the 8th Byte and after of the Detail Information Byte correspond to Byte 01 and after of Error Byte.

Error Byte										Contents
01	02	03	04	05	06	07	08	09	10	
XX	61									The scsa_byenctl function failed. (FC Check, Bypass)
XX	62									The fbp_alpachk function failed. (FC Check, Bypass)
XX	63									The scsa_byenctl function failed. (FC Check, Enable)
XX	64									The fbp_alpachk function failed. (FC Check, Enable)

Notes: Replace Error Code on Diagnosis Log of SVP Information since the 8th Byte and after of the Detail Information Byte correspond to Byte 01 and after of Error Byte.

Error Byte										Contents
01	02	03	04	05	06	07	08	09	10	
XX	B1									Register read failed. (Register read test)
XX	B2									Register read failed. (Register read test2)
XX	B3									Compare error (Register read test)
XX	B4									Register read failed. (Register W/R test)
XX	B5									Register write failed. (Register W/R test)
XX	B6									Register read failed. (Register W/R test)
XX	B7									Compare error (Register W/R test)
XX	B8									Register write failed. (Register W/R test)
XX	B9									Register write failed. (Register W/R test2)
XX	BA									Register read failed. (Register W/R test2)
XX	BB									Compare error (Register W/R test2)
XX	BC									LBS_RW0 register read failed. (HBC ERROR RESET)
XX	BD									LBUS_ERR register write failed. (HBC ERROR RESET)
XX	BE									PK_STAT register write failed. (HBC ERROR RESET)
XX	BF									Bypass test compare error.

Notes: Replace Error Code on Diagnosis Log of SVP Information since the 8th Byte and after of the Detail Information Byte correspond to Byte 01 and after of Error Byte.

Error Byte										Contents
01	02	03	04	05	06	07	08	09	10	
XX	C1	D#	P#	LED						GEN_IN0 register read failed. (Bypass test)
XX	C2	D#	P#	LED						GEN_IN0 register write failed. (Bypass test)
XX	C3	D#	P#	LED						GEN_IN0 register read failed. (Bypass test)
XX	C4	D#	P#	LED						GEN_IN0 register write failed. (Bypass test)
XX	C5	D#	P#	LED						PKCTRL register read failed. (Bypass test)
XX	C6	D#	P#	LED						PKCTRL register write failed. (Bypass test)
XX	C7	D#	P#	LED						LBS_RW0 register read failed. (Bypass test)
XX	C8	D#	P#							The scsa_byenctl function failed. (Bypass test)
XX	C9	D#	P#	LED						BYPSEL register read failed. (Bypass test)
XX	CA	D#	P#	LED						H_BYP register read failed. (Bypass test)
XX	CB	D#	P#	LED						GEN_IO0 register read failed. (REV check)
XX	CC	D#	P#	LED						GEN_IO0 register write failed. (REV check)
XX	CD	D#	P#	LED						REV register read failed. (REV check)
XX	CE	D#	P#							REV compare error.
XX	CF	D#	P#	LED						GEN_IO0 register write failed. (REV check)

D# : MIX# P# : PORT# LED : LEDSTS

(*1)

*1: MIX#, PORT#, UNIT# mapping

MIX# : 0, 4	PORT# : 4-7	LEDSTS
0 : MIX-1A	4 : HDU-00, 10, 20, 30 5 : HDU-01, 11, 21, 31 6 : HDU-02, 12, 22, 32 7 : HDU-03, 13, 23, 33	Bit09 : DKU Status 0 Bit10 : ACK Error Bit11 : DKU Status 1 Bit12 : Read Data Parity Error Bit13 : DKU Output Error Bit14 : Read Busy Bit15 : Write Busy
4 : MIX-2F		

Notes: Replace Error Code on Diagnosis Log of SVP Information since the 8th Byte and after of the Detail Information Byte correspond to Byte 01 and after of Error Byte.

Error Byte										Contents
01	02	03	04	05	06	07	08	09	10	
XX	D1	D#	P#	LED						PKCTRL register read failed. (Pretreatment)
XX	D2	D#	P#							The FSW Shut Down LED is on. Extraction and insertion of a FSW has a possibility of not carrying out.
XX	D3	D#	P#	LED						PKCTRL register write failed. (Pretreatment)
XX	D4	D#	P#	LED						LBS_PADR register read failed. (address check)
XX	D5	D#	P#	LED						PK_STAT register read failed. (address check)
XX	D6	D#	P#							SELA0 check error
XX	D7	D#	P#	LED						PK_STAT register read failed. (AL_PA check)
XX	D8	D#	P#							AL_PA_Unit not connected.
XX	D9	D#	P#							Terminator check error
XX	DA	D#	P#							Error not occurred in FORCE-ERROR TEST.
XX	DB	D#	P#	LED						LFORCE_ERR register write failed. (FORCE-ERROR TEST)
XX	DC	D#	P#							Error not occurred in FORCE-ERROR TEST. (*2)
XX	DD	D#	P#	LED						LBS_RW0 register read failed. (FCA ERROR RESET)
XX	DE	D#	P#	LED						LBUS_ERR register write failed. (FCA ERROR RESET)
XX	DF	D#	P#	LED						PK_STAT register write failed. (FCA ERROR RESET)

D# : MIX# P# : PORT# LED : LEDSTS

(*1)

*1: MIX#, PORT#, UNIT# mapping

MIX# : 0, 4	PORT# : 4-7	LEDSTS
0 : MIX-1A	4 : HDU-00, 10, 20, 30 5 : HDU-01, 11, 21, 31 6 : HDU-02, 12, 22, 32 7 : HDU-03, 13, 23, 33	Bit09 : DKU Status 0 Bit10 : ACK Error Bit11 : DKU Status 1 Bit12 : Read Data Parity Error Bit13 : DKU Output Error Bit14 : Read Busy Bit15 : Write Busy
4 : MIX-2F		

*2: There is the possibility of the FSW error on the same HBC cable.

Notes: Replace Error Code on Diagnosis Log of SVP Information since the 8th Byte and after of the Detail Information Byte correspond to Byte 01 and after of Error Byte.

Error Byte										Contents
01	02	03	04	05	06	07	08	09	10	
XX	E1									The Bypass Check command failed.
XX	E2									The Reset Bypass command failed.
XX	E3									Communication of between DKC and SVP was TIME OUT.
XX	E4									Communication failed.
XX	E5									The LIP command failed.
XX	E6									The Set Bypass command failed.
XX	E8									The Start INLINE command failed.
XX	E9									The End INLINE command failed.
XX	EA									The specified HDD does not exist.
XX	EB									SVP error (Program Error)
XX	EC									Windows error
XX	ED									SVP error (DKC-SVP Communication)

Notes: Replace Error Code on Diagnosis Log of SVP Information since the 8th Byte and after of the Detail Information Byte correspond to Byte 01 and after of Error Byte. Refer to from [DIAG06-60](#) to [DIAG06-110](#), when there is nothing to the following error code tables.

Error Byte											Contents	
01	02	03	04	05	06	07	08	09	10	11		
A0	01											The Reset Bypass command failed.
A0	02											The Bypass check command failed.
A0	03											Communication of the INQUIRY command failed.
A0	04											The INQUIRY information failed.
A0	05											The INQUIRY command failed.
A0	06											The Vender ID doesn't match.
A0	07											PORT mistake. There is the possibility of a FC cable connection mistake.
A0	0B											Bypass check error
A0	1X	D#	P0S	P1S	P2S	P3S	P4S	P5S	P6S	P7S	Obstruction occurred in a part of the PATH.	
A0	2X	D#	P0S	P1S	P2S	P3S	P4S	P5S	P6S	P7S	Obstruction occurred in all the PATH.	
A0	AD	D#										Invalid HBC BUS address data. ^(*3) (Refer to A0AE for detail)
A0	AE	D#	P#	U#	EV ^(*2)		RV					Invalid HBC BUS address data. ^(*3)
A0	AF	D#	P#	U#								AL-PA setting error

D# : MIX# P# : PORT# U# : UNIT# EV : Expected Value

RV : Received Value P(0-7)S : PORT#(0-7) report (FF : Normal, Not FF : Abnormal)

(*1)

*1: MIX#, PORT#, UNIT# mapping

MIX# : 0, 4	PORT# : 4-7	UNIT# : 0-3
0 : MIX-1A	4 : HDU-00, 10, 20, 30 5 : HDU-01, 11, 21, 31	0 : DKU-RK0 1 : DKU-RK1
4 : MIX-2F	6 : HDU-02, 12, 22, 32 7 : HDU-03, 13, 23, 33	2 : DKU-RK2 3 : DKU-RK3

*2: Refer to HBC Bus Address mapping ([DIAG06-210 ~ 240](#)) for Expected Value.

*3: There is the possibility of a HBC cable connection mistake or a jumper setting mistake of DKUPS.

Refer to location section ([LOC06-50 ~ 71](#)) for the setting of the jumper socket and switch.

Notes: Replace Error Code on Diagnosis Log of SVP Information since the 8th Byte and after of the Detail Information Byte correspond to Byte 01 and after of Error Byte. Refer to from [DIAG06-60](#) to [DIAG06-110](#), when there is nothing to the following error code tables.

Error Byte											Contents	
01	02	03	04	05	06	07	08	09	10	11		
A1	01											The Reset Bypass command failed.
A1	02											The Bypass check command failed.
A1	03											Communication of the INQUIRY command failed.
A1	04											The INQUIRY information failed.
A1	05											The INQUIRY command failed.
A1	06											The Vender ID doesn't match.
A1	07											PORT mistake. There is the possibility of a FC cable connection mistake.
A1	0B											Bypass check error
A1	1X	D#	P0S	P1S	P2S	P3S	P4S	P5S	P6S	P7S	Obstruction occurred in a part of the PATH	
A1	2X	D#	P0S	P1S	P2S	P3S	P4S	P5S	P6S	P7S	Obstruction occurred in all the PATH.	
A1	AD	D#										Invalid HBC BUS address data. ^(*3) (Refer to A1AE for detail)
A1	AE	D#	P#	U#	EV ^(*2)		RV					Invalid HBC BUS address data. ^(*3)
A1	AF	D#	P#	U#								AL-PA setting error

D# : MIX# P# : PORT# U# : UNIT# EV : Expected Value

RV : Received Value P(0-7)S : PORT#(0-7) report (FF : Normal, Not FF : Abnormal)

(*1)

*1: MIX#, PORT#, UNIT# mapping

MIX# : 0, 4	PORT# : 4-7	UNIT# : 0-3
0 : MIX-1A	4 : HDU-00, 10, 20, 30 5 : HDU-01, 11, 21, 31	0 : DKU-RK0 1 : DKU-RK1
4 : MIX-2F	6 : HDU-02, 12, 22, 32 7 : HDU-03, 13, 23, 33	2 : DKU-RK2 3 : DKU-RK3

*2: Refer to HBC Bus Address mapping ([DIAG06-210 ~ 240](#)) for Expected Value.

*3: There is the possibility of a HBC cable connection mistake or a jumper setting mistake of DKUPS.

Refer to location section ([LOC06-50 ~ 71](#)) for the setting of the jumper socket and switch.

Notes: Replace Error Code on Diagnosis Log of SVP Information since the 8th Byte and after of the Detail Information Byte correspond to Byte 01 and after of Error Byte. Refer to from [DIAG06-60](#) to [DIAG06-110](#), when there is nothing to the following error code tables.

Error Byte										Contents
01	02	03	04	05	06	07	08	09	10	
A2	01									Set Bypass command failed (Multi HDD).
A2	02									Reset Bypass command failed (Single HDD).
A2	03									LIP command failed (Single HDD).
A2	04									Inquiry command failed.
A2	05									Set Bypass command failed (Single HDD).
A2	06									Reset Bypass command failed (Multi HDD).
A2	07									LIP command failed (Multi HDD).
A2	08									Start INLINE command failed.
A2	09									End-INLINE command failed.
A2	0A									Inquiry command failed.
A2	0B									Inquiry information failed.
A2	10									ERROR DRIVE exists. (Refer to the Diag Log for details.)

Notes: Replace Error Code on Diagnosis Log of SVP Information since the 8th Byte and after of the Detail Information Byte correspond to Byte 01 and after of Error Byte. Refer to from [DIAG06-60 to DIAG06-110](#), when there is nothing to the following error code tables.

Error Byte										Contents
01	02	03	04	05	06	07	08	09	10	
A3	01									The Drive Read command failed.
A3	02									The Drive Read failed.
A3	10									ERROR DRIVE exists.

Notes: Replace Error Code on Diagnosis Log of SVP Information since the 8th Byte and after of the Detail Information Byte correspond to Byte 01 and after of Error Byte. Refer to from [DIAG06-60](#) to [DIAG06-110](#), when there is nothing to the following error code tables.

Error Byte											Contents	
01	02	03	04	05	06	07	08	09	10	11		
A5	01											The Reset Bypass command failed.
A5	02											The Bypass check command failed.
A5	03											Communication of the INQUIRY command failed.
A5	04											The INQUIRY information failed.
A5	05											The INQUIRY command failed.
A5	06											The Vender ID doesn't match.
A5	07											PORT mistake. There is the possibility of a FC cable connection mistake.
A5	0B											Bypass check error
A5	1X	D#	P0S	P1S	P2S	P3S	P4S	P5S	P6S	P7S		Obstruction occurred in a part of the PATH
A5	2X	D#	P0S	P1S	P2S	P3S	P4S	P5S	P6S	P7S		Obstruction occurred in all the PATH.
A5	AD	D#										Invalid HBC BUS address data. ^(*3) (Refer to A5AE for detail)
A5	AE	D#	P#	U#	EV ^(*2)		RV					Invalid HBC BUS address data. ^(*3)
A5	AF	D#	P#	U#								AL-PA setting error

D# : MIX# P# : PORT# U# : UNIT# EV : Expected Value

RV : Received Value P(0-7)S : PORT#(0-7) report (FF : Normal, Not FF : Abnormal)

(*1)

*1: MIX#, PORT#, UNIT# mapping

MIX# : 0, 4	PORT# : 4-7	UNIT# : 0-3
0 : MIX-1A	4 : HDU-00, 10, 20, 30 5 : HDU-01, 11, 21, 31	0 : DKU-RK0 1 : DKU-RK1
4 : MIX-2F	6 : HDU-02, 12, 22, 32 7 : HDU-03, 13, 23, 33	2 : DKU-RK2 3 : DKU-RK3

*2: Refer to HBC Bus Address mapping ([DIAG06-210 ~ 240](#)) for Expected Value.

*3: There is the possibility of a HBC cable connection mistake or a jumper setting mistake of DKUPS.

Refer to location section ([LOC06-50 ~ 71](#)) for the setting of the jumper socket and switch.

Notes: Replace Error Code on Diagnosis Log of SVP Information since the 8th Byte and after of the Detail Information Byte correspond to Byte 01 and after of Error Byte. Refer to from [DIAG06-60](#) to [DIAG06-110](#), when there is nothing to the following error code tables.

Error Byte											Contents	
01	02	03	04	05	06	07	08	09	10	11		
A6	01											The Reset Bypass command failed.
A6	02											The Bypass check command failed.
A6	03											Communication of the INQUIRY command failed.
A6	04											The INQUIRY information failed.
A6	05											The INQUIRY command failed.
A6	06											The Vender ID doesn't match.
A6	07											PORT mistake. There is the possibility of a FC cable connection mistake.
A6	0B											Bypass check error
A6	1X	D#	P0S	P1S	P2S	P3S	P4S	P5S	P6S	P7S	Obstruction occurred in a part of the PATH	
A6	2X	D#	P0S	P1S	P2S	P3S	P4S	P5S	P6S	P7S	Obstruction occurred in all the PATH.	
A6	AD	D#										Invalid HBC BUS address data. ^(*3) (Refer to A6AE for detail)
A6	AE	D#	P#	U#	EV ^(*2)		RV					Invalid HBC BUS address data. ^(*3)
A6	AF	D#	P#	U#								AL-PA setting error

D# : MIX# P# : PORT# U# : UNIT# EV : Expected Value

RV : Received Value P(0-7)S : PORT#(0-7) report (FF : Normal, Not FF : Abnormal)

(*1)

*1: MIX#, PORT#, UNIT# mapping

MIX# : 0, 4	PORT# : 4-7	UNIT# : 0-3
0 : MIX-1A	4 : HDU-00, 10, 20, 30 5 : HDU-01, 11, 21, 31	0 : DKU-RK0 1 : DKU-RK1
4 : MIX-2F	6 : HDU-02, 12, 22, 32 7 : HDU-03, 13, 23, 33	2 : DKU-RK2 3 : DKU-RK3

*2: Refer to HBC Bus Address mapping ([DIAG06-210 ~ 240](#)) for Expected Value.

*3: There is the possibility of a HBC cable connection mistake or a jumper setting mistake of DKUPS.

Refer to location section ([LOC06-50 ~ 71](#)) for the setting of the jumper socket and switch.

Notes: Replace Error Code on Diagnosis Log of SVP Information since the 8th Byte and after of the Detail Information Byte correspond to Byte 01 and after of Error Byte. Refer to from [DIAG06-60 to DIAG06-110](#), when there is nothing to the following error code tables.

Error Byte										Contents	
01	02	03	04	05	06	07	08	09	10		
A8	01	Return Code									Set Bypass command failed (Multi HDD).
A8	02	Return Code									Reset Bypass command failed (Multi HDD).
A8	03	Return Code									LIP command failed (Multi HDD).
A8	04	Return Code									Reset Bypass command failed (Single HDD).
A8	05	Return Code									LIP command failed (Single HDD).
A8	06	Return Code									Set Bypass command failed (Single HDD).
A8	07	Return Code									Drive Read command failed. (HDD individual test)
A8	08	Return Code									Inquiry command failed. (HDD individual test)
A8	0A	Return Code									Reset Bypass command failed (Through Path Test.).
A8	0B	Return Code									LIP command failed (Through Path Test).
A8	0C	Return Code									Drive Read command failed (Through Path Test).
A8	0D	Return Code									Set Bypass command failed (Through Path Test).
A8	10										Detected Error Drive. (Refer to the Diag Log for details.)

Notes: Replace Error Code on Diagnosis Log of SVP Information since the 8th Byte and after of the Detail Information Byte correspond to Byte 01 and after of Error Byte.

Error Byte										Contents
01	02	03	04	05	06	07	08	09	10	
A9	01									FAN Warning has occurred.
A9	04	D#	H#							FSW access error when platter revision is acquired.
A9	05	D#	H#							FSW access error when FAN connection is checked.
A9	06	D#	H#							FSW access error when equipping is checked.
A9	08	K#								Platter check error. (Error DKU specification)
A9	09	K#								FSW that doesn't exist in configuration information is equipped. Please confirm equipping FSW.
A9	20									Platter check error.

D# : MIX# H# : HDU# K# : DKU#

(*1)

*1: MIX#, HDU#, DKU# mapping

MIX# : 0, 4	PORT# : 0-3	UNIT# : 0-3
0 : MIX-1A	0 : HDU-00, 10, 20, 30	0 : DKU-RK0
	1 : HDU-01, 11, 21, 31	1 : DKU-RK1
4 : MIX-2F	2 : HDU-02, 12, 22, 32	2 : DKU-RK2
	3 : HDU-03, 13, 23, 33	3 : DKU-RK3

(A) HBC BUS Address Bit definition

Bit0	1	2	3	4	5	6	7	8	9	10	11	12	13	14	15
Box-Side	PA6	PA5	PA4	PA3	PA2	PA1	PA0	L0 A0	L0 A1	L0 A2	Rsv	L1 A0	L1 A1	L1 A2	Rsv

Box-Side : R/L Identity (0:L; 1:R)

PA5, 6 : HDU number (0,0:HDU#0; 0,1:HDU#1; 1,0:HDU#2; 1,1:HDU#3)

PA4 : HDU number (0:DKU-RK0/2; 1:DKU-RK1/3)

PA3 : 0 fixed (0)

PA2 : 0 fixed (0)

PA1 : DKU number (0:DKU-RK0/1; 1:DKU-RK2/3)

PA0 : Cluster number (0:CL1; 1:CL2)

L0A0 : 1st LSI FSW P/K LSI select (1)

L0A1,2 : 1st LSI FSW P/K select (11:DKU-RK0; 10:DKU-RK1;
00:DKU-RK3; 01:DKU-RK2)

L1A0 : 2nd LSI FSW P/K LSI select (0)

L1A1,2 : 2nd LSI FSW P/K select (11:DKU-RK0; 10:DKU-RK1;
00:DKU-RK3; 01:DKU-RK2)

Rsv : Reserve (0)

(B) HBC BUS Address (Expected Value)

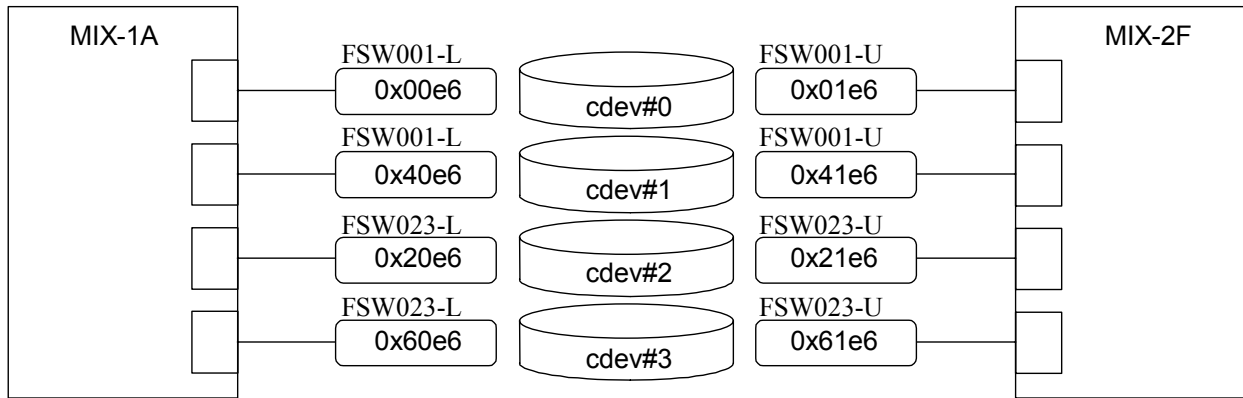

Fig. 6.2-1 HBC Bus Address mapping (DKU-RK0 Unit)

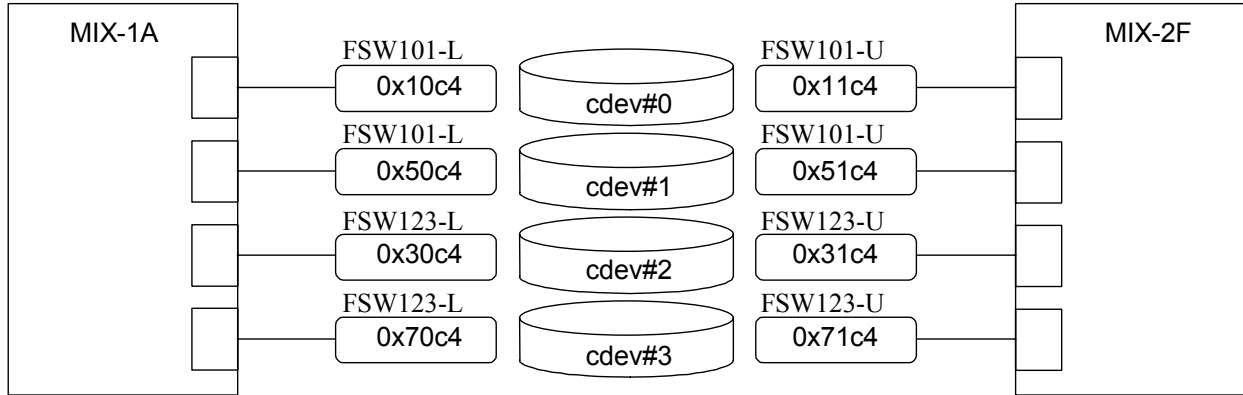

Fig. 6.2-2 HBC Bus Address mapping (DKU-RK1 Unit)

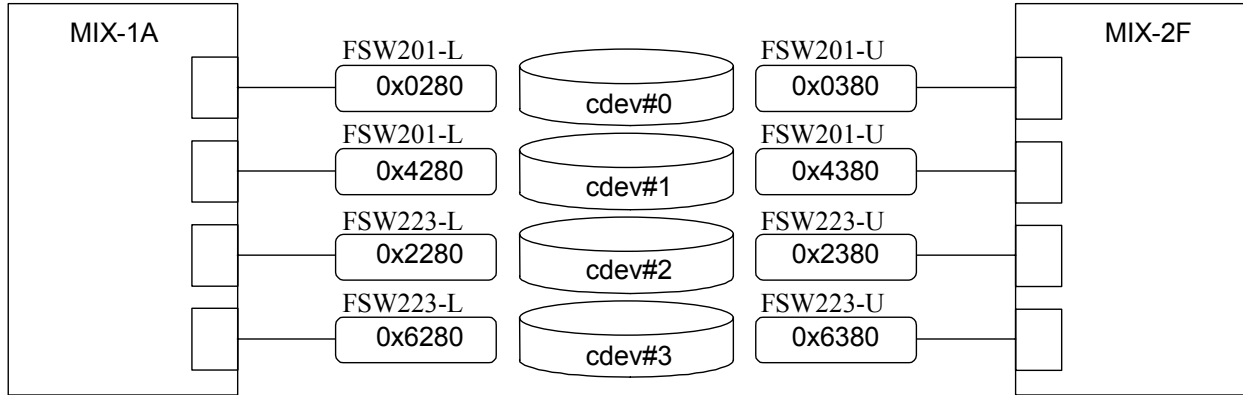

Fig. 6.2-3 HBC Bus Address mapping (DKU-RK2 Unit)

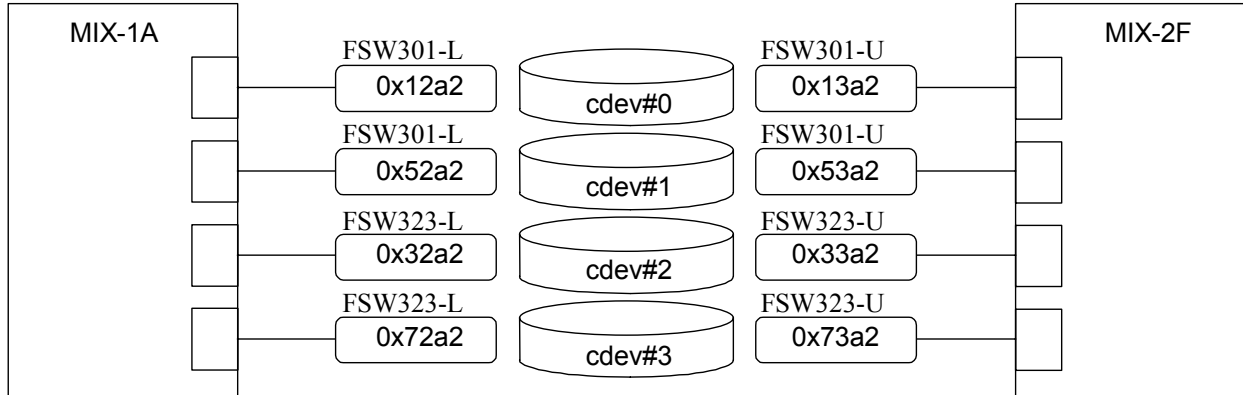

Fig. 6.2-4 HBC Bus Address mapping (DKU-RK3 Unit)

6.3 CUDG error code list

LSI classification	Test Item	Error Code	Error Contents
CMA	0101		Register R/W Test. (Common Part)
		1000	Error occurred in Register Write.
		2000	Error occurred in Register Read.
		0040	CHK2 Error occurred.
		0001	Data Compare Error occurred.
	0102		Memory R/W Test (A)
		8000	Error occurred in Memory Read.
		4000	Error occurred in Memory Write.
		0002	Data Compare Error occurred.
		0040	CHK2 Error occurred.
	0103		Memory R/W Test (B)
		1000	Error occurred in Register Write.
		2000	Error occurred in Register Read.
		8000	Memory Read Error occurred.
		4000	Memory Write Error occurred.
		0002	Data Compare Error occurred.
		0040	CHK2 Error occurred.
	0104		General Memory Test (A)(Write Activation Part)
		1000	Error occurred in Register Write.
		0040	CHK2 Error occurred.
	0105		General Memory Test (A)(Polling Part)
		2000	Error occurred in Register Read.
		0004	Polling Time Out.
		0040	CHK2 Error occurred.
	0106		General Memory Test (A)(Status Confirmation Part after Write)
		2000	Error occurred in Status Confirmation Register Read.
		0001	Data Compare Error occurred.
		0040	CHK2 Error occurred.
	0107		General Memory Test (A)(Read Activation Part)
		1000	Error occurred in TESTADRH/L Write.
		0040	CHK2 Error occurred.
	0108		General Memory Test (A)(Status Confirmation Part after READ)
		1000	Error occurred in Register Write.
		2000	Error occurred in Register Read.
		0001	Uncorrectable or Correctable Error occurred.
		0002	Data Compare Error occurred.
		0040	CHK2 Error occurred.

LSI classification	Test Item	Error Code	Error Contents
CMA	0109		General Memory Test (A)(Write Activation Part)
		1000	Error occurred in Register Write.
		0040	CHK2 Error occurred.
	010a		General Memory Test (A)(Polling Part)
		2000	Error occurred in Register Read.
		0004	Polling Time Out.
		0040	CHK2 Error occurred.
	010b		General Memory Test (A)(Status Confirmation Part after Write)
		2000	Error occurred in Register Read.
		0001	Data Compare Error occurred.
		0040	CHK2 Error occurred.
	010c		General Memory Test (A)(Read Activation Part)
		1000	Error occurred in TESTADRH/L Write
		0040	CHK2 Error occurred.
	010d		General Memory Test (A)(Status Confirmation Part after Read)
		1000	Error occurred in Register Write.
		2000	Error occurred in Register Read.
		0001	Uncorrectable or Correctable Error occurred.
		0002	Data Compare Error occurred.
		0040	CHK2 Error occurred.
	010e		ECC Circuit Test. (A)
		2000	Error occurred in Register Read.
		1000	Error occurred in Register Write.
		0001	Data Compare Error occurred.
		0002	Data Compare Error occurred.
		0040	CHK2 Error occurred.
		4000	Memory Write Error occurred.
		8000	Memory Read Error occurred.
	010f		ECC Circuit Test. (B)
		2000	Error occurred in Register Read.
		1000	Error occurred in Register Write.
		0001	Data Compare Error occurred.
		0002	Data Compare Error occurred.
		0040	CHK2 Error occurred.
		4000	Memory Write Error occurred.
		8000	Error occurred in Memory Read.

LSI classification	Test Item	Error Code	Error Contents
CMA	0110		ECC LOG Register Test
		2000	Error occurred in Register Read.
		1000	Error occurred in Register Write.
		0001	Data Compare Error occurred.
		0002	Data Compare Error occurred.
		0040	CHK2 Error occurred.
		4000	Memory Write Error occurred.
		8000	Memory Read Error occurred.
	0111		SLRC Test
		2000	Error occurred in Register Read.
		1000	Error occurred in Register Write.
		0001	Data Compare Error occurred.
		0002	Data Compare Error occurred.
		0040	CHK2 Error occurred.
	0112		Force Error Test (A)
		2000	Error occurred in Register Read.
		1000	Error occurred in Register Write.
		0001	Data Compare Error occurred.
		0002	Data Compare Error occurred.
		0040	CHK2 Error occurred.
	0113		Force Error Test (B)
		2000	Error occurred in Register Read.
		1000	Error occurred in Register Write.
		0001	Data Compare Error occurred.
		0002	Data Compare Error occurred.
		0040	CHK2 Error occurred.
		4000	Memory Write Error occurred.
	0114		Self-refresh (Write Activation Part)
		2000	Error occurred in Register Read.
		1000	Error occurred in Register Write.
		0001	Data Compare Error occurred.
		0002	Data Compare Error occurred.
		0040	CHK2 Error occurred.

LSI classification	Test Item	Error Code	Error Contents
CMA	0115		Self-refresh (Polling Part)
		2000	Error occurred in Register Read.
		1000	Error occurred in Register Write.
		0001	Data Compare Error occurred.
		0002	Data Compare Error occurred.
		0004	Polling Timeout.
		0040	CHK2 Error occurred.
	0116		Self-refresh (Status Confirmation Part after Write)
		2000	Error occurred in Register Read.
		1000	Error occurred in Register Write.
		0001	Data Compare Error occurred.
		0002	Data Compare Error occurred.
		0040	CHK2 Error occurred.
	0117		Self-refresh (Read Activation Part)
		2000	Error occurred in Register Read.
		1000	Error occurred in Register Write.
		0001	Data Compare Error occurred.
		0002	Data Compare Error occurred.
		0040	CHK2 Error occurred.
	0118		Self-refresh (Status Confirmation Part after Read)
		2000	Error occurred in Register Read.
		1000	Error occurred in Register Write.
		0001	Data Compare Error occurred.
		0002	Data Compare Error occurred.
		0040	CHK2 Error occurred.
	0119		Self-refresh (set/reset)
		2000	Error occurred in Register Read.
		1000	Error occurred in Register Write.
		0001	Data Compare Error occurred.
		0002	Data Compare Error occurred.
		0040	CHK2 Error occurred.

LSI classification	Test Item	Error Code	Error Contents
CMA	011a		PD Check.
		2000	Error occurred in Register Read.
		1000	Error occurred in Register Write.
		0001	Data Compare Error occurred.
		0002	Data Compare Error occurred.
		0100	In use CACHE PCB, the installing cache memory size is not supported. Execute the version upgrade of CACHE PCB.
		0040	CHK2 Error occurred.
	011b		PROM Test.
		2000	Error occurred in Register Read.
		1000	Error occurred in Register Write.
		0001	Data Compare Error occurred.
		0002	Data Compare Error occurred.
		0040	CHK2 Error occurred.
	011c		GTL Impedance Control.
		2000	Error occurred in Register Read.
		0001	Data Compare Error occurred.
		0040	CHK2 Error occurred.
	011d		Register W/R.
		2000	Error occurred in Register Read.
		1000	Error occurred in Register Write.
		0001	Data Compare Error occurred.
		0002	Data Compare Error occurred.
		0040	CHK2 Error occurred.
	011e		Timer Count Up Test.
		2000	Error occurred in Register Read.
		1000	Error occurred in Register Write.
		0001	Data Compare Error occurred.
		0002	Data Compare Error occurred.
		0040	CHK2 Error occurred.
	011f		Timer Count Reset Test.
		2000	Error occurred in Register Read.
		1000	Error occurred in Register Write.
		0001	Data Compare Error occurred.
		0002	Data Compare Error occurred.
		0040	CHK2 Error occurred.

LSI classification	Test Item	Error Code	Error Contents
CMA	0120		Force Error Test. (A)
		2000	Error occurred in Register Read.
		1000	Error occurred in Register Write.
		0001	Data Compare Error occurred.
		0002	Data Compare Error occurred.
		0040	CHK2 Error occurred.
	0121		Force Error Test. (B)
		2000	Error occurred in Register Read.
		1000	Error occurred in Register Write.
		0001	Data Compare Error occurred.
		0002	Data Compare Error occurred.
		0040	CHK2 Error occurred.
	0122		FIFO Memory Test.
		2000	Error occurred in Register Read.
		1000	Error occurred in Register Write.
		0001	Data Compare Error occurred.
		0002	Data Compare Error occurred.
		0040	CHK2 Error occurred.
		4000	Memory Write Error occurred.
		8000	Memory Read Error occurred.
	0123		Normal Packet Access. (dw)
		2000	Error occurred in Register Read.
		1000	Error occurred in Register Write.
		0001	Data Compare Error occurred.
		0002	Data Compare Error occurred.
		0040	CHK2 Error occurred.
		4000	Memory Write Error occurred.
		8000	Memory Read Error occurred.
	0124		Normal Packet Access. (bcp)
		2000	Error occurred in Register Read.
		1000	Error occurred in Register Write.
		0001	Data Compare Error occurred.
		0002	Data Compare Error occurred.
		0040	CHK2 Error occurred.
		0200	Cache to Copy Error occurred.
		4000	Memory Write Error occurred.
		8000	Memory Read Error occurred.

LSI classification	Test Item	Error Code	Error Contents
CMA	0125		Normal Packet Access.(icp)
		2000	Error occurred in Register Read.
		1000	Error occurred in Register Write.
		0001	Data Compare Error occurred.
		0002	Data Compare Error occurred.
		0040	CHK2 Error occurred.
		0400	Cache in Copy Error occurred.
		4000	Memory Write Error occurred.
		8000	Memory Read Error occurred.
	0126		Retry Function Confirmation Test.
		2000	Error occurred in Register Read.
		1000	Error occurred in Register Write.
		0001	Data Compare Error occurred.
		0002	Data Compare Error occurred.
		0040	CHK2 Error occurred.
		4000	Memory Write Error occurred.
		8000	Memory Read Error occurred.

LSI classification	Test Item	Error Code	Error Contents
CMA	0168		Force Error Generating Check Test. (Group C-1)
		0040	CHK2 Error occurred.
		1000	Register Write Error occurred.
		3000	Register Read/Write Error occurred.
		0001	Register Compare Error occurred.
	0169		Force Error Generating Check Test. (Group C-2)
		0040	CHK2 Error occurred.
		1000	Register Write Error occurred.
		2000	Register Read Error occurred.
		3000	Register Read/Write Error occurred.
		C000	Memory Read/Write Error occurred.
		0001	Register Compare Error occurred.
	016a		Force Error Generating Check Test. (Group A)
		0040	CHK2 Error occurred.
		1000	Register Write Error occurred.
		2000	Register Read Error occurred.
		3000	Register Read/Write Error occurred.
		C000	Memory Read/Write Error occurred.
		0001	Register Compare Error occurred.
	016b		Force Error Generating Check Test. (Group B)
		0040	CHK2 Error occurred.
		1000	Register Write Error occurred.
		2000	Register Read Error occurred.
		4000	Memory Write Error occurred.
		8000	Memory Read Error occurred.
		C000	Memory Read/Write Error occurred.
		0001	Register Compare Error occurred.
	016c		Force Error Generating Check Test. (Group C)
		0040	CHK2 Error occurred.
		1000	Register Write Error occurred.
		2000	Register Read Error occurred.
		3000	Register Read/Write Error occurred.
		4000	Memory Write Error occurred.
		C000	Memory Read/Write Error occurred.
		0001	Register Compare Error occurred.

LSI classification	Test Item	Error Code	Error Contents	
CMA	016d		Force Error Generating Check Test. (Group D)	
		0040	CHK2 Error occurred.	
		1000	Register Write Error occurred.	
		2000	Register Read Error occurred.	
		3000	Register Read/Write Error occurred.	
		4000	Memory Write Error occurred.	
		C000	Memory Read/Write Error occurred.	
		0001	Register Compare Error occurred.	
	016e		Force Error Generating Check Test. (Group E)	
			0040	CHK2 Error occurred.
			1000	Register Write Error occurred.
			2000	Register Read Error occurred.
			4000	Memory Write Error occurred.
			8000	Memory Read Error occurred.
			C000	Memory Read/Write Error occurred.
			0001	Register Compare Error occurred.
	016f		Force Error Generating Check Test. (Group F)	
			0040	CHK2 Error occurred.
			1000	Register Write Error occurred.
			2000	Register Read Error occurred.
			3000	Register Read/Write Error occurred.
			4000	Memory Write Error occurred.
C000			Memory Read/Write Error occurred.	
0001			Register Compare Error occurred.	

LSI classification	Test Item	Error Code	Error Contents
CMA	0187		CACHE Correctable Test1
		4000	Error occurred in Memory Write.
		8000	Memory Read Error occurred.
		0002	Correctable Error occurred.
		0040	CHK2 Error occurred.
	0189		CACHE Correctable Test2 (Write Activation Part)
		1000	Error occurred in Register Write.
		0040	CHK2 Error occurred.
	018a		CACHE Correctable Test2 (Polling Part)
		2000	Error occurred in Register Read.
		0004	Polling Time Out.
		0040	CHK2 Error occurred.
	018b		CACHE Correctable Test2 (Status Confirmation Part after Write)
		2000	Error occurred in Register Write.
		0001	Data Compare Error occurred.
		0040	CHK2 Error occurred.
	018c		CACHE Correctable Test1 (Read Activation Part)
		1000	Error occurred in Register Write.
		0040	CHK2 Error occurred.
	018d		CACHE Correctable Test2 (Status Confirmation Part after Read)
		1000	Error occurred in Register Read.
		2000	Error occurred in Register Write.
		0001	Uncorrectable or Correctable Error occurred.
		0002	Data Compare Error occurred.
		0040	CHK2 Error occurred.
	0190		ACCKEY/CUDGKEY Setting Check Test.
		0100	Data Compare Error occurred.
		0110	Parameter Error occurred.
		0120	Transmission Mode Error occurred.
		0200	Status Compare Error occurred.
		1000	Register Write Error occurred.
		2000	Register Read Error occurred.
		4000	Memory Write Error occurred.
		8000	Memory Read Error occurred.
		0040	CHK2 Error occurred.

LSI classification	Test Item	Error Code	Error Contents
CMA	0191		SHUT UP Control Check Test.
		0100	Data Compare Error occurred.
		1000	SHUT UP Test Error occurred.
		2000	Register Read Error occurred.
		0040	CHK2 Error occurred.
	0192		SPROM Force Error Test
		1000	Register Write Error occurred.
		2000	Register Read Error occurred.
		0100	Data Compare Error occurred.
		0040	CHK2 Error occurred.
	0193		Memory Address Logging Test
		1000	Register Write Error occurred.
		2000	Register Read Error occurred.
		8000	Memory Read Error occurred.
		00fd	Timeout Errorr occurred.
		0100	Data Compare Error occurred.
		0200	Status Compare Error occurred.
		0040	CHK2 Error occurred.
	0194		Memory capacity setting check test
		1000	Register Write Error occurred.
		2000	Register Read Error occurred.
		4000	Memory Write Error occurred.
		8000	Memory Read Error occurred.
		00fd	Timeout Errorr occurred.
		0100	Data Compare Error occurred.
		0200	Status Compare Error occurred.
		0040	CHK2 Error occurred.
	0195		between modules write/read test.
		1000	Register Write Error occurred.
		2000	Register Read Error occurred.
		4000	Memory Write Error occurred.
		8000	Memory Read Error occurred.
		0100	Data Compare Error occurred.
		0002	
		0040	CHK2 Error occurred.

LSI classification	Test Item	Error Code	Error Contents
SMA	0201		SM Normal Access Test.
		0200 0300 0600 0700	Write/Read un-match Error occurred of Test area.
		0040 0100 0400 0500	CHK3 Error occurred.
	0202		SM Resources Lock Access Test.
		0100	Write/Read un-match Error occurred at 2 word of Test area.
		0040	CHK3 Error occurred.
	0203		Atomic Access Test.
		0040 0100 0300	CHK3 Error occurred.
		0200 0400 0500	Write/Read un-match Error occurred of Test area.
	0204		Resources Lock Out Test.
		0040 0100 0300 0500	CHK3 Error occurred.
		0200 0400 0600	Write/Read un-match Error occurred of Test area.
	0205		Target Broadcast Test.
		0200	Broadcast Register Data un-match Error occurred.
		0040 0100	CHK3 Error occurred.
	0206		Self MP Status Read Test.
		0100 0200 0300	MP_STATUSREG Data un-match Error occurred.
		0040	CHK3 Error occurred.
	0207		General Memory Read Test
		0040 0100	CHK3 Error occurred.

LSI classification	Test Item	Error Code	Error Contents
SMA	020c		Configuration Check.
		0040	CHK3 Error occurred.
		0050 0100	Error occurred in PD Register Read. (CHK3)
		0200	Configuration un-match Error occurred.
	020d		SM Voltage Establish Control routine.
		0100	PS_DETINT Establish Error occurred.
		0200	PS_DET_INH Establish.
		0300	Parameter Error occurred.
		0040	CHK3 Error occurred.
	0211		Register Test 1
		0100	Data Compare Error occurred.
		0040	CHK3 Error occurred.
	0212		Register Test 2
		0100	Data Compare Error occurred.
		0200	Data Compare Error occurred. (0 Clear)
		0300	Data Compare Error occurred.
		0400	Data Compare Error occurred. (0 Clear)
		0040	CHK3 Error occurred.
	0221		BC Register Test 1
		0100	Data Compare Error occurred.
		0200	Data Compare Error occurred. (0 Clear)
		0300	Data Compare Error occurred.
		0400	Data Compare Error occurred. (0 Clear)
		0040	CHK3 Error occurred.
	0222		BC Register Test 2
		0100	Data Compare Error occurred.
		0200	Data Compare Error occurred. (BC Register)
		0300	Status Error occurred in BCINT OFF.
		0040	CHK3 Error occurred.

LSI classification	Test Item	Error Code	Error Contents
SMA	0231		SC Register Test 1.
		0100	Data Compare Error occurred. (SCAN_WRITE_DATA Register Test)
		0200	Data Compare Error occurred. (0 Clear)
		0300	Data Compare Error occurred. (SCAN_WRITE_DATA Register Test)
		0400	Data Compare Error occurred. (0 Clear)
		1100	Data Compare Error occurred. (SCAN_READ_DATA Register Test)
		1200	Data Compare Error occurred. (0 Clear)
		1300	Data Compare Error occurred. (SCAN_READ_DATA Register Test)
		1400	Data Compare Error occurred. (0 Clear)
		2100	Data Compare Error occurred. (SCAN STATUS Register Test)
		2200	Data Compare Error occurred. (0 Clear)
		2300	Data Compare Error occurred. (SCAN STATUS Register Test)
		2400	Data Compare Error occurred. (0 Clear)
		0040	CHK3 Error occurred.
	0232		SC Register Test 2.
		0100	Scan Time Out Error occurred.
		0200	Data Compare Error occurred. (0 Clear)
		0300	Scan Time Out Error occurred.
		0040	CHK3 Error occurred.
	0241		MPST Register Test 1.
		0100 0300	Data Compare Error occurred.
		0200 0400	Data Compare Error occurred. (0 Clear)
		0040	CHK3 Error occurred.
	0251		ECC Test 1.
		0100	Status Data Compare Error occurred.
		0200	Data Compare Error occurred.
		0300	Correctable Error Undetected.
		0400	Data un-match Error occurred.
		0040	CHK3 Error occurred.

LSI classification	Test Item	Error Code	Error Contents
SMA	0252		ECC Test 2/3
		0100	Uncorrectable Error occurred.(ECC Test 2)
		0200	Uncorrectable Error occurred. (ECC Test 3)
		0040	CHK3 Error occurred.
	0261		Single Write/Read Test.
		0100 0300 0400 0700 0800	Data Compare Error occurred.
		0200 0500 0600 0900 0a00	Data Compare Error occurred.
		1100	Data Compare Error occurred.
		1200	Data Compare Error occurred.
		1300	Data Compare Error occurred.
		1400	Data Compare Error occurred.
		2100	Data unmatched Error occurred. (CHK 3)
		2200	Data unmatched Error occurred.
		2300	Data unmatched Error occurred. (CHK 3)
		2400	Data unmatched Error occurred.
		0040	CHK3 Error occurred.

LSI classification	Test Item	Error Code	Error Contents
SMA	0261		
		3000	Single W/R Compare Error occurred.
		3050	CHK3 Error occurred.
		3100	Correctable Error occurred.
		3200	Single W/R Compare Error occurred.
		3250	CHK3 Error occurred.
		3300	Correctable Error occurred.
		3400	Single W/R Compare Error occurred.
		3500	Single W/R Compare Error occurred.
		3550	CHK3 Error occurred.
		3600	Correctable Error occurred.
		3700	Single W/R Compare Error occurred.
		3800	Single W/R Compare Error occurred.
		3850	CHK3 Error occurred.
		3900	Correctable Error occurred.
		3a00	Single W/R Compare Error occurred.
		3b00	Single W/R Compare Error occurred.
		3b50	CHK3 Error occurred.
		3c00	Correctable Error occurred.
		3d00	Single W/R Compare Error occurred.
		3e00	Single W/R Compare Error occurred.
		3e50	CHK3 Error occurred.
		3f00	Correctable Error occurred.
		4100	Single Write/Double Read Compare Error occurred. (Side A)
		4200	Single Write/Double Read Compare Error occurred. (Side B)
		4300	Correctable Error occurred.
		4400	Single Write/Double Read Compare Error occurred. (Side A)
		4500	Single Write/Double Read Compare Error occurred. (Side B)
		4600	Correctable Error occurred.

LSI classification	Test Item	Error Code	Error Contents
SMA	0262		Read Modify Write Function (Atomic operation Function) Test.
		0100 0200 0300	Read Data Error.
		0040	CHK3 Error occurred.
		1100 1300 1400	Read Modify Write Error occurred.
		1200 1500	Correctable Error occurred.
	0263		Function Test 3.
		0100	Correctable Error occurred.
		0200	Data Compare Error occurred.
		0300	Correctable Error occurred.
		0400	Data Compare Error occurred.
		0500	Correctable Error occurred.
		0600	Data Compare Error occurred.
		0700	Correctable Error occurred.
		0800	Data Compare Error occurred.
		0040	CHK3 Error occurred.
	0264		Function Test 4.
		0100 0200	PD_DATA Compare un-match Error occurred.
		0400	Data Compare Error occurred.
		0500	Data Compare Error occurred.
		0040	CHK3 Error occurred.
	0265		Function Test 5.
		0100	Memory Read Error occurred.
		0200	Memory not Ready Error occurred.
		0300	Memory Data Compare Error occurred.
		0400	Memory Data Compare Error occurred.
		0040	CHK3 Error occurred.

LSI classification	Test Item	Error Code	Error Contents
SMA	0266		Function Test 6.
		0100	Error Status Compare Error occurred.
		0200	All Lock Register Read Status Error occurred.
		0300	Read Data Compare Error occurred.
		0400	Memory Read Compare Error occurred.
		0500	Double All Lock Status Compare Error occurred.
		0600	All Lock Status Compare Error occurred.
		0700	Double All Lock Status Compare Error occurred.
		0800	All Lock Status Compare Error occurred.
		0900	All Lock Status Compare Error occurred.
		0a00	All Lock Status Compare Error occurred.
		0b00	All Lock Status Compare Error occurred.
		0040	CHK3 Error occurred.
	0269		Function Test 9.
		0100	Count Value Status Compare Error occurred.
		0200	COUNTER_ERROR_STATUS Register Status Compare Error occurred.
		0040	CHK3 Error occurred.
	026a		Function Test 10.
		0100	Timer Stop Status Compare Error occurred.
		0200	Timer Stop Status Compare Error occurred.
		0300	Timer Operation Status Compare Error occurred.
		0400	Timer Operation Status Compare Error occurred.
		0040	CHK3 Error occurred.
	026b		Function Test 11.
		0100	Error Status Compare Error occurred.
		1100	Error Status Compare Error occurred.
		1200	Error Status Compare Error occurred. (details)
		2100	Error Status Compare Error occurred.
		2200	Error Status Compare Error occurred.
		2300	Error Status Compare Error occurred. (details)
		0040	CHK3 Error occurred.

LSI classification	Test Item	Error Code	Error Contents
SMA	026c		Function Test 11b.
		1100	Double Lock Error occurred.
		1200	Lock Error occurred.
		2100	Error occurred.
		2200	Double Lock Error occurred.
		2300	Lock Error occurred.
		0040	CHK3 Error occurred.
	026d		Function Test 12.
		0100	Data Compare Error occurred.
		0200	Data Compare Error occurred.
		0300	Data Compare Error occurred.
		0400	Data Compare Error occurred.
		0040	CHK3 Error occurred.
	0271		Counter Test 1 (Path Counter W/R Test)
		0100	Data Compare Error occurred.
		0200	Data Compare Error occurred.
		0300	Data Compare Error occurred.
		0400	Data Compare Error occurred.
		0500	Data Compare Error occurred.
		0600	Data Compare Error occurred.
		0040	CHK3 Error occurred.
	0272		Counter Test 2 (Path Counter Function Test)
		0100	Data Compare Error occurred.
		0200	Data Compare Error occurred.
		0300	Data Compare Error occurred.
		0400	Data Compare Error occurred.
		0500	Data Compare Error occurred.
		0600	Data Compare Error occurred.
		0040	CHK3 Error occurred.
	0273		Counter Test 3 (Memory Counter W/R Test)
		0100	Data Compare Error occurred.
		0200	Data Compare Error occurred.
		0300	Data Compare Error occurred.
		0040	CHK3 Error occurred.

LSI classification	Test Item	Error Code	Error Contents
SMA	0274		Counter Test 4 (Memory Counter Function Test)
		0100	Data Compare Error occurred.
		0200	Data Compare Error occurred.
		0300	Data Compare Error occurred.
		0040	CHK3 Error occurred.
	0275		Counter Test 5 (Scan Counter W/R Test)
		0100	Data Compare Error occurred.
		0200	Data Compare Error occurred.
		0300	Data Compare Error occurred.
		0040	CHK3 Error occurred.
	0276		Counter Test 6 (Scan Counter Function Test)
		0100	Data Compare Error occurred.
		0200	Data Compare Error occurred.
		0300	Data Compare Error occurred.
		0040	CHK3 Error occurred.
	0277		Counter Test 7 (FIFO Management Counter W/R Test)
		0100	Data Compare Error occurred.
		0200	Data Compare Error occurred.
		0300	Data Compare Error occurred.
		0040	CHK3 Error occurred.
	0278		Counter Test 8 (FIFO Management Counter Function Test)
		0100	Data Compare Error occurred.
		0200	Data Compare Error occurred.
		0300	Data Compare Error occurred.
		0040	CHK3 Error occurred.

LSI classification	Test Item	Error Code	Error Contents
SMA	0281		Disconnect 1 Test
		0100	Transfer End Waiting Error occurred.
		0150	SM Status Error occurred.
		0200	CHK3 Error occurred.
		0300	SM Data Check Error occurred.
		0700	Data Compare occurred.
		0040	CHK3 Error occurred.
	0282		Disconnect 2 Test
		0100	Transfer End Waiting Error occurred.
		0150	SM Status Error occurred.
		0200	CHK3 Error occurred.
		0040	CHK3 Error occurred.
	0283		Disconnect 3 Test
		0100	Transfer End Waiting Error occurred.
		0200	CHK3 Error occurred.
		0040	CHK3 Error occurred.
	0284		Disconnect 4 Test.
		0100	Transfer End Waiting Error occurred.
		0200	CHK3 Error occurred.
		0300	LOG Address Data Check Error occurred.
		0400	LOG Read Data Error occurred.
		0500	LOG Read ECC Error occurred.
		0700	Board Check Error occurred.
		0040	CHK3 Error occurred.
	0287		INLINE CUDG Disconnect Test 1.
		0040	CHK3 Error occurred.
	0288		INLINE CUDG Disconnect Test 2.
		0100	Transfer End Waiting Timeout.
		0200	Transfer End Waiting Error occurred.
		0300	Transfer End Waiting Error occurred.
		0400	Transfer End Waiting Error occurred.
		0040	CHK3 Error occurred.

LSI classification	Test Item	Error Code	Error Contents
SMA	0291		Hard Error Test 1.
		0100	MPA Status Compare Error occurred.
		0200	MPA_MSTCHK3 Status Compare Error occurred.
		0300	PAHT0 Error Status Compare Error occurred.
		0400	PATH1 Error Status Compare Error occurred.
		0500	PATH0 Error Detail 0 Status Compare Error occurred.
		0600	PATH1 Error Detail 1 Status Compare Error occurred.
		0700	PATH Error Detail 0 Status Error occurred.
		0800	PATH Error Detail 0 Status Error occurred.
		0900	PATH Error Detail 1 Status Error occurred.
		1000	PATH Error Detail 1 Status Error occurred.
		1100	BOARD Error Status Error occurred.
		1200	BOARD Error Status Error occurred. (Details)
		1300	PATH0 Error Status Error occurred.
		1400	PATH1 Error Status Error occurred.
		1500	PATH0 Error Detail Status Error occurred.
		1600	PATH1 Error Detail Status Error occurred.
		0040	CHK3 Error occurred.
	0292		Hard Error Test 2.
		0100	MPA Status Error occurred.
		0200	MCTL SINGLE ERROR Status Compare Error occurred.
		0300	MCTL SINGLE ERROR Status Compare Error occurred.
		0400	Board Error Status Compare Error occurred.
		0500	Board Error Status Compare Error occurred. (Details)
		0600	DIMM Status Compare Error occurred.
		0700	MPA_STATUS Error occurred.
		0800	MCTL SINGLE Status Compare Error occurred.
		0900	MCTL SINGLE Status Compare Error occurred.
		0a00	PATH0 Status Compare Error occurred.
		0b00	PATH1 Status Compare Error occurred.
		0040	CHK3 Error occurred.

LSI classification	Test Item	Error Code	Error Contents
SMA	0293		Hard Error Test 3.
		0100	MPA Status Compare Error occurred.
		0200	PATH0 Common Board Status Compare Error occurred.
		0300	PATH1 Common Board Error Status Error occurred.
		0400	Board Error Status Compare Error occurred.
		0500	Board Error Status Compare Error occurred. (Details)
		0600	PARITY Error Status Compare Error occurred.(Detail 0)
		0700	PARITY Error Status Compare Error occurred.(Detail 1)
		0800	DIAG_MODE REG Status Error occurred.
		0900	DIAG_DATA REG Status Error occurred.
		0a00	PATH0 Non-Error Status Error occurred.
		0b00	PATH1 Non-Error Status Error occurred.
		0040	CHK3 Error occurred.
	294		Hard Error Test 4
		0100	MPA Status Compare Error occurred.
		0200	PATH0 Common Board Status Compare Error occurred.
		0300	PATH1 Common Board Error Status Error occurred.
		0400	Board Error Status Compare Error occurred.
		0500	Board Error Status Compare Error occurred.(Details)
		0600	PARITY Error Status Compare Error occurred.(Detail 0)
		0700	PARITY Error Status Compare Error occurred.(Detail 1)
		0800	DIAG MODE REG Status Error occurred.
		0900	DIAG DATA REG Status Error occurred.
		0a00	PATH0 Non-Error Status Error occurred.
		0b00	PATH1 Non-Error Status Error occurred.
		0040	CHK3 Error occurred.
	02a1		Memory Test 1.
		0100	MSA Status Error occurred.
		0200	Transfer End Waiting Status Compare Error occurred.
		0300	Non-Error Status Compare Error occurred.
		0400	MSA Status Error occurred.
		0500	Transfer End Waiting Error occurred.
		0600	Non-Error Status Compare Error occurred.
		0040	CHK3 Error occurred.

LSI classification	Test Item	Error Code	Error Contents
SMA	02a2		Memory Test 2.
		0100	Data Compare Error occurred.
		0040	CHK3 Error occurred.
	02a3		Memory Test 3.
		0100	Disconnect Status Compare Error occurred.
		0200	Transfer End Waiting Error occurred.
		0300	Error Status Compare Error occurred.
		0400	MSA Status Error occurred.
		0500	Self Refresh Mode Cancel Check Error occurred.
		0600	Disconnect Finish Check Error occurred.
		0700	Error Status Check Error occurred.
		0040	CHK3 Error occurred.
	02a4		Memory Test 4.
		0100	Read Data Compare Error occurred.
		0200	CHK3 Error occurred.
		0300	Correctable Error occurred.
		0040	CHK3 Error occurred.
		0d00	CHK3 Error occurred.
		0e00	In use SM PCB, the 1024MByte memory module is not supported. Execute the version upgrade of SM PCB.
		0f00	SM module combination error (installing pattern illegality) Refer to the maintenance manual (Installation section), and confirm the installation of the SM module.
	02a5		Memory Test 5.
		0100	Data Read Compare Error occurred. (Write Area)
		0200	Data Read Compare Error occurred. (Initial Area)
		0300	ECC Read Compare Error occurred. (Write Area)
		0400	ECC Read Compare Error occurred. (Initial Area)
		0040	CHK3 Error occurred.
	02b1		Lock Test 1.
		0100	SMA Status Register Compare Error occurred.
		0200	Data Compare Error occurred.
		0300	Data Compare Error occurred.
		0400	Read Status Compare Error occurred.
		0040	CHK3 Error occurred.

LSI classification	Test Item	Error Code	Error Contents
OHUB	0301		Register Test. (Direct Register Test part of PCI/DMA, HSN, HARB.)
		0100	Data Compare Error occurred. (0xb0010300 to 0xb00112d4)
		0200	Data Compare Error occurred. (0xb00103c to 0xb00112d8)
		0040	CHK2 Error occurred.
	0302		Register Test. (Indirect Register Test Part of PCI/DMA.)
		0100	Data Compare Error occurred. (0x00000020 to 0x00001063)
		0200	Data Compare Error occurred. (0x00000050 to 0x0000005f)
		0300	Data Compare Error occurred. (0x00000000 to 0x0000000a)
		0040	CHK2 Error occurred.
	0303		Register Test. (Indirect Register Test part of HSN.)
		0100	Data Compare Error occurred.
		0040	CHK2 Error occurred.
	0304		Register Test. (Indirect Register Test part of HARB.)
		0100	Data Compare Error occurred.
		0040	CHK2 Error occurred.
	0305		Counter Test (Indirect Register Test part of PCI/DMA.)
		0100	Data Compare Error occurred.
		0040	CHK2 Error occurred.
	0306		Counter Test (Indirect Register Test part of HSN.)
		0100	Data Compare Error occurred.
		0040	CHK2 Error occurred.
	0307		DBFLOOP Test.
		0100	Data Compare Error occurred.
		0200	Time Out Error occurred.
		0300	XFS Register Status Error occurred.
		0040	CHK2 Error occurred.

LSI classification	Test Item	Error Code	Error Contents
OHUB	0308		DBF Memory Test.
		0100	Bit ON/OFF Data Compare Error occurred.
		0200	Address Data Compare Error occurred.
		0040	CHK2 Error occurred.
	0309		XBF Memory Test.
		0100	Bit ON/OFF Data Compare Error occurred in Data Block.
		0200	Bit ON/OFF Data Compare Error occurred in Data Block.
		0300	Bit ON/OFF Data Compare Error occurred in Data Block.
		0400	Bit ON/OFF Data Compare Error occurred in Data Block.
		0500	Bit ON/OFF Data Compare Error occurred in Data Block.
		0600	Bit ON/OFF Data Compare Error occurred in Data Block.
		0040	CHK2 Error occurred.
	030a		Forced Error Test.
		0100	Status Compare Error occurred.
		0040	CHK2 Error occurred.
	030b		Impedance Adjustment Quality Judgment Test.
		0101	IMP_DAH DAL Value Base within the scope Error occurred.
		0040	CHK2 Error occurred.

LSI classification	Test Item	Error Code	Error Contents
MPA	0800		MP resources exclusion in PK.
		0100	Exclusion Time Out.
	0801		Register Test Part of occupational MPA.
			Initial default Read Test.
		0100	Error occurred in Initial default Read.
		0200	Data Compare Error occurred.
			Counter Test.
		0300	Count Master Data un-match Error occurred.
			Sequencer Test.
		0400	Data Compare Error occurred.
		0040	CHK1B Error occurred.
	0802		Register Test part of common MPA.
		0500	SCINT_IF Register Initial default Read Test Error occurred.
		0600	SCINT_IF Register Write/Read Test Error occurred.
		0700	SM_IF Register Initial Read Test Error occurred.
		0800	SM_IF Register Write/Read Test Error occurred.
		0040	CHK1B Error occurred.
	0803		GTL Impedance Adjustment Quality Judgment Test.
		0100	GTL Impedance Error occurred.
		0040	CHK1B Error occurred.

LSI classification	Test Item	Error Code	Error Contents
QDTA	0901		Register Test.
		0040	CHK1B Error occurred.
		0100	Data Compare Error occurred.
		0200	Register Reset Error occurred.
	0902		Data/Latch Test.
		0040	CHK1B Error occurred.
		0100	Data Compare Error occurred.
		0200	Register Reset Error occurred.
	0903		Sequencer Test.
		0040	CHK1B Error occurred.
		0100	Data Compare Error occurred.
		0200	Register Reset Error occurred.
	0904		Counter Register Test.
		0040	CHK1B Error occurred.
		0100	Data Compare Error occurred.
		0200	Register Reset Error occurred.
	0905		Inside RAM WRITE/READ Test.
		0040	CHK1B Error occurred.
		0100	Error occurred in Register Read/Write.
		0200	Data Compare Error occurred.
	0907		QDTA→CACHE Data Transfer Test.
		0040	CHK1B Error occurred.
		0100	Error occurred in Register Read/Write.
		0200	Data Compare Error occurred.
	0908		LA Change Test.
		0040	CHK2 Error occurred.
		0100	Error occurred in CACHE Read/Write.
		0200	Data Compare Error occurred.
	0909		GTL Impedance Test.
		0040	CHK1B Error occurred.
	0100	High-order Bit of IMONO Compare Error.	
	0200	Error occurred in Byte Normal Scope Judgment.	

LSI classification	Test Item	Error Code	Error Contents
QDTA	090a		Forced Error Test.
		0040	CHK2 Error occurred.
		0100	Error occurred in CHK2 Forced Error Test.
		0200	Error occurred in CHK1B Forced Error Test.
	090b		Parity Part LA Test.
		0040	CHK2 Error occurred.
		0100	Data Read Error occurred.
	090c		CACHE Transfer Test2.
		0040	CHK1B Error occurred.
		0100	Write/Read Error occurred.
		0200	Write/Read Error occurred.
		0300	Data Compare Error occurred.
		0400	CMA Register Write Error occurred.
	090d		2side command multi Test.
		0040	CHK1B Error occurred.
		0200	Write/Read Error occurred.
		0300	Data Compare Error occurred.
	090e		Forced Error Test2.
		0040	CHK2 Error occurred.
		0100	Data Compare Error occurred.

LSI classification	Test Item	Error Code	Error Contents
CARB	0c01		P Path Test.
		0100	Error occurred in Initial default Read Test.
		0200	Error occurred in Register Read/Write Test.
		0300	Error occurred in Counter/Sequencer Test.
		0040	CHK2 Error occurred.
	0c02		Common Path.
		0100	Error occurred in Initial default Read Test.
		0200	Error occurred in Register Read/Write Test.
		0300	Error occurred in Counter/Sequencer Test.
		0040	CHK2 Error occurred.
	0c03		C0 Path Test.
		0100	Error occurred in Initial default Read Test.
		0200	Error occurred in Register Read/Write Test.
		0300	Error occurred in Counter/Sequencer Test.
		0500	Error occurred in register restoration.
		0040	CHK2 Error occurred.
	0c04		C1 Path Test.
		0100	Error occurred in Initial default Read Test.
		0200	Error occurred in Register Read/Write Test.
		0300	Error occurred in Counter/Sequencer Test.
		0500	Error occurred in register restoration.
		0040	CHK2 Error occurred.
	0c05		C2 Path Test.
		0100	Error occurred in Initial default Read Test.
		0200	Error occurred in Register Read/Write Test.
		0300	Error occurred in Counter/Sequencer Test.
		0500	Error occurred in register restoration.
		0040	CHK2 Error occurred.
	0c06		C3 Path Test.
		0100	Error occurred in Initial default Read Test.
		0200	Error occurred in Register Read/Write Test.
		0300	Error occurred in Counter/Sequencer Test.
		0500	Error occurred in register restoration.
		0040	CHK2 Error occurred.

LSI classification	Test Item	Error Code	Error Contents
CARB	0c07		C4 Path Test.
		0100	Error occurred in Initial default Read Test.
		0200	Error occurred in Register Read/Write Test.
		0300	Error occurred in Counter/Sequencer Test.
		0500	Error occurred in register restoration.
		0040	CHK2 Error occurred.
	0c08		C5 Path Test.
		0100	Error occurred in Initial default Read Test.
		0200	Error occurred in Register Read/Write Test.
		0300	Error occurred in Counter/Sequencer Test.
		0500	Error occurred in register restoration.
		0040	CHK2 Error occurred.
	0c09		C6 Path Test.
		0100	Error occurred in Initial default Read Test.
		0200	Error occurred in Register Read/Write Test.
		0300	Error occurred in Counter/Sequencer Test.
		0500	Error occurred in register restoration.
		0040	CHK2 Error occurred.
	0c0b		C7 Path Test.
		0100	Error occurred in Initial default Read Test.
		0200	Error occurred in Register Read/Write Test.
		0300	Error occurred in Counter/Sequencer Test.
		0500	Error occurred in register restoration.
		0040	CHK2 Error occurred.
	0c0f		Initialze
		0100	REV Register Read Error occurred.
	0c10		GTL Impedance Test.
		0040	CHK2 Error occurred.
		0100	Register Read Error occurred.
		0200	Data Compare Error occurred.

LSI classification	Test Item	Error Code	Error Contents
FCA	0f01		Register Initial default Test.
		0100	Initial default Read un-match Error occurred.
		0200	CHK1 occurred.
		0040	CHK1B Error occurred.
	0f02		Data Register W/R Test.
		0100	Data Compare Error occurred.
		0200	CHK1 occurred.
		0040	CHK1B Error occurred.
	0f03		Slave Register Test.
		0100	Data Compare Error occurred.
		0200	CHK1 occurred.
		0040	CHK1B Error occurred.
	0f04		Counter Test.
		0100	Data Compare Error occurred.
		0200	CHK1 occurred.
		0040	CHK1B Error occurred.
	0f05		Special Register Test.
		0100	Data Compare Error occurred.
		0200	CHK1 occurred.
		0040	CHK1B Error occurred.
	0f06		Inside RAM Test.
		0100	Data Compare Error occurred. (Address match Data)
		0200	CHK1 occurred.
		0300	Data Compare Error occurred. (Fixed Data)
		0400	CHK1 occurred.
		0040	CHK1B Error occurred.
	0f07		Error Latch Test.
		0100	Test case 1 Data Compare Error occurred.
		0200	Test case 2 Data Compare Error occurred.
		0300	Test case 3 Data Compare Error occurred.
		0400	Test case 4 Data Compare Error occurred.
		0040	CHK1B Error occurred.

LSI classification	Test Item	Error Code	Error Contents
FCA	0f08		TL Loop Test.
		0100	Initialization Error occurred.
		0200	Data Compare Error occurred.
		0801	Data Compare Error occurred.
		0802	Data Compare Error occurred.
		0040	CHK1B Error occurred.
	0f09		CHSN Test.
		0100	Data transfer Test Error.
		0010	CM Write Error occurred.
		0020	CM Read Error occurred.
		0030	Data Compare Error occurred.
		0040	CHK1B Error occurred.
	0f0a		PAL Test
		0010	CM Write Error occurred.
		0040	CHK1B Error occurred.
	0f0b		CHSN Test 2
		0010	CM Write Error occurred.
		0020	CM Read Error occurred.
		0030	Data Compare Error occurred.
		0040	CHK1B Error occurred.
	0f0c		Double Write/Read Test.
		0010	CM Write Error occurred.
		0020	CM Read Error occurred.(SLV0)
		0021	CM Read Error occurred.(SLV1)
		0030	Data Compare Error occurred.(SLV0)
		0031	Data Compare Error occurred.(SLV1)
		0040	CHK1B Error occurred.
	0f0d		LDEV FMT Test.
		0020	CM Read Error occurred.
		0030	Data Compare Error occurred.
		0040	CHK1B Error occurred.
	0f0e		BITMAP Test.
		0010	CM FMT Write Error occurred.
		0011	CM BITMAP Write Error occurred.
		0020	CM Read Error occurred.
		0030	Data Compare Error occurred.
		0040	CHK1B Error occurred.

LSI classification	Test Item	Error Code	Error Contents
FCA	0f0f		MRCF Test
		0010	CM Write Error occurred.
		0020	CM Read Error occurred.
		0030	Data Compare Error occurred.
		0040	CHK1B Error occurred.
	0f10		Data Register W/R Test 2.
		0100	Data Compare Error occurred.
		0200	CHK1 occurred.
		0040	CHK1B Error occurred.
	0f11		Data Register W/R Test 3.
		0100	Data un-match Error occurred.
		0200	CHK1 occurred.
		0040	CHK1B Error occurred.
	0f12		Inside RAM Test 2.
		0100	Data Compare Error in H side.
		0200	CHK1 occurred.
		0040	CHK1B Error occurred.
	0f13		Inside RAM Test 3.
		0100	Word Access Data Compare Error occurred.
		0200	Short Access Data Compare Error occurred.
		0300	Byte Access Data Compare Error occurred.
		0040	CHK1B Error occurred.
	0f14		Slave Register Test 2.
		0100	Data Compare Error occurred.
		0200	CHK1 occurred.
		0040	CHK1B Error occurred.
	0f15		LED Register Test.
		0100	Read Compare Error occurred.
		0200	CHK1 Status Error occurred.
		0300	CHK1 Status Error occurred. (End)
		0040	CHK1B Error occurred.

LSI classification	Test Item	Error Code	Error Contents
FCA	0f16		REQIN Test.
		0010	CM Write Error occurred.
		0020	CM Read Error occurred.
		0030	Data Compare Error occurred.
		0040	CHK1B Error occurred.
	0f17		PARITY Transfer Test.
		0010	CM Write Error occurred.
		0020	CM Read Error occurred.
		0030	Data Compare Error occurred.
		0040	CHK1B Error occurred.
	0f18		DRIVE Micro Transfer Test.
		0010	CM Write Error occurred.
		0020	CM Read Error occurred.
		0030	Data Compare Error occurred.
		0040	CHK1B Error occurred.
	0f19		Preread Transfer Test.
		0010	CM Write Error occurred.
		0020	CM Read Error occurred.
		0030	Data Compare Error occurred.
		0040	CHK1B Error occurred.

LSI classification	Test Item	Error Code	Error Contents
ESA	1001		Initial default Test.
		0040	CHK1 Error occurred.
		0100	Data Compare Error occurred.
		0200	CHK1 Error occurred.
	1002		Register W/R Test.
		0040	CHK1 Error occurred.
		0100	Data Compare Error occurred.
		0200	CHK1 Error occurred.
	1003		Memory Data Bus Bit Test 1.
		0040	CHK1 Error occurred.
		0100	Data Compare Error occurred.
		0200	CHK1 Error occurred.
	1004		Memory Data Bus Bit Test 2.
		0040	CHK1 Error occurred.
		0100	Data Compare Error occurred.
		0200	CHK1 Error occurred.
	1005		Memory Address Test 1.
		0040	CHK1 Error occurred.
		0100	Data Compare Error occurred.
		0200	Data Compare Error occurred.
		0300	CHK1 Error occurred.
	1006		Memory Address Test 2.
		0040	CHK1 Error occurred.
		0100	CHK1 Error occurred.
		0200	Data Compare Error occurred.
		0300	CHK1 Error occurred.
		0400	Data Compare Error occurred.
		0500	CHK1 Error occurred.
1007		Data Transfer in P/K Test 1.	
	0040	CHK1 Error occurred.	
	0100	CHK2 Error occurred.	
	0200	Data Compare Error occurred.	

LSI classification	Test Item	Error Code	Error Contents
ESA	1008		Data Transfer in P/K Test 2.
		0040	CHK1 Error occurred.
		0100	CHK2 Error occurred.
		0200	CHK2 Error occurred.
		0300	Data Compare Error occurred.
	1009		Forced Error CHK2 Test.
		0040	CHK1 Error occurred.
		0100	CHK2 Error occurred.
	100a		Forced Error CHK1 Test.
		0040	CHK1 Error occurred.
		0100	CHK1 Error occurred.
		0200	Data Compare Error occurred.
		0300	CHK1 Error occurred.
		0400	Data Compare Error occurred.
	100b		Impedance Test.
		0040	CHK1 Error occurred.
		0100	CHK1 Error occurred.
		0200	Data Compare Error occurred.

LSI classification	Test Item	Error Code	Error Contents
Common			Main
	0000	0000	Machine Constitution data acquisition function error occurred.
	0005	0000	BSA LSI Resource acquisition error occurred.
	0006	0000	No Valid CHSN.
	0007	0000	No Machine Constitution data CMG.
	0008	0000	No Machine Constitution data CMG.
	0009	0000	CARB Register Initialize error occurred.
	000a	0000	CMA Register Initialize error occurred.
	000b	0000	SVP Parameter Error.
	0127	0000	Cache Register Initialize error occurred.

LSI classification	Test Item	Error Code	Error Contents
MHUB	1301		Initial default Test.
		0000	CHK1 Error occurred.
		0100	Data Compare Error occurred.
		0200	CHK1 Error occurred.
		ff00	CHK1 Error occurred.
	1302		Register W/R Test.
		0000	CHK1 Error occurred.
		0100	Data Compare Error occurred.
		ff00	CHK1 Error occurred.
	1303		Memory Data Bus Bit Test 1.
		0000	CHK1 Error occurred.
		0100	Data Compare Error occurred.
		0200	CHK1 Error occurred.
		0300	Data Compare Error occurred.
		0400	CHK1 Error occurred.
		ff00	CHK1 Error occurred.
	1304		Memory Data Bus Bit Test 2.
		0000	CHK1 Error occurred.
		0100	Data Compare Error occurred.
		0200	CHK1 Error occurred.
		0300	Data Compare Error occurred.
		0400	CHK1 Error occurred.
		ff00	CHK1 Error occurred.
	1305		Memory Address Test 1.
		0000	CHK1 Error occurred.
		0100	Data Compare Error occurred.
		0200	Data Compare Error occurred.
		0300	Data Compare Error occurred.
		0400	CHK1 Error occurred.
		ff00	CHK1 Error occurred.

LSI classification	Test Item	Error Code	Error Contents
MHUB	1306		Memory Address Test 2.
		0000	CHK1 Error occurred.
		0100	CHK1 Error occurred.
		0200	Data Compare Error occurred.
		0300	CHK1 Error occurred.
		0400	Data Compare Error occurred.
		0500	CHK1 Error occurred.
		0600	Data Compare Error occurred.
		0700	CHK1 Error occurred.
		ff00	CHK1 Error occurred.
	1307		Outside Memory Data Bus Bit Test
		0000	CHK1 Error occurred.
		0100	CHK2 Error occurred.
		0200	CHK2 Error occurred.
		0300	Data Compare Error occurred.
		ff00	CHK1 Error occurred.
	1308		Outside Memory Address Test 1.
		0000	CHK1 Error occurred.
		0100	CHK2 Error occurred.
		0200	CHK2 Error occurred.
		0300	Data Compare Error occurred.
		ff00	CHK1 Error occurred.
	130a		Forced Error CHK2 Test.
		0000	CHK1 Error occurred.
		0100	CHK2 Error occurred.
		ff00	CHK1 Error occurred.
	130b		Forced Error CHK1 Test.
		0000	CHK1 Error occurred.
		0100	CHK1 Error Not occurred.
		0200	Data Compare Error occurred.
		0300	CHK1 Error Not occurred.
		0400	Data Compare Error occurred.
		ff00	CHK1 Error occurred.

LSI classification	Test Item	Error Code	Error Contents
MHUB	130c		GTL Impedance Test.
		0000	CHK1 Error occurred.
		0100	Except a regulation value Error occurred.
		0200	Poring TimeOut Error occurred.
		ff00	CHK1 Error occurred.
	130d		Forced Error Test.
		0000	CHK1 Error occurred.
		0100	Data Compare Error occurred.
		0200	Data Compare Error occurred.
		0300	Data Compare Error occurred.
		0400	Data Compare Error occurred.
		0500	Data Compare Error occurred.
		0600	Data Compare Error occurred.
		ff00	CHK1 Error occurred.
	1311		Data Transfer Test(DXBF → CBF) in P/K.
		0000	CHK1 Error occurred.
		0100	CHK2 Error occurred.
		0200	CHK2 Error occurred.
		0300	Data Compare Error occurred.
		ff00	CHK1 Error occurred.
	1312		Data Transfer Test(DXBF → WRBF) in P/K.
		0000	CHK1 Error occurred.
		0100	CHK2 Error occurred.
		0200	CHK2 Error occurred.
		0300	Data Compare Error occurred.
		ff00	CHK1 Error occurred.
	1313		Data Transfer Test(RDBF → CBF) in P/K.
		0000	CHK1 Error occurred.
		0100	CHK2 Error occurred.
		0200	CHK2 Error occurred.
		0300	Data Compare Error occurred.
		ff00	CHK1 Error occurred.

LSI classification	Test Item	Error Code	Error Contents
MHUB	1314		Data Transfer Test(RDBF → DXBF) in P/K.
		0000	CHK1 Error occurred.
		0100	CHK2 Error occurred.
		0200	CHK2 Error occurred.
		0400	CHK2 Error occurred.
		0500	Data Compare Error occurred.
		ff00	CHK1 Error occurred.
	1315		Search Test 1(DXBF → SCH ← RDBF)
		0000	CHK1 Error occurred.
		0100	CHK2 Error occurred.
		0200	CHK2 Error occurred.
		0300	CHK2 Error occurred.
		0400	Data Compare Error occurred.
		ff00	CHK1 Error occurred.
	1316		Search Test 2 (DXBF → SCH ← CBF)
		0000	CHK1 Error occurred.
		0100	CHK2 Error occurred.
		0200	CHK2 Error occurred.
		0300	Data Compare Error occurred.
		ff00	CHK1 Error occurred.
	1317		Data Truncation Test(RDBF → DXBF) in P/K.
		0000	CHK1 Error occurred.
		0100	CHK2 Error occurred.
		0200	CHK2 Error occurred.
		0300	CHK2 Error occurred.
		0400	Truncation Error Not occurred.
		0500	CHK2 Error occurred.
		0600	Data Compare Error occurred.
		ff00	CHK1 Error occurred.
	1318		Data Truncation Test(DXBF → CBF) in P/K.
		0000	CHK1 Error occurred.
		0100	CHK2 Error occurred.
		0200	CHK2 Error occurred.
		0300	Truncation Error Not occurred.
		0400	Data Compare Error occurred.
		ff00	CHK1 Error occurred.

LSI classification	Test Item	Error Code	Error Contents
MHUB	1319		IO Short Test(CBF → DXBF) in P/K.
		0000	CHK1 Error occurred.
		0100	CHK2 Error occurred.
		0200	Truncation Error Not occurred.
		0300	CHK2 Error occurred.
		0400	Data Compare Error occurred.
		ff00	CHK1 Error occurred.
	131a		IO Short Test(DXBF → CBF) in P/K.
		0000	CHK1 Error occurred.
		0100	CHK2 Error occurred.
		0200	CHK2 Error occurred.
		0300	IO Short Error Not occurred.
		0400	Data Compare Error occurred.
		ff00	CHK1 Error occurred.
	131b		Data Chain Test(DXBF → CBF) in P/K.
		0000	CHK1 Error occurred.
		0100	CHK2 Error occurred.
		0200	CHK2 Error occurred.
		0300	CHK2 Error occurred.
		0400	CHK2 Error occurred.
		0500	CHK2 Error occurred.
		0600	Truncation Error Not occurred.
		0700	CHK2 Error occurred.
		0800	Truncation Error Not occurred.
		0900	Data Compare Error occurred.
		0a00	Data Compare Error occurred.
		ff00	CHK1 Error occurred.

LSI classification	Test Item	Error Code	Error Contents
MHUB	131c		Data Chain Test(CBF → DXBF) in P/K.
		0000	CHK1 Error occurred.
		0100	CHK2 Error occurred.
		0200	CHK2 Error occurred.
		0300	CHK2 Error occurred.
		0400	CHK2 Error occurred.
		0500	CHK2 Error occurred.
		0600	Truncation Error Not occurred.
		0700	CHK2 Error occurred.
		0800	Truncation Error Not occurred.
		0900	CHK2 Error occurred.
		0a00	Data Compare Error occurred.
		0b00	Data Compare Error occurred.
		ff00	CHK1 Error occurred.

LSI classification	Test Item	Error Code	Error Contents
ISP4010	1601		LM ↔ ISP ↔ DXBF data transfer diagnosis.
		00a0	CHK1B/CHK2/CHK3 Error detected.
		0602	IOCB data transfer Write—Timeout Error occurred.
		0607	IOCB data transfer Write—IOCB End Check Error detected.
		0702	IOCB data transfer Read—Timeout Error occurred.
		0707	IOCB data transfer Read—IOCB End Check Error detected.
		08a1	CHK1B Error detected.
		08a2	CHK2AB Error detected.
		08a3	CHK2CD Error detected.
		0908	Transfer Data Compare Error occurred.
		c0c0	iCRC Write default/Read default compare Error.
		c0c1	iCRC Write/Read Part Error Check Error detected.
	1602		LM ↔ ISP ↔ LM data transfer diagnosis.
		00a0	CHK1B/CHK2/CHK3 Error detected.
		0602	IOCB data transfer Write—Timeout Error occurred.
		0607	IOCB data transfer Write—IOCB End Check Error detected.
		08a1	CHK1B Error detected.
		08a2	CHK2AB Error detected.
		08a3	CHK2CD Error detected.
		0908	Transfer Data Compare Error occurred.
	1603		Mailbox Command diagnosis.
		00a0	CHK1B/CHK2/CHK3 Error detected.
		2002	Test Local RAM Size Command—Mailbox Command Execution Timeout Error occurred.
		2005	Test Local RAM Size Command—Mailbox Command Status Error occurred.
		2102	Test Local RAM Read/Write Command—Mailbox Command Execution Timeout Error occurred.
		2105	Test Local RAM Read/Write Command—Mailbox Command Status Error occurred.
		2109	Test Local RAM Read/Write Command—Bit Error detected.
		2202	Test RISC RAM Command—Mailbox Command Execution Timeout Error occurred.
		2205	Test RISC RAM Command—Mailbox Command Status Error occurred.
		2302	Test Network Internal Loopback Command—Mailbox Command Execution Timeout Error occurred.
		2305	Test Network Internal Loopback Command—Mailbox Command Status Error occurred.

LSI classification	Test Item	Error Code	Error Contents
ISP4010	1603		
		2402	Test Network External Loopback Command—Mailbox Command Execution Timeout Error occurred.
		2405	Test Network External Loopback Command—Mailbox Command Status Error occurred.
		2602	Test DMA Transfer Command—Mailbox Command Execution Timeout Error occurred.
		2605	Test DMA Transfer Command—Mailbox Command Status Error occurred.
		2702	No Operation Command—Mailbox Command Execution Timeout Error occurred.
		2705	No Operation Command—Mailbox Command Status Error occurred.
		2802	Mailbox Register Test Command—Mailbox Command Execution Timeout Error occurred.
		2805	Mailbox Register Test Command—Mailbox Command Status Error occurred.
		2808	Mailbox Register Test Command—Register Test Data Compare Error occurred.
		2902	About Firmware Command—Mailbox Command Execution Timeout Error occurred.
		2905	About Firmware Command—Mailbox Command Status Error occurred.
		4102	Write Flash ROM Command—Mailbox Command Execution Timeout Error occurred.
		4105	Write Flash ROM Command—Mailbox Command Status Error occurred.
		4602	Initialize Firmware Command—Mailbox Command Execution Timeout Error occurred.
		4605	Initialize Firmware Command—Mailbox Command Status Error occurred.
		4902	Set Device Database Entry Command—Mailbox Command Execution Timeout Error occurred.
		4905	Set Device Database Entry Command—Mailbox Command Status Error occurred.
		4906	Set Device Database Entry Command—Asynchronous Event Error occurred.
		6002	Execute Firmware Command—Mailbox Command Execution Timeout Error occurred.
		6005	Execute Firmware Command—Mailbox Command Status Error occurred.

LSI classification	Test Item	Error Code	Error Contents
ISP4010	1603		
		92a1	ISP Configuration Register setting—CHK1B Error detected.
		92a2	ISP Configuration Register setting—CHK2AB Error detected.
		92a3	ISP Configuration Register setting—CHK2CD Error detected.
		93a1	ISP Soft reset—CHK1B Error detected.
		93a2	ISP Soft reset—CHK2AB Error detected.
		93a3	ISP Soft reset—CHK2CD Error detected.
		93e0	ISP Initialize—TX Output Error occurred.
		9402	ISP Boot—Timeout Error occurred.
		94a1	ISP Soft reset—CHK1B Error detected.
		94a2	ISP Soft reset—CHK2AB Error detected.
		94a3	ISP Soft reset—CHK2CD Error detected.
		9502	ISP Soft reset—Timeout Error detected.
		95a1	ISP Soft reset—CHK1B Error detected.
		95a2	ISP Soft reset—CHK2AB Error detected.
		95a3	ISP Soft reset—CHK2CD Error detected.
		9708	Test DMA Transfer Command—Transfer Data Compare Error occurred.
		f402	NVRAM MAC Address ISP—FM Write Timeout Error occurred.
		f4f3	NVRAM SUM Check Error occurred.
		f4f6	NVRAM MAC Address Default Error.
		f4f7	NVRAM MAC Address ISP—FM Write Error occurred.
		f4f8	NVRAM MAC Address ISP—FM Write failed.