

MICRO-FC SECTION

REV.0	Jun.2001					
-------	----------	--	--	--	--	--

Contents

1 Overview.....	MICRO-FC01-10
1.1 Micro-program Types	MICRO-FC01-10
1.2 Micro-program Exchange Flow.....	MICRO-FC01-20
1.3 Micro-program Exchange	MICRO-FC01-30
2 Micro-program substitution in the SVP	MICRO-FC02-10
3 Micro-program Exchange Procedure (Off-line).....	MICRO-FC03-10
3.1 Processing before exchange	MICRO-FC03-10
3.2 Storing the micro-programs to be substituted in the SVP.....	MICRO-FC03-20
3.3 Transferring micro-programs to the DKC.....	MICRO-FC03-250
3.4 Hard Disk Download.....	MICRO-FC03-270
3.5 Version Down	MICRO-FC03-290
3.6 FTP	MICRO-FC03-310
3.7 Checking the functions after exchange	MICRO-FC03-330
4 Micro-program Exchange Procedure (On-line).....	MICRO-FC04-10
4.1 Processing before exchange	MICRO-FC04-10
4.2 Storing the micro-programs to be substituted in the SVP.....	MICRO-FC04-20
4.3 Transferring micro-programs	MICRO-FC04-100
4.3.1 Transferring micro-programs to the DKC/DKU	MICRO-FC04-100
4.3.2 Transferring micro-programs to SVP/SSVP	MICRO-FC04-140
4.4 Hard Disk Download.....	MICRO-FC04-160
4.5 Version Down	MICRO-FC04-170
4.6 FTP	MICRO-FC04-190
4.7 Checking the functions after exchange	MICRO-FC04-200
5 MP Install.....	MICRO-FC05-10
5.1 Over view.....	MICRO-FC05-10
5.2 MP Install.....	MICRO-FC05-20
6 LCP Patch	MICRO-FC06-10
6.1 Methods of entering a patch file	MICRO-FC06-10
6.1.1 Entering the patch file from the SVP by using a patch editor	MICRO-FC06-10
6.2 Methods of sending a patch file.....	MICRO-FC06-60
6.2.1 Rewriting LCP itself	MICRO-FC06-60
6.2.2 Including the patch into a load module and update FM.....	MICRO-FC06-90
7 Trouble Recovery Procedure in Exchanging Micro-programs	MICRO-FC07-10
7.1 Recovery procedure in on-line menu was selected	MICRO-FC07-10
7.2 Recovery procedure in off-line menu was selected	MICRO-FC07-100

8 Config Exchange Procedure.....MICRO-FC08-10

8.1 Config Version UpMICRO-FC08-10

8.2 Config BackupMICRO-FC08-40

8.3 Define Configuration & InstallMICRO-FC08-60

8.4 Manual version up processing.....MICRO-FC08-80

MICRO-FC

Two types of MICRO-FCs are provided with micro-program exchange and on-line patch. Micro-program exchange is explained in chapter 1 to 5.4, and on-line patch in chapter 5.

1 Overview

1.1 Micro-program Types

The micro-programs listed below can be exchanged via the SVP. Therefore, the exchange of micro-programs requires operational knowledge of the SVP.

Micro-program	Written to
Setup installer	—
DKCMAIN	FM
MAIN DIFF	FM
SVP	Hard disk in the SVP
LCP/LCDG	FM
HTP/FCDG	FM
CUDG4	Hard disk in the SVP
DKU	HDU
SSVP	FM
RAM BOOT	FM
CONFIG	Hard disk in the SVP

1.2 Micro-program Exchange Flow

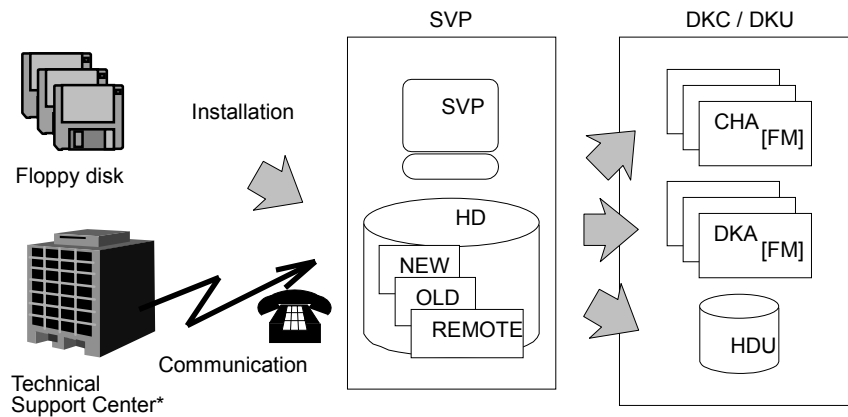

The SVP keeps two generations (new and old versions) of micro-programs.

* Technical Support Center : A base of maintenance service and technical support

Micro-programs can be exchanged in four ways.

- (1) Downloading after storing the micro-programs from CD-ROM or floppy disk to the hard disk
- (2) Downloading of the latest versions on the hard disk in the SVP
- (3) Remote (downloading of the micro-programs transferred from the maintenance center)
- (4) Version Down (downloading of old versions on the hard disk)

1.3 Micro-program Exchange

Micro-programs can be exchanged off-line or on-line.

(1) Off-line

All processors are blocked for maintenance. → Micro-programs are rewritten. → All processors are recovered. → The DKC is turned off then on again.

(2) On-line

The processor is blocked for maintenance. → Micro-programs are rewritten. → The processor is recovered.

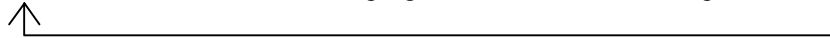

This is performed for each exchanging unit.

Note:

- The SVP checks the version of the micro-program to be substituted before rewriting it. When the SVP determines that the micro-program cannot be rewritten, it displays an error message and cancels the exchange of the micro-program.
- The SVP terminates the exchange of micro-programs when the error status is displayed (i.e. when a message “ error ” or “ failed ” is displayed) or when the [Cancel] button is selected.

If you want to retry the exchange, please start from the first step of the MICRO-FC procedure.

However, when the error status is displayed in downloading from SVP to DKC (FM) or DKU by 3.3 Transferring micro-program to the DKC or by 5.4.3 Transferring micro-program, you can retry by 3.4 Hard Disk Download or by 4.4 Hard Disk Download.

 **CAUTION**

In case of HMRCF/HOMRCF, Differential bit map data on shared memory of DKC is lost by offline micro exchange operation.

To avoid loss of differential bit map, online micro exchange should be used.

2 Micro-program substitution in the SVP

We remove replace procedure of PC from SVP section to Replace section, Because the procedure is held right after replacing PC.

3 Micro-program Exchange Procedure (Off-line)

If an error occurs during a micro-program exchange, retry the exchanging procedure from the beginning.

3.1 Processing before exchange

- Check the subsystem status through the entire status display. (Check the versions of the all programs through the version display.)
- Make sure that collection copy and other processing are not in progress.)
- Perform postprocessing for PIN data.
- Check that all processors are normal.
- Check that all CHL pass to the subsystem are off-line (to block all micro-programs).
- LCP, LCDG, HTP, FCDG, DKCMAIN, MAIN DIFF, and RAMBOOT micro-programs can be exchanged on off-line.
- In the case of HRC Asynchronous components, suspending all volume pairs is required prior to the **RCU's** off-line micro-program exchange. Refer to 3.17.8.1 Managing HRC Asynchronous Subsystems (5) Micro-program Exchange: [THEORY03-1470](#).
- In the case of existing relationship of ShadowImage-FlashCopy(R)option and performing off-line micro-program exchange operation, it is necessary to follow the procedure of THEORY OF OPERATION SECTION”3.14.8 Micro-program Exchange (1) Off-line Micro-program Exchange”.

Off-line Micro-program Exchange time (approximate)

(unit : minutes)

	CD-ROM → HDD		Downloading
LCP	3	CHA	2
LCDG			
HTP			
FCDG		DKA	2
DKCMAIN			
MAIN DIFF			
RAMBOOT			
TOTAL	3	Reboot	3
		TOTAL	7

Note: After you execute this operation, DKC will clear the condition that DKC reports SIM to the host. Therefore, DKC will report the next SIM to the host when the host accesses 16K I/O, and after you wait for an hour if P/S on is executed.

3.2 Storing the micro-programs to be substituted in the SVP

(1) <Initial screen>

(2) Change the mode to [Modify Mode] (CL).
Select (CL) [Install].

(3) In the 'Install' window, select (CL) [Micro Program Install].

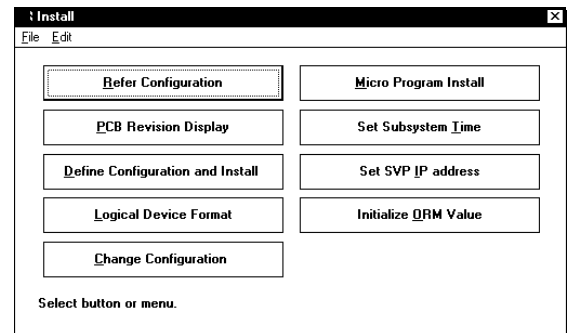

- (4) Select (CL) [Micro Program] and select (CL) [OK].

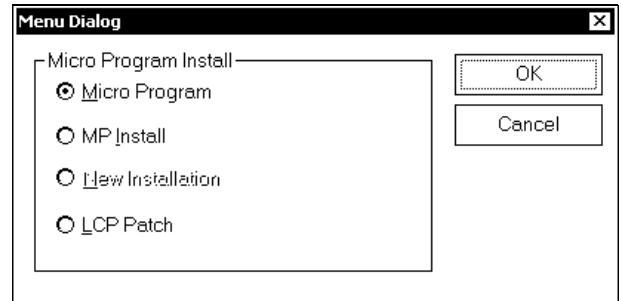

- (5) In the 'Setup Microprogram' dialog box,
 [How]: select (CL) [Offline].
 [From]: select (CL) the source from which to store the micro-programs.

CD-ROM: After being stored on the hard disk from CD-ROM, the micro-programs are downloaded. --- Select(CL) [OK] and Go to (6).

Hard Disk: The latest versions on the SVP hard disk are downloaded.--- Go to 3.4 (1). ([MICRO-FC03-270](#))

Floppy Disk: After being stored on the hard disk from floppy disks, the micro-programs are downloaded. --- Select(CL) [OK] and Go to (6).

Version Down: Old versions on the hard disk are downloaded. --- Go to 3.5 (1). ([MICRO-FC03-290](#))

Ftp: After being stored on the hard disk by FTP transfer, the micro-programs are downloaded. --- Select (CL) [OK] and Go to 3.6 (1)

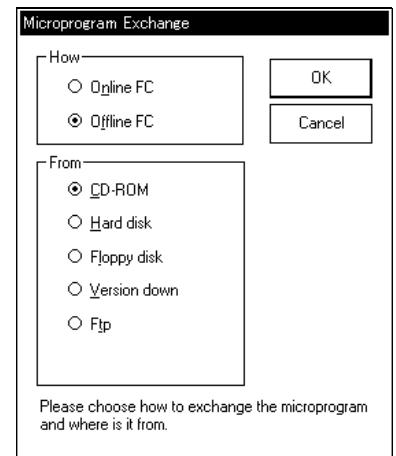

Selecting (CL) [Cancel] returns you to be step (4).

- (6) If you want to continue this process, select (CL) [OK] and enter the password, and select (CL) [OK].

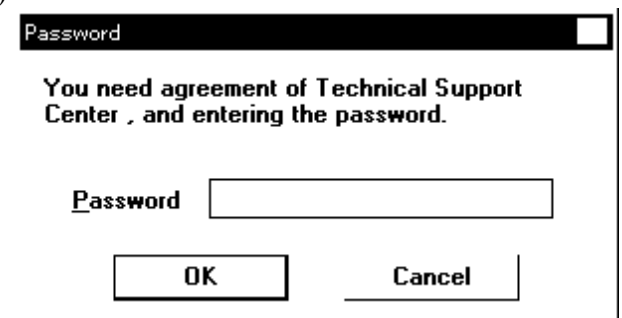

- (7) The 'Micro-program Exchange' dialog box appears.
Select (CL) one or more items from the list of the type of micro-programs, and select (CL) [OK].

: Micro-programs to be substituted.

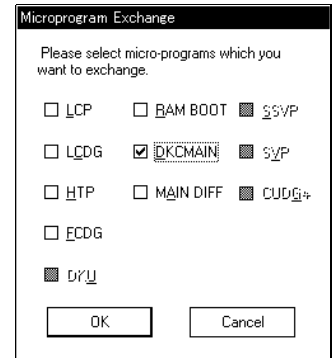

One of messages are displayed by the subsystem configuration.

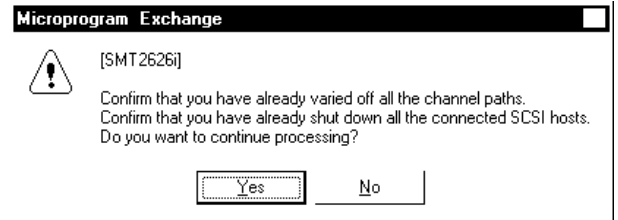
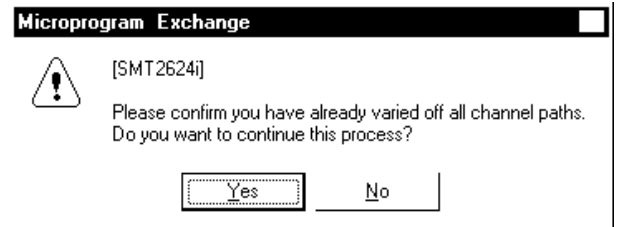
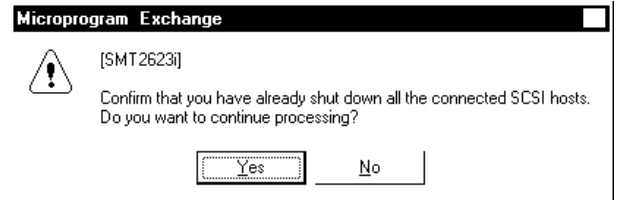

After you confirm that you have already varied all the CHL paths to off-line, select (CL) [Yes].

- (8) If you select CD-ROM, a dialog “Insert CD-ROM in CD-ROM DRIVE” appears. Insert the CD-ROM and select (CL) [OK].

If you select floppy disk, in response to the message “Insert No.n FD of DKCMAIN in FDD”, remove the inserted floppy disk and insert the appropriate floppy disk and select (CL) [OK].

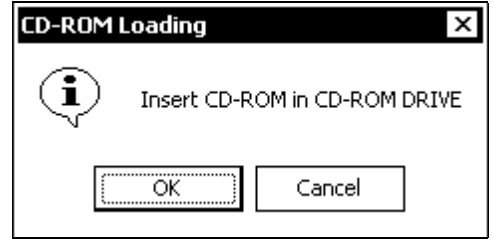

<<Error>>

No CD-ROM or no floppy disk or uncorrect CD-ROM or uncorrect floppy disk in the disk drive:

The same message is displayed again, returning you to (8).

Internal error:

- “Old files erase failed, copy stop.”
- “Memory error has occurred.”
- “File I/O error has occurred.”
- “Logical error has occurred.”
- “The directory create error and copy stop.”
- “The file size is Wrong and copy stop.”

- (9) If you select CD-ROM, the message “Copying CD-ROM files to HD DKCMAIN” appears. If you select floppy disk, the message “Copying FD files to HD DKCMAIN” appears. Execute the steps (8) to (9) once for each floppy disk.

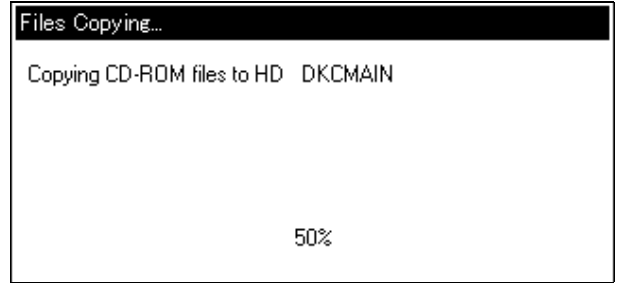

<<Error>>

Internal error:

- “The file size is Wrong and copy stop.”
- “The directory create error and copy stop.”
- “Micro-program version disagreement and copy stop.”
- “Logical error has occurred.”
- “File I/O error has occurred.”
- “Memory error has occurred.”

Note : When the error message “File I/O error has occurred.” or “Memory error has occurred.” is displayed, power SVP off and on again if the same message appears after reexecuting the micro-program exchange (see [SVP01-50](#) in the SVP SECTION). Then execute the same micro-program exchange again. If the same error occurs (the same error message is displayed), replace SVP hardware (see [REP01-170](#) in the REPLACE SECTION).

- (10) If you select CD-ROM, a dialog “Remove CD-ROM” appears. Remove the CD-ROM and select (CL) [OK]. If you select floppy disk, upon completion of reading from all floppy disks, the message “Remove FD” appears. In response to this message, remove the floppy disk and select (CL) [OK].

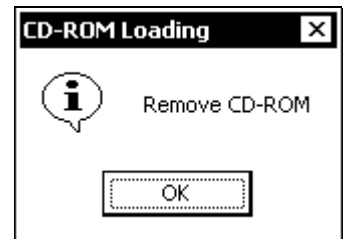

After copy end, sum checker starts. While checking, the message appears.



(11) On the 'Software Maintenance' dialog box, the micro-program types, current versions, new versions, and message are displayed.

<Display with no error>

The message “Confirm the following configuration list.” is displayed below the title bar. The micro-program can be replaced only when all rows in the information column show “OK”, “Not change” or “Warning”.

To make processing progress, select (CL) [OK].

To terminate micro-program replacement, select (CL) [Cancel].

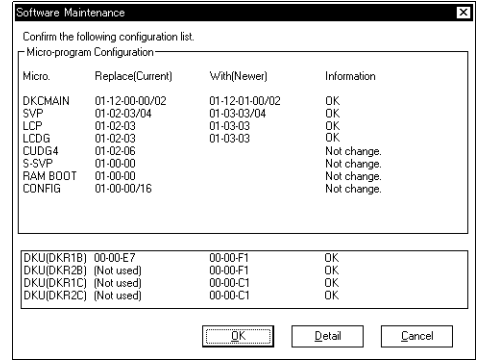

CAUTION

If “Warning” is displayed. Refrain from selecting (CL) “OK” or “Cancel”. Select (CL) “Detail” surely. Confirm the contents and ask the technical support center for decision for selecting “OK” or “Cancel” according to the contents. To make processing progress, select (CL) [OK], input the password and select (CL) [OK]. Password is needed for this operation. Please call Technical Support Center to obtain password and authorization.

<Display with an error>

A sample display at occurrence of an error is shown on the right. An error message is displayed below the title bar. At the same time, error information is displayed in the information column.

Select (CL) [Cancel] to terminate micro-program replacement. (Note: The [OK] button is not displayed.)
 Select (CL) [Detail] to display detailed error information.

Before making an attempt to rerun, be sure to correct the cause of the error by referring to the entire status (SVP SECTION), action code (ACC SECTION), and other information.

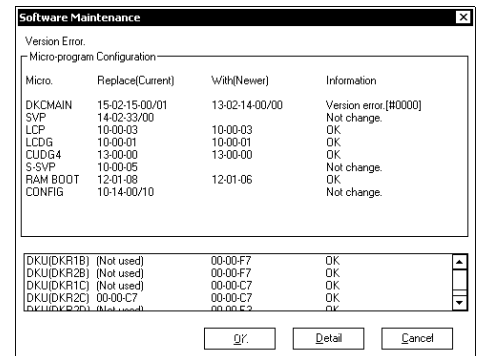

Below are messages and information that may be displayed in the Information column.

Note: Select (CL) [Detail] to display detailed error information, and confirm the cause of these errors.

- “Version error”
- “Revision error”
- Warning”
- “Can’t read the configuration of the micro-program.”
- “Warning” (Function bit map error)

Version Check Message Table.

	Message :	Contents and Maintenance
1	Confirm the following configuration list.	Check the version (Normal or Warning). If Warning, it is necessary to be approved by TSC (Technical Support Center).
2	Version error.	Incorrect version. Confirm the micro-program version.
3	Can't read the configuration of the micro-program.	Error caused while the micro-program configuration is being read. Recover the blockade of a concerned processor.
4	Internal error. (On SVP Logic)	Inconsistent logic. (SVP logic) Retry exchange. If the same message is displayed, power SVP off and on.
5	Internal error. (On SVP Memory)	Inconsistent logic. (SVP memory) Retry exchange. If the same message is displayed, power SVP off and on.
6	Internal error. (On Temporary Files)	Inconsistent logic. (temporary file) Retry exchange. If the same message is displayed, power SVP off and on.
7	Version error. (Previous maintenance needed)	Incorrect version. (partial replacement) Confirm the micro-program version.
8	Version error. (Incompatible MP exists)	Incorrect version. (partial replacement) Confirm the micro-program version.
9	Sum Check error.	Sum check code is incorrect. Micro-program data in FD isn't correct. Exchange the FD.
10	Revision error	Incorrect revision. Confirm the micro-program revision.
11	The micro-program is incompatible with the system.	Incorrect micro-program. Confirm the micro-program version and system. Contact TSC (Technical Support Center).
12	Combination error	Incorrect micro-program exchange process. Confirm the combination of micro-program version and the exchange process.

	Information	Contents
1	OK	The micro-program is replaceable.
2	Version error [#xxxx]	MP has an incorrect micro-program version. [processor number]
3	FC Condition [#xxxx]	MP has an incorrect micro-program version with partial replacement. [processor number]
4	Internal error [#xxxx]	Inconsistent logic error has occurred. [internal error code]
5	Not change	The micro-program will not be replaced.
6	Read error	An error has occurred while reading the current configuration.
7	Sum Check error	The sum check code is incorrect.
8	Warning	It is necessary to contact TSC (Technical support center) for approval.
9	Revision error	MP has an incorrect micro-program revision.
10	Package condition	The combination error of micro-program and package has occurred.
11	Facility condition [#xxxx]	MP has an incorrect micro-program version with function of system. [Facility condition error code]
12	Combination error [#xxxx]	The combination error of more than two micro-programs has occurred. [Combination error code]

	Internal error code	Contents
1	0001	Parameter error.
2	0002, 0003	Memory allocation error.
3	0005	File I/O error.

	Combination error code	Contents
1	8000	High Speed Adapter error
2	8001	Compressed LCDG error

	Facility condition error code	Contents
1	C000 ~ C011	Reserve
2	C012	Compressed DKCMAIN error

Function Bit Map Table			
Bit Pattern	Function	Contents	Action (*1)
0100 0000	HMRCF/HRC/ HIHSM effective flag setting function	HMRCF/HRC/HIHS M effective flag setting functional support without SM capacity change	An error message is not displayed for this function.
0010 0000	Extended Copy Manager	Extended Copy Manager Support	Please stop the E-COPY commands and remove E-COPY Group. (The backup process send the E- COPY commands)
0000 1000 0000	OracleData Check Sum	Oracle Check Sum Support	Please perform again after deleting "DB Check Sum Enabler" Program Product.
0000 0100 0000	HMRCF	ShadowImage- FlashCopy (R) Option support	Please delete all HMRCF pairs and retry again.

Function Bit Map Table			
Bit Pattern	Function	Contents	Action (*1)
0000 0010 0000	HRC, HORC	Fibre HRC/HORC Performance Function Support. Escon HRC Support.	Please Suspend or delete all Fibre HRC/HORC Pairs, and delete all Escon HRC/HORC RCUs, Pairs and CT Groups. And then retry exchange again.
0000 0000 1000 0000	DB Validation Enabler	DB Validation Enabler Function Support	Please deinstall DB Validation Enabler P.P. Key.
0000 0100 0000 0000 0000 0000 0000 0000 0000 0000 0000 0000 0000 0000 0000 0000 0000	CMG ONDEMAND	CMG ONDEMAND support	De-Install Ondemand Cache Memory Modules. And retry.

(*1) If SVP displayed an error message as 2179 during microcode exchange, please check which function is detected by this message, and do the corresponding action. After , please retry exchanging.

Blank Sheet

REV.0	Jun.2001					
-------	----------	--	--	--	--	--

Blank Sheet

REV.0	Jun.2001					
-------	----------	--	--	--	--	--

Blank Sheet

REV.0	Jun.2001					
-------	----------	--	--	--	--	--

Blank Sheet

REV.0	Jun.2001					
-------	----------	--	--	--	--	--

Blank Sheet

REV.0	Jun.2001					
-------	----------	--	--	--	--	--

Blank Sheet

REV.0	Jun.2001						
-------	----------	--	--	--	--	--	--

Blank Sheet

REV.0	Jun.2001					
-------	----------	--	--	--	--	--

Blank Sheet

REV.0	Jun.2001					
-------	----------	--	--	--	--	--

Blank Sheet

REV.0	Jun.2001					
-------	----------	--	--	--	--	--

Blank Sheet

REV.0	Jun.2001					
-------	----------	--	--	--	--	--

Blank Sheet

REV.0	Jun.2001					
-------	----------	--	--	--	--	--

Blank Sheet

REV.0	Jun.2001					
-------	----------	--	--	--	--	--

(12) The message “Making a backup of micro-program files. Please Wait...” appears.

**Making a backup of
microprogram files. Please
wait...**

(13) File copy in SVP

Go to 3.3 (1).

File Copy
Copying...
From : C:\DKC200\TMP\MP\DKC\CHA\ZCULOAD.C.PRG
To : C:\DKC200\MP\DKC\CHA\ZCULOAD.C.PRG

3.3 Transferring micro-programs to the DKC

- (1) The message “Reading subsystem configuration...” appears.

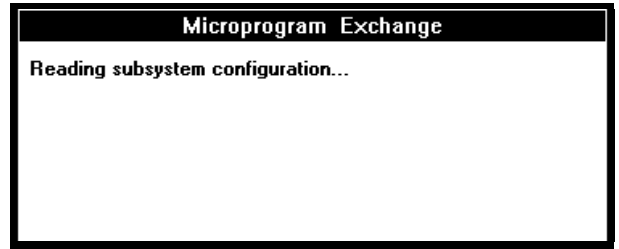

<<Error>>

- “On exchanging a micro-program, An error has occurred. XX processing is stopped”
- “The processor of an obstacle blockade exits. XX processing is stopped”
- “The processor that failed in an exchange of micro-program exists”
- “An error had occurred in XX blockade processing”
- “File size check error”
- “Invalid file contents”

- (2) The message “Downloading *** micro-program...” (***: MAIN, ...) appears.

- (3) The message “Now MP Rebooting... Group# n/N” appears.
All processors are recovered.

- (4) After downloading the micro-programs, SVP makes the sub-system to be enable and displays the following message “An exchange of a microprogram finished. Please check subsystem status and microprogram version with MAINTENANCE.”, select (CL) [OK].
Go to 3.6 ([MICRO-FC03-310](#)).

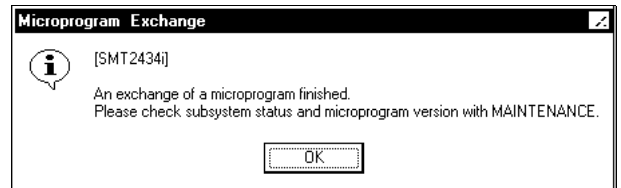

3.4 Hard Disk Download

The latest version of the DKCMAIN micro-program on the SVP hard disk is downloaded to the DKC.

- (1) [How]: Select (CL) [Offline].
 [From]: Select (CL) [Hard Disk] in the 'Setup Microprogram' dialog box.
 And select (CL) [OK].

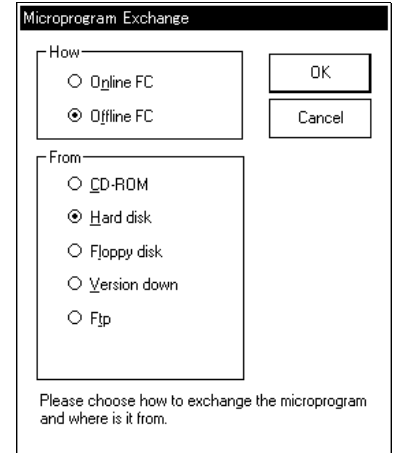

If you want to continue this process, select (CL) [OK], enter the password, and select (CL) [OK].

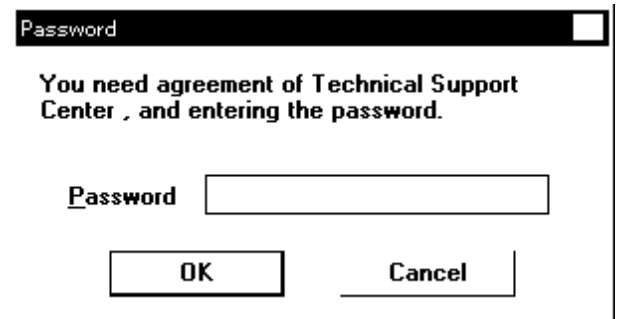

The 'Micro-program Exchange' dialog box appears. Select (CL) one or more items from the list of the type of micro-programs, and select (CL) [OK].

: Micro-programs to be substituted.

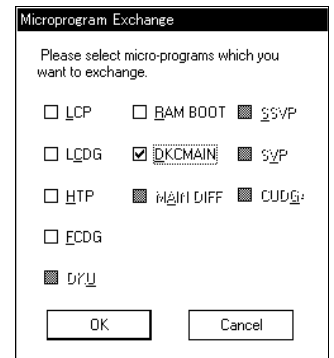

One of messages are displayed by the subsystem configuration.

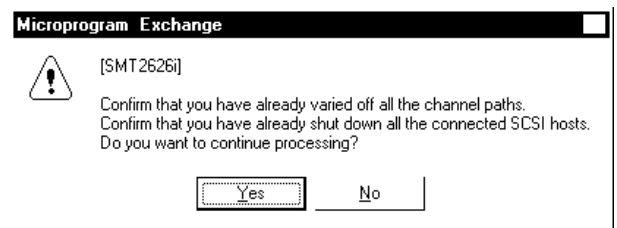
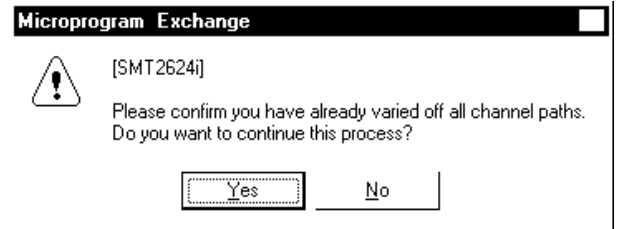
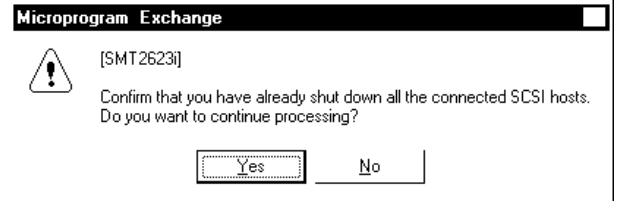

After you confirm that you have already varied all the CHL paths to off-line, select (CL) [Yes].

Go to 3.2 (11). ([MICRO-FC03-70](#))

If an error occurs in downloading micro-programs to DKC, remove the cause of an error using Maintenance Display (SVP section), Action Code (Action Code section), and other information to execute the exchange again. Then start from the first step of MICRO-FC procedure. At this time, you can select [Hard Disk] at 3.4 ([MICRO-FC03-270](#)) or [Floppy Disk] at 3.2 (5) ([MICRO-FC-03-30](#)).

(2)

Go to 3.3 (1) ([MICRO-FC03-250](#)).

3.5 Version Down



CAUTION

Ask the technical support center about the appropriateness of the operation.

If you want to restore the micro-program to the previous version of the micro-program after the exchange (by CD-ROM, Floppy Disk, Ftp or Remote function) , execute the Version Down function.

- (1) [How]: Select (CL) [Offline].
 [From]: Select (CL) [Version Down] in the 'Setup Microprogram' dialog box.
 And select (CL) [OK].

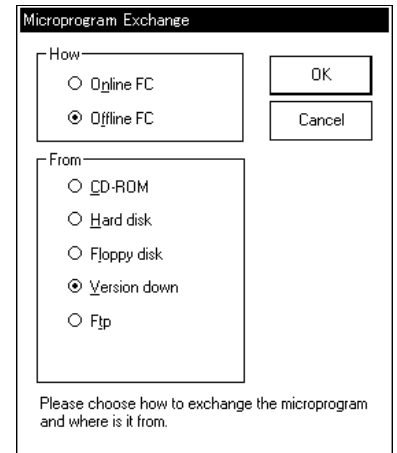

If you want to continue this process, select (CL) [OK], enter the password, and select (CL) [OK].

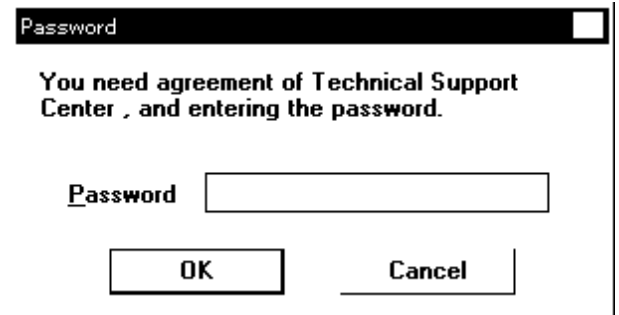

The 'Micro-program Exchange' dialog box appears.
 Select (CL) one or more items from the list of the type of micro-programs, and select (CL) [OK].

: Micro-programs to be substituted.

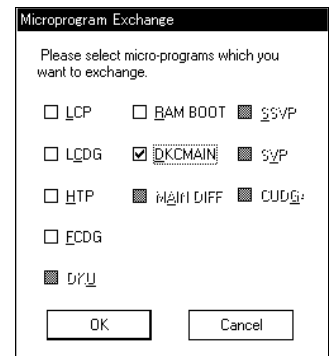

One of messages are displayed by the subsystem configuration.

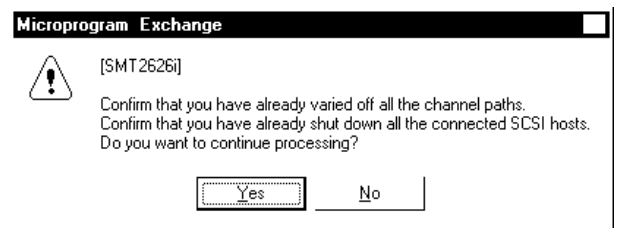
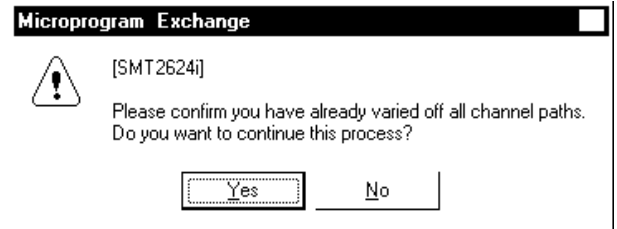
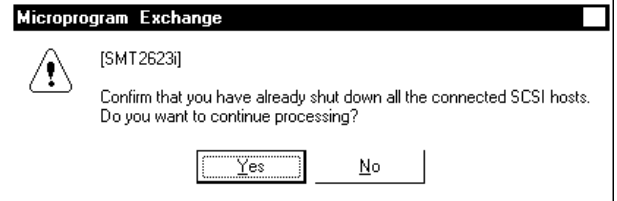

After you confirm that you have already varied all the CHL paths to off-line, select (CL) [Yes].

Go to 3.2 (11). ([MICRO-FC03-70](#))

- (2) Copy source and copy destination are displayed.

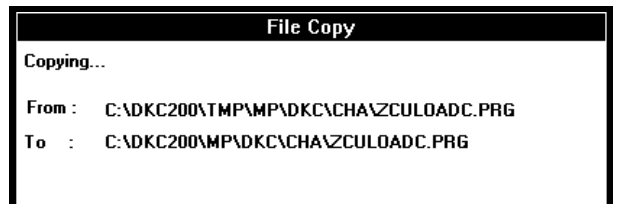

3.6 FTP

After being stored on the hard disk by FTP transfer, the micro-programs are downloaded to the DKC.

- (1) [How] : Select (CL) [Offline].
 [From]: Select (CL) [Ftp] in the 'Microprogram Exchange' dialog box.
 And select (CL) [OK].

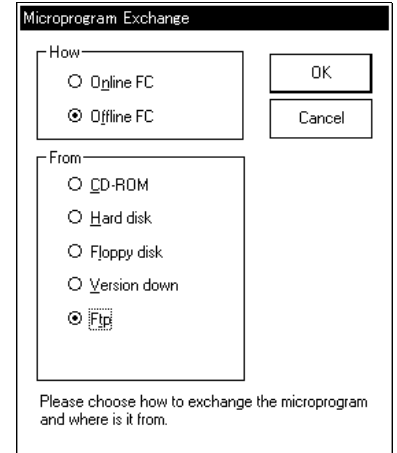

If you want to continue this process, select (CL) [OK], enter the password, and select (CL) [OK].

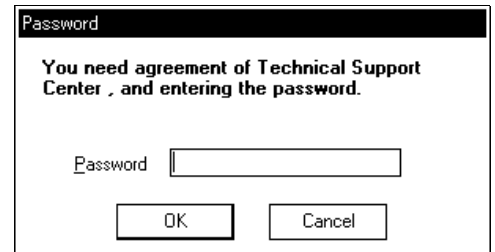

Input the information of the server that the microprogram which is transported by FTP, and select (CL) [OK]

URL: The micro program storing server name and the file path from a home directly

User Name: The user name for making FTP connection at the micro program storing server.

Password: Password.

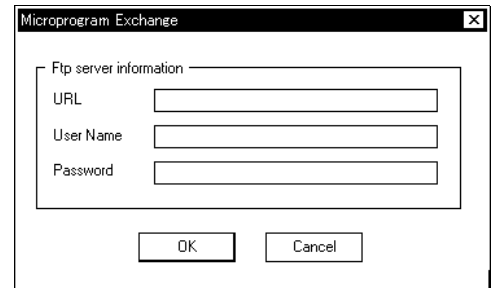

The 'Microprogram Exchange' dialog box appears. Select (CL) one or more items from the list of the type of micro-programs, and select (CL) [OK].

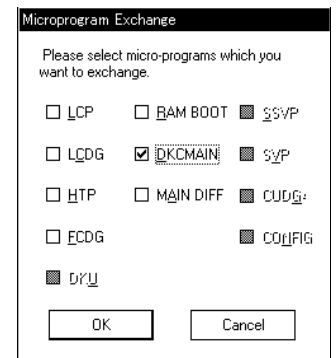

One of messages are displayed by the subsystem configuration.

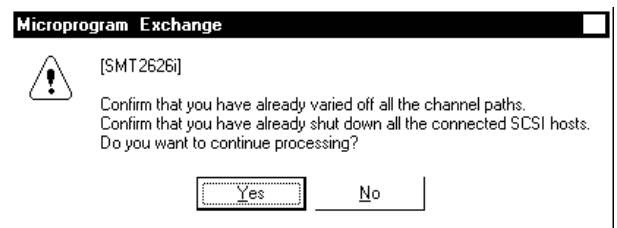
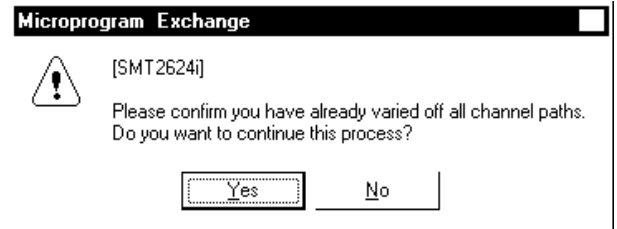
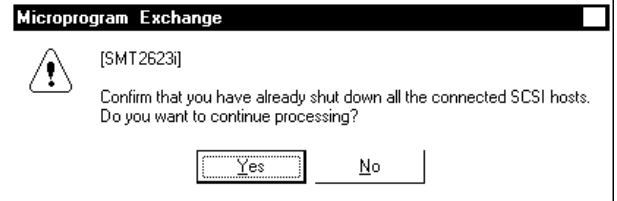

After you confirm that you have already varied all the CHL paths to off-line, select (CL) [Yes].

Go to 3.2 (11). ([MICRO-FC03-70](#))

If an error occurs in downloading micro-programs to DKC, remove the cause of an error using Maintenance Display (SVP section), Action Code (Action Code section), and other information to execute the exchange again. Then start from the first step of MICRO-FC procedure. At this time, you can select [Hard Disk] at 3.4 ([MICRO-FC03-270](#)) or [Floppy Disk] at 3.2 (5) ([MICRO-FC-03-30](#)).

(2)

Go to 3.3 (1) ([MICRO-FC03-250](#)).

3.7 Checking the functions after exchange

Check that the version of the recently installed micro-program is the same as that of the replaced micro-program by using the version display in the MAINTENANCE function.

(See SVP SECTION.)

Note: If you find “??-??...” or incompatibility version, recover the status following the section 7.2.

4 Micro-program Exchange Procedure (On-line)

If an error occurs during a micro-program exchange, retry the exchanging procedure from the beginning or execute the procedure explained in Chapter 7 “Trouble Recovery Procedure in Exchanging Micro-programs”.

Note : In case an error occurs during an exchange of the DKU micro-programs, make a note on the number of the DKU in which the error occurred when the error is recovered.

4.1 Processing before exchange

- Check the subsystem status through the entire status display. (Check the versions of all the programs through the version display.)
- Make sure that collection copy and other processing are not in progress.
- Perform postprocessing for PIN data.
- Check that all processors are normal.

On-line Micro-Program Exchange time (approximate)

(unit : minutes)

	CD-ROM → HDD	Download HDD → SM/(HDD → FM)	MP Reboot
LCP	3	1/(3)	6
LCDG		1/(3)	
HTP		1/(3)	
FCDG		1/(3)	
DKCMAIN		4	
MAIN DIFF		4	
RAM BOOT		1	
DKU		60	
SSVP	2	15	—
SVP		3	—
CUDG4		0	—
Total	5	86/(92)	6

(Processors : 16, Drive capacity : 180GB)

4.2 Storing the micro-programs to be substituted in the SVP

(1) <Initial screen>

(2)
Change the mode to [Modify Mode] (CL).
Select (CL) [Install].

(3)
In the 'Install Subsystem' window, select (CL)
[Micro Program Install].

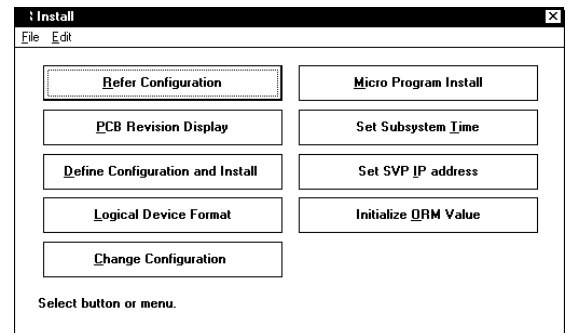

- (4)
 Select (CL) [Micro Program].
 Select (CL) [OK].
 Selecting (CL) [Cancel] returns you to step (3).

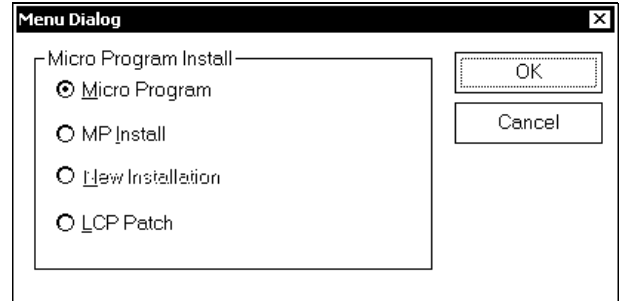

- (5)
 In the 'Setup Microprogram' dialog box,
 [How] : select (CL) [Online].
 [From]: select (CL) the source from which to store the micro-
 programs.

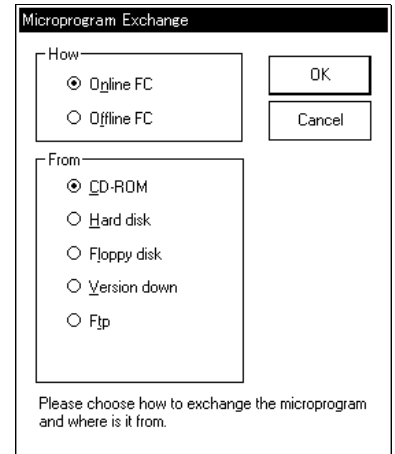

CD-ROM: After being stored on the hard disk from CD-ROM, the micro-programs are downloaded. --- Select(CL) [OK] and Go to (6).

Hard Disk: The latest versions on the SVP hard disk are downloaded. --- Go to 4.4 (1). (MICRO-FC04-160)

Floppy Disk: After being stored on the hard disk from floppy disks, the micro-programs are downloaded. --- Select (CL) [OK] and Go to (6).

Version Down: Old versions on the hard disk are downloaded. --- Go to 4.5 (1). (MICRO-FC04-170)

Ftp: After being stored on the hard disk by FTP transfer, the micro-programs are downloaded. --- Select (CL) [OK] and Go to 4.6 (1)

Selecting (CL) [Cancel] returns you to be step (4).

- (6) The 'Micro-program Exchange' dialog box appears.
 Select (CL) one or more items from the list of the type of micro-
 programs, and select (CL) [OK].

: Micro-programs to be substituted.

Note : SVP changed the message in FM download process. If an operator selected "LCP" or "LCDG", SVP displayed a message as "LCP/LCDG" during the download.

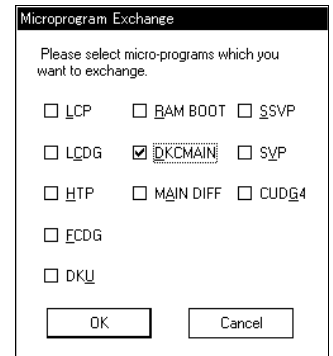

(7)

When DKCMAIN, MAIN DIFF or RAMBOOT were selected, you can select the reboot pattern from the list.

 **CAUTION**

Please select a reboot pattern by taking the following table into account.

REBOOT PATTERN		BY 1/2	BY 1/4	BY 1/8	BY ONE
EXCHANGE TIME	STANDARD VALUE(*) [MINUTE][APPROX.]	14	19	37	78
		SHORT ←————→ LONG			
EFFECT ON PERFORMANCE OF DKC		BIG ←————→ SMALL			

(*) MEASURE CONDITION : 32MP (CHA(SERIAL) × 4, DKA × 4), NO I/O.

Sometimes an “error” message is displayed temporarily in [Reboot status display].
But, there is no problem if the reboot is finished without error.

Please select (CL) one of these patterns and select (CL) [OK].

By 1/2 : Reboot by half MPs in the DKC sub system.
 By 1/4 : Reboot by quarter MPs in the DKC sub system.
 By 1/8 : Reboot by 1/8 MPs in the DKC sub system.
 By One : Reboot by minimum reboot unit MPs in the DKC sub system.

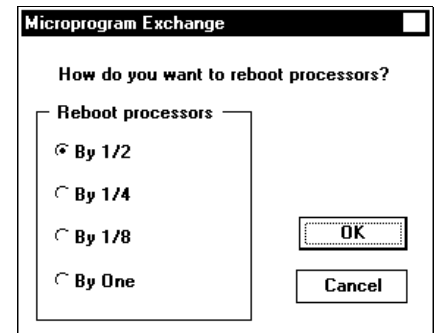

- (8) <If SCSI channel adapter is equipped>
 Select (CL) one of the exchange modes of DKCMAIN micro-program as follows, and select (CL) [OK].

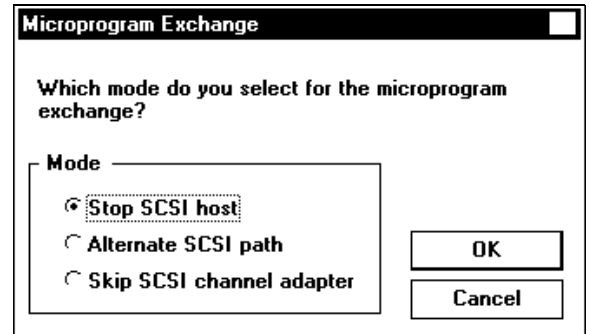

- “Stop SCSI host” : Exchange micro-programs by varying off-line the SCSI host paths.

CAUTION

You should request your customer to shut down the SCSI host. However, it is possible to operate a microprogram exchange without stopping I/O for some kinds of SCSI hosts. See [OPEN13-10](#) in detail.

- “Alternate SCSI path” : Exchange micro-programs by changing the SCSI host path to the alternative path.
- “Skip SCSI channel adapter” : Exchange micro-programs without a SCSI channel adapter.

- (8-1) <If “Stop SCSI host” is selected>
 Shut down all the SCSI hosts and select (CL) [OK]. Go to step (9).
 When [Cancel] is selected (CL), the processing is returned to (8).

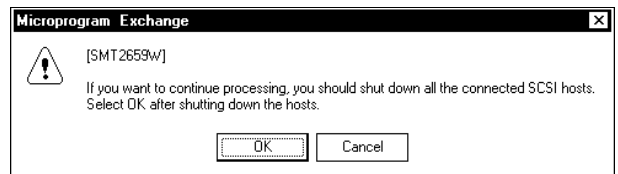

- (8-2) <If “Alternate SCSI path” is selected>
 It is necessary to switch the SCSI path to the alternate path before executing the microprogram FC for the CHA (SCSI) PCB. To continue the processing, select (CL) [Yes]. Go to step (10).
 When [No] is selected (CL), the processing step is returned to (8).

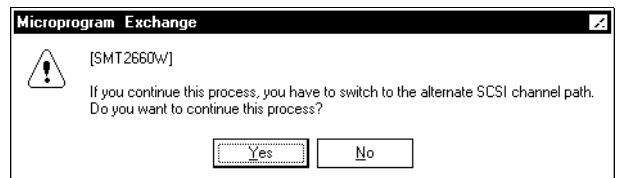

(8-3) <If “Skip SCSI channel adapter” is selected>

The microprogram FC for the CHA (SCSI) PCB will not be executed. Execute it in the future in the Stop SCSI host mode or the Alternate SCSI path mode.

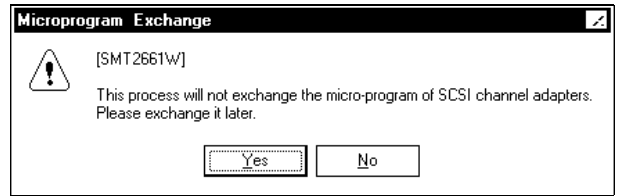

 **CAUTION**

Ask the technical support center about the appropriateness of the operation, and input a password after getting an approval of executing the operation.

If you want to continue this process, select (CL) [Yes], enter the password, and select (CL) [OK].

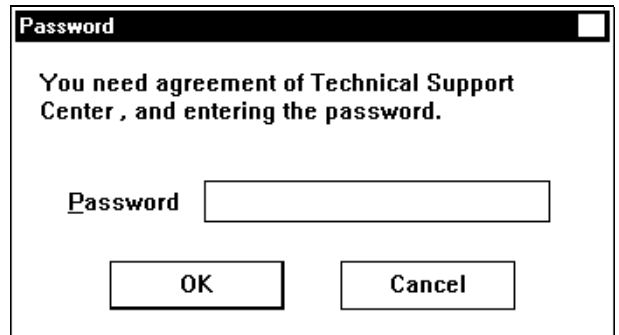

(9) <If SCSI channel adapter is installed when DKCMAIN or RAMBOOT were selected.>
After you confirm that you have stopped all SCSI channel paths, select (CL) [Yes].

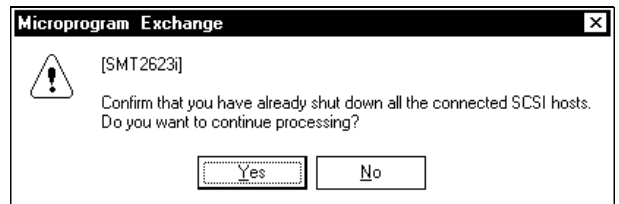

(10) If you select CD-ROM, a dialog “Insert CD-ROM in CD-ROM DRIVE” appears.

Insert the CD-ROM and select (CL) [OK].

If you select floppy disk, in response to the message “Insert No.n FD of DKCMAIN in FDD”, remove the inserted floppy disk, insert the appropriate floppy disk and select (CL) [OK].

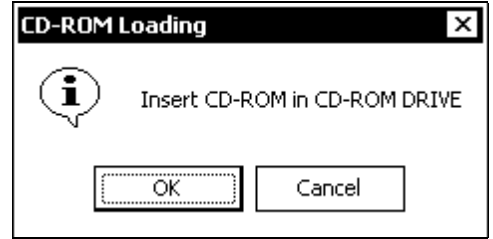

<<Error>>

No CD-ROM or No floppy disk or uncorrect CD-ROM or uncorrect floppy disk in the floppy disk drive:

The same message is displayed again, returning you to (10).

Internal error:

- “Old files erase failed, copy stop.”
- “Memory error has occurred.”
- “File I/O error has occurred.”
- “Logical error has occurred.”
- “The directory create error and copy stop.”
- “The file size is Wrong and copy stop.”

(11) If you select CD-ROM, the message “Copying CD-ROM files to HD DKCMAIN” appears.

If you select floppy disk, the message “Copying FD files to HD” appears.

Execute the steps (10) to (11) once for each floppy disk.

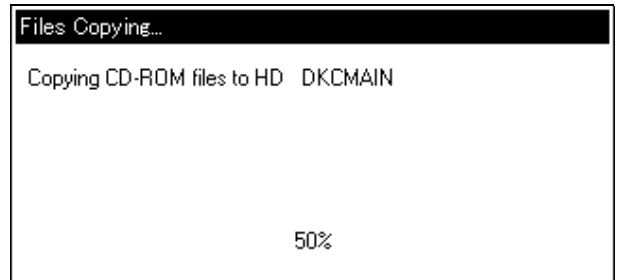

<<Error>>

Internal error:

- “The file size is Wrong and copy stop.”
- “The directory create error and copy stop.”
- “Micro-program version disagreement and copy stop.”
- “Logical error has occurred.”
- “File I/O error has occurred.”
- “Memory error has occurred.”

Note : When the error message “File I/O error has occurred.” or “Memory error has occurred.” is displayed, power SVP off and on again if the same message appears after reexecuting the micro-program exchange (see [SVP01-50](#) in the SVP SECTION).

Then execute the same micro-program exchange again. If the same error occurs (the same error message is displayed), replace the SVP hardware (see [REP01-170](#) in the REPLACE SECTION.).

- (12) If you select CD-ROM, a dialog “Remove CD-ROM” appears.

Remove the CD-ROM and select (CL) [OK].

If you select floppy disk, upon completion of reading from all floppy disks, the message “Remove FD” appears.

In response to this message, remove the floppy disk and select (CL) [OK].

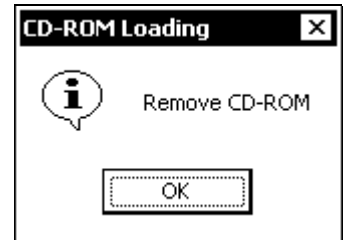

After copy end, sum checker starts.

While checking, the message appears.



- (13) On the ‘Software Maintenance’ dialog box, the micro-program types, current versions, new versions, and message are displayed.

<Display with no error>

The message “Confirm the following configuration list.” is displayed below the title bar. The micro-program can be replaced only when all rows in the information column show “OK”, “Not change” or “Warning”.

To continue processing, select (CL) [OK].

To terminate micro-program replacement, select (CL) [Cancel].

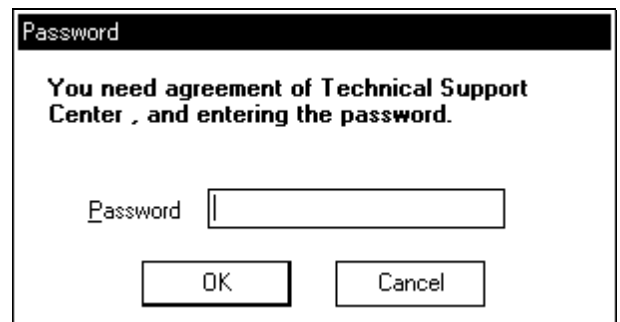
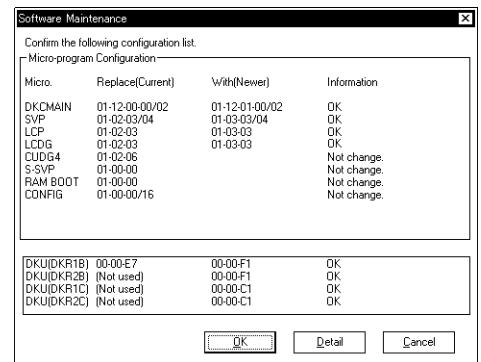

CAUTION

If “Warning” is displayed. Select (CL) “Detail” surely. Confirm the contents and ask the technical support center for decision for selecting “OK” or “Cancel” according to the contents. To make processing progress, select (CL) [OK], input the password and select (CL) [OK]. Password is needed for this operation. Please call Technical Support Center to obtain password and authorization.

<Display with an error>

A sample error display is shown on the right. An error message is displayed below the title bar. At the same time, error information is displayed in the information column.

Select (CL) [Cancel] to terminate the micro-program replacement. (Note: The [OK] button is not displayed.)
 Select (CL) [Detail] to display detailed error information.
 Before attempting to rerun, be sure to correct the cause of the error. Refer to the entire status (SVP SECTION), action code (ACC SECTION), and other information.

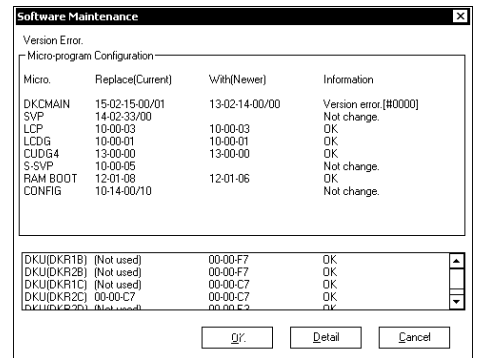

See Version Check Message Table ([MICRO-FC03-80](#)).

Note : Select (CL) [Detail] to display detailed error information, and confirm the cause of these error

- “Version error”
- “Revision error”
- “Warning”
- “Can’t read the configuration of the micro-program”
- “Warning” (Function bit map error)

(14) The message “Making a backup of micro-program files. Please Wait...” appears.

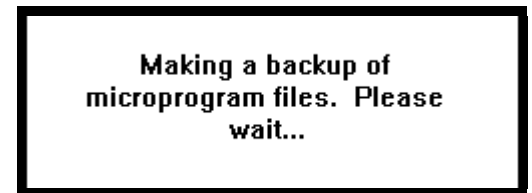

(15) File copy in SVP

Go to 4.3.1 (1) ([MICRO-FC04-100](#)) or
 4.3.2 (1) ([MICRO-FC04-140](#)) or
 4.3.2 (5) ([MICRO-FC04-150](#)).

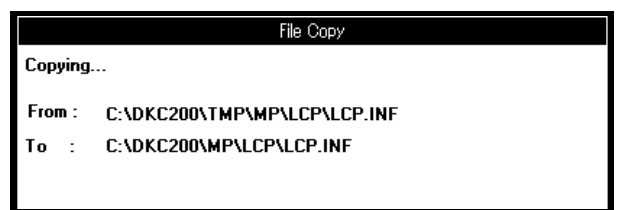

4.3 Transferring micro-programs

4.3.1 Transferring micro-programs to the DKC/DKU

- (1) The message “Reading subsystem configuration...” appears.

Read the current DKC configuration.

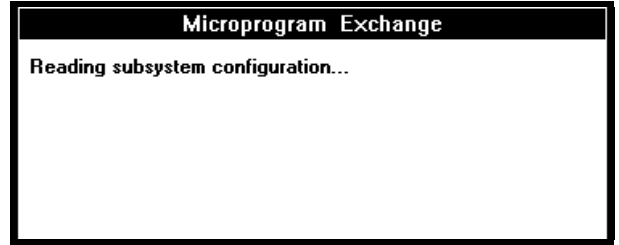

Note: When a match is not found in the version and revision between the micro-program in the DKC and that on the SVP hard disk, the micro-program cannot be exchanged on on-line. In this case, the message “Is the device off-line?” appears, and the exchange is canceled.

When a processor is blocked due to a failure, the message “Processing cannot be continued because of a processor blocked due to a failure” appears, and the exchange is canceled.

If an error occurs in downloading micro-programs, resolve the cause of an error using Maintenance Display (SVP section), Action Code (Action Code section), and other information to execute the exchange again. Then start from the beginning of the MICRO-FC procedure. At this time, you can select [Hard Disk] at 4.4 ([MICRO-FC04-160](#)) or [Floppy Disk] at 4.2 (5) ([MICRO-FC04-30](#)).

<LCP/HTP Micro code Exchange>

If LCP/HTP Micro code Exchange, the following message appears.

- (a) The message displays the execution status of the online patch in the installed LCP/HTP.

<Explanation of status>

Not selected-----Not selected as the target.
 Waiting for Execution---Execution is awaited.
 Executing... -----Execution is in progress.
 XXXX Blockade Error--Processor XXXX is
 blockaded.

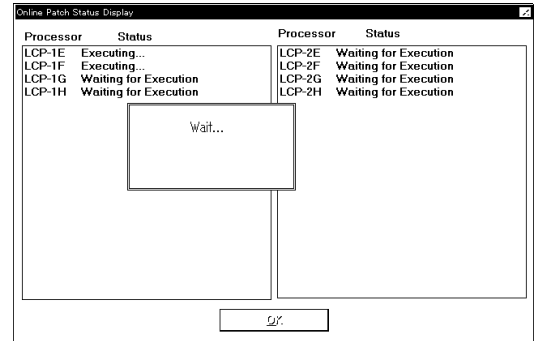

- (b) When execution is completed for all targets, you will go to step (2). If some errors occur, you can now select [OK].
 Select (CL) [OK].
 You will return to 4.2 (3).

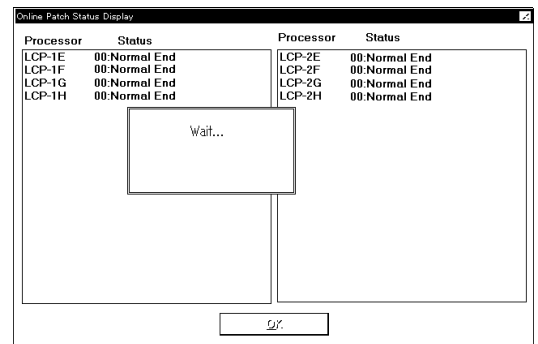

(2) The message “Downloading *** micro- program...” (***: MAIN, LCP, ...) appears.

<Replacement of the DKU micro-program>

(a) When the SVP hard disk and the HDU have DKU micro-programs of the same revision, the replacement of the DKU micro-program ends with the following message on the screen:

“The DKU microprogram is not updated because of the same revision.”



(b) When the revision of the DKU micro-program in the HDU is older than that in the SVP hard disk, the HDD location number and the revision are displayed in the Revision Down HDU list.

When you select (CL) [Up], the DKU micro-program in the revised HDU only is updated.

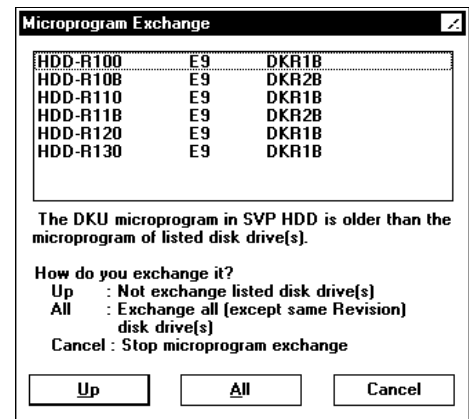

When you select (CL) [All], the message shown on the right is displayed.

When you select (CL) [Yes] in response to the message, DKU micro-programs of the HDUs having micro-programs of different versions are updated.

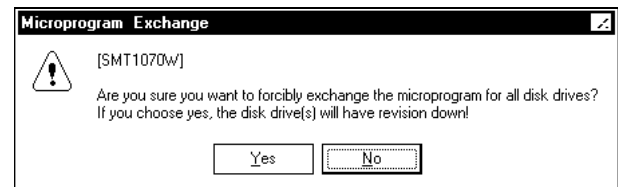

- (3) The message “Now MP Rebooting... Group# n/N” appears.
The processor is recovered.
SVP executes steps (2) and (3) for each exchanging unit.

- (4) In response to the message “An exchange of a microprogram finished. Please check subsystem status and microprogram version with MAINTENANCE”, select (CL) [OK].

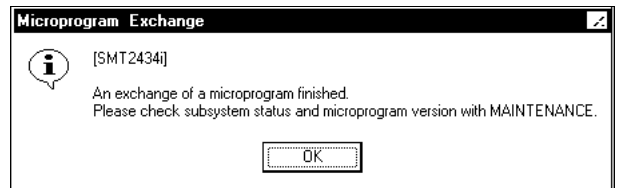

Go to 4.6. ([MICRO-FC04-190](#))

4.3.2 Transferring micro-programs to SVP/SSVP

- (1) Start of the exchange (SSVP).
The message “Changing SSVP microprogram.
Wait...” is displayed.

**Changing SSVP microprogram.
Wait...**

<<Error>>

Internal error :

- “Read/Write error has occurred !”
- “Information file doesn’t exist or open error has occurred!”
- “SSVP RESET switch on.”
- “Communication Initialize error!”
- “Cannot change SSVP micro-program while following process is in action. SSVP micro-program download. SSVP memory dump. SVP-SSVP communication error.”
- “Information file doesn’t exist or open error has occurred!”

- (2) The message “SSVP microprogram download.” is displayed.

**SSVP microprogram download.
(1/16)**

- (3) Start of the exchange (SVP).
The message “Blocking SVP-SSVP communication
Wait...” is displayed.

**Blocking SVP-SSVP
communication. Wait...**

<<Error>>

Internal error :

- “Information file doesn’t exist or open error has occurred!”
- “SVP-SSVP communication blockade error has occurred.”

- (4) The message “Blocking DKC-SVP communication. Wait...” is displayed.



Blocking DKC-SVP
communication. Wait...

<<Error>>

Internal error :

- “DKC-SVP communication blockade error has occurred.”
- “DKC-SVP communication restore error has occurred. Confirm the cables are connected correctly.”

- (5) The message “Changing SVP microprogram. Wait...” is displayed.

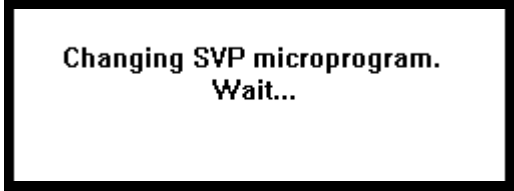

Changing SVP microprogram.
Wait...

<<Error>>

Internal error :

- “Read/Write error has occurred !”
- “Information file doesn’t exist or open error has occurred!”
- “Can’t find a file (BKTASK.DAT)!”

- (6) End of the exchange (SVP).
Select (CL) [OK].
Terminate some application programs, so
SVP is rebooted automatically.

Go to 4.6. ([MICRO-FC04-190](#))



<<Error>>

- “The change of SVP microprogram has failed.”

<<Action>>

- Stop SVP and Power off PC.
- Power on PC again.

4.4 Hard Disk Download

The latest version of micro-programs on the SVP hard disk are downloaded to DKC.

- (1) [How]: Select (CL) [Online].
 [From]: Select (CL) [Hard Disk] in the 'Setup Microprogram' dialog box.
 And select (CL) [OK].

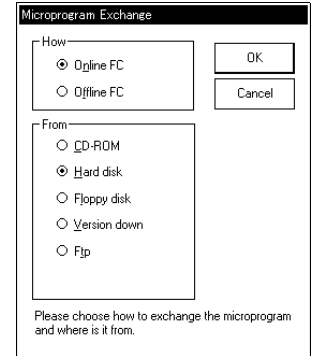

- (2) Select (CL) one or more items from the list of the type of micro-programs.
 And select (CL) [OK].

: Micro-programs to be substituted.

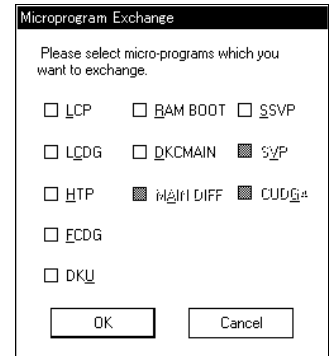

- (3) Go to 4.2 (7) ([MICRO-FC04-40](#)).

- (4) Execute from 4.3.1 (1).
 Go to 4.3.1 (1) ([MICRO-FC04-100](#)).

4.5 Version Down



CAUTION

Please ask your TSC if you can operate this.

If you want to restore micro-programs to the previous versions of the micro-programs after the exchange (by CD-ROM, Floppy Disk, Ftp or Remote function), execute the Version Down function.

- (1) [How]: Select (CL) [Online].
[From]: Select (CL) [Version Down] in the 'Setup Microprogram' dialog box.
And select (CL) [OK].

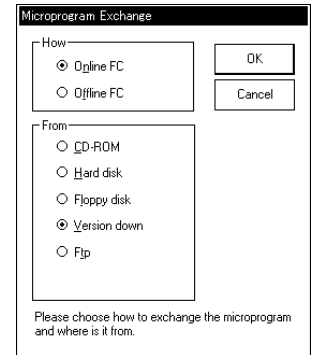

- (2) Micro-programs to be restored are displayed in the 'Micro-program Exchange' dialog box.

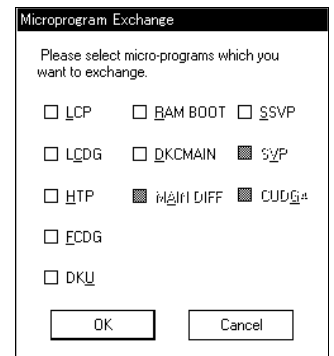

- (3) Go to 4.2 (7) ([MICRO-FC04-40](#)).

(4) Copy source and copy destination are displayed.

Execute 4.3 (1).

Go to 4.3.1 (1) ([MICRO-FC04-100](#))

Note:

- The Version Down function can restore only micro-programs that have been exchanged by Floppy Disk or Remote function of the MICRO-FC.
When the MICRO-FC (Floppy Disk or Remote function) has not been executed the Version Down function cannot be executed until the next MICRO-FC is done.
- After LCP Version Down, replace the PCB.

4.6 FTP

After being stored on the hard disk by FTP transfer, the micro-programs are downloaded to the DKC.

- (1) [How]: Select (CL) [Online].
[From]: Select (CL) [Ftp] in the 'Microprogram Exchange' dialog box.
And select (CL) [OK].

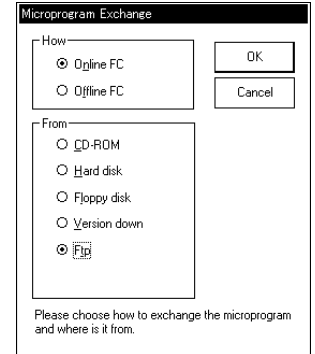

Input the information of the server that the microprogram which is transported by FTP, and select (CL) [OK]

URL: The micro program storing server name and the file path from a home directly

User Name: The user name for making FTP connection at the micro program storing server.

Password: Password.

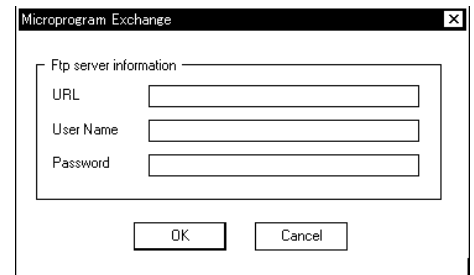

The 'Microprogram Exchange' dialog box appears.

Select (CL) one or more items from the list of the type of micro-programs, and select (CL) [OK].

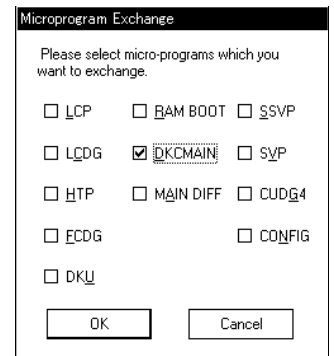

-
- (2) Execute 4.2 (7), (8), (9).
Go to [MICRO-FC04-40](#).

-
- (3) Execute from 4.2 (13).
Go to [MICRO-FC04-80](#).

4.7 Checking the functions after exchange

Conduct the same testing which was performed at the installation.

Check that the version of the recently installed micro-program is the same as that of the replaced micro-program by using the version display in the MAINTENANCE function.

(See SVP SECTION.)

Note: If you find “??-??...” or incompatibility version, recover the status following the section 7.1.

5 MP Install

5.1 Over view

This facility is used to restore a processor that failed to complete the rewrite of the micro-programs in FM (Flash Memory) due to an error during the micro-program download.

Since a processor that encountered such a problem started unsuccessfully without loading micro-programs, it is loaded with the FM write only programs. Whenever the FM write only program are loaded, a SIM with reference code = 7900X0 (for the CHA (Channel adaptor))/7901X0 (for the DKA (Disk Adaptor)) is reported. Also, an SSB (F/M = 8C, EC = 3309) is reported. The user must examine this SIM or SSB and perform MP Install on the processor that issued the SIM or the SSB. If MP Install has failed, please replace the PCB. (see REPLACE SECTION)

5.2 MP Install

(1) Select (CL) the [Install] icon in the 'SVP' window.

(2) Select (CL) [Micro Program Install] in the 'Install. Subsystem' window box

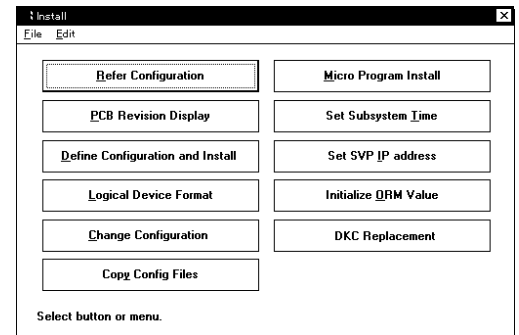

(3) Select (CL) the [Install] menu in the 'Menu Dialog' window and select (CL) [MP Install].

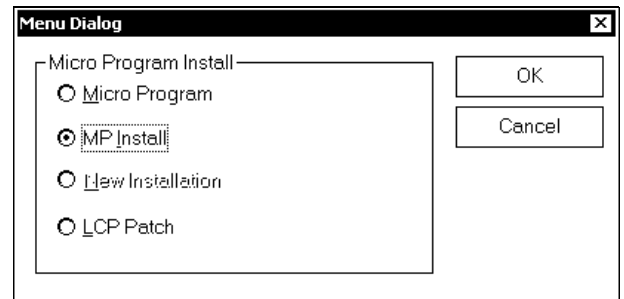

- (4) Select (CL) a processor in the 'To' and select (CL) [OK].

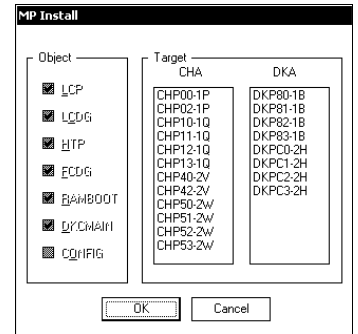

- (5) Progress Dialog appears.
Executing PCB button blink.
When MP Install process finished, the dialog will be closed automatically.
- [Detail]: You can see detail status.
See following "Detail status display".
 - [Cancel]: You can interrupt MP Install process.

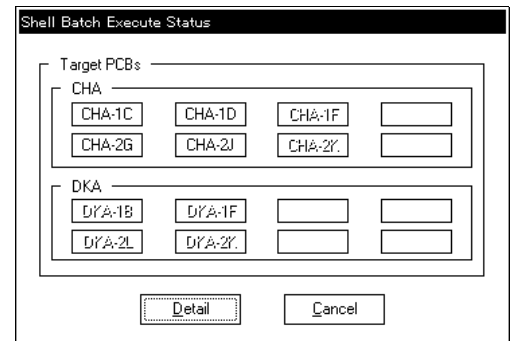

"Detail status display"

Executing MP location and detail status are displayed.
Select (CL) [Close] and return progress dialog.

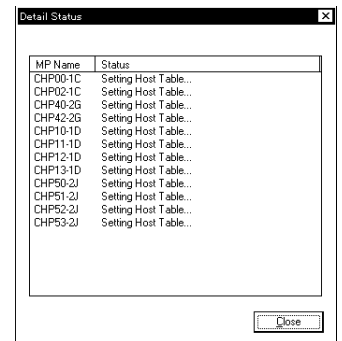

- (6) In response to the message “An exchange of a microprogram finished.”, select (CL) [OK].

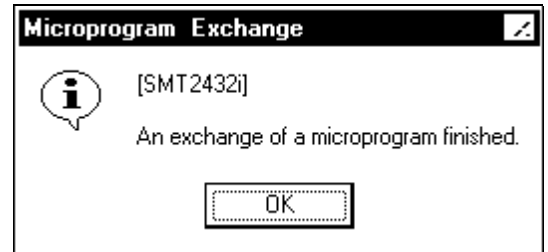

- (7) You will return to the 'Install' screen.

6 LCP Patch

6.1 Methods of entering a patch file

6.1.1 Entering the patch file from the SVP by using a patch editor

- (1) <Mode Change>
Change the mode to [Modify Mode] (CL).

- (2) Select (CL) [Install].

- (3) Select (CL) [Micro Program Install].

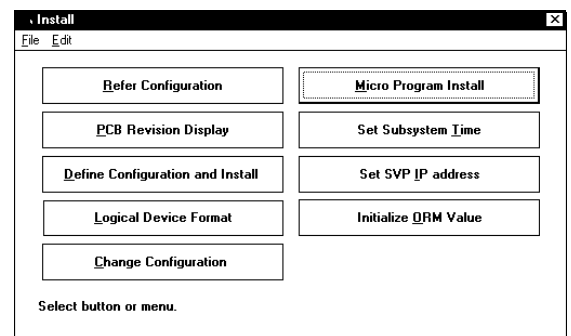

- (4) Select (CL) [LCP Patch] and select (CL) [OK].

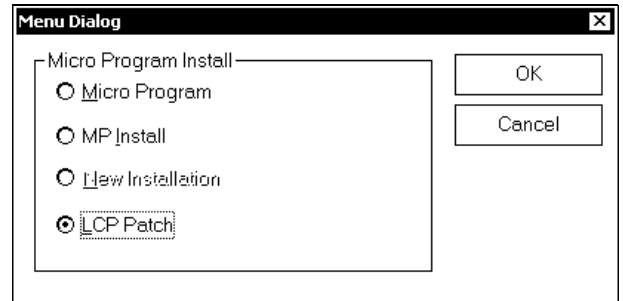

- (5) Select (CL) [LCP Patch] and select (CL) [OK].

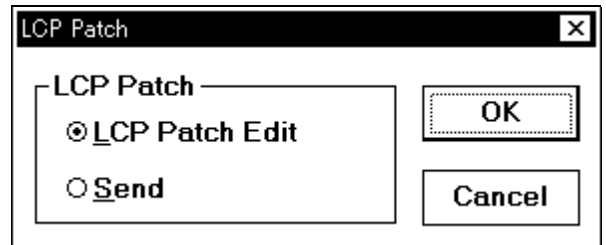

- (6) Editing patch data

A procedure to edit the LCP patch data is shown below as an example.

- (6-0) Entry No. selection screen
- (6-1) Changing patch data
- (6-2) Adding patch data
- (6-3) Deleting patch data
- (6-4) Inserting patch data
- (6-5) Clearing patch data
- (6-6) Copying patch data
- (6-7) Cutting patch data
- (6-8) Pasting patch data
- (6-9) Printing patch data
- (6-10) Stopping editing
- (6-11) Searching patch data

(6-0) Entry No. selection screen

Execute “New addition (or insertion is allowed) of entry No.” or “Selection of entry No. of registered data” on the entry No. selection screen.

When the [Editor...] button is selected (CL), the ‘LCP Patch Editor -’ screen appears.

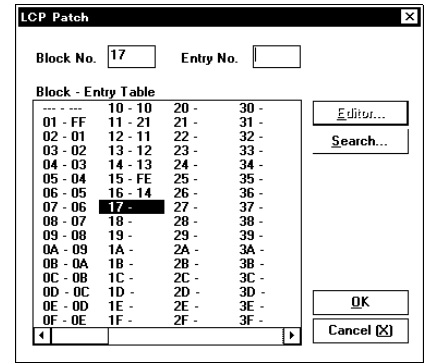

(6-1) Changing patch data

- Select (CL) the patch data to be edited from the patch data list in the lower part of the screen and select (CL) the [Change] button. Edit the list in the upper part of the screen.
- After editing the list, select (CL) the [Confirm] button and register the patch data.

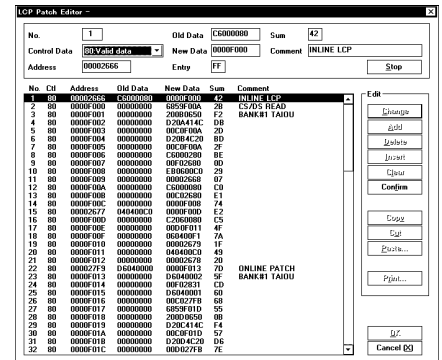

(6-2) Adding patch data

- When the [Add] button is selected (CL), the data full of “0” is added to the end of the data list. Edit the data in the upper part of the screen.
- After editing, select (CL) the [Confirm] button and register the patch data.

(6-3) Deleting patch data

- Select (CL) the patch data (multiple patch data can be selected) and select (CL) the [Delete] button.
- The selected patch data will be deleted.

(6-4) Inserting patch data

- (1) Select (CL) an insert line in the patch list and select (CL) the [Insert] button. The data full of "0" is inserted to the selected line. Edit the data in the upper part of the screen.
- (2) After editing, select (CL) the [Confirm] button and register the patch data.

(6-5) Clearing patch data

- (1) Select (CL) the [Clear] button.
- (2) Deletion of the patch data for each entry No.

(6-6) Copying patch data

- (1) Select (CL) the patch data (multiple patch data can be selected) and select (CL) the [Copy] button.
- (2) The selected patch data will be copied.

(6-7) Cutting patch data

- (1) Select (CL) the patch data (multiple patch data can be selected) and select (CL) the [Cut] button.
- (2) The selected patch data will be cut (copied and deleted).

(6-8) Pasting patch data

- (1) Select (CL) the one line to paste the copied or cut patch data and select (CL) the [Paste...] button. The 'Paste Position' screen appears.
- (2) [Current Line] : Pastes patch data to the selected line.
[End of Entry] : Pastes patch data to the end of the entry.

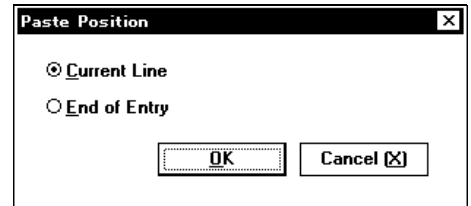

(6-9) Printing patch data

- (1) Select (CL) the patch data (multiple patch data can be selected) and select (CL) the [Print...] button. The 'Text Out' screen appears.
- (2) Input a file name of "*.txt" file and select (CL) [OK].

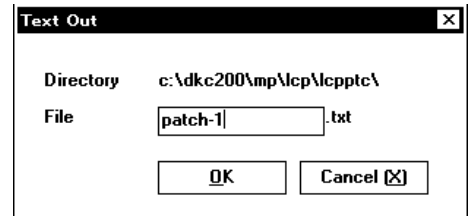

(6-10) Stopping editing

- (1) Select (CL) the [Stop] button to stop editing (changing, adding, or inserting) patch data.

(6-11) Searching patch data

- (1) Select (CL) the [Search...] button in the entry No. selection screen. The 'Search' screen appears. Address, Old Data or New Data searching can be done.
- (2) Input an Address, an Old Data or a New Data, and select (CL) the [Next] button. The data found is displayed at the bottom of this screen.
- (3) If you need to edit the found patch data, select (CL) the [Editor...] button. The 'LCP Patch Editor -' screen appears. And (6-1)-(6-10) operations will be available.

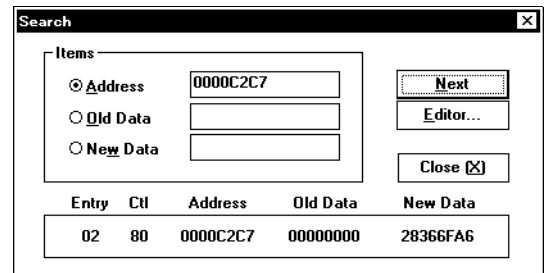

6.2 Methods of sending a patch file

6.2.1 Rewriting LCP itself

This subsection describes how to send the online-patch record specified by Execute Entry NO. to the processor specified by TARGET.

- (1) <Mode Change>
Change the mode to [Modify Mode] (CL).

-
- (2) Select (CL) [Install].

-
- (3) Select (CL) [Micro Program Install].

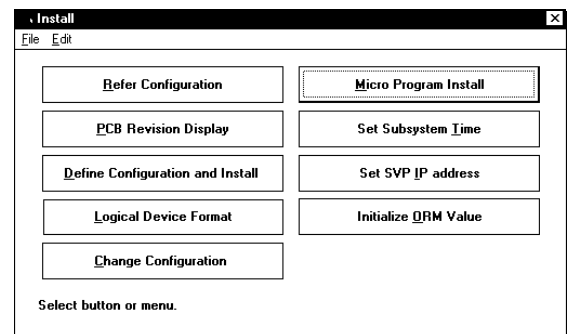

- (4) Select (CL) [LCP Patch] and select (CL) [OK].

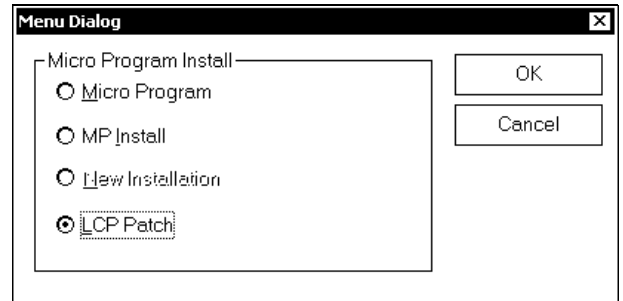

- (5) Select (CL) [Send] and select (CL) [OK].

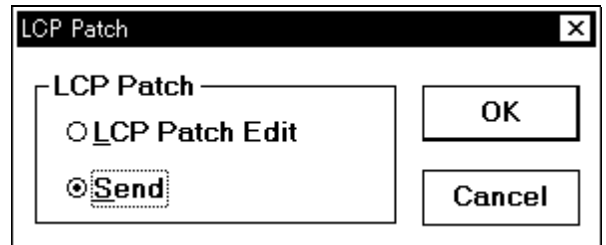

- (6) 'LCP Online Patch' is displayed.
Enter an execute entry number, then select (CL) [Execute].

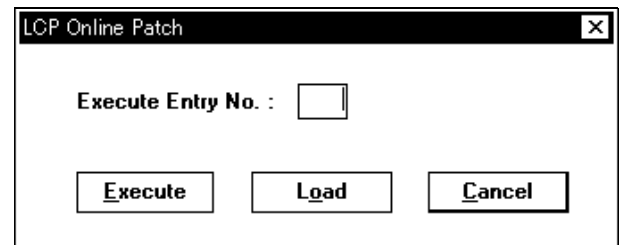

Execute entry number : Specify the registration number (two-digit hexadecimal number) of the online-patch record.

- (7) The execution status of the online patch in the installed LCP is displayed.

<Explanation of status>

Not selected	Not selected as the target.
Waiting for Execution	Execution is awaited.
Executing...	Execution is in progress.
XXXX Blockade Error	Processor XXXX is blockaded.

- (8) When execution is completed for all targets,
you can now select [OK].
Select (CL) [OK].
You will return to step (6).

<Explanation of status>

Sumcheck Error

Version Error

Data Error

Bank Error

Address Error

Level Error

Record Count Over Error

ID Error

Access Mode Error

CBF CHK2 Error

Busy Time Out Error *1

Not Ready Error

Time Out Error before Patch Transfer

Time Out Error during Patch Transfer

Time Out Error after Patch Transfer

Status = "Dead"

Status = "HOLD"

Abnormal Error Check

Busy Retry Error *1

Other Frame Receive Error

Time Out Error

Abnormal Error

DMA Abnormal Error

Parameter Error

Asynchronous Error

Processor	Status	Processor	Status
LCP-1A	04:Version Error	LCP-2A	Waiting for Execution
LCP-1B	04:Version Error	LCP-2B	Waiting for Execution
LCP-1C	Not Selected	LCP-2C	Not Selected
LCP-1D	Not Selected	LCP-2D	Not Selected

OK

*1 : When "Execute" is performed in the processor which is going along I/O, it turns into this error.

Then, till it becomes Normal End, "Execute" is performed.

6.2.2 Including the patch into a load module and update FM

This subsection describes how to download the load module containing all records in the online-patch file to the “Executed” processor. If “Execute” is not yet done for the processor, the load module is downloaded to the processor currently specified by TARGET.

- (1) <Mode Change>
Change the mode to [Modify Mode] (CL).

-
- (2) Select (CL) [Install].

-
- (3) Select (CL) [Micro Program Install].

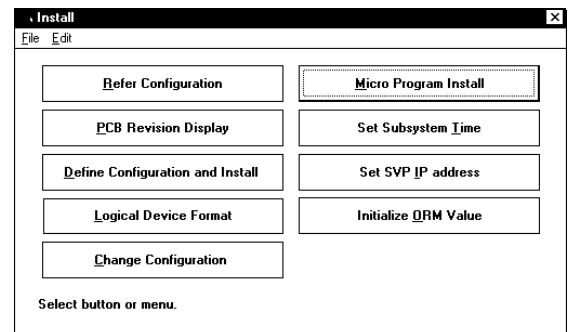

- (4) Select (CL) [LCP Patch] and select (CL) [OK].

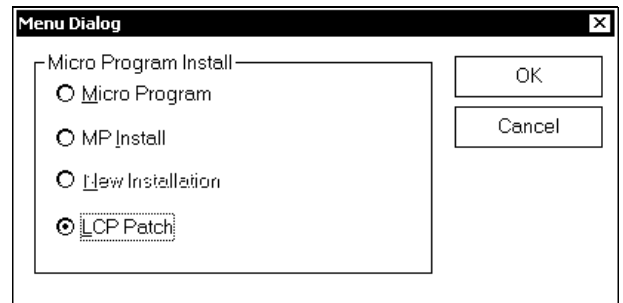

- (5) Select (CL) [Send] and select (CL) [OK].

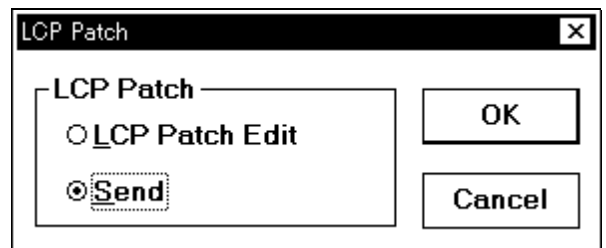

- (6) When you have mode the Execute operation on LCP Online Patch, select (CL) [Load].

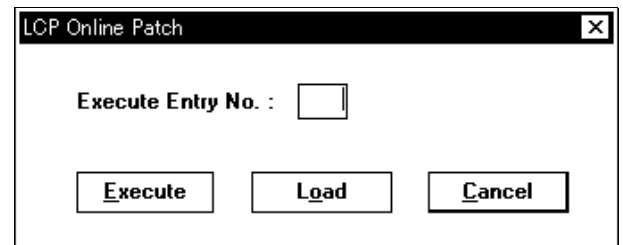

- (7) The message “Are you sure you want to download LCP micro-program?” is displayed. Select (CL) [Yes].

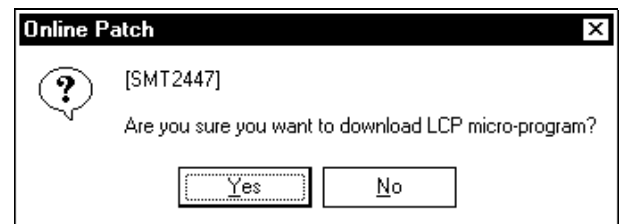

-
- (8) SM is being updated.
“Now Down Loading...” is displayed.

-
- (9) FM is being updated.
“Now Down Loading... [XXX]” (XXX : PCB location) is displayed.

-
- (10) Upon completion of downloading, the message
“An exchange of a microprogram finished” is
displayed.
In response to this message, select (CL) [OK].

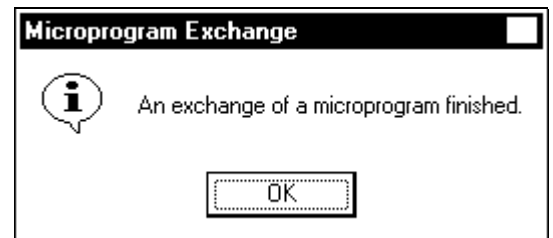

7 Trouble Recovery Procedure in Exchanging Micro-programs

7.1 Recovery procedure in on-line menu was selected

If trouble occurs while the micro-programs are being exchanged, symptoms (1) to (6) below can be observed apparently. In these cases, use the recovery procedures shown in flowcharts [A] to [D]. And if you want to return the version of micro-program to the previous version, use the procedure shown in (7) and flowchart [E].

- (1) A power failure occurs.
→Go to [A] ([MICRO-FC07-30](#))
- (2) The time-out message is displayed on the SVP screen.
 - (a) Trouble in downloading the micro-program (the message “Downloading Main micro-program” is displayed).
→Go to [B] ([MICRO-FC07-40](#))
 - (b) Trouble in blocking the processor (the message “Processor in now blocking” is displayed).
→Go to [C] ([MICRO-FC07-50](#))
 - (c) Trouble in recovering the processor (the message “Processor in now recovering” is displayed).
→Go to [C] ([MICRO-FC07-50](#))
 - (d) Trouble in downloading the micro-program (the message “Downloading DKU micro-program” is displayed).
→Go to [F] ([MICRO-FC07-90](#)).
- (3) An error occurs in data transferred to the DKC.
(The message “It failed in the writing to the flash memory” is displayed.)
→Go to [B] ([MICRO-FC07-40](#))
- (4) An I/O error occurs on the SVP hard disk.
(The message “File I/O error has occurred” is displayed)
(The message “Memory error has occurred” is displayed)
→Go to [D] ([MICRO-FC07-60](#))
- (5) An AP error occurs, resulting in PC trouble (Key-in operations are disabled and the screen disappears).
→Go to [B] ([MICRO-FC07-40](#))
- (6) Recovery of a cache failure during the micro-program exchange of DKCMAIN Action.

- (7) Procedure for returning the micro-program version to the previous version.
→Go to [E] ([MICRO-FC07-70](#))
- (8) In case of uncorrect version display (“??-??…” or incompatibility).
→Go to [B] ([MICRO-FC07-40](#))

[Sections to be referenced for recovery procedure]

- (i) Status display : 3.4 Main screen on SVP section
- (ii) Version display : 3.9 Micro-program version on SVP section
- (iii) MP installation : 5 MP Install
- (iv) Package exchange : 1 Hot Replace on REPLACE section
- (v) PC exchange : 1 Hot Replace on REPLACE section

[Recovery Procedure for Power Failure]

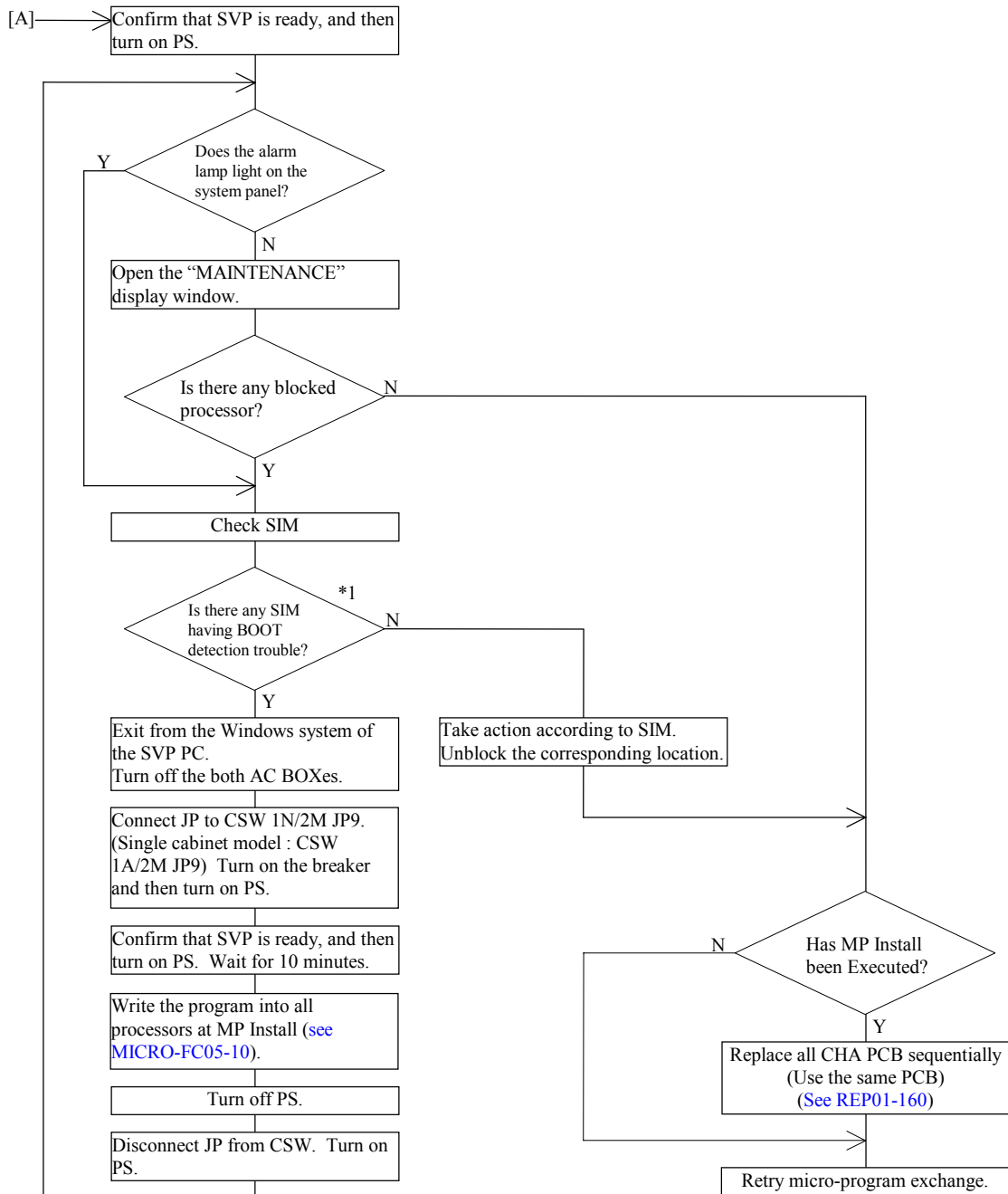

[Recovery Procedure for Communication Time-out/PC Trouble in Downloading Micro-program /Version incompatibility]

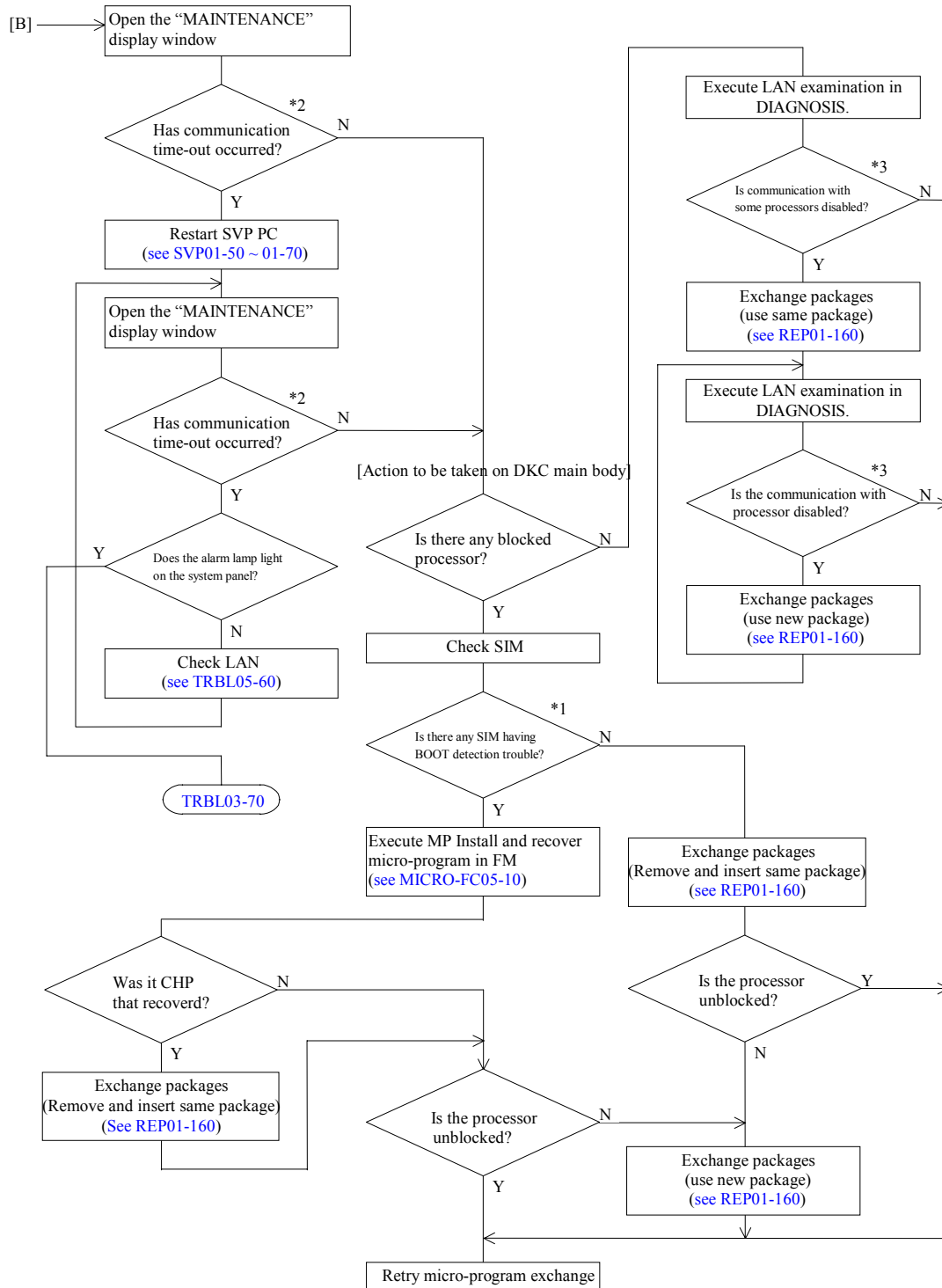

[Recovery Procedure for Communication Time-out in Blocking/Unblocking Processor]

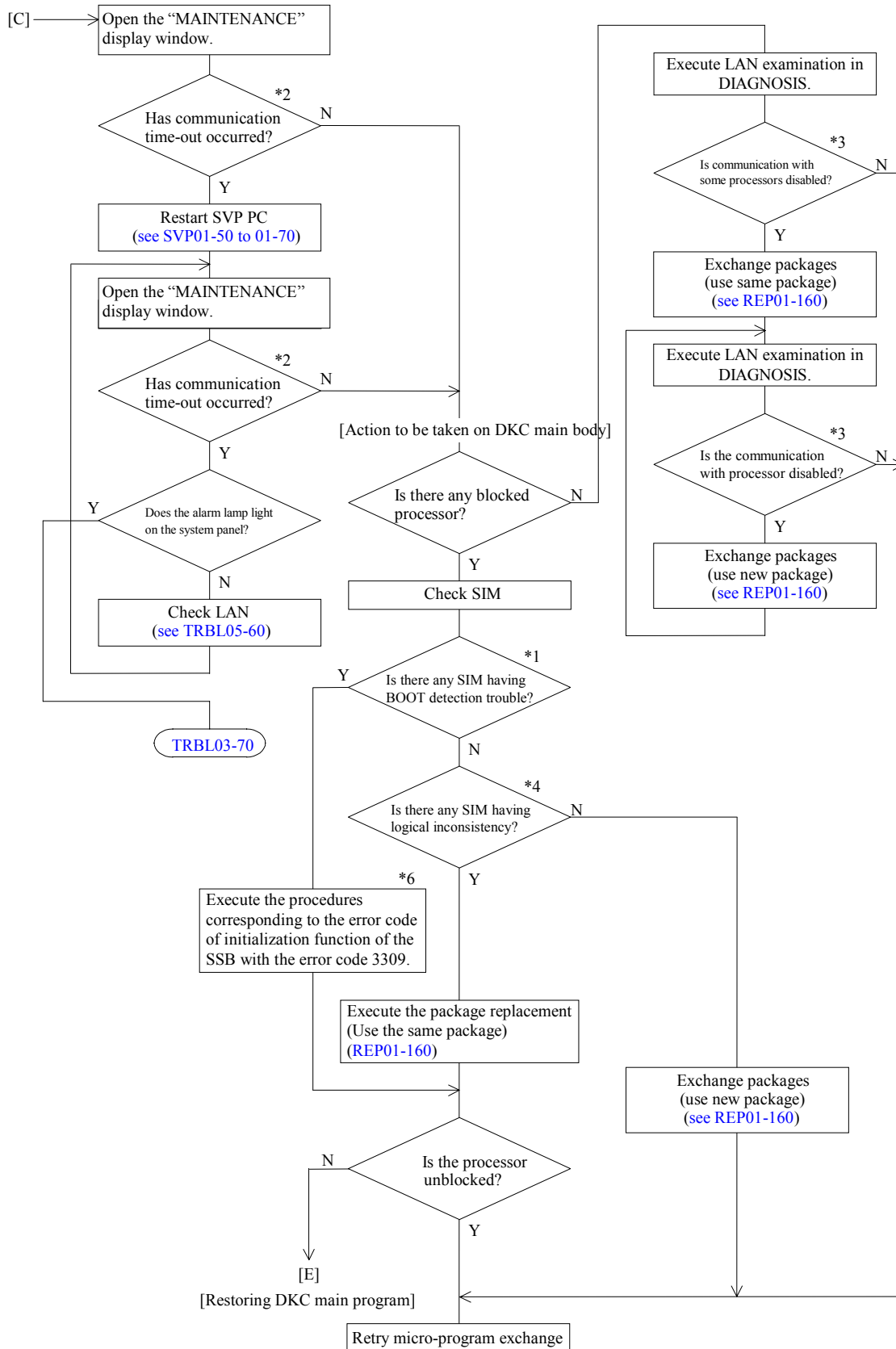

[Recovery Procedure for I/O Error on SVP Hard Disk]

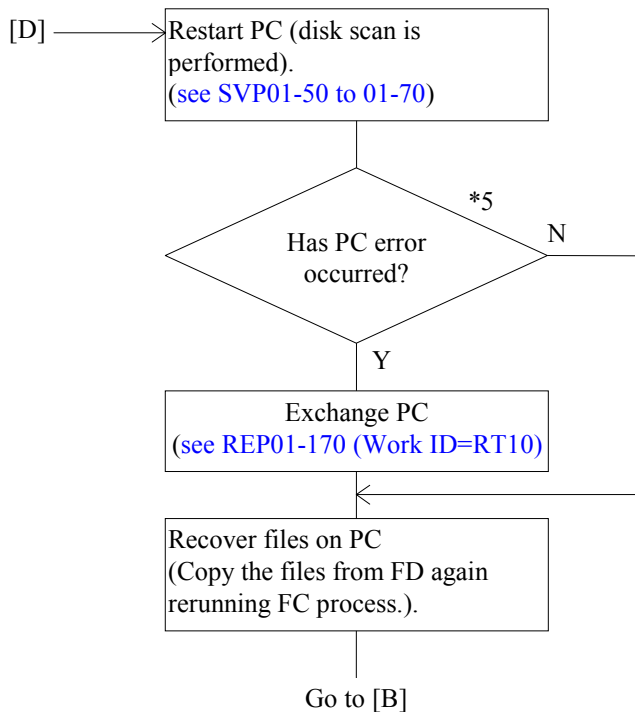

- *1) Reference code “7900X0” or “7901X0”
X: Shows processor id. (see SIM-RC02-270)
For details of the trouble, refer to the explanation about the BOOT detected error at SSB (Byte27 =8C).
(see SSBLOG05-1620)
- *2) The message “connection error occurred SVP-DKC” is displayed.
- *3) Each LAN error processor button blinks.
- *4) Reference code
3080x0:Indicates that a WCHK1 dump has occurred.
3081x0:Indicates that an ABEND dump has occurred.
x: Shows processor id.
- *5) The message “Please turn off SVP and replace it” is displayed.
- *6) Refer to “SSBLOG05-1620” for the SSB with the error code 3309.
Also, the error code of initialization function is shown in 5C-5Fth byte of the SSB. The procedures corresponding to the error code of initialization function are as follows.

Error code of initialization function	Procedures	Note
56000041	① SVP Replace ② MP Install ③ Package Replace	Use the same package in ③. Refer to “REP01-170 (Work ID : RT10)” for SVP Replace.
others	① MP Install ② Package Replace	Use the same package in ②.

[Procedure for returning the micro-program version to the previous version]

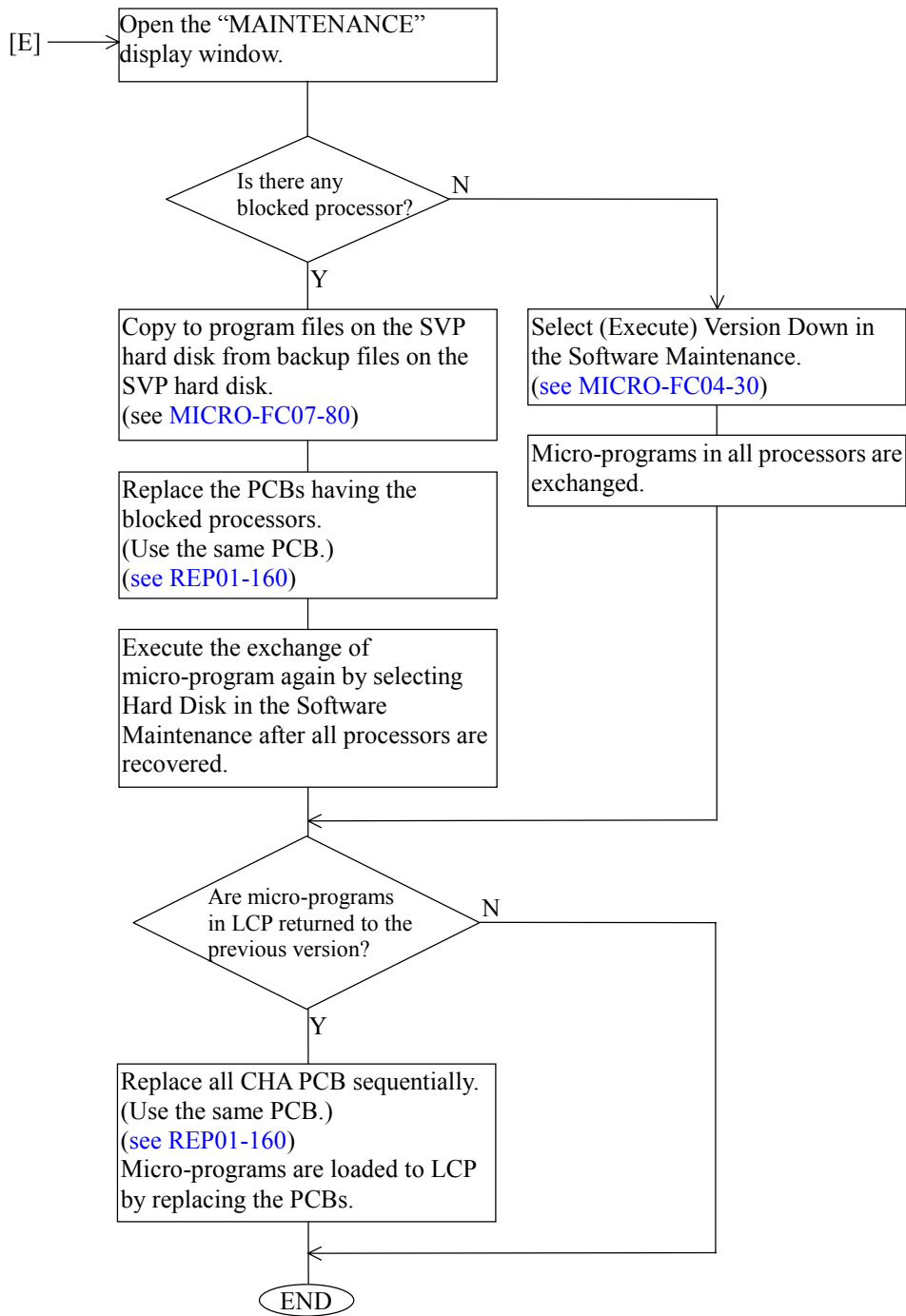

[Copy to program files from backup files on the SVP hard disk]

- (1) Select (CL) [Run...] from the [Start] button.



- (2) Insert the Micro-program media (CD-ROM) in the CD-ROM drive, and wait until the CD-ROM drive recognizes the CD-ROM.

- (3) Input the file name "E:\mainbk.bat" in 'Open' and select (CL) [OK].

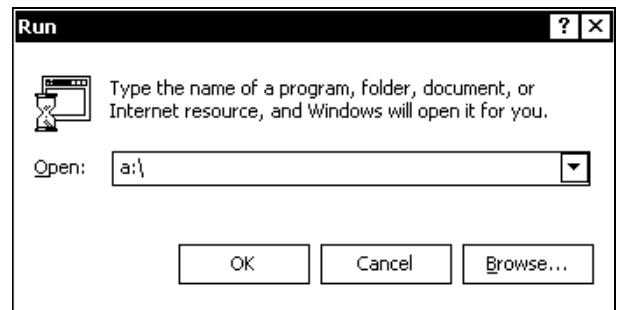

[Recovery procedure when a DKU error occurs during a downloading of the micro-program (DKU micro-program)]

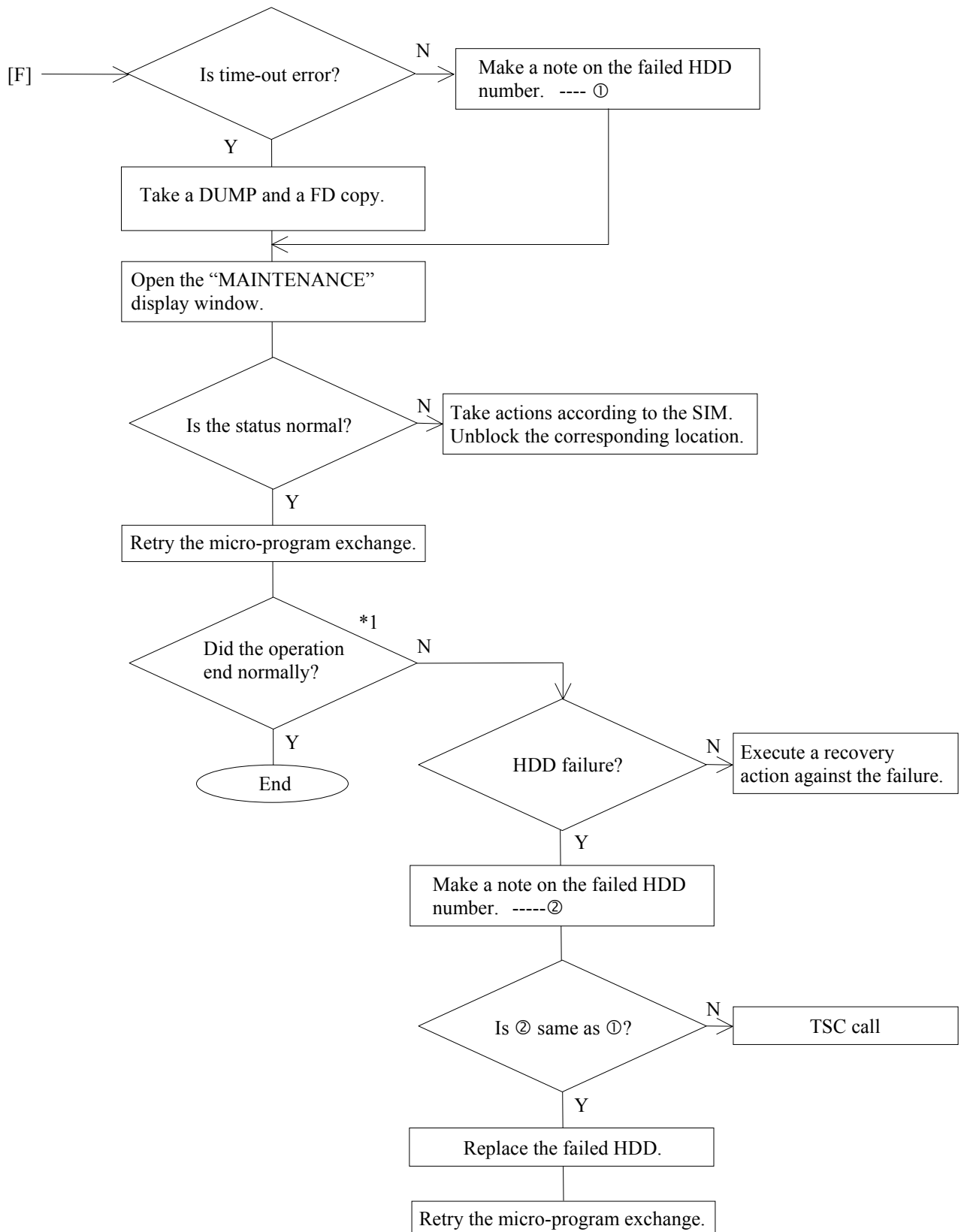

7.2 Recovery procedure in off-line menu was selected

If trouble occurs while the micro-programs are being exchanged, symptoms (1) to (8) below can be observed apparently. In these cases, use the recovery procedures shown in flowcharts [A] to [F].

- (1) A power failure occurs.
→Go to [A] ([MICRO-FC07-120](#))
- (2) Time-out display appears on SVP screen. (“On exchanging a microprogram. An error has occurred. Processing is stopped. Confirm the status and Version of subsystem. Phase: xxxx” message is displayed.)
 - (a) System block processing (phase: preprocedure display) error.
→Go to [B] ([MICRO-FC07-130](#))
 - (b) Micro-program downloading (phase: download display) error.
→Go to [C] ([MICRO-FC07-130](#))
 - (c) System recovery processing (phase: recover display) error.
→Go to [D] ([MICRO-FC07-140](#))
- (3) An error occurs in data transferred to the DKC.
(The message “It failed in the writing to the flash memory” is displayed.)
→Go to [E] ([MICRO-FC07-150](#))
- (4) An I/O error occurs on the SVP hard disk.
(The message “File I/O error has occurred” is displayed)
(The message “Memory error has occurred” is displayed)
→Go to [F] ([MICRO-FC07-160](#))
- (5) An AP error occurs, resulting in PC trouble (Key-in operations are disabled and the screen disappears).
→Go to [E] ([MICRO-FC07-150](#))
- (6) Off-line micro-program exchange function not supported.
(“The version of Main microprogram is inconsistent with the SVP.” message is displayed.)
- (7) Recovery of a cache failure during the micro-program exchange of DKCMAIN Action.
- (8) In case of uncorrect version display (“??-??...” or incompatibility).
→Go to [B] ([MICRO-FC07-130](#))

[Sections to be referenced for recovery procedure]

- (i) Status display : 3.4 Main screen on SVP section
- (ii) Version display : 3.9 Micro-program version on SVP section
- (iii) MP installation : 5 MP Install
- (iv) Package exchange : 1 Hot Replace on REPLACE section
- (v) PC exchange : 1 Hot Replace on REPLACE section

[Recovery Procedure for Power Failure]

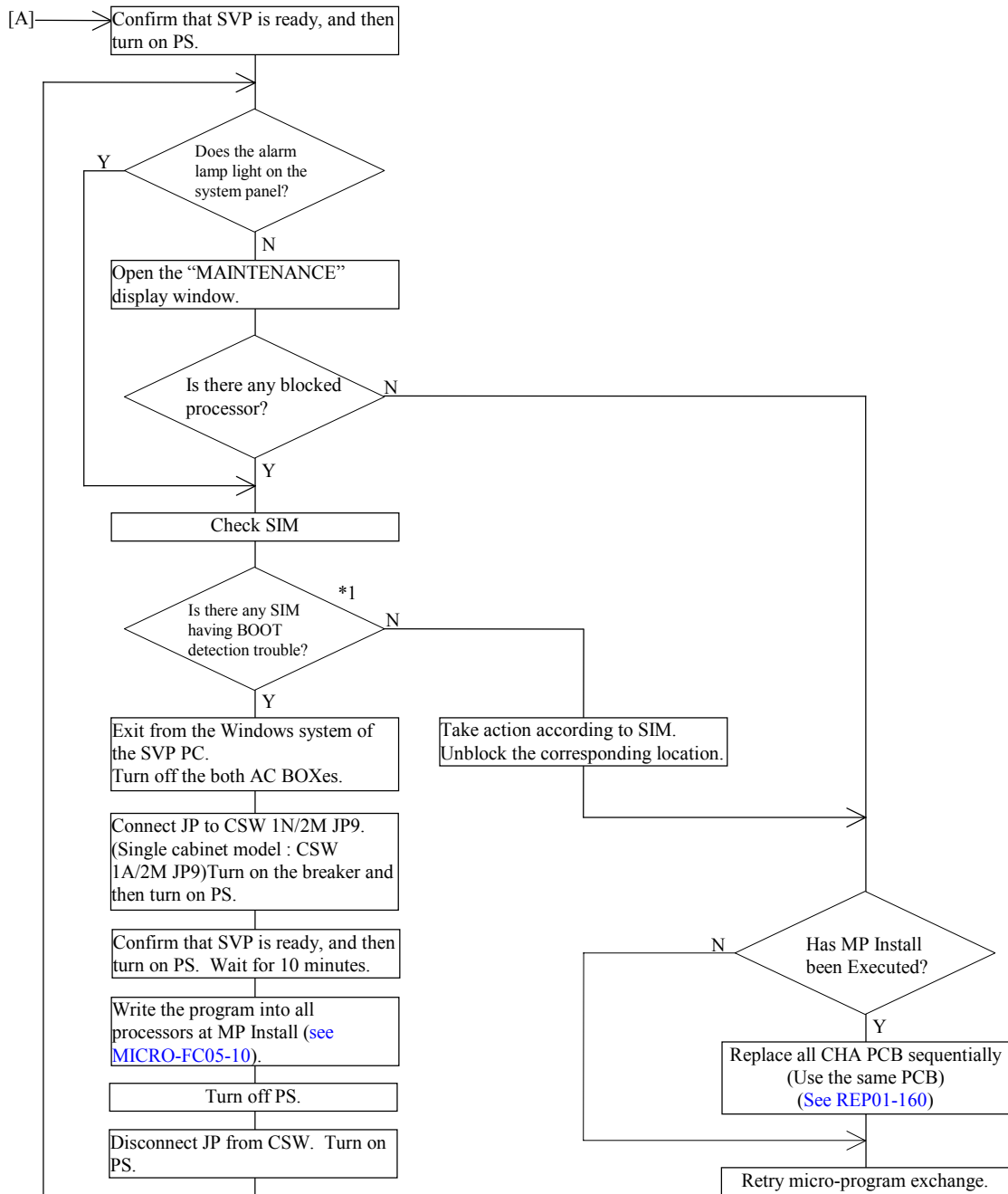

[Recovery procedure for communication time-out during system block processing/micro-program downloading/Version incompatibility]

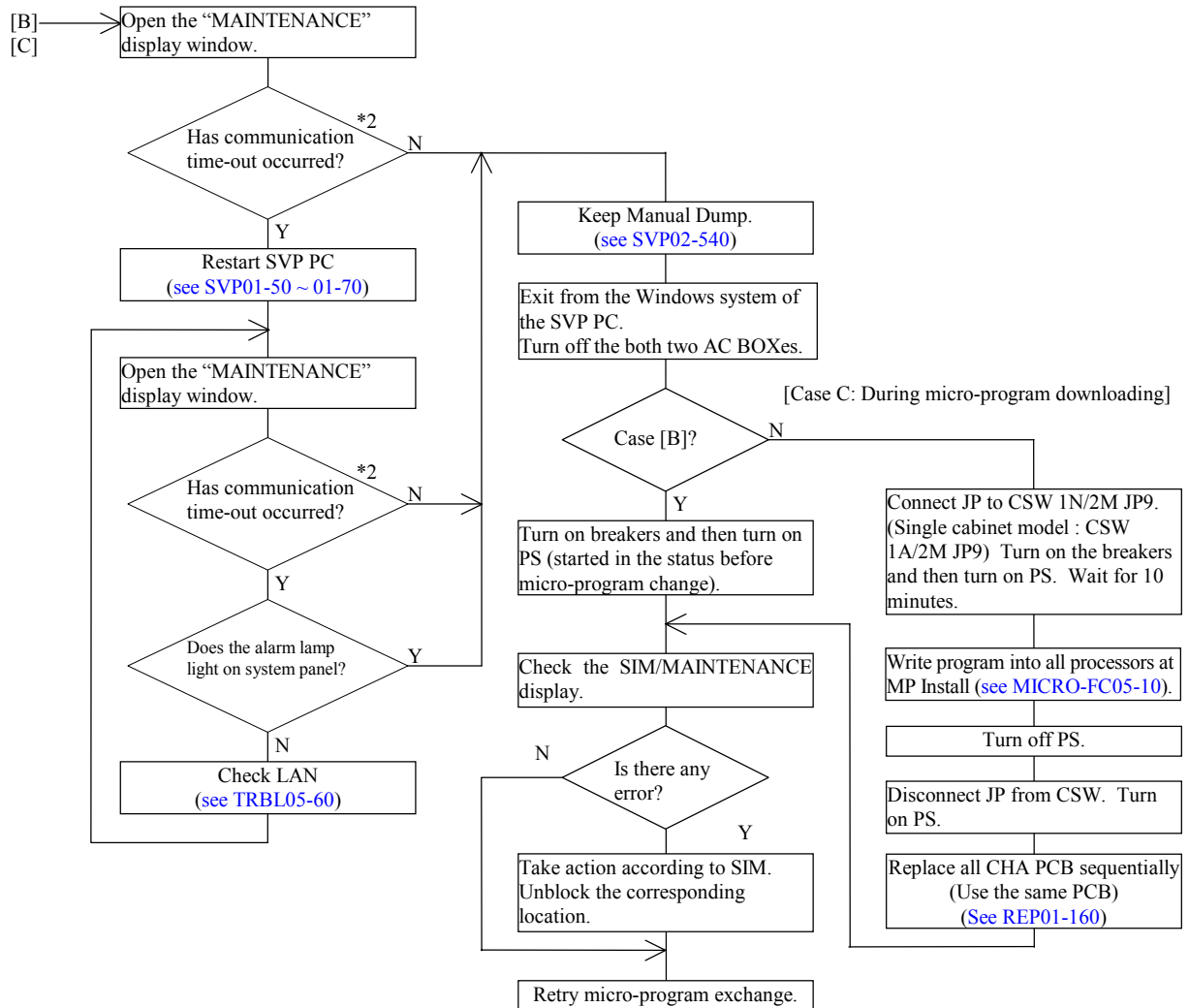

[Recovery procedure for communication time-out during system recovery processing]

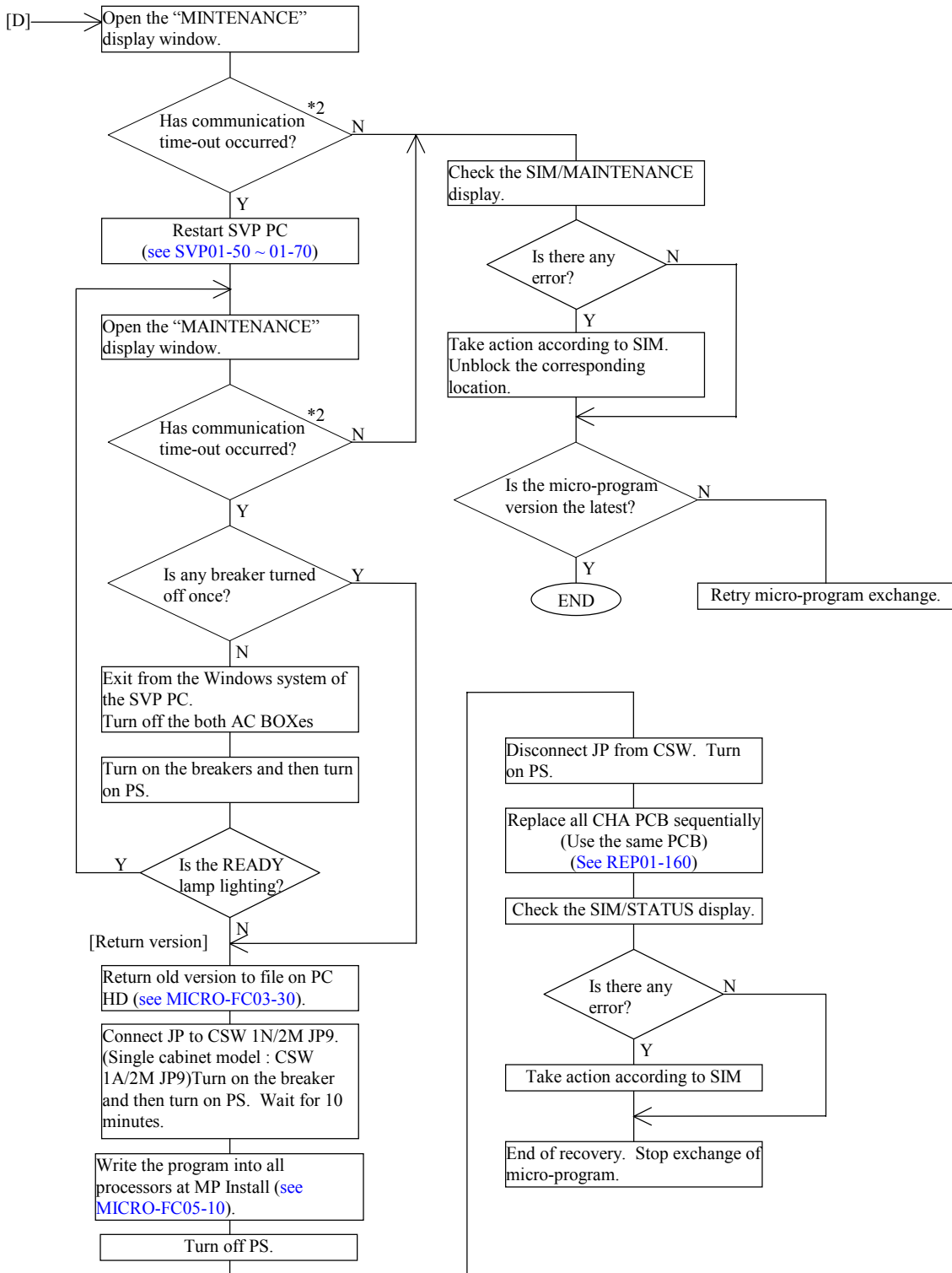

[Recovery Procedure for an error in data transferred to the DKC/AP error/PC error]

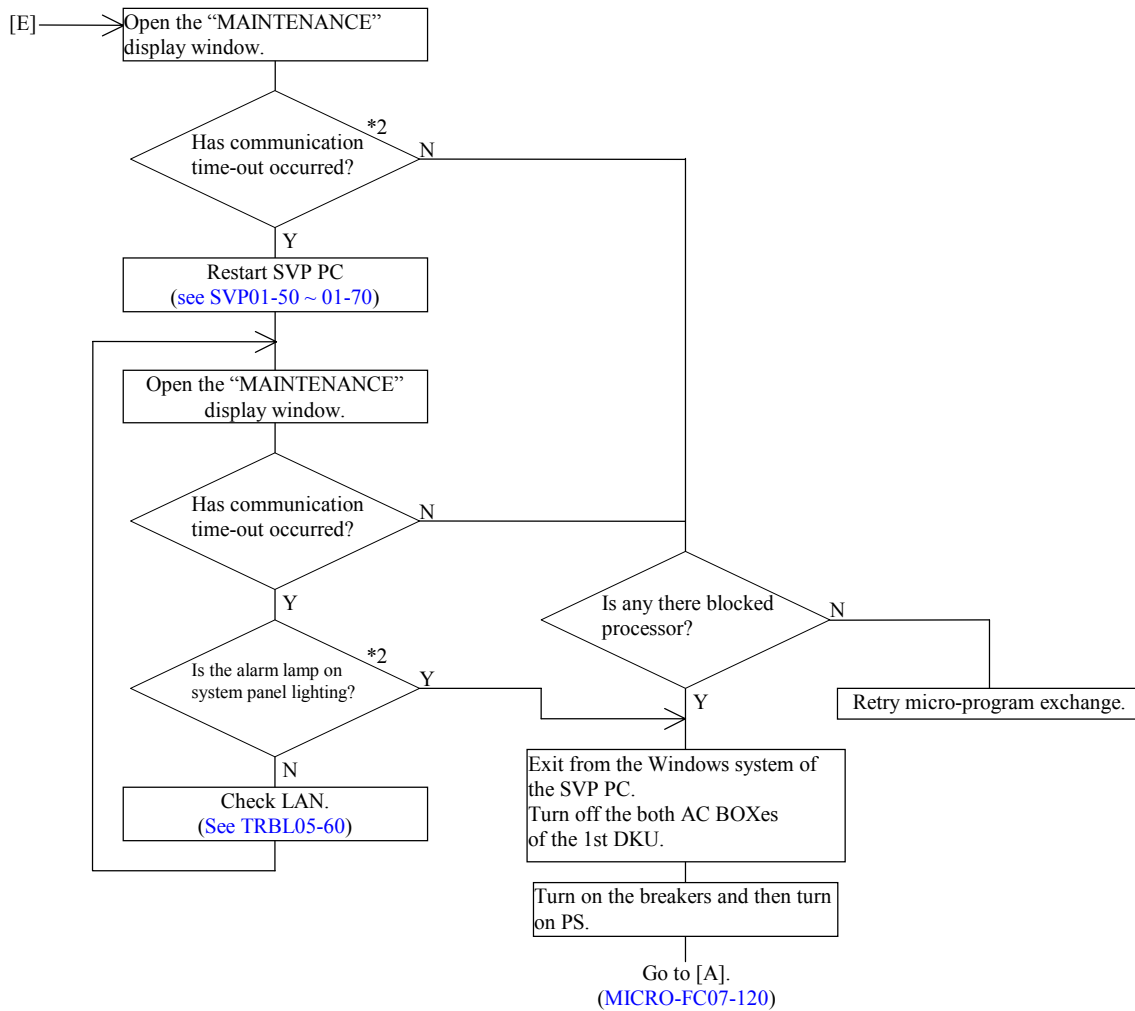

[Recovery Procedure for I/O Error on SVP Hard Disk]

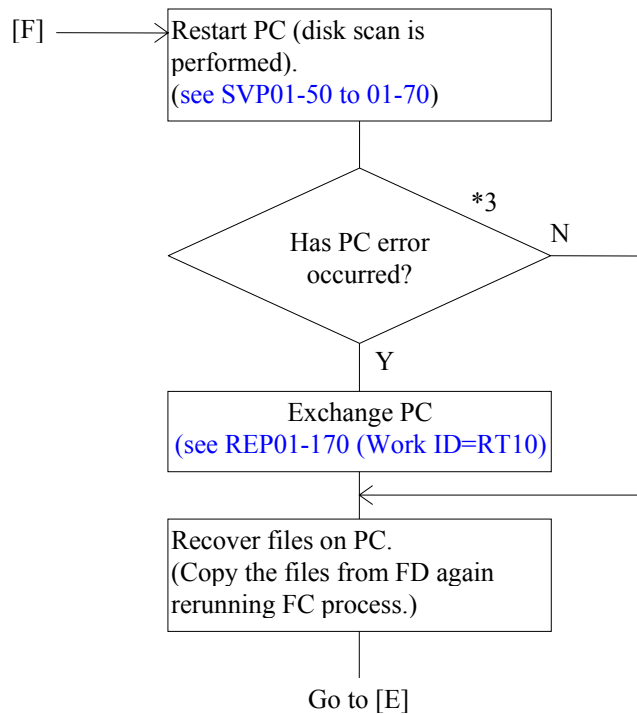

*1) Reference code “7900X0” or “7901X0”

X: Shows processor id. (See [SIM-RC02-270](#))

For details of the trouble, refer to the explanation about the BOOT detected error at SSB (Byte27 =8C).

(See [SSBLOG05-1620](#))

*2) The message “connection error occurred SVP-DKC” is displayed.

*3) The message “Please turn off SVP and replace it” is displayed.

<Recovery of a cache failure during the micro-program exchange of DKCMAIN Action>

1. Retry micro-program exchange of DKCMAIN program.
 - For Version up by Offline FC : Refer to [MICRO-FC03-270](#).
 - For Version up by Online FC : Refer to [MICRO-FC04-160](#).
 - For Version down by Offline FC : Refer to [MICRO-FC03-290](#).
 - For Version down by Online FC : Refer to [MICRO-FC04-170](#).

<Note>

 - The processors which had finished the micro-program exchange to new version will be skipped.
 - Password is necessary.

2. Then, replace the failure parts according to SIM message and M.M..

8 Config Exchange Procedure

8.1 Config Version Up

(1) Select (CL) [Install] in the 'SVP' window and select (CL) [Copy Config Files] in the 'Install'.

(2) Select (CL) [Configuration Update] in the 'Copy Config Files'.

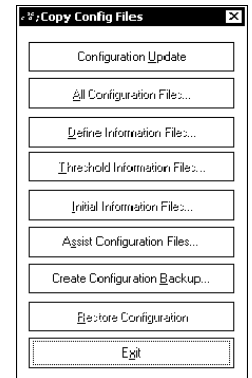

(3) Select (CL) [OK] after the Config FD insertion for upgrade.



(4) Perform copy processing of composition information from Config FD to SVP.
In the meantime, the 'CNFCPY Wait...' window is displayed.

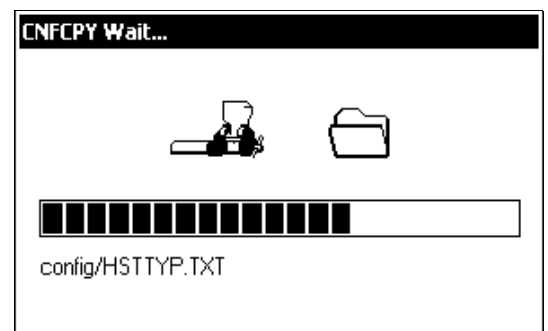

- (5) Select (CL) [OK] in response to 'Please remove the Config FD'.



- (6) Processing for reflecting composition information is performed.
In the meantime, the wait window is displayed.

- (7) Select (CL) [OK] after the Config FD insertion for backup.

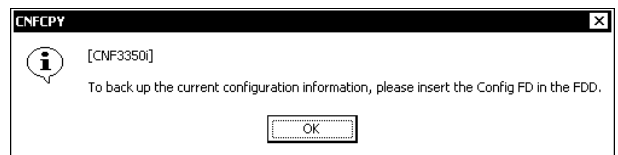

- (8) If you want to continue, select (CL) [Yes].
(Select (CL) [No], when the backup to Config FD is unnecessary.)

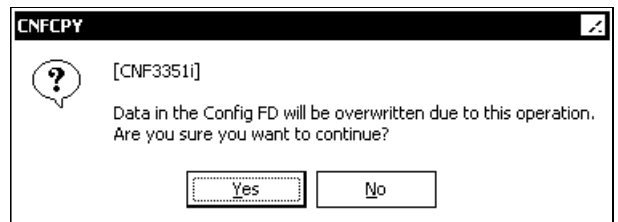

- (9) Perform backup processing of composition information to Config FD for backup. In the meantime, the 'CNFCPY Wait...' window is displayed.

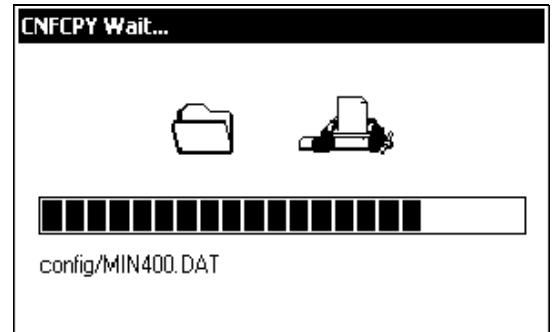

- (10) Select (CL) [OK] in response to 'Please remove the Config FD'.



- (11) When Selecting [OK] to the message 'The SVP will be rebooted.' SVP PC reboots.

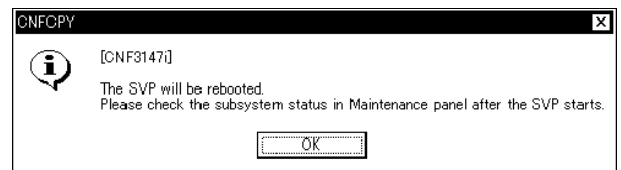

- (12) After SVP PC starts, select (CL) [MAINTENANCE] in the 'SVP' windows (See [SVP03-10](#)).

8.2 Config Backup

- (1) Select (CL) [Install] in the 'SVP' window and select (CL) [Copy Config Files] in the 'Install'.

- (2) Select (CL) [Create Configuration Backup...] in the 'Copy Config Files'.

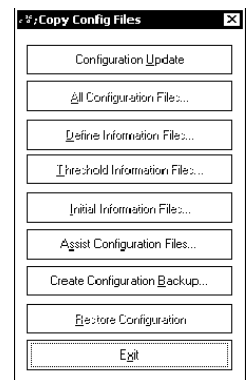

- (3) Select (CL) [OK] after the Config FD insertion for backup.



- (4) The 'CNFCPY Wait...' window is displayed.

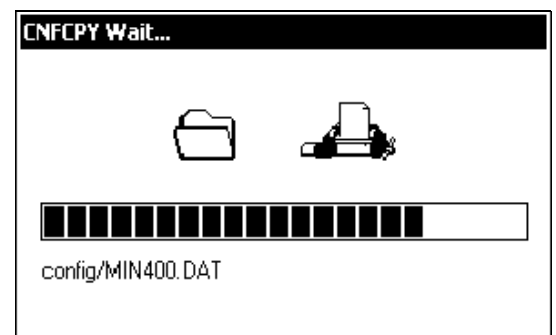

-
- (5) Select (CL) [OK] in response to 'Please remove the Config FD'.



-
- (6) Select (CL) [Exit] of the 'Copy Config Files' to finish this operation.

8.3 Define Configuration & Install

- (1) It changes into [Initial Setting] mode on the 'SVP' window.
(Select (CL) [Shift] + [Ctrl] + [I], and enter the password and select (CL) [OK].)
Select (CL) [Install] in the 'SVP' window and select (CL) [Copy Config Files] in the 'Install'.

- (2) Select (CL) [All Configuration Files...] in the 'Copy Config Files'.

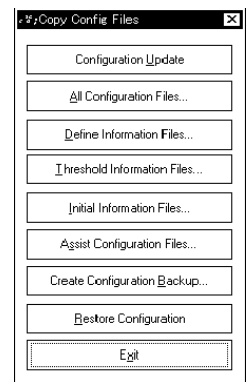

- (3) Select (CL) [OK] after the Config FD insertion for initial installation.



- (4) The 'CNFCPY Wait...' window is displayed.

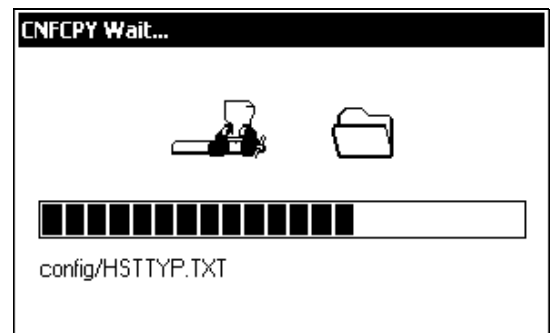

- (5) Select (CL) [OK] in response to 'Please remove the Config FD'.



- (6) Select (CL) [Exit] of the 'Copy Config Files', and execute 'Define Configuration & Install' (go to [INST05-80](#)).

8.4 Manual version up processing

- (1) It changes into [Initial Setting] mode on the 'SVP' window.
(Select (CL) [Shift] + [Ctrl] + [I], and enter the password and select (CL) [OK].)
Select (CL) [Install] in the 'SVP' window and select (CL) [Copy Config Files] in the 'Install'.

-
- (2) Select (CL) [Initial Information Files...] in the 'Copy Config Files'.
Please remove Config FD.

-
- (3) Please reboot SVP PC.

-
- (4) After processing of (1), Select (CL) [Define Information Files...] in the 'Copy Config Files'.

-
- (5) Select (CL) [Threshold Information Files...] in the 'Copy Config Files'.
Please remove Config FD.

-
- (6) Select (CL) [Set IP Address] in the 'Install Subsystem' window. (See [INST05-60](#))
(i) Select (CL) [SVP] and then select (CL) [OK] after entering IP Address and Subnet Mask.
(ii) In response to the message "This will reboot SVP.", select (CL) [OK].

-
- (7) Select (CL) [Install] in 'SVP'.
Select (CL) [Change Configuration] in the 'Install Subsystem' window.
Select (CL) [Tuning Parameter] in the 'Menu Dialog' window and select (CL) [OK] (See [SVP02-1210](#)).

-
- (8) Select (CL) [MAINTENANCE] in the 'SVP' windows (See [SVP03-10](#)).