

DKC REPLACEMENT PROCEDURE SECTION

Contents

DKC REPLACEMENT

1 DKC Change	DKCREP01-10
1.1 Abstract	DKCREP01-10
1.2 Measures to attain the purpose	DKCREP01-10
1.3 Old subsystem configuration restrictions	DKCREP01-10
1.4 New subsystem configuration restrictions	DKCREP01-20
1.5 Restrictions of configuration expansion	DKCREP01-20
1.6 The kind of reported SSB and SIM (Only when a SCSI cable and an environment monitor cable don't connect it.)	DKCREP01-20
2 DKC Change flowchart	DKCREP02-10
3 Procedure of saving configuration information to FD for DKC Change	DKCREP03-10
4 Procedure of loading configuration information from FD (used in new DKC)	DKCREP04-10
5 Procedure of Micro-program replacement to SVP	DKCREP05-10
6 Procedure of setting System Option Mode	DKCREP06-10
7 Procedure of Removing and Inserting RS232C cable	DKCREP07-10
8 Rip & Ship	DKCREP08-10
8.1 Abstract	DKCREP08-10
8.2 Measures to attain purpose	DKCREP08-10
8.3 Restrictions	DKCREP08-10
8.4 The kind of reported SSB and SIM	DKCREP08-10
8.5 Operations	DKCREP08-10
8.6 Troubleshooting	DKCREP08-10
9 DKC SWAP (from RAID400 to RAID450)	DKCREP09-10
9.1 Outline	DKCREP09-10
9.1.1 Abstract	DKCREP09-10
9.1.2 Measures to attain the purpose	DKCREP09-10
9.1.3 Old subsystem (RAID400) configuration restrictions	DKCREP09-15
9.1.4 New subsystem configuration restrictions	DKCREP09-20
9.1.5 Re-establishment item	DKCREP09-30
9.1.6 The kind of reported SSB and SIM	DKCREP09-30
9.2 Change flowchart	DKCREP09-50
9.3 Procedure of saving Configuration Information to FD (used in RAID400)	DKCREP09-230
9.4 Machine Installation Procedure	DKCREP09-250
9.5 Procedure of loading configuration Information from FD (used in RAID450)	DKCREP09-260

9.6 Work sheet.....	DKCREP09-410
9.6.1 System Option Modes.....	DKCREP09-410
9.6.2 Program Product.....	DKCREP09-430
9.6.2.1 HPAV.....	DKCREP09-430
9.6.2.2 LDEV Security	DKCREP09-450
9.6.2.3 E-Copy.....	DKCREP09-470
9.6.2.4 LUN Security	DKCREP09-490
9.6.2.5 HIHSM	DKCREP09-560
9.6.2.6 HMRCF.....	DKCREP09-600
9.6.2.7 HOMRCF.....	DKCREP09-650
9.6.2.8 TRUE COPY.....	DKCREP09-700

1 DKC Change

1.1 Abstract

Purpose of DKC change is to enable user's LDEV/PDEV resources to be continuously used when the DKC is exchanged.

1.2 Measures to attain the purpose

Information to be handed over is saved on FD by the SVP of the former subsystem and installed by the SVP of the new subsystem.

NOTE : DKC replacement procedure needs two blank FDs.

1.3 Old subsystem configuration restrictions

No.	Condition/restriction	Detail	Restriction guard
1	STATUS of subsystem	<ul style="list-style-type: none"> • The switching is allowed even if a failed part or a PIN exist. • The switching is not allowed if a Correction copy or Drive copy is running. • The switching is not allowed if a Verify function is running. • Micro-code version must be changed to supported version. 	If the restriction is violated, the FD is not supported.
2	HDD type	<ul style="list-style-type: none"> • There is no restriction. 	
3	RAID level	<ul style="list-style-type: none"> • There is no restriction. 	
4	Cache configuration	<ul style="list-style-type: none"> • There is no restriction. 	
5	Emulation type	<ul style="list-style-type: none"> • There is no restriction. 	

1.4 New subsystem configuration restrictions

No	Condition/restriction	Detail	Restriction guard
1	A failed part or a blocked part status.	<ul style="list-style-type: none"> CHA/DKA/Cache/CSW/SM, etc. must be all normal status. LDEV/PDEV/FSW, drive port can be Blocked. 	If the restriction is violated, the FD is not supported.
2	Cache configuration	<ul style="list-style-type: none"> Cache capacity must be the same as that of the old subsystem. Cache SIMM size and its location must be the same as those of the old subsystem. 	Restriction is violated, configuration information error will occur (SSB, SIM or blocked parts). Configuration information must be checked by technical support.
3	SM configuration	<ul style="list-style-type: none"> SM capacity must be the same as that of the old subsystem. SM SIMM size and its location must be the same as those of the old subsystem. 	
4	Number of CHA/DKA PCBs and their locations	<ul style="list-style-type: none"> Number of CHA/DKA PCBs and their locations must be the same as those of the old subsystem. 	
5	Number of Channels and their locations	<ul style="list-style-type: none"> Number of channels and their locations must be the same as those of the old subsystem. 	
6	Number of Cache PCBs and their locations	<ul style="list-style-type: none"> Number of Cache PCBs and their locations must be the same as those of the old subsystem. 	

1.5 Restrictions of configuration expansion

There are no restrictions.

1.6 The kind of reported SSB and SIM

(Only when a SCSI cable and an environment monitor cable don't connect it.)

SIM CODE	contents	Note
3da0	FSW LED bus test error.	An influence by the un-connection of FIBRE cable.
7410	SSVP error.	An influence by the unconnection of the RS232C cable.
7ff2xx	Stand by SVP error.	An influence by the SVP high reliability kit.
ac50	HDU power off.	An influence by the un-connection of the FIBRE cable.
bfx	Environmental Error.	An influence by the un-connection of the environment monitor cable.
ffe7	Shared memory is volatilized.	An influence due to breaker Off/on.

Error Code	contents	Note
001d	From FM, to SM, micro-transfer practice	At the time of the Shared Memory volatile mode.
32cc	HDU power off.	An influence due to breaker Off/on.
35ac	SVP-DKC communication error.	The subsystem configuration not include CHT PCB.
9b3o	Request of sleep.	An influence by the un-connection of the FIBRE cable.
9fo1	After the DMP job I/O error, recovery process is stop.	
a040	Maintenance process LIP or Login is time out.	
a47c	A SCSI Cable cutout is removed.	An influence due to breaker Off/on.
aec9	The status injustice of SPC interrupts.	
ae57	BUS DEVICE RESET	
ae5c	DRIVE LED NG.	
b440	TPC initialize success.	The subsystem configuration include CHT PCB.
b453	TPC blockade success.	
b60e	Link up by "Auto Speed = 2GB".	
b60f	Link up by "Auto Speed = 1GB".	

2 DKC Change flowchart

NOTICE

Field Engineers are to perform a check referring to "Restrictions" before you start DKC Change.
Reference : [DKCREP01-10 ~ DKCREP01-20](#)

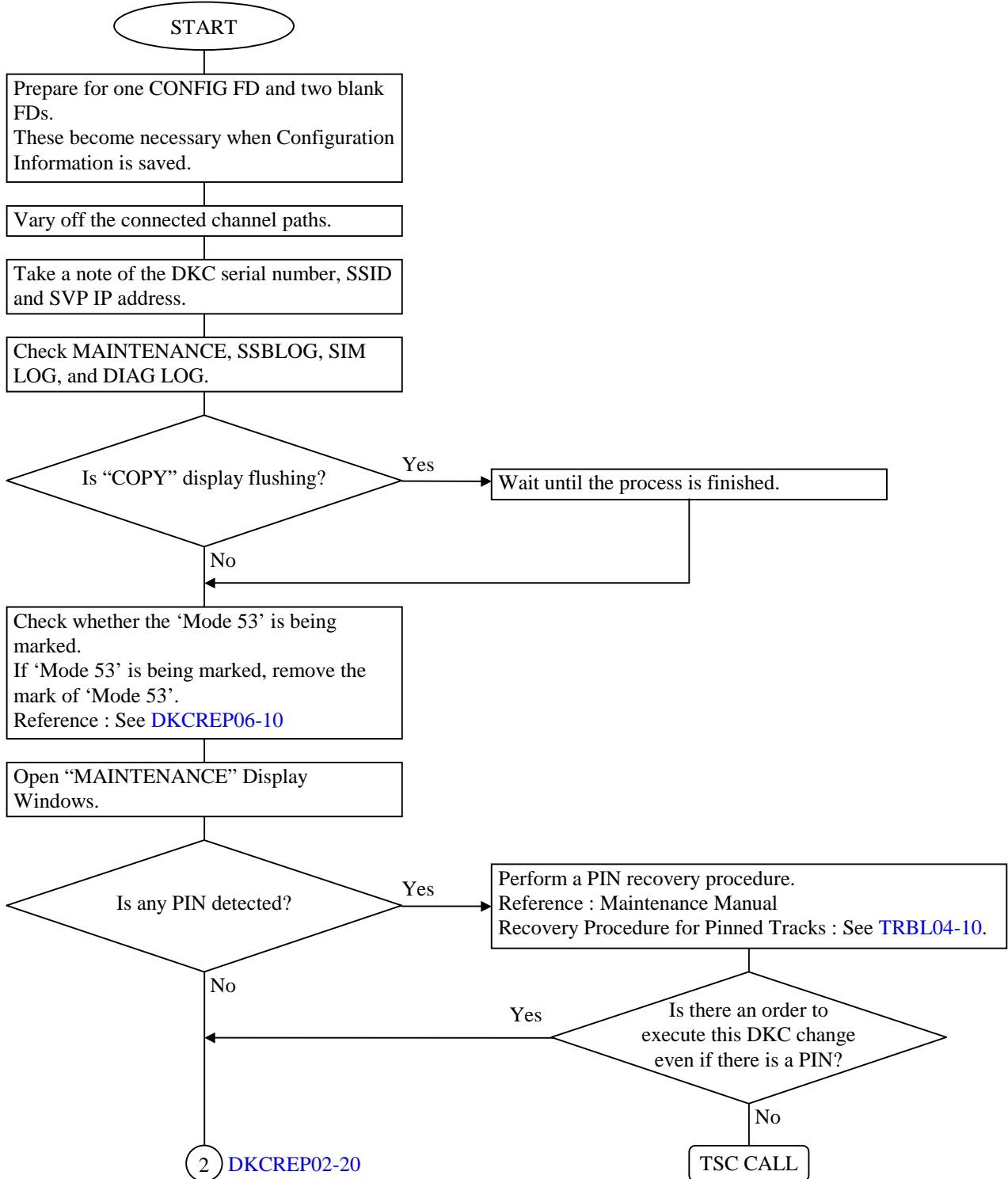

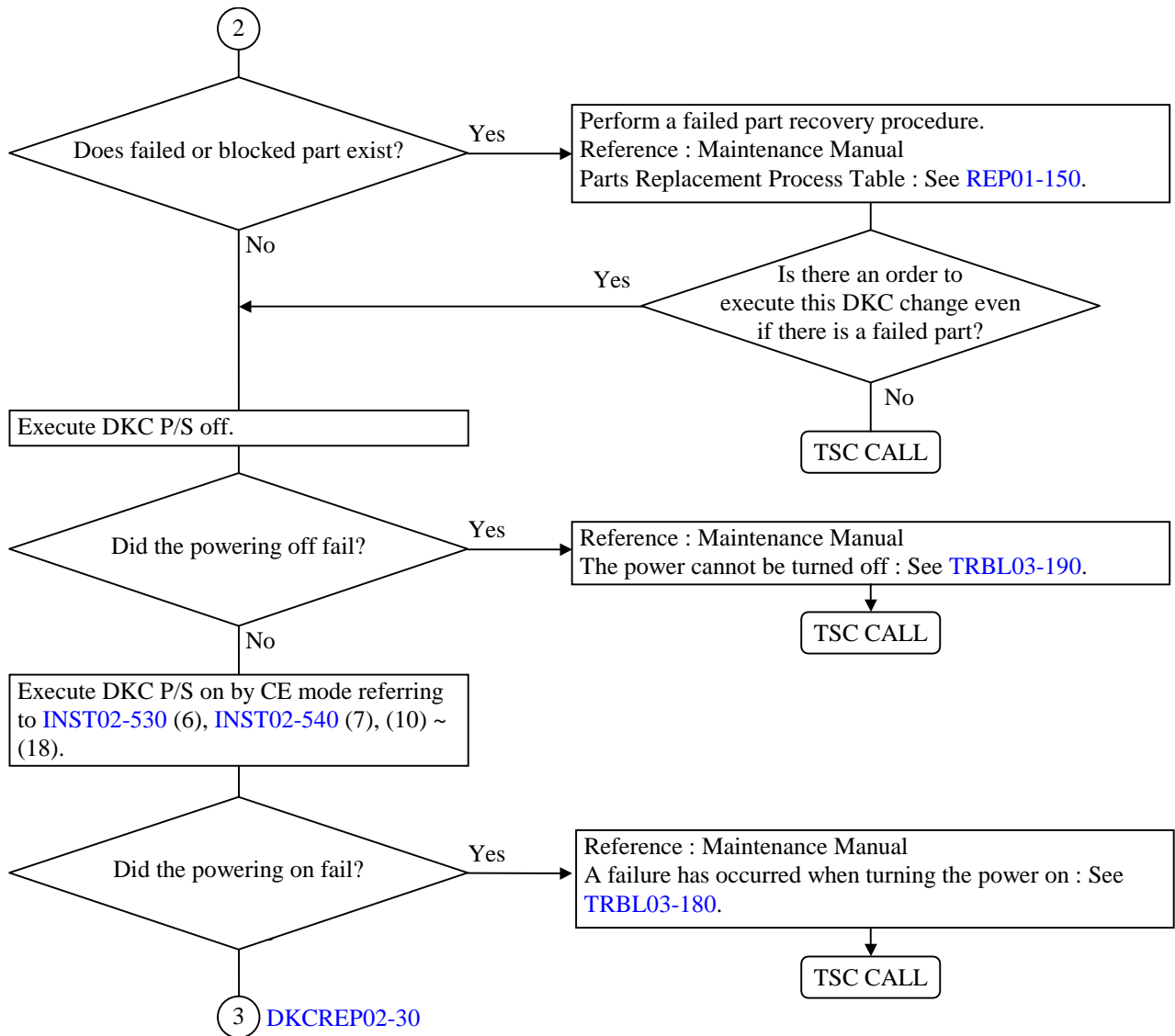

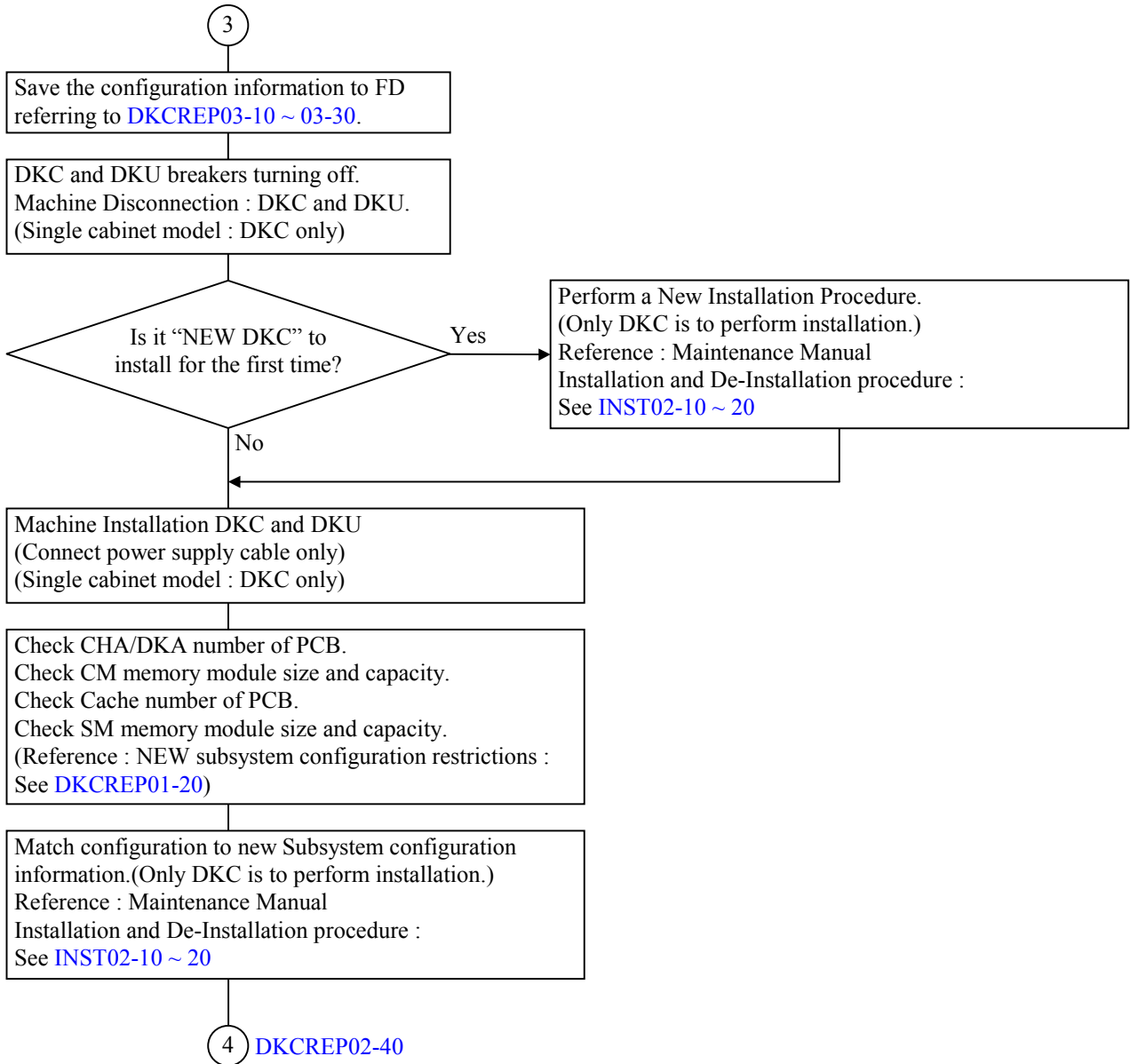

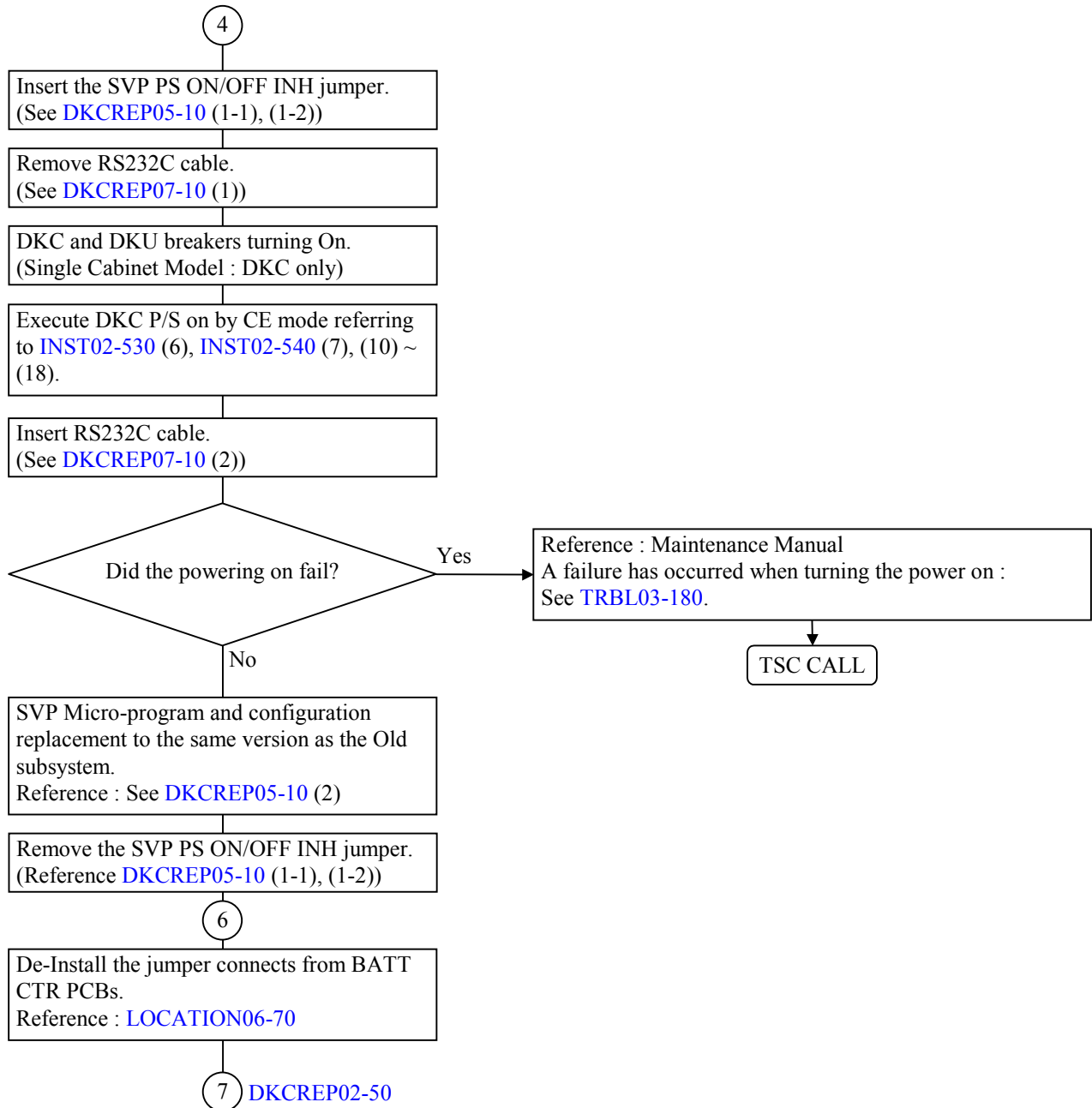

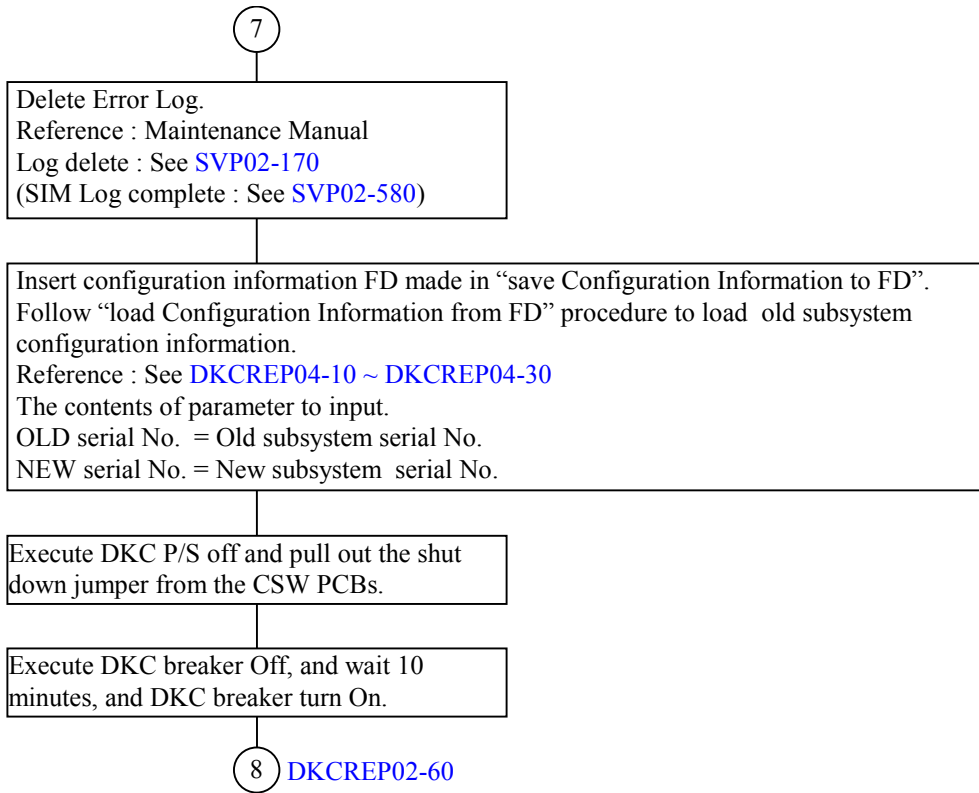

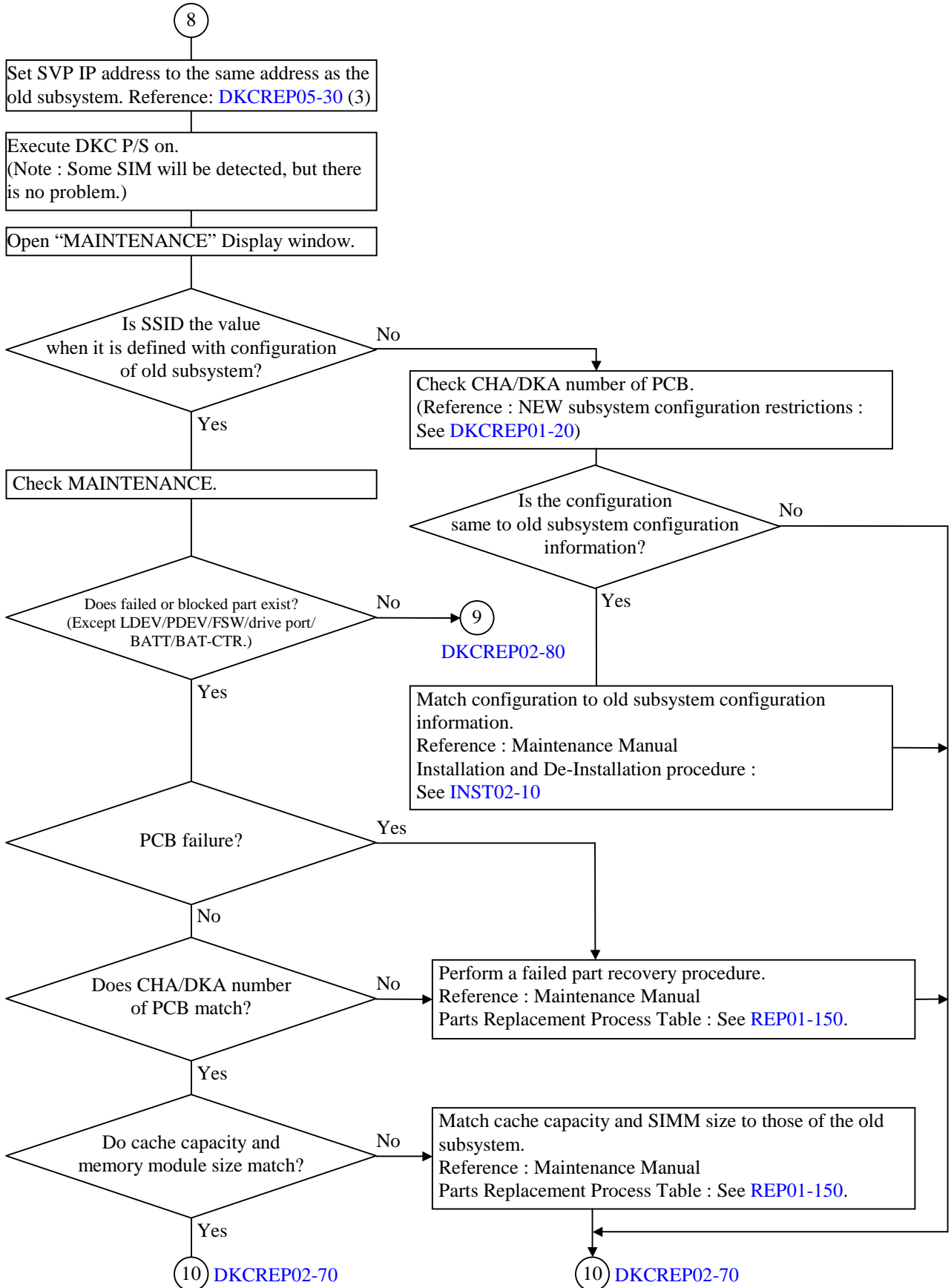

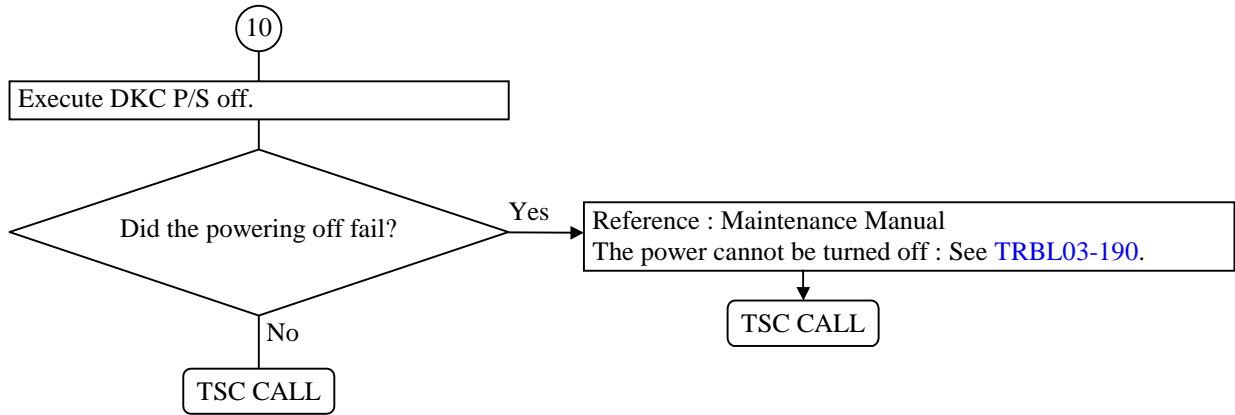

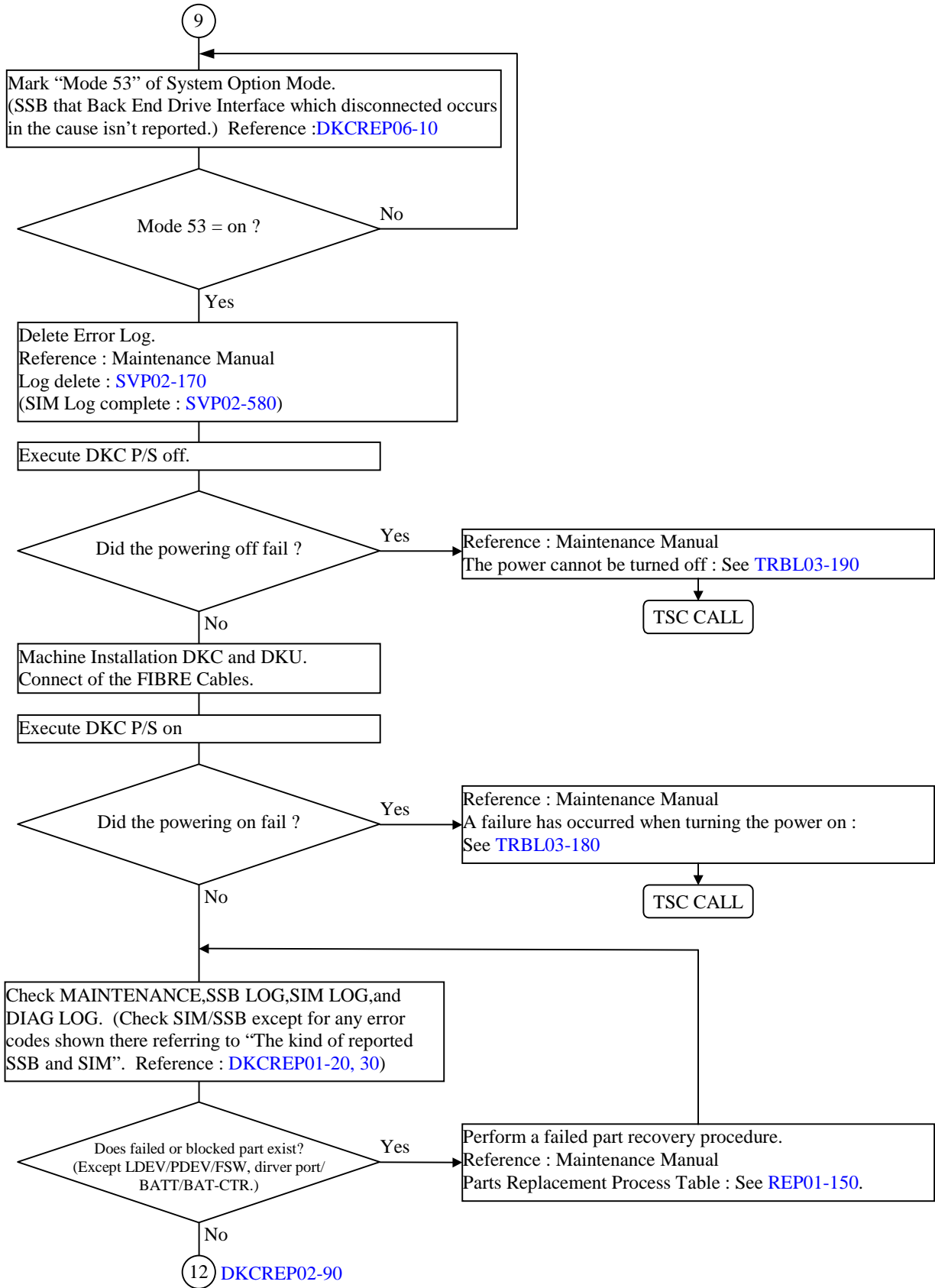

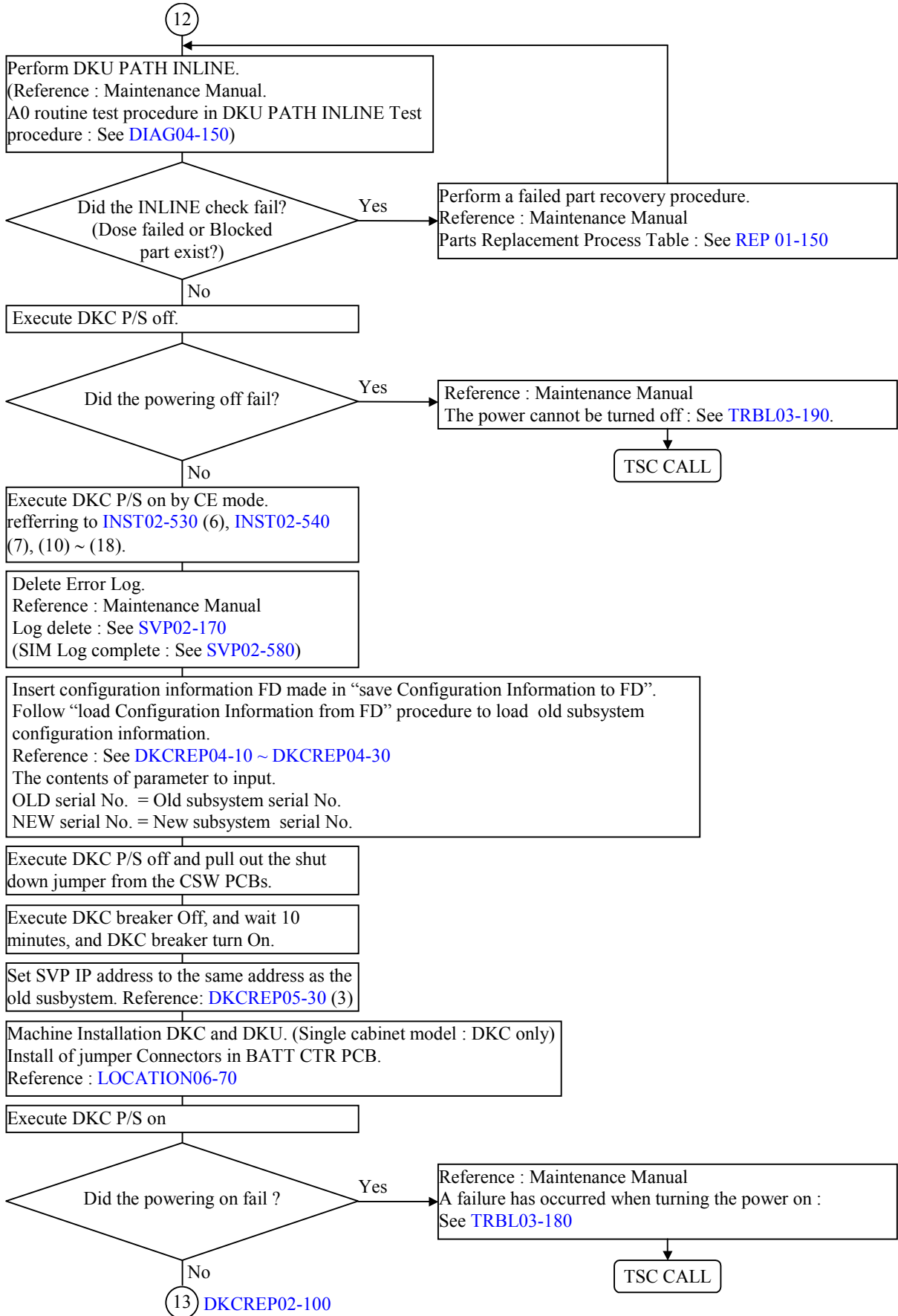

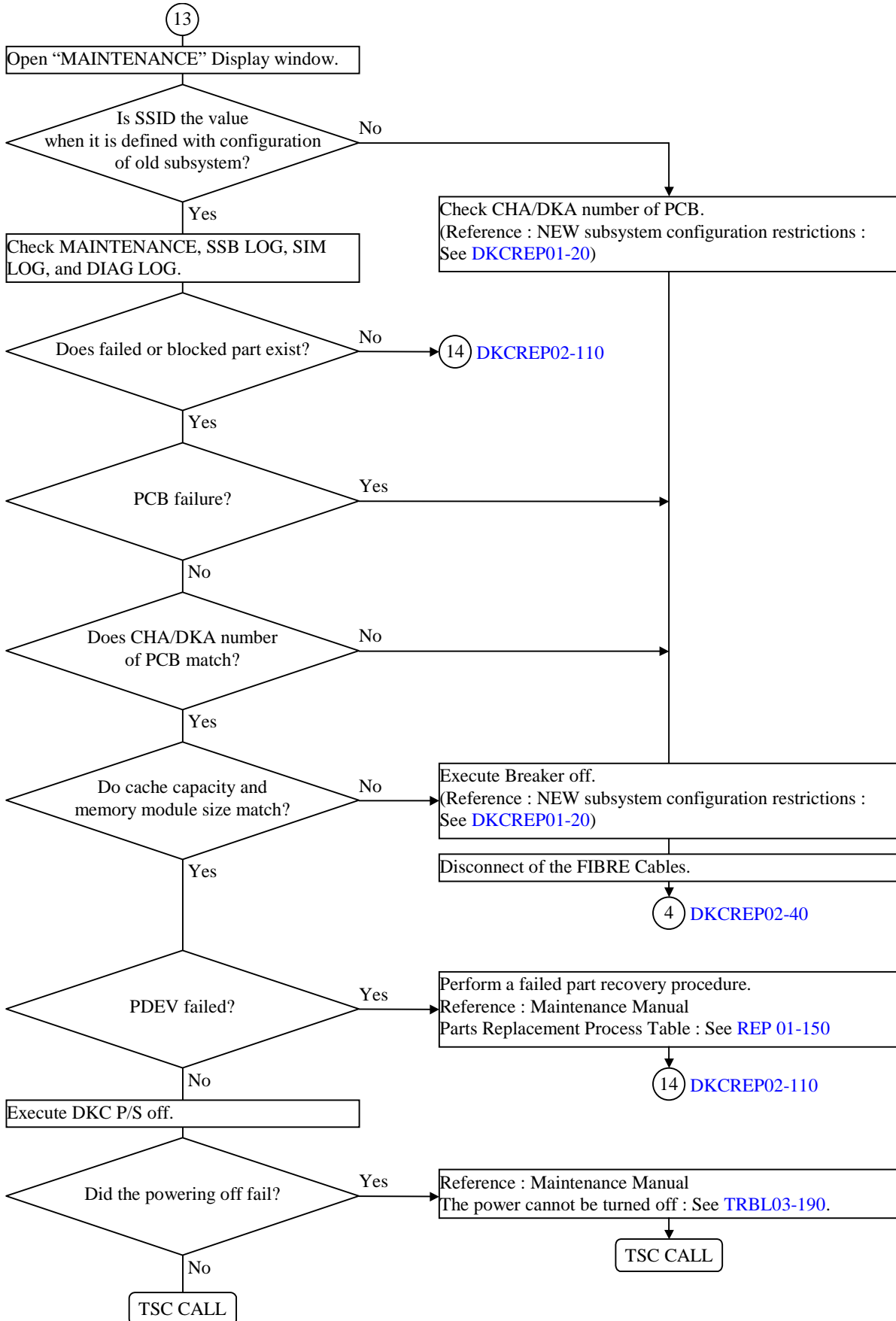

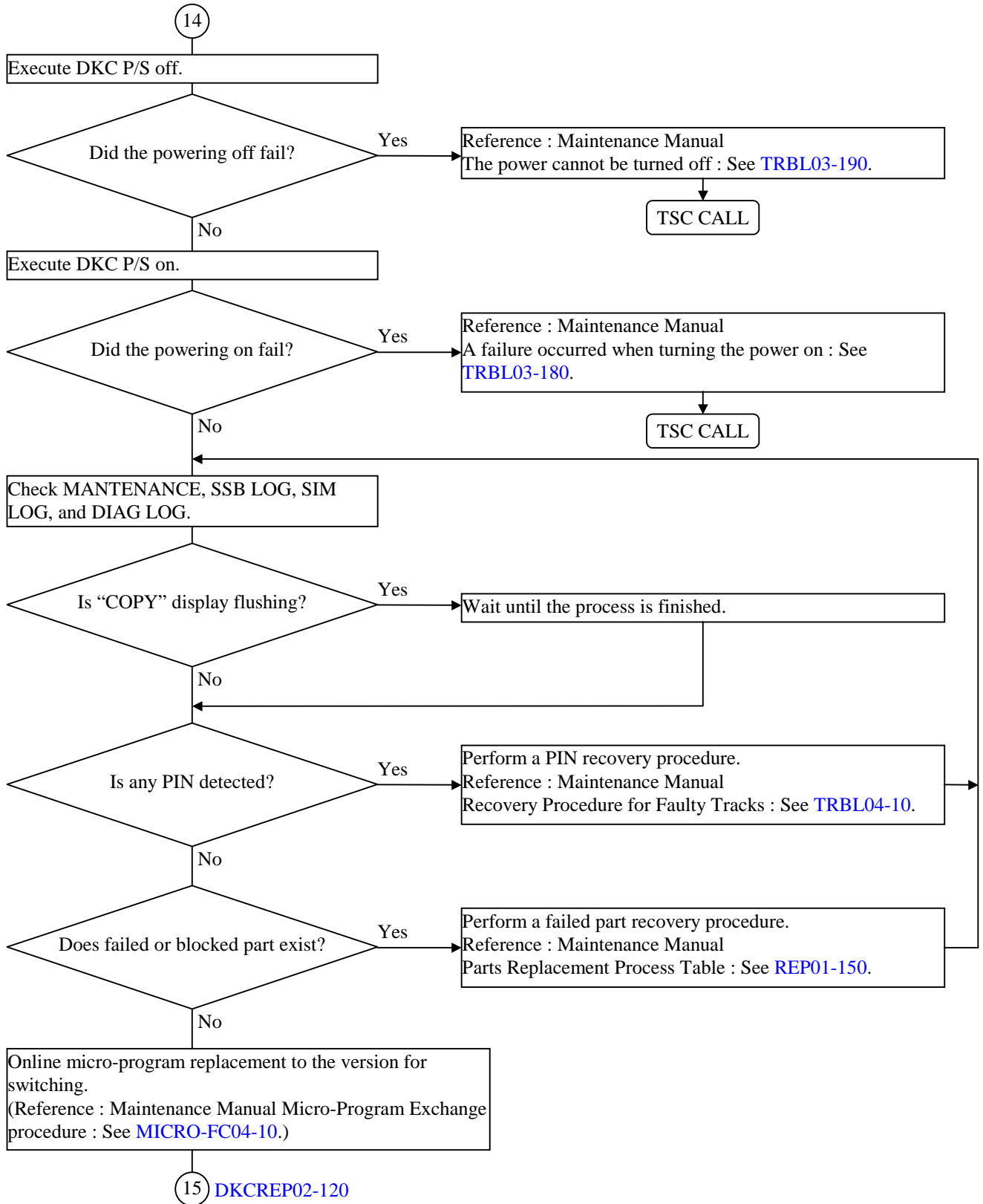

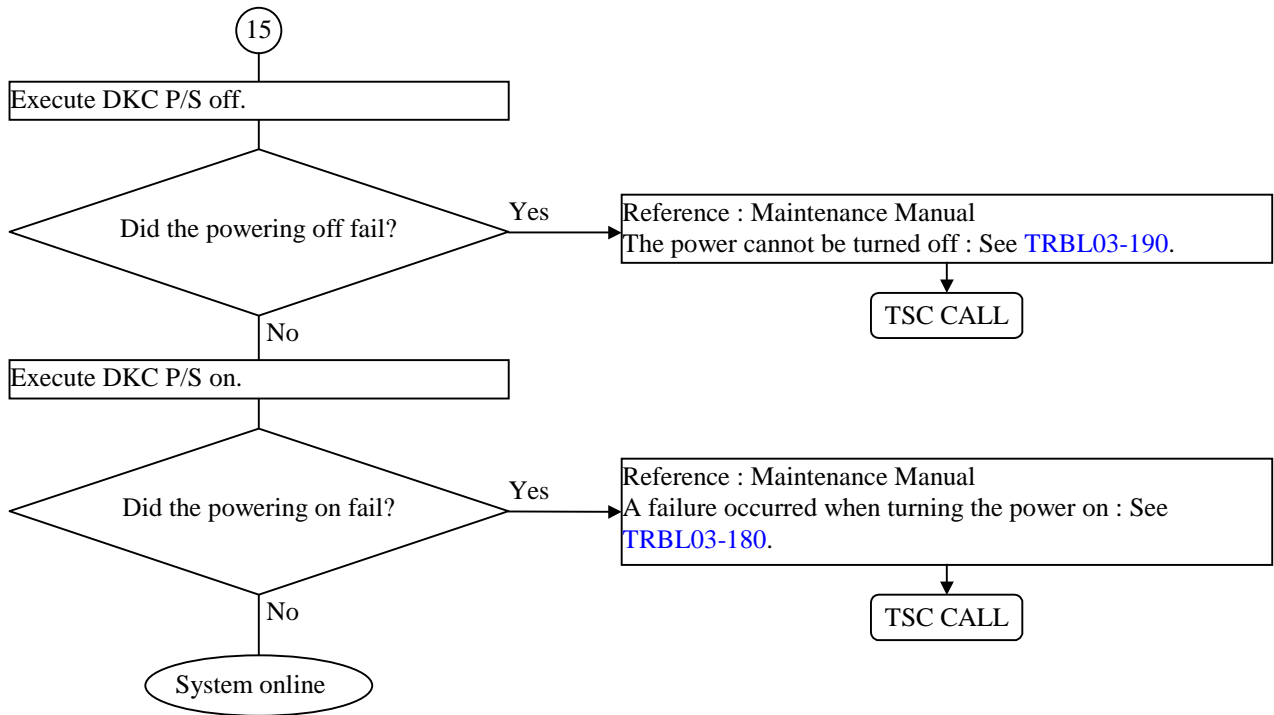

3 Procedure of saving configuration information to FD for DKC Change

- (1) Change the mode to [Swap Mode].
 - Select “Shift”+“Ctrl”+“Alt”+“P”.
 - Enter the password and select (CL) [OK].
 - Select (CL) [Install].

- (2) <DKC REPLACEMENT>
Select (CL) [DKC REPLACEMENT].

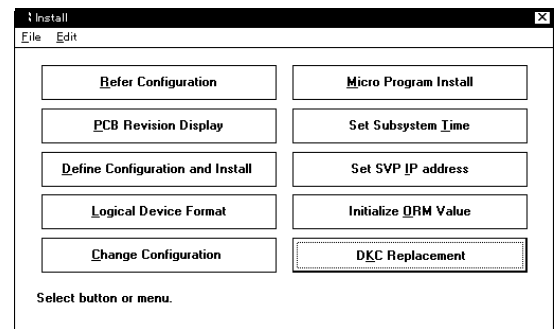

- (3) Enter the password and select (CL) [OK].
Password is needed for this operation.
Please call Technical Support Center to obtain password and authorization.

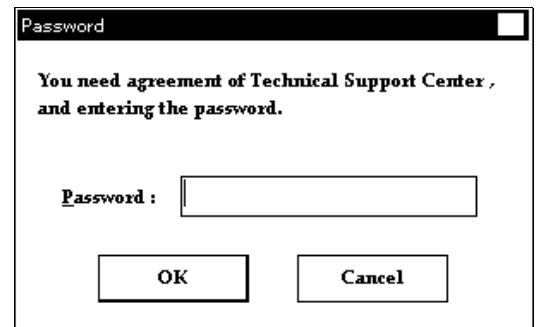

- (4) Select (CL) “Save Configuration information to FD (used in old DKC)” and select (CL) [OK] in the [DKC Replacement] window.

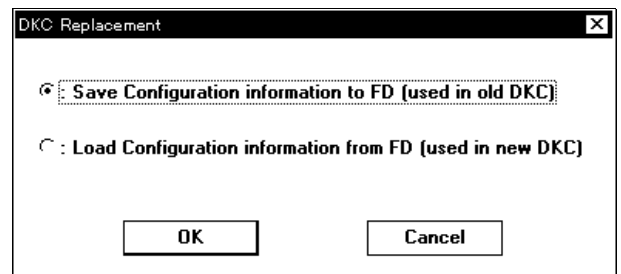

- (5) Insert a blank FD for CHA in FDD.
Then select (CL) [OK].
Next, please insert a blank FD for DKA.
Then select (CL) [OK].

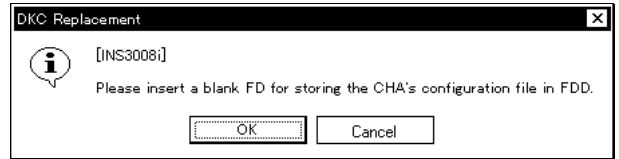

<Error case>

- Insert correct FD.
Then select (CL) [OK].

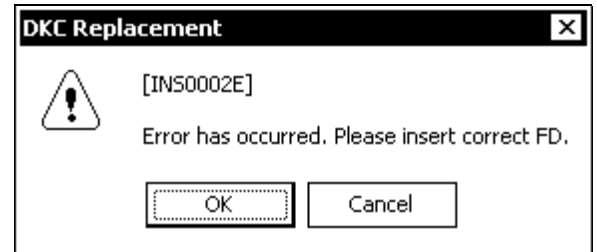

<Error case>

- Remove the write-protection.
Then select (CL) [OK].

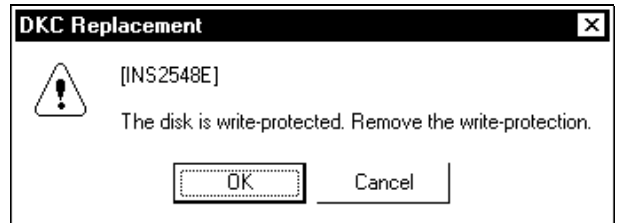

- (6) Remove FD and turn off the subsystem.
Wait until power is off.
Then select (CL) [OK].

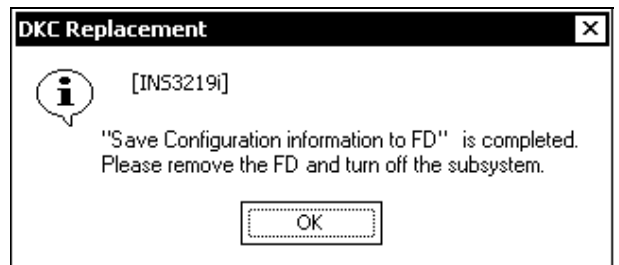

(7) Select(CL) [OK].

Note: Do not connect the old DKU to the new DKC.

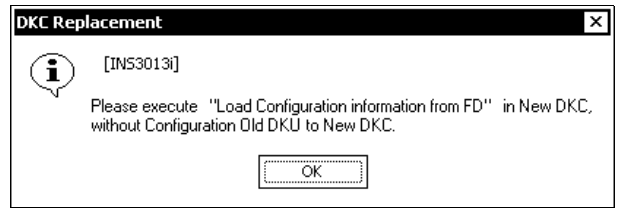

(8) Select (CL) [OK].

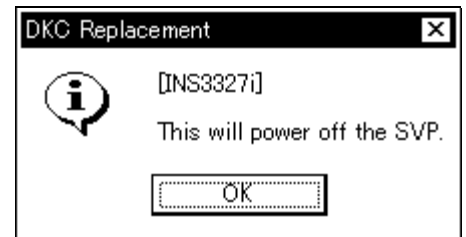

4 Procedure of loading Configuration information from FD (used in new DKC)

- (1) Change the mode to [Swap Mode]
 - Select “Shift” + “Ctrl” + “Alt” + “P”.
 - Enter the password and select (CL) [OK].
 - Select (CL) [Install].

- (2) <DKC REPLACEMENT>
Select (CL) [DKC REPLACEMENT].

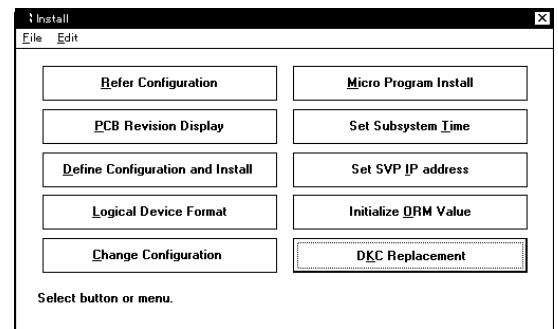

- (3) Enter the password and select (CL) [OK].
Password is needed for this operation.
Please call Technical Support Center to obtain password and authorization.

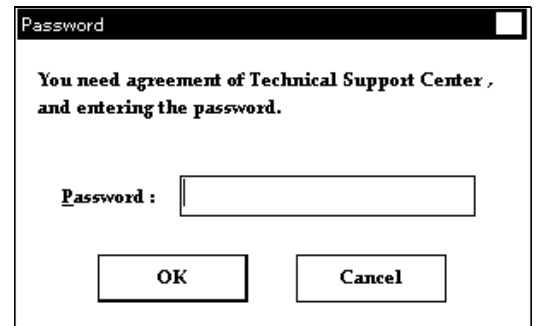

- (4) Select (CL)
“Load Configuration information from FD (used in new DKC)” and select (CL) [OK] in the ‘DKC Replacement’ window.

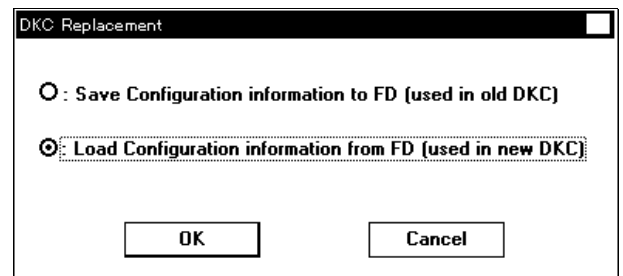

- (5) Please insert the FD which stored the CHA's configuration file in FDD.
Then select (CL) [OK].
Next, please insert the FD for DKA.
Then select (CL) [OK].

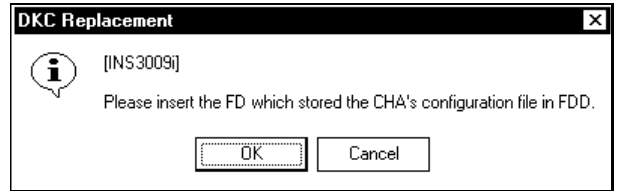

<Error case>

Please insert correct FD.
After select (CL) [OK].

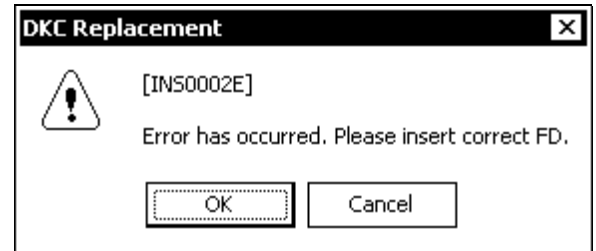

- (6) Please remove the FD from FDD.
Then select (CL) [OK].

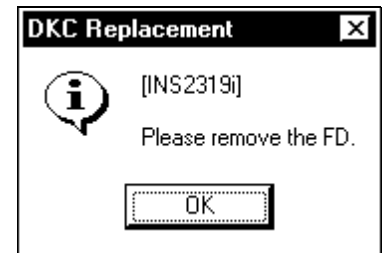

- (7) Please input DKC serial#.
After select (CL) [OK].

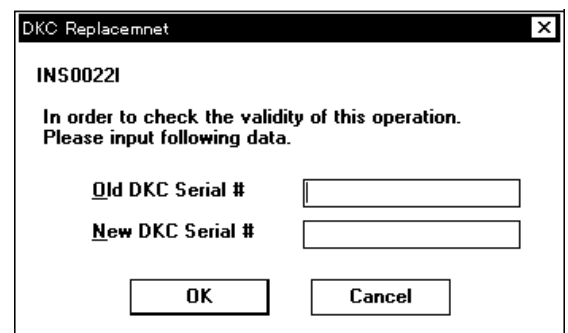

<Error case>

Illegal DKC serial number.
Select (CL) [OK].

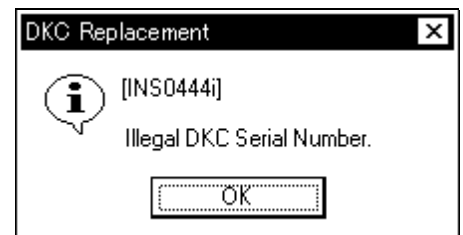

(8) Select (CL) [OK].

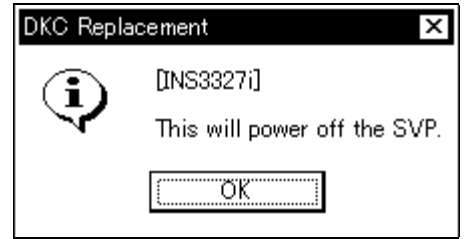

5 Procedure of Micro-program replacement to SVP

(1) Insert the SVP PS ON/OFF INH jumper.

NOTE : Check the SVP PS ON/OFF INH jumper JP2 on the RS CON PCB. If the jumper is set execute this procedure from DKCREP05-10 (2).

(1-1) Open the front door and then open the DKC-PANEL.

(1-2) Insert the SVP PS ON/OFF INH jumper into the JP2 on the RS CON PCB.
(see [LOCATION06-50](#))

(2) Installation of Micro-program.

(2-1) Insert the CD-ROM disk into the CD-ROM drive and then wait one minute.

(2-2) Select (CL) [Start]. Select (CL) [Run...].

(2-3) Input “e:\setup.exe” on ‘open’ and select (CL) [OK].

(2-4) The right dialog is displayed.
Then insert the Config FD in the FDD and select (CL) [OK].



(2-5) The right dialog is displayed.
Then remove the Config FD and select (CL) [OK].



(2-6) JAVA setup is executed. Select (CL) [Yes] or [Next] in All dialogs.

(2-7) The right dialog is displayed.

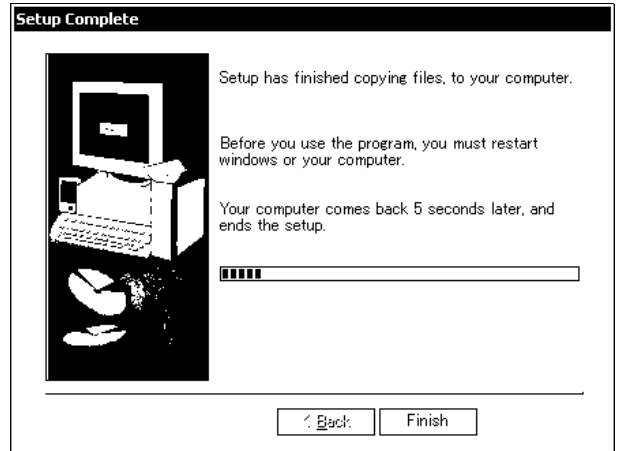

Since SVP is rebooted automatically, wait for Windows to start.

(3) Set IP address of SVP.

(3-1) Change the SVP mode to [Modify Mode].

(3-2) Open [Install].

Select (CL) [Install] from 'SVP'.

(3-3) Select [Set Subsystem IP Address...].

Select (CL) [Set IP Address...] from 'Install'.

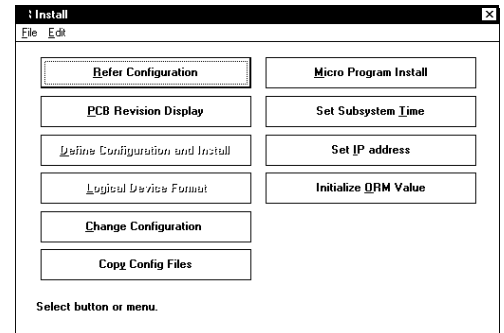

(3-4) Set IP Address.

Select (CL) [SVP] from [Target] and [Specified] from [IP Address], enter "126", "255", "255" in IP Address and enter in Subnet Mask. Select (CL) [OK].

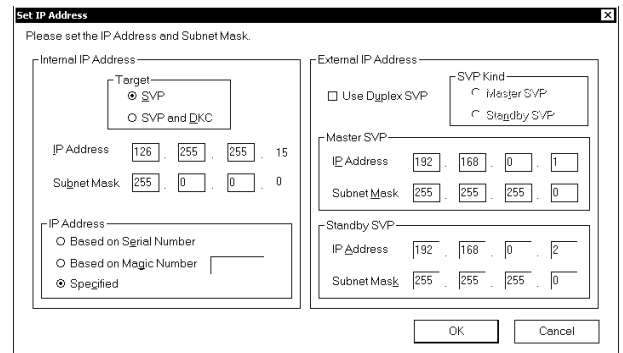

(3-5) "Please insert the Config FD in the FDD." is displayed.

Do not insert 'CONFIG FD' in FDD, Select (CL) [OK].

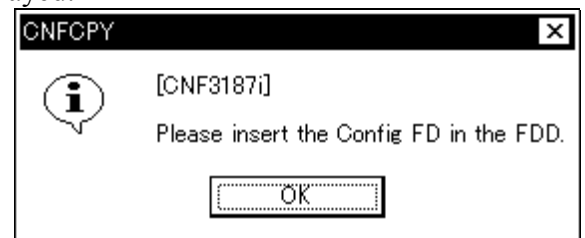

(3-6) "Failed to back up. Please insert a correct Config FD, and select the Retry button." is displayed.

Select (CL) [Cancel].

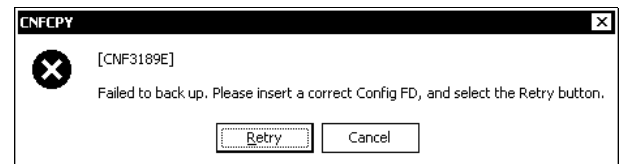

(3-7) Select (CL) [Yes].

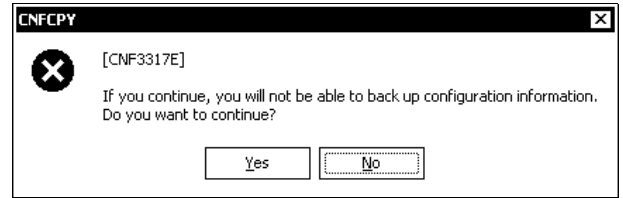

(3-8) Check SVP reboot.
Select (CL) [OK].

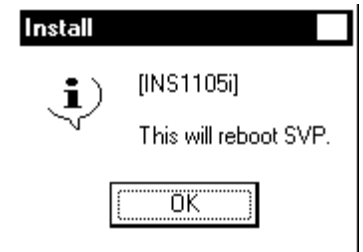

(4) SIM Complete
See [SVP02-580](#).

6 Procedure of setting System Option Mode

- (1) Make it on the screen which shows SVP in the following.

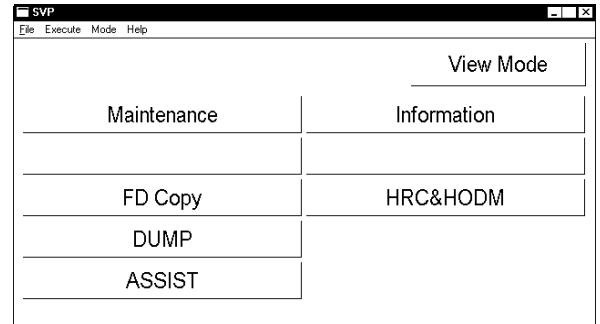

- (2) Put down the following keys at one to input in the password and. Select (CL) [OK].
“[CTL]”, “[Shift]” and “[M]”.

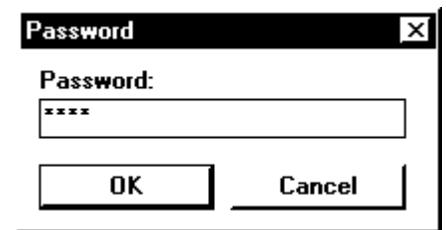

- (3) Select (CL) the [Install].

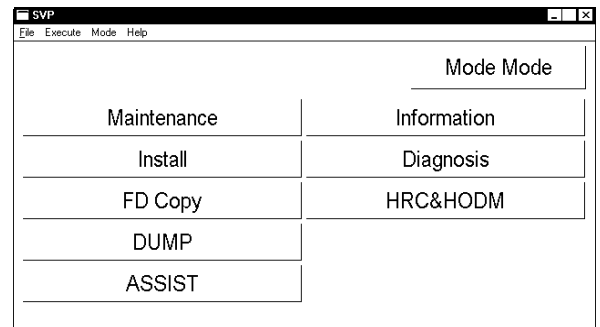

- (4) Select (CL) the [Change Configuration].

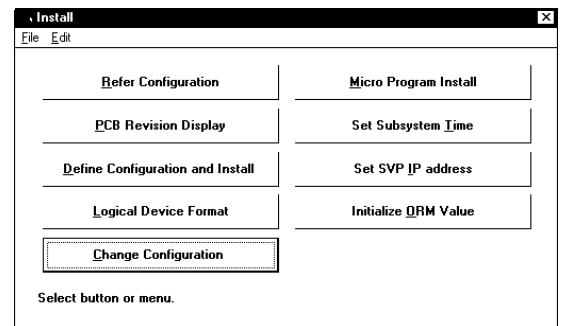

(5) “Reading configuration...” is displayed.

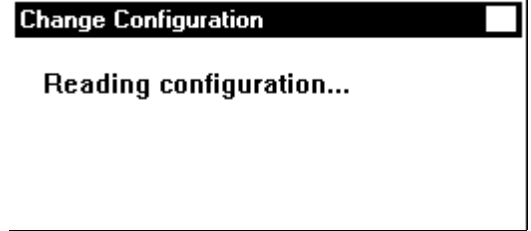

(6) Select (CL) the [System Option] and select (CL) [OK].

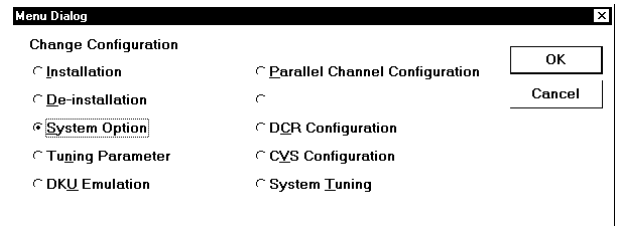

(7) Select (CL) the [Mode].

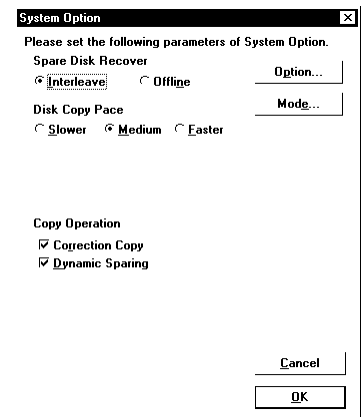

(8) Select (CL) the [Up>>].
the message is displayed with select (CL) the [OK].

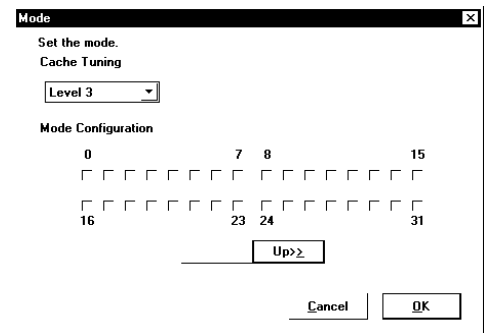

(9) Select (CL) the [Mode 53] and select (CL) [OK].

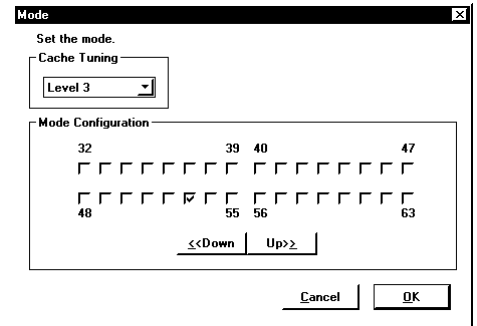

(10) Select (CL) [OK].

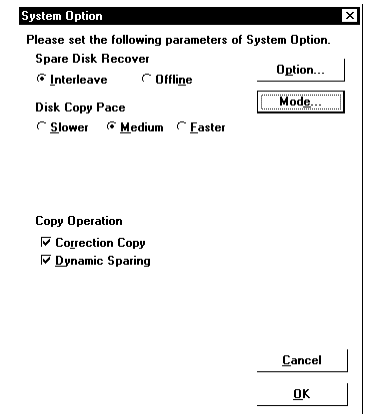

(11) "Loading configuration..." is displayed.

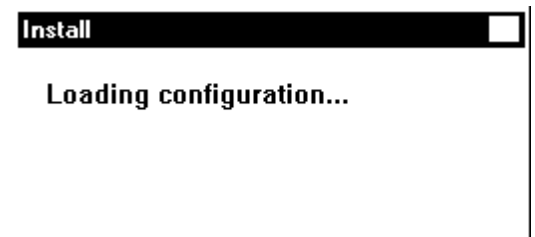

(12) "Change Configuration was completed" is displayed.
Select (CL) [OK].

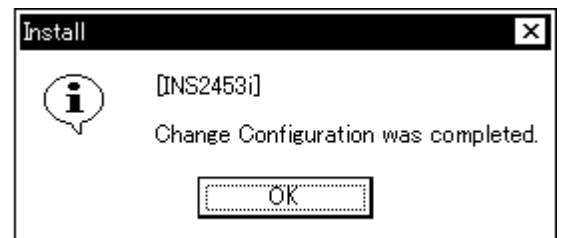

(13) “Reading Subsystem configuration data...” is displayed.

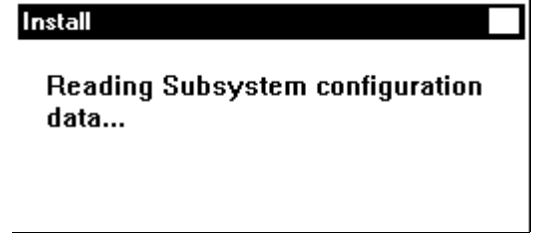

(14) “Please insert the Config FD in the FDD.” is displayed.
Do not insert ‘CONFIG FD’ in FDD, Select (CL) [OK].

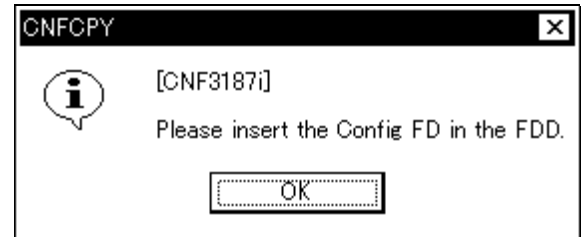

(15) “Failed to back up. Please insert a correct Config FD, and select the Retry button.” is displayed.
Select (CL) [Cancel].

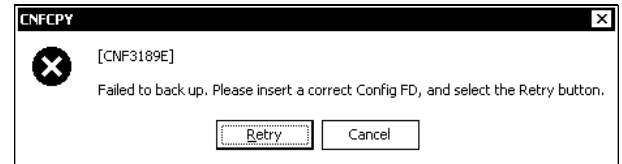

(16) “If you continue, you will not be able to backup configuration information.
Do you want to continue?” is displayed.
Select (CL) [Yes].

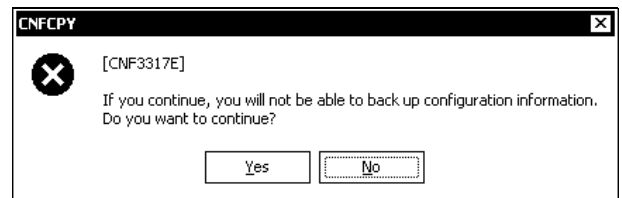

(17) Check system Option (Mode 53).

Perform procedure (4) to (8).

Confirm that 'Mode 53' is being marked.

Select (CL) the [Cancel], Return to 'System Option' screen.

Select (CL) the [Cancel], Return to 'Install' screen.

(18) Close the 'Install' window, change view Mode.

7 Procedure of Removing and Inserting RS232C cable

(1) Please remove the cable from RS CON PCB. (See Fig. 7-1)

(2) Please insert the cable into RS CON PCB. (See Fig. 7-1)

(Multi Cabinet Model)

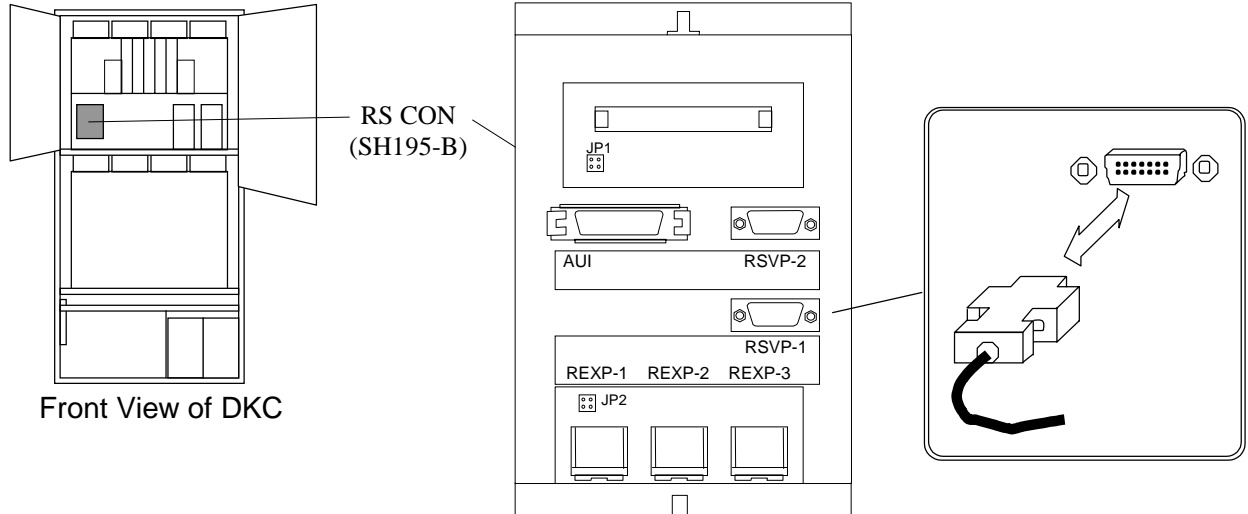

(Single Cabinet Model)

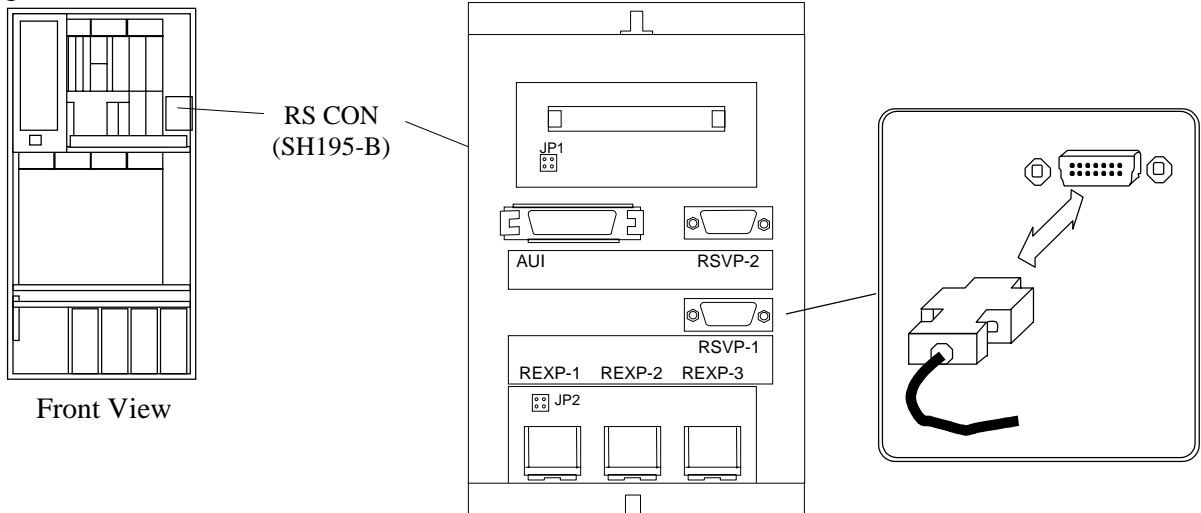

Fig. 7-1

8 Rip & Ship

8.1 Abstract

Purpose of Rip & Ship is to enable user's LDEV/PDEV resources to be continuously used when the PDEV are moved from a DKC to another.

It is able to move all parity groups in a DKC to another DKC by Rip & Ship function.

It is not supported to select some parity groups to move.

8.2 Measures to attain purpose

Information to be handed over is saved on FD by the SVP of the former subsystem and installed by the SVP of the new subsystem.

Note: This procedure needs two blank FDs.

This procedure is the same as DKC replacement.

8.3 Restrictions

Restrictions are same as DKC replacement, so please see DKC Change pages.

Configuration of before DKC and after DKC have to be the same.

Such as cache size, ACP number and position etc.

8.4 The kind of reported SSB and SIM

Restrictions are same as DKC replacement, so please see DKC Change pages.

8.5 Operations

Operations for Rip & Ship is the same as DKC replacement, so please see DKC Change pages.

Caution! Be sure to mark the position of the each HDD.
For example put a label written a position code on it.

8.6 Troubleshooting

- (1) When some HDDs are blocked.
At first you should confirm the position of HDDs are correct.
And second, you should confirm the connection of cabling.
If you will find an error, firstly you fix it and you retry from first step.

9 DKC SWAP (from RAID400 to RAID450)

9.1 Outline

9.1.1 Abstract

Purpose of DKC swapping programs is to enable user's volume data to be continuously used when the subsystem is switched from the RAID400 to the RAID450.

It is necessary to restore the volume with "Forcible Restoration". Then one time password is needed. Ask the TSC about the appropriateness of this operation.

Notes: The System Option Mode , the PP and the connective information of CPU and DKC are not handed over.

So, before executing DKC SWAP you must plan what System Option Mode and PP should be set to DKC, and what information should be set to CPU.

Use work sheets of [DKCREP09-410](#) for recording the System Option Mode and the PP of RAID400.

9.1.2 Measures to attain the purpose

Information to be handed over is saved on the Config FD by the SVP of the former RAID400 subsystem and installed by the SVP of the new RAID450 subsystem.

The format of configuration information of the RAID450 is different from one of the RAID400, so the conversion of configuration information is performed on the SVP of the RAID450 subsystem.

Notes: DKC SWAP procedure needs the config FD of the former RAID400.

9.1.3 Old subsystem (RAID400) configuration restrictions

No.	Condition/ Restriction	Detail	Restriction guard												
1	Subsystem configuration	<ul style="list-style-type: none"> • HA subsystem. • Cannot SWAP SC subsystem. 	Please realize by the data migration using HRC etc.												
2	STATUS of the subsystem	<ul style="list-style-type: none"> • All normal status. • No spare HDD is used as data HDD. • The switching is not allowed if a failed part or a PIN exist. • The switching is not allowed if a Correction copy or Drive copy are running. • The switching is not allowed if a Verify function is running. 	If restriction is violated, DKC SWAP is not supported. "Define Configuration and Install" will fail.												
3	HDD type	<ul style="list-style-type: none"> • There is no restriction. 													
4	RAID level	<ul style="list-style-type: none"> • There is no restriction. 													
5	Cache configuration	<ul style="list-style-type: none"> • There is no restriction. 													
6	Volume Emulation type	<p>Following types are not allowed to switch.</p> <table border="0"> <tr> <td>3380-E</td> <td>3380-J</td> <td>3380-K</td> </tr> <tr> <td>3380-KA</td> <td>3380-KB</td> <td>3380-KC</td> </tr> <tr> <td>3390-1</td> <td>3390-2</td> <td>OPEN-K</td> </tr> <tr> <td>OPEN-M</td> <td></td> <td></td> </tr> </table>	3380-E	3380-J	3380-K	3380-KA	3380-KB	3380-KC	3390-1	3390-2	OPEN-K	OPEN-M			If restriction is violated, DKC SWAP is not supported. "Dkc Replacement" will fail.
3380-E	3380-J	3380-K													
3380-KA	3380-KB	3380-KC													
3390-1	3390-2	OPEN-K													
OPEN-M															

9.1.4 New subsystem configuration restrictions

No.	Condition / Restriction	Detail	Restriction guard
1	Subsystem configuration	MC subsystem Cannot SWAP SC subsystem	Please realize by the data migration using HRC etc.
2	A failed part or a Blocked part status.	<ul style="list-style-type: none"> CHA/DKA/Cache, etc. must be all normal status. 	If restriction is violated, DKC SWAP is not supported. "Define Configuration and Install" will fail.
3	Cache configuration	<ul style="list-style-type: none"> Cache capacity fulfills all the conditions are written on "INSTALLATION SECTION (1.1.2 Configuration and number of necessary options)" 	If restriction is violated, a failure will occur when turning the power on.
4	SM configuration	<ul style="list-style-type: none"> SM capacity fulfills all the conditions are written on "INSTALLATION SECTION (1.1.2 Configuration and number of necessary options)" 	If restriction is violated, a failure will occur when turning the power on.
5	Number of CHA/DKA PCBs, and their locations	<ul style="list-style-type: none"> There is no restriction. 	
6	Number of Channels, and their locations	<ul style="list-style-type: none"> There is no restriction. 	

9.1.5 Re-establishment item

The configuration information which needs a re- establishment is as follows.

No.	Item	Restriction
1	DKC serial No.	A serial number is defined by "Define configuration and Install".
2	Program Products (P.P.) * HRC/HORC/HMRCF/ HOMRCF etc.	A P.P. for RAID450 is different from P.P. for RAID400. So it is necessary to make a contract for the P.P. anew and to set information for the P.P. But following informations are handed over for keeping user's volume data. <ul style="list-style-type: none"> • The connective information of logical devices for "LUSE". • The information of "CV". • The information of "LUN On-Demand".
3	System Option Modes	There are some System Option Modes whose meaning is different from meaning on RAID400. So System Option Modes are not handed over. Set System Option Modes which are needed for the site. (See MODE01-10)
4	LUN	There is no restriction with number of CHA PCBs , number of channels and their location. To realize those, a information of LUN isn't handed over.
5	SSID	It is changed into a setup of 256 boundaries when SSID is set as 128 boundaries. When SSID changes to a setup of 256 boundaries, SSID set up in the first half is handed over. So, when SSID is not set as the portion in the first half at the time of RAID400, SSID is not handed over. It is necessary to set up again the portion which is not set up.

9.1.6 The kind of reported SIM and SSB

The following SIM and SSB will be reported in DKC SWAP operations.

SIM CODE	Contents	Note
3073	CHP is failed.	An influence by Fixed Minimum Configuration Information.
3990	CHP is failed, because it isn't installed in configuration information.	An influence by Fixed Minimum Configuration Information.
3d90	DKP is failed, because it isn't installed in configuration information.	An influence by Fixed Minimum Configuration Information.
3da0	FSW LED bus test error.	An influence by un-connection of FIBRE cable.
3db0	DKP is failed.	An influence by un-connection of FIBRE cable.
AC50	HDU power off.	An influence by un-connection of FIBRE cable.
BFxx	Environmental Error.	An influence by un-connection of FIBRE cable.

Error Code	Contents	Note
0007	MP is failed, because it's been late for "P/S ON".	An influence by Fixed Minimum Configuration Information.
0009	MP is failed, because it isn't installed in configuration information.	An influence by Fixed Minimum Configuration Information.
000C	MP is failed, because the type of PCB in configuration information isn't equal to the actual type.	An influence by Fixed Minimum Configuration Information.
001D	From FM to SM, micro-transfer practice.	At the time of the Shared Memory volatile mode.
15DA	Information at making configuration information.	It always is reported when execute "Define Configuration & Install".
32CC	HDU power off.	An influence by un-connection of FIBRE cable.
32EC	The bus mode in configuration information isn't equal to the actual mode. Configuration information is corrected.	It is reported when execute temporary "Define Configuration & Install".
A040	Maintenance process LIP or Login is time out.	An influence by un-connection of FIBRE cable.
A042	Information at FIBRE failure.	An influence by un-connection of FIBRE cable.
A210	Failure at initializing FSW or FIBRE loop.	An influence by un-connection of FIBRE cable.
A9A0	Information at FIBRE failure.	An influence by un-connection of FIBRE cable.
A9F1	Information at FIBRE failure.	An influence by un-connection of FIBRE cable.
A9F8	Link failure..	An influence by un-connection of FIBRE cable.
AB45	Link failure.	An influence by un-connection of FIBRE cable.
AE5D	Failure to read/write FSW buffer.	An influence by un-connection of FIBRE cable.
B110	Failure to exchange an attribute of channel port.	An influence by Fixed Minimum Configuration Information.
B440	Success to initialize TPC.	It always is reported when execute ordinary "P/S ON".
B441	MP doesn't execute to initialize TPC.	An influence by Fixed Minimum Configuration Information.
B453	Success to stop TPC.	It always is reported when execute ordinary "P/S OFF".

9.2 Change flowchart

NOTICE :

Field Engineers are to perform a check referring to “Restrictions” before you start DKC SWAP.

(General flowchart)

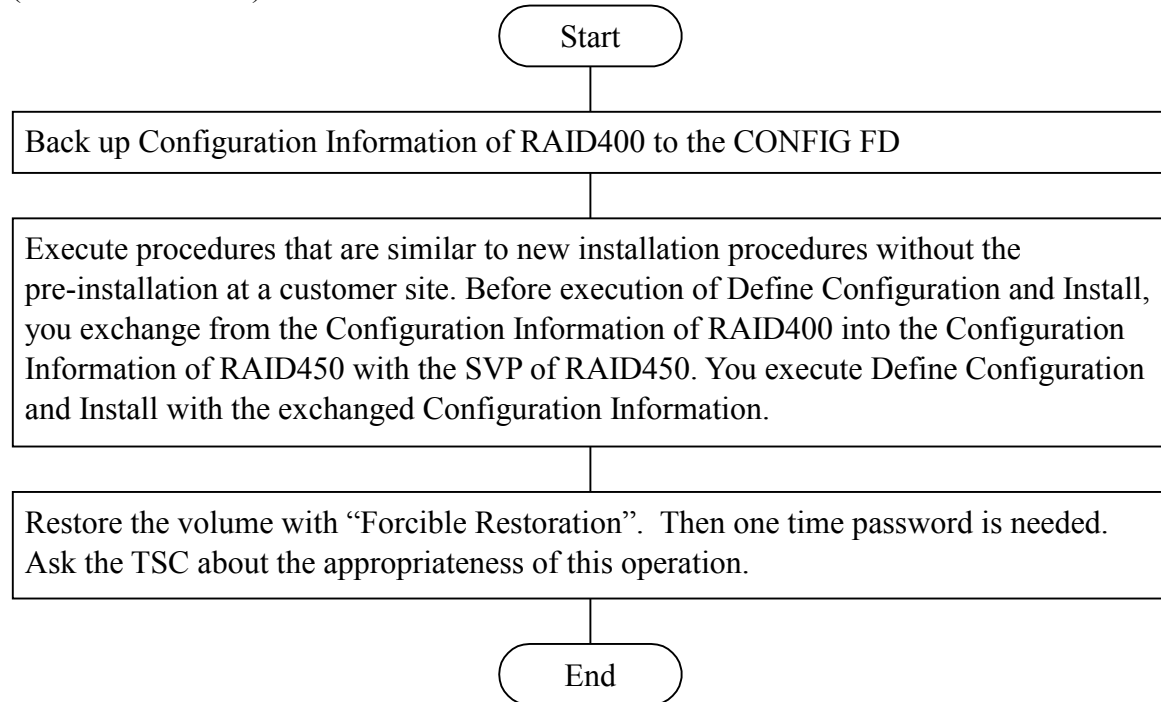

(Detail flowchart)

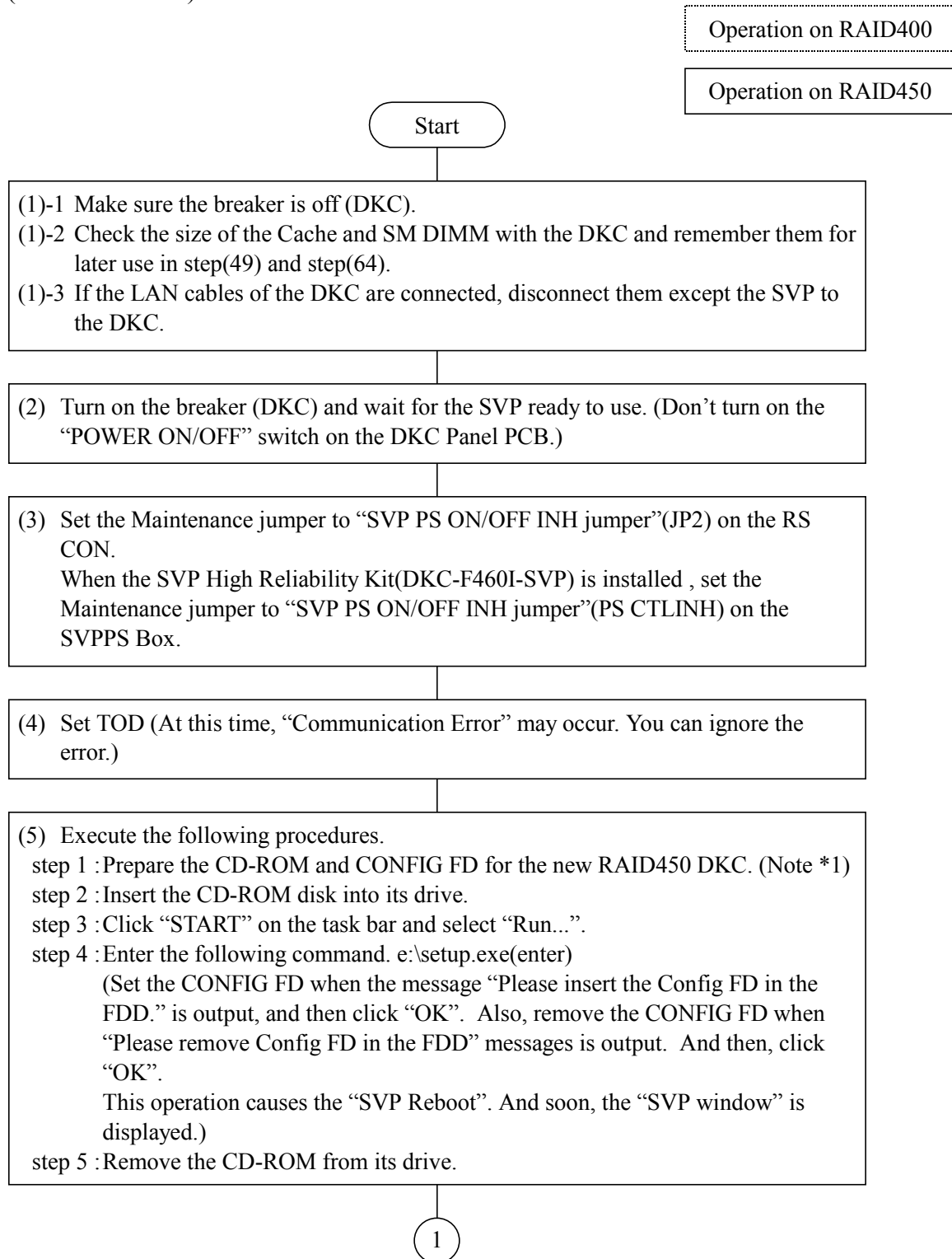

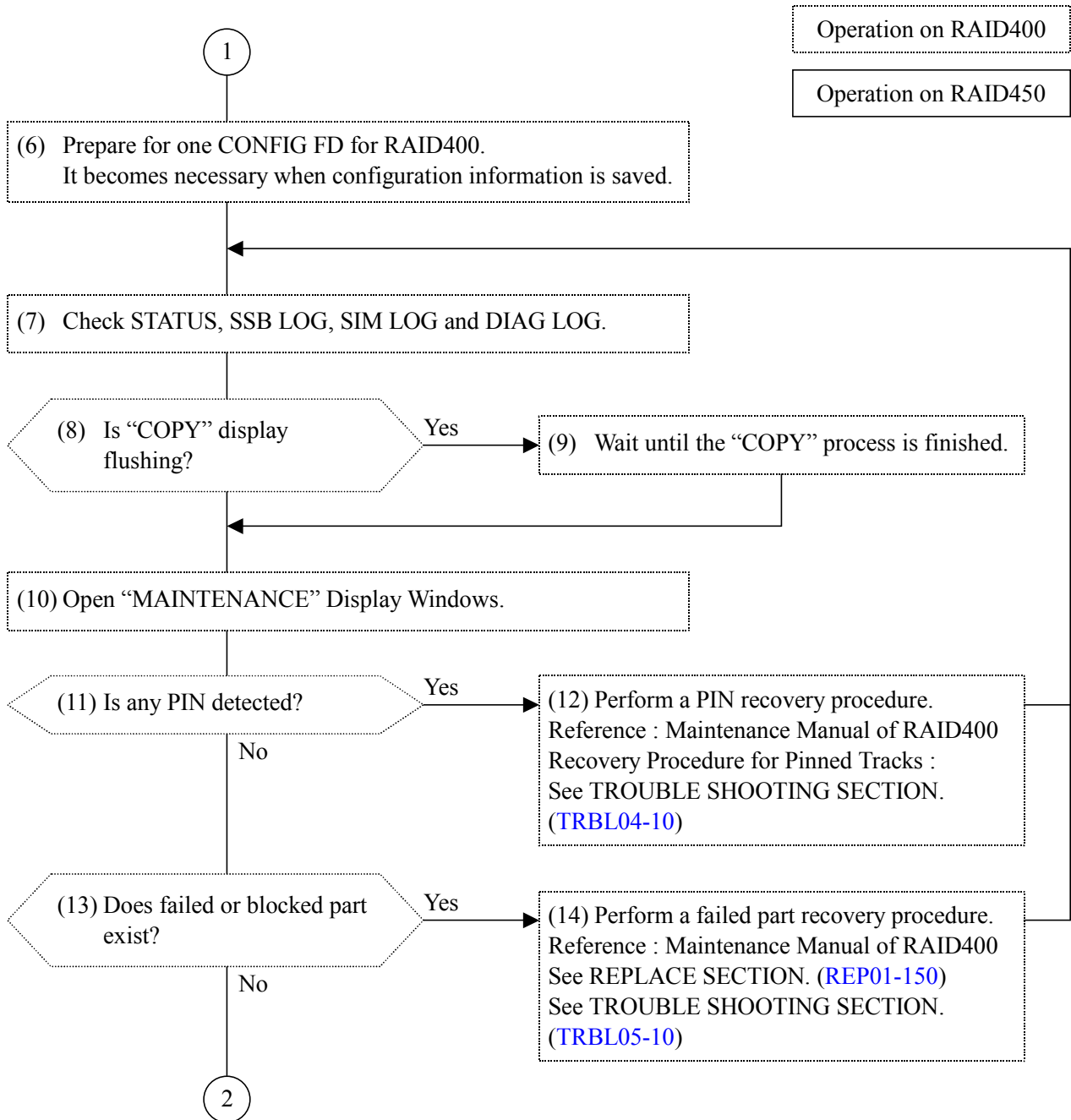

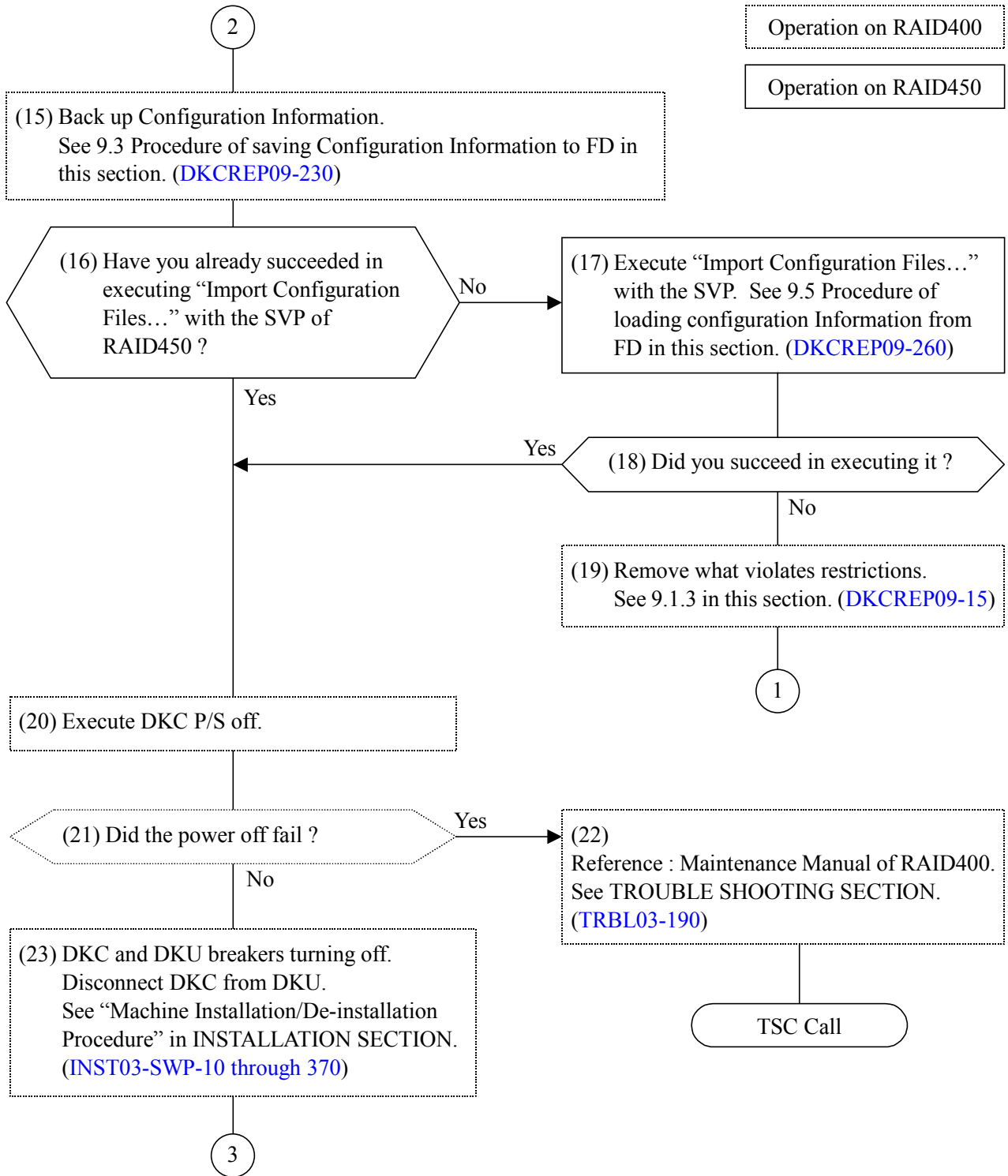

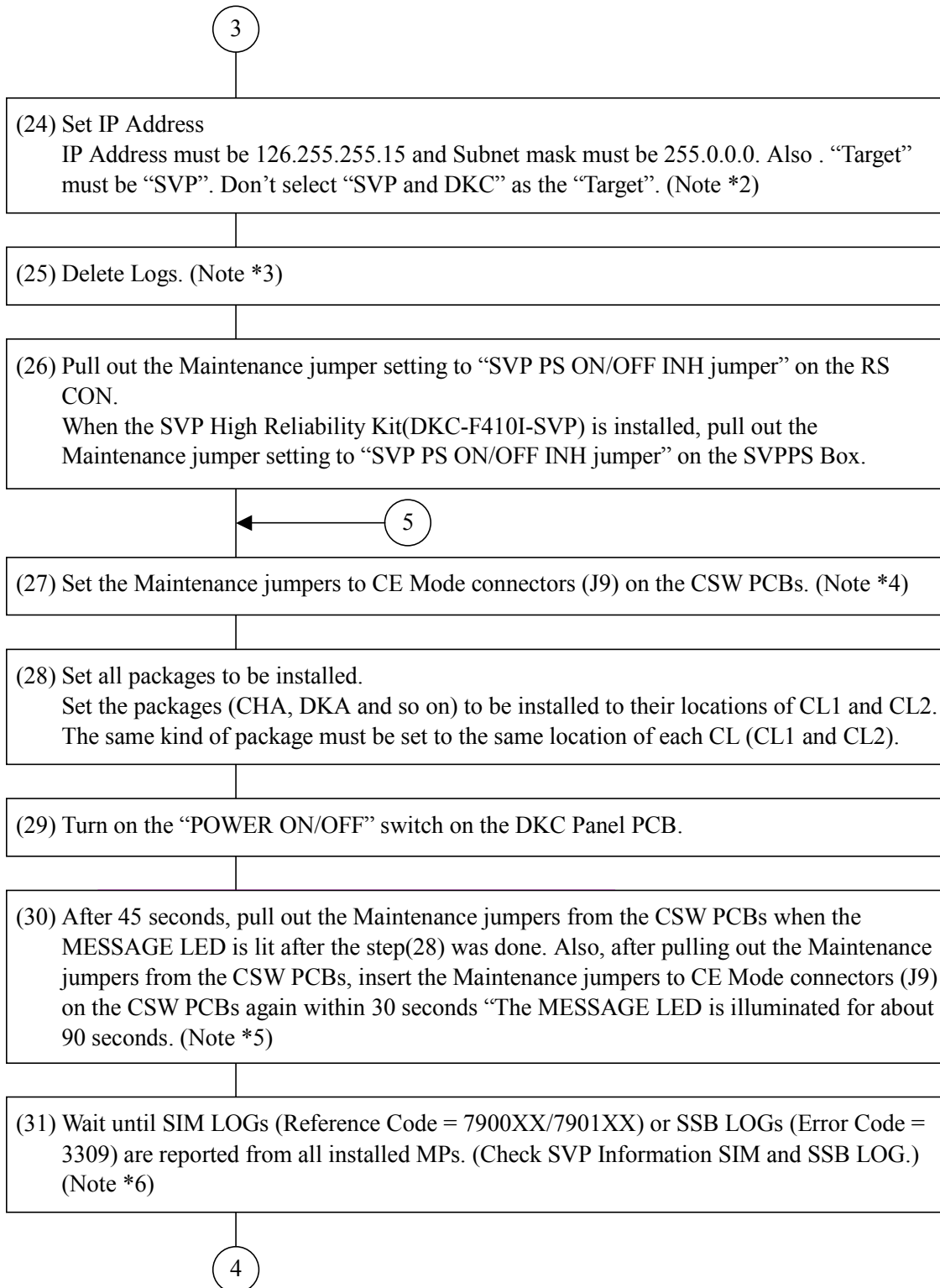

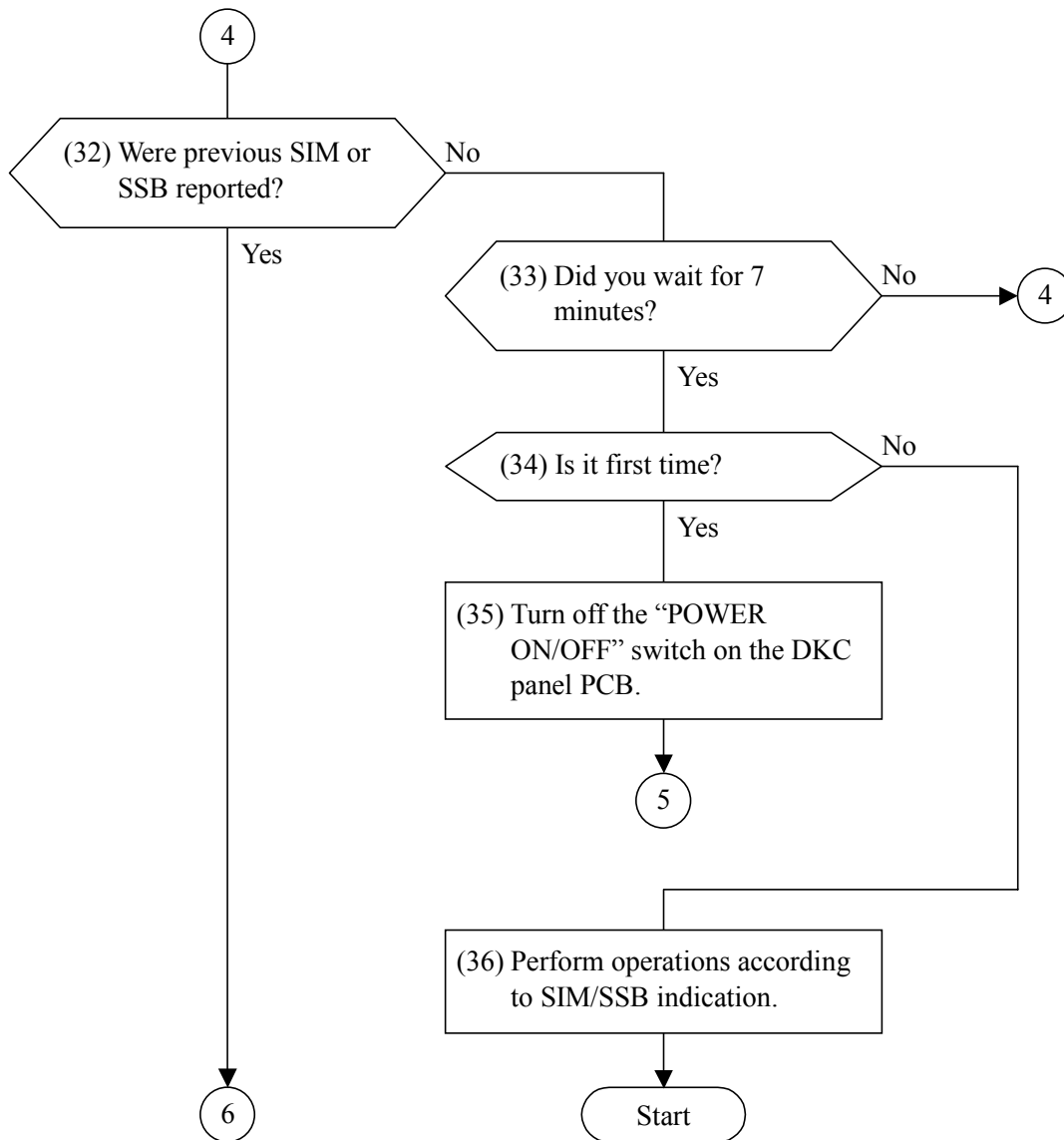

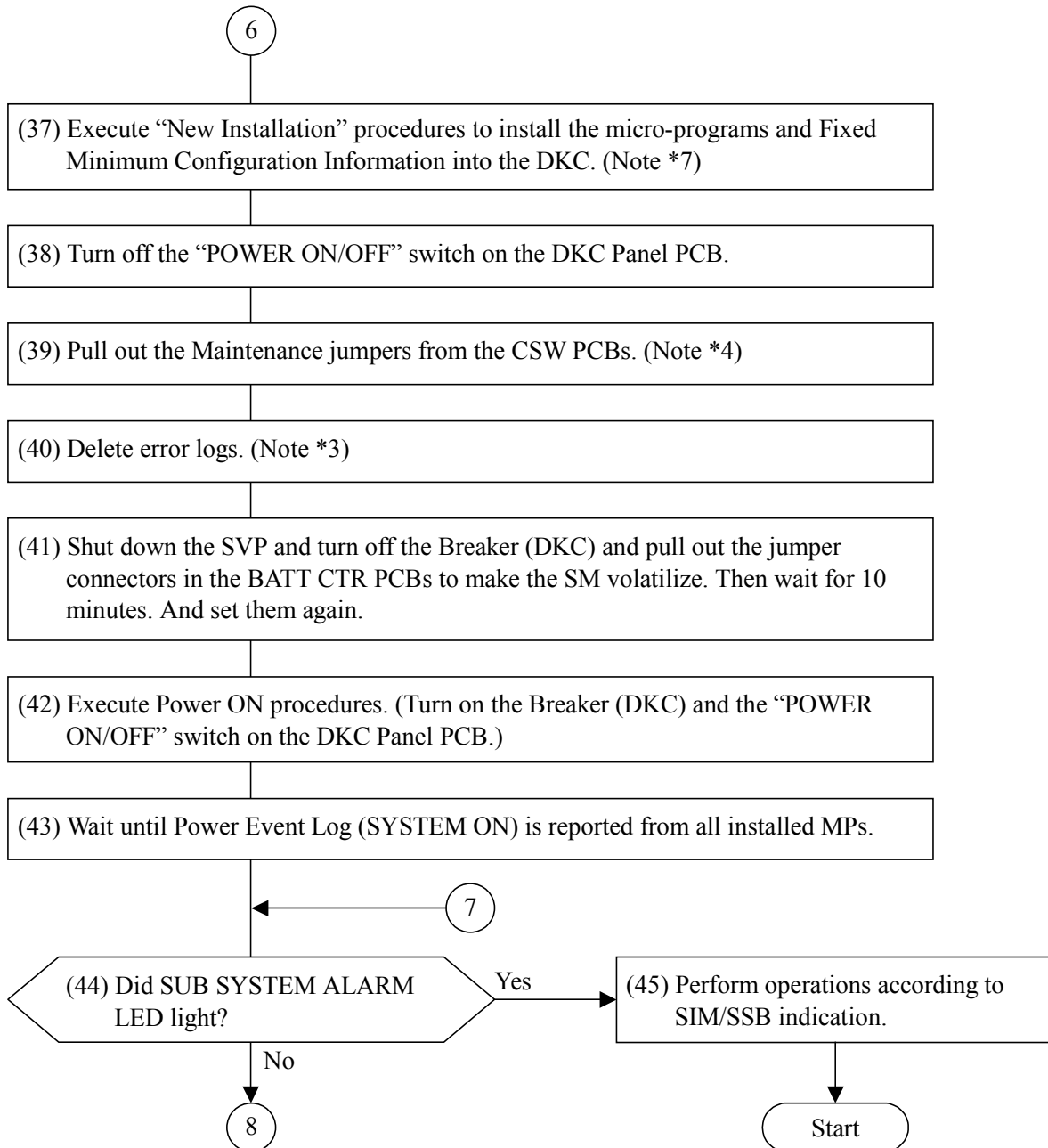

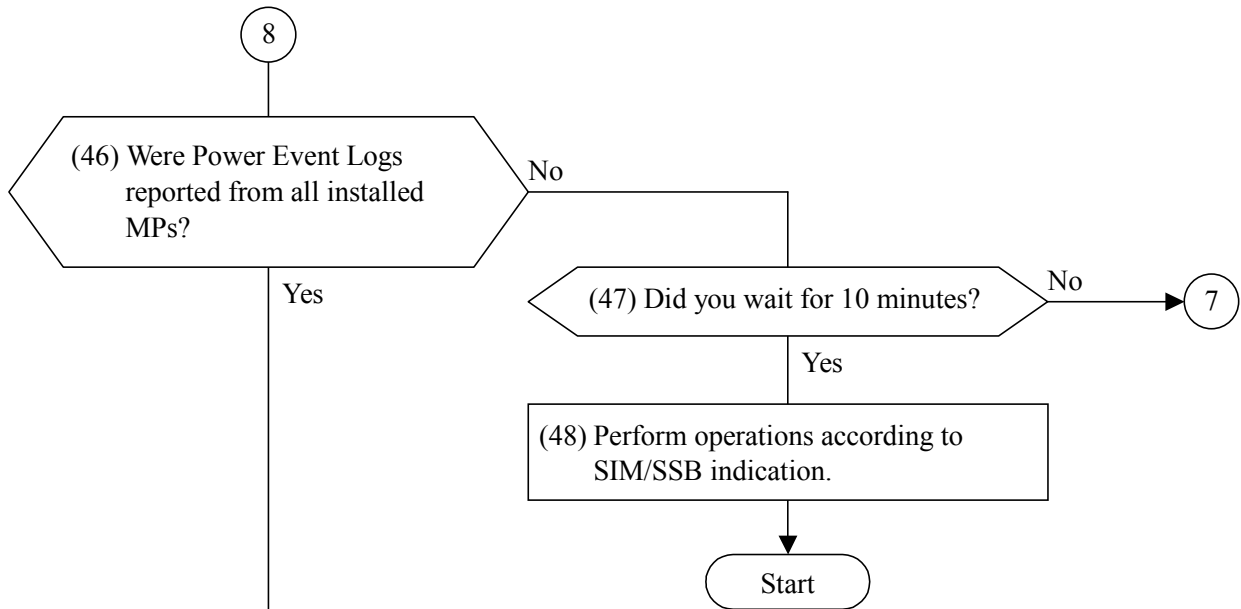

- (49)-1 Execution of Config Exchange Procedure.
Select the “Install” in the “SVP” window and select “Copy Config Files” in the “Install” window. And select “All Configuration Files” in the “Copy Config Files” window.
- (49)-2 Define the configuration information that is similar to what you want to install for this DKC. Some volume emulation type needs P.P. So it is necessary to define the temporary configuration information. The temporary configuration information has the following distinctive features.
- (1) The defined group must be group 1-1.
 - (2) The defined type of PDEV must be DKR1B-J047FC.
 - (3) The defined volume emulation type must be 3390-3 or OPEN-3.
 - (4) The defined size of the Cache and SM DIMM must be equal to ones of the Cache and SM DIMM equipped for the DKC. (Note *10. Note *11)
 - (5) The configuration information must be defined according to the SVP guidance. Especially, you must not forget the definition of the following information.
 - ① DKC Serial No., IP Address.
 - ② Cache Configuration
 - ③ Host Interface Configuration : ex. Serial 4ch, 8GS Fibre 4ch-2mp, etc.

9

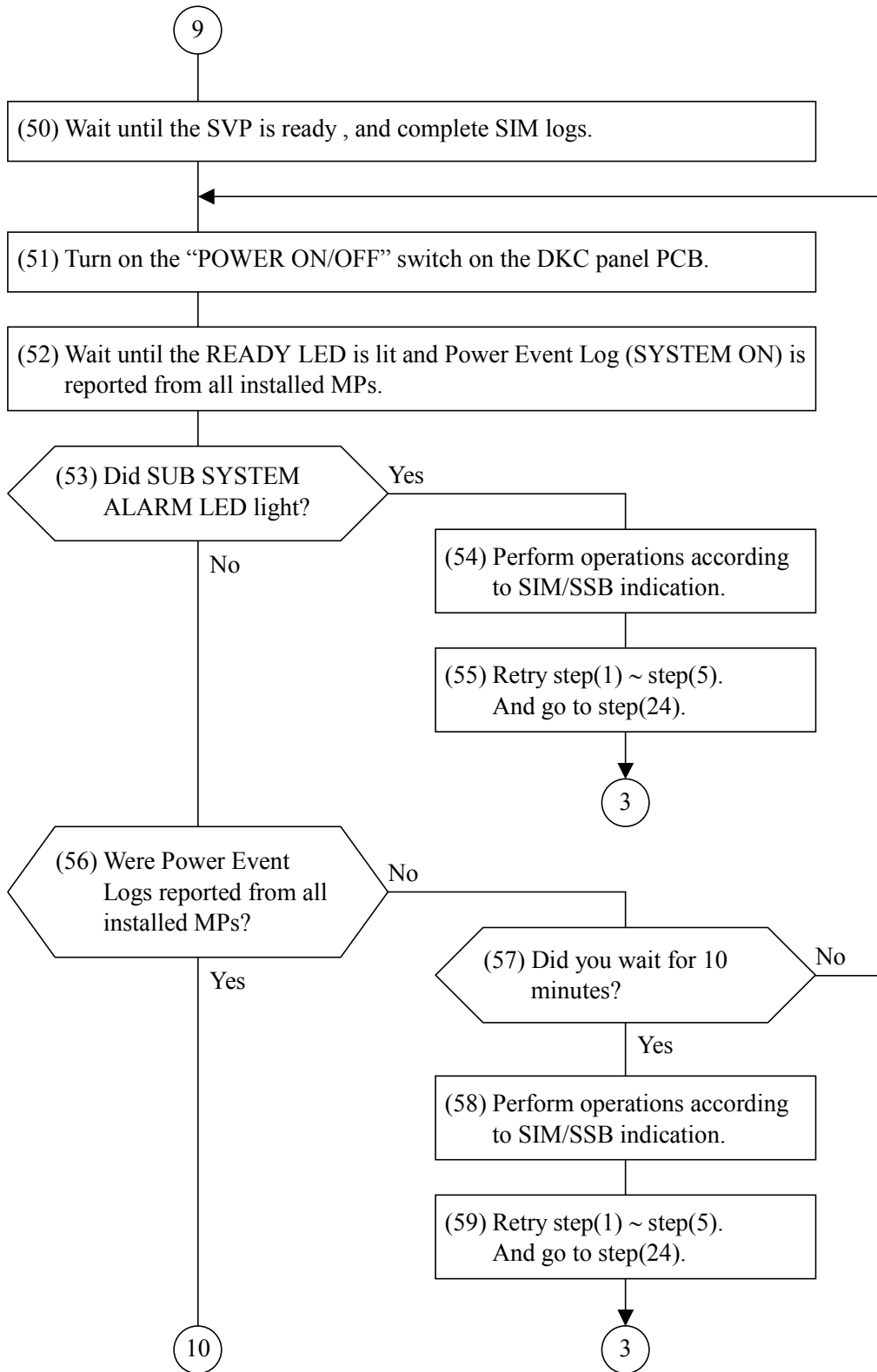

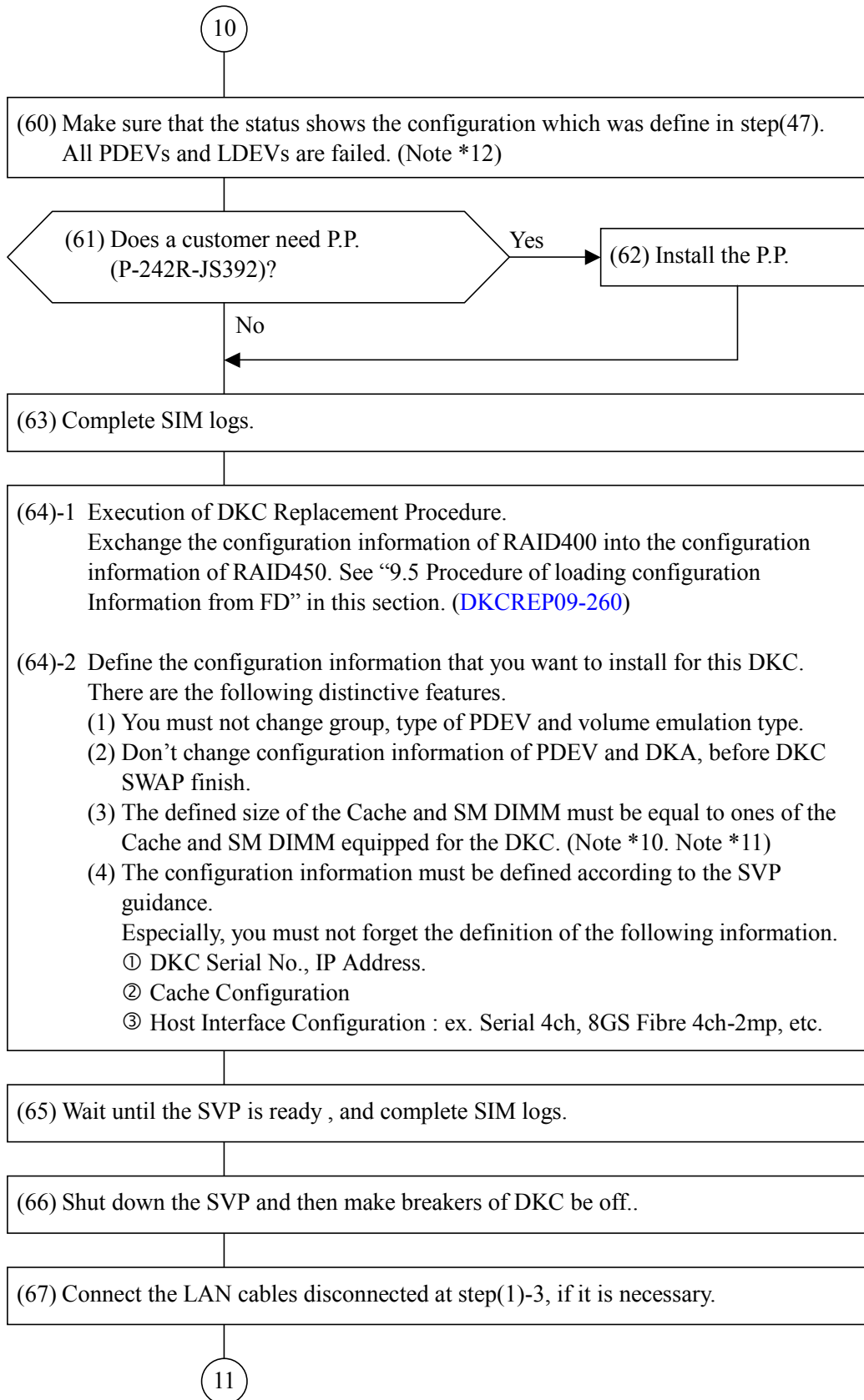

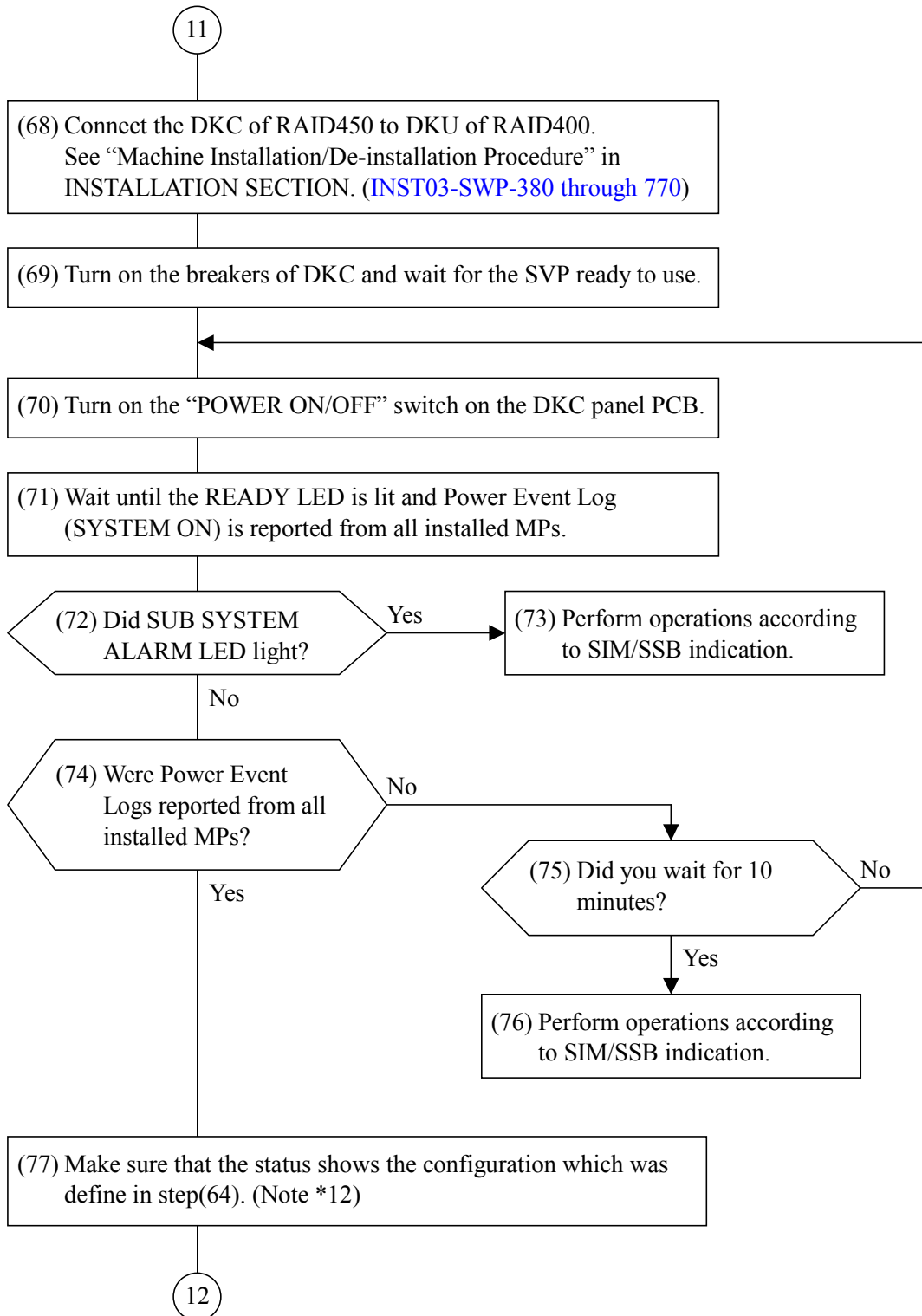

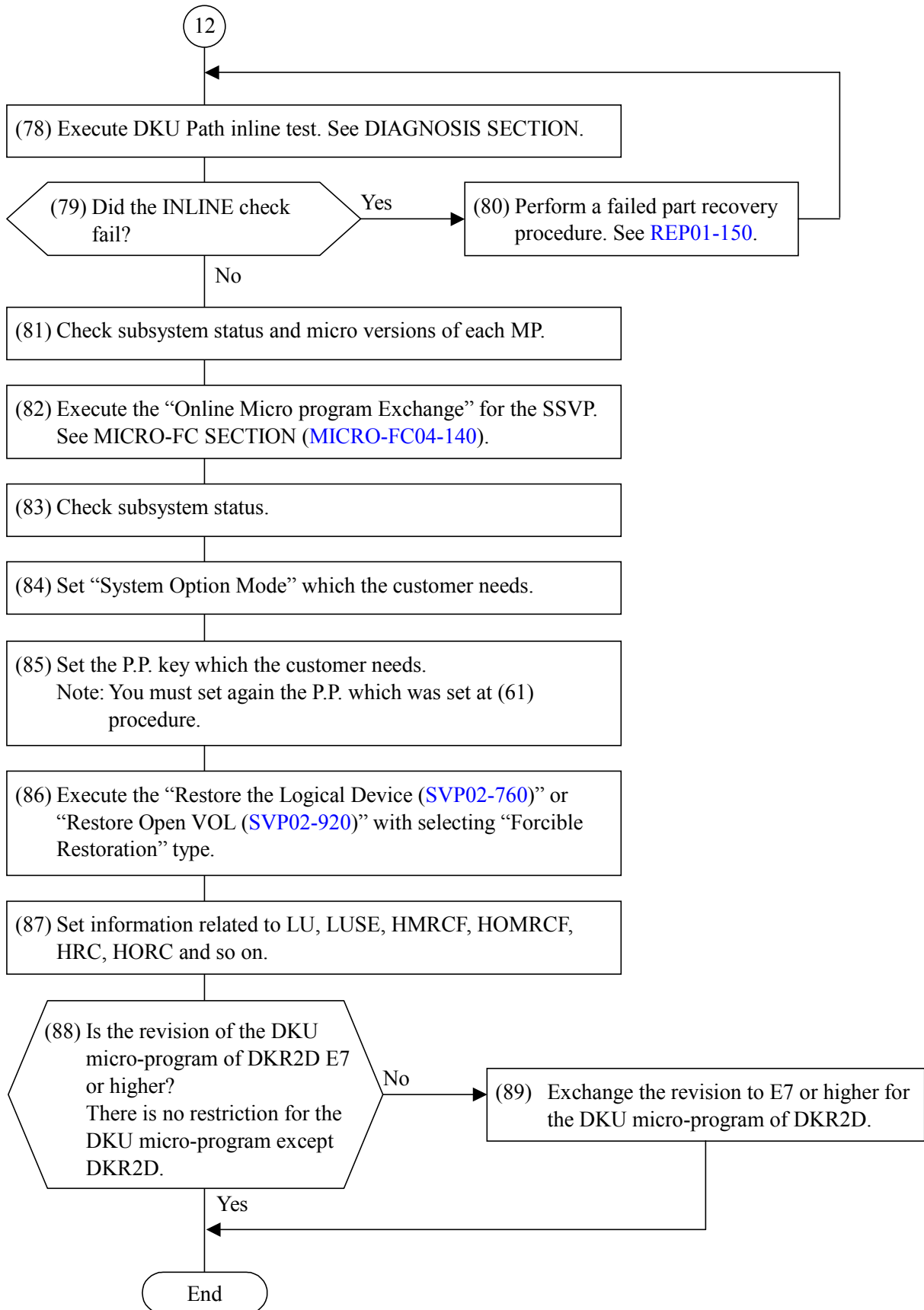

Note *1 : The CD-ROM includes the micro-programs to be installed into the DKC subsystem.

And the FD should correspond to the micro-program version.

Note *2 : Even if the “IP Address” is “126.255.255.15” and the “Subnet Mask” is “255.0.0.0” on the screen of “Set IP Address”, be sure to select “OK” and reply “OK” to the message “This will reboot SVP.”.

Note *3 : It’s necessary to execute the procedure of “SIM Log Complete” before deleting the SIM data.

Note *4 : Refer to the following about the Maintenance Jumpers.

- “INST02-30 Note *1” (Multi Cabinet Model)
- “INST02-20 Note *1” (Single Cabinet Model)

Note *5 : The detail of the jumper operation is as follows.

- (1) Turn on the P/S ON switch.
 - (2) At 45 seconds after (1), pull out the Maintenance Jumpers from the CSW PCBs. Then, MESSAGE LED illuminates. The LED is lighting for about 90 seconds.
 - (3) Insert the Maintenance Jumpers to the CE Mode connectors (J9) on the CSW PCBs again quickly (within 30 seconds) after pulling out the Jumpers at (2).
- Operations (2) and (3) must be executed during the Message LED is lighting.

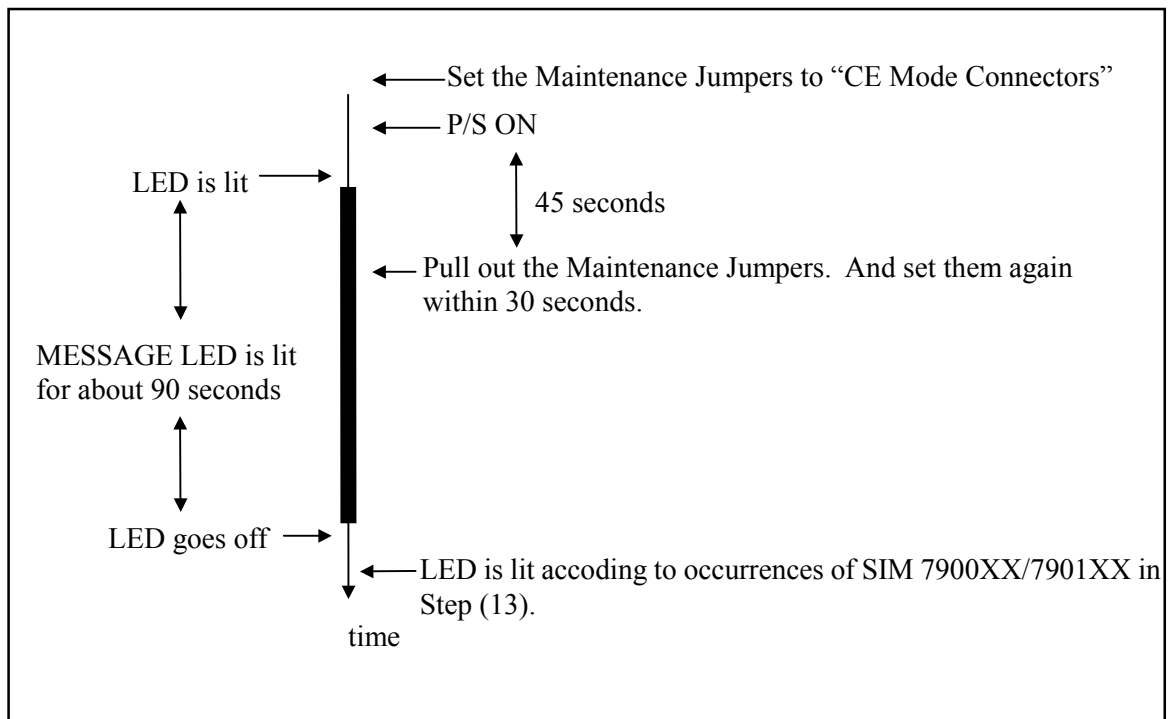

Note *6 : Count SSB Logs (Error Code = 3309). The number is same as the number of the installed MPs.

Note *7 : The procedures of “New Installation” are as follows.

- (1) Return to the SVP window.
- (2) Press the following keys at the same time to change the mode to “Initial Setting”.
[SHIFT], [CTRL], [I]
- (3) Enter the password.

This password must be used only for this procedure. Don't use for other purposes without approval by the technical support center or the factory.

Enter the password. (Note *13)

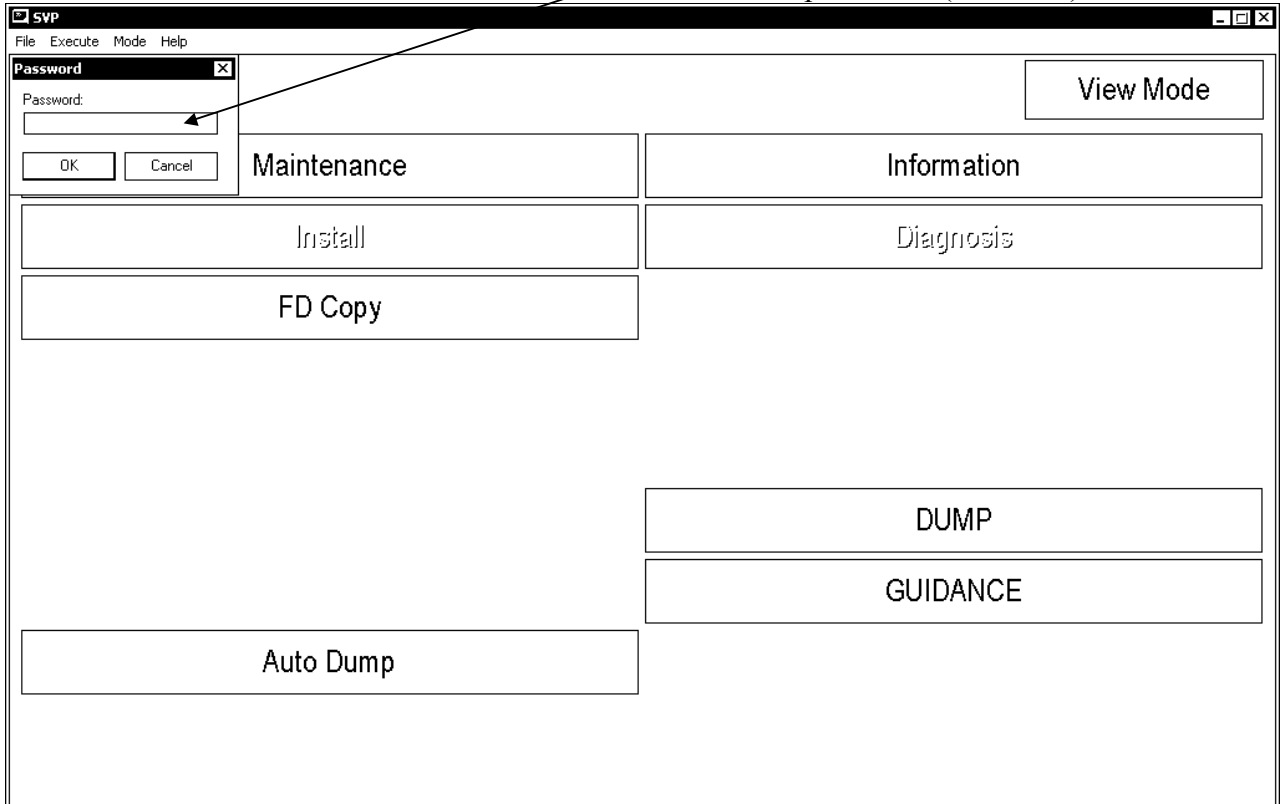

- (4) Select “Install”.
- (5) <Install Window>
Select “Micro Program Install”.
- (6) <Menu Dialog Window>
Select “New Installation”.
- (7) Select “Yes” to the following message.
“Are you sure you want to execute new installation?”
- (8) <New Installation PCB configuration Window>
After (7), the following window is displayed. At the window, specify as follows:
 - ① Select “All microprograms”. (“Fixed Minimum Configuration” should be selected automatically.) (Note *14)
 - ② Select the package type (host interface and so on) of the current packages setting in their locations of “CHA” or “DKA”.
 - ③ Select “OK” after finishing the above specifications.

[Example of operations]

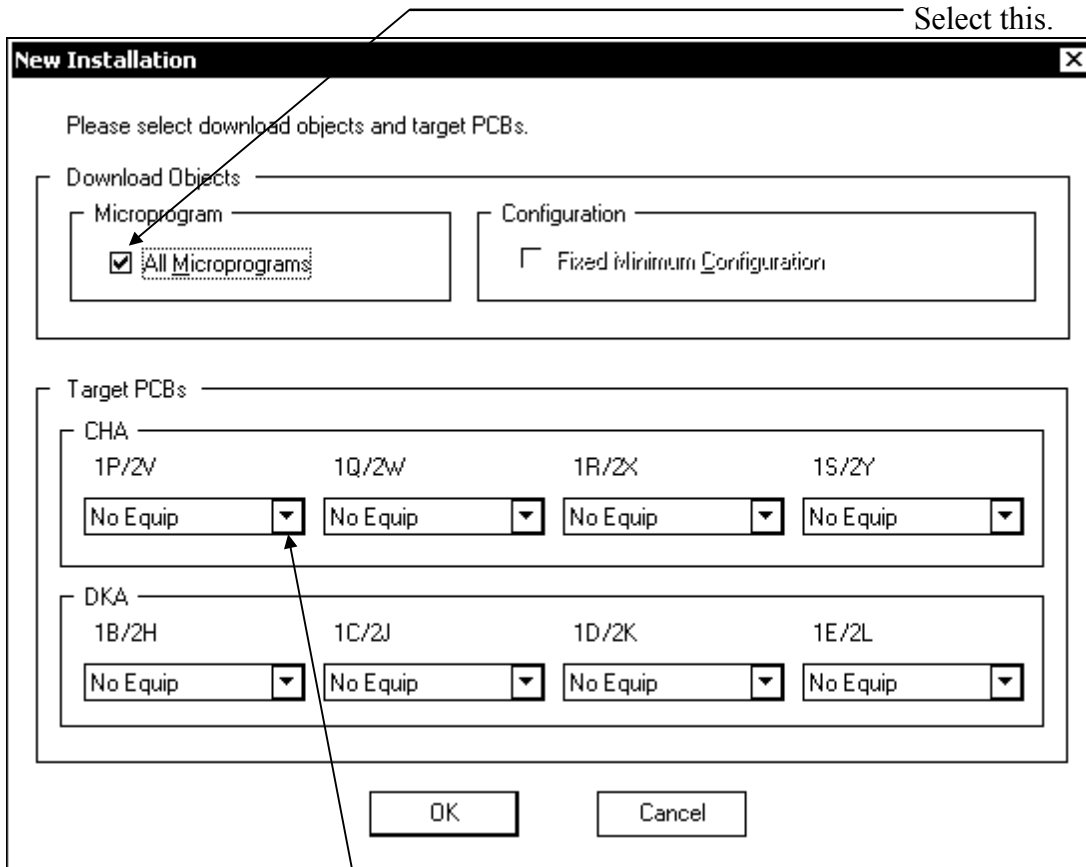

Click here, and the pull-down menu is displayed.

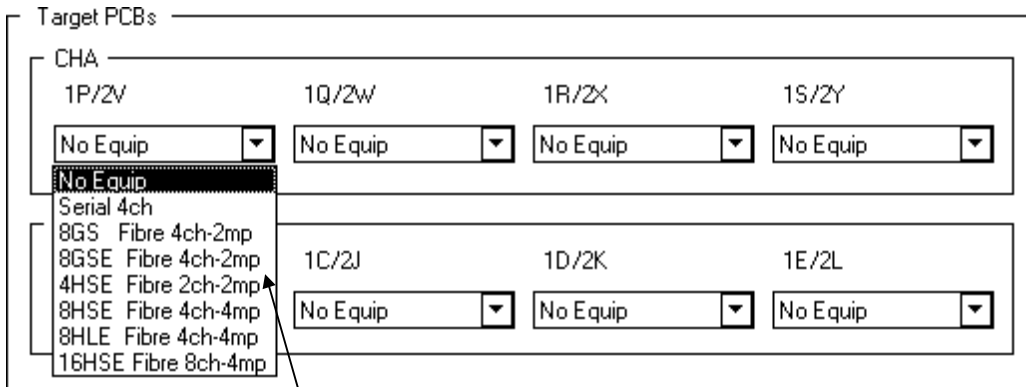

Select one that matches the CHA type installed for each PCB Location (1P/2V, 1Q/2W, 1R/2X, 1S/2Y).

Target PCBs

CHA			
1P/2V	1Q/2W	1R/2X	1S/2Y
No Equip	No Equip	No Equip	No Equip

DKA			
1B/2H	1C/2J	1D/2K	1E/2L
No Equip	No Equip	No Equip	No Equip

Click here, and the pull-down menu is displayed.

Target PCBs

CHA			
1P/2V	1Q/2W	1R/2X	1S/2Y
No Equip	No Equip	No Equip	No Equip

DKA			
1B/2H	1C/2J	1D/2K	1E/2L
No Equip	No Equip	No Equip	No Equip
No Equip			
DKF 4mp			
DKF 2mp			

Select one that matches the DKA type installed for each PCB location. (1B/2H, 1C/2J, 1D/2K, 1E/2L)

- (9) The message, “[INS3302i] New installation finished normally.”, is output. Then, click “OK”, and the “Installation window” is closed.
 (Till the message, “[INS3302i] New installation finished normally.”, is output, you must not select “Cancel” in the “Shell Batch Execute Status” window. If “Cancel” is selected, this process is interrupted. If “Cancel” is selected by a mistake operation, try again from (6) of [INST02-530](#).)

- Note *8 : The following SIM Logs are output by pulling out the jumper connectors in the BATCTR PCBs.
SIM Logs: bf5010, bf5210, bf5020, bf5220
But you can ignore them.
- Note *9 : At this time, the initializing processings of the DKC subsystem are performed by using the minimum configuration. The minimum configuration is the special configuration for the New Installation Procedure (Note *14). So, the READY LED is not lit. Also, the SIM Log (3073XX, 3173XX, 3390XX, 3D90XX and FFE800) may be output if the current configuration is different from the “Fixed Minimum Configuration”. But they should be ignored. And you should not select “Maintenance” in “SVP window” until the Define Configuration Procedure is performed at step (31).
- Note *10: Press the following keys at the same time to change the mode to “Initial Setting”.
[SHIFT], [CTRL], [I]
And input the password. (Note *13)
- Note *11: In this definition, specify the actual DKC Serial Number.
Also, “IP Address” should be specified as follows:
- ① Specifying the IP Address according to the DKC Serial Number Select “Based on Serial Number”, and the IP Address will be assigned automatically.
 - ② Specifying the IP Address according to the magic number
Select “Based on Magic Number” and specify a magic number. Then, the IP Address will be assigned automatically.
 - ③ Specifying in option
Select “Specified” and specify the optional address for the IP Address.
And, the defined value for the size of the Cache and SM DIMM should be equal to the value that was confirmed at (1) in the processing flow. After the configuration information is defined, P/S OFF of the DKC and the reboot of the SVP will be executed.
- Note *12: Surely, check the following status:
- (1) the condition of each PCB status.----- PCB Kind/Normal or not/etc
 - (2) the micro-program version
- Note *13: For the password, ask the technical support center. And use it with their approval.

Note *14: The “Fixed Minimum configuration” is a temporary configuration to unify the condition of the power-on processing in Step (24) and is not concerned with the current configuration. It is used only in “New Installation” procedure.

The following information is defined in the “Fixed Minimum Configuration”.

- ① Basic DKC Configuration (1P/2V for “CHA”, 1B/2H for “DKA”)
IP Address = 126.255.255.xx
Serial 4ch for Host interface configuration
4mp for the DKA
- ② Option PCBs Configuration (1Q/2W, 1R/2X, 1S/2Y, 1C/2J, 1D/2K, 1E/2L)
: None (No equip)
- ③ Cache size : 512 MB for each side.
- ④ SM size : 256 MB for each side.
(DIMM : 128 MB × 2)
- ⑤ LDEV/PDEV/LCP Configuration : None

9.3. Procedure of saving Configuration Information to FD (used in RAID400)

The backup processing of necessary composition information is done for the DKC exchange. The backup procedure of composition information is shown in the following. DKC is exchanged based on Config FD made here.

(1) Change the mode to [Modify Mode], and select(CL) [Install].

(2) Select (CL) [Copy Config Files].

(3) Select (CL) [Create Configuration Backup...].

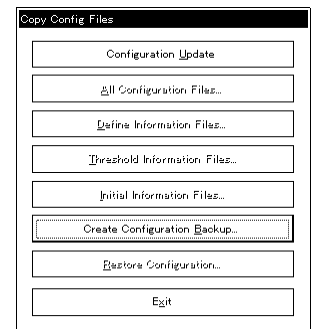

- (4) Please insert the Config FD, and then select [OK].

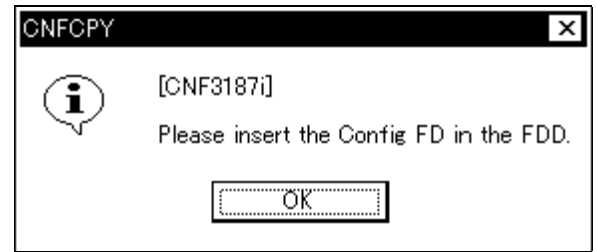

- (5) The backup processing inside window is displayed.

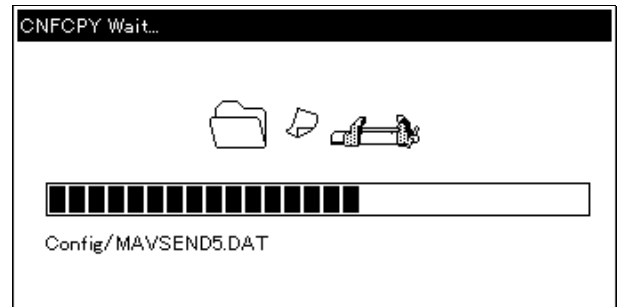

- (6) Please remove the FD from FDD, and then select (CL) [OK].

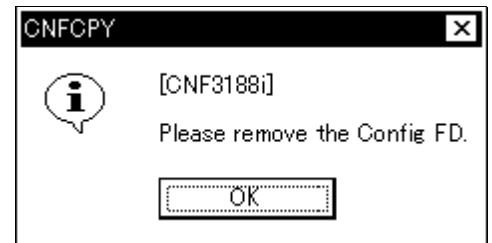

9.4. Machine Installation Procedure

Please connect the DKU of RAID400 with DKC of RAID450. (Refer to the Install section.)

9.5. Procedure of loading configuration Information from FD (used in RAID450)

The exchange processing of DKC is done based on composition information on RAID400. The loading procedure of composition information is shown in the following.

- (1) Change the mode to [Swap Mode].
 - Select [Shift] + [Ctrl] + [Alt] + [P].
 - Enter the password and select (CL) [OK].
 - Select (CL) [Install].

- (2) Select (CL) [Copy Config Files].

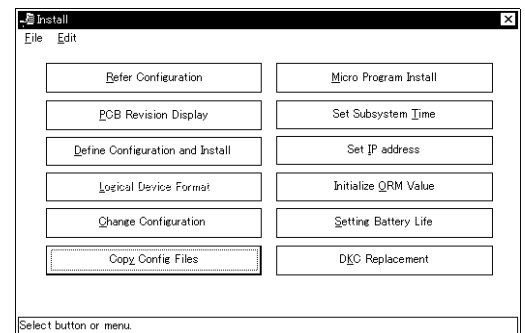

- (3) Select (CL) [Import Configuration Files...].

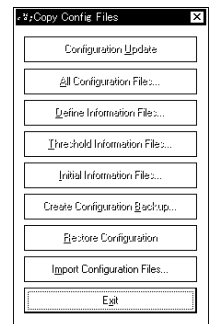

- (4) Please insert the Config FD made by 9.3, and then select [OK].

When invalid Config FD is inserted, the error message is displayed. Please remake the Config FD from old subsystem, and retry the operation.

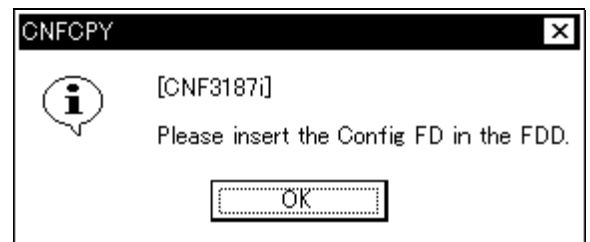

(5) The processing inside window is displayed.

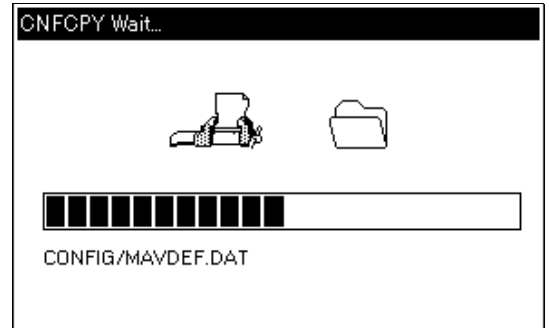

(6) Please remove the FD from FDD, and then select (CL) [OK].

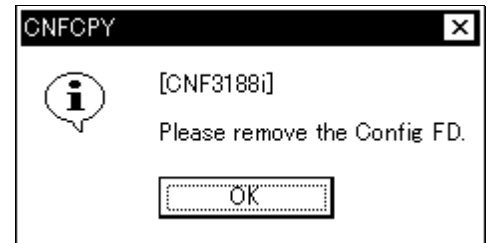

(7) Select (CL) [Exit].

(8) Select (CL)[Define Configuration and Install] form [INSTALL].

(9)

NOTICE:
 LDEV/PDEV of an old subsystem is reflected in a new subsystem by the DKC exchange. Therefore, please do not change information of the setting location “(13)-(18)” of the LDEV/PDEV. It is special (exception) work to need the password input. Ask the technical support center about the appropriateness of the operation, and input the password after getting an approval of executing the operation.

Select (CL) [OK] in response to the confirmation message

“<Important CAUTION>

This Operation is new installation. If you want to Non-disruptive Install or Non-disruptive de-install, terminate this procedure by [CANCEL] button and select INSTALL-CHANGE CONFIGURATION menu.”



Select (CL) [OK] in response to the confirmation message

“<Important CAUTION>

When you continue this operation, finally you need DKC PS OFF. Are you sure you want to continue this operation?”

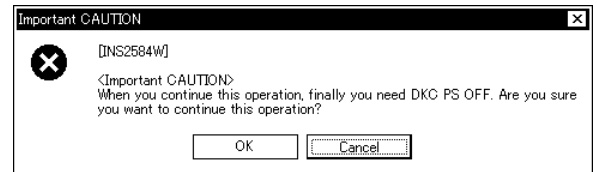

Select (CL) [OK] in response to the confirmation message

“<Important CAUTION>

When you continue this operation, customer’s DATA is LOST. Are you sure you want to continue this operation?”

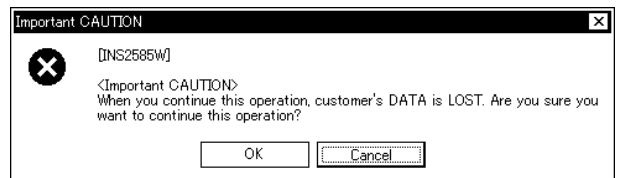

Enter the password and select (CL) [OK].
 Entering the password is required in this operation.
 Please call Technical Support Center for asking it.

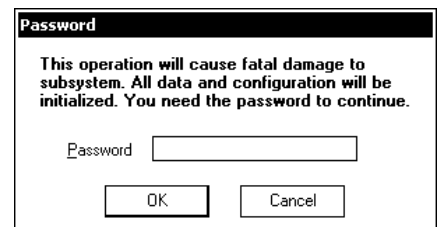

Select (CL) [OK] in response to the confirmation message “Installation data of option product in the Configuration table will be initialized by this operation. After finishing this procedure, please set the product installation again.”

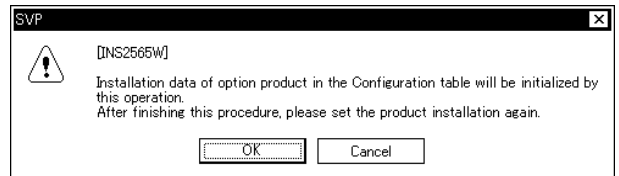

(10) <Define configuration information>

Define the device configuration information from 'DKC Configuration' according to the device configuration worksheet. After defining all input items is completed, select (CL) [>>Next]. If [Cache Configuration] is selected, the 'Cache Configuration' dialog box is displayed. (See step (10-2))
 If [System Option] is selected, the 'System Option' dialog box is displayed. (See step (10-3))
 If [Power Supply] is selected, the 'Redundant Power Supply' dialog box is displayed. (See step (10-4))
 If [Cancel] is selected, this procedure is terminated.

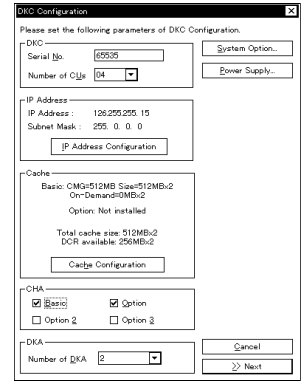

Note: Please does not change "Number of CUs" for the DKC exchange.

(10-1) <Setting IP Address>

Set the IP Address and Subnet Mask in the 'Set IP Address Configuration' dialog box. After setting up all items, select (CL) [OK]. Go to step (10). Selecting (CL) [Cancel] returns you to step 4.

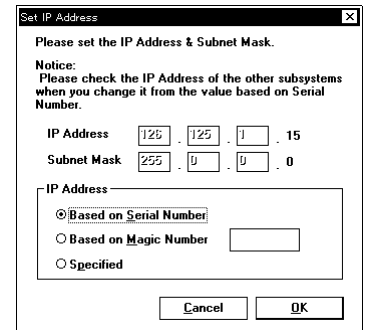

(10-2) <Define Cache Capacity>

Define the cache capacity in the 'Cache Configuration' dialog box. When the [Change...] is selected (CL), the 'DCR Available Size' dialog box is displayed. (Refer to Step (10-2-1)) (See SSD Optional Function Section)

Note: For Single Cabinet Model, Option is not displayed.

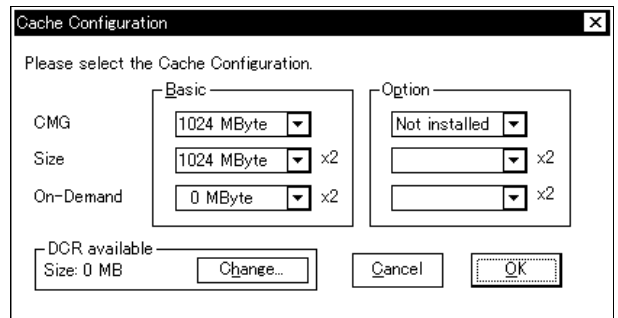

(10-2-1) <Setting DCR size>

Set the DCR Available size in the 'DCR Available Size' window and select (CL) the [OK] button. Return to Step (10-2).

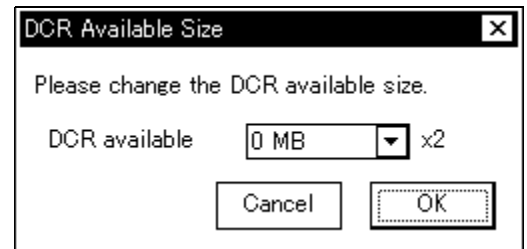

(10-3) <Define System Options>

Define the device configuration information from 'System Option Setup' according to the device configuration worksheet.

After setting up all items, select (CL) [OK].

Go to step (10).

Selecting (CL) [Cancel] returns you to step (10)

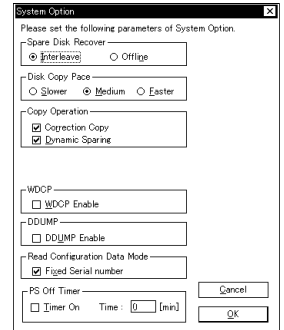

(10-4) <Set Power Supply>

Set the power supply information in the 'Redundant Power Supply' dialog box.

After setting up all items, select (CL) [OK].

Go to step (10).

Selecting (CL) [Cancel] returns you to step (10).

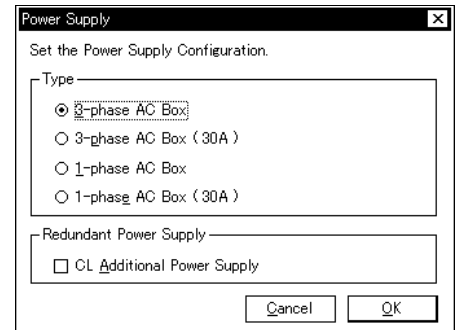

(11) <Setting channel type>

Set the subsystem configuration information in the 'Host Interface Configuration' window according to the subsystem configuration information work sheet.

When [Fibre *] is selected, select (CL) [Mode Set...] and go to step (11-1).

Select (CL) [Next>>]. Go to step (11-6).

When [Serial 4 ch] is selected, select (CL) [RCP Set...] and go to step (11-2).

(Execute the operation above for all the channels installed.)

After all the items are set, select (CL)

[>>Next]. Go to step (12).

When [Before<<] is selected (CL), the screen is returned to the previous one.

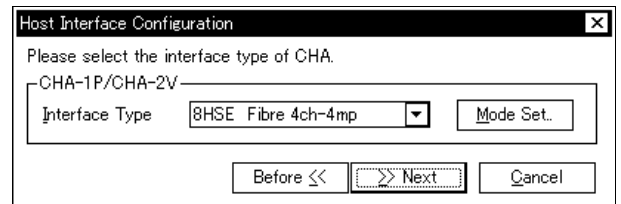
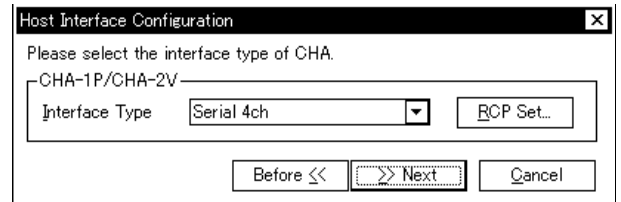

(11-1) <Setting Fibre Mode>

Set the Fibre Mode in the 'Fibre Mode Configuration' dialog box.
 After setting up all items, select (CL) [OK].
 Go to step (11).
 Selecting (CL) [Cancel] returns you to step (11).

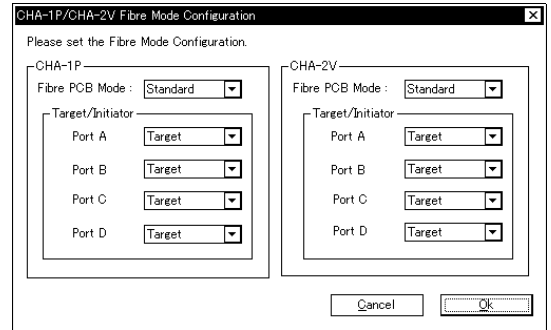

(11-2) <Setting RCP port>

Select (CL) the port defined as the RCP port and select (CL) [OK].
 Go to step (11-3).
 When [Cancel] is selected (CL), the routine returns to step (11).

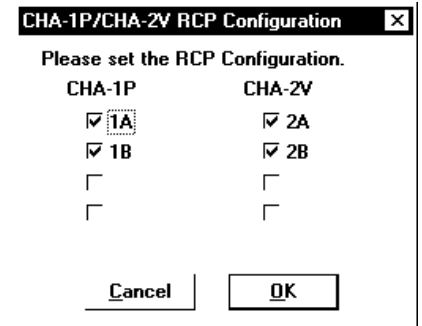

(11-3) <Setting DKC emulation type>

Set the subsystem configuration information in the 'DKC Emulation Configuration' window according to the subsystem configuration information work sheet.
 After the setting is completed, select (CL) [>>Next]. Go to step (11-4).
 When [Before<<] is selected (CL), the routine returns to step (11).

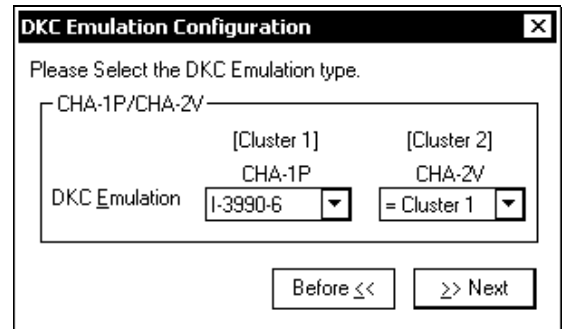

(11-4) <Setting CU number>

CU number is displayed.
 After the setting is completed, select (CL) [>>Next]. Go to step (11-5).
 When [Before<<] is selected (CL), the routine returns to step (11-3).

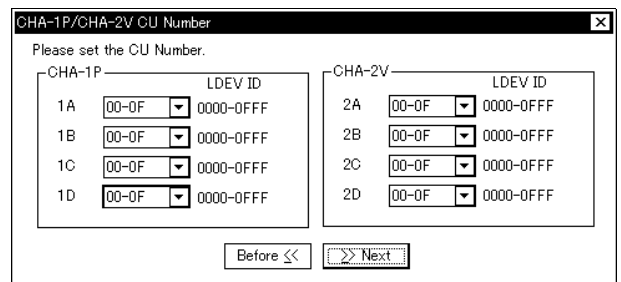

(11-5) <SVP message>

Select (CL) [OK] in response to the confirmation message “xxxxx”.
Returns to step (11).



(11-6) <Setting Channel>

Set the ‘Channel Speed’.
After setting up, select (CL) [>>Next].
Go to step (12).
When [Before<<] is selected (CL), the routine returns to step (11).

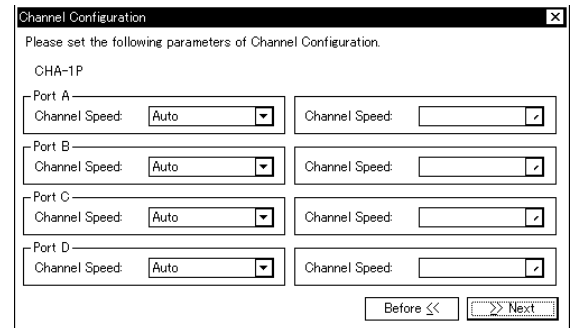

(12) <Set DKF type>

Set the ‘DKF Type’.
After setting up, select (CL) [>>Next].
Go to step (13).
When [Before<<] is selected (CL), the routine returns to step (11).

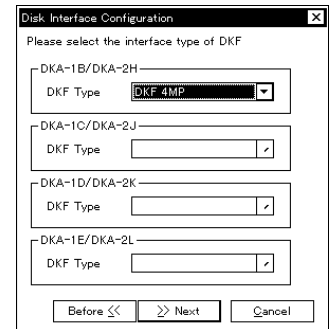

(13) <Set DKU Equipment>

Please select [>>Next] without changing the setting.
Selecting (CL) [Before<<] returns you to the previous screen.
This procedure is terminated by selecting (CL) [Cancel].

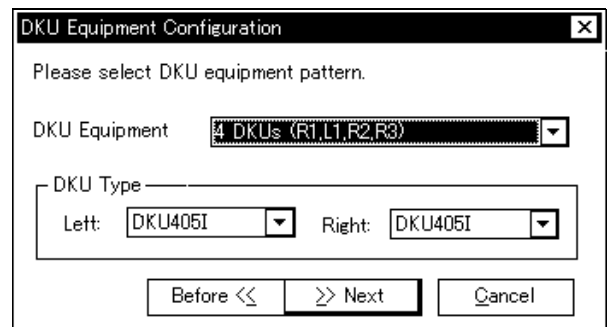

(14) <Install Drive Configuration Information>

Please select [>>Next] without changing the setting.
 Selecting (CL) [Before<<] returns you to the previous screen.

This procedure is terminated by selecting (CL) [Cancel].

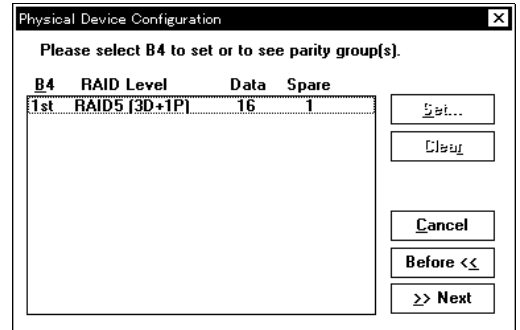

(15) <Define Device Emulation>

Please select [>>Next] without changing the setting.

Selecting (CL) [Before<<] returns you to the previous screen.

This procedure is terminated by selecting (CL) [Cancel].

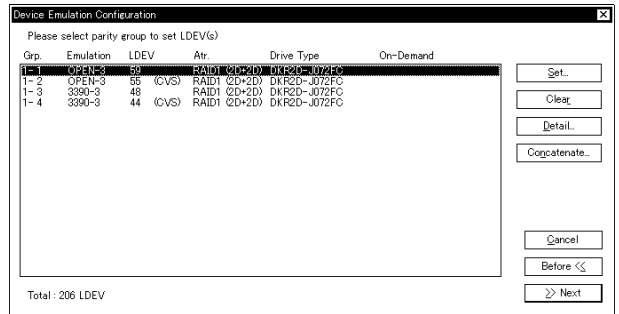

(16) <Define LDEV ID>

Please select [>>Next] without changing the setting.

Selecting (CL) [Before<<] returns you to the previous screen.

This procedure is terminated by selecting (CL) [Cancel].

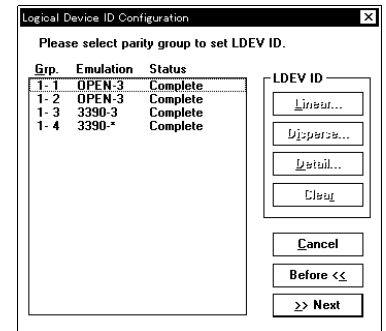

(17) <Define Subsystem ID Boundary>

Please select [>>Next] without changing the setting.

Selecting (CL) [Before<<] returns you to the previous screen.

This procedure is terminated by selecting (CL) [Cancel].

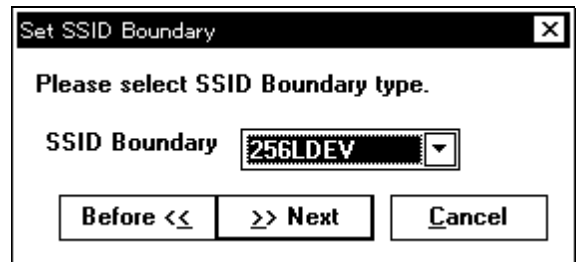

(18) <Define Subsystem ID>

Please select [>>>Next] without changing the setting.
 Selecting (CL) [Before<<] returns you to the previous screen.
 This procedure is terminated by selecting (CL) [Cancel].

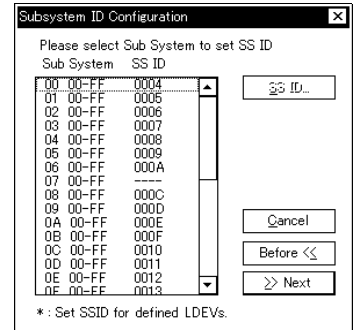

(19) <Defining DCR>

(19-1) Select (CL) a parity group having LDEV(s) for which the DCR is to be set on the “DCR Configuration” screen and press (CL) the [Detail...] button.

Total cache memory size which DCR area use is displayed.

If the selected parity group has a DCR area, the BIND size and to PRIO size are displayed under the “DCR Configuration” screen.

After setting above, select (CL) [>>>Next].

This procedure is terminated by selecting (CL) [Cancel].

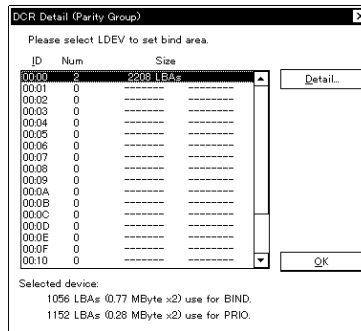
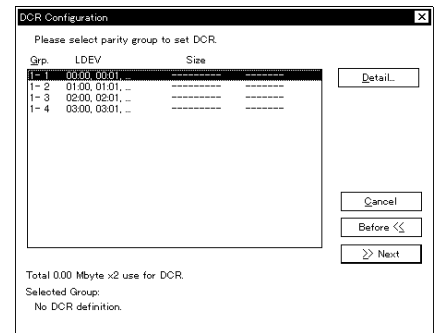

(For open system)

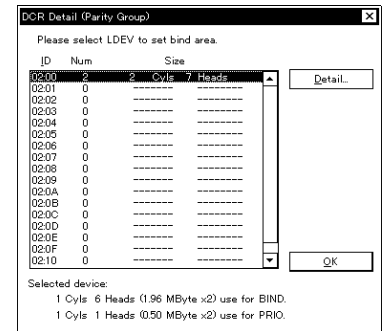

(For Mainframe system)

(19-2) Select (CL) an LDEV where the DCR is to be set on the “DCR Detail (Parity Group)” screen and press (CL) the [Detail...] button.

If the selected LDEV has a DCR area, the BIND size and the PRIO size are displayed under the “DCR Detail (Parity Group)” screen.

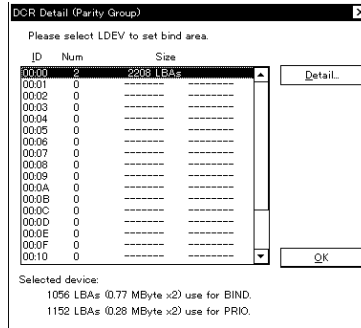

(For open system)

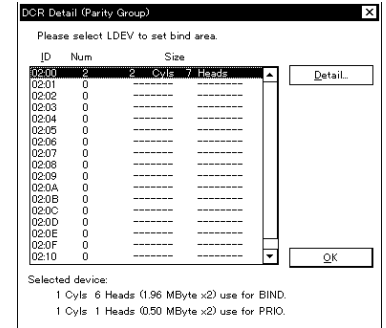

(For Mainframe system)

(19-3) Confirm the LDEV size and the number of slots allowed to be set for each type on the “DCR Detail (Logical Device)” screen. Press (CL) the [Set...] button to set the DCR area.

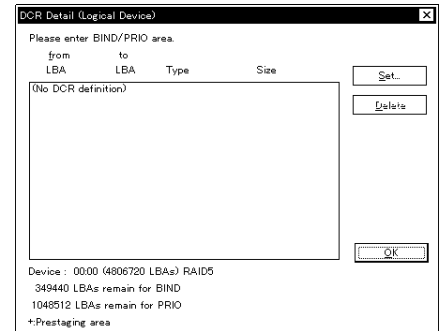

(19-4) Enter the type, starting cylinder number, starting head number, ending cylinder number, and ending head number (for Mainframe system. Refer to the screen on the right.) or the type, starting LBA, and ending LBA (for open system. Refer to the screen on the left.) on the “DCR Define” screen and select (CL) [OK].
For open system, all items are allowed to be set.

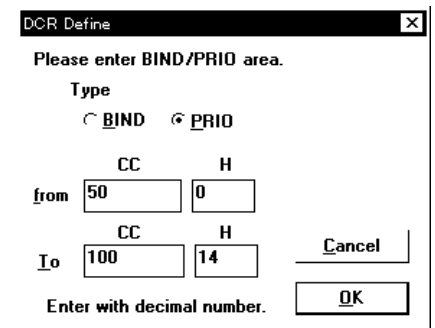
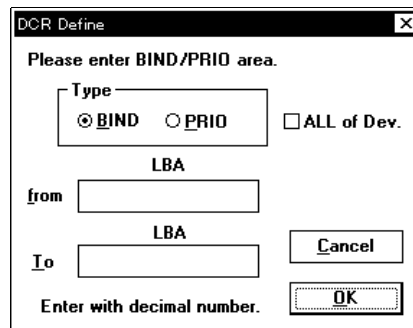

(19-5) When the screen is returned to the “DCR Detail (Logical Device)” screen, the entrance result is displayed.

from LBA	to LBA	Type	Size
0	1055	BIND+	1056 LBA
1920	3071	PRIO+	1152 LBA

Device : 0000 (4806720 LBA) RAID5
348000 LBA remain for BIND
1044192 LBA remain for PRIO
+Prestaging area

(For open system)

from CC HH	to CC HH	Type	Size
0 00	1 05	BIND+	1 Cyls 6 Heads
2 00	3 00	PRIO+	1 Cyls 1 Heads

Device : 0200 (3339 Cylinders) RAID5
179 Cyls 8 Heads remain for BIND
538 Cyls 9 Heads remain for PRIO
+Prestaging area

(For Mainframe system)

(19-6) When an item in the list box is selected (CL) and the [Delete] button is pressed (CL) on the “DCR Detail (Logical Device)” screen, the DCR setting is deleted. When the setting is completed, press (CL) [OK].

from CC HH	to CC HH	Type	Size
2 00	3 00	PRIO+	1 Cyls 1 Heads

Device : 0200 (3339 Cylinders) RAID5
179 Cyls 8 Heads remain for BIND
538 Cyls 9 Heads remain for PRIO
+Prestaging area

(19-7) If you want to set other LDEV(s) in the parity group which you selected, repeat steps (19-2) to (19-6) for the LDEV(s).

(19-8) If you want to set other LDEV(s) in other parity group, repeat steps (19-1) to (19-6) for the LDEV(s).

(20) <Define Shared Memory Size>

Define the shared memory module size in the 'Shared Memory Size Configuration' dialog box.

Select (CL) [>>Next].

This procedure is terminated by selecting (CL) [Cancel].

Go to [INST05-610](#).

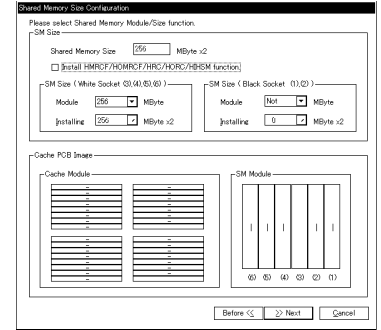

(21) <Include configuration information>

(21-1) Select (CL) [Yes] in response to the confirmation message "Are you sure you want to install the defined configuration?". "Wait..." is displayed, then "Turn off DKC subsystem" is displayed.

Selecting (CL) [No] suppresses the

configuration inclusion processing and terminates the installation procedure.

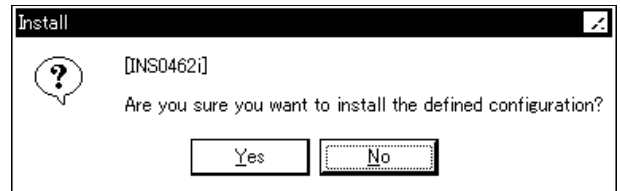

(21-2) Select (CL) [OK] in response to the confirmation message

"<Important CAUTION>

When you continue this operation, finally you need DKC PS OFF. Are you sure you want to continue this operation?"

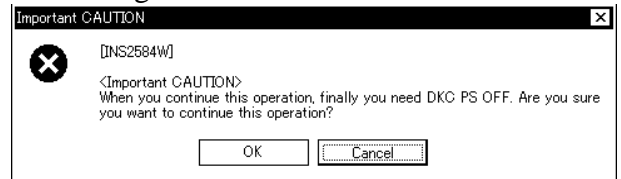

(21-3) Select (CL) [OK] in response to the confirmation message

"<Important CAUTION>

When you continue this operation, customer's DATA is LOST. Are you sure you want to continue this operation?"

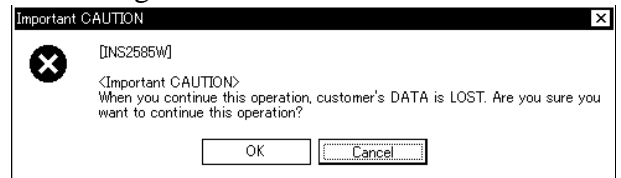

(21-4) Select (CL) [OK] in response to the confirmation message

“<Important CAUTION>

When you continue this operation, configuration data will be changed. Are you sure you want to continue this operation?”.

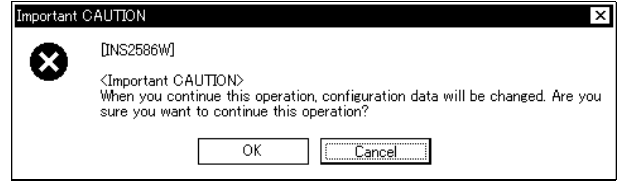

(21-5) Select (CL) [OK] in response to the confirmation message

“<Important CAUTION>

When you select [OK] button, you can't cancel this operation. Are you sure you want to continue this operation?

If you terminate this operation by some

forcible method, the subsystem be in UNRECOVERABLE SERIOUSLY DAMAGE.”.

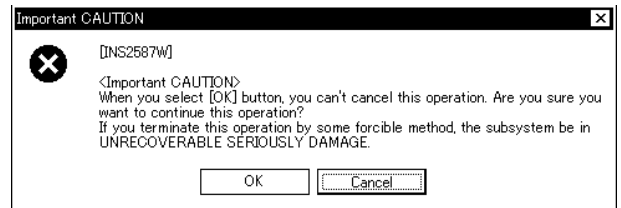

(21-6) Select (CL) [OK] in response to the confirmation message

“<Important CAUTION>

You must not RE-BOOT SVP(PC).”.

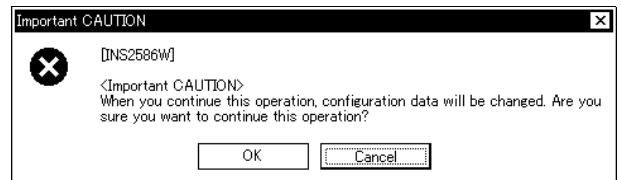

(22) <Power off DKC P/S>

Make sure that “Turn off DKC, and wait.” is displayed and perform the power-off procedure from the DKC maintenance panel.

After a while, “Wait...” will be displayed.

Turn off DKC, and wait.

(23)

This step allows the contents of the SVP HD to be loaded into SM and FM.
When this procedure is completed, "Battery Life Warning SIM" is displayed.

(24)

Select [Set...] applying the check to 'Battery Life Warning SIM'.

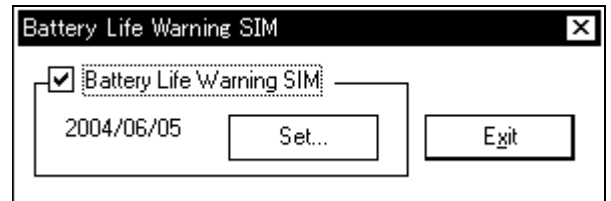

(25)

Select (CL) [OK] after inputting the remainder days by reporting on warning SIM.

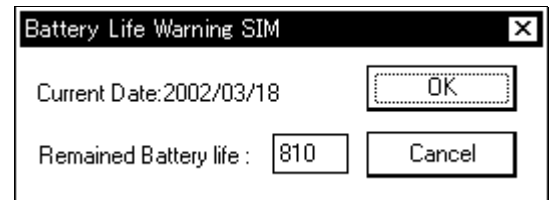

(26)

Insert the configuration FD into FDD, and select (CL) [OK].



(27)

When this procedure is completed, the message “Please remove the Config FD.” is displayed.
Remove the FD, and then select (CL) [OK].

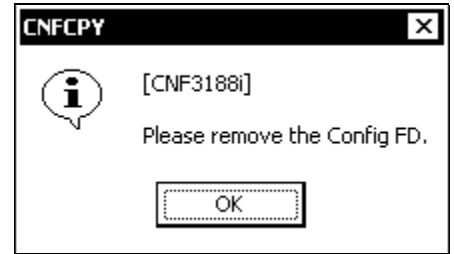

(28)

After making sure that the DKC power is turned off, select (CL) [OK] in response to “Installation was finished.”.

Select (CL) [OK] in response to “Please reboot PC.”.

The initial Install screen is restored.

Note: SVP power will not turn off or reboot even when DKC is powered off.

Go to [INST02-550](#) step (31).

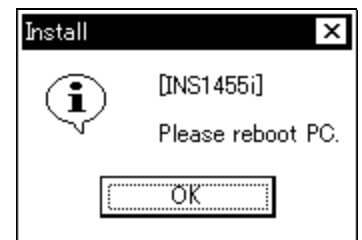

(29)

Please execute the compulsion recovery of LDEV after DKC reactivates.
Go to [SVP02-730](#).

9.6 Work sheet

Please write the following information to a work sheet from the composition of RAID400.

9.6.1 System Option Modes

Please write to System Option Mode Work Sheet with reference to System Option Modes.

There are some System Option Modes whose meaning is different from meaning on RAID400.
So System Option Modes are not handed over.

Set System Option Modes which are needed for the site. See [MODE01-10](#).

System Option Mode Work Sheet

0	7	8	15
<input type="text"/>	<input type="text"/>	<input type="text"/>	<input type="text"/>
16	23	24	31
<input type="text"/>	<input type="text"/>	<input type="text"/>	<input type="text"/>
32	39	40	47
<input type="text"/>	<input type="text"/>	<input type="text"/>	<input type="text"/>
48	55	56	63
<input type="text"/>	<input type="text"/>	<input type="text"/>	<input type="text"/>
64	71	72	79
<input type="text"/>	<input type="text"/>	<input type="text"/>	<input type="text"/>
80	87	88	95
<input type="text"/>	<input type="text"/>	<input type="text"/>	<input type="text"/>
96	103	104	111
<input type="text"/>	<input type="text"/>	<input type="text"/>	<input type="text"/>
112	119	120	127
<input type="text"/>	<input type="text"/>	<input type="text"/>	<input type="text"/>
128	135	136	143
<input type="text"/>	<input type="text"/>	<input type="text"/>	<input type="text"/>
144	151	152	159
<input type="text"/>	<input type="text"/>	<input type="text"/>	<input type="text"/>
160	167	168	175
<input type="text"/>	<input type="text"/>	<input type="text"/>	<input type="text"/>
176	183	184	191
<input type="text"/>	<input type="text"/>	<input type="text"/>	<input type="text"/>
192	199	200	207
<input type="text"/>	<input type="text"/>	<input type="text"/>	<input type="text"/>
208	215	216	223
<input type="text"/>	<input type="text"/>	<input type="text"/>	<input type="text"/>
224	231	232	239
<input type="text"/>	<input type="text"/>	<input type="text"/>	<input type="text"/>
240	247	248	255
<input type="text"/>	<input type="text"/>	<input type="text"/>	<input type="text"/>

9.6.2 Program Product

When the following P.P. exists, please write information required for a work sheet.

9.6.2.1 HPAV

- HPAV Work Sheet

Please write all the combination of CU#, Base Volume, Alias Counts, and Alias Volume from “HAPV” panel.

Note 1: A value should write with hexadecimal

Note 2: Since Free Volume which overlaps Base Volume does not exist, be careful not to overlap.

9.6.2.2 LDEV Security

- LDEV Security Work Sheet

Please prepare the number sheet of Node to need.

A setup of this sheet is performed for every host Node.

Please write TYPE/MODEL, SEQNUMBER, and LPAR# from “LDEV Security” panel.

Please write CU# and LDEV# displayed on Prohibit to Access from “Set LDEV Security” panel.

When you set up Ldev Security, please write “Yes” to Prohibit To Access LDEV.

Note 1: Please write the Node information of the host who sets up LDEV Security to TYPE/MODEL, SEQNUMBER, and LPAR#.

Note 2: Please write the LDEV information which sets up LDEV Security to CU# and Prohibit To Access LDEV.

LDEV Security Work Sheet

Node	TYPE/MODEL	SEQNUMBER	LPAR#	CU#	Prohibit To Access LDEV
				0	
				1	
				2	
				3	
				0	
				1	
				2	
				3	
				0	
				1	
				2	
				3	
				0	
				1	
				2	
				3	
				0	
				1	
				2	
				3	
				0	
				1	
				2	
				3	
				0	
				1	
				2	
				3	
				0	
				1	
				2	
				3	
				0	
				1	
				2	
				3	
				0	
				1	
				2	
				3	
				0	
				1	
				2	
				3	
				0	
				1	
				2	
				3	

9.6.2.3 E-Copy

- Extended Copy Manager Work Sheet

Please write “-” to Port Group# of Port which is not installed.

When you click each Port Group tab ,please write Port Group# which contains displayed Port# from “SCSI PATH” panel.

Please write “Nothing” to Port# which is not written after writing all Port Group.

Note 1: Please write "N" or "00"-"0F" to E-COPY Port Group#. When package is not installed , please write “-”.

Note 2: Please write “Target” or “Initiator” to the Target/Initiator attribute of Port. When not installed, write “-”. RCU Target is also set to Target.

Extended Copy Manager Work Sheet

Port#	Port Group#	Target/Initiator
1A		
1B		
1C		
1D		
1E		
1F		
1G		
1H		
1J		
1K		
1L		
1M		
1N		
1P		
1Q		
1R		

Port#	Port Group#	Target/Initiator
2A		
2B		
2C		
2D		
2E		
2F		
2G		
2H		
2J		
2K		
2L		
2M		
2N		
2P		
2Q		
2R		

9.6.2.4 LUN Security

- LUN Security Sheet
 - Please prepare the number Sheet of Port to need.
 - Please check Port# of Port which will write.
 - Please write all WWN and WWN Group displayed on LUN/LUN Group and "Permitted WWN/WWN Group" from "Security" panel.

- LUN Group Sheet
 - Please prepare the number Sheet of Port to need.
 - Please check Port# of Port which will write.
 - Please write Nickname of LUN Group from "Group" panel, and write all LUN Number displayed on Group Member .

- WWN Group Sheet
 - Please prepare the number Sheet of Port to need.
 - Please check Port# of Port which will write.
 - Please write all of WWN and Nickname from "WWN List" panel.
 - Please write NickName and WWN for every WWN Group,

- Fibre Path Sheet
 - Please prepare the number Sheet of Port to need.
 - Please check Port# of Port which will write.
 - Please write all the combination of LUN , CU and LDEV from "Set SCSI Path Parameter" panel from every Port.

- Fibre PORT Work Sheet
 - Please write HOST MODE from "Set Host Mode" panel.
 - From "Fibre Parameter" panel, please write Fibre Address and check Fabric and Connection.

- PCB Mode Sheet
 - Please write all the PCB modes of each Port from "Fibre PCB Mode" panel.

Fibre Path Sheet

CHA	
Port#	
1A	1B
1C	1D
1E	1F
1G	1H
1J	1K
1L	1M
1N	1P
1Q	1R
2A	2B
2C	2D
2E	2F
2G	2H
2J	2K
2L	2M
2N	2P
2Q	2R

	LUN, CU#, and LDEV#																									
	0		1		2		3		4		5		6		7		8		9							
	LUN	CU#	LUN	CU#	LUN	CU#	LUN	CU#	LUN	CU#	LUN	CU#	LUN	CU#	LUN	CU#	LUN	CU#	LUN	CU#	LUN	CU#	LUN	CU#		
0																										
1																										
2																										
3																										
4																										
5																										
6																										
7																										
8																										
9																										
10																										
11																										
12																										
13																										
14																										
15																										
16																										
17																										
18																										
19																										
20																										
21																										
22																										
23																										
24																										
25																										

Fibre PORT Work Sheet

Fibre				
Port#	HOST MODE	ADDRESS	Fabric	Connection
1A			ON / OFF	FC-AL / P to P
1B			ON / OFF	FC-AL / P to P
1C			ON / OFF	FC-AL / P to P
1D			ON / OFF	FC-AL / P to P
1E			ON / OFF	FC-AL / P to P
1F			ON / OFF	FC-AL / P to P
1G			ON / OFF	FC-AL / P to P
1H			ON / OFF	FC-AL / P to P
1J			ON / OFF	FC-AL / P to P
1K			ON / OFF	FC-AL / P to P
1L			ON / OFF	FC-AL / P to P
1M			ON / OFF	FC-AL / P to P
1N			ON / OFF	FC-AL / P to P
1P			ON / OFF	FC-AL / P to P
1Q			ON / OFF	FC-AL / P to P
1R			ON / OFF	FC-AL / P to P

Fibre				
Port#	HOST MODE	ADDRESS	Fabric	Connection
2A			ON / OFF	FC-AL / P to P
2B			ON / OFF	FC-AL / P to P
2C			ON / OFF	FC-AL / P to P
2D			ON / OFF	FC-AL / P to P
2E			ON / OFF	FC-AL / P to P
2F			ON / OFF	FC-AL / P to P
2G			ON / OFF	FC-AL / P to P
2H			ON / OFF	FC-AL / P to P
2J			ON / OFF	FC-AL / P to P
2K			ON / OFF	FC-AL / P to P
2L			ON / OFF	FC-AL / P to P
2M			ON / OFF	FC-AL / P to P
2N			ON / OFF	FC-AL / P to P
2P			ON / OFF	FC-AL / P to P
2Q			ON / OFF	FC-AL / P to P
2R			ON / OFF	FC-AL / P to P

PCB Mode work SheetPCB Mode Sheet

PCB#	PCB Mode
CL1 Basic	Standard/High Speed
CL1 Option	Standard/High Speed
CL1 Option2	Standard/High Speed
CL1 Option3	Standard/High Speed
CL2 Basic	Standard/High Speed
CL2 Option	Standard/High Speed
CL2 Option2	Standard/High Speed
CL2 Option3	Standard/High Speed

9.6.2.5 HIHSM

- Pair information Sheet

If Source Volume and Destination Volumes is displayed on “Pair Status” panel, copy CU# and Volume#.

- Reserve Volume information Sheet

Select “ALL DEVS” at “Change Attribute” panel and check “Reserved” box.
Copy all of Volume number displayed on “Volume List”.

- System Option Mode

Set the System Option Mode written in that table to RAID450.

Performance Management-Cruise Control Function Work Sheet

System Option Mode

System Option Mode	
119	

9.6.2.6 HMRCF

- Pair information Sheet
Copy “Source/Target Volume”, “Pair Status” and “Copy Pace” from “Pairedisplay” panel.
When “Pair Status” is HCAFE, set mark to work sheet.
- Reserve Volume information Sheet
Copy all of reserved CU and volume from “HMRCF” panel.
- Option Information Sheet
Copy all option from “Option Display” panel.
- System Option Mode
Set the System Option Mode written in that table to RAID450.

Notes: When “Pair Status” is Duplex, ask the customer about “Copy Pace”.
When “Pair Status” is Split, Suspend or HCAFE, there is no information for “Copy Pace”.

HMRCF Work SheetOption information Sheet

Option name	ON/OFF
Swap&Freeze Option	
HCAFE Option	

HMRCF Work SheetSystem Option Mode

System Option Mode	
025	
030	
080	
087	
119	

9.6.2.7 HOMRCF

- Pair information Sheet
Copy “Primary/Secondary Volume”, “Pair Status” and “Copy Pace” from “Pairedisplay” panel.
Copy “MU Number” from the setting file of RAID Manager. Ask the customer about the setting file.
- Reserve Volume information Sheet
Copy all of reserved volumes from “HOMRCF” panel.
- Option Information Sheet
Copy all option from “Option Display” panel.
- System Option Mode
Set the System Option Mode written in that table to RAID450.

Notes: When “Pair Status” is PAIR, ask the customer about “Copy Pace”.
When “Pair Status” is PSUS or PSUE, there is no information for “Copy Pace”.

HOMRCF Work SheetOption information Sheet

Option name	ON/OFF
Swap&Freeze Option	

HOMRCF Work SheetSystem Option Mode

System Option Mode	
025	
030	
080	
087	
119	

9.6.2.8 TRUE COPY

- Port Type Sheet
Copy PCB TYPE and attribute of port from “RCU Operation” panel.
- RCU Sheet(Fibre channel interface)
Copy informations from “RCU Operation” panel, and set those to each column.
- RCU Sheet(Serial channel interface)
Copy informations from “RCU Operation” panel, and set those to each column.
- Async Group Sheet
Copy informations from “Asynchrotrons Operation” panel, and set those to each column.
- Async Group (Option) Sheet
Copy “Pending Update Data Rate” and “Offloading Timer” from “Asynchrotrons Operation” panel.
- Pair Sheet (True Copy)
Copy informations from “Pair Operation” panel, and set those to each column.
- Pair Sheet (True Copy-S/390)
Copy informations from “Pair Operation” panel, and set those to each column.

TRUE COPY Work SheetPort Type Sheet

Port#	PCB TYPE	
	CHT	CHE
1A	Target / Initiator / RCU-Target	LCP / RCP
1B	Target / Initiator / RCU-Target	LCP / RCP
1C	Target / Initiator / RCU-Target	LCP / RCP
1D	Target / Initiator / RCU-Target	LCP / RCP
1E	Target / Initiator / RCU-Target	LCP / RCP
1F	Target / Initiator / RCU-Target	LCP / RCP
1G	Target / Initiator / RCU-Target	LCP / RCP
1H	Target / Initiator / RCU-Target	LCP / RCP
1J	Target / Initiator / RCU-Target	LCP / RCP
1K	Target / Initiator / RCU-Target	LCP / RCP
1L	Target / Initiator / RCU-Target	LCP / RCP
1M	Target / Initiator / RCU-Target	LCP / RCP
1N	Target / Initiator / RCU-Target	LCP / RCP
1P	Target / Initiator / RCU-Target	LCP / RCP
1Q	Target / Initiator / RCU-Target	LCP / RCP
1R	Target / Initiator / RCU-Target	LCP / RCP
2A	Target / Initiator / RCU-Target	LCP / RCP
2B	Target / Initiator / RCU-Target	LCP / RCP
2C	Target / Initiator / RCU-Target	LCP / RCP
2D	Target / Initiator / RCU-Target	LCP / RCP
2E	Target / Initiator / RCU-Target	LCP / RCP
2F	Target / Initiator / RCU-Target	LCP / RCP
2G	Target / Initiator / RCU-Target	LCP / RCP
2H	Target / Initiator / RCU-Target	LCP / RCP
2J	Target / Initiator / RCU-Target	LCP / RCP
2K	Target / Initiator / RCU-Target	LCP / RCP
2L	Target / Initiator / RCU-Target	LCP / RCP
2M	Target / Initiator / RCU-Target	LCP / RCP
2N	Target / Initiator / RCU-Target	LCP / RCP
2P	Target / Initiator / RCU-Target	LCP / RCP
2Q	Target / Initiator / RCU-Target	LCP / RCP
2R	Target / Initiator / RCU-Target	LCP / RCP

TRUE COPY Work Sheet

RCU Sheet

- MCU-RCU: Fibre channel interface

MCU#	RCU Serial No.	Controller ID	RCU CU#	SSID	MCU Port#	RCU Port#	RCU Option			
							Minimum paths	Maximum Init. Copy Activity	RIO MIH Time	Path Blockade Watch
								4/16		
								4/16		
								4/16		
								4/16		

TRUE COPY Work SheetAsync Group Sheet

CT Group#	MCU-RCU Path	Time Out (Copy pending)	Time Out (RCU Ready)
0			
1			
2			
3			
4			
5			
6			
7			
8			
9			
A			
B			
C			
D			
E			
F			
10			
11			
12			
13			
14			
15			
16			
17			
18			
19			
1A			
1B			
1C			
1D			
1E			
1F			

CT Group#	MCU-RCU Path	Time Out (Copy pending)	Time Out (RCU Ready)
20			
21			
22			
23			
24			
25			
26			
27			
28			
29			
2A			
2B			
2C			
2D			
2E			
2F			
30			
31			
32			
33			
34			
35			
36			
37			
38			
39			
3A			
3B			
3C			
3D			
3E			
3F			

CT Group#	MCU-RCU Path	Time Out (Copy pending)	Time Out (RCU Ready)
40			
41			
42			
43			
44			
45			
46			
47			
48			
49			
4A			
4B			
4C			
4D			
4E			
4F			
50			
51			
52			
53			
54			
55			
56			
57			
58			
59			
5A			
5B			
5C			
5D			
5E			
5F			

CT Group#	MCU-RCU Path	Time Out (Copy pending)	Time Out (RCU Ready)
60			
61			
62			
63			
64			
65			
66			
67			
68			
69			
6A			
6B			
6C			
6D			
6E			
6F			
70			
71			
72			
73			
74			
75			
76			
77			
78			
79			
7A			
7B			
7C			
7D			
7E			
7F			

TRUE COPY Work SheetAsync Group (Option) Sheet

Pending Update Data Rate	Offloading Timer
[%]	[sec]

TRUE COPY Work Sheet

Pair Sheet

- True Copy-S/390

MCU#	PVOL	SVOL	RCU#/SSID	Pair Option										Err. Level
				Copy mode	Fende Level	Init. Copy Pace	Priority	Diff. Manage.	CFW Data	DFW to RVOL	CT Group#			
				Sync/Async	Never/Status/Data				Track/Cylinder	Only M-VOL/ Copy to RVOL	not Required / Required		VOL/Grp	
				Sync/Async	Never/Status/Data				Track/Cylinder	Only M-VOL/ Copy to RVOL	not Required / Required		VOL/Grp	
				Sync/Async	Never/Status/Data				Track/Cylinder	Only M-VOL/ Copy to RVOL	not Required / Required		VOL/Grp	
				Sync/Async	Never/Status/Data				Track/Cylinder	Only M-VOL/ Copy to RVOL	not Required / Required		VOL/Grp	
				Sync/Async	Never/Status/Data				Track/Cylinder	Only M-VOL/ Copy to RVOL	not Required / Required		VOL/Grp	
				Sync/Async	Never/Status/Data				Track/Cylinder	Only M-VOL/ Copy to RVOL	not Required / Required		VOL/Grp	
				Sync/Async	Never/Status/Data				Track/Cylinder	Only M-VOL/ Copy to RVOL	not Required / Required		VOL/Grp	
				Sync/Async	Never/Status/Data				Track/Cylinder	Only M-VOL/ Copy to RVOL	not Required / Required		VOL/Grp	
				Sync/Async	Never/Status/Data				Track/Cylinder	Only M-VOL/ Copy to RVOL	not Required / Required		VOL/Grp	
				Sync/Async	Never/Status/Data				Track/Cylinder	Only M-VOL/ Copy to RVOL	not Required / Required		VOL/Grp	
				Sync/Async	Never/Status/Data				Track/Cylinder	Only M-VOL/ Copy to RVOL	not Required / Required		VOL/Grp	
				Sync/Async	Never/Status/Data				Track/Cylinder	Only M-VOL/ Copy to RVOL	not Required / Required		VOL/Grp	
				Sync/Async	Never/Status/Data				Track/Cylinder	Only M-VOL/ Copy to RVOL	not Required / Required		VOL/Grp	
				Sync/Async	Never/Status/Data				Track/Cylinder	Only M-VOL/ Copy to RVOL	not Required / Required		VOL/Grp	
				Sync/Async	Never/Status/Data				Track/Cylinder	Only M-VOL/ Copy to RVOL	not Required / Required		VOL/Grp	
				Sync/Async	Never/Status/Data				Track/Cylinder	Only M-VOL/ Copy to RVOL	not Required / Required		VOL/Grp	
				Sync/Async	Never/Status/Data				Track/Cylinder	Only M-VOL/ Copy to RVOL	not Required / Required		VOL/Grp	