

TROUBLE SHOOTING SECTION

Contents

1 Overview of TRBL	TRBL01-10
2 Point out a Failed Part	TRBL02-10
3 Isolating a Failed Part	TRBL03-10
3.1 Analyze the SIM log, SSB log or Remote Diagnostic Data	TRBL03-10
3.2 A failure has been reported to the customer but the DKC has not been connected to the Remote Maintenance	TRBL03-20
3.2.1 SIM has been reported	TRBL03-30
3.2.2 SSB has been reported	TRBL03-35
3.2.3 OS cannot recover the subsystem error (MIH, Job ABEND)	TRBL03-40
3.2.4 OS has detected the subsystem error (ICC, CC=3)	TRBL03-60
3.2.5 The lamp on the subsystem panel has failed	TRBL03-70
3.2.6 PC (SVP) failure recovery procedure.....	TRBL03-140
3.2.7 A failure has occurred when turning the power on	TRBL03-180
3.2.8 The power cannot be turned off	TRBL03-190
3.2.9 Multiple parts have failed	TRBL03-210
3.2.10 SSVP alarm lamp has been blinking or has lighted on	TRBL03-230
3.2.11 MESSAGE lamp has been blinking	TRBL03-230
3.2.12 AC Power failure in the case that the UPS is connected	TRBL03-240
3.2.13 Web Console failure	TRBL03-245
3.3 SVP Power Trouble Shooting	TRBL03-250
4 Recovery for Pinned Tracks	TRBL04-10
4.1 Recovery Procedure for Pinned Tracks	TRBL04-40
5 Error Recovery	TRBL05-10
5.1 FSW Access Error/FSW LED Bus Test Error (SIM = BF9XXX, 3DAXXX)	TRBL05-10
5.2 Isolation and Recovery Procedures for Common Fibre Loop Error (SIM = DF6YXX, DF7YXX, DF8YXX, DF9YXX)	TRBL05-20
5.3 Recovery Procedure for LAN Error (SIM = 1400X0, 1500X0, 73XX00)	TRBL05-60
5.4 Error Recovery Procedure during CHA/DKA replacement	TRBL05-100
5.5 Recovery Procedure for Cache Replace Failure (SIM = 3993XX, 3D93XX, FFE40X)	TRBL05-140
5.6 Recovery Procedure for Cache Error (Both sides) (SIM = FFF50X)	TRBL05-150
5.7 Recovery Procedures for Status in changing is not released	TRBL05-160
5.8 Drive failure recovery procedure	TRBL05-170
5.8.1 In the case of normal termination (SIM RC= 452YXX/462YXX)	TRBL05-180
5.8.2 In the case of termination with a warning (SIM RC = 455YXX/465YXX)	TRBL05-190
5.8.3 In the case of termination owing to abortion (SIM RC = 454YXX/464YXX)	TRBL05-200
5.8.4 In the case of abnormal termination (SIM RC = 453YXX/463YXX)	TRBL05-200

5.8.5 Correction access status -----	TRBL05-250
5.8.6 Parity group blockade -----	TRBL05-260
5.8.7 Preventive maintenance -----	TRBL05-260
5.9 Recovery Procedure for SM Capacities Inequality (SIM = FFE3XY) -----	TRBL05-270
5.10 Cache Memory Error Isolation Procedure (SIM = FFF0XX, FFF1XX, FFF2XX, FE0XX, FFE1XX, FFE2XX) -----	TRBL05-300
5.11 Recovery Procedure for LDEV Blocking (SIM = CF90XY, EF9YXX, DFAYXX, DFBYXX) -----	TRBL05-320
5.12 Voltage alarm (SIM = BF2XYY) -----	TRBL05-340
5.13 Environment monitors disagreement error (SIM = BFA1XX) -----	TRBL05-460
5.14 PS warning error (SIM = BF4XXX) -----	TRBL05-510
5.15 Recovery procedure when LDEV formatting failed -----	TRBL05-520
5.17 Recovery procedure when WDCP information is lost -----	TRBL05-530
5.18 Recovery procedure when recovering SM is impossible -----	TRBL05-540
5.19 Recovery procedure when installation/de-installation Cache and DCR is impossible -----	TRBL05-550
5.20 Recovery procedure for failed CSW PCB replacement -----	TRBL05-560
5.21 DKCMNs disagreement error (SIM = BF93XX) -----	TRBL05-570
5.22 Recovery Procedure for Warning of SM DISABLE (SIM = 399AXY, 3D9AXY) -----	TRBL05-580
5.23 Recovery Procedure for Injustice DC voltage control and Injustice CE MODE (SIM = 399DX0, 399EX0, 3D9DX0, 3D9EX0, FFF60X, FFF70X, FF200X, FF210X) -----	TRBL05-590
5.24 Recovery Procedure when Change the IP Address is failed -----	TRBL05-600
5.25 Duplex SVP Setup failed (SIM = BFE3A2) -----	TRBL05-630
5.26 The recovery procedure at the time of disorder generating after a power failure etc. -----	TRBL05-640
6 HRC/HODM/HORC Error Recovery -----	TRBL06-10
6.1 Recovery Procedure for HRC/HODM Error -----	TRBL06-10
6.2 HORC Error Recovery Procedure -----	TRBL06-30
6.3 Pinned Track Recovery Procedure for HRC/HODM/HORC -----	TRBL06-270
6.4 Recovery Action of Path Status Error -----	TRBL06-310
7 Trouble Shooting of Multiplatform -----	TRBL07-10
7.1 Trouble Shooting of error on host Fibre channel interface -----	TRBL07-10
7.1.1 Possible error and cause -----	TRBL07-10
7.1.2 Checking item when some errors occur on host Fibre channel path ---	TRBL07-20
7.2 -----	
7.3 Pinned track recovery of SCSI LDEV -----	TRBL07-110
7.3.1 Faulty Tracks -----	TRBL07-110
7.3.2 Error Types -----	TRBL07-110
7.3.3 Pinned track erasing procedure -----	TRBL07-150

9 HMRCF & HOMRCF Error Recovery	TRBL09-10
9.1 PIN Track recovery procedure for HMRCF	TRBL09-10
9.2 Recovery Procedure for Suspend Pair	TRBL09-20
9.3 Procedure for recovery from ShadowImage-FlashCopy (R) Option failure (SIM = 4B0XXX, 47E600)	TRBL09-60
9.4 Procedure for Recovery from ShadowImage-FlashCopy (R) version2 Option failure (SIM=4B2XYY)	TRBL09-100
10 Recovery procedure of AL_PA conflict (SIM = 2190XY)	TRBL10-10
11 HIHSM Error Recovery	TRBL11-10
11.1 HIHSM Error Recovery Flowchart	TRBL11-20
12 Recovery procedure of HDD/DKU installation failure	TRBL12-10
13 Recovery procedure of failure on replacement of SSVP	TRBL13-10
14 WebConsole Error Recovery	TRBL14-10
14.1 Recovery Procedure for WebConsole Error	TRBL14-10
15 Recovery procedure for DCR Pre-Staging ABNORMAL END	TRBL15-10
16 HI-COPY Error Recovery	TRBL16-10
16.1 Path failure recovery method	TRBL16-10
16.2 Device failure recovery method	TRBL16-20
16.3 Path failure and Device failure recovery method	TRBL16-30
16.4 HI-COPY Copy abnormal end recovery procedure (SIM = 4B1XXXX)	TRBL16-40
17 SFP Optical Failure (SIM = 21A8XY)	TRBL17-10
18 Mainframe port error recovery	TRBL18-10
18.1 ESCON/FICON Port Error Recovery	TRBL18-20
19 Recovery procedure of an IP address conflict (SIM = 21A9XY)	TRBL19-10

1 Overview of TRBL

The figure below shows the flowchart of creating and reporting the SIM and SSB after the DKC microprogram has detected a failure. It also shows the section of maintenance manual which should be referred to.

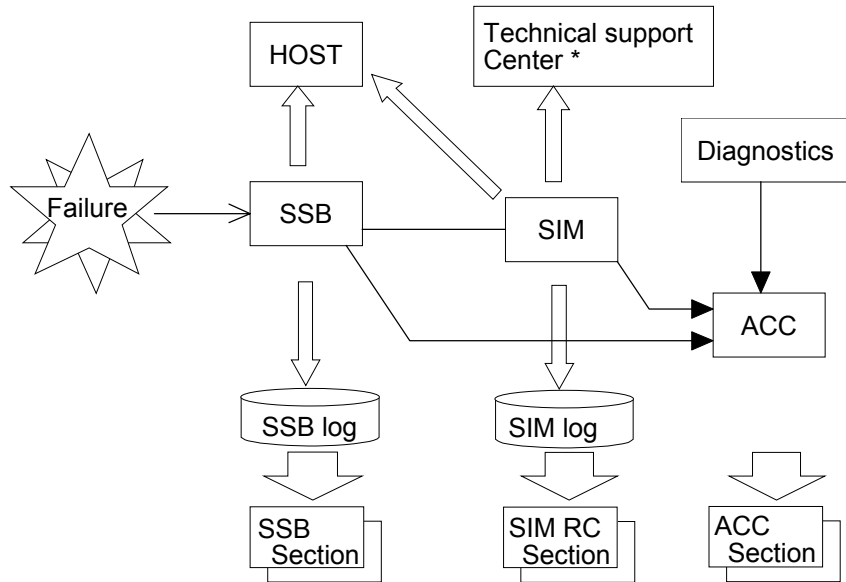

Since the subsystem starts its maintenance work based on the SIM and ACC, if a failure occurs check the ACC first and start troubleshooting.

For the failure which does not produce the ACC, isolate the failed part depending on its phenomenon.

* Technical Support Center: Responsible section of maintenance service and technical support.

2 Point out a Failed Part

[1] The ACC has been collected -----See [TRBL03-10](#)

[2] The ACC has not been collected -----See [TRBL03-20](#)

3 Isolating a Failed Part

3.1 Analyze the SIM log, SSB log or Remote Diagnostic Data

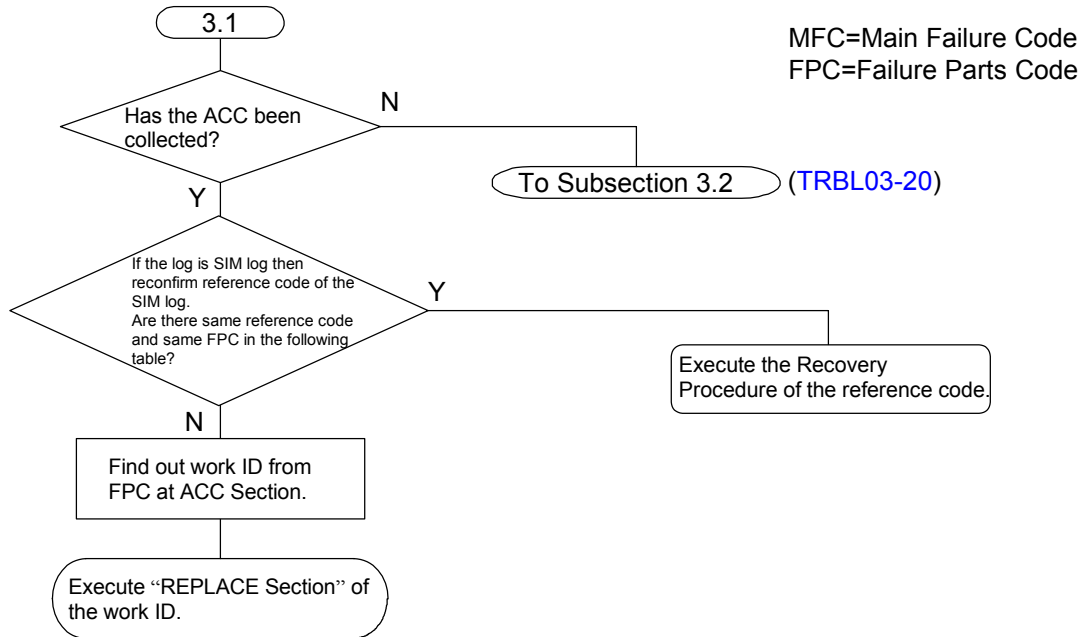

Reference Code	FPC	Recovery Procedure
DF6YXX, DF7YXX	80000000	5.2 Isolation and Recovery Procedures for Common Fibre Loop Error (TRBL05-20)
DF8YXX, DF9YXX	80000000	
BF2XYY	80000000	5.12 Voltage alarm (TRBL05-340)
BF4XXX	80000000	5.14 PS warning error (TRBL05-510)
BF93XX	80000000	5.21 DKCMNs disagreement error (TRBL05-570)
BFA1XX	80000000	5.13 Environment monitors disagreement error (TRBL05-460)
BFE3A2	80000000	5.25 Duplex SVP Setup failed (TRBL05-630)
CF90XY	80000000	5.11 Recovery Procedure for LDEV Blocking (TRBL05-320)
DF8YXX, DF9YXX	80000000	
EF9YXX	80000000	
DFA0XY	60D0	Collect Dump/Log and T.S.C call
EF50XY		
EF90XX	80000000	5.11 Recovery Procedure for LDEV Blocking (TRBL05-320)
D4XYYY	80000000	6 HRC/HODM/HORC Error Recovery (TRBL06-10)
DBXYYY	80000000	
2180XY	80000000	
2190XY	80000000	10 Recovery procedure of AL PA conflict (TRBL10-10)
47DXYY	80000000	9 HMRCF & HOMRCF Error Recovery (TRBL09-10)
47FYXX	80000000	11 HIHSM Error Recovery (TRBL11-10)
399AXY, 3D9AXY	80000000	5.22 Recovery Procedure for Warning of SM DISABLE (TRBL05-580)
399DX0, 399EX0, 3D9DX0, 3D9EX0, FFF60X, FFF70X, FF200X, FF210X	80000000	5.23 Recovery Procedure for Injustice DC voltage control and Injustice CE MODE (TRBL05-590)
BF9XXX	80000000	5.1 FSW Access Error/FSW LED Bus Test Error (TRBL05-10)
3DAXXX		
3999XY	80000000	5.4 Error Recovery Procedure during CHA/DKA replacement (TRBL05-100)
4821XX	80000000	15 Recovery Procedure for DCR Pre-Staging ABNORMAL END (TRBL15-10)
4B1XXXX	80000000	16 HI-COPY Error Recovery (TRBL16-10)
213ZXY, 21A2XY, 21A3XY	10xxy000	18 Mainframe Port Error Recovery (TRBL18-10)

3.2 A failure has been reported to the customer but the DKC has not been connected to the Remote Maintenance

Isolate the failed part depending on the following phenomenon.

- [1] The SIM has been reported. ----- [TRBL03-30](#)
- [2] The SSB has been reported. ----- [TRBL03-30](#)
- [3] The OS cannot recover the subsystem error. (MIH, Job ABEND, etc.) ----- [TRBL03-40](#)
- [4] The OS has detected the subsystem error. (ICC, CC=3) ----- [TRBL03-60](#)
- [5] The lamp on the subsystem panel has failed. ----- [TRBL03-70](#)
- [6] PC (SVP) failure recovery procedure. ----- [TRBL03-140](#)
- [7] A failure has occurred when turning the power on. ----- [TRBL03-180](#)
- [8] The power cannot be turned off. ----- [TRBL03-190](#)
- [9] The multiple parts have failed. ----- [TRBL03-210](#)

3.2.1 SIM has been reported

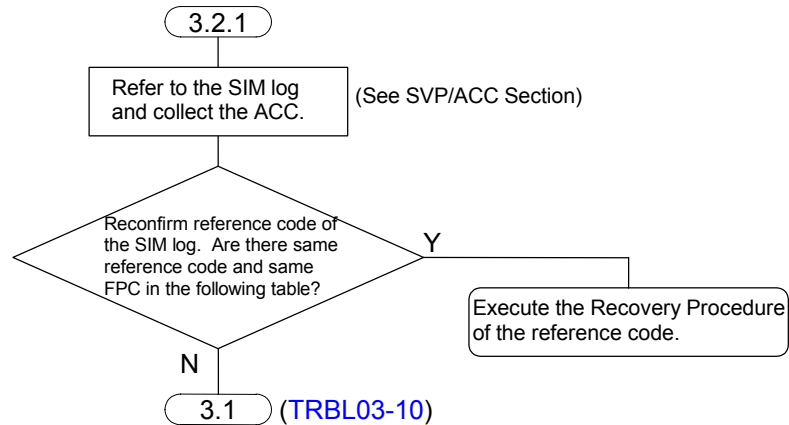

Reference Code	FPC	Recovery Procedure
DF6YXX, DF7YXX	80000000	5.2 Isolation and Recovery Procedures for Common Fibre Loop Error
DF8YXX, DF9YXX	80000000	(TRBL05-20)
BF2XYY	80000000	5.12 Voltage alarm (TRBL05-340)
BF4XXX	80000000	5.14 PS warning error (TRBL05-510)
BF93XX	80000000	5.21 DKCMNs disagreement error (TRBL05-570)
BFA1XX	80000000	5.13 Environment monitors disagreement error (TRBL05-460)
BFE3A2	80000000	5.25 Duplex SVP Setup failed (TRBL05-630)
CF90XY	80000000	
DF8YXX, DF9YXX	80000000	5.11 Recovery Procedure for LDEV Blocking (TRBL05-320)
EF9YXX	80000000	
D4XYYY	80000000	6 HRC/HODM/HORC Error Recovery (TRBL06-10)
DBXYYY	80000000	
2180XY	80000000	
2190XY	80000000	10 Recovery procedure of AL_PA conflict (TRBL10-10)
47DXYY	80000000	9 HMRCF & HOMRCF Error Recovery (TRBL09-10)
47FYXX	80000000	11 HIHSM Error Recovery (TRBL11-10)
399AXY, 3D9AXY	80000000	5.22 Recovery Procedure for Warning of SM DISABLE (TRBL05-580)
399DX0, 399EX0, 3D9DX0, 3D9EX0, FFF60X, FFF70X, FF200X, FF210X	80000000	5.23 Recovery Procedure for Injustice DC voltage control and Injustice CE MODE (TRBL05-590)
BF9XXX	80000000	5.1 FSW Access Error/FSW LED Bus Test Error (TRBL05-10)
3DAXXX		
3999XY	80000000	5.4 Error Recovery Procedure during CHA/DKA replacement (TRBL05-100)
4821XX	80000000	15 Recovery Procedure for DCR Pre-Staging ABNORMAL END (TRBL15-10)
4B1XXXX	80000000	16 HI-COPY Error Recovery (TRBL16-10)
21A8XY	80000000	17 SFP optical failure (TRBL17-10)
21A9XY	80000000	19 Recovery Procedure of an IP address conflict (TRBL19-10)
2193XY, 2194XY	80000000	7.1 Recovery method for failure on Fibre channel interface (TRBL07-10)
213ZXY, 21A2XY, 21A3XY	10xyy000	18 Mainframe Port Error Recovery (TRBL18-10)

3.2.2 SSB has been reported

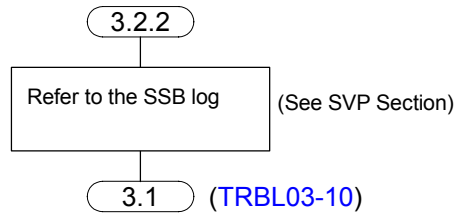

3.2.3 OS cannot recover the subsystem error.(MIH, Job ABEND)

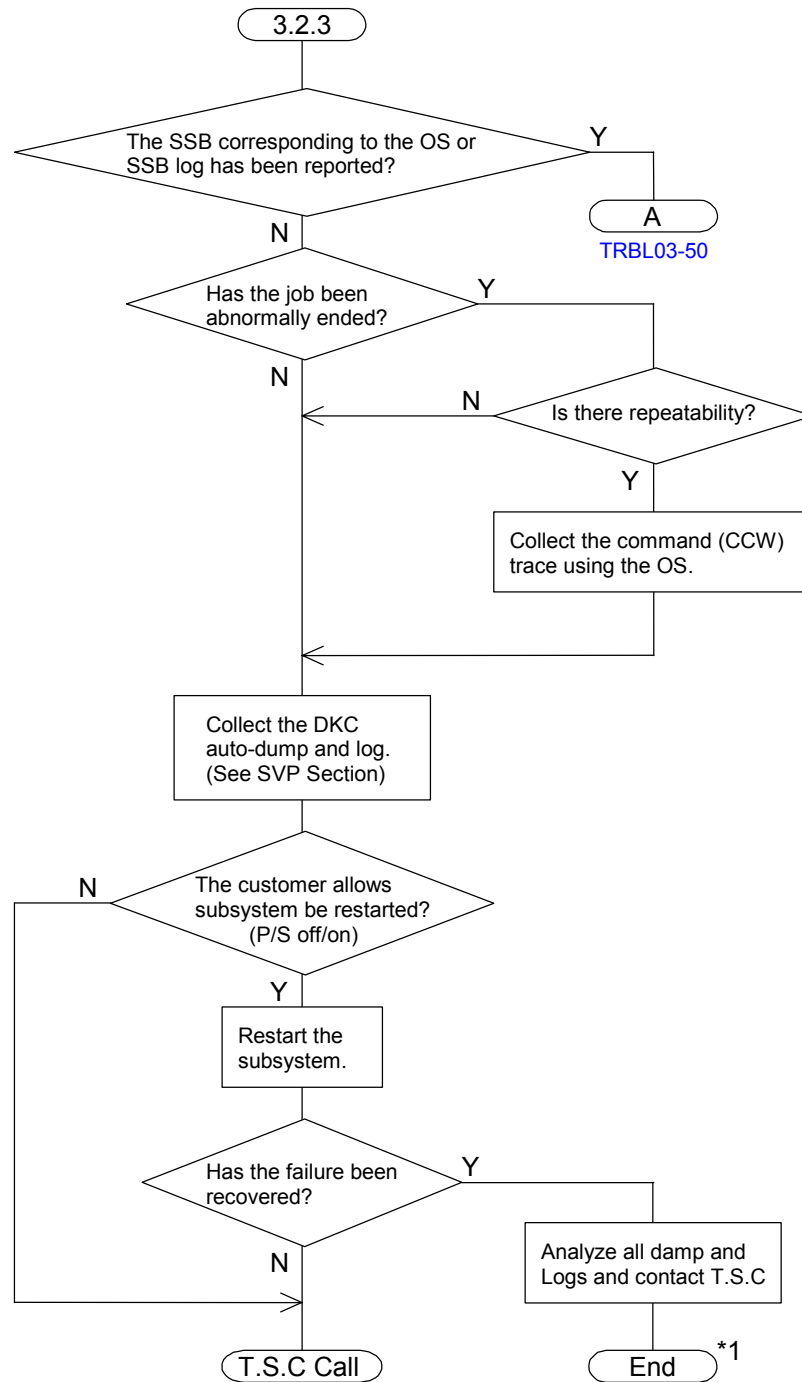

*1 : If you finished the Maintenance, delete the log and SIM complete. (Refer to [SVP02-170, 580](#))

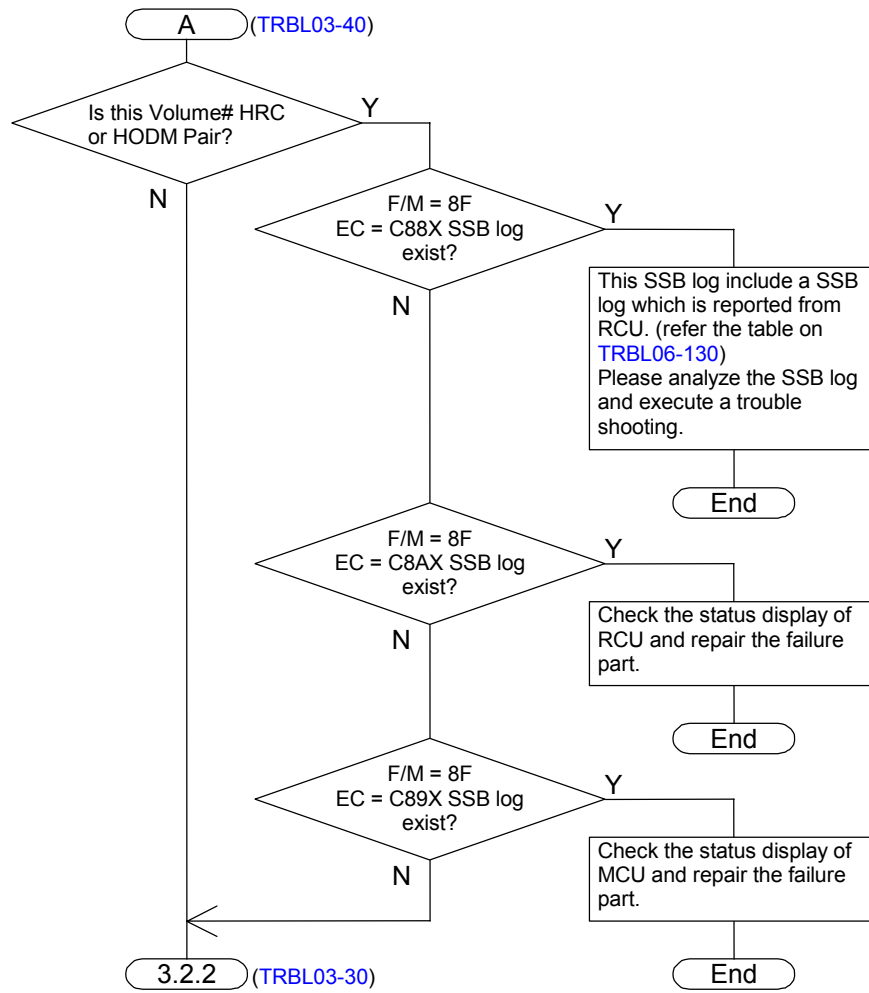

3.2.4 OS has detected the subsystem error (ICC, CC=3)

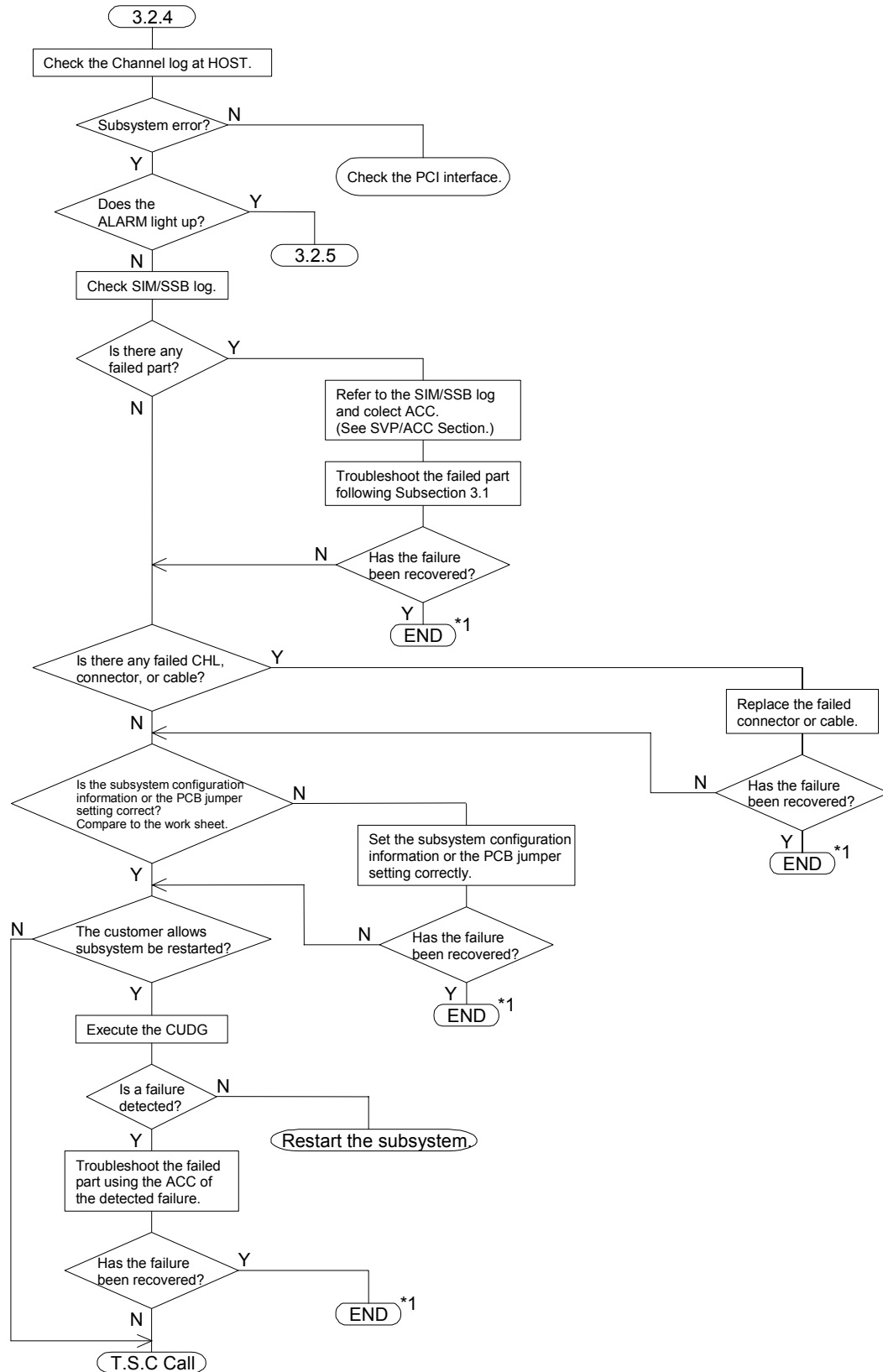

*1 : If you finished the Maintenance, delete the log and SIM complete. (Refer to [SVP02-170, 580](#))

3.2.5 The lamp on the subsystem panel has failed

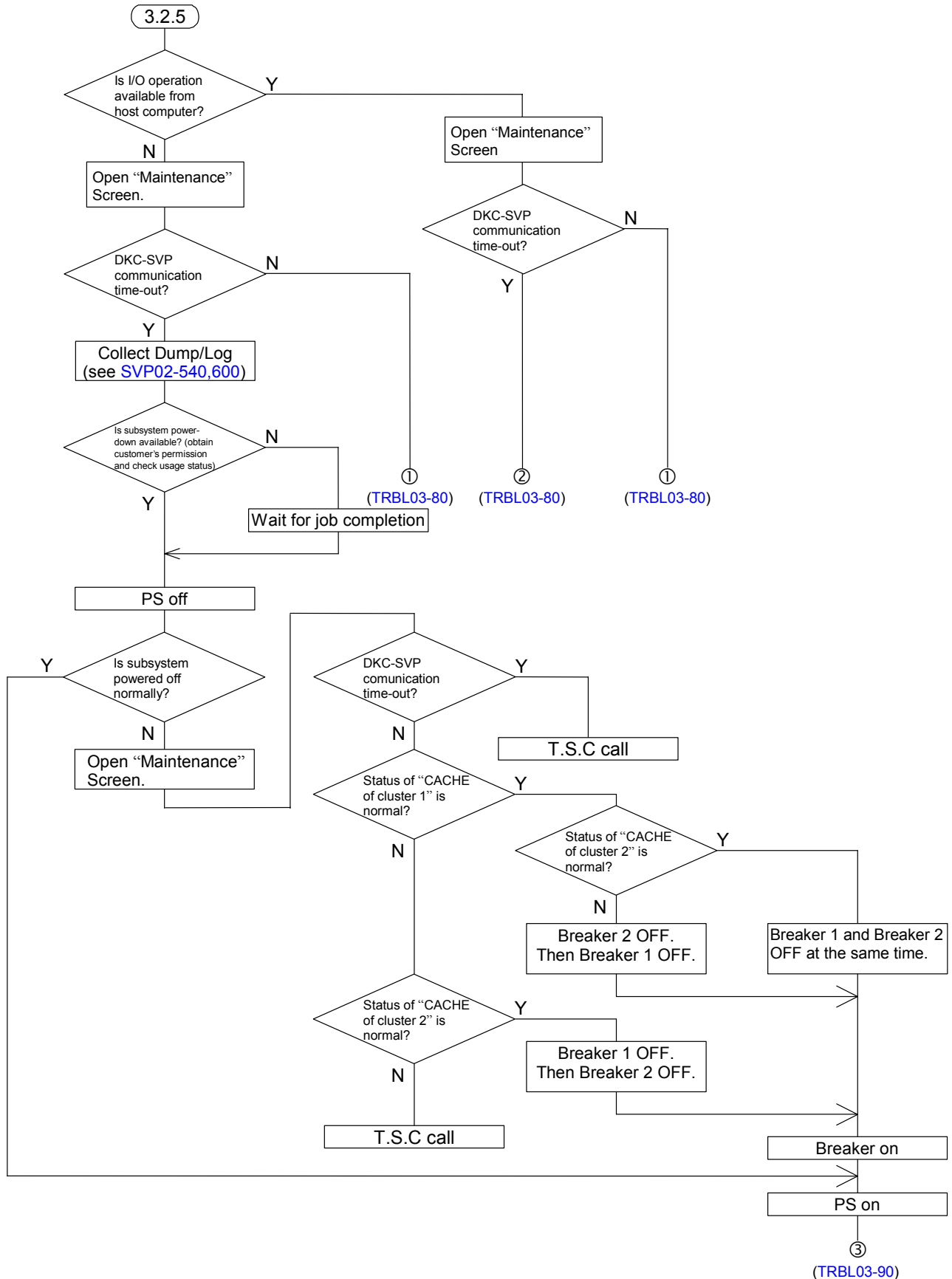

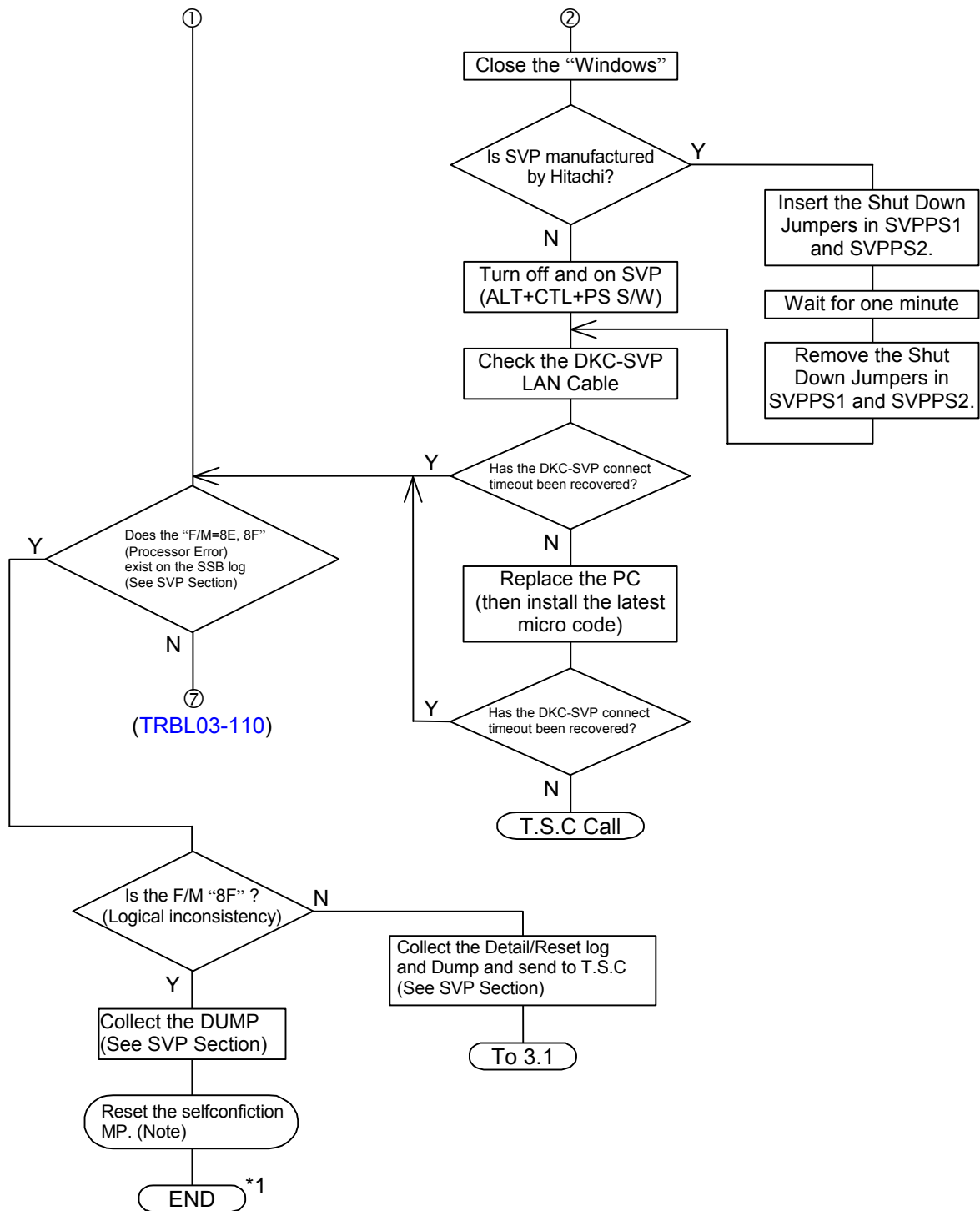

(Note) Replace the failure processor PCB.

*1 : If you finished the Maintenance, delete the log and SIM complete. (Refer to [SVP02-170, 580](#))

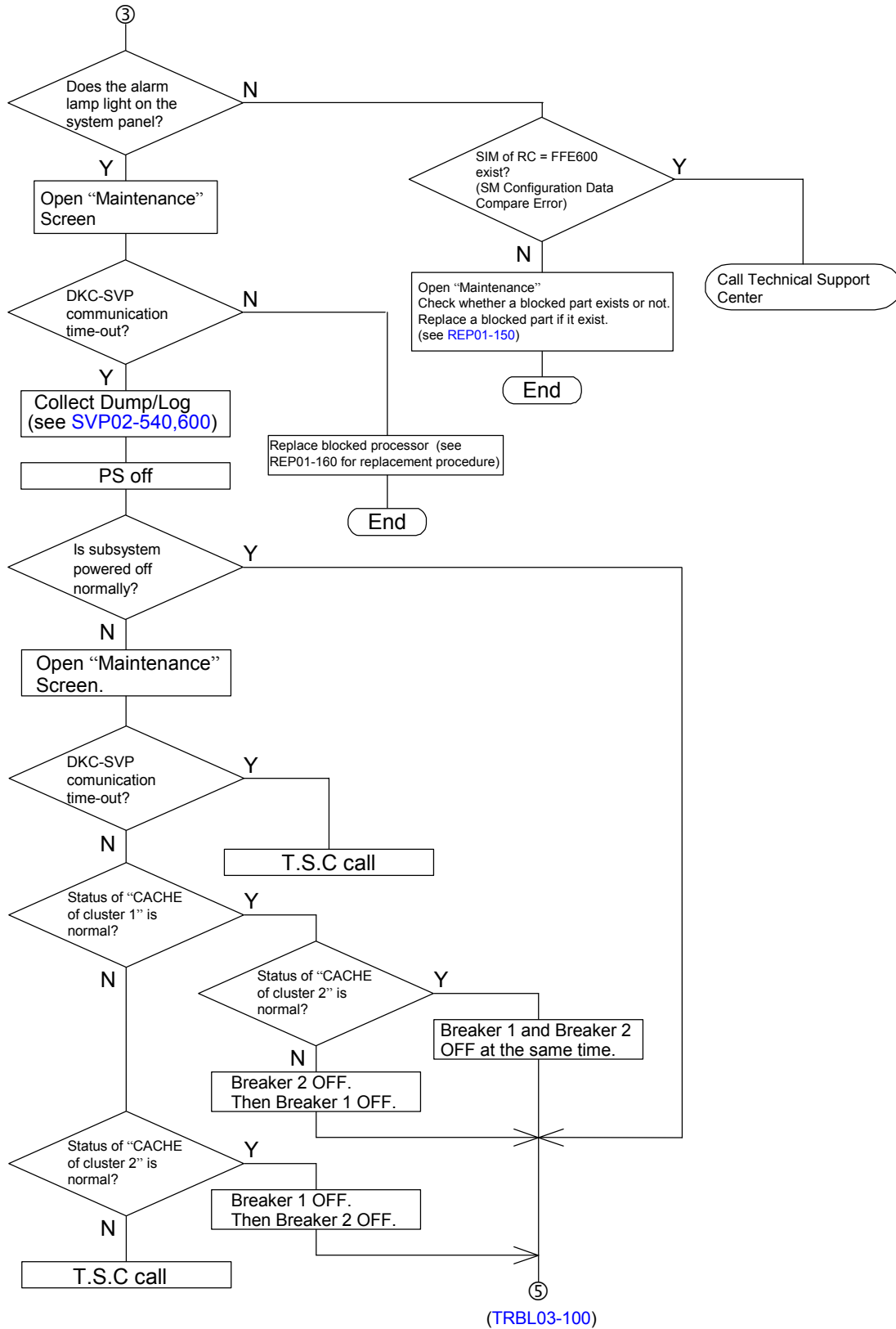

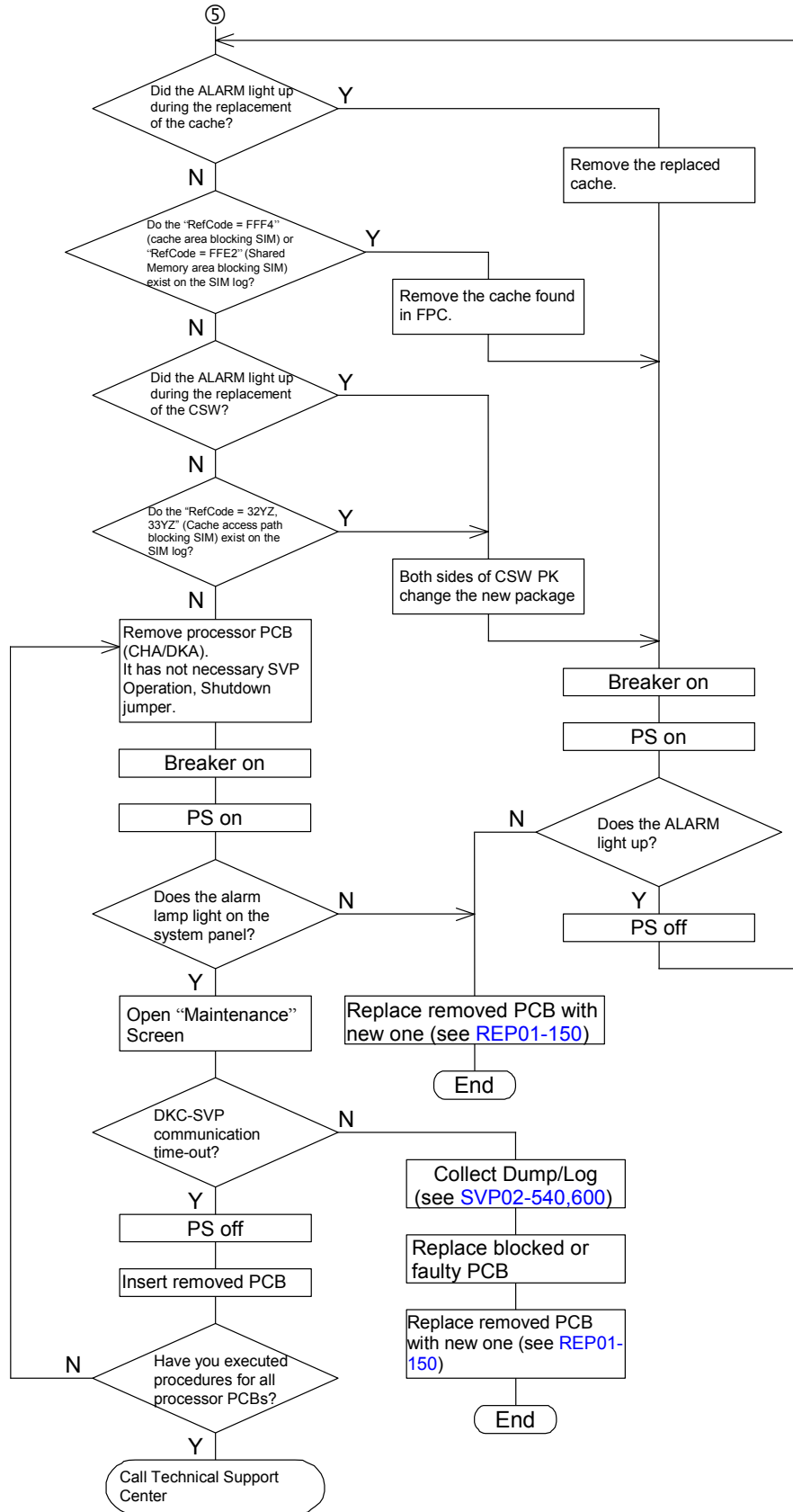

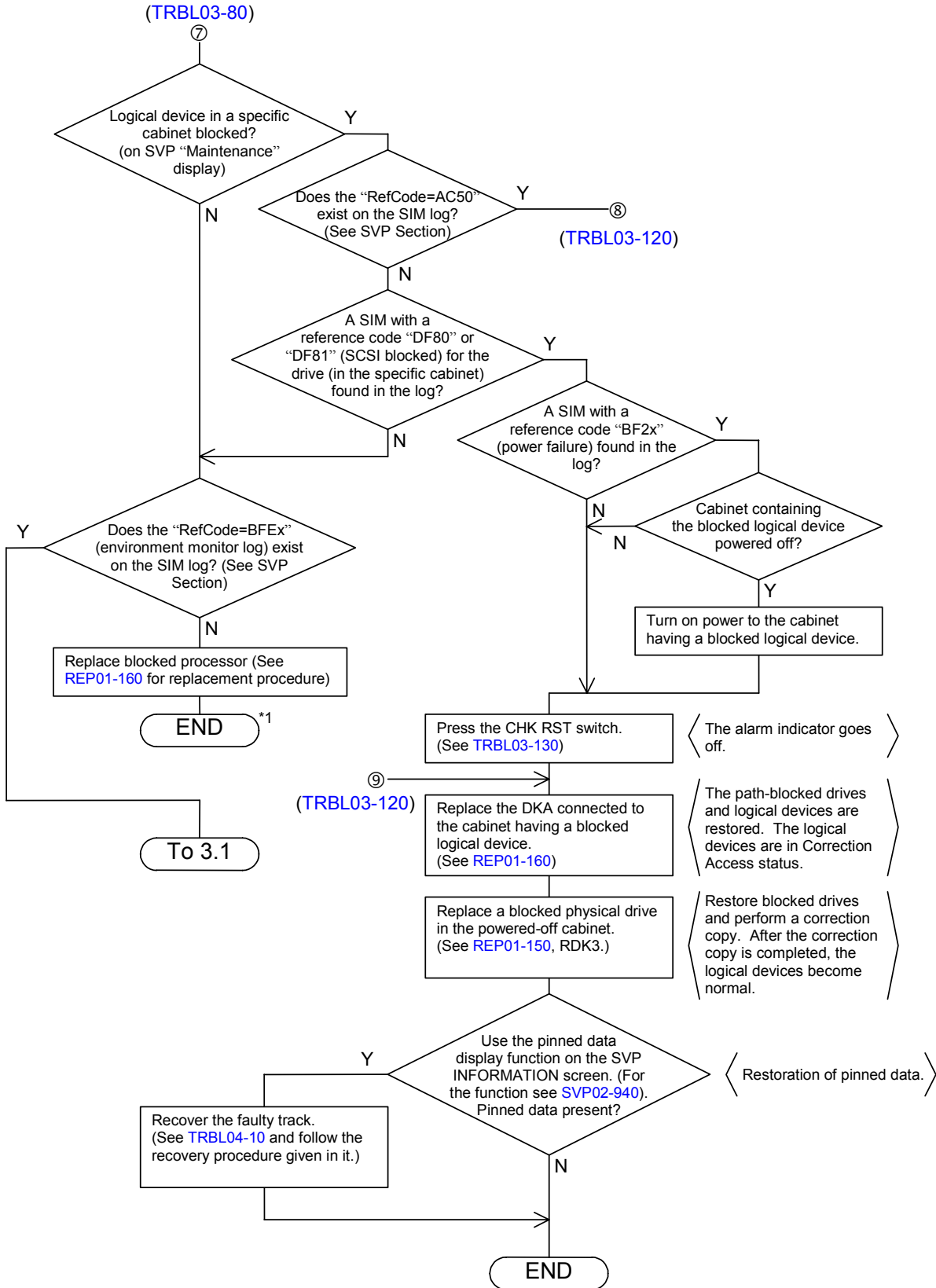

*1 If you finished the Maintenance, delete the log and SIM complete. (Refer to SVP02-170, 580)

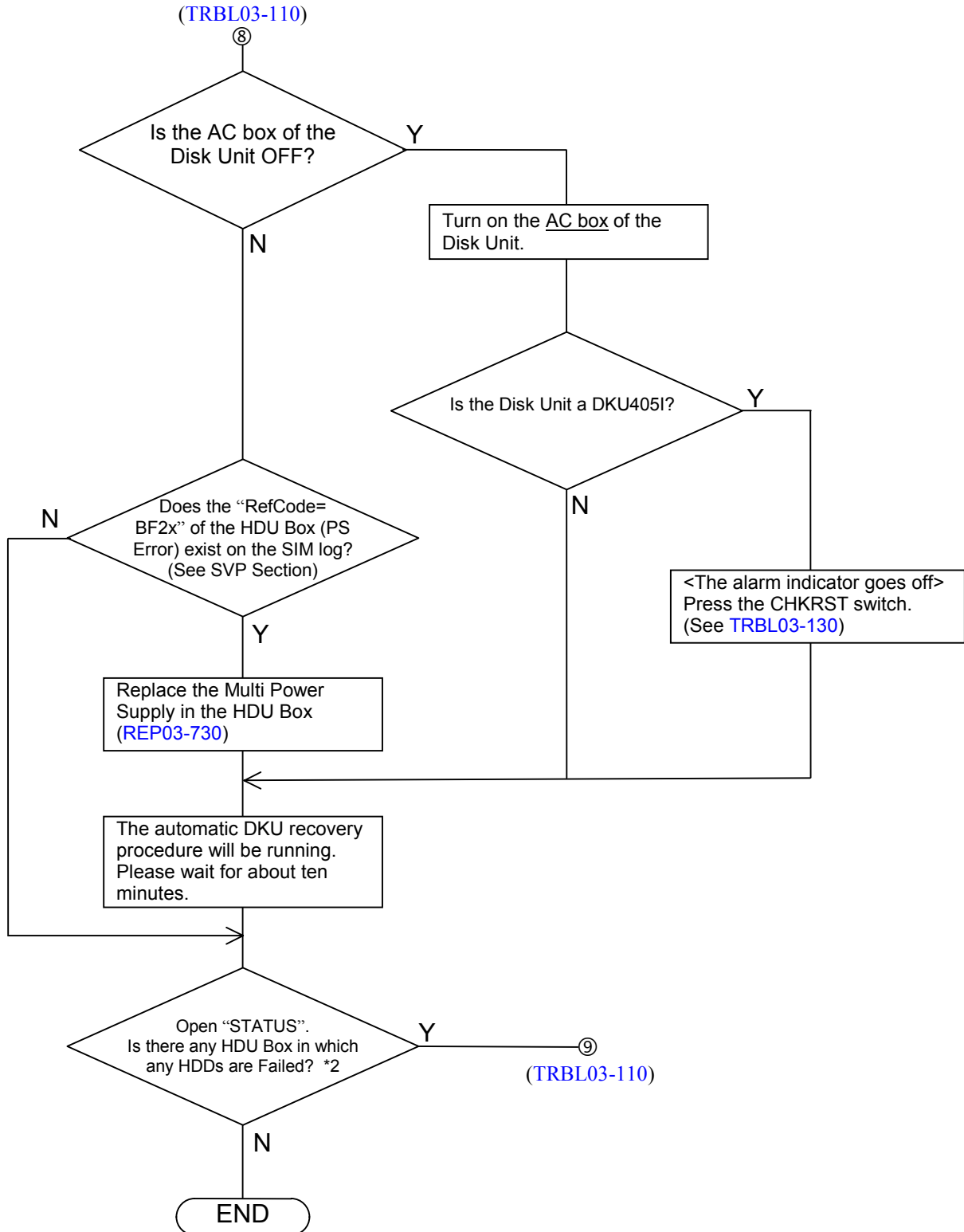

*2 The automatic DKU recovery procedure is not effective for some cases. ex, very short period power down.

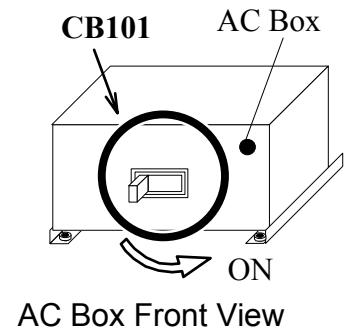
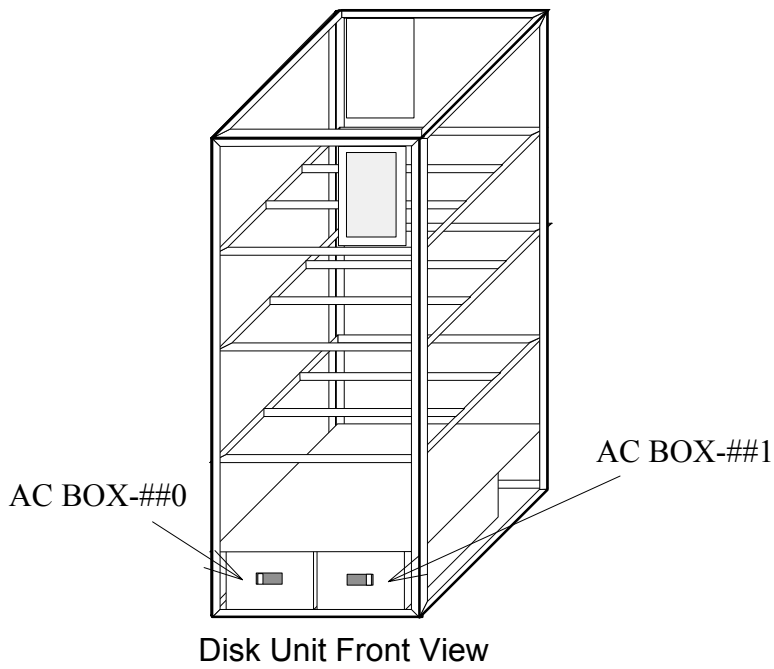
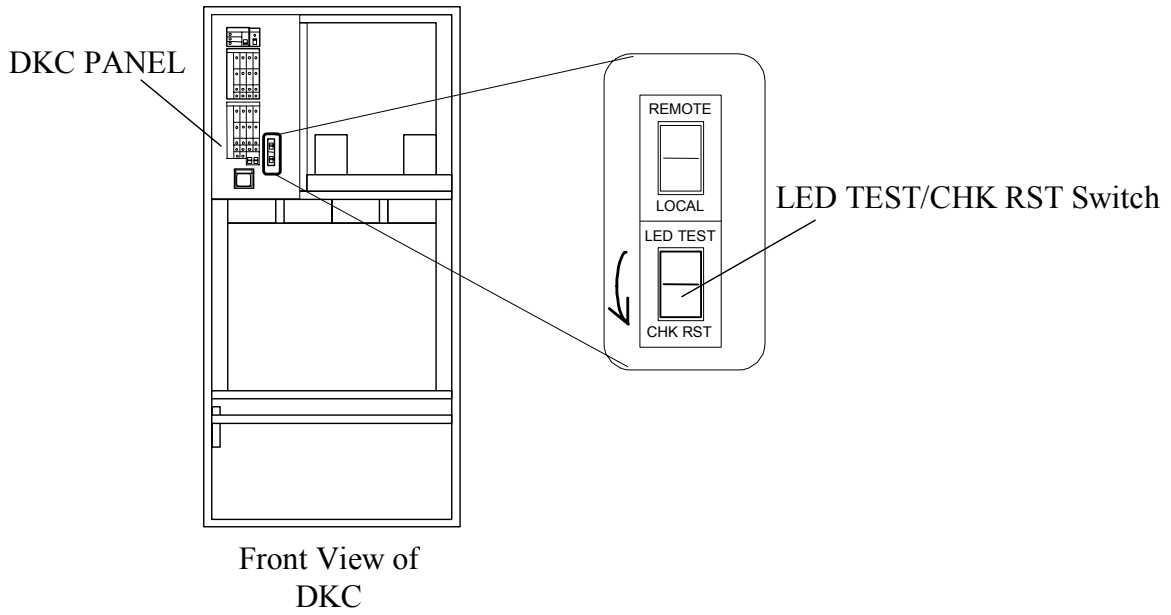

3.2.6 PC (SVP) failure recovery procedure

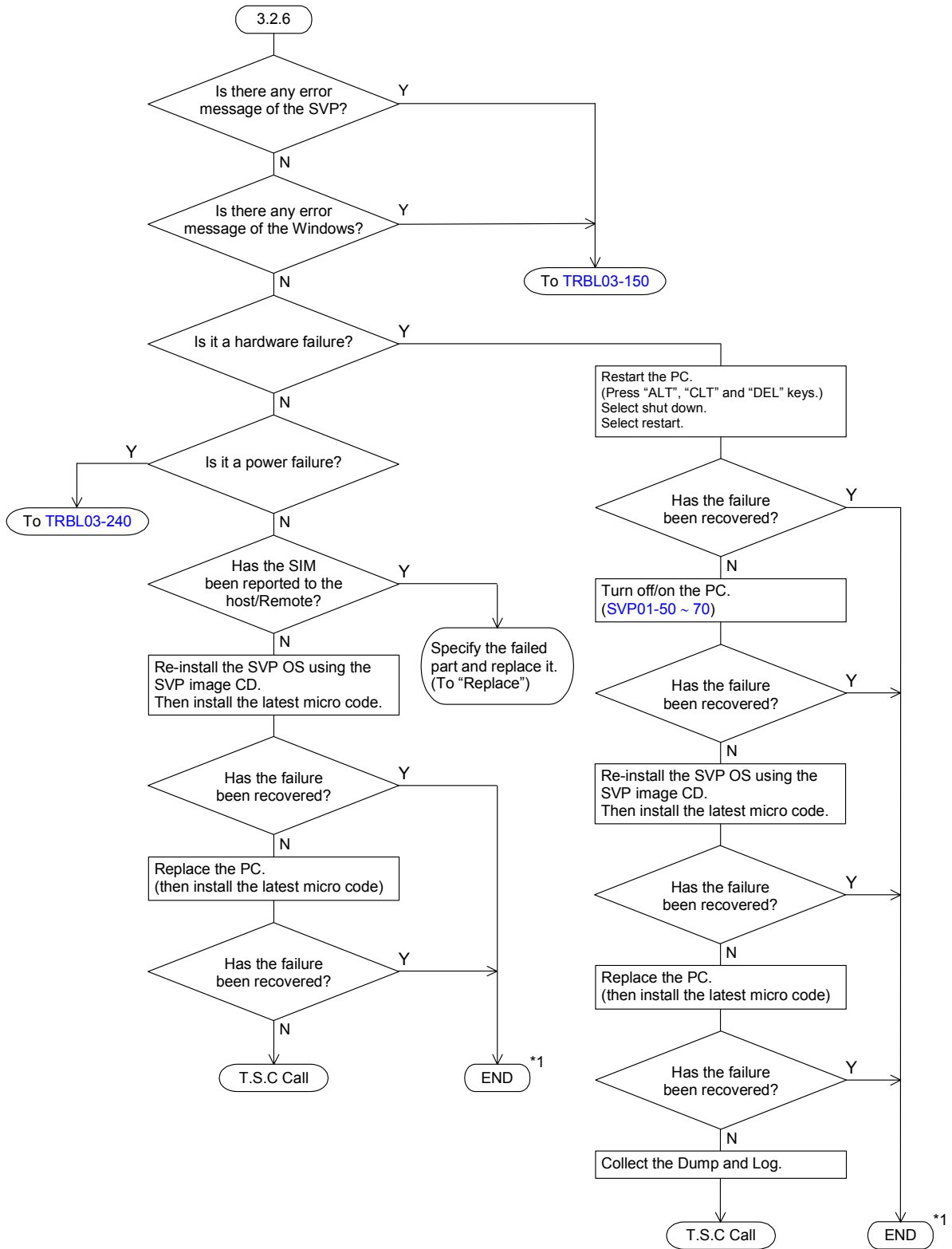

*1 : If you finished the Maintenance, delete the log and SIM complete. (Refer to [SVP02-170, 580](#))

(1) Types of SVP failures

- ① Display of “Program Error” windows dialog box.
- ② Windows display hang up.
 - (i) Keyboard operation possible.
 - (ii) Keyboard operation not possible.
- ③ Display of non windows error. (System error)

(2) Recovery procedure based on type of failure.

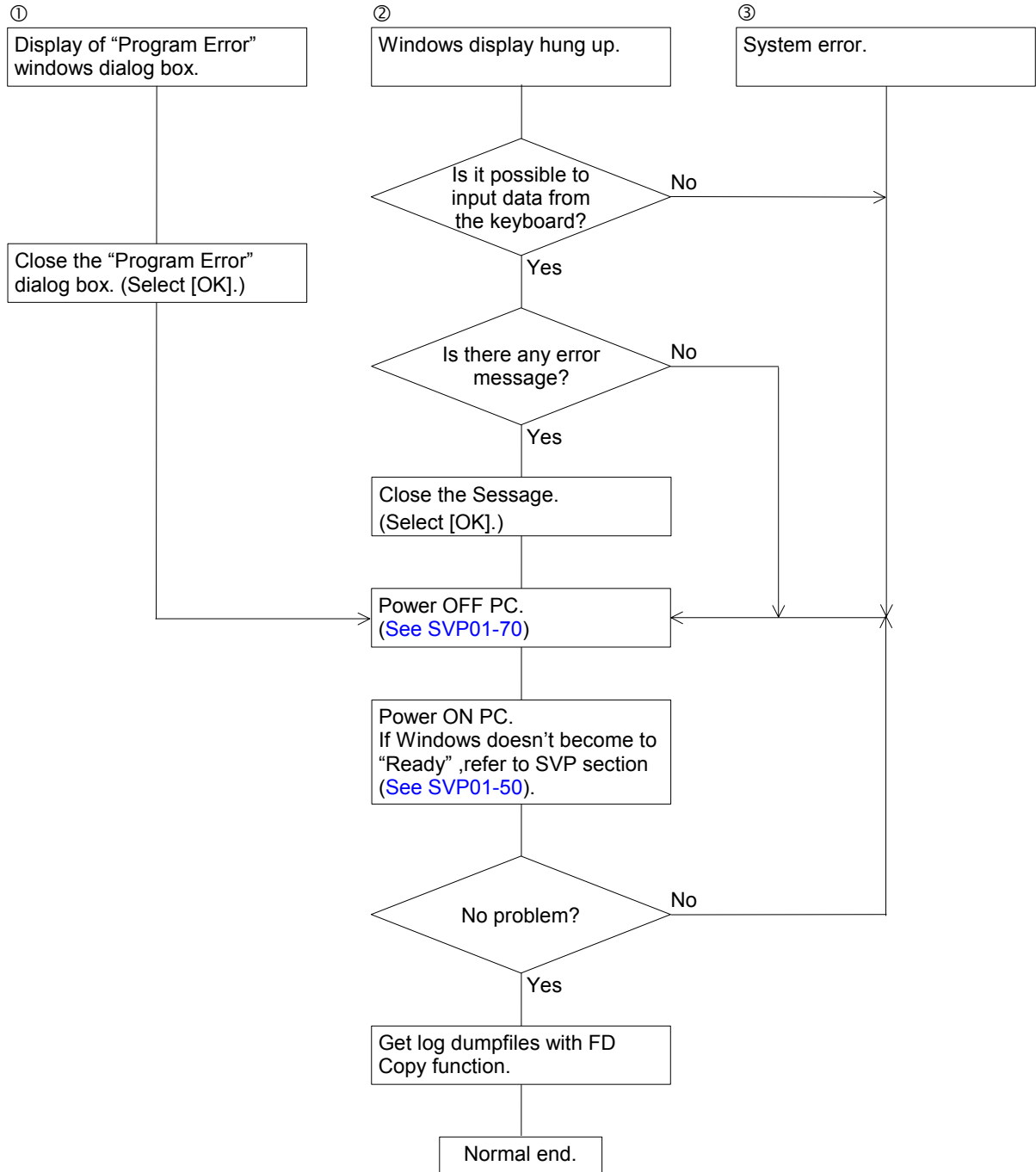

3.2.6.1 CD Image procedure

NOTE1: Please check the CD Image type well.

If the other type CD Images use, SVPPC will not restart correctly.

NOTE2: Please remove flash card and LAN&MODEM card before using CD Image.

If OS re-establishment continue without removing them, SVPPC will restart with wrong setting.

NOTE3: Please remove write-protection of the boot FD.

If the boot FD is write-protected, OS re-establishment will not finish correctly.

<Pre procedure>

1. Open the front door and then open the DKC panel.

2. Turn the SVP Assy and turn off the power for the SVP.

3. See

- from [REP03-460 to REP03-480](#) (in case of DKC460I)

- from [REP03-460 to REP03-470](#) (in case of DKC465I)

in the maintenance manual, insert the maintenance jumper into JP1 on the RS CON PCB or SVPPS BOX.

<Post procedure>

See

- from [REP03-460 to REP03-480](#) (in case of DKC460I)

- from [REP03-460 to REP03-470](#) (in case of DKC465I)

in the maintenance manual, pull out the maintenance jumper on the RS CON PCB or SVPPS BOX.

1. Removal of Flash Card and LAN&MODEM Card

- (1) Loosen the screws and remove the SVP cover.
- (2) Operate the card IN/OUT button to remove the flash card and the LAN&MODEM card from the SVP.

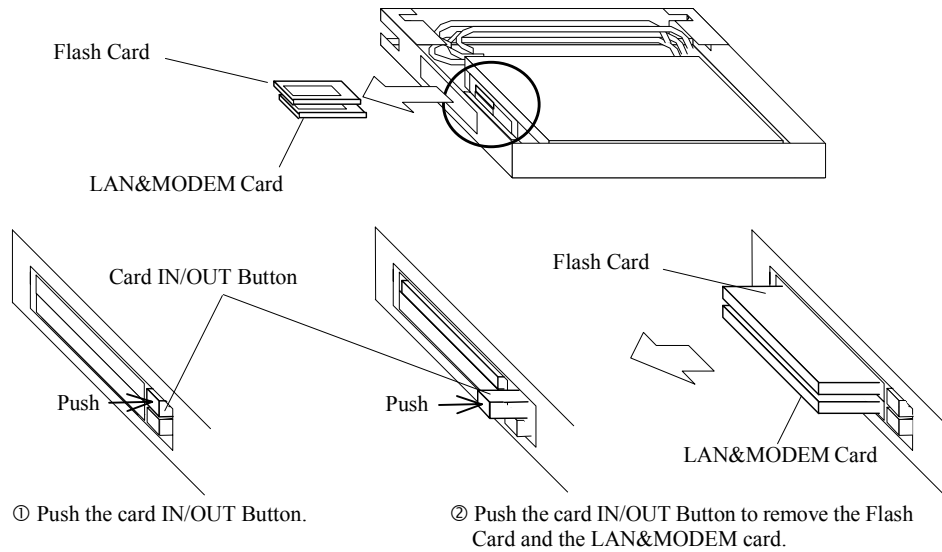

How to remove the Flash Card and the LAN&MODEM Card

**Fig. 3.2.6.1-1 Replacing the flash card and the LAN&MODEM Card
(for FLORA270HX/270W)**

When the SVP is FLORA270HX, go to [TRBL03-162](#).
When the SVP is FLORA270W, go to [TRBL03-164](#).

2. SVP OS Re-installation Procedure for FLORA270HX

- (1) Push the power-on button (upper right side of the keyboard) to restart the SVPPC.
- (2) If the message “Press [F2] to enter Setup...” appears, push [F2] key.
(If Windows starts without pushing [F2] key, please restart SVPPC again.)
- (3) Select the menu “Load Default Settings” in the BIOS Utility window using [↓] [↑] key and push [Enter] key.

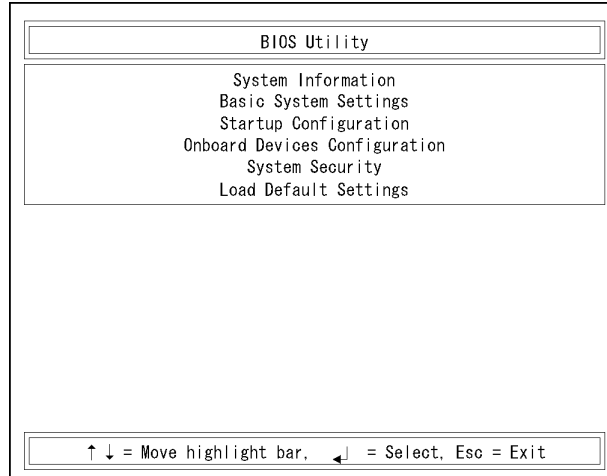

- (4) The message “Do you want to load default settings?” appears, then select [Yes] and push [Enter] key.

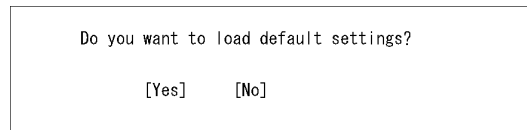

- (5) Push [Esc] key.
- (6) If the message “Settings have been changed. Do you want to save CMOS settings? ” appears, insert the boot FD (NW05_2K_US_006_FD) into FD drive and CD Image (NW05_2K_US_006_CD Disk1) into CD-ROM drive. Then select [Yes] and [Enter] key. (SVPPC reboots.)

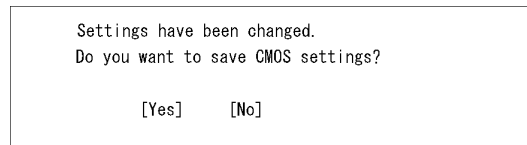

- (7) If the message “Do you continue this installation?”, push [Y] key.
(If this message is not displayed, please check CD Image type and try again pushing [Ctrl] [Alt] [Delete] keys.)
- (8) If the message “Insert next media and press enter to continue...” appears, change the CD to “NW05_2K_US_006_CD Disk2”. Then select [OK] button and push [Enter] key.
- (9) After installation end, the message “INSTALL END”.
(If the installation is not end correctly, please change SVP ASSY.)
- (10) Remove the boot FD from drive and CD Image from CD-ROM drive, push [Ctrl] [Alt] [Delete] key to reboot SVPPC. (SVPPC reboots.)

(11) The following message may come out. If it appears, select (CL) [Yes].

“Windows 2000 has finished installing new devices. You must restart your computer before the new settings will take effect.
Do you want to restart your computer now?”

(12) Check Windows2000 starts normally, select (CL) [Start]-[ShutDown].
(If Windows 2000 does not start normally, please change SVP ASSY.)

(13) Select the menu “Shut down” and (CL) [OK].

Go to [TRBL03-170](#).

3. SVP OS Re-installation Procedure for FLORA270W

- (1) Push the power-on button (upper right side of the keyboard) to restart the SVPPC.
- (2) If the message “Press [F2] to enter Setup...” appears, push [F2] key.
(If Windows starts without pushing [F2] key, please restart SVPPC again.)
- (3) Select the menu “Load Default Settings” in the BIOS Utility window using [↓] [↑] key and push [Enter] key.

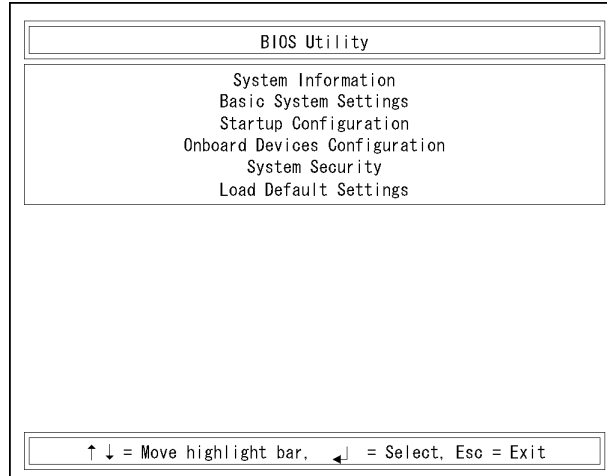

- (4) The message “Do you want to load default settings?” appears, then select [Yes] and push [Enter] key.

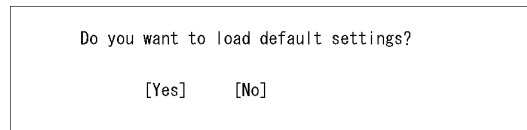

- (5) Push [Esc] key.
- (6) If the message “Settings have been changed. Do you want to save CMOS settings? ” appears, insert the boot FD (NW06_2K_US_004_FD) into FD drive and CD Image (NW06_2K_US_004_CD Disk1) into CD-ROM drive. Then select [Yes] and [Enter] key. (SVPPC reboots.)

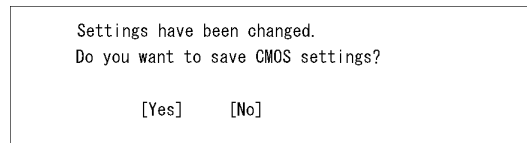

- (7) If the message “Do you continue this installation?”, push [Y] key.
(If this message is not displayed, please check CD Image type and try again pushing [Ctrl] [Alt] [Delete] keys.)
- (8) If the message “Insert next media and press enter to continue...” appears, change the CD to “NW06_2K_US_004_CD Disk2”. Then select [OK] button and push [Enter] key.
- (9) After installation end, the message “INSTALL END”.
(If the installation is not end correctly, please change SVP ASSY.)
- (10) Remove the boot FD from drive and CD Image from CD-ROM drive, push [Ctrl] [Alt] [Delete] key to reboot SVPPC. (SVPPC reboots.)

(11) The following message may come out. If it appears, select (CL) [Yes].

“Windows 2000 has finished installing new devices. You must restart your computer before the new settings will take effect.
Do you want to restart your computer now?”

(12) Check Windows2000 starts normally, select (CL) [Start]-[ShutDown].
(If Windows 2000 does not start normally, please change SVP ASSY.)

(13) Select the menu “Shut down” and (CL) [OK].

Go to [TRBL03-166](#).

4. Insertion of Flash Card and LAN&MODEM Card

(1) Insert the flash card and the LAN&MODEM card into the PC card slot.

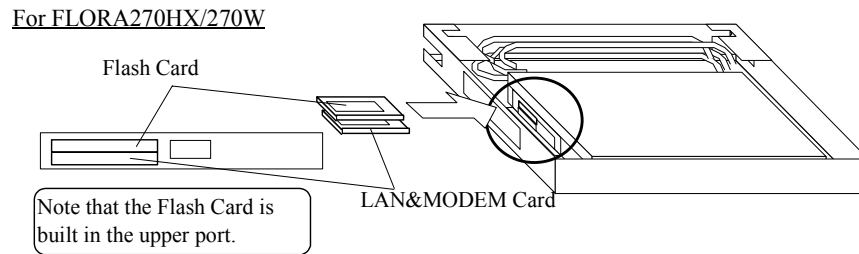

How to insert the Flash Card and the LAN&MODEM Card

**Fig.3.2.6.1-2 Inserting the flash card and the LAN&MODEM Card
(for FLORA270HX/270W)**

(2) Attach the SVP cover with the screws.

5. Confirmation of System Properties

- (1) Push the power-on button (upper right side of the keyboard) to restart the SVPPC.
- (2) Check the below window which is appeared by right click of “My Computer” and select (CL) [Properties].

If the display is “Service Pack 4”, close the “System Properties” window.

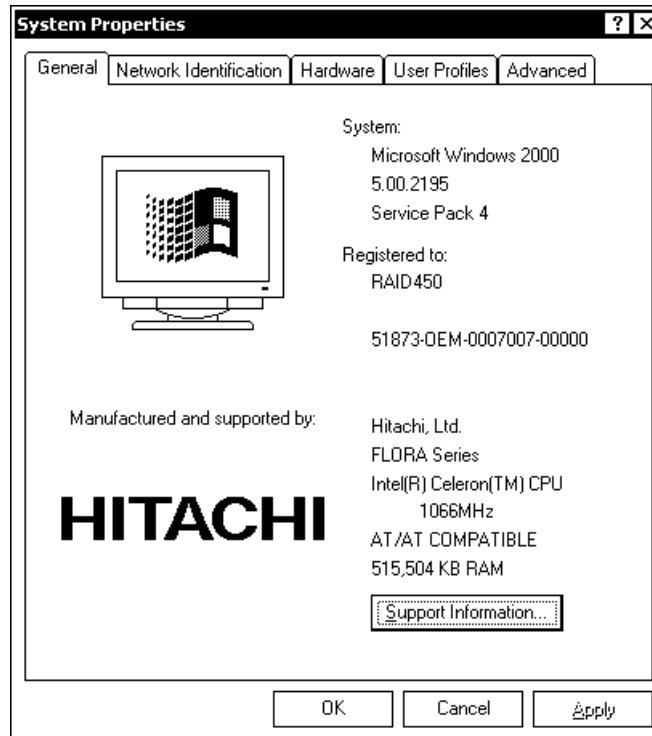

- (3) Select (CL) [Start]-[ShutDown].
- (4) Select the menu “Shut down” and (CL) [OK]

3.2.7 A failure has occurred when turning the power on

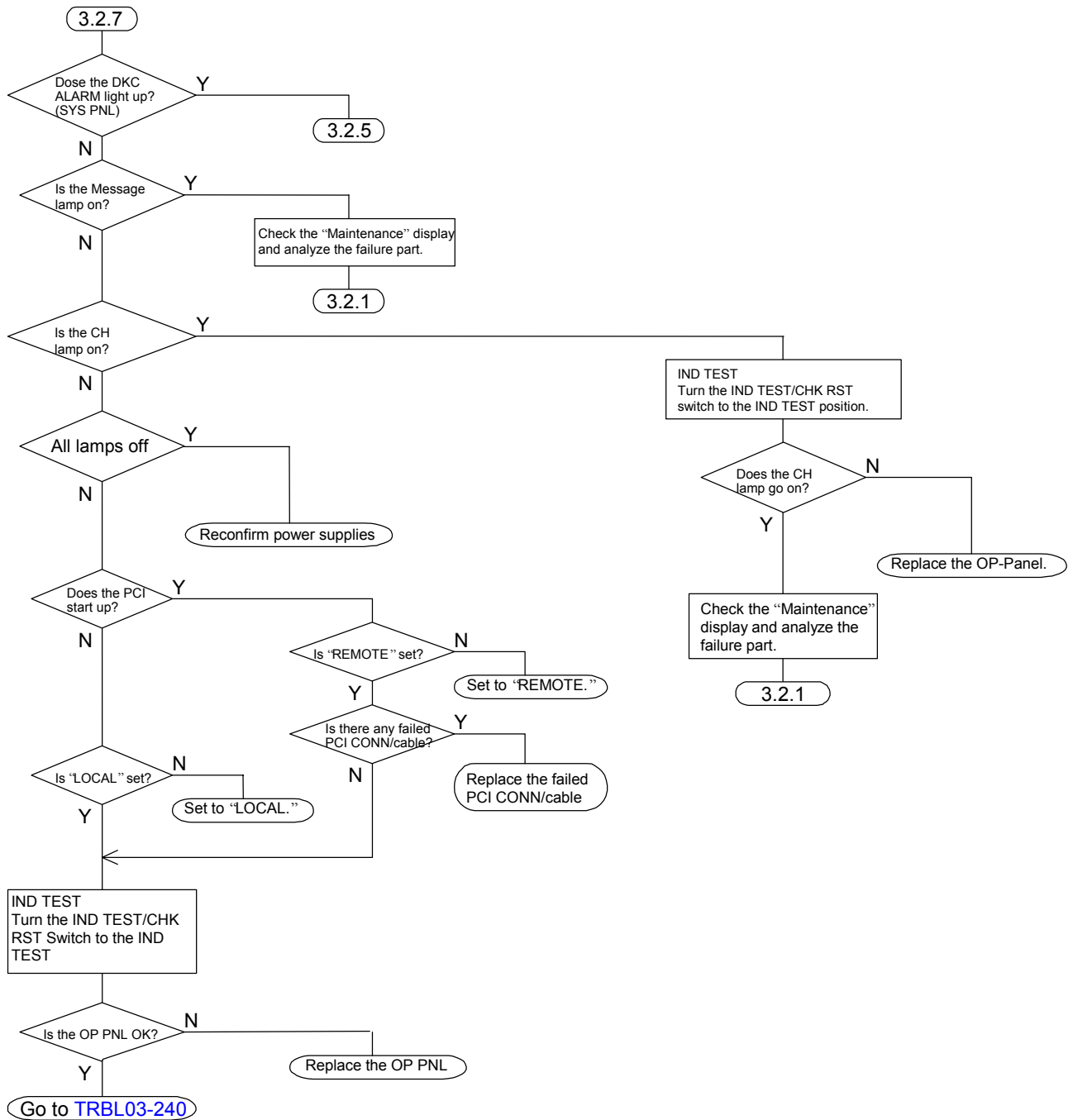

*1 : If you finished the Maintenance, delete the log and SIM complete. (Refer to [SVP02-170, 580](#))

3.2.8 The power cannot be turned off

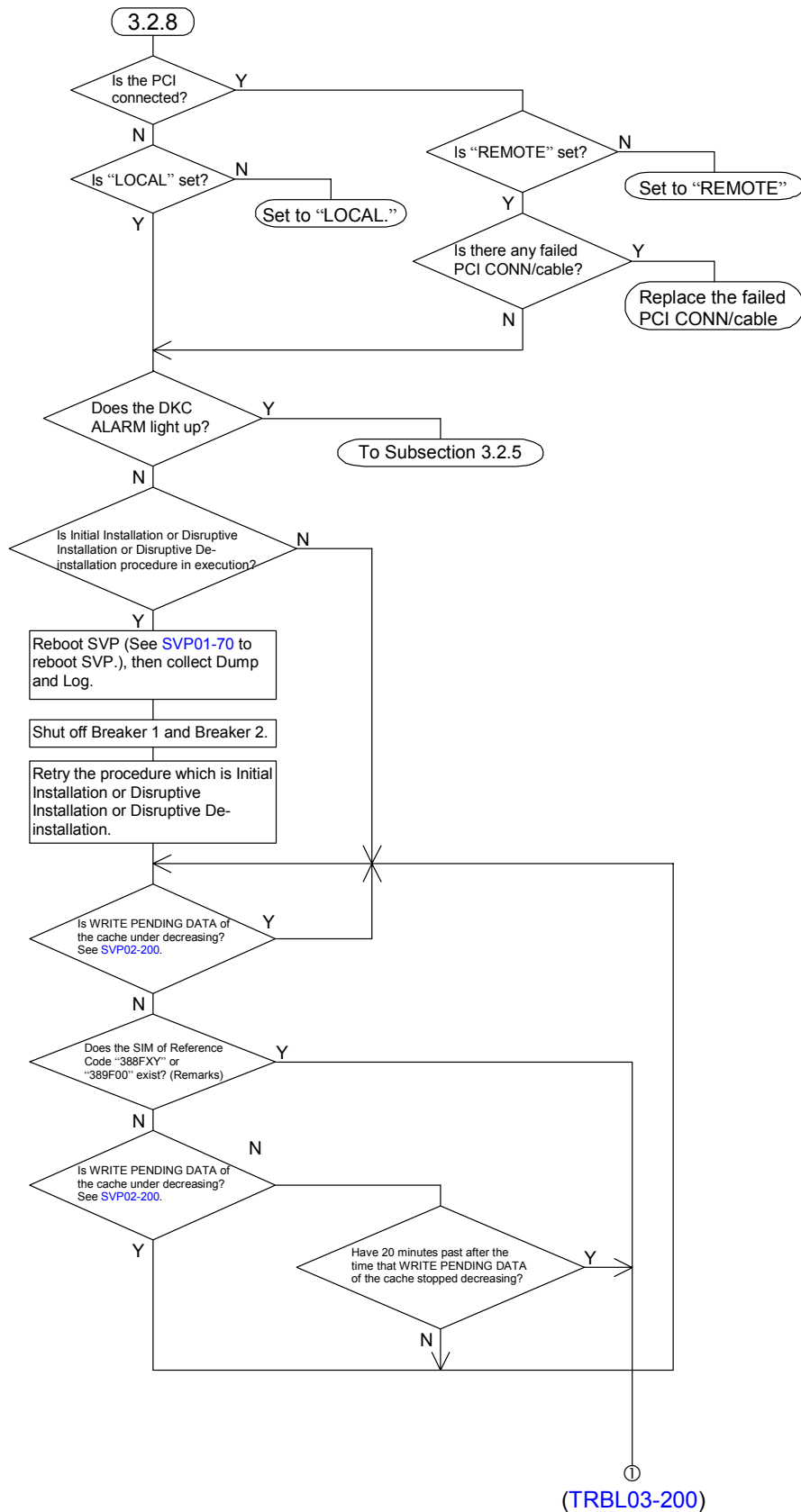

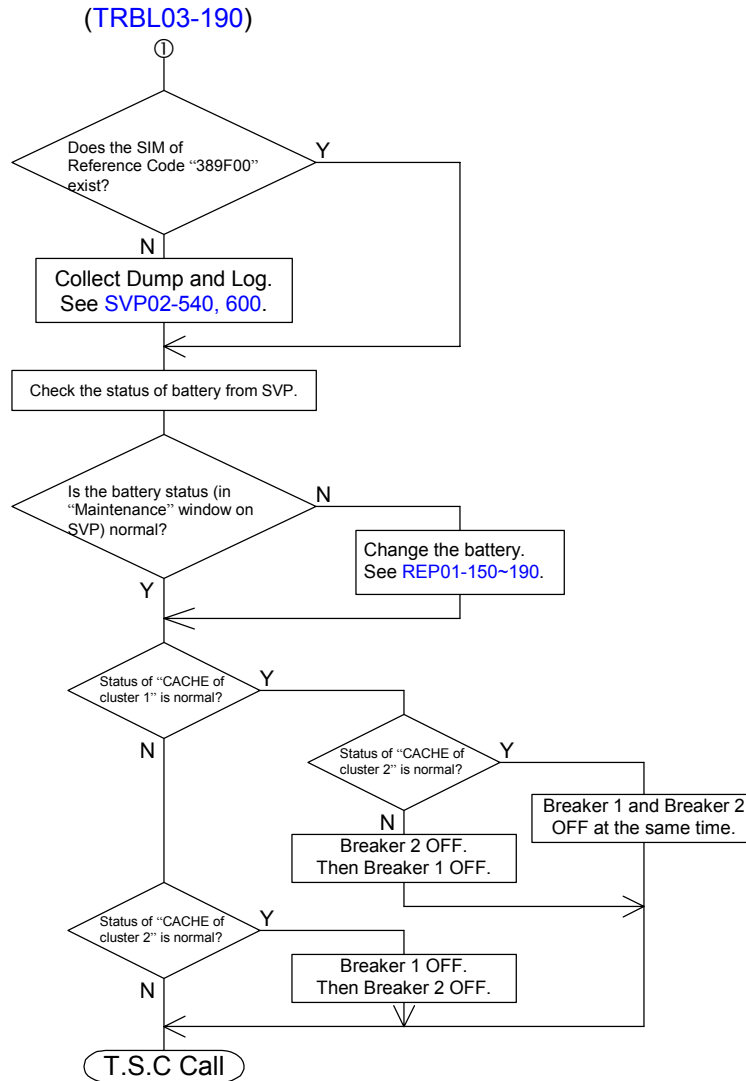

Remarks

- There is a case that it takes more than 10 minutes to report SIM of Reference Code “388FXY” or “389F00”, and that especially it takes about 1 hour in case that emergency destage does not complete.
- There is a case that p/s off procedure is normally finished, even after SIM of Reference Code “388FXY” or “389F00” is reported.

3.2.9 Multiple parts have failed

Maintenance Priority

If there are many parts which need maintenance in the system, you should plan the maintenance schedule under the priority mentioned in this page.

If you have to maintain two parts, first you should maintain a part whose priority is higher than the other.

Table 1 shows that a part with a smaller priority number has a higher priority.

Table 1 Priority Table

| Priority | Parts name | Maintenance method |
|----------|---------------|--------------------|
| 1 | DKA | Replace |
| 2 | CHA | Replace |
| 3 | Cache Memory | Replace |
| 4 | Shared Memory | Replace |
| 5 | CSW | Replace |
| 6 | FIBRE switch | Replace |
| 7 | HDD | Replace |
| 8 | LDEV | Format or Restore |
| 9 | Hardware etc. | Replace |
| 10 | Software | Exchange |

Maintenance priority chart

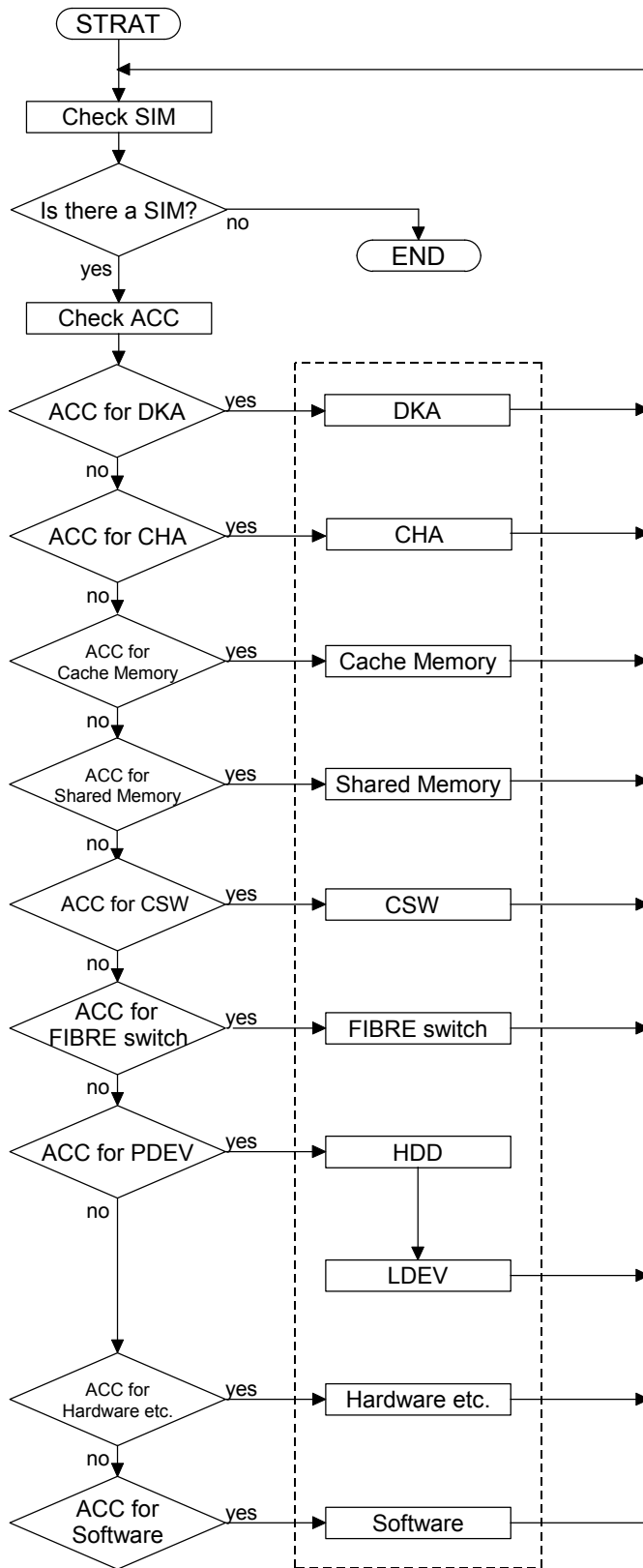

3.2.10 SSVP alarm lamp has been blinking or has lighted on.

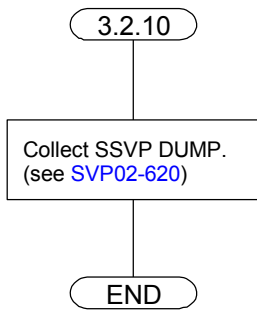

3.2.11 MESSAGE lamp has been blinking

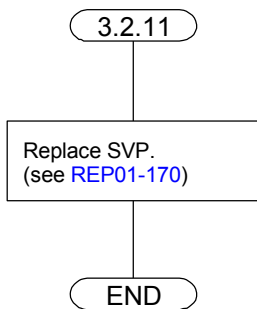

3.2.12 AC Power failure in the case that the UPS is connected

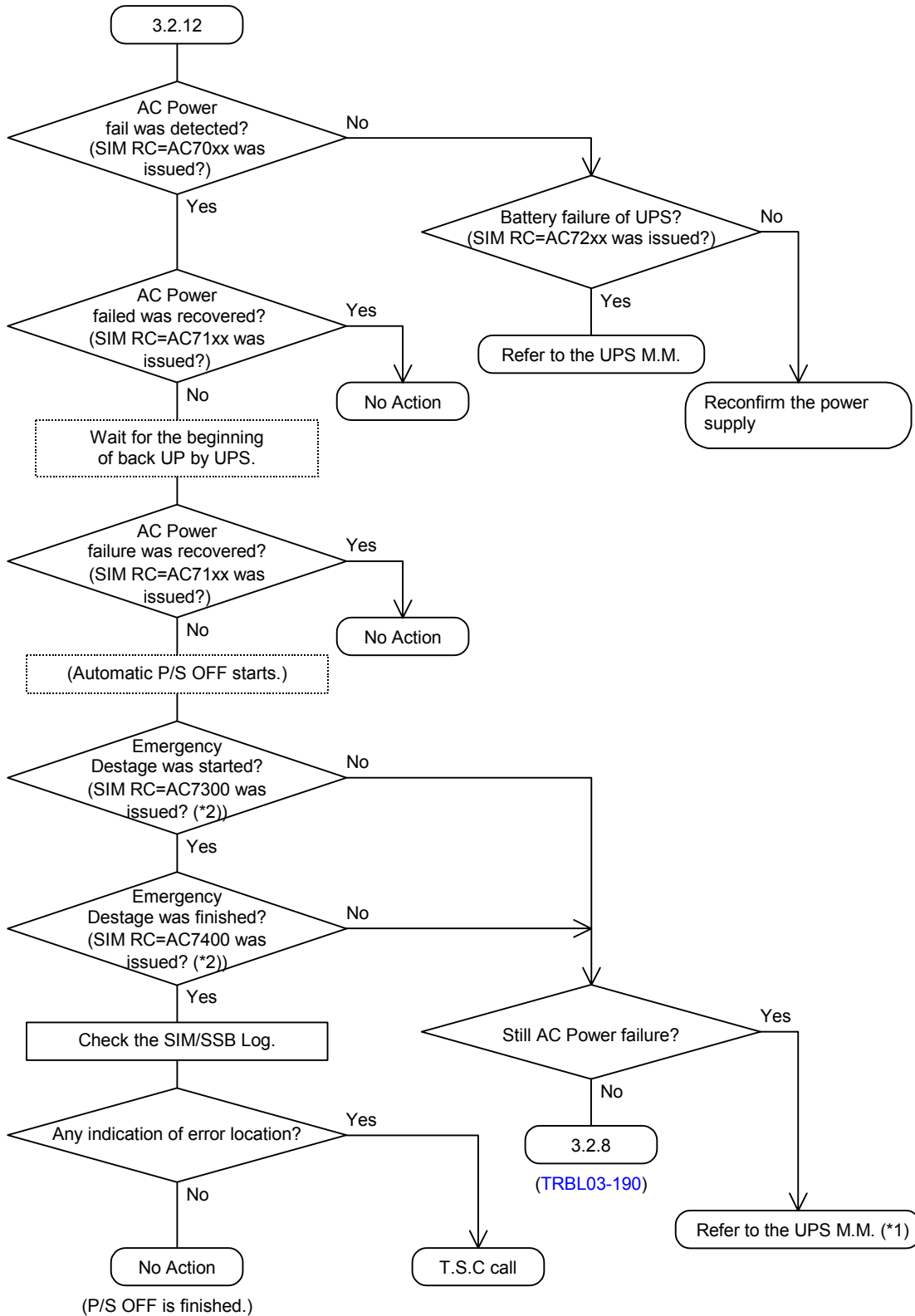

(*1) You have to recover AC Power failure within 48 hours or Memory is being kept by battery.

(*2) As for SIMAC7300 and SIMAC7400, The order of indication time can be inverted. The Log number continues in serial order.

3.2.13 Web Console failure

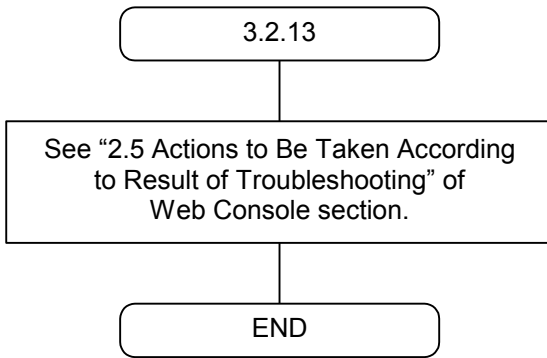

3.3 SVP Power Trouble Shooting

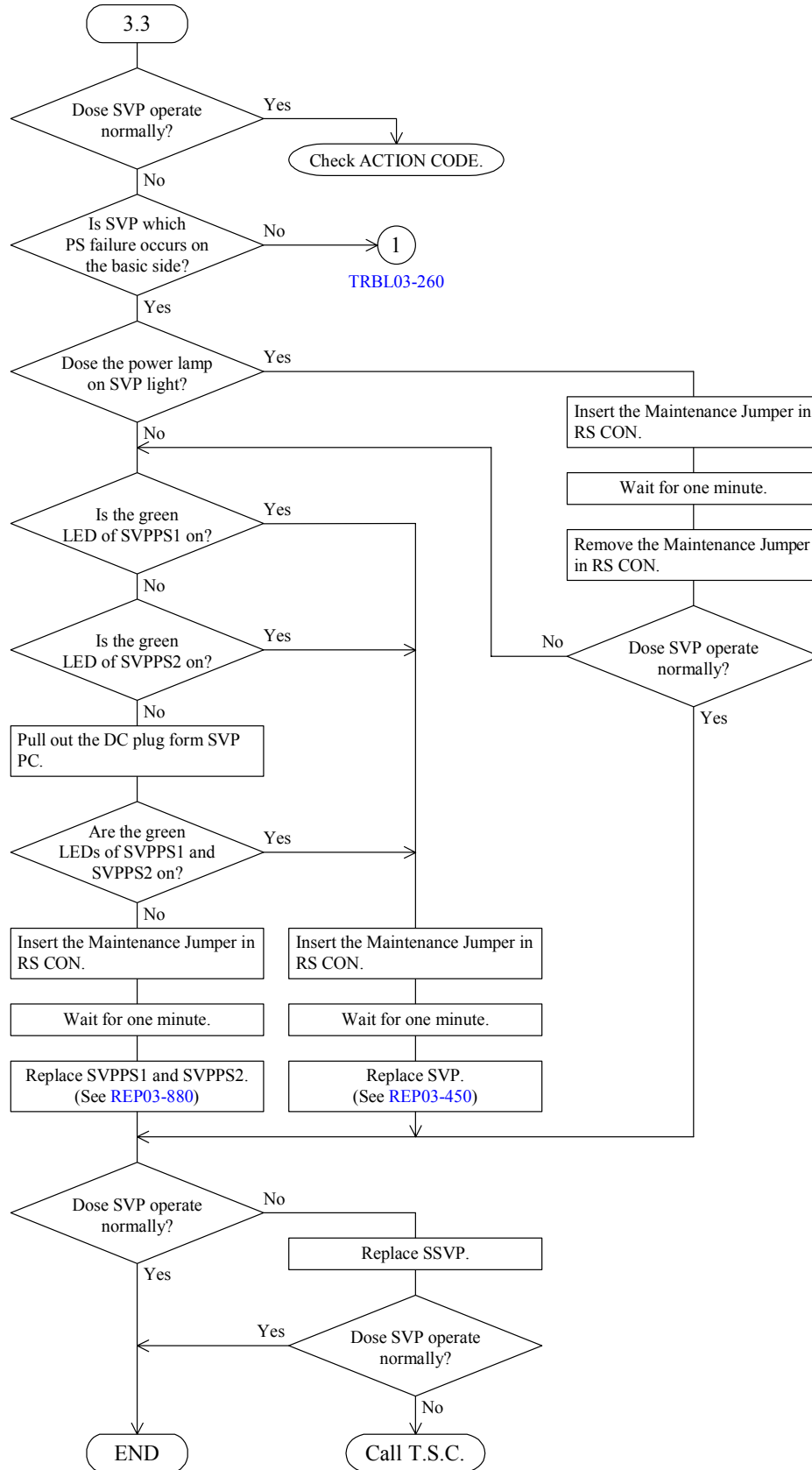

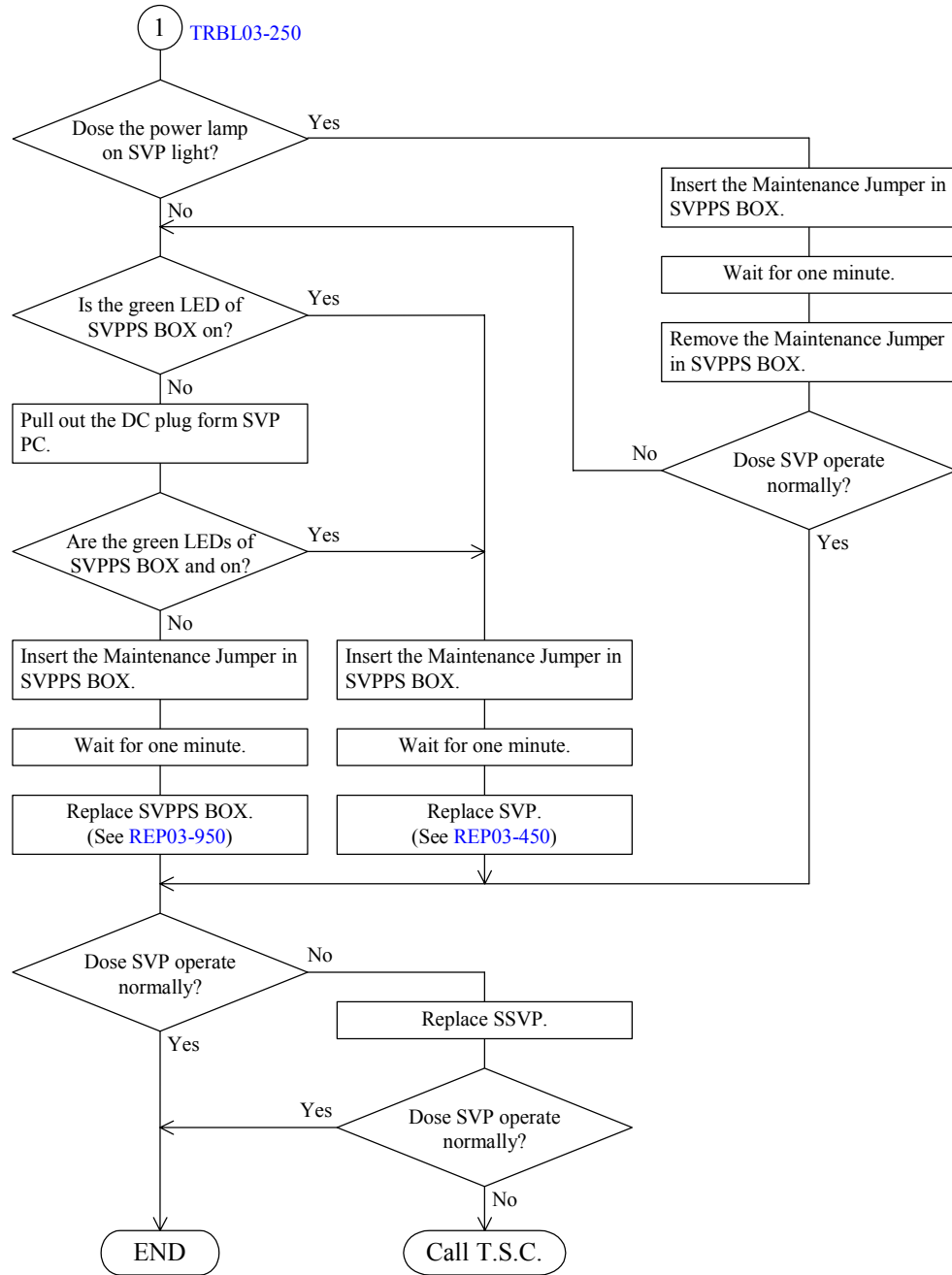

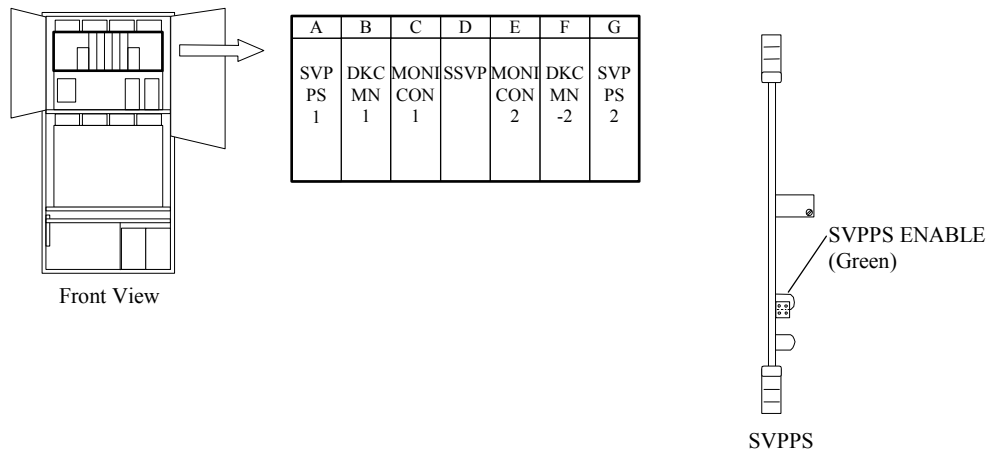

Fig. 3.3-1 Location of SVPPS

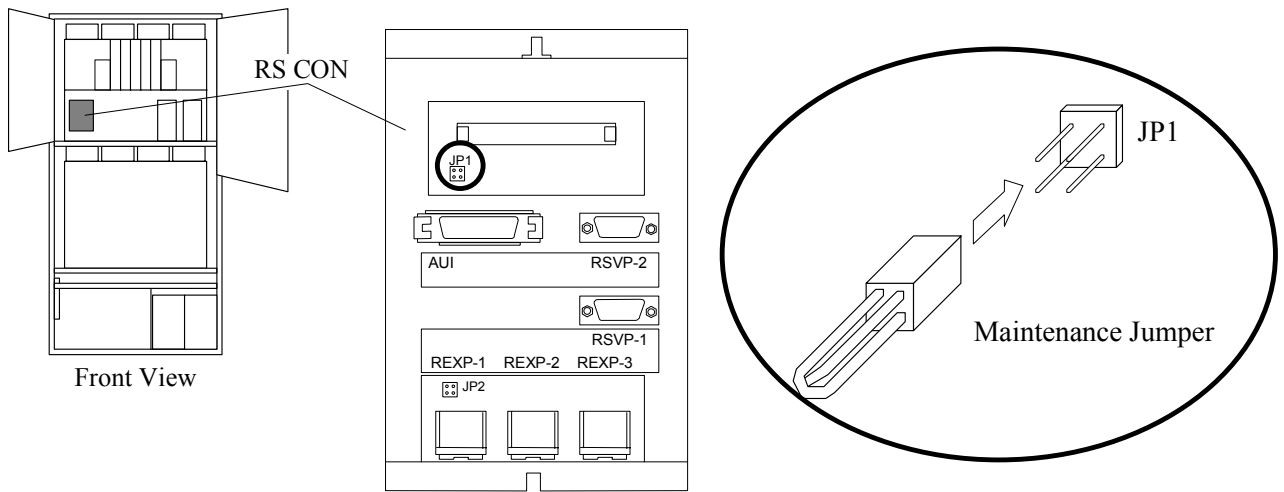

Fig. 3.3-2 Location of RS CON

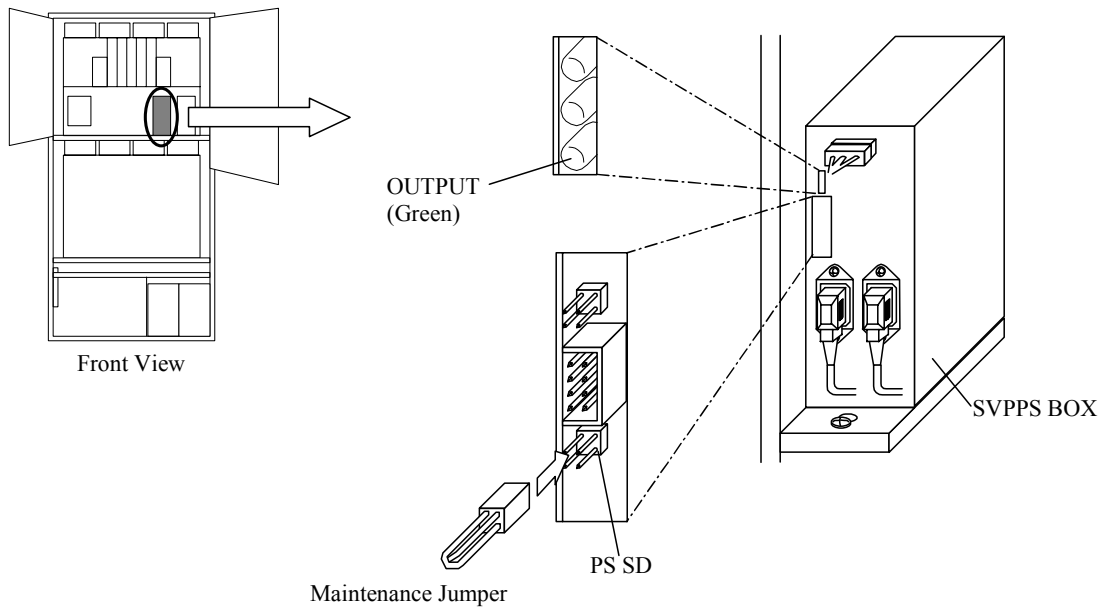

Fig. 3.3-3 Location of SVPPS BOX

4 Recovery for Pinned Tracks

Hardware errors sometimes cause a pinned track.

This document explains pinned tracks and how to recover from them.

The following reports inform of the occurrence of a pinned track:

- Permanent Data Check
- Repeated report of Host Adapter CHK2 on the same track
- SIM report of a pinned track

| SIM REF. CODE | Meaning | Comment |
|---------------|--|-------------------|
| EF4X-YY | Unable to write a track to a PDEV | X:CU#
YY:LDEV# |
| FF4X-YY | Unable to process a track to or from Cache | X:CU#
YY:LDEV# |

To recover pinned tracks, the following information is necessary:

- Address in LDEV (LDEV number, Cylinder & Head address)
- First and last Cylinder & Head addresses of the stripe containing the pinned track
- The error type of the pinned track (Write or ECC/LRC)
- The PDEV number of the drive containing the pinned track

This information can be obtained from the “Pinned Data Display Function” ([SVP03-250](#)) of the SVP.

There are 2 types of pinned track error:

| Display on SVP | Meaning | Recovery |
|----------------|--|---------------------|
| Write Error | Unable to write a track to a PDEV | Replacement of PDEV |
| ECC/LRC Error | Unable to process a track to or from Cache | Data recovery |

Pages TRBL04-XX explain the error types of pinned tracks and have flowcharts for recovery. For HRC or HODM volumes, the flowcharts for recovery are shown in [TRBL06-270 through TRBL06-300](#).

For HMRCF volumes, the flowcharts for recovery are shown in [TRBL09-10](#).

For OPEN volumes, the flowcharts for recovery are shown in [TRBL07-150](#).

ECC/LRC Error

Causes:

- (1) During a write operation new data is written into Cache. If less than a full stripe (3 data tracks & their parity track) are written, the corresponding old data and old parity tracks are staged into Cache to create a new parity track. When a new parity track is created, the new parity track and the new data tracks are ready to be destaged to the DKUs. These tracks are called "Dirty Data". An ECC/LRC pinned track will occur:
 - (a) When Dirty Data cannot be read from Cache by the host. This will lead to Permanent Data Check and the data will be lost. The data will have to be reconstructed by the host from back-up files, etc.
 - (b) When Dirty Data cannot be destaged to DKU (CHK2 errors). This type of pinned data can usually be read by the host.
- (2) An ECC/LRC type of pinned track occurs when a new parity track cannot be properly reconstructed. During the parity track creation, if any of the old data or old parity tracks cannot be staged to Cache to construct the new parity track, or if a new parity track cannot be destaged due to a drive failure, the parity track will be pinned. Data can still be read by the host.
- (3) An ECC/LRC type of pinned track occurs when a track cannot be correctly reconstructed during Correction Copy. This will lead to a Permanent Data Check and the original data will be lost.
- (4) An ECC/LRC type of pinned track occurs if; there is a write type pinned track due to drive failure; the DKC is powered down by manual operation of the P/S OFF switch; the batteries fail or are unplugged, then the Write pinned track will become an ECC/LRC pinned track.

Result of host I/O operation:

- (1) When a track with an ECC/LRC error is accessed by a host I/O and the data can be read, the result will be a normal end.
- (2) If the data cannot be read, there will be a failure reported of Permanent Data Check. In this case the data is lost.
- (3) Repeated Host Adapter CHK2 errors reported. Data is usually still readable but is not being destaged from cache.

Recovering ECC/LRC pinned tracks:

- (1) Execute ICKDSF ANALYZE SCAN using LDEV, CC, HH information from the SVP PINNED TRACK display to determine whether Failure is reported or not.
 - (a) No Failure. Data can be read. Read the data and save it to tape, another volume, or memory, etc.
 - (b) Failure. Data cannot be read. It must be reconstructed by host from backup files, etc.
- (2) Run ICKDSF INSPECT NOPRESRVE (NOCHECK if 3390-3R) to the affected track. This will write all zeros to the track and will clear the pinned track indication.
- (3) Restore the track with the saved data from step 1a or the reconstructed data 1b.
- (4) If a Pinned Track recurs, resolve hardware problem and repeat steps 1-3.

Pinned Track disappearance:

Under certain circumstances, pinned tracks may disappear with no recovery action having been taken.

This can occur from:

- (1) The entire stripe is written. This discards all the old data & parity in the stripe.
- (2) A Format Write from R1 is issued to the pinned track. This rewrites the entire stripe and all old data in the stripe is discarded.
- (3) If dirty data that could not be destaged due to CHK2 error is read successfully by the host, pinned tracks will be turned off.
- (4) If a parity track is unable to be destaged due to a drive failure and the drive is replaced using Correction Copy (drive replacement by copying to a spare will not clear Pinned Tracks).

Write Error**Cause:**

A write error type of pinned track will be made when the data destaging process to a PDEV is unsuccessful due to a drive failure. When a drive failure occurs, the drive and the DKC both attempt to recover the problem. If the recovery attempts are unsuccessful, a Write type pinned track is posted. The recovery attempts are:

- (1) Media failure : Automatic reallocation of data to an alternate sector.
- (2) Other failure : Alternate path retry.

Write error count for each PDEV is stored in the DKC. If the write error count for a PDEV exceeds the threshold value, the PDEV is blocked. Only one PDEV per parity group will be blocked. One blocked PDEV in a parity group will not stop DKC operation to that parity group. However, the parity group will be in correction access mode. If a write type pinned track is accessed by the host after its PDEV has been blocked, the pinned track status will be reset.

Result of host I/O operation:

All access to write type pinned tracks will be successful and return a normal end.

Recovering Write Error pinned tracks:

Replace the PDEV with the pinned track. At this time if there is already a blocked PDEV in the same parity group, replace the blocked PDEV first. Then replace the PDEV with the pinned track. If more than one PDEV in a parity group has write error pinned tracks, check the ORM display on the SVP Panel.

Replace the PDEV with the highest error rate first, then second highest, etc. The pinned track(s) will be recovered by correction copy.

4.1 Recovery Procedure for Pinned Tracks

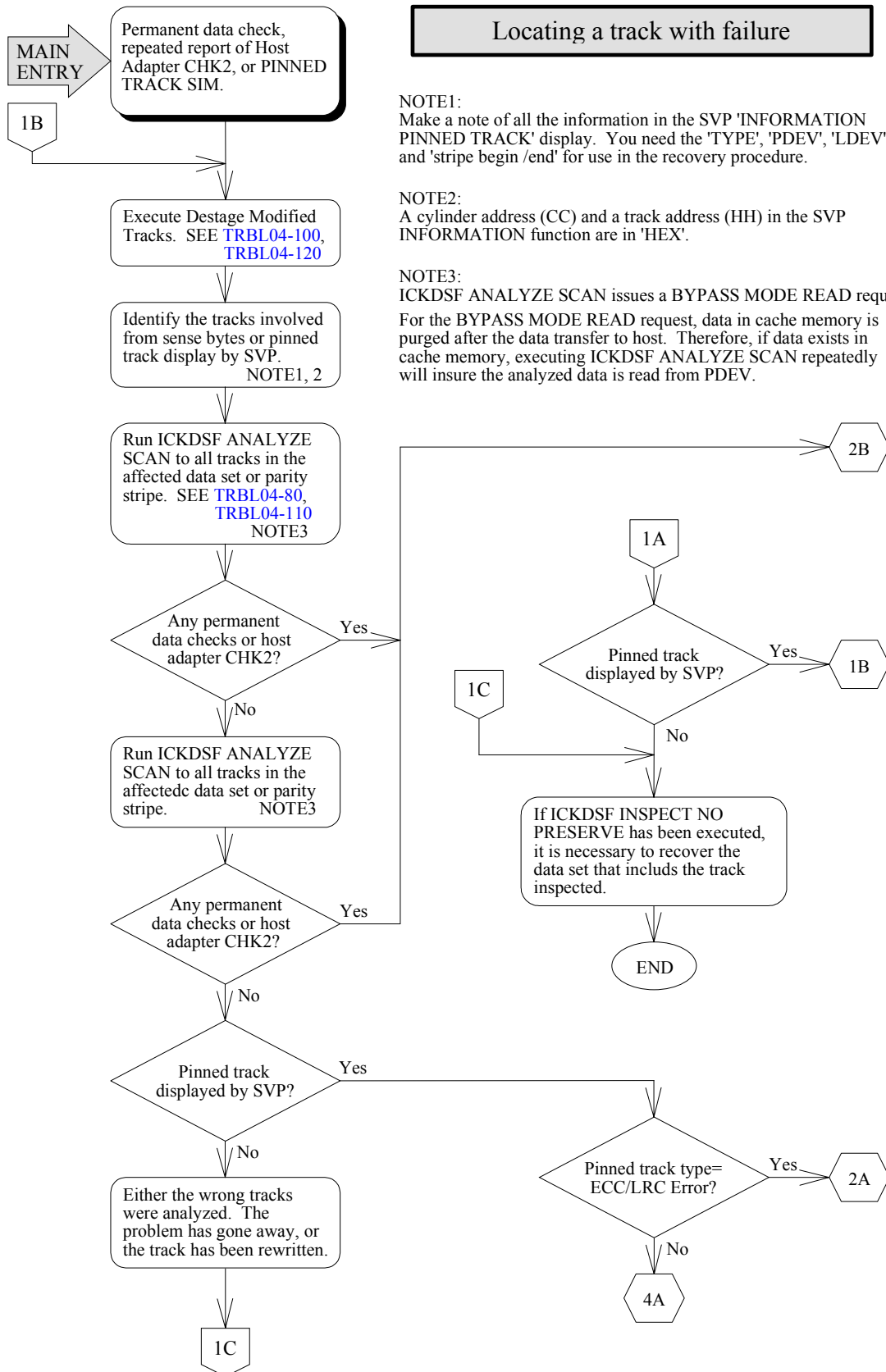

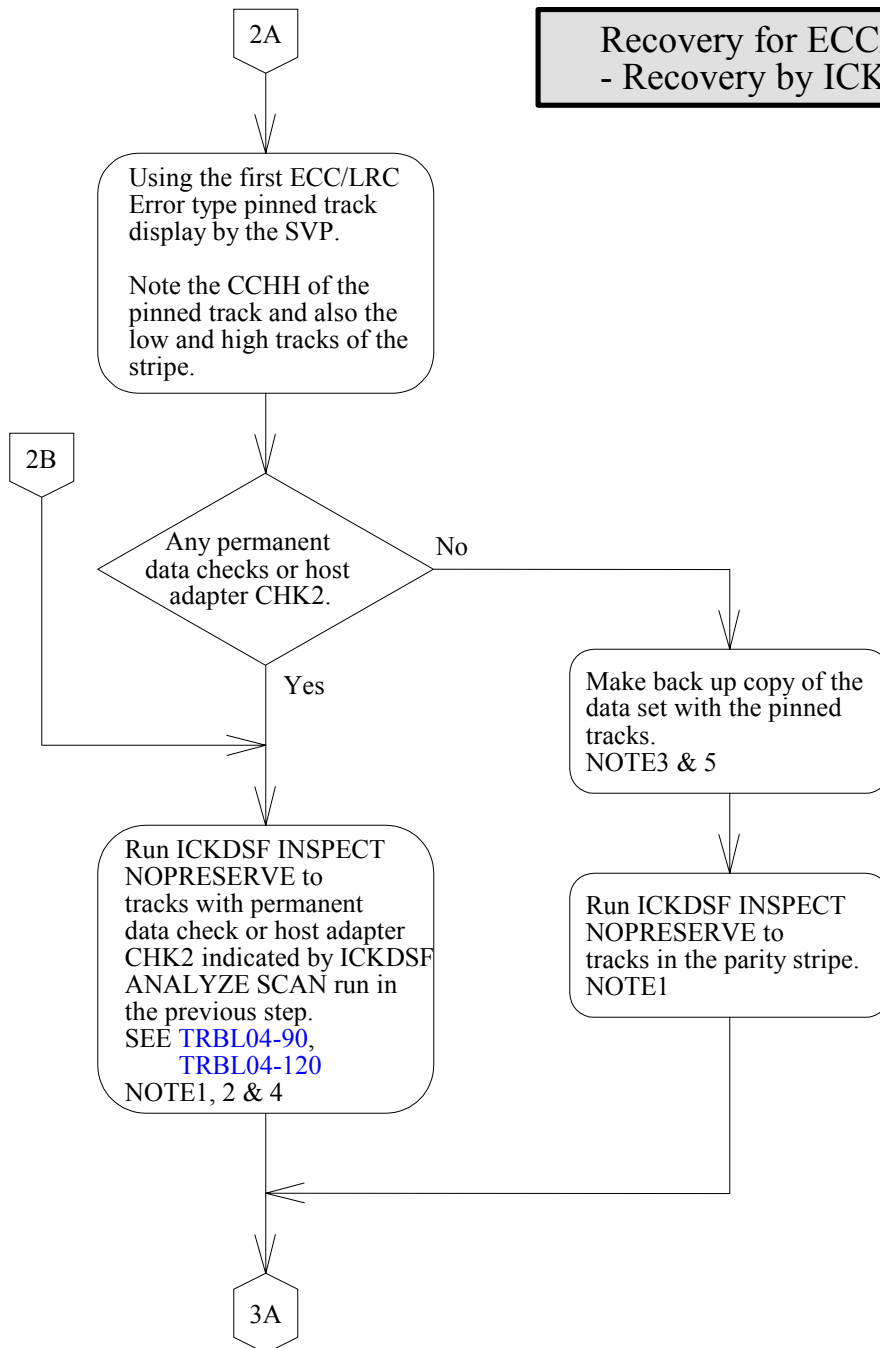

NOTE1 Remember all tracks on which the ICKDSF INSPECT NO PRESERVE is run as customer data has been lost. Customer will have to recover files for each data set.

NOTE2 If you execute ICKDSF INSPECT in the tracks of VTOC, the volume should be set to offline. In this case the entire volume will have to be restored.

NOTE3

- During a file recovery from the backup procedure to the restore procedure of the data set, the data set can not be accessed until the recovery is complete.
- If a file recovery for PDS data is set, execute the backup/restore procedure to the data set (all members).

NOTE4 When the drive emulation type is 3390-3R, add NOCHECK to ICKDSF INSPECT parameter.

NOTE5 ① Execute File Back up for dataset including pinned track. Store the backed-up file to another media (tape or another dasd).

② After executing NO PRESERVE INSPECT, restore the backed-up file to its original location.

**Recovery for ECC/LRC Error tracks
- Check after executing ICKDSF INSPECT -**

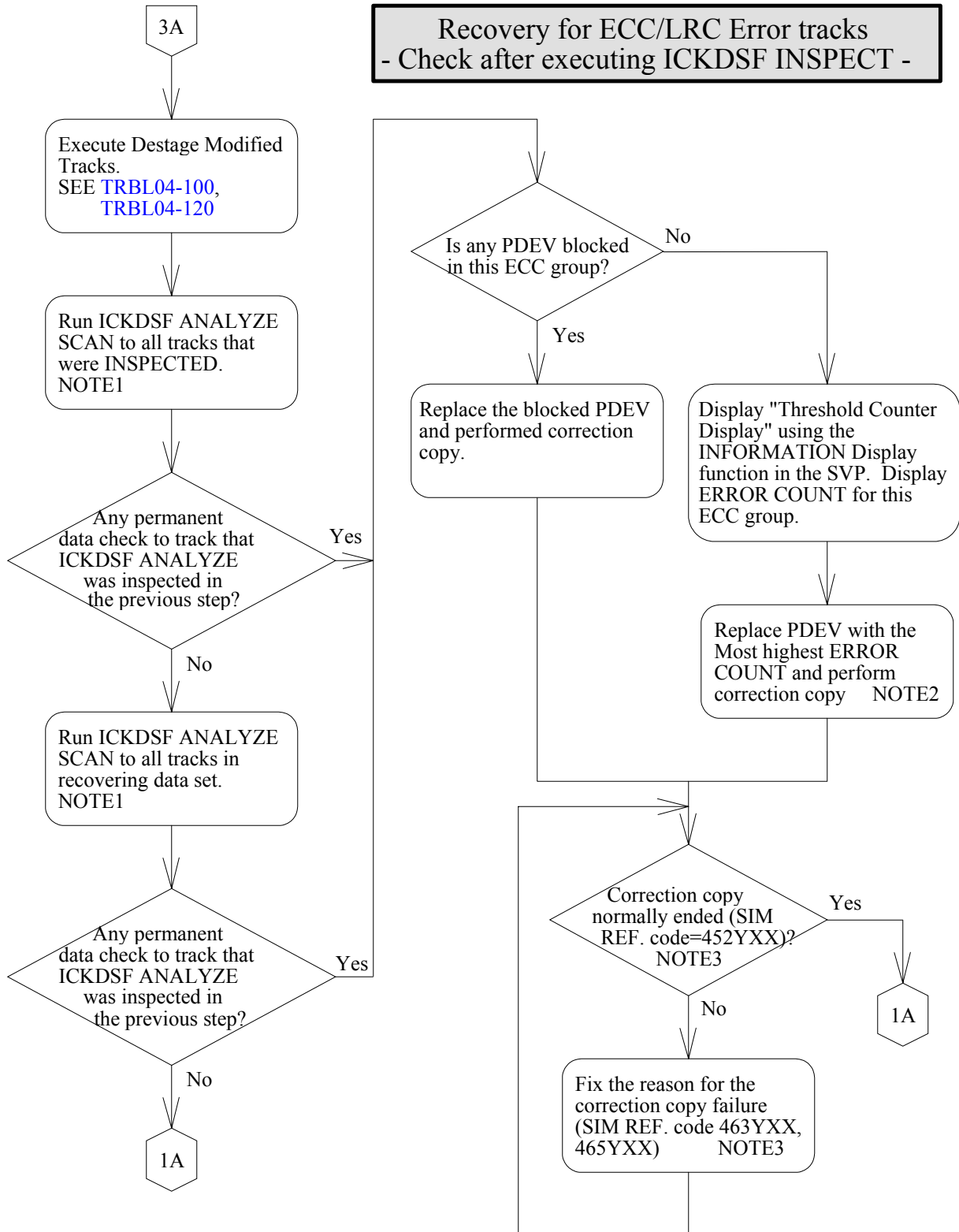

NOTE1 Repeat ICKDSF ANALYZE SCAN twice for the purpose verifying the data written on the physical device actually.

NOTE2 If Spare drives are available, you can perform Drive Copy instead of Correction copy.

NOTE3 If Drive copy ended abnormally, SIM REF. code is "463YXX" or "465YXX".

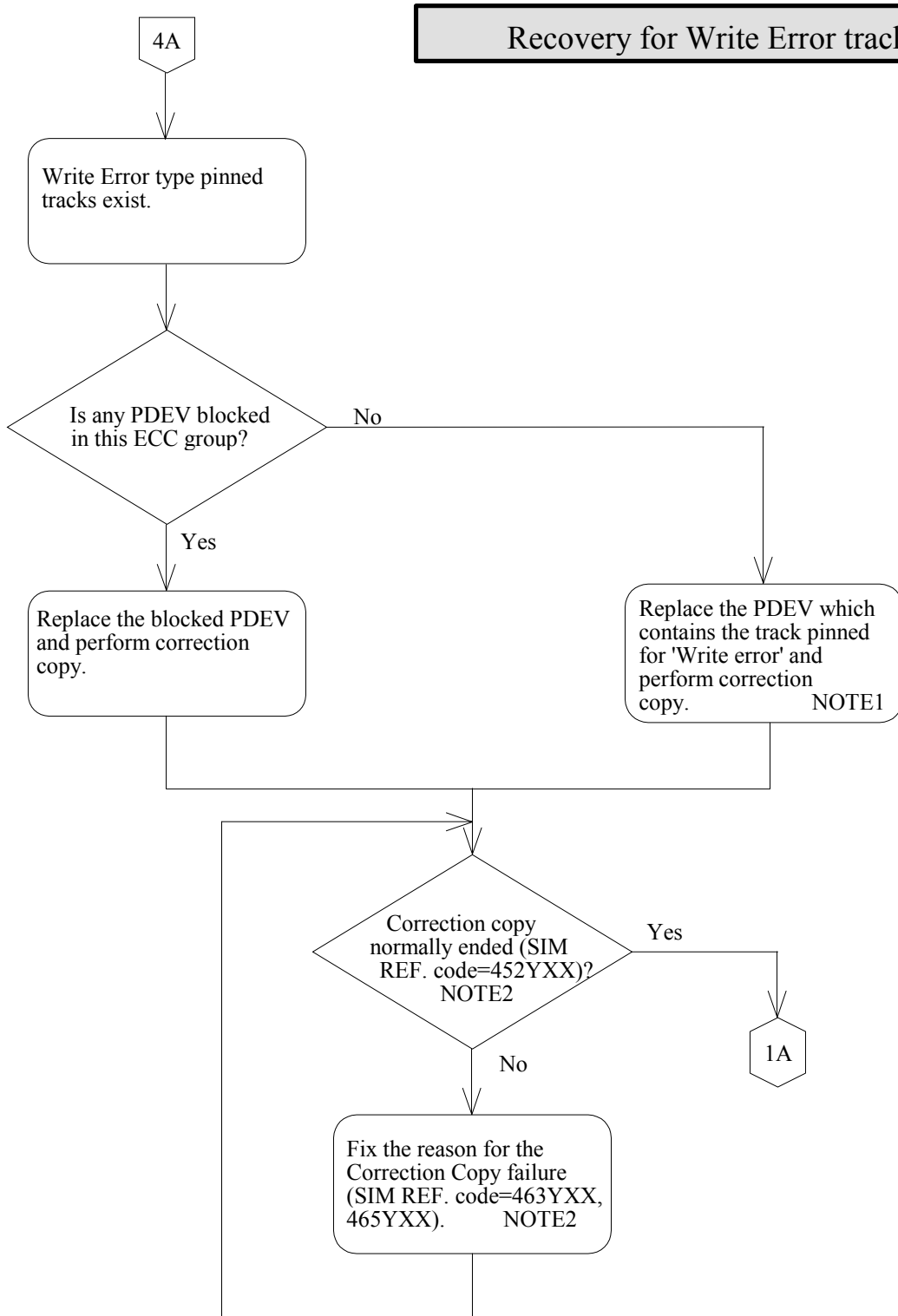

NOTE1 In the case where a spare drive is set, the drive copy can substitute for the correction copy. However, when the drive copy has been made, watch the pace of the copy and whether or not a failure SSB occurs in the copy source drive for ten minutes after the subsystem is started. If it is detected that “the copy has made no progress” or “an SSB (EC = Axxx) related to a drive has occurred” in the drive concerned, interrupt the drive copy and make the correction copy.

NOTE2 If Drive copy ended abnormally, SIM REF. code is “463YXX” or “465YXX”.

JCL example (under MVS)

A. Check if any pinned track by using DSF (ANALYZE).

[In case target LDEV to be recovered is ONLINE state]

```
//ANALYZE JOB MSGCLASS=x,MSGLEVEL=(1,1)
//STEP EXEC PGM=ICKDSF
//SYSPRINT DD SYSOUT=*
//DASD DD UNIT=DASD,VOL=SER=xxxxxxx,DISP=SHR
//SYSIN DD *
ANALYZE DDNAME(DASD) SCAN
/*
//
```

[In case target LDEV to be recovered is OFFLINE state]

```
//ANALYZE JOB MSGCLASS=x,MSGLEVEL=(1,1)
//STEP EXEC PGM=ICKDSF
//SYSPRINT DD SYSOUT=*
//SYSIN DD *
ANALYZE UNIT(cuu) SCAN
/*
//
```

B. Recover pinned tracks by using DSF (INSPECT).

(1) When the drive emuration type is other than 3390-3R.

[In case target LDEV to be recovered is ONLINE state]

```
//INSPECT JOB MSGCLASS=x,MSGLEVEL=(1,1)
//STEP EXEC PGM=ICKDSF
//SYSPRINT DD SYSOUT=*
//DASD DD UNIT=DASD,VOL=SER=xxxxxxx,DISP=SHR
//SYSIN DD *
INSPECT DDNAME(DASD) NOVERIFY NOPRESERVE -
FROM(X'ccc',X'h') TO(X'ccc',X'h')
/*
//
```

[In case target LDEV to be recovered is OFFLINE state]

```
//INSPECT JOB MSGCLASS=x,MSGLEVEL=(1,1)
//STEP EXEC PGM=ICKDSF
//SYSPRINT DD SYSOUT=*
//SYSIN DD *
INSPECT UNIT(cuu) NOVERIFY NOPRESERVE -
FROM(X'ccc',X'h') TO(X'ccc',X'h')
/*
//
```

(2) When the drive emuration type is 3390-3R.

[In case target LDEV to be recovered is ONLINE state]

```
//INSPECT JOB MSGCLASS=x,MSGLEVEL=(1,1)
//STEP EXEC PGM=ICKDSF
//SYSPRINT DD SYSOUT=*
//DASD DD UNIT=DASD,VOL=SER=xxxxxxx,DISP=SHR
//SYSIN DD *
INSPECT DDNAME(DASD) NOVERIFY NOPRESERVE NOCHECK
-
TRACKS(X'ccc',X'h')
/*
//
```

[In case target LDEV to be recovered is OFFLINE state]

```
//INSPECT JOB MSGCLASS=x,MSGLEVEL=(1,1)
//STEP EXEC PGM=ICKDSF
//SYSPRINT DD SYSOUT=*
//SYSIN DD *
INSPECT UNIT(cuu) NOVERIFY NOPRESERVE NOCHKCK -
TRACKS(X'ccc',X'h')
/*
//
```

C. Execute Destage Modified Tracks

```
//DESTDATA JOB
MSGCLASS=x,MSGLEVEL=(1,1),REGION=nnnnK
//STEP1 EXEC PGM=IDCAMS
//SYSPRINT DD SYSOUT=*
//SYSIN DD *
SETCACHE VOLUME(xxxxxx) unit(DASD) DESTAGE
/*
//
```

Operation example (under VM)

Note : This recovery procedure is executable only under VM/ESA 1.1 or higher release with DEVMAINT authority.

A. Check if any pinned track by using DSF (ANALYZE).

```
ickdsf
ICK030E DEFINE INPUT...
console
CONSOLE
ICK031E DEFINE OUTPUT...
console
CONSOLE
ICKDSF - CMS DEVICE SUPPORT FACILITY...

ENTER INPUT COMMAND:
analyze unit(cuu) scan
      .
      .
end
  END
```

B. Recover pinned tracks by using DSF(INSPECT).

(1) When the drive emuration type is other than 3390-3R.

```

ickdsf
ICK030E DEFINE INPUT...
console
CONSOLE
ICK031E DEFINE OUTPUT...
console
CONSOLE
ICKDSF - CMS DEVICE SUPPORT FACILITY...

ENTER INPUT COMMAND:
inspect unit(cuu) norecovery nopriserve from(x'ccc',x'h'
to(x'ccc',x'h')
.
.
end
END

```

(2) When the drive emuration type is 3390-3R.

```

ickdsf
ICK030E DEFINE INPUT...
console
CONSOLE
ICK031E DEFINE OUTPUT...
console
CONSOLE
ICKDSF - CMS DEVICE SUPPORT FACILITY...

ENTER INPUT COMMAND:
inspect unit(cuu) norecovery nopriserve nocheck
tracks(x'ccc',x'h')
.
.
end
END

```

C. Execute Destage Modified Tracks

```

destage rdev

```

5 Error Recovery

5.1 FSW Access Error/FSW LED Bus Test Error (SIM = BF9XXX, 3DAXXX)

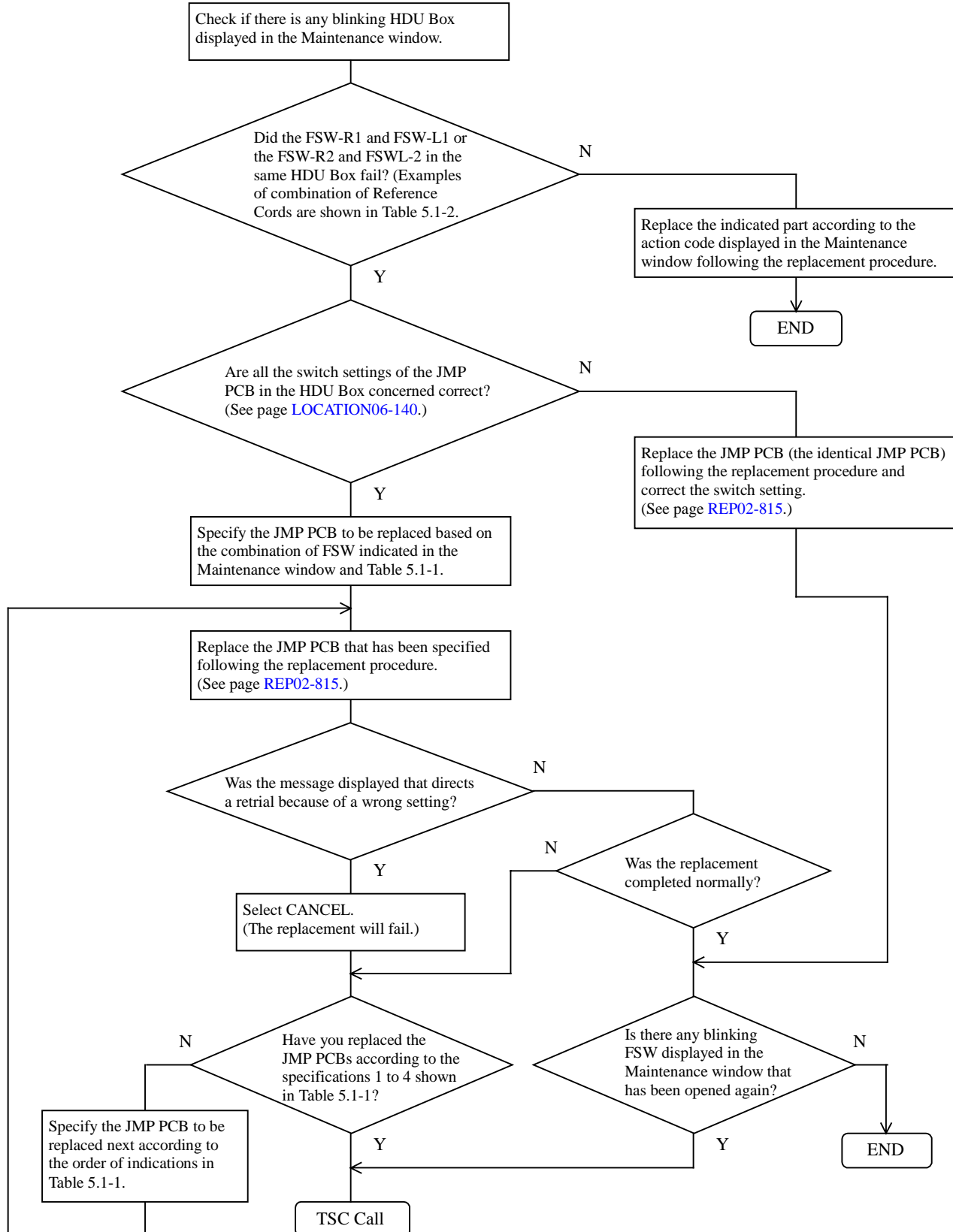

Table 5.1-1 Indication of a part to be replaced (HA Model)

| No | ACC Indication part | | A part to be replaced | | | |
|----|---------------------|-----------|-----------------------|--------------|--------------|--------------|
| | CL1 | CL2 | Indication 1 | Indication 2 | Indication 3 | Indication 4 |
| 1 | FSW-R1xR1 | FSW-R1xL1 | JMP-R1xR1 | JMP-R1xR2 | JMP-R2xR1 | JMP-R2xR2 |
| 2 | FSW-R1xR2 | FSW-R1xL2 | JMP-R1xL1 | JMP-R1xL2 | JMP-R2xL1 | JMP-R2xL2 |
| 3 | FSW-R2xR1 | FSW-R2xL1 | JMP-R1xR1 | JMP-R1xR2 | JMP-R2xR1 | JMP-R2xR2 |
| 4 | FSW-R2xR2 | FSW-R2xL2 | JMP-R1xL1 | JMP-R1xL2 | JMP-R2xL1 | JMP-R2xL2 |
| 5 | FSW-L1xR1 | FSW-L1xL1 | JMP-L1xR1 | JMP-L1xR2 | JMP-L2xR1 | JMP-L2xR2 |
| 6 | FSW-L1xR2 | FSW-L1xL2 | JMP-L1xL1 | JMP-L1xL2 | JMP-L2xL1 | JMP-L2xL2 |
| 7 | FSW-L2xR1 | FSW-L2xL1 | JMP-L1xR1 | JMP-L1xR2 | JMP-L2xR1 | JMP-L2xR2 |
| 8 | FSW-L2xR2 | FSW-L2xL2 | JMP-L1xL1 | JMP-L1xL2 | JMP-L2xL1 | JMP-L2xL2 |

(See page [LOCATION02-80](#))

Table 5.1-2 Example of a combination of the reference codes (HA Model)

| No | CL1 | CL2 |
|----|--------|--------|
| 1 | 3DAx00 | 3DAx40 |
| 2 | 3DAx01 | 3DAx41 |
| 3 | 3DAx02 | 3DAx42 |
| 4 | 3DAx03 | 3DAx43 |
| 5 | 3DAx10 | 3DAx50 |
| 6 | 3DAx11 | 3DAx51 |
| 7 | 3DAx12 | 3DAx52 |
| 8 | 3DAx13 | 3DAx53 |
| 9 | 3DAx20 | 3DAx60 |
| 10 | 3DAx21 | 3DAx61 |
| 11 | 3DAx22 | 3DAx62 |
| 12 | 3DAx23 | 3DAx63 |
| 13 | 3DAx30 | 3DAx70 |
| 14 | 3DAx31 | 3DAx71 |
| 15 | 3DAx32 | 3DAx72 |
| 16 | 3DAx33 | 3DAx73 |

(x: FSW PCB#)

5.2 Isolation and Recovery Procedures for Common Fibre Loop Error (SIM = DF6YXX, DF7YXX, DF8YXX, DF9YXX)

When a Fibre port error SIM for a drive (PDEV) is reported, this section provides the procedures for judging whether the error is caused by the pertinent drive error or common Fibre Loop error, and how to recover the error.

As a Fibre port error SIM managed in each PDEV, a Fibre temporary error (REF code = DF6YXX, DF7YXX) is reported when a warning is issued, and Fibre blocking (REF code = DF8YXX, DF9YXX) is reported when the equipment is blocked (Y: CDEV#, XX: RDEV#).

Possible causes for the malfunction are:

- (1) Failure of drive specified in FPC
- (2) Defects in Fibre Chip for DKF
- (3) Defects in Fibre Loop (cable, FSW(Fibre switch))
- (4) Other drive failure
- (5) HDU Box platter failure

Before performing the maintenance and replacement only for the failed drive, follow these isolation and recovery procedures to check that a common Fibre port error occurs on other PDEVs on the same Fibre Loop. If a common error exists, perform the appropriate recovery for the common error parts.

In the case where it is judged that a drive is to be replaced as a result of the location of the failed part, if a failure SSB has occurred in the alternative port of the drive concerned, it is required to perform not the dynamic sparing but the correction copy after detaching the drive for the purpose of maintenance.

Common Fibre Loop Error Isolation Procedure

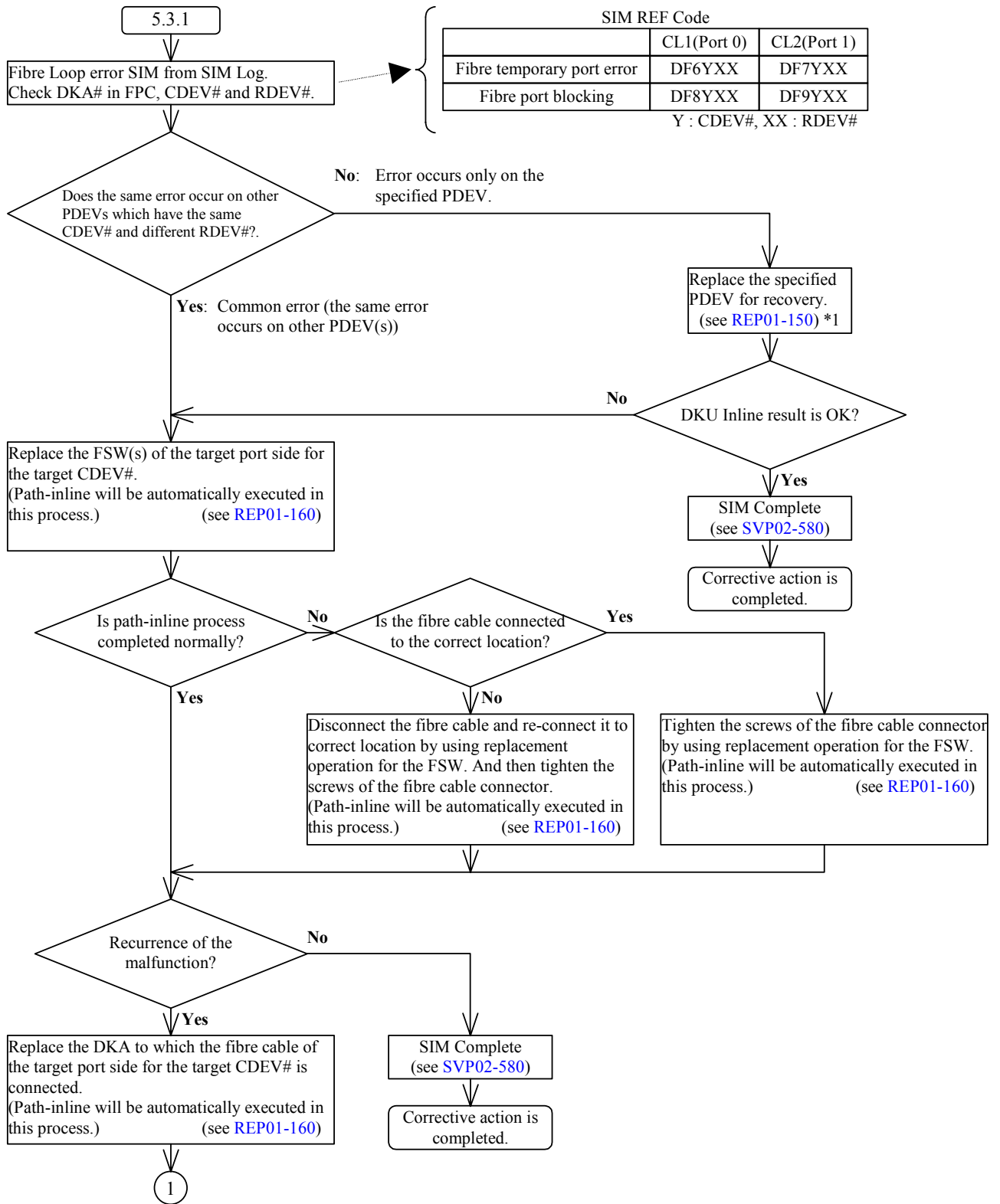

TRBL05-40

*1: When a failure SSB has also occurred in the alternative port of the drive concerned, solve the trouble by replacing the drive and making the correction copy.

TRBL05-30

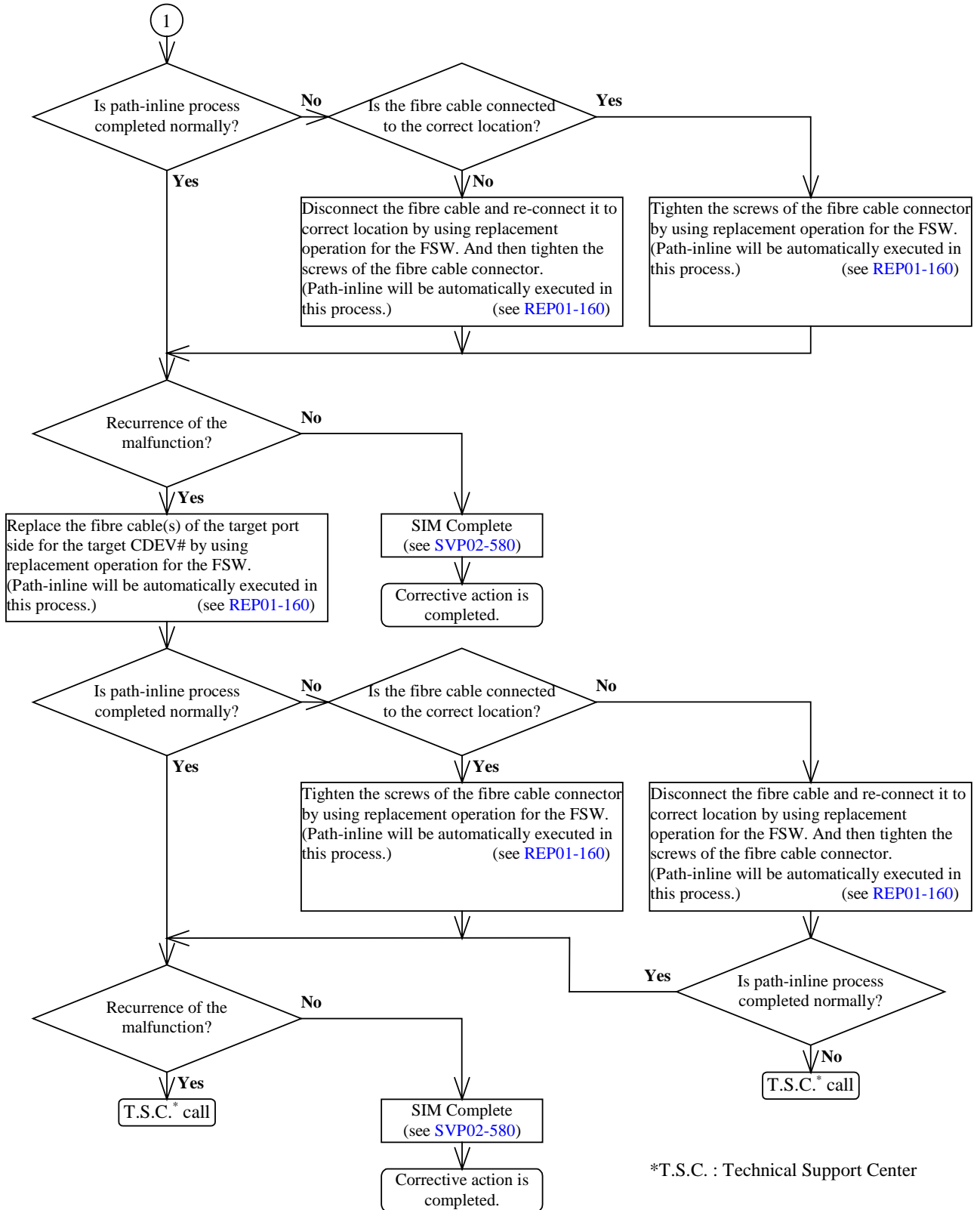

*T.S.C. : Technical Support Center

5.3 Recovery Procedure for LAN Error (SIM = 1400X0, 1500X0, 73XX00)

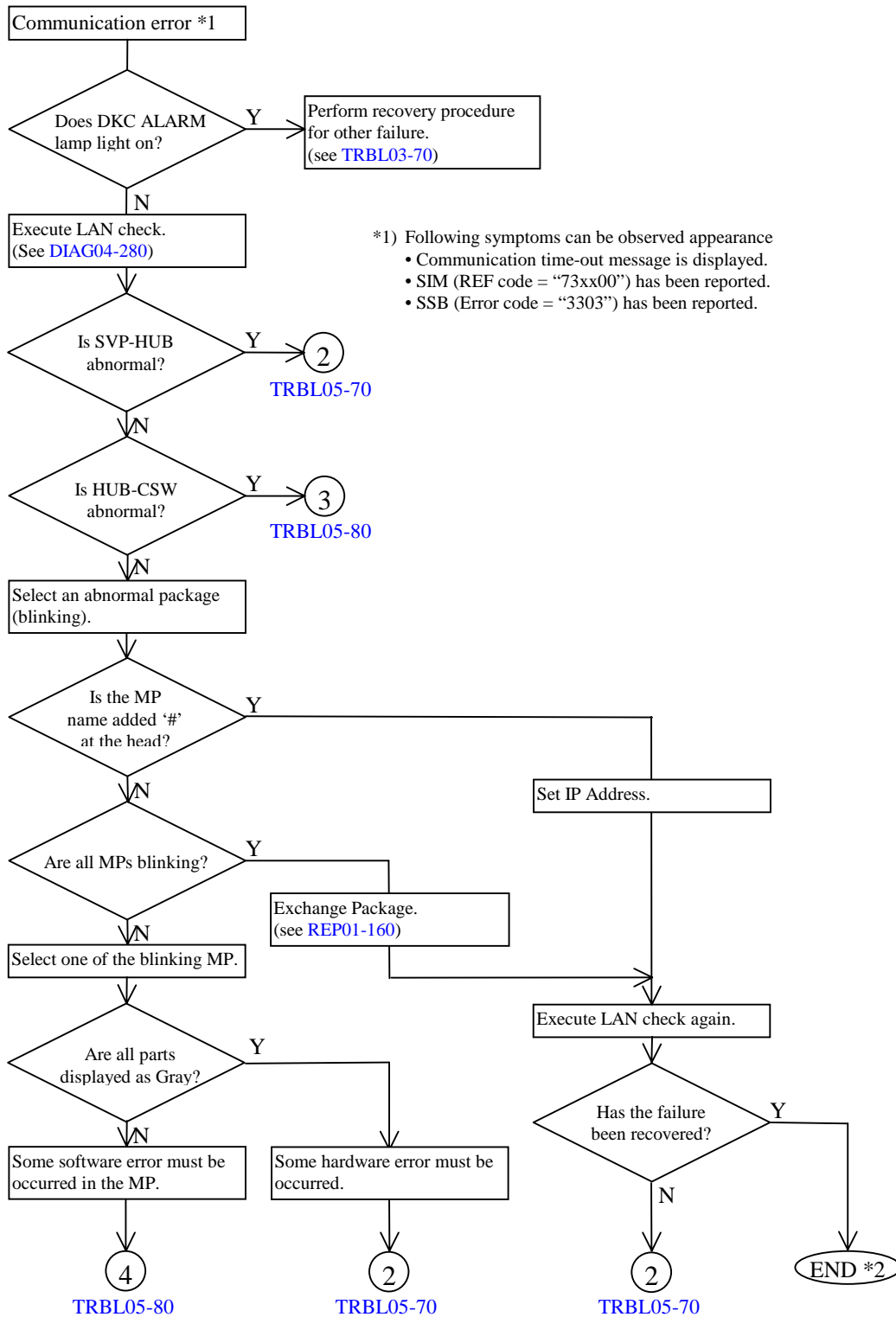

*2) After finishing the error recovery, execute SIM complete and delete logs. (Refer to SVP02-170, 580)

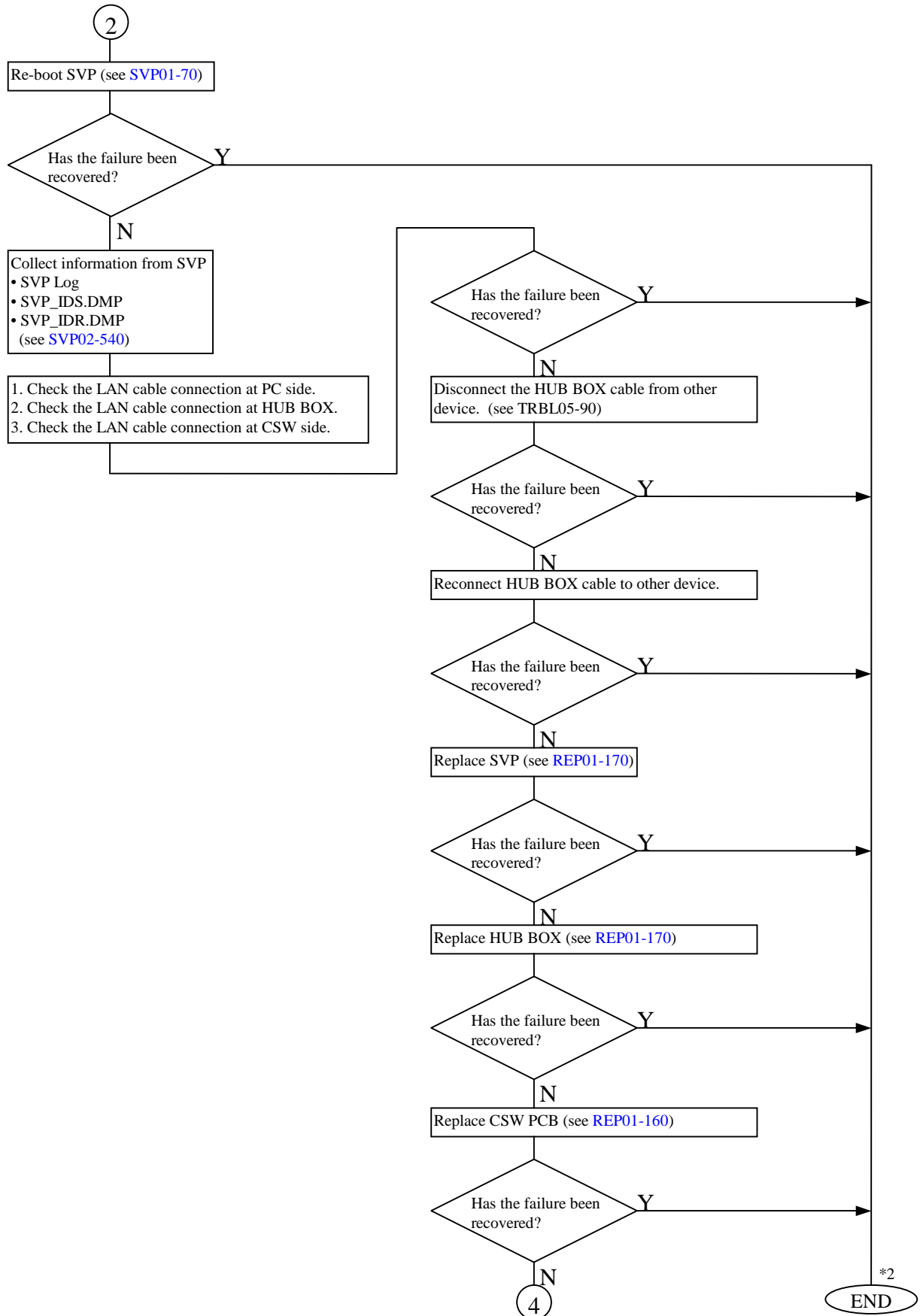

TRBL05-80

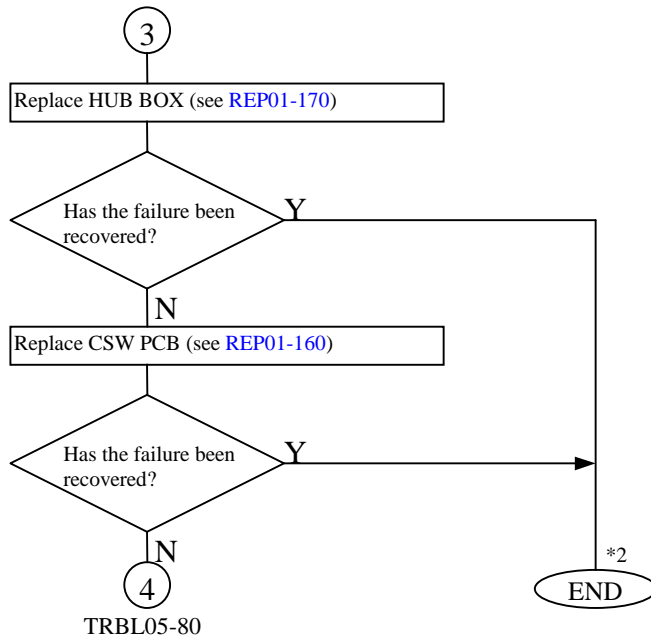

*2: After finishing the error recovery, execute SIM complete and delete logs. (see [SVP02-170](#), [580](#))

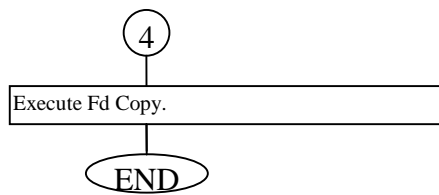

5.4 Error Recovery Procedure during CHA/DKA replacement

Perform the appropriate recovery procedure according to case (1) or (2).

(1) Blocking error occurrence

If the following message is displayed when CHA/DKA is being blocked (when the message “The CHA is being blocked...” or “The DKA is being blocked...” is being displayed), perform the following recovery procedures.

“There is no response from DKC within the time limit.”

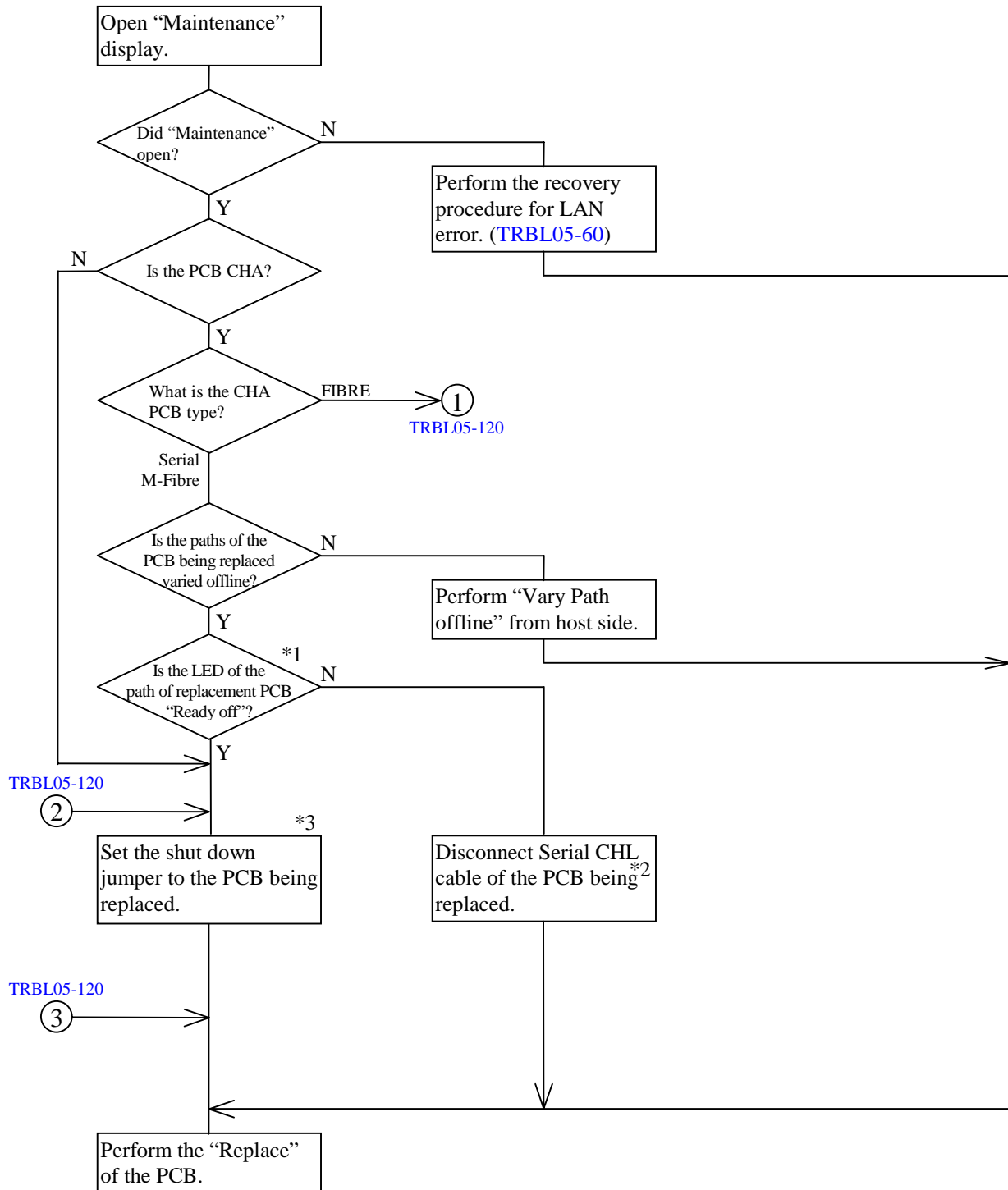

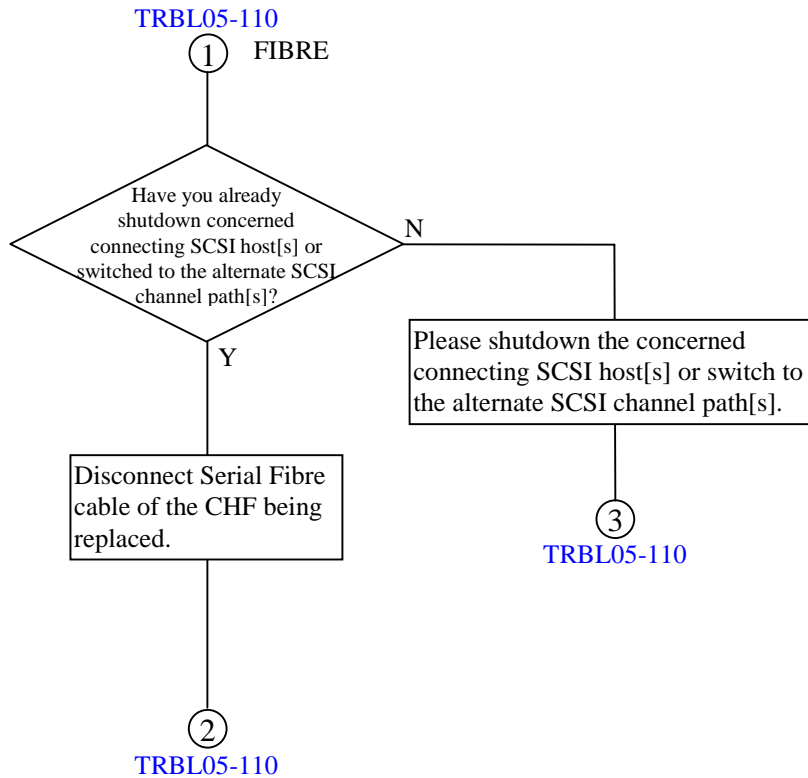

- *1) Verify that channel lamp of operating panel is turned off.
- *2) After this operating, error message may be displayed at host side.
- *3) After this operation, error SIM and SSB may occur. Refer to the following pages for shut down jumper insertion method depending on the type of PCB.
 - Serial Channel CHA : see #1 in [REP03-80](#)
 - Fibre Channel CHA : see #1 in [REP03-110](#)
 - M-Fibre Channel CHA : see #1 in [REP03-140](#)
 - DKA : see #1 in [REP03-170](#)

(2) Other cases

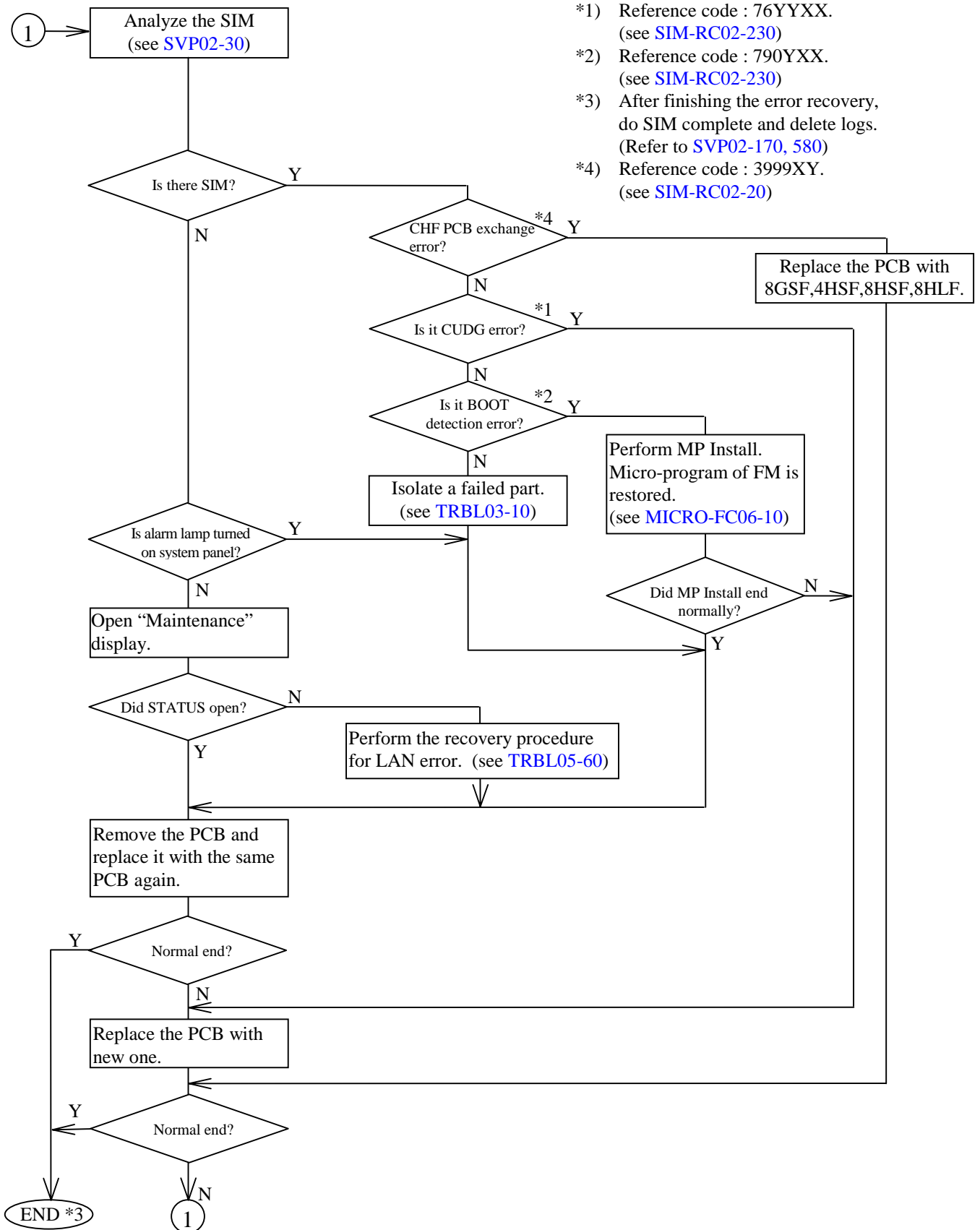

- *1) Reference code : 76YYXX.
(see SIM-RC02-230)
- *2) Reference code : 790YXX.
(see SIM-RC02-230)
- *3) After finishing the error recovery,
do SIM complete and delete logs.
(Refer to SVP02-170, 580)
- *4) Reference code : 3999XY.
(see SIM-RC02-20)

5.5 Recovery Procedure for Cache Replace Failure (SIM = 3993XX, 3D93XX, FFE40X)

This recovery procedure is provided for cache replacement when replace failure SIM is reported.

- Cache replace failure caused by processor error
(REF code = 0x3993XY, 0x3D93XY : X = PK ID, Y = MP ID in PK)
 - ① Insert the shut down jumper into the processor PCB shown in the SIM REF code.
(Serial channel CHA see #1 [REP03-80](#)).
(Fibre channel CHA see #1 [REP03-110](#)).
(M-Fibre channel CHA see #1 [REP03-140](#)).
(DKA see #1 [REP03-170](#)).

In this case, CHK3 or other equipment error are reported because no processing is performed. However, you should ignore these errors.

 - ② Retry the suspended cache replacement.
 - ③ Replace the PCB into which the shut down jumper inserted in Step ①.

- Cache replace failure caused by Shared Memory error
(REF code = FFE40X : X:(0) = side A, (1) = side B)
When this SIM occurs, SM failure can be the cause. But, when SM failure occurred without INLINE CUDG error, this error maybe caused by intermittent error. Therefore,
 - ① Conduct cache replacement again.
 - ② When normal end, cache replacement is completed.
 - ③ When SM failure SIM is reported again, replace other cache P/K which was not replaced.

5.6 Recovery Procedure for Cache Error (Both sides) (SIM = FFF50X)

This procedure is to recover errors of the both sides of cache (SIM = FFF5) at powering on the subsystem.

At this time, if pending data (non-written data to the drive) exists on the cache, the drive will be blocked and the L-dev formatted drive will be required.

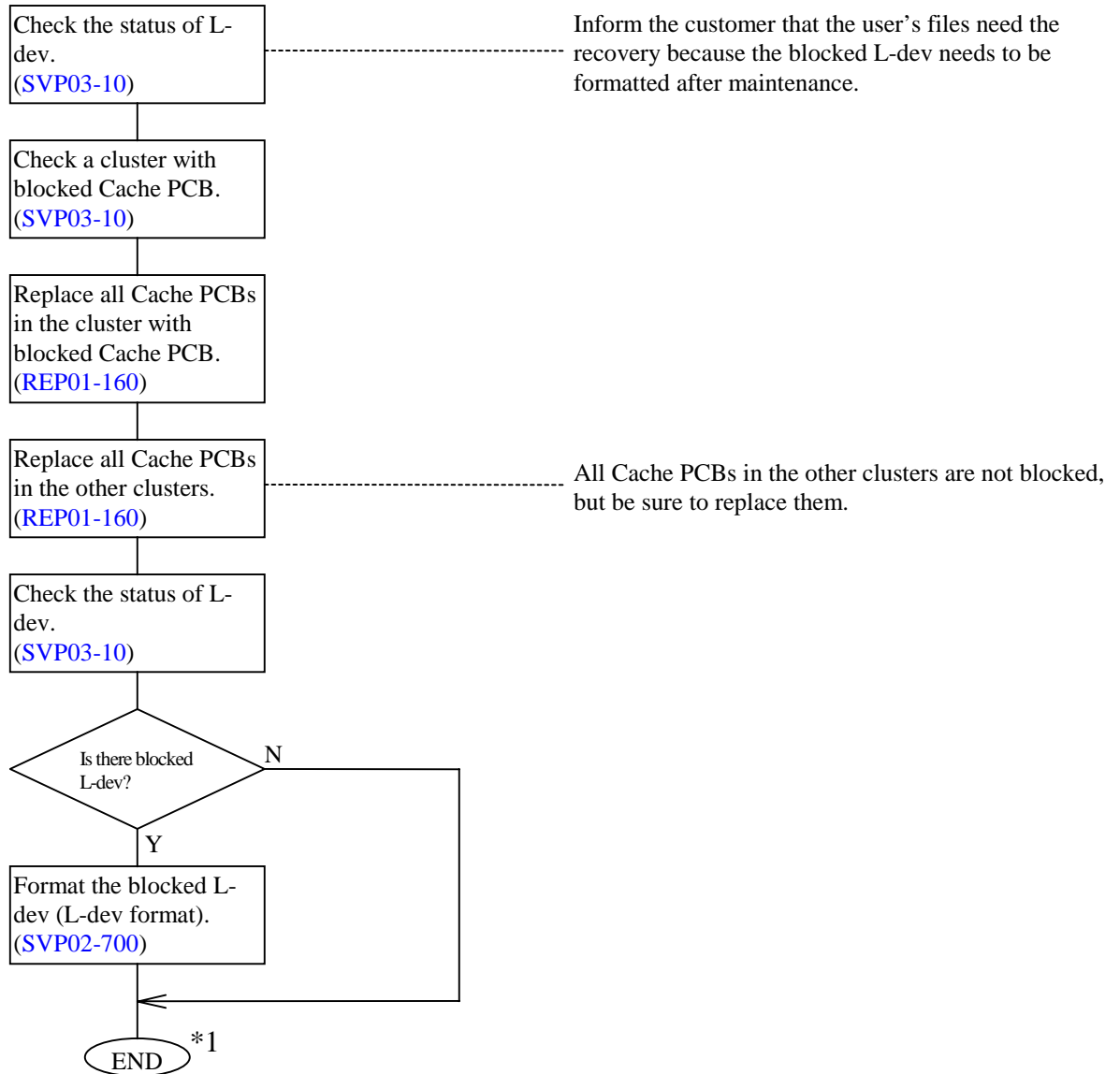

*1) Delete Log after the end of this procedure. (SVP02-170)

5.7 Recovery Procedures for Status in changing is not released

The SVP protects maintenance operation while the DKC is changing its status. If the SVP detects such condition before executing maintenance process, the message as “Internal subsystem status is under maintenance (reason). No maintenance can be performed now.” is displayed. The reason is one of the following messages.

- | | |
|------------------------------|---|
| (1) LDEV format in progress. | (3) CHA-xx (or DKA-xx) changing the status. |
| (2) Copy in progress. | (4) Cache-xx changing the status. |
- xx:package number

If one of the above message appears, try the following recovery procedure.

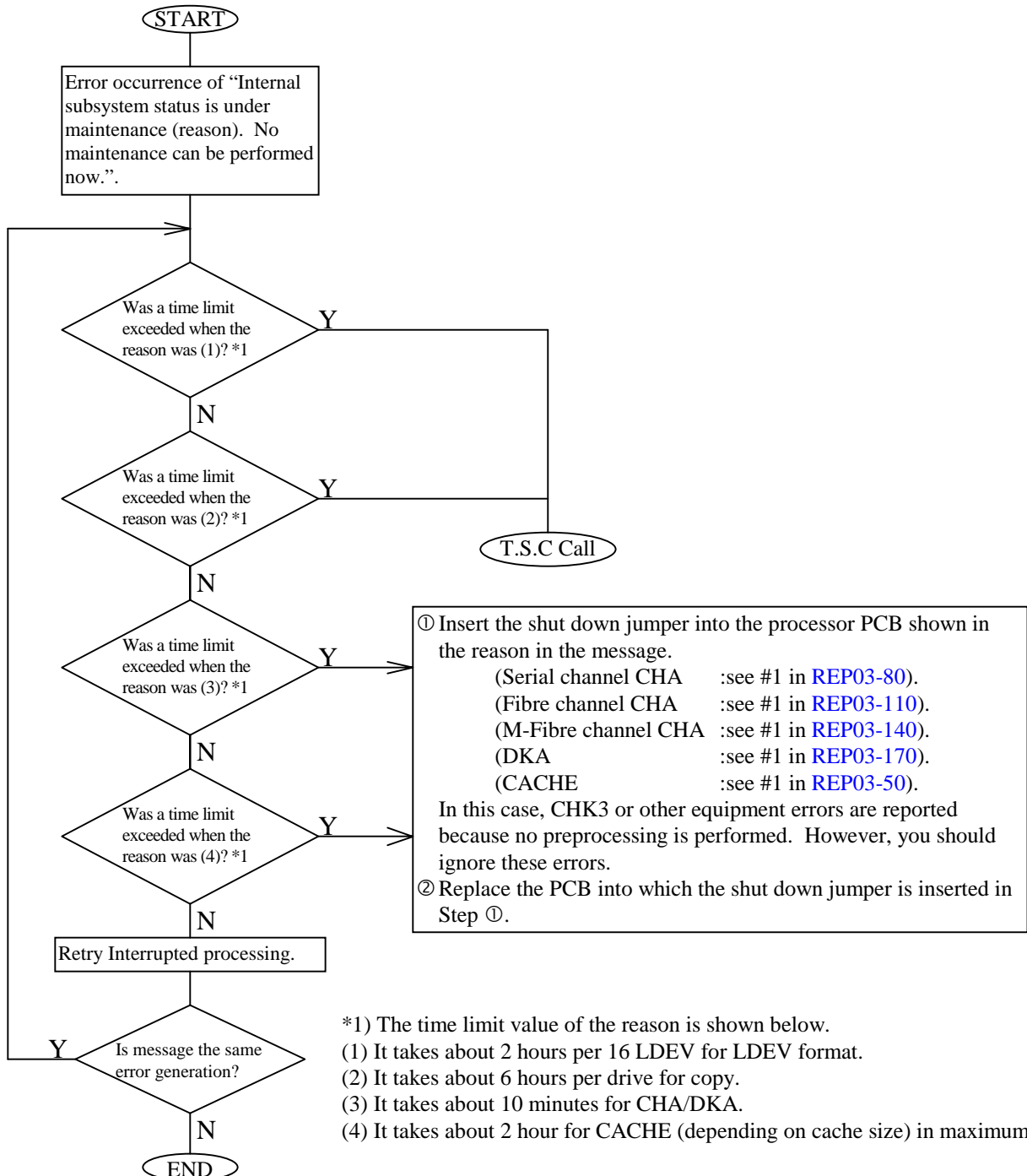

5.8 Drive failure recovery procedure

Explanation:

Types of the drive copy are shown below. Confirm the copy type and execute the drive recovery procedure.

| Copy type | Description | Operation occasion |
|-----------------|--|---|
| Correction copy | This is an operation to restore and copy the data of the blocked drive using the data of another drive and parity data when the data drive is blocked. <ul style="list-style-type: none"> A correction copy to the spare drive is referred to as another drive correction copy. A correction copy to the replacement drive which has been installed instead of the blocked drive is referred to as a self-drive correction copy. | <ul style="list-style-type: none"> Automatic operation owing to a failure Operation instructed by the maintenance personnel |
| Drive copy | This is an operation to copy data to the spare drive from the data drive. A copy automatically performed owing to a warning level failure is referred to as dynamic sparing. | <ul style="list-style-type: none"> Automatic operation owing to a failure Operation instructed by the maintenance personnel |
| Copy back | This is a copy for returning data which has been copied to the spare drive by another drive correction copy or drive copy to the original data drive. | <ul style="list-style-type: none"> Operation instructed by the maintenance personnel |

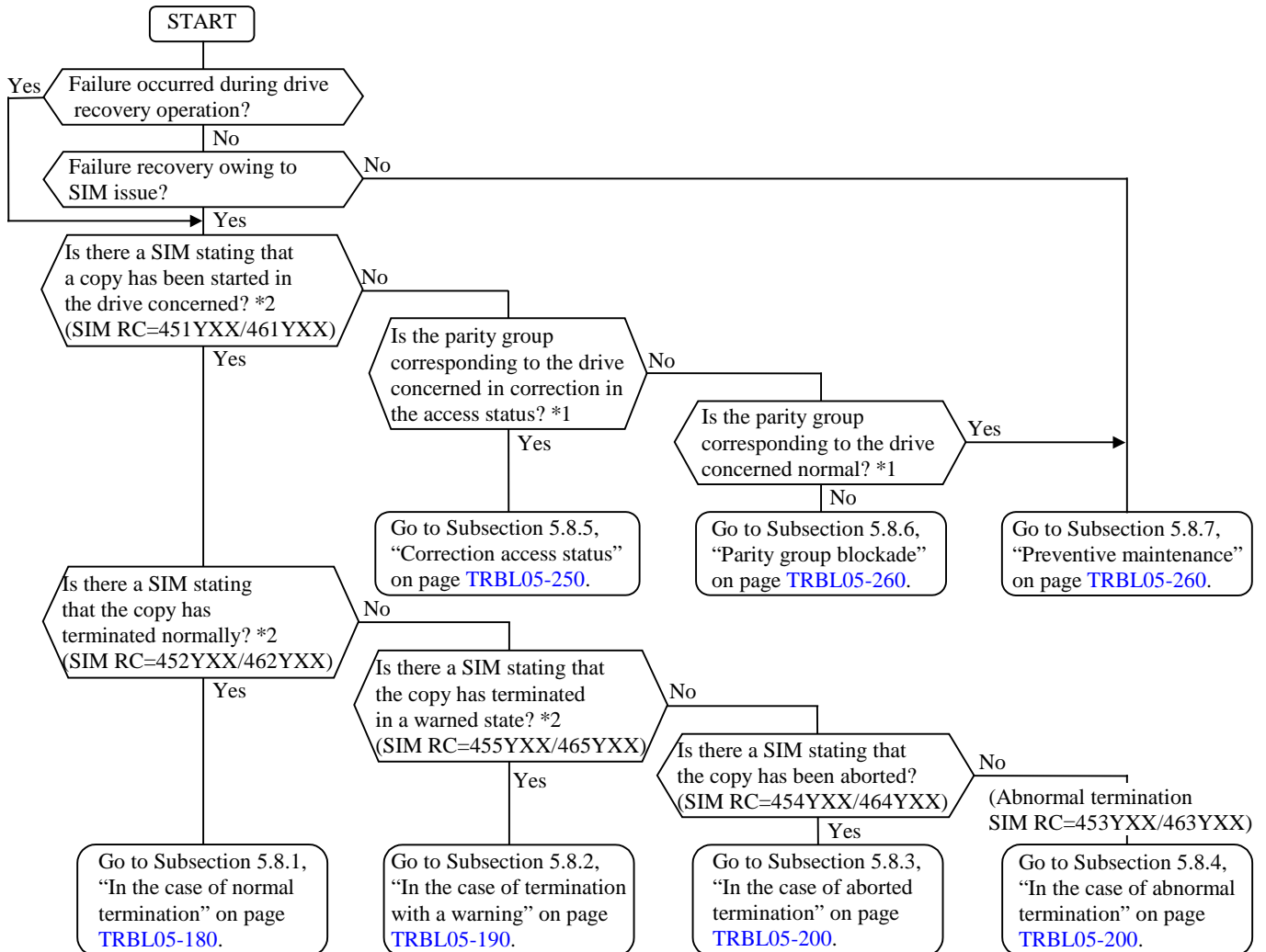

*1: Confirm the status of the parity group corresponding to the drive concerned by means of the SVP status.

For the procedure for referring to the SVP status, refer to Section 3.8, "Logical device" on page SVP03-170.

*2: The term "copy" means drive copy, copy back, or correction copy.

5.8.1 In the case of normal termination (SIM RC=452YXX/462YXX)

The procedure below is that used after a drive copy, copy back, or correction copy terminates normally.

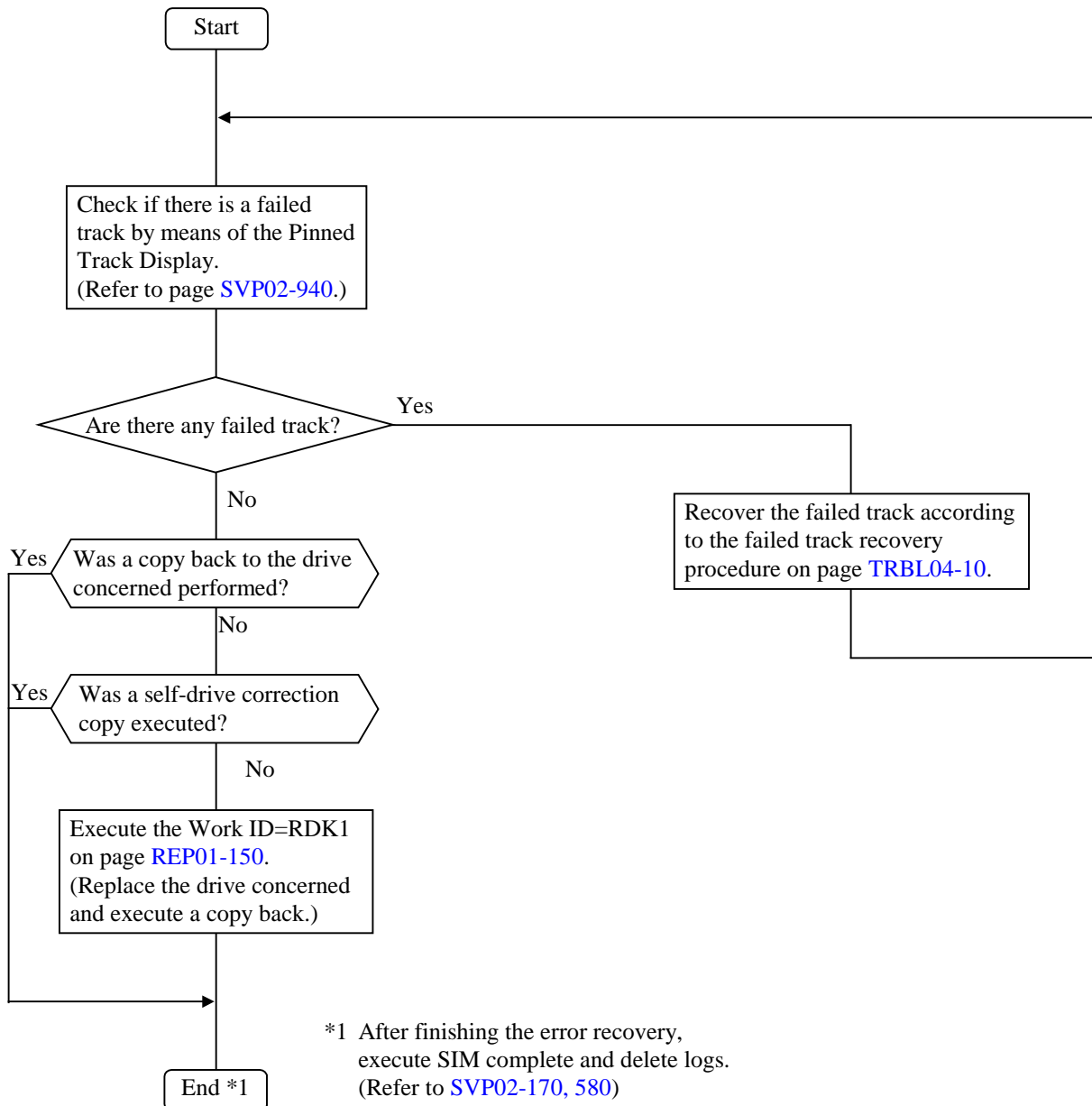

5.8.2 In the case of termination with a warning (SIM RC=455YXX/465YXX)

The procedure explained below is that used when the drive copy, copy back, or correction copy terminates but one of the following is detected:

- (1) A failed track was detected, but the copy was continued.
- (2) One or more blocked LDEVs were detected in the same parity group. Copy of data of the blocked LDEVs was skipped.

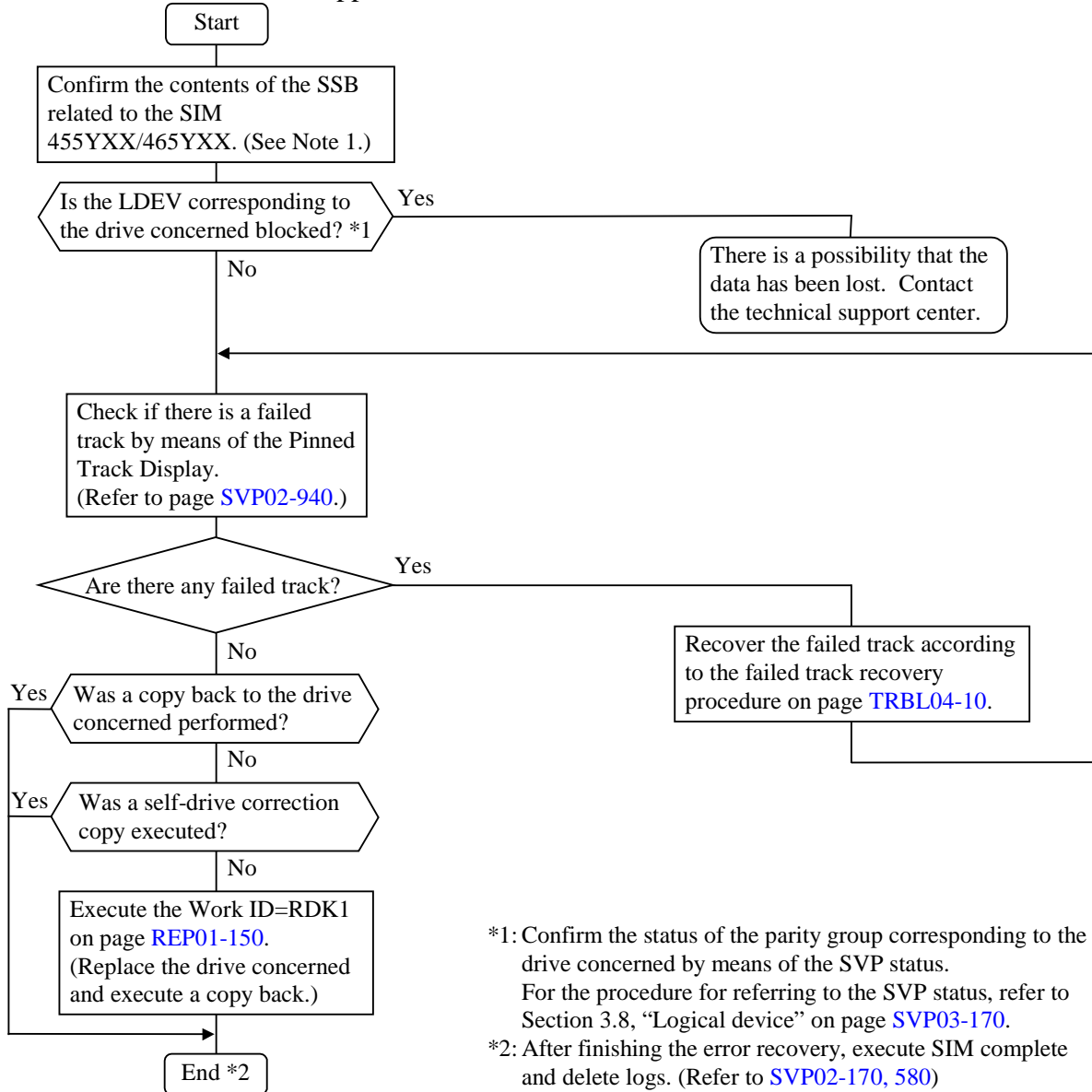

Note 1: Meaning of bytes 40 to 7E of SSB F/M=9F EC=9355 related to SIM RC=455YXX/465YXX

| Byte (Hex.) | Item | Meaning |
|-------------|-------------------------|--|
| 40 | Number of failed tracks | Number of failed tracks |
| 41 | Number of blocked LDEVs | Number of blocked LDEVs |
| 42 | Blocked LDEV #0 | Blocked LDEV No. (Up to 30 LDEVs can be inputted from the top.)
However, 0Xff is inputted in the unused part. |
| : | : | |
| 7D | Blocked LDEV #29 | |
| 7E | E.O.D | Means the end of data |

5.8.3 In the case of termination owing to abortion (SIM RC=454YXX/464YXX)

The procedure below is that used when a drive copy, copy back, or correction copy is aborted owing to the SVP operation by the service personnel. Since the status of the drive concerned is that before starting copy, execute the recovery operation for the same drive once again.

5.8.4 In the case of abnormal termination (SIM RC=453YXX/463YXX)

The procedure below is that used when a drive copy, copy back, or correction copy terminates abnormally.

Since the recovery procedure may differ depending on the copy type, confirm the description on page [TRBL05-170](#) and execute the following procedure.

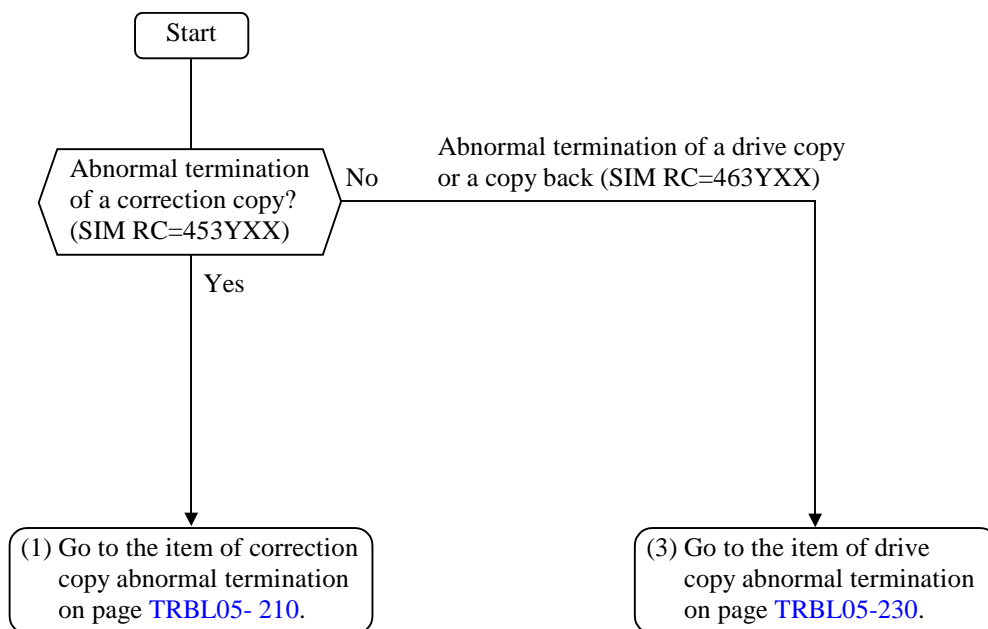

(1) In the case of correction copy abnormal termination

The procedure below is that used when a correction copy terminates abnormally.

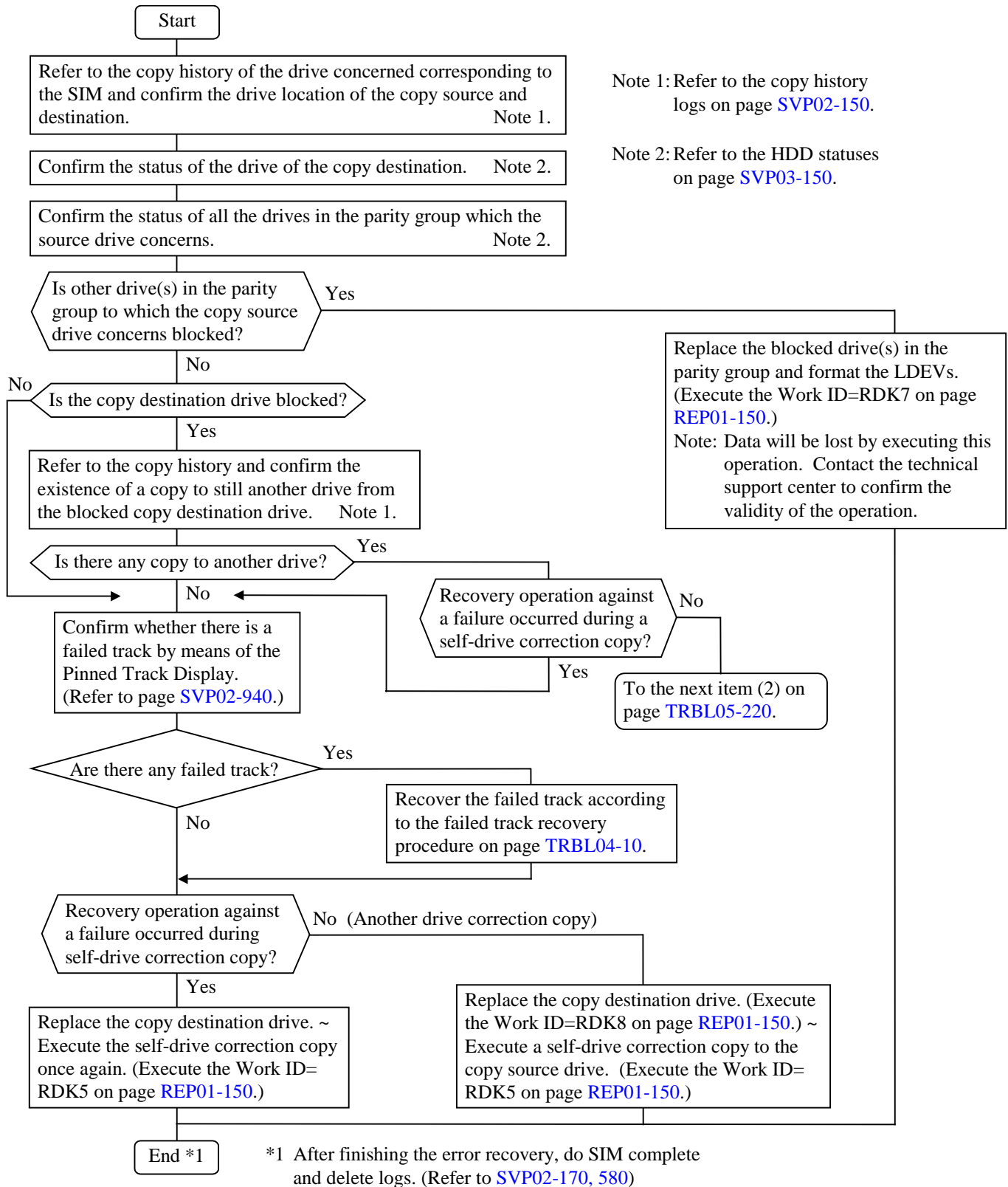

(2) In the case of correction copy abnormal termination (in which an unused spare drive is available)

This is a case in which a correction copy terminates abnormally owing to a failure in the copy destination drive. However, if an unused spare drive exists, the correction copy is automatically performed to the unused spare drive.

In the following procedure, the copy source is referred to as a original copy source, the copy destination is referred to as a copy source, and the unused spare drive is referred to as a copy destination.

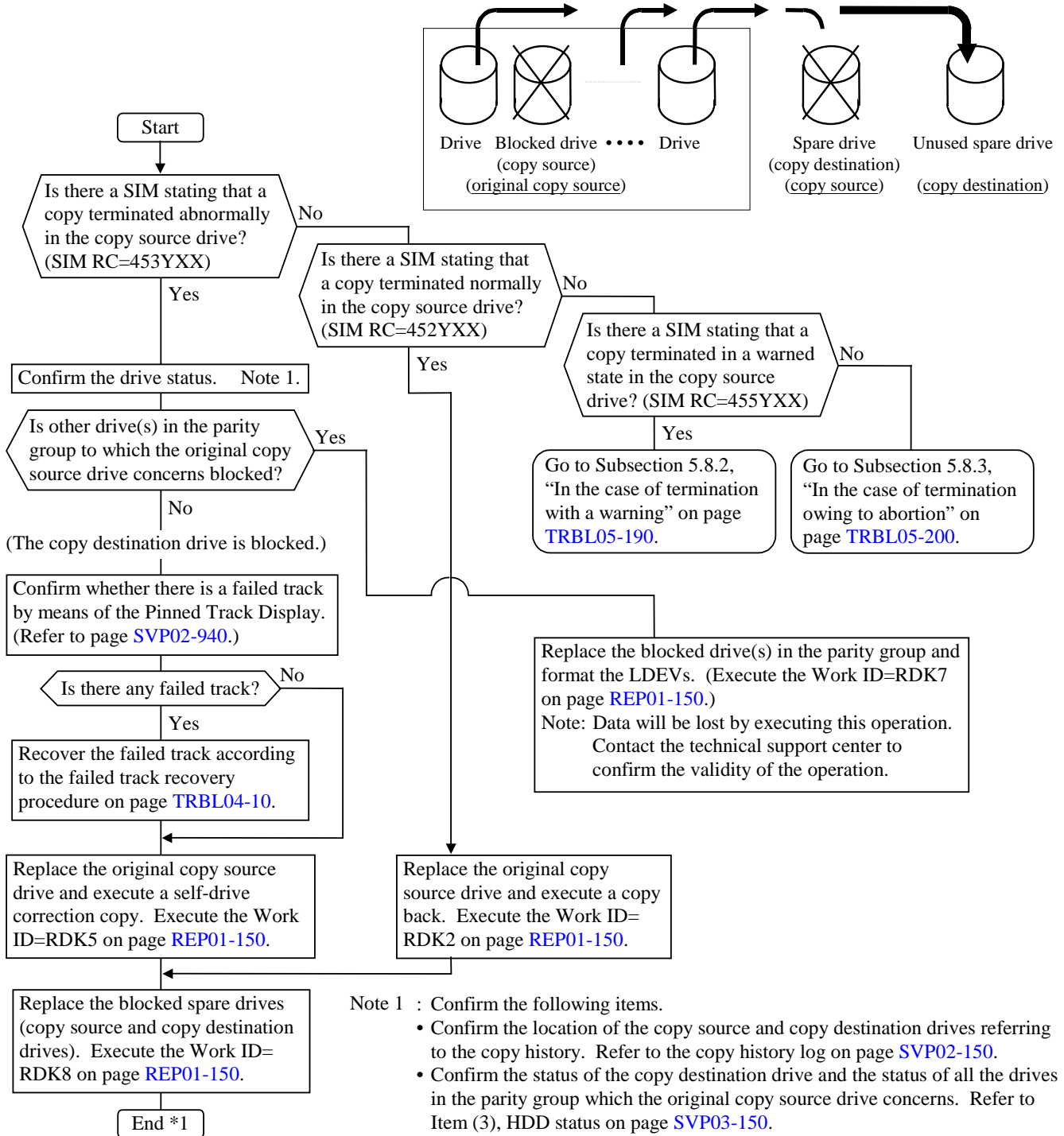

Note 1 : Confirm the following items.

- Confirm the location of the copy source and copy destination drives referring to the copy history. Refer to the copy history log on page SVP02-150.
- Confirm the status of the copy destination drive and the status of all the drives in the parity group which the original copy source drive concerns. Refer to Item (3), HDD status on page SVP03-150.

*1 After finishing the error recovery, do SIM complete and delete logs. (Refer to SVP02-170, 580)

(3) In the case of drive copy abnormal termination

The procedure below is that used when a drive copy or a copy back terminates abnormally.

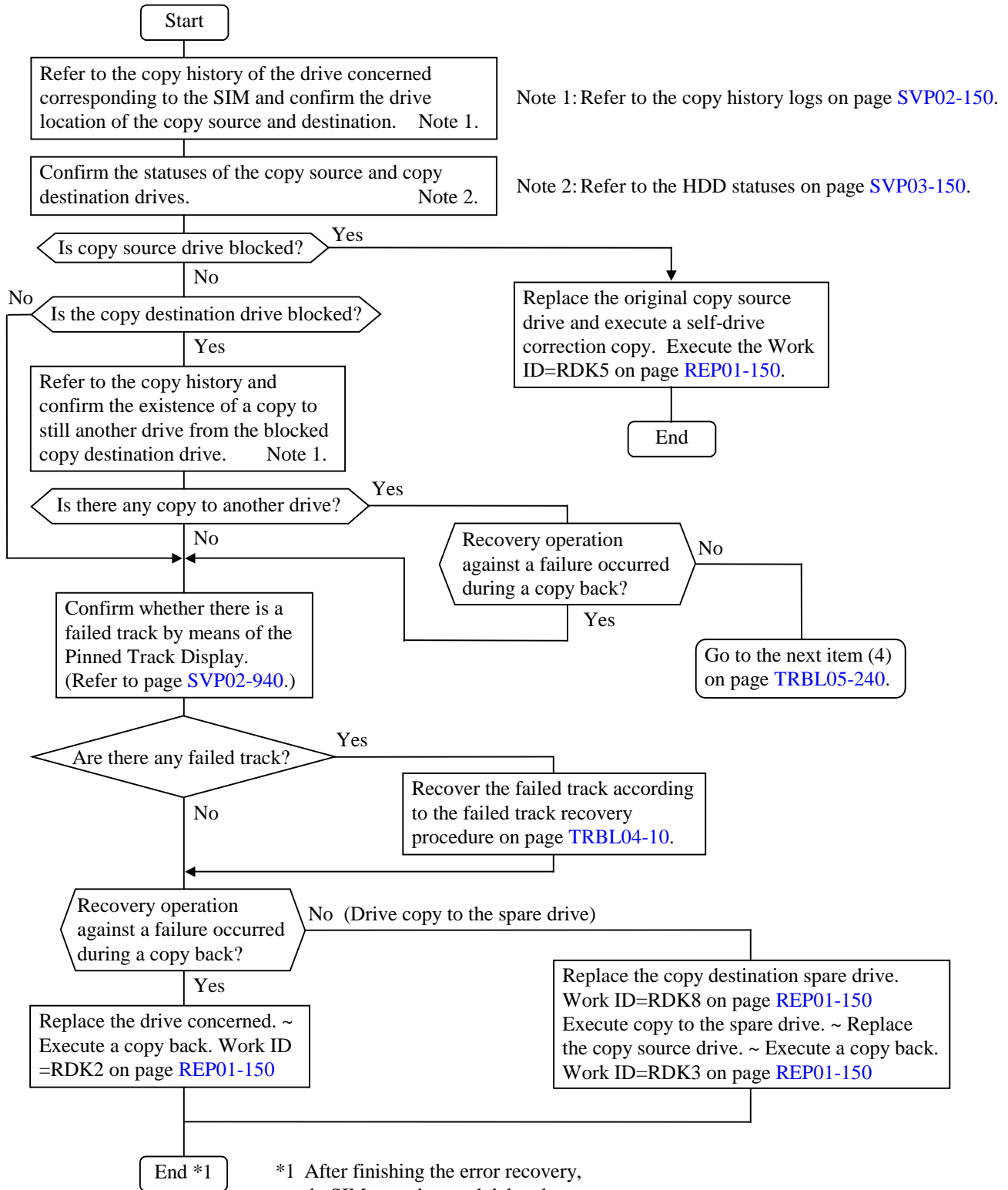

*1 After finishing the error recovery, do SIM complete and delete logs. (Refer to SVP02-170, 580)

- (4) In the case of drive copy abnormal termination (in which an unused spare drive is available)
This is a case in which a drive copy terminates abnormally owing to a failure in the copy destination drive. However, if an unused spare drive exists, the drive copy is automatically performed to the unused spare drive.

In the following procedure, the copy source is referred to as an original copy source, the copy destination is referred to as a copy source, and the unused spare drive is referred to as a copy destination.

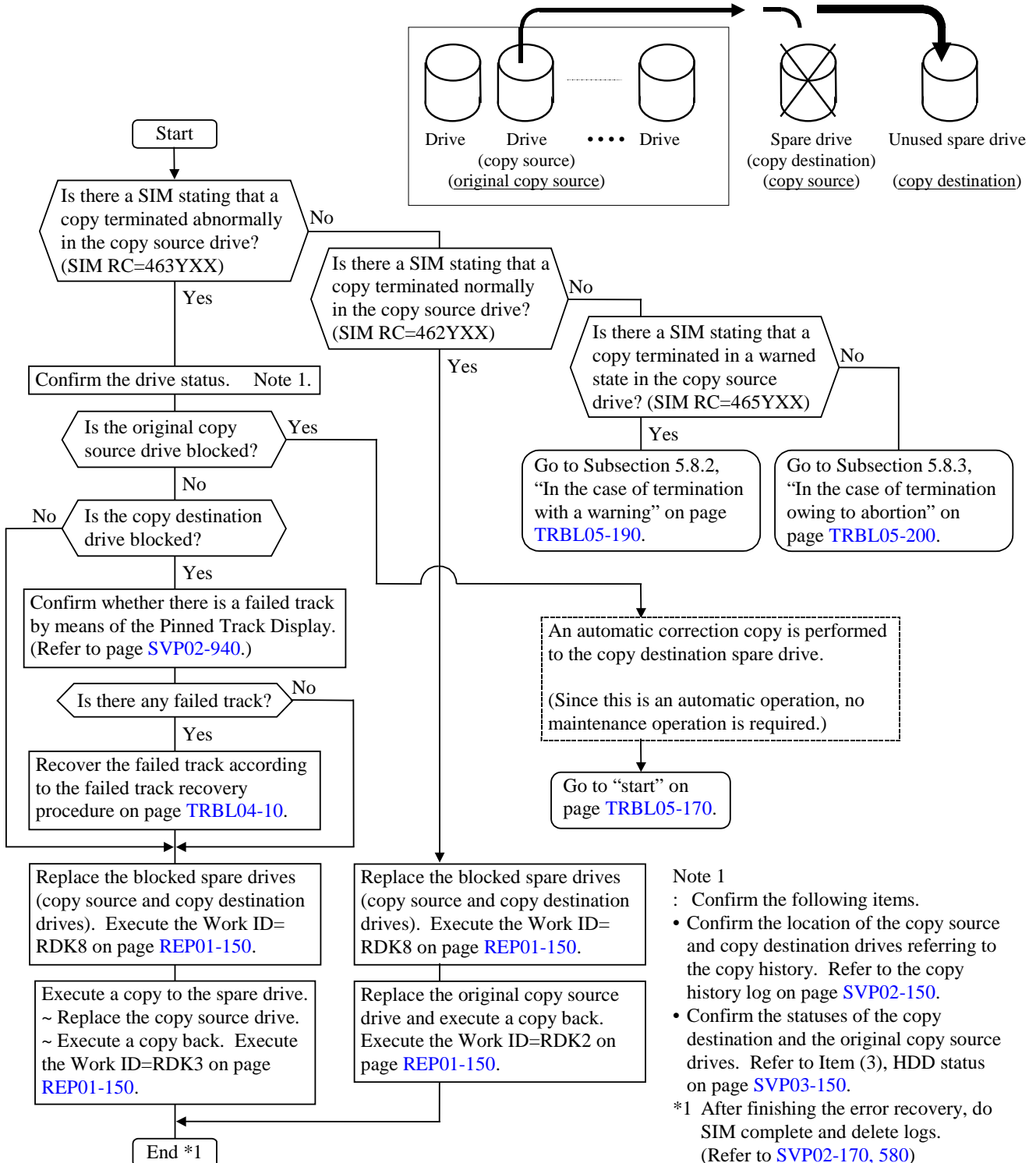

5.8.5 Correction access status

The procedure below is that used when one drive in the parity group is blocked.

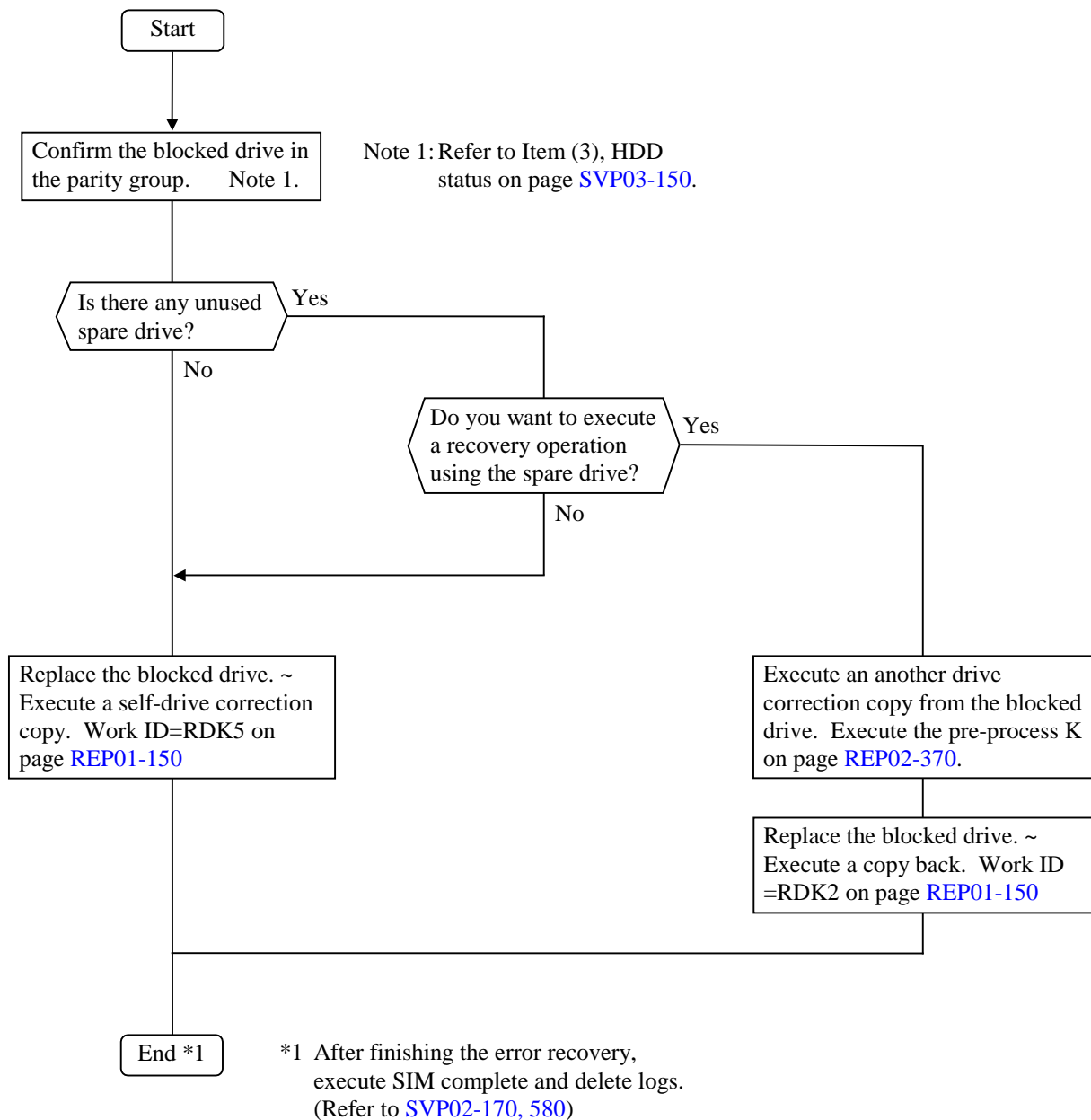

5.8.6 Parity group blockade

The procedure below is that used when the two or more drives are blocked in the parity group.

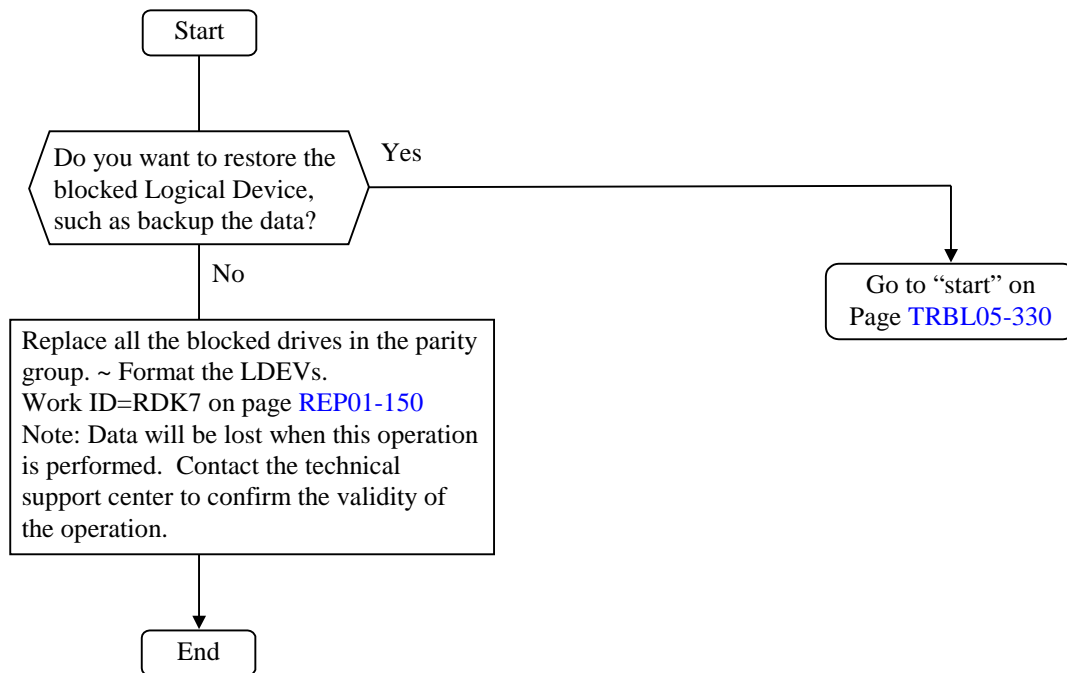

5.8.7 Preventive maintenance

The procedure below is that used when the drive is not blocked but it must be replaced.

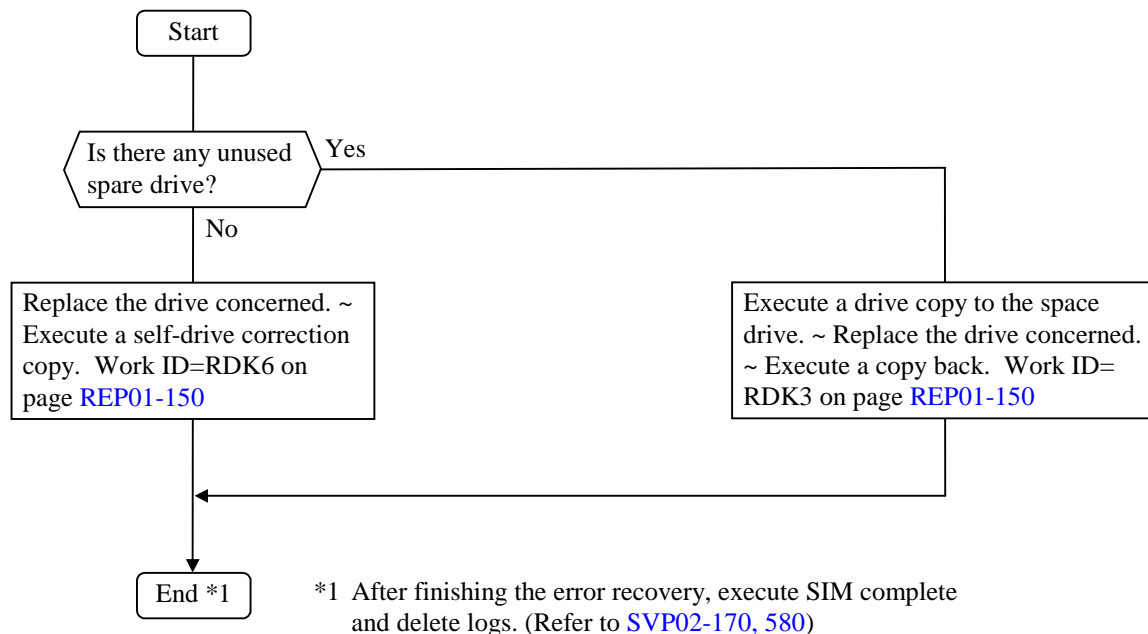

5.9 Recovery Procedure for SM Capacities Inequality (SIM = FFE3XY)

The mounted SM capacities inequality error (ffe3 xy/FPC = 80000000) should be recovered following the procedure below.

The number of CACHE-1T/CACHE-2G* SM modules mounted is set in x/y respectively.

This error occurs if an SM is blocked because the mounted SM capacity differs between CACHE-1T and CACHE-2G (PCBs mounting SM modules). Therefore, the number of SM modules mounted must be adjusted correctly to recover this error.

*) For the Single Cabinet Model, read this flowchart by converting CACHE-1T and CACHE-2G to CACHE-1E and CACHE-2H respectively.

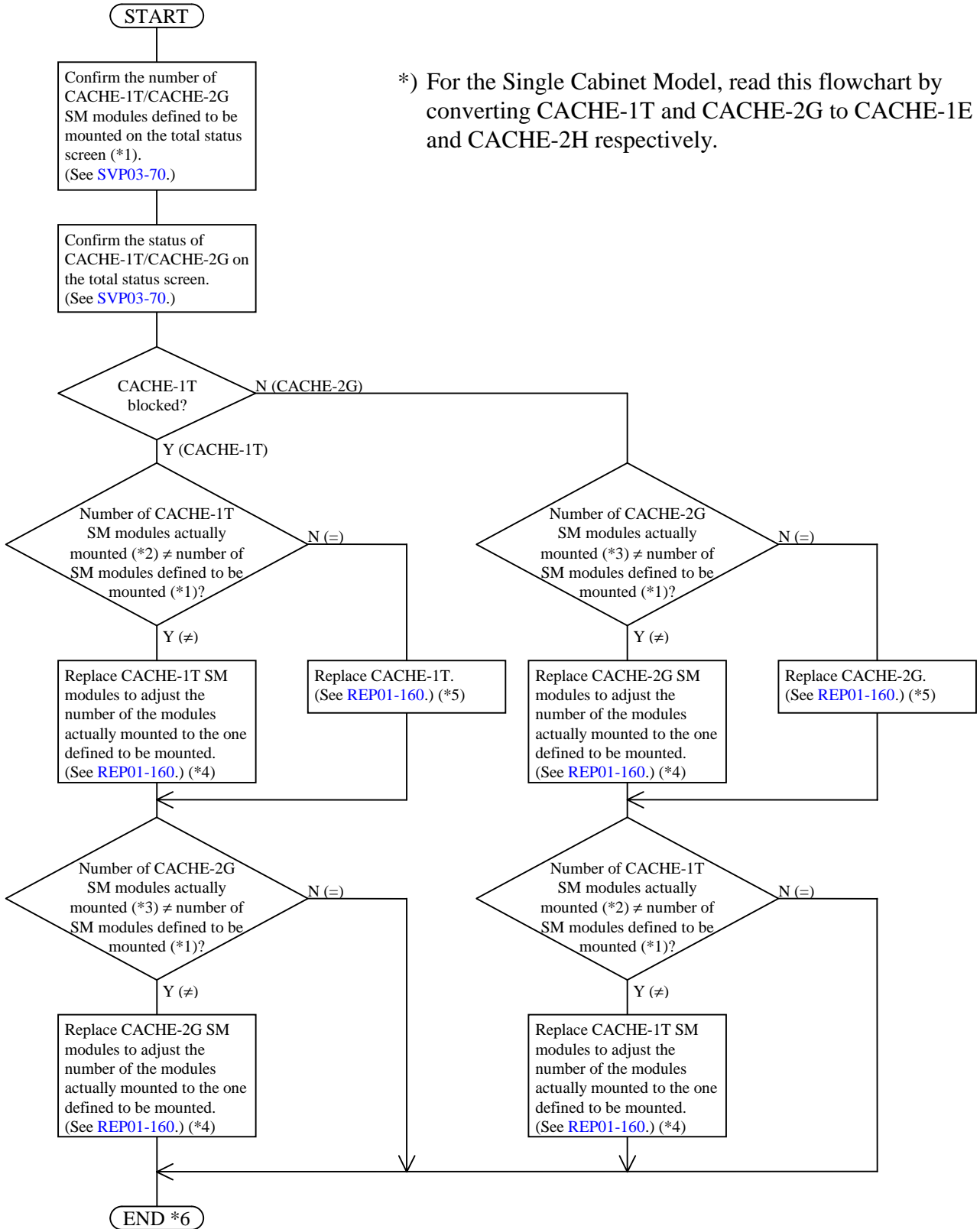

- *1: Number of SM modules indicated not to be “not-mounted” on the status screen.
- *2: Value x (number of SM modules) in REF-CD = FFE3xy
- *3: Value y (number of SM modules) in REF-CD = FFE3xy
- *4: Confirm the number of mounted SM modules to adjust it.
- *5: No need to adjust the number of SM modules mounted nor replace any of them.
- *6: After finishing the error recovery, do SIM complete and delete logs.
(Refer to [SVP02-170, 580](#))

5.10 Cache Memory Error Isolation Procedure (SIM = FFF0XX, FFF1XX, FFF2XX, FFE0XX, FFE1XX, FFE2XX)

Isolate a cache memory or shared memory error according to the procedure given below.

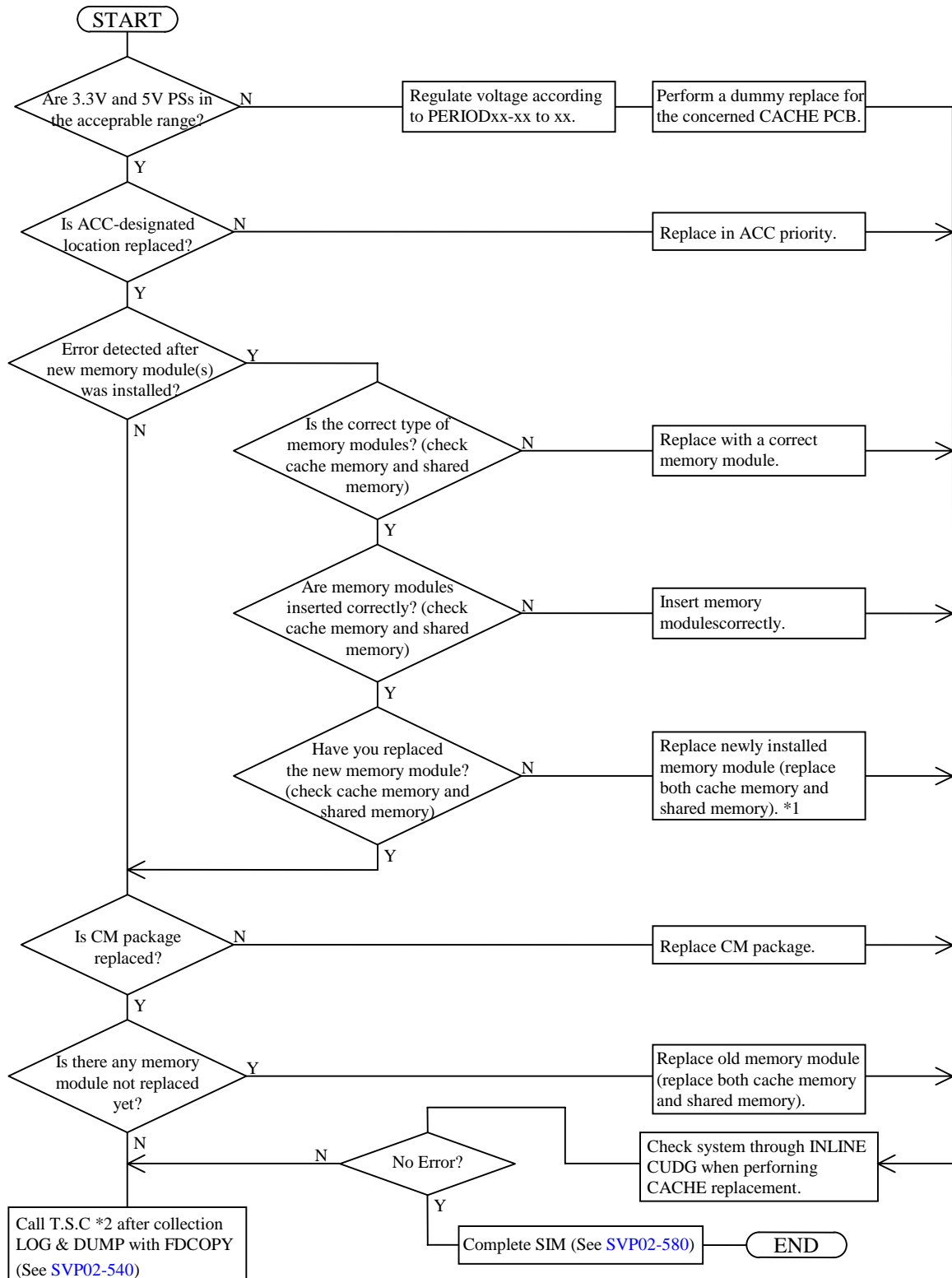

- *1: If there are multiple module groups, replace one by one.
If the symptom is not cleared even after replacement, de-install newly installed memory modules to return to the original configuration.
- *2: T.S.C : Technical Support Center

5.11 Recovery Procedure for LDEV Blocking (SIM = CF90XY, EF9YXX, DFAYXX, DFBYXX)

When LDEVs are blocked in the case of blocking several PDEVs (SIM RC=EF9Yxx, DFAYxx, DFBYxx), or in the case of blocking FCA (SIM RC=CF90XY), perform the following recovery procedures.

Be sure to call T.S.C. before you perform PDEV replace. It causes a DATA-LOSS in some cases.

Notice : When you execute a Recovery Procedure for LDEV Blocking, you must delete the HRC/HODM pair.

After recovering it, if necessary, you execute establish pair.

SIM RC = CF90, DF9y, DfAy, DFBy

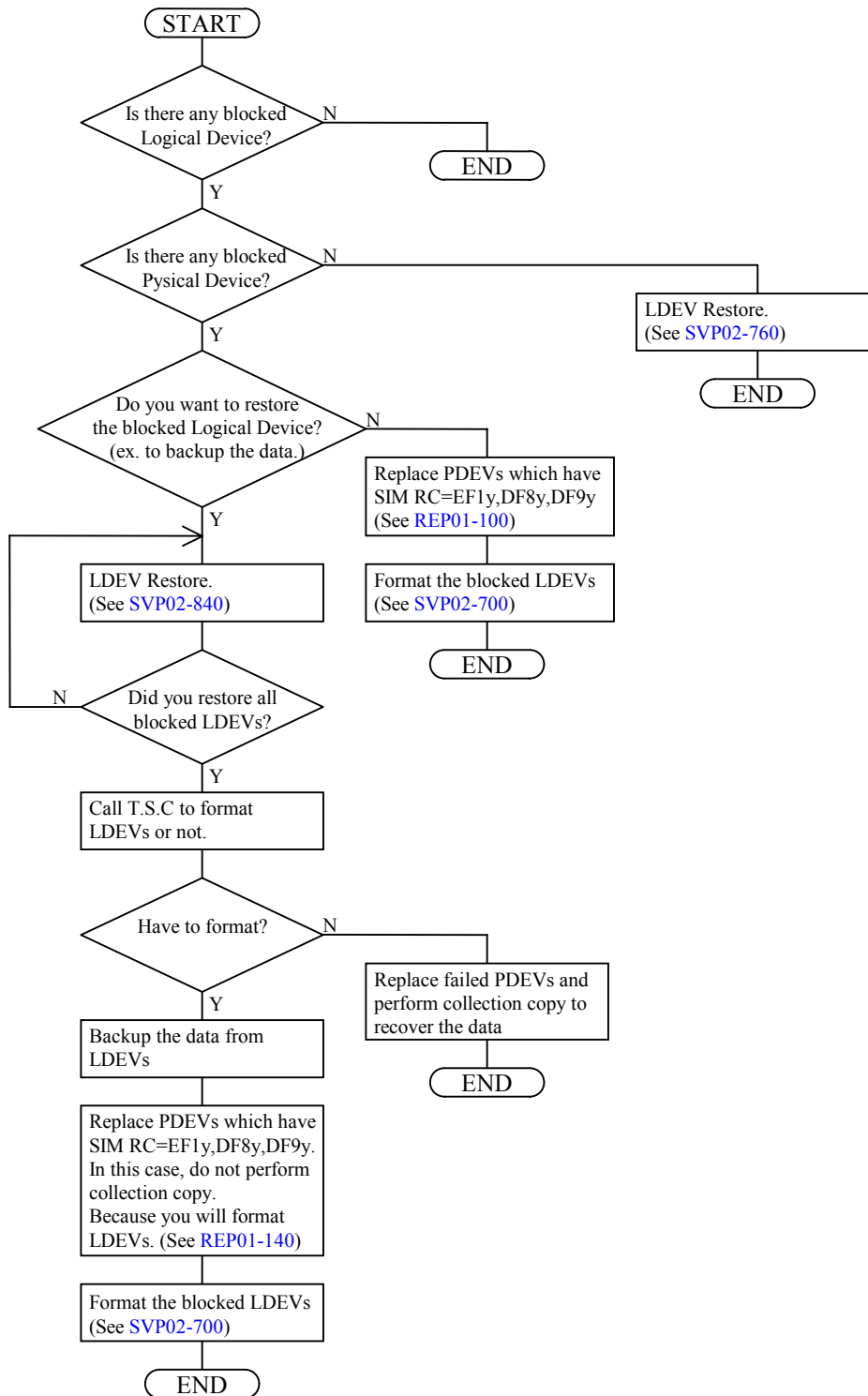

5.12 Voltage alarm (SIM = BF2XYY)

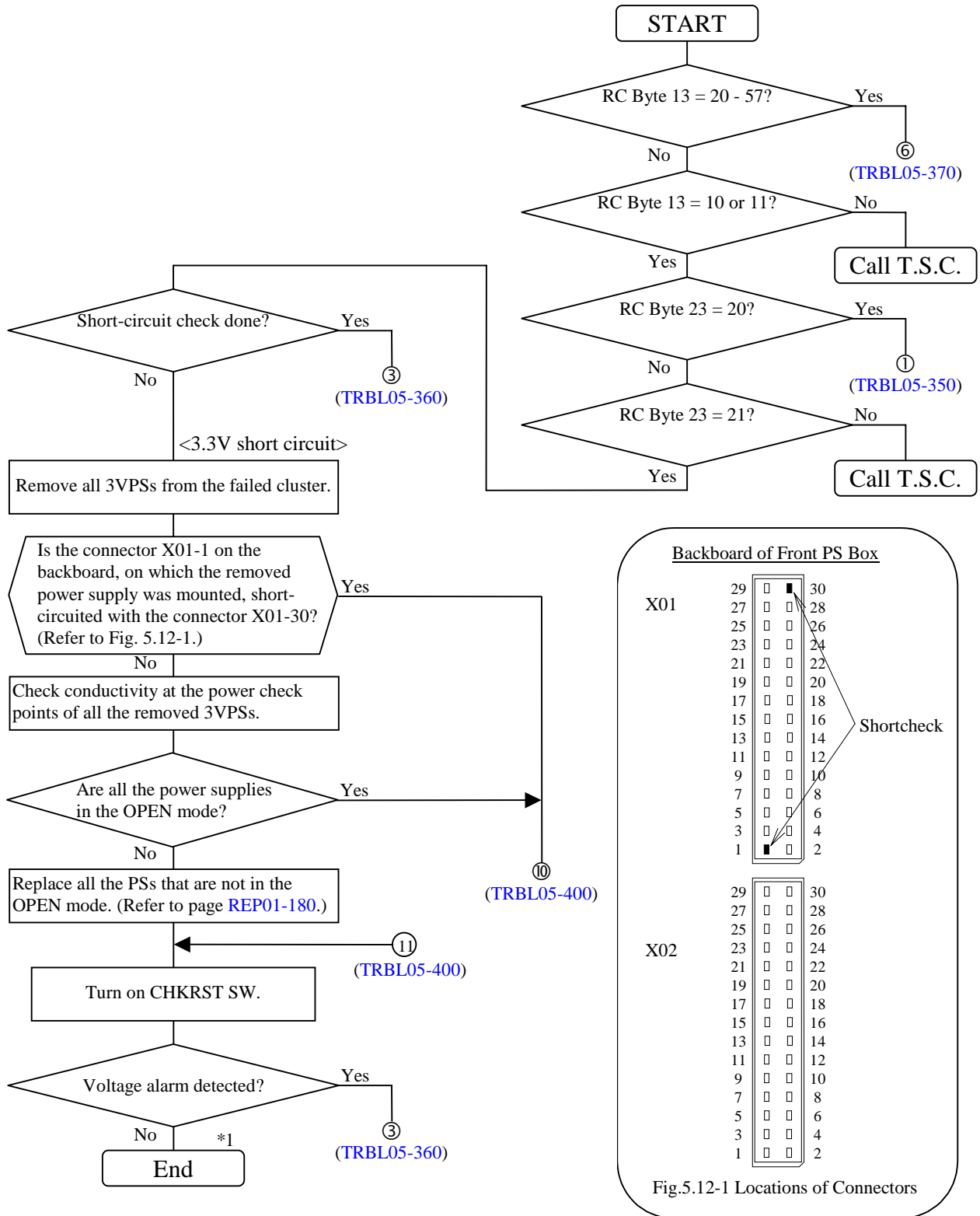

*1: If you finish the maintenance, delete the log, SIM complete and recover Cluster. (Refer to SVP02-170, 580 and 1110.)

*2: Confirm that the failed cluster is inactive, prior to checking short-circuit.

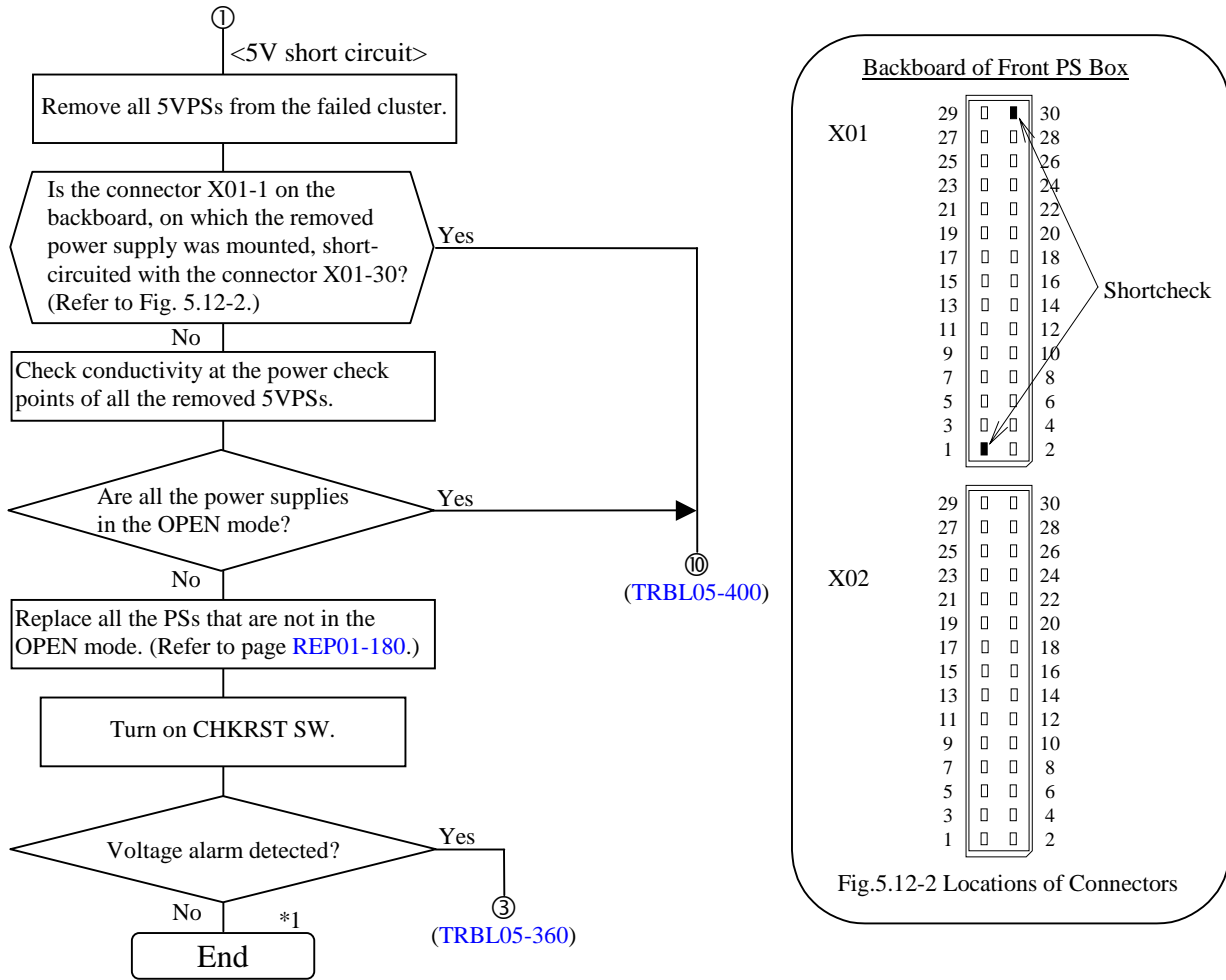

*1 : If you finished the maintenance, delete the log, SIM complete and recover Cluster.(Refer to SVP02-170, 580 and 1110.)

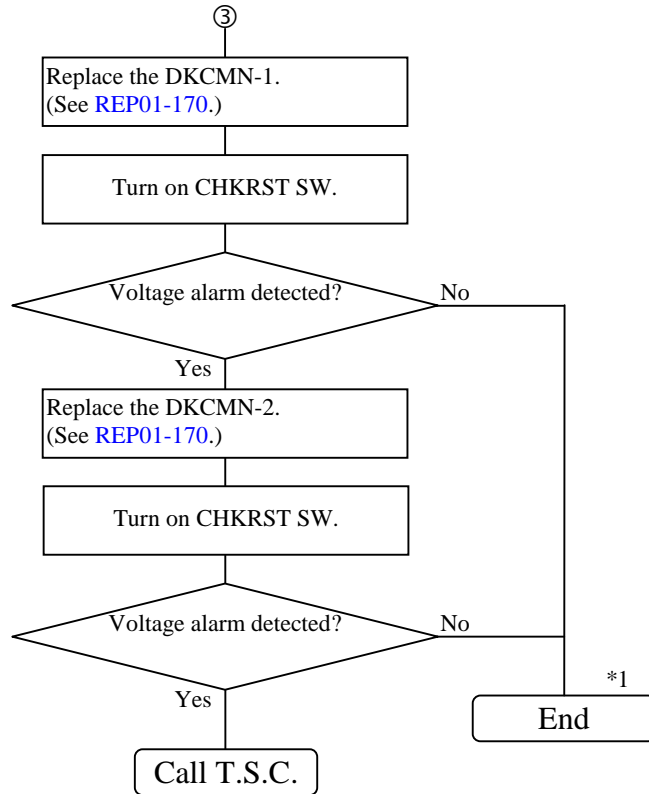

*1 : If you finished the maintenance, delete the log, SIM complete and recover Cluster.(Refer to [SVP02-170, 580](#) and [1110](#).)

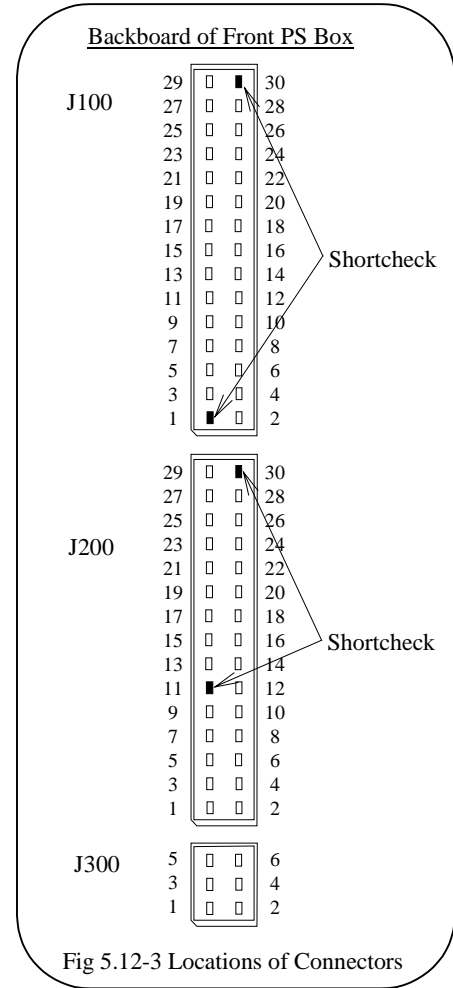
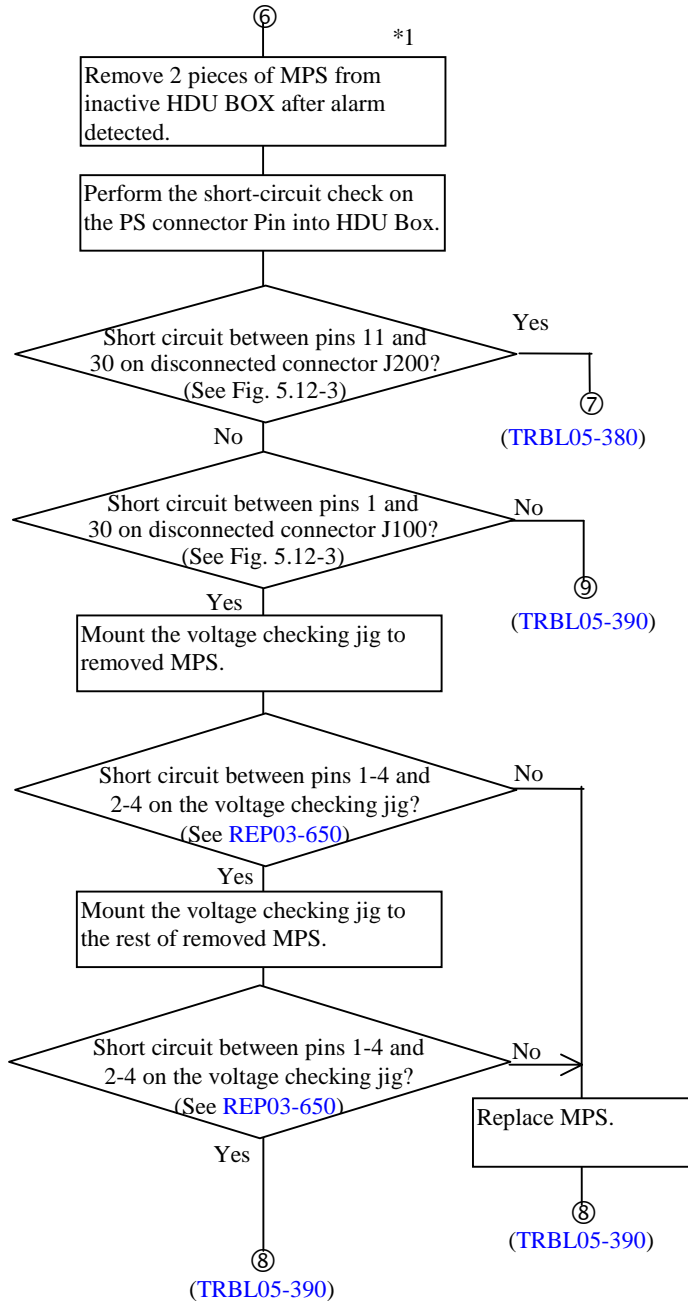

*1: Confirm that the failed HDU Box is inactive, prior to checking short-circuit.

*2: When a connector is removed, SIM is detected in several. If you finish the maintenance, delete the log, SIM complete and recover Cluster (Refer to SVP02-170, 580 and 1110).

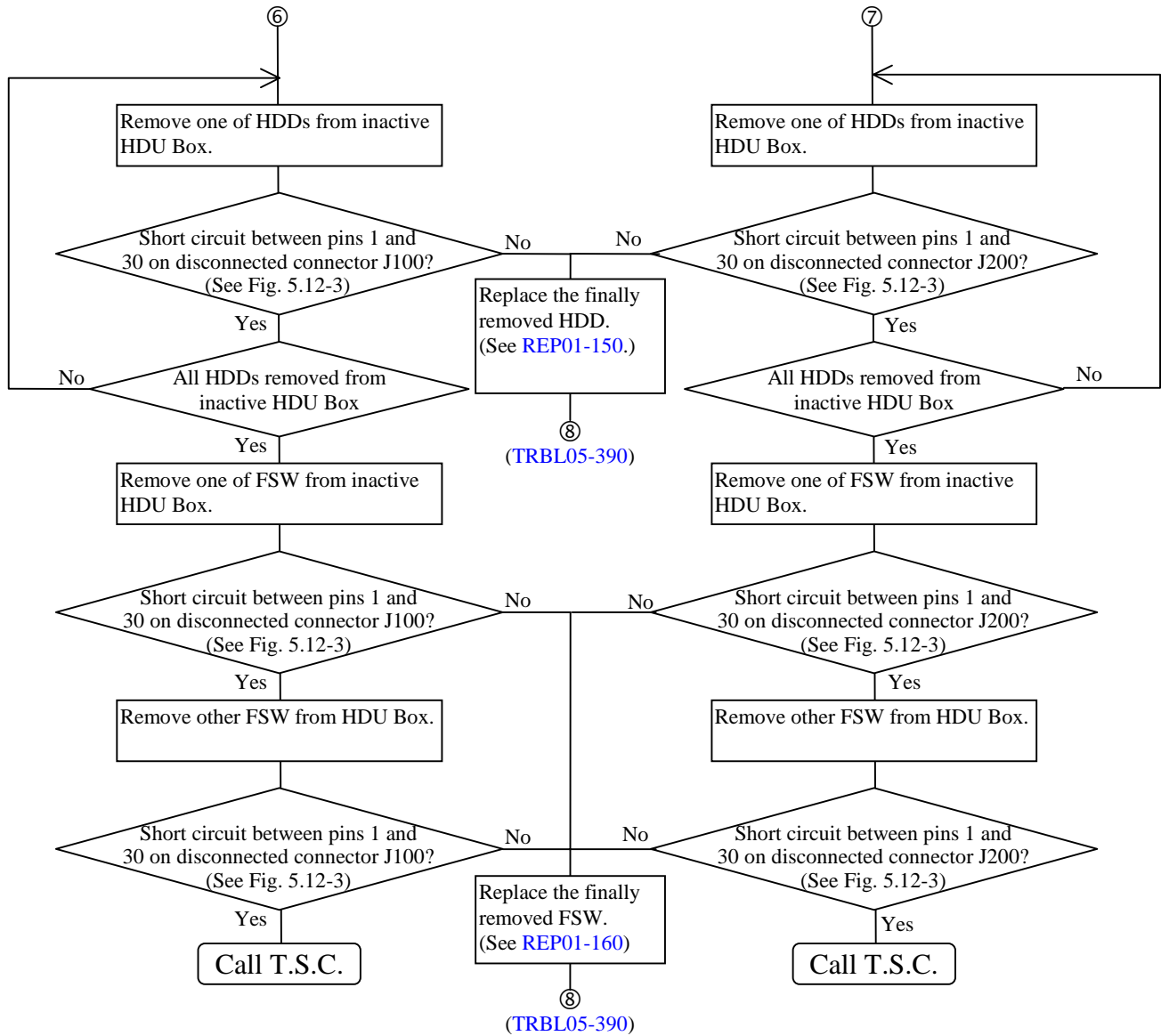

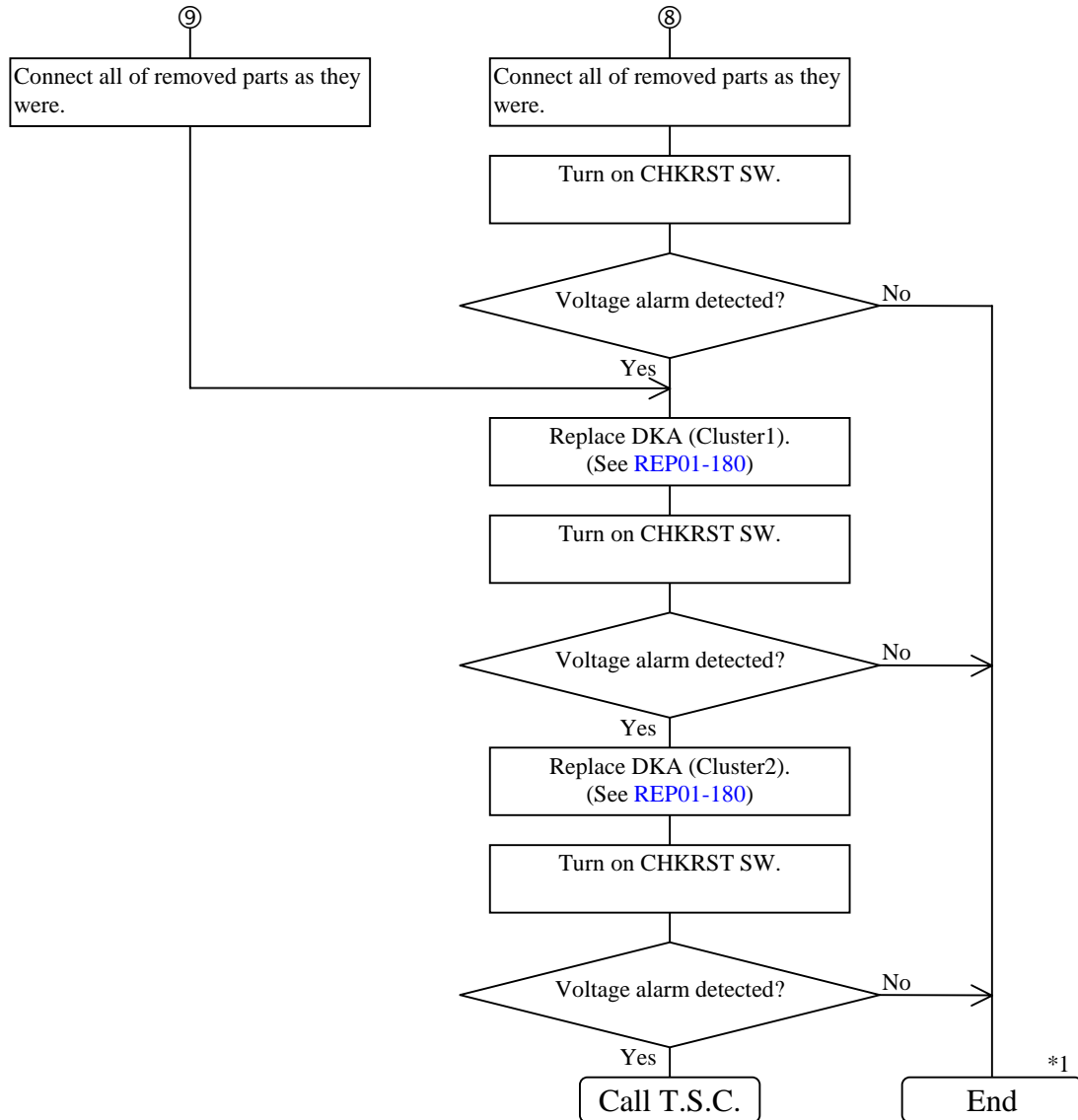

*1: If you finish the maintenance, delete the log, SIM complete and recover Cluster. (Refer to SVP02-170, 580 and 1110.)

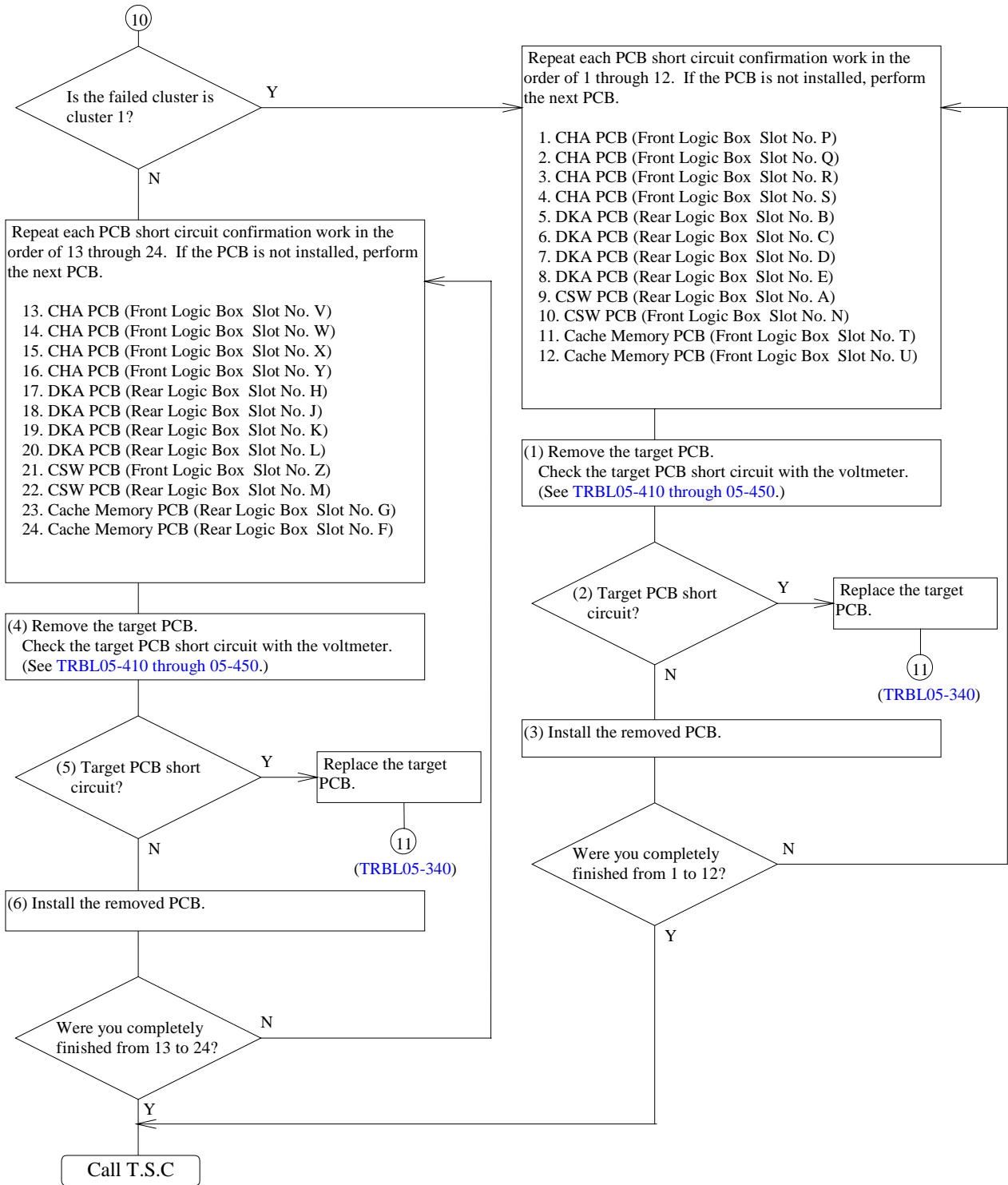

Serial Channel Adapter PCB (WP462)

The check points of the PCB short circuit are shown in the following table.

| No. | Voltage | Point (VCC) | Point (GND) | Part Name | Normal Value |
|-----|---------|-------------|-------------|----------------|--------------------------------------|
| 1 | @5VIN | 17H-1pin | 17H-11pin | CHIP CAPACITOR | 1k Ω or more after 10 seconds |
| 2 | @3VIN | 17H-33pin | 17H-11pin | CHIP CAPACITOR | 2k Ω or more after 10 seconds |
| 3 | @5V | 04B-14pin | 04B-7pin | CHIP CAPACITOR | 4 Ω or more after 10 seconds |
| 4 | @3V | 12B-20pin | 12B-10pin | CHIP CAPACITOR | 1k Ω or more after 10 seconds |

Serial Channel Adapter PCB(WP462)

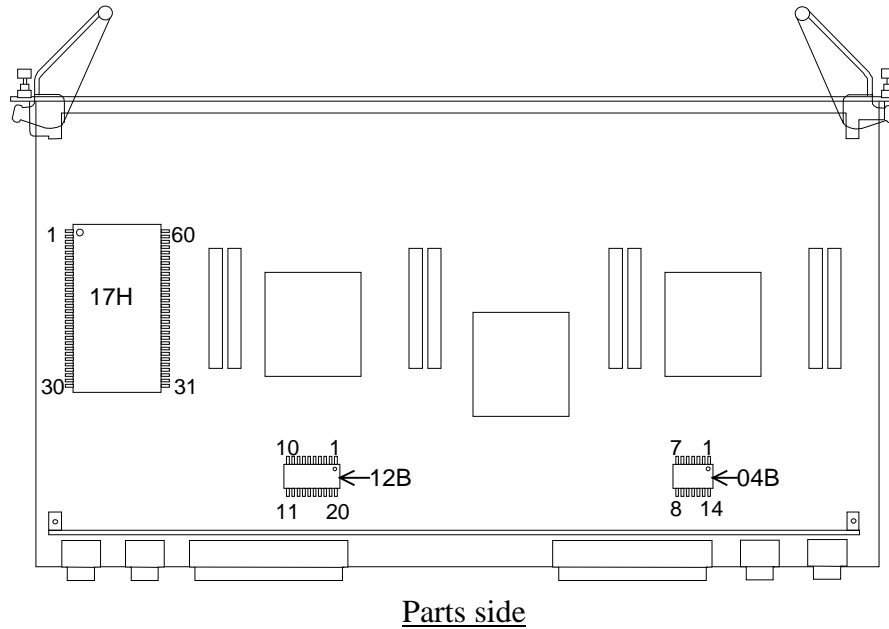

Fibre Channel Adapter PCB (WP461)

The check points of the PCB short circuit are shown in the following table.

| No. | Voltage | Point (VCC) | Point (GND) | Part Name | Normal Value |
|-----|---------|-------------|-------------|-----------------|------------------------------------|
| 1 | @5V | 14D-14 | 14A-7 | IC(TTL) | 50 Ω or more after 5seconds |
| 2 | @3V | 05D-14 | 05D-7 | IC(LVA) | 7 Ω or more after 5seconds |
| 3 | @2.5V | 20C-60 | 20C-7 | DC-DC converter | 50 Ω or more after 5seconds |
| 4 | @1.8V | 20C-37 | 20C-7 | DC-DC converter | 50 Ω or more after 5seconds |
| 5 | @1.5V | 20C-27 | 20C-7 | DC-DC converter | 15 Ω or more after 5seconds |

Fibre Channel Adapter PCB (WP461)

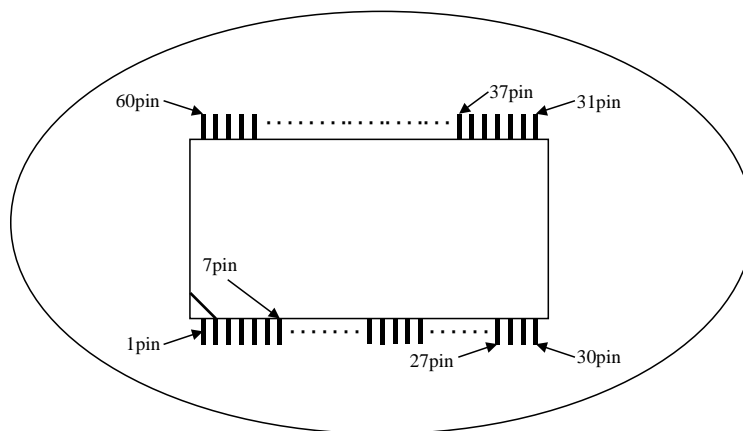
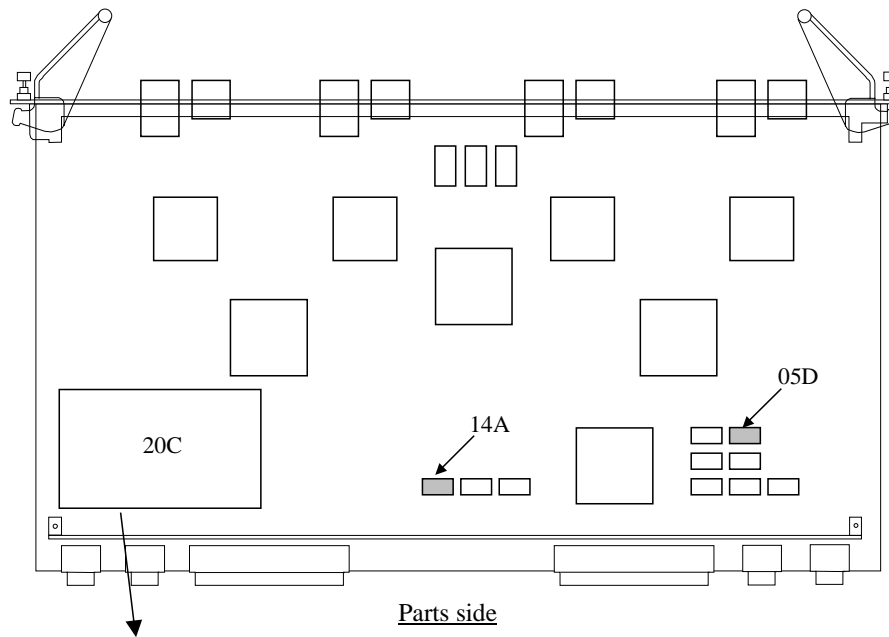

DKA PCB (WP471)

The check points of the PCB short circuit are shown in the following table.

| No. | Voltage | Point (VCC) | Point (GND) | Part Name | Normal Value |
|-----|---------|-------------|-------------|----------------|-----------------------------|
| 1 | 5VIN | C1320-1 | C1320-2 | CHIP CAPACITOR | 10Ω or more after 5 seconds |
| 2 | 3.3VIN | C1333-1 | C1333-2 | CHIP CAPACITOR | 10Ω or more after 5 seconds |
| 3 | @5V | C1323-1 | C1323-2 | CHIP CAPACITOR | 10Ω or more after 5 seconds |
| 4 | @3.3V | C548A-1 | C548A-2 | CHIP CAPACITOR | 10Ω or more after 5 seconds |

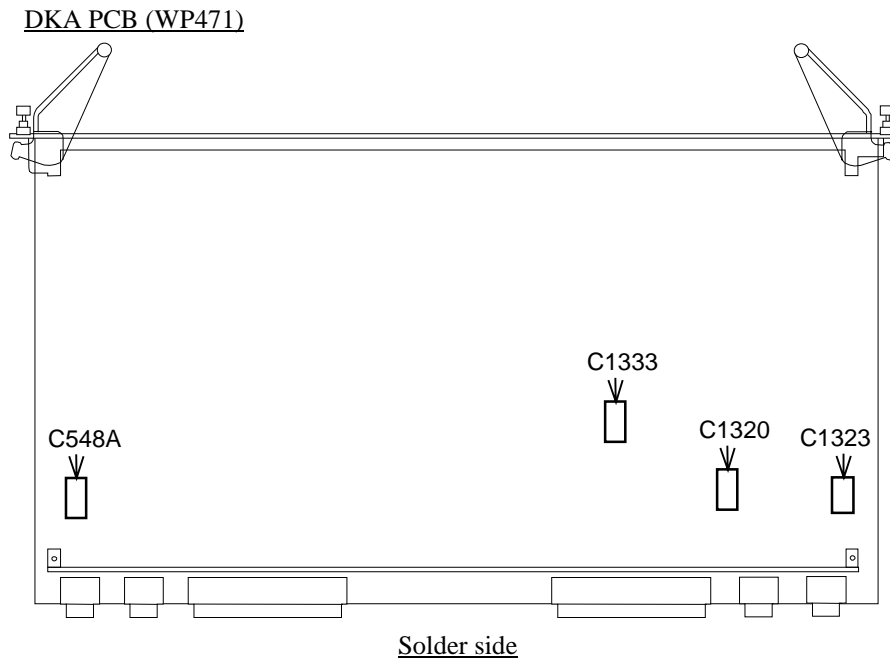

R*** (CHIP RESISTOR)

C*** (CHIP CAPACITOR)

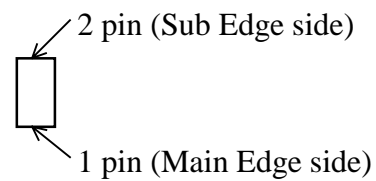
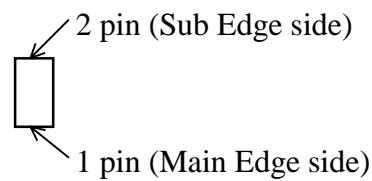

Cache Memory PCB (WP490)

The check points of the PCB short circuit are shown in the following table.

| No. | Voltage | Point (VCC) | Point (GND) | Part Name | Normal Value |
|-----|---------|-------------|-------------|-----------------|------------------------------|
| 1 | @3VIN | DC1-33 | DC1-7 | DC-DC CONVERTER | 100Ω or more after 5 seconds |
| 2 | @5VIN | DC1-1 | DC1-7 | DC-DC CONVERTER | 100Ω or more after 5 seconds |
| 3 | @2.5V | DC1-60 | DC1-7 | DC-DC CONVERTER | 100Ω or more after 5 seconds |
| 4 | @1.8V | DC1-37 | DC1-7 | DC-DC CONVERTER | 100Ω or more after 5 seconds |
| 5 | @1.5V | DC1-28 | DC1-7 | DC-DC CONVERTER | 10Ω or more after 5 seconds |
| 6 | @3V | DC1-15 | DC1-7 | DC-DC CONVERTER | 10Ω or more after 5 seconds |
| 7 | @5V | DC1-16 | DC1-7 | DC-DC CONVERTER | 100Ω or more after 5 seconds |
| 8 | @3VCM | DC2-2 | DC1-7 | BACKUP MODULE | 100Ω or more after 5 seconds |
| 9 | @3VSM | DC2-3 | DC1-7 | BACKUP MODULE | 100Ω or more after 5 seconds |

Cache Memory PCB (WP490)

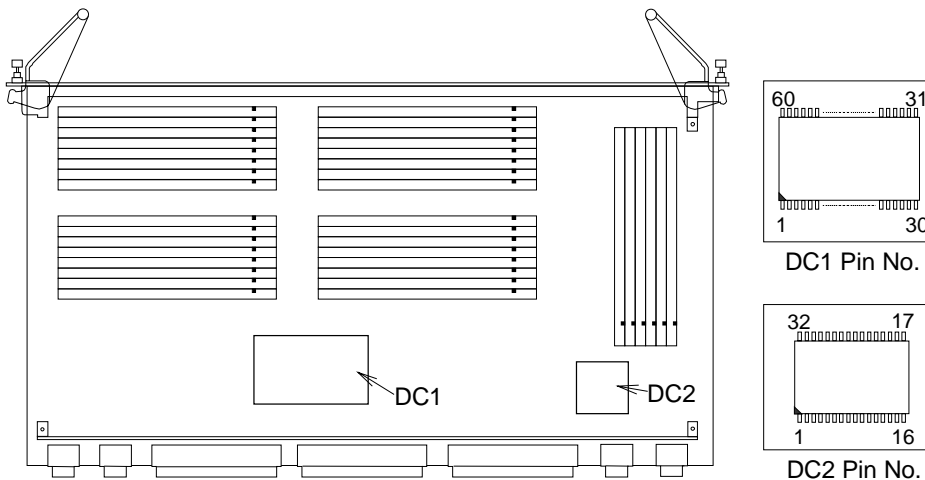

Parts side

CSW PCB (WP481)

The check points of the PCB short circuit are shown in the following table.

| No. | Voltage | Point (VCC) | Point (GND) | Part Name | Normal Value |
|-----|---------|-------------|-------------|--------------|------------------------------|
| 1 | @5VIN | Q283-4 | 18B-7 | POWER MOSFET | 100Ω or more after 5 seconds |
| 2 | @3.3VIN | Q5-4 | 18B-7 | POWER MOSFET | 100Ω or more after 5 seconds |
| 3 | @5V | Q283-3 | 18B-7 | POWER MOSFET | 100Ω or more after 5 seconds |
| 4 | @3.3V | Q5-3 | 18B-7 | POWER MOSFET | 100Ω or more after 5 seconds |

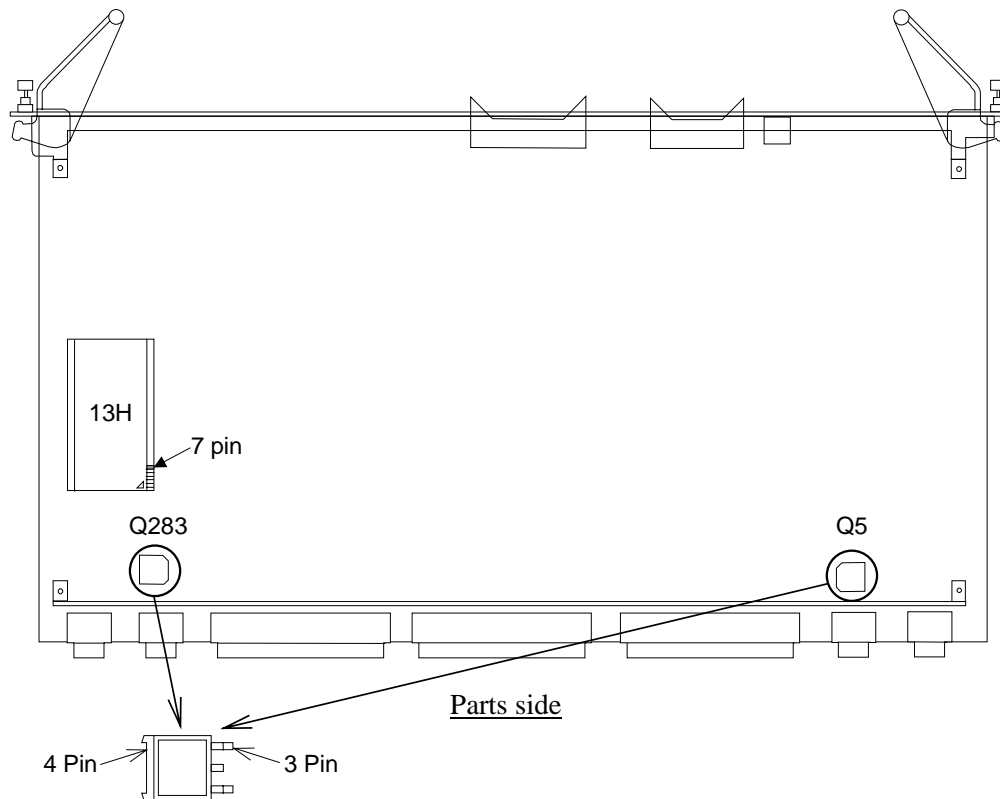
CSW PCB (WP481)

5.13 Environment monitors disagreement error (SIM = BFA1XX)

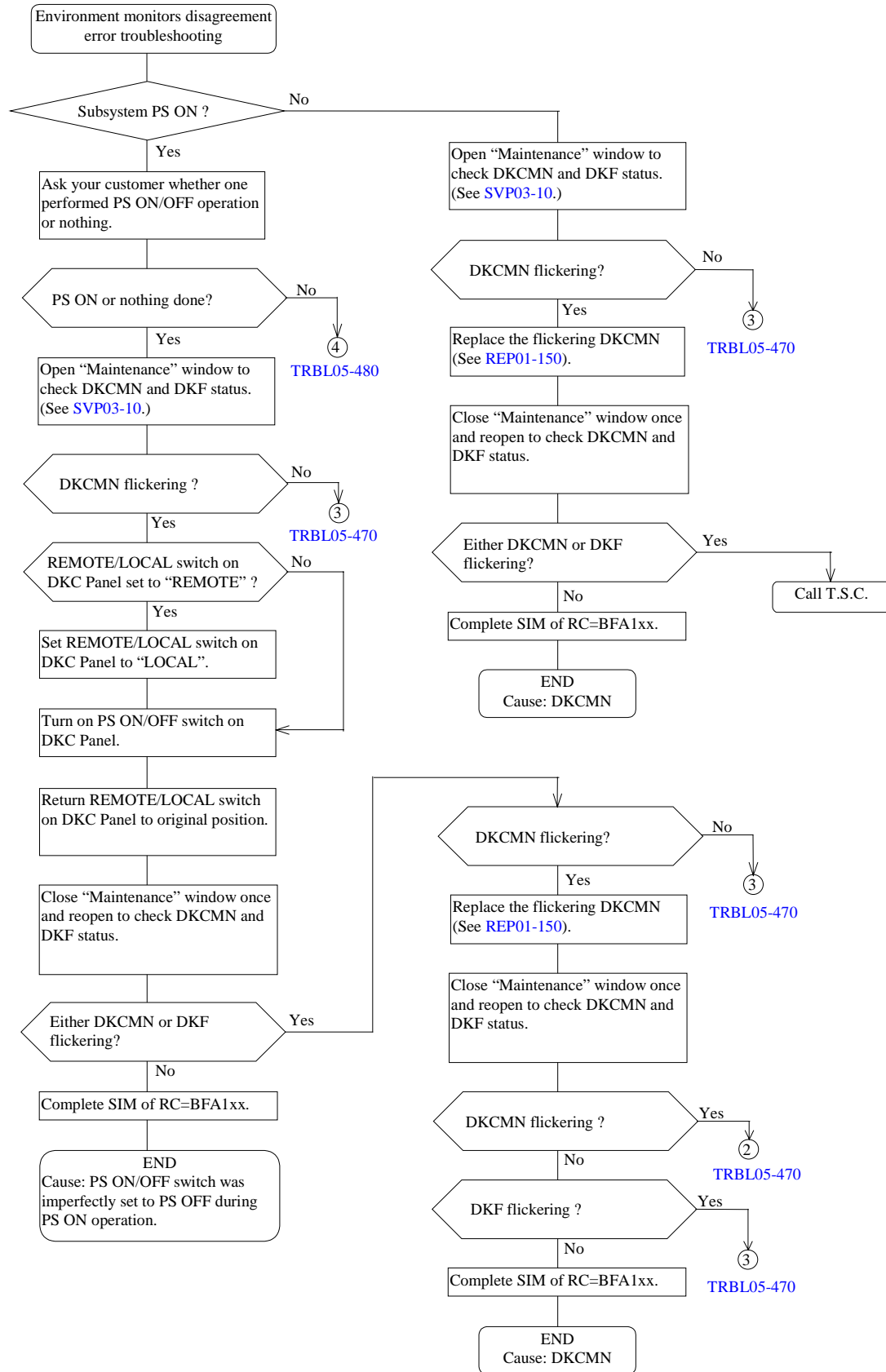

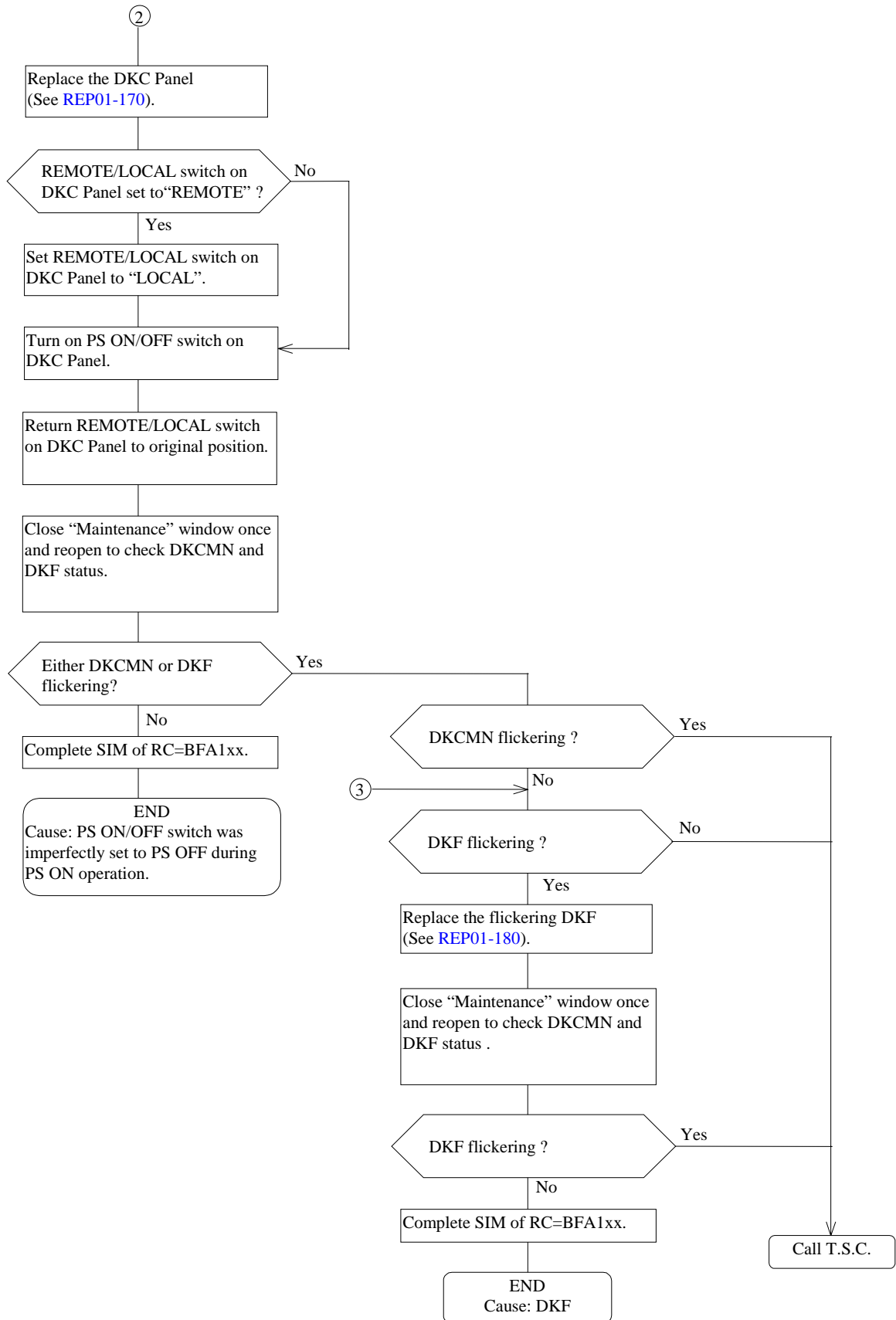

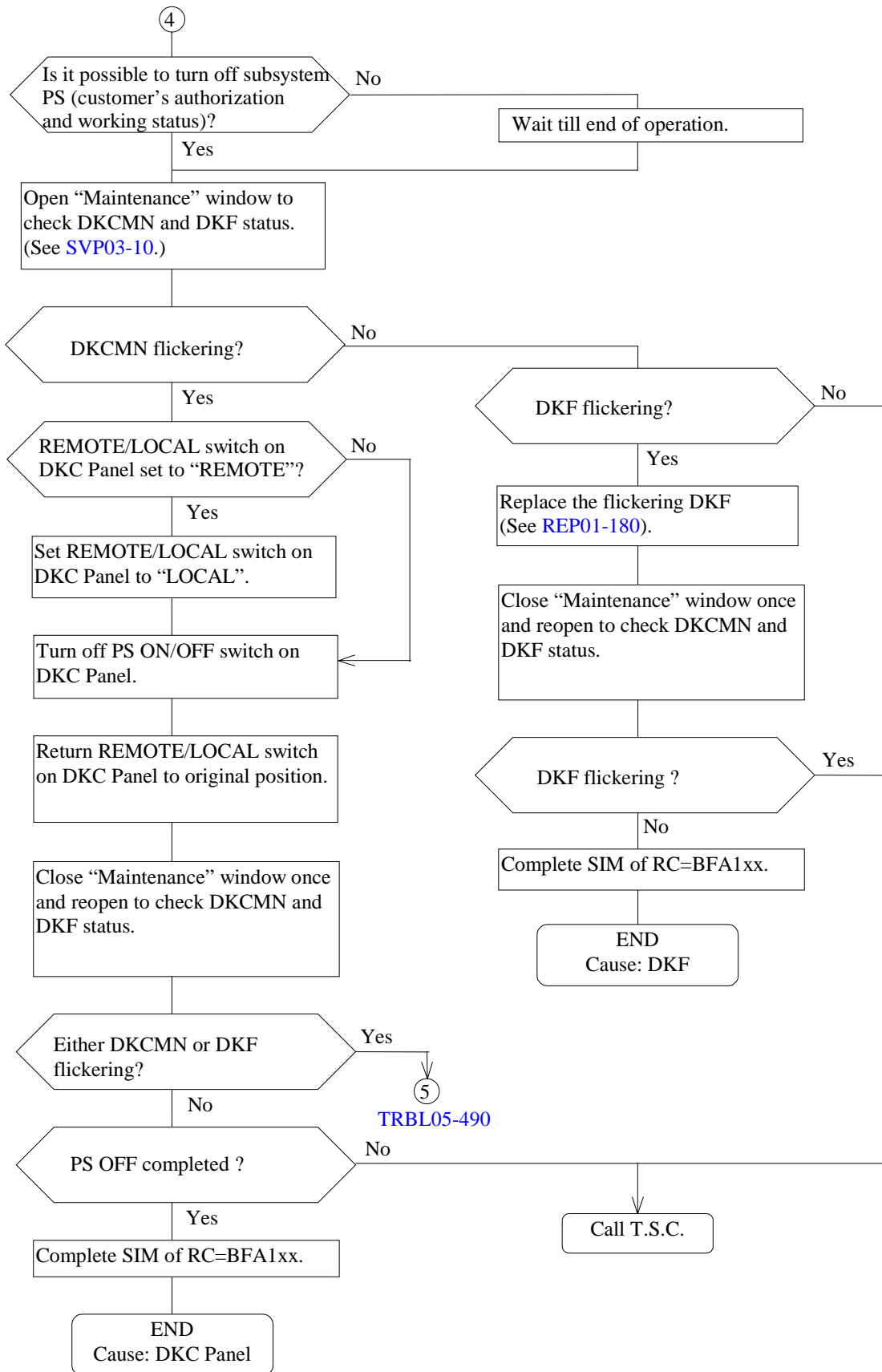

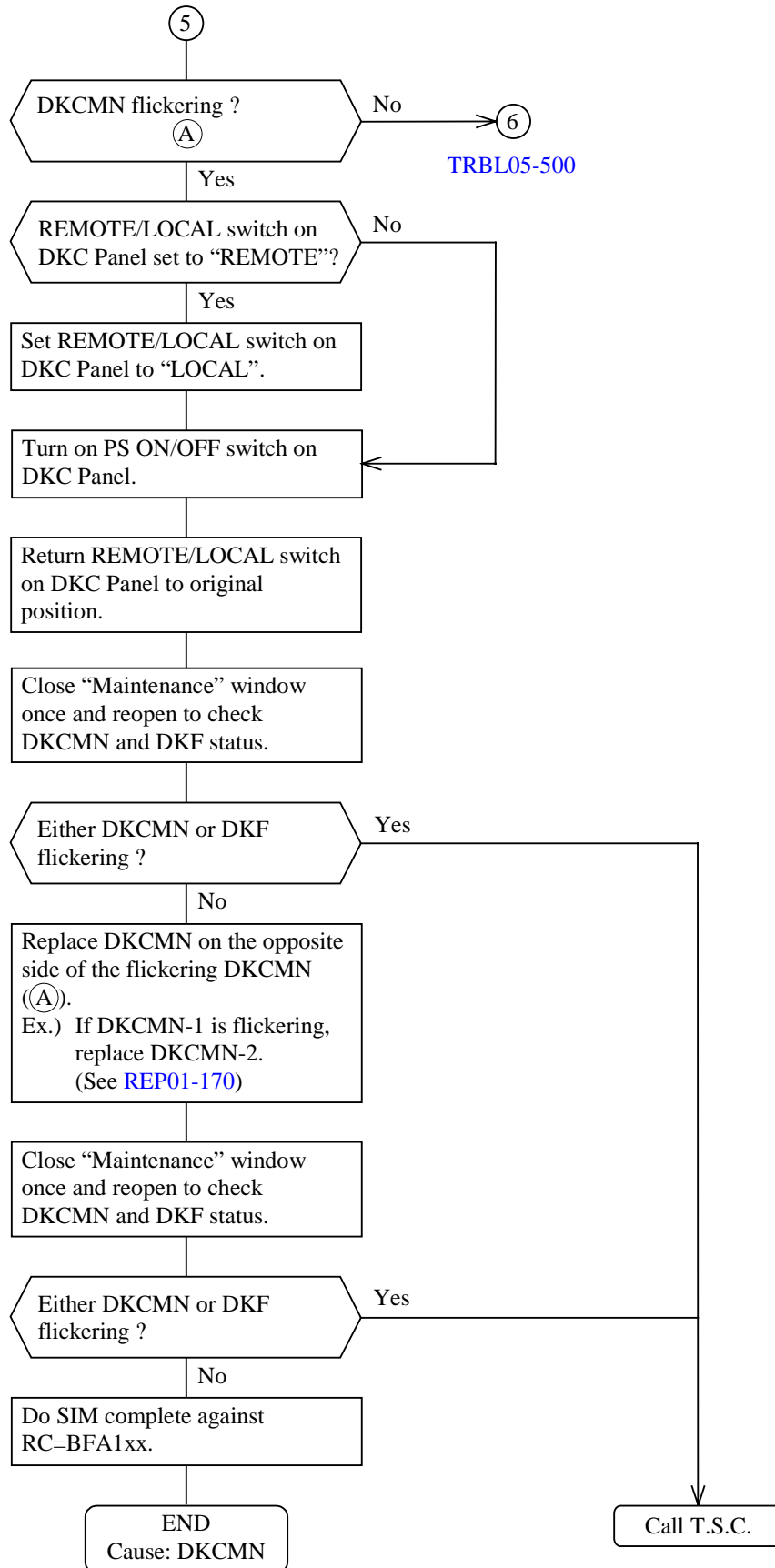

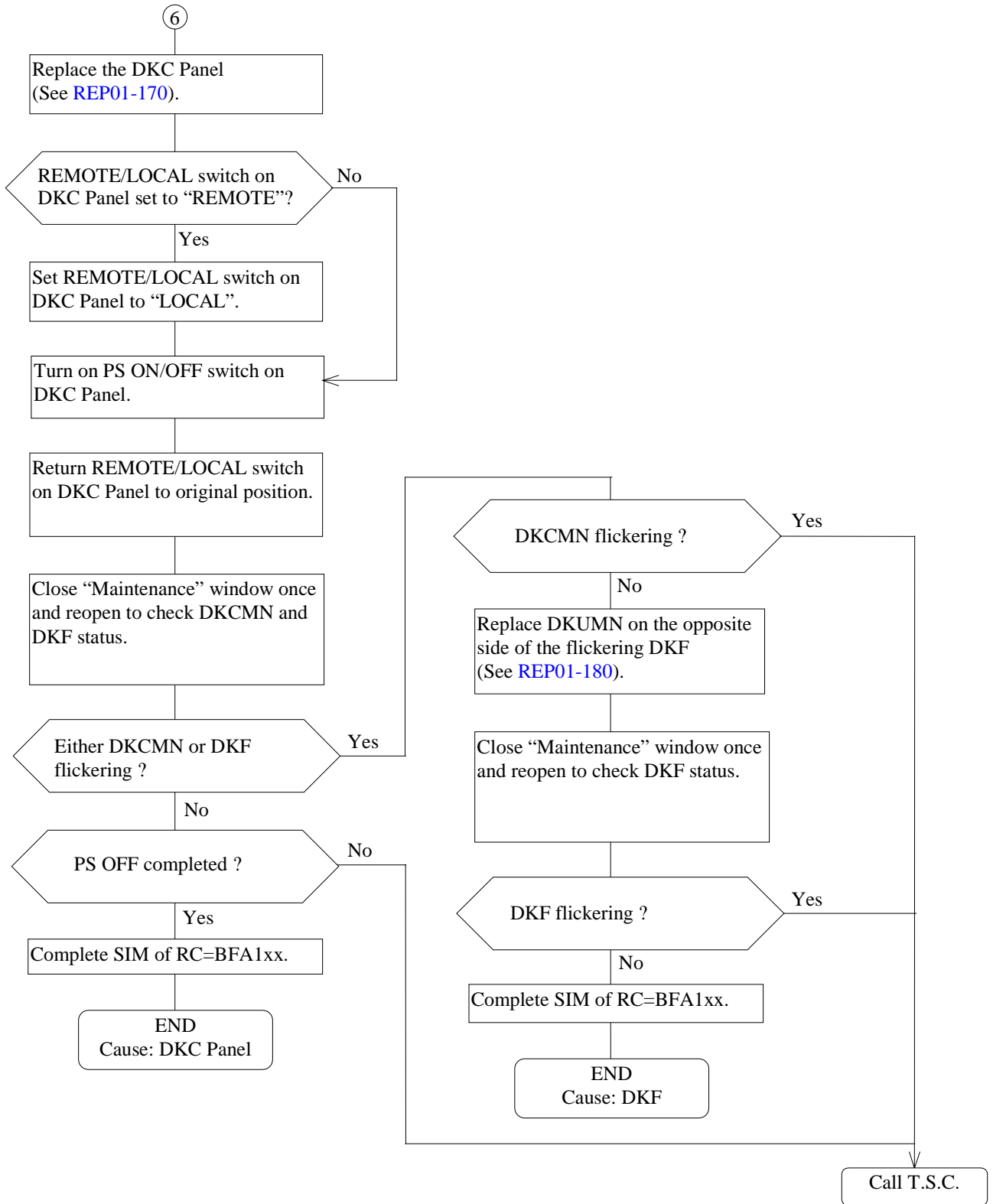

5.14 PS warning error (SIM=BF4XXX)

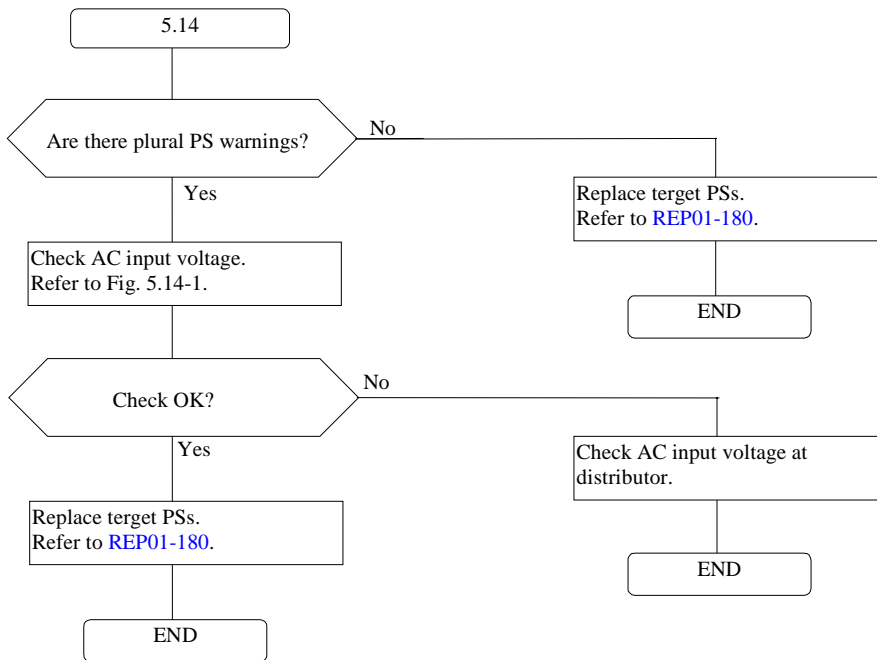

[AC Input voltage check]

- a. Remove the INLET cable of target PS.
- b. Measure AC Input voltage at INLET cable.

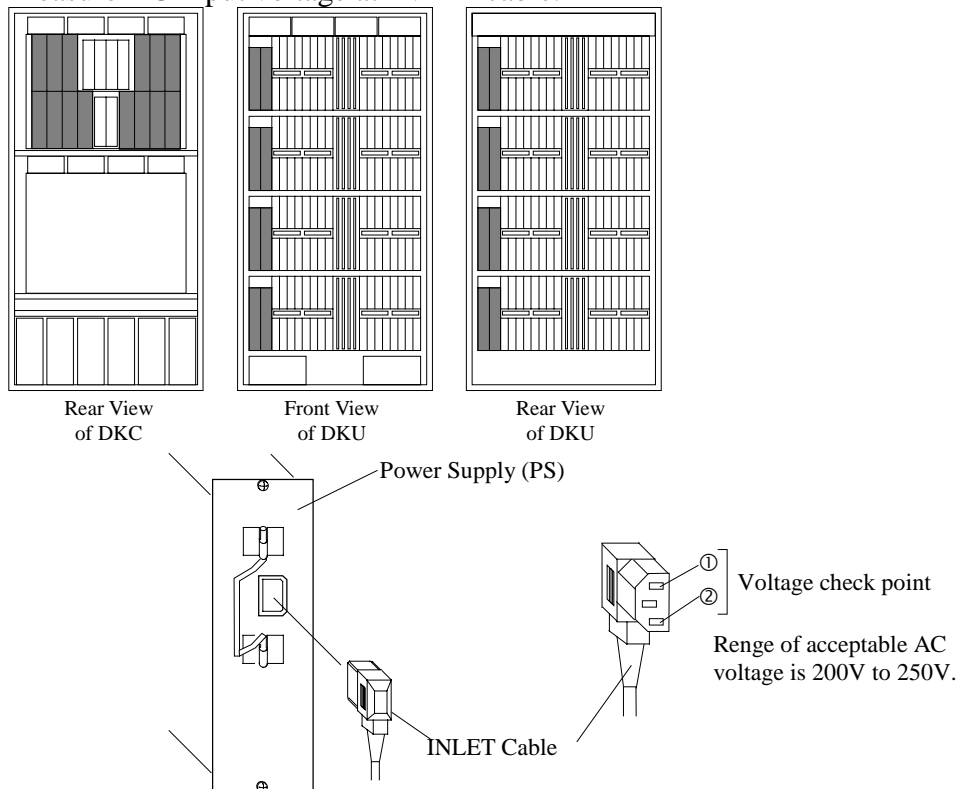
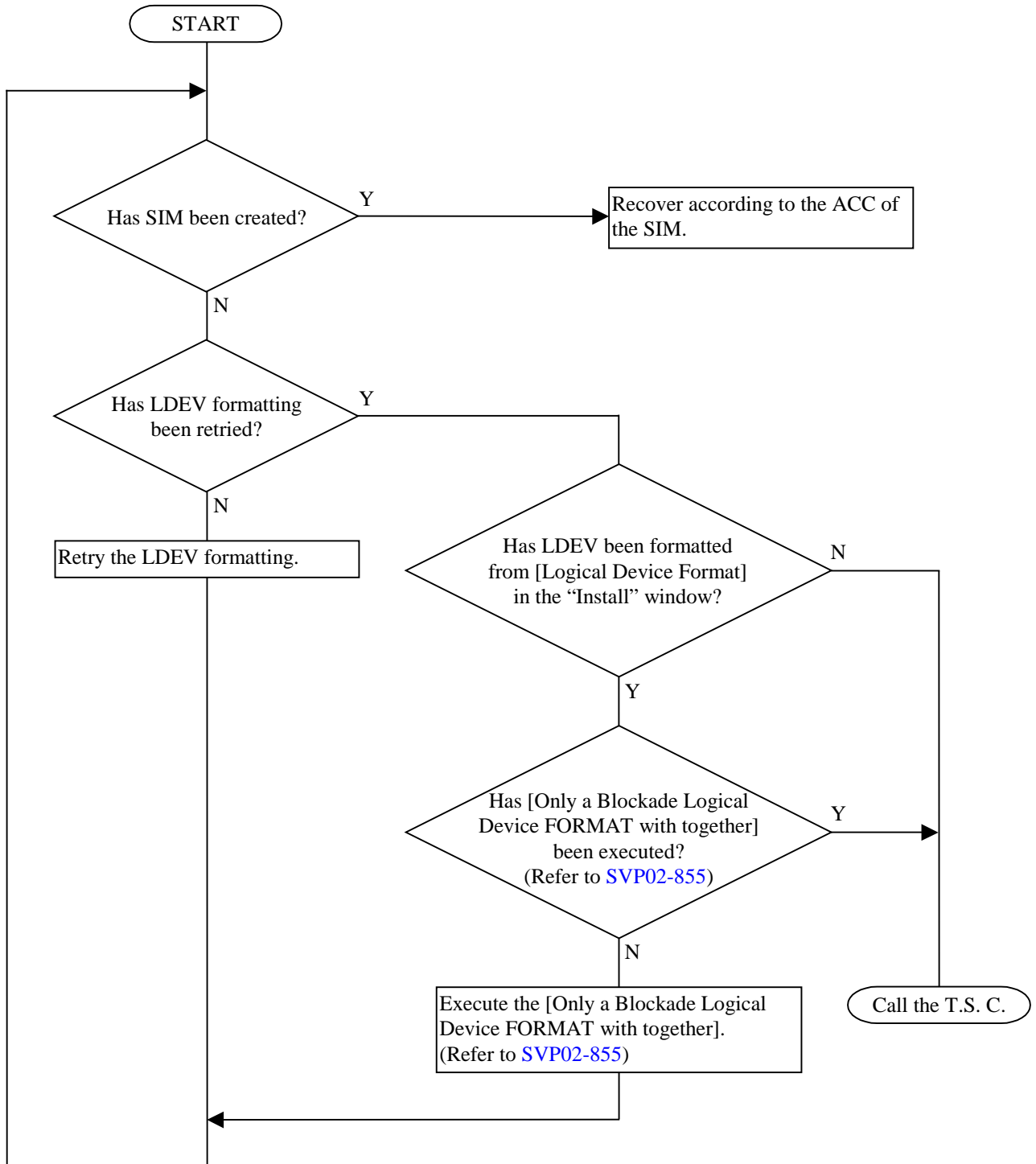

Fig. 5.14-1 AC Input Voltage Check

5.15 Recovery procedure when LDEV formatting failed

When “Formatting logical devices rejected by DKC.” or “Formatting the logical device is failed.” is displayed at the end of the LDEV formatting and when “Blocked” is displayed for the LDEV formatted by “Logical Device Status”, make a recovery according to the following procedure.



5.17 Recovery procedure when WDCP information is lost

(1) When only this SIM is reported

When this SIM is reported at the time of the subsystem powering on 192 hours or more after the previous breaker turning off, no maintenance is required.

When this SIM is reported at the time of the subsystem powering on less than 192 hours after the previous breaker turning off, (a) failure(s) may occur in the cache PCB, cache memory, battery, or battery charge. Replace the failed part(s).

(2) When another SIM is reported together with this SIM

When the SIM concerning the cache, shared memory, or battery, perform the maintenance of the failed part(s).

When the SIM not concerning the above is reported at the same time, perform the maintenance of the failed part(s) and see “(1) When only this SIM is reported”.

(3) WDCP system recovery procedure

For the procedure for recovering the WDCP system, see the instruction manual of the OS concerned.

5.18 Recovery procedure when recovering SM is impossible

The following flowchart shows the recovery procedure when SM cannot be recovered during Cache PCB replacement, SM/CM installation/de-installation, or cluster recovery procedure .

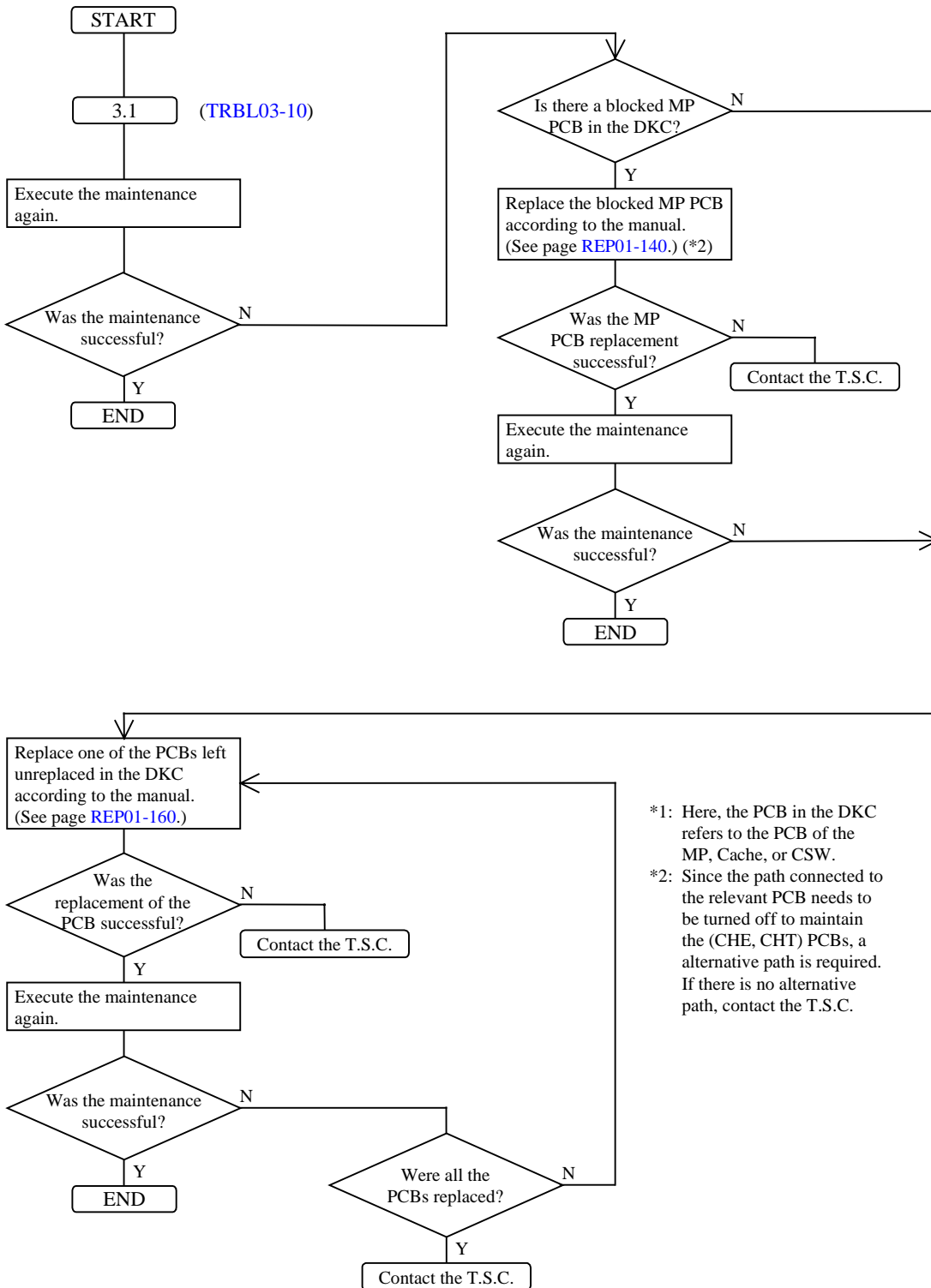

*1: Here, the PCB in the DKC refers to the PCB of the MP, Cache, or CSW.
 *2: Since the path connected to the relevant PCB needs to be turned off to maintain the (CHE, CHT) PCBs, a alternative path is required. If there is no alternative path, contact the T.S.C.

5.19 Recovery procedure when installation/de-installation Cache and DCR is impossible

The recovery procedure when installation/de-installation Cache and DCR available size simultaneously is impossible.

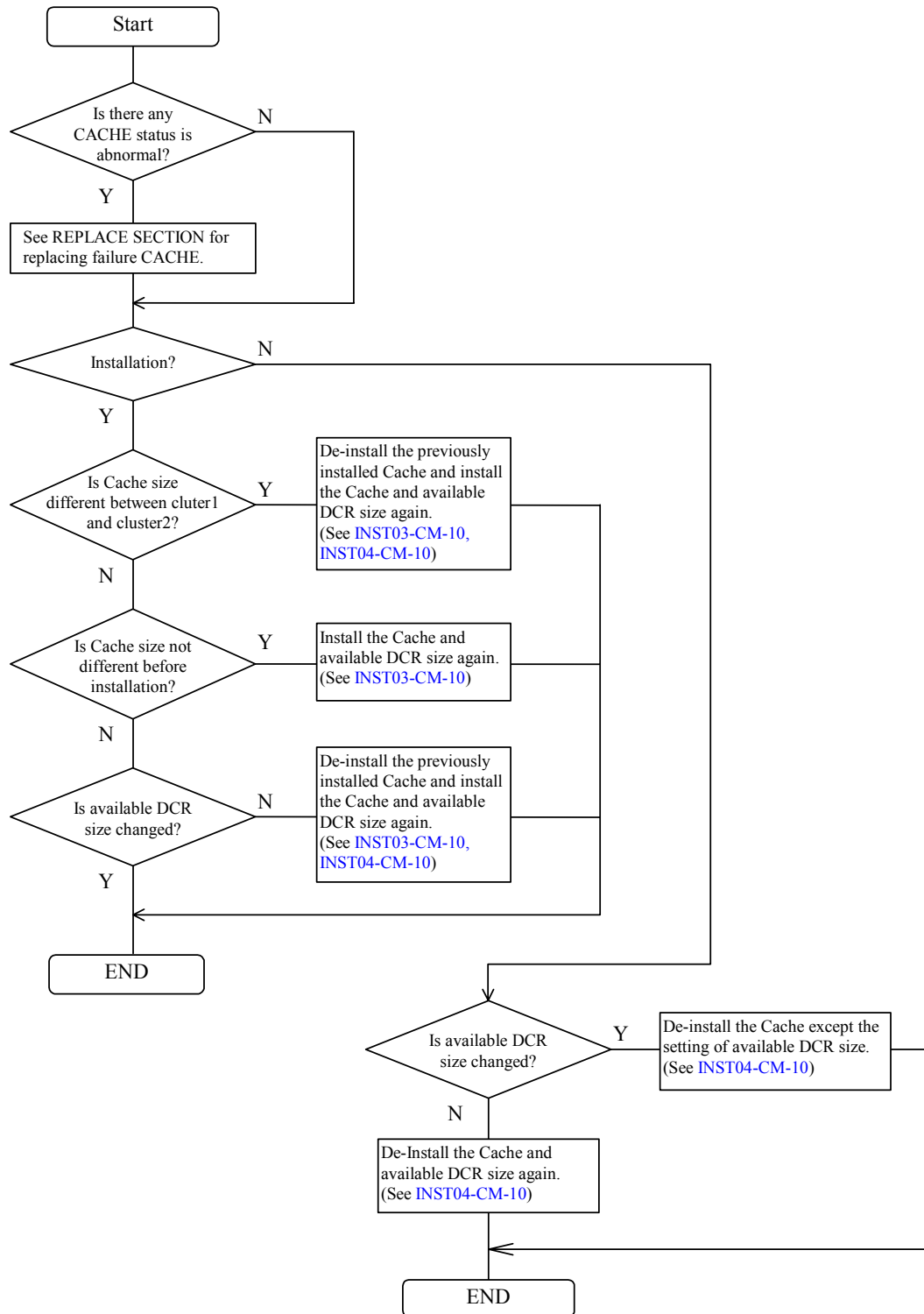

5.20 Recovery procedure for failed CSW PCB replacement

When “Some Memory access paths are blockade. Do you want to refer to the path Status?” is displayed at the end of the CSW PCB replacement, recover the status according to the following procedure.

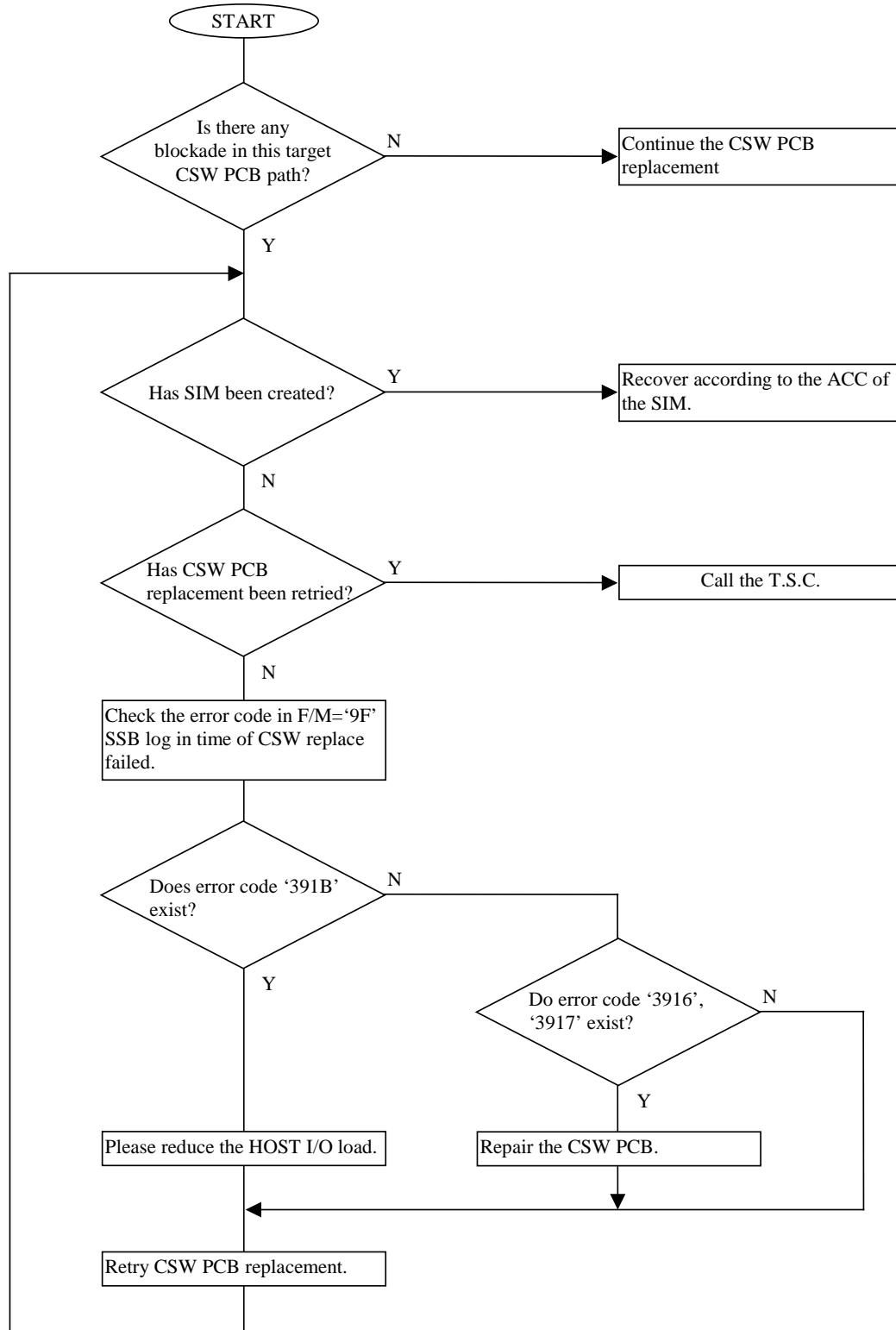

5.21 DKCMNs disagreement error (SIM = BF93XX)

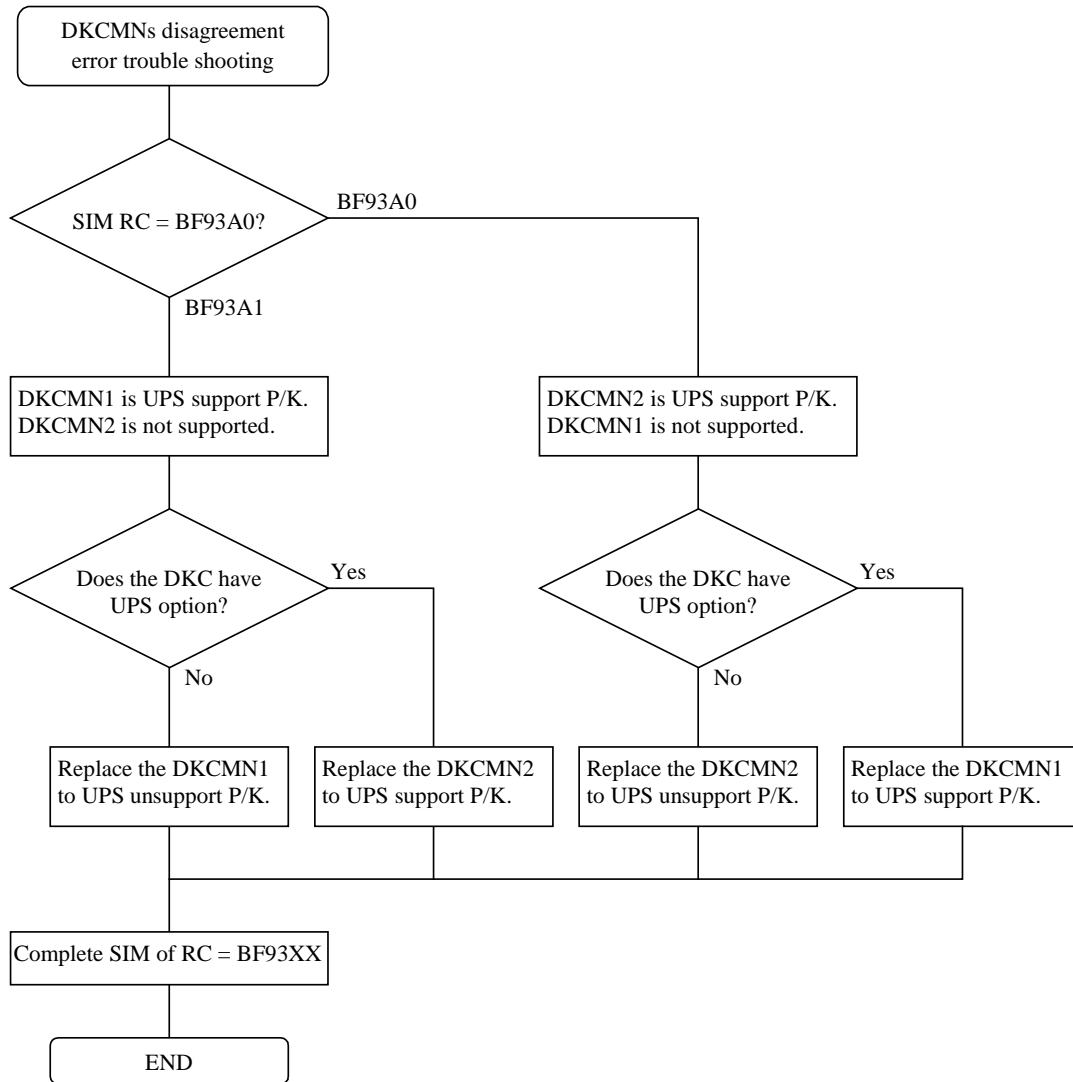

5.22 Recovery Procedure for Warning of SM DISABLE (SIM = 399AXY, 3D9AXY)

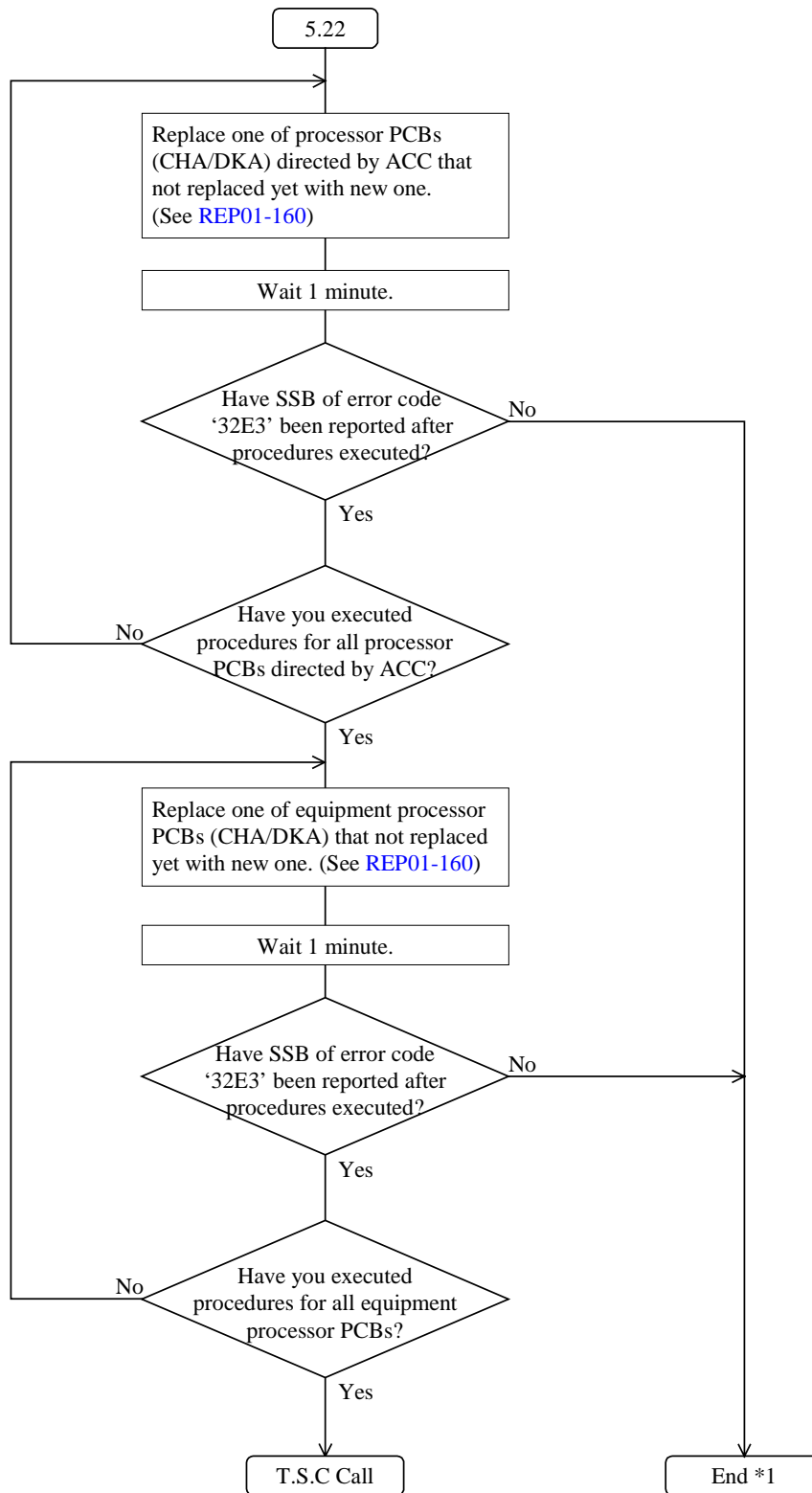

*1 After finishing the error recovery, execute SIM complete and delete logs. (Refer to [SVP02-170, 580](#))

5.23 Recovery Procedure for Injustice DC voltage control and Injustice CE MODE (SIM = 399DX0, 399EX0, 3D9DX0, 3D9EX0, FFF60X, FFF70X, FF200X, FF210X)

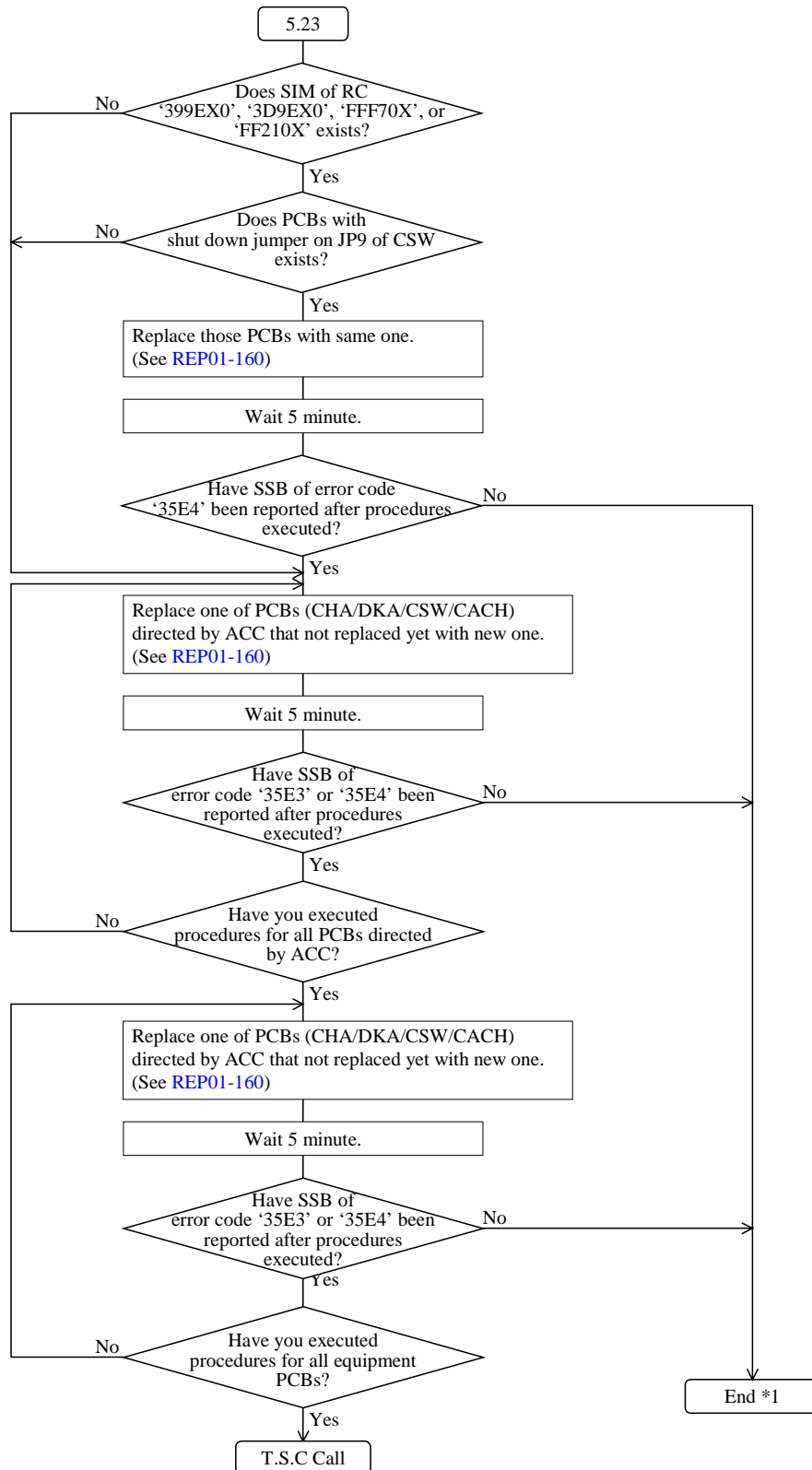

*1 After finishing the error recovery, execute SIM complete and delete logs. (Refer to [SVP02-170](#), [580](#))

5.24 Recovery Procedure when Change the IP Address is failed

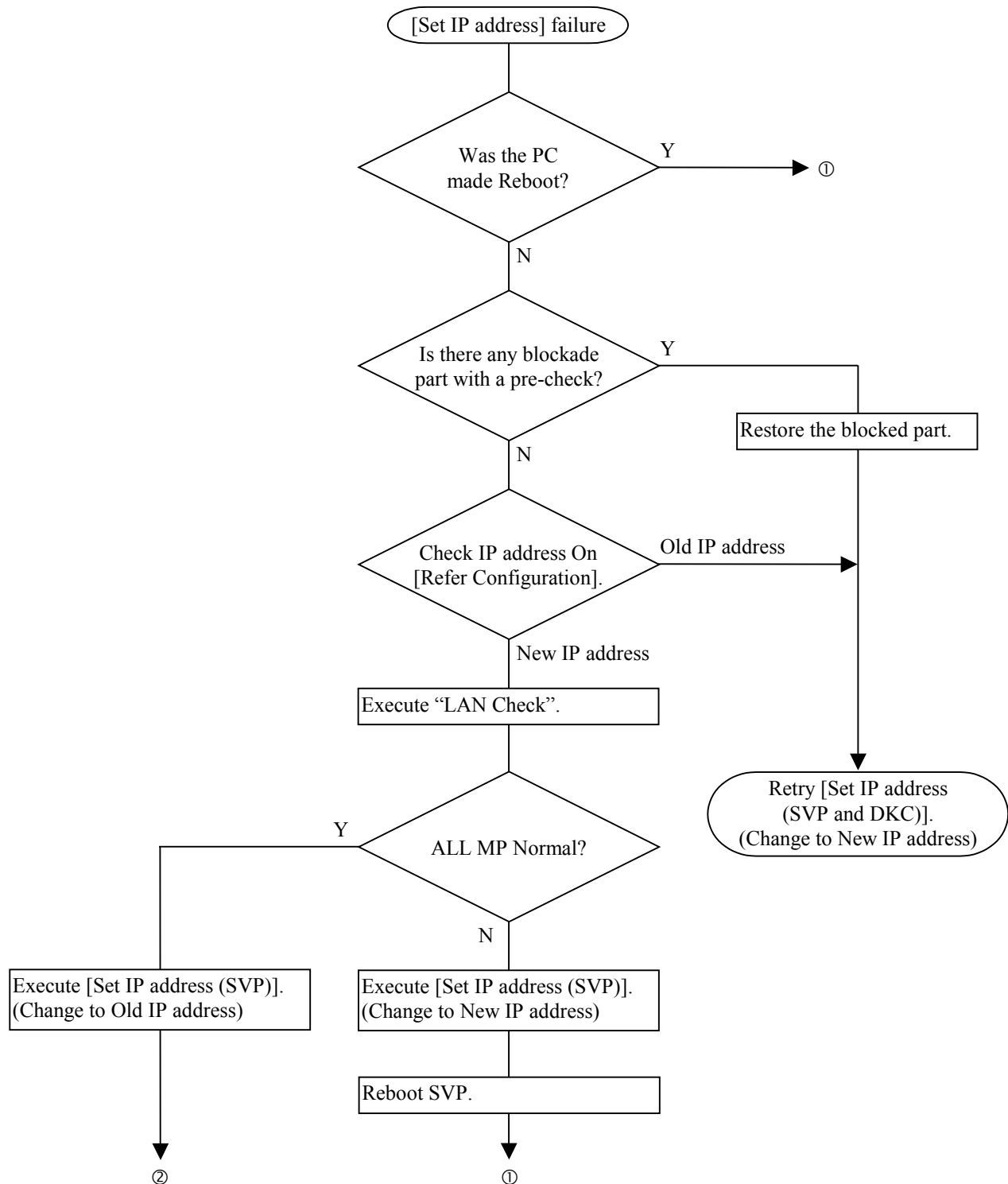

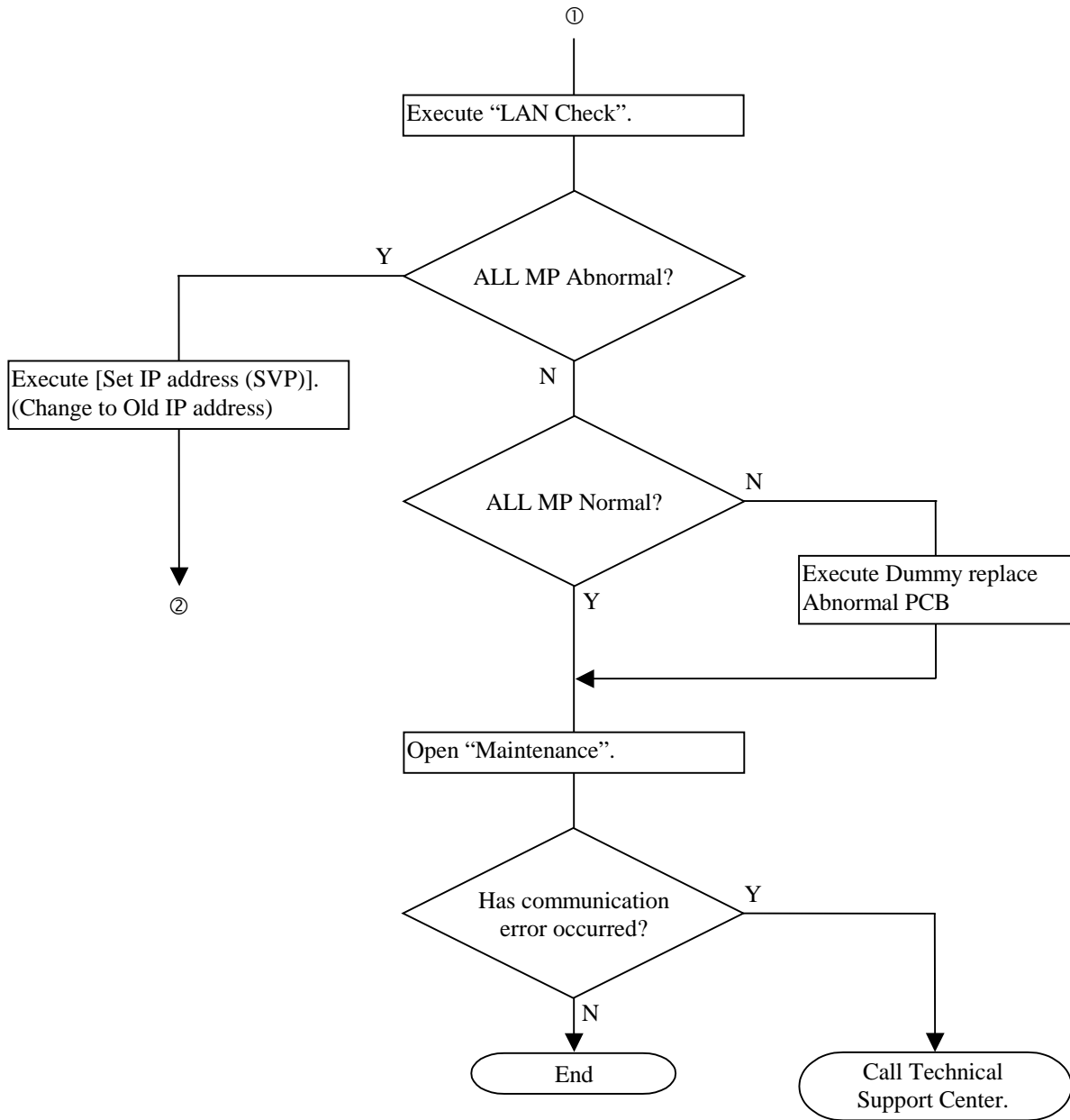

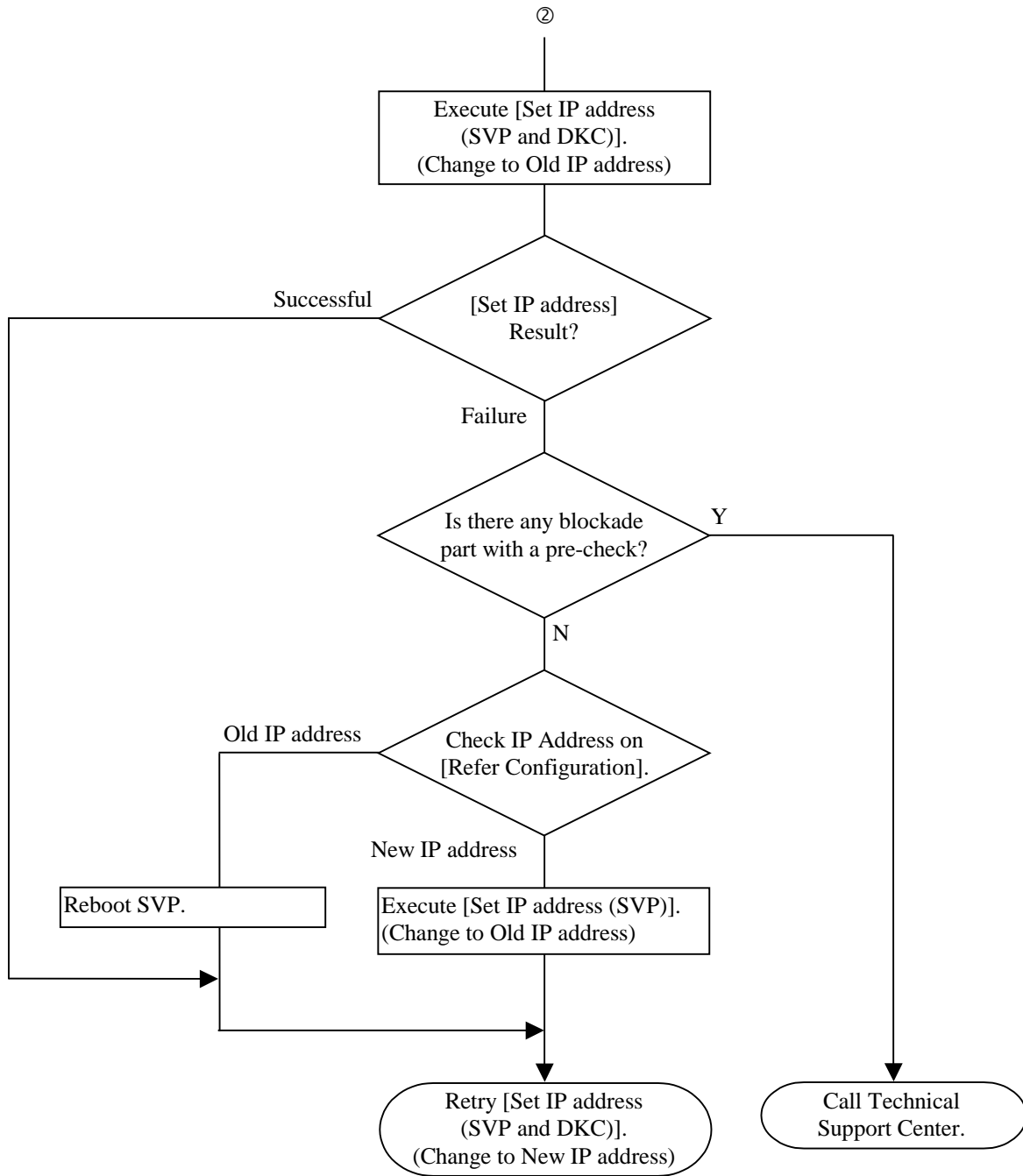

5.25 Duplex SVP Setup failed (SIM = BFE3A2)

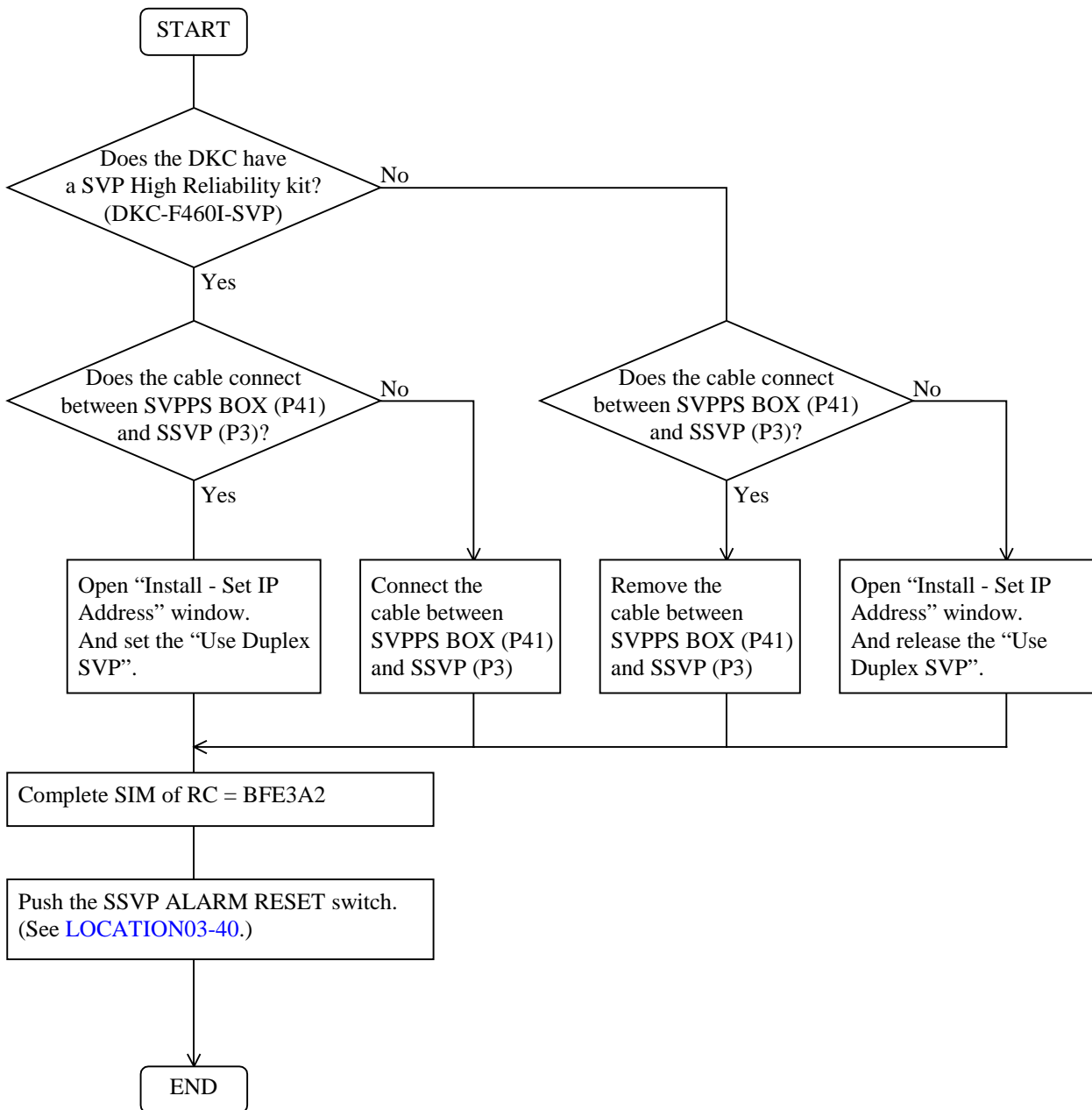

5.26 The recovery procedure at the time of disorder generating after a power failure etc.

It is a recovery procedure at the time of the abnormalities in equipment at DKC PS/ON, such as after breaker-on.

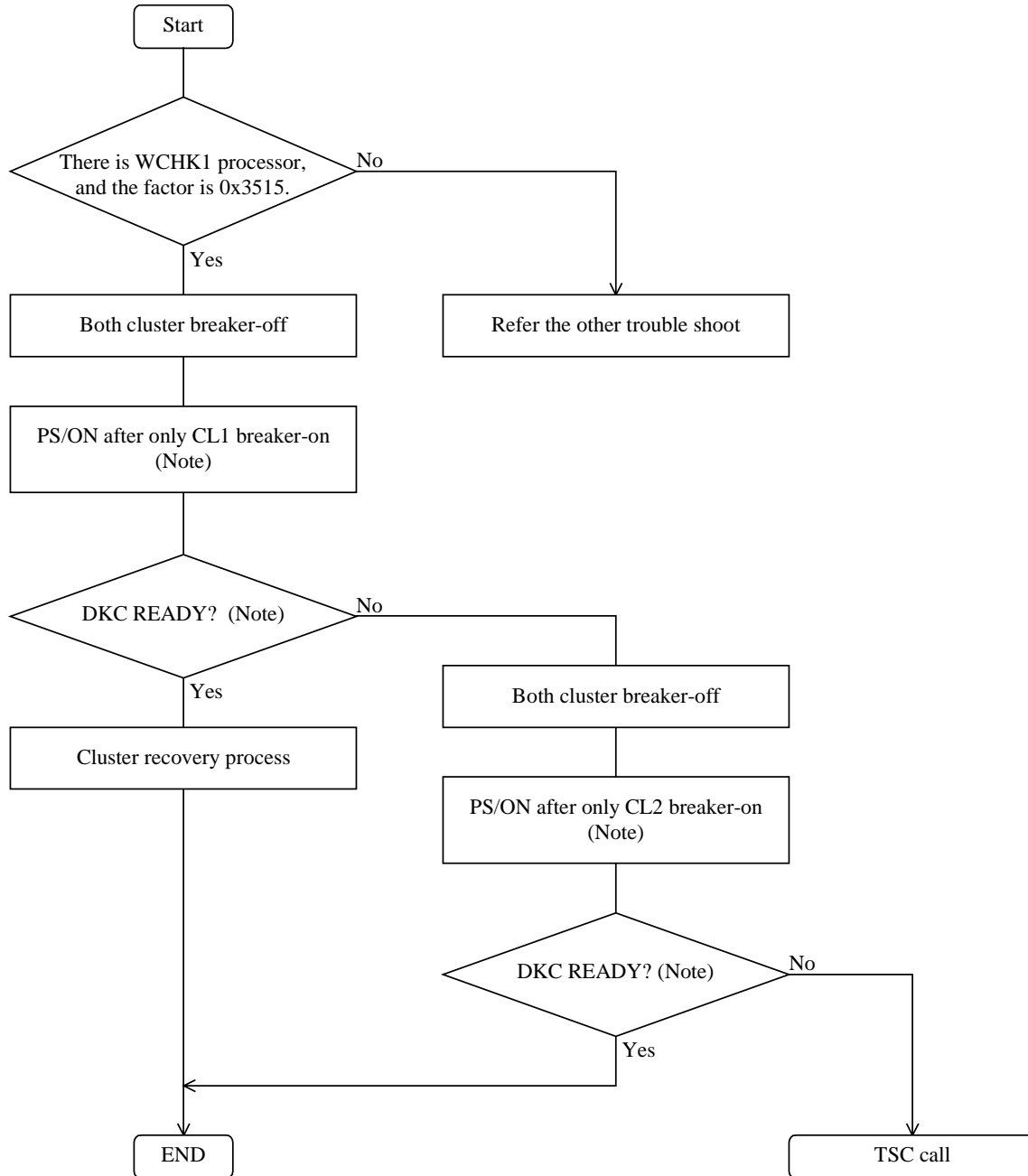

- (Note) 1. A DKC alarm lamp is turned on in PS/ON only in a one side cluster.
 2. Only by the one side cluster, even if 30 minutes pass, when you do not carry out DKC READY lamp lighting after PS/ON. Please judge that equipment starting is impossible.

6 HRC/HODM/HORC Error Recovery

6.1 Recovery Procedure for HRC/HODM Error

Hardware error sometimes causes HRC/HODM error which is a pair suspend or a path disable. This document explain the HRC/HODM Error and how to recover it.

Following reports indicate HRC/HODM error occurrence.

- SIM report of HRC/HODM path disable occurrence
- SIM report of HRC/HODM pair suspend occurrence
- SIM report of HODM Erase Error occurrence
- SIM report of RCU Acute or Serious Level SIM detection
- SIM report of RCU Moderate Level SIM detection

Table 6.1-1 HRC/HODM SIM REF.CODE

| SIM REF. CODE | meaning | comment |
|---------------|--|-------------------------------|
| D4XY-YY | HRC/HODM pair is suspended | X:0~5 or F
YYY:LDEV number |
| DBXY-YY | HRC Asynchronous pair is suspended | X:0~8 or F
YYY:LDEV number |
| D48Y-YY | HODM Erase Error occurred | YYY:LDEV number |
| D4EY-YY | RCU Acute or Serious Level SIM reported | YYY:LDEV number |
| DBEY-YY | RCU (Asynchronous pair) Acute or Serious Level SIM reported. | YYY:LDEV number |
| D4DY-YY | RCU Moderate Level SIM reported | YYY:LDEV number |
| DBDY-YY | RCU (Asynchronous pair) Moderate Level SIM reported. | YYY:LDEV number |
| 2180-XY | HRC/HODM path is disabled | X:Processor No.
Y:LCP No. |
| 2182-XY | MCU has received the notification of communication line error detection from extender. | X:Processor No.
Y:LCP No. |

Following pages explain each error type of HRC/HODM Error and recovery flow chart for the HRC/HODM Error is showed. Concerning to the Disaster Recovery Procedures, please refer to THEORY SECTION ([THEORY03-690 ~ 790](#)).

The delete pair operation with Delete Pair by Force option is supported for HRC asynchronous recovery procedure. If hung-up conditions may occur at HRC asynchronous, this operation can be executed from SVP or Remote Console. Refer to Forcible Delete Operation([TRBL06-210](#)).

Note: Please check a fence Level Parameter for the suspended pair by SVP Pair Option. And if M-VOL Fence Level is 'R-VOL Data' or M-VOL Fence Level is 'R-VOL Status' and suspended SIM is 'D4FYYY', write I/O operations to the M-VOL will be rejected. So you must execute Delete Pair for the suspended pair, before execution of the recovery flow chart.

If you find out the F/M = '8F' SSB log which have following error code (C870, C871, C872), it is not the original cause of the suspended pair. It means that the SSB log is created by the pair status change timing. So you have no need to execute a recovery action.

6.2 HORC Error Recovery Procedure

A HORC pair suspension or a HORC pass blockade may occur owing to hardware errors. This section explains the recovery procedure against them. Occurrences of HORC errors can be known through the following.

- HORC error message on the Syslog outputted by the RAID manager/HORC (Note 1)
- Report of a HORC pass blockade occurrence by the SIM
- Report of a HORC pair suspension occurrence by the SIM

Table 6.2-1 HORC SIM REF.CODE

| SIM REF. CODE | Meaning | Remarks |
|---------------|--|--|
| D4XY-YY | HORC pair suspend | X: 0 - 2, 4 - 5 or F
YYY: LDEV number |
| DBXY-YY | HORC Asynchronous pair suspend | X: 0 - 8, F
YYY: LDEV number |
| 2180-XY | HORC pass blockade | X: Processor #
Y: LCP# |
| 2182-XY | MCU has received the notification of communication line error detection from extender. | X: Processor #
Y: LCP# |

SIM outputted when the HORC is suspended or the HORC pass is blocked has the same REF. CODE and meaning as those outputted when the HRC/HODM pair is suspended or the HRC/HODM pass is blocked.

Furthermore, the error recovery procedure is the same as that against an HRC/HODM error. Therefore, follow the procedures shown in the flowcharts on page TRBL06-30 and succeeding pages to recover from a HORC pair error.

When a message indicating that a HORC pair error has occurred is displayed on the Syslog, check the SIM log of the connected DKC and confirm the conformance of the message on the Syslog with the SIM logged on the DKC side before starting the recovery using the above flow chart.

Note 1; When the HORC pair is suspended, the RAID manager/HORC displays the following message on the Syslog.

[HORCM_102] Detected a suspending status on this paired volume
(Volume: ○○○○, code: XXXX).

○○○○: Volume name

XXXX: Factor code

The delete pair operation with Delete Pair by Force option is supported for HORC asynchronous recovery procedure. If hung-up conditions may occur at HORC asynchronous, this operation can be executed from SVP or Remote Console. Refer to Forcible Delete Operation([TRBL06-210](#)).

When the pair status is 'Suspending' a command for creating pairs or deleting pairs from RAID manager is rejected [EX_CMDRJE] at HORC asynchronous. In this case, retry the command after the pair status is fixed (PSUE, PFUS).

Recovery for HRC/HODM/HORC Error

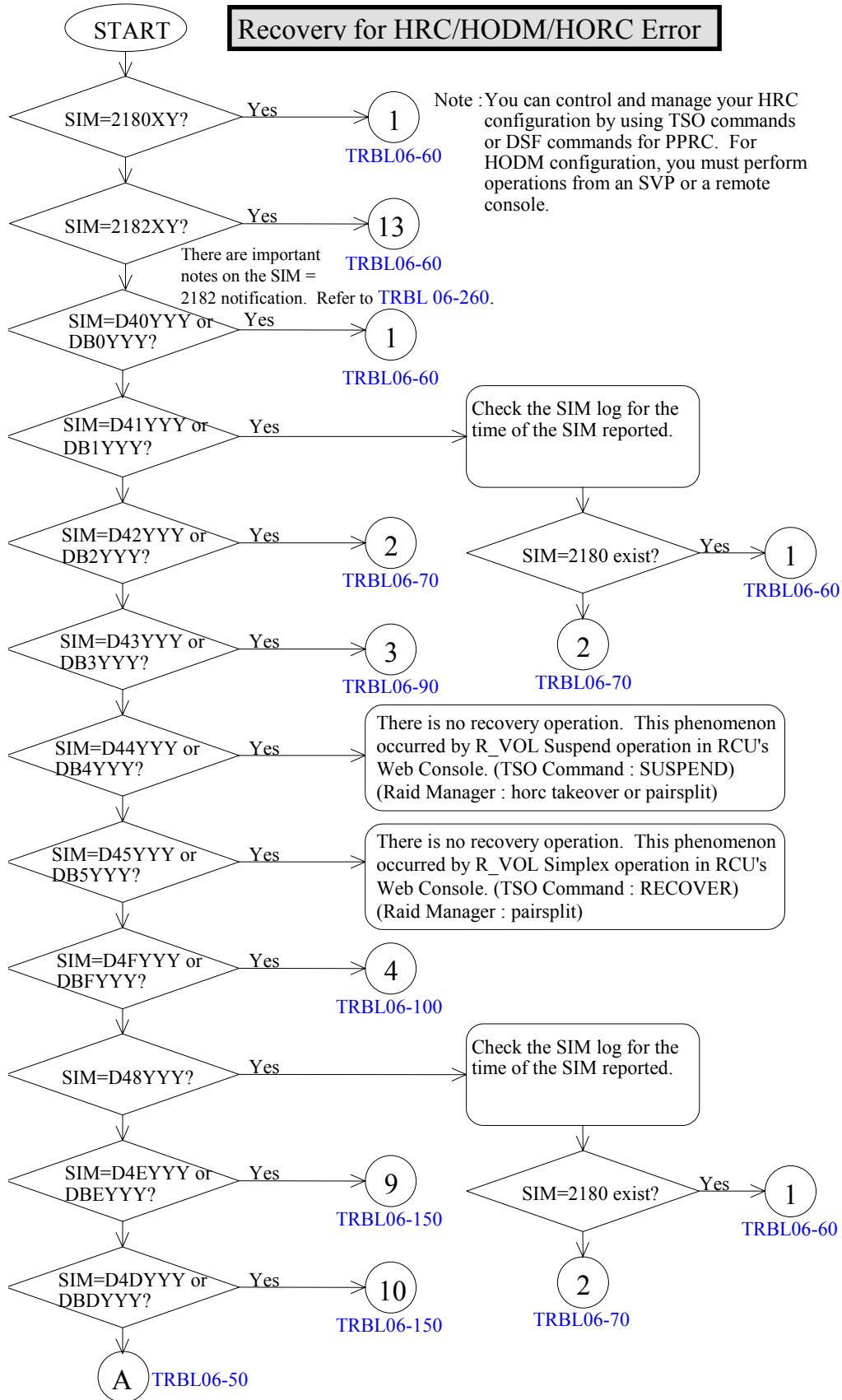

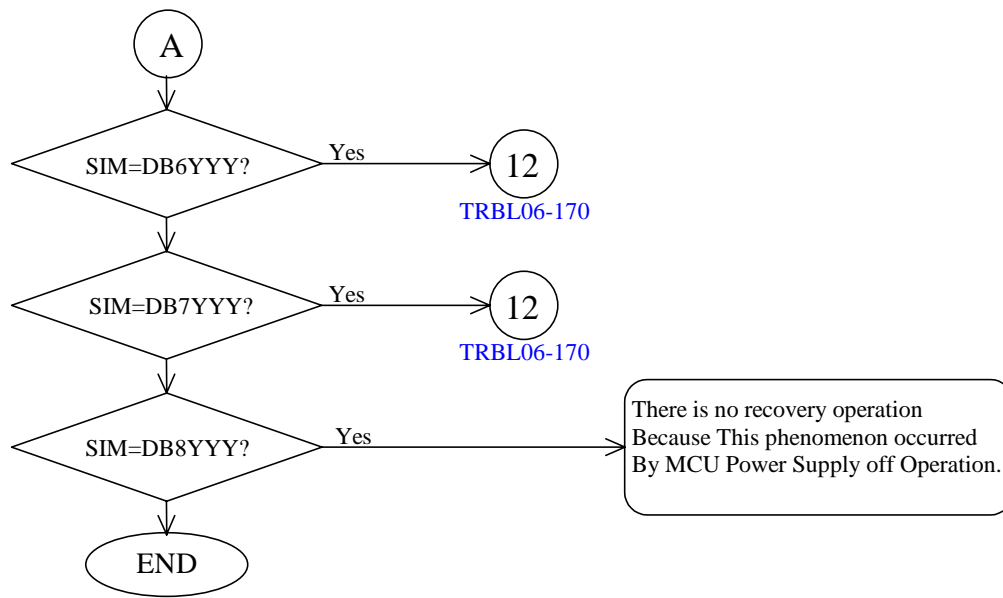

HRC/HODM/HORC Path Recovery Section

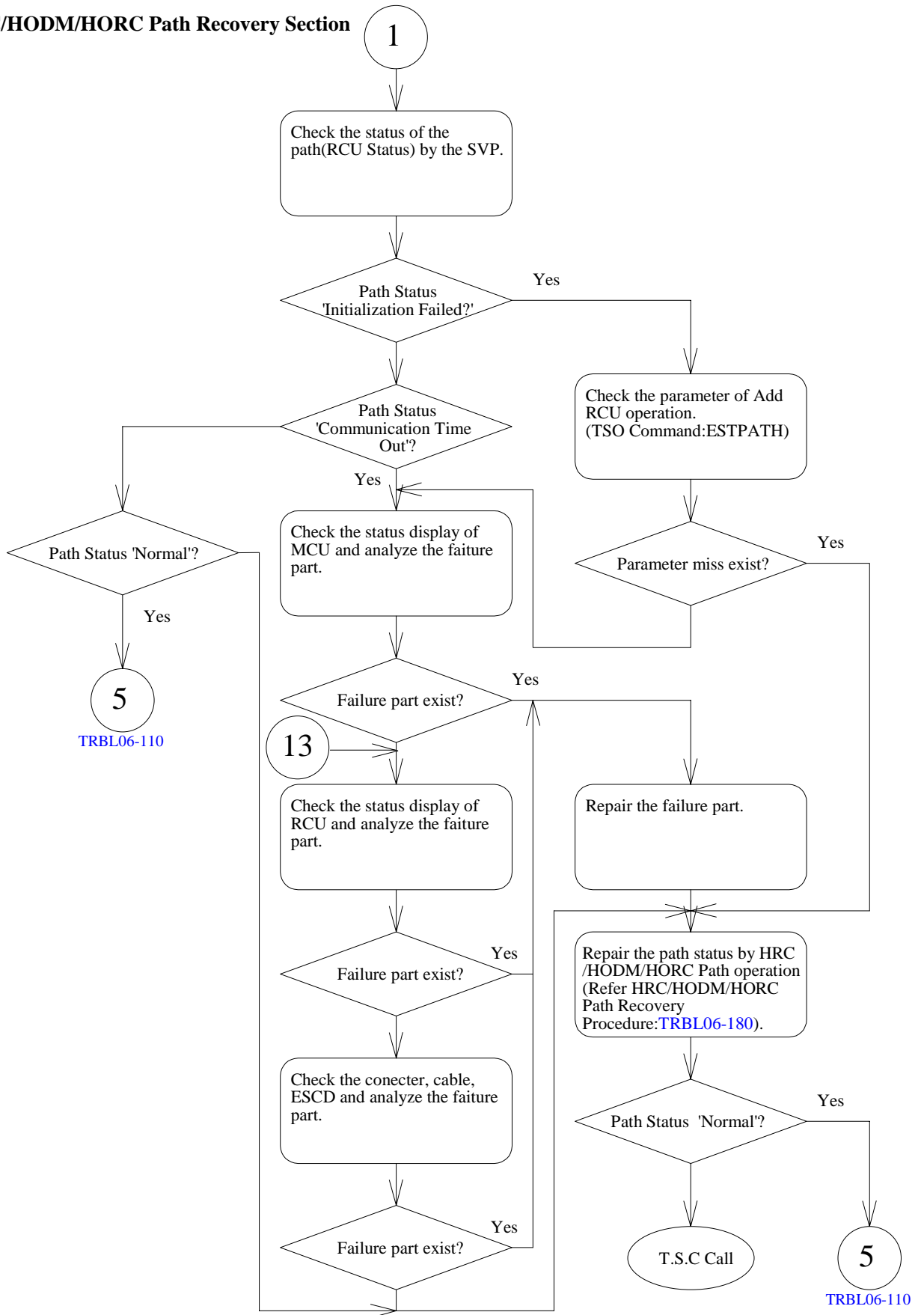

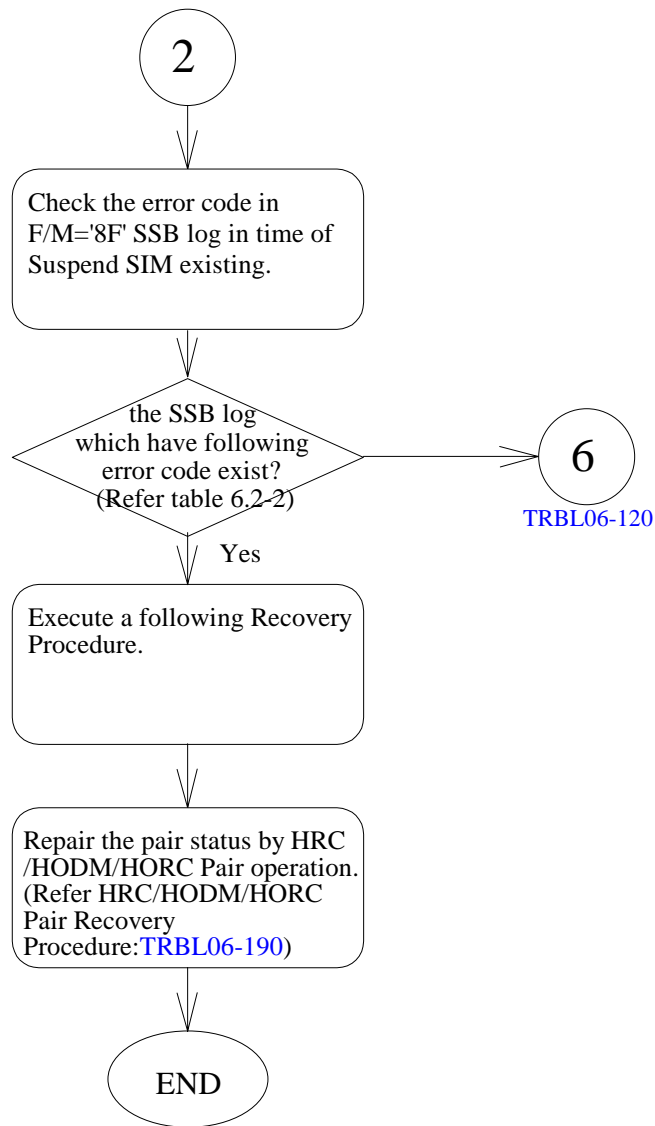

Table 6.2-2 HRC/HODM Recovery Procedure for F/M = '8F'

| No. | F/M | error code | mean | Recovery Procedure |
|-----|-----|------------|---|---|
| 1 | 8F | C969 | Detect a nonstandard R0 track in R_VOL. (HODM operation) | Change the track format to standard R0 track for the following track. CCHD is as follows.*
SSB log byte43:R_VOL#
byte72/73:CYL#
byte74/75:HD# |
| 2 | 8F | C96F | (F/M) 8F
(error code) C96F
(mean) Detect a over run track in R-VOL.
(HODM operation)
(Recovery Procedure) | Recovery the following (over run) track.
CCHD is as follows.
SSB log byte43:R_VOL#
byte72/73:CYL#
byte74/75:HD# |
| 3 | 8F | C4CE | Detect a nonstandard R0 track in M_VOL.
(HRC or PPRC operation) | Change the track format to standard R0 track for the following track. CCHD is as follows.*
(Note 1)
LDEV in the 'SSB log' window : M_VOL#
SSB log byte44/45:CYL#
byte46:HD# |
| 4 | 8F | C883 | Detect time-over during retrial for RCU detected error.
(HODM operation) | *(Note 2) |
| 5 | 8F | C884 | An SCP reported from RCU.
(HODM operation) | *(Note 2) |
| 6 | 8F | C88E | Detect an I/O error for R-VOL not recoverable with retrial.
(HODM operation) | *(Note 2) |

* use DSF INSPECT NOPRESERVE

Note 1 If you canceled HODM Pair Operation before this phenomenon has occurred, you must execute format the blocked LDEVs (See [SVP02-700](#)) or DSF (Medial initialization) or DSF (INSTALL) for the Suspended Vol. Because this Volume data is incomplete. If the volume type is RAMAC, you can not change the track format to standard R0 track by DSF.

Note 2 Erase operation after migration copy from IBM RAMAC after migration copy may fail with SSB EC = C883, C884 or C88E due to SCP reported from RAMAC. In this case, reduce the concurrency of erase operation to 1 or 2 and retry the operation.

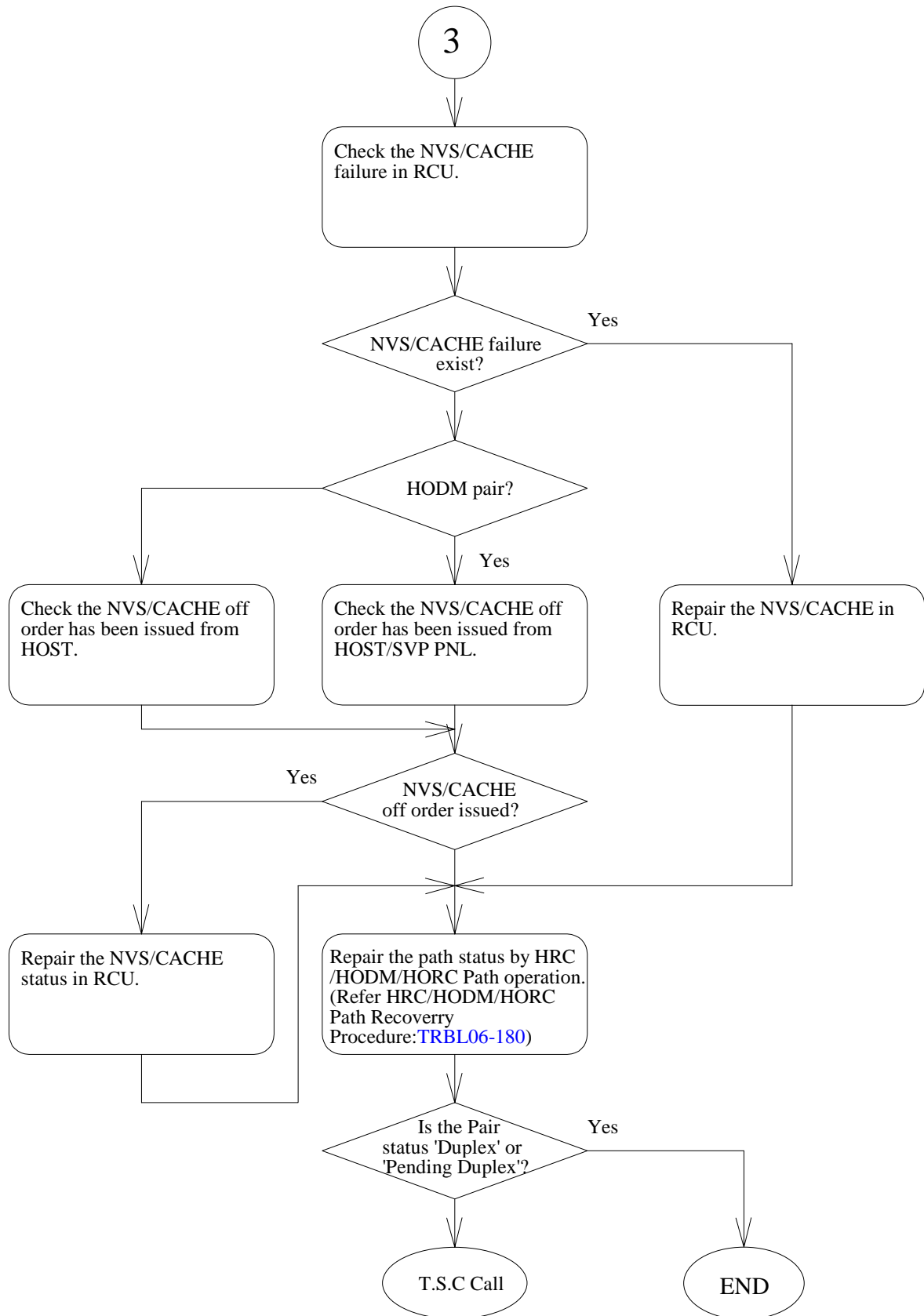

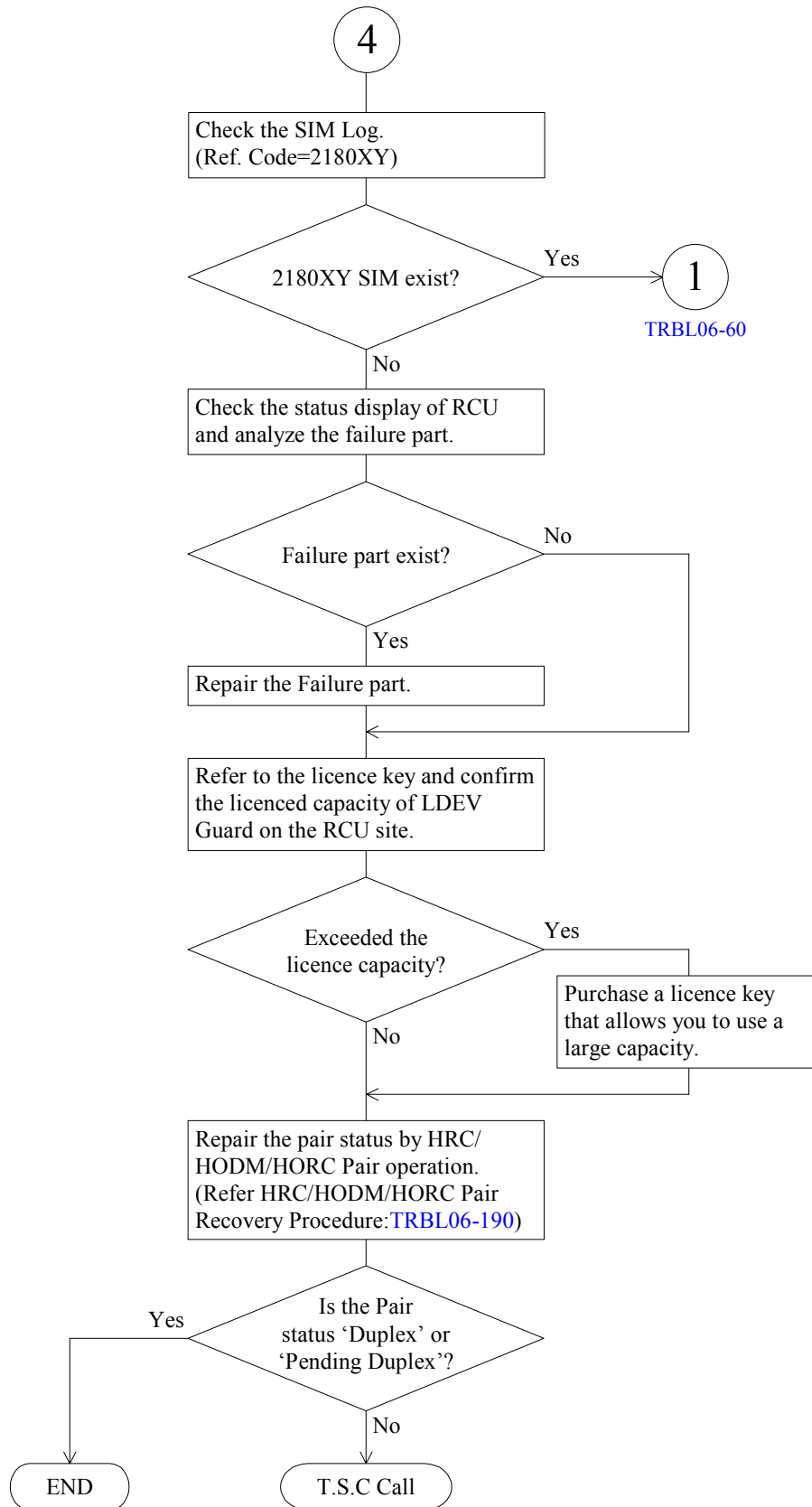

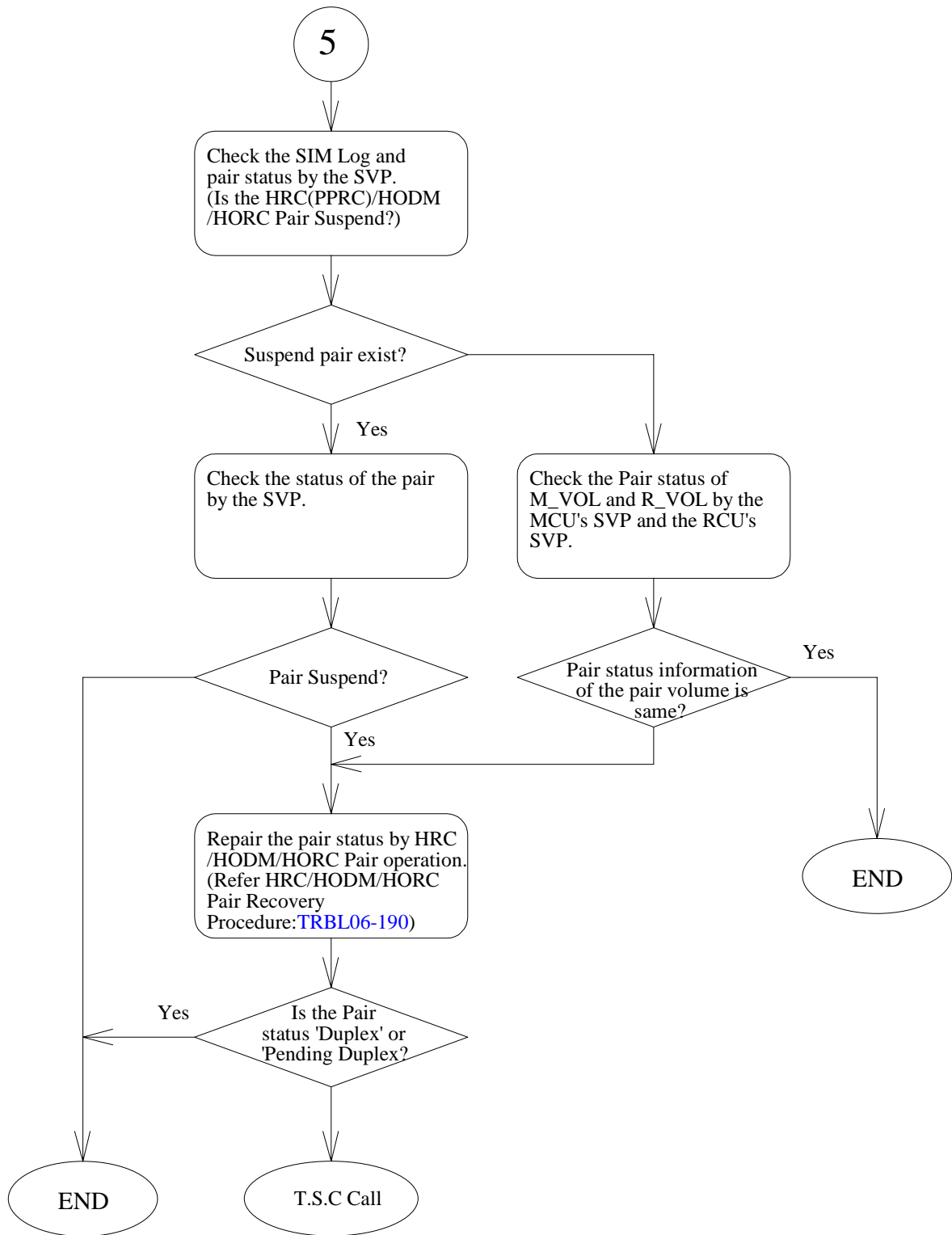

* In the case of the HORC, confirm the SSB log of F/M='FB' in the suspended volume concerned. When the log of 'FB' does not exist, confirm the SSB error code of FM='FB' in the time zone for reporting a SIM concerned.

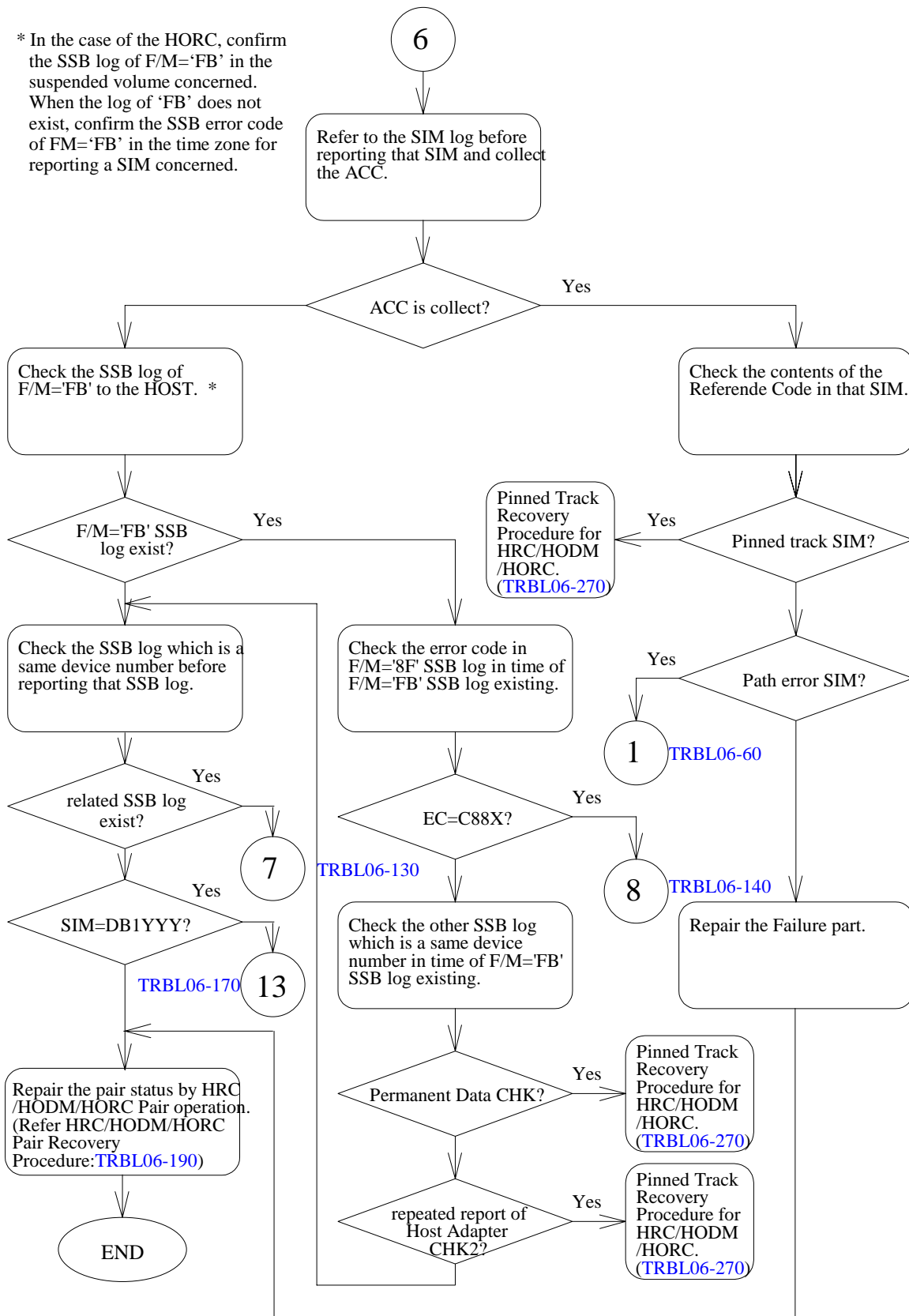

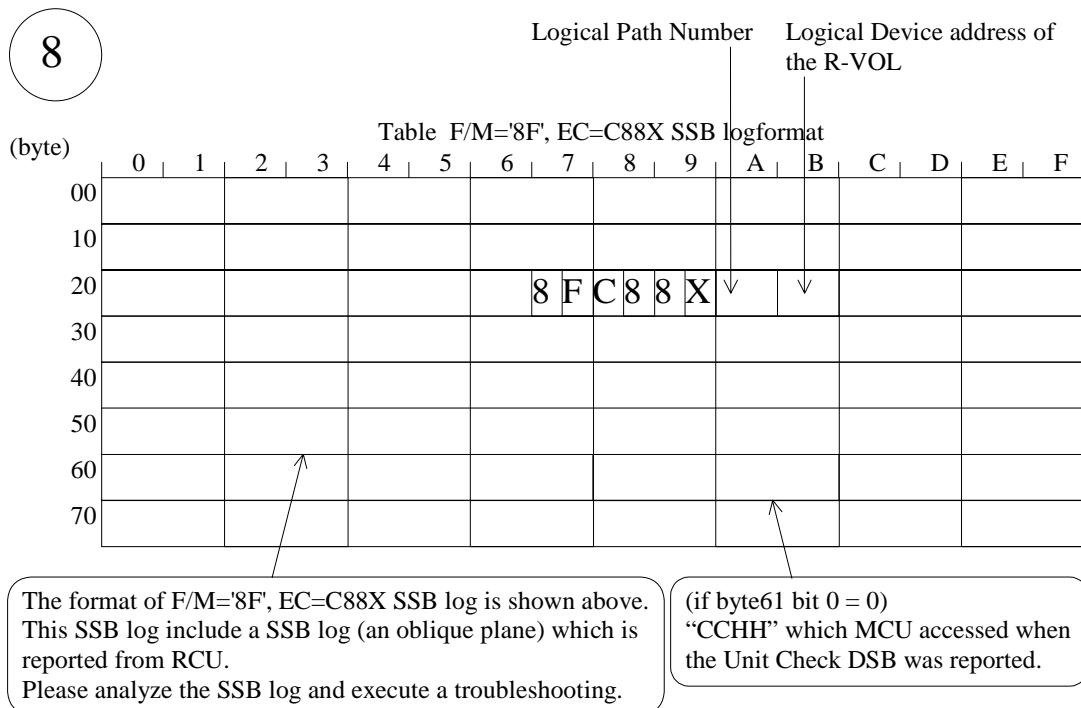
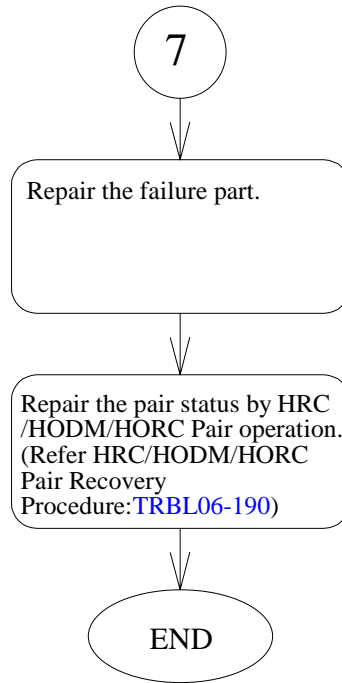

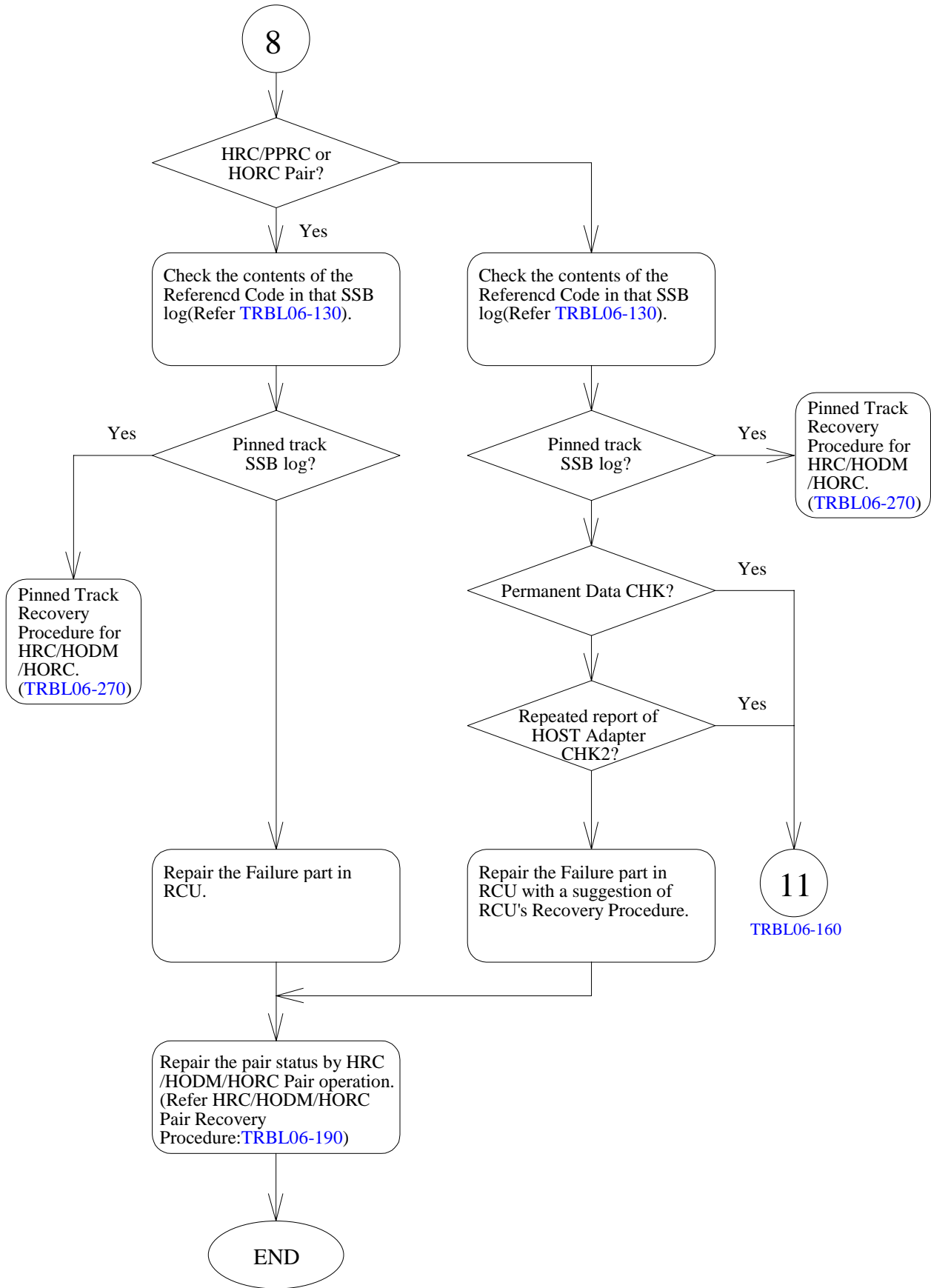

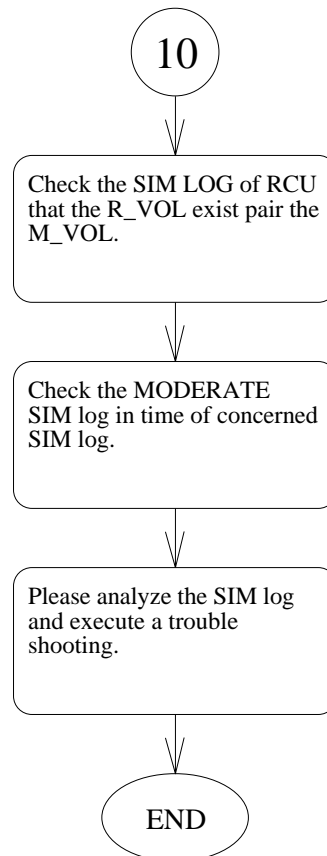
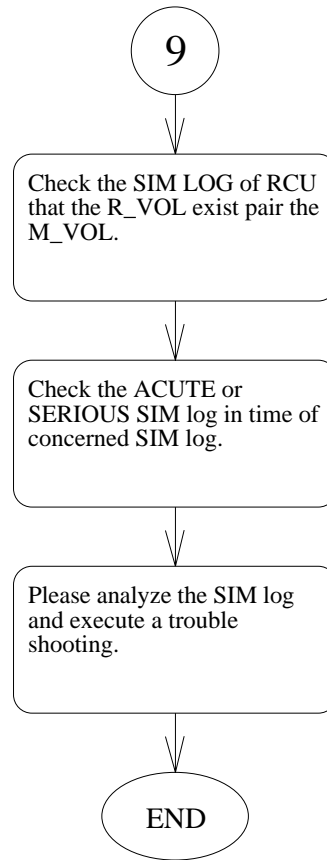

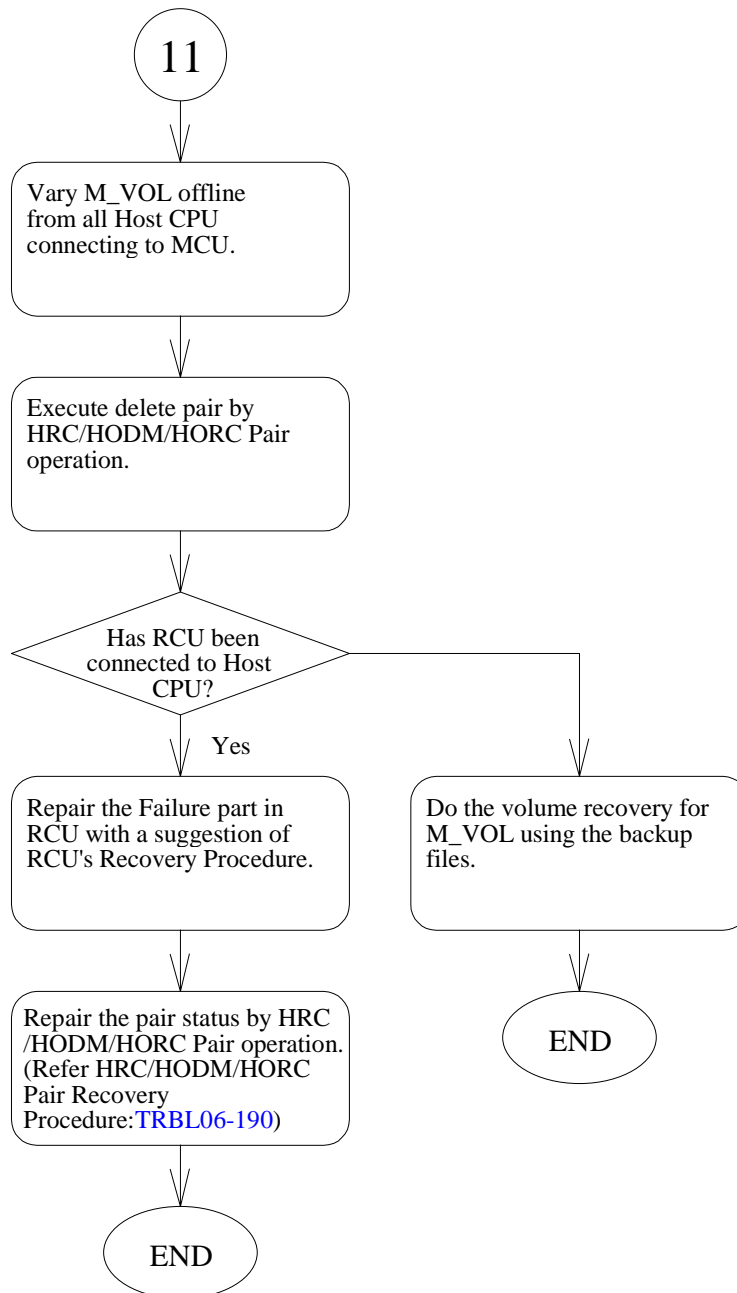

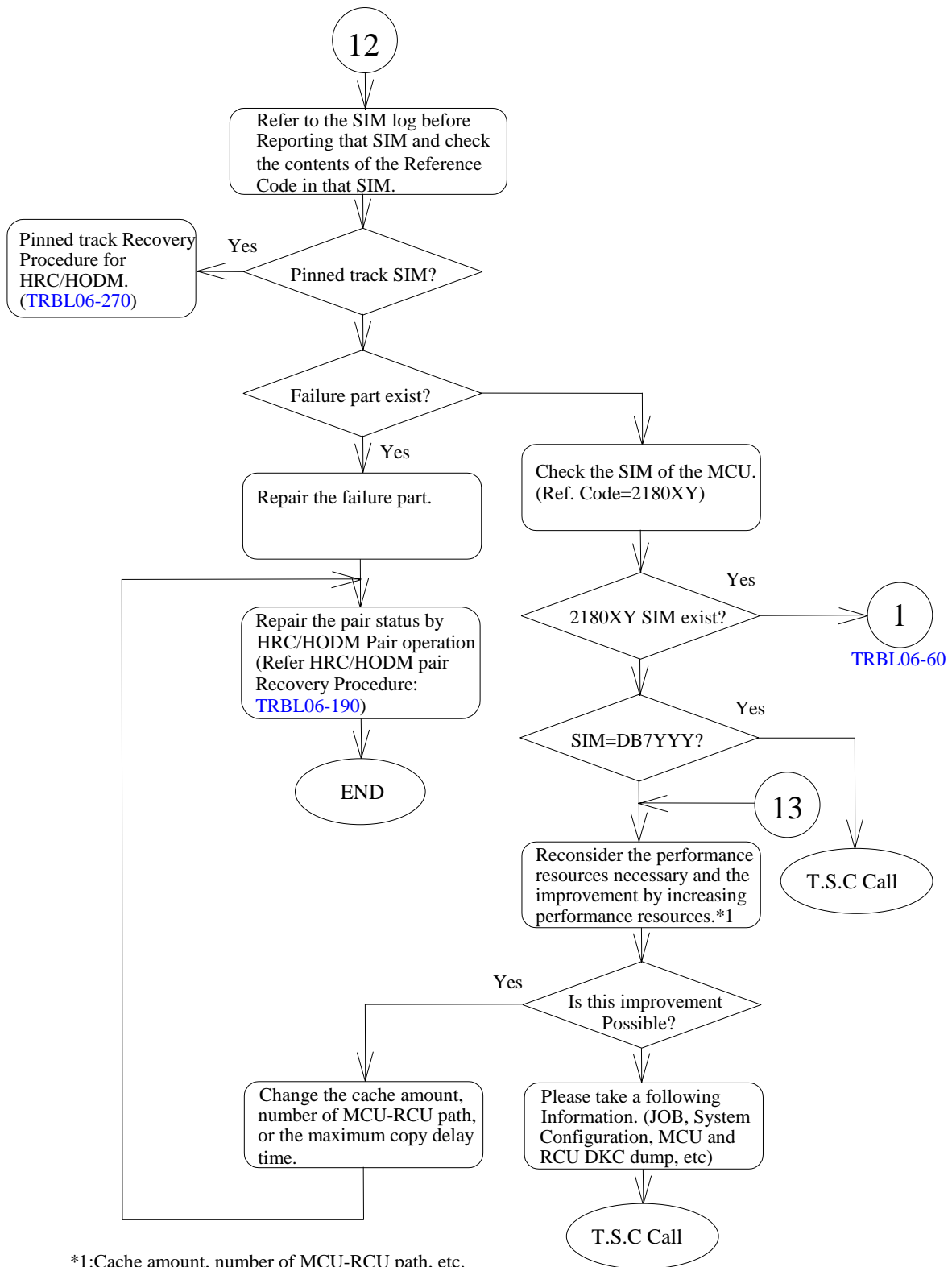

HRC/HODM/HORC Path Recovery Procedure

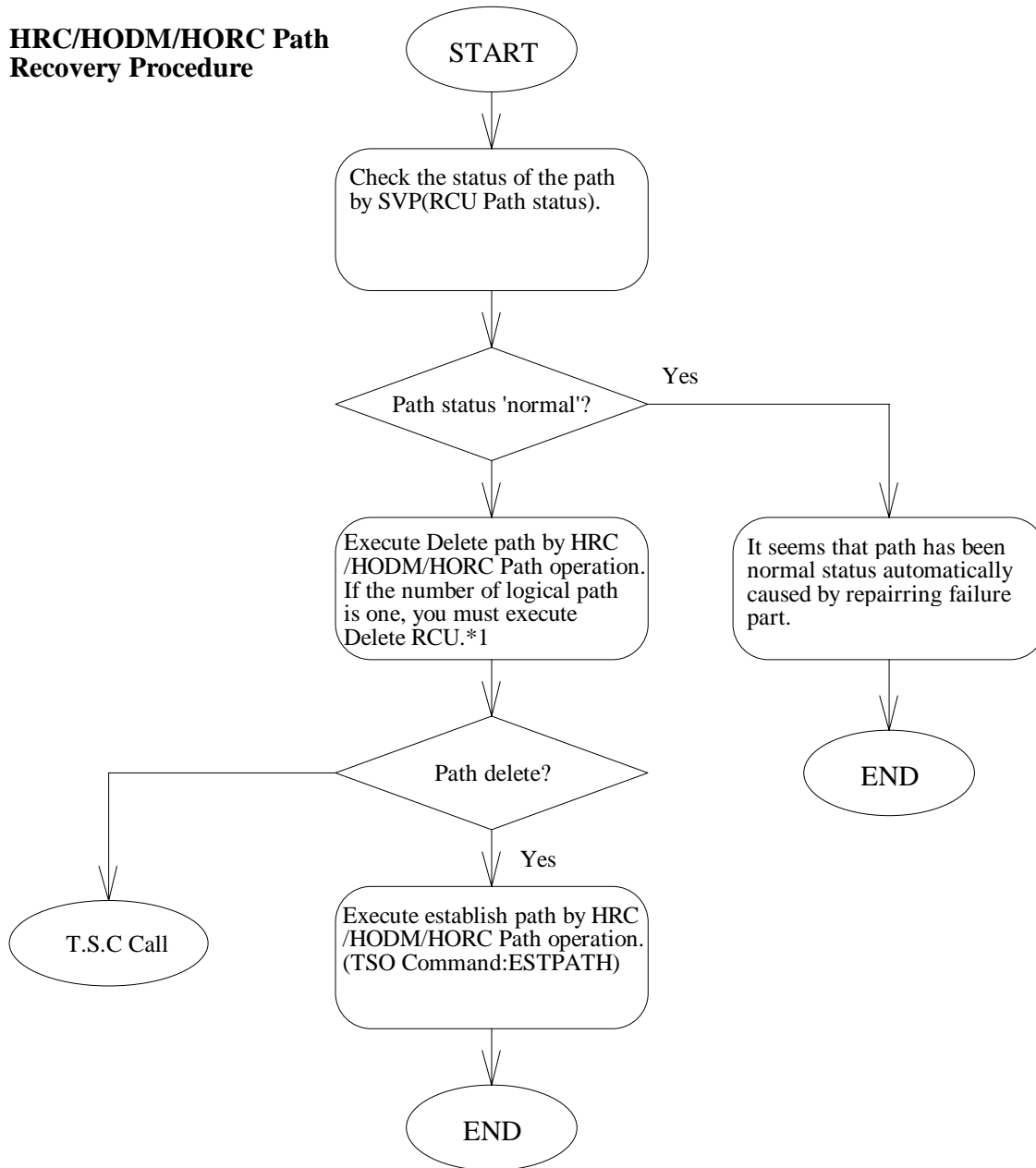

*1 For TSO Command operation, you issue ESTPATH Command, specified the path that established by the last ESTPATH Command issued except failed path. If the number of logical path is one, you must issue DELPATH Command. (Refer IBM PPRCOPY Commands Manual)

HRC/HODM/HORC Pair Recovery Operation(1/2)

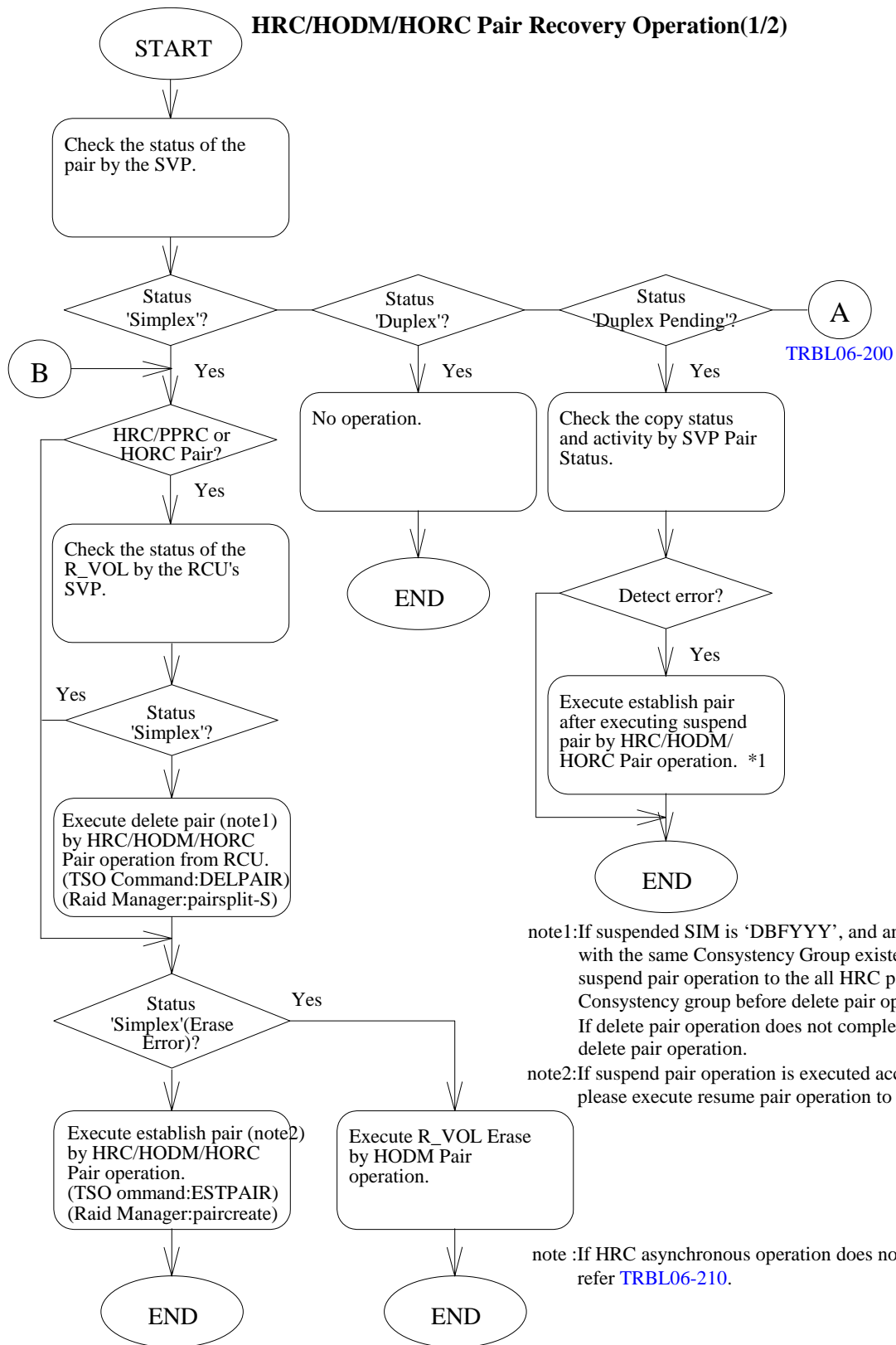

note1:If suspended SIM is 'DBFYYY', and another HRC pair with the same Consistency Group existed, please execute suspend pair operation to the all HRC pair with the same Consistency group before delete pair operation. If delete pair operation does not complete, please try force delete pair operation.

note2:If suspend pair operation is executed according to note1, please execute resume pair operation to these HRC pairs.

note :If HRC asynchronous operation does not complete, please refer [TRBL06-210](#).

*1 For TSO Command operation, you issue ESTPAIR Command after SUSPEND Command issued.

In the case of the Raid Manager, issue the Pairesync command after the Pairsplit command is issued.

*2 For TSO Command operation, you issue ESTPAIR Command after DELPAIR Command issued.

In the case of the Raid Manager, issue the Paircreate command after the Pairsplit-S command is issued.

HRC/HODM/HORC Pair Recovery Operation(2/2)

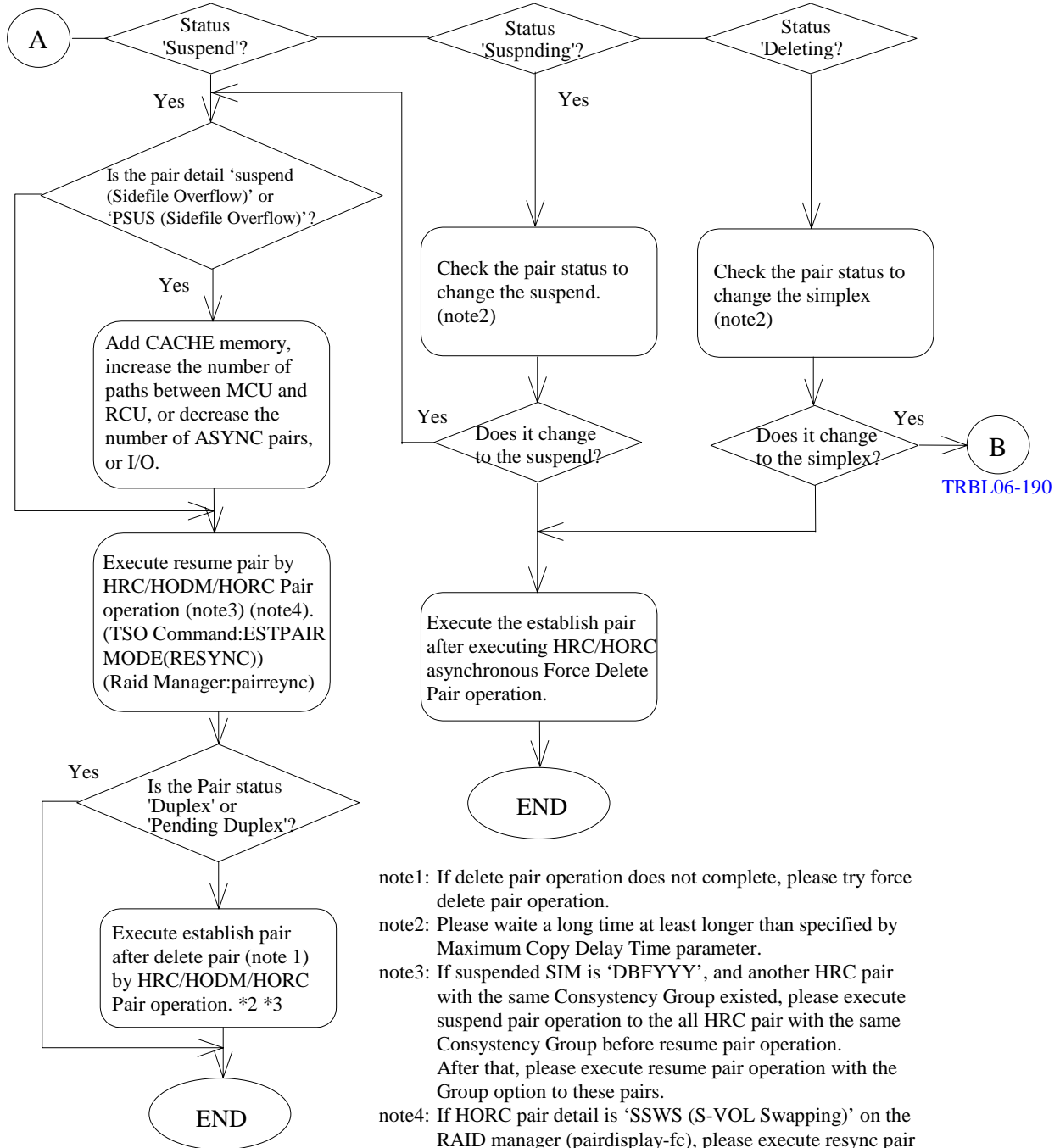

note1: If delete pair operation does not complete, please try force delete pair operation.

note2: Please wait a long time at least longer than specified by Maximum Copy Delay Time parameter.

note3: If suspended SIM is 'DBFYYY', and another HRC pair with the same Consistency Group existed, please execute suspend pair operation to the all HRC pair with the same Consistency Group before resume pair operation. After that, please execute resume pair operation with the Group option to these pairs.

note4: If HORC pair detail is 'SSWS (S-VOL Swapping)' on the RAID manager (pairdisplay-fc), please execute resync pair operation (pairresync-swaps).

note: If HRC asynchronous operation does not complete, Please refer [TRBL06-210](#).

*1 For TSO Commnad operation, you issue ESTPAIR Command after SUSPEND Command issued.

In the case of the Raid Manager, issue the Pairresync command after the Pairsplit command is issued.

*2 For TSO Command operation, you issue ESTPAIR Command after DELPAIR Command issued.

In the case of the Raid Manager, issue the Paircreate command after the Pairsplit-S command is issued.

*3 After force-deleting a HORC asynchronous pair whose detailed status was 'SSWS (S-VOL Swapping)', please delete the C/T group from Web Console, which the deleted pair belonged to, before executing paircreate.

HRC/HORC asynchronous Pair Recovery Operation

HRC/HORC asynchronous pair recovery operation is the same as it of the HRC synchronous pair basically. Please pay attention to the following.

(1) Extent of the suspend pair volume

When the volume pair which error level is Group is suspended due to the failure, all volume pairs in the same consistency group will be suspended together. In this case, All volume pairs in the same consistency group are in need of Resume Pair operation.

On condition that failure volume pair status is the Duplex pending(volume failure occur during Initial Copy), suspend is only this volume.

(2) Resume pair Operation

It specifies whether all suspended volume pairs, which belong to the same consistency group and whose M-VOLs are behind this MCU, should be resumed together or not.

(3) Force Delete Operation

This section describes the error recovery procedures to recover from the following hung-up conditions:

- The volume pairs were suspended due to some kind of failure. However the pair status of the affected volume pairs remained **unchanged from Suspending** for a long time (at least longer than specified by Maximum Copy Delay Time parameter).
- **Delete Pair** or **Suspend Pair** operation completed without error message. However the pair status of the volume pairs to be deleted or suspended remained **unchanged from Deleting or Suspending** for a long time (at least longer than specified by Maximum Copy Delay Time parameter).
- Add Pair operation failed with Web Console messages '**6005 8808**' or '**6005 8809**' and the operation could not complete after several times of retries.
- **Suspend Pair, Delete Pair** or **Delete Group** operation failed with Web Console messages '**6005 8844**', '**6005 8855**' or '**6005 8880**' respectively and the operation could not complete after several times of retries.

The recovery procedure is described in the next figure on [TRBL06-230](#).

(3-1) Operating Delete Pair with Delete Pair by Force option

Delete pair operation with Delete Pair by Force option is effective to recover from such hung-up conditions. Being specified with this option, the specified control unit (MCU or RCU) performs the forcible delete process as follows:

- Changes the volume status of all the volumes that are behind the specified control unit and belong to the consistency group to simplex.
- Discard all the record sets that are pending (not sent to the RCU or not settled yet) in the specified control unit.

Note that the specified control unit performs the forcible delete without communicating with the paired control unit. Since both the MCU and RCU manages volume pair status and can have the pending record set within, this operation **must be done at both the MCU and RCU**.

(3-2) Re-establishing Volume Pair

After completing delete pair operation at both the MCU and RCU, establish volume pair(s) again to check that hung-up conditions are recovered. Be sure that **the same consistency group number** must be specified as before. If the different consistency group number is specified, the result is unpredictable.

(3-3) Performing Dummy-Replacement of Cache PCB

If the delete pair operation can not recover from hung-up conditions (establishing volume pair results in failure with message '6005 8808' or '6005 8809'), some inconsistent condition may remain in the Sidefile structure. To recover from this situation, dummy-replacement of cache PCB requires to be performed for **both A and B sides**. The operated control unit discards all the inconsistent Sidefiles during replacement procedure.

Only the Sidefiles of the deleted consistency group is discarded. Therefore dummy-replacement can be performed while other consistency groups are working at the control unit.

HRC asynchronous Force Delete Operation

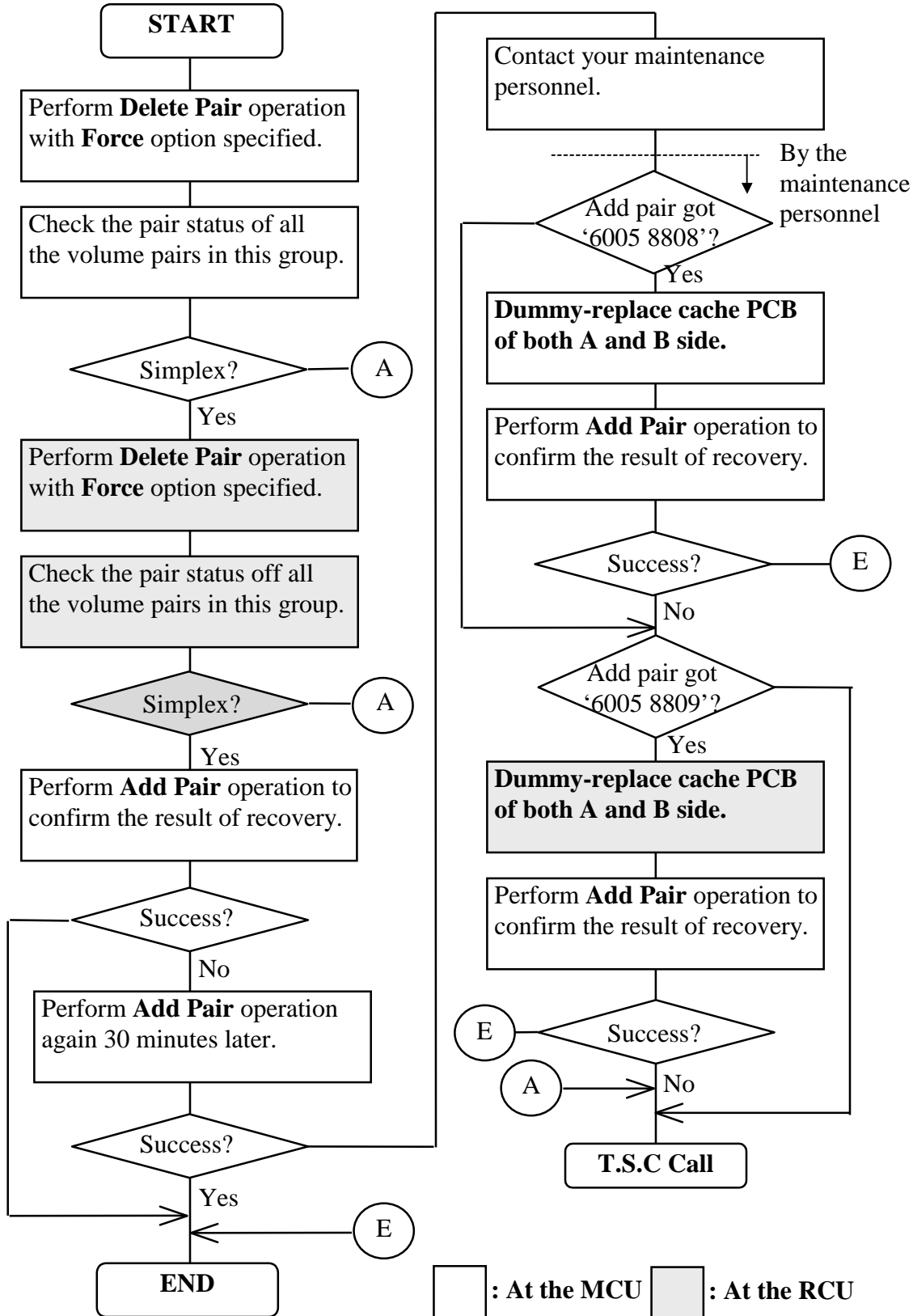

Recovery Operation of the Suspended HORC Pair

This document which is addition of the HRC/HODM/HORC Pair Recovery Operation ([TRBL06-190](#)) explain the recovery operation for the suspended HORC pair in the extended LU.

After repairing the failure part, execute a resume (pair resync) operation for the suspended pair. HORC resume operation can be executed from SVP, Remote Console, and Raid Manager. A means, an object and a procedure of the resume operation are shown in a following table.

Table HORC Resume Operation Procedure in the extended LU

| means | object | procedure |
|--------------|--------------|--|
| Web Console | Volume | (1) Check the volume number of the suspend pair from the F/M="FB" SSB.
(2) Check the LU pair status which comprises the suspended pair volume is a "Suspend", "Duplex (W)", or "Pending Duplex (W)".
(3) Execute a resume pair operation to the suspended volume pair.
(4) Check the pair status is a "Duplex" or a "Pending Duplex". |
| | Logical Unit | (1) Check the volume number of the suspend pair from the F/M="FB" SSB.
(2) Check the LU pair status which comprises the suspended pair volume is a "Suspend", "Duplex (W)", or "Pending Duplex (W)".
(3) Execute a resume pair operation to the suspended LU pair.
(4) Check the pair status is a "Duplex" or a "Pending Duplex". |
| Raid Manager | Logical Unit | (1) Check the volume number of the suspend pair from the F/M="FB" SSB.
(2) Check the LU pair status which comprises the suspended pair volume is a "PDUB".
(3) A pairresync command issues to the suspended LU pair.
(4) Check the pair status is a "Pair" ("Duplex") or a "Copy" ("Pending Duplex"). |

If pair status does not change "Duplex" or "Pending Duplex" after executing a resume operation, please try delete pair operation (pairsplit-s command for Raid Manager), and execute Add pair operation (paircreate command for Raid Manager) again.

Procedure when the host hangs

If a host hangs up while it is writing data in HORC P-Vols, data difference between paired P-Vol and S-Vol may occur because of reasons as follows.

1. A write command didn't finish normally for some reason in DKC and it reported check condition to the host, but because of the hang-up, the host didn't retry the command.
2. During a process of a write command in DKC, a reset message was issued from the host and stopped the write command process, but because of the hang-up, the host didn't retry the command.

In this case, since write data of the last write command before hang-up was not written on the disk completely, please restart the job in order to complete the aborted command.

Recovery procedure when an error of HORC pair operation occurs

When either MCU or RCU is in a highly loaded condition, a pair operation (a command for paircreate, pairsplit, or pairsplit-S) from a RAID Manager to one or multiple HORC pair volume(s) may fail in (EX_CMDRJE or EX_CMDIOE). In this case, please check the pair status of the volumes that are objects of the operation. If the status is the same as before the pair operation, please retry the same pair operation.

Special mentions on SIM = 2182-XY

The SIM = 2182 host report is supported for the HRC/HORC activity with the CNT extender (Ultranet) between the MCU and RCU.

The SIM = 2182 indicates that the extender has detected a failure that occurred in a communication line or the ESCON link of a remote site and the failure has been reported to the MCU.

However, there are several special mentions on the SIM = 2182 report.

[Special mentions]

- ① When one extender has some alternative communication lines and a failure occurs on one line, the device will retry for another active line. Therefore, no line failure report is sent from the extender when the retrying succeeds.
- ② -The remote copy logical path that has received a line failure notification from the line extender is blocked (Path status: Communication Time Out).
-When recovering the logical path, please follow the HRC/HORC path recovery procedure ([TRBL06-180](#)).

6.3 Pinned Track Recovery Procedure for HRC/HODM/HORC

Pinned track recovery procedure for HRC/HODM/HORC is as follows.

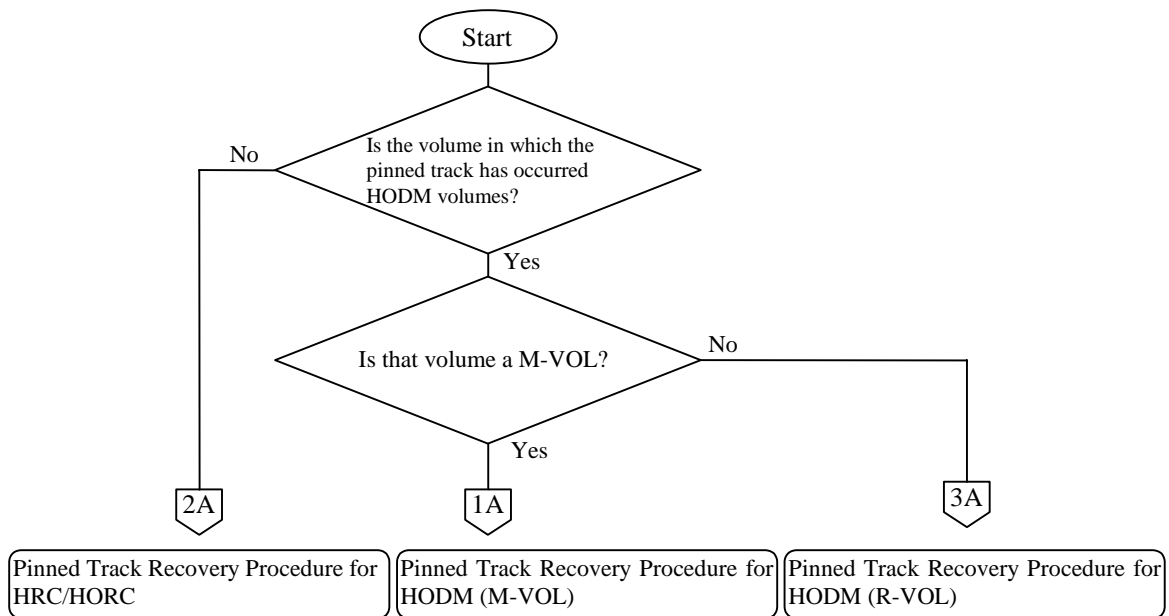

(Note)

If the pinned track has occurred in both M-VOL and R-VOL, recover the volumes according to the following sequence.

HRC/HORC : ① M-VOL → ② R-VOL

HODM : ① R-VOL → ② M-VOL

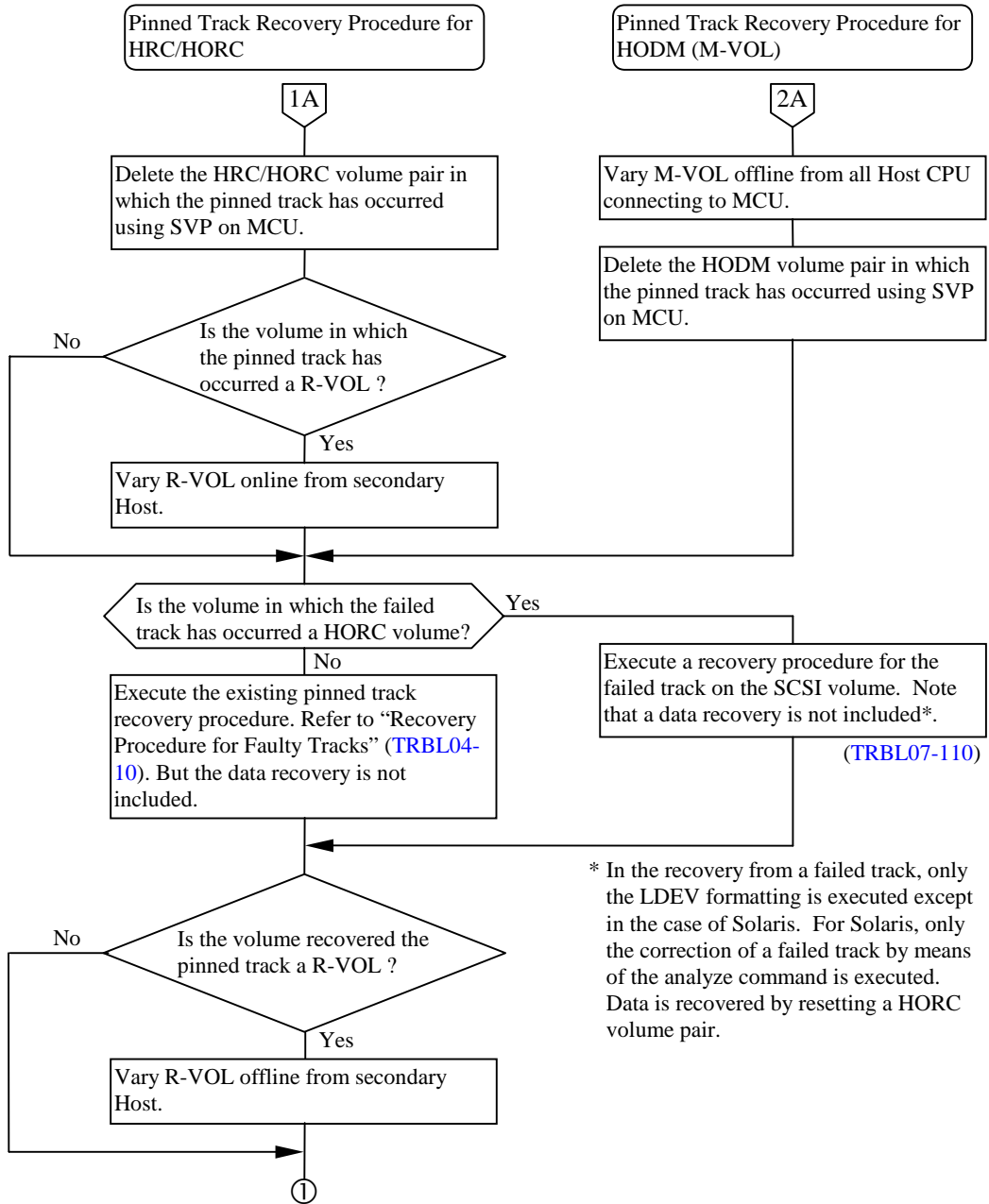

* In the recovery from a failed track, only the LDEV formatting is executed except in the case of Solaris. For Solaris, only the correction of a failed track by means of the analyze command is executed. Data is recovered by resetting a HORC volume pair.

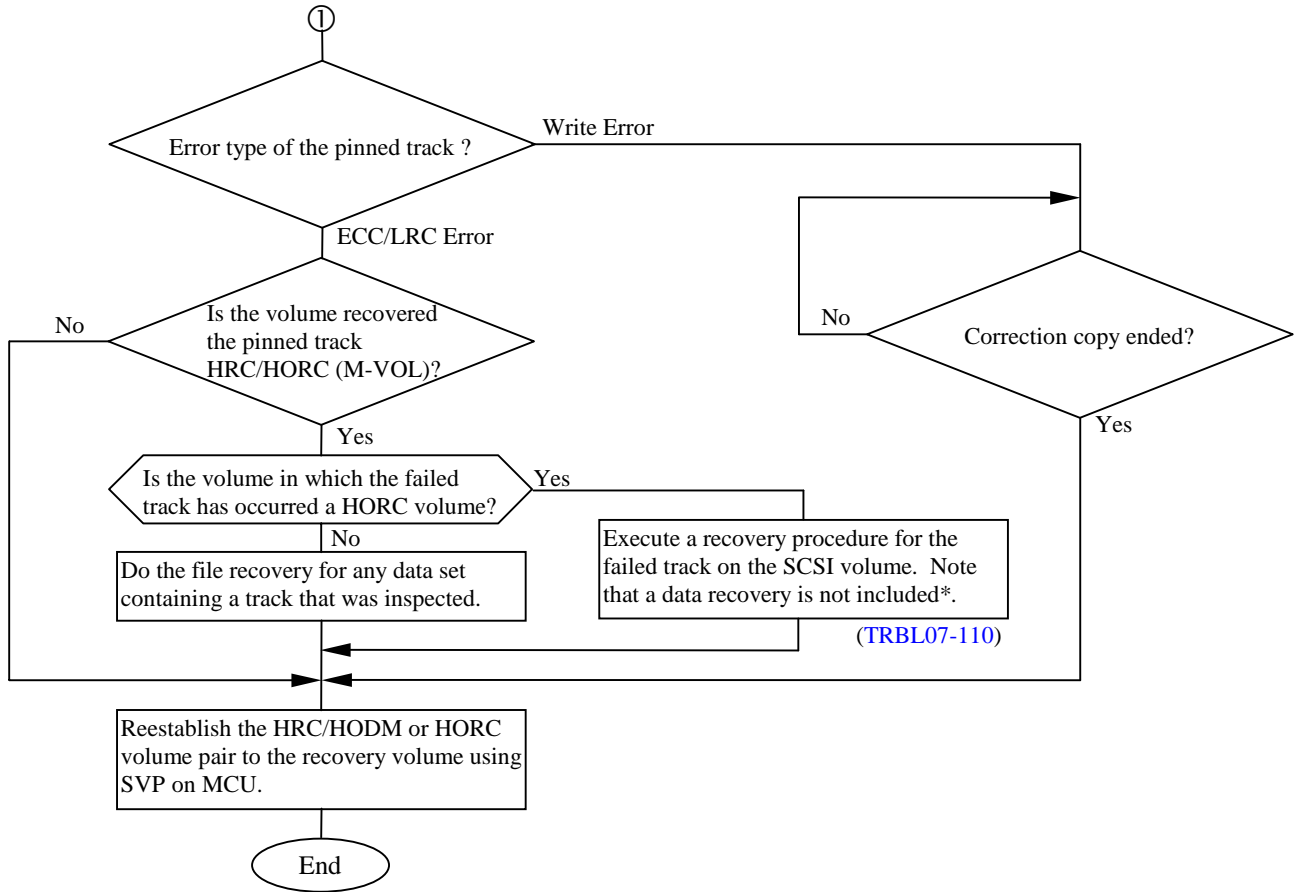

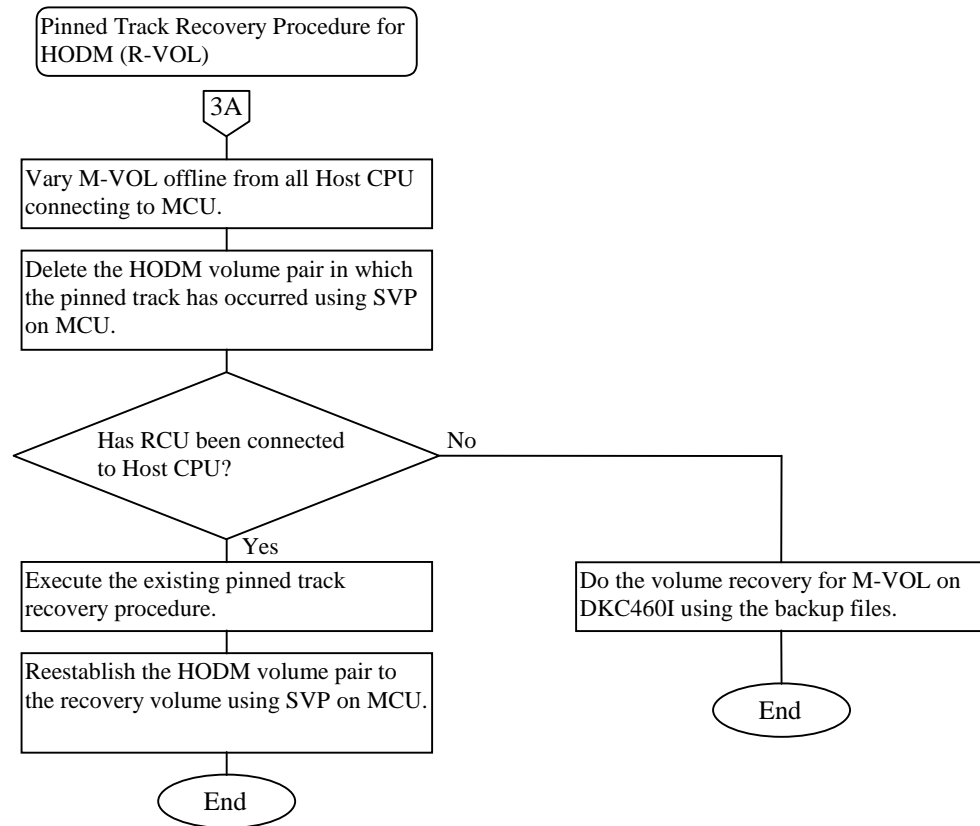

6.4 Recovery Action of Path Status Error

| Path Status | Factor | Recovery Action |
|---------------------------|---|--|
| “Nothing” | Establishing path or deleting path | Delete the path with “Edit Path” or “Delete RCU”, add a new path with “Edit Path” or “Add RCU”. |
| “Initialization Failed” | Incorrect the physical connection between the MCU and RCU | Correct the physical path connection between the MCU, RCU and the path relay equipment. |
| | Incorrect the Port topology settings.
(Fibre connection) | Setup the port topology of the both MCU and RCU correctly. |
| | Blockade of the MP or Port on the RCU | Repair the MP status or Port status on the RCU. |
| | Broken the connection cable physically | Replace the broken cable. |
| | Incorrect the path relay equipment settings or the path relay equipment doesn't work. | Correct the path relay equipment settings or repair it. |
| “Communication Time Out” | Blockade of the MP or Port on the MCU | Repair the MP status or Port status on the MCU. |
| “Resource Shortage (MCU)” | MCU resource over | Too many path in the MCU or the RCU. |
| “Resource Shortage (RCU)” | RCU resource over | Delete the paths and RCUs not currently in use. |
| “Serial Number Mismatch” | Incorrect the RCU S/N or Controller ID
(Fibre connection) | Delete the path with “Delete RCU”, add a new path with the correct RCU S/N and Controller ID with “Add RCU” again. |
| | Incorrect the physical connection between the MCU and RCU | Correct the physical path connection between the MCU, RCU and the path relay equipment. |
| | Incorrect the Port topology settings.
(Fibre connection) | Setup the port topology of the both MCU and RCU correctly. |
| | Blockade of the MP or Port on the RCU | Repair the MP status or Port status on the RCU. |
| | Broken the connection cable physically | Replace the broken cable. |
| | Incorrect the path relay equipment settings or the path relay equipment doesn't work. | Correct the path relay equipment settings or repair it. |

(To be continued)

(Continued from the preceding page)

| Path Status | Factor | Recovery Action |
|-------------------------------------|---|---|
| “Invalid Port” | Specified port is not existence on the MCU. | Delete the path with “Edit Path” or “Delete RCU”, add a new path with correct port on MCU again. |
| | Incorrect specified port type “Serial/Fibre”. | Delete the path with “Edit Path” or “Delete RCU”, add a new path with correct port type “Serial/Fibre” again. |
| | Specified MCU port type is not RCP or Initiator. | Change the channel type of the MCU port to RCP or Initiator. |
| | Incorrect the specified CU of MCU
(Serial connection) | Delete the path with “Edit Path” or “Delete RCU”, and add a new path with correct CU again. |
| | Incorrect the specified link address.
(Serial connection) | When MCU and RCU connects directly, set the link address to except "00".
When MCU and RCU does not connect directly, set the link address to "00". |
| | Exists the same path. | Confirm the MCU port , link address or RCU port, and logical address or CU#, and delete the path with “Edit Path”. |
| “RCU Port Number Mismatch” | Incorrect the specified RCU port. | Delete the path with “Edit Path” or “Delete RCU”, and add a new path with correct RCU port again. |
| | Incorrect the physical connection between the MCU and RCU | Correct the physical path connection between the MCU, RCU and the path relay equipment. |
| | Incorrect the Port topology settings.
(Fibre connection) | Setup the port topology of the both MCU and RCU correctly. |
| | Blockade of the MP or Port on the RCU | Repair the MP status or Port status on the RCU. |
| | Broken the connection cable physically | Replace the broken cable. |
| | Incorrect the path relay equipment settings or the path relay equipment doesn't work. | Correct the path relay equipment settings or repair it. |
| “RCU Port type is not 'RCU Target'” | Incorrect specified RCU port. | Delete the path with “Edit Path” or “Delete RCU”, and add a new path with correct RCU port again. |
| | Specified RCU port type is not RCU Target | Change the channel type of the RCU port to RCU Target. |
| “Communication Failed” | Blockade of the MP or Port on the RCU | Repair the MP status or Port status on the RCU. |
| | The path relay equipment doesn't work. | Repair the path relay equipment |

7 Trouble shooting of Multiplatform

7.1 Trouble shooting of error on host Fibre channel interface

This section describes troubleshooting of error on host Fibre channel interface.

7.1.1 Possible error and cause

Table 7-1 Possible error and cause

| No. | Possible error | Cause |
|-----|--|---|
| 1 | DKC460 LDEV is not recognized by Fibre initiator | (1) SCSI installation, i.e. recognition and connecting procedure from SCSI initiator is not executed correctly
(2) Problem of Fibre cable or connection
(3) Problem of Fibre initiator.
Fibre board, device driver version, parameters, etc.
(4) SCSI path definition from SVP
(5) Other |

7.1.2 Checking item when some errors occur on host Fibre channel path

Check item (correct value)

- (1) Is the DKC ready lamp lit? (The ready lamp should be lit. Check visually.)
- (2) Is the concerned channel port lamp lit? (The concerned channel port lamp should be lit. Check visually.)
- (3) Is the concerned LDEV status normal? (The LDEV status should be normal or correction access. Check on SVP.)
- (4) Is the concerned FCP/FOP status normal? (Check on SVP.)
- (5) Is the concerned CHF status normal? (Check on SVP.)
- (6) Are the CHF locations of Basic/Additional 1/Additional 2/Additional 3 or Cluster 1/Cluster 2 and the I/F connector panel location understood precisely?
Refer to [LOCATION04-80](#), [LOCATION04-100](#), [LOCATION05-50](#) and [INST03-FIB-10 through INST03-FIB-80](#) on DKC460I Maintenance Manual for correct information.
- (7) Is the concerned Fibre cable the one used without any problem?
Do the concerned Fibre cable work well with other Fibre devices?
Do another Fibre cable work well if it is replaced with the concerned Fibre cable?
- (8) Is the concerned Fibre cable connected to the I/F connector panel stably? *1
- (9) Is the concerned Fibre cable connected to the host Fibre board connector? *1
- (10) Isn't there any duplication of AL-PA (port ID)? (Check SVP path definition, Port ID of the host board, and ID of other devices.)
- (11) Is the SVP SCSI path definition correct?
- (12) Is Fibre installation work from Fibre host done correctly?
- (13) When the problem is not resolved by above methods, extracting the information of [TRBL7-40](#) ③, please contact TSC (Technical Support Center)

*1 : Check visually or check by shutting down the Fibre host disconnect and reconnect the cable.

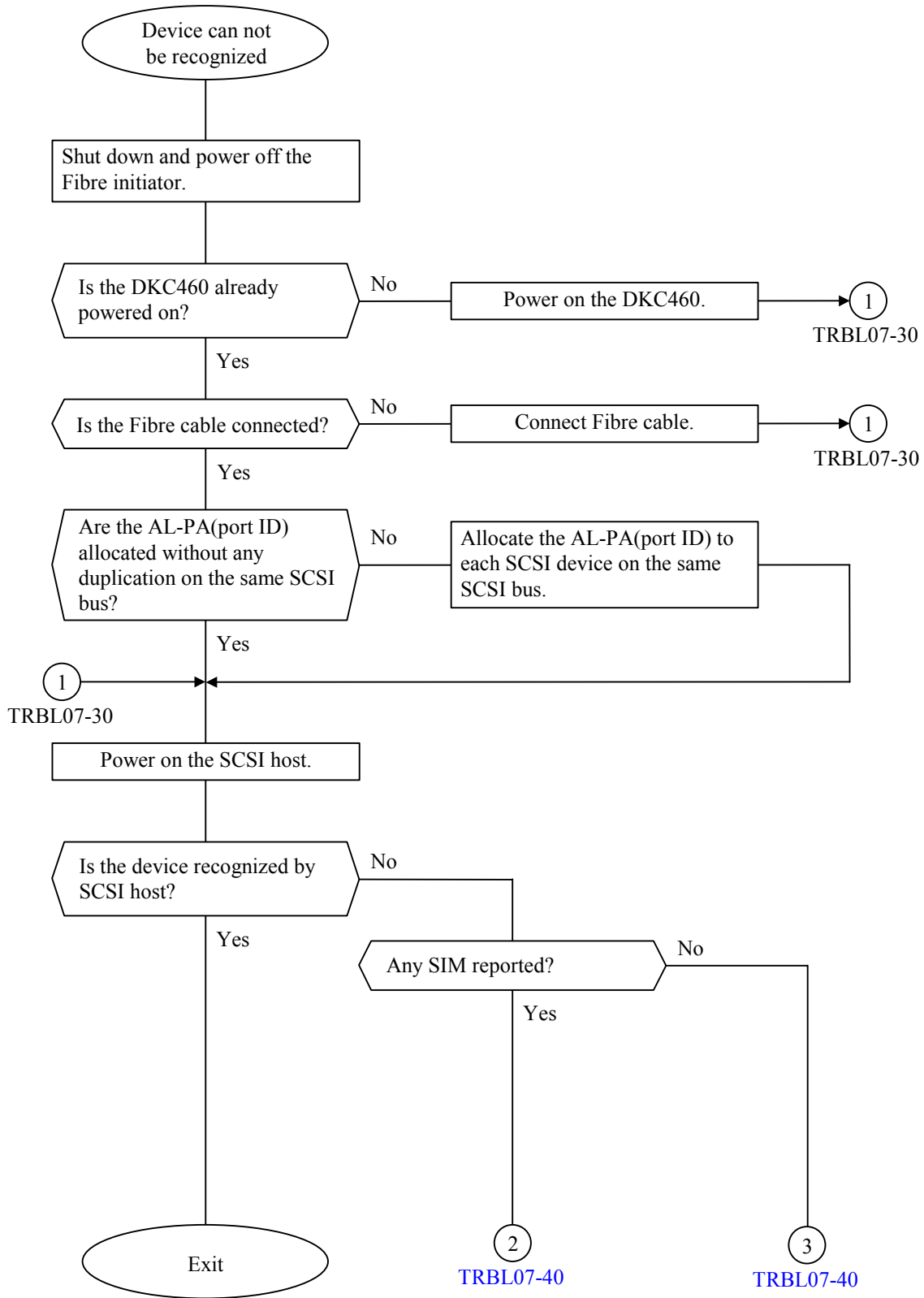

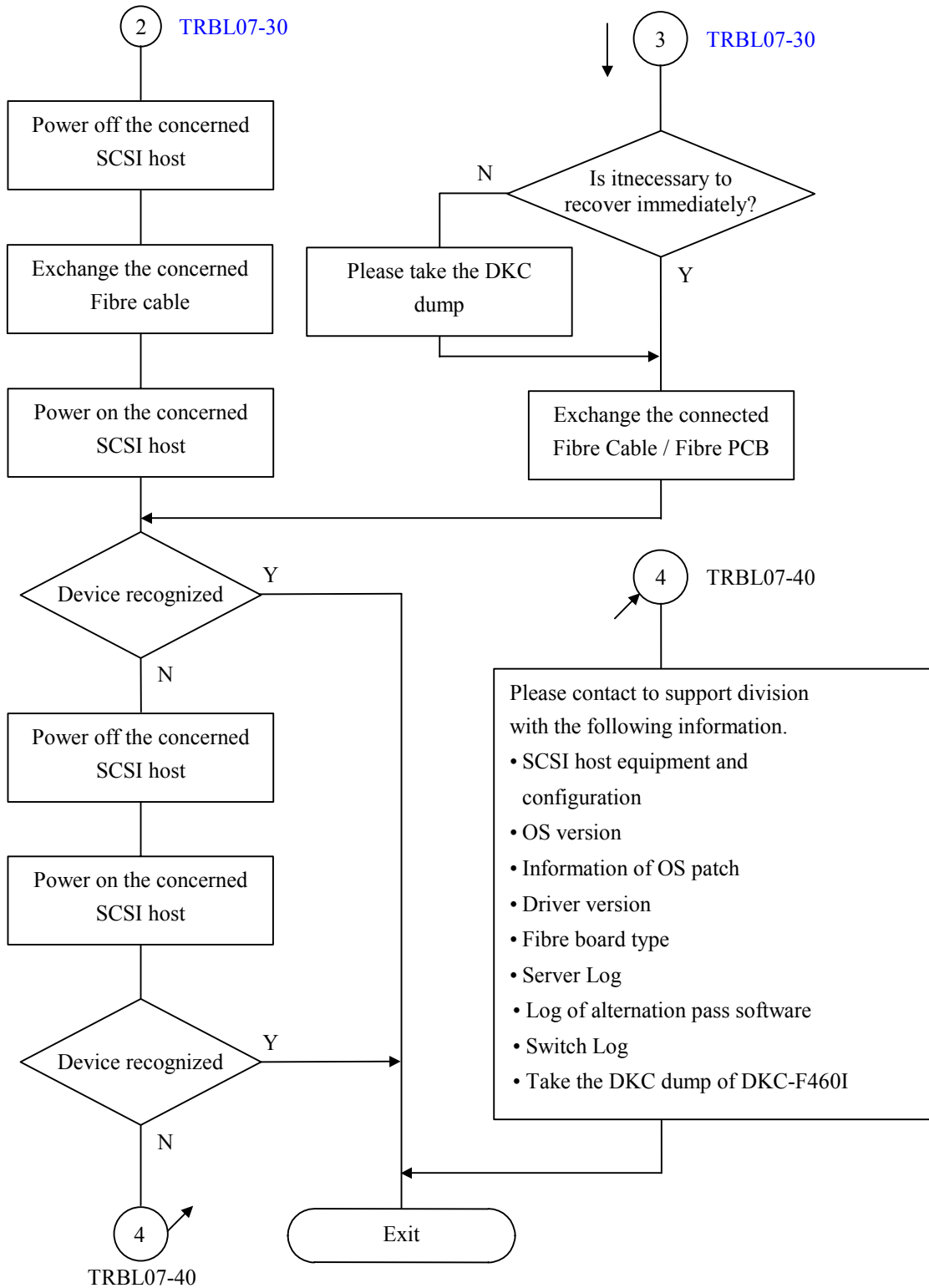

7.3 Pinned track recovery of SCSI LDEV

This chapter shows about the explanation and the recovery procedure for faulty tracks in the OPEN-VOL.

7.3.1 Faulty Tracks

Hardware error sometimes causes pinned track to occur.

The following reports are to inform pinned track occurrence.

- The read-error report or the time-out error report from Application occurs.
- SIM report of pinned track occurrence.

| SIM REF.CODE | Meaning | Comment |
|--------------|---------------------------------------|-----------------------|
| EF4X-XX | Unable to write to PDEV on a track. | X-XX : CU-LDEV number |
| FF4X-XX | Unable to read from cache on a track. | X-XX : CU-LDEV number |

To recover pinned tracks, the following information about the pinned track to be recovered are necessary.

- Address in LDEV(LDEV number)
- First and last LBA of stripe including the pinned track
* LBA : Logical Block Address
- Error type of the pinned track
- PDEV number including the pinned track

These information can be obtained by “Pinned Data indication” ([SVP02-940](#)) in SVP.

7.3.2 Error Types

Pinned track has 2 error types as follows.

| Display on SVP | | Meaning | Cause | Recovery method |
|----------------|---------------|----------------------------|-------------|---------------------|
| Slot | Reason | | | |
| — | Write Error | Unable to write to PDEV. | Drive error | Replacement of PDEV |
| DATA | ECC/LRC Error | Unable to read from Cache. | Cache error | File recovery |
| PRTY | ECC/LRC Error | Unable to generate parity | Cache error | — |

The following document explains each error type of the pinned track and shows the recovery flow chart for the ECC/LRC Error in the OPEN-VOL. As for the pinned track except the ECC/LRC error condition in the OPEN-VOL, refer to [TRBL04-10](#) section.

7.3.2.1 ECC/LRC Error

Cause:

- (1) An ECC/LRC type of a pinned track is caused when dirty data stored in both Cache sides A/B can not be accessed correctly. Also, during a dirty data de-stage process the data read from Cache sides A/B is failed, an ECC/LRC Error is set. In this case, the host I/O operation is processed normally. However, if the host I/O access to Cache side A/B is failed, the original data for the track is lost.
- (2) ECC/LRC type of a pinned track is caused when a failed de-staging track occurs due to a drive failure during P/S Off and On without batteries. In this case, the original data for the track is lost.
- (3) ECC/LRC type of a pinned track is caused when a track cannot be correctly reconstructed during a correction copy. In this case as stated above in (2), the original data for the track is lost.
- (4) ECC/LRC type of a pinned track is caused when a parity track cannot be correctly reconstructed during a parity construction process. This means that all data tracks in the stripe do not match up with a parity track.
Factors involving a parity construction failure are as follows.
 - (a) When all necessary data required for a party reconstruction process is not gathered correctly due to a failure drive etc. In a detail, when one or more data tracks(old data) within the stripe have failed staging tracks due to a drive failure.
 - (b) When a parity data de-staging failed due to a drive failure.

Result of host I/O operation:

When a track with an ECC/LRC Error is accessed, the result of the host I/O operation is as follows;

- (a) If the read in the track is possible, the host I/O operation ends normally.
- (b) If it isn't possible to read a track, "(03)h: Medium Error" or "(0b)h: Abort" to I/O operation is reported to the host. In this case, data is lost.

The outline of the recovery procedure:

A track with ECC/LRC Error means that the original data for the track may be lost. Therefore, we recommend to a customer that a recovery of the data for the track with ECC/LRC Error in the OPEN-VOL should be performed from a back-up file etc.

A recovery method for the track with ECC/LRC Error in the OPEN-VOL is as follows;

- (1) Obtains the CU-LDEV number which the pinned track occurred by “Pinned Data Indication”(SVP02-940) in SVP and the head and the last LBAs of the pinned track.
- (2) Executes the “showrel” tool and examine the relation in fault LDEV and the device which the file system recognizes.
- (3) Checks a volume on the file system which is composed of the device and also checks data in the volume. (Using the command like **sum**)
- (4) Requests the customer the recovery of the data whth “I/O error” or “read error” from a back-up file, etc.
- (5) Confirms pinned track information by “Pinned Data Indication” (SVP02-940) in SVP. If there is not a display of the pinned track and the system test result is normal, the recovery is ended. If a new pinned track occurs, back to the process of hard error recovery.
- (6) If an old pinned track display is left, executes the Pin Track Tool.
- (7) For the “slot:PRTY” display, the Pin Track Tool isn’t necessary.
It is automatically recovered when the pinned track of the “slot:DATA” display is recovered.

The cancellation of the faulty tracks

When data is written to the whole stripe, the whole stripe data is fixed and the fault track is canceled.

7.3.2.2 Write Error

Cause:

Write Error type of a pinned track is caused when the data de-staging process to the PDEV failed due to a drive failure. When a drive failure occurs, the drive itself and the DKC perform the following recovery procedure. A write Error occurs when the following recovery procedure failed.

- (1) Medium failure : Automatic reallocation of alternate sector.
- (2) Other failure : Alternate path retry.

Write Error count information per PDEV is stored in DKC. When a Write Error count exceeds the threshold value, the PDEV is blocked. One PDEV blocked per parity group will not stop the DKC operation to the parity group. When a track with Write Error is accessed by the host after the PDEV is blocked, the Write Error status will reset.

Result of host I/O operation:

Any access to a track with Write Error will be successful.

Recovery Method:

The PDEV containing a track with Write Error is replaced. At this time, if the blocked PDEV already exist within the parity group, first replace the blocked PDEV which already exists. Next, replace the PDEV containing a track with Write Error. Also, if there are many PDEVs containing a track with Write Error, check the ORM Display on the SVP Panel, then replace the PDEV with the Highest Error Rate. A track with Write Error is recovered by a correction copy.

7.3.3 Pinned track erasing procedure

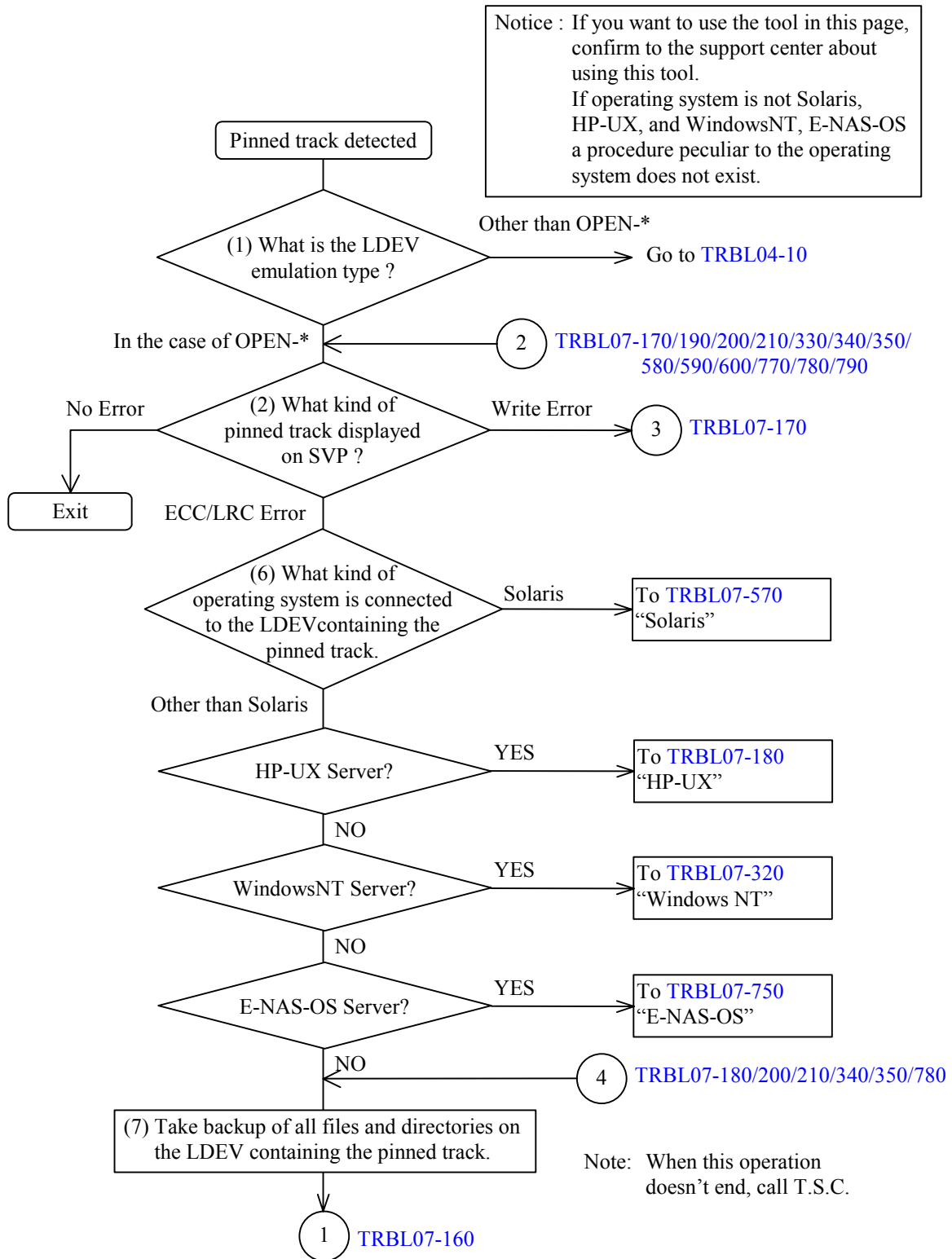

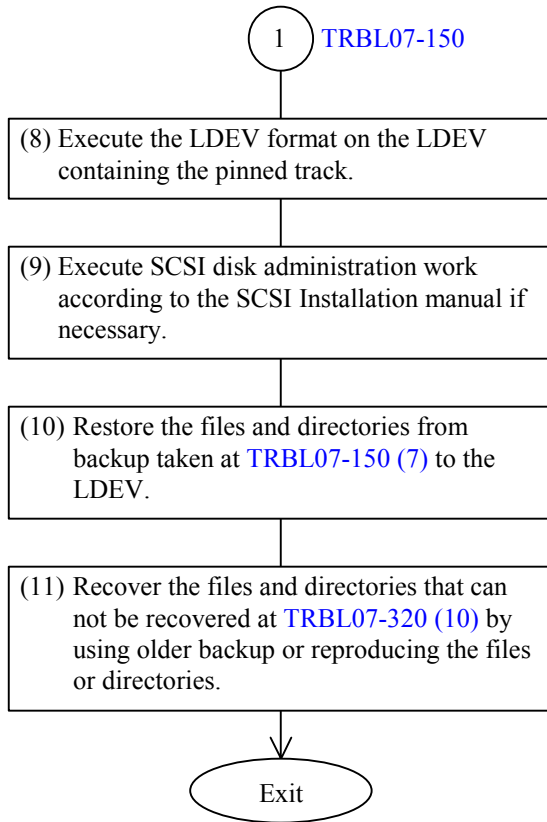

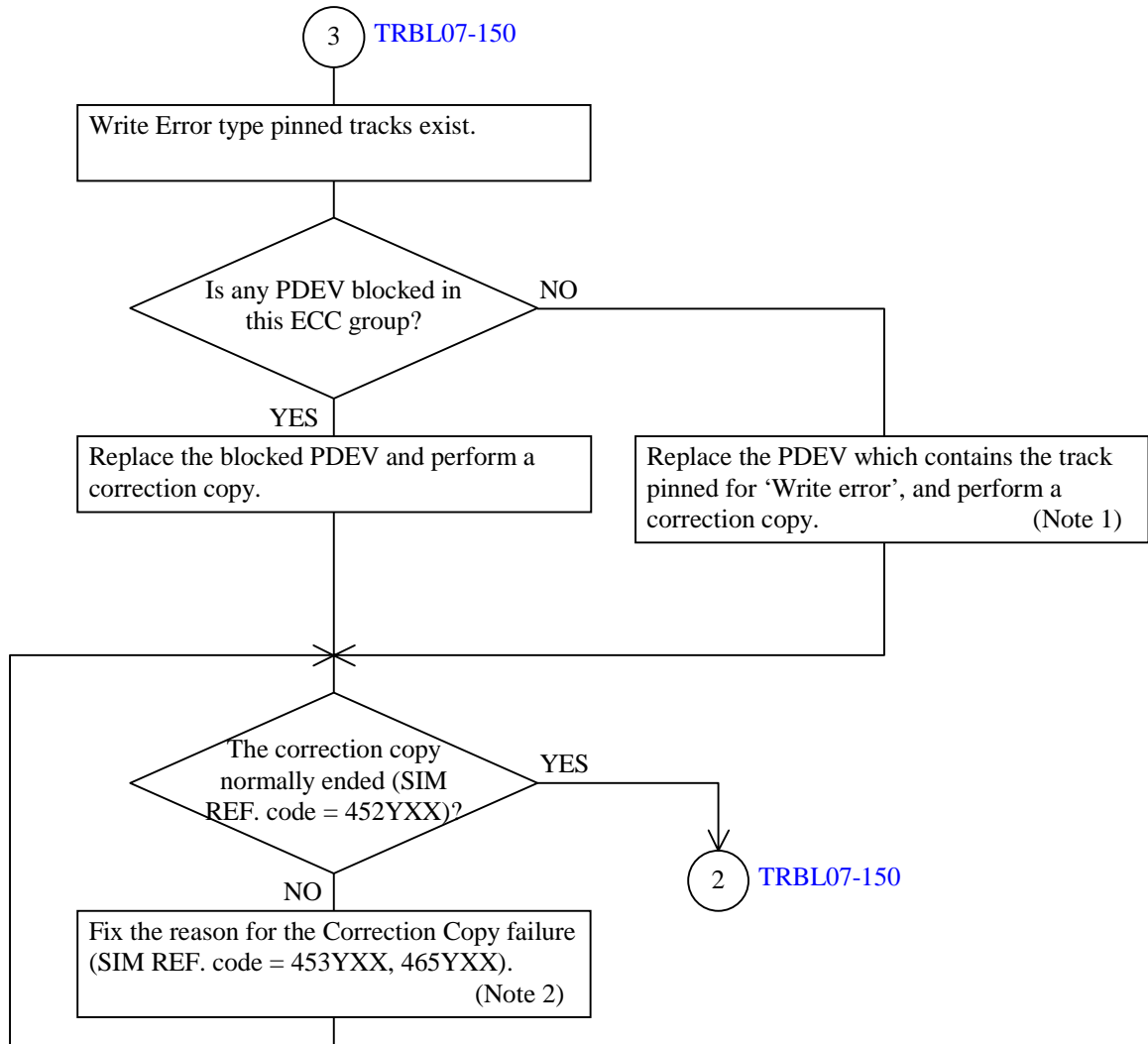

Note 1 If spare drives are available, you can perform Drive copy instead of Correction copy.

Note 2 If Drive copy abnormally ended, the SIM REF. code is “453YXX” or “465YXX”.

7.3.3.1 HP-UX Procedure

This chapter shows the pinned track erasing flow about the HP-UX system.
 Procedure Flow

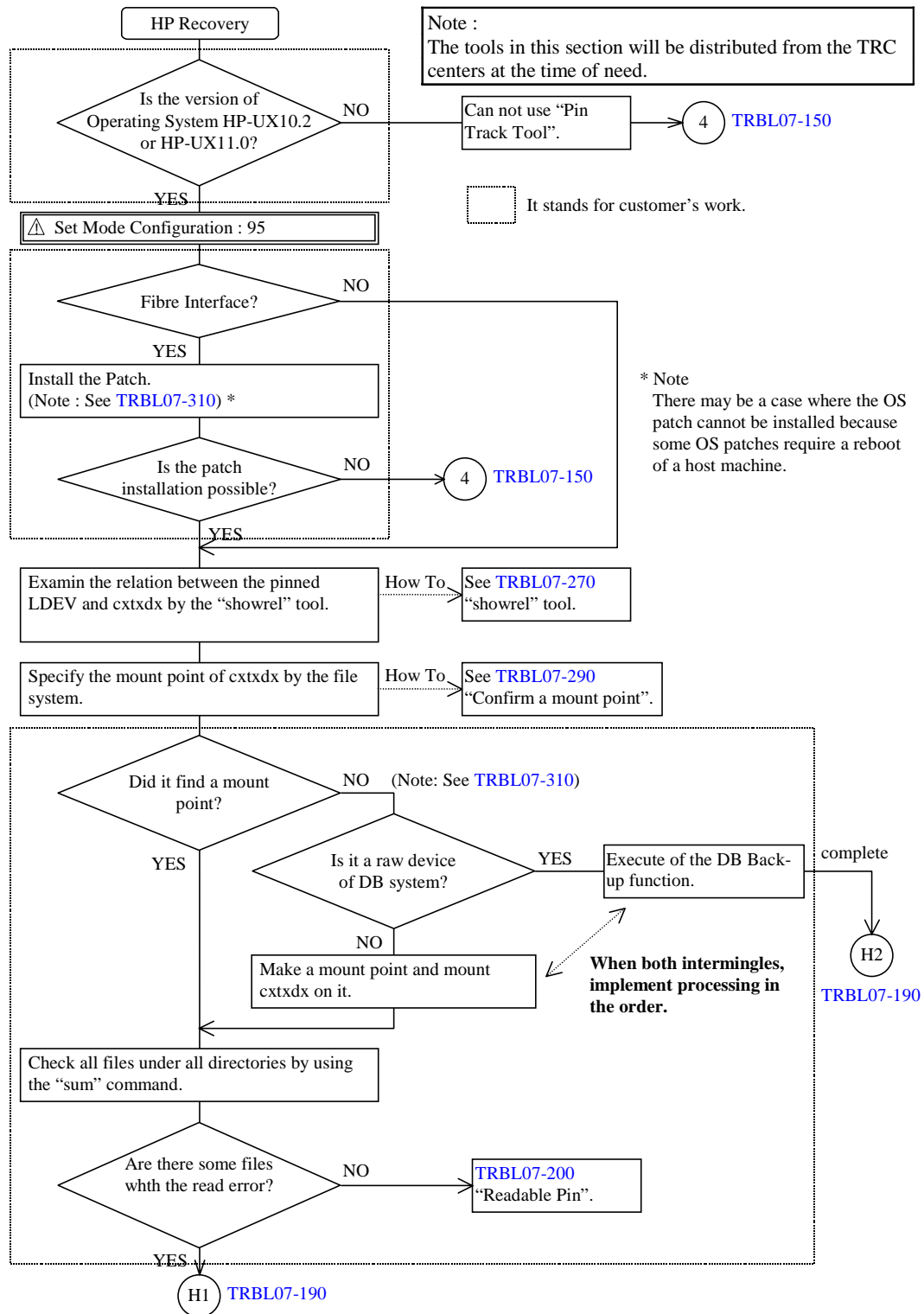

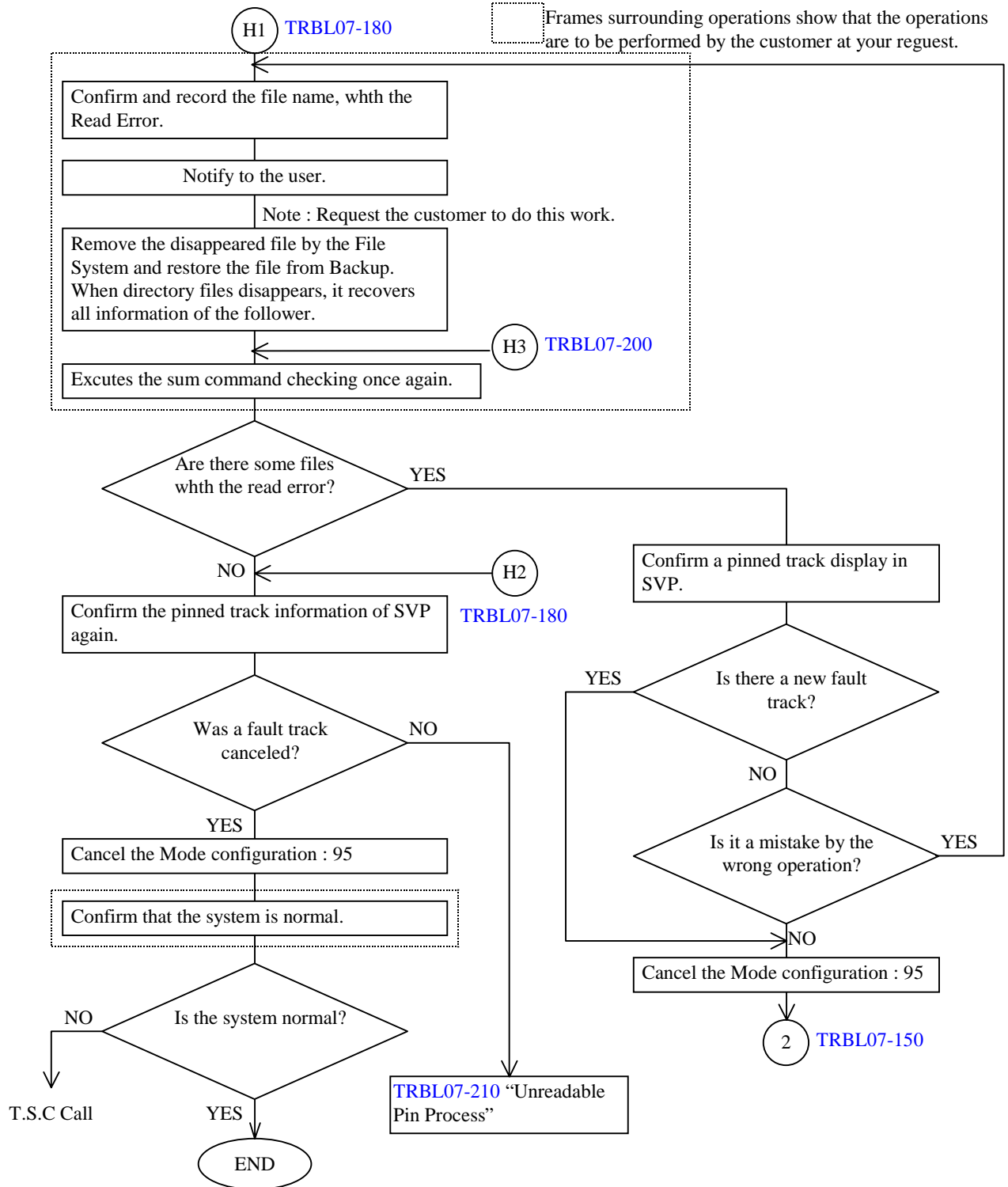

Readable Pin Process

The erasing flow in the readable pinned track by Pin Track Tool is as follows.

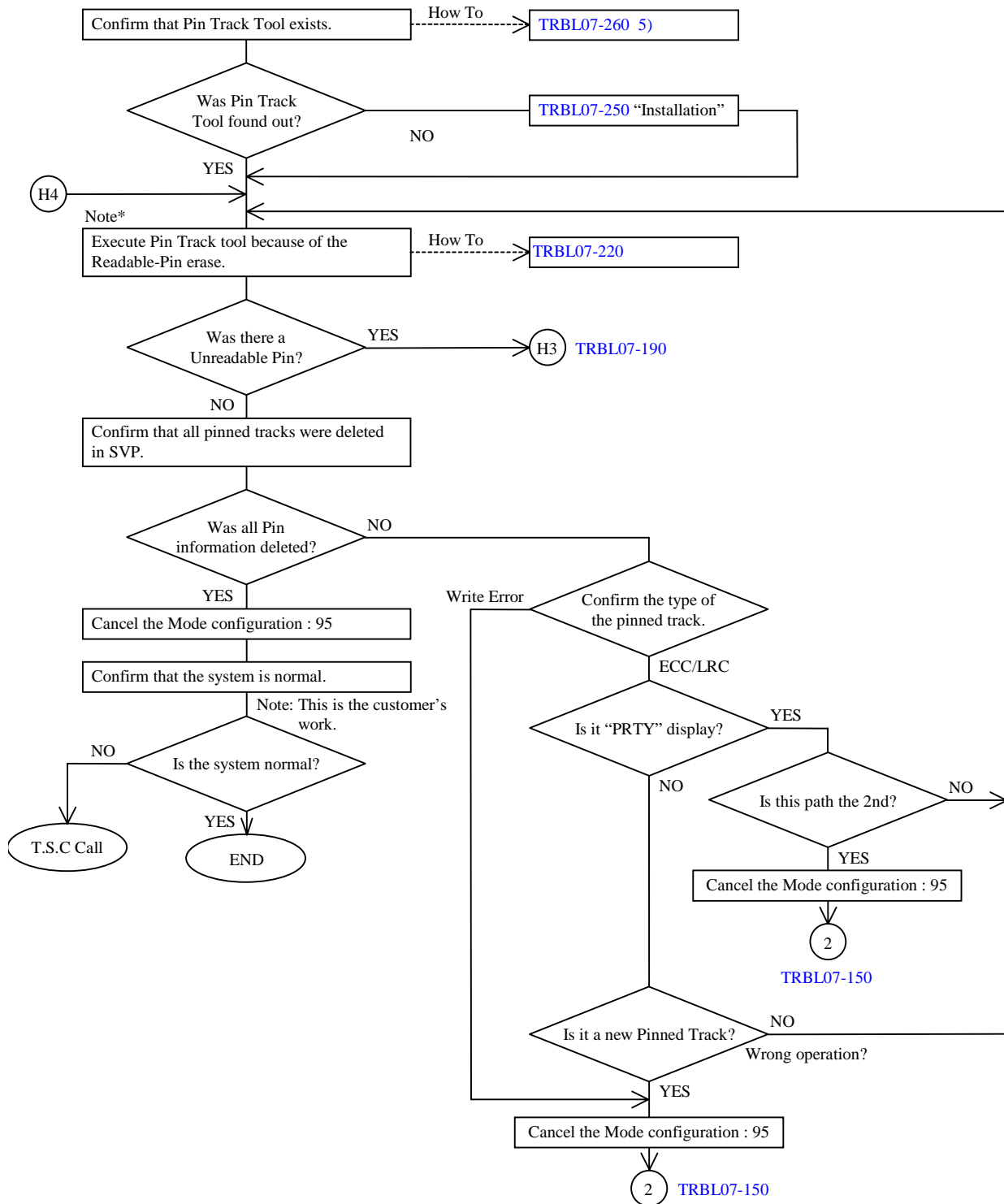

*** Note** - On an SIM reported owing to a use of the Pin Track Tool -
 When two or more Pins have been generated in the LBAs adjacent in the same LU, a generation of a new temporary Pin caused by the parity calculation performed in the Pin Track process may occur and a SIM may be reported. Since this Pin is erased at the same time when the erasing process of the Pin concerned completes, complete the SIM when the erasure of all the Pins by the Pin Track Tool is confirmed.

Unreadable Pin Process

The erasing flow in the unreadable pinned track by Pin Track Tool is as follows.

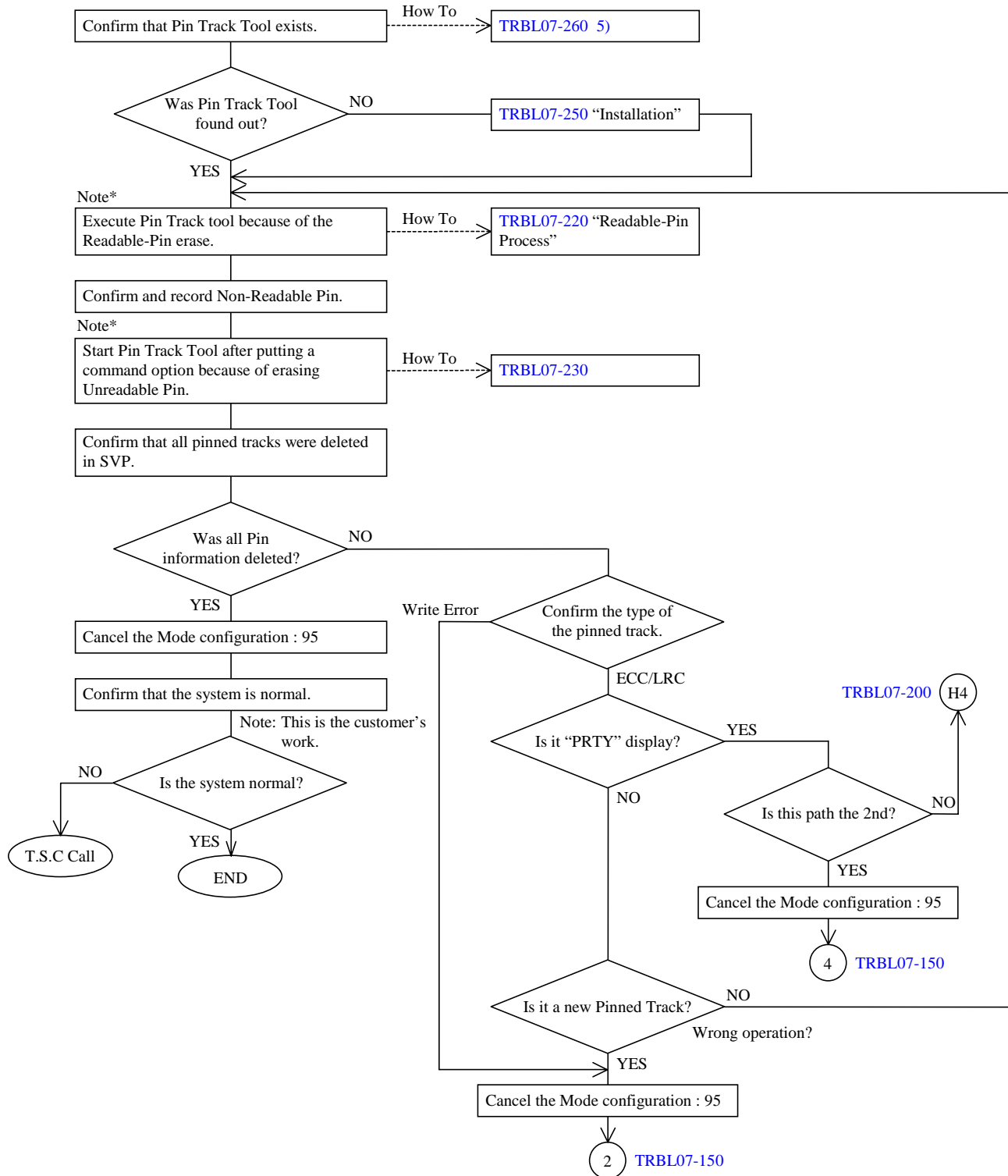

* **Note** - On an SIM reported owing to a use of the Pin Track Tool -
When two or more Pins have been generated in the LBAs adjacent in the same LU, a generation of a new temporary Pin caused by the parity calculation performed in the Pin Track process may occur and a SIM may be reported. Since this Pin is erased at the same time when the erasing process of the Pin concerned completes, complete the SIM when the erasure of all the Pins by the Pin Track Tool is confirmed.

Operation of Readable-Pin Process (HP-UX)

This clause describes how to operate the Pin Track Tool to erase Readable-Pin.

<Operation>

- 1) Move to the directory of the Pin Track Tool.

```
# cd /usr/raidopen/pinhp
```

- 2) Execute the Pin Track Tool without a command option.

```
# ./pinhp.exe -log (Put pass ".")
```

Note: This option “-log” collects detailed logs.

However, when processing LBA with (60)h length, the log becomes about 400KB.

Be careful of the available capacity of the disk. (refer to [TRBL07-280](#).)

- 3) According to the question, input the appropriate information.

```
# ./pinhp.exe -log
```

```
Input Device Name -> /dev/rdisk/c3t0d0
```

```
Input Start LBA Data -> 180
```

```
Input End LBA Data -> 1df
```

```
Input Next LBA?(Y/N) -> n
```

```
Input Next Device?(Y/N) -> n
```

(Input the LBA number which was acquired from SVP.
Do not input the LBA of the “slot:PRTY” display.)

(When there still is a fault track in the same Device, it inputs "y".)

(When erasing different Device at the same time, it inputs "v".)

- 4) Because an input data list is displayed, check the input information.

| Device Name | Start LBA | End LBA |
|-------------------|-----------|----------|
| /dev/rdisk/c3t0d0 | 00000180 | 000001DF |

Before you try to proceed the readable pin,
please check the pin information on SVP.
If the pin data has been cleared, please do not try to proceed the pin data again.
Do you want to do the process of the readable Pin?
Please input[y/n(default n)] : y

When the input is not collect, input “n” or just hit [Return] and then start the procedure again from (2).

Confirm whether or not a pinned track is deleted from the display of SVP.

When the data is already deleted, input "n" or just hit [return]. When canceled, input "y" and [return].

- 5) When the Pin is judged, Unreadable through the pin type judgment, go to [TRBL07-230](#).

Unreadable Pin:

| Device Name | Start LBA | End LBA |
|-------------------|-----------|----------|
| /dev/rdisk/c3t0d0 | 00000180 | 000001DF |

Note: This tool recognizes an inputted range as the 1 processing unit.

Therefore, the range where Unreadable pin exists is displayed in the inputted range.

- 6) When Pin Track Tool ends, a log file (month -day -hour -minute -second .log) is made on the same directory. (ex:0614200552.log)

As for the log file, the execution result of the Pin Track processing is recorded.

Confirm that processing was normally ended (there is “Pin Track Process completed” in the log file).

Operation of Unreadable Pin Process (HP-UX)

This clause describes how to operate the Pin Track Tool to erase Unreadable Pin.

<Operation>

- 1) Move to the directory of the Pin Track Tool.

```
# cd /usr/raidopen/pinhp
```

- 2) Put a command option and execute a pin recovery tool.

```
# ./pinhp.exe -f -log
```

(Put command option “-f”)

Note: This option “-log” collects detailed logs.

However, when processing LBA with (60)h length, the log becomes about 400KB.

Be careful of the available capacity of the disk. (refer to [TRBL07-280](#).)

- 3) According to the question, input the appropriate information.

```
# ./pinhp.exe -f -log
```

```
Input Device Name -> /dev/rdisk/c3t0d0
```

```
Input Start LBA Data-> 180
```

```
Input End LBA Data -> 1df
```

```
Input Next LBA?(Y/N) -> n
```

```
Input Next Device?(Y/N) -> n
```

Input the LBA number which was acquired from SVP.
Do not input the LBA of the “slot:PRTY” display.

(when there still is a fault track in the same device, it input “y”.)

(When erasing different device at the same time, it inputs “y”.)

- 4) Because an input data list is displayed, check the input information.

| Device Name | Start LBA | End LBA |
|-------------------|-----------|----------|
| /dev/rdisk/c3t0d0 | 00000180 | 000001DF |

Before you try to proceed the readable pin,
please check the pin information on SVP.
If the pin data has been cleared, please do not try to proceed the pin data again.
Do you want to do the process of the readable Pin?
Please input[y/n(default n)]: y

When the Input is not correct, input “n” or just hit [Return] and then start the procedure again
From (2).

Confirm whether or not a pinned track is deleted from the display of SVP.

When the data is already deleted, input “n” or just hit [return]. When canceled, input “y” and
[return].

- 5) When Unreadable Pin is judged, the following message is displayed.

```

Unreadable Pin:
Device Name          Start LBA          End LBA
/dev/rdisk/c3t0d0   00000180          000001DF
Do you want to do the process of the unreadable Pin?
WARNING! if you input 'y', Pin Blocks will be over written by '0'.
Please input[y/n(default n)]: y

```

When erasing by the "0" writing to Unreadable Pin, input "y" and [Return].

Note: This tool recognizes an inputted range as the 1 processing unit.

Therefore, the range where Unreadable pin exists is displayed in the inputted range.

- 6) When “y” is chosen by (5), the check message is displayed at once for every number of inputs. In case of plural number input, an operator can cancel the pin recovery processing for the device which you does not want to execute.

```

Unreadable Pin:
Device Name          Start LBA          End LBA
/dev/rdisk/c3t0d0   00000180          000001DF
Do you want to do the process of the unreadable Pin?
WARNING! if you input 'y', Pin Blocks will be over written by '0'.
Please input[y/n(default n)]:y
Do you want to do the process of the unreadable Pin? (The strip of LBA is
00000180-000001DF). (Y/N)

```

- 7) When Pin Track Tool ends, a log file (month -day -hour -minute -second .log) is made on the same directory. (ex:0614200552.log)
As for the log file, the execution result of the Pin Track processing is recorded.
Confirm that processing was normally ended (there is “Pin Track Process completed” in the log file).

How to read the Read Test for whole of a disk (HP-UX)

This chapter describes how to discover the Unreadable Pin on select device.

This processing requires long time.

- 1) Move to the directory of the Pin Track Tool.
cd /usr/raidopen/pinhp
- 2) Execute the Pin Track Tool without a command option.
./pinhp.exe -all (The “-f” will become invalid if this option is used.)
- 3) According to the question, input the appropriate information.
./pinhp.exe -all
Input Device Name -> /dev/rdisk/c3t0d0
Input Next Device ?(Y/N) ->n (Recommend to “n”) (When erasing different Device at the same time, it inputs “y”)
- 4) The Input data list is displayed.

| Device Name | Start LBA | End LBA |
|--------------------------|-----------------|-----------------|
| /dev/rdisk/c3t0d0 | 00000000 | 001F2285 |

Show all domain of LAB which is specified device, and execute.

- 5) When Pin Track Tool ends, a log file (month -day -hour -minute -second .log) is made on the same directory. (ex:0614200552.log)
The log when two area (120-17F, 1E023F) of Unreadable Pin exists in specified DeviceName becomes as follows.

| |
|---|
| Input Device Name = /dev/rdisk/c3t0d0
ERROR: Read Error LBA 00000120-0000017F
ERROR: Read Error LBA 000001E0-0000023F |
|---|

Note: The area and number of Unreadable Pin listed by other factors here may differ from the area and number of Unreadable Pin displayed by SVP.

Installation of Pin Track Tool (HP-UX)

This clause describes the installation of Pin Track Tool.

The preliminary preparation

If work logs need to be collected by the Pin Track Tool, confirm that there is the disk capacity for collecting in the work log.

An installation procedure from the tape device (ex: 4mmDDS-DAT) is shown below.

Installation

- 1) Login to the host as "root".
- 2) Move to the install area by the "cd" command and make a directory "raidopen".
 - # **cd /usr** (ex: Move to the "/usr")
 - # **mkdir raidopen** (ex: Make the directory "raidopen")
- 3) Move to the created directory and copy a file from the tape by the "tar" command.
 - # **cd raidopen** (ex: Move to the "raidopen")

-In case of DDS-DAT-(Devide Name depends on each host)

- # **mt -t /dev/rmt/0m rew** (ex: Rewing a tape)
- # **tar -xvf /dev/rmt/0m** (ex: copy a file from the tape.)
- # **tar -xvf ./pinhpXX.tar** (ex: copy the tar file for HP-UX)

-In case of CDROM-(Devide Name depends on each host)

- # **mount -F cdfs -o cdcase /dev/dsk/c2t6d0 SD_CDROM** (ex: mount the CDROM)
- # **tar -xvf /SD_CDROM/program/ment/pintrack/hp_ux/pinhpXX.tar** (ex: copy a file from the CDROM.)

- 4) After the thawing is complete, confirm a file name.
 - # **cd ./pinhp** (ex: Move to the directory made by the thawing.)
 - # **ls -l** (ex: Display a file list.)

- 5) Refer to the contents of “Ver-Rev.txt” file and confirm each file size of the list.
more /usr/raidopen/pinhp/Ver-Rev.txt display contents of the file

```
HITACHI RAID Subsystem PinTrackTool for HP-UX
Ver XX-YY-/Z (Revision ID)
All right reserved, Copyright (c) 1999,2000, Hitachi Ltd.
File size (Bytes) pinhp.exe (Module ID)
File size (Bytes) showrelh.exe (Module ID)
```

Confirm that the contents of “Ver-Rev.txt” and a list of the “ls -l” command are identical.

File preservation and the way of removing Pin Track Tool.

Log-File preservation

- 1) Compress the log file made by the pin recovery.
 - # cd /usr/raidopen/pinhp** (ex: Move to the working directory.)
 - # mkdir ./log** (ex: Make to the directory for Log-file.)
 - # mv *.log ./log** (ex: Move logfiles to the directory for Log-file.)
 - # tar -cvf pinlog.tar ./log** (ex: Make the tar file from logdir.)
 - # compress pinlog.tar** (ex: Compress the “pinlog.tar” file.)
- 2) Preserve the log file at the tape and rewind it..
 - # tar -cvf /dev/rmt/0m pinlog.tar.Z** (ex: Preserve log file)
 - # mt -t /dev/rmt/0m rew** (ex: rewind the tape)

The way of removing Pin Track Tool

The removal of the Pin Track Tool deletes all bottoms of the installed directory.

- # cd /** (ex: Move to the root directory.)
- # \rm -r /usr/raidopen/pinhp*** (ex: Deletes all bottoms of the installed directory)

The acquisition of the device information(HP-UX)

This chapter describes the tool “showrel” to acquire the device information.

- 1) Move to the installed directory.
cd /usr/raidopen/pinhp
- 2) Input commands as follows.
./showrelh.exe (Put the path “./”)

<Display Example>

The display depends on the specification of the disk subsystem.

For the Hitachi specification, it is displayed as follows.

```

#./showrelh.exe

Device File      ---> Port   Serial#  LDEV#
/dev/rdisk/c0t0d1 ---> CL1M    3ABE    01A6
/dev/rdisk/c0t0d2 ---> CL1M    3ABE    01A7
/dev/rdisk/c0t0d3 ---> CL1M    3ABE    01A8
/dev/rdisk/c0t0d4 ---> CL1M    3ABE    01A9
/dev/rdisk/c0t0d5 ---> CL1M    3ABE    01AA
/dev/rdisk/c0t0d6 ---> CL1M    3ABE    01AB
  
```

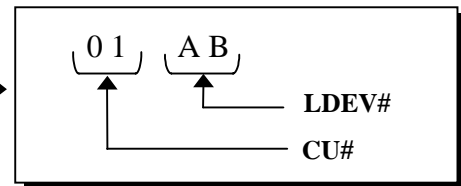

For the OEM specification, it is displayed as follows.

The point of view of CU:LDEV# is the same.

```

#./showrelh.exe

Device File      ---> Port   Serial#  LDEV#
/dev/rdisk/c7t2d1 ---> CL2E   00010028 03C0
/dev/rdisk/c7t2d2 ---> CL2E   00010028 03C1
/dev/rdisk/c7t2d3 ---> CL2E   00010028 03C2
/dev/rdisk/c7t2d4 ---> CL2E   00010028 03C3
/dev/rdisk/c7t2d5 ---> CL2E   00010028 03C4
/dev/rdisk/c7t2d6 ---> CL2E   00010028 03C5
  
```

“LDEV#” is composed of the CU number and the LDEV number. Confirm CU# and LDEV# with the pinned track displayed in SVP and specify a clearing device file.

Device File name is input information to Pin Track Tool.

(Example) Above mentioned “For the Hitachi specification”,

LDEV# = **01A6** → Device File = **/dev/rdisk/c0t0d1**

Notice: In the case of HP-UX, If there is LDEV that is non given LUN#, LDEV#159F or LDEV#FFFF are displayed to LUN# non-given a definition by showrelh.exe.

The way of examining Mount Point which has a Pinned Track(HP-UX)

Note : As for the following work, request a system administrator to operate.

- 1) Input the "vgdisplay" command and to display a Volume Group list.

```
# vgdisplay -v
```

- 2) Specify "lvol(/dev/vgx/lvolx)" which is composed of Physical Volume(cxtxdx) with the Pinned Track.

<Display Example>

| | | |
|--------------------------|-----------------|--|
| --- Volume groups --- | | |
| VG Name | /dev/vg11 | ← Volume Group Name |
| VG Write Access | read/write | |
| VG Status | available | |
| Max LV | 255 | |
| Cur LV | 1 | |
| Open LV | 1 | |
| Max PV | 16 | |
| Cur PV | 4 | |
| Act PV | 4 | |
| Max PE per PV | 1016 | |
| VGDA | 8 | |
| PE Size (Mbytes) | 4 | |
| Total PE | 2344 | |
| Alloc PE | 2000 | |
| Free PE | 344 | |
| Total PVG | 0 | |
| Total Spare PVs | 0 | |
| Total Spare PVs in use | 0 | |
| --- Logical volumes --- | | |
| LV Name | /dev/vg11/lvol1 | ← "/dev/vg11/lvol1" is made in a Volume Group("/dev/vg11") |
| LV Status | available/syncd | |
| LV Size (Mbytes) | 8000 | |
| Current LE | 2000 | |
| Allocated PE | 2000 | |
| Used PV | 4 | |
| --- Physical volumes --- | | |
| PV Name | /dev/dsk/c9t1d0 | } PV(cxtxdx) which composes volume group "/dev/vg11" is displayed. |
| PV Status | available | |
| Total PE | 586 | |
| Free PE | 0 | |
| PV Name | /dev/dsk/c9t1d1 | } PV(cxtxdx) which composes volume group "/dev/vg11" is displayed. |
| PV Status | available | |
| Total PE | 586 | |
| Free PE | 0 | |
| PV Name | /dev/dsk/c9t1d2 | } PV(cxtxdx) which composes volume group "/dev/vg11" is displayed. |
| PV Status | available | |
| Total PE | 586 | |
| Free PE | 0 | |
| PV Name | /dev/dsk/c9t1d3 | } PV(cxtxdx) which composes volume group "/dev/vg11" is displayed. |
| PV Status | available | |
| Total PE | 586 | |
| Free PE | 344 | |

- 3) Check if `"/etc/fstab"` is displayed.

```
#cat /etc/fstab
```

- 4) Specify all the mount points for PV which was confirmed in `"vgdisplay"`.

<Display Example>

```
# System /etc/fstab file. Static information about the file systems
# See fstab(4) and sam(1M) for further details on configuring devices.
/dev/vg00/lvol3 /vxfs delaylog 0 1
/dev/vg00/lvol1 /stand hfs defaults 0 1
/dev/vg00/lvol4 /tmp vxfs delaylog 0 2
/dev/vg00/lvol5 /home vxfs delaylog 0 2
/dev/vg00/lvol6 /opt vxfs delaylog 0 2
/dev/vg00/lvol7 /usr vxfs delaylog 0 2
/dev/vg00/lvol8 /var vxfs delaylog 0 2
/dev/vg00/lvol10 /home1 vxfs rw,suid,nolargefiles,delaylog,datainlog 0 2
/dev/vg11/lvol1 /open3 vxfs delaylog 0 4
```

— **mount point (in bold)**

- 5) Input the `"bdf"` command and confirm the mount point.

```
#bdf
```

<Display Example>

| Filesystem | kbytes | used | avail | %used | Mounted on |
|-------------------------|---------|---------|---------|---------------|---------------|
| /dev/vg00/lvol3 | 86016 | 26109 | 56212 | 32% | / |
| /dev/vg00/lvol1 | 67733 | 31932 | 29027 | 52% | /stand |
| /dev/vg00/lvol8 | 512000 | 159876 | 331072 | 33% | /var |
| /dev/vg00/lvol7 | 614400 | 428475 | 174362 | 71% | /usr |
| /dev/vg00/lvol4 | 32768 | 1131 | 29663 | 4% | /tmp |
| /dev/vg00/lvol6 | 258048 | 102174 | 146171 | 41% | /opt |
| /dev/vg00/lvol101544192 | 2858 | 1445062 | 0% | /home1 | |
| /dev/vg00/lvol5 | 20480 | 6078 | 13595 | 31% | /home |
| /dev/vg11/lvol1 | 8192000 | 3149893 | 4726982 | 40% | /open3 |

- 6) Determine Mount Point to check by the `"sum"` command.

The attention item for HP-UX.

This clause explains notes when using Pin Track Tool.

The notes for use of the Pin Track Tool.

- 1) Specify the start and end LBAs in SVP for the setting range of Pin Track Tool. 1 slot is composed of 96 LBAs ((60)h LBA). The fault can not be cleared is the value is less than 96 LBAs.
- 2) Pin Track Tool is not a tool to recover data. Therefore, when Unreadable Pin occurs, it is necessary to be restored using the back-up data of the customer.
- 3) There is a case that O/S patch is prepared which has an influence to the fault track read operation. For HP Server which has Fibre Interface, the following patch is necessary.
 - PHSS_18326 Fibre Channel Mass Storage Driver Patch. (HP-UX10.2)
 - PHSS_18652 Fibre Channel Mass Storage Driver Patch. (HP-UX11.0)
or XSWG1100 HP-UX General Release Patches, June 2001
XSWHWCR1100 HP-UX Hardware Enablement and Critical Patches, June 2001 : (HP-UX11.0)
 - PHCO_18217 Cumulative SAM/ObAM Patch. (HP-UX10.2)
 - PHKL_16751 SIG_IGN/SIGCLD,LVM,JFS,PCI/SCSI cumulative patch. (HP-UX10.2)

The patch information is as of Jun/99.

The patch information of OS may change at frequent intervals. Confirm the latest information. Request the system administrator to install patch.

When the system administrator judges this action may impact on the system, cancel the Mode Configuration:95 and return to [TRBL07-150](#) ④.

- 4) When it isn't possible to use Pin Track Tool, use the LDEV Format to clear.
- 5) Because HP-UX executing retry to read the pinned track where it isn't possible to read many times, It sometimes takes 3 hours maximum about processing 1 slot.

The erasing process of Pinned Track on the DB(HP-UX, Solaris)

DB has two types of the Pinned Track earasing.

- 1) Raw device-based Data Base type :
Without passing O/S, by the physical level, the data base soft wear manages a disk.
(It is managed by the LBA unit on the physical level.)
The device of local type isn't mounted on File System. Then, it has a powerful back-up function.
- 2) File system-based Data Base type :
Mounted an File System.

In case of (2), it is necessary to be restored from the backup data.

In case of (1), it be restored by the backup-restore feature of the DBMS.

If a pin is left after the data recovers, erase a pin by the Pin Track Tool.

The most important thing is to execute the recovery function in the DB software.

7.3.3.2 Procedure on Windows NT

- The following is an erasing procedure to be used when a Pin failure occurs on Windows NT.

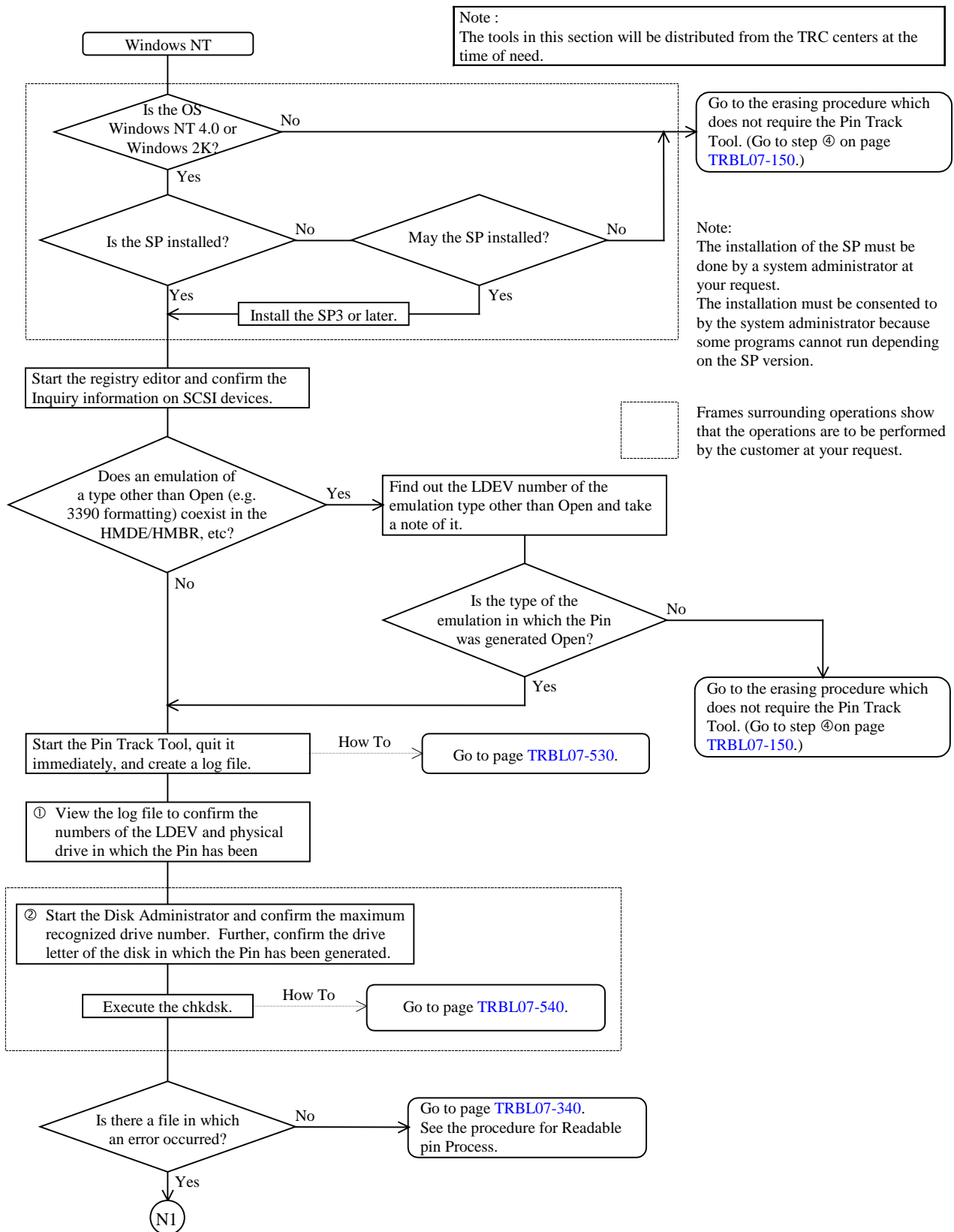

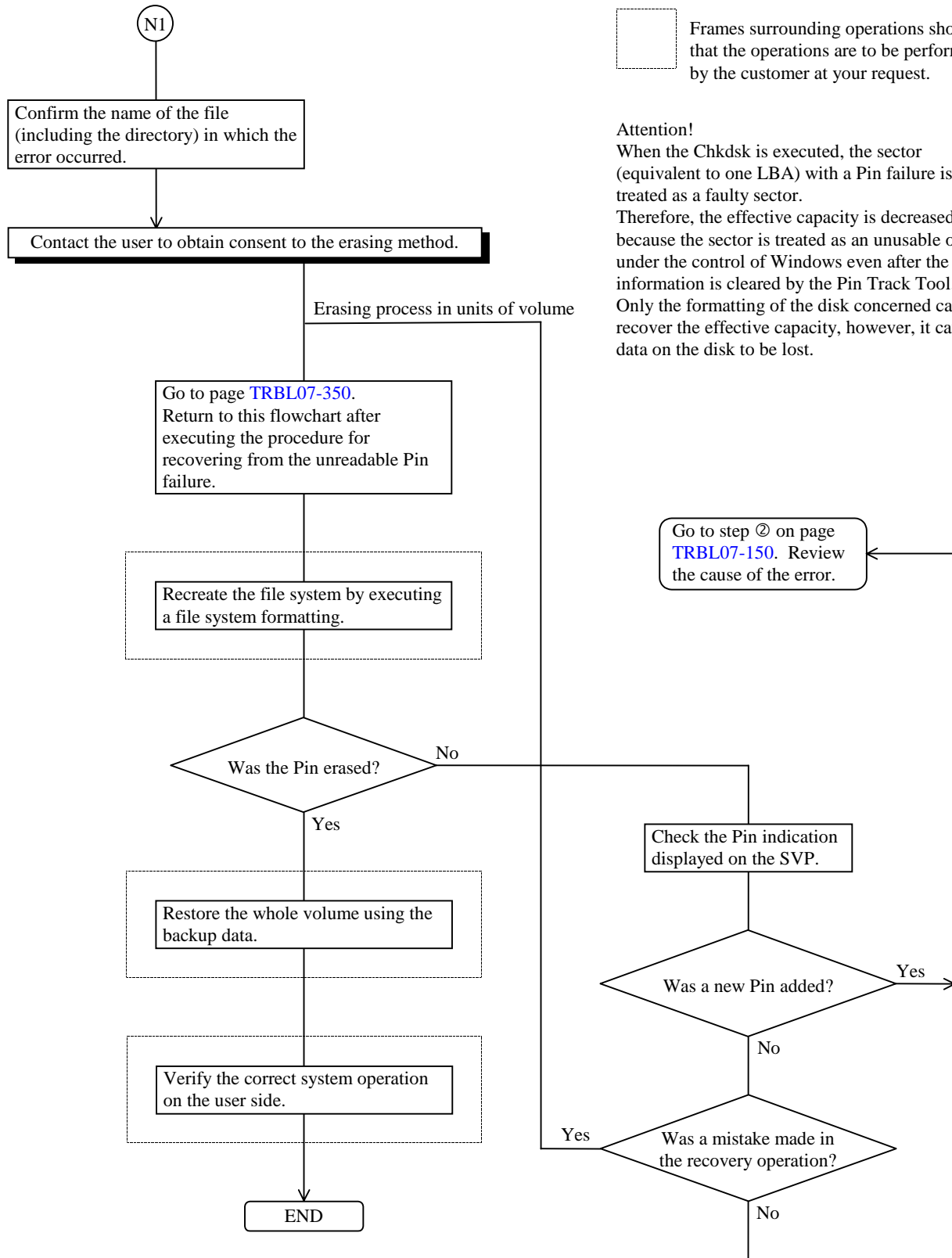

Frames surrounding operations show that the operations are to be performed by the customer at your request.

Attention!
When the Chkdsk is executed, the sector (equivalent to one LBA) with a Pin failure is treated as a faulty sector. Therefore, the effective capacity is decreased because the sector is treated as an unusable one under the control of Windows even after the Pin information is cleared by the Pin Track Tool. Only the formatting of the disk concerned can recover the effective capacity, however, it causes data on the disk to be lost.

Go to step ② on page TRBL07-150. Review the cause of the error.

Readable Pin Process (Windows NT)

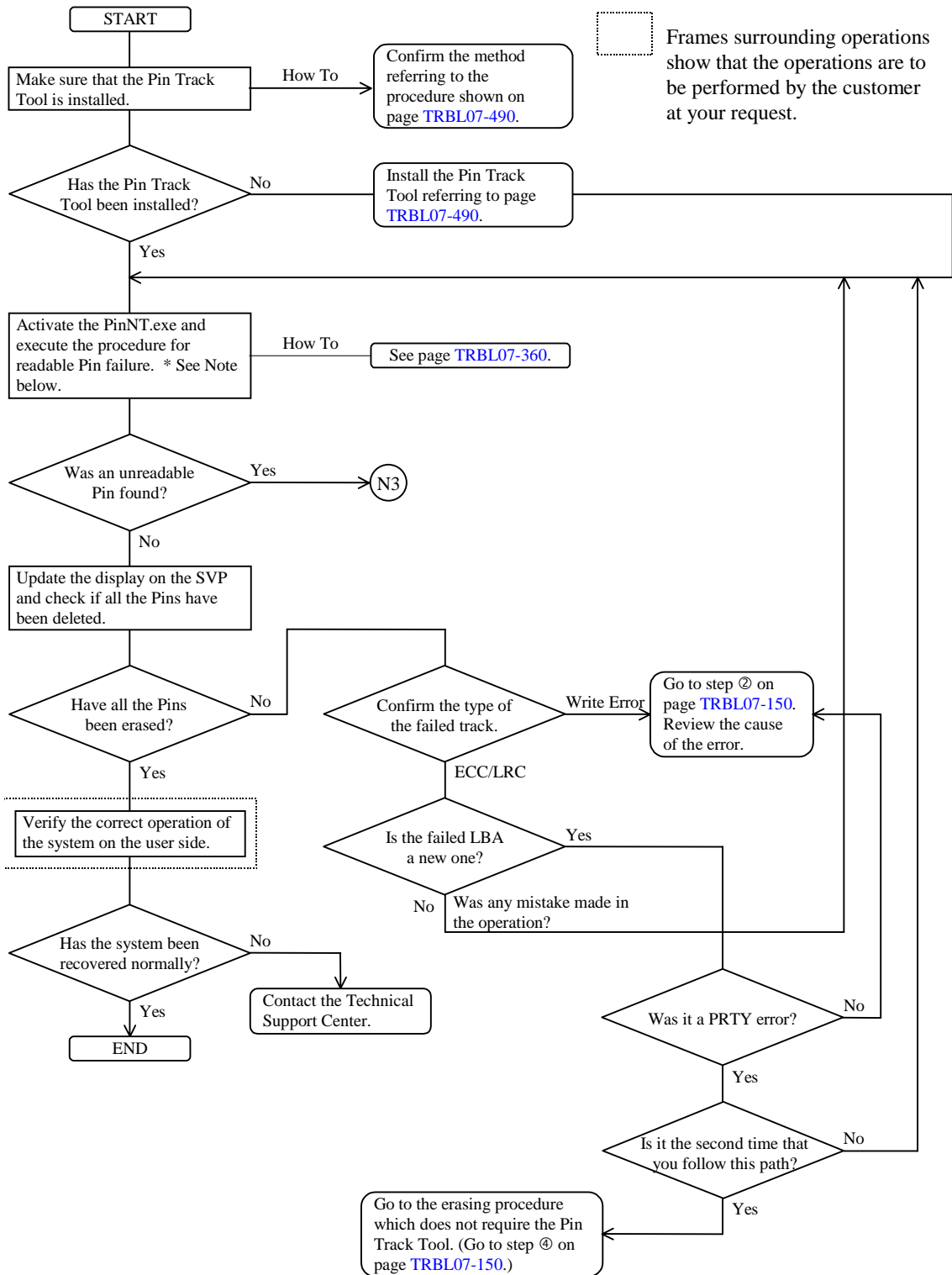

*** Note -** On an SIM reported owing to a use of the Pin Track Tool -
 When two or more Pins have been generated in the LBAs adjacent in the same LU, a generation of a new temporary Pin caused by the parity calculation performed in the Pin Track process may occur and an SIM may be reported. Since this Pin is erased at the same time when the erasing process of the Pin concerned completes, complete the SIM when the erasure of all the Pins by the Pin Track Tool is confirmed.

Unreadable Pin Process (Windows NT)

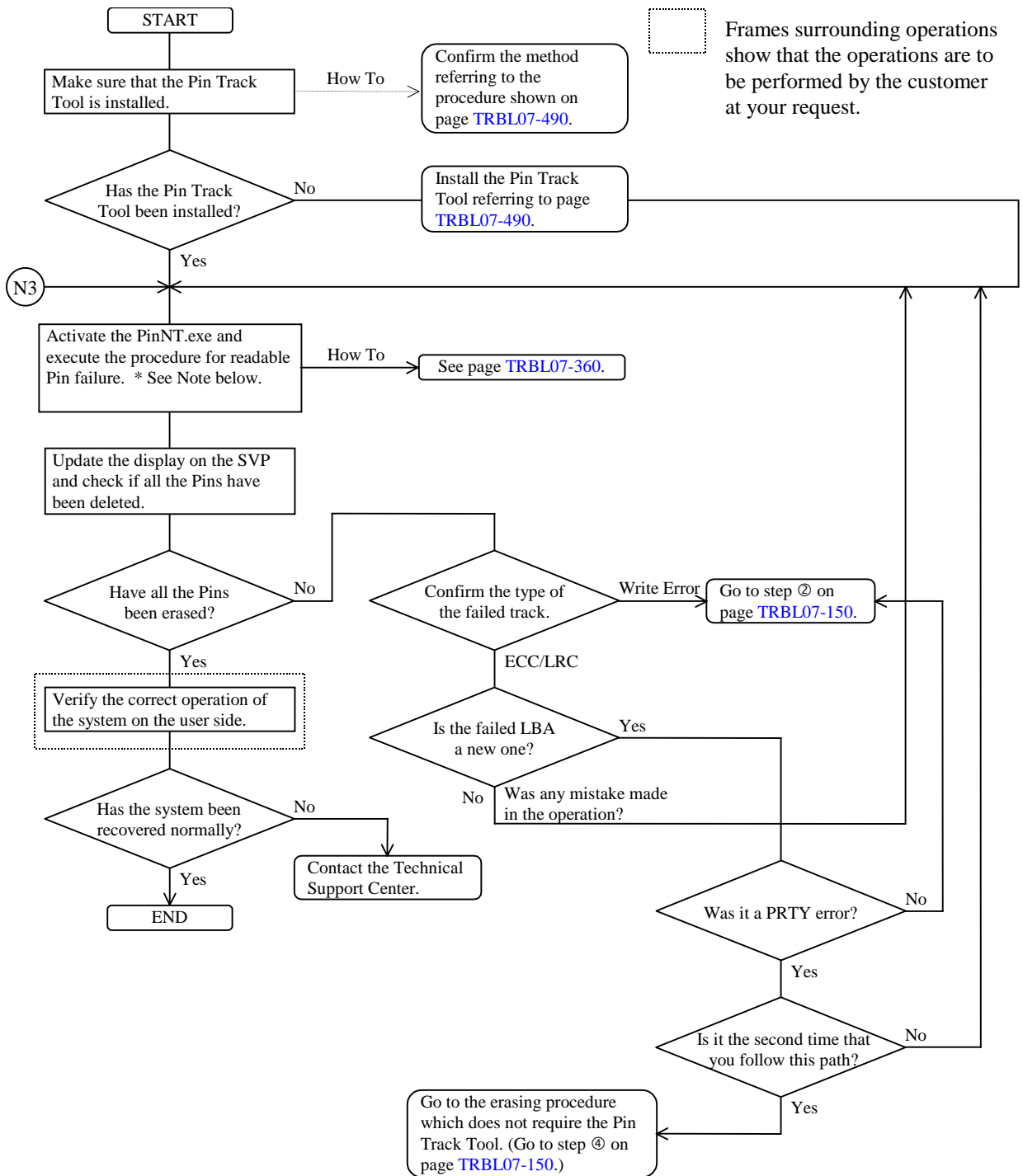

Frames surrounding operations show that the operations are to be performed by the customer at your request.

*** Note** - On an SIM reported owing to a use of the Pin Track Tool -
 When two or more Pins have been generated in the LBAs adjacent in the same LU, a generation of a new temporary Pin caused by the parity calculation performed in the Pin Track process may occur and an SIM may be reported. Since this Pin is erased at the same time when the erasing process of the Pin concerned completes, complete the SIM when it is confirmed that all the Pins have been erased by the Pin Track Tool.

Operation of Readable Pin Process (Windows NT)

The following explains how to operate the Pin Track Tool for erasing a readable Pin.

The procedure for erasing a readable Pin is to be firstly applied to all types of Pins.

A Pin which cannot be erased by the readable Pin erasing process will be erased by a process which treats it as an unreadable Pin.

*** Note** - On an SIM reported owing to a use of the Pin Track Tool -

When two or more Pins have been generated in the LBAs adjacent in the same LU, a generation of a new temporary Pin caused by the parity calculation performed in the Pin Track process may occur and an SIM may be reported.

Since this Pin is erased at the same time when the erasing process of the Pin concerned completes, complete the SIM when it is confirmed that all the Pins have been erased by the Pin Track Tool.

(1) Activate the Pin Track Tool.

- Execute the PinNT.exe in the folder in which the tool is installed after activating it by selecting "Open" by clicking it with the right mouse button or double-clicking it with the left mouse button..

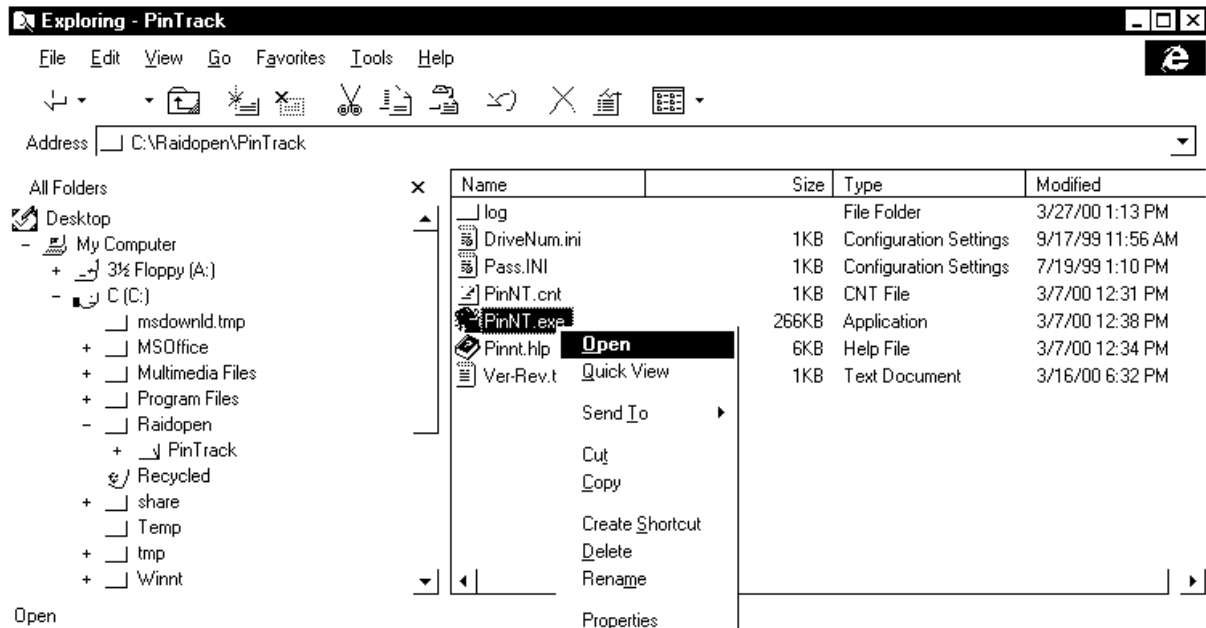

- When the PinNT.exe is executed, the following window is displayed.

Pin Track Tool
 Operation Help

Pin Track Drive List

| Physical Drive Name | Port | LDEV | Start LBA | End LBA | Status |
|---------------------|------|------|-----------|---------|--------|
| | | | | | |

Drive Name: Port: LDEV:

Start-LBA:

End-LBA:

Proceed unreadable Pin Read Test for whole of a disk

Operation

- (2) Input the information, which has been got from the SVP, on the device from which the Pin is to be erased.
- * You can enter two or more Pins in order.
 - ① Find a name of a drive to which the LDEV in which the Pin has been generated is allocated.
 - Select a physical drive for which the LDEV number of the device in which the Pin has been generated is displayed using an acquired port number (e.g. 1J for CL1J).

Pin Track Tool
 Operation Help

Pin Track Drive List

| Physical Drive Name | Port | LDEV | Start LBA | End LBA | Status |
|---------------------|------|------|-----------|---------|--------|
| | | | | | |
| | | | | | |
| | | | | | |
| | | | | | |

Drive Name: Port: LDEV:

Start-LBA:

End-LBA:

Proceed unreadable Pin Read Test for whole of a disk

Operation

- * The drive names are not sorted in order of the drive numbers.

Input the Start LBA and End LBA of the drive input in step ① to specify the range where the Pin has been generated.

Pin Track Tool

Operation Help

Pin Track Drive List

| Physical Drive Name | Port | LDEV | Start LBA | End LBA | Status |
|---------------------|------|------|-----------|---------|--------|
| | | | | | |

Drive Name: Port: LDEV:

Start-LBA:

End-LBA:

Proceed unreadable Pin Read Test for whole of a disk

Operation

- When specifying the LBAs, the allowable range for them is as follows.
[Ox60 ≥ End LBA - Start LBA]
Input the range of the Ox60 shown on the SVP.

- (3) Add the input device to the Pin Track Device List.
- When the "Add" button is clicked after making sure that the selected and input items are correct, the drive is added to the list.

Pin Track Tool
 Operation Help

Pin Track Drive List

| Physical Drive Name | Port | LDEV | Start LBA | End LBA | Status |
|---------------------|------|------|-----------|----------|--------|
| \\.\PhysicalDrive9 | 2F | 0017 | 00000180 | 000001DF | |

Drive Name: Port: LDEV:

Start-LBA:

End-LBA:

Proceed unreadable Pin Read Test for whole of a disk

Operation

- (4) Erase the readable Pin.
- Check if the input information is correct. When correcting it, select the device and input the LBA over again by selecting the item concerned from the list and clicking the "Delete" button.
 - When you want to add two or more devices, you can do it by repeating the input. When they are added, the Pin erasing process is applied to them in an ascending order of the listing.
- * Since the readable Pin is to be erased here, do not check off the check box of the Unreadable PIN.

- When no wrong input is found, click the “Proceed” button to erase the readable Pin.

When the “Proceed” button is clicked, the program checks whether a free area for outputting a log is ensured in the current drive in which the Pin Track Tool is installed.

If the free area is less than 10 MB, the following dialog box is displayed to warn it.

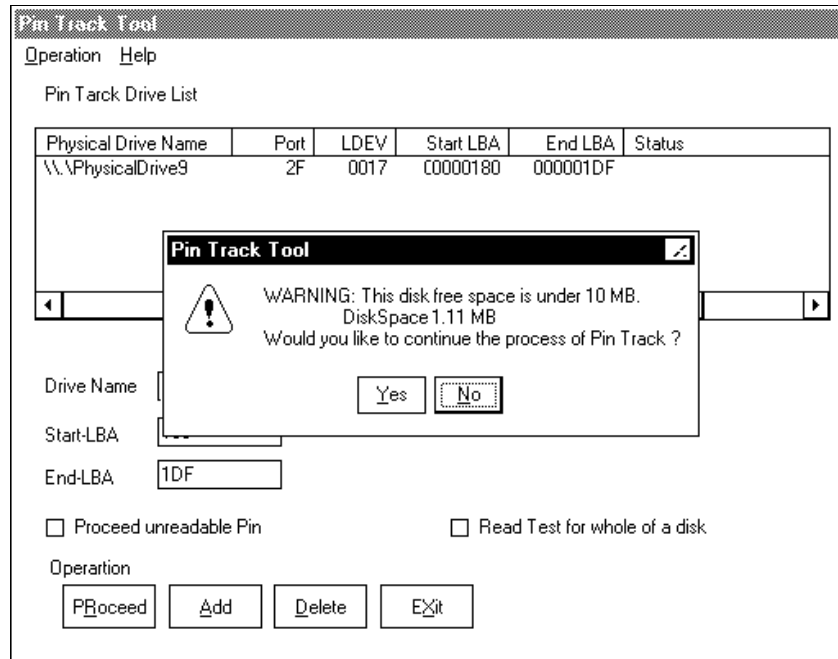

The current free area on the disk is displayed in the dialog box. A free area of approximately 400 kB is required to erase a Pin. When the necessary free area is provided, the processing can be continued.

Note: Install the program in a drive in which the enough free area can be ensured.

When “Yes” is selected, the processing is continued. If the disk capacity is less than that required for the log, as large log file as can be accommodated is acquired.

Normally, select “Yes” only when the free area is enough.

When “No” is selected, the routine is returned to the main window. If the option has been checked off, it is cancelled. Ensure a free area in the drive, put the collected log file in order, or install the program in another drive.

When the “Proceed” button is clicked to continue the processing, status of each drive is displayed in the main window and the following dialog box is displayed.

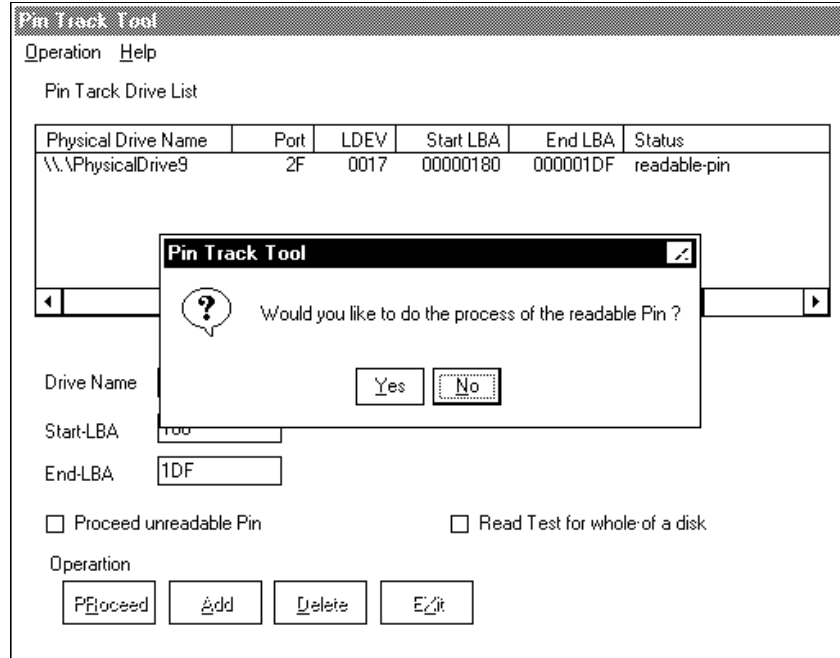

When “readable-pin” is displayed in the “Status” column, it shows that the slot is a readable Pin.

When “Unreadable-pin” is displayed in the “Status” column, it shows that the slot is an unreadable Pin.

- Update the display on the SVP before executing the erasing process and check if the Pin of the input device has been erased.
When the Pin has already been erased, click the “No” button to return to the main window.
When the Pin has not been erased, click the “Yes” button to erase the readable Pin.

- (5) The Pin erasing process is executed.
When the Pin erasing process is executed, the following dialog box is displayed.

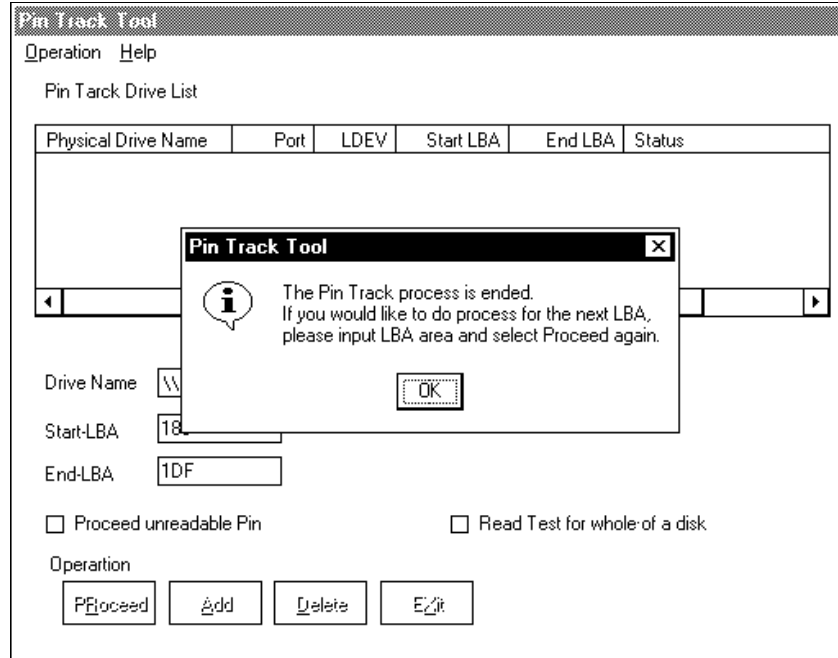

When the Pin erasing process completes normally, the items are deleted from the list automatically. Confirm the execution result of the Pin erasing process in the log file.

- Open the PinTrack.log file in the folder in which the tool is installed by using a memo pad, etc.

```

2000/03/27 13:22:16 Pin Track Tool started.

\\.\PhysicalDrive0
        No information

\\.\PhysicalDrive1
        Product Serial R400 00030036 0042
        Port Number    1E
        LDEV Number    002A
        Disk Capacity  2461040640 bytes
        Maximum LBA    0049583F

\\.\PhysicalDrive2
\\.\PhysicalDrive3
\\.\PhysicalDrive4

\\.\PhysicalDrive9
        Product Serial R400 00030036 0023
        Port Number    2F
        LDEV Number    0017
        Disk Capacity  2461040640 bytes
        Maximum LBA    0049583F

Read Data: Top Pin No=00000180
00000000:00 00 00 00 00 00 00 00 00 00 00 00 00 00 00 00
00000010:00 00 00 00 00 00 00 00 00 00 00 00 00 00 00 00
00000020:00 00 00 00 00 00 00 00 00 00 00 00 00 00 00 00

0000BFE0:00 00 00 00 00 00 00 00 00 00 00 00 3E BC 12 E6
0000BFF0:00 00 00 00 00 00 00 00 00 00 00 00 00 00 00 00

Read Data (After Writing): Top Pin No=00000180
00000000:00 00 00 00 00 00 00 00 00 00 00 00 00 00 00 00
00000010:00 00 00 00 00 00 00 00 00 00 00 00 00 00 00 00
00000020:00 00 00 00 00 00 00 00 00 00 00 00 00 00 00 00

0000BFE0:00 00 00 00 00 00 00 00 00 00 00 00 3E BC 12 E6
0000BFF0:00 00 00 00 00 00 00 00 00 00 00 00 00 00 00 00

Write Data: Top Pin No=00000180
00000000:00 00 00 00 00 00 00 00 00 00 00 00 00 00 00 00
00000010:00 00 00 00 00 00 00 00 00 00 00 00 00 00 00 00
00000020:00 00 00 00 00 00 00 00 00 00 00 00 00 00 00 00

0000BFE0:00 00 00 00 00 00 00 00 00 00 00 00 3E BC 12 E6
0000BFF0:00 00 00 00 00 00 00 00 00 00 00 00 00 00 00 00

2000/03/27 13:23:13
\\.\PhysicalDrive9,Start LBA=00000180,End LBA=000001DF,The Pin Track process is completed.
2000/03/27 13:23:48 Pin Track Tool is exited.

```

The log file is backed up to the log folder under the directory in which the tool is installed with a name given as “PinTrack-year-month-date-hours-minutes-seconds.log”.

- When “The Pin Track process is completed.” is displayed in the log file, it means that the Pin has been erased. View the display on the SVP to confirm that the Pin has been erased.
- (6) When you erase another readable Pin successively, repeat the procedure from step (2).
- When an unreadable Pin exists in the device added to the list
When the “Proceed” button is pressed in the case where an unreadable Pin exists in the list, the following is displayed.

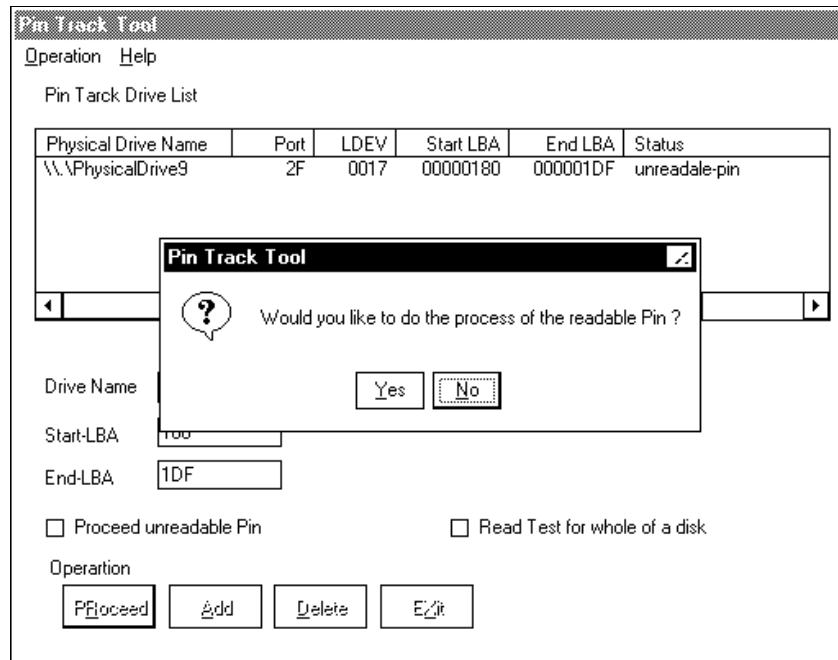

“unreadable” is displayed in the “Status” column showing that the slot is an unreadable Pin. In this case, the Pin is not erased even if the procedure for erasing a readable Pin is executed and the device is not deleted from the list as follows.

The log when two area (120-17F, 1E023F) of Unreadable Pin exists in specified DeviceName (PhysicalDrive2) becomes as follows.

```

2002/09/03 14:17:55 Pin Track Tool started.

\\.\PhysicalDrive0
  No information
\\.\PhysicalDrive1
  Product Serial No information
  Port Number NG
  LDEV Number NG
  Disk Capacity 0 bytes
  Maximum LBA FFFFFFFF

\\.\PhysicalDrive2
  Product Serial HITACHI R4516F700009
  Port Number 1K
  LDEV Number 0009
  Disk Capacity 2461040640 bytes
  Maximum LBA 0049583F

2002/09/03 14:18:00
\\.\PhysicalDrive2, Start LBA=00000120, End LBA=0000017F,
An error occurred when reading.
2002/09/03 14:18:00
\\.\PhysicalDrive2, Start LBA=000001E0, End LBA=0000023F,
An error occurred when reading.
2002/09/03 14:18:40 Pin Track Tool is exited.

```

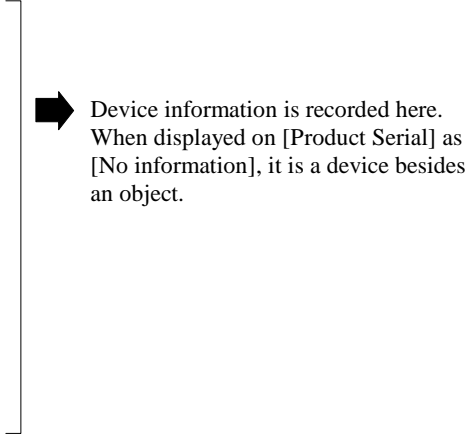
 Device information is recorded here. When displayed on [Product Serial] as [No information], it is a device besides an object.

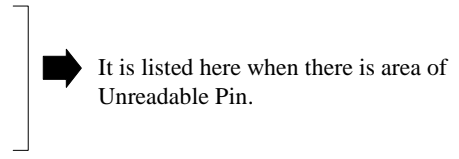
 It is listed here when there is area of Unreadable Pin.

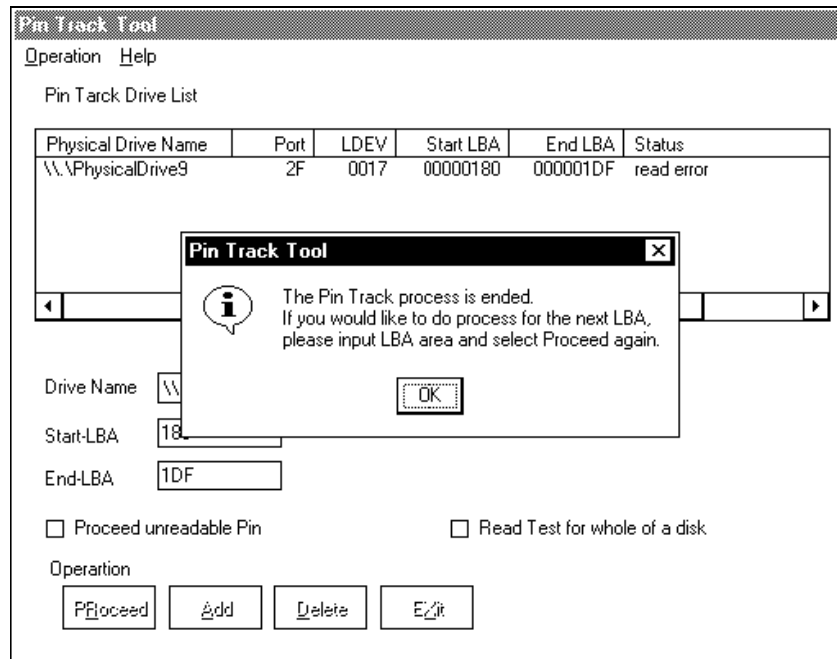

When the status is changed to “read error” and the device remains in the list, go to Subsection [TRBL07-450](#), “Procedure for erasing unreadable Pin”.

Operation of Unreadable Pin Process (Windows NT)

The following explains how to operate the Pin Track Tool for erasing an unreadable Pin. Since the procedure for erasing a readable Pin is to be applied to all the Pins first, follow the procedure below after executing the procedure given in Subsection [TRBL07-360](#), “Procedure for erasing readable Pin”.

* **Note** - On an SIM reported owing to a use of the Pin Track tool -
 When two or more Pins have been generated in the LBAs adjacent in the same LU, a generation of a new temporary Pin caused by the parity calculation performed in the Pin Track process may occur and an SIM may be reported.
 Since this Pin is erased at the same time when the erasing process of the Pin concerned completes, complete the SIM when it is confirmed that all the Pins have been erased by the Pin Track Tool.

- (1) When the log file (PinTrack.log) is open, close it.
- (2) Reconfirm the device, which was not deleted from the list when the readable Pin erasing process was executed, and the display on the SVP.
- (3) Specify the unreadable Pin erasing process.
 After confirming that the input information is correct, check off the check box of the Unreadable Pin. When it is checked off, the password dialog box is displayed.

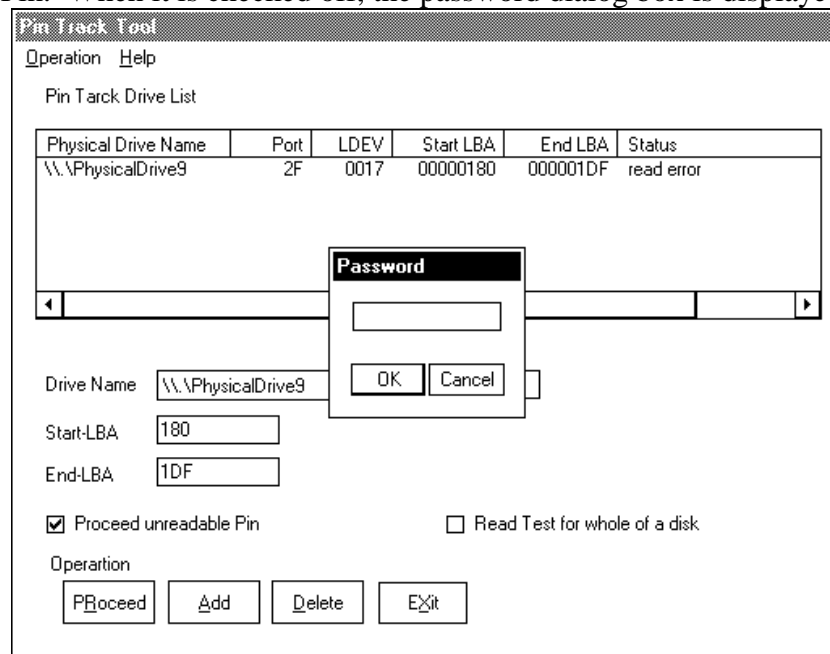

The password is to be obtained from the Technical Support Center. Without the password, the unreadable Pin cannot be erased.

Input the password and click the “OK” button.

When the correct password is input, the check box is checked off.

If the box is not checked off although the correct password has been input, copy the Pass.INI file in the folder in which the tool is installed from the media for installation again.

(3) Erase the unreadable Pin.

- Check off the check box. When no wrong input is found, click the “Proceed” button to erase the unreadable Pin.

| Physical Drive Name | Port | LDEV | Start LBA | End LBA | Status |
|---------------------|------|------|-----------|----------|------------|
| \\.\PhysicalDrive9 | 2F | 0017 | 00000180 | 000001DF | read error |

Drive Name: \\.\PhysicalDrive9 Port: 2F LDEV: 0017

Start-LBA: 180 End-LBA: 1DF

Proceed unreadable Pin Read Test for whole of a disk

Operation:

When the “Proceed” button is clicked, the program checks whether a free area for outputting a log is ensured in the current drive in which the Pin Track Tool is installed.

If the free area is less than 10 MB, the following dialog box is displayed to warn it.

Pin Track Tool

WARNING: This disk free space is under 10 MB.
DiskSpace 1.11 MB
Would you like to continue the process of Pin Track ?

The current free area on the disk is displayed in the dialog box. A free area of approximately 400 kB is required to erase a Pin. When the necessary free area is provided, the processing can be continued.

Note: Install the program in a drive in which the enough free area can be ensured.

When “Yes” is selected, the processing is continued. If the disk capacity is less than that required for the log, as large log file as can be accommodated is acquired.

Normally, select “Yes” only when the free area is enough.

When “No” is selected, the routine is returned to the main window. If the option has been checked off, it is cancelled. Ensure a free area in the drive, put the collected log file in order, or install the program in another drive.

When the “Proceed” button is clicked to continue the processing, the following dialog box is displayed.

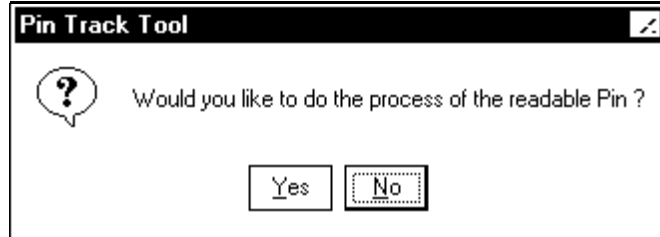

Try to erase the readable Pin first. When the readable Pin Track process cannot be executed when the “Yes” is clicked here, the following dialog box is displayed.

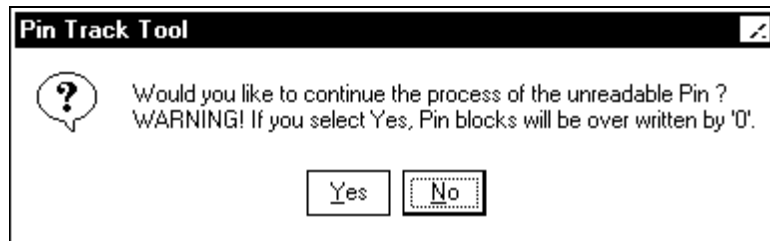

A dialog box for confirming whether to execute the unreadable Pin Track process is displayed. Execution of the unreadable Pin Track process must be decided carefully because it overwrites the Pin blocks with “0” data.

In case of the unreadable pin erasing operation, Confirmation of execution is demanded every contents in the pin track drive list. Operator can select execution or cancellation for each operation.

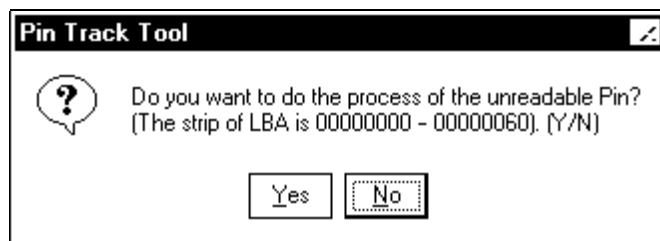

- Update the display on the SVP before executing the unreadable Pin Track process and check if the Pin of the input device has been erased. When the Pin has already been erased, click the “No” button to return to the main window.
- When the Pin has not been erased, click the “Yes” button to erase the unreadable Pin. When the “Yes” button is clicked, the unreadable Pin Track process is executed and the following window is displayed.

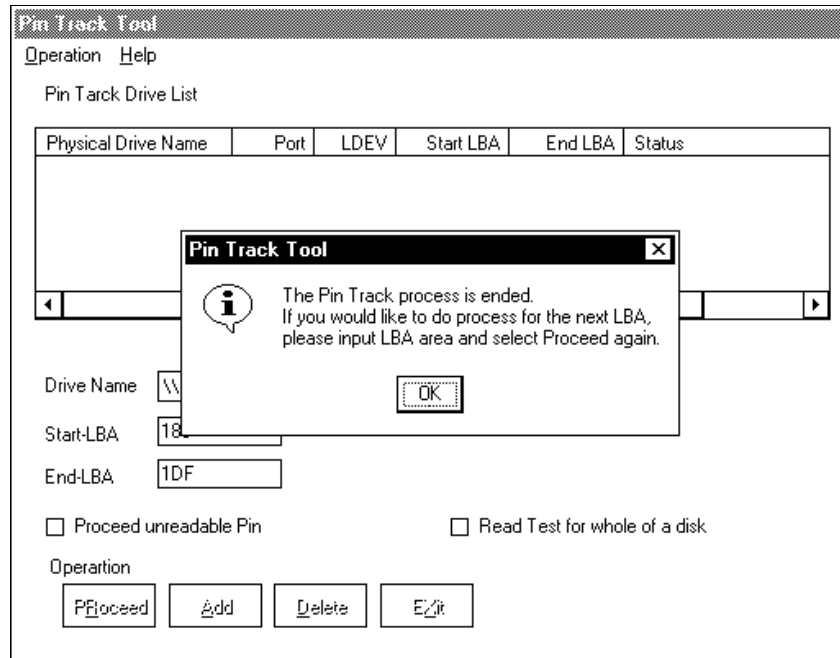

- (4) Check the log of the Pin Track Tool.
 - Open the PinTrack.log file in the folder in which the tool is installed by using a memo pad, etc. The log file is backed up to the log folder under the directory in which the tool is installed with a name given as “PinTrack-year-month-date-hours-minutes-seconds.log”.
 - When “Pin Track process is completed” is displayed in the log file, it means that the Pin has been erased.
View the display on the SVP to confirm that the Pin has been erased.
- (5) When you proceed another Pin successively, repeat the “Procedure for erasing readable Pin” in [TRBL07-360](#).

How to Read Test for whole of a disk (Windows NT)

This chapter describes how to discover the Unreadable Pin on select device.
This processing requires long time.

- (1) If a check box “Read Test for whole of a disk” is clicked, It becomes impossible to input “Start LBA” and “End LBA”.
(Then all the contents currently displayed on the Pin Track Drive List are cleared.)

Pin Track Tool

Operation Help

Pin Track Drive List

| Physical Drive Name | Port | LDEV | Start LBA | End LBA | Status |
|---------------------|------|------|-----------|---------|--------|
| | | | | | |

Drive Name: \\PhysicalDrive1 Port: 1E LDEV: 002A

Start-LBA:

End-LBA:

Proceed unreadable Pin Read Test for whole of a disk

Operation

Proceed Add Delete Exit

- (2) Select device name and click the add button, Drive and all domain of LBA which are specified by the pin track drive list are indicated.

Pin Track Tool

Operation Help

Pin Track Drive List

| Physical Drive Name | Port | LDEV | Start LBA | End LBA | Status |
|---------------------|------|------|-----------|----------|--------|
| \\.\PhysicalDrive9 | 2F | 0017 | 00000180 | 000001DF | |

Drive Name: \\.\PhysicalDrive9 Port: 2F LDEV: 0017

Start-LBA: 180

End-LBA: 1DF

Proceed unreadable Pin Read Test for whole of a disk

Operation

Proceed Add Delete Exit

- (3) All LBA in the selected device is started by clicking Proceed button.
(This function is only reading and writing is not performed.)

Installation of Pin Track Tool (Windows NT)

* Perform the installation only when it is required.

<Preparation>

The Pin Track Tool is provided being contained in one 3.5-inch floppy disk or CD-ROM. A free area of more than 10 MB is required on the disk on which the program is to be installed as the area for collecting a log. The size of the log file is approximately 400 kB per one erasing process. The log is collected in the log folder under the folder in which the tool is to be installed each time the Pin erasing process completes.

Since the log is collected after the processing, prepare an empty floppy disk.

<Copying from floppy disk to local disk>

- (1) Logon to the Windows NT system as administrator permission.
- (2) Execute the Explorer, and open the Floppy disk or CD-ROM

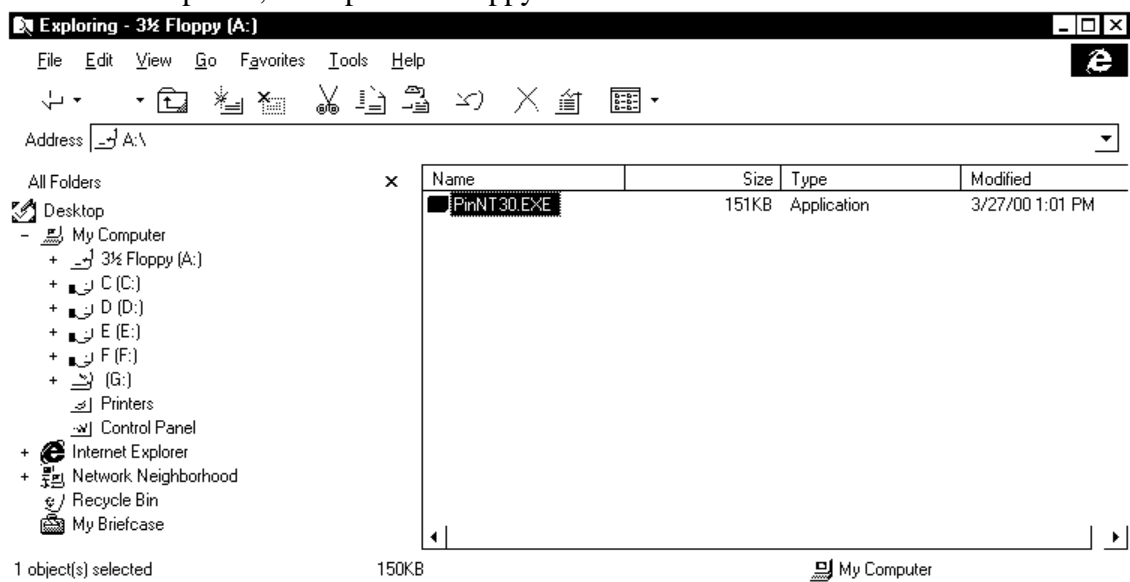

For CD-ROM, the path is different.

(Example : X:\Program\Ment\PINTRACK\WIN_NT\)

- (3) When executing the PinNTxx.exe., the following dialog is displayed.

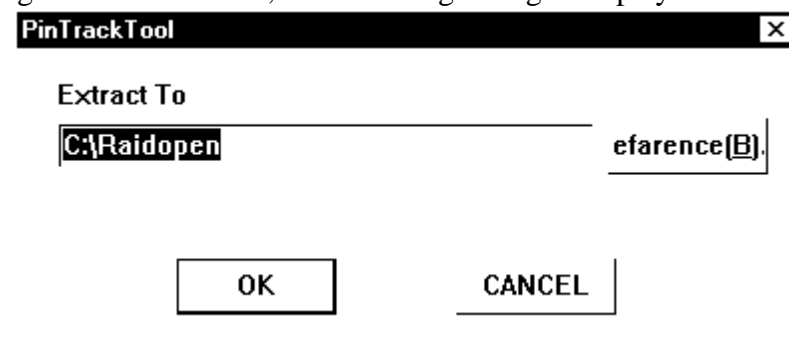

- (4) If you specify an extracting folder and click the [OK] button, Pin Track Tool are extracted by itself.

- Check the file name and file size displaying on the following windows.

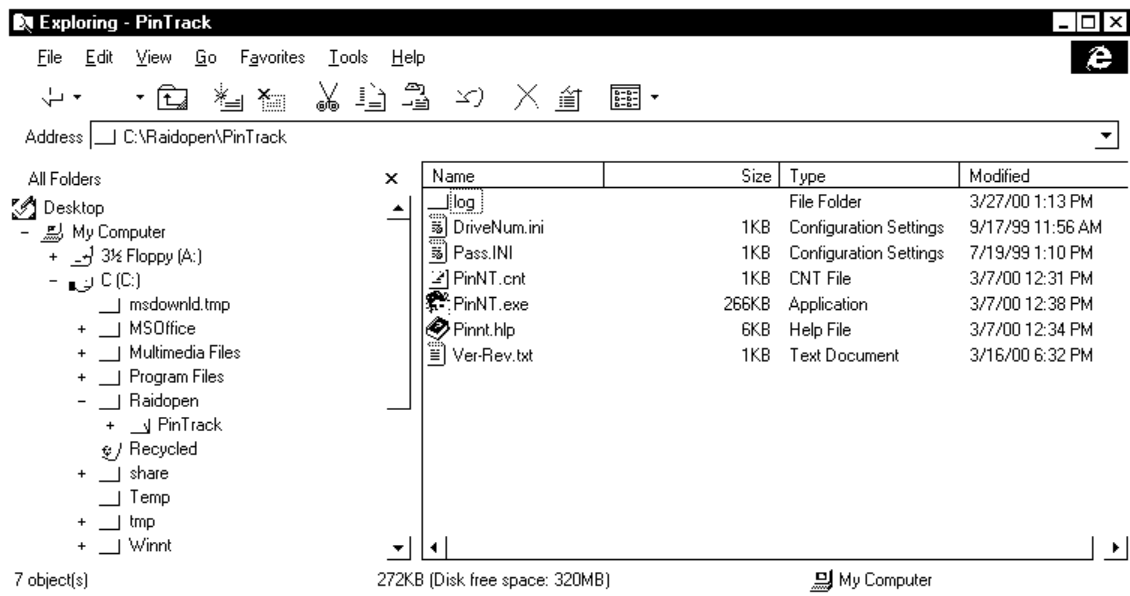

The execution file name is PinNT.exe. When the PinNT.exe is executed, a log file, PinTrack.log, is created in the folder in which the tool has been installed. When the program is quit, the log file is copied to the log folder with a name given as “PinTrack-year-month-date-hours-minutes-seconds.log”.

- Log file
In the log file, only the head LBA of Read/Write data of specified device is recorded. It can also record Read/Write data of all the LBAs.
- * When logs of all the LBAs are recorded, a log file of approximately 400 kB is created for each erasing process in the list. Therefore, be careful of the free capacity on the disk on which the tool is installed.

When a log of only the head LBA is recorded, open the DriveNum.ini file in the folder in which the tool is installed and replace “LogMode=1” with “LogMode=0”.

Data in the log file is recorded in the format shown below.

```

2000/03/27 13:22:16 Pin Track Tool started.
\\.\PhysicalDrive0
        No information
\\.\PhysicalDrive1
        Product Serial R400 00030036 0042
        Port Number    1E
        LDEV Number    002A
        Disk Capacity  2461040640 bytes
        Maximum LBA    0049583F

2000/03/27 13:23:13
\\.\PhysicalDrive1,Start LBA=00000180, LBA=000001DF,An error occurred when reading.

Read Data: Top Pin No=00000180
00000000:** ** ** ** **
00000010:** ** ** ** **
00000020:** ** ** ** **

0000BFE0:** ** ** ** **
0000BFF0:** ** ** ** **

Read Data: Top Pin No=00000181
Read Data: Top Pin No=00000182

Read Data: Top Pin No=000001DF
0000BFE0:** ** ** ** **
0000BFF0:** ** ** ** **

Write Data: Top Pin No=00000180
00000000:00 00 00 00 00 00 00 00 00 00 00 00 00 00 00
00000010:00 00 00 00 00 00 00 00 00 00 00 00 00 00 00
00000020:00 00 00 00 00 00 00 00 00 00 00 00 00 00 00

0000BFE0:00 00 00 00 00 00 00 00 00 00 00 00 00 00 00
0000BFF0:00 00 00 00 00 00 00 00 00 00 00 00 00 00 00

2000/03/27 13:24:13
\\.\PhysicalDrive9,Start LBA=00000180,End LBA=000001DF,The Pin Track process is completed.
2000/03/27 13:24:48 Pin Track Tool is exited.

```

[Displayed items]

- Time when the program was started : Date and time are indicated.
- SCSI device information : Port No., LDEV No., disk capacity, maximum LBA, etc. are displayed.
- Read log : Readable Pins in a specified LBA range are displayed in the lump. Unreadable Pins are displayed for each LBA. Each unreadable Pin is recorded with an asterisk (*).
- Write log : Pins in a specified LBA range are displayed in the lump.
- Entered information : Selected devices, Start LBA, and End LBA are displayed.
- Error information : When a Pin is unreadable, "read error" is displayed. Besides, when an error occurs in the program, details of it are displayed.
- Time when the program is quit : Date and time are displayed.

Log file saving and de-installation

* Perform the de-installation only when it is required.

<Saving of log file>

- (1) Save the log file which executed Pin Track Tool.
Execute Explorer to open the folder in which the tool is installed.
- (2) Insert the empty floppy disk prepared for the log collection and copy the whole log directory to the floppy disk.
- (3) Delete the files under the log directory if they are not necessary.

<De-installation of Pin Track Tool>

To uninstall the Pin Track Tool, delete all the files concerned by deleting the whole PinTrack folder in which the tool is installed.

Acquisition of disk information

You can confirm information of the disk connected to Windows NT by viewing the log file.

- (1) Execute the PinNT.exe.
- (2) When the window is displayed, open the PinTrack.log file.
- (3) A list of the connected devices is recorded in the file.

<Log file>

- For disks other than the disk subsystem, “No Information” is displayed.
- Since the disk information is acquired using the OS function, the recording order in the log may vary.

<Variation of device information>

The display in the log file varies depending on the disk subsystem configuration.

For the HITACHI Specification

```

\\.\PhysicalDrive14
  Product Serial  HITACHI R4003ABE0108
  Port Number      2N
  LDEV Number      0108
  Disk Capacity    2461040640 bytes
  Maximum LBA      0049583F
  
```

The “LDEV Number” is the intact “Product Serial” expressed in hexadecimal.

For the OEM Specification

```

\\.\PhysicalDrive13
  Product Serial  R400 00015038 0012
  Port Number      1J
  LDEV Number      000C
  Disk Capacity    1874903040 bytes
  Maximum LBA      0037E05F
  
```

The “LDEV Number” is the “Product Serial” converted from hexadecimal to decimal.

Identification of files affected by Pin failure

When a drive letter possible to have a Pin failure is found, identify files affected by the failure using the chkdsk command.

- (1) Execute Explorer, click the drive concerned by the right mouse button, and display the property.
- (2) Open the tool tab and click "Check" in the "Error Check".
- (3) Check off all the check disk options and click the "Start" button.
- (4) When the dialog box is displayed, follow the instruction given in it.
- (5) Perform the above operations for all the drives concerned.

Verification of files and recovery of them using backup

When a file is repaired or partially deleted by the chkdsk command, verify whether the file is normal.

When the file was partially deleted or broken, delete the file and restore it using the backup.

After the file is recovered normally, check the Pin status. If a Pin remains, erase it by executing the readable Pin Track process first.

7.3.3.3 Procedure on Solaris

The following is an erasing procedure to be used when a Pin failure occurs on Solaris.

= Notices =

In Solaris, disk device is shown as cXtYdZsN, which denotes controller, SCSI target ID, logical unit number, and slice (partition). One LDEV can be logically divided into eight portions, s0 to s7, and the each portion can be used as a disk drive. For a slice, a capacity can be set in units of cylinder, and the user accesses each slice treating it as a disk drive having LBAs starting from LBA 0.

In Solaris, note that some restrictions on the Pin erasing are induced by handling the disk drive as cXtYdZsN.

- Ensure a free capacity on the disk on which the Pin Track Tool is to be installed.
The showrel tool, which identifies device files of Solaris according to the LDEV and LBA range shown on the SVP, creates a temporary file on the disk in order to acquire device information. If the free capacity on the disk is insufficient, the information cannot be displayed accurately.
- The Pin erasing process cannot be applied to all the LBAs.
In Solaris, the last two cylinders are not allocated to the file system because they are reserved as alternate cylinders. For example, in OPEN-3, the two of the total 3338 cylinders (a range of the LBA from 0x494D00 to 0x49583F out of LBAs maximum LBA number in which is 0x495840) are not allocated to the data cylinders. Therefore, if a Pin including such a range is generated, the Pin shown on the SVP cannot be erased because I/Os cannot be issued. The remedy for it is limited to an elimination of unreadable LBAs in the file system.
- The Pin Track Tool cannot be used against a Pin including the inaccessible cylinder.
In the case where cylinders are divided to be allocated to slices and there exist cylinders which are not allocated to any of the slices, if a Pin including such a range is generated, the Pin shown on the SVP cannot be erased because I/Os cannot be issued. The remedy for it is limited to an elimination of unreadable LBAs in the file system.

- When an unreadable Pin is generated in the head LBA, the Pin cannot be erased.
The management information including the device geometry is recorded in the range of the LBA0x0 to LBA0x5F corresponding to the slot#15. If a Pin including this range is generated, the device cannot be recognized to be a disk by the OS. Format the LDEV following the maintenance manual.

- Specify the LBA to be input in the Pin Track Tool correctly.
When the input LBA is wrong, Solaris judges the specified range to be an unreadable Pin. Even if you try to apply the unreadable Pin Track process to it specifying the range, a write error will be caused and it is not erased. Make sure that the input LBA is correct before executing the process.

- After executing the Pin Track process, verify that the processing has completed normally referring to a log.
To verify the execution result of the Pin Track process, refer to the log file. Read/write errors are not displayed on the screen. Furthermore, check if the input information was correct when a write error occurred as described above.

When you have to eliminate the unreadable LBA in the file system on the above conditions, operate according to the flowchart on the following pages.

When you can not use the Pin Track Tool, perform at the [TRBL07-720](#).

○ The following is an erasing procedure to be used when a Pin failure occurs on Solaris.

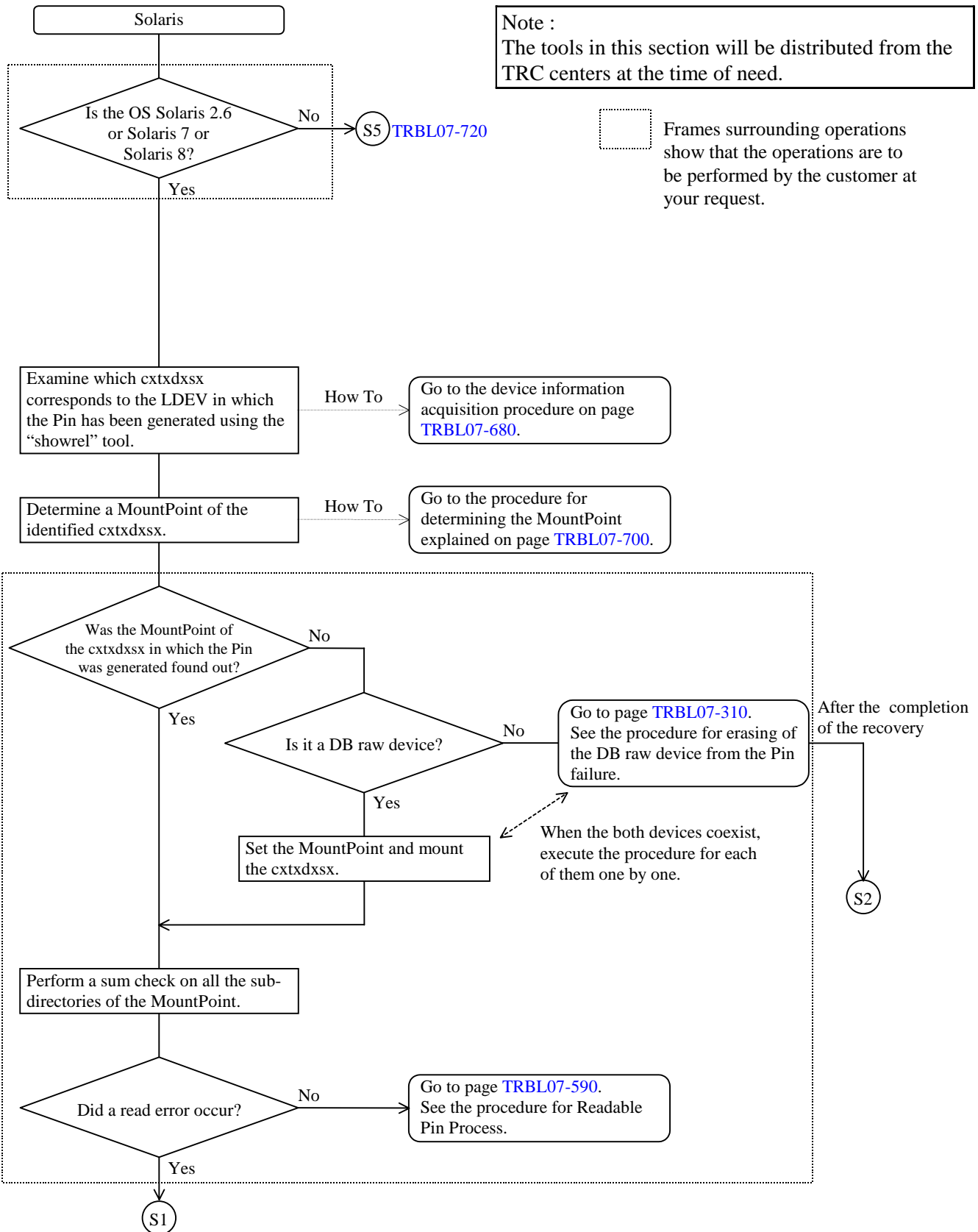

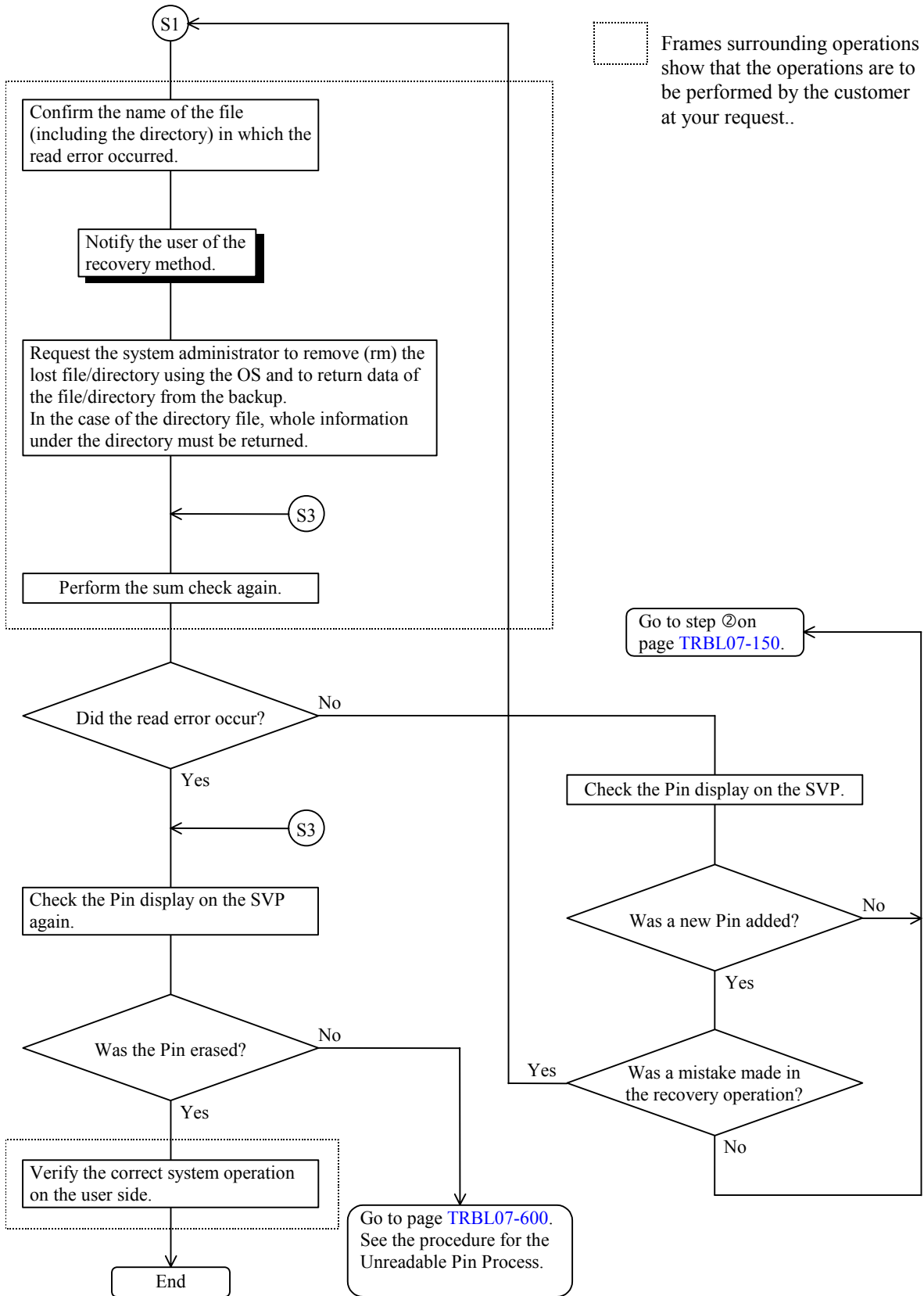

Readable Pin Process (Solaris)

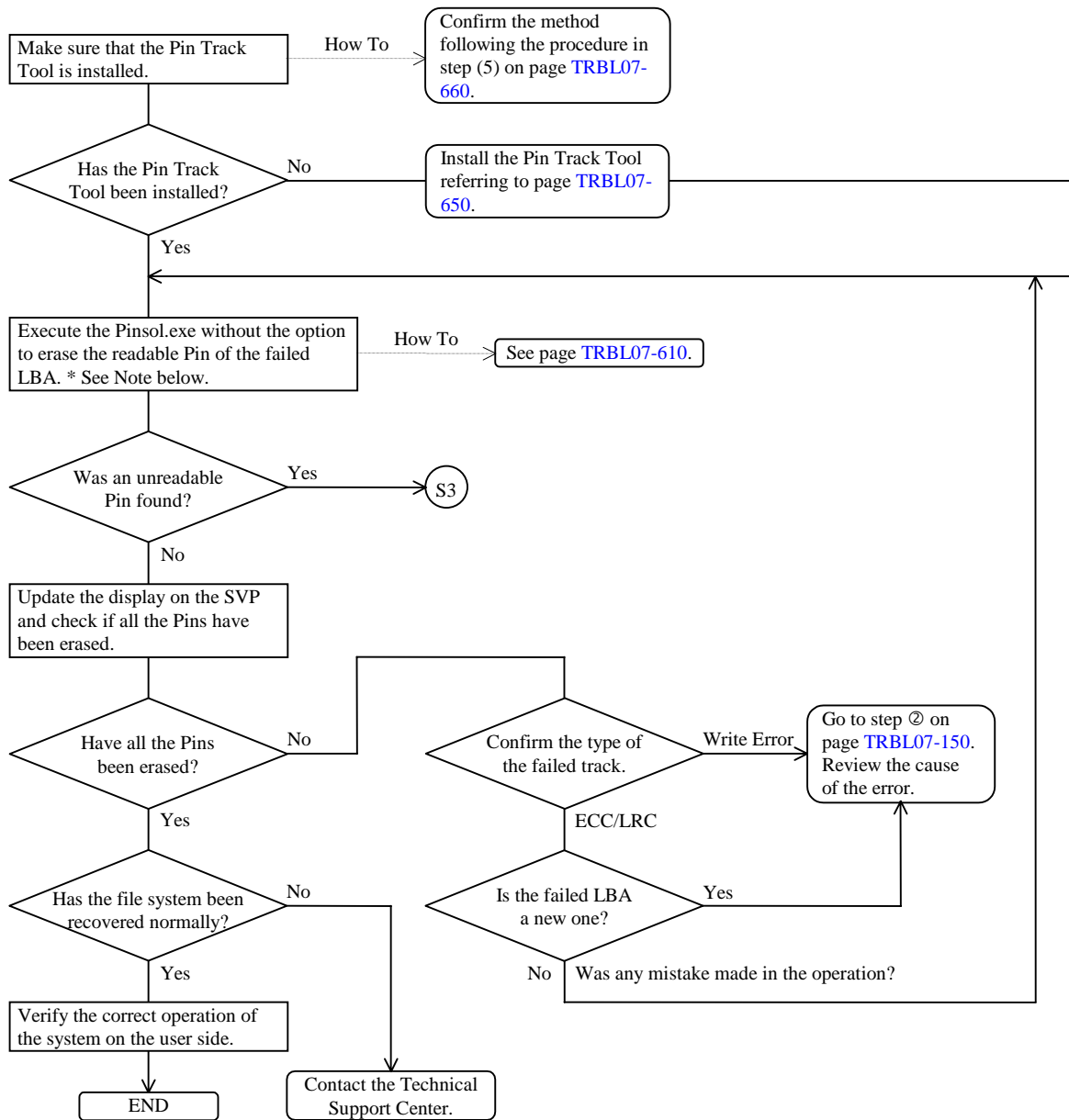

*** Note** - On an SIM reported owing to a use of the Pin Track Tool -
 When two or more Pins have been generated in the LBAs adjacent in the same LU, a generation of a new temporary Pin caused by the parity calculation performed in the Pin Track process may occur and an SIM may be reported.
 Since this Pin is erased at the same time when the erasing process of the Pin concerned completes, complete the SIM when the erasure of all the Pins by the Pin Track Tool is confirmed.

Unreadable Pin Process (Solaris)

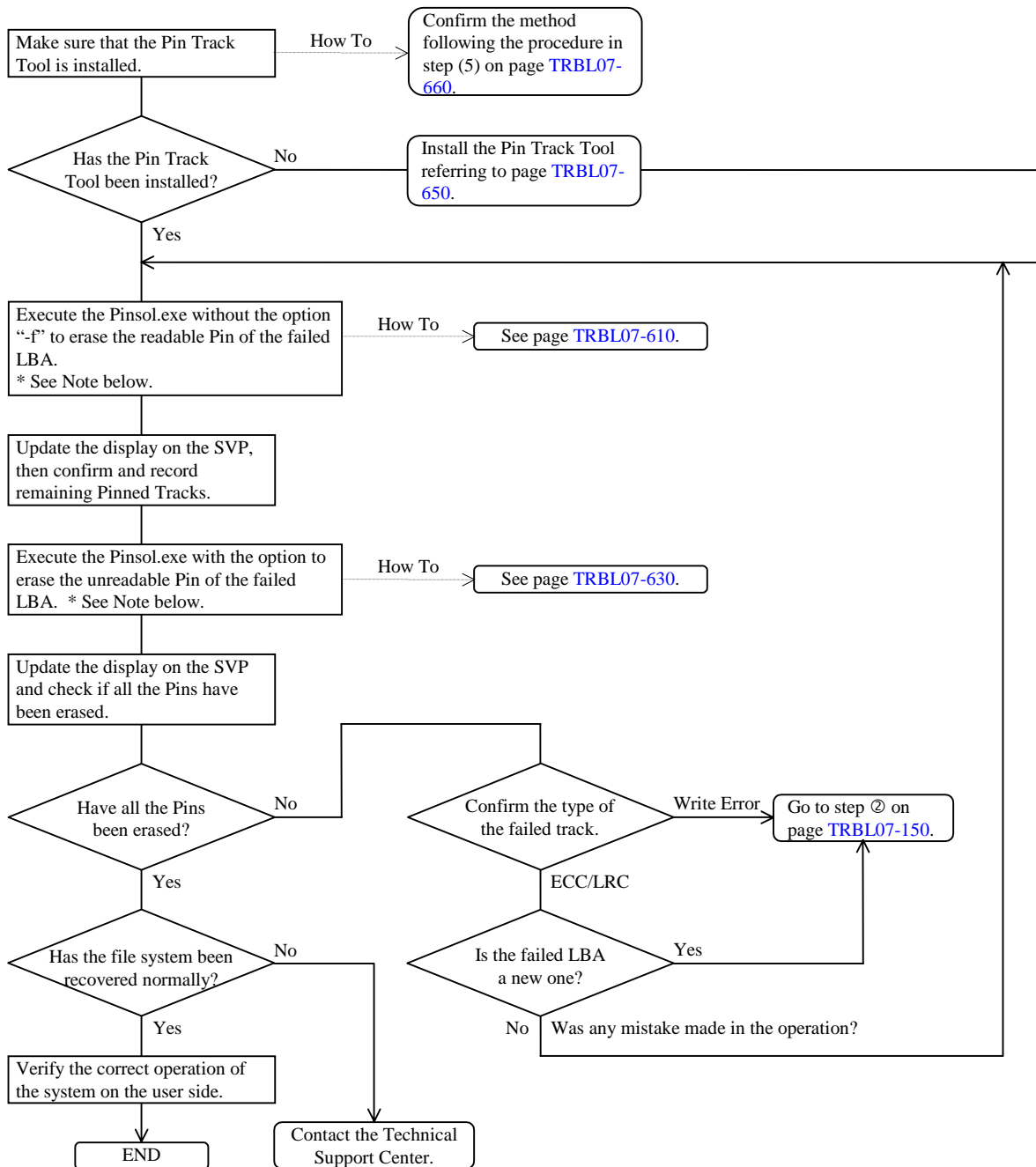

* Note - On an SIM reported owing to a use of the Pin Track Tool -
 When two or more Pins have been generated in the LBAs adjacent in the same LU, a generation of a new temporary Pin caused by the parity calculation performed in the Pin Track process may occur and an SIM may be reported.
 Since this Pin is erased at the same time when the erasing process of the Pin concerned completes, complete the SIM when it is confirmed that all the Pins have been erased by the Pin Track Tool.

Operation of Readable Pin Process (Solaris)

The following explains how to operate the Pin Track Tool for erasing a readable Pin.

*** Note** - On an SIM reported owing to a use of the Pin Track Tool -
 When two or more Pins have been generated in the LBAs adjacent in the same LU, a generation of a new Pin caused by the parity calculation performed in the Pin Track process may occur and an SIM may be reported.
 Since this Pin is erased at the same time when the erasing process of the Pin concerned completes, complete the SIM when it is confirmed that all the Pins have been erased by the Pin Track Tool.

- (1) Move to the directory of the installed Pin Track Tool.

```
#cd /usr/raidopen/pinsol
```
- (2) Execute the pinsol.exe without the option.

```
# ./pinsol.exe -log
```

 Execute with a path “./”.
- (3) Input the following information in response to questions.

| | |
|--|---|
| <pre># ./pinsol.exe -log</pre> | |
| Input Device Name -> /dev/rdsk/c3t0d0s2 | Input the cxytdzsn. |
| Input Start LBA Data-> 180 | Input the Start LBA. |
| Input End LBA Data-> 1df | Input the End LBA. |
| Input Next LBA?(Y/N) ->n | When two or more LBAs exist in the same device, input “y”. |
| Input Next Device?(Y/N) ->n (Input of “n” is recommended.) | |
| | When erasing Pins of two or more devices simultaneously, input “y”. |

To input the LBA, convert the LBA of the LDEV shown by the SVP into the slice of Solaris the device file of which corresponds to the LBA, and input the slice. For the conversion of indication between the LBA and slice, refer to Section 6.2, “Acquisition of Device Information”.

The showrel tool may display the two or more corresponding LBAs depending on the slice structure. In this case, the same LBA range is possible to be designated as different slices. Execute the Pin erasing process for the LBAs in the list shown by the showrel one by one in a descending order, and check the display on the SVP each time.

Note: When the input LBA does not exist in the device file of the specified slice, it is judged to be an unreadable Pin and causes a write error if the operation is continued leaving it as it is. Make sure that the input information is correct before starting the processing and that the Pin has been erased normally referring to the log after the processing terminates.

- (4) Since the input data and a message for confirming whether to erase the Pin, check if the input data is correct.

Device Name	Start LBA	End LBA
/dev/rdisk/c3t0d0s2	00000180	000001DF

Before you try to proceed the readable pin, please check the pin information on SVP.

If the pin data have been created, please do not try to proceed the pin track again.

Do you want to do the process of the readable Pin?

Please input[y/n(default n)]:y

If the input data is incorrect, input “n” or simply press the “Return” key and perform the data input over again from step (2).

Update the display on the SVP and check if the Pin concerned has been erased following the message.

When the Pin has already been erased, terminate the processing by inputting “n” or simply press the “Return” key.

When the Pin has not been erased, input “y” and press the “Return” key.

- (5) When the Pin is judged unreadable through the Pin type judgment, go to [TRBL07-630](#).

Unreadable Pin:

Device Name	Start LBA	End LBA
/dev/rdisk/c3t0d0s2	00000180	000001DF

- (6) When the Pin Track Tool is quit, a log file is created on the same directory.

The log file name is given as “mm-dd-hh-m‘m’-ss.log” (m: month; d: date; h: hours; m’: minutes; s: seconds).

Example:

0614200552.log means a log file created at 5minutes and 52 seconds after 20 o’clock on June 14.

In the log file, the execution result of the Pin Track process is recorded. Make sure that the process has completed normally by checking if “pin track process complete” is displayed.

Operation of Unreadable Pin Process (Solaris)

The following explains how to operate the pintool for erasing an unreadable Pin.

*** Note** - On an SIM reported owing to a use of the Pin Track Tool -
 When two or more Pins have been generated in the LBAs adjacent in the same LU, a generation of a new temporary Pin caused by the parity calculation performed in the Pin Track process may occur and an SIM may be reported.
 Since this Pin is erased at the same time when the erasing process of the Pin concerned completes, complete the SIM when it is confirmed that all the Pins have been erased by the Pin Track Tool.

- (1) Move to the directory of the installed Pin Track Tool.

```
# cd /usr/raidopen/pinsol
```
- (2) Execute the pintool with the option.

```
# ./pinsol.exe -f -log
```

When “-f” is added, the unreadable LBA is overwritten with “0” data.
- (3) Input the following information in response to questions.

```
# ./pinsol.exe -f -log
```

Input Device Name -> /dev/rdisk/c3t0d0s2	Input the cxydzsn.
Input Start LBA Data-> 180	Input the Start LBA.
Input End LBA Data-> 1df	Input the End LBA.
Input Next LBA?(Y/N) ->n	When two or more LBAs exist in the same device, input “y”.
Input Next Device?(Y/N) ->n (Input of “n” is recommended.)	When erasing Pins of two or more devices simultaneously, input “y”.

To input the LBA, convert the LBA of the LDEV shown by the SVP into the slice of Solaris the device file of which corresponds to the LBA, and input the slice. For the conversion of indication between the LBA and slice, refer to Section [TRBL07-680](#), “Acquisition of Device Information”. The showrel tool may display the two or more corresponding LBAs depending on the slice structure. In this case, the same LBA range is possible to be designated as different slices. Execute the Pin erasing process for the LBAs in the list shown by the showrel one by one in a descending order, and check the display on the SVP each time.

Note: When the input LBA does not exist in the device file of the specified slice, it is judged to be an unreadable Pin and causes a write error if the operation is continued leaving it as it is. Make sure that the input information is correct before starting the processing and that the Pin has been erased normally referring to the log after the processing terminates.

- (4) Since the input data and a message for confirming whether to erase the Pin, check if the input data is correct.

Device Name	Start LBA	End LBA
/dev/rdisk/c3t0d0s2	00000180	000001DF

Before you try to proceed the readable pin,
please check the pin information on SVP.

If the pin data have been created, please do not try to proceed the pin track again.

Do you want to do the process of the readable Pin?

Please input[y/n(default n)]:y

If the input data is incorrect, input “n” or simply press the “Return” key and perform the data input over again from step (2).

Update the display on the SVP and check if the Pin concerned has been erased following the message.

When the Pin has already been erased, terminate the processing by inputting “n” or simply press the “Return” key.

When the Pin has not been erased, input “y” and press the “Return” key.

- (5) The following message is displayed and the Pin is judged unreadable through the Pin type judgment.

Unreadable Pin:

Device Name	Start LBA	End LBA
/dev/rdisk/c3t0d0s2	00000180	000001DF

Do you want to do the process of the unreadable Pin?

WARNING! if you input ‘y’, Pin Blocks will be over written by ‘0’.

Please input[y/n(default n)]:y

In the Pin Track Process, the window may be changed into monochrome, and the following message may be showed on the window. In the case, please do not pay attention to them.

After 3 minutes or so, the window will back to originally status.

Example:

This is a message which it is displayed on the monochromic window .

WARNING: /sbus@if, 0/fc0@1, 0/sd@0, 0(sd15)

Error for Command: read Error Level: Retryable (or Fatal)

Requested Block: 766560 Error Block: 766560

Vender: HP Serial Number: 0450F4290000

Sense key: Media Error

ASC: 0x11 (unrecovered read error), ASCQ: 0x0, FRU: 0x0

- (6) When “y” is chosen by (5), the check message is displayed at once for every number of inputs. In case of plural number input, an operator can cancel the pin recovery processing for the device which you does not want to execute.

```

Unreadable Pin:
Device Name          Start LBA          End LBA
/dev/rdisk/c3t0d0s2  00000180          000001DF
Do you want to do the process of the unreadable Pin?
WARNING! if you input 'y',Pin Blocks will be over written by '0'.
Please input[y/n(default n)]:y
Do you want to do the process of the unreadable Pin? (The strip of LBA is 00000180-
000001DF). (Y/N)

```

- (7) When Pin Track Tool ends, a log file (month -day -hour -minute -second .log) is made on the same directory. (ex:0614200552.log)
As for the log file, the execution result of the Pin Track processing is recorded. Make sure that the process has completed normally by checking if “pin track process complete” is displayed.

How to read the Read Test for whole of a disk (Solaris)

This chapter describes how to discover the Unreadable Pin on select device.

This processing requires long time.

- 1) Move to the directory of the Pin Track Tool.

```
# cd /usr/raidopen/pinsol
```

- 2) Execute the Pin Track Tool without a command option.

```
# ./pinsol.exe -all (The "-f" will become invalid if this option is used.)
```

- 3) According to the question, input the appropriate information.

```
# ./pinsol.exe -all
```

```
Input Device Name -> /dev/rdisk/c3t0d0s2
```

(Please input the slice which indicate the whole device.) (Usually indicated "s2".)

```
Input Next Device?(Y/N) ->n
```

(Recommend to "n") (When erasing different Device at the same time, it inputs "y")

- 4) The Input data list is displayed.

Device Name	Start LBA	End LBA
/dev/rdisk/c3t0d0s2	00000000	001F2285

Show all domain of LAB which is specified device, and execute.

- 5) When Pin Track Tool ends, a log file (month -day -hour -minute -second .log) is made on the same directory. (ex:0614200552.log)

The log when two area (120-17F, 1E023F) of Unreadable Pin exists in specified DeviceName becomes as follows.

```
Input Device Name = /dev/rdisk/c3t0d0s2
ERROR: Read Error LBA 00000120-0000017F
ERROR: Read Error LBA 000001E0-0000023F
```

Note: The area and number of Unreadable Pin listed by other factors here may differ from the area and number of Unreadable Pin displayed by SVP.

Installation of Pin Track Tool (Solaris)

Perform the installation only when it is required.

<Preparation>

Since the Pin Track Tool is provided being contained in a 4-mm DDS DAT or 3.5-inch floppy disks, a drive for installing it is necessary in the host device which controls the Pin erasing operation or on the network which includes the device concerned.

Acquire a name for the device beforehand.

Besides, ensure a free area on the disk necessary for a log collection because a log of approximately 400 bytes per failed track is output when the log is collected using the pintool.

Note: If the free capacity on the disk is insufficient, the whole information cannot be collected.

The showrel tool for LBA-slice conversion ensures a memory and creates a temporary file in order to acquire device information. Make sure that the memory capacity (larger than 128MB/CPU) and the disk free capacity (larger than 10MB) sufficient for the server are ensured.

<Copying from media to disk>

- (1) Login to the host as “root”.
- (2) Move to the install directory by the “cd” command and make a directory “raidopen”.

```
# cd /usr          (Move to the “/usr”)
# mkdir raidopen  (Make the directory “raidopen”)
# cd raidopen     (Move to the “raidopen”)
```
- (3) Move to the created directory and copy the files from the distribution medium.

<In the case of DDS DAT> (device name depends on each host.)

```
# mt -t /dev/rmt/0 rew  (Rewind a tape.)
# tar -xvf /dev/rmt/0   (Copy a file from the tape.)
# tar -xvf pinsolXX.tar (Copy the tar file for Solaris.)
```

<In case of the Floppy disk or CD-ROM>

```
# volcheck          recognize a floppy disk or CD-ROM
confirm the label, and copy the files from the distribution medium.
# tar -xvf /floppy/no_name/PINSOLxx.TAR (Floppy)
# tar -xvf /cdrom/zzzz/program/ment/pintrack/solaris/pinsolXX.tar (CD-ROM)
```

Note: (The volume label (no_name) and directory name (ZZZZ) is depend on the system.)

If the copy from the floppy disk to the disk ends, it takes out a floppy disk.

```
# eject          Eject the medium.
```

If necessary, it pushes an eject button and it takes out a floppy disk.

- (4) After the thawing is complete, confirm the file name.
- ```
cd ./pinsol (Move to the directory made by the thawing.)
ls -l (Display a file list.)
```
- (5) Refer to the contents of the “Ver-Rev.txt” file and confirm each file size of the list.
- ```
# more /usr/raidopen/pisol/Ver-Rev.txt      display contents of the file
```

```
HITACHI RAID Subsystem PinTrackTool for Solaris
Ver XX-YY-/Z (Revision ID)
All right reserved, Copyright (c) 1999,2000, Hitachi Ltd.
File Size (Bytes) pinsol.exe (Module ID)
File Size (Bytes) showrels.exe (Module ID)
```

Refer to the contents of “Ver-Rev.txt” file and confirm each file size of the list.

Saving of log file and de-installation of Pin erasing tool

Perform the de-installation only when it is required.

<Saving of log file>

In order to save the log file created through the Pin erasure, compress the file.

```
# cd /usr/raidopen/pinsol      Move to the execution directory.
# mkdir ./log                  Create a directory for the log file.
# mv *.log ./log               Move the log file to the logdir.
# tar -cvf pinlog.tar ./log    Create the tar file.
# compress pinlog.tar          Compress the tar file.
Save the log file to the media.
# tar -cvf /dev/rmt/0 pinlog.tar.Z (In the case of DDS DAT)
# tar -cvf /vol/dev/rdiskette0/unlabeled pinlog.tar.Z (In the case of floppy disk (tar))
# cp pinlog pinlog.tar.Z /vol/dev/rdiskette0/raidopen (In the case of floppy disk(DOS))
```

<De-installation of Pin Track Tool>

To uninstall the Pin Track Tool, delete all the files concerned by deleting the whole directory in which the tool is installed.

```
# cd /                          Move to the root directory.
# \rm -r /usr/raidopen/pinsol*   Delete files created under the /usr/raidopen.
                                  When “\” is added, the alias is invalidated.
```

Procedure for collecting detail log

You can acquire detailed information on the erasing process from the Pin failure by adding the option to the Pin Track Tool.

Method of use: `./pinsd.exe(-f) -log`

By executing the above, you can acquire data which was read and written in the process for erasing from the Pin failure.

Example:

```

Input Device Name = /dev/rdisk/c1t0d0s2
Input Start LBA = 00000180
Input End LBA = 000001DF
/dev/rdisk/c1t0d0s2, Start LBA=00000180, End LBA=000001df readable Pin Track read error
Read Data: Top Pin No=00000180
00000000: 00 00 00 00 00 00 00 00 00 00 00 00 00 00 00 00
00000010: 00 00 00 00 00 00 00 00 00 00 00 00 00 00 00 00
00000020: 00 00 00 00 00 00 00 00 00 00 00 00 00 00 00 00
00000030: 00 00 00 00 00 00 00 00 00 00 00 00 00 00 00 00
00000040: 00 00 00 00 00 00 00 00 00 00 00 00 00 00 00 00
...
Read Data: Top Pin No=00000181
...
Read Data: Top Pin No=00000182
...
Read Data: Top Pin No=00000183
...
Read Data: Top Pin No=000001DF
000001A0: 00 00 00 00 00 00 00 00 00 00 00 00 00 00 00 00
000001B0: 00 00 00 00 00 00 00 00 00 00 00 00 00 00 00 00
000001C0: 00 00 00 00 00 00 00 00 00 00 00 00 00 00 00 00
000001D0: 00 00 00 00 00 00 00 00 00 00 00 00 00 00 00 00
000001E0: 00 00 00 00 00 00 00 00 00 00 00 00 00 00 00 00
000001F0: 00 00 00 00 00 00 00 00 00 00 00 00 00 00 00 00
Write Data: Top Pin No=00000180
...
00000000: 00 00 00 00 00 00 00 00 00 00 00 00 00 00 00 00
00000010: 00 00 00 00 00 00 00 00 00 00 00 00 00 00 00 00
00000020: 00 00 00 00 00 00 00 00 00 00 00 00 00 00 00 00
00000030: 00 00 00 00 00 00 00 00 00 00 00 00 00 00 00 00
00000040: 00 00 00 00 00 00 00 00 00 00 00 00 00 00 00 00
...
...
0000BFC0: 00 00 00 00 00 00 00 00 00 00 00 00 00 00 00 00
0000BFD0: 00 00 00 00 00 00 00 00 00 00 00 00 00 00 00 00
0000BFE0: 00 00 00 00 00 00 00 00 00 00 00 00 00 00 00 00
0000BFF0: 00 00 00 00 00 00 00 00 00 00 00 00 00 00 00 00
/dev/rdisk/c1t0d0s2, Start LBA=00000180, End LBA=000001DF Pin Track Process is complete!!

```

The log size is approximately 400 kB per one Pin erasure.

When the `-log` option is not added, data for each LBA is recorded for each of reading and writing.

Acquisition of device information (how to use showrel tool) on Solaris

When the program has been installed, confirm the failed track information.

- (1) Move to the installed directory.

```
# cd /usr/raidopen/pinsol
```

Moving of the directory

- (2) Execute the following program

# ./showrels.exe	Add the ./ path and execute.
Input LDEV -> 000A	Input the device name shown on the SVP.
Input Start LBA -> 00044000	Input the start LBA shown on the SVP.
Input End LBA -> 0004405F	Input the End LBA shown on the SVP.

Input example and output result.

#./showrels.exe
Input LDEV -> 0123
Input Start LBA -> 0000ABE0
Input End LBA -> 0000AC3F
DeviceName=c0t1d0s6 Port=1A LDEV=0123
Start=00000FA0 End=00000FFF

The LDEV number is indicated with the CU:LDEV number of four figures. Confirm the CU number and LDEV number of the Pin displayed on the SVP and identify the slice of the device file. The device file name identified here is used as the input information in the process for the Pin failure.

[Note]

- The showrel tool issues commands peculiar to the disk subsystem to all the disk devices in order to acquire device information. Therefore, when the command is issued to a disk other than the disk subsystem such as a built-in disk, an error (Illegal Request) may be reported to the system. It is not a problem, though.
- When an unreadable Pin is generated in the slot#15 including the head LBA in which the disk management information is recorded, the device information cannot be acquired because the disk becomes unable to respond to the OS.

The following may be displayed depending on the setting of the slice.

When there is no information of the input LDEV in the device management table.
LDEV=010C This is not a target disk.

Check if the input LDEV number is correct.

When an LDEV which does not belong to any slice is input
DeviceName=c2t3d0s6 Port=1D LDEV=0189 The target LBA is missing or invalid.

In this case, the Pin shown on the SVP cannot be erased. However, it does not have any effect on the file system.

When a Pin extends over multiple slices
DeviceName=c0t1d0s5 Port=1A LDEV=000A
Start=00001357 End=00001387
DeviceName=c0t1d0s1 Port=1A LDEV=000A
Start=00000000 End=0000002F

When it is displayed that a Pin extends over multiple slices, specify the LBA displayed for each slice when executing the pinsol.exe. The Pin cannot be erased unless all the range concerned are processed by the pinsol.exe.

When an LDEV is allocated to multiple ports
DeviceName=c1t1d0s6 Port=1A LDEV=0123
Start=00000FA0 End=00000FFF
DeviceName=c0t3d0s6 Port=1C LDEV=0123
Start=00000FA0 End=00000FFF

When an LDEV is displayed at the different ports with the same LBA range of the slice, a single LDEV is allocated to multiple ports. In this case, specify any one of the devices to execute the pinsol.exe.

When multiple LBAs are displayed for an LDEV
DeviceName=c0t3d0s2 Port=1A LDEV=0123
Start=00000FA0 End=00000FFF
DeviceName=c0t3d0s6 Port=1A LDEV=0123
Start=00000FA0 End=00000FFF

When two slices are displayed with the same LBA range for an LDEV, a slice to which the same cylinder is allocated may exist. Normally one of the slices is 2. In this case, specify a device described ahead in order to execute the pinsol.exe. If the Pin is not erased when the SVP display is checked after the Pin erasing process has terminated normally, execute the pinsol.exe for another device.

Procedure for determining MountPoint (on Solaris)

The following operation must be performed by the system administrator at your request checking result at each step.

Display by the showrel

When the showrel explained in [TRBL07-680](#) is used, the LDEV number shown on the SVP and to which device file the range between the Start LBA and End LBA corresponds are displayed. Refer to [TRBL07-680](#), “How to use showrel tool”.

Display by prtvtoc

Input “#prtvtoc <raw-device-name>” to display the slice list and find out all the slices in which Pins have been generated.

```
* /dev/rdisk/c0t1d0s5 partition map
*
* Dimension:
* 512 bytes/sector
* 80 sectors/track
* 9 tracks/cylinder
* 720 sectors/cylinders
* 2500 cylinders
* 1151 accessible cylinders
*
* Flags:
* 1: unmountable
* 10: read-only
*
*
*          First Sector Last
* Partition Tag  Flags  Sector  Count  Sector  Mount Directory
* 0         2    00     0      76320  76319
* 1         3    01    76320  132480 208799
* 2         5    00     0      828720 828719
* 5         6    00   208800  131760 340559 /opt
* 6         4    00   340560  447120 787679 /usr
* 7         8    00   787680  41040  828719 /export/home
```

You can confirm the current MountPoint by viewing the display of the Mount Directory.

Determination using /etc/vfstab

Find out the MountPoint where the /dev/dsk/cxytdzsn is mounted using the #cat/etc/fstab.

```
# cat /etc/vfstab
#device    device      mount      FS    fsck  mount mount
#to mount  to fsck     point      type  pass  at boot options
fd    -    /dev/fd fd    -    no    -
/proc  -    /proc  proc  -    no    -
/dev/dsk/c0t3d0s1  -    -    swap  -    no    -
/dev/dsk/c0t3d0s0  /dev/rdisk/c0t3d0s0  /    ufs  1  no  -
/dev/dsk/c0t3d0s6  /dev/rdisk/c0t3d0s6  /usr  ufs  1  no  -
/dev/dsk/c0t3d0s3  /dev/rdisk/c0t3d0s3  /var  ufs  1  no  -
/dev/dsk/c0t3d0s7  /dev/rdisk/c0t3d0s7  /export/home  ufs  2  yes  -
/dev/dsk/c0t1d0s7  /dev/rdisk/c0t1d0s7  /export/home1  ufs  3  yes  -
swap  -    /tmp  tmpfs  -    yes  -
#
```

You can make sure whether the object device is mounted automatically or not.

Determination using df

Reconfirm the “Ivol name” and “mount point” recognized by the filesystem using the #df -k.

```
# df -k
Filesystem      kbytes    used    avail  capacity  Mounted on
/dev/dsk/c0t3d0s0  76767  17735  58956   24%  /
/dev/dsk/c0t3d0s6  738902  552048  185931   75%  /usr
/proc            0         0         0     0%  /proc
fd                0         0         0     0%  /dev/fd
/dev/dsk/c0t3d0s3  30807  17911  12866   59%  /var
/dev/dsk/c0t3d0s7  53535   7923  45559   15%  /export/home
/dev/dsk/c0t1d0s7  489702  189635  299578   39%  /export/home1
swap            121856    212  121644    1%  /tmp
/dev/dsk/c1t0d0s0  7095037 2163405 4860682   31%  /open9-0
/dev/dsk/c1t1d0s0  7095757 2049632 4975168   30%  /open9-1
#
```

You can make sure whether the object device is being mounted currently or not.

Decide the MountPoint to be checked by the “sum” command following the procedure above.

<Erasing procedure which does not require the Pin Track Tool>

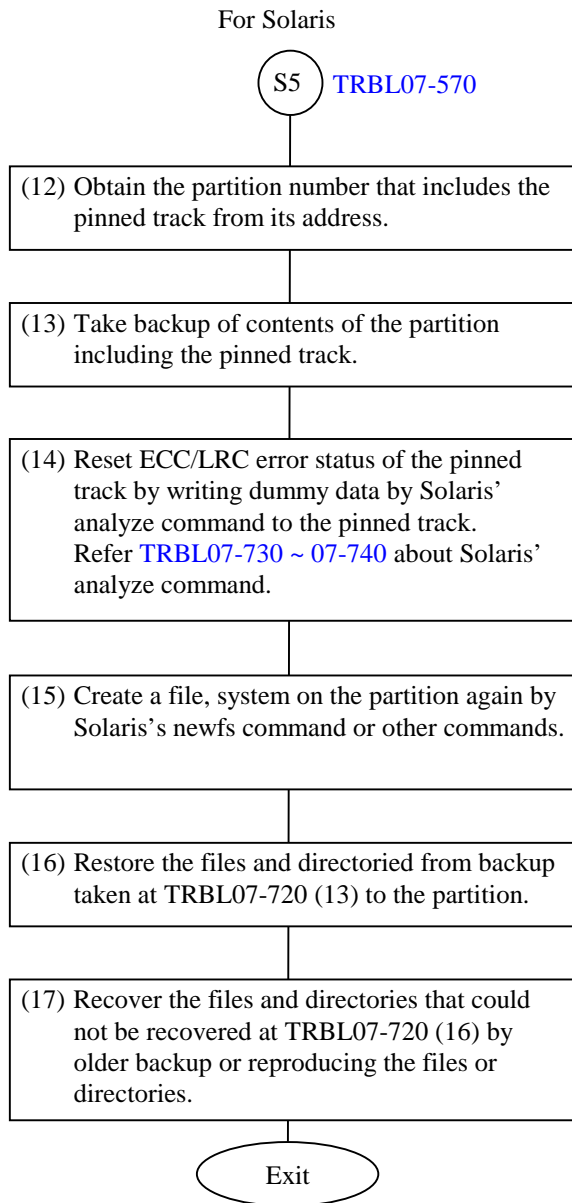

Reset ECC/LRC error status of pinned track by Solaris analyze command (Solaris)

ECC/LRC error status of a pinned track can be resetted by writing dummy data by the analyze command in case of the LDEV containing the pinned track is connected to Solaris.

The procedure is described below. Input commands are shown by boldface characters.

- 1) Login to the Solaris as supseruser

Example

```
host console login: root↵
password: sorry↵
```

- 2) Writing dummy data to the pinned track by the analyze command

The analyze command is a subcommand of the format command

Example

```
# format↵
Searching for disks...done

AVAILABLE DISK SELECTIONS:
(recognized SCSI disks are listed here.)
Specify disk (enter its number):n↵           ...device number of the LDEV
                                                including the pinned track.

selecting n
[disk formatted]

FORMAT MENU:
(format command menu is listed here.)
format> analyze↵
(analyze subcommand menu is listed here.)
analyze> setup↵
Analyze entire disk[no]? no↵
Enter starting block number[0, 0/0/0]: starting LBA of the pinned track
Enter ending block number[5806479, 3336/14/115]: ending LBA of the track
Loop countinuously[no] no↵
Repair defective blocks[yes] ↵
Stop after first error[no] ↵
Use random bit parrerns[no] ↵
```

```

Enter number of blocks per transfer[126, 0/1/10]: 1↵
Verify media after formatting [yes]? no↵
Enable extended messages[no]? yes↵
Restore defect list[yes]? ↵
Restore disk label[yes]? ↵

analyze> write↵
Ready to analyze (will corrupt data). This takes a long time,
but is interruptable with CTRL-C. Continue? y↵

    PASS 0 - pattern = c6dec6de
    cylinder number/head number/block counts

Total of 0 defective blocks repaired.
analyze> quit↵

```

(Note)

- 1) The above procedure and messages may depend on Solaris versions.
- 2) The device number cxtxdx used for Solaris is different from the DKC460 LDEV number. The device number cxtxdx should be obtained by DKC460 SCSI path configuration.
 - (a) Isolate the LDEV number of the LDEV containing the pinned track by SVP.
 - (b) Obtain the SCSI port number (CL1A through CL2R) and SCSI target ID and LUN that constructing the SCSI path from Solaris to the LDEV.
 - (c) Login to Solaris as superuser and execute the format command. Determine the device number cxtxdx by SCSI port number and SCSI target ID and LUN and the SCSI board installed into SUN to which the DKC460 SCSI port is connected.
- 3) Whole track range must be specified by the start and end LBAs. 1 track has 96 blocks for OPEN-3 and OPEN-9. It happens that a pinned track is not correctly resetted if whole track range is not specified.
- 4) Data written on a pinned track must be recovered by a backup file because the analyze command writes dummy data on the pinned track.
- 5) The files or directories written with dummy data can not be determined because of structure of the UNIX file systems. The whole files and directories on the partition containing a pinned track must be recovered from backup file.

7.3.3.4 E-NAS-OS (Linux) Procedure

A procedure for clearing pinned data occurs when using E-NAS-OS (Linux) is shown below.

= Notices =

○ E-NAS-OS uses the following device files.

User LU: /dev/enas/luL (pP) (For a user volume)

System LU: /dev/enassys/luS (pP) (For a system LU)

Symbol	Denotation
L	LUN (00 ~ FF)
S	LUN (00 ~ 08) 00: For a system disk 01: For dump storage 05: For command device binding 06: For maintenance data collecting work 08: Shared LU 02 ~ 04 and 07: Reserved
P	Partition number (1 ~ 15)

- When unreadable pinned data occurs in the Start LBA, it cannot be cleared.
In the area between the LBA0x0 and LBA0x5F corresponding to the slot #15, management information including the device geometry is recorded. When pinned data including the area occurs, the device concerned becomes unable to be recognized as a disk by the OS. Format the LDEV following the Maintenance Manual.
- Do not clear pinned data using Pin Track Tool from the device file (/dev/enassys/luS[pP]) for a system LU (see ④ Recovery procedure for a system LU on page [TRBL07-150](#)). That is because it is feared that the LBA is overwritten with zeros.
- Specify a correct LBA which is to be entered for Pin Track Tool.
If a wrong LBA is entered, E-NAS-OS judges the specified area to be unreadable pinned data. Even if a clearance of the unreadable pinned data is attempted specifying the area, it will be unsuccessful because a write error is caused. Make sure that the entered LBA is correct before executing Pin Track Tool.
- After executing Pin Track Tool, make sure that the process has been completed normally by referring to a log.
To check the result of the pinned data clearance, refer to the log file. Read/write errors are not displayed in the window. When a write error occurs as described above, check if the entered information was correct.

When removing the unreadable LBA from a file system under those conditions, operate following the flowcharts shown below.

- The following is a flow of operations to be done when a failure (pinned data) occurs while E-NAS-OS is used.

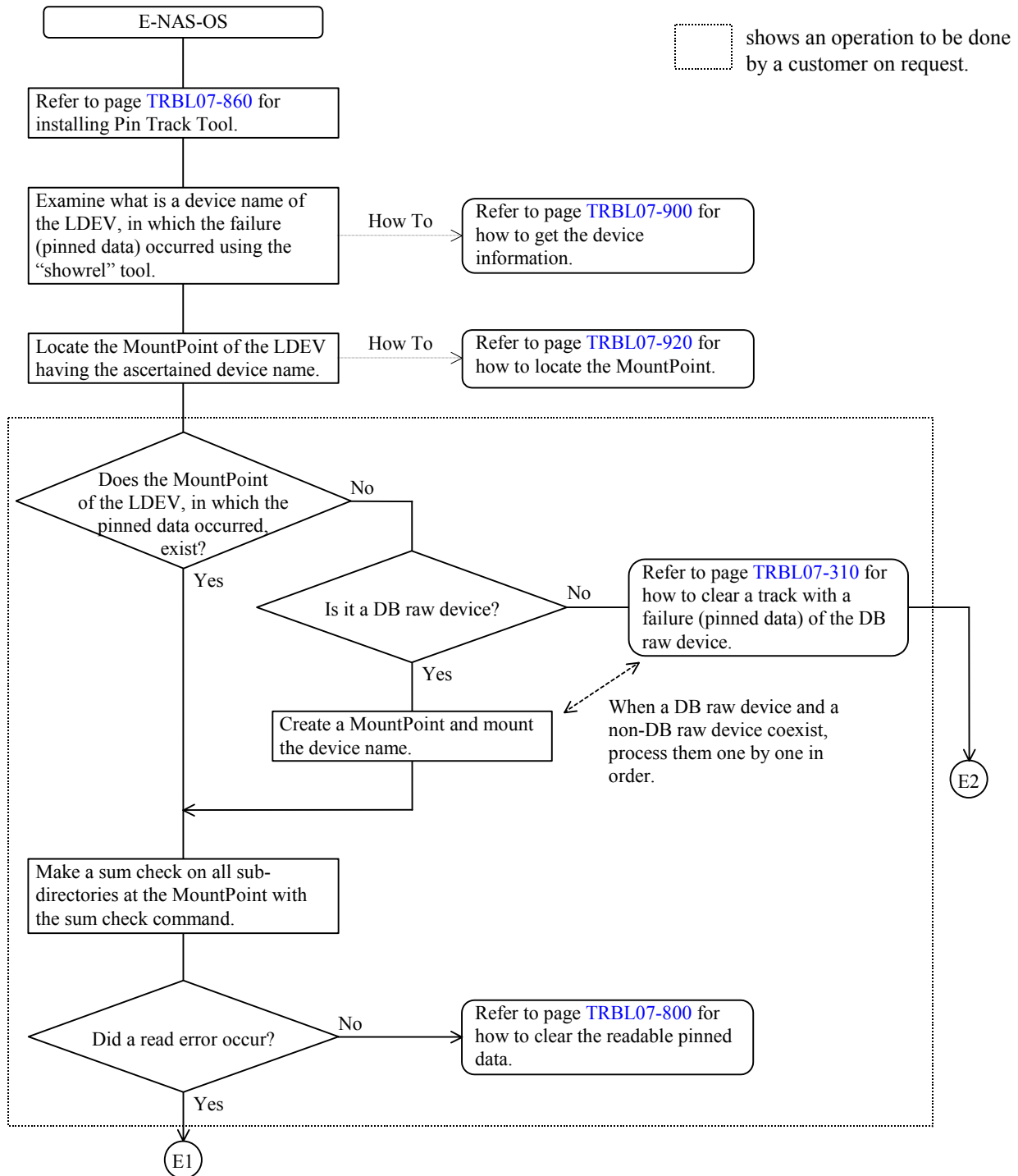

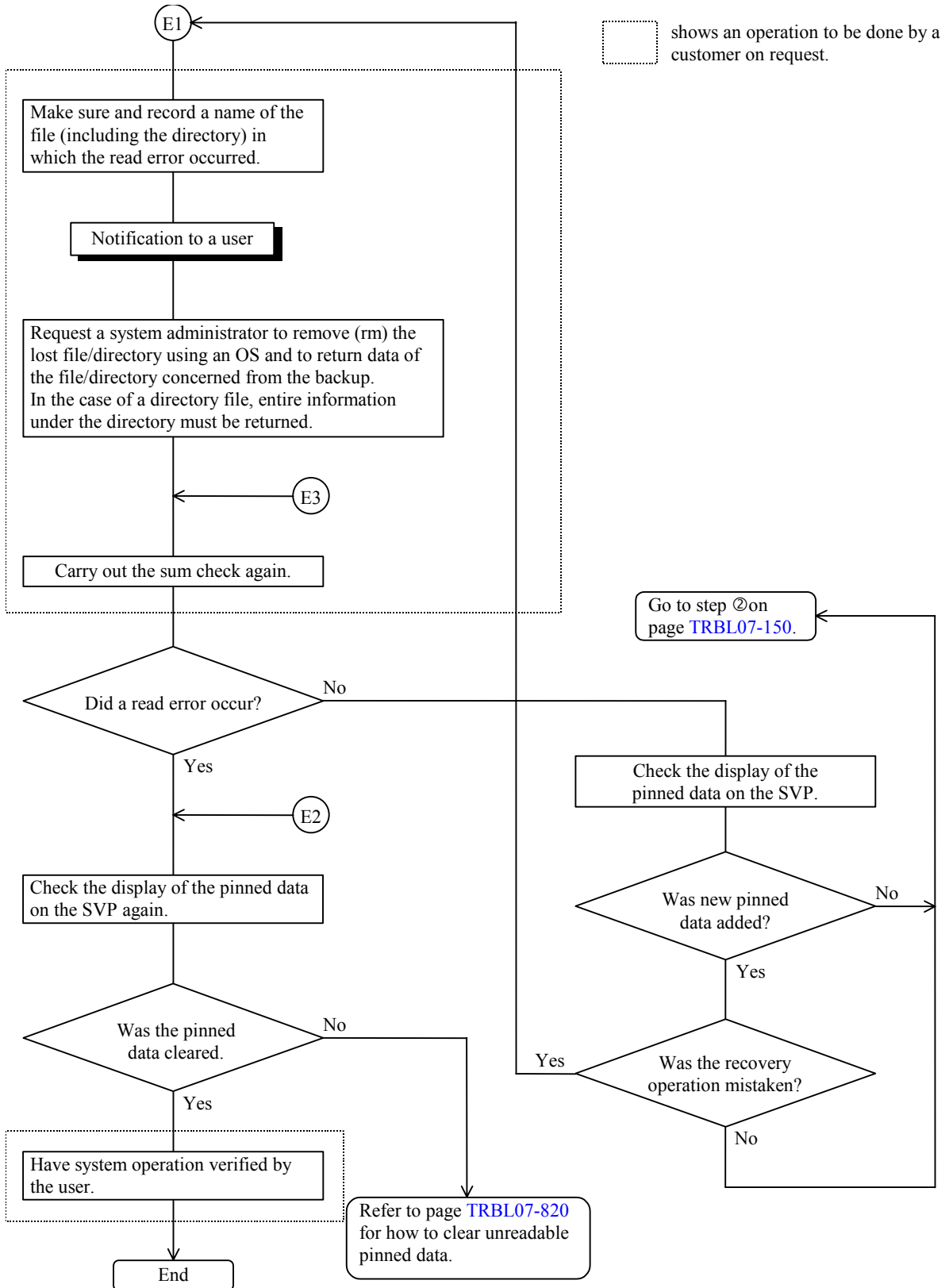

Processing Readable Pin (E-NAS-OS)

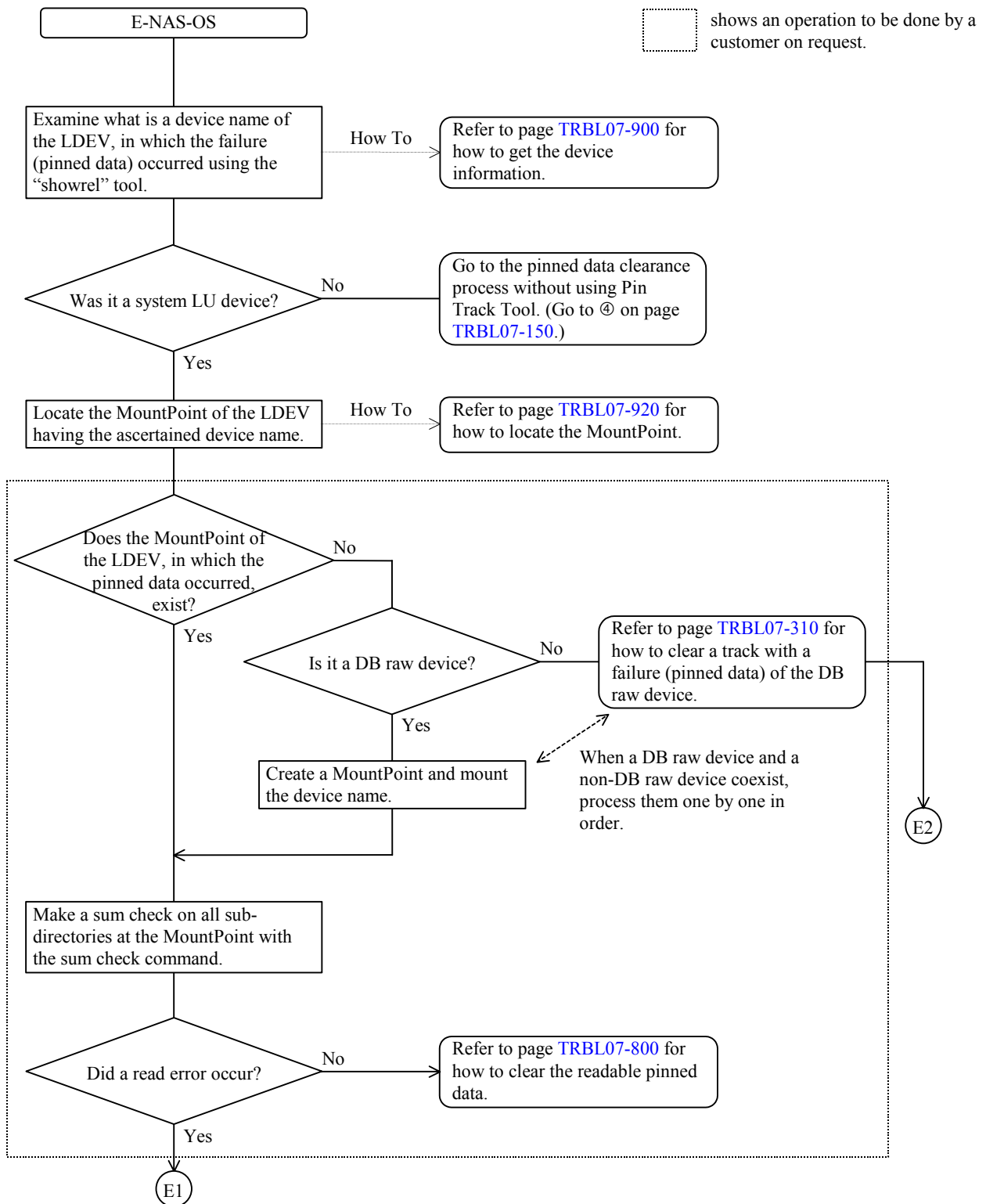

Processing Unreadable Pin (E-NAS-OS)

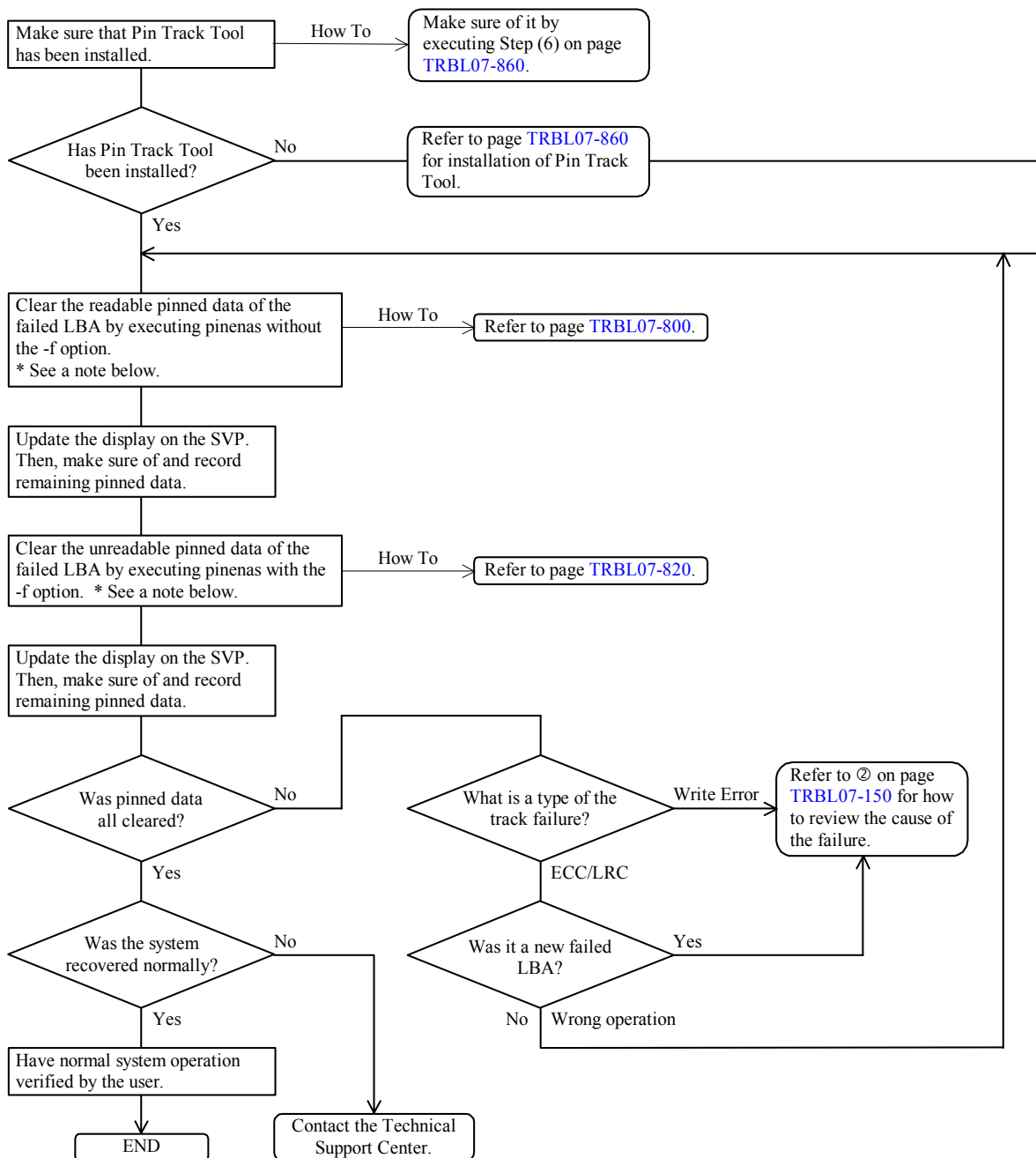

*** Note - SIM reporting using Pin Track Tool -**

When two or more pieces of pinned data have occurred in two LBAs contiguous to each other in the same LU, new pinned data may be generated temporarily owing to the parity calculation at the time of a pinned data clearance and a SIM concerning it is reported. Since the pinned data is cleared at the same time when clearance of the pinned data of the LU concerned is completed, complete the SIM when it becomes sure that the pinned data has been entirely cleared by Pin Track Tool.

Procedure for clearing readable pinned data (for E-NAS-OS)

Operation of Pin Track Tool for clearing readable pinned data is explained below.

*** Note - SIM reporting using Pin Track Tool -**

When two or more pieces of data have occurred in two LBAs contiguous to each other in the same LU, new pinned data may be generated temporarily owing to the parity calculation at the time of a pinned data clearance and a SIM concerning it is reported.

Since the pinned data is cleared at the same time when clearance of the pinned data of the LU concerned is completed, complete the SIM when it becomes sure that the pinned data has been entirely cleared by Pin Track Tool.

- (1) Go to the following directory of Pin Track Tool that has been installed.

```
# cd /usr/raidopen/pinenas
```

- (2) Execute pinenas.exe with no option.

```
# ./pinenas -log      Execute it with the path,“./”.
                        -log option is recommended.
```

- (3) Enter information in response to inquiries.

```
# ./pinenas -log
Input Device Name -> /dev/enas/lu00      Enter a device name.
Input Start LBA Data-> 180              Enter the Start LBA.
Input End LBA Data-> 1df                 Enter the End LBA.
Input Next LBA?(Y/N) ->n                When two or more LBAs exist in the
                                          same device, enter “y”.
Input Next Device?(Y/N) ->n (n is recommended.) When processing two or more devices at
                                          the same time, enter “y”.
```

When entering an LBA, enter a volume (partition) of E-NAS-OS which is converted from an LBA of an LDEV displayed on the SVP based on a criterion that a device file of the volume (partition) is equivalent to the LBA. For the conversion of expression from LBA to partition, refer to an item on getting device information on page [TBL07-900](#). There may be a case where two or more LBAs concerned are displayed by the showrel tool depending on a partition structure. In such a case, it is possible that the same LBA area is shown as another partition. Enter the LBAs one by one in order starting from the top of the list shown by the showrel tool and check the display on the SVP each time of the entry.

Note: When the entered LBA does not exist in the device file of the specified volume (partition), it is judged to be unreadable pinned data and a write error is caused if the process is continued leaving the LBA as it is. Check if no wrong entry has been made before executing Pin Track Tool, and after the execution, check that the process has been done normally by referring to a log.

- (4) Since the entered data and a message asking for confirmation is displayed, check if no wrong data is found.

Device Name	Start LBA	End LBA
/dev/enas/lu00	00000180	000001DF

Before you try to proceed the readable pin,
please check the pin information on SVP.

If the pin data have been cleared, please do not try to proceed the pin track again.

Do you want to do the process of the readable Pin?

Please input[y/n(default n)]:y

If a wrong data is found, enter “n” or [Return] and operate over again from Step (2).

Update the display on the SVP following the message, and then check whether the pinned data has been cleared or not.

When the pinned data has been cleared, finish the operation by entering “n” or [Return].

When the pinned data has not been cleared, enter “y” [Return].

- (5) When the pinned data is judged unreadable through judgment of pinned data kind, go to page [TRBL07-820](#).

Unreadable Pin:

Device Name	Start LBA	End LBA
/dev/enas/lu00	00000180	000001DF

- (6) When execution of pinenas.exe is completed, a log file is produced under the same directory. The log file name is expressed as month, month, date, date, hours, hours, minutes, minutes, seconds, seconds. log.)

Example:

0614200552.log → A log file produced at 5 minutes and 52 seconds after 20 o'clock on June 14

On the log file, result of the pinned data clearance process is recorded. Check if the process has been completed normally based on the fact that “pin track process complete” is displayed.

Procedure for clearing unreadable pinned data (for E-NAS-OS)

Operation of Pin Track Tool for clearing unreadable pinned data is explained below.

*** Note - SIM reporting using Pin Track Tool -**

When two or more pieces of data have occurred in two LBAs contiguous to each other in the same LU, new pinned data may be generated temporarily owing to the parity calculation at the time of a pinned data clearance and a SIM concerning it is reported.

Since the pinned data is cleared at the same time when clearance of the pinned data of the LU concerned is completed, complete the SIM when it becomes sure that the pinned data has been entirely cleared by Pin Track Tool.

- (1) Go to the following directory of Pin Track Tool that has been installed.

```
# cd /usr/raidopen/pinenas
```

- (2) Execute pinenas.exe with options.

```
# ./pinsol.exe -f -log
```

When the -f option is added, the unreadable LBA is overwritten with zeros.
-log option is recommended.

- (3) Enter information in response to inquiries.

```
# ./pinenas -f -log
```

```
Input Device Name -> /dev/enas/lu00
```

Enter a device name.

```
Input Start LBA Data-> 180
```

Enter the Start LBA.

```
Input End LBA Data-> 1df
```

Enter the End LBA.

```
Input Next LBA?(Y/N) ->n
```

When two or more LBAs exist in the same device, enter "y".

```
Input Next Device?(Y/N) ->n (n is recommended.)
```

When processing two or more devices at the same time, enter "y".

When entering an LBA, enter a volume (partition) of E-NAS-OS which is converted from an LBA of an LDEV displayed on the SVP based on a criterion that a device file of the volume (partition) is equivalent to the LBA. For the conversion of expression from LBA to partition, refer to an item on getting device information on page [TRBL07-900](#). There may be a case where two or more LBAs concerned are displayed by the showrel tool depending on a partition structure. In such a case, it is possible that the same LBA area is shown as another partition. Enter the LBAs one by one in order starting from the top of the list shown by the showrel tool and check the display on the SVP each time of the entry.

Note: When the entered LBA does not exist in the device file of the specified volume (partition), it is judged to be unreadable pinned data and a write error is caused if the process is continued leaving the LBA as it is. Check if no wrong entry has been made before executing Pin Track Tool, and after the execution, check that the process has been done normally by referring to a log.

- (4) Since the entered data and a message asking for confirmation is displayed, check if no wrong data is found.

Device Name	Start LBA	End LBA
/dev/enas/lu00	00000180	000001DF

Before you try to proceed the readable pin,
please check the pin information on SVP.

If the pin data have been cleared, please do not try to proceed the pin track again.

Do you want to do the process of the readable Pin?

Please input[y/n(default n)]:y

If a wrong data is found, enter “n” or [Return] and operate over again from Step (2).

Update the display on the SVP following the message, and then check whether the pinned data has been cleared or not.

When the pinned data has been cleared, finish the operation by entering “n” or [Return].

When the pinned data has not been cleared, enter “y” [Return].

- (5) The pinned data is judged unreadable through judgment of pinned data kind and the following message is displayed.

Unreadable Pin:

Device Name	Start LBA	End LBA
/dev/enas/lu00	00000180	000001DF

Do you want to do the process of the unreadable Pin?

WARNING! if you input ‘y’, Pin Blocks will be over written by ‘0’.

Please input[y/n(default n)]:y

When clearing the pinned data by overwriting the unreadable LBA with zeros, enter “y” [Return].

- (6) When “y” [Return] is selected for the clearance of the unreadable pinned data, confirmation for execution is asked each time when the entry is made.

By virtue of the above, an operator can prevent the clearance from being executed for a device to which you do not want to apply the clearance.

Unreadable Pin:		
Device Name	Start LBA	End LBA
/dev/enas/lu00	00000180	000001DF
Do you want to do the process of the unreadable Pin?		
WARNING! if you input ‘y’, Pin Blocks will be over written by ‘0’.		
Please input[y/n(default n)]:y		
Do you want to do the process of the unreadable Pin? (The strip of LBA is 00000180-000001DF). (Y/N)		

- (7) When execution of pinenas.exe is completed, a log file is produced under the same directory. The log file name is expressed as month, month, date, date, hours, hours, minutes, minutes, seconds, seconds. log.)

Example:

0614200552.log → A log file produced at 5 minutes and 52 seconds after 20 o’clock on June 14

On the log file, result of the pinned data clearance process is recorded. Check if the process has been completed normally based on the fact that “pin track process complete” is displayed.

Procedure for reading whole device specified (For E-NAS-OS)

This is a procedure for finding unreadable area in the specified device.

It takes a long time to carry out this process.

- 1) Go to the following directory of Pin Track Tool that has been installed.

cd /usr/raidopen/pinenas

- 2) Execute pinenas with an option.

./pinenas -all (When this option is used, -f is invalidated.)

- 3) Enter information in response to inquiries.

./pinenas -all

Input Device Name -> **/dev/enas/lu00** (Enter a device name only.)

(Specify a slice ("s2", normally) that shows the whole device.)

Input Next Device?(Y/N) ->n

(n is recommended.) (Enter "y" when processing two or more devices at the same time.)

- 4) Data that has been entered is displayed

Device Name	Start LBA	End LBA
/dev/enas/lu00	00000000	001F2285

The whole area of the LBA of the specified device is displayed and pinenas is executed in succession.

- 5) When the execution of pinenas is completed, a log file is produced under the same directory. The log file name is expressed as month, month, date, date, hours, hours, minutes, minutes, seconds, seconds. log.)

Example:

In the case where two unreadable LBAs (120-17F and 1E023F) exist in the specified device (device name), the log is as shown below.

Input Device Name = /dev/enas/lu00
ERROR: Read Error LBA 00000120-0000017F
ERROR: Read Error LBA 000001E0-0000023F

Note: The unreadable LBAs listed above may be different from those displayed on the SVP.

Installing Pin Track Tool

The installation should be done only when it is necessary.

<Preparations required>

- (1) Prepare a medium storing the Pin Track Tool.
Supplied medium: User P.P., CD-ROM, etc.
- (2) Create a work directory (c:\pintmp, etc.) on the SVP (or user's terminal).
- (3) Copy the Pin Track Tool from the medium to the work directory.
- (4) Install the SSH client tool on the SVP (or user's terminal)^{*1}.
- (5) Make a key for a logging in from the SVP (or user's terminal) to the CHN with the SSH^{*1}.
- (6) Register the open key using Nas Manager^{*1}.

* Only Nas Manager can register the open key. Therefore, to register the open key, which has been made using the SVP, it is required to ask a user to do the registration or borrow a user's terminal.

<Transferring the tool from the SVP to the CHN>

- (1) Log in the CHN having the file system in which the pinned data occurred from the SVP (or user's terminal) using the SSH^{*1}.
Account name^{*2}: *****
- (2) Change the account to super user on the CHN.
su -
Password^{*2}: ++++++
- (3) Make a directory for opening the tool on the CHN.
cd/usr
mkdir raidopen (Makes the raidopen directory.)
- (4) Transfer the tool from the work directory of the SVP (or user's terminal) to a home directory of the ***** using the scp^{*1}.
- (5) Get the tool ready for use on the CHN.
cd raidopen
mv /home/*****/pinenasXX.tar ./
tar xvf pinenasXX.tar
The file is opened having the following directory structure.
./pinenas/pinenas (PIN clearance tool)
./pinenas/showrele (showrel tool)
./pinenas/Ver-Rev.txt
- (6) Make sure of a file size referring to the following file.
more Ver-Rev.txt (Displays the text file.)

```
HITACHI RAID Subsystem Pin Track Tool for ENAS
Ver XX-YY-/Z (Revision ID)
All Rights Reserved, Copyright © 2003, Hitachi, Ltd.
File size (Bytes) pinenas (Module ID)
File size (Bytes) showrele (Module ID)
```

Make sure that the contents of the file above is consistent with the execution result of the ls command displayed.

*1: Refer to the file appended.

*2: For the account password, ask the system administrator.

Storing the log file and de-installing Pin Track Tool

The de-installation should be done only when it is necessary.

<Storing the log file>

- (1) Compress the file in order to store the log file produced through the pinned data recovery.
 - # cd /usr/raidopen/pinenas (Moves the file to the work directory.)
 - # mkdir ./log (Creates a directory for the log file.)
 - # mv *.log ./log (Moves the log file to the log.)
 - # tar zcvf pinlog.tar.gz ./log (Creates a log file.)
- (2) Get the log file from the SVP (or user's terminal) with the scp and store it in a medium.
- (3) Store the log file, which has been transferred to the c:\pintmp directory on the SVP, on an FD.

<De-installation>

When de-installing Pin Track Tool, delete all files together with the directory installed.

```
# \rm -r /usr/raidopen/pinenas* (Deletes files created under raidopen.)
```

<Post-procedure>

- (1) Delete the work directory and files under it created on the SVP.
- (2) De-install the SSH client tool. ^{*1}

*1: Refer to the file appended.

Procedure for collecting detailed log (For E-NAS-OS)

When an option is attached to pinenas, detailed information on the pinned data clearance can be got.

Usage: ./pinenas (-f) -log

You can get data that were read and written during the pinned data clearance through the above operation.

Example:

```

Input Device Name = /dev/enas/lu00
Input Start LBA = 00000180
Input End LBA = 000001DF
/dev/enas/lu00, Start LBA=00000180, End LBA=000001df readable PIN Recovery read error
Read Data: Top Pin No=00000180
00000000: 00 00 00 00 00 00 00 00 00 00 00 00 00 00 00 00
00000010: 00 00 00 00 00 00 00 00 00 00 00 00 00 00 00 00
00000020: 00 00 00 00 00 00 00 00 00 00 00 00 00 00 00 00
00000030: 00 00 00 00 00 00 00 00 00 00 00 00 00 00 00 00
00000040: 00 00 00 00 00 00 00 00 00 00 00 00 00 00 00 00
. . .
Read Data: Top Pin No=00000181
. . .
Read Data: Top Pin No=00000182
. . .
Read Data: Top Pin No=00000183
. . .
Read Data: Top Pin No=000001DF
000001A0: 00 00 00 00 00 00 00 00 00 00 00 00 00 00 00 00
000001B0: 00 00 00 00 00 00 00 00 00 00 00 00 00 00 00 00
000001C0: 00 00 00 00 00 00 00 00 00 00 00 00 00 00 00 00
000001D0: 00 00 00 00 00 00 00 00 00 00 00 00 00 00 00 00
000001E0: 00 00 00 00 00 00 00 00 00 00 00 00 00 00 00 00
000001F0: 00 00 00 00 00 00 00 00 00 00 00 00 00 00 00 00
Write Data: Top Pin No=00000180
. . .
00000000: 00 00 00 00 00 00 00 00 00 00 00 00 00 00 00 00
00000010: 00 00 00 00 00 00 00 00 00 00 00 00 00 00 00 00
00000020: 00 00 00 00 00 00 00 00 00 00 00 00 00 00 00 00
00000030: 00 00 00 00 00 00 00 00 00 00 00 00 00 00 00 00
00000040: 00 00 00 00 00 00 00 00 00 00 00 00 00 00 00 00
. . .
. . .
. . .
0000BFC0: 00 00 00 00 00 00 00 00 00 00 00 00 00 00 00 00
0000BFD0: 00 00 00 00 00 00 00 00 00 00 00 00 00 00 00 00
0000BFE0: 00 00 00 00 00 00 00 00 00 00 00 00 00 00 00 00
0000BFF0: 00 00 00 00 00 00 00 00 00 00 00 00 00 00 00 00
/dev/enas/lu0, Start LBA=00000180, End LBA=000001DF PinTrack process completed!!

```

A log size per pinned data clearance process is about 400 kB.

When the -log option is not attached, each of read and write logs is recorded for each LBA.

Getting device information (Usage of the showrel tool) (For E-NAS-OS)

When the program is installed, check the information on the failed track that has been collected.

- (1) Go to the directory in which the program has been installed.

```
# cd raidopen/pinenas           Movement to the directory.
```

- (2) Execute the following programs.

# ./showrele	Execution with the ./ path
Input LDEV -> 000A	...Entry of a device name displayed on the SVP
Input Start LBA -> 00044000	...Entry of the Start LBA displayed on the SVP
Input End LBA -> 0004405F	...Entry of the End LBA displayed on the SVP

Example of the entries and a result output

./showrele
Input LDEV -> 0123
Input Start LBA -> 0000ABE0
Input End LBA -> 0000AC3F
DeviceName= /dev/enas/lu00 Port=1A LDEV=0123
Start=00000FA0 End=00000FFF

CU: LDEV number of four characters is displayed as an LDEV number. Identify the volume (partition) of the device file by referring to the CU number and LDEV number of the pinned data. The identified device file name is to be used as the entry information for the pinned data clearance process.

[Notice]

- The showrel tool issues a command, which is peculiar to a disk subsystem, for getting the device information to all disk devices connected to E-NAS-OS. Therefore, an illegal request error may be reported to a system concerning disks other than those within the disk subsystem such as built-in disks, however, that is not a trouble.
- When unreadable pinned data occurs in the slot #15 including the Start LBA, in which the disk management information is recorded, the device information cannot be got because the disk becomes unable to respond to the OS (except the Open-V volume).
- When the failed part is turned out to be a device file (/dev/enassys/luS [pP]) as a result of execution of the showrel tool, do not clear pinned data with Pin Track Tool (see ④ Recovery procedure for a system LU on page [TRBL07-150](#)). That is because the LBA is feared to be overwritten with zeros.

The following information may be displayed depending on the setting of the volume (partition).

When no LDEV information that has been entered is present in the device management table
LDEV=010C This is not a target disk.

Check if the LDEV number entered is correct.

When information on an LBA, which does not belong to any volume (partition), was entered
DeviceName=/dev/enas/lu00 Port=1D LDEV=0189 The target LBA is missing or invalid.

In this case, no influence is exerted upon the file system though the pinned data cannot be cleared. The pinned data shown on the SVP cannot be cleared in this case,

When an LBA extends over volumes (partitions)
DeviceName=/dev/enas/lu00 Port=1A LDEV=000A
Start=00001357 End=00001387
DeviceName=/dev/enas/lu01 Port=1A LDEV=000A
Start=00000000 End=0000002F

In the case where it is shown that the LBA extends over volumes (partitions), specify a displayed LBA for each volume (partition) when executing pinenas. The pinned data cannot be cleared unless the whole area concerned are processed with pinenas.

Procedure for locating MountPoint (For E-NAS-OS)

Carry out the following work requesting a system administrator to do the necessary operations and making confirmations.

Display by showrel

When using the showrel tool as explained on page [TRBL07-900](#), it is shown to which device file the LDEV number and the area between the Start and End LBAs shown on the SVP are equivalent. Refer to page [TRBL07-900](#) for the usage of the showrel tool.

Confirming the /etc/fstab

Locate the MountPoint using the #cat/etc/fstab.

```
# cat /etc/fstab
# /etc/fstab: static file system information.
#
# <file system> <mount point> <type> <options> <dump> <pass>
/dev/enas/lu00p1 / hixfs defaults 0 1
/dev/enas/lu00p2 none swap sw 0 0
proc /proc proc defaults 0 0
#
```

It can be checked whether the target device is to be mounted automatically or not.

Confirmation with the df

Make sure of the device file name and MountPoint recognized by FileSystem again using the #df -k.

```
# df -k
Filesystem      1k-blocks  Used Available Use% Mounted on
/dev/enas/lu00p1 3666020 431172 3234848 12% /
#
```

It can be checked whether the target device is currently mounted or not.

Decide the MountPoint to be checked with the “sum” command in the above procedure.

7.3.3.5 List of Pin Track Tool directories

- /program/MENT/pintrack/Readme.txt
- /program/MENT/pintrack/HowToUseSSH.txt
- /program/MENT/pintrack/HowToUseSSH_j.txt

- /program/MENT/pintrack/HP-UX/pinhpXX.tar
- /program/MENT/pintrack /Solaris/pinsolXX.tar
- /program/MENT/pintrack /Windows/PinNTxx.exe
- /program/MENT/pintrack/ENAS/pinenasXX.tar

- /program/MENT/pintrack/PuTTY/putty.exe
- /program/MENT/pintrack/PuTTY/puttygen.
- /program/MENT/pintrack/PuTTY/pscp.exe
- /program/MENT/pintrack/PuTTY/README.txt
- /program/MENT/pintrack/PuTTY/LICENCE.txt
- /program/MENT/pintrack/PuTTY/website
- /program/MENT/pintrack/PuTTY/putty.hlp

9 HMRCF & HOMRCF Error Recovery

9.1 PIN Track recovery procedure for HMRCF

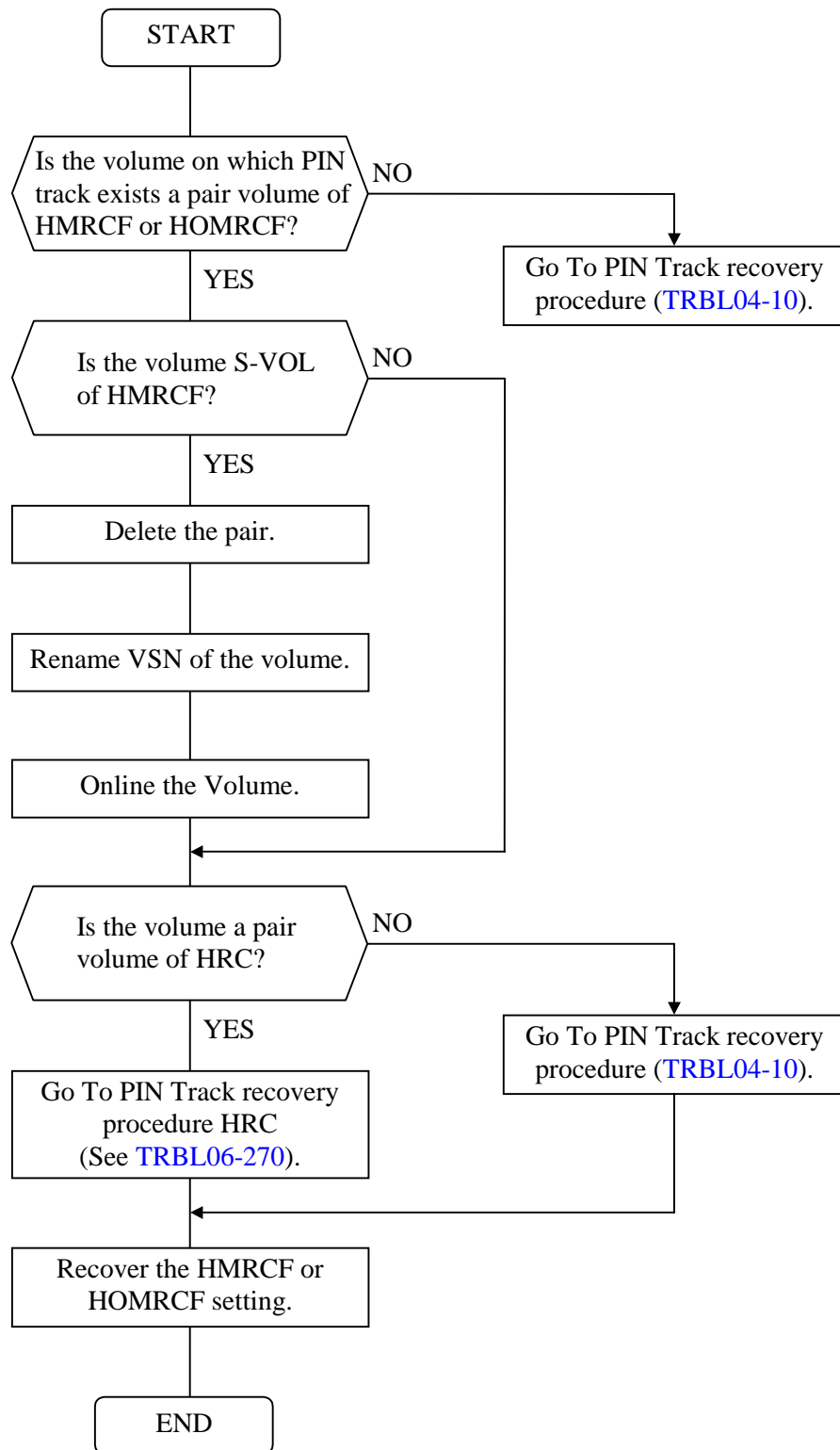

9.2 Recovery Procedure for Suspend Pair

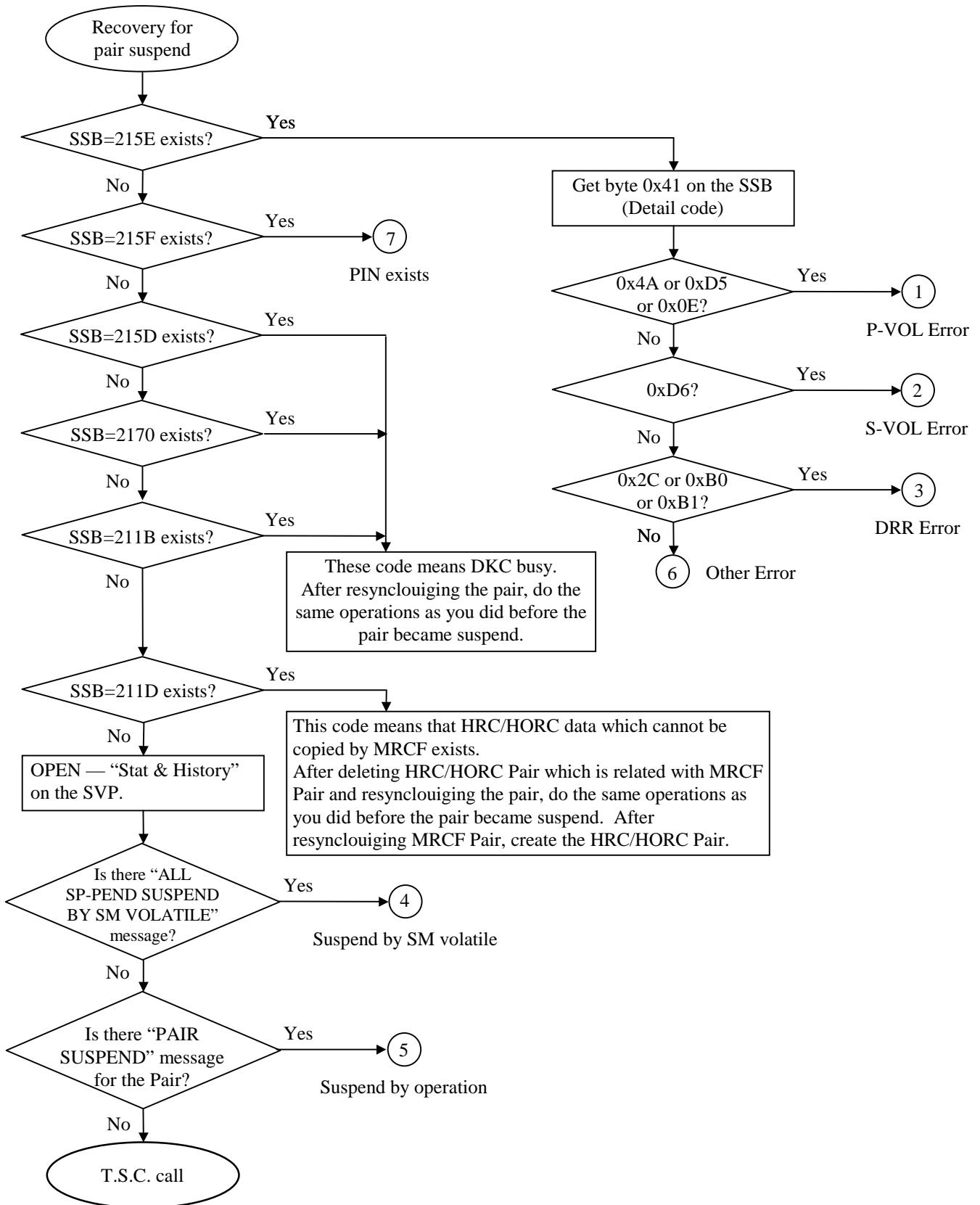

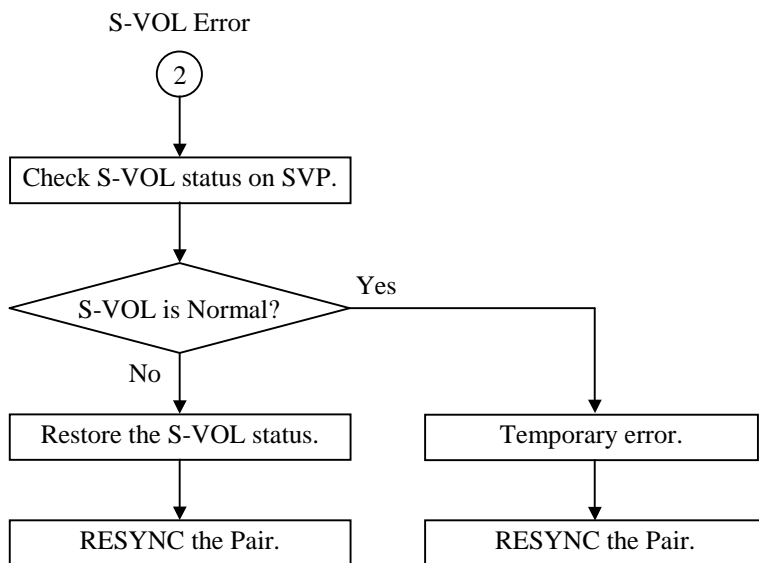
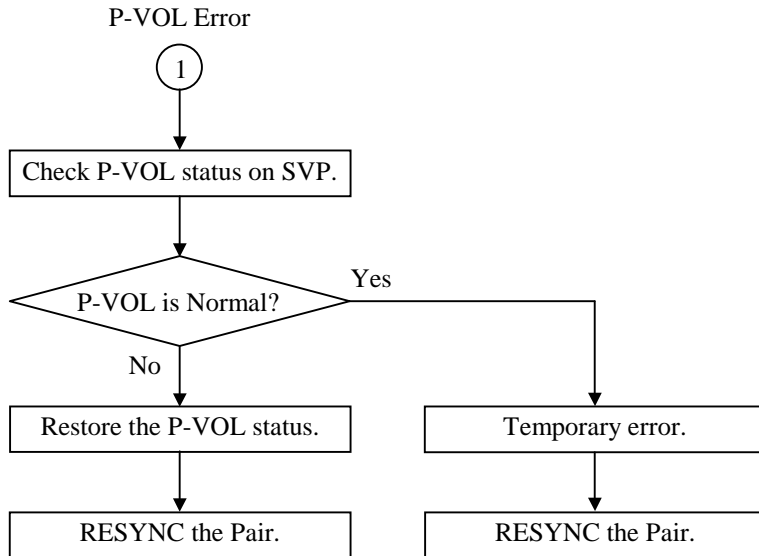

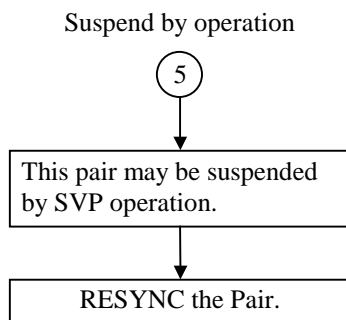
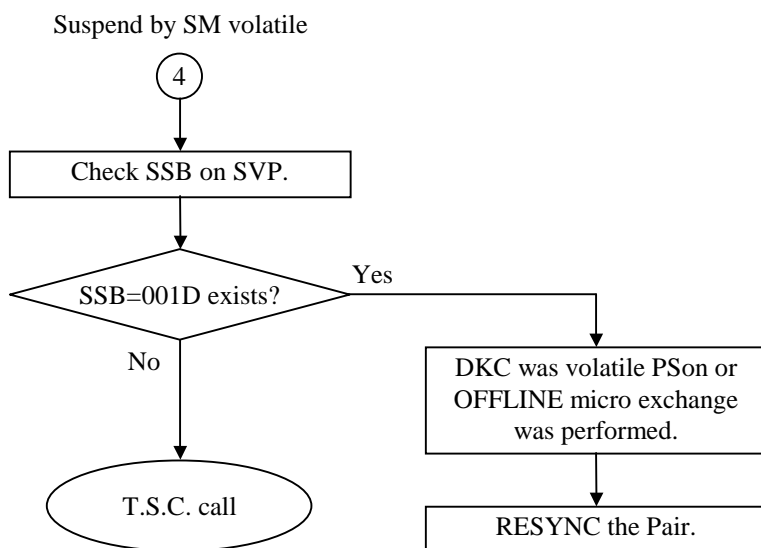
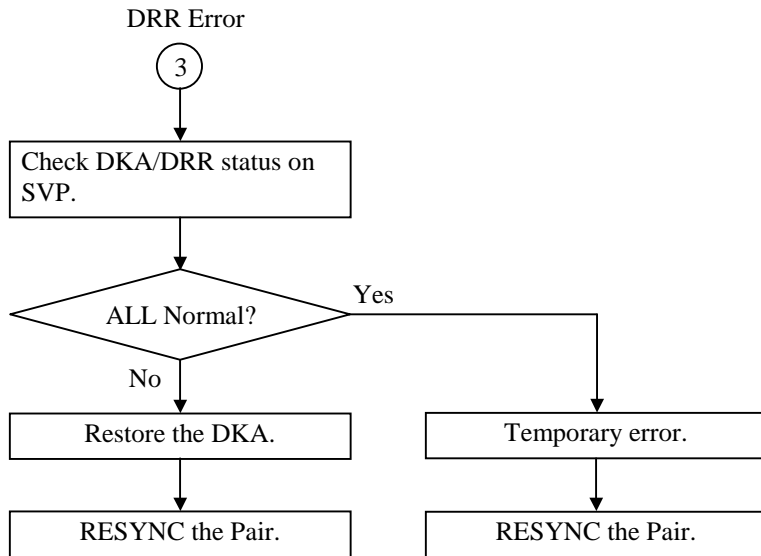

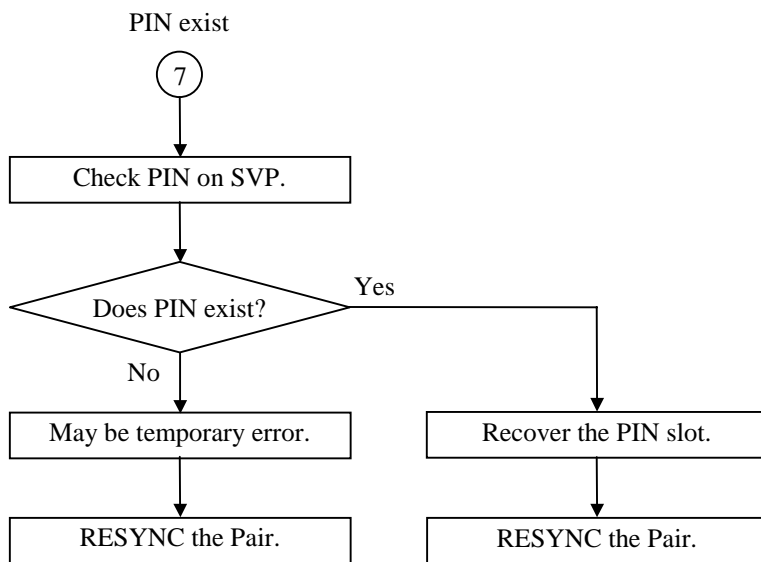
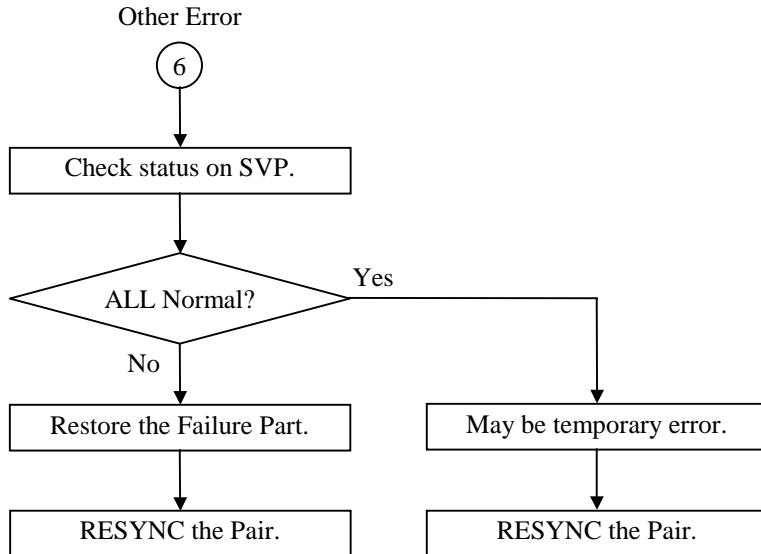

9.3 Procedure for recovery from ShadowImage-FlashCopy (R) Option failure (SIM=4B0XXX, 47E600)

The procedure for recovery from an ShadowImage-FlashCopy (R) Option failure is explained below.

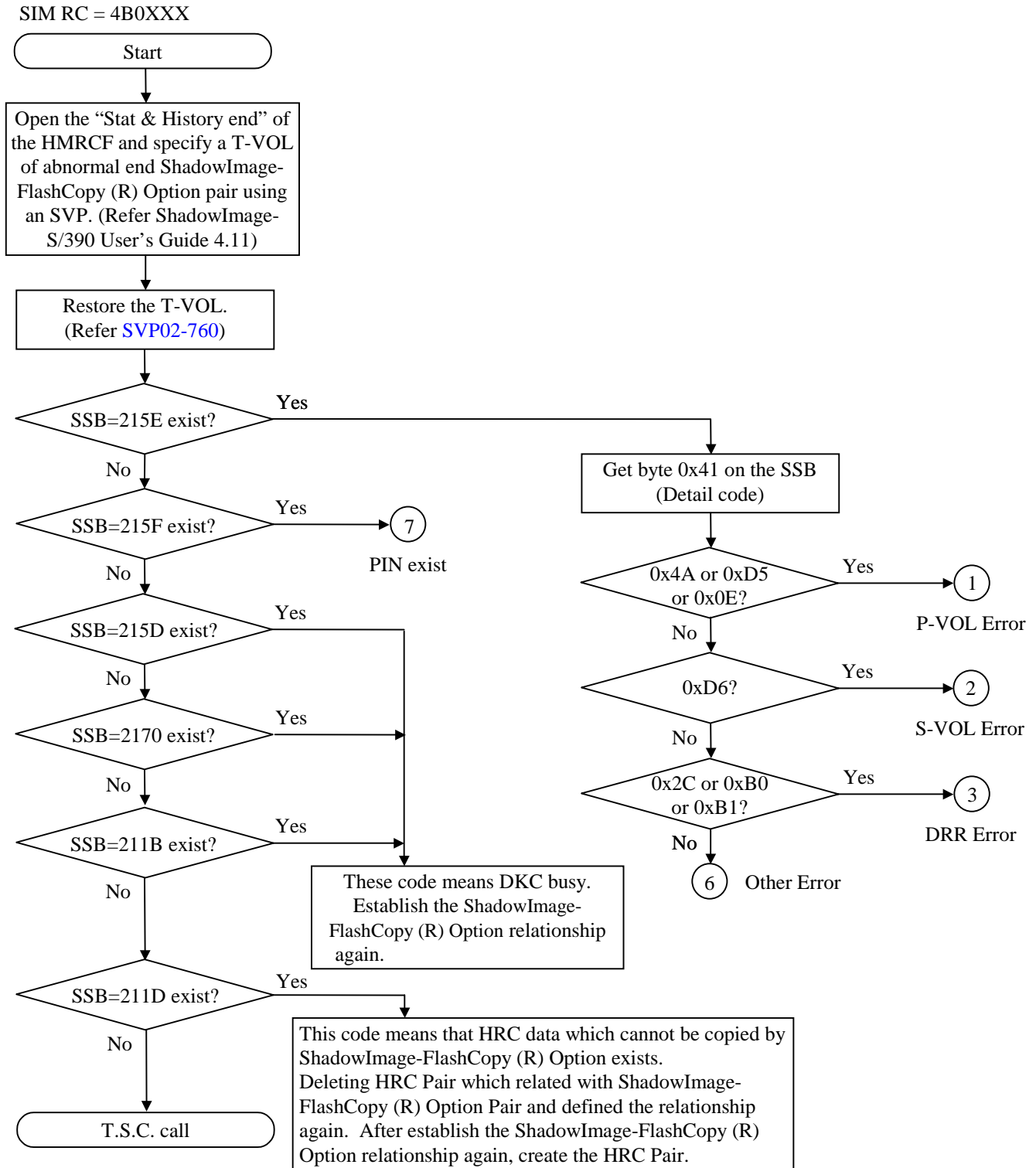

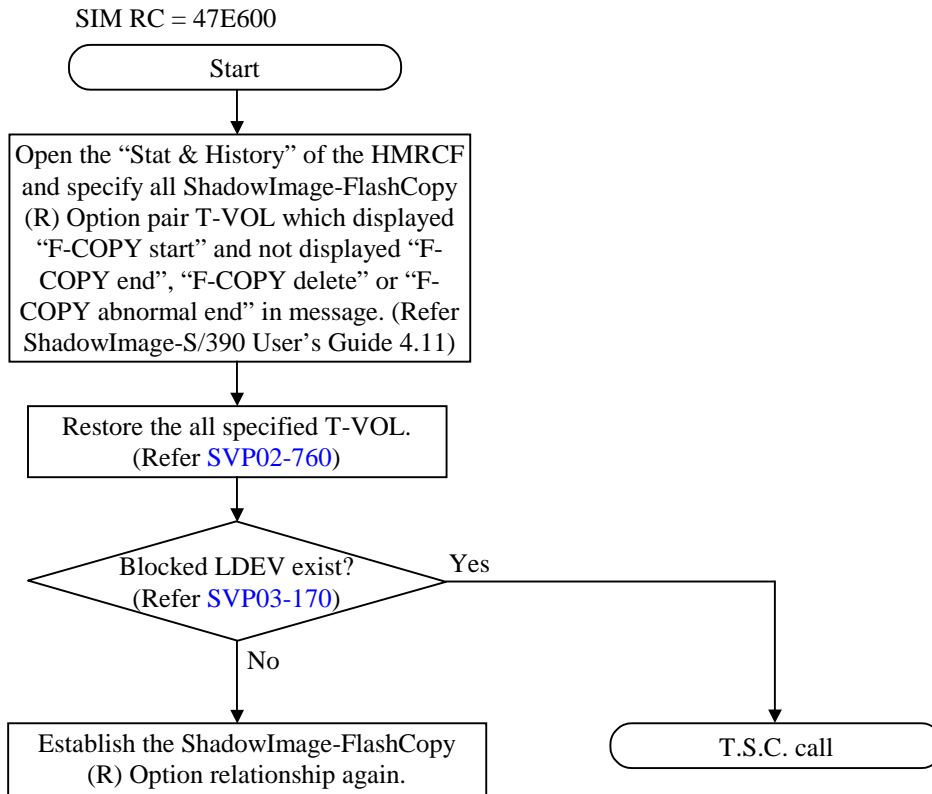

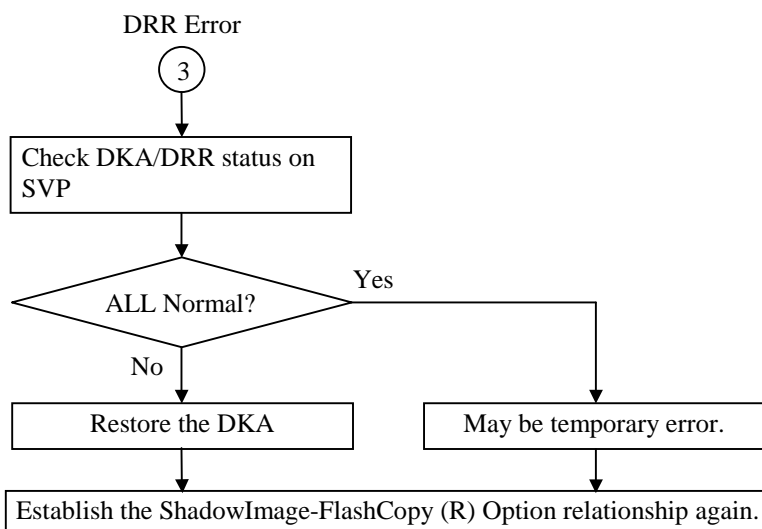
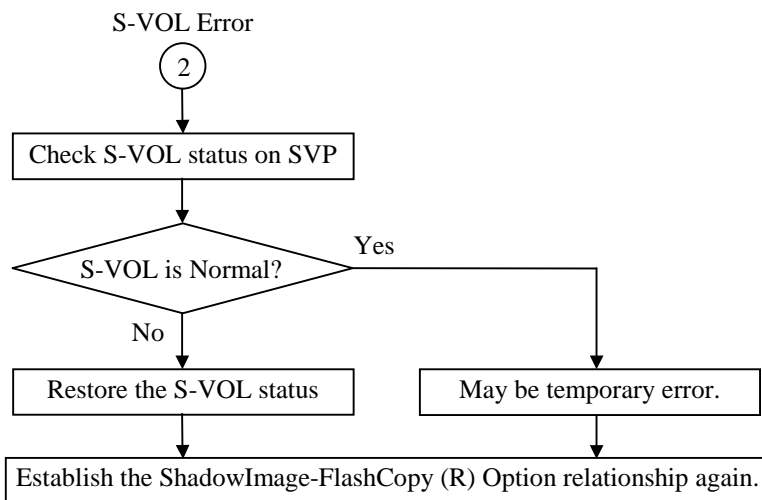
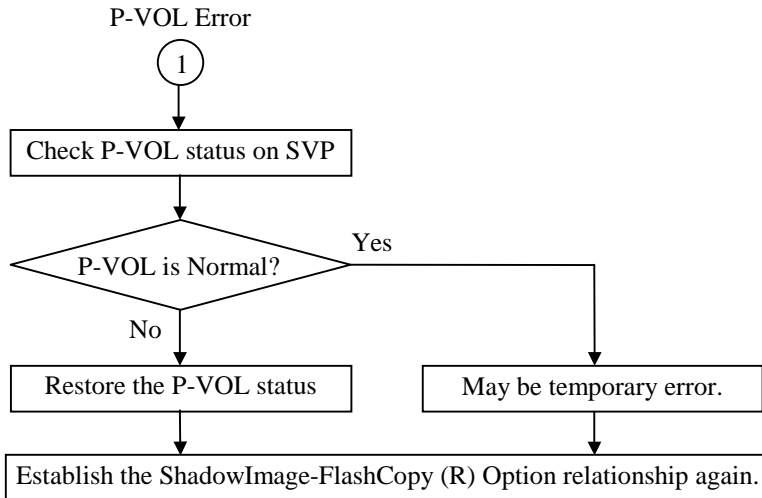

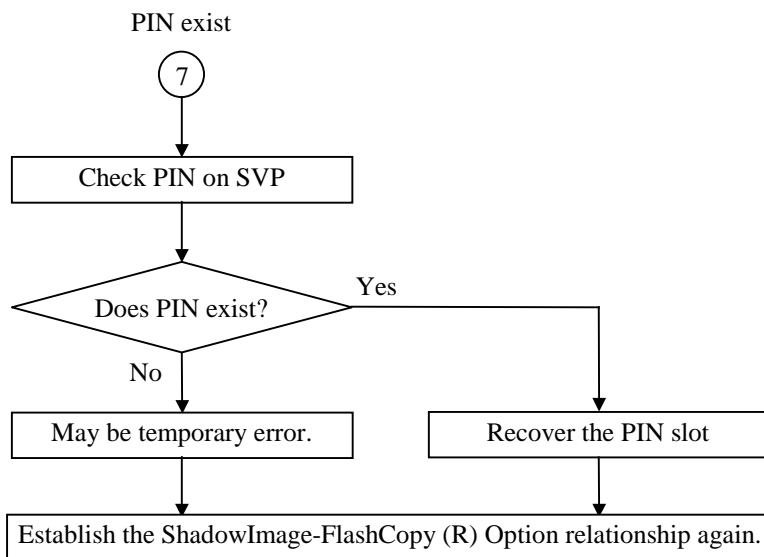
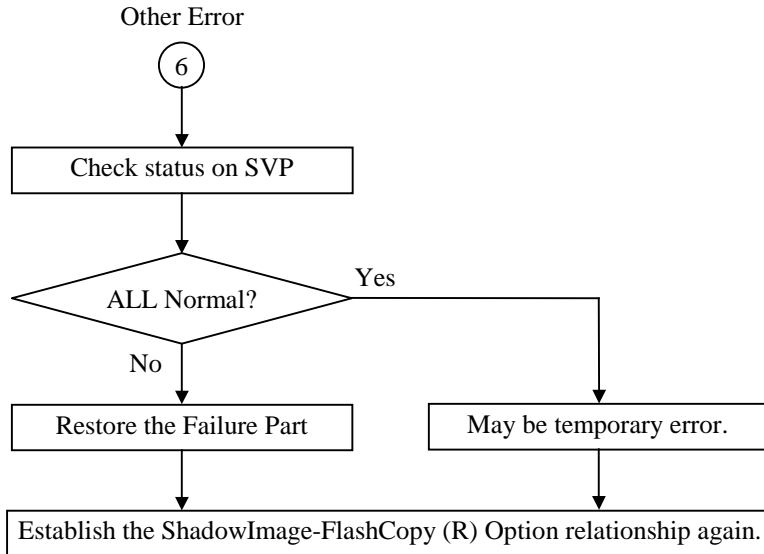

9.4 Procedure for Recovery from ShadowImage-FlashCopy (R) version2 Option failure (SIM=4B2XYY)

The procedure for recovery from a failure occurs in a pair of ShadowImage-FlashCopy (R) version2 Option is explained below.

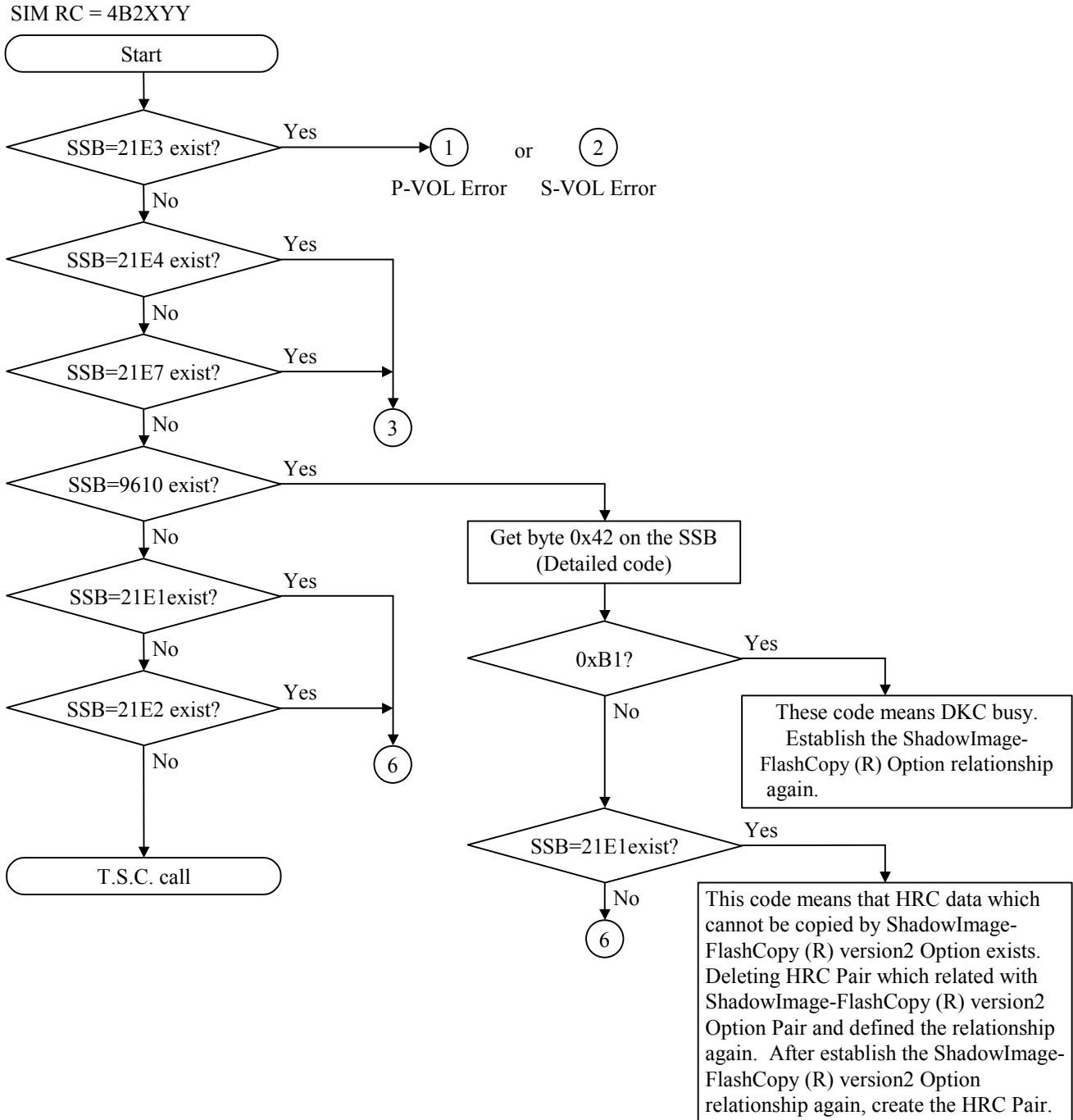

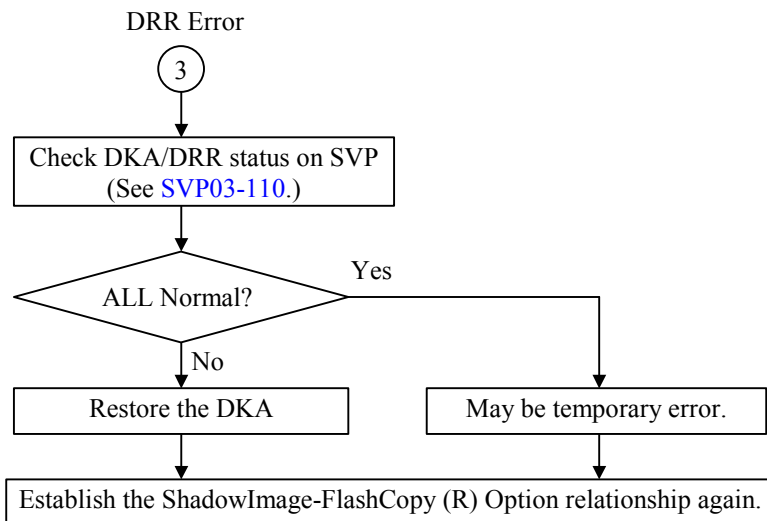
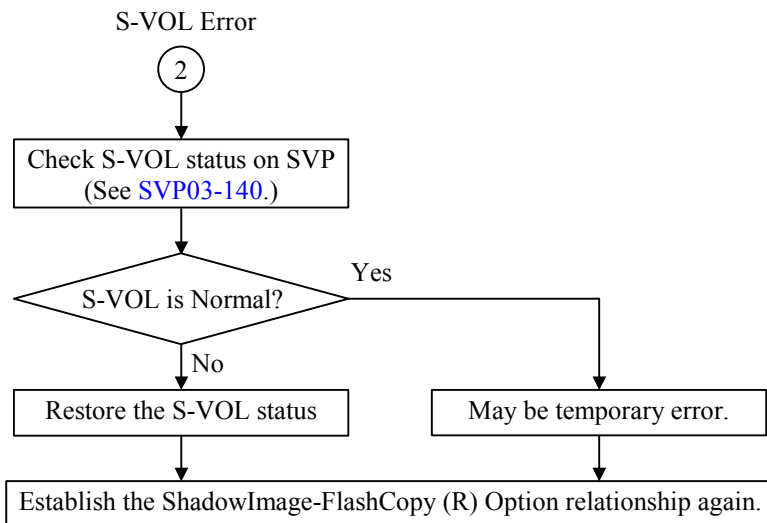
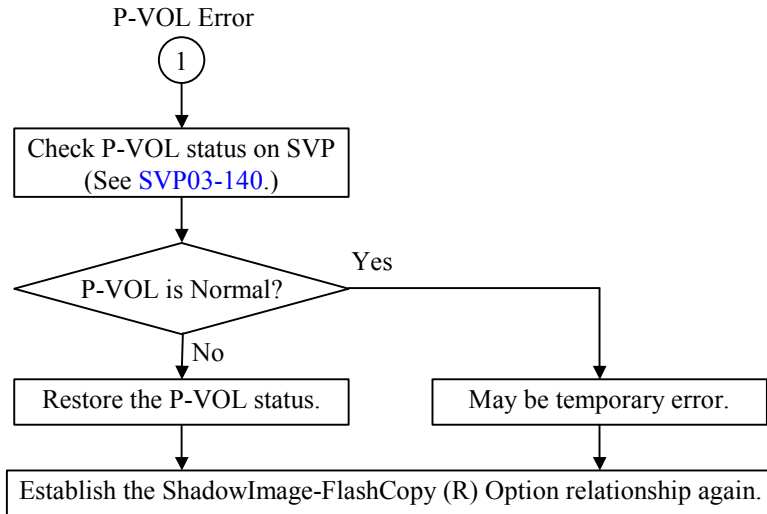

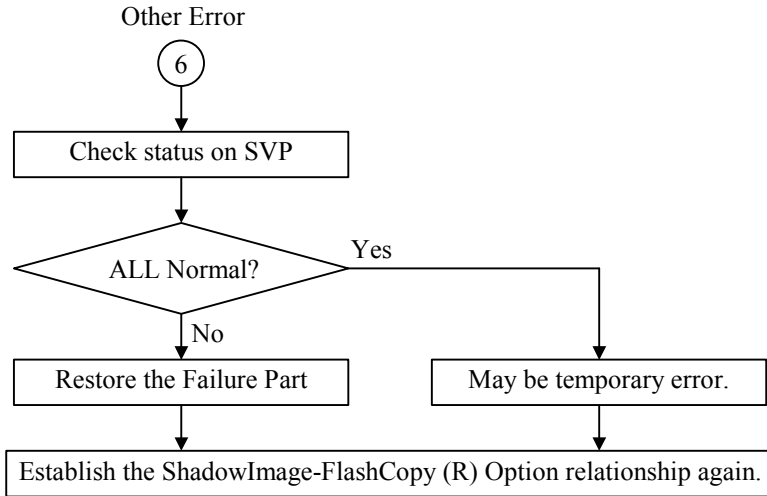

10 Recovery procedure of AL_PA conflict (SIM = 2190XY)

The following flow chart is a recovery procedure in the case where AL_PA of the nodes (CHT port, Host's Fibre channel port) which exist on the same loop overlaps. Before performing the following recovery procedure, the AL_PA of a SIM reporting port is automatically changed into an other AL_PA from previously given AL_PA. But AL_PA doesn't affect the values on SVP.

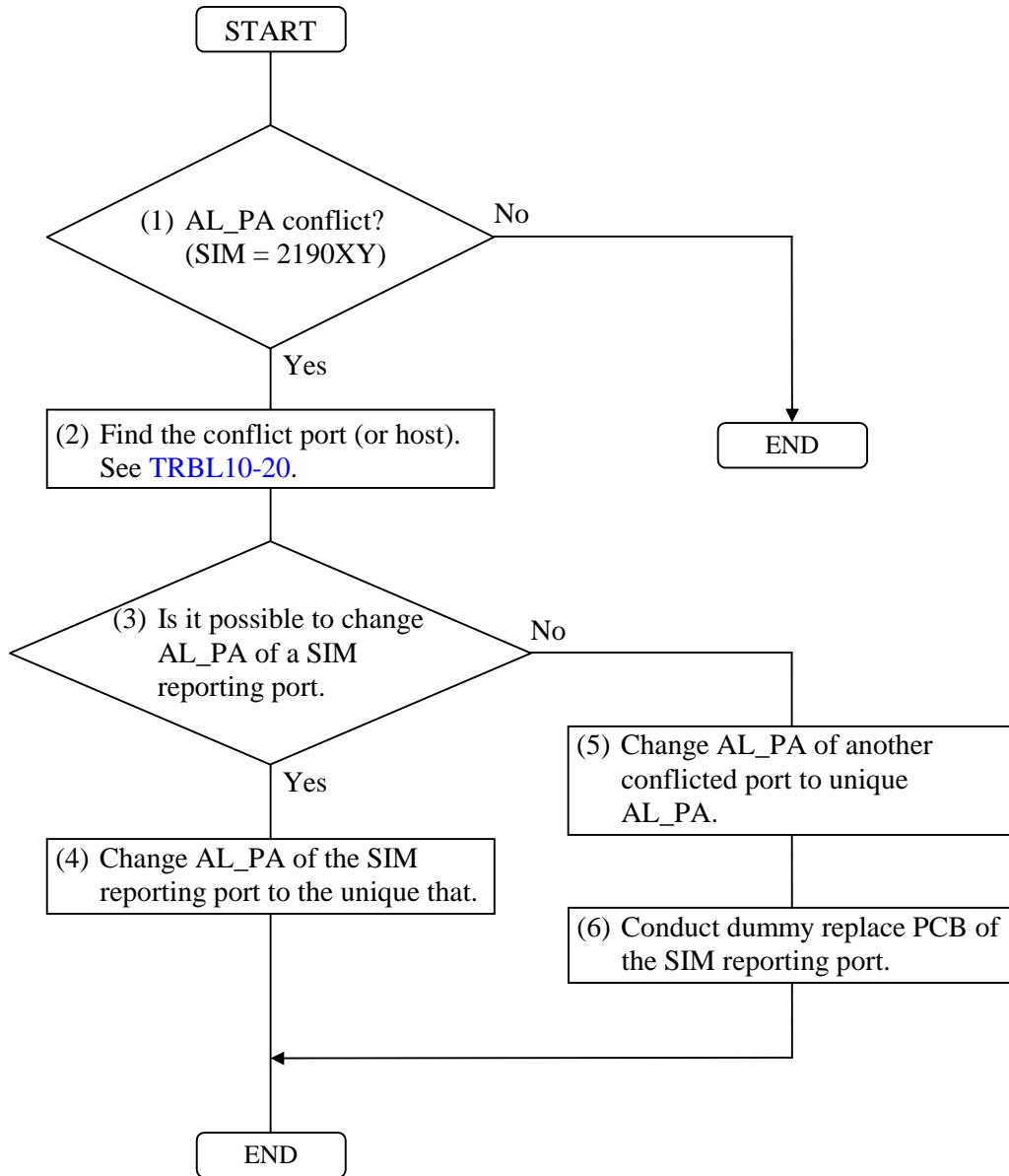

* Whether AL_PA of (3) is changed or not depends on the condition under operation.

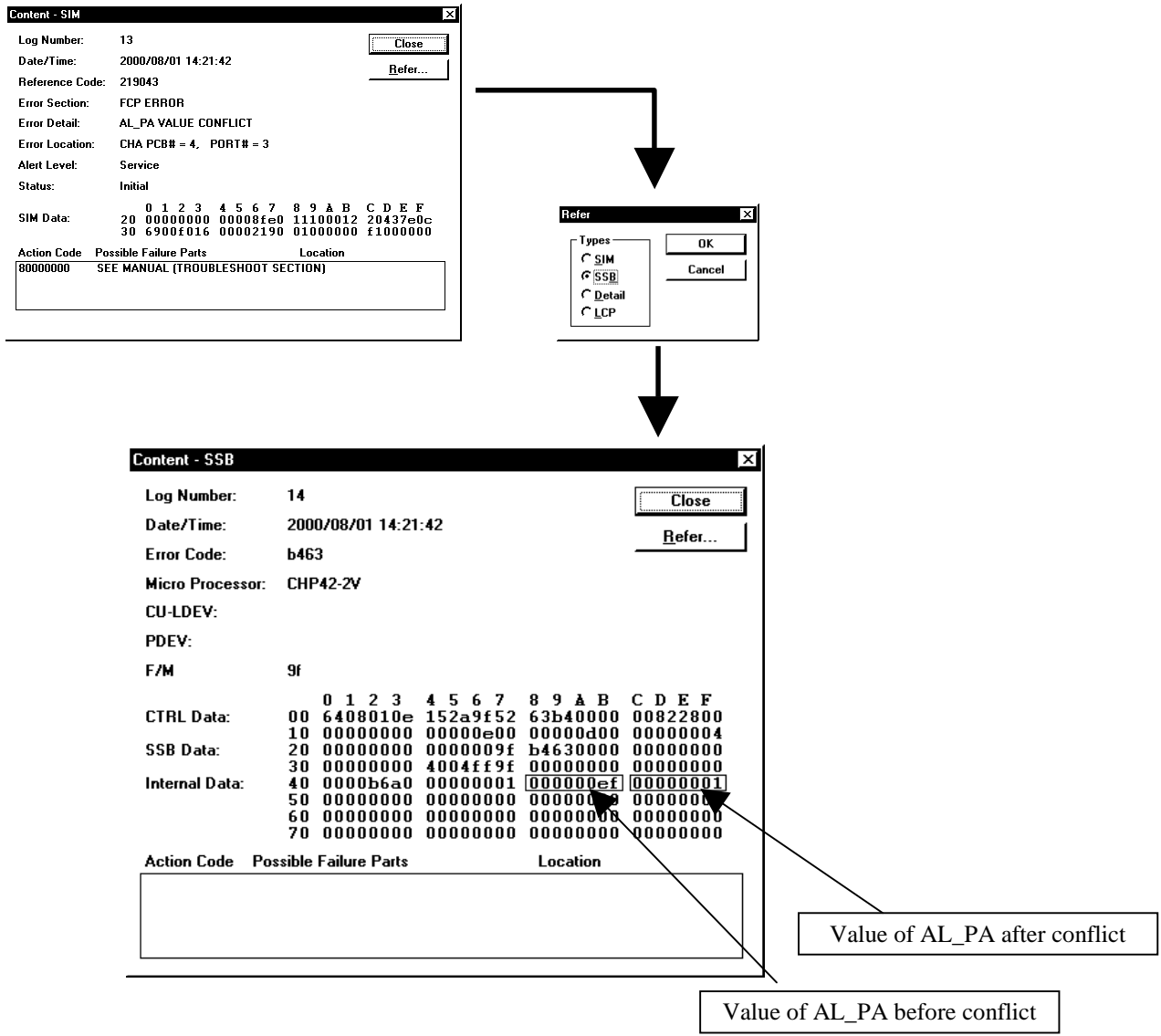

1. Please refer to the SSB corresponded to the SIM (=2190XY) to specify values of AL_PA before/after conflict.
2. When the value of AL_PA before conflict is determined, please find RAID's port or host HBA's port whose AL_PA conflicts with this port.

11 HIHSM Error Recovery

When it lapses into the state where a system does not expect, volume move processing of HIHSM sometimes carries out an unusual end. In this case, the state of S-VOL and T-VOL which was during movement is not changing from the state before movement. So, there is no necessity of daring carry out recovery to resume VOL move processing. Please resume processing after checking states, such as a hard part, with reference to SSB/SIM.

Please carry out recovery procedure with reference to the following flowchart.

Table 11.1-1 HIHSM SIM REF.CODE

SIM REF. CODE	meaning	comment
47FYXX	HIHSM VOL Move unusual end	XX: T-VOL No. Y: CU No.

11.1 HIHSM Error Recovery Flowchart

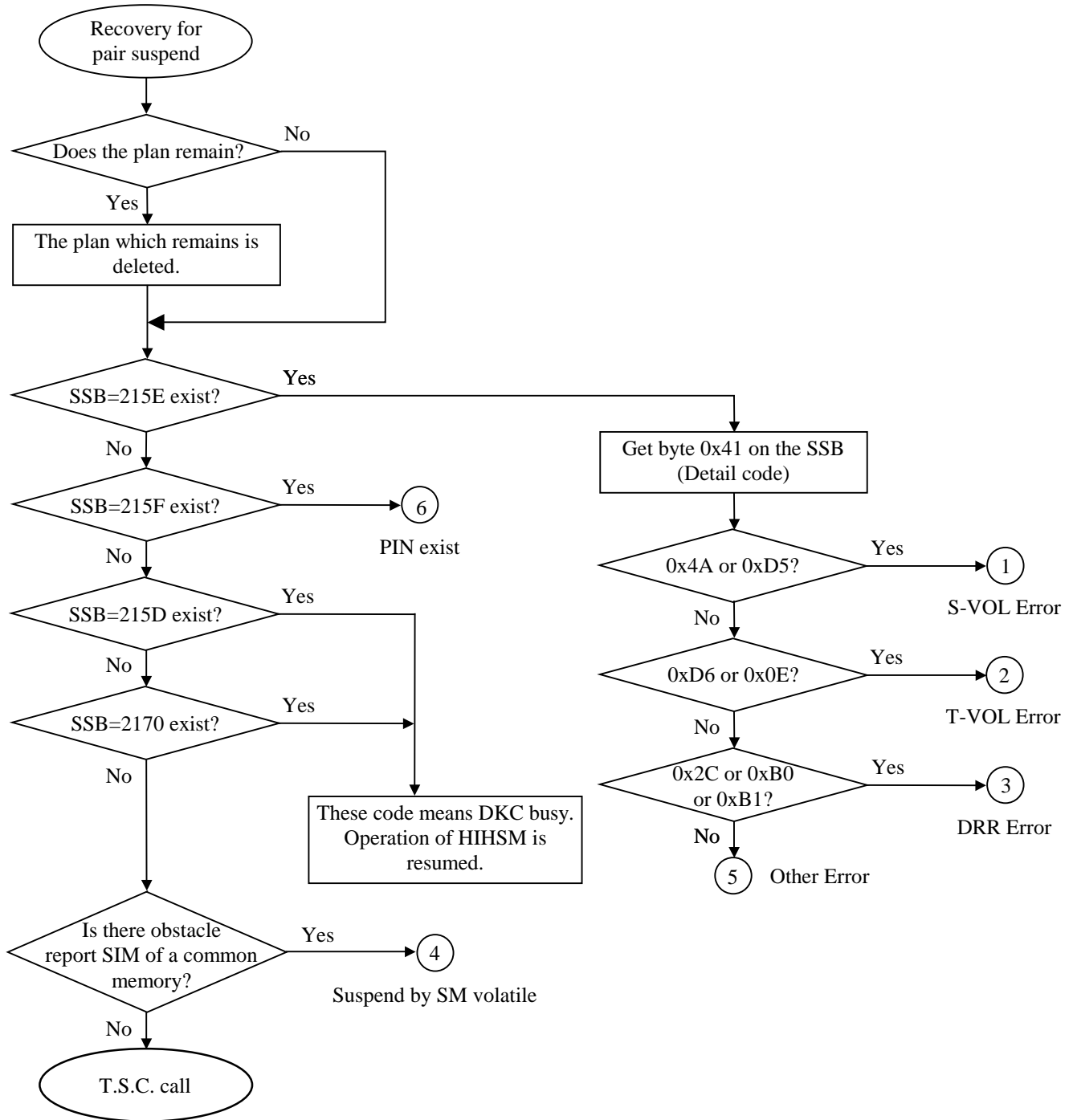

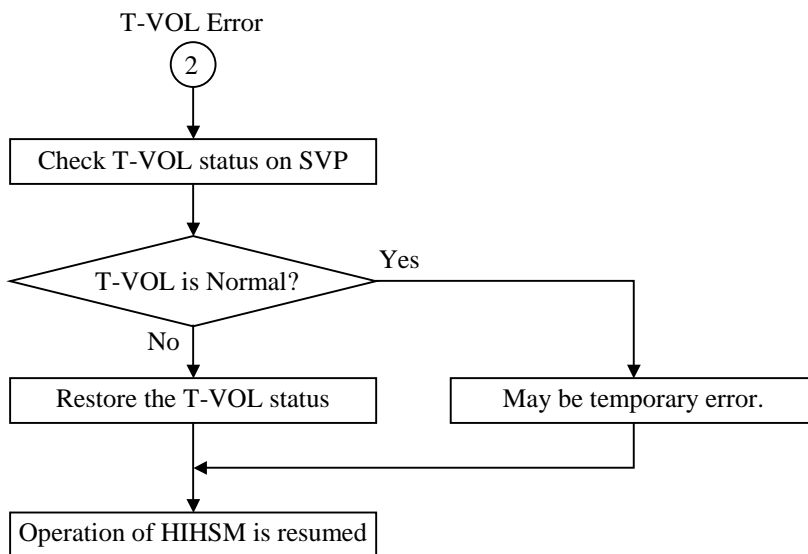
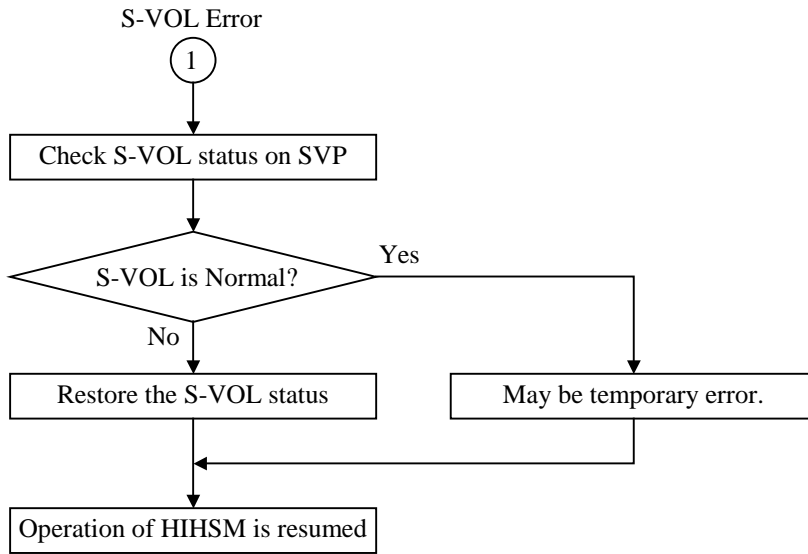

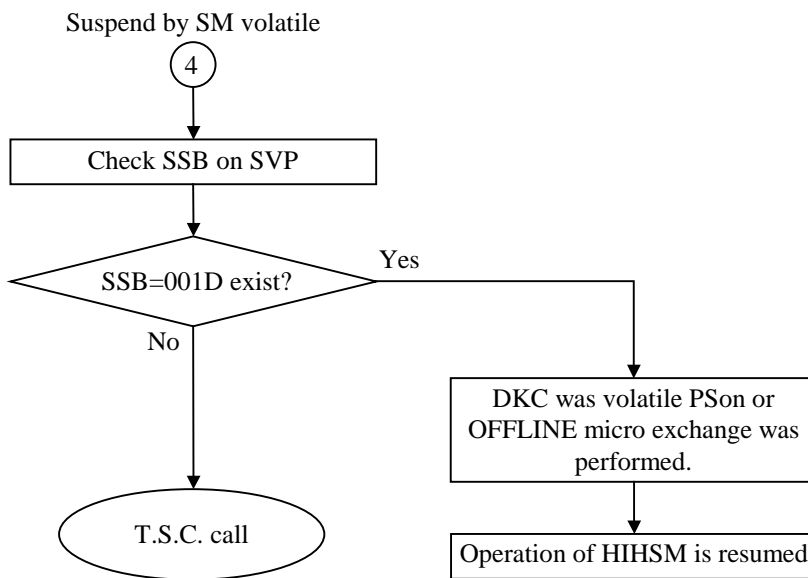
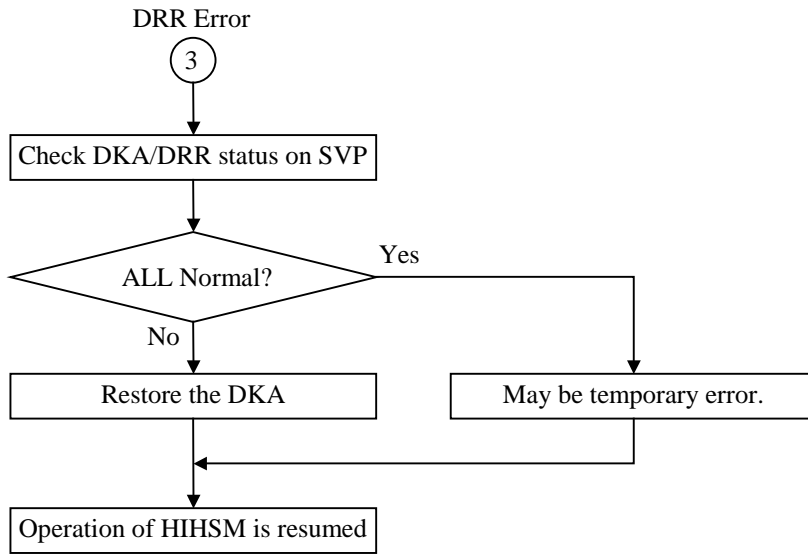

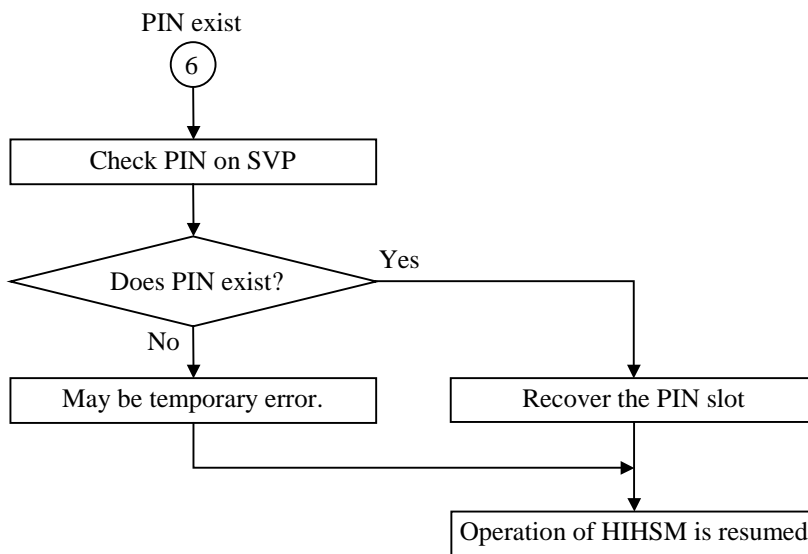
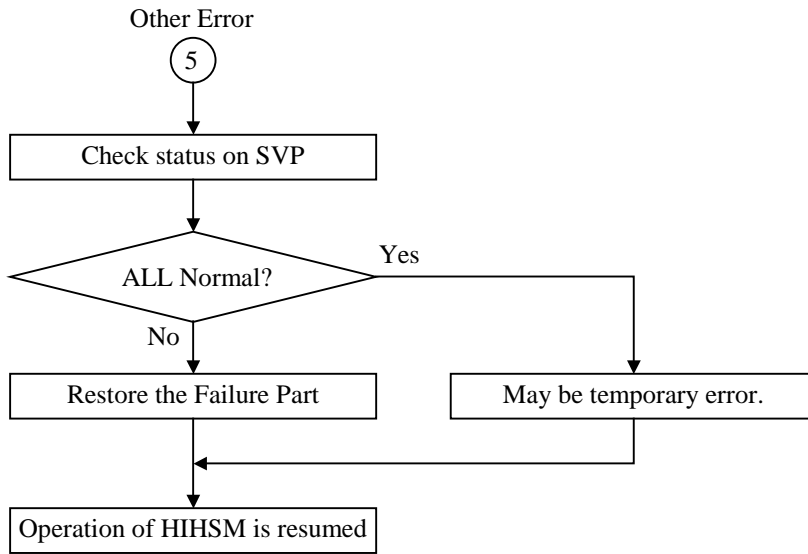

12 Recovery procedure of HDD/DKU installation failure

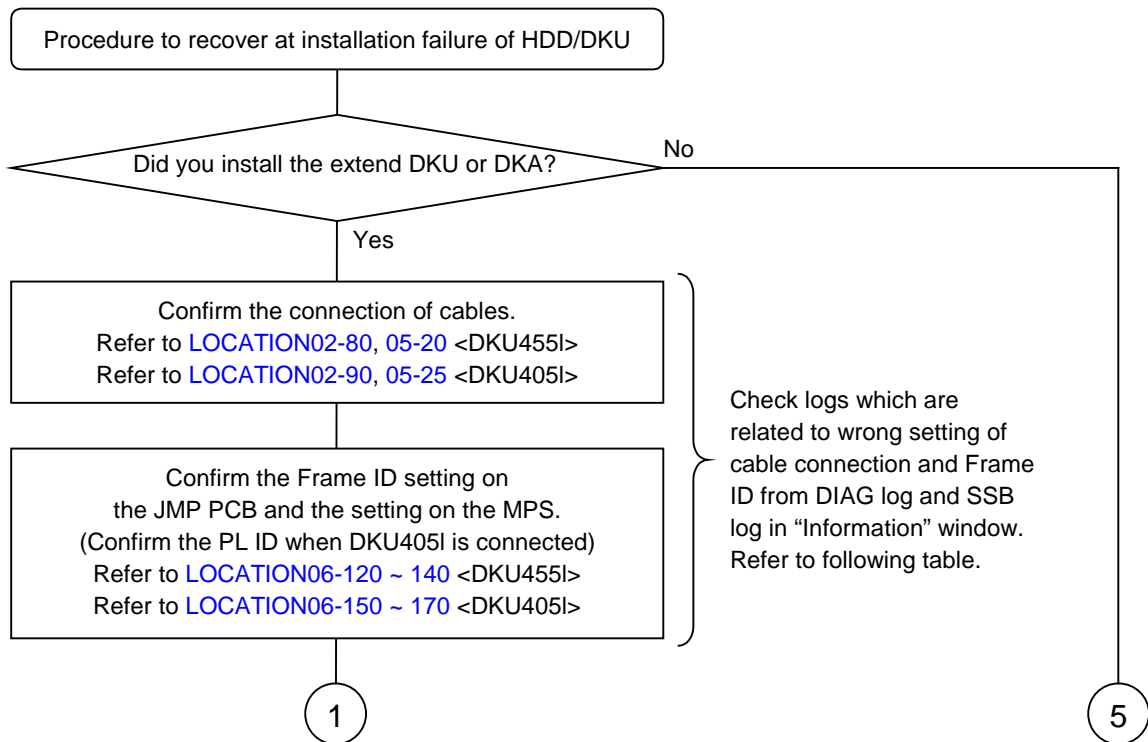

Diag Log Error Code	Meaning (See DIAG06-120 ~ 180)	
Ax 05	Wrong Setting of JMP PCB/MPS or Wrong Connection of the FC cable.	*1, *2
Ax 07 Ax FC	Wrong Connection of the FC cable.	*2
Ax AD	Wrong Connection of the LED BUS	*2, *3
Ax AE	Wrong Connection of the LED BUS	*2, *3

SSB Error Code	Meaning	
A047	Access error of FSW	*4
A9FB	Link Failure occurred during installation	*4

- *1: There is a possibility of wrong setting of Frame ID on the MPS/JMP PCB (PL ID : DKU405I) indicated by DIAG LOG.
- *2: There is a possibility of wrong FC cable connection indicated by DIAG LOG.
- *3: There is a possibility of wrong LED BUS connection indicated by DIAG LOG.
- *4: There is a possibility of wrong setting of Frame ID on the MPS/JMP PCB (PL ID : DKU405I) connected to the MP by reported the SSB (Refer to Fig 12-1, 12-2).

Fig. 12-1 DKU455I

SSBMP#	P/K#	DKP#	FSW#	SSBMP#	P/K#	DKP#	FSW#
MP#20	DKA1B	1R-B11&B12	FSWR10-R1,R2&FSWR20-R1,R2	MP#30	DKA2H	2R-J11&J12	FSWR10-L1,L2&FSWR20-L1,L2
MP#21		1R-B21&B22	FSWR11-R1,R2&FSWR21-R1,R2	MP#31		2R-J21&J22	FSWR11-L1,L2&FSWR21-L1,L2
MP#22		1R-B31&B32	FSWR12-R1,R2&FSWR22-R1,R2	MP#32		2R-J31&J32	FSWR12-L1,L2&FSWR22-L1,L2
MP#23		1R-B41&B42	FSWR13-R1,R2&FSWR23-R1,R2	MP#33		2R-J41&J42	FSWR13-L1,L2&FSWR23-L1,L2
MP#24	DKA1C	1R-C11&C12	FSWR14-R1,R2&FSWR24-R1,R2	MP#34	DKA2J	2R-K11&K12	FSWR14-L1,L2&FSWR24-L1,L2
MP#25		1R-C21&C22	FSWR15-R1,R2&FSWR25-R1,R2	MP#35		2R-K21&K22	FSWR15-L1,L2&FSWR25-L1,L2
MP#26		1R-C31&C32	FSWR16-R1,R2&FSWR26-R1,R2	MP#36		2R-K31&K32	FSWR16-L1,L2&FSWR26-L1,L2
MP#27		1R-C41&C42	FSWR17-R1,R2&FSWR27-R1,R2	MP#37		2R-K41&K42	FSWR17-L1,L2&FSWR27-L1,L2
MP#28	DKA1D	1R-D11&D12	FSWL10-R1,R2&FSWL20-R1,R2	MP#38	DKA2K	2R-L11&L12	FSWL10-L1,L2&FSWL20-L1,L2
MP#29		1R-D21&D22	FSWL11-R1,R2&FSWL21-R1,R2	MP#39		2R-L21&L22	FSWL11-L1,L2&FSWL21-L1,L2
MP#2A		1R-D31&D32	FSWL12-R1,R2&FSWL22-R1,R2	MP#3A		2R-L31&L32	FSWL12-L1,L2&FSWL22-L1,L2
MP#2B		1R-D41&D42	FSWL13-R1,R2&FSWL23-R1,R2	MP#3B		2R-L41&L42	FSWL13-L1,L2&FSWL23-L1,L2
MP#2C	DKA1E	1R-E11&E12	FSWL14-R1,R2&FSWL24-R1,R2	MP#3C	DKA2L	2R-M11&M12	FSWL14-L1,L2&FSWL24-L1,L2
MP#2D		1R-E21&E22	FSWL15-R1,R2&FSWL25-R1,R2	MP#3D		2R-M21&M22	FSWL15-L1,L2&FSWL25-L1,L2
MP#2E		1R-E31&E32	FSWL16-R1,R2&FSWL26-R1,R2	MP#3E		2R-M31&M32	FSWL16-L1,L2&FSWL26-L1,L2
MP#2F		1R-E41&E42	FSWL17-R1,R2&FSWL27-R1,R2	MP#3F		2R-M41&M42	FSWL17-L1,L2&FSWL27-L1,L2

Fig. 12-2 DKU405I

SSBMP#	P/K#	DKP#	FSW#	SSBMP#	P/K#	DKP#	FSW#
MP#20	DKA1B	1R-B11&B12	FSW-R10R,FSW-R20R,FSW-R30R	MP#30	DKA2H	2R-J11&J12	FSW-R10L,FSW-R20L,FSW-R30L
MP#21		1R-B21&B22	FSW-R11R,FSW-R21R,FSW-R31R	MP#31		2R-J21&J22	FSW-R11L,FSW-R21L,FSW-R31L
MP#22		1R-B31&B32	FSW-R12R,FSW-R22R,FSW-R32R	MP#32		2R-J31&J32	FSW-R12L,FSW-R22L,FSW-R32L
MP#23		1R-B41&B42	FSW-R13R,FSW-R23R,FSW-R33R	MP#33		2R-J41&J42	FSW-R13L,FSW-R23L,FSW-R33L
MP#24	DKA1C	1R-C11&C12	FSW-R14R,FSW-R24R,FSW-R34R	MP#34	DKA2J	2R-K11&K12	FSW-R14L,FSW-R24L,FSW-R34L
MP#25		1R-C21&C22	FSW-R15R,FSW-R25R,FSW-R35R	MP#35		2R-K21&K22	FSW-R15L,FSW-R25L,FSW-R35L
MP#26		1R-C31&C32	FSW-R16R,FSW-R26R,FSW-R36R	MP#36		2R-K31&K32	FSW-R16L,FSW-R26L,FSW-R36L
MP#27		1R-C41&C42	FSW-R17R,FSW-R27R,FSW-R37R	MP#37		2R-K41&K42	FSW-R17L,FSW-R27L,FSW-R37L
MP#28	DKA1D	1R-D11&D12	FSW-L10R,FSW-L20R,FSW-L30R	MP#38	DKA2K	2R-L11&L12	FSW-L10L,FSW-L20L,FSW-L30L
MP#29		1R-D21&D22	FSW-L11R,FSW-L21R,FSW-L31R	MP#39		2R-L21&L22	FSW-L11L,FSW-L21L,FSW-L31L
MP#2A		1R-D31&D32	FSW-L12R,FSW-L22R,FSW-L32R	MP#3A		2R-L31&L32	FSW-L12L,FSW-L22L,FSW-L32L
MP#2B		1R-D41&D42	FSW-L13R,FSW-L23R,FSW-L33R	MP#3B		2R-L41&L42	FSW-L13L,FSW-L23L,FSW-L33L
MP#2C	DKA1E	1R-E11&E12	FSW-L14R,FSW-L24R,FSW-L34R	MP#3C	DKA2L	2R-M11&M12	FSW-L14L,FSW-L24L,FSW-L34L
MP#2D		1R-E21&E22	FSW-L15R,FSW-L25R,FSW-L35R	MP#3D		2R-M21&M22	FSW-L15L,FSW-L25L,FSW-L35L
MP#2E		1R-E31&E32	FSW-L16R,FSW-L26R,FSW-L36R	MP#3E		2R-M31&M32	FSW-L16L,FSW-L26L,FSW-L36L
MP#2F		1R-E41&E42	FSW-L17R,FSW-L27R,FSW-L37R	MP#3F		2R-M41&M42	FSW-L17L,FSW-L27L,FSW-L37L

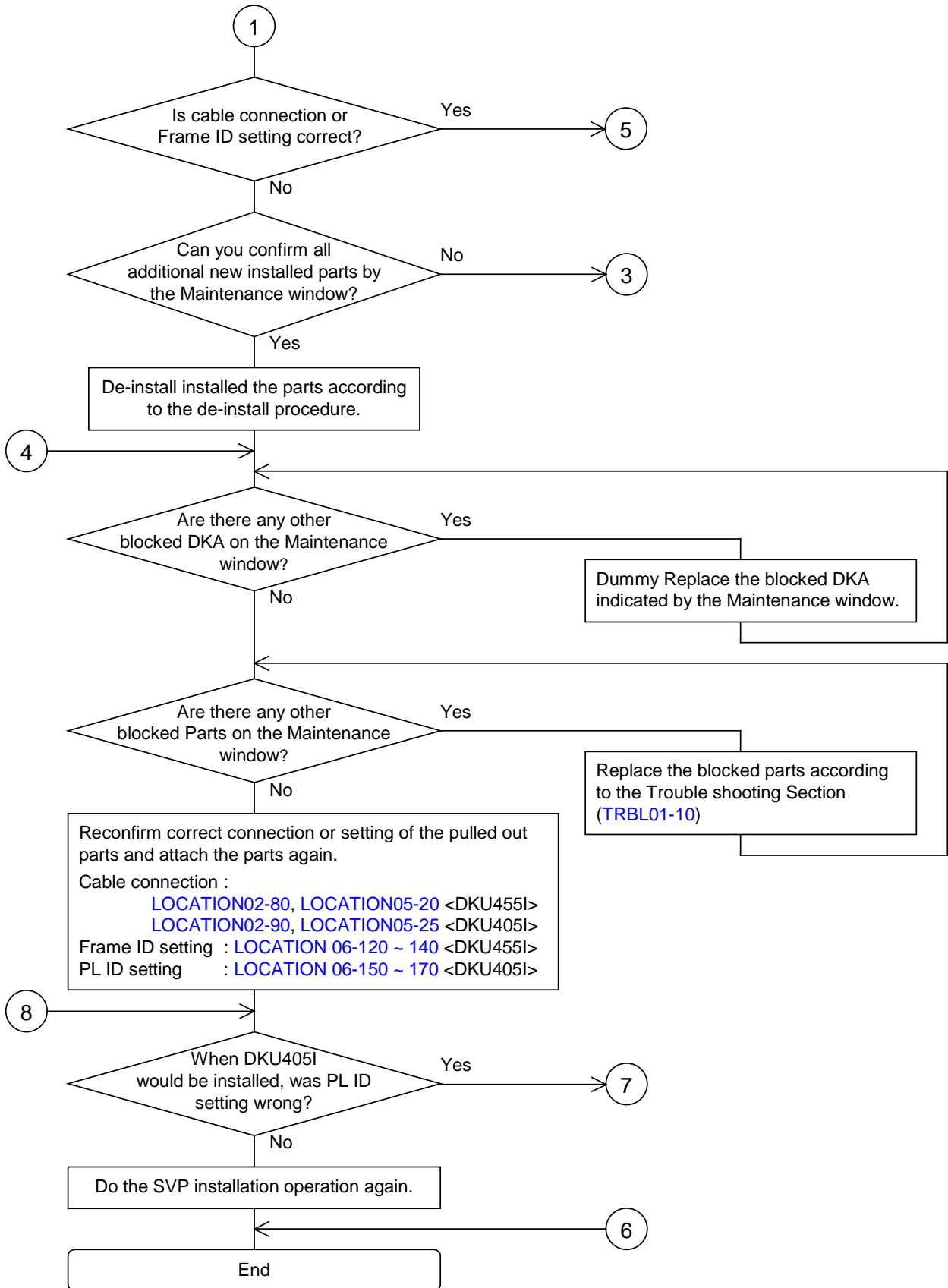

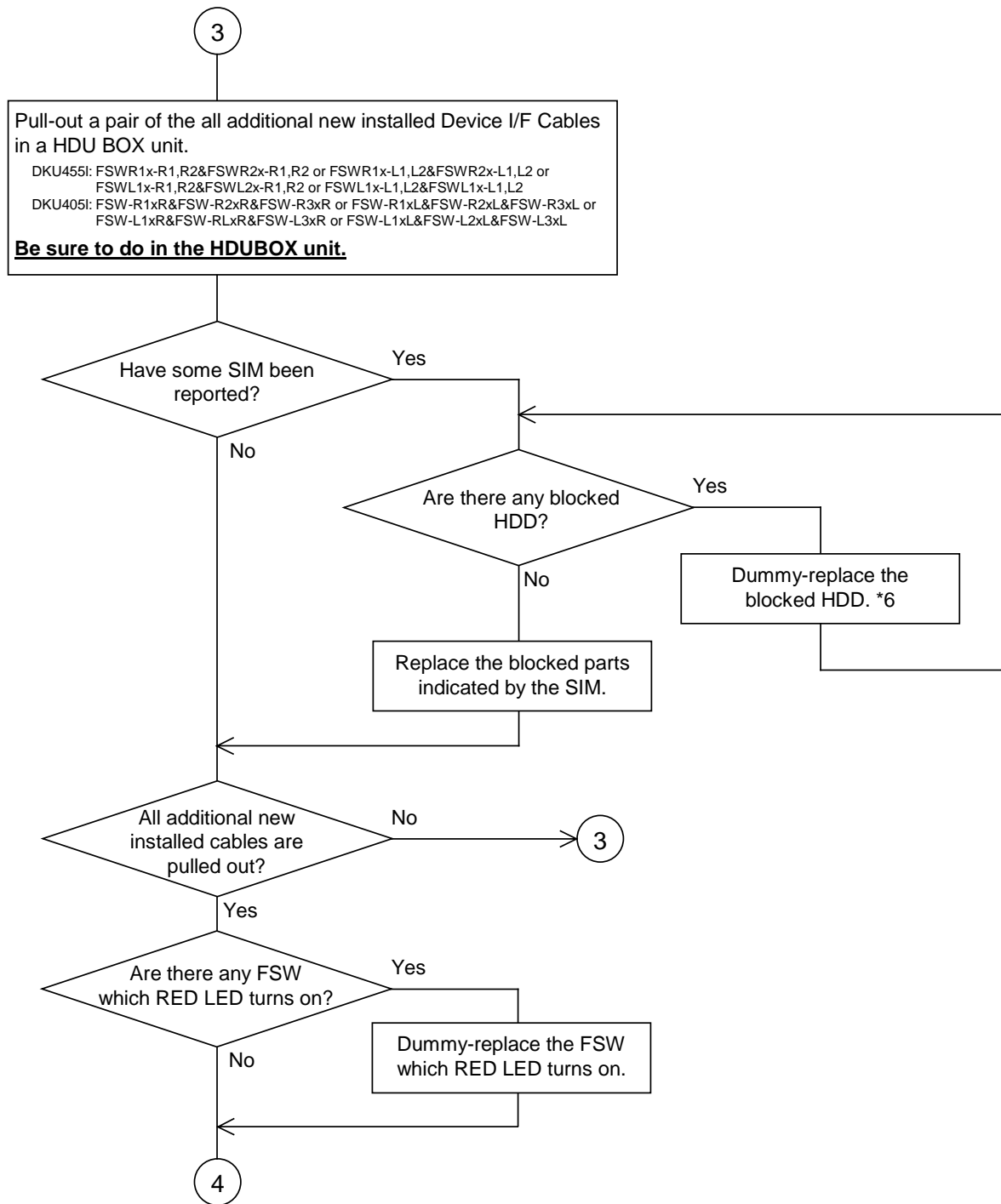

*6: Execute dummy-replacing correctly referring to [REP03-30 ~ 35](#).

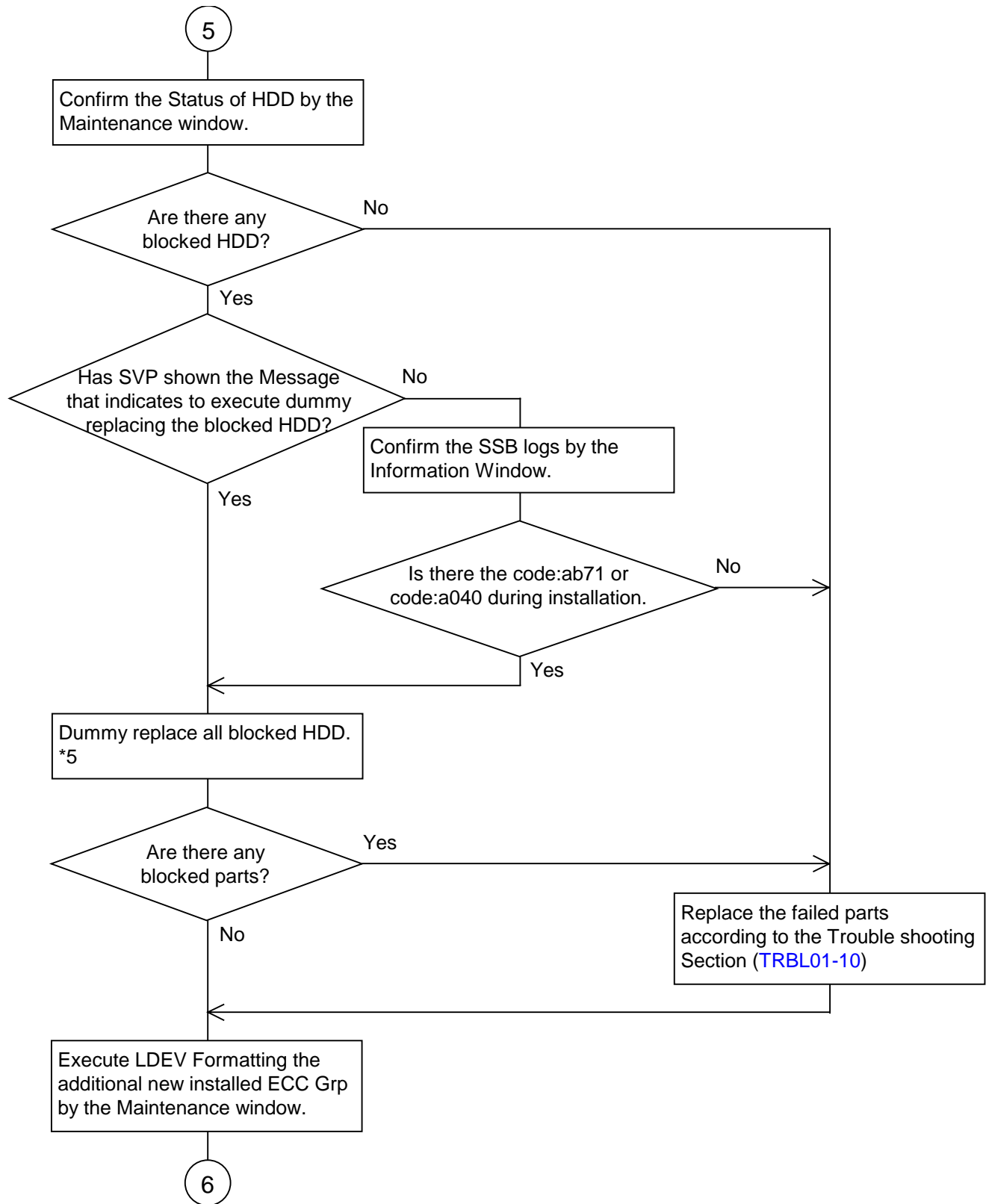

*5: When dummy replacing fails 3 times, please replace with new HDD.

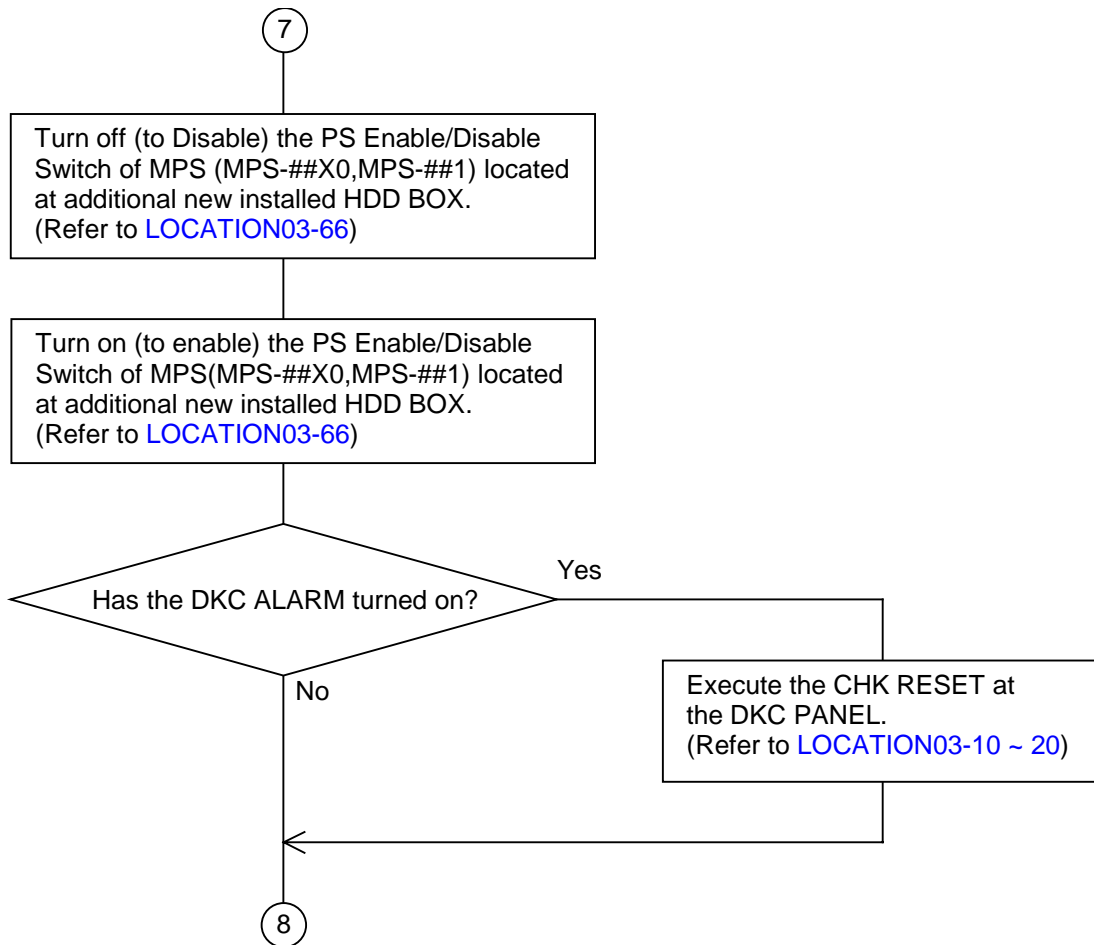

13 Recovery procedure of failure on replacement of SSVP

The following is the recovery procedure when the message “Can’t read SSVP micro program version from SSVP.” is displayed at replacement of SSVP.

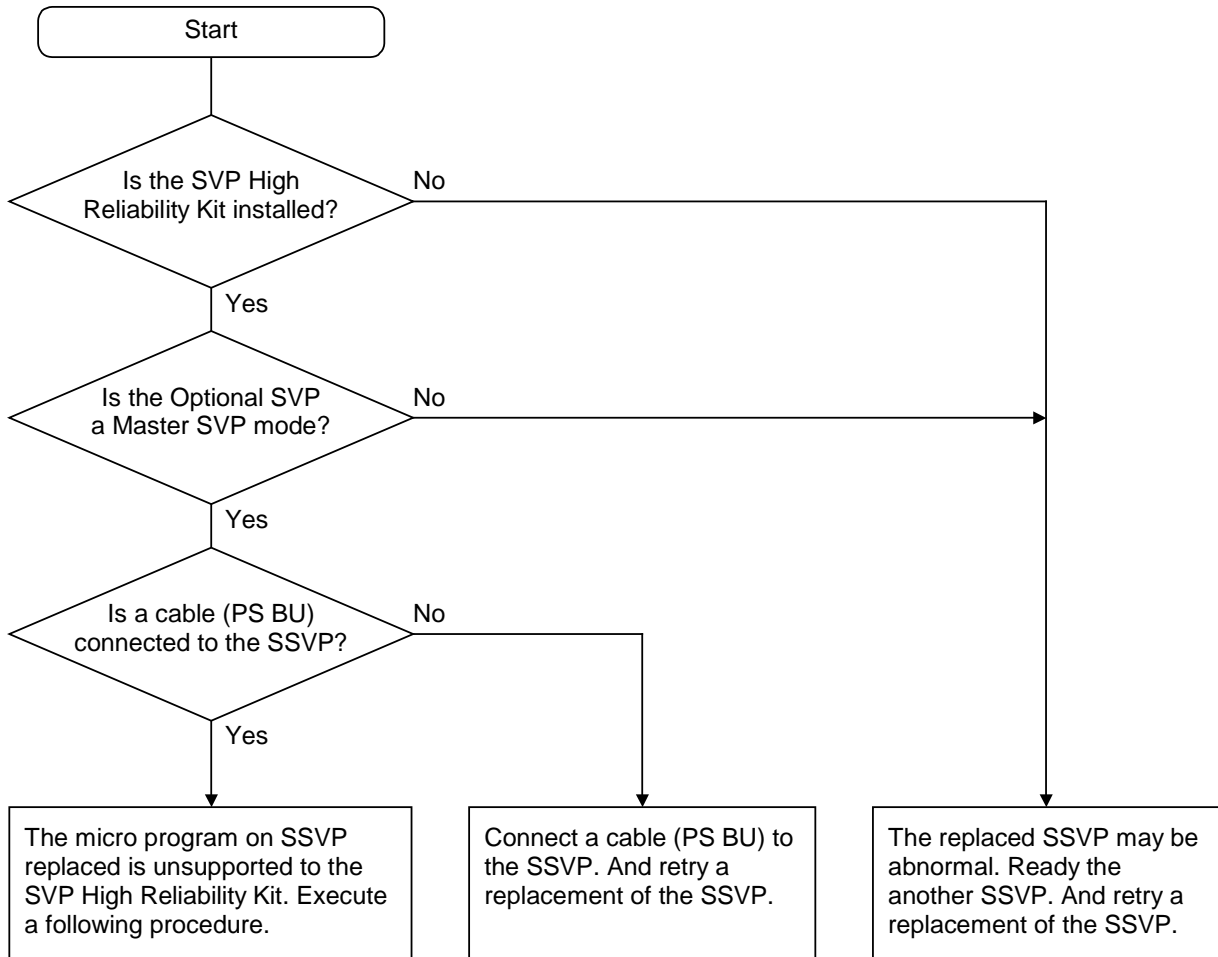

- ① Pull out a RS232C cable connected to RSVP-1 of RS CON, and put in a RS232C cable pulled out from RSVP-2 to RSVP-1. (See [LOCATION06-50](#))
- ② Download micro program of SSVP from Hard Disk. (See [MICRO-FC04-10](#))
- ③ Put RS232C cables back where they were after downloaded micro program of SSVP.
- ④ Reset SSVP (Push SSVP ALARM RESET button).
- ⑤ Open 'Maintenance' window.
If error has not occurred, go to ⑥.
If error has occurred, the replaced SSVP may be abnormal. Ready the another SSVP. And retry a replacement of the SSVP.
- ⑥ SIM Complete. (See [SVP02-580](#))
Close 'Maintenance' window.

14 WebConsole Error Recovery

This section describes troubleshooting of error on WebConsole

14.1 Recovery Procedure for WebConsole Error

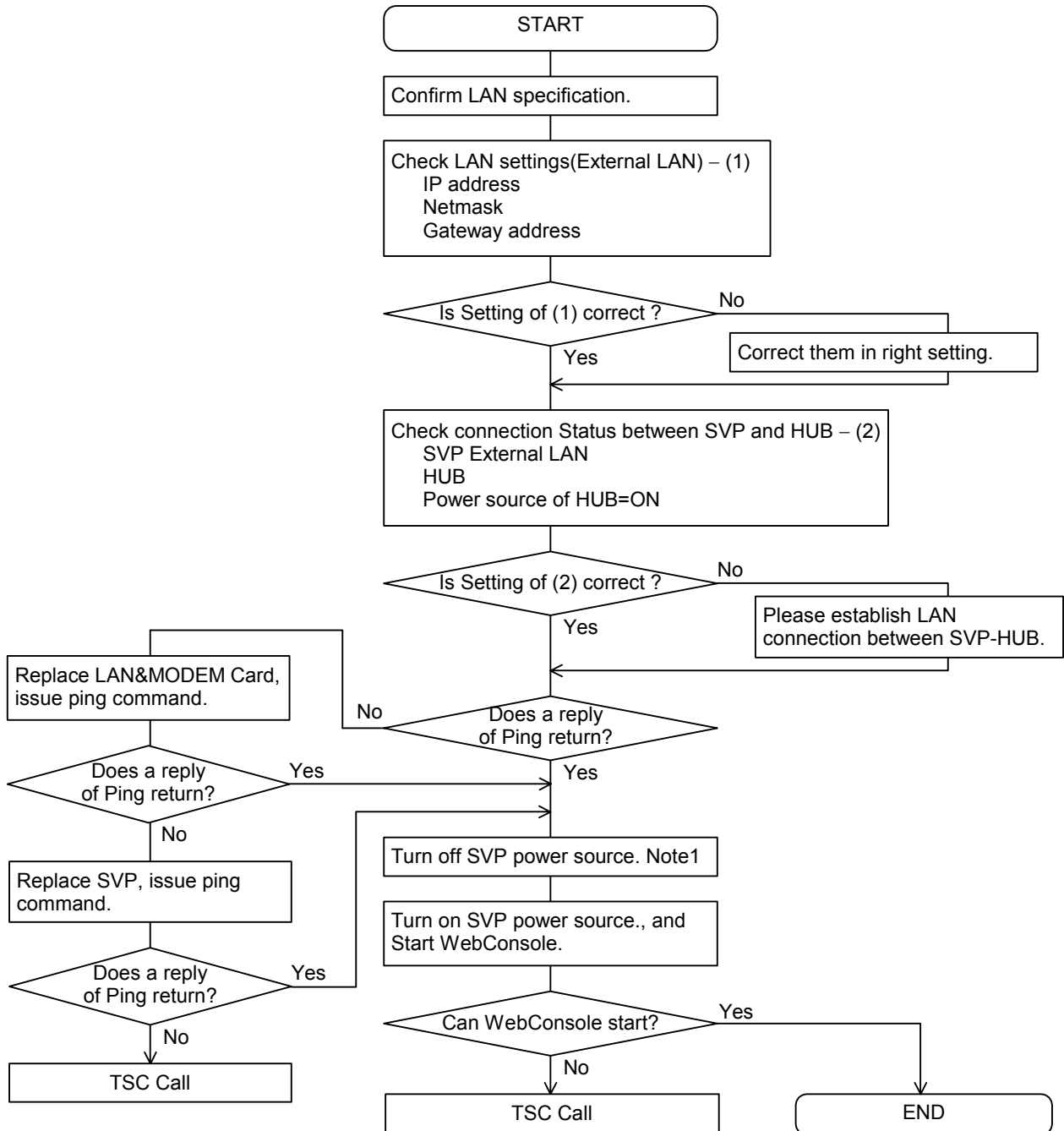

(Note1) The state that excluded LAN cable connection of SVP side of External LAN or LAN cable connection of HUB side or a power supply of HUB is an Off state, and reboot SVP, and WebConsole cannot start when connected outside LAN after that.

15 Recovery Procedure for DCR Pre-Staging ABNORMAL END

The recovery method for DCR Pre-Staging ABNORMAL END (SIM RC=4821-XX) factor is shown below.

Factor XX	Meaning	The recovery method
“10” or “E1”	No DCR PP	Pre-staging re-execution after DCR PP Install.
“20” or “E2”	Subsystem Busy	Pre-staging re-execution.
“40” or “E4”	Staging Time Over	Pre-staging re-execution.
“50” or “E5”	Cache Blockade	Pre-staging re-execution after CACHE recovery.
“60” or “E6”	LDEV Warning	LDEV is Failure State. Pre-staging re-execution after LDEV recovery.
“70” or “E7”	Staging Failure	HDD is Failure State. Pre-staging re-execution after HDD recovery.
“80” or “E8”	P/S OFF	Pre-staging re-execution after P/S ON.
“90”	Pre-Staging Canceled	Pre-staging re-execution.
“A0” or “EA”	Cache Over Load	Pre-Staging Re-perform at the time of low loading.

16 HI-COPY Error Recovery

The following is the recovery procedure when the ABNORMAL END (SIM RC = 21D0-XY, EFD000) is occurred for HI-COPY.

16.1 Path failure recovery method

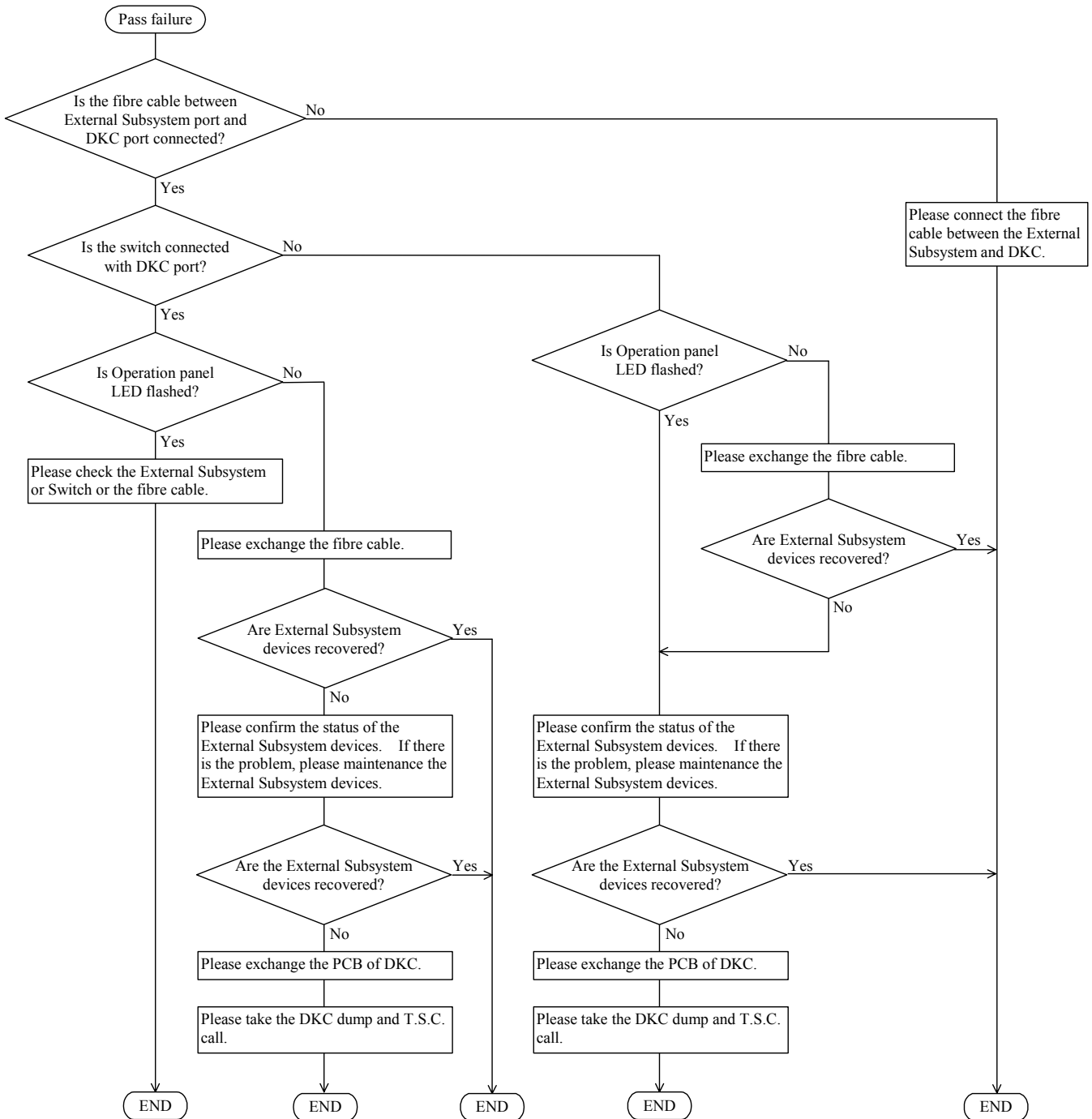

16.2 Device failure recovery method

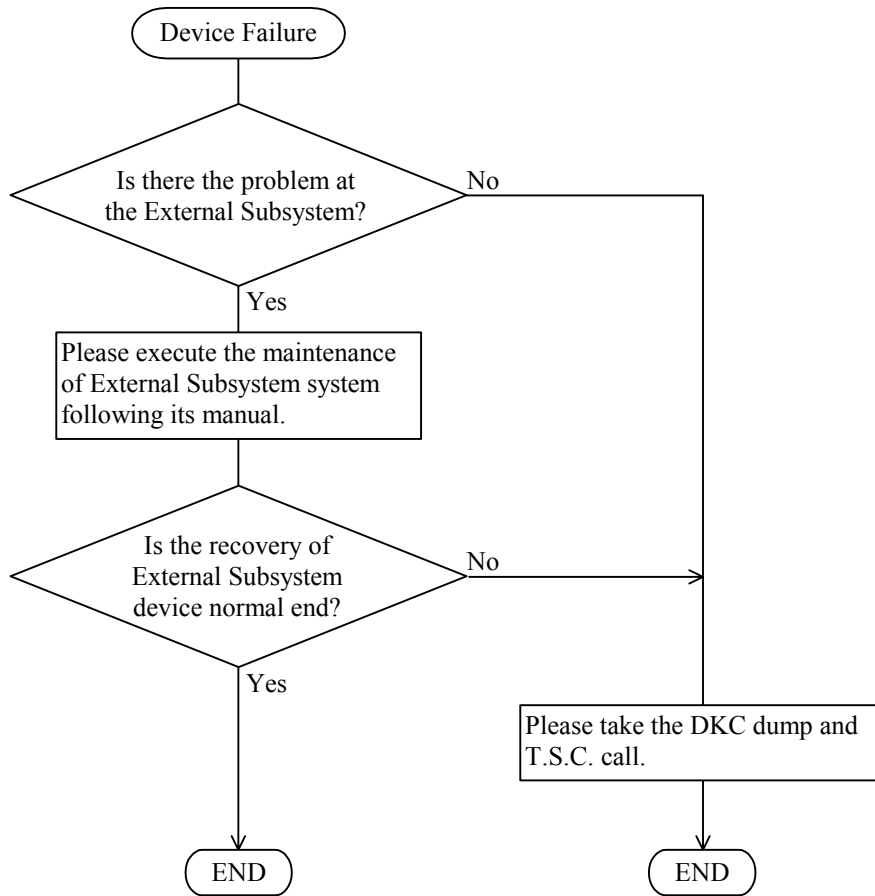

16.3 Path failure and Device failure recovery method

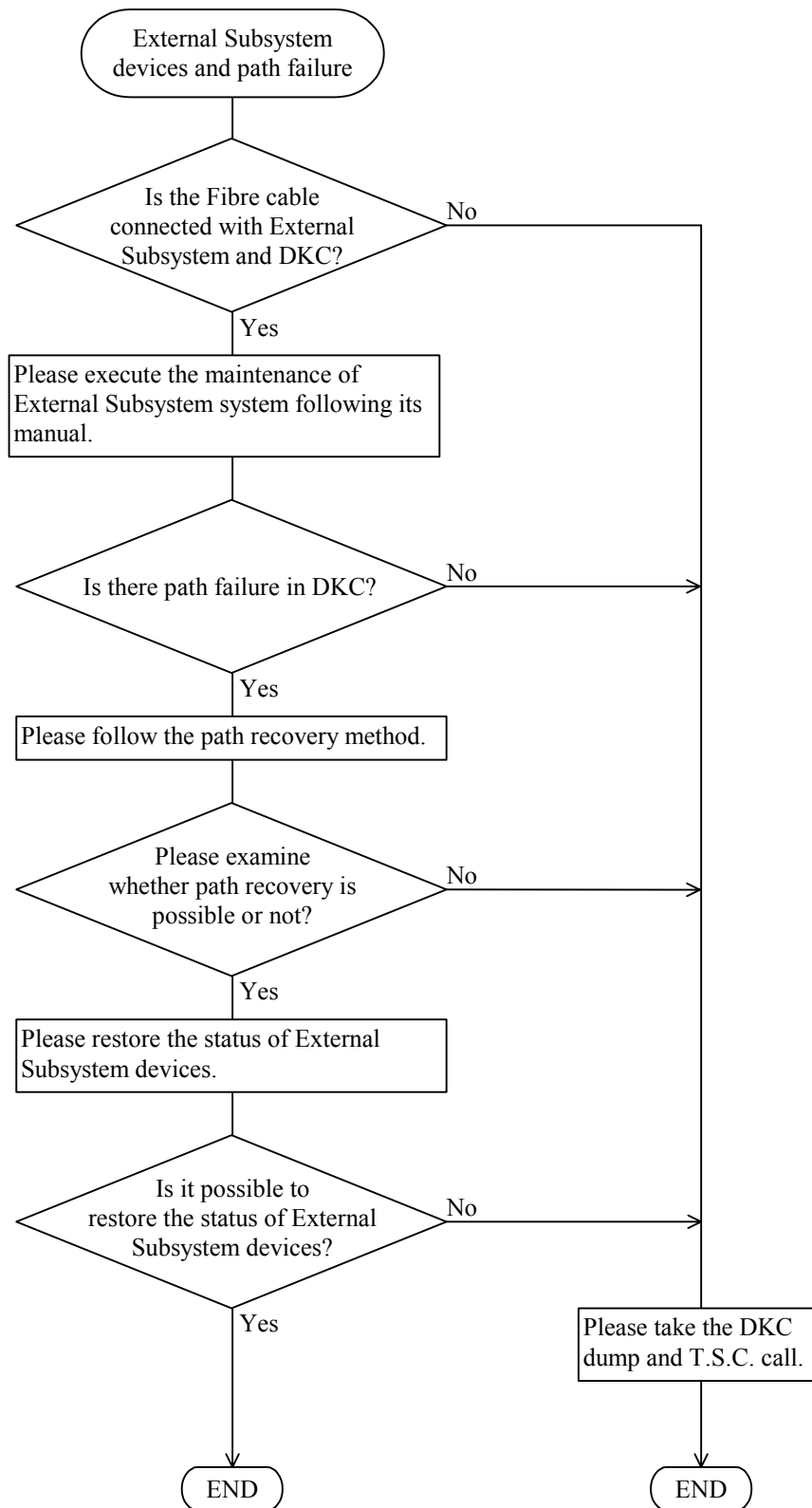

16.4 HI-COPY Copy abnormal end recovery procedure (SIM = 4B1XXXX)

The recovery procedure of a HI-COPY copy pair is shown below.

SIM RC = 4B1XXXX

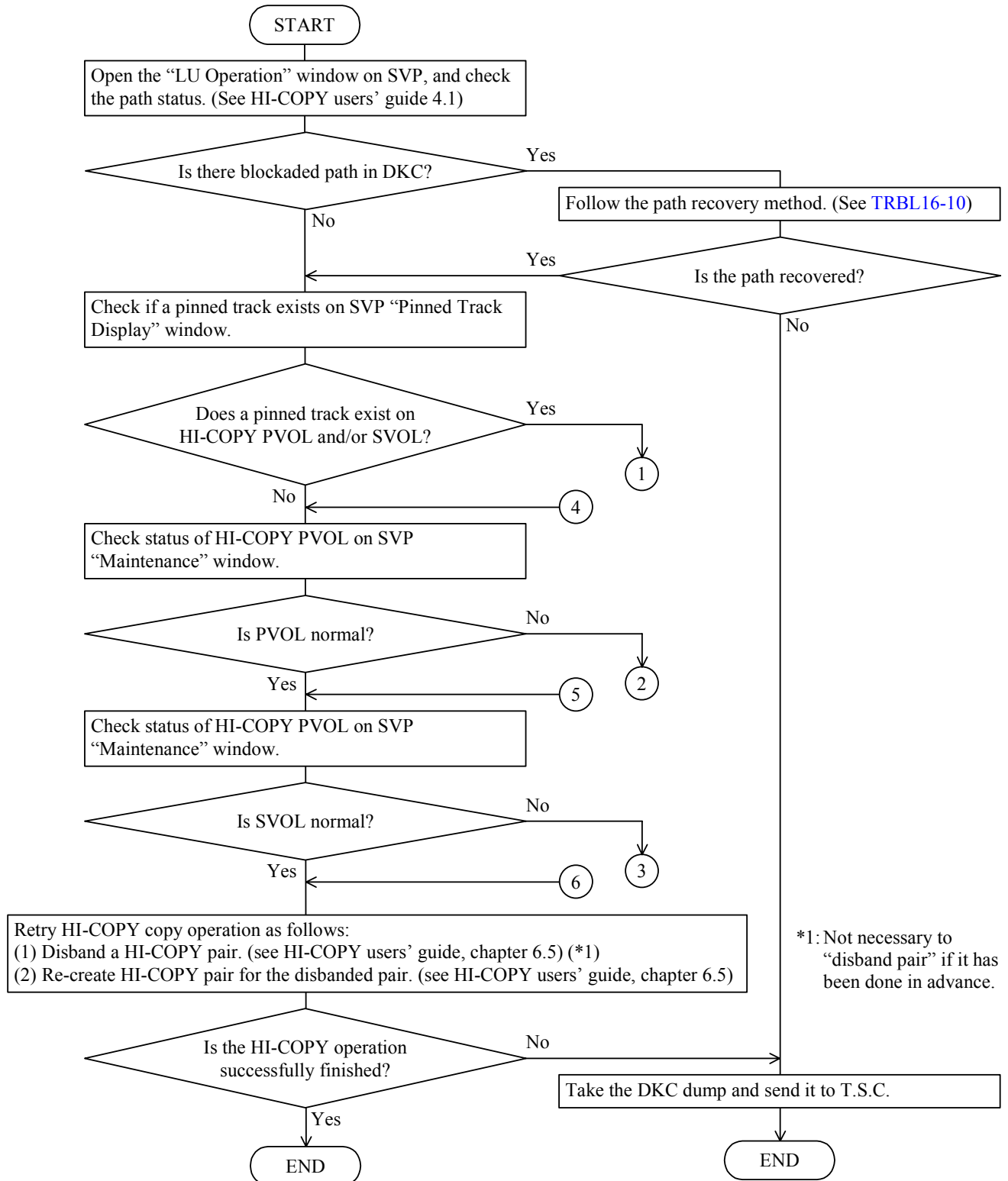

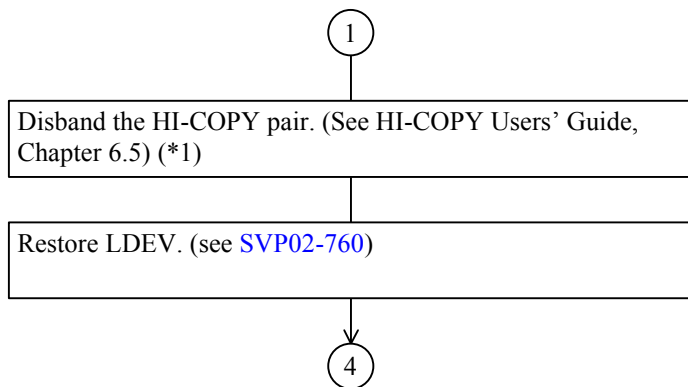
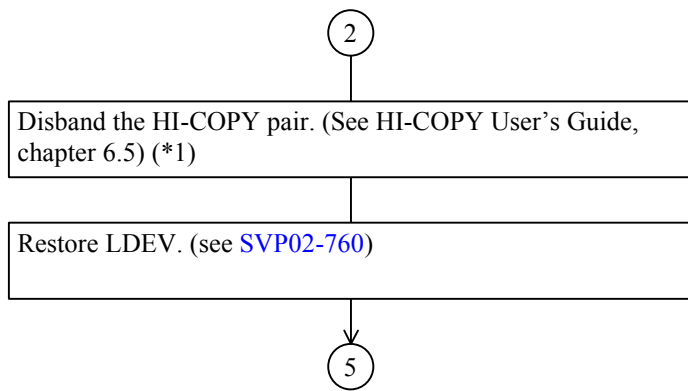
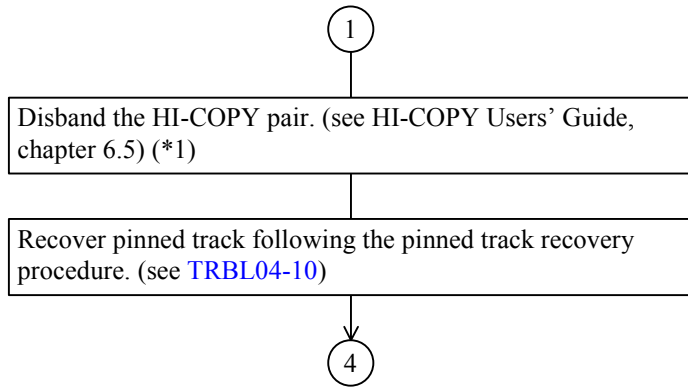

*1: Not necessary to "disband pair" if it has been done in advance.

17 SFP Optical Failure (SIM = 21A8XY)

A procedure for troubleshooting to be done when a SFP optical failure is detected is shown below.

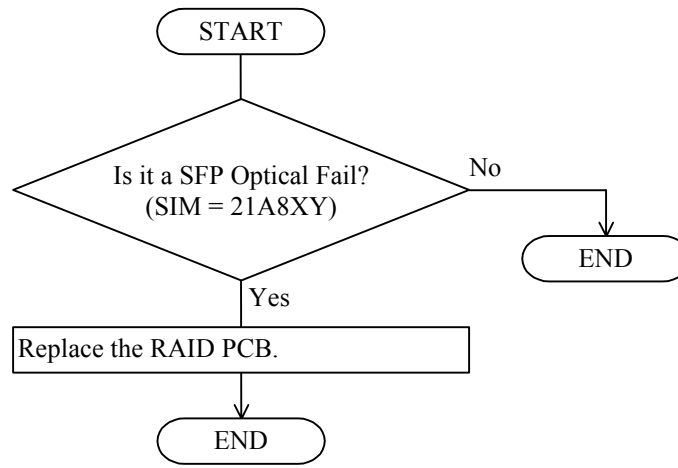

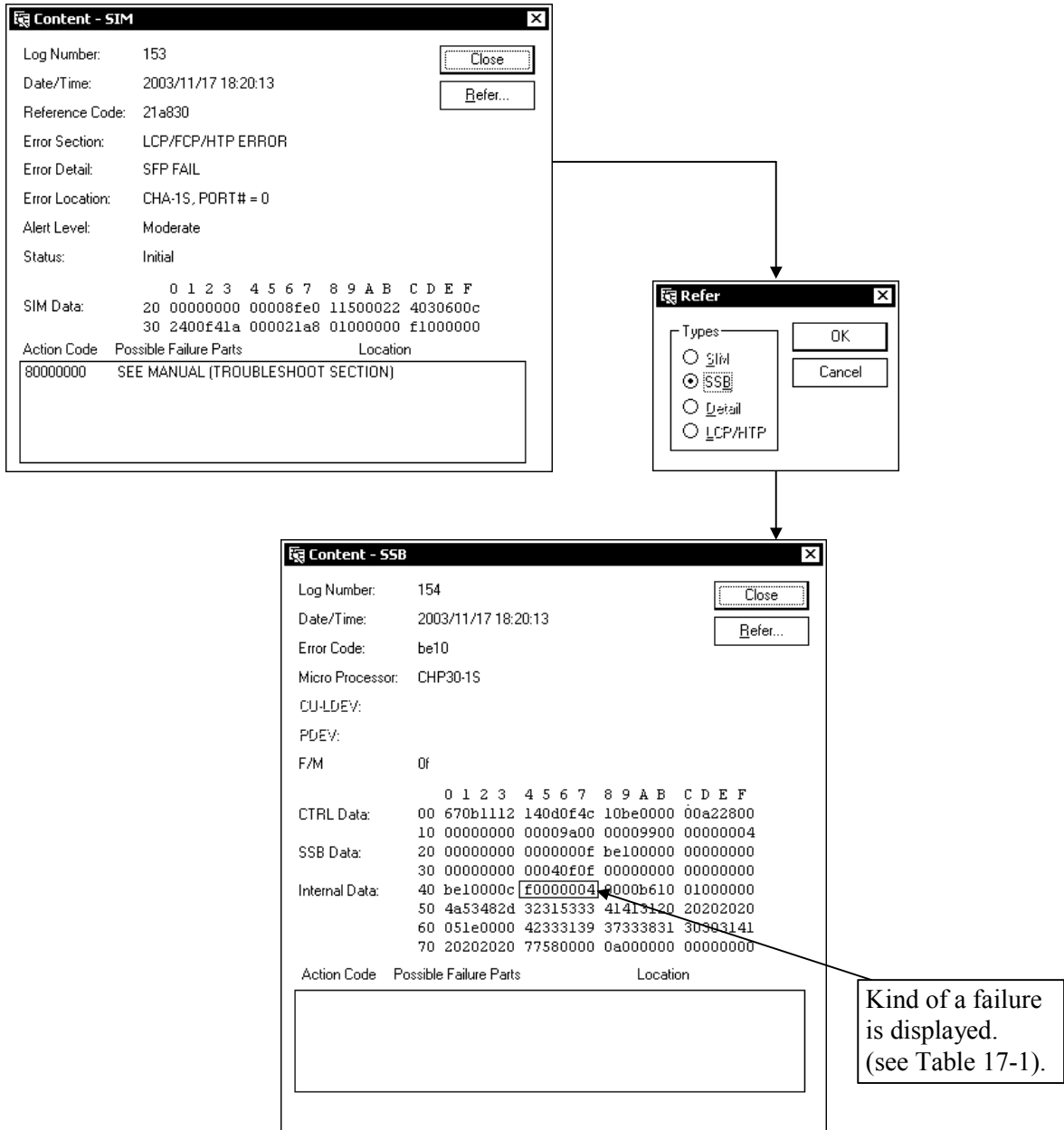

(1) To identify a kind of an SFP failure, refer to the SSB correlated with the SIM (21a8XY).

Table 17-1 List of Symptoms Caused by Failures

No.	Code	Failure symptom
1	F0000001	Uninstalled SFP module: The SFP module cannot be recognized.
2	F0000002	Illegal authentication: The authentication code is not the one showing that the SFP has been examined.
3	F0000003	Information reading rejected: The information in the EEPROM of the SFP cannot be read.
4	F0000004	Illegal identification: The identification code that shows the SFP type is illegal.

18 Mainframe port error recovery

To recover a mainframe (ESCON/FICON) port failure, please replace the CHA according to the “REPLACE” section.

However, only if it is likely that the CHA replacement will have a significant impact on other normal ports, please consult with Technical Support Department.
And if necessary, please perform the recovery operation using the restart switch function.

(The failure parts to be recovered by Restart Switch function)

- FICON port blockade
- ESCON port blockade
- HTP-CHP internal path blockade
- LCP-CHP internal path blockade

Note: However, if the error described below has occurred, please perform the normal recovery procedure according to the “REPLACE” section, without executing Restart Switch recovery.

- LCP is defined as RCP, and RCP failure has occurred.
- CHP WCHK1 has occurred.

The recovery procedure by using the restart switch is shown in “18.1”.

18.1 ESCON/FICON Port Error Recovery

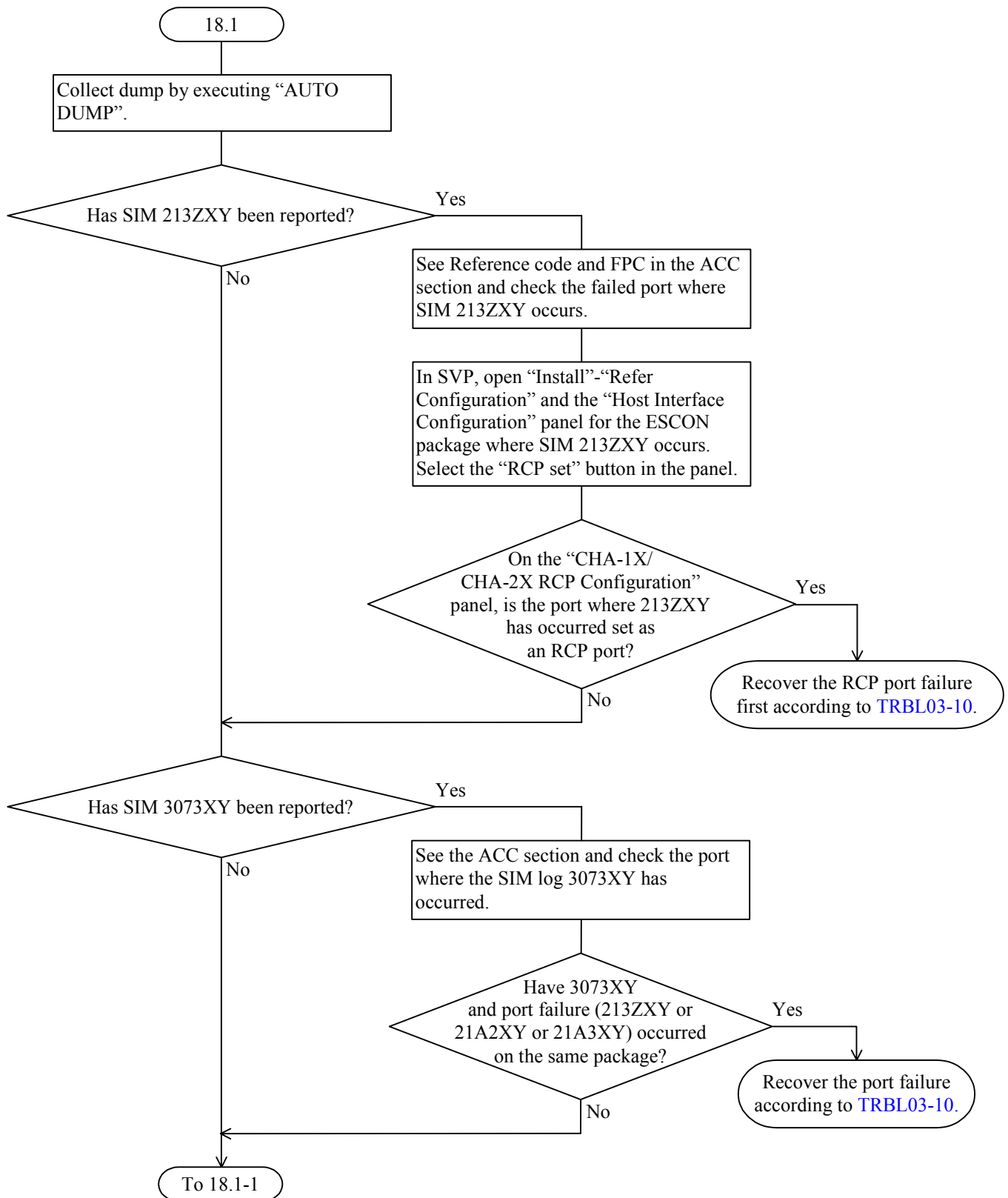

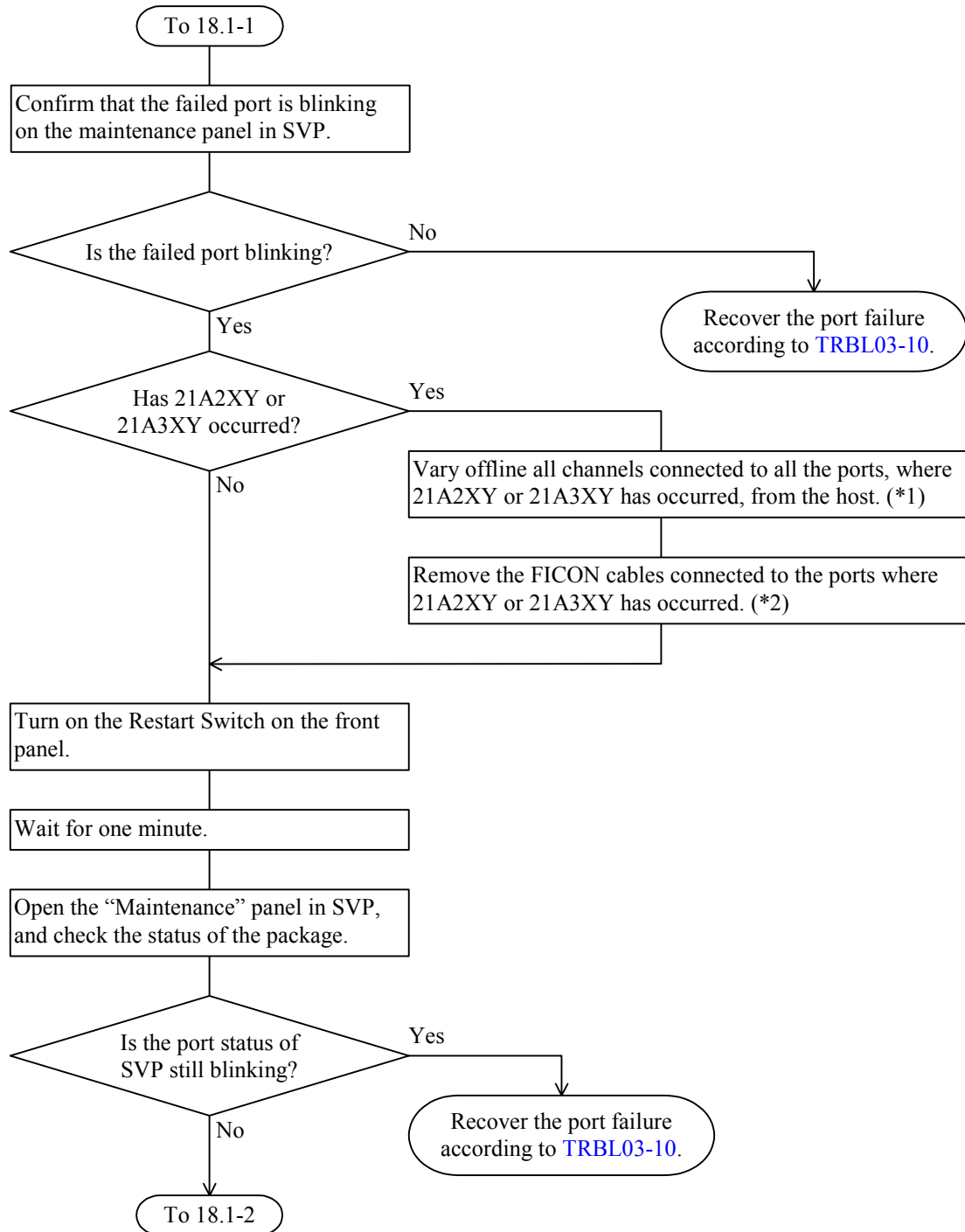

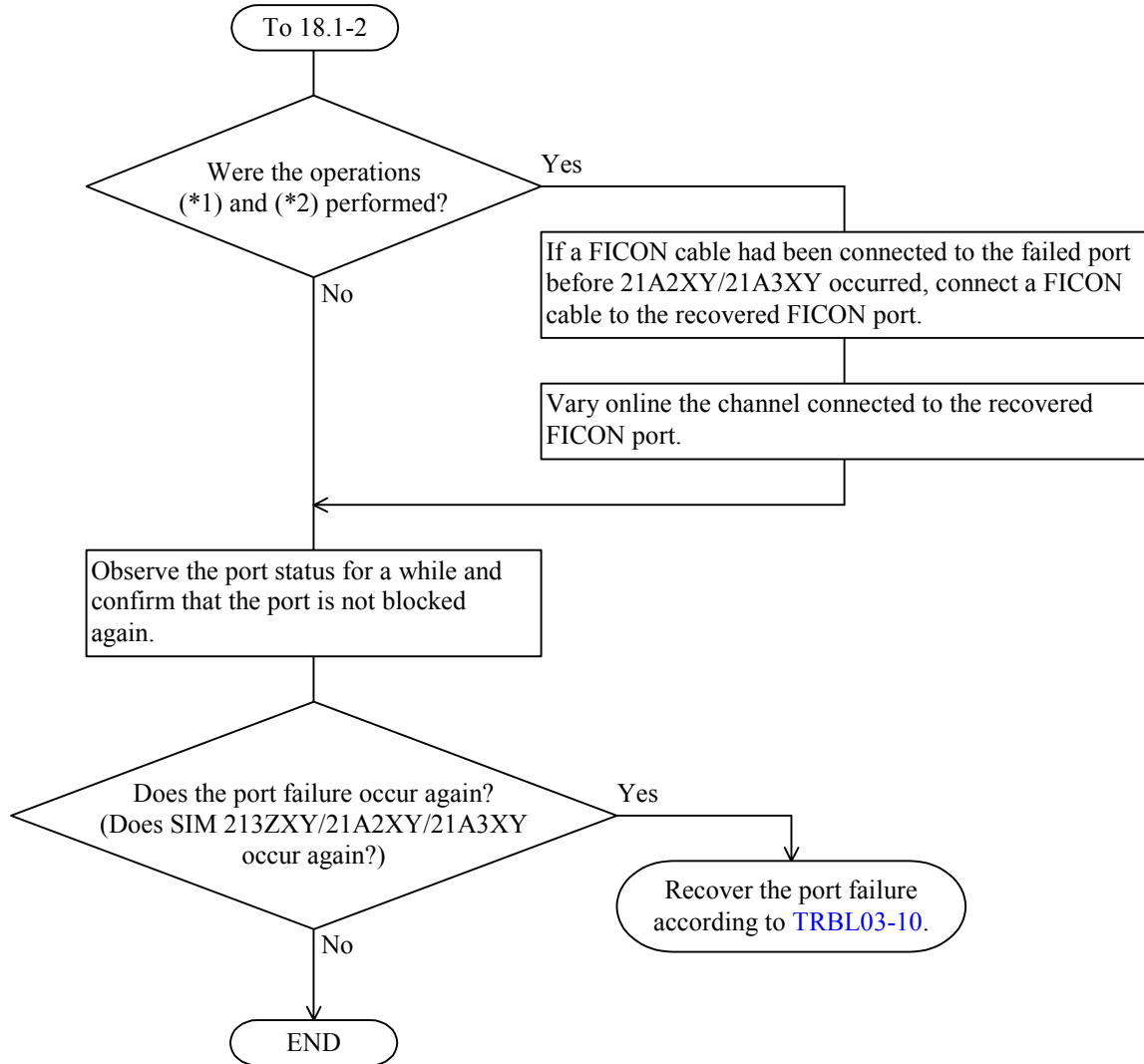

19 Recovery procedure of an IP address conflict (SIM = 21A9XY)

The following chart shows a recovery procedure for a case where IP addresses of nodes (CHI port and iSCSI port on the host side) that exist in the same network duplicate.

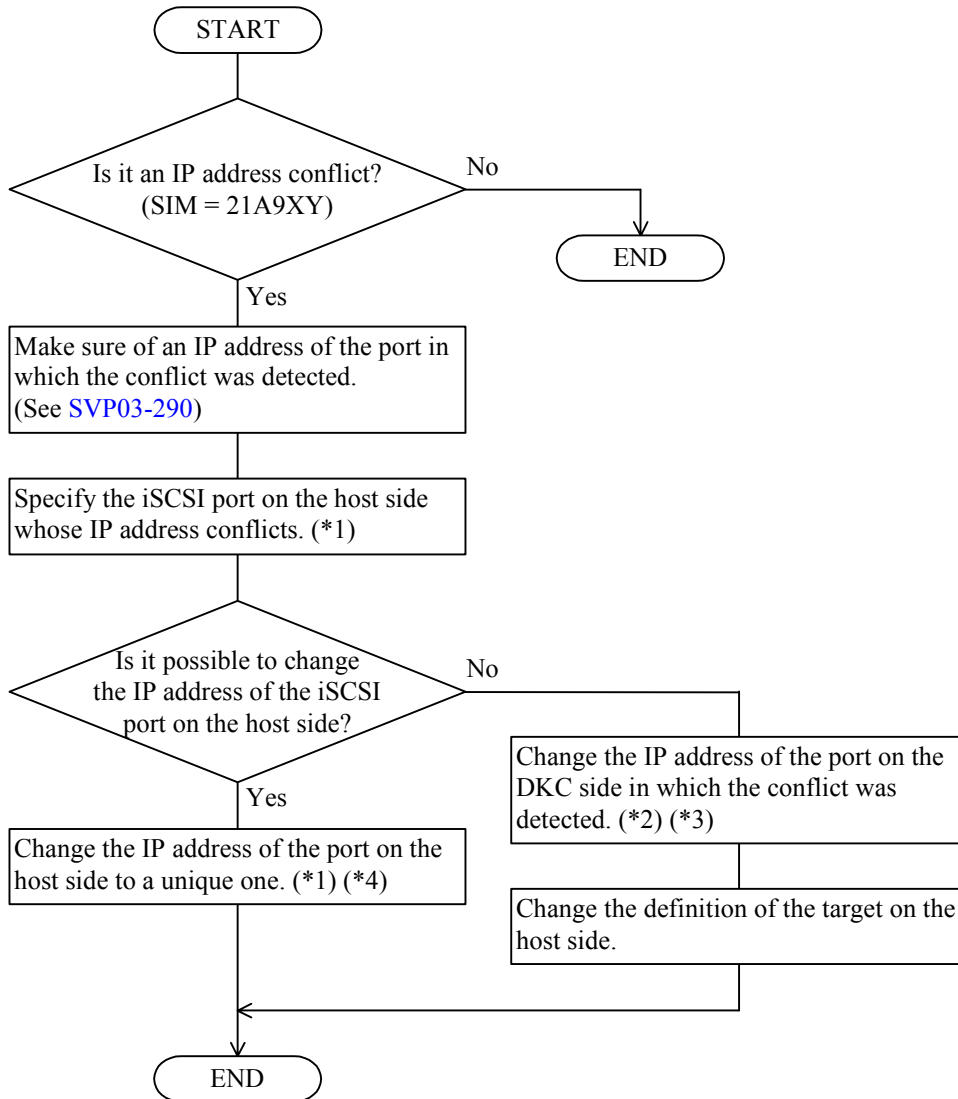

- *1: This operation is to be performed by a user.
- *2: The new IP address is to be specified by a user.
The operation for the change is to be performed by a user or service personnel controlled by a user.
- *3: The change of the IP address of the port on the DKC side is made through WebConsole.
For details of the change, refer to page [WEB02-40](#) and Section 3.9, “Setting iSCSI Port” in the LUN Management User’s Guide.
- *4: For procedures for various settings of the port on the host side, refer to an instruction manual of the iSCSI adapter or driver.