

NAS Software Section

Contents

1.	Overview	NAS01-10
1.1	Maintenance Tasks and Reference Locations	NAS01-10
1.2	Related Manuals.....	NAS01-40
1.3	Overview of Each Chapter.....	NAS01-50
2.	NAS Blade System Device Explanation	NAS02-10
2.1	Overview.....	NAS02-10
2.2	NAS Blade System Hardware Configuration	NAS02-20
2.3	NAS Blade System Software Configuration and Operating Environment.....	NAS02-30
2.4	Minimum and Maximum Configurations	NAS02-70
2.5	Maintenance Personnel.....	NAS02-80
2.5.1	Roles of the Maintenance Personnel and System Administrators ...	NAS02-80
2.5.2	Maintenance Terminal (Not Required for Ordinary Operations).....	NAS02-100
2.5.3	SSH Account for Maintenance Personnel and System Administrators (Not Required for Ordinary Operations).....	NAS02-110
3.	NAS Installation.....	NAS03-10
3.1	Overview.....	NAS03-10
3.2	Prerequisites.....	NAS03-10
3.2.1	Creating NAS System LUs.....	NAS03-20
3.2.2	Defining the Paths to NAS System LUs.....	NAS03-40
[1]	Defining paths to the NAS OS LU and the dump LU	NAS03-40
[2]	Defining paths to a command device, error information LU, NAS Cluster Management LU, and backup LU of NAS Cluster Management LU	NAS03-60
3.2.3	Defining Paths to User LUs.....	NAS03-70
3.3	New Installation (Setup Performed By the Manufacturer)	NAS03-80
3.4	On-Site Installation (On-Site Setup)	NAS03-90
3.5	Operations on the SVP.....	NAS03-100
3.5.1	Overview of Setup on SVP.....	NAS03-100
3.5.2	Implementing Setup on SVP	NAS03-110
[1]	Installing Setup on SVP	NAS03-110
[2]	Starting and stopping Setup on SVP.....	NAS03-180
[3]	Uninstalling Setup on SVP	NAS03-200
3.5.3	NAS Package Status	NAS03-260
3.5.4	Installing the NAS OS and Related Program Products	NAS03-290
[1]	NAS OS installation for the first time.....	NAS03-310
[2]	NAS OS expansion installation	NAS03-400
[3]	Optional program product installation	NAS03-500
[4]	Installation Containing LU Initialization (Use this procedure by developers' instruction only when the error cannot be recovered)	NAS03-540

3.5.5	Uninstalling Optional Program Products	NAS03-600
3.5.6	Setting Up the Network Environment	NAS03-630
3.5.7	Setting Up a License	NAS03-660
[1]	Setting up licenses individually	NAS03-660
[2]	Setting up licenses in the batch mode	NAS03-700
[3]	Checking or changing license information	NAS03-740
[4]	Deleting licenses	NAS03-760
3.5.8	Controlling the NAS OS (Stopping, Starting, and Restarting)	NAS03-790
[1]	Stopping the NAS OS	NAS03-790
[2]	Starting the NAS OS	NAS03-830
[3]	Restarting the NAS OS	NAS03-850
3.5.9	Resetting CHA	NAS03-890
3.5.10	Collecting the Hibernation Dump	NAS03-920
[1]	Collecting the hibernation dump.....	NAS03-920
[2]	Canceling collection of the hibernation dump	NAS03-950
3.5.11	Viewing the Settings (Refer Configuration Button).....	NAS03-970
3.5.12	Restoring a NAS OS LU.....	NAS03-1000
3.5.13	Restoring a NAS Cluster Management LU	NAS03-1050
3.5.14	Downloading Dump Files	NAS03-1090
3.6	Operations Using the NAS/Management GUI	NAS03-1300
3.6.1	Registering System Administrators	NAS03-1300
3.6.2	Setting Up the NAS Package Cluster Configuration	NAS03-1300
3.6.3	Setting Up the Configuration For Services	NAS03-1300
3.6.4	Setting Up the Network (Routing)	NAS03-1310
3.6.5	Setting Up the Network (DNS, NIS)	NAS03-1310
3.6.6	Setting Up Users and Groups	NAS03-1310
3.6.7	Creating File Systems	NAS03-1310
3.6.8	Setting Up File Shares (NFS, CIFS)	NAS03-1320
3.6.9	Specifying Settings Related to Error-Monitoring Functionality	NAS03-1320
3.6.10	Settings Related to the Save Function for NAS System LUs (NAS OS LU and NAS Cluster Management LU)	NAS03-1330

4.	NAS Hardware Replacement.....	NAS04-10
4.1	Overview.....	NAS04-10
4.2	Types of Hardware Replacement Operations.....	NAS04-20
4.2.1	Flowcharts for Replacing Hardware	NAS04-30
(1)	Replacing the NAS Package (During Periodic Replacement).....	NAS04-40
(2)	Replacing Data LAN Cables (During Periodic Replacement)	NAS04-71
(3)	Hot-replacing Hardware Other Than the NAS Package.....	NAS04-80
5.	NAS Software FC.....	NAS05-10
5.1	Overview.....	NAS05-10
5.2	Preparing for Software Upgrade Operations (System LU Backup).....	NAS05-20
5.3	Types of Software Upgrade Operations	NAS05-30
5.3.1	Flowcharts for Upgrading Software.....	NAS05-60
(1)	Upgrading Setup on SVP	NAS05-60
(2)	Upgrading NAS OS by an Updated Version (Preventive Upgrade: While Operating)	NAS05-70
(3)	Replacing the NAS OS By a Patch Version — Restarting the NAS OS Is Not Required (Preventive Upgrade: While Operating).....	NAS05-130
(4)	Replacing the NAS OS By a Patch Version — Restarting the NAS OS Is Required (Preventive Upgrade: While Operating).....	NAS05-220
(5)	Upgrading NAS OS by an Updated Version (Preventive Upgrade: While the Cluster is Stopped).....	NAS05-310
(6)	Replacing the NAS OS By a Patch Version — Restarting the NAS OS Is Not Required (Preventive Upgrade: While the Cluster is Stopped)	NAS05-350
(7)	Replacing the NAS OS By a Patch Version — Restarting the NAS OS Is Required (Preventive Upgrade: While the Cluster is Stopped)	NAS05-420
(8)	Upgrading NAS/Management (Preventive Upgrade)	NAS05-490
(9)	Upgrading an Optional Program Product (Preventive Upgrade)	NAS05-510
5.3.2	Procedures for Upgrading the NAS OS and Related Program Products	NAS05-540
[1]	Upgrading the NAS OS (update version).....	NAS05-560
[2]	Upgrading the NAS OS (patch version)	NAS05-660
[3]	Upgrading the NAS/Management (update version)	NAS05-710
[4]	Upgrading the optional program product.....	NAS05-750
5.3.3	Going Back To an Earlier Software Version.....	NAS05-790
(1)	To Go Back To an Earlier Version of the NAS OS.....	NAS05-790
(2)	To Go Back To an Earlier Version of NAS/Management.....	NAS05-790
(3)	To Go Back To an Earlier Version of an Optional Program Product.....	NAS05-790

6.	NAS Configuration (Reconfiguration)	NAS06-10
6.1	Overview	NAS06-10
6.2	Reconfiguring Hardware	NAS06-20
6.2.1	Types of Hardware Reconfiguration	NAS06-20
6.2.2	Flowcharts for Reconfiguring Hardware	NAS06-30
	(1) Adding a RAID Group (User LU)	NAS06-40
	(2) Removing a RAID Group (User LU)	NAS06-60
	(3) Adding or Removing RAID Cache Memory or Reconfiguring (DCR)	NAS06-80
	(4) Adding a NAS Package	NAS06-90
	(5) Removing a NAS Package	NAS06-130
	(6) Increasing LU Capacity (User LU)	NAS06-150
	(7) Decreasing LU Capacity (User LU)	NAS06-180
6.3	Reconfiguring Software	NAS06-210
6.3.1	Types of Software Reconfiguration	NAS06-210
7.	NAS Troubleshooting	NAS07-10
7.1	Overview	NAS07-10
7.2	Detecting and Identifying Failures	NAS07-20
7.2.1	Detecting Failures	NAS07-30
	(1) Failure Detection By Maintenance Personnel:	NAS07-30
	(2) Failure Detection By System Administrators:	NAS07-40
7.2.2	Identifying Failures and Taking Countermeasures	NAS07-50
7.2.3	Obtaining Detailed Information about a Failure	NAS07-60
	(1) Detailed Information for Maintenance Personnel:	NAS07-60
	(2) Detailed Information for System Administrators:	NAS07-80
7.2.4	Preparing for Failure Recovery Operations (System LU Backup)	NAS07-90
7.3	Lists of Failures	NAS07-100
7.3.1	Hardware Failures	NAS07-100
7.3.2	Software Failures	NAS07-150

7.4	Troubleshooting Procedures	NAS07-200
7.4.1	Hardware Troubleshooting Procedures	NAS07-280
(1)	NAS Package Failure Detected By a Processor in the NAS Package	NAS07-290
(2)	NAS Package Failure Detected By a NAS OS Driver	NAS07-310
(3)	RAID Failure (User LU)	NAS07-330
(4)	RAID Failure (2 PDEVs: NAS System LUs — NAS OS LUs in the Cluster Belong to Different RAID groups).....	NAS07-350
(5)	RAID Failure (2 PDEVs: NAS System LUs — NAS OS LUs in the Cluster Belong to the Same RAID Group).....	NAS07-370
(6)	RAID Failure (2 PDEVs: NAS Cluster Management LUs).....	NAS07-390
(7)	RAID Failure (2 PDEVs: Dump LUs).....	NAS07-410
(8)	RAID Failure (2 PDEVs: Error Information LUs)	NAS07-430
(9)	RAID Failure (2 PDEVs: Command Devices)	NAS07-450
(10)	RAID Failure (2 PDEVs: Backup LUs of NAS Cluster Management LUs).....	NAS07-470
(11)	Hardware Failure (Correctable).....	NAS07-490
(12)	Network Failure (Network Settings Failed).....	NAS07-510
7.4.2	Software Troubleshooting	NAS07-530
(1)	NAS OS Failure (Panic)	NAS07-540
(2)	NAS OS Failure (Hangup).....	NAS07-560
(3)	NAS OS Failure (Slowdown).....	NAS07-590
(4)	Application Failure (Failover Provided)	NAS07-620
(5)	Application Failure (Failover Not Provided).....	NAS07-650
(a)	Application failure in something other than the Web server:.....	NAS07-650
(b)	Application Failure in the Web Server.....	NAS07-680
(6)	NAS OS Failure (In Start/Stop Processing)	NAS07-710
(7)	Failure when NAS OS LU is full	NAS07-740
(8)	NAS OS File System Failure.....	NAS07-761
(9)	NAS OS Failure During Startup or Stop (Invalid Dump LU).....	NAS07-764
(10)	NAS OS Failure During Startup or Stop (Unable to Connect NTP Server).....	NAS07-766
(11)	NAS OS Application Failure (Unable to Set Internal IP Address)	NAS07-769A

7.5	Replacement Flowcharts When a Failure Occurs	NAS07-770
7.5.1	Replacing Hardware.....	NAS07-780
[1]	Types of Hardware Replacement Operations.....	NAS07-780
[2]	Procedures for Replacing Hardware	NAS07-800
(1)	Replacing the NAS Package (When a Failure Occurs).....	NAS07-810
(2)	Hot-replacing Hardware Other Than the NAS Package	NAS07-840
(3)	Replacing Two PDEVs (User LUs).....	NAS07-860
(4)	Replacing Two PDEVs (NAS OS LU: When the NAS OS LU and the Dump LU Belong to Different RAID Groups).....	NAS07-900
(5)	Replacing Two PDEVs (NAS OS LU: When the NAS OS LUs for CHA-1P and CHA-2V Belong to the Same RAID Group)	NAS07-940
(6)	Replacing Two PDEVs (NAS Cluster Management LU)	NAS07-960
(7)	Replacing Two PDEVs (Dump LU)	NAS07-980
(8)	Replacing Two PDEVs (Error Information LU).....	NAS07-1030
(9)	Replacing Two PDEVs (Command Device).....	NAS07-1050
(10)	Replacing Two PDEVs (Backup LUs of NAS Cluster Management LUs)	NAS07-1070
(11)	Replacing Data LAN Cables (When a Failure Occurs)	NAS07-1081
7.5.2	Upgrading and Downgrading Software	NAS07-1090
[1]	Types of Software Upgrade Operations.....	NAS07-1090
[2]	Procedures for Upgrading Software.....	NAS07-1110
(1)	Upgrading the NAS OS By a Update Version (When a Failure Occurs)	NAS07-1120
(2)	Upgrading the NAS OS By a Patch Version — Restarting the NAS OS Is Not Required (When a Failure Occurs).....	NAS07-1160
(3)	Upgrading the NAS OS By a Patch Version — Restarting the NAS OS Is Required (When a Failure Occurs).....	NAS07-1220
(4)	Upgrading NAS/Management (When a Failure Occurs).....	NAS07-1270
(5)	Upgrading an Optional Program Product (When a Failure Occurs).	NAS07-1290
7.5.3	Going Back To an Earlier Software Version.....	NAS07-1310
(1)	To Go Back To an Earlier Version of the NAS OS.....	NAS07-1310
(2)	To Go Back To an Earlier Version of NAS/Management.....	NAS07-1310
(3)	To Go Back To an Earlier Version of an Optional Program Product	NAS07-1310

8. Setup Procedures When Implementing NAS Blade System for the First Time	NAS08-10
8.1 Operations Using the SVP.....	NAS08-20
[1] Setting up the network environment.....	NAS08-20
[2] Setting the license of NAS/Management	NAS08-50
8.2 Operations Using the NAS/Management GUI	NAS08-100
[1] Confirming that Setup on SVP is stopped.....	NAS08-100
[2] Connecting LAN cables.....	NAS08-110
[3] Registering system administrators	NAS08-120
[4] Setting up the NAS Package cluster configuration	NAS08-220
8.3 Confirmation of the settings.....	NAS08-290
[1] Connection of LAN cable	NAS08-290
[2] Starting the cluster	NAS08-310
[3] Confirmation of the connection from a client.....	NAS08-390
9. Appendixes	NAS09-10
9.1 Appendix A Using the Command Line To Obtain Error Information	NAS09-10
9.1.1 Overview.....	NAS09-10
9.1.2 Types of Error Information.....	NAS09-10
9.1.3 How to Obtain a Crash Dump.....	NAS09-30
9.1.4 How to Obtain a Hibernation Dump	NAS09-80
9.1.5 How to Obtain an LM Dump	NAS09-150
9.1.6 How to Obtain an Event Trace.....	NAS09-180
9.2 Appendix B List of Log and Core Files.....	NAS09-220
9.3 Appendix C Initializing Dump LUs.....	NAS09-250
9.4 Appendix D How to Obtain Error Information When the NAS OS Has Not Started	NAS09-280
9.4.1 Overview.....	NAS09-280
9.4.2 Confirming that NAS OS is stopped	NAS09-280
9.4.3 How to Obtain an Auto Dump.....	NAS09-280
9.4.4 How to Obtain an NAS Dump.....	NAS09-300
9.5 Appendix E NAS Dump (Attachment of USB Memory).....	NAS09-320

1. Overview

1.1 Maintenance Tasks and Reference Locations

The maintenance tasks and corresponding reference locations in this *NAS Software Section* are as follows:

Table 1.1-1 Maintenance Tasks and Corresponding Reference Locations in this Document

#	Classification	Task	Reference location in <i>NAS Software Section</i>
1	NAS Blade system initial build	Performing a new installation	3.2 Prerequisites [NAS03-10] 3.3 New Installation (Setup Performed By the Manufacturer) [NAS03-80] 3.5 Operations on the SVP [NAS03-100]
		Performing on-site installation	3.2 Prerequisites [NAS03-10] 3.4 On-Site Installation (On-Site Settings) [NAS03-90] 3.5 Operations on the SVP [NAS03-100]
		Testing settings (new and on-site installation)	8. Setup Procedures When Implementing NAS Blade System for the First Time [NAS08-10]
2	Replacing hardware	- Replacing NAS Packages - Replacing PDEVs	4. NAS Hardware Replacement [NAS04-10]
3	Adding/removing hardware	- Adding/removing a RAID group - Adding/removing RAID cache memory - Adding/removing a NAS package - Increasing/decreasing LU capacity	6.2 Reconfiguring Hardware [NAS06-20]
4	Upgrading and downgrading software version (updated or patch version)	- Upgrading and downgrading the NAS OS version - Upgrading and downgrading the NAS/Management version - Upgrading and downgrading the optional program product version	5. NAS Software FC [NAS05-10]
5	Software reconfiguration	-	6.3 Reconfiguring Software [NAS06-210]

(Continues on the next page.)

(Continued from the previous page.)

#	Classification	Task	Reference location in NAS Software Section
6	Failure detection and countermeasure	Identifying failures	7.2 <i>Detecting and Identifying Failures</i> [NAS07-20]
		Troubleshooting hardware	7.3 <i>Lists of Failures</i> [NAS07-100] 7.4.1 <i>Hardware Troubleshooting</i> [NAS07-280]
		Troubleshooting software	7.3 <i>Lists of Failures</i> [NAS07-100] 7.4.2 <i>Software Troubleshooting</i> [NAS07-530]
		Obtaining error information	7.2.3 <i>Obtaining Detailed Information about a Failure</i> [NAS07-60] 9.1 <i>Appendix A Using the Command Line to Obtain Error Information</i> [NAS09-10] 9.2 <i>Appendix B List of Log and Core Files</i> [NAS09-220] 9.3 <i>Appendix C Initializing Dump LUs</i> [NAS09-250] 9.4 <i>Appendix D How to Obtain Error Information When the NAS OS Has Not Started</i> [NAS09-280]

The reference locations in other sections are as follows:

Table 1.1-2 Reference Locations in Other Sections

#	Task item	Section to be referenced
1	Performing the NAS initial build	<i>INSTALLATION</i> Section [INST01-10]
2	Replacing hardware	<i>REPLACE</i> Section [REP01-10]
3	Adding/removing hardware	<i>INSTALLATION</i> Section [INST01-10] <i>SVP</i> Section [SVP01-10]
4	Troubleshooting hardware	<i>TROUBLE SHOOTING</i> Section [TRBL01-10]
5	Troubleshooting software	

This *NAS Software Section* uses the following abbreviations to refer to software products and components.

Table 1.1-3 Abbreviations for Software Products and Components

#	Abbreviation	Description
1	NAS/Backup Restore	Hitachi Network Attached Storage/Backup Restore
2	NAS/Base - Data Control	Hitachi Network Attached Storage/ Base - Data Control
3	NAS/Base - File Sharing	Hitachi Network Attached Storage/ Base - File Sharing This is a Linux-based product.
4	NAS/Management	Hitachi Network Attached Storage/ Management A generic name referring to NAS/ Management, NAS/Backup Restore, and NAS/Anti Virus Agent.
5	NAS OS	A generic name referring to both NAS/Base - Data Control and NAS/Base - File Sharing.
6	NAS/Anti Virus Agent	Hitachi Network Attached Storage/Anti Virus Agent A generic name referring to NAS/Anti Virus Agent.
7	NAS/Sync Image	Hitachi Network Attached Storage/Sync Image A generic name referring to NAS/Sync Image.

1.2 Related Manuals

The related manuals are the user's guide for disk subsystems (Table 1.2-1) and the user's guide for NAS/Management software products (Table 1.2-2).

Table 1.2-1 User's guide for disk subsystems

#	Manual	Contents
1	<i>Remote Console – Storage Navigator User's Guide</i>	Describes Remote Console GUI operations in general, and how to install program products into a disk subsystem, etc.
2	<i>LUN Manager User's Guide</i>	Describes functionality and operations of LU creation and path/port settings, etc.
3	<i>FlashAccess User's Guide</i>	Describes functionality and operations of Partial Cache Residence and Dynamic Cache Residence, etc.
4	<i>LUN Expansion (LUSE)/Virtual LVI/LUN (VLL) User's Guide</i>	Describes functionality and operations of LUSE volumes.

Table 1.2-2 User's guide for the NAS/Management software products

#	Manual	Contents
1	<i>Hitachi Network Attached Storage /Management User's Guide</i>	Describes functionality and operations of NAS/Management.
2	<i>Hitachi Network Attached Storage /Backup Restore User's Guide</i>	Describes functionality and operations of NAS/Backup Restore (snapshot, backup).
3	<i>Hitachi Network Attached Storage /Sync Image User's Guide</i>	Describes functionality and operations of NAS/Sync Image (differential-data snapshot).

1.3 Overview of Each Chapter

The chapters in this *NAS Software Section* are as follows:

Chapter 1. *Overview*

This chapter gives an overview of each chapter in the *NAS Software Section*.

Chapter 2. *NAS Blade System Device Explanation*

Explains the NAS Blade system hardware configuration, software configuration, and operating environment. This chapter also explains and lists the major tasks for which the maintenance personnel and system administrators are responsible.

Chapter 3. *NAS Installation*

Explains the procedures for the NAS Blade system initial build from installing hardware to providing file services to end users.

Section 3.2 *Prerequisites* outlines how to create NAS system LUs and user LUs, and how to define paths.

Two tables list the steps in the installation procedures:

Table 3.3-1 Procedure for Installing NAS for the First Time (Setup Performed by the Manufacturer) and *Table 3.4-1 Procedure for NAS On-Site Installation*.

The shaded parts in the tables indicate the tasks for which maintenance personnel are responsible.

Section 3.5 *Content and Procedure of Each Task* describes the contents and procedure for each task listed in the tables mentioned above. The subsection gives only an outline of the tasks for which system administrators are responsible.

Chapter 4. *NAS Hardware Replacement*

Explains the procedure for replacing NAS Blade system hardware if a failure occurs or when preventive replacement is performed. This chapter also explains the procedure for upgrading the software.

Table 4.X-1 Types of Hardware Replacement Operations lists the contents of tasks and conditions for each part of replacement.

In subsection *4.x.x Flowcharts For Replacing Hardware*, the flowcharts illustrate the procedures for each part of the replacements listed in the table mentioned above. Each description of a procedure consists of the following:

- a figure giving an outline of the procedure,
- a table listing the steps in the procedure, and
- a detailed flowchart of the procedure.

The area of a detailed flowchart is divided into three columns:

- the left column shows the task of maintenance personnel,
- the mid-column shows the task of system administrators, and
- the right-column shows the status of the NAS Blade system.

The following shows a sample description of a procedure.

<Sample Description of a Procedure>

(2) Replacing the NAS Package (Preventive Replacement)

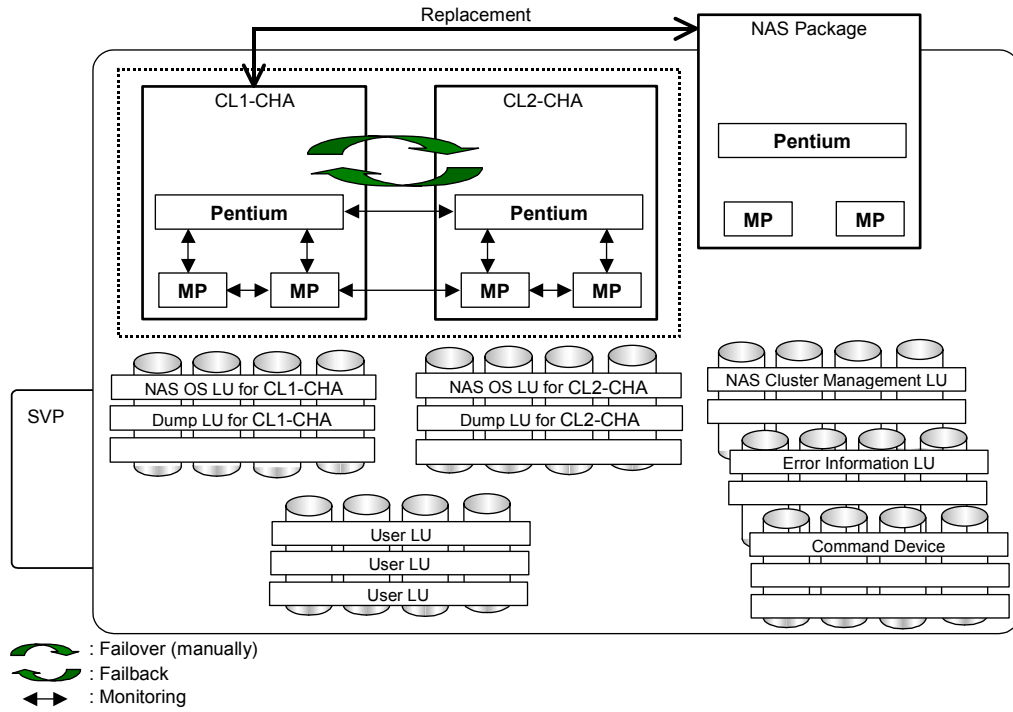

Step	Procedure	Notes
1	Check the operating status of the NAS Blade system.	
2	Perform the failover.	
3	Stop the NAS OS.	Stop the NAS OS while the target NAS Package is running.
4	Replace the NAS Package.	
5	Perform the failback.	

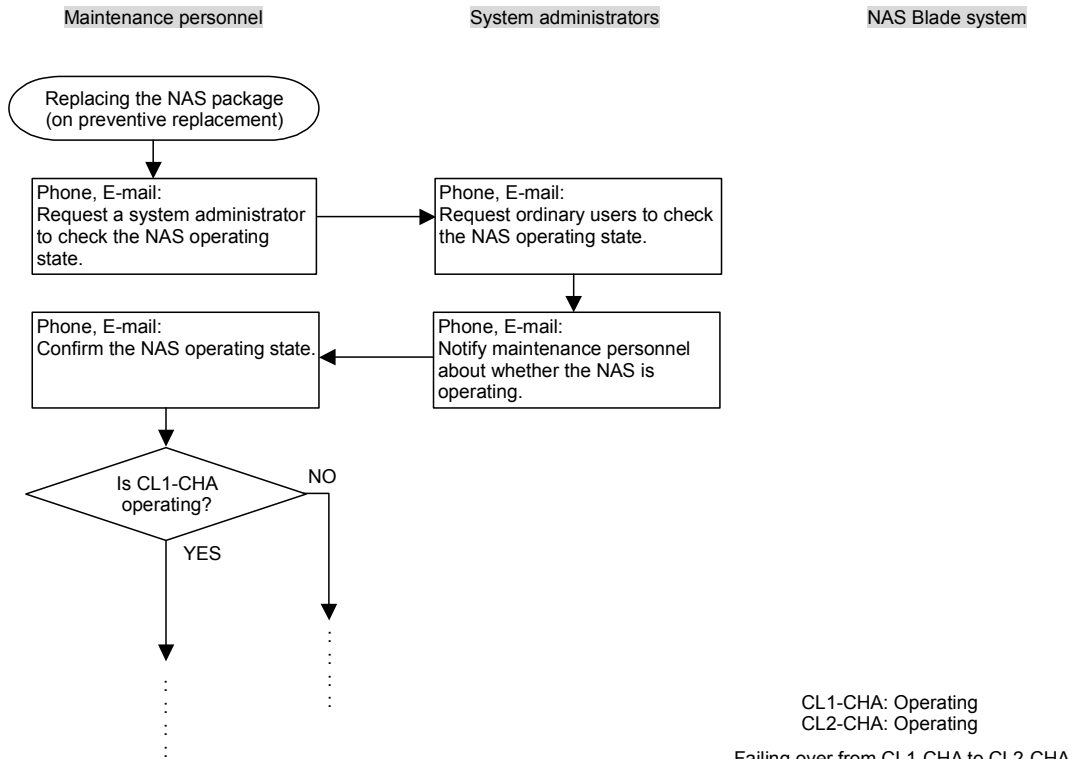

CL1-CHA: Operating
 CL2-CHA: Operating
 Failing over from CL1-CHA to CL2-CHA
 Failover notification
 - NAS/Management GUI
 (CL2-CHA notification)
 :
 :
 :

Examples of the NAS conditions shown in procedures is below:
 Operating: NAS services are provided to users.
 Running: NAS services are not provided to users although NAS OS has been started.
 Not running: NAS services are not provided to users and NAS OS has been stopped.

Chapter 5. *NAS Software FC*

Explains the procedure for upgrading the software on preventive replacement.

Table of Types of Software Upgrading Procedures lists the contents of tasks and conditions for each program.

In subsection *5.x.x Flowcharts for Software Upgrading*, the flowcharts illustrate the procedures for each program listed in *Table 5.X-1*. The format of the descriptions is the same as that for hardware replacement in *Chapter 4*.

Chapter 6. *NAS Configuration (Reconfiguration)*

Explains the procedures for reconfiguring a NAS Blade system, which may become necessary due to an increase in the volume of data or changes in the type of work.

Table 6.2-1 Types of Hardware Reconfiguration lists the contents of tasks and conditions for each part of reconfiguration.

In subsection *6.2.2 Flowcharts For Reconfiguring Hardware*, the flowcharts illustrate the procedures for each task listed in the table mentioned above. Each description of a procedure consists of the following:

- a figure giving an outline of the procedure,
- a table listing the steps in the procedure, and
- a detailed flowchart of the procedure.

The format of the descriptions is the same as that of the flowcharts describing replacement procedures in chapter four.

Table 6.3-1 Types of Software Reconfiguration lists the classifications of software reconfigurations according to software components and functionality.

Chapter 7. NAS Troubleshooting

Explains how to detect a failure, how to identify the type of failure, and how to troubleshoot.

Section 7.2 *Detecting and Identifying Failures* uses tables to list the types of errors that might occur and the error information that is reported by the system.

Subsection 7.2.1 *Detecting Failures* uses a table to list the NAS-specific error information from the various types of error information reported by SIM.

Subsection 7.2.3 *Detailed Information about a Failure* lists the error information (log, dump, trace) managed by maintenance personnel and outlines when and how to produce it.

Tables 7.3-1 *Hardware Failures* and 7.3-2 *Hardware Failure Classifications and Countermeasure Overview* list the types of hardware failures and give an overview of the corresponding countermeasures.

Tables 7.3-3 *Software Failures* and 7.4-4 *Software Failure Classifications and Countermeasure Overview* list the types of software failures and give an overview of the corresponding countermeasures.

In section 7.4 *Flowcharts For Troubleshooting*, the flowcharts illustrate the procedures for each task listed in the tables mentioned above. Each description of a procedure consists of the following:

- a figure giving an outline of the procedure,
- a table listing the steps in the procedure, and
- a detailed flowchart of the procedure.

The format of the descriptions is the same as that of the flowcharts describing replacement procedures in *Chapter 4*.

Chapter 8. *Setup Procedures When Implementing NAS Blade System for the First Time*

Explains how to set up the settings for both new and on-site installations.

Chapter 9. *Appendixes*

Appendix A. Using the Command Line to Obtain Error Information explains how to obtain a crash dump, hibernation dump, LM dump, and event trace.

Appendix B. List of Log and Core Files lists the operational information (log files) and the error information (core files) that are managed by system administrators.

Appendix C. Initializing Dump LUs explains how to initialize dump LUs.

Appendix D. How to Obtain Error Information When the NAS OS Has Not Started explains the procedure for obtaining the error information of the NAS Package where the NAS OS has not started from other NAS Package where the NAS OS has started.

Appendix E. NAS Dump (Attachment of USB Memory)

For more information on attachment of USB memory, see 3.5.14 *Downloading Dump Files* [[NAS03-1090](#)].

Appendix F. How to Configure SSH and Connect to a NAS Blade System explains how to set SSH configuration and connect E-NAS. Windows 2000 and Linux (Red Hat 7.2) are assumed as OSs to be connected.

2. NAS Blade System Device Explanation

2.1 Overview

This chapter describes the device configuration (including devices, programs, and limit values) for the NAS Blade system, and also describes the NAS Blade system operating environment.

2.2 NAS Blade System Hardware Configuration

Figure 2.2-1 shows the hardware configuration of the NAS Blade system.

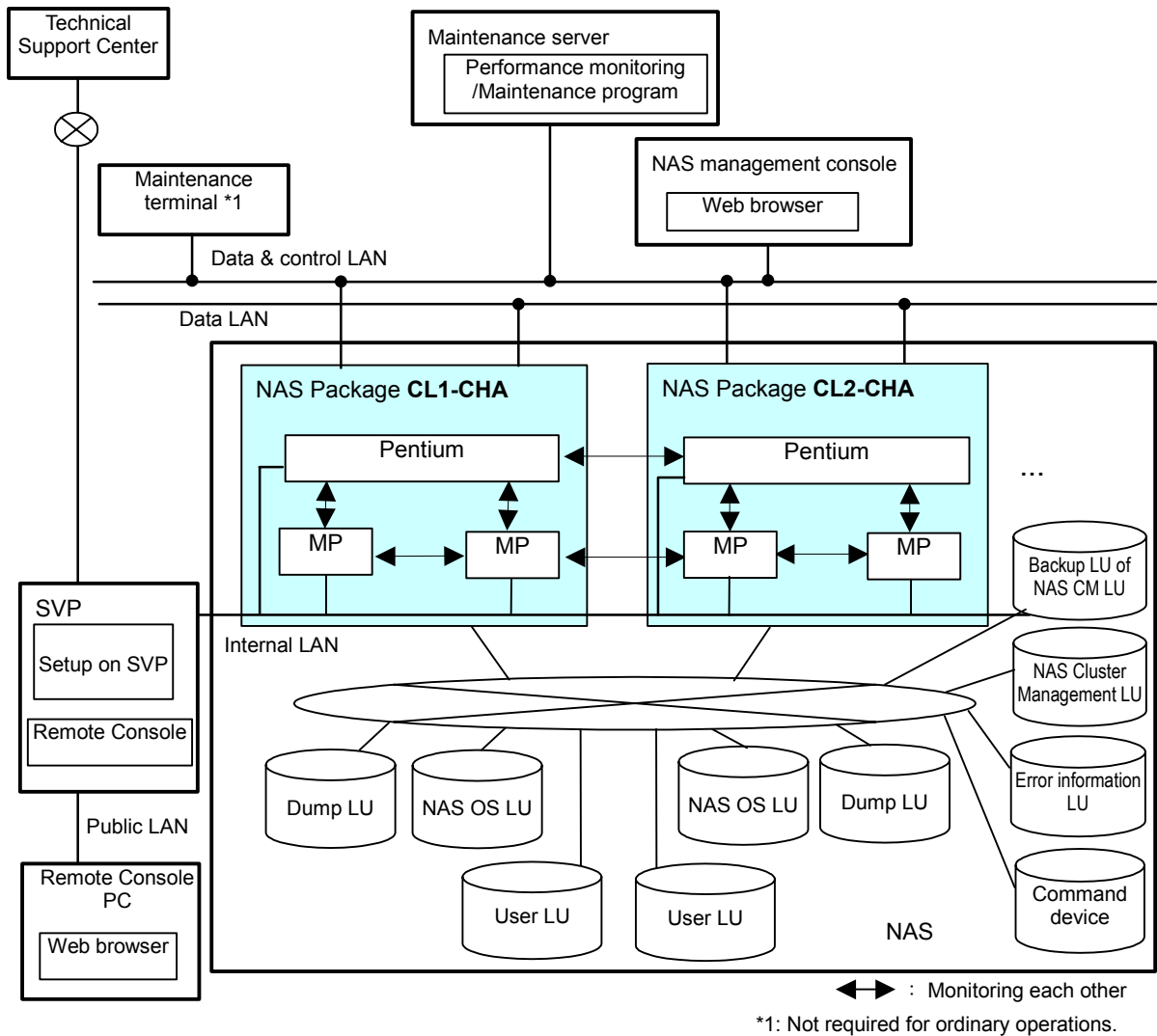

Figure 2.2-1 Hardware Configuration of the NAS Blade System

The Pentium processor and micro-processors (MPs) on a NAS Package are connected via the internal LAN to the SVP. The internal LAN should always be active. A NAS Package requires the following five NAS system LUs:

- NAS OS LU to store programs necessary for operation
- NAS cluster management LU (including a backup LU of NAS cluster management LU) to store programs necessary for operation
- Dump LU to store error information
- Error information LU to store the edited error information
- Command device to operate RAID programs such as ShadowImage

2.3 NAS Blade System Software Configuration and Operating Environment

Figure 2.3-1 shows the basic configuration of the NAS Blade system.

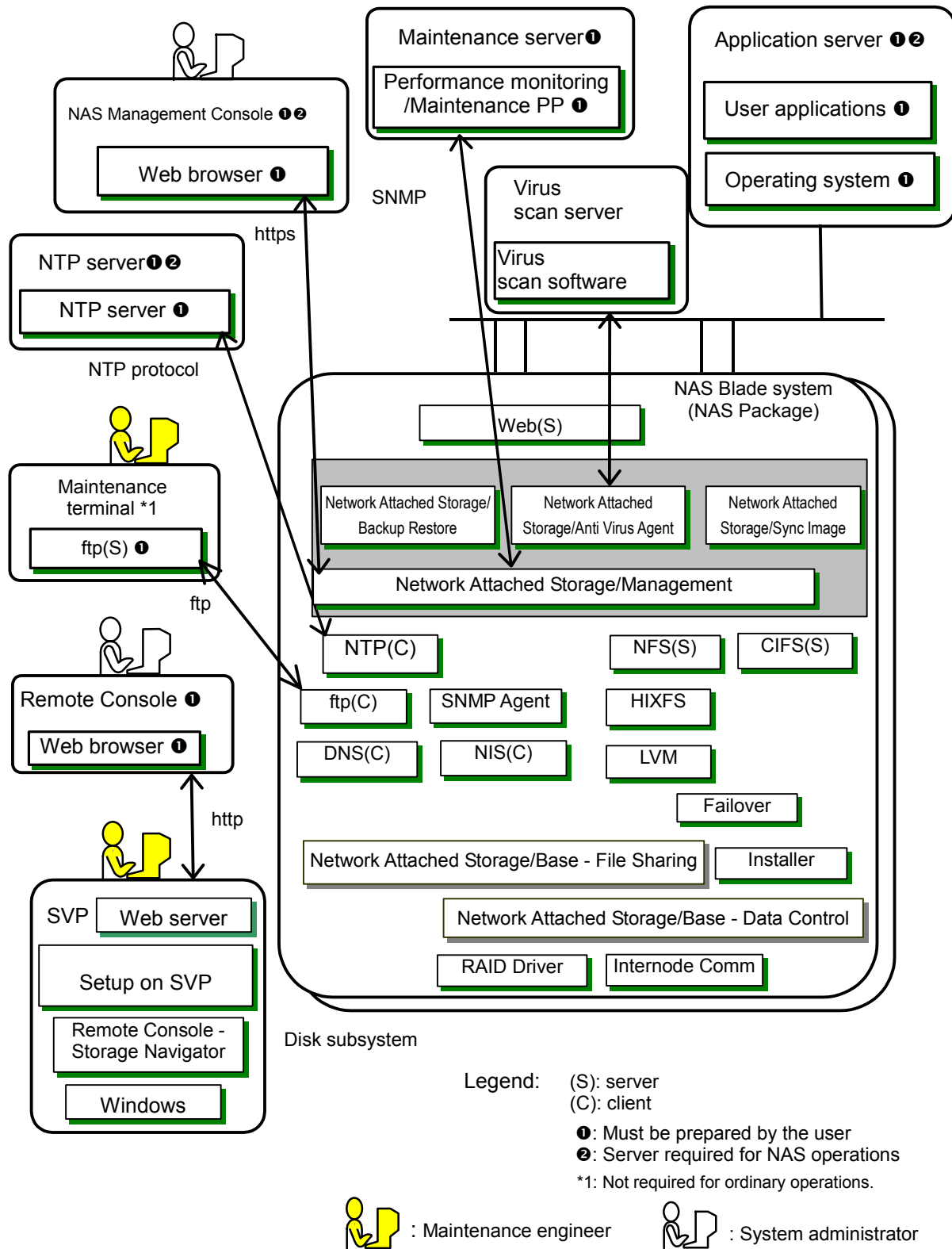

Figure 2.3-1 Basic Configuration of the NAS Blade System

The NAS Blade system operation/management software consists of:

- Software on the SVP

Software on the SVP includes *Setup on SVP* and *Remote Console - Storage Navigator*.

This software is basically used for operations and management (of the NAS OS and the disk subsystem) at or below the NAS OS level.

- NAS/Management

The software *NAS/Management* is basically used for operations and management (of file systems and failover functionality) above the NAS OS level.

Note that the NAS OS includes NAS/Base - File Sharing and NAS/Base - Data Control.

The system administrator (the customer's operations administrator) uses a Web browser from the NAS Management Console to give operating instructions to NAS/Management. NAS/Management receives the instructions, and executes them in accordance with the NAS OS and application programs in use.

Table 2.3-1 lists the servers and PCs used for the NAS Blade system.

Table 2.3-1 List of NAS Servers and PCs

#	Server/PC	Description	Installation by user	Mandatory
1	Application server	Machine that uses the disk subsystem as the file server	Yes	Yes
2	Maintenance server	Server that monitors error and performance information.	Yes	—
3	NTP server	Works with the NTP client of each NAS Package to synchronize the clock of each NAS Package.	Yes	Yes
4	Virus scan server	Server running a virus scan software. The file that a client accessed is transmitted, and the virus check and the extermination processing are performed as required.	Yes	—
5	SVP	Notebook computer used for maintenance. The SVP is incorporated into the disk subsystem and is operated by the maintenance personnel.	—	Yes
6	NAS Management Console	PC used by the system administrator to operate NAS/Management. A Web browser runs on this PC.	Yes	Yes
7	Remote Console PC	PC used by the system administrator to operate Remote Console - Storage Navigator. A Web browser runs on this PC.	Yes	—
8	Maintenance terminal *1	When error information cannot be obtained, or failure recovery is unsuccessful by regular procedures, use the command line to obtain error information, or to recover from the error.	Yes	—

*1: Required when error information cannot be obtained, or regular failure recovery operations have failed and when requested to use by the developer. Not required for ordinary operations.

Table 2.3-2 lists the programs that make up the NAS.

Table 2.3-2 List of Programs that Make Up the NAS Blade System

#	Program	Description	Shipped with NAS	Mandatory *1
1	Web server	Provides browsing functionality via Web browsers that are compatible with NAS/Management.	Yes	Yes
2	NAS/Management	Provides basic functionality in the NAS environment.	Yes	Yes
3	NAS/Backup Restore	Provides snapshot and backup/restore functionality in the NAS environment.	Yes (key management)	—
4	NAS/Anti Virus Agent	Provides the functionality for protecting data in the disk subsystem from viruses, linking with the virus scan server.	Yes (key management)	—
5	NAS/Sync Image	Provides the differential-data snapshot functionality in the NAS environment.	Yes (key management)	—
6	Setup on SVP	Provides NAS OS installation and other setup functionality when a NAS Package is installed.	Yes	Yes
7	SNMP agent	Sends error and performance information to the maintenance server by using SNMP.	Yes	—
8	NTP client	Works with the NTP server to synchronize the clock of each NAS Package.	Yes	Yes
9	FTP server	Provides an FTP service to maintenance personnel and system administrators.	Yes	Yes
10	FTP client	Provides an FTP service to maintenance personnel and system administrators.	Yes	Yes
11	NIS client	Works with an NIS server to enable management of NFS users, based on the NIS server	Yes	—
12	DNS client	Works with a DNS server to provide DNS functionality.	Yes	—
13	Failover	Implements failover functionality between NAS Packages.	Yes	Yes
14	Installer	Performs the initial installation of the NAS OS in conjunction with the BIOS. Also, performs installation of various service programs, and provides license key management.	Yes	Yes
15	NFS server	Provides file sharing functionality for UNIX clients.	Yes	Yes*2
16	CIFS server	Provides file sharing functionality for Windows clients.	Yes	Yes*2
17	HIXFS	Provides an XFS file system: an enhanced XFS optimized for NAS. HIXFS has journaling functionality.	Yes	Yes
18	LVM	Provides functionality to manage volumes flexibly by hiding the physical volume configuration.	Yes	—
19	NAS/Base- Data Control	NAS Blade system basic functionality	Yes	Yes

(Continues on the next page.)

(Continued from the previous page.)

#	Program	Description	Shipped with NAS	Mandatory *1
20	NAS/Base- File Sharing	NAS operating system (NAS OS kernel)	Yes	Yes
21	RAID Driver	Driver suitable for RAID functionality.	Yes	Yes
22	Internode Comm	Provides inter-NAS Package communication functionality, such as StarNet IP.	Yes	Yes

*1: Yes : Program required for NAS Blade system operation

— : Program that might not be used depending on the system.

*2: Either an NFS server or a CIFS server is required.

2.4 Minimum and Maximum Configurations

Table 2.4-1 lists the devices and components managed by NAS/Management and the specific quantities for the minimum and maximum configuration requirements.

Table 2.4-1 Minimum and Maximum Configurations

#	Device/component	Minimum configuration	Maximum configuration	Remarks
1	Disk array device	1	1	—
2	NAS boards (NAS Packages)	2	8 (Multi-cabinet model)	One cluster consists of two NAS boards. Cluster configuration: A minimum of 1 to a maximum of 4
			4 (Single cabinet model)	One cluster consists of two NAS boards. Cluster configuration: A minimum of 1 to a maximum of 2
3	Cluster configuration	2	2	Number of boards (NAS Packages) per cluster
4	Device files	1	256	Limit set to NAS/Management according to the RAID function specifications. (Number of device files per cluster)
5	Logical volumes	1	256	Limit set by NAS/Management according to the RAID function specifications. (Number of logical volumes per cluster)
6	XFS file systems	1	256	Limit set by the failover functionality. (Number of XFS file systems per cluster)
7	NFS shares	0	256	Limit set by the failover functionality. (Number of NFS shares per cluster.)
8	CIFS shares	0	256	— (Number of CIFS shares per cluster)

2.5 Maintenance Personnel

2.5.1 Roles of the Maintenance Personnel and System Administrators

Basically, the maintenance personnel use the SVP(Setup on SVP) and the maintenance terminal to operate and service the hardware (disk subsystem functionality) and the NAS OS in a NAS Package.

System administrators (NAS Blade system managers) use the NAS Management Console (NAS/Management) and the Remote Console PC to operate and service the functionality above the NAS OS of the NAS Package. However, system administrators who have already purchased certain functionality of Remote Console - Storage Navigator can operate and service most of the disk subsystem functionality. For convenience, system administrators are also capable of operating some of the NAS OS functionality (for example, specifying network settings or using syslog).

Table 2.5-1 lists key operations performed by the maintenance personnel and system administrators.

Table 2.5-1 Key Operations by Maintenance Personnel and System Administrators

#	Key operation	Maintenance personnel		System administrator	
		SVP	Maintenance terminal *3	NAS Management Console	Remote Console PC
1	Implementing NAS system LUs	Available			
2	Configuring NAS user LUs	Available			
3	Installing <i>Setup on SVP</i>	Available			
4	Installing the NAS OS	Available			
5	Installing patch versions of the NAS OS	Available		Available	
6	Starting/ending the NAS OS	Available		Available	
7	Installing NAS/Management	Available		Available	
8	Installing/uninstalling optional program products of NAS/Management	Available		Available	
9	Setting up the license	Available		Available	
10	Setting up the network (fixed IP address or NTP)	Available		Available	
11	Setting up Partial Cache Residence functionality				Available
12	Setting up the NAS Package cluster configuration			Available	
13	Defining configuration of services			Available	
14	Setting up the network (routing)			Available	
15	Setting up the network (DNS and NIS)			Available	
16	Creating file systems			Available	
17	Setting up file shares			Available	
18	Managing users and groups			Available	
19	Setting up error monitoring			Available	
20	Setting up system administrators			Available	
21	Backing up and recovering system information	Available*1		Available*2	
22	Performing manual failover or failback			Available	
23	Obtaining log files	Available*4	Available	Available	
24	Obtaining core dump files			Available	
25	Obtaining event traces	Available*4	Available		
26	Obtaining crash dumps	Available*5	Available		
27	Obtaining hibernation dumps	Available*5	Available		
28	Obtaining LM dumps		Available		

*1: The recovery processing only can be executed.

*2: The save processing only can be executed.

*3: Required when ordinary failure recovery operations have failed and when requested to use by the developer. Not required for ordinary operations.

*4: Obtained by auto dump [NAS07-60].

*5: Obtained by NAS dump [NAS07-60].

2.5.2 Maintenance Terminal (Not Required for Ordinary Operations)

The maintenance terminal is used to operate the dumps and logs it receives when an error occurs in the NAS OS. The maintenance personnel use ssh to log in to the NAS Package [NAS09-400], and enter commands on the command line to perform operations in Table 2.5-1 on the dumps and logs.

The FTP protocol is used to send dumps and logs to the maintenance terminal. Thus, an FTP server should be active at this terminal. If an error occurs, a vast amount of information is stored on the storage medium. This requires the maintenance terminal to have a storage device with enough space to accommodate all the information. Table 2.5-2 shows the operating environment recommended for the maintenance terminal.

Table 2.5-2 Operating Environment Recommended for the Maintenance Terminal

#	Item	Specifications
1	CPU	Environment for operating the FTP server and CUI interface console
2	Memory	Same as above
3	Available hard disk space	40 GB or more
4	Resolution and maximum color count	Environment for operating the FTP server and CUI interface console
5	Keyboard and mouse	Need not satisfy any particular conditions.
6	LAN card for TCP/IP networks	10 Base-T or better
7	Operating system	Environment for operating the FTP server and CUI interface console
8	Storage device	DAT, DVD-RW, CD-RW, or any other storage device that can store 4.0 GB or more data.
9	Others	Requires that an FTP server be operating.

2.5.3 SSH Account for Maintenance Personnel and System Administrators (Not Required for Ordinary Operations)

The maintenance personnel and system administrators are provided with one fixed account to log in to the NAS Package via ssh and execute the commands provided by NAS functionality. This account is shared in common among the maintenance personnel and system administrators. Without this account, they cannot perform operations using ssh. Table 2.5-3 shows details of the ssh account.

Table 2.5-3 SSH Account

#	Item	Value	Remarks
1	User name	nasroot	Unchangeable
2	User ID	99	Unchangeable
3	Group ID	99	Unchangeable
4	Password	-	No initial password
5	Comment	nasroot	
6	Home directory	/home/nasroot	
7	Shell	/bin/bash	

3. NAS Installation

3.1 Overview

This chapter describes the initial implementation steps from setting up the NAS Blade system hardware to providing file services to customers. This chapter describes, in detail, the operations required at or above the level for installing the NAS OS into the NAS Packages (that is, the operations for software-related functionality), and the functions used by maintenance personnel. This chapter also gives an overview of the operations required at or below the level for creating LUs for the disk subsystem (that is, the operations for hardware-related functionality) and the functionality used by system administrators. For details, see the *INSTALLATION Section* [INST01-10].

Table 3.1-1 lists the initial implementation patterns for NAS Blade system. The sections below describe the operations for each pattern.

Table 3.1-1 Initial Implementation Patterns for NAS Blade system

#	Pattern	Content
1	New installation	The manufacturer (or the supplier in charge of shipment) will be responsible for setting up the NAS Blade system, up to and including the installation of the program products (these are operations required for performing a new installation).
2	On-site installation	The manufacturer (or the supplier in charge of shipment) will be responsible for setting up the hardware only (these are operations required for installing additional NAS Packages).

3.2 Prerequisites

The following settings are specific to NAS functionality, and must be completed by the time the setup work required up to the level of creating LUs for the disk subsystem (or, the setup of hardware-related functionality) is through. Table 3.2-1 lists the items to be set. For details, see the *INSTALLATION Section* [INST05-950].

Table 3.2-1 Hardware-Related Functionality

#	Pattern	Operated with	Operated by	Content
1	Creating NAS system LUs	SVP	Vendor, maintenance personnel	Creating the LUs for NAS management.
2	Defining the paths to the NAS system LUs	SVP	Vendor, maintenance personnel	Setting up the paths to the LUs for NAS management in order to make the NAS Packages recognize the NAS system LUs.
3	Defining the paths to the user LUs	SVP, Remote Console	Vendor, maintenance personnel	Setting up the paths to the user LUs. Defining paths that take into account the cluster configuration.

3.2.1 Creating NAS System LUs

Unlike other CHAs, a NAS Package requires the following six NAS system LUs:

- NAS OS LU to store programs necessary for operation,
- NAS Cluster Management LU to store programs necessary for operation,
- LU to store a backup of NAS Cluster Management LU,
- Dump LU to store error information,
- Error information LU to store the edited error information, and the
- Command device to operate RAID programs such as ShadowImage.

For information on (the minimum values of) NAS system LU capacities, see the *INSTALLATION Section* [INST05-961].

To prepare NAS system LUs, you must first generate LDEVs by emulating volumes of emulation types (such as OPEN-8, OPEN-9, OPEN-E, or OPEN-L) on one or more RAID groups, and let the NAS Blade system use those LDEVs as NAS system LUs.

Table 3.2-2 and Table 3.2-3 show the relationship between the number of clusters and the number of NAS system LUs for a multi-cabinet model and a single cabinet model.

Table 3.2-2 Relationship between the number of clusters and the number of NAS system LUs (For a multi-cabinet model)

#	Cluster (number of NAS Packages)	NAS OS LU	Dump LU	Error information LU	NAS Cluster Management LU	Backup LU of NAS Cluster Management LU	Command device	NAS system LU
1	1 (2)	2	2	1	1	2	1	9
2	2 (4)	4	4	1	1	2	1	13
3	3 (6)	6	6	1	1	2	1	17
4	4 (8)	8	8	1	1	2	1	21

Table 3.2-3 Relationship between the number of clusters and the number of NAS system LUs (For a single cabinet model)

#	Cluster (number of NAS Packages)	NAS OS LU	Dump LU	Error information LU	NAS Cluster Management LU	Backup LU of NAS Cluster Management LU	Command device	NAS system LU
1	1 (2)	2	2	1	1	2	1	9
2	2 (4)	4	4	1	1	2	1	13

Either of the following two configurations is applied according to the customer's request: a configuration in which NAS system LUs are dispersed among multiple RAID groups, or the configuration in which the NAS system LUs are put together in one RAID group. Figure 3.2-1 shows an example of how NAS system LUs are configured (the former case showing NAS system LUs dispersed among multiple RAID groups).

In the case of a multi-cabinet model:

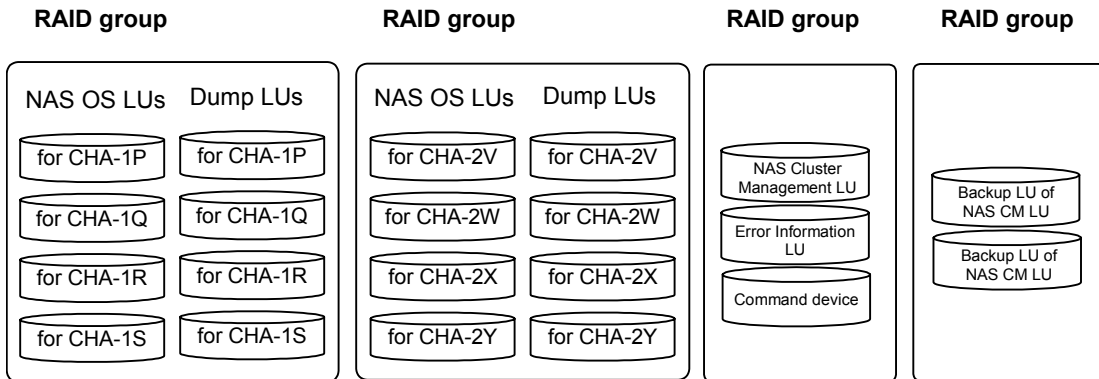

In the case of a single-cabinet model:

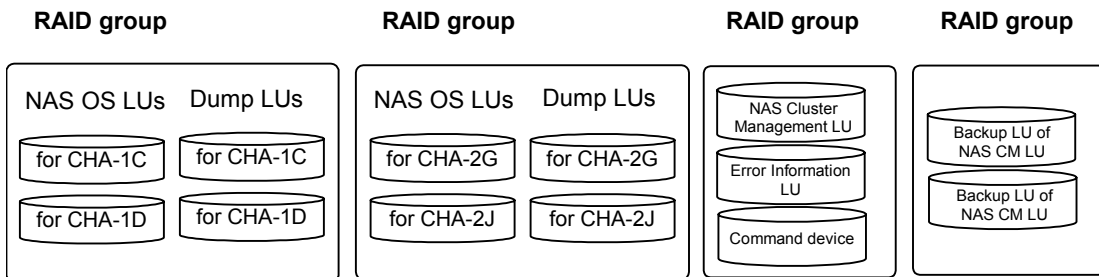

Figure 3.2-1 Examples of NAS System LU Configurations

3.2.2 Defining the Paths to NAS System LUs

The path to a NAS system LU is defined by setting the IID and LUN respectively with the values shown in the tables below.

An IID (initiator ID) is an ID that indicates that the LU indicated by the *LU-number* is either a NAS system LU or a user LU. One of the following numbers appears:

- 0: Displays when the target LU is an NAS system LU.
- 1: Displays when the target LU is a user LU.

[1] Defining paths to the NAS OS LU and the dump LU

The following paths to a NAS OS LU and a dump LU need to be defined separately:

- from a local NAS Package
- from other NAS Packages

Such paths from other NAS Packages are defined so that various types of information (such as error information and definitions) can be collected from the other NAS Package in the same cluster when one NAS Package goes down.

Table 3.2-4 and Table 3.2-5 show definitions of paths from its own NAS Package to the NAS system LU, and from other NAS Packages to the NAS system LU.

Table 3.2-4 shows that a path from a local NAS Package to its own NAS OS LU or own dump LU is always defined by the IID and LUN.

Table 3.2-4 Definitions of Paths from a NAS Package to NAS System LUs (When the NAS System LUs Are The NAS Package's Own NAS System LUs)

#	NAS System LU	IID	LUN
1	NAS OS LU	0	00
2	Dump LU	0	01

Table 3.2-5 shows that paths from a NAS Package to other NAS OS LUs or other dump LUs (that is, these NAS system LUs are not the NAS Package's own system LUs) are defined by the NAS Package-specific IID and LUN.

You need not manually define paths from a NAS Package to other NAS OS LUs or other dump LUs, because the paths shown in Table 3.2-5 are defined automatically after you have defined the paths from a NAS Package to its own NAS OS LU or dump LU.

Table 3.2-5 Definitions of Paths from a NAS Package to NAS System LUs (When the NAS System LUs Are Not the NAS Package's Own NAS System LUs)

- In the case of a multi-cabinet model:

#	NAS system LU	IID	LUN
1	NAS OS LU for CHA-1P	0	0B
2	NAS OS LU for CHA-1Q	0	0C
3	NAS OS LU for CHA-1R	0	0D
4	NAS OS LU for CHA-1S	0	0E
5	NAS OS LU for CHA-2V	0	0F
6	NAS OS LU for CHA-2W	0	10
7	NAS OS LU for CHA-2X	0	11
8	NAS OS LU for CHA-2Y	0	12
9	Dump LU for CHA-1P	0	1B
10	Dump LU for CHA-1Q	0	1C
11	Dump LU for CHA-1R	0	1D
12	Dump LU for CHA-1S	0	1E
13	Dump LU for CHA-2V	0	1F
14	Dump LU for CHA-2W	0	20
15	Dump LU for CHA-2X	0	21
16	Dump LU for CHA-2Y	0	22

- In the case of a single cabinet model:

#	NAS system LU	IID	LUN
1	NAS OS LU for CHA-1C	0	0B
2	NAS OS LU for CHA-1D	0	0C
3	NAS OS LU for CHA-1F	0	0D
4	NAS OS LU for CHA-2G	0	0F
5	NAS OS LU for CHA-2J	0	10
6	NAS OS LU for CHA-2K	0	11
7	Dump LU for CHA-1C	0	1B
8	Dump LU for CHA-1D	0	1C
9	Dump LU for CHA-1F	0	1D
10	Dump LU for CHA-2G	0	1F
11	Dump LU for CHA-2J	0	20
12	Dump LU for CHA-2K	0	21

- [2] Defining paths to a command device, error information LU, NAS Cluster Management LU, and backup LU of NAS Cluster Management LU

The paths to a command device, error information LU, and NAS Cluster Management LU are respectively defined by the IID and LUN as shown in Table 3.2-6.

Table 3.2-6 Definitions of Paths to a Command Device, Error Information LU, and NAS Cluster Management LU

#	NAS System LU	IID	LUN
1	Command device	0	05
2	Error information LU	0	06
3	NAS Cluster Management LU	0	08
4	Backup LU of NAS Cluster Management LU	0	09
5	Backup LU of NAS Cluster Management LU	0	0A

 **CAUTION**

To delete a path to a NAS system LU, you must first stop the NAS OS on the NAS Package that has the NAS system LU. Use Setup on SVP to stop the NAS OS, and then delete the path.

3.2.3 Defining Paths to User LUs

The value 1 is used for the IID to define a path to a user LU.

Each user LU must be shared by the two NAS Packages in the cluster, and its path from any NAS Package must be defined using the same LUN.

Note: To define the paths to user LUs, you must specify the LUNs by using odd numbers and even numbers evenly. This definition is required to obtain adequate I/O processing performance of an NAS Package. If you specify the LUNs by using either odd numbers only or even numbers only, I/O processing performance might be inadequate because one of the MPs in the NAS Package processes even-numbered LUNs, and the other MP processes odd-numbered LUNs. (If an error occurs, the MPs might process LUNs differently.)

Figure 3.2-2 shows an example of defined paths to user LUs.

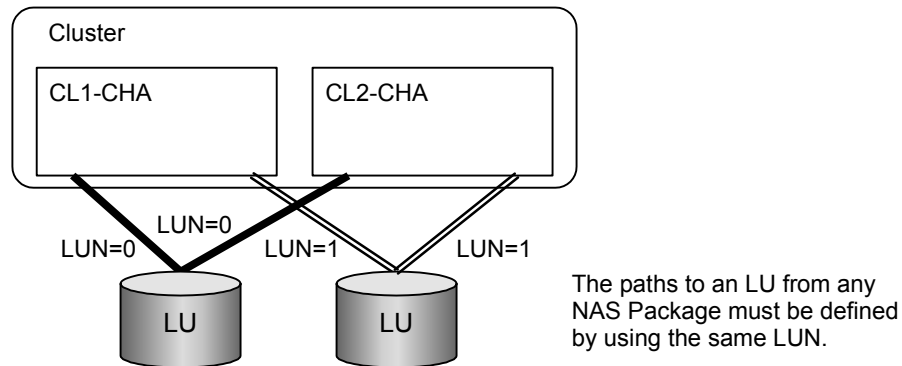

Figure 3.2-2 Example of How Paths to User LUs are Defined

CAUTION

To delete a path to a user LU being used (that is, to delete a LUN assigned to a user LU being used), the following operations must be performed on the user LU:

- Delete file shares.
- Unmount the file system.
- Delete the file system.

Ask a system administrator to perform the above operations. Make sure that the operations have finished, and then delete the path.

3.3 New Installation (Setup Performed By the Manufacturer)

Table 3.3-1 lists the procedure for installing a NAS Blade system for the first time. The shaded parts in the table indicate tasks for which the maintenance personnel are responsible.

Table 3.3-1 Procedure for Installing NAS Blade system for the First Time
(Setup Performed by the Manufacturer)

Step	Process	Location	Operated with	Operated by	Task Description	Reference
1	CTO	(RSD)	SVP	Vendor	Create NAS system LUs	*1
2					Install Setup on SVP	3.5.2 [1] [NAS03-110]
3			Setup on SVP	Vendor	Install the NAS OS and related program products	3.5.4 [NAS03-290]
4	NAS setup		Setup on SVP	Vendor	Set up the network (fixed IP address, NTP) provisionally	8.1[1] [NAS08-20]
5					Set up the license provisionally	8.1[2] [NAS08-50]
6					SVP (NAS/Management)	Set up the cluster configuration provisionally
7			On-site	Maintenance personnel	Confirm the provisional settings	8.3 [NAS08-290]
8			Web Console	System administrator	Set up the Partial Cache Residence functionality	---
9			NAS/Management	Account administrator	Set up system administrator(s)	3.6.1 [NAS03-1300]
10			System administrator	Define the configuration for the services (e.g., NFS, CIFS, HIXFS) [Service management]	3.6.3 [NAS03-1300]	
11				Set up the network (Routing)	3.6.4 [NAS03-1310]	
12				Set up the network (DNS, NIS)	3.6.5 [NAS03-1310]	
13				Manage users and groups [User management]	3.6.6 [NAS03-1310]	
14				Create the file systems [File sharing management]	3.6.7 [NAS03-1310]	
15				Set up file shares (NFS/CIFS) [File sharing management]	3.6.8 [NAS03-1320]	
16				Specify settings related to error-monitoring functionality [Error information (RAS) management]	3.6.9 [NAS03-1320]	

*1: (1) See [INST05-440] in the *INSTALLATION Section* to select LUN Management.

(2) See [INST05-950] in the *INSTALLATION Section* to create a NAS system LU.

For more information on the content and procedures of each task, see 3.5 *Operations on the SVP* [NAS03-100], 8. *Setup Procedures When Implementing NAS Blade System for the First Time* [NAS08-10] and 3.6 *Operations Using the NAS/Management GUI* [NAS03-1300].

3.4 On-Site Installation (On-Site Setup)

Table 3.4-1 lists the procedure for the NAS Blade system on-site installation (on-site setup). On-site installation applies when additional NAS Packages need to be installed. On-site installation differs from a new installation in the settings (from “Create NAS system LUs” to “Set up the network (Fixed IP address, NTP) provisionally”) that are performed on site by the maintenance personnel. The shaded parts in the table indicate the tasks for which maintenance personnel are responsible.

Table 3.4-1 Procedure for NAS Blade System On-Site Installation (On-Site Setup)

Step	Process	Location	Operated with	Operated by	Task Description	Reference	
1	NAS Setup	On-site	SVP	Maintenance personnel	Create NAS system LUs	*1	
2					Install Setup on SVP	3.5.2 [1] [NAS03-110]	
3			Setup on SVP	Maintenance personnel	Install the NAS OS and related program products	3.5.4 [NAS03-290]	
4					Set up the network (Fixed IP address, NTP) provisionally	8.1[1] [NAS08-20]	
5					Set up the license provisionally	8.1[2] [NAS08-50]	
6			SVP (NAS/Management)		Setup the cluster configuration provisionally	8.2[1] [NAS08-100]	
7					Confirm the provisional settings	8.3 [NAS08-290]	
8			Web Console	System administrator	Set up the Partial Cache Residence functionality	---	
9			NAS/Management		Account administrator	Set up the system administrator(s)	3.6.1 [NAS03-1300]
10					System administrator	Define the configuration for services (e.g., NFS, CIFS, HIXFS) [Service management]	3.6.3 [NAS03-1300]
11						Set up the network (Routing)	3.6.4 [NAS03-1310]
12						Set up the network (DNS, NIS)	3.6.5 [NAS03-1310]
13						Manage users/groups [User management]	3.6.6 [NAS03-1310]
14						Create the file systems [File sharing management]	3.6.7 [NAS03-1310]
15						Set up file shares (NFS/CIFS) [File sharing management]	3.6.8 [NAS03-1320]
16						Specify settings related to error-monitoring functionality [Error information (RAS) management]	3.6.9 [NAS03-1320]
17						Specify settings related to the save function for NAS system LUs	3.6.10 [NAS03-1330]

*1: (1) See [INST05-440] in the *INSTALLATION Section* to select LUN Management.

(2) See [INST05-950] in the *INSTALLATION Section* to create a NAS system LU.

For more information on the content and procedures of each task, see 3.5 *Operations on SVP* [NAS03-100], 8. *Setup Procedures When Implementing NAS Blade System for the First Time* [NAS08-10] and 3.6 *Operations Using the NAS/Management GUI* [NAS03-1300].

3.5 Operations on the SVP

This section describes maintenance personnel operations on the SVP.

3.5.1 Overview of Setup on SVP

Setup on SVP is used to install programs (such as the NAS OS and related program products) to the NAS Packages and to set up a basic network for accessing the NAS Packages from a public LAN.

The following figure shows the entire configuration of Setup on SVP.

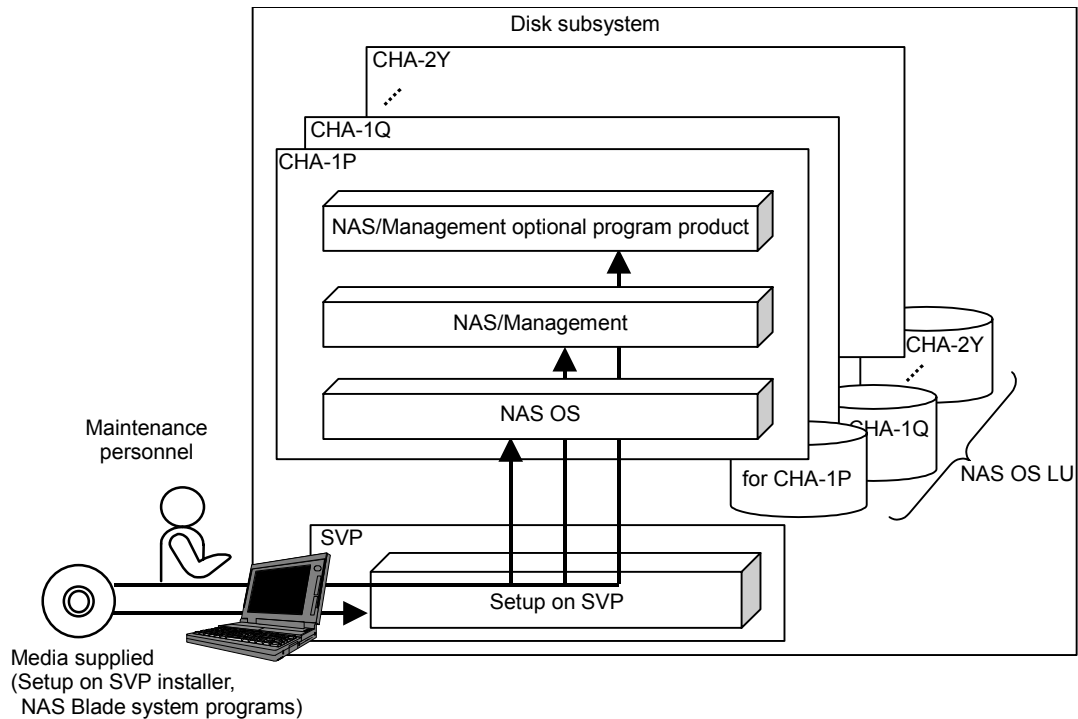

Figure 3.5-1 Entire Configuration of Setup on SVP (for a Multi-Cabinet Model)

3.5.2 Implementing Setup on SVP

- [1] Installing Setup on SVP ----- [NAS03-110](#)
 [2] Starting and stopping Setup on SVP ----- [NAS03-180](#)
 [3] Uninstalling Setup on SVP ----- [NAS03-200](#)

[1] Installing Setup on SVP

When you install *Setup on SVP*, the following two programs are installed:

- PXE Server Suite
- Setup on SVP

Note: Installing Setup on SVP:

If you use the *SVP high availability kit*, keep the following points in mind when installing Setup on SVP:

- Make sure that you install Setup on SVP on both SVPs.
- When you upgrade Setup on SVP, make sure that you upgrade Setup on SVP on both SVPs.
- If you replace one of the SVPs due to some failure, make sure that you install Setup on SVP on the new SVP.
- When the Web Console is being used, it must be stopped in advance because SVP is rebooted.

To install Setup on SVP:

- (1) Make sure that the **NAS Setup** button is *not* displayed in the ‘SVP’ window.
 If the **NAS Setup** button is displayed, see 3.5.2 [3] *Uninstalling Setup on SVP* and uninstall Setup on SVP [[NAS03-200](#)].

(2) Insert the Setup on SVP installer (CD-ROM) into the CD drive of the SVP.

(3) Close all windows except for the ‘SVP’ window.

(4) Click the **Start** button to display the **Start** menu, and then choose **Run**.

- (5) Type `e:\setup.bat` in **Open:**, and then click the **OK** button.
- (6) The following window appears.
Press any key to continue.

```

C:\WINNT\System32\cmd.exe
=====
This will Install [PXE Server Suite] and [Setup on SUP].
=====
Starting Installation of [PXE Server Suite].
Please do NOT reboot SUP during the installation
even if a dialog box indicates you to do so.
=====
Press any key to continue . . . _

```

- (7) The following window appears temporarily.
PXE Server Suite Installer will execute automatically.
Do not perform any operation on this window, and go to step (8).

Note: Do not use the mouse or keyboard during this step.

```

C:\WINNT\System32\cmd.exe
=====
This will Install [PXE Server Suite] and [Setup on SUP].
=====
Starting installation of [PXE Server Suite].
Please do NOT reboot SUP during the installation
even if a dialog box indicates you to do so.
=====
Press any key to continue . . .
Now installing [PXE Server Suite].
=====
... Please wait around 10 sec. after finishing the installation ...

```

- (8) The following window appears temporarily before PXE Server Suite Installer starts. Do not perform any operation on this window, and go to step (9).

Note: Do not use the mouse or keyboard during this step.

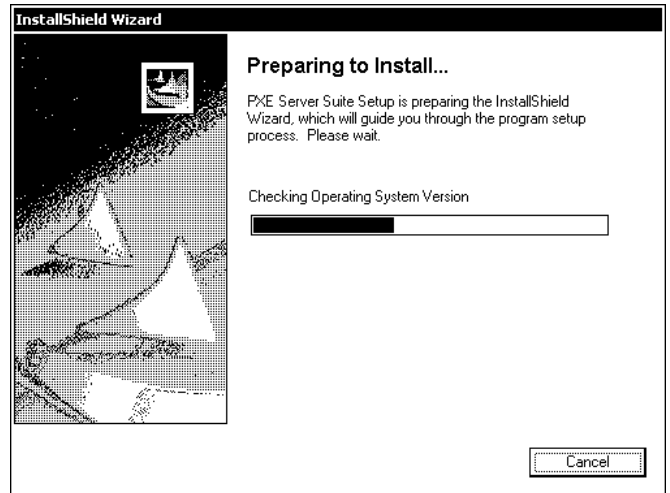

- (9) When PXE Server Suite Installer is ready to start, the following window appears. Click the **Next** button.

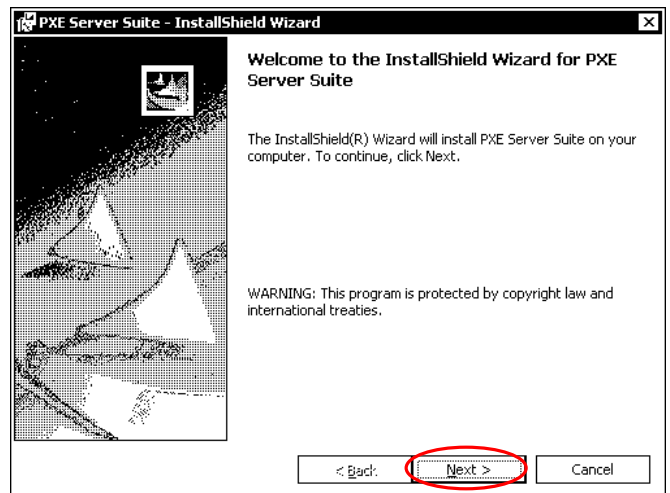

- (10) Installation of PXE Server Suite starts, and the progress of installation is displayed.
Do not perform any operation on this window, and go to step (11).

Note: Do not use the mouse or keyboard during this step.

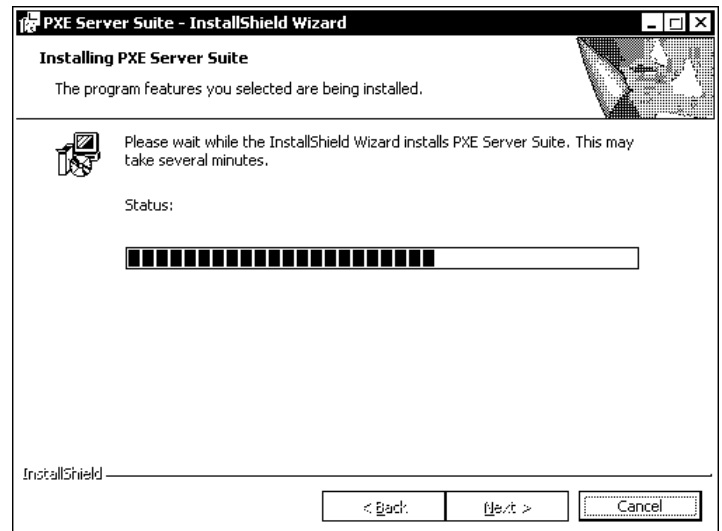

- (11) When the installation of PXE Server Suite finishes, the following window appears.
Click the **Finish** button.

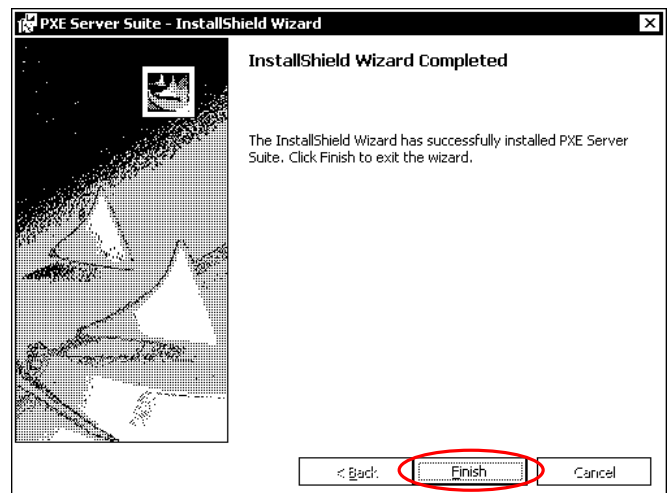

Note: When the message "You must restart your system for the configuration changes made to PXE Server Suite to take effect." appears, Click the **No** button.

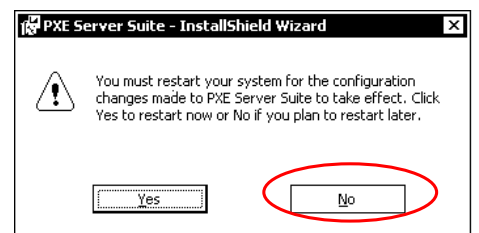

(12) The following window appears.

Follow the message displayed in the window, and wait for about 10 seconds.

Do not perform any operation on this window, and go to step (13).

Note: Do not use the mouse or keyboard during this step.

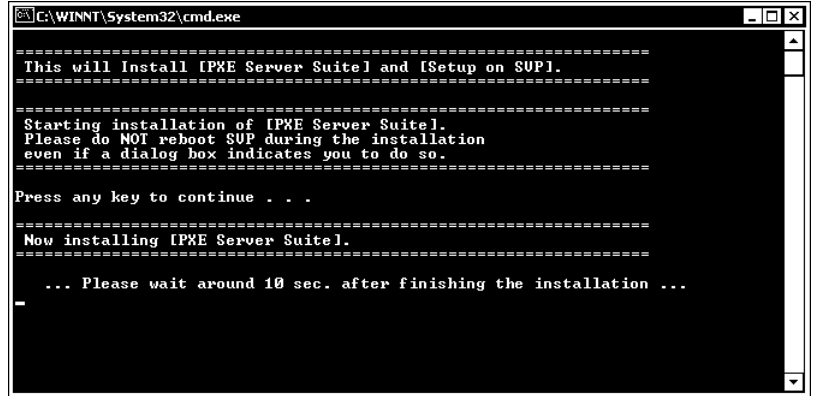

```

C:\WINNT\System32\cmd.exe
=====
This will Install [IPXE Server Suite] and [Setup on SUP].
=====
Starting installation of [IPXE Server Suite].
Please do NOT reboot SUP during the installation
even if a dialog box indicates you to do so.
=====
Press any key to continue . . .
=====
Now installing [IPXE Server Suite].
=====
.. Please wait around 10 sec. after finishing the installation ...
-

```

(13) The message “Starting installation of [Setup on SVP].” appears.

When the message “Press any key to continue...” appears, press any key.

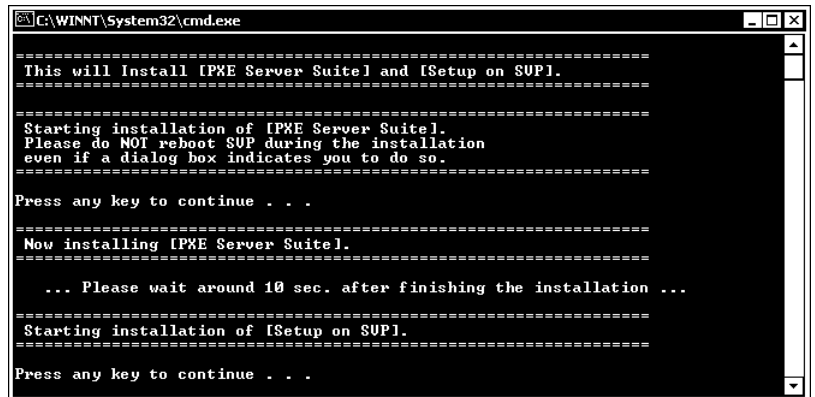

```

C:\WINNT\System32\cmd.exe
=====
This will Install [IPXE Server Suite] and [Setup on SUP].
=====
Starting installation of [IPXE Server Suite].
Please do NOT reboot SUP during the installation
even if a dialog box indicates you to do so.
=====
Press any key to continue . . .
=====
Now installing [IPXE Server Suite].
=====
.. Please wait around 10 sec. after finishing the installation ...
=====
Starting installation of [Setup on SUP].
=====
Press any key to continue . . .

```

- (14) Installation of Setup on SVP starts.
Go to step (15).

Note: Setup on SVP Installer runs in the background, and so no messages or dialog boxes will be displayed during the installation.

```

C:\WINNT\System32\cmd.exe
=====
Starting installation of [PXE Server Suite].
Please do NOT reboot SUP during the installation
even if a dialog box indicates you to do so.
=====
Press any key to continue . . .
=====
Now installing [PXE Server Suite].
=====
.. Please wait around 10 sec. after finishing the installation ...
=====
Starting installation of [Setup on SUP].
=====
Press any key to continue . . .
=====
Now installing [Setup on SUP]...
=====

```

- (15) The message “The NAS Setup on SVP installation has finished successfully.” is displayed.
Click the **OK** button in the message window.



- (16) The following window appears.
Press any key to continue.

```

C:\WINNT\System32\cmd.exe
=====
Starting installation of [PXE Server Suite].
Please do NOT reboot SUP during the installation
even if a dialog box indicates you to do so.
=====
Press any key to continue . . .
=====
Now installing [PXE Server Suite].
=====
.. Please wait around 10 sec. after finishing the installation ...
=====
Starting installation of [Setup on SUP].
=====
Press any key to continue . . .
=====
Now installing [Setup on SUP]...
=====
Press any key to continue . . .
=====

```

- (17) The message “End of the installation of [PXE Server Suite] and [Setup on SVP].” appears.
When the message “Press any key to continue...” appears, press any key.

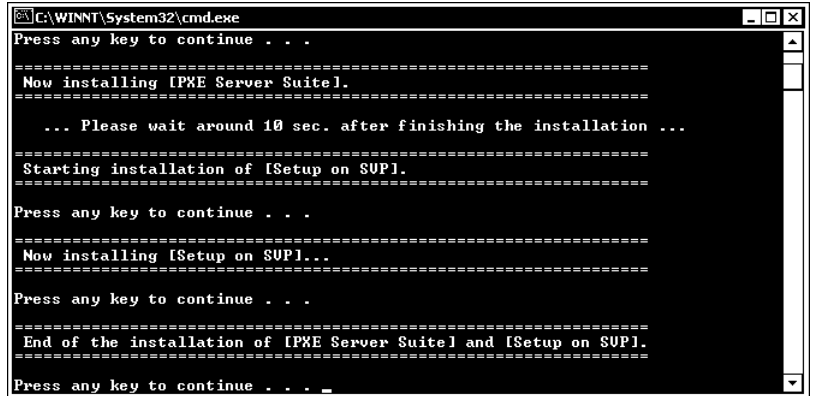

```

C:\WINNT\System32\cmd.exe
Press any key to continue . . .
=====
Now installing [PXE Server Suite].
=====
... Please wait around 10 sec. after finishing the installation ...
=====
Starting installation of [Setup on SVP].
=====
Press any key to continue . . .
=====
Now installing [Setup on SVP]..
=====
Press any key to continue . . .
=====
End of the installation of [PXE Server Suite] and [Setup on SVP].
=====
Press any key to continue . . .

```

- (18) The command prompt window closes automatically.
Remove the Setup on SVP installer (CD-ROM) from the CD drive of the SVP.
- (19) Click the **Start** button, choose **Shutdown**, choose **Restart**, and then click the **OK** button.
The SVP will be restarted.
- (20) Make sure that the **NAS Setup** button is displayed on the ‘SVP’ window.
- (21) Installation of Setup on SVP finishes.

[2] Starting and stopping Setup on SVP

To start and stop Setup on SVP:

(1) In the 'SVP' window, change **View Mode** to **Modify Mode**.

(2) Click the **NAS Setup** button to start Setup on SVP.

Note: The **NAS Setup** button can be used in **Modify Mode** only.

- (3) Make sure that 'NAS Setup on SVP (Main)' window appears.

For a multi-cabinet model:

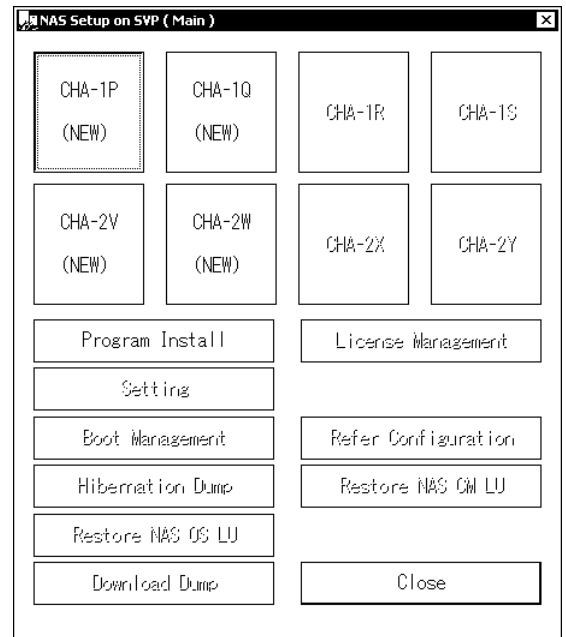

For a single cabinet model:

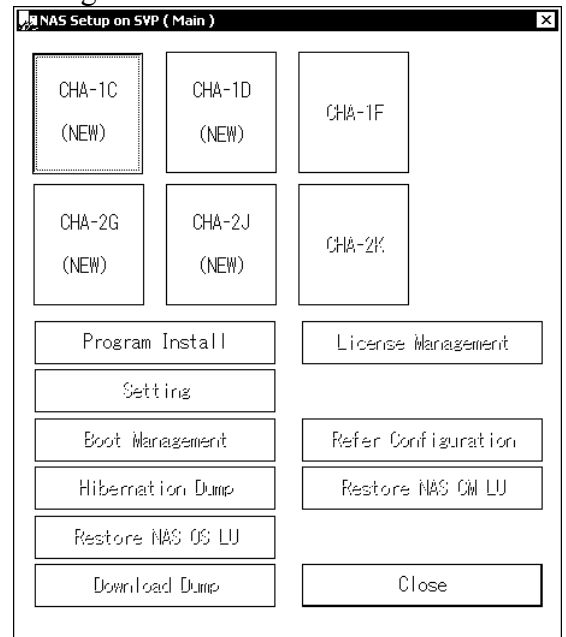

- (4) To stop Setup on SVP (the NAS Setup program), click the **Close** button in the 'NAS Setup on SVP (Main)' window.

Note: To finish Setup on SVP (the NAS Setup program), you must close all windows that have been opened by using the buttons of the 'NAS Setup on SVP (Main)' window.

- (5) If you are using the SVP high availability kit:
 Perform <switching the SVP> in the *REPLACE Section* [REP02-805] to switch the base SVP (basic) to the additional SVP (option), perform step (1) through step (21) [NAS03-110], and then perform step (1) through step (5) [NAS03-180] on the additional SVP (option).
 After setting the additional SVP (option), perform <switching the SVP> in the *REPLACE Section* [REP02-805] to switch the additional SVP (option) to the base SVP (basic).

[3] Uninstalling Setup on SVP

When you uninstall *Setup on SVP*, the following two programs are uninstalled:

- PXE Server Suite
- Setup on SVP

Note: Uninstalling Setup on SVP:

Keep the following points in mind when uninstalling Setup on SVP:

- If you want to remove the NAS functionality from the DKC, make sure that you delete all NAS Packages first, and then perform this operation (uninstallation).
- If you use the *SVP high availability kit*, make sure that you uninstall Setup on SVP from both SVPs.

To uninstall Setup on SVP:

- (1) Make sure that the **NAS Setup** button is displayed in the 'SVP' window.
 If the **NAS Setup** button is not displayed, Setup on SVP has already been uninstalled, and so this operation (uninstallation) is unnecessary.

- (2) Insert the Setup on SVP installer (CD-ROM) into the CD drive of the SVP.

- (3) Close all windows except the 'SVP' window.

- (4) Make sure that Setup on SVP is not running.
 If it is running, stop Setup on SVP.

- (5) Click the **Start** button to display the **Start** menu, and then choose **Run**.

- (6) Type `e:\setup.bat` in **Open:**, and then click the **OK** button.

- (7) The following window appears.
Press any key to continue.

```

C:\WINNT\System32\cmd.exe
=====
Some old versions of [PXE Server Suite] and [Setup on SUP] exist.
This will uninstall [PXE Server Suite] and [Setup on SUP].
=====
If you would like to install [PXE Server Suite] and [Setup on SUP]
stored in this CD-ROM, please rerun this batch after this
uninstallation process has once completed.
=====
Starting uninstall of [PXE Server Suite].
=====
Press any key to continue . . .

```

- (8) Pre-processing of the PXE Server Suite uninstallation is executed, and the following window appears.
Do not perform any operation on this window, and go to step (9).

Note: Do not use the mouse or keyboard during this step

```

C:\WINNT\System32\cmd.exe
=====
Starting uninstall of [PXE Server Suite].
=====
Press any key to continue . . .
=====
Now uninstalling [PXE Server Suite]...
=====
PXE Server stopped
Service 'PXE Server' removed
TFTP Server stopped
Service 'TFTP Server' removed
DHCP Server stopped
Service 'DHCP Server' removed
=====
Please run "Add/Remove Programs" on Control Panel,
then remove the entry of "PXE Server Suite".
=====
When deletion finished.
Press any key to continue . . . _

```

- (9) Click the **Start** button to display the **Start** menu, and then choose **Settings** and **Control Panel**.

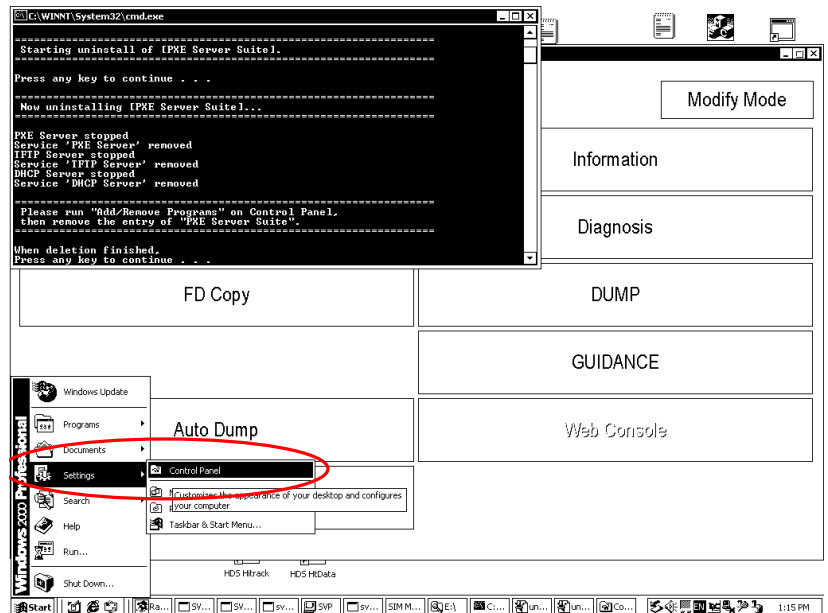

- (10) The 'Control Panel' window appears.

Double-click (execute) **Add/Remove Programs**.

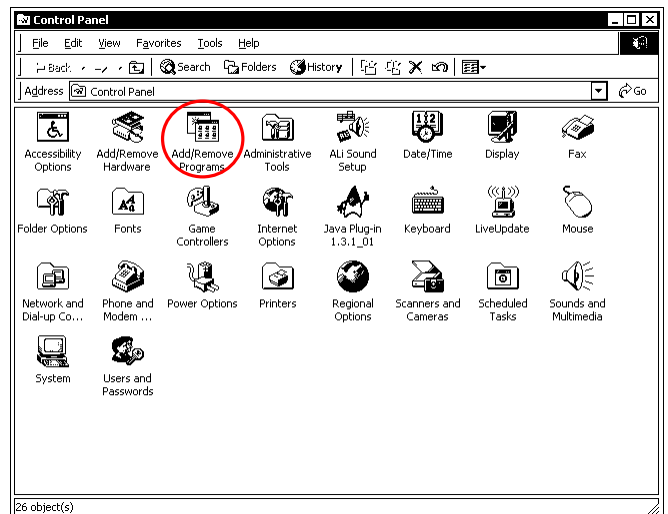

(11) The 'Add/Remove Programs' window appears.

From **Change or Remove Programs**, select **PXE Server Suite**, and then click the **Remove** button.

Note: If you remove an inappropriate program, the SVP might not run properly.

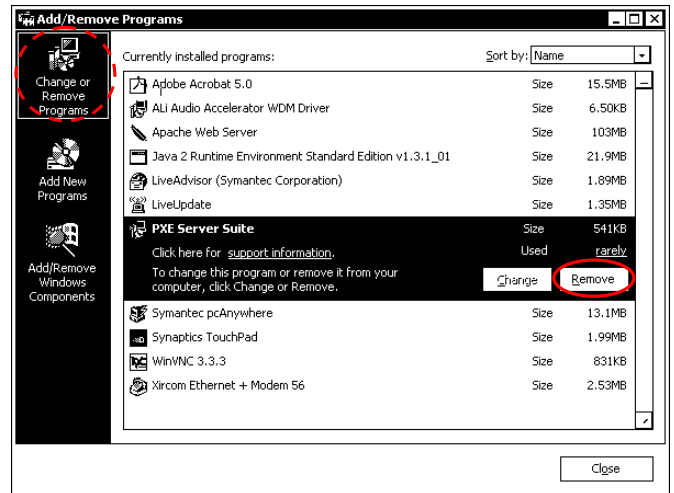

(12) The message "Are you sure you want to remove PXE Server Suite from your computer?" is displayed.

Click the **Yes** button in the message window.

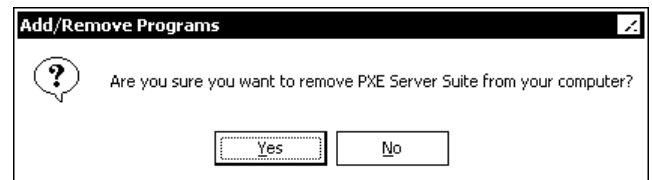

(13) Uninstallation of **PXE Server Suite** starts (this is the post-processing of this uninstallation procedure), and the progress is displayed.

Got to step (14).

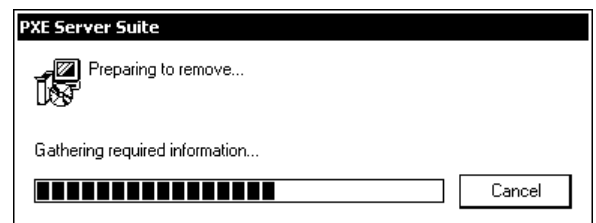

- (14) Make sure that **PXE Server Suite** is not displayed in **Change or Remove Programs** in the 'Add/Remove Programs' window.

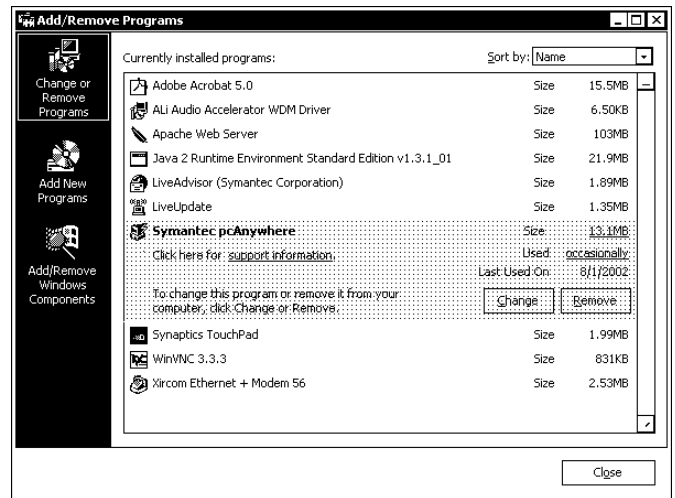

- (15) Click the **Close** button in the 'Add/Remove Programs' window to close the 'Add/Remove Programs' window.

- (16) Click the button in the 'Control Panel' window to close the 'Control Panel' window.

- (17) The following window appears.
Press any key to continue.

```

C:\WINNT\System32\cmd.exe
=====
Starting uninstall of [PXE Server Suite].
=====
Press any key to continue . . .
=====
Now uninstalling [PXE Server Suite]..
=====
PXE Server stopped
Service 'PXE Server' removed
TFTP Server stopped
Service 'TFTP Server' removed
DHCP Server stopped
Service 'DHCP Server' removed
=====
Please run "Add/Remove Programs" on Control Panel,
then remove the entry of "PXE Server Suite".
=====
When deletion finished,
Press any key to continue . . .

```

- (18) The message “End of the uninstall of [PXE Server Suite] and [Setup on SVP].” appears.
When the message “Press any key to continue...” appears, press any key.

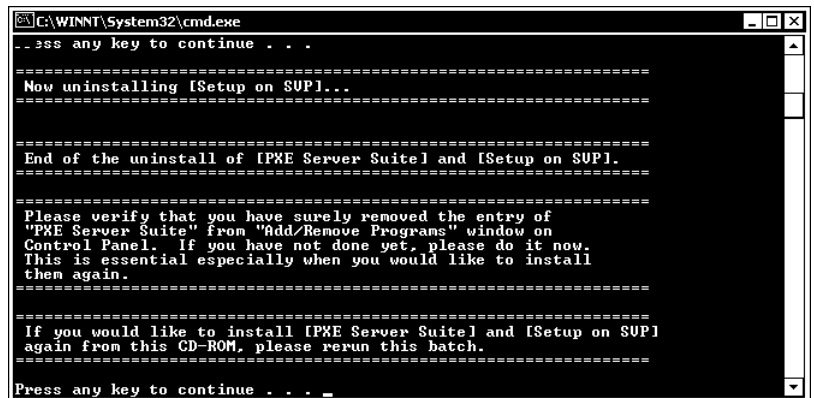

```

C:\WINNT\System32\cmd.exe
Press any key to continue . . .

=====
Now uninstalling [Setup on SVP]...
=====

=====
End of the uninstall of [PXE Server Suite] and [Setup on SVP].
=====

=====
Please verify that you have surely removed the entry of
"PXE Server Suite" from "Add/Remove Programs" window on
Control Panel. If you have not done yet, please do it now.
This is essential especially when you would like to install
then again.
=====

=====
If you would like to install [PXE Server Suite] and [Setup on SVP]
again from this CD-ROM, please rerun this batch.
=====

Press any key to continue . . .

```

- (19) The window closes.
Remove the Setup on SVP installer (CD-ROM) from the CD drive of the SVP.
- (20) Click the **Start** button, choose **Shutdown**, choose **Restart**, and then click the **OK** button.
The SVP will be restarted.
- (21) Make sure that the **NAS Setup** button is not displayed in the ‘SVP’ window.
- (22) Right-click the **Start** button, start Explorer, and then make sure that the `C:\CHNMGR` folder and `C:\dhcp.ini` file do not exist.

Uninstallation of Setup on SVP finishes.

3.5.3 NAS Package Status

When the **NAS Setup** button is selected in **Modify Mode** in the 'SVP' window, the 'NAS Setup on SVP (Main)' window appears.

This section describes the related statuses of the NAS Package and the function buttons.

Figure 3.5-2 shows the 'NAS Setup on SVP (Main)' window.

Note: The status displayed in the 'Setup on the SVP (Main)' Window is refreshed approximately every 30 seconds. The displayed status of the NAS Package can be different from the actual one because of this time lag.

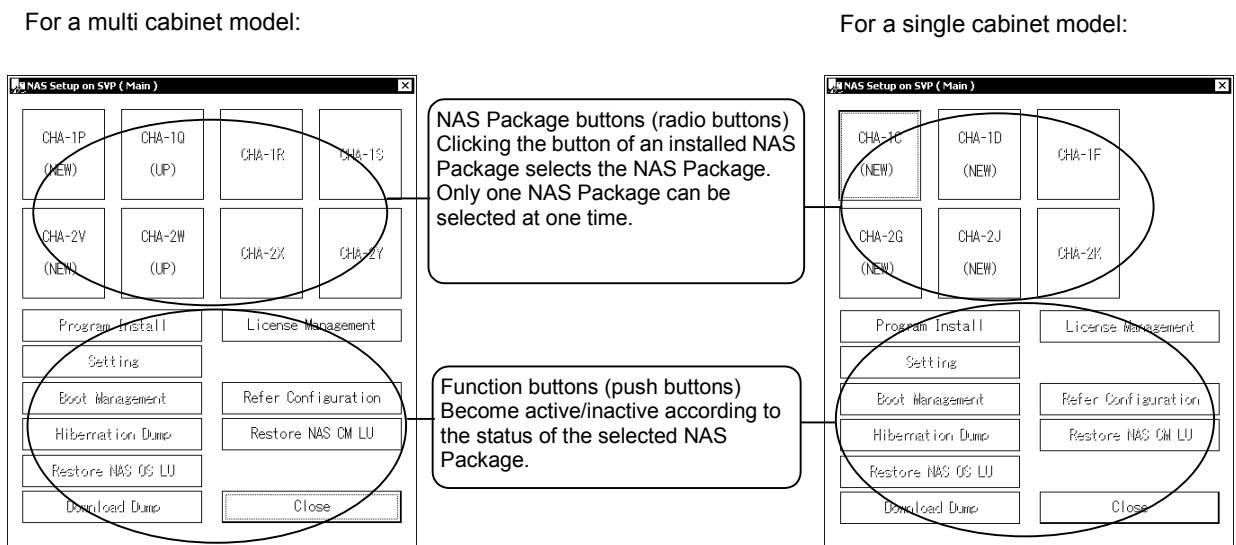

Figure 3.5-2 'NAS Setup on SVP (Main)' Window

Table 3.5-1 shows the relationship between the string in the status displayed ‘NAS Setup on SVP (Main)’ window, the status of the NAS Package, and the action by maintenance personnel.

Table 3.5-1 Relationships among the String in the Status Area, the Status of the NAS Package, and the Action by Maintenance Personnel

String Displayed in Status Area	Status of the NAS Package	Action by maintenance personnel
NEW	The NAS OS is not installed.	---
INST	The NAS OS is being installed.	---
UP	Both the NAS OS and node is running	---
DOWN	The NAS OS has stopped.	---
BUSY	The NAS OS is being started or stopped.	---
INACTIVE	The NAS OS is running and the node is not running.	---
DUMP	The hibernation dump is being collected.	After the status changes from DUMP to DOWN , obtain a hibernation dump according to 3.5.14 <i>Downloading Dump Files</i> . [NAS03-1090].
ERROR	The NAS OS is in an abnormal state. (The panic dump is being collected.)	After the status changes to DOWN , obtain a crash dump according to the procedure in subsection 3.5.14 <i>Downloading Dump Files</i> [NAS03-1090].
WARN	(1) NAS/Management is not installed. (2) The NAS OS is running and the node status is unknown.	(1) Check if NAS/Management is installed in the Program Install window. If so, perform (2). If not, install NAS/Management. (2) Acquire detailed information by using Auto Dump and ask the developer for an investigation. For the procedures, see the <i>NAS Section</i> [NAS07-60].
UNKNOWN	The NAS OS cannot communicate with Setup on SVP.	Acquire detailed information by using Auto Dump and ask the developer for an investigation. For the procedures, see the <i>NAS Section</i> [NAS07-60].
FATAL	No operation can be performed.	Check the subsystem status in the Maintenance window, and the error logs in the Information window. For the procedures, see the <i>SVP Section</i> [SVP02-30] [SVP03-10]. Setup on SVP must be restarted after the error cause is removed.

Using the 'NAS Setup on SVP (Main)' window enables you to select the NAS Package on which an operation is to be performed, and choose desired function buttons. Table 3.5-2 shows the function buttons in the 'NAS Setup on SVP (Main)' window.

Table 3.5-2 Function Buttons in the 'NAS Setup on SVP (Main)' Window

Button name	Description	Reference
Program Install	Windows related to the NAS OS and program products appear. You can install the NAS OS and NAS/Management, or install and uninstall optional program products for the selected NAS Package.	3.5.4 [NAS03-290] 3.5.5 [NAS03-600]
Setting	A window for setting network information appears. You can specify network settings, such as the fixed IP address of the NAS Package, and NTP server.	3.5.6 [NAS03-630]
License Management	Windows related to the license for optional program products appear.	3.5.7 [NAS03-660]
Boot Management	A window for controlling the NAS OS appears. You can start, stop, or restart the NAS OS (the OS for the NAS Blade system). You can also reset CHA.	3.5.8 [NAS03-790] 3.5.9 [NAS03-890]
Hibernation Dump	A window for collecting the hibernation dump appears. You can also stop dump collection by clicking the Cancel button.	3.5.10 [NAS03-920]
Refer Configuration	Windows related to program products in the NAS Package and the network settings can be displayed one by one in view mode. (You can view, but not modify, the settings.)	3.5.11 [NAS03-970]
Restore NAS OS LU	A window for restoring data in the NAS OS LU appears.	3.5.12 [NAS03-1000]
Restore NAS CM LU	A window for restoring data in the NAS Cluster Management LU appears.	3.5.13 [NAS03-1050]
Download Dump	A window for downloading dump files appears.	3.5.14 [NAS03-1090]
Close	The Main window closes and Setup on SVP ends.	---

3.5.4 Installing the NAS OS and Related Program Products

You can install the NAS OS (NAS/Base-Data Control and NAS/Base-File Sharing), NAS/Management, and related optional program products to a NAS Package. There are four types of installation as shown in [1] to [4].

- [1] NAS OS installation for the first time----- [NAS03-310](#)
- [2] NAS OS expansion installation----- [NAS03-400](#)
- [3] Optional program product installation----- [NAS03-500](#)
- [4] Installation Containing LU Initialization (Use this procedure by developers' instruction only when the error cannot be recovered) ----- [NAS03-540](#)

Table 3.5-3 shows the installation types and meaning.

Table 3.5-3 NAS OS installation, related program product installation, and related tasks

Installation type	Meaning
[1] NAS OS installation for the first time	Install the NAS OS and NAS/Management on the disk subsystem for the first time.
[2] NAS OS expansion installation	Install the NAS OS and NAS/Management, in the NAS Package added on the disk subsystem that has the NAS functionality.
[3] Optional program product installation	Install the optional program product (for the first time or for expansion).
[4] Installation Containing LU Initialization (Use this procedure by developers' instruction only when the error cannot be recovered)	Initialize the LU and install the NAS OS when the error cannot be recovered. Developers' instruction is required to perform this procedure.

Notes:

- As a rule, you must install the same program products and versions into NAS Packages (i.e., multi-cabinet models including CHA-1P and CHA-2V, and CHA-1Q and CHA-2W, and single cabinet models including CHA-1C and CHA-2G, and CHA-1D and CHA-2J) on the same cluster.

 **CAUTION**

If you plan to expand, reduce, or replace a NAS Package, first close the NAS Setup on SVP window, and then re-open it.

Before starting installation, choose an appropriate installation type based on the flow chart shown below. Once the installation type is determined, perform installation from the SVP and the Setup on SVP window according to the installation procedures.

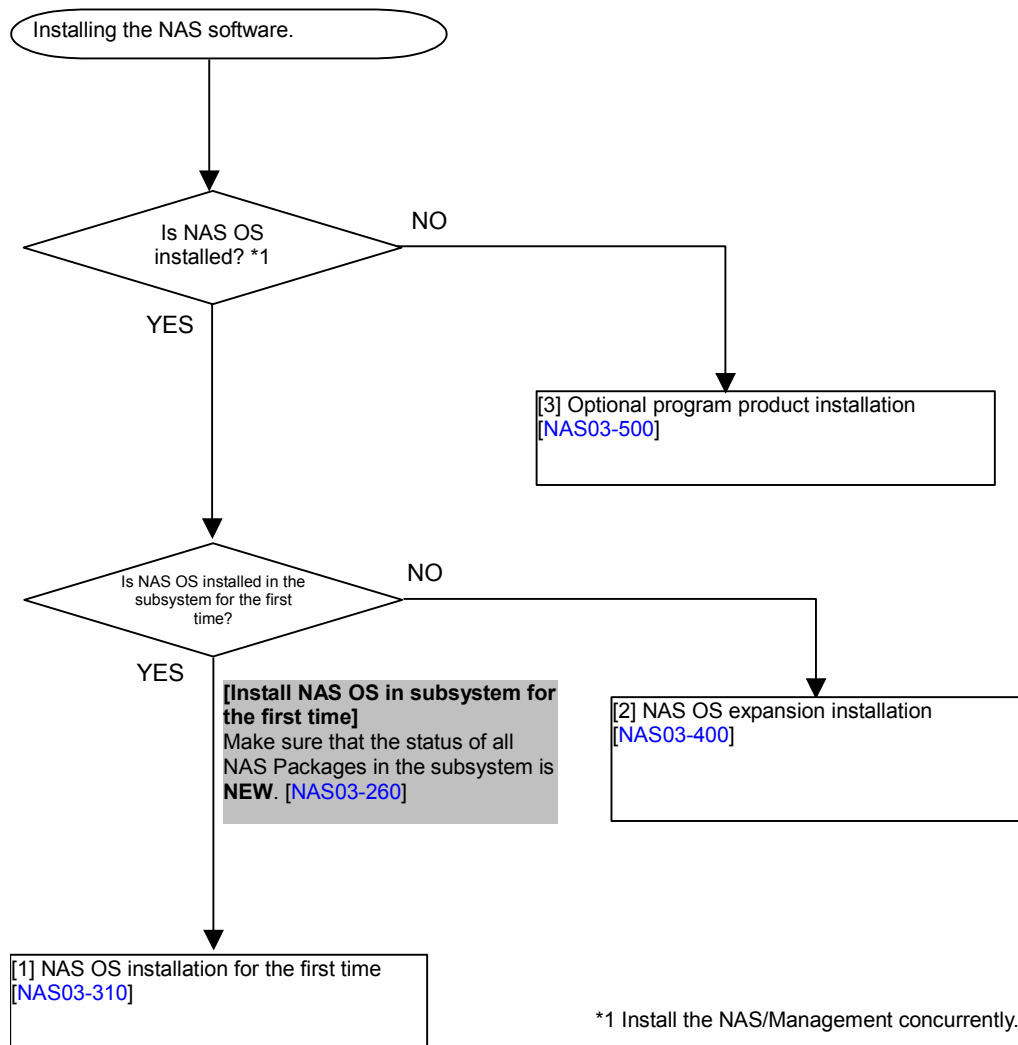

Figure 3.5-3 Installation Type Flowchart

[1] NAS OS installation for the first time

To install the NAS OS:

(1) Insert the NAS OS media (CD-ROM) into the CD drive of the SVP.

(2) In the 'SVP' window, change **View Mode** to **Modify Mode**.

(3) Click the **NAS Setup** button to start Setup on SVP.

Note: The **NAS Setup** button can be used in **Modify Mode** only.

Note: Close all windows except for the 'SVP' window during 'NAS Setup on SVP' is running.

(4) In the 'NAS Setup on SVP (Main)' window select the NAS Package to be installed, and then click the **Program Install** button.

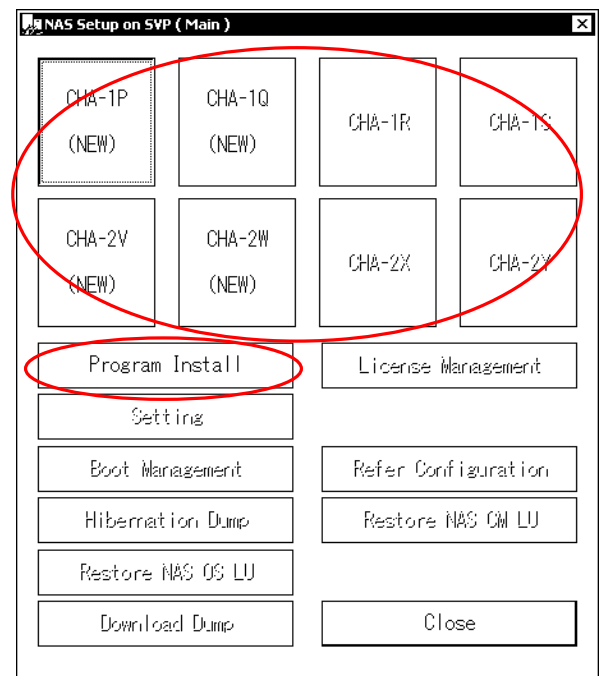

- (5) The 'NAS Setup on SVP (Program Install)' window appears.

From a list of the program products displayed in **Program Product in Media**, select the program product to be installed (NAS OS(Hitachi Network Attached Storage/Base - Data Control, Hitachi Network Attached Storage/Base - File Sharing), "NAS/Management(Hitachi Network Attached Storage/Management)").

Note: You can install NAS OS and NAS/Management concurrently when you install NAS OS for the first time.

The screenshot shows the 'NAS Setup on SVP (Program Install)' window. It contains the following elements:

- CHA-1P**: System identifier.
- Available Program Product**: An empty table with columns 'Program Product Name' and 'Version'.
- Uninstall**: A button located below the 'Available Program Product' table.
- Program Product in Media**: A table with columns 'Program Product Name' and 'Version'. It contains two entries:

Program Product Name	Version
Hitachi Network Attached Storage/Base - Da...	02-00-01
Hitachi Network Attached Storage/Management	02-00-01
- Initialize**: A section with two checkboxes:
 - NAS Cluster Management LU
 - Error Information LU
- Install**: A button located to the right of the 'Initialize' section.
- Close**: A button located below the 'Install' button.

Callouts provide the following information:

- A list of the installed program products is displayed. You can select only one program product, and cannot select multiple program products.
- Becomes active when an item in the above list is selected. Clicking this button uninstalls the selected optional program product.
- The program products stored in the supplied NAS OS media are displayed. You can select multiple items at one time.
- If you select an item from the above list, this button becomes active. Clicking this button installs the selected program product.

CAUTION

Except for failure recovery purposes, you do not need to select **NAS Cluster Management LU** and **Error Information LU** in the **Initialize** area.

You need to enter a password to select these check boxes and continue the operation. Contact the Technical Support Center (TSC) to confirm the validity of the operation and obtain the password.

 **CAUTION**

When the NAS OS is to be installed to the subsystem for the first time, the NAS Cluster Management LU is initialized, therefore, you must first install the NAS OS only. When the NAS OS is installed to the first NAS Package successfully, you can install the NAS OS on another NAS Package in parallel. (While you are installing the NAS OS on one NAS package, you can install it on any other ones.) Install the NAS OS on another NAS Package.

- (6) The message “The NAS OS will be installed for the first time. ...” appears.
Click the **OK** button in the message window.

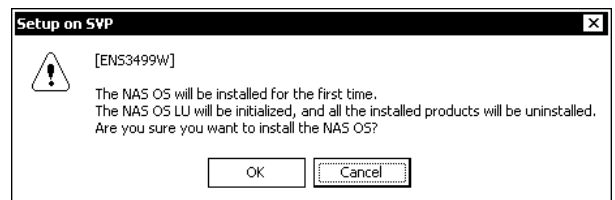

- (7) The message “You are installing the NAS OS on the disk subsystem for the first time. ...” appears.
Click the **OK** button in the message window.
The installation starts.

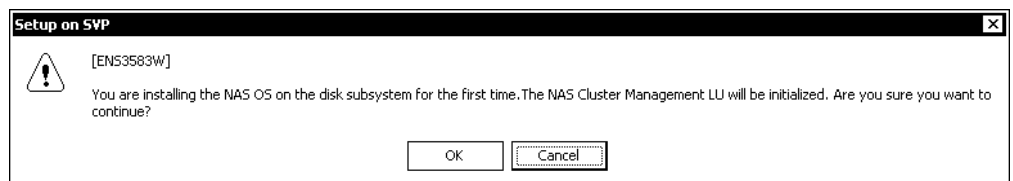

- (8) The 'NAS Setup on SVP (Install Progress)' window appears, and then the installation progress for the selected program product is displayed. If you selected multiple program products, the installation starts in descending order from the top item. When installation finishes successfully, go to step (10).

Note: It takes approximately 10 minutes to install the NAS OS in one NAS Package, and up to 90 minutes to install it in more than one NAS Package at the same time.

Note: Select (CL) [Cancel (the leftover products)] if you want to cancel subsequent PP installation.

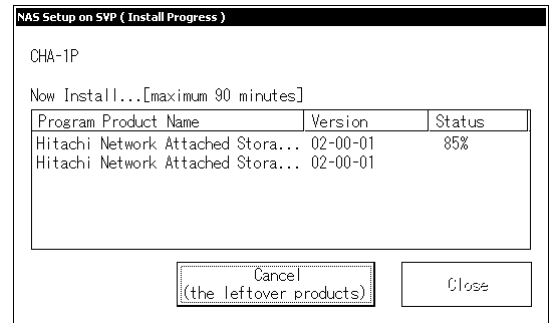

- (9) If installation of the NAS OS finished abnormally:

(9-1)

If a message whose ID is ENSxxxxx appears, see the *SVP MESSAGE Section* for the corresponding action to take.

(9-2)

Make sure that there is no blocked part or error in the 'SVP (Maintenance)' window. If there is a blocked part or an error, see the *SVP Section* [[SVP02-30](#)] [[SVP03-10](#)], and then take action.

(9-3)

If the **Status** area in the 'Install Progress' window remains at **1%**, and then installation finishes abnormally, use the following procedure to check the **Event Viewer** of the SVP.

(9-3-1)

Click the **Start** button to display the **Start** menu, and then choose **Settings** and **Control Panel**.

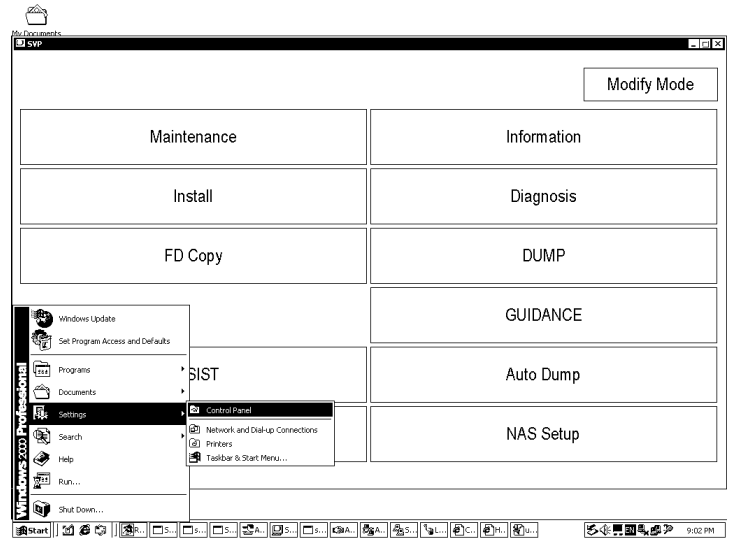

(9-3-2)

The 'Control Panel' window appears.
Double-click **Administrative Tools**.

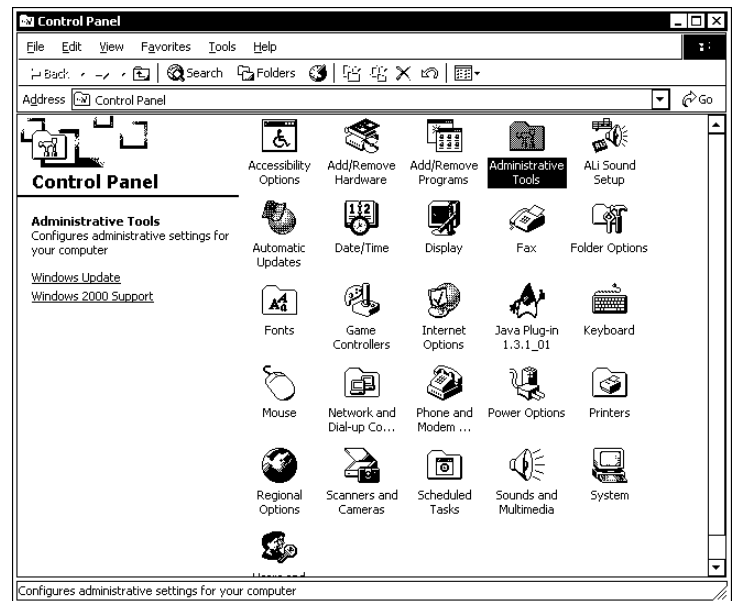

(9-3-3)
Double-click **Event Viewer**.

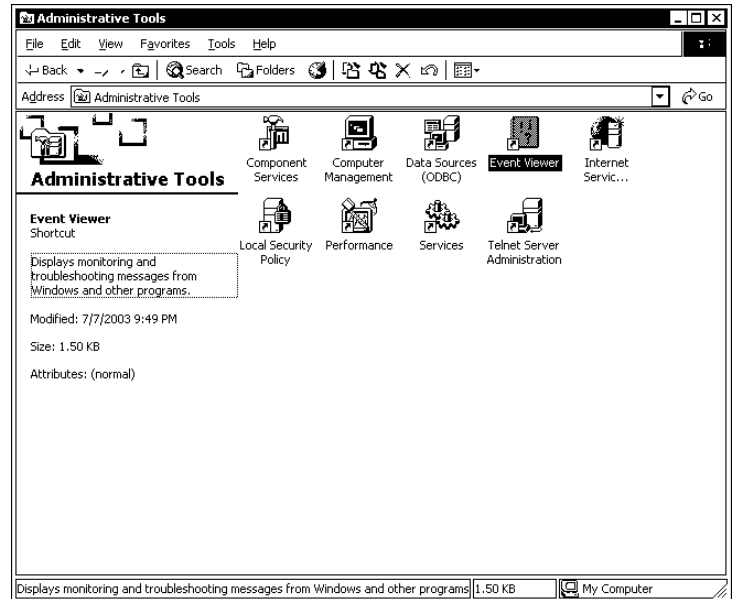

(9-3-4)
From the tree display, click **Application Log**.

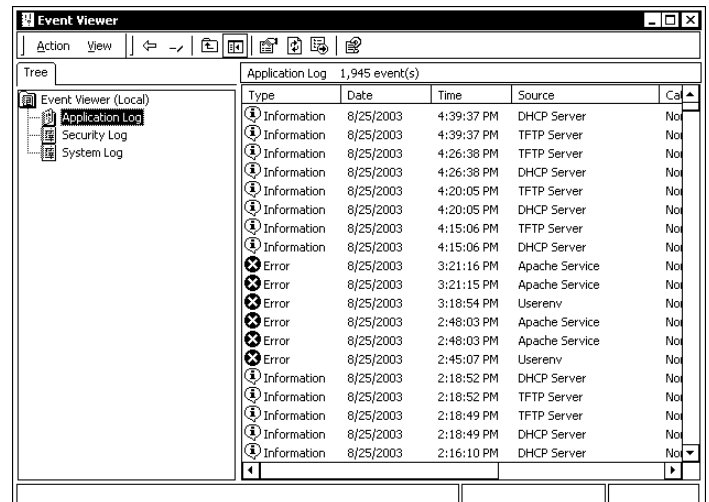

(9-3-5)

In the Event column, check if DHCP Server error 1009 was reported at the time the installation failed.

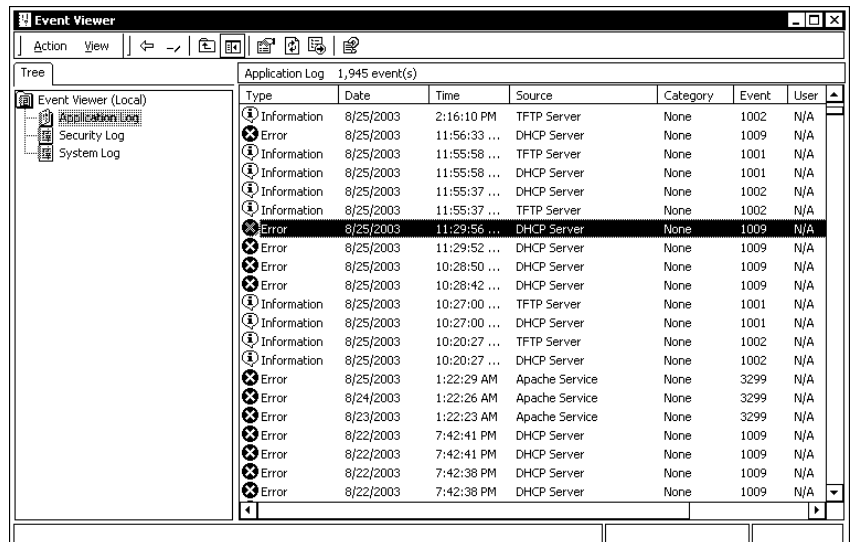

(9-3-6)

If there is a DHCP error 1009, double-click the error and check the description.

If the above error does not exist, remove the NAS OS media (CD-ROM) from the CD drive of the SVP, reboot the SVP PC, and then install the NAS OS from step (1).

If the same phenomenon occurs repeatedly, contact the Technical Support Center (TSC).

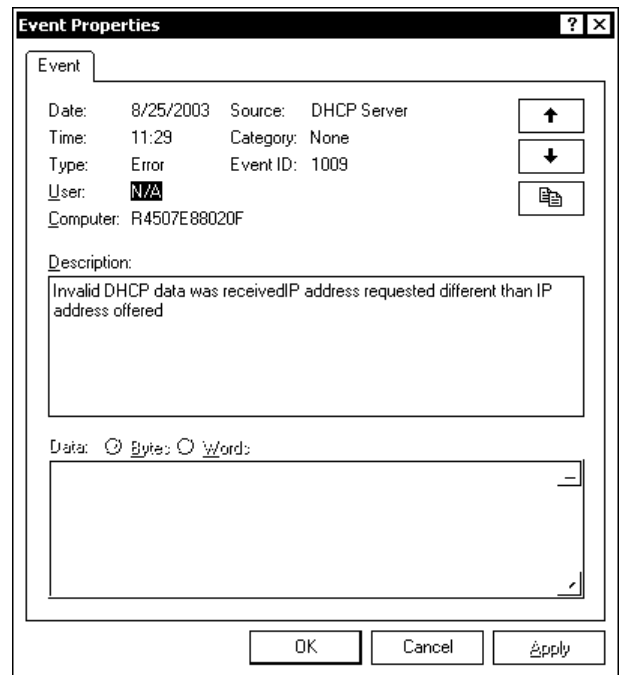

(9-3-7)

Check if the error description includes the following sentence:

IP address requested different than IP address offered.

(9-3-8)

A DHCP server other than the SVP may be operating.

Although a user LAN is not supposed to be able to connect to a DKC internal HUB (internal LAN), this error might occur if the user LAN (excluding a LAN for ASSIST or Hi-Track) is mistakenly connected to the internal LAN. See the *LOCATION Section* [LOCATION05-50] and check if the user LAN is connected to HUB EXP-1 or EXP-2. If the user LAN is connected, disconnect it.

(9-3-9)

Re-execute installation.

- (10) When all the statuses of the program products displayed in the 'NAS Setup on SVP (Install Progress)' window become **Completed**, the installation has finished. Click the **Close** button in the 'NAS Setup on SVP (Install Progress)' window.

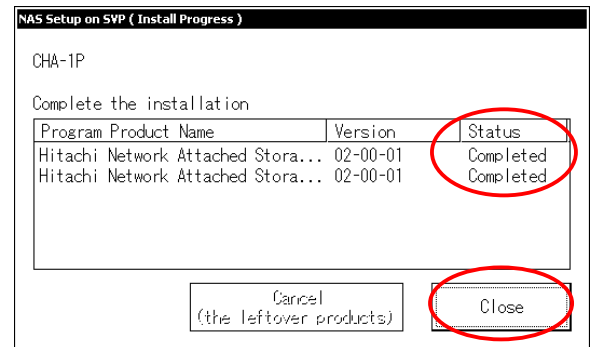

(11) The 'NAS Setup on SVP (Program Install)' window appears.

Make sure that the installed program products are listed in **Available Program Product**, and that their versions match to that of the NAS OS media (CD-ROM), and then click the **Close** button.

Installation now finishes.

Note: Although you selected one NAS OS, either Hitachi Network Attached Storage/Base - Data Control or Hitachi Network Attached Storage/Base - File Sharing in **Program Product in Media** of the NAS Setup on SVP (Program Install) window when installing a NAS OS, after installation, **Available Program Product** lists two items, Hitachi Network Attached Storage/Base - Data Control and Hitachi Network Attached Storage/Base - File Sharing.

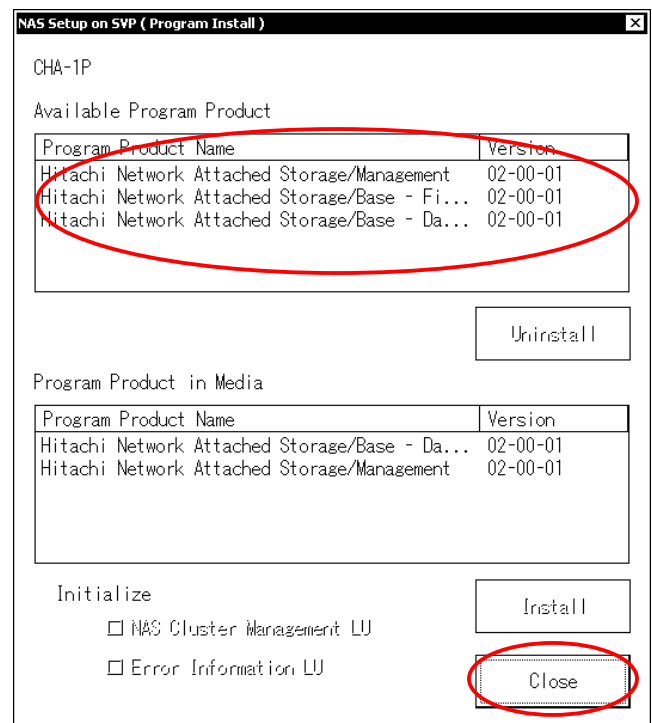

[2] NAS OS expansion installation

To install the NAS OS:

(1) Insert the NAS OS media (CD-ROM) into the CD drive of the SVP.

(2) In the 'SVP' window, change **View Mode** to **Modify Mode**.

(3) Click the **NAS Setup** button to start Setup on SVP.

Note: The **NAS Setup** button can be used in **Modify Mode** only.

Note: Close all windows except for the 'SVP' window during 'NAS Setup on SVP' is running.

(4) In the 'NAS Setup on SVP (Main)' window select the NAS Package to be installed, and then click the **Program Install** button.

Note: Make sure that the status of the NAS OS in the target NAS Package that you want to install is **NEW**.

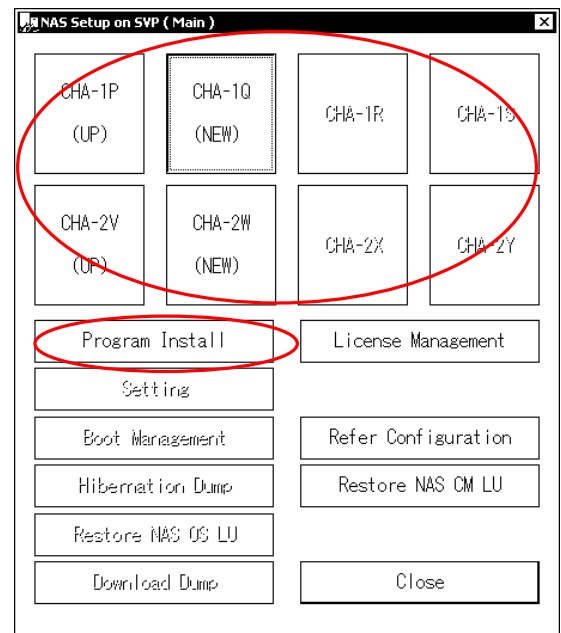

(5) The 'NAS Setup on SVP (Program Install)' window appears.

CAUTION

Except for failure recovery purposes, you do not need to select **NAS Cluster Management LU** and **Error Information LU** in the **Initialize** area.

If there exists a NAS Package (other than the NAS Package on which the operation is being performed) for which a NAS OS has been installed, selecting these check boxes might cause a fatal error such as a system crash. You need to enter a password to select these check boxes and continue the operation. Contact the Technical Support Center (TSC) to confirm the validity of the operation and obtain the password.

For more information on the operating procedure, see 3.5.4 [4] *Installation Containing LU Initialization* (Use this procedure by developers' instruction only when the error cannot be recovered) [NAS03-540].

From a list of the program products displayed in **Program Product in Media**, select the program product to be installed (NAS OS (Hitachi Network Attached Storage/Base - Data Control, Hitachi Network Attached Storage/Base - File Sharing), "NAS/Management (Hitachi Network Attached Storage/Management)").

If you want to install multiple program products, select the program products while holding down the **Ctrl** key.

Click the **Install** button to continue.

Note: You can install NAS OS and NAS/Management concurrently in a NAS OS expansion installation.

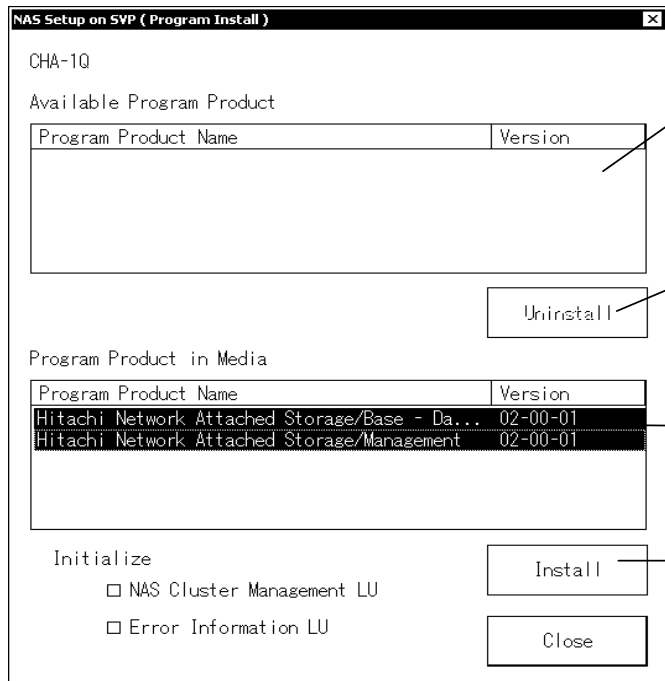

The screenshot shows the 'NAS Setup on SVP (Program Install)' window. It contains the following elements:

- CHA-10** (System identifier)
- Available Program Product** section with a table:

Program Product Name	Version
- Uninstall** button (becomes active when an item is selected in the 'Available Program Product' list).
- Program Product in Media** section with a table:

Program Product Name	Version
Hitachi Network Attached Storage/Base - Da...	02-00-01
Hitachi Network Attached Storage/Management	02-00-01
- Initialize** section with checkboxes:
 - NAS Cluster Management LU
 - Error Information LU
- Install** button (becomes active when an item is selected in the 'Program Product in Media' list).
- Close** button.

Callouts provide the following explanations:

- A list of the installed program products is displayed. You can select only one program product, and cannot select multiple program products.
- Becomes active when an item in the above list is selected. Clicking this button uninstalls the selected optional program product.
- The program products stored in the supplied the NAS OS media are displayed. You can select multiple items at one time.
- If you select an item from the above list, this button becomes active. Clicking this button installs the selected program product.

- (6) The message “The NAS OS will be installed for the first time. ...” appears.
Click the **OK** button in the message window.
The installation starts.

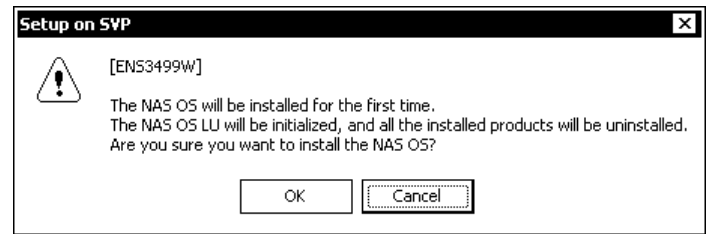

- (7) The ‘NAS Setup on SVP (Install Progress)’ window appears, and then the installation progress for the selected program product is displayed. If you selected multiple program products, the installation starts in descending order from the top item on the list.

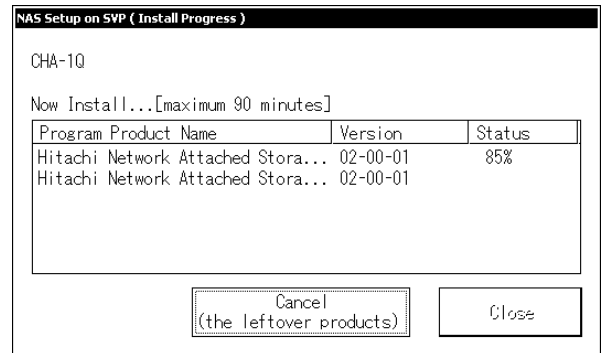

You can install the NAS OS on another NAS Package in parallel. (While you are installing the NAS OS on one NAS package, you can install it on any other ones.) Install the NAS OS in the NAS Package (**NEW** status) that was added.

If installation finishes successfully, go to step (9)

Note: It takes approximately 10 minutes to install the NAS OS in one NAS Package, and up to 90 minutes to install it in more than one NAS Package at the same time.

Note: Select (CL) [Cancel (the leftover products)] if you want to cancel subsequent PP installation.

(8) If installation of the NAS OS finished abnormally:

(8-1)

If a message whose ID is ENSxxxxx appears, see the *SVP MESSAGE Section* for the corresponding action to take.

(8-2)

Make sure that there is no blocked part or error in the 'SVP (Maintenance)' window. If there is a blocked part or an error, see the *SVP Section* [[SVP02-30](#)] [[SVP03-10](#)], and then take action.

(8-3)

If the **Status** area in the 'Install Progress' window remains at **1%**, and then installation finishes abnormally, use the following procedure to check the **Event Viewer** of the SVP.

(8-3-1)

Click the **Start** button to display the **Start** menu, and then choose **Settings** and **Control Panel**.

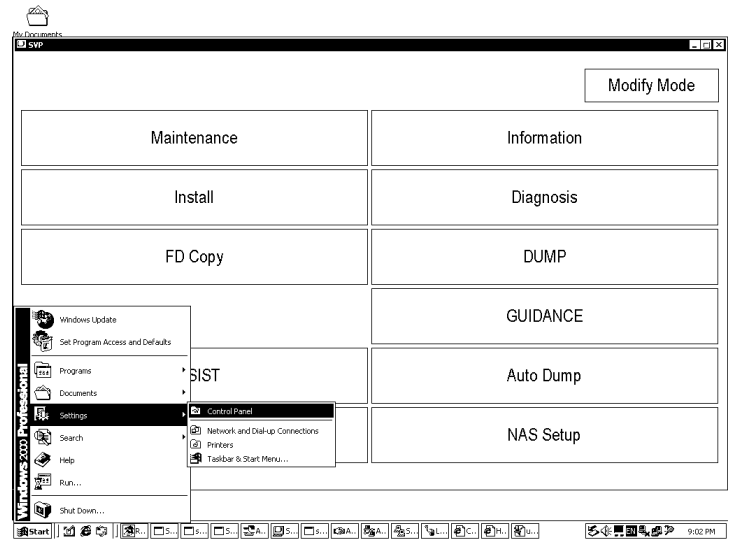

(8-3-2)

The 'Control Panel' window appears.
Double-click **Administrative Tools**.

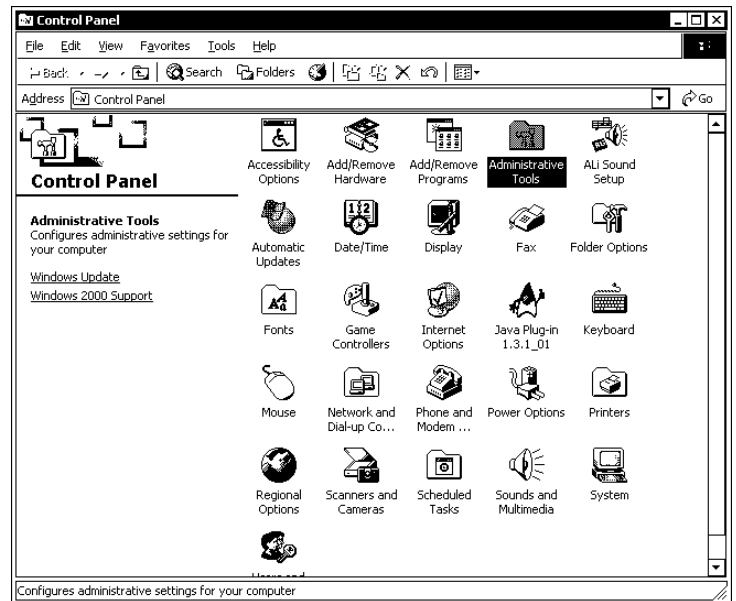

(8-3-3)

Double-click **Event Viewer**.

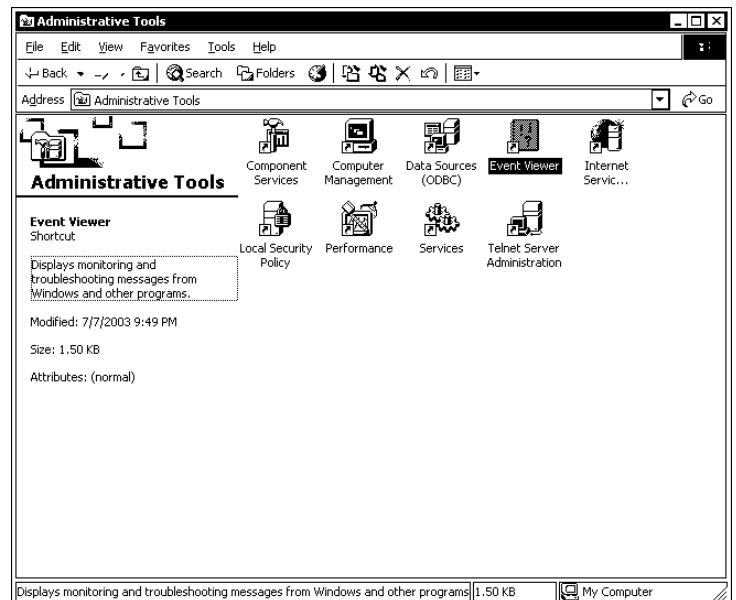

(8-3-4)

From the tree display, click **Application Log**.

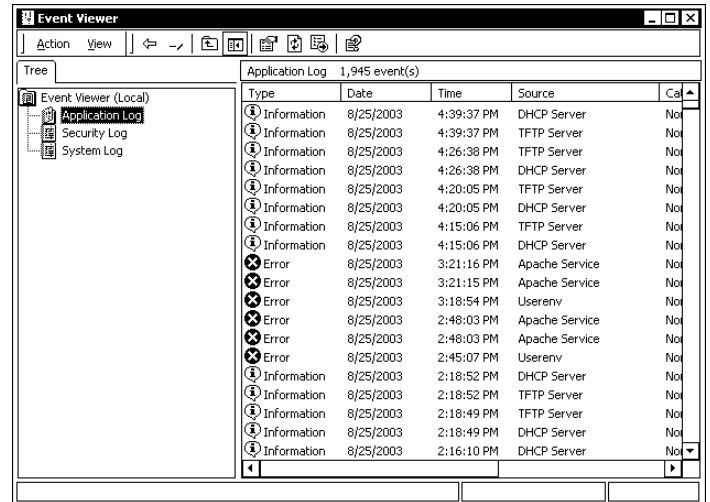

(8-3-5)

Under Event, check if DHCP Server error 1009 was reported at the time the installation failed.

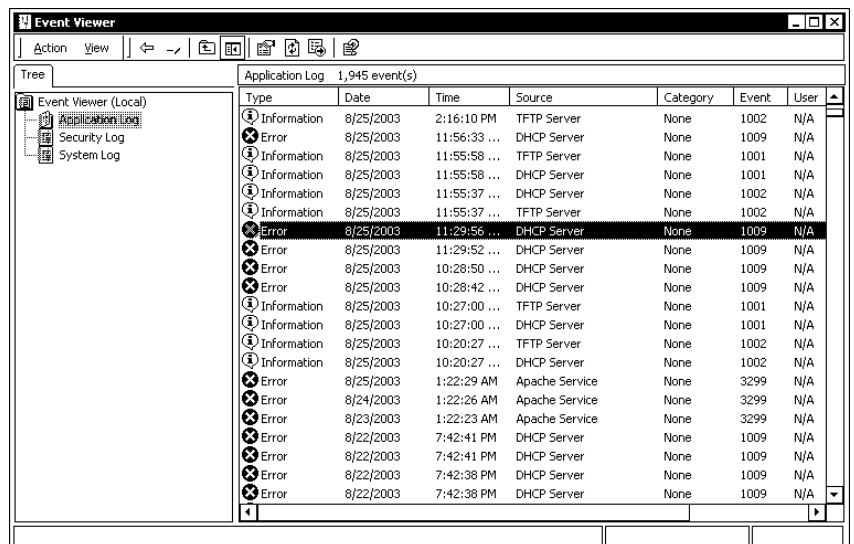

(8-3-6)

If there is a DHCP error 1009, double-click the error and check the description.

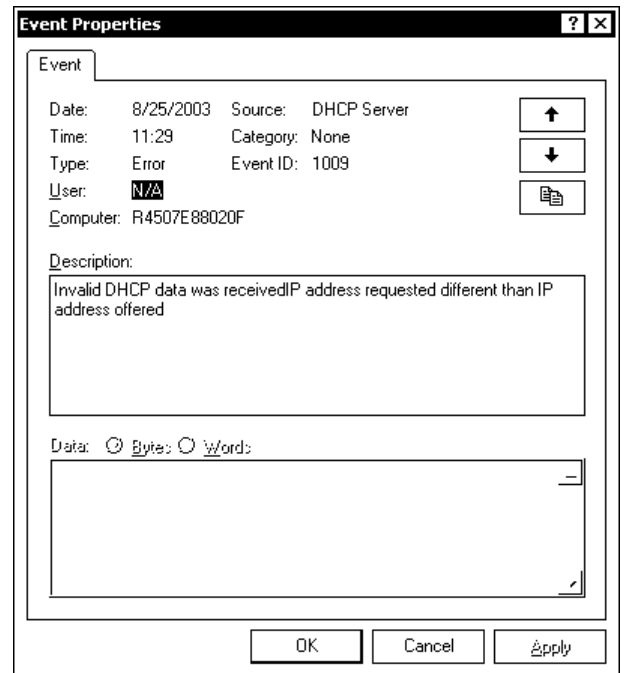

(8-3-7)

Check if the error description includes the following sentence:

IP address requested different than IP address offered.

If so, go to step (8-3-8).

If the above error does not exist, remove the NAS OS media (CD-ROM) from the CD drive of the SVP, reboot the SVP, and then install the NAS OS from step (1).

If the same phenomenon occurs repeatedly, contact the Technical Support Center (TSC).

(8-3-8)

A DHCP server other than the SVP may be operating.

Although a user LAN is not supposed to be able to connect to a DKC internal HUB (internal LAN), this error might occur if the user LAN (excluding a LAN for ASSIST or Hi-Track) is mistakenly connected to the internal LAN. See the *LOCATION Section* [LOCATION05-50] and check if the user LAN is connected to HUB EXP-1 or EXP-2. If the user LAN is connected, disconnect it.

(8-3-9)

Re-execute installation.

- (9) When all the statuses of the program products displayed in the 'NAS Setup on SVP (Install Progress)' window become **Completed**, the installation has finished. Click the **Close** button in the 'NAS Setup on SVP (Install Progress)' window.

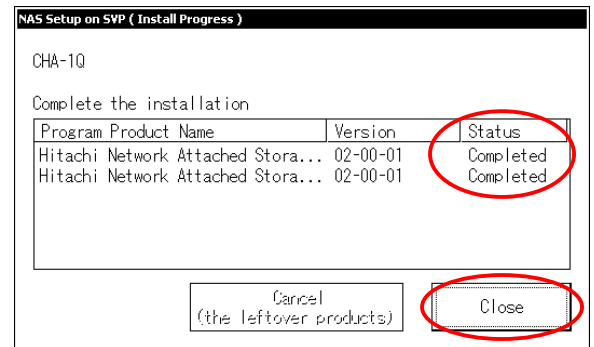

(10) The ‘NAS Setup on SVP(Program Install)’ window appears.

Make sure that the version displayed in **Ver.** corresponds with the version of the NAS OS media (CD-ROM) and also the program product name in **Name in Available Program Product** corresponds with the program product name of the NAS OS media (CD-ROM), and then click the **Close** button.

The installation finishes.

Note: When NAS/OS is installed, you select “NAS OS(Hitachi Network Attached Storage/Base - Data Control, Hitachi Network Attached Storage/Base - File Sharing)” from **Program Product in Media** in the ‘NAS Setup on SVP(Program Install)’ window, however, after the installation finishes, two program products (“Hitachi Network Attached Storage/Base - Data Control” and “Hitachi Network Attached Storage/Base - File Sharing”) are displayed in **Available Program Product**.

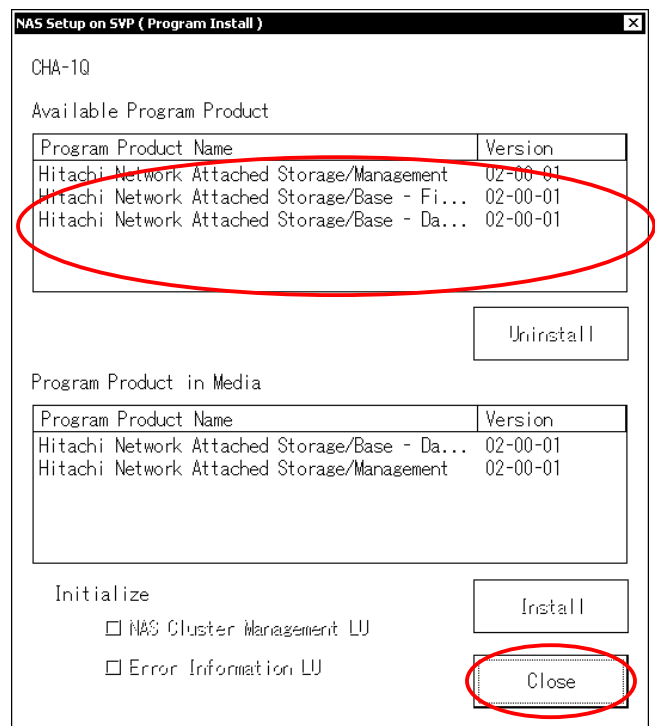

[3] Optional program product installation

To install the optional program products:

(1) Insert the NAS PP media (CD-ROM) into the CD drive of the SVP.

(2) In the 'SVP' window, change **View Mode** to **Modify Mode**.

(3) Click the **NAS Setup** button to start Setup on SVP.

Note: The **NAS Setup** button can be used in **Modify Mode** only.

Note: Close all windows except for the 'SVP' window during 'NAS Setup on SVP' is running.

(4) In the 'NAS Setup on SVP(Main)' window select the NAS Package to be installed, and then click the **Program Install** button.

Note: Make sure that the status of the NAS OS in the target NAS Package that you want to install is **UP** or **INACTIVE**.

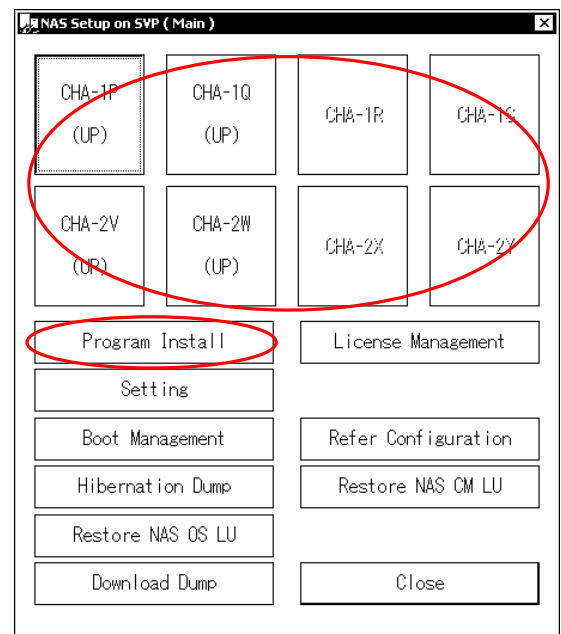

- (5) The 'NAS Setup on SVP (Program Install)' window appears.

From a list of the program products displayed in **Program Product in Media**, select the program product to be installed.

If you want to install multiple program products, select the program product while holding down the **Ctrl** key.

Click the **Install** button to continue.

Note: In the window example below, NAS/Backup Restore is installed from the optional program products stored in the NAS PP media.

The screenshot shows a window titled "NAS Setup on SVP (Program Install)". It contains two main sections: "Available Program Product" and "Program Product in Media".

Available Program Product:

Program Product Name	Version
Hitachi Network Attached Storage/Management	02-00-01
Hitachi Network Attached Storage/Base - Fi...	02-00-01
Hitachi Network Attached Storage/Base - Da...	02-00-01

Program Product in Media:

Program Product Name	Version
Hitachi Network Attached Storage/Anti Viru...	02-00-01
Hitachi Network Attached Storage/Backup Re...	02-00-01
Hitachi Network Attached Storage/Sync Image	02-00-01

At the bottom, there is an "Initialize" section with two checkboxes: "NAS Cluster Management LU" and "Error Information LU". Buttons for "Uninstall", "Install", and "Close" are also present.

Callouts:

- A list of the installed program products is displayed. You can select only one program product, and cannot select multiple program products.
- Becomes active when an item in the above list is selected. Clicking this button uninstalls the selected optional program product.
- The program products stored in the supplied the NAS PP media are displayed. You can select multiple items at one time.
- If you select an item from the above list, this button becomes active. Clicking this button installs the selected program product.

CAUTION

When you install the optional program product, you cannot select both the **NAS Cluster Management LU** and **Error Information LU** in the Initialize area.

- (6) The 'NAS Setup on SVP (Install Progress)' window appears, and then the installation progress for the selected program product is displayed. If you selected multiple program products, the installation starts in the order from the top item.

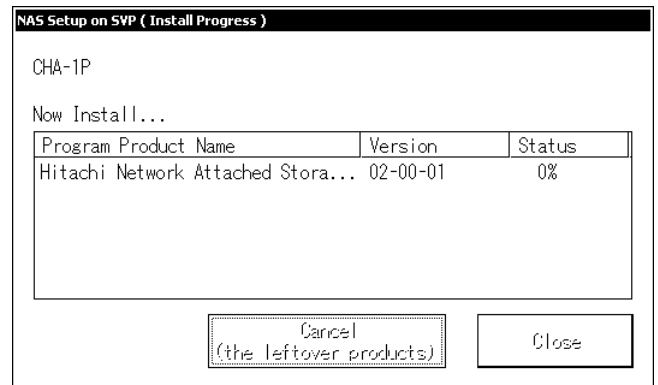

You can install the optional program product on the other NAS Package in parallel. (While you are installing the NAS OS on one NAS package, you can install it on any other ones.)

If installation finishes successfully, go to step (8).

Note: Select (CL) [Cancel (the leftover products)] if you want to cancel next and consecutive PP installation.

- (7) When the optional program product installation has ended abnormally:

(7-1)

When a message whose ID is ENSxxxxx appears, see the *SVP MESSAGE Section* for the corresponding action to take.

(7-2)

In the 'SVP(Maintenance)' window, make sure that no blocked part or failure is displayed. If there is a blocked part or failure, see the *SVP Section* [[SVP02-30](#)] [[SVP03-10](#)] for the corresponding action to take.

- (8) When all the statuses of the program products displayed in the 'NAS Setup on SVP (Install Progress)' window become **Completed**, the installation has finished. Click the **Close** button in the 'NAS Setup on SVP (Install Progress)' window.

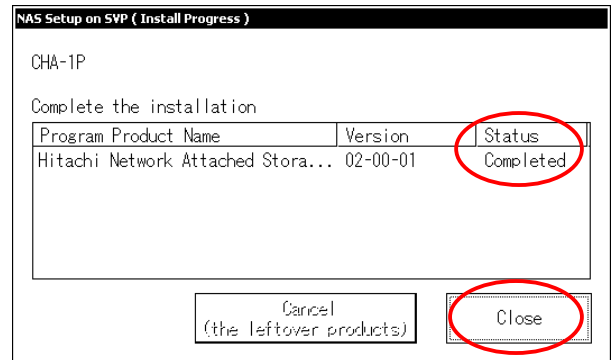

- (9) The 'NAS Setup on SVP (Program Install)' window appears. Make sure that the version displayed in **Ver.** corresponds with the version of the NAS PP media (CD-ROM) and also the program product name in **Name in Available Program Product** corresponds with the program product name of the NAS PP media (CD-ROM), and then click the **Close** button. The installation finishes.

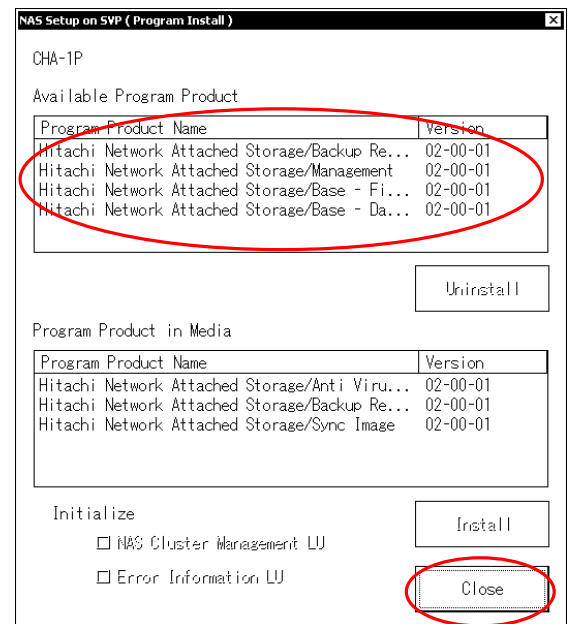

- [4] Installation Containing LU Initialization (Use this procedure by developers' instruction only when the error cannot be recovered)

A NAS Cluster Management LU (**NAS Cluster Management LU**) and error information LU (**Error Information LU**) can be initialized concurrently when the NAS OS is installed.

This operation can be performed only when the NAS OS is installed for the first time. When the NAS OS is being upgraded, this operation cannot be performed.

Note: If all the statuses of the NAS Packages are **NEW** in the 'NAS Setup on SVP (Main)' window, follow the procedure in 3.5.4 [1] NAS OS installation for the first time [[NAS03-310](#)].

 **CAUTION**

Make sure that you stop all of the NAS OSs running in the disk subsystem before performing this operation.

This operation might cause a fatal error such as a system crash. Before performing this operation, you need to enter a password. Contact the Technical Support Center (TSC) to confirm the validity of this operation and receive an approval.

To install the NAS OS containing LU initialization:

- (1) Insert the NAS OS media (CD-ROM) into the CD drive of the SVP.

- (2) In the 'SVP' window, change **View Mode** to **Modify Mode**.

- (3) Click the **NAS Setup** button to start Setup on SVP.

Note: The **NAS Setup** button can be used in **Modify Mode** only.

Note: Close all windows except for the 'SVP' window during 'NAS Setup on SVP' is running.

- (4) In the 'NAS Setup on SVP (Main)' window select the NAS Package to be installed, and then click the **Program Install** button.

- (5) The 'NAS Setup on SVP (Program Install)' window appears.
 From a list of the program products displayed in **Program Product in Media**, select the NAS OS to be installed. If you want to install multiple program products, select the program product while holding down the **Ctrl** key.
 Check the LU that you want to initialize, and then click the **Install** button.

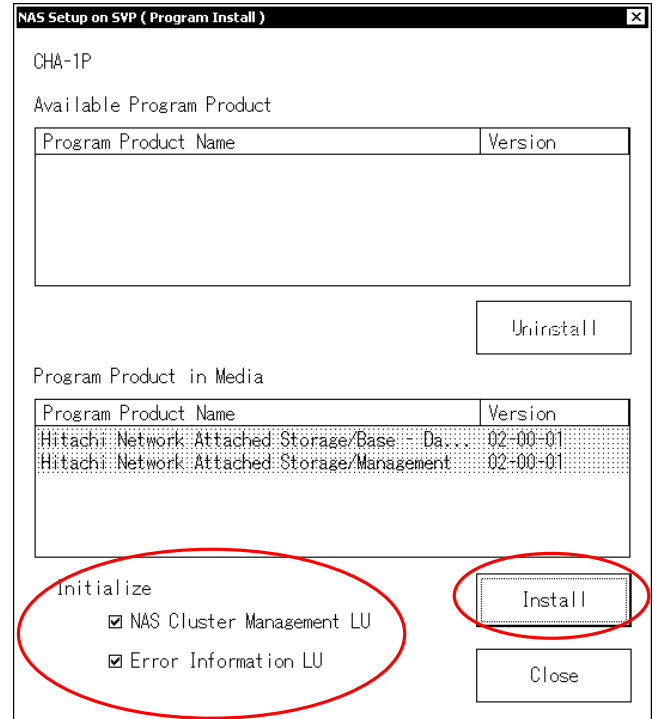

- (6) The message "The NAS OS will be installed for the first time. The NAS OS LU will be installed, and all the installed products will be uninstalled. Are you sure you want to install the NAS OS?" is displayed.
 Click the **OK** button in the message window.

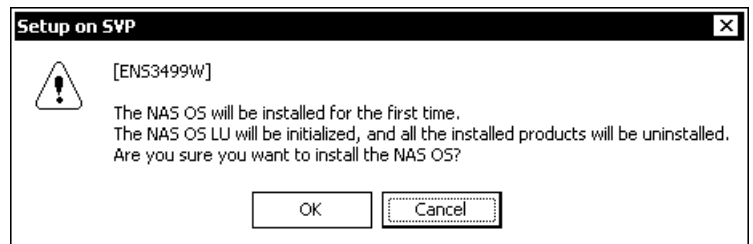

- (7) Depending on the LU selected in the 'NAS Setup on SVP (Program Install)' window, the following message appears:

When only **NAS Cluster Management LU** is selected, the message "NAS Cluster Management LU: ON, Error Information LU: OFF The LU that you selected will be initialized. But then the running NAS package system may be affected by this process. Is this OK?" appears.

Click the **OK** button in the message window.

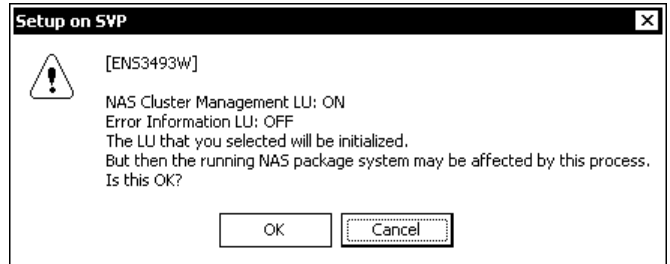

When only **Error Information LU** is selected, the message "NAS Cluster Management LU: OFF, Error Information LU: ON The LU that you selected will be initialized. But then the running NAS package system may be affected by this process. Is this OK?" is displayed.

Click the **OK** button in the message window.

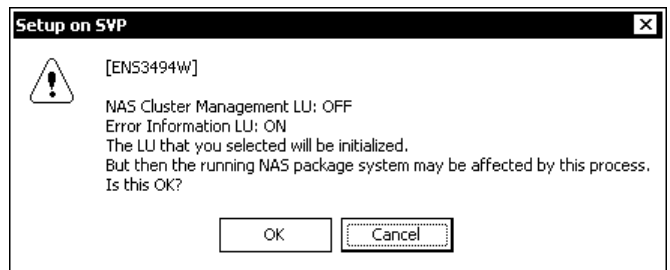

When both **NAS Cluster Management LU** and **Error Information LU** are selected, the message "NAS Cluster Management LU: ON, Error Information LU: ON The LU that you selected will be initialized. But then the running NAS package system may be affected by this process. Is this OK?" is displayed.

Click the **OK** button in the message window.

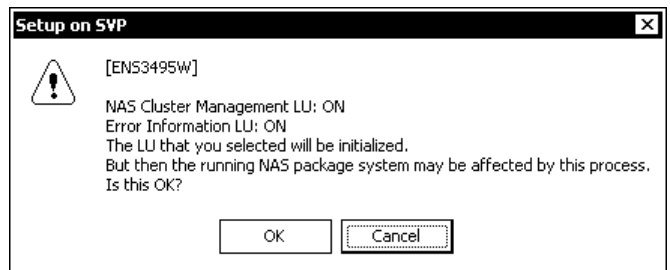

- (8) The 'NAS Setup on SVP (Password)' window appears.
Enter the password, and then click the **OK** button.
The installation including LU initialization starts.

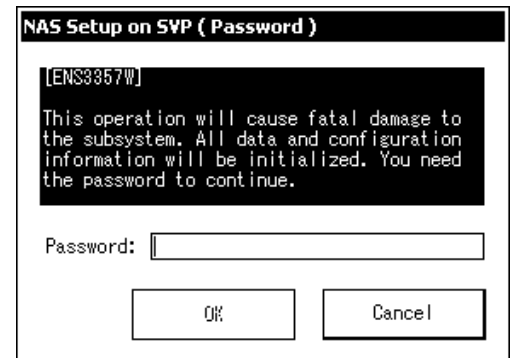

- (9) The 'NAS Setup on SVP (Install Progress)' window appears, and then the installation progress for the selected program product is displayed. If you selected multiple program products, the installation starts in the order from the top item.

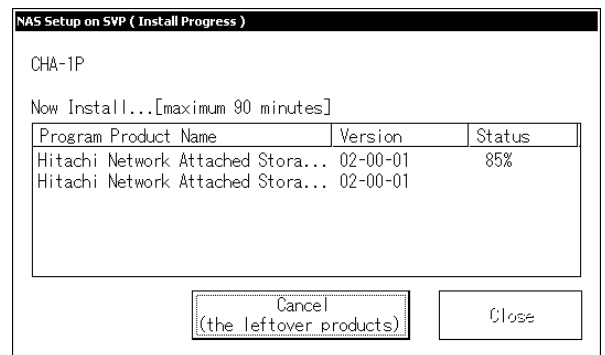

If installation finishes successfully, go to step (11).

Note: It takes approximately 10 minutes to install the NAS OS in one NAS Package, and a maximum of 90 minutes to install it in more than one NAS Package at the same time.

Note: Select (CL) [Cancel (the leftover products)] if you want to cancel next and consecutive PP installation.

(10) When an installation of NAS OS finishes abnormally:

(10-1)

When a message whose ID is ENSxxxxx appears, see the *SVP MESSAGE Section* for the corresponding action to take.

(10-2)

Make sure that there is no blocked part or error in the ‘NAS Setup on SVP (Maintenance)’ window. If there is a blocked part or an error, see the *SVP Section* [SVP02-30] [SVP03-10], and then take actions.

(10-3)

Perform the procedure for installing NAS OS containing LU initialization.

(11) When all the statuses of the program products displayed in the ‘NAS Setup on SVP (Install Progress)’ window become **Completed**, the installation finishes.

Click the **Close** button in the ‘NAS Setup on SVP (Install Progress)’ window.

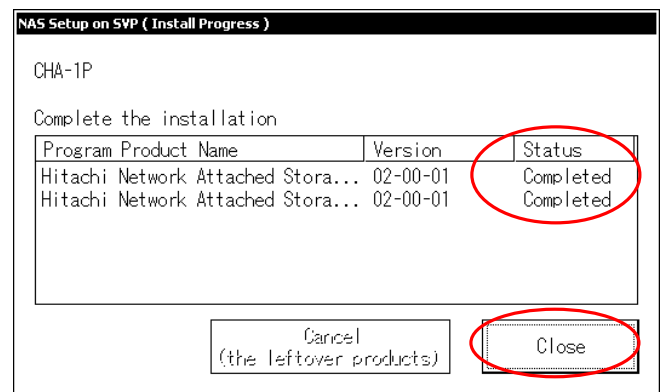

(12) The ‘NAS Setup on SVP (Program Install)’ window appears.

Make sure that the version displayed in **Version** corresponds with the version of the NAS OS media (CD-ROM) and also the program product name in **Program Product Name** in **Available Program Product** corresponds with the program product name of the NAS OS media (CD-ROM), and then click the **Close** button.

The installation finishes.

Note: When NAS OS is installed, you select “NAS OS(Hitachi Network Attached Storage/Base - Data Control, Hitachi Network Attached Storage/Base - File Sharing)” from **Program Product in Media** in the ‘NAS Setup on SVP(Program Install)’ window. However, after the installation finishes, two program products (“Hitachi Network Attached Storage/Base - Data Control” and “Hitachi Network Attached Storage/Base - File Sharing”) are displayed in **Available Program Product**.

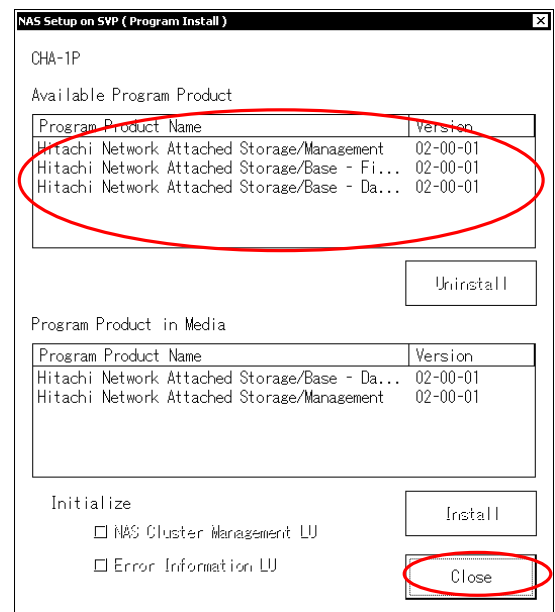

3.5.5 Uninstalling Optional Program Products

To uninstall the optional program products:

- (1) In the 'NAS Setup on SVP (Main)' window select the NAS Package (**UP** or **INACTIVE** status) on which the operation is to be performed, and then click the **Program Install** button.
-
- (2) The 'NAS Setup on SVP (Program Install)' window appears.
From a list of the program products in **Available Program Product**, select the optional program product to be uninstalled, and then click the **Uninstall** button.

Note: You can uninstall optional program products only.

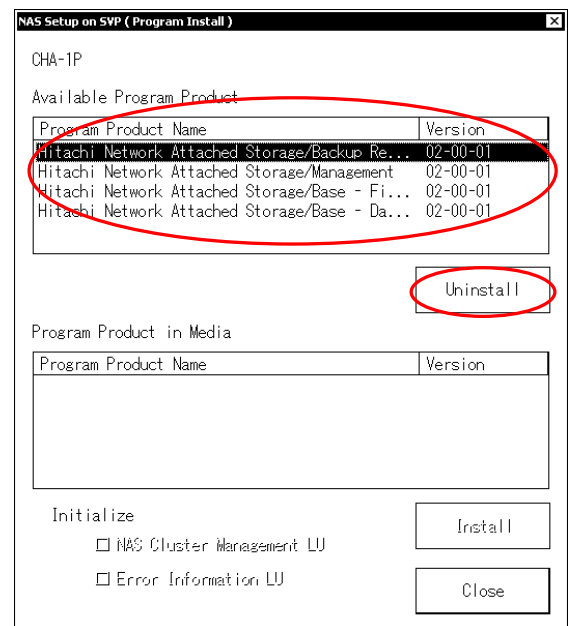

- (3) The message “Are you sure you want to uninstall *XXXXX*?” is displayed.
Click the **OK** button in the message window.
The uninstallation starts.

Note: *XXXX* indicates a program product name.

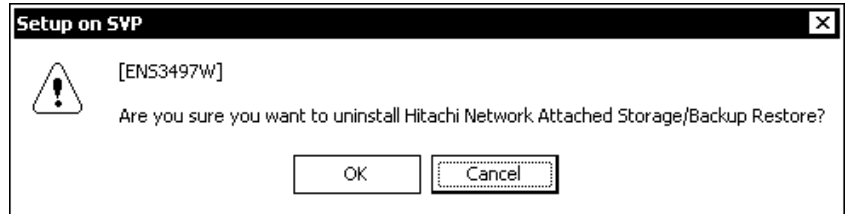

- (4) When uninstallation finishes, the message “The process ended normally.” is displayed.
Click the **OK** button in the message window.

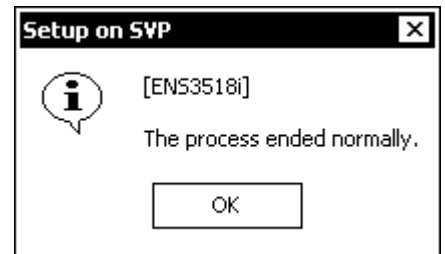

- (5) 'NAS Setup on SVP (Program Install)' window, make sure that the program product that was uninstalled is not displayed in **Available Program Product**, and then click the **Close** button.

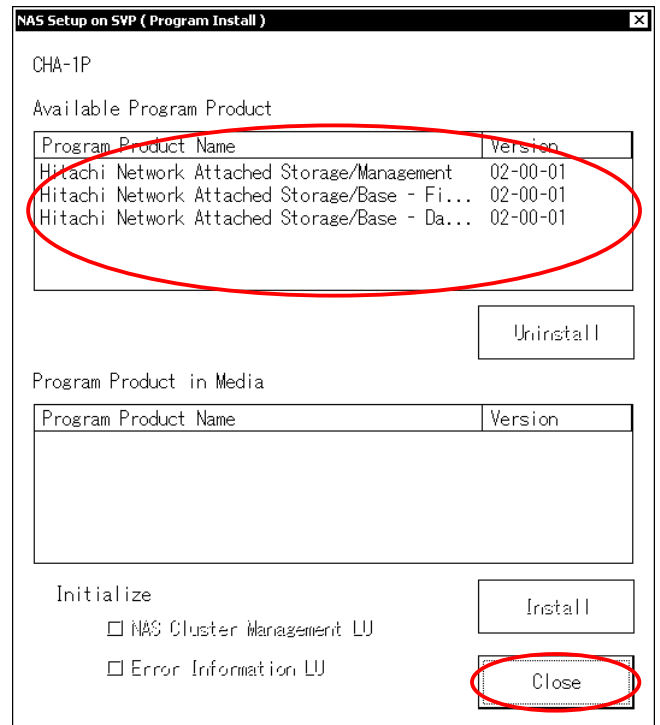

3.5.6 Setting Up the Network Environment

The network information, such as the NTP server corresponding to the NAS Package and the fixed IP address of the NAS Package NIC, can be configured. Note, however, that the settings of a NAS Package in a cluster configuration cannot be changed.

Note when setting the network:

- If you changed the network environment configuration according to this procedure after setting up the license of Hitachi Network Attached Storage/Backup Restore, restart the NDMP server. For details, see the *Hitachi Network Attached Storage/Backup Restore User's Guide (3.5.3 Restarting the NDMP server)*.
- The IP addresses of the following networks must not be used. The following networks are reserved in the subsystem. Please contact the Technical Support Center if you need to use these IP addresses.
 - - from 172.29.1.0/24 to 172.29.4.0/24, and
 - - the networks of the IP addresses set for the SVP.
- The reserved words for NAS Blade systems cannot be used for a channel adapter name. Table 3.5-4 shows the reserved words for NAS Blade systems.

Table 3.5-4 List of Reserved Words in NAS Blade Systems

Initial letter	Reserved words
A	add, admin
C	CLU_partition, cluster
D	define, delete
F	Failover_policy, Filesystem, for, force
H	ha_parameter, ha_services, hostname
I	in, IP_address
L	localhost, log_group, LVM_volume
M	maintenance_off, maintenance_on, modify, move
N	nasos, NFS, NFS_admin, node
O	offline, online
R	remove, resource, resource_group, resource_type
S	set, show, start, status, stnet_xxx ^{*1} , stop
T	to

*1: Any word starts with stnet_

To set up the network environment:

- (1) In the 'NAS Setup on SVP (Main)' window select the NAS Package (**INACTIVE** status), and then click the **Setting** button.

- (2) The 'NAS Setup on SVP (Setting)' window appears. The current setting is displayed in each item.

Enter the desired value for each item, and then click the **Setup** button.

Note:

- In **CHA Name**, specify a unique name in the disk subsystem.
- Be sure to enter all the items except **Server 2** in **NTP Server**.
- In **NTP Server**, specify the same value for each NAS Package comprising the cluster.

The screenshot shows the 'NAS Setup on SVP (Setting)' window with the following fields and callouts:

- CHA-1Q**: Channel Adapter name.
- CHA Name**: . Callout: "Set the Channel Adapter name. Specify a name that is unique in the disk subsystem. (Required)"
- 1E**: Network interface 1E.
 - IP Address**: . Callout: "Set the IP address and network mask. (Required)"
 - Subnet Mask**:
 - MTU**: . Callout: "Displays the currently set MTU value (specifiable range: 1500-16110, the default is 1500.) The value can be modified only when the cluster is stopped, after the cluster is defined."
- 1F**: Network interface 1F.
 - IP Address**: . Callout: "Set the IP address and network mask. (Required)"
 - Subnet Mask**:
 - MTU**:
- Default Gateway**:
 - IP Address**: . Callout: "Set the default gateway IP address, and select the NIC (port) that uses the default gateway IP address. (Required)"
 - Port**: Radio buttons for 1E (selected) and 1F.
- NTP Server**:
 - Server 1**: . Callout: "The IP address and host name for the NTP server can be specified (Server 1 is required.)."
 - Server 2**:
- Buttons**: **Setup** and **Close**. Callout: "The specified information is set up."

- (3) The message "Are you sure you want to apply the setting to the NAS OS?" is displayed. Confirm the setting contents again, and then click the **OK** button in the message window. The settings are applied.

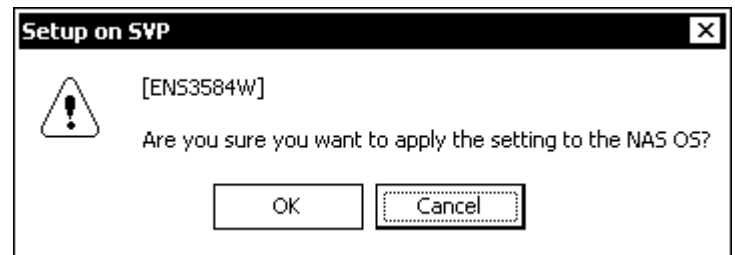

-
- (4) When the setting contents are changed, the message “The setup ended normally.” is displayed.
Click the **OK** button in the message window.

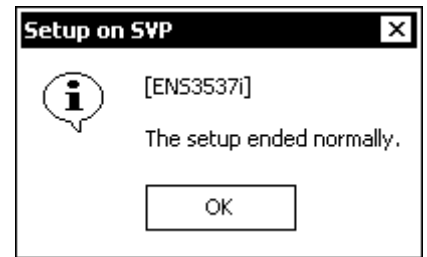

-
- (5) Click the **Close** button in the ‘NAS Setup on SVP (Setting)’ window.

-
- (6) Restart the NAS OS of the operated NAS Package. For details, see 3.5.8 [3] *Restarting the NAS OS* [[NAS03-850](#)].

3.5.7 Setting Up a License

- [1] Setting up licenses individually----- [NAS03-660](#)
- [2] Setting up licenses in the batch mode----- [NAS03-700](#)
- [3] Checking or changing license information----- [NAS03-740](#)
- [4] Deleting licenses ----- [NAS03-760](#)

You can set and delete the licenses of NAS/Management and optional program products for each cluster.

A license key is a password necessary for using the NAS/Management and optional program product. A license key is issued for each NAS/Management and optional program product with a purchased license. Table 3.5-5 shows the license types.

Table 3.5-5 License types

Type	Description
Permanent	The function is available for an unlimited period (the license has no expiration date). Within the scope of the license, you can transfer the usage right to the optional program product to another cluster.
Temporary	The function is available for a predetermined period of time. During this period, the function can be used in all clusters. The final availability date is determined from the license's duration and its initial date. Once the final availability date is reached, the license cannot be set again.
Emergency	The function is available for 10 days, during which period the user can use the function in the cluster. The final availability date is determined from the license's duration and its initial date. The license can be set again after the final availability date.

Note: If there is no NAS Package whose status is **UP**, **INACTIVE**, or **WARN**(NAS/Management is not installed), no license can be set.

[1] Setting up licenses individually

To use the license key to set up the license for a NAS/Management or optional program product:

- (1) In the 'NAS Setup on SVP (Main)' window, click the **License Management** button.

- (2) The 'NAS Setup on SVP (License Management)' window appears.
 In the 'NAS Setup on SVP (License Management)' window, enter the license key in **Key Code:**, and then click the **Accept** button.

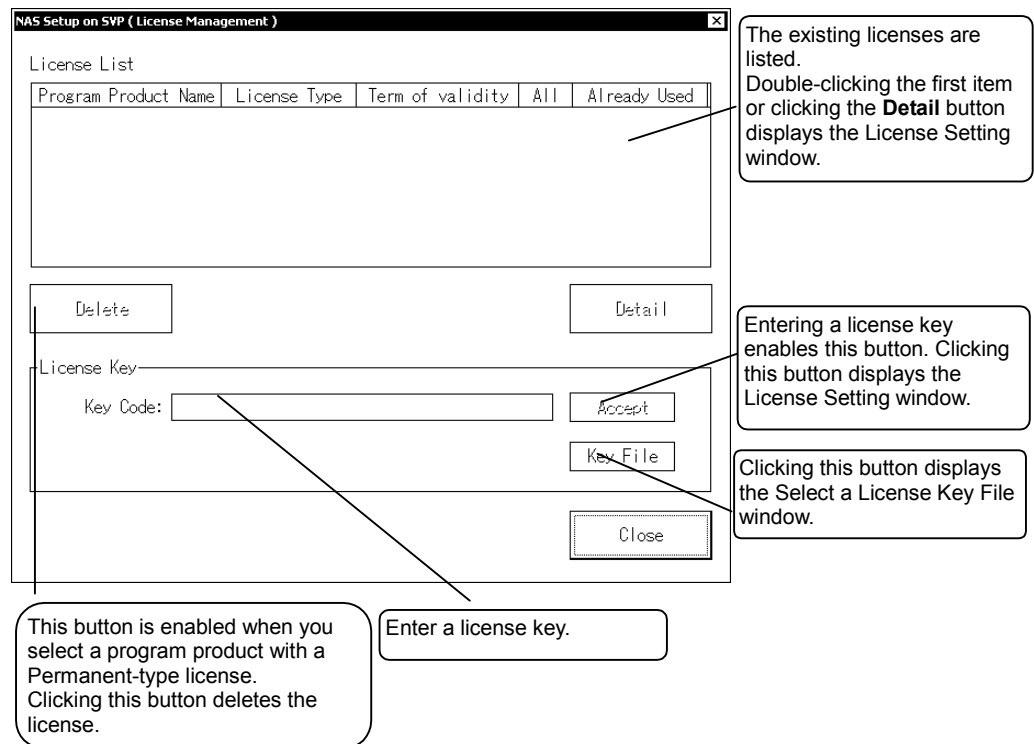

- (3) The 'NAS Setup on SVP (License Setting)' window appears.

In the 'NAS Setup on SVP (License Setting)' window, in **Distribution** select (switch the status to ON) the cluster to which you want to apply the license, and then click the **Accept** button.

Note: To set a permanent license, the number of remaining licenses displayed in **Remaining License** should be 2 or greater.

For a multi-cabinet model:

NAS Setup on SVP (License Setting)

Program Product Name
Hitachi Network Attached Storage/Backup Restore

License Type Term of validity
Remaining License

Distribution

<input type="checkbox"/> CHA-1P	<input type="checkbox"/> CHA-1Q	<input type="checkbox"/> CHA-1R	<input type="checkbox"/> CHA-1S
<input type="checkbox"/> CHA-2V	<input type="checkbox"/> CHA-2W	<input type="checkbox"/> CHA-2X	<input type="checkbox"/> CHA-2Y

Accept
Close

Displays product name and the type that are either selected in the License List window or specified by entering the license key.

For a permanent license, the **Term of validity** box displays "-" and the **Remaining License** box displays the remaining licenses.
For temporary and emergency licenses, the **Term of validity** box displays the time limit for usage and the **Remaining License** box displays "-".

Click this button to set the information of the entered (displayed) license.

Distribution buttons:
Switching the selection (ON indicates that the target cluster is selected and OFF indicates that the target cluster is not selected) enables the license to be set and enables you to check which clusters have a license, etc.

For a single cabinet model:

NAS Setup on SVP (License Setting)

Program Product Name
Hitachi Network Attached Storage/Backup Restore

License Type Term of validity
Remaining License

Distribution

<input type="checkbox"/> CHA-1C	<input type="checkbox"/> CHA-1D	<input type="checkbox"/> CHA-1F
<input type="checkbox"/> CHA-2G	<input type="checkbox"/> CHA-2J	<input type="checkbox"/> CHA-2K

Accept
Close

Displays product name and the type that are either selected in the License List window or specified by entering the license key.

For a permanent license, the **Term of validity** box displays "-" and the **Remaining License** box displays the remaining licenses.
For temporary and emergency licenses, the **Limit** box displays the time **Term of validity** for usage and the **Remaining License** box displays "-".

Click this button to set the information of the entered (displayed) license.

Distribution buttons:
Switching the selection (ON indicates that the target cluster is selected and OFF indicates that the target cluster is not selected) enables the license to be set and enables you to check which clusters have a license, etc.

- (4) The message “Are you sure you want to apply the setting to the NAS OS?” is displayed. Confirm that the selected cluster is the one to which you want to apply the license, and then click the **OK** button in the message window. The setting is applied.

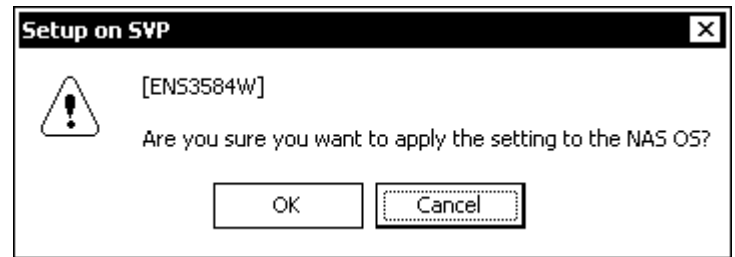

- (5) When the settings finish, the message “The License is accepted.” is displayed. Click the **OK** button in the message window.

Note: To set a permanent license, the number of remaining licenses displayed in **Remaining License** should be 2 or greater.



- (6) Click the **Close** button in the ‘NAS Setup on SVP (License Setting)’ window to close the ‘NAS Setup on SVP (License Setting)’ window.

- (7) Confirm that the license that was set is displayed in **License List** of the ‘NAS Setup on SVP (License Management)’ window, and then click the **Close** button.

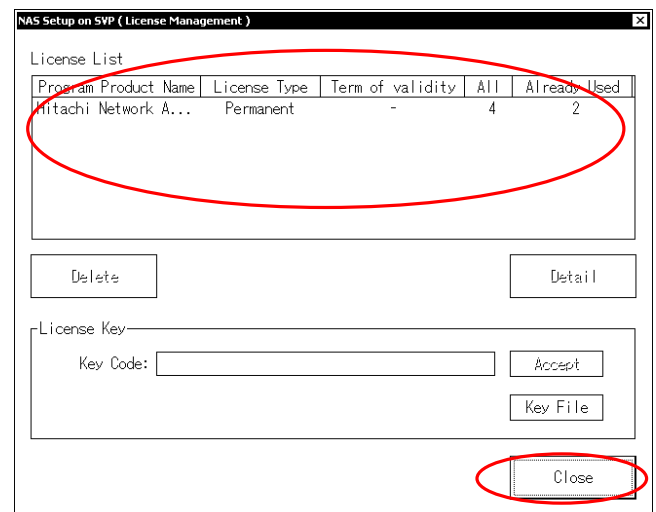

[2] Setting up licenses in the batch mode

To set up the licenses for the NAS/Management or multiple optional program products by means of a license key file:

(1) In the 'NAS Setup on SVP (Main)' window, click the **License Management** button.

(2) The 'NAS Setup on SVP (License Management)' window appears.

In the 'NAS Setup on SVP (License Management)' window, click the **Key File** button.

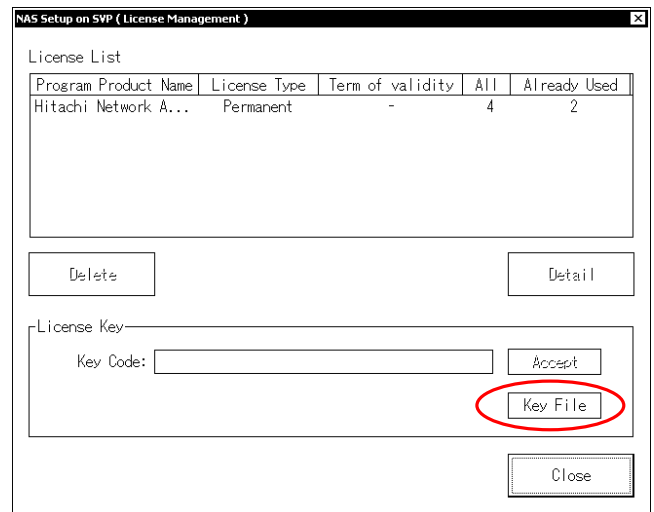

(3) The 'Select a License Key File' window is displayed.

Select a license key file, and then click the **Open** button.

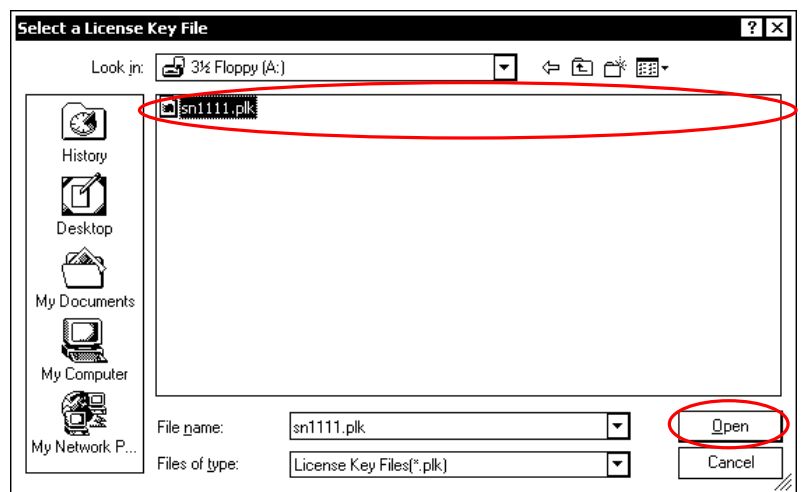

- (4) The 'NAS Setup on SVP (License Key File)' window appears.
In the 'NAS Setup on SVP (License Key File)' window, select from **License Key List** a license to be set up, and then click the **Accept** button.

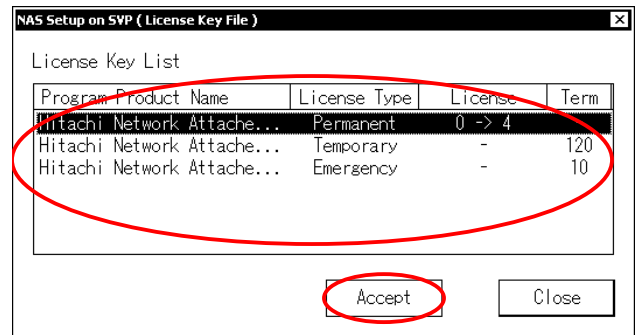

- (5) The 'NAS Setup on SVP (License Setting)' window appears.
In the 'NAS Setup on SVP (License Setting)' window, under **Distribution**, select the cluster to which the license is to be assigned, and then click the **Accept** button.

Note: To set a permanent license, the number of remaining licenses displayed in **Remaining License** should be 2 or greater.

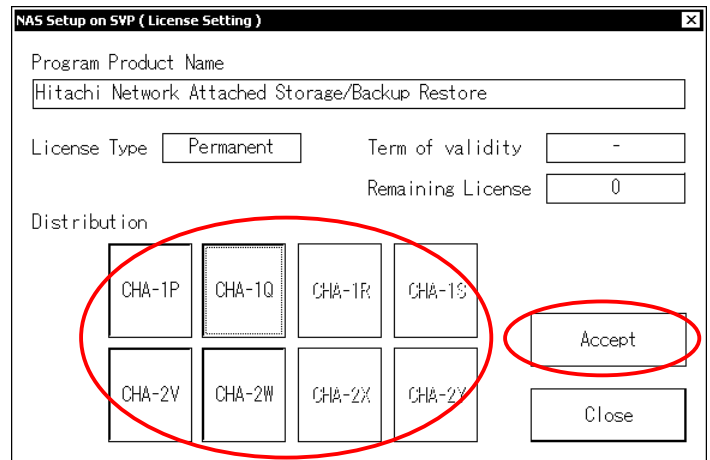

- (6) The message “Are you sure you want to apply the setting to the NAS OS?” is displayed. Recheck the cluster to which the license is to be assigned, and then click the **OK** button. The setting is applied.

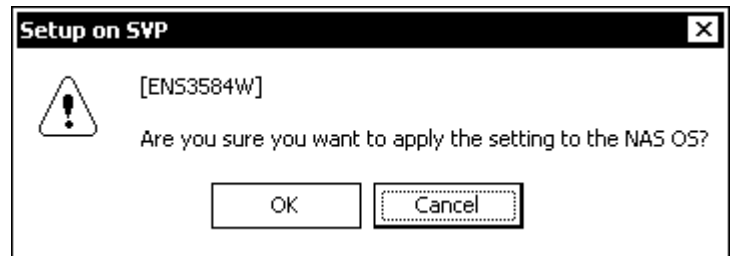

- (7) The message “The license is accepted” is displayed. Click the **OK** button.



- (8) The 'NAS Setup on SVP (License Key File)' window appears.
In the 'NAS Setup on SVP (License Key File)' window, click the **Close** button to close the window.

- (9) The 'NAS Setup on SVP (License Key File)' window appears.

When setting up multiple licenses:

Repeat steps (4) through (8).

When all needed licenses have been set up:

In the 'NAS Setup on SVP (License Key File)' window, click the **Close** button to close the window.

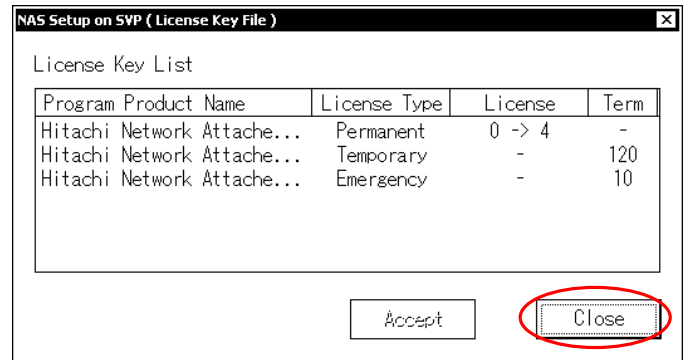

- (10) The 'NAS Setup on SVP (License Management)' window appears.
Check that the licenses that were set up in the NAS Setup on SVP (License Key File) window are displayed, and then click the **Close** button.

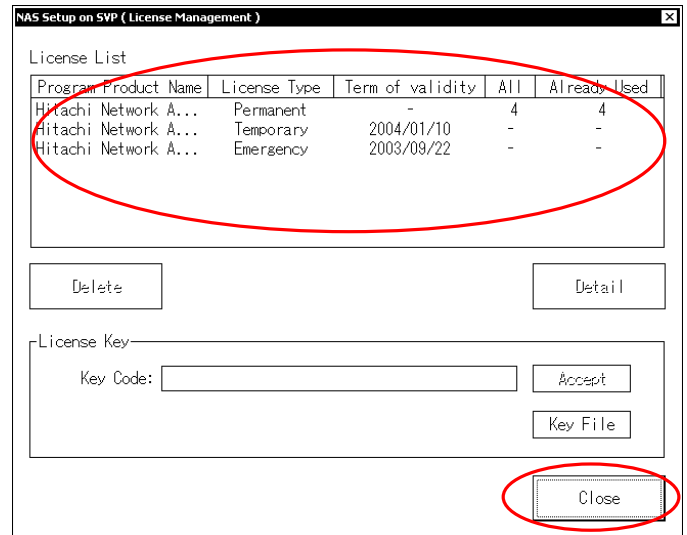

[3] Checking or changing license information

To check or change license information:

- (1) Click the **License Management** button in the 'NAS Setup on SVP (Main)' window.

- (2) The 'NAS Setup on SVP (License Management)' window appears.
From **License List** in the 'NAS Setup on SVP (License Management)' window, select the license for which detailed information is to be displayed, and then click the **Detail** button.

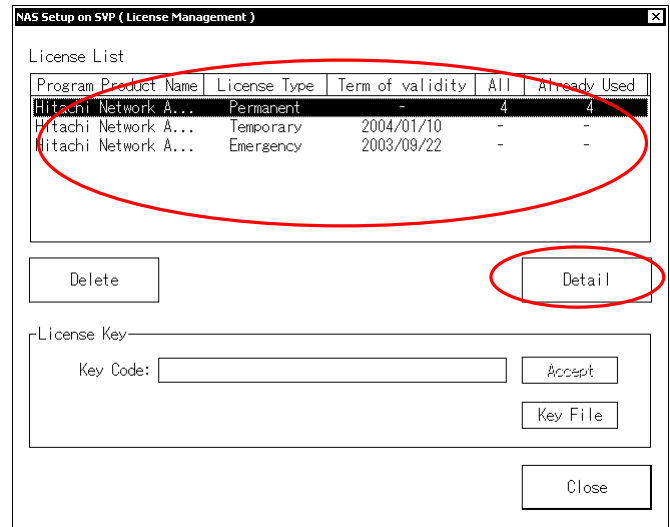

- (3) The 'NAS Setup on SVP (License Setting)' window appears.
Make sure that license information is to be displayed, and then click the **Close** button to close the 'NAS Setup on SVP (License Setting)' window.

When changing the setting of a permanent license:

Perform the procedure from step (3) in 3.5.7 [1] *Setting up licenses individually* [NAS03-660].

The screenshot shows a window titled "NAS Setup on SVP (License Setting)". It contains the following fields and buttons:

- Program Product Name: Hitachi Network Attached Storage/Backup Restore
- License Type: Permanent
- Term of validity: -
- Remaining License: 2
- Distribution buttons: CHA-1P, CHA-1Q, CHA-1R, CHA-1S, CHA-2V, CHA-2W, CHA-2X, CHA-2Y
- Action buttons: Accept, Close (circled in red)

- (4) Click the **Close** button in the 'NAS Setup on SVP (License Management)' window.

[4] Deleting licenses

You can delete the licenses for each disk subsystem. The licenses are deleted from all clusters in a disk subsystem and the corresponding program products become unavailable.

You can delete the license key for a program product whose license type is Permanent. You cannot delete a license whose type is Temporary or Emergency.

To delete a license:

- (1) In the 'NAS Setup on SVP (Main)' window, click the **License Management** button.

- (2) The 'NAS Setup on SVP (License Management)' window appears.
In the 'NAS Setup on SVP (License Management)' window, select from **License List** the license to be deleted, and then click the **Delete** button.

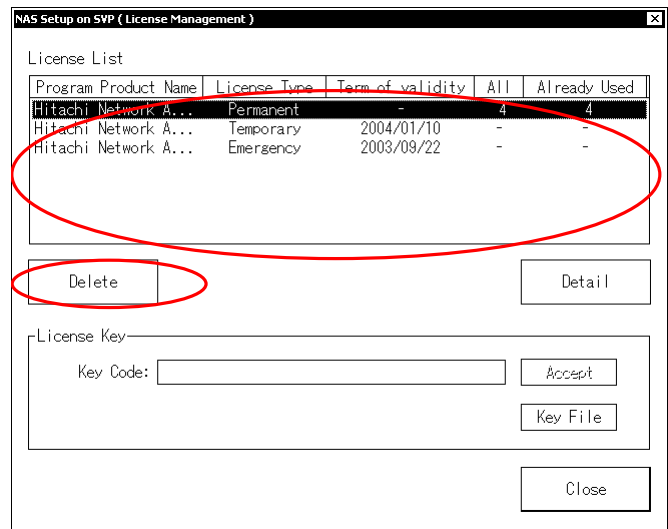

- (3) The message “The license (XXXX) will be removed. You will be unable to use the function corresponding to this license. Are you sure you want to remove the license?” is displayed.
Click the **OK** button.
The license is removed.

Note: XXXX indicates a program product name.



- (4) When license deletion has been completed, the message “The license was removed.” is displayed.
Click the **OK** button.

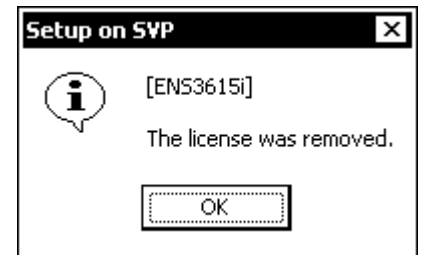

- (5) In the ‘NAS Setup on SVP (License Setting)’ window, click the **Close** button to close window.

- (6) In the 'NAS Setup on SVP (License Management)' window, check that the deleted license is no longer listed under **License List**, and then click the **Close** button.

License List

Program Product Name	License Type	Term of validity	All	Already Used
Hitachi Network A...	Temporary	2004/01/10	-	-
Hitachi Network A...	Emergency	2003/09/22	-	-

Delete Detail

License Key

Key Code: Accept

Key File

Close

3.5.8 Controlling the NAS OS (Stopping, Starting, and Restarting)

- [1] Stopping the NAS OS ----- [NAS03-790](#)
 [2] Starting the NAS OS ----- [NAS03-830](#)
 [3] Restarting the NAS OS ----- [NAS03-850](#)

This section describes the procedures for controlling the NAS OS.

[1] Stopping the NAS OS

CAUTION

Before stopping the NAS OS, switch the services running on the target NAS Package (node) to be stopped to run on an alternative node, and then request the system administrator to stop the target node.

To stop the NAS OS:

- (1) In the 'NAS Setup on SVP (Main)' window, select the NAS Package on which the operation is to be performed, and then click the **Boot Management** button.
-
- (2) The 'NAS Setup on SVP (Boot Management)' window appears.
 Make sure that **Status** is **INACTIVE** or **WARN**, and then click the **Shutdown** button.

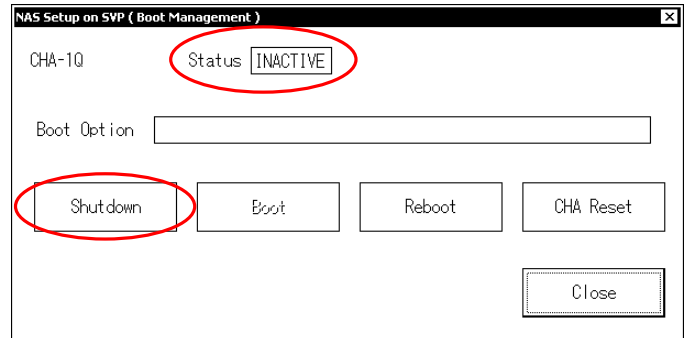

- (3) The message “Are you sure you want to shut down the NAS OS?” is displayed.
Click the **OK** button in the message window.

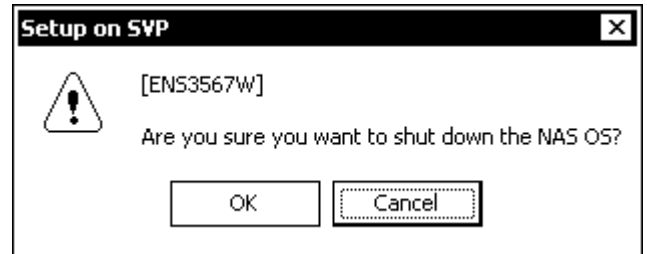

(3-1)

If the node is stopped, the shutdown processing starts.

Go to step (4).

(3-2)

If the node is running, the message “This node is active. Please ask a system administrator to switch the service to the alternative node and stop this node...” appears.

Click the **Cancel** button to stop the operation, and then request the system administrator to switch the services to an alternative node and stop the target node.

To forcibly shut down the NAS OS, click the **OK** button.

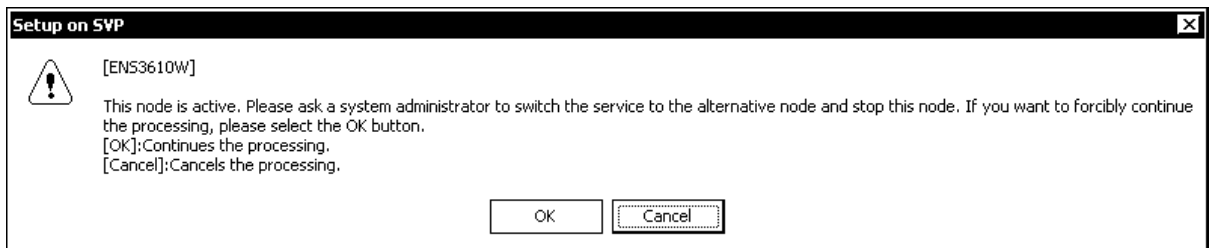

Go to step (3-4).

Note: If the node is running, the password is required to stop the NAS OS. The NAS OS is not stopped until you finish entering the password in the ‘NAS Setup on SVP (Password)’ window.

(3-3)

If the system is unable to recognize the status of the cluster, the message “Failed to get the cluster status. Please select the **Cancel** button, and then retry the operation...” appears. Click the **Cancel** button to stop the operation, and then go back to step (2) to retry the operation.

If the same message appears repeatedly, click the **OK** button to forcibly shut down the NAS OS.

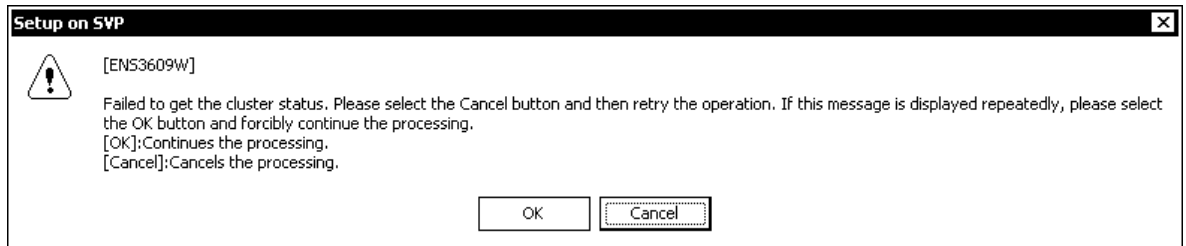

Go to step (3-4).

(3-4)

The message “The cluster system may be affected by this process. Do you want to continue the processing?” appears.

Click the **OK** button in the message window.

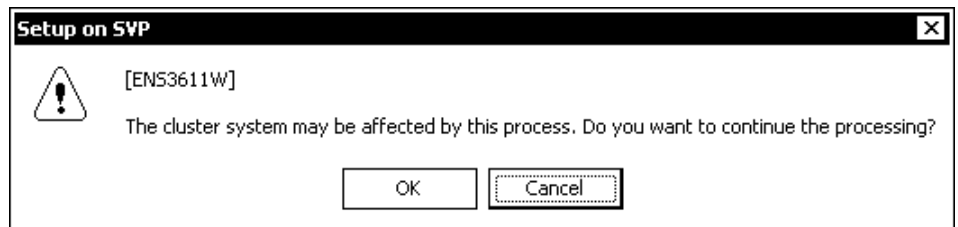

(3-5)

The ‘NAS Setup on SVP (Password)’ window appears.

Enter the password, and then click the **OK** button.

Shutdown processing of the NAS OS starts.

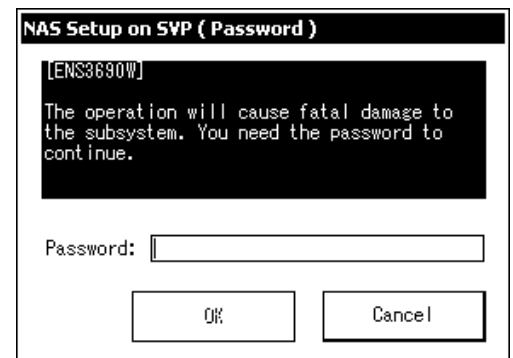

- (4) In the middle of the processing, **Status** changes to **BUSY** in the ‘NAS Setup on SVP (Boot Management)’ window.

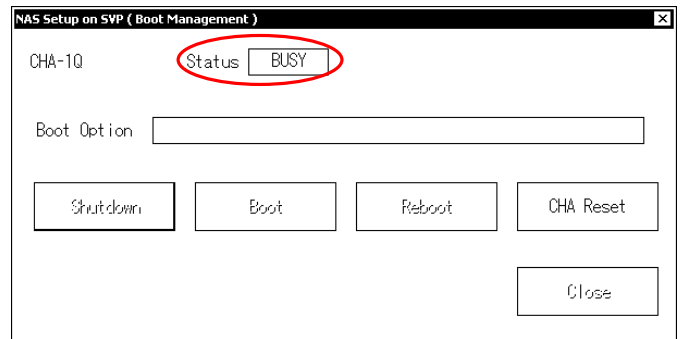

- (5) When the processing finishes, the message “NAS OS has shut down.” is displayed. Click the **OK** button in the message window.

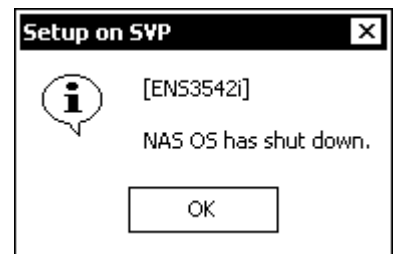

- (6) Make sure that **Status** is **DOWN** in the ‘NAS Setup on SVP (Boot Management)’ window, and then click the **Close** button.

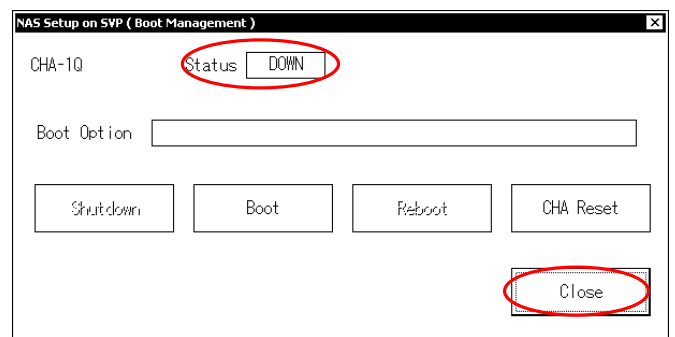

[2] Starting the NAS OS

To start the NAS OS:

- (1) In the 'NAS Setup on SVP (Main)' window, select the NAS Package on which the operation is to be performed, and then click the **Boot Management** button.
-
- (2) The 'NAS Setup on SVP (Boot Management)' window appears. Make sure that **Status** is **DOWN**, and then click the **Boot** button.

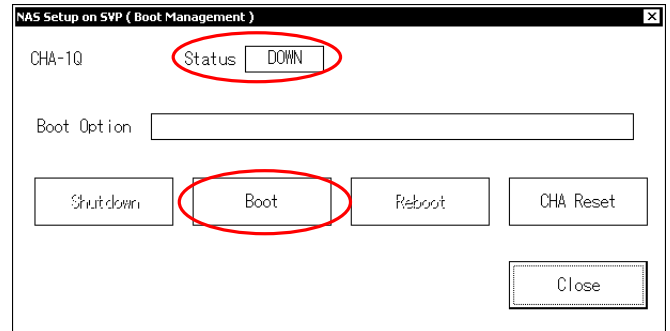

- (3) The message "Are you sure you want to boot the NAS OS?" is displayed. Click the **OK** button in the message window. The start processing is performed.

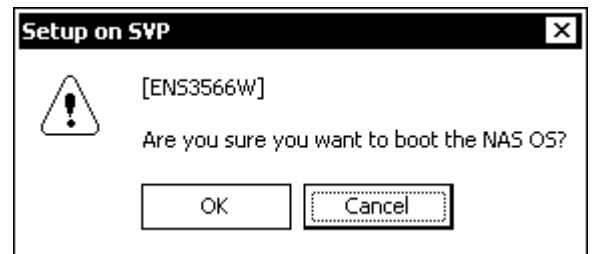

- (4) In the middle of the processing, **Status** changes to **BUSY** in the ‘NAS Setup on SVP (Boot Management)’ window.

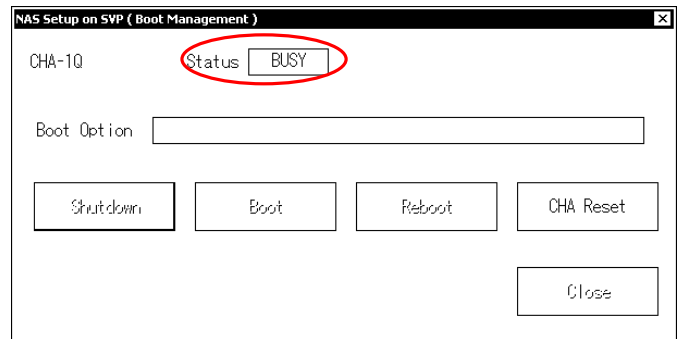

- (5) The message “NAS OS has booted.” is displayed.
Click the **OK** button in the message window.



- (6) Make sure that **Status** is **UP**, **INACTIVE**, or **WARN**(NAS/Management is not installed) in the ‘NAS Setup on SVP (Boot Management)’ window, and then click the **Close** button.

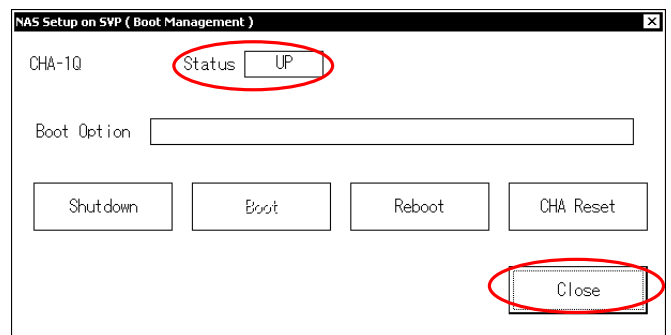

[3] Restarting the NAS OS

⚠ CAUTION

Before restarting the NAS OS, switch the services running on the target NAS Package (node) to be restarted to run on an alternative node, and then request the system administrator to stop the target node.

To restart the NAS OS:

- (1) In the 'NAS Setup on SVP (Main)' window, select the NAS Package on which the operations is to be performed, and then click the **Boot Management** button.
- (2) The 'NAS Setup on SVP (Boot Management)' window appears.
Make sure that **Status** is **INACTIVE**, or **WARN**, and then click the **Reboot** button.

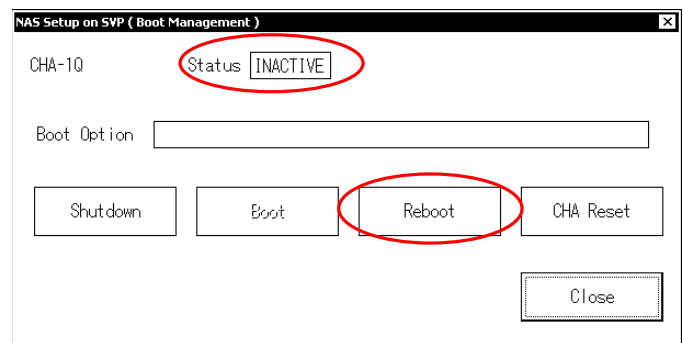

- (3) The message “Are you sure you want to reboot the NAS OS?” is displayed.
Click the **OK** button in the message window.

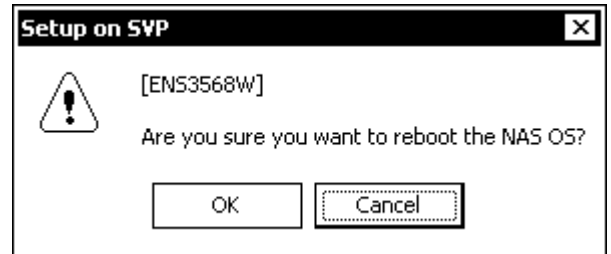

(3-1)

If the node is stopped, the restart processing starts.

Go to step (4).

(3-2)

If the node is running, the message “This node is active. Please ask a system administrator to switch the service to the alternative node and stop this node...” appears.

Click the **Cancel** button to stop the operation, and then request the system administrator to switch the services to an alternative node and stop the target node.

To forcibly restart the NAS OS, click the **OK** button.

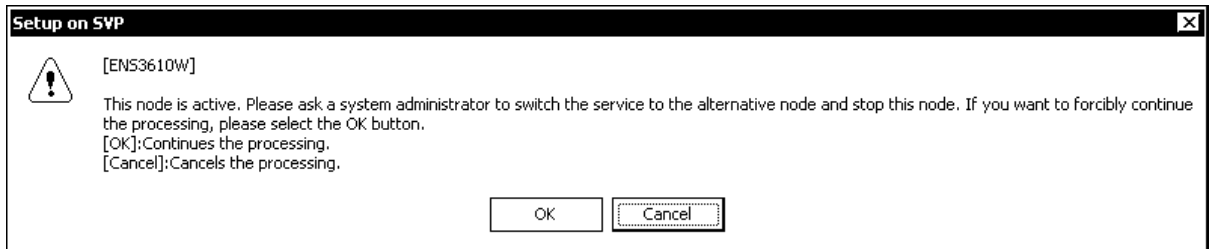

Go to step (3-4).

(3-3)

If the system is unable to recognize the status of the cluster, the message “Failed to get the cluster status. Please select the **Cancel** button, and then retry the operation...” appears. Click the **Cancel** button to stop the operation, and then go back to step (2) to retry the operation.

If the same message appears repeatedly, click the **OK** button to forcibly shut down the NAS OS.

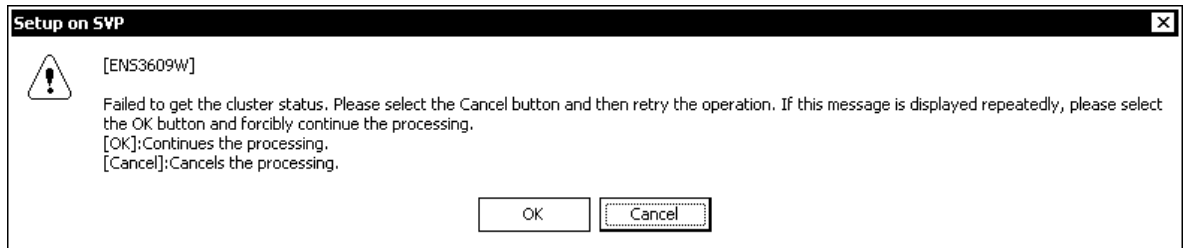

Go to step (3-4).

(3-4)

The message “The cluster system may be affected by this process. Do you want to continue the processing?” appears.

Click the **OK** button in the message window.

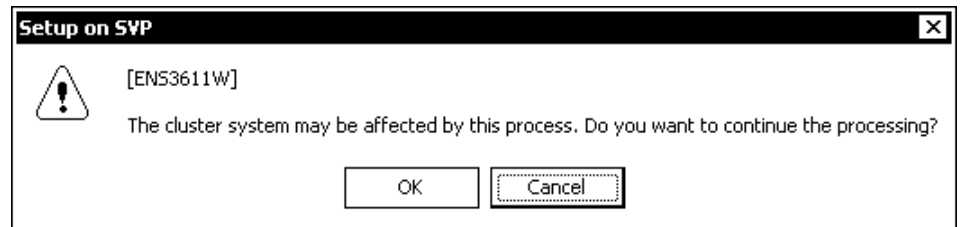

(3-5)

The ‘NAS Setup on SVP (Password)’ window appears.

Enter the password, and then click the **OK** button.

The NAS OS is restarted.

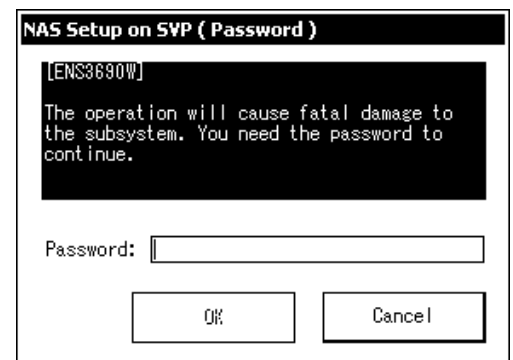

- (4) In the middle of the processing, **Status** changes to **BUSY** in the ‘NAS Setup on SVP (Boot Management)’ window.

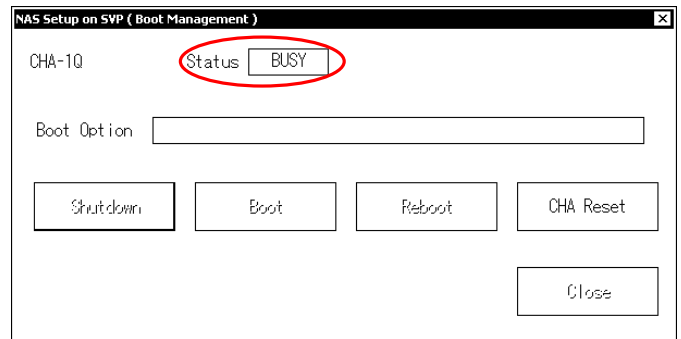

- (5) The message “NAS OS has rebooted.” is displayed.
Click the **OK** button in the message window.



- (6) Make sure that **Status** is **UP**, **INACTIVE**, or **WARN**(NAS/Management is not installed) in the ‘NAS Setup on SVP (Boot Management)’ window, and then click the **Close** button.

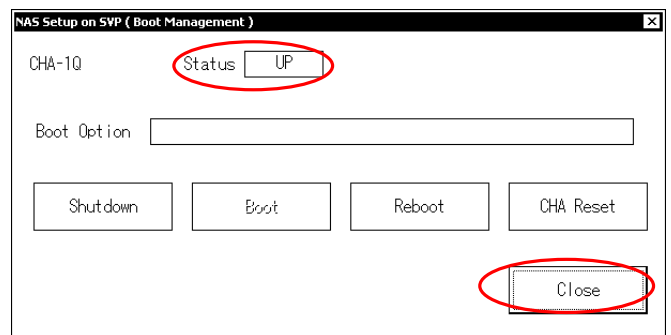

3.5.9 Resetting CHA

CAUTION

Regardless of the NAS OS status, this operation forces the NAS OS to stop instantly. Before performing this operation, contact the Technical Support Center (TSC) to confirm the validity of this operation.

Also make sure that, before resetting CHA, you request the system administrator to stop the cluster.

To reset CHA:

- (1) In the 'NAS Setup on SVP (Main)' window select the NAS Package on which the operation is to be performed, and then click the **Boot Management** button.
-
- (2) The 'NAS Setup on SVP (Boot Management)' window appears. Click the **CHA Reset** button in the 'NAS Setup on SVP (Boot Management)' window.

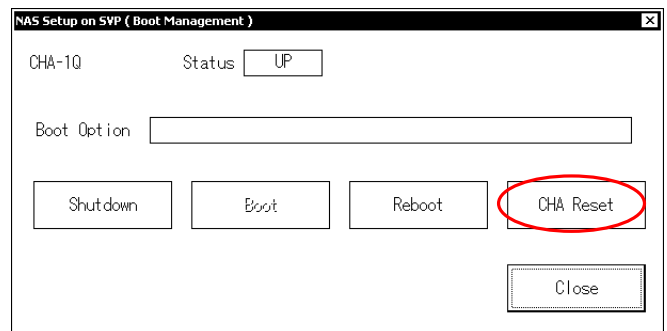

- (3) The message "Are you sure you want to reset the CHA?" is displayed. Click the **OK** button in the message window.

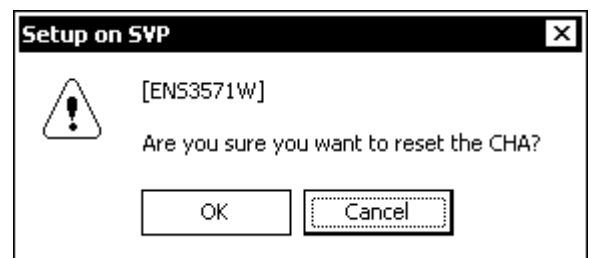

- (4) The message “This processing will stop the NAS OS forcibly and immediately, regardless of the NAS OS status. Do you want to continue the processing?” is displayed.
Click the **OK** button in the message window.

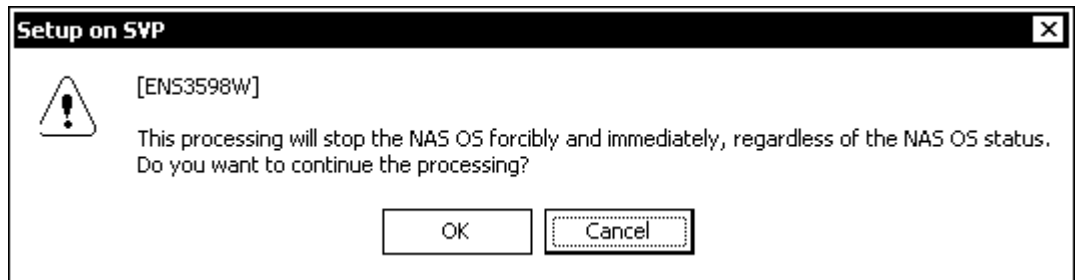

- (5) The ‘NAS Setup on SVP (Password)’ window appears.
Enter the password, and then click the **OK** button.
The CHA is reset.



- (6) When the CHA reset operation finishes, the message “The process ended normally.” is displayed.
Click the **OK** button in the message window.

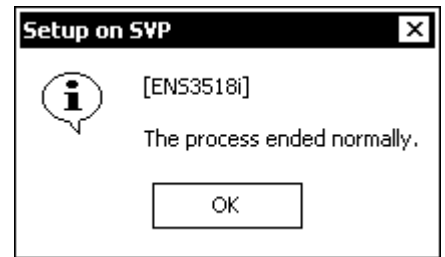

- (7) Make sure that **Status** is **DOWN** in the ‘NAS Setup on SVP (Boot Management)’ window, and then click the **Close** button.

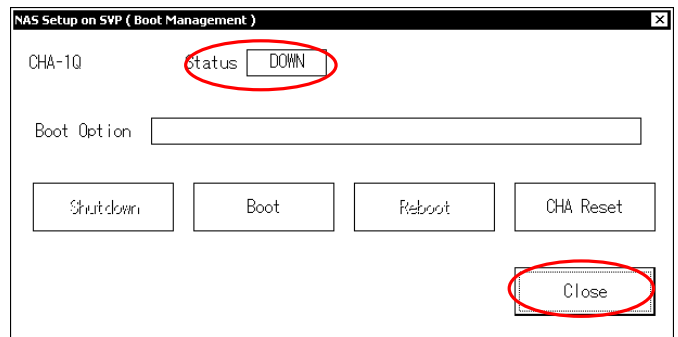

3.5.10 Collecting the Hibernation Dump

- [1] Collecting the hibernation dump ----- [NAS03-920](#)
 [2] Canceling collection of the hibernation dump ----- [NAS03-950](#)

This section describes the procedure for collecting the hibernation dump and canceling the collection.

CAUTION

Regardless of the NAS OS status, this operation forces the NAS OS to stop instantly. Before performing this operation, contact the Technical Support Center (TSC) to confirm the validity of this operation.

[1] Collecting the hibernation dump

To collect the hibernation dump:

Note: When you cancel collection of the hibernation dump, the SIM=ac84x0 (NAS OS failure) is reported. Complete this SIM [[SVP02-550](#)] because this is caused by the processing to stop the NAS OS when you collect the hibernation dump, and there is no problem.

- (1) In the 'NAS Setup on SVP (Main)' window select a NAS Package whose status is **UP**, **INACTIVE**, **WARN**, **BUSY**, or **ERROR**, and then click the **Hibernation Dump** button.
-
- (2) The 'NAS Setup on SVP (Hibernation Dump)' window appears.
Click the **Dump** button in the 'NAS Setup on SVP (Hibernation Dump)' window.

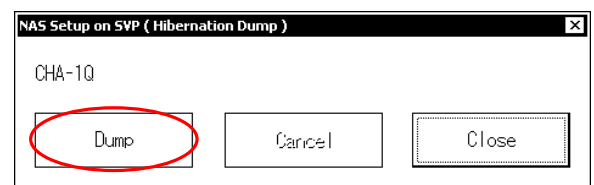

- (3) The message “Collection of hibernation dump takes about 25 minutes. Are you sure you want to collect the hibernation dump?” is displayed.
Click the **OK** button in the message window.

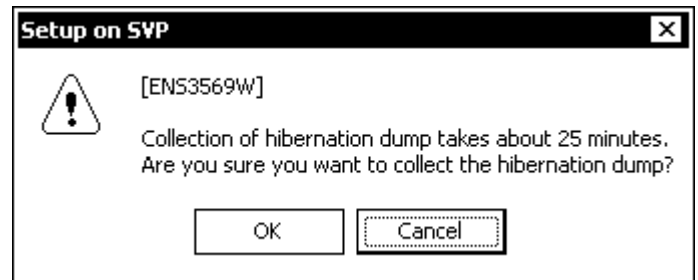

- (4) The message “This processing will stop the NAS OS forcibly and immediately, regardless of the NAS OS status. Do you want to continue the processing?” is displayed.
Click the **OK** button in the message window.

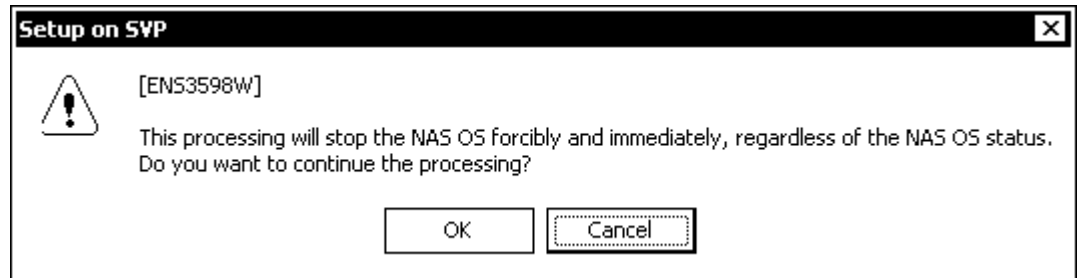

- (5) The ‘NAS Setup on SVP (Password)’ window appears.
Enter the password, and then click the **OK** button.
The hibernation dump is collected.

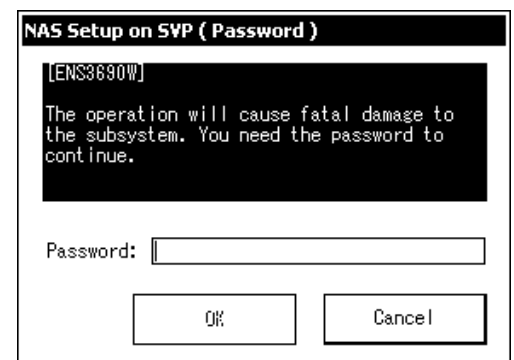

-
- (6) Click the **Close** button in the 'NAS Setup on SVP (Hibernation Dump)' window.

Note: Click **Close** button to check the status of the NAS Package being operated via 'NAS Setup on SVP'. You do not have to wait until hibernation dump finishes.

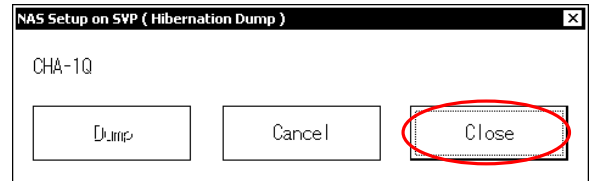

-
- (7) In the 'NAS Setup on SVP (Main)' window, make sure that the status of the NAS Package for which the operation is being performed is **DUMP**.
-
- (8) When the status of the NAS Package changes from **DUMP** to **UP**, **INACTIVE**, or **WARN** in the 'NAS Setup on SVP (Main)' window, collection of the hibernation dump has finished. Obtain a hibernation dump (follow the procedure in *3.5.14 Downloading Dump Files*) [[NAS03-1090](#)].

[2] Canceling collection of the hibernation dump

To cancel collection of the hibernation dump:

- (1) In the 'NAS Setup on SVP (Main)' window select the NAS Package that has the **DUMP** status, and then click the **Hibernation Dump** button.
-
- (2) The 'NAS Setup on SVP (Hibernation Dump)' window appears.
Click the **Cancel** button in the 'NAS Setup on SVP (Hibernation Dump)' window.

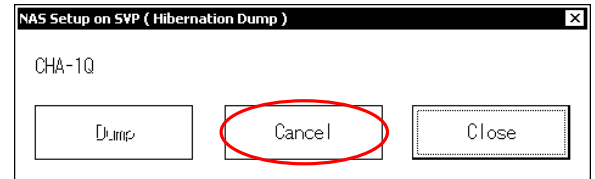

-
- (3) The message "Are you sure you want to cancel collection of the hibernation dump?" is displayed.
Click the **OK** button in the message window.
The cancel operation is performed.

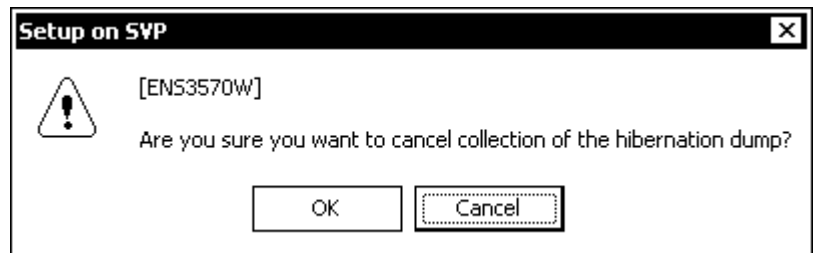

- (4) When the cancel operation for the hibernation dump finishes, the message “The process ended normally.” is displayed.
Click the **OK** button in the message window.

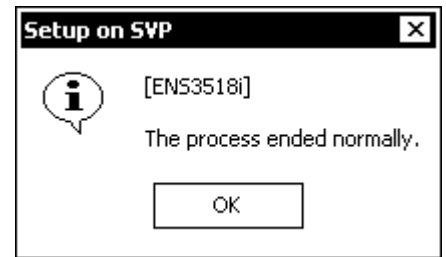

- (5) Click the **Close** button in the ‘NAS Setup on SVP (Hibernation Dump)’ window.

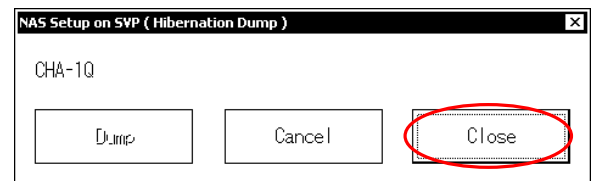

- (6) In the ‘NAS Setup on SVP (Main)’ window, make sure that the status of the selected NAS Package is **DOWN**.

- (7) Start NAS OS of the NAS Package (See 3.5.8 [2] *Starting the NAS OS*) [[NAS03-830](#)]

- (8) In the ‘NAS Setup on SVP(Main)’ window, select the NAS Package in which the error occurred, and then select **Download Dump** (See 3.5.14 *Downloading Dump Files*) [[NAS03-1090](#)]. Make sure that ‘NAS Setup on SVP (Download Dump)’ does not appear. If ‘NAS Setup on SVP (Download Dump)’ appears, make sure that **Download Status** indicating the dump acquisition status is **Normal** and also the same date is not displayed in **Last Save Date**. After confirmation, make sure that collection of the hibernation dump has been canceled.

3.5.11 Viewing the Settings (Refer Configuration Button)

NAS Package information can be confirmed in **View Mode**.

The NAS Package information is displayed in sequence. First information about the installed program products is displayed. Second, information about the configured network is displayed. Only NAS Packages whose statuses are **UP**, **INACTIVE**, or **WARN**(NAS Management is not installed) are displayed. Finally, configured license information is displayed.

Note: If there is no NAS Package whose status is **UP**, **INACTIVE**, or **WARN**(NAS Management is not installed), this function cannot be used.

- (1) Click the **Refer Configuration** button in the 'NAS Setup on SVP (Main)' window.
- (2) The 'NAS Setup on SVP (Program Install)' window for each CHA appears in View Mode. Click the >> **Next** button in the 'NAS Setup on SVP (Program Install)' window.

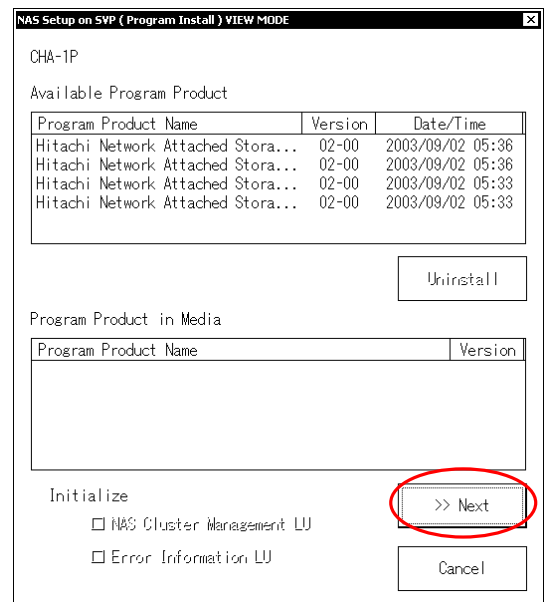

- (3) The 'NAS Setup on SVP (Setting)' window for each CHA appears in **View Mode**.
Click the >> **Next** button in the 'NAS Setup on SVP (Setting)' window.

- (4) When you repeat steps (2) and step (3), the NAS Package information is displayed in order.
For a NAS Package whose status is not **UP**, **INACTIVE**, or **WARN**(NAS Management is not installed), the message “You cannot refer to configuration information about CHA-XX, because the status is **DOWN**.” is displayed.
When you click the **OK** button, the next NAS Package information is displayed.

Note: XX indicates a NAS Package location.

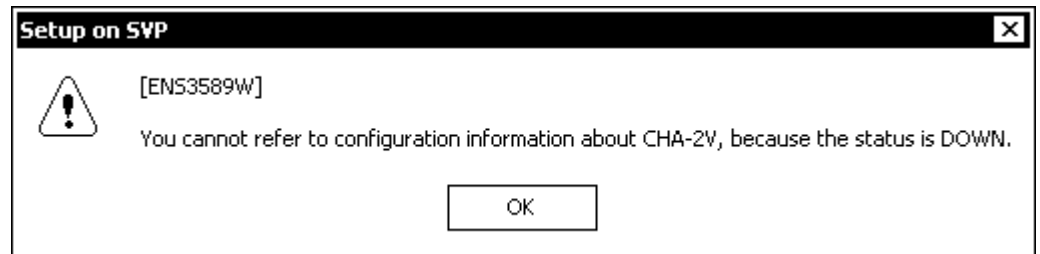

- (5) When all the NAS Package information is displayed, the 'NAS Setup on SVP (License Management)' window is displayed in **View Mode**.
Select the license from **License List** for which detailed information is to be displayed, and then click the **Detail** button.

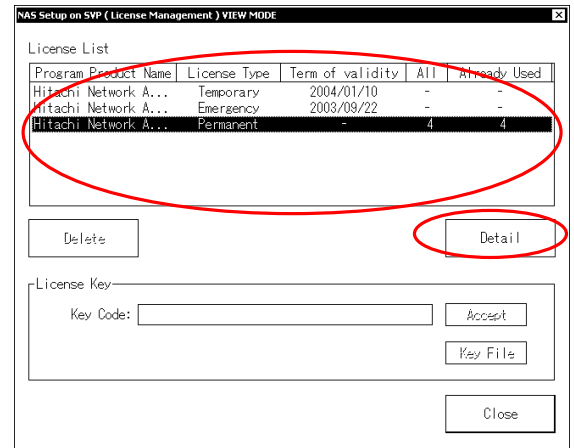

- (6) The 'NAS Setup on SVP (License Setting)' window is displayed in **View Mode**.
Confirm that the license information is correct, and then click the **Close** button to close the 'NAS Setup on SVP (License Setting)' window.

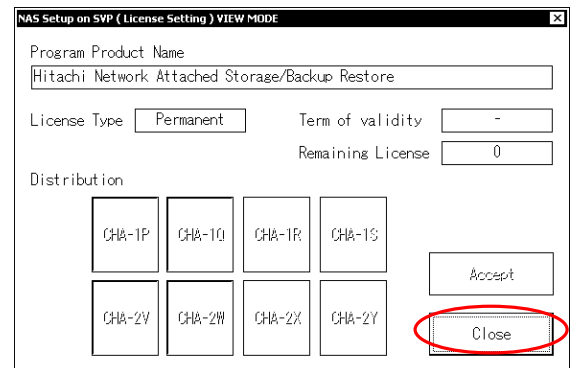

- (7) When the **Close** button is clicked in the 'NAS Setup on SVP (License Management)' window, the window is closed.

3.5.12 Restoring a NAS OS LU

If an error occurs on a NAS OS LU, the NAS OS may not function correctly and the system may not recognize the correct NAS Blade system configuration information (file systems and NFS/CIFS shares). On request from the system administrator, the maintenance personnel will recover the NAS OS LU using backup data collected by the system administrator who uses the NAS/Management GUI.

 **CAUTION**

If an error occurs in a system LU, make sure to obtain the auto dump and send it to the developer. The instructions to restore the system LU will be given by the developer, determined from the analysis result of the auto dump.

If the configuration of the NAS Blade system has been changed since the NAS OS LU was saved, restoring the NAS OS LU may not restore the NAS Blade system. If the configuration has been changed since a backup was made but the initial status is restored, the NAS OS LU can be restored (for example, if you constructed a file system after saving the NAS OS LU, you can restore the NAS OS LU if that file system has already been deleted).

An attempt to restore a NAS OS LU while it and a NAS Cluster Management LU are being saved or restored will not be successful.

 **CAUTION**

Ensure that except from the maintenance personnel executing this operation, no maintenance personnel, account administrator, or system administrator logs onto any NAS Package in the disk subsystem until the NAS OS LU is restored.

Before restoring a NAS OS LU, the maintenance personnel must complete the following tasks:

- Check that failover to the normal node has been completed. If failover has not been completed, ask the system administrator to change the execution node for the resource group (manual failover).
See 4.5.12 *Changing the execution node of a resource group* in the manual *Hitachi Network Attached Storage/Management User's Guide*.
- Eliminate the cause of the error.
See Chapter 7. *NAS Troubleshooting* [NAS07-10].
- Install the NAS OS and the related program products on the NAS OS LU whose error has been eliminated. Install the same program products as the ones installed before the error occurs.
See 3.5.4 *Installing the NAS OS and Related Program Products* [NAS03-290].
A warning message appears and prompts you to enter a password during installation. Ignore the message and enter a password.
- Set up the network environment in the NAS Package where the error cause has been removed. You must save the NAS OS LU after changing the network environment because the setting contents that you saved must match the setting contents before the error occurs.
See 3.5.6 *Setting Up the Network Environment* [NAS03-630]. Also in this section, the setting contents that you saved must match the setting contents before the error occurs.

When the NAS OS LU has been restored, restart the NAS OS using the procedure described in [3] in Section 3.5.8[[NAS03-850](#)], and then ask the system administrator to execute failback.

To restore a NAS OS LU:

- (1) In the 'NAS Setup on SVP (Main)' window, select the NAS Package for which the NAS OS LU is to be restored, and then click the **Restore NAS OS LU** button.
-
- (2) The 'NAS Setup on SVP (Restore NAS OS LU)' window appears.
In the 'NAS Setup on SVP (Restore NAS OS LU)' window, make sure that **NAS OS LU Status** is **Normal**, the saved date is shown in **Last Save Date**, and then click the **Restore** button.

Note: You cannot restore the NAS OS LU when the status is other than **Normal**.

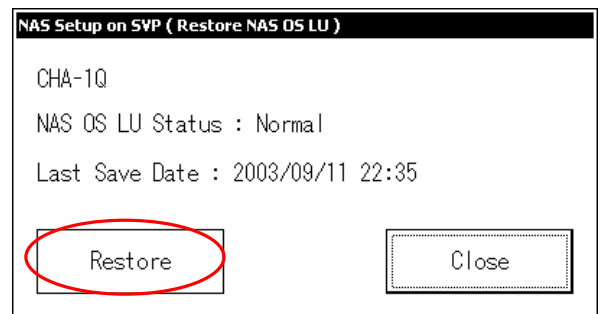

- (3) The message "To restore the NAS OS LU of CHA-XX, you must enter the password. Do you want to continue the processing?" is displayed.
Click the **OK** button.

Note: XX indicate a NAS Package location.

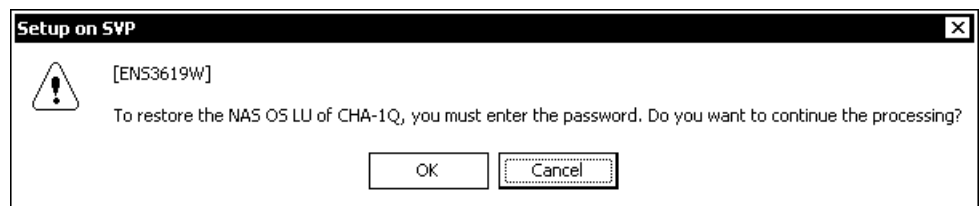

- (4) The 'NAS Setup on SVP (Password)' window appears.
Enter the password, and then click the **OK** button.
The NAS OS LU begins to be restored.

Note: If the NAS OS LU and NAS Cluster Management LU are being saved, only clicking the **OK** button results in an error.

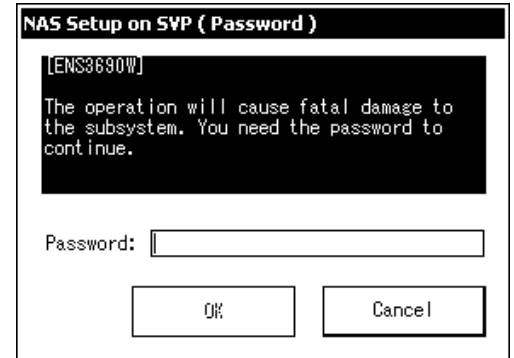

- (5) In the NAS Setup on SVP (Restore NAS OS LU) window, **NAS OS LU Status** changes to **Now restoring...**

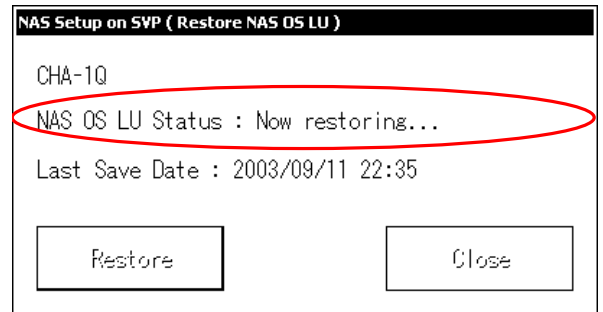

- (6) When restoration processing has been completed, the message "The NAS OS LU of CHA-XX has been restored successfully." is displayed.
Click the **OK** button.

Note: XX indicates a NAS Package location.

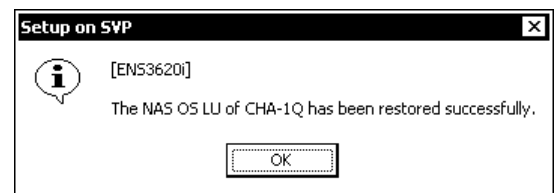

- (7) In the 'NAS Setup on SVP (Restore NAS OS LU)' window, make sure that **NAS OS LU Status** is **Normal**, and then click the **Close** button.

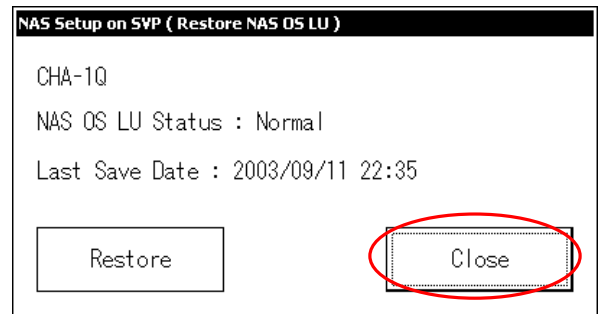

3.5.13 Restoring a NAS Cluster Management LU

If an error occurs on a NAS Cluster Management LU, the NAS OS may not function correctly and the system may not recognize the correct NAS Blade system configuration information (file systems and NFS/CIFS shares). On request from the system administrator, the maintenance personnel will recover the NAS Cluster Management LU using backup data collected by the system administrator who uses the NAS/Management GUI.

 **CAUTION**

If an error occurs in a system LU, make sure to obtain the auto dump and send it to the developer. The instructions to restore the system LU will be given by the developer, determined from the analysis result of the auto dump.

If the configuration of the NAS Blade system has been changed since the NAS Cluster Management LU was saved, restoring the NAS Cluster Management LU may not restore the NAS Blade system. If the configuration has been changed since a backup was made but the initial status is restored, the NAS Cluster Management LU can be restored (for example, if you constructed a file system after saving the NAS Cluster Management LU, you can restore the NAS Cluster Management LU if that file system has been deleted during the restoration processing).

An attempt to restore a NAS OS LU while it and a NAS Cluster Management LU are being saved or restored will not be successful.

 **CAUTION**

Ensure that except from the maintenance personnel executing this operation, no maintenance personnel, account administrator, or system administrator logs onto any NAS Package in the disk subsystem until the NAS OS LU is restored.

To restore a NAS Cluster Management LU, all NAS Packages in the disk subsystem must be in the **UP**, **INACTIVE**, or **WARN**(NAS/Management is not installed) status.

Note: If an error occurs during restoration of the NAS Cluster Management LU, re-execute the processing. If an error still results after the second or third attempt, contact the developer.

To restore a NAS Cluster Management LU:

- (1) In the 'NAS Setup on SVP (Main)' window, click the **Restore CM LU** button.
-
- (2) The 'NAS Setup on SVP (Restore NAS Cluster Management LU)' window appears. In the 'NAS Setup on SVP (Restore NAS Cluster Management LU)' window, make sure that **Status** is **Normal**, the saved date is shown in **Last Save Date**, and then click the **Restore** button.

Note: You cannot restore the NAS Cluster Management LU when the status is other than **Normal**.

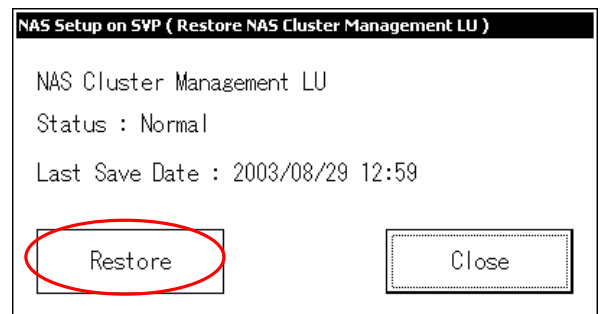

- (3) The message "The NAS Cluster Management LU will be restored. Execute the following procedures:..." is displayed.

Click the **OK** button.

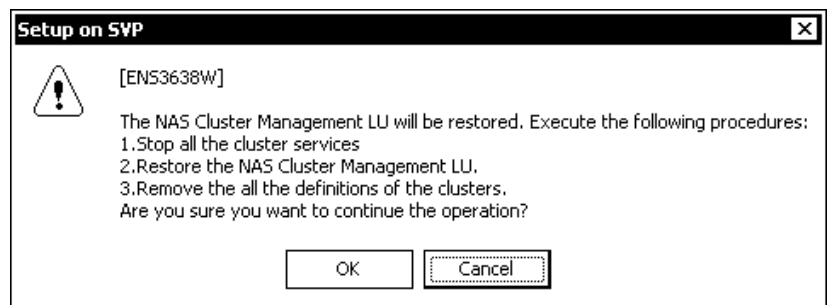

- (4) The message “To restore the NAS Cluster Management LU, you must enter the password. Do you want to continue the processing?” is displayed.
Click the **OK** button.

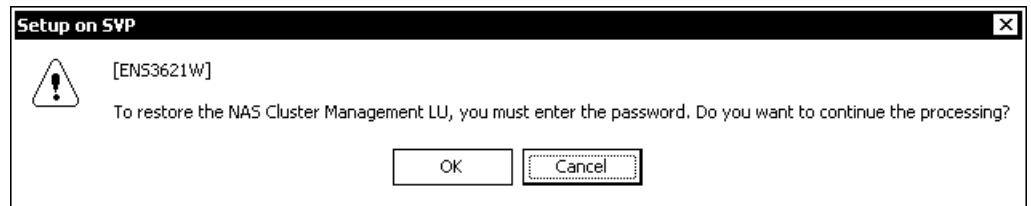

- (5) The ‘NAS Setup on SVP (Password)’ window appears.
Enter the password, and then click the **OK** button.
Restoration of the NAS Cluster Management LU starts.

Note: If the NAS OS LU and NAS Cluster Management LU are being saved or restored, only clicking the **OK** button results in an error.

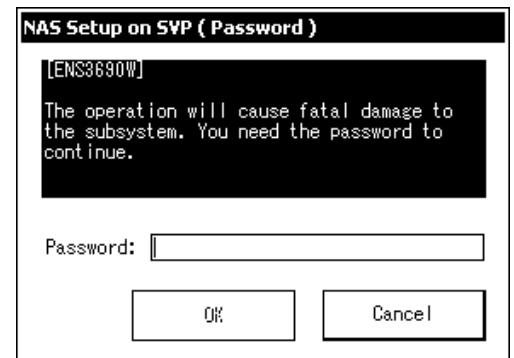

- (6) In the ‘NAS Setup on SVP (Restore NAS Cluster Management LU)’ window, **Status** changes to **Now stopping the cluster...**, and then to **Now restoring...**, and then to **Now removing the cluster...**

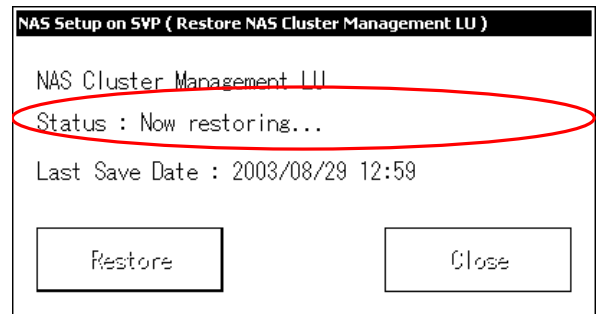

- (7) When restoration processing has been completed, the message “The NAS Cluster Management LU has been restored successfully.” is displayed. Click the **OK** button.

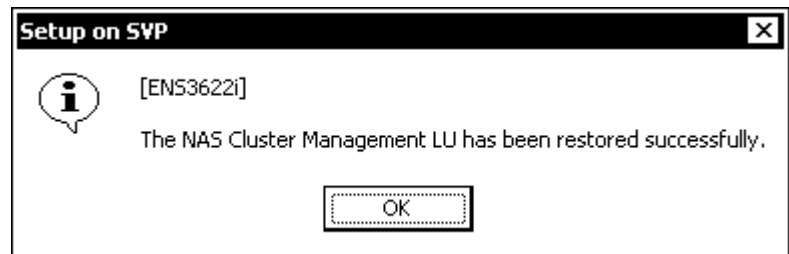

- (8) In the ‘NAS Setup on SVP (Restore NAS Cluster Management LU)’ window, make sure that **Status** changes to **Normal**, and then click the **Close** button.

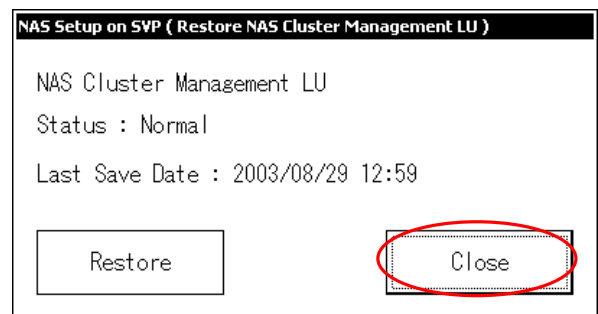

3.5.14 Downloading Dump Files

To download dump files (Nas Dump (See *Table 7.2-5* [[NAS07-60](#)])):

Note: The dump file might be still being generated immediately after the NAS OS is started. Wait for about 30 minutes after the NAS OS is started, and then start downloading dump files.

(1) If USB Memory is available, go to (2). Otherwise go to (10). USB Memory may not be available, for example, when the dump has been collected but has not been transferred to the manufacturer yet.

(2) Attachment of USB Memory

(2-1) Open the front door and then pull down the SVP ASSY.

(2-2) Remove the SVP cover.

Loosen the screws to remove the SVP cover.

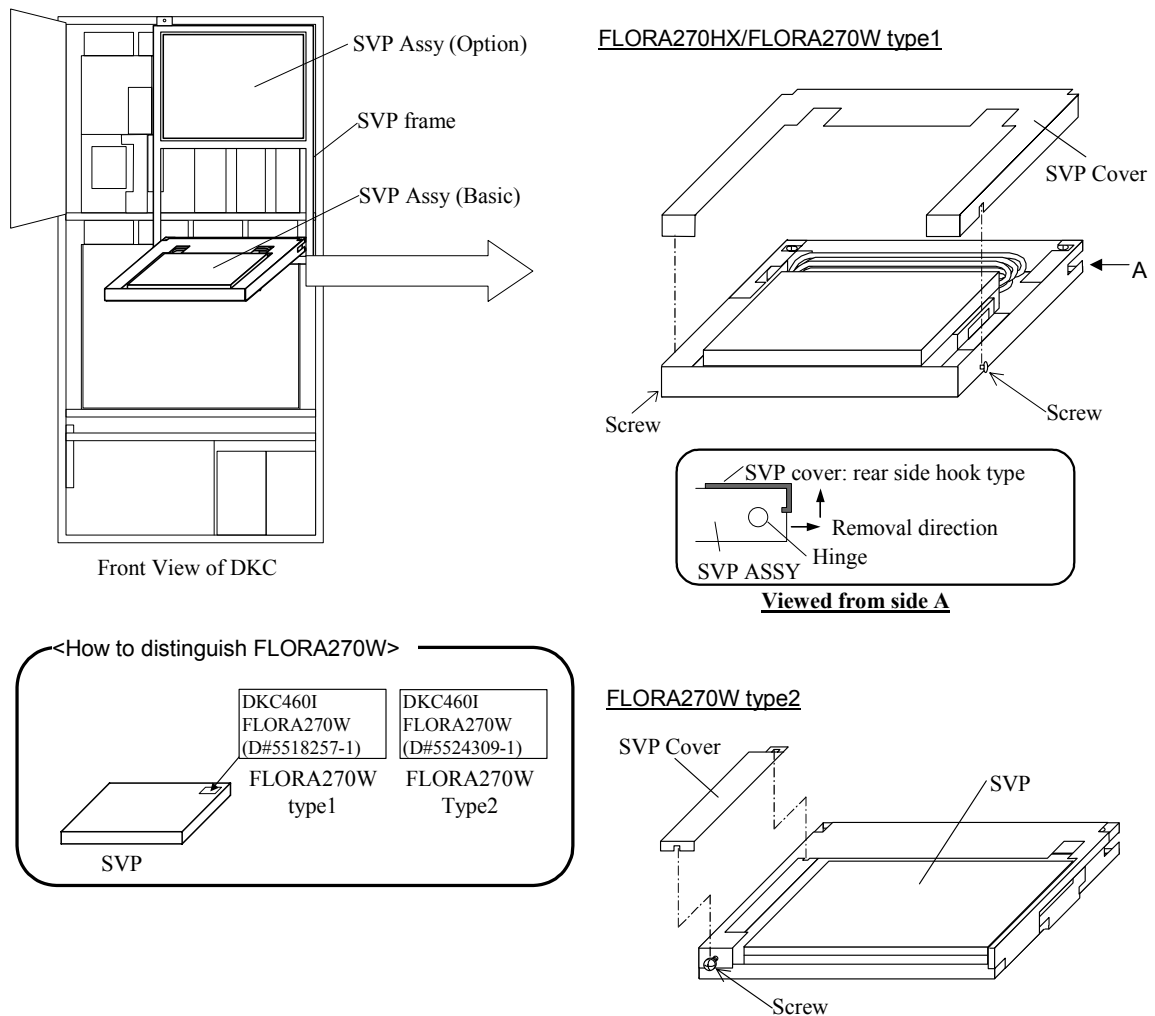

(2-3) When installed SVP is FLORA270HX or FLORA270W type1, take the Modem Cable, LAN Cable, and RS232C cable out of SVP ASSY.
When installed SVP is FLORA270W type2, go to step (2-4).

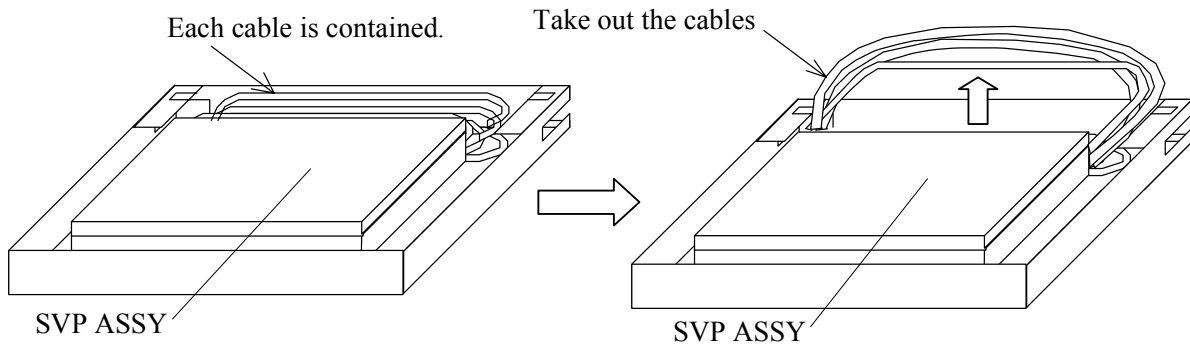

(2-4) Attach the USB Memory.

- a. Take the USB memory out of the clamp and remove the connector cover from the USB cable.
- b. Attach the USB cable to the USB port on the SVP.
- c. Place the USB memory into SVP ASSY and open up the display of the SVP.

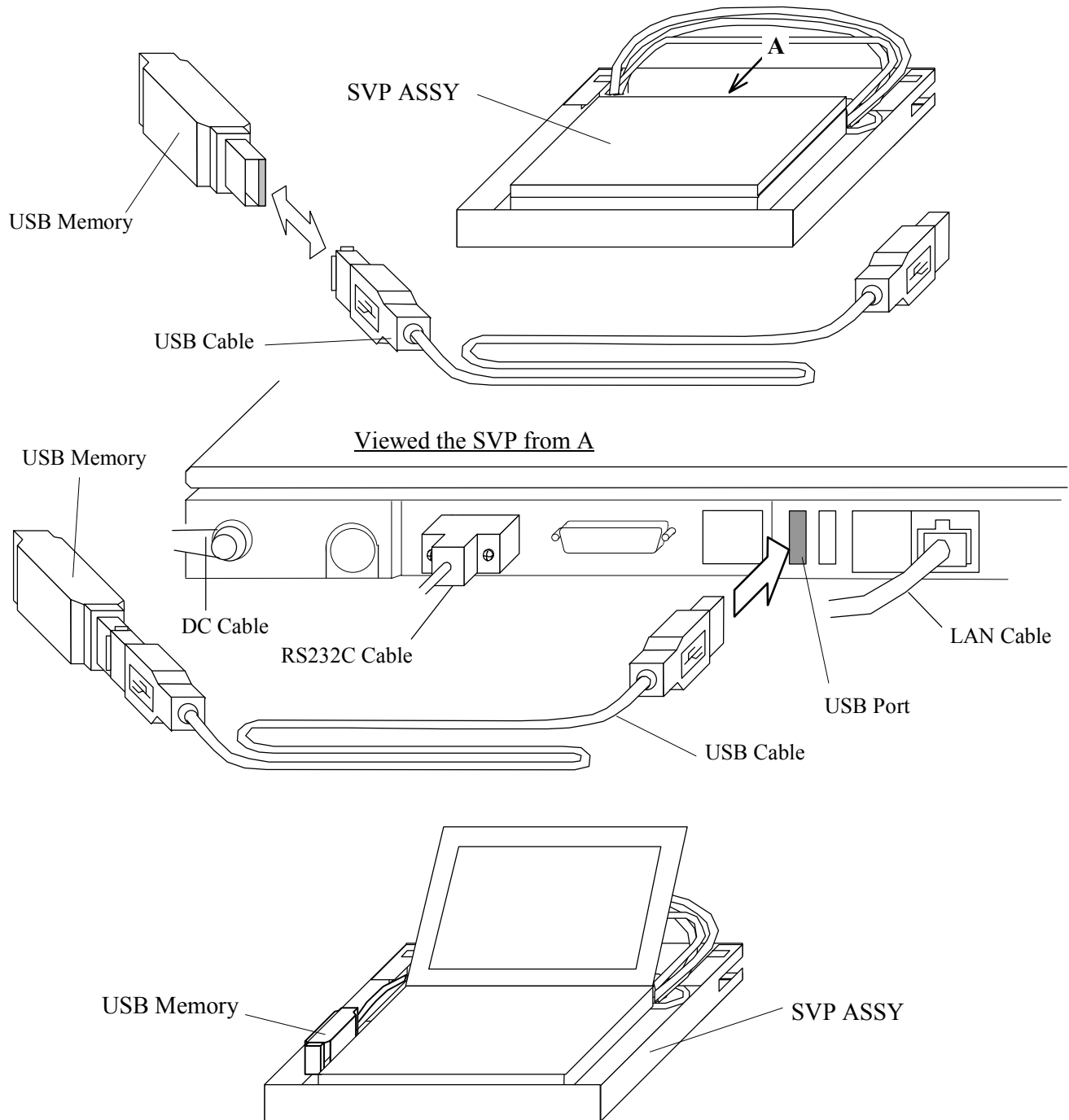

(3) NAS dump preparation

(3-1) Setting a password of USB Memory

(i) Select 'Run' from the Start menu.



(ii) Run "G:/KeySafe.exe".

Input characters can be in either upper or lower case.

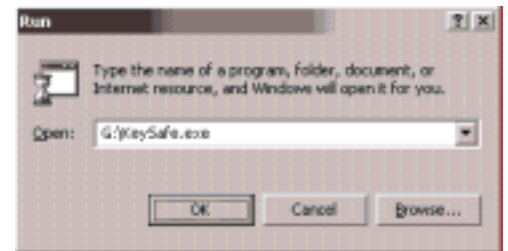

(iii) Select "English[U.S.]" and press "OK".

"English[U.S.]" must be chosen here.

Check box should be left unchecked.



(iv) Press 'OK' when the message box appears.



(v) Set Password and Zone Size then select 'OK'. Password and Zone Size should be set as follows:

(a) RAID-NAS

Note: All characters must be in uppercase.

(b) Expand the Zone Size as large as Maximum Privacy Zone(902.00MB). (The expanded area is shown in orange.)

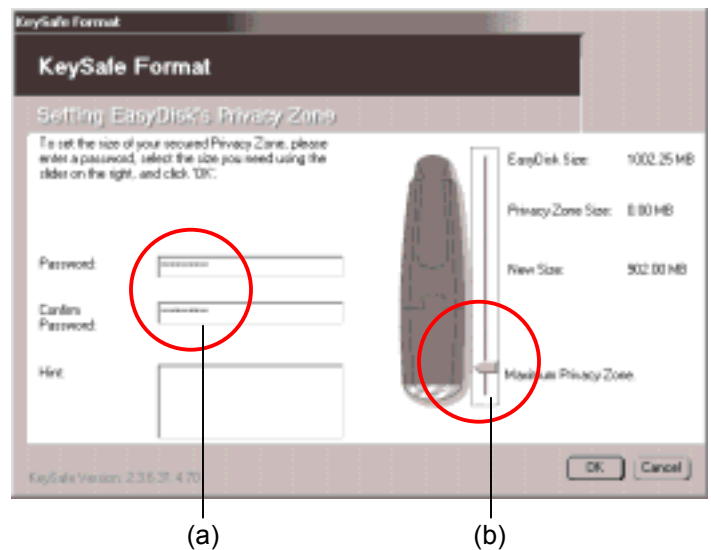

(vi) Select 'OK' when message appears.



Formatting starts.

(vii) Press 'OK' when the completion message appears.



(viii) Input the password set at the procedure (v) (RAID-NAS).



(ix) Press 'OK' when the message appears.
Check box should be left unchecked.



(x) The preparation of dump correction has been finished when the folder window appears.
Select [x] on the upper-right side of the window to close the window.

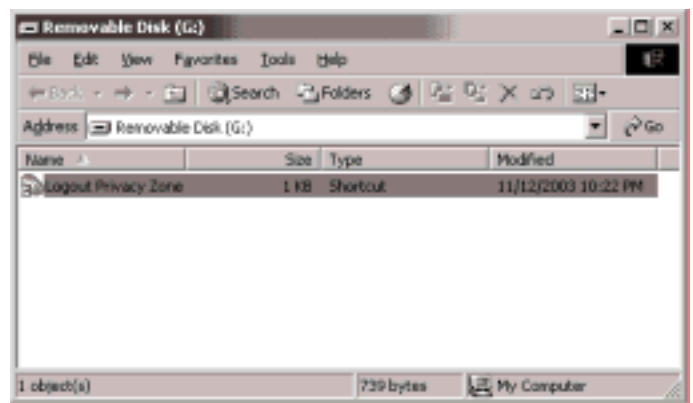

- (4) In the 'NAS Setup on SVP (Main)' window, select a NAS Package that you want to download the dump files, and then click the **Download Dump** button.

- (5) The 'NAS Setup on SVP (Download Dump)' window appears.
In the 'NAS Setup on SVP (Download Dump)' window, make sure that **Download Status** is **Normal**, and **Last Save Date** shows the target date, and then click the **Download** button.

Note: You cannot download dump files when **Download Status** is other than **Normal**.

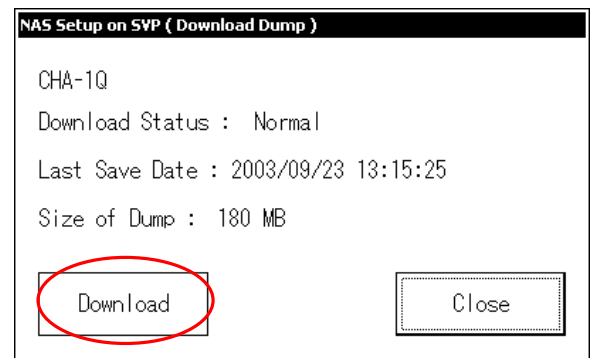

- (6) The message "The dump files for the CHA-XX will be downloaded. Are you sure you want to continue the operation?" is displayed.
Click the **OK** button in the message window.
The dump files will be downloaded.

Note: XX indicates a NAS Package location.

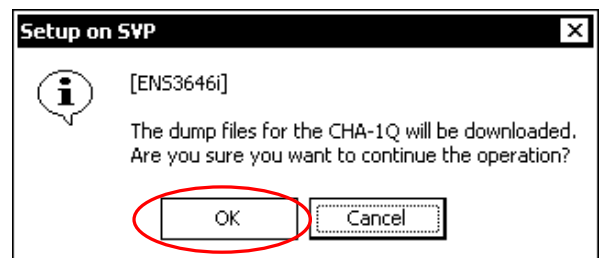

- (7) In the ‘NAS Setup on SVP (Download Dump)’ window, the status in **Download Status** changes to **Now downloading...**

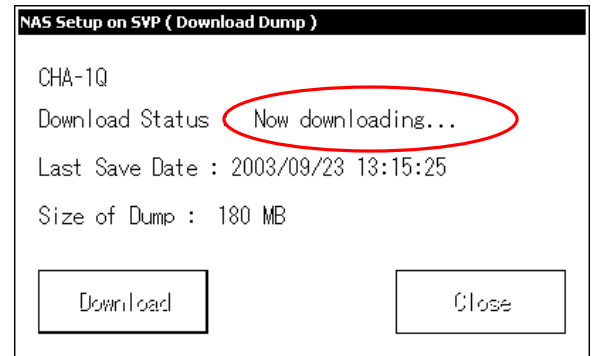

- (8) When the dump files are downloaded, the message “The dump files of CHA-XX have been downloaded successfully...” and the location of the dump files are displayed in the message.

Click the **OK** button in the message window.

Note: XX indicates a NAS Package location.

Note: See [NAS09-320] when you download dump files to a USB memory. When there is no USB memory, download dump files to D drive of SVP (This is a special procedure, which is not usually performed). See [NAS09-370].

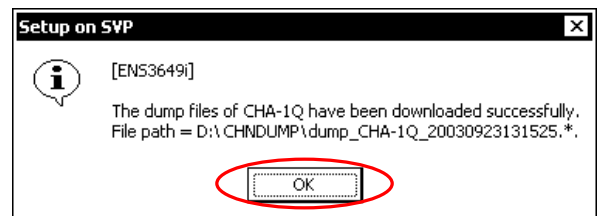

- (9) In the 'NAS Setup on SVP (Download Dump)' window, make sure that **Download Status** is **Normal**, and then click the **Close** button.

Go to (19).

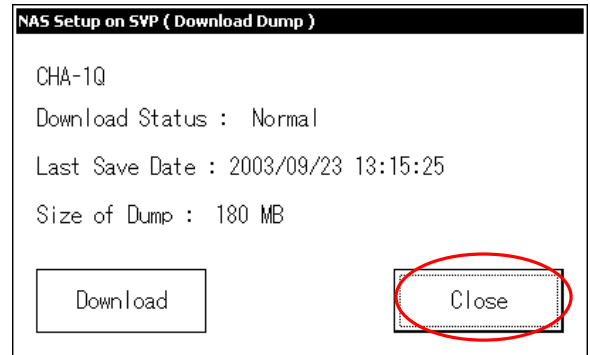

(10) In the 'NAS Setup on SVP (Main)' window, select a NAS Package that you want to download the dump files, and then click the **Download Dump** button.

(11) The 'NAS Setup on SVP (Download Dump)' window appears.

In the 'NAS Setup on SVP (Download Dump)' window, make sure that **Download Status** is **Normal**, and **Last Save Date** shows the target date, and then click the **Download** button.

Note: You cannot download dump files when **Download Status** is other than **Normal**.

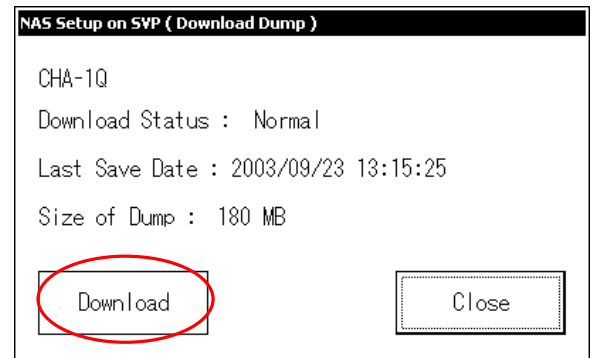

(12) The message "The dump files for the CHA-XX will be downloaded. Are you sure you want to continue the operation?" is displayed.

Click the **OK** button in the message window.

The dump files will be downloaded.

Note: XX indicates a NAS Package location.

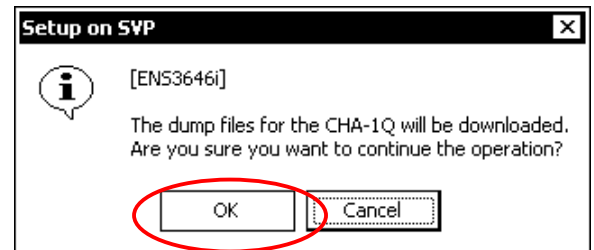

- (13) In the 'NAS Setup on SVP (Download Dump)' window, the status in **Download Status** changes to **Now downloading...**

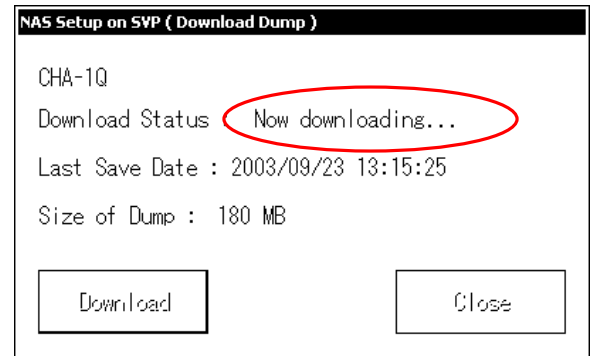

- (14) When the dump files are downloaded, the message "The dump files of CHA-XX have been downloaded successfully..." and the location of the dump files are displayed in the message.

Click the **OK** button in the message window.

Note: XX indicates a NAS Package location.

Note: When there is no USB memory, downloaded dump files are stored to D drive of SVP. When there is USB memory, download dump files are stored to USB, which is G drive of SVP.

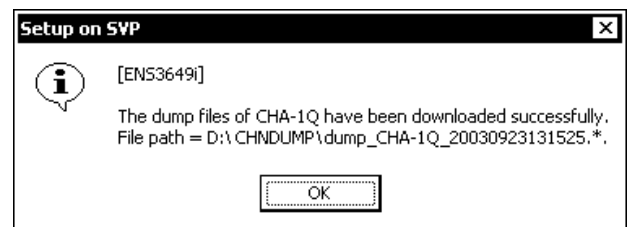

(15) In the ‘NAS Setup on SVP (Download Dump)’ window, make sure that **Download Status** is **Normal**, and then click the **Close** button.

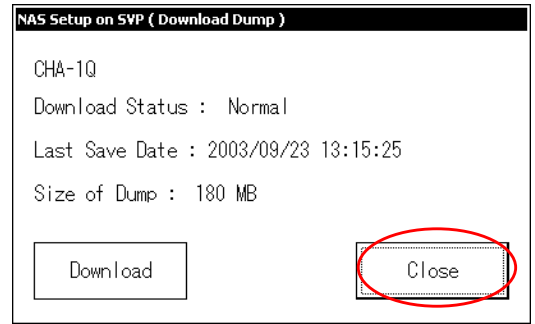

The procedure is suspended here if USB memory is not available. Resume the procedure from (16) when the UBS memory becomes available.

(16) Attachment of USB Memory

(16-1) Open the front door and then pull down the SVP ASSY.

(16-2) Remove the SVP cover.

Loosen the screws to remove the SVP cover.

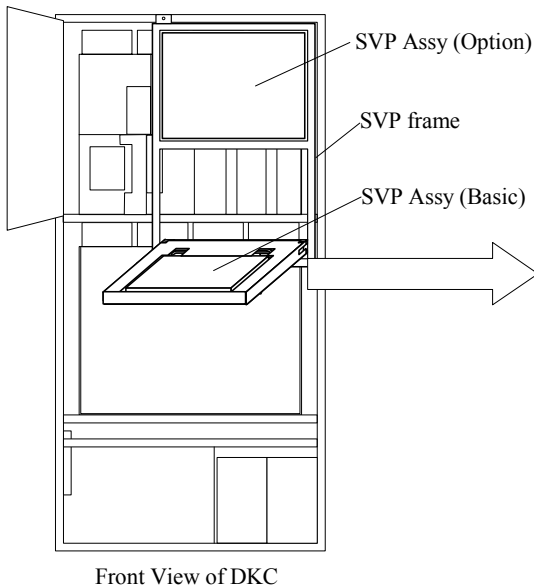

FLORA270HX/FLORA270W type1

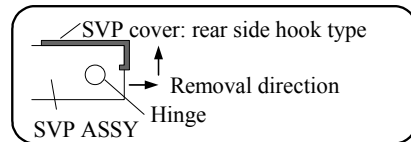
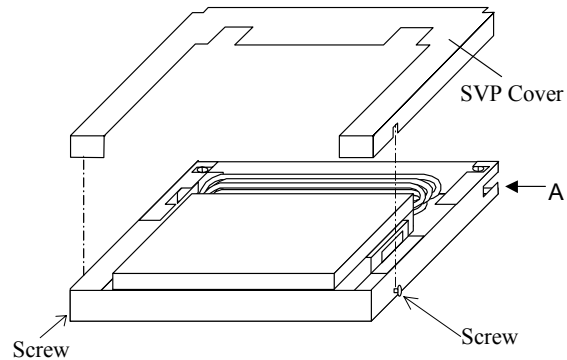

Viewed from side A

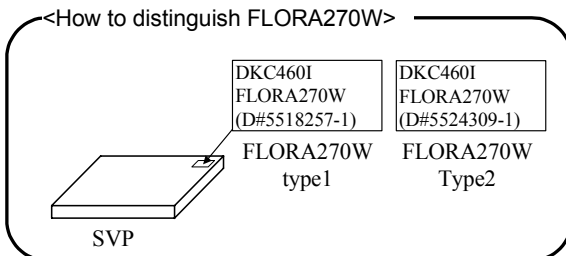

FLORA270W type2

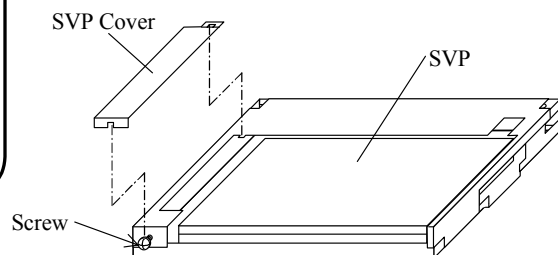

- (16-3) When installed SVP is FLORA270HX or FLORA270W type1, take the Modem Cable, LAN Cable, and RS232C cable out of SVP ASSY.
When installed SVP is FLORA270W type2, go to step (16-4).

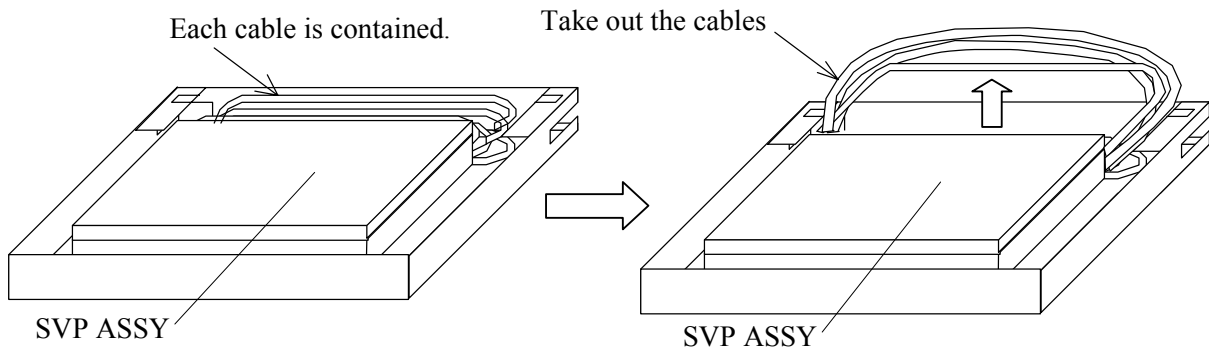

(16-4) Install the USB Memory.

- a. Take the USB memory out of the cramp and remove the connector cover from the USB cable.
- b. Attach the USB cable to the USB port on the SVP.
- c. Place the USB memory into SVP ASSY and open up the display of the SVP.

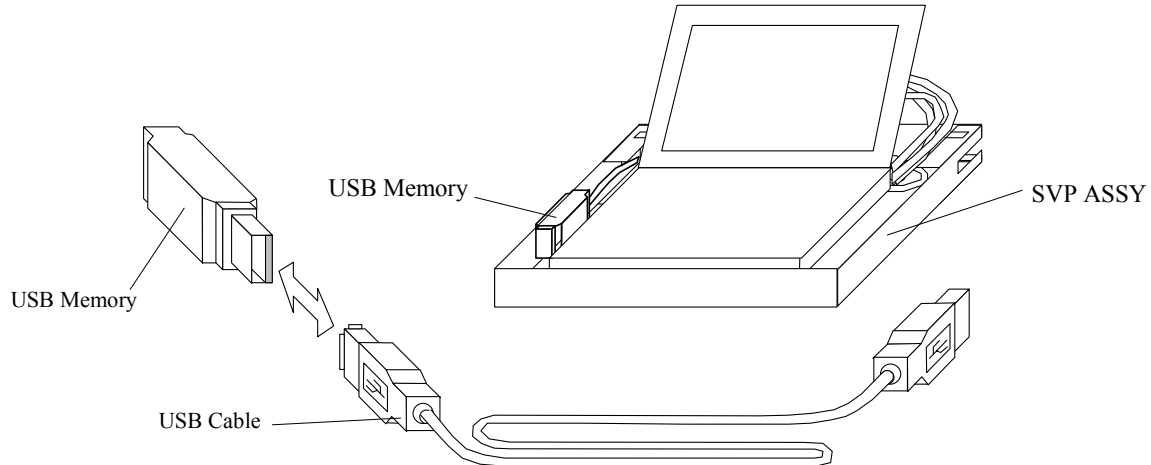
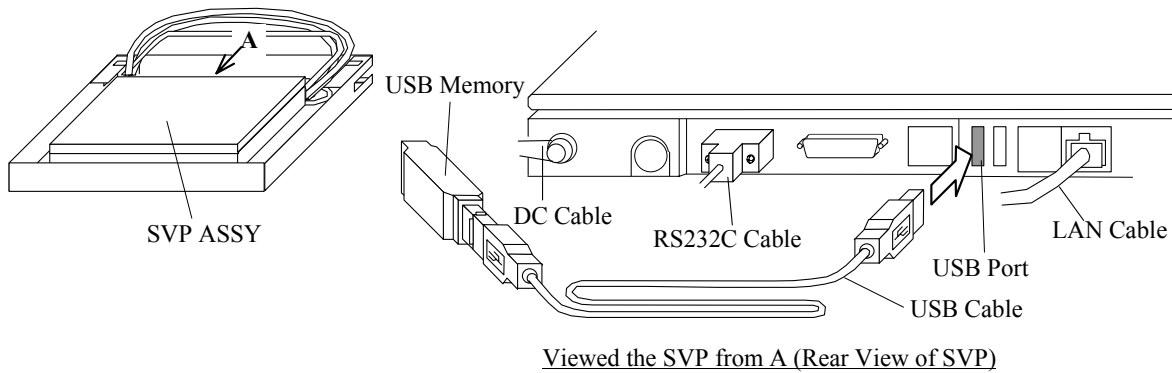
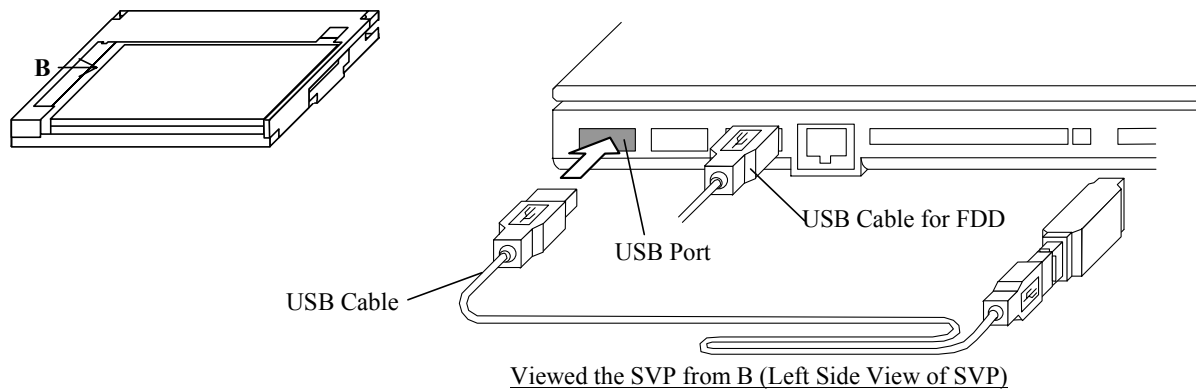
FLORA270HX/FLORA270W type1FLORA270W type2

(17) NAS dump preparation

(17-1) Setting a password of USB Memory

(i) Select 'Run' from the Start menu.



(ii) Run "G:/KeySafe.exe".

Input characters can be in either upper or lower case.

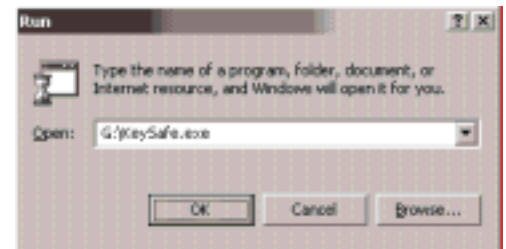

(iii) Select "English[U.S.]" and press "OK".

"English[U.S.]" must be chosen here.

Check box should be left unchecked.



(iv) Press 'OK' when the message box appears.



(v) Set Password and Zone Size then select 'OK'. Password and Zone Size should be set as follows:

(a) RAID-NAS

Note: All characters must be in uppercase.

(b) Expand the Zone Size as large as Maximum Privacy Zone (902.00MB). (The expanded area is shown in orange.)

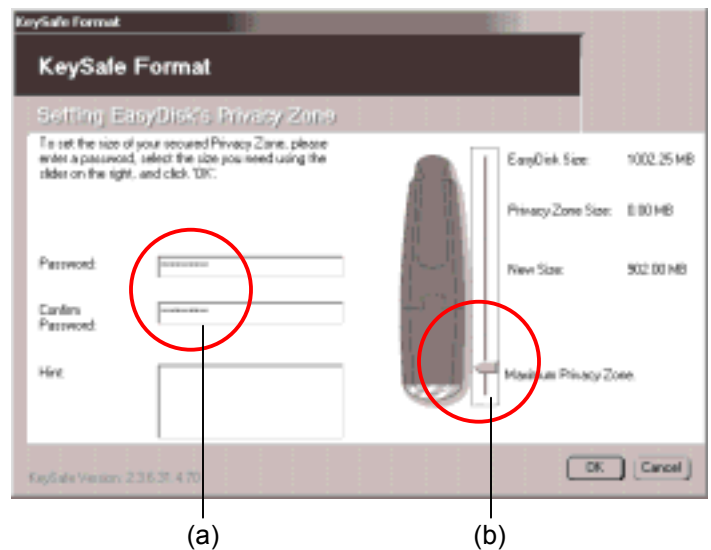

(vi) Select 'OK' when message appears.



Formatting starts.

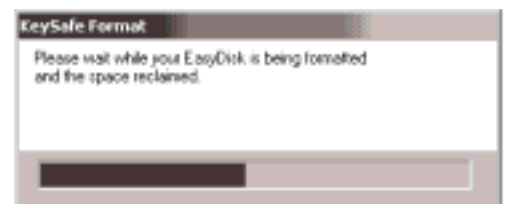

(vii) Press 'OK' when completion message appears.



(viii) Input the password set at the procedure (v) (RAID-NAS).



(ix) Press 'OK' when the message appears.
Check box should be left unchecked.



(x) When the folder window appears, the preparation of dump correction has been finished. Select [x] on the upper-right side of the window to close the window.

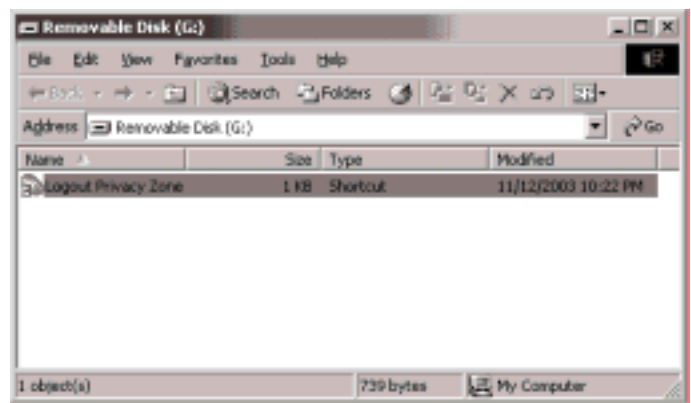

(18) Copying NAS dumps

(i) Select 'Run' on Start menu.



(ii) Run "C:\DKC200\MP\PC\CPNASDM.BAT" on the 'Run' window.

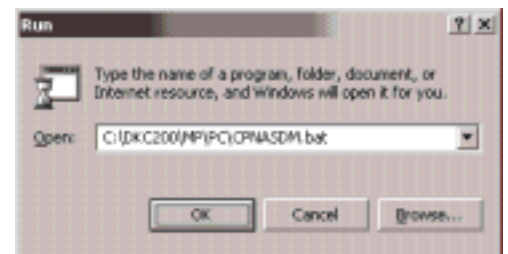

(iii) A window appears and file copy starts.

Press any key when the message "Are you sure you want to delete the files which the copy ended?" appears.

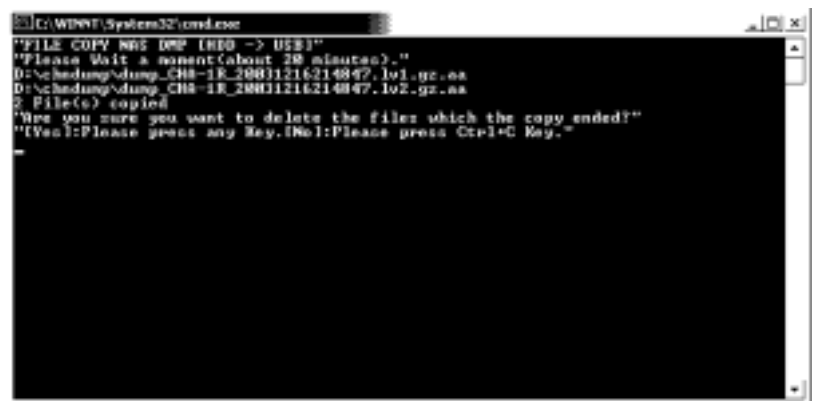

(iv) Input 'y' then press the enter key to respond the message "d:\chndump\..., Delete (Y/N)?" for all files.

```

C:\WINDOWS\system32\cmd.exe
FILE COPY WAS DMP (DDO -> USB)
Please Wait a moment (about 20 minutes).
D:\chndump\dump_CH0-1R_20031216214847_lo1.gc.sa
D:\chndump\dump_CH0-1R_20031216214847_lo2.gc.sa
2 File(s) copied
Are you sure you want to delete the files which the copy ended?
(Yes): Please press any Key. (No): Please press Ctrl+C Key.
D:\chndump\dump_CH0-1R_20031216214847_lo1.gc.sa, Delete (Y/N)? y
D:\chndump\dump_CH0-1R_20031216214847_lo2.gc.sa, Delete (Y/N)? y

```

(v) Press any key when the message "Please press any key." appears. The window is closed.

```

C:\WINDOWS\system32\cmd.exe
FILE COPY WAS DMP (DDO -> USB)
Please Wait a moment (about 20 minutes).
D:\chndump\dump_CH0-1R_20031216214847_lo1.gc.sa
D:\chndump\dump_CH0-1R_20031216214847_lo2.gc.sa
2 File(s) copied
Are you sure you want to delete the files which the copy ended?
(Yes): Please press any Key. (No): Please press Ctrl+C Key.
Please press any key.

```

(19) Pre-Procedure of removal of USB Memory

(i) Choose the icon of "Unplug or Eject Hardware" on the task bar. When the menu bar is displayed, choose "Stop USB Mass Storage Device (G:)"



Note: Don't choose any messages other than "Stop USB Mass Storage Device (G:)." Otherwise, the selected device will stop. In this case, please re-install the stopped device.



- (ii) Confirm that the following message appears, then select 'OK'.
 "The 'USB MASS Storage Device' device can now be safely removed from the system."

If any other message appears, the wrong device has been stopped. In this case, install the device again then start over from (19).

Go to (20) to remove the USB Memory.



(20) Remove the USB Memory

- Remove the USB cable from the USB port on the SVP.
- Put the connector cover on the USB cable.

FLORA270HX/FLORA270W type1

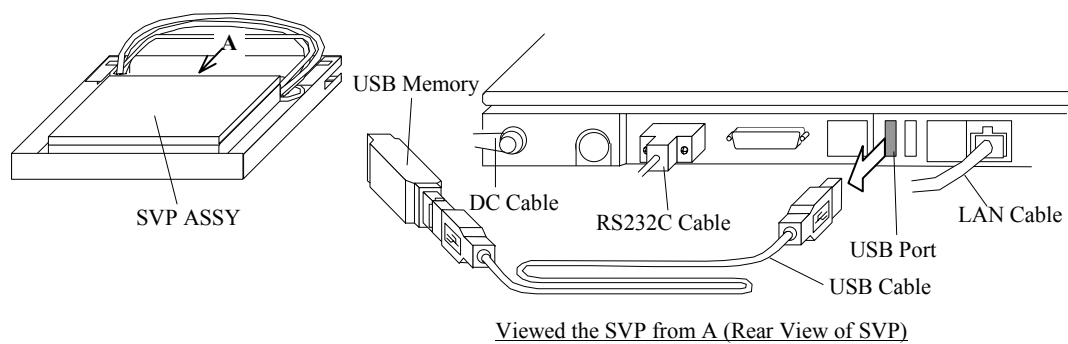

FLORA270W type2

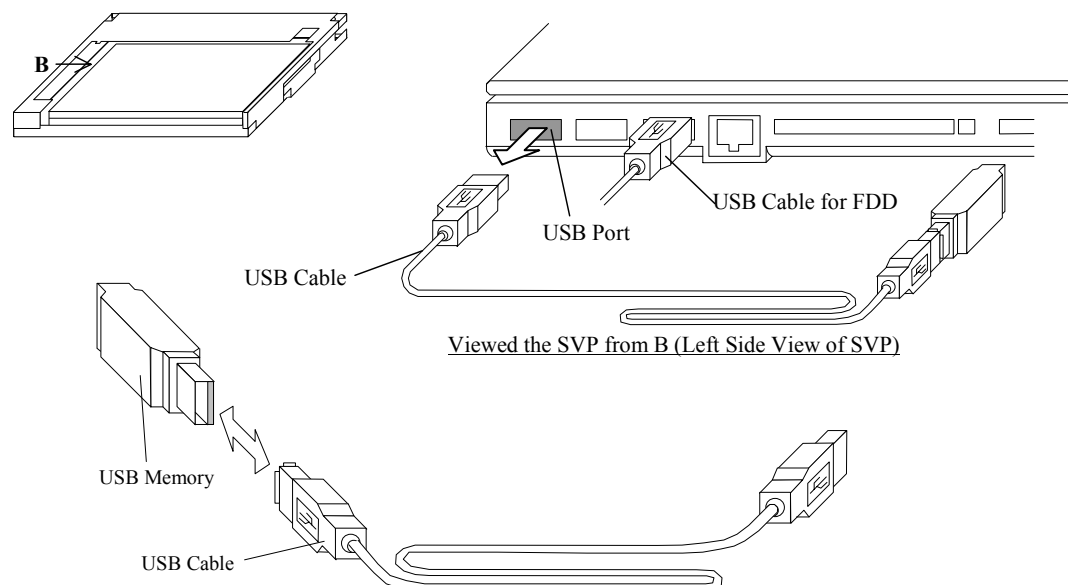

- (21) When installed SVP is FLORA270HX or FLORA270W type1, put back the Modem Cable, LAN Cable and RS232C cable in SVP ASSY.
 When installed SVP is FLORA270W type2, go to step (22).

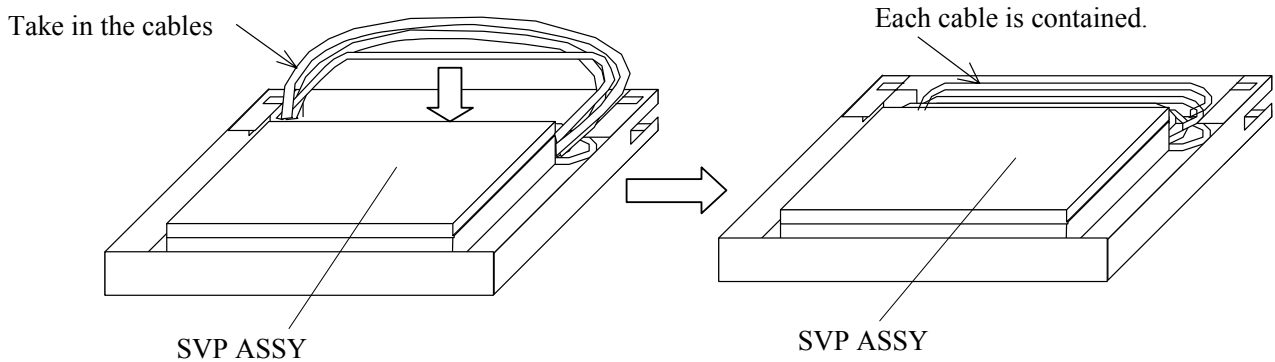

- (22) Attach the SVP cover.
 a. Attach the SVP cover and fasten the screws.
 b. Put the SVP ASSY back into the SVP Frame.

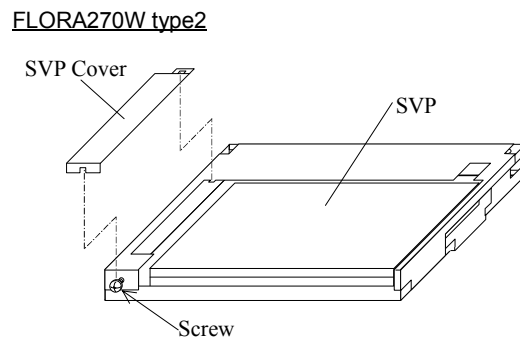
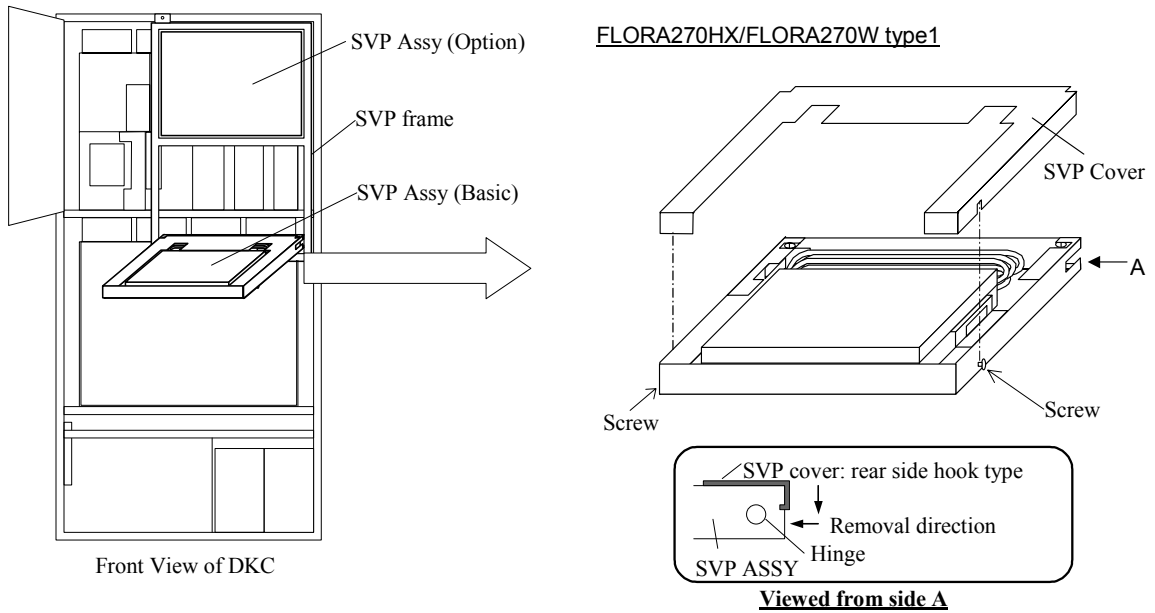

This is the end of the procedure of collecting dumps.

3.6 Operations Using the NAS/Management GUI

3.6.1 Registering System Administrators

The account administrator registers system administrators. The account administrator can change and view the user information for all the registered system administrators.

The account administrator uses his or her own account to log in to NAS/Management, creates one or more authorized accounts for system administrators.

3.6.2 Setting Up the NAS Package Cluster Configuration

A system administrator uses the NAS/Management GUI to perform manual failover or failback. To define the cluster configuration among NAS Packages, a system administrator uses it. To define a tentative cluster configuration among NAS Packages, a maintenance personnel or the manufacturer uses it.

When a cluster configuration is being defined, the system checks whether the path definitions to the user LUs are all the same among the target nodes. If the path definitions and program versions are changed after operation has started, these path definitions and program versions in the cluster must be made the same.

When the NAS Cluster Management LU is saved and recovered, fix the NAS Package where a cluster configuration was defined. When the NAS Cluster Management LU is recovered, the NAS Package where a cluster configuration is defined must be matched.

When replacing hardware or upgrading/downgrading software for the NAS Packages in a cluster, a system administrator performs a manual failover and failback.

3.6.3 Setting Up the Configuration For Services

Set up the configuration for the services. This configuration includes settings for controlling the starting and stopping of NFS, settings for performance-related features such as the number of processes, settings for controlling the starting and stopping of CIFS, settings for user authentication, and settings for ssh security.

The following table lists the services managed by the service management.

Table 3.6-1 Service Management

#	Service name	Configurable	Start up control
1	nfs_service	Yes	Yes
2	cifs_service	Yes	Yes
3	ssh_service	Yes	---

Legend:

Yes: Supported.

---: Not supported.

A system administrator can use the NAS/Management GUI to perform operations such as starting or stopping the services.

3.6.4 Setting Up the Network (Routing)

Set up the routing table for the NAS Packages.

A system administrator can use the NAS/Management GUI to perform operations such as viewing the routing list for the user LAN, and adding and deleting a routing. The routings for the internal LAN cannot be viewed or set.

The items to be set are as follows:

- Interface (the target NIC: eth1 or eth2)
- Method for specifying the target (network or host)
- Routing targets
- Gateway
- Net mask
- Denial of route
- Metrics
- MSS

3.6.5 Setting Up the Network (DNS, NIS)

Set the IP address of the DNS server when using DNS, and set the IP address of the NIS server when using NIS.

The following items related to the DNS server can be set:

- Default domain name
- Primary DNS server
- Secondary DNS server

The following items related to the NIS server can be set:

- NIS domain name
- NIS server

3.6.6 Setting Up Users and Groups

Set up the general users who will use the NFS environment and the CIFS environment. For details about setup for system administrators, see *3.6.1 Registering System Administrators*. [[NAS03-1110](#)]

A system administrator can use the NAS/Management GUI to perform operations such as adding a new general user, and editing or deleting information about general users. In addition, the administrator can add a new group, and edit or delete the group information for the general users who use the CIFS environment.

3.6.7 Creating File Systems

A system administrator can use the NAS/Management GUI to perform operations such as listing the file systems, creating and deleting a file system that can be used on the NAS Blade system, and expanding existing file systems. In addition, the administrator can mount or unmount existing file systems.

3.6.8 Setting Up File Shares (NFS, CIFS)

A system administrator can use the NAS/Management GUI to specify settings for the NFS and CIFS environments. The following table lists the items to be set or viewed.

Table 3.6-2 File Sharing Management

#	Item	NFS environment	CIFS environment
1	Viewing file shares	Yes	Yes
2	Setting up file shares	Yes	Yes
3	Changing the contents of file shares	Yes	Yes
4	Releasing settings for file shares	Yes	Yes

Legend:

Yes: Configurable.

No: Not configurable.

The following major items can be specified when setting up file sharing:

- Shared directories (paths to public directories)
- Whether or not to create a new directory (when a specified shared directory does not exist)
- The owner and access permissions for a directory (when a new directory is created)
- The group and access permissions for a directory (when a new directory is created)
- The access mode for a file share (Read only or Read/Write)
- The host or network on which an NFS share is made public
- The host or network on which a CIFS share is made public

3.6.9 Specifying Settings Related to Error-Monitoring Functionality

Specify the settings related to error-monitoring functionality: for example, settings for log files, message files, dump files, and SNMP.

When installing a NAS Blade system device or when increasing the number of NAS boards, a system administrator might need to change the settings of the following items using the NAS/Management GUI to enable error monitoring for these devices.

Table 3.6-3 Settings Related to Error-Monitoring Functionality

#	Item	Setting
1	syslog files	Settings related to syslog.conf, such as the output level and output destination of the syslog file.
2	SNMP	Settings related to the SNMP Manager server, such as its address and security.
3	Automatic deletion of core files	Settings related to automatic deletion of core files.
4	Log files, etc.	Settings related to log files, such as the file size and number of wraparounds.

3.6.10 Settings Related to the Save Function for NAS System LUs (NAS OS LU and NAS Cluster Management LU)

You can perform necessary settings for saving data in the NAS OS LU and NAS Cluster Management LU automatically, or save them manually.

If the NAS Blade system configuration has been changed, the system administrator must use the NAS/Management GUI to save data in the NAS OS LU and NAS Cluster Management LU. As a general rule, data in the NAS OS LU and NAS Cluster Management LU needs to be saved at the following times:

- When a file system is constructed or deleted
- When a copy device is defined or released*1
- When a snapshot is created*1
- When a differential-data storage device is set or released*2
- When a differential-data snapshot is created or deleted*2

*1: Applicable when the NAS/Backup Restore optional program product is used.

*2: Applicable when the NAS/Sync Image optional program product is used.

 **CAUTION**

When you change the NAS Blade system configuration, the NAS OS LU and NAS Cluster Management LU might not be able to be recovered if you do not save data on the NAS OS LU and NAS Cluster Management LU.

4. NAS Hardware Replacement

This chapter describes the procedure of maintenance personnel and system administrators for replacing the NAS Blade system hardware.

4.1 Overview

This section describes replacement procedures when a failure occurs or after preventive diagnostics are performed.

You can perform hot replacement of the hardware in a disk subsystem without stopping user services (except for cases such as when a RAID group is not usable because of a PDEV failure).

Also, by using failover, you can replace NAS Packages in the NAS Blade system, without stopping user services. When replacing NAS Packages, maintenance personnel and system administrators need to consider whether the NAS OS needs to be stopped and whether to perform a failover.

4.2 Types of Hardware Replacement Operations

Hardware is replaced in the following two situations:

- Replacement when a hardware failure occurs
This replacement operation replaces the failed hardware.
- Replacement when preventive replacement is performed
This replacement operation replaces hardware based on the results, for example, of periodic diagnostics or correctable errors.

This section describes replacement when preventive replacement is performed.

Such replacement operations are classified based on the operations performed by maintenance personnel or system administrators and the NAS Blade system behavior, as follows.

This chapter assumes that a RAID group has a configuration formed by RAID5 (3D+1P).

Table 4.2-1 Types of Hardware Replacement Operations

#	Target hardware	Corresponding tasks	Restart the NAS OS?	Perform a failback?	Can ordinary users continue operations? *1	Reference info. for preventive replacement
1	NAS Package	Replace the NAS Package.	Yes	Yes	Yes	Figure 4.2-1 [NAS04-40]
2	Data LAN cable	Replace the data LAN cable	No	Yes	Yes	Figure 4.2-2 [NAS04-71]
3	Hardware other than NAS Package ²	Replace the hardware (hot replacement).	No	No	Yes	Figure 4.2-3 [NAS04-80]

*1: Yes: Business tasks continue except for a double failure. However, if the application server is connected with Windows client (CIFS share) when a failover and a failback occur, the CIFS share is released. Therefore you must reconnect the server with CIFS share.

No: Ordinary users cannot perform operations related to the failed PDEV(s).

*2: For details, see the *REPLACE Section* [\[REP01-10\]](#).

4.2.1 Flowcharts for Replacing Hardware

In this section, the cluster is assumed to consist of CL1-CHA and CL2-CHA, and Figure 4.2-1 and Figure 4.2-3 show examples of flowcharts of hardware replacement on CL1-CHA.

Make sure that CL2-CHA is properly referred to as the actual location when replacing the CHA location.

Table 4.2-2 shows the actual CHA locations in the NAS cluster configuration.

Table 4.2-2 CHA Location in the NAS Cluster Configuration

Model	CHA location	CL1-CHA	CL2-CHA
Multi-cabinet	Basic	1P	2V
	Option 1	1Q	2W
	Option 2	1R	2X
	Option 3	1S	2Y
Single cabinet ^{*1}	Basic	1C	2G
	Option 1	1D	2J
	Option 2	1F	2K

*1: Only two of the three, basic, option 1, or option 2, can be used.

#	Hardware replacement	Reference
(1)	Replacing the NAS Package (during preventive replacement)	Figure 4.2-1 [NAS04-40]
(2)	Replacing the data LAN cable (during preventive replacement)	Figure 4.2-2 [NAS04-71]
(3)	Hot-replacing hardware other than the NAS Package	Figure 4.2-3 [NAS04-80]

(1) Replacing the NAS Package (During Preventive Replacement)

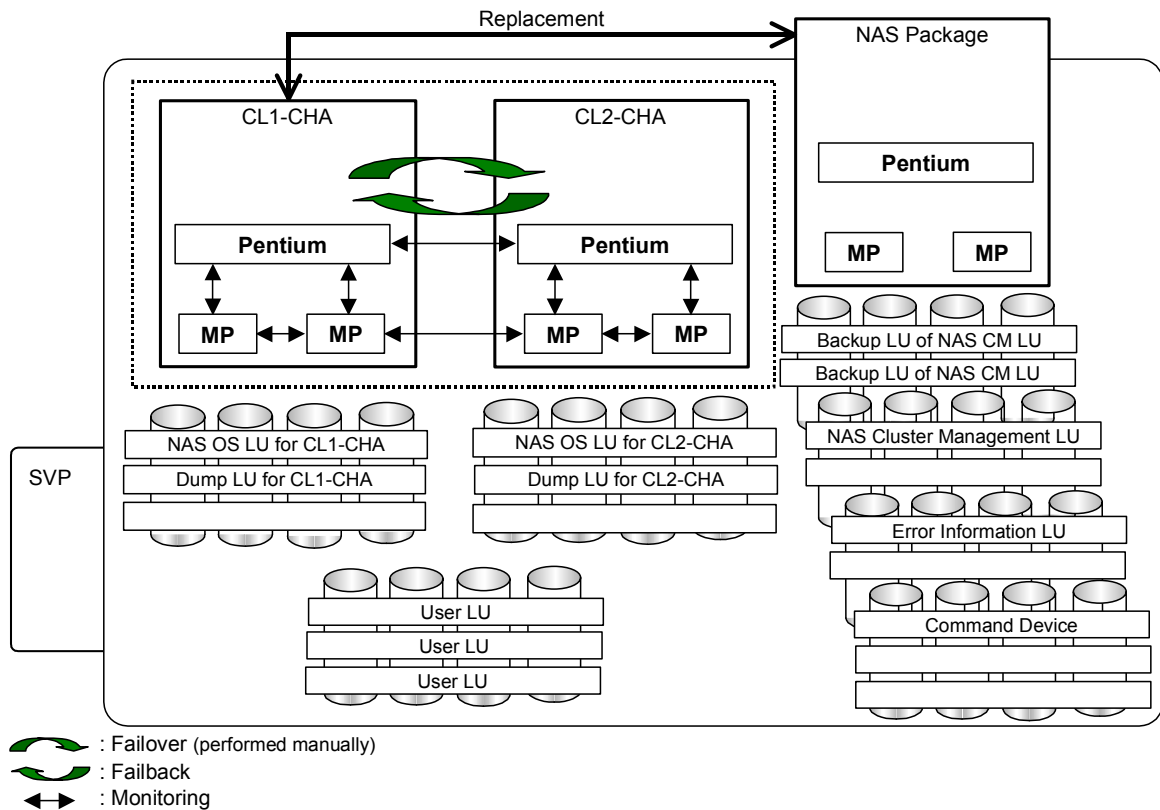

Figure 4.2-1 Replacing the NAS Package (During Preventive Replacement) (1/4)

Step	Procedure	Notes
1	Check the operating status of the NAS Blade system.	
2	Perform the failover.	
3	Stop the node.	
4	Stop the NAS OS.	Stop the NAS OS while the target NAS Package (CL1-CHA) is running
5	Replace the NAS Package.	
6	Start the node.	
7	Perform failback.	

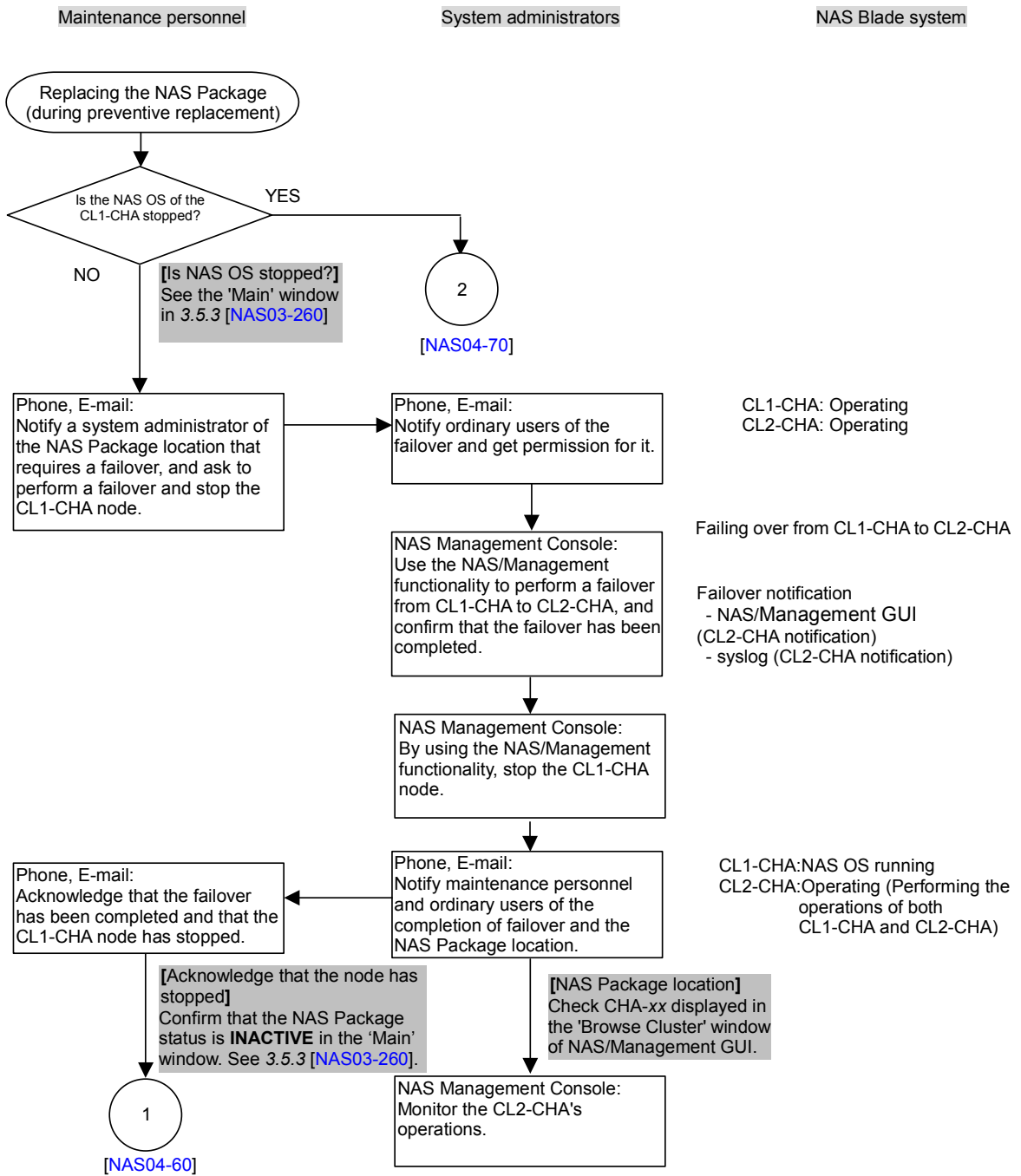

Figure 4.2-1 Replacing the NAS Package (During Preventive Replacement) (2/4)

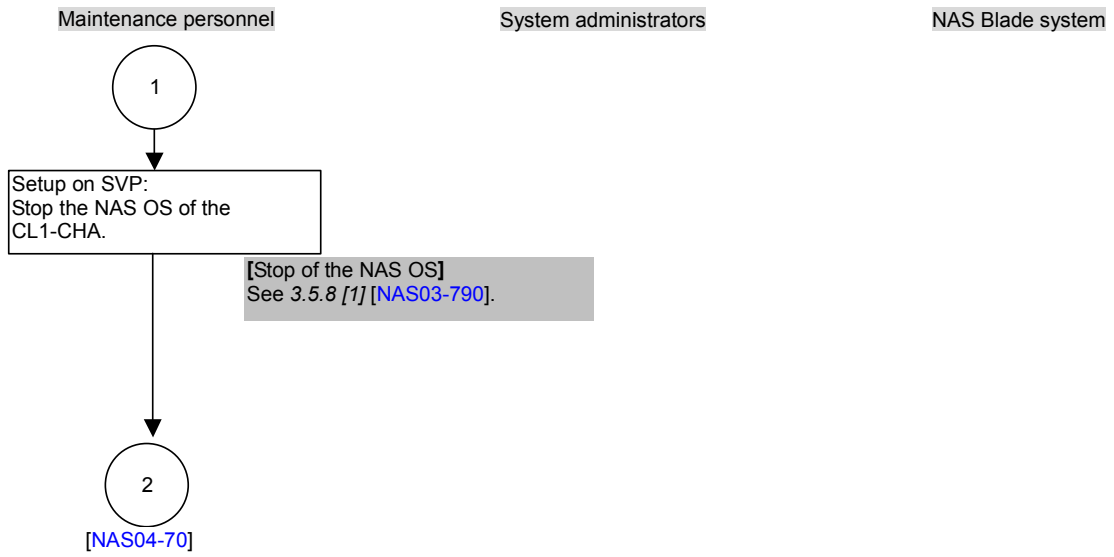

Figure 4.2-1 Replacing the NAS Package (During Preventive Replacement) (3/4)

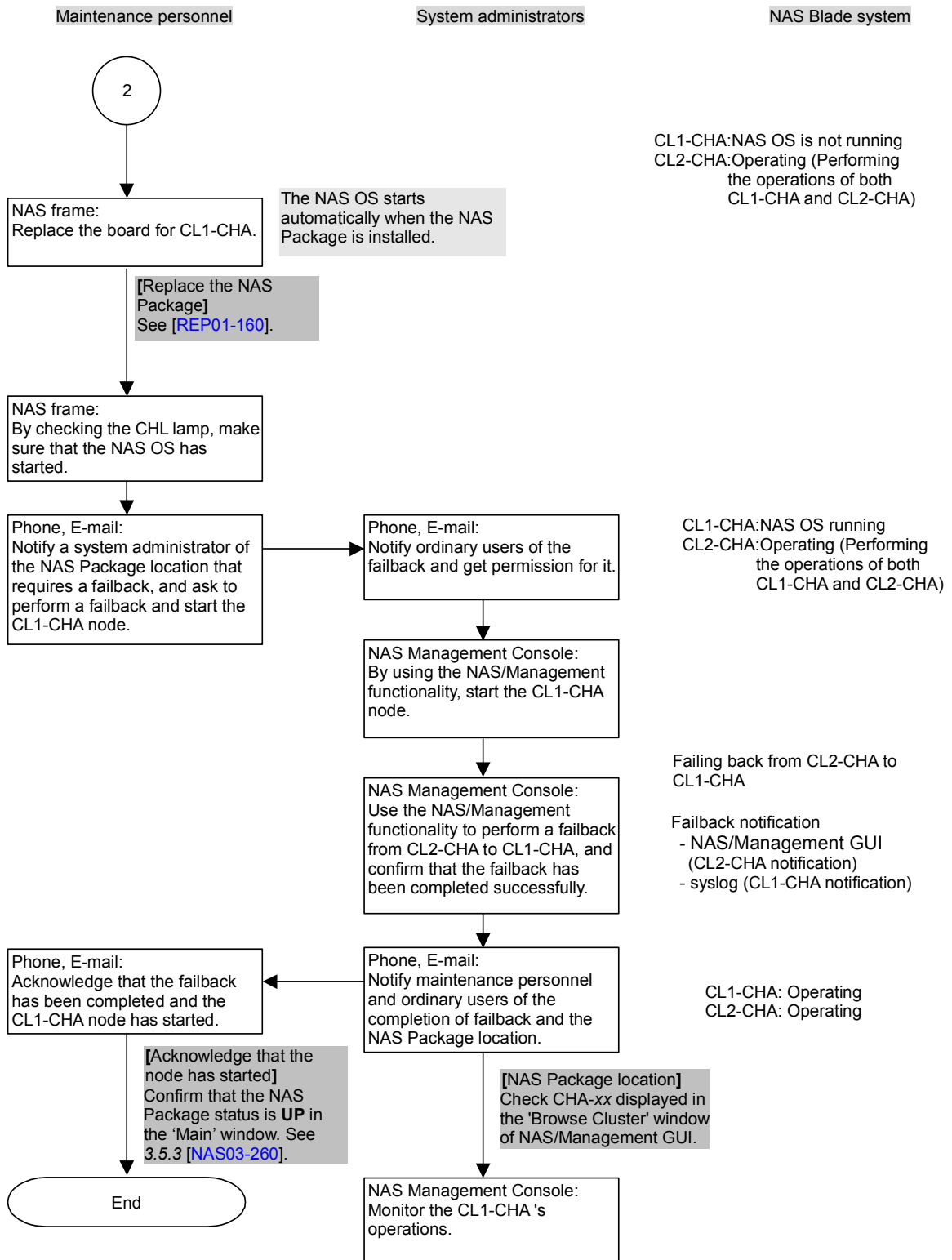

Figure 4.2-1 Replacing the NAS Package (During Preventive Replacement) (4/4)

(2) Replacing Data LAN Cables (During Periodic Replacement)

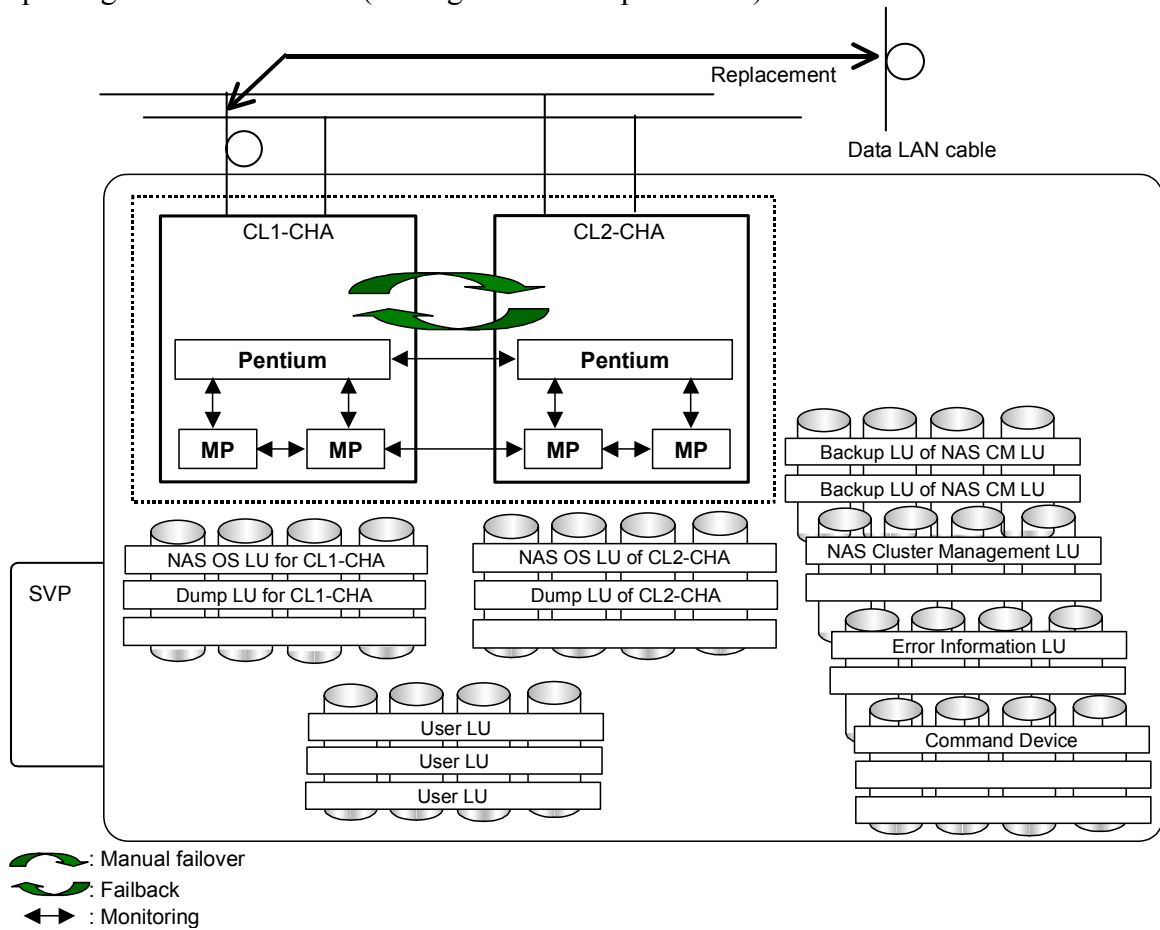

Figure 4.2-2 Replacing Data LAN Cables (During Periodic Replacement) (1/4)

Step	Procedure	Notes
1	Check the operating status of the NAS Blade system.	
2	Perform the failover.	
3	Replace the data LAN cable.	
6	Check the network status.	
7	Perform failback.	

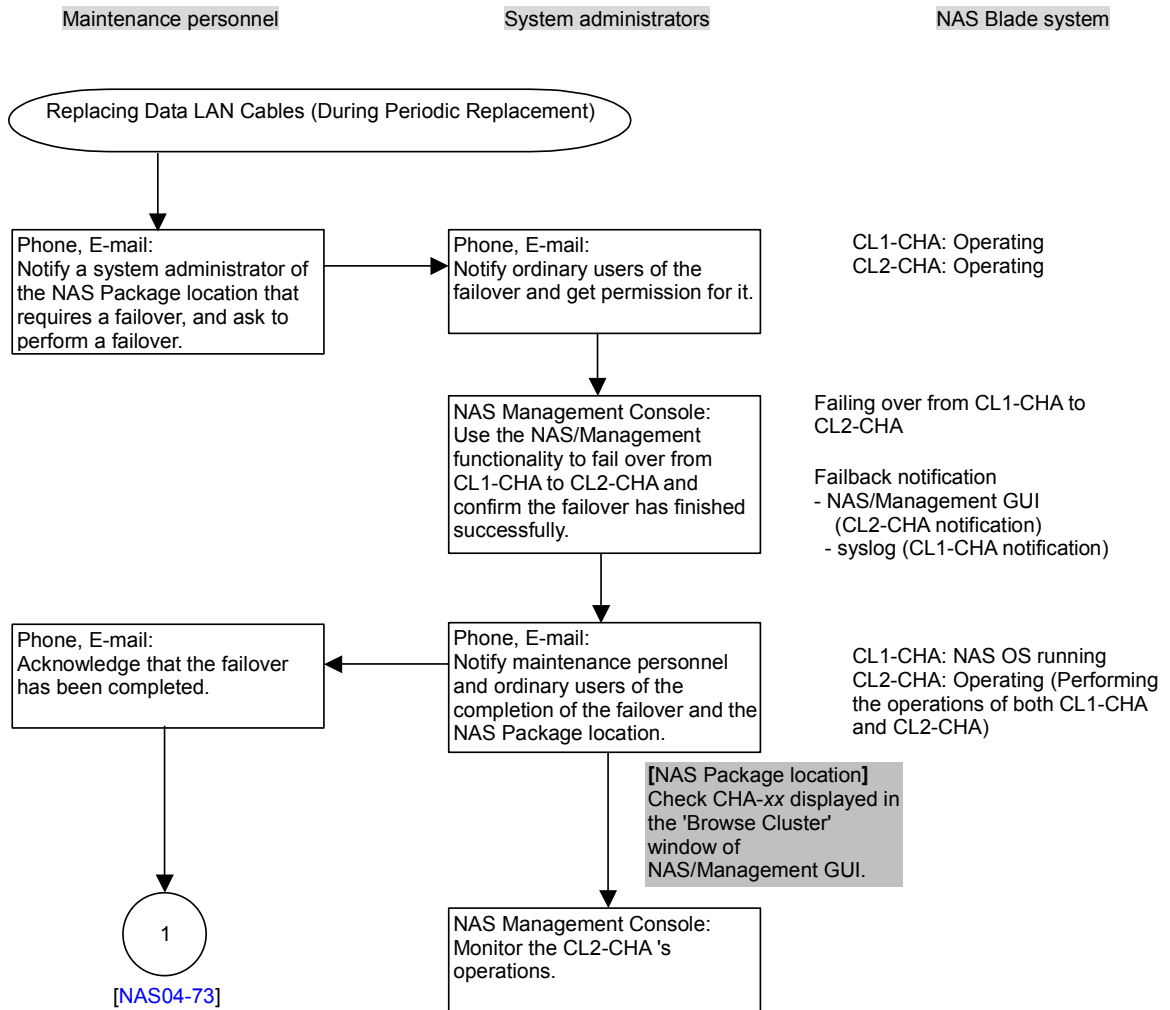

Figure 4.2-2 Replacing Data LAN Cables (During Periodic Replacement) (2/4)

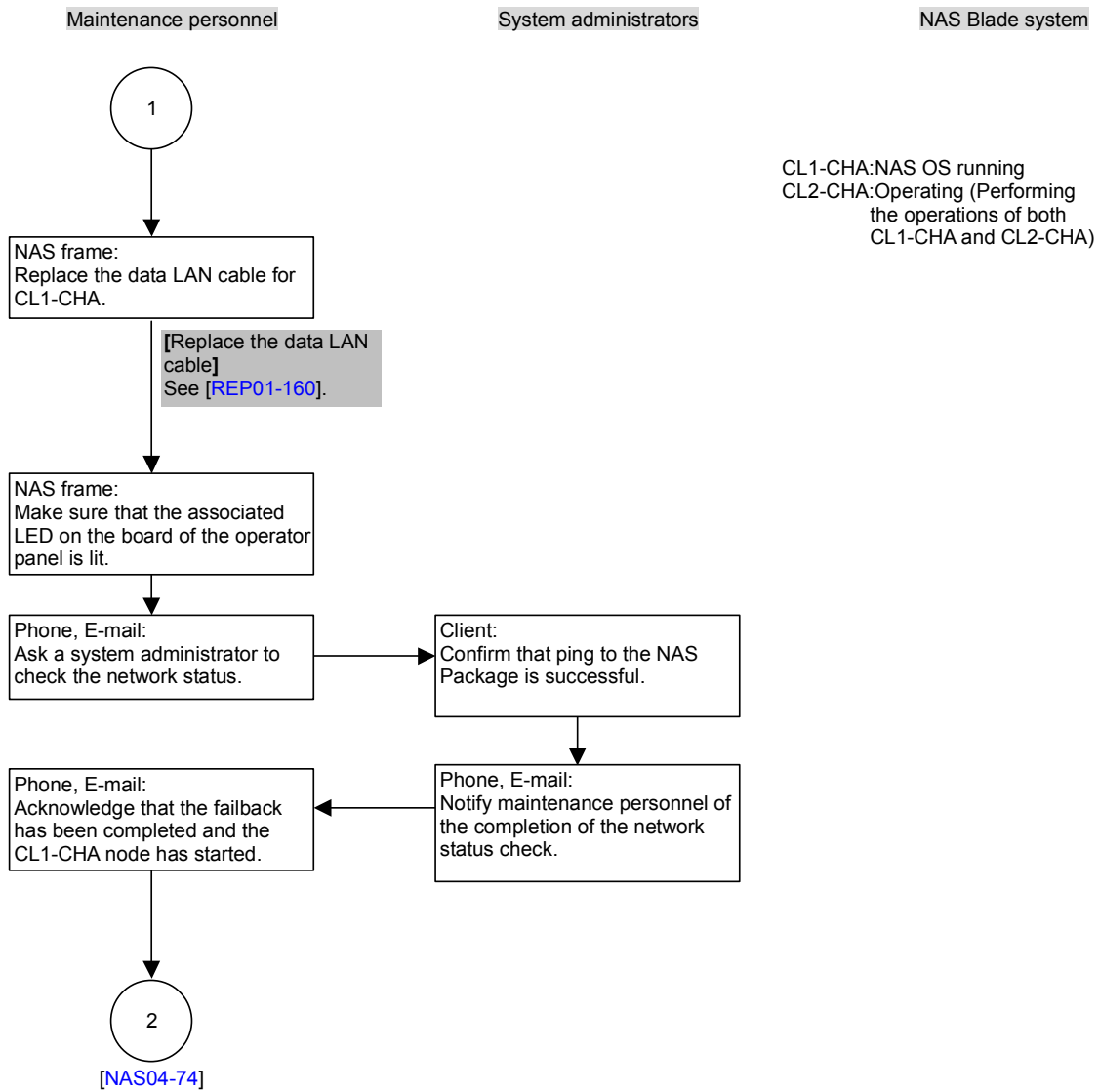

Figure 4.2-2 Replacing Data LAN Cables (During Periodic Replacement) (3/4)

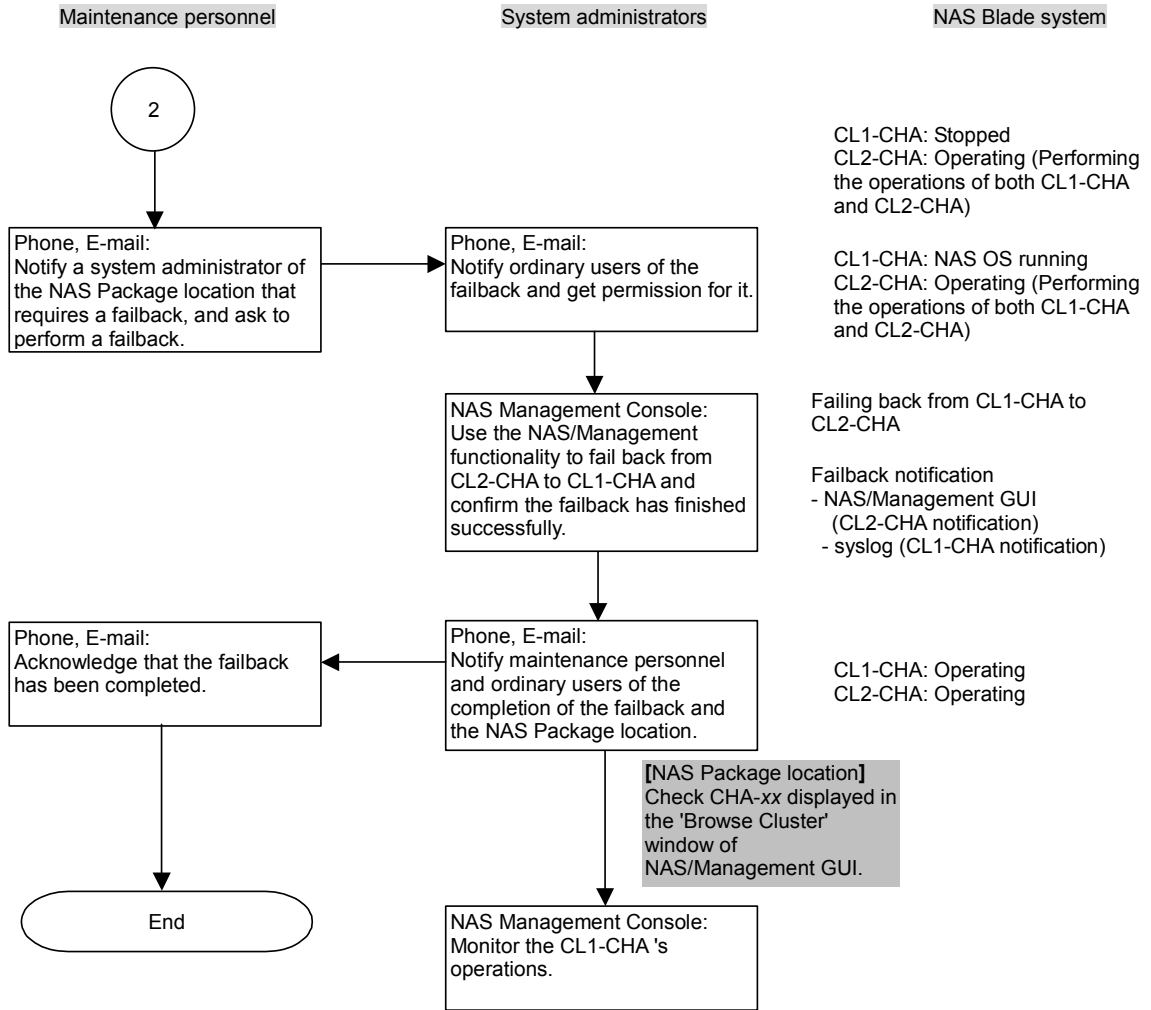

Figure 4.2-2 Replacing Data LAN Cables (During Periodic Replacement) (4/4)

(3) Hot-replacing Hardware Other Than the NAS Package

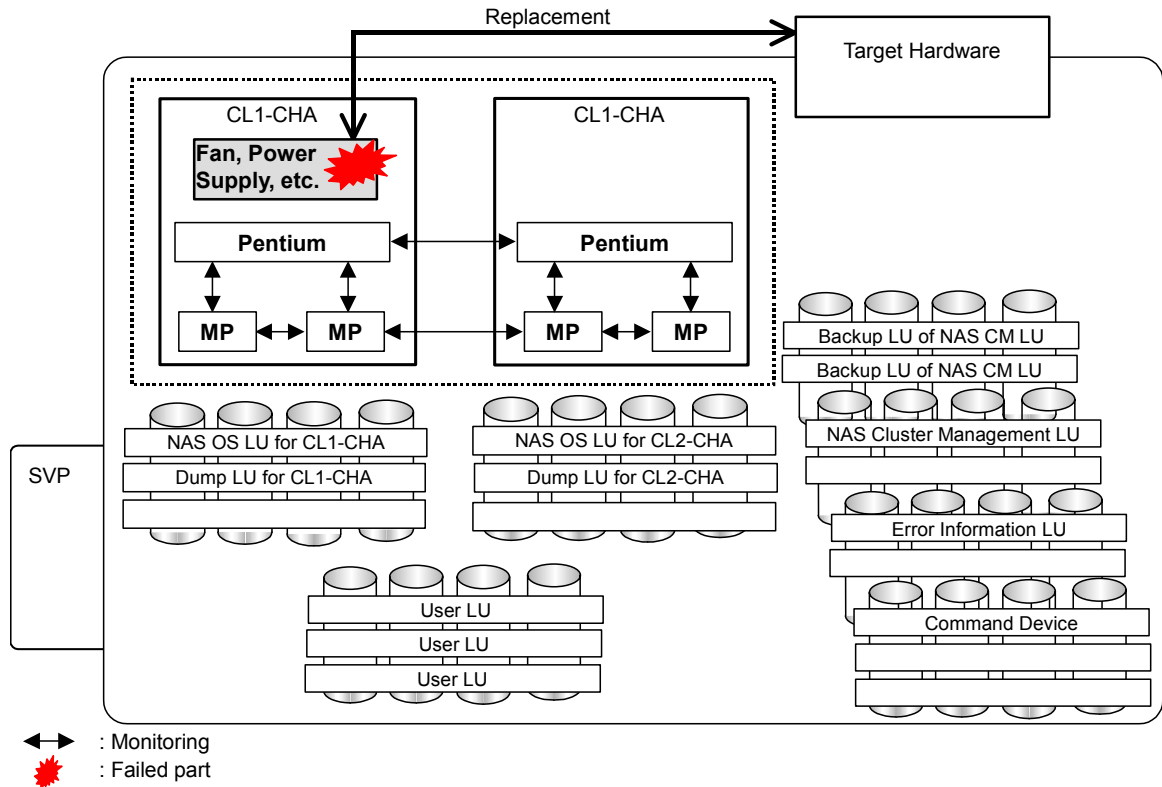

Figure 4.2-3 Hot-Replacing Hardware Other than the NAS Package(1/2)

Step	Procedure	Notes
1	Replace the target hardware.	

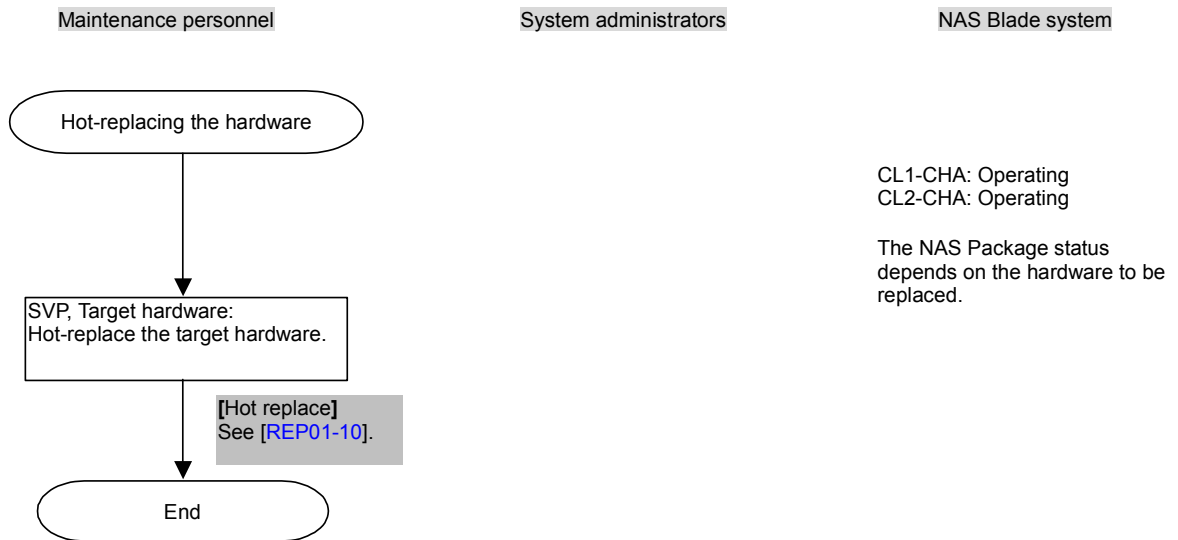

Figure 4.2-3 Hot-Replacing Hardware Other than the NAS Package(2/2)

5. NAS Software FC

This chapter describes operations for maintenance personnel and system administrators on NAS software FC (upgrade).

5.1 Overview

This section describes software upgrade procedure for the NAS Blade system when a failure occurs or during preventive maintenance.

You can perform online replacement of micro-programs in a disk subsystem without stopping user services (except for cases such as when a RAID group is not usable because of a PDEV failure).

Also, by using failover, you can replace NAS Packages in the NAS Blade system, without stopping user services. When replacing NAS Packages, maintenance personnel and system administrators need to consider whether the NAS OS needs to be stopped and whether to perform a failover.

5.2 Preparing for Software Upgrade Operations (System LU Backup)

In preparation for failing to upgrade the NAS Package program, ask the system administrator to back up the system LUs (NAS OS LU and NAS Cluster Management LU) when the settings are added, deleted, or changed by the NAS/Management GUI.

CAUTION

Recovery might not be correct if the state of the NAS Cluster Management LU at the time of the NAS OS LU recovery differs from the state at the time of the backup.

Ask system administrators to make sure that the following condition is met when a NAS OS LU recovery is performed:

- Software has not been reconfigured (for example, file systems have not been created or removed, and NFS or CIFS shares have not been created, removed or changed) since the last NAS OS LU backup.

5.3 Types of Software Upgrade Operations

Software is upgraded in the following two situations (Note that all instances of the same software in a cluster are upgraded because all the software running on NAS Packages in the same cluster must be the same version.):

- Upgrade when a software failure occurs
This upgrade operation upgrades the failed software.
- Software preventive upgrade
This upgrade operation is performed for preventive maintenance.

This section describes software preventive upgrade.

Such upgrade operations are classified based on the operations performed by maintenance personnel or system administrators and the NAS Blade system behavior, as shown in Table 5.3-1. To perform upgrade operations, always start from the number (#) 1, regardless of whether all target software must be upgraded or not.

Table 5.3-1 Types of NAS Software Upgrade Operations

#	Target software	Can ordinary users continue operations?	Explanation	Installation procedure	Provided by	Upgrade operation target	Can NAS/Management console be used? ^{*1}	Restart the NAS OS?	Perform a fallback?	Reference for preventive upgrade
1	Setup on SVP	Yes	FC of Setup on SVP. Perform installation and FC after uninstallation.	Setup on SVP	CD provided by the software developer	Setup on SVP	No	No	No	3.5.2 [1] [NAS03-110] 3.5.2 [3] [NAS03-200]
2	NAS OS (upgrade while operating)	Yes *2	FC of NAS OS. Failover, NAS OS FC, and failback are performed. Windows clients must be reconnected because services are stopped. The same FC is required for all NAS Packages in the same cluster. See the ECN for the procedures.	Upgrading NAS OS by an Updated Version	CD provided by the software developer	Setup on SVP NAS/Management	No	Yes	Yes	Figure 5.3-1 [NAS05-70]
				Upgrading NAS OS by a Patch Version (restart not required)	CD provided by the software developer	Setup on SVP NAS/Management	Yes	No	Yes	Figure 5.3-2 [NAS05-130]
				Upgrading NAS OS by a Patch Version (restart required)	CD provided by the software developer	Setup on SVP NAS/Management	Yes	Yes	Yes	Figure 5.3-3 [NAS05-220]
3	NAS OS (upgrade while the cluster is stopped)	Yes	FC of NAS OS. All services are stopped, NAS OS FC is performed, and the cluster is started. The same FC is required for all NAS Packages in the same cluster. See the ECN for the procedures.	Upgrading NAS OS by an Updated Version	CD provided by the software developer	Setup on SVP NAS/Management	No	Yes ^{*3}	No	Figure 5.3-4 [NAS05-310]
				Upgrading NAS OS by a Patch Version (restart not required)	CD provided by the software developer	Setup on SVP NAS/Management	Yes	No	No	Figure 5.3-5 [NAS05-350]
				Upgrading NAS OS by a Patch Version (restart required)	CD provided by the software developer	Setup on SVP NAS/Management	Yes	Yes	No	Figure 5.3-6 [NAS05-420]

(Continues on the next page.)

(Continued from the previous page.)

#	Target software	Can ordinary users continue operations?	Explanation	Installation procedure	Provided by	Upgrade operation target	Can NAS/Management console be used? ^{*1}	Restart the NAS OS?	Perform a failback ?	Reference for preventive upgrade
4	NAS/Management	Yes	FC of NAS/Management. The same FC is required for all NAS Packages in the same cluster.	Upgrading NAS/Management	CD provided by the software developer	Setup on SVP NAS/Management	Yes	No	No	Figure 5.3-7 [NAS05-490]
5	Optional program product	Yes *3	FC of optional program product. The same FC is required for all NAS Packages in the same cluster. The target optional program product must be stopped.	Upgrading an Optional Program Product	CD provided by the software developer	Setup on SVP NAS/Management	Yes	No	No	Figure 5.3-8 [NAS05-510]

*1: This is the upgrade operation that a system administrator performs using the NAS Management Console.

*2: Yes: Operations is possible while online.

However, CIFS share is released when a failover or failback occur. Therefore you must reconnect the server with CIFS share if there are windows clients (CIFS share) connecting the application server.

No: Offline. All applications must be stopped.

*3: However, the target optional program product must be stopped.

5.3.1 Flowcharts for Upgrading NAS Software

In this section, the cluster is assumed to consist of CL1-CHA and CL2-CHA, and Figure 5.3-1 through Figure 5.3-8 show examples of flowcharts of upgrading software on CL1-CHA.

Make sure that CL2-CHA is properly referred to as the actual location when upgrading software on the CHA location.

Table 5.3-2 shows the actual CHA locations in the NAS cluster configuration.

Table 5.3-2 CHA Location in the NAS Cluster Configuration

Model	CHA location	CL1-CHA	CL2-CHA
Multi-cabinet	Basic	1P	2V
	Option 1	1Q	2W
	Option 2	1R	2X
	Option 3	1S	2Y
Single cabinet *1	Basic	1C	2G
	Option 1	1D	2J
	Option 2	1F	2K

*1: Only two of the three, basic, option 1, or option 2, can be used.

(1) Upgrading Setup on SVP

The procedures for upgrading Setup on SVP are the same as installing Setup on SVP.

For the procedures for upgrading Setup on SVP, see 3.5.2 [1] *Installing Setup on SVP* [[NAS03-110](#)].

(2) Upgrading NAS OS by an Updated Version (Preventive Upgrade: While Operating)

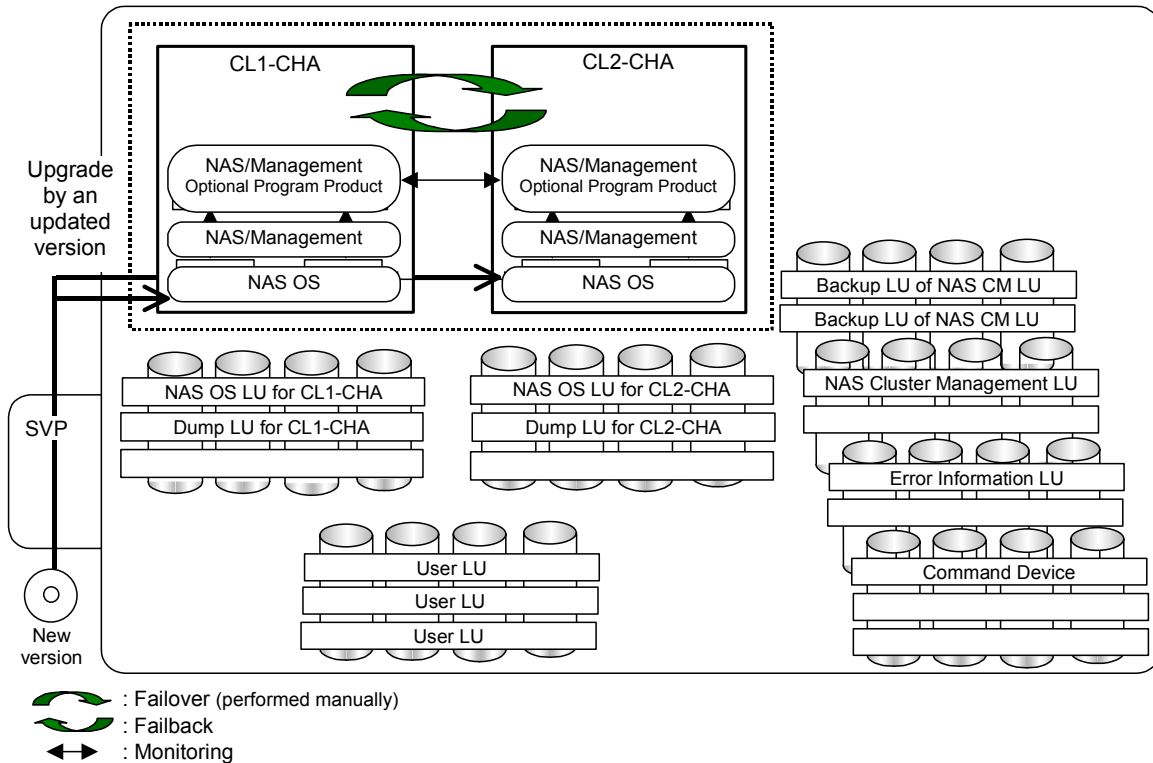

Figure 5.3-1 Upgrading NAS OS by an Updated Version
(Preventive Upgrade: While Operating) (1/6)

Step	Procedure	Notes
1	Obtain the corrected version (NAS OS).	
2	Back up NAS OS LU and NAS Cluster Management LU.	
3	Check the operating status of the NAS Blade system.	
4	Perform the failover.	
5	Stop the node.	
6	Upgrade NAS OS by an updated version.	
7	Upgrade NAS/Management.	
8	Start the node.	
9	Perform failback.	

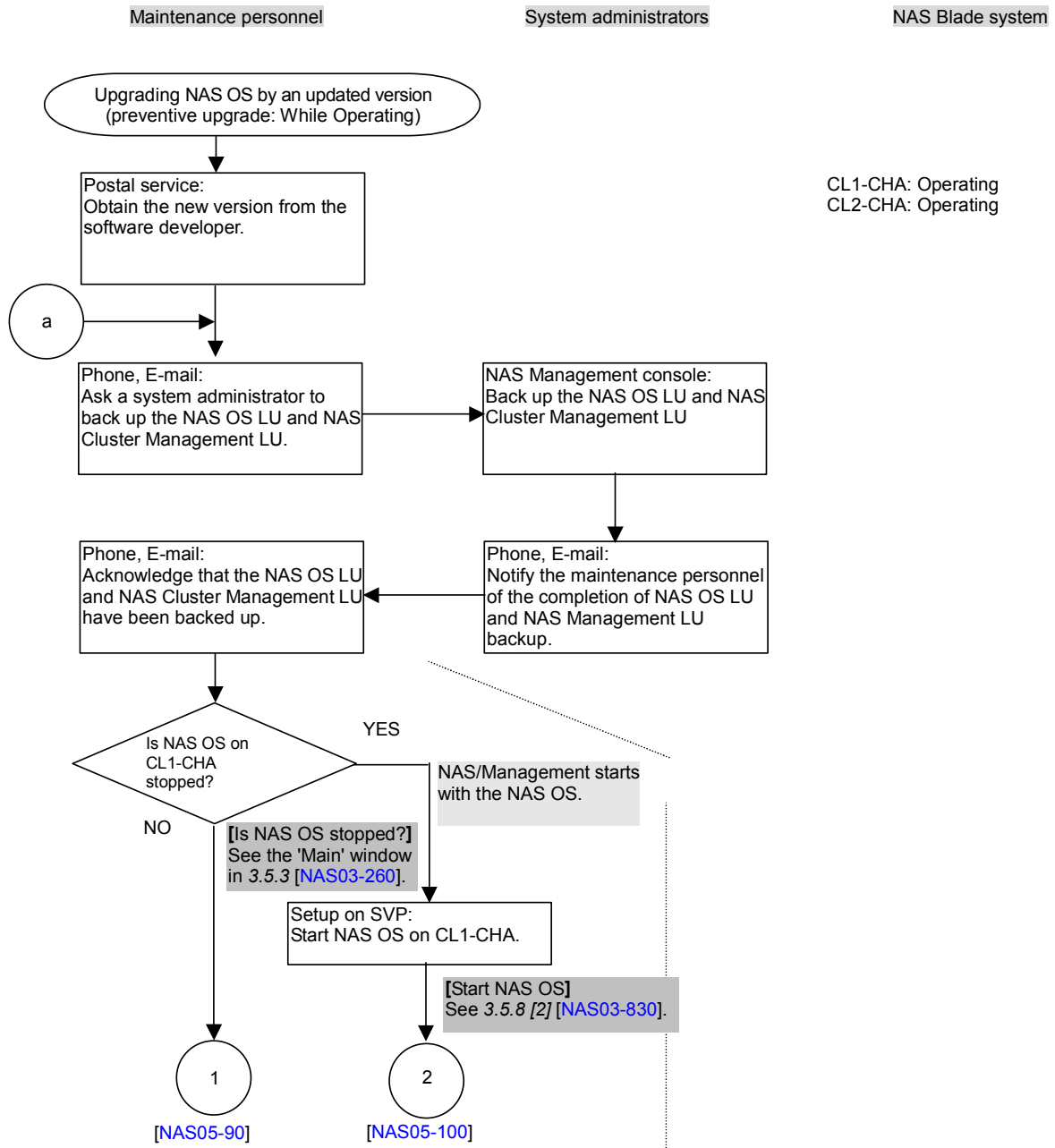

Figure 5.3-1 Upgrading NAS OS by an Updated Version
(Preventive Upgrade: While Operating) (2/6)

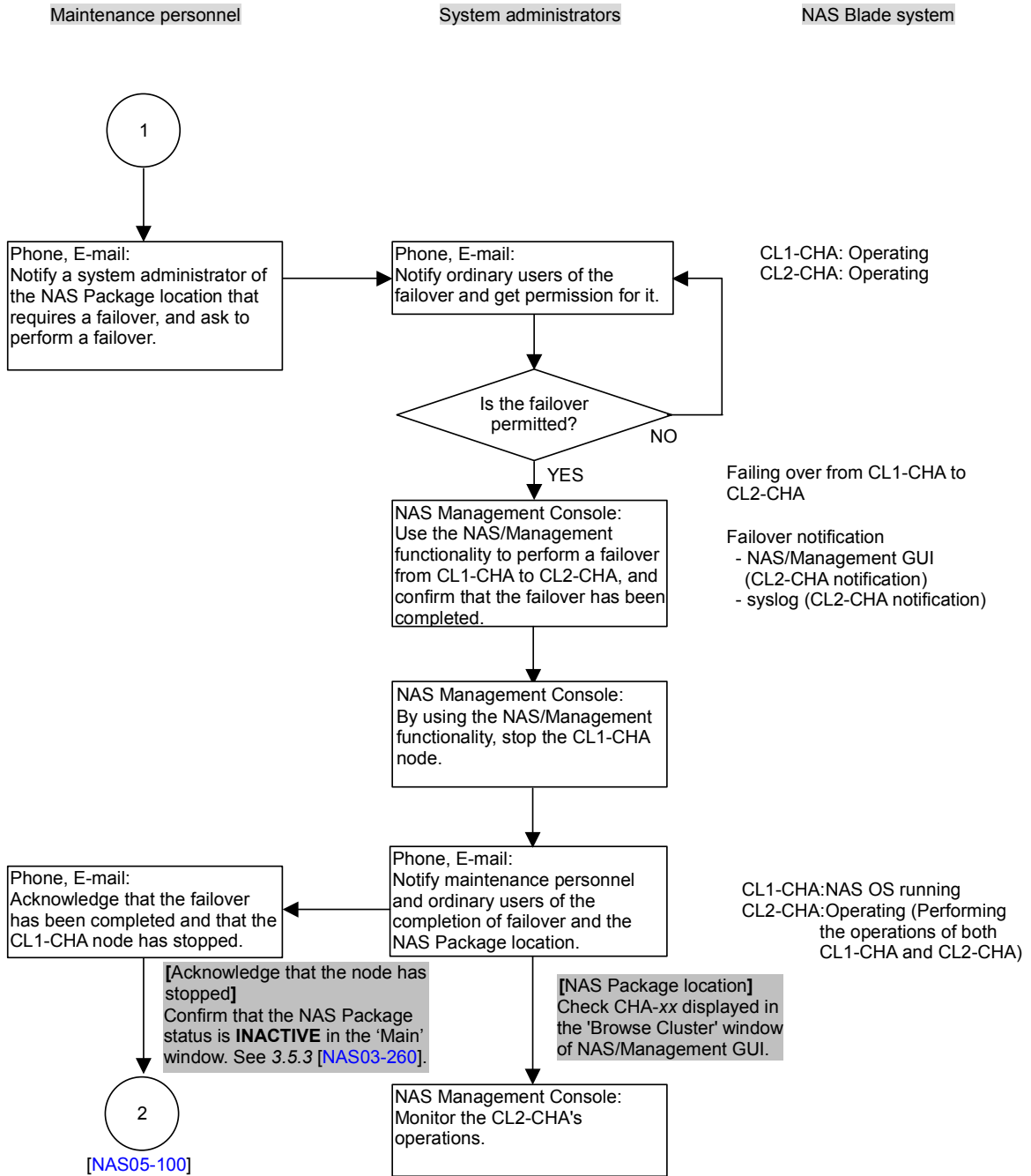

Figure 5.3-1 Upgrading NAS OS by an Updated Version (Preventive Upgrade: While Operating) (3/6)

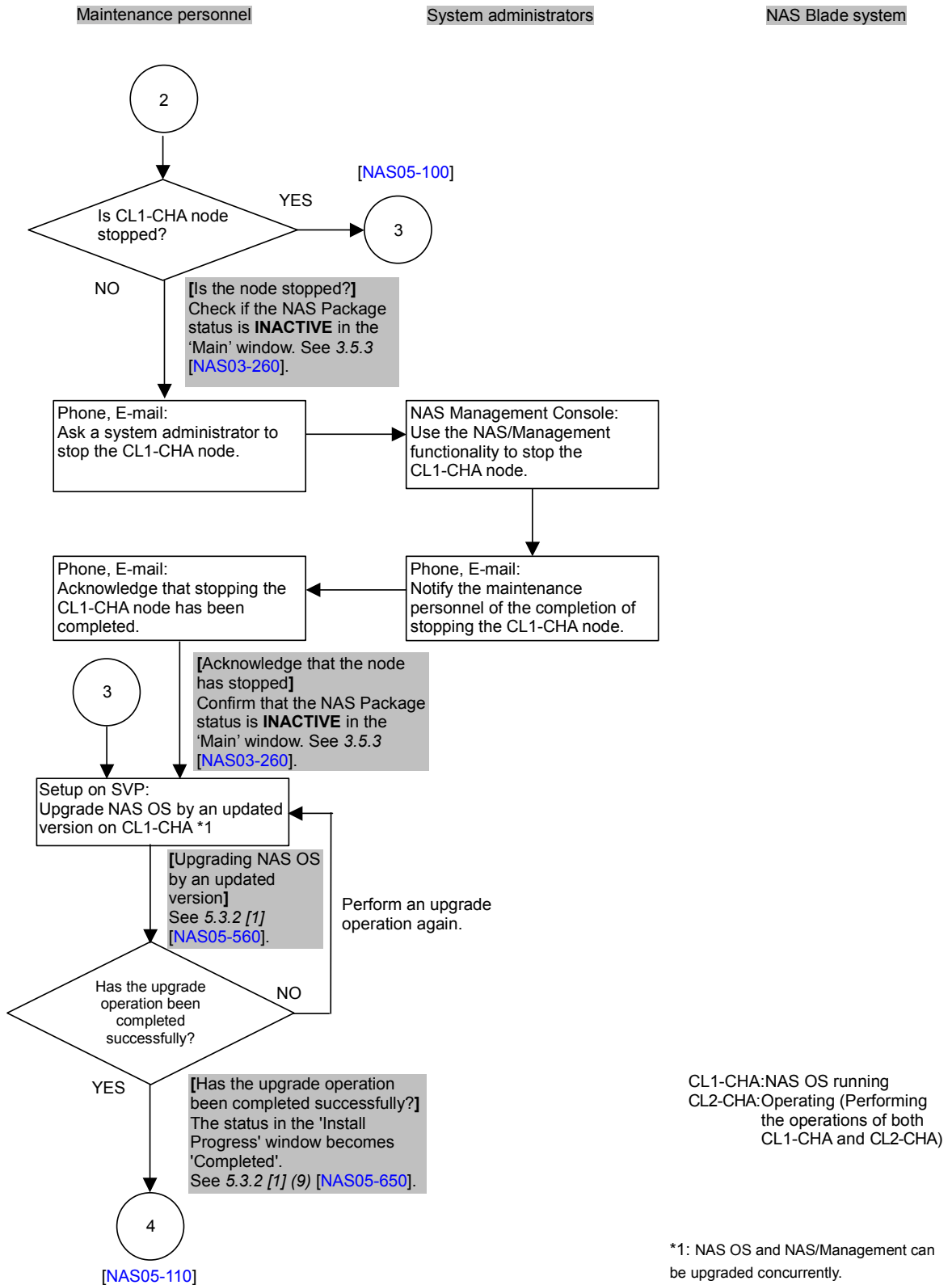

Figure 5.3-1 Upgrading NAS OS by an Updated Version
(Preventive Upgrade: While Operating) (4/6)

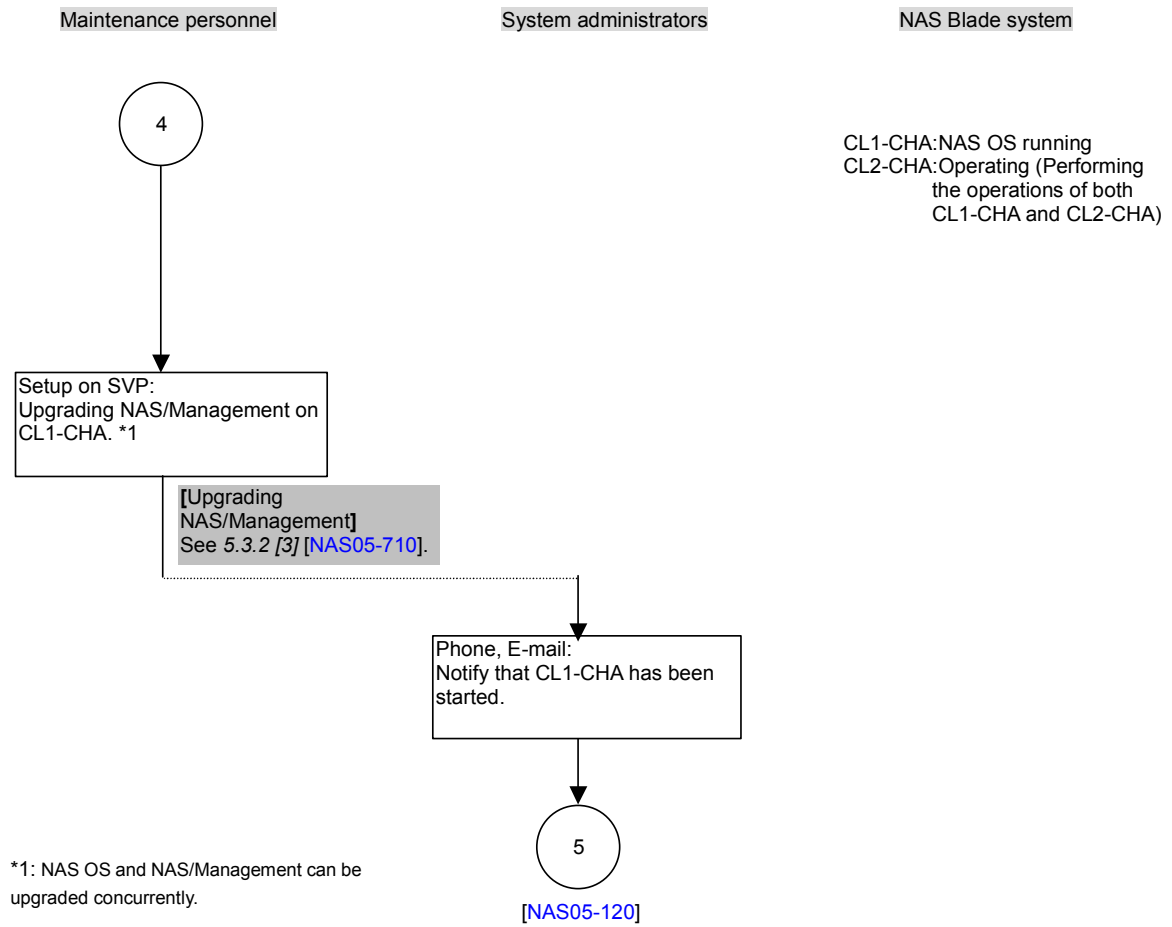

Figure 5.3-1 Upgrading NAS OS by an Updated Version
(Preventive Upgrade: While Operating) (5/6)

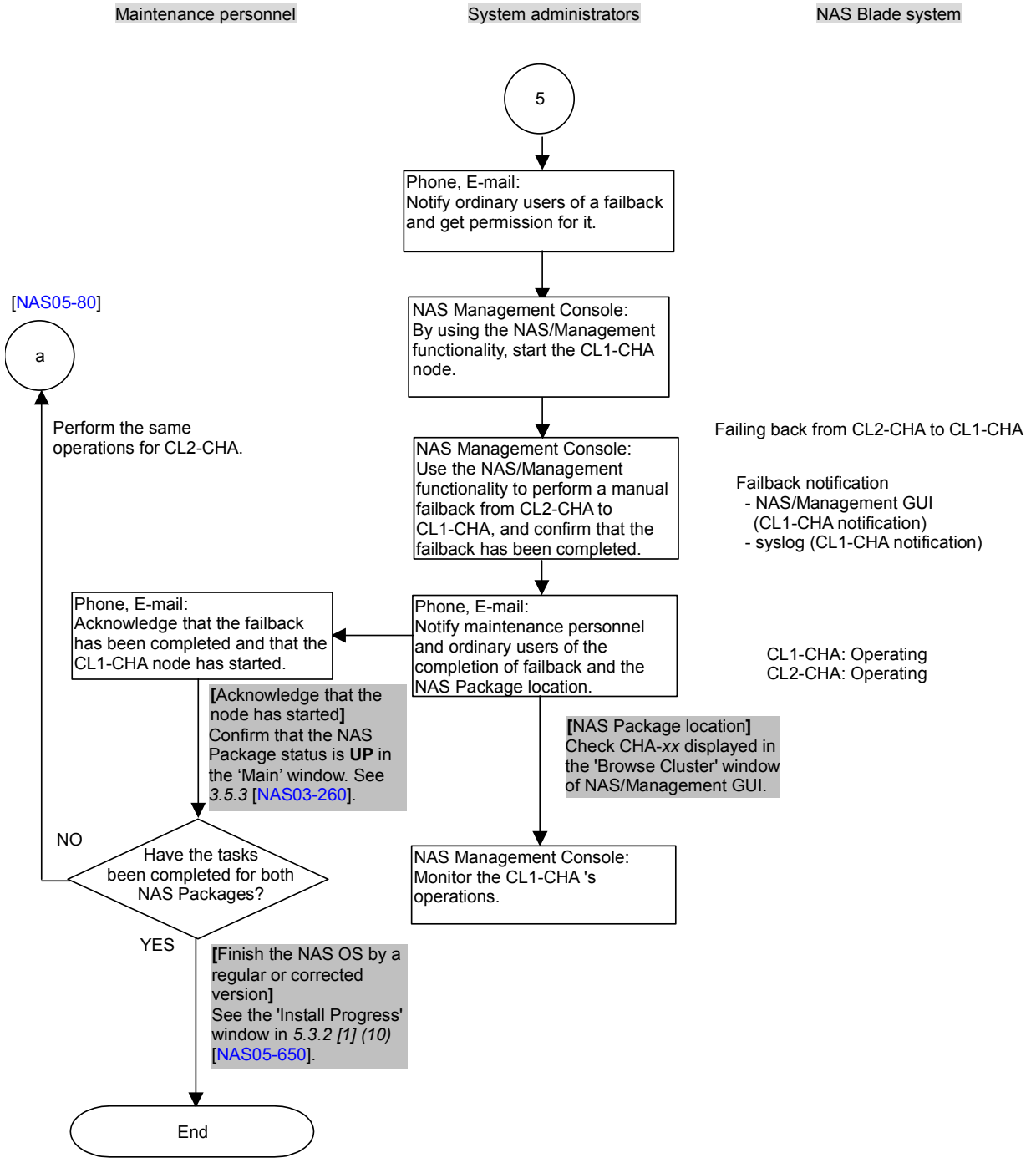

Figure 5.3-1 Upgrading NAS OS by an Updated Version
(Preventive Upgrade: While Operating) (6/6)

(3) Replacing the NAS OS By a Patch Version — Restarting the NAS OS Is Not Required
(Preventive Upgrade: While Operating)

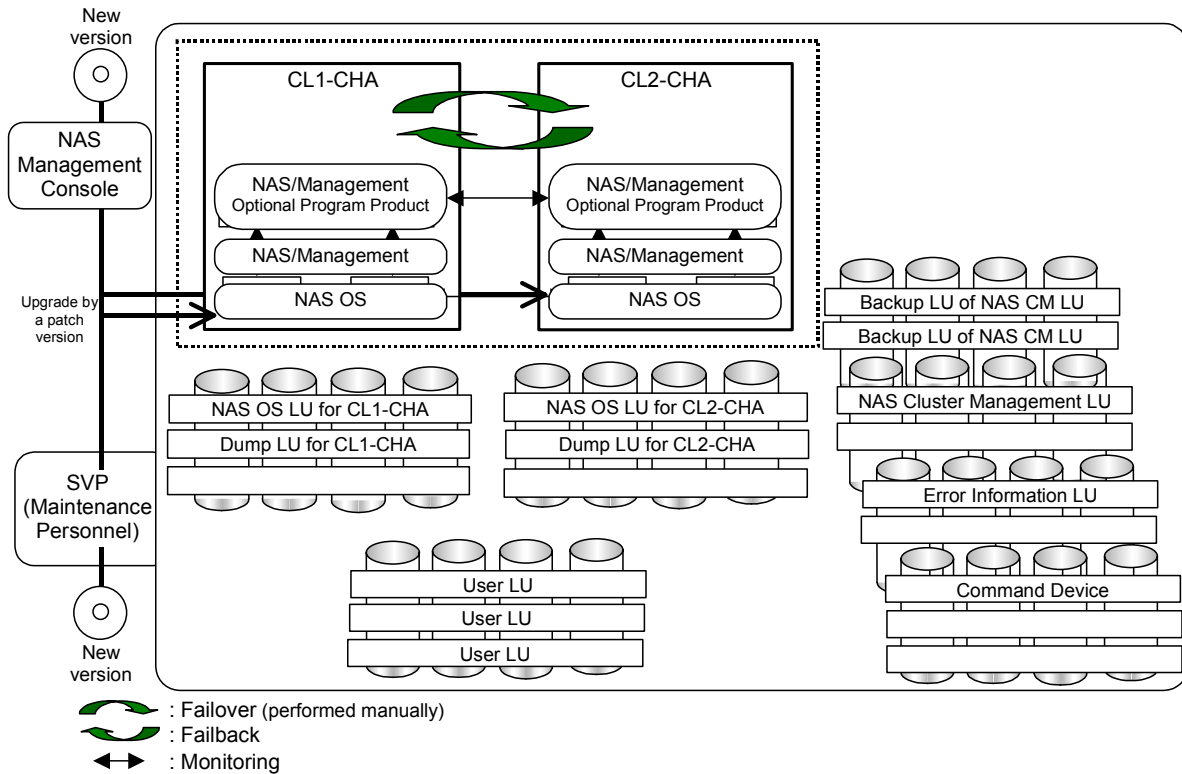

Figure 5.3-2 Upgrading NAS OS By a Patch Version —
Restarting the NAS OS Is Not Required (Preventive Upgrade: While Operating) (1/9)

Step	Procedure	Notes
1	Obtain the corrected version (NAS OS).	
2	Back up the NAS OS LU and NAS Cluster Management LU.	
3	Check the operating status of the NAS Blade system.	
4	Perform the failover.	
5	Start the NAS OS.	Do this only if the NAS OS of the target NAS Package is not running.
6	Upgrade NAS OS by a patch version.	
7	Perform failback.	

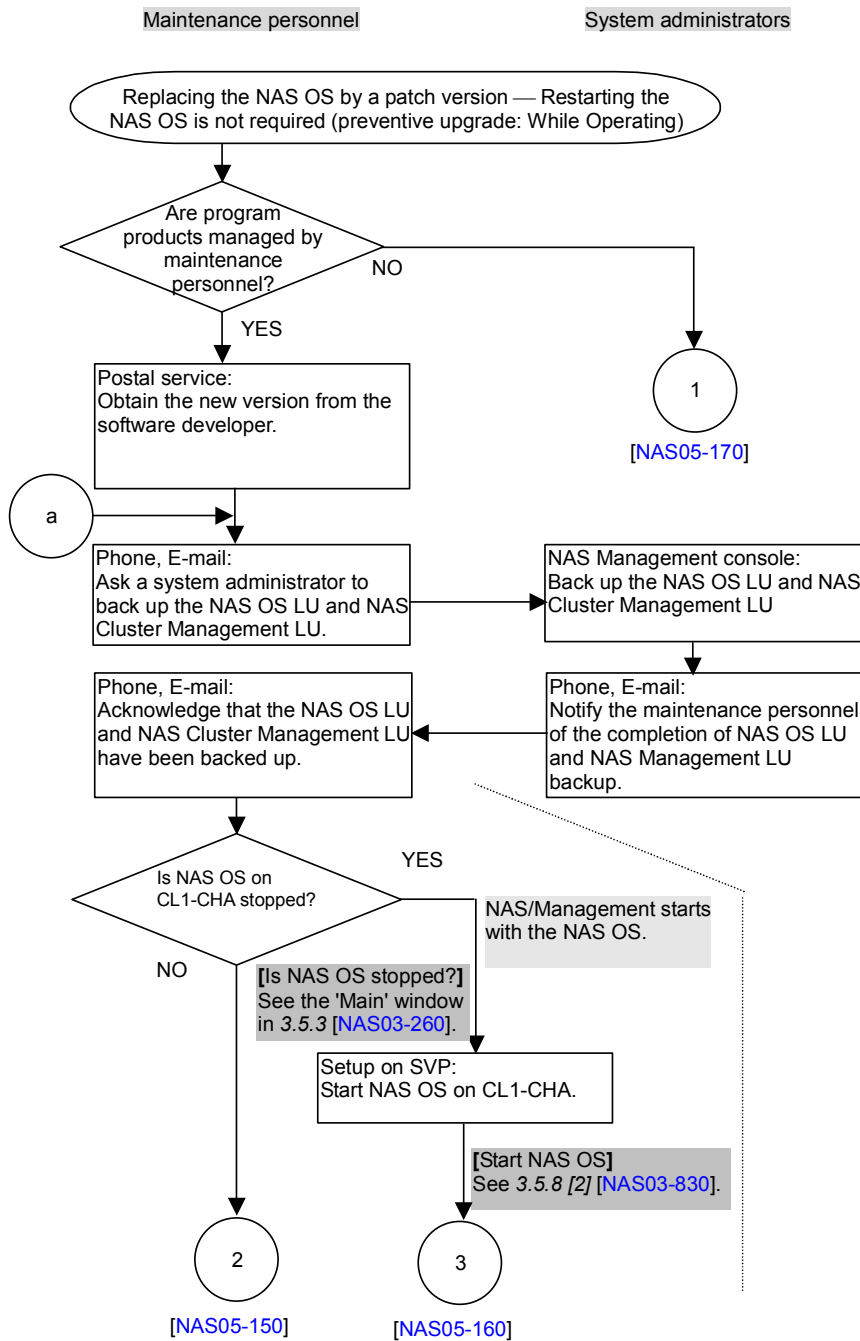

Figure 5.3-2 Upgrading NAS OS By a Patch Version — Restarting the NAS OS Is Not Required (Preventive Upgrade: While Operating) (2/9)

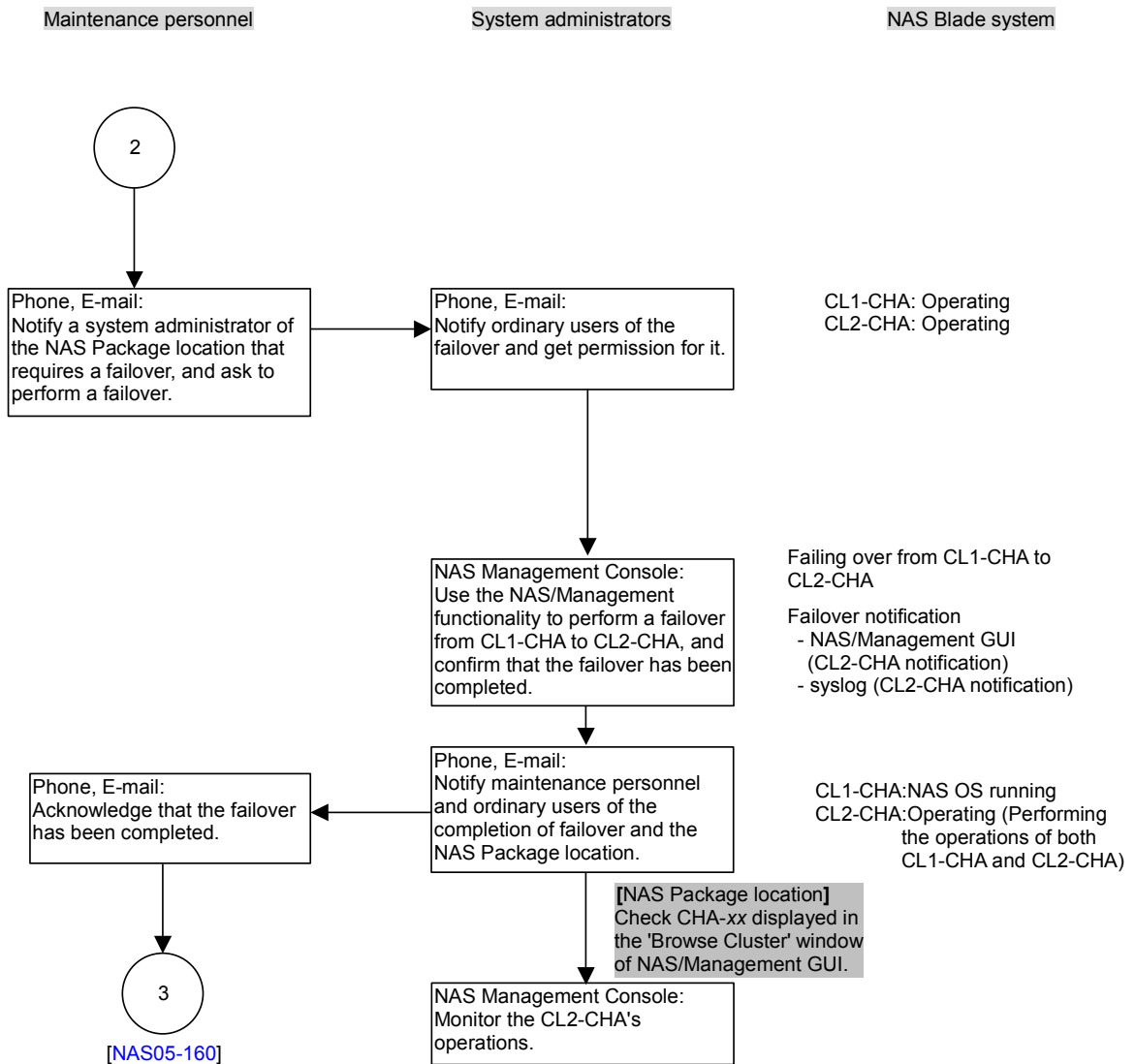

Figure 5.3-2 Upgrading NAS OS By a Patch Version —
Restarting the NAS OS Is Not Required (Preventive Upgrade: While Operating) (3/9)

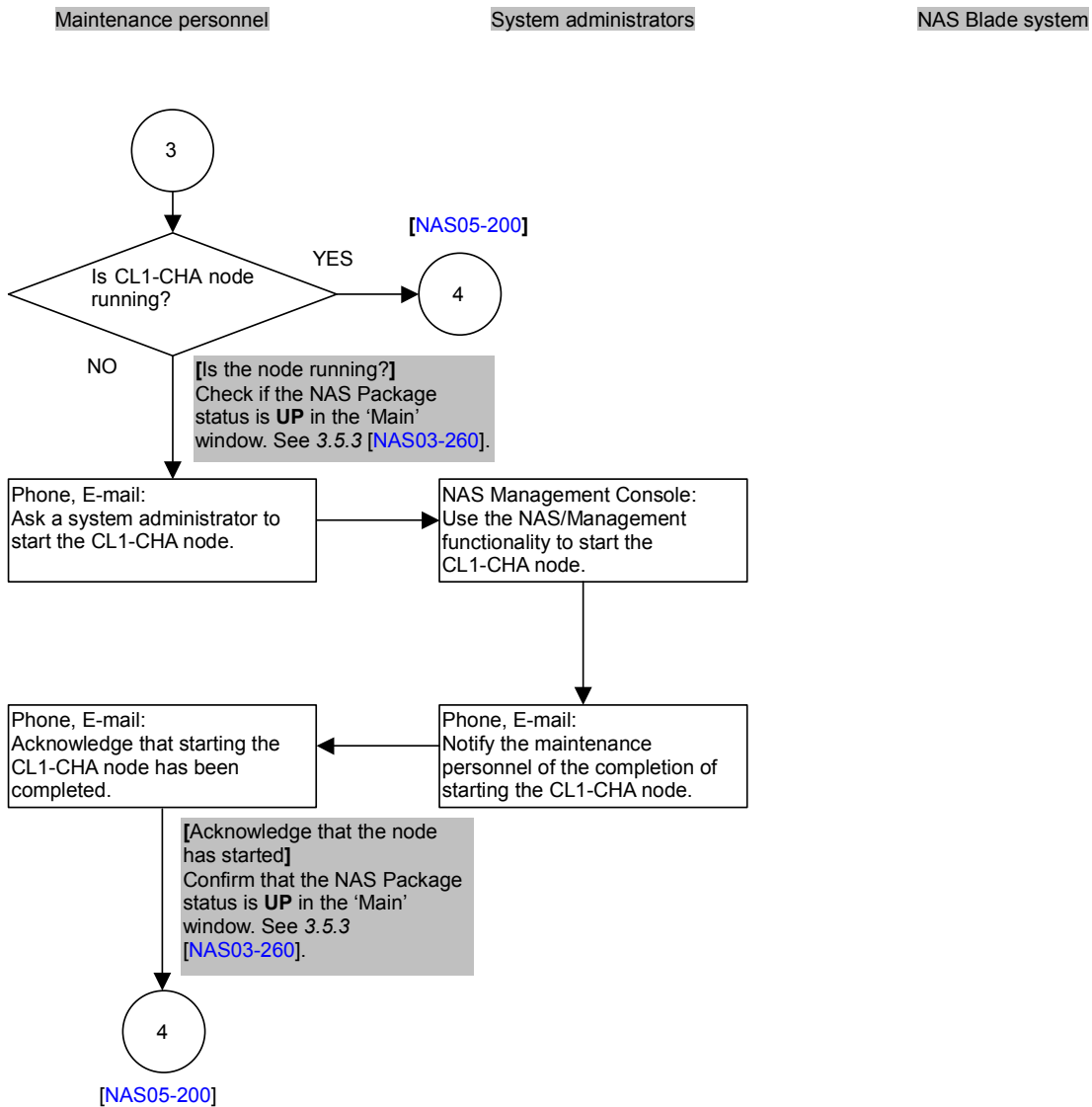

Figure 5.3-2 Upgrading NAS OS By a Patch Version —
Restarting the NAS OS Is Not Required (Preventive Upgrade: While Operating) (4/9)

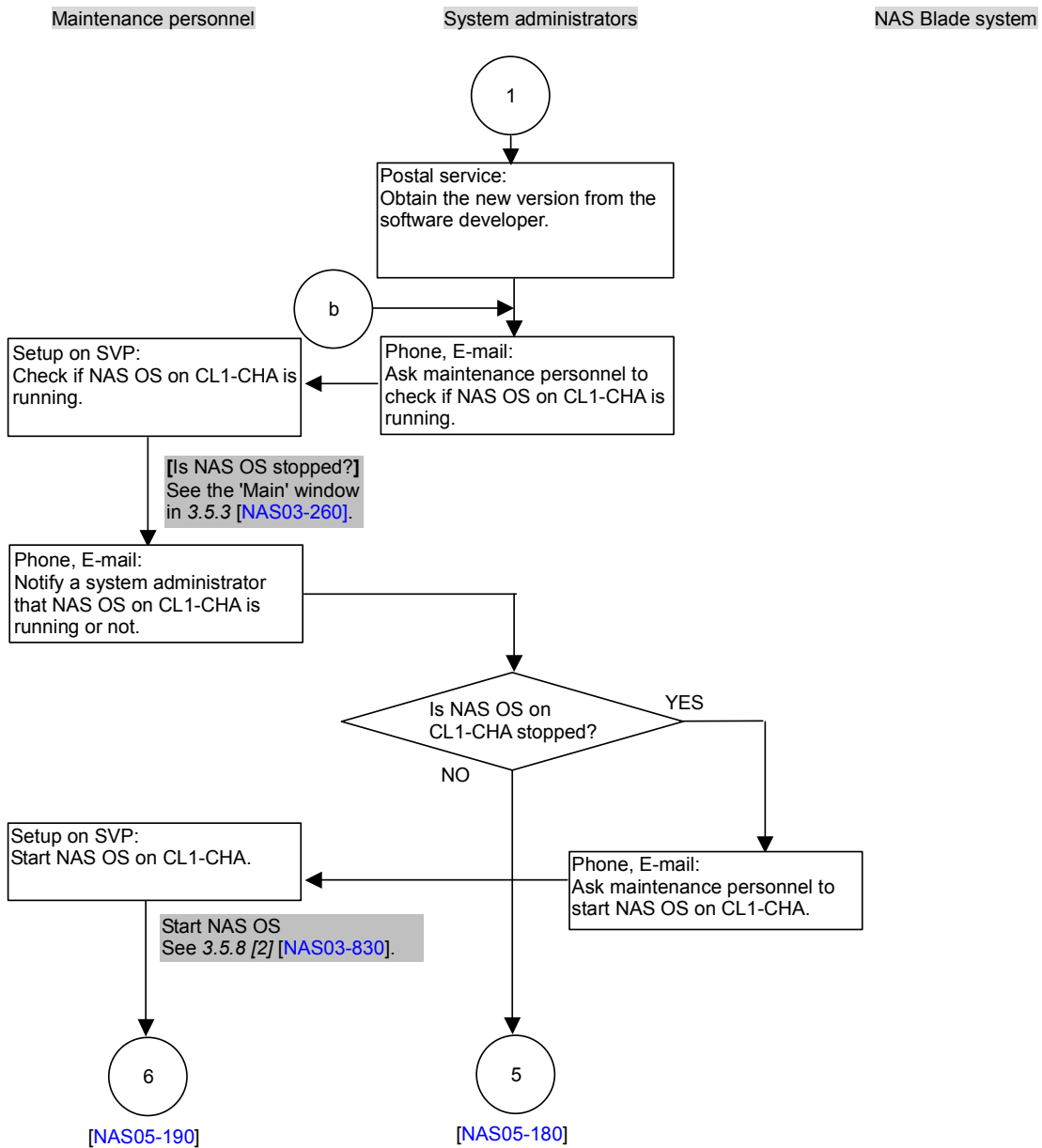

Figure 5.3-2 Upgrading NAS OS By a Patch Version —
Restarting the NAS OS Is Not Required (Preventive Upgrade: While Operating) (5/9)

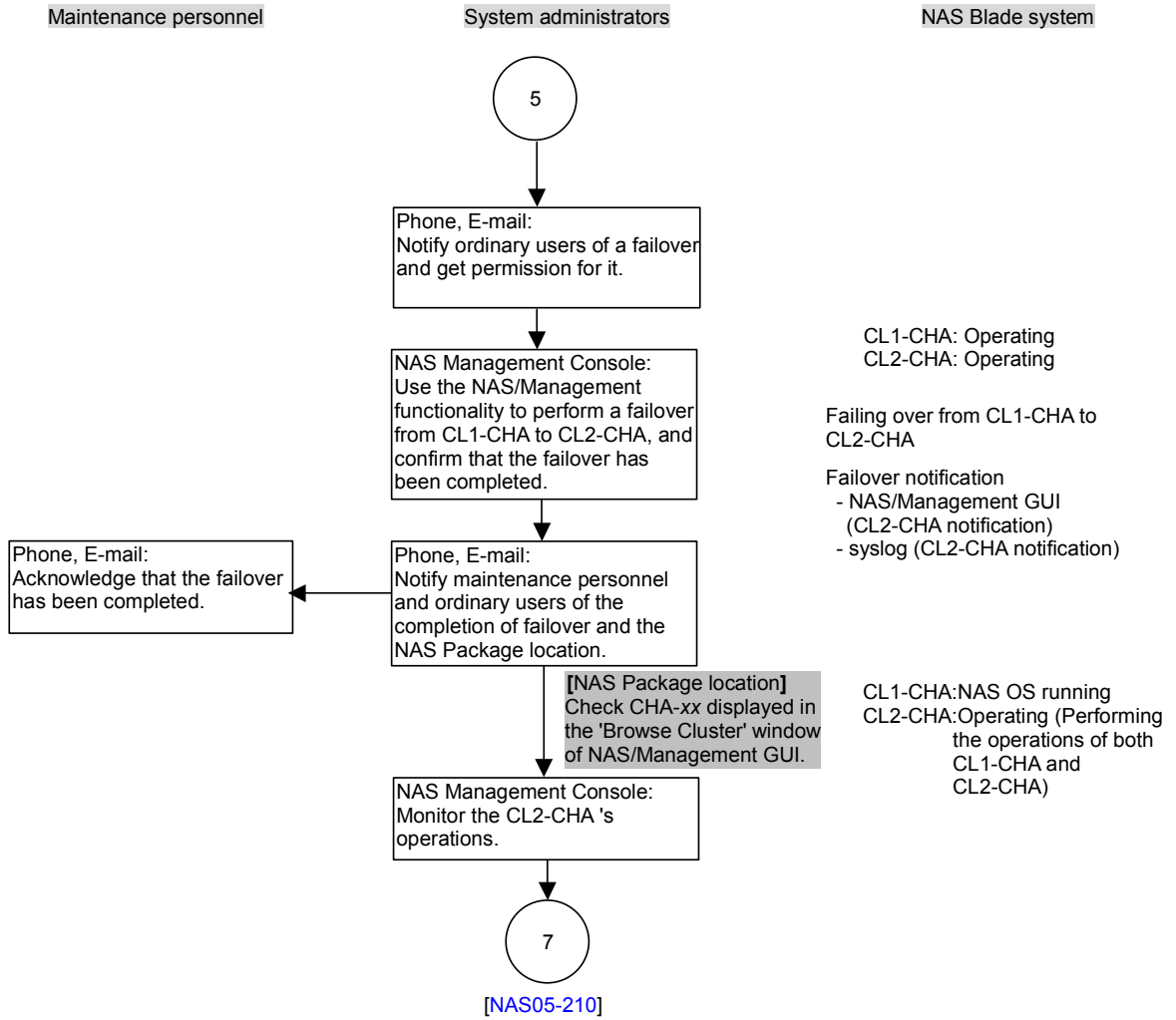

Figure 5.3-2 Upgrading NAS OS By a Patch Version —
Restarting the NAS OS Is Not Required (Preventive Upgrade: While Operating) (6/9)

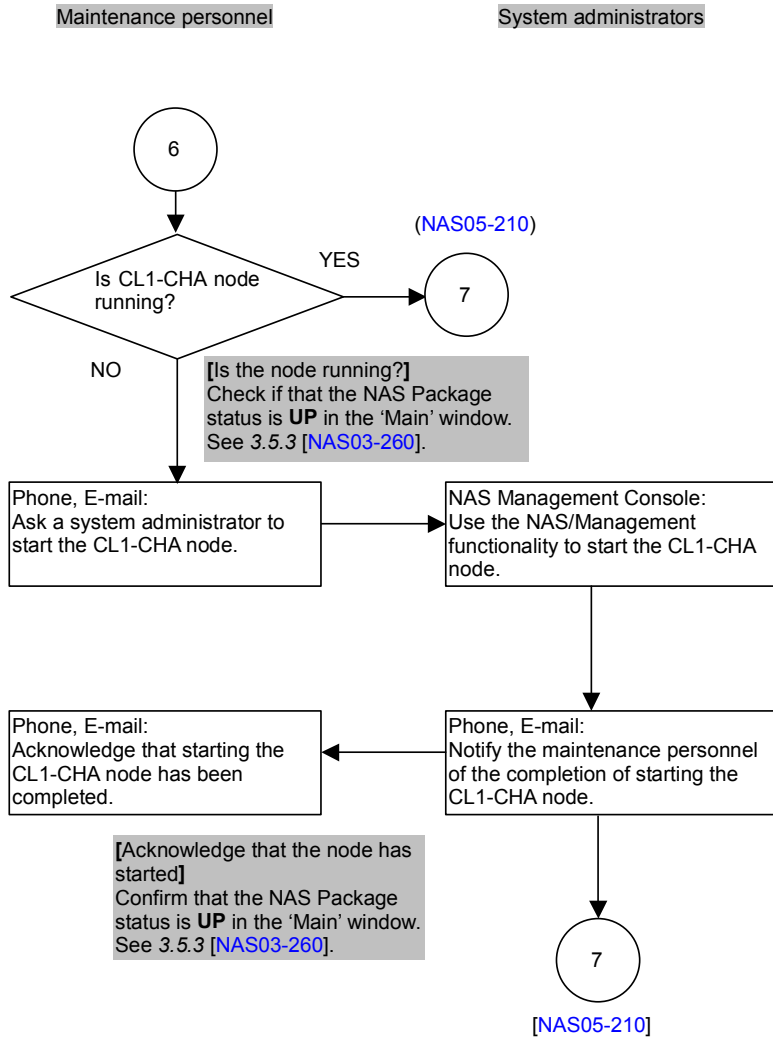

Figure 5.3-2 Upgrading NAS OS By a Patch Version —
Restarting the NAS OS Is Not Required (Preventive Upgrade: While Operating) (7/9)

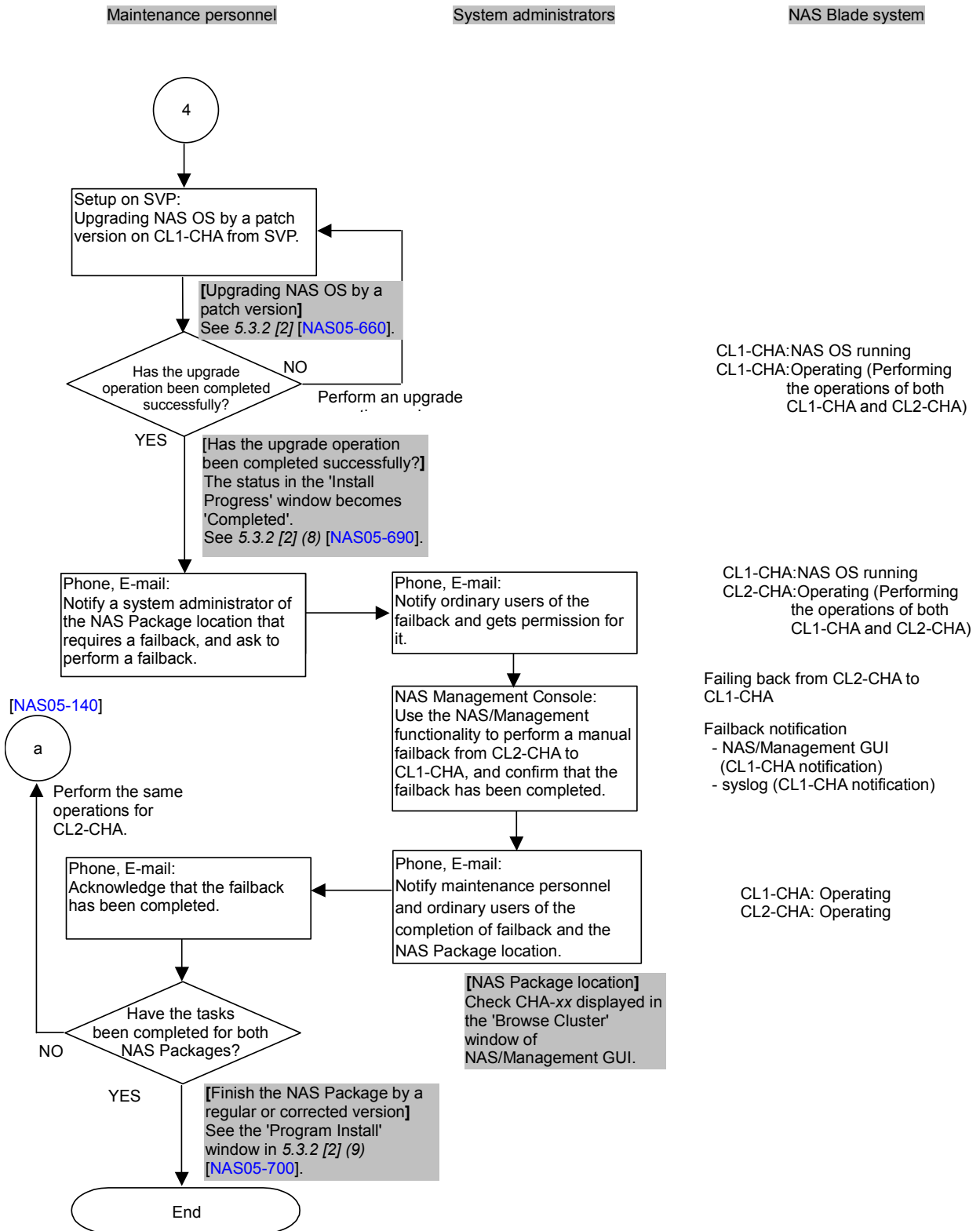

Figure 5.3-2 Upgrading NAS OS By a Patch Version —
Restarting the NAS OS Is Not Required (Preventive Upgrade: While Operating) (8/9)

Maintenance personnel

System administrators

NAS Blade system

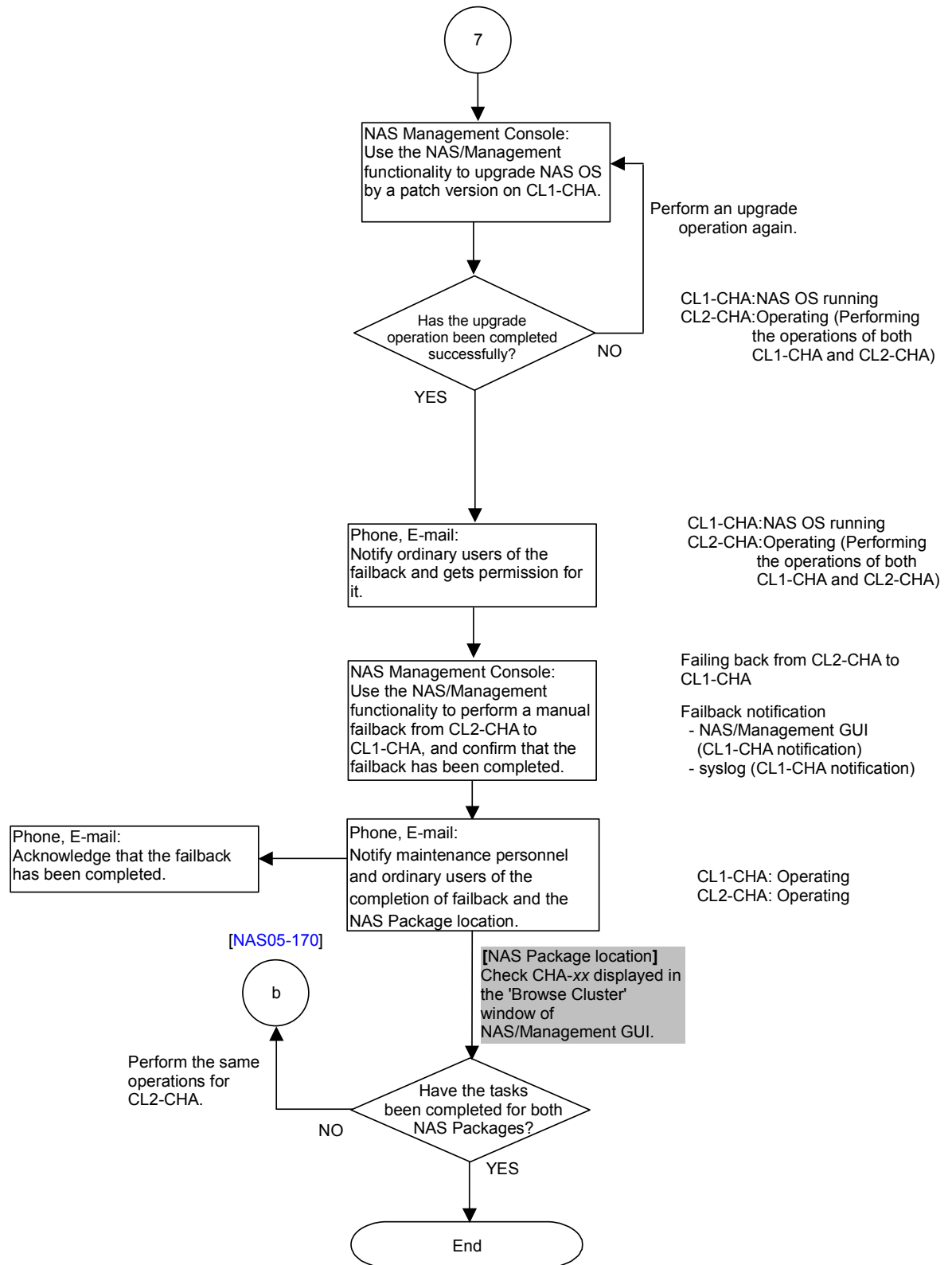

Figure 5.3-2 Upgrading NAS OS By a Patch Version —
Restarting the NAS OS Is Not Required (Preventive Upgrade: While Operating) (9/9)

(4) Replacing the NAS OS By a Patch Version — Restarting the NAS OS Is Required (Preventive Upgrade: While Operating)

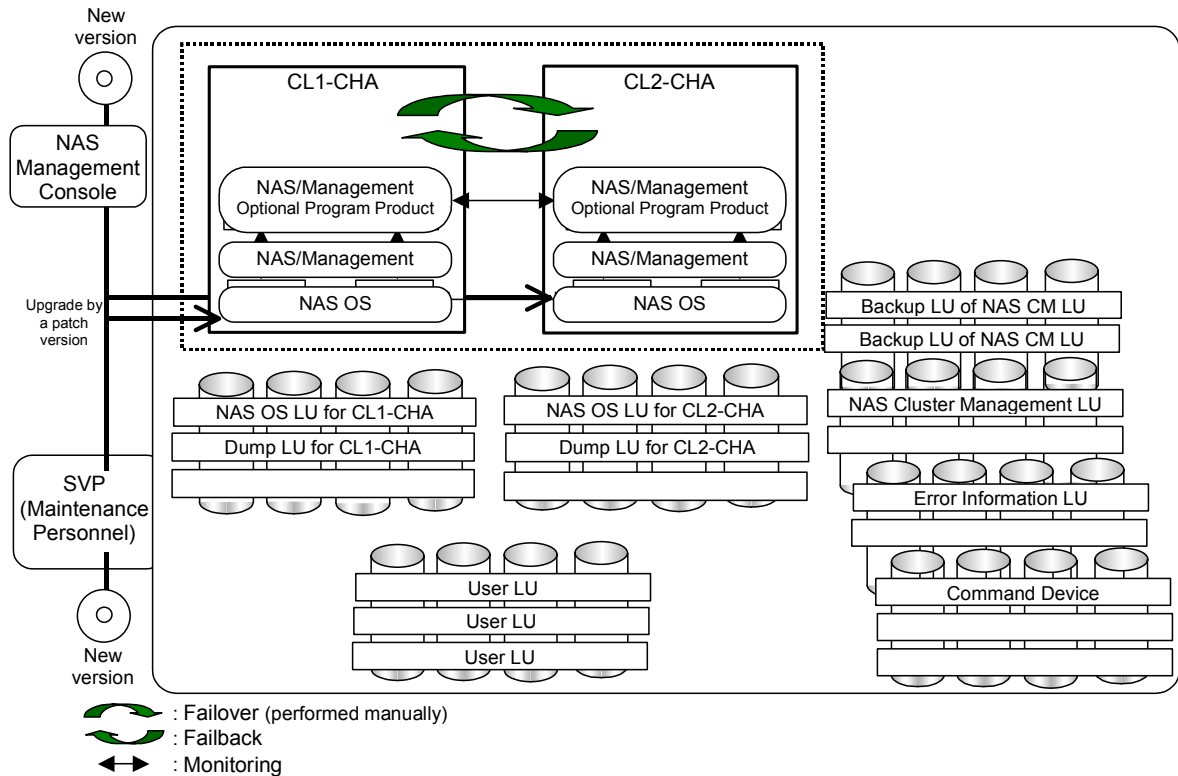

Figure 5.3-3 Upgrading NAS OS By a Patch Version —
Restarting the NAS OS Is Required (Preventive Upgrade: While Operating) (1/9)

Step	Procedure	Notes
1	Obtain the corrected version (NAS OS).	
2	Back up the NAS OS LU and NAS Cluster Management LU.	
3	Check the operating status of the NAS Blade system.	
4	Perform the failover.	
5	Stop the node.	
6	Start the NAS OS.	Do this only if the NAS OS of the target NAS Package is not running.
7	Operate the software according to the relevant documentation provided with the software.	Do this only if NAS OS definitions have changed.
8	Upgrade NAS OS by a patch version.	
9	Restart the NAS OS.	Use the NAS/Management functionality to perform NAS OS upgrade by a patch version.
10	Start the node.	
11	Perform failback.	

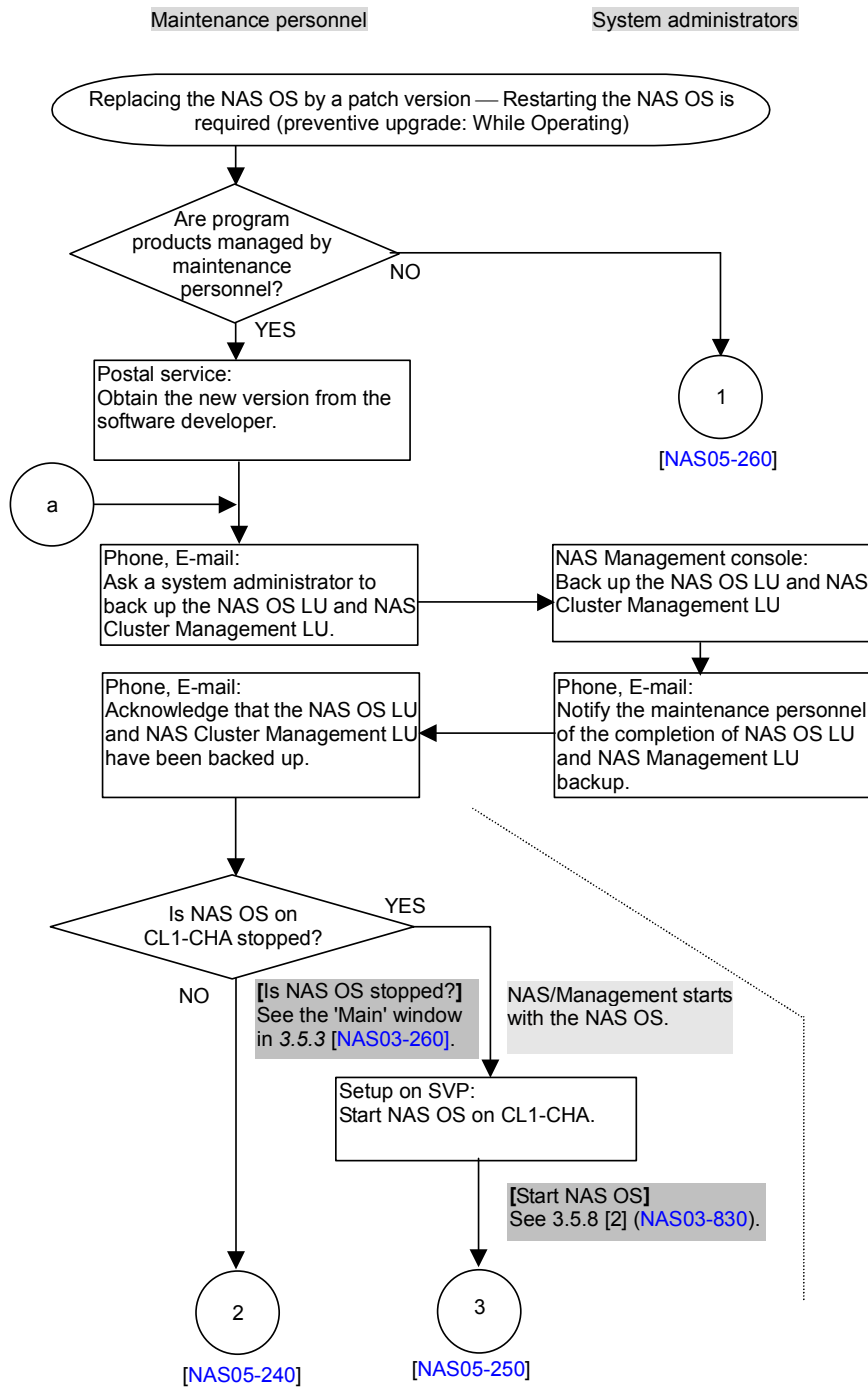

Figure 5.3-3 Upgrading NAS OS By a Patch Version — Restarting the NAS OS Is Required (Preventive Upgrade: While Operating) (2/9)

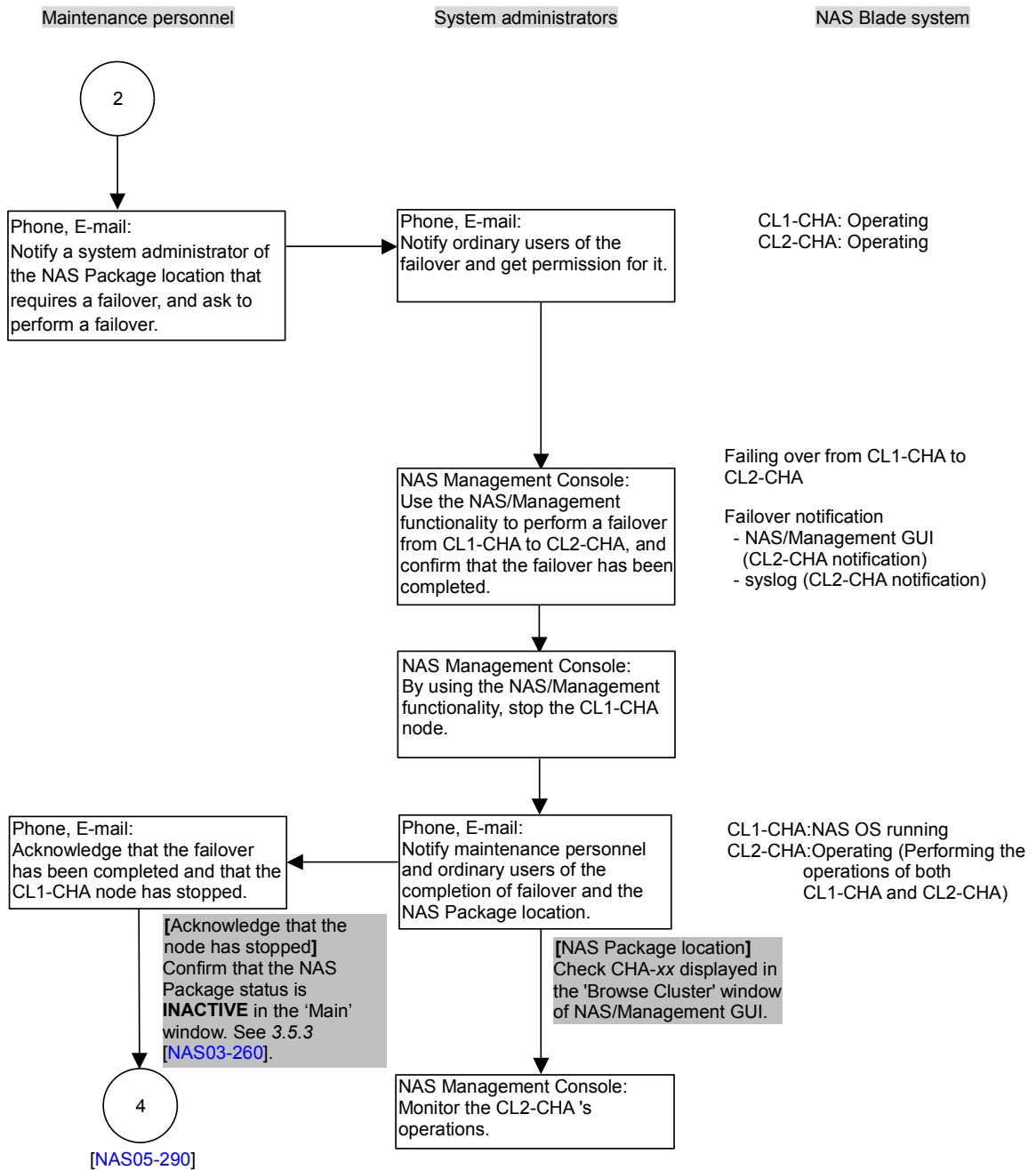

Figure 5.3-3 Upgrading NAS OS By a Patch Version —
Restarting the NAS OS Is Required (Preventive Upgrade: While Operating) (3/9)

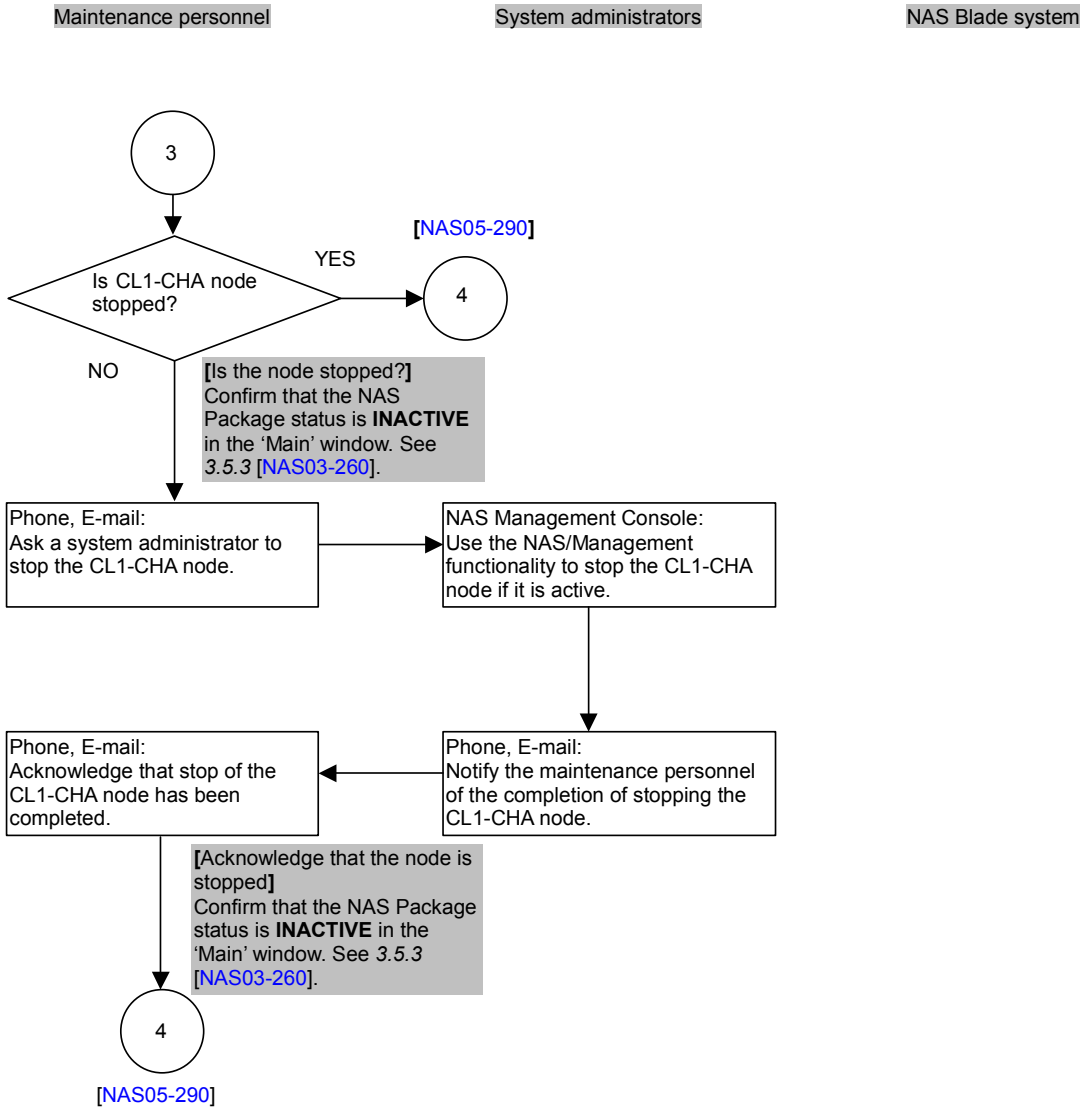

Figure 5.3-3 Upgrading NAS OS By a Patch Version —
Restarting the NAS OS Is Required (Preventive Upgrade: While Operating) (4/9)

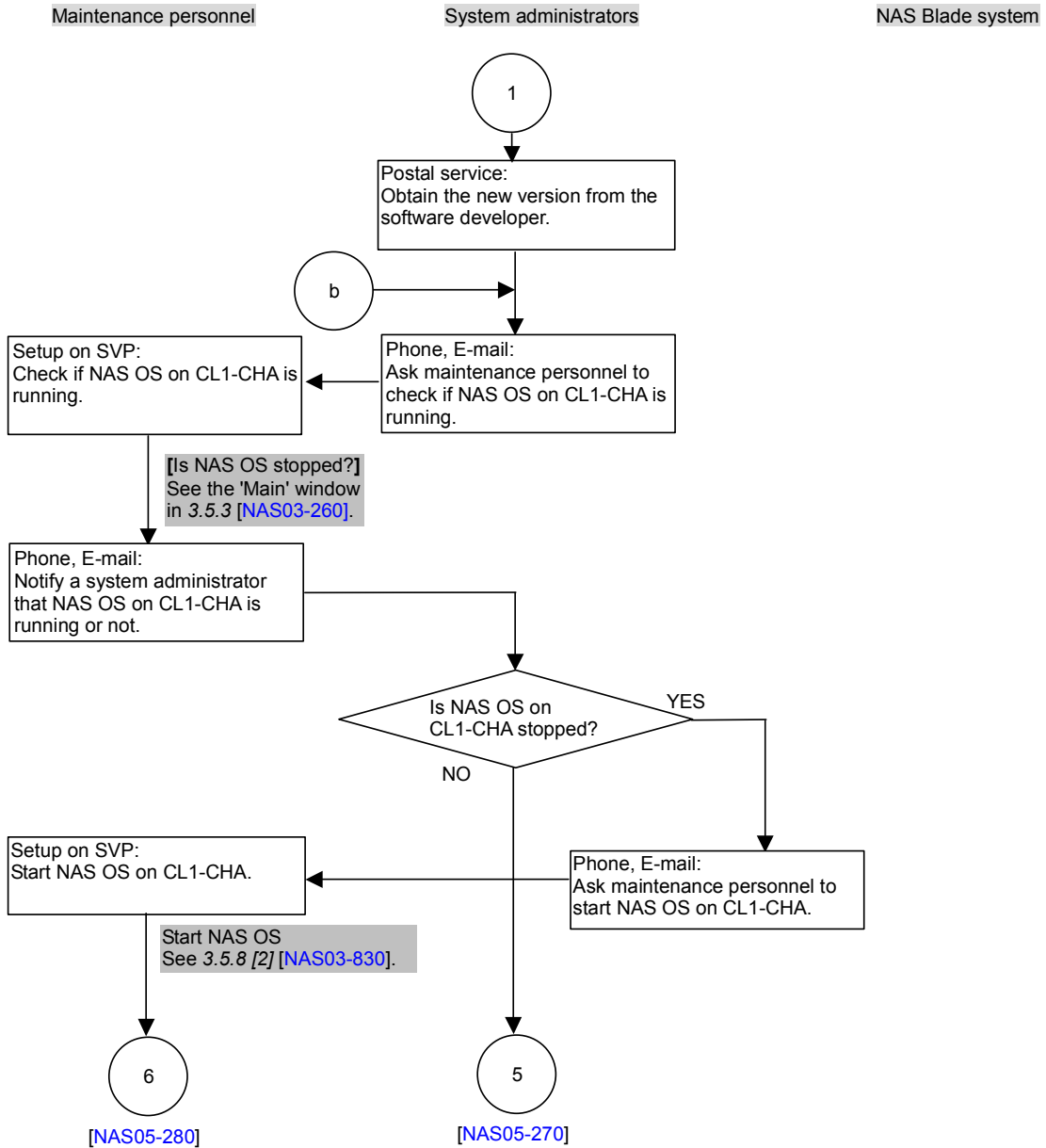

Figure 5.3-3 Upgrading NAS OS By a Patch Version —
Restarting the NAS OS Is Required (Preventive Upgrade: While Operating) (5/9)

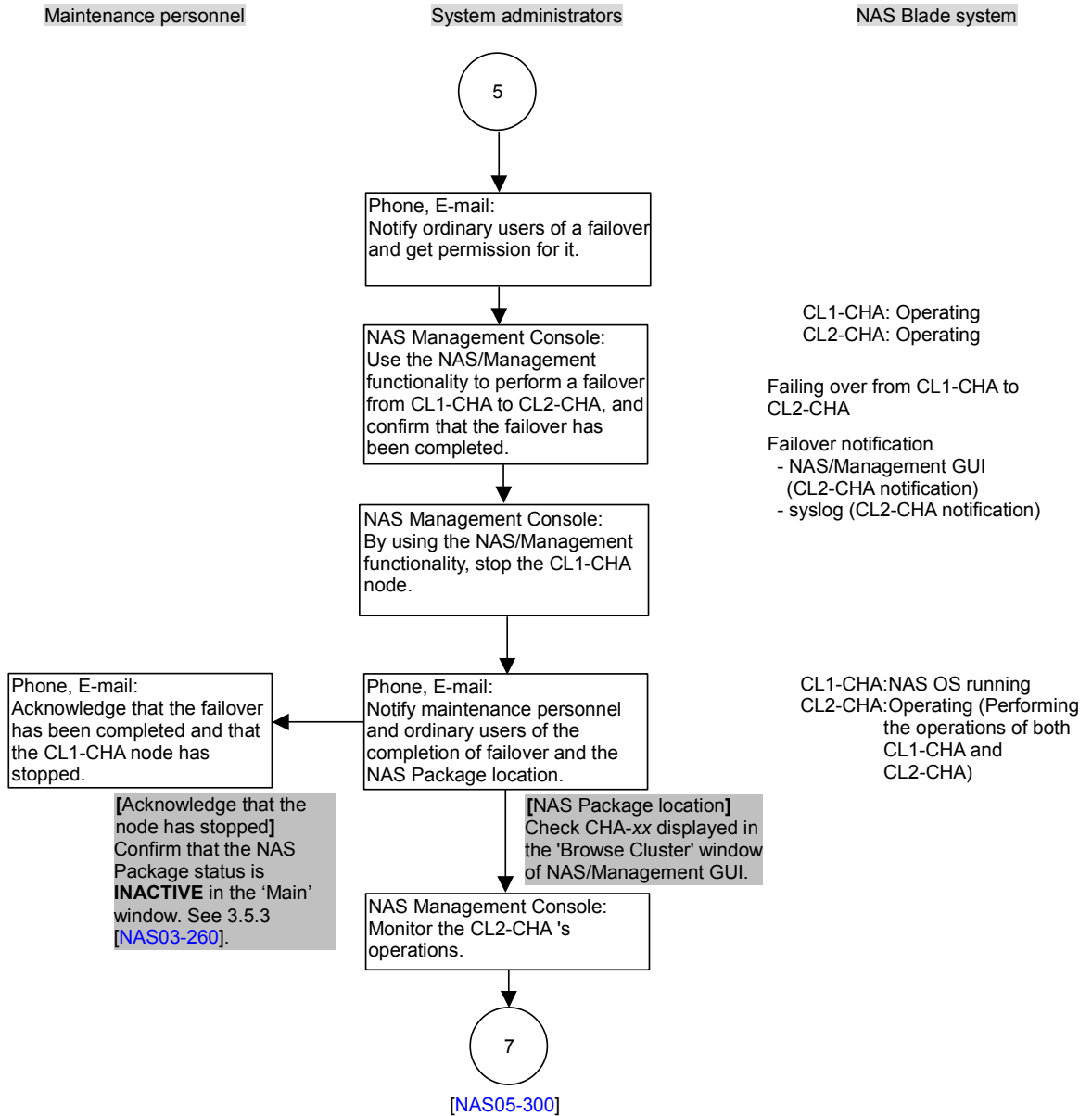

Figure 5.3-3 Upgrading NAS OS By a Patch Version —
Restarting the NAS OS Is Required (Preventive Upgrade: While Operating) (6/9)

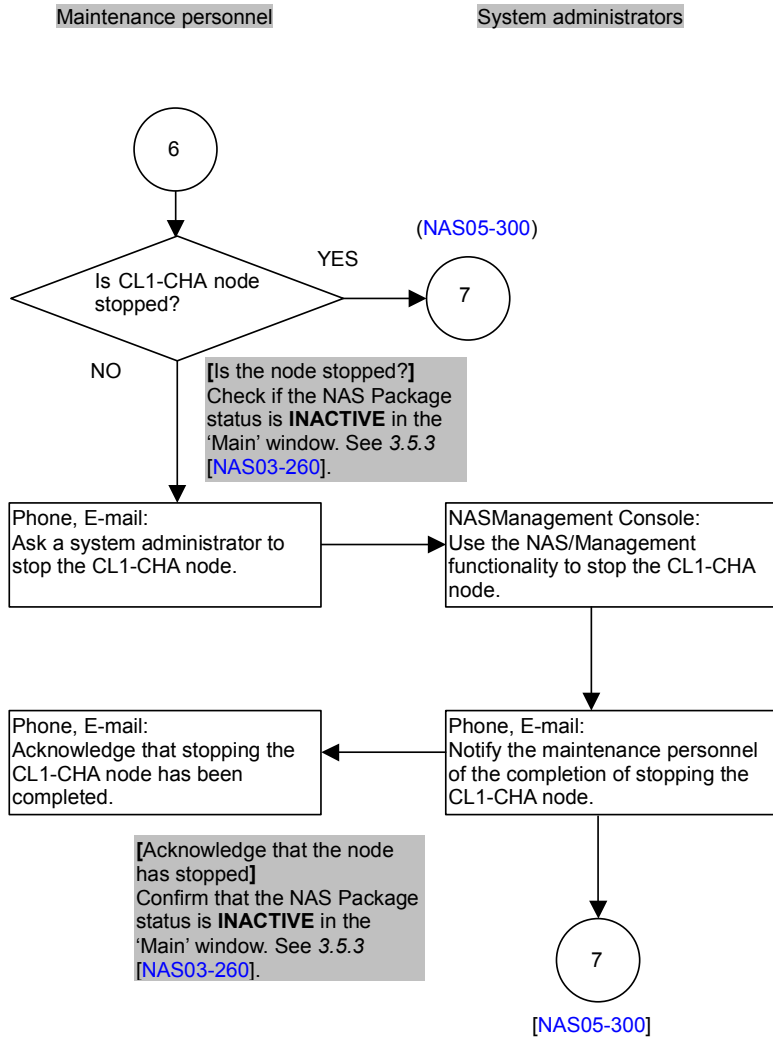

Figure 5.3-3 Upgrading NAS OS By a Patch Version —
Restarting the NAS OS Is Required (Preventive Upgrade: While Operating) (7/9)

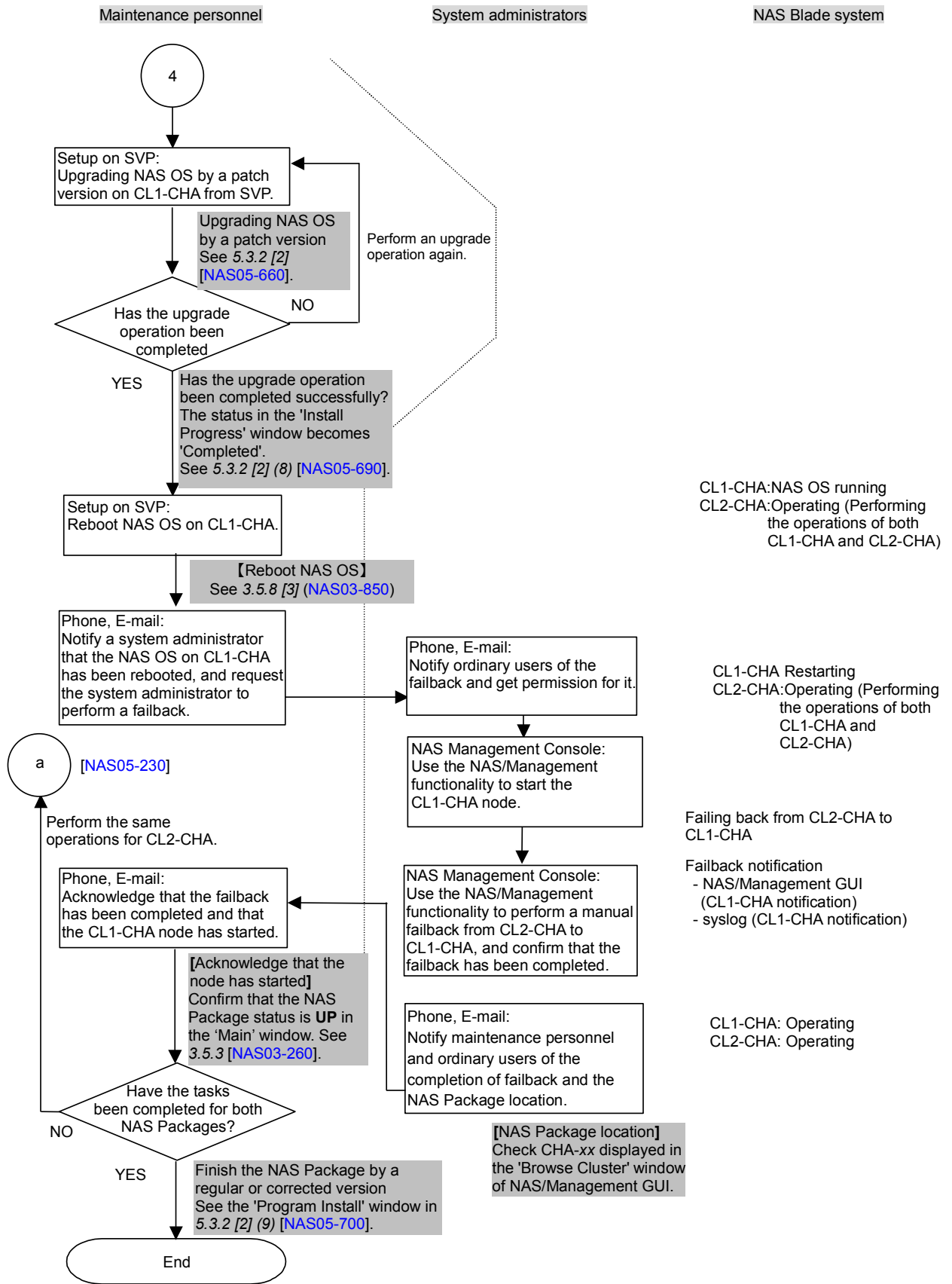

Figure 5.3-3 Upgrading NAS OS By a Patch Version —
Restarting the NAS OS Is Required (Preventive Upgrade: While Operating) (8/9)

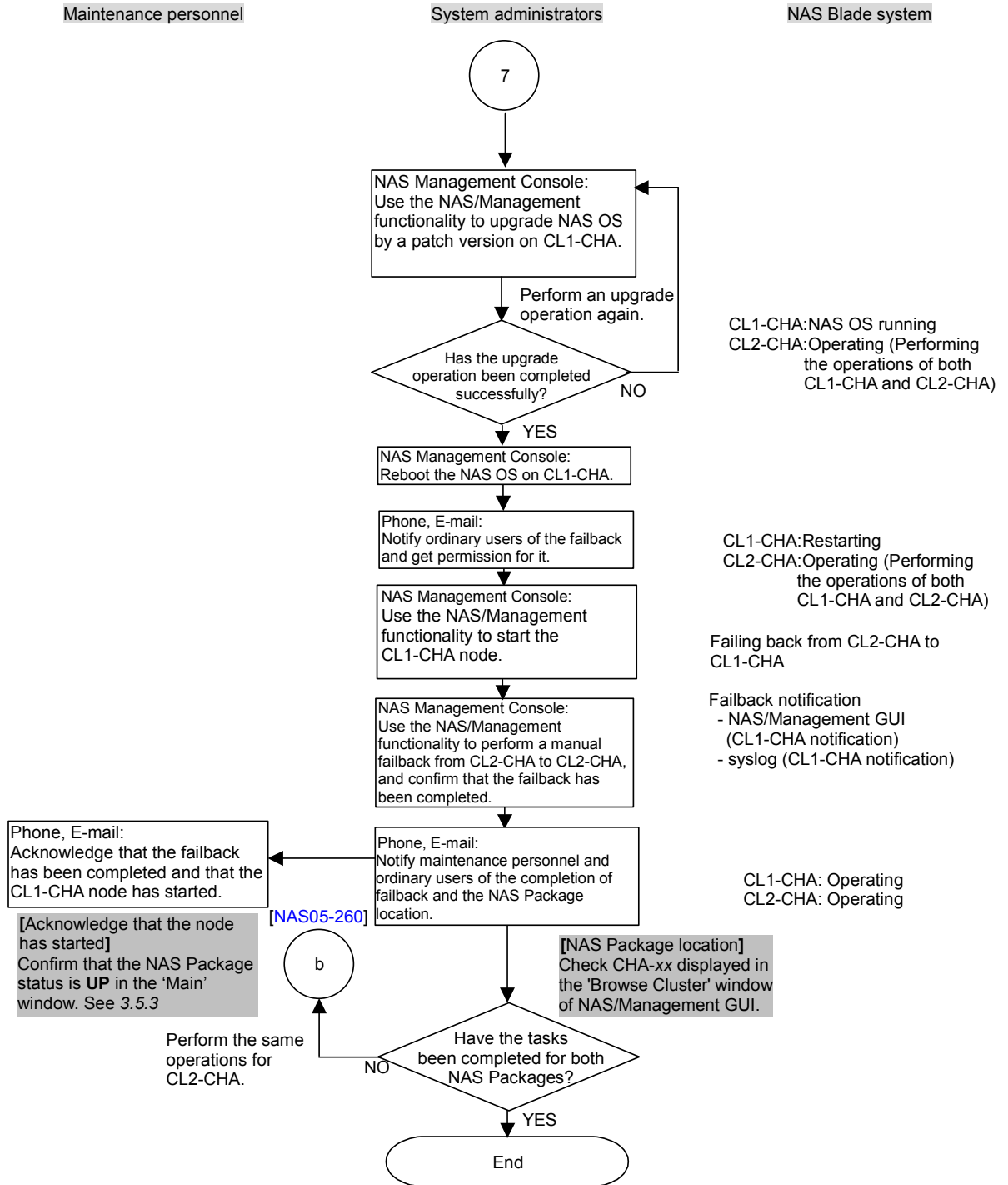

Figure 5.3-3 Upgrading NAS OS By a Patch Version —
Restarting the NAS OS Is Required (Preventive Upgrade: While Operating) (9/9)

(5) Upgrading NAS OS by an Updated Version (Preventive Upgrade: While the Cluster is Stopped)

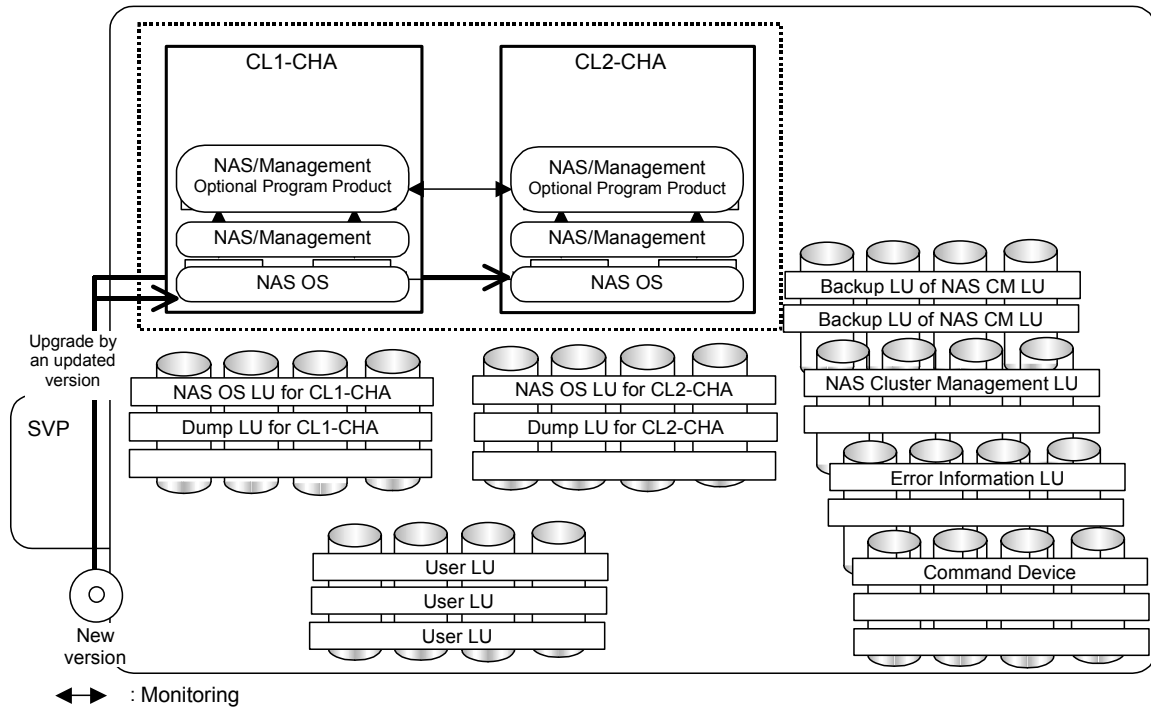

Figure 5.3-4 Upgrading NAS OS by an Updated Version (Preventive Upgrade: While the Cluster is Stopped) (1/4)

Step	Procedure	Notes
1	Obtain the corrected version (NAS OS).	
2	Back up the NAS OS LU and NAS Cluster Management LU.	
3	Stop the cluster.	
4	Upgrade NAS OS by an updated version.	
5	Upgrade NAS/Management.	
6	Start the cluster.	

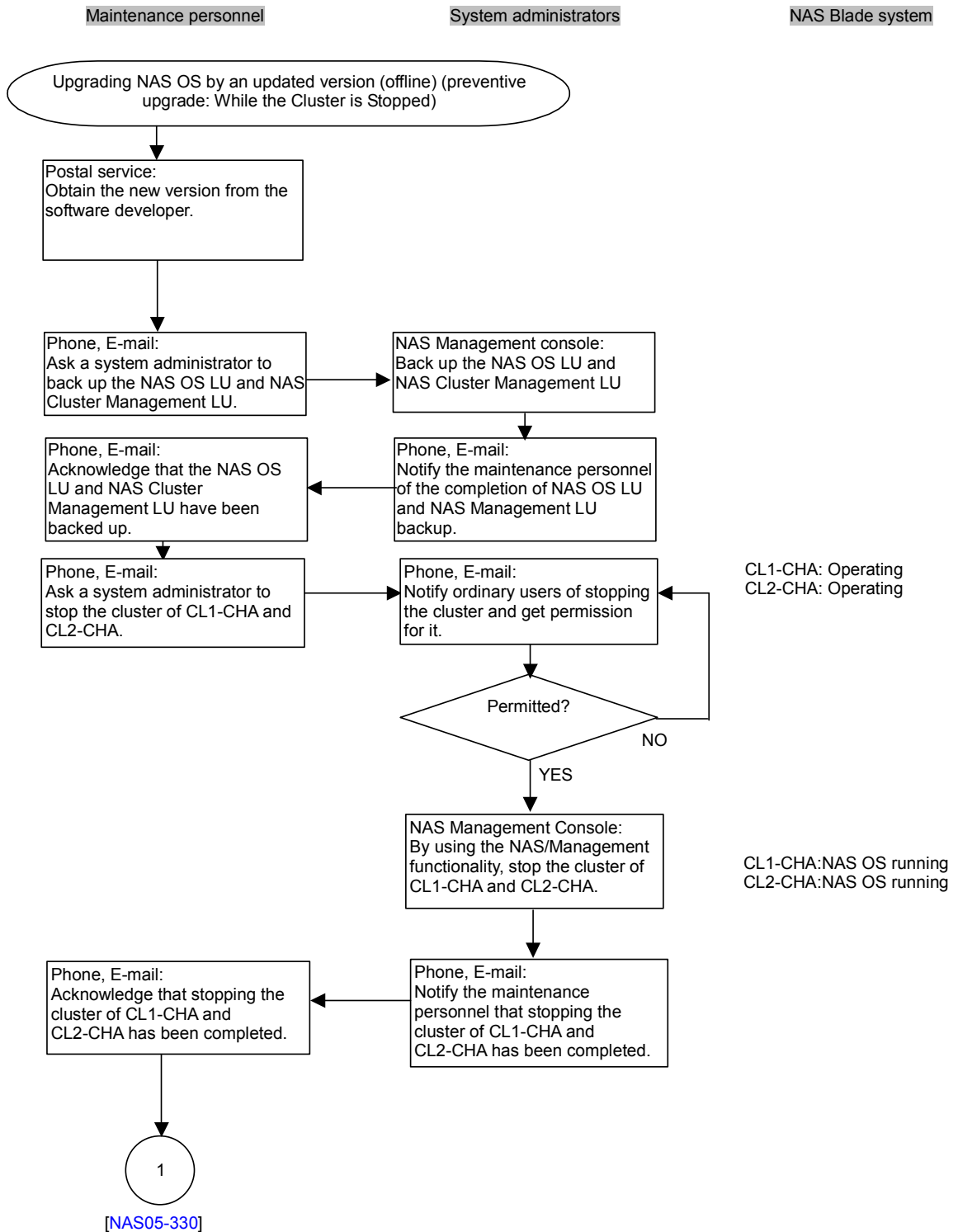

Figure 5.3-4 Upgrading NAS OS by an Updated Version (Preventive Upgrade: While the Cluster is Stopped) (2/4)

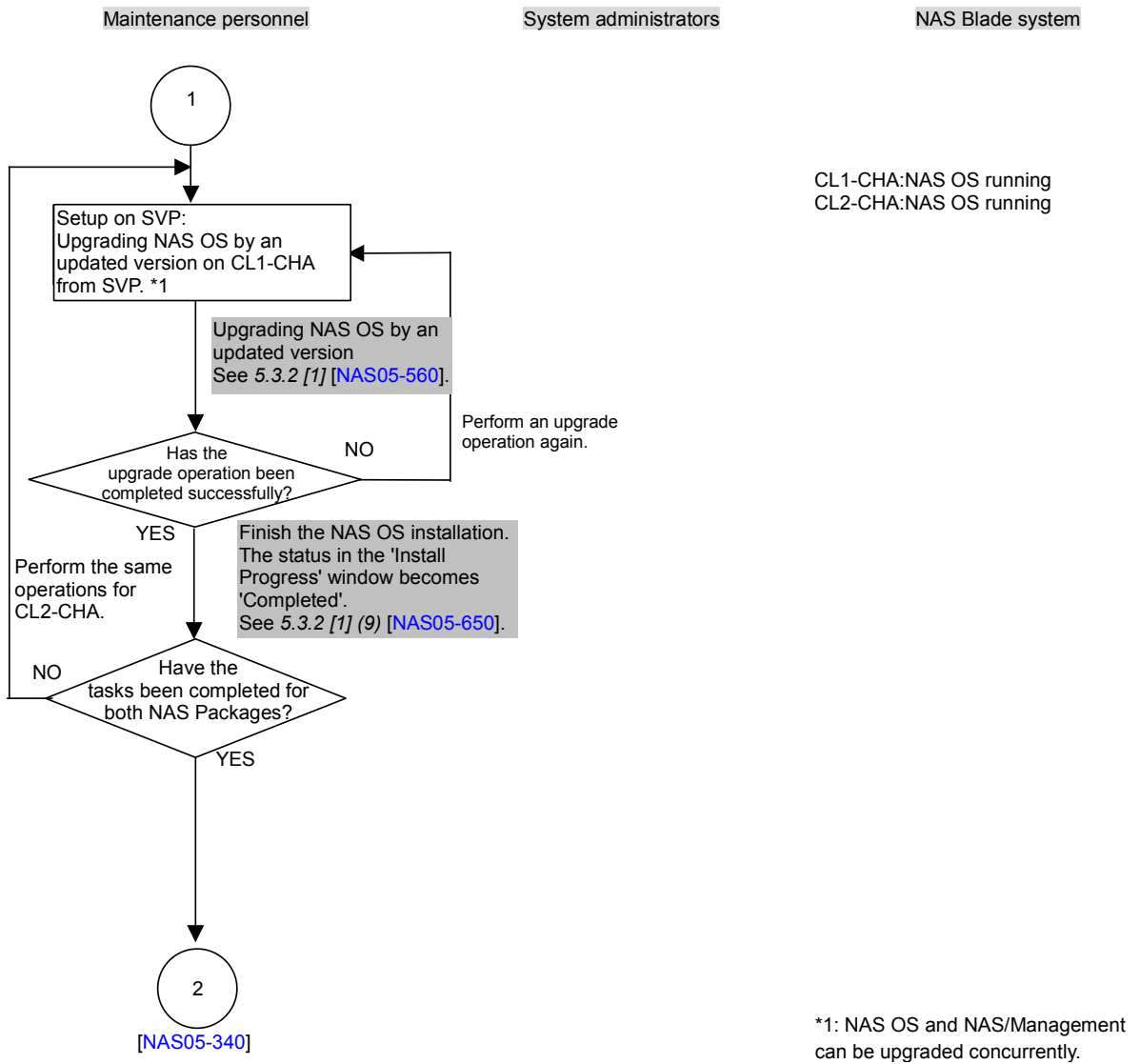

Figure 5.3-4 Upgrading NAS OS by an Updated Version (Preventive Upgrade: While the Cluster is Stopped) (3/4)

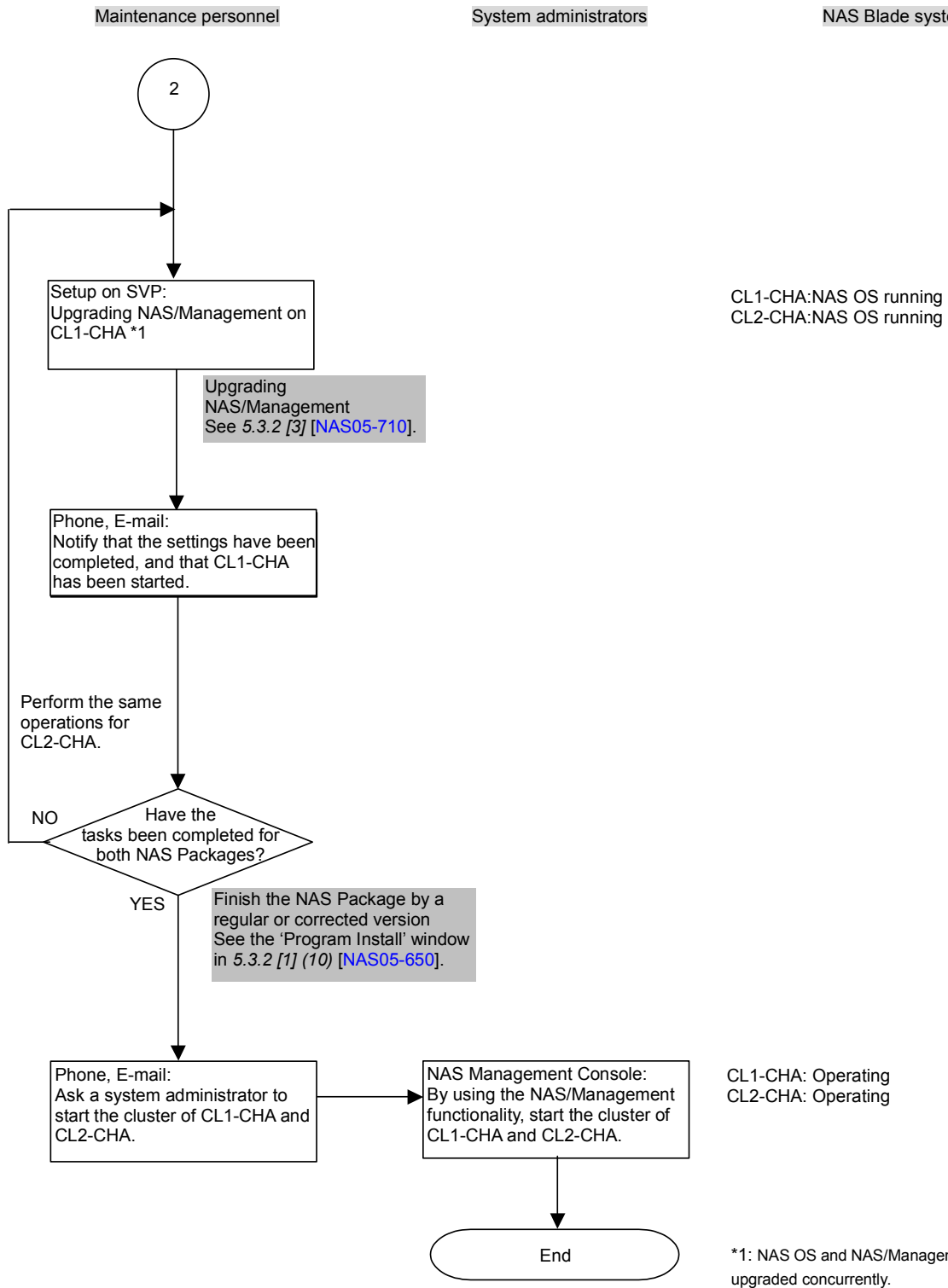

Figure 5.3-4 Upgrading NAS OS by an Updated Version (Preventive Upgrade: While the Cluster is Stopped) (4/4)

(6) Replacing the NAS OS By a Patch Version — Restarting the NAS OS Is Not Required
(Preventive Upgrade: While the Cluster is Stopped)

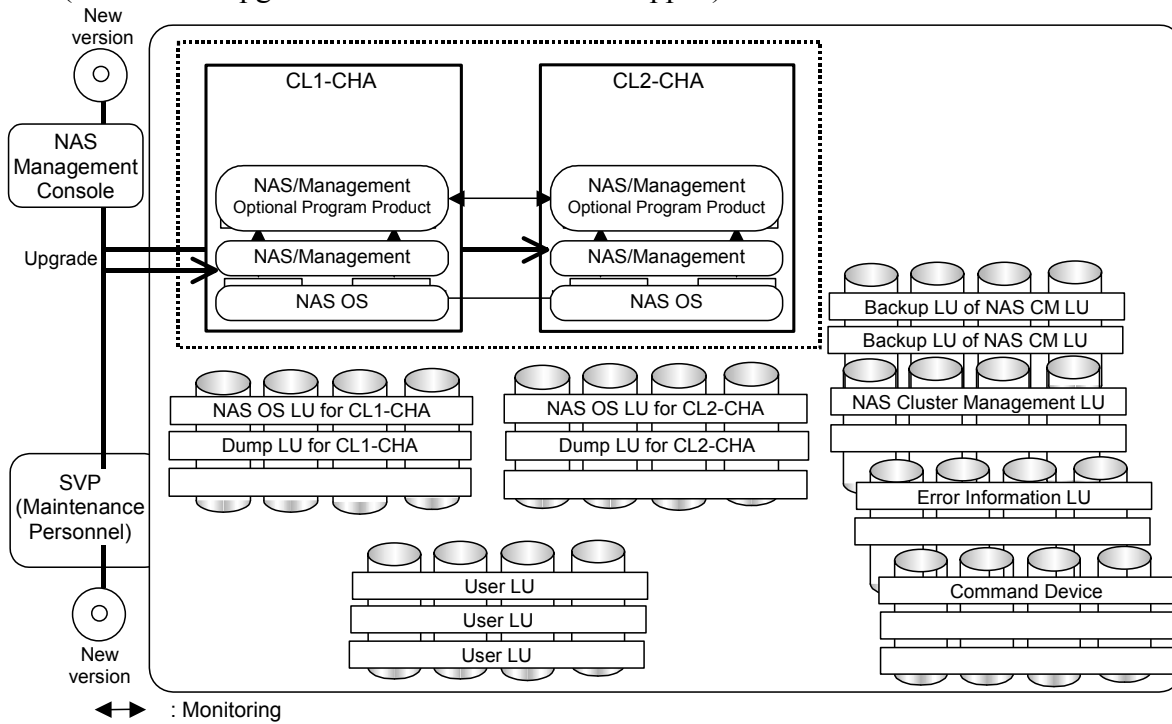

Figure 5.3-5 Replacing the NAS OS By a Patch Version — Restarting the NAS OS Is Not Required (Preventive Upgrade: While the Cluster is Stopped) (1/7)

Step	Procedure	Notes
1	Obtain the corrected version (NAS OS).	
2	Back up the NAS OS LU and NAS Cluster Management LU.	
3	Stop the cluster.	
4	Upgrade NAS OS by a Patch Version.	
5	Upgrade NAS/Mangement.	
6	Start the cluster.	

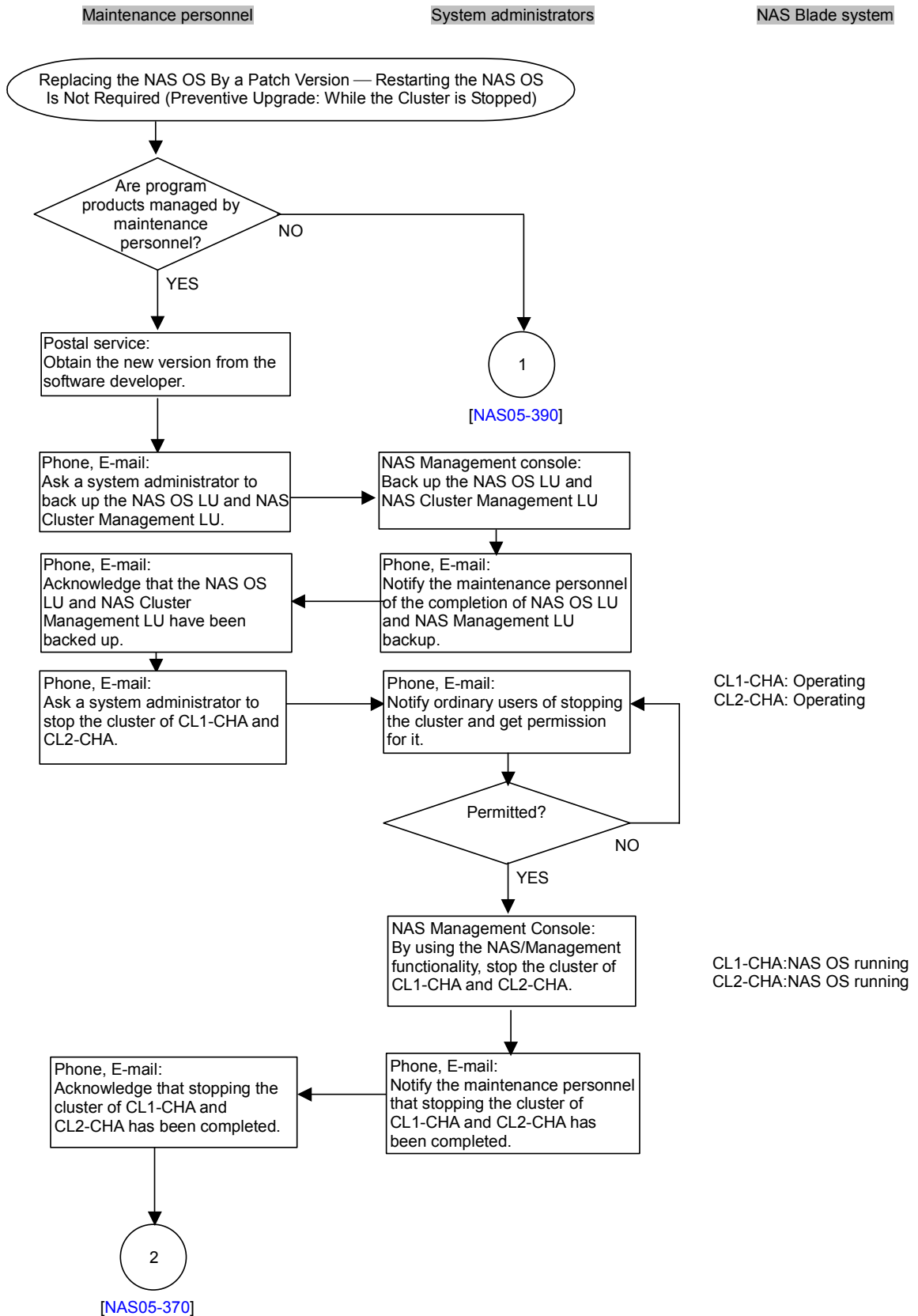

Figure 5.3-5 Replacing the NAS OS By a Patch Version — Restarting the NAS OS Is Not Required (Preventive Upgrade: While the Cluster is Stopped) (2/7)

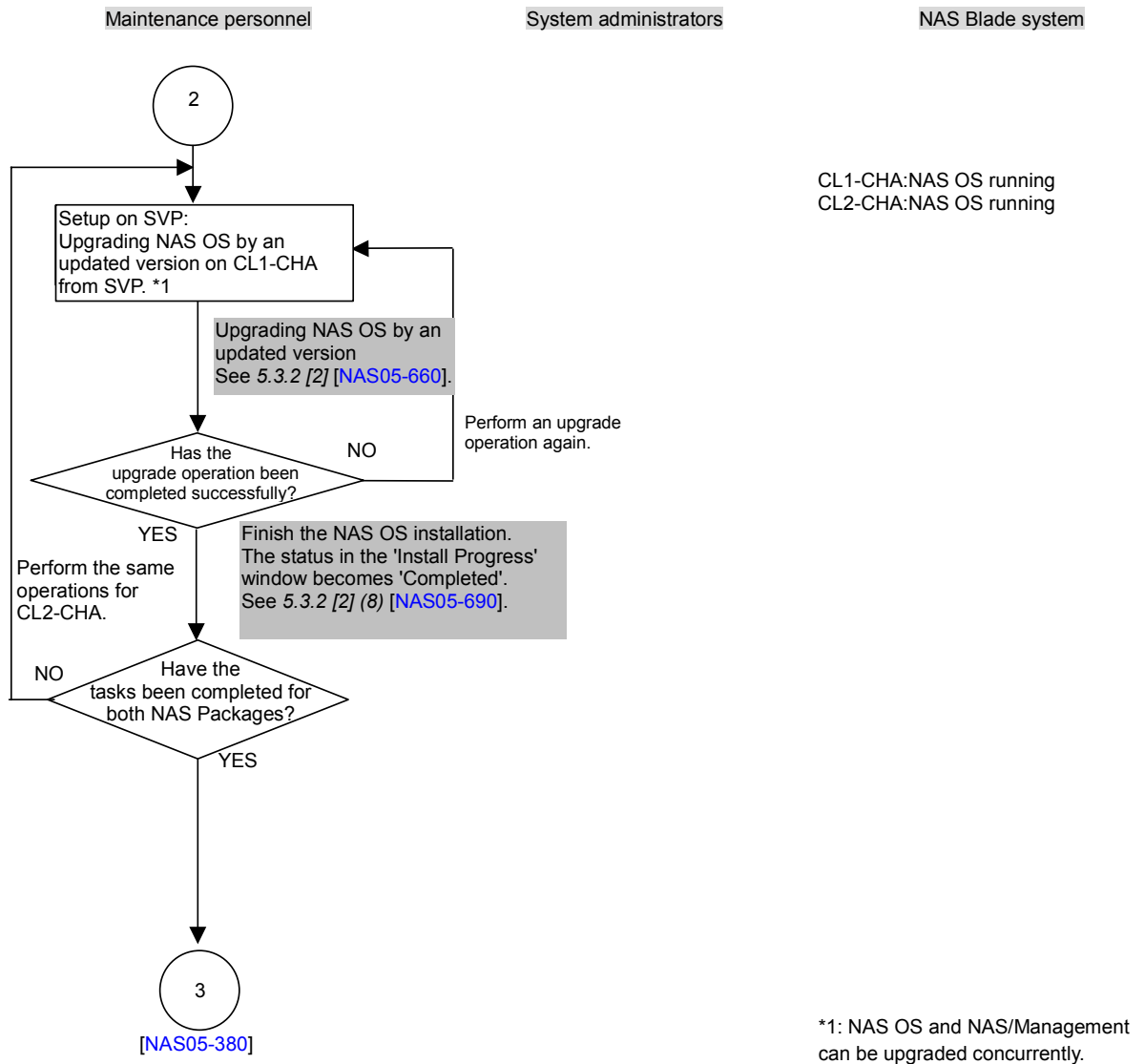

Figure 5.3-5 Replacing the NAS OS By a Patch Version — Restarting the NAS OS Is Not Required (Preventive Upgrade: While the Cluster is Stopped) (3/7)

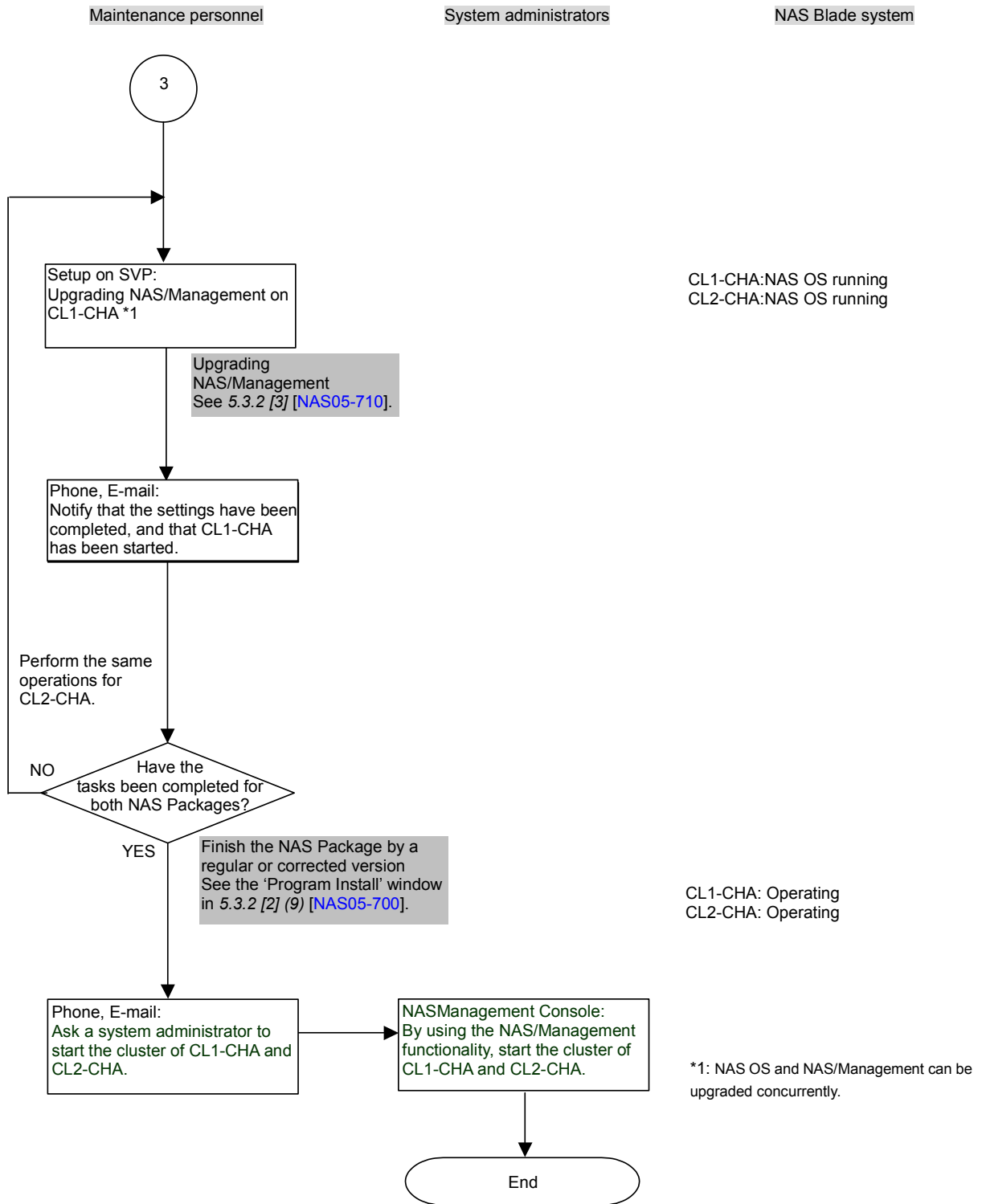

Figure 5.3-5 Replacing the NAS OS By a Patch Version — Restarting the NAS OS Is Not Required (Preventive Upgrade: While the Cluster is Stopped) (4/7)

Maintenance personnel

System administrators

NAS Blade system

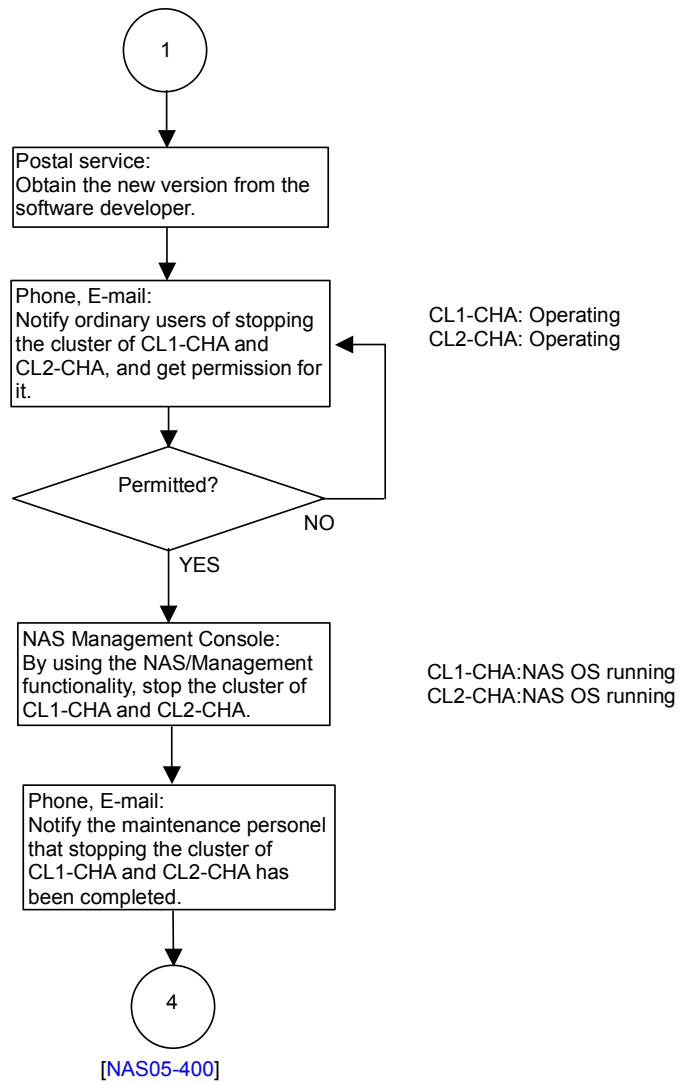

Figure 5.3-5 Replacing the NAS OS By a Patch Version — Restarting the NAS OS Is Not Required (Preventive Upgrade: While the Cluster is Stopped) (5/7)

Maintenance personnel

System administrators

NAS Blade system

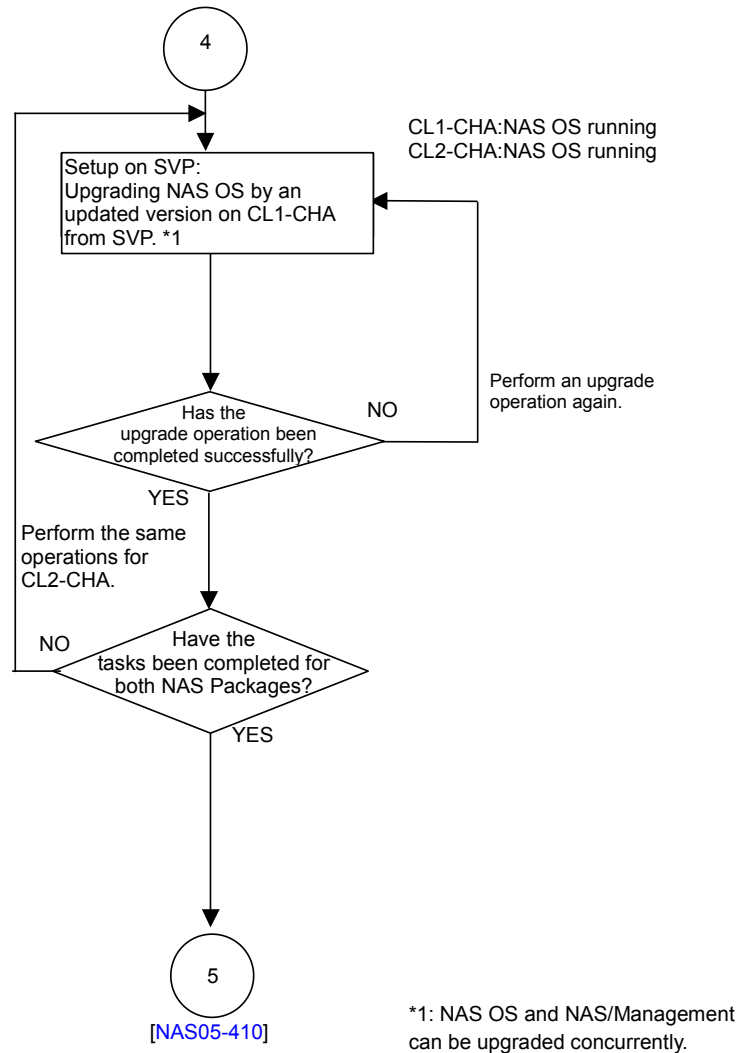

Figure 5.3-5 Replacing the NAS OS By a Patch Version — Restarting the NAS OS Is Not Required (Preventive Upgrade: While the Cluster is Stopped) (6/7)

Maintenance personnel

System administrators

NAS Blade system

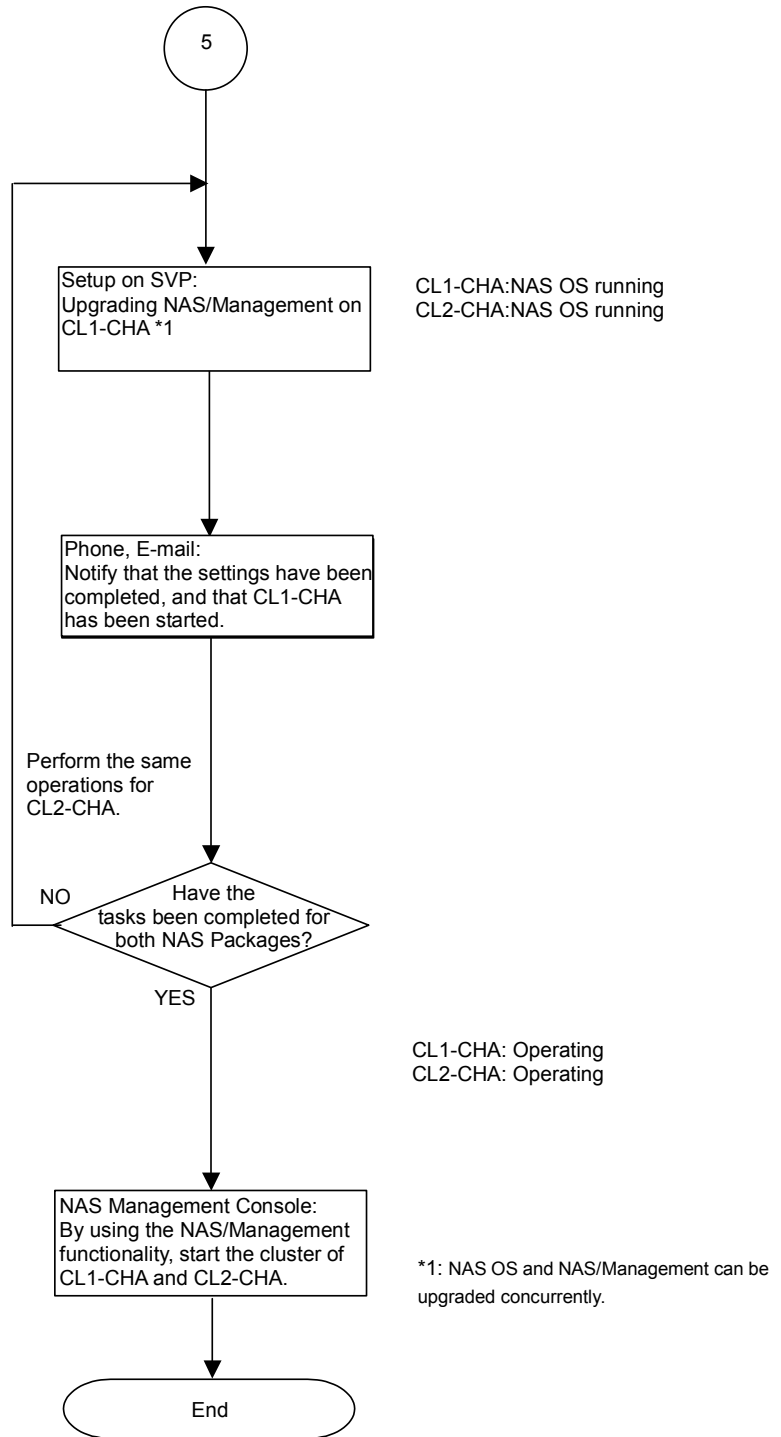

Figure 5.3-5 Replacing the NAS OS By a Patch Version — Restarting the NAS OS Is Not Required (Preventive Upgrade: While the Cluster is Stopped) (7/7)

(7) Replacing the NAS OS By a Patch Version — Restarting the NAS OS Is Required (Preventive Upgrade: While the Cluster is Stopped)

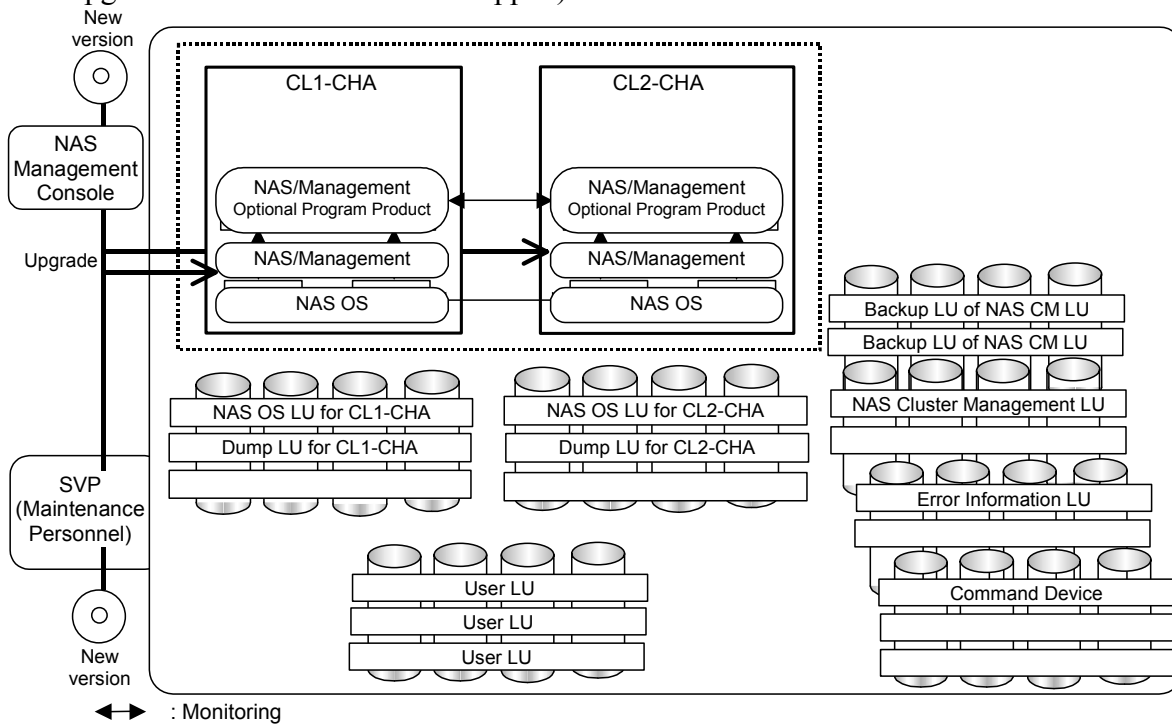

Figure 5.3-6 Replacing the NAS OS By a Patch Version — Restarting the NAS OS Is Required (Preventive Upgrade: While the Cluster is Stopped) (1/7)

Step	Procedure	Notes
1	Obtain the corrected version (NAS OS).	
2	Back up the NAS OS LU and NAS Cluster Management LU.	
3	Stop the cluster.	
4	Upgrade NAS OS by a Patch Version .	
5	Reboot NAS OS.	
6	Upgrade NAS/Mangement.	
7	Start the cluster.	

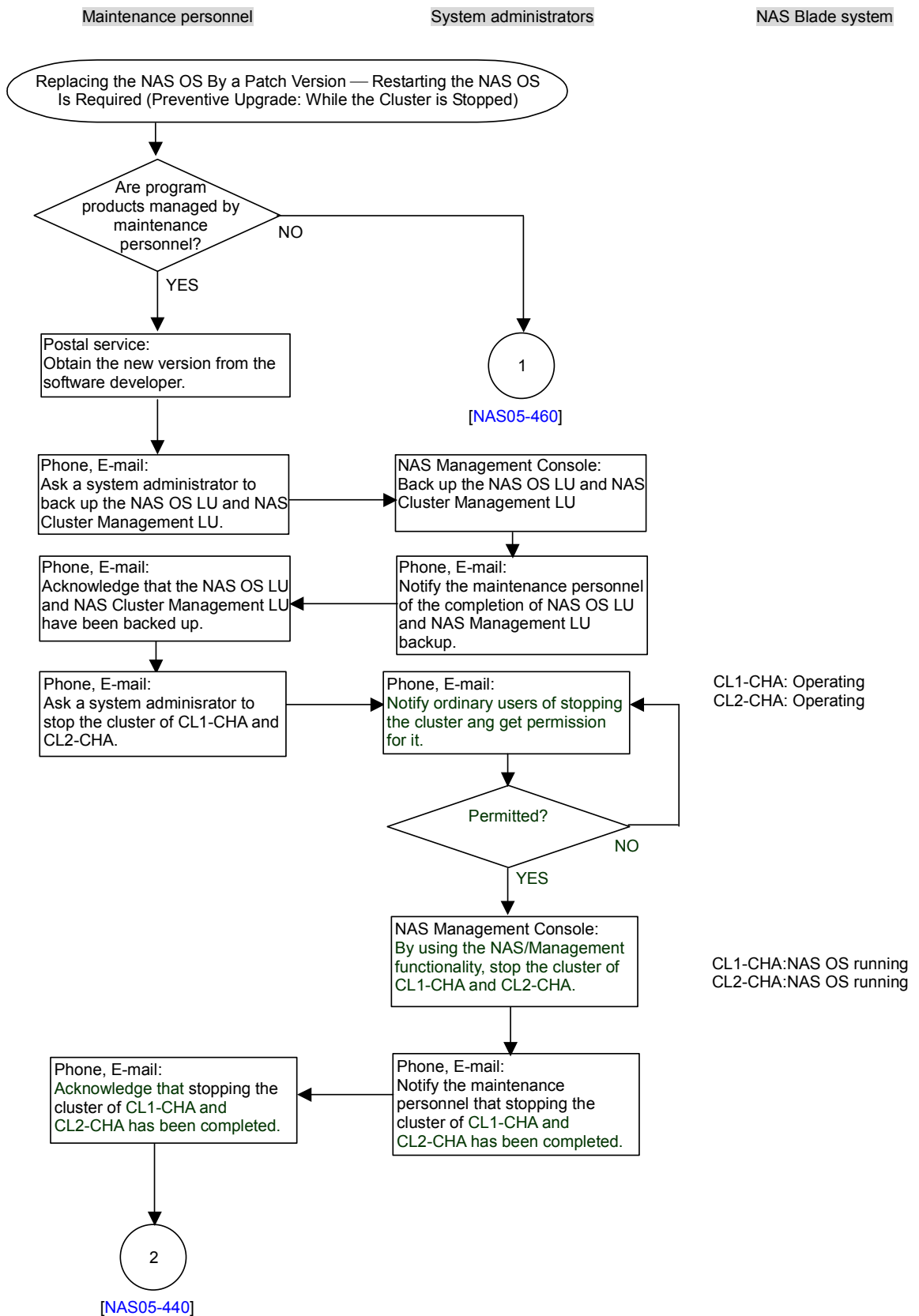

Figure 5.3-6 Replacing the NAS OS By a Patch Version — Restarting the NAS OS Is Required (Preventive Upgrade: While the Cluster is Stopped) (2/7)

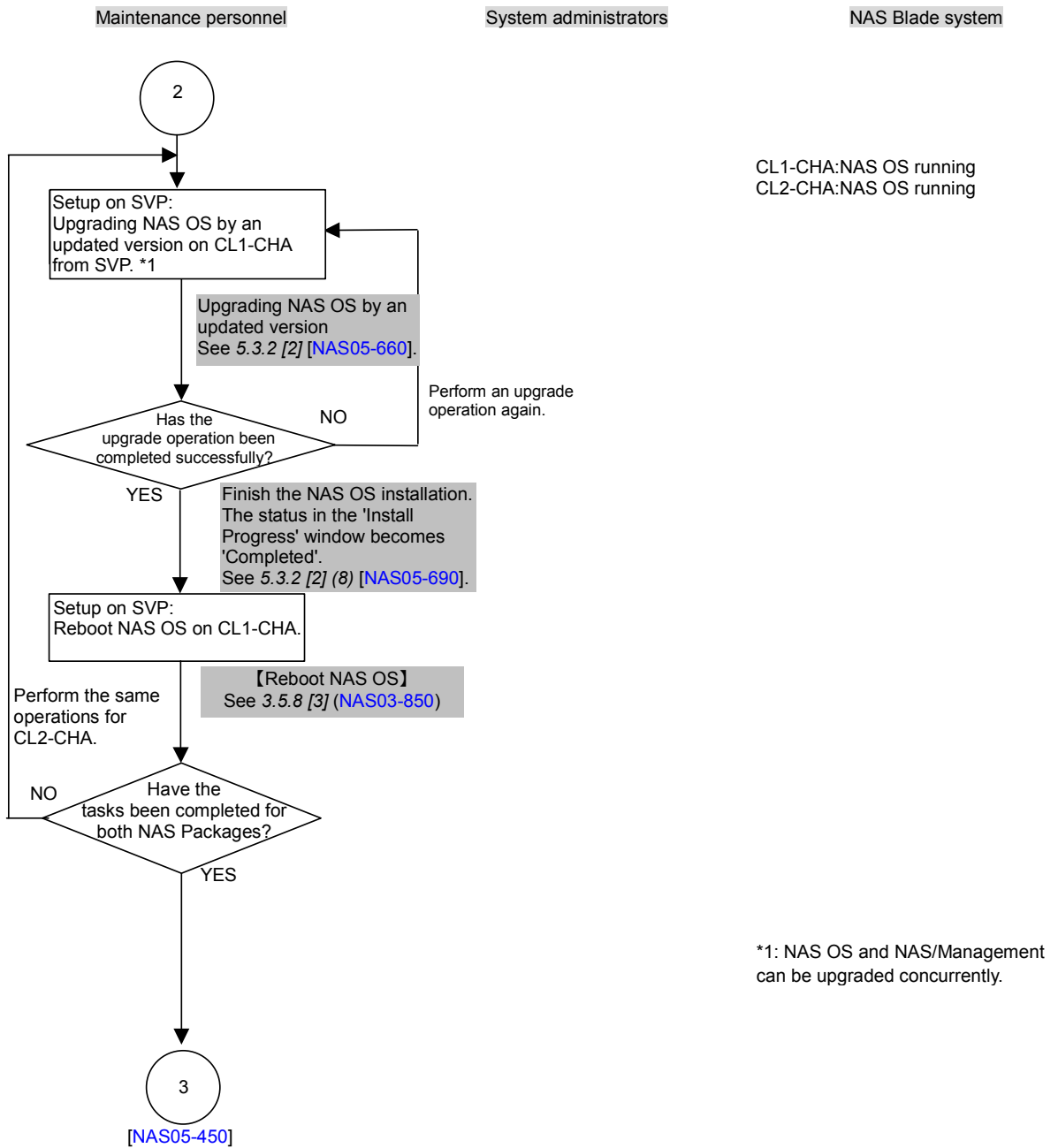

Figure 5.3-6 Replacing the NAS OS By a Patch Version — Restarting the NAS OS Is Required (Preventive Upgrade: While the Cluster is Stopped) (3/7)

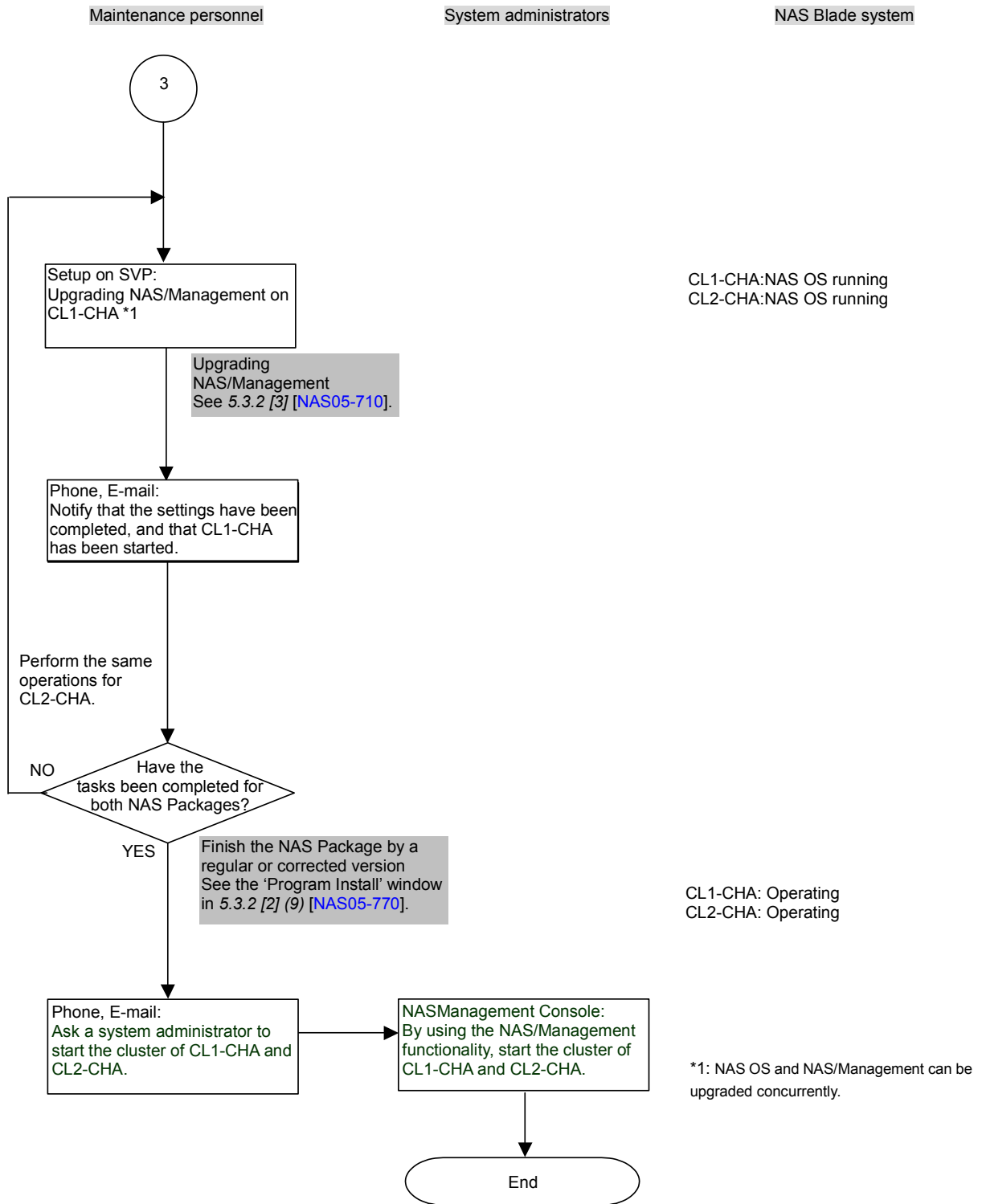

Figure 5.3-6 Replacing the NAS OS By a Patch Version — Restarting the NAS OS Is Required (Preventive Upgrade: While the Cluster is Stopped) (4/7)

Maintenance personnel

System administrators

NAS Blade system

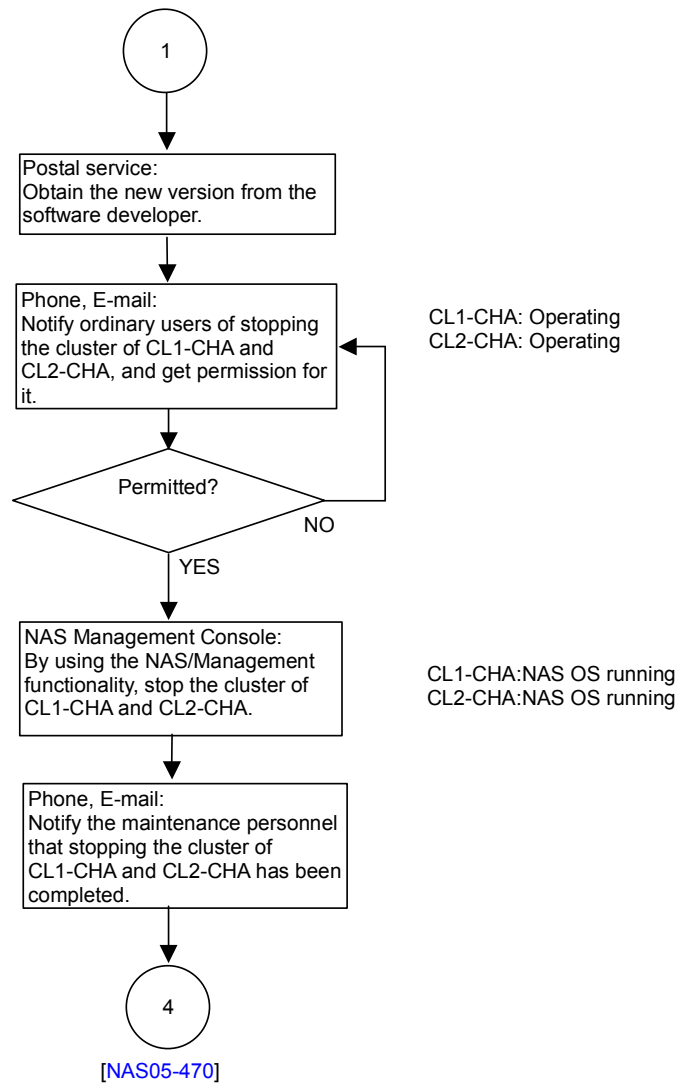

Figure 5.3-6 Replacing the NAS OS By a Patch Version — Restarting the NAS OS Is Required
(Preventive Upgrade: While the Cluster is Stopped) (5/7)

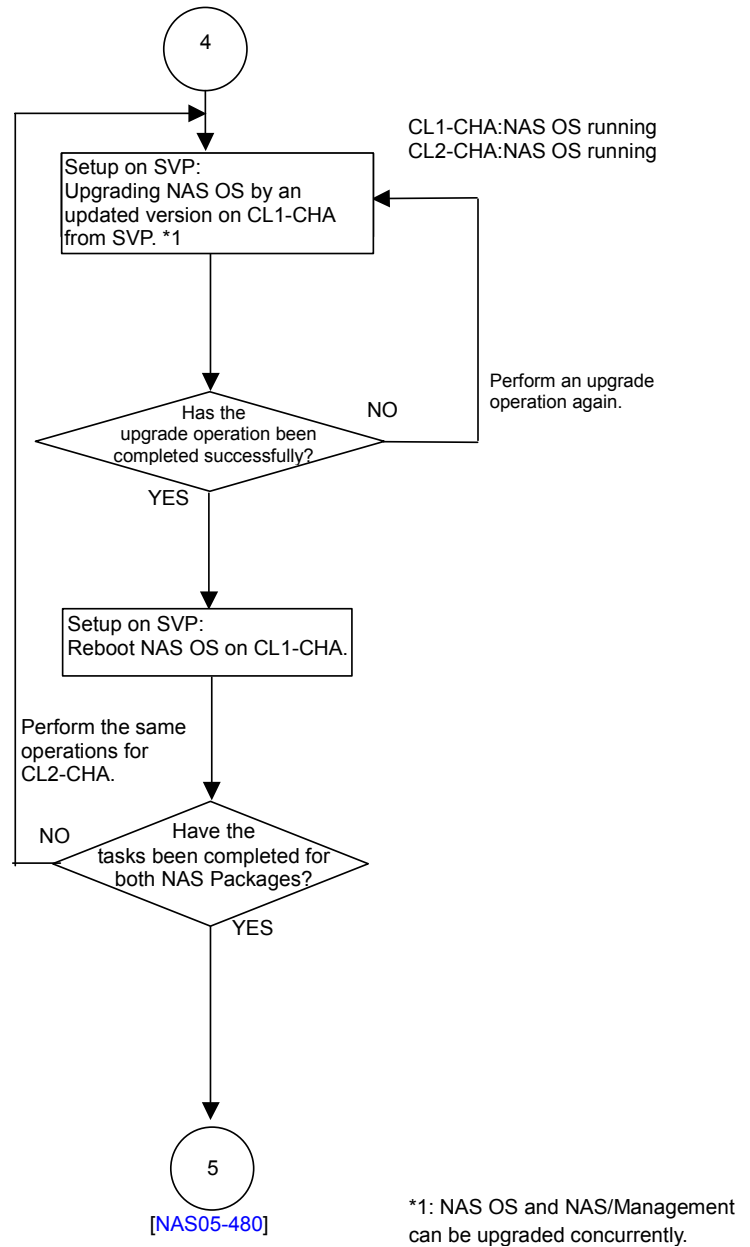

Figure 5.3-6 Replacing the NAS OS By a Patch Version — Restarting the NAS OS Is Required (Preventive Upgrade: While the Cluster is Stopped) (6/7)

Maintenance personnel

System administrators

NAS Blade system

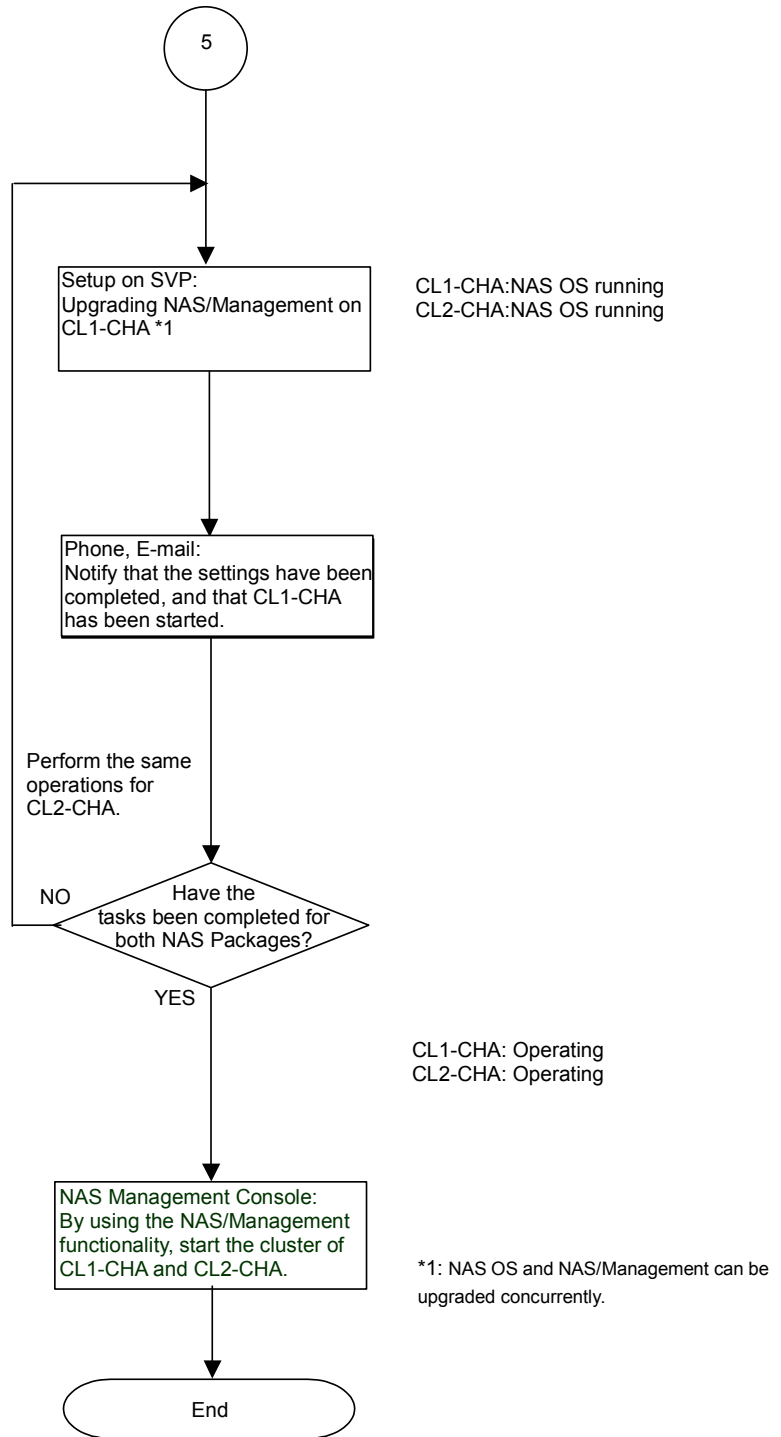

Figure 5.3-6 Replacing the NAS OS By a Patch Version — Restarting the NAS OS Is Required (Preventive Upgrade: While the Cluster is Stopped) (7/7)

(8) Upgrading NAS/Management (Preventive Upgrade)

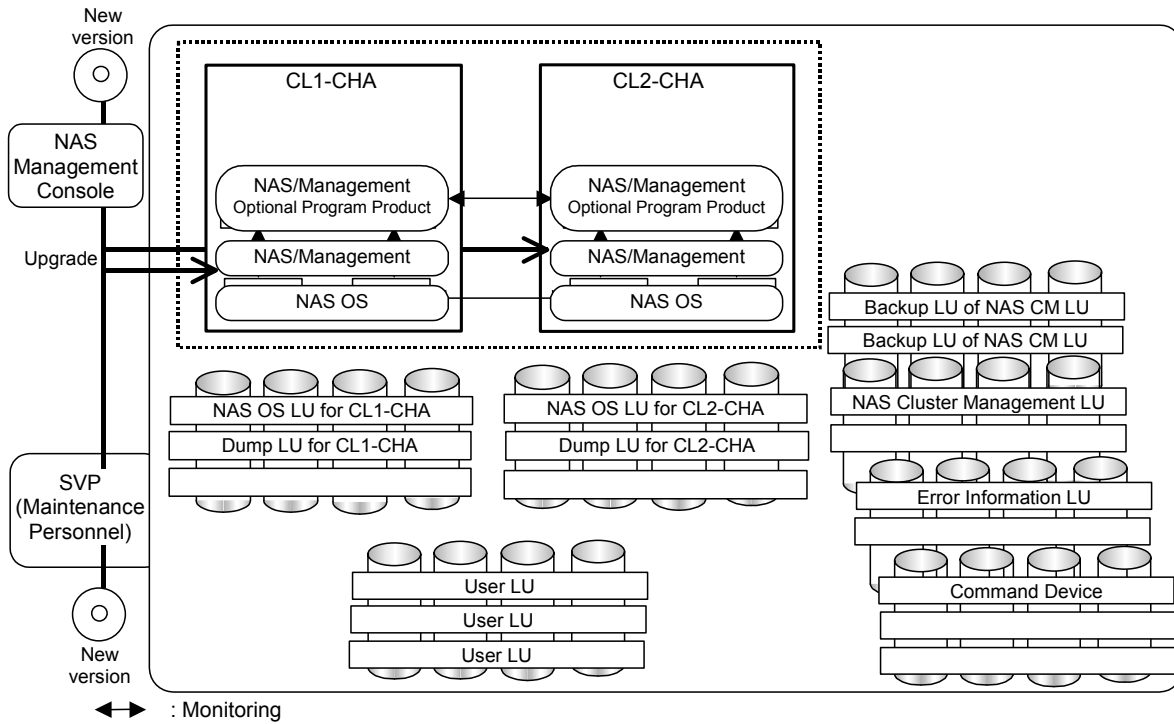

Figure 5.3-7 Upgrading NAS/Management (Preventive Upgrade) (1/2)

Step	Procedure	Notes
1	Obtain the corrected version (NAS/Management).	
2	Upgrade NAS/Management.	

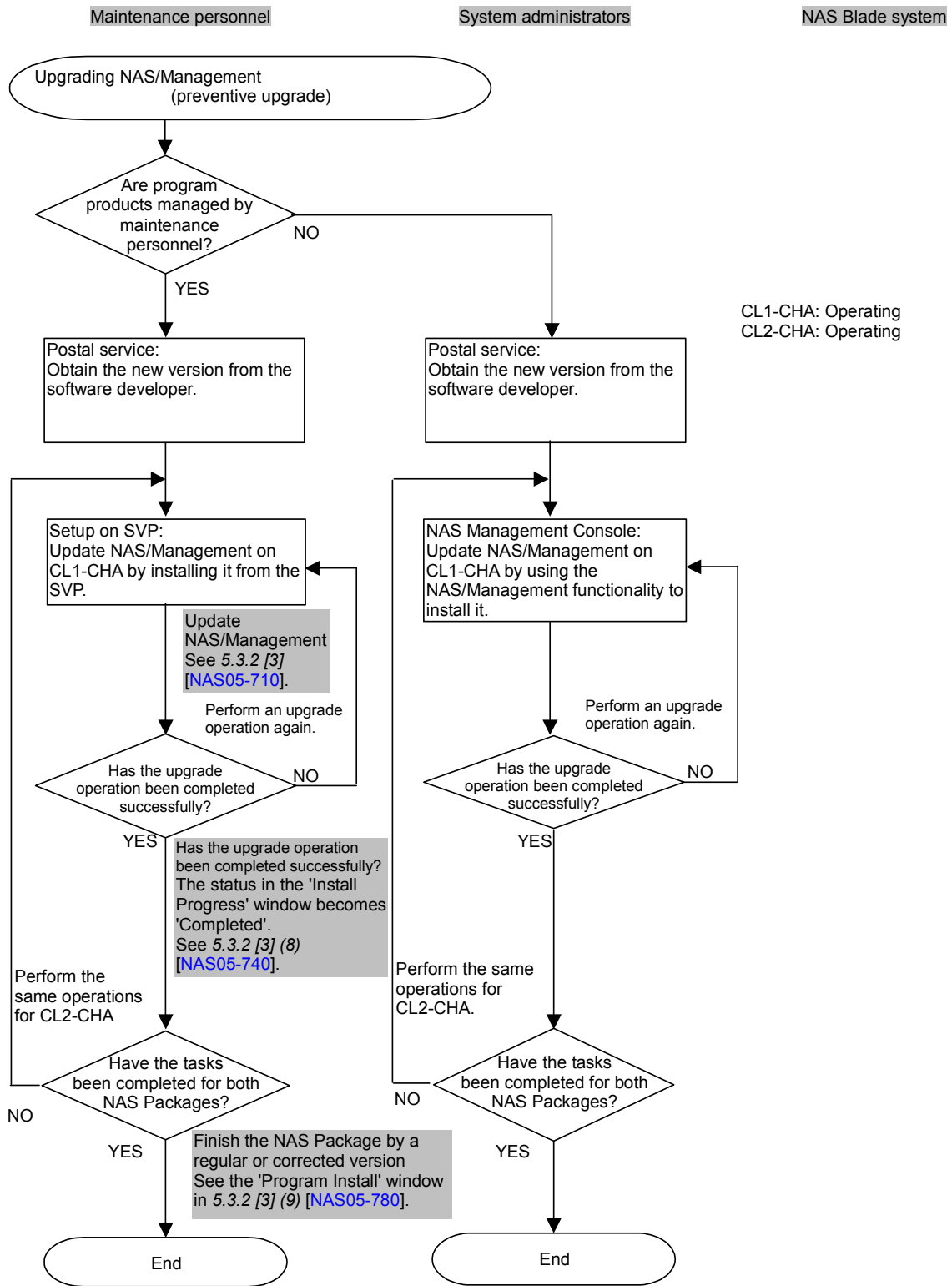

Figure 5.3-7 Upgrading NAS/Management (Preventive Upgrade) (2/2)

(9) Upgrading an Optional Program Product (Preventive Upgrade)

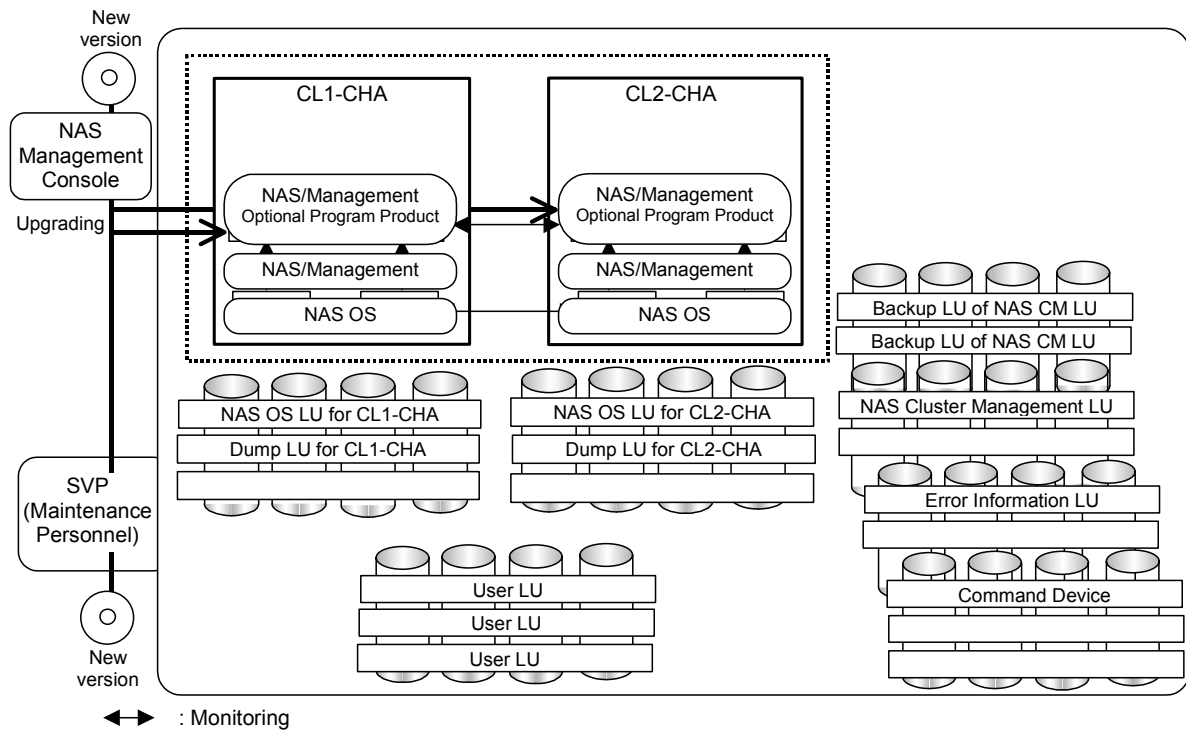

Figure 5.3-8 Upgrading an Optional Program Product (Preventive Upgrade) (1/3)

Step	Procedure	Notes
1	Obtain the corrected version (optional program product).	
2	Stop the function of an optional program product.	
3	Upgrade an optional program product.	

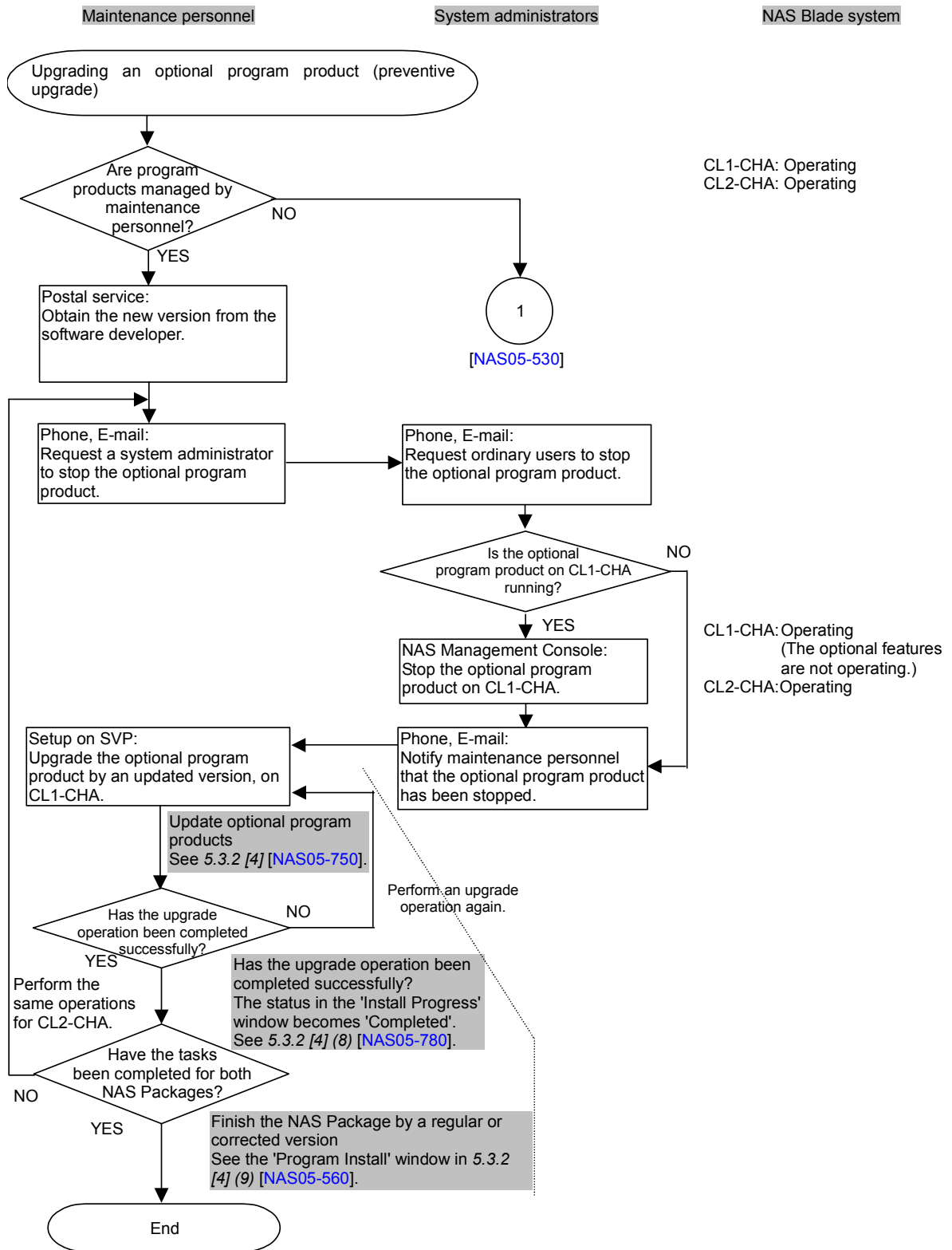

Figure 5.3-8 Upgrading an Optional Program Product (Preventive Upgrade) (2/3)

Maintenance personnel

System administrators

NAS Blade system

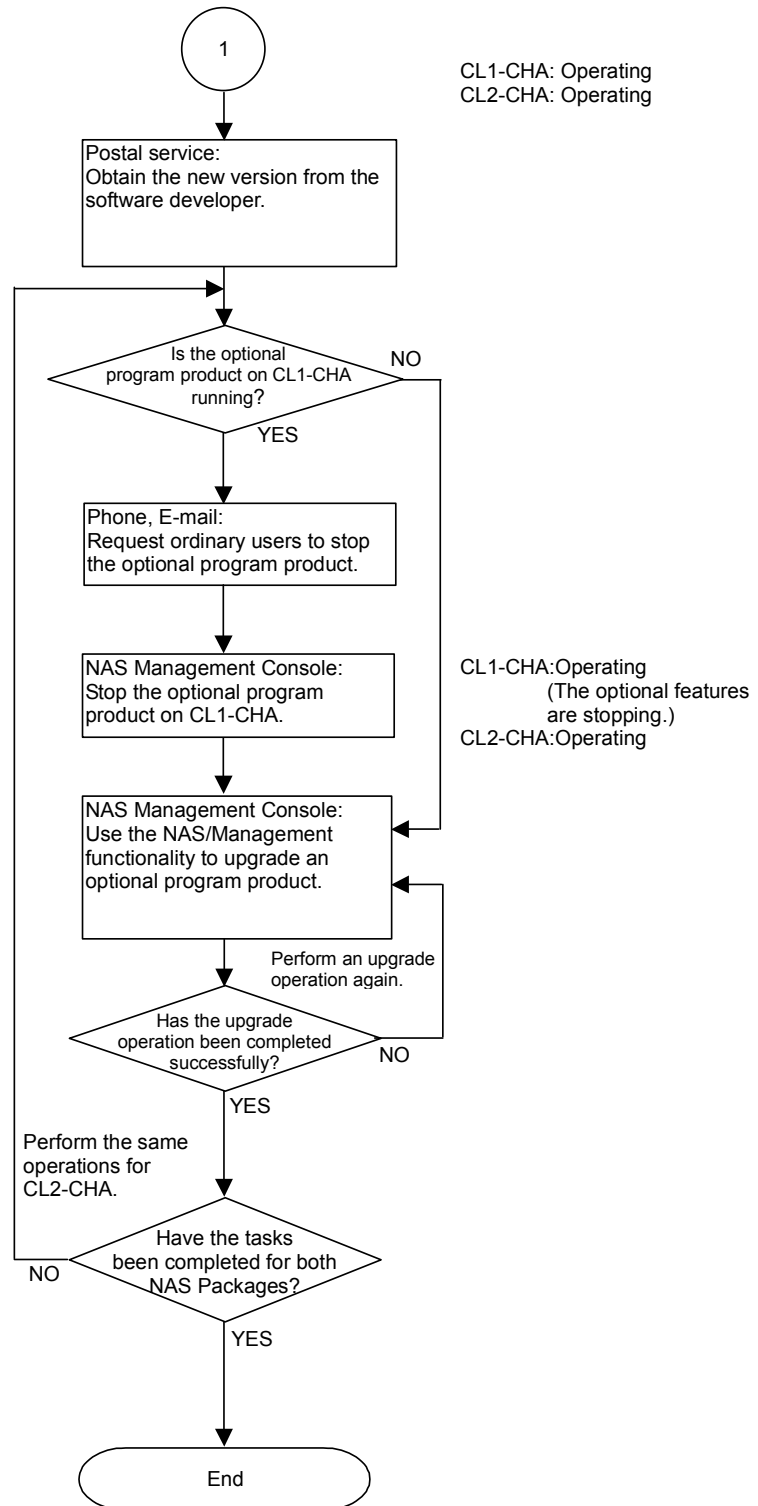

Figure 5.3-8 Upgrading an Optional Program Product (Preventive Upgrade) (3/3)

5.3.2 Procedures for Upgrading the NAS OS and Related Program Products

You can upgrade, in the NAS Package, the NAS OS (NAS/Base-Data Control, NAS/Base-File Sharing) and the related program product such as NAS/Management.

Upgrading the NAS OS and related program products is categorized into four sections. Table 5.3-3 illustrates the related tasks for each upgrade method.

Table 5.3-3 Related tasks for upgrading the NAS OS and the related program product

Upgrade method	Description
[1] Upgrading the NAS OS (update version)	Upgrade the NAS OS such as by adding the NAS OS functionality.
[2] Upgrading the NAS OS (patch version)	Upgrade the NAS OS for emergency measures such as security measures.
[3] Upgrading the NAS/Management (update version)	Upgrade the NAS Management.
[4] Upgrading the optional program product	Upgrade the optional program product.

Notes:

- As a rule, you must upgrade the same program products and versions into NAS Packages (i.e., multi-cabinet models including CHA-1P and CHA-2V, and CHA-1Q and CHA-2W, and single-cabinet models including CHA-1C and CHA-2G, and CHA-1D and CHA-2J) on the same cluster.

 **CAUTION**

If you plan to expand, reduce, or replace a NAS Package, first close the NAS Setup on SVP window, and then re-open it.

Before starting upgrade, determine appropriate upgrade type based on the flow chart shown below. Once the upgrade type is determined, perform upgrade from the SVP and the Setup on SVP window according to the upgrade procedures.

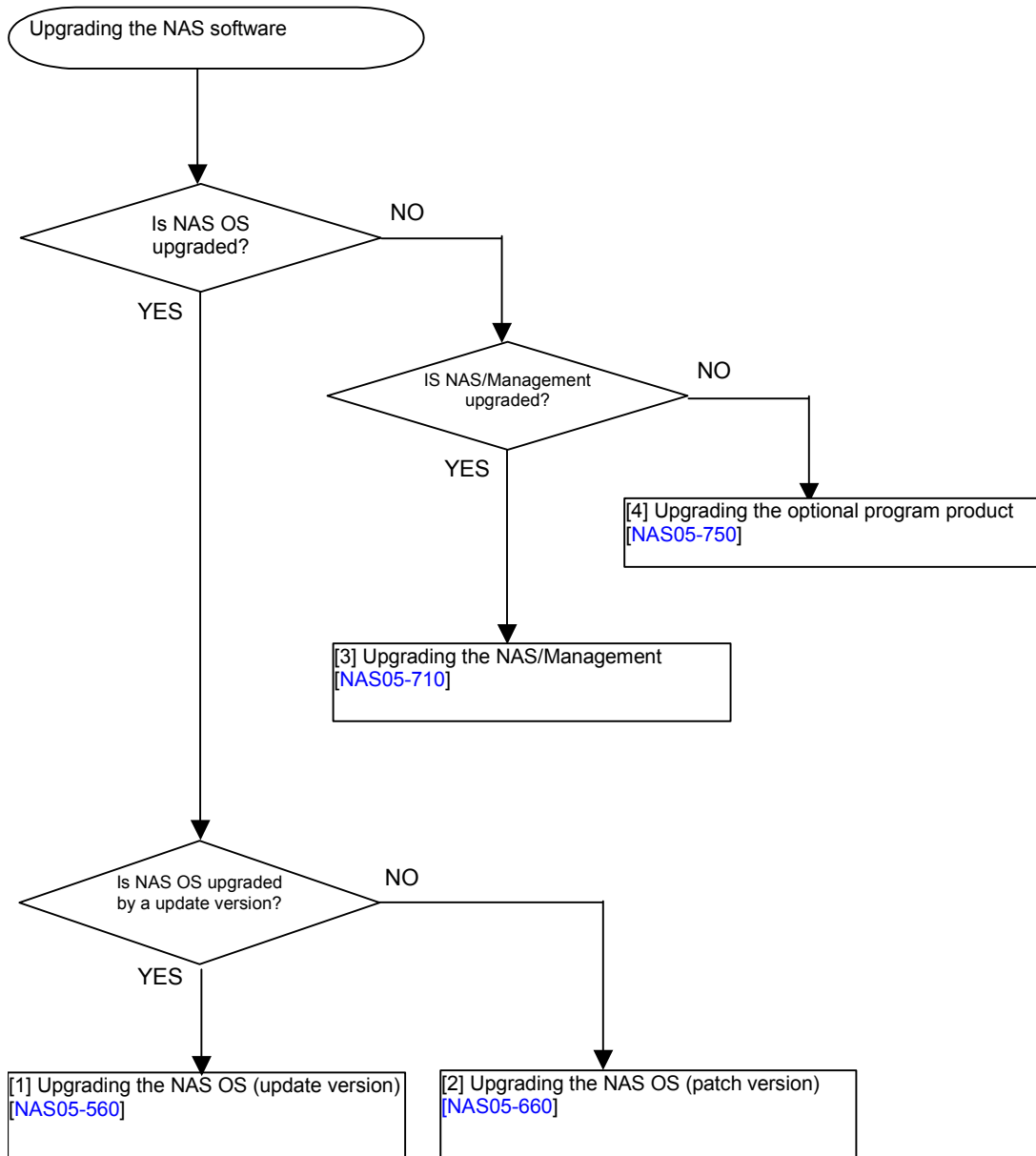

Installation Type Flowchart

- [1] Upgrading the NAS OS (update version)----- [NAS05-560](#)
- [2] Upgrading the NAS OS (patch version)----- [NAS05-660](#)
- [3] Upgrading the NAS/Management (update version)----- [NAS05-710](#)
- [4] Upgrading the optional program product----- [NAS05-750](#)

- [1] Upgrading the NAS OS (update version)

To upgrade the NAS OS:

⚠ CAUTION

Before upgrading the NAS OS, switch the services running on the target NAS Package (node) to be upgraded to run on an alternative node, and then request the system administrator to stop the target node.

- (1) Insert the NAS OS media (CD-ROM) into the CD drive of the SVP.

- (2) In the ‘SVP’ window, change **View Mode** to **Modify Mode**.

- (3) Click the **NAS Setup** button to start Setup on SVP.

Note: The **NAS Setup** button can be used in **Modify Mode** only.

- (4) In the ‘NAS Setup on SVP (Main)’ window select the NAS Package to be upgraded, and then click the **Program Install** button.

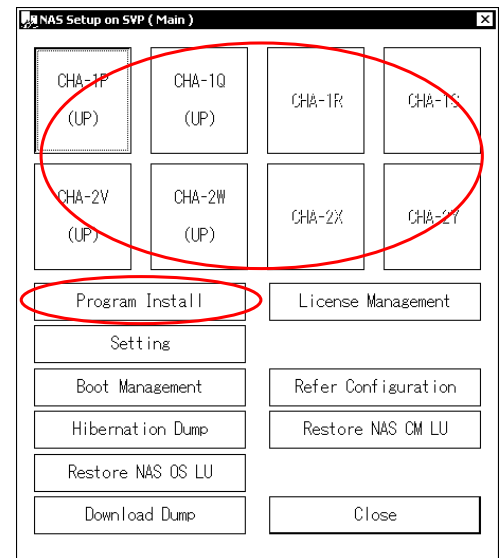

(5) The 'NAS Setup on SVP(Program Install)' window appears.

CAUTION

Except for failure recovery purposes, you do not need to select **NAS Cluster Management LU** and **Error Information LU** in the **Initialize** area.

If there exists a NAS Package (other than the NAS Package on which the operation is being performed) for which a NAS OS has been installed, selecting these check boxes might cause a fatal error such as a system crash. You need to enter a password to select these check boxes and continue the operation. Contact the Technical Support Center (TSC) to confirm the validity of the operation and obtain the password.

For more information on the operating procedure, see 3.5.4 [4] *Installation Containing LU Initialization* [[NAS03-540](#)].

From a list of the program products displayed in **Program Product in Media**, select the program product to be upgraded (NAS OS (Hitachi Network Attached Storage/Base - Data Control, Hitachi Network Attached Storage/Base - File Sharing)).

If you want to upgrade multiple program products, select the program product while holding down the **Ctrl** key.

Click the **Install** button to continue.

Note: In the window example below, the NAS OS stored in the NAS OS media is upgraded.

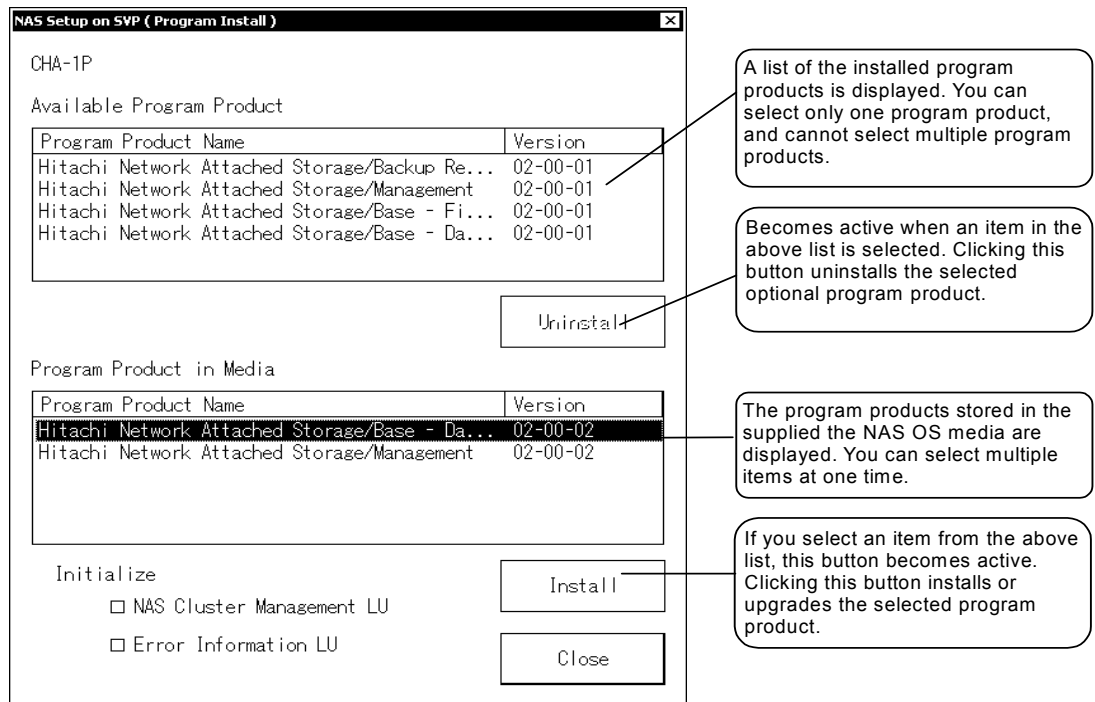

The screenshot shows the 'NAS Setup on SVP (Program Install)' window. It contains the following elements:

- CHA-1P** (System ID)
- Available Program Product** table:

Program Product Name	Version
Hitachi Network Attached Storage/Backup Re...	02-00-01
Hitachi Network Attached Storage/Management	02-00-01
Hitachi Network Attached Storage/Base - Fi...	02-00-01
Hitachi Network Attached Storage/Base - Da...	02-00-01
- Uninstall** button
- Program Product in Media** table:

Program Product Name	Version
Hitachi Network Attached Storage/Base - Da...	02-00-02
Hitachi Network Attached Storage/Management	02-00-02
- Initialize** section:
 - NAS Cluster Management LU
 - Error Information LU
- Install** button
- Close** button

Callouts provide the following information:

- A list of the installed program products is displayed. You can select only one program product, and cannot select multiple program products.
- Becomes active when an item in the above list is selected. Clicking this button uninstalls the selected optional program product.
- The program products stored in the supplied the NAS OS media are displayed. You can select multiple items at one time.
- If you select an item from the above list, this button becomes active. Clicking this button installs or upgrades the selected program product.

- (6) The message “Are you sure you want to update the NAS OS?” appears.
Click the **Yes** button in the message window.

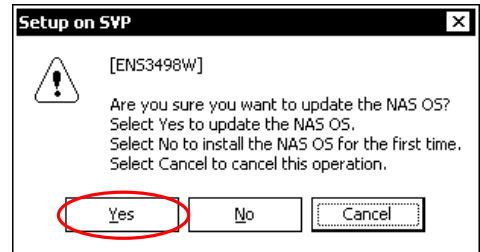

- (6-1)
When the node is stopped:
The NAS OS is installed.
Go to step (7).

- (6-2)
When the node is active.
The message “This node is active...” appears.
Click the **Cancel** button in the message window to cancel the processing. Ask a system administrator to switch the service to the alternative node and stop the node.

If you want to forcibly continue the processing, click the **OK** button.

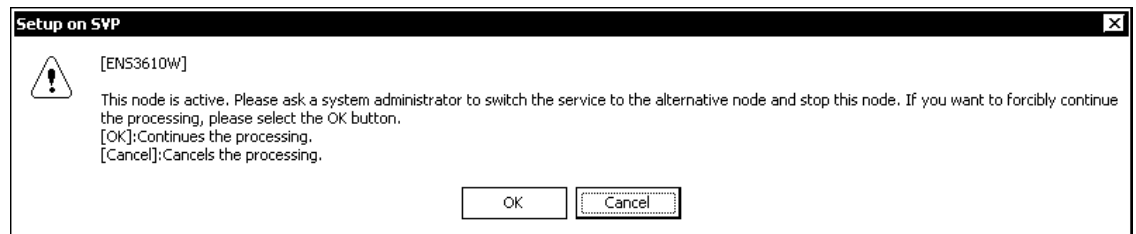

Go to step (6-4).

(6-3)

When the system could not recognize the cluster status:

The message “Failed to get the cluster status...” appears.

Click the **Cancel** button in the message to stop the processing, and then go back to step (5).

If the same message appears repeatedly, click the **OK** button to forcibly continue the processing .

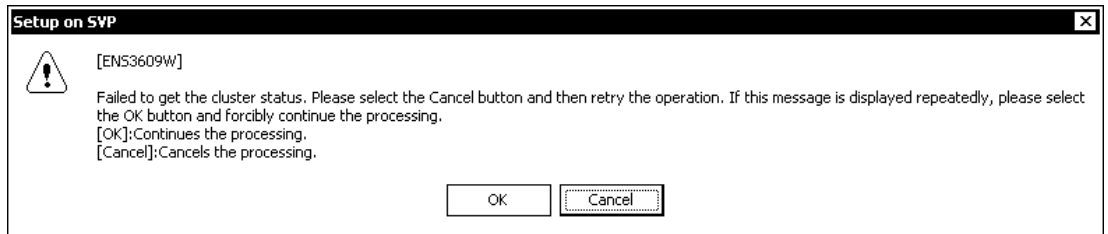

Go to step (6-4).

(6-4)

The message “The cluster system may be affected by this process...” appears.
Click the **OK** button in the message.

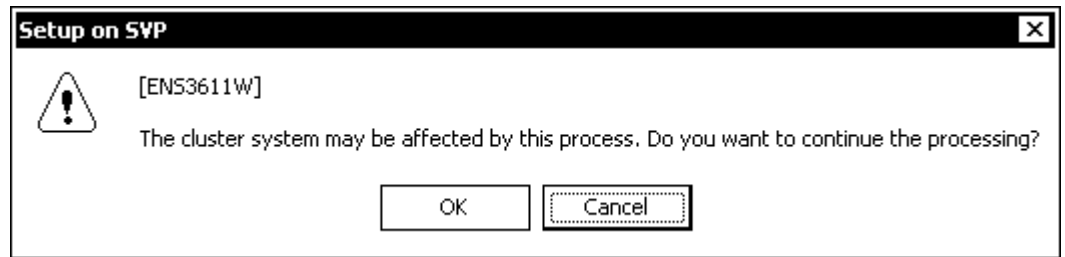

(6-5)

The ‘NAS Setup on SVP (Password)’ window appears.
Enter the password, and then click the **OK** button.
The NAS OS is installed.

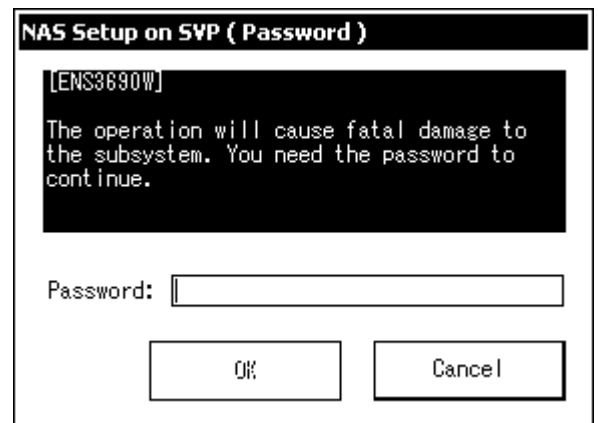

- (7) The 'NAS Setup on SVP (Install Progress)' window appears, and then the upgrade progress for the selected program product is displayed. If you selected multiple program products, the upgrade starts in the order from the top item.

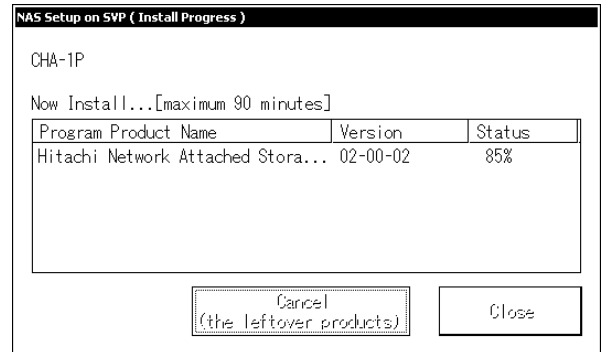

When you upgrade the NAS OS on the other NAS Package, before the upgrade starts, make sure whether failover was performed on the NAS Package for which the NAS OS is to be installed. See the flowcharts in *Chapter 5* and *Chapter 7*, and then go back to step (2) to continue.

If installation finishes successfully, go to step (9).

Note: It takes approximately 10 minutes to upgrade the NAS OS in one NAS Package, and a maximum of 90 minutes to upgrade it in more than one NAS Package at the same time.

Note: Select (CL) [Cancel (the leftover products)] if you want to cancel next and consecutive PP installation.

(8) When upgrade of the NAS OS finished abnormally:

(8-1)

When a message whose ID is ENSxxxxx appears, see the *SVP MESSAGE Section* for the corresponding action to take.

(8-2)

Make sure that there is no blocked part or error in the 'NAS Setup on SVP (Maintenance)' window. If there is a blocked part or an error, see the *SVP Section* [SVP02-30] [SVP03-10], and then take action.

(8-3)

If the **Status** area in the 'Install Progress' window remains at **1%**, and then installation finishes abnormally, use the following procedure to check the **Event Viewer** of the SVP.

(8-3-1)

Click the **Start** button to display the **Start** menu, and then choose **Settings** and **Control Panel**.

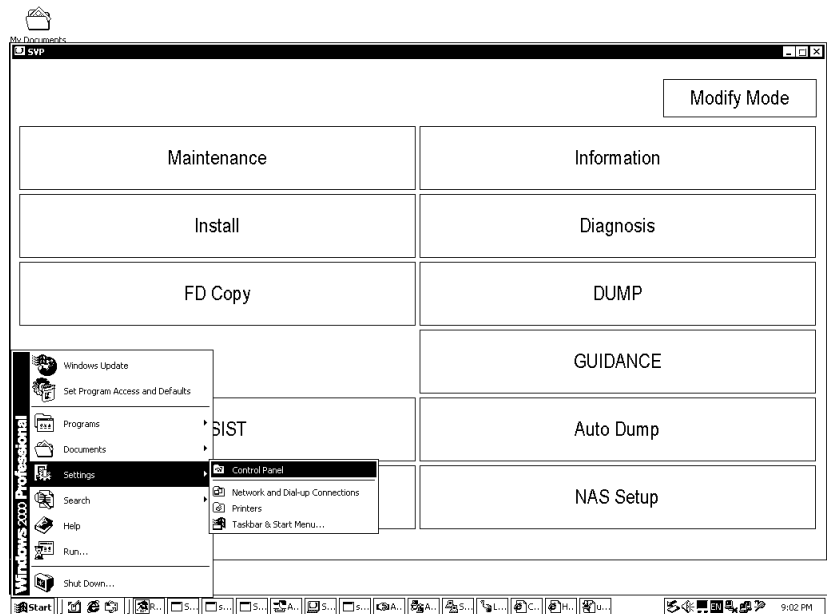

(8-3-2)

The 'Control Panel' window appears.
Double-click **Administrative Tools**.

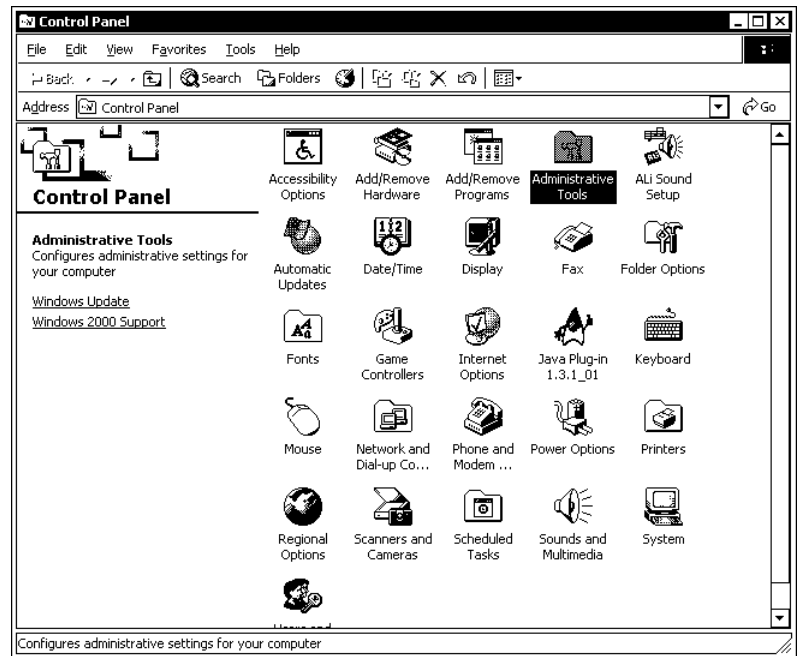

(8-3-3)

Double-click **Event Viewer**.

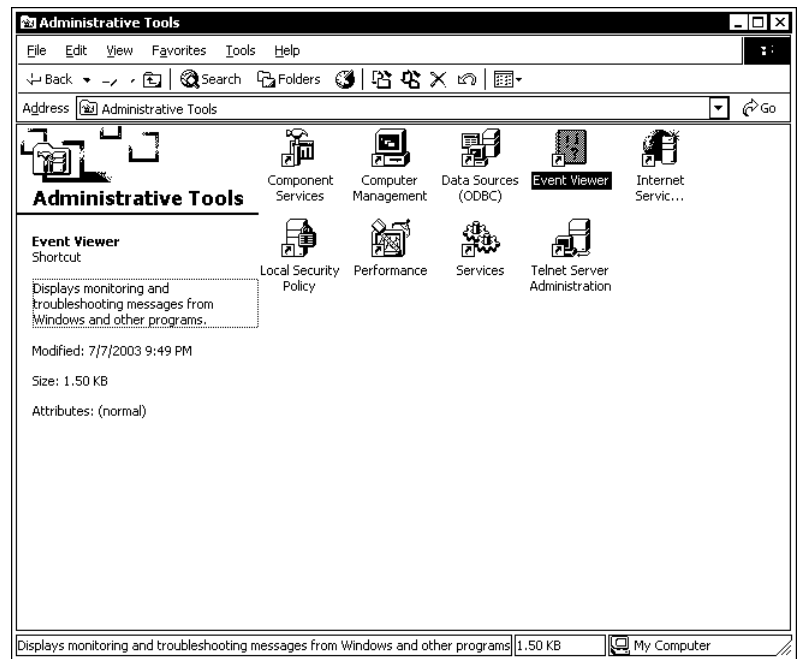

(8-3-4)

If there is a DHCP error 1009, double-click the error and check the description.

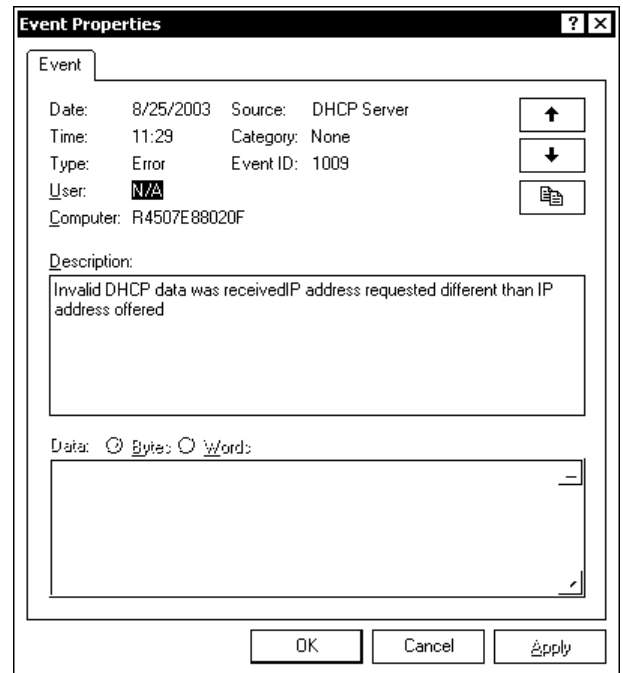

(8-3-5)

Check if the error description includes the following sentence:

IP address requested different than IP address offered.

If so, go to step (8-3-6).

If the above error does not exist, remove the NAS OS media (CD-ROM) from the CD drive of the SVP, reboot the SVP PC, and then install the NAS OS from step 1.

If the same phenomenon occurs repeatedly, contact the Technical Support Center (TSC).

(8-3-6)

A DHCP server other than the SVP may be operating.

Although a user LAN is not supposed to be able to connect to a DKC internal HUB (internal LAN), if the user LAN (excluding a LAN for ASSIST or Hi-Track) is mistakenly connected to the internal LAN, this error might occur. See the *LOCATION Section* [[LOCATION05-50](#)] and check if the user LAN is connected to HUB EXP-1 or EXP-2. If the user LAN is connected, disconnect it.

(8-3-7)

Re-execute upgrade.

- (9) When all the statuses of the program products displayed in the ‘NAS Setup on SVP (Install Progress)’ window become **Completed**, the upgrade has finished. Click the **Close** button in the ‘NAS Setup on SVP (Install Progress)’ window.

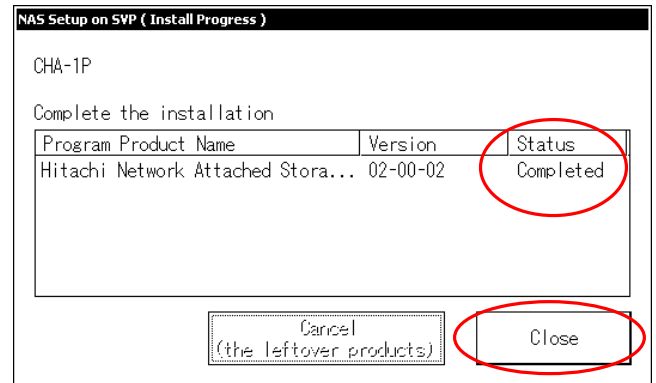

- (10) The ‘NAS Setup on SVP(Program Install)’ window appears.

Make sure that the upgraded version displayed in **Ver.** corresponds with the version of the NAS OS media (CD-ROM) and also the program product name in **Name** in **Available Program Product** corresponds with the program product name of the NAS OS media (CD-ROM), and then click the **Close** button.

The upgrade finishes.

Note: When NAS/OS is upgraded, you select “NAS OS(Hitachi Network Attached Storage/Base - Data Control, Hitachi Network Attached Storage/Base - File Sharing)” from **Program Product in Media** in the ‘NAS Setup on SVP(Program Install)’ window, however, after the upgrade finishes, upgraded version of two program products (“Hitachi Network Attached Storage/Base - Data Control” and “Hitachi Network Attached Storage/Base - File Sharing”) are displayed in **Available Program Product**.

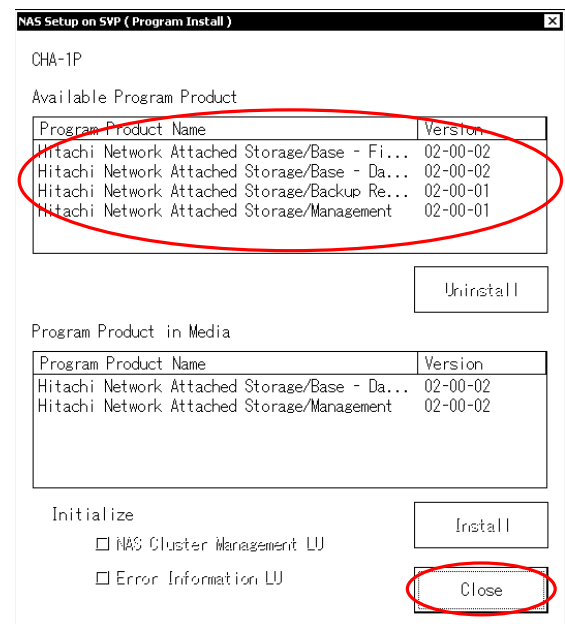

[2] Upgrading the NAS OS (patch version)

To upgrade the NAS OS:

(1) Insert the NAS OS media (CD-ROM) into the CD drive of the SVP.

(2) In the 'SVP' window, change **View Mode** to **Modify Mode**.

(3) Click the **NAS Setup** button to start Setup on SVP.

Note: The **NAS Setup** button can be used in **Modify Mode** only.

(4) In the 'NAS Setup on SVP(Main)' window select the NAS Package to be upgraded, and then click the **Program Install** button.

Note: Make sure that the status of the NAS OS in the target NAS Package that you want to upgrade is **UP**, **INACTIVE**, or **WARN**(NAS Management is not installed).

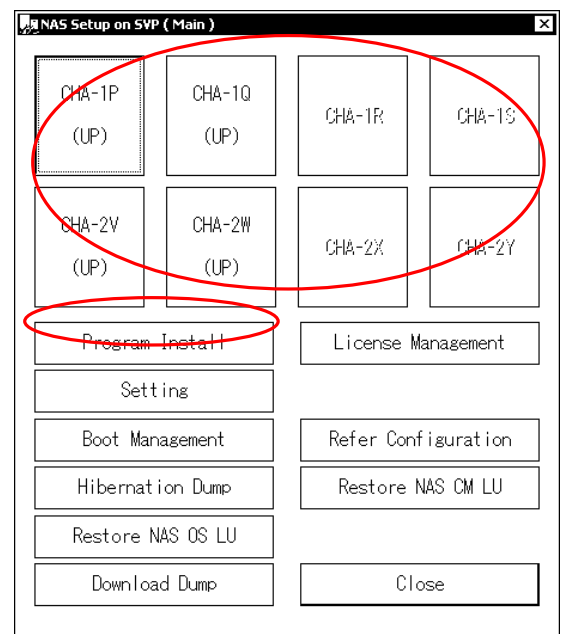

- (5) The 'NAS Setup on SVP(Program Install)' window appears.

From a list of the program products displayed in **Program Product in Media**, select the program product to be upgraded (NAS OS (Hitachi Network Attached Storage/Base - Data Control, Hitachi Network Attached Storage/Base - File Sharing)).

If you want to upgrade multiple program products, select the program product while holding down the **Ctrl** key.

Click the **Install** button to continue.

Note: In the window example below, the NAS OS stored in the NAS OS media is upgraded.

The screenshot shows the 'NAS Setup on SVP (Program Install)' window. It contains the following elements:

- CHA-1P** (System ID)
- Available Program Product** table:

Program Product Name	Version
Hitachi Network Attached Storage/Backup Re...	02-00-01
Hitachi Network Attached Storage/Management	02-00-01
Hitachi Network Attached Storage/Base - Fi...	02-00-01
Hitachi Network Attached Storage/Base - Da...	02-00-01
- Uninstall** button (disabled)
- Program Product in Media** table:

Program Product Name	Version
20-07-SF (1/1)	02-00-01
- Initialize** section:
 - NAS Cluster Management LU
 - Error Information LU
- Install** button (active)
- Close** button

Callouts provide the following explanations:

- A list of the installed program products is displayed. You can select only one program product, and cannot select multiple program products.
- Becomes active when an item in the above list is selected. Clicking this button uninstalls the selected optional program product.
- The program products stored in the supplied the NAS OS media are displayed. You can select multiple items at one time.
- If you select an item from the above list, this button becomes active. Clicking this button installs or upgrades the selected program product.

CAUTION

When you upgrade the NAS OS (patch version), you cannot click both the **NAS Cluster Management LU** and **Error Information LU** in the **Initialize** area.

- (6) The 'NAS Setup on SVP (Install Progress)' window appears, and then the upgrade progress for the selected program product is displayed. If you selected multiple program products, the upgrade starts in the order from the top item.

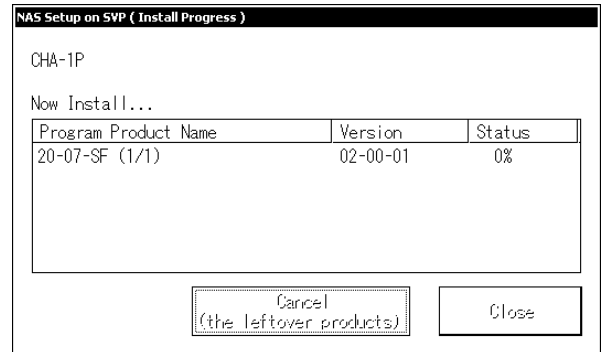

When you upgrade the NAS OS on the other NAS Package, upgrade the NAS OS on the NAS Package of the same cluster. Before the upgrade starts, make sure whether failover was performed on the NAS Package for which the NAS OS is to be installed. See the flowcharts in *Chapter 5* and *Chapter 7*, and then go back to step (2) to continue.

If installation finishes successfully, go to step (8).

Note: It takes approximately 1 minute to upgrade the NAS OS (corrected patch version) in one NAS Package, and several minutes to upgrade it in more than one NAS Package at the same time.

Note: Select (CL) [Cancel (the leftover products)] if you want to cancel next and consecutive PP installation.

(7) When upgrade of the NAS OS finished abnormally:

(7-1)

When a message whose ID is ENSxxxxx appears, see the *SVP MESSAGE Section* for the corresponding action to take.

(7-2)

Make sure that there is no blocked part or error in the 'NAS Setup on SVP (Maintenance)' window. If there is a blocked part or an error, see the *SVP Section* [[SVP02-30](#)] [[SVP03-10](#)], and then take action.

(8) When all the statuses of the program products displayed in the 'NAS Setup on SVP (Install Progress)' window become **Completed**, the upgrade has finished. Click the **Close** button in the 'NAS Setup on SVP (Install Progress)' window.

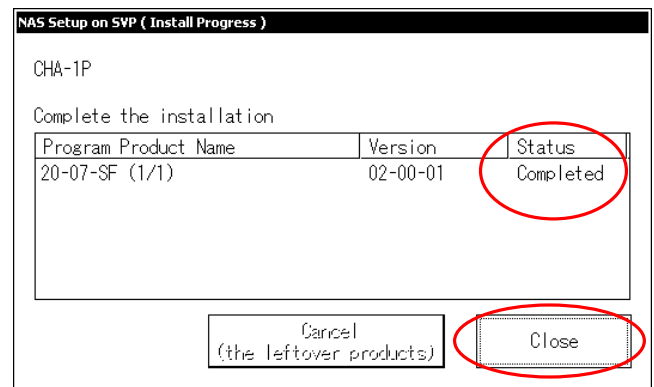

- (9) The ‘NAS Setup on SVP (Program Install)’ window appears.
 Make sure that the upgraded version displayed in **Ver.** corresponds with the version of the NAS OS media (CD-ROM) and also the program product name in **Name** in **Available Program Product** corresponds with the program product name of the NAS OS media (CD-ROM), and then click the **Close** button.
 The upgrade finishes.

Note: When NAS OS is upgraded, you select “NAS OS(Hitachi Network Attached Storage/Base - Data Control, Hitachi Network Attached Storage/Base - File Sharing)” from **Program Product in Media** in the ‘NAS Setup on SVP(Program Install)’ window, however, after the upgrade finishes, the upgrade version two program products (“Hitachi Network Attached Storage/Base - Data Control” and “Hitachi Network Attached Storage/Base - File Sharing”) are displayed in **Available Program Product**.

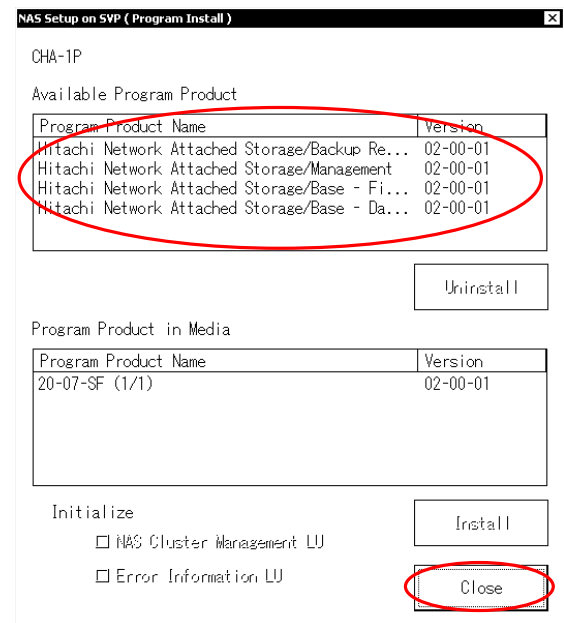

[3] Upgrading the NAS/Management (update version)

To upgrade the NAS/Management:

(1) Insert the NAS OS media (CD-ROM) into the CD drive of the SVP.

(2) In the 'SVP' window, change **View Mode** to **Modify Mode**.

(3) Click the **NAS Setup** button to start Setup on SVP.

Note: The **NAS Setup** button can be used in **Modify Mode** only.

(4) In the 'NAS Setup on SVP(Main)' window select the NAS Package to be upgraded, and then click the **Program Install** button.

Note: Make sure that the status of the NAS OS in the target NAS Package that you want to upgrade is **UP** or **INACTIVE**.

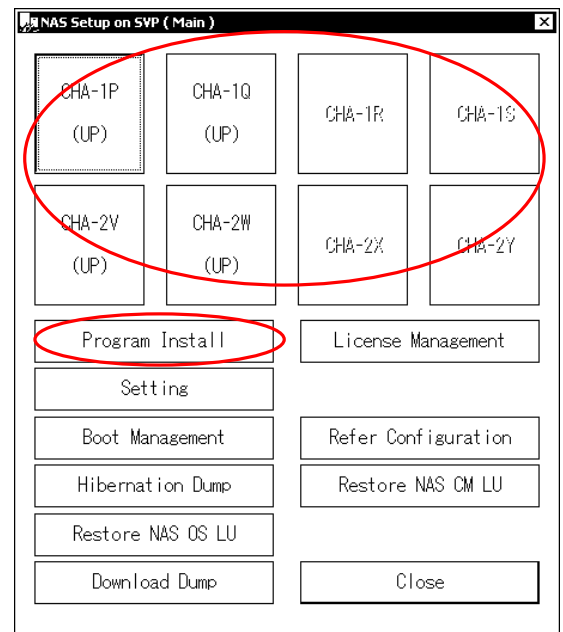

- (5) The 'NAS Setup on SVP (Program Install)' window appears.
 Select the program product that you want to upgrade ("NAS Management (Hitachi Network Attached Storage/Management)") from a list of program products displayed in the **Program Product in Media** field.
 Click the **Install** button to continue.

The screenshot shows a window titled "NAS Setup on SVP (Program Install)" with the following elements:

- CHA-1P** (System identifier)
- Available Program Product** table:

Program Product Name	Version
Hitachi Network Attached Storage/Base - Fi...	02-00-02
Hitachi Network Attached Storage/Base - Da...	02-00-02
Hitachi Network Attached Storage/Backup Re...	02-00-01
Hitachi Network Attached Storage/Management	02-00-01
- Uninstall** button
- Program Product in Media** table:

Program Product Name	Version
Hitachi Network Attached Storage/Base - Da...	02-00-02
Hitachi Network Attached Storage/Management	02-00-02
- Initialize** section:
 - NAS Cluster Management LU
 - Error Information LU
- Install** button
- Close** button

Callouts provide the following information:

- A list of the installed program products is displayed. You can select only one program product, and cannot select multiple program products.
- Becomes active when an item in the above list is selected. Clicking this button uninstalls the selected optional program product.
- The program products stored in the supplied the NAS OS media are displayed. You can select multiple items at one time.
- If you select an item from the above list, this button becomes active. Clicking this button installs or upgrades the selected program product.

CAUTION

When you upgrade the NAS/Management, you cannot select both the **NAS Cluster Management LU** and **Error Information LU** in the Initialize area.

- (6) The 'NAS Setup on SVP (Install Progress)' window appears, and then the upgrade progress for the selected program product is displayed. If you selected multiple program products, the upgrade starts in descending order from the top item.

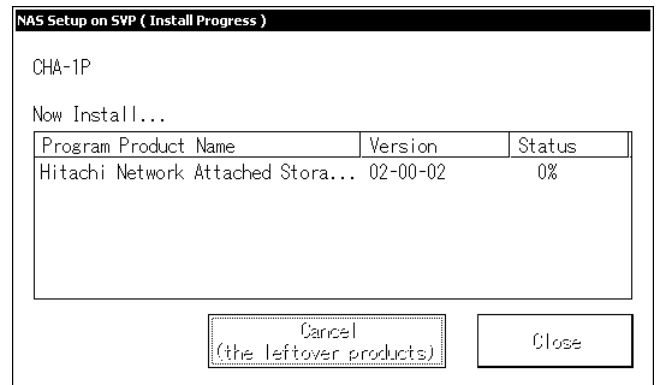

When you upgrade the NAS OS on the other NAS Package, upgrade the NAS OS on the NAS Package of the same cluster. See the flowcharts in *Chapter 5* and *Chapter 7*, and then go back to step (2) to continue.

If installation finishes successfully, go to step (8).

Note: Select (CL) [Cancel (the leftover products)] if you want to cancel next and consecutive PP installation.

- (7) When the NAS/Management upgrade has ended abnormally:

(7-1)

When a message whose ID is ENSxxxxx appears, see the *SVP MESSAGE Section* for the corresponding action to take.

(7-2)

In the 'SVP(Maintenance)' window, make sure that no blocked part or failure is displayed. If there is a blocked part or failure, see the *SVP Section* [[SVP02-30](#)] [[SVP03-10](#)] for the corresponding action to take.

- (8) When all the statuses of the program products displayed in the 'NAS Setup on SVP (Install Progress)' window become **Completed**, the upgrade has finished. Click the **Close** button in the 'NAS Setup on SVP (Install Progress)' window.

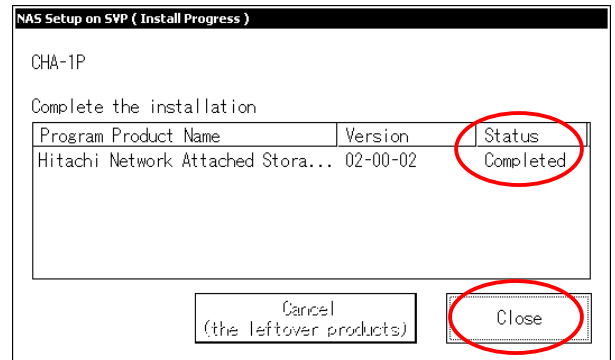

- (9) The 'NAS Setup on SVP (Program Install)' window appears. Make sure that the upgraded version displayed in **Ver.** corresponds with the version of the NAS OS media (CD-ROM) and also the program product name in **Name** in **Available Program Product** corresponds with the program product name of the NAS OS media (CD-ROM), and then click the **Close** button. The upgrade finishes.

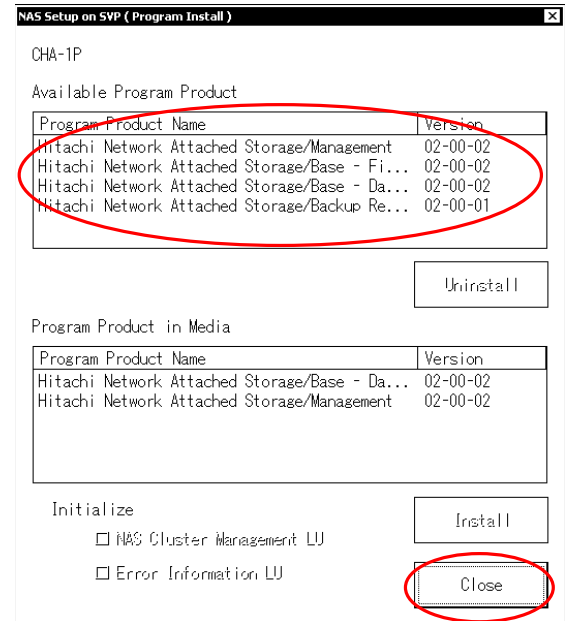

[4] Upgrading the optional program product

To upgrade the optional program product:

(1) Insert the NAS PP media (CD-ROM) into the CD drive of the SVP.

(2) In the 'SVP' window, change **View Mode** to **Modify Mode**.

(3) Click the **NAS Setup** button to start Setup on SVP.

Note: The **NAS Setup** button can be used in **Modify Mode** only.

(4) In the 'NAS Setup on SVP(Main)' window select the NAS Package to be upgraded, and then click the **Program Install** button.

Note: Make sure that the status of the NAS OS in the target NAS Package that you want to upgrade is **UP** or **INACTIVE**.

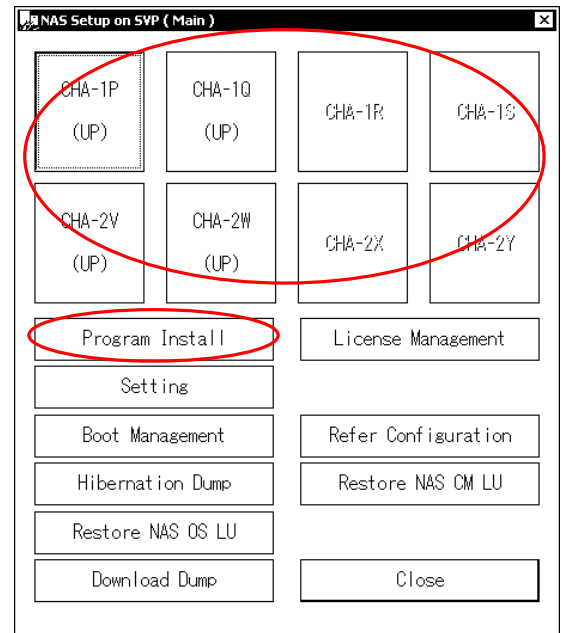

- (5) The 'NAS Setup on SVP (Program Install)' window appears.

From a list of the program products displayed in Program Product in Media, select the program product to be upgraded.

If you want to upgrade multiple program products, select the program product while holding down the **Ctrl** key.

Click the **Install** button to continue.

Note: In the window example below, NAS/Backup Restore is installed from the optional program products stored in the NAS PP media.

The screenshot shows a window titled "NAS Setup on SVP (Program Install)" with the following elements:

- CHA-1P** (top left)
- Available Program Product** section containing a table:

Program Product Name	Version
Hitachi Network Attached Storage/Management	02-00-02
Hitachi Network Attached Storage/Base - Fi...	02-00-02
Hitachi Network Attached Storage/Base - Da...	02-00-02
Hitachi Network Attached Storage/Backup Re...	02-00-01
- Uninstall** button (bottom right of the first table)
- Program Product in Media** section containing a table:

Program Product Name	Version
Hitachi Network Attached Storage/Anti Viru...	02-00-02
Hitachi Network Attached Storage/Backup Re...	02-00-02
Hitachi Network Attached Storage/Sync Image	02-00-02
- Initialize** section with checkboxes:
 - NAS Cluster Management LU
 - Error Information LU
- Install** button (bottom right)
- Close** button (bottom right)

Callouts provide the following information:

- A list of the installed program products is displayed. You can select only one program product, and cannot select multiple program products.
- Becomes active when an item in the above list is selected. Clicking this button uninstalls the selected optional program product.
- The program products stored in the supplied the NAS PP media are displayed. You can select multiple items at one time.
- If you select an item from the above list, this button becomes active. Clicking this button installs or upgrades the selected program product.

CAUTION

When you upgrade the optional program product, you cannot select both the **NAS Cluster Management LU** and **Error Information LU** in the Initialize area.

- (6) The 'NAS Setup on SVP (Install Progress)' window appears, and then the upgrade progress for the selected program product is displayed. If you selected multiple program products, the upgrade starts in descending order from the top item.

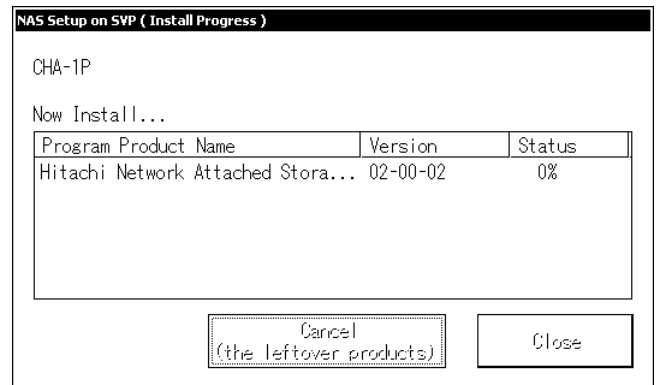

When you upgrade the NAS OS on the other NAS Package, upgrade the NAS OS on the NAS Package of the same cluster. See the flowcharts in *Chapter 5* and *Chapter 7*, and then go back to step (2) to continue.

If installation finishes successfully, go to step (8).

Note: Select (CL) [Cancel (the leftover products)] if you want to cancel next and consecutive PP installation.

- (7) When the optional program product upgrade has ended abnormally:

(7-1)

When a message whose ID is ENSxxxxx appears, see the *SVP MESSAGE Section* for the corresponding action to take.

(7-2)

In the 'SVP(Maintenance)' window, make sure that no blocked part or failure is displayed. If there is a blocked part or failure, see the *SVP Section* [[SVP02-30](#)] [[SVP03-10](#)] for the corresponding action to take.

- (8) When all the statuses of the program products displayed in the 'NAS Setup on SVP (Install Progress)' window become **Completed**, the upgrade has finished. Click the **Close** button in the 'NAS Setup on SVP (Install Progress)' window.

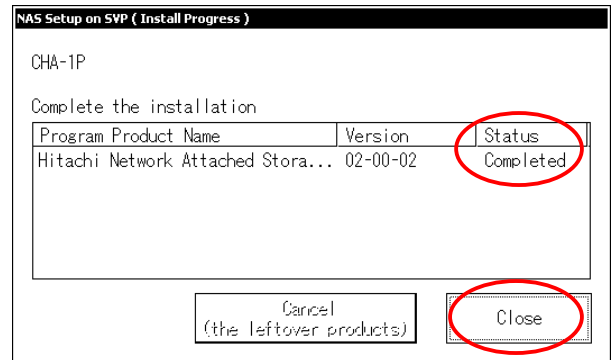

- (9) The 'NAS Setup on SVP (Program Install)' window appears. Make sure that the upgraded version displayed in **Ver.** corresponds with the version of the NAS PP media (CD-ROM) and also the program product name in **Name** in **Available Program Product** corresponds with the program product name of the NAS PP media (CD-ROM), and then click the **Close** button. The upgrade finishes.

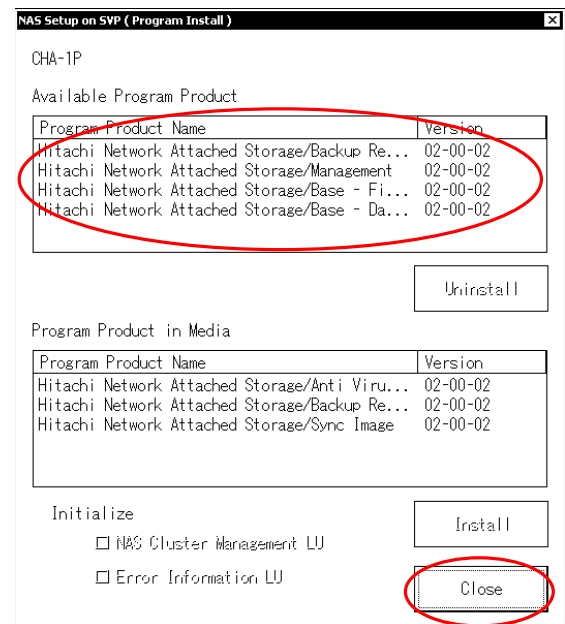

5.3.3 Going Back To an Earlier Software Version

Before updating, and when the settings are added, deleted, or changed by the NAS/Management GUI, you should make a backup of the NAS OS LU by using the NAS OS LU save/recovery functionality of NAS/Management. If the upgrade fails, use the following procedure to go back to the previous version.



CAUTION

When you downgrade software, contact the Technical Support Center (TSC) and perform operations according to its instructions.

The NAS Blade system does not provide the functionality to go back to an earlier update version. To go back to a previous software version:

- (1) To Go Back To an Earlier Version of the NAS OS
 - (a) When the NAS OS LU, NAS Cluster Management LU and user LU Have Been Backed Up
Restore NAS OS LU[[NAS03-1050](#)] and NAS Cluster Management LU[[NAS03-1000](#)] by using the NAS OS LU save/recovery functionality. Ask a system administrator to restore user LU.
You can go back to an earlier version of NAS/Management and an optional program product by this procedure.
 - (b) When the NAS OS LU, NAS Cluster Management LU and user LU Have Not Been Backed Up
Perform an expansion installation of the NAS OS[[NAS03-400](#)] to install the earlier version to overwrite the current version[[NAS05-130](#)][[NAS05-220](#)], until you reach the target version you want.
Upgrade the version of NAS/Management and an optional program product to an earlier version[[NAS03-490](#)][[NAS03-510](#)] at this time.
- (2) To Go Back To an Earlier Version of NAS/Management
Upgrade the version of NAS/Management to an earlier version[[NAS03-490](#)].
To go back to an earlier version of NAS/Management, you also need to go back to an earlier version of the NAS OS. After going back to an earlier version of the NAS OS, as described in (1), upgrade the target version of NAS/Management.
- (3) To Go Back To an Earlier Version of an Optional Program Product
Upgrade the version of an optional program product to an earlier version[[NAS03-510](#)].
To go back to an earlier version of an optional program product, you also need to go back to an earlier version of the NAS OS. After going back to an earlier version of the NAS OS, as described in (1), upgrade the target version of an optional program product.

6. NAS Configuration (Reconfiguration)

6.1 Overview

This chapter describes the procedures for reconfiguring a NAS Blade disk subsystem. Such reconfiguration may become necessary due to increases in data volumes or changes in the type of work. When reconfiguring a NAS Blade disk subsystem, maintenance personnel or system administrators need to take into consideration such factors as the necessity of stopping the NAS OS, the necessity of performing a backup, and the interrelationships among the LUs, device files, and file systems.

6.2 Reconfiguring Hardware

In this section, the cluster is assumed to consist of CL1-CHA and CL2-CHA, and this section shows operations of maintenance personnel and system administrators when reconfiguring hardware.

Make sure that CL2-CHA is properly referred to as the actual location when reconfiguring hardware.

Table 6.2-1 shows the actual CHA locations in the NAS cluster configuration.

Table 6.2-1 CHA Location in the NAS Cluster Configuration

Model	CHA location	CL1-CHA	CL2-CHA
Multi-cabinet	Basic	1P	2V
	Option 1	1Q	2W
	Option 2	1R	2X
	Option 3	1S	2Y
Single cabinet ^{*1}	Basic	1C	2G
	Option 1	1D	2J
	Option 2	1F	2K

*1: Only two of the three, basic, option 1, or option 2, can be used.

6.2.1 Types of Hardware Reconfiguration

The following table shows how hardware reconfiguration procedures are classified depending on the type of the target hardware, the reason for reconfiguration, and the operations of the maintenance personnel and system administrator.

Table 6.2-2 Types of Hardware Reconfiguration

#	Major Classification	Minor Classification	Reason for Reconfiguration	Target Device	NAS Backup Required ? ^{*1}	Restart NAS OS?	Operation status ^{*4}	See:
1	RAID group	Adding	Data added due to an increase in data capacity	SVP (Remote Console)	No	No	Yes	Figure 6.2-1 [NAS06-40]
2		Removing	Data deleted because related work became unnecessary	SVP (Remote Console), Setup on SVP, NAS/Management	No	No	No	Figure 6.2-2 [NAS06-60]
3	RAID cache memory	Adding	Performance enhancement due to increase in loads of related work	SVP	No	No	Yes	— ^{*2}
4		Removing	Due to decrease in loads of related work	SVP	No	No	Yes	— ^{*2}

(Continues on the next page.)

(Continued from the previous page.)

#	Major Classification	Minor Classification	Reason for Reconfiguration	Target Device	NAS Backup Required? ^{*1}	Restart NAS OS?	Operation status ^{*4}	See:
5	RAID cache memory	Reconfiguring (DCR)	Performance enhancement undertaken when there are high-access LUs	SVP	No	No	Yes	— ^{*2}
6	NAS Package	Adding	Related work became necessary	SVP (Remote Console), Setup on SVP, NAS/Management	No	No	Yes	Figure 6.2-3 [NAS06-90]
7		Removing	Related work became unnecessary	SVP (Remote Console), Setup on SVP, NAS/Management	No	No	Yes	Figure 6.2-4 [NAS06-130]
8	LU	Increasing capacity (LUSE) (Change of emulation type)	Data capacity increased. Involves LU reconfiguration.	SVP (Remote Console), Setup on SVP, NAS/Management	Yes	No	No	Figure 6.2-5 [NAS06-150]
9		Decreasing capacity (Change of emulation type) (CVS)	Data capacity decreased. Involves LU reconfiguration.	SVP (Remote Console), Setup on SVP, NAS/Management	Yes	No	No	Figure 6.2-6 [NAS06-180]
10	MP memory (PCR)	Reconfiguring	Performance enhancement	Remote Console	No	No	Yes	— ^{*3}

Yes: Required. No: Not required.

*1: Backup in directory or file units is used.

*2: For more information, see the *REPLACE* Section [REP01-10], *SSD Optional Function* [SSDOPT02-10]

*3: For more information, see the *FlashAccess User's Guide*.

*4: Yes: Ordinary users can continue their operations.

No: Some applications of ordinary users related to reconfiguration are stopped.

6.2.2 Flowcharts for Reconfiguring Hardware

The following table lists general procedures for reconfiguring hardware:

#	General procedure for reconfiguration	For details, see ...
(1)	Adding a RAID group (user LU)	Figure 6.2-1 [NAS06-40]
(2)	Removing a RAID group (user LU)	Figure 6.2-2 [NAS06-60]
(3)	Adding or removing RAID cache memory or reconfiguring (DCR)	[REP01-10] [SSDOPT02-10] Adding CM: from [INST03-CM-10] Removing CM: from [INST04-CM-10]
(4)	Adding a NAS Package	Figure 6.2-3 [NAS06-90]
(5)	Removing a NAS Package	Figure 6.2-4 [NAS06-130]
(6)	Increasing LU capacity (user LU)	Figure 6.2-5 [NAS06-150]
(7)	Decreasing LU capacity (user LU)	Figure 6.2-6 [NAS06-180]

(1) Adding a RAID Group (User LU)

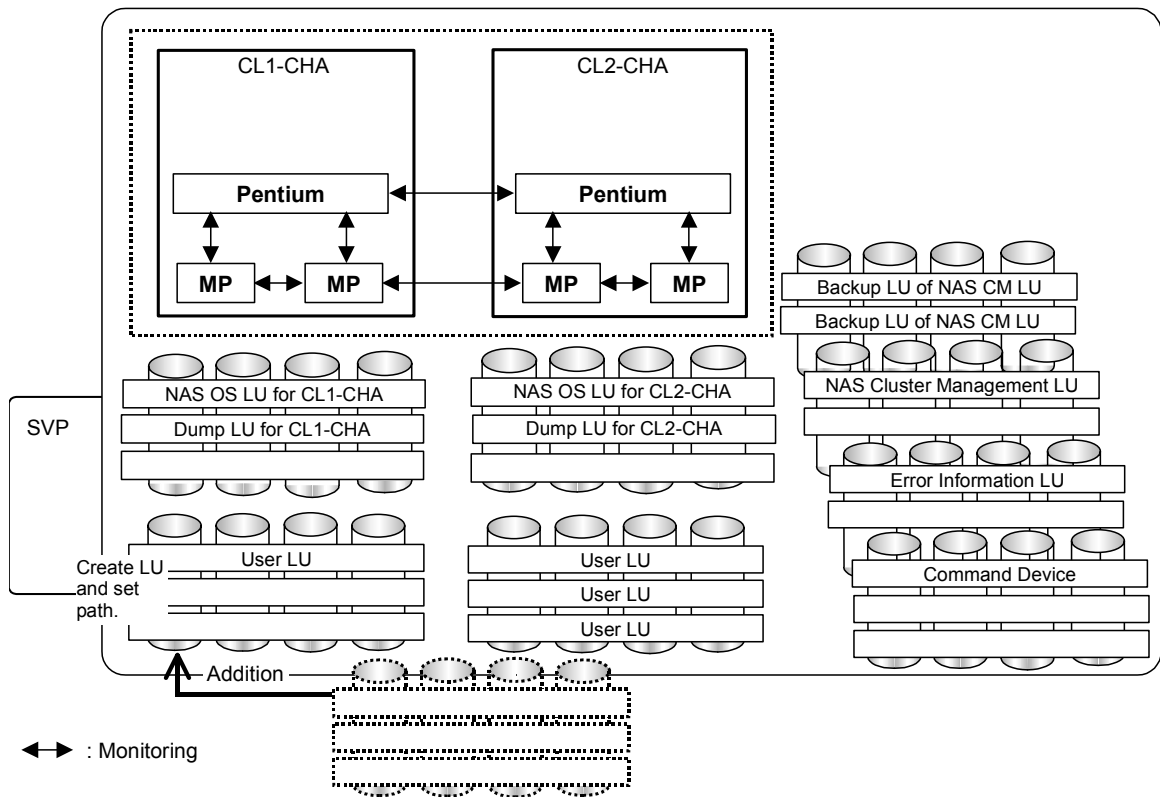

Figure 6.2-1 Adding a RAID Group (User LU)(1/2)

Step	Procedure	Notes
1	Add a RAID group (PDEV).	
2	Define the user LU. (Create the LU and set the path).	

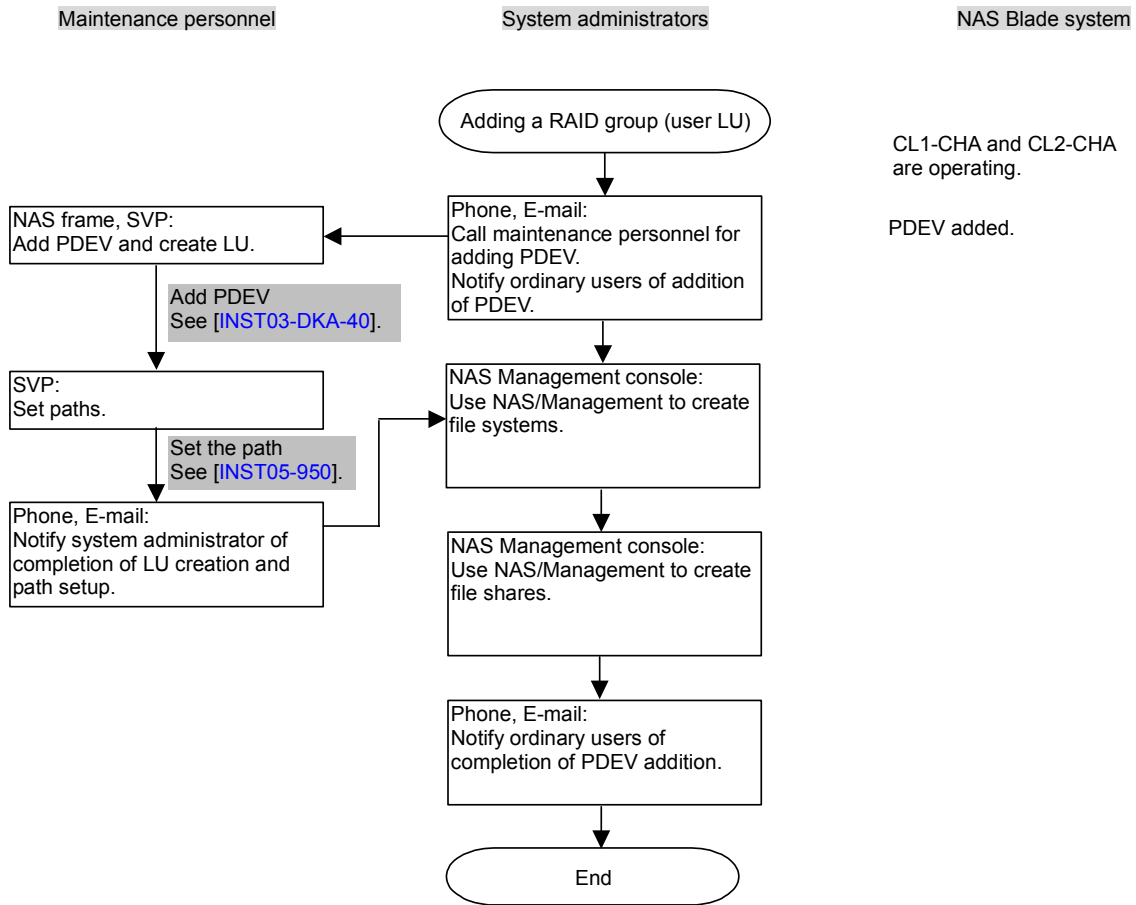

Figure 6.2-1 Adding a RAID Group (User LU)(2/2)

(2) Removing a RAID Group (User LU)

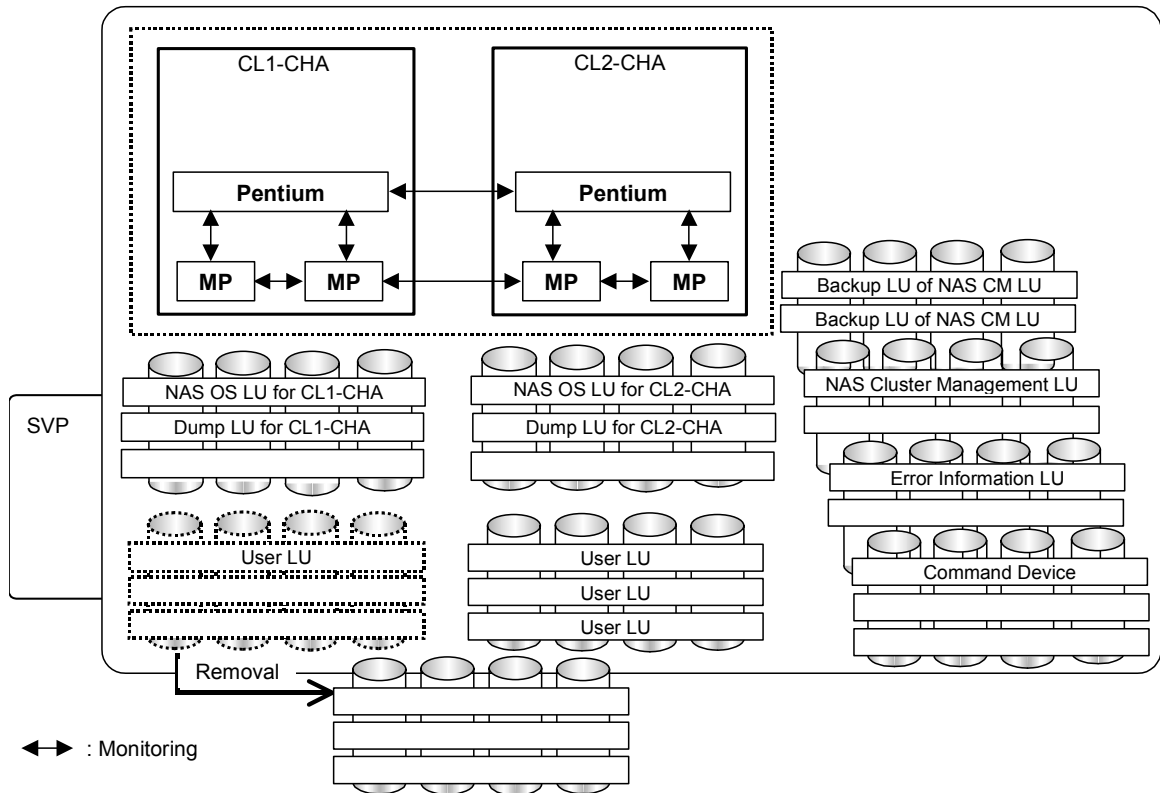

Figure 6.2-2 Removing a RAID Group (User LU)(1/2)

Step	Procedure	Notes
1	Delete all the file shares on the RAID group to be removed.	Delete unnecessary setting information.
2	Delete all the file systems on the RAID group subject to be removed.	Delete unnecessary setting information.
3	Stop the cluster on the NAS Package subject to be removed.	
4	From the LUNs set for the file systems to be deleted, specify the LDEV numbers of the RAID group to be removed.	From these LDEV numbers, maintenance personnel specify the RAID group (PDEV) to be removed.
5	Stop the NAS OS.	
6	Delete all the paths to and from the RAID group to be removed.	Delete unnecessary setting information.
7	Remove the RAID group (PDEVs).	

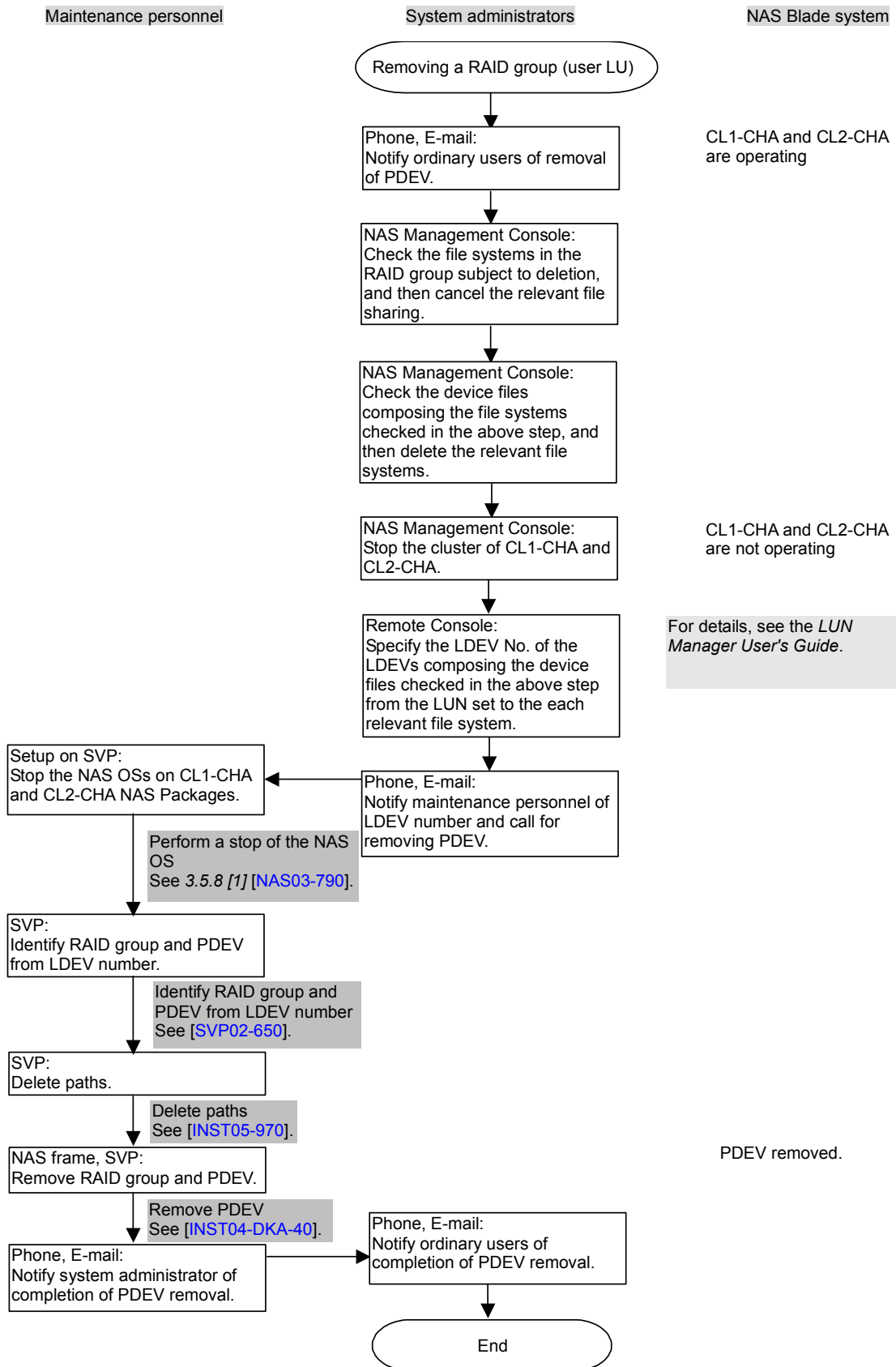

Figure 6.2-2 Removing a RAID Group (User LU)(2/2)

(3) Adding or Removing RAID Cache Memory or Reconfiguring (DCR)

For details, refer to the *REPLACE Section* [[REP01-10](#)], *SSD OPTIONAL FUNCTION SECTION* [[CVSDCR02-10](#)].

For details about adding cache memory, refer to the *INSTALLATION Section* (from [[INST-03-CM-10](#)]).

For details about removing cache memory, refer to the *INSTALLATION Section* (from [[INST-04-CM-10](#)]).

(4) Adding a NAS Package

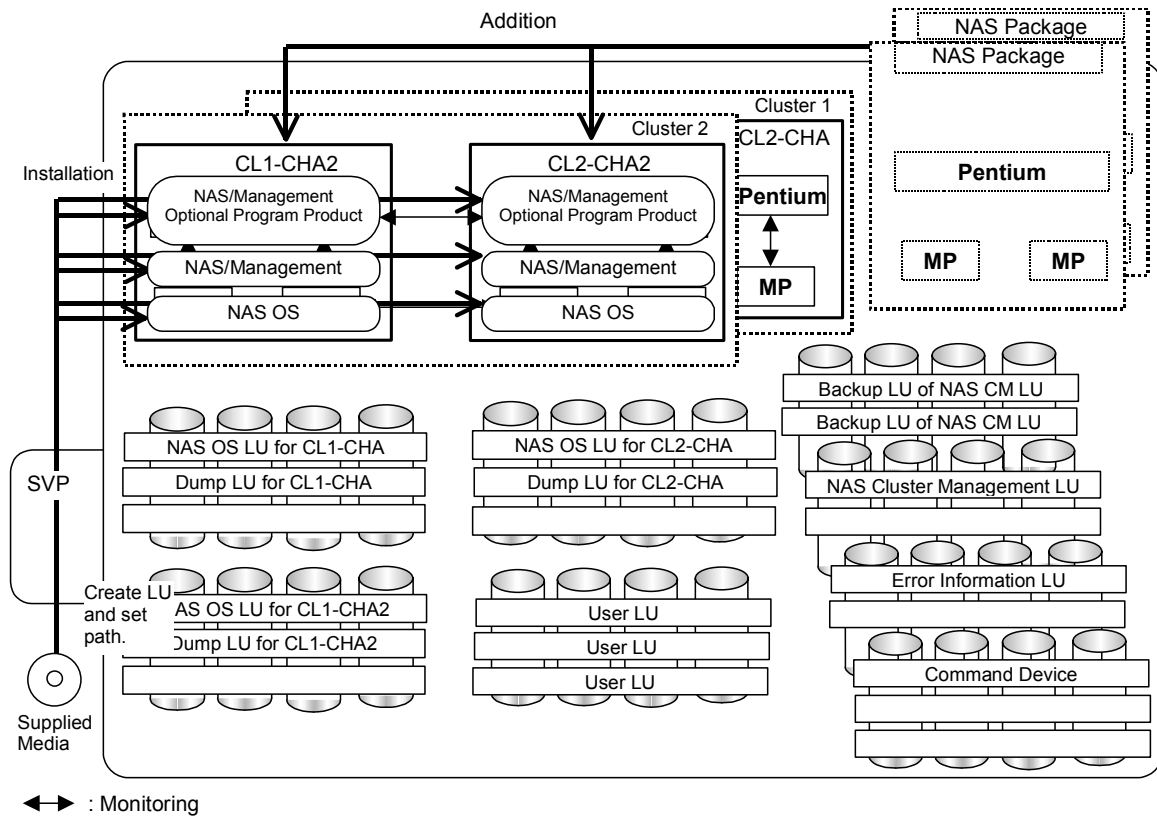
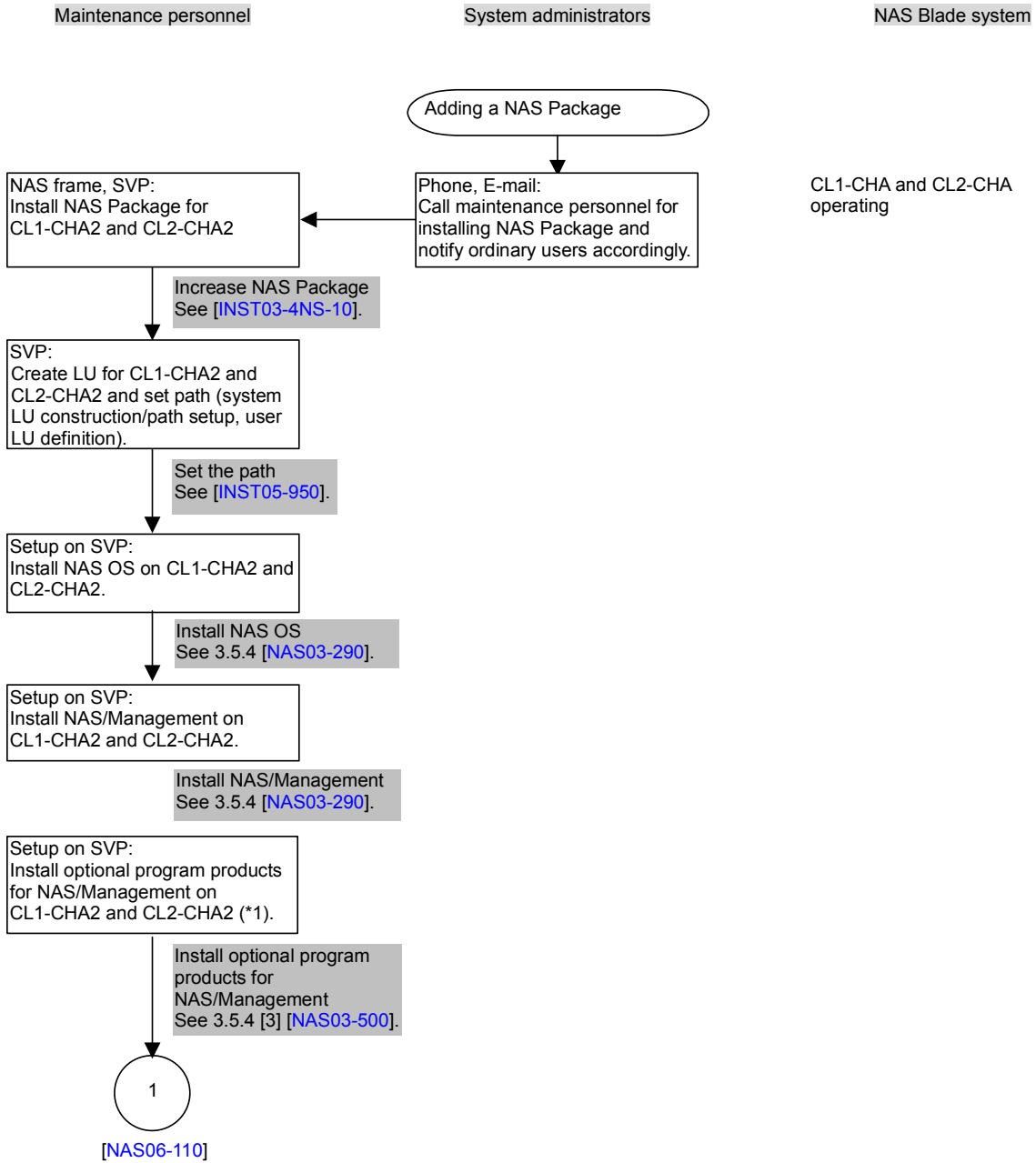

Figure 6.2-3 Adding a NAS Package (1/4)

Step	Procedure	Notes
1	Add the NAS Package to the NAS Blade system frame.	
2	Create the NAS system LUs for the added NAS Package, set the paths and define the user LU.	
3	Build the system.	Carry out the series of tasks from reinstalling the NAS OS to setting up the functionality related to error monitoring.



(*1) Required only when optional program products are used.

Figure 6.2-3 Adding a NAS Package (2/4)

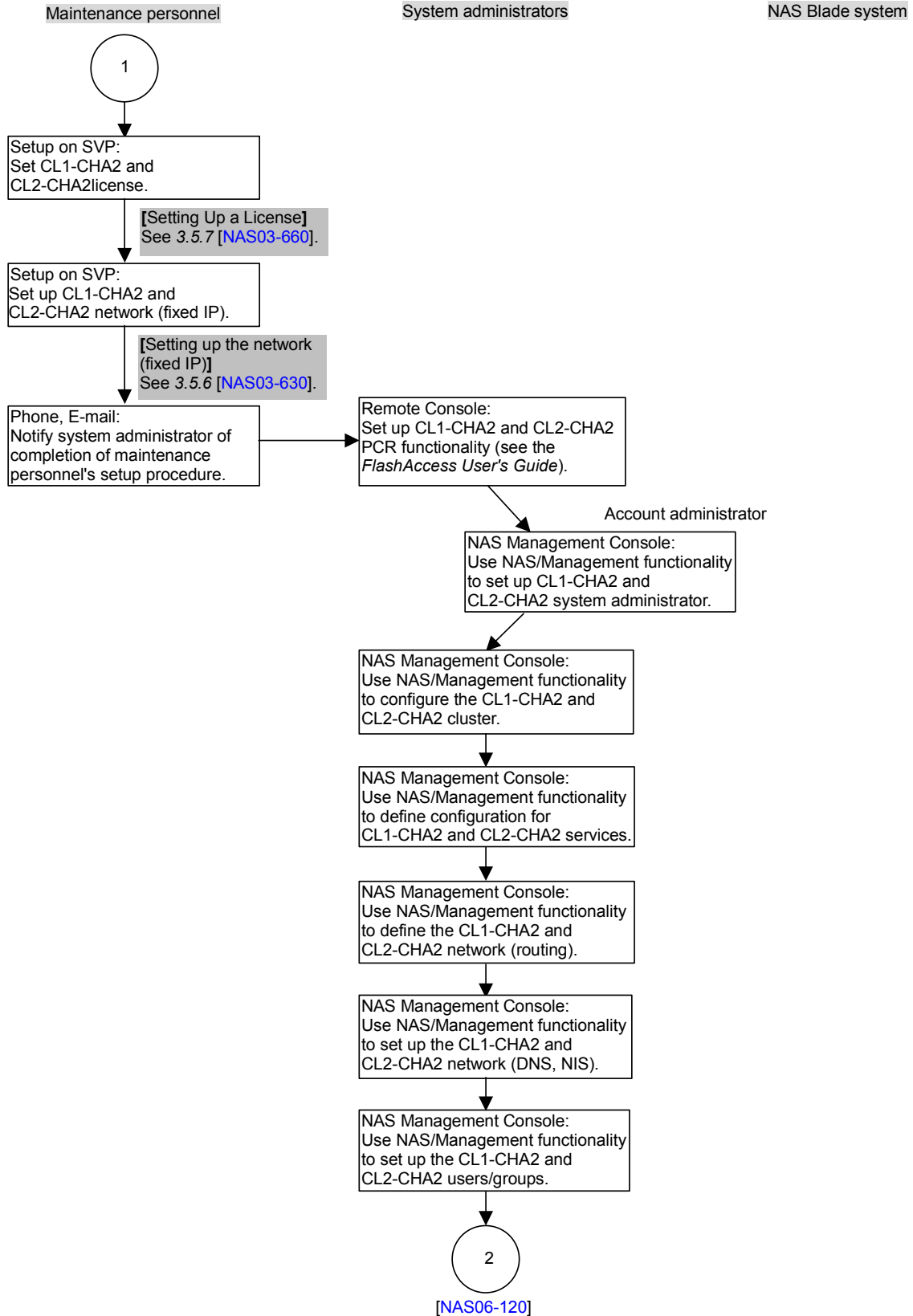

Figure 6.2-3 Adding a NAS Package (3/4)

Maintenance personnel

System administrators

NAS Blade system

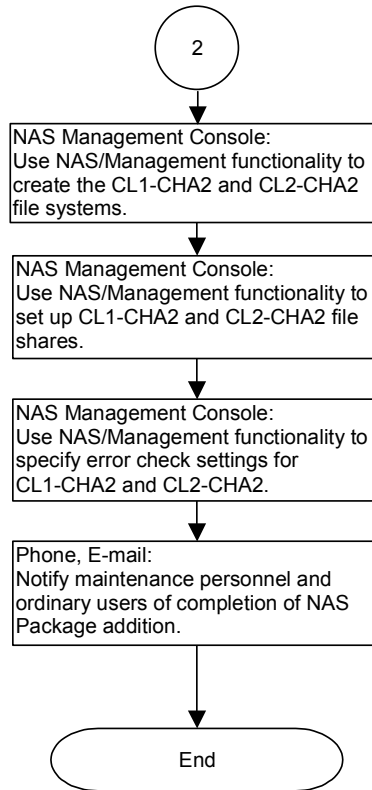

Figure 6.2-3 Adding a NAS Package (4/4)

(5) Removing a NAS Package

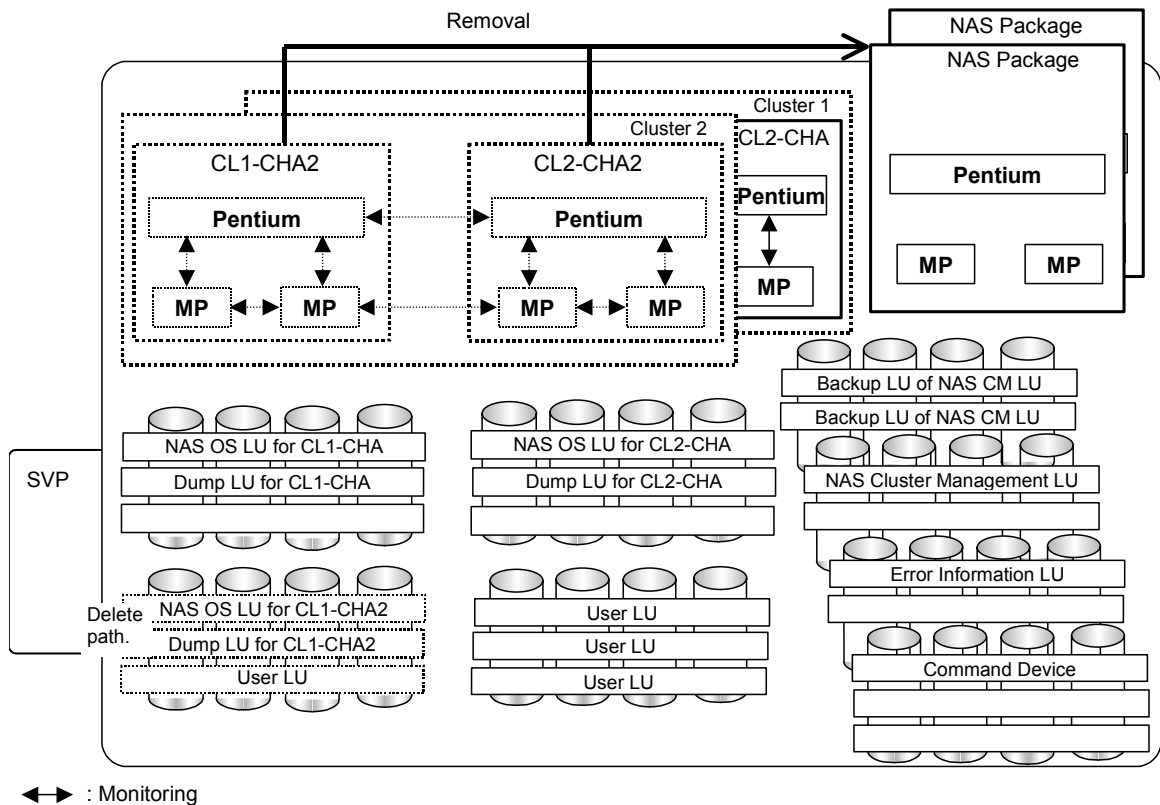

Figure 6.2-4 Removing a NAS Package (1/2)

Step	Procedure	Notes
1	Stop operation of the NAS Package that is to be removed.	
2	Delete all file shares on the NAS Package that is to be removed.	Delete unnecessary setting information.
3	Delete all file systems on the NAS Package that is to be removed.	Delete unnecessary setting information.
4	Stop the cluster on the NAS Package that is to be removed.	
5	Stop the NAS OS on the NAS Package that is to be removed.	
6	Delete the NAS system LUs and user LUs on the NAS Package that is to be removed. (Delete their paths.)	Delete unnecessary setting information.
7	Remove the NAS Package that is to be removed.	

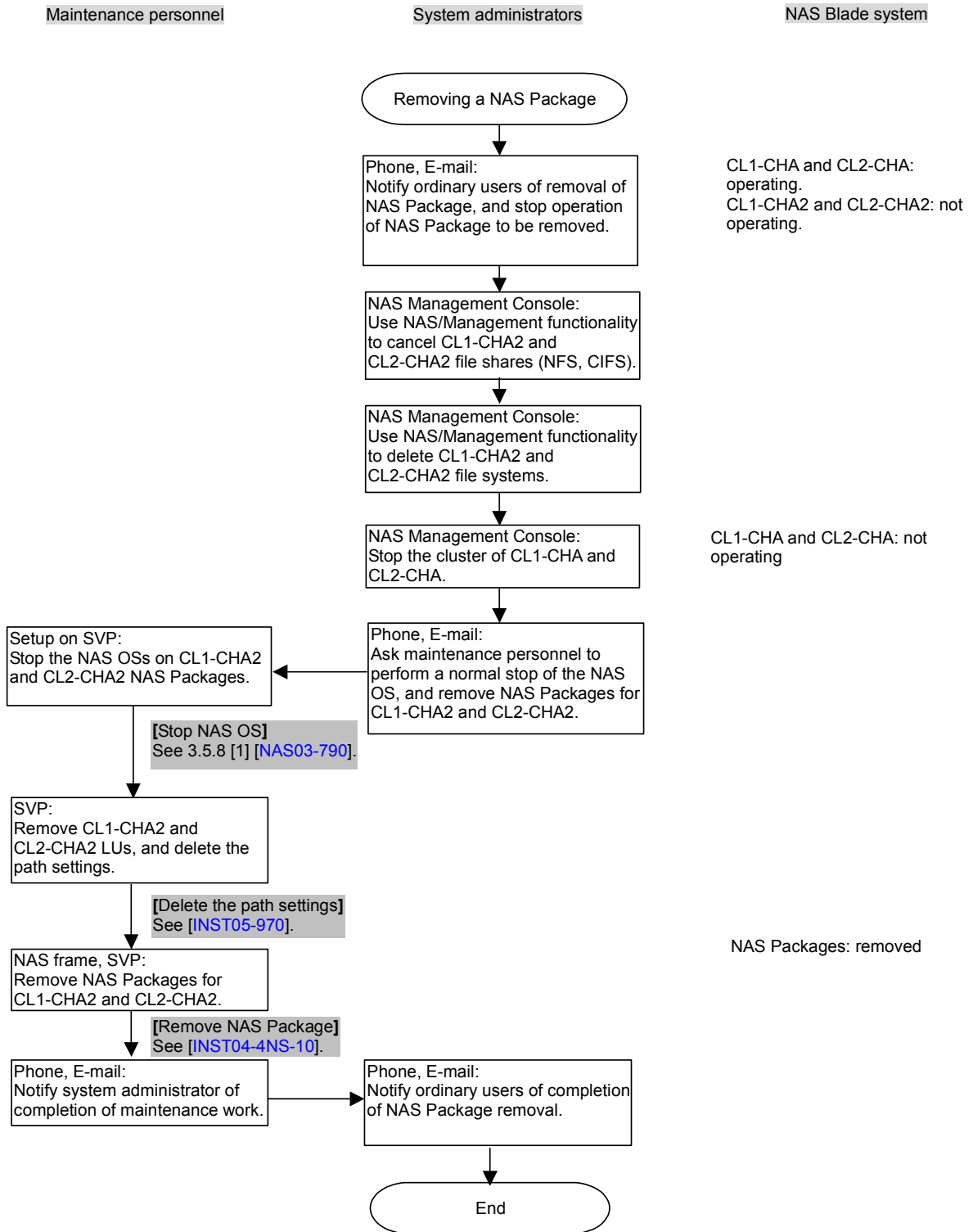

Figure 6.2-4 Removing a NAS Package (2/2)

(6) Increasing LU Capacity (User LU)

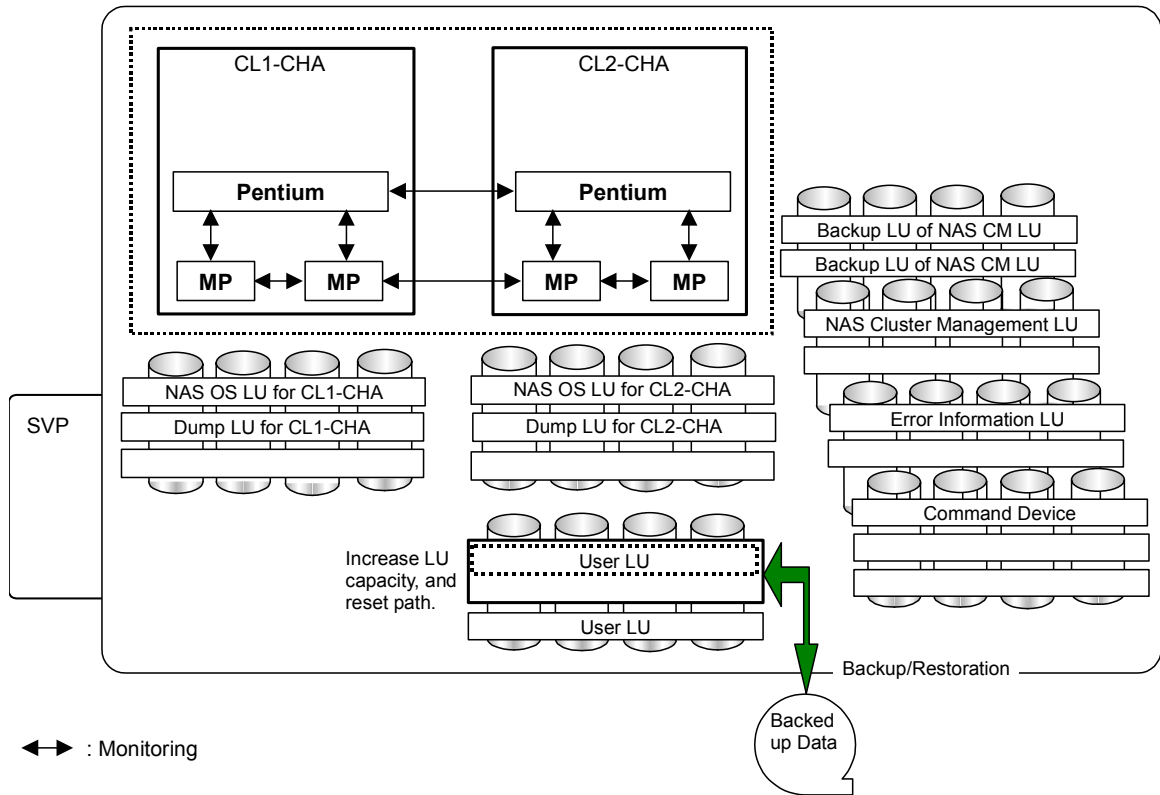

Figure 6.2-5 Increasing LU Capacity (User LU) (1/3)

Step	Procedure	Notes
1	Stop the operation of the user LU to which capacity is to be added.	
2	Back up the data on the user LU to which capacity is to be added.	
3	Delete the file shares on the user LU to which capacity is to be added.	
4	Delete the file systems on the user LU to which capacity is to be added.	
5	Increase the PDEVs in the NAS Blade system frame.	Execute this step when the remaining capacity of the existing PDEVs becomes insufficient.
6	Increase the LU capacity and reset the paths.	
7	Re-create the file systems.	
8	Renew the file shares.	
9	Restore the data in the user LU.	

Maintenance personnel

System administrators

NAS Blade system

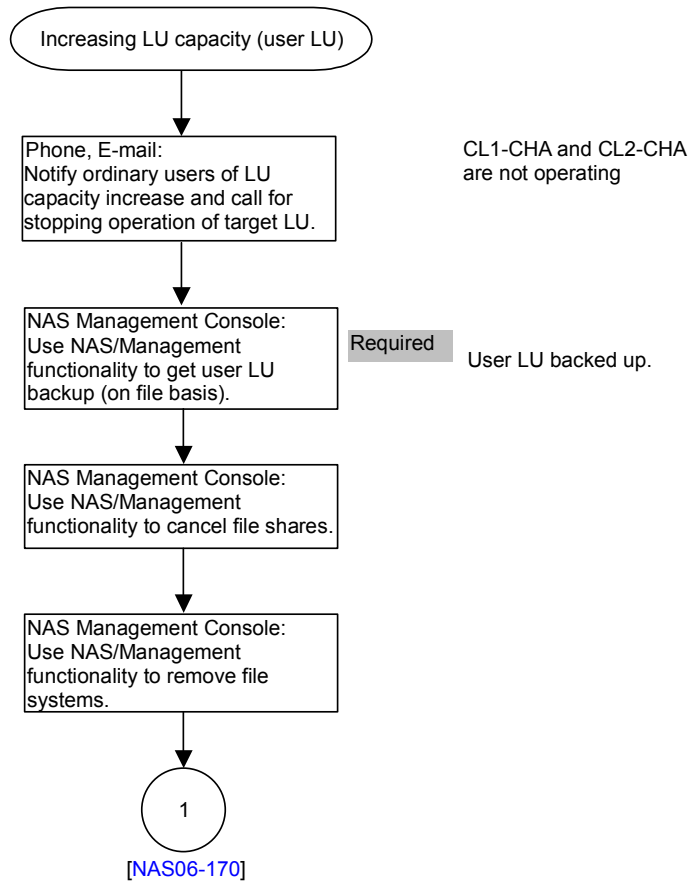

Figure 6.2-5 Increasing LU Capacity (User LU) (2/3)

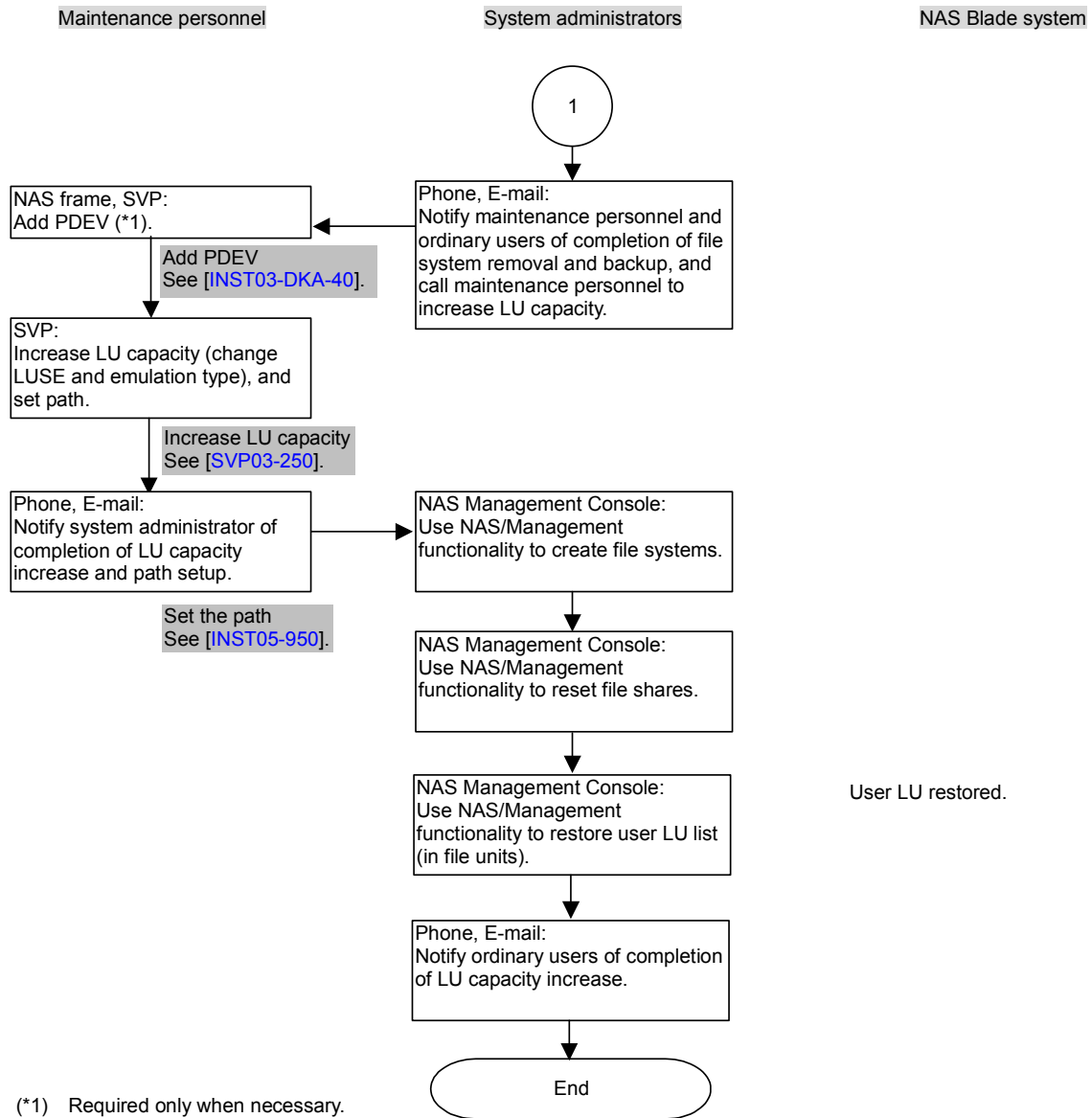

Figure 6.2-5 Increasing LU Capacity (User LU) (3/3)

(7) Decreasing LU Capacity (User LU)

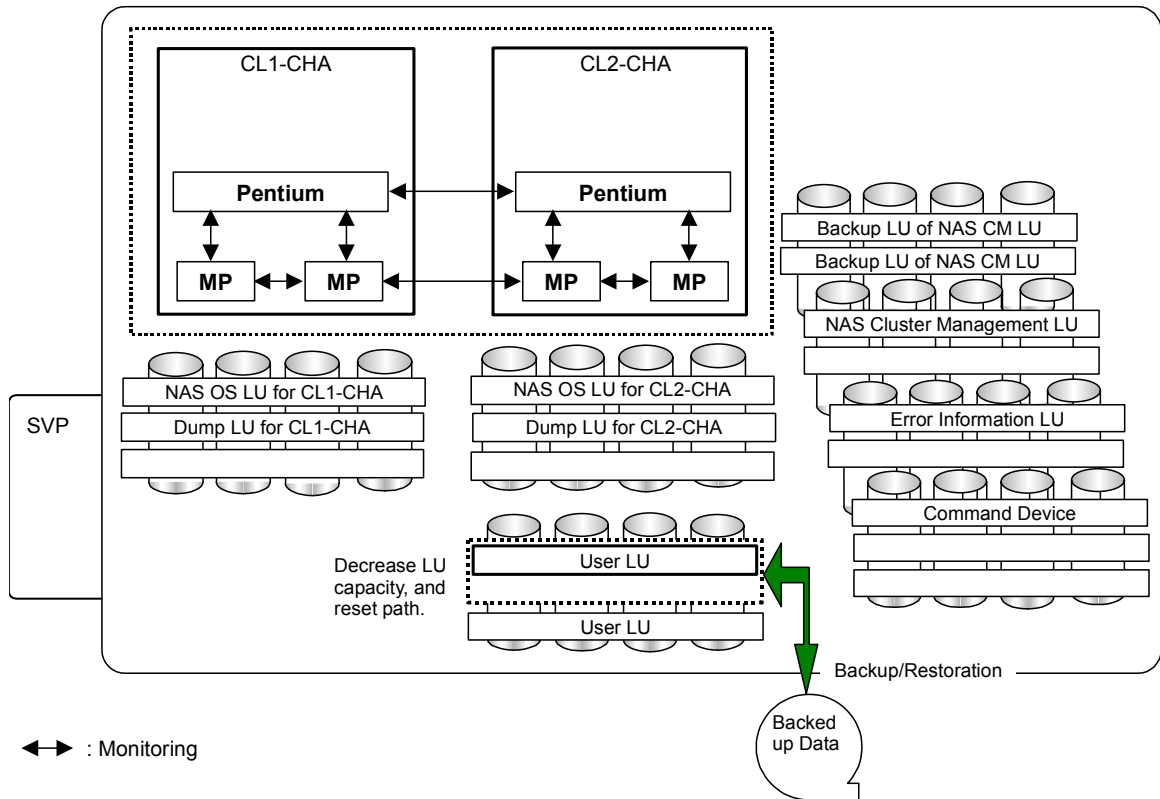

Figure 6.2-6 Decreasing LU Capacity (User LU) (1/3)

Step	Procedure	Notes
1	Stop the operation of the user LU to be removed.	
2	Obtain the backup data of the user LU to be removed.	
3	From the LUNs, specify the LDEV numbers of the user LU to be removed.	From the LUNs, the maintenance personnel specify the LDEV numbers of the user LU to be removed.
4	Delete, all at once, the file shares on the user LU subject to be removed.	
5	Delete, all at once, the file systems in the user LU to be removed.	
6	Remove the LU capacity and reset the path.	
7	Re-create the file systems.	
8	Reset the file shares.	
9	Restore the data in the user LU.	

Maintenance personnel

System administrators

NAS Blade system

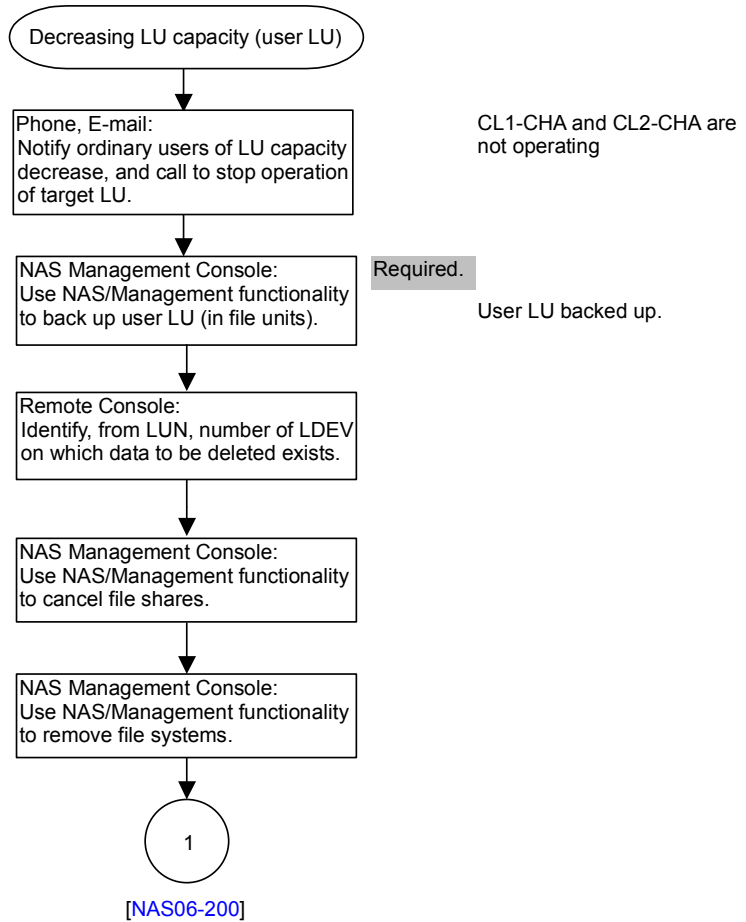

Figure 6.2-6 Decreasing LU Capacity (User LU) (2/3)

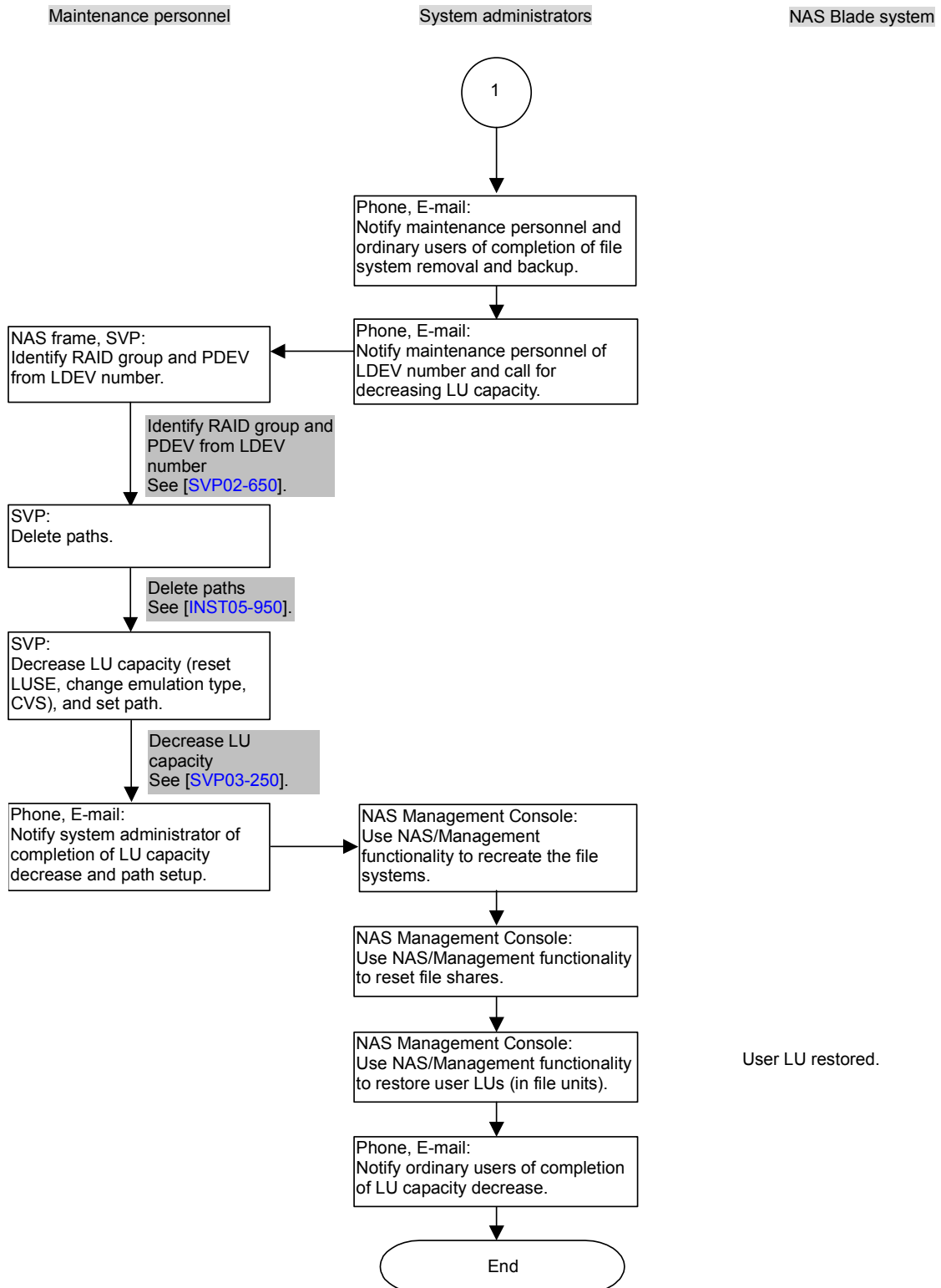

Figure 6.2-6 Decreasing LU Capacity (User LU) (3/3)

6.3 Reconfiguring Software

6.3.1 Types of Software Reconfiguration

The following table shows how software reconfiguration procedures are classified depending on the type of the software, and the operations of the maintenance personnel and system administrator. You can configure software by using the NAS/Management GUI. You do not need to operate the SVP or Remote Console, or restart the NAS OS. For details on using the NAS/Management GUI, see the *Hitachi Network Attached Storage/Management User's Guide*.

Table 6.3-1 Types of Software Reconfiguration

#	Major Classification	Minor Classification	Target	Perform NAS Backup? *1	Restart the NAS OS?	See: *2
1	File system	Expanding file system capacity ³	NAS/Management	No	No	File System Management
2		Deleting a file system ³	NAS/Management	No	No	
3	Network reconfiguration	Fixed IP address	Setup on SVP, NAS/Management	No	No	System Settings
4		Service IP address	NAS/Management	No	No	Cluster Management
5		Routing information	NAS/Management	No	No	System Settings
6		DNS	NAS/Management	No	No	
7		NTP	Setup on SVP (server specification only), NAS/Management	No	Yes	
8		NIS	NAS/Management	No	No	
9		PDC	NAS/Management	No	No	Service Management
10		Error checking (syslog)	NAS/Management	No	No	System Settings
11		Error checking (SNMP)	NAS/Management	No	No	
12		System administrator	NAS/Management	No	No	Administrator Setup
13	Ordinary user	NAS/Management	No	No	User Management	
14	File sharing (NFS, CIFS)	Setting up shares	NAS/Management	No	No	File Sharing Management
15	File sharing (NFS, CIFS)	Canceling shares	NAS/Management	No	No	

Yes: Required. No: Not required.

*1: Backup in directory or file units is used.

*2: These correspond to chapters or subsections in the *Hitachi Network Attached Storage/Management User's Guide*.

*3: Involves no hardware reconfiguration operations such as adding or removing LUs.

7. NAS Troubleshooting

7.1 Overview

This chapter describes how to detect and identify failures, and countermeasures to take when a failure occurs.

Maintenance personnel should use information such as SIM logs, SSB logs, and ACC reports from the SVP to detect triggers of failover and NAS OS failures due to hardware or software failures. See the flowchart for software troubleshooting given in section 7.4 *Troubleshooting Procedures* [NAS07-200], and take the appropriate action.

System administrators should use the NAS/Management GUI, SNMP, and information such as logs to detect NAS functionality failures, and then report the failures to maintenance personnel. Maintenance personnel should decide the appropriate course of action based on the information from the system administrators and from the SVP, and should cooperate with the system administrators to take the appropriate action.

Figure 7.1-1 gives an overview of detecting failures and obtaining error information.

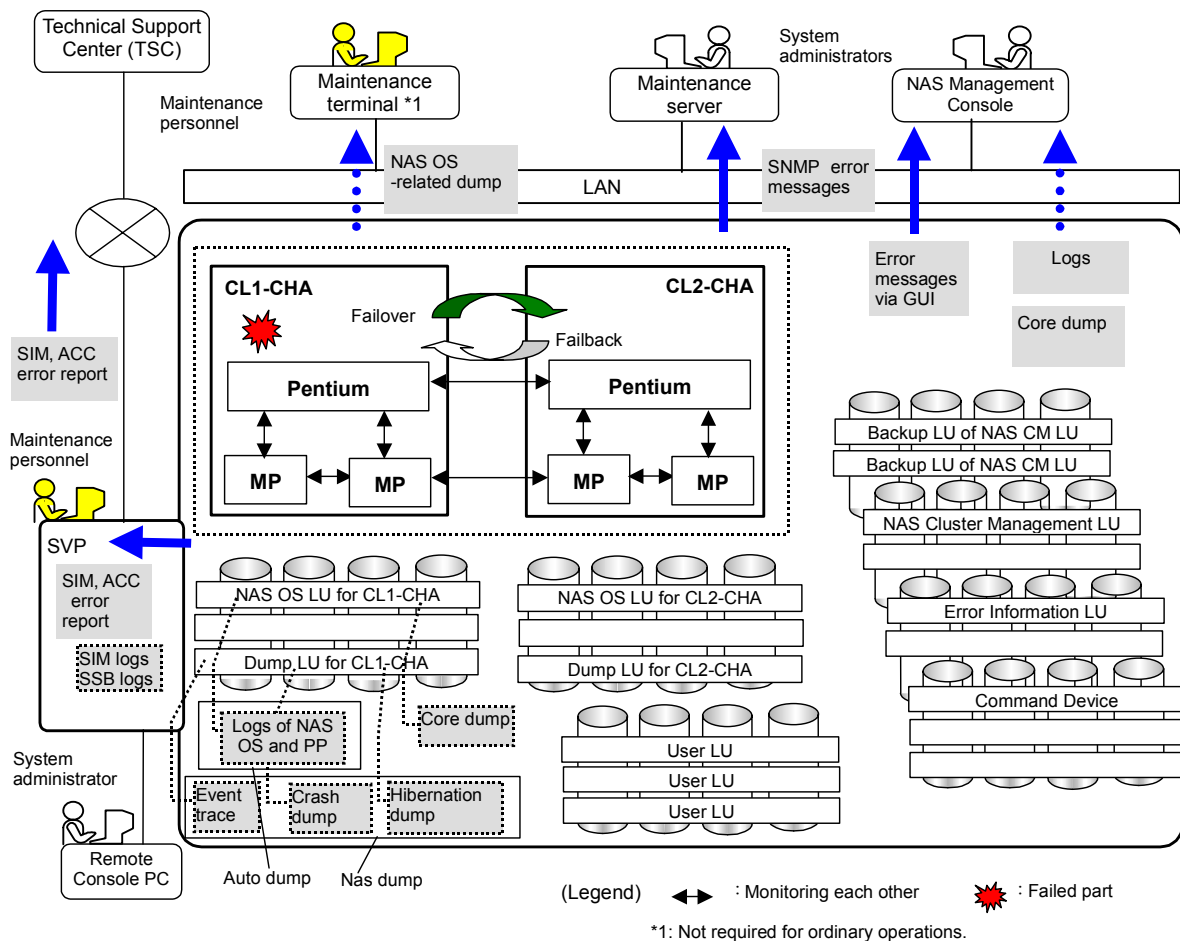

Figure 7.1-1 Detecting Failures and Obtaining Error Information

7.2 Detecting and Identifying Failures

The following table shows the major types of failures that might occur.

Table 7.2-1 Types of Failures

Type of failures	Failed part	Description
Hardware	NAS Package	Failures in processors and microprograms in the NAS Package
	RAID	RAID disk failures
	Other hardware	Disk subsystem hardware failures: for example, in cache memory, power supply equipment, or fans.
Software	NAS OS (kernel)	NAS OS panic/hangup (fatal), slowdown, etc.
	Some NAS OS applications (part of the NAS OS applications: for example, NFS and CIFS)	Abnormal termination of applications
	NAS/Management -Base	Failures related to the management functionality of NAS/Management
	Optional program products	Failures related to optional program products such as NAS/Backup Restore

Hardware failures, NAS OS kernel failures, failover failures, triggers of failover, failed part locations that are unable to use at service startup, are reported to the SVP. Other software failures are monitored by NAS/Management in the NAS Package and reported to the NAS management console.

Maintenance personnel and system administrators should detect failures by examining the failure information received at the SVP, NAS/Management console, and maintenance server. The following table shows this information.

Table 7.2-2 Failure Information Received

Staff	Receiving device	Failure information received
Maintenance personnel	SVP	SIM, SIM log, and ACC
System administrators	NAS management console	Messages on the NAS/Management GUI, Management log
	Maintenance server	SNMP report and MIB information

Also, maintenance personnel and system administrators should identify the failure by the above information, take the emergency measures described in section 7.4 *Troubleshooting Procedures* [NAS07-200], and at the same time, obtain details about the failure.

7.2.1 Detecting Failures

(1) Failure Detection By Maintenance Personnel:

If a failure message appears on the SVP, find out the nature and location of the failure by examining the SIM, SIM log, and ACC.

SIM includes failure information that is unique to the NAS functionality.

For details, see *SIM-RC Section* [[SIM-RC02-20](#)].

Table 7.2-3 SIM Information Unique to the NAS Functionality

#	SIM code/ACC	Failure	Occurrence conditions	Recovery method
1	AC82xx (moderate) ACC=102Exxxx (processor)	NAS OS processor failure NAS OS bus failure	- Pentium WCHK1 - BIOS failure - PCI bus failure (between Pentium and MP) - Pentium memory / hub interface B / P64H2 failure - ECC uncorrectable error	- Replace the NAS Package.
2	AC83xx (moderate) ACC=102Exxxx (processor)	NAS OS processor environment abnormality failure	- Pentium heat failure	- Replace the fan. - Replace the NAS Package.
3	AC84x0 (moderate) ACC=102Exxxx (processor)	NAS OS failure	- NAS OS panic - NAS OS boot timeout - NAS OS shutdown timeout - Timeout during a health check on the PCI bus between Pentium and MP	- Upgrade the NAS OS. - Replace the NAS Package.
4	AC84x2 (moderate) ACC=102Exxxx (processor)	Failover failure	- Failover startup/stop - Failed part due to failover startup - Failed part due to service startup	- Replace the NAS Package. - Upgrade NAS OS. - Check the network cables.
5	AC85xx (moderate) ACC=102Exxxx (processor)	NAS OS bus failure	- Pentium memory / hub interface B / P64H2 failure - ECC correctable error	- Replace the NAS Package.
6	AC86xx (moderate) ACC=102Exxxx (processor)	Network port failure	- Network failure	- Check the network cables. - Replace the NAS package.
7	AC8△x1 ACC=102Exxxx (processor)	NAS OS error monitoring	- NAS OS system failure detected by error monitoring in the NAS OS	- Reboot the NAS OS. - Reinstall the NAS OS.
8	AC8△x2 ACC=102Exxxx (processor)	NAS OS file system failure	- Failure in NAS OS - Failure in the file system to which the service is provided	- Reboot the NAS OS. - Reinstall the NAS OS. - Restore the target volume from the backup data.
9	AC8△x3 ACC=102Exxxx (processor)	NAS OS application (NFS, CISF, etc) failure	- Abnormal ending of NAS OS applications	- Reboot the NAS OS. - Upgrade the NAS OS.
10	AC8△x4 ACC=102Exxxx (processor)	NAS/Management failure	- Unable management operation due to NAS/Management failure	- Reboot the NAS OS. - Reinstall the NAS OS.
11	AC8△xa ACC=102Exxxx (processor)	NAS OS failure during startup or stop	- Failure detected during NAS OS startup or stop	- Reboot the NAS OS. - Backup the NAS OS LU.

Note: xxxx displayed for ACC indicates the failed part.

△ represents the fourth byte of the SIM, numbered from 7 to 9 according to the level of importance.

7: serious, 8: moderate, 9: service.

x represents the fifth byte of the SIM, numbered from 0 to 7 for a multi-cabinet model and 0 to 5 for a single cabinet model. It indicates the location of a failed NAS Package.

Table 7.2-4 indicates mapping of x values in relation to NAS Package locations.

Table 7.2-4 Mapping of x Values in Relation to NAS Package Locations

Model	Location of NAS Package	x (Fifth byte of SIM)
Multi-cabinet	1P	0
	1Q	1
	1R	2
	1S	3
	2V	4
	2W	5
	2X	6
	2Y	7
Single cabinet	1C	0
	1D	1
	1F	2
	2G	3
	2J	4
	2K	5

For other SIM information about the RAID device and for details about how to read the SIM, SIM logs, and ACC, see the *SIM-RC Section* [[SIM-RC01-10](#)], *ACC (ACTION CODE) Section* [[ACC01-10](#)], and *TROUBLESHOOTING Section* [[TRBL01-10](#)].

(2) Failure Detection By System Administrators:

- Find out the nature and location of a failure by examining both the list of NAS/Management GUI messages and the management logs.
- Find out the nature and location of a failure by examining the failure information (MIB information) provided to the maintenance server.

7.2.2 Identifying Failures and Taking Countermeasures

Maintenance personnel should work with the system administrators to identify the failure, select an appropriate countermeasure, and carry out the countermeasure. This countermeasure is intended to keep the customer business running as long as possible in the face of a failure. It is also intended to obtain detailed information while exerting a minimum influence on the customer business.

To identify the failure and carry out the countermeasure, maintenance personnel should follow these steps:

1. If the failures or failed parts detected by SIMs, SIM logs, and ACCs are related to the NAS Blade system, see *Figure 7.4-0 Flowcharts for Troubleshooting Related to Failure Phenomena* to decide the corresponding countermeasures.
2. By cooperating with the system administrators, the maintenance personnel should follow the troubleshooting procedures of the flowchart decided in step 1, obtain necessary logs and dumps about failure information, take an emergency measure, and then report to the system administrators.
3. The maintenance personnel will receive appropriate countermeasures investigated by the failure information obtained in step 2. When the failed parts become replaceable, or the software becomes able to be upgraded, by the emergency measure, the maintenance personnel should replace the failed parts by following the replacement or upgrade procedures and by cooperating the system administrators.

Depending on the error information obtained from NAS/Management and SNMP, the system administrator checks the nature and location of the failure, and, working with maintenance personnel, obtains error information such as logs and dumps, takes remedial actions, and performs software upgrade operations.

7.2.3 Obtaining Detailed Information about a Failure

To correctly determine the cause and location of a failure, obtain details while taking countermeasures against the failure.

(1) Detailed Information for Maintenance Personnel:

Maintenance personnel should obtain the following information.

Table 7.2-5 Failure Information Obtained by Maintenance Personnel

#	Detailed information	Content	Output source	How to obtain
1	Auto Dump	<p>Information on disk subsystem This information is included in the information obtained in Table 2.5-1 Key Operations by Maintenance Personnel and System Administrators (#23, #25, #26 and #27) [NAS02-90]. The number of generations of NAS-related logs to be collected depends on the dump type (Manual Dump or Auto Dump), or the Auto Dump type (Rapid, Normal, or Detail).</p> <ul style="list-style-type: none"> - For Manual Dump: 3 generations - For Auto Dump (Rapid): Not to be collected - For Auto Dump (Normal): 1 generation - For Auto Dump (Detail): 3 generations 	SVP	<p>In the 'SVP' window, click the Auto Dump button. [SVP02-610].</p> <p>Logs and dumps are collected from all NAS packages when [Auto Dump] button is clicked. To collect them from a specific NAS package, click [Dump] on the SVP window and download them by pointing out the NAS package, then perform FD Copy [SVP02-570].</p>
2	Nas Dump	<p>Information on NAS Packages This information is included in the information obtained in Table 2.5-1 Key Operations by Maintenance Personnel and System Administrators (#26 and #27) [NAS02-90]. The level of information ranges from 1 to 3. You can obtain level 1 and level 2 information using SVP. Level 3 information, which includes the user data connected with NFS share and CIFS share (Windows client), can be obtained by system administrators using NAS/Management GUI.</p>	SVP NAS/ Management GUI	<p>In the 'Setup on SVP' window, click the Download Dump button. See 3.5.14 [NAS03-1090]</p> <p>For details on using the NAS/Management GUI, see the <i>Hitachi Network Attached Storage/Management User's Guide</i>.</p>

Note: Nas Dump can be collected only when both NAS OS LU and dump LU are in normal state (If PDEVs used by those LUs are blocked, Nas dump cannot be collected).

Figure 7.2-1 shows the flowchart for obtaining detailed information on failures.

Flowchart of procedures for obtaining failure information

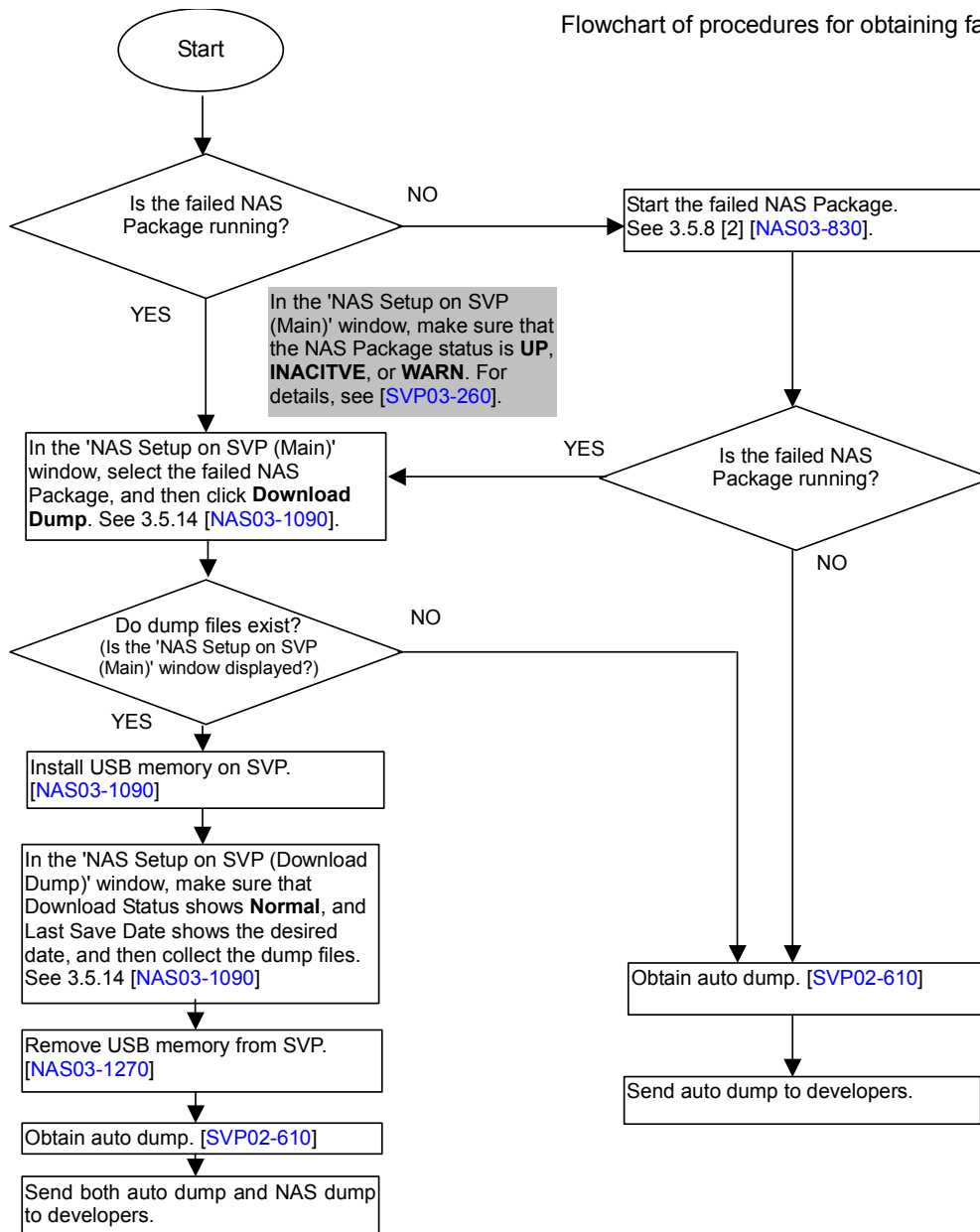

Figure 7.2-1 Flowchart of Procedures for Obtaining Failure Information

If the developer clears up the cause of a failure by analyzing the detailed information, the failure recovery method can be determined. Failure recovery usually involves hardware replacement and software upgrade.

(2) Detailed Information for System Administrators:

System administrators should obtain operation information and failure information (log files and core files) from the NAS/Management GUI window. They should send the error messages, log files, and core files to maintenance personnel and ask the personnel to determine the cause of the failure.

For details on the names of various log files and core files, and for details about the output sources, see *9.2 Appendix B Log Files and Core Files* [[NAS09-220](#)].

7.2.4 Preparing for Failure Recovery Operations (System LU Backup)

In preparation for failing to access the system LU (NAS OS LU and NAS Cluster Management LU) due to a disk failure, or upgrade the NAS Package program, ask the system administrator to back up the system LU (NAS OS LU and NAS Cluster Management LU) when the settings are added, deleted, or changed by the NAS/Management GUI.

 **CAUTION**

Recovery might not be correct if the state of the NAS cluster management LU at the time of the NAS OS LU recovery differs from the state at the time of the backup. Make sure that the following condition is met when you perform a NAS OS LU recovery:

- Software has not been reconfigured (for example, file systems have not been created or removed, and NFS or CIFS shares have not been created, removed or changed) since the last NAS OS LU backup.

7.3 Lists of Failures

In this section, the cluster is assumed to consist of CL1-CHA and CL2-CHA, and Table 7.3-2 and Table 7.3-3 list items related to NAS functionality failures by hardware and by software respectively. The listed items also include necessity of failover, destination of failure report, and major dumps obtained at the time of failures.

Table 7.3-1 shows the actual CHA locations in the NAS cluster configuration.

Table 7.3-1 CHA Location in the NAS Cluster Configuration

Model	CHA location	CL1-CHA	CL2-CHA
Multi-cabinet	Basic	1P	2V
	Option 1	1Q	2W
	Option 2	1R	2X
	Option 3	1S	2Y
Single cabinet ^{*1}	Basic	1C	2G
	Option 1	1D	2J
	Option 2	1F	2K

*1: Only two of the three, basic, option 1, or option 2, can be used.

7.3.1 Hardware Failures

Table 7.3-2 lists NAS functionality hardware failures.

Depending on the failure item, see the flowcharts for troubleshooting that describe countermeasures (*7.4 Troubleshooting Procedures* [[NAS07-200](#)]). For the upgrade operations, see *7.5 Upgrade Procedures When a Failure Occurs* [[NAS07-770](#)].

In this table, information about each failure specifies:

- whether failover occurs,
- whether the failure report is from the SVP and/or from NAS/Management,
- whether dumps can be obtained, and
- whether the business tasks continue or are partly disabled.

Table 7.3-2 Hardware Failures

#	Phenomenon	Failure	Failure report		Failure information			NAS status		Troubleshooting procedure	For details on replacement, see ...
			Report from SVP	Report from NAS/Management ^{*10}	Core dump	Crash dump	Hibernation dump	Fail-over	Operation status ^{*1}		
1	NAS OS processor failure	Pentium internal error Machine check exception	Yes	No	No	No	No	Yes	Yes	Figure 7.4-1 [NAS07-290]	Figure 7.5-1 [NAS07-810]
2		Failure in PCI bus (MCH, ICH3)	Yes	No	No	No	No	Yes	Yes	Figure 7.4-1 [NAS07-290]	Figure 7.5-1 [NAS07-810]
3		Failure in PCI bus (between Pentium and MP)	Yes	No	No	No	No	Yes	Yes	Figure 7.4-1 [NAS07-290]	Figure 7.5-1 [NAS07-810]
4		Failure in PCI bus (between Pentium and network board)	Yes	No	No	No	No	Yes	Yes	Figure 7.4-1 [NAS07-290]	Figure 7.5-1 [NAS07-810]
5		Failure at startup of BIOS (FWH failure)	Yes	No	No	No	No	Yes ^{*12}	Yes	Figure 7.4-1 [NAS07-290]	Figure 7.5-1 [NAS07-810]
6	NAS OS processor environment failure	Temperature rise in Pentium	Yes	Yes	No	No	Yes ^{*15} Yes ^{*16}	Yes	Yes	Figure 7.4-2 [NAS07-310]	Figure 7.5-1 [NAS07-810]
7	NAS OS failure	Internal error hangup in Pentium (MP health check expired)	Yes	No	No	No	Yes ^{*16}	Yes	Yes	Figure 7.4-14 [NAS07-560]	Figure 7.5-12 [NAS07-1120] Figure 7.5-13 [NAS07-1160] Figure 7.5-14 ³ [NAS07-1220]
8		Internal error hangup in Pentium (heartbeat disconnected between Pentiums)	Yes	No	No	No	Yes ^{*16}	Yes	Yes	Figure 7.4-14 [NAS07-560]	Figure 7.5-12 [NAS07-1120] Figure 7.5-13 [NAS07-1160] Figure 7.5-14 ³ [NAS07-1220]
9	NAS OS memory failure and NAS OS bus failure	Correctable memory/hub interface B/P64H2 ECC error (1st, 2nd, and 3rd time)	No	Yes	No	No	No	No	Yes	No action required	No action required ^{*2}
10		Correctable memory/hub interface B/P64H2 ECC error (4th time)	Yes	Yes ^{*11}	No	No	No	Yes	Yes	Figure 7.4-1 [NAS07-290]	Figure 7.5-1 [NAS07-810]
11		Uncorrectable memory /hub interface B/P64H2 ECC error	Yes	No	No	No	No	Yes	Yes	Figure 7.4-1 [NAS07-290]	Figure 7.5-1 [NAS07-810]

(Continues on the next page.)

(Continued from the previous page.)

#	Phenomenon	Failure	Failure report		Failure information			NAS status		Trouble-shooting procedure	For details on replacement, see ...
			Report from SVP	Report from NAS/Management ^{*10}	Core dump	Crash dump	Hibernation dump	Fail-over	Operation status ^{*1}		
12	Network port failure (inaccessible)	Internal error in network board of data LAN	Yes ^{*17}	Yes ^{*9*17}	No	No	No	Yes	Yes	Figure 7.4-2 [NAS07-310]	Figure 7.5-1 [NAS07-810]
		Link down of data LAN cable	Yes ^{*17}	Yes ^{*9*17}	No	No	No	Yes	Yes	Figure 7.4-2 [NAS07-310]	Figure 7.5-11 [NAS07-1081]
13	NAS OS slowdown occurred.	Timeout of disk I/O (response from target MP, retry successful)	Yes	Yes	No	No	No	No	Yes	Figure 7.4-11 [NAS07-490]	Figure 7.5-1 ^{*2} [NAS07-810]
14		RAID internal error (except MP) (recoverable)	Yes	No	No	No	No	No	Yes	Figure 7.4-11 [NAS07-490]	Figure 7.5-1 ^{*2} [NAS07-810]
15	One MP is blocked. NAS OS slowdown occurred.	MP failure (only 1 unit down) detected by MP monitoring	Yes	Yes	No	No	No	No	Yes	Figure 7.4-11 [NAS07-490]	Figure 7.5-1 ^{*2} [NAS07-810]
16		Timeout of disk I/O (no response from target MP, other MP unblocked)	Yes	Yes	No	No	No	No	Yes	Figure 7.4-11 [NAS07-490]	Figure 7.5-1 ^{*3} [NAS07-810]
17	Failover occurred due to MP failure.	MP failure (2 units down at the same time)	Yes	No	No	No	No ^{*13}	Yes	Yes	Figure 7.4-1 [NAS07-290]	Figure 7.5-1 [NAS07-810]
18		Timeout of disk I/O (no response from target MP, other MP blocked)	No	Yes	No	No	No ^{*13}	Yes	Yes	Figure 7.4-14 [NAS07-560]	Figure 7.5-1 [NAS07-810]
19		RAID internal (MP) error (unrecoverable)	Yes	No	No	No	No ^{*13}	Yes	Yes	Figure 7.4-1 [NAS07-290]	Figure 7.5-1 [NAS07-810]
20	I/O error occurred in an LU other than a NAS OS LU.	Timeout error of disk I/O in an LU other than a NAS OS LU (response from target MP, retry unsuccessful)	Yes	Yes	No	No	Yes ^{*4} No ^{*16}	No	— ^{*5}	Figure 7.4-15 [NAS07-590]	Figure 7.5-12 [NAS07-1120] Figure 7.5-13 [NAS07-1160] Figure 7.5-14 ^{*3} [NAS07-1220]

(Continues on the next page.)

(Continued from the previous page.)

#	Phenomenon	Failure	Failure report		Failure information			NAS status		Trouble-shooting procedure	For details on replacement, see ...
			Report from SVP	Report from NAS/Management ^{*10}	Core dump	Crash dump	Hibernation dump	Fail-over	Operation status ^{*1}		
21	I/O error occurred in user LU.	RAID failure (2 PDEVs: User LU)	Yes	Yes	No	No	No	No	No	Figure 7.4-3 [NAS07-330]	Figure 7.5-3 [NAS07-860]
22	I/O error occurred in a system LU.	RAID failure (2 PDEVs: NAS OS LUs in the cluster belong to the same RAID group.)	Yes	No	No	No	No	No	No	Figure 7.4-5 [NAS07-370]	Figure 7.5-5 [NAS07-940]
23		RAID failure (NAS cluster management LU)	Yes	No	No	No	No	No	— ^{*7}	Figure 7.4-6 [NAS07-390]	Figure 7.5-6 [NAS07-960]
24		RAID failure (Dump LU)	Yes	Yes	No	No	No	No	Yes	Figure 7.4-7 [NAS07-410]	Figure 7.5-7 [NAS07-980]
25		RAID failure (error information LU)	Yes	Yes	No	No	No	No	Yes	Figure 7.4-8 [NAS07-430]	Figure 7.5-8 [NAS07-1030]
26		RAID failure (command device)	Yes	Yes	No	No	No	No	Yes ^{*8}	Figure 7.4-9 [NAS07-450]	Figure 7.5-9 [NAS07-1050]
27		RAID failure (Backup LU of NAS CM LU)	Yes	Yes	No	No	No	No	Yes	Figure 7.4-10 [NAS07-470]	Figure 7.5-10 [NAS07-1070]
28	Failover occurred due to an I/O error in a NAS OS LU.	RAID failure (2 PDEVs: NAS OS LUs in the cluster belong to different RAID groups.)	Yes	Yes	No	No	No	Yes	— ^{*6}	Figure 7.4-4 [NAS07-350]	Figure 7.5-4 [NAS07-900]
29		Timeout error of disk I/O in NAS OS LU (response from target MP, retry unsuccessful)	Yes	No	No	No	No	Yes	Yes	Figure 7.4-14 [NAS07-560]	Figure 7.5-12 [NAS07-1120] Figure 7.5-13 [NAS07-1160] Figure 7.5-14 ³ [NAS07-1220]
30		Network failure (Failed to set network settings)	No	No	No	No	No	No	No ^{*14}	Figure 7.4-12 [NAS07-510]	--

- *1: Yes: Business tasks continue.
However, if the application server is connected with Windows client (CIFS share) when a failover occurs, the CIFS share is released, therefore, you must reconnect the server with CIFS share.
No: Business tasks partially stop.
- *2: To cope with the failure, only alarm notification is carried out while business tasks continue. Other countermeasures should be taken immediately.
- *3: Possible abnormalities include NAS OS driver failure, MP microprogram failure, and performance problems (with an application).
If an MP microprogram failure is detected, see the *MICRO-FC Section* [[M-FC01-10](#)].
If a performance problem is detected, determine the countermeasure for the application from the obtained performance information.
- *4: A hibernation dump should be obtained manually as failure information.
- *5: There is no response until a hibernation dump is manually obtained.
- *6: Operation status depends on the location of user LUs and NAS OS LUs in the RAID groups.
- *7: NAS/Management is not operational (depending on the NAS cluster management LU status).
- *8: Backup Restore operations have stopped.
- *9: If the NIC of the management LAN has failed, no report can be sent to the NAS/Management.
- *10: If the system is heavily loaded, NAS/Management performance might become slow, and a report might be delayed. Also, if the system goes down, it is possible that no report will be sent.
- *11: If a system goes down repeatedly because of failures, it is possible that no report will be sent to NAS/Management for the fourth time.
- *12: When the BIOS startup program starts, failover will not occur if the CHN of the same cluster is not operating.
- *13: A hibernation dump might be produced, depending on the error.
- *14: Business tasks that are not related to the failed network can continue.
- *15: A hibernation dump will be collected until the Pentium stops automatically due to a temperature rise.
- *16: A hibernation dump will not be collected when NAS OS LU failure or dump LU failure occurred.
- *17: The failover function reports the failure as failed part to the SVP or NAS/Management when a failure occurs in the resources managed by the failover function, such as LVM, file systems, and NFS public directories, at the startup of such services. The failover function reports the failed part (location) where services cannot be provided due to a hardware or software failure, to the system administrators via the NAS/Management GUI, and to the maintenance personnel via the SVP. The failover function also reports the start and completion of failover to the maintenance personnel and system administrators via the SVP and NAS/Management GUI respectively. Table 7.3-4 shows the types of failures reported by the failover function.

7.3.2 Software Failures

Table 7.3-3 lists NAS functionality software failures.

Depending on the failure item, see the flowcharts for troubleshooting that describe countermeasures (*7.4 Troubleshooting Procedures* [[NAS07-200](#)]). For the replacement and upgrade operations, see *7.5 Replacement Procedures When a Failure Occurs* [[NAS07-770](#)].

In this table, information about each failure specifies:

- whether system administrators can perform operations from the NAS management console,
- whether failover occurs,
- whether failure reports are from the SVP or from the NAS/Management,
- whether dumps can be obtained, and
- whether business tasks are continued or partly disabled.

Table 7.3-3 Software Failures

#	Failure	Failure report		Failure information			NAS status			Trouble-shooting procedure	For upgrade, see ...
		Report from SVP	Report from NAS/Management	Core dump	Crash dump	Hibernation dump	Operations from the NAS management console *1	Fail-over	Operation status *2		
31	NAS OS panic	Yes	No *3	No	Yes	No	Yes	Yes	Yes	Figure 7.4-13 [NAS07-540]	Figure 7.5-12 [NAS07-1120] Figure 7.5-13 [NAS07-1160] Figure 7.5-14 [NAS07-1220]
32	NAS OS hangup	Yes	No *3	No	No	Yes	Yes	Yes	Yes	Figure 7.4-14 [NAS07-560]	Figure 7.5-12 [NAS07-1120] Figure 7.5-13 [NAS07-1160] Figure 7.5-14 [NAS07-1220]
33	NAS OS slowdown	No	No	No	No	Yes *4	Yes	Yes	— *5	Figure 7.4-15 [NAS07-590]	Figure 7.5-12 [NAS07-1120] Figure 7.5-13 [NAS07-1160] Figure 7.5-14 [NAS07-1220]
34	Application failure (failover provided)	No *3,*8	Yes *8	Yes	No	No	Yes	Yes	Yes	Figure 7.4-16 [NAS07-620]	Figure 7.5-15 [NAS07-1270] Figure 7.5-16 [NAS07-1290]
35	Application failure (failover not provided, other than web server)	No	Yes	Yes	No	No	Yes	No	Yes	Figure 7.4-17 [NAS07-650]	Figure 7.5-15 [NAS07-1270] Figure 7.5-16 [NAS07-1290]
36	Application failure (failover not provided, web server)	No	Yes	Yes	No	No	No *6	No	Yes	Figure 7.4-18 [NAS07-680]	Figure 7.5-12 [NAS07-1120] Figure 7.5-13 [NAS07-1160] Figure 7.5-14 [NAS07-1220]

(Continues on the next page.)

(Continued from the previous page.)

#	Failure	Failure report		Failure information			NAS status			Trouble-shooting procedure	For upgrade, see ..
		Report from SVP	Report from NAS/Management	Core dump	Crash dump	Hibernation dump	Operations from the NAS management console *1	Fail-over	Operation status *2		
37	Failure in start processing	Yes ^{*8}	Yes ^{*8}	No	No	Yes	No	No	No	Figure 7.4-19 [NAS07-710]	Figure 7.5-12 [NAS07-1120] Figure 7.5-13 [NAS07-1160] Figure 7.5-14 [NAS07-1220]
38	Failure in stop processing	Yes ^{*8}	Yes ^{*8}	No	No	Yes	No	No	No	Figure 7.4-19 [NAS07-710]	Figure 7.5-12 [NAS07-1120] Figure 7.5-13 [NAS07-1160] Figure 7.5-14 [NAS07-1220]
39	Failure when NAS OS LU is full	No	Yes	No	No	No ^{*9}	No	No ^{*9}	No	Figure 7.4-20 [NAS07-740]	Figure 7.5-12 [NAS07-1120] Figure 7.5-13 [NAS07-1160] Figure 7.5-14 [NAS07-1220]
40	Failure in NAS OS file system	Yes	No	No	No	No	No	Yes	Yes	Figure 7.4-21 [NAS07-761]	Figure 7.5-12 [NAS07-1120] Figure 7.5-13 [NAS07-1160] Figure 7.5-14 [NAS07-1220]
41	Failure during NAS OS startup or stop (invalid dump LU)	Yes	No	No	No	No	No	No	Yes	Figure 7.4-22 [NAS07-764]	-
42	Failure during NAS OS startup or stop (unable to connect NTP server)	Yes	No	No	No	No	No	No	Yes	Figure 7.4-23 [NAS07-766]	-
43	NAS OS application failure (unable to set internal IP address)	Yes	No	No	No	No	No	No	Yes	Figure 7.4-24 [NAS07-769A]	-

*1: This operations are performed from the NAS management console until necessary data is obtained.

*2: Yes: Business tasks continue.

However, if the application server is connected with Windows client (CIFS share) when a failover occurs, the CIFS share is released, therefore, you must reconnect the server with CIFS share.

No: Business tasks are (partly) disabled.

- *3: Only the start and end of the failover are reported.
- *4: A hibernation dump should be obtained manually as failure information.
- *5: There is no response until a hibernation dump is manually obtained.
- *6: The command line should be used because NAS/Management is not operational.
- *7: Operation status depends on the way in which failback abnormally terminates. See the *Hitachi Network Attached Storage/Management User's Guide (9.4.3 Viewing error information in the Browse Cluster Status window and taking recovery action)* .
- *8: The failover function reports resource names to the SVP or NAS/Management when a failure occurs in the services such as LVM, file systems, and NFS public directories, at the startup of such services.
- *9: Depending on how the NAS OS LU was full, a failover may occur. In this case the hibernation dump is collected.

The failover function reports the failed part (location) where services cannot be provided due to a hardware or software failure, to the system administrators via the NAS/Management GUI, and to the maintenance personnel via the SVP. The failover function also reports the start and completion of failover to the maintenance personnel and system administrators via the SVP and NAS/Management GUI respectively. Table 7.3-4 shows the types of failures reported by the failover function.

Table 7.3-4 Failures Reported by the Failover Function

#	Report to SVP		Report to NAS/Management	Explanation	Failed part	
	SIM code	Sub code*2			Hardware	Software
1	ac84x2	00000000	KAQG72006-E	A failure is detected in LVM when services start.	Yes	Yes
2		00010000		A failure is detected in the NAS Cluster Management LU used by the failover function when services start.	Yes	Yes
3		00020000		A failure is detected in NFS when services start.	-	Yes
4		00030000	KAQG72006-E	A failure is detected in the file system when services start.	Yes	Yes
5		00040000	KAQG72006-E	A failure is detected in NFS share when services start.	Yes	Yes
6		00050000	KAQG72007-E	A failure is detected in the up of a service IP address when services start.	Yes	Yes
7		00060000		A failure is detected in samba when services start.	Yes	Yes
8		00080000		A failure is detected in the OS or application when services start.	-	Yes
9		01000000		A failure is detected in LVM when services stop.	Yes	Yes
10		01010000		A failure is detected in the NAS Cluster Management LU used by the failover function when services stop.	Yes	Yes
11		01020000		A failure is detected in NFS when services stop.	-	Yes
12		01030000		A failure is detected in the file system when services stop.	Yes	Yes
13		01040000		A failure is detected in the release of NFS share when services stop.	Yes	Yes
14		01050000		A failure is detected in the down of a service IP address when services stop.	Yes	Yes
15		01060000		A failure is detected in stopping a samba service when services stop.	Yes	Yes
16		01080000		A failure is detected in the OS of application when services stop.	-	Yes
17		02070000	KAQG70000-I	An automatic failover has started.	Yes	Yes
18		03070000	*1	An automatic failover has completed.	Yes	Yes
19		04090000		The network interface has been in the link down state for more than 60 seconds.	Yes	-

*1: Either KAQG70001-E, or KAQG72000-E to KAQG72005-E will be reported.

*2: Select the ac84x2 code of the SIM logs, click the **Refer** button in the 'Content-SIM' window, and then click the **SSB** button and **OK** button in the 'Refer' window. Check the contents of internal data from 0x44 to 0x47. For details, see [SVP02-60].

7.4 Troubleshooting Procedures

Figure 7.4-0 shows the flowchart for software troubleshooting related to the failure phenomena listed in Table 7.3-3. The numbers from 1 to 43 in the following figures correspond to the phenomena listed in and Table 7.3-2 [NAS07-110] and Table 7.3-3 [NAS07-160].

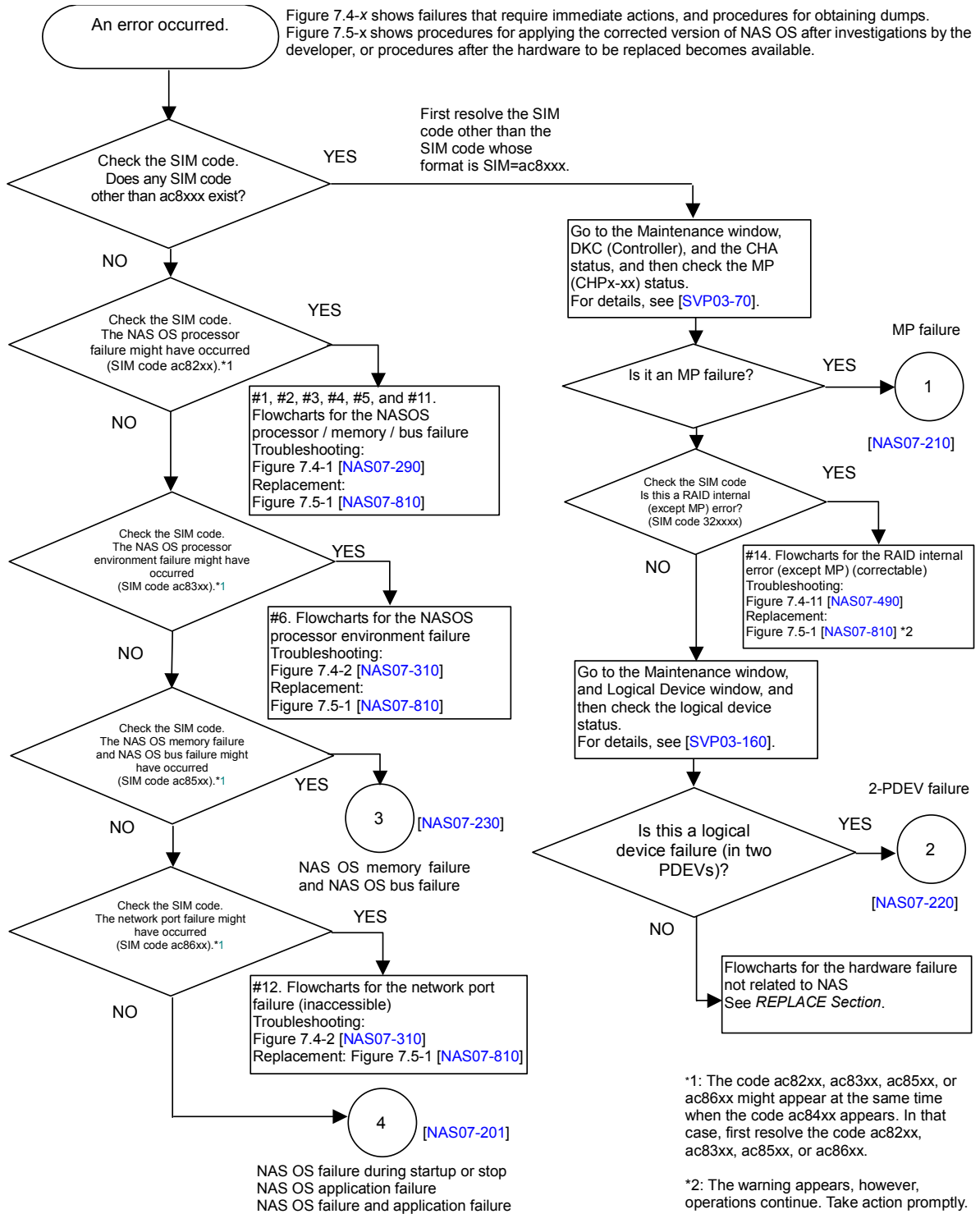

Figure 7.4-0 Flowcharts for Troubleshooting Related to Failure Phenomena (1/11)

Flowchart for NAS OS application failure

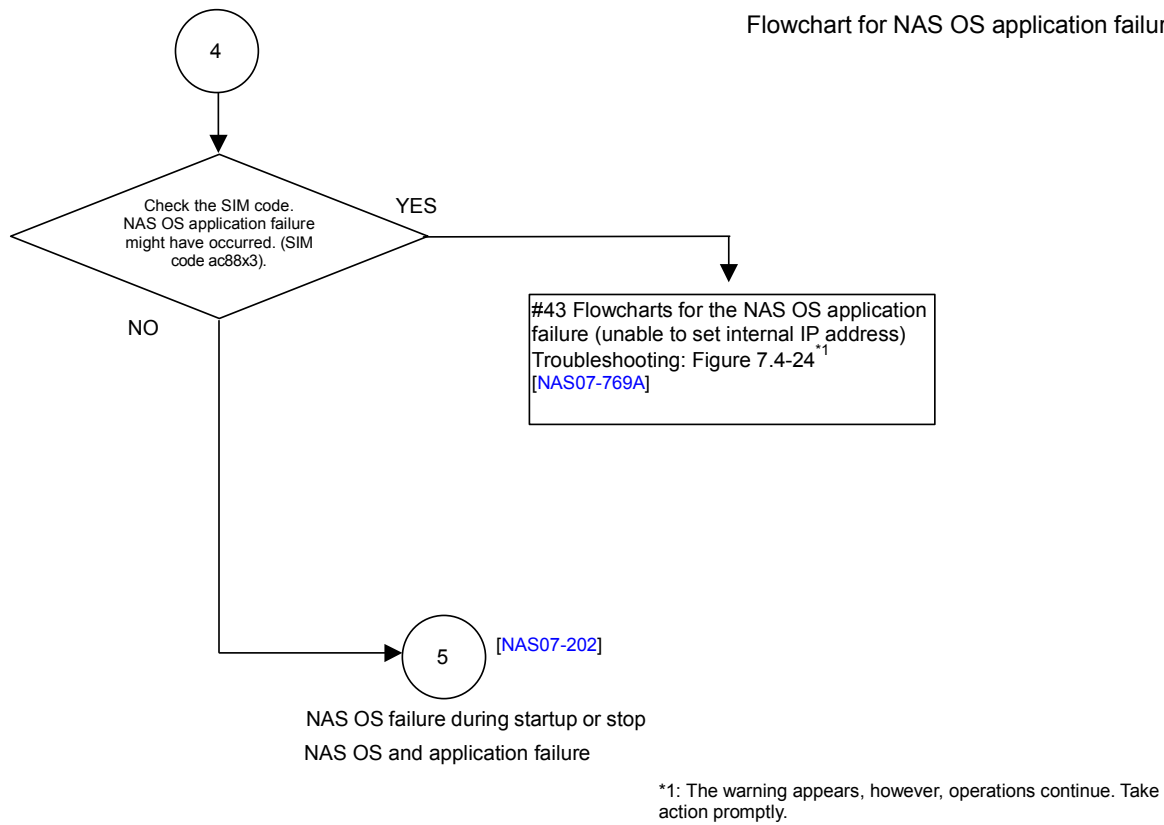
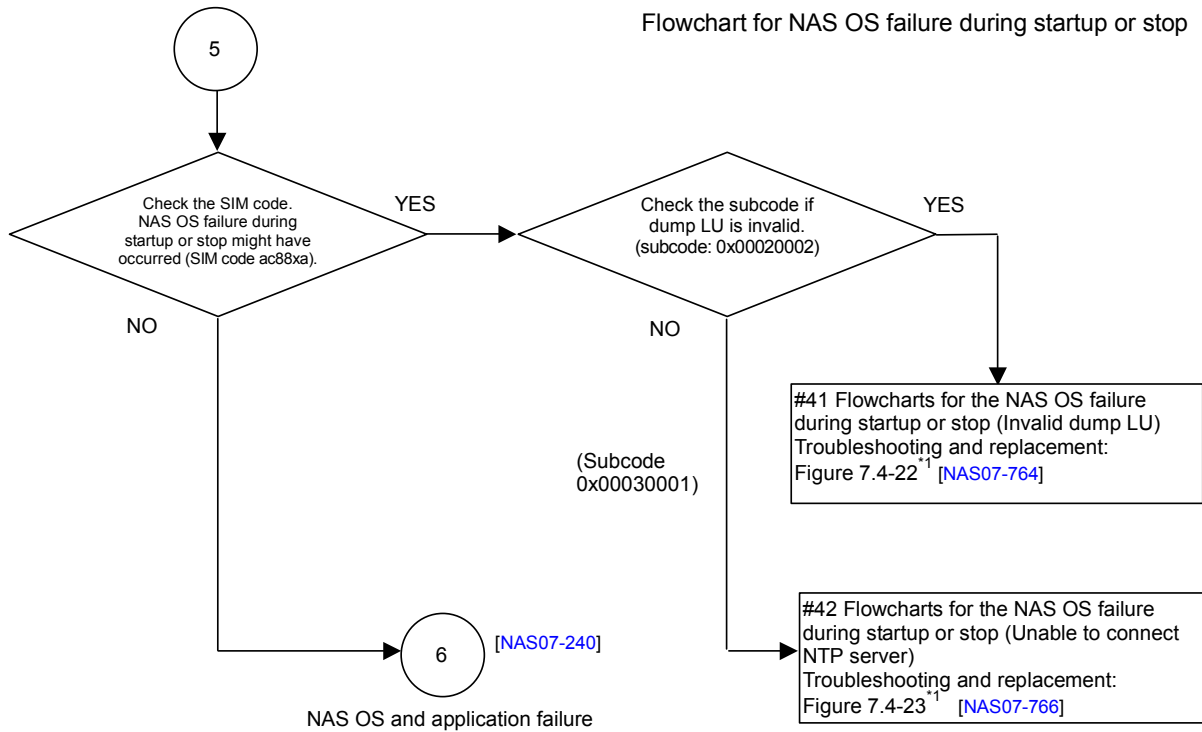

Figure 7.4-0 Flowcharts for Troubleshooting Related to Failure Phenomena (2/11)

Flowchart for NAS OS failure during startup or stop



*1: The warning appears, however, operations continue. Take action promptly.

Figure 7.4-0 Flowcharts for Troubleshooting Related to Failure Phenomena (3/11)

Flowchart for the MP failure

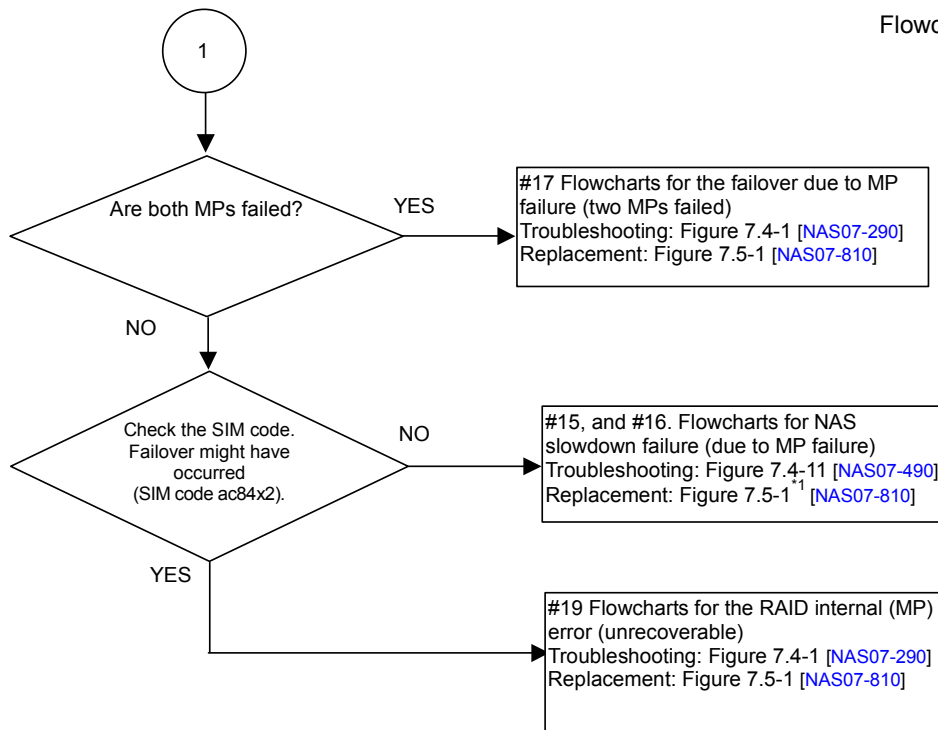

*1: The warning appears, however, operations continue. Take action promptly.

Figure 7.4-0 Flowcharts for Troubleshooting Related to Failure Phenomena (4/11)

Flowchart for the 2-PDEV failure

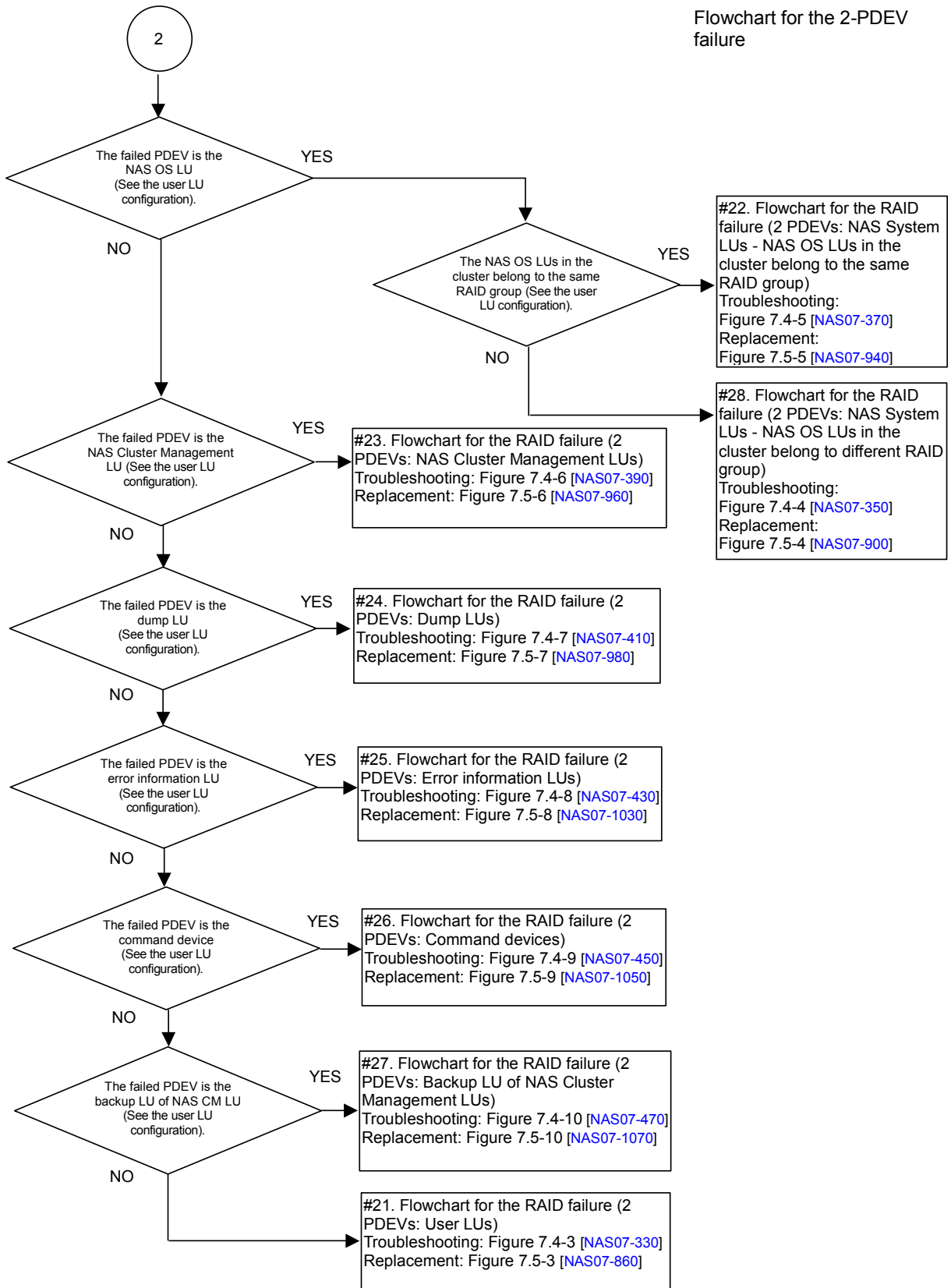
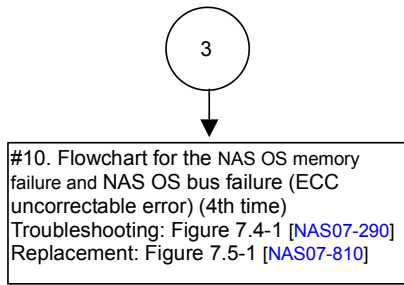
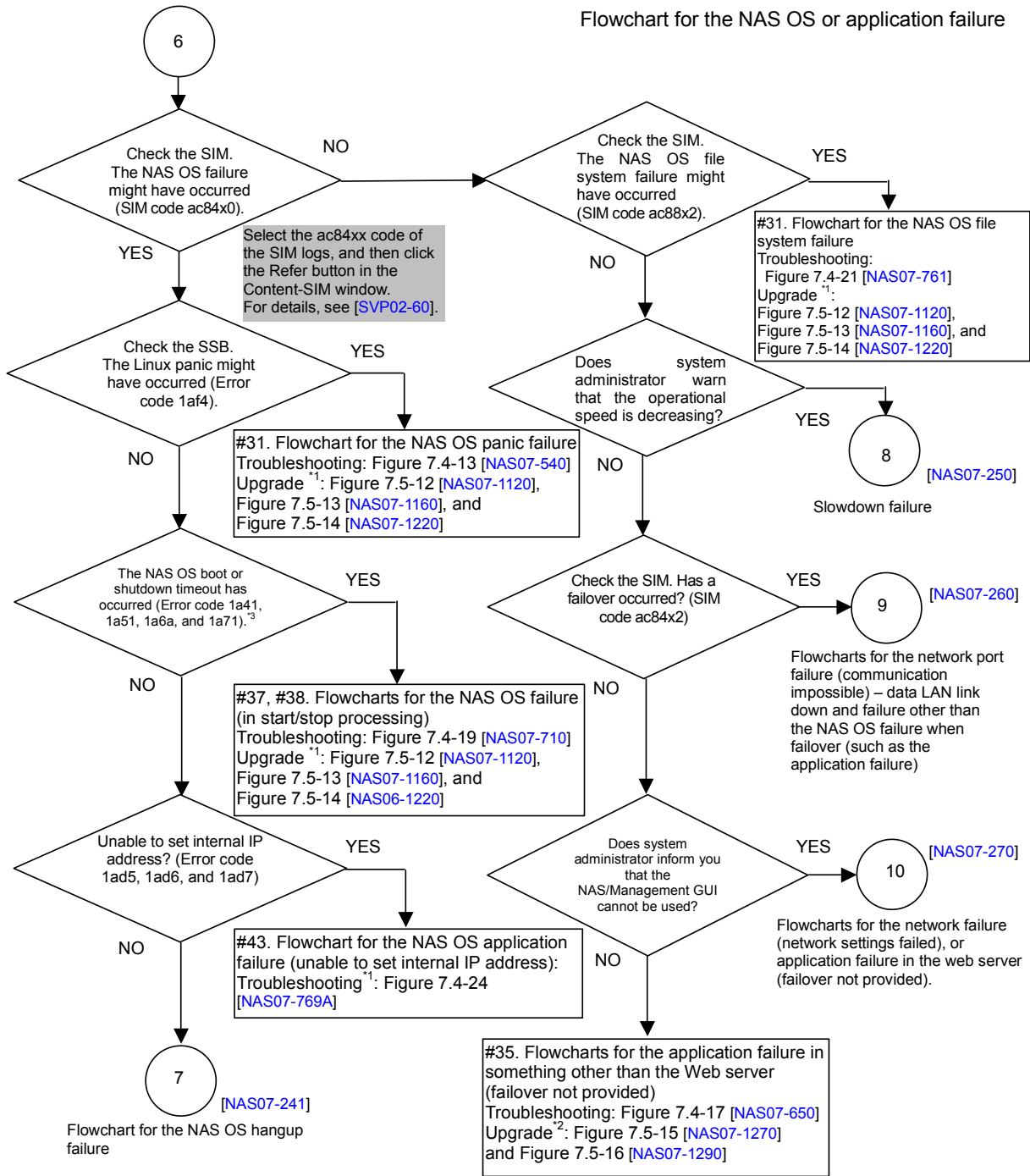

Figure 7.4-0 Flowcharts for Troubleshooting Related to Failure Phenomena (5/11)



Flowchart for the NAS OS memory failure and NAS OS bus failure

Figure 7.4-0 Flowcharts for Troubleshooting Related to Failure Phenomena (6/11)



*1 The types of upgrade (NAS OS) are:
 Figure 7.5-12: Upgrading the NAS OS by an Update Version (When a Failure Occurs)
 Figure 7.5-13: Upgrading the NAS OS by a Patch Version – Restarting the NAS OS is not Required (When a Failure Occurs)
 Figure 7.5-14: Upgrading the NAS OS by a Patch Version – Restarting the NAS OS is Required (When a Failure Occurs)

*2 The types of upgrading (NAS/Management, optional program products) are:
 Figure 7.5-15: Upgrading NAS/Management (When a Failure Occurs)
 Figure 7.5-16: Upgrading an Optional Program Product (When a Failure Occurs)

*3 A timeout occurs:
 - After 10 minutes if NAS OS is booted.
 - After 60 minutes if NAS OS is shut down.

Figure 7.4-0 Flowcharts for Troubleshooting Related to Failure Phenomena (7/11)

Flowchart for the NAS OS hangup failure

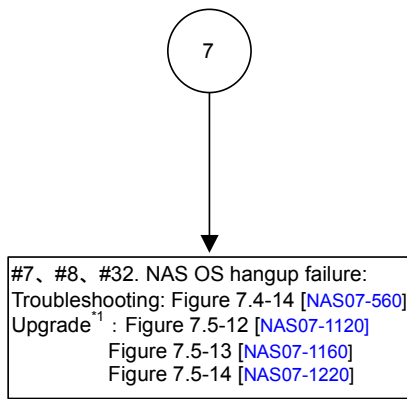

*1 The types of upgrade (NAS OS) are:

Figure 7.5-12: Upgrading the NAS OS by an Update Version (When a Failure Occurs)

Figure 7.5-13: Upgrading the NAS OS by a Patch Version – Restarting the NAS OS is not

Required (When a Failure Occurs)

Figure 7.5-14: Upgrading the NAS OS by a Patch Version – Restarting the NAS OS is Required (When a Failure Occurs)

Figure 7.4-0 Flowcharts for Troubleshooting Related to Failure Phenomena (8/11)

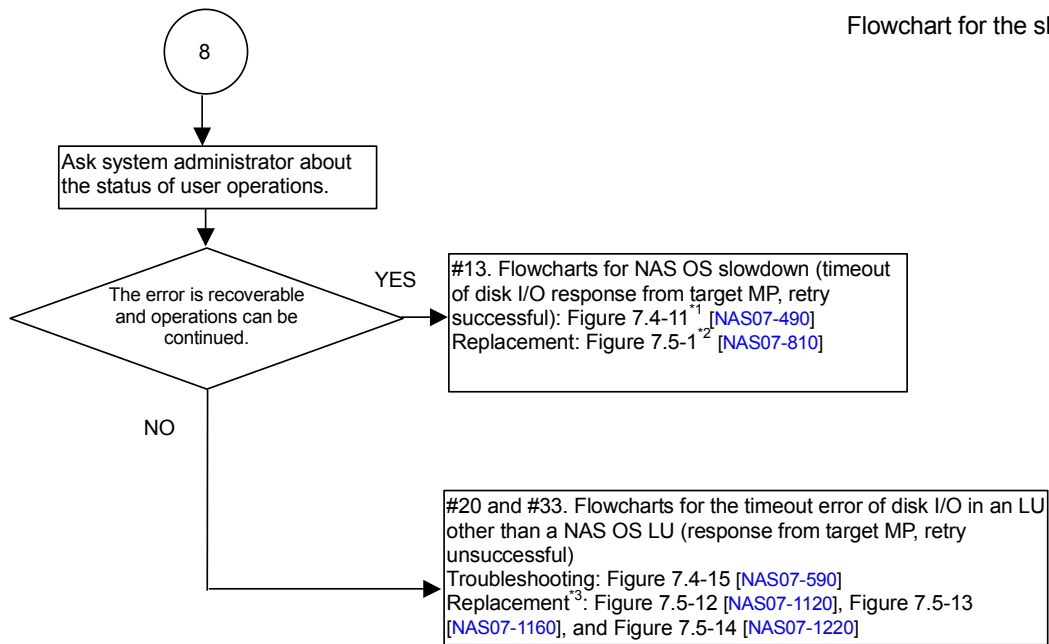

*1 SIM is not reported, but the SSB code 1699 is reported.

*2 The warning appears, however, operations continue. Take action promptly.

*3 The types of upgrade (NAS OS) are:

Figure 7.5-12: Upgrading the NAS OS by an Update Version (When a Failure Occurs)

Figure 7.5-13: Upgrading the NAS OS by a Patch Version – Restarting the NAS OS is not Required (When a Failure Occurs)

Figure 7.5-14: Upgrading the NAS OS by a Patch Version – Restarting the NAS OS is Required (When a Failure Occurs)

Figure 7.4-0 Flowcharts for Troubleshooting Related to Failure Phenomena (9/11)

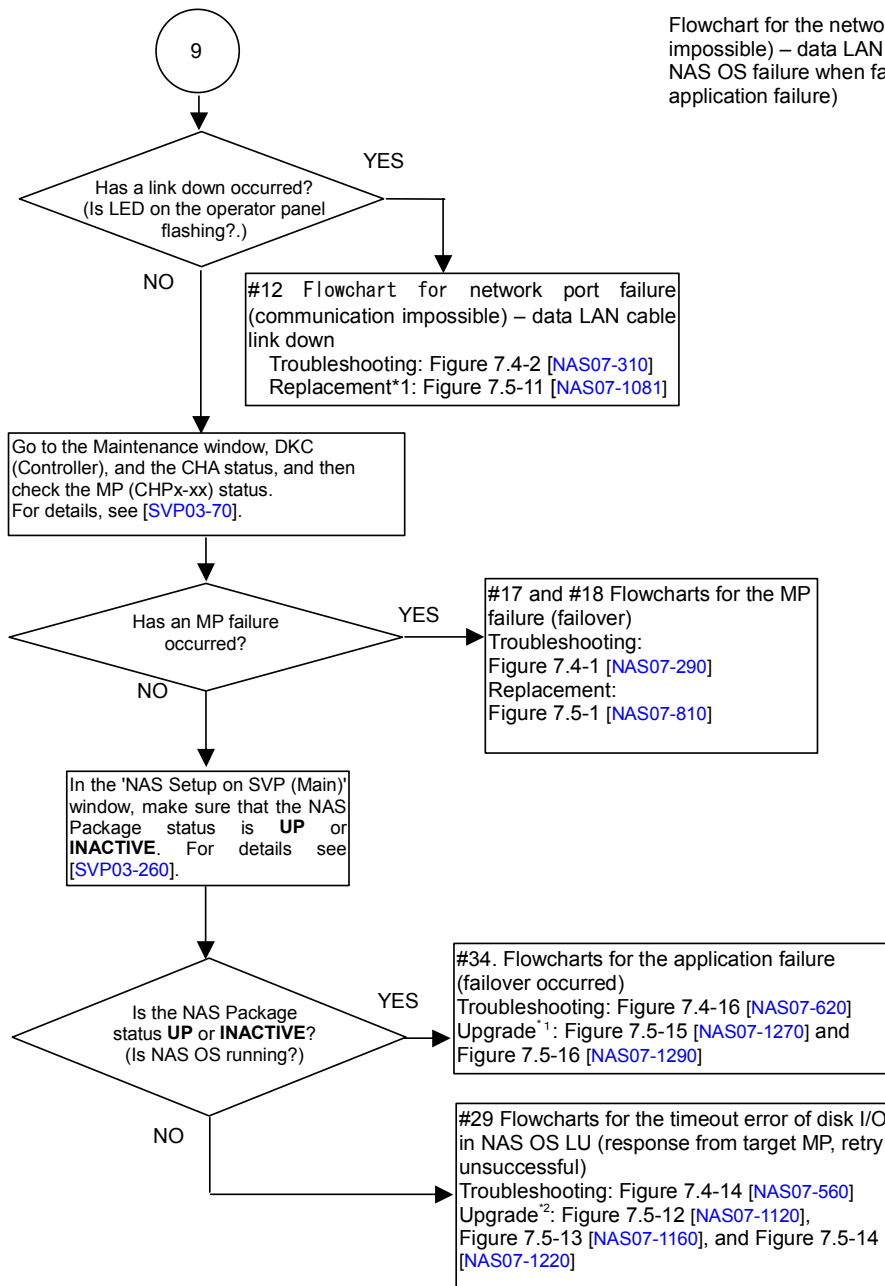

*1 The types of upgrade (NAS OS) are:

Figure 7.5-12: Upgrading the NAS OS by an Update Version (When a Failure Occurs)

Figure 7.5-13: Upgrading the NAS OS by a Patch Version – Restarting the NAS OS is not

Required (When a Failure Occurs)

Figure 7.5-14: Upgrading the NAS OS by a Patch Version – Restarting the NAS OS is Required (When a Failure Occurs)

*2 The types of upgrading (NAS/Management, optional program products) are:

Figure 7.5-15: Upgrading NAS/Management (When a Failure Occurs)

Figure 7.5-16: Upgrading an Optional Program Product (When a Failure Occurs)

Figure 7.4-0 Flowcharts for Troubleshooting Related to Failure Phenomena (10/11)

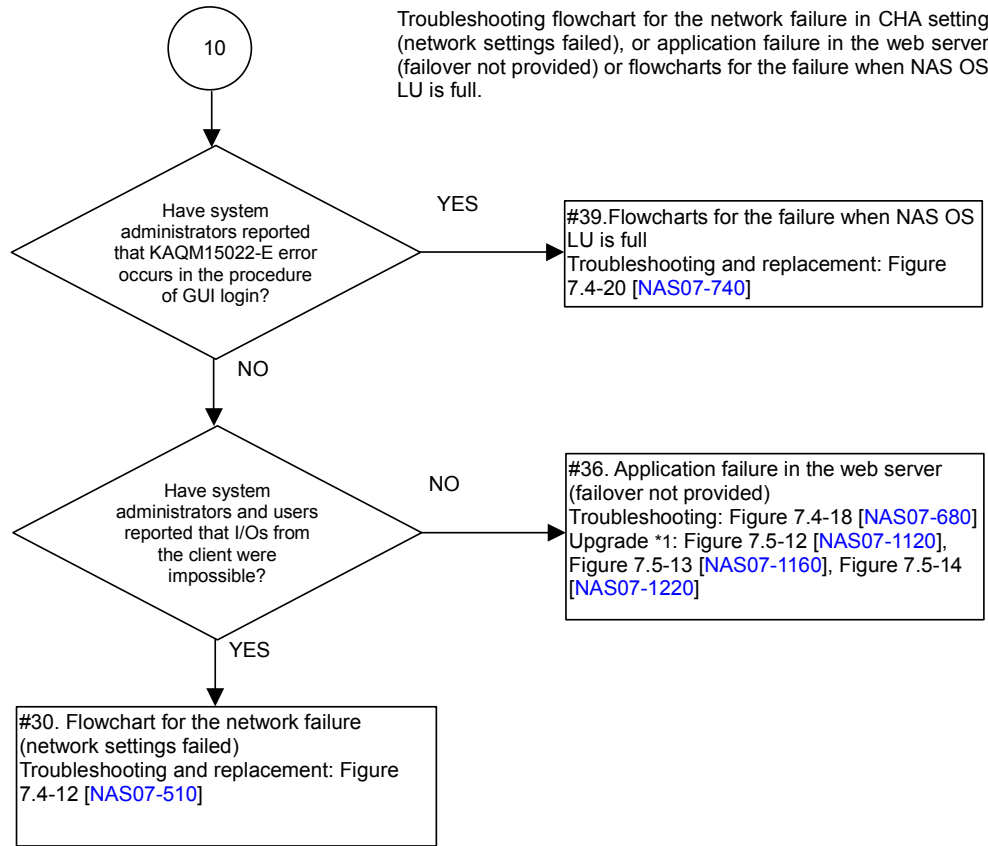

Troubleshooting flowchart for the network failure in CHA setting (network settings failed), or application failure in the web server (failover not provided) or flowcharts for the failure when NAS OS LU is full.

*1 The types of upgrade (NAS OS) are:
 Figure 7.5-12: Upgrading the NAS OS by an Update Version (When a Failure Occurs)
 Figure 7.5-13: Upgrading the NAS OS by a Patch Version – Restarting the NAS OS is not Required (When a Failure Occurs)
 Figure 7.5-14: Upgrading the NAS OS by a Patch Version – Restarting the NAS OS is Required (When a Failure Occurs)

Figure 7.4-0 Flowcharts for Troubleshooting Related to Failure Phenomena (11/11)

7.4.1 Hardware Troubleshooting Procedures

In this section, the cluster is assumed to consist of CL1-CHA and CL2-CHA, and the following tables show the flowcharts for hardware troubleshooting from Figure 7.4-1 to Figure 7.4-12.

Make sure that CL2-CHA is properly referred to as the actual location for hardware troubleshooting when a software failure occurs on the CHA location.

Table 7.4-1 shows the actual CHA locations in the NAS cluster configuration.

Table 7.4-1 CHA Location in the NAS Cluster Configuration

Model	CHA location	CL1-CHA	CL2-CHA
Multi-cabinet	Basic	1P	2V
	Option 1	1Q	2W
	Option 2	1R	2X
	Option 3	1S	2Y
Single cabinet ^{*1}	Basic	1C	2G
	Option 1	1D	2J
	Option 2	1F	2K

*1: Only two of the three, basic, option 1, or option 2, can be used.

No.	Failure	For details see ...
(1)	NAS Package failure detected by a processor in the NAS Package	Figure 7.4-1 [NAS07-290]
(2)	NAS Package failure detected by a NAS OS driver	Figure 7.4-2 [NAS07-310]
(3)	RAID failure (user LU)	Figure 7.4-3 [NAS07-330]
(4)	RAID failure (2 PDEVs: NAS System LUs — NAS OS LUs in the cluster belong to different RAID groups)	Figure 7.4-4 [NAS07-350]
(5)	RAID failure (2 PDEVs: NAS System LUs — NAS OS LUs in the cluster belong to the same RAID group)	Figure 7.4-5 [NAS07-370]
(6)	RAID failure (2 PDEVs: NAS Cluster Management LUs)	Figure 7.4-6 [NAS07-390]
(7)	RAID failure (2 PDEVs: dump LUs)	Figure 7.4-7 [NAS07-410]
(8)	RAID failure (2 PDEVs: error information LUs)	Figure 7.4-8 [NAS07-430]
(9)	RAID failure (2 PDEVs: command devices)	Figure 7.4-9 [NAS07-450]
(10)	RAID failure (2 PDEVs: Backup LUs of NAS Cluster Management LUs)	Figure 7.4-10 [NAS07-470]
(11)	Hardware failure (correctable)	Figure 7.4-11 [NAS07-490]
(12)	Network failure (network settings failed)	Figure 7.4-12 [NAS07-510]

(1) NAS Package Failure Detected By a Processor in the NAS Package

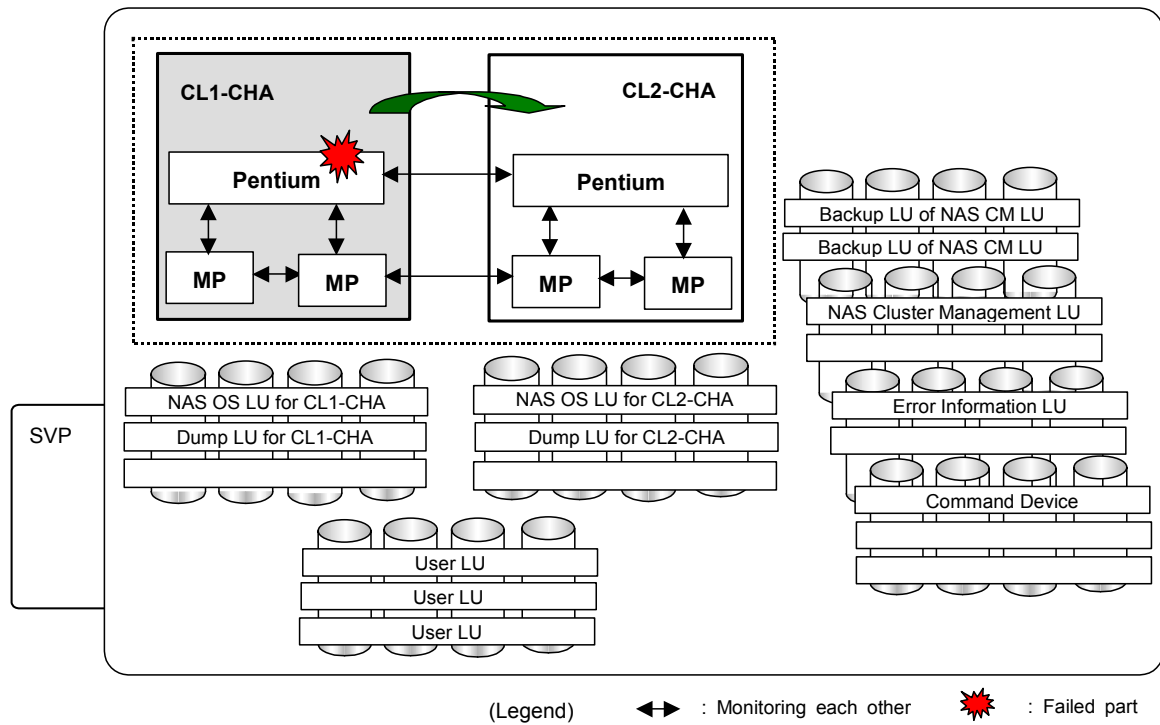

Figure 7.4-1 NAS Package Failure Detected By a Processor in the NAS Package (1/2)

Step	Procedure	Notes
1	Examine the messages to determine whether a hardware failure and a failover occurred.	
2	Check that the failover finished.	
3	Notify ordinary users of the hardware failure.	

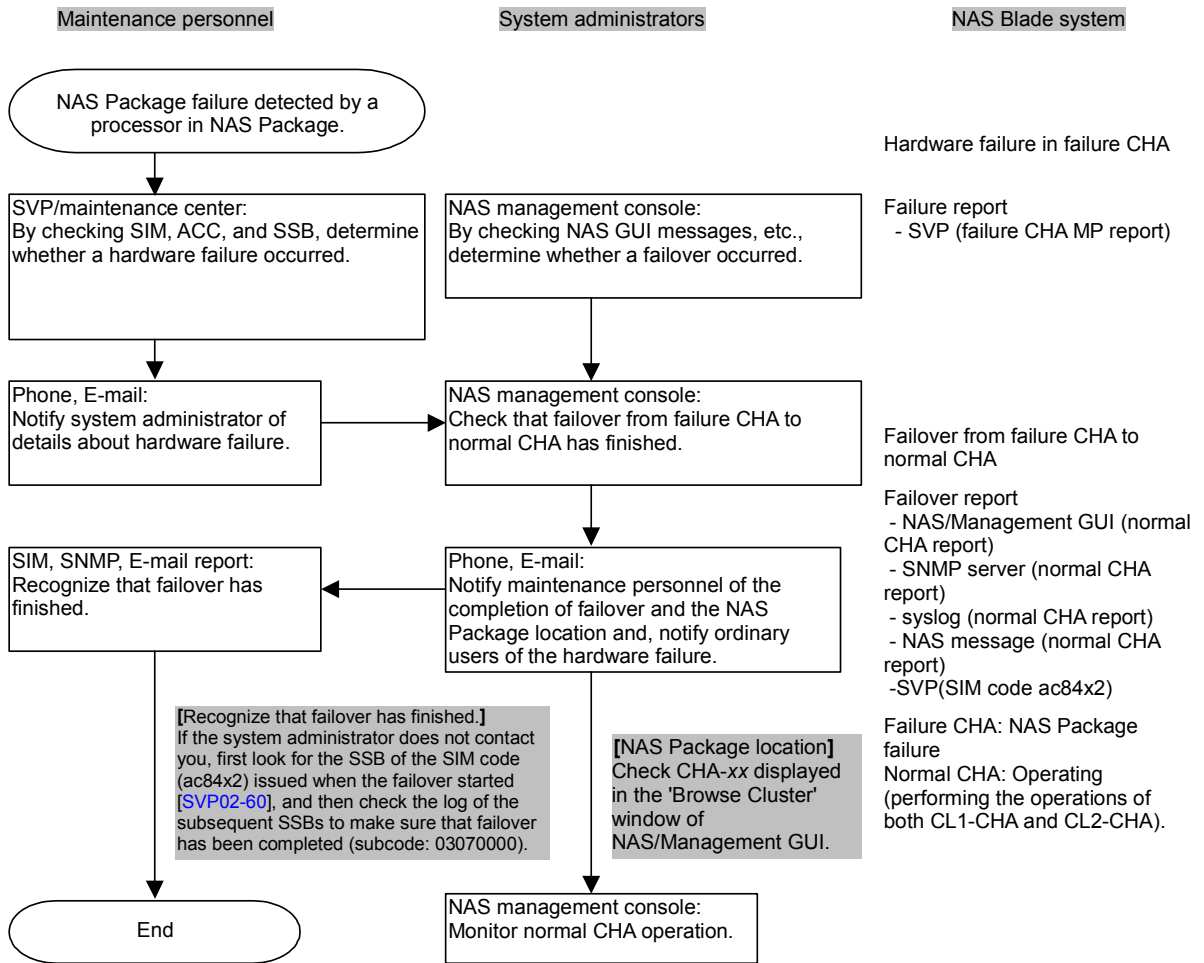

Figure 7.4-1 NAS Package Failure Detected By a Processor in the NAS Package (2/2)

(2) NAS Package Failure Detected By a NAS OS Driver

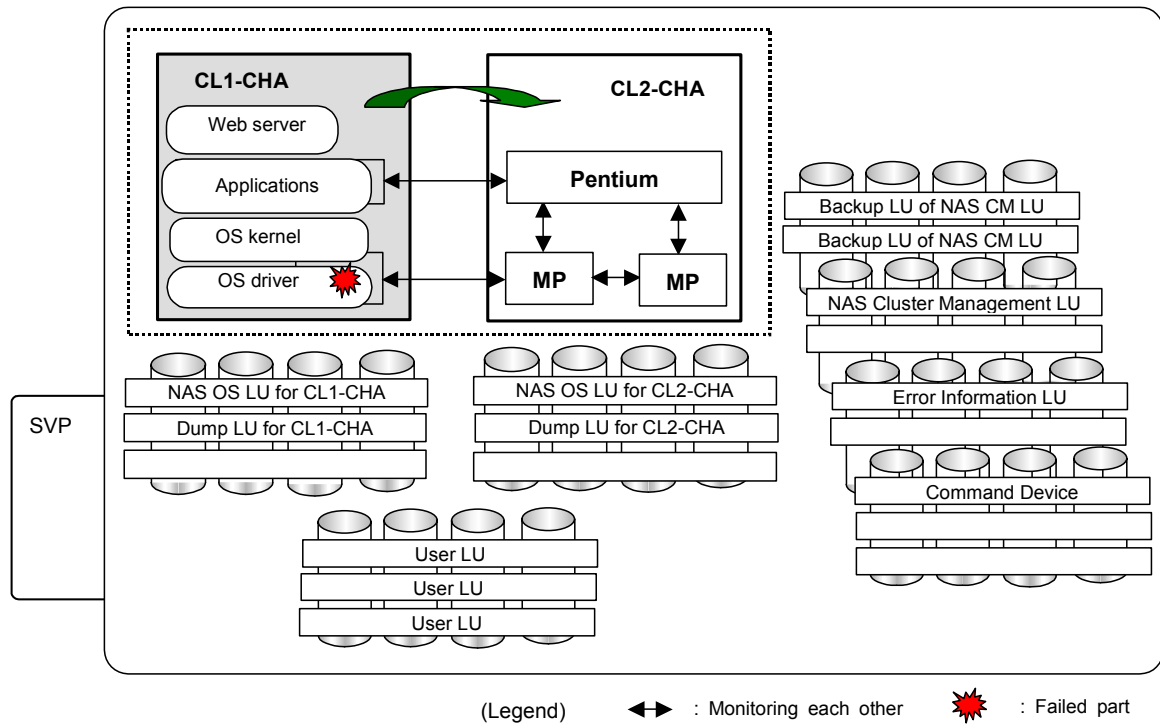

Figure 7.4-2 NAS Package Failure Detected By a NAS OS Driver (1/2)

Step	Procedure	Notes
1	Examine messages to determine whether a hardware failure and a failover occurred.	
2	Check that the failover finished.	
3	Notify ordinary users of the hardware failure.	

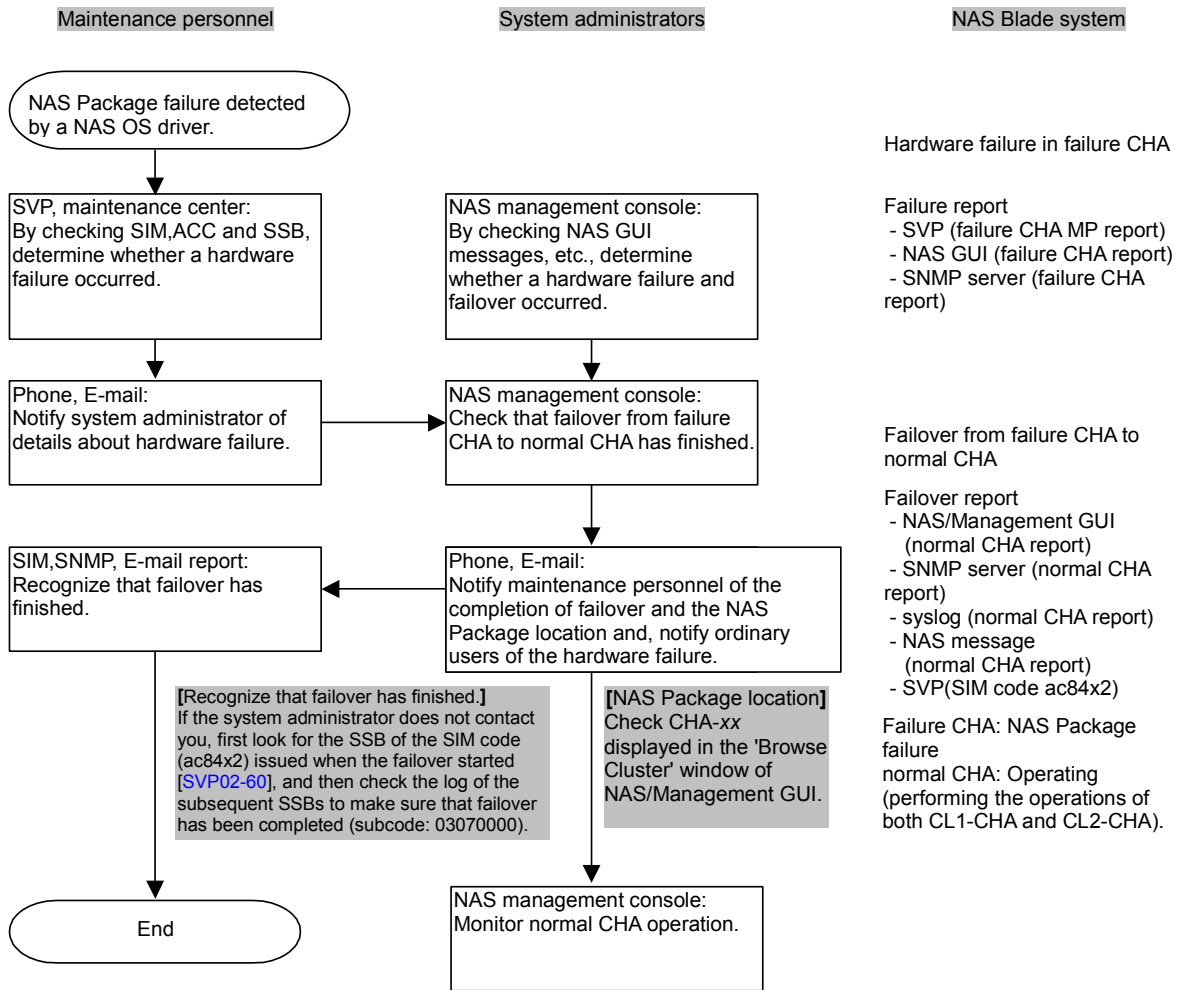

Figure 7.4-2 NAS Package Failure Detected By a NAS OS Driver (2/2)

(3) RAID Failure (User LU)

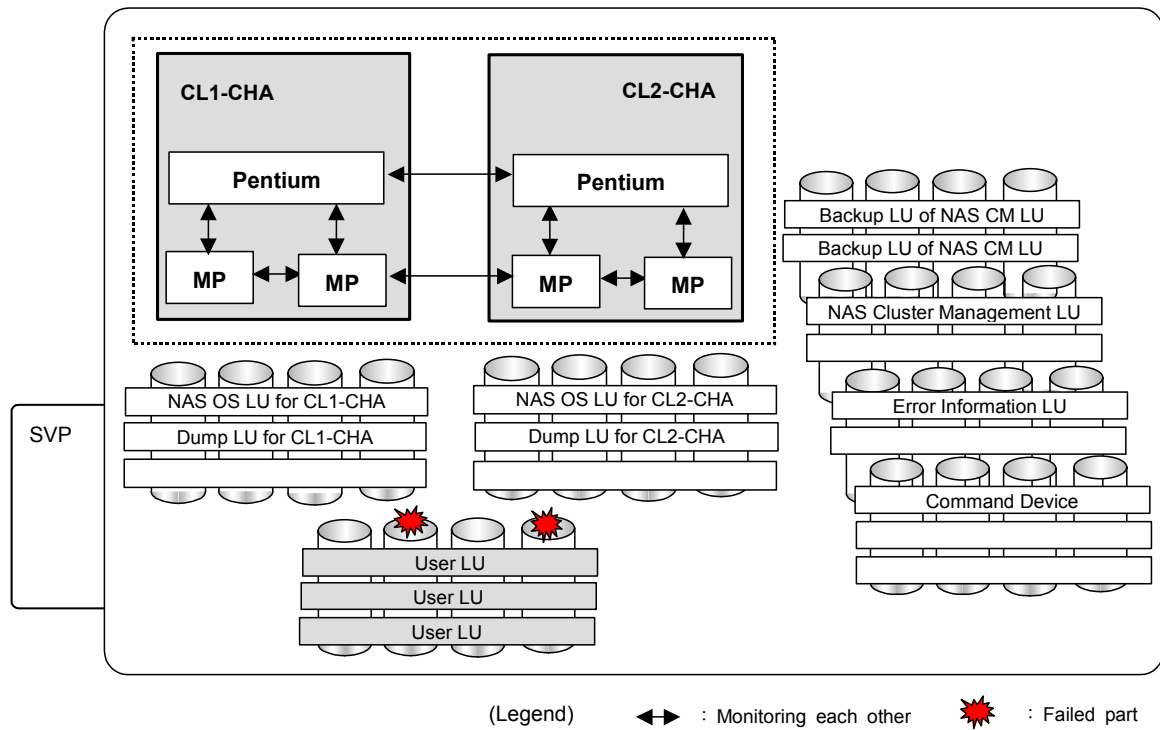

Figure 7.4-3 RAID Failure (User LU) (1/2)

Step	Procedure	Notes
1	Determine whether a failure occurred in the RAID in which a user LU exists.	
2	Check that the file system is deleted in the user LU on which the error occurred.	
3	Notify ordinary users of the RAID failure.	

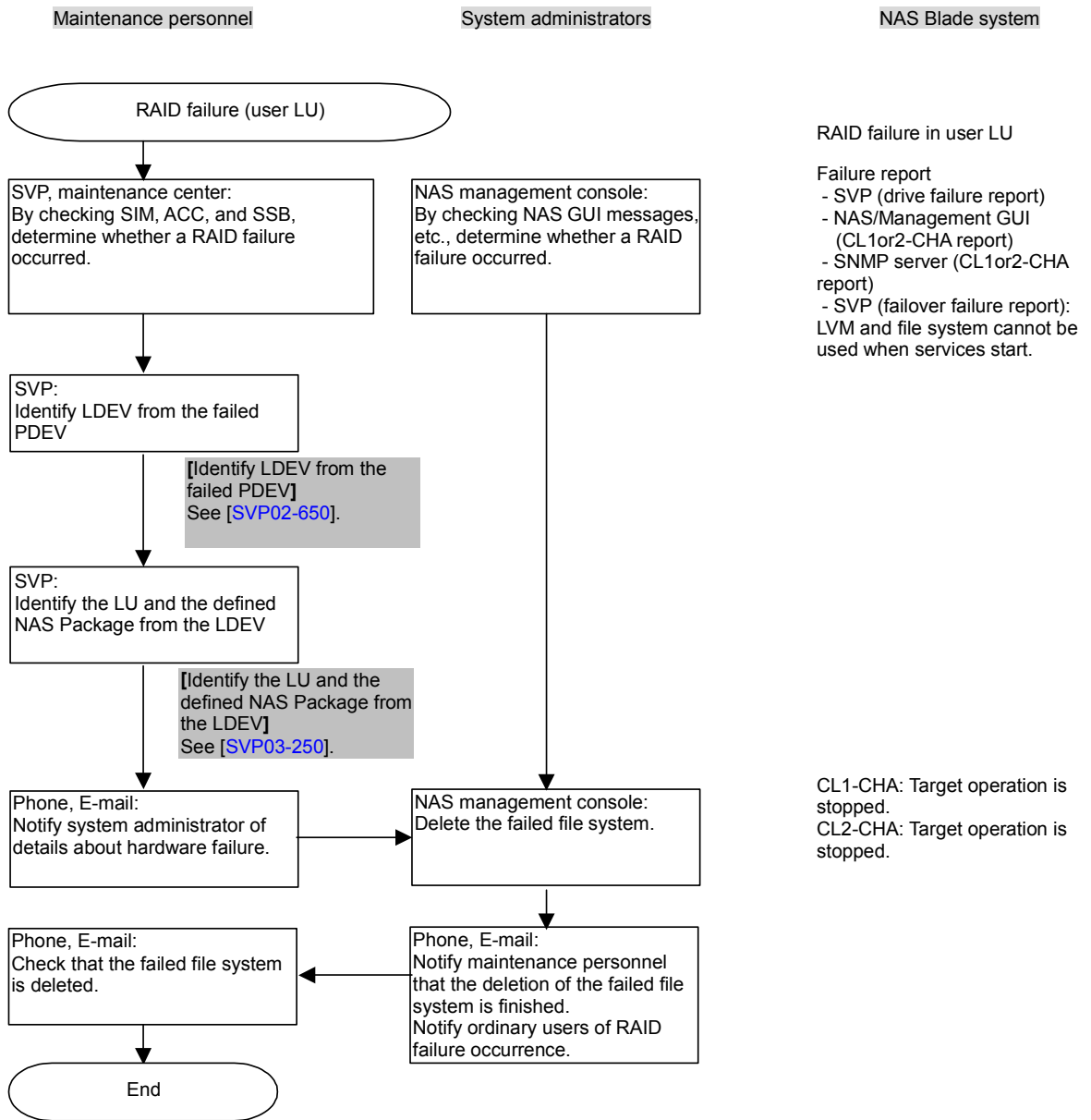

Figure 7.4-3 RAID Failure (User LU) (2/2)

(4) RAID Failure (2 PDEVs: NAS System LUs — NAS OS LUs in the Cluster Belong to Different RAID groups)

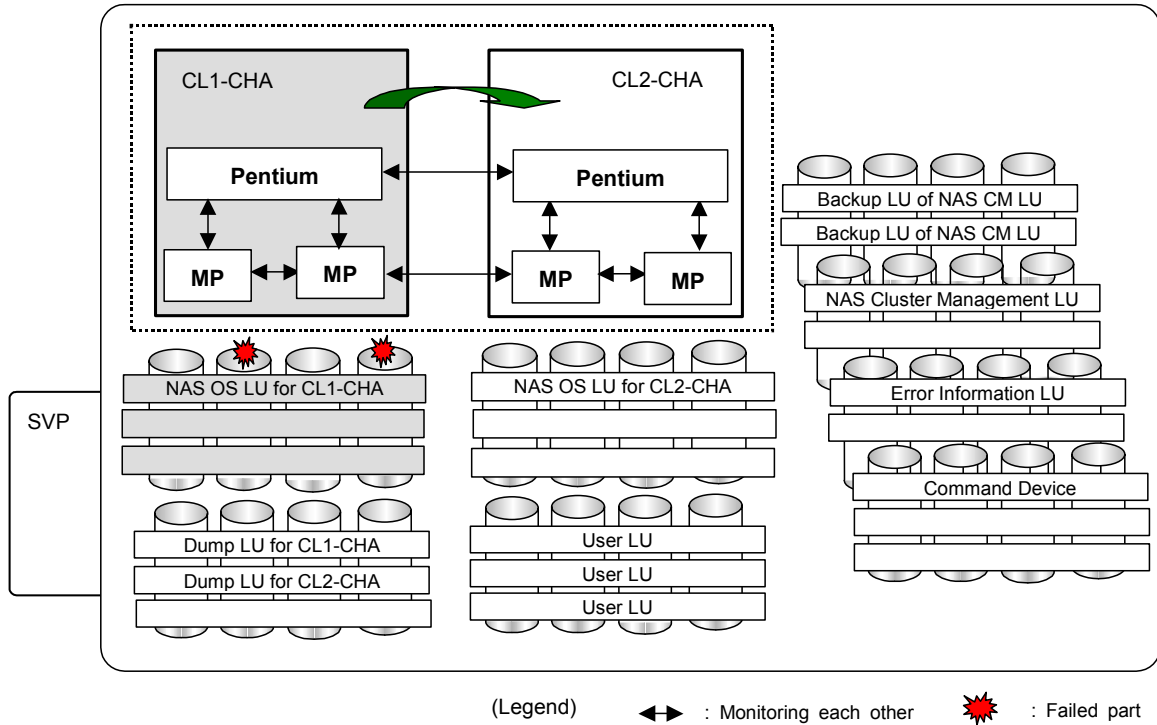

Figure 7.4-4 RAID Failure (2 PDEVs: NAS System LUs — NAS OS LUs in the Cluster Belong to Different RAID groups) (1/2)

Step	Procedure	Notes
1	Determine whether a failure occurred in the RAID in which a NAS OS LU exists, and whether a failover occurred.	
2	Check that the failover finished.	
3	Notify ordinary users of the RAID failure.	

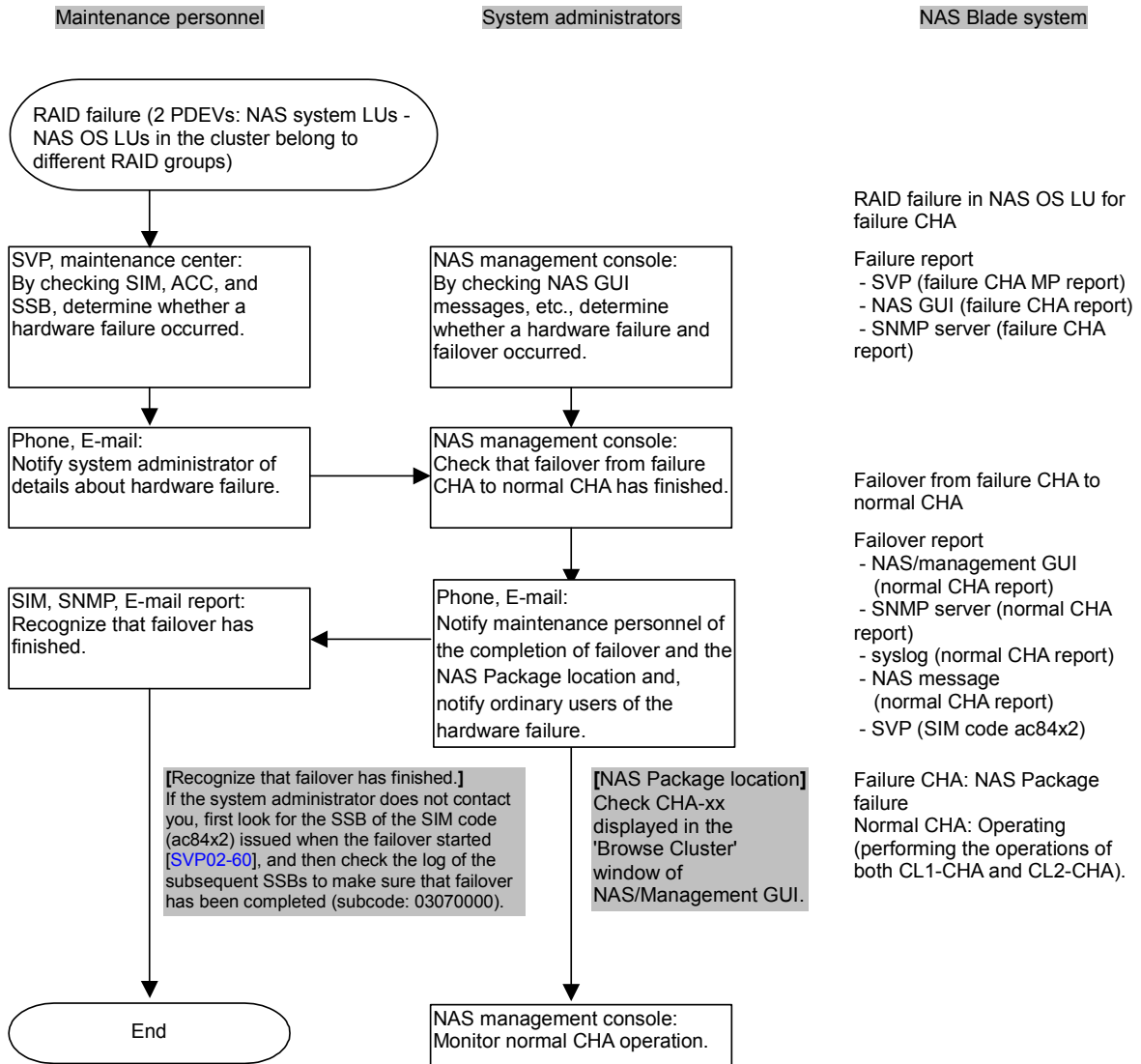

Figure 7.4-4 RAID Failure (2 PDEVs: NAS System LUs — NAS OS LUs in the Cluster Belong to Different RAID groups)(2/2)

(5) RAID Failure (2 PDEVs: NAS System LUs — NAS OS LUs in the Cluster Belong to the Same RAID Group)

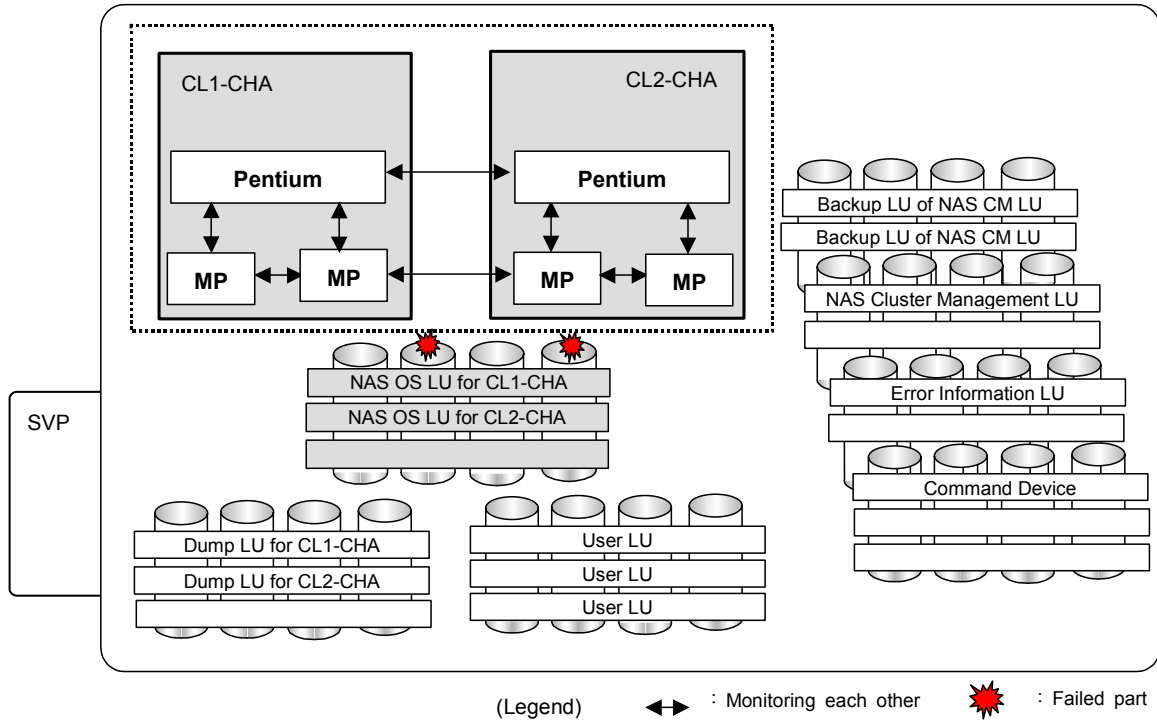

Figure 7.4-5 RAID Failure (2 PDEVs: NAS System LUs — NAS OS LUs in the Cluster Belong to the Same RAID Group) (1/2)

Step	Procedure	Notes
1	Determine whether a failure occurred in the RAID in which NAS OS LUs exist, and whether a failover occurred.	

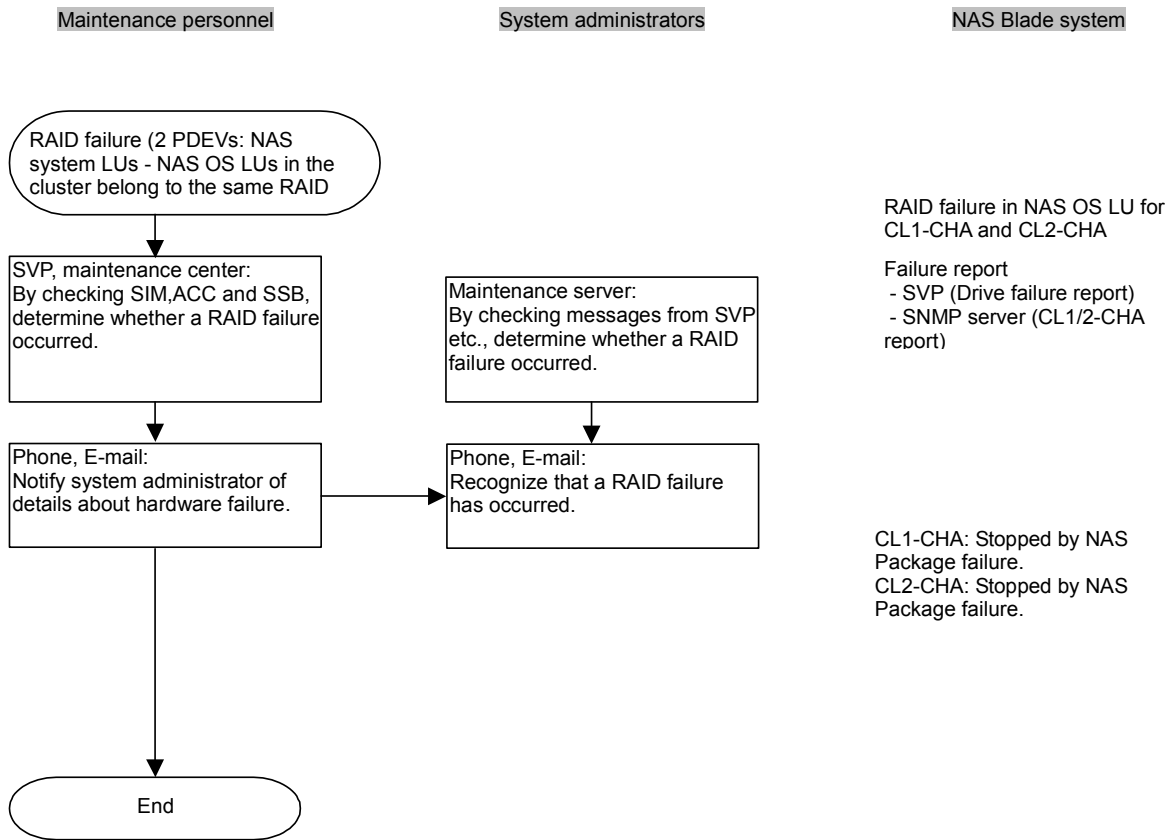

Figure 7.4-5 RAID Failure (2 PDEVs: NAS System LUs — NAS OS LUs in the Cluster Belong to the Same RAID Group) (2/2)

(6) RAID Failure (2 PDEVs: NAS Cluster Management LUs)

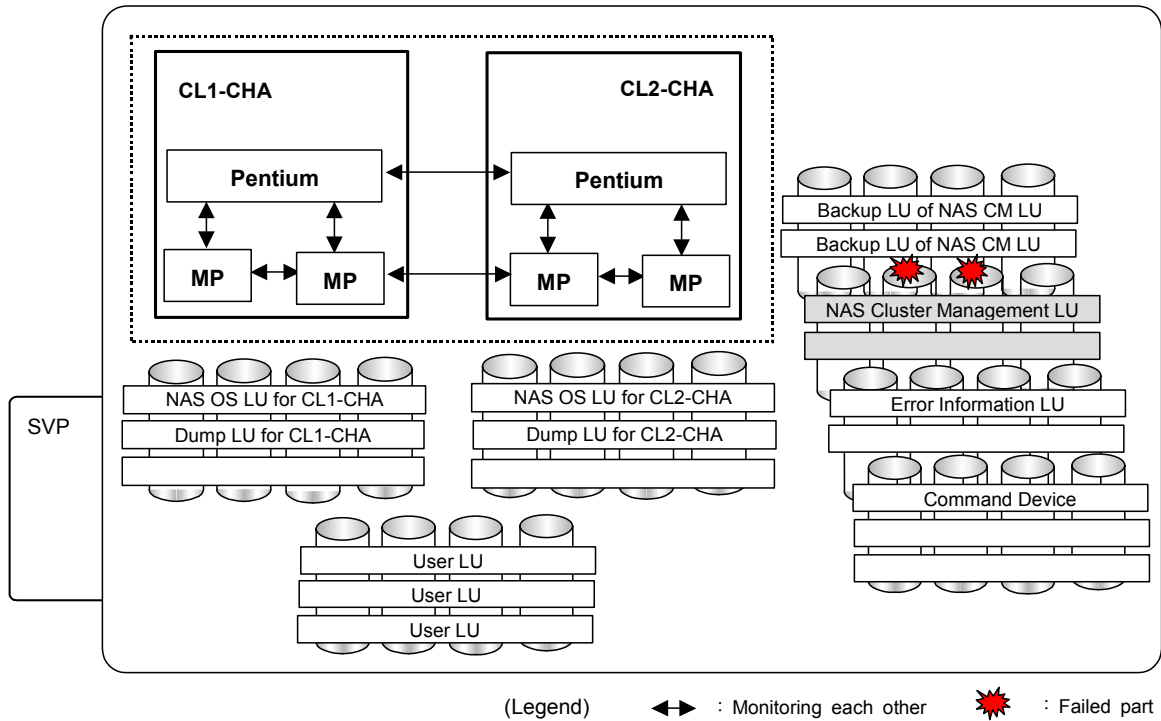

Figure 7.4-6 RAID Failure (2 PDEVs: NAS Cluster Management LUs) (1/2)

Step	Procedure	Notes
1	Determine whether a failure occurred in the RAID in which a NAS cluster management LU exists, and whether a failover occurred.	

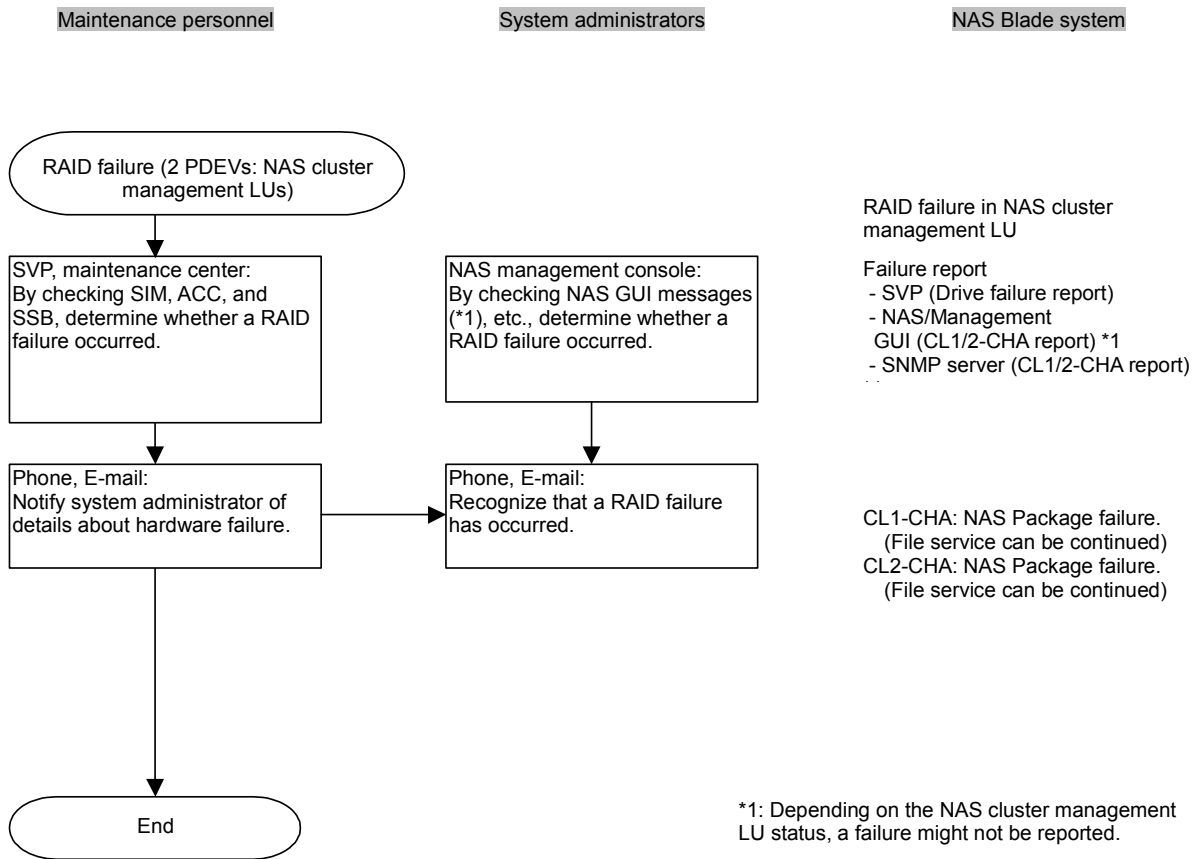

Figure 7.4-6 RAID Failure (2 PDEVs: NAS Cluster Management LUs) (2/2)

(7) RAID Failure (2 PDEVs: Dump LUs)

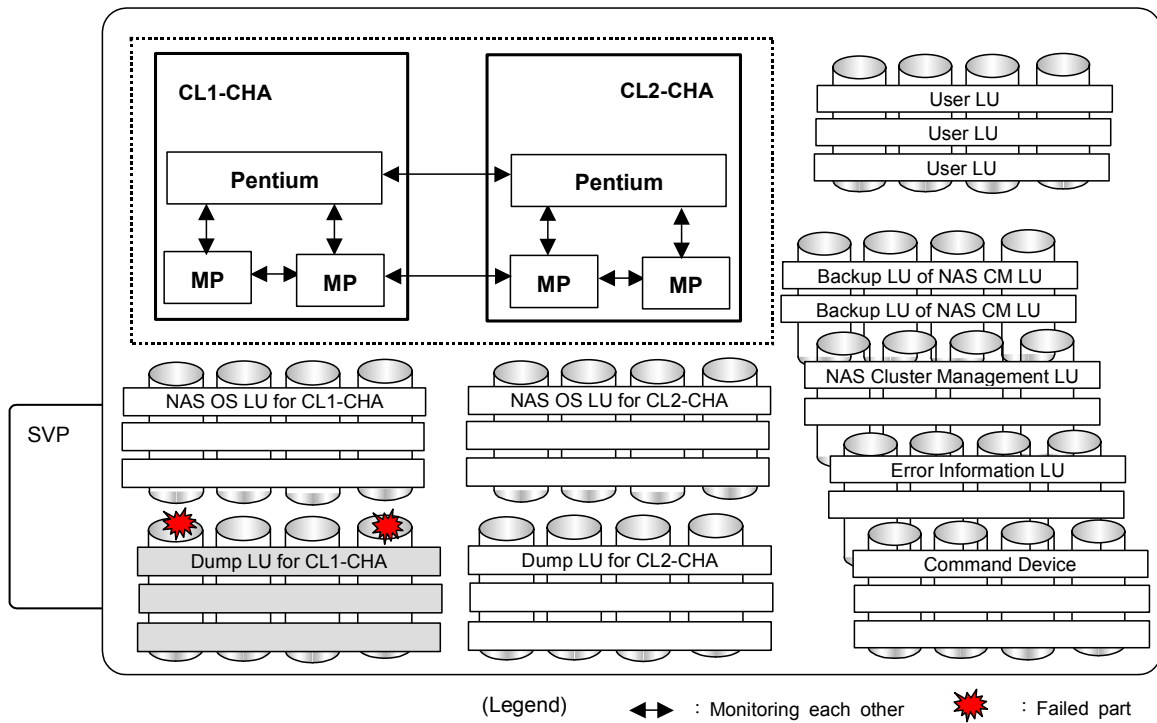

Figure 7.4-7 RAID Failure (2 PDEVs: Dump LUs) (1/2)

Step	Procedure	Notes
1	Determine whether a failure occurred in the RAID in which a dump LU exists.	

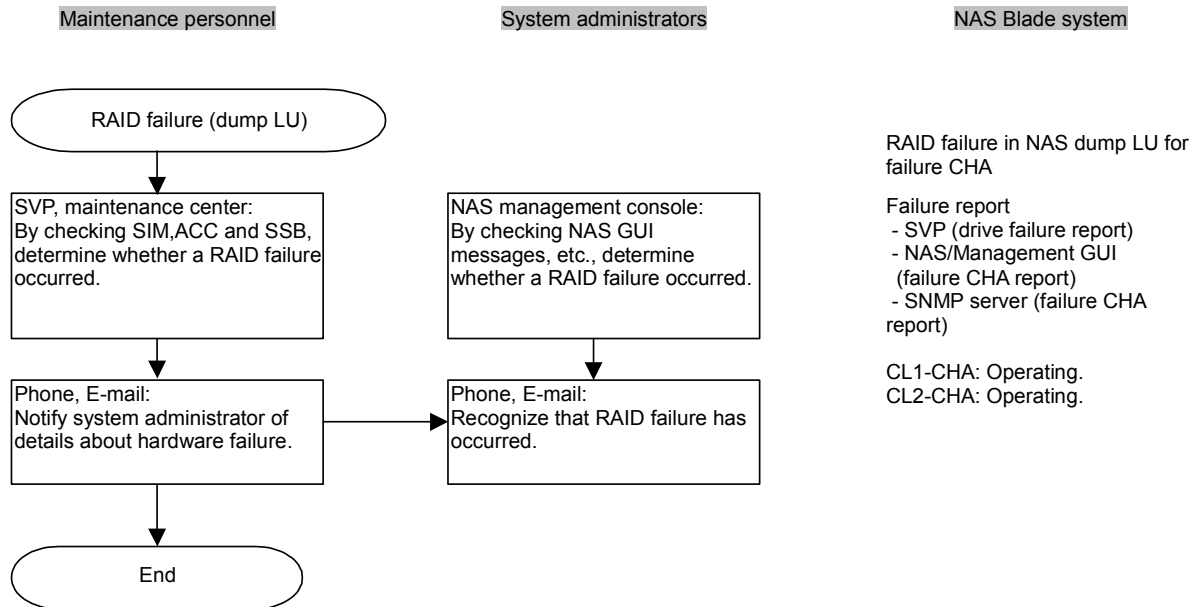

Figure 7.4-7 RAID Failure (2 PDEVs: Dump LUs) (2/2)

(8) RAID Failure (2 PDEVs: Error Information LUs)

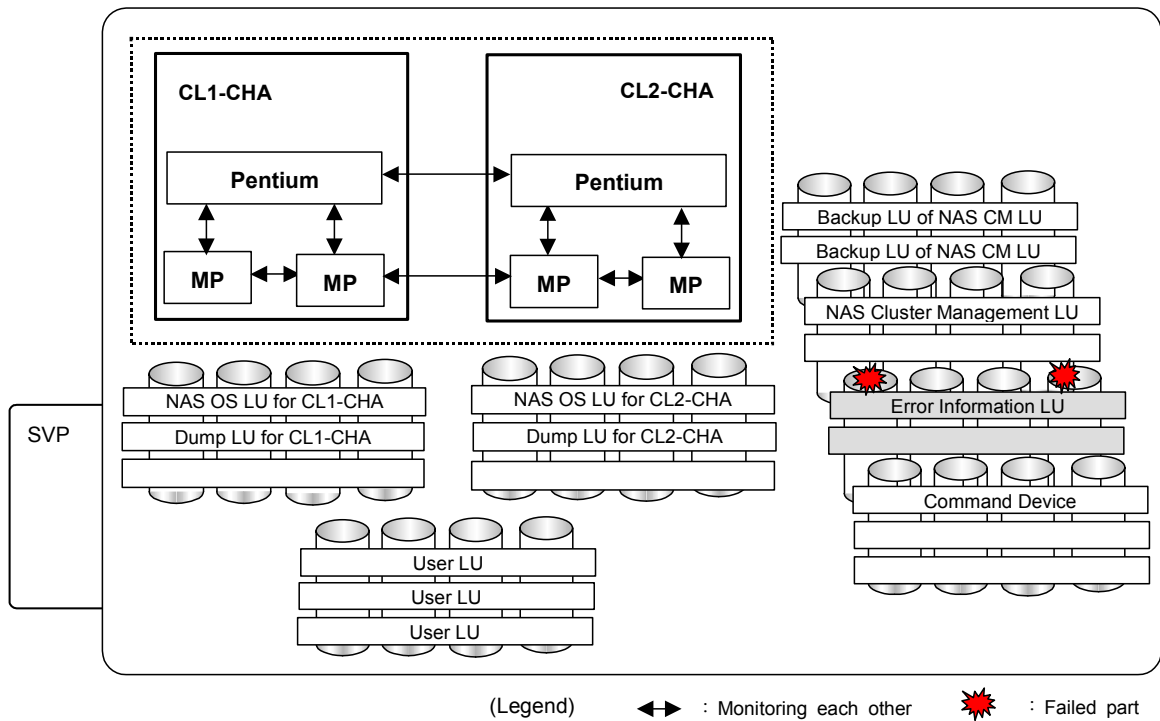

Figure 7.4-8 RAID Failure (2 PDEVs: Error Information LUs) (1/2)

Step	Procedure	Notes
1	Determine whether a failure occurred in the RAID in which an error information LU exists.	

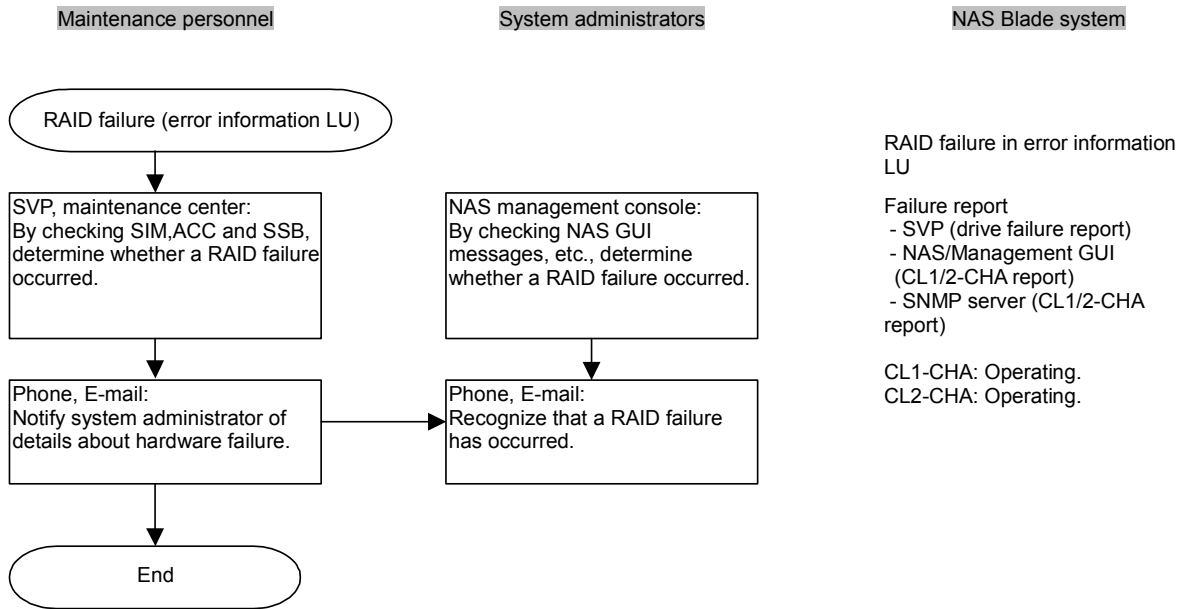

Figure 7.4-8 RAID Failure (2 PDEVs: Error Information LUs) (2/2)

(9) RAID Failure (2 PDEVs: Command Devices)

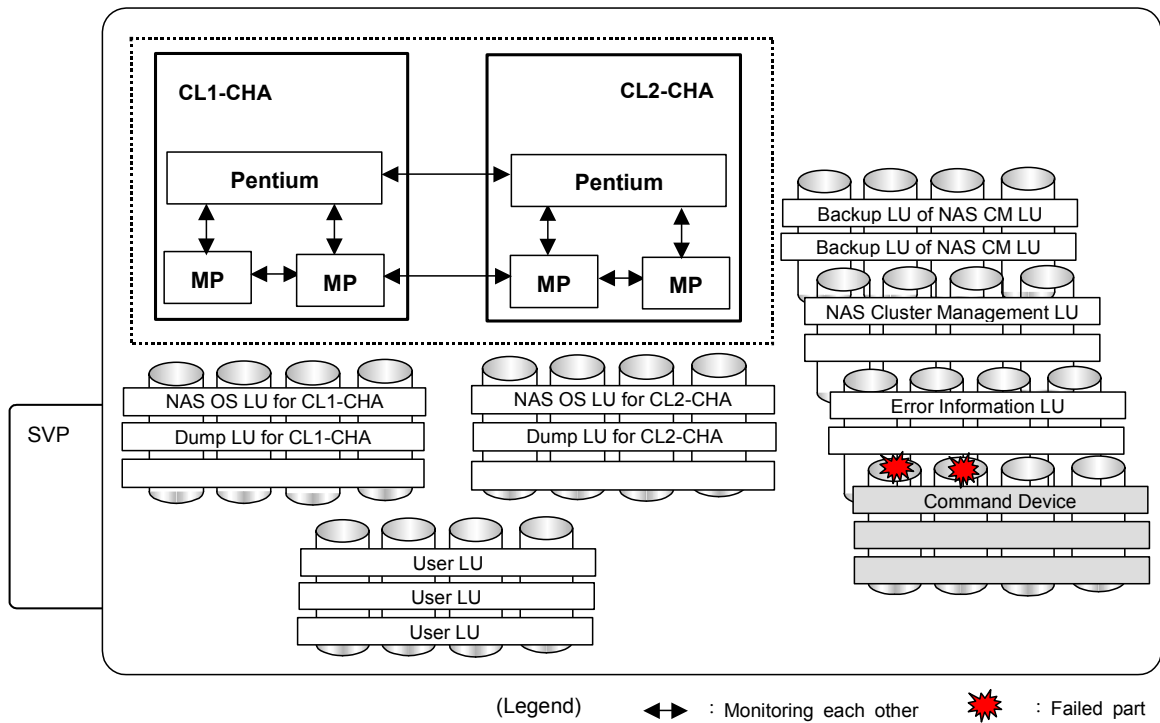

Figure 7.4-9 RAID Failure (2 PDEVs: Command Devices) (1/2)

Step	Procedure	Notes
1	Determine whether a failure occurred in the RAID in which a command device exists.	

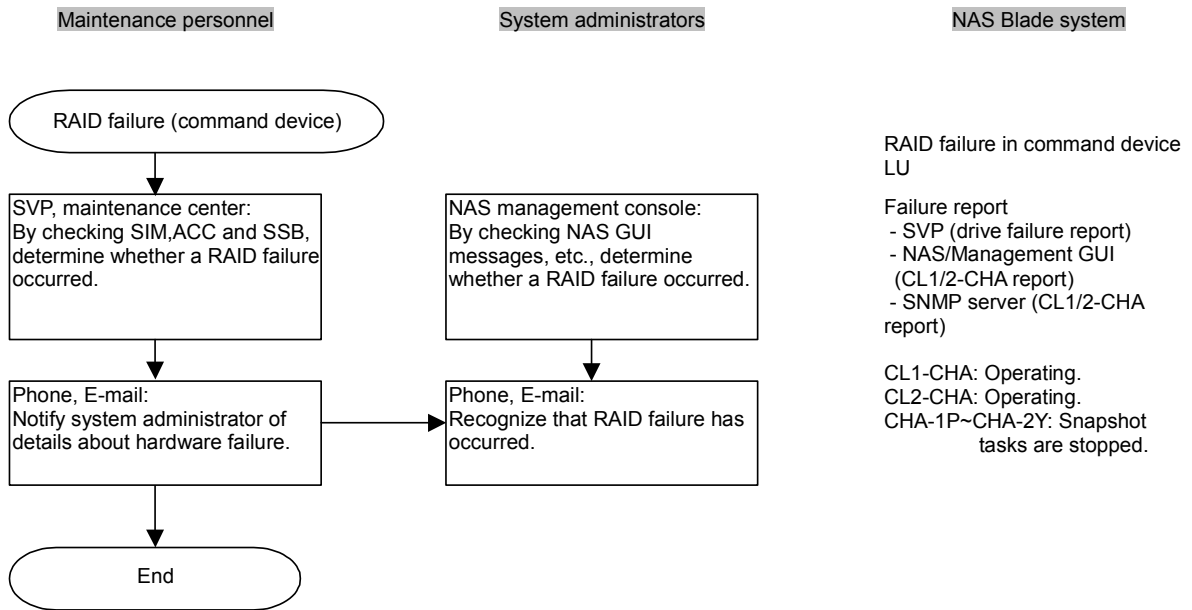

Figure 7.4-9 RAID Failure (2 PDEVs: Command Devices) (2/2)

(10) RAID Failure (2 PDEVs: Backup LUs of NAS Cluster Management LUs)

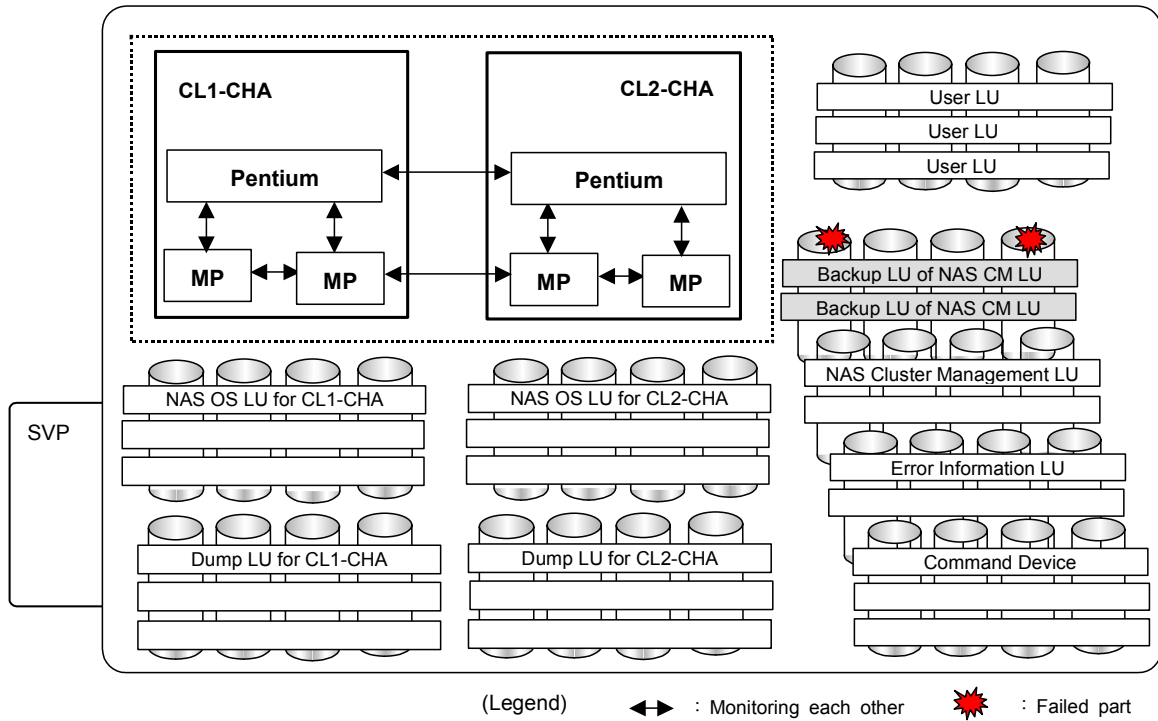

Figure 7.4-10 RAID Failure (2 PDEVs: Backup LUs of NAS Cluster Management LUs) (1/2)

Step	Procedure	Notes
1	Determine whether a failure occurred in the RAID in which a backup LU of NAS Cluster Management LU exists.	

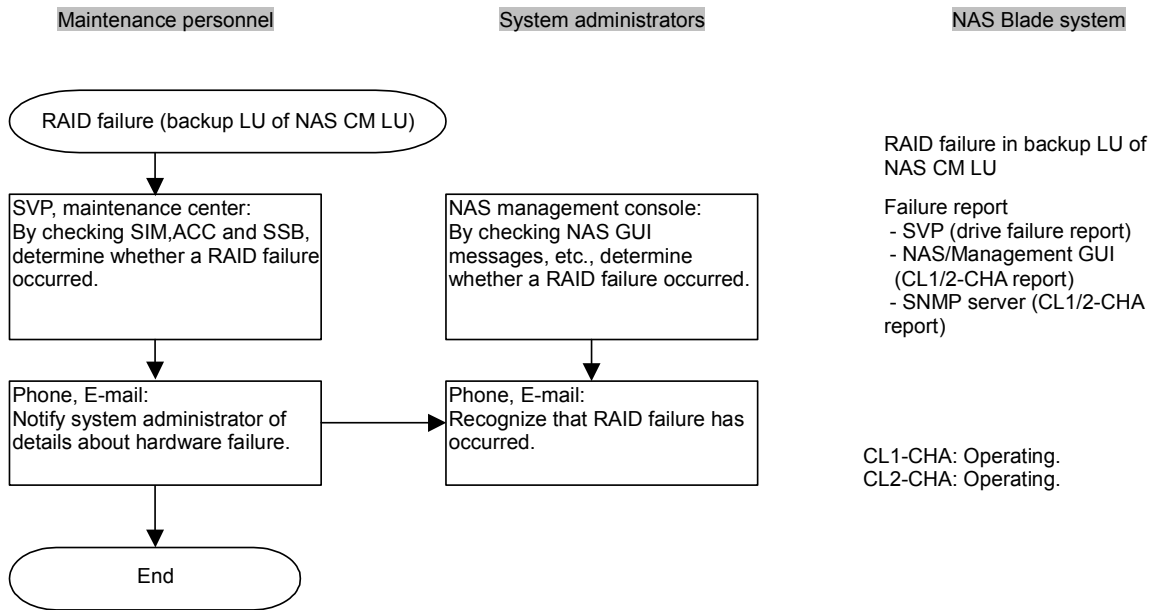

Figure 7.4-10 RAID Failure (2 PDEVs: Backup LUs of NAS Cluster Management LUs) (2/2)

(11) Hardware Failure (Correctable)

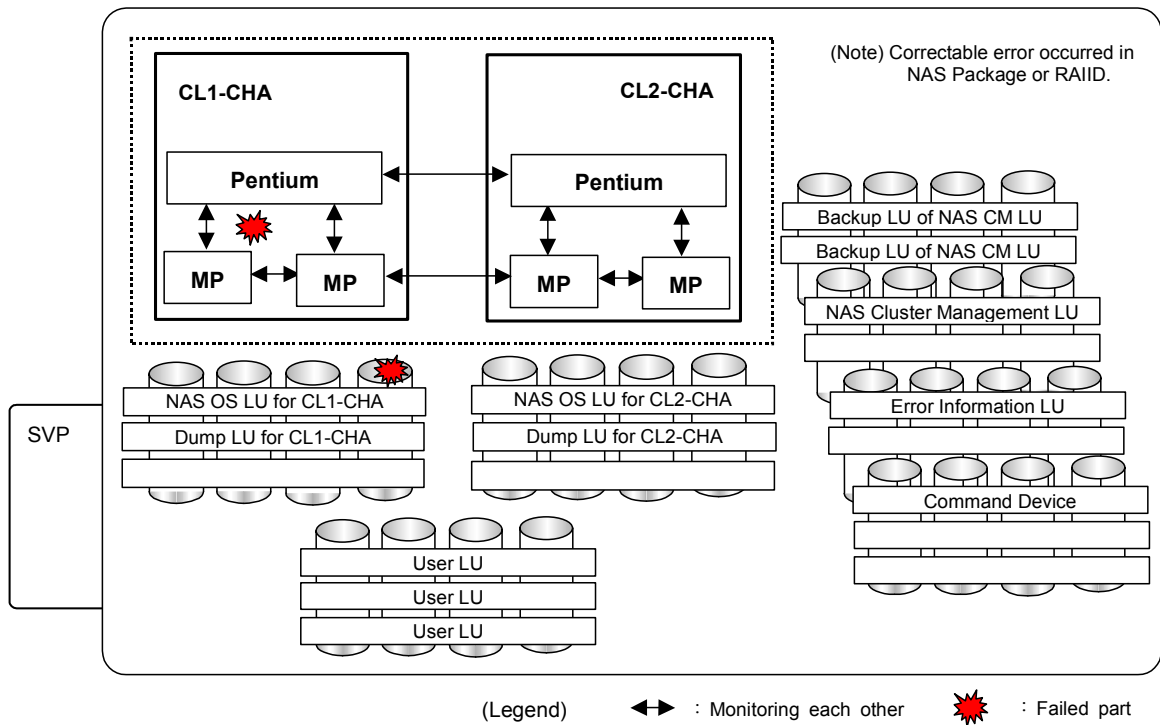

Figure 7.4-11 Hardware Failure (Correctable) (1/2)

Step	Procedure	Notes
1	Examine messages to determine whether a correctable hardware failure occurred.	

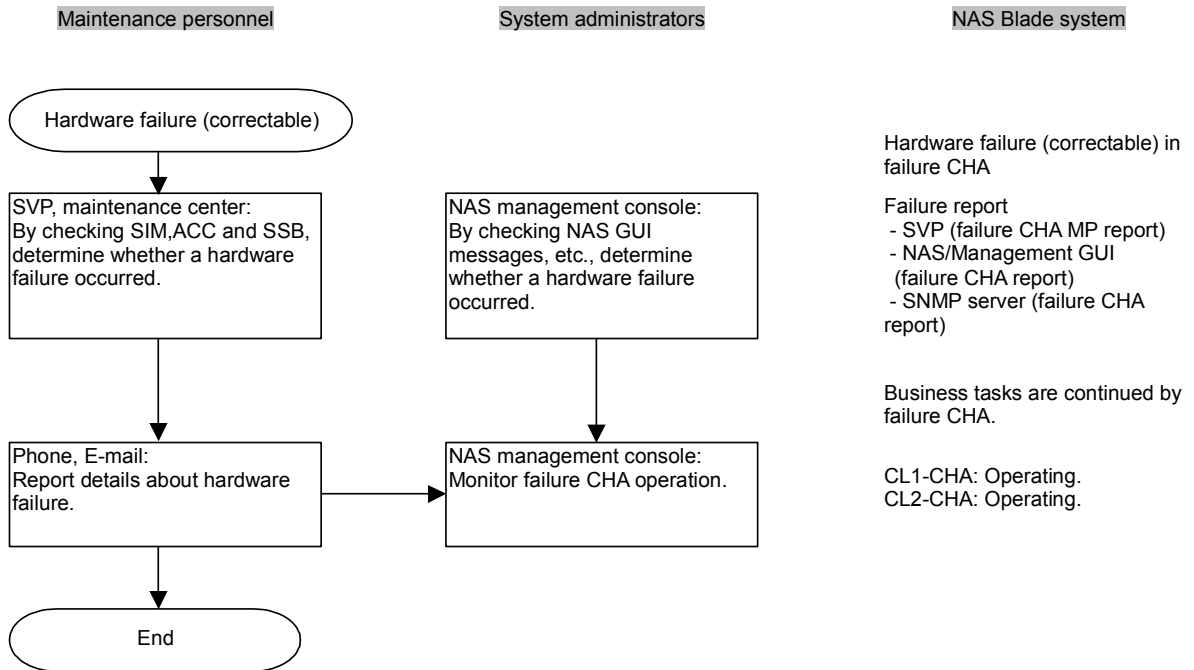

Figure 7.4-11 Hardware Failure (Correctable) (2/2)

(12) Network Failure (Network Settings Failed)

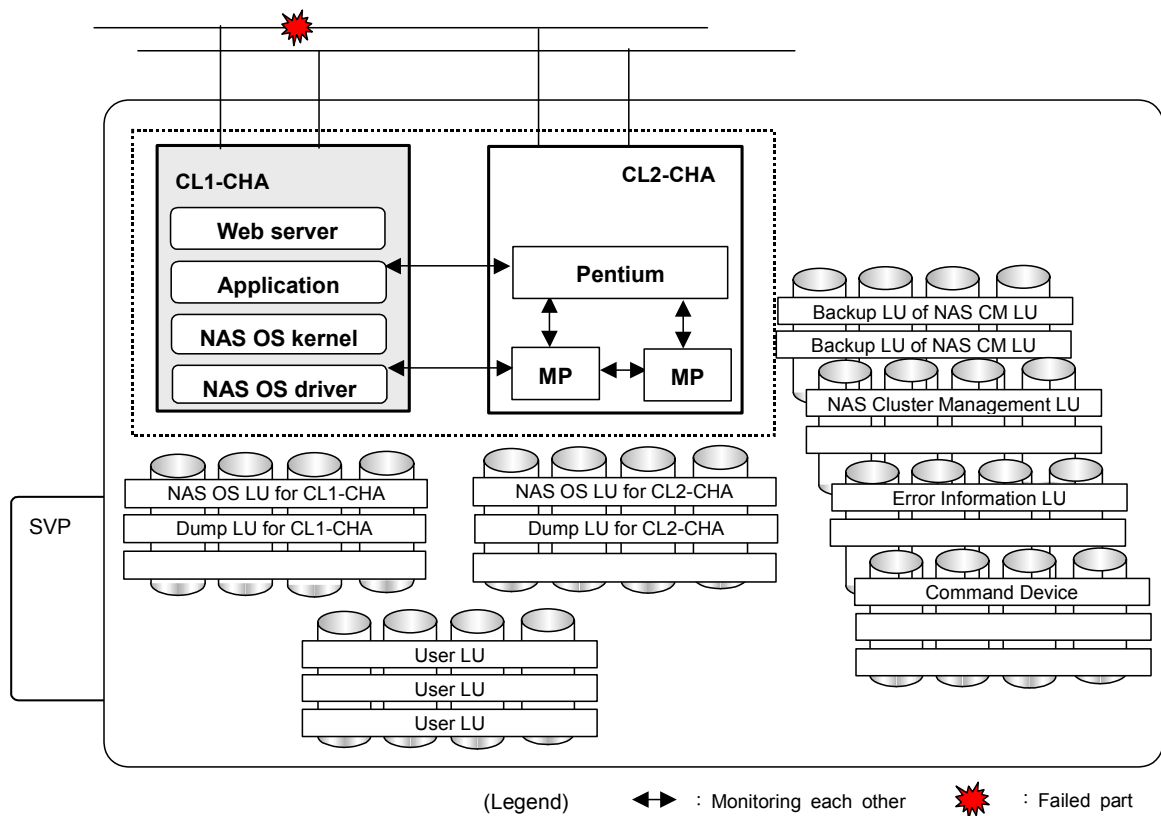

Figure 7.4-12 Network Failure (Network Settings Failed) (1/3)

Step	Procedure	Notes
1	Make sure that this is not a CHA failure.	
2	Make sure that the network is working correctly.	
3	Check if the MTU value is compatible with the peripheral devices, and if not, reset the MTU value.	The cluster needs to be stopped and restarted when setting the MTU value using Setup on SVP.
4	Make sure that the communication is successful.	

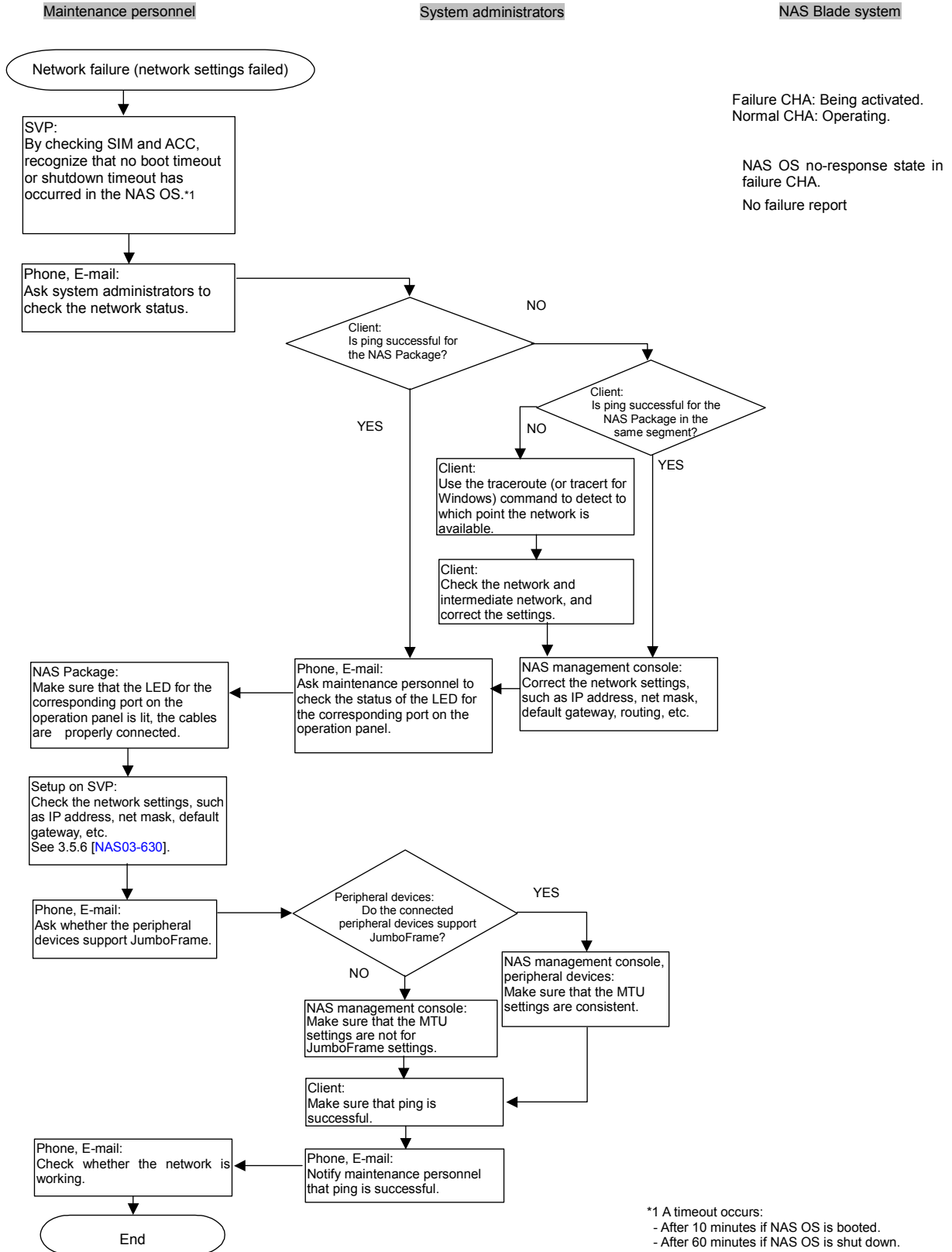

Figure 7.4-12 Network Failure (Network Settings Failed) (2/3)

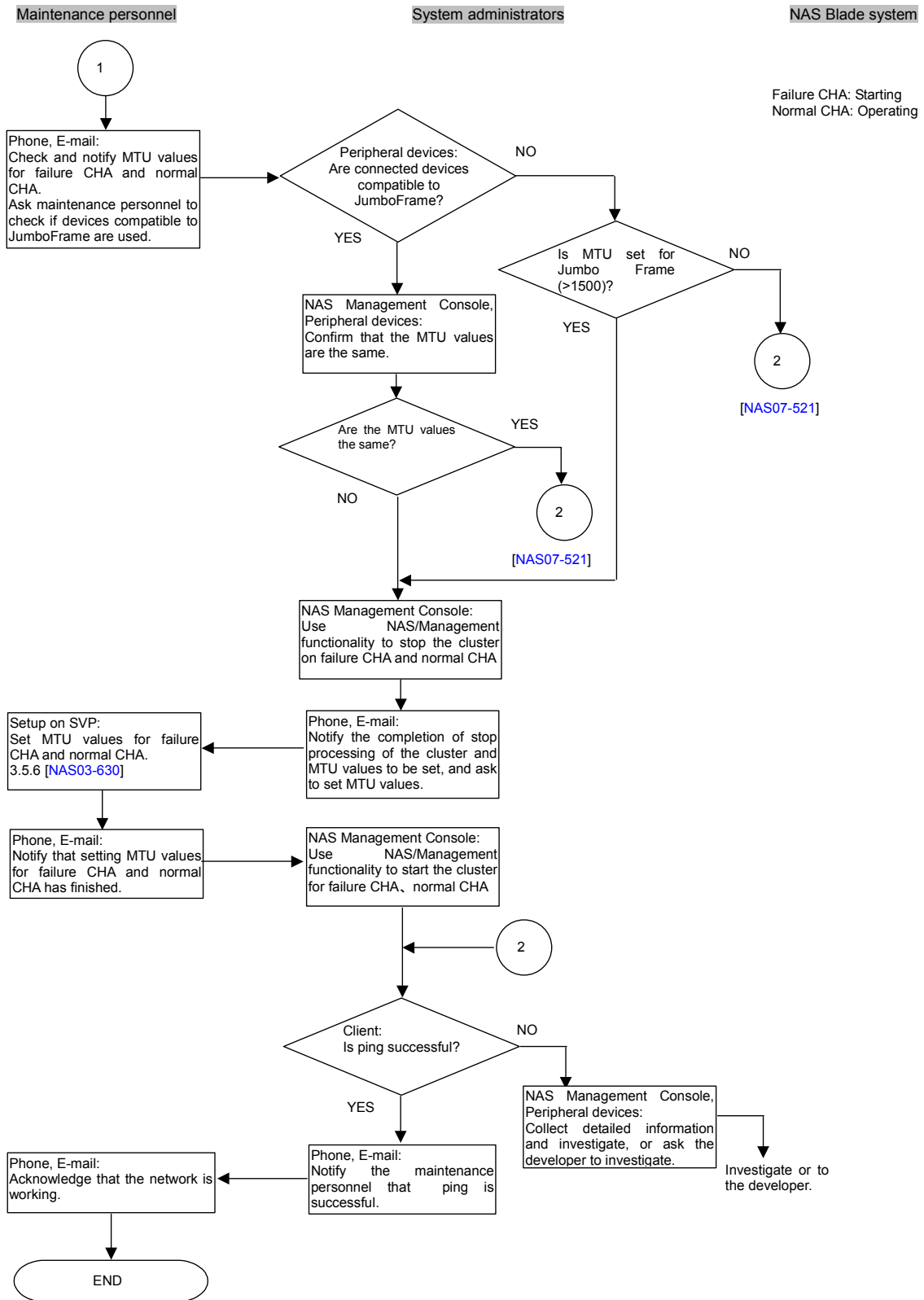

Figure 7.4-12 Network Failure (Network Settings Failed) (3/3)

7.4.2 Software Troubleshooting

In this section, the cluster is assumed to consist of CL1-CHA and CL2-CHA, and the following tables show the flowcharts for software troubleshooting from Figure 7.4-13 to Figure 7.4-24.

Make sure that CL2-CHA is properly referred to as the actual location when a software failure occurs on the CHA location.

Table 7.4-2 shows the actual CHA locations in the NAS cluster configuration.

Table 7.4-2 CHA Location in the NAS Cluster Configuration

Model	CHA location	CL1-CHA	CL2-CHA
Multi-cabinet	Basic	1P	2V
	Option 1	1Q	2W
	Option 2	1R	2X
	Option 3	1S	2Y
Single cabinet ^{*1}	Basic	1C	2G
	Option 1	1D	2J
	Option 2	1F	2K

*1: Only two of the three, basic, option 1, or option 2, can be used.

No.	Failure	For details see ...
(1)	NAS OS failure (panic)	Figure 7.4-13 [NAS07-540]
(2)	NAS OS failure (hangup)	Figure 7.4-14 [NAS07-560]
(3)	NAS OS failure (slowdown)	Figure 7.4-15 [NAS07-590]
(4)	Application failure (failover provided) ^{*1}	Figure 7.4-16 [NAS07-620]
(5)	Application failure (failover not provided) (a) Application failure in something other than the Web server ^{*1}	Figure 7.4-17 [NAS07-650]
	Application failure (failover not provided) (b) Application failure in the Web server ^{*1}	Figure 7.4-18 [NAS07-680]
(6)	NAS OS failure (in start/stop processing)	Figure 7.4-19 [NAS07-710]
(7)	Failure when a NAS OS LU is full	Figure 7.4-20 [NAS07-740]
(8)	NAS OS file system failure	Figure 7.4-21 [NAS07-761]
(9)	Failure during NAS OS startup or stop (invalid dump LU)	Figure 7.4-22 [NAS07-764]
(10)	Failure during NAS OS startup or stop (unable to connect NTP server)	Figure 7.4-23 [NAS07-766]
(11)	NAS OS application failure (unable to set internal IP address)	Figure 7.4-24 [NAS07-769A]

*1 Operations performed by system administrators. For details, refer to the *Hitachi Network Attached Storage/Management User's Guide (9.1 General procedure for troubleshooting)*.

(1) NAS OS Failure (Panic)

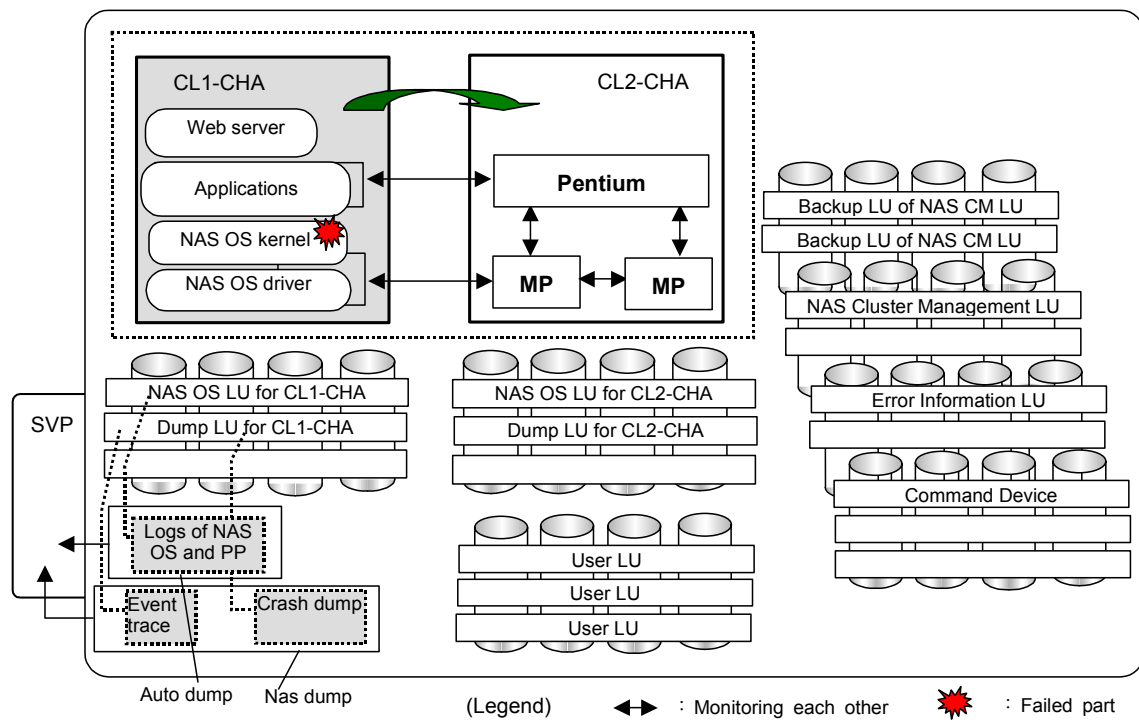

Figure 7.4-13 NAS OS Failure (Panic) (1/2)

Step	Procedure	Notes
1	Examine the messages to determine whether a NAS OS panic and a failover occurred.	
2	Check that the failover finished.	
3	Notify ordinary users of the failure and failover completion.	
4	Send the detailed information to developers.	

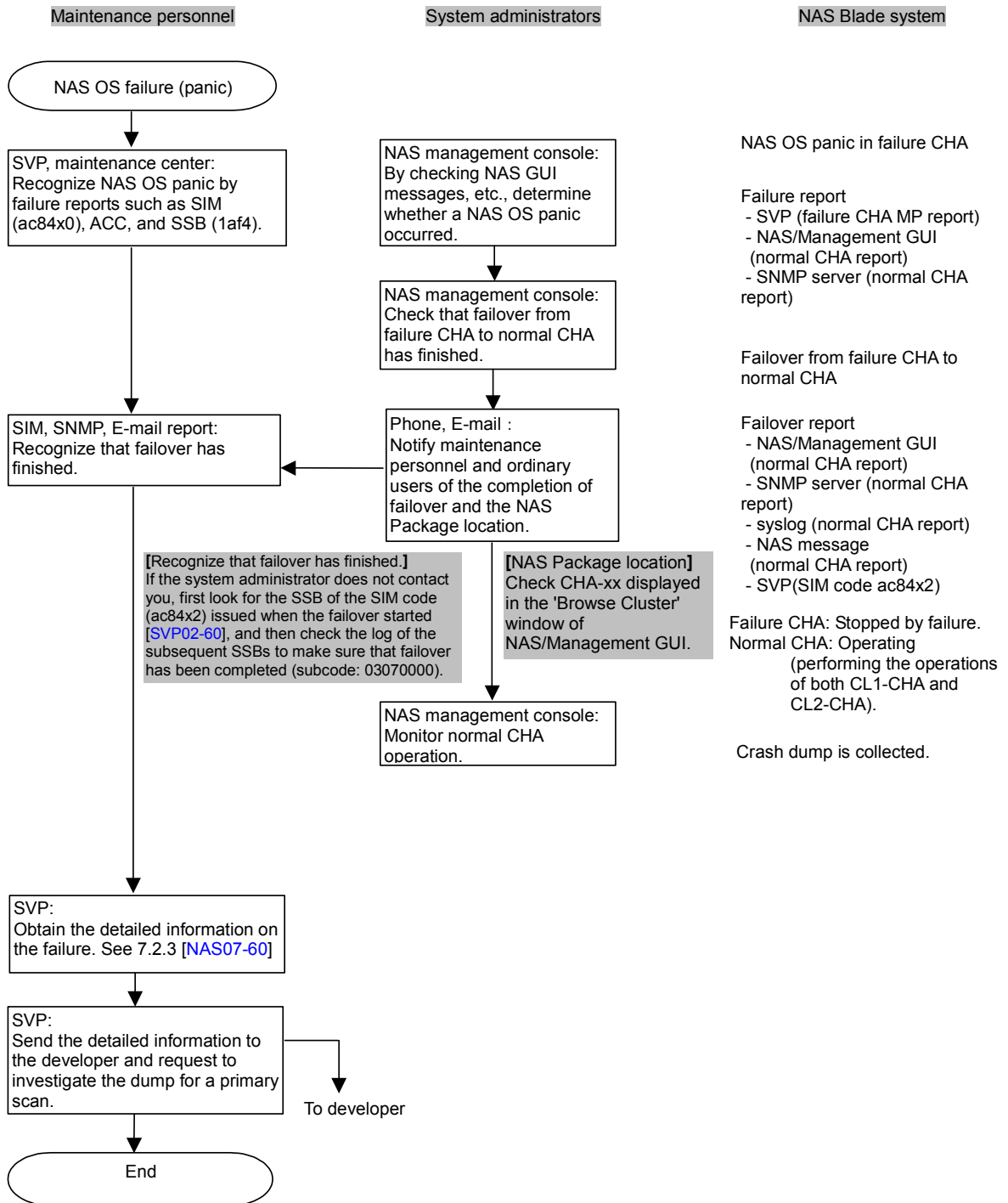

Figure 7.4-13 NAS OS Failure (Panic) (2/2)

(2) NAS OS Failure (Hangup)

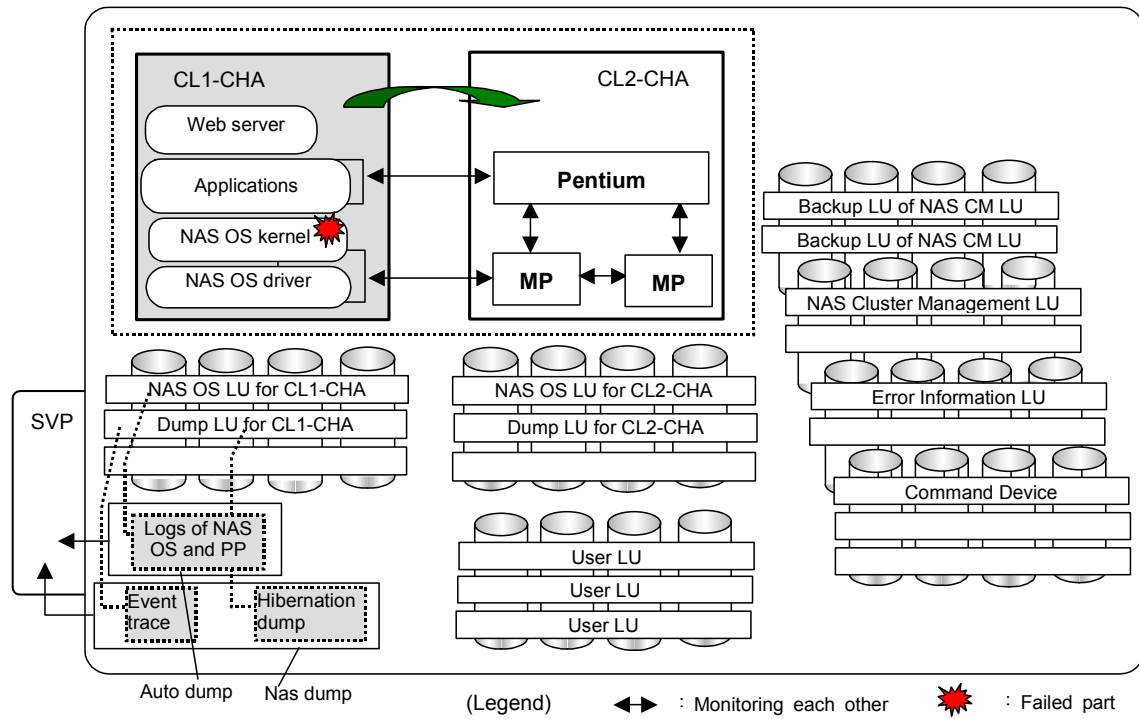

Figure 7.4-14 NAS OS Failure (Hangup) (1/3)

Step	Procedure	Notes
1	Examine the messages to determine whether a hangup and a failover occurred.	
2	Check that the failover finished.	
3	Notify ordinary users of the failure and failover completion.	
4	Send the detailed information to developers.	

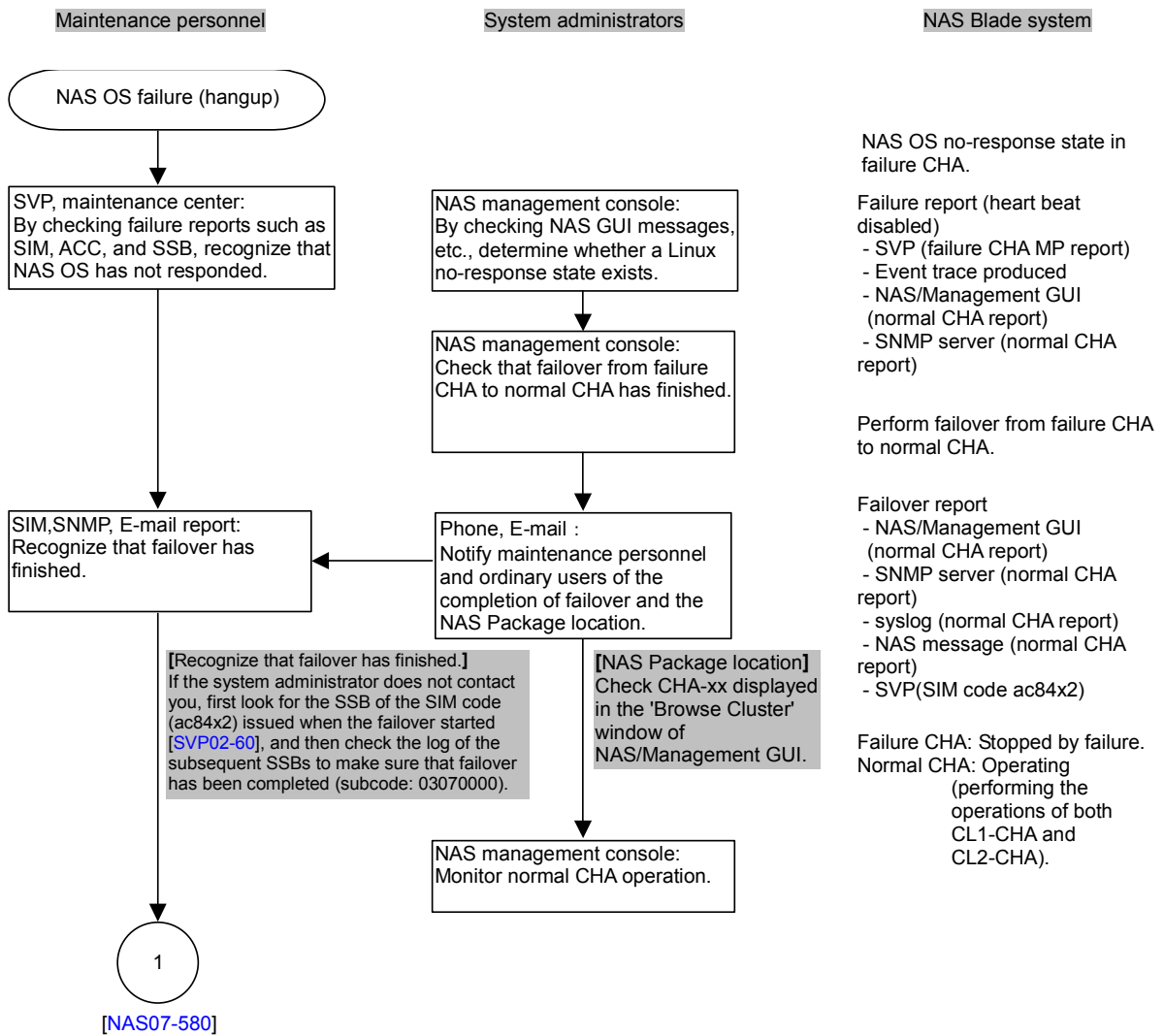

Figure 7.4-14 NAS OS Failure (Hangup) (2/3)

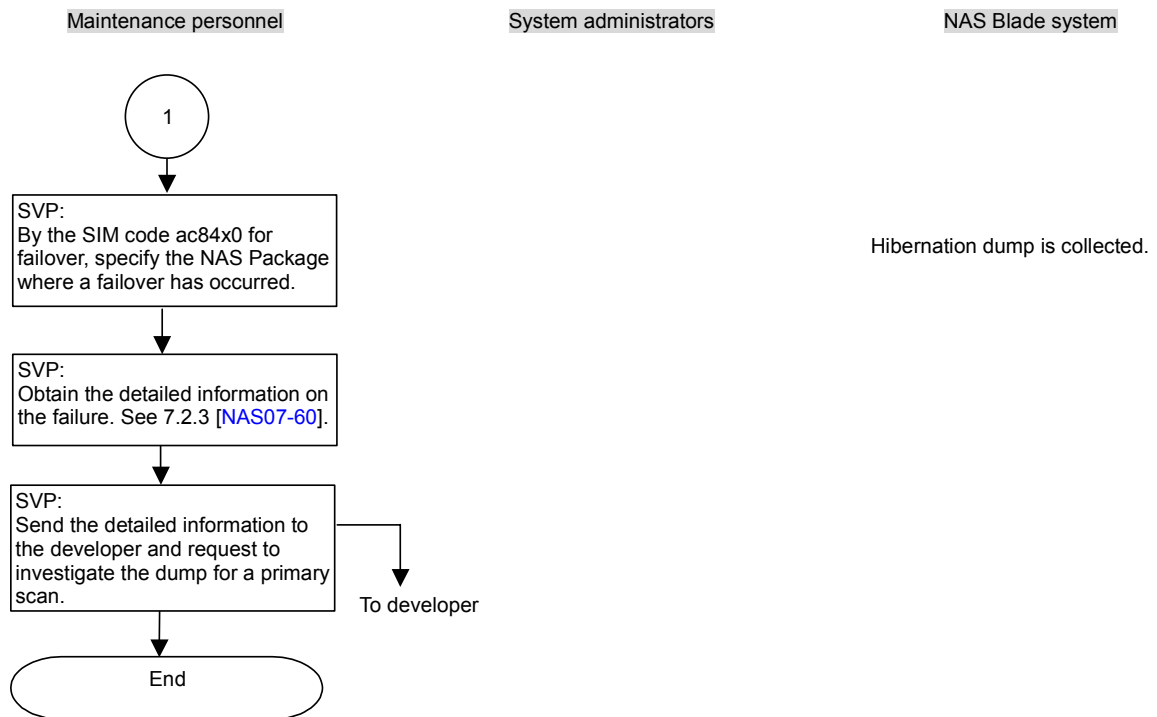

Figure 7.4-14 NAS OS Failure (Hangup) (3/3)

(3) NAS OS Failure (Slowdown)

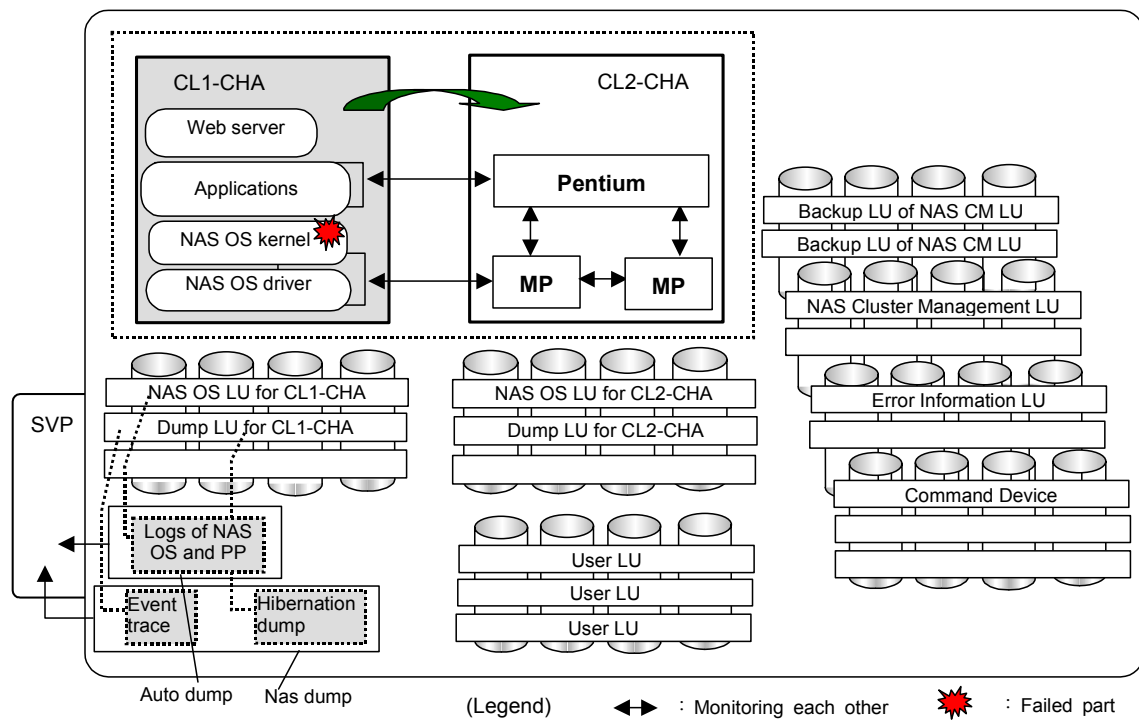

Figure 7.4-15 NAS OS Failure (Slowdown) (1/3)

Step	Procedure	Notes
1	Determine whether there is no response from the processing of business tasks and whether a slowdown has occurred.	Act on messages if they have been issued.
2	Obtain performance information and either investigate it or send it to developers.	
3	Manually obtain the hibernation dump.	
4	Send the detailed information to developers.	

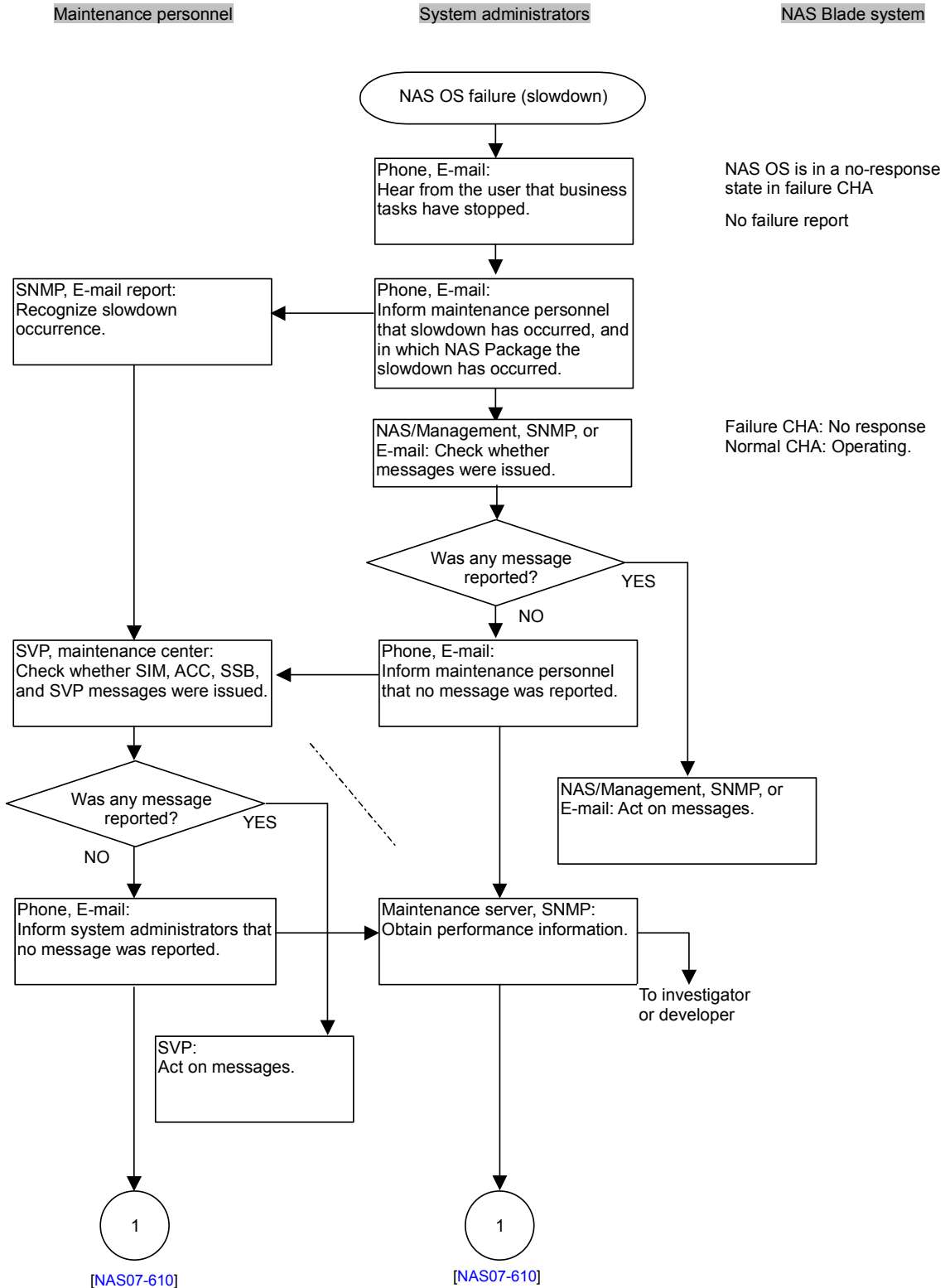

Figure 7.4-15 NAS OS Failure (Slowdown) (2/3)

Maintenance personnel

System administrators

NAS Blade system

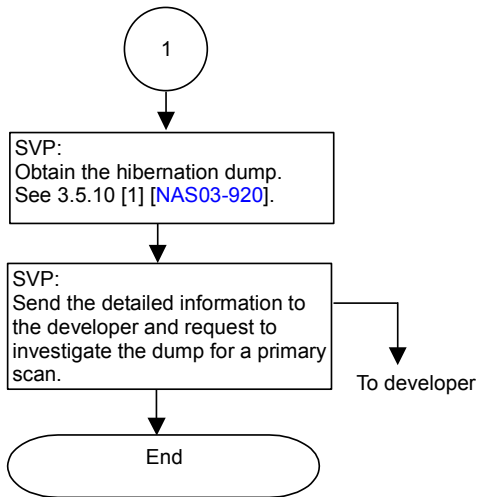

Figure 7.4-15 NAS OS Failure (Slowdown) (3/3)

(4) Application Failure (Failover Provided)

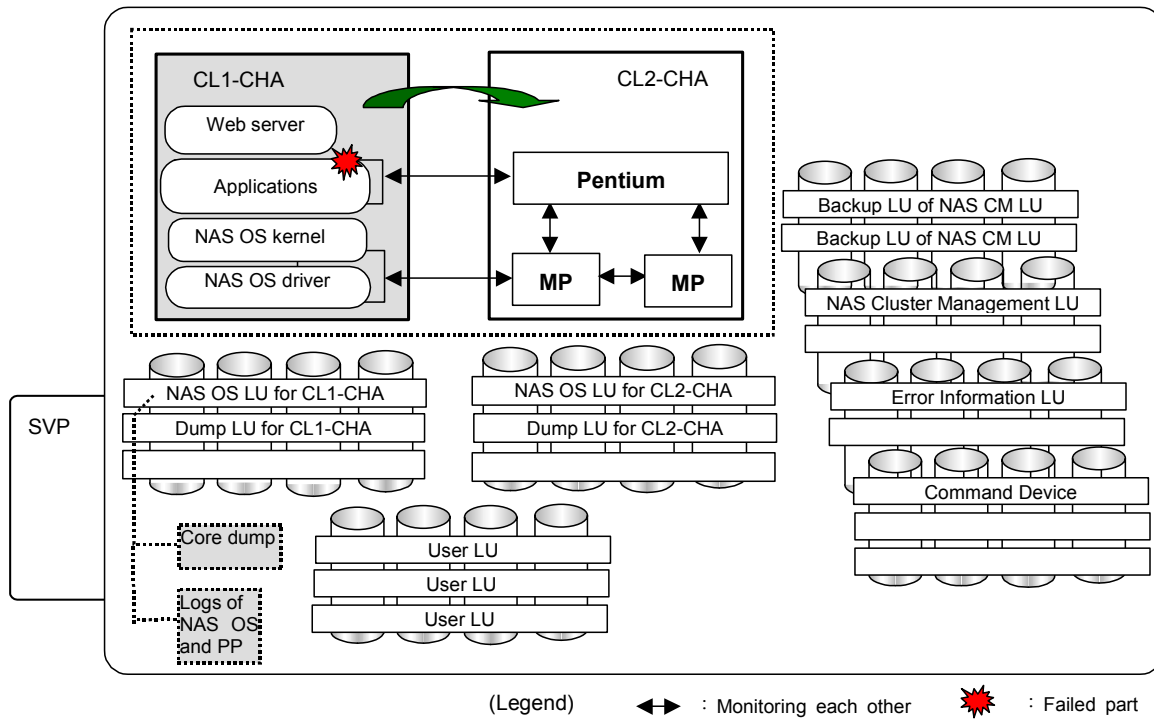

Figure 7.4-16 Application Failure (Failover Provided) (1/3)

Step	Procedure	Notes
1	Determine whether an application failure occurred, and whether a failover occurred.	
2	Check that the failover finished.	
3	Obtain the logs of the NAS OS and program products and the core dump, and then send it to developers.	

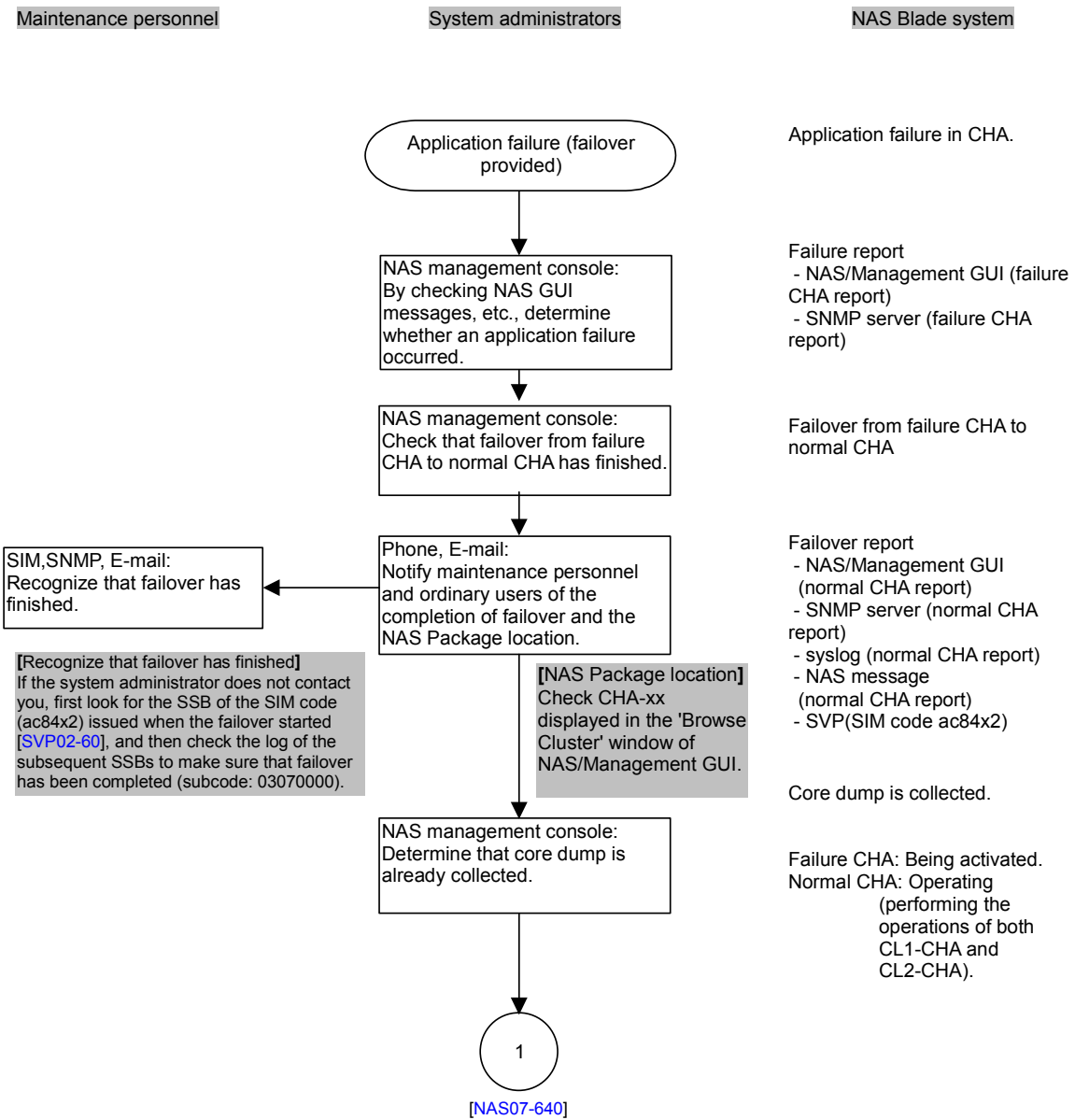

Figure 7.4-16 Application Failure (Failover Provided) (2/3)

Maintenance personnel

System administrators

NAS Blade system

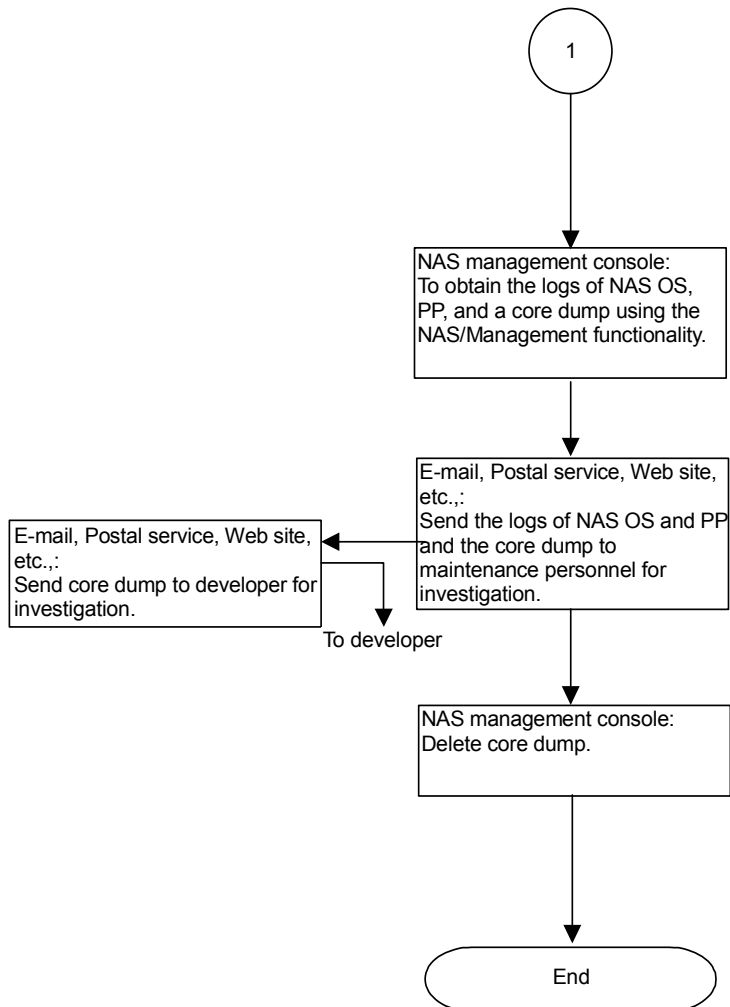

Figure 7.4-16 Application Failure (Failover Provided) (3/3)

(5) Application Failure (Failover Not Provided)

(a) Application failure in something other than the Web server:

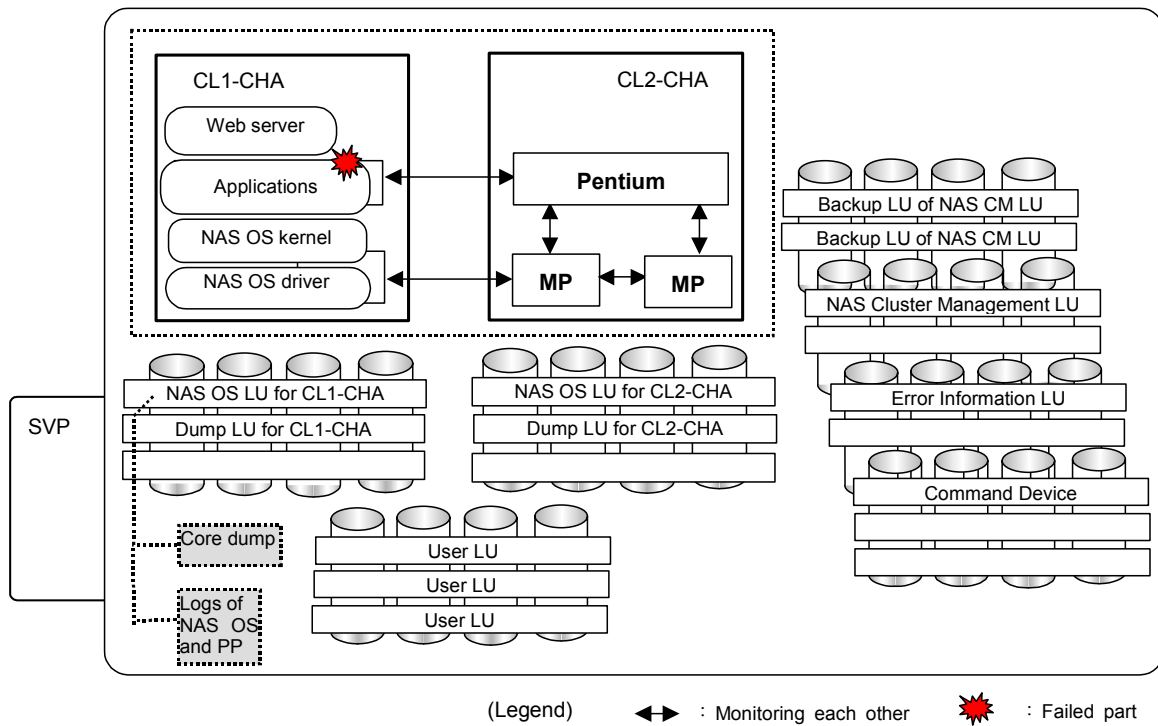

Figure 7.4-17 Application Failure in Something Other Than the Web Server
(Failover Not Provided) (1/3)

Step	Procedure	Notes
1	Determine whether an application failure occurred.	
2	Notify ordinary users of the failure.	In case the failure affects user tasks.
3	Obtain the logs of the NAS OS and program products and the core dump, and then send it to developers.	

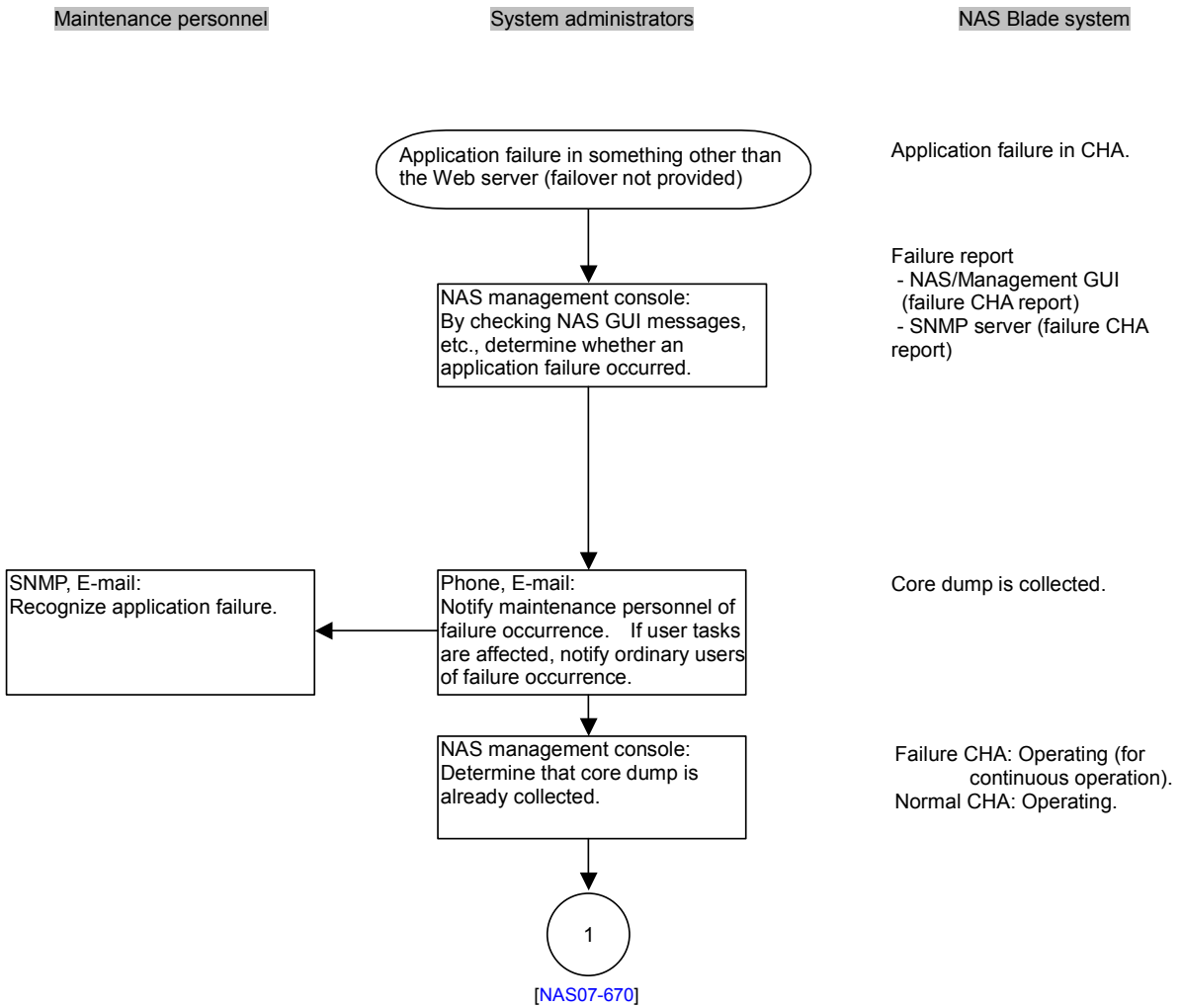

Figure 7.4-17 Application Failure in Something Other Than the Web Server (Failover Not Provided) (2/3)

Maintenance personnel

System administrators

NAS Blade system

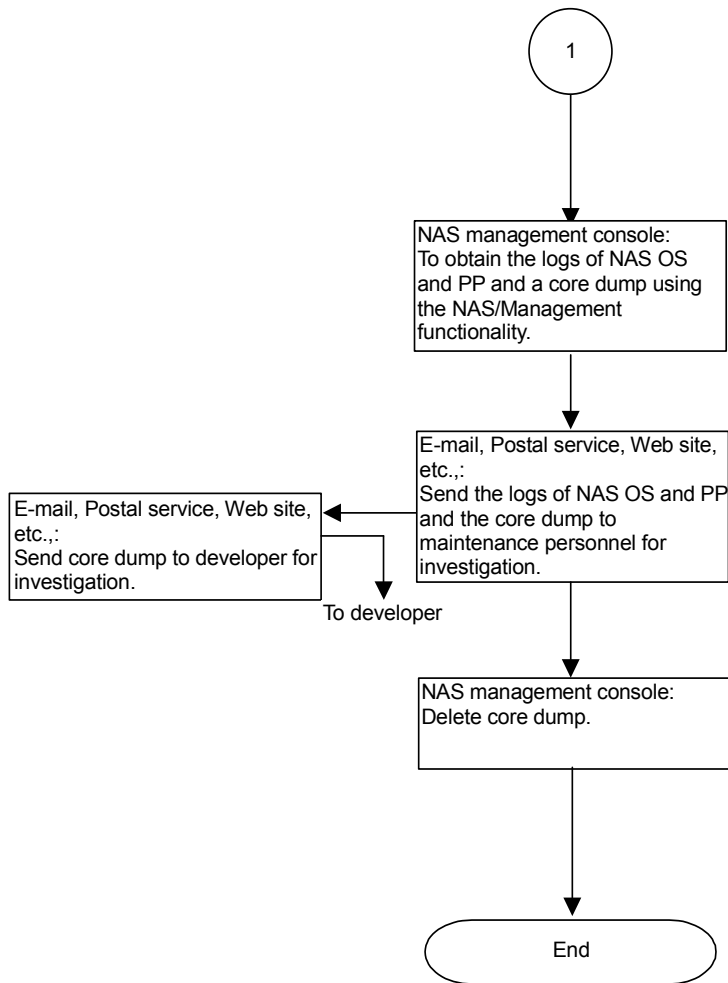

Figure 7.4-17 Application Failure in Something Other Than the Web Server
(Failover Not Provided) (3/3)

(b) Application Failure in the Web Server

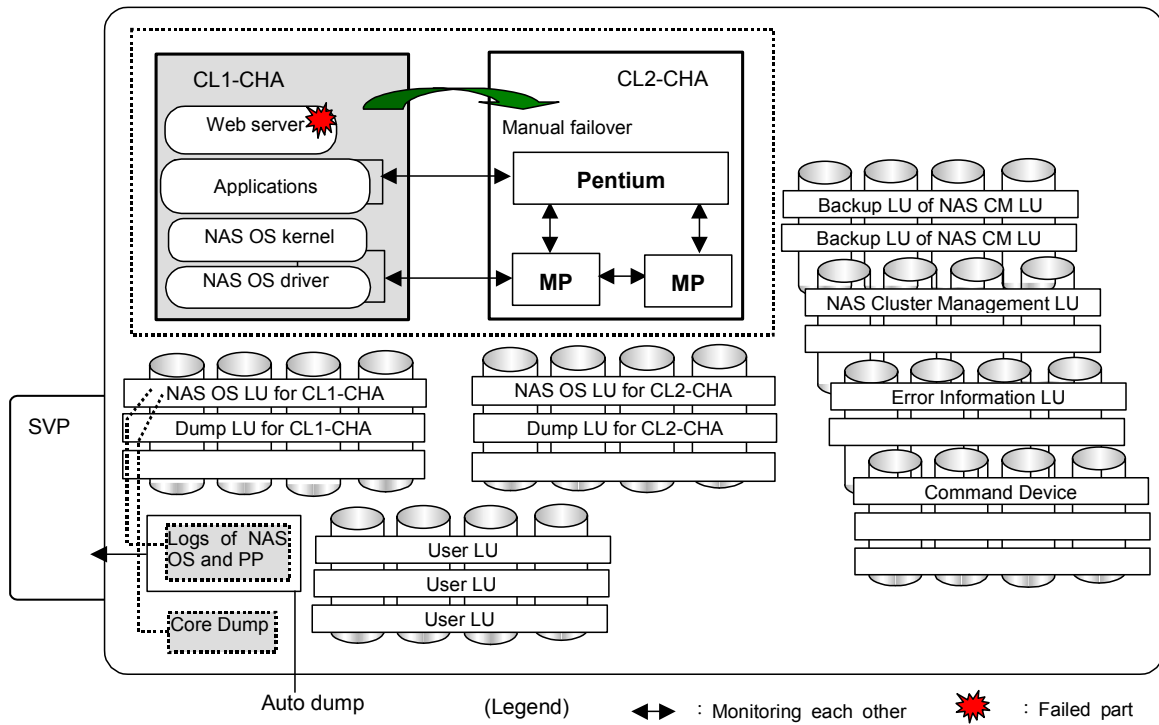

Figure 7.4-18 Application Failure in the Web Server (Failover Not Provided) (1/3)

Step	Procedure	Notes
1	Determine whether the application failure occurred in a Web server.	
2	Send the detailed information to developers.	

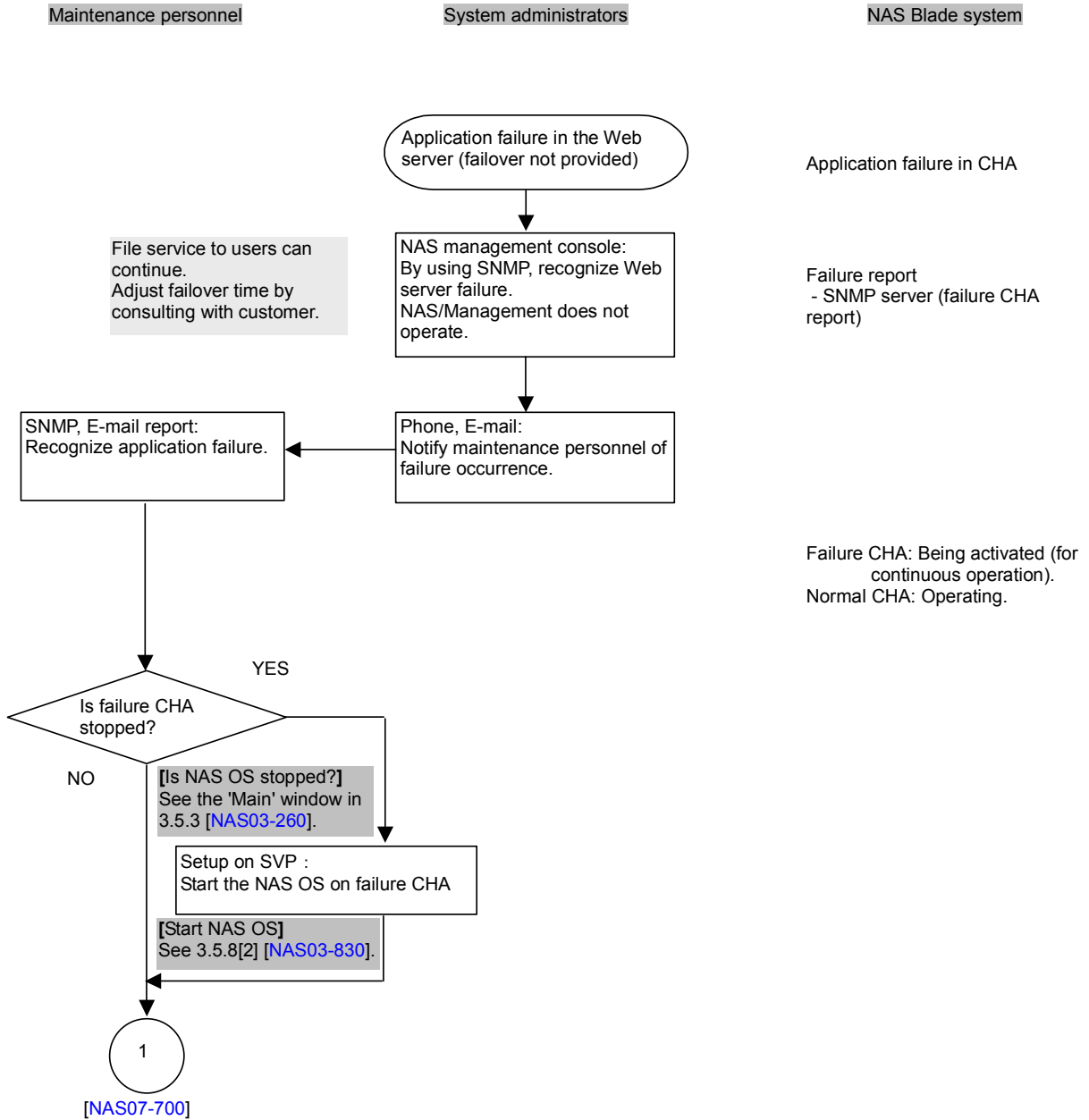

Figure 7.4-18 Application Failure in the Web Server (Failover Not Provided) (2/3)

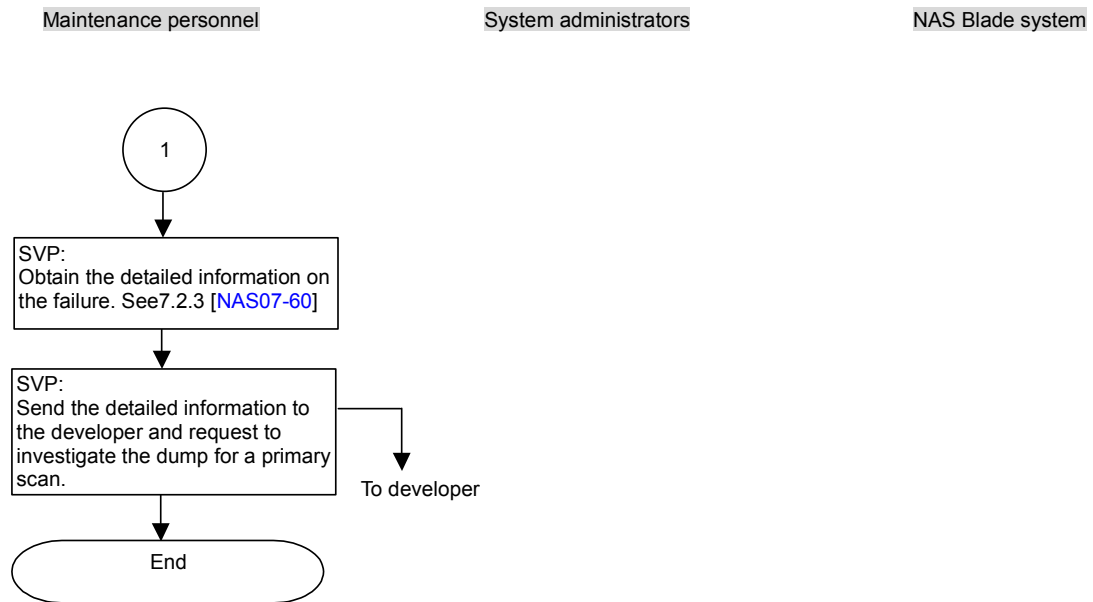

Figure 7.4-18 Application Failure in the Web Server (Failover Not Provided) (3/3)

(6) NAS OS Failure (In Start/Stop Processing)

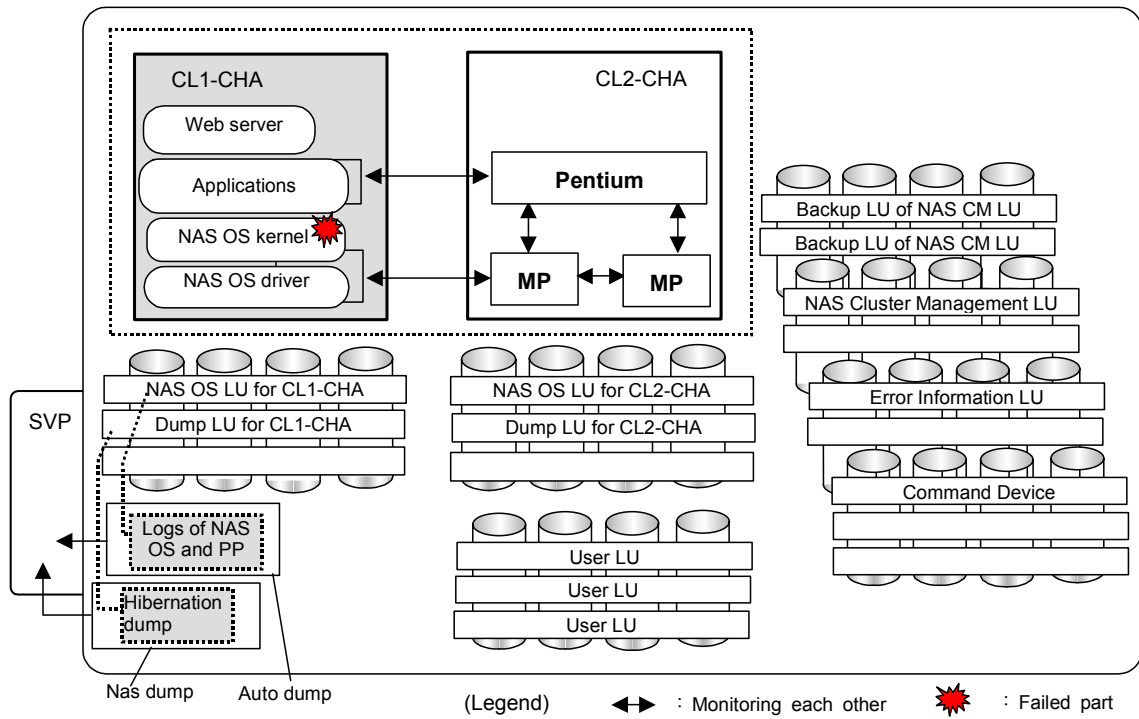

Figure 7.4-19 NAS OS Failure (In Start/Stop Processing) (1/3)

Step	Procedure	Notes
1	Determine whether there is any response from a NAS OS.	The NAS OS is in the process of starting or stopping.
2	Send the detailed information to developers.	

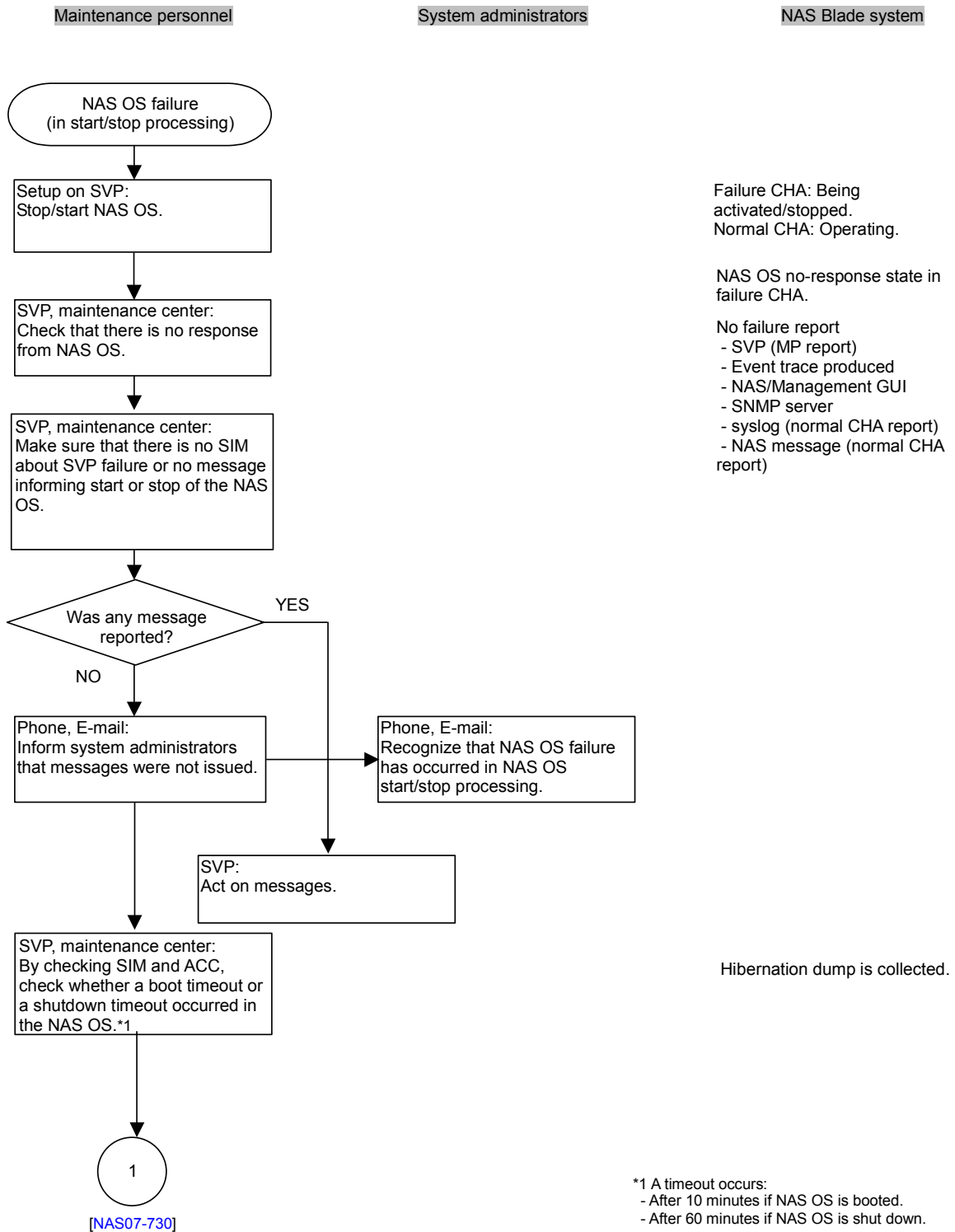

Figure 7.4-19 NAS OS Failure (In Start/Stop Processing) (2/3)

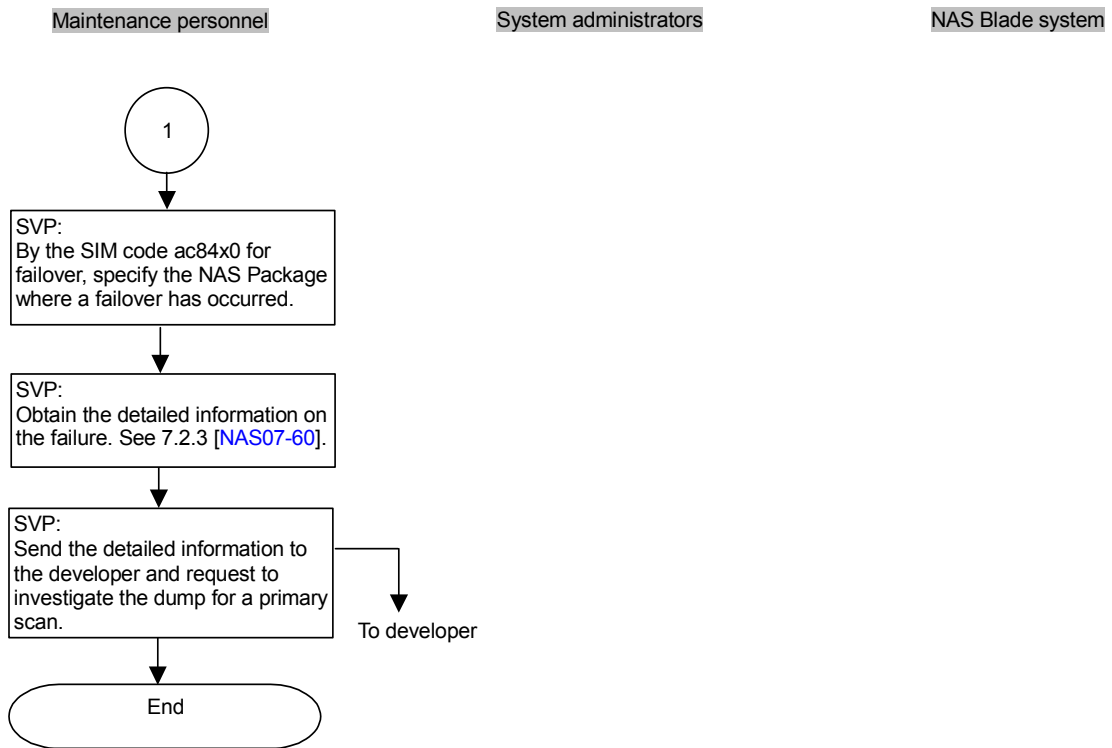

Figure 7.4-19 NAS OS Failure (In Start/Stop Processing) (3/3)

(7) Failure When a NAS OS LU is Full

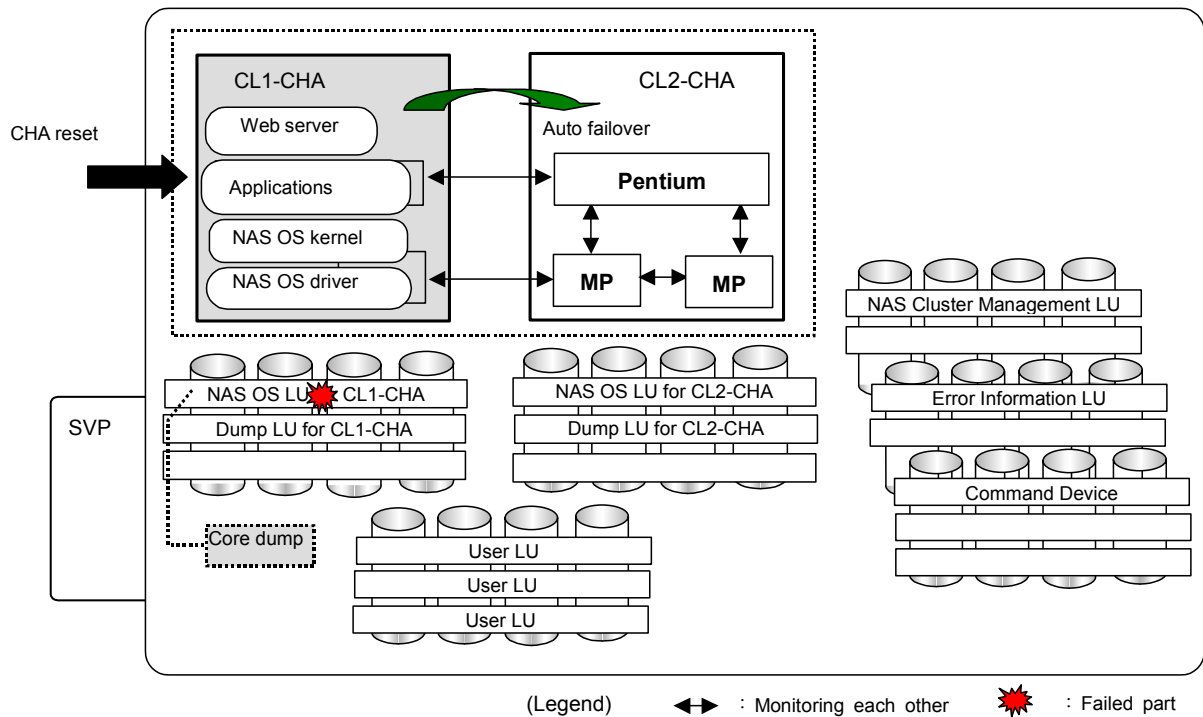

Figure 7.4-20 Failure when NAS OS LU is full (1/3)

Step	Procedure	Notes
1	Determine whether the failure occurred in a Web server when NAS OS LU is full .	Depending on how the NAS OS was full, an auto failover may occur since other CHA in same cluster resets the CHA of which NAS OS LU is full.
2	Notify ordinary users of the failure in case the failure affects user tasks.	
3	Obtain an auto dump and send it to developers.	
4	Perform a CHA reset and confirm one minute elapsed after the reset, then perform a CHA boot.	Normally an auto failover is done during the CHA reset.
5	Ask system administrators to log in to the NAS management console and delete log files using the (RAS) management functionality.	In case the log in using GUI is impossible, ask to log in via ssh and delete log files.

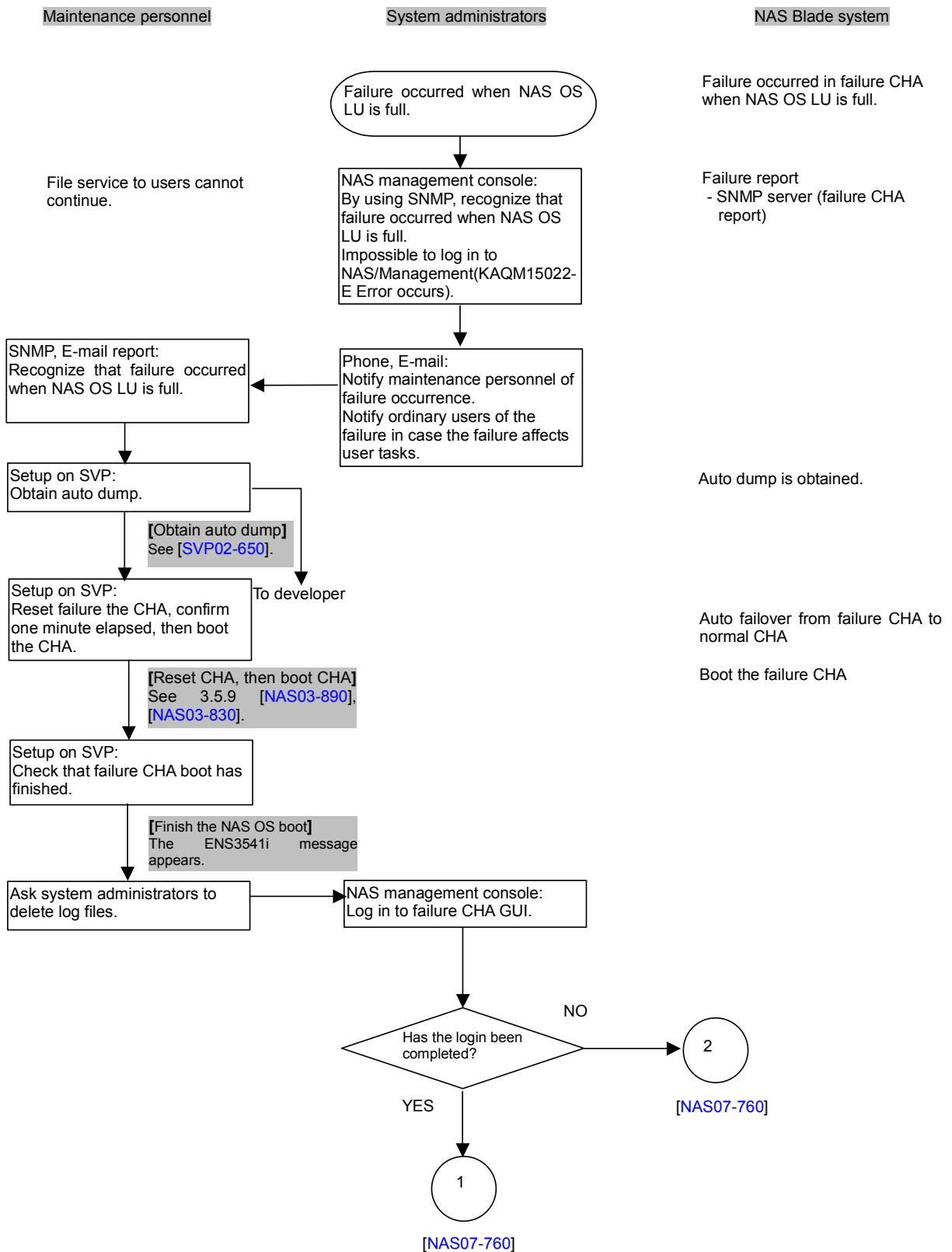

Figure 7.4-20 Failure when NAS OS LU is full (2/3)

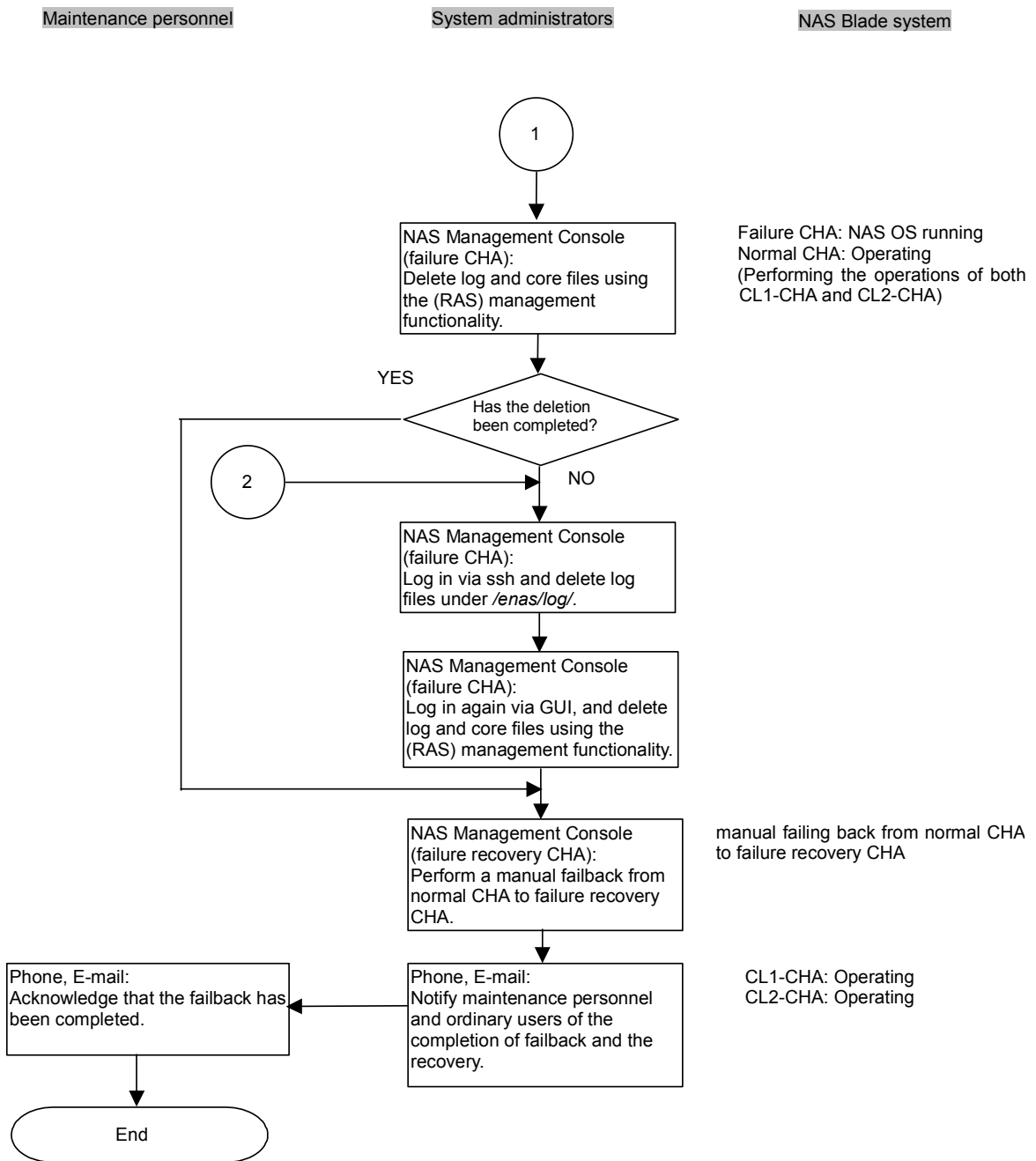

Figure 7.4-20 Failure when NAS OS LU is full (3/3)

(8) NAS OS File System Failure

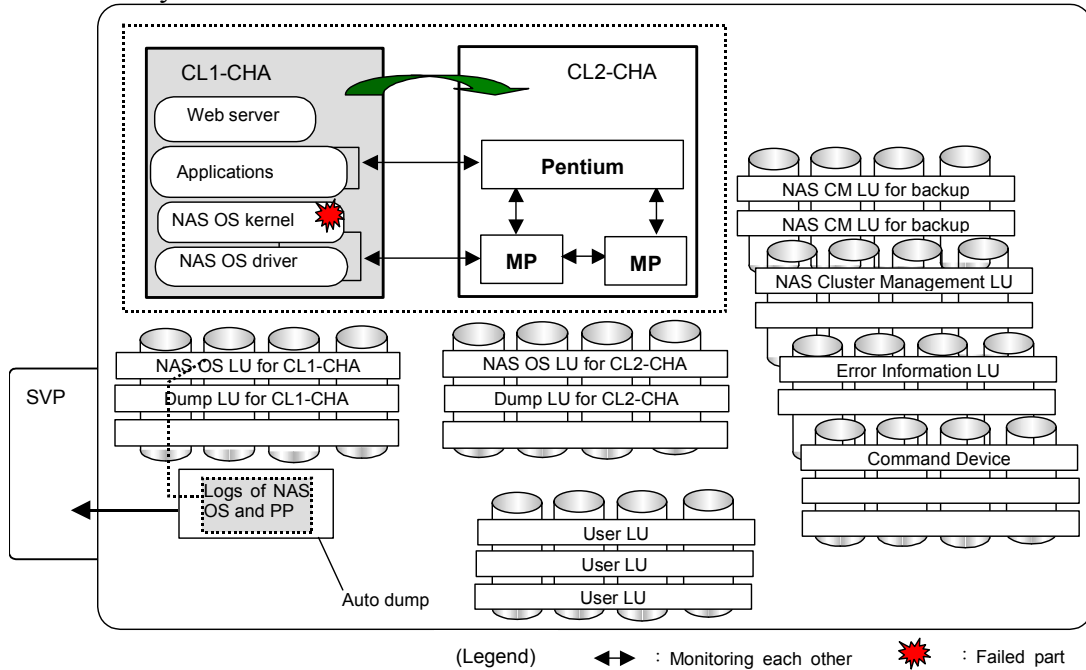

Figure 7.4-21 NAS OS File System Failure (1/3)

Step	Procedure	Notes
1	Determine whether NAS OS file system failure occurred.	
2	Check that the failover has completed.	
3	Reset and reboot the CHA.	
4	Determine whether NAS OS file system has recovered from the failure.	Go to step 5 if the file system has recovered from the failure. Go to step 5a if the file system has not recovered from the failure.
5	Obtain the auto dump and send it to developers.	
6	Perform failback.	

■ Procedure when the file system has not recovered from the failure by CHA reset and reboot

Step	Procedure	Notes
5a	Stop NAS Package by resetting CHA.	
6	Install NAS OS.	After the expansion installation, recover from the failure by upgrading the NAS OS to the version at the time of failure occurrence.
7	Install NAS/Management and optional program products.	Upgrade to the version at the time of failure occurrence.
8	Set up the network information(fixed IP address, NTP).	Use the settings that were used at the time of failure occurrence.
9	Restore the NAS OS LU.	Do so only if the backup data of the NAS OS LU already exists.
10	Start the NAS OS.	
11	Obtain auto dump and send it to developers.	
12	Perform failback.	

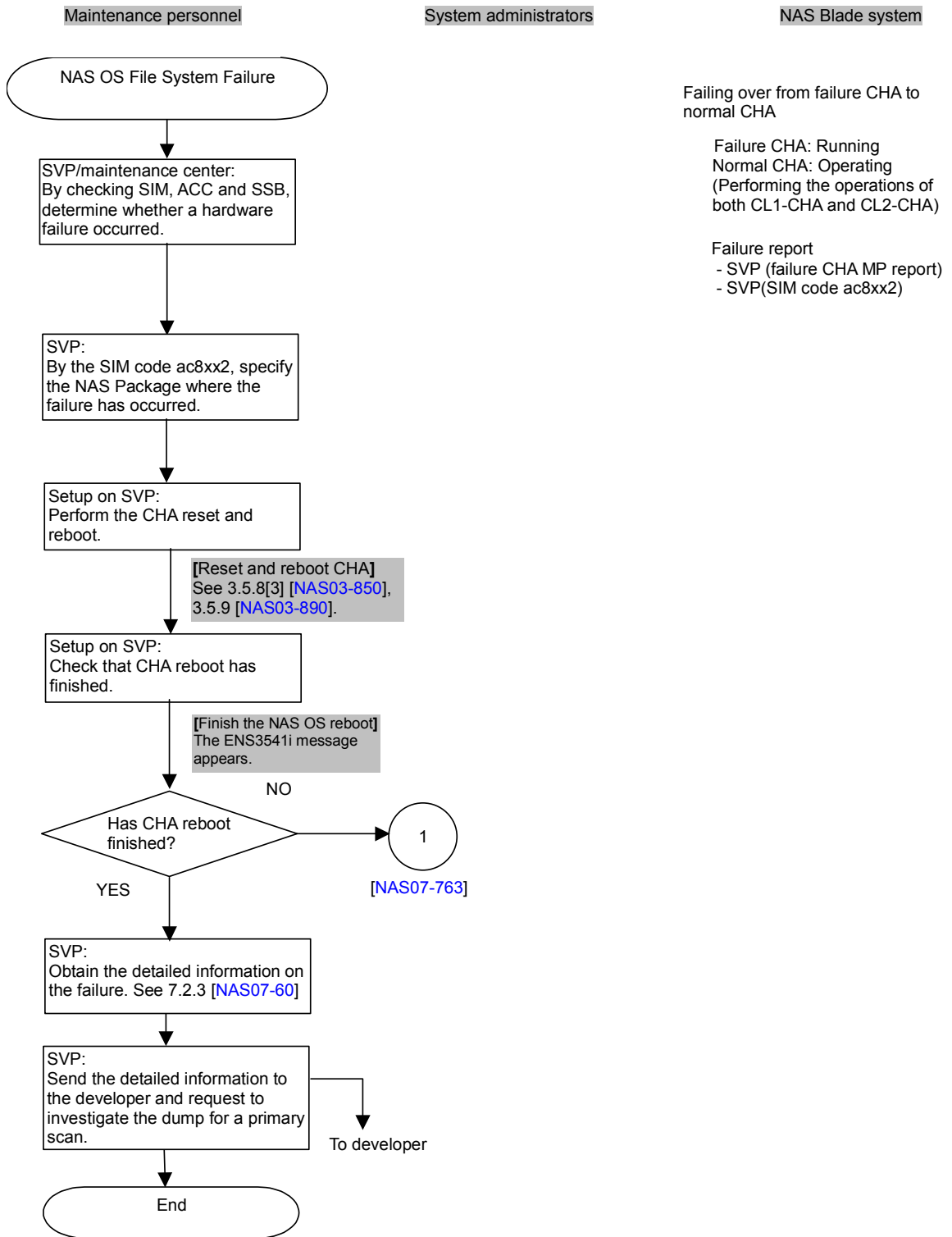

Figure 7.4-21 NAS OS File System Failure (2/3)

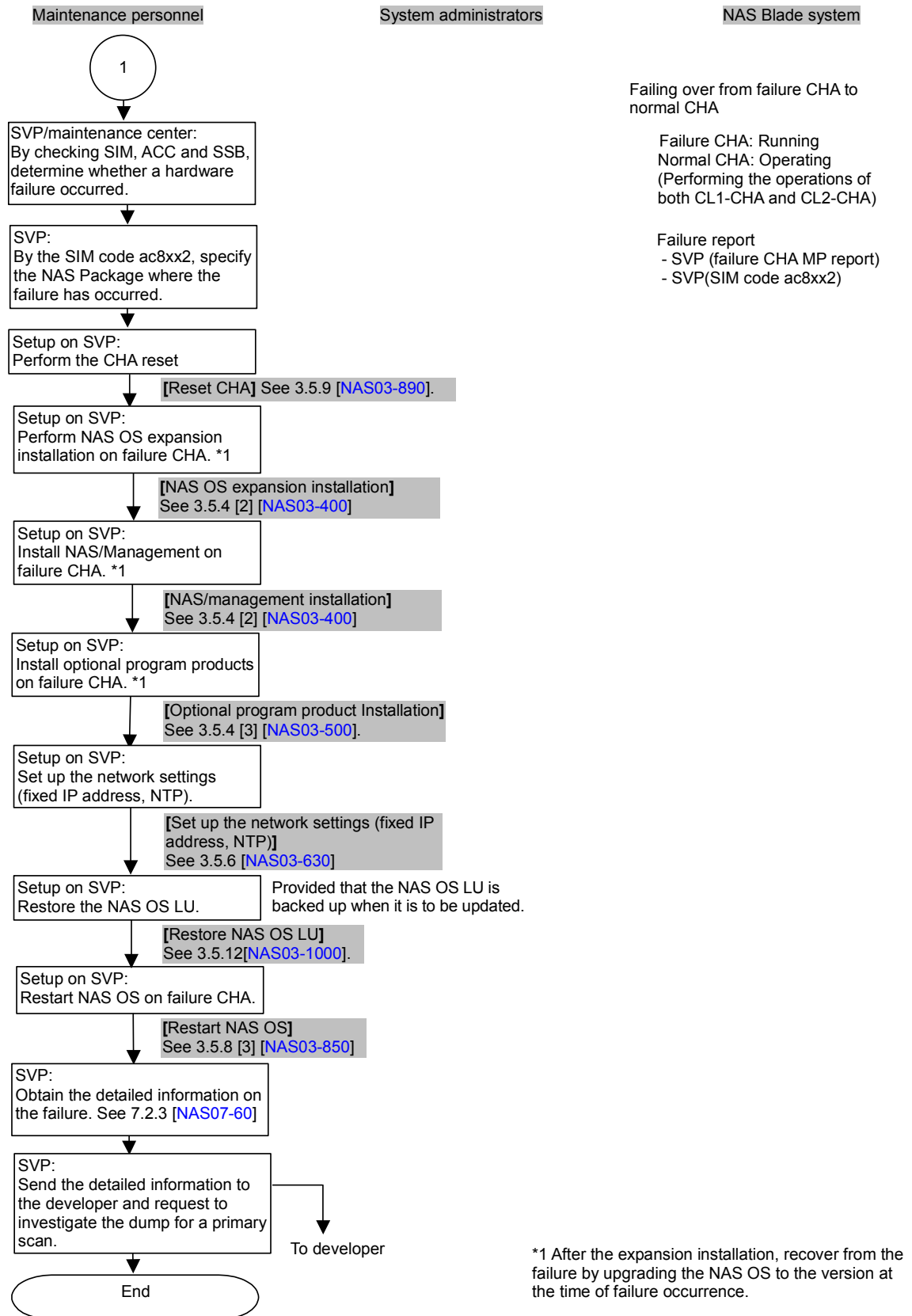

Figure 7.4-21 NAS OS File System Failure (3/3)

(9) NAS OS Failure During Startup or Stop (Invalid Dump LU)

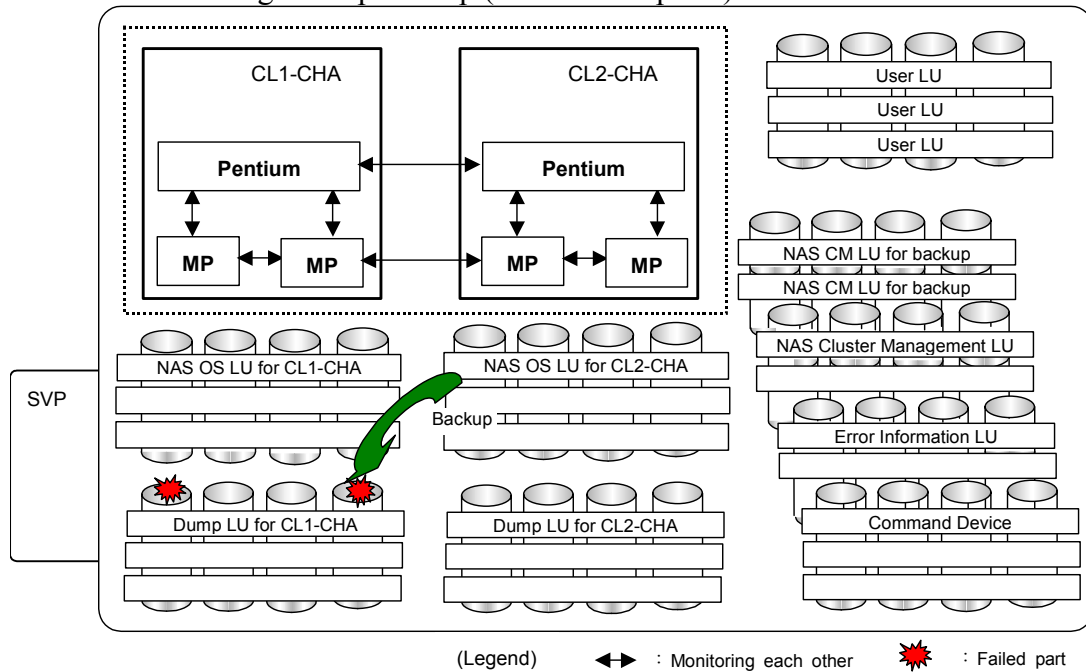

Figure 7.4-22 NAS OS Failure During Startup or Stop (Invalid Dump LU) (1/2)

Step	Procedure	Notes
1	Determine whether the content of the dump LU was invalid while starting or stopping NAS OS.	
2	Start NAS OS.	Execute if the failure occurred while NAS OS is stopped.
3	Backup NAS OS LU in the same cluster as the failure CHA.	

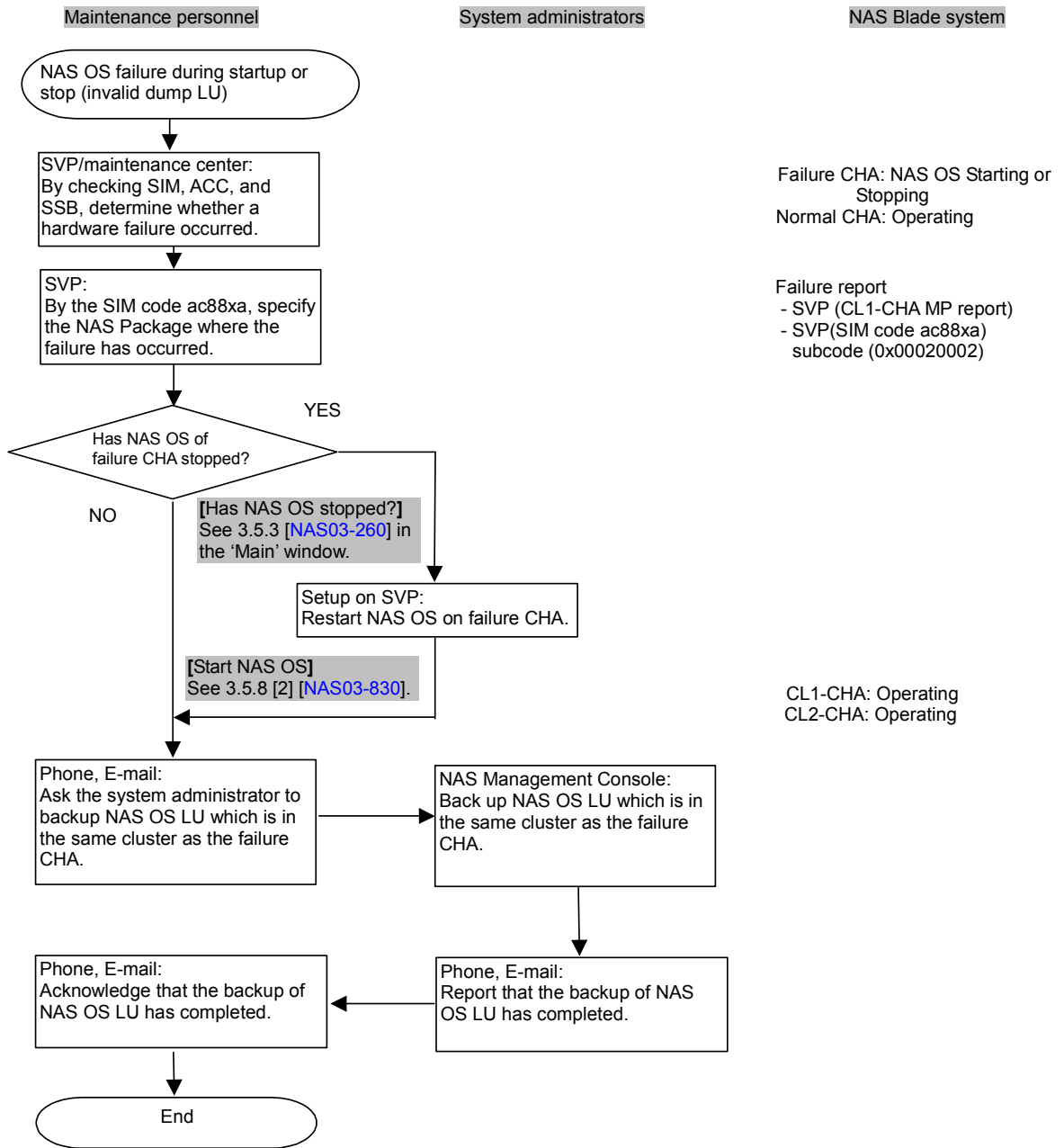

Figure 7.4-22 NAS OS Failure During Startup or Stop (Invalid Dump LU) (2/2)

(10) NAS OS Failure During Startup or Stop (Unable to Connect NTP Server)

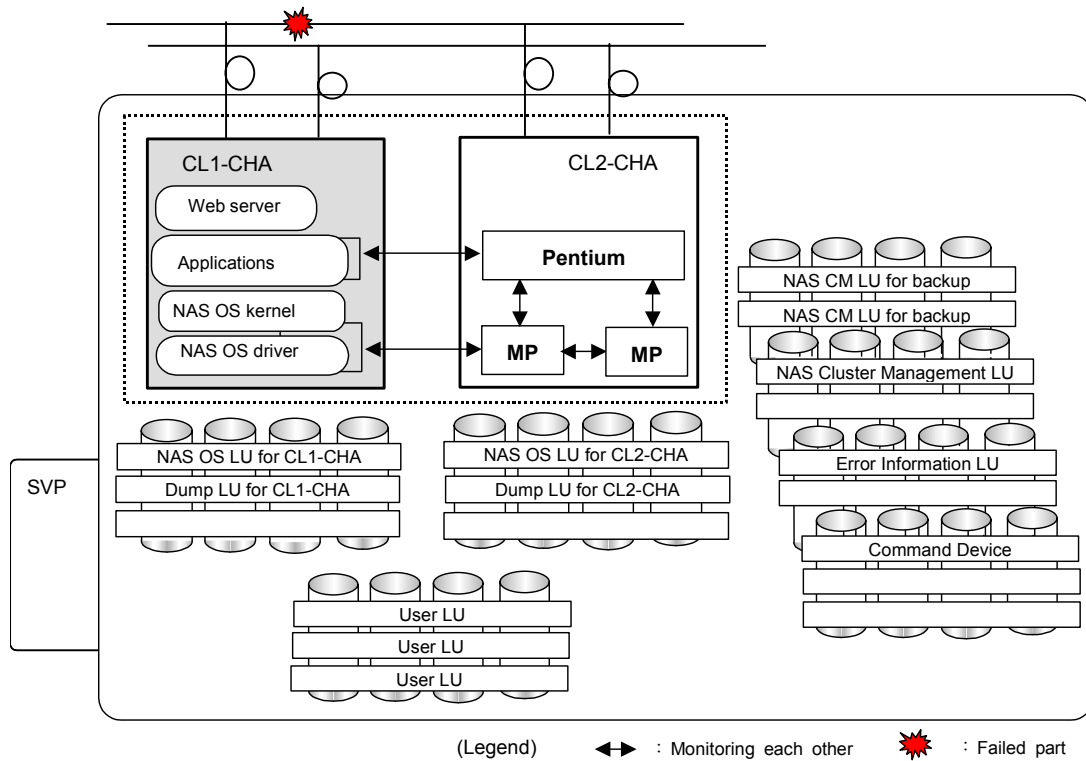

Figure 7.4-23 NAS OS Failure During Startup or Stop (Unable to Connect NTP Server) (1/4)

Step	Procedure	Notes
1	Determine whether the NTP server can be connected while starting or stopping NAS OS.	
2	Check the NTP server settings and network configuration, and then change them if necessary.	
3	Restart NAS OS.	

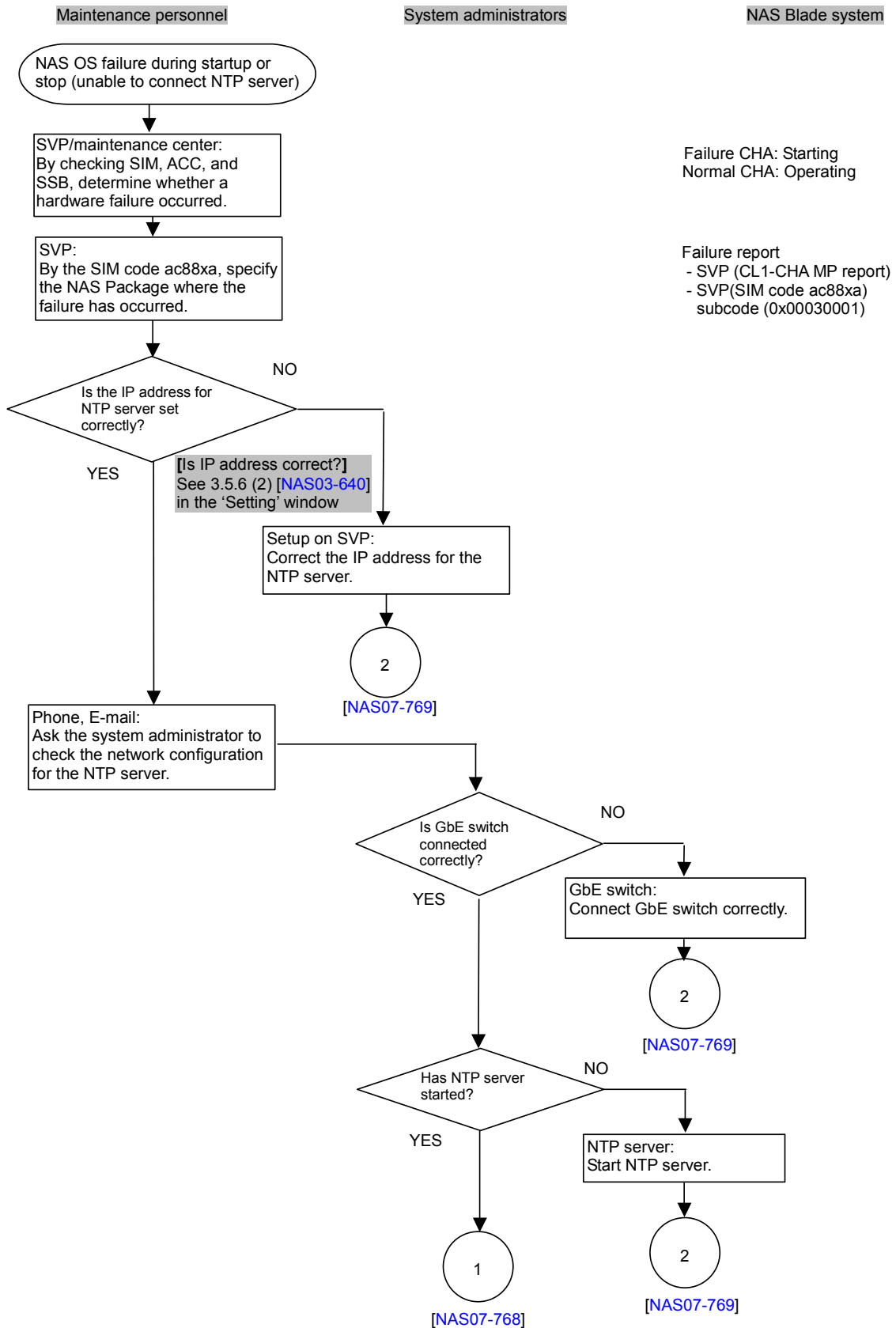

Figure 7.4-23 NAS OS Failure During Startup or Stop (Unable to Connect NTP Server) (2/4)

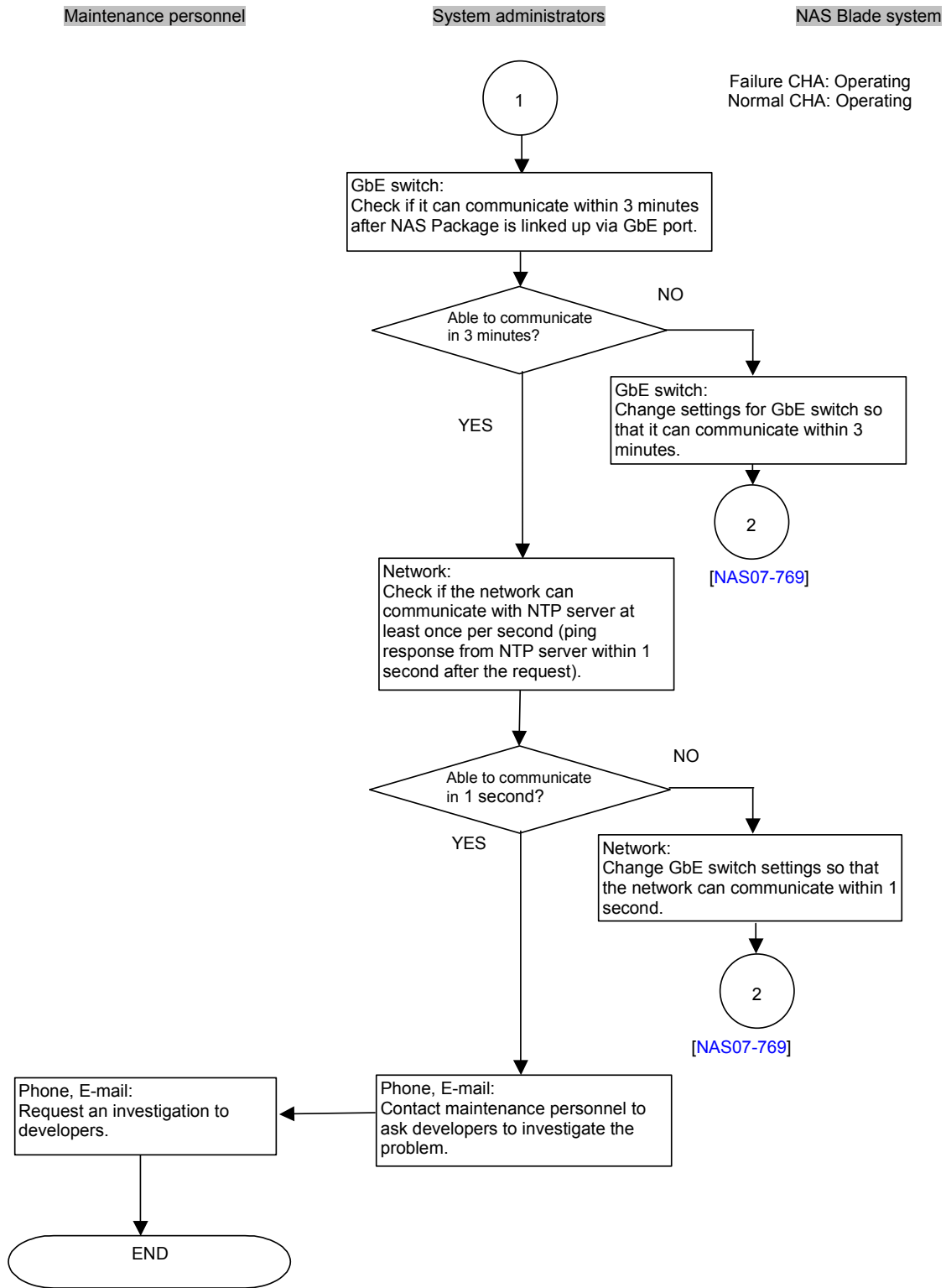

Figure 7.4-23 NAS OS Failure During Startup or Stop (Unable to Connect NTP Server) (3/4)

(11) NAS OS Application Failure (Unable to Set Internal IP Address)

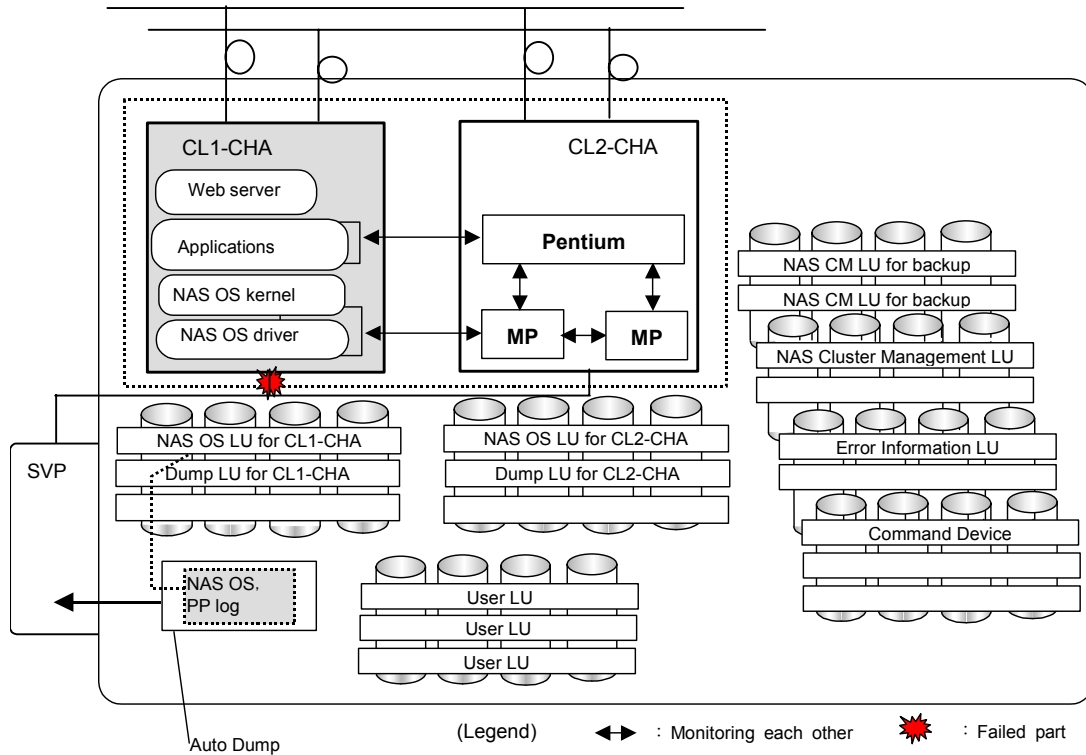

Figure 7.4-24 NAS OS Application Failure (Unable to Set Internal IP Address) (1/4)

Step	Procedure	Notes
1	Determine whether the internal IP address can be set.	
2	Ask the system administrator to acquire all the log data by using error information management functionality of NAS/Management and to request an investigation to the developer.	
3	Set the IP address back to the one before the change, collect detailed information, and send it to the developer.	
4	Reset the internal IP address to the new IP address.	
5	Perform failover.	
6	Restart NAS OS.	
7	Perform failback.	

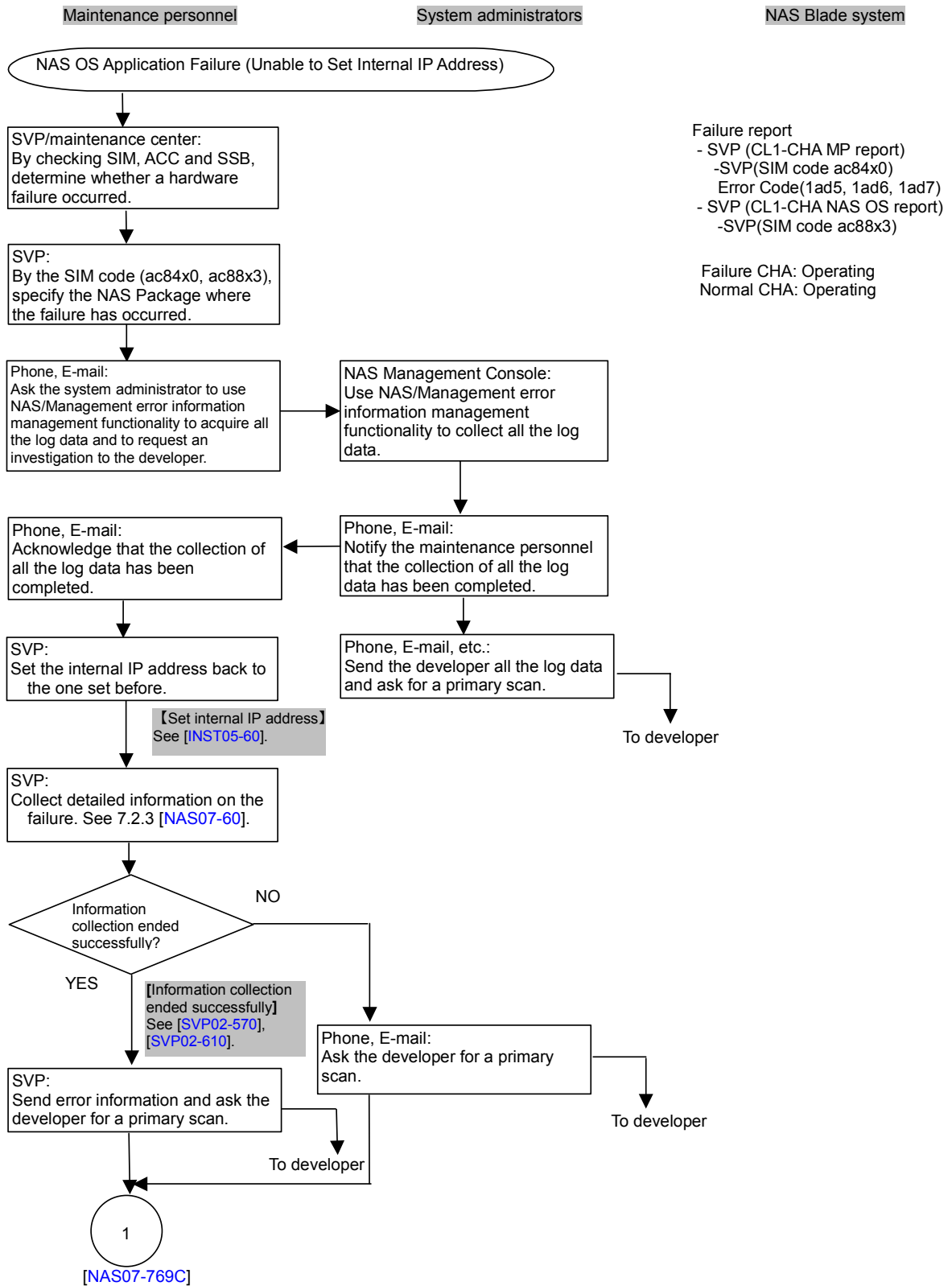

Figure 7.4-24 NAS OS Application Failure (Unable to Set Internal IP Address) (2/4)

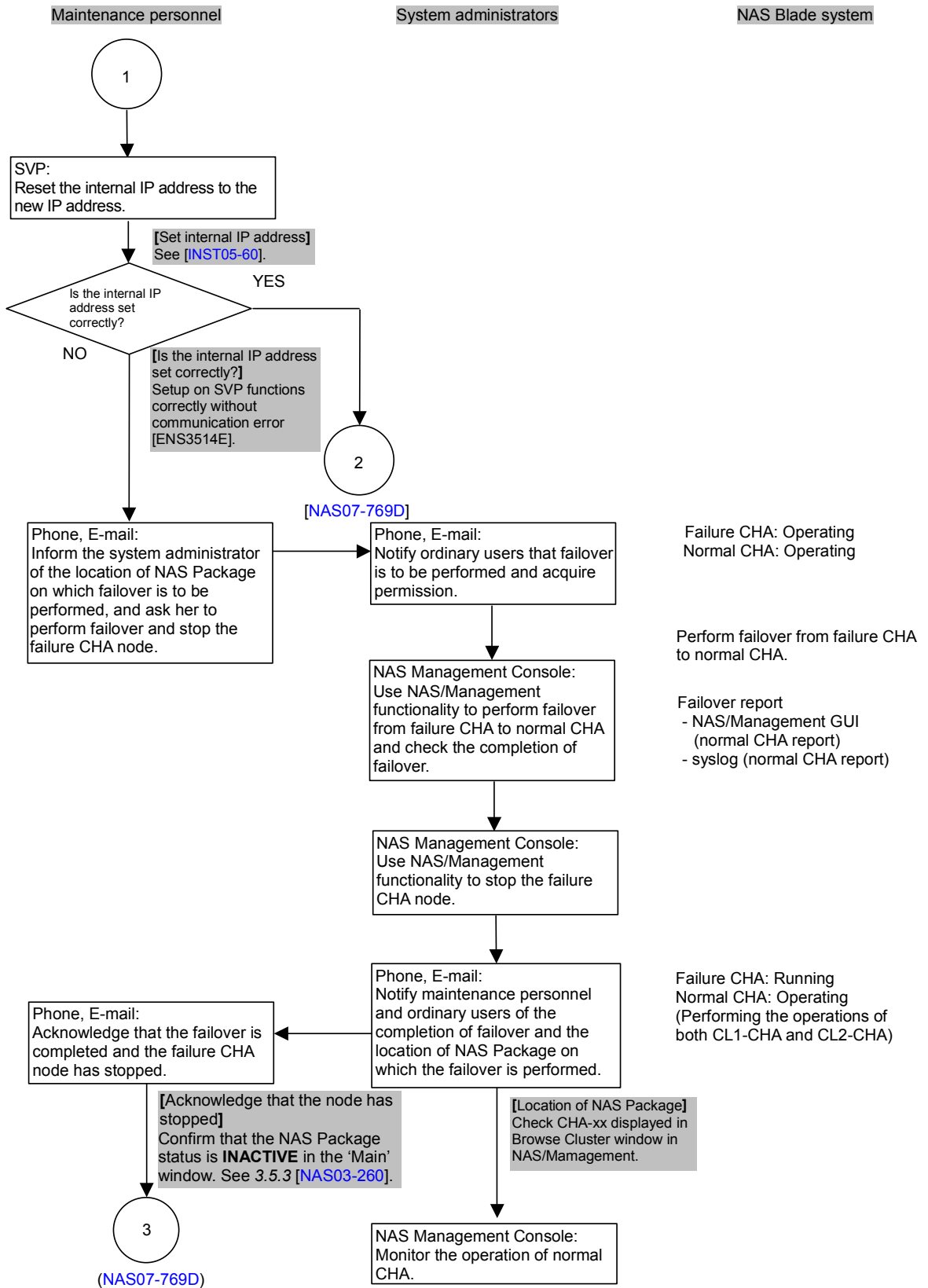

Figure 7.4-24 NAS OS Application Failure (Unable to Set Internal IP Address) (3/4)

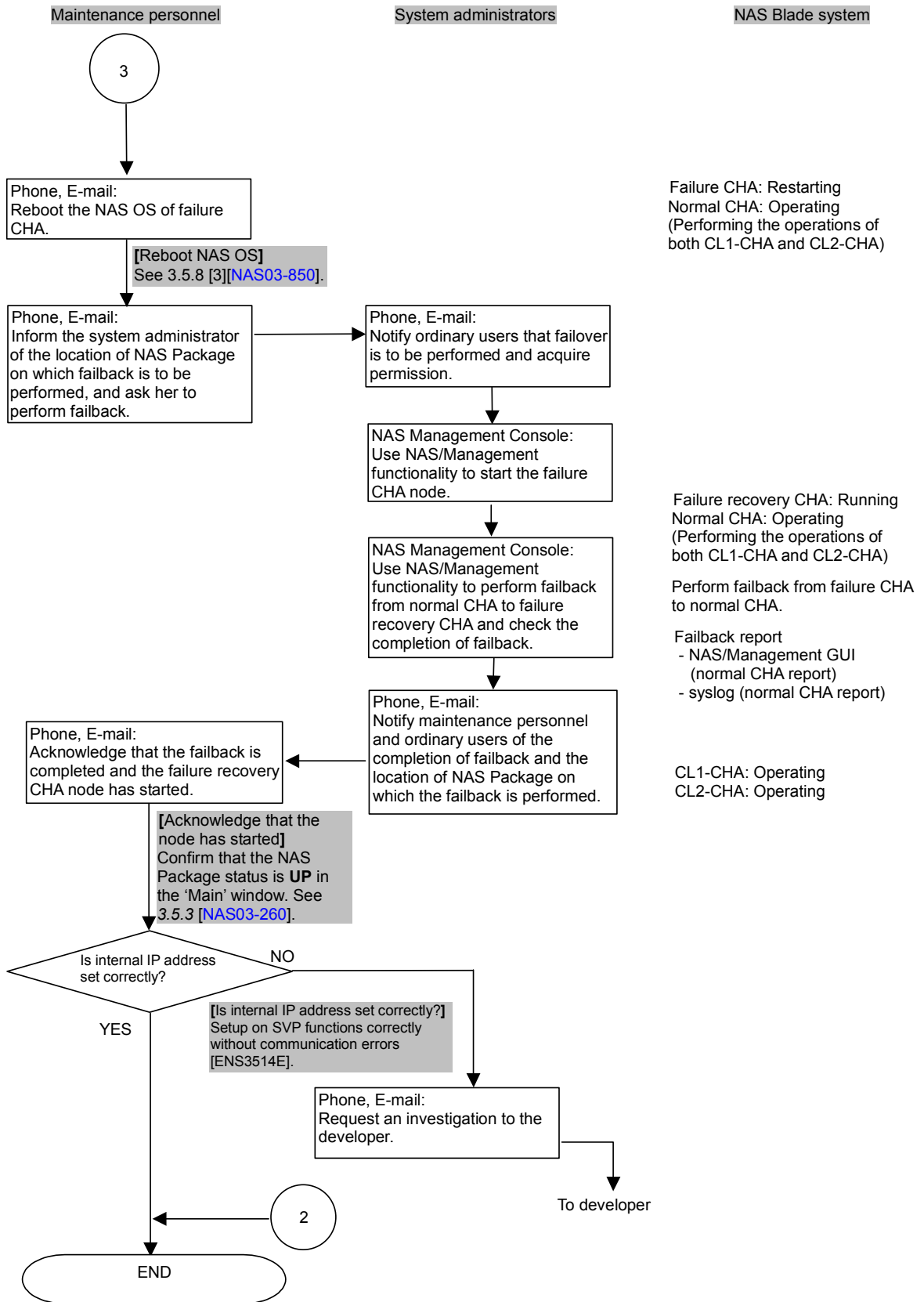

Figure 7.4-24 NAS OS Application Failure (Unable to Set Internal IP Address) (4/4)

7.5 Replacement Procedures When a Failure Occurs

This section shows the replacement of the hardware in the NAS Blade system and the software replacement operations when the version of the software is updated.

You can perform hot replacement of the hardware and online replacement of micro-programs in a disk subsystem without stopping user services (except for cases such as when a RAID group is not usable because of a PDEV failure).

Also, by using failover, you can replace NAS Packages in the NAS Blade system, without stopping user services. When replacing NAS Packages, maintenance personnel and system administrators need to consider whether the NAS OS needs to be stopped and whether to perform a failover.

7.5.1 Replacing Hardware

The following sections describe the hardware replacement operations performed by maintenance personnel and system administrators.

[1] Types of Hardware Replacement Operations

Hardware is replaced in the following two situations:

- Replacement when a hardware failure occurs
This replacement operation replaces the failed hardware.
- Replacement during periodic hardware replacement
This replacement operation replaces hardware based on the results, for example, of periodic diagnostics or correctable errors.

This section shows the replacement when a hardware failure occurs.

Such replacement operations are classified based on the operations performed by maintenance personnel or system administrators and the NAS Blade system behavior, as follows.

This chapter assumes that a RAID group has a configuration formed by RAID5 (3D+1P).

Table 7.5-1 Types of Hardware Replacement Operations

#	Target hardware	Corresponding tasks	Restart the NAS OS?	Perform a failback?	Can ordinary users continue operations? *1	Reference info. for when a failure occurs
1	NAS Package	Replace the NAS Package.	Yes	Yes	Yes	Figure 7.5-1 [NAS07-810]
2	Hardware other than NAS Package ^{*2}	Replace the hardware (hot replacement).	No	No	Yes	Figure 7.5-2 [NAS07-840]
3	Two PDEVs (user LUs) ^{*3}	Replace two PDEVs. Release the RAID group's blocked state.	Yes	Yes	No	Figure 7.5-3 [NAS07-860]
4	Two PDEVs (NAS OS LUs: when the NAS OS LU and the dump LU belong to different RAID groups)	Replace two PDEVs. Release the RAID group's blocked state. Restore a NAS OS LU.	Yes	Yes	Yes	Figure 7.5-4 [NAS07-900]
5	Two PDEVs (NAS OS LUs: when the NAS OS LU for CL1-CHA and that for CL2-CHA belong to the same RAID group)	Replace two PDEVs. Release the RAID group's blocked state. Rebuild.	Yes	No ^{*3}	No	Figure 7.5-5 [NAS07-940]
6	Two PDEVs (NAS Cluster Management LUs)	Replace two PDEVs. Release the RAID group's blocked state. Rebuild.	Yes	No ^{*3}	No	Figure 7.5-6 [NAS07-960]
7	Two PDEVs (dump LUs)	Replace two PDEVs. Release the RAID group's blocked state.	Yes	Yes	Yes ^{*5}	Figure 7.5-7 [NAS07-980]
8	Two PDEVs (error information LUs)	Replace two PDEVs. Release the RAID group's blocked state.	No	No	Yes ^{*6}	Figure 7.5-8 [NAS07-1030]
9	Two PDEVs (command devices)	Replace two PDEVs. Release the RAID group's blocked state.	No	No	Yes ^{*7}	Figure 7.5-9 [NAS07-1050]
10	Two PDEVs (Backup LUs of NAS Cluster Management LUs)	Replace two PDEVs. Release the RAID group's blocked state.	No	No	Yes ^{*8}	Figure 7.5-10 [NAS07-1070]
11	Data LAN (GbE)	Check the data LAN (GbE) connection and the network.	No	Yes	Yes	Figure 7.5-11 [NAS07-1081]

*1: Yes: Ordinary users can continue their operations.

However, if the application server is connected with Windows client (CIFS share) when a failback occurs, the CIFS share is released, therefore, you must reconnect the server with CIFS share.

No: Ordinary users cannot perform operations related to the failed PDEV(s).

*2: For details, see the *REPLACE* Section [REP01-10].

*3: Failover cannot be performed.

*4: Not applicable to periodic replacement

- *5: The hibernation dump, the LM dump and the crash dump cannot be collected when a NAS OS failure occurred.
- *6: The hibernation dump, the LM dump and the crash dump cannot be obtained.
- *7: Snapshots and backups cannot be performed.
- *8: The NAS Cluster Management LU cannot be backed up.

[2] Procedures for Replacing Hardware

In this section, the cluster is assumed to consist of CL1-CHA and CL2-CHA, and the following tables show the flowcharts for hardware replacement on CL1-CHA from Figure 7.5-1 to Figure 7.5-11.

Make sure that CL2-CHA is properly referred to as the actual location when for hardware replacement on the CHA location.

Table 7.5-2 shows the actual CHA locations in the NAS cluster configuration.

Table 7.5-2 CHA Location in the NAS Cluster Configuration

Model	CHA location	CL1-CHA	CL2-CHA
Multi-cabinet	Basic	1P	2V
	Option 1	1Q	2W
	Option 2	1R	2X
	Option 3	1S	2Y
Single cabinet ^{*1}	Basic	1C	2G
	Option 1	1D	2J
	Option 2	1F	2K

*1: Only two of the three, basic, option 1, or option 2, can be used.

(1) Replacing the NAS Package (When a Failure Occurs)

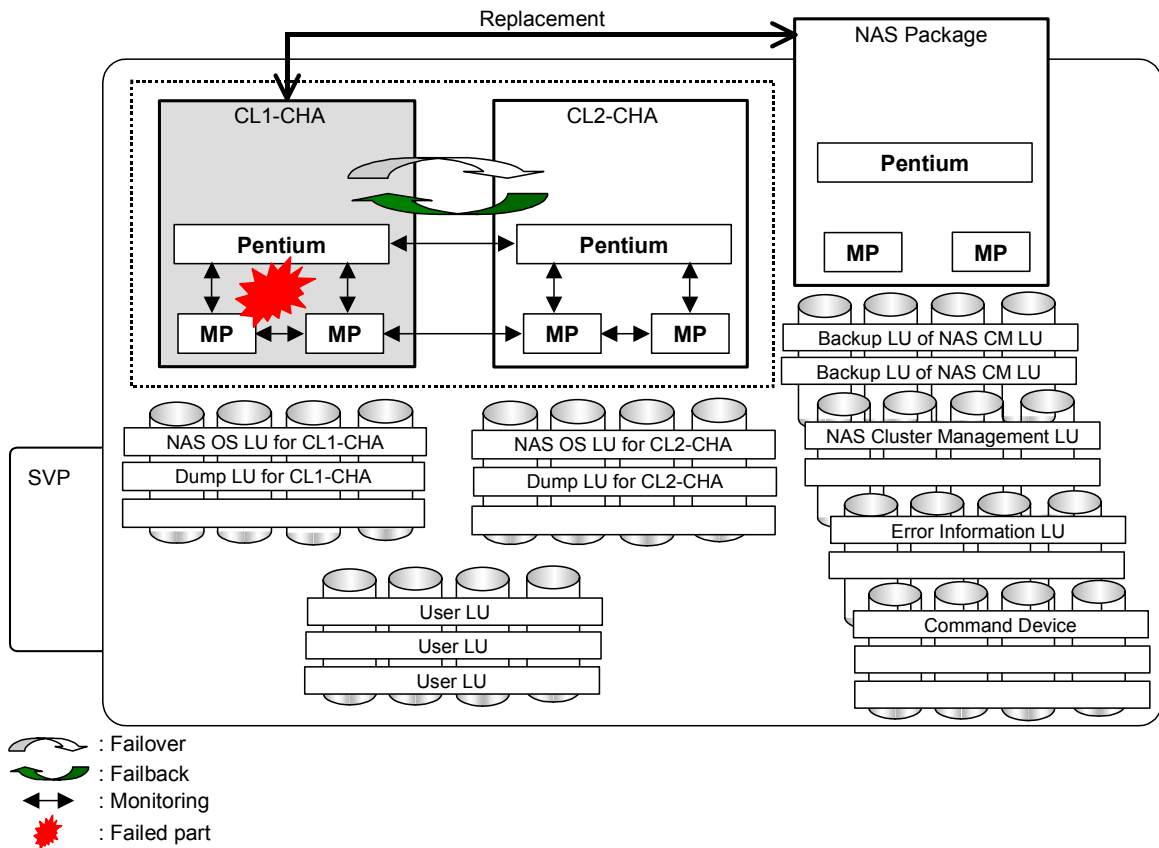

Figure 7.5-1 Replacing the NAS Package (When a Failure Occurs) (1/3)

Step	Procedure	Notes
1	Replace the NAS Package.	
2	Perform failback.	

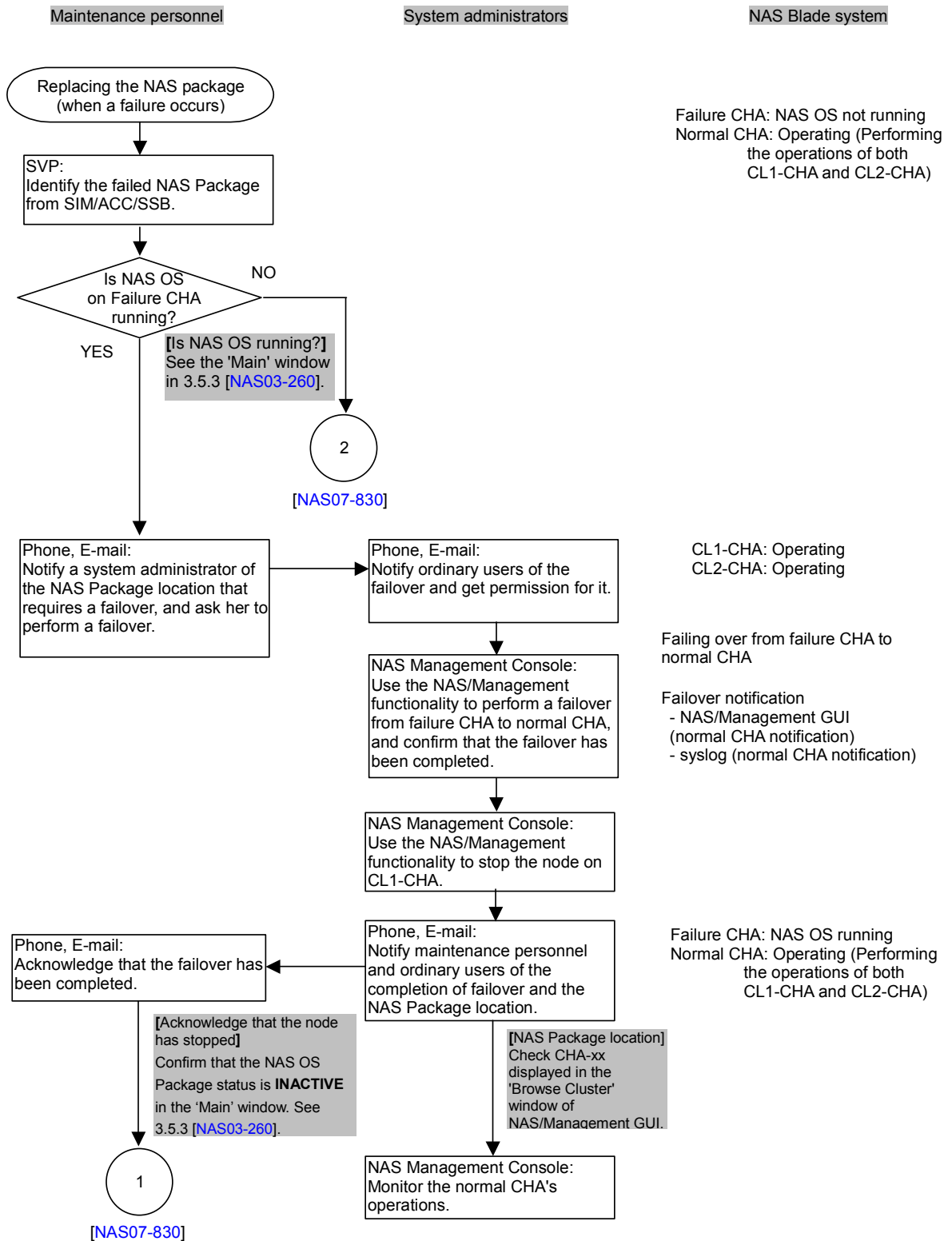

Figure 7.5-1 Replacing the NAS Package (When a Failure Occurs) (2/3)

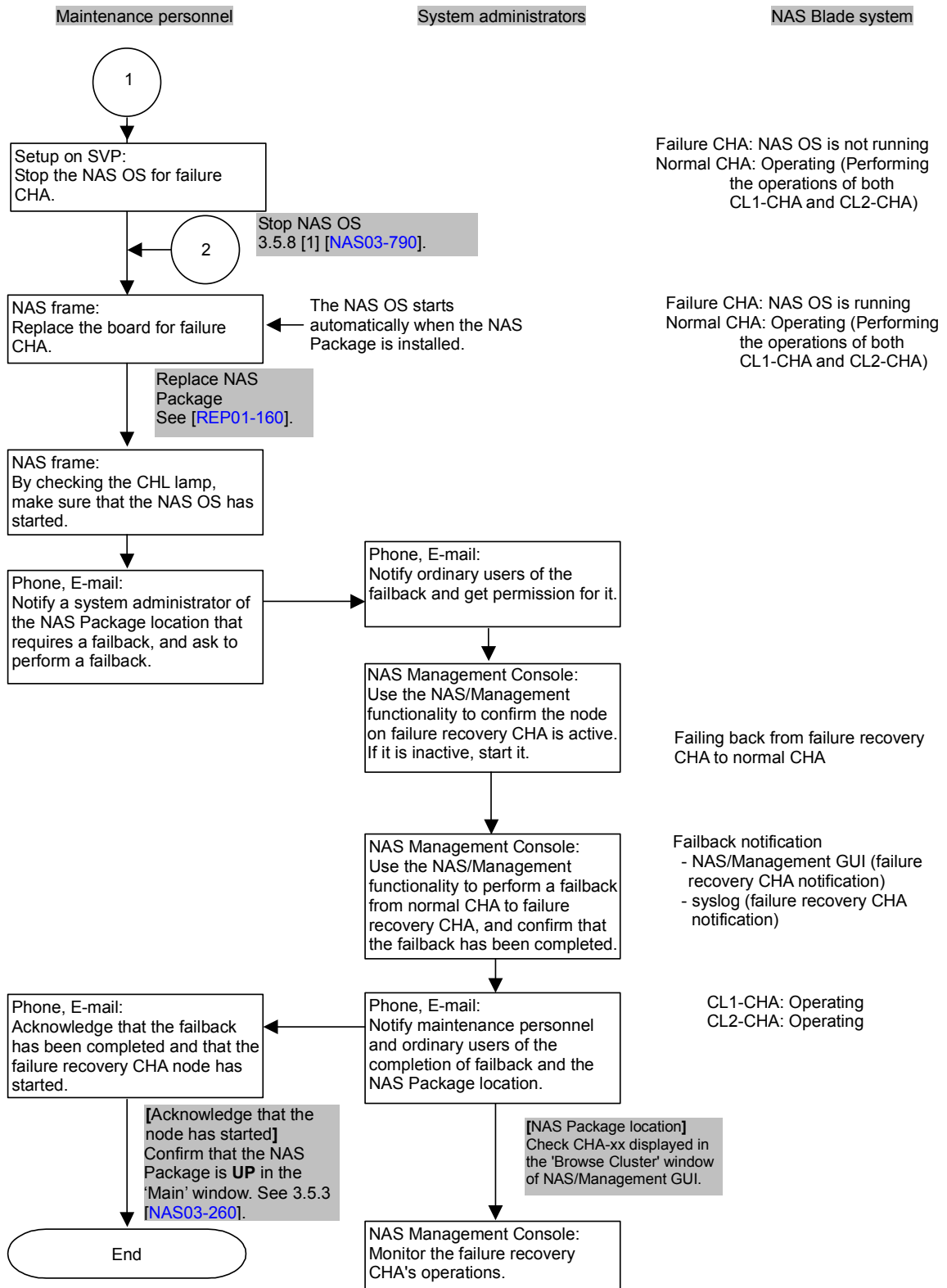

Figure 7.5-1 Replacing the NAS Package (When a Failure Occurs) (3/3)

(2) Hot-replacing Hardware Other Than the NAS Package

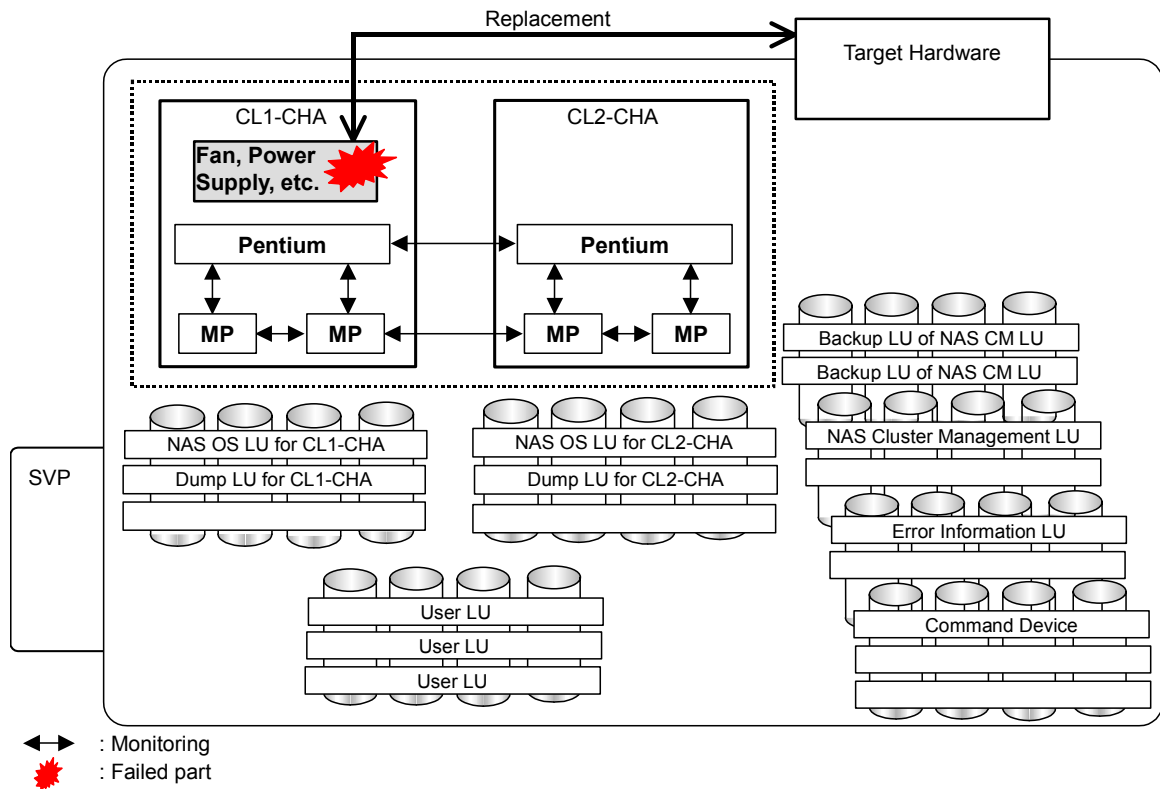

Figure 7.5-2 Hot-Replacing Hardware Other than the NAS Package (1/2)

Step	Procedure	Notes
1	Replace the target hardware.	

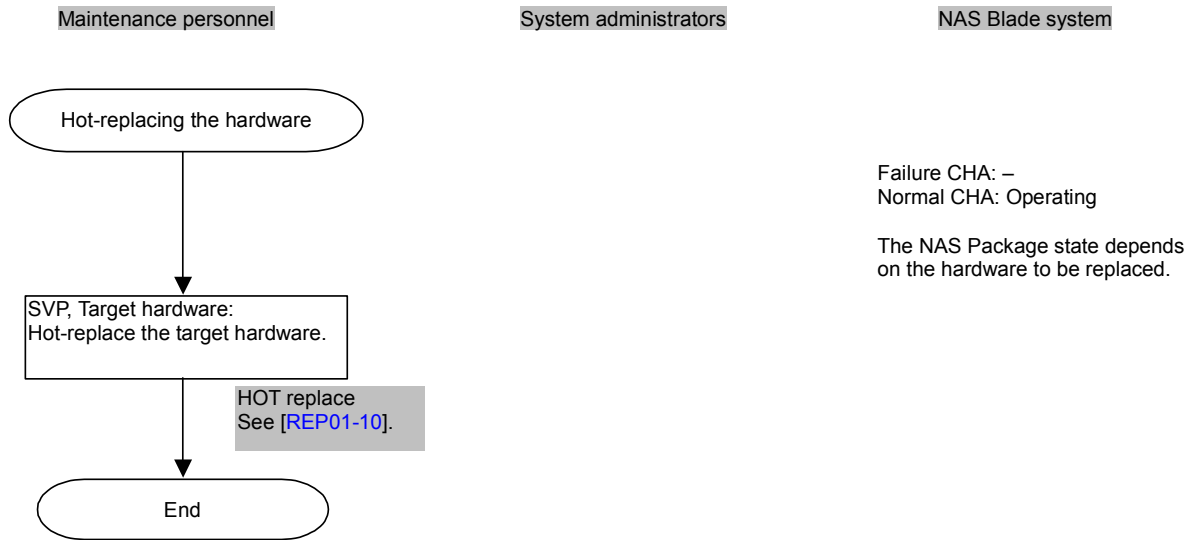

Figure 7.5-2 Hot-Replacing Hardware Other than the NAS Package (2/2)

(3) Replacing Two PDEVs (User LUs)

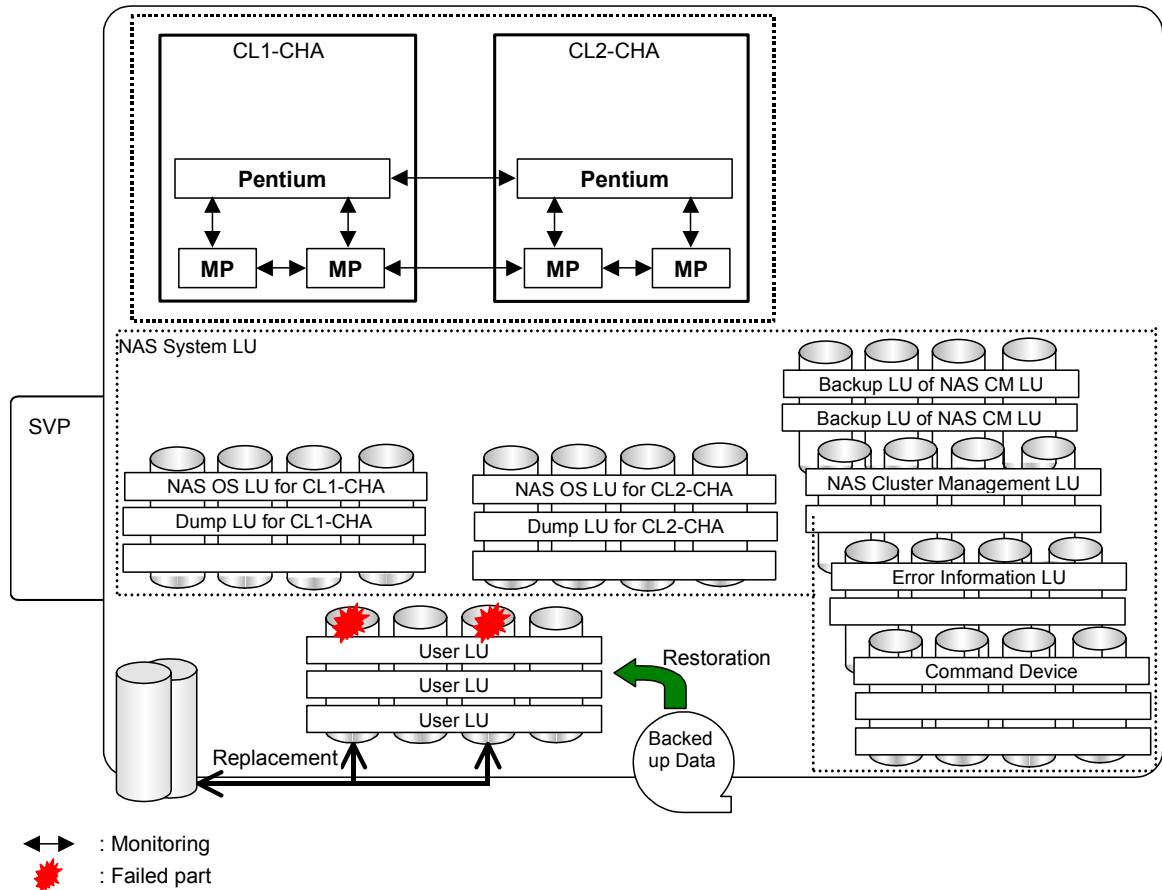

Figure 7.5-3 Replacing Two PDEVs (User LUs) (1/4)

Step	Procedure	Notes
1	Check that the file system is deleted in the user LU on which the error occurred.	
2	Perform the failover.	
3	Stop the node.	
4	Restart the NAS OS of the user LU on which the error occurred.	
5	Start the node.	
6	Perform failback.	
7	Replace the target PDEV.	
8	Release the RAID group's blocked state.	
9	Re-create a file system in the user LU.	
10	Restore the user data.	Do so only if the backup data already exists.

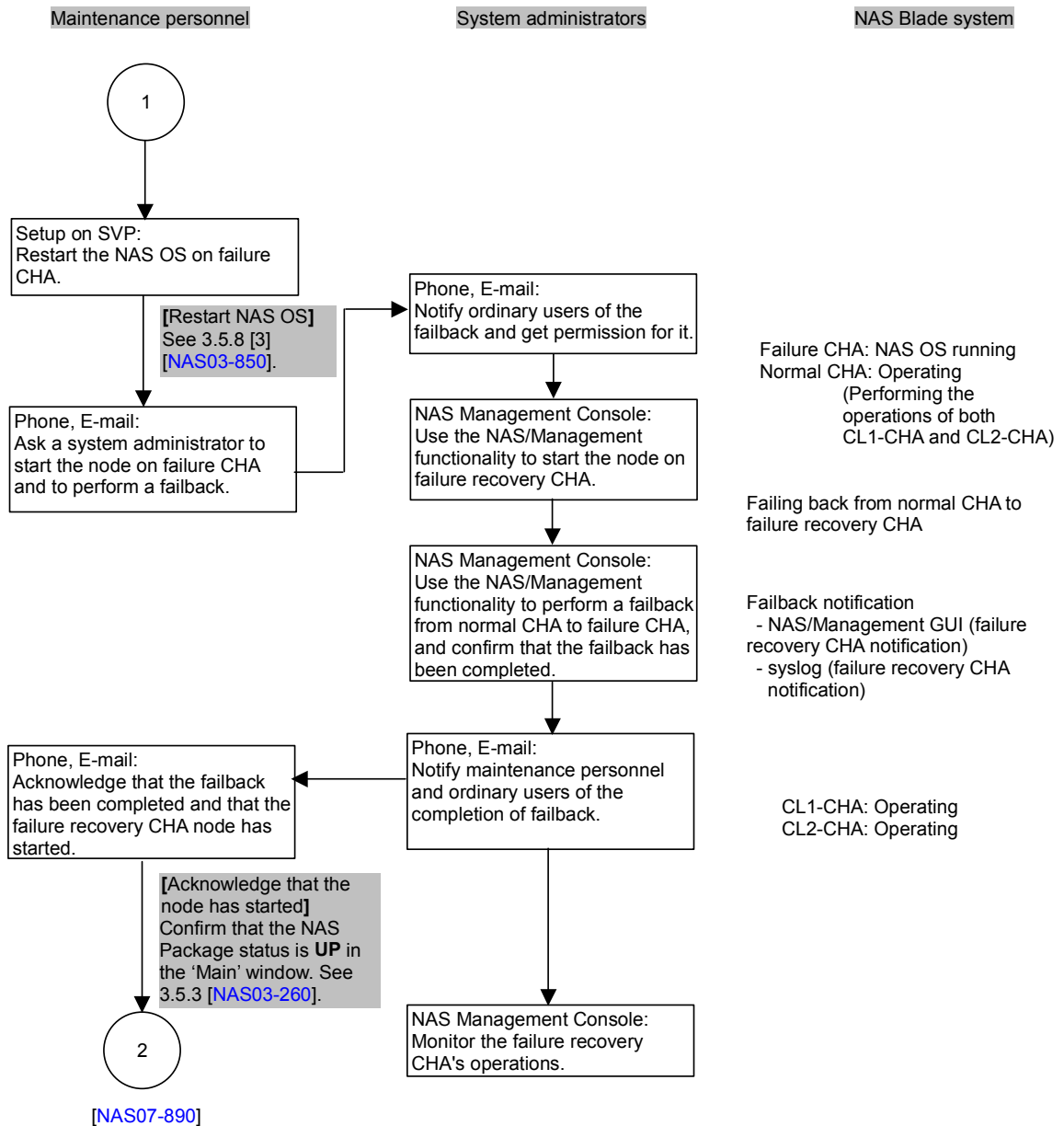

Figure 7.5-3 Replacing Two PDEVs (User LUs) (3/4)

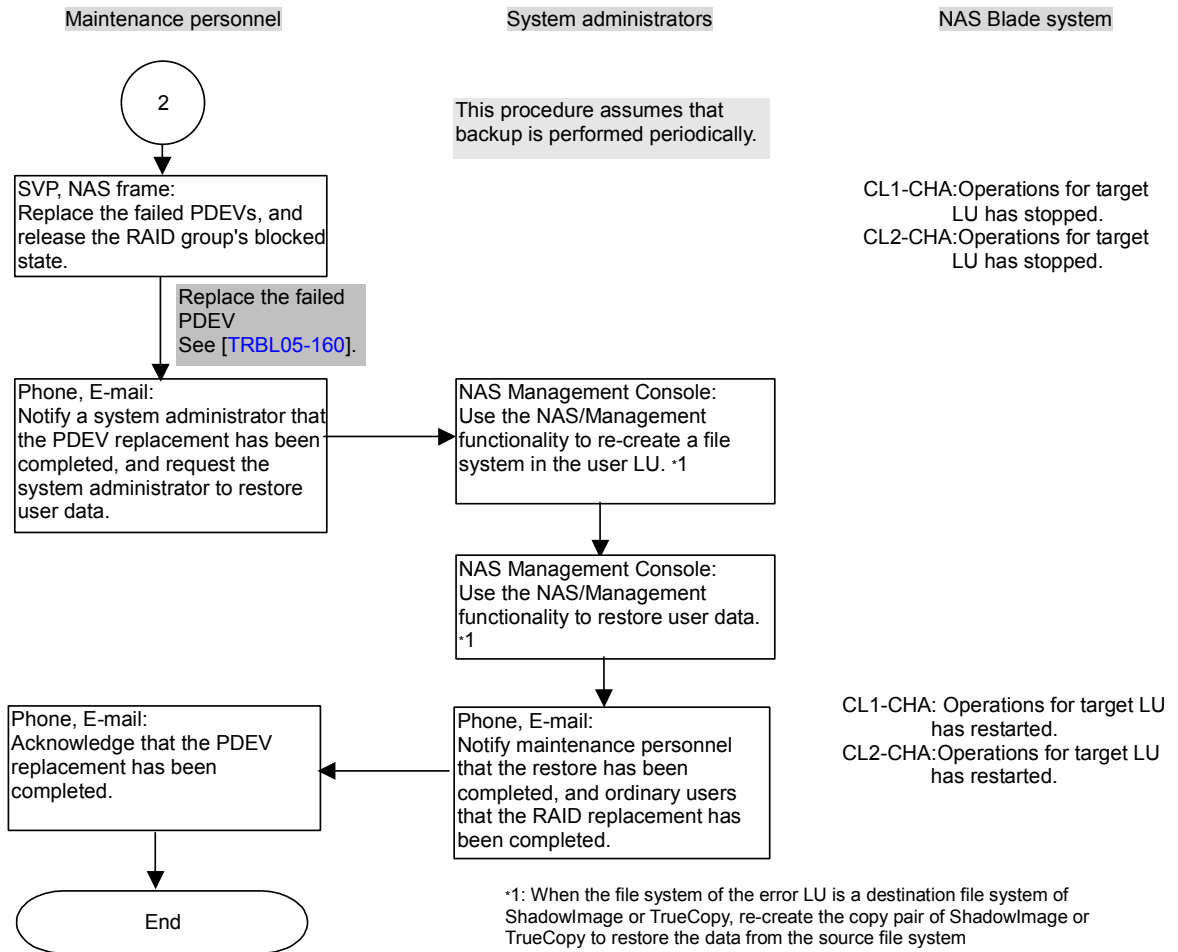

Figure 7.5-3 Replacing Two PDEVs (User LUs) (4/4)

(4) Replacing Two PDEVs (NAS OS LUs: When the NAS OS LU and the Dump LU Belong to Different RAID Groups)

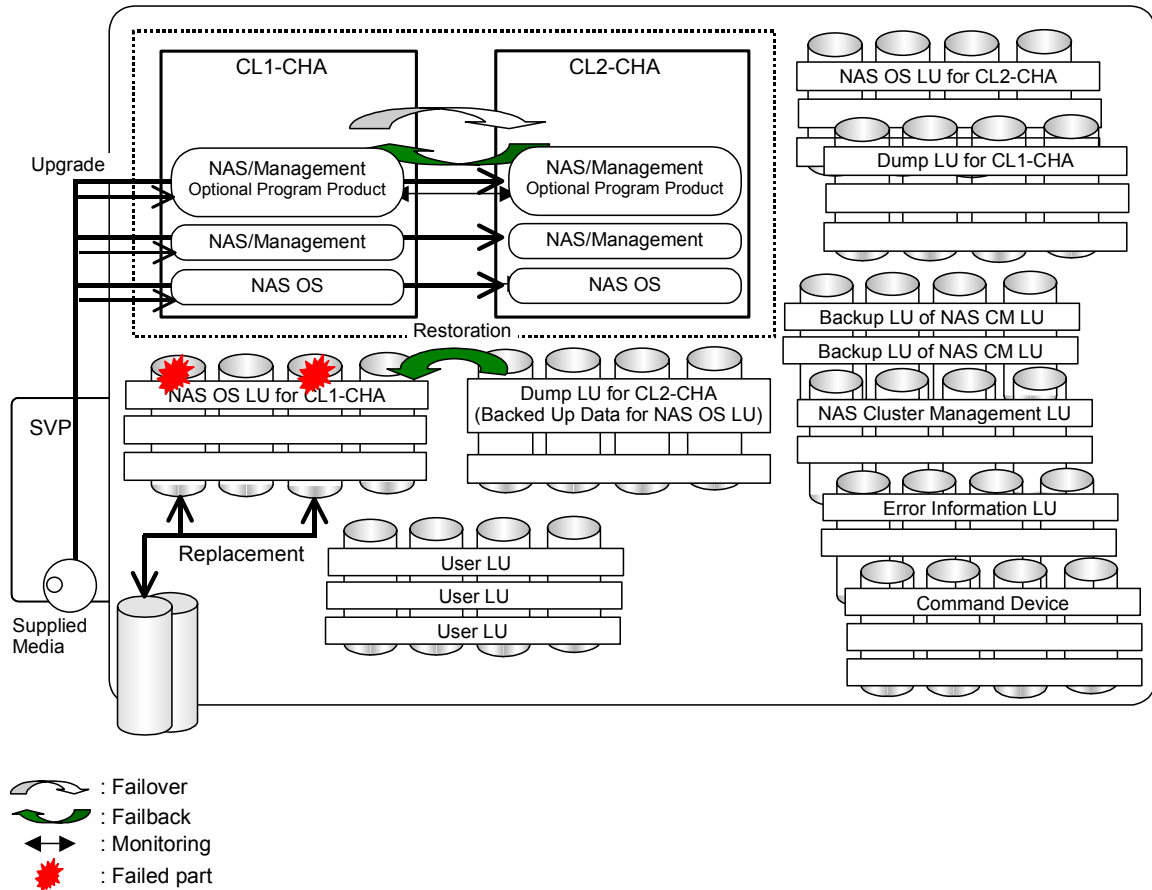

Figure 7.5-4 Replacing Two PDEVs (NAS OS LUs: When the NAS OS LU and the Dump LU Belong to Different RAID Groups) (1/4)

Step	Procedure	Notes
1	Replace the target PDEV.	
2	Release the RAID group's blocked state.	
3	Install NAS OS.	After the expansion installation, recover from the failure by upgrading the NAS OS to the version at the time of failure occurrence.
4	Install NAS/Management, and optional program products.	Upgrade to the version at the time of failure occurrence.
5	Set up the network information.	Use the settings that were used at the time of failure occurrence.
6	Restore the NAS OS LU.	Do so only if the backup data of the NAS OS LU already exists.
7	Restart the NAS OS.	
8	Perform failback.	

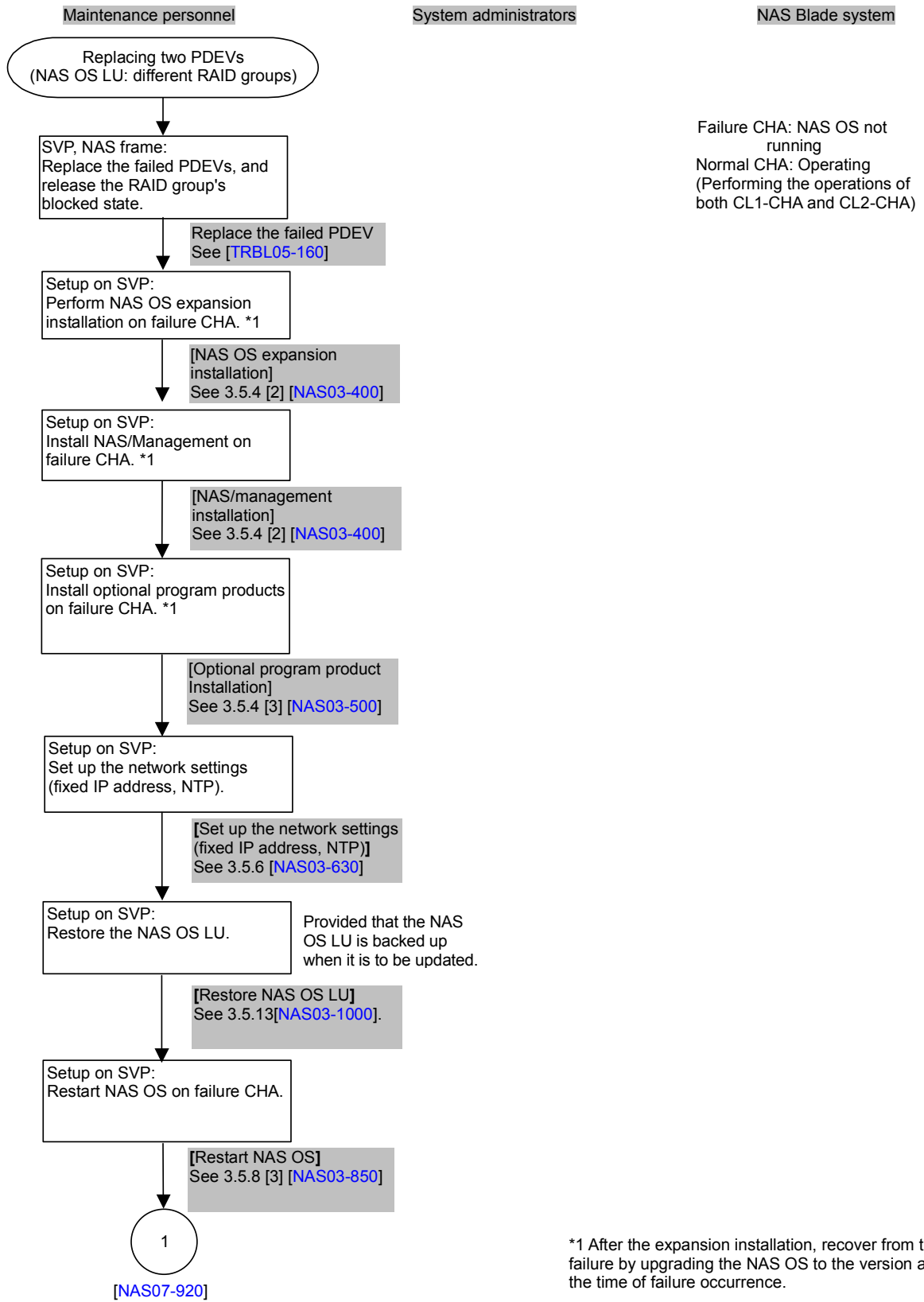

Figure 7.5-4 Replacing Two PDEVs (NAS OS LUs: When the NAS OS LU and the Dump LU Belong to Different RAID Groups) (2/4)

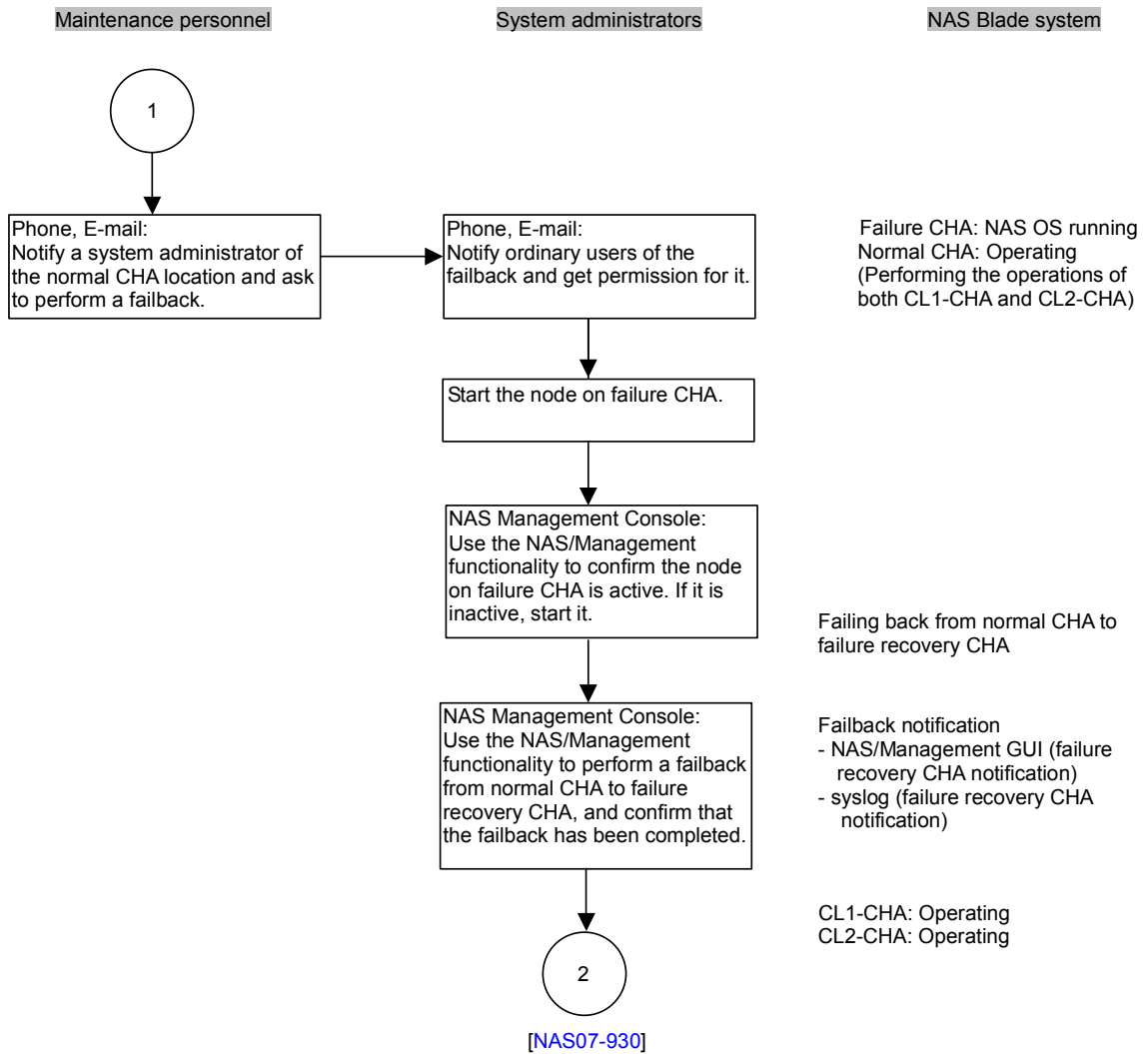

Figure 7.5-4 Replacing Two PDEVs (NAS OS LUs: When the NAS OS LU and the Dump LU Belong to Different RAID Groups) (3/4)

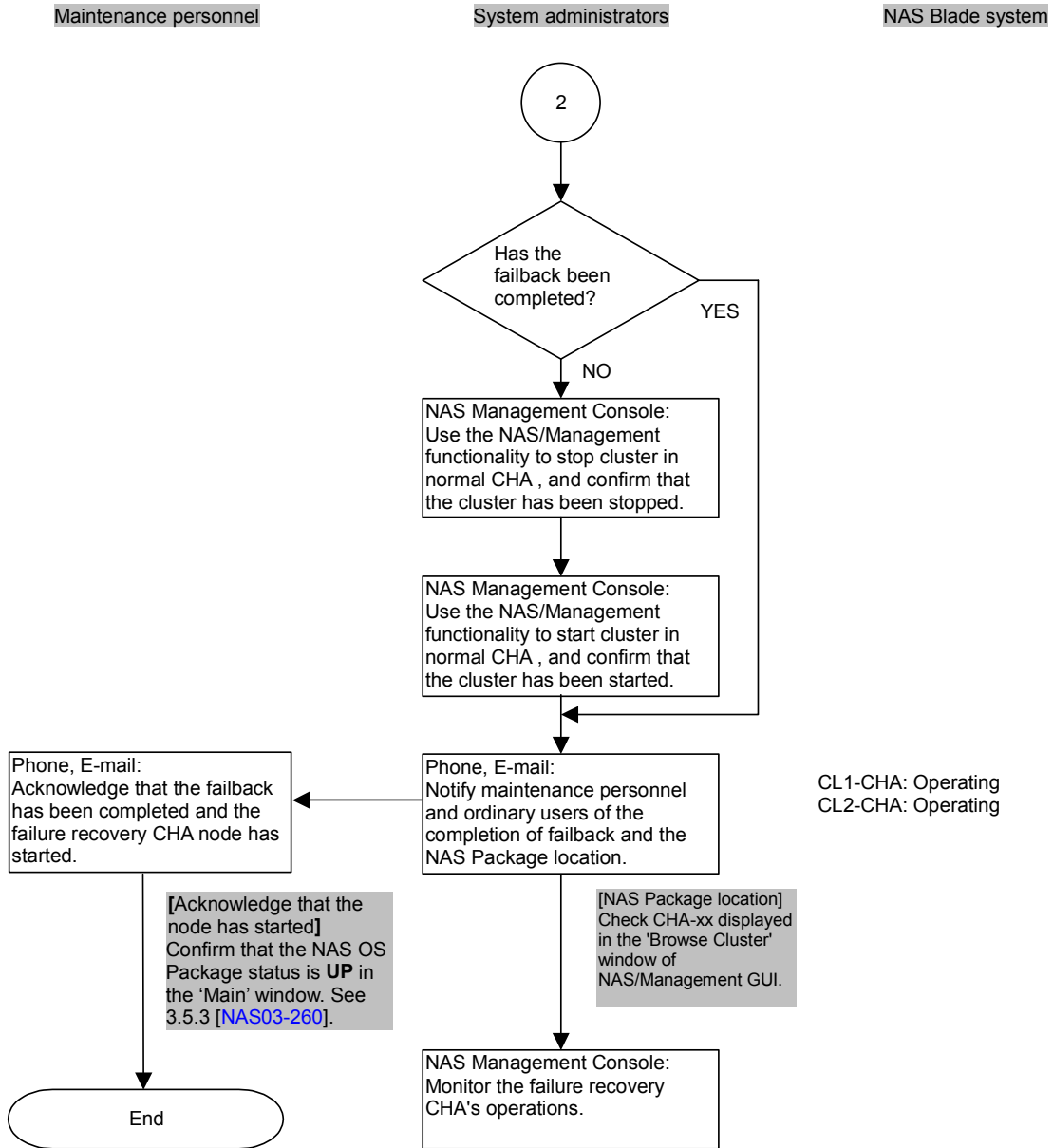

Figure 7.5-4 Replacing Two PDEVs (NAS OS LUs: When the NAS OS LU and the Dump LU Belong to Different RAID Groups) (4/4)

(5) Replacing Two PDEVs (NAS OS LU: When the NAS OS LUs for CL1-CHA and CL2-CHA Belong to the Same RAID Group)

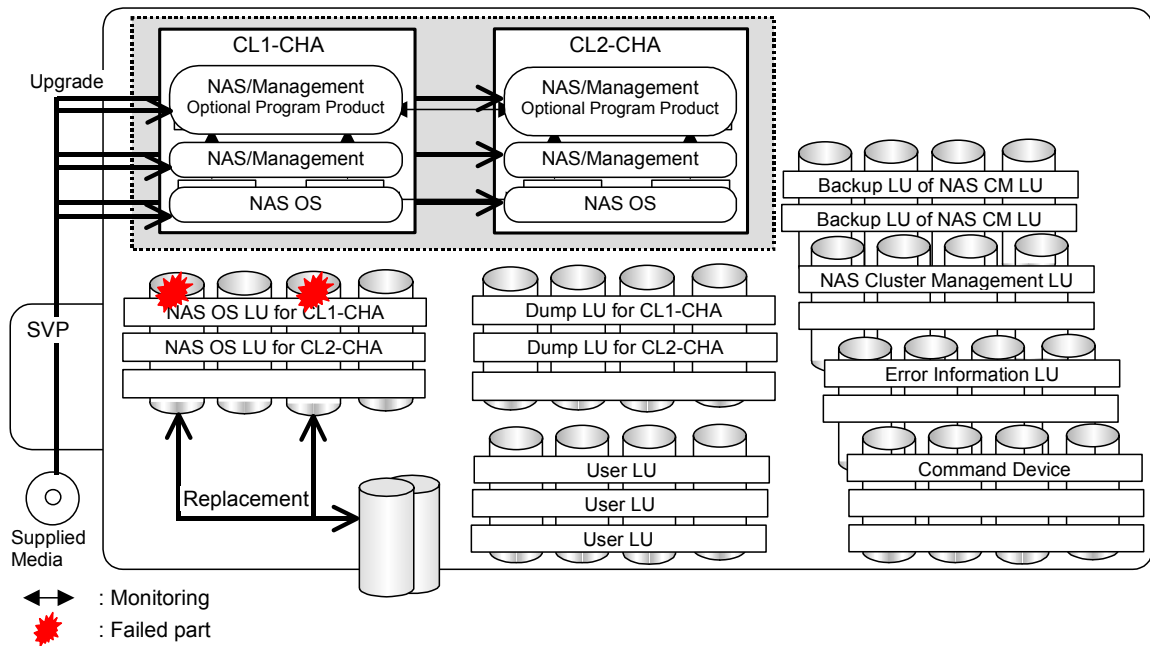

Figure 7.5-5 Replacing Two PDEVs (NAS OS LUs: When the NAS OS LUs for CL1-CHA and CL2-CHA Belong to the Same RAID Group) (1/2)

Step	Procedure	Notes
1	Replace the target PDEV.	
2	Release the RAID group's blocked state.	
3	Perform the expansion installation of NAS OS.	After the expansion installation, recover from the failure by upgrading the NAS OS to the version at the time of failure occurrence.
4	Reconfigure the system.	Implement the series of tasks from upgrading the NAS OS to setting up the functionality related to error monitoring.

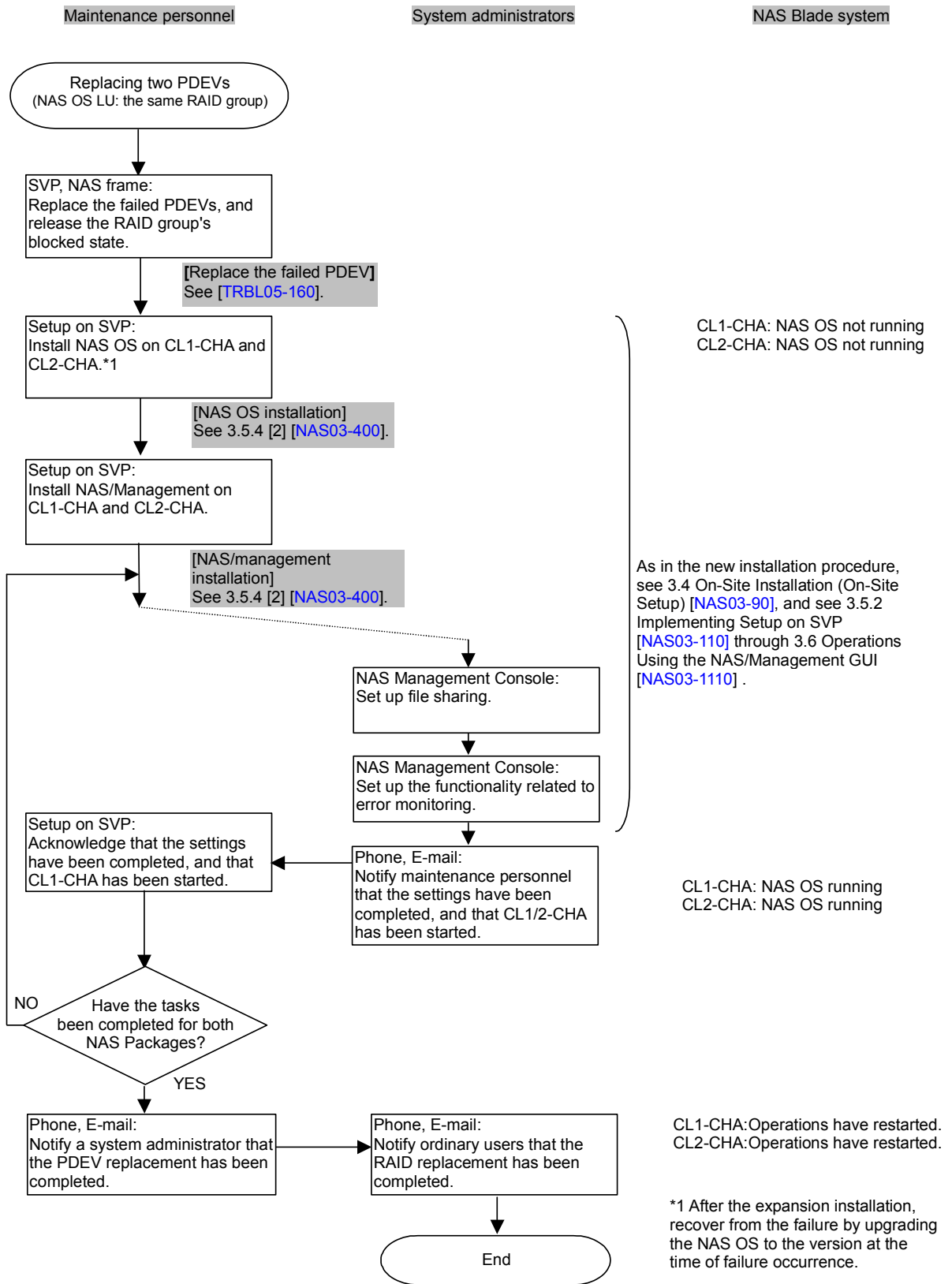

Figure 7.5-5 Replacing Two PDEVs (NAS OS LU: When the NAS OS LUs for CL1-CHA and CL2-CHA Belong to the Same RAID Group) (2/2)

(6) Replacing Two PDEVs (NAS Cluster Management LUs)

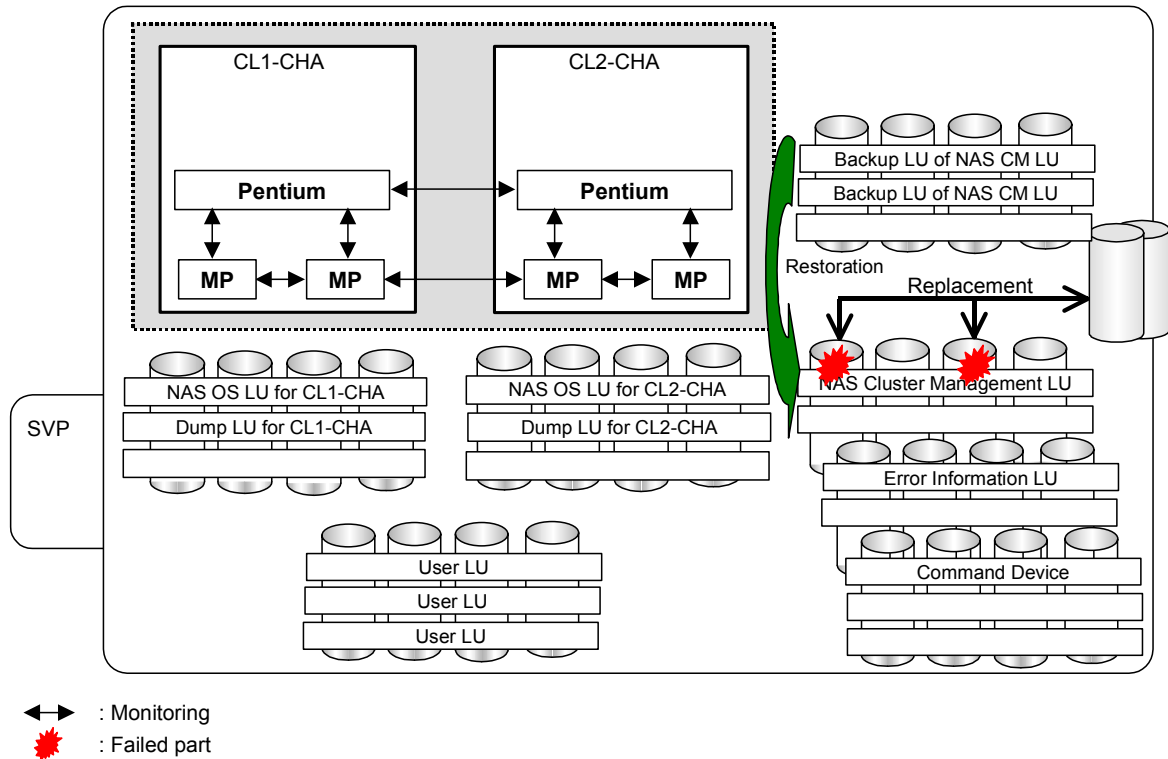

Figure 7.5-6 Replacing Two PDEVs (NAS Cluster Management LUs) (1/2)

Step	Procedure	Notes
1	Replace the target PDEV.	
2	Release the RAID group's blocked state.	
3	Restart all NAS OSs.	Restart NAS OS of each NAS package that makes a cluster. CHN that has larger CHN number must be restarted first. (CL2-CHN first, then CL1-CHA.) Password input need at the time of OS restart.
4	Restore the NAS Cluster Management LU.	
5	Restart all NAS OSs.	

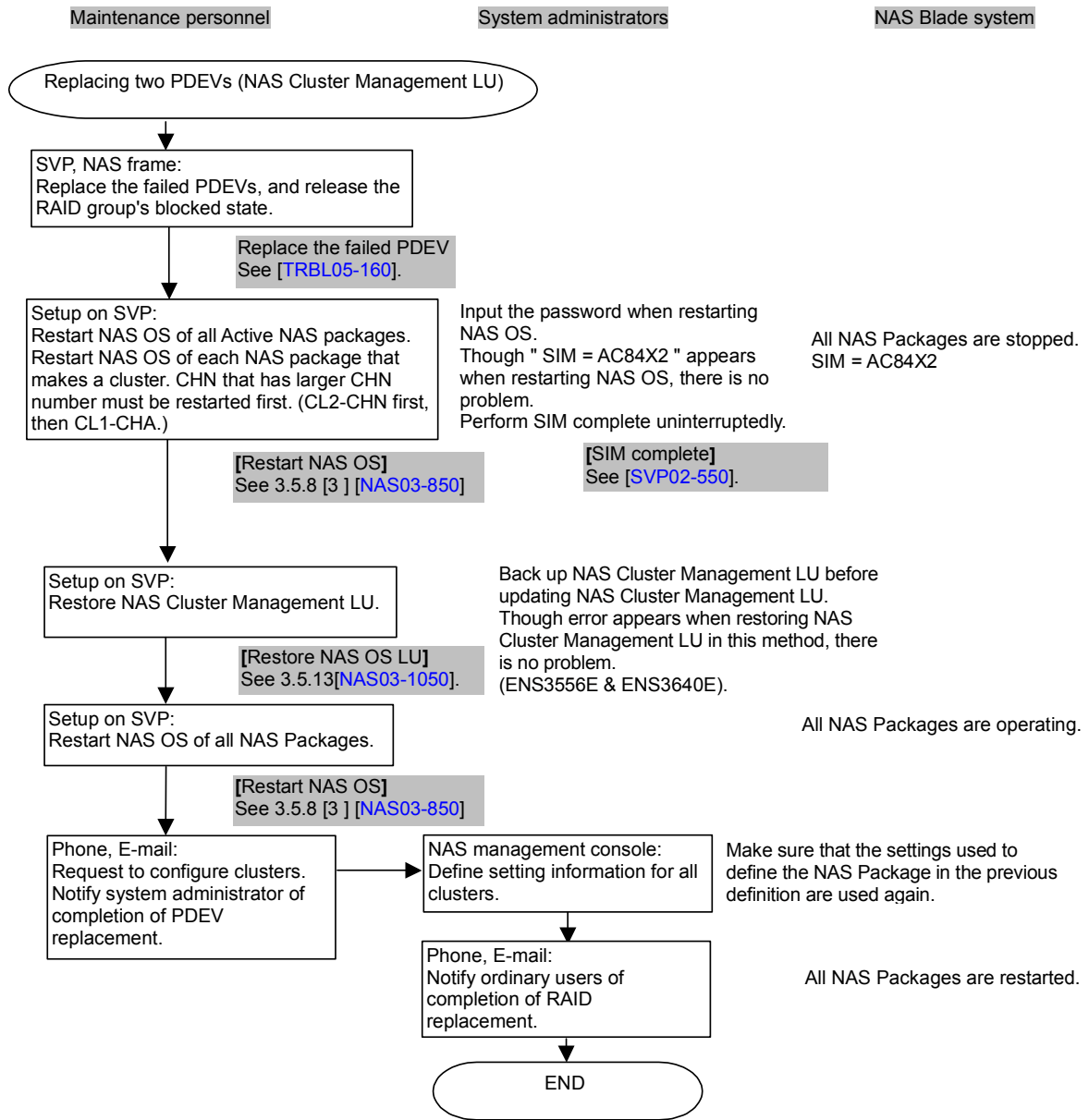

Figure 7.5-6 Replacing Two PDEVs (NAS Cluster Management LU) (2/2)

(7) Replacing Two PDEVs (Dump LUs)

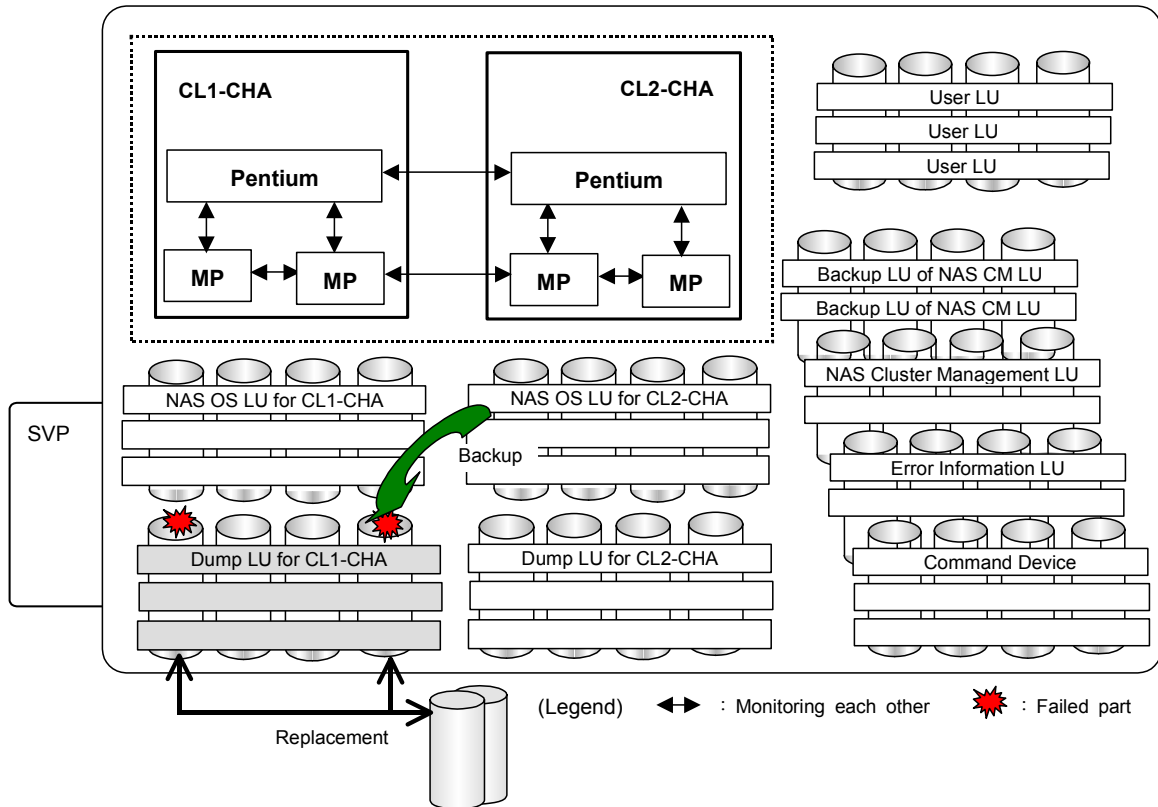

Figure 7.5-7 Replacing Two PDEVs (Dump LUs) (1/5)

Step	Procedure	Notes
1	Check the operating status of the NAS Blade system.	
2	Perform the failover.	
3	Stop the node.	
4	Release the setting of automatic save of the NAS OS LU.	
5	Replace the target PDEV.	
6	Release the RAID group's blocked state.	
7	Reboot the NAS OS.	
8	Start the node.	
9	Perform failback.	
10	Backup NAS OS LU.	
11	Change the setting of automatic save of the NAS OS LU.	

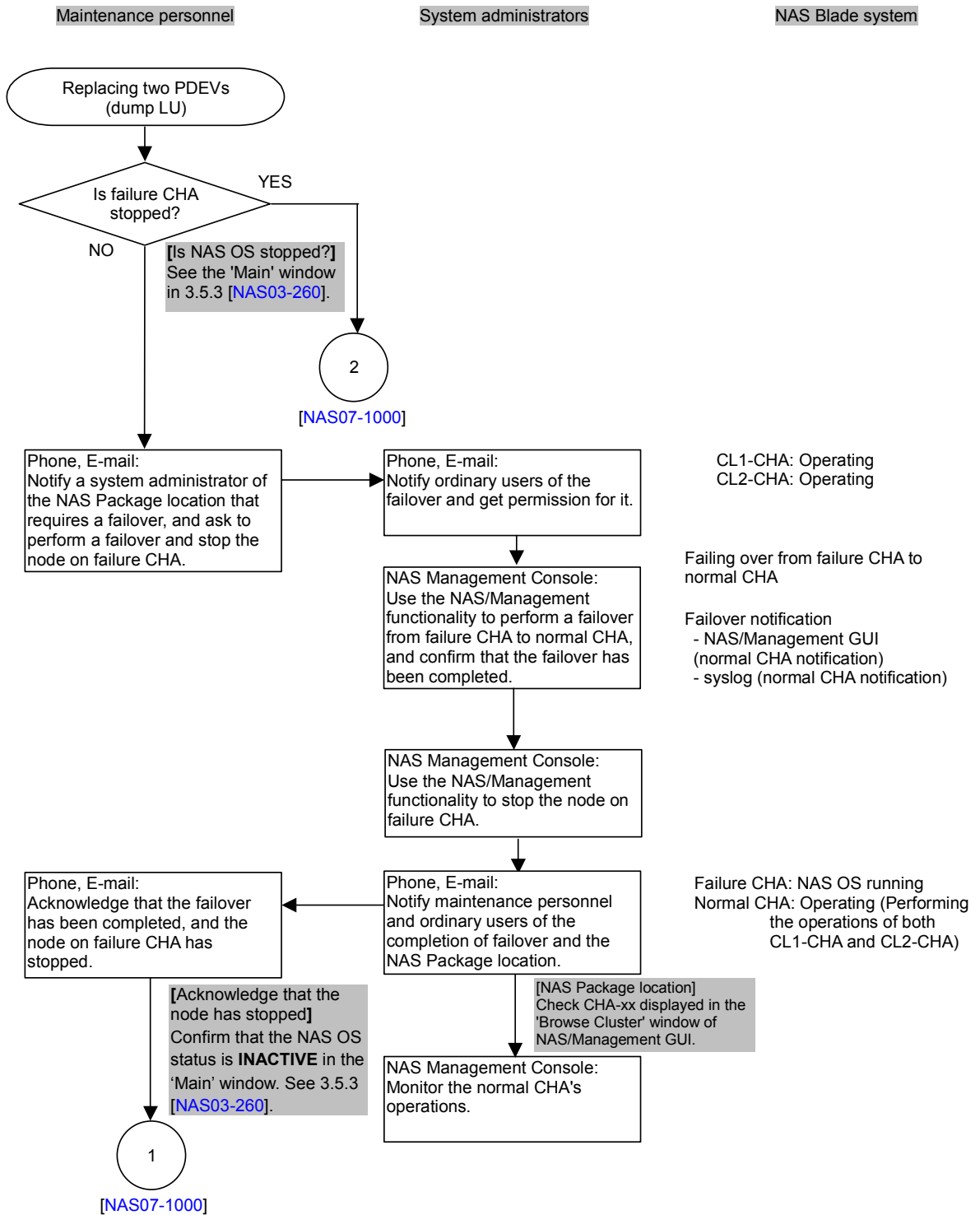

Figure 7.5-7 Replacing Two PDEVs (Dump LUs) (2/5)

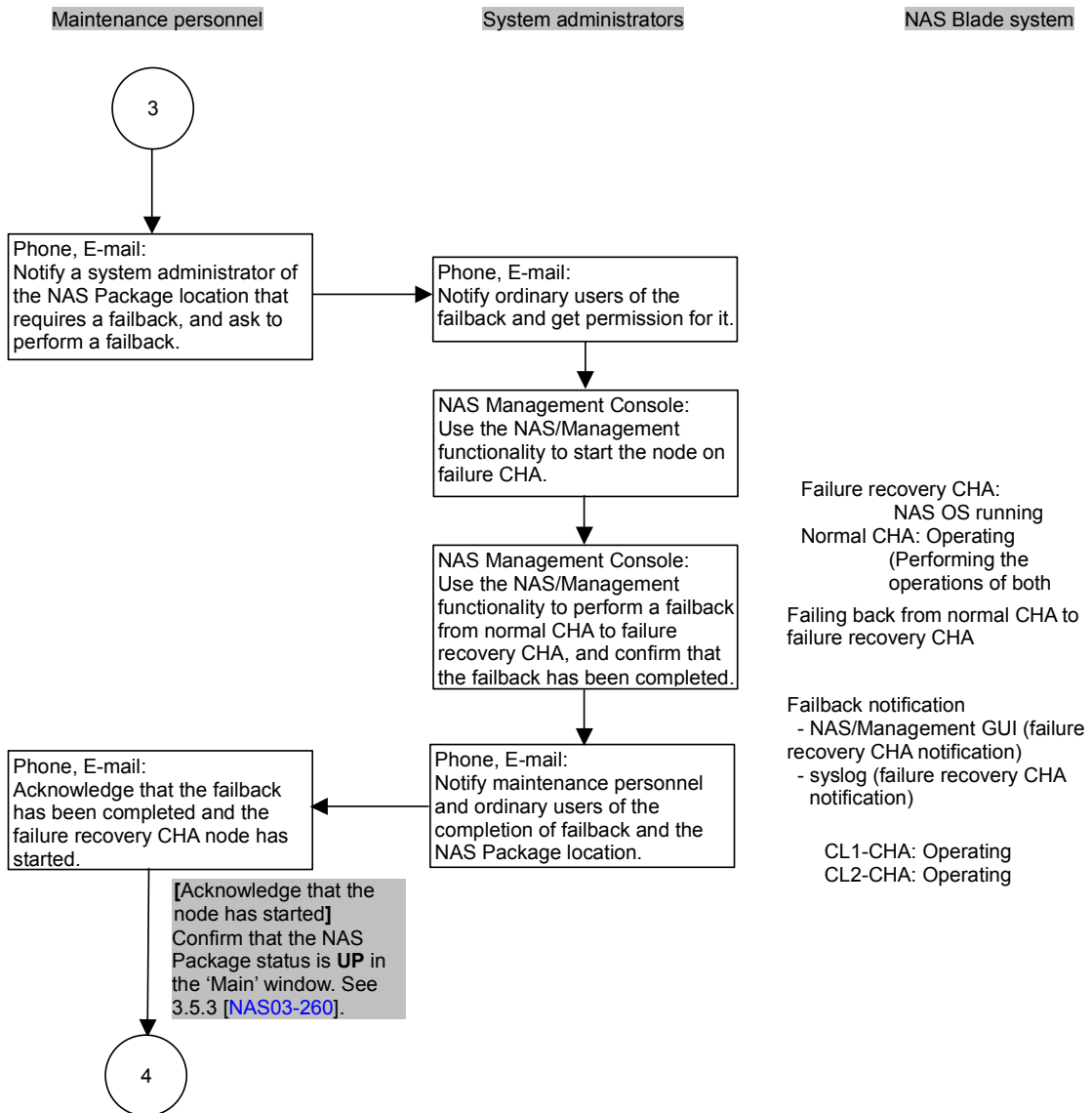

Figure 7.5-7 Replacing Two PDEVs (Dump LUs) (4/5)

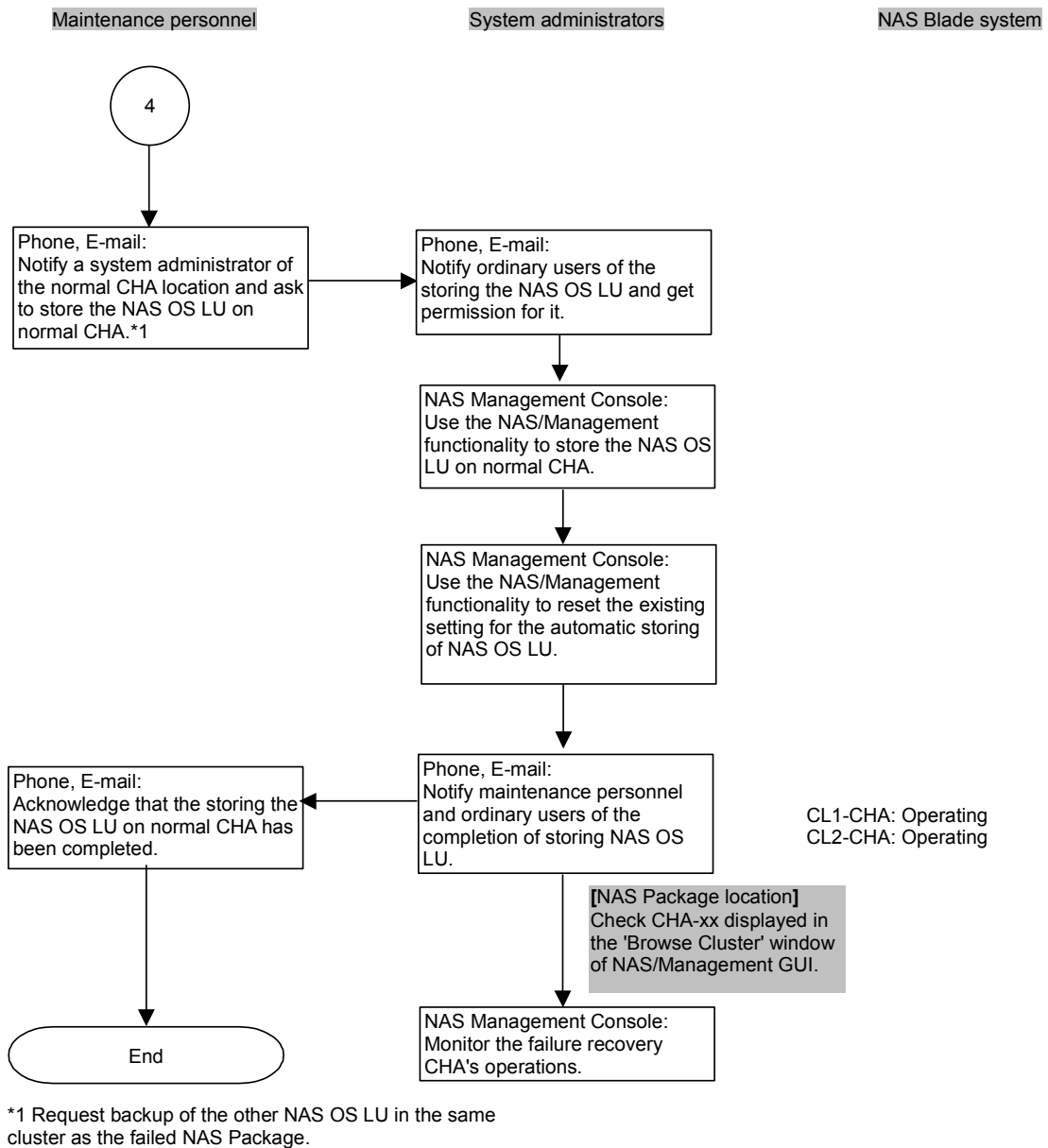

Figure 7.5-7 Replacing Two PDEVs (Dump LU) (5/5)

(8) Replacing Two PDEVs (Error Information LUs)

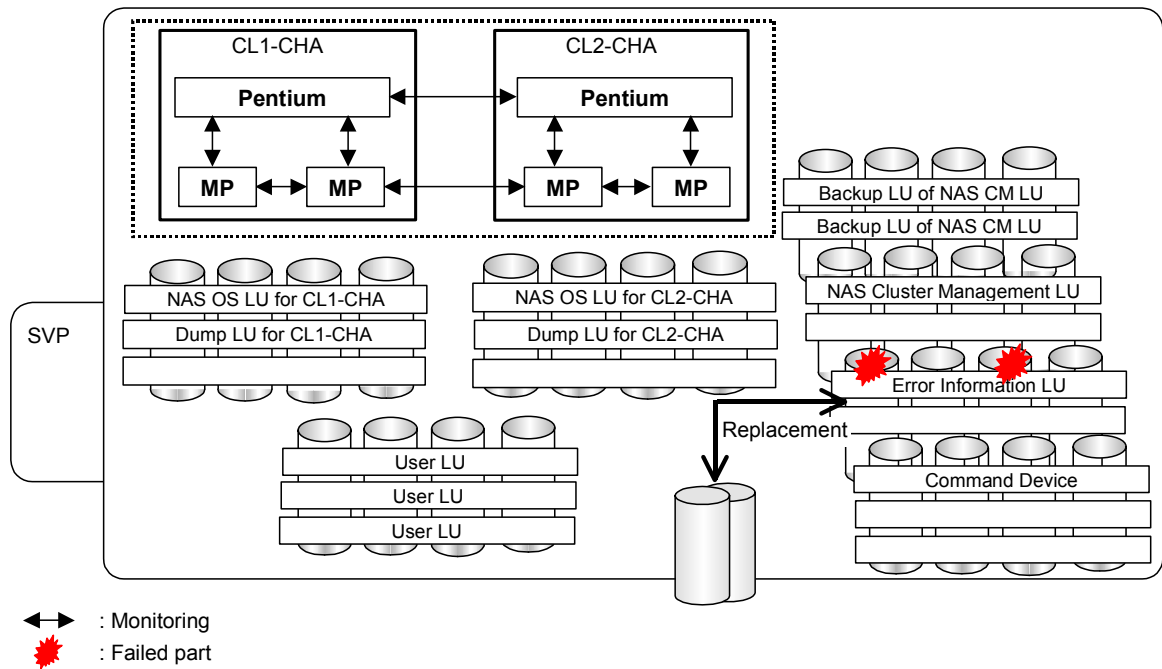

Figure 7.5-8 Replacing Two PDEVs (Error Information LUs) (1/2)

Step	Procedure	Notes
1	Replace the target PDEV.	
2	Release the RAID group's blocked state.	

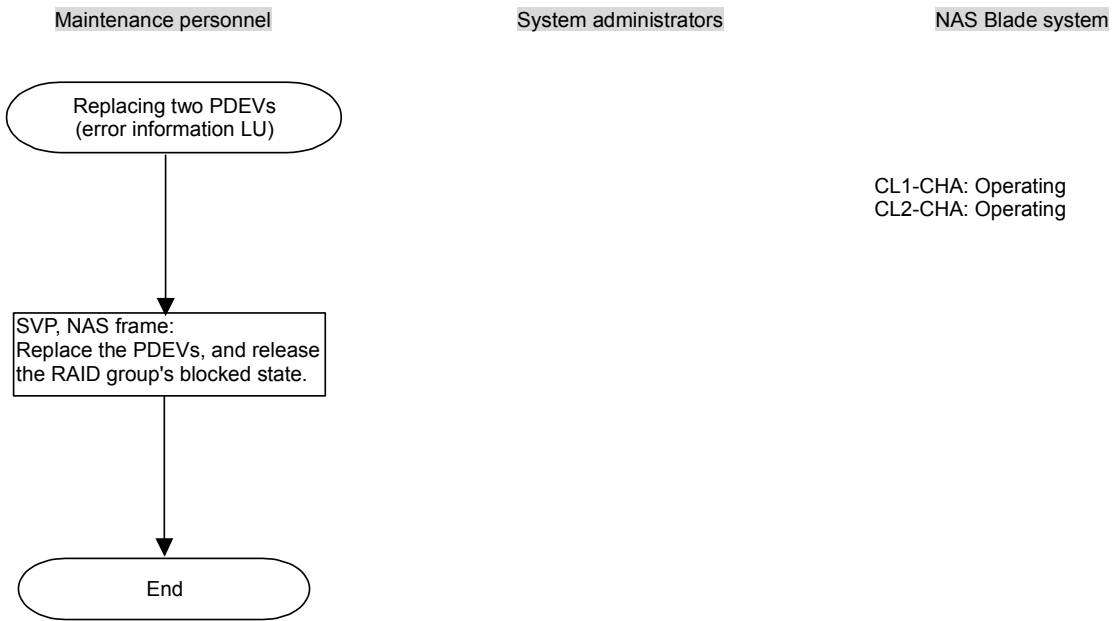

Figure 7.5-8 Replacing Two PDEVs (Error Information LUs) (2/2)

(9) Replacing Two PDEVs (Command Device)

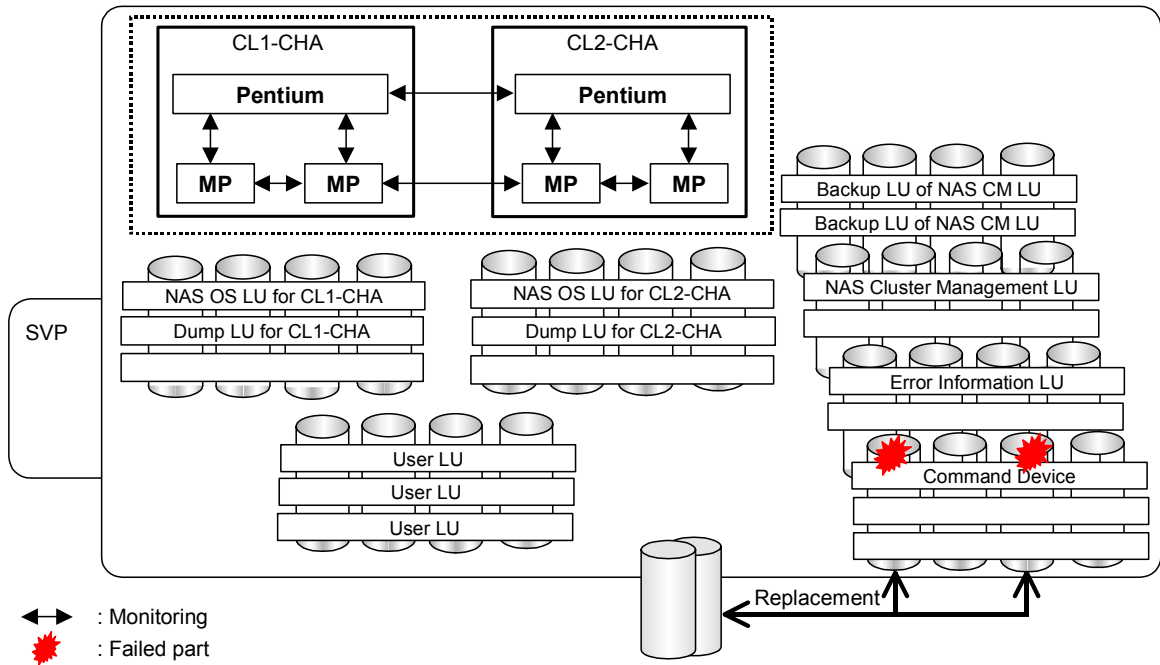

Figure 7.5-9 Replacing Two PDEVs (Command Devices) (1/2)

Step	Procedure	Notes
1	Replace the target PDEV.	
2	Release the RAID group's blocked state.	
3	Restart the snapshot and/or backup functions.	Restart if the snapshot and/or backup functions were running when the error occurred.

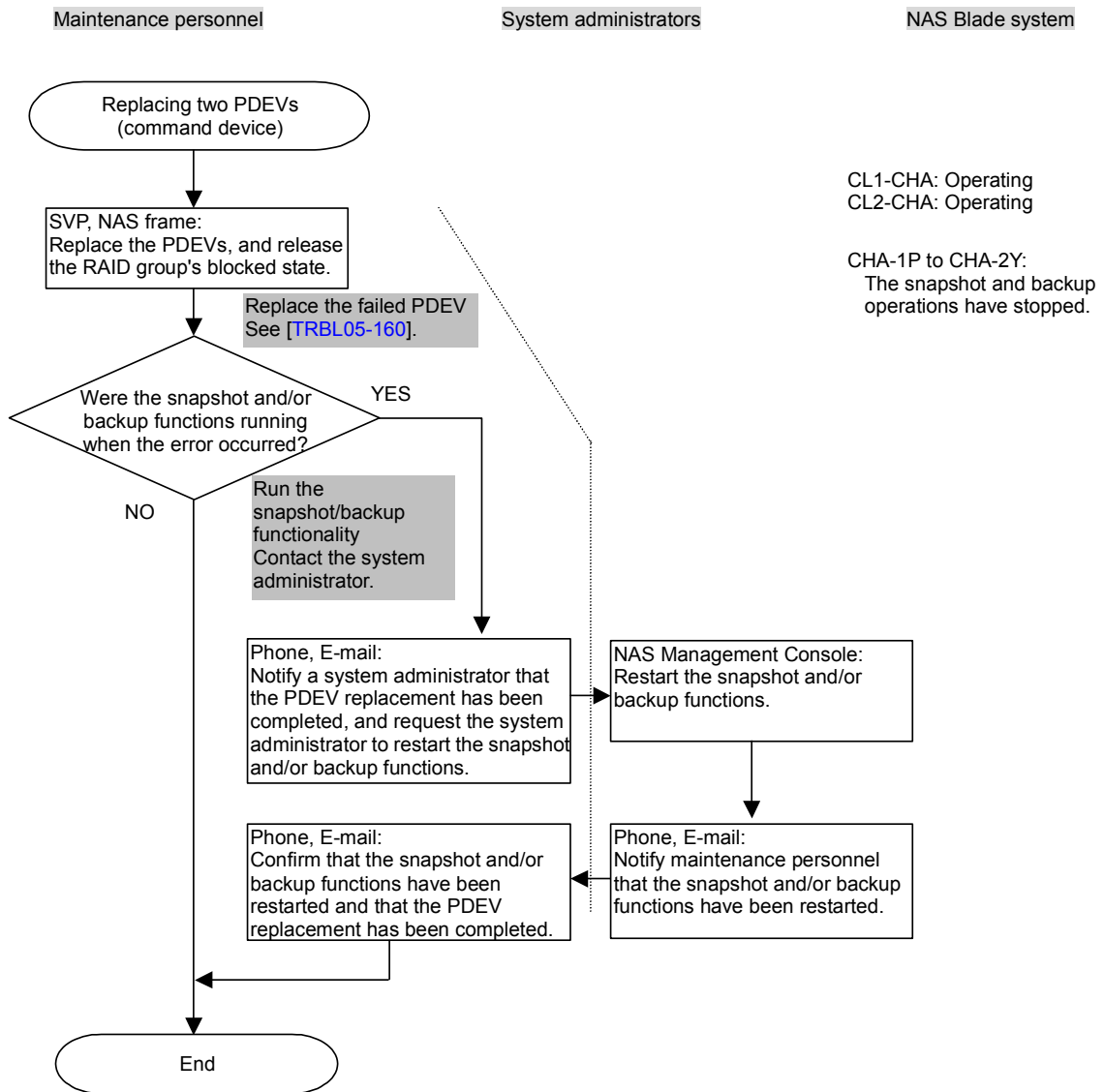

Figure 7.5-9 Replacing Two PDEVs (Command Device) (2/2)

(10) Replacing Two PDEVs (Backup LUs of NAS Cluster Management LUs)

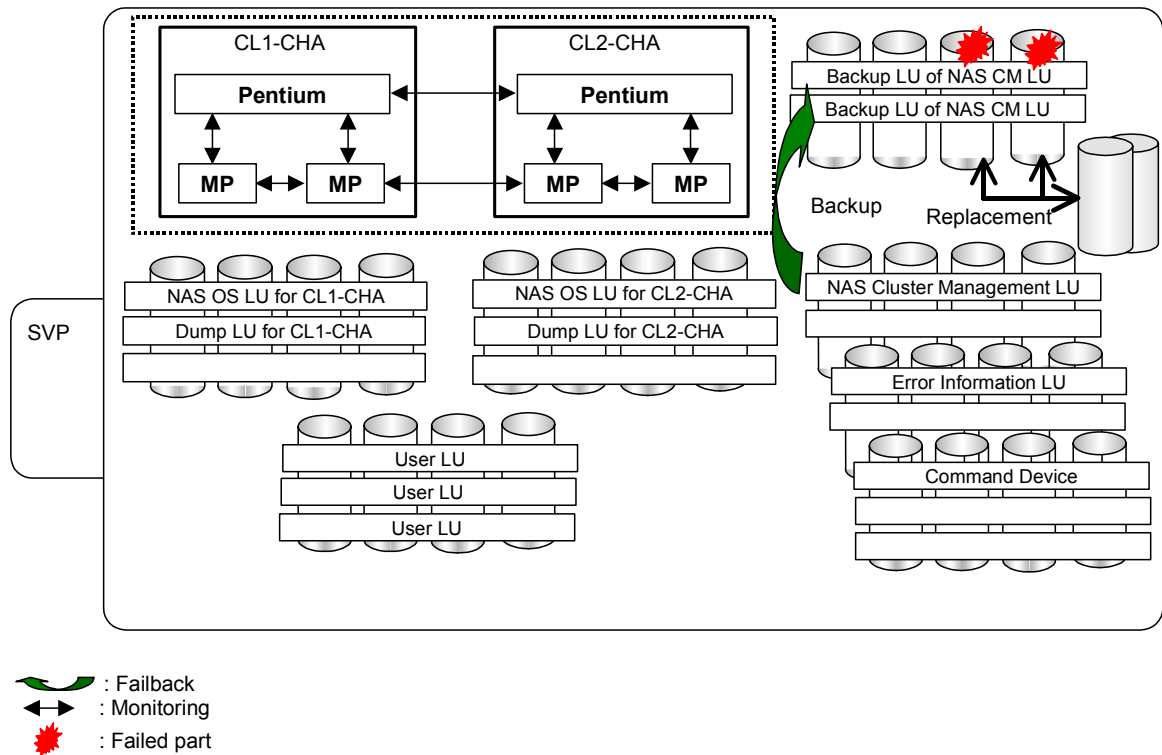

Figure 7.5-10 Replacing Two PDEVs (Backup LUs of NAS Cluster Management LUs) (1/2)

Step	Procedure	Notes
1	Release the setting of automatic save of the NAS Cluster Management LU.	
2	Replace the target PDEV.	
3	Save the NAS Cluster Management LU.	
4	Change the setting of automatic save of the NAS Cluster Management LU.	

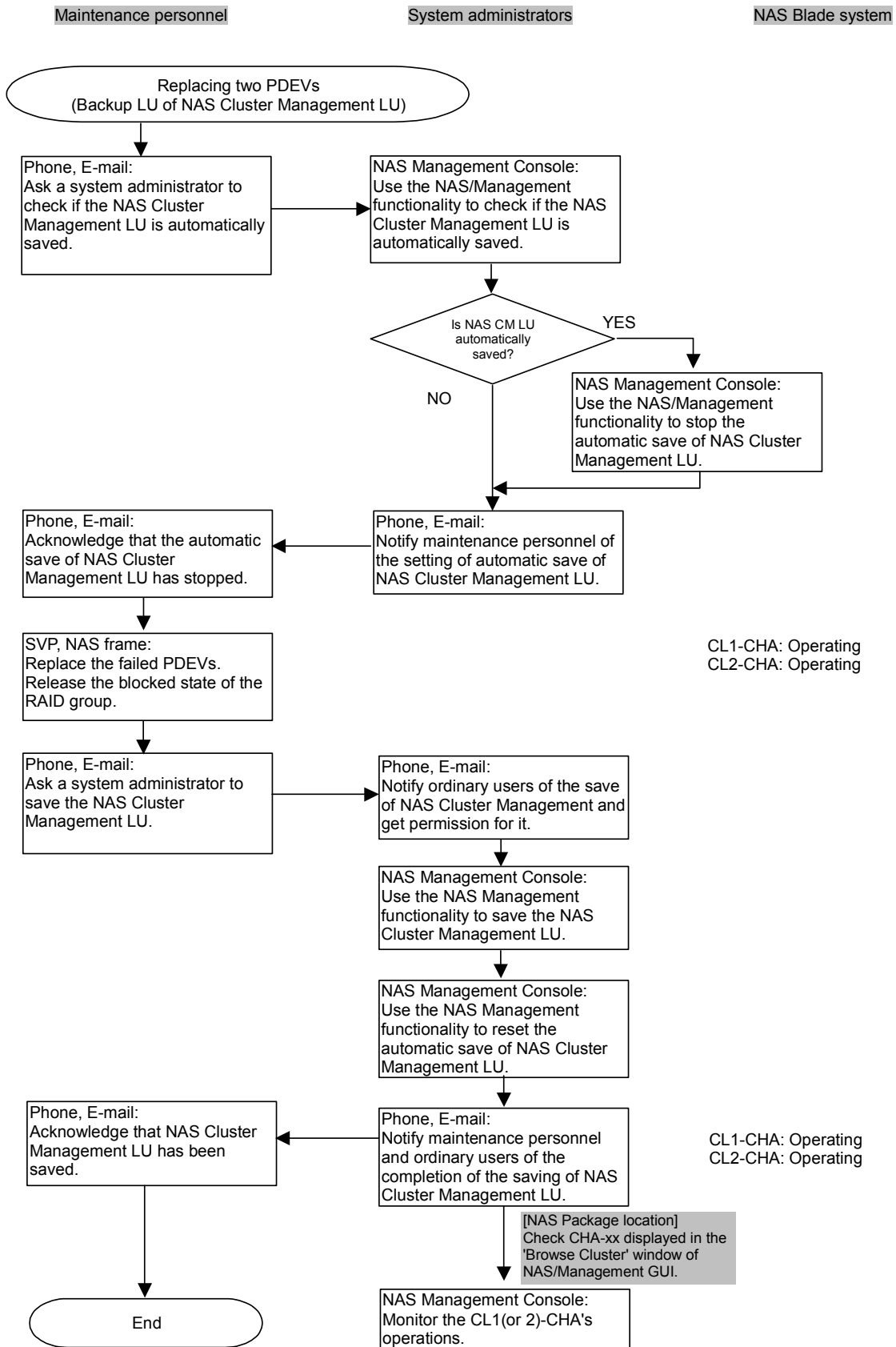

Figure 7.5-10 Replacing Two PDEVs (Backup LUs of NAS Cluster Management LUs) (2/2)

(11) Replacing Data LAN Cables (When a Failure Occurs)

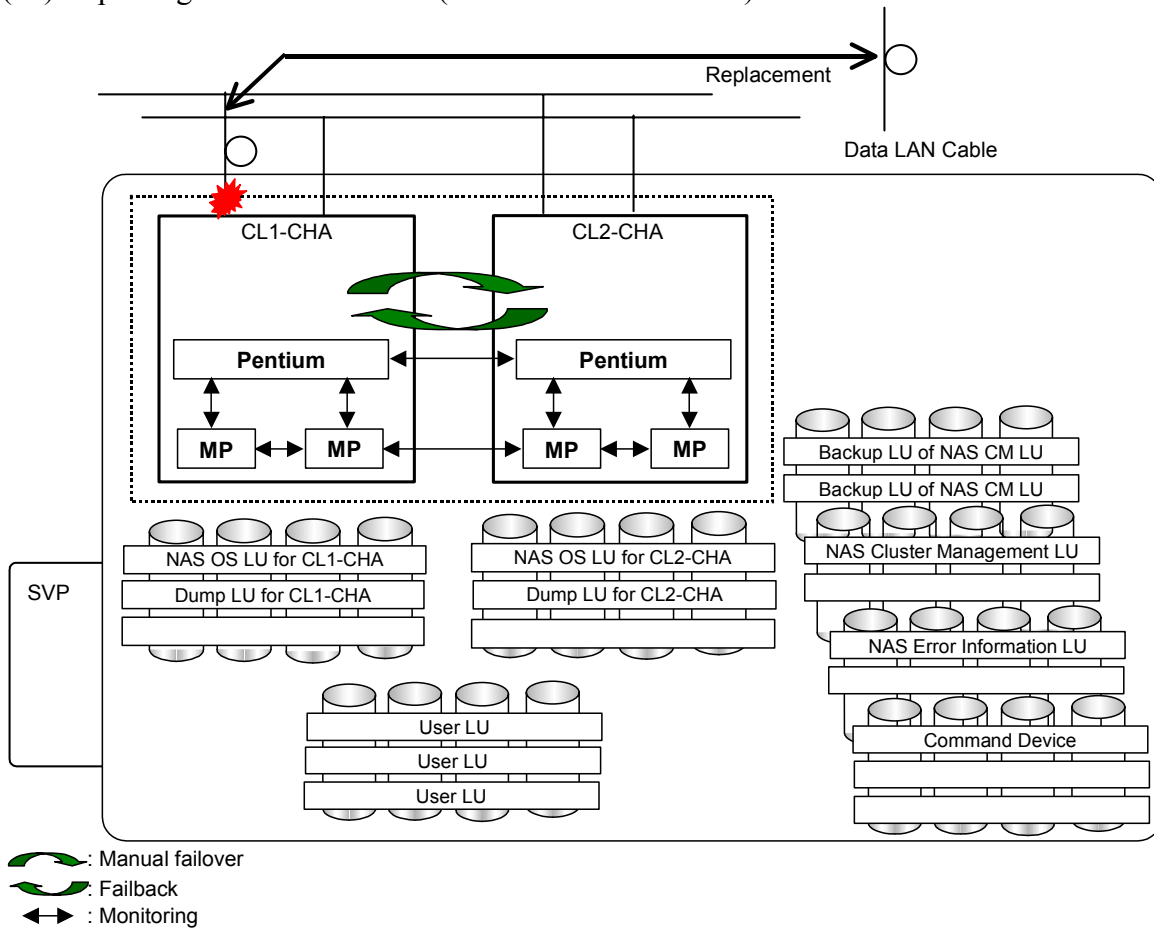

Figure 7.5-11 Replacing Data LAN Cables (When a Failure Occurs) (1/3)

Step	Procedure	Notes
1	Check the operation status of the NAS Blade system.	
2	Establish data LAN (GbE) network.	Take corrective actions such as replacing the data LAN cable, connecting it to the port, etc.
3	Check the network status.	
4	Perform failback.	

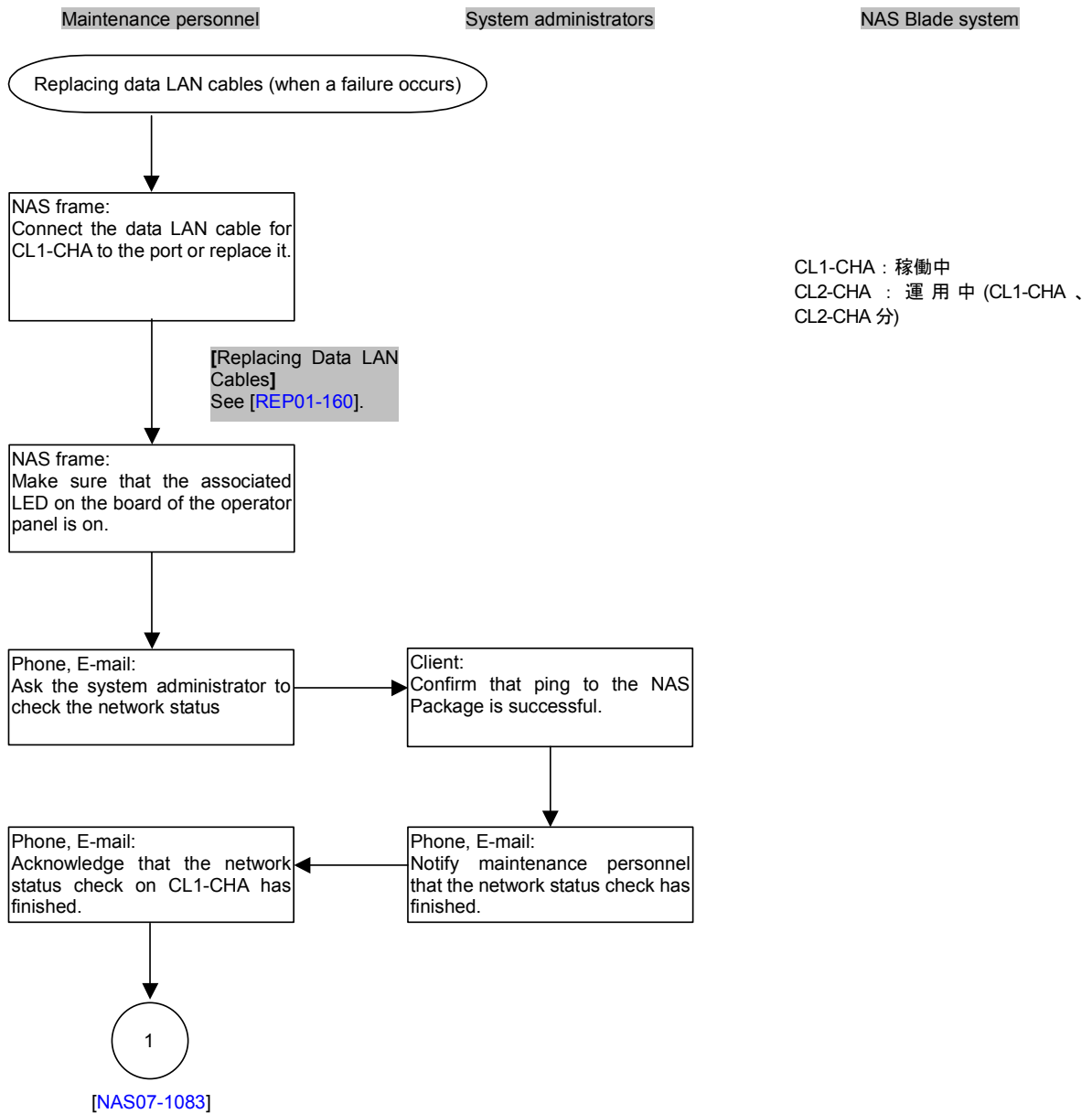

Figure 7.5-11 Replacing Data LAN Cables (When a Failure Occurs) (2/3)

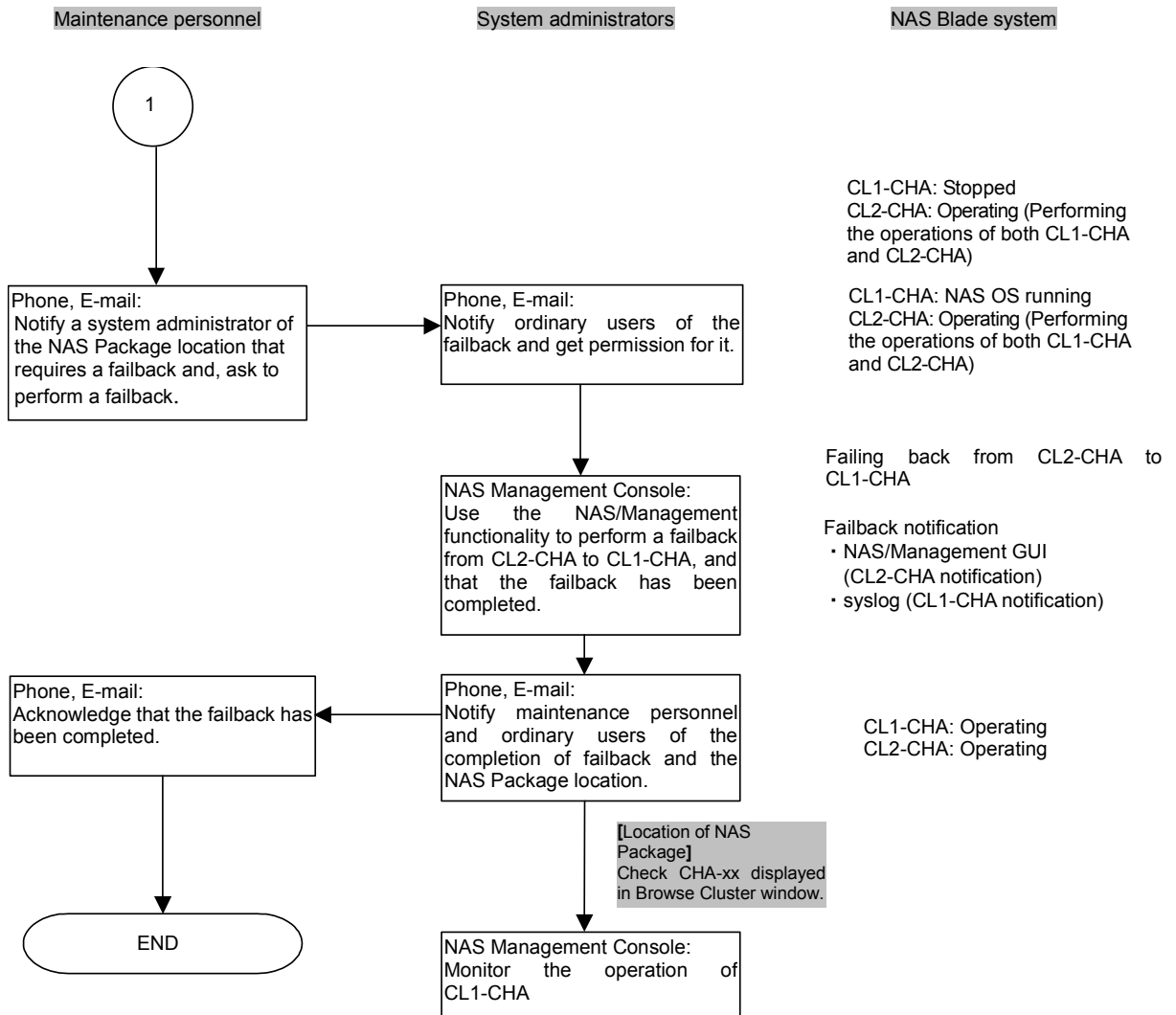

Figure 7.5-11 Replacing Data LAN Cables (When a Failure Occurs) (3/3)

7.5.2 Upgrading and Downgrading Software

This section describes the software upgrade and downgrade operations performed by maintenance personnel and system administrators.

[1] Types of Software Upgrade Operations

Software is upgraded in the following two situations (Note that all instances of the same software in a cluster are upgraded because all the software running on NAS Packages in the same cluster must be the same version.):

- Upgrade when a software failure occurs
This upgrade operation upgrades the version of the failed software.
- Upgrade during a preventive software upgrade
This upgrade operation upgrades during a preventive software upgrade.

This section shows the upgrade when a software failure occurs.

Such upgrade operations are classified based on the operations performed by maintenance personnel or system administrators and the NAS Blade system behavior, as shown in Table 7.5-3.

Table 7.5-3 Types of Software Upgrade Operations

#	Target software	Can ordinary users continue operations? ^{*2}	Overview and Notice	Installation method	Distribution method	Upgrade target	Is Operation from the NAS management console possible? ^{*1}	Restart the NAS OS?	Perform a fail-back?	Reference info. for upgrade during a preventive software upgrade
1	NAS OS (Upgraded while running)	Yes ^{*2}	FC of NAS OS. Failover, NAS OS FC, and failback are performed. Windows clients must be reconnected because services are stopped. The same FC is required for all NAS Packages in the same cluster. See the ECN for the procedures.	Upgrading NAS OS by an Updated Version	CD provided by the software developer	Setup on SVP NAS/ Management	No	Yes	Yes	Figure 7.5-12 [NAS07-1120]
				Upgrading NAS OS by a Patch Version (restart not required)	CD provided by the software developer	Setup on SVP, NAS/ Management	Yes	No ^{*3}	Yes	Figure 7.5-13 [NAS07-1160]
				Upgrading NAS OS by a Patch Version (restart required)	CD provided by the software developer	Setup on SVP, NAS/ Management	Yes	Yes	Yes	Figure 7.5-14 [NAS07-1220]
2	NAS/ Management	Yes	FC of NAS/ Management. The same FC is required for all NAS Packages in the same cluster.	NAS/Management upgrade	CD provided by the software developer	Setup on SVP, NAS/ Management	Yes	No	No	Figure 7.5-15 [NAS07-1270]
3	Optional program product	Yes ^{*3}	FC of optional program product. The same FC is required for all NAS Packages in the same cluster. The target optional program product must be stopped.	Optional program product upgrade	CD provided by the software developer	Setup on SVP, NAS/ Management	Yes	No	No	Figure 7.5-16 [NAS07-1290]

*1: This is the upgrade operation that a system administrator performs using the NAS Management Console.

*2: Yes: Operations is possible while online. However, if the application server is connected to Windows client (CIFS share) when a failover or a failback occurs, the CIFS share is released, therefore, you must reconnect the server with CIFS share.

No: Offline. All applications must be stopped.

*3: Need for NAS OS restart or failback depends on the operation. See the ECN for the procedures.

[2] Procedures for Upgrading Software

In this section, the cluster is assumed to consist of CL1-CHA and CL2-CHA, and the following tables show the flowcharts for upgrading software when a software failure occurs from Figure 7.5-12 to Figure 7.5-16.

Make sure that CL2-CHA is properly referred to as the actual location for upgrading software when a software failure occurs on the CHA location.

Table 7.5-4 shows the actual CHA locations in the NAS cluster configuration.

Table 7.5-4 CHA Location in the NAS Cluster Configuration

Model	CHA location	CL1-CHA	CL2-CHA
Multi-cabinet	Basic	1P	2V
	Option 1	1Q	2W
	Option 2	1R	2X
	Option 3	1S	2Y
Single cabinet ^{*1}	Basic	1C	2G
	Option 1	1D	2J
	Option 2	1F	2K

*1: Only two of the three, basic, option 1, or option 2, can be used.

(1) Upgrading the NAS OS By a Update Version (When a Failure Occurs)

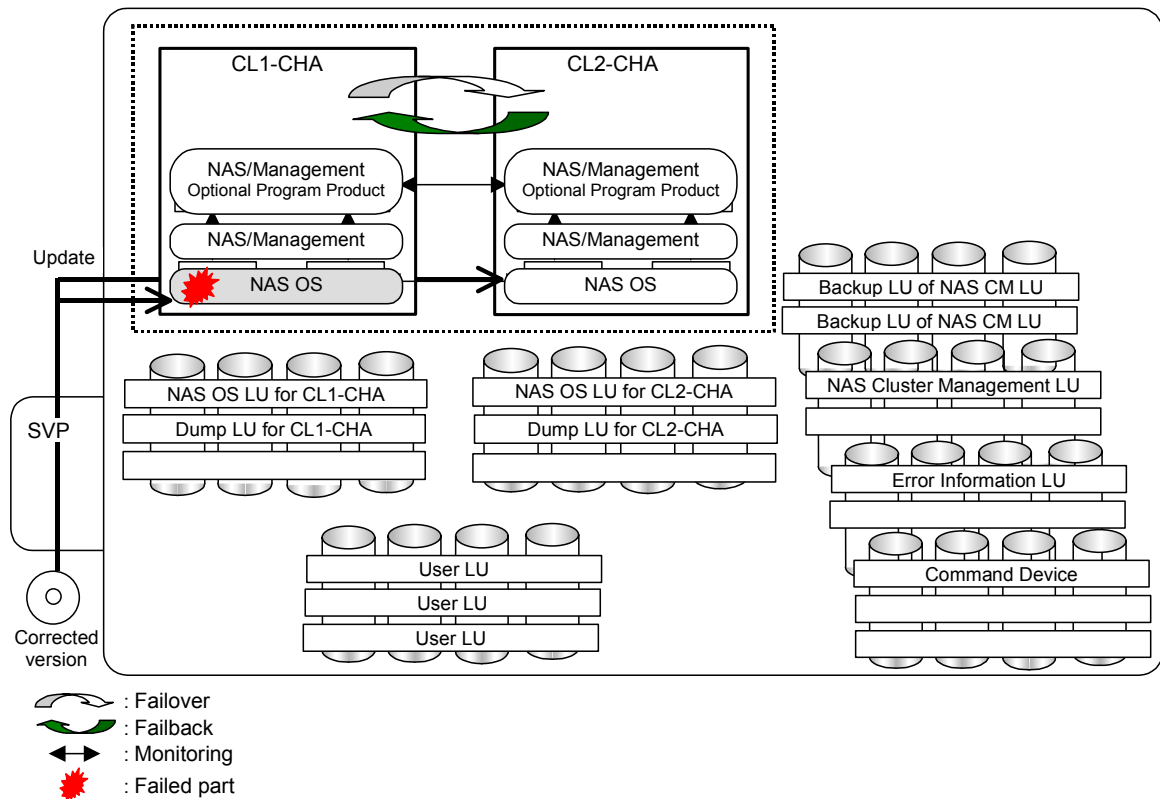

Figure 7.5-12 Upgrading the NAS OS By a Update Version
(When a Failure Occurs) (1/4)

Step	Procedure	Notes
1	Obtain the corrected version of NAS OS.	
2	Start the NAS OS.	Do so if the NAS OS is not running.
3	Stop the node.	
4	Upgrade the NAS OS by a update version.	
5	Upgrade NAS/Management.	
6	Start the node.	
7	Perform failback.	

Before you start replacing the NAS OS for CL2-CHA by using a method similar to that for CL1-CHA, after the CL1-CHA processing has finished you need to manually perform failover from CL2-CHA to CL1-CHA.

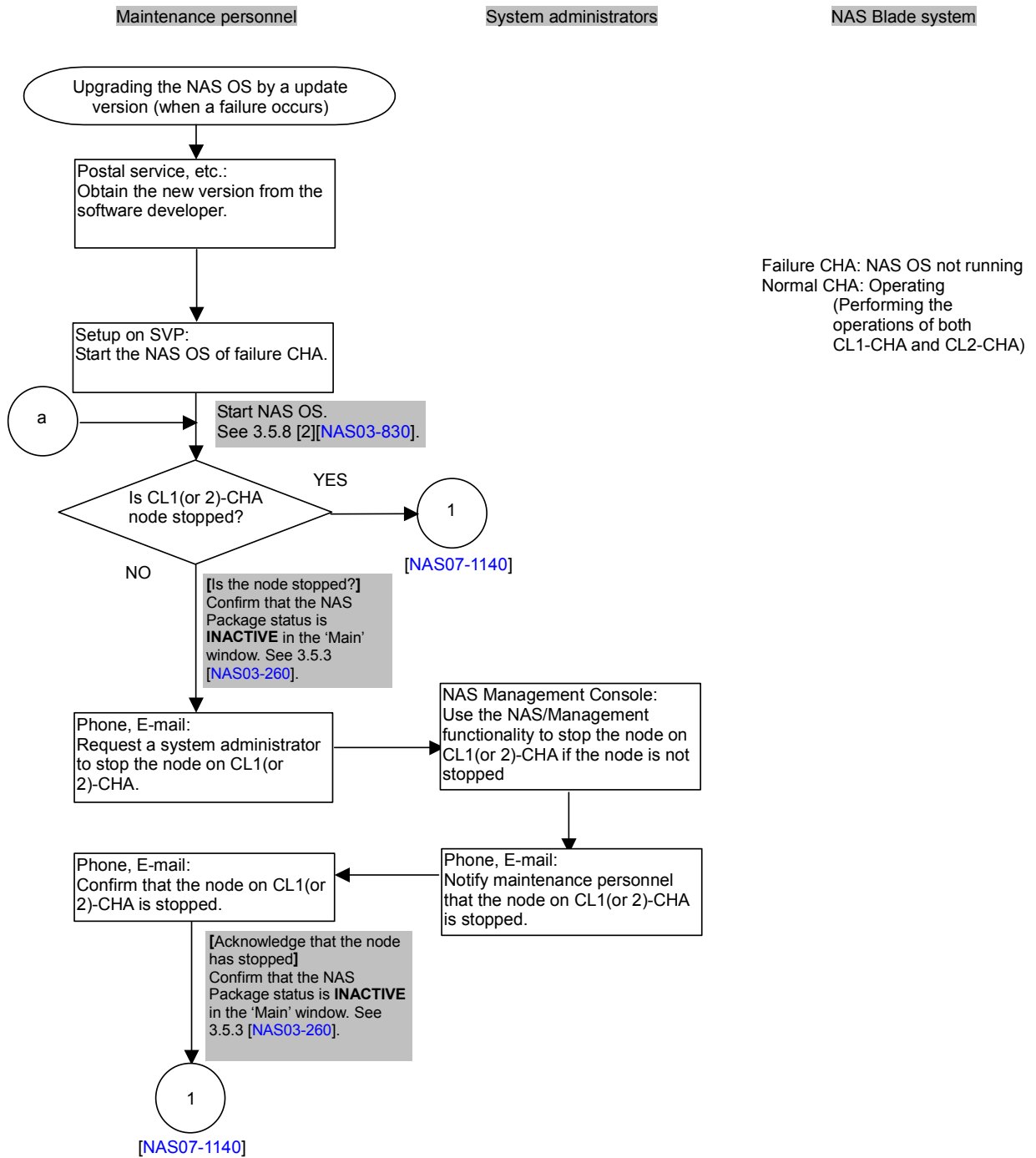

Figure 7.5-12 Upgrading the NAS OS By a Update Version (When a Failure Occurs) (2/4)

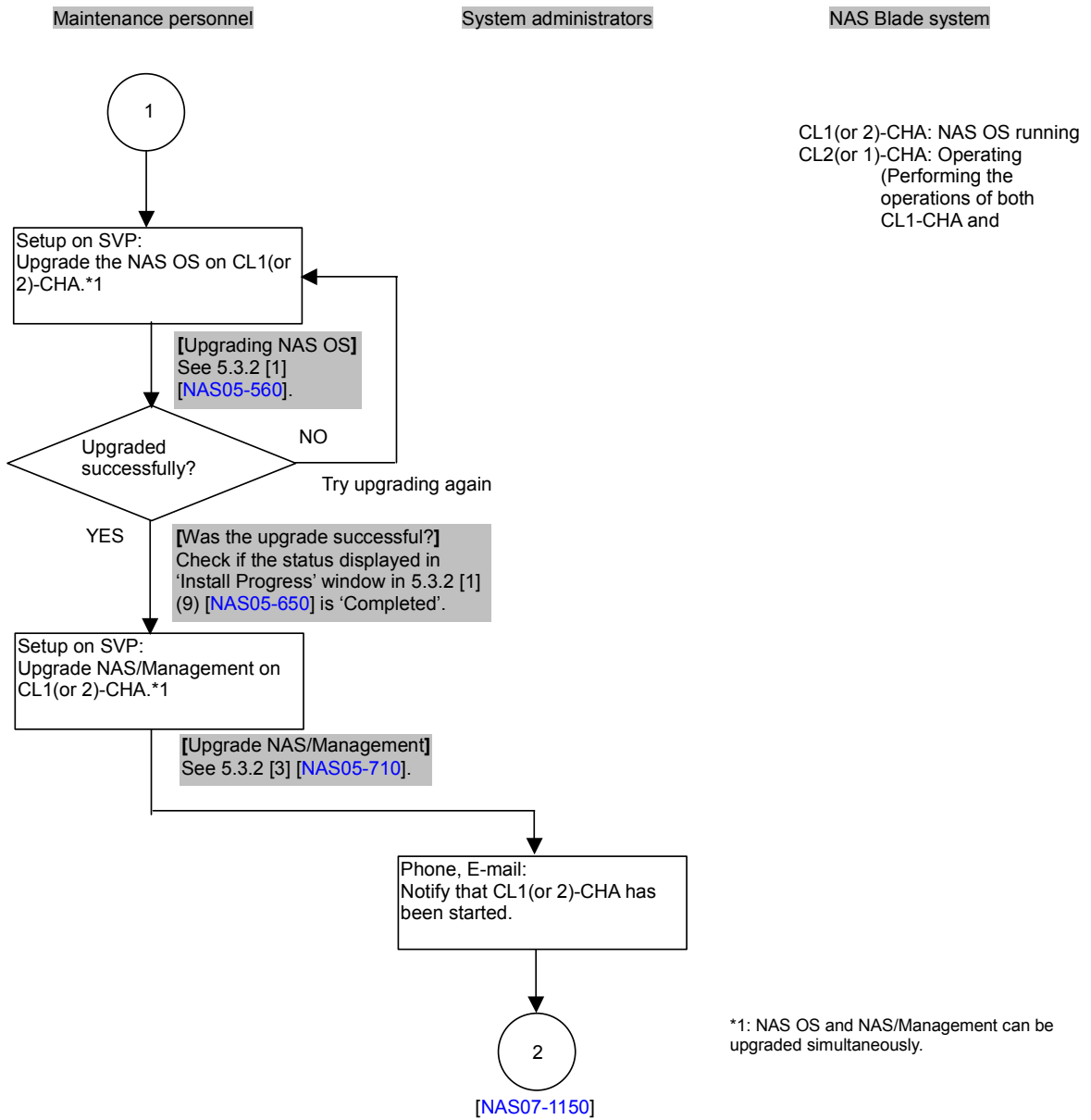

Figure 7.5-12 Upgrading the NAS OS By a Update Version (When a Failure Occurs) (3/4)

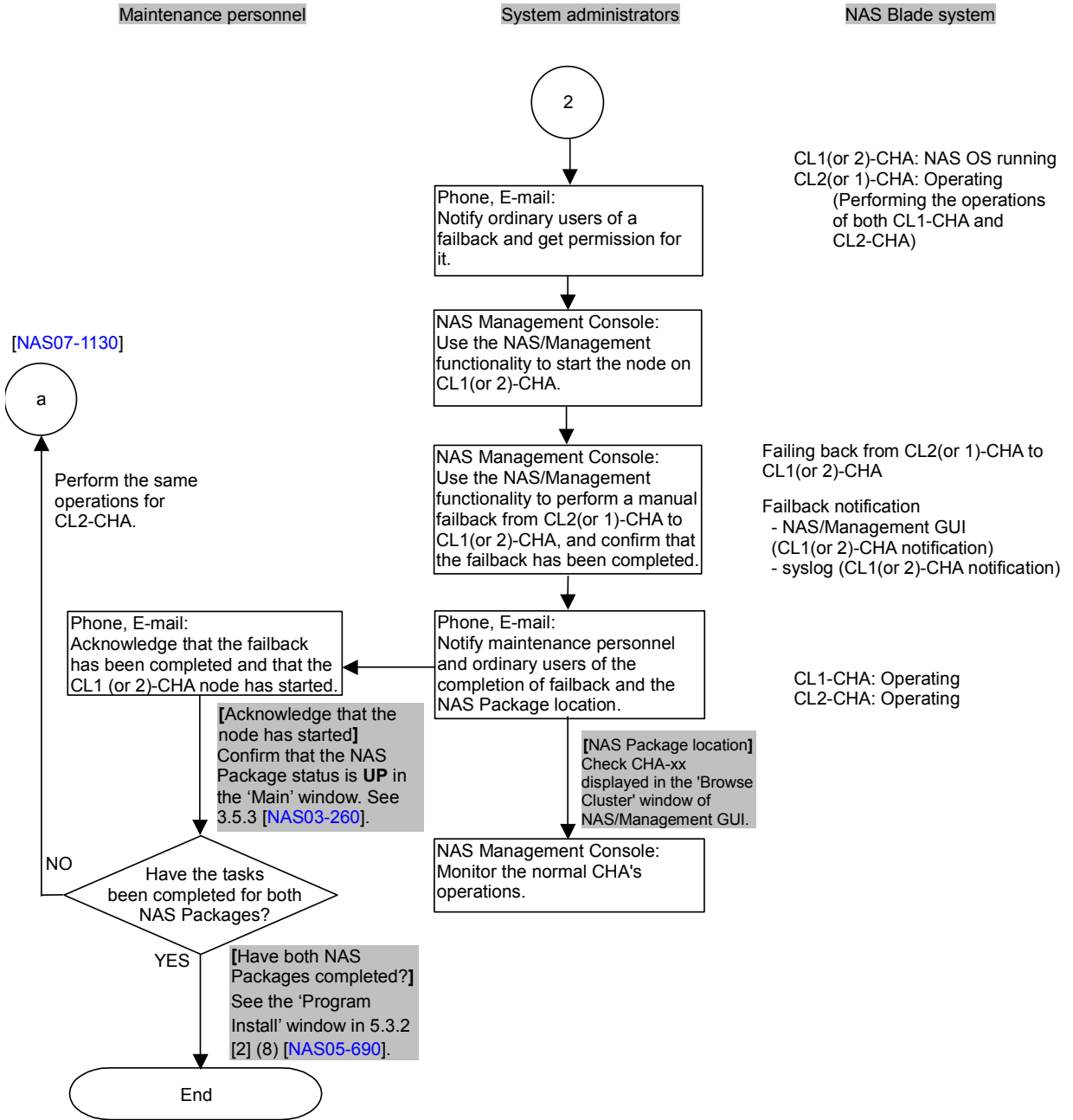

Figure 7.5-12 Upgrading the NAS OS By a Update Version (When a Failure Occurs) (4/4)

(2) Upgrading the NAS OS By a Patch Version — Restarting the NAS OS Is Not Required (When a Failure Occurs)

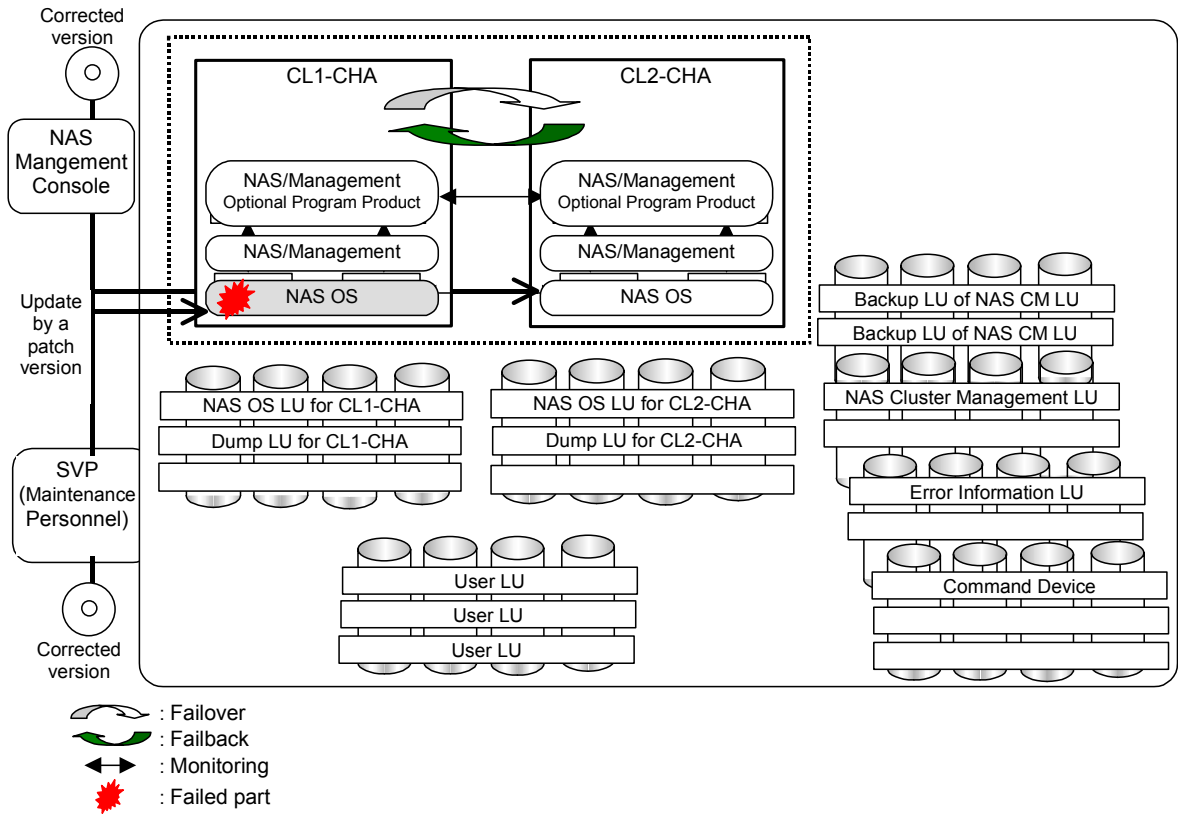

Figure 7.5-13 Upgrading the NAS OS By a Patch Version — Restarting the NAS OS Is Not Required (When a Failure Occurs) (1/5)

When maintenance personnel perform the upgrade operations:

Step	Procedure	Notes
1	Obtain the corrected NAS OS version (patch version).	
2	Start the NAS OS.	Do this for the NAS OS of the NAS Package in which the error occurred.
3	Upgrade to the corrected NAS OS version.	Use the Setup on SVP functionality to upgrade.
4	Start the node.	
5	Perform failback.	

When system administrators perform the upgrade operations (operations using NAS Management Console):

Step	Procedure	Notes
1	Obtain the corrected NAS OS version (patch version).	
2	Start the NAS OS.	Do this for the NAS OS of the NAS Package in which the error occurred.
3	Upgrade to the corrected NAS OS version (patch version).	Use NAS/Management functionality to upgrade.
4	Start the node.	
5	Perform failback.	

Before you start replacing the NAS OS for CL2-CHA by using a method similar to that for CL1-CHA, after the CL1-CHA processing has finished you need to manually perform failover from CL2-CHA to CL1-CHA.

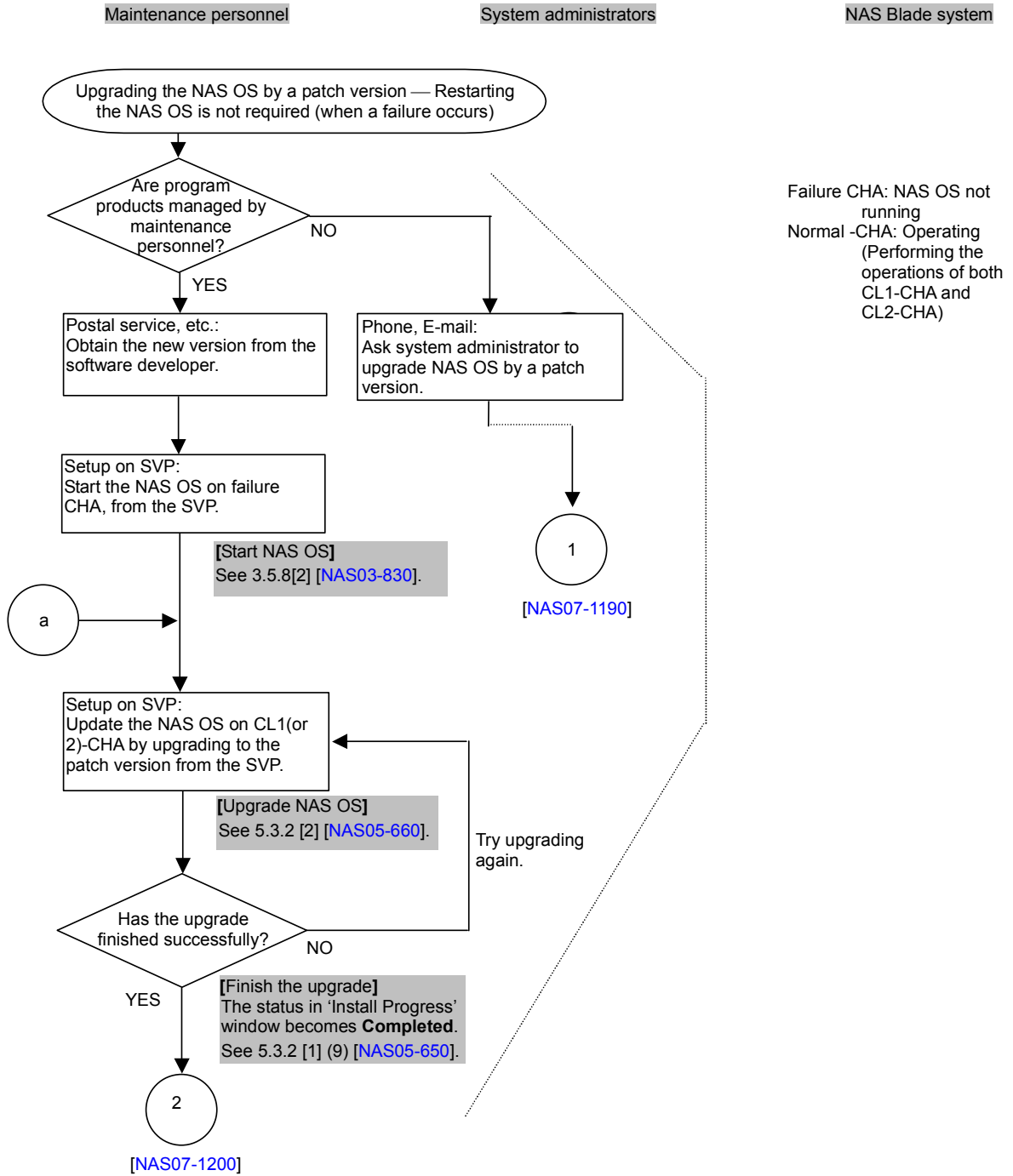

Figure 7.5-13 Upgrading the NAS OS By a Patch Version — Restarting the NAS OS Is Not Required (When a Failure Occurs) (2/5)

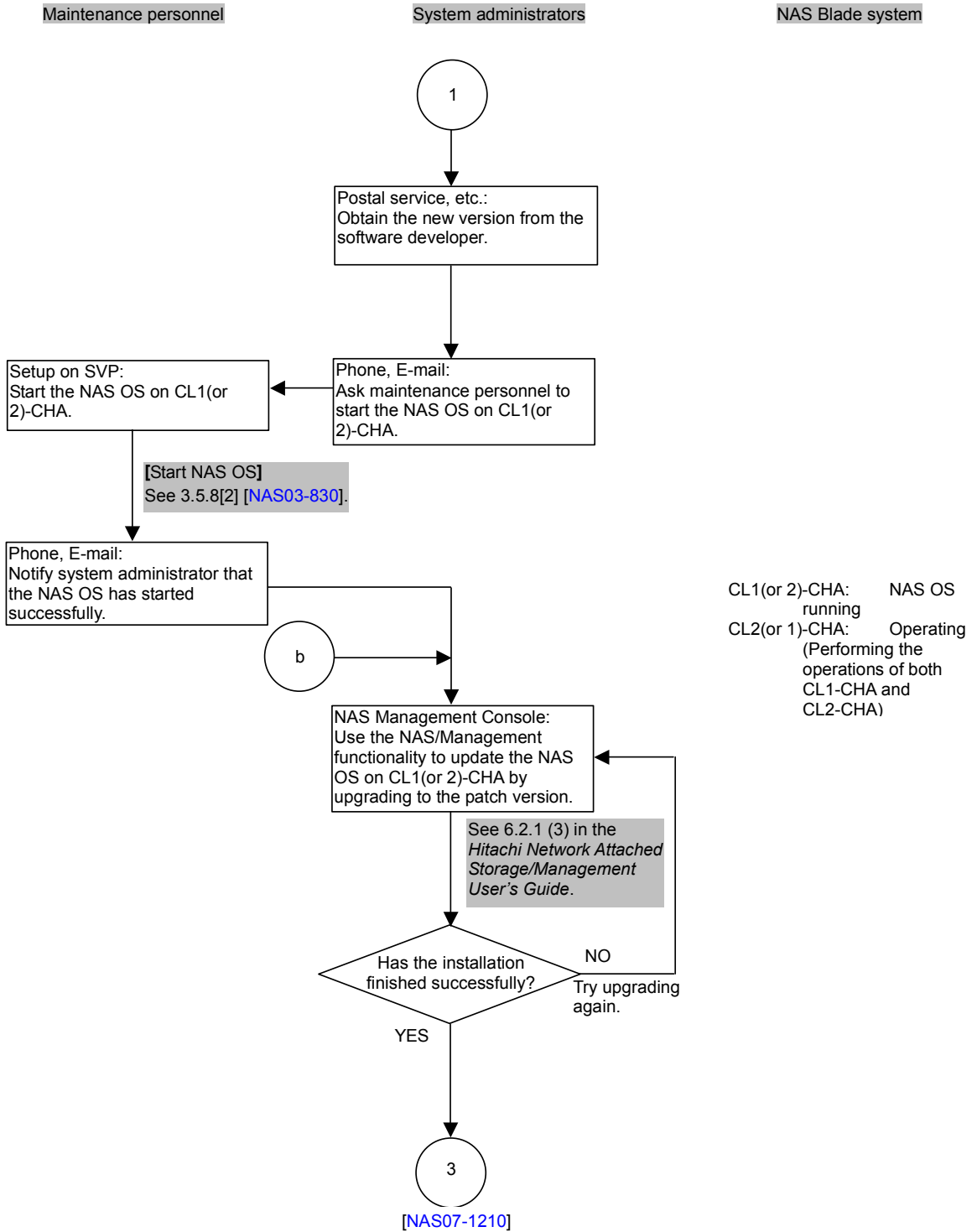

Figure 7.5-13 Upgrading the NAS OS By a Patch Version —
 Restarting the NAS OS Is Not Required (When a Failure Occurs) (3/5)

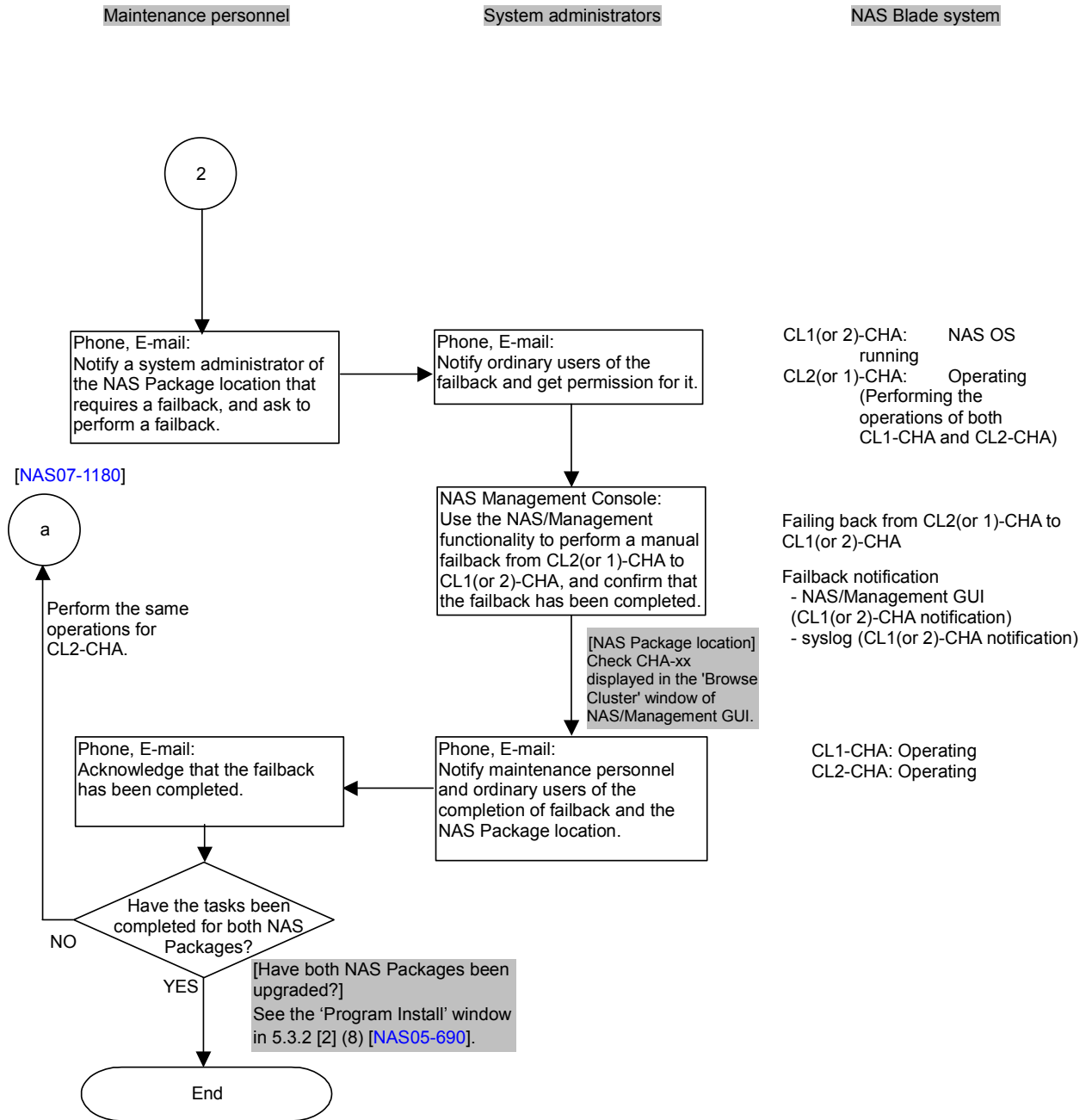

Figure 7.5-13 Upgrading the NAS OS By a Patch Version — Restarting the NAS OS Is Not Required (When a Failure Occurs) (4/5)

Maintenance personnel

System administrators

NAS Blade system

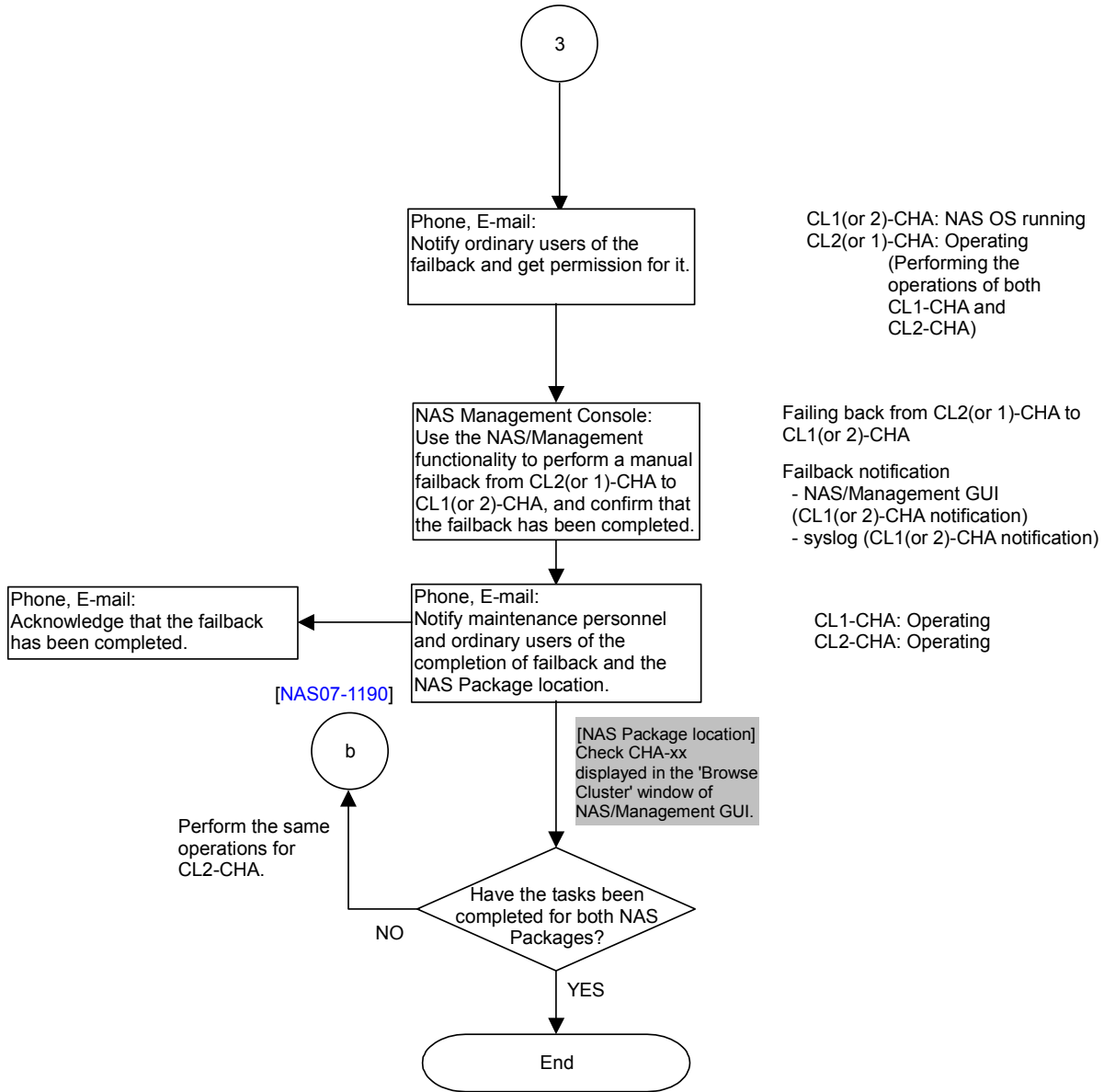

Figure 7.5-13 Upgrading the NAS OS By a Patch Version —
Restarting the NAS OS Is Not Required (When a Failure Occurs) (5/5)

(3) Upgrading the NAS OS By a Patch Version — Restarting the NAS OS Is Required (When a Failure Occurs)

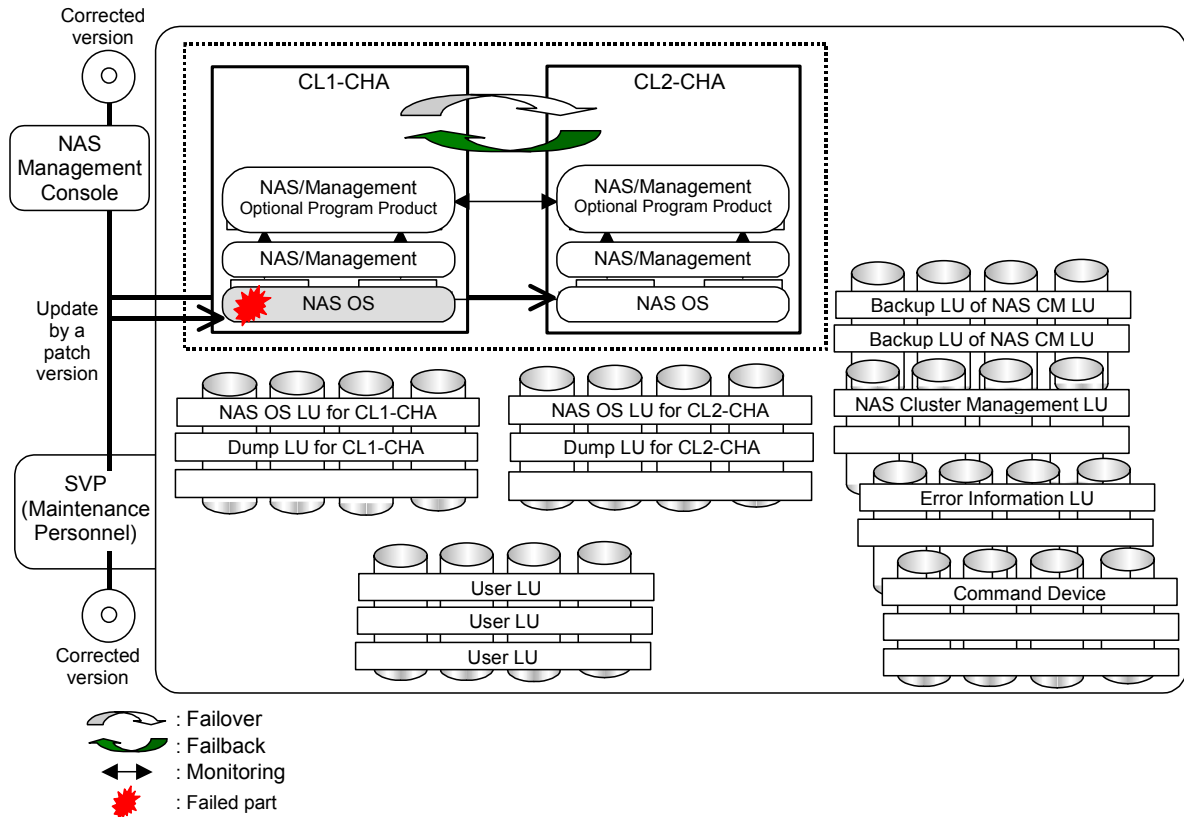

Figure 7.5-14 Upgrading the NAS OS By a Patch Version — Restarting the NAS OS Is Required (When a Failure Occurs) (1/6)

Step	Procedure	Notes
1	Obtain the corrected NAS OS version (patch version).	
2	Start the NAS OS.	Do this for the NAS OS of the NAS Package in which the error occurred.
3	Upgrade to the patch version of NAS OS.	
4	Stop the node.	
5	Restart the NAS OS.	Do this only if it is upgraded to the patch version using the NAS/Management functionality.
6	Start the node.	
7	Perform failback.	

Before you start replacing the NAS OS for CL2-CHA by using a method similar to that for CL1-CHA after the CL1-CHA processing has finished, you need to manually perform failover from CL2-CHA to CL1-CHA.

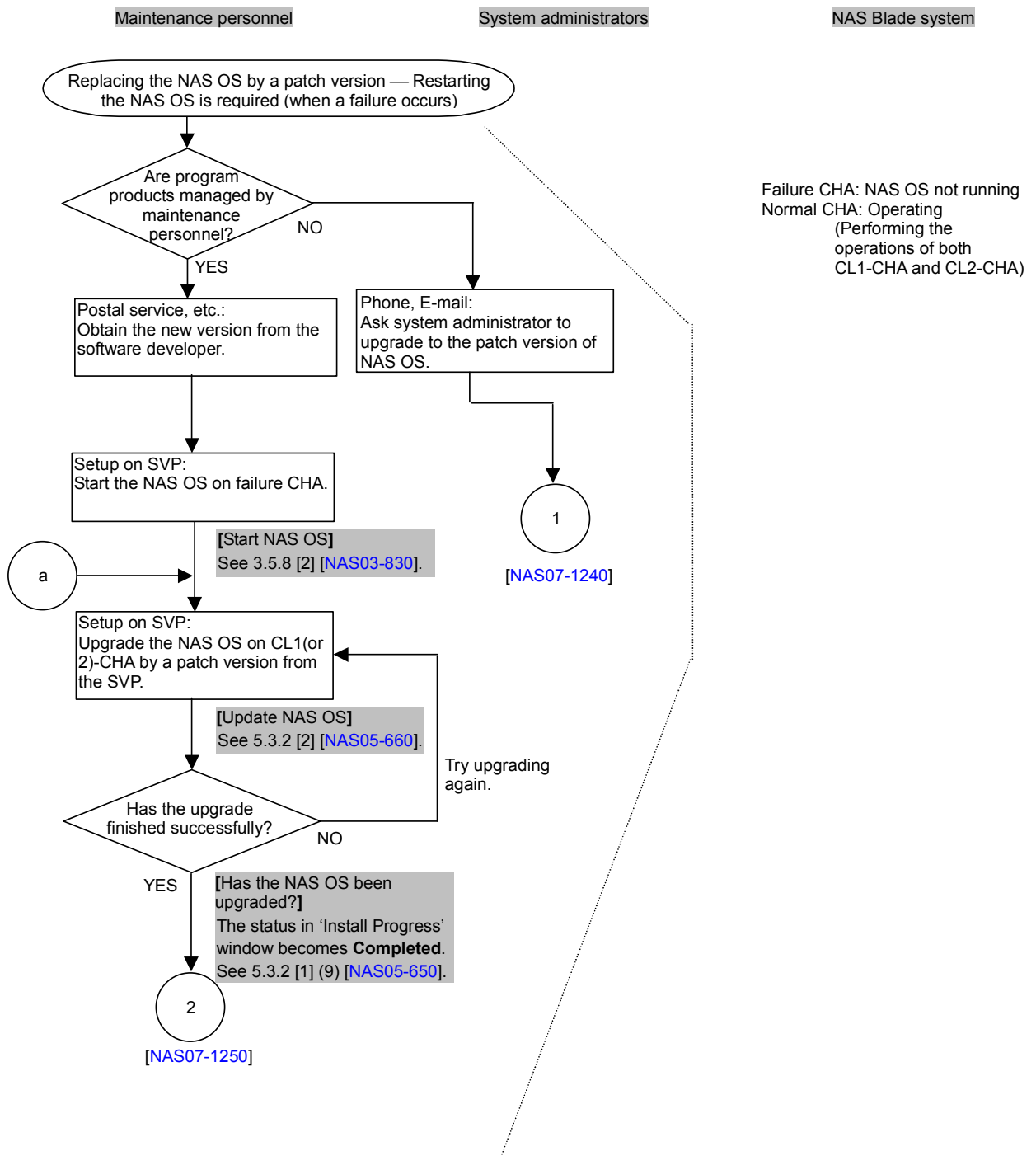

Figure 7.5-14 Upgrading the NAS OS By a Patch Version — Restarting the NAS OS Is Required (When a Failure Occurs) (2/6)

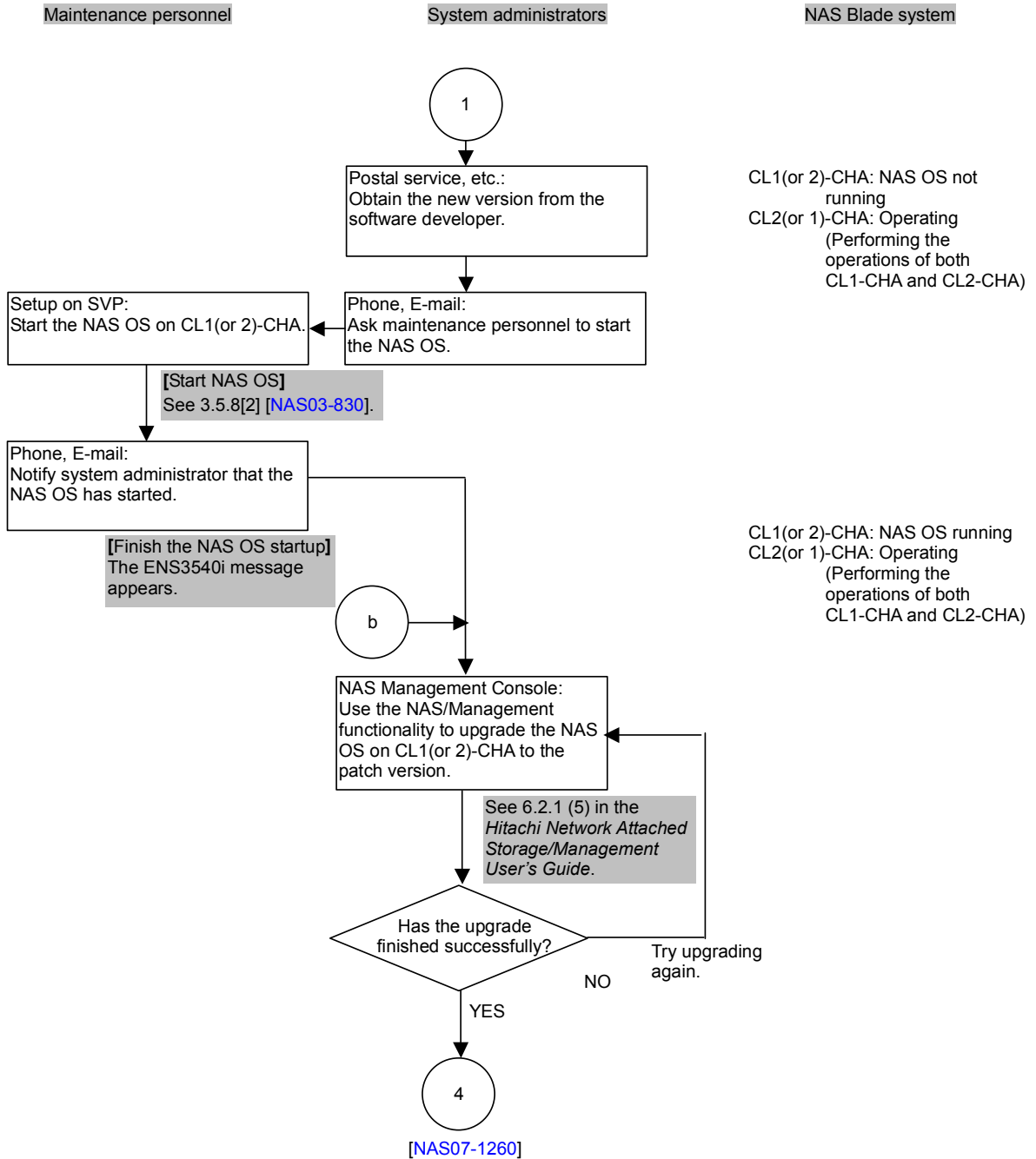

Figure 7.5-14 Upgrading the NAS OS By a Patch Version —
Restarting the NAS OS Is Required (When a Failure Occurs) (3/6)

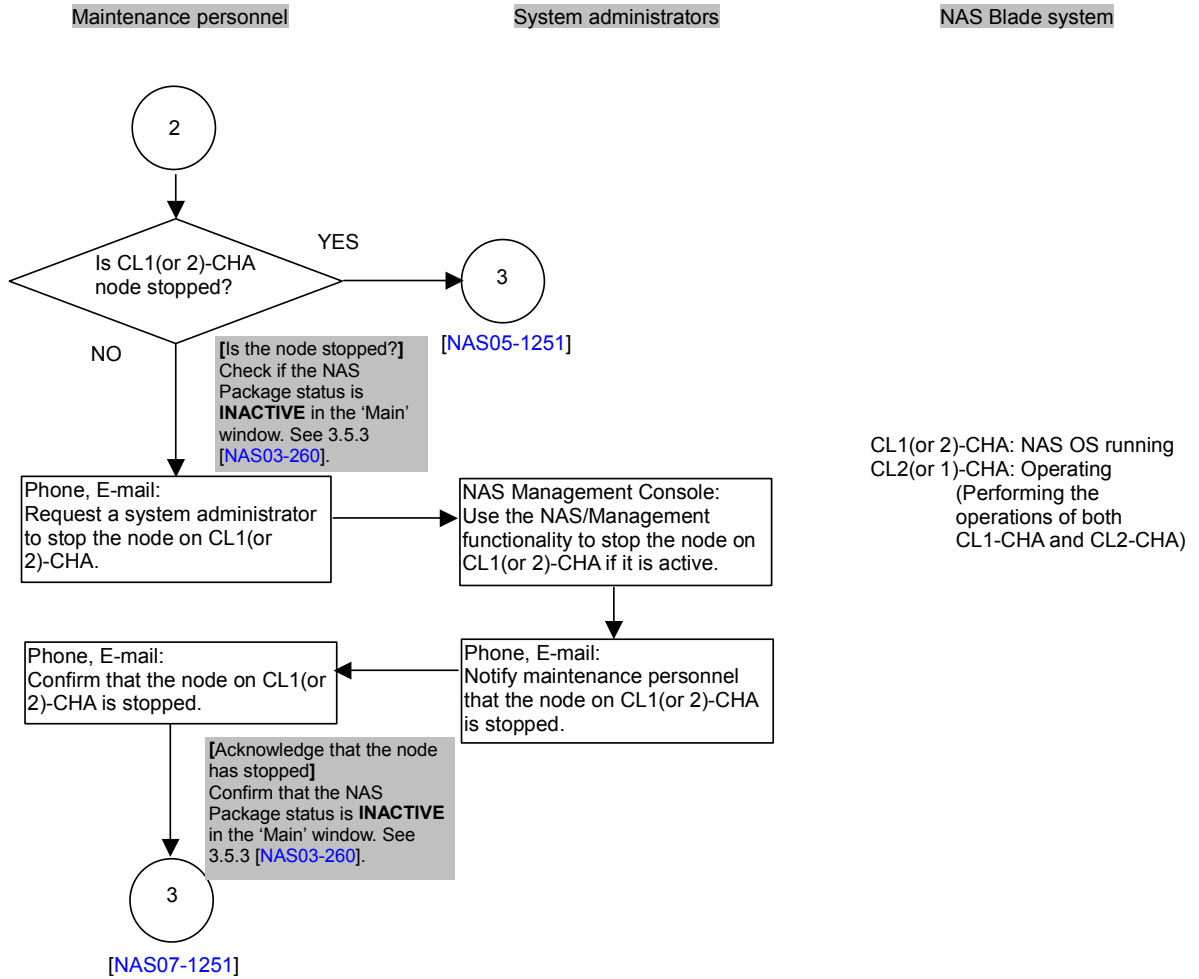

Figure 7.5-14 Upgrading the NAS OS By a Patch Version — Restarting the NAS OS Is Required (When a Failure Occurs) (4/6)

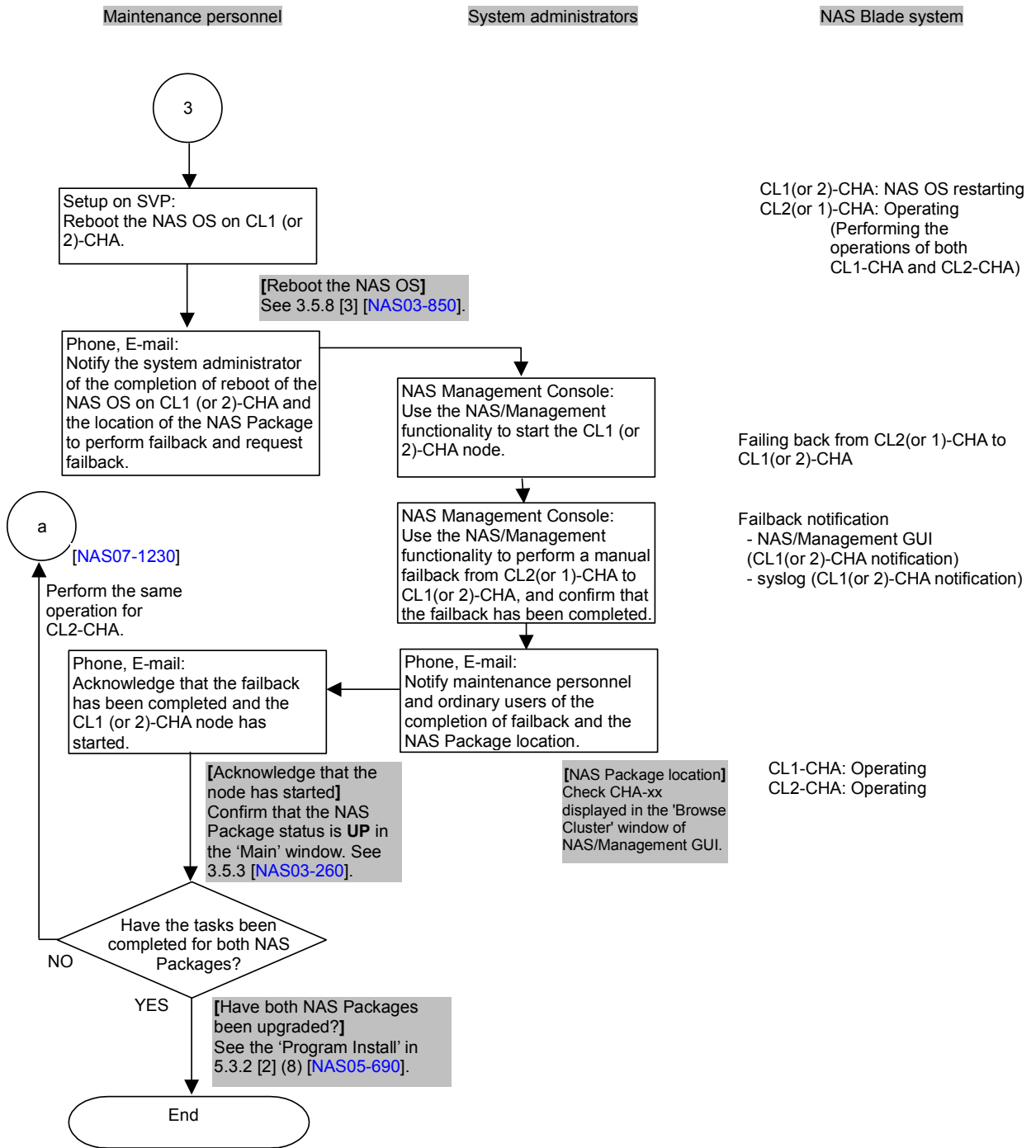

Figure 7.5-14 Upgrading the NAS OS By a Patch Version —
Restarting the NAS OS Is Required (When a Failure Occurs) (5/6)

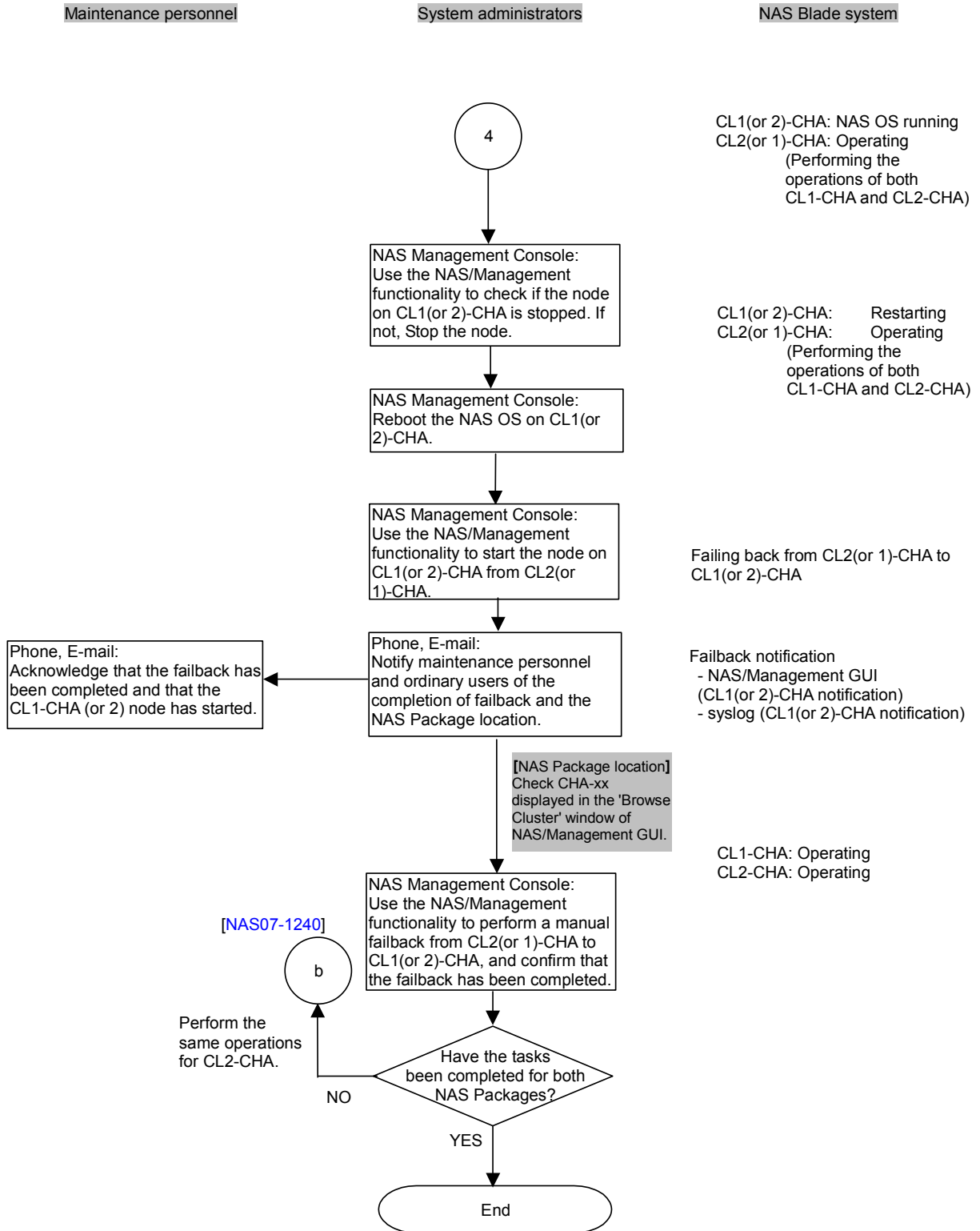

Figure 7.5-14 Upgrading the NAS OS By a Patch Version — Restarting the NAS OS Is Required (When a Failure Occurs) (6/6)

(4) Upgrading NAS/Management (When a Failure Occurs)

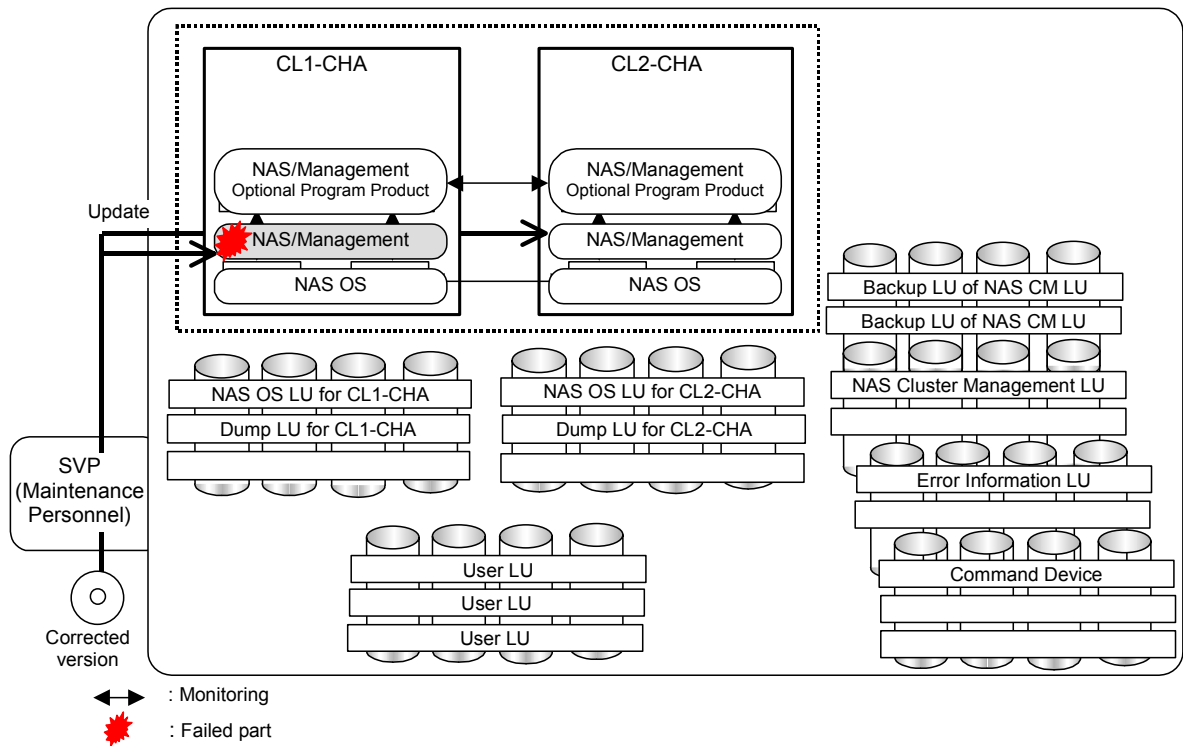

Figure 7.5-15 Upgrading NAS/Management (When a Failure Occurs) (1/2)

Step	Procedure	Notes
1	Obtain the corrected version of NAS/Management.	
2	Upgrade to the corrected version of NAS/Management.	

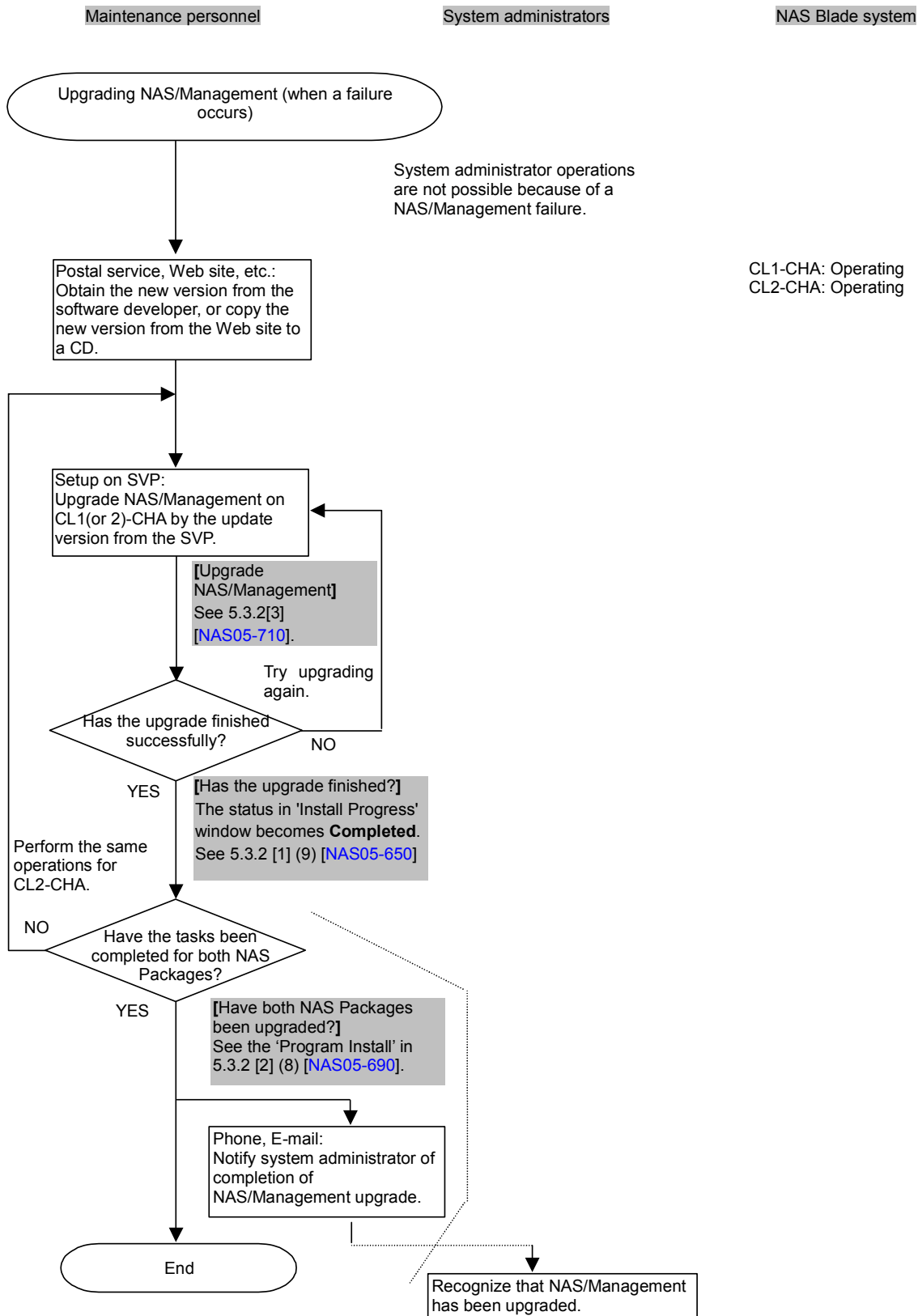

Figure 7.5-15 Upgrading NAS/Management (When a Failure Occurs) (2/2)

(5) Upgrading an Optional Program Product (When a Failure Occurs)

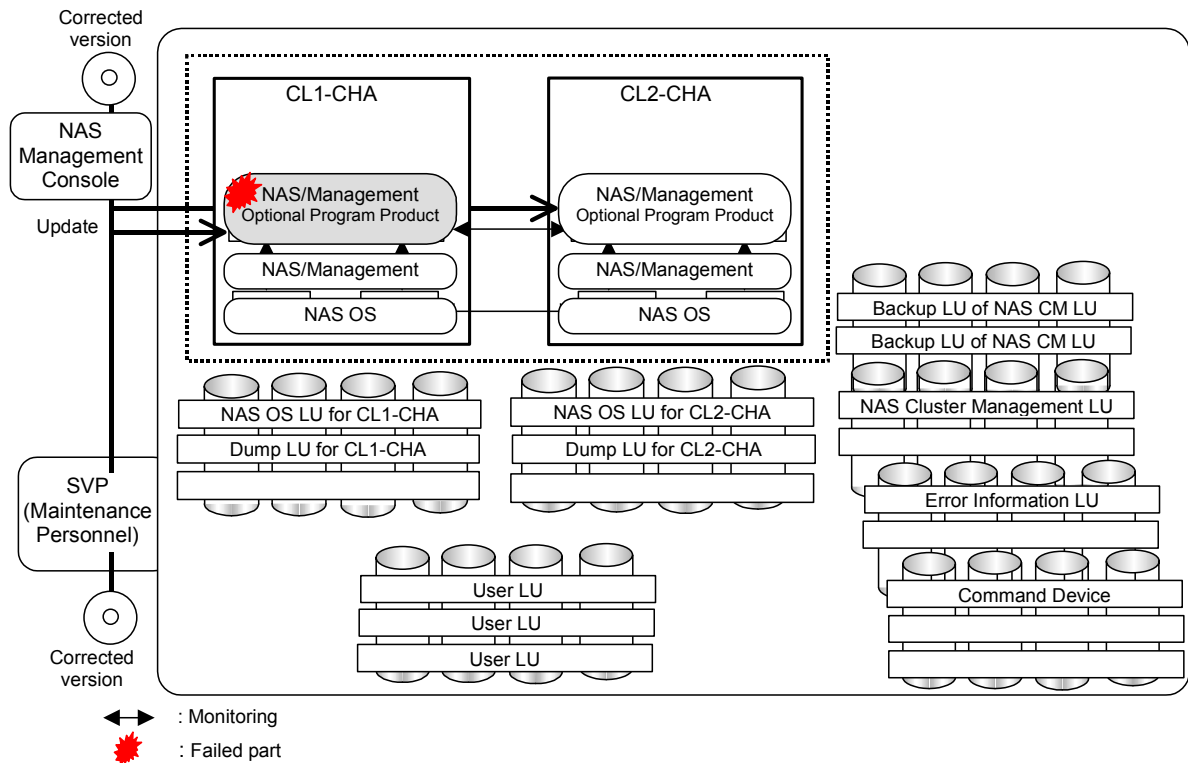

Figure 7.5-16 Upgrading an Optional Program Product (When a Failure Occurs) (1/2)

Step	Procedure	Notes
1	Obtain the corrected version of an optional program product.	
2	Upgrade to the new version of an optional program product.	

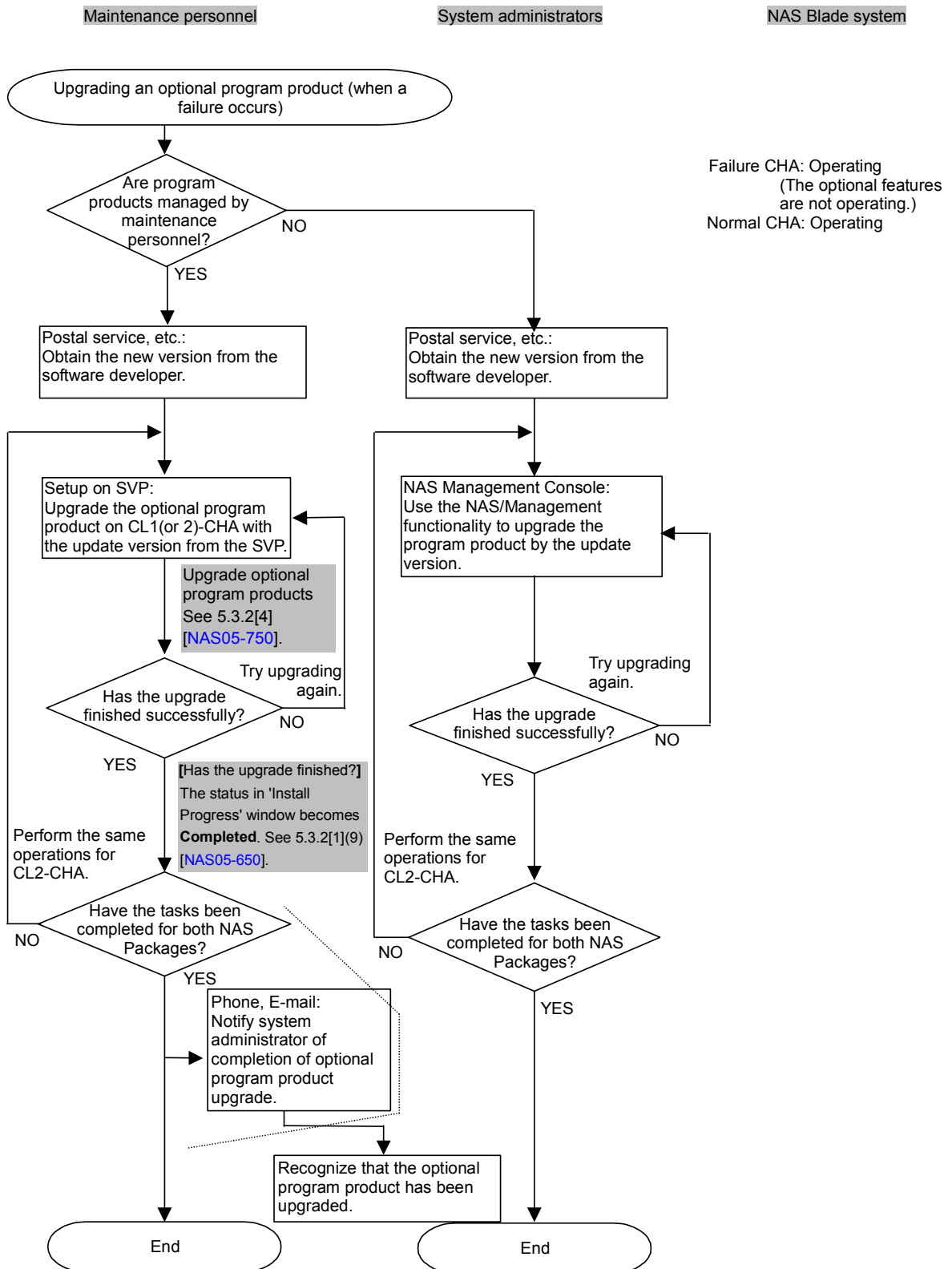

Figure 7.5-16 Upgrading an Optional Program Product (When a Failure Occurs) (2/2)

7.5.3 Going Back To an Earlier Software Version

Before updating, and when the settings are added, deleted, or changed by the NAS/Management GUI, you should make a backup of the NAS OS LU by using the NAS OS LU save/recovery functionality of NAS/Management. If the upgrade fails, use the following procedure to go back to the previous version.



CAUTION

When you downgrade software, contact the Technical Support Center (TSC) and perform operations according to its instructions.

The NAS Blade system does not provide the functionality to go back to an earlier update version. To go back to a previous software version:

- (1) To Go Back To an Earlier Version of the NAS OS
 - (a) When the NAS OS LU, NAS Cluster Management LU and user LU Have Been Backed Up
Restore NAS OS LU[[NAS03-1050](#)] and NAS Cluster Management LU[[NAS03-1050](#)] by using the NAS OS LU save/recovery functionality. Ask a system administrator to restore user LU.
You can go back to an earlier version of NAS/Management and an optional program product by this procedure.
 - (b) When the NAS OS LU, NAS Cluster Management LU and user LU Have Not Been Backed Up
Perform an expansion installation of the NAS OS[[NAS03-400](#)] to install the earlier version to overwrite the current version[[NAS05-130](#)][[NAS05-220](#)], until you reach the target version you want.
Upgrade the version of NAS/Management and an optional program product to an earlier version[[NAS03-490](#)][[NAS03-510](#)] at this time.
- (2) To Go Back To an Earlier Version of NAS/Management
Upgrade the version of NAS/Management to an earlier version[[NAS03-490](#)].
To go back to an earlier version of NAS/Management, you also need to go back to an earlier version of the NAS OS. After going back to an earlier version of the NAS OS, as described in (1), upgrade the target version of NAS/Management.
- (3) To Go Back To an Earlier Version of an Optional Program Product
Upgrade the version of an optional program product to an earlier version[[NAS03-510](#)].
To go back to an earlier version of an optional program product, you also need to go back to an earlier version of the NAS OS. After going back to an earlier version of the NAS OS, as described in (1), upgrade the target version of an optional program product.

8. Setup Procedures When Implementing NAS Blade System for the First Time

In this section both new installation (the configuration is set in the factory) and on-site installation (the configuration is set at the customer's site) procedures are described.

The following setup procedures must have been completed before performing operations described in this section.

- Definition of NAS system LUs, and
- Installation of Setup on SVP, NAS OS and related optional program products.

Each settings should be carefully entered as indicated in the System Assurance Documentation.

For new installation of DKC and NAS Blade system, procedures described in section 8.1 *Operations Using the SVP* [NAS08-20] and 8.2 *Operations Using the NAS/Management GUI* [NAS08-100] have already been performed by the manufacturer, therefore maintenance personnel need to perform operations described in section 8.3 *Confirmation of the settings* [NAS08-290] only.

For on-site installation of NAS Blade system, maintenance personnel need to perform all operations described in 8.1 *Operations Using the SVP* [NAS08-20] through 8.3 *Confirmation of the settings* [NAS08-290].

Detailed procedures are described in the following sections.

8.1 Operations Using the SVP

- [1] Setting up the network environment----- [NAS08-20](#)
 [2] Setting the license of NAS/Management ----- [NAS08-50](#)

[1] Setting up the network environment

The network information, such as the NTP server corresponding to the NAS Package and the fixed IP address of the NAS Package NIC, will be configured.

CAUTION

-The IP addresses of the following networks must not be used. The following networks are reserved in the subsystem. Please contact the Technical Support Center if you need to use these IP addresses.

- from 172.29.1.0/24 to 172.29.4.0/24, and
- the networks of the IP addresses set for the SVP.

-The reserved words for NAS Blade systems cannot be used for a channel adapter name.

Table 8.1-1 shows the reserved words for NAS Blade systems.

Table 8.1-1 List of Reserved Words in NAS Blade Systems

Initial letter	Reserved words
A	add, admin
C	CLU_partition, cluster
D	define, delete
F	Failover_policy, Filesystem, for, force
H	ha_parameter, ha_services, hostname
I	in, IP_address
L	localhost, log_group, LVM_volume
M	maintenance_off, maintenance_on, modify, move
N	nasos, NFS, NFS_admin, node
O	offline, online
R	remove, resource, resource_group, resource_type
S	set, show, start, status, stnet_xxx ^{*1} , stop
T	to

*1: Any word starts with stnet_

[1-1] Connecting the LAN cables

Connect the LAN cables to the ports on the NAS Packages.

- (1) Connect the LAN cables to each port, for which the Service IP Address is specified in the System Assurance Documentation, of all the NAS Packages composing a cluster. When the two or more clusters exist, also connect the LAN cables to all the NAS Packages that are components of all the clusters.

 **CAUTION**

The eth 1 and eth 2 correspond to the ports CH-A/E/J/N and CH-B/F/K/P on the NAS Package respectively.

-
- (2) Connect connectors at the opposite ends of the LAN cables to devices such as the LAN switches, routers, and clients that are in operation. Then make sure that the lamps of the ports on the NAS Packages are lit indicating that the Packages are linked up.

 **CAUTION**

If the LAN cable is disconnected from the port, for which the Service IP Address on the NAS Package has been specified, when a cluster is being configured or after a cluster is activated, a failover will occur in the NAS cluster and it may take a long time for recovery. Therefore, do not disconnect the LAN cable which has been connected while the cluster is being configured or the cluster is activated.

[1-2] To set up the network environment:

(1) Change SVP mode from **View Mode** to **Modify Mode**.

(2) Click the **NAS Setup** button, and then the 'NAS Setup on SVP (Main)' window appears. In the 'NAS Setup on SVP (Main)' window select the NAS Package (**INACTIVE** status), and then click the **Setting** button.

(3) Enter the required information according to System Assurance Documentation, and then click the **Setup** button.

CAUTION

- In **CHA Name**, specify a unique name in the disk subsystem.
- Be sure to enter all the items except **Server 2** in **NTP Server**.
- In **NTP Server**, specify the same value for each NAS Package comprising the cluster.
- If a wrong IP address is specified for the NTP Server or when no NTP server is connected to the network, the SIM (ac88xa that means that the NTP server cannot be connected) will be issued when the NAS OS is restarted. Further, the date when (Available From) the license to use the NAS PP becomes effective may be advanced or delayed by one day because the time of the NAS OS may not be set correctly.

Table 8.1-2 shows the settings (network information) in the 'Setting' window.

Table 8.1-2 Settings in the 'Setting' Window

Item		Description
CHA Name		Specify a name that is unique in the disk subsystem. (Required)
IP Address		Set the IP address. (Required)
Network Mask		Set network mask for the IP address. (Required)
MTU		Specify a MTU value (IP packet data size). (specifiable range: 1500-16100, the default is 1500)
Default Gateway	IP Address	Set the default gateway IP address, and select the NIC (port) that uses the default gateway IP address. (Required)
	Port	
NTP Server	Server1/Server2	The IP address and host name for the NTP server can be specified (Server 1 is required.).

- (4) The message “Are you sure you want to apply the setting to the NAS OS?” is displayed. Confirm the setting contents again, and then click the **OK** button in the message window. The settings are applied.

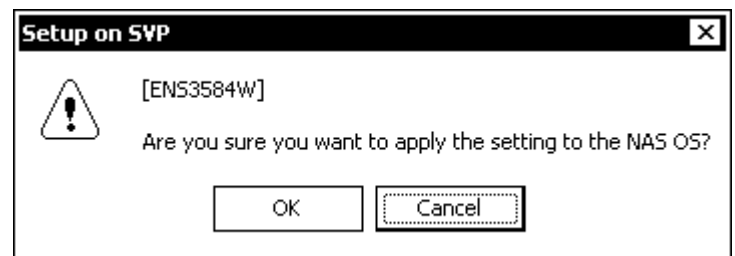

- (5) When the setting contents are changed, the message “The setup ended normally.” is displayed. Click the **OK** button in the message window.

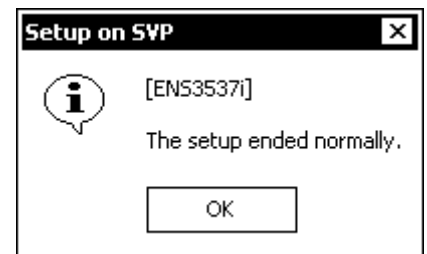

- (6) Click the **Close** button in the 'NAS Setup on SVP (Setting)' window.

- (7) Ask the customer to confirm that access to the NTP server that was set in Step (3) is really possible and the time of the NAS Package is in the state in which it can be synchronous with that of the NTP server. When the time is in the state in which it can be synchronous, go to Step (8). If not, go to Step (10).

- (8) Restart the NAS OS of the operated NAS Package. For details, see 3.5.8 [3] *Restarting the NAS OS* [NAS03-850].

- (9) Repeat through step (1) to step (8) to each newly installed or expanded NAS Package.
When the operation is finished, go to Item [2], “Setting the license of NAS/Management” (on page [NAS08-50](#)).

- (10) Make sure that the same PCB as that selected in Step (2) has been selected in the ‘NAS Setup on SVP (Main)’ window, and then select (CL) **Boot Management**.

- (11) The ‘NAS Setup on SVP (Boot Management)’ window is displayed.
Make sure that the **Status** is **INACTIVE** or **UP**, and then elect (CL) the **Shutdown**.

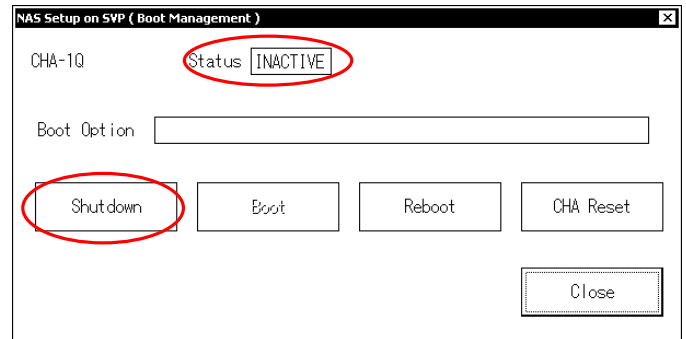

- (12) A message, “Are you sure you want to shut down the NAS OS?” is displayed.
In response to the message, select (CL) the **OK** button.
An operation to shut down the NAS OS is performed.

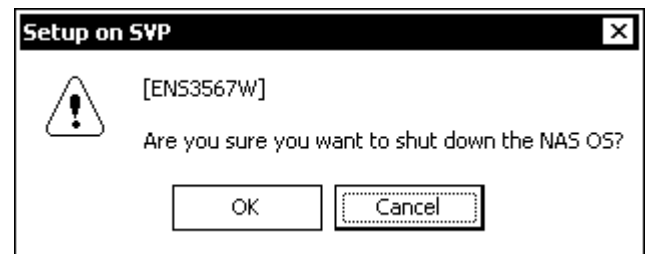

- (13) During the operation above, the **Status** in the ‘NAS Setup on SVP (Boot Management)’ window is changed to **BUSY**.

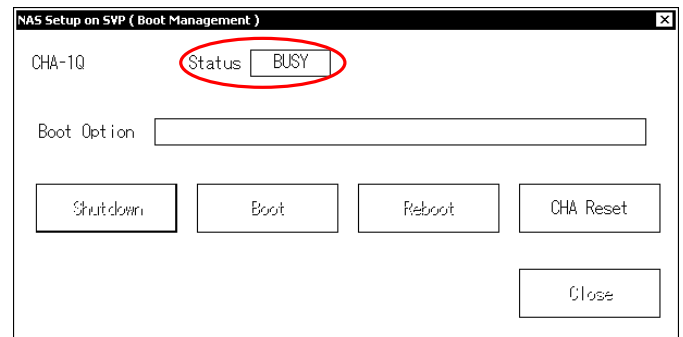

- (14) When the operation is completed, a message, “NAS OS has shut down.” is displayed. In response to the message, select (CL) the **OK** button.

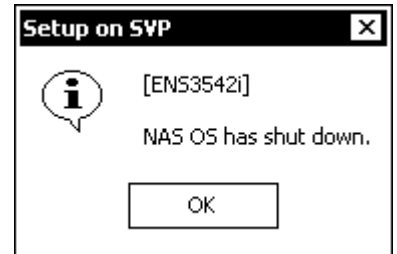

- (15) Make sure that the **Status** in the ‘NAS Setup on SVP (Boot Management)’ window has been changed to **DOWN**.

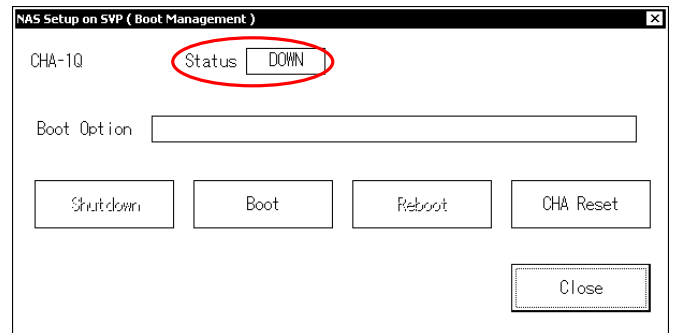

- (16) Enter the name of the necessary option in the **Boot Option** box, and then select (CL) the **Boot**. Regarding the name of the necessary option, contact the Technical Support Center and get it.

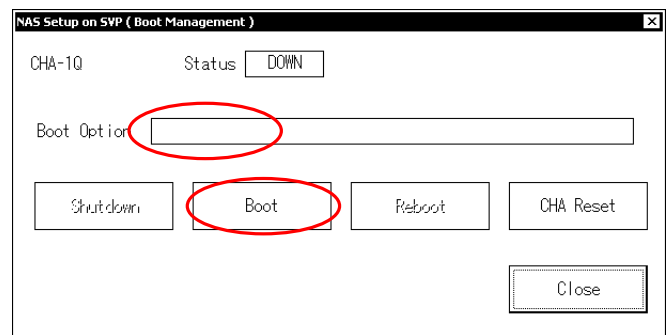

- (17) A message, “Are you sure you want to boot the NAS OS?” is displayed.

In response to the message, select (CL) the **OK** button.

An operation to activate the NAS OS is performed.

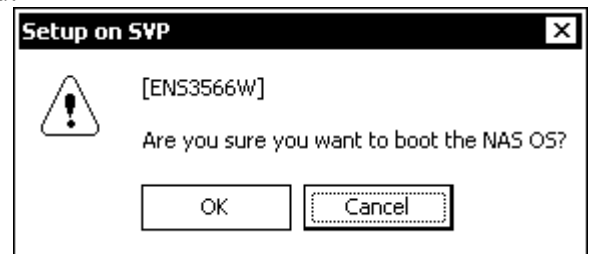

- (18) During the operation above, the **Status** in the 'NAS Setup on SVP (Boot Management)' window is changed to **BUSY**.

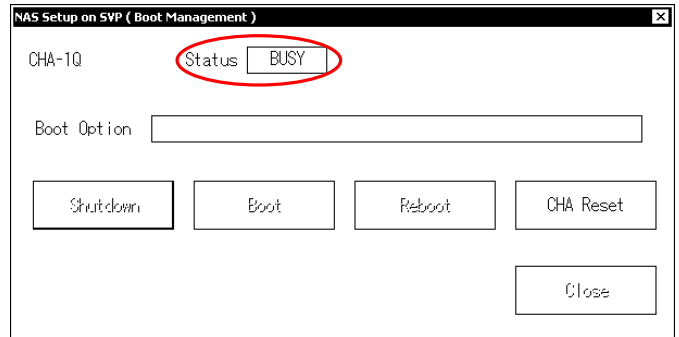

- (19) A message, "NAS OS has booted." is displayed.
In response to the message, select (CL) the **OK** button.

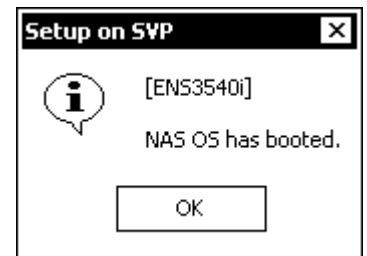

- (20) Make sure that the **Status** in the 'NAS Setup on SVP (Boot Management)' window has been changed to **INACTIVE** or **UP**, and then select (CL) the **Close** button.

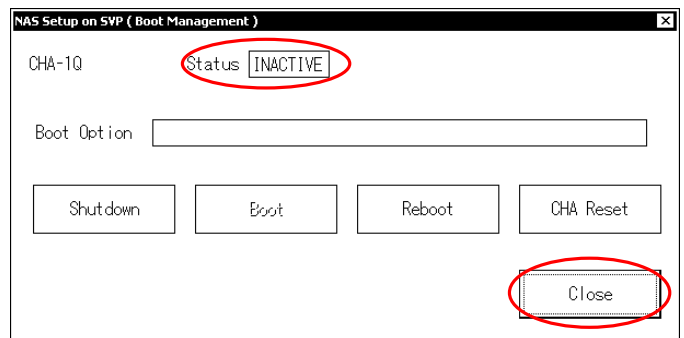

(21) Select (CL) **Install** on the SVP launcher.

(22) Select (CL) **Refer Configuration** in the 'Install' window.

(23) The 'DKC Configuration' window is opened.

(i) Get the upper three bytes of the IP address from the **IP Address** box.

126.244.47.xxx

(Upper three bytes)

DKC Configuration

Please set the following parameters of DKC Configuration.

DKC

Serial No.

Number of CUs

System Option...

Power Supply...

IP Address

IP Address **126.244. 47. 15**

Subnet Mask 255. 0. 0. 0

IP Address Configuration

Cache

Basic: CMG=1024MB Size=1024MBx2
On-Demand=0MBx2

Option: Not installed

Total cache size: 1024MBx2
DCR available: 0MBx2
PCR available: 0MBx2

CHA

DKA

Number of DKA

Cancel

>> Next

- (ii) Fix the value of the lowermost byte according to the location of the NAS Package referring to the following table.

Package location		Lowermost byte of IP address
Multi cabinet model	Single cabinet model	peculiar to NAS Package
CHA-1P,	CHA-1C	51
CHA-1Q,	CHA-1D	67
CHA-1R,	CHA-1F	83
CHA-1S		99
CHA-2V,	CHA-2G	115
CHA-2W	, CHA-2J	131
CHA-2X,	CHA-2K	147
CHA-2Y		163

Example: According to the explanation in (i) and (ii), when the subsystem type is multi cabinet and the IP Address shown in the 'DKC Configuration' window is 126.244.47.15, the IP address peculiar to the NAS Package installed in the location CHA-1P is 126.244.47.51.

(24) Selecting **Run...**

Select (CL) **Run...** from the **Start** of the SVP.



(25) Entering the execution command

Enter "telnet <IP address peculiar to the NAS Package fixed in Step (23)>" in the **Open** box, and then select (CL) the **OK** button.

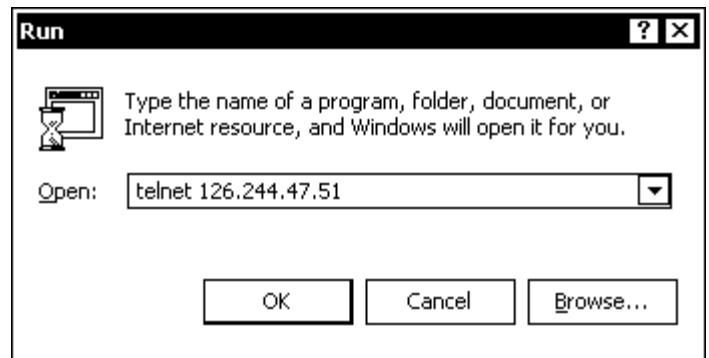

(26) Setting time using the date command

Set the time by entering information in the following window. As to a user's name and a password to be used exclusively in the following Steps (i), (ii), and (iv), contact the Technical Support Center and get them.

```

C:\WINNT\System32\telnet.exe
enas407a login:
Password:
Last login: Mon Apr  5 14:47:08 2004 from 192.168.1.189 on pts/0
Linux enas407a 2.4.17-enas0202-SI22K011 #1 Thu Apr 1 11:59:06 JST 2004 i686 unkn
own

Most of the programs included with the Debian GNU/Linux system are
freely redistributable; the exact distribution terms for each program
are described in the individual files in /usr/share/doc/*/copyright

Debian GNU/Linux comes with ABSOLUTELY NO WARRANTY, to the extent
permitted by applicable law.
enasroot@enas407a:~$ su
Password:
enas407a:/home/enasroot# date 040715092004.00
Wed Apr  7 15:09:00 GMT 2004
enas407a:/home/enasroot# exit
exit
enasroot@enas407a:~$ exit.

```

- (i) login: Enter a user's name for exclusive use in response to a prompt and press the Return key.
- (ii) Password: Enter a password in response to a prompt and press the Return key. It is not a problem that the password that has been entered is not displayed in the window then.
- (iii) When a prompt with a symbol \$ put at the end is displayed, enter 'su' and press the Return key.
- (iv) Password: Enter a password in response to a prompt and press the Return key. It is not a problem that the password that has been entered is not displayed in the window then.
- (v) When a prompt with a symbol # put at the end is displayed, a service person is requested to fix the current GMT date and time correctly based on a clock (such as a wrist watch) and specify the date and time following the rule shown below. When doing this, it is not a problem if the time contains an error of several seconds.

Example: In the case where the place is in Japan and the watch reading is 4/8 00:09:00, the time to be specified is 4/8 00:09:00 – 9:00:00 = 4/7 15:09:00 (advanced by 9 hours) because the Japanese time is 9 hours earlier than the GMT. Be careful to calculate the time taking a date in consideration.

“date△”: The description is fixed. (Be careful not to omit the space of half size following the “date.”)

“040715092004.00”: To be described in the format of MMDDhhmmyyyy.ss.

MM: Month (2 figures: 01 to 12)

DD: Day (2 figures: 01 to 31)

hh: Hours (2 figures: 00 to 23)

mm: Minutes (2 figures: 00 to 59)

yyyy: Dominical year (4 figures)

.: Period (“.”) The description is fixed.

ss: Seconds (2 figures: 00 to 59)

Note: When a number of figures of the MM, DD, hh, mm, yyyy, or ss is less than the specified one, add “0” (zero) as a top figure.

- (vi) Make sure that the date and time is displayed correctly in the line next to the line in which the date command was entered.
- (vii) When a prompt with a symbol # put at the end is displayed, enter ‘exit’ and then press the Return key.
- (viii) When a prompt with a symbol \$ put at the end is displayed, enter ‘exit’ and then press the Return key. This operation closes the window.

(27) Perform the operations in Steps (10) to (26) for all the PCBs that were added or newly installed.

(28) In the 'NAS Setup on SVP (Main)' window, make sure that one of the PCBs that were added or newly installed has been selected, and then select (CL) **Boot Management**.

(29) The 'NAS Setup on SVP (Main)' window is displayed.
Make sure that the **Status** is **INACTIVE** or **UP**, and then select (CL) the **Shutdown** button.

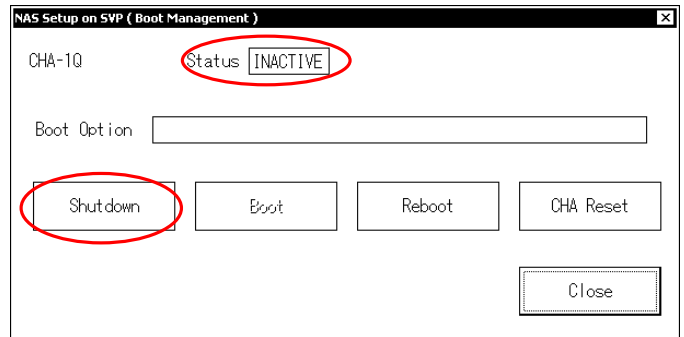

(30) A message, "Are you sure you want to shut down the NAS OS?" is displayed.

In response to the message, select (CL) the **OK** button.

An operation to inactivate the NAS OS is performed.

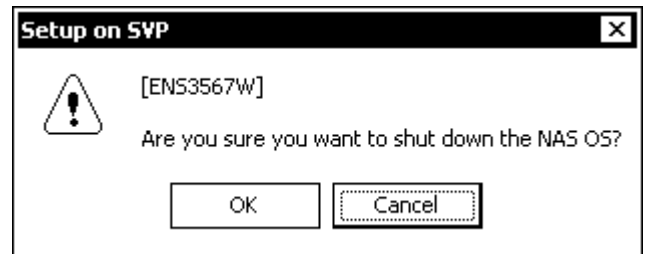

(31) During the operation above, the **Status** in the 'NAS Setup on SVP (Boot Management)' window is changed to **BUSY**.

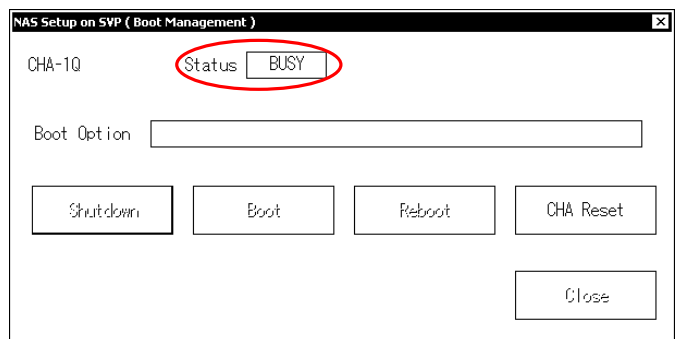

- (32) When the operation is completed, a message, “NAS OS has shut down.” is displayed.
In response to the message, select (CL) the **OK** button.

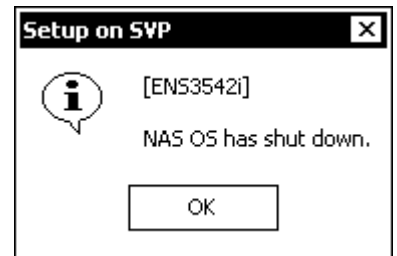

- (33) Make sure that the **Status** in the ‘NAS Setup on SVP (Boot Management)’ window has been changed to **DOWN**.

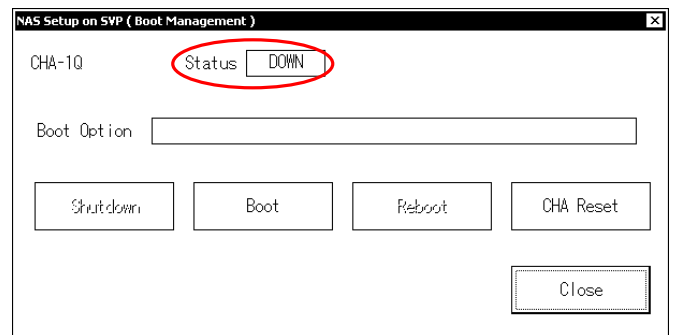

- (34) Enter the name of the necessary option in the **Boot Option** box and select (CL) the **Boot**.
Regarding the name of the necessary option, contact the Technical Support Center and get it.

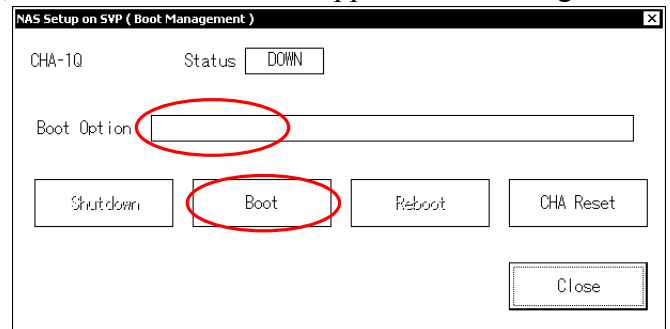

- (35) A message, “Are you sure you want to boot the NAS OS?” is displayed.
In response to the message, select (CL) the **OK** button.
An operation to activate the NAS OS is performed.

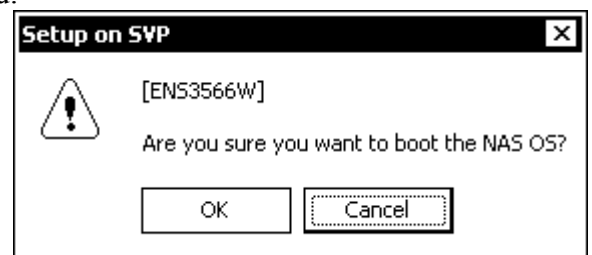

- (36) During the operation above, the **Status** in the ‘NAS Setup on SVP (Boot Management)’ window is changed to **BUSY**.

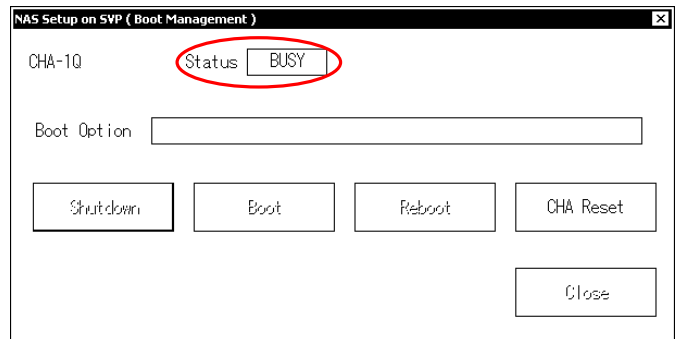

- (37) A message, “NAS OS has booted.” is displayed.
In response to the message, select (CL) the **OK** button.



- (38) Make sure that the **Status** in the ‘NAS Setup on SVP (Boot Management)’ window has been changed to **INACTIVE** or **UP**, and then select (CL) the **Close** button.

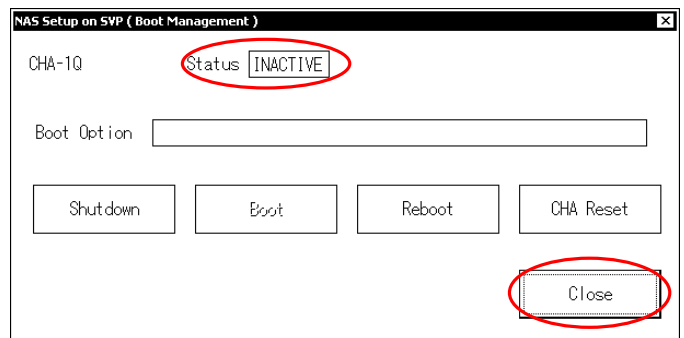

- (39) Perform the operations in Steps (28) to (38) for all the PCBs that were added or newly installed.
When the operation is finished, go to Item [2], “Setting the license of NAS/Management” (on page [NAS08-50](#)).

[2] Setting the license of NAS/Management

To use the license key to set up the license for an optional program product:

- (1) In the 'NAS Setup on SVP (Main)' window, click the **License Management** button.
The 'License Management' window appears.

NAS Setup on SVP (License Management)

License List

Program Product Name	License Type	Term of validity	All	Already Used
Hitachi Network A...	Permanent	-	8	2

Delete **Detail**

License Key

Key Code:

Accept
Key File
Close

(2) The 'NAS Setup on SVP (License Management)' window appears.

In the 'NAS Setup on SVP (License Management)' window, enter the license key in **Key Code:**, and then click the **Accept** button.

Go to step (5).

To use the license key file, click the **Key File** button, and then go to step (3).

 **CAUTION**

You must install the same version of optional program products in the NAS Packages comprising the same cluster, and set the license to all NAS Packages in that cluster. If the version or license of the installed optional program products is different between the NAS Packages in a cluster, they cannot be used in both NAS Packages in that cluster.

Table 8.1-3 shows the information to be set in the 'License Management' window.

Table 8.1-3 Listed items in the 'License Management' window

Item	Description
License List	The existing licenses are listed. Double-clicking the first item or clicking the Detail button displays the 'License Setting' window.
Accept	Entering a license key enables this button. Clicking this button displays the 'License Setting' window.
Key Code:	Enter a license key.
Key File	Clicking this button displays the 'Select a License Key File' window.

- (3) In the 'NAS Setup on SVP (License Management)' window, click the **Key File** button. The 'Select a License Key File' window is displayed. Select a license key file (.plk), and then click the **Open** button.

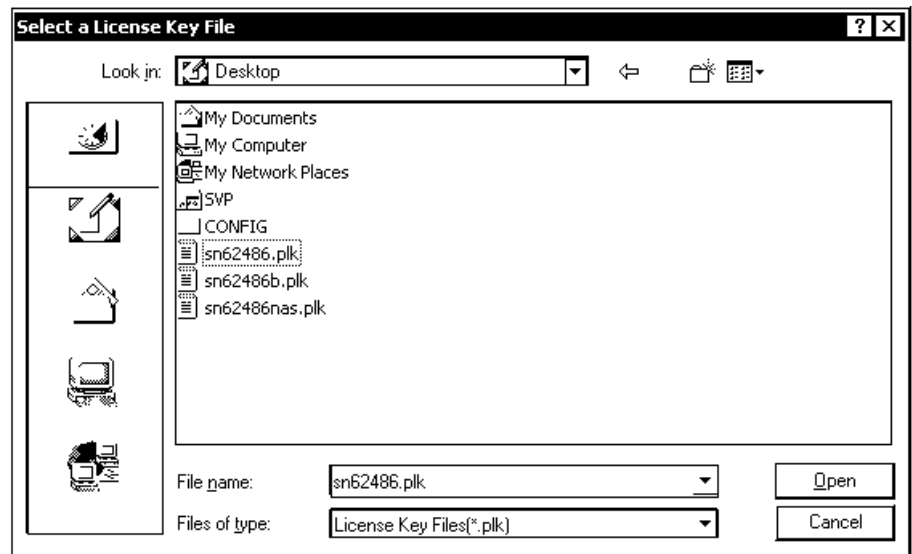

- (4) The 'NAS Setup on SVP (License Key File)' window appears. In the 'NAS Setup on SVP (License Key File)' window, select **Hitachi Network Attached Storage/Management**, and then click the **Accept** button.

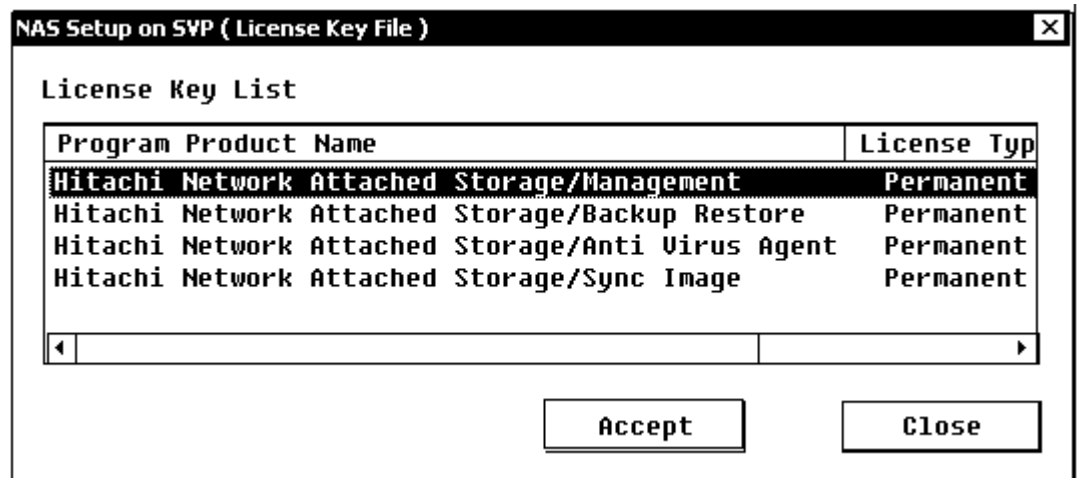

- (5) The 'NAS Setup on SVP (License Setting)' window appears.
 In the 'NAS Setup on SVP (License Setting)' window, under **Distribution**, select the cluster to which the license is to be assigned, and then click the **Accept** button.

The screenshot shows a window titled "NAS Setup on SVP (License Setting)". Inside, there is a text field for "Program Product Name" containing "Hitachi Network Attached Storage/Management". Below this are three fields: "License Type" set to "Permanent", "Term of validity" set to "-", and "Remaining License" set to "6". A section labeled "Distribution" contains two rows of checkboxes. The first row has a checked box for "CHA-1P" and three unchecked boxes. The second row has a checked box for "CHA-2U" and three unchecked boxes. At the bottom right, there are "Accept" and "Close" buttons.

Table 8.1-4 Listed items in the 'License Setting' window

#	Item	Description
1	Program Product Name	Displays product name that are either selected in the License List window or specified by entering the license key.
2	License Type	Displays product type that are either selected in the License List window or specified by entering the license key.
3	Term of validity	For a permanent license, the Term of validity box displays - and the Remaining License box displays the remaining licenses. For temporary and emergency licenses, the Term of validity box displays the time limit for usage and the Remaining License box displays -.
	Remaining License	
4	Accept	Click this button to set the information of the entered (displayed) license.
5	Distribution	Switching the selection (ON/OFF) enables the license to be set and enables you to check which clusters have a license, etc.

- (6) The message “Are you sure you want to apply the setting to the NAS OS?” is displayed. Recheck the cluster to which the license is to be assigned, and then click the **OK** button.

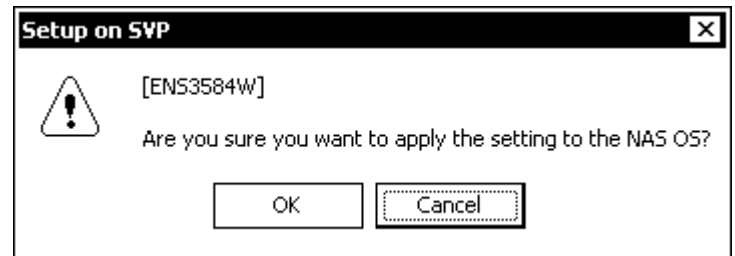

- (7) The message “The license is accepted” is displayed. Click the **OK** button.



- (8) In the ‘NAS Setup on SVP (License Setting)’ window, click the **Close** button to close the window.

In case of having multiple license keys which are [Hitachi Network Attached Storage/Backup Restore] etc. in same license file, repeat through step (4) to step (8).

- (9) In the ‘NAS Setup on SVP (License Key File)’ window, click the **Close** button to close the window.

In case of having each license key in different file, repeat through step (2) to step (9).

- (10) Make sure the licenses that were set up in the ‘License List’ box, and then click the **Close** button.

- (11) In the ‘NAS Setup on SVP (Main)’ window, click the **Close** button to close the window.

- (12) Next, you must perform operations using the NAS/Management GUI. Go to next section.

- (13) Change SVP mode from **Modify Mode** to **View Mode**.

8.2 Operations Using the NAS/Management GUI

- [1] Confirming that Setup on SVP is stopped ----- [NAS08-100](#)
- [2] Connecting LAN cables ----- [NAS08-110](#)
- [3] Registering system administrators ----- [NAS08-120](#)
- [4] Setting up the NAS Package cluster configuration ----- [NAS08-220](#)

This section describes the operations using the NAS/Management GUI via the Internet Explorer running on the SVP. The procedures are as follows:

- [1] Confirming that Setup on SVP is stopped
 - (1) Make sure that Setup on SVP on the SVP has stopped.
-
- (2) If Setup on SVP is still running, select the **Close** button in the 'NAS Setup on SVP(Main)' window to stop the NAS Setup on SVP. If multiple Setup on SVP programs are running, close all windows named as 'NAS Setup on SVP(Main)'.

 **CAUTION**

Do not perform any NAS/Management operations on the SVP while Setup on SVP is running.

[2] Connecting LAN cables

To connect LAN cables to ports on NAS Packages:

When they have already been connected, go to the step [3], “Registering system administrators” on page [NAS08-120](#).

- (1) Connect LAN cables to each port that **Service IP Address** is defined in the System Assurance Documentation. Also, connect LAN cables to each NAS Package in a cluster. If multiple clusters exist, connect LAN cables to each port that **Service IP Address** is defined, in each NAS Package in all clusters.

 **CAUTION**

eth1 corresponds to port CH-A/E/J/N on NAS Package, and eth2 corresponds to port CH-B/F/K/P on NAS Package.

- (2) Connect opposite sides of the LAN cables to available peripheral devices, such as LAN switches, routers, clients and so on. Make sure that the port lamp on the NAS Package is lit and indicates that the link is up.

 **CAUTION**

When a cluster is being configured, or when a cluster is activated, disconnecting a LAN cable from a port of a NAS Package that **Service IP Address** is defined will cause a failover in the cluster, and it might take long to failback. Therefore, do not disconnect LAN cables when a cluster is being configured, or when a cluster is activated.

[3] Registering system administrators

To register system administrators, log in to NAS/Management by an account administrator, and then register system administrators.

To register system administrators:

- (1) Start a Web browser on the SVP.
Select **Start - Programs - Internet Explorer**.

If address bar is already shown on the Web browser, go to step (3).

If address bar is not shown on the Web browser, go to step (2).

- (2) Display the address bar on the Web browser.
Select **View - Toolbars - Address Bar** from the menu bar.

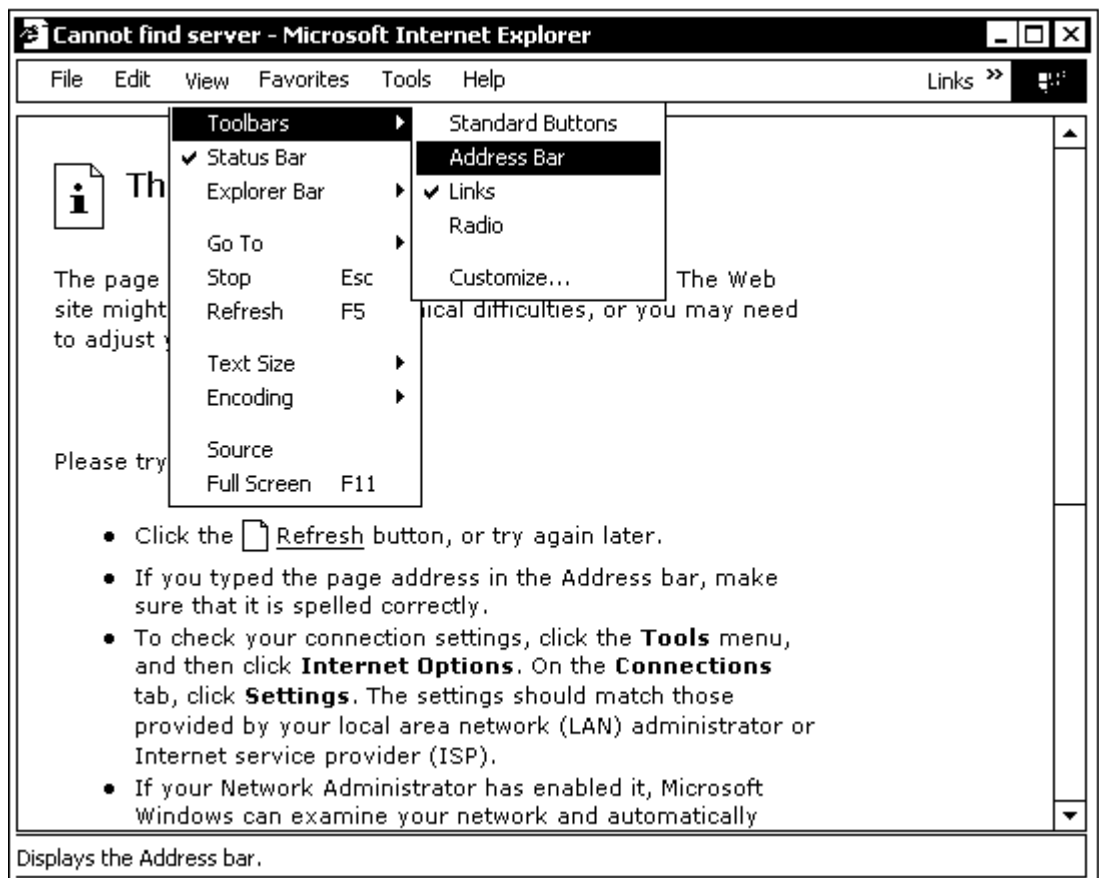

- (3) Type the URL of the 'Login' window, at the address bar on the Web browser.
Enter the following URL:

`https://fixed-IP-address-of-NAS-Package-for-connection/admin.cgi`

The 'Security Alert' window appears.



Click Yes button, and then the 'Login' window appears.

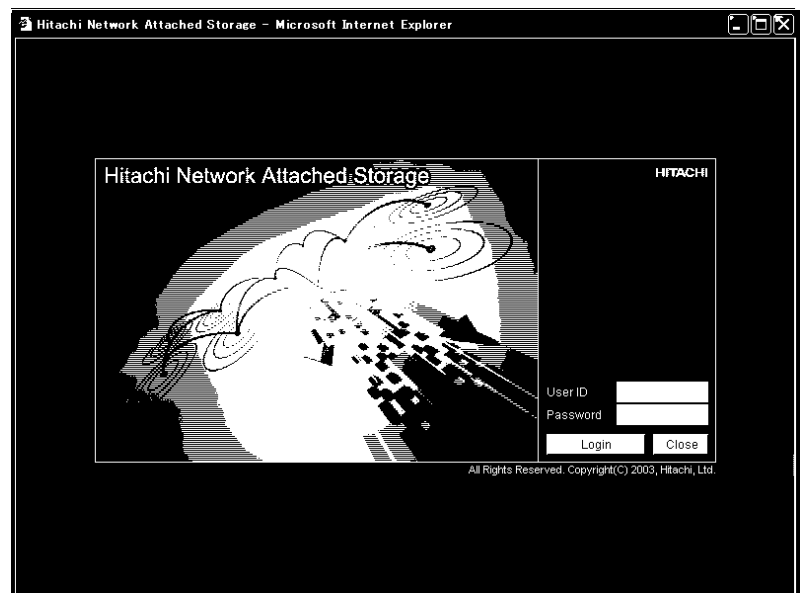

To obtain the fixed IP address for the NAS Package, select **Install - Refer Configuration** in the 'SVP' window.

Obtain the first 3 bytes of the IP address from the IP address displayed in 'DKC Configuration' window, and obtain the lowest one byte from a value shown in Table 8.2-1 [NAS08-150] according to the NAS Package location.

✕

Please set the following parameters of DKC Configuration.

DKC

Serial No.

Number of CUs

IP Address

IP Address : 126.244. 22. 15

Subnet Mask 255. 0. 0. 0

Cache

Basic: CMG=1024MB Size=8192MBx2
On-Demand=0MBx2

Option: CMG=1024MB Size=8192MBx2
On-Demand=0MBx2

Total cache size: 16384MBx2
DCR available: 0MBx2
PCR available: 0MBx2

CHA

DKA

Number of DKA

Table 8.2-1 shows the lowest byte of the fixed IP address of NAS Package.

Table 8.2-1 Lowest byte of fixed IP address of NAS Package

#	Package	DKC cluster	Package Location	Lowest byte of fixed IP address of NAS Package
1	CHN	CL1	Basic	51
2			Option-1	67
3			Option-2	83
4			Option-3 *1	99
5		CL2	Basic	115
6			Option-1	131
7			Option-2	147
8			Option-3 *1	163

*1: Option-3 is unavailable in a single cabinet model.

As shown in this example, if the IP address obtained by **Install – Refer Configuration** on the SVP is 126.244.22.15, the fixed IP address of NAS Package of the basic location on CL1 for example, will become 126.244.22.51.

- (4) The 'Login' window appears.

In **User ID**, enter `nasmgr` (the default user name of the account administrator), and in **Password**, enter `raid-mgr`, and then click the **Login** button.

If NAS Packages have already been being used by the customer, the user ID and password of the account administrator may have been changed. If so, ask the customer for the current user ID and password to log in.

The following table lists the information to be specified in the 'Login' window.

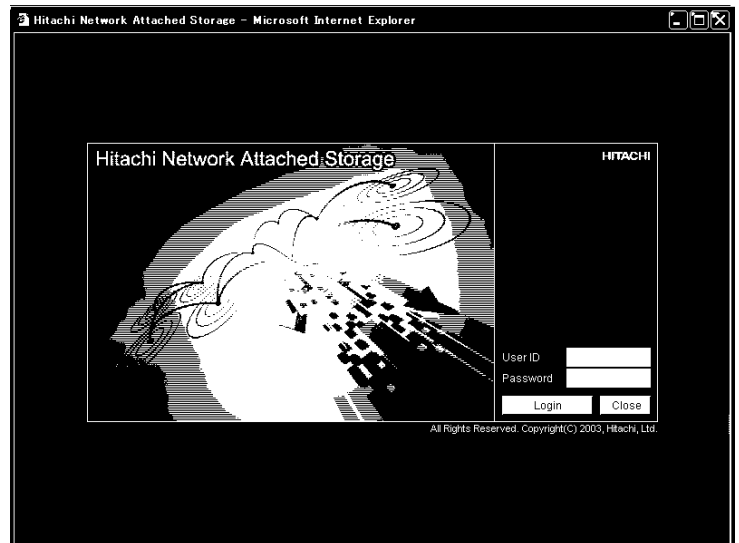
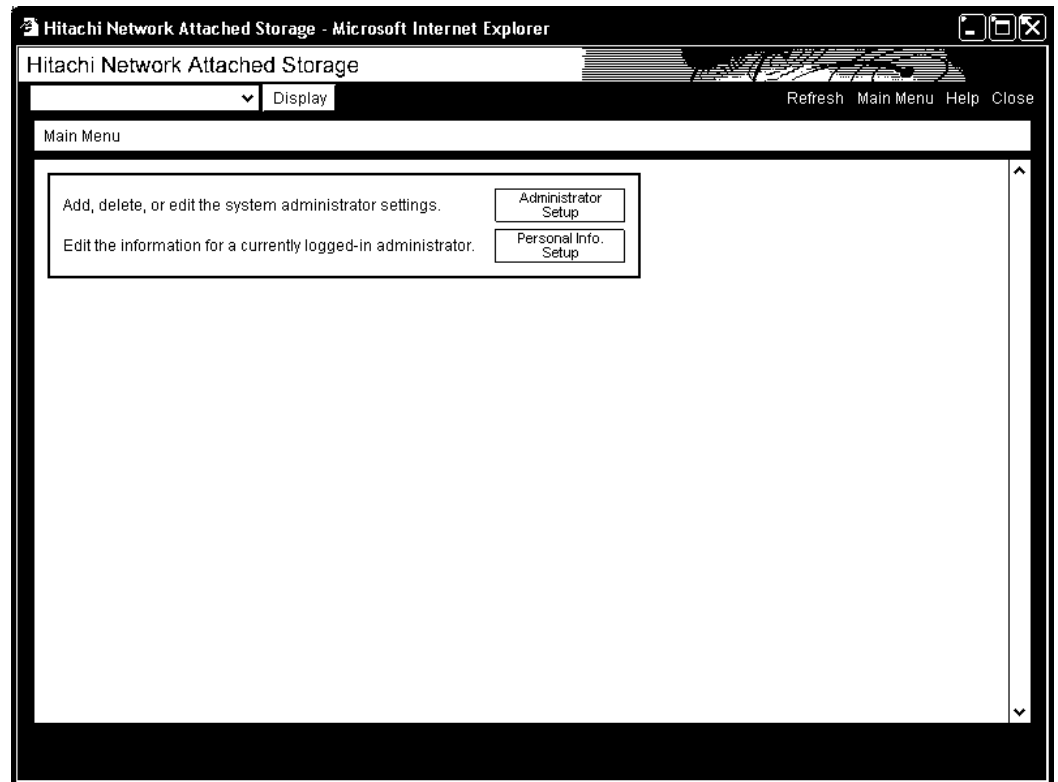

Table 8.2-2 Information specified in the 'Login (account administrator)' window

#	Item	Description
1	User ID	Enter the user name of the account administrator for the NAS Blade system.
2	Password	Enter the password of the account administrator.

- (5) In the 'Main Menu (account administrator)' window, click the **Administrator Setup** button.



The 'List of Administrators' window appears.

- (6) When registering system administrator, click the **Add Administrator** button and go to step (7). When adding or reducing the packages which system administrator manages, select desired system administrator and then click the **Edit Administrator** and go to step (8).

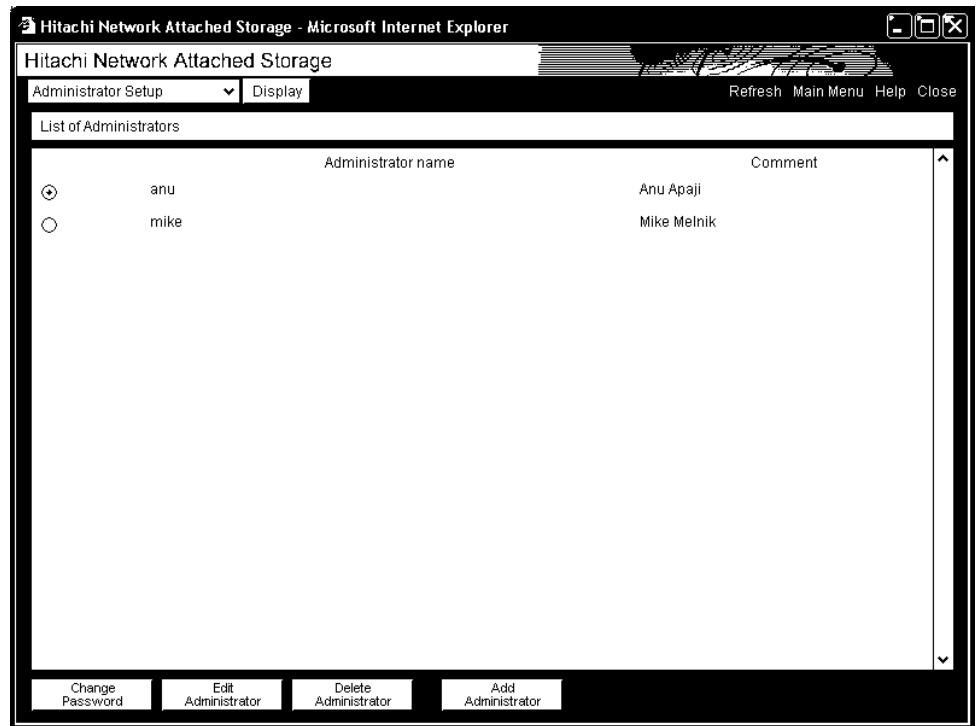

The 'Add Administrator' window appears.

- (7) Enter the required information according to the settings in the System Assurance Documentation, and then click the **Add** button.
The system administrator is added, and the 'List of Administrators' window reappears.
Go to step (9).

Hitachi Network Attached Storage - Microsoft Internet Explorer

Hitachi Network Attached Storage

Administrator Setup | Display | Refresh Main Menu Help Close

List of Administrators > Add Administrator

Administrator name: david

Comment: David Kreger

Password:

Re-enter password:

Managed NAS-CHAS

<input checked="" type="checkbox"/>	CHA-1P	<input checked="" type="checkbox"/>	CHA-1Q	<input checked="" type="checkbox"/>	CHA-1R	<input checked="" type="checkbox"/>	CHA-1S
<input checked="" type="checkbox"/>	CHA-2V	<input checked="" type="checkbox"/>	CHA-2W	<input checked="" type="checkbox"/>	CHA-2X	<input checked="" type="checkbox"/>	CHA-2Y

Add Back

The following table lists the information to be specified in the 'Add Administrator' window.

Table 8.2-3 Information specified in the 'Add Administrator' window

#	Item	Description
1	Administrator name	Enter the user name of the system administrator you are registering. Specify a maximum of 16 alphabetic characters or numeric characters. The first character must be an alphabetic character. You can use any alphanumeric character, hyphen (-), and underscore (_) after the first character. Specify a unique user name. This user name must differ from the name of the account administrator.
2	Comment	Enter a comment for the system administrator you are registering. Enter a maximum of 32 characters. You can use any alphanumeric character, number sign (#), percent sign (%), ampersand (&), apostrophe ('), left parenthesis ((), right parenthesis ()), asterisk (*), plus sign (+), hyphen (-), period (.), forward slash (/), semicolon (;), left angle bracket (<), right angle bracket (>), question mark (?), at mark (@), left bracket ([), right bracket (]), caret (^), underscore (_), left brace ({), vertical bar (), right brace (}), and tilde (~). You can also specify spaces but spaces cannot be specified at the beginning or at the end of the character string. This item is optional.
3	Password	Enter the password of the system administrator you are registering. Specify a maximum of 8 characters. You can use any alphanumeric character, exclamation mark (!), quote ("), number sign (#), dollar sign (\$), percent sign (%), ampersand (&), apostrophe ('), left parenthesis ((), right parenthesis ()), asterisk (*), plus sign (+), comma (,) hyphen (-), period (.), forward slash (/), colon (:), semicolon (;), left angle bracket (<), equal sign (=), right angle bracket (>), question mark (?), at mark (@), left bracket ([), backslash (\), right bracket (]), caret (^), underscore (_), grave accent (`), left brace ({), vertical bar (), right brace (}), and tilde (~).
4	Re-enter password	Re-enter the system-administrator password that you specified in Password .
5	Managed NAS-CHAS	Select the check box for the NAS Package you want to allocate to the system administrator you are registering. You can specify more than one NAS Package.

- (8) Mark check which system administrator would like to add or reduce the packages in 'Managed NAS-CHAs' check box.

Hitachi Network Attached Storage - Microsoft Internet Explorer

Hitachi Network Attached Storage

Administrator Setup | Display Refresh | Main Menu | Help | Close

List of Administrators > Edit Administrator

Administrator name anu

Comment Anu Apaji

Managed NAS-CHAs

<input checked="" type="checkbox"/>	CHA-1P	<input checked="" type="checkbox"/>	CHA-1Q	<input checked="" type="checkbox"/>	CHA-1R	<input checked="" type="checkbox"/>	CHA-1S
<input checked="" type="checkbox"/>	CHA-2V	<input checked="" type="checkbox"/>	CHA-2W	<input checked="" type="checkbox"/>	CHA-2X	<input checked="" type="checkbox"/>	CHA-2Y

OK Back

- (9) Click **Close** in the menu area.
 You will log out from NAS/Management, and the Web browser will close.
 Make sure that you log out first, and then close the Web browser. If you close the Web browser first, you cannot log out properly.

[4] Setting up the NAS Package cluster configuration

The system administrator defines the cluster configuration of NAS Packages using the GUI of NAS/Management.

To log in to NAS/Management as a system administrator and define the cluster configuration:

- (1) Type the URL of the Login window, at the address bar on the Web browser.
Enter the following URL:

`https://fixed-IP-address-of-NAS-Package-for-connection/admin.cgi`

The fixed IP address of NAS Package should be same as you got at step (3) in 8.2 [3] *Registering system administrators* [[NAS08-120](#)].

- (2) The 'Security Alert' window appears. Click **Yes** button, and then the 'Login' window appears.

Enter **User ID** and **Password**, and then click the **Login** button.

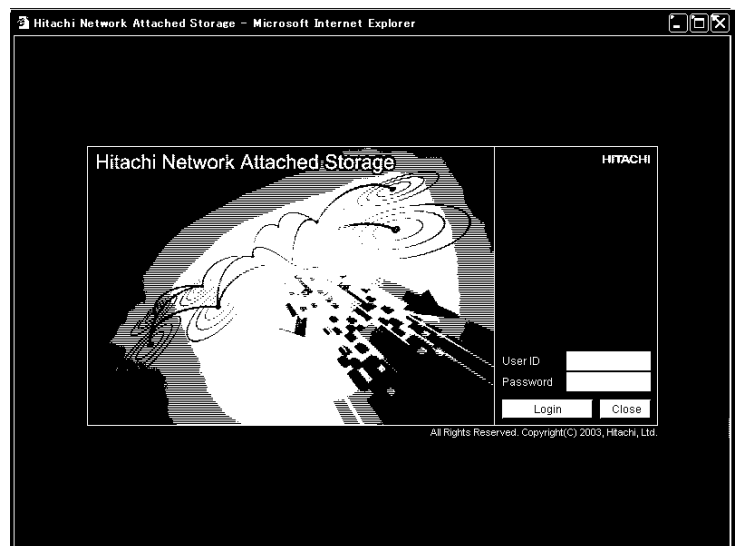
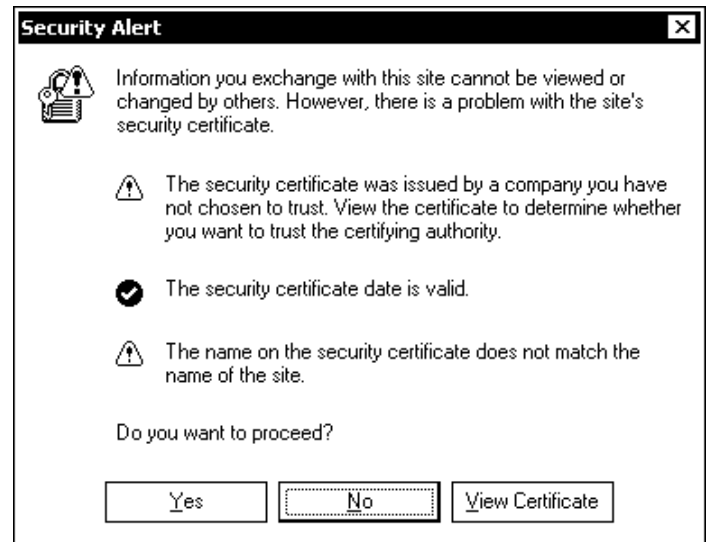

The following table lists the information to be specified in the 'Login' window.

Table 8.2-4 Information specified in the 'Login' window

#	Item	Description
1	User ID	Enter the user name of a system administrator according to the System Assurance Documentation.
2	Password	Enter the password of the system administrator according to the System Assurance Documentation.

- (3) The 'Define Cluster Configuration' window appears for the NAS Package you selected, and a dialog box prompts you to define the cluster configuration. Click the **OK** button.



- (4) The 'Define Cluster Configuration' window appears. Enter the required information according to the System Assurance Documentation, and then click the **OK** button.

- (5) The 'Do you want to define the cluster?' window appears.
Click the **OK** button.

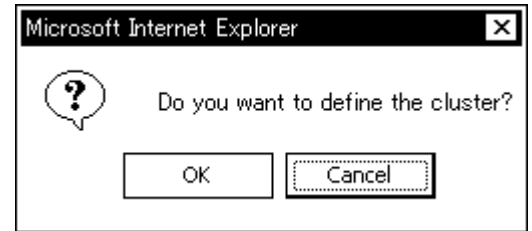

- (6) Settings will be saved within around 10 minutes.

The following table lists the information to be specified in the 'Define Cluster Configuration' window.

Table 8.2-5 Information specified in the 'Define Cluster Configuration' window

#	Item	Description
1	Cluster name	<p>Enter any name to identify the cluster consisting of nodes, that is, NAS Packages in pairs. You can use a maximum of 22 characters. You can use any alphanumeric character, hyphen (-), period (.), forward slash (/), colon (:), at mark (@), and underscore (_). However, you cannot use an underscore (_) as the first character. Note that you cannot specify words reserved by the system. For details on reserved words, see Table 8.1-1 [NAS08-20].</p>
2	Node name	<p>Enter any name as the node name. A node name is the name of an element that corresponds to each NAS Package in the cluster. This node name differs from the channel adapter name set for the NAS Package. You can use a maximum of 22 characters. You can use any alphanumeric character, hyphen (-), period (.), forward slash (/), colon (:), at mark (@), and underscore (_). You cannot use an underscore (_) as the first character. Note that you cannot specify words reserved by the system. For details on reserved words, see Table 8.1-1 [NAS08-20].</p>
3	Service IP address Service net mask	<p>Enter the service IP address used by a client to connect to each service in the resource group, and allocate a service netmask for each service. One service IP address, either for eth1 or eth2, or two service IP addresses, one for eth1 and the other for eth2, can be specified per node. After entering the service IP addresses and service netmask, click the Add button to add them to the list box. Information not added to the list box will not be set. To delete a service IP address from the list box, select the service IP address and click the Delete button. Do not specify the following IP addresses for the network because these addresses are reserved by the disk subsystem. If you must specify these addresses, consult our Technical Support Center (TSC). • An IP address from 172.29.1.0 to 172.29.4.255 • Network for the IP address set for the SVP For details on the network for the IP address set for the SVP, ask the maintenance personnel for confirmation.</p>

- (7) The cluster configuration settings are saved and the 'Main Menu' window appears.

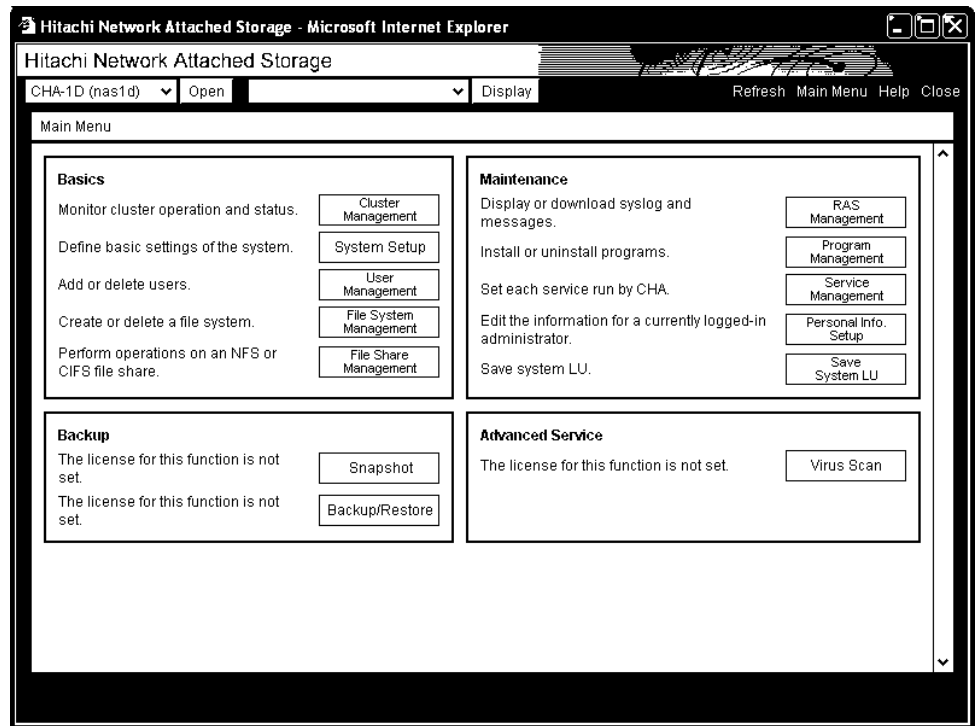

- (8) Log out from NAS/Management.
In the menu area of the window for the NAS Package from which you want to log out, click **Close**.
- (9) Start a Web browser on the SVP.
Select **Start - Programs - Internet Explorer**.

(10) Hide the address bar on the Web browser.

Select **View - Toolbars - Address Bar** from the menu bar to clear the check.

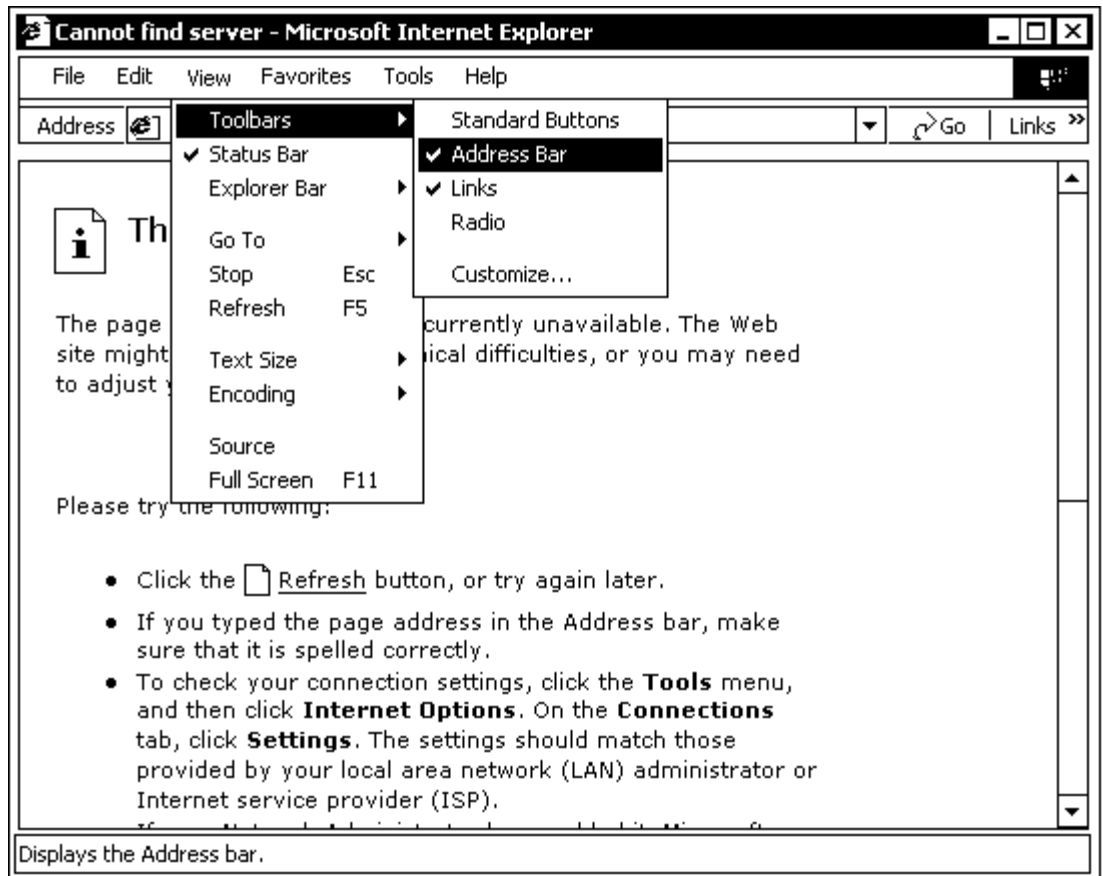

(11) Make sure that the address bar is not displayed in the Web browser.

(12) Select **File - Close** in the Web browser to exit.

8.3 Confirmation of the settings

Confirm the settings as following procedure.

- [1] Connection of LAN cable----- [NAS08-290](#)
- [2] Starting the cluster----- [NAS08-310](#)
- [3] Confirmation of the connection from a client----- [NAS08-390](#)

[1] Connection of LAN cable

- (1) For new installation of DKC and NAS Blade system, go to step (2).

For on-site installation of NAS Blade system, go to step (4).

(2) Connect LAN cable to eth1 port of NAS Packages.

In case **Service IP Address** of eth2 is specified in the System Assurance Documentation, go to step (3).

In case **Service IP Address** of eth2 is not specified in the System Assurance Documentation, go to step (4).

(3) Connect LAN cables to eth2 ports of NAS Packages.

- (4) Make sure that the LAN cables are connected to ether ports of NAS Packages according as ether ports which are described in **Service IP Address** column of the System Assurance Documentation. Also, make sure that the opposite sides of the LAN cables to available peripheral devices, such as LAN switches, routers, clients and so on. Make sure that the port lamp on the NAS Package is lit and indicates that the link is up. (In some installation cases, there is no need to connect LAN cable to eth2 port.)

 **CAUTION**

eth1 corresponds to port CH-A/E/J/N on NAS Package, and eth2 corresponds to port CH-B/F/K/P on NAS Package.

 **CAUTION**

When a cluster is being configured, or when a cluster is activated, disconnecting a LAN cable from a port of a NAS Package that **Service IP Address** is defined will cause a failover in the cluster, and it might take long to failback. Therefore, do not disconnect LAN cables when a cluster is being configured, or when a cluster is activated.

- (5) For new installation of DKC and NAS Blade system, go to 8.3 [2] *Starting the cluster* [NAS08-310].

If DKC has already been installed at the customer's site, and NAS Blade system is to be installed or added, the clusters should have been activated by maintenance personnel following the procedures described in section 8.1 *Operations Using the SVP* [NAS08-20] and 8.2 *Operations Using the NAS/Management GUI* [NAS08-100]. In this case, go to 8.3 [3] *Confirmation of the connection from a client* [NAS08-390].

[2] Starting the cluster

To start NAS cluster, log in to NAS/Management using a maintenance personnel on SVP, and then start the cluster using GUI.

To start the cluster:

- (1) Start a Web browser on the SVP.
Select **Start - Programs - Internet Explorer**.

If address bar is already shown on the Web browser, proceed to step (3).

If address bar is not shown on the Web browser, proceed to step (2).

- (2) Display the address bar on the Web browser.
Select **View - Toolbars - Address Bar** from the menu bar.

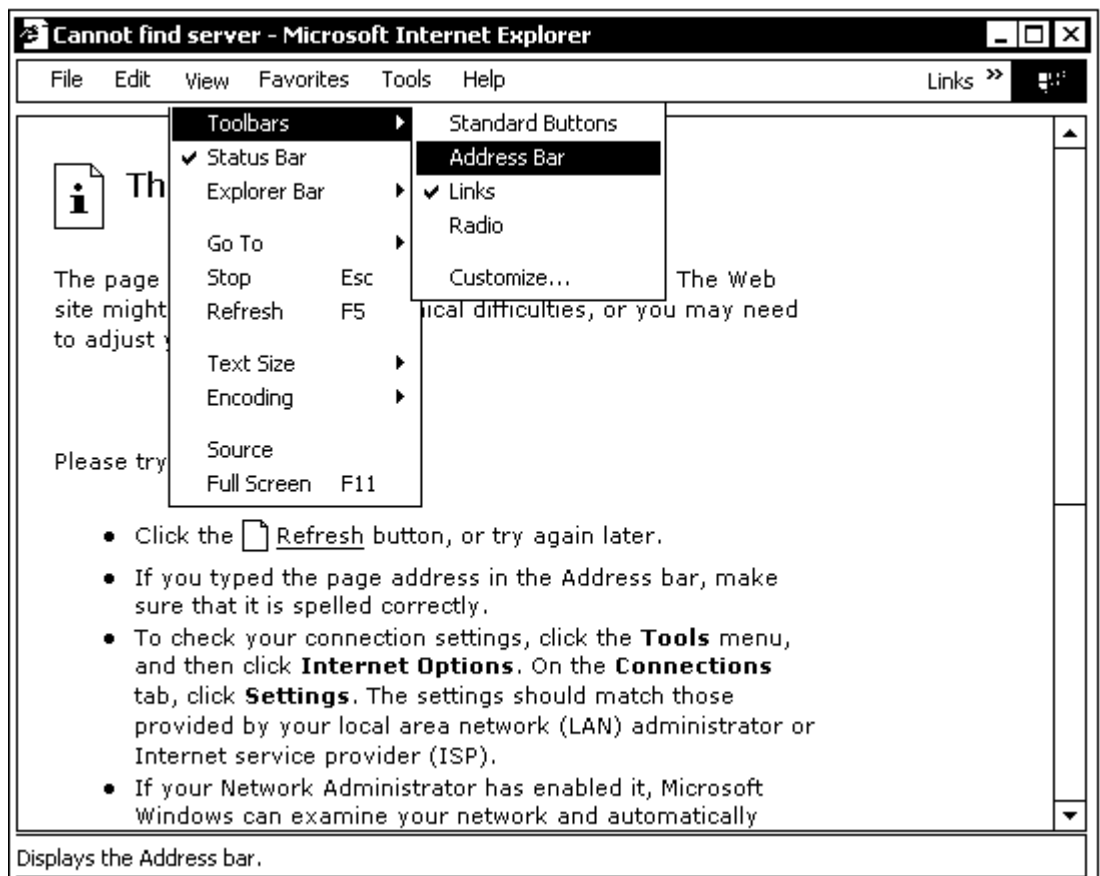

- (3) Type the URL of the 'Login' window, at the address bar on the Web browser.
Enter the following URL:

`https://fixed-IP-address-of-NAS-Package-for-connection/admin.cgi`

The 'Security Alert' window appears.



Click the **Yes** button, and then the 'Login' window appears.

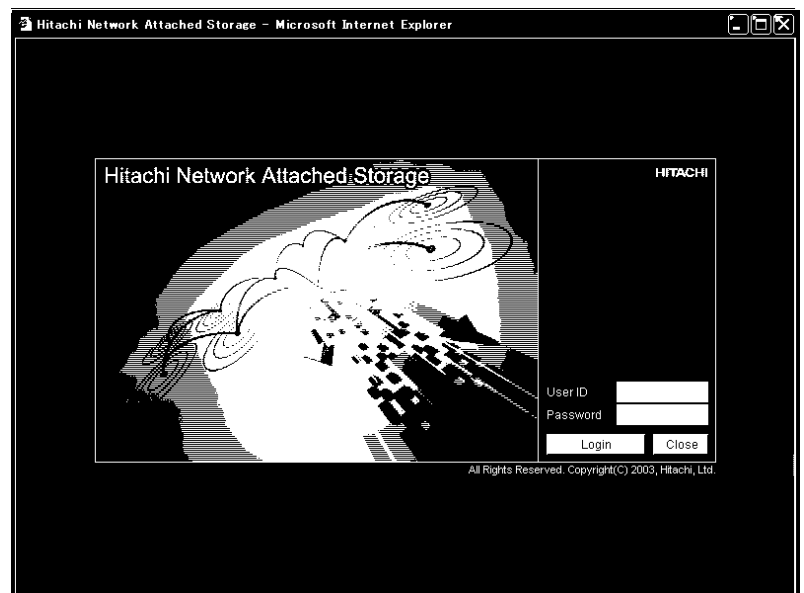

To get the fixed IP address of NAS Package, open **Install - Refer Configuration** of the SVP.

Get upper 3 bytes of the IP address from this window, then apply Table 8.3-1 [NAS08-340] to get the lowest byte according to the location of the NAS Package.

DKC Configuration ✕

Please set the following parameters of DKC Configuration.

DKC

Serial No.

Number of CUs

IP Address

IP Address : 126.244. 22. 15

Subnet Mask 255. 0. 0. 0

Cache

Basic: CMG=1024MB Size=8192MBx2
On-Demand=0MBx2

Option: CMG=1024MB Size=8192MBx2
On-Demand=0MBx2

Total cache size: 16384MBx2
DCR available: 0MBx2
PCR available: 0MBx2

CHA

DKA

Number of DKA

Table 8.3-1 shows the lowest byte of the fixed IP address of NAS Package.

Table 8.3-1 Lowest byte of fixed IP address of NAS Package

#	Package	DKC cluster	Package Location	Lowest byte of fixed IP address of NAS Package
1	CHN	CL1	Basic	51
2			Option-1	67
3			Option-2	83
4			Option-3 *1	99
5		CL2	Basic	115
6			Option-1	131
7			Option-2	147
8			Option-3 *1	163

*1: Option-3 is unavailable in a single cabinet model.

As shown in this example, if the IP address obtained by **Install – Refer Configuration** on the SVP is 126.244.22.15, the fixed IP address of NAS Package of the basic location on CL1 for example, will become 126.244.22.51.

The following table lists the information to be specified in the 'Login' window.

Table 8.3-2 Information specified in the 'Login' window

#	Item	Description
1	User ID	Enter the user name of a system administrator according to the System Assurance Documentation.
2	Password	Enter the password of the system administrator according to the System Assurance Documentation.

- (4) Enter the **User name** and **Password** of a system administrator, and click **Login** button. The 'Main Menu' window appears.
-
- (5) In the 'Main Menu' window, click the **Cluster Management** button.
-
- (6) Click the **Start** button for the appropriate cluster. (The cluster will be started within around 10 minutes.)

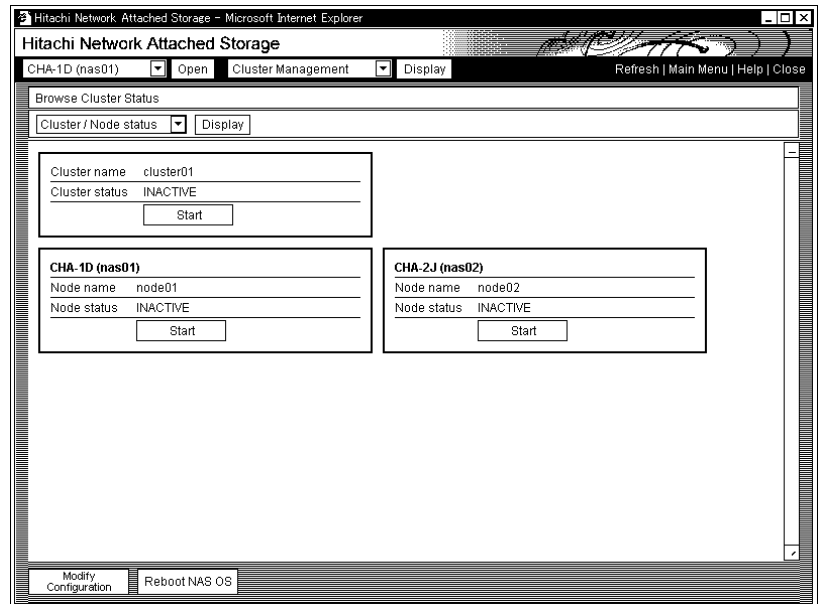

- (7) In the 'Browse Cluster Status (Cluster / Node Status)' window, make sure that **Cluster Status** is 'Active' and **No Status** is 'UP' on each node.

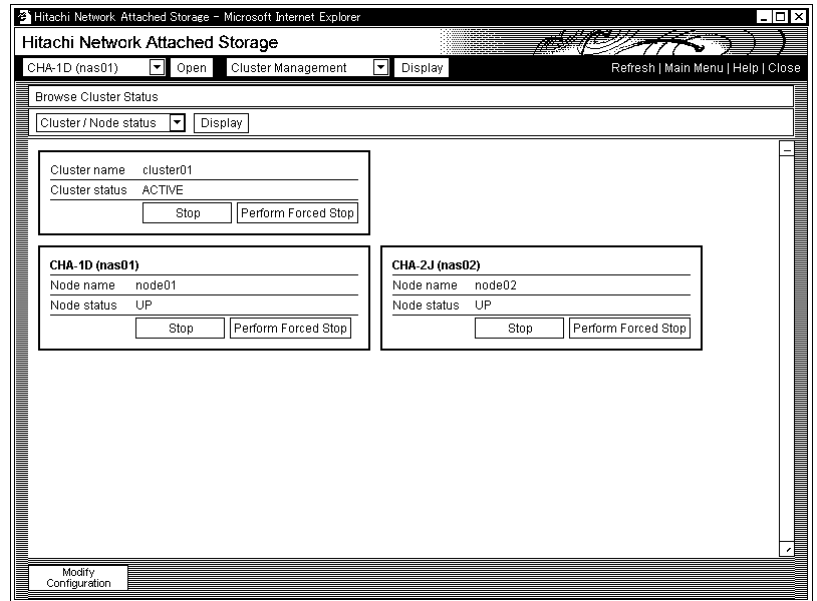

- (8) In the 'Browse Cluster Status (Resource group Status)' window, select **Resource group Status** from drop down list. Click the **Display** button.

- (9) The 'Browse Cluster Status (Resource Group Status)' window appears. Make sure that **Resource group Status** is **Online/No error**.

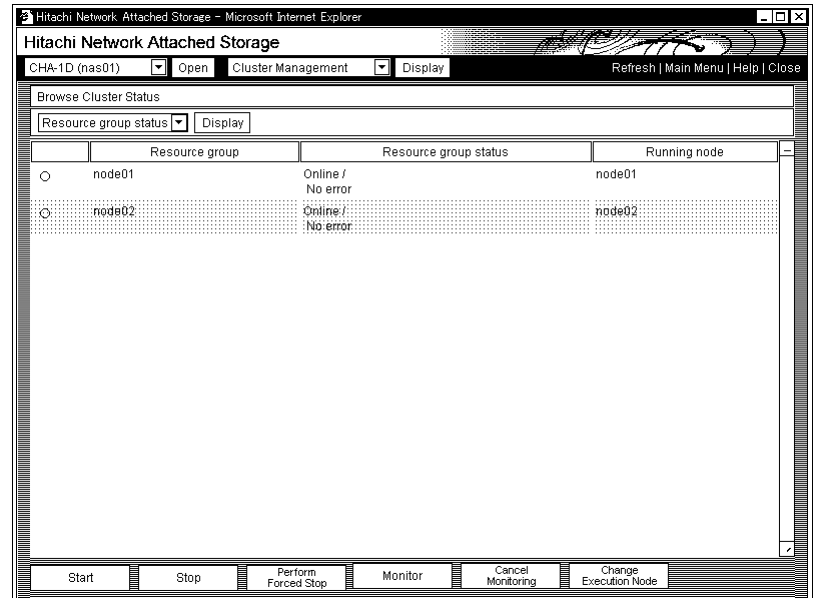

(10) Log out from NAS/Management.

In the menu area of the window for the NAS Package from which you want to log out, click **Close**.

(11) Start a Web browser on the SVP.

Select **Start - Programs - Internet Explorer**.

- (12) Hide the address bar on the Web browser.
 Select **View - Toolbars - Address Bar** from the menu bar.

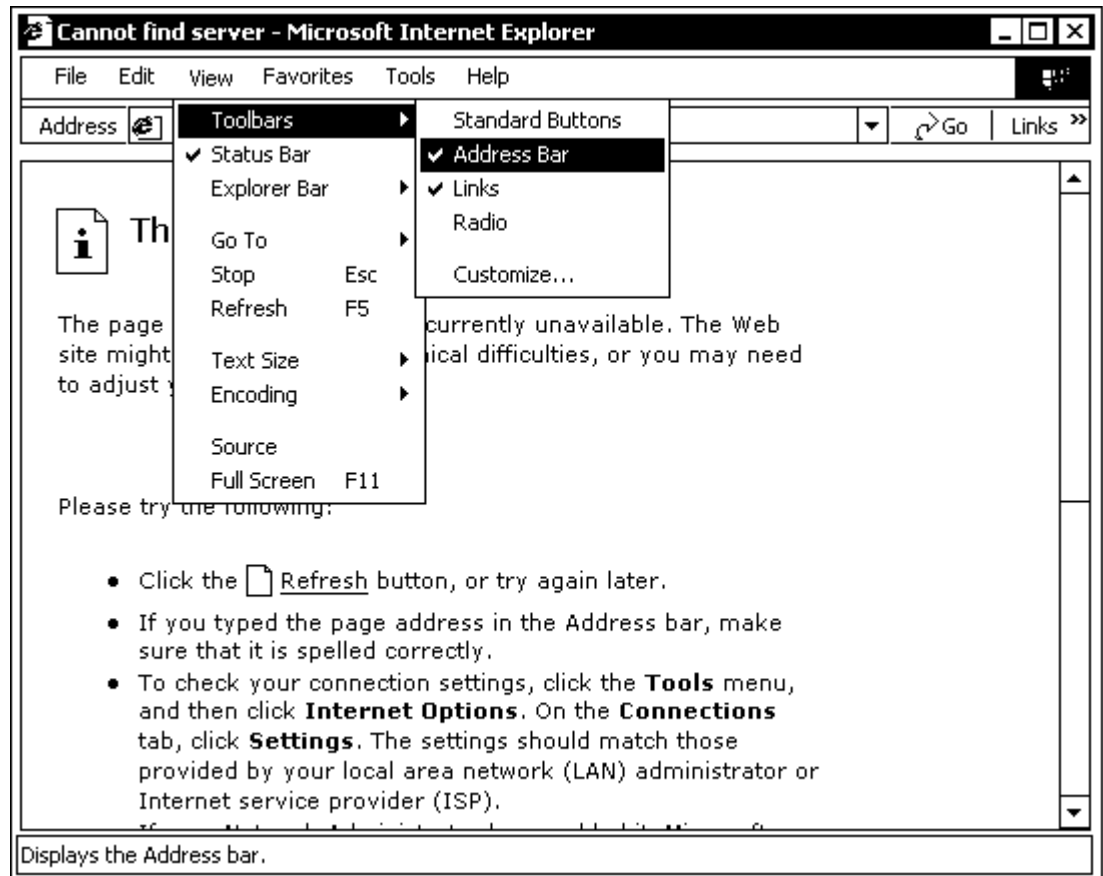

- (13) Make sure that the address bar is not displayed on the Web browser.

- (14) Select **File - Close** in the Web browser to exit.

- (15) Go to 8.3 [3] *Confirmation of the connection from a client* [NAS08-390] .

[3] Confirmation of the connection from a client

On the client which can reach the NAS Packages, execute the `ping` command for the fixed IP addresses and Service IP addresses of both `eth1` and `eth2` ports of NAS Packages.

Obtain the fixed IP addresses and service IP addresses of `eth1` and `eth2` port of NAS Packages from the System Assurance Documentation.

Make sure the fixed IP addresses and service IP addresses of all installed or added NAS Packages.

The following shows an example of the `ping` command:

```
ping Fixed-IP-Address-of-eth1-or-eth2-port-of-NAS-Package
ping Service-IP-Address-of-eth1-or-eth2-port-of-NAS-Package
```

The following figure shows an example of the `ping` command execution from the CIFS client.

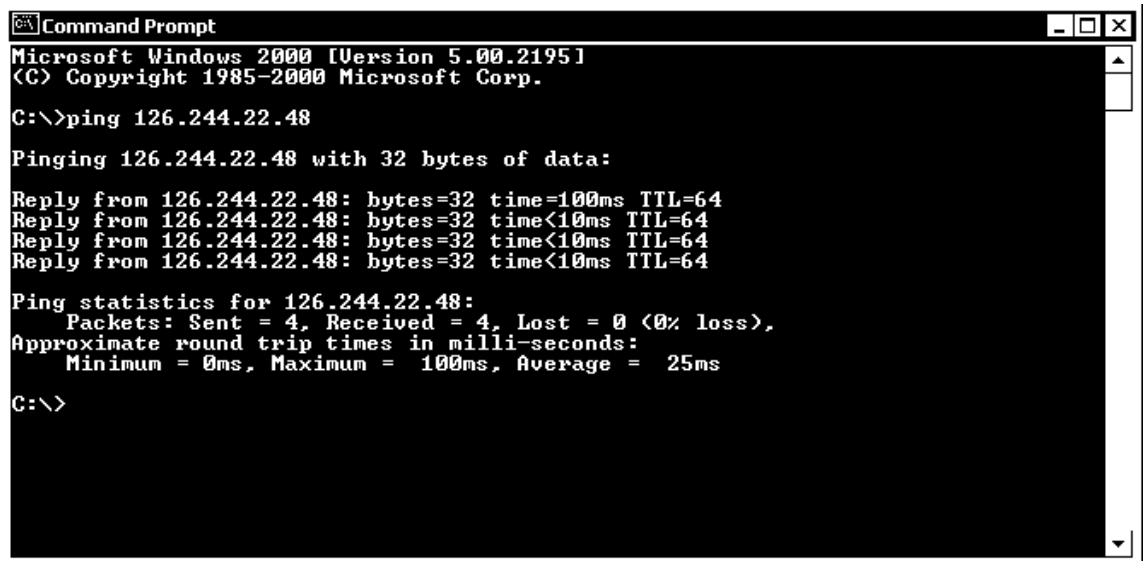

```

Command Prompt
Microsoft Windows [Version 5.00.2195]
(C) Copyright 1985-2000 Microsoft Corp.

C:\>ping 126.244.22.48

Pinging 126.244.22.48 with 32 bytes of data:

Reply from 126.244.22.48: bytes=32 time=100ms TTL=64
Reply from 126.244.22.48: bytes=32 time<10ms TTL=64
Reply from 126.244.22.48: bytes=32 time<10ms TTL=64
Reply from 126.244.22.48: bytes=32 time<10ms TTL=64

Ping statistics for 126.244.22.48:
    Packets: Sent = 4, Received = 4, Lost = 0 (0% loss),
    Approximate round trip times in milli-seconds:
        Minimum = 0ms, Maximum = 100ms, Average = 25ms

C:\>

```

In response of the `ping` command, if the echo `Reply from indicated-IP-address: bytes=xxx` is displayed, the IP address defined at the port is confirmed to be valid.

This is the end of NAS configuration for both new installation and on-site installation.

9. Appendixes

9.1 Appendix A Using the Command Line To Obtain Error Information

9.1.1 Overview

This chapter describes the command line procedures that are needed to obtain dump information and traces of error information generated from NAS functionality software errors.

9.1.2 Types of Error Information

Table 9.1-1 lists the error information (dumps) that the system obtains, and for which you must use the command line, if a NAS functionality software error occurs.

Table 9.1-1 Error Information (Dumps) that Requires Use of the Command Line

#	Name	Error location	Generated by	Collected when	Feature	Write format
1	Crash dump	NAS OS	NAS OS	NAS detects its abnormal condition.	If an error occurs, the kernel runs a program that selects the necessary parts and performs a dump automatically, before initiating a system shutdown.	raw write, memory image, no compression
2	Hibernation dump		BIOS (Pentium)	Another NAS Package detects a NAS OS hangup or an error occurs during the NAS OS's startup or termination processing.	A reset is performed after the error occurred and a full memory dump is performed via the BIOS.	raw write, memory image, no compression
				A slowdown occurs.	A reset is performed as specified by SVP and a full memory dump is performed via the BIOS. ^{*1}	
3	LM dump	MP	An error occurs (software errors only).	The MP is notified of the range of areas, in page units, where dumps are performed when the NAS OS is started. After the error occurs, the MP read the contents of the Pentium's memory and writes them to a disk.	raw write, memory image, no compression	

*1: Specify by using the **Hibernation Dump** button in the SVP's **NAS Setup on SVP (Main)** window.

Table 9.1-2 lists the error information (logs and traces) that the system obtains, and for which you must use the command line, if a NAS functionality software error occurs.

Table 9.1-2 Error Information (Logs and Traces) that Requires Use of the Command Line

#	Name	Error location	Generated by	Collected when	Feature	Write format
1	Event trace	—	MP	A failure (hangup or panic) occurs.	A history of events such as task switches is stored in the Pentium's memory in wraparound mode while the NAS OS is running. After an error occurs, the MP reads the contents of that memory area and writes them to a disk.	raw write, memory image, no compression
			NAS OS	A slowdown occurs.	A history of events such as task switches is stored in the Pentium's memory in wraparound mode while the NAS OS is running. The NAS OS extracts the contents of that memory area whenever the <code>lkstbuf</code> command is run.	

9.1.3 How to Obtain a Crash Dump

Since all operations involved in obtaining a crash dump are done only for maintenance purposes, they must be carried out via the CUI (Console User Interface). The crash dump is obtained by connecting a maintenance terminal (maintenance PC) to the data LAN and by using ssh from that PC to access the failed NAS Package.

In collection of a crash dump after an error occurs, you can use the `lkcd_save` command to collect the crash dump from another node (NAS Package). The dump-collection destination is a maintenance terminal, which is assumed here to be a Linux machine. Collection is also possible from a Windows machine running an ftp server. Figure 9.1-1 shows a flowchart of the procedure for obtaining a crash dump, followed by a step-by-step description of the procedure.

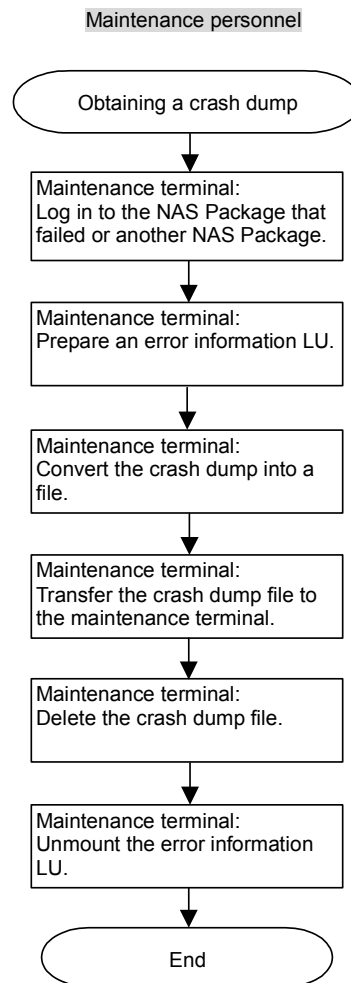

Figure 9.1-1 Flowchart for Obtaining a Crash Dump

1. Use ssh to log in to a NAS Package.

If the failed NAS Package has restarted, use ssh to connect to that NAS Package. If the failed NAS Package has not restarted, use ssh to connect to another NAS Package. Note, however, that you will probably be able to restart the failed NAS Package because most failures are caused by software.

Obtaining a crash dump via another NAS Package depends on the settings of the dump destination. Therefore, if the failed NAS Package has not restarted and you want to obtain a crash dump via another NAS Package, contact the developers.

To perform the processing described in this subsection, you must first use the `su` command to become a superuser with root privileges because operations such as mounting and unmounting disks are required.

Note: This example shows the default password. For security reason, we recommend that you change the password to a more difficult one when you use it for the first time.

```
% ssh -l nasroot xx.xx.xx.xx
The authenticity of host 'xx.xx.xx.xx (xx.xx.xx.xx)' can't be established.
RSA key fingerprint is xxxxxxxxxxxxxxxxxxxxxxxxxxxxxxxxxxxxxxxxxxxxxxxxxxxxxxx.
Are you sure you want to continue connecting (yes/no)? yes
Warning: Permanently added 'xx.xx.xx.xx' (RSA) to the list of known hosts.
Password:
Linux e-nas 2.4.17-enas0100 #4 Fri Nov 1 12:46:35 JST 2002 i686 unknown
Last login: Mon Dec 9 08:56:17 2002 from xx.xx.xx.xx
enasroot@nas2y:~$ (This prompt is an example.)
enasroot@nas2y:~$ su
Passwd: (enas)
nas2y:/home/nasroot#
```

2. Prepare an error information LU for the crash dump.

Use `/dev/enassys/lu06p1`, which is reserved as a spare partition, as the error information LU. A partition that is to be used for a crash dump is designed to be referenced from all NAS Packages. However, since the partition needs to be shared by all NAS Packages, it is used as a temporary destination of the save until its contents are placed onto a storage medium after a crash dump is performed.

All NAS Packages can reference this partition, so make sure that no other NAS Package is referencing the partition before you attempt to initialize the partition.

```
nas2y:/home/nasroot# mkfs.hixfs -f /dev/enassys/lu06p1
meta-data=/dev/enassys/lu06p1   isize=256   agcount=8, agsize=131281 blks
data      =                       bsize=4096   blocks=1050241, imaxpct=25
          =                       sunit=0     swidth=0 blks, unwritten=0
naming    =version 2              bsize=4096
log       =internal log          bsize=4096   blocks=1200
realtime  =none                  extsz=65536  blocks=0, rtextents=0
```

It is likely that a file system has already been created (by using `hixfs`) in the partition. Even in such a case, create a file system by using the `mkfs.hixfs` command as above.

```
nas2y:/home/nasroot# mkdir /var/log/dump/work
nas2y:/home/nasroot# mount -t hixfs /dev/enassys/lu06p1 /var/log/dump/work
```

3. Convert the crash dump to a file.

Enter the `lkcd_save` command. The first argument is the name of the device to which the dump is written when a crash occurs and the second argument is the target directory in which the dump is to be restored as an ordinary file.

The following is a sample command line for the `lkcd_save` command (with default arguments) when you logged in to the failed NAS Package.

```
Command Syntax: lkcd_save dumpdev dumpdir
```

```
nas2y:/home/nasroot# lkcd_save /dev/vmdump /var/log/dump/work
- 10.4%
/ 64.9%
| 75.6%
```

When the `lkcd_save` command is entered, the progress of processing is displayed in percents and with a spinner as shown above. An indication of 100% marks the end of processing. The target files are generated in the `dump-directory/0` directory. You can review the files with the `ls -l` command. Three file names with a suffix 0 will appear.

```
nas2y:/home/nasroot# ls -l /var/log/dump/work/0
total 3552852
-rw-r--r--  1 root   root   3637503744 Apr  5 23:16 dump.0
-rw-r--r--  1 root   root   141992 Apr  5 23:16 kerntypes.0
-rw-r--r--  1 root   root   527321 Apr  5 23:16 map.0
```

Note: The suffix number starts at zero and is incremented (for example, `dump.0` becomes `dump.1`) as more dumps are obtained. However, when obtaining crash dumps, the suffix number is always zero because multiple dumps are not kept at the dump destination.

4. Change the directory to the dump-collection destination.

```
nas2y:/home/nasroot# cd /var/log/dump/work/0
```

5. Transfer the crash dump file to the maintenance terminal.

Use the `ftp` command to collect the dump file onto the maintenance terminal. Since the size of the dump file will exceed 2 GB, make sure that the maintenance terminal is able to receive a file of this size.

```
nas2y:/var/log/dump/work/0# ftp xx.xx.xx.xx (maintenance terminal)
Connected to xx.xx.xx.xx.
220 enas-devel FTP server (Version 6.4/OpenBSD/Linux-ftp-0.17) ready.
Name (xx.xx.xx.xx:root): guest
331 Password required for guest.
Password:
230- Linux enas-devel 2.4.17-enas0100-s970141 #3 Sat Apr 5 10:41:37 JST 2003 i686 unknown
230-
230- Most of the programs included with the Debian GNU/Linux system are
230- freely redistributable; the exact distribution terms for each program
230- are described in the individual files in /usr/share/doc/*/copyright
230-
230- Debian GNU/Linux comes with ABSOLUTELY NO WARRANTY, to the extent
230- permitted by applicable law.
230 User guest logged in.
Remote system type is UNIX.
Using binary mode to transfer files.
ftp> bin
200 Type set to I.
ftp> prompt
Interactive mode off.
ftp> mput *.0
local: dump.0 remote: dump.0
200 PORT command successful.
150 Opening BINARY mode data connection for 'dump.0'.
226 Transfer complete.
local: kerntypes.0 remote: kerntypes.0
200 PORT command successful.
150 Opening BINARY mode data connection for 'kerntypes.0'.
226 Transfer complete.
141992 bytes sent in 0.75 secs (185.6 kB/s)
local: map.0 remote: map.0
200 PORT command successful.
150 Opening BINARY mode data connection for 'map.0'.
226 Transfer complete.
527321 bytes sent in 0.04 secs (13455.3 kB/s)
ftp> bye
221 Goodbye.
```

6. Check the size of the dump files.

Confirm that the size of the dump file that has been transferred to the maintenance terminal via ftp is equal to that of the original one.

In the above step 5, the dump file is transferred to the direct directory `/home/guest` on the maintenance terminal. Use the `ls` command to confirm the dump file on the maintenance terminal.

```
enas-devel:/home/guest#ls -l
total 3552852
-rw-r----- 1 mary mary 3637503744 Apr  6 18:32 dump.0
-rw-r----- 1 mary mary  141992 Apr  6 18:32 kerntypes.0
-rw-r----- 1 mary mary   527321 Apr  6 18:32 map.0
```

The destination of the dump file is a shared partition that can be mounted by all NAS Packages simultaneously. It is likely that the file will be destroyed if multiple NAS Packages mount the partition simultaneously. Basically, multiple NAS Package must not convert a dump into a file simultaneously. We recommend, however, that you make sure that the sizes agree in order to confirm that the transfer finished successfully.

By using the `lkcd_save` command again, you can obtain the dump that the NAS OS produced, even if the file system has been destroyed, because the dump that the NAS OS produced remains on the disk. However reconfirm the mount state of the destination LU when the file system has been destroyed.

Note: Checking the activation of the dump analyzer:

It is more reliable to confirm the transferred dump if possible.

Try to activate the dump analyzer `lcrash` if it is provided on the maintenance terminal.

1. Type in `/sbin/lcrash -n 0`
2. Confirm that the prompt (`>>>`) of `lcrash` appears.

Depending on the settings, including the case in which `lcrash` is not provided, it is possible that `lcrash` will fail to start. For details, contact the developers.

7. Unmount the error information LU of the crash dump.

Since the partition that is used as the error information LU of the dump needs to be shared by all NAS Packages, delete the files and then unmount the error information LU `/dev/enassys/lu06p1` after collection processing with ftp has finished. Next, use the `mount` command to make sure that `/dev/enassys/lu06p1` is not mounted.

```
nas2y:/var/log/dump/work/0# rm *.0
nas2y:/var/log/dump/work/0# cd
nas2y:~# umount /dev/enassys/lu06p1
nas2y:~# mount
/dev/enassys/lu00p1 on / type hixfs (rw)
proc on /proc type proc (rw)
devpts on /dev/pts type devpts (rw,gid=5,mode=620)
/dev/enassys/lu08p12 on /enassys/hifailsafe/CHN8 type hixfs (rw,sync)
nas2y:~#
```

9.1.4 How to Obtain a Hibernation Dump

A hibernation dump is obtained if a slowdown occurs or if a hangup occurs.

- If a slowdown occurs, or an error occurs during startup or termination of the NAS OS:
Maintenance personnel must use the SVP to specify that a hibernation dump is to be obtained, by using the **Hibernation Dump** button in the **NAS Setup on SVP (Main)** window.
- If a hangup occurs:
Another NAS Package in the same cluster detects the hangup, and a hibernation dump is performed automatically.

Since all operations involved in the obtaining of a hibernation dump are done only for maintenance purposes in either case, they must be carried out via the CUI (Console User Interface). The hibernation dump is obtained by connecting a maintenance terminal (maintenance PC) to the data LAN and by using ssh from that PC to access the failed NAS Package. However, a hardware failure might occur when the hibernation dump is collected. If no hardware failure is detected, restart the failed NAS Package, log in to that NAS Package, and then use the `/sbin/saveto` command to collect the hibernation dump. If you are not sure whether a hardware failure occurred in the NAS Package, log in to another normal NAS Package, and use the command to collect the hibernation dump.

Note: Executing the `/sbin/saveto` command places a load on the system, so do not execute the `/sbin/saveto` command on heavily-loaded nodes. Also, since the size of the hibernation dump amounts to 4 GB, it is impossible to collect the dump onto the NAS OS LU. The dump must be collected into an error information LU that is also used by LKCD.

Figure 9.1-2 shows the flowchart for obtaining a hibernation dump.

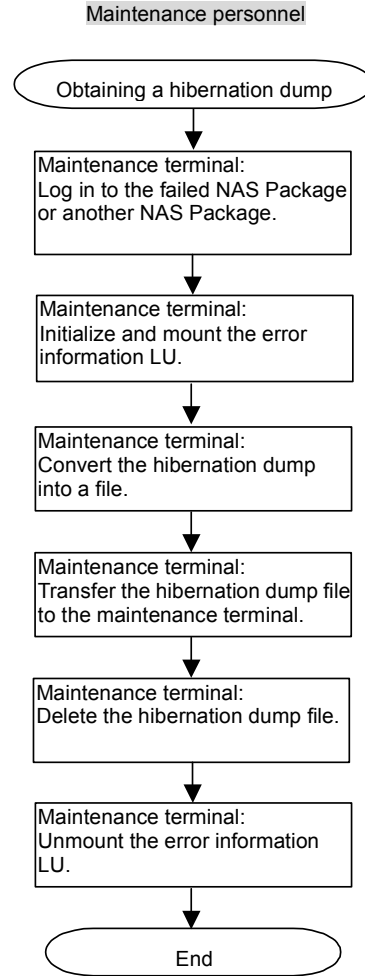

Figure 9.1-2 Flowchart for Obtaining a Hibernation Dump

1. Use ssh to log in to a NAS Package.

Use ssh to connect to the failed NAS Package or another NAS Package (if no hardware failure is detected, restart the failed NAS Package and log in to it).

To perform the processing described in this subsection, you must first change your access privileges to become a superuser because operations such as mounting and unmounting disks are required.

Note: This example shows the default password. For security reason, we recommend that you change the password to a more difficult one when you use it for the first time.

```

% ssh -l nasroot xx.xx.xx.xx
The authenticity of host 'xx.xx.xx.xx (xx.xx.xx.xx)' can't be established.
RSA key fingerprint is xxxxxxxxxxxxxxxxxxxxxxxxxxxxxxxxxxxxxxxxxxxxxxxxxxxxxxx.
Are you sure you want to continue connecting (yes/no)? yes
Warning: Permanently added 'xx.xx.xx.xx' (RSA) to the list of known hosts.
Password:
Linux e-nas 2.4.17-enas0100 #4 Fri Nov 1 12:46:35 JST 2002 i686 unknown
Last login: Mon Dec 9 08:56:17 2002 from xx.xx.xx.xx
enasroot@nas2y:~$ (This prompt is an example.)
enasroot@nas2y:~$ su
Passwd: (enas)
nas2y:/home/nasroot#
  
```

2. Initialize and mount an error information LU.

Use the `/sbin/saveto` command to collect hibernation dumps. Before doing this, initialize and mount an error information LU for storing the dumped file.

All NAS Packages can reference this error information LU, so make sure that no other NAS Package is referencing the area before you attempt to initialize the area.

```
nas2y:/home/nasroot# mkfs.hixfs -f /dev/enassys/lu06p1
meta-data=/dev/enassys/lu06p1   isize=256   agcount=8, agsize=131281 blks
data      =                      bsize=4096   blocks=1050241, imaxpct=25
          =                      sunit=0      swidth=0 blks, unwritten=0
naming    =version 2             bsize=4096
log       =internal log         bsize=4096   blocks=1200
realtime  =none                 extsz=65536  blocks=0, rtextents=0
```

It is likely that a file system has already been created (by using `hixfs`) in the partition. Even in such a case, create a file system by using the `mkfs.hixfs` command as above.

```
nas2y:/home/nasroot# mkdir /var/log/hibernation
nas2y:/home/nasroot# mount -t hixfs /dev/enassys/lu06p1 /var/log/hibernation/
```

3. Convert a hibernation dump into a file.

Enter the `saveto` command to convert a hibernation dump into a file.

Note: If you execute the `saveto` command for multiple NAS Packages simultaneously, it might not execute successfully. Make sure that the command is not being executed for any other NAS Package, and then execute it for the desired NAS Package.

```
nas2y:/home/nasroot# cd /var/log/hibernation/
nas2y:/home/nasroot# /sbin/saveto
Command (m for help): p
CHN# Status      Date
1      Written    - Sun Mar 30 03:02:09 2003
5      Unused
Command (m for help):
```

NAS Blade system reserves one area for storing hibernation dump data for each NAS Package. The `p` subcommand shows the current status of hibernation entries. In the above example, the NAS Packages are placed in slots 1 and 5, and slot 1 contains a written but unconverted hibernation dump. Next, use the `s` command to convert the unconverted hibernation dump into a real file. The system shows the latest entry and prompts you to dump that entry. Normally, respond by typing `y` (the system assumes your reply is `y` unless you reply `n`).

```

Command (m for help): s
The current status is:
CHN#   Status   Date
1      Written  - Sun Mar 30 03:02:09 2003
5      Unused
CHN1 is the latest hibernation dump.
Would you like to save CHN1?(Yes/No)y
save hibernation dump till the following dots reaches here ----->|
Writing.....Done

```

It will take several minutes to process this command depending on conditions. These minutes are needed for the system to write data while reading data from an area as large as 4 GB. The progress of execution is shown by dots (.). Since one dot character represents 64 MB of data, 64 dots mark the end of processing. When processing finishes, the entry is flagged as a free entry. Quit with the `q` command.

Table 9.1-3 summarizes the suboptions of the `saveto` command. There are few cases in which you need to use subcommands other than `s`, `p`, and `q`.

Table 9.1-3 `saveto` Suboptions

#	Suboption	Description
1	<code>p</code> (print):	Shows the status of the hibernation entries for each NAS Package. The items shown include the CHA number, used/unused state, and the time written, on one line for each NAS Package.
2	<code>c</code> (change): <code>t</code> (turn):	Changes the magic number of the specified entry and toggles the used/unused state.
3	<code>d</code> (delete):	Deletes a given entry. The hibernation entry associated with the specified NAS Package is removed.
4	<code>n</code> (new):	Creates a new entry. This option is valid only when there is no entry associated with the specified NAS Package. The suboption prompts you to write one entry.
5	<code>s</code> (save): <code>w</code> (write):	Converts a hibernation dump into a file. The file will be created in the place where the command was issued unless customization is performed.
6	<code>l</code> :	Creates a disk image file in the area specified by the command. This subcommand is an emergency measure to save the hibernation dump when the <code>s</code> (save) and <code>w</code> (write) subcommand cannot save the dump. *1
7	<code>q</code> (quit):	Terminates the command.

*1: This `l` subcommand is provided as an emergency measure. Similar to the `dd` command, the `l` subcommand writes the disk image in the hibernation dump to a file. Usually, you would use the `s` or `w` subcommand to convert a hibernation dump to a file but if these subcommands cannot convert the dump for some reason, as an emergency measure use the `l` subcommand to save the hibernation dump. If you accidentally use the `l` subcommand during maintenance procedures, press the **Ctrl** and **C** keys to cancel it.

Table 9.1-4 shows a command option that can be specified as a parameter in the `saveto` command. The parameter `i` (initialize) is specified to initialize the partition for the hibernation dump. Basically, the `saveto -i` command is executed automatically when the NAS OS is installed for the first time. Therefore, maintenance personnel do not need to initialize the partition for the hibernation dump. However, if the partition could not be initialized for some reason, maintenance personnel must use the `saveto -i` command to initialize the partition manually.

Table 9.1-4 Command Option Specified as a Parameter in the `saveto` Command

#	Command option	Description
1	<code>i</code> (initialize):	Initializes the partition for the hibernation dump, for which the correct magic number is not specified.

4. Transfer the hibernation dump to the maintenance terminal.

Use the `ftp` command to collect the dump onto the maintenance terminal. The file generated by the conversion processing has the name `dump.0`. This is the only file to be transferred. Since the size of the dump file will exceed 2 GB, make sure that the maintenance terminal is able to receive a file of this size.

```
nas2y:/var/log/dump/work/0# ftp xx.xx.xx.xx (maintenance terminal)
Connected to xx.xx.xx.xx.
220 enas-devel FTP server (Version 6.4/OpenBSD/Linux-ftpd-0.17) ready.
Name (xx.xx.xx.xx:root): guest
331 Password required for guest.
Password:
230- Linux enas-devel 2.4.17-enas0100-s970141 #3 Sat Apr 5 10:41:37 JST 2003 i686 unknown
230-
230- Most of the programs included with the Debian GNU/Linux system are
230- freely redistributable; the exact distribution terms for each program
230- are described in the individual files in /usr/share/doc/*/copyright
230-
230- Debian GNU/Linux comes with ABSOLUTELY NO WARRANTY, to the extent
230- permitted by applicable law.
230 User guest logged in.
Remote system type is UNIX.
Using binary mode to transfer files.
ftp> bin
200 Type set to I.
ftp> mput dump.0
mput dump.0? y
200 PORT command successful.
150 Opening BINARY mode data connection for 'dump.0'.
226 Transfer complete.
1056768 bytes sent in 454.35 secs (2.3 kB/s)
ftp> bye
221 Goodbye.
```

5. Check the size of the dump file.

Confirm that the size of the dump file that has been transferred to the maintenance terminal via ftp is equal to the size of the original one.

In the above step 4, the dump file is transferred to the direct directory `/home/guest` on the maintenance terminal. Use the `ls` command to confirm the dump file on the maintenance terminal.

```
enas-devel:/home/guest#ls -l
total 3605512
-rw-r--r--  1 root    root    3638165504 Aug 18 17:24 dump.0
```

The destination of the dump file is a shared partition that can be mounted by all NAS Packages simultaneously. Note, however, that the file will probably be destroyed if multiple NAS Packages mount the partition simultaneously. Basically, multiple NAS Packages must not convert a dump into a file simultaneously. We recommend, however, that you make sure that the sizes agree in order to confirm that the transfer finished successfully.

The dump that NAS OS produced remains on the disk, so that even if the file system has been destroyed, you can use the `saveto` command again to obtain the dump that the NAS OS produced. If, however, the file system has been destroyed, reconfirm the mount state of the destination LU.

Note: Checking the activation of the dump analyzer:

To improve reliability, check the transferred dump if possible.

Try to activate the dump analyzer `lcrash` if it is provided on the maintenance terminal.

1. Enter `/sbin/lcrash -n 0`
2. Confirm that the `lcrash` prompt (`>>`) appears.

Depending on the settings, including the case in which `lcrash` is not provided, it is possible that `lcrash` will fail to start. For details, contact the developers.

6. Unmount the error information LU.

Since the error information LU that is used as the spare destination of the dump needs to be shared by all NAS Packages, delete the file and then unmount the error information LU `/dev/enassys/lu06p1` after collection processing with `ftp` has finished. Next, use the `mount` command to make sure that `/dev/enassys/lu06p1` is not mounted.

```
nas2y:/var/log/hibernation# rm dump.0
nas2y:/var/log/hibernation# cd
nas2y:~# umount /dev/enassys/lu06p1
nas2y:~# mount
/dev/enassys/lu00p1 on / type hixfs (rw)
proc on /proc type proc (rw)
devpts on /dev/pts type devpts (rw,gid=5,mode=620)
nas2y:~#
```

9.1.5 How to Obtain an LM Dump

Since all operations involved in obtaining an LM dump are done only for maintenance purposes, they must be carried out via the CUI (Console User Interface). The LM dump is obtained by connecting a maintenance terminal (maintenance PC) to the data LAN and by using ssh from that PC to access the failed NAS Package.

LM dumps are memory dumps that are written on dedicated raw devices. They are used in situations in which no hibernation dump can be performed. Normally, crash or hibernation dumps are used as error information. When collecting LM dumps because of a developer's request, however, it is necessary to perform the procedure that is explained below. Figure 9.1-3 shows the flowchart for obtaining an LM dump, followed by a step-by-step description of the procedure.

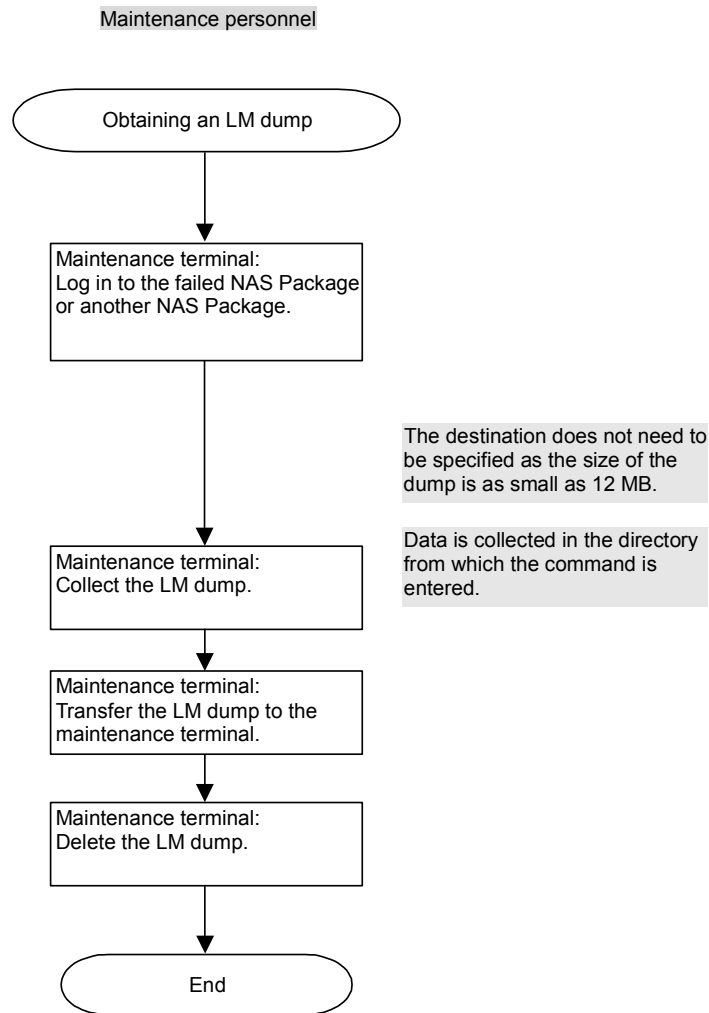

Figure 9.1-3 Flowchart for Obtaining an LM Dump

1. Use ssh to log in to a NAS Package.

If the failed NAS Package has restarted, use ssh to connect to that NAS Package. If the failed NAS Package has not restarted, use ssh to connect to another NAS Package.

To perform the processing described in this subsection, you must first change your access privileges to become a superuser because operations such as mounting and unmounting disks are required.

Note: This example shows the default password. For security reason, we recommend that you change the password to a more difficult one when you use it for the first time.

```
% ssh -l nasroot xx.xx.xx.xx
The authenticity of host 'xx.xx.xx.xx (xx.xx.xx.xx)' can't be established.
RSA key fingerprint is xxxxxxxxxxxxxxxxxxxxxxxxxxxxxxxxxxxxxxxxxxxxxxxxxxxxxxx.
Are you sure you want to continue connecting (yes/no)? yes
Warning: Permanently added 'xx.xx.xx.xx' (RSA) to the list of known hosts.
Password:
Linux e-nas 2.4.17-enas0100 #4 Fri Nov 1 12:46:35 JST 2002 i686 unknown
Last login: Mon Dec 9 08:56:17 2002 from xx.xx.xx.xx
enasroot@nas2y:~$ (This prompt is an example.)
enasroot@nas2y:~$ su
Passwd: (enas)
nas2y:/home/nasroot#
```

2. Collect the LM dump.

Enter the `lmdump_save` command to collect the dump.

Command syntax: `lmdump_save entry size`

Note: If you execute the `lmdump_save` command for multiple NAS Packages simultaneously, it might not execute successfully. Make sure that the command is not being executed for any other NAS Package, and then execute it for the desired NAS Package.

```
nas2y:/home/nasroot# lmdump_save 8
lmdump.8 generated.
nas2y:/home/nasroot# ls -l
total 4156
-rw-r--r--  1 root   root    12582912 Apr  6 02:12 lmdump.8
```

The first argument is an entry number. It specifies the number of the slot that has the failed NAS Package. The slots are numbered from 1 to 8, starting at the leftmost slot. The second argument is the size of the dump file specified in kilobytes. It is optional and may normally be omitted. The default is 12 MB (12,288 KB), which is adequate for covering the written data. Since the size of this dump is smaller than those of other types of dumps, the command may be entered from any directory. The dump file is generated in the directory from which the command is entered with a name of `lmdump.n` ($n=1$ to 8).

3. Transfer the dump to the maintenance terminal.

Use the `ftp` command to collect the dump onto the maintenance terminal.

```
nas2y:/home/nasroot# ftp xx.xx.xx.xx (maintenance terminal)
Connected to xx.xx.xx.xx.
220 enas-devel FTP server (Version 6.4/OpenBSD/Linux-ftpd-0.17) ready.
Name (xx.xx.xx.xx:root): guest
331 Password required for guest.
Password:
230- Linux enas-devel 2.4.17-enas0100-s970141 #3 Sat Apr 5 10:41:37 JST 2003 i686 unknown
230-
230- Most of the programs included with the Debian GNU/Linux system are
230- freely redistributable; the exact distribution terms for each program
230- are described in the individual files in /usr/share/doc/*/copyright
230-
230- Debian GNU/Linux comes with ABSOLUTELY NO WARRANTY, to the extent
230- permitted by applicable law.
230 User mary logged in.
Remote system type is UNIX.
Using binary mode to transfer files.
ftp> bin
200 Type set to I.
ftp> mput lmdump.8
mput lmdump.8? y
200 PORT command successful.
150 Opening BINARY mode data connection for 'lmdump.8'.
226 Transfer complete.
4194304 bytes sent in 0.35 secs (11682.4 kB/s)
ftp> bye
221 Goodbye.
nas2y:/home/nasroot#.
```

4. Delete the LM dump in the NAS Package.

The last step is to delete the LM dump in the NAS Package.

```
nas2y:/home/nasroot# rm lmdump.8
```

9.1.6 How to Obtain an Event Trace

Since all operations involved in obtaining an event trace are done only for maintenance purposes, they must be carried out via the CUI (Console User Interface). An event trace is obtained by connecting a maintenance terminal (maintenance PC) to the data LAN and by using ssh from that PC to access the failed NAS Package.

Normally, event trace information cannot be acquired directly by any NAS Package in operation. The sole exception occurs when a slowdown takes place and the system allows accessing via ssh. Figure 9.1-4 shows the flowchart of the procedure for obtaining an event trace, followed by a step-by-step description of the procedure.

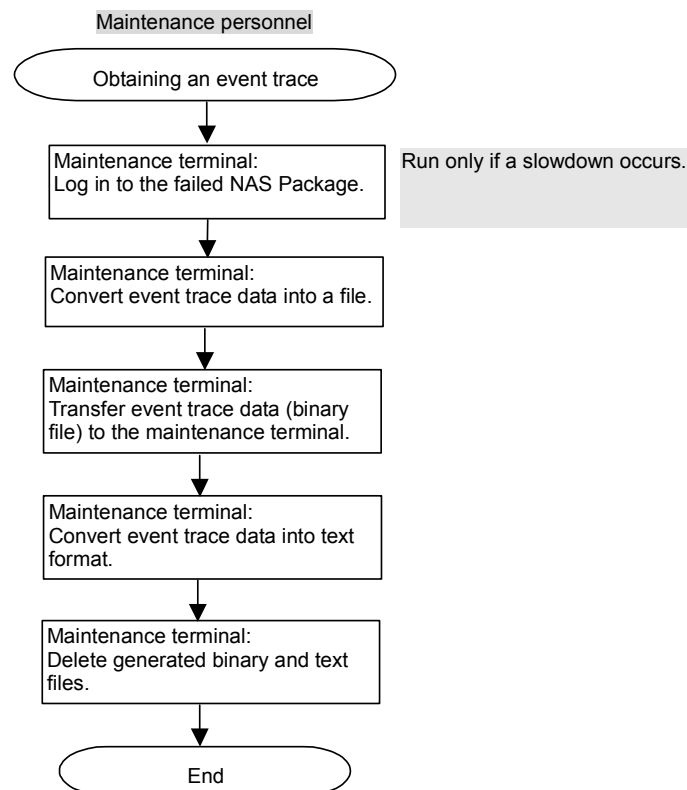

Figure 9.1-4 Flowchart for Obtaining an Event Trace

Note: Stopping and restarting LKST: LKST is enabled when the NAS OS starts up. If you want to stop and restart LKST for some reason, log in to a NAS Package, use the `lkst stop` command to stop LKST, and use the `lkst start` command to restart LKST. An example is shown below.

```

nas2y:/home/nasroot# lkst stop
Stop LKST event tracing.
nas2y:/home/nasroot# lkst start
Start LKST event tracing.
nas2y:/home/nasroot#
  
```

For the login procedure, see step 1 in subsection 9.1.6

1. Use ssh to log in to a NAS Package.

Use ssh to connect to the failed NAS Package.

To perform the processing described in this subsection, you must first change your access privileges to become a superuser because operations such as mounting and unmounting disks are required.

Note: This example shows the default password. For security reason, we recommend that you change the password to a more difficult one when you use it for the first time.

```
% ssh -l nasroot xx.xx.xx.xx
The authenticity of host 'xx.xx.xx.xx (xx.xx.xx.xx)' can't be established.
RSA key fingerprint is xxxxxxxxxxxxxxxxxxxxxxxxxxxxxxxxxxxxxxxxxxxxxxxxxxxxxxx.
Are you sure you want to continue connecting (yes/no)? yes
Warning: Permanently added 'xx.xx.xx.xx' (RSA) to the list of known hosts.
Password:
Linux e-nas 2.4.17-enas0100 #4 Fri Nov 1 12:46:35 JST 2002 i686 unknown
Last login: Mon Dec 9 08:56:17 2002 from xx.xx.xx.xx
enasroot@nas2y:~$ (This prompt is an example.)
enasroot@nas2y:~$ su
Passwd: (enas)
nas2y:/home/nasroot#
```

2. Convert the event trace data into a file.

Enter the `lkstbuf` command to convert the trace data in memory into a file. This file is in binary format and cannot be viewed as trace information.

```
Command syntax: lkstbuf read -f targetfile
```

Note: *targetfile* denotes the name of a binary file.

```
nas2y:/home/nasroot# lkstbuf read -f logfile
```

A file with a size of approximately 12 MB has been created. The size of the file is limited unless you change the default.

```
nas2y:/home/nasroot# ls -l
total 12288
-rw-r--r--  1 root   root      12581629 Jun 10 18:40 logfile
```

3. Transfer the event trace to the maintenance terminal.

Use the `ftp` command to collect the output file onto the maintenance terminal.

```
nas2y:/home/nasroot# ftp xx.xx.xx.xx (maintenance terminal)
Connected to xx.xx.xx.xx.
220 enas-devel FTP server (Version 6.4/OpenBSD/Linux-ftpd-0.17) ready.
Name (xx.xx.xx.xx:root): guest
331 Password required for guest.
Password:
230- Linux enas-devel 2.4.17-enas0100-s970141 #3 Sat Apr 5 10:41:37 JST 2003 i686 unknown
230-
230- Most of the programs included with the Debian GNU/Linux system are
230- freely redistributable; the exact distribution terms for each program
230- are described in the individual files in /usr/share/doc/*/copyright
230-
230- Debian GNU/Linux comes with ABSOLUTELY NO WARRANTY, to the extent
230- permitted by applicable law.
230 User mary logged in.
Remote system type is UNIX.
Using binary mode to transfer files.
ftp> prompt
Interactive mode off.
ftp> bin
200 Type set to I.
ftp> mput outfile
local: outfile remote: outfile
200 PORT command successful.
150 Opening BINARY mode data connection for 'outfile'.
226 Transfer complete.
199148 bytes sent in 0.01 secs (17994.1 kB/s)
ftp> by
221 Goodbye.
```

4. Convert the event trace (binary file) to a text file.

Enter the `lkstbuf print` command to convert this binary file into text format. The results are directed to the standard output by default, so they must be redirected into a file.

```
enas-devel:/home/guest# lkstbuf print -f logfile >outfile
enas-devel:/home/guest# ls -l
total 35476
-rw-r--r--  1 root    root      12581629 Jun 10 19:07 logfile
-rw-r--r--  1 root    root      23742752 Jun 10 19:07 outfile
```

A trace file of the format shown below will be generated.

```
enas-devel:/home/guest# vi output
Items displayed (example)
event_type=overwritten_record
  cpu=00, pid=00000944
  time= Sep 07 05:44:49.99328701 2002
  arg1=0x00000036 0x00000000 : old arg1
  arg2=0x00000000 0x00000000 : old arg2
  arg3=0x00000000 0x00000000 : old arg3
  arg4=0x00000030 0x00000000 : old event_type

event_type=system_call_exit
  cpu=00, pid=00000944
  time= Sep 07 05:44:49.99323694 2002
  arg1=0x00000004 0x00000000 : call number
  arg2=0x00000000 0x00000000 : return value(errno)

...
...
...
...
...

event_type=interrupt_bh_entry
  cpu=00, pid=00000000
  time= Sep 07 05:44:48.25912744 2002
  arg1=0x00000000 0x00000000 : interrupt type(nr)
  arg2=0xc011ca3c 0x00000000 : action address(bh_base)

event_type=overwritten_record
  cpu=00, pid=00000000
  time= Sep 07 05:44:48.25912496 2002
  arg1=0xc0119730 0x00000000 : old arg1
  arg2=0x00000000 0x00000000 : old arg2
  arg3=0x00000000 0x00000000 : old arg3
  arg4=0x00000012 0x00000000 : old event_type

(Omitted)
```

5. Delete the event trace on the NAS Package.

The last step is to delete the generated binary files.

```
nas2y:/home/nasroot# rm logfile
```

9.2 Appendix B List of Log and Core Files

Table 9.2-1 shows a list of operation files (log files) and error information (core files) that the system administrator manages. All of these files are stored on the NAS OS LU.

Table 9.2-1 List of Log and Core Files

#	Name	Generated by	Output directory	File name	Format	Capacity
1	Syslog	Kernel, drivers, Failover, NAS/Management, NAS/ Backup Restore	/var/log	syslog	ASCII	Defined by NAS/Management Default: 2 MB × 3 generations
2	Start-time message	Kernel	/var/log	dmesg	ASCII	Overwritten at start time.
3	Kernel log	Kernel, driver	/var/log	kern.log	ASCII	Defined by NAS/Management. Default: 1 MB × 3 generations
4	Message	Kernel	/var/log	message	ASCII	Defined by NAS/Management. Default: 1 MB × 3 generations
5	Daemon log	Kernel	/var/log	daemon.log	ASCII	Defined by NAS/Management. Default: 1 MB × 3 generations
6	User authentication log	Kernel	/var/log	auth.log	ASCII	Defined by NAS/Management. Default: 1 MB × 9 generations
7	Application log	All components	/var/log	user.log	ASCII	Defined by NAS/Management. Default: 1 MB × 9 generations
8	Web server log	Web server	/var/log/apache	access.log	ASCII	Defined by NAS/Management. Default: 1 MB × 6 generations
9	Web server log	Web server	/var/log/apache	error.log	ASCII	Defined by NAS/Management. Default: 1 MB × 6 generations
10	System	NAS OS	/var/log	wtmp	ASCII	Defined by NAS/Management. Default: 1 MB × 3 generations

(Continues on the next page.)

(Continued from the previous page.)

#	Name	Generated by	Output directory	File name	Format	Capacity
11	System	NAS OS	/var/log	btmpt	ASCII	Defined by NAS/Management. Default: 1 MB × 3 generations
12	System	NAS OS	/var/log	lvm	ASCII	Defined by NAS/Management. Default: 1 MB × 3 generations
13	CIFS log	CIFS	/var/log/samba	log.nmbd	ASCII	Defined by NAS/Management. Default: 2 MB × 3 generations
14	CIFS log	CIFS	/var/log/samba	log.smbd	ASCII	Defined by NAS/Management. Default: 2 MB × 3 generations
15	CIFS log	CIFS	/var/log/samba	log.winbindd	ASCII	Defined by NAS/Management. Default: 2 MB × 3 generations
16	System message	Operation management	/enas/data	em_alertfile	ASCII	Defined by NAS/Management. Default: 1 MB × 3 generations
17	Failover daemon log	Failover	/var/log/failsafe	xxx_CHA name *1 *2	ASCII	Defined by NAS/Management. Default: 1 MB × 3 generations
18	NAS/Backup Restore message	NAS/Backup Restore	/enas/log	ebr_alertfile	ASCII	Defined by NAS/Management. Default: 1 MB × 3 generations
19	NAS/Backup Restore trace log	NAS/Backup Restore	/enas/log	backuprestore.trace	ASCII	Defined by NAS/Management. Default: 1 MB × 3 generations
20	NDMP server message	NAS/Backup Restore	/enas/log	ndmpserver.log	ASCII	Defined by NAS/Management. Default: 4 MB × 1 generation
21	NDMP archive log	NAS/Backup Restore	/enas/log	ndmptar.log	ASCII	Defined by NAS/Management. Default: 4 MB × 1 generation
22	NAS/Management message	Operation management	/enas/log	management.log	ASCII	Defined by NAS/Management. Default: 1 MB × 3 generations
23	NAS/Management trace	Operation management	/enas/log	management.trace	ASCII	Defined by NAS/Management. Default: 2 MB × 3 generations

(Continues on the next page.)

(Continued from the previous page.)

#	Name	Generated by	Output directory	File name	Format	Capacity
24	Core dump	Operation management	/var/core	core-pid_ <i>process name_time</i>	Binary	No limit
25	Core dump	Failover	/var/core	core-pid_ <i>process name_time</i>	Binary	No limit
26	Core dump	Driver	/var/core	core-pid_ <i>process name_time</i>	Binary	No limit
27	Core dump	Kernel	/var/core	core-pid_ <i>process name_time</i>	Binary	No limit
28	Core dump	NAS/Backup Restore	/var/core	core-pid_ <i>process name_time</i>	Binary	No limit
29	Dump	NAS OS	/lu00p6/dump_transfer_temp	dump_management_ <i>information</i>	Binary	No limit

*1: *xxx* denotes a daemon name (crsd, cmsd, failsafe, gcd, ifd, srmd, script, cli, cmond, cdbd, for a total of 10 names).

*2: Since *CHA name* denotes a CHA name (host name obtained with `gethostname`), the log file name is changed as the CHA name is changed. In this case, the log file having the old CHA name is renamed to the new CHA name.

9.3 Appendix C Initializing Dump LUs

To recover from failure occurred in dump LUs, usually follow the instructions in *Replacing Two PDEVs (Dump LU)* [NAS07-980]. However, if restarting the NAS OS is impossible due to operational circumstances, you must initialize the dump LUs by following the procedure described in this section.

Since all operations involved in initializing a dump LU are done only for maintenance purposes, the operations must be carried out via the CUI (Console User Interface). You can initialize a dump LU by connecting a maintenance terminal (maintenance PC) to the data LAN and by using ssh from that PC to access the NAS Package that is used by the failed dump LU.

Figure 9.3-1 shows a flowchart of the procedure for initializing a dump LU, followed by a step-by-step description of the procedure.

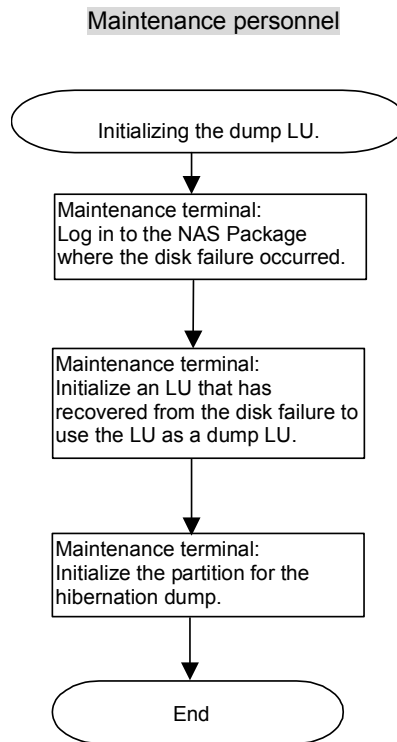

Figure 9.3-1 Flowchart for Initializing a Dump LU

1. Use ssh to log in to a NAS Package.

Use ssh to connect to the failed NAS Package.

To perform the processing described in this section, you must first change your access privileges to become a superuser because operations such as mounting and unmounting disks are required.

Note: This example shows the default password. For security reason, we recommend that you change the password to a more difficult one when you use it for the first time.

```
% ssh -l nasroot xx.xx.xx.xx
The authenticity of host 'xx.xx.xx.xx (xx.xx.xx.xx)' can't be established.
RSA key fingerprint is xxxxxxxxxxxxxxxxxxxxxxxxxxxxxxxxxxxxxxxxxxxxxxxxxxxxxxx.
Are you sure you want to continue connecting (yes/no)? yes
Warning: Permanently added 'xx.xx.xx.xx' (RSA) to the list of known hosts.
Password:
Linux e-nas 2.4.17-enas0100 #4 Fri Nov 1 12:46:35 JST 2002 i686 unknown
Last login: Mon Dec 9 08:56:17 2002 from xx.xx.xx.xx
enasroot@nas2y:~$ (This prompt is an example.)
enasroot@nas2y:~$ su
Passwd: (enas)
nas2y:/home/nasroot#
```

2. Initialize an LU that has recovered from the disk failure to use it as a dump LU.

Enter the `sfdisk` command to create a partition for the hibernation dump.

```
Command syntax: sfdisk -uM /dev/enassys/lu01 < /root/dump.sfdisk
```

CAUTION

Make sure that you enter all the commands correctly. In particular, 1 (one) and l (lowercase L) are easily mistaken so be careful not to mistype them. For example, the command syntax above shows lu01 (LU one). If you type the command incorrectly, important LUs might be destroyed by mistake.

The format shown below will be displayed.

```

nas2y:/home/nasroot# sfdisk /dev/enassys/lu01 < /root/dump.sfdisk
Checking that no-one is using this disk right now ...
Disk /dev/enassys/lu01: 897 cylinders, 255 heads, 63 sectors/track
Old situation:
Units = cylinders of 8225280 bytes, blocks of 1024 bytes, counting from 0

   Device Boot Start      End  #cyls  #blocks  Id System
/dev/enassys/lu01p1          0+   523    524-  4208998+  a0  IBM Thinkpad hibernation
/dev/enassys/lu01p2        524    537     14   112455   83  Linux
/dev/enassys/lu01p3        538    603     66   530145   83  Linux
/dev/enassys/lu01p4          0      -      0        0    0  Empty
New situation:
Units = sectors of 512 bytes, counting from 0

   Device Boot  Start      End  #sectors  Id System
/dev/enassys/lu01p1          63  8418059  8417997  a0  IBM Thinkpad hibernation
/dev/enassys/lu01p2      8418060  8642969  224910   83  Linux
/dev/enassys/lu01p3      8642970  9703259  1060290   83  Linux
/dev/enassys/lu01p4          0      -          0    0  Empty
Warning: no primary partition is marked bootable (active)
This does not matter for LILO, but the DOS MBR will not boot this disk.
Successfully wrote the new partition table

Re-reading the partition table ...

If you created or changed a DOS partition, /dev/foo7, say, then use dd(1)
to zero the first 512 bytes: dd if=/dev/zero of=/dev/foo7 bs=512 count=1
(See fdisk(8).)

```

3. Initialize the partition for the hibernation dump.

Enter the `saveto` command to initialize the partition for the hibernation dump.

```
Command syntax: saveto -i
```

The format shown below will be displayed.

```

nas2y:/home/nasroot# saveto -i
 1 UNUSED - Fri May 30 23:06:46 2003
 2 UNUSED
 3 UNUSED - Fri May 23 10:01:47 2003
 4 UNUSED - Wed May 28 11:53:00 2003
 5 UNUSED - Sat May 31 15:44:13 2003
 6 UNUSED
 7 UNUSED - Mon May 19 21:43:39 2003
 8 UNUSED - Thu Jun  5 21:49:58 2003

```

9.4 Appendix D How to Obtain Error Information When the NAS OS Has Not Started

9.4.1 Overview

Normally, downloading auto dump and NAS dump for error information is performed with NAS OS started. But, the situation might be possible that you cannot start NAS OS in particular condition of the error. In this section, procedure to obtain the error information of the NAS Package where the NAS OS has not started from other NAS Package where the NAS OS has started is described.

9.4.2 Confirming that NAS OS is stopped

Confirm that NAS OS is stopped first. The procedure described here is premised on the situation that the NAS OS of the target NAS Package is stopped. It is likely that the NAS OS LU will be destroyed if the NAS OS of the target NAS Package is started. Therefore, make sure to reset CHA (NAS Package) according to the procedure in subsection 3.5.9 Resetting CHA [[NAS03-890](#)].

9.4.3 How to Obtain an Auto Dump

To obtain an auto dump from the NAS Package where the NAS OS has not started, you should obtain an auto dump from the NAS Package where the NAS OS has started beforehand. Then you can obtain the auto dump via SVP. Figure 9.4-1 shows the flowchart for obtaining an auto dump, followed by a step-by-step description of the procedure.

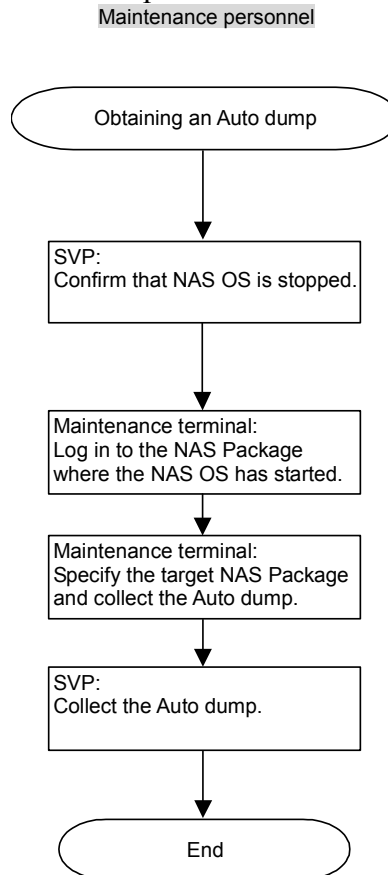

Figure 9.4-1 Flowchart for Obtaining an Auto Dump

1. Confirm that NAS OS is stopped

Confirm that NAS OS is stopped following the procedure shown in section 9.4.2 *Confirming that NAS OS is stopped*.

2. Use ssh to log in to a NAS Package.

Use ssh to connect to the target NAS Package where the NAS OS has started.

To perform the processing described in this subsection, you must first change your access privileges to become a superuser because operations such as mounting and unmounting disks are required.

Note: This example shows the default password. For security reason, we recommend that you change the password to a more difficult one when you use it for the first time.

```
% ssh -l nasroot xx.xx.xx.xx
The authenticity of host 'xx.xx.xx.xx (xx.xx.xx.xx)' can't be established.
RSA key fingerprint is xx:xx:xx:xx:xx:xx:xx:xx:xx:xx:xx:xx:xx:xx:xx:xx.
Are you sure you want to continue connecting (yes/no)? yes
Warning: Permanently added 'xx.xx.xx.xx' (RSA) to the list of known hosts.
Password:
Linux nas1s 2.4.17-enas0200-SI20K014 #1 Thu Oct 23 13:35:50 JST 2003 i686 unknown
Last login: Mon Dec 9 08:56:17 2002 from xx.xx.xx.xx
nasroot@nas2y:~$(This prompt is an example.)
nasroot@nas2y:~$ su
Passwd: (enas)
nas2y:/home/nasroot#
```

3. Collect the auto dump in the target NAS Package.

Specify the target NAS Package and to collect the auto dump.

Note: The NAS Package location specified in the command is not case-sensitive.

```
nas2y:/home/nasroot# cd /sbin
nas2y:/sbin# chmod +x enas_autodump.sh
nas2y:/sbin# enas_autodump.sh CHA-1S (Specify the NAS Package location)
If you want to continue, input a displayed number.
0123456789 (Ten random figures will be displayed.)
input > 0123456789 (Specify the same figures displayed in the prior line.)
again > 0123456789 (Specify the same figures again.)
Success.
nas2y:/sbin#
```

4. Collect the auto dump.

In the 'SVP' window, click the **Auto Dump** button to collect the auto dump.



Make sure that you enter all the commands correctly. In particular, 1 (one) and l (lowercase L) are easily mistaken so be careful not to mistype them. For example, the command syntax above shows lu01 (LU one).

9.4.4 How to Obtain an NAS Dump

To obtain a NAS dump from the NAS Package where the NAS OS has not started, you should obtain a NAS dump from the NAS Package where the NAS OS has started beforehand. Then you can download the NAS dump via SVP. Figure 9.4-2 shows the flowchart for obtaining an NAS dump, followed by a step-by-step description of the procedure.

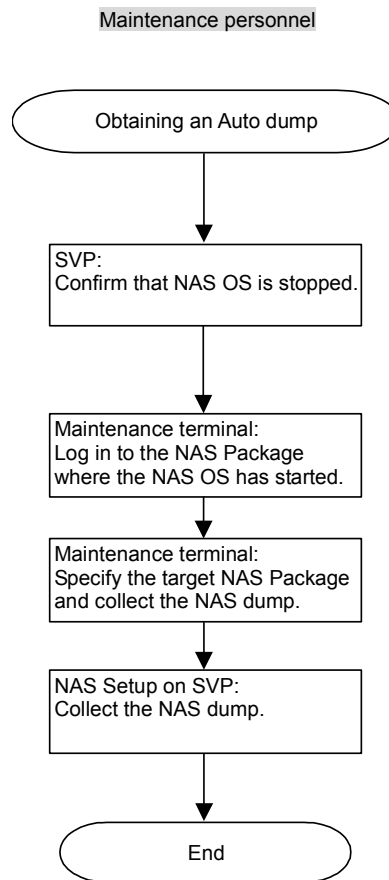

Figure 9.4-2 Flowchart for Obtaining an NAS Dump

1. Confirm that NAS OS is stopped

Confirm that NAS OS is stopped following the procedure shown in section 9.4.2 *Confirming that NAS OS is stopped*.

2. Use ssh to log in to a NAS Package.

Use ssh to connect to the target NAS Package where the NAS OS has started.

To perform the processing described in this subsection, you must first change your access privileges to become a superuser because operations such as mounting and unmounting disks are required.

Note: This example shows the default password. For security reason, we recommend that you change the password to a more difficult one when you use it for the first time.

```
% ssh -l nasroot xx.xx.xx.xx
The authenticity of host 'xx.xx.xx.xx (xx.xx.xx.xx)' can't be established.
RSA key fingerprint is xx:xx:xx:xx:xx:xx:xx:xx:xx:xx:xx:xx:xx:xx:xx:xx.
Are you sure you want to continue connecting (yes/no)? yes
Warning: Permanently added 'xx.xx.xx.xx' (RSA) to the list of known hosts.
Password:
Linux nas1s 2.4.17-enas0200-SI20K014 #1 Thu Oct 23 13:35:50 JST 2003 i686 unknown
Last login: Mon Dec 9 08:56:17 2002 from xx.xx.xx.xx
nasroot@nas2y:~$(This prompt is an example.)
nasroot@nas2y:~$ su
Passwd: (enas)
nas2y:/home/nasroot#
```

3. Collect the NAS dump in the target NAS Package.

Specify the target NAS Package and to collect the NAS dump.

Note: The NAS Package location specified in the command is not case-sensitive.

```
nas2y:/home/nasroot# cd /sbin
nas2y:/sbin# chmod +x enas_nasdump.sh
nas2y:/sbin# enas_nasdump.sh CHA-1S (Specify the NAS Package location)
If you want to continue, input a displayed number.
0123456789 (Ten random figures will be displayed.)
input > 0123456789 (Specify the same figures displayed in the prior line.)
again > 0123456789 (Specify the same figures again.)
Success.
nas2y:/sbin#
```

4. Collect the NAS dump.

Download the NAS dump following the procedure shown in section 3.5.14 *Downloading Dump Files*. Confirm that the NAS Package location is contained in the filename displayed in the message from NAS Setup on SVP.



CAUTION

Make sure that you enter all the commands correctly. In particular, 1 (one) and l (lowercase L) are easily mistaken so be careful not to mistype them. For example, the command syntax above shows lu01 (LU one).

9.5 Appendix E NAS Dump (Attachment of USB Memory)

For more information on attachment of USB memory, see *3.5.14 Downloading Dump Files* [[NAS03-1090](#)].

Blank Sheet

REV.1	Jan.2004	Mar.2004				
-------	----------	----------	--	--	--	--

Blank Sheet

REV.1	Jan.2004	Mar.2004				
-------	----------	----------	--	--	--	--

Blank Sheet

REV.1	Jan.2004	Mar.2004				
-------	----------	----------	--	--	--	--

Blank Sheet

REV.1	Jan.2004	Mar.2004				
-------	----------	----------	--	--	--	--

Blank Sheet

REV.1	Jan.2004	Mar.2004				
-------	----------	----------	--	--	--	--

Blank Sheet

REV.1	Jan.2004	Mar.2004				
-------	----------	----------	--	--	--	--

Blank Sheet

REV.1	Jan.2004	Mar.2004				
-------	----------	----------	--	--	--	--