

# ***PERIODIC CHECK SECTION***

## Contents

1 PERIODIC CHECK LIST .....	PERIOD01-10
2 Confirmation Method of DC Voltage .....	PERIOD02-10
3 Cleaning of Air Filter .....	PERIOD03-10
4 Check and Replacement of Battery .....	PERIOD04-10
4.1 Type and Backup Duration Time of battery .....	PERIOD04-10
4.2 Inspecting Battery .....	PERIOD04-20

## 1. PERIODIC CHECK LIST

The following table shows the items of the periodic check for the DKC.

When the parts are replaced, refer to 'PARTS REPLACEMENT SECTION' of this manual.

Table 1-1 Periodic Check List

No.	Item	Tools	Frequency of Periodic Check	Check Time	Reference Page
2	Check of air filter	• Vacuum cleaner	Once per year	10 min.	PERIOD 03-10
3	Check and Replacement of battery	• Philips screwdriver	Once per year	Check time: 10 min. per subsystem. Replacement time: 10 min. per battery.	PERIOD 04-10 to PERIOD 04-20

Table 1-2 Confirmation

No.	Item	Tools	Occasion to check	Check Time	Reference Page
1	Confirmation of DC voltage	• Digital voltmeter • Voltage check fixture	Check the voltage when the Technical Support Center instructs to do that. (The check is not required at the time of the periodical inspection.)	5 min. per logical part	PERIOD 02-10 to PERIOD 02-30

## 2. Confirmation Method of DC Voltage

- a. Measure DC +3.3V, DC +5V, and, DC +12V current at the check point with a digital voltmeter.  
Refer to the following table and figure:

Table 2-1 'Range of Acceptable DC Voltage' on PERIOD 02-10

Fig. 2-1 'Location of Power Supplies' on PERIOD 02-20

Fig. 2-2 'Location of Voltage Check Point' on PERIOD 02-30

Table 2-1 Range of Acceptable DC Voltage

No.	Logic Part	Standard DC Voltage (Between +DC and GRD)	Acceptable Range (Between +DC and GRD)	Power Supply Location	Remarks	
1	Cluster 1	+5V/+3.3V (5/3VPS)	5V : +4.95V to +5.30V	5/3VPS1A		
2			3.3V : +3.30V to +3.57V	5/3VPS1B		
3		+3.3V (3VPS)	3.3V : +3.30V to +3.57V		3VPS1A	
4					3VPS1B	
5		+3.3V/+12V (3/12VPS)	3.3V : +3.30V to +3.57V		3/12VPS1A	
6			12V : +12.0V to +13.0V		3/12VPS1B	
7		+5V/+12V (SUBPS)	5V : +4.90V to +5.20V		SUBPS1	
8			12V : +11.83V to +12.57V			
9	Cluster 2	+5V/+3.3V (5/3VPS)	5V : +4.95V to +5.30V	5/3VPS2A		
10			3.3V : +3.30V to +3.57V	5/3VPS2B		
11		+3.3V (3VPS)	3.3V : +3.30V to +3.57V		3VPS2A	
12					3VPS2B	
13		+3.3V/+12V (3/12VPS)	3.3V : +3.30V to +3.57V		3/12VPS2A	
14			12V : +12.0V to +13.0V		3/12VPS2B	
15		+5V/+12V (SUBPS)	5V : +4.90V to +5.20V		SUBPS2	
16			12V : +11.83V to +12.57V			
17	HDU-0	+5V/+12V (Multi PS)	5V : +4.85V to +5.35V	MPS00		
18			12V : +11.45V to +12.65V	MPS01		
19	HDU-1	+5V/+12V (Multi PS)	5V : +4.85V to +5.35V	MPS10		
20			12V : +11.45V to +12.65V	MPS11		
21	HDU-2	+5V/+12V (Multi PS)	5V : +4.85V to +5.35V	MPS20		
22			12V : +11.45V to +12.65V	MPS21		
23	HDU-3	+5V/+12V (Multi PS)	5V : +4.85V to +5.35V	MPS30		
24			12V : +11.45V to +12.65V	MPS31		

- b. To check the output voltage of the power supplies, measure it with the voltmeter, by connecting the voltmeter to the voltage check point.  
 If the output voltage of the power supply is not within the acceptable DC voltage, replace it to the spare part. Refer to REPLACE SECTION [REP01-180].

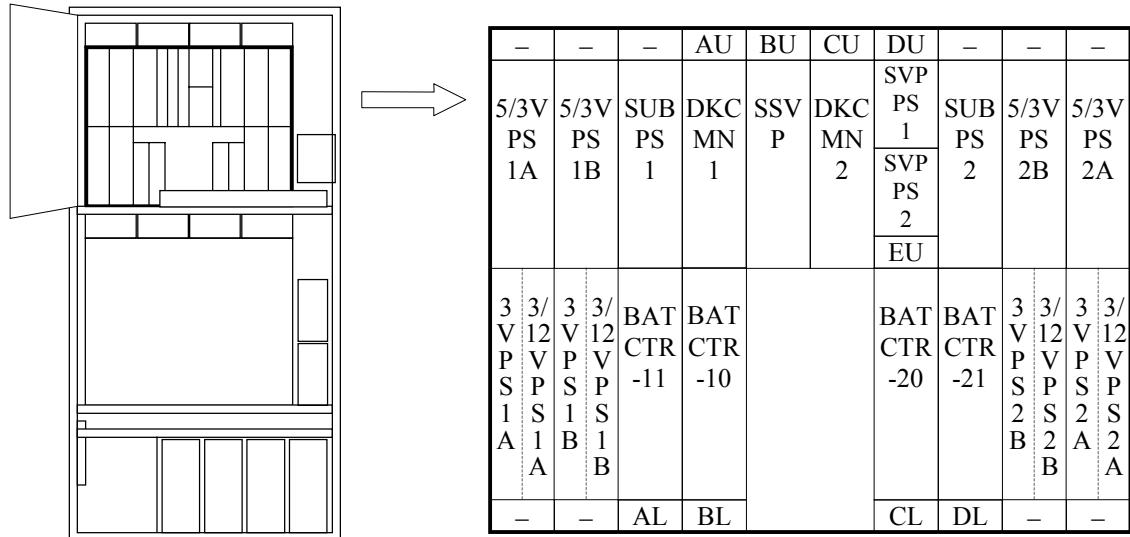

Front View

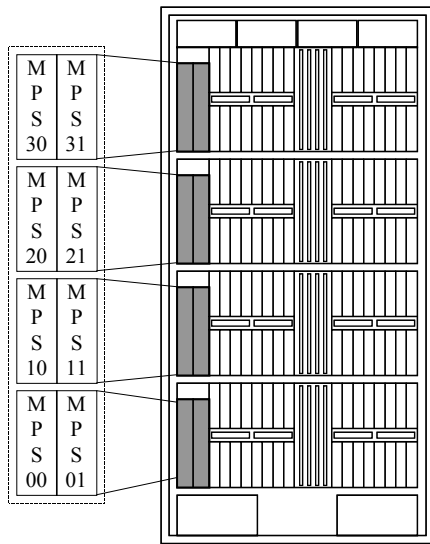

Rear View

Fig. 2-1 Location of Power Supplies

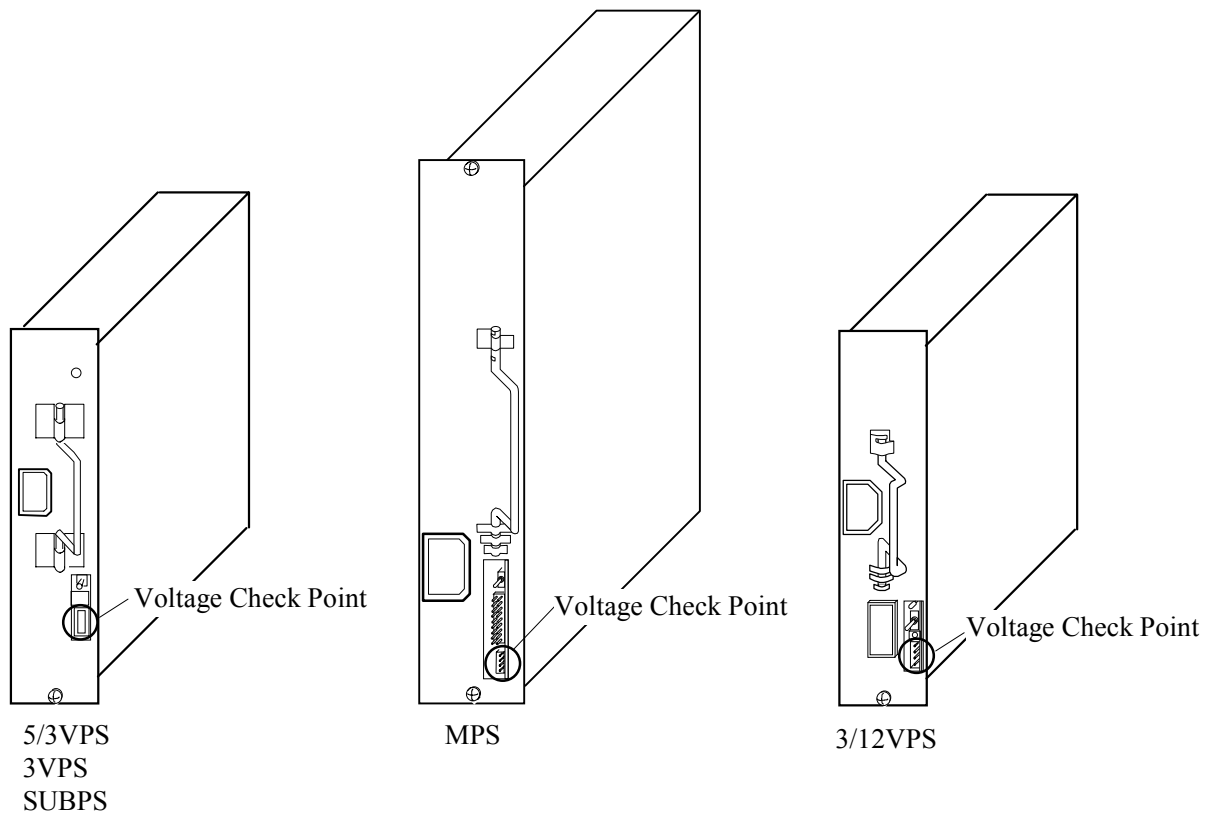

Voltage Check Point

Pin No.	DC Voltage				
	5/3VPS	3VPS	SUBPS	MPS	3/12VPS
1	+5V	+3.3V	+12V	+12V	+3.3V
2	+3.3V	—	+5V	+5V	+12V
3	—	—	—	—	—
4	GRD	GRD	GRD	GRD	GRD

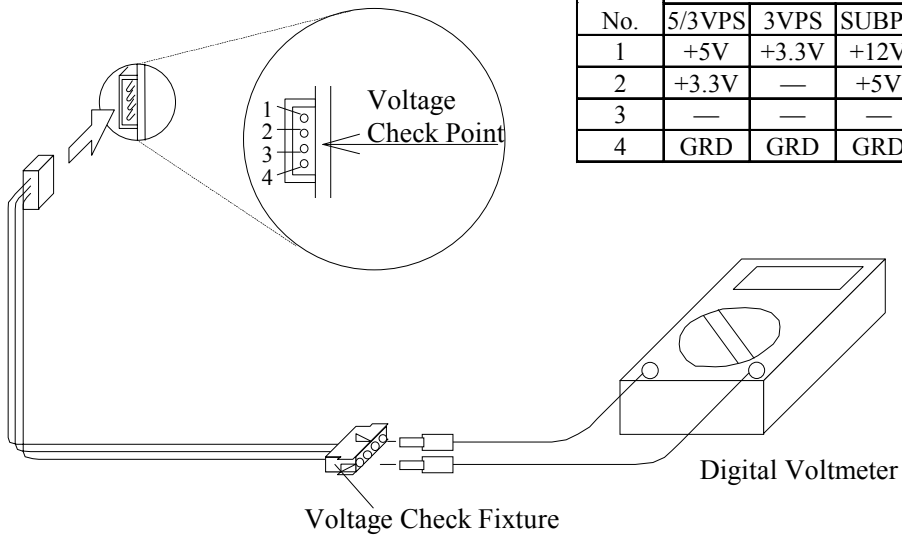

Fig. 2-2 Location of Voltage Check Point

### 3. Cleaning of Air Filter

Clean the air filters located at the bottom of the Front Logic Box and inside the front and rear doors. The location of the air filters are shown in Fig. 3-1.

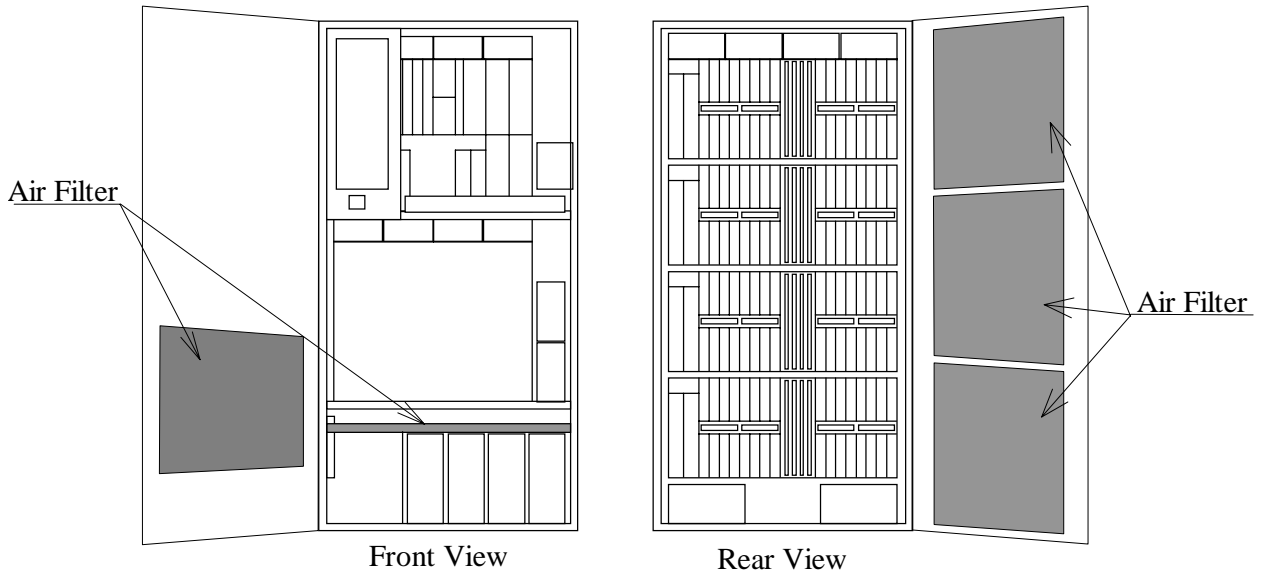

Fig. 3-1 Air Filter Location in DKC

The method of how to remove the air filter is shown below.

(1) How to remove the air filter on the door

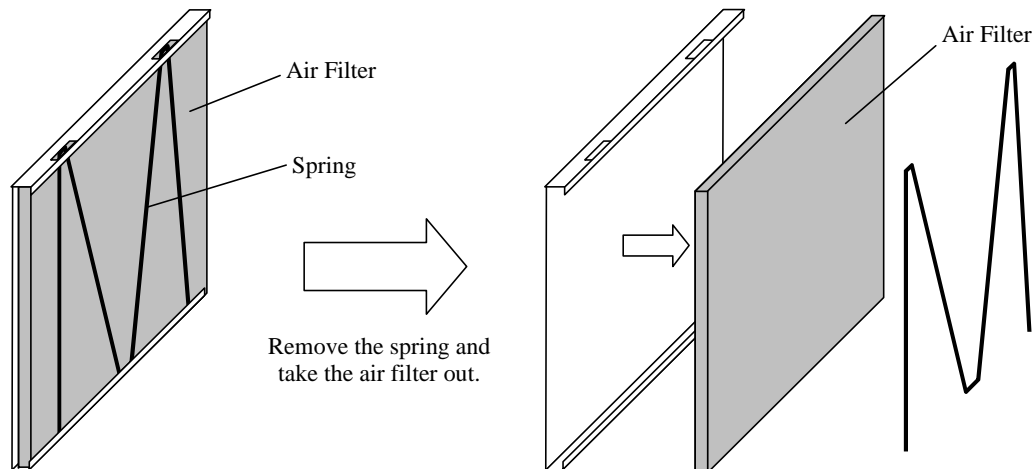

Fig. 3-2 How to Remove Air Filter on Door

## (2) How to remove the air filter at the bottom of the Front Logic Box

Take out the air filter following the procedure below after removing the cover of the Logic Box, and then clean them.

When taking out or reinstalling the air filter, work carefully not to catch the channel I/F and DEV I/F cables by it.

There are two types of air filter installed at the bottom of the Front Logic Box, that is, the separate type and unified type.

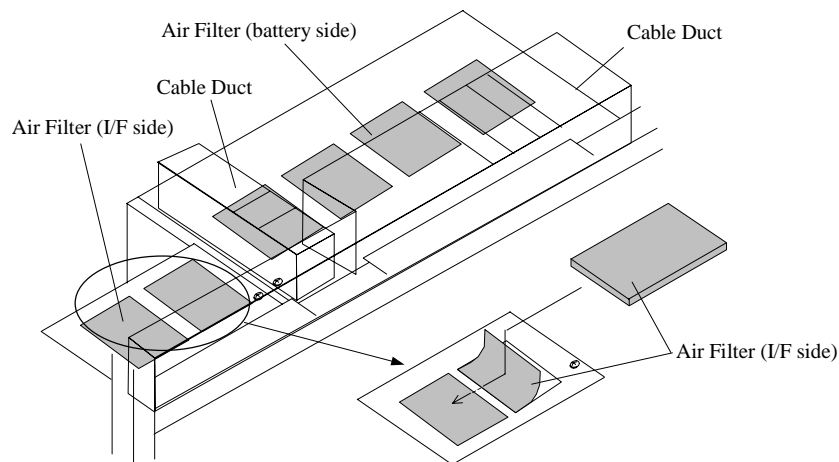
Separate type air filter

Note: The air filter (battery side) need not be cleaned because it cannot be taken out.

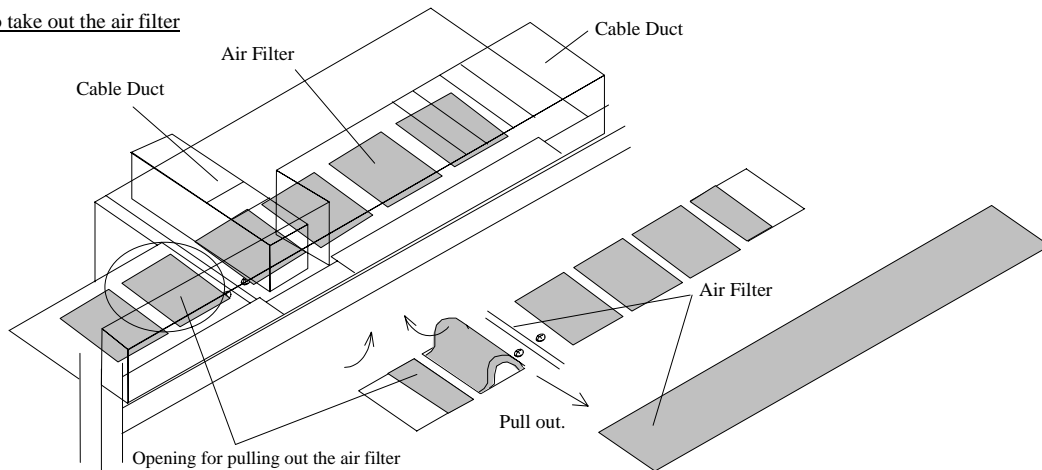
Unified type air filterHow to take out the air filterHow to reinstall the air filter

Roll the air filter and push it in the opening from which it was taken out in the right direction.

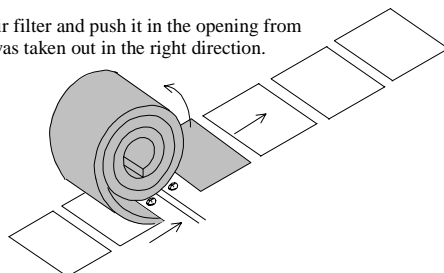

After pushing in the air filter in the right direction, fold the rest of it, and then push it in the opening in the left direction.

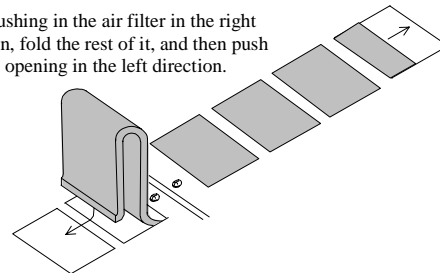

Fig. 3-3 How to Take Out Air Filter Installed at the Bottom of Logic Box

## 4. Check and Replacement of Battery

### 4.1 Type and Backup Duration Time of battery

The DKC has the batteries shown in Table 4.1-1 and Fig. 4.1-1. The Backup duration time of battery is shown in Table 4.1-2.

Table 4.1-1 Batteries used in DKC

No.	Battery Name	Logic Part
1	BATTERY-10	Cluster 1 Shared Memory
2	BATTERY-11	Cluster 1 Cache Memory
3	BATTERY-20	Cluster 2 Shared Memory
4	BATTERY-21	Cluster 2 Cache Memory

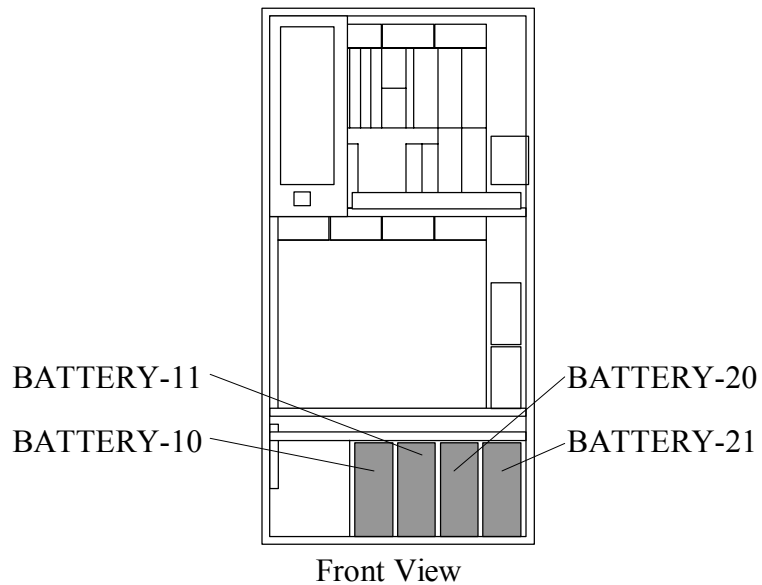

Fig. 4.1-1 Battery Location

Table 4.1-2 Backup Duration Time for Each Memory

No.	Memory to be backed up	Maximum backup duration time
1	Shared Memory	168 hours (seven days)
2	Cache Memory	48 hours (two days)

## 4.2 Inspecting Battery

### (1) Periodic inspection of the battery

Inspect the batteries installed in the subsystem on the following matters once a year.

- ① Check if no SIM concerning the battery has been issued.
- ② Check if no trouble such as liquid leakage is observed in the external appearance.
- ③ Check if the working days of the battery is within the service life of the battery shown in the table below referring to the maintenance history and production date shown in the label affixed on the battery.

Table 4.2-1 Battery Specifications

No.	Battery type	Service life
1	For SM	2.5 years
2	For CM	

### (2) Replacing the battery

The battery must be replaced before the service life above expires. For the replacement procedure, refer to the Replacement Section (Work ID RT14 on page [REP01-170](#)).

When the replacement is completed, set the warning SIM concerning the battery that demands the next periodic replacement following the directions given on page [SVP02-1290](#) in the SVP Section.

### (3) Inspection of battery being stored (Batteries installed in the stored DKC are included)

Allowable storage period and specifications for refilling charge of batteries stored as maintenance parts are shown in the following table.

Table 4.2-2 Specifications for Batteries Stored for Maintenance

No.	Battery type	Allowable storage period	Allowable times of refilling charges <sup>*1</sup>	Time when refilling charge is to be done	Method of refilling charge
1	For SM and	Six months (when stored at 25°C or lower)	Once	Until the time shown on the left elapses after the production date written on the label affixed to the battery	Mount the battery in the DKC and apply power to it for longer than 48 hours.
2	For CM	Three months (when stored at 25°C to 32°C)	Three times		

\*1: When the refilling charge is done, update the production date of the battery written on the label to the date when the refilling charge is done.

\*2: When the storage environment exceeds 32°C the batteries must be discarded.

Dispose of the battery that has been stored longer than the storable period after the refilling charge.

### (4) When re-installing the DKC, replace all the batteries.

#### CAUTION

The Battery (Battery Box) is an industrial waste. Dispose of it following the directions given by the manufacturer.