

REPLACE SECTION

SAFETY SUMMARY

Notes on the operation on the password inputting screen.

The password inputting screen is displayed on the SVP screen to arouse maintenance person's attention when the operation concerned can cause a serious failure such as a system down or a data loss.

- When the password inputting screen is displayed, be sure to observe the cautions given in the procedure concerned in the maintenance manual.
- When a confirmation by the technical support center is required in the maintenance manual, be sure to get it before executing the maintenance procedure concerned.
- Each PCB is operated by the microprogram owned by it individually.

If the PCB is replaced in the procedure that makes the version of the microprogram disagree with that of the PCB, the subsystem cannot operate normally. Be sure to make the revisions consistent each other.

Contents

1. Hot Replace -----	REP01-10	
1.1 Hot Replace Flowchart -----	REP01-10	
1.2 Concept of Drive Maintenance -----	REP01-20	
1.3 Concept of Cache Maintenance -----	REP01-90	
1.4 How to Interpret the Hot Replace Procedure -----	REP01-100	
1.5 Parts Replacement Process Table-----	REP01-150	
1.6 Procedure contents table-----	REP01-190	
1.7 MAINTENANCE outline -----	REP01-200	
1.8 Availability of the online maintenance when HRC/HORC is used -----	REP01-210	
1.9 Availability of the online maintenance when HODM is used -----	REP01-230	
1.10 Availability of the online maintenance when HMRCF is used-----	REP01-240	
1.11 Availability of the online maintenance when HXRC is used -----	REP01-250	
[Pre A] -- REP02-10	[Hardware A]----- REP03-10	[Post a] ----- REP04-10
[Pre B] -- REP02-30	[Hardware B]----- REP03-50	[Post b] ----- REP04-50
[Pre C] -- REP02-90	[Hardware C] ----- REP03-80	[Post c] ----- REP04-90
[Pre D] -- REP02-130	[Hardware D] ----- REP03-110	[Post d] ----- REP04-150
[Pre E] -- REP02-180	[Hardware E]----- REP03-140	[Post e] ----- REP04-180
[Pre F] -- REP02-240	[Hardware F]----- REP03-170	[Post f] ----- REP04-210
[Pre H] -- REP02-300	[Hardware G] ----- REP03-200	[Post i] ----- REP04-240
[Pre K] -- REP02-370	[Hardware T1] ---- REP03-230	[Post j] ----- REP04-270
[Pre L] -- REP02-410	[Hardware T2] ---- REP03-280	[Post k] ----- REP04-300
[Pre M] -- REP02-460	[Hardware T3] ---- REP03-330	[Post t1] ---- REP04-320
[Pre T1] REP02-510	[Hardware T4] ---- REP03-360	[Post t3] ---- REP04-900
[Pre T3] REP02-660	[Hardware T5] ---- REP03-410	[Post t4] ---- REP04-1000
[Pre T4] REP02-750	[Hardware T6] ---- REP03-430	[Post t5] ---- REP04-1100
[Pre T5] REP02-820	[Hardware T7] ---- REP03-450	[Post u] ----- REP04-1360
[Pre V] -- REP02-880	[Hardware T8] ---- REP03-550	[Post z] ----- REP04-1400
	[Hardware T11] -- REP03-570	
	[Hardware T12] -- REP03-600	
	[Hardware T13] -- REP03-620	
	[Hardware T15] -- REP03-660	
	[Hardware T16] -- REP03-690	
	[Hardware T19] -- REP03-710	
	[Hardware T20] -- REP03-730	
	[Hardware T21] -- REP03-750	
	[Hardware T23] -- REP03-880	
	[Hardware T24] -- REP03-910	
	[Hardware T25] -- REP03-930	
	[Hardware T26] -- REP03-950	
	[Hardware T27] -- REP03-970	
	[Hardware H] ----- REP03-1000	
	[Hardware I]----- REP03-1040	

1 Hot Replace

1.1 Hot Replace Flowchart

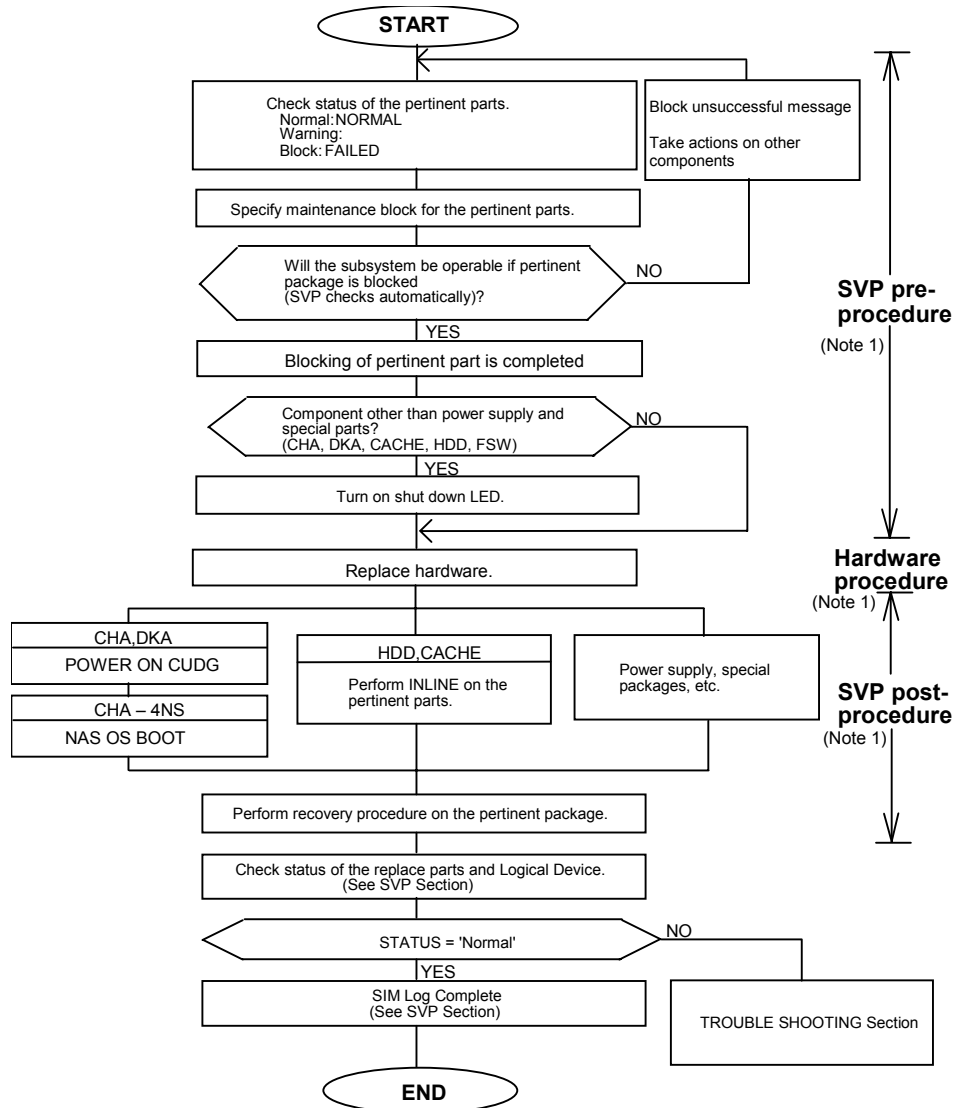

Note 1:

SVP pre-procedure: An SVP (PC) process of issuing a maintenance block instruction after checking the status of the parts to be replaced so that the live parts can be removed and replaced.

Hard ware procedure: A process of removing a parts to be replaced (shut down LED on) and installing a maintenance package.

Be sure to wear your wrist strap, and attach to ground, prior to performing the following work.

This will insure that the IC and LSI on the PCB, are protected from static electricity.

SVP post-procedure: An SVP (PC) process of making functional checks (CUDG and INLINE) on the replacement package and building it into the subsystem.

1.2 Concept of Drive Maintenance

[Spare drive present]

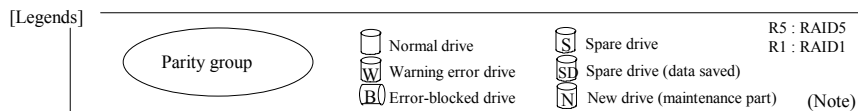
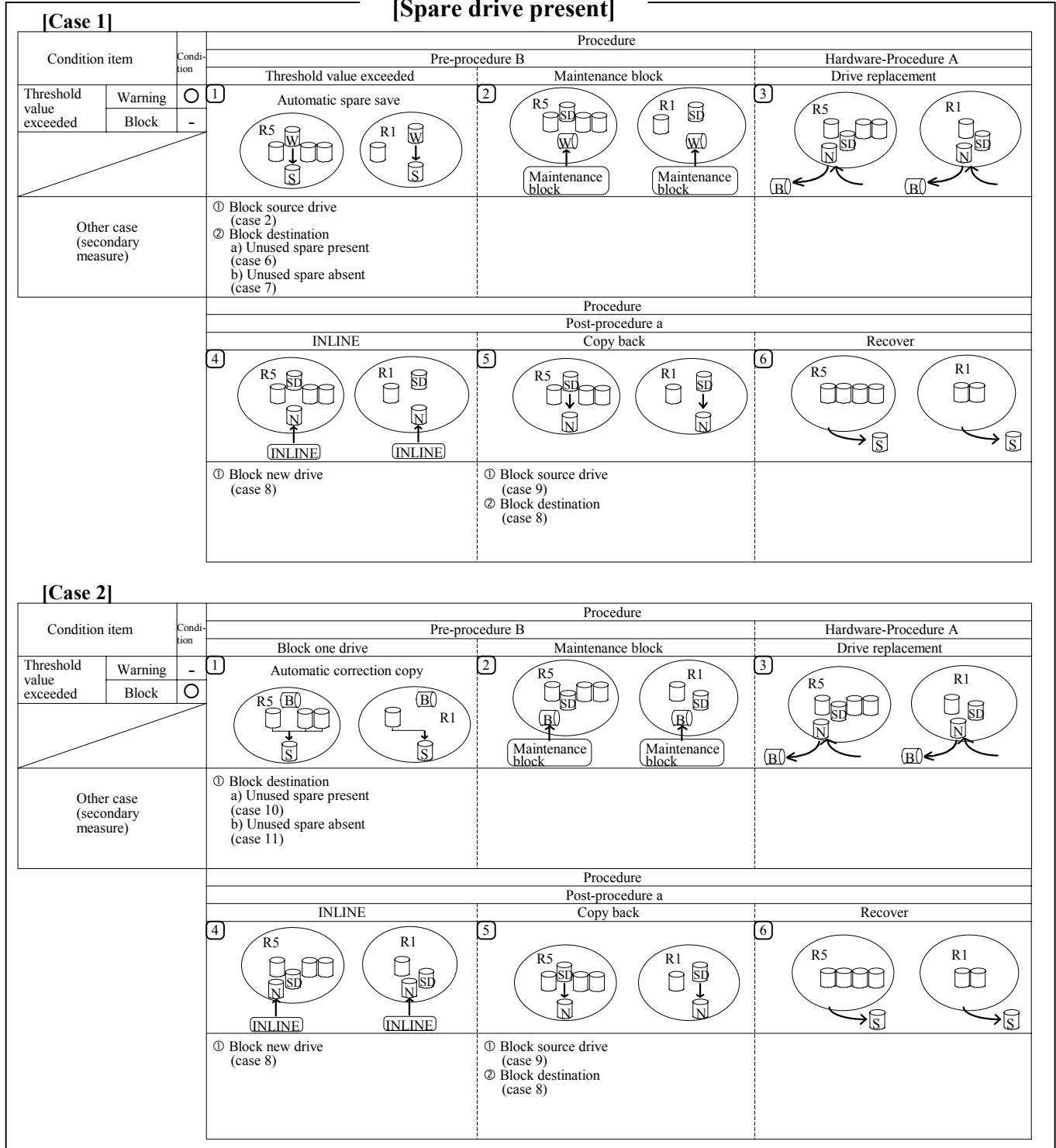

(Note) In RAID 1 method, Parity group consists of four drives.

[Spare drive absent]

[Case 3]

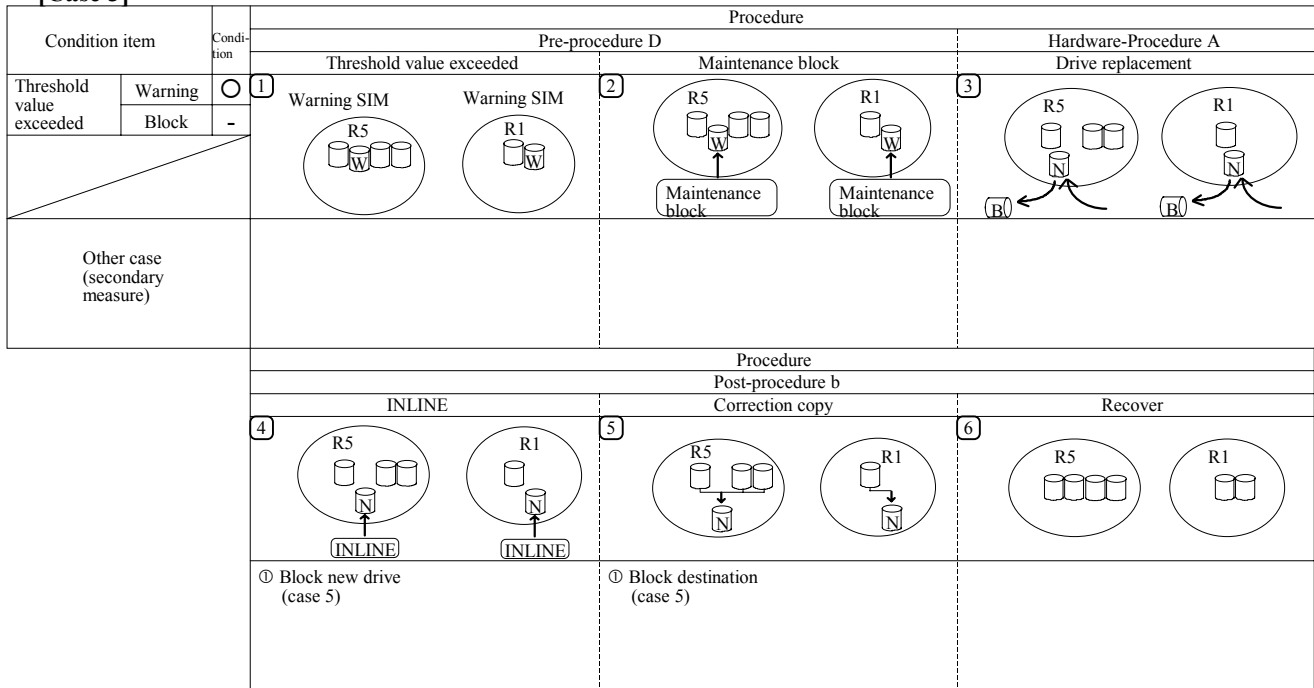

[Case 4]

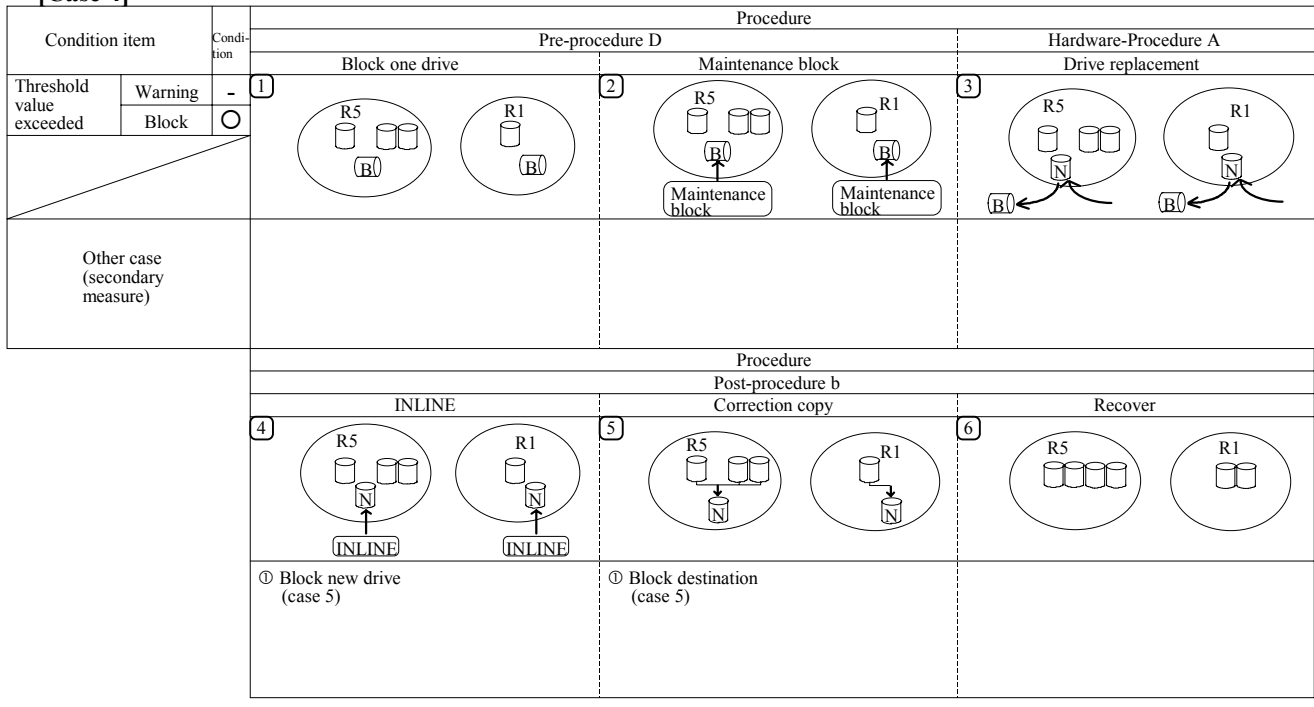

[Legends]

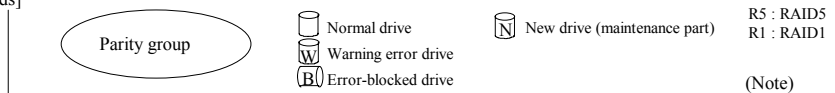

(Note) In RAID 1 method, Parity group consists of two drives.

[Case 5] [Case in which a secondary error occurred during error]

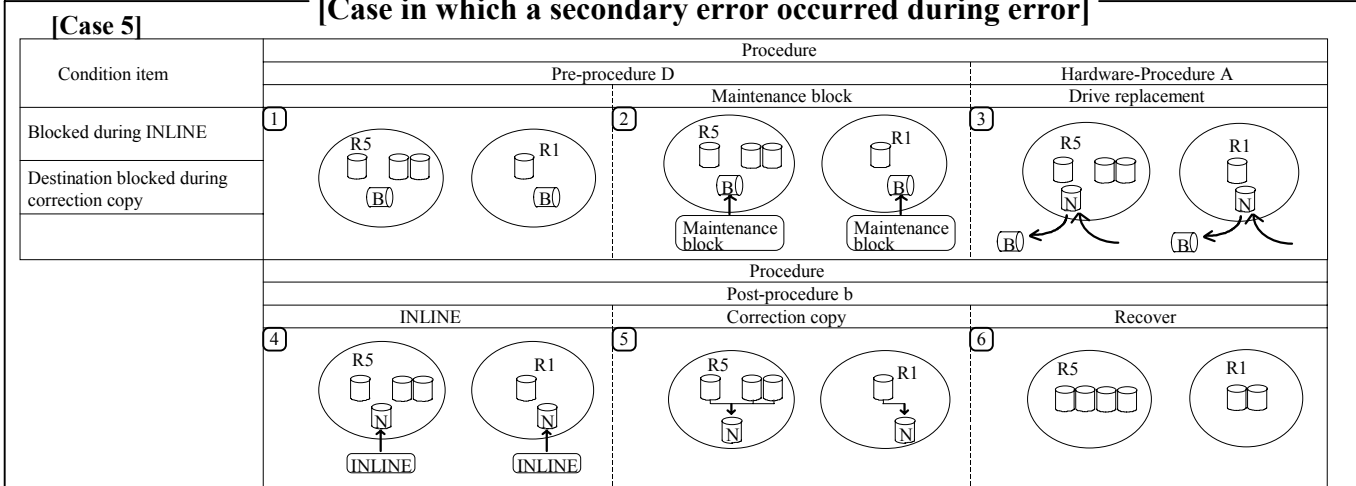

[Case 6]

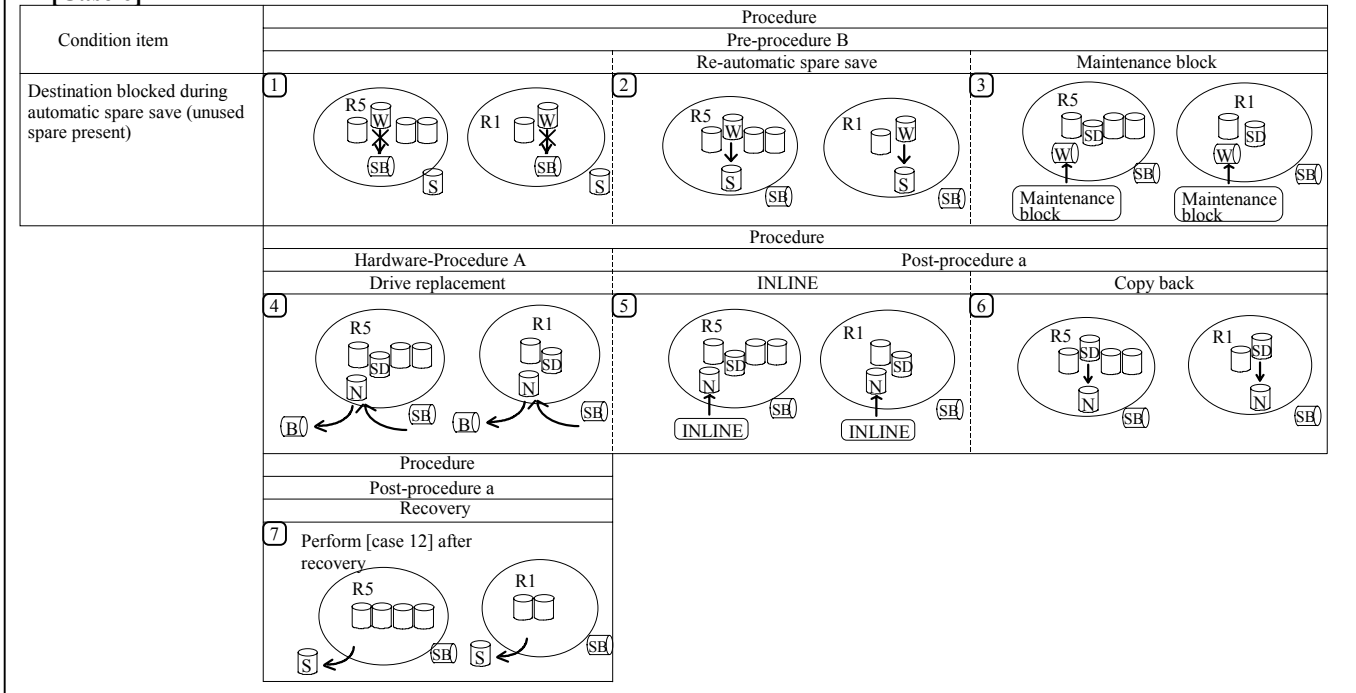

[Legends]

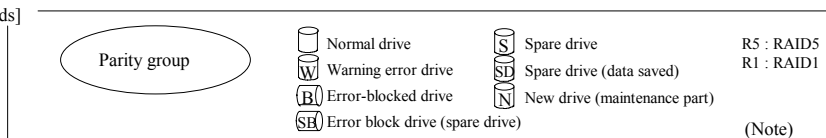

(Note) In RAID 1 method, Parity group consists of two drives.

[Case 7] [Case in which a secondary error occurred during error recovery]

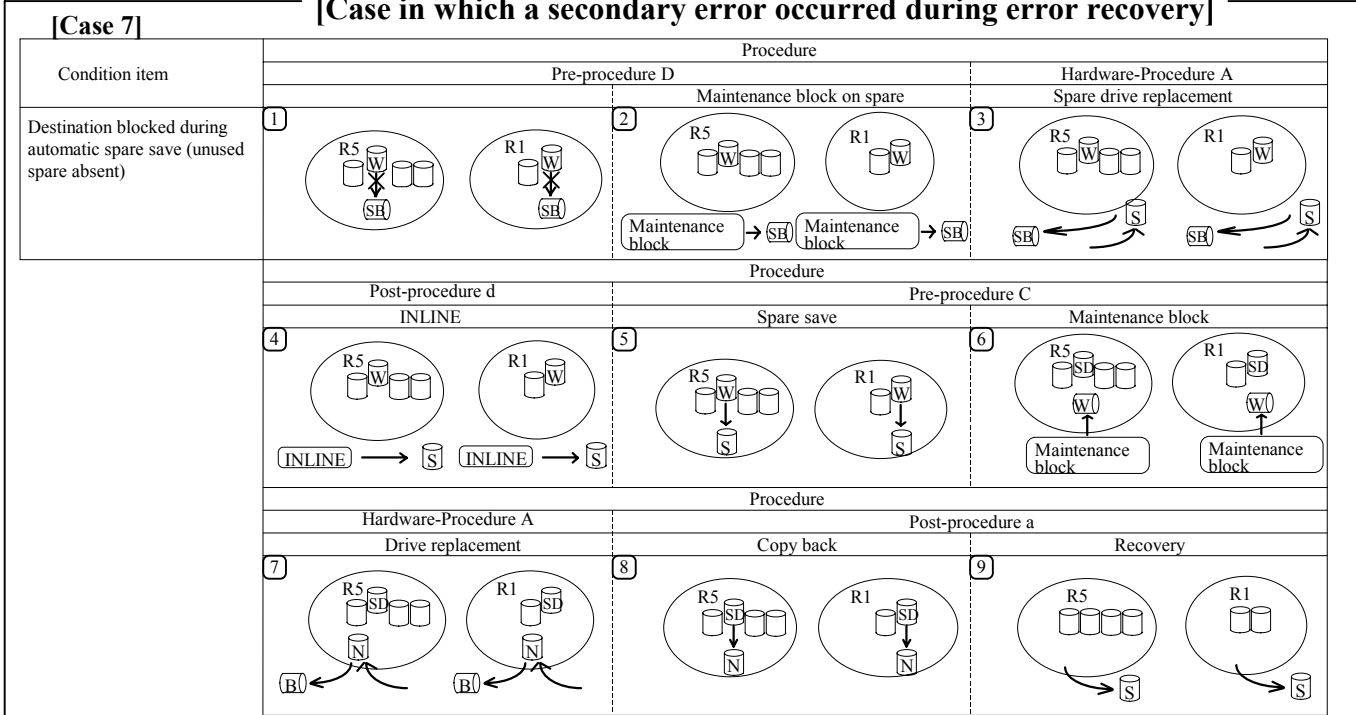

[Case 8]

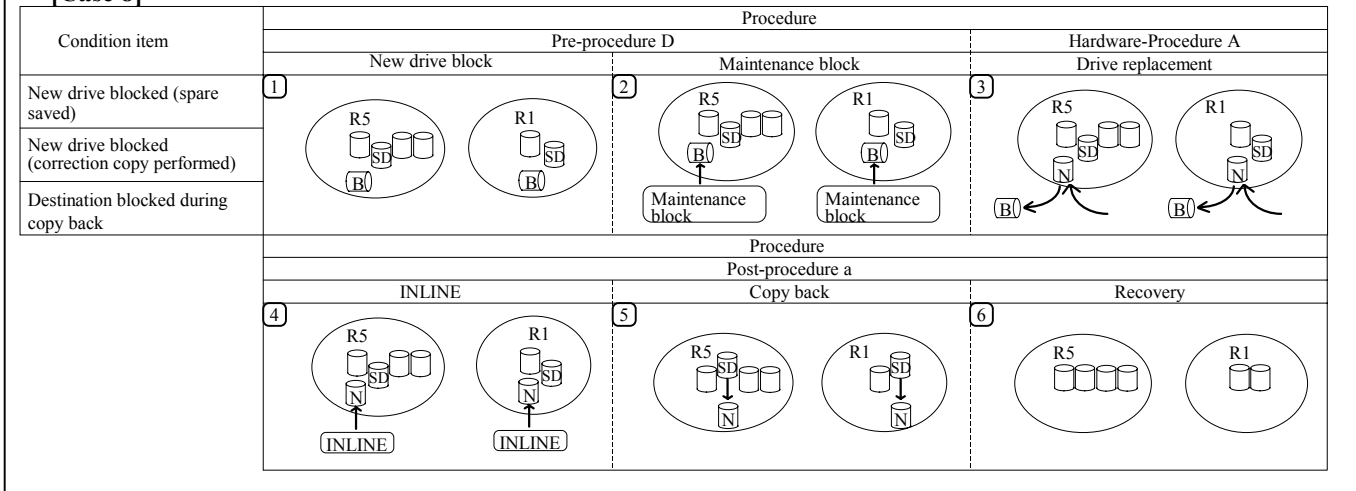

[Legends]

			R5 : RAID5
			R1 : RAID1
			(Note)

(Note) In RAID 1 method, Parity group consists of two drives.

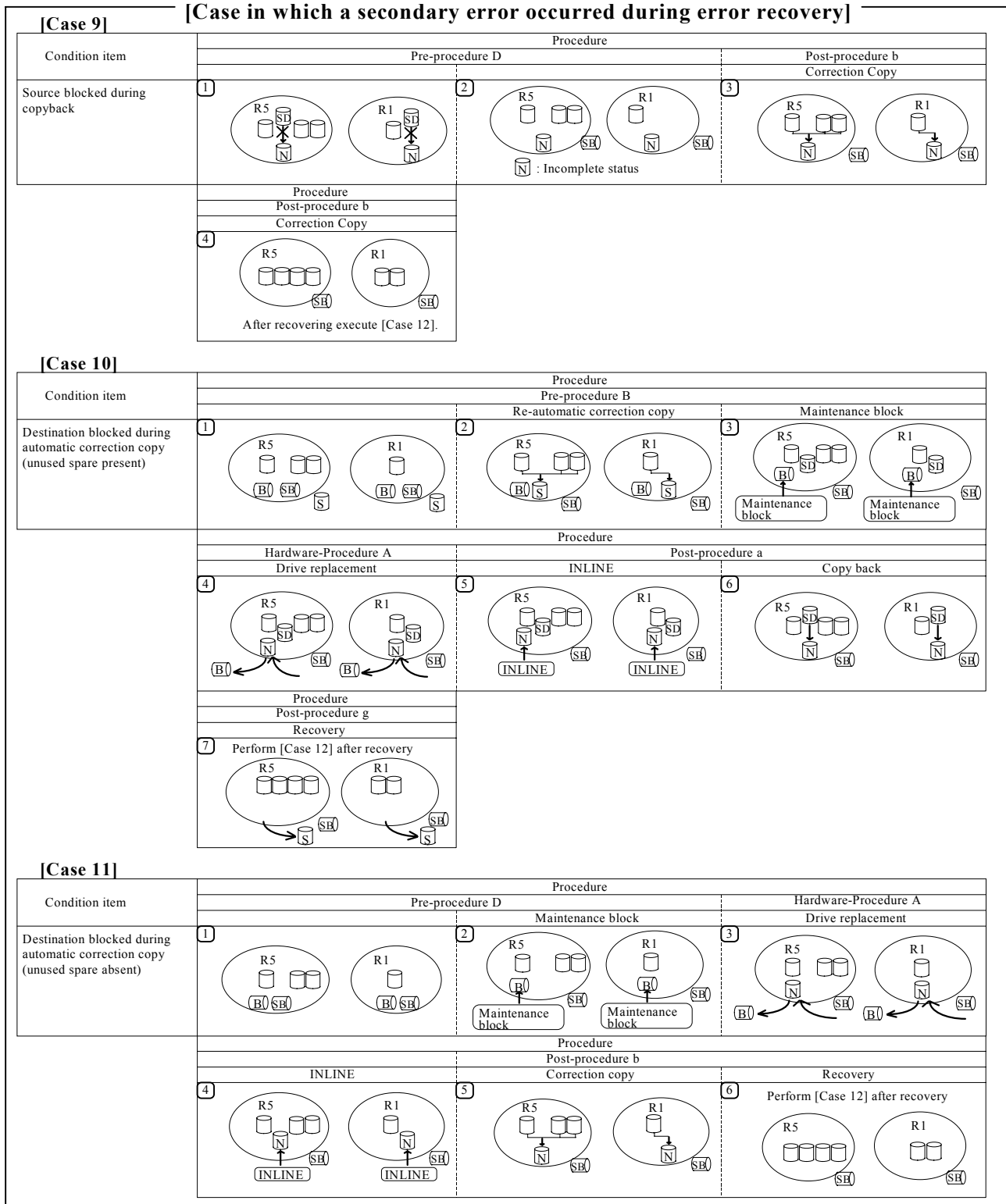

[Legends]

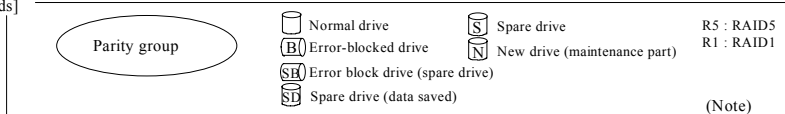

(Note) In RAID 1 method, Parity group consists of two drives.

[Case 12] (Spare drive blocked)		[Other Cases]	
Condition item		Procedure	
Threshold value exceeded	Warning	Pre-procedure D	
	Block	Hardware-Procedure A	
Error block SIM		○	
Other case (secondary measure)			
		Procedure	
		Post-procedure d	
Other case (secondary measure)		① Block spare drive (case 12)	

[Case 13] (Case in which a block level error occurred in a normal drive with a redundancy level of 0)		Procedure	
Condition item		Pre-procedure E	
Threshold value exceeded	Warning	Error at redundancy level of 0 or higher	
	Block	Parity group block	
Error block SIM		○	
Other case (secondary measure)			
		Procedure	
		Pre-procedure E	
		Post-procedure c	
Other case (secondary measure)			

[Legends]

			R5 : RAID5
			R1 : RAID1
			(Note)

(Note) In RAID 1 method, Parity group consists of two drives.

[Case 14] (Preventive drive replacement 1) [Other cases]

Condition item		Condition	Procedure		
			Replacement	Pre-procedure C	Maintenance block
Threshold value exceeded	Warning	-	① Unusual noise, etc.	② Unusual noise, etc.	③
	Block	-			
Others (unusual noise, etc.)		○			
Spare drive		○			
Other case (secondary measure)			① Block source drive (case 2) ② Block destination drive a) Unused spare present (case 6) b) Unused spare absent (case 7)		
Condition item		Condition	Procedure		
			Hardware-Procedure A	Post-procedure a	Copy back
Threshold value exceeded	Warning	-	④	⑤	⑥
	Block	-			
Others (unusual noise, etc.)		○			
Spare drive		○			
Other case (secondary measure)			① Block new drive (case 8) ② Block source drive (case 9) ③ Block destination drive (case 8)		
Condition item		Condition	Procedure		
			Post-procedure a	Recovery	
Threshold value exceeded		-	⑦		
Others (unusual noise, etc.)		○			
Spare drive		○			
Other case (secondary measure)					

[Case 15] (Preventive drive replacement 2)

Condition item		Condition	Procedure		
			Pre-procedure D	Maintenance block	Hardware Procedure A
Threshold value exceeded	Warning	-	① Unusual noise, etc.	② Unusual noise, etc.	③
	Block	-			
Others (unusual noise, etc.)		○			
Spare drive		-			
Other case (secondary measure)					
Condition item		Condition	Procedure		
			INLINE	Post-procedure b	Recovery
Threshold value exceeded	Warning	-	④	⑤	⑥
	Block	-			
Others (unusual noise, etc.)		○			
Spare drive		-			
Other case (secondary measure)			① Block new drive (case 5) ② Block destination drive (case 5)		

[Legends]

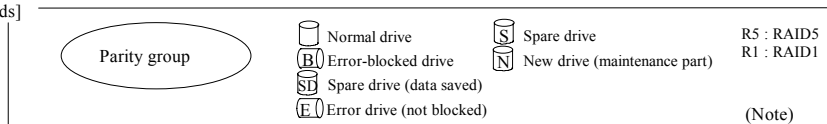

(Note) In RAID 1 method, Parity group consists of two drives.

1.3 Concept of Cache Maintenance

[Case 1]

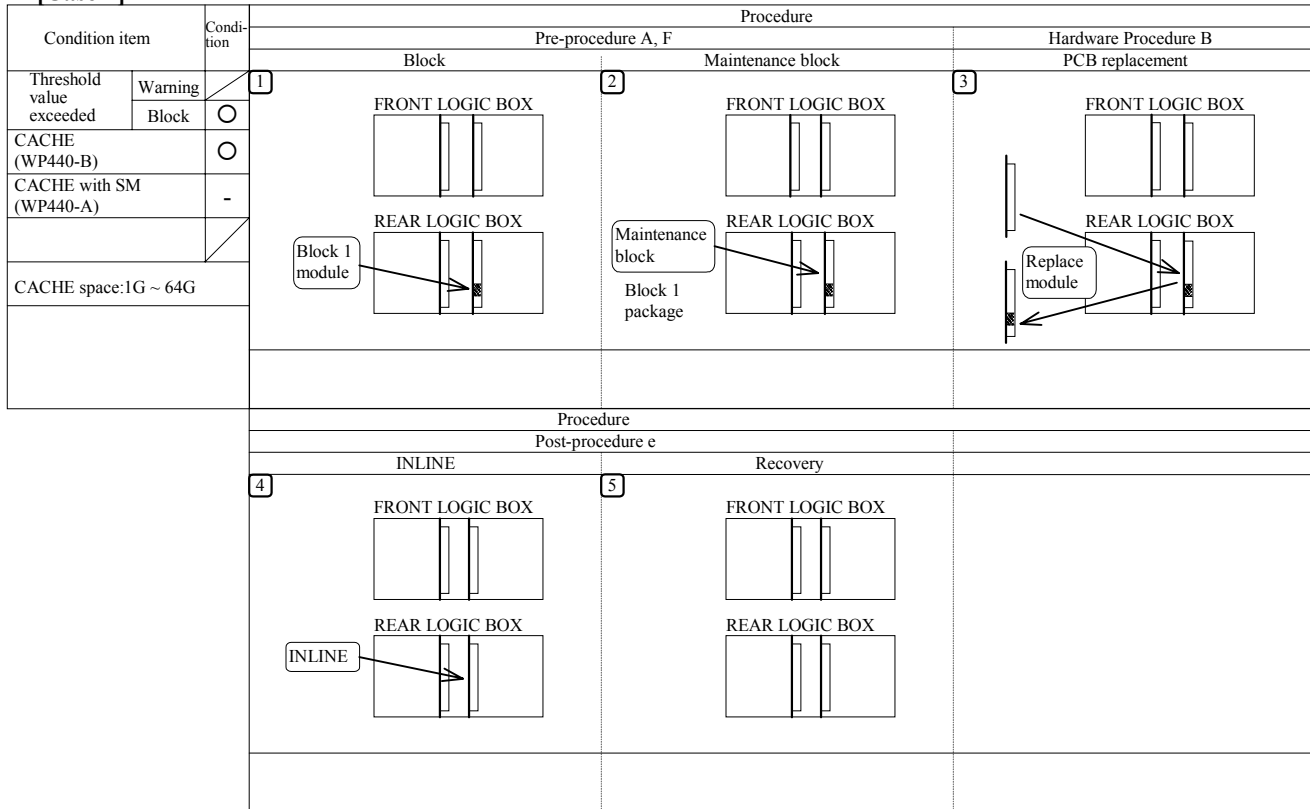

[Case 2]

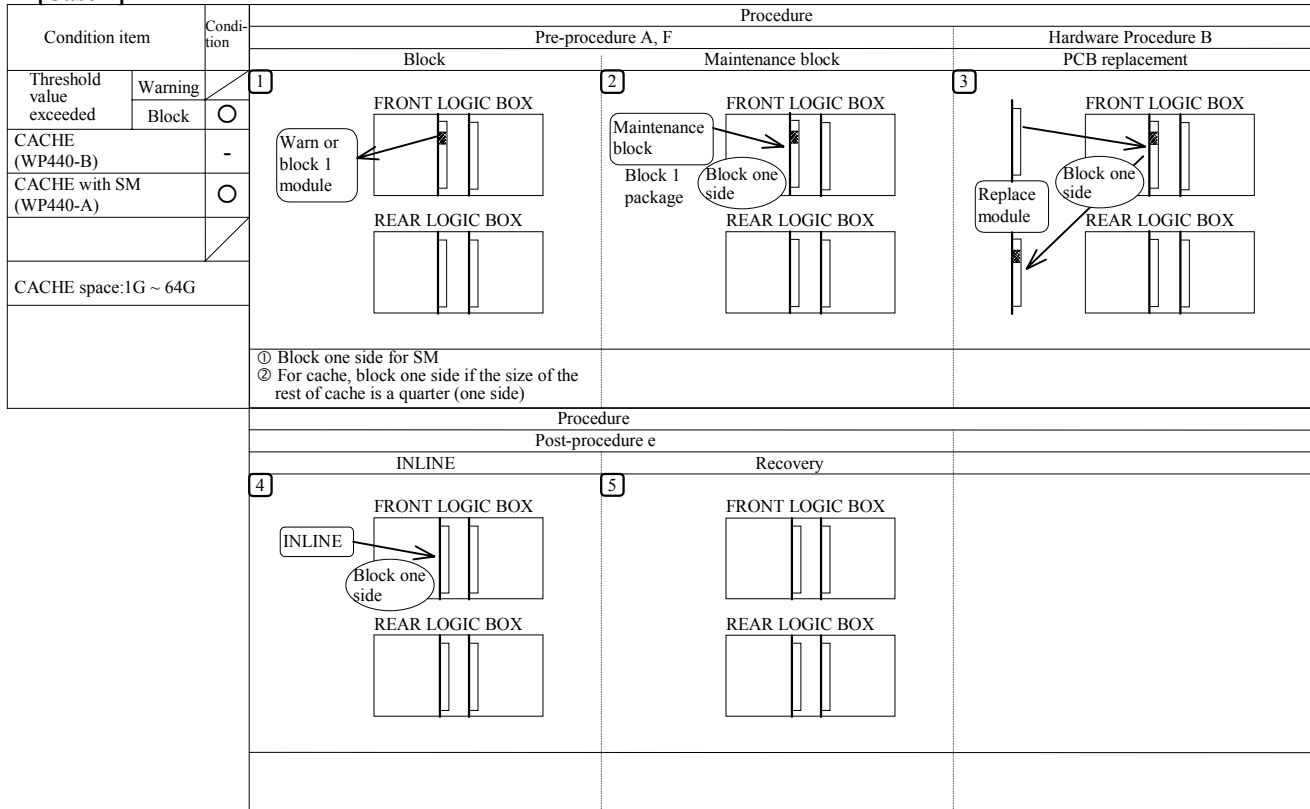

1.4 How to Interpret the Hot Replace Procedure

[In case of replacement when SIM was reported]

- ① Search a work ID which coincides with the work ID corresponding to SIM ACC(FPC) (refer to FPC list on page [ACC04-10](#)) from Parts Replacement Process Table on page [REP01-150](#).
Search a work ID corresponding to the pertinent condition if "Condition Item" is described in Parts Replacement Process Table.
- ② If the work ID is found,
 - Take actions according to the SVP pre-procedure, hardware procedure, SVP post-procedure number that match the work ID.
 If no work ID is found,
 - Search a work ID corresponding to SIM ACC(FPC, and error details) from Parts Replacement Process Table on page [REP01-150](#).
 - Take actions according to the SVP pre-procedure, hardware procedure, SVP post-procedure number that match the work ID.

Note : See page [REP01-130](#) for the procedure for searching a work ID to replace a drive.
When replacing a drive, be sure to see page [REP01-110](#) and [REP01-120](#).

[In case of replacement when SIM was not reported]

- ① Search a work ID corresponding to the part to be replaced from Parts Replacement Process Table on page [REP01-150](#).
- ② Take actions according to the SVP pre-procedure, hardware procedure, SVP post-procedure number that match the work ID.

Note : See page [REP01-130](#) for the procedure for searching the work ID to replace a drive.
When replacing a drive, be sure to see page [REP01-110](#) and [REP01-120](#).

-----<Example>-----

Condition to replace

SIM was reported

Work ID corresponding to SIM ACC FPC is RCA1

* Search an applicable Work ID identified by shaded area in the following sample of Parts Replacement Process Table under the above conditions.

<CACHE>

Work ID	Part name	Procedure			Replacing time
		SVP re-procedure	Hardware procedure	SVP post-procedure	
RCA1	CACHE with SM (WP440-A)	Pre A, pre F	Hardware B	Post e	15 minutes
RCA2					

PROCEDURE BEFORE PDEV EXCHANGE AND CORRECTION COPY

Instructions before blocking and exchanging PDEV with a drive failure error is listed below.

When exchanging unblocked PDEV, redundancy in the ECC group is lost. Therefore, during PDEV exchange, the other PDEV in the same ECC group is fenced by a drive failure error, all the LDEV in the ECC group is fenced. Accordingly, to prevent the above problem from occurring, the status of PDEV. When there is a PDEV in the same ECC group having more drive failure errors than the exchanging PDEV exists, replace the PDEV with highest drive failure errors.

Before PDEV exchange, following items are checked.

#	Items checked	Procedure
1	Error Count	“Threshold Counter Display” (See SVP02-460)
2	ORM Over Rate	“ORM Over Rate HDD# Display” (See SVP02-290)
3	Write Error	“Pinned Track Display” (See SVP02-940)

PROCEDURE BEFORE PDEV EXCHANGE and CORRECTION COPY.

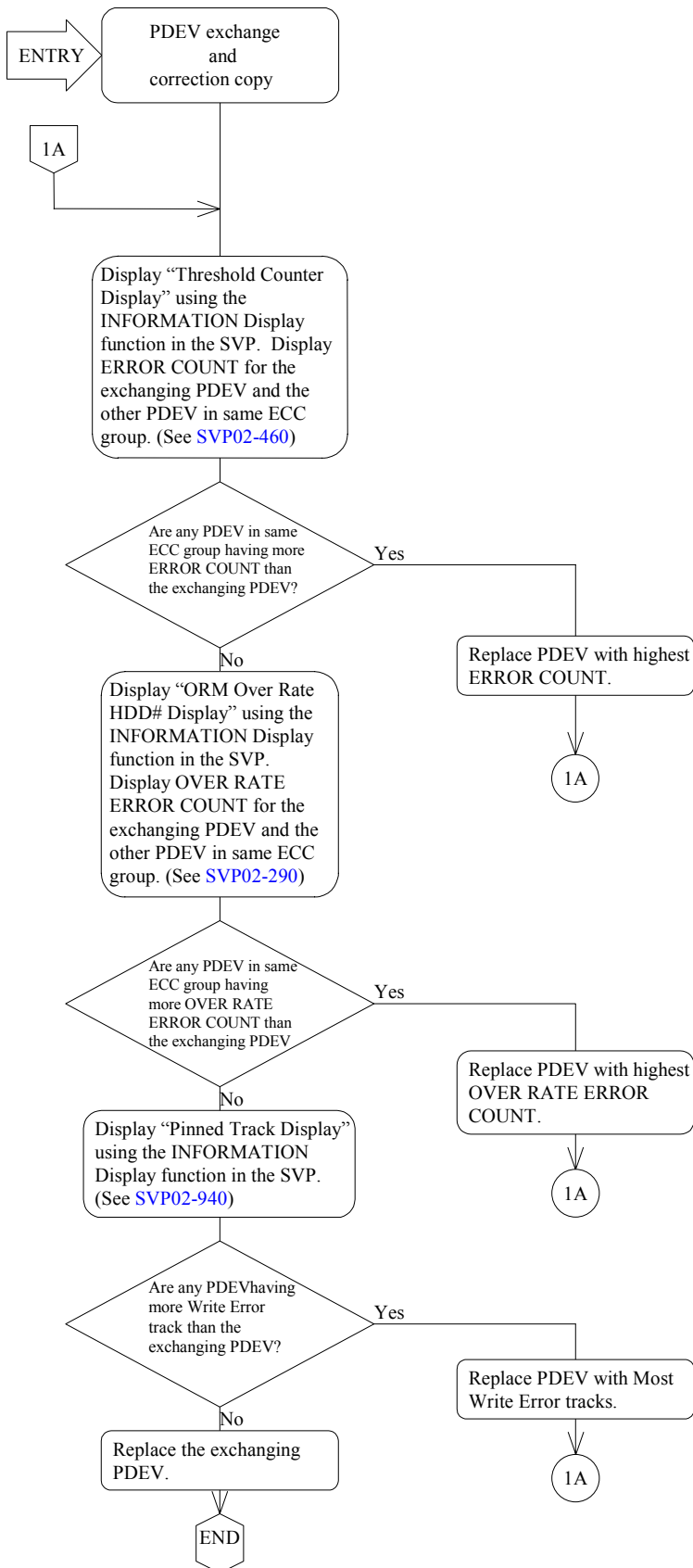

How to search a work ID to replace a drive

Note: When a work ID cannot be found by this procedure or when multiple errors in drives, see the page [TRBL05-170](#) on TROUBLR SHOOTING section.

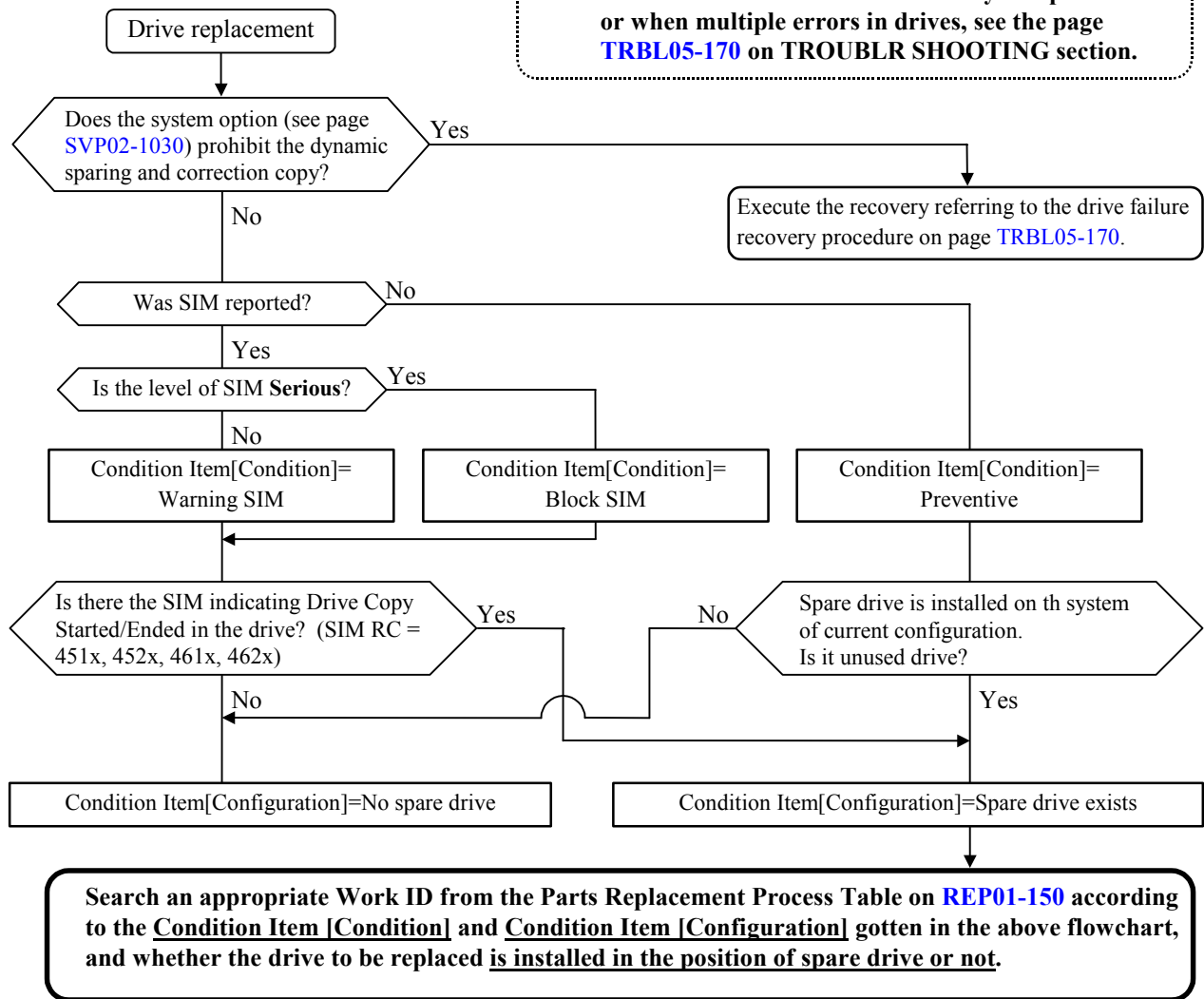

<<Example>>

- SIM was reported.
 - Level of the SIM is not "Serious". = Condition Item[Condition] is "Warning SIM".
 - There is the SIM that RC is 451x in the drive. = Condition Item[Configuration] is "Unused spare drive exists".
 - The drive to be replaced is not a spare drive. = "Data Drive"
- * Under the above conditions, the shaded area is searched from Parts Replacement Process Table.
Therefore, in this example Work ID should be RDK1.

<Data Drive, Spare Drive>

Work ID	Parts Name	Condition Item				Procedure			Reference information Image of replacement	
		Condition		Configu- ration	Unused spare drive	SVP pre-procedure	Hardware procedure	SVP post-procedure	Outline	Case
		Failure								
		Warning SIM	Block SIM							
RDK1	Data Drive	×	-	-	Yes	Pre A, Pre B *1	Hard A *1	Post a *1	Drive replacement~ Copy back	Case 1
RDK2	Data Drive	-	×	-	Yes					

1.5 Parts Replacement Process Table

Note : If any other message than the list is displayed, see the SVP Message Section ([SVPMSG00-00](#)).

<Data Drive, Spare Drive>

Work ID	Parts Name	Condition Item				Configuration	Procedure		Note 1	Reference information			
		Condition		Preventive	Unused Spare drive		SVP pre-procedure	Hardware procedure		SVP post-procedure	Replacing time Note 3	Outline	Case Note 2
		Failure											
		Warning SIM	Block SIM										
RDK1	Data Drive Note 4	×	-	-	Yes	Pre A, Pre B Note 1	Hardware A Note 1	Post a, Post z Note 1	20 min	Drive replace ~ Copy back	Case1		
RDK2	Data Drive Note 4	-	×	-	Yes	Pre A, Pre B Note 1	Hardware A Note 1	Post a, Post z Note 1	20 min	Drive replace ~ Copy back	Case 2		
RDK3	Data Drive Note 4,8	-	-	×	Yes	Pre A, Pre C, Pre B Note 1	Hardware A Note 1	Post a, Post z Note 1	—	Copy to Spare drive ~ Drive replace ~ Copy back	Case 14		
RDK4	Data Drive Note 4,7	×	-	-	No	Pre A, Pre D Note 1	Hardware A Note 1	Post b, Post z Note 1	20 min	Drive replace ~ Correction copy	Case 3		
RDK5	Data Drive Note 4,7	-	×	-	No	Pre A, Pre D Note 1	Hardware A Note 1	Post b, Post z Note 1	20 min	Drive replace ~ Correction copy	Case 4		
RDK6	Data Drive Note 4,7	-	-	×	No	Pre A, Pre D Note 1	Hardware A Note 1	Post b, Post z Note 1	20 min	Drive replace ~ Correction copy	Case 15		
RDK7 Note 5 Note 6	Data Drive Note 4	Note 5				Pre A, Pre E Note 1	Hardware A Note 1	Post c, Post z Note 1	—	LDEV formatting after replacing all the HDDs blocked in a parity group Note 6	Case 13		
RDK8	Spare Drive Note 4	-				Pre A, Pre D Note 1	Hardware A Note 1	Post d, Post z Note 1	20 min	Spare drive replace	Case 12		

- Note 1) Refer to [REP01-190](#) Note 2) Refer to [REP01-20](#)
 Note 3) This time does not include copy back time of data in HDD.
 Note 4) Parts Name is indicates attribute of a drive.
 Data Drive : The drive is installed in the position for a drive except spare drive (Data Drive).
 Spare Drive : The drive is installed in the position for a spare drive.
 Note 5) RDK7 is a Work ID for a work which is applicable to a case that two or more drives in a same parity group are blocked. When the procedures instructed by RDK7 are executed, data will be lost. Ask the technical support center about the appropriateness of the operation. When you want to restore LDEV status for the purpose of data backup, please go to [TRBL05-320](#).
 Note 6) Confirm the parity group and the LDEV No. corresponding to the HDD through the SVP STATUS. See page [SVP03-130](#) for the procedure for referring to SVP STATUS
 Note 7) See “PROCEDURE BEFORE PDEV EXCHANGE AND CORRECTION COPY” ([REP01-110](#)).
 Note 8) When making the drive copy, watch the pace of the copy and whether or not a failure SSB occurs in the copy source drive for ten minutes after the subsystem is started. If it is detected that “the copy has made no progress” or “an SSB (EC = Axxx) related to a drive has occurred” in the drive concerned, interrupt the drive copy detach the drive concerned for the purpose of maintenance, and make the correction copy.

Note : If a Work ID cannot be found or if multiple drive error is occurring, see page [TRBL05-170](#) on TROUBLE SHOOTING section.

<Cache>

Work ID	Part Name	Procedure *1			*2 Replacing Time
		SVP Pre-procedure	Hardware procedure	SVP post-procedure	
RCA1	CACHE (with SM) (WP490-A)	Pre A, Pre F	Hardware B	Post e, Post z	15 min

*1 Refer to [REP01-190](#)

*2 This time does not include destaging time

Note : Cache PCB Exchange for preventive cause cache close.
Therefore subsystem ability may fall.

<Channel Adapter, Disk Adapter, FSW, and CARB Switch>

Work ID	Parts Name	Procedure *1			Replacing Time
		SVP Pre-procedure	Hardware procedure	SVP Post-procedure	
RCH1	Serial CHA	Pre A, Pre H	Hardware C	Post f, Post z	20 min
RCH5	Fibre CHA *2	Pre A, Pre H	Hardware D	Post f, Post z	20 min
RCH6	MF Fibre CHA	Pre A, Pre H	Hardware E	Post f, Post z	20 min
RCH7	NAS CHA *3	Pre A, Pre H	Hardware H	Post f, Post z	30 min
RCH9	iSCSI CHA	Pre A, Pre H	Hardware I	Post f, Post z	20 min
RDA1	DKA	Pre A, Pre H	Hardware F	Post f, Post z	20 min
RFS1	FSW	Pre A, Pre L	Hardware T20	Post j, Post z	13 min
RCS1	CSW	Pre A, Pre M	Hardware G	Post k, Post z	13 min

*1: Refer to [REP01-190](#)

*2: For notes on replacement between the PCBs supporting and not supporting DB Validator, see Notes 1 to 3 on page [REP03-110](#).

If a failure occurs in replacing a channel adaptor or a disk adaptor, see “Error Recovery Procedure during CHA/DKA replacement” ([TRBL05-100](#)).

If a failure occurs in replacing a CARB Switch, see “Recovery procedure when CSW PCB replacement failed” ([TRBL05-560](#)).

*3: See [NAS04-10](#) “NAS Hardware Replacement”. Maintenance personal must consult system administrator.

<DKC, special P/K, Fan, Others>

Work ID	Parts Name	Procedure <small>Note 1)</small>			Replacing Time
		SVP pre-procedure	Hardware procedure	SVP post-procedure	
RT1	DKC Panel	Pre A, Pre T1	Hardware T1	Post t1, Post z	16 min
RT4	EPO SW	Pre A, Pre T1	Hardware T2	Post t1, Post z	12 min
RT5	DKCMN	Pre A, Pre T1	Hardware T3	Post t1, Post z	22 min
RT6	PCI CON <small>Note 2)</small>	Pre A, Pre T1	Hardware T4	Post t1, Post z	16 min
RT8	Fan assembly(DKC)	Pre A, Pre T3	Hardware T5	Post t3, Post z	8 min
RT9	Thermostat assembly	Pre A, Pre T3	Hardware T6	Post t3, Post z	8 min
RT10	<ul style="list-style-type: none"> • SVP • Flash Card 	Pre A, Pre T1 <small>Note 3)</small>	Hardware T7	Post t1	40 min
		Pre A, Pre T5 <small>Note 4)</small>	Hardware T7	Post t5, Post z	60 min
RT10	LAN&MODEM Card	(none)	Hardware T7	(none)	20 min
RT11	SSVP	Pre A, Pre T1	Hardware T8	Post t1, Post z	29 min
RT14	Battery Box <small>Note 5)</small>	Pre A, Pre T3	Hardware T11	Post t3, Post z	11 min
RT15	BAT CTR	Pre A, Pre T3	Hardware T12	Post t3, Post z	8 min
RT17	RS CON	Pre A, Pre T1	Hardware T19	Post t1, Post z	8 min
RT18	Flash Card	Pre A, Pre T1	Hardware T7	Post t1, Post z	15 min
RT35	AC BOX-0, AC BOX-1 (Single Phase/50A Model)	Pre A, Pre T4	Hardware T21	Post t4, Post z	28 min
RT36	AC BOX-0, AC BOX-1 (3 Phase/30A Model)	Pre A, Pre T4	Hardware T21	Post t4, Post z	28 min
RT16	SVPPS	Pre A, Pre T3	Hardware T23	Post t3, Post z	8 min
RT38	HUB Box	Pre A, Pre T1	Hardware T25	Post t1, Post z	20 min
RT40	SVPPS Box <small>Note 4)</small>	Pre A, Pre T1	Hardware T26	Post t1, Post z	8 min
RT6	UPS CON	Pre A, Pre T1	Hardware T27	Post t1, Post z	16 min
RT42	AC BOX-0, AC BOX-1 (Single Phase/30A Model)	Pre A, Pre T1	Hardware T21	Post t4	28 min

Note 1) Refer to [REP01-190](#)

Note 2) All connected devices to DKC465I are powered off by EPO signal of PCI when the PCI CON PCB is removed.

Prevent the trouble for connected devices from EPO signal.

Note 3) When SVP is not able to operate, start from Hardware procedure. (When SVP High Reliability Kit is not installed.)

Note 4) Valid when SVP High Reliability Kit is installed.

Note 5) In case of the preventive maintenance, set the Battery Warning SIM.

<DKC Power Supply>

Work ID	Parts Name	Procedure Note 1)			Replacing Time
		SVP pre-procedure	Hardware procedure	SVP post-procedure	
RT20	SW PS(LOGIC, 5/3V)	Pre A, Pre T3	Hardware T13	Post t3, Post z	
RT23	SW PS(LOGIC, Sub PS)	Pre A, Pre T3	Hardware T13	Post t3, Post z	
RT26	SW PS(LOGIC, 3.3V)	Pre A, Pre T3	Hardware T13	Post t3, Post z	
RT26	SW PS(LOGIC, 3/12V)	Pre A, Pre T3	Hardware T13	Post t3, Post z	

Note 1) Refer to [REP01-190](#).

<DKU, Special P/K, Power Supply, Fan>

Work ID	Parts Name	Procedure Note 1)			Replacing Time
		SVP pre-procedure	Hardware procedure	SVP post-procedure	
RT37	JMP	Pre A, Pre T4	Hardware T24	Post t4, Post z	10 min
RT30	SW PS(DKU Multi)	Pre A, Pre T4 Note 2)	Hardware T15	Post t4, Post z	10 min
RT31	Fan assembly(DKU)	Pre A, Pre T4 Note 2)	Hardware T16	Post t4, Post z	5 min

Note 1) Refer to [REP01-190](#).

Note 2) When SVP is not able to operate, start from Hardware procedure.

1.6 Procedure contents table

SVP Pre	GO TO	Hardware		GO TO	SVP Post	GO TO
		Procedure	Parts Name			
Pre A	REP02-10	Hardware A	HDD Canister	REP03-10	Post a	REP04-10
Pre B	REP02-30	Hardware B	Cache Memory PCB	REP03-50	Post b	REP04-50
Pre C	REP02-90	Hardware C	Serial CHA	REP03-80	Post c	REP04-90
Pre D	REP02-130	Hardware D	Fibre CHA	REP03-110	Post d	REP04-150
Pre E	REP02-180	Hardware E	Mainframe Fibre CHA	REP03-140	Post e	REP04-180
Pre F	REP02-240	Hardware F	DKA	REP03-170	Post f	REP04-210
Pre H	REP02-300	Hardware G	CSW	REP03-200	Post i	REP04-240
Pre K	REP02-370	Hardware H	NAS CHA	REP03-1000	Post j	REP04-270
Pre L	REP02-410	Hardware I	iSCSI CHA	REP03-1040	Post k	REP04-300
Pre M	REP02-460	Hardware T1	DKC Panel	REP03-230	Post t1	REP04-320
Pre T1	REP02-510	Hardware T2	EPO Switch	REP03-280	Post t3	REP04-900
Pre T3	REP02-660	Hardware T3	DKCMN	REP03-330	Post t4	REP04-1000
Pre T4	REP02-750	Hardware T4	PCI CON	REP03-360	Post t5	REP04-1100
Pre T5	REP02-820	Hardware T5	Fan Assembly(DKC)	REP03-410	Post u	REP04-1360
Pre V	REP02-880	Hardware T6	Thermostat Assembly	REP03-430	Post z	REP04-1400
		Hardware T7	<ul style="list-style-type: none"> • SVP • Flash Card • Additional SVP Memory • LAN&MODEM Card 	REP03-450		
		Hardware T8	SSVP	REP03-550		
		Hardware T11	Battery Box	REP03-570		
		Hardware T12	BAT CTR	REP03-600		
		Hardware T13	Power Supply(DKC)	REP03-620		
		Hardware T15	Power Supply(DKU)	REP03-660		
		Hardware T16	HDD Fan Assembly	REP03-690		
		Hardware T19	RS CON	REP03-710		
		Hardware T20	FSW	REP03-730		
		Hardware T21	AC BOX (Single Phase/50A) AC BOX (3 Phase/30A) AC BOX (Single Phase/30A)	REP03-750		
		Hardware T23	SVPPS	REP03-880		
		Hardware T24	JMP	REP03-910		
		Hardware T25	HUB Box	REP03-930		
		Hardware T26	SVPPS Box	REP03-950		
		Hardware T27	UPS CON	REP03-970		

1.7 MAINTENANCE outline

(1) How to interpret the status display

- ① The status information is displayed on the SVP screen is not on a realtime basis. It reflects the state that was established.

1.8 Availability of the online maintenance when HRC/HORC is used

Component	Maintenance Type	Condition	HRC path established		During initial copy		After completing initial copy		Suspend	
			MCU	RCU	MCU	RCU	MCU	RCU	MCU	RCU
Logical Device	Blockade	—	×	×	SVP2031W	SVP2034W	SVP2031W	SVP2034W	SVP2031W	SVP2034W
	Recovery	—	×	×	SVP2031W	SVP2034W	SVP2031W	SVP2034W	SVP2031W	SVP2034W
	Format	—	×	×	SVP2031W	SVP2034W	SVP2031W	SVP2034W	SVP2031W	SVP2034W
	Verify	—	×	×	×	×	×	×	×	×
HDD canister	Replace	—	×	×	×	×	×	×	×	×
Cache PCB	Replace	—	×	×	SVP2059W	SVP2079W	×	×	×	×
CHE or CHF	Replace	With Alternate path.	×	×	×	SVP2038W	×	SVP2038W	×	SVP2038W
		Without Alternate path.	×	×	SVP2073W	SVP2038W	SVP2074W	SVP2038W	×	SVP2038W
DKA	Replace	—	×	×	×	×	×	×	×	×
CSW PCB	Replace	—	×	×	×	×	×	×	×	×
DKC	Replace	With Alternate path.	×	×	SVP2059W	SVP2079W	×	SVP2038W	×	SVP2038W
		Without Alternate path.	×	×	SVP2059W	SVP2079W	SVP2074W	SVP2038W	×	SVP2038W

Component	Maintenance Type	Condition	Suspending		Deleting	
			MCU	RCU	MCU	RCU
Logical Device	Blockade	—	SVP2031W	SVP2034W	SVP2031W	SVP2034W
	Recovery	—	SVP2031W	SVP2034W	SVP2031W	SVP2034W
	Format	—	SVP2031W	SVP2034W	SVP2031W	SVP2034W
	Verify	—	×	×	×	×
HDD canister	Replace	—	×	×	×	×
CACHE	Replace	—	×	×	×	×
CHE or CHF	Replace	With Alternate path.	×	SVP2038W	×	SVP2038W
		Without Alternate path.	SVP2075W	SVP2038W	SVP2075W	SVP2038W
DKA	Replace	—	×	×	×	×
CSW PCB	Replace	—	×	×	×	×
DKC	Replace	With Alternate path.	×	SVP2038W	×	SVP2038W
		Without Alternate path.	SVP2075W	SVP2038W	SVP2075W	SVP2038W

× : Maintenance is available.

SVPXXXXW : Maintenance is not available based on the specification. Refer to SVP-MSG SECTION.

Note.1 About replacement of CHE in the RCU side

If the CHE that will be replaced is connected to a path, from MCU please confirm that the Path is deleted from MCU.

After replacement, please add the Path.

The pair can be suspended if the ESTPAIR or paircreate (pairresync) command is issued during the HDD Canister or the Cache PCB replacement. Please ask your customer before the online maintenance operation.

Refer to “8.3.5 Procedures for online microprogram exchange and CHS/CHF replacement using alternate path” ([MICRO-FC10-10](#)).

* : For HRC ASYNC Pairs, a maintenance with the cache blockage is recommended to operate with capacities of Sidefile and Write Pending Data being 20% below. If the above maintenance is Performed with high capacities of Sidefile and Write Pending Data, the operation will take long and way cause impact such as MIH occurrence on the host operation.

Besides, in the case of cache de-install operation, you must suspend ASYNC HRC pairs by RMC (SVP) before operation regardless of the capacities of Sidefile and Write Pending Data. If you don't suspend the ASYNC pairs as above, available cache capacity will decrease to suspend the pairs.

Refer to “Monitoring” in the SVP SECTION for the Sidefile monitor.

1.9 Availability of the online maintenance when HODM is used

Component	Maintenance Type	Condition	HODM path		During initial copy		Waiting to erased		Suspend	
			MCU	RCU	MCU	RCU	MCU	RCU	MCU	RCU
Logical Device	Blocade	—	×		SVP2031W		SVP2031W		SVP2031W	
	Recovery	—	×		SVP2031W		SVP2031W		SVP2031W	
	Format	—	×		SVP2031W		SVP2031W		SVP2031W	
	Verify	—	×		×		×		×	
HDD canister	Replace	—	×		SVP2059W		×		×	
Cache PCB	Replace	—	×		SVP0259W		×		×	
CHE	Replace	With Alternate path.	×		×		×		×	
		Without Alternate path.	×		SVP2076W		SVP2078W		SVP2077W	
CHT	Replace	—	×		×		×		×	
DKA	Replace	—	×		×		×		×	
CSW PCB	Replace	—	×		×		×		×	

Component	Maintenance Type	Condition	During R-Vol Erasing		Erasing Error	
			MCU	RCU	MCU	RCU
Logical Device	Blocade	—	SVP2031W		SVP2031W	
	Recovery	—	SVP2031W		SVP2031W	
	Format	—	SVP2031W		SVP2031W	
	Verify	—	×		×	
HDD canister	Replace	—	×		×	
Cache PCB	Replace	—	×		×	
CHE	Replace	With Alternate path.	×		×	
		Without Alternate path.	SVP2078W		SVP2078W	
CHT	Replace	—	×		×	
DKA	Replace	—	×		×	
CSW PCB	Replace	—	×		×	

× : Maintenance is available.

SVPXXXXW : Maintenance is not available based on the specification. Refer to SVP-MSG SECTION.

Note.1 About replacement of CHE in the RCU side

If the CHE to be replaced is connected to a path, please confirm that the Path is deleted from MCU.

After the replacement, please reconnect the path.

Refer to “8.3.5 Procedures for online microprogram exchange and CHS/CHF replacement using alternate path” ([MICRO-FC10-10](#)).

1.10 Availability of the online maintenance when HMRCF/HOMRCF is used

Component	Maintenance Type	Condition	Reserve-Volume	Pending/Resync/SP-PEND		Duplex		Split		Suspend	
				S-VOL/ P-VOL	T-VOL/ S-VOL	S-VOL/ P-VOL	T-VOL/ S-VOL	S-VOL/ P-VOL	T-VOL/ S-VOL	S-VOL/ P-VOL	T-VOL/ S-VOL
Logical Device	Blockade	—	SVP2484W	SVP2483W	SVP2485W	SVP2483W	SVP2485W	SVP2483W	SVP2485W	×	
	Restore	—	SVP2484W	SVP2483W	SVP2485W	SVP2483W	SVP2485W	SVP2483W	SVP2485W	×	
	Format	—	SVP2484W	SVP2483W	SVP2485W	SVP2483W	SVP2485W	SVP2483W	SVP2485W	×	
	Verify	—	×	×		×		×		×	
HDD canister	Replace	—	×	×		×		×		×	
	Dynamic Sparing	—	×	SVP2486W		×		×		×	
	Correction Copy	—	×	SVP2486W		×		×		×	
Cache PCB	Replace	—	×	×		×		×		×	
CHA	Replace	—	×	×		×		×		×	
DKA	Replace	—	×	×		×		×		×	
LTM PCB	Replace	—	×	×		×		×		×	

1.11 Availability of the online maintenance when HXRC is used

Component	Maintenance Type	During initial copy		Established		Suspend	
		Primary	Secondary	Primary	Secondary	Primary	Secondary
Logical Device	Blockade	**	**	**	**	**	**
	Recovery	**	**	**	**	**	**
	Format	**	**	**	**	**	**
	Verify	x	x	x	x	x	x
HDD canister	Replace	x	x	x	x	x	x
Cache PCB	Replace	*	x	*	x	*	x
CHA	Replace	x	x	x	x	x	x
DKA	Replace	x	x	x	x	x	x
LTM PCB	Replace	x	x	x	x	x	x

x: Maintenance is available

*: When a maintenance operation is needed while HXRC is being used, I/O's for HXRC pair volumes or HXRC itself should be stopped before the maintenance operation.

If the maintenance operation must be done while HXRC is being used, you must confirm that the usage of Sidefile monitor is less than 20% of total Cache capacity before you start the maintenance operation. Only when the usage of Sidefile monitor is less than 20% of total Cache capacity, you can proceed the maintenance operation.

Refer to "Monitoring" in the SVP SECTION about Sidefile monitor.

Select the [Information] icon in the 'SVP' window.

Next select the [Monitor] menu in the 'Information' window and select [start....].

Next select the 'Sidefile' box in the 'Item' menu in the 'Monitoring' window and select [OK].

** : When a maintenance operation is needed while HXRC is being used, HXRC should be stopped before the maintenance operation.

[PRE-PROCEDURE A]

— OUTLINE —

- ① Display Initial Screen.
- ② Change SVP operation mode.
- ③ Open Maintenance window.

1. <Initial screen>

- ## 2. <Operation mode change>
- Change the mode to [Modify Mode].
Select (CL) [Maintenance].

- ## 3. <Maintenance window>
- The 'Maintenance' window is displayed.

(Multi Cabinet Model)

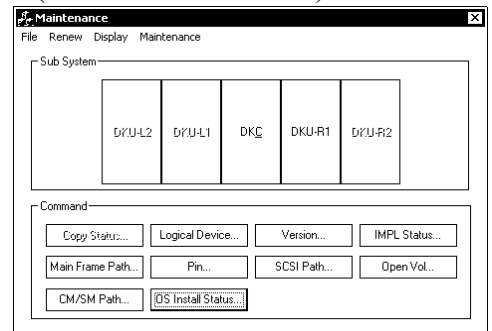

(Single Cabinet Model)

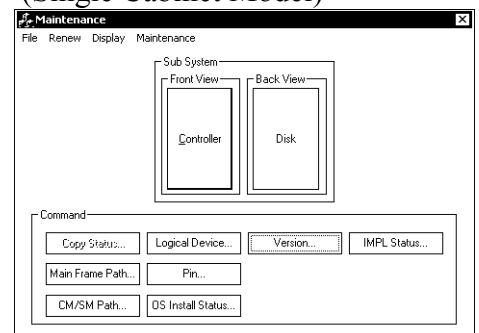

[PRE-PROCEDURE B]

— OUTLINE —

- ① Select drive (status check).
- ② Check progress of copy processing
- ③ Specify Replacement.
- ④ Place HDD into unpluggable state.

1. <Maintenance window>

(Multi Cabinet Model)

In the 'Maintenance' window, check and select (CL) [DKU-Rn] or [DKU-Ln] to be replaced.

(Single Cabinet Model)

In the 'Maintenance' window, check and select (CL) [Disk] to be replaced.

(Multi Cabinet Model)

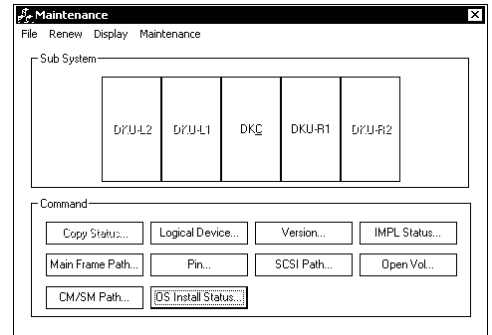

(Single Cabinet Model)

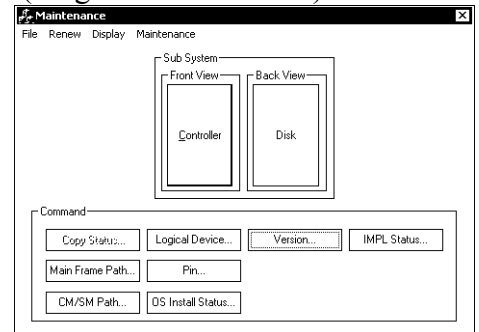

2. <Select HDU-BOX>

(Multi Cabinet Model)

Check and select (CL) [HDU-Rnn] or [HDU-Lnn] to be replaced.

(Single Cabinet Model)

Check and select (CL) [HDU-n] to be replaced.

Selecting (CL) [Close] returns you to step 1.

(Multi Cabinet Model)

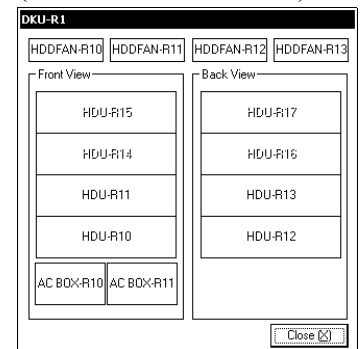

(Single Cabinet Model)

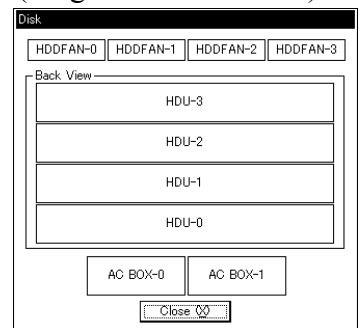

3. <Select HDD>

(Multi Cabinet Model [DKU455])
 Check and select (CL) [nn] to be replaced.

(Multi Cabinet Model [DKU405])
 Check and select (CL) [Rnnn] or [Lnnn] to be replaced.

(Single Cabinet Model)
 Check and select (CL) [nn] to be replaced.

Selecting (CL) [Close] returns you to step 2.

(Multi Cabinet Model [DKU455])

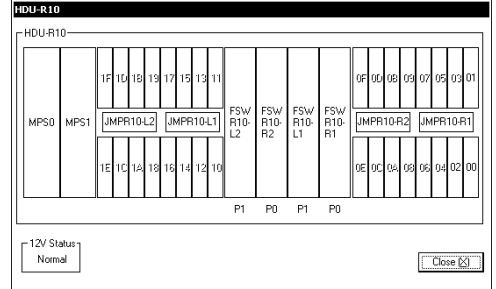

(Multi Cabinet Model [DKU405])

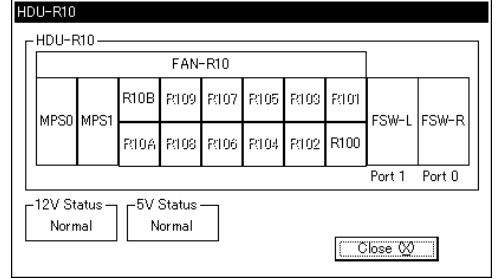

(Single Cabinet Model)

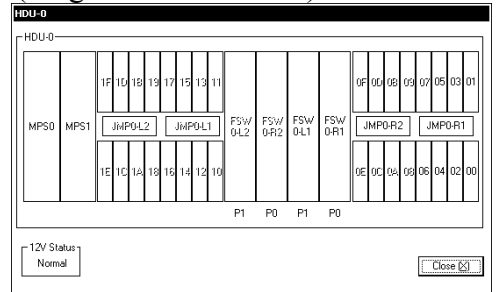

4. <Specify replacement on HDD>

Make sure that the status is FAILED or WARNING.

Select (CL) [Replace].

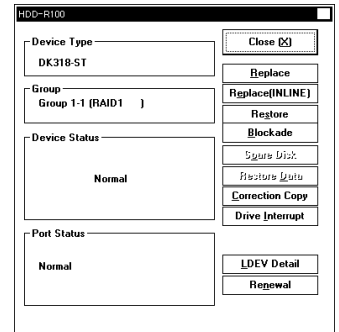

5. <Check progress of copy processing>

(Multi Cabinet Model)

Check the status (other than preventive) of [HDD-nn] to be replaced from [HDU-Rnn] or [HDU-Lnn].

(Single Cabinet Model)

Check the status of the [HDD-nn] to be replaced in the [HDU-n] window (in the case of other than preventive maintenance).

[Warning threshold value]

* [RECOVERING] :Copy processing is in progress.

[FAILED] (S/D set to S) : End of copy processing.

[Block threshold value]

* [FAILED] (S/D set to D) : Copy processing is in progress.

[FAILED] (S/D set to S) : End of copy processing.

6. <Check progress of copy processing>

See SVP section. ([SVP03-160](#))

After copy processing is complete, perform the replacement procedure.

If any other message than the list is displayed, see the SVP Message Section ([SVPMMSG00-00](#)).

7. <Checking the P-DEV status>
 “Checking...” is displayed.

8. <P-DEV blocking>

⚠ CAUTION

When the screen appears prompting the operator to input a password to prevent multiple maintenance or for executing a pin check, contact the technical support center to ask for instructions.

Select (CL) [Yes] in response to “Are you sure you want to replace the physical device?”.

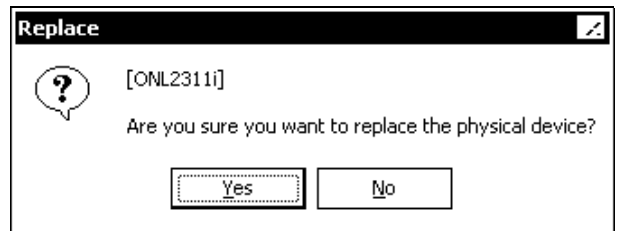

9. <Blocking the Physical device>
 “Blocking...” is displayed.

10. <Spin down the Physical device>
 “Spinning down...” is displayed.

11. <Check shut down LED>

CAUTION

If a wrong HDD is removed, a data loss or a system down may occur.

Check the shut down LED on the HDD to be replaced.

If LED is off, reconfirm the location of the HDD to be replaced with LOCATION SECTION before replacing the hardware.

12. <Confirm Replacement.>

Select (CL) [OK] in response to “Please replace the physical device, and then select OK.” after the unit is replaced.

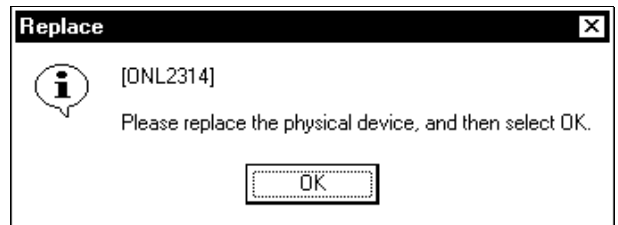

13. <Replace HDU>

Replace HDU.

See HARDWARE A ([REP03-10](#)).

[PRE-PROCEDURE C]

— OUTLINE —

- ① Select drive (status check).
- ② Specify Replacement.
- ③ Save Spare.

1. <Maintenance window>

(Multi Cabinet Model)

In the 'Maintenance' window, check and select (CL) [DKU-Rn] or [DKU-Ln] to be replaced.

(Single Cabinet Model)

In the 'Maintenance' window, select (CL) [Disk].

(Multi Cabinet Model)

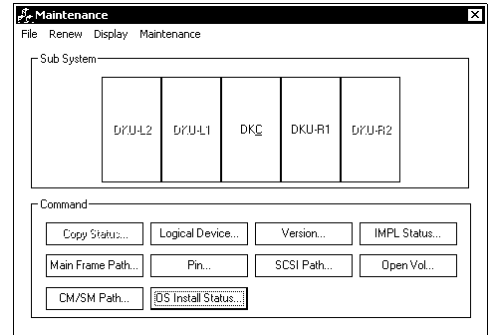

(Single Cabinet Model)

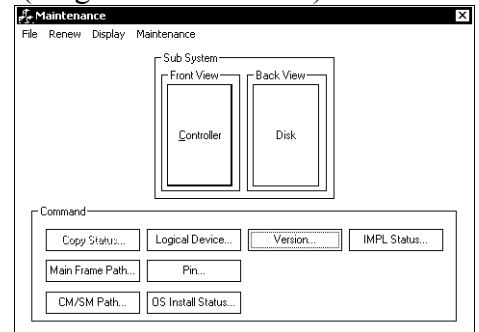

2. <Select HDU-BOX>

(Multi Cabinet Model)

Check and select (CL) [HDU-Rnn] or [HDU-Lnn] to be replaced.

(Single Cabinet Model)

Check and select (CL) [HDU-n] to be replaced.

Selecting (CL) [Close] returns you to step 1.

(Multi Cabinet Model)

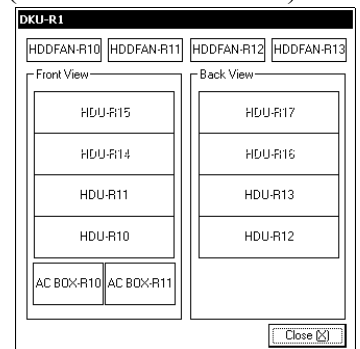

(Single Cabinet Model)

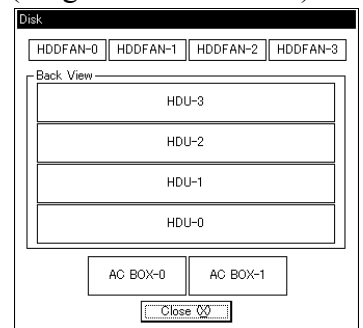

3. <Select HDD>

(Multi Cabinet Model [DKU455])

Check and select (CL) [nn] to be replaced.

(Multi Cabinet Model [DKU405])

Check and select (CL) [Rnnn] or [Lnnn] to be replaced.

(Single Cabinet Model)

Check and select (CL) [nn] to be replaced.

Selecting (CL) [Close] returns you to step 2.

(Multi Cabinet Model [DKU455])

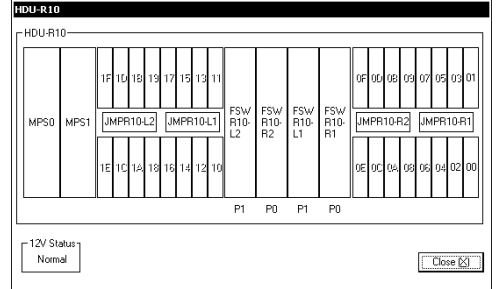

(Multi Cabinet Model [DKU405])

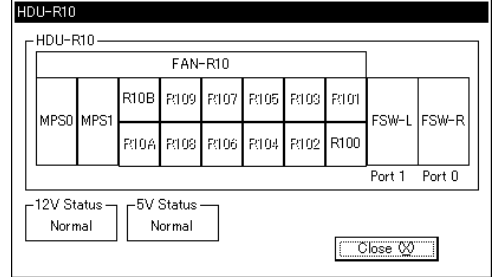

(Single Cabinet Model)

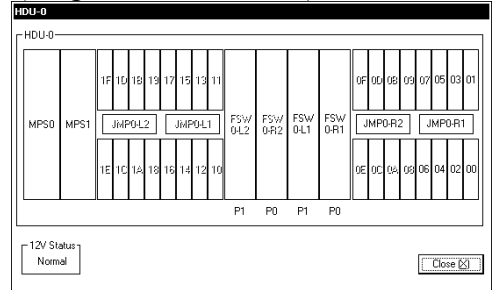

4. <Specify replacement on HDD>

Make sure that the status is FAILED or WARNING.

Select (CL) [Spare Disk].

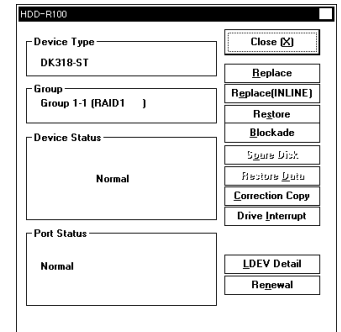

If any other message than the list is displayed, see the SVP Message Section ([SVPMSG00-00](#)).

5. <Checking the P-DEV status>

 **CAUTION**

When the screen appears prompting the operator to input a password to prevent multiple maintenance, or for executing a pin check, contact the technical support center to ask for instructions.

“Checking...” is displayed.

6. <Saving the spare>

Select (CL) [Yes] in response to “Are you sure you want to copy data in the physical device to spare?”.

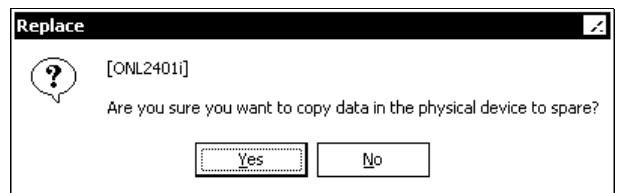

7. <Saving in process>

“Copying...” is displayed.

8. <End of spare saving>
Select (CL) [OK] in response to “Copying data in the physical device to spare has been started.”.

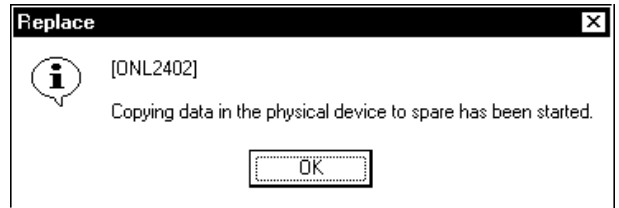

9. To interrupt the copy, select (CL) the [Drive Interrupt] button.

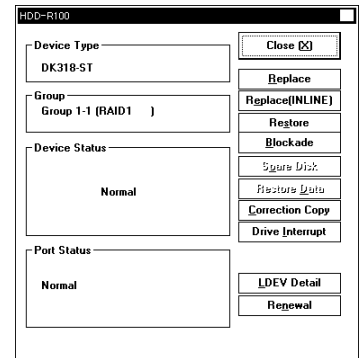

10. Please execute Pre procedure B after finishing copy. ([REP02-30](#))

[PRE-PROCEDURE D]

— OUTLINE —

- ① Select P-DEV (status check).
- ② Specify Replacement.
- ③ Place HDD into unpluggable state.

1. <Maintenance window>

(Multi Cabinet Model)

In the 'Maintenance' window, check and select (CL) [DKU-Rn] or [DKU-Ln] to be replaced.

(Single Cabinet Model)

In the 'Maintenance' window, select (CL) [Disk].

(Multi Cabinet Model)

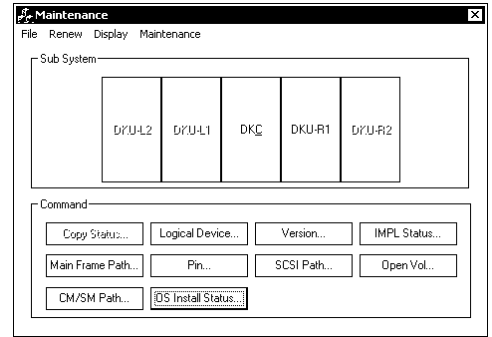

(Single Cabinet Model)

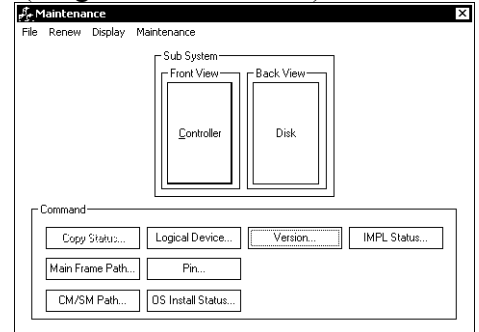

2. <Select HDU-BOX>

(Multi Cabinet Model)

Check and select (CL) [HDU-Rnn] or [HDU-Lnn] to be replaced.

(Single Cabinet Model)

Check and select (CL) [HDU-n] to be replaced.

Selecting [Close] (CL) returns you to step 1.

(Multi Cabinet Model)

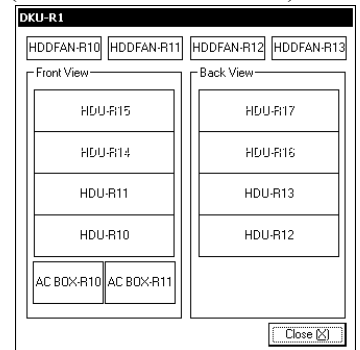

(Single Cabinet Model)

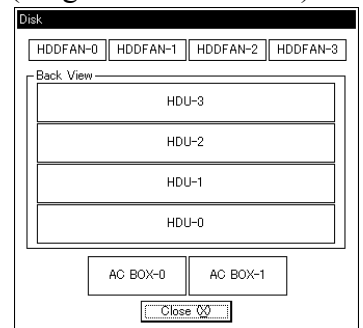

3. <Select HDD>

(Multi Cabinet Model [DKU455])
 Check and select (CL) [nn] to be replaced.

(Multi Cabinet Model [DKU405])
 Check and select (CL) [Rnnn] or [Lnnn] to be replaced.

(Single Cabinet Model)
 Check and select (CL) [nn] to be replaced.

Selecting (CL) [Close] returns you to step 2.

(Multi Cabinet Model [DKU455])

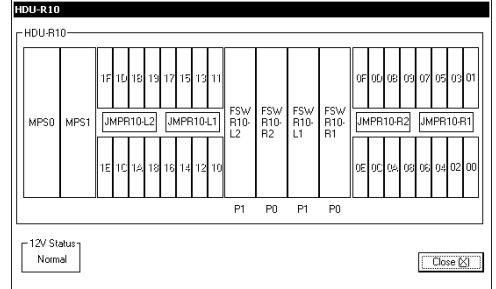

(Multi Cabinet Model [DKU405])

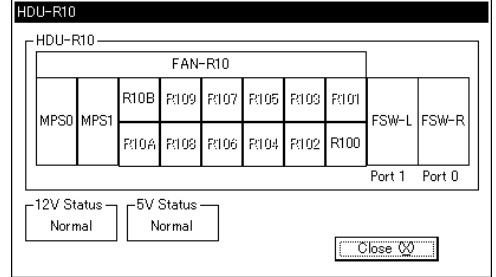

(Single Cabinet Model)

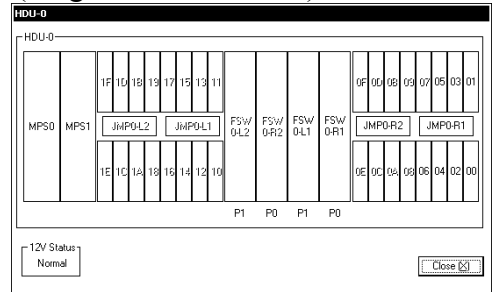

4. <Specify replacement on HDD>

Make sure that the status is FAILED or WARNING.

Select (CL) [Replace].

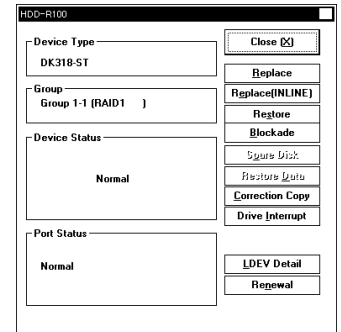

If any other message than the list is displayed, see the SVP Message Section ([SVPMSG00-00](#)).

5. <Checking the P-DEV status & saving the spare>

 **CAUTION**

When the screen appears prompting the operator to input a password to prevent multiple maintenance or for executing a pin check, contact the technical support center to ask for instructions.

“Checking...” is displayed.

6. <P-DEV blocking>

Select (CL) [Yes] in response to “Are you sure you want to replace the physical device?”.

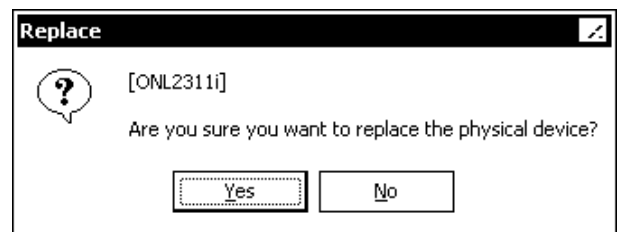

7. <Blocking the Physical device>

“Blocking...” is displayed.

8. <Spin down the Physical device>

“Spinning down...” is displayed

9. <Check shut down LED>

⚠ CAUTION

If a wrong HDD is removed, a data loss or a system down may occur.

Check the shut down LED on the HDD to be replaced.

If LED is off, reconfirm the location of the HDD to be replaced with LOCATION SECTION before replacing the hardware.

10. <Confirmation of replace>

Select (CL) [OK] in response to “Please replace the physical device, and then select OK.” after the unit is replaced (Step 11).

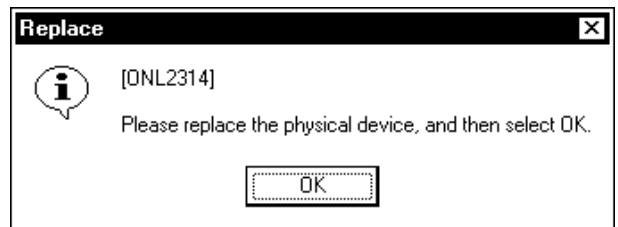

11. <Replace HDD>

Replace HDD.

See HARDWARE A ([REP03-10](#)).

[PRE-PROCEDURE E]

— OUTLINE —

- ① Select HDD (status check).
- ② Specify Replacement.
- ③ Block parity group (enter password).
- ④ Place HDD into unpluggable state.
- ⑤ Replace HDD.
- ⑥ Perform steps ② to ⑤ on blocked drives in parity group.



CAUTION

This is a special (exceptional) operation that can cause a serious failure such as a system down or a data loss and requires an input of a password. Ask the technical support center about the appropriateness of the operation, and input the password after getting an approval of executing the operation.

1. <Maintenance window>

(Multi Cabinet Model)

In the 'Maintenance' window, check and select (CL) [DKU-Rn] or [DKU-Ln] to be replaced.

(Single Cabinet Model)

In the 'Maintenance' window, check and select (CL) [Disk] to be replaced.

(Multi Cabinet Model)

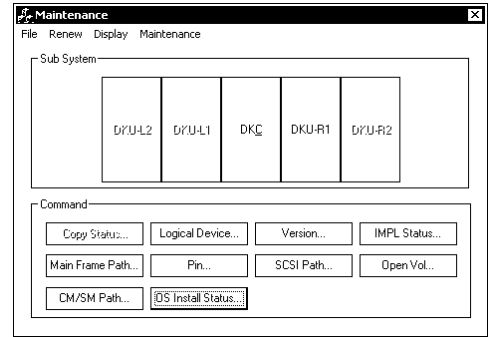

(Single Cabinet Model)

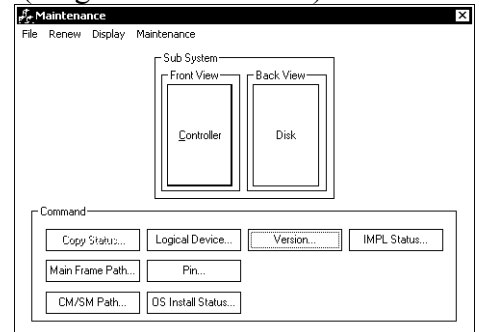

2. <Select HDU-BOX>

(Multi Cabinet Model)

Check and select (CL) [HDU-Rnn] or [HDU-Lnn] to be replaced.

(Single Cabinet Model)

Check and select (CL) [HDU-n] to be replaced.

Selecting [Close] (CL) returns you to step 1.

(Multi Cabinet Model)

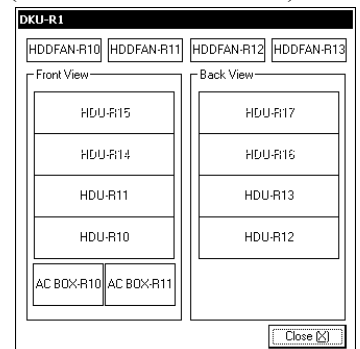

(Single Cabinet Model)

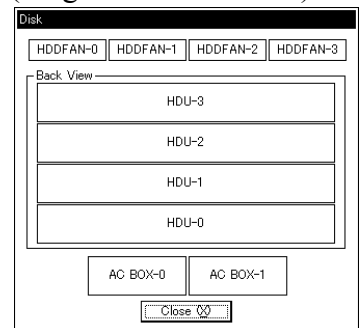

3. <Select HDD>

(Multi Cabinet Model [DKU455])

Check and select (CL) [nn] to be replaced.

(Multi Cabinet Model [DKU405])

Check and select (CL) [Rnnn] or [Lnnn] to be replaced.

(Single Cabinet Model)

Check and select (CL) [nn] to be replaced.

Selecting [Close] (CL) returns you to step 2.

(Multi Cabinet Model [DKU455])

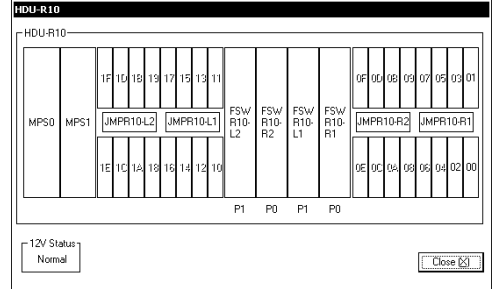

(Multi Cabinet Model [DKU405])

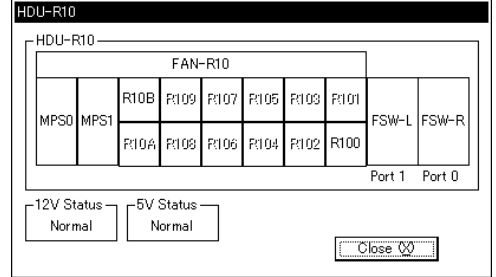

(Single Cabinet Model)

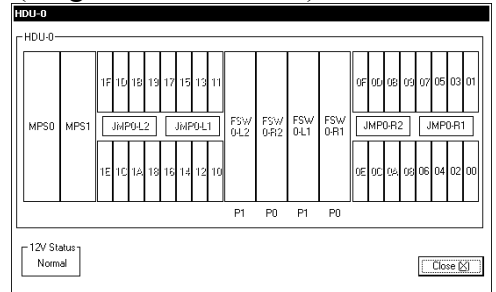

4. <Specify replacement on HDD>

Make sure that the status is FAILED.

Select (CL) [Replace].

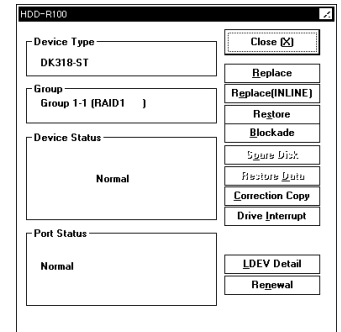

5. <Confirm lost data>

CAUTION

Executing this operation may cause a serious error such as a system down or a data loss. Accordingly, confirmation of the appropriateness of the operation and input of a password on the succeeding password input screen is required.

Select (CL) [No] in response to “Redundancy is lost and blocking this part stops subsystem functionality. Do you want to stop this process?”

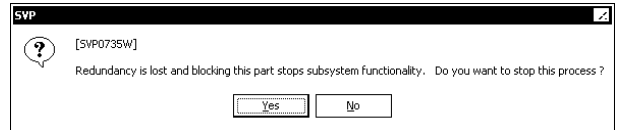

6. <Enter password>

CAUTION

This is a special (exceptional) operation that can cause a serious failure such as a system down or a data loss and requires an input of a password. Ask the technical support center about the appropriateness of the operation, and input the password after getting an approval of executing the operation.

Enter the password in response to “Ask the TSC about the appropriateness of this operation, and enter the password.” and select (CL) [OK].
Password is needed for this operation.

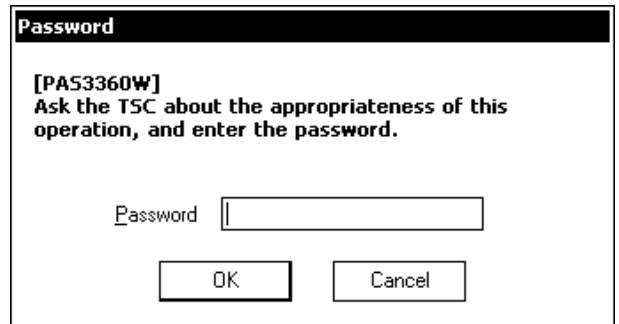

If any other message than the list is displayed, see the SVP Message Section ([SVPMSG00-00](#)).

7. <Checking the P-DEV status>

“Checking...” is displayed.

When “You can restore the replaced physical device by restoring logical devices. Do you continue to this operation?” is displayed, PDEV is automatically recovered by recovering LDEV.

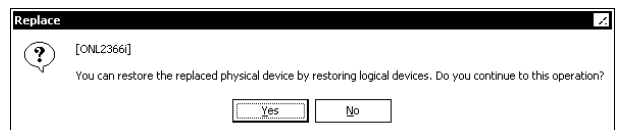

When you replace PDEV and format LDEV, please select (CL) [Yes].

When you want to change LDEV into a collection access state for the purpose of data backup, please select [No] and go to LDEV recovery for multiple PDEV failures ([SVP02-840](#)).

8. <P-DEV blocking>
Select (CL) [Yes] in response to “Are you sure you want to replace the physical device?”.

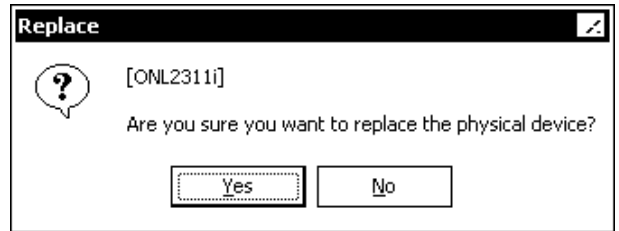

9. <Blocking the Physical device>
“Blocking...” is displayed.

10. <Spin down the Physical device>
“Spinning down...” is displayed.
The Shut down LED is lit.

11. <Replace HDU>
Select (CL) [OK] in response to “Please replace the physical device, and then select OK.” after the unit is replaced.
(See [HARDWARE A \(REP03-10\)](#))

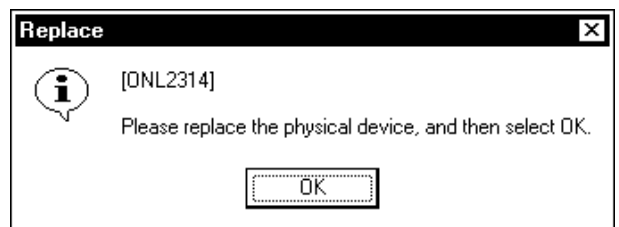

- 12. <Replace HDD>
Replace HDD.
See HARDWARE A ([REP03-10](#)).

[PRE-PROCEDURE F]

— OUTLINE —

- ① Select (main platter) cache (status check).
- ② Specify Replacement.
- ③ Place PCB into unpluggable state.

1. <Maintenance window>

The 'Maintenance' window is displayed.

(Multi Cabinet Model)

In the 'Maintenance' window, check and select (CL) [DKC] to be replaced.

(Single Cabinet Model)

In the 'Maintenance' window, check and select (CL) [Controller] to be replaced.

(Multi Cabinet Model)

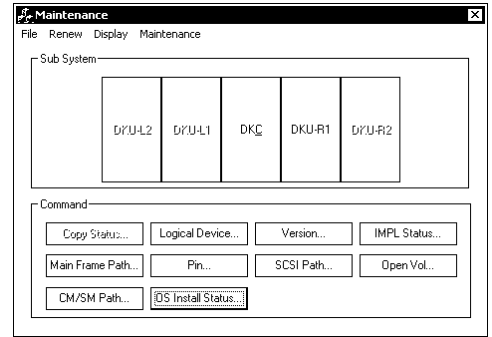

(Single Cabinet Model)

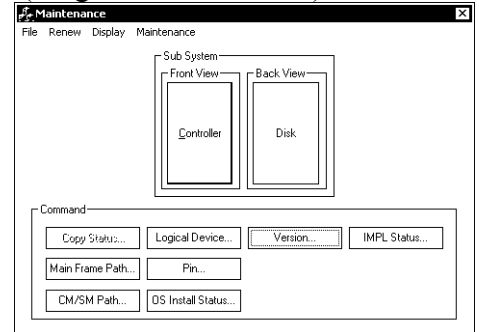

2.

(Multi Cabinet Model)

<DKC window>

Select (CL) [Cluster-n] in the 'DKC'.

(Single Cabinet Model)

<Controller window>

Select (CL) [Cluster-n] in the 'Controller'.

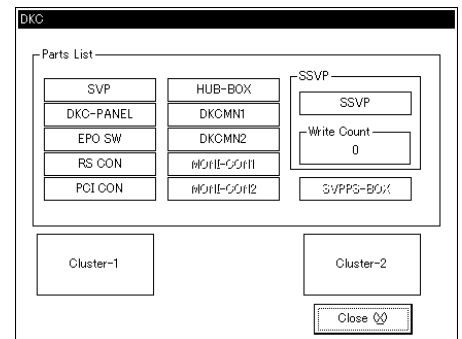

3. <Select Part>
Select (CL) the appropriate part.

(Multi Cabinet Single Phase Model,
Multi Cabinet 3 Phase Model
[30A AC BOX])

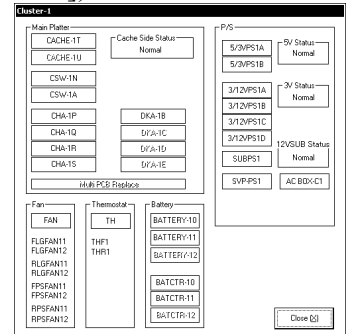

(Multi Cabinet 3 Phase Model
[Without 30A AC BOX])

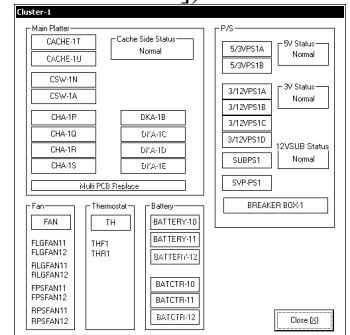

(Single Cabinet Model)

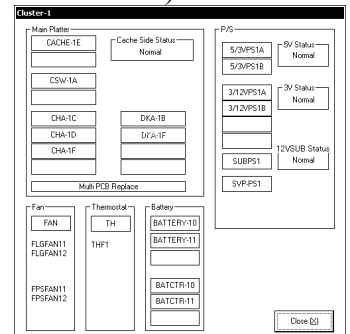

(ex. Cluster-1)

4. <Select Cache>

 **CAUTION**

When the screen appears prompting the operator to input a password to prevent multiple maintenance or for executing a pin check, contact the technical support center to ask for instructions.

Check status display.

Select (CL) a cache and select (CL) [Replace].

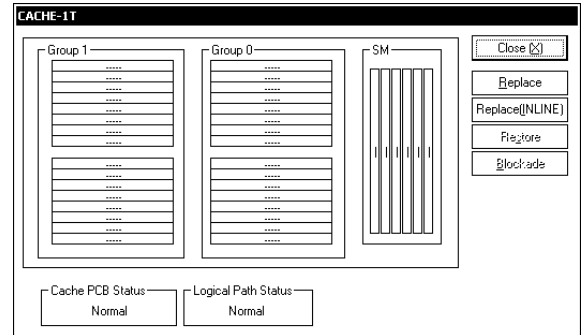

If any other message than the list is displayed, see the SVP Message Section ([SVPMSG00-00](#)).

5. <Check the beginning of cache blocking>

Select (CL) [Yes] after making sure that the package to be blocked is correct in response to:

* For CACHE (with SM) -- [Go to step 6]

“Are you sure you want to block the Shared Memory and Cache Memory PCB? If you select [Yes], physically pulling off and putting in of PCB will be unavoidable.”

* For CACHE ----- [Go to step 6]

“Are you sure you want to block the cache memory? If you select [Yes] in response to this inquiry, it is required to pull out and reinsert the cache memory PCBA concerned.”

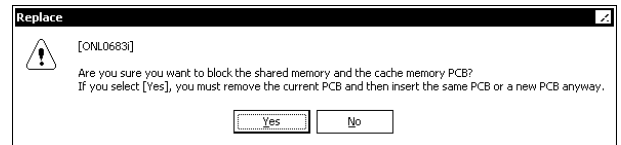

6. <Cache blocking>

“The Cache Memory PCB is being blocked.” is displayed.

“The Shared Memory PCB is being blocked...” is displayed.

7. <Check removal of cache>

Select (CL) [Yes] in response to:

* For CACHE (with SM)

“Do you want to pull out the Shared Memory and Cache Memory PCB now?”

* For CACHE

“Do you want to pull out the Cache Memory PCB now?”

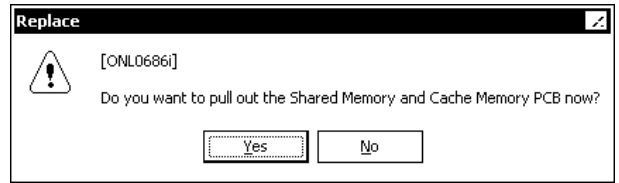

8. <Check shut down LED>

Select (CL)

* [Yes] if LED is on

* [No] if LED is off

in response to “Is the LED of the target PCB lit?”.

When [No] is selected, the same message is displayed again.

Check the LED and then reply to a message.

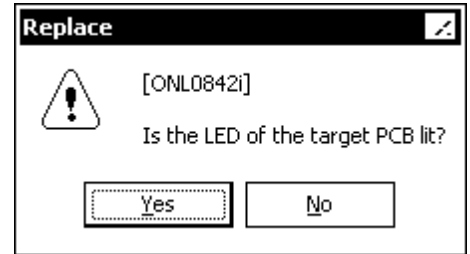

<Forcing shut down LED on>

CAUTION

If the jumper is inserted in the wrong PCB, a system down may be caused.

If [No] is selected:

Insert a jumper in response to “Please insert jumper into the target PCB (CACHE-*nn*), then pull it out without considering the status of the LED”.

(Refer [REP03-50](#))

Go to step 9.

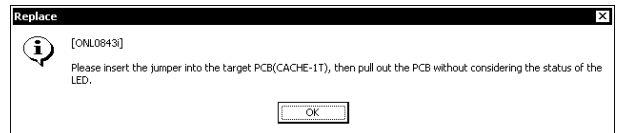

9. <Cache Replacement>

“Please replace the PCB (CACHE-*nn*), and then select OK.” is displayed.

(Select (CL) [OK] after replacing the PCB.)

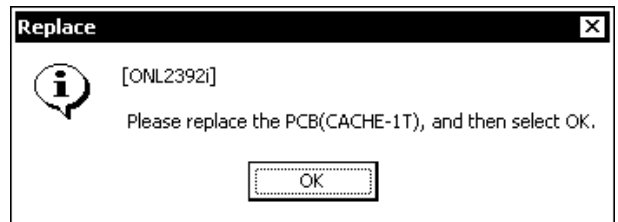

10. <Replace cache PCB>

Replace cache.

For CACHE (with SM) see HARDWARE B ([REP03-50](#))

[PRE-PROCEDURE H]

— OUTLINE —

- ① Select CHA/DKA (status check).
- ② Specify Replacement.
- ③ Place PCB into blocked state.

1. <Set path offline>

**CAUTION**

The path to be placed offline is that connected with the CHA concerned.

Set the path offline from HOST when replacing the CHA by your customer.

2. <Maintenance window>

The 'Maintenance' window is displayed.

(Multi Cabinet Model)

In the 'Maintenance' window, check and select (CL) [DKC] to be replaced.

(Single Cabinet Model)

In the 'Maintenance' window, check and select (CL) [Controller] to be replaced.

(Multi Cabinet Model)

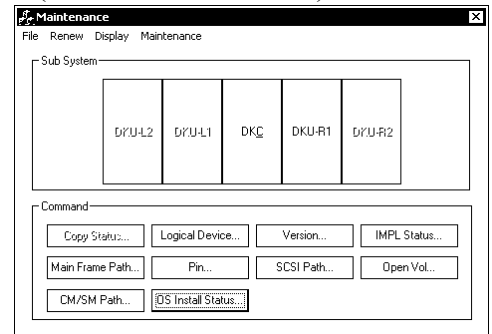

(Single Cabinet Model)

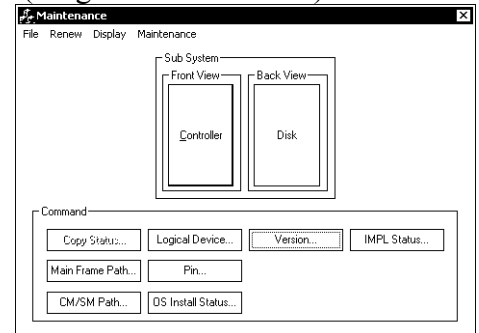

3.

(Multi Cabinet Model)

<DKC window>

Select (CL) [Cluster] in the 'DKC'.

(Single Cabinet Model)

<Controller window>

Select (CL) [Cluster] in the 'Controller'.

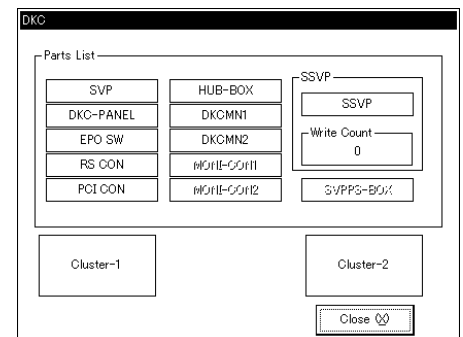

4. <Select CHA/DKA>
Select (CL) CHA/DKA.

Selecting (CL) [Close] returns you to step 3.

(Multi Cabinet Single Phase Model,
Multi Cabinet 3 Phase Model
[30A AC BOX])

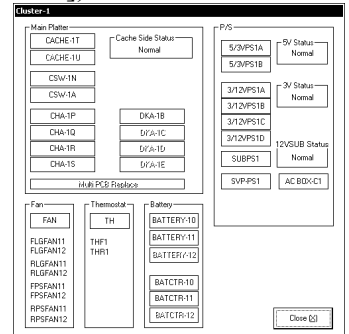

(Multi Cabinet 3 Phase Model
[Without 30A AC BOX])

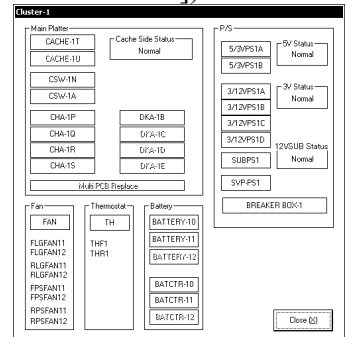

(Single Cabinet Model)

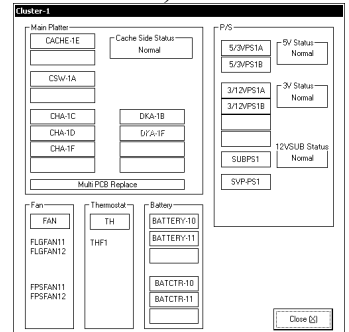

(ex. Cluster-1)

5. <Specify Replacement of CHA/DKA>

CAUTION

When the subsystem is placed online, ask the customer to place it offline. (When the CHA replace)

CAUTION

When the screen requests an operator to input a password in order to prevent multiple maintenance contact the technical support center to ask for instructions.

Make sure that the status is WARNING.
Select (CL) [Replace].

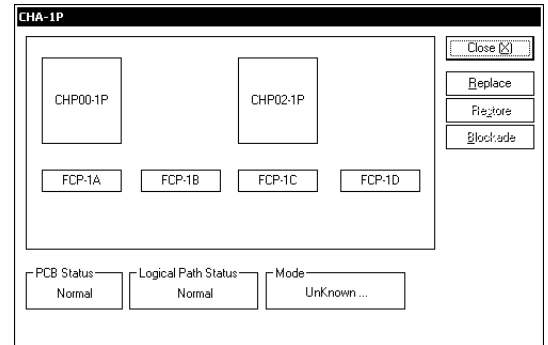

If any other message than the list is displayed, see the SVP Message Section ([SVPMSG00-00](#)).

6. <CHA/DKA blocking>

Select (CL) [Yes] in response to:

* For CHA

“Are you sure you want to block the CHA? If you select [Yes], physically pulling off and putting in of PCB will be unavoidable.”
Go to step 7.

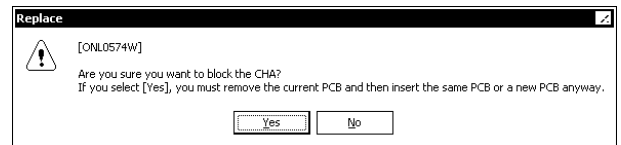

* For DKA

“Are you sure you want to block the DKA? If you select [Yes], physically pulling off and putting in of PCB will be unavoidable.”
Go to step 8.

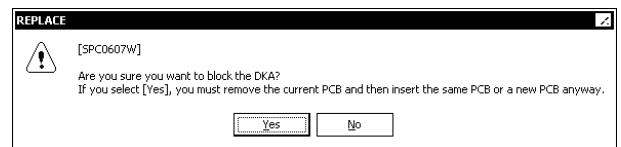

7. <Confirm Channel Path offline>

Select (CL) [OK] in response to:
 “Please confirm you have already varied off the concerned Channel paths. If OK, please press OK.”

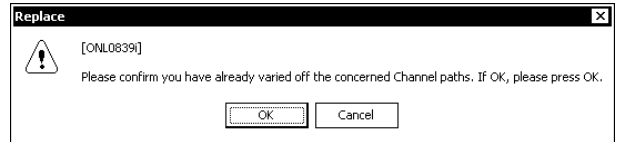

If Fibre channel adapter is installed:
 After you confirm that you have stopped the concerned SCSI channel paths, select (CL) [Yes].

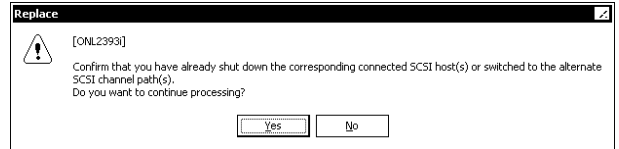

If a NAS adapter is installed:
 After you confirm that you have stopped concerned service, select (CL) [Yes].

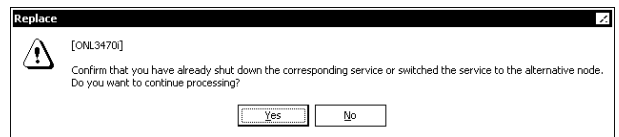

8. <Caution message for system down>



“Automatic subsystem check for error prevention will be performed when blocking target PCB.

Yes = Normal replacement
 No = Forcible replacement
 (Possible critical errors)”

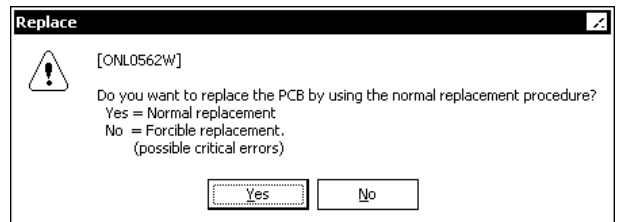

9. <CHA/DKA blocking>

* For CHA

“The CHA-xx is being blocked... Usually, several minutes (maximum 15 minutes)”

* For DKA

“The DKA is being blocked...”

10. <Removal of CHA/DKA>

Select (CL) [Yes] in response to:

* For CHA

“Do you want to pull out the CHA now?”

* For DKA

“Do you want to pull out the DKA now?”

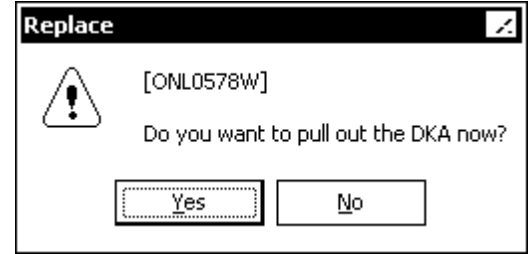

(ex. DKA)

11. <Check to see if the shut down LED is lit>

Select (CL)

* [Yes] if LED is on

* [No] if LED is off

in response to “Is the LED of the target PCB lit?”.

If [No] is selected:

Select in response to “Is the LED of the target PCB lit?” again.

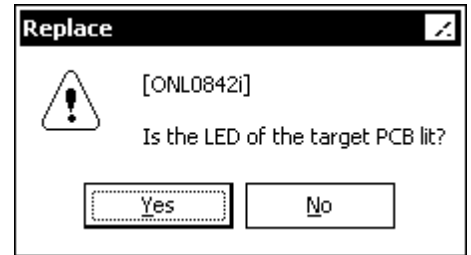

<Forcing shut down LED on>

 **CAUTION**

If the jumper is inserted in the wrong PCB, a system down may occur.

If [No] is selected twice:

Insert a jumper in response to “Please insert the jumper into the target PCB (CHA-
nn/DKA-
nn), then pull it out without considering the status of the LED”. (Refer [REP03-80](#))

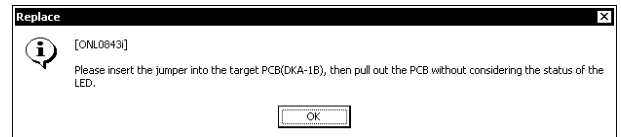

(ex. DKA)

For Serial CHA ([REP03-80](#))
 For Fibre CHA ([REP03-110](#))
 For MF Fibre CHA ([REP03-140](#))
 For DKA ([REP03-170](#))

12. <Beginning of CHA/DKA Replacement>

“Please replace the PCB (CHA-*nn*/DKA-*nn*), and then select OK.” is displayed. Select (CL) [OK] after replacing the PCBs.

For Serial CHA Go to ([REP03-80](#))
 For Fibre CHA Go to ([REP03-110](#))
 For MF Fibre CHA Go to ([REP03-140](#))
 For DKA Go to ([REP03-170](#))

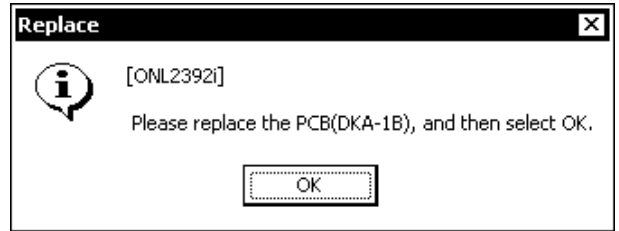

(ex. DKA)

[PRE-PROCEDURE K]

— OUTLINE —

- ① Select drive (status check).
- ② Check progress of copy processing
- ③ Specify Correction Copy
- ④ Save Spare

1. <Maintenance window>

(Multi Cabinet Model)

In the 'Maintenance' window, check and select (CL) [DKU-Rn] or [DKU-Ln] to be replaced.

(Single Cabinet Model)

In the 'Maintenance' window, select (CL) [Disk].

(Multi Cabinet Model)

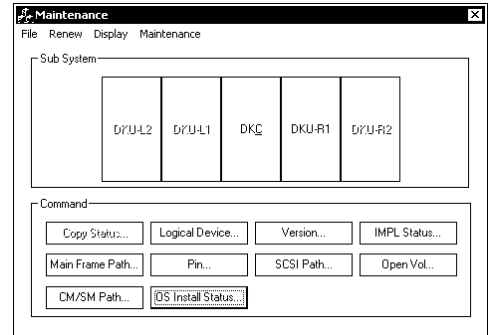

(Single Cabinet Model)

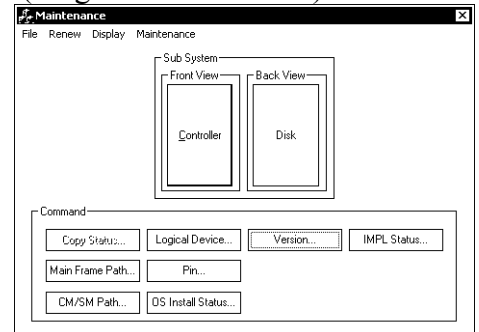

2. <Select HDU-BOX>

(Multi Cabinet Model)

Check and select (CL) [HDU-Rnn] or [HDU-Lnn] to be replaced.

(Single Cabinet Model)

Check and select (CL) [HDU-n] to be replaced.

Selecting (CL) [Close] returns you to step 1.

(Multi Cabinet Model)

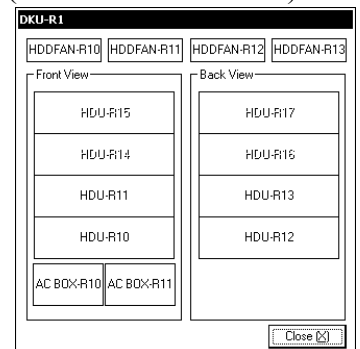

(Single Cabinet Model)

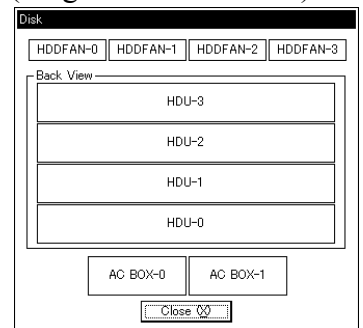

3. <Select HDD>

(Multi Cabinet Model [DKU455])
 Check and select [nn] to be replaced.

(Multi Cabinet Model [DKU405])
 Check and select [Rnnn] or [Lnnn] to be replaced.

(Single Cabinet Model)
 Check and select [nn] to be replaced.

Selecting (CL) [Close] returns you to step 2.

(Multi Cabinet Model [DKU455])

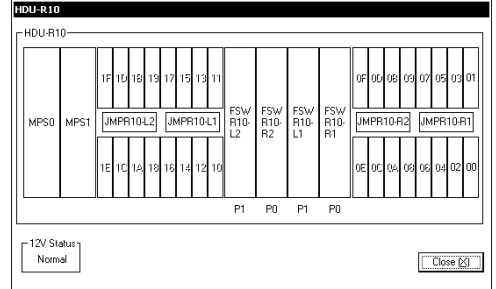

(Multi Cabinet Model [DKU405])

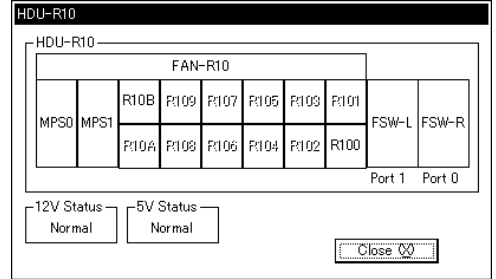

(Single Cabinet Model)

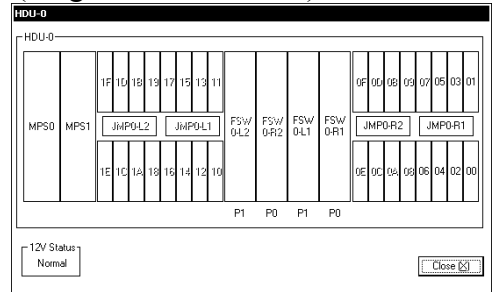

4. <Specify replacement on HDD>

Make sure that the status is FAILED or WARNING.

Select (CL) [Correction Copy].

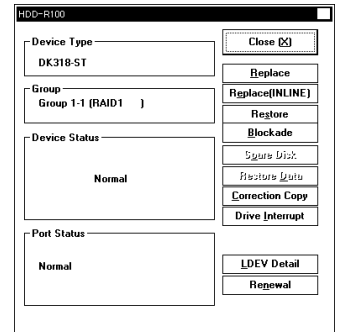

If any other message than the list is displayed, see the SVP Message Section ([SVPMSG00-00](#)).

5. <Reading the subsystem configuration data and Checking the P-DEV status>
“Checking...” is displayed.

6. <Saving the spare>
Select (CL) [Yes] in response to “Are you sure you want to correct data in the physical device?”.

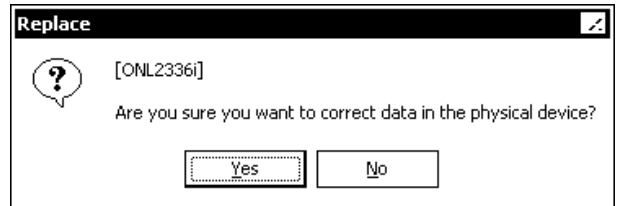

7. <Correction copy in progress>
“Correcting...” is displayed.

8. <End of starting correction copy>
Select (CL) [OK] in response to “Correcting data in the physical device has been started.”.

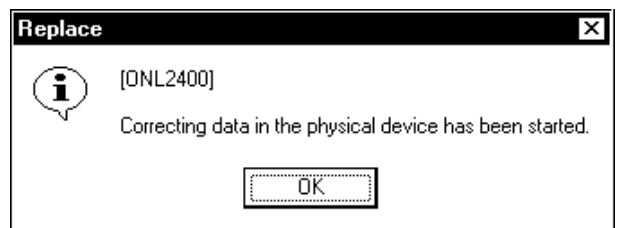

9. To interrupt the correction copy, select the PDEV to which the copy is being made and select (CL) the [Drive Interrupt] button.

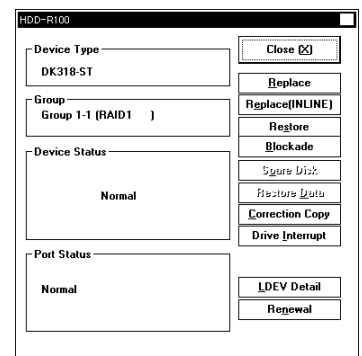

[PRE-PROCEDURE L]

— OUTLINE —

- ① Select FSW.
- ② Specify Replacement.
- ③ Please FSW into unpluggable state.

1. <Maintenance window>

(Multi Cabinet Model)

In the 'Maintenance' window, check and select (CL) [DKU-Rn] or [DKU-Ln] to be replaced.

(Single Cabinet Model)

In the 'Maintenance' window, check and select (CL) [Disk] to be replaced.

(Multi Cabinet Model)

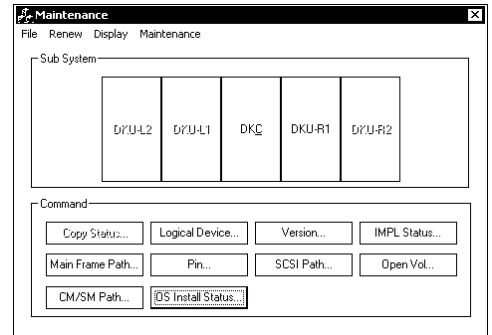

(Single Cabinet Model)

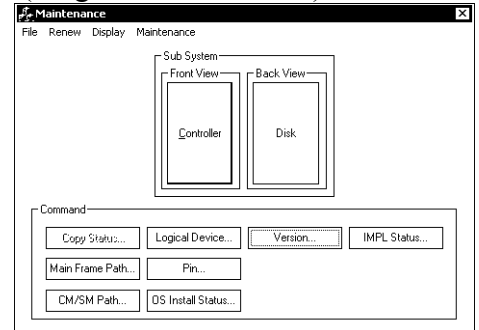

2. <Select HDU-BOX>

(Multi Cabinet Model)

Check and select (CL) [HDU-Rnn] or [HDU-Lnn] to be replaced.

(Single Cabinet Model)

Check and select (CL) [HDU-n] to be replaced.

Selecting (CL) [Close] returns you to step 1.

(Multi Cabinet Model)

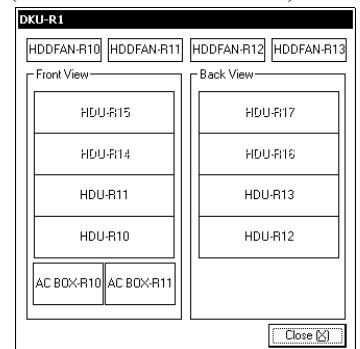

(Single Cabinet Model)

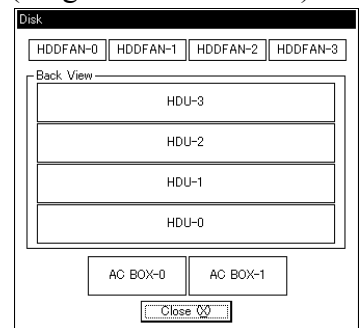

3. <Select FSW>

(Multi Cabinet Model)

Select (CL) [FSWXnn-Xn] to be replaced.

(Single Cabinet Model)

Select (CL) [FSWn-Xn] to be replaced.

Selecting (CL) [Close] returns you to step 2.

(Multi Cabinet Model [DKU455])

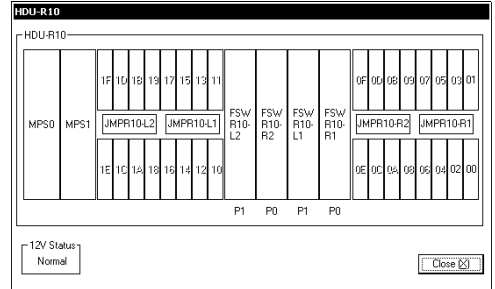

(Multi Cabinet Model [DKU405])

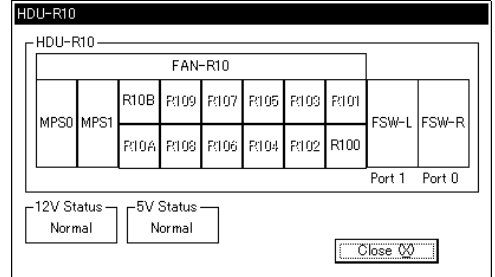

(Single Cabinet Model)

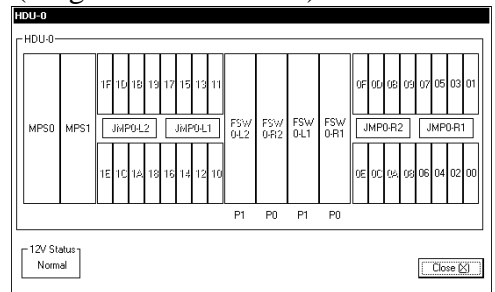

4. <Specify replacement>

CAUTION

When the screen requests an operator to input a password in order to prevent multiple maintenance, contact the technical support center to ask for instructions.

Select (CL) [Execute].

Selecting (CL) [Cancel] returns you to step 3.

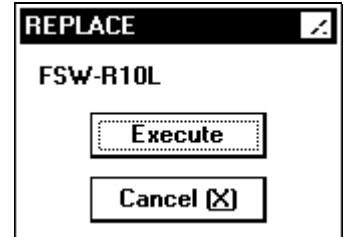

If any other message than the list is displayed, see the SVP Message Section ([SVPMSG00-00](#)).

5. <Check beginning of DKP blocking>

Select (CL) [Yes] in response to “Are you sure you want to replace the FSW? If you select [Yes], blocking of the DKP will be unavoidable.”.

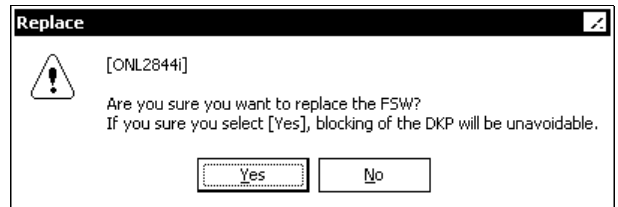

6. <Check system down>

CAUTION

Select (CL) [Yes] in response to the message below.

“Automatic subsystem check for error prevention will be performed when blocking target PCB.

Yes = Normal replacement
No = Forcible replacement
(Possible critical errors)”

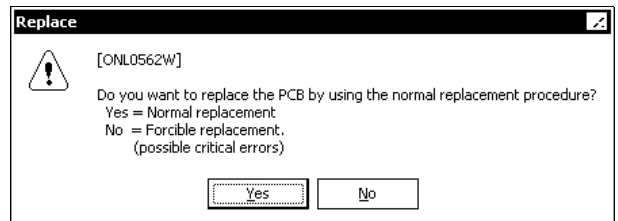

7. <Check DKP blocking>
 “The DKP is being blocked...” is displayed.

8. <Replace FSW>

“Please replace the FSW, and then select OK. (FSW-nnnn)” or “Please replace the FSW which connected by same Fibre Interface cable, and then select OK. (FSW-nnnn-...)” is displayed.

Make sure of the FSW PCB location is displayed, select (CL) the [OK] button after replaced all target FSW PCB.

If the FSW LED is not turned on, please replace FSW PCB.

Refer HARDWARE T20 ([REP03-730](#))

(A PCB to be replaced)

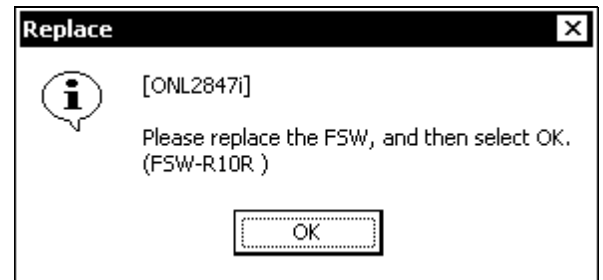

(Two or more PCBs to be replaced)

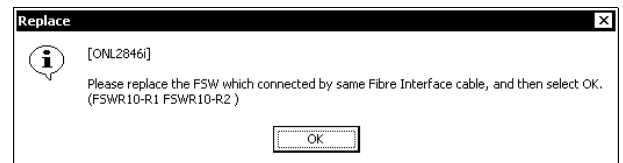

[PRE-PROCEDURE M]

— OUTLINE —

- ① Select CSW (status check).
- ② Specify Replacement.
- ③ Place PCB into blocked state.

1. <Maintenance window>

(Multi Cabinet Model)

In the 'Maintenance' window, check and select (CL) [DKC] to be replaced.

(Single Cabinet Model)

In the 'Maintenance' window, check and select (CL) [Controller] to be replaced.

(Multi Cabinet Model)

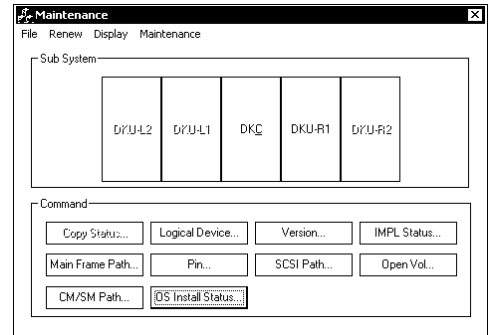

(Single Cabinet Model)

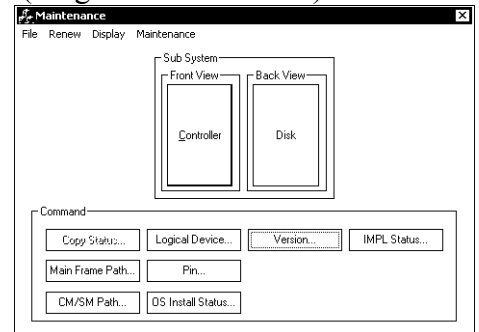

2.

(Multi Cabinet Model)

<DKC window>

Select (CL) [Cluster] in the 'DKC'.

(Single Cabinet Model)

<Controller window>

Select (CL) [Cluster] in the 'Controller'.

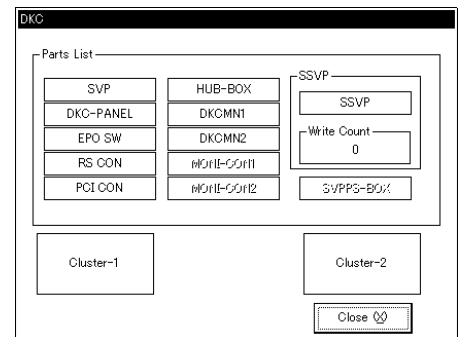

3. <Select CSW>
 Select (CL) [CSW]
 Selecting (CL) [Close] returns you to step 2.

(Multi Cabinet Single Phase Model,
 Multi Cabinet 3 Phase Model
 [30A AC BOX])

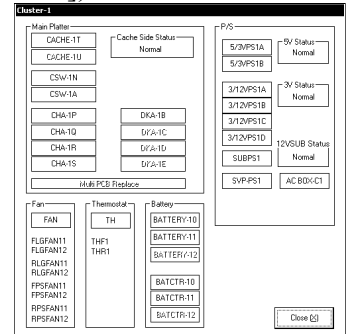

(Multi Cabinet 3 Phase Model
 [Without 30A AC BOX])

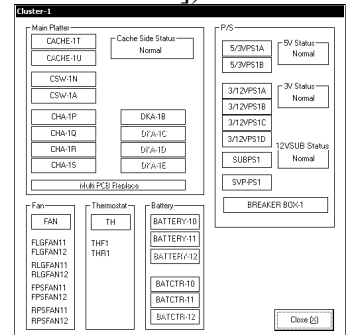

(Single Cabinet Model)

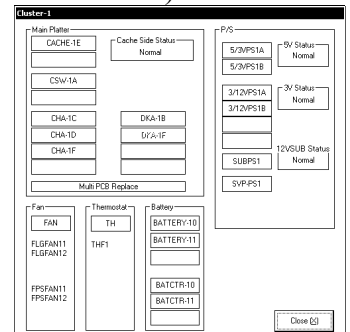

(ex. Cluster-1)

4. <Specify replacement>

CAUTION

Be sure to operate procedure 5 to 7 within thirty minutes.

Select (CL) [Execute].

Selecting (CL) [Cancel] returns you to step 3.

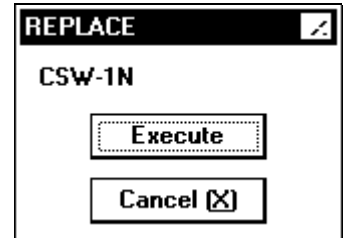

If any other message than the list is displayed, see the SVP Message Section ([SVPMSG00-00](#)).

5. <Check CSW blocking>

“Blocking the CSW...” is displayed.

6. <Check to see if shut down LED is lit>

Select (CL)

* [Yes] if the LED is on

* [No] if the LED is off

in replace to “Is the LED of the target CSW lit?”.

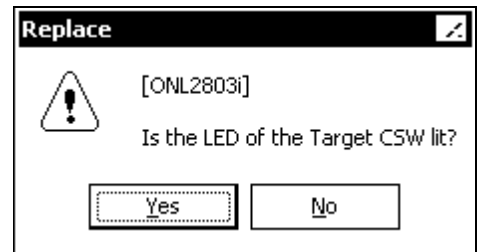

<Forcing shut down LED on>

CAUTION

If the jumper is inserted in the wrong PCB, a system down may be caused.

If [No] is selected twice:

Insert a jumper in response to “Please insert the jumper into the target PCB (CSW-*nn*), then pull out the target PCB without considering the status of the LED”. (Refer [REP03-210](#))

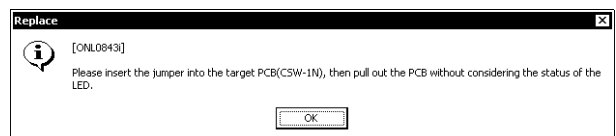

7. <Beginning of CSW replacement>

The LED on the operator panel shown in the following table goes out during a period from a pulling off of the CSW to an insertion of the new CSW.

Location of CSW to be replaced	LED on the operator panel	
	Cluster 1	Cluster 2
CSW-1A	ABCD EFGH JKLM	—
CSW-2M	—	ABCD EFGH JKLM

 **CAUTION**

If you take procedure 5 to 7 operation, the 'ONL0117E' message will be displayed on SVP after you select [OK]. Please start PRE-PROCEDURE M all over again.

“Please replace the CSW (CSW-nn), and then select OK.” is displayed.
Select (CL) [OK] after replacing the CSW.

Go to HARDWARE G ([REP03-200](#))

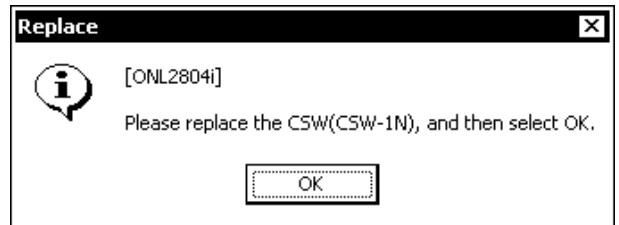

[PRE-PROCEDURE T1]

— OUTLINE —

- ① Select special (DKC) part (status check).
- ② Specify Replacement.
- ③ Detach parts related to special part.

[1] Select special part

**CAUTION**

When you want to replace the FLASH CARD, Complete SIM before operation.

1. <Maintenance window>
'Maintenance' window is displayed.

(Multi Cabinet Model)

In the 'Maintenance' window, check and select (CL) [DKC] to be replaced.

(Single Cabinet Model)

In the "Maintenance' window, check and select (CL) [Controller] to be replaced.

(Multi Cabinet Model)

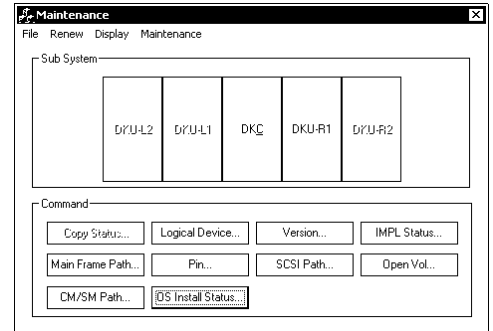

(Single Cabinet Model)

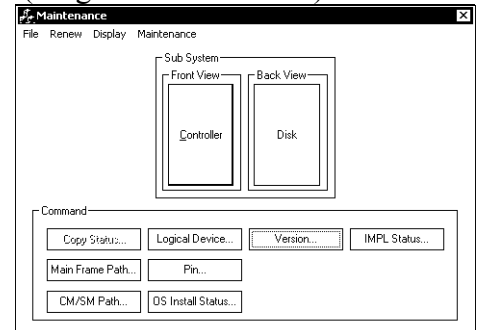

2. <Specify special part>

(Multi Cabinet Model)

Select (CL) part [XXXXXX] to be replaced from 'DKC'.

(Single Cabinet Model)

Select (CL) part [XXXXXX] to be replaced from 'Controller'.

Valid [XXXXXX] values are listed below.

- DKC-PANEL ----- [DKC-PANEL]
- DKCMN ----- [DKCMN 1/2]
- PCI CON ----- [PCI CON]
- UPS CON ----- [PCI CON]
- EPO SW ----- [EPO SW]
- SVP----- [SVP]
- SSVP ----- [SSVP]
- RS CON ----- [RS CON]
- SVP&FLASH CARD- [SVP]
- FLASH CARD ----- [SVP]
- HUB-BOX----- [HUB-BOX]
- MONI-CON ----- [MONI-CON]
- Switch SVP----- [SVP]
- SVPPS-BOX ----- [SVPPS-BOX]

Note: When replacing the UPS CON, select (CL) [PCI CON].

(Multi Cabinet Model)

(Single Cabinet Model)

3. <Execute>

CAUTION

When the screen prompting an operator to input a password in order to prevent a multiple maintenance, contact the technical support center to ask for an instruction.

If any other message than the list is displayed, see the SVP Message Section ([SVPMSG00-00](#)).

When the part you have selected in step 1 is one of the following, a window shown on the right is displayed.

- DKC-PANEL
- DKCMN
- PCI CON (UPS CON)
- EPO SW
- SSVP
- HUB-BOX
- RS CON
- MONI-CON

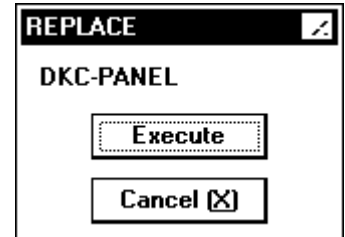

(ex. DKC-PANEL)

Select (CL) [Execute].

When the part you have selected in step 2 is the following, a window shown on the right is displayed.

- SVP

When you replace a part, select (CL) [Replace], select (CL) replacement parts [XXXXX], and select (CL) [Execute].

Valid [XXXXX] values are listed below.

- SVP -----[SVP]
- SVP&FLASH CARD-[SVP], [FLASH CARD]
- FLASH CARD -----[FLASH CARD]

When you switch a Master SVP to a Standby SVP and vice versa, select (CL) [Switch SVPs with Transfer Config Data], and select (CL) [Execute].

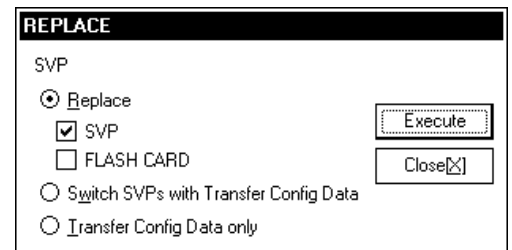
**CAUTION**

If you continue to operate that operation moreover, the communication between Master SVP and Web Console is disconnected and you are not able to use Web Console.

When you transfer Master SVP's Configuration Data to a Standby SVP, select (CL) [Transfer Config Data only], and select (CL) [Execute].

4. <Check beginning of special part Replacement>
 Select (CL) [Yes] in response to “Do you want to replace the "XXXXX?"”.

XXXXX represents one of the part names listed in step 2.

- “DKC-PANEL” ----- Go to [2] ([REP02-550](#))
- “EPO SW” ----- Go to [3] ([REP02-560](#))
- “DKCMN 1/2” ----- Go to [5] ([REP02-590](#))
- “RS CON” ----- Go to [10] ([REP02-650](#))
- “MONI-CON” ----- Go to [9] ([REP02-640](#))

- “SVPPS-BOX” -----

When replacing the SVPPS-BOX, the SVP in operation is checked before confirming the replacement start. In response to a message, “Are you using the basic SVP now?” select (CL) [Yes] when the SVP being operated is a Basic SVP or select (CL) [No] when the SVP being operated is an Optional SVP. When a Basic SVP is being operated, go to Item [11] ([REP02-651](#)).

When an Optional SVP is being operated, a message, “When the optional SVP is operating as the master SVP, you cannot

replace SVPPS-BOX. You must ensure that the basic SVP is operating as the master SVP.” is displayed. Select (CL) [OK]. Replace the SVPPS-BOX after switching the Master SVP (by selecting “Switch SVP”) since replacement of the SVPPS-BOX cannot be performed when the Optional SVP is activated.

- “SVP” ----- Go to [6] ([REP02-600](#))
- “SVP&FLASH CARD” - Go to [6] ([REP02-600](#))
- “FLASH CARD” ----- Go to [8] ([REP02-620](#))

If SVP High Reliability Kit is installed , the following message is displayed. “There are duplicated SVPs. It is safer if you switch to the other SVP and replace SVP according to the instruction in the maintenance manual. Do you want to replace SVP?”

Since procedure differs, select (CL) [No]. Refer to PRE-PROCEDURE T5 ([REP02-820](#)).

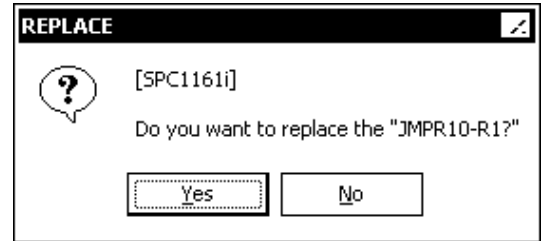

(ex. DKC-PANEL)

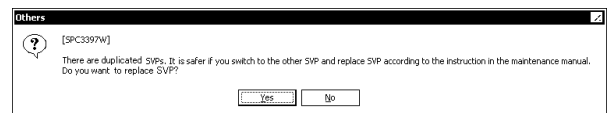
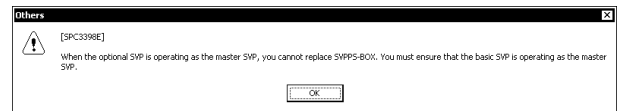
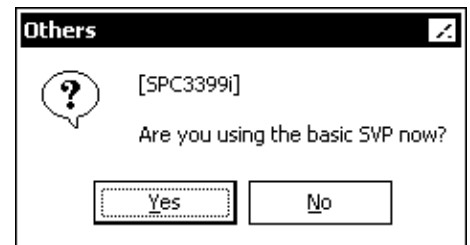

(ex. SVP)

- “HUB-BOX” ----- Go to [10] ([REP02-650](#))

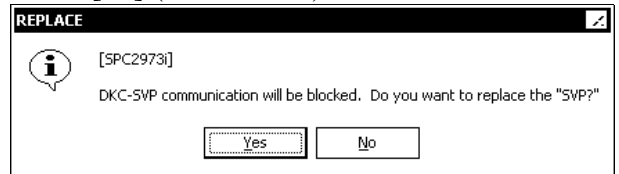

(ex. SVP)

- “SSVP” ----- Go to [7] ([REP02-610](#))

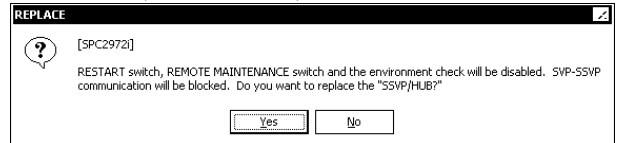

- “PCI CON”(UPS CON) ----- Go to [4] ([REP02-570](#))

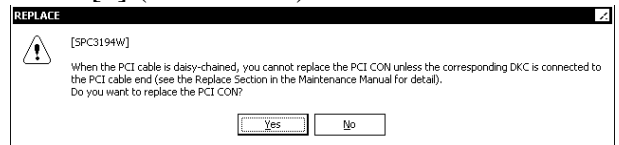

- “Switch SVPs with Transfer Config Data” ---- Go to [12] ([REP02-652](#))

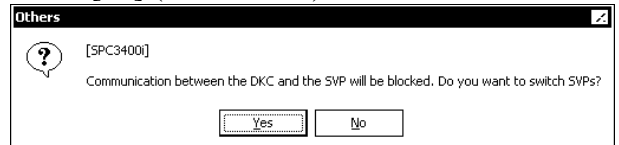

- “Transfer Config Data only” ----- Go to [13] ([REP02-653](#))

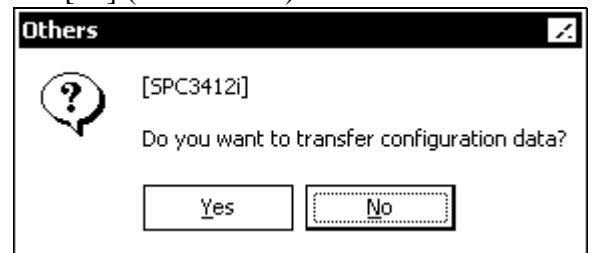

Note: When replacing the UPS CON, execute the PCI CON replacement procedure.

[2] DKC-PANEL

1. <Read environment monitor>

The SVP automatically read REMOTE/LOCAL position of the CE part. When SVP occurred read failure, "Is the REMOTE/LOCAL switch of DKC-PANEL LOCAL position?" is displayed.

In the case REMOTE/LOCAL switch is LOCAL position, select (CL) [Yes].

In the case REMOTE/LOCAL switch is REMOTE position, select (CL) [No].

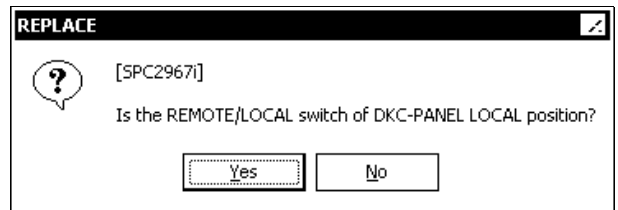

2. <Check jumper installation>

Attach jumper on DKCMN 1/2 in response to "Please attach DKC Panel INH jumper plug. Then press OK.". (see [HARDWARE T1 \(REP03-230 step 2\)](#)).

Select (CL) [OK] after confirming that jumper is attached.

Go to step 4.

If jumper plug is not attached, go to step 3.

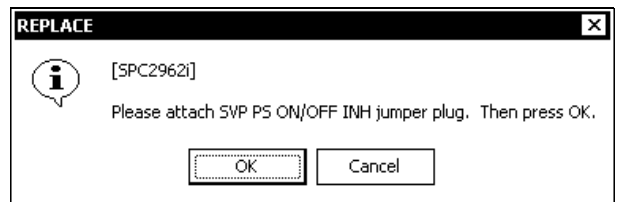

3. <Check jumper reinstallation>

"The DKC Panel INH jumper plug is not attached. If you want to abort the replacement of the DKC-PANEL, press Cancel." is displayed if no jumper is attached. Attach jumper and select (CL) [OK].

Go to step 4.

If jumper plug is not attached, step 3 again.

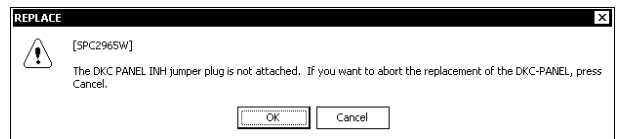

4. <Check beginning of special part Replacement>

"Please replace the "DKC-PANEL." After replacement, press OK." is displayed. (Reply with [OK] after replacing the special part.)

see [HARDWARE T1 \(REP03-230\)](#)

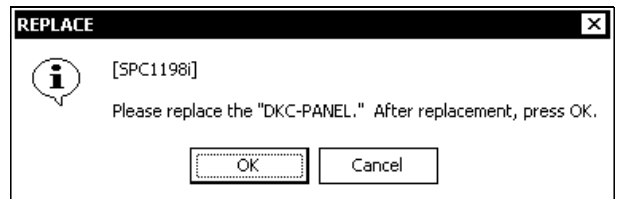

[End of PRE-PROCEDURE]

[3] EPO SW

1. <Check jumper installation>

Attach jumper on DKCMN 1/2 in response to “Please attach DKC PANEL ON/OFF INH jumper plug. Then press OK.”.
 (see HARDWARE T2 ([REP03-280 step 1](#))).
 Select (CL) [OK] after confirming that jumper is attached.
 Go to step 3.
 If jumper plug is not attached, go to 2.

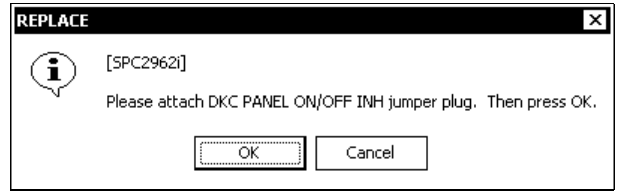

2. <Check jumper reinstallation>

“The DKC Panel INH jumper plug is not attached. If you want to abort the replacement of the DKC-PANEL, press Cancel.” is displayed if no jumper is attached. Attach jumper and select (CL) [OK].
 Go to step 3.
 If jumper plug is not attached, step 2 again.

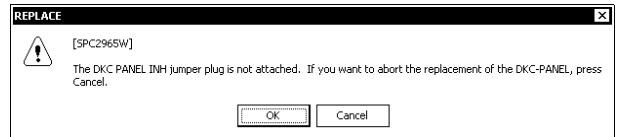

3. <Check beginning of special part Replacement>

“Please replace the "XXXXX." After replacement, press OK.” is displayed.
 (Reply with [OK] after replacing the special part.)

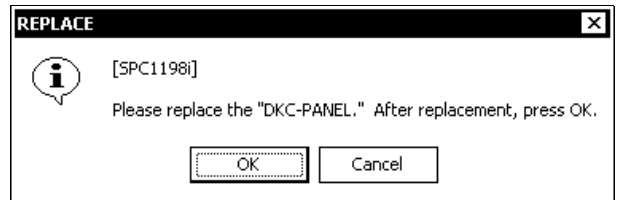

(ex. DKC-PANEL)

see HARDWARE T2 ([REP03-280](#))

[End of PRE-PROCEDURE]

[4] PCI CON (UPS CON)

⚠ CAUTION

< When the part concerned is the PCI CON >

Replacement of PCI CON Panel causes other devices running on the same PCI connection line to be powered off except a) and b) shown below (because giving the EPO instruction is assumed). Therefore, stop the other device before performing replacement.

- a) If PCI cable is not connected to the replacing DKC.
- b) If the replacing DKC (DKC concerned) is connected to the end of the PCI cable as shown below.

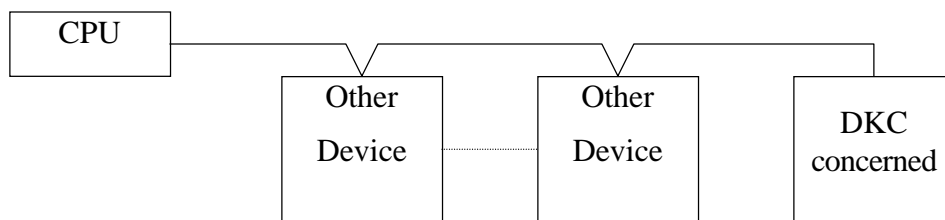

1. <Check DKC-PANEL switches>

Set REMOTE/LOCAL switch to LOCAL and select (CL) [OK] in response to "Please switch REMOTE/LOCAL switch, on "DKC-PANEL" to the LOCAL position. Then press OK.". (see HARDWARE T4 ([REP03-360 step 1](#)))

Go to step 3.

If REMOTE/LOCAL switch is not LOCAL, go to 2.

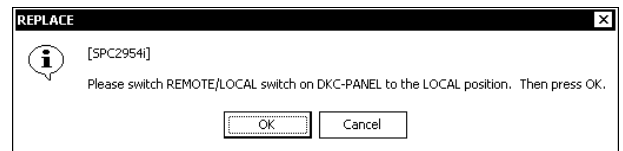

2. <Check that the REMOTE/LOCAL switch of DKC-PANEL is LOCAL>

“REMOTE/LOCAL switch is not LOCAL. Please check it. If you want to abort the replacement of the PCI CON, press Cancel.”

is displayed if REMOTE/LOCAL switch is not LOCAL. Turn to LOCAL and select (CL) [OK], or [Cancel] to terminate replacing. If REMOTE/LOCAL switch is not LOCAL, step 2 again.

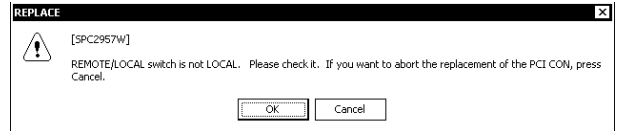

3. <Check jumper installation>

Attach jumper on DKCMN 1/2 in response to “Please attach DKC PANEL ON/OFF INH jumper plug. Then press OK.”.

(see HARDWARE T4 ([REP03-360 step 2](#))). Select (CL) [OK] after confirming that jumper is attached.

Go to step 5.

If jumper plug is not attached, go to 4.

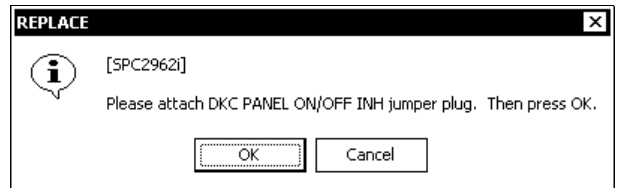

4. <Check jumper reinstallation>

“The DKC PANEL INH jumper plug is not attached. If you want to abort the replacement of the DKC-PANEL press Cancel.” is displayed if no jumper is attached. Attach jumper and select (CL) [OK].

Go to step 5.

If jumper plug is not attached, step 4 again.

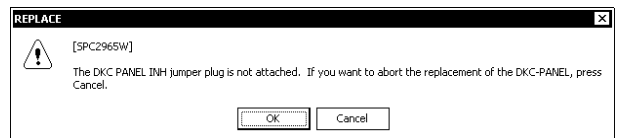

5. <Check beginning of special part Replacement>

“Please replace the “XXXXX.” After replacement, press OK.” is displayed. (Reply with [OK] after replacing the special part.)

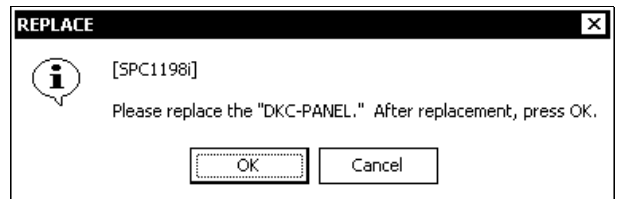

(ex. DKC-PANEL)

PCI CON -- see HARDWARE T4 ([REP03-360](#))
UPS CON-- see HARDWARE T27 ([REP03-970](#))

[End of PRE-PROCEDURE]

[5] DKCMN

1.

The message “Are the LED of the target PCB(s) turned on?” is displayed.

If you select (CL) [Yes], go to step 3.

If you select (CL) [No], go to step 2.

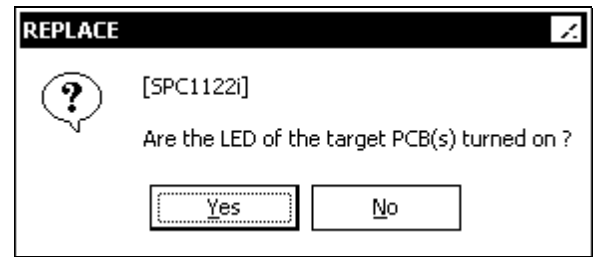

2.

The message shown on the right is displayed.

Check the location of the DKCMN.

(see HARDWARE T3 ([REP03-330](#)))

Select (CL) [OK].

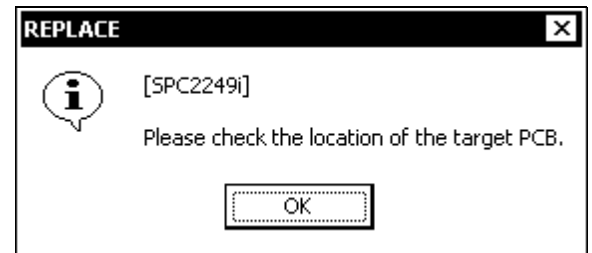

3. <Check beginning of special part Replacement>

“Please replace the "DKCMNx." After replacement, press OK.” is displayed.

(Reply with [OK] after replacing the special part.)

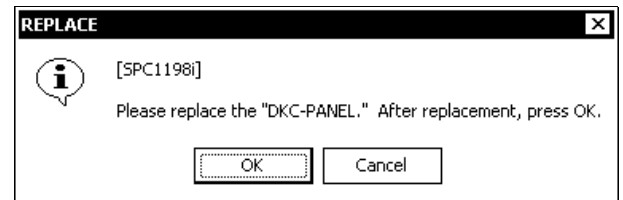

(ex. DKC - PANEL)

see HARDWARE T3 ([REP03-330](#))

[End of PRE-PROCEDURE]

[6] SVP, SVP&FLASH CARD

1. <Attaching a jumper plug>

Attach a jumper plug to JP2 on the RSCON following a message, "Please attach SVP PS ON/OFF INH jumper plug. Then press OK." (see HARDWARE T7 (on page [REP03-450](#))). After checking that the jumper plug has been attached, select (CL) [OK].

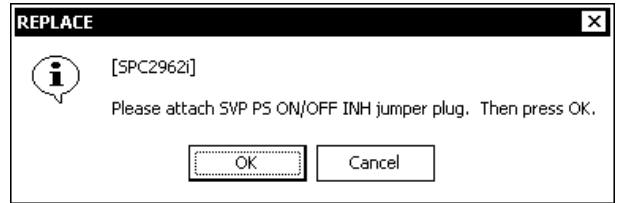

Note: Do not attach Shut Down jumper plug to JP1 on the RS CON.

Go to step 3.

When the jumper plug has not been attached, go to step 2.

2. <Checking re-attachment of the jumper plug>

When the jumper plug has not been attached, a message, "The SVP PS ON/OFF INH jumper plug is not attached. If you want to abort the replacement of the SVP, press Cancel." is displayed. Attach the jumper plug and select (CL) [OK].

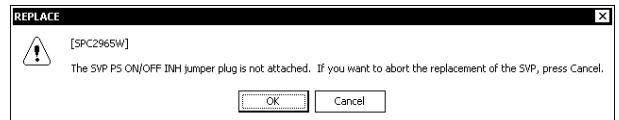

Go to step 3.

When the jumper plug has not been attached, execute step 2 again.

3.

The message "After the SVP was turned off automatically, replace the XXXXX." is displayed.

- In the case that SNMP Option and/or Web Console is installed.

Go to 4.

- In the case that SNMP Option and Web Console is not installed.

If the CD-ROM disk inserted into the CD-ROM drive, remove the CD-ROM disk.

Select (CL) [OK], so SVP is turned off automatically.

(See HARDWARE T7 ([REP03-450](#)))

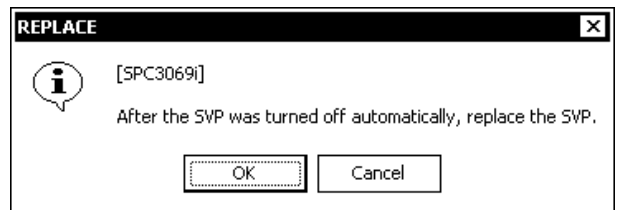

(ex. SVP)

[End of PRE-PROCEDURE]

4. <Check of SNMP / WebConsole Network>

- (1) <Open “Network and Dial-up Connections”>
 Select (DR) [Settings] and then [Network and Dial-up Connections] from [start].

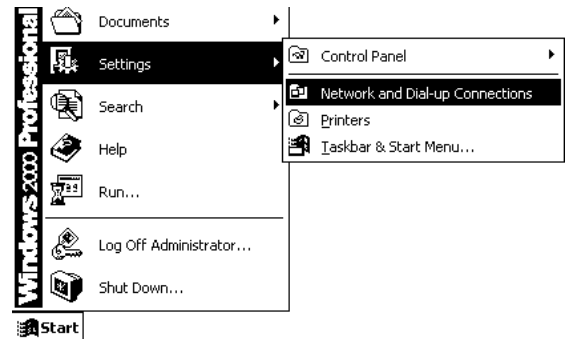

- (2) <Open “Local Area Connection2” or “Local Area Connection3”>

Select (DC) “Local Area Connection2” or “Local Area Connection3” from “Network and Dial-up Connections”.

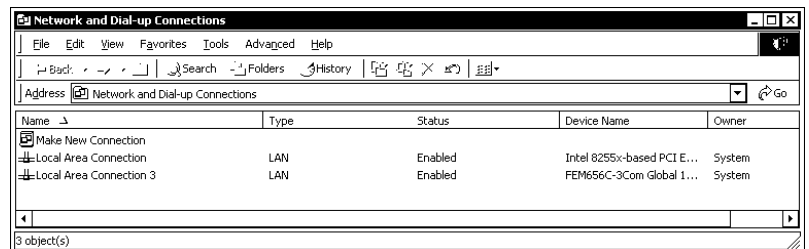

- (3) <Open “Properties”>

Select (DR) “Properties” from “General”.

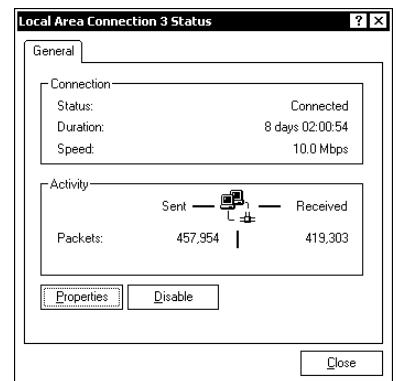

- (4) <Open “TCP/IP Properties”>
 Select (CL) “Internet Protocol(TCP/IP)” from “General”, and select (CL) [Properties].

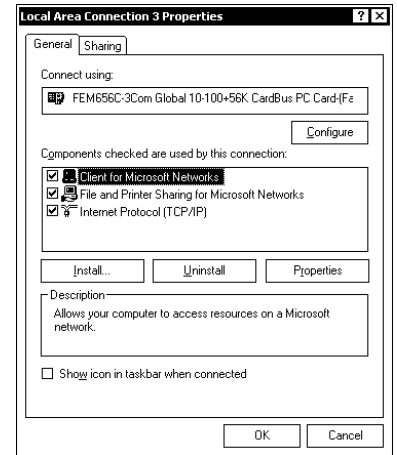

- (5) <Check “General” from “Internet Protocol(TCP/IP)”>
 a) Refrain from the check mark of “Obtain an IP address automatically” and “Use the following IP address” to the work sheet.
 Refrain from the setting of “IP address”, “Subnet mask” and “Default gateway” to the work sheet.
 Refrain from the check mark of “Obtain DNS server address automatically” and “Use the following DNS server address” to the work sheet.
 Refrain from the setting of “Preferred DNS server” and “Alternate DNS server” to the work sheet.
 b) Select (CL) [Advanced ...] from “Internet Protocol(TCP/IP)”.

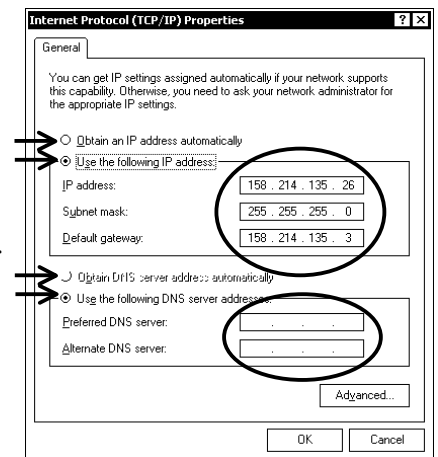

- (6) <Check “IP Setting” from “Advanced TCP/IP Settings”>
 a) Refrain from the setting of “Interface metric” to the work sheet.
 b) Select (CL) “DNS” from “Advanced TCP/IP Settings”.

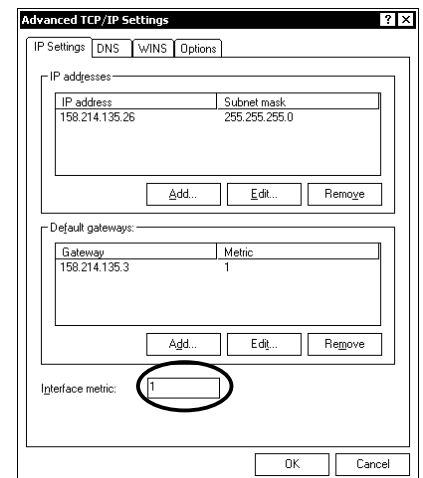

- (7) <Check “DNS” from “Advanced TCP/IP Settings”>
- Refrain from the setting of “DNS server addresses, in order of use”, “Append these DNS suffixes (in order)” and “DNS suffix for this connection” to the work sheet.
Refrain from the check mark of “Append primary and connection specific DNS suffixes”, “Append parent suffixes of the primary DNS suffix”, “Append these DNS suffixes (in order)”, “Register this connection’s addresses in DNS” and “Use this connection’s DNS suffix in DNS registration” to the work sheet.
 - Select (CL) “WINS” from “Advanced TCP/IP Settings”.

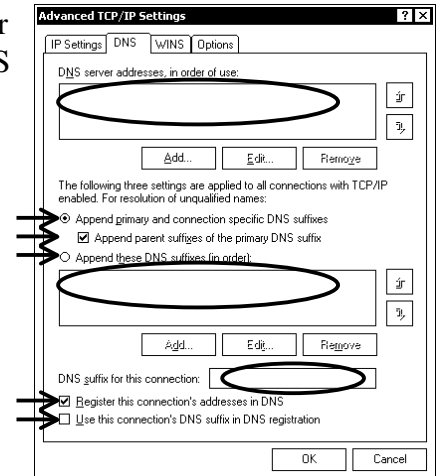

- (8) <Check “WINS” from “Advanced TCP/IP Settings”>
- Refrain from the setting of “WINS addresses, in order of use” to the work sheet.
Refrain from the check mark of “Enable LMHOSTS lookup”, “Enable NetBIOS over TCP/IP”, “Disable NetBIOS over TCP/IP” and “Use NetBIOS setting from the DHCP server” to the work sheet.
 - Select (CL) “Options” from “Advanced TCP/IP Settings”.

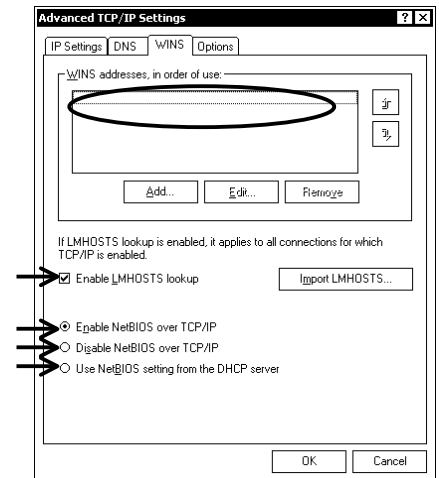

- (9) <Open “Options” from “Advanced TCP/IP Settings”>
- Select (CL) “IP security” from “Options”, and select (CL) [Properties]. Go to (10)
 - Select (CL) “TCP/IP Filtering” from “Options”, and select (CL) [Properties]. Go to (11)
 - Select (CL) “Cancel” from “Advanced TCP/IP Settings”. Go to (12)

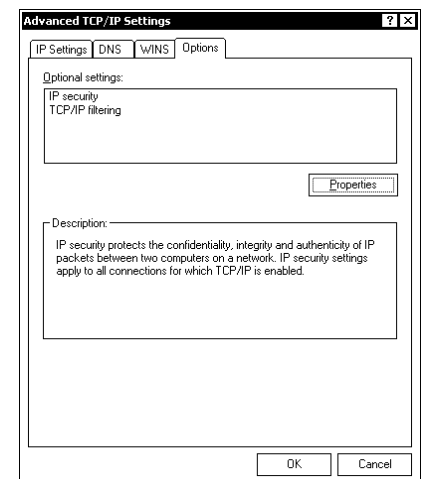

(10) <Check “IP Security” >

- a) Refrain from the check mark of “Do not use IPSEC” and “Use this IP security policy” to the work sheet.
- b) Select (CL) “Cancel”. Back to (9)

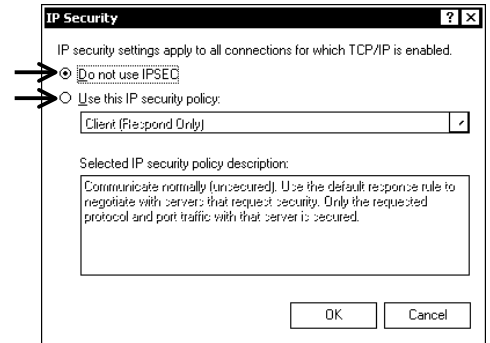

(11) <Check “TCP/IP Filtering(All adapters)” >

- a) Refrain from the check mark of “Enable TCP/IP Filtering(All adapters)”, “Permit All” and “Permit Only” to the work sheet.
- b) Select (CL) “Cancel”. Back to (9)

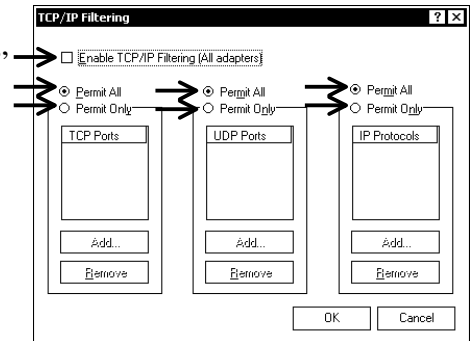

(12) <Close “Internet Protocol(TCP/IP)”>

- Select (CL) [Cancel] from “General” of “Internet Protocol(TCP/IP)”.

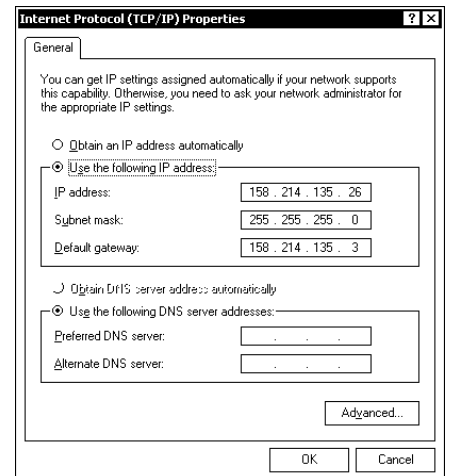

- (13) <Close “Local Area Connection2 Properties” or “Local Area Connection3 Properties”>
 Select (CL) [Cancel] from “General” of “Local Area Connection2 Properties” or “Local Area Connection3 Properties”.

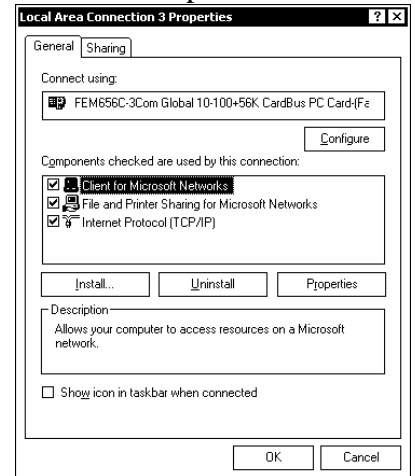

- (14) <Close “Local Area Connection2 Status” or “Local Area Connection3 Status”>
 Select (CL) [Close] from “General” of “Local Area Connection2 Status” or “Local Area Connection3 Status”.

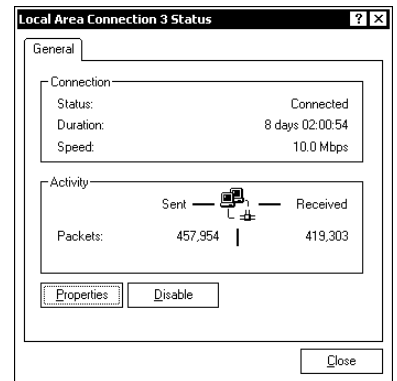

- (15) <Close “Network and Dial-up Connections”>
 Select (CL) [Files] on “Network and Dial-up Connections”.
 Select (CL) [Close].

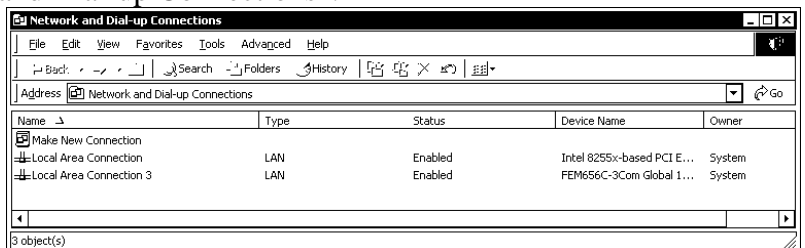

[End of PRE-PROCEDURE]

5. <Work Sheet of SNMP/WebConsole Option Network Settings>

(1) "General" for "Internet Protocol(TCP/IP)"

- "Obtain an IP address automatically" -----
- "Use the following IP address" -----
- "IP address" ----- " . . . "
- "Subnet mask" ----- " . . . "
- "Default gateway" ----- " . . . "
- "Obtain DNS server address automatically" -----
- "Use the following DNS server address" -----
- "Preferred DNS server" ----- " . . . "
- "Alternate DNS server" ----- " . . . "

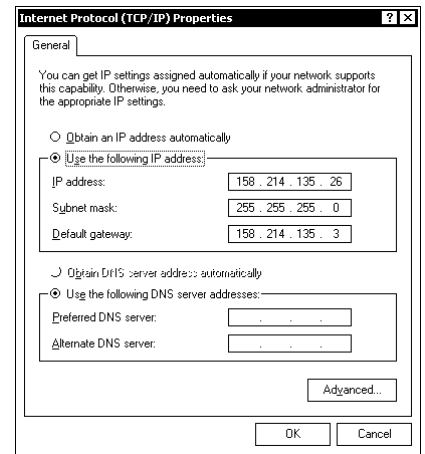

(2) "IP Settings"

- "Interface metric" ----- " "

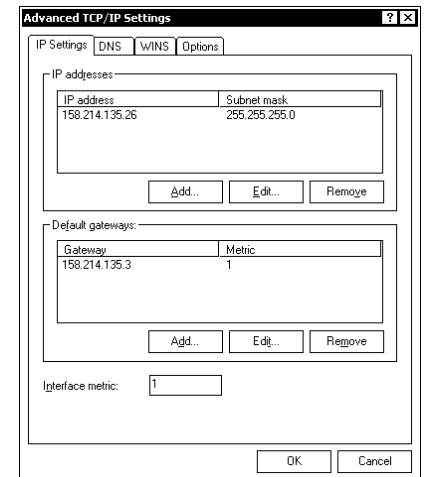

(3) "DNS"

- "DNS server addresses, in order of use" ----- " "
- "Append primary and connection specific DNS suffixes" -----
- "Append parent suffixes of the primary DNS suffix" -----
- "Append these DNS suffixes (in order)" -----
- "DNS suffix for this connection" ----- " "
- "Register this connection's addresses in DNS" -----
- "Use this connection's DNS suffix in DNS registration" -----

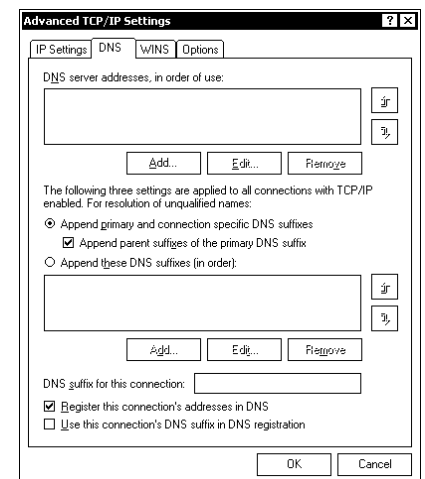

- (4) “WINS”
- “WINS addresses, in order of use” ----- “ ”
- “Enable LMHOSTS lookup” -----
- “Enable NetBIOS over TCP/IP” -----
- “Disable NetBIOS over TCP/IP” -----
- “Use NetBIOS setting from the DHCP server” -

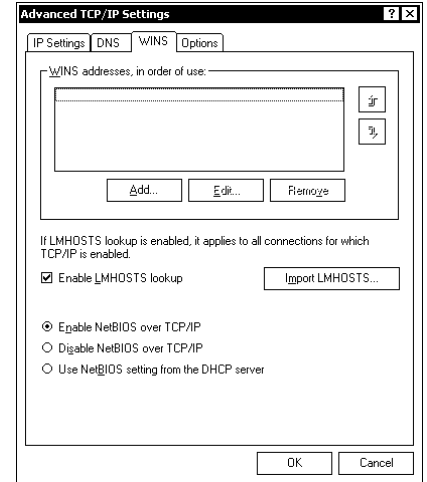

- (5) “IP Security”
- “Do not use IPSEC” -----
- “Use this IP security policy” -----

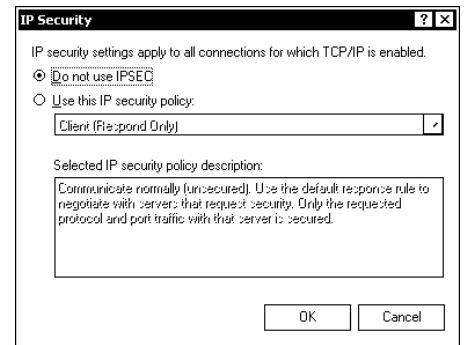

- (6) “TCP/IP Filtering”
- “Enable TCP/IP Filtering(All adapters)” -----
- left side:
- “Permit All” -----
- “Permit Only” -----
- center side:
- “Permit All” -----
- “Permit Only” -----
- right side:
- “Permit All” -----
- “Permit Only” -----

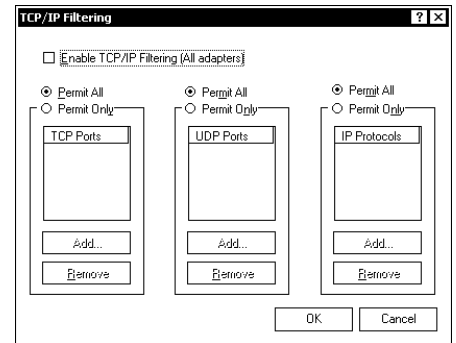

[7] SSVp

1.

The message “Are the LED of the target PCB(s) turned on?” is displayed.

If you select (CL) [Yes], go to step 3.

If you select (CL) [No], go to step 2.

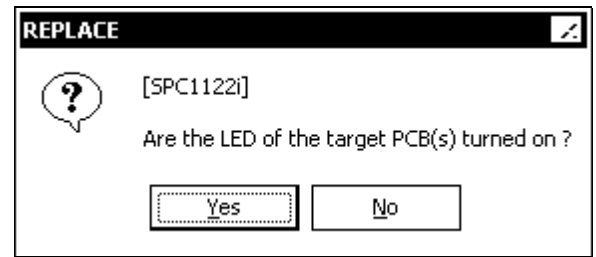

2.

The message shown on the right is displayed.

Check the location of the SSVp.

(see HARDWARE T8 ([REP03-550](#)))

Select (CL) [OK].

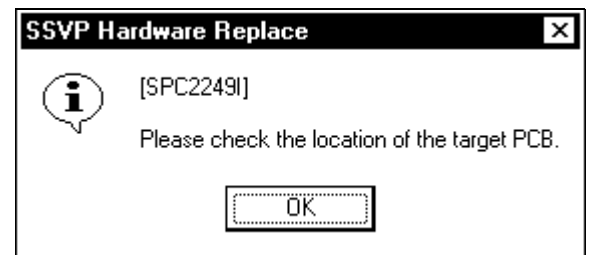

3. <Check beginning of special part Replacement>

“Please replace the "SSVP." After replacement, press OK.” is displayed.

(Reply with [OK] after replacing the special part.)

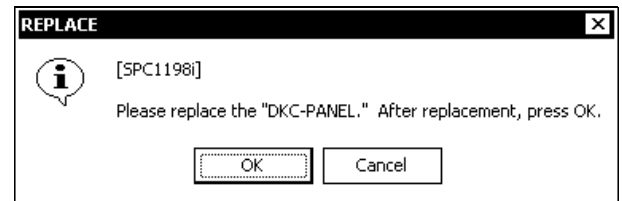

(ex. DKC - PANEL)

see HARDWARE T8 ([REP03-550](#))

[End of PRE-PROCEDURE]

[8] FLASH CARD

 **CAUTION**

When the “Explorer” windows are executing, close them before replacement procedure.

1. <Check beginning of FLASH CARD Replacement>

The message “After the SVP was turned off automatically, replace the FLASH CARD.” is displayed.

Select (CL) [OK], so it will reboot the SVP, and the files on FLASH CARD are moved to HD. Then SVP is turned off automatically. (See HARDWARE T7 ([REP03-450](#)))

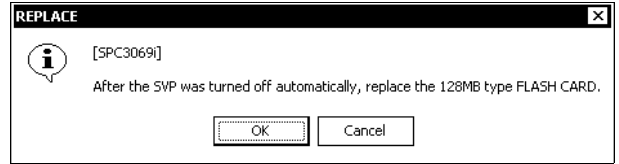

[End of PRE-PROCEDURE]

[9] MONI-CON 1/2

1. <Checking DKUMN switch>

Set the DKUMN switches to “DISABLE” and then select (CL) the [OK] in response to the following message.

“Please switch “DKUMN-n” of all DKUs (the DKUMN-F switches are located on the front side of the DKUs and the DKUMN-R switches, on the rear side of the DKUs) to “DISABLE.” Then press OK.”

(For the locations and connections of the DKUMN switches, refer to pages [LOCATION02-10](#) and [LOCATION05-40](#) of LOCATION SECTION respectively.

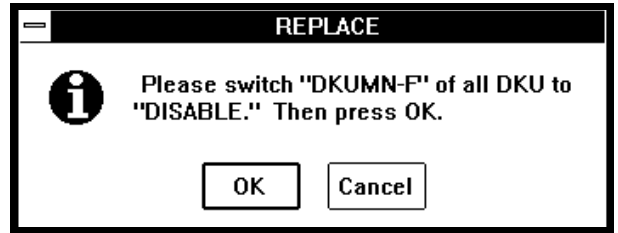

DKUMN-n:

- In the case of the MONI-CON1
 - n = F (DKUMN-F): Reset the DKUMN switch on the front side of the DKU to “DISABLE.”
- In the case of the MONI-CON2
 - n = R (DKUMN-F): Reset the DKUMN switch on the rear side of the DKU to “DISABLE.”

2. <Checking beginning of special part replacement>

A message, “Please replace the XXXXX. After replacement, press OK.” is displayed. (Select (CL) the [OK] after replacing the special part.)

See HARDWARE Tx (page REP03-xxx).

[End of PRE-PROCEDURE]

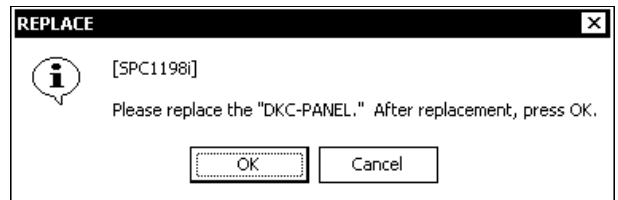

(ex. DKC - PANEL)

[10] RS CON, HUB-BOX

1. <Check beginning of special part Replacement>
 “Please replace the "XXXXXX." After replacement, press OK.” is displayed.
 (Reply with [OK] after replacing the special part.)

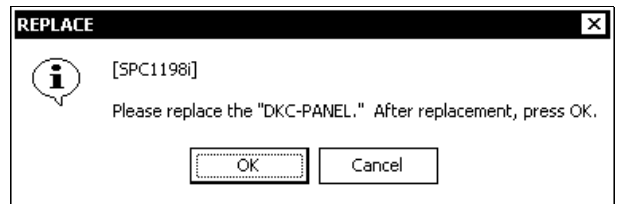

(ex. DKC-PANEL)

RS CON -----see HARDWARE T19 ([REP03-710](#))HUB-BOX-----see HARDWARE T25 ([REP03-930](#))

[End of PRE-PROCEDURE]

[11] SVPPS-BOX

1. <Check environment monitor stopped state>
“Processing to disable the environment check...” is displayed.

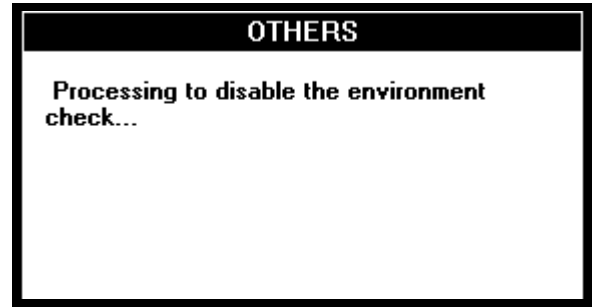

2. <Attaching a jumper plug>
You must ensure that an Optional SVP is powered off.
Attach a jumper plug to the SVPPS-BOX in response to a message, “Please attach PS SD jumper plug. Then press OK.”
(See Steps 2 and 3 in HARDWARE T26 (REP03-960).)

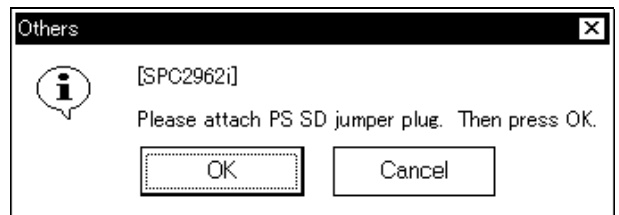

After making sure that the jumper plug has been attached, select (CL) [OK].

3. <Check beginning of special part Replacement>
“Please replace the "XXXXX." After replacement, press OK.” is displayed.
(Select (CL) [OK] after the replacement.)

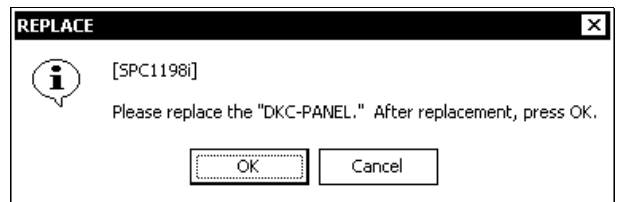

(ex. DKC-PANEL)

See HARDWARE T26 (REP03-950).

[End of PRE-PROCEDURE]

[12] Switch SVPs with Transfer Config Data

1. <Transferring Subsystem Configuration Data>

The message “Transferring subsystem configuration data...” is displayed.

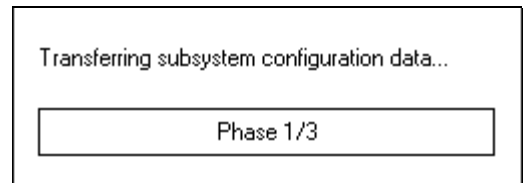

2. <Checking beginning of the SVP switching >

The message “Switching SVPs has started.” is displayed.
The SVP is powered off automatically owing to the SVP switching. Make sure that the Standby SVP has started up.

See SVP POST-PROCEDURE t1 ([REP04-320](#)).

[End of PRE-PROCEDURE]

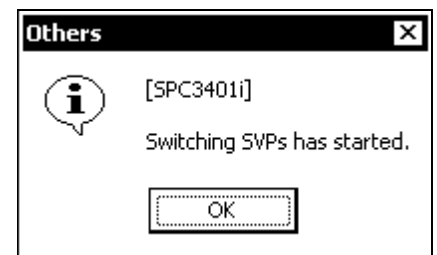

[13] Transfer configuration data only

1. <Status>
“Transferring subsystem configuration data...” is displayed.

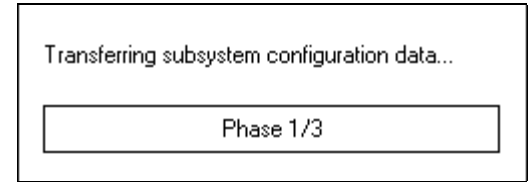

2. <Check end of transferring>
“Configuration data has been transferred.” is displayed. Select OK.

See SVP POST-PROCEDURE t1 ([REP04-320](#)).

[End of PRE-PROCEDURE]

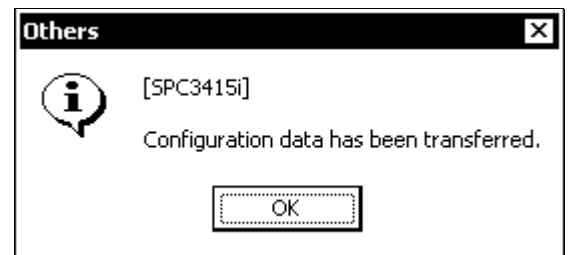

3.
(Multi Cabinet Model)
Close 'DKC' window.
Close 'Maintenance' window.

(Single Cabinet Model)
Close 'Controller' window.
Close 'Maintenance' window.

Go to POST-PROCEDURE z ([REP04-1400](#)).

[PRE-PROCEDURE T3]

— OUTLINE —

- ① Select special (DKC) part (status check).
- ② Specify Replacement.
- ③ Detach parts related to special part.
- ④ Place parts related to special part into unpluggable state.

[1] Select special part

1. <Maintenance window>

(Multi Cabinet Model)

In the 'Maintenance' window, check and select (CL) [DKC] to be replaced.

(Single Cabinet Model)

In the 'Maintenance' window, check and select (CL) [Controller] to be replaced.

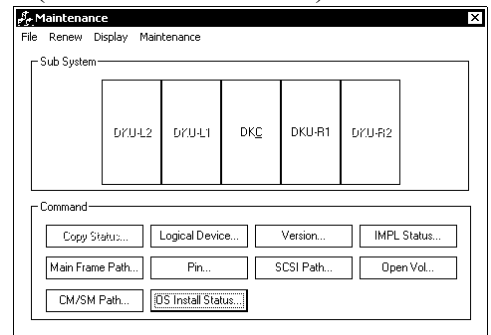
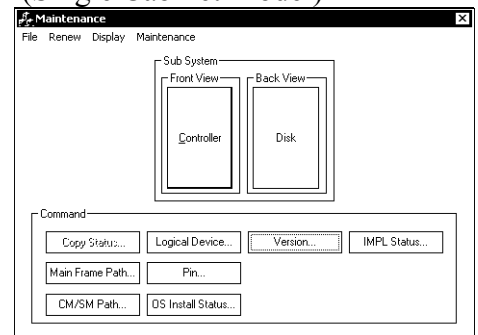
(Multi Cabinet Model)**(Single Cabinet Model)**

2. <DKC window>

(Multi Cabinet Model)

Select (CL) [Cluster-n] in the 'DKC'.

(Single Cabinet Model)

Select (CL) [Cluster-n] in the 'Controller'.

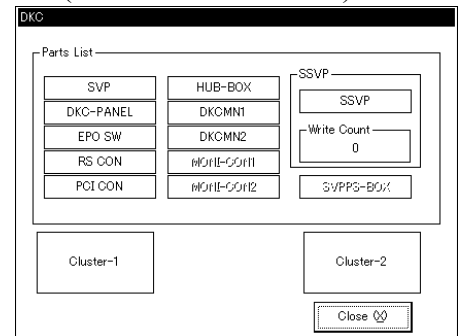
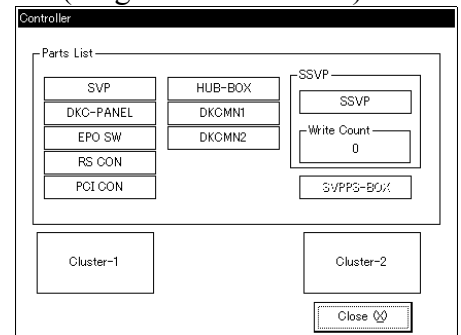
(Multi Cabinet Model)**(Single Cabinet Model)**

3. <Select special part>

If any other message than the list is displayed, see the SVP Message Section (SVPMSG00-00).

Select (CL) part [XXXX] to be replaced from [Cluster-n] (Multi Cabinet Single Phase Model, Multi Cabinet 3 Phase Model window.

Valid [XXXX] values are listed below.

- Fan assembly(DKC) ... [FAN]
- PS..... [5/3VPSn], [3VPSn], [3/12VPSn], [SUBPS] (Select [3VPSn], go to step 4.)
- SVP-PS [SVP-PSn]
- Battery, BAT CTR..... [BATTERY-mm, BAT CTR-mm]
- Breaker Box [BREAKER BOX-n]
- Thermostat assembly .. [TH]
- AC BOX(DKC) [AC BOX-Cn]

Go to step 5.

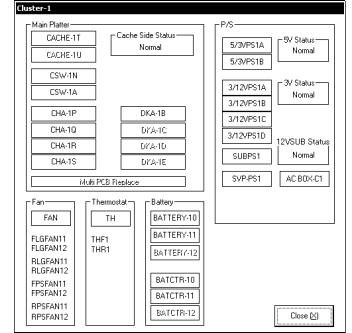

(Multi Cabinet 3 Phase Model [Without 30A AC BOX])

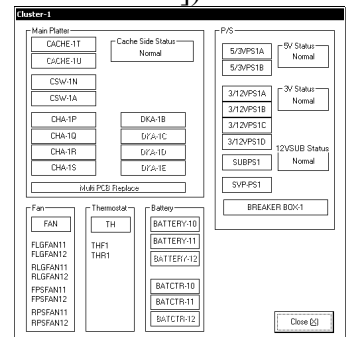

(Single Cabinet Model)

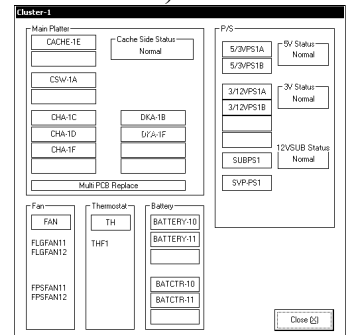

(ex. Cluster-1)

4.

A message “If you want to install the ENABLER KIT, select the [Install ENABLER] check box.” is displayed.

If you want to install the ENABLER KIT

----- Select the [Install ENABLER] check box, select (CL) [OK].

If you don't want to install the ENABLER KIT

----- Select (CL) [OK].



5.

Select (CL) [Execute].

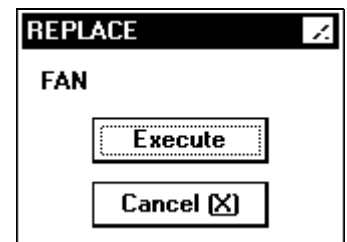

(ex. Fan assembly)

6. <Check beginning of special part Replacement>

Select (CL) [Yes] in response to “Do you want to replace the "XXXXX?".”.

XXXXX represents one of the part names listed in step 3.

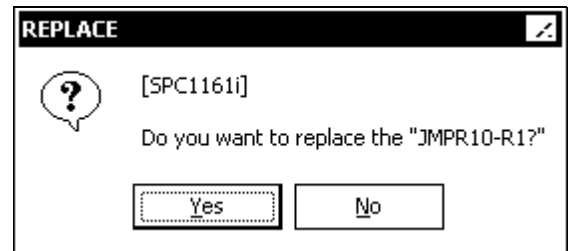

(ex. JMPR10-R1)

- “Fan assembly” ----- Go to [2] ([REP02-700](#))
- “Thermostat assembly” -- Go to [2] ([REP02-700](#))
- “5/3V PSn” ----- Go to [3] ([REP02-710](#))
- “3V PSn” ----- Go to [3] ([REP02-710](#))
- “3/12V PSn” ----- Go to [3] ([REP02-710](#))
- “SUBPSn” ----- Go to [3] ([REP02-710](#))
- “BATTERY-n” ----- Go to [4] ([REP02-720](#))
- “BAT CTR-n” ----- Go to [5] ([REP02-730](#))
- “SVP-PSn” ----- Go to [7] ([REP02-745](#))
- “BREAKER BOX-n” ---- Go to [6] ([REP02-740](#))
- “AC BOX-Cn” ----- Go to [6] ([REP02-740](#))

[2] Fan assembly, Thermostat assembly

1. <Check environment monitor stopped state>
“Processing to disable the environment check...” is displayed.

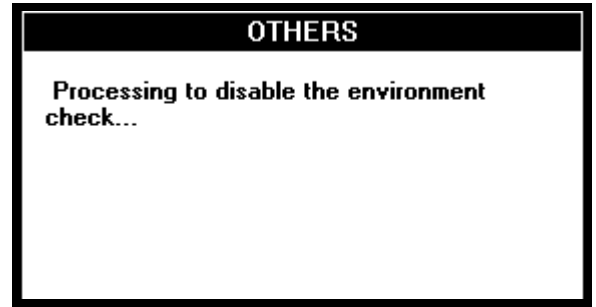

2. <Special part Replacement>
“Please replace the "XXXXX." After replacement, press OK.” is displayed.
(Reply with [OK] after replacing the special part.)

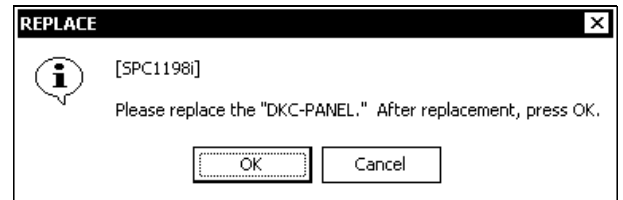

(ex. DKC-PANEL)

Fan assembly----- see HARDWARE T5 ([REP03-410](#))
Thermostat assembly---- see HARDWARE T6 ([REP03-430](#))

[End of PRE-PROCEDURE]

[3] 5/3V PS, 3V PS, 3/12V PS, SUBPS

1. <Check matching power supply>

The SVP automatically checks the power supply to see if it is replaceable.

2. <Environment monitor state>

“Processing to disable the environment check...” is displayed.

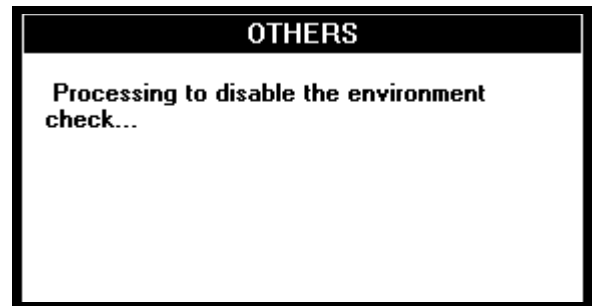

3. <Special part replacement>

- v The message shown on the right is displayed.
(Reply with [OK] after replacing the special part.)

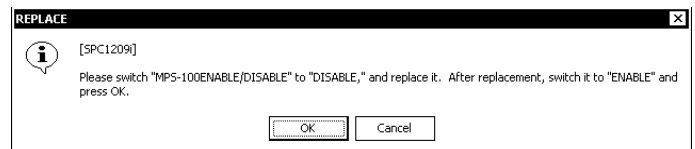

(ex. MPS-R100)

see HARDWARE T13 ([REP03-620](#))

[End of PRE-PROCEDURE]

[4] BATTERY

1. <Check BAT CTR>

The message which checks revision of BAT-CTR is displayed.

Check whether the revision of specified BATCTR.

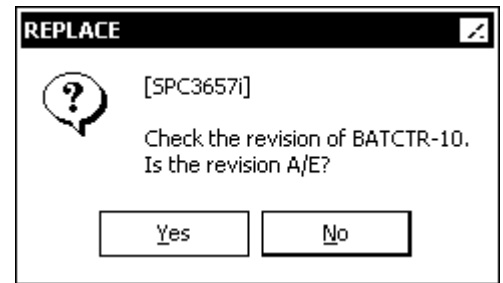

(ex. Replacement of BATTERY-10)

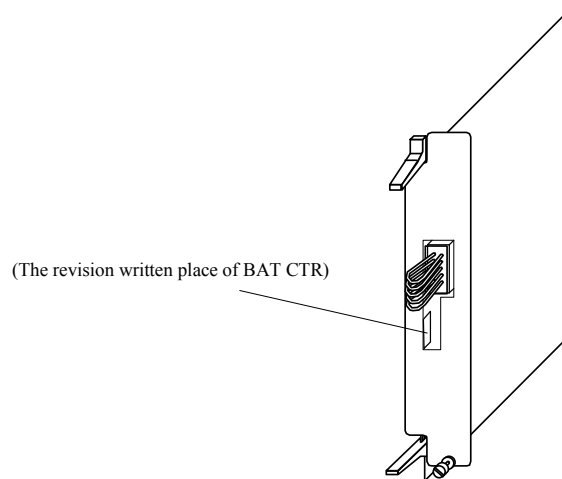

- A/E: BATTERY of this revision cannot be replaced. Select (CL) [Yes] and end this processing.
- Except A/E: Select (CL) [No] and go to step 2.

2. <Check of BATCTR removal>

“When you want to replace a BATTERY-XX, you should remove the BATCTR-XX from the subsystem.

Do you want to replace the BATTERY-XX?” is displayed.

Select (CL) [Yes].

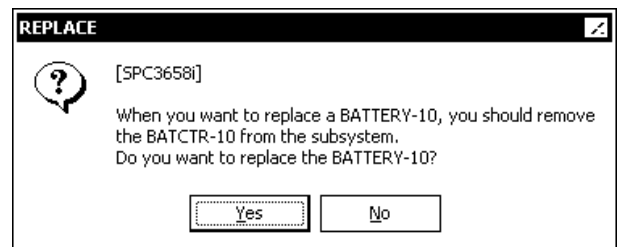

(ex. BATTERY-10)

3. <Check source power>

The SVP automatically checks the 5/3V power supply to determine whether it is not shut down.

4. <Check environment monitor stopped state>
 “Processing to disable the environment check...” is displayed.

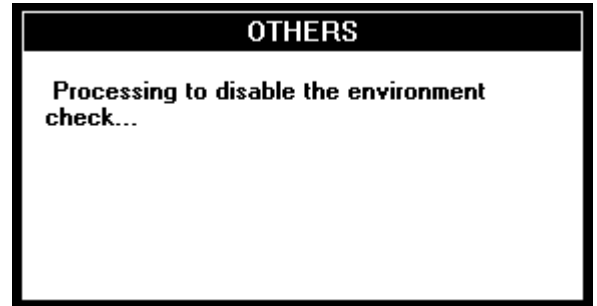

5. The message “Is the LED of BATCTR-XX turned on?” is displayed.
 If you select (CL) [Yes], go to step 4.
 If you select (CL) [No], go to step 3.

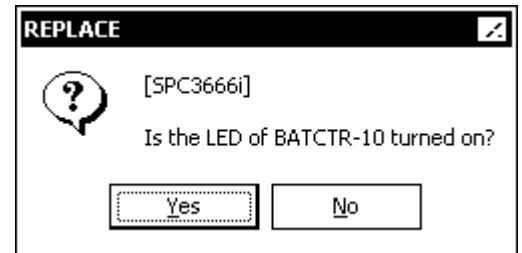

(ex. Replacement of BATTERY-10)

6. The message shown on the right is displayed.
 Check the location of the BATCTR.
 (see HARDWARE T12 ([REP03-600](#)))
 Select (CL) [OK].

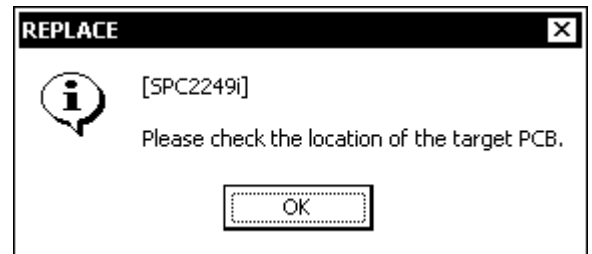

7.

Remove a specified BATCTR according to the following message.

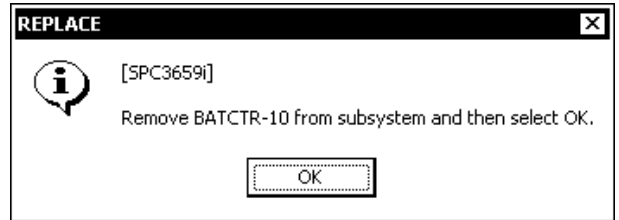

(ex. Replacement of BATTERY-10)

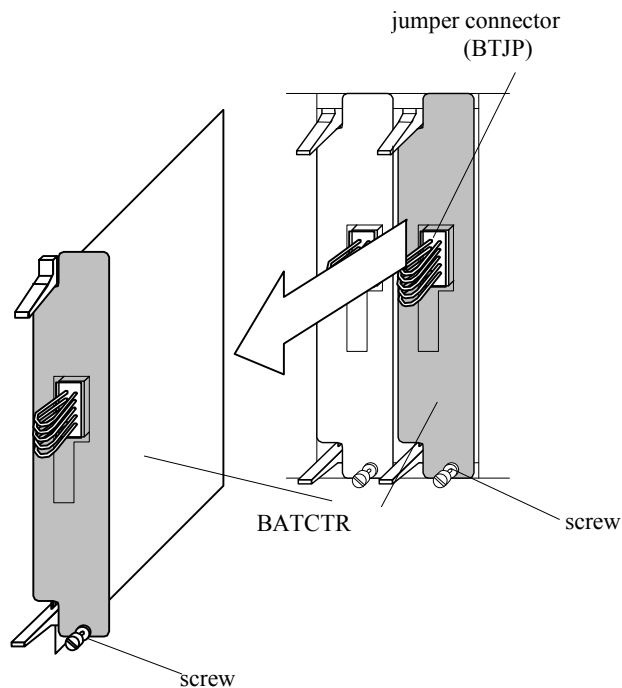

(BAT CTR remove)

Loosen the screw and remove BATCTR10 with jumper connector.

Select (CL) [OK].

8. <Check beginning of special part Replacement>
 “Please replace the "XXXXX." After replacement, press OK.” is displayed.
 (Reply with [OK] after replacing the special part.)

see HARDWARE T11 ([REP03-570](#)).

[End of PRE-PROCEDURE]

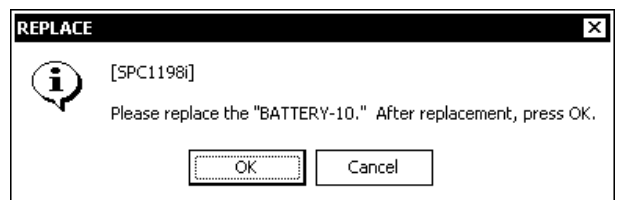

(ex. BATTERY-10)

[5] BATCTR

1. <Check source power>

The SVP automatically checks the 5/3V power supply to determine whether it is not shut down.

2.

The message “Are the LED of the target PCB(s) turned on?” is displayed.

If you select (CL) [Yes], go to step 4.

If you select (CL) [No], go to step 3.

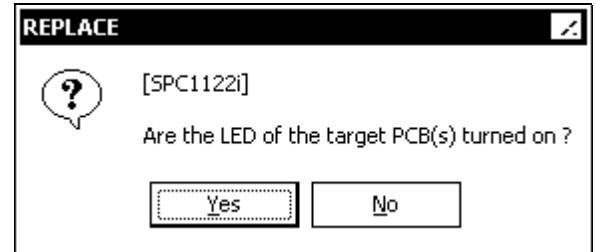

3.

The message shown on the right is displayed.

Check the location of the BATCTR.

(see HARDWARE T12 ([REP03-600](#)))

Select (CL) [OK].

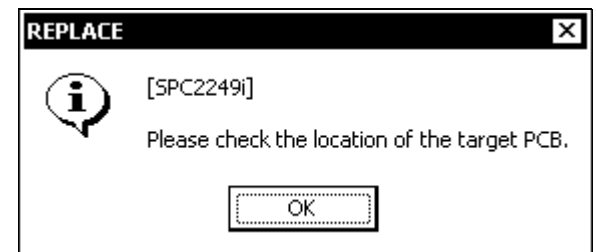

4. <Check beginning of special part Replacement>

“Please replace the "XXXXX." After replacement, press OK.” is displayed.

(Reply with [OK] after replacing the special part.)

see HARDWARE T12 ([REP03-600](#))

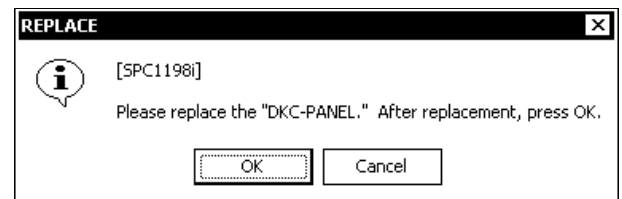

(ex. DKC-PANEL)

[End of PRE-PROCEDURE]

[6] BREAKER BOX, AC BOX(DKC)

These parts equip Multi Cabinet Model only.

1. <Check matching power supply>

The SVP automatically checks the power supplies to see if the part is replaceable.

2. <Check environment monitor stopped state>

“Processing to disable the environment check...” is displayed.

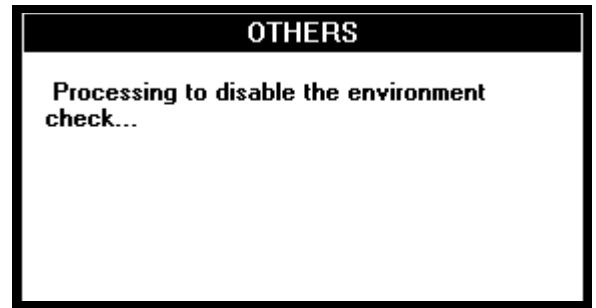

3.

In the case of Breaker Box replacement with 1-Phase Power Supply option, SVP displays “Installed AC BOX is 1-Phase type. Turn off the DKC AC BOX which supplies power source for XXXXX, when you replace it.” Message. Select (CL) [OK].
In the other case, go to [4].

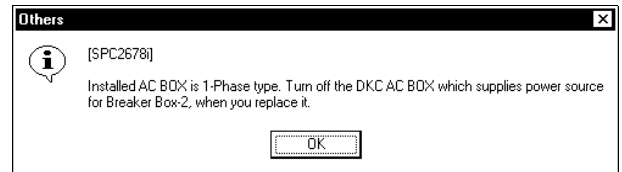

(ex. BREAKER BOX-2)

4.

The message shown on the right is displayed. (Reply with [OK] after replacing the special part.)

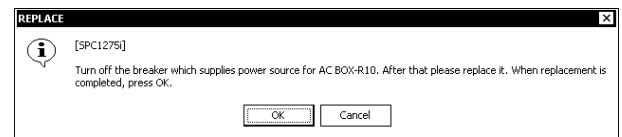

(ex. AC BOX-R10)

BREAKER BOX-1 -----see HARDWARE T9 (REP03-1000) of Multi Cabinet Model
Maintenance Manual

BREAKER BOX-2 -----see HARDWARE T10 (REP03-1070) of Multi Cabinet Model
Maintenance Manual

AC BOX(DKC) -----see HARDWARE T21 (REP03-750) of Multi Cabinet Model
Maintenance Manual

[End of PRE-PROCEDURE]

[7] SVPPS

1. <Check matching power supply>

The SVP automatically checks the power supply to see if it is replaceable.

2.

Please attach the jumper in response to the displayed message.
(see **HARDWARE T23 (REP03-890)** step 1))
Select (CL) [OK].

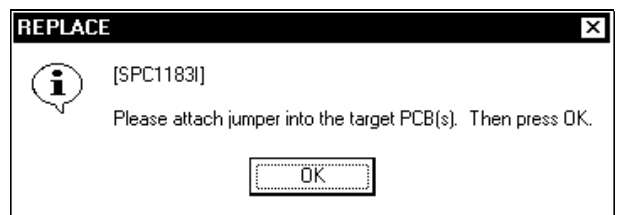

3.

The message "Please replace the "SVPPS1."
After replacement, press OK." is displayed.
(Reply with [OK] after replacing the special part.)

see **HARDWARE T23 (REP03-880)**

[End of PRE-PROCEDURE]

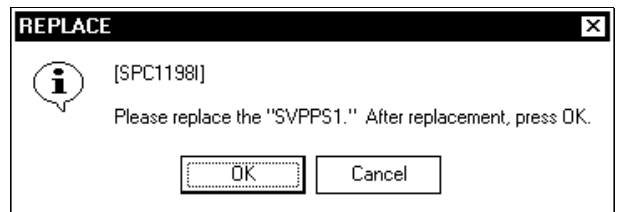

[PRE-PROCEDURE T4]

— OUTLINE —

- ① Select special (DKU) part (status check).
- ② Specify Replacement.
- ③ Detach parts related to special part.
- ④ Place part into unpluggable state.

[1] Select special part

1. <Select DKU-X>

(Multi Cabinet Model)

Select (CL) [DKU] from 'Maintenance'.

(Single Cabinet Model)

Select (CL) [Disk] from 'Maintenance'.

(Multi Cabinet Model)

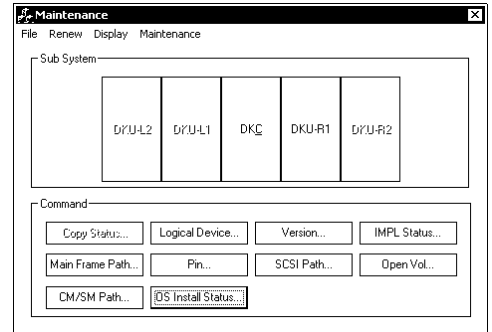

(Single Cabinet Model)

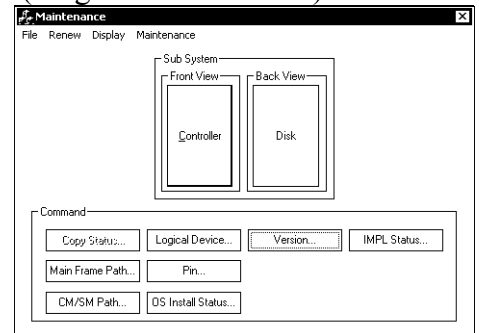

2. <Specify special part>

Select part [XXXXXX] to be Replaced.

- DKUMN ----- [DKUMN-X]
- AC BOX ----- [AC BOX-X]
- Fan assembly (DKU455, Single Cabinet Model)
----- [HDDFAN-X]

Go to step 4.

- Fan assembly (DKU405)
- SW PS (DKU Multi)
- JMP

Select (CL) [HDU-X]. Go to step 3.

(Multi Cabinet Model [DKU455])

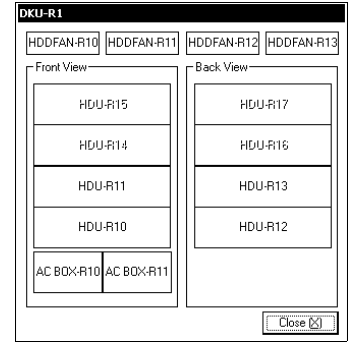

(ex. DKU-R1)

(Multi Cabinet Model [DKU405])

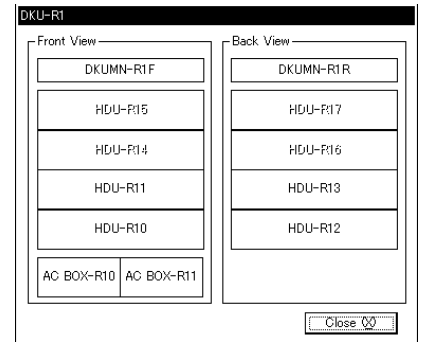

(ex. DKU-R1)

(Single Cabinet Model)

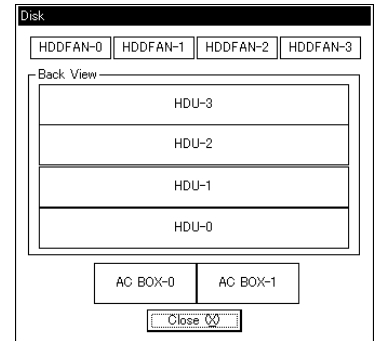

3. <Specify special part>

Perform the replacement using the [HDU-x] window.
Select (CL) [xxxxxx].

- Fan assembly (DKU405) ---- [FAN-X]
- SW PS (DKU, Multi) ----- [MPS-n]
- JMP----- [JMPY-m]

(Multi Cabinet Model [DKU455])

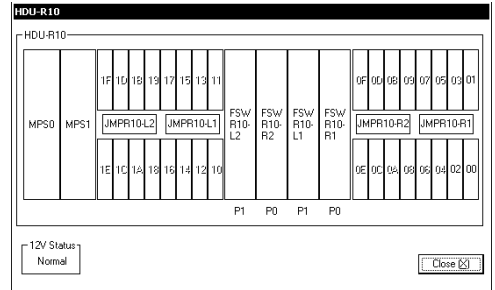

(ex. HDU-R10)

(Multi Cabinet Model [DKU405])

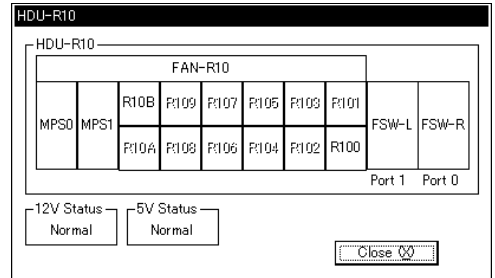

(ex. HDU-R10)

(Single Cabinet Model)

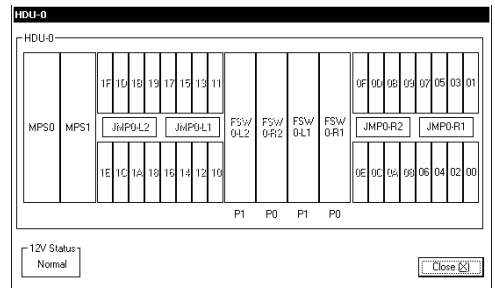

(ex. HDU-0)

4. <Specify special part Replacement>

If any other message than the list is displayed, see the SVP Message Section ([SVPMSG00-00](#)).

Select (CL) [Execute].



(ex. DKUMN-R1F of Multi Cabinet Model)

5. <Special part Replacement>

Select (CL) [Yes] in response to “Do you want to replace the "XXXXXX?"”.

XXXXXX represents one of the part names listed in step 2 or 3.

Valid [XXXXXX] values are listed below.

- ‘DKUMN-X’ -----Go to [2] ([REP02-780](#))
- ‘MPS-X’ -----Go to [3] ([REP02-790](#))
- ‘Fan assembly’ -----Go to [4] ([REP02-800](#))
- ‘AC BOX-X’ -----Go to [5] ([REP02-810](#))
- ‘JMPY-m’ -----Go to [6] ([REP02-815](#))

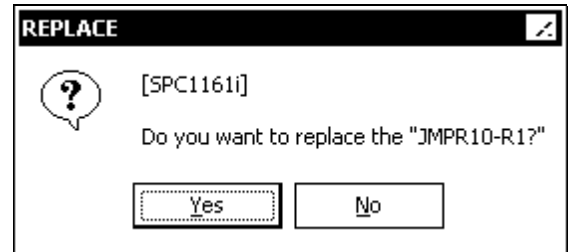

(ex. Jmpr1U-R1)

[2] DKUMN PCB

1. <Environment monitor state>
 “Processing to disable the environment check...” is displayed.

(Multi Cabinet Model)

- DKUMN-R3n, DKUMN-L3n ----- Go to 3

(Single Cabinet Model)

Go to 3.

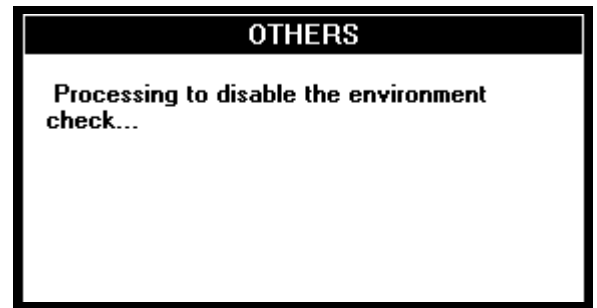

2. <Disable DKUMN>

When Multi Cabinet Model, if DKUMN-XXX (listed below) is installed, this message is displayed.

Disable the DKUMN in response to “Please switch DKUMN-X to DISABLE.

Then press OK.” (see HARDWARE T14 (REP03-xxx)).

After confirming that the DKUMN-X has been disabled, select (CL) [OK].

DKUMN-X (Multi Cabinet Model):

Replace parts	X
DKUMN-R1F	R2F, R3F
DKUMN-R1R	R2R, R3R
DKUMN-R2F	R3F
DKUMN-R2R	R3R
DKUMN-L1F	L2F, L3F
DKUMN-L1R	L2R, L3R
DKUMN-L2F	L3F
DKUMN-L2R	L3R

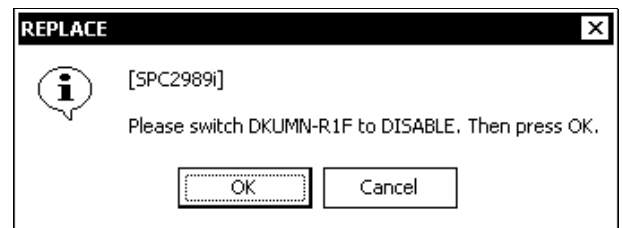

(ex. Replacement of the DKUMN-R1F)

3. <Special part Replacement>

“Please switch "DKUMN-X" to "DISABLE," and replace it. After replacement, switch it to "ENABLE" and press OK.” is displayed.

(Reply with [OK] after replacing the special part.)

see HARDWARE T24 ([REP03-910](#))

[End of PRE-PROCEDURE]

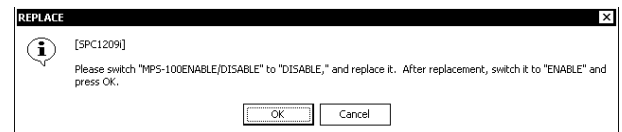

(ex. MPS-R100)

[3] MPS (DKU, Disk)

1. <Check matching power supply>

The SVP automatically checks that the mate power supply is normal.

2. <Environment monitor state>

“Processing to disable the environment check...” is displayed.

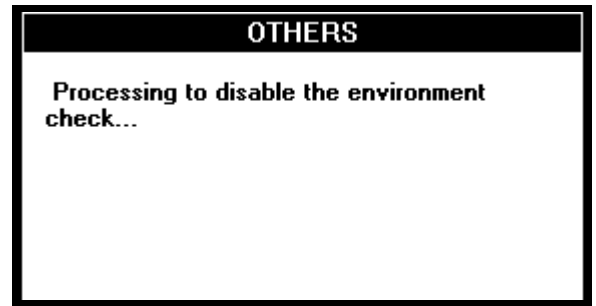

3. <Special part replacement>

The message shown on the right is displayed.
(Reply with [OK] after replacing the special part.)

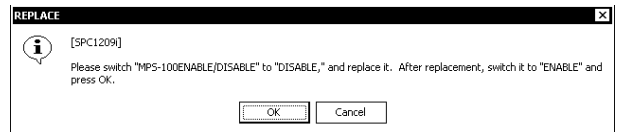

(ex. MPS-R100)

see HARDWARE T15 ([REP03-660](#))

[End of PRE-PROCEDURE]

[4] Fan assembly

1. <Environment monitor state>
“Processing to disable the environment check...” is displayed.

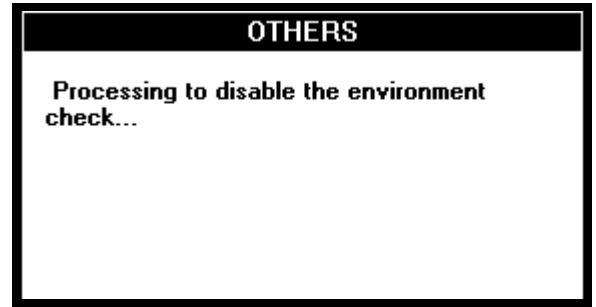

2. <Special part Replacement>
“Please replace the "XXXXX." After replacement, press OK.” is displayed.
(Reply with [OK] after replacing the special part.)

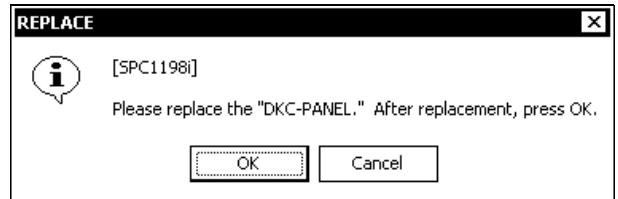

(ex. DKC-PANEL)

see HARDWARE T16 ([REP03-690](#))

[End of PRE-PROCEDURE]

[5] AC BOX

1.

(Multi Cabinet Model)

“The AC BOX that you will replace is XXXX. Please confirm type of maintenance part. Do you want to continue?” is displayed. Confirm the maintenance part “XXXX” with Power Supply option, and select (CL) [Yes].
 XXXX : 3-Phase type
 1-Phase type

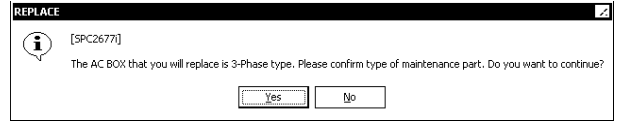

(Single Cabinet Model)

Go to 2.

2.

The SVP automatically checks the power supplies to see if AC BOX is replaceable.

3.

<Check environment monitor stopped state>
 “Processing to disable the environment check...” is displayed.

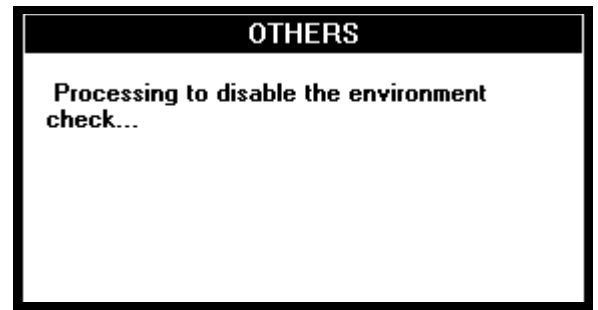

4.

“Turn off the breaker which supplies power source for AC-BOX-X. After that please replace it. When replacement is completed, press OK.” is displayed.
 (Reply with [OK] after replacing the special part.)

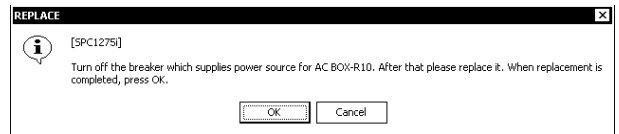

(ex. AC BOX-R10 of Multi Cabinet Model)

AC BOX-R10(3 Phase Type for Multi Cabinet Model)

-----see HARDWARE T17

AC BOX(except AC BOX-R10 of 3 Phase Type for Multi Cabinet Model)

-----see HARDWARE T18

AC BOX(1 Phase Type for Multi Cabinet Model) -----see HARDWARE T22

AC BOX(Single Cabinet Model) -----see HARDWARE T21 ([REP03-750](#))

[End of PRE-PROCEDURE]

[6] JMP

1. <Check environment monitor stopped state>
“Processing to disable the environment check...” is displayed.

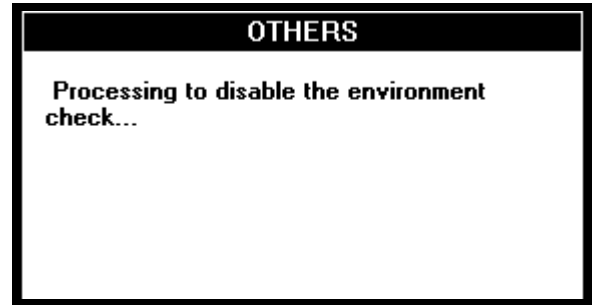

2. The message “Are the LED of the target PCB(s) turned on?” is displayed.
If you select (CL) [Yes], go to step 4.
If you select (CL) [No], go to step 3.

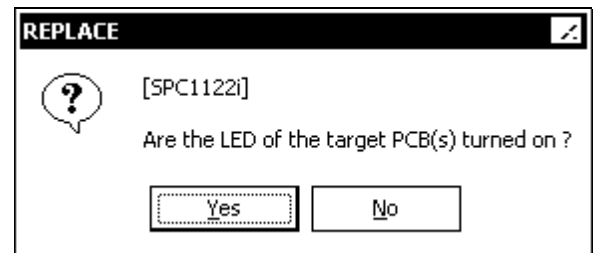

3. The message shown on the right is displayed.
Check the location of the JMP.
(see HARDWARE T24 ([REP03-910](#)))
Select (CL) [OK].

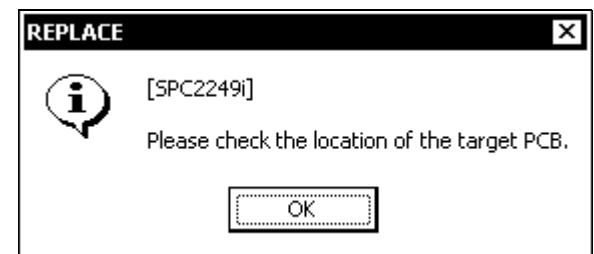

4. <Check beginning of special part Replacement>
“Please replace the "XXXXX." After replacement, press OK.” is displayed.
(Reply with [OK] after replacing the special part.)

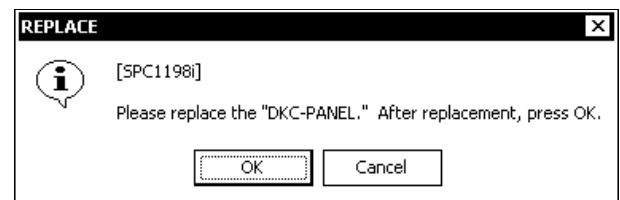

(ex. DKC-PANEL)

Note: If the switch is wrongly set, an error message is displayed. Reset the switch correctly and replace the part concerned. After the replacement, select (CL) [Retry].

[End of PRE-PROCEDURE]

[PRE-PROCEDURE T5]

— OUTLINE —

- ① Select a procedure for SVP replacement.
- ② Replace an SVP.

[1] Select a procedure for the SVP replacement.

If SVP High Reliability Kit is installed, SVP of a standby state and Flash Card of a master state replaced are to foundations. When SVP for replacement and/or SVP in which Flash Card, replace it after switching the SVP to a suitable state.

1.

Select a procedure for replacing an SVP and/or a Flash Card according to a part(s) to be replaced.

- “SVP” ----- Go to [2] ([REP02-835](#))
- “SVP & FLASH CARD” ----- Go to [2] ([REP02-835](#))
- “FLASH CARD” ----- Go to [3] ([REP02-840](#))

But when you must replace SVP and/or SVP in which Flash Card is working as a master.

- “SVP”, “SVP & FLASH CARD” (by the side of a Master)
----- Go to [4] ([REP02-845](#))

[2] Replacement of an SVP with or without a Flash Card

1. <Checking the SVP to be replaced>

Check whether the SVP to be replaced is a Basic SVP or an Optional SVP. (For the location of the SVP, refer to LOCATION SECTION ([LOCATION02-10](#))).

When the SVP to be replaced is operating as a Standby SVP and powered off, go to Step4.

When the SVP to be replaced is operating as a Master SVP, go to Step 2.

When the SVP to be replaced is powered on, go to Step 3.

2. <Switching the SVP>

When you want to replace an SVP, it is necessary to place it in the Standby mode. Replace the SVP from the beginning (PRE-PROCEDURE A) after switching (Switch SVP ([REP02-525](#))) it if necessary. When you want to replace the SVP without performing the switching, refer to Item [4] Replacement of an SVP, a Flash Card (by the side of Master) ([REP02-845](#)).

3. <Powering off the Standby SVP>

When the SVP to be replaced is powered on, shutdown the OS by manual operation and go to Step 4 after checking that the SVP has been powered off.

4. <Replacing hardware>

Replace the SVP according to HARDWARE T7 ([REP03-450](#)).

[End of PRE-PROCEDURE]

[3] Replacement of a Flash Card

1. <Checking the SVP to be replaced>

Check whether the SVP in which the Flash Card to be replaced is inserted is a Basic SVP or an Optional SVP. (For the location of the SVP, refer to LOCATION SECTION (LOCATION02-10).)

When the SVP to be replaced is operating as a Master SVP, go to Step 3.

When the SVP to be replaced is operating as a Standby SVP, go to Step 2.

2. <Switching the SVP>

When you want to replace a FLASH CARD, it is necessary to place it in the Master mode. Replace the FLASH CARD from the beginning (PRE-PROCEDURE A) after switching the SVP (Switch SVP (REP02-525)) if necessary.

3. <Specify special part>

(Multi Cabinet Model)

Select (CL) part [SVP] to be replaced from “DKC”.

(Single Cabinet Model)

Select (CL) part [SVP] to be replaced from “Controller”.

(Multi Cabinet Model)

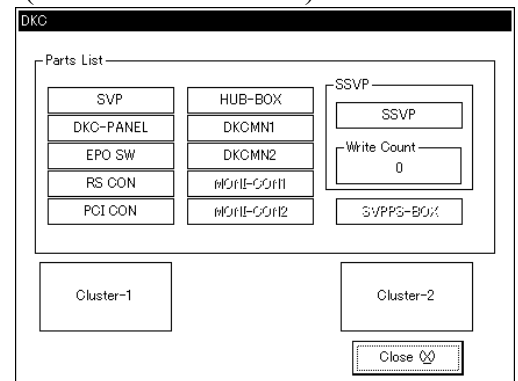

(Single Cabinet Model)

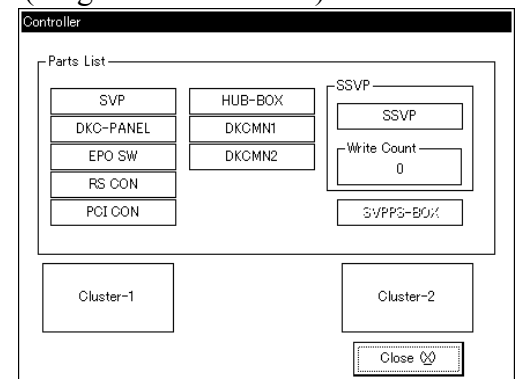

A window shown on the right is displayed.
Select (CL) “Replace” and select replacement parts [FLASH CARD], and select (CL) [Execute].

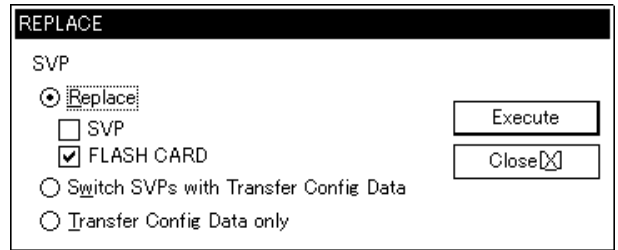

<Check beginning of special part Replacement>

In response to a message, “There are duplicated SVPs. It is safer if you switch to the other SVP and replace FLASH CARD according to the instruction in the maintenance manual. Do you want to replace FLASH CARD?”, select (CL) [Yes]. Since procedure differs, select (CL) [No].

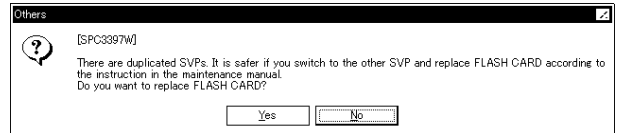

In response to a message, “DKC-SVP communication will be blocked. Do you want to replace the “FLASH CARD?””, select (CL) [Yes].

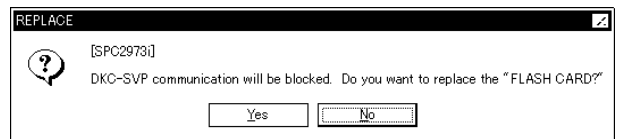

4. <Check beginning of FLASH CARD>

The message “After the SVP was turned off automatically, replace the 128MB type FLASH CARD.” is displayed.

Select (CL) [OK], so it will reboot the SVP, and the files on FLASH CARD are moved to HD. Then SVP is turned off automatically.

See HARDWARE T7 ([REP03-450](#)).

[End of PRE-PROCEDURE]

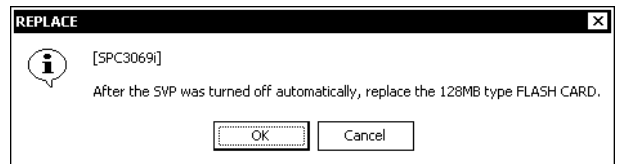

[4] Replacement of an SVP with or without a FLASH CARD (by the side of Master)

1. <Specify special part>

(Multi Cabinet Model)

Select (CL) part [SVP] to be replaced from "DKC".

(Single Cabinet Model)

Select (CL) part [SVP] to be replaced from "Controller".

(Multi Cabinet Model)

The screenshot shows a window titled "DKC" with a "Parts List" section. The parts list is organized into several columns and rows:

SVP	HUB-BOX	SSVP
DKC-PANEL	DKCMN1	SSVP
EPO SW	DKCMN2	Write Count 0
RS CON	MONI-CON1	SVPPS-BOX
PCI CON	MONI-CON2	

Below the parts list, there are two buttons labeled "Cluster-1" and "Cluster-2", and a "Close" button with a mouse cursor icon.

(Single Cabinet Model)

The screenshot shows a window titled "Controller" with a "Parts List" section. The parts list is organized into several columns and rows:

SVP	HUB-BOX	SSVP
DKC-PANEL	DKCMN1	SSVP
EPO SW	DKCMN2	Write Count 0
RS CON		SVPPS-BOX
PCI CON		

Below the parts list, there are two buttons labeled "Cluster-1" and "Cluster-2", and a "Close" button with a mouse cursor icon.

A window shown on the right is displayed.
 Select (CL) "Replace" and select replacement parts
 [xxxxx], and select (CL) [Execute].
 Valid [XXXXX] values are listed below.

- SVP----- [SVP]
- SVP & FLASH CARD -- [SVP][FLASH CARD]

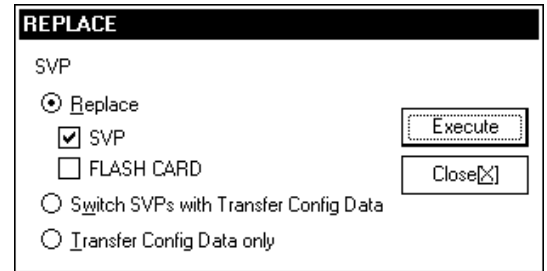

<Check beginning of special part Replacement>

In response to a message, "There are duplicated SVPs. It is safer if you switch to the other SVP and replace SVP according to the instruction in the maintenance manual. Do you want to replace SVP?", select (CL) [Yes].

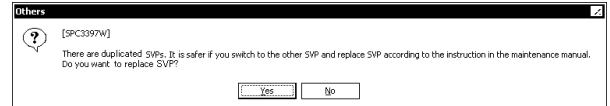

In response to a message, "DKC-SVP communication will be blocked. Do you want to replace the "SVP?"", select (CL) [Yes].

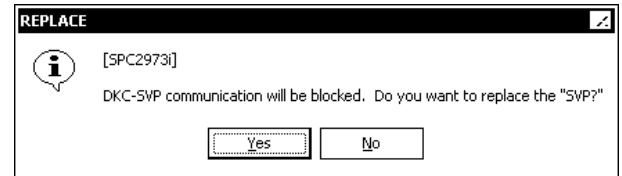

(ex. SVP)

2. <Checking the SVP to be replaced>

Check whether the Master SVP is a Basic SVP or an Optional SVP. (For the location of the SVP, refer to LOCATION SECTION ([LOCATION02-10](#).)

3. <Attaching a jumper plug>

The attachment position of a jumper is different with mounted positions of SVP for replacement.

When the SVP is a Basic SVP:

Attach a jumper plug to JP2 on the RS CON in response to a message, “Please attach SVP PS ON/OFF INH jumper plug. Then press OK.” (See HARDWARE T7 (Step 4 on [REP03-470](#)))

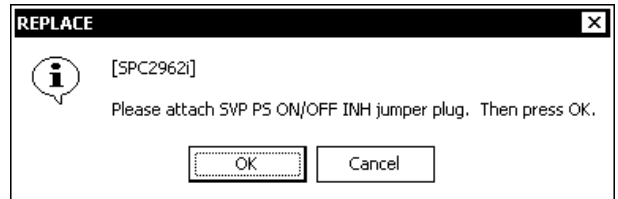

When the SVP is an Optional SVP:

Attach a jumper plug to PS CTLINH PIN on the SVPPS-BOX and JP2 on the RS CON in response to a message, “Please attach PS CTLINH jumper plug. Then press OK.” (See HARDWARE T7 (Step 4 on [REP03-470](#)))



After making sure that the jumper plug has been attached, select (CL) [OK].

Note: Do not attach the shutdown jumper (JP1 on the RS CON, PS SD PIN on the SVPPS BOX).

4.

SIM bf85a2 is reported when a jumper is inserted to SVP PS ON/OFF INH PIN at Step 3. SIM can be referred to [Information]-[Log].

5.

The message “After the SVP turned off automatically, replace the XXXXX.” is displayed.

If the CD-ROM disk inserted into the CD-ROM drive, remove the CD-ROM disk. Select (CL) [OK], so SVP is turned off automatically.

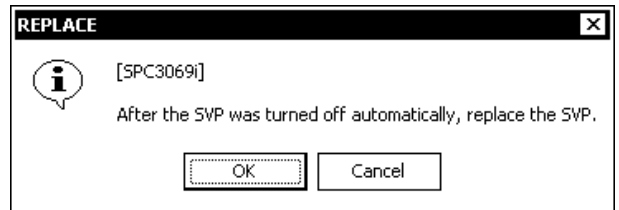

See HARDWARE T7 ([REP03-450](#)).

[End of PRE-PROCEDURE]

Blank Sheet

REV.4	Jun.2002	Jul.2002	Sep.2002	Sep.2003	Jan.2004	
-------	----------	----------	----------	----------	----------	--

[PRE-PROCEDURE V]

— OUTLINE —

- ① Select P-DEV (status check).
- ② Specify Replacement.
- ③ Place HDD into unpluggable state.

CAUTION

This processing is a special operation for detecting a cause of a Fibre loop error.
Ask the technical support center about the appropriateness of the operation.

⚠ CAUTION

This processing is a special operation for detecting a cause of a Fibre loop error. Ask the technical support center about the appropriateness of the operation.

1. <Maintenance window> (Multi Cabinet Model)
In the 'Maintenance' window, check and select (CL) [DKU-Rn] or [DKU-Ln] to be replaced.

(Single Cabinet Model)

In the 'Maintenance' window, select (CL) [Disk].

(Multi Cabinet Model)

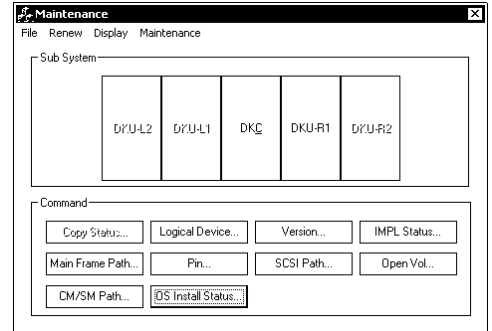

(Single Cabinet Model)

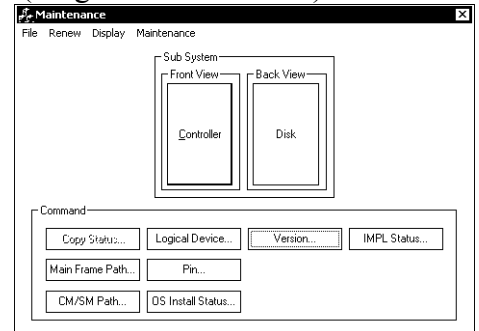

2. <Select HDU-BOX> (Multi Cabinet Model)
Check and select (CL) [HDU-Rnn] or [HDU-Lnn] to be replaced.

(Single Cabinet Model)

Check and select (CL) [HDU-n] to be replaced.

Selecting (CL) [Close] returns you to step 1.

(Multi Cabinet Model)

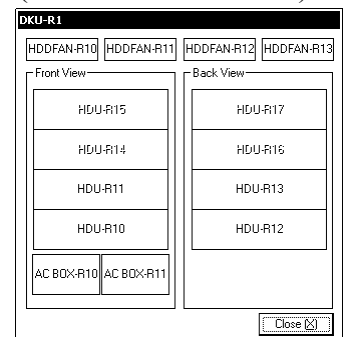

(Single Cabinet Model)

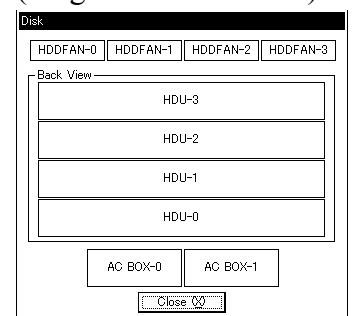

CAUTION

This processing is a special operation for detecting a cause of a Fibre loop error. Ask the technical support center about the appropriateness of the operation.

3. <Select HDD>

(Multi Cabinet Model [DKU455])
Check and select (CL) [nn] to be replaced.

(Multi Cabinet Model [DKU405])
Check and select (CL) [Rnnn] or [Lnnn] to be replaced.

(Single Cabinet Model)
Check and select (CL) [nn] to be replaced.

Selecting (CL) [Close] returns you to step 2.

(Multi Cabinet Model [DKU455])

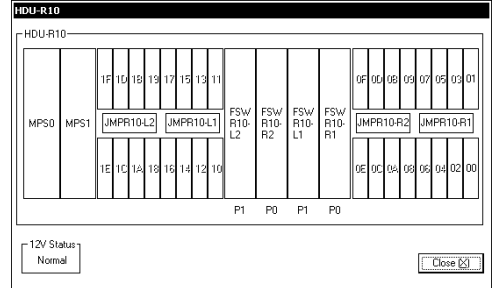

(Multi Cabinet Model [DKU405])

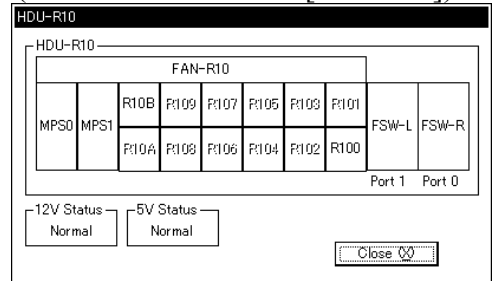

(Single Cabinet Model)

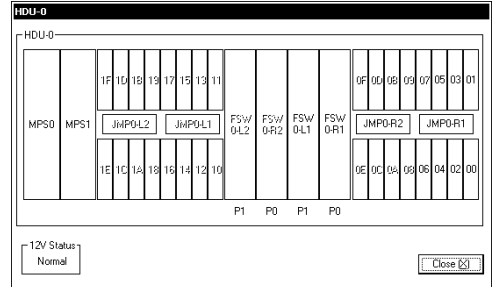

4. <Specify replacement on HDD>

Make sure that the status is FAILED or WARNING.

Select (CL) [Replace (INLINE)].

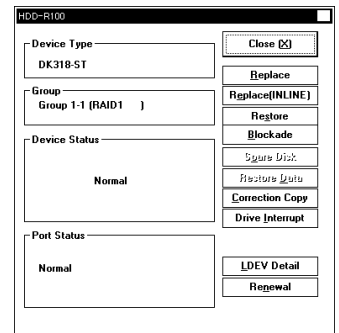

 **CAUTION**

This processing is a special operation for detecting a cause of a Fibre loop error. Ask the technical support center about the appropriateness of the operation.

If any other message than the list is displayed, see the SVP Message Section ([SVPMSG00-00](#)).

5. <Checking the P-DEV status & saving the spare>

 **CAUTION**

When the screen appears prompting the operator to input a password to prevent multiple maintenance or for executing a pin check, contact the technical support center to ask for instructions.

“Checking...” is displayed.

6. <P-DEV blocking>

Select (CL) [Yes] in response to “Are you sure you want to block the physical device?”.

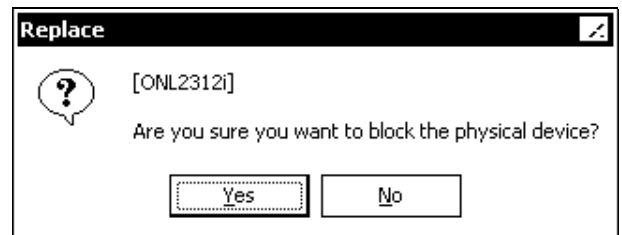

7. <Blocking the Physical device>

“Blocking...” is displayed.

8. <Spin down the Physical device>

“Spinning down...” is displayed

9. <P-DEV pull out>

Select (CL) [Yes] in response to “Are you sure you want to pull out the physical device?”.

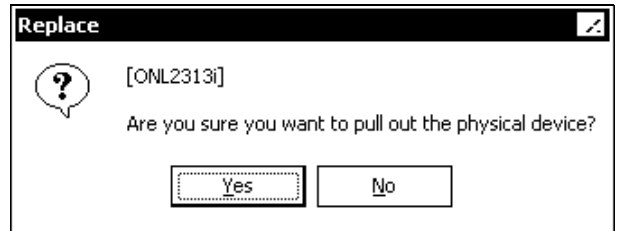

⚠ CAUTION

This processing is a special operation for detecting a cause of a Fibre loop error. Ask the technical support center about the appropriateness of the operation.

10. <Check shut down LED>

Check the shut down LED on the HDD to be replaced.

If LED is off, reconfirm the location of the HDD to be replaced with LOCATION SECTION before replacing the hardware.

⚠ CAUTION

If a wrong HDD is removed, a data loss or a system down may occur.

11. <Confirmation of replace>

Select (CL) [OK] in response to “Please replace the physical device, and then select OK.” after the unit is replaced (Step 12).

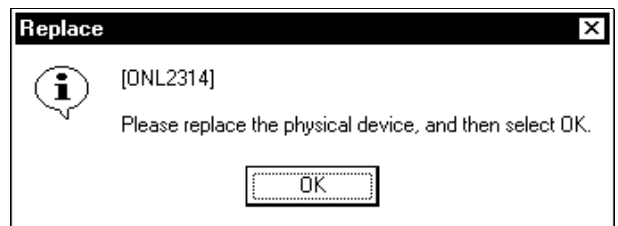

12. <Replace HDD>

Replace HDD.

See HARDWARE A ([REP03-10](#)).

[HARDWARE A]

Location	Function Name of Component		Part Name	HDA Label
HDU Box	1	HDD Canister	HDU450-36K1FC	DKS2B-K36FC DKS2C-K36FC
			HDU450-72J1FC	DKR2D-J72FC DKR2E-J72FC
			HDU450-72K1FC	DKS2C-K72FC
			HDU450-146J1FC	DKR2E-J146FC
			HDU450-146JSFC	DKS2C-J146FC
			HDU450-146JMFC	DKR2E-J146FC
				DKS2C-J146FC

NOTICE:

Replace the HDD canister in the subsystem power on status only.
Do not replace with the subsystem power off status.

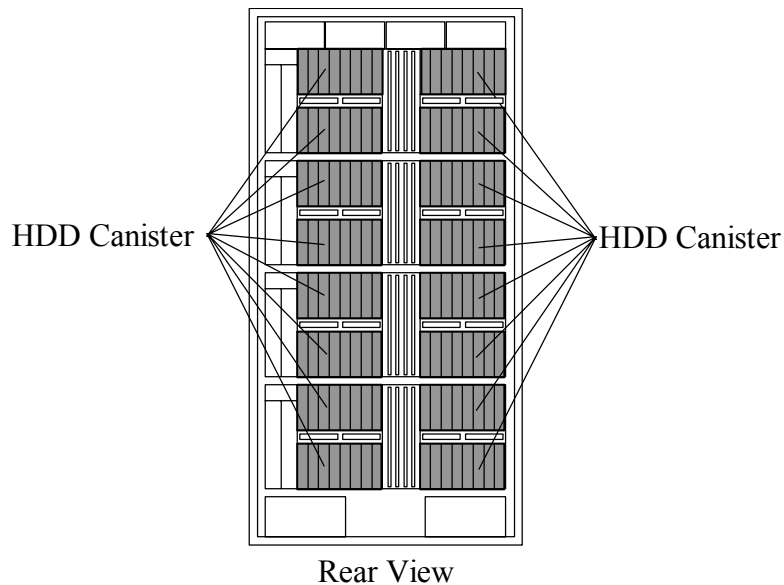

NOTICE:

- (1) Be sure to wear your wrist strap and attach to ground prior to performing the following work.
This will ensure that the IC and LSI on the PCB are protected from static electricity.
- (2) HDD is a precise component. Be careful in handling HDD to avoid vibration and impact.

1. The following figure shows the correct way to replace the HDD canister.
 - a. Check Shut Down LED on the JMP PCB.

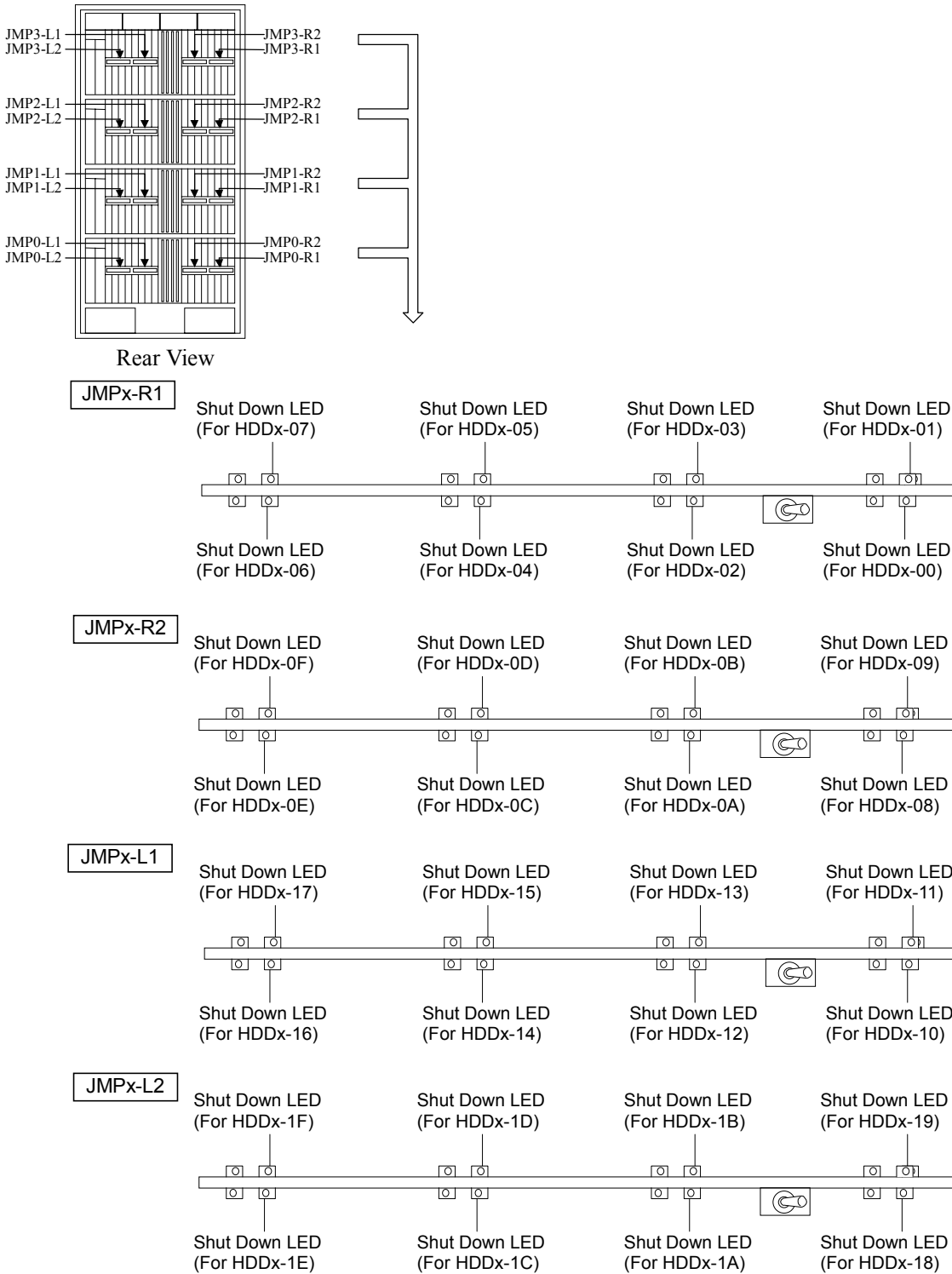

! CAUTION

A system down may be caused by a replacement of an HDD canister other than that to be replaced. Make sure that it is the HDD canister to be replaced.

- b. After pushing up the stopper on the front side of the HDD canister, pull the handle toward you to remove the HDD canister.
- c. Install a spare HDD canister. (For the detailed procedure for installation, refer to the procedure for installing HDD canister on page [REP03-35](#).)

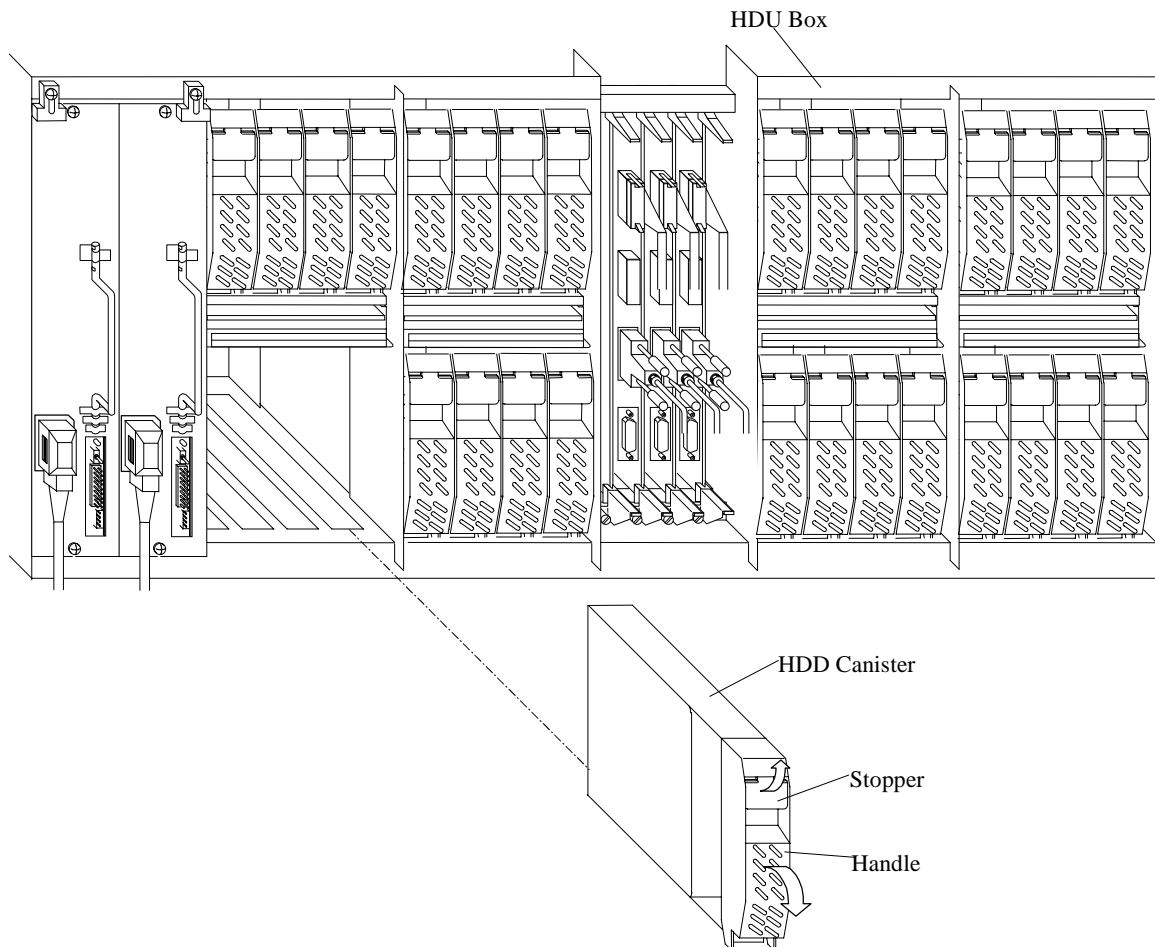

HDD canister install procedure

Note on the installation: Do not insert the HDD canister by pushing its frame.

- (1) Insert the HDD canister into the HDU Box holding its handle.

(Insert the canister until the claws that are located at the bottom of the handle come in contact with the front side of the HDU Box.)

- (2) Turn the handle at a stroke by pushing its top with your thumb.
(Turn the handle until it latches with the stopper. Do not stop the handle on its way of turning.)

Handling of the canister

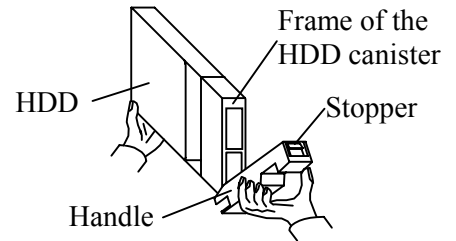

- (1) Insert the HDD canister into the HDU Box holding its handle.

A gap exists between the connectors.

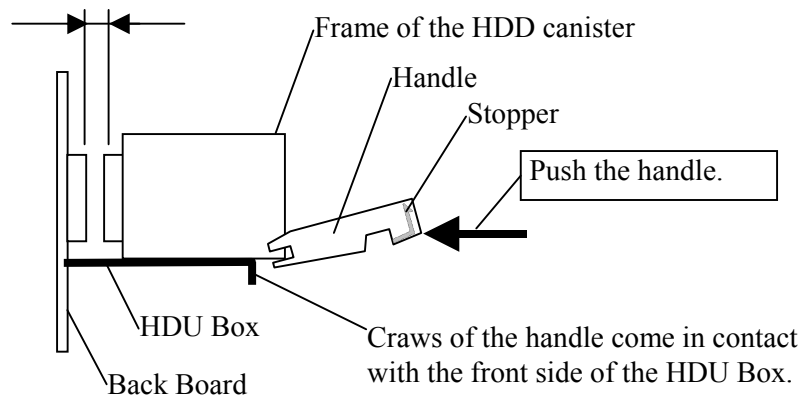

- (2) Turn the handle at a stroke by pushing its top with your thumb.
(Do not stop the handle on its way of turning.)

The connectors have been coupled.

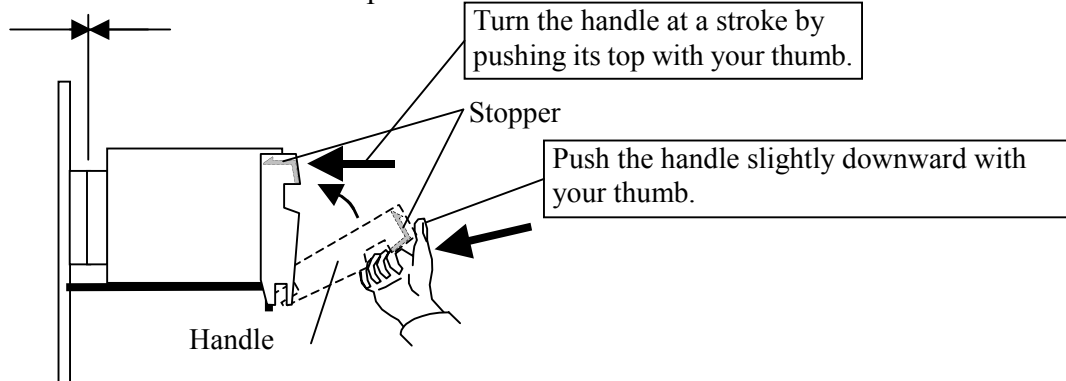

Fig. A-1 Method of Installing HDD Canister

2. See SVP post-procedure as follows.

Note: Before starting the <Check the beginning of recovery> operation in POST-PROCEDURES a, b, c and d, be sure to insert a floppy disk for dump, collect failure information, and return the floppy disk with the failed HDD.
A dump floppy disk is attached with a Spare HDD.

<Data drive, spare drive>

Work ID	Part name	Condition Item				Configuration	Procedure *1
		Condition		Preventive	Unused Spare drive		
		Failure					
		Warning SIM	Block SIM				
RDK1	Data Drive Note 1	×	-	-	Yes	Post a *1	
RDK2	Data Drive Note 1	-	×	-	Yes	Post a *1	
RDK3	Data Drive Note 1	-	-	×	Yes	Post a *1	
RDK4	Data Drive Note 1	×	-	-	No	Post b *1	
RDK5	Data Drive Note 1	-	×	-	No	Post b *1	
RDK6	Data Drive Note 1	-	-	×	No	Post b *1	
RDK7 Note 2 Note 3	Data Drive Note 1	Note 2					Post c *1
RDK8	Spare Drive Note 1	-					Post d *1

*1: Refer to REP01-190

Note 1) Parts Name is indicates attribute of a drive.

Data Drive : The drive is installed in the position for a drive except spare drive (Data Drive).

Spare Drive : The drive is installed in the position for a spare drive.

Note 2) RDK7 is a Work ID for a work which is applicable to a case that two or more drives in a same parity group are blocked.

When the procedures instructed by RDK7 are executed, data will be lost. Ask the technical support center about the appropriateness of the operation.

Note 3) Confirm the parity group and the LDEV No. corresponding to the HDD through the SVP STATUS. See page [SVP03-130](#) for the procedure for referring to SVP STATUS.

Note : If a Work ID cannot be found or if multiple drive error is occurring, see page [TRBL05-170](#) on TROUBLE SHOOTING section.

[HARDWARE B]

Location	Function Name of Component		Part Name	Remarks
Front Logic Box	1	Cache Memory PCB	• WP490-A	Color of PCB lever : Blue
	2	Cache Memory Module on Cache Memory PCB	• SH288-B	
			• SH288-C	
	3	Shared Memory Module on Cache Memory PCB	• SH287-B	
• SH287-C				

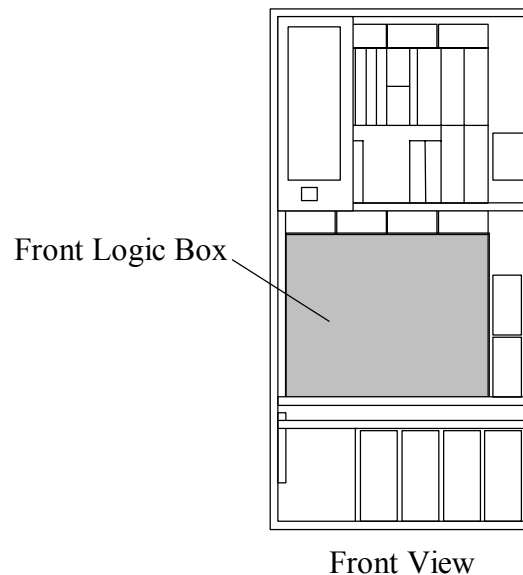

NOTICE:

Be sure to wear your wrist strap and attach to ground prior to performing the following work. This will ensure that the IC and LSI on the PCB are protected from static electricity.

1. Remove the Cache Memory PCB.
 - a. Check that the Shut Down LED is on. If not, connect the Maintenance Jumper to the Shut Down Connector. (only hot replace)

⚠ CAUTION

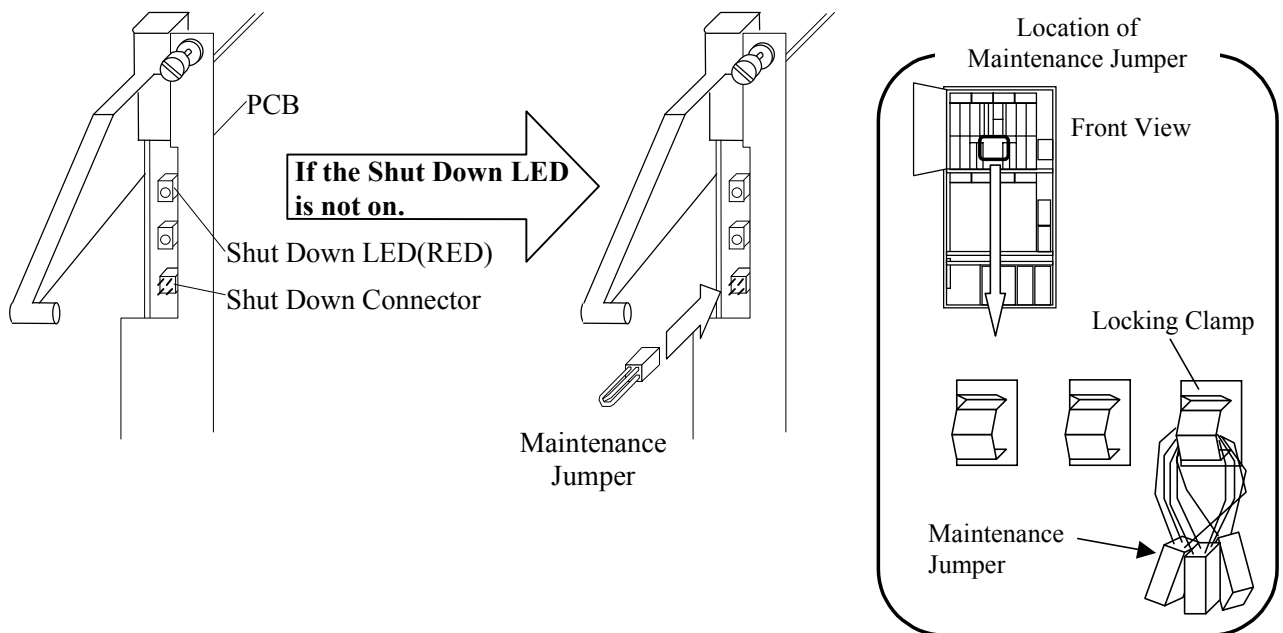
A system down may be caused if the Maintenance Jumper is inserted in a PCB other than that to be replaced. Make sure that it is the PCB to be replaced.



- b. Remove the two screws and remove the Cache Memory PCB.

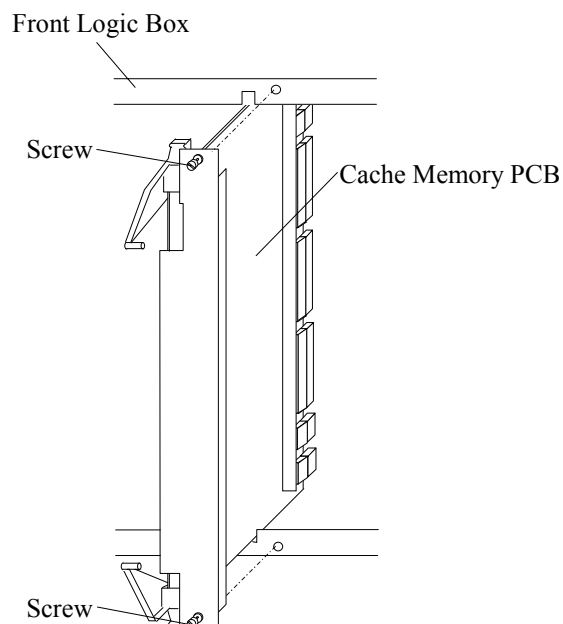

- c. Remove the Maintenance Jumper if it is mounted.

2. Replace the failed part to spare part.
 - a. When replacing the CM PCB, move all the shared memory modules and cache memory modules (including dust covers if any) mounted on an extracted PCB to the same mounting positions on the spare PCB.
 - b. When the failed part is Cache Memory Module, replace the Cache Memory Module.
 - c. When the failed part is Shared Memory Module, replace the Shared Memory Module.

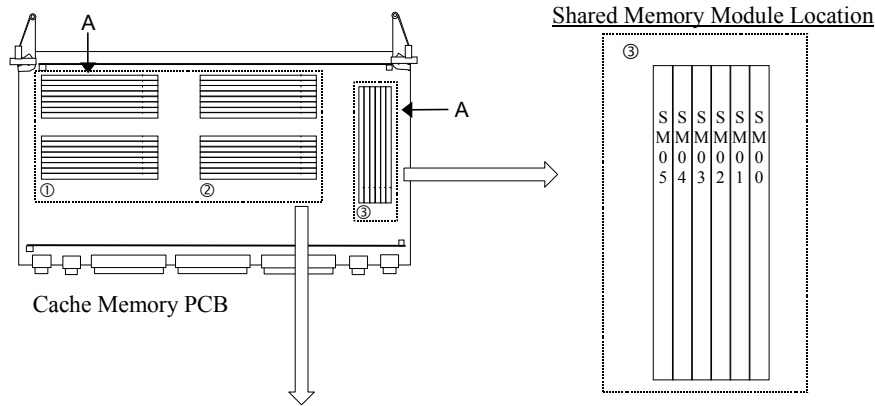

Cache Memory Module Location

<p>①</p> <table border="1" style="width: 100%;"> <tr><td>BCM007 (MG#15)</td></tr> <tr><td>BCM006 (MG#13)</td></tr> <tr><td>BCM005 (MG#11)</td></tr> <tr><td>BCM004 (MG#9)</td></tr> <tr><td>BCM003 (MG#7)</td></tr> <tr><td>BCM002 (MG#5)</td></tr> <tr><td>BCM001 (MG#3)</td></tr> <tr><td>BCM000 (MG#1)</td></tr> </table> <table border="1" style="width: 100%;"> <tr><td>BCM107 (MG#15)</td></tr> <tr><td>BCM106 (MG#13)</td></tr> <tr><td>BCM104 (MG#11)</td></tr> <tr><td>BCM104 (MG#9)</td></tr> <tr><td>BCM103 (MG#7)</td></tr> <tr><td>BCM102 (MG#5)</td></tr> <tr><td>BCM101 (MG#3)</td></tr> <tr><td>BCM100 (MG#1)</td></tr> </table>	BCM007 (MG#15)	BCM006 (MG#13)	BCM005 (MG#11)	BCM004 (MG#9)	BCM003 (MG#7)	BCM002 (MG#5)	BCM001 (MG#3)	BCM000 (MG#1)	BCM107 (MG#15)	BCM106 (MG#13)	BCM104 (MG#11)	BCM104 (MG#9)	BCM103 (MG#7)	BCM102 (MG#5)	BCM101 (MG#3)	BCM100 (MG#1)	<p>②</p> <table border="1" style="width: 100%;"> <tr><td>ACM007 (MG#14)</td></tr> <tr><td>ACM006 (MG#12)</td></tr> <tr><td>ACM005 (MG#10)</td></tr> <tr><td>ACM004 (MG#8)</td></tr> <tr><td>ACM003 (MG#6)</td></tr> <tr><td>ACM002 (MG#4)</td></tr> <tr><td>ACM001 (MG#2)</td></tr> <tr><td>ACM000 (MG#0)</td></tr> </table> <table border="1" style="width: 100%;"> <tr><td>ACM107 (MG#14)</td></tr> <tr><td>ACM106 (MG#12)</td></tr> <tr><td>ACM105 (MG#10)</td></tr> <tr><td>ACM104 (MG#8)</td></tr> <tr><td>ACM103 (MG#6)</td></tr> <tr><td>ACM102 (MG#4)</td></tr> <tr><td>ACM101 (MG#2)</td></tr> <tr><td>ACM100 (MG#0)</td></tr> </table>	ACM007 (MG#14)	ACM006 (MG#12)	ACM005 (MG#10)	ACM004 (MG#8)	ACM003 (MG#6)	ACM002 (MG#4)	ACM001 (MG#2)	ACM000 (MG#0)	ACM107 (MG#14)	ACM106 (MG#12)	ACM105 (MG#10)	ACM104 (MG#8)	ACM103 (MG#6)	ACM102 (MG#4)	ACM101 (MG#2)	ACM100 (MG#0)
BCM007 (MG#15)																																	
BCM006 (MG#13)																																	
BCM005 (MG#11)																																	
BCM004 (MG#9)																																	
BCM003 (MG#7)																																	
BCM002 (MG#5)																																	
BCM001 (MG#3)																																	
BCM000 (MG#1)																																	
BCM107 (MG#15)																																	
BCM106 (MG#13)																																	
BCM104 (MG#11)																																	
BCM104 (MG#9)																																	
BCM103 (MG#7)																																	
BCM102 (MG#5)																																	
BCM101 (MG#3)																																	
BCM100 (MG#1)																																	
ACM007 (MG#14)																																	
ACM006 (MG#12)																																	
ACM005 (MG#10)																																	
ACM004 (MG#8)																																	
ACM003 (MG#6)																																	
ACM002 (MG#4)																																	
ACM001 (MG#2)																																	
ACM000 (MG#0)																																	
ACM107 (MG#14)																																	
ACM106 (MG#12)																																	
ACM105 (MG#10)																																	
ACM104 (MG#8)																																	
ACM103 (MG#6)																																	
ACM102 (MG#4)																																	
ACM101 (MG#2)																																	
ACM100 (MG#0)																																	

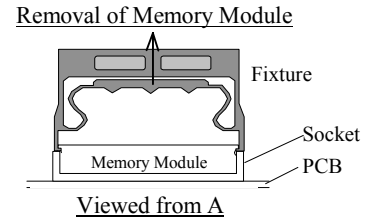
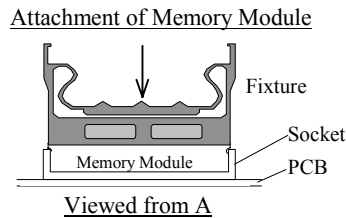
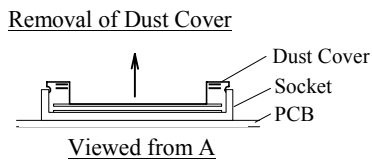

3. Insert the Cache Memory PCB.

Note: Make sure that a color of the levers of the PCB to be installed is blue.
Never insert a PCB whose lever is not blue.

- a. Insert the Cache Memory PCB and fasten the two screws.

4. Go to SVP post-procedure e [[REP04-180](#)].

[HARDWARE C]

Location	Function Name of Component	Part Name	Remarks
Front Logic Box	1 CHA (Channel Adapter) PCB for serial channel	• WP462-A ×1 & SH281-C ×4	Color of PCB lever : Blue

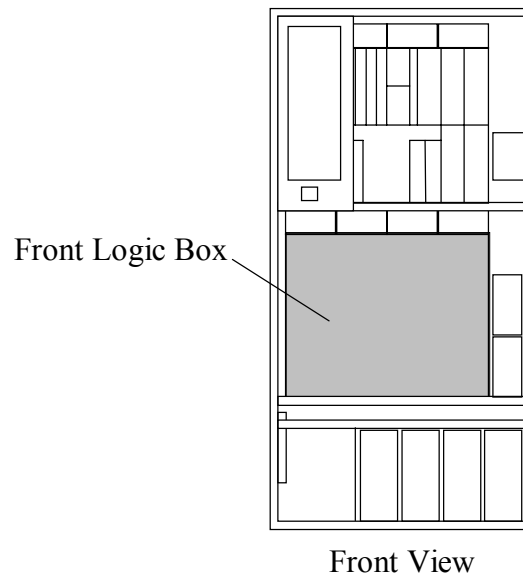

NOTICE:

Be sure to wear your wrist strap and attach to ground prior to performing the following work. This will ensure that the IC and LSI on the PCB are protected from static electricity.

1. Check that the Shut Down LED is on. If not, connect the Maintenance Jumper to the Shut Down Connector. (only hot replace)

CAUTION

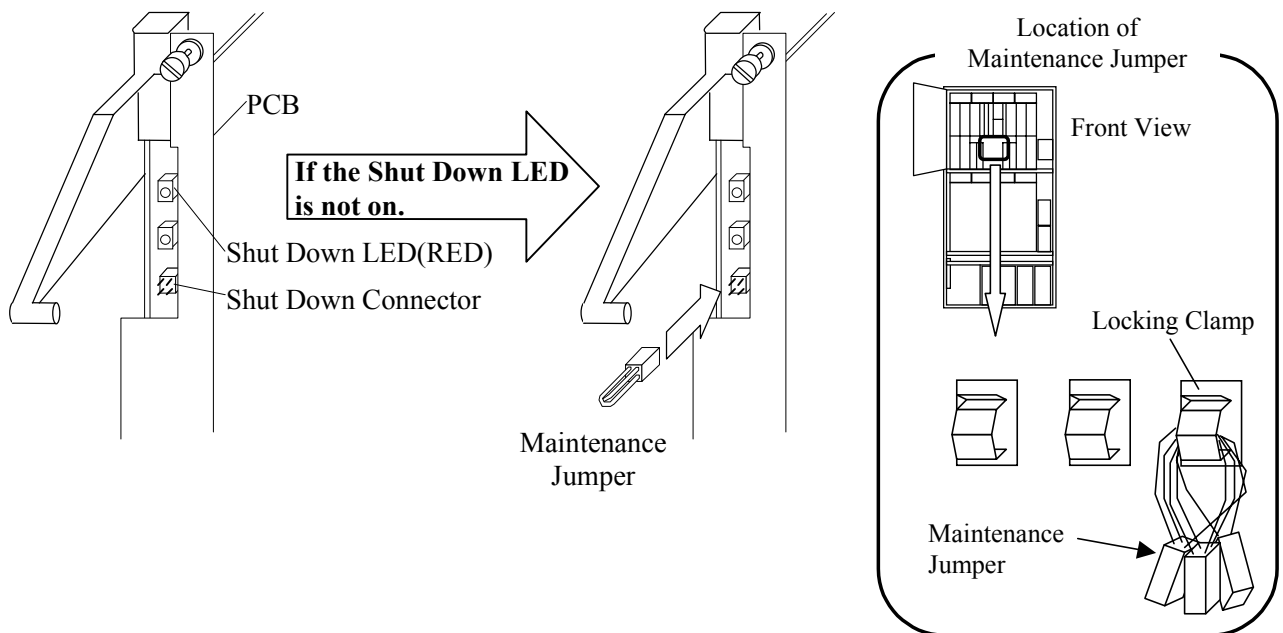
A system down may be caused if the Maintenance Jumper is inserted in a PCB other than that to be replaced. Make sure that it is the PCB to be replaced.



2. Disconnect the optical fiber cables from the failed Channel Adapter PCB.

3. Remove the two screws and remove the failed PCB.

Note: If the Maintenance Jumper is used, remove it.

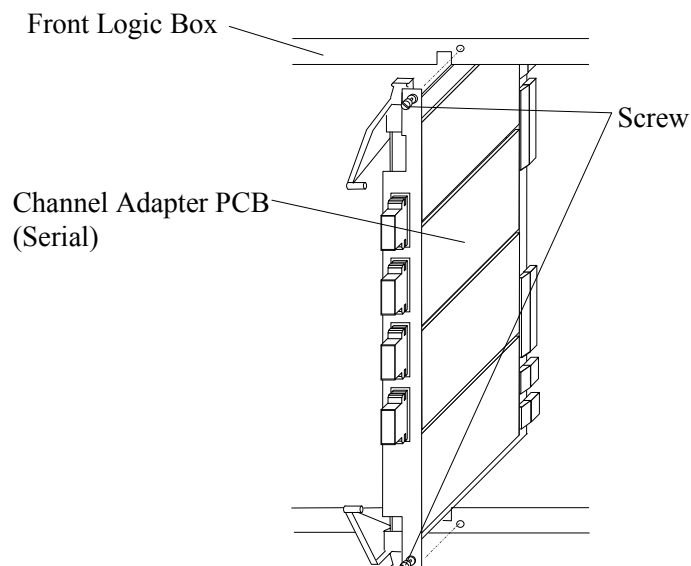

-
4. Insert the spare PCB to the correct location and fasten the two screws.

<p>Note: Make sure that a color of the levers of the PCB to be installed is blue. Never insert a PCB whose lever is not blue.</p>
--

-
5. Cleaning the fiber cable connectors.

For the tools needed for the cleaning, refer to the tool list on page [PARTS06-10](#).

- a. Blow compressed gas against the connector using an air sprayer (for about five seconds).
- b. Wipe the connector lightly with a piece of cut gauze wet with ethyl alcohol.
- c. Blow compressed air again and check the result of the cleaning. (None of dust, sticking of foreign matter, and dirt must be observed.)

-
6. Connect the optical fiber cables to the spare PCB.

-
7. Go to SVP post procedure f [[REP04-210](#)].

[HARDWARE D]

Location	Function Name of Component	Part Name	Remarks	
Front Logic Box	1	Fibre 4-port Adapter PCB for Short Wavelength (DKC-F460I-8GSE)	• WP461-D ×1 & SH281-A ×2 *1	Color of PCB lever : Blue
	2	Fibre 2-port Adapter PCB for Short Wavelength (DKC-F460I-4HSE)	• WP461-E ×1 & SH281-A ×2 *1	
	3	Fibre 4-port Adapter PCB for Short Wavelength (DKC-F460I-8HSE)	• WP461-B ×1 & SH281-A ×4 *1	
	4	Fibre 4-port Adapter PCB for Long Wavelength (DKC-F460I-8HLE)	• WP461-C ×1 & SH281-A ×4 *1	
	5	Fibre 4-port Adapter PCB for Short Wavelength (DKC-F460I-8GSF)	• WP461-H ×1 & SH281-A ×2 *2	
	6	Fibre 2-port Adapter PCB for Short Wavelength (DKC-F460I-4HSF)	• WP461-J ×1 & SH281-A ×2 *2	
	7	Fibre 4-port Adapter PCB for Short Wavelength (DKC-F460I-8HSF)	• WP461-F ×1 & SH281-A ×4 *2	
	8	Fibre 4-port Adapter PCB for Long Wavelength (DKC-F460I-8HLF)	• WP461-G ×1 & SH281-A ×4 *2	
	9	Fibre 8-port Adapter PCB for Short Wavelength (DKC-F460I-16HSF)	• WP463-B ×1 & SH281-D ×4 *3	

*1: PCB not supporting DB Validator

*2: PCB supporting DB Validator (for subsystems with DKCMAIN Ver. 21-02-2X and the later)

*3: PCB supporting DB Validator (for subsystems with DKCMAIN Ver. 21-03-0X and the later)

Note 1: You cannot use a PCB not supporting DB Validator¹ as a replacement part of a PCB supporting DB Validator² for the subsystem with DKCMAIN Ver. 21-02-2X or the later. (The subsystem is guarded from such replacement by the microprogram.)

Note 2: It is not a problem to use a PCB supporting DB Validator² as a replacement part of a PCB not supporting DB Validator¹ because the former is compatible with the latter. However, for the subsystem with DKCMAIN Ver. 21-02-2X or the later, you cannot use a PCB not supporting DB Validator¹ as a replacement part of a PCB supporting DB Validator² that has been installed once. (The subsystem is guarded from such replacement by the microprogram.)

Note 3: Concerning the subsystem with DKCMAIN earlier than Ver. 21-02-2X, a PCB supporting DB Validator² is compatible with a PCB not supporting DB Validator¹.

For the correspondence between the PCBs not supporting and supporting DB Validator, see page [REP03-130](#).

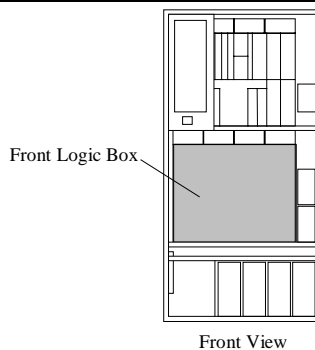

NOTICE:

Be sure to wear your wrist strap and attach to ground prior to performing the following work. This will ensure that the IC and LSI on the PCB are protected from static electricity.

Copyright ©2001,2002, Hitachi, Ltd.

REV.4	Jun.2001	Feb.2002	Jul.2002	Aug.2002	Sep.2002	
-------	----------	----------	----------	----------	----------	--

1. Check that the Shut Down LED is on. If not, connect the Maintenance Jumper to the Shut Down Connector. (only hot replace)

⚠ CAUTION

A system down may be caused if the Maintenance Jumper is inserted in a PCB other than that to be replaced. Make sure that it is the PCB to be replaced.

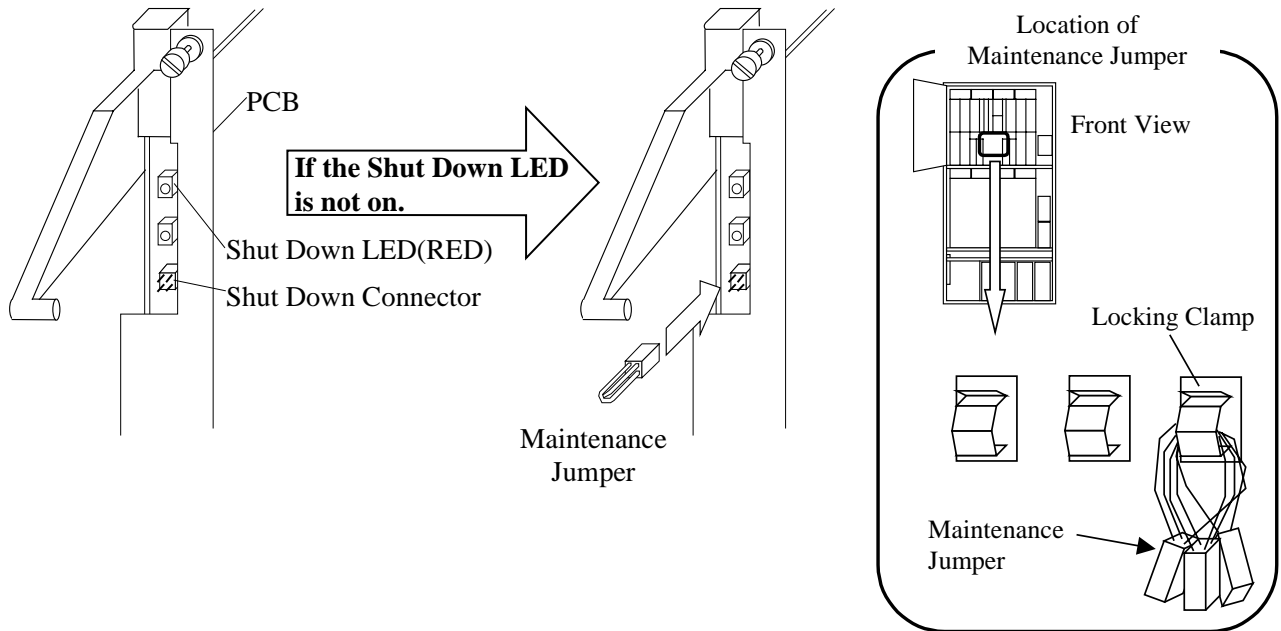

2. Disconnect the fibre cables from the failed PCB.

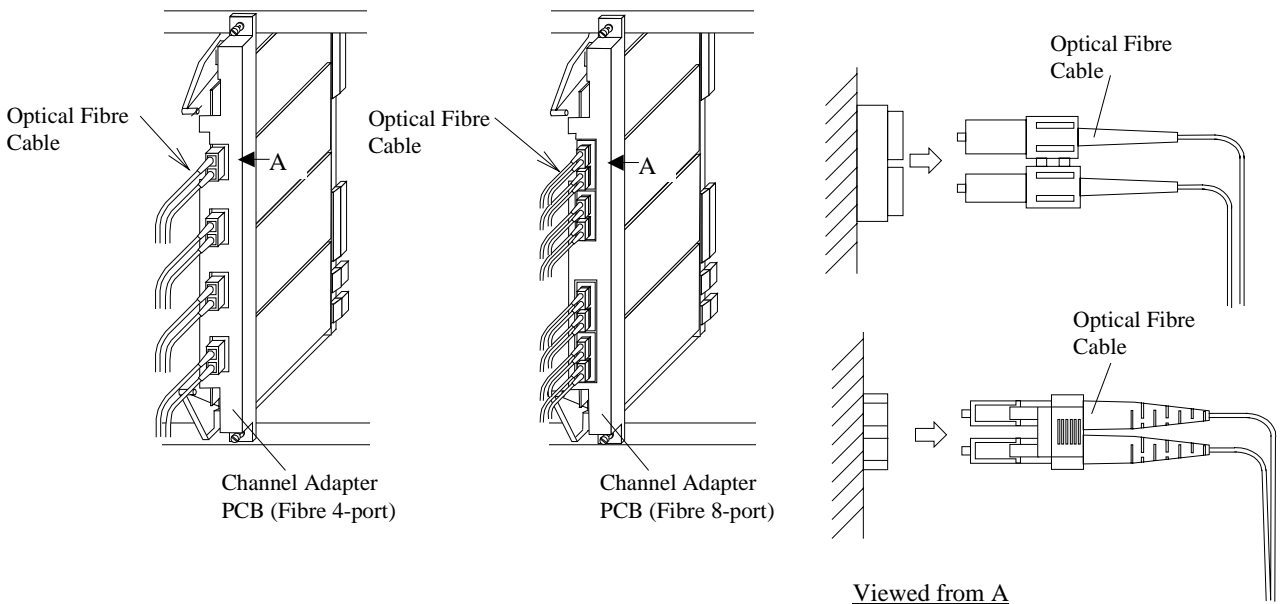

3. Remove the two screws and remove the failed PCB.

Note: If the Maintenance Jumper is used, remove it.

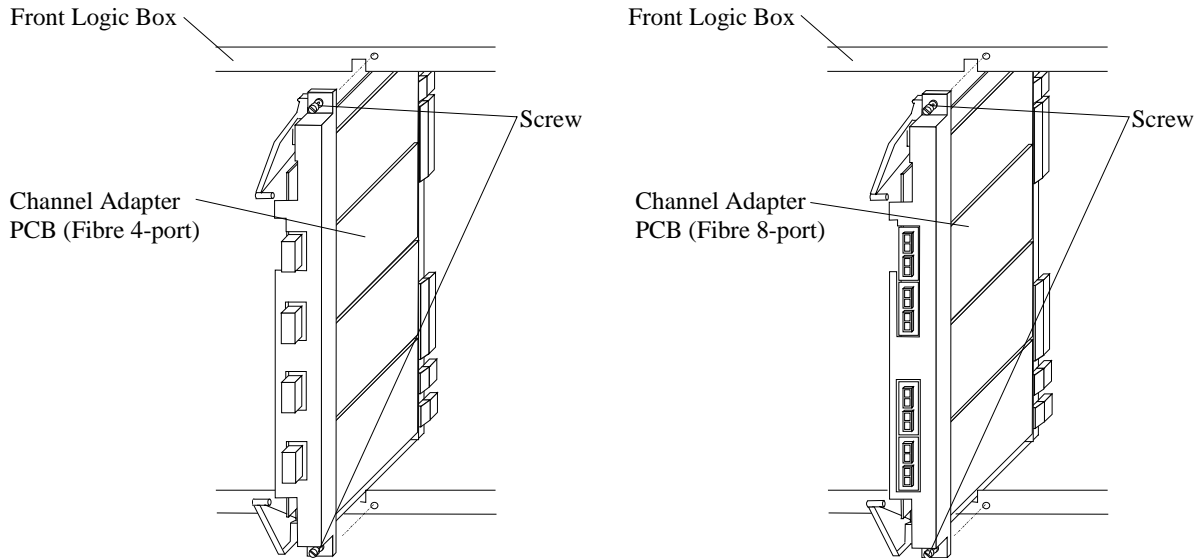

4. Insert the spare PCB to the correct location and fasten the two screws.

Note: 1. Make sure that a color of the levers of the PCB to be installed is blue.
Never insert a PCB whose lever is not blue.
2. Perform the replacement after you read and understand Notes 1 to 3 on page [REP03-110](#).

Correspondence between PCBs Supporting and Not Supporting DB Validator

PCB not supporting DB Validator ^{*1}		PCB supporting DB Validator ^{*2, *3}	
Model name	PCB name	Model name	PCB name
DKC-F460I-8GSE	WP461-D & SH281-A × 2	DKC-F460I-8GSF	WP461-H & SH281-A × 2
DKC-F460I-4HSE	WP461-E & SH281-A × 2	DKC-F460I-4HSF	WP461-J & SH281-A × 2
DKC-F460I-8HSE	WP461-B & SH281-A × 4	DKC-F460I-8HSF	WP461-F & SH281-A × 4
DKC-F460I-8HLE	WP461-C & SH281-A × 4	DKC-F460I-8HLF	WP461-G & SH281-A × 4
—	—	DKC-F460I-16HSF	WP463-B & SH281-D × 4

5. Cleaning the fiber cable connectors.

For the tools needed for the cleaning, refer to the tool list on page [PARTS06-10](#).

- a. Blow compressed gas against the connector using an air sprayer (for about five seconds).
- b. Wipe the connector lightly with a piece of cut gauze wet with ethyl alcohol.
- c. Blow compressed air again and check the result of the cleaning. (None of dust, sticking of foreign matter, and dirt must be observed.)

6. Connect the fibre cables to the spare PCB.

7. Go to SVP post procedure f [[REP04-210](#)].

[HARDWARE E]

Location		Function Name of Component	Part Name	Remarks
Front Logic Box	1	MF Fibre 4-port Adapter PCB for Short Wavelength (DKC-F460I-8MS)	• WP465-A ×1 & SH281-D ×4	Color of PCB lever : Blue
	2	MF Fibre 4-port Adapter PCB for Long Wavelength (DKC-F460I-8ML)	• WP465-B ×1 & SH281-D ×4	

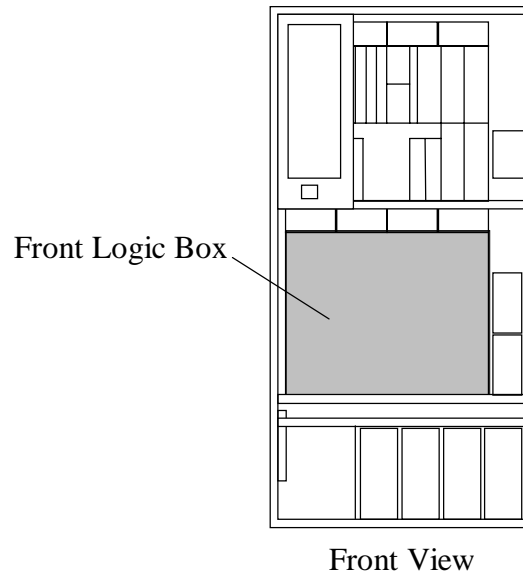

NOTICE:

Be sure to wear your wrist strap and attach to ground prior to performing the following work. This will ensure that the IC and LSI on the PCB are protected from static electricity.

1. Check that the Shut Down LED is on. If not, connect the Maintenance Jumper to the Shut Down Connector. (only hot replace)

CAUTION

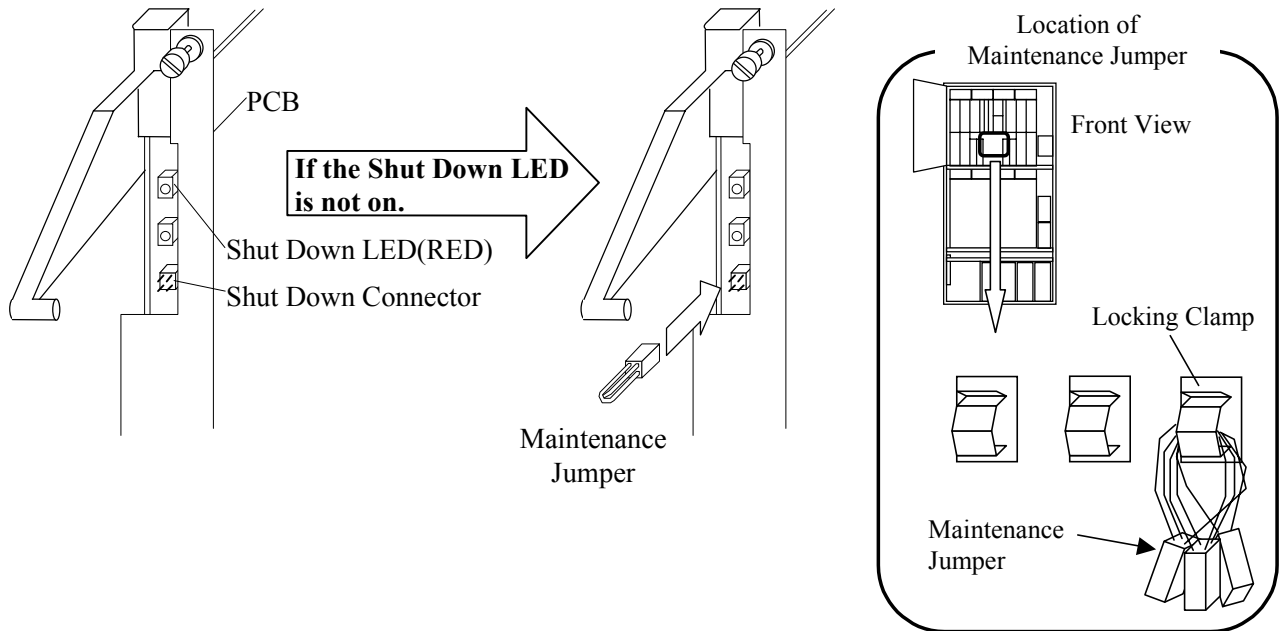
A system down may be caused if the Maintenance Jumper is inserted in a PCB other than that to be replaced. Make sure that it is the PCB to be replaced.



2. Disconnect the fibre cables from the failed PCB.

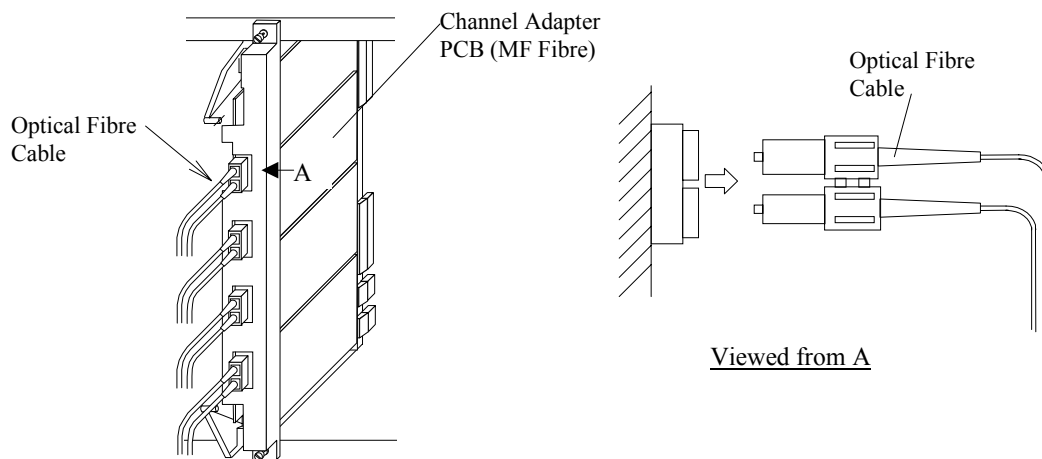

3. Remove the two screws and remove the failed PCB.
Note: If the Maintenance Jumper is used, remove it.

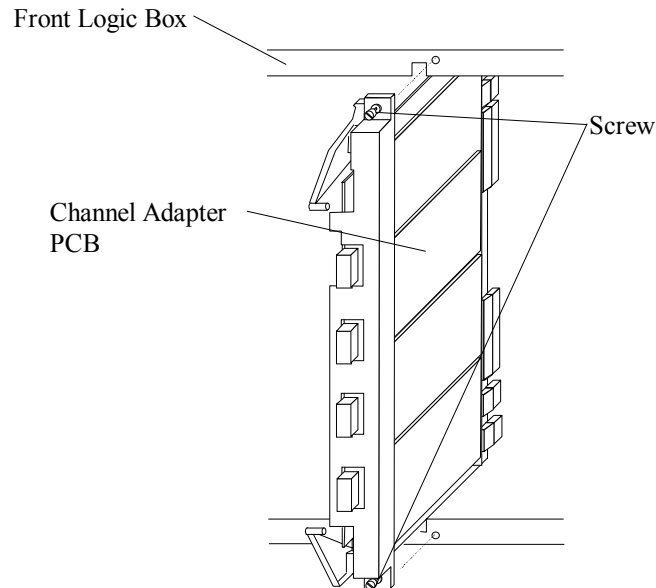

4. Insert the spare PCB to the correct location and fasten the two screws.

Note: Make sure that a color of the levers of the PCB to be installed is blue.
 Never insert a PCB whose lever is not blue.

5. Cleaning the fiber cable connectors.
 For the tools needed for the cleaning, refer to the tool list on page [PARTS06-10](#).
- a. Blow compressed gas against the connector using an air sprayer (for about five seconds).
 - b. Wipe the connector lightly with a piece of cut gauze wet with ethyl alcohol.
 - c. Blow compressed air again and check the result of the cleaning. (None of dust, sticking of foreign matter, and dirt must be observed.)

6. Connect the fibre cables to the spare PCB.

7. Go to SVP post procedure f [[REP04-210](#)].

[HARDWARE F]

Location	Function Name of Component	Part Name	Remarks
Front Logic Box	1	DKA (Disk Adapter) PCB	• WP471-A & SH281-B × 2
			• WP471-B & SH281-B × 4
			Color of PCB lever : Blue

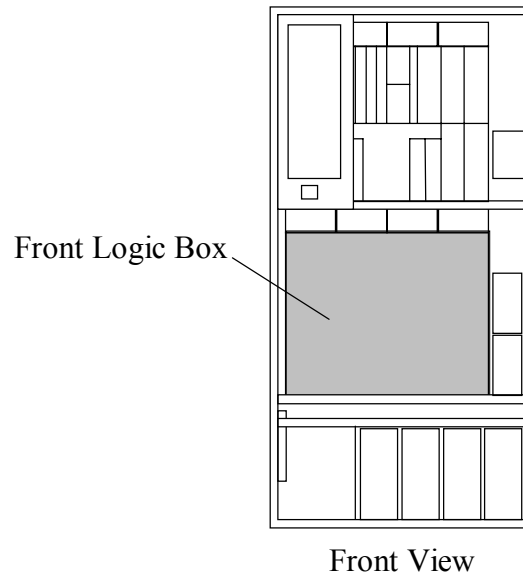

Front View

NOTICE:

Be sure to wear your wrist strap and attach to ground prior to performing the following work. This will ensure that the IC and LSI on the PCB are protected from static electricity.

1. Check that the Shut Down LED is on. If not, connect the Maintenance Jumper to the Shut Down Connector. (only hot replace)

⚠ CAUTION

A system down may be caused if the Maintenance Jumper is inserted in a PCB other than that to be replaced. Make sure that it is the PCB to be replaced.

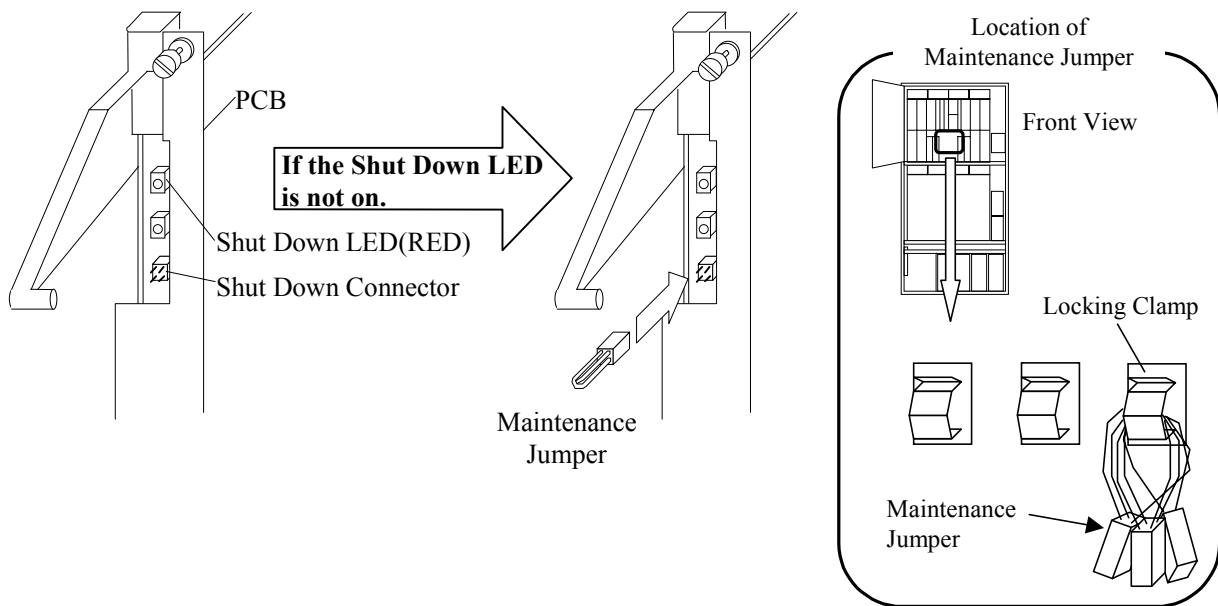

2. Remove the PCB.
 - a. Disconnect the cables.
 - b. Remove two screws and remove the failed Disk Adapter PCB.
 - c. If the Maintenance Jumper is used, remove it.

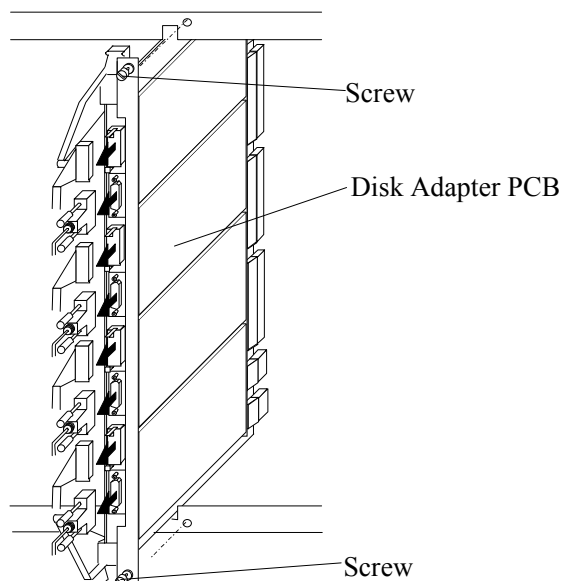

3. Insert the spare PCB to the correct location and fasten the screws.

<p>Note: Make sure that a color of the levers of the PCB to be installed is blue. Never insert a PCB whose lever is not blue.</p>

-
4. Connect the cables to the spare PCB.

-
5. Go to SVP post procedure f [[REP04-210](#)].

[HARDWARE G]

Location		Function Name of Component	Part Name	Remarks
Front Logic Box	1	CSW PCB	• WP481-C	Color of PCB lever : Blue

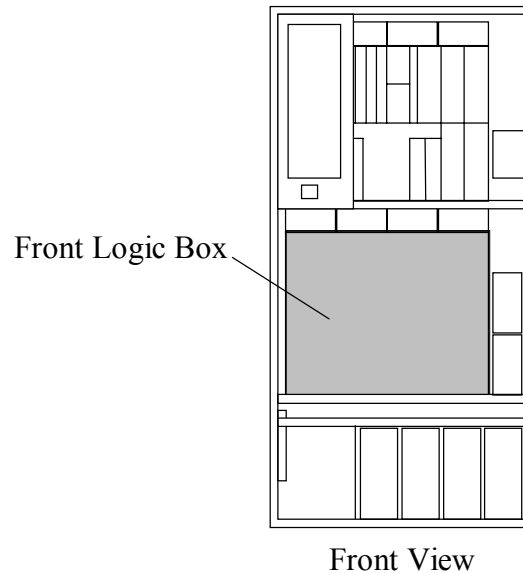

NOTICE:

Be sure to wear your wrist strap and attach to ground prior to performing the following work. This will ensure that the IC and LSI on the PCB are protected from static electricity.

1. Check that the Shut Down LED is on. If not, connect the Maintenance Jumper to the Shut Down Connector. (only hot replace)

⚠ CAUTION

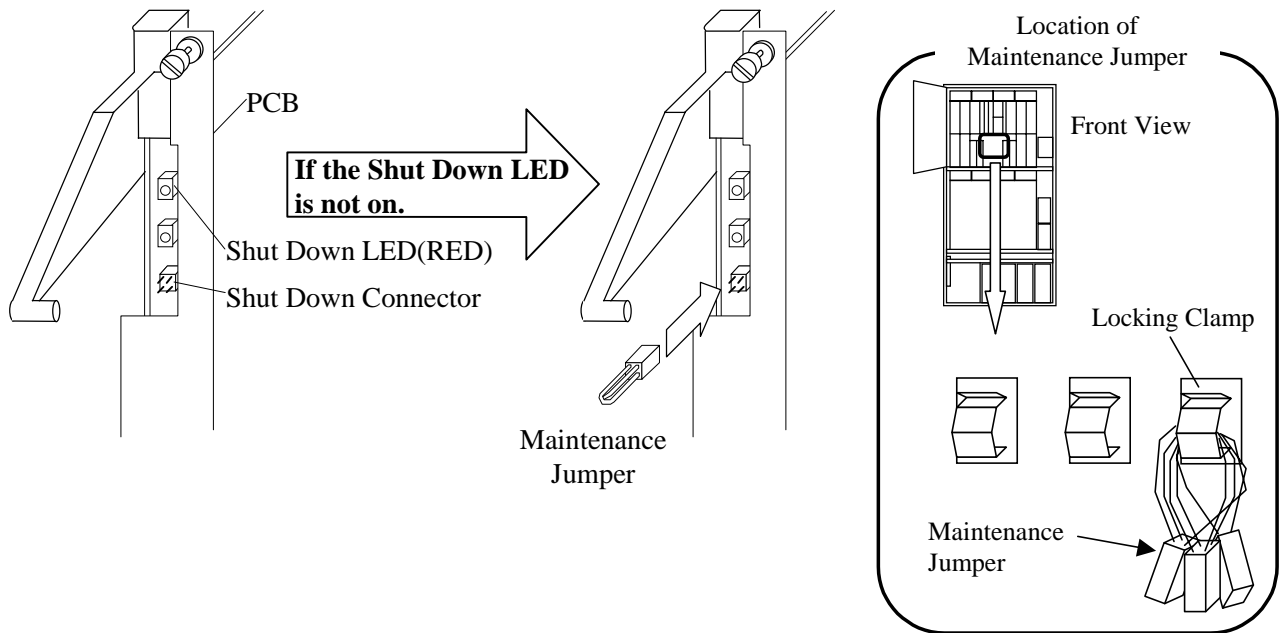
A system down may be caused if the Maintenance Jumper is inserted in a PCB other than that to be replaced. Make sure that it is the PCB to be replaced.



2. Remove the CSW PCB.

The LED on the operator panel shown in the following table goes out during a period from a pulling off of the CSW to an insertion of the new CSW.

Location of CSW to be replaced	LED on the operator panel	
	Cluster 1	Cluster 2
CSW-1A	ABCD EFGH JKLM	—
CSW-2M	—	ABCD EFGH JKLM

- a. Disconnect the cables from the sub-edge of the failed PCB.
- b. Remove the two screws and remove the failed CSW PCB.
- c. If the Maintenance Jumper is used, remove it.

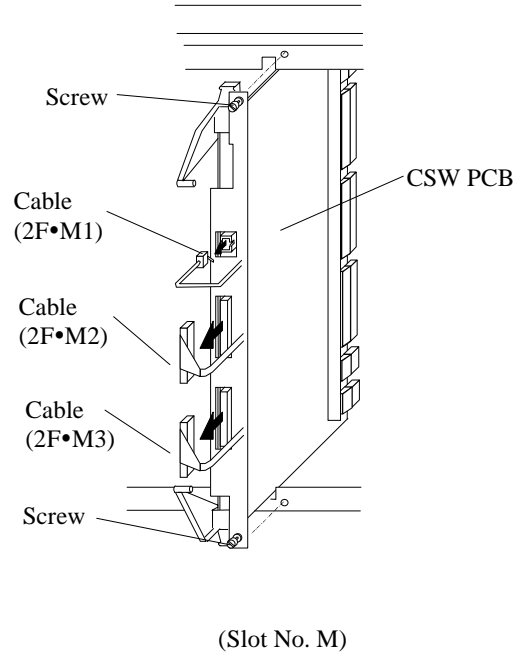
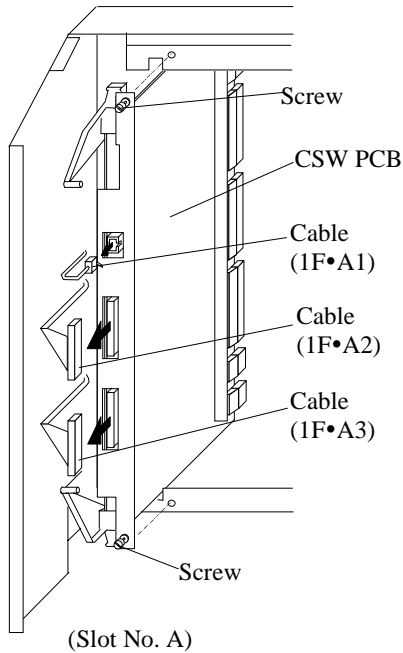

3. Insert the spare PCB to the correct location and fasten the screws.

Note: Make sure that a color of the levers of the PCB to be installed is blue.
Never insert a PCB whose lever is not blue.

(When you plug in new PCB, the Shut Down LED is lit on again.)

4. Connect the cable to the sub-edge of the spare PCB.

5. Go to SVP post procedure k [[REP04-300](#)].

[HARDWARE T1]

Location	Function Name of Component		Part Name
Front of DKC	1	DKC Panel	<ul style="list-style-type: none"> • SH302-A • SH302-C (for UPS)

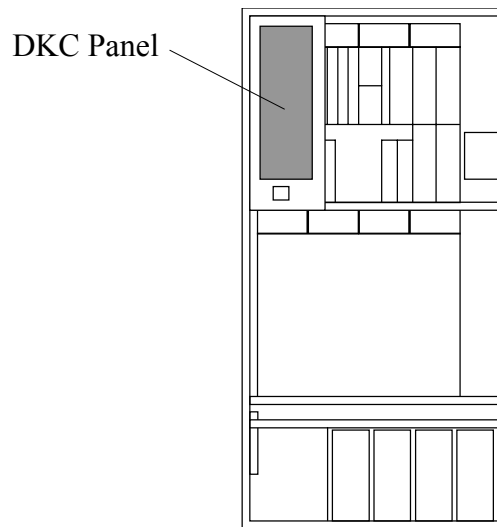

Front View

NOTICE:

Be sure to wear your wrist strap and attach to ground prior to performing the following work. This will ensure that the IC and LSI on the PCB are protected from static electricity.

Note: The COMP signal of PCI is turned off, if the DKC Panel is removed.

1. Set the switches of the spare PCB to the same positions as those of the failed PCB.
2. Connect the Maintenance Jumper to the connector plug on the DKCMN1 and DKCMN2.

⚠ CAUTION

A system down is caused if the Maintenance Jumper is not inserted. Be sure to insert the Maintenance Jumper before starting the work.

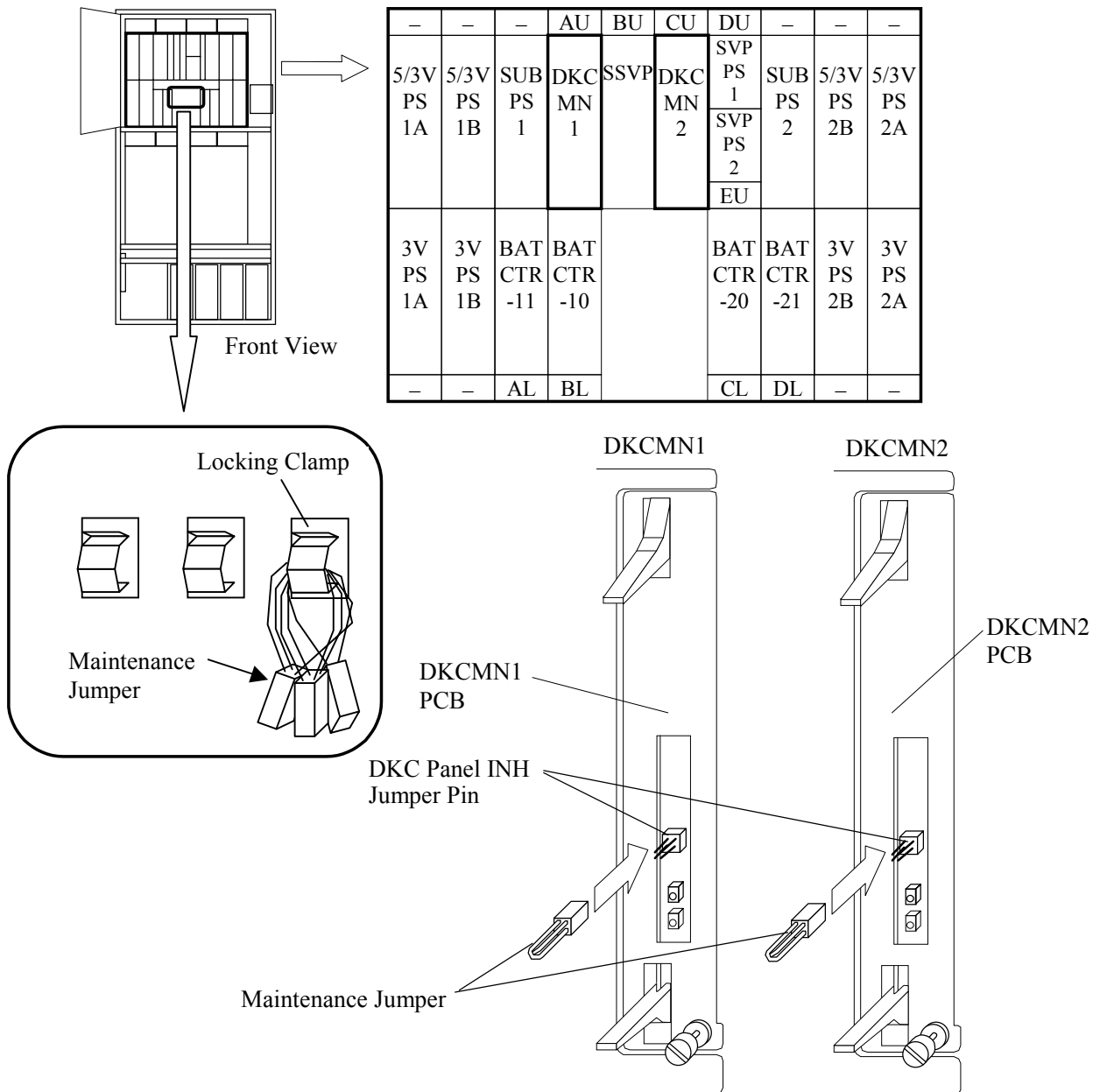

Fig. T1-1 Insertion of Maintenance Jumpers

3. Remove the plate from the Movable rack.
 - a. Loosen the screw and remove the plate from the Movable rack.

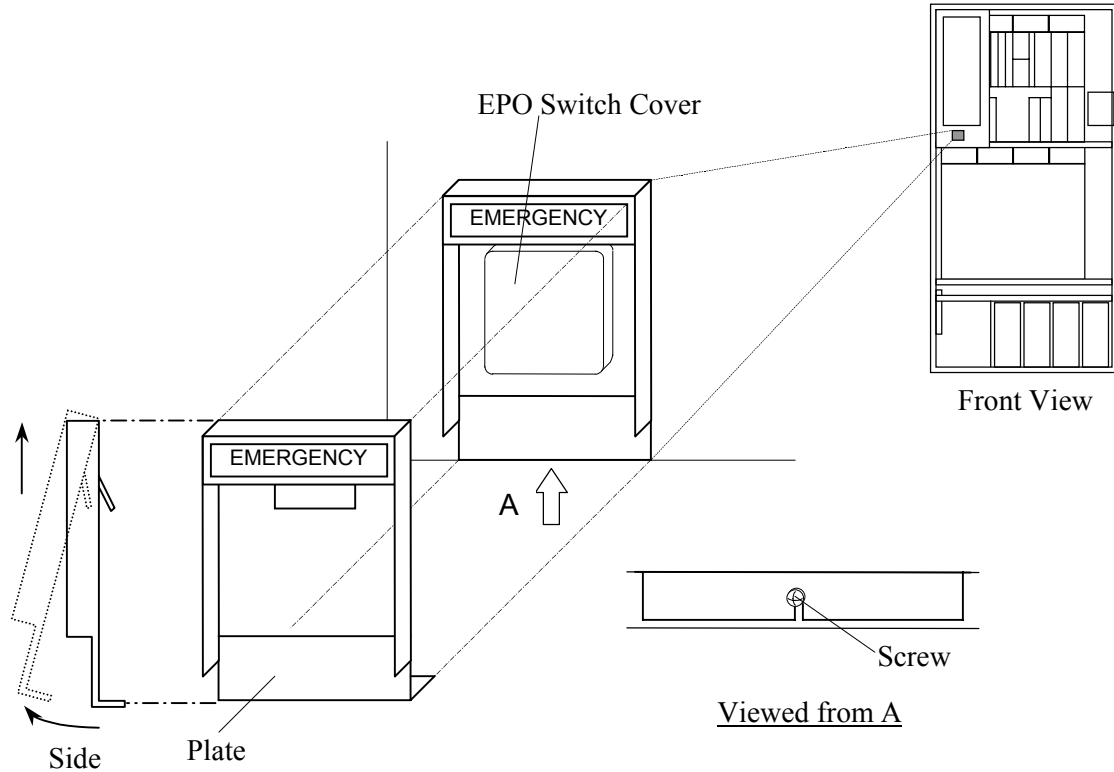

Fig. T1-2 Removal of Plate

- b. Remove the EPO Switch cover.

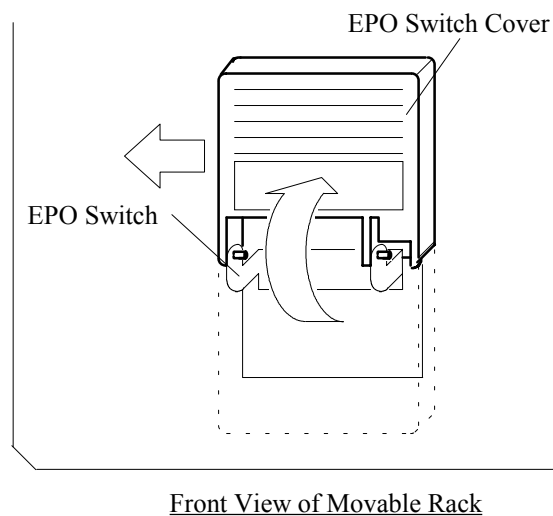

Fig. T1-3 Removal of EPO Switch Cover

- c. Loosen the three screws and remove the plate.

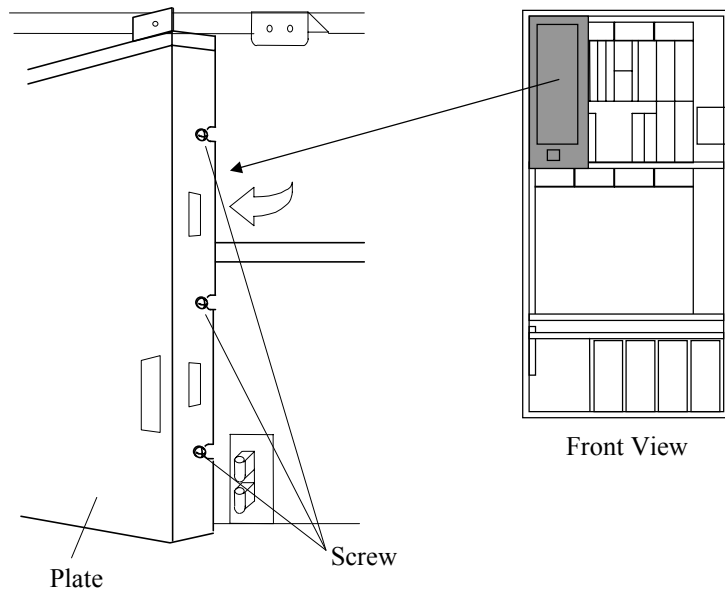

Fig. T1-4 Removal of Plate

4. Replace the PCB.
- Disconnect the cables from the DKC Panel PCB.
 - Loosen the six screws and remove the DKC Panel PCB from the Movable rack.
 - Attach the spare PCB and fasten the six screws.
 - Connect the cables to the spare PCB.

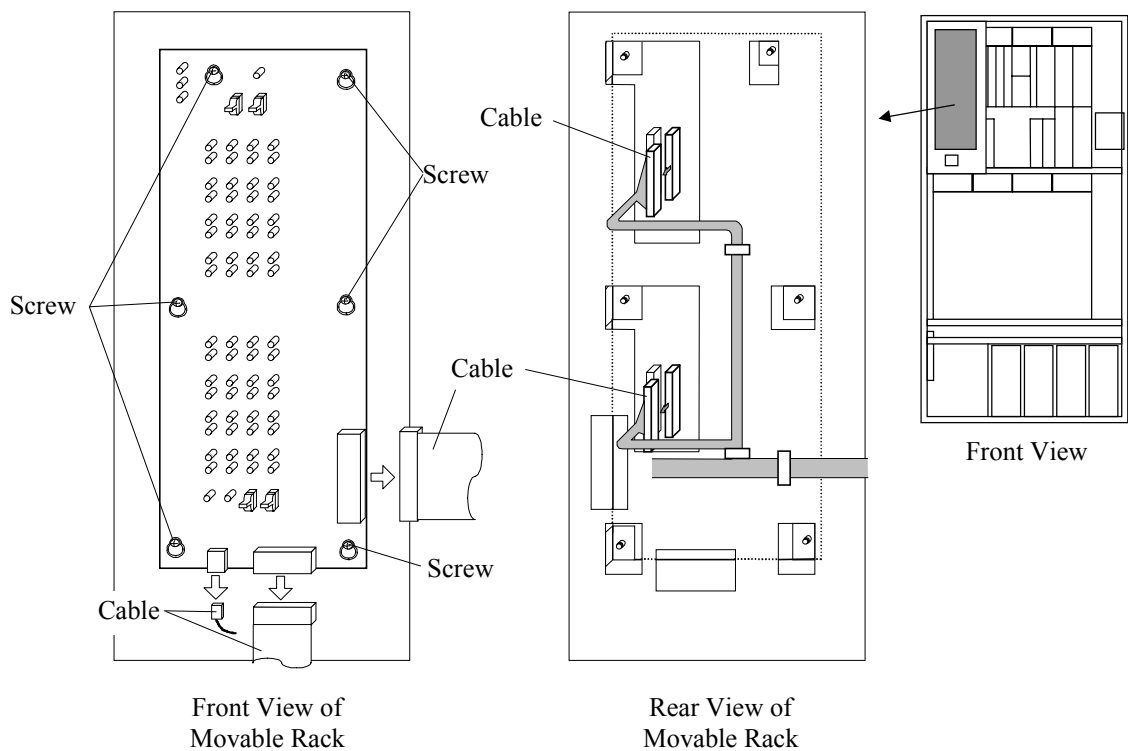

Fig. T1-5 Replace of PCB

5. Make sure of condition of the EPO switch.
 - a. Make sure that the EPO switch is in normal condition. If the EPO switch is in a condition in which it has been operated, return its condition to normal by pressing the plunger after pressing down the spring.

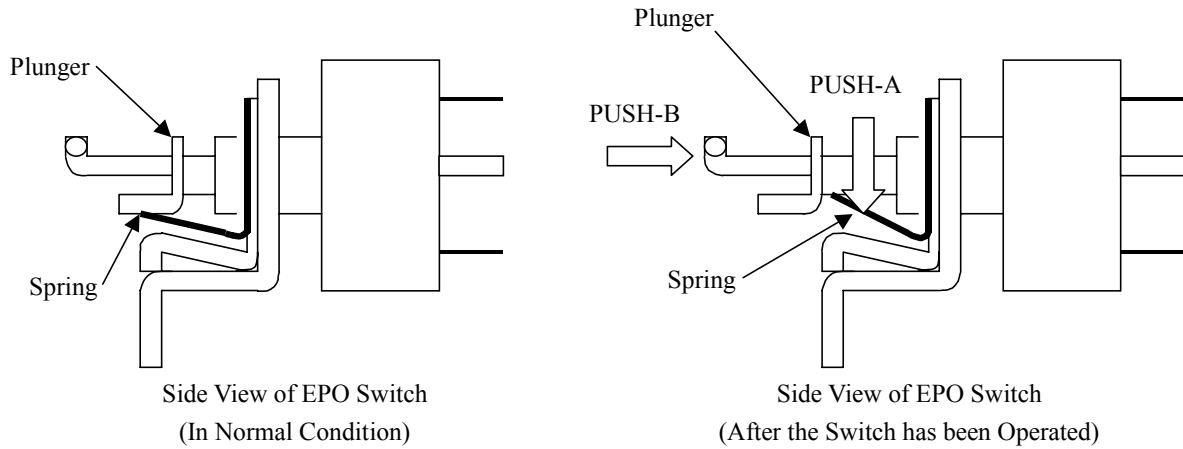

Fig. T1-6 Condition of the EPO switch

6. Attach the Plate.
 - a. Attach the plate to the Movable rack and fasten the three screws. Refer to Fig. T1-4.
 - b. Attach the EPO Switch cover. Refer to Fig. T1-3.
 - c. Attach the plate and fasten the screw. Refer to Fig. T1-2.
7. Go to SVP post procedure t1 [[REP04-320](#)].

⚠ CAUTION

Disconnect the Maintenance Jumper from the connector plug on the DKCMN according to the guidance of SVP.

[HARDWARE T2]

Location	Function Name of Component	
Front of DKC	1	EPO Switch
(Reference) The related PCB for replacement of EPO Switch 1. DKCMN PCB (Front PS Box)		

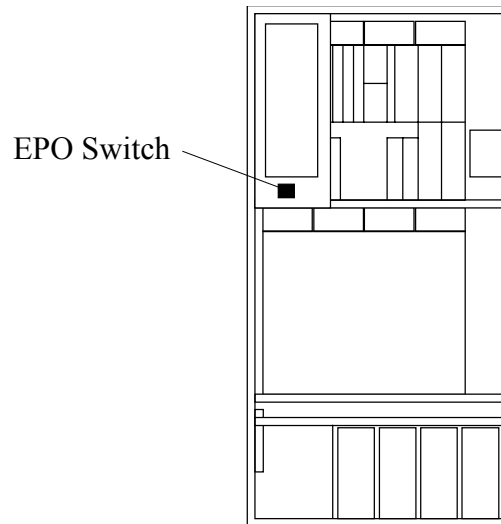

Front View

NOTICE:

Be sure to wear your wrist strap and attach to ground prior to performing the following work. This will ensure that the IC and LSI on the PCB are protected from static electricity.

1. Connect the Maintenance Jumper connector to the connector plug on the DKCMN1 and DKCMN2.

⚠ CAUTION

A system down is caused if the Maintenance Jumper is not inserted. Be sure to insert the Maintenance Jumper before starting the work.

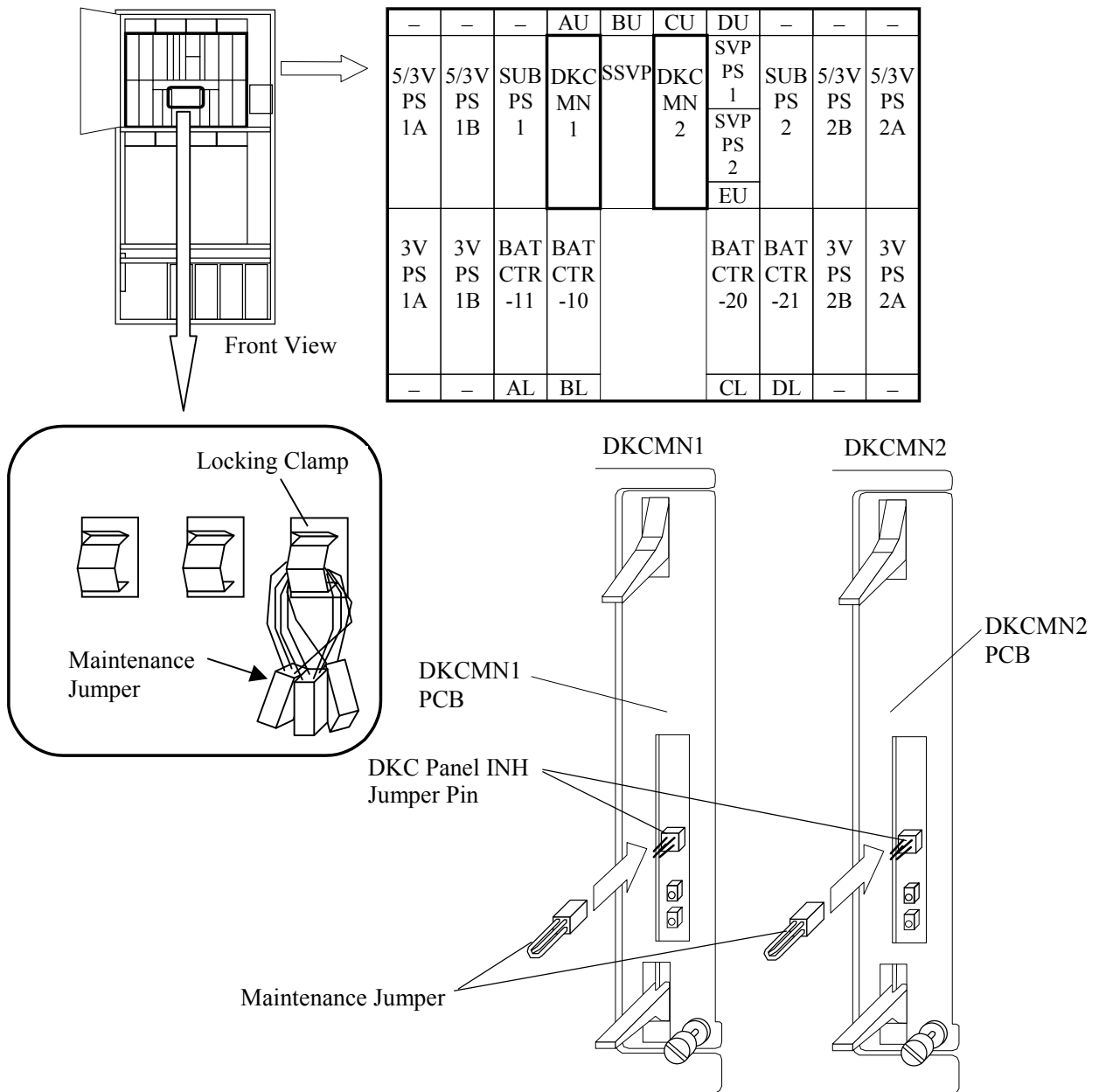

Fig. T2-1 Insertion of Maintenance Jumpers

2. Remove the plate from the Movable rack.
 - a. Loosen the screw.
 - b. Pull the plate forward, then lift up and remove it. (Make sure you don't pull and turn off EPO switch.)

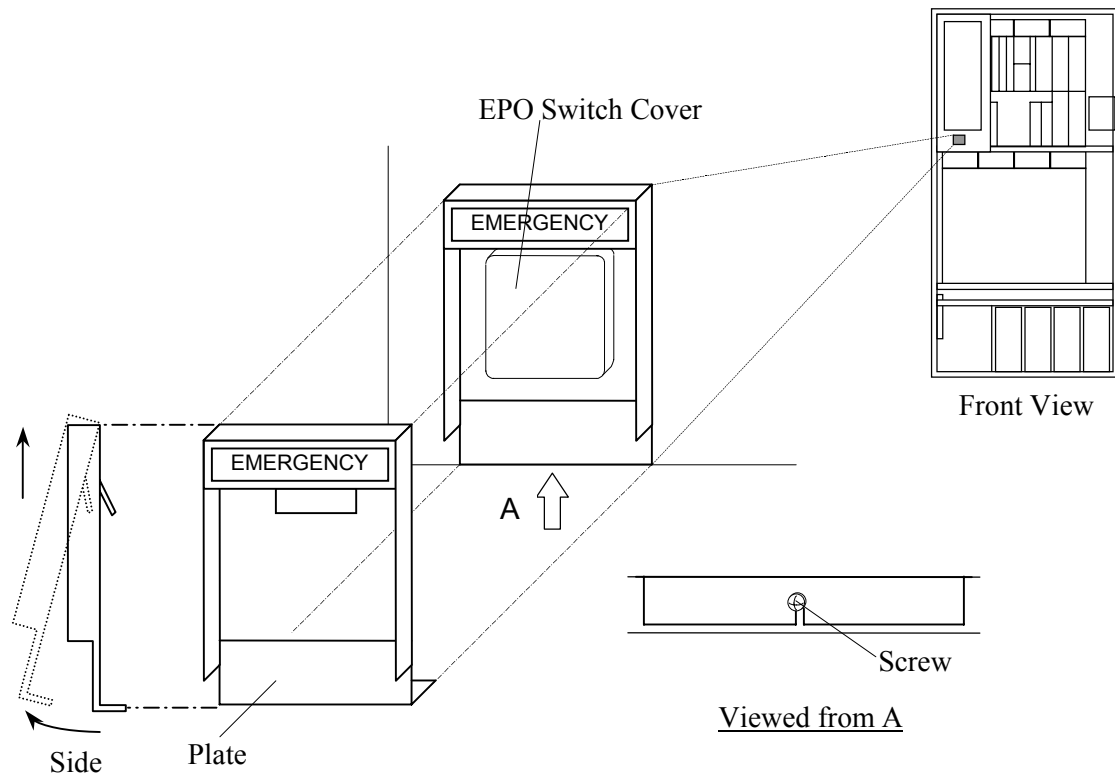

Fig. T2-2 Removal of Plate

- c. Remove the EPO switch cover.

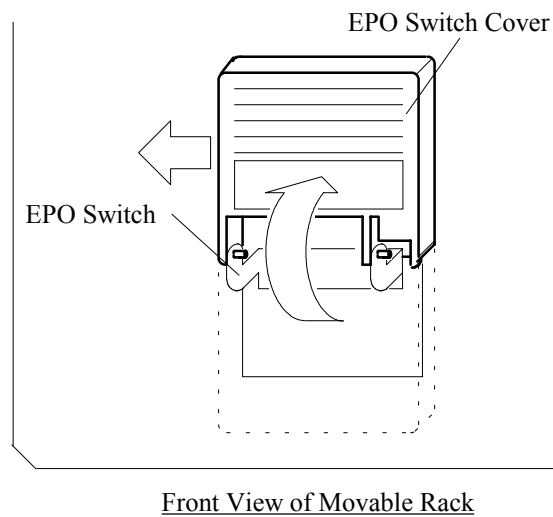

Fig. T2-3 Removal of EPO Switch Cover

- d. Loosen the three screws and remove the plate.

CAUTION

When removing the plate of the DKC panel, do it with care not to touch the EPO switch.

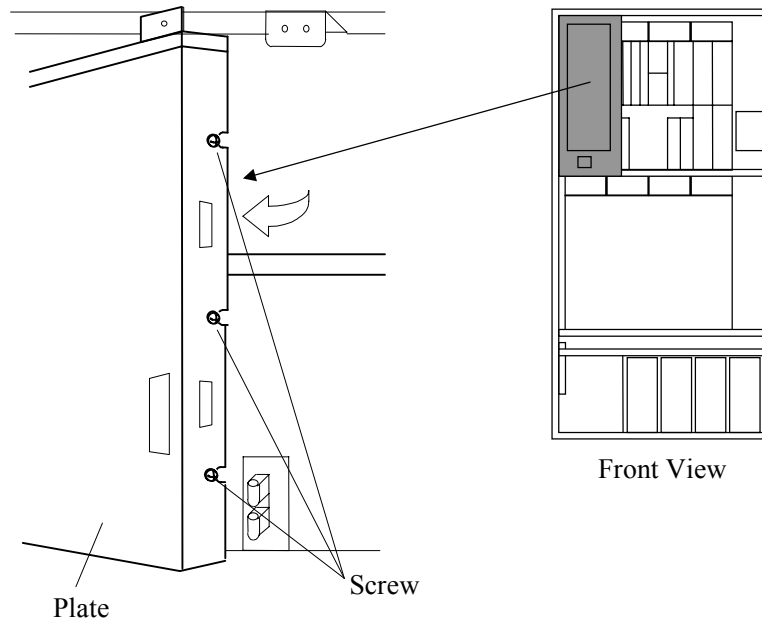
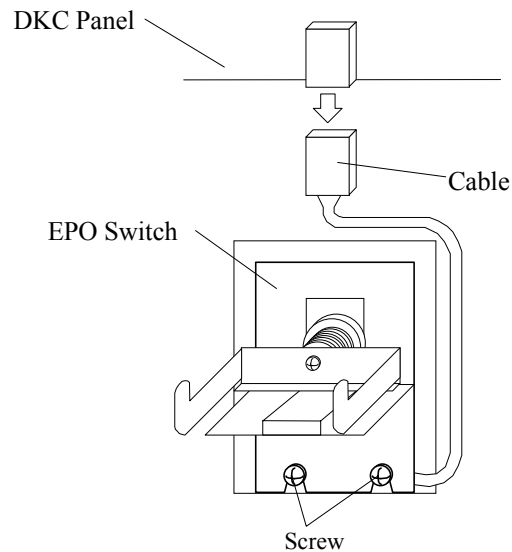

Fig. T2-4 Removal of Plate

3. Remove the EPO Switch.
- Disconnect the cable from the DKC panel.
 - Loosen the two screws and remove the EPO switch.



Front View of Movable Rack

Fig. T2-5 Removal of EPO Switch

4. Make sure of condition of the spare part EPO switch.
 - a. Make sure that the spare part EPO switch is in normal condition. If the spare part EPO switch is in a condition in which it has been operated, return its condition to normal by pressing the plunger after pressing down the spring.

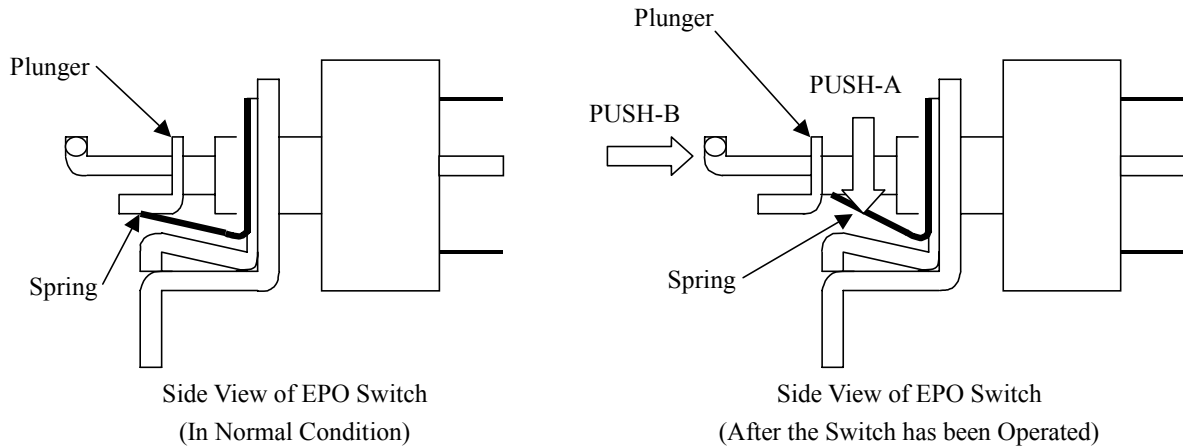

Fig. T2-6 Condition of the spare part EPO switch

5. Attach the EPO Switch
 - a. Attach the spare EPO switch with the two screws. Refer to Fig. T2-5.
 - b. Connect the cable to the DKC panel.
 - c. Attach the plate and fasten the three screws. Refer to Fig. T2-4.
 - d. Attach the EPO switch cover. Refer to Fig. T2-3.
 - e. Attach the plate and fasten the screw. Refer to Fig. T2-2.

6. Go to SVP post procedure t1 [[REP04-320](#)].

⚠ CAUTION

Disconnect the Maintenance jumper from the connector plug on the DKCMN according to the guidance of SVP.

[HARDWARE T3]

Location	Function Name of Component		Part Name
Front PS Box	1	DKCMN1 or DKCMN2	• SH307-A
			• SH307-B (for UPS)

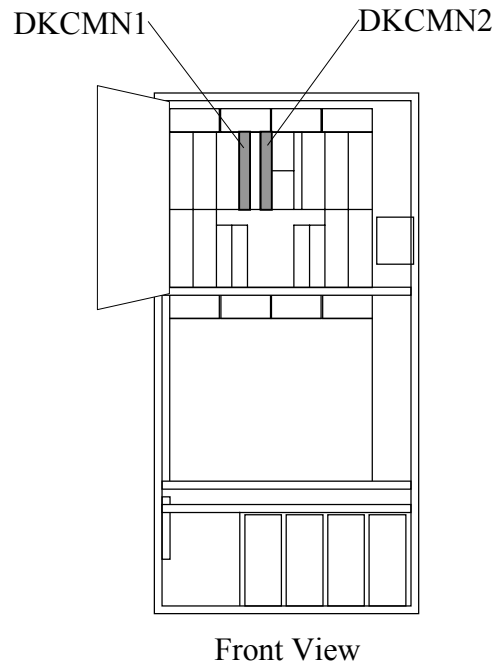
NOTICE:

Be sure to wear your wrist strap and attach to ground prior to performing the following work. This will ensure that the IC and LSI on the PCB are protected from static electricity.

DKCMN1 or DKCMN2

Note: Do not replace DKCMN1 PCB and DKCMN2 PCB at the same time.

If you want to replace the both PCB, first complete the replacement of one PCB and then start the replacement of the other.

1. Check that the Shut Down LED is on. (only hot replace)

CAUTION

A system down is caused by a replacement of the DKCMN PCB other than that to be replaced. Make sure that it is the DKCMN PCB to be replaced.

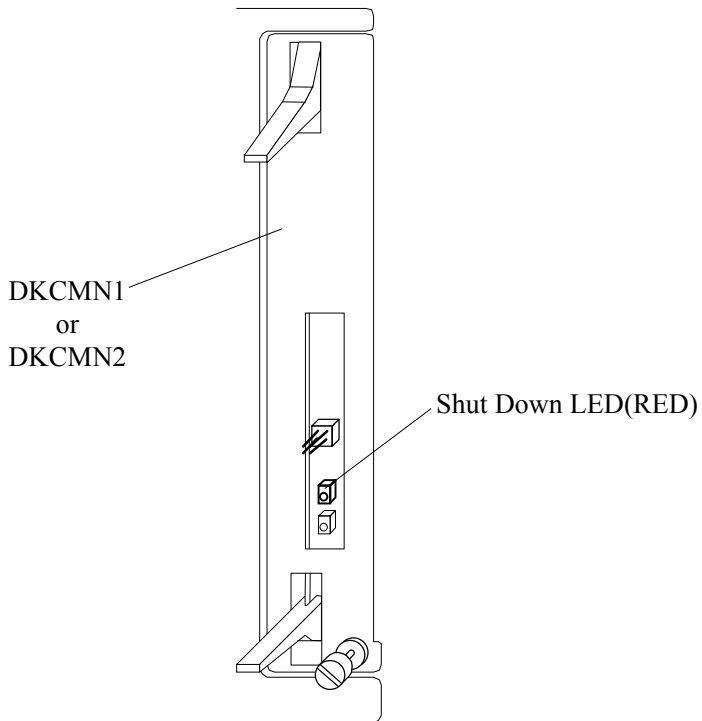
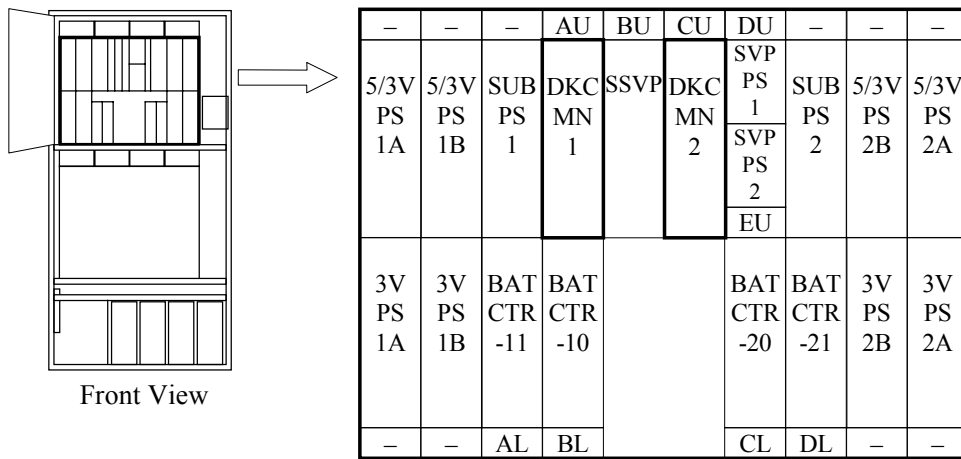

2. Replace the DKCMN PCB.
 - a. Loosen the screw and remove the DKCMN PCB.
 - b. Insert the spare DKCMN PCB and fasten the screw.

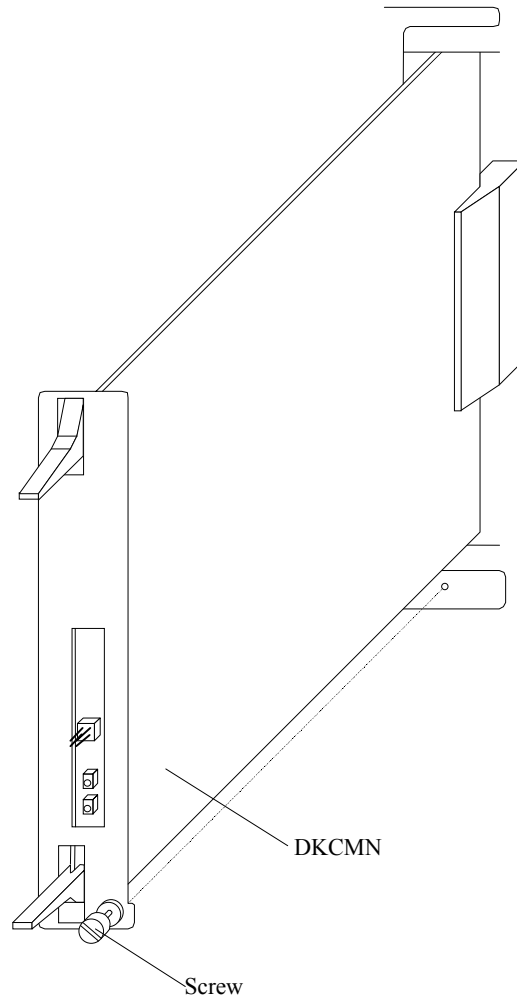

3. Go to SVP post procedure t1 [[REP04-320](#)].

[HARDWARE T4]

Location	Function Name of Component		Part Name
Lower left front of DKC	1	PCI CON	• SH218-A
(Reference) The related PCB for replacement of PCI CON. 1. DKC Panel PCB (Front of DKC) 2. DKCMN PCB (Front PS Box in DKC)			

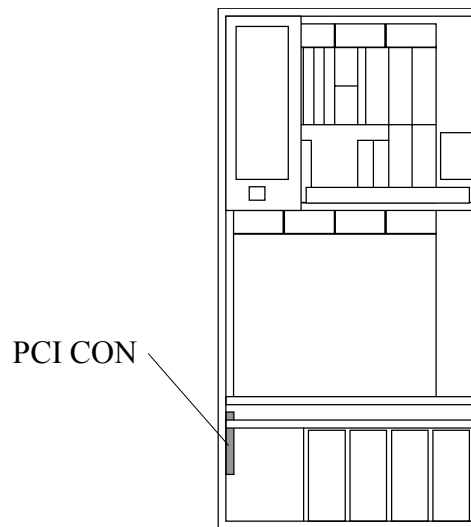

Front View

NOTICE:

Be sure to wear your wrist strap and attach to ground prior to performing the following work. This will ensure that the IC and LSI on the PCB are protected from static electricity.

CAUTION

- 1: Replacement of PCI CON Panel causes other devices running on the same PCI connection line to be powered off except a and b shown below (because giving the EPO instruction is assumed). Therefore, stop the other device before performing replacement.
 - a. If PCI cable is not connected to the replacing DKC.
 - b. If the replacing DKC (DKC concerned) is connected to the end of the PCI cable as shown below.

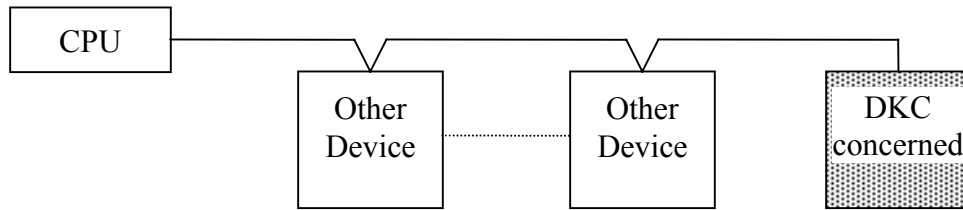

- 2: The COMP signal of PCI is turned off, if the PCI cable is disconnected.

1. Confirm that the REMOTE/LOCAL Switch of DKC Panel is set to LOCAL. If not, set the REMOTE/LOCAL Switch to LOCAL.

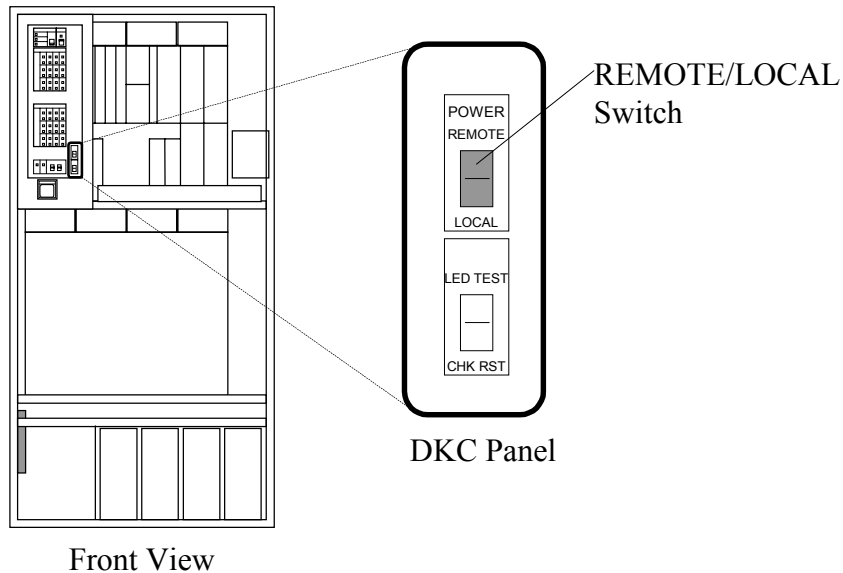

2. Connect the Maintenance Jumper to the connector plug on the DKCMN1 and DKCMN2.

⚠ CAUTION

A system down is caused if the Maintenance Jumper is not inserted. Be sure to insert the Maintenance Jumper before starting the work.

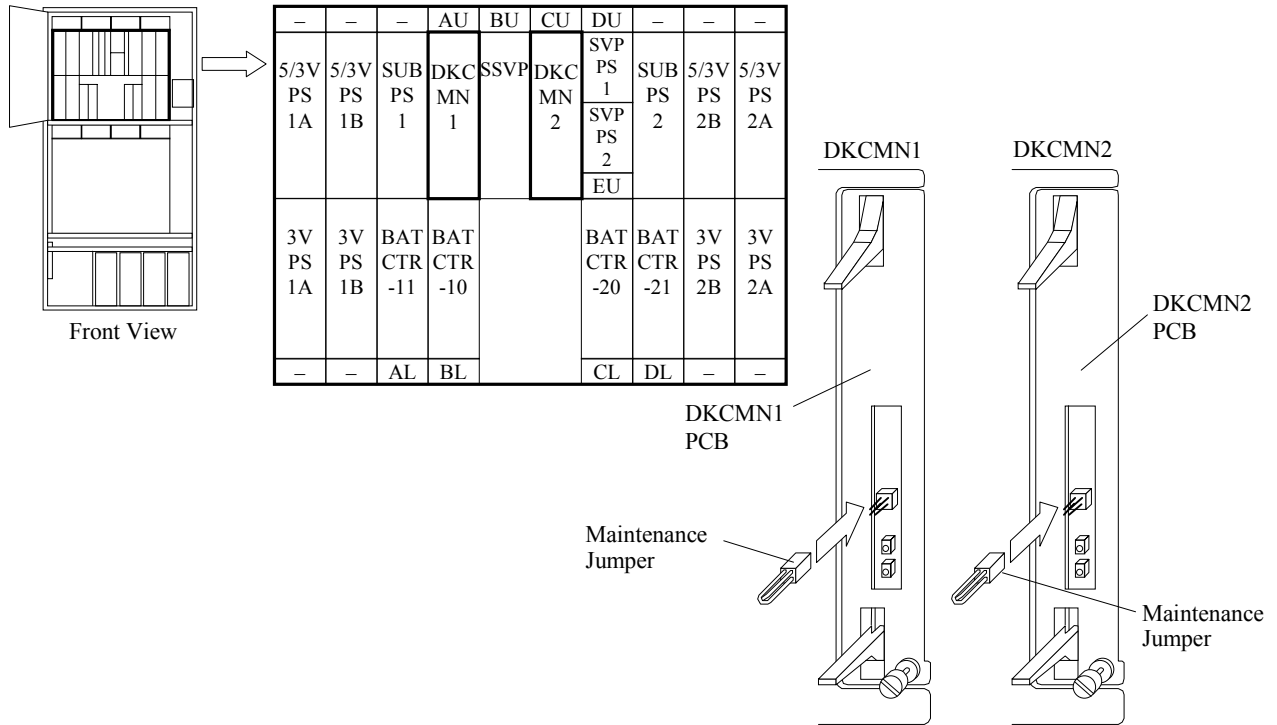

3. Set the jumper connectors(J1 and J2) of the spare PCI CON PCB to the same positions as those of the failed PCB.

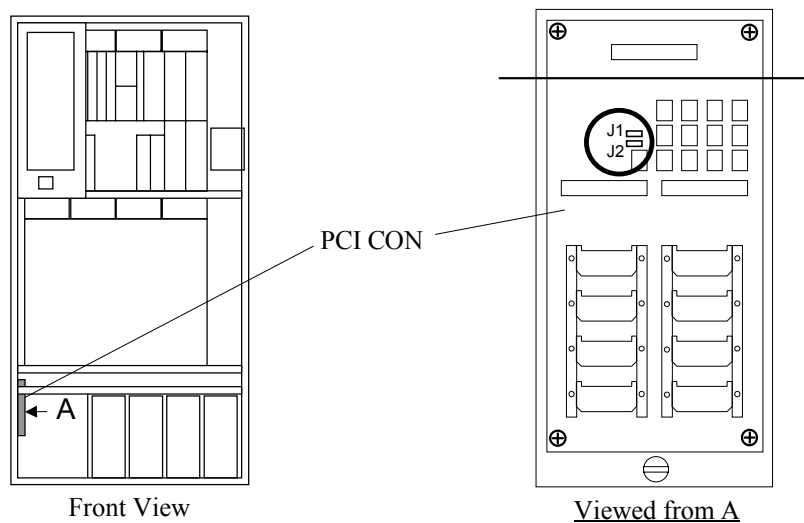

4. Replace the PCI CON.
 - a. Disconnect all cables from PCI CON.
 - b. Loosen the screw① and remove the screw② from base plate.
 - c. Slide the plate and turn it using the screw① as an axis.
 - d. Remove the screw③ and remove the PCI CON.

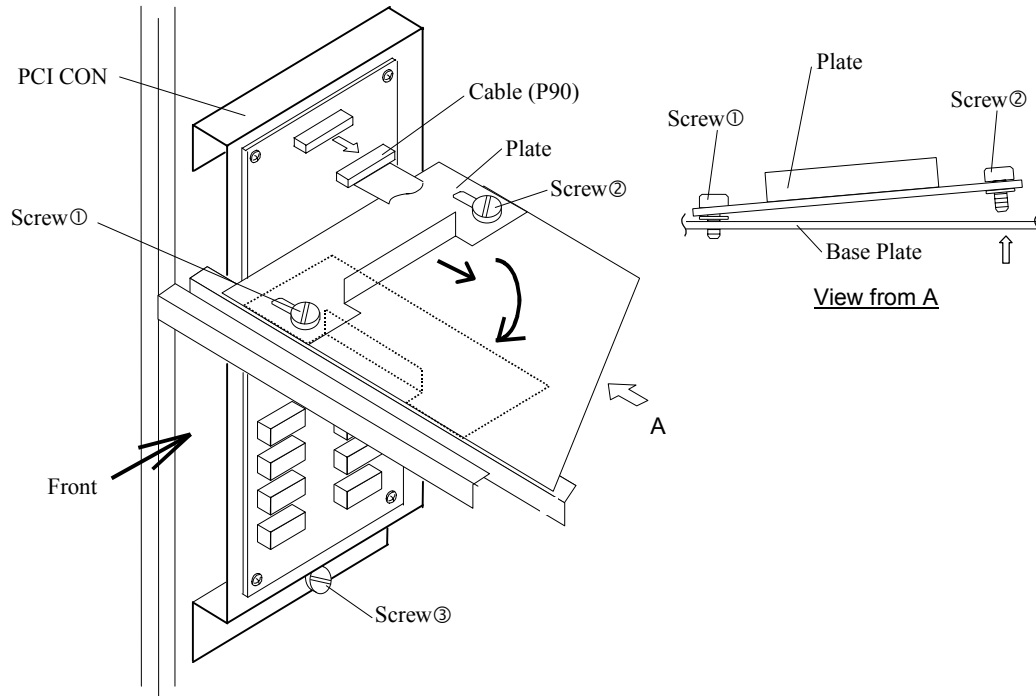

5. Remove the plate from the failed PCB, and then attach them to the spare PCB.
 - a. Remove the six screws and the plate from the failed PCB.
 - b. Attach the plate to the spare PCB and fasten the six screws.

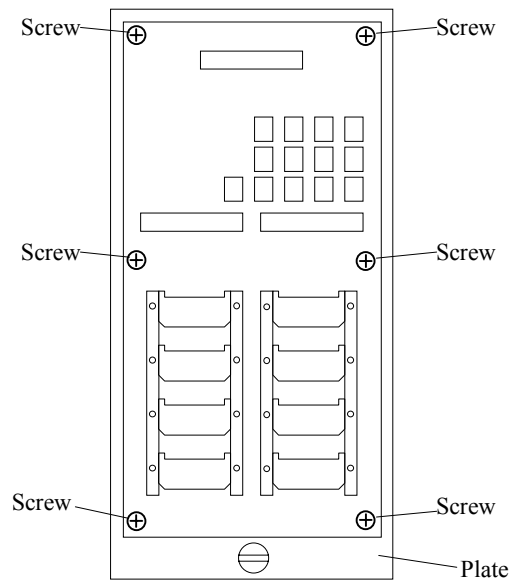

6. Attach the PCI CON.
 - a. Attach the PCI CON and fasten the screw②.
 - b. Slide the plate and fasten the screw① and ②.
 - c. Connect the cables.

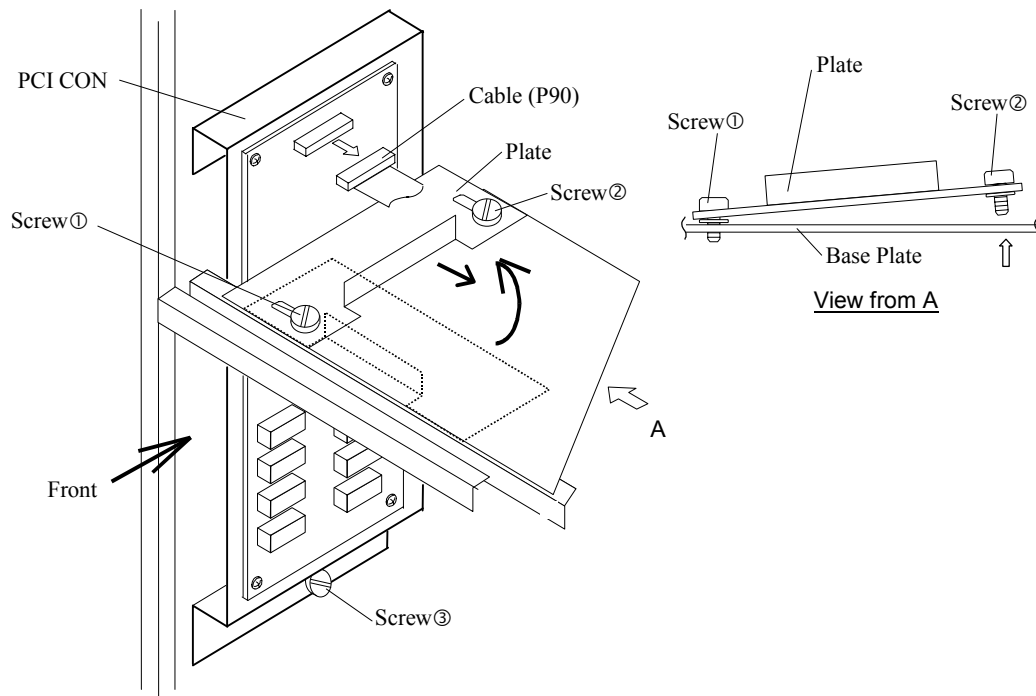

7. Restore the REMOTE/LOCAL switch on the DKC panel in step 1.
8. Disconnect the Maintenance Jumper from the connector plug on the DKCMN.
9. Go to SVP post procedure t1 [[REP04-320](#)].

[HARDWARE T5]

Location	Function Name of Component		
Top of Box	1	NAS not Support Fan Assembly	DKC FAN ASSY(A)
			DKC FAN ASSY(B)
	2	NAS Support Fan Assembly	DKC FAN(NAS) ASSY(A)
			DKC FAN(NAS) ASSY(B)

NOTE:

It is not a problem to use a NAS support FAN assembly as a replacement part of a NAS not support FAN assembly because the former is compatible with the latter. However, you cannot use a NAS not support FAN assembly as a replacement part of a NAS support FAN assembly.

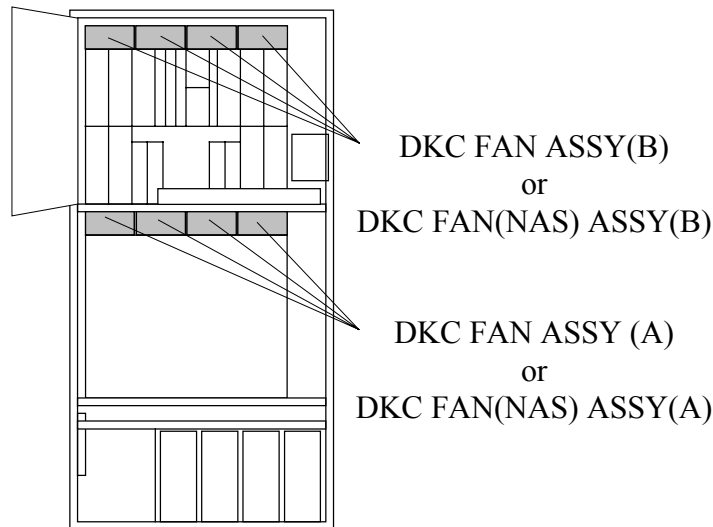

Front View

NOTICE:

Be sure to wear your wrist strap and attach to ground prior to performing the following work. This will ensure that the IC and LSI on the PCB are protected from static electricity.

Fan Assembly

**CAUTION**

Hazardous rotating mechanism:
Can cause injury if touched. Stay clear of it when machine is running.

1. The following figure shows the correct way to replace the Fan Assembly.
 - a. Loosen the screw.
 - b. Replace the Fan Assembly.
 - c. Fasten the screw.

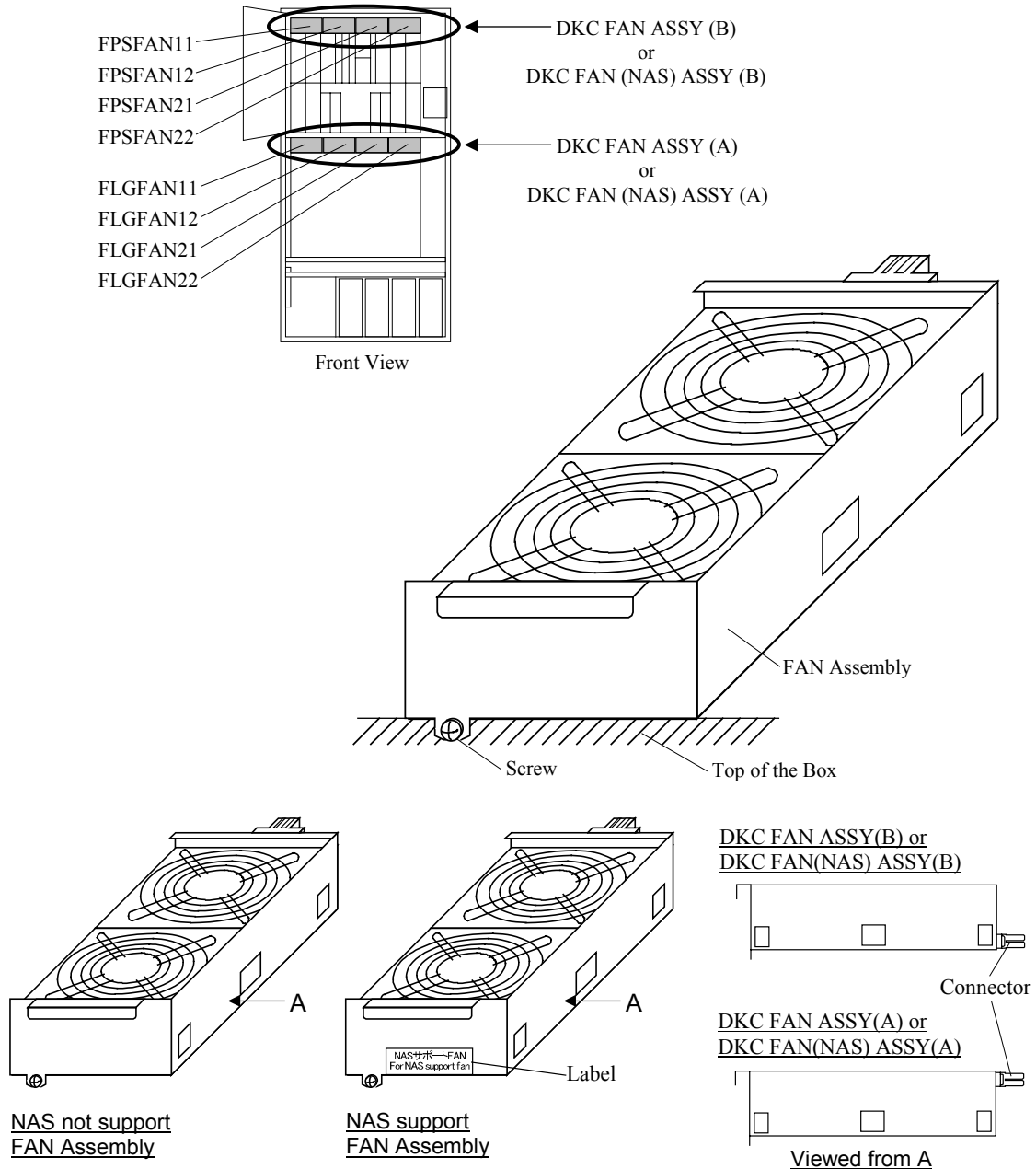

2. Go to SVP post procedure t3 [[REP04-900](#)].

[HARDWARE T6]

Location	Function Name of Component	
Front Logic Box	1	Thermostat Assembly

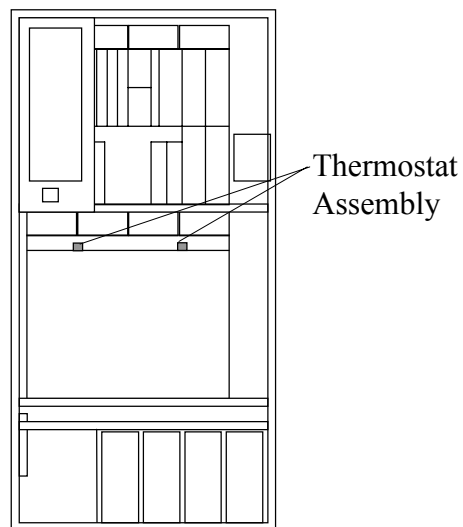

Front View

NOTICE:

Be sure to wear your wrist strap and attach to ground prior to performing the following work. This will ensure that the IC and LSI on the PCB are protected from static electricity.

Thermostat Assembly

1. The following figure shows the correct way to replace the Thermostat Assembly.
 - a. Disconnect the cable.
 - b. Loosen the screw and remove the thermostat assembly.
 - c. Attach a spare thermostat assembly and tighten the screw.
 - d. Connect the cable.

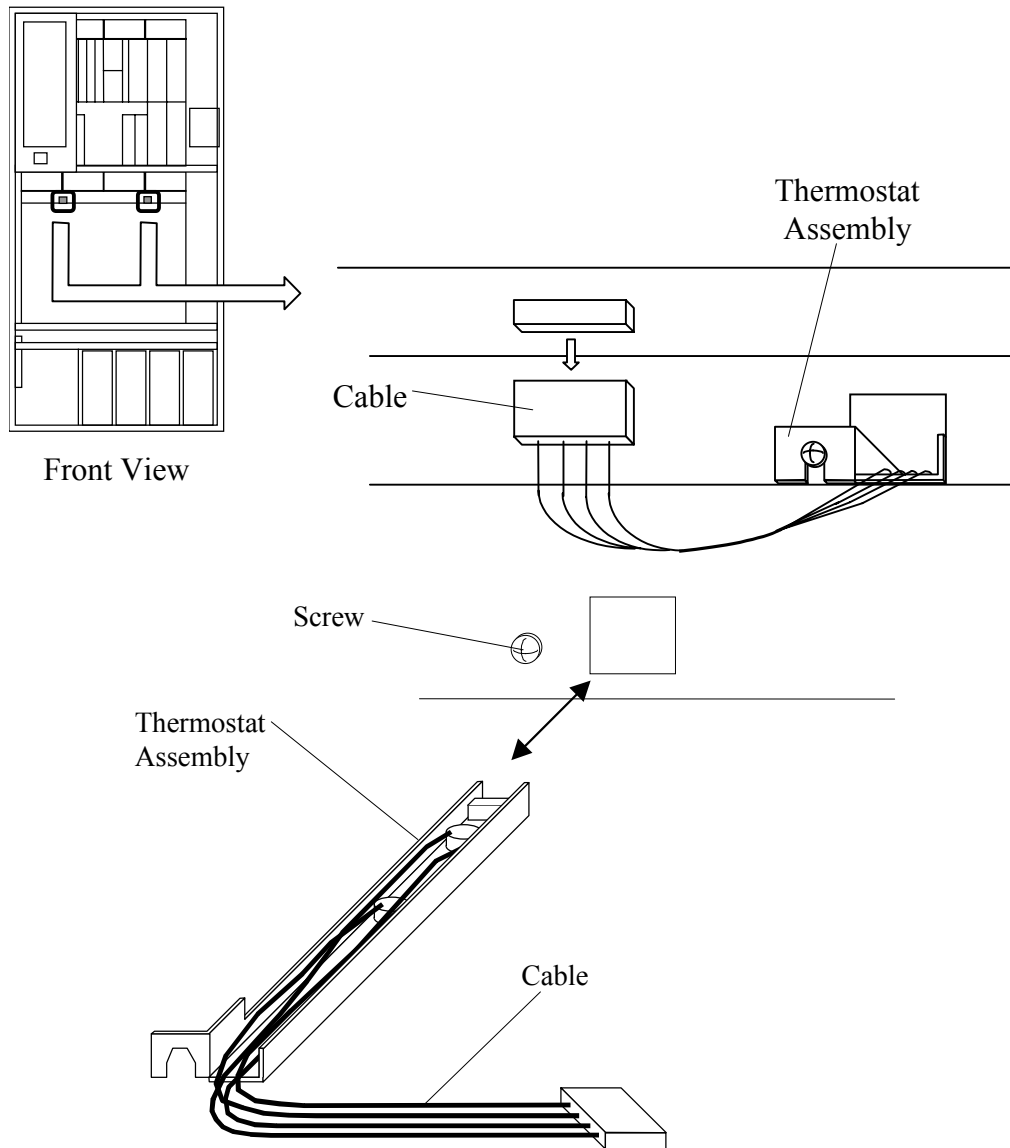

2. Go to SVP post procedure t3 [[REP04-900](#)].

[HARDWARE T7]

Location	Function Name of Component	Part Name	
Front upside of DKC	1	SVP ASSY	<ul style="list-style-type: none"> • FLORA270HX (HITACHI) • FLORA270W type1 (HITACHI) <Note1> • FLORA270W type2 (HITACHI)
	2	SVP ASSY	<ul style="list-style-type: none"> • FLORA270HX (HITACHI) (DKC-F460I-256M install Type)
	3	Flash Card	<ul style="list-style-type: none"> • PCCF-H128MS • AD-CFG128
	4	Additional SVP Memory	
	5	LAN&MODEM Card	<ul style="list-style-type: none"> • 3CXFEM656C

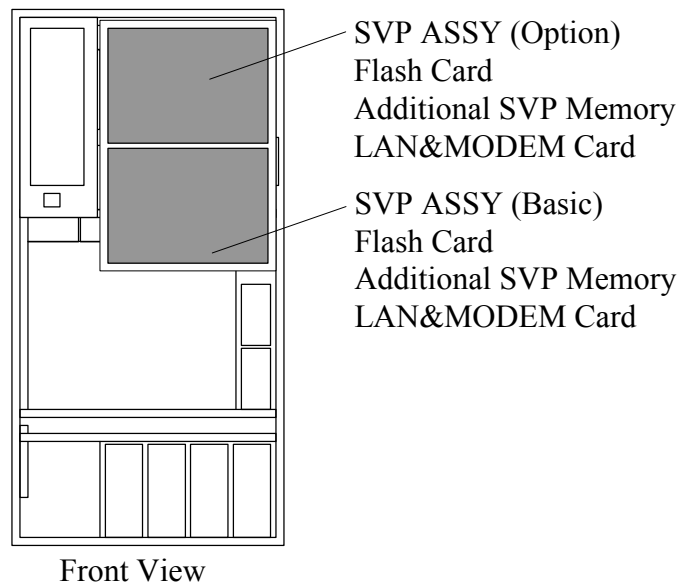

<Note1>

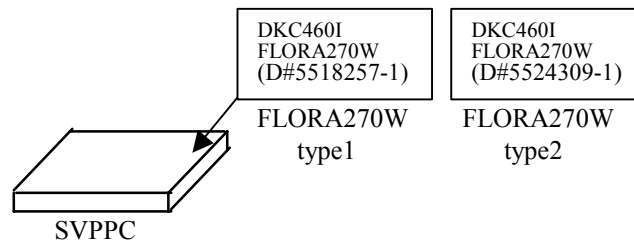

NOTICE:

Be sure to wear your wrist strap and attach to ground prior to performing the following work. This will ensure that the IC and LSI on the PCB are protected from static electricity.

Replacement of SVP ASSY

1. Open the front door and then open the DKC panel.
2. Turn the SVP Assy and turn off the power for the SVP.
(When you operate this operation from Pre-Procedure T1, do not this operation.)
3. Open the SVP frame.
There are two kinds of SVP frames. Choose from the following.

SVP frame type1

- a. Loosen the screw① and open the SVP frame.

SVP frame type2

- a. Loosen the screw② and the SVP stopper is slide to the left.
- b. Open the SVP ASSY (Basic).
- c. Loosen the screw③ and open the SVP frame.

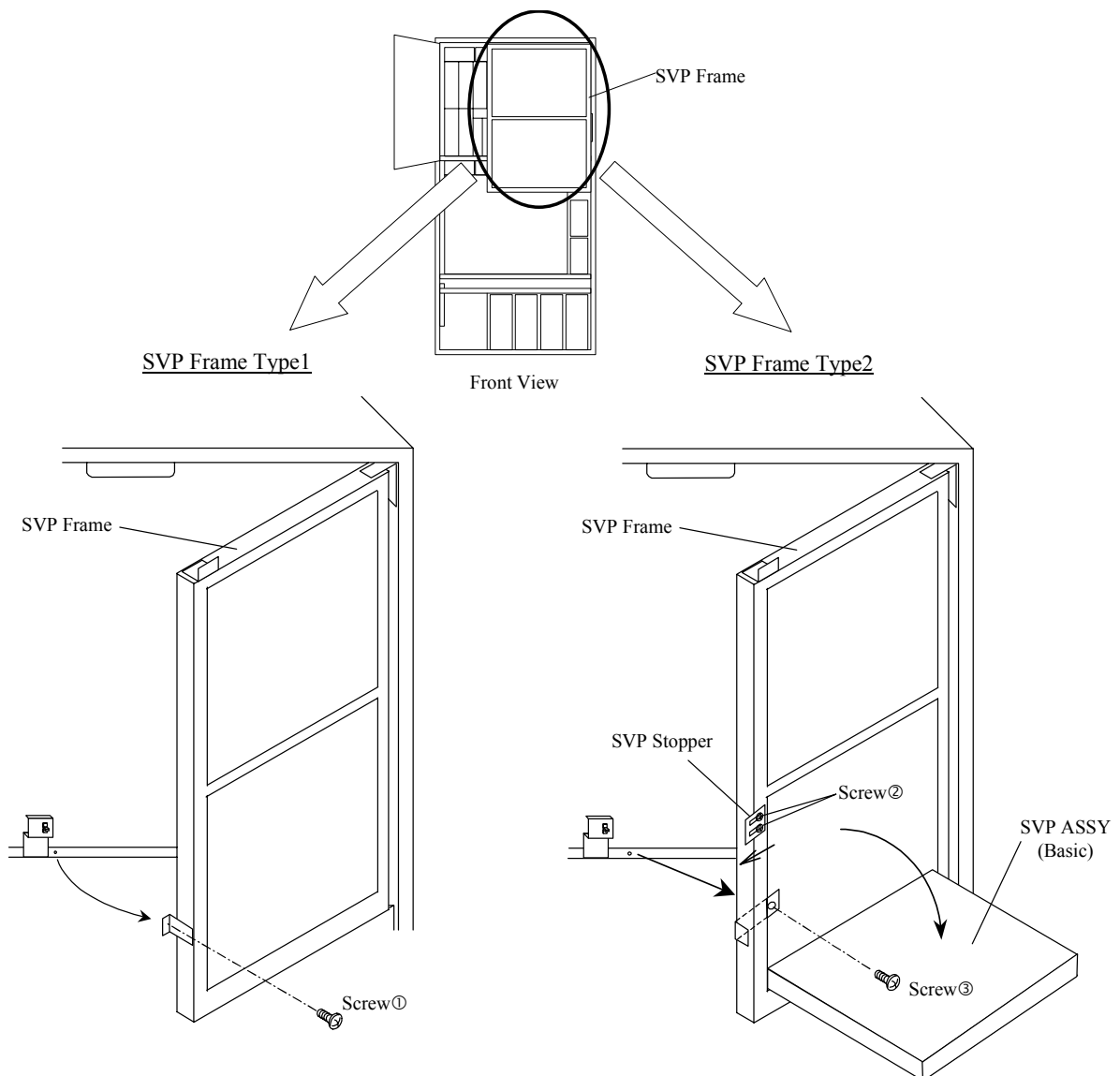

Fig. T7.1-1 Open the SVP Frame

4. Insert the Jumper.
Insert the maintenance jumper in the pin by the side of replaced SVP.

Replacement of Basic SVP ASSY

- a. Insert the maintenance jumper into JP1 on the RS CON PCB.

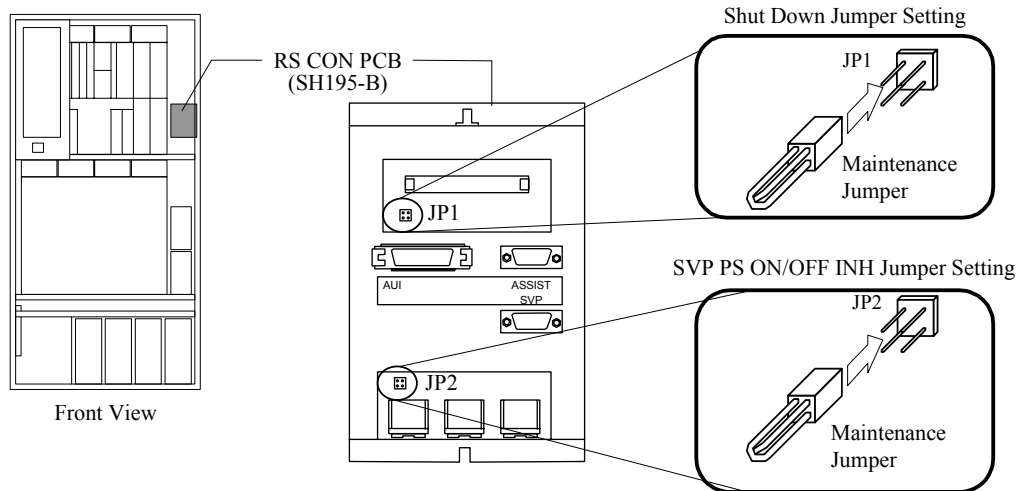

Fig. T7.1-2 Jumper settings of RS CON PCB

Replacement of Option SVP ASSY

- a. Insert the maintenance jumper into PS SD on the SVPPS BOX.

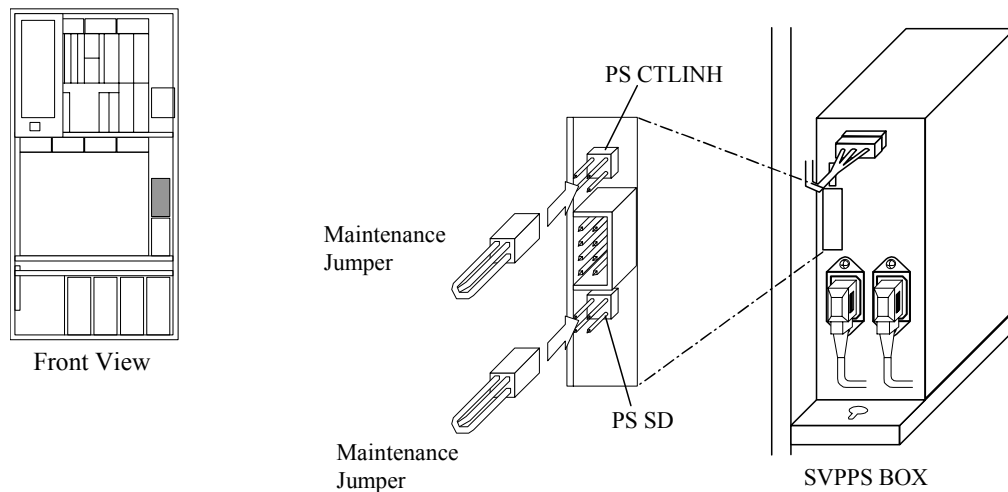

Fig. T7.1-3 Jumper settings of SVPPS BOX

5. Remove the cables.
Disconnect the cables by the side of replaced SVP.

Replacement of Basic SVP ASSY

- a. Disconnect the cables (PSVP-1 and RSVP-1) from the RS CON PCB.

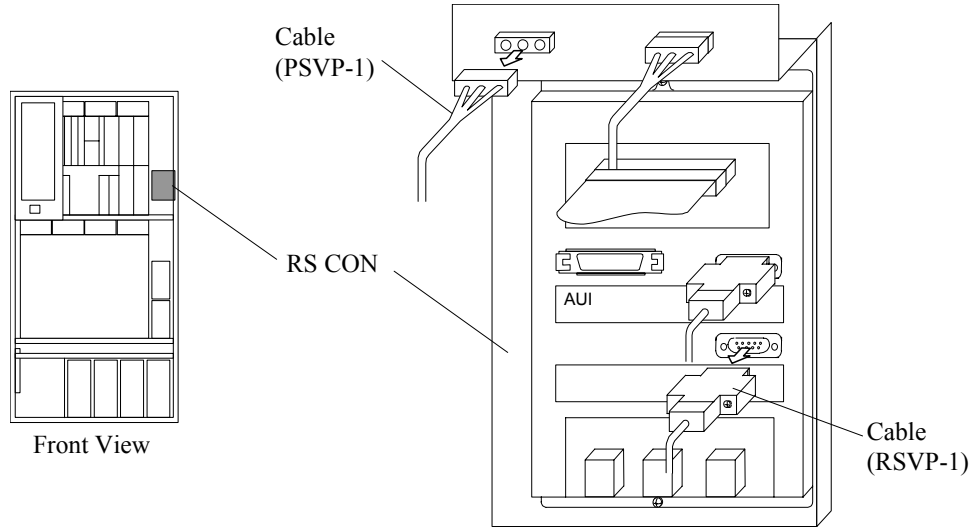

Fig. T7.1-4 Disconnect of Cables

- b. Disconnect the LAN cable (LSVP-1) from the HUB BOX.

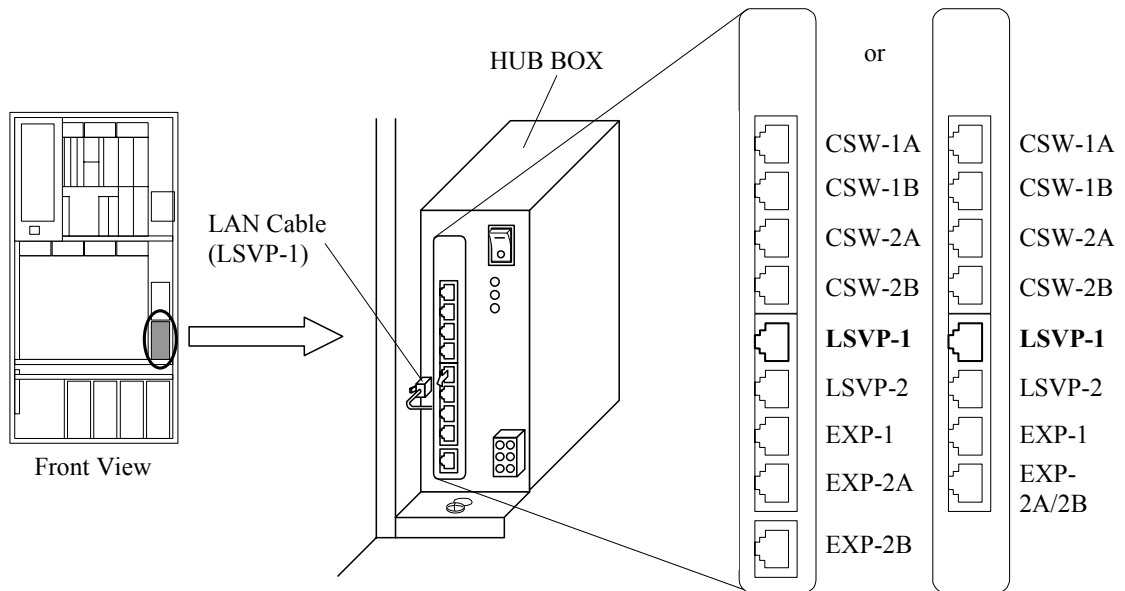

Fig. T7.1-5 Disconnect of LAN Cable

c. Open the locking clamps and remove the cables.

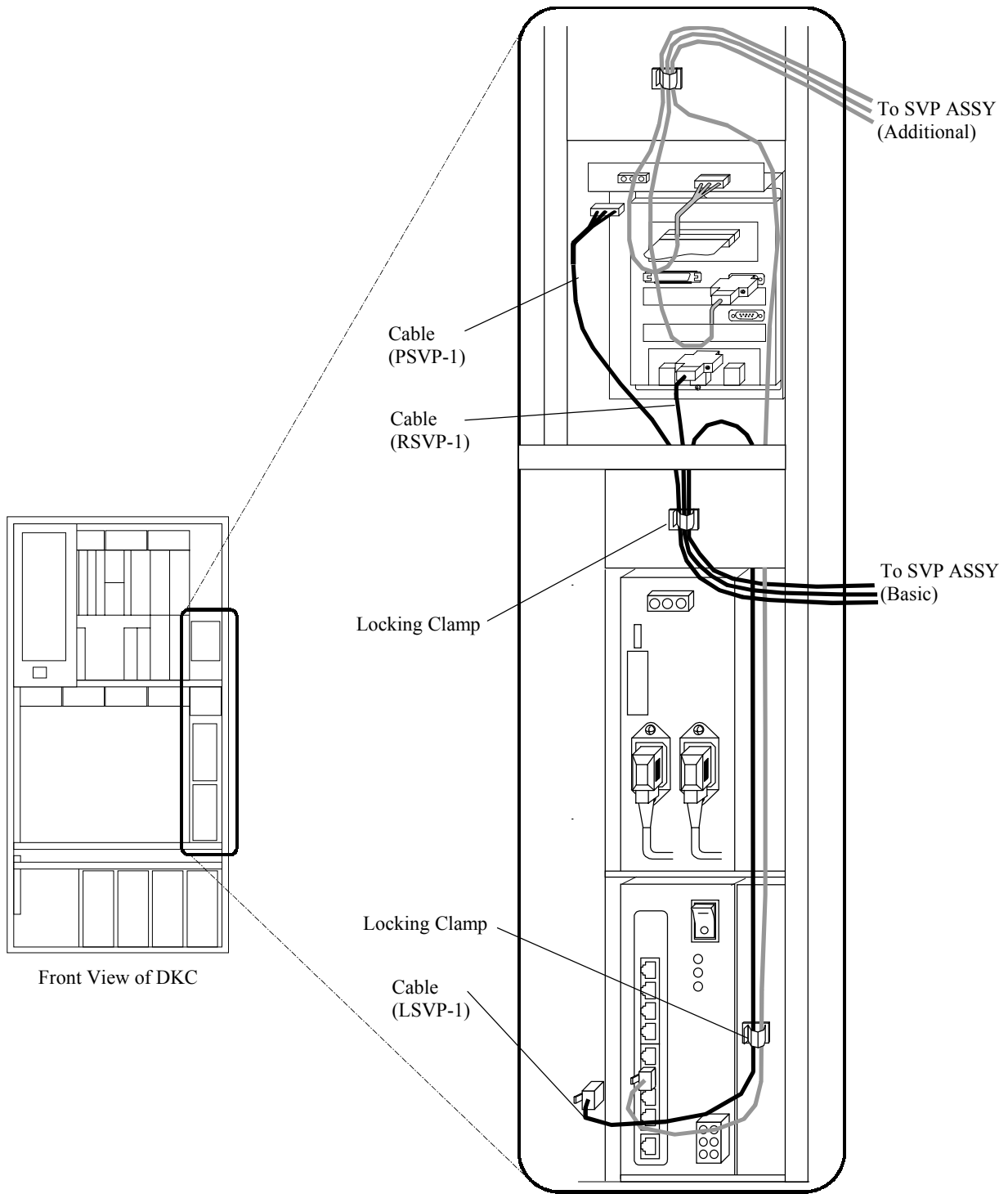

Fig. T7.1-6 Removal of Cables

Replacement of Option SVP ASSY

a. Disconnect the cables (PSVP-2 and RSVP-2) from the RS CON PCB.

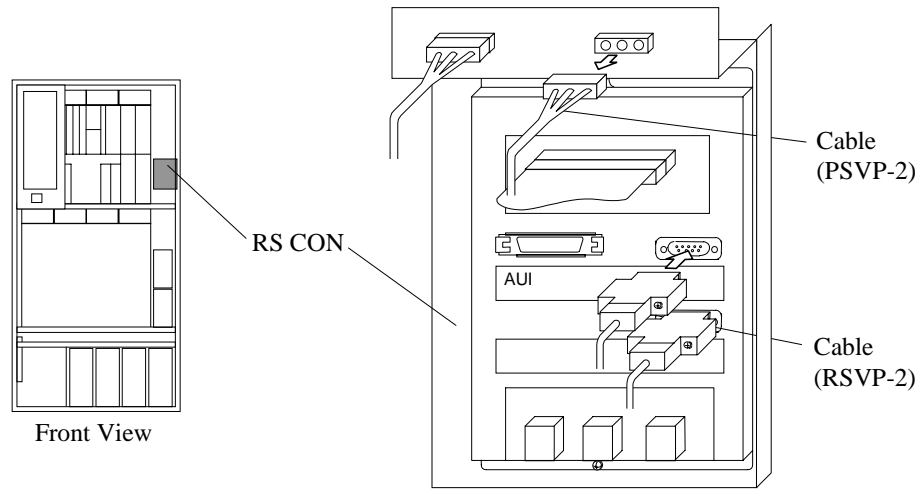

Fig. T7.1-7 Disconnect of Cables

b. Disconnect the LAN cable (LSVP-2) from the HUB BOX.

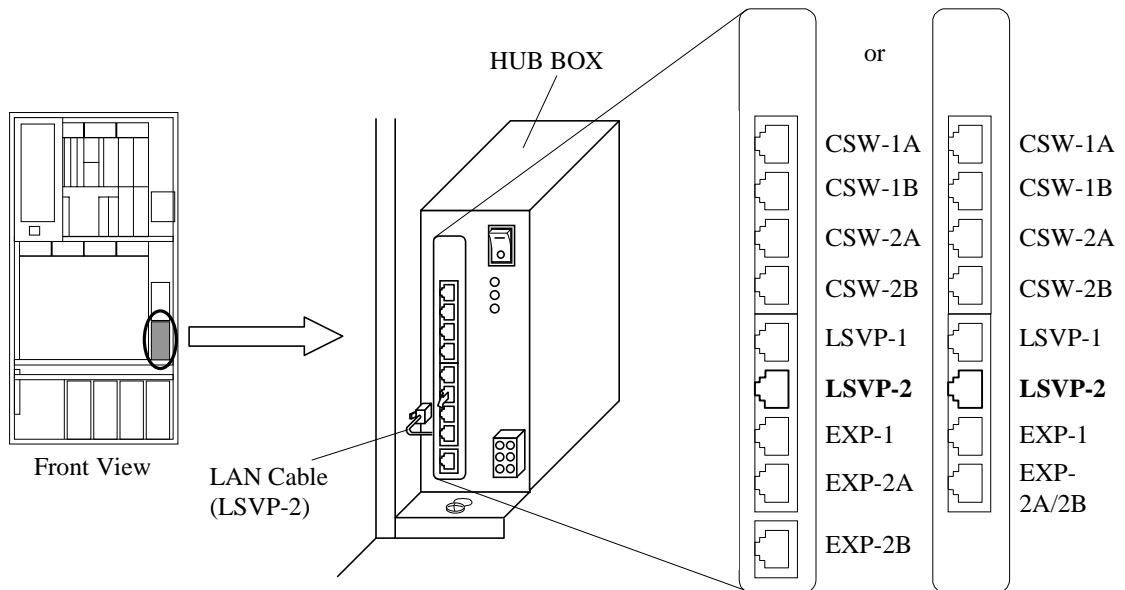

Fig. T7.1-8 Disconnect of LAN Cable

c. Open the locking clamps and remove the cables.

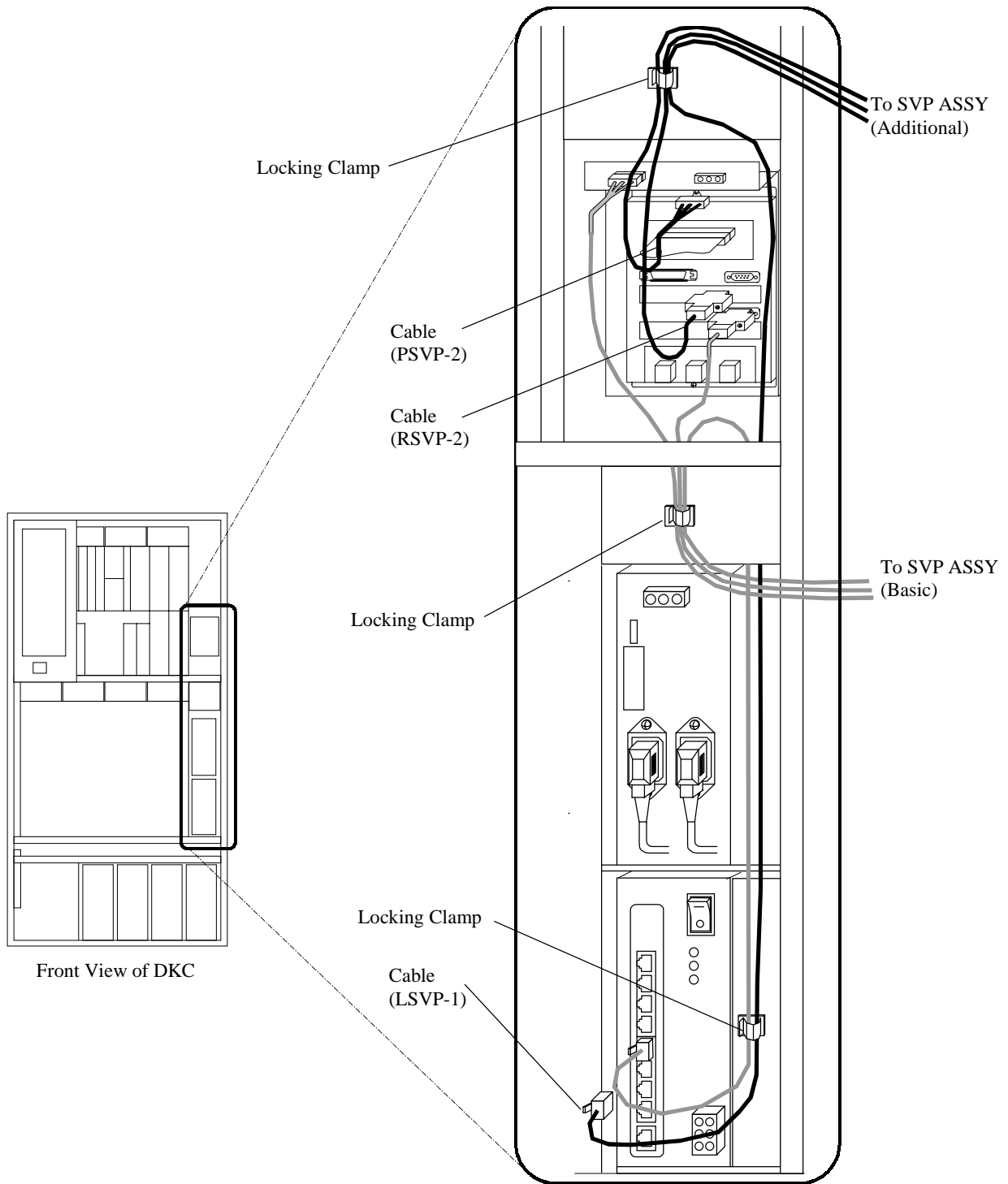

Fig. T7.1-8A Removal of Cables

6. Remove the SVP cover.
 - a. Close the SVP frame.
 - b. Loosen the screws and remove the SVP cover.

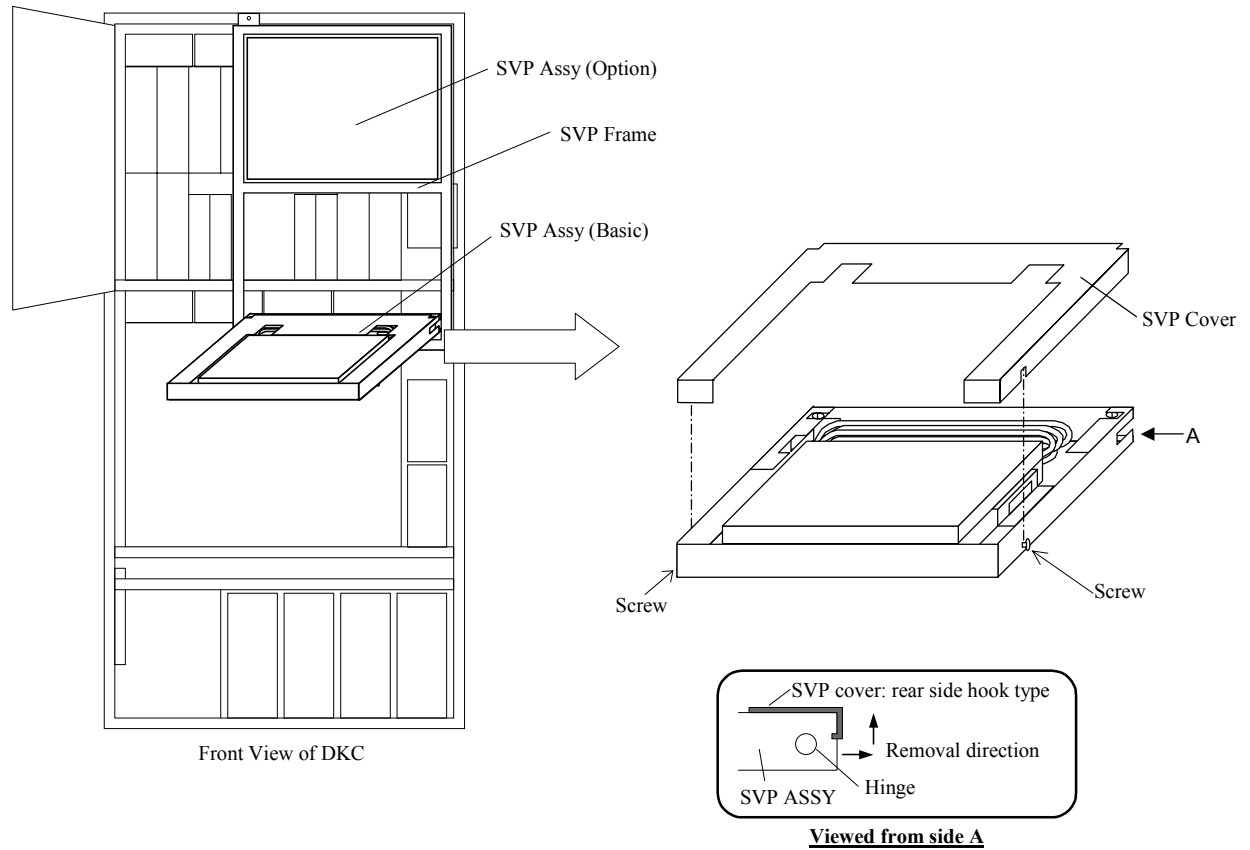

Fig. T7.1-9 Removing SVP cover

7. Loosen the screws and remove the stopper.
8. Pull out the defective SVP Assy.
9. Remove the flash card which are attached to the SVP and attach it to a spare SVP. (See [REP03-540](#).)

CAUTION

For taking over the DKC information to the replacement SVP, remove the Flash Card from the original SVP and install it in the replacement SVP (spare part).

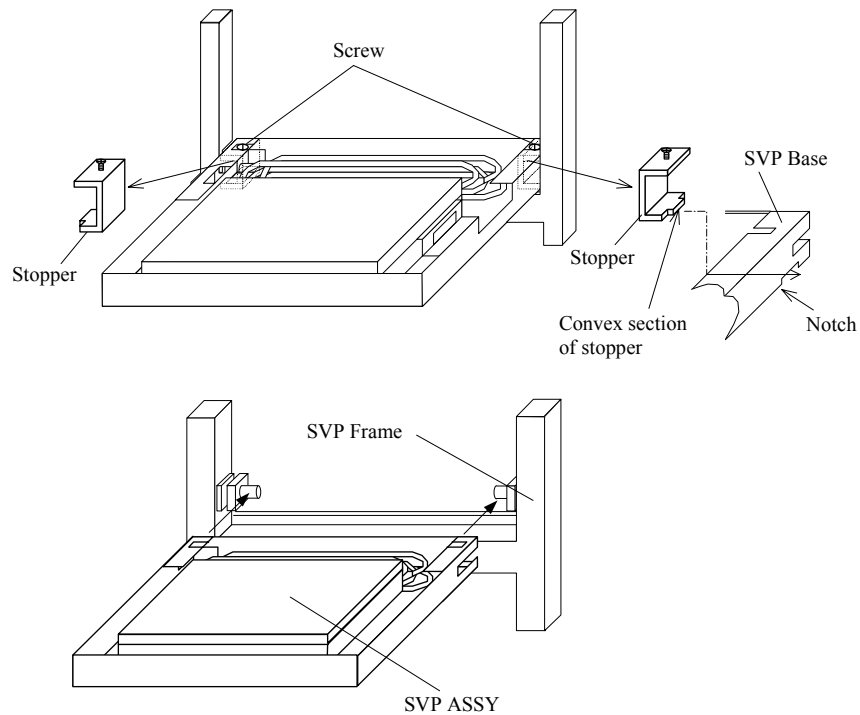

Fig. T7.1-10 Removing and installing the SVP Assy

10. Install a spare SVP Assy.

- a. Loosen the screws and remove the SVP cover and stopper from the SVP Assy.
- b. When the Additional SVP memory (DKC-F460I-256M) is installed, and Additional SVP memory is not installed for spare SVP, remove the Additional SVP memory which are attached to the SVP and attach it to a spare SVP. (See [REP03-541 through 03-544](#).)
- c. Install the SVP Assy to the SVP frame and attach the stoppers with screws. At the time, confirm that the convex sections of the stoppers are inserted into the notches of the SVP base. (See Fig. T7.1-10.)
- d. Attach the SVP Assy cables to the RS CON PCB and HUB BOX. And then close the four locking clamps. (See Fig. T7.1-7.)

However, do not connect the LAN cable to the HUB BOX when replacing the Standby SVP in the case where the SVP High Reliability Kit (DKC-F460I-SVP) is installed.

- e. Install the SVP cover.

11. Set the Jumper.

Replacement of Basic SVP ASSY

- a. Remove the maintenance jumper of the JP1 on the RS CON PCB. (See Fig. T7.1-2.)
- b. Insert the maintenance jumper into the JP2 on the RS CON PCB. (See Fig. T7.1-2.)
(If the maintenance jumper was inserted at pre procedure, this operation is unnecessary.)
- c. Check that power supply of the SVP is turned on.

Replacement of Option SVP ASSY

- a. Remove the maintenance jumper of the PS SD on the SVPPS BOX. (See Fig. T7.1-3.)
- b. Insert the maintenance jumper into the JP2 on the RS CON PCB. (See Fig. T7.1-2.)
Insert the maintenance jumper into the PS CTLINH on the SVPPS BOX. (See Fig. T7.1-3.)
(If the maintenance jumper was inserted at pre procedure, this operation is unnecessary.)
- c. Check that power supply of the SVP is turned on.

12.

SVP High Reliability Kit (DKC-F460I-SVP) is not installed

Go to SVP post procedure t1 [[REP04-320](#)].

SVP High Reliability Kit (DKC-F460I-SVP) is installed

Go to SVP post procedure t5 [[REP04-1100](#)].

Replacement of Flash Card

1. Open the front door and then open the DKC panel.
2. Turn the SVP Assy and turn off the power for the SVP.
3. Insert the jumper.

Replacement of Basic SVP ASSY

Insert the maintenance jumper into JP1 on the RS CON PCB. (See Fig. T7.1-2 [REP03-470].)

Replacement of Option SVP ASSY

Insert the maintenance jumper into PS SD on the SVPPS BOX. (See Fig. T7.1-3 [REP03-470].)

4. Loosen the screws and remove the SVP cover. (See Fig. T7.1-9 [REP03-520].)
5. Operate the card IN/OUT lever to remove the flash card from the SVP.
6. Insert a spare flash card.

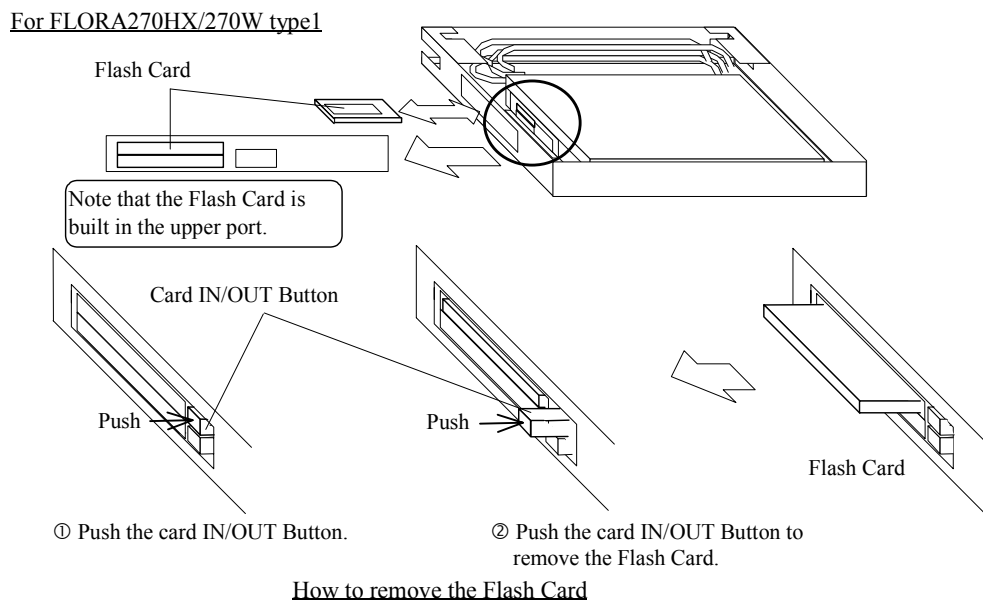

Fig. T7.2-1 Replacing the flash card (for FLORA270HX/270W type1)

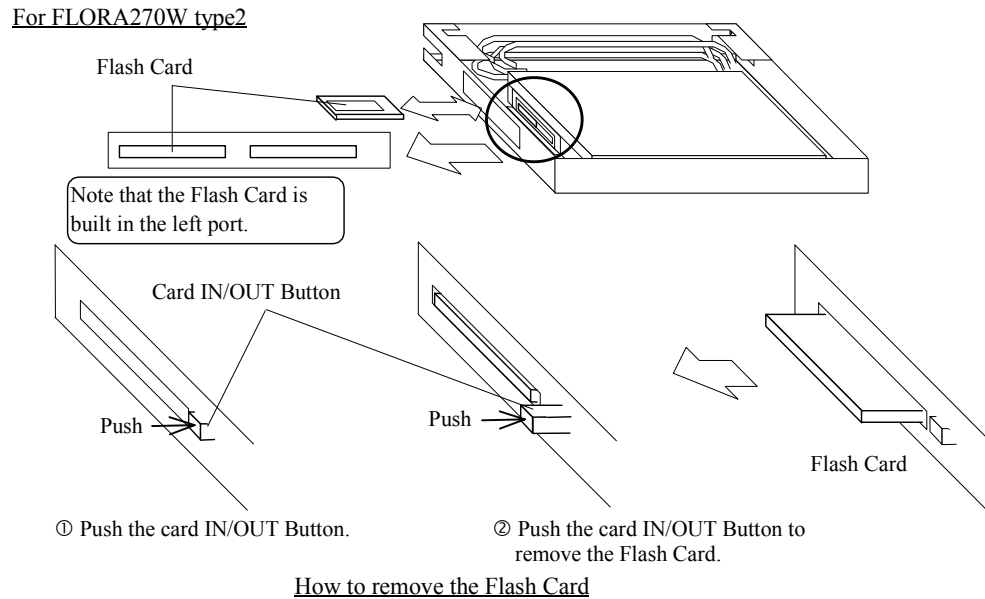

Fig. T7.2-2 Replacing the flash card (for FLORA270W type2)

7. Attach the SVP cover.
8. Pull out the maintenance jumper on the RS CON PCB or SVPPS BOX. (See Fig. T7.1-2 [REP03-470].)
(When the maintenance jumper is pulled off, power supply of the SVP is turned on.)

-
9. SVP High Reliability Kit (DKC-F460I-SVP) is not installed
Go to SVP post procedure t1 [REP04-320].

- SVP High Reliability Kit (DKC-F460I-SVP) is installed
Go to SVP post procedure t5 [REP04-1100].

Replacement of Additional SVP Memory

1. Open the front door and then open the DKC panel.
2. Turn the SVP ASSY and turn off the power for the SVP.
3. Loosen the screw and open the SVP frame. (See Fig. T7.1-1 [[REP03-460](#)].)
4. Insert the jumper.

Replacement of Basic SVP ASSY

Insert the maintenance jumper into JP1 on the RS CON PCB. (See Fig. T7.1-2 [[REP03-470](#)].)

Replacement of Option SVP ASSY

Insert the maintenance jumper into PS SD on the SVPPS BOX. (See Fig. T7.1-3 [[REP03-470](#)].)

5. Remove the cables.

Replacement of Basic SVP ASSY

- a. Disconnect the RS232C cable (RSVP-1) from the RS CON PCB. (See Fig. T7.1-4 [[REP03-480](#)].)
- b. Disconnect the LAN cable (LSVP-1) from the HUB BOX.
Disconnect the SVP PS cable (PSVP-1) from the CON PLATE. (See Fig. T7.1-5 [[REP03-480](#)].)
- c. Open the locking clamps and remove the cables. (See Fig. T7.1-6 [[REP03-490](#)].)

Replacement of Option SVP ASSY

- a. Disconnect the RS232C cable (RSVP-2) from the RS CON PCB. (See Fig. T7.1-7 [[REP03-500](#)].)
- b. Disconnect the LAN cable (LSVP-2) from the HUB BOX.
Disconnect the SVP PS cable (PSVP-2) from the CON PLATE. (See Fig. T7.1-8 [[REP03-500](#)].)
- c. Open the locking clamps and remove the cables. (See Fig. T7.1-8A [[REP03-510](#)].)

6. Loosen the screws and remove the SVP cover. (See Fig. T7.1-9 [[REP03-520](#)].)
7. Loosen the screws and remove the stopper. (See Fig. T7.1-10 [[REP03-530](#)].)
8. Pull out the defective SVP ASSY. (See Fig. T7.1-10 [[REP03-530](#)].)

9. Remove the DC Cable LAN Cable and LAN Port cable.

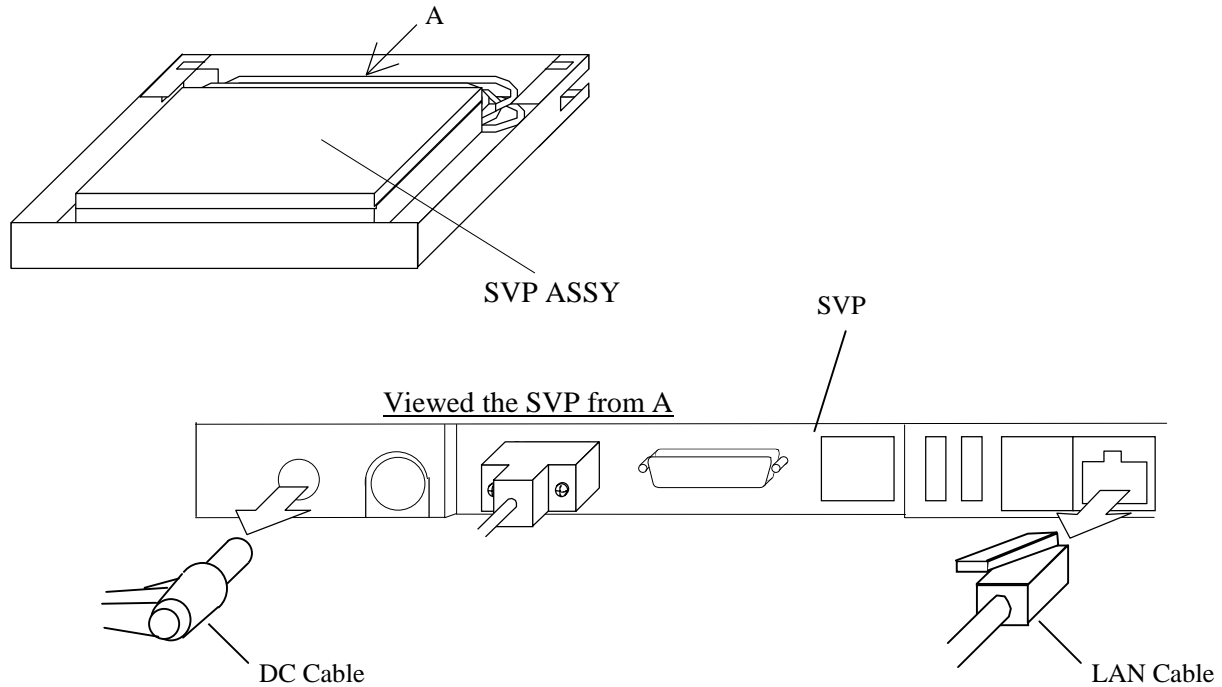

Fig. T7.3-1 Removing and installing Cables

10. Loosen the screw and remove the SVP stoppers.

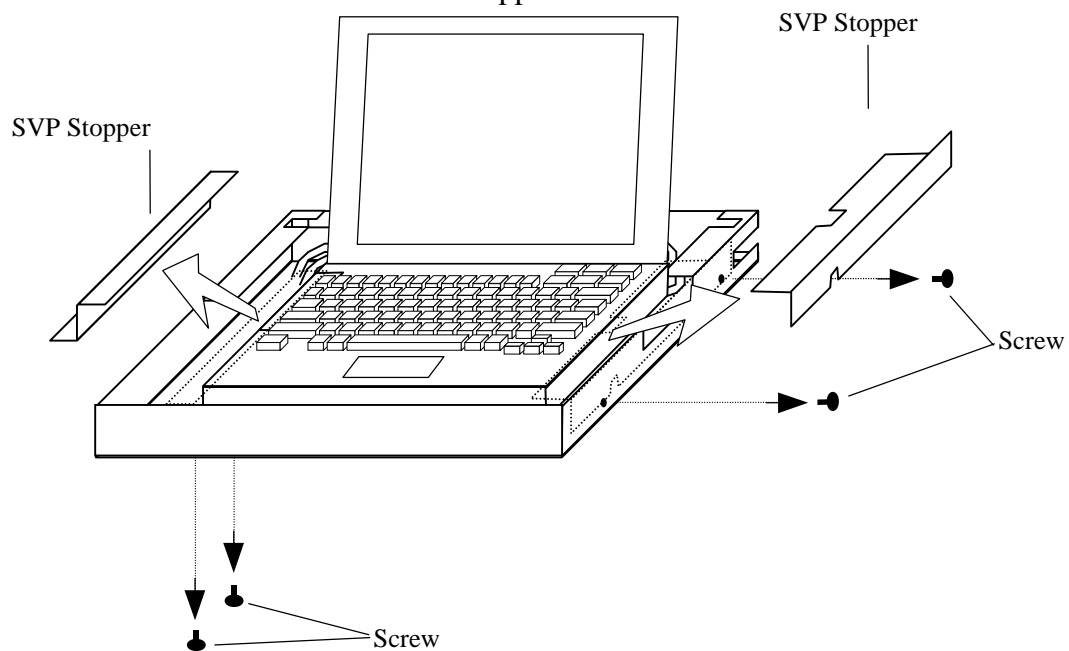

Fig. T7.3-2 Removing and installing the SVP Stoppers

11. Remove the RS232C Cable from the SVP ASSY.

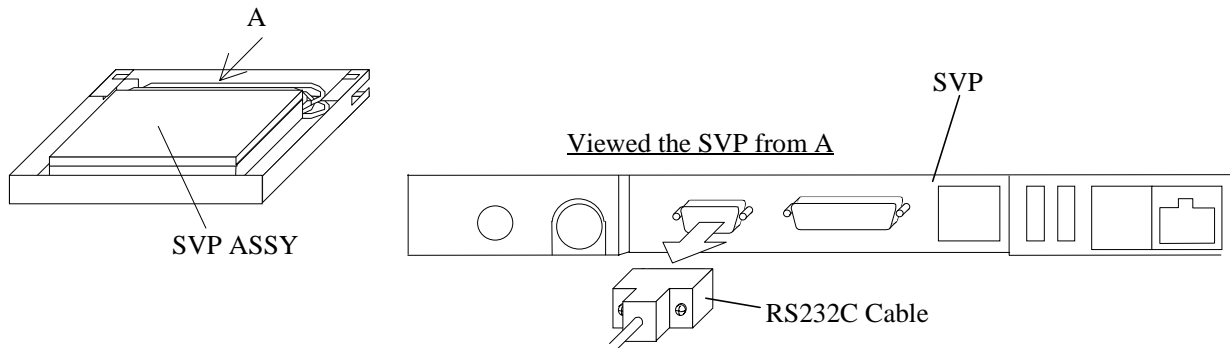
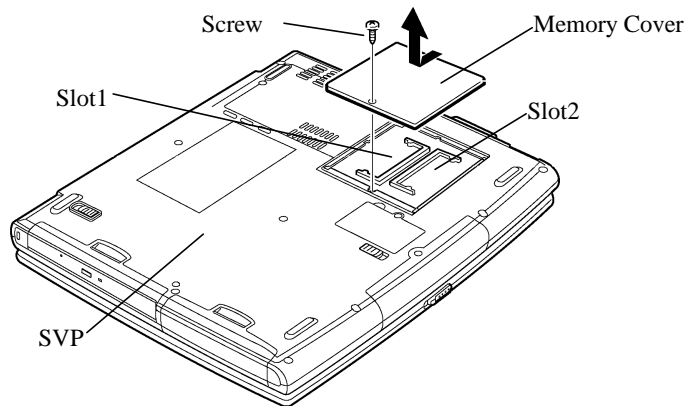

Fig. T7.3-3 Removing and installing RS232C Cable

12. Replacement of Additional SVP Memory

- a. Loosen the screw and remove the Memory cover.



- b. Remove the Memory module.

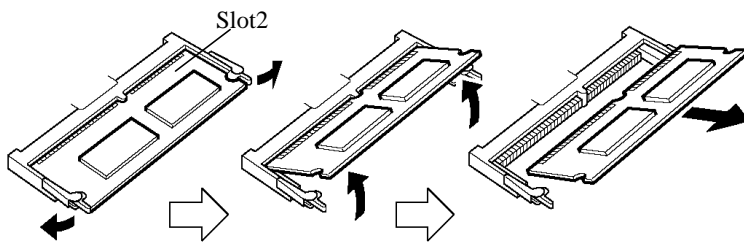

- c. Insert the Memory module.

- d. Attach the Memory cover with screw.

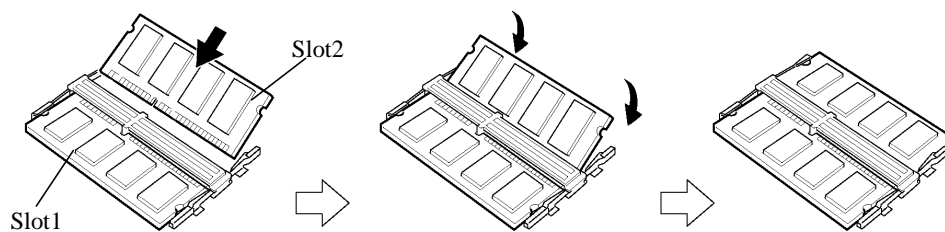

Fig. T7.3-4 Replacing the Additional SVP Memory

13. Install a SVP.

- a. Attach the SVP and RS232C Cable. (See Fig. T7.3-3.)
- b. Install the SVP to the SVP ASSY and attach the SVP stoppers with screws. (See Fig. T7.3-2)
- c. Connect the LAN cable and DC cable to the SVP. (See Fig. T7.3-1.)

14. Install a SVP Assy.

- a. Install the SVP to the SVP ASSY and attach the SVP stoppers with screws. (See Fig. T7.1-10 [REP03-530].)
- b. Attach the SVP ASSY cables to the RS CON PCB, HUB BOX and CON PLATE. And then close the locking clamps. (See Fig. T7.1-2 through T7.1-8A [REP03-470 through 520].)
- c. Attach the SVP cover. (See Fig. T7.1-9 [REP03-520].)

15. Set the Jumper.

Replacement of Additional SVP Memory of Basic SVP ASSY

- a. Remove the maintenance jumper of the JP1 on the RS CON PCB. (See Fig. T7.1-2 [REP03-470].)
- b. Insert the Maintenance jumper into the JP2 on the RS CON PCB. (See Fig. T7.1-2 [REP03-470].)

Replacement of Additional SVP Memory of Option SVP ASSY

- a. Remove the maintenance jumper of the PS SD on the SVPPS BOX. (See Fig. T7.1-3 [REP03-470].)
- b. Insert the Maintenance jumper into the PS CTLINH on the SVPPS BOX. (See Fig. T7.1-3 [REP03-470].)

Replacement of LAN&MODEM Card

1. Open the front door and then open the DKC panel.
2. Turn the SVP Assy and turn off the power for the SVP.
3. Insert the jumper.

Replacement of Basic SVP ASSY

Insert the maintenance jumper into JP1 on the RS CON PCB. (See Fig. T7.1-2 [REP03-470].)

Replacement of Option SVP ASSY

Insert the maintenance jumper into PS SD on the SVPPS BOX. (See Fig. T7.1-3 [REP03-470].)

4. Loosen the screws and remove the SVP cover. (See Fig. T7.1-9 [REP03-520].)
5. Operate the card IN/OUT lever to remove the LAN&MODEM Card from the SVP.
6. Insert a spare LAN&MODEM Card.

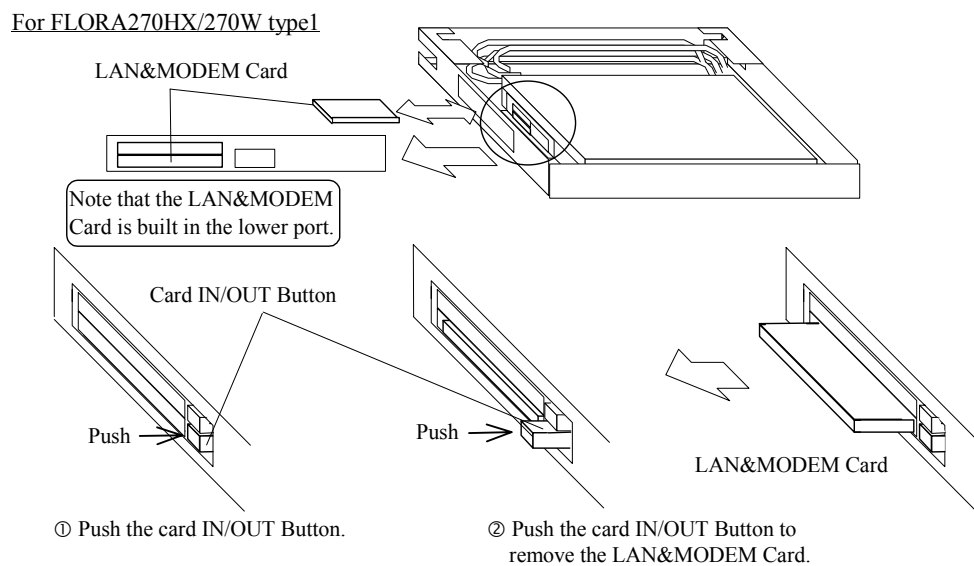

How to remove the LAN&MODEM Card

Fig. T7.4-1 Replacing the LAN&MODEM card (for FLORA270HX/270W type1)

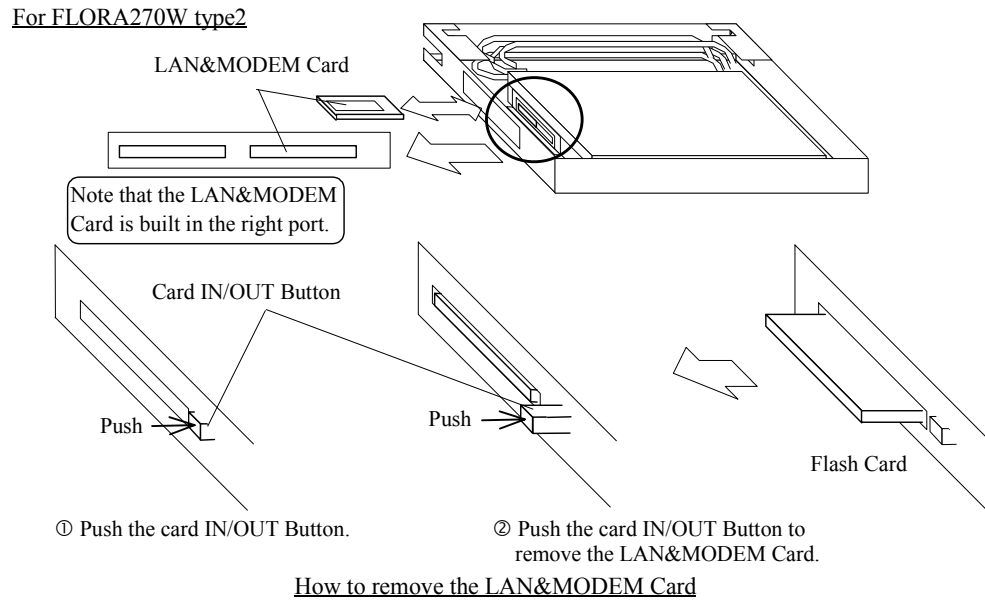
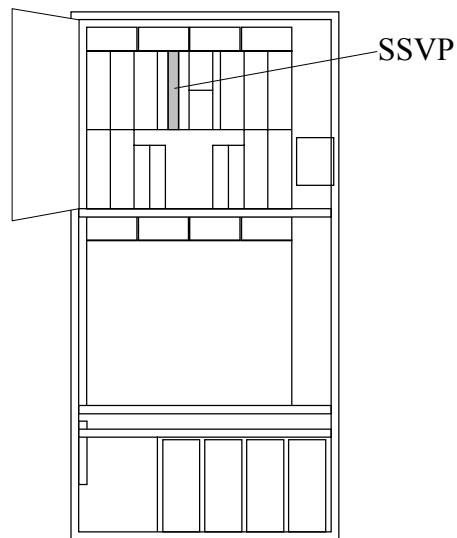

Fig. T7.4-2 Replacing the LAN&MODEM card (for FLORA270W type2)

9. Attach the SVP cover.
 10. Pull out the maintenance jumper on the RS CON PCB or SVPPS BOX. (See Fig. T7.1-2 [REP03-470].)
(When the maintenance jumper is pulled off, power supply of the SVP is turned on.)
-
11. Replacement work is end. (Post procedure is unnecessary.)

[HARDWARE T8]

Location	Function Name of Component		Part Name
Front PS Box	1	SSVP PCB	• SH313-A



Front View

NOTICE:

Be sure to wear your wrist strap and attach to ground prior to performing the following work. This will ensure that the IC and LSI on the PCB are protected from static electricity.

SSVP PCB

1. Checking that the shut-down LED is turned on.
 - a. Check that the shut-down LED on the SSVP PCB in the front PS box is turned on.
-
2. Replacing the SSVP PCB.
 - a. Disconnect the cable from SSVP PCB.
 - b. Loosen the screw and remove the SSVP PCB.
 - c. Inset the spare SSVP PCB and fix it with the screw.
 - d. Connect the cable to the SSVP PCB.
 - e. Push the SSVP ALARM RESET switch.

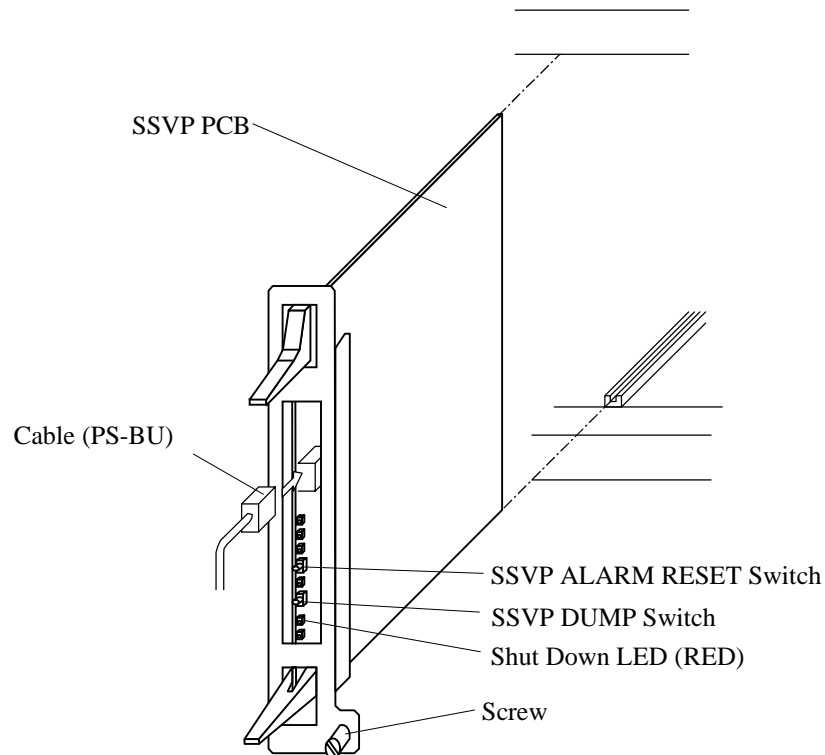
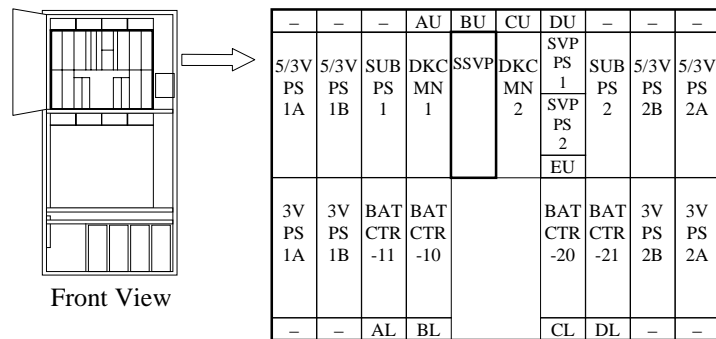

3. Go to SVP post procedure t1 [[REP04-320](#)].

[HARDWARE T11]

Location	Function Name of Component		Part Name
Lower front	1	BATTERY BOX	<ul style="list-style-type: none"> • BATTERY-10 (CL1 Shared Memory) • BATTERY-11 (CL1 Cache Memory) • BATTERY-20 (CL2 Shared Memory) • BATTERY-21 (CL2 Cache Memory)

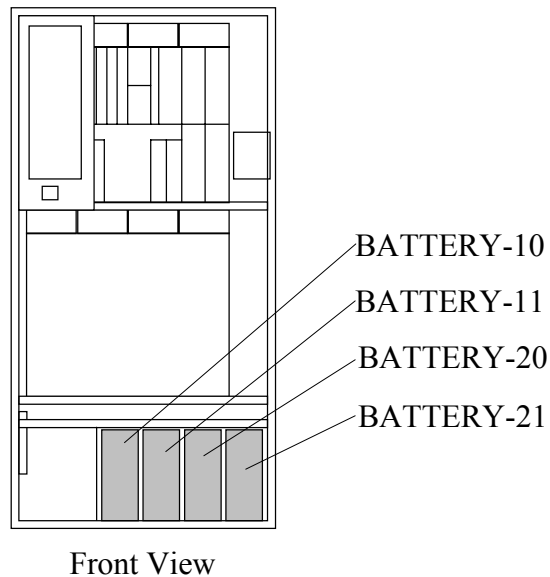
NOTICE:

Be sure to wear your wrist strap and attach to ground prior to performing the following work. This will ensure that the IC and LSI on the PCB are protected from static electricity.

BATTERY BOX

CAUTION

The weight of the battery box is 20 kg. When you handle it, be sure to hold the grip at the front and rear sides by both hands firmly.

Paying attention to falls:

If the battery box falls, injury may occur. Hold the battery box firmly by both hands and use caution to prevent it from falling.

Watching for short-circuits:

A Short-circuit may cause a fire.

Never insert metal or the like into the battery box connector or a short-circuit may occur.

1. Insert the pins of the digital voltmeter into the Connectors on the spare part to make sure that battery voltage is within the allowable voltage.

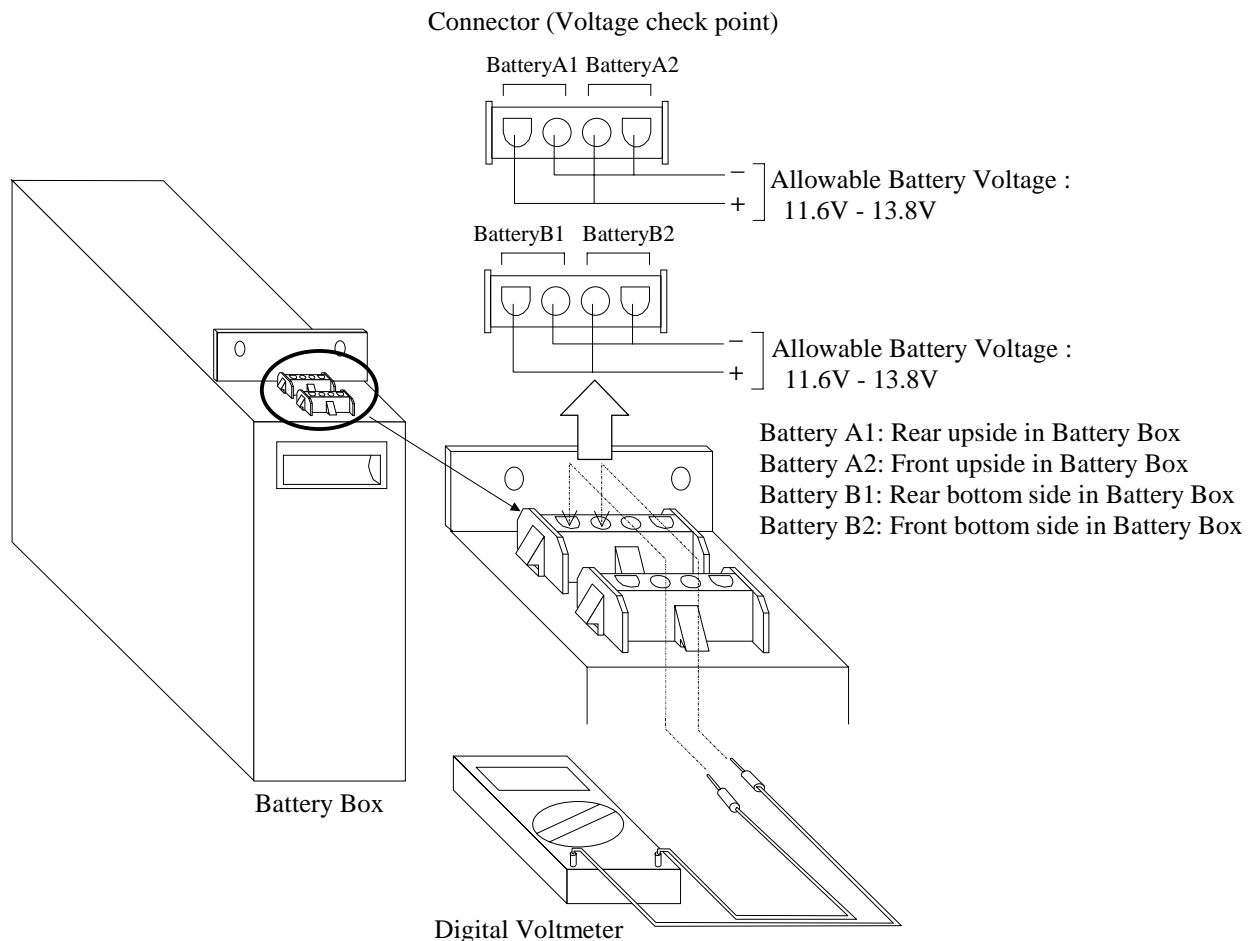

2. Replacing the battery box.
 - a. Remove the cables connected to the battery box you intend to remove.
 - b. Loosen the screws and remove the battery box.
 - c. Insert the spare battery box and tighten with the screws.
 - d. Connect the cables to the battery box.

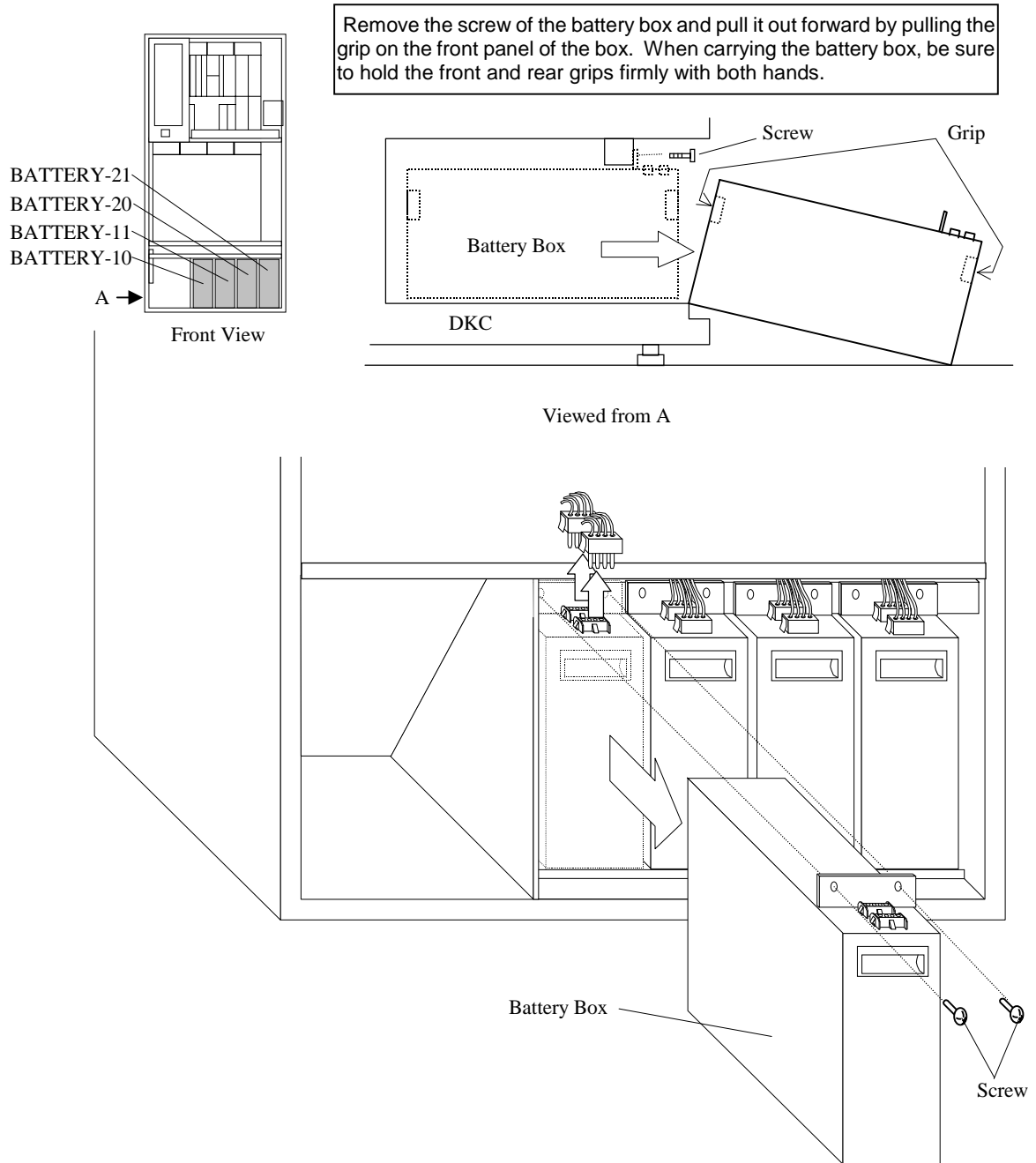

3. Go to SVP post procedure t3 [[REP04-900](#)].

[HARDWARE T12]

Location	Function Name of Component		Part Name
Front PS Box	1	BAT CTR (Battery Control) PCB	• SH200-A

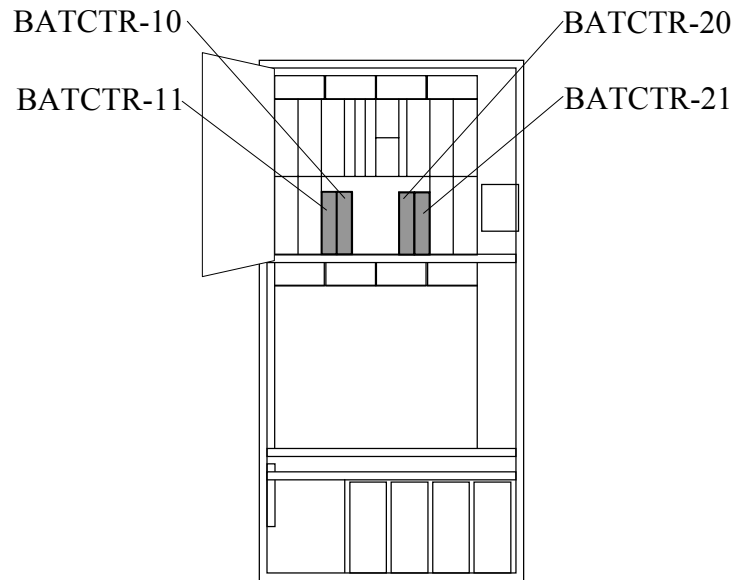

Front View

NOTICE:

Be sure to wear your wrist strap and attach to ground prior to performing the following work. This will ensure that the IC and LSI on the PCB are protected from static electricity.

BAT CTR PCB

1. Replacing the BAT CTR PCB.

- a. Loosen the screw① and turn the stopper. (Perform this when replacing the BATCTR-10/11 only.)
- b. Remove the jumper connector connected to the BAT CTR PCB you intend to remove.
- c. Loosen the screw② and remove the BAT CTR PCB.
- d. Replace the BAT CTR PCB with a spare BAT CTR PCB.
- e. Insert the spare BAT CTR PCB with the jumper connector and tighten with the screw②.
- f. Return the stopper and tighten the screw①. (Perform this when replacing the BATCTR-10/11 only.)

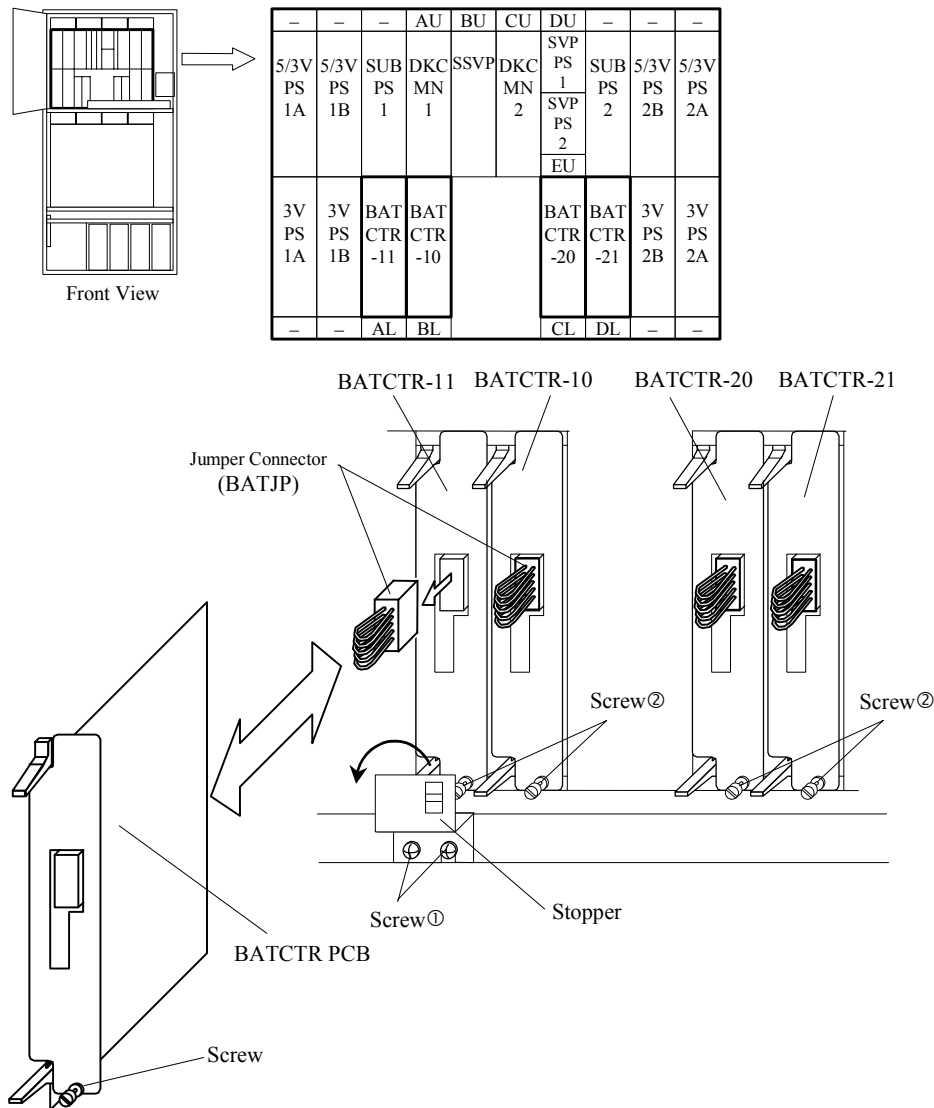

2. Go to SVP post procedure t3 [REP04-900].

[HARDWARE T13]

Location	Function Name of Component		Part Name
Front PS Box	1	3V Power Supply	<ul style="list-style-type: none"> • PPD03130 • HS0429
	2	5/3V Power Supply	<ul style="list-style-type: none"> • PPD5002-1 • HS0482
	3	SUB Power Supply	<ul style="list-style-type: none"> • PPD7502 • HS0591
	4	3/12V Power Supply	<ul style="list-style-type: none"> • HS0669 • PPD7002

NOTE:

It is not a problem to use a 3/12VPS as a replacement part of a 3VPS because the former is compatible with the latter. However, you cannot use a 3VPS as a replacement part of a 3/12VPS.

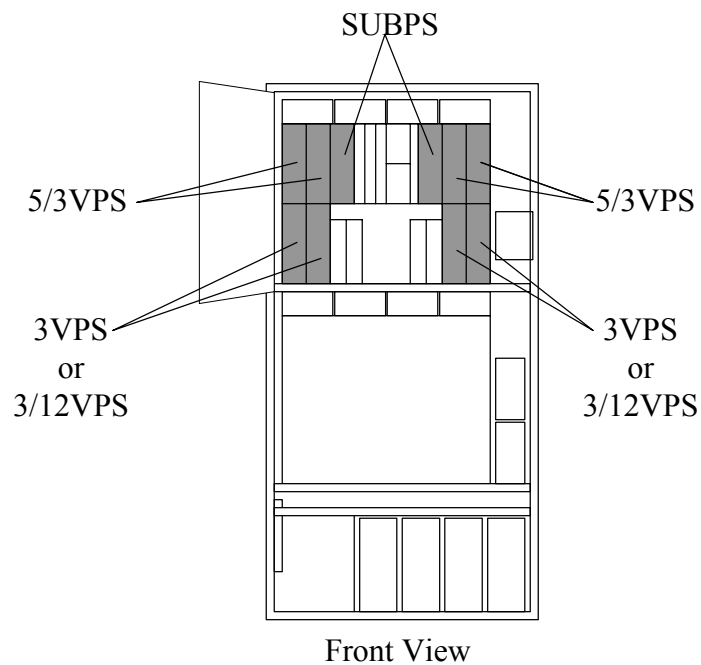

Replacement of Power Supply

1. Open the front door and then open the DKC panel.
2. Turn the SVP Assy and turn off the power for the SVP.
(When you operate this operation from Pre-Procedure T1, do not this operation.)
3. Open the SVP frame.

SVP frame type1

- a. Loosen the screw① and open the SVP frame.

SVP frame type2

- a. Loosen the screw② and the SVP stopper is slide to the left.
- b. Open the SVP ASSY (Basic).
- c. Loosen the screw③ and open the SVP frame.

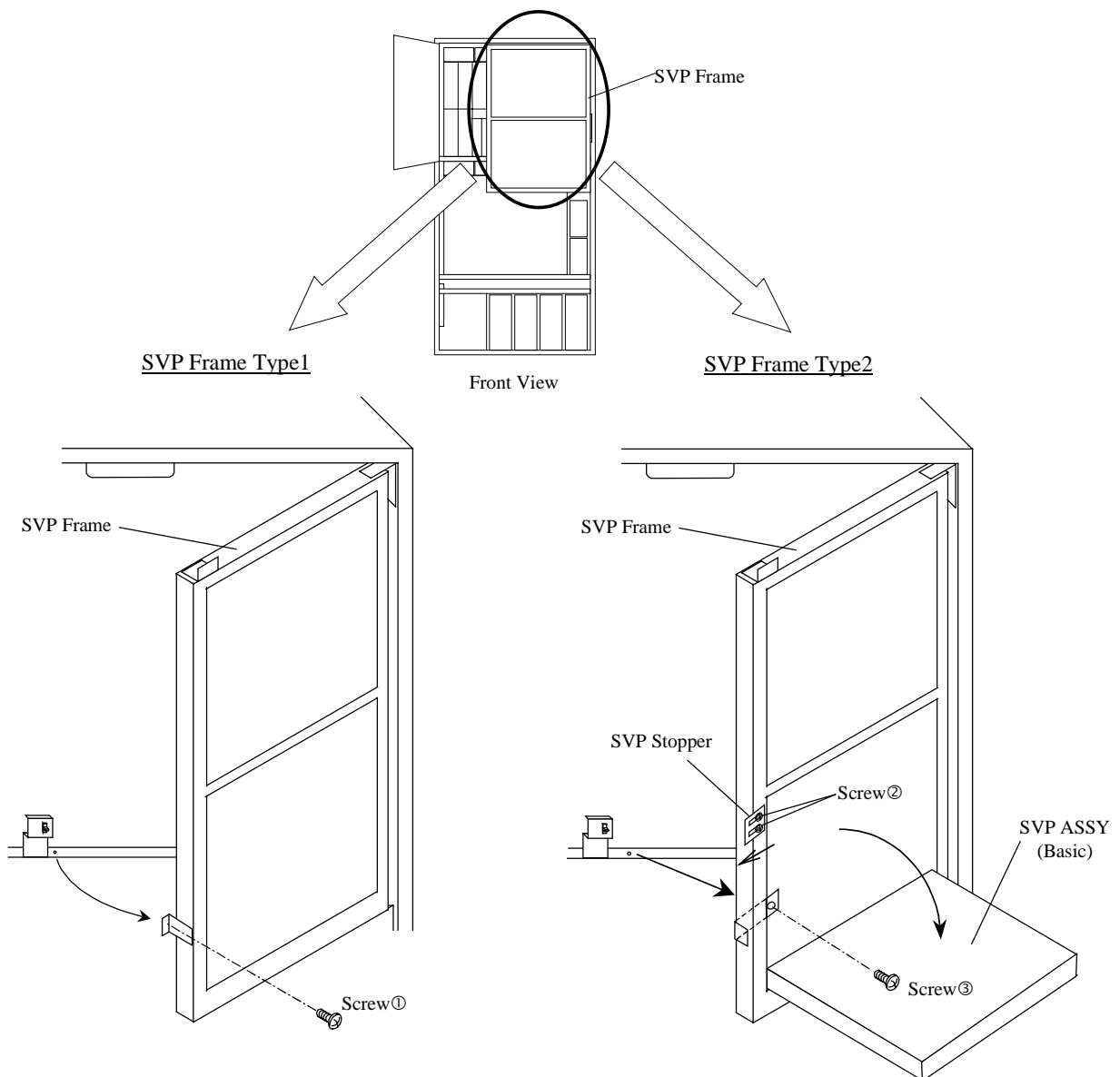

Fig. T13-1 Open the SVP Frame

3. The following figure shows the correct way to replace the power supply (PS).
 - a. Set PS Enable/Disable Switch to Disable (DOWN).

⚠ CAUTION

A system down may be caused by setting the PS Enable/Disable switch of the power supply other than that to be replaced to "Disable". Make sure that it is a power supply to be replaced.

- b. Remove the power supply lever and disconnect the cables.
- c. Loosen the screw and remove the failed PS.
- d. Perform the short circuit check on the spare power supply. (Refer to [REP03-650](#).)
- e. Confirm that PS Enable/Disable Switch of spare PS is set to Disable (DOWN)
- f. Insert the spare PS and fasten the screw.
- g. If the 3/12VPS is installed, remove the dummy connector. If not, go to next step.
- h. Connect the cables and secure inlet cable with the lever.

⚠ CAUTION

When replacing the 3/12V power supply, a system down may be caused if the 12V power cable is not connected to it. Be sure to connect the 12V power cable to the power supply.

- i. Set PS Enable/Disable Switch to Enable (UP).

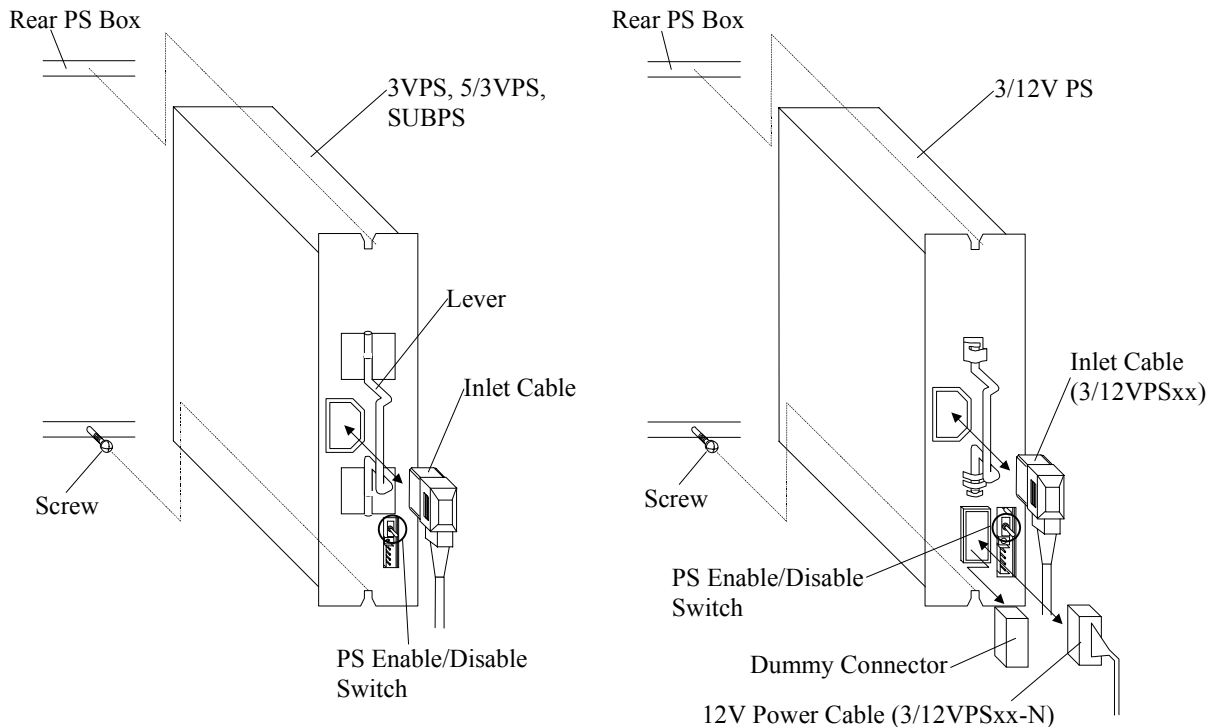

Fig. T13-2 Replacement of Power Supply

4. Close the SVP frame and fasten the screw.
5. Go to SVP post procedure t3 [[REP04-900](#)].

Procedure for short circuit check on the power supply

- Check the power supply for short circuit by connecting the voltage checking jig to the short circuit check point of the power supply as shown below.
- Measure the resistance at the check points on the individual power supply before installation shown below. Confirm that the measured resistance values are over the value shown in the table below. If the resistance values are not over the value, replace it to the new part.

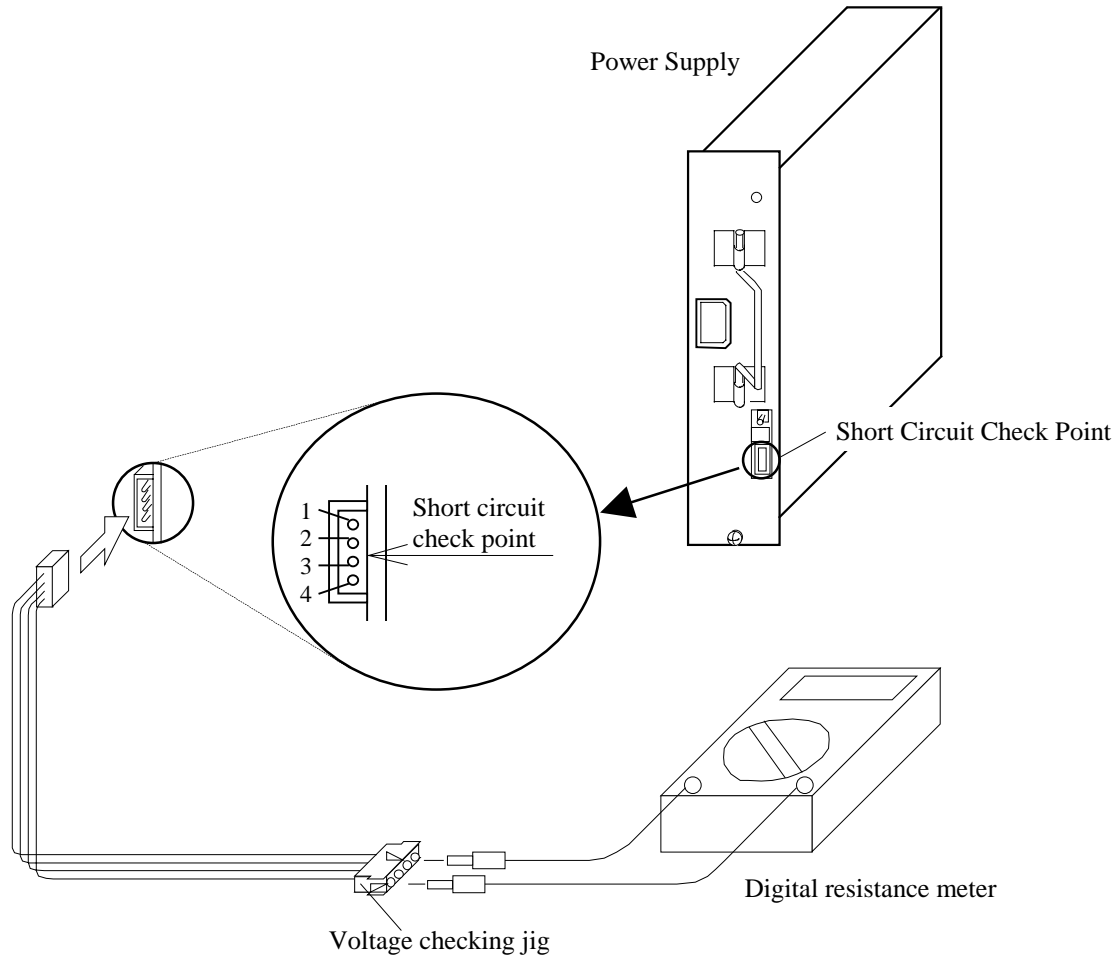

Fig. T13-3 Short Circuit Check Point

Table T13-1 Short Circuit Check Point

PS	Check pin	Resistance
3V PS	Between 1 and 4	1.7 k Ω
5/3V PS	Between 1 and 4	1.7 k Ω
	Between 2 and 4	1.7 k Ω
SUB PS	Between 1 and 4	1.7 k Ω
	Between 2 and 4	1.7 k Ω
3/12V PS	Between 1 and 4	1.7 k Ω
	Between 2 and 4	1.7 k Ω

Note: Pin number 4 is ground.

[HARDWARE T15]

Location	Function Name of Component		Part Name
Rear Side	1	Multi Power Supply	<ul style="list-style-type: none"> • PPD13502 • HS1182

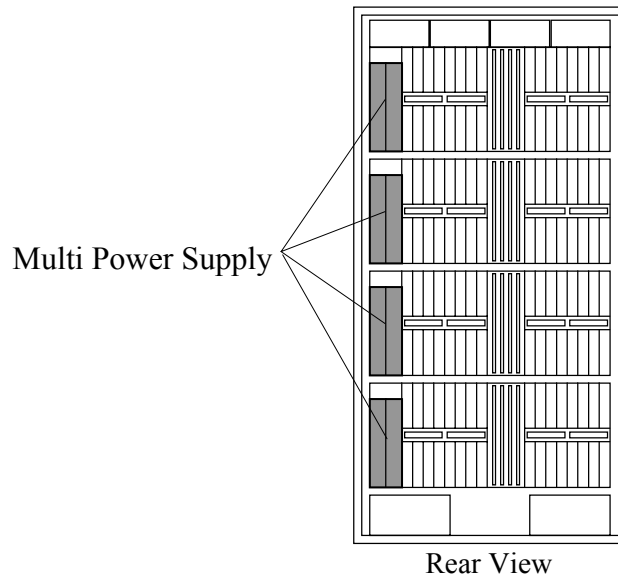

Replacement of Multi Power Supply

1. The following figure shows the correct way to replace the multi power supply (MPS).
 - a. Set PS Enable/Disable Switch to Disable (DOWN).

⚠ CAUTION

A system down may be caused by setting the PS Enable/Disable switch of the power supply other than that to be replaced to "Disable". Make sure that it is a power supply to be replaced.

- b. Disconnect the inlet cable and remove the two screws①.
- c. Move up the rubber absorber.
- d. Remove the multi power supply (MPS).
- e. Perform the short circuit check on the spare power supply. (Refer to [REP03-680](#).)
- f. Set the jumper plugs of the spare power supply. (Refer to [LOCATION06-120](#).)
- g. Confirm that PS Enable/Disable Switch of the spare PS is set to Disable (DOWN).
- h. With the rubber absorber set down, insert the spare PS. Shock caused by the insertion is absorbed by the rubber absorber.
- i. With the rubber absorber set up, push the MPS into the HDU box until secure.
- j. Secure the MPS with the two screws① and connect the inlet cable.
- k. Set PS Enable/Disable Switch to Enable (UP).

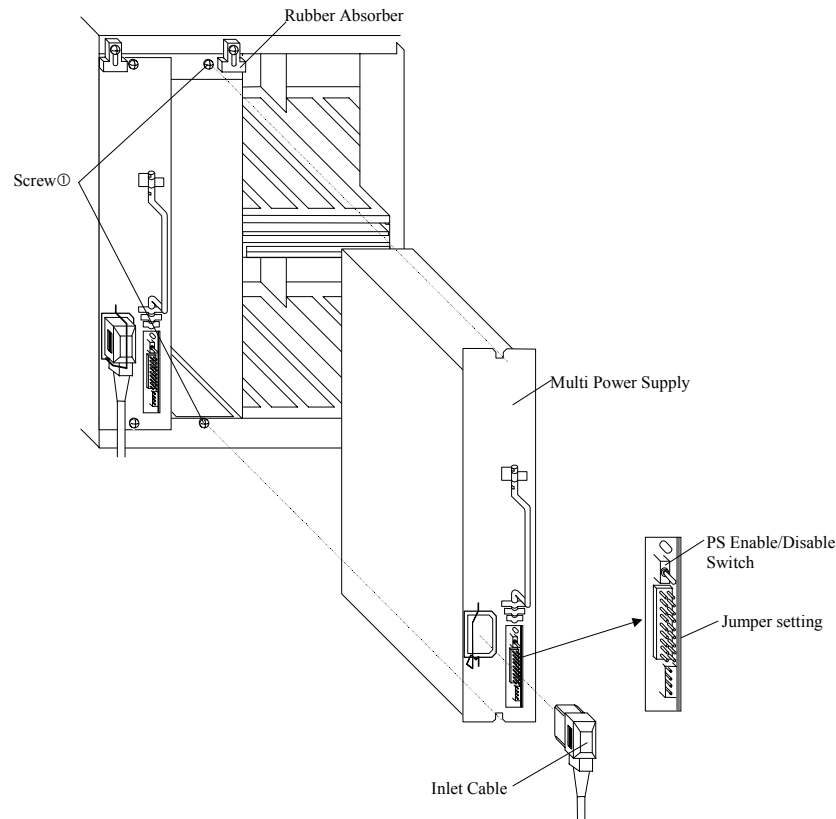

Fig. T15-1 Replacement of Multi Power Supply

2. Go to SVP post procedure t4 [[REP04-1000](#)].

Procedure for short circuit check on the power supply

- Check the power supply for short circuit by connecting the voltage checking jig to the short circuit check point of the power supply as shown below.
- Measure the resistance at the check points on the individual power supply before installation shown below. Confirm that the measured resistance values are over the value shown in the table below. If the resistance values are not over the value, replace it to the new part.

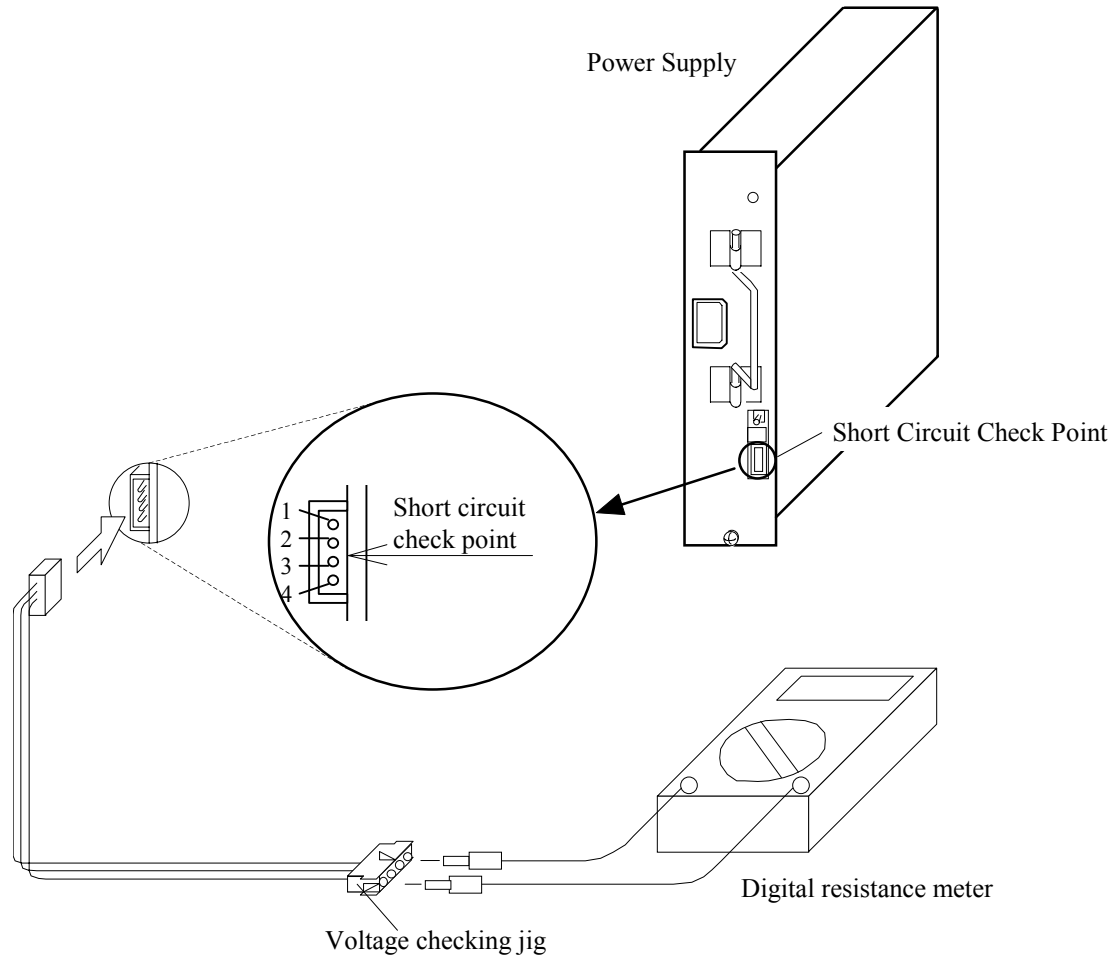

Fig. T15-2 Short Circuit Check Point

Table T15-1 Short Circuit Check Point

PS	Check pin	Resistance	
		TAJ-490HS	PPD5002
Multi PS	Between 1 and 4	1.7 k Ω	1.7 k Ω
	Between 2 and 4	1.7 k Ω	1.7 k Ω

Note: Pin number 4 is ground.

[HARDWARE T16]

Location	Function Name of Component	
Top of HDD BOX	1	HDD FAN Assembly

HDD FAN Assembly

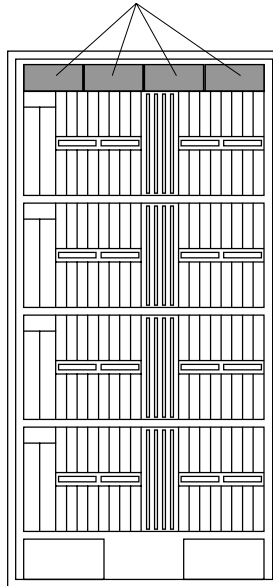

Rear View

NOTICE:

Be sure to wear your wrist strap and attach to ground prior to performing the following work. This will ensure that the IC and LSI on the PCB are protected from static electricity.

Replacement of HDD FAN Assembly

 **CAUTION**
Hazardous rotating mechanism

Can cause injury if touched. Stay clear when machine is running.

1. The following figure shows the correct way to replace the HDD FAN Assembly.
 - a. Disconnect the cables (x-P401 and x-P402) from the HDD FAN Assembly.
 - b. Loosen the two screws.
 - c. Replace the HDD FAN assembly.
 - d. Fasten the screw.
 - e. Connect the cables to HDD FAN Assembly.

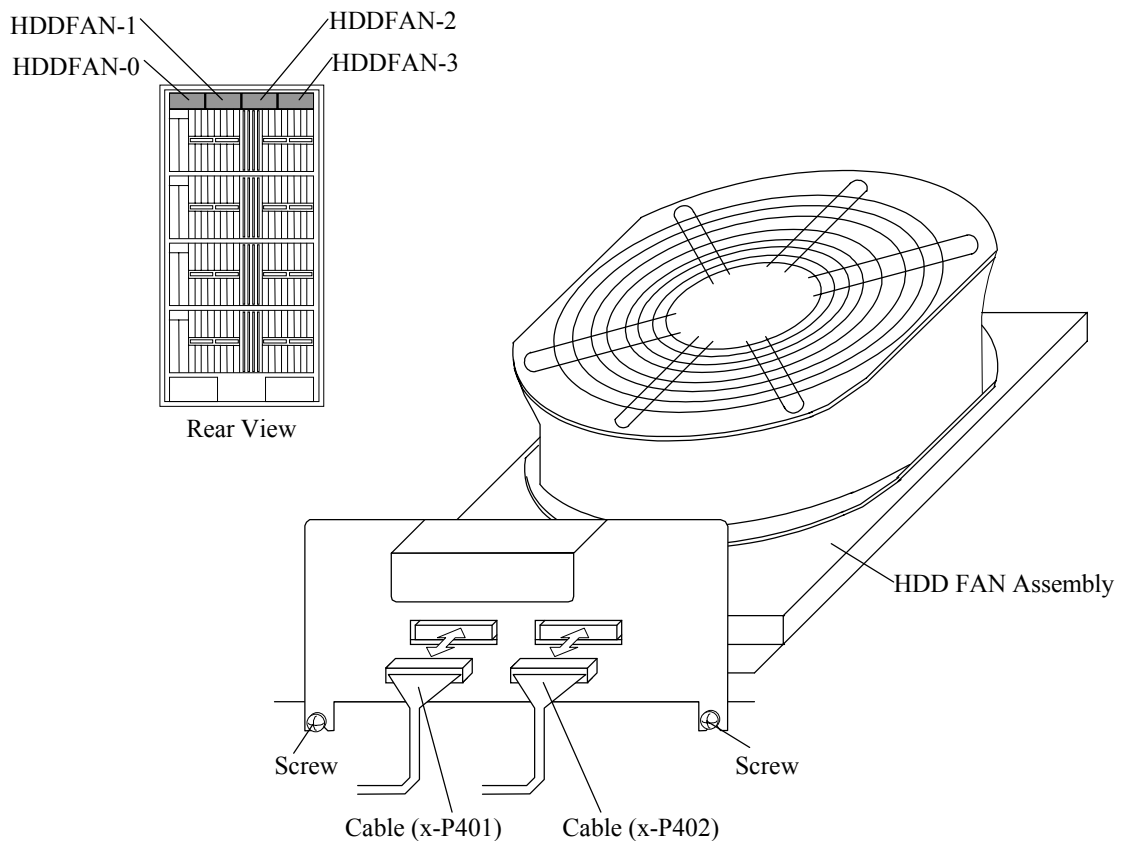
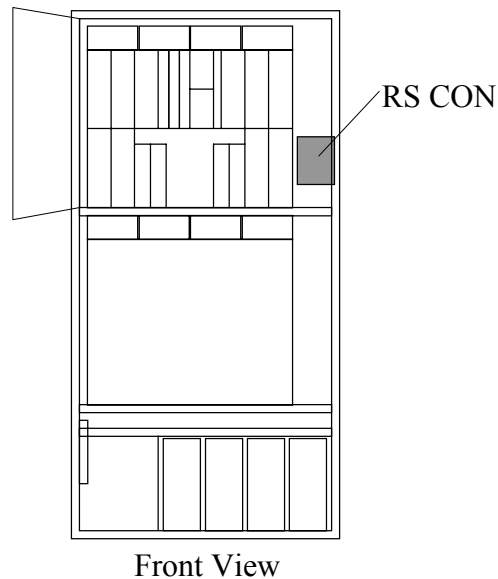

Fig. T16-1 Removal of HDD FAN Assembly

2. Go to SVP post procedure t4 [[REP04-1000](#)].

[HARDWARE T19]

Location	Function Name of Component		Part Name
Upper right front of DKC	1	RS CON (Connector) Panel	• SH195-B



Front View

NOTICE:

Be sure to wear your wrist strap and attach to ground prior to performing the following work. This will ensure that the IC and LSI on the PCB are protected from static electricity.

Replacement of RS CON (Connector) Panel

1. The following figure shows the correct way to replace the RS CON.
 - a. Disconnect all cables from RS CON.
 - b. Slide the stopper and pull out the Connector.
 - c. Loosen two screws and remove RS CON.
 - d. Attach the RS CON and fasten two screws.
 - e. Attach the Connector and slide the stopper.
 - f. Connect all the cables.

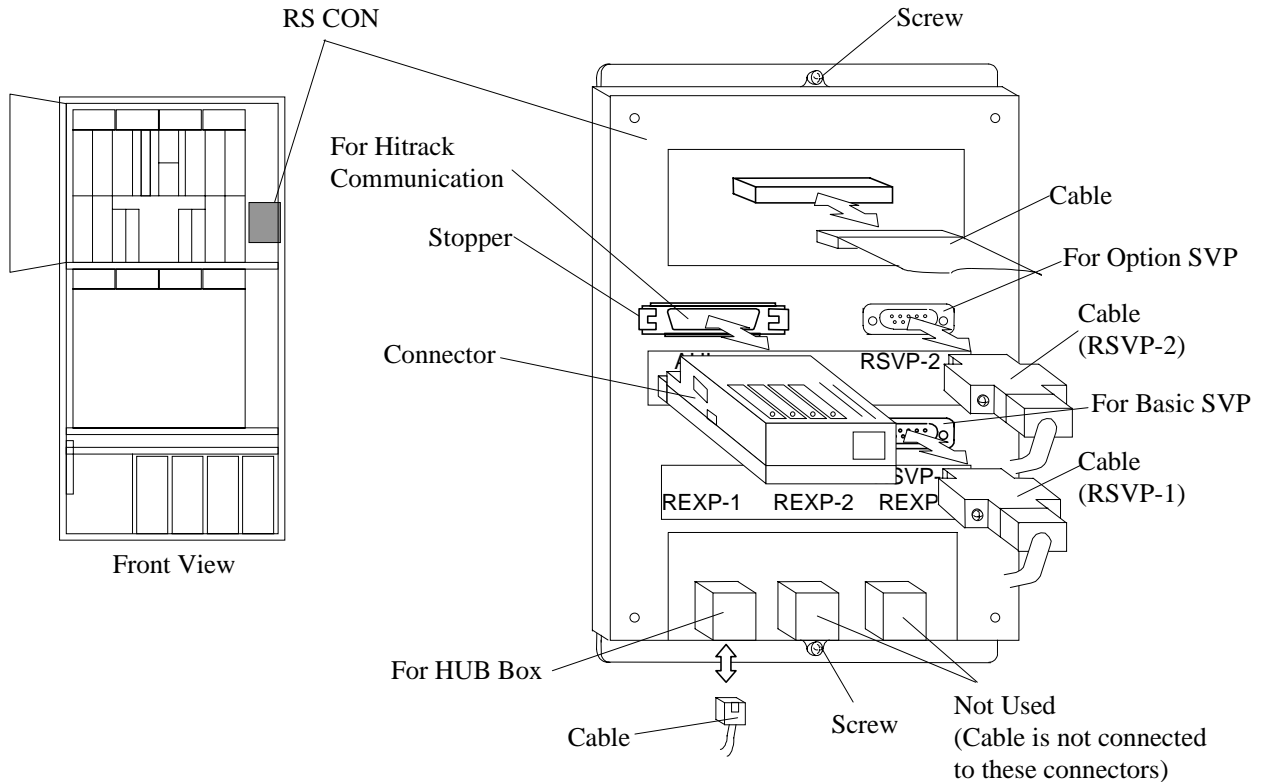
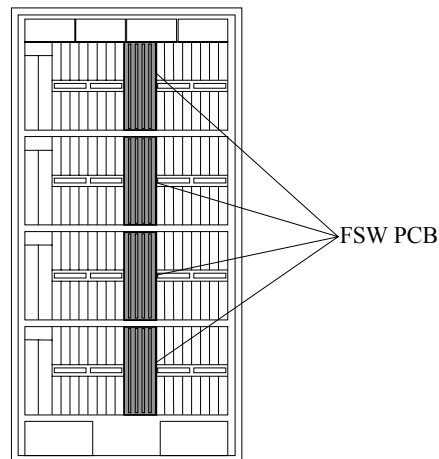

Fig. T19-1 Replacement of RS CON

2. Go to SVP post procedure t1 [[REP04-320](#)].

[HARDWARE T20]

Location	Function Name of Component		Part Name
HDU Box	1	FSW PCB	• SH303-A
			• SH303-B
			• SH303-C



Rear View

NOTICE:

- ① Be sure to wear your wrist strap and attach to ground prior to performing the following work. This will ensure that the IC and LSI on the PCB are protected from static electricity.
- ② Replace the FSW to be replaced following the direction given in “Replace the FSW PCB”. Make the Shut Down LEDs go out by removing all the FSWs (whose Shut Down LEDs are on) once and then installing them.

③

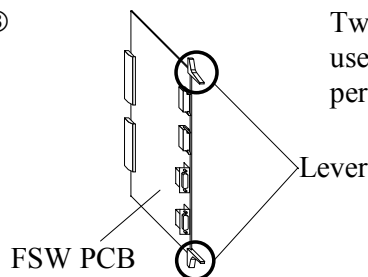

Two types of levers for inserting/removing the FSW, large and small ones, are used. The levers were enlarged to make the operation easier, accordingly their performance and function are the same.

1. Replace the FSW PCB.
 - a. Loosen the screws ① and remove the cable cover.
 - b. Check Shut Down LED on the FSW PCB.

⚠ CAUTION

A system down is caused by a replacement of the FSW PCB other than that to be replaced. Make sure that it is the FSW PCB to be replaced.

- c. Disconnect the DEV interface cables.
- d. Loosen the screw ② and rotate the stopper.
- e. Make sure that the model name of the spare FSW PCB is correct.
- f. Replace the FSW PCB.
- g. Rotate the stopper and fasten the screw ②.
- h. Connect the DEV interface cables.
- i. Attach the cable cover with the screws ①.

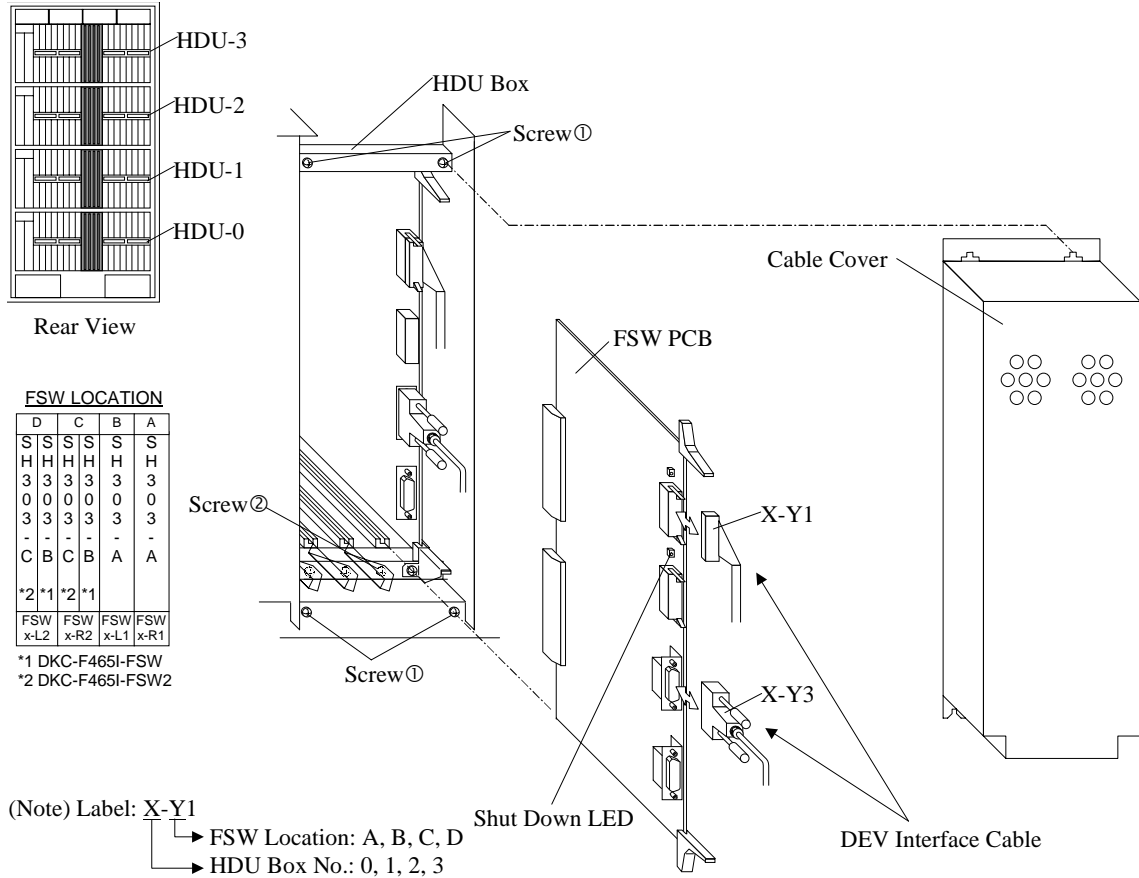
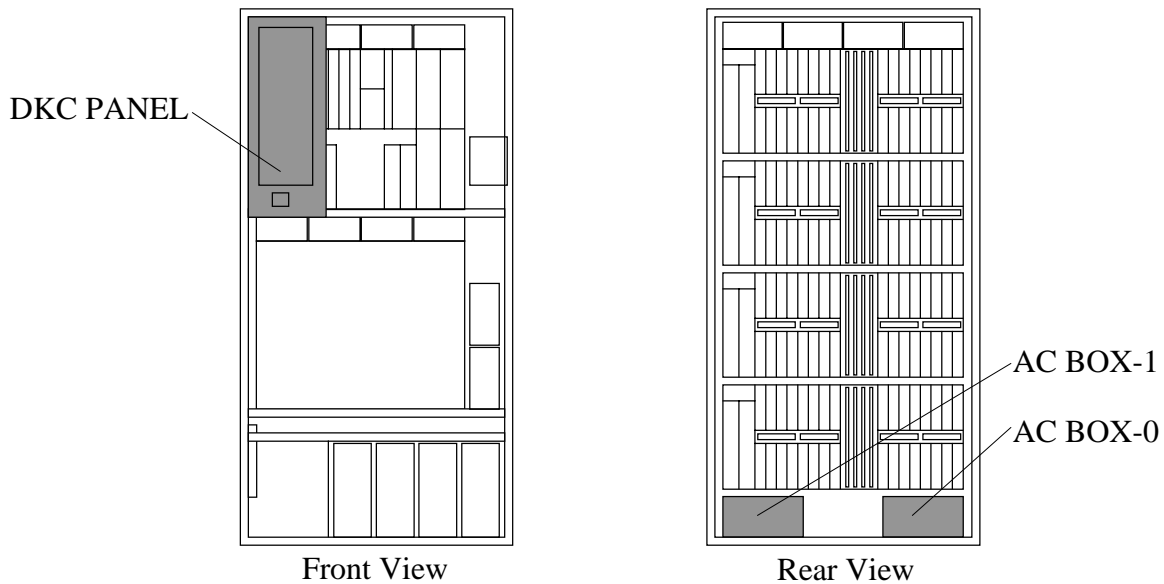

Fig. T20-1 Replacement of FSW PCB

2. Go to SVP post procedure j [[REP04-270](#)].

[HARDWARE T21]

Location	Function Name of Component		Part Name
Lower Rear of DKC	1	AC BOX (Single Phase 50A Model)	•AC BOX-0, 1
	2	AC BOX (3 Phase 30A Model)	•AC BOX-0, 1
	3	AC BOX (Single Phase 30A Model)	•AC BOX-0, 1
(Reference)			
The related parts for replacement of AC BOX-0			
1. DKC PANEL PCB (Front Upside in DKC)			
2. Circuit breakers on the power distribution panel that are connected to the AC BOX-0			
The related parts for replacement of AC BOX-1			
1. DKC PANEL PCB (Front Upside in DKC)			
2. Circuit breakers on the power distribution panel that are connected to the AC BOX-1			



NOTICE:

Be sure to wear your wrist strap and attach to ground prior to performing the following work. This will ensure that the IC and LSI on the PCB are protected from static electricity.

Replacement of AC BOX for Single Phase 50A Model

1. Open the front door.
2. Connection of the Jumper.
 - a. Connect the Maintenance Jumper to the connector on the DKC Panel PCB.

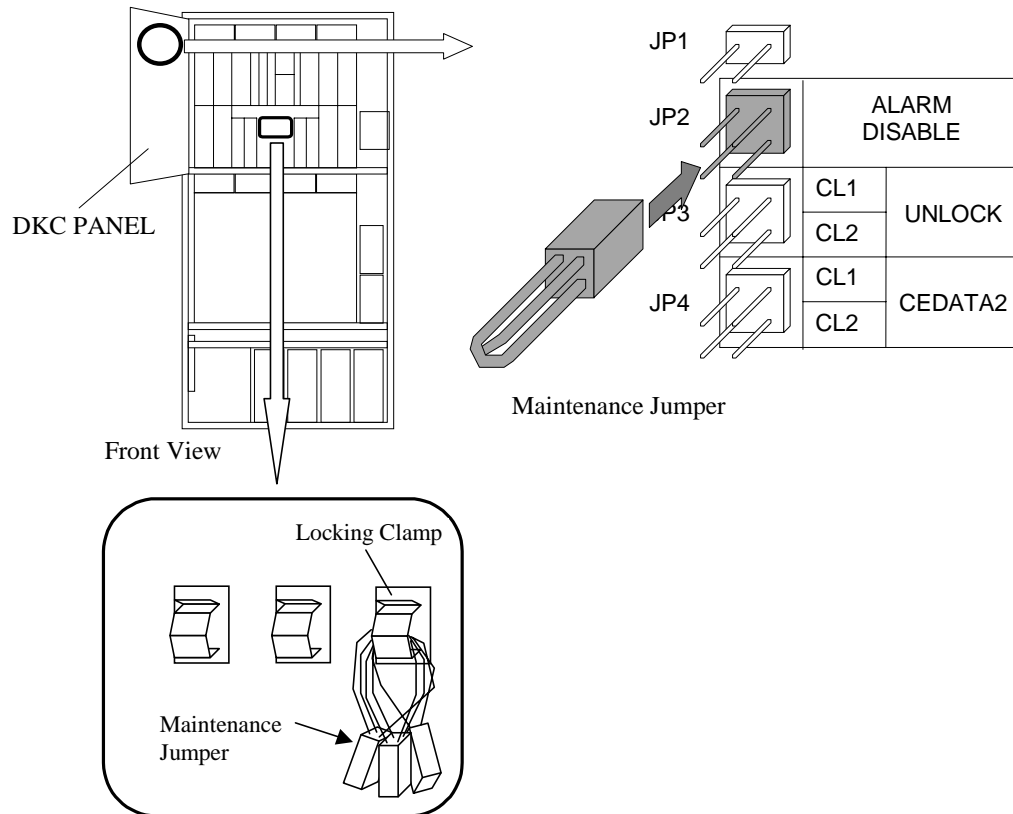

Fig. T21-1 Connection of Alarm INH Jumper

3. Power Off the Component to be Replaced

WARNING

Be Careful of Electric Shock

- The power to the device is still on after turning off the breakers shown below.
- The device may be powered off when turning off the breakers not shown below.
- The circuit has residual voltage for one minute after turning off the breakers, so be sure to disconnect all the connectors after this period.

- a. Turn off the circuit breaker (CB101) on AC BOX.

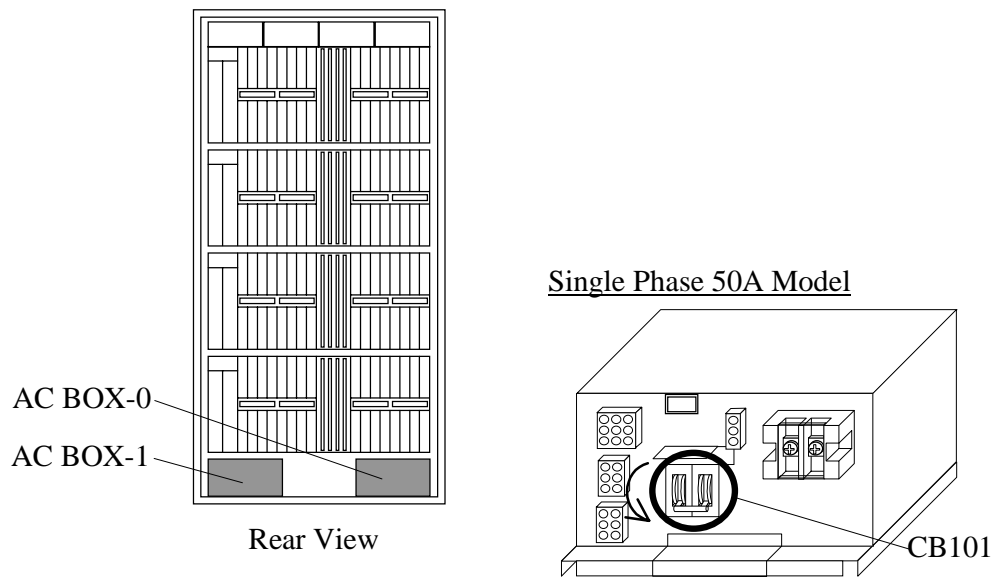

Fig. T21-2 Circuit Breakers to be Turned Off When Replacing AC BOX

- b. Turn off the circuit breakers on the power distribution panel in the plant that are connected to AC BOX.

WARNING

Warning: You will get an electric shock if you fail to turn it off.

Start your work after turning off the breaker on the distribution board connected to the AC BOX.

4. Removal of AC BOX

⚠ WARNING

Warning: You will get an electric shock if you fail to turn it off.
Start your work after turning off the breaker on the distribution board connected to the AC BOX.

- a. Disconnect the cable connectors (P101-#, P102-#, P103-# and P104-#) from AC BOX.
- b. Remove the terminal block cover from AC BOX. Remove the three screws, and then disconnect the AC power cable and frame ground cable.

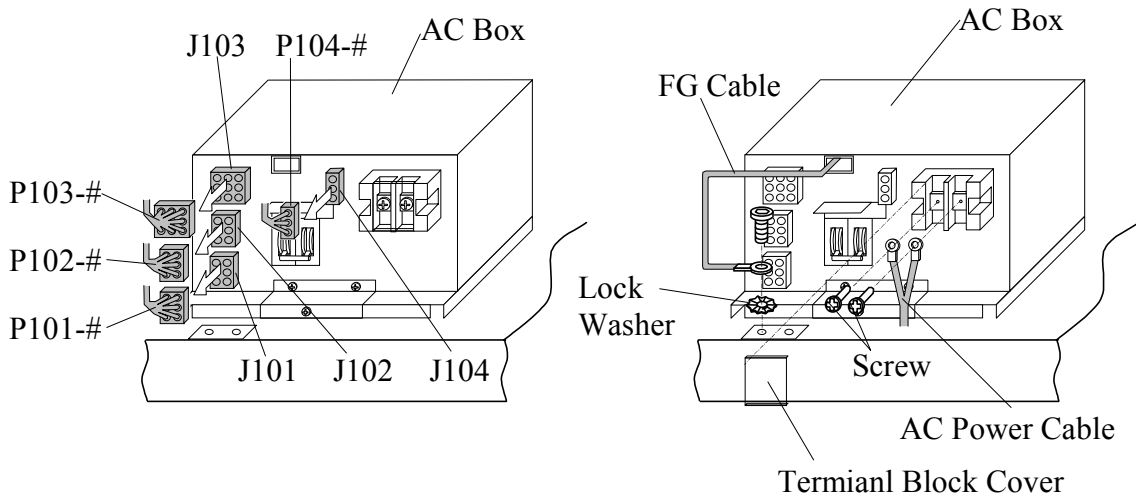

(1) Removal of Cable Connector

(2) Disconnection of AC Power Cable

Fig. T21-3 Removal of Cable Connector

- c. Remove the three screws.
- d. Remove AC BOX.

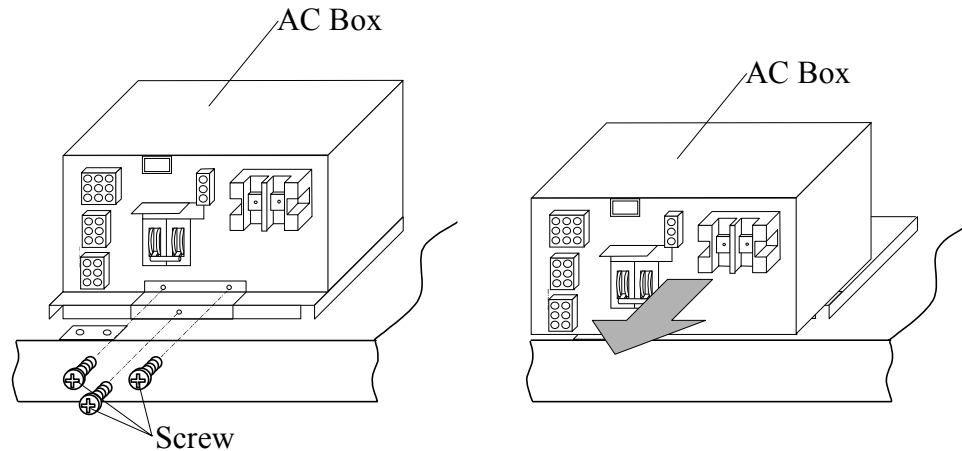

(3) Removal of screws

(4) Removal of AC Box

Fig. T21-4 Removal of AC BOX

5. Installation of Spare AC BOX

- Check that the circuit breaker (CB101) on the spare AC BOX are turned off.
- Attach the spare AC BOX.
- Secure AC BOX at the front with the screws.

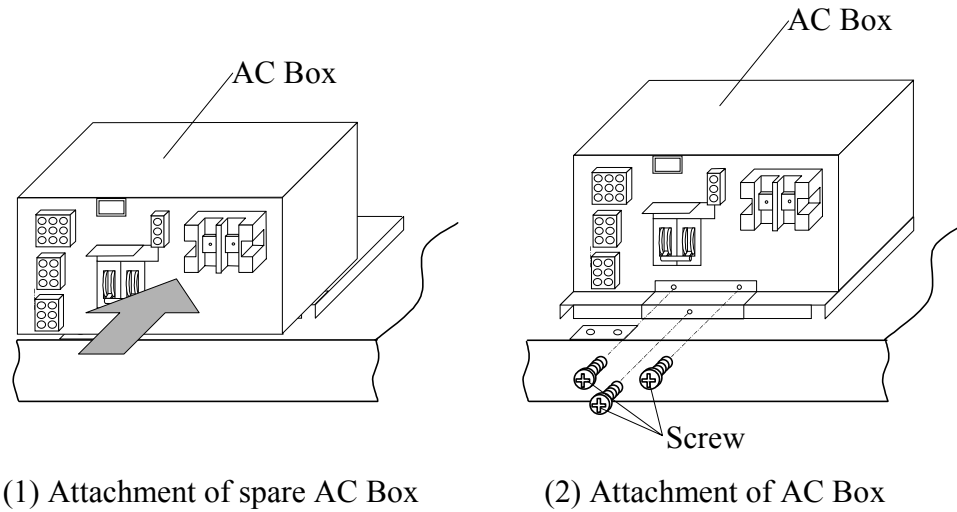

Fig. T21-5 Attachment of AC BOX

- Connect the frame ground cable to the frame ground.
- Connect the AC power cable to the terminal block. Attach the terminal block cover.

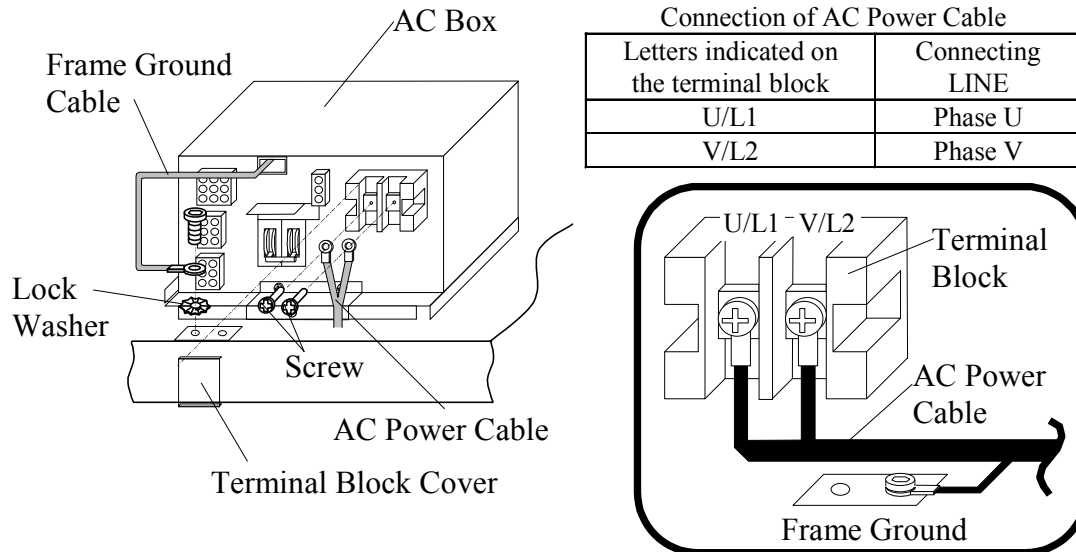

Fig. T21-6 Connection of AC Power Cable

- f. Connect the cable connectors (P101-#, P102-#, P103-# and P104-#) to AC BOX.

Table T21-1 Cable Connection of AC BOX

No.	Cable No.		Connector No.	Remarks
	AC BOX-0	AC BOX-1		
1	P101-1	P101-2	J101	
2	P102-1	P102-2	J102	
3	P103-1	P103-2	J103	
4	P104-1	P104-2	J104	

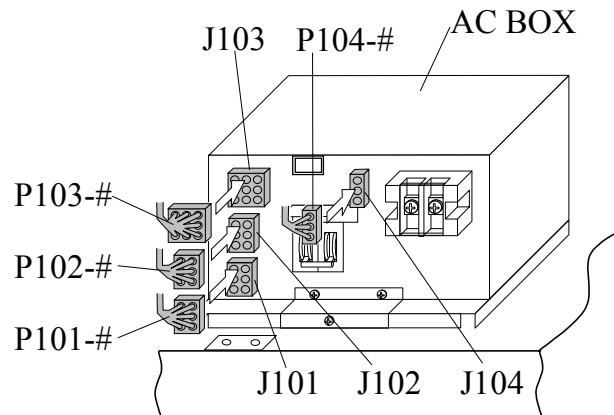

Fig. T21-7 Connection of Cable Connectors

6. Power On the Replacement Component
 - a. Turn on the circuit breakers on the power distribution panel that are connected to AC BOX.
 - b. Turn on all the circuit breakers on AC BOX.
 - c. Turn “LED TEST/CHK RST” switch on the DKC panel to “CHK RST”.

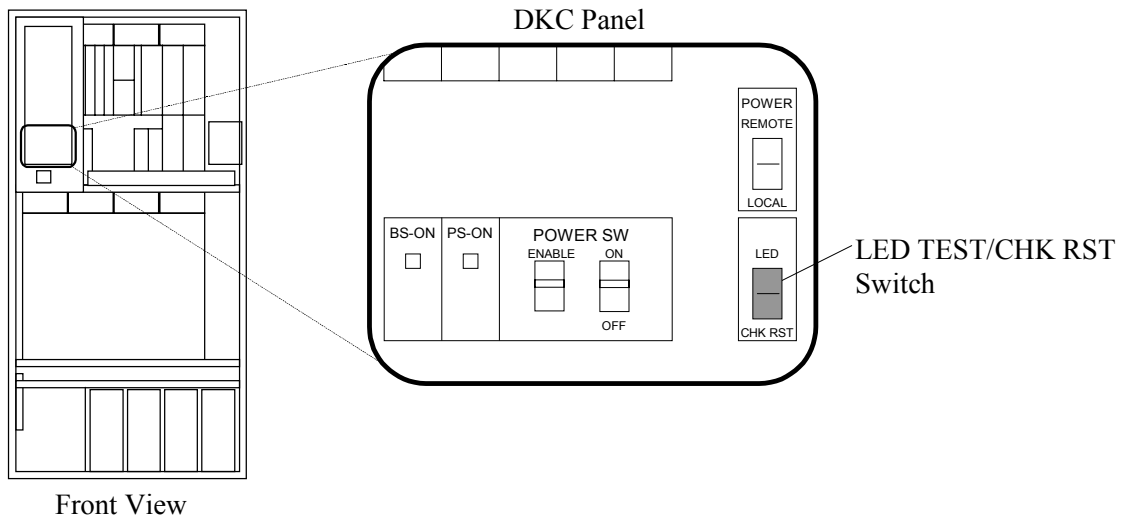

Fig. T21-8 Setting of LED TEST/CHK RST Switch

7. Disconnection of the Jumper
 - a. Disconnect the Maintenance Jumper from the connector on the DKC Panel PCB.

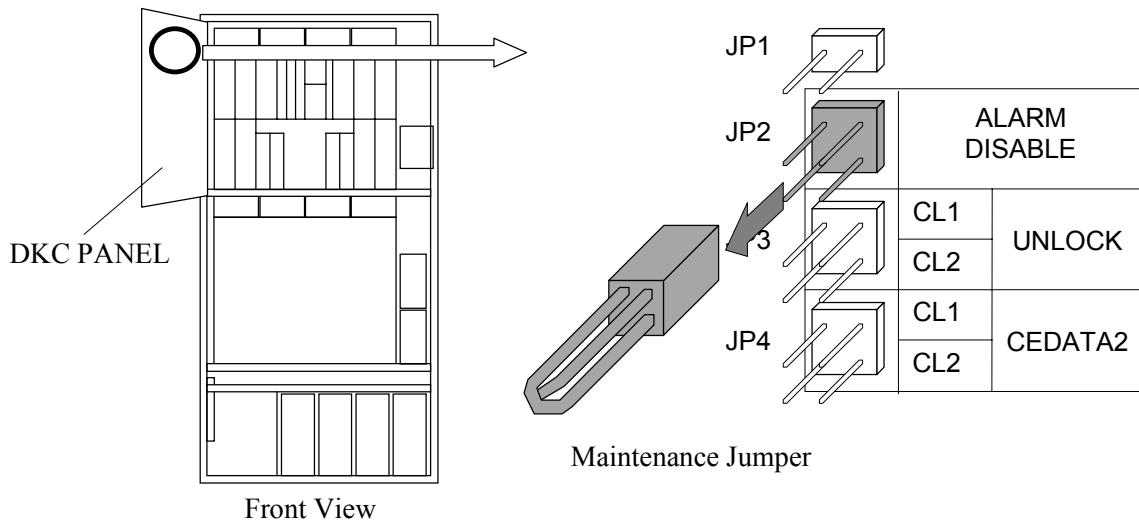

Fig. T21-9 Disconnection of Jumper

8. Go to SVP post-procedure t4 [[REP04-1000](#)].

Replacement of AC BOX for 3 Phase 30A Model

1. Open the front door.
2. Connection of the Jumper
 - a. Connect the Maintenance Jumper to the connector on the DKC Panel PCB.

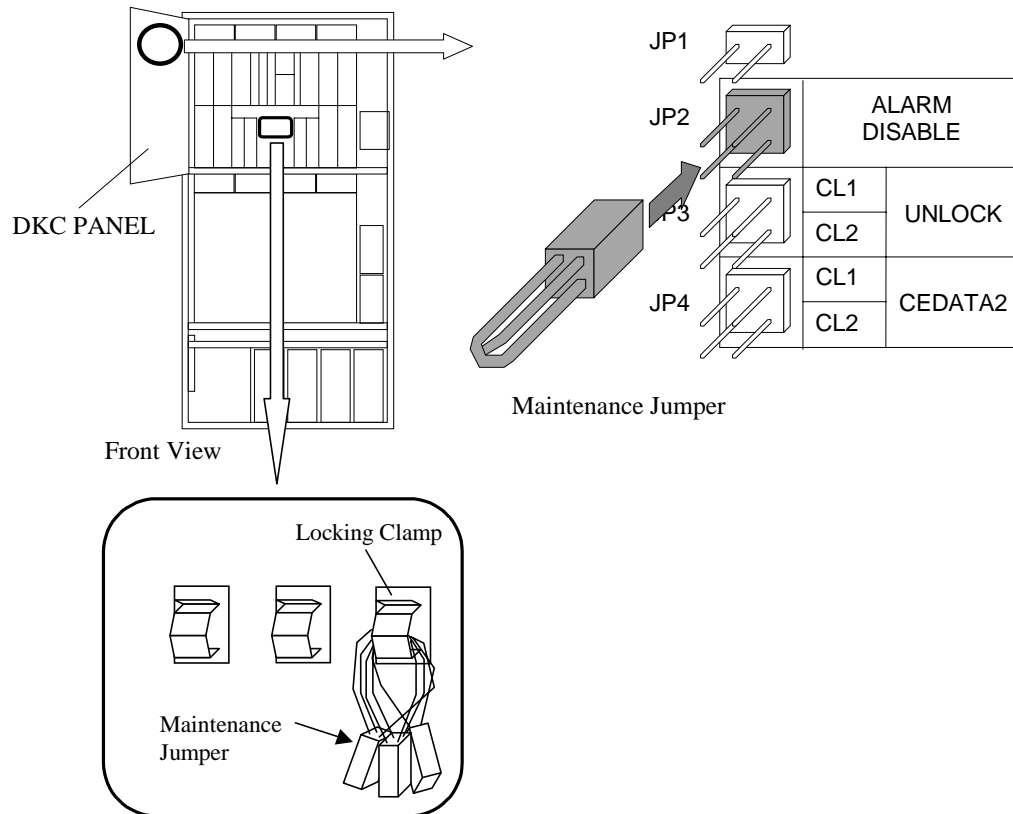

Fig. T21-10 Connection of Alarm INH Jumper

3. Power Off the Component to be Replaced

WARNING

Be Careful of Electric Shock

- The power to the device is still on after turning off the breakers shown below.
- The device may be powered off when turning off the breakers not shown below.
- The circuit has residual voltage for one minute after turning off the breakers, so be sure to disconnect all the connectors after this period.

- a. Turn off the circuit breaker (CB101) on AC BOX.

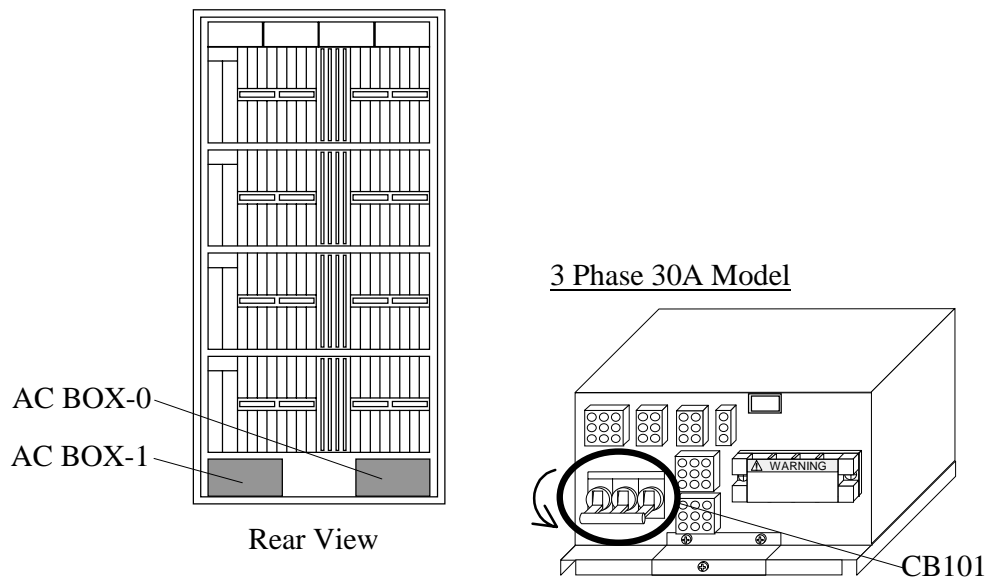

Fig. T21-11 Circuit Breakers to be Turned Off When Replacing AC BOX

- b. Turn off the circuit breakers on the power distribution panel in the plant that are connected to AC BOX.

WARNING

Warning: You will get an electric shock if you fail to turn it off.

Start your work after turning off the breaker on the distribution board connected to the AC BOX.

4. Removal of AC BOX

⚠ WARNING

Warning: You will get an electric shock if you fail to turn it off.

Start your work after turning off the breaker on the distribution board connected to the AC BOX.

- Disconnect the cable connectors (P101-#, P102-#, P103-# and P104-#) from AC BOX.
- Remove the terminal block cover from AC BOX. Remove the screws, and then disconnect the AC power cable and frame ground cable.

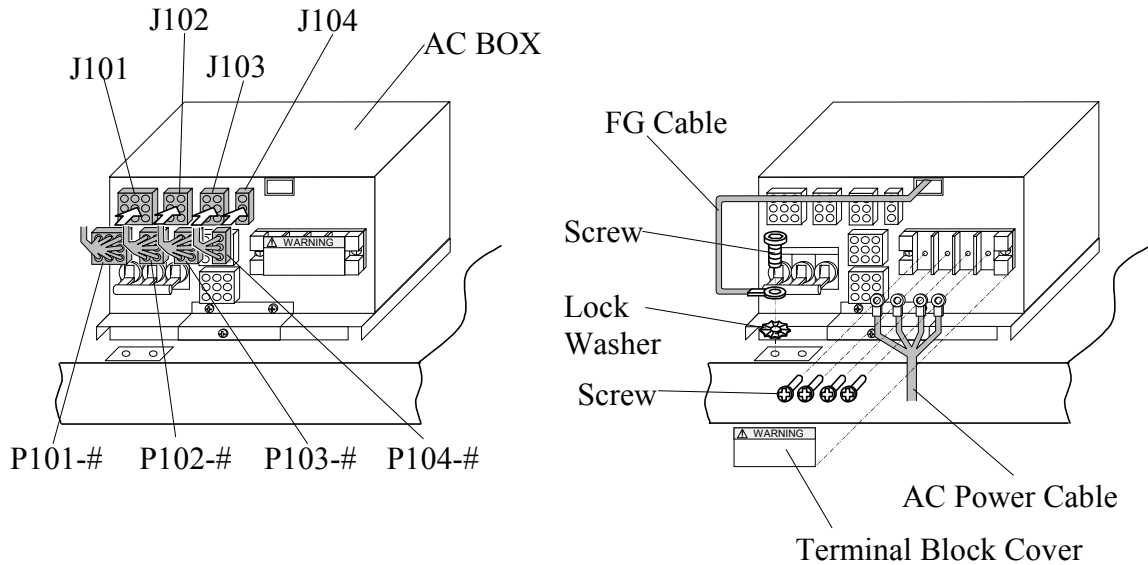

(1) Removal of Cable Connector

(2) Disconnection of AC Power Cable

Fig. T21-12 Removal of Cable Connector

- Remove the three screws.
- Remove AC BOX.

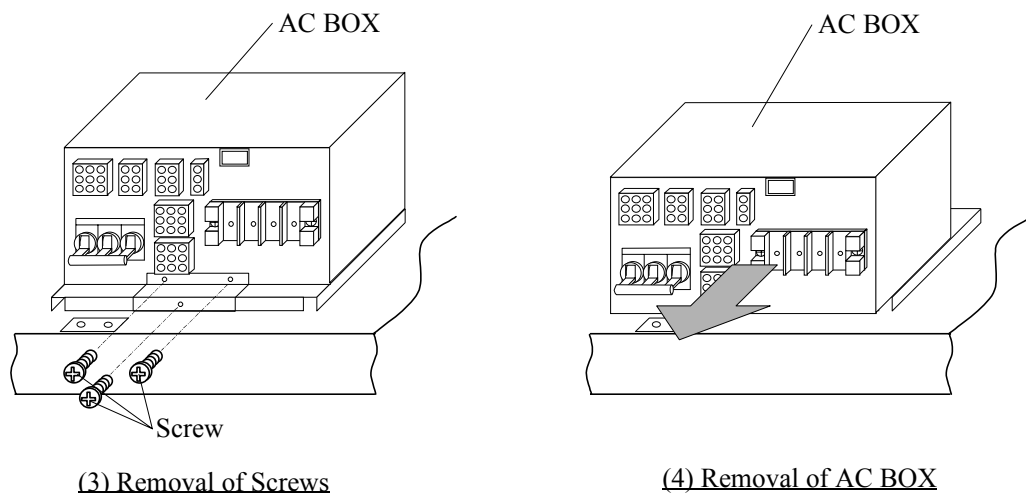

(3) Removal of Screws

(4) Removal of AC BOX

Fig. T21-13 Removal of AC BOX

5. Installation of Spare AC BOX

- a. Check that the circuit breaker (CB101) on the spare AC BOX are turned off.
- b. Attach the spare AC BOX.
- c. Secure AC BOX at the front with the screws.

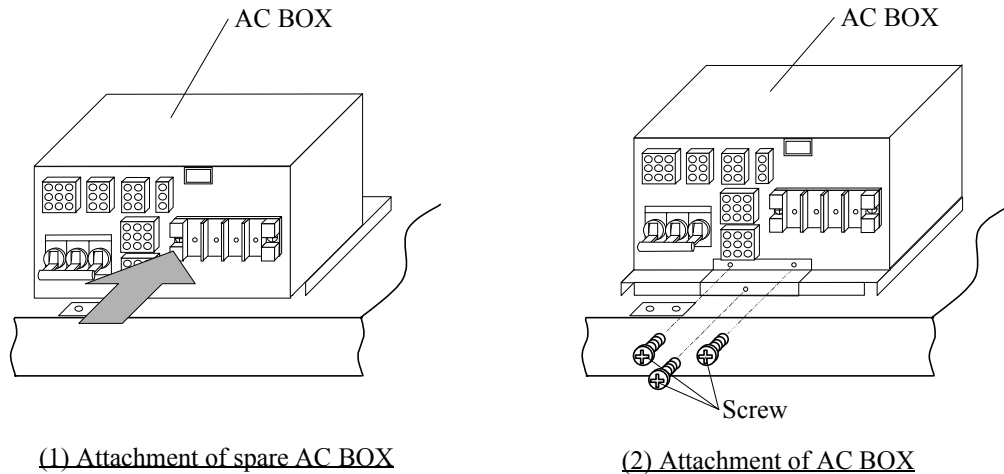

Fig. T21-14 Attachment of AC BOX

- d. Connect the frame ground cable to the frame ground.
- e. Connect the AC power cable to the terminal block. Attach the terminal block cover.

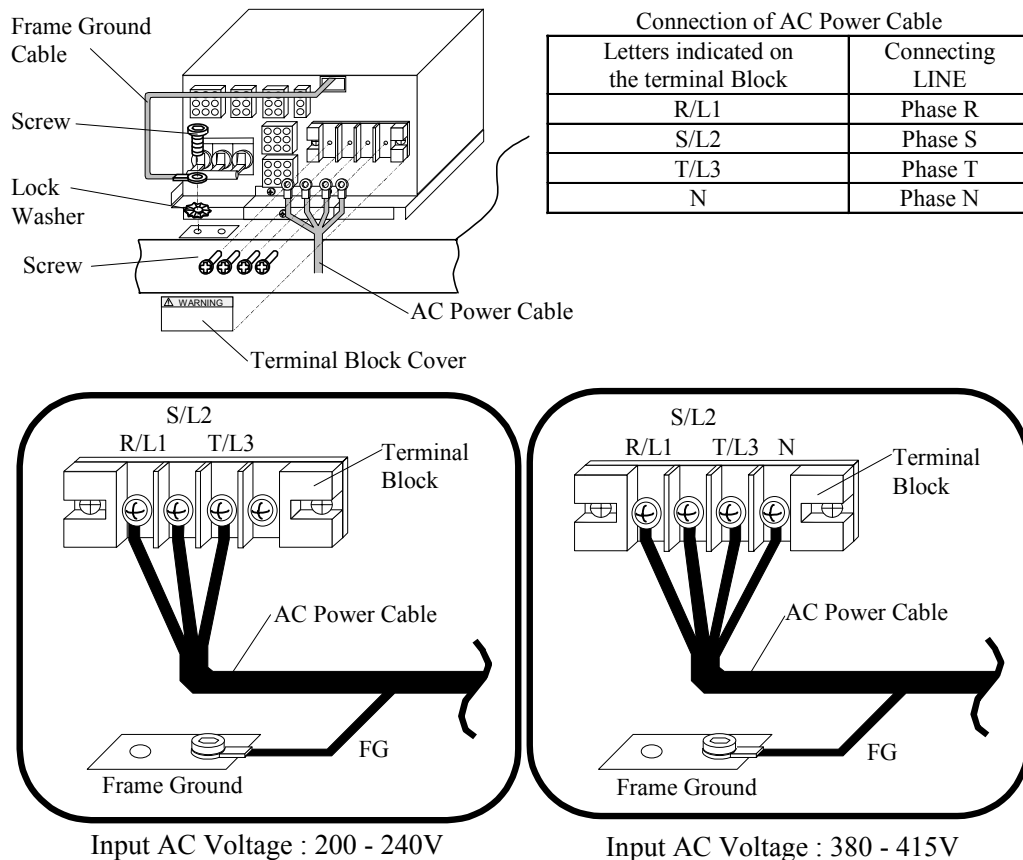

Fig. T21-15 Connection of AC Power Cable

- f. Connect the cable connectors (P101-#, P102-#, P103-#, P104-# and P105) and dummy connector to AC BOX.

⚠ CAUTION

The mate connectors of the P105 shown as No.5 in Table T21-2 vary depending on the voltage of the AC power inputted.

Never make a wrong connection because the subsystem will be damaged if the connection is wrongly made.

Table T21-2 Cable Connection of AC BOX

No.	Cable No.		Connector No.	Remarks
	AC BOX-0	AC BOX-1		
1	P101-1	P101-2	J101	
2	P102-1	P102-2	J102	
3	P103-1	P103-2	J103	
4	P104-1	P104-2	J104	
5	P105	P105	J105-1	Input AC Voltage 200-240V
6	Dummy Connector	Dummy Connector	J105-2	
7	Dummy Connector	Dummy Connector	J105-1	Input AC Voltage 380-415V
8	P105	P105	J105-2	

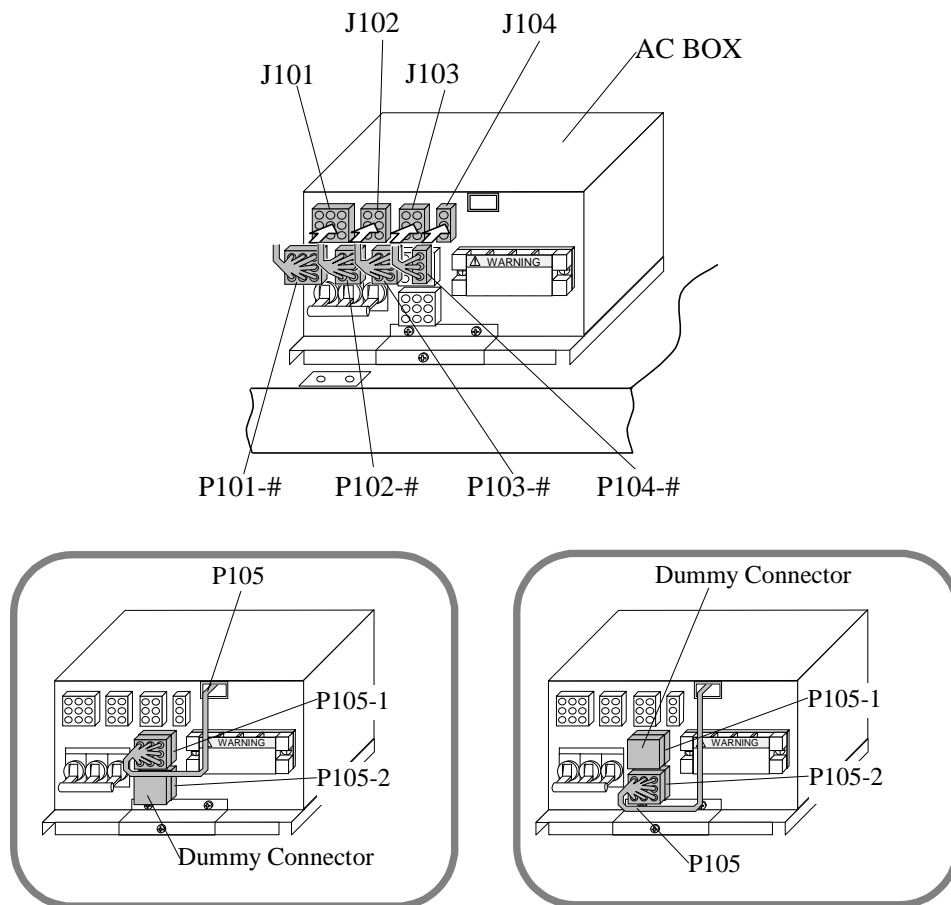

Fig. T21-16 Connection of Cable Connector

6. Power On the Replacement Component
 - a. Turn on the circuit breakers on the power distribution panel that are connected to AC BOX.
 - b. Turn on all the circuit breakers on AC BOX.
 - c. Turn “LED TEST/CHK RST” switch on the DKC panel to “CHK RST”.

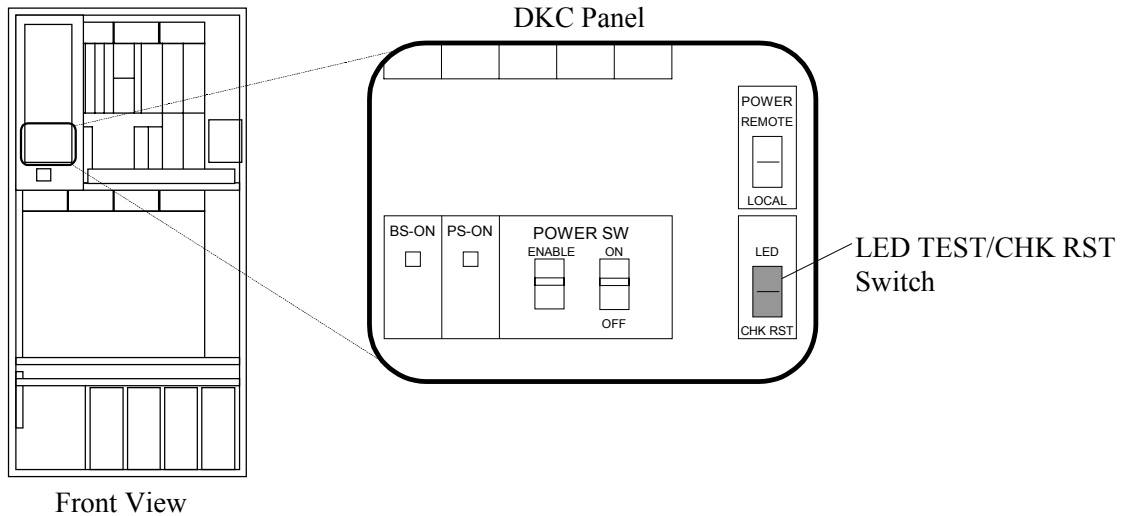

Fig. T21-17 Setting of LED TEST/CHK RST Switch

7. Disconnection of the Jumper
 - a. Disconnect the Maintenance Jumper from the connector on the DKC Panel PCB.

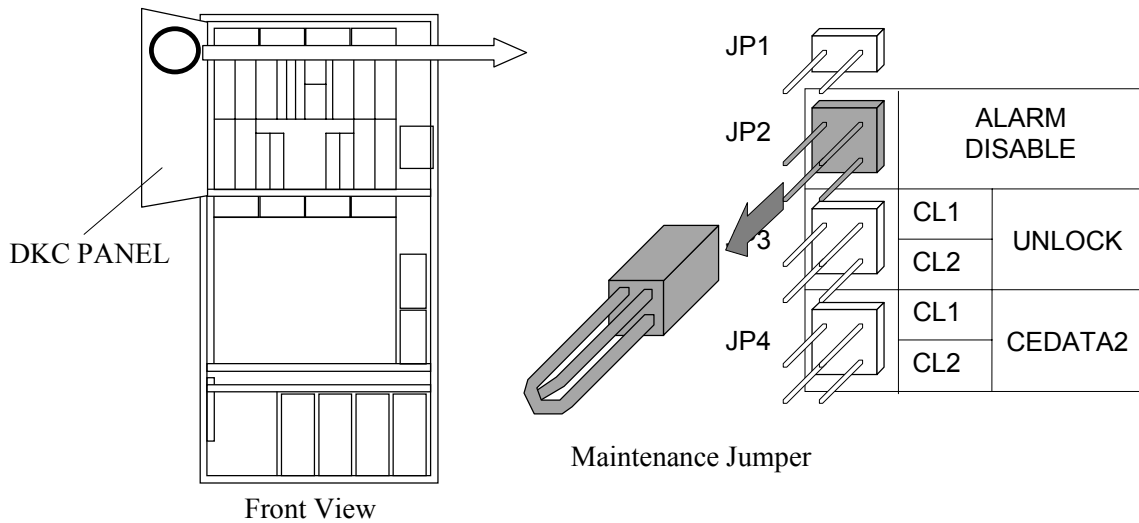

Fig. T21-18 Disconnection of Jumper

8. Go to SVP post-procedure t4 [[REP04-1000](#)].

Replacement of AC BOX for Single Phase 30A Model

1. Open the front door.
2. Connection of the Jumper
 - a. Connect the Maintenance Jumper to the connector (JP2) on the DKC Panel PCB.

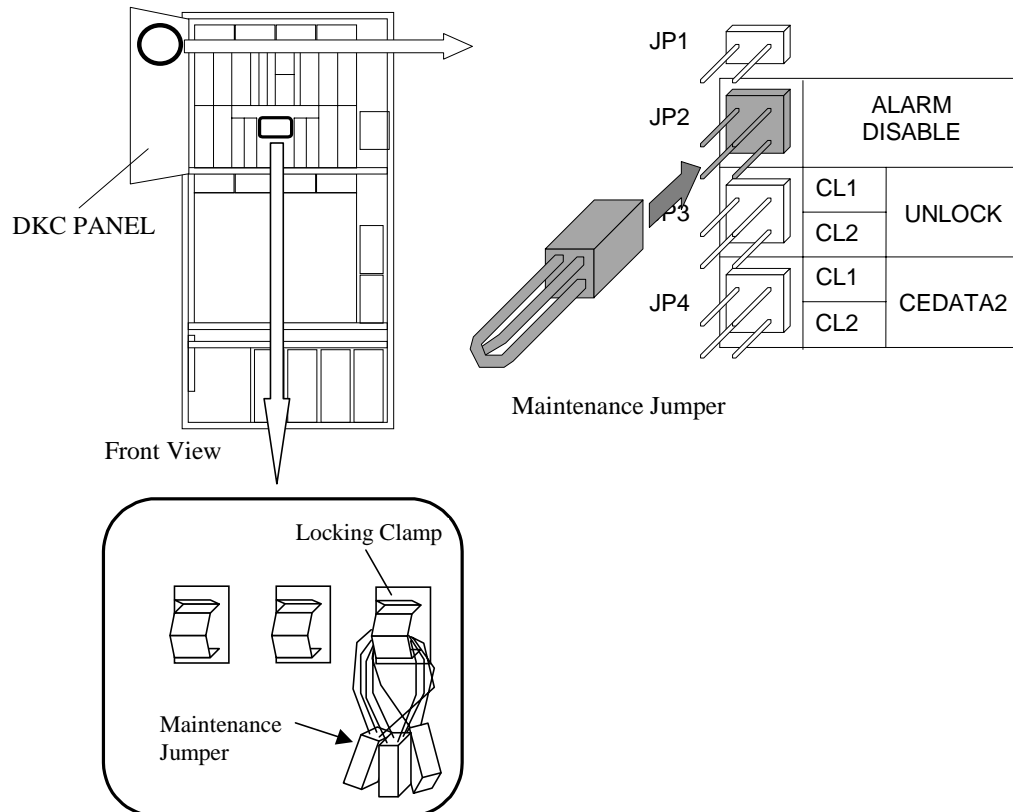

Fig. T21-19 Connection of Alarm INH Jumper

3. Power Off the Component to be Replaced

WARNING

Be Careful of Electric Shock

- The power to the device is still on after turning off the breakers shown below.
- The device may be powered off when turning off the breakers not shown below.
- The circuit has residual voltage for one minute after turning off the breakers, so be sure to disconnect all the connectors after this period.

- a. Turn off the circuit breaker (CB101) on the failed AC BOX.

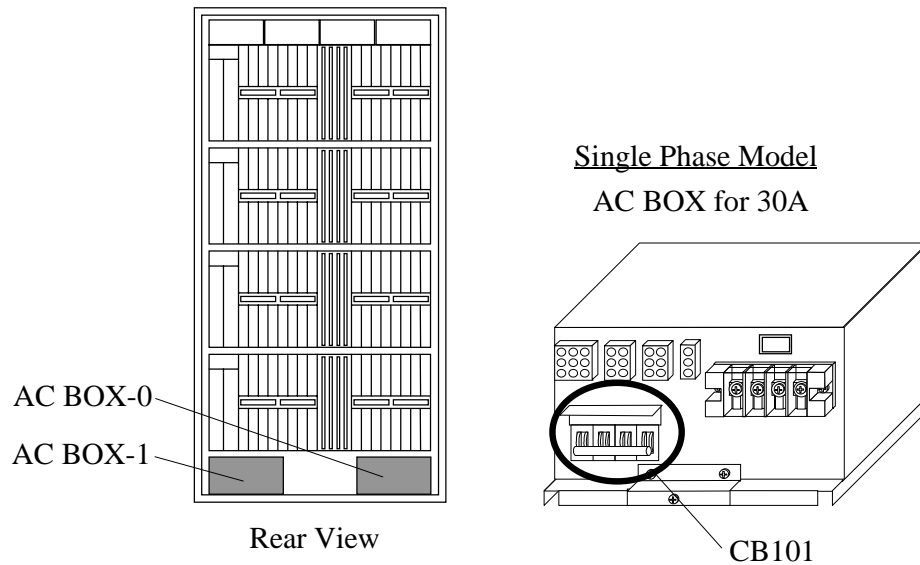

Fig. T21-2 Circuit Breakers to be Turned Off When Replacing AC BOX

- b. Turn off the two circuit breakers on the power distribution panel in the plant that are connected to the failed AC BOX.

WARNING

Warning: You will get an electric shock if you fail to turn it off.

Start your work after turning off the two breakers on the distribution board connected to the AC BOX.

4. Removal of AC BOX

⚠ WARNING

Warning: You will get an electric shock if you fail to turn it off.
Start your work after turning off the breaker on the distribution board connected to the AC BOX.

- a. Disconnect the cable connectors (P101-#, P102-#, P103-# and P104-#) from AC BOX.
- b. Remove the terminal block cover from AC BOX. Remove the five screws, and then disconnect the AC power cables and frame ground cable.

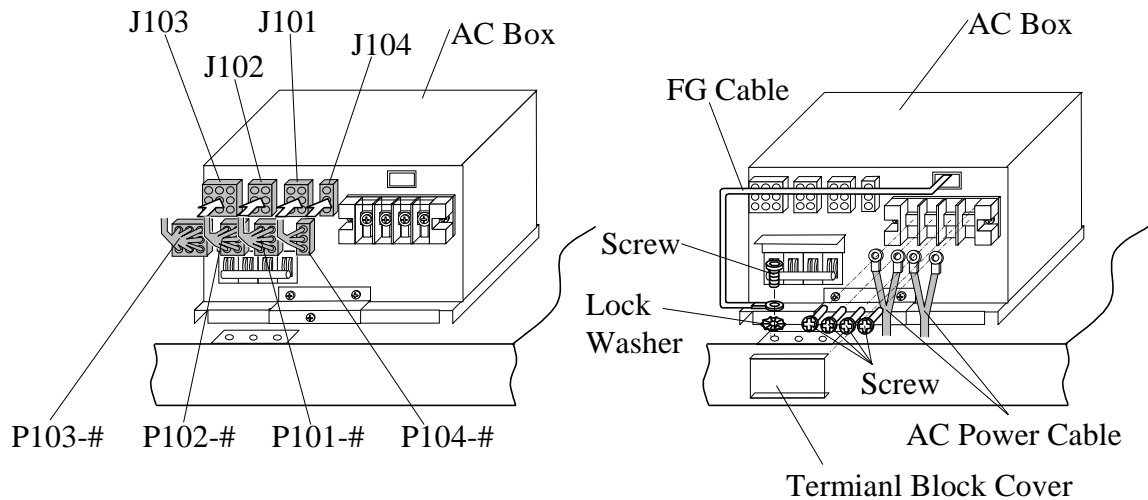

(1) Removal of Cable Connector

(2) Disconnection of AC Power Cable

Fig. T21-20 Removal of Cable Connector

- c. Remove the three screws.
- d. Remove AC BOX.

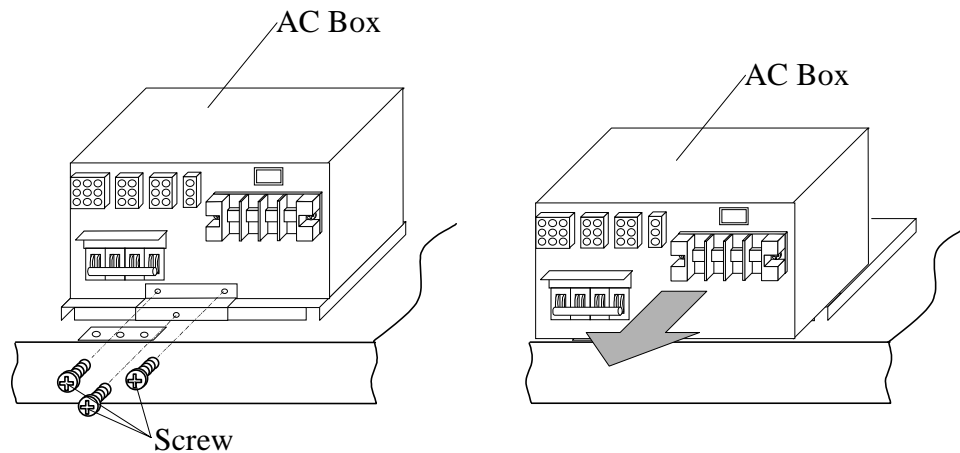

(3) Removal of screws

(4) Removal of AC Box

Fig. T21-21 Removal of AC BOX

5. Installation of Spare AC BOX

- a. Check that the circuit breaker (CB101) on the spare AC BOX is turned off.
- b. Attach the spare AC BOX.
- c. Secure AC BOX at the front with the screws.

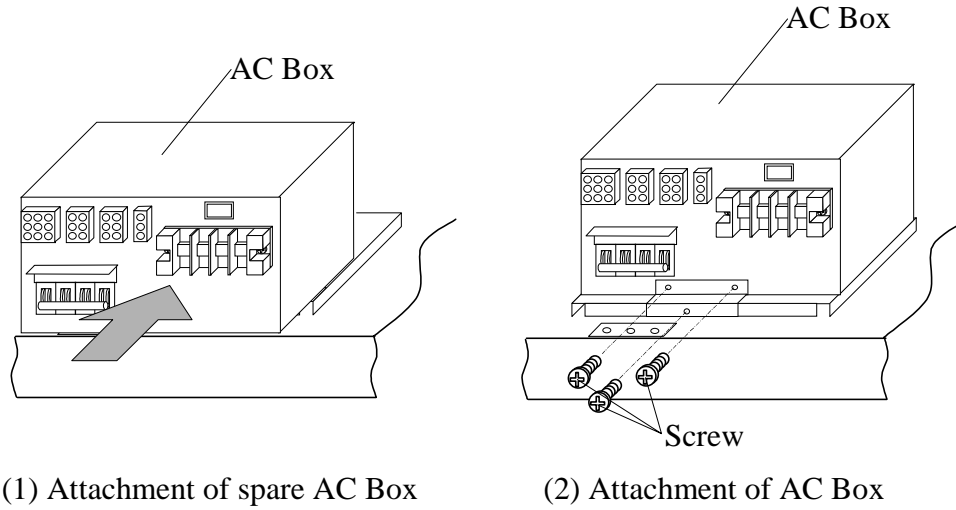

Fig. T21-22 Attachment of AC BOX

- d. Connect the frame ground cable to the frame ground.
- e. Connect the AC power cables to the terminal block. Attach the terminal block cover.

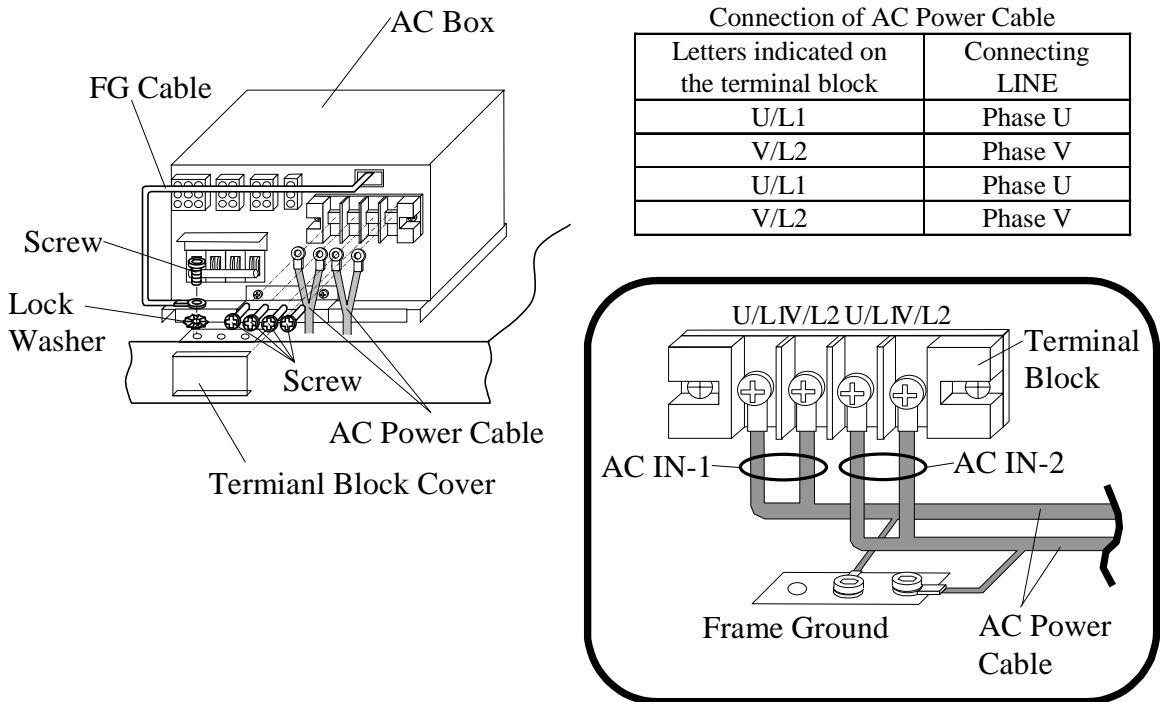

Fig. T21-23 Connection of AC Power Cable

- f. Connect the cable connectors (P101-#, P102-#, P103-# and P104-#) to AC BOX.

Table T21-3 Cable Connection of AC BOX

No.	Cable No.		Connector No.	Remarks
	AC BOX-0	AC BOX-1		
1	P101-1	P101-2	J101	
2	P102-1	P102-2	J102	
3	P103-1	P103-2	J103	
4	P104-1	P104-2	J104	

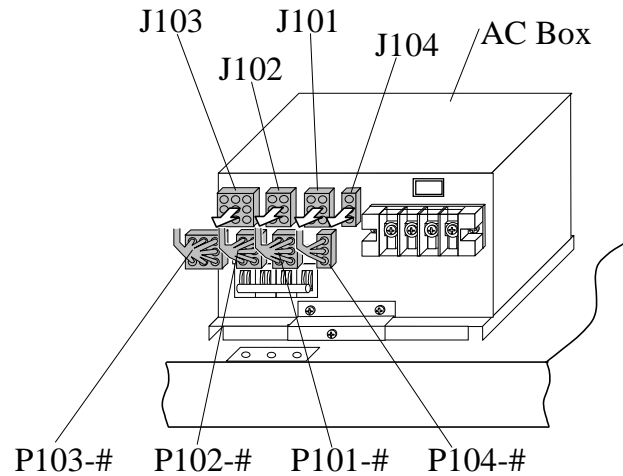

Fig. T21-24 Connection of Cable Connectors

6. Power On the Replacement Component
 - a. Turn on the two circuit breakers on the power distribution panel that are connected to AC BOX.
 - b. Turn on all the circuit breakers on AC BOX.
 - c. Turn “LED TEST/CHK RST” switch on the DKC panel to “CHK RST”.

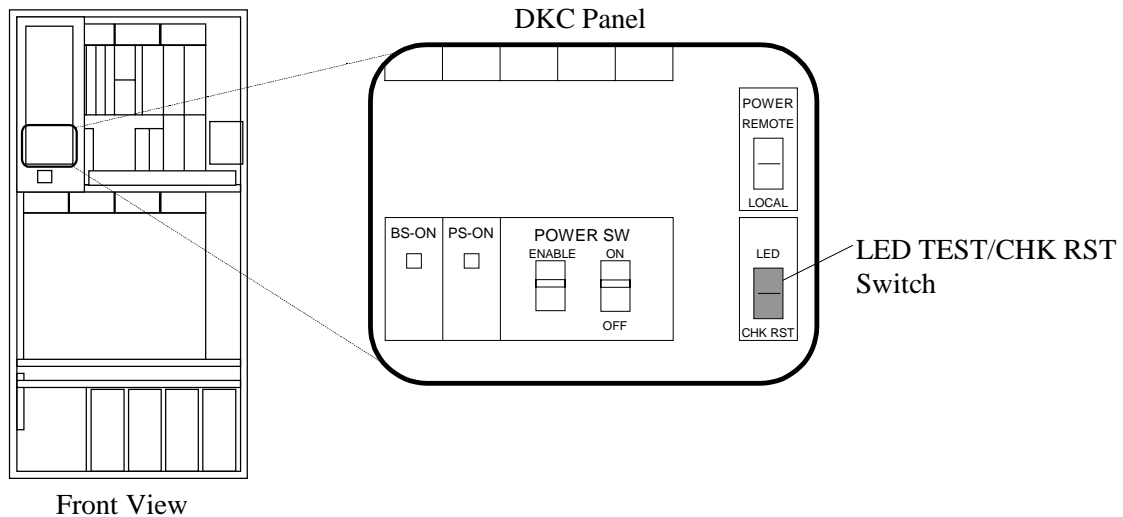

Fig. T21-25 Setting of LED TEST/CHK RST Switch

7. Disconnection of the Jumper
 - a. Disconnect the Maintenance Jumper from the connector (JP2) on the DKC Panel PCB.

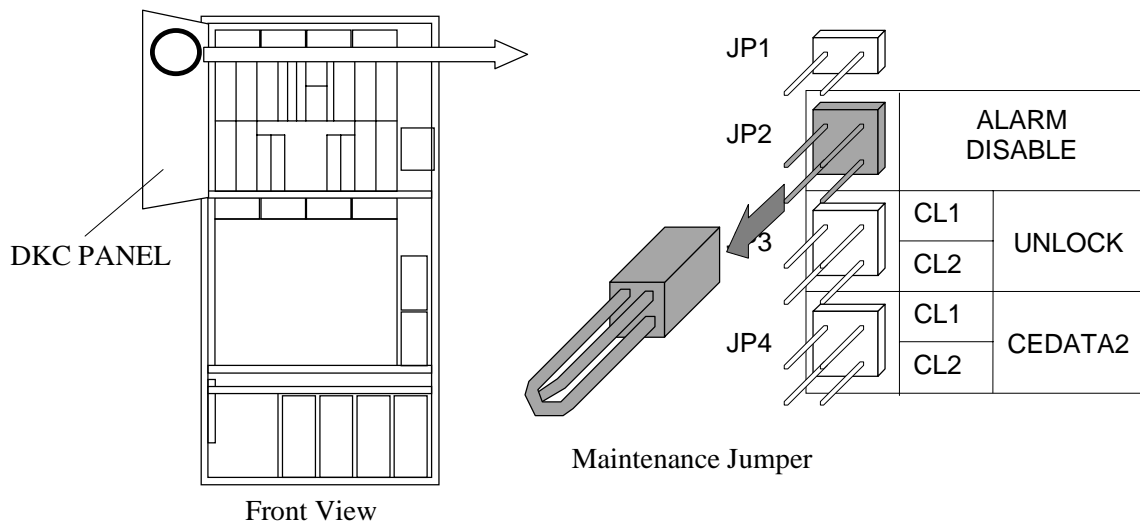
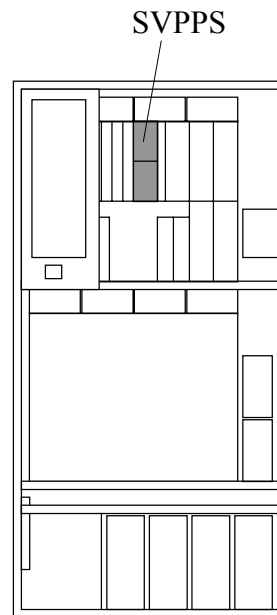

Fig. T21-26 Disconnection of Jumper

8. Go to SVP post-procedure t4 [[REP04-1000](#)].

[HARDWARE T23]

Location	Function Name of Component		Part Name
Front PS Box	1	SVPPS PCB	• SH111-B



Front View

NOTICE:

Be sure to wear your wrist strap and attach to ground prior to performing the following work. This will ensure that the IC and LSI on the PCB are protected from static electricity.

Replacement of SVPPS

Note: Do not replace SVPPS 1 and SVPPS 2 at the same time.

If you want to replace the both PCB, first complete the replacement of one PCB and then start the replacement of the other.

1. Check that the Shut Down LED is on. (only hot replace)

⚠ CAUTION

A system down is caused by a replacement of the PCB other than that to be replaced. Make sure that it is the PCB to be replaced.

- a. Check that the Shut Down LED is on.
- b. Connect the Maintenance Jumper to the Shut Down connector. When the Maintenance Jumper is inserted, go to step c.
- c. Wait for 15 seconds after inserting the jumper, then go to next operation.

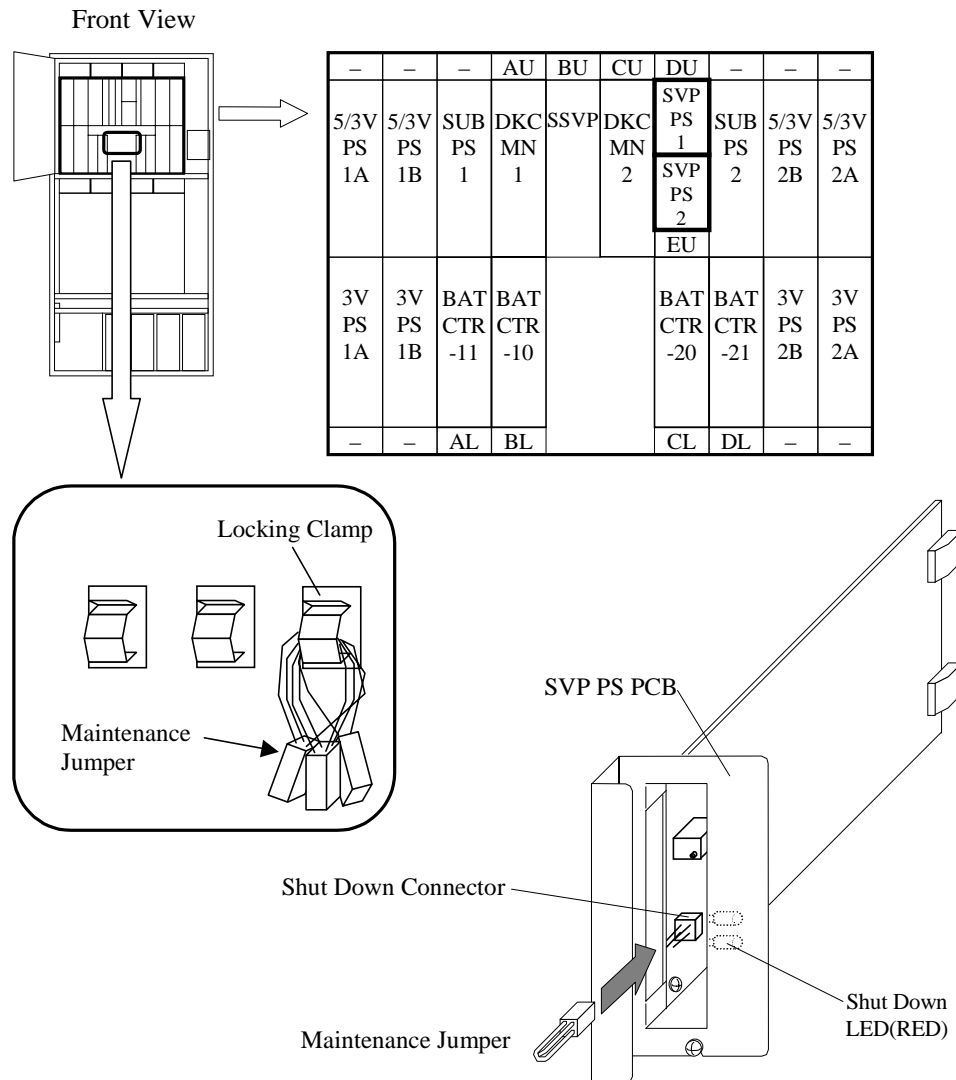

2. Replace the SVPPS PCB.

- a. Loosen the screw and remove the SVPPS PCB.
- b. Remove the maintenance jumper and connect it to the spare PCB.
- c. Insert the spare PCB and fasten the screw.

Note:

Remove the maintenance jumper attached to the SVP PS PCB in Step (3) following instructions given by the SVP.

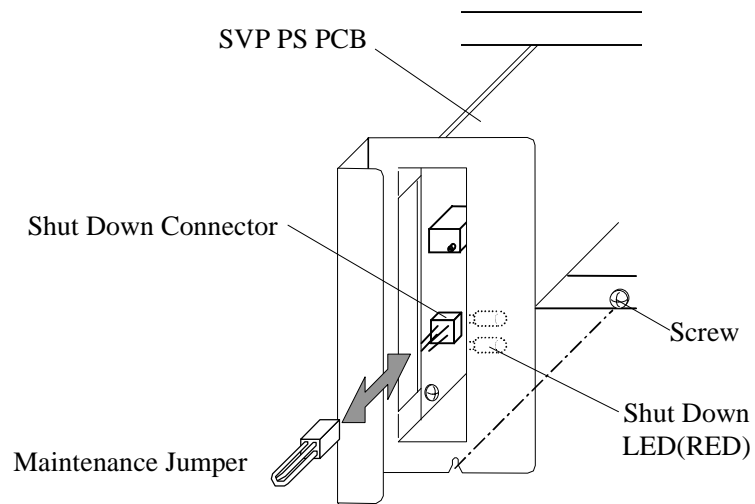

3. Go to SVP post procedure t3 [[REP04-900](#)].

[HARDWARE T24]

Location	Function Name of Component		Part Name
HDU Box	1	JMP PCB	• SH304-A

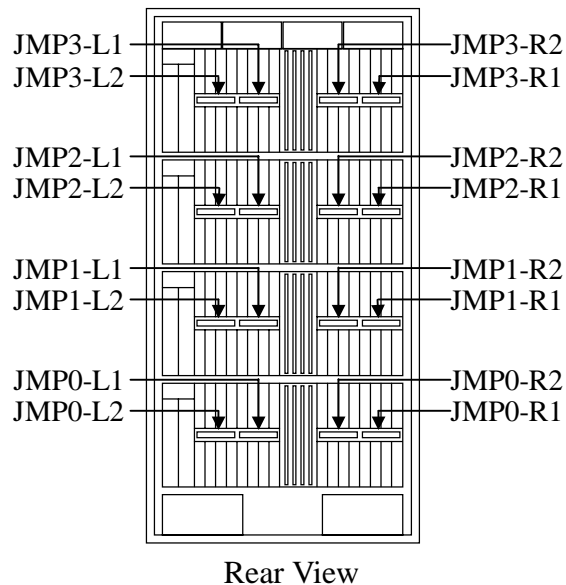
NOTICE:

- ① Be sure to wear your wrist strap and attach to ground prior to performing the following work. This will ensure that the IC and LSI on the PCB are protected from static electricity.
- ② When the Shut Down LED on the JMP PCB to be replaced is on, replace the JMP PCB irrespective of the status of the HDD ENABLE LED (green) on the JMP PCB concerned.

Replacement of JMP PCB

NOTICE:

- ① When replacing the JMP PCB, check if the switches on the other three JMP PCBs installed in the same HDU BOX are set correctly.
- ② If any of the switches on the JMP PCB to be replaced and the other ones installed are wrongly set, an error of SIM = 3daxxx (such as an LED BUS TEST error) occurs. Set them correctly as shown in the figure below.

1. Check that the Shut Down LED is on.



2. Replace the JMP PCB.

- a. Loosen the two screws and remove the JMP PCB.
- b. The switch of the spare JMP PCB is set to the right side.
- c. Insert the spare JMP PCB and fasten the two screws.

NOTICE: Shut Down LED light off when you operated post procedure on SVP.

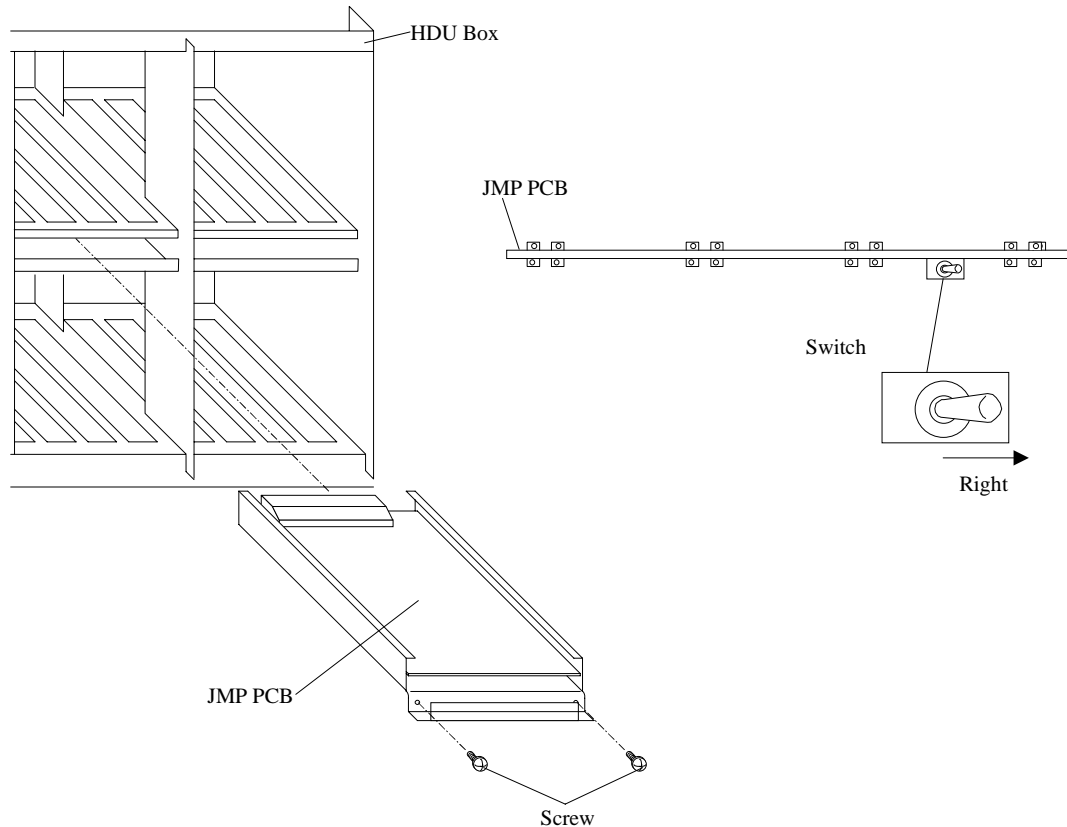

3. Go to SVP post procedure t4 [[REP04-1000](#)].

[HARDWARE T25]

Location	Function Name of Component		Part Name
Right of Front Logic Box	1	HUB Box	HUB Box

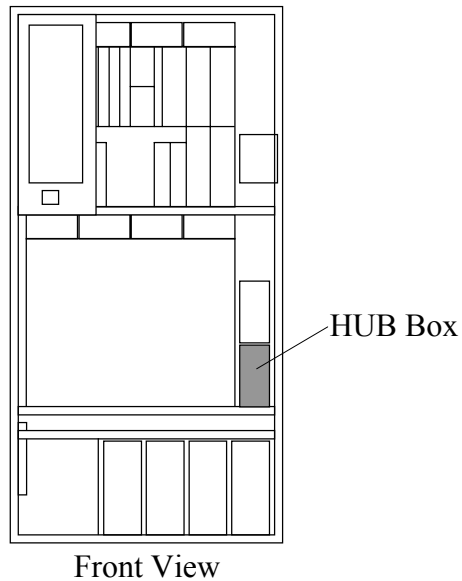

Front View

NOTICE:

Be sure to wear your wrist strap and attach to ground prior to performing the following work. This will ensure that the IC and LSI on the PCB are protected from static electricity.

Replacement of HUB BOX

1. Replace the HUB BOX.
 - a. Turn off the HUB BOX ENABLE switch on the HUB BOX.
 - b. Disconnect the cables from the HUB BOX.
 - c. Loosen the screw and remove the HUB BOX.
 - d. Insert the spare HUB BOX and fasten the screw.
 - e. Connect the cables to the HUB BOX.
 - f. Turn on the HUB BOX ENABLE switch on the HUB BOX.

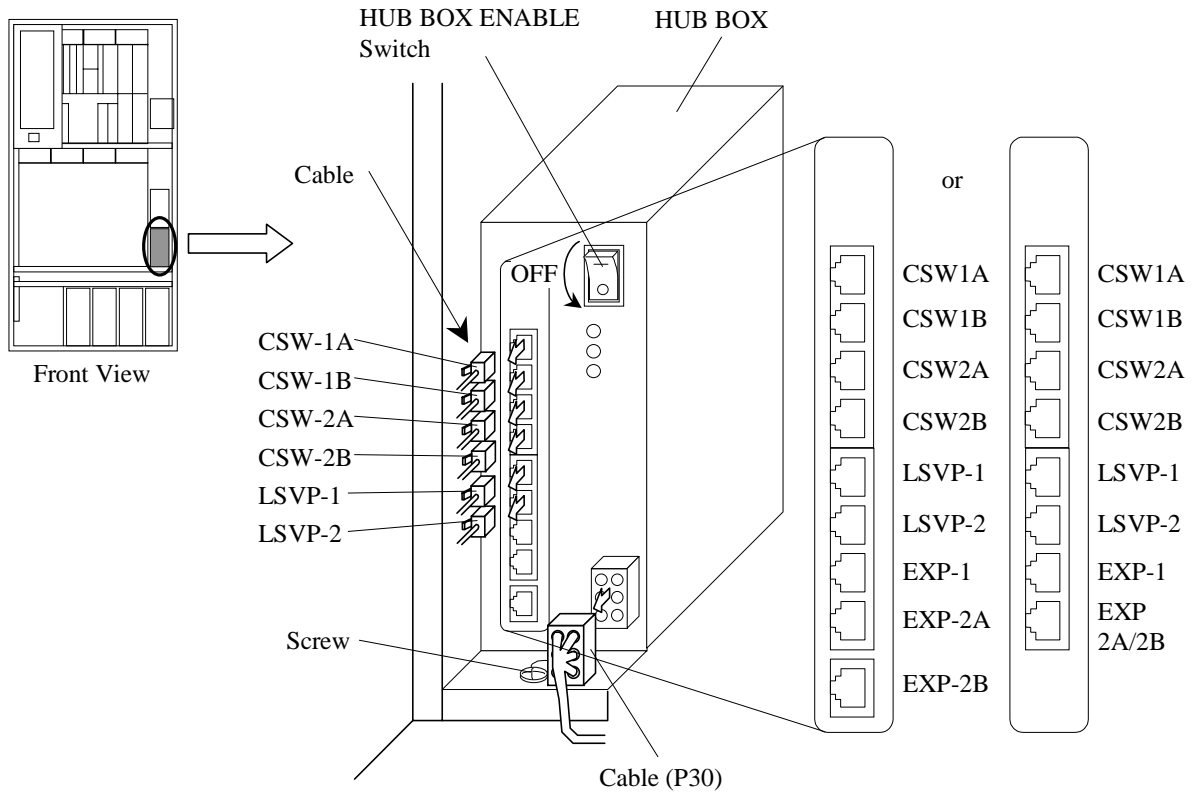

2. Go to SVP post procedure t1 [[REP04-320](#)].

[HARDWARE T26]

Location	Function Name of Component		Part Name
Right of Front Logic Box	1	SVPPS Box	SVPPS Box

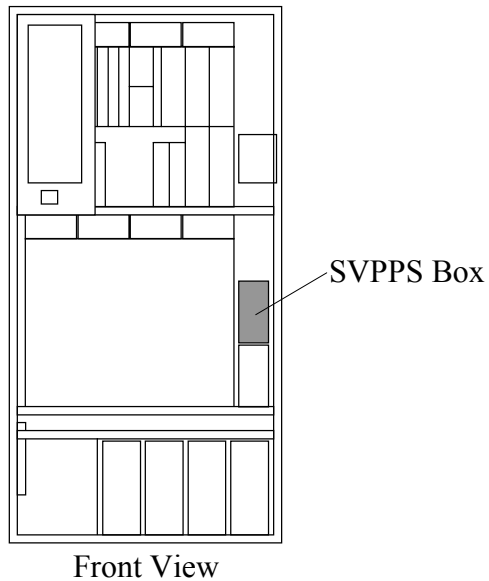

Front View

NOTICE:

Be sure to wear your wrist strap and attach to ground prior to performing the following work. This will ensure that the IC and LSI on the PCB are protected from static electricity.

Replacement of SVPPS Box

1. Insert the maintenance jumper into PS SD on the SVPPS BOX.

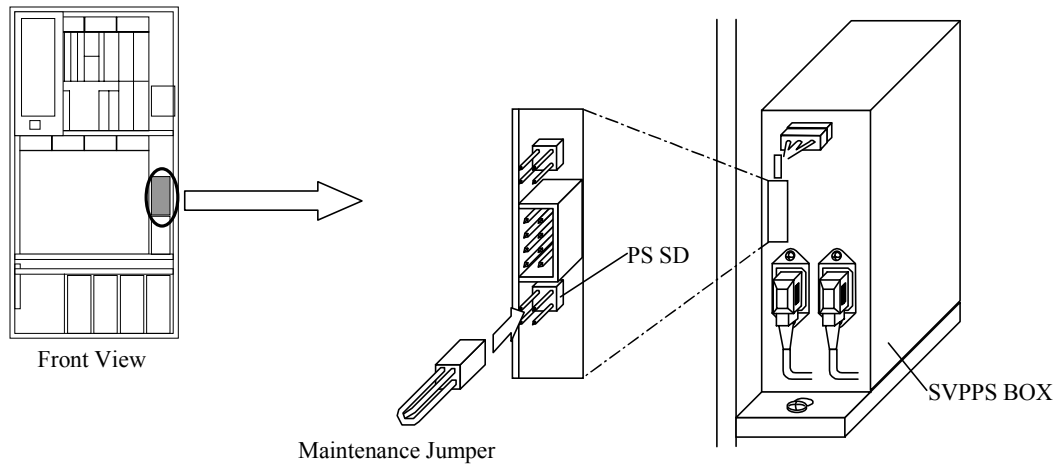

2. Replace the SVPPS BOX.
 - a. Disconnect the cables from the SVPPS BOX.
 - b. Loosen the screw and remove the SVPPS BOX.
 - c. Insert the spare SVPPS BOX and fasten the screw.
 - d. Connect the cables to the SVPPS BOX.

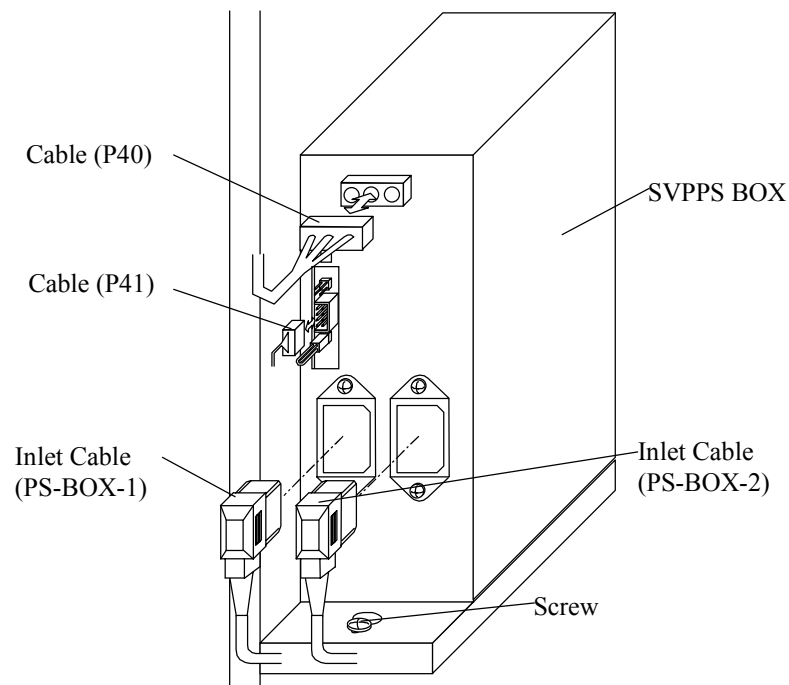

3. Go to SVP post procedure t1 [[REP04-320](#)].

[HARDWARE T27]

Location	Function Name of Component		Part Name
Lower left front of DKC	1	UPS CON	• SH298-A

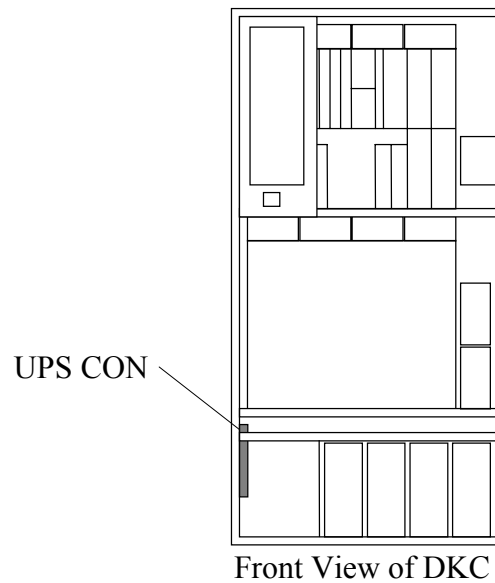

NOTICE:

Be sure to wear your wrist strap and attach to ground prior to performing the following work. This will ensure that the IC and LSI on the PCB are protected from static electricity.

1. Disconnect the DBUS Cables.
 - a. Disconnect the DBUS cables from the UPS CON.

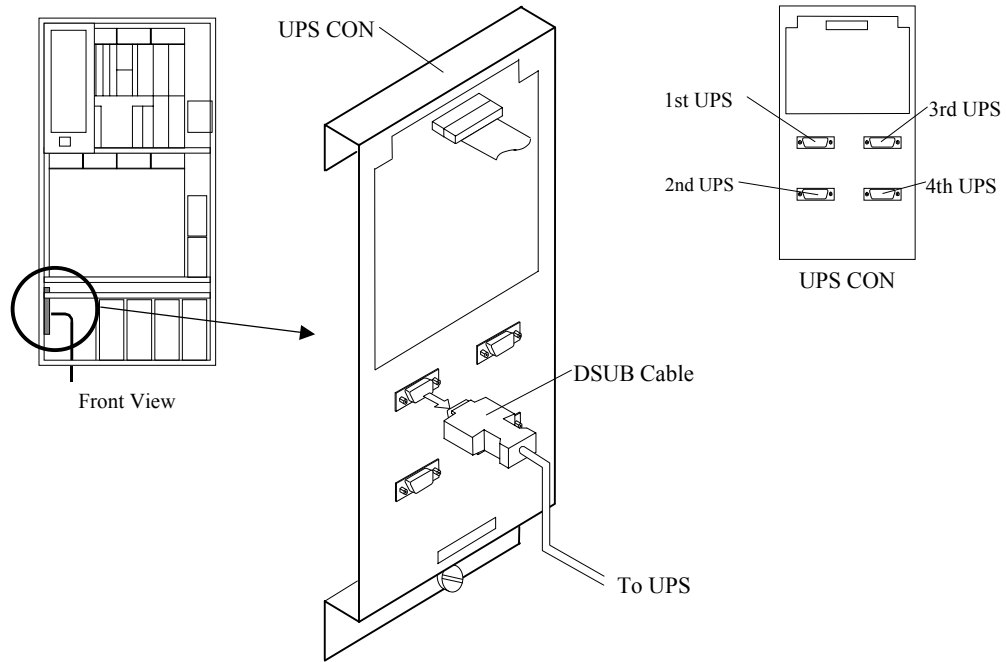

Fig. T27-1 Disconnection of Cables

2. Replace the UPS CON.
 - a. Disconnect cable from UPS CON.
 - b. Loosen the screw① and remove the screw② from the base plate
 - c. Slide the plate and turn it using the screw① as an axis.
 - d. Remove the screw③ and remove the UPS CON.
 - e. Attach the UPS CON of spare parts and fixed it with screw③.
 - f. Return the plate as it was and tighten the screw① and ②.
 - g. Connect the cable to the UPS CON.

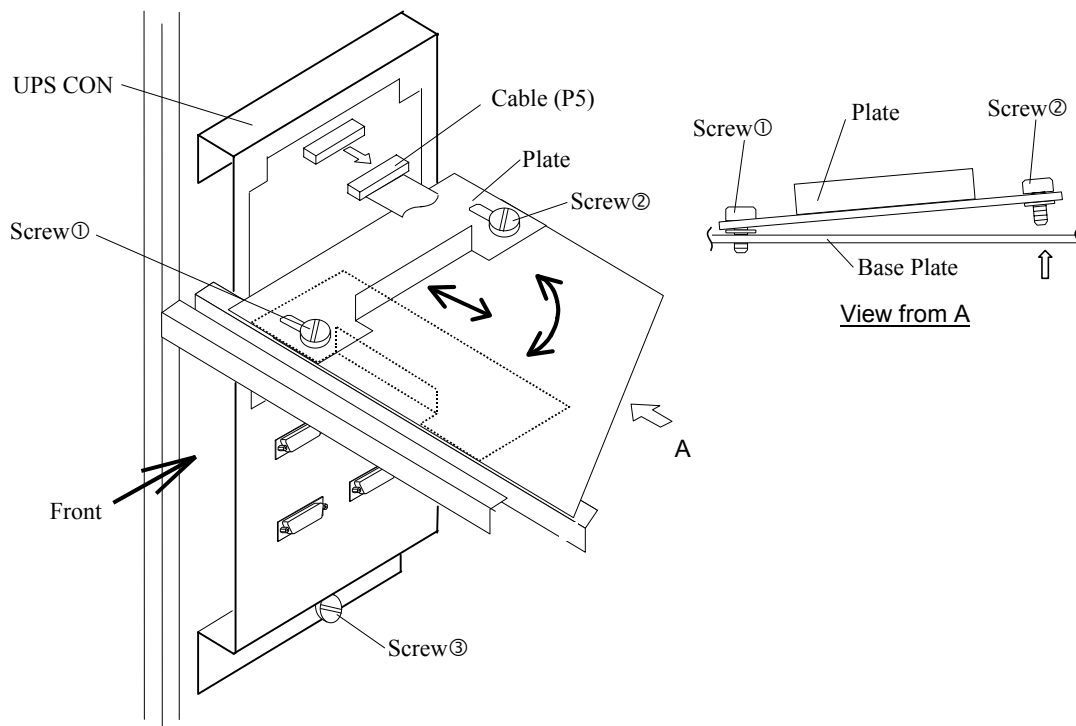
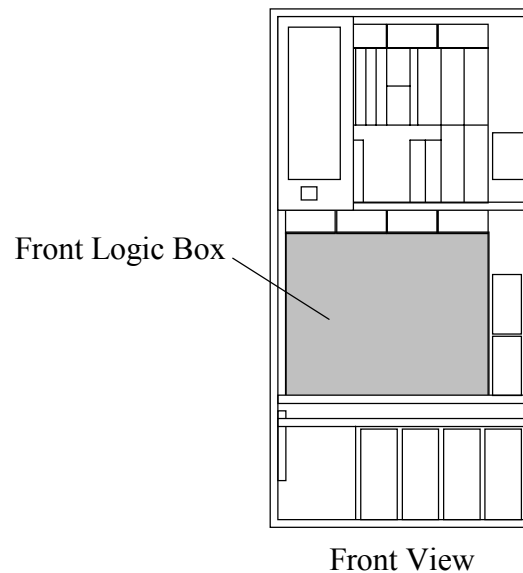

Fig. T27-2 Replacement of UPS CON

3. Connect the DBUS Cables.
 - a. Connect the DBUS cables to UPS CON. Refer to Fig. T27-1.
4. Go to SVP post procedure t1 [[REP04-320](#)].

[HARDWARE H]

Location		Function Name of Component	Part Name	Remarks
Front Logic Box	1	NAS 2-port Adapter PCB (DKC-F460I-4NS)	• WP467-A ×1 & SH281-D ×2	Color of PCB lever : Blue



NOTICE:

Be sure to wear your wrist strap and attach to ground prior to performing the following work. This will ensure that the IC and LSI on the PCB are protected from static electricity.

Note: When removing the CHA PCB for the NAS, be sure to remove the cable before removing the PCB.

1. Check that the Shut Down LED is on. If not, connect the Maintenance Jumper to the Shut Down Connector. (only hot replace)

⚠ CAUTION

A system down may be caused if the Maintenance Jumper is inserted in a PCB other than that to be replaced. Make sure that it is the PCB to be replaced.

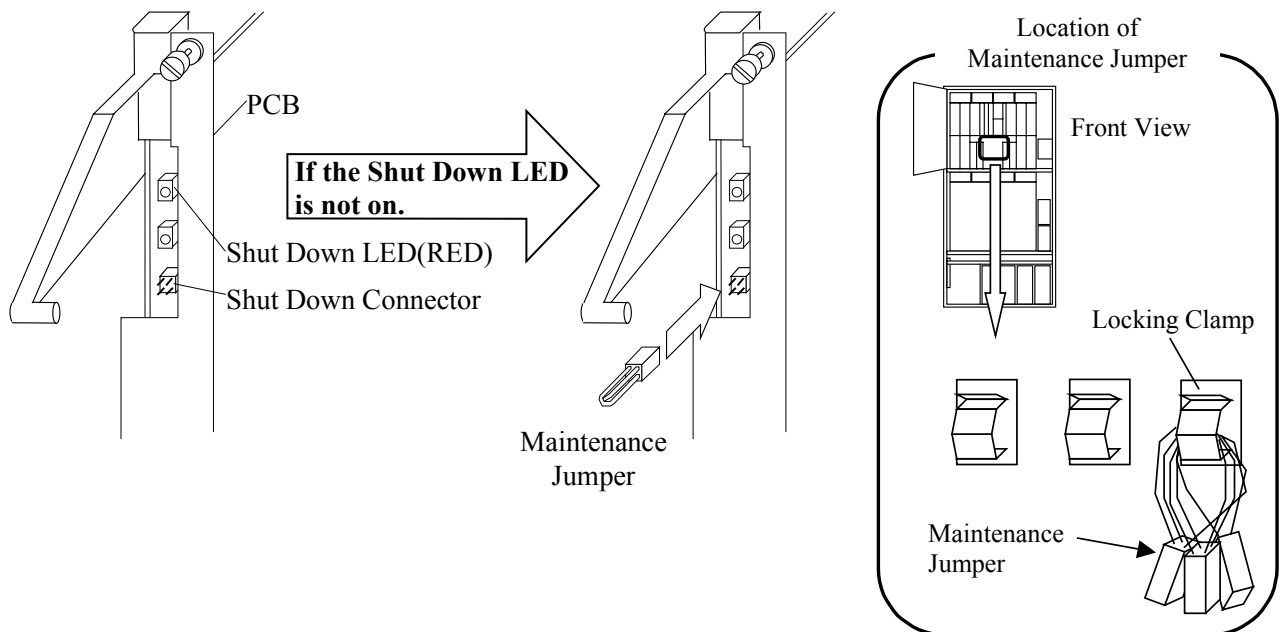

2. Disconnect the cables from the failed PCB.

Note: When the 12V power cable is removed from the CHA PCB for the NAS, the Shut DOWN LED that came on in Step 1 goes out.

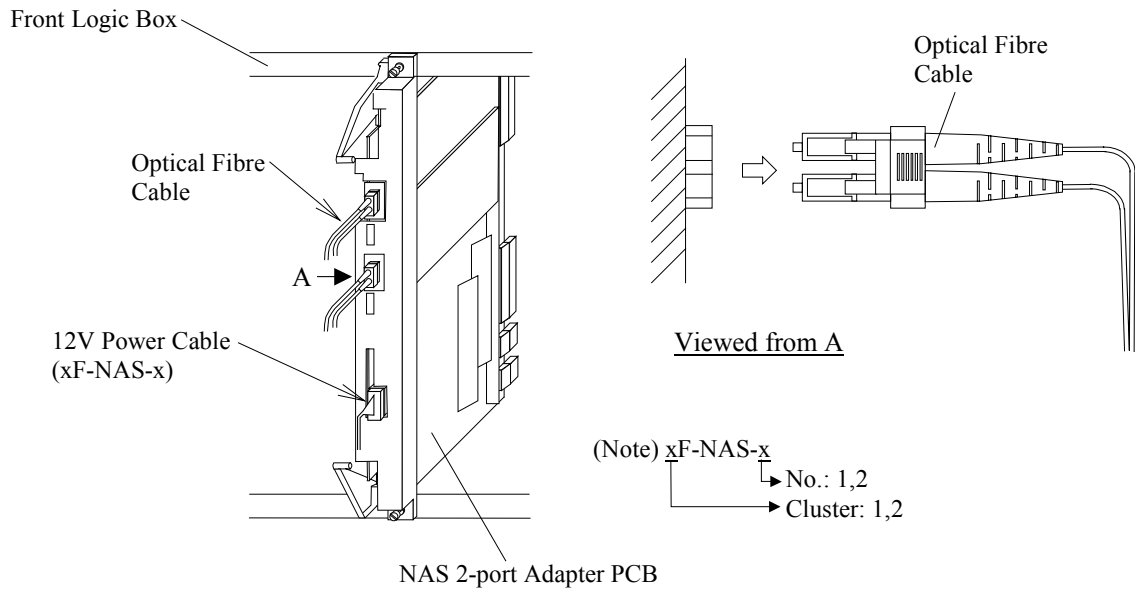

3. Remove the two screws and remove the failed PCB.

Note: If the Maintenance Jumper is used, remove it.

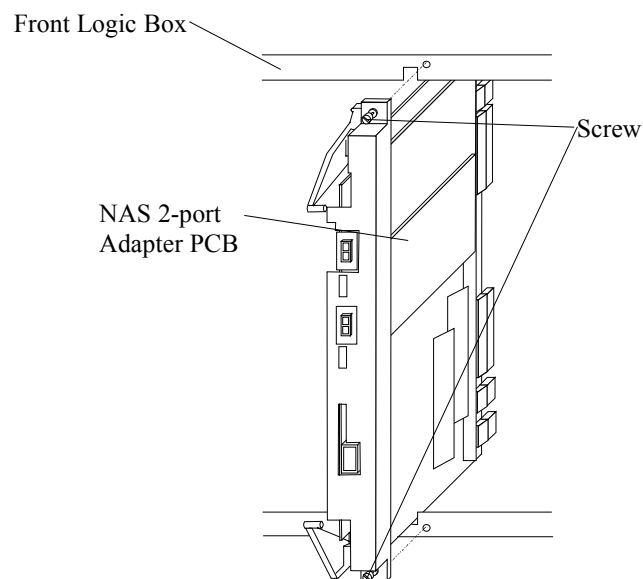

-
4. Insert the spare PCB to the correct location and fasten the two screws.

Note: Make sure that a color of the levers of the PCB to be installed is blue.
Never insert a PCB whose lever is not blue.

-
5. Cleaning the fiber cable connectors.

For the tools needed for the cleaning, refer to the tool list on page [PARTS06-10](#).

- a. Blow compressed gas against the connector using an air sprayer (for about five seconds).
- b. Wipe the connector lightly with a piece of cut gauze wet with ethyl alcohol.
- c. Blow compressed air again and check the result of the cleaning. (None of dust, sticking of foreign matter, and dirt must be observed.)

-
6. Connect the cables to the spare PCB.

-
7. Go to SVP post procedure f [[REP04-210](#)].

[HARDWARE I]

Location	Function Name of Component	Part Name	Remarks
Front Logic Box	1 iSCSI 4-port Adapter PCB	<ul style="list-style-type: none"> WP466-A ×1 & SH281-D ×4 	Color of PCB lever : Blue

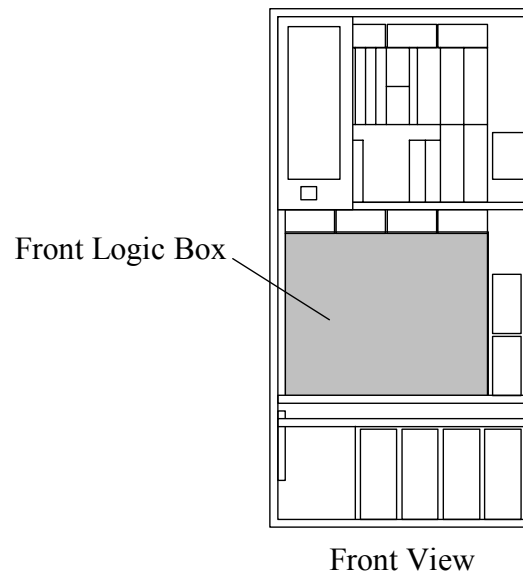

NOTICE:

Be sure to wear your wrist strap and attach to ground prior to performing the following work. This will ensure that the IC and LSI on the PCB are protected from static electricity.

1. Check that the Shut Down LED is on. If not, connect the Maintenance Jumper to the Shut Down Connector. (only hot replace)

⚠ CAUTION

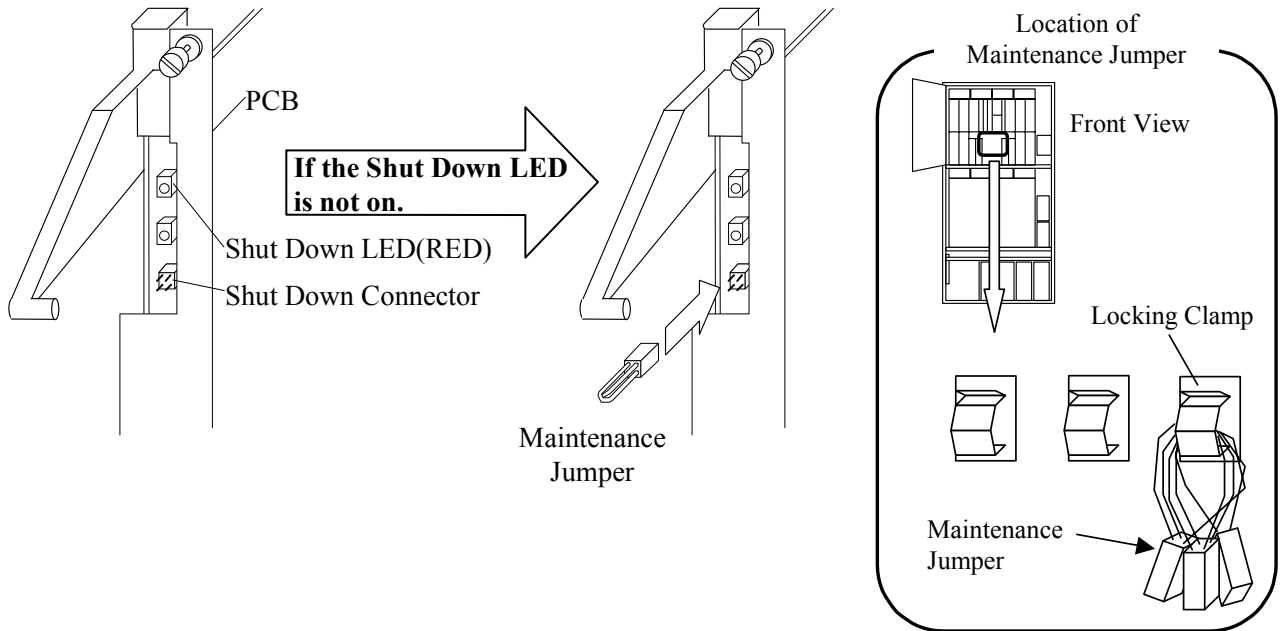
A system down may be caused if the Maintenance Jumper is inserted in a PCB other than that to be replaced. Make sure that it is the PCB to be replaced.



2. Disconnect the fibre cables from the failed PCB.

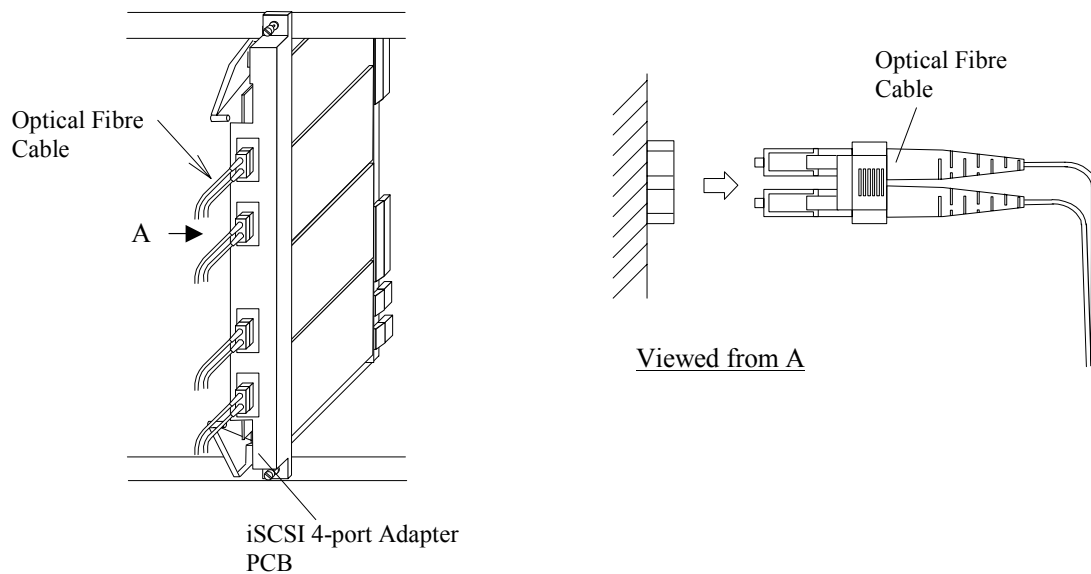

3. Remove the two screws and remove the failed PCB.
Note: If the Maintenance Jumper is used, remove it.

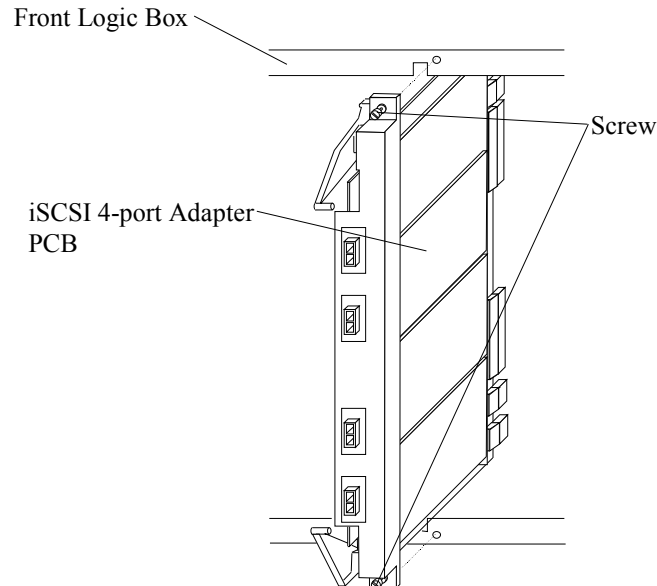

4. Insert the spare PCB to the correct location and fasten the two screws.

Note: 1. Make sure that a color of the levers of the PCB to be installed is blue.
 Never insert a PCB whose lever is not blue.

5. Cleaning the fiber cable connectors.
 For the tools needed for the cleaning, refer to the tool list on page [PARTS06-10](#).
- a. Blow compressed gas against the connector using an air sprayer (for about five seconds).
 - b. Wipe the connector lightly with a piece of cut gauze wet with ethyl alcohol.
 - c. Blow compressed air again and check the result of the cleaning. (None of dust, sticking of foreign matter, and dirt must be observed.)

6. Connect the fibre cables to the spare PCB.

7. Go to SVP post procedure f [[REP04-210](#)].

[POST-PROCEDURE a]

— OUTLINE —

- ① Execute CUDG on P-DEV.
- ② Specify recovery.
- ③ Copy back
- ④ SIM Complete

CAUTION

Before starting the <Check the beginning of recovery> operation in POST-PROCEDURES a, b, c and d, be sure to insert a floppy disk for dump, collect failure information, and return the floppy disk with the failed HDD.
A dump floppy disk is attached with a Spare HDD.

1. <Check the beginning of recovery>
Please insert the floppy disk and select (CL) [OK].
Failure information of the physical device is written to the floppy disk.

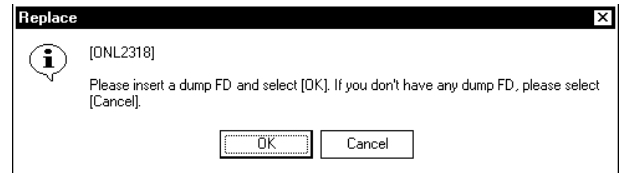

- [After the completion of writing failure information:]
"Please remove the FD." is displayed.
Please remove the floppy disk and select (CL) [OK].



2. <Spin up the Physical Drive>
"Spinning up..." is displayed.

3. <DKU INLINE>
"DKU INLINE is now running..." is displayed.

4. <Replacement of the DKU micro-program>

When the revision of the DKU micro-program in the SVP hard disk is newer than that in the PDEV, the following message appears on the screen.

The message “Exchanging DKU micro-program...” appears.

5. <Restore Physical Drive>

“Restoring...” is displayed.

6. <Check the Physical Drive>

“Checking...” is displayed.

7. <Check the beginning of copyback>

Select (CL) [Yes] in response to “Are you sure you want to copy data in spare device to the physical device?”.

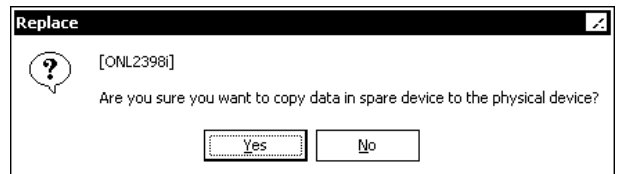

8. <Check starting of copyback>
 “Copying...” is displayed.
 Select (CL) [OK] in response to “Copying data in spare device to the physical device has been started.”.

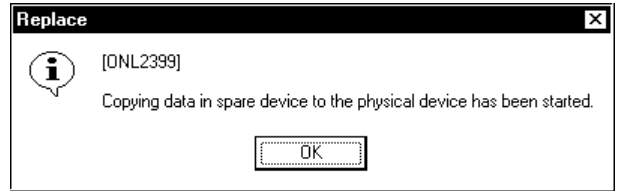

9. To interrupt the copy, select (CL) the [Drive Interrupt] button.

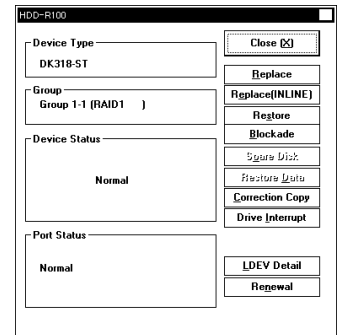

10. <SIM Complete>
 Refer to [SVP02-580](#).

[POST-PROCEDURE b]

— OUTLINE —

- ① Execute CUDG on P-DEV.
- ② Specify recovery.
- ③ Correction copy
- ④ Reset ORM Error Count on the P-DEV.
- ⑤ Reset Threshole Counter
- ⑥ SIM Complete

CAUTION

Before starting the <Check the beginning of recovery> operation in POST-PROCEDURES a, b, c and d, be sure to insert a floppy disk for dump, collect failure information, and return the floppy disk with the failed HDD.
A dump floppy disk is attached with a Spare HDD.

1. <Check the beginning of recovery>
Please insert the floppy disk and select (CL) [OK].
Failure information of the physical device is written to the floppy disk.

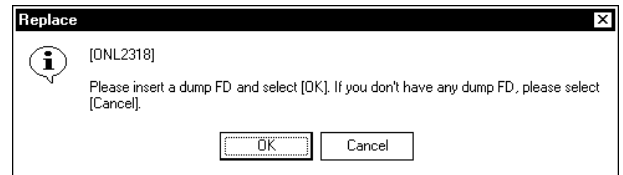

- [After the completion of writing failure information:]
“Please remove the FD.” is displayed.
Please remove the floppy disk and select (CL) [OK].



2. <Spin up the Physical Drive>
“Spinning up...” is displayed.

3. <DKU INLINE>
“DKU INLINE is now running...” is displayed.

-
4. <Restore Physical Drive>
“Restoring...” is displayed.

-
5. <Check the Drive Status>
“Checking...” is displayed.
Device is still blocked.

-
6. <Check the beginning of correction copy>
Select (CL) [Yes] in response to “Are you sure you want to correct data in the physical device?”.

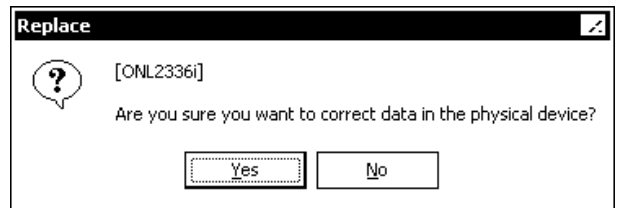

-
7. <Correct data>
“Correcting...” is displayed.

8. <Check the starting of Correction copy>
Select (CL) [OK] in response to “Correcting data in the physical device has been started.”.

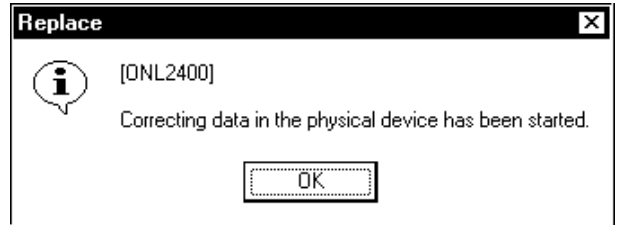

9. <Check the end of P-DEV recovery>
Select (CL) [OK] in response to “Replace finished.”.

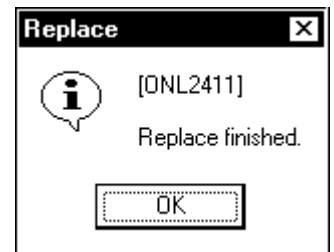

10.
To interrupt the correction copy, select the PDEV to which the copy is being made and select (CL) the [Drive Interrupt] button.

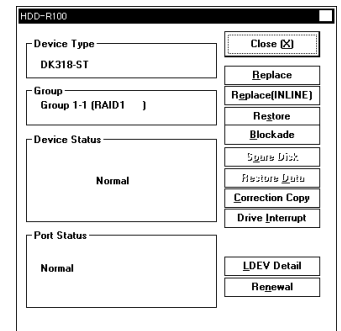

11. <SIM Complete>
Refer to [SVP02-580](#).

[POST-PROCEDURE c]

— OUTLINE —

- ① Perform L-DEV formatting on P-DEV.
- ② Reset ORM Error Count on P-DEVs.
- ③ Recover with backup data.
- ④ Reset Threshold Counter
- ⑤ SIM Complete

⚠ CAUTION

Before starting the <Check the beginning of recovery> operation in POST-PROCEDURES a, b, c and d, be sure to insert a floppy disk for dump, collect failure information, and return the floppy disk with the failed HDD.
A dump floppy disk is attached with a Spare HDD.

1. <Check the beginning of recovery>
Insert the floppy disk and select (CL) [OK].
Failure information of the physical device is written to the floppy disk.

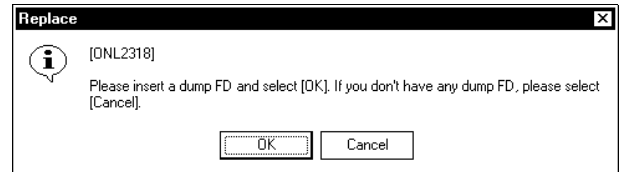

[After the completion of writing failure information:]
“Please remove the FD.” is displayed.
Remove the floppy disk and select (CL) [OK].



2. <Spin up the Physical Drive>
“Spinning up...” is displayed.

3. <DKU INLINE>
“DKU INLINE is now running...” is displayed.

4. <Replacement of the DKU micro-program>

When the revision of the DKU micro-program in the SVP hard disk is newer than that in the PDEV, the following message appears on the screen.

The message “Exchanging DKU micro-program...” appears.

5. <Restore Physical Drive>

“Restoring...” is displayed.

6. <Check the Drive Status>

“Checking...” is displayed.

7. <Correction Copy disable message>

CAUTION

If a blocked HDD exists in the same parity group, replace the HDD.
After confirming that "NORMAL" is indicated for all the HDDs in the same parity group, execute an L-DEV formatting following the procedure below.

Select (CL) [OK] in response to "Correcting data in the physical device could not be done."

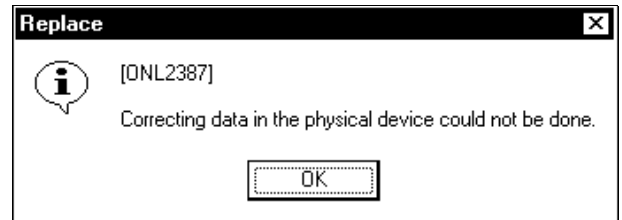

8. <Select [Logical Device]>

CAUTION

Before you perform following steps, be sure to call T.S.C.
Data housed in Logical Device will be lost due to formatting Logical Device.

Select (CL) [Logical Device] from [Maintenance].

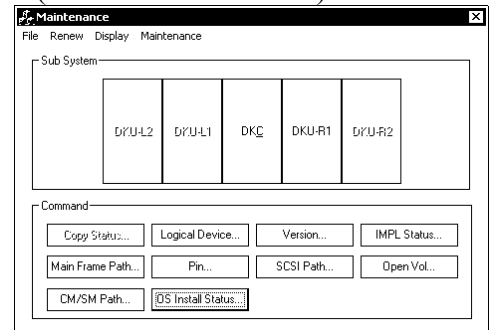
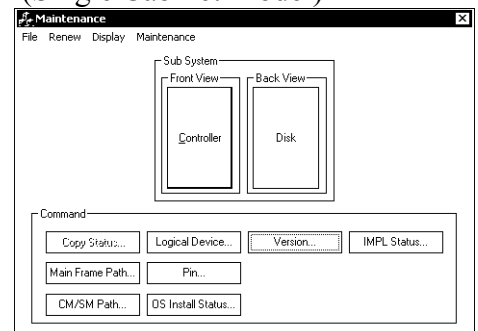
(Multi Cabinet Model)**(Single Cabinet Model)**

9. <Logical Device Status>
Select (CL) [Format...].

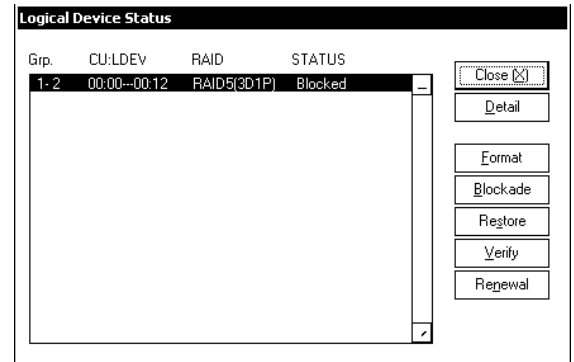

10. <Format Logical Device>

Select (CL) corresponding LDEV from the LDEV ID list in the 'Logical Device' dialog box and select (CL) [OK].

If the target LDEV is not blocked, return to 'Logical Device Status' dialog box.

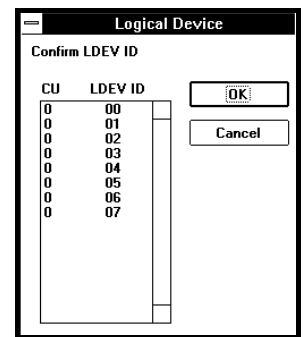

11. <Caution message for DATA lost>

CAUTION

This is a special (exceptional) operation that can cause a serious failure such as a system down or a data loss and requires an input of a password. Ask the technical support center about the appropriateness of the operation, and input the password after getting an approval of executing the operation.

“Data in the specified logical device may be lost due to this operation. You need the password to continue.” is displayed.
Enter the password and select (CL) [OK].

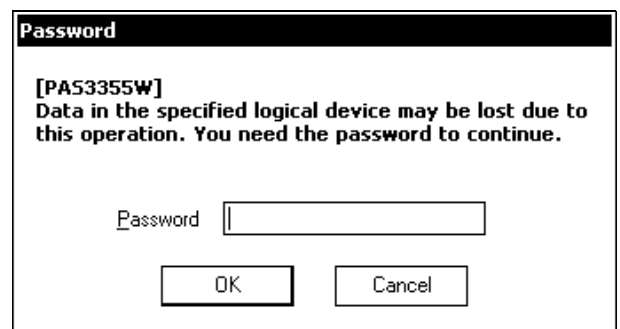

12. <Check Formatting the logical Device>
 “Formatting the logical device...” is displayed.

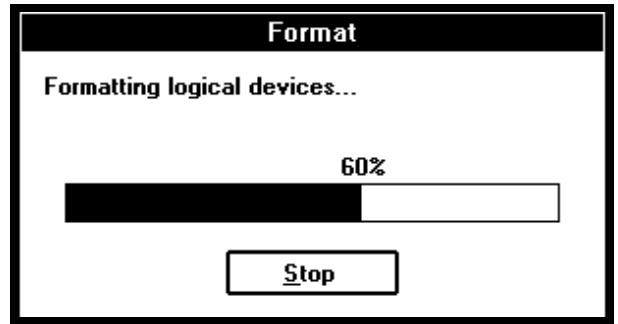

13. <Check the end of Format Logical Device>
 Select (CL) [OK] in response to “Formatting was finished.”.

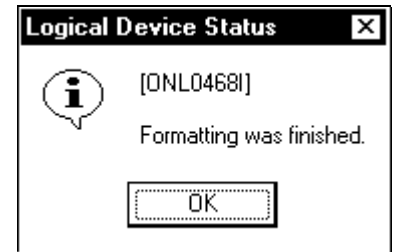

14. <SIM Complete>
 Refer to [SVP02-580](#).

15. <Recover data>
 Ask the customer for recovering data with backup data.

[POST-PROCEDURE d]

— OUTLINE —

- ① Execute CUDG on P-DEV.
- ② Specify recovery.
- ③ Reset ORM Error Count on the P-DEV.
- ④ Reset Threshold Counter.
- ⑤ SIM Complete.

 **CAUTION**

Before starting the <Check the beginning of recovery> operation in POST-PROCEDURES a, b, c and d, be sure to insert a floppy disk for dump, collect failure information, and return the floppy disk with the failed HDD.
A dump floppy disk is attached with a Spare HDD.

1. <Check the beginning of recovery>
Please insert the floppy disk and select (CL) [OK].
Failure information of the physical device is written to the floppy disk.

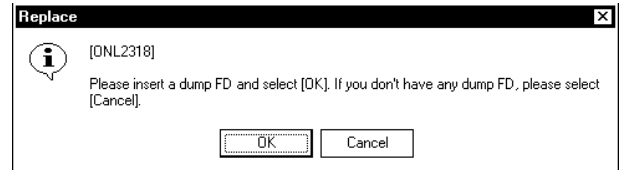

[After the completion of writing failure information:]
“Please remove the FD.” is displayed.
Please remove the floppy disk and select (CL) [OK].



2. <Check the spin up process>
“Spinning up...” is displayed.

3. <Check the INLINE process>
“DKU INLINE is now running...” is displayed.

4. <Replacement of the DKU micro-program>

When the revision of the DKU micro-program in the SVP hard disk is newer than that in the PDEV, the following message appears on the screen.

The message “Exchanging DKU micro-program...” appears.

5. <Restore Physical Drive>

“Restoring...” is displayed.

6. <Check the end of P-DEV recovery>

Select (CL) [OK] in response to “Replace finished.”.

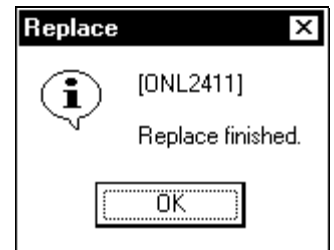

7. <SIM Complete>

Refer to [SVP02-580](#).

[POST-PROCEDURE e]

— OUTLINE —

- ① Execute CUDG on cache.
- ② Specify recovery.
- ③ SIM Complete

1. <INLINE CUDG>
“INLINE CUDG is now running...” is displayed.

2. <Check the beginning of cache/SM recovery>

**CAUTION**

Selecting "No" stops the recovery and places the cache in the status being blocked for maintenance.

Select (CL) [Yes] in response to:

* For CACHE (with SM)

“Do you want to restore the Shared Memory and Cache Memory PCB now?”

* For CACHE ----- [Go to step 4]

“Do you want to restore the Cache Memory PCB now?”

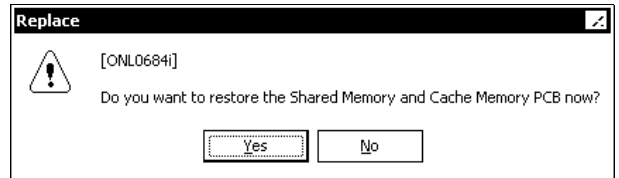

3. <Restore the Shared Memory>
“Restoring the Shared Memory PCB...” is displayed.

4. <Restore the Cache Memory>
“Restoring the Cache Memory PCB...” is displayed.

5. <Check the end of Cache/Shared Memory recovery>
Select (CL) [OK] in response to “Replace finished.”.



6. <SIM Complete>
Refer to [SVP02-580](#).

7.
Close the 'cache-xx' window.
Close the 'cluster-n' window.

(Multi Cabinet Model)
Close 'DKC' window.

(Single Cabinet Model)
Close 'Controller' window.

Close 'Maintenance' window.

[POST-PROCEDURE f]

— OUTLINE —

- ① Specify recovery for CHA/DKA.
- ② Path online (for CHA)
- ③ SIM Complete

<For CHA/DKA>

1. <Waiting for Power Event>
“Waiting for Power Event...
Usually several minutes (maximum 15 minutes).” is displayed.

-
2. “DKU PATH INLINE is now running...” is displayed.

-
3. <Check the recovery processing>
The following message is displayed:

* For DKA

“Restoring the DKA...”

4. <Check the end of CHA/DKA recovery>

CAUTION

Confirm the version of the exchanged CHA/DKA microprogram on the "STATUS" screen.

Select (CL) [OK] in response to "Replace finished."



5. <Path on-line when CHA is replaced>

Whenever a CHA is replaced, set the path (from the host) on the replaced CHA to ONLINE by your customer.

6. <SIM Complete>

Refer to [SVP02-580](#).

7.

Close the 'CHA-xx' window.
Close the 'cluster-n' window.

(Multi Cabinet Model)

Close 'DKC' window.

(Single Cabinet Model)

Close 'Controller' window.

Close 'Maintenance' window.

[POST-PROCEDURE i]

— OUTLINE —

- ① Specify recovery for DKA.
- ② SIM Complete

CAUTION

This processing is a special procedure for detecting a cause of a path error.
Contact the technical support center before performing this processing.

 **CAUTION**

This processing is a special procedure for detecting a cause of a path error.
Contact the technical support center before performing this processing.

1. <Check the execution of PATH INLINE>
Select (CL) [Yes] in response to:
“Are you sure you want to perform DKU
PATH INLINE for the physical device?”
Go to step 2.
Select (CL) [No] in response to:
Go to step 3.

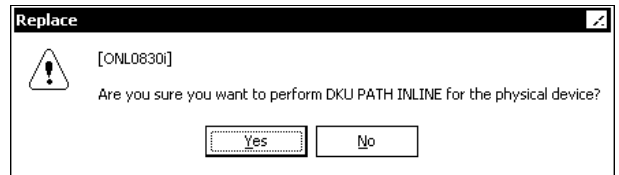

2.
“DKU PATH INLINE is now running...” is displayed.

3. <Check the DKA recovery processing>
The following message is displayed:
“Restoring the DKA...”

 **CAUTION**

This processing is a special procedure for detecting a cause of a path error.
Contact the technical support center before performing this processing.

4. <Check the end of DKA recovery>
Select (CL) [OK] in response to “Replace finished.”.



5. <SIM Complete>
Refer to [SVP02-580](#).

- 6.
- Close the ‘DKA-xx’ window.
 - Close the ‘cluster-n’ window.

 - (Multi Cabinet Model)
 - Close ‘DKC’ window.

 - (Single Cabinet Model)
 - Close ‘Controller’ window.

 - Close ‘Maintenance’ window.

[POST-PROCEDURE j]

— OUTLINE —

- ① Specify recovery of DKP was connected FSW.
- ② SIM Complete

1. <Check the beginning of DKP recovery>
Select (CL) [Yes] in response to “Do you want to restore the DKP now?”.

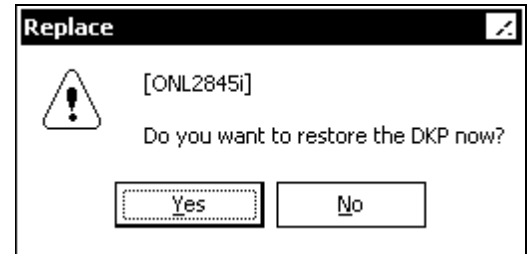

2. <DKU PATH INLINE>
“DKU PATH INLINE is now running...” is displayed.

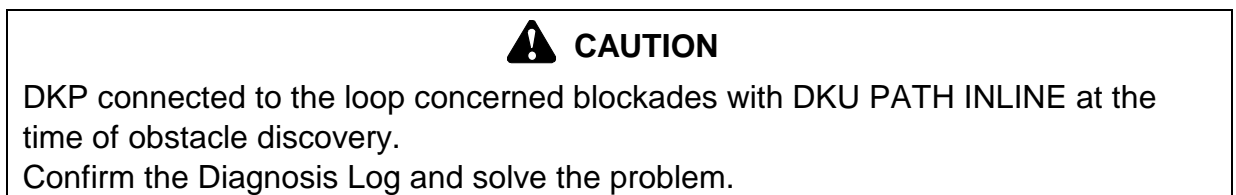

3. <Check DKP recovery processing>
“Restoring the DKP...” is displayed.

4. <Check the end of FSW replace>
Select (CL) [OK] in response to “Replace finished.”.

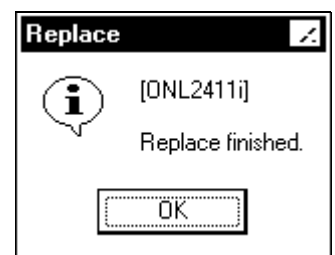

-
5. <SIM Complete>
Refer to [SVP02-580](#).

-
6.
Close the 'HDU-xxx' window.
Close the 'Disk-xx' window.
Close 'Maintenance' window.

[POST-PROCEDURE k]

— OUTLINE —

- ① Specify recovery of CSW.
- ② SIM Complete

1. <Check the CSW recovery procedure>
“Restoring the CSW...” is displayed.

2. <Check the CSW replace finished>
Select (CL) [OK] in response to “Replace finished.”.



3. <SIM Complete>
Refer to [SVP02-580](#).

4.
Close 'Cluster-n' window.

(Multi Cabinet Model)
Close 'DKC' window.

(Single Cabinet Model)
Close 'Controller' window.

Close 'Maintenance' window.

[POST-PROCEDURE t1]

— OUTLINE —

- ① Specify end of special part replacement.
- ② Reinstall related parts.
- ③ Start environment monitor.
- ④ SIM Complete.

[1] Start of POST-PROCEDURE

1. <Check replacement of special part>

Select (CL) [OK] in response to "Please replace the "XXXXX." After replacement, press OK."

Valid "XXXXX" values are listed below.

- DKC-PANEL ---Go to [2] ([REP04-340](#))
- PCI CON-----Go to [3] ([REP04-370](#))
- UPS CON-----Go to [3] ([REP04-370](#))
- EPO SW -----Go to [6] ([REP04-400](#))
- RS CON-----Go to [5] ([REP04-390](#))
- DKCMN 1/2-----Go to [4] ([REP04-380](#))
- SSVP -----Go to [7] ([REP04-410](#))
- HUB-BOX-----Go to [8] ([REP04-430](#))
- MONI-CON1/2 -Go to [9] ([REP04-440](#))
- SVPPS-BOX ----Go to [12] ([REP04-590](#))

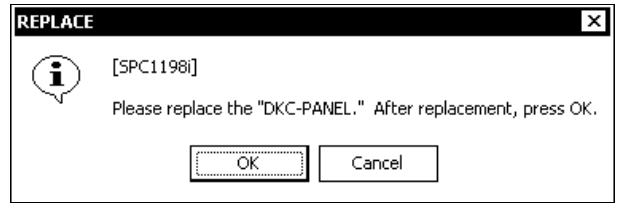

(ex. DKC-PANEL)

For each of the following, no message is displayed when a part (hardware) of it has been replaced. Proceed to the respective steps shown below.

- SVP-----Go to [10] ([REP04-460](#))
- SVP&FLASH ---Go to [10] ([REP04-460](#))
- FLASH CARD--Go to [11] ([REP04-580](#))
- Switch SVP-----Go to [13] ([REP04-610](#))

Note: When you want to replace UPS CON, execute PCI CON Replacement Process.

[2] DKC-PANEL

1. <LED TEST>

Select (CL) [OK] in response to “Please turn the LED TEST/CHK RST switch to LED TEST, and check if LEDs are on. Then select OK.”.

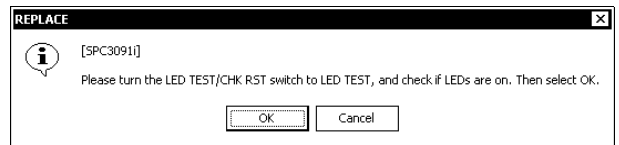

2.

Select (CL) [OK] in response to “REMOTE MAINTENANCE SWITCH TEST: After turning switch to ENABLE position, press OK.”.

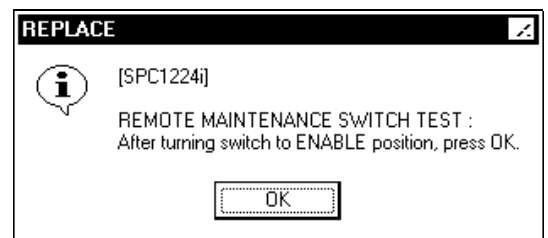

3.

If an error has occurred in the switch test, an error message is displayed.
If you select (CL) [Yes], go back to step 2.
If you select (CL) [No], go to step 8.

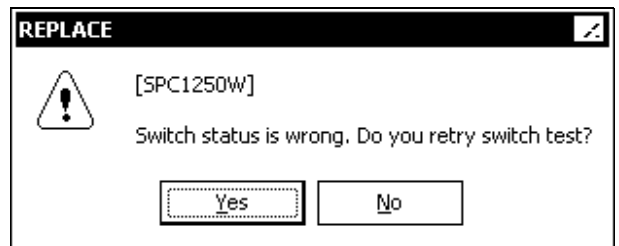

4.

Select (CL) [OK] in response to “REMOTE MAINTENANCE SWITCH TEST: After turning switch to DISABLE position, Press OK.”.

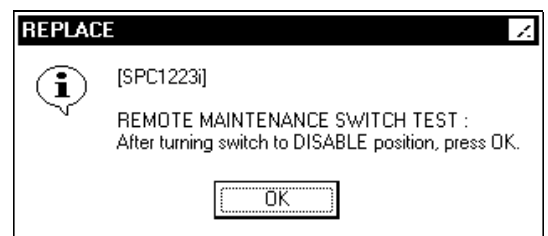

5.

If an error has occurred in the switch test, an error message is displayed.

If you select (CL) [Yes], go back to step 4.

If you select (CL) [No], go to step 8.

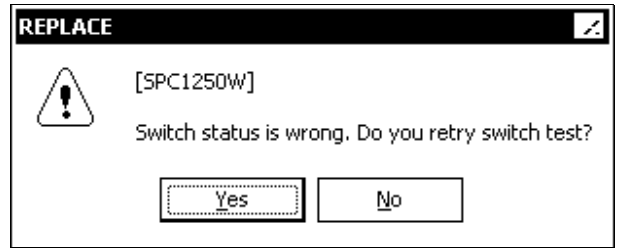

6.

Select (CL) [OK] in response to "RESTART SWITCH TEST: After turning switch, press OK."

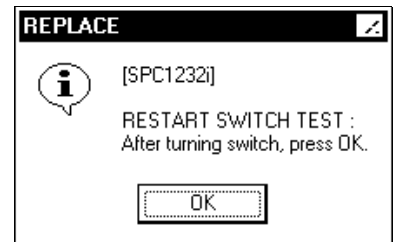

7.

If an error has occurred in the switch test, an error message is displayed.

If you select (CL) [Yes], go back step 6.

If you select (CL) [No], go to step 8.

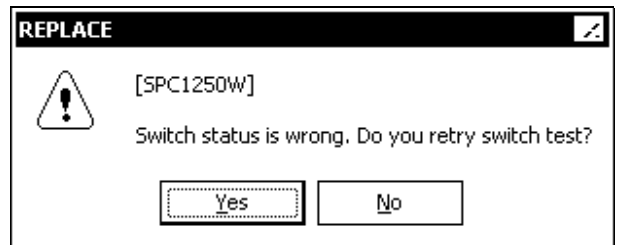

8. <Set REMOTE/LOCAL>

Set REMOTE/LOCAL switch, in response to the message "Please set "REMOTE/LOCAL" switch of "DKC-PANEL" "LOCAL". Then press OK."

After confirming that switch set, select (CL) [OK].

The SVP automatically checks the REMOTE/LOCAL switch status.

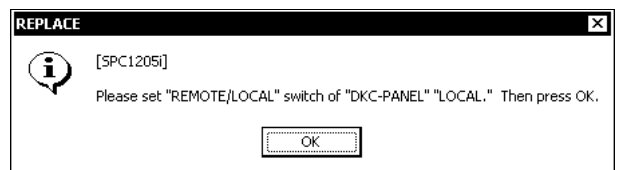

9. <Detach jumper>

Detach jumper from DKCMN in response to “Please detach DKC Panel INH jumper plug. Then press OK.”.

After confirming that jumper is detached, select (CL) [OK].

The SVP automatically checks that jumper plug is detached.



10. <Reset REMOTE/LOCAL switch>

Reset REMOTE/LOCAL switch to original value in response to “Please return REMOTE/LOCAL switch, on DKC-PANEL as before. Then press OK.” ([REP03-370](#)).

After checking SW setting, select (CL) [OK].

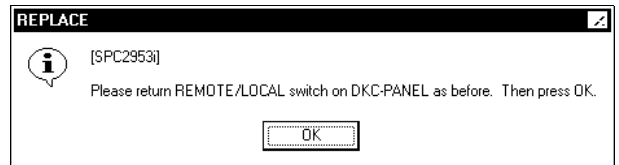

11. <Check end of replacement>

Select (CL) [OK] in response to “Replacement of the "DKC-PANEL" is done.”.

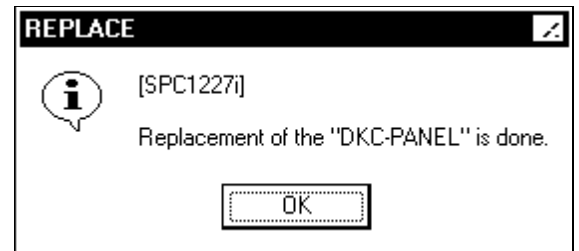

(ex. RS CON)

12. <SIM Complete>

See [SVP02-580](#).

(Multi Cabinet Model)

Close ‘DKC’ window.

Close ‘Maintenance’ window.

(Single Cabinet Model)

Close ‘Controller’ window.

Close ‘Maintenance’ window.

Go to POST-PROCEDURE z ([REP04-1400](#)).

[3] PCI CON (UPS CON)

1. <Detach jumper>

Detach jumper from DKCMN in response to “Please detach DKC Panel INH jumper plug. Then press OK.”.

After confirming that jumper is detached, select (CL) [OK].

The SVP automatically checks that jumper plug is detached.

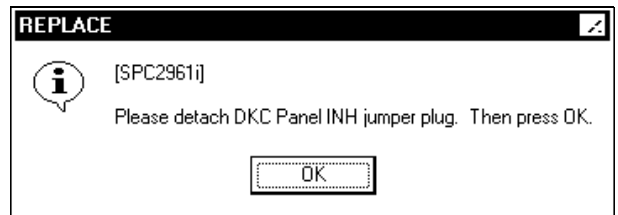

2. <Reset DKC-PANEL switch>

Reset REMOTE/LOCAL switch to original value in response to “Please return REMOTE/LOCAL switch, on DKC-PANEL as before. Then press OK.” (REP03-370).

After checking SW setting, select (CL) [OK].

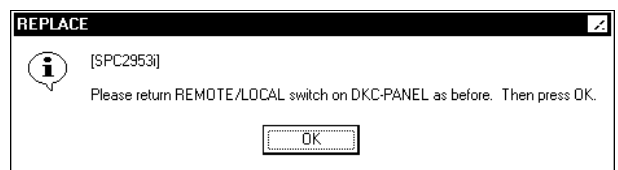

3. <Check end of replacement>

Select (CL) [OK] in response to “Replacement of the "PCI CON" is done.”.

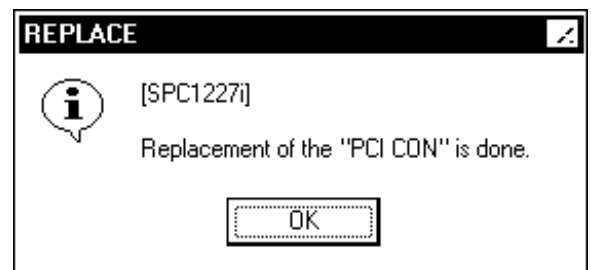

(ex. RS CON)

4. <SIM Complete>

See [SVP02-580](#).

(Multi Cabinet Model)

Close ‘DKC’ window.

Close ‘Maintenance’ window.

(Single Cabinet Model)

Close ‘Controller’ window.

Close ‘Maintenance’ window.

Go to POST-PROCEDURE z ([REP04-1400](#)).

[4] DKCMN 1/2

1. <Check environment monitor start processing>
“Processing to enable the environment check...”
is displayed.

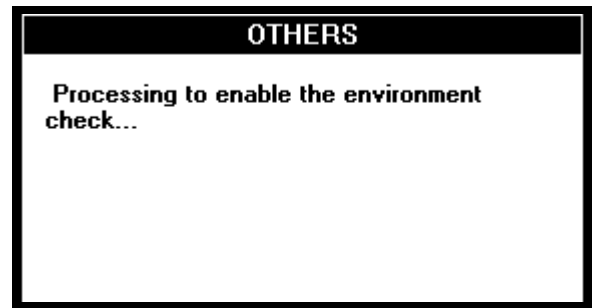

2. <Check end of replacement>
Select (CL) [OK] in response to “Replacement of the "DKCMNn" is done.”.

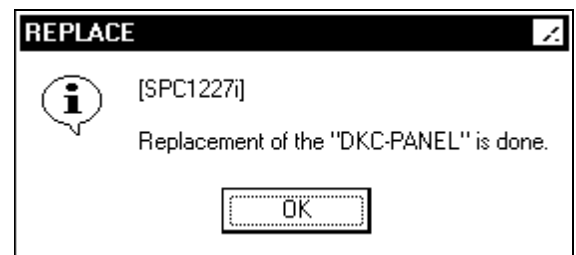

(ex. RS CON)

3. <Confirm status>
 - DKCMN 1/2
Confirm the status display.
If button is normal (lighting), go to step 4.
If button is blinking, replace the target part again, or see TROUBLE SHOOTING SECTION.

4. <SIM Complete>

See [SVP02-580](#).

(Multi Cabinet Model)
Close 'DKC' window.
Close 'Maintenance' window.

(Single Cabinet Model)
Close 'Controller' window.
Close 'Maintenance' window.

Go to POST-PROCEDURE z ([REP04-1400](#)).

[5] RS CON

1. <Check end of replacement>
Select (CL) [OK] in response to "Replacement of the "RS CON" is done."

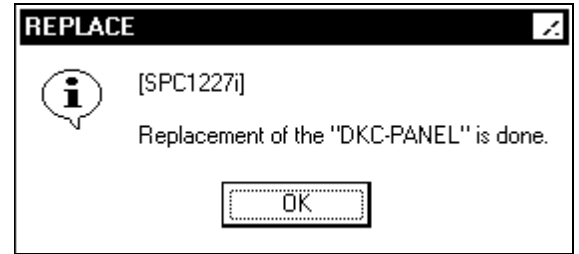

2. <Check normal operation of the remote maintenance support system>
When the remote maintenance support system (ASSIST) is not installed, go to step 3.
Perform the line connection test on the SVP connecting line of the remote maintenance support system.

3. <SIM Complete>

See [SVP02-580](#).

(Multi Cabinet Model)
Close 'DKC' window.
Close 'Maintenance' window.

(Single Cabinet Model)
Close 'Controller' window.
Close 'Maintenance' window.

Go to POST-PROCEDURE z ([REP04-1400](#)).

[6] EPO SW

1.

The SVP automatically checks the EPO SW status.

2. <Detach jumper>

Detach jumper from DKCMN in response to "Please detach DKC Panel INH jumper plug. Then press OK."

After confirming that jumper is detached, select (CL) [OK].

The SVP automatically checks that jumper plug is detached.

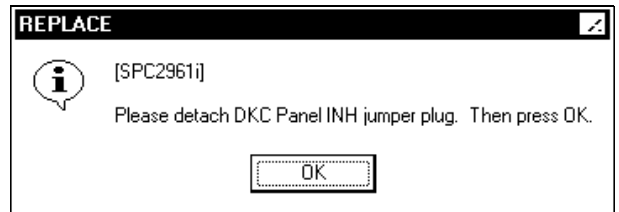

3. <Check end of replacement>

Select (CL) [OK] in response to "Replacement of the "EPO SW" is done."

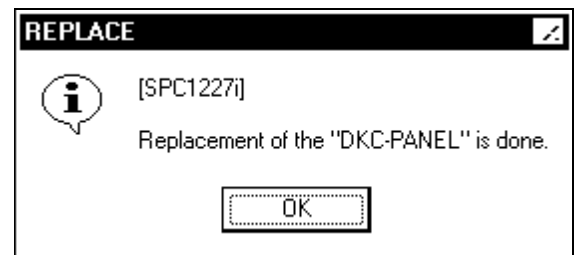

(ex. RS CON)

4. <SIM Complete>

See [SVP02-580](#).

(Multi Cabinet Model)

Close 'DKC' window.

Close 'Maintenance' window.

(Single Cabinet Model)

Close 'Controller' window.

Close 'Maintenance' window.

Go to POST-PROCEDURE z ([REP04-1400](#)).

[7] SSVP

1. <Warning message>

 **CAUTION**

When performing a down-load, a request for an entry of a password is displayed. Contact the Technical Support Center to ask for an instruction.

When versions of the microprogram to be downloaded to the SSVP and that stored in an ROM in the SSVP are the same, a message, “The version of SSVP micro program in SSVP and SVP are same. So micro program is not downloaded.” is displayed. Select (CL) [OK], go to step 3.

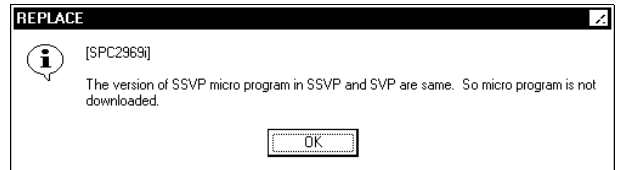

When a number of the SSVP microprogram down-loads exceeds 100, a message, “Write count of SSVP micro program exceeds warranted value (100). Do you want to continue?” is displayed.

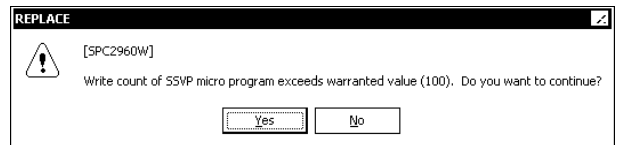

When you want to download, select (CL) [Yes] and go to the next step. When you do not want to download, select (CL) [No] and go to step 3.

When the SVP High Reliability Kit is installed, sometimes the following message is displayed. “Can’t read SSVP micro program version from SSVP.” Select (CL) [OK]. And then the message “The replacement has failed.” is displayed. Select (CL) [OK].

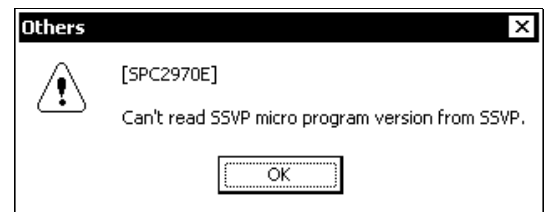

The message “Connection error occurred. SVP-SSVP” is displayed. Select (CL) [OK].

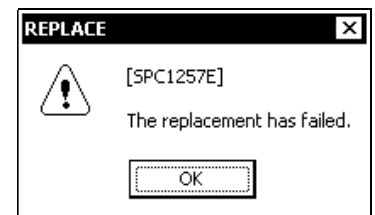

(Multi Cabinet Model)
Close ‘DKC’ window.
Close ‘Maintenance’ window.

(Single Cabinet Model)
Close ‘Controller’ window.
Close ‘Maintenance’ window.

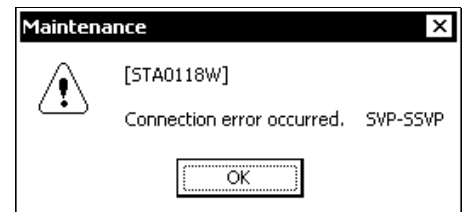

See page [TRBL12-10](#) on TROUBLE SHOOTING section.

2.

The message "SSVP microprogram download." is displayed.

SSVP microprogram download.[07/16]

3. <Check end of replacement>

Select (CL) [OK] in response to "Replacement of the "SSVP" is done."

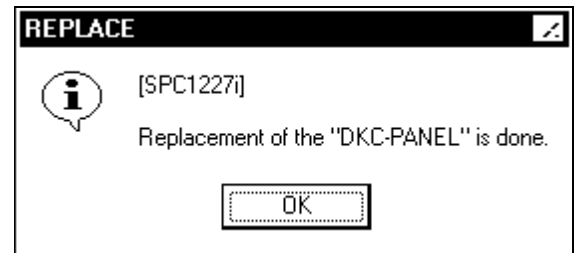

4. <SIM Complete>

See [SVP02-580](#).

(Multi Cabinet Model)

Close 'DKC' window.

Close 'Maintenance' window.

(Single Cabinet Model)

Close 'Controller' window.

Close 'Maintenance' window.

Go to POST-PROCEDURE z ([REP04-1400](#)).

[8] HUB-BOX

1. <Check end of replacement>
Select (CL) [OK] in response to "Replacement of the "HUB-BOX" is done."

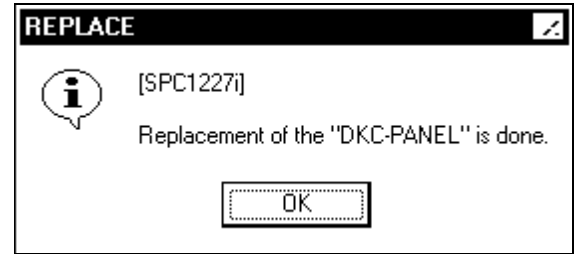

(ex. RS CON)

2. <SIM Complete>

See [SVP02-580](#).

(Multi Cabinet Model)

Close 'DKC' window.

Close 'Maintenance' window.

(Single Cabinet Model)

Close 'Controller' window.

Close 'Maintenance' window.

Go to POST-PROCEDURE z ([REP04-1400](#)).

[9] MONI-CON 1/2

1. <Enable DKUMN>

Enable DKUMN in response to “Please switch “DKUMN-n” of all DKU to “ENABLE.” Then press OK.”.

After confirming DKUMN is enabled, select (CL) [OK].



DKUMN-n

- For MONI-CON1:
[Power on DKUMN on front side of DKU]
- For MONI-CON2:
[Power on DKUMN on rear side of DKU]

2. <Check environment monitor start processing>
“Processing to enable the environment check...”
is displayed.

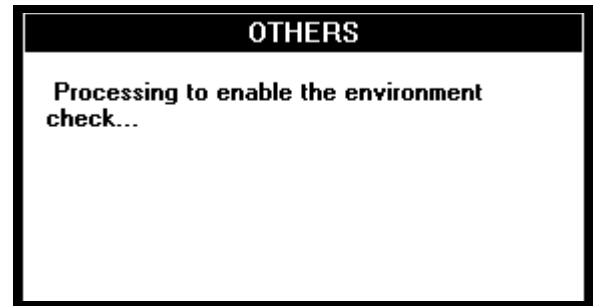

3. <Check end of replacement>

Select (CL) [OK] in response to “Replacement of the “MONI-CONn” is done.”.

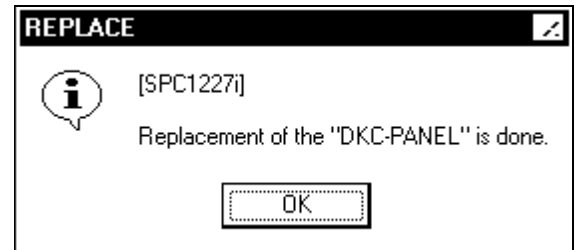

(ex. RS CON)

4. <SIM Complete>

See [SVP02-580](#).

(Multi Cabinet Model)

Close 'DKC' window.

Close 'Maintenance' window.

(Single Cabinet Model)

Close 'Controller' window.

Close 'Maintenance' window.

Go to POST-PROCEDURE z ([REP04-1400](#)).

[10] SVP, SVP&FLASH CARD

1. Powering up the SVP

CAUTION

If the MESSAGE LED on DKC-PANEL has lit on when power on SVP, please complete SIM before operation.
(Although “SIM RC = BFE010 (SVP PS1 Warning) and BFE011 (SVP PS2 Warning)” may occur, because it was generated in the process which replaces a SVP, and there is no problem.)

CAUTION

When an SSVP alarm is issued during replacement of the PC, reset the SSVP.

CAUTION

If the message “Do you want to restart your computer now?” is displayed during the SVP reboot after replacement, select (CL) [Yes]

1-1. Set Date/Time

(1) <Open [Control Panel]>

Select (DR) [Settings] and then [Control Panel] from [Start].

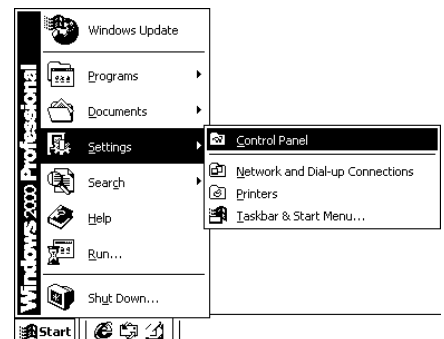

(2) <Open [Date/Time]>

Select (DC) [Date/Time] from [Control Panel].

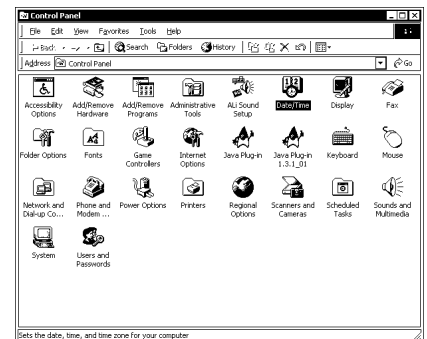

- (3) <Select [Time Zone]>
Select (CL) [Time Zone].

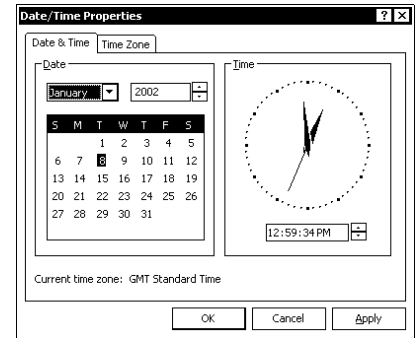

- (4) <Check the setting of [Time Zone]>
Make sure that the setting of [Time Zone] is without the relation of a subsystem position “[GMT] Greenwich Mean Time; Dublin, Edinburgh, Lisbon, London”. Also, make sure that a check box on the left of “Automatically adjust clock for daylight saving changes” is (without a check mark). Then, select (CL) [Date/Time].

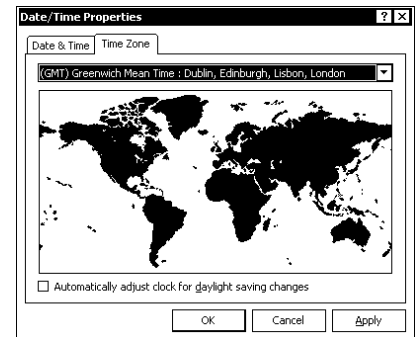

- (5) <Set the [Date/Time]>
Check if the [Date/Time] is set to the current time and date. If not, reset it correctly. Then, select (CL) [OK].

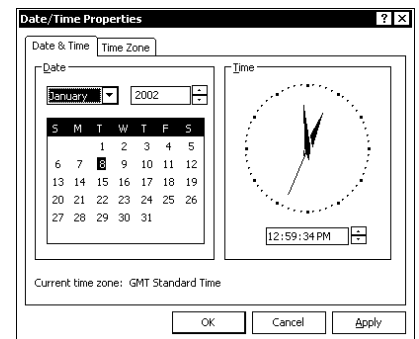

- (6) <Close “Control Panel”>
Select (CL) [File] on “Control Panel”.
Select (CL) [Close].

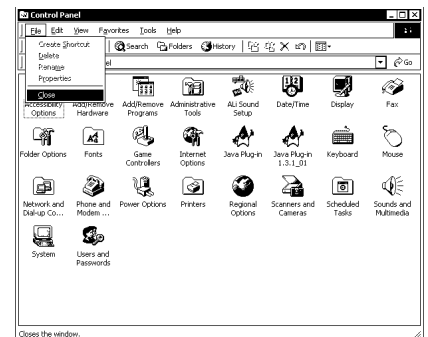

2. Installation of Micro-program

2.1 Preparation

When the SVP program is already installed, perform the following procedure.

2.1.1 Uninstallation of Apache

You need to uninstall the Apache installed in the SVP. Uninstall the Apache by following procedure.

2.1.1.1 Checking Apache version

Use the following procedure and check the version of the Apache currently installed in the SVP.

- (1) Select (DR) [Start]-[Settings]-[Control Panel].

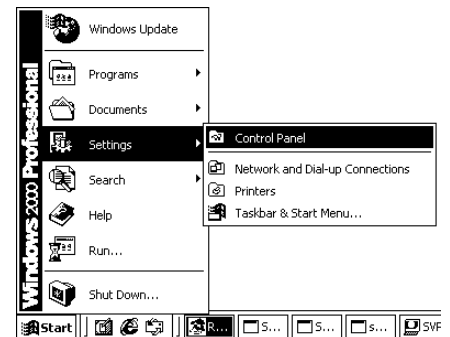

- (2) Select (DC) [Add/Remove Programs], and then press the [Enter] key.

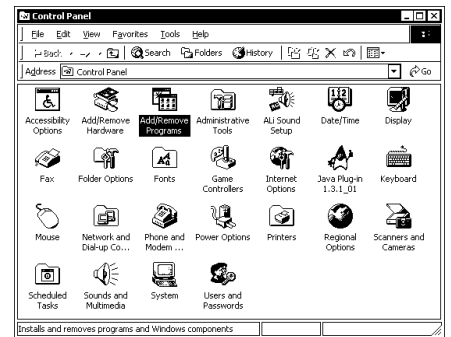

- (3) Check the content of [Currently installed programs] in the 'Add/Remove Programs' panel.

If [Apache Web Server] exists, Apache 1.3.14 is installed. If [Apache HTTP Server 1.3.27] exists, Apache 1.3.27 is installed. In order to uninstall Apache 1.3.14, go to 2.1.1.2. In order to uninstall Apache 1.3.27, go to 2.1.1.3.

When the Apache version check is completed, select (CL) [×] button and close the window.

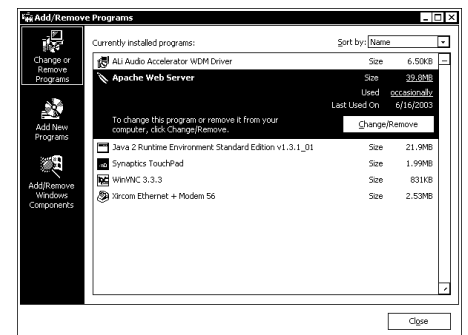

2.1.1.2 Uninstallation of Apache 1.3.14

- (1) Select (DR) [Start]-[Programs]-[Apache Web Server]-[Apache as a service]-[Stop Service]. Service of Apache will stop.

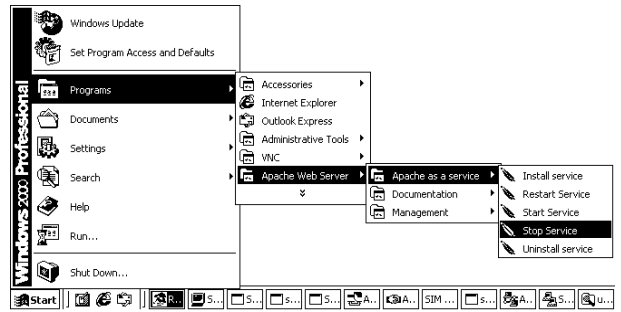

- (2) Select (DR) [Start]-[Programs]-[Apache Web Server]-[Apache as a service]-[Uninstall service].

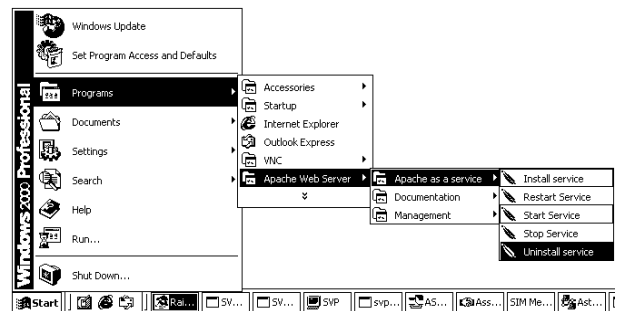

- (3) Select (DR) [Start]-[Shut Down...], and reboot the SVP. Select (CL) [Restart] in the Shut Down Windows panel, and then select (CL) the [OK] button.



- (4) When Windows is rebooted, select (DR) [Start]-[Settings]-[Control Panel].

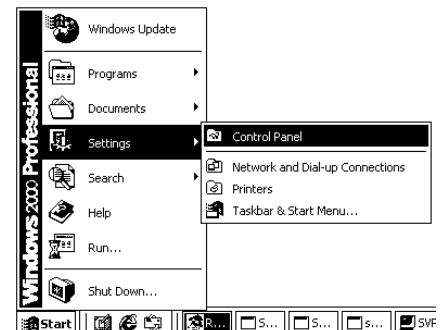

- (5) Select (DC) [Add/Remove Programs], and then press the [Enter] key.

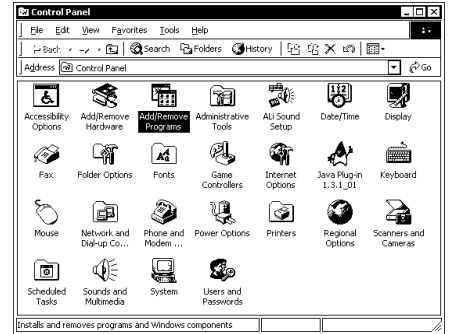

- (6) Select [Apache Web Server], and then select (CL) the [Change/Remove] button.

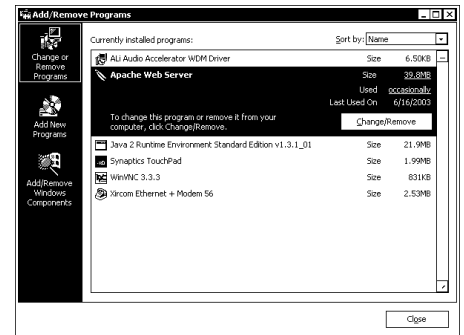

- (7) The message, “Are you sure you want to completely remove ‘Apache Web Server’ and all of its components?” is displayed. Select (CL) the [Yes] button.

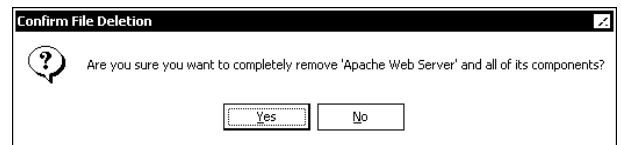

- (8) Uninstallation of Apache starts. When all of the deleted items are checked and the [OK] button becomes selectable, select (CL) the [OK] button.

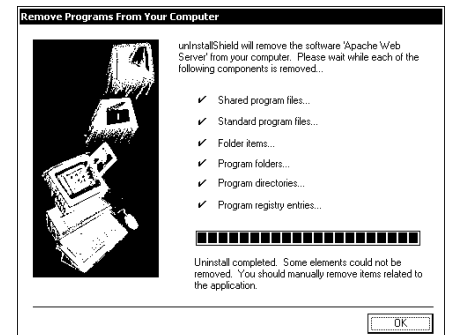

- (9) [Apache Web Server] is removed from the 'Add/Remove Programs' panel.
Select (CL) [×] button, and close this window.

Go to 2.1.2.

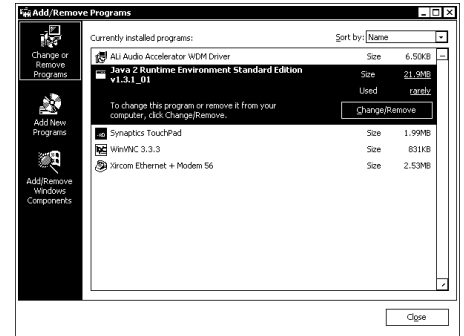

2.1.1.3 Uninstallation of Apache 1.3.27

- (1) Select (DR) [Start]-[Programs]-[Apache HTTP Server]-[Control Apache Server]-[Stop]. Service of Apache will stop.

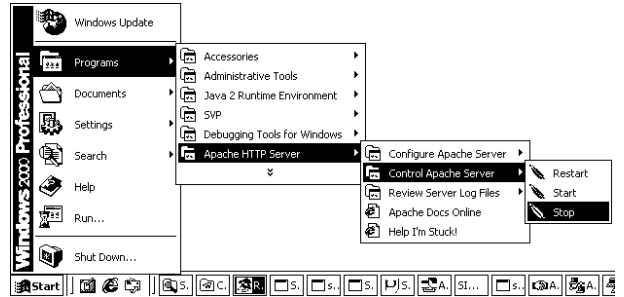

- (2) Select (DR) [Start]-[Settings]-[Control Panel].

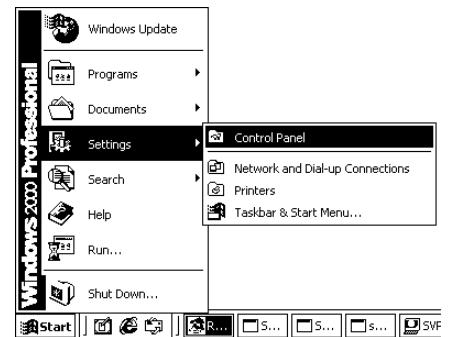

- (3) Select (DC) [Add/Remove Programs], and then press the [Enter] key.

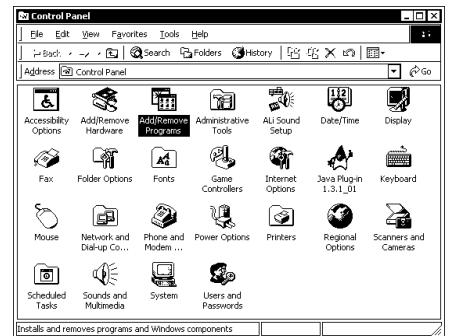

- (4) Select [Apache HTTP Server 1.3.27], and then select (CL) the [Remove] button.

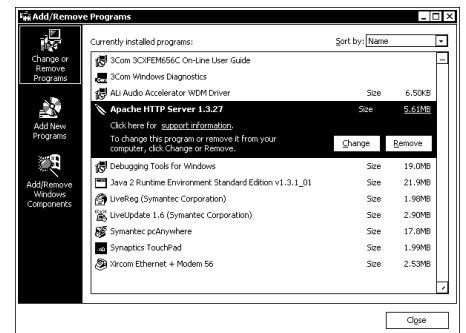

- (5) The message, “Are you sure you want to remove Apache HTTP Server 1.3.27 from your computer?”, is displayed. Select (CL) the [Yes] button.

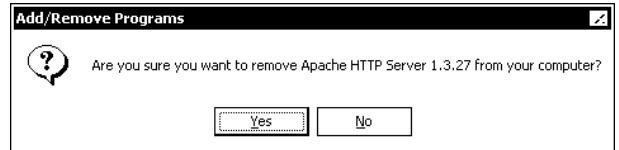

- (6) Uninstallation of Apache 1.3.27 starts.

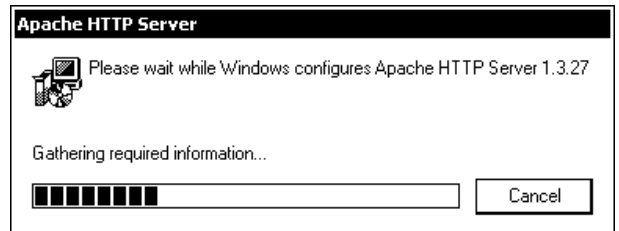

- (7) [Apache HTTP Server 1.3.27] is removed from the ‘Add/Remove Programs’ panel. Select (CL) [×] button, and close this window.

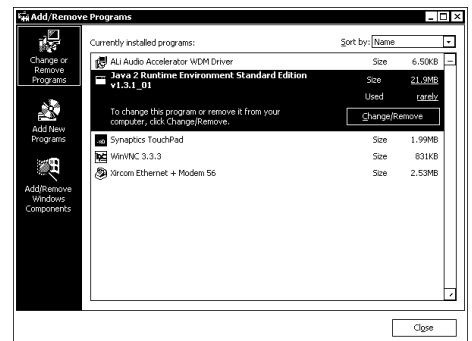

- (8) Select (DR) [Start]-[Shut Down...], and reboot the SVP. Select (CL) [Restart] in the Shut Down Windows panel, and then select (CL) the [OK] button.

When Windows is rebooted, go to 2.1.2.



2.1.2 Uninstallation of Java

(1) Select (DR) [Start]-[Settings]-[Control Panel].

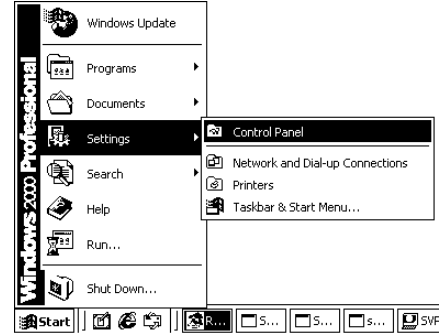

(2) Select (DC) [Add/Remove Programs], and then press the [Enter] key.



(3) Select [Java 2 Runtime Environment Standard Edition v1.3.1_01], and then select (CL) the [Change/Remove] button.

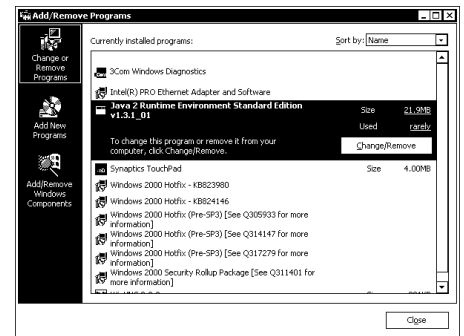

(4) The message, “Are you sure you want to completely remove ‘Java 2 Runtime Environment Standard Edition v1.3.1_01’ and all of its components?”, is displayed. Select (CL) the [Yes] button.

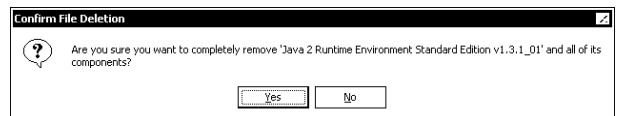

- (5) Uninstallation of Java starts. When all of the deleted items are checked and the [OK] button becomes selectable, select (CL) the [OK] button.

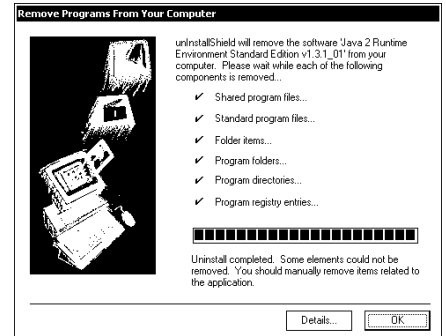

- (6) The message, “Java 2 Runtime Environment Standard Edition v1.3.1_01’ has been removed from your system. It is recommended that you restart your machine to remove files that were in use during uninstall.”, is displayed. Select (CL) the [OK] button.



- (7) [Java 2 Runtime Environment Standard Edition v1.3.1_01] is removed from the ‘Add/Remove Programs’ panel. Select (CL) [X] button, and close this window.

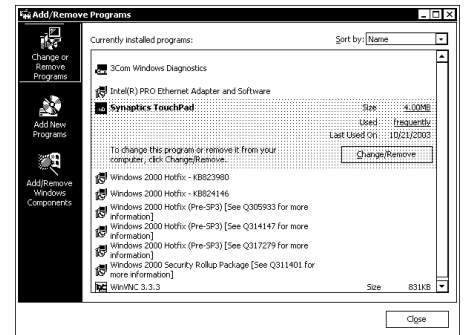

- (8) Select (DR) [Start]-[Shut Down...], and reboot the SVP. Select (CL) [Restart] in the Shut Down Windows panel, and then select (CL) the [OK] button.

When Windows is rebooted, go to 2.1.3.



2.1.3 Performance Monitor Data file delete

- (1) Select (DR) [Start]-[Programs]-[Accessories]-[Windows Explorer].

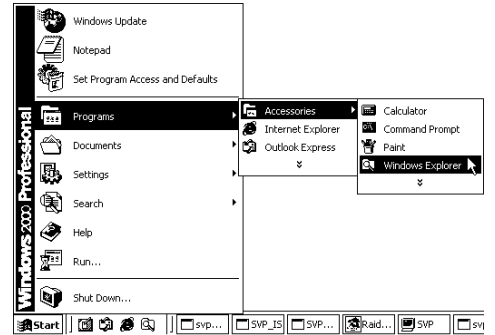

- (2) Select (CL) "D:\Mondat" directory, and delete it.

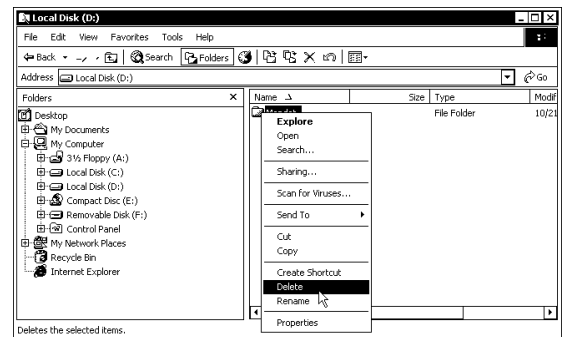

- (3) Select [Yes].

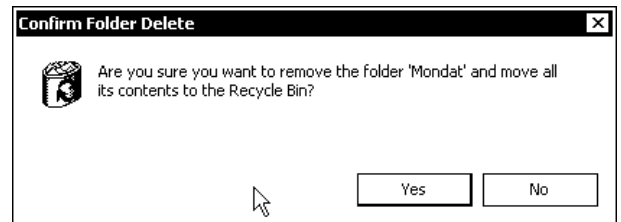

- (4) Finish the Explore.

2.2 Install

- ① Insert the CD-ROM disk into the CD-ROM drive and then wait one minute.
- ② Select (CL) [Run...] from the [Start]. Enter “e:\setup.exe” and select (CL) [OK].

If a message “An old version of Apache has been detected. Please uninstall this version and then perform Setup.exe again.” is displayed, perform again after uninstalling Apache 1.3.14.

The procedure of uninstallation of Apache 1.3.14 is shown 5.2 of WEB CONSOLE SECTION.



3. Installation of Configuration

(1) Inserting the Config FD

- ① A message “Please insert the Config FD into the FDD.” is displayed.
- ② Insert the Config FD into the FDD and select (CL) [OK].

If you insert the previously backed-up Config FD, the original configuration is recovered.

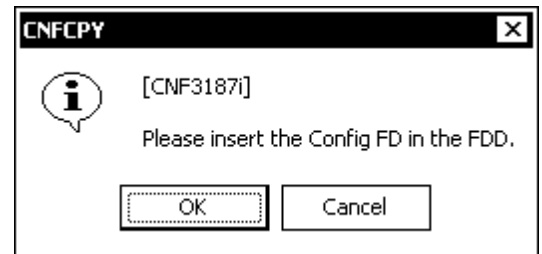

(2) Removing the Config FD

- ① When the copying of the Config is completed, a message “Please remove the Config FD.” is displayed.
- ② Remove the Config FD from the FDD and select (CL) [OK].

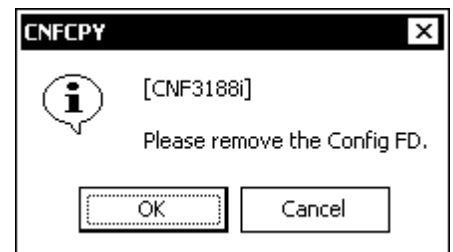

4. JAVA Setup

4-1 JAVA Setup

Java Setup is executed. When Java is installed, it progresses to step 4-2.

(1)

Select (CL) [Yes].

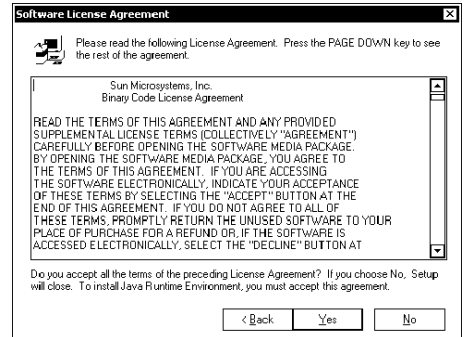

(2)

Select (CL) [Next].

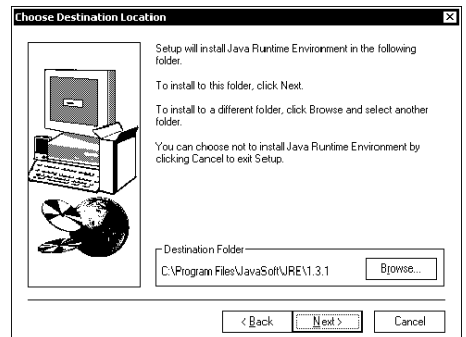

4-2 Setup Process of Apache

Execute Setup of Apache.

If the following panel is not displayed, Apache is already installed. Go to 3-5. If the SVP version is earlier than 21-06-20/00, Apache 1.3.14 will be installed. Use the following procedure to install it. If the SVP version is 21-06-20/00 or later, Apache 1.3.27 will be installed. Go to 4-3.

- (1)
Select (CL) [Next].

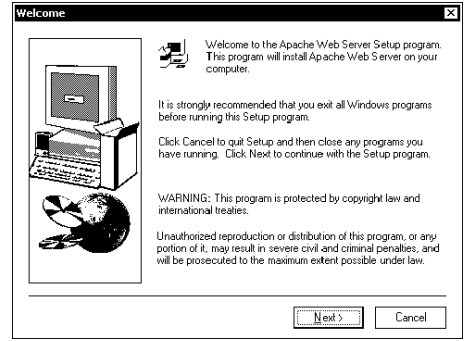

- (2)
Select (CL) [Yes].

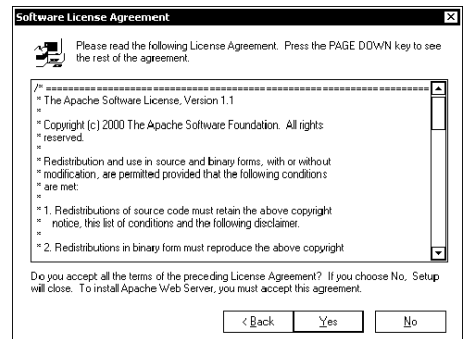

- (3)
Select (CL) [Next].

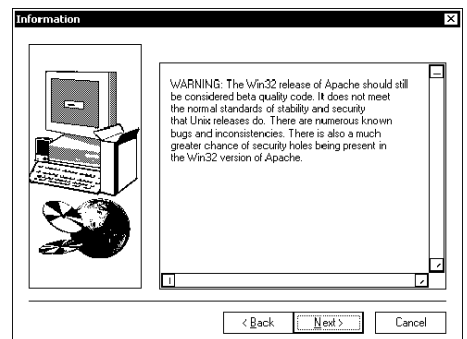

- (4)
Select (CL) [Next].

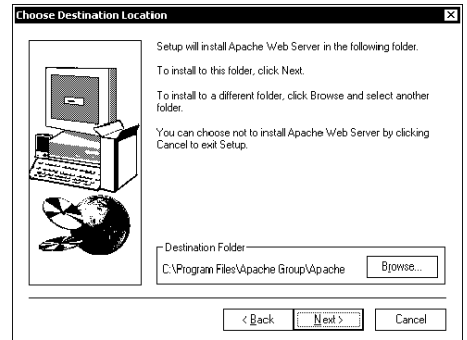

- (5)
Select (CL) [Next].

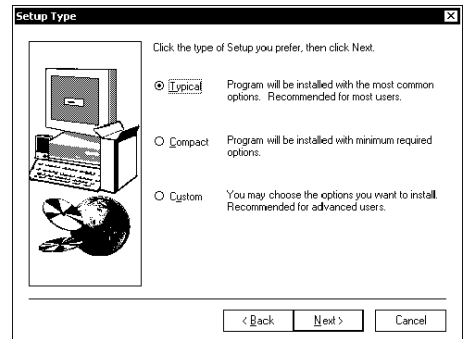

- (6)
Select (CL) [Next].

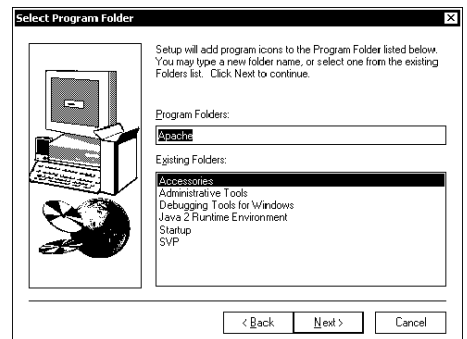

- (7)
Remove the check box of "Yes and I want to view the README file.", and select (CL) [Finish].

Go to Step 5.

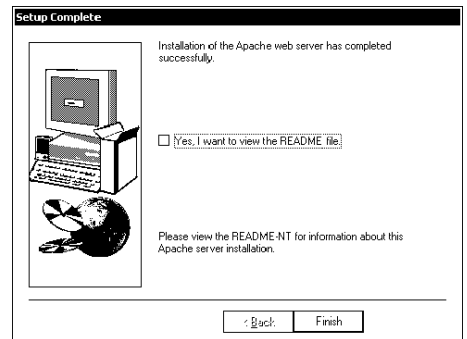

4-3 Setup Process of Apache 1.3.27

- (1) Select (CL) the [Next>] button.

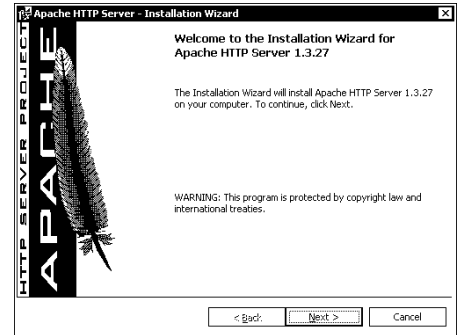

- (2) After selecting (CL) "I accept the terms in the license agreement", select (CL) the [Next>] button.



- (3) Select (CL) the [Next>] button.

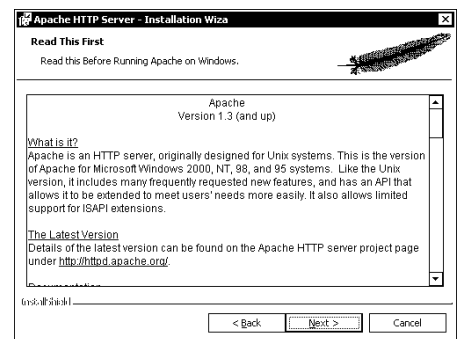

- (4) Enter "domain" to the Network Domain field, "svp" to the Server Name field, and "admin@domain.com" to the Administrator's Email Address field. After selecting (CL) "Run as a service for All Users – Recommended", select (CL) the [Next >] button.

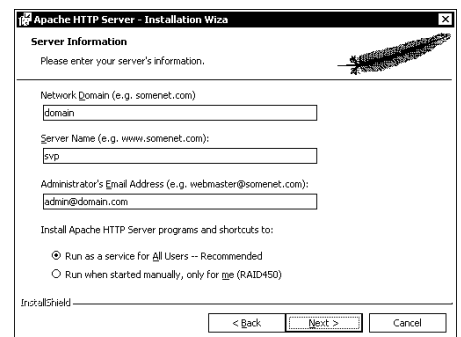

- (5) Select (CL) “Complete,” and then select (CL) the [Next>] button.

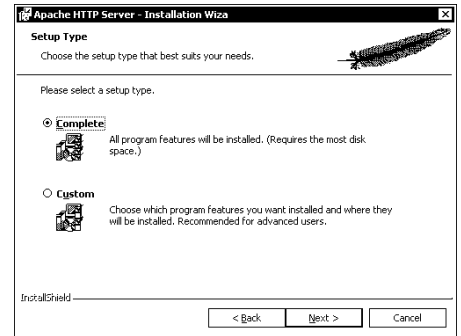

- (6) Select (CL) the [Next>] button.

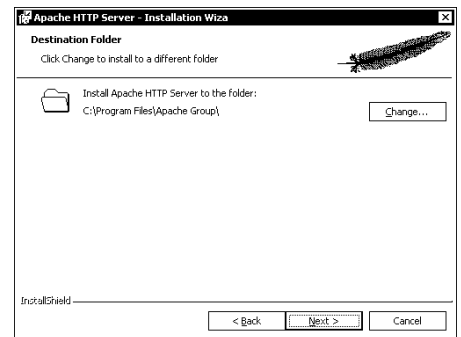

- (7) Select (CL) the [Install] button. Copying of the file will start.

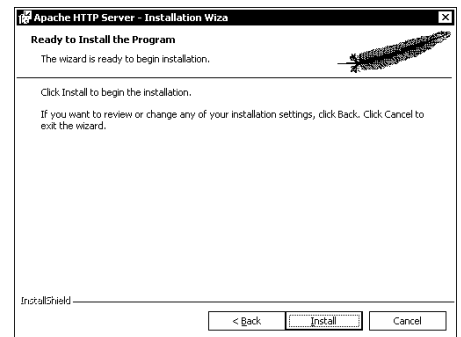

- (8) When copying of the file is completed, this panel is displayed. Select (CL) the [Finish] button.

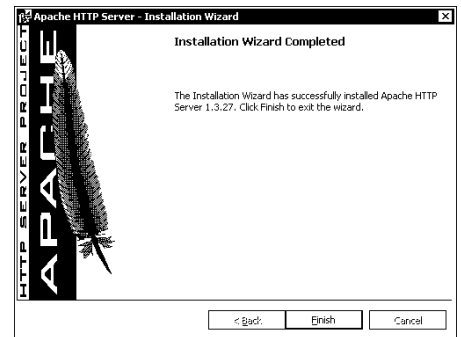

5. Restarting the SVP

When the setup is completed, the SVP restarts automatically.

5-1 < Installation of OpenSA >

If you are going to replace the SVP with OpenSA installed, it is necessary to install OpenSA also in the SVP that has been replaced. ([WEB06-10](#))

If you are going to replace the SVP without OpenSA installed, go to 6.

6. Removing the SVP PS ON/OFF INH jumper

Remove the SVP PS ON/OFF INH jumper plug that was attached according to Step1 of [6] in PRE-PROCEDURE T1 ([REP02-510](#)).

 **CAUTION**

Although "RC = bf85a2" may occur, it generated in process of replacement, and there is no problem. Please complete SIM before operation.

7. Set IP address of SVP

- (1) <Open [Install]>
Select (CL) [Install] from 'SVP'.

- (2) <Select [Set Subsystem IP Address...]>
Select (CL) [Set IP Address...] from 'Install'.

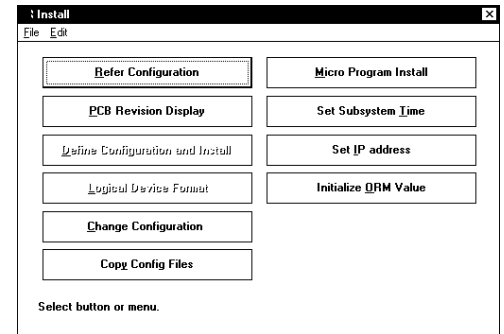

- (3) <Set IP Address>
Select (CL) [SVP] from [Target], confirm "IP Address" and "Subnet Mask".
If the IP Address or Subnet Mask is wrong, enter a correct value.
If you need external IP Address (When using Web Console made remote connection or using the SNMP Agent function), enter "IP Address" and "Subnet Mask" on [External IP Address]-[Master SVP].
Select (CL) [OK].

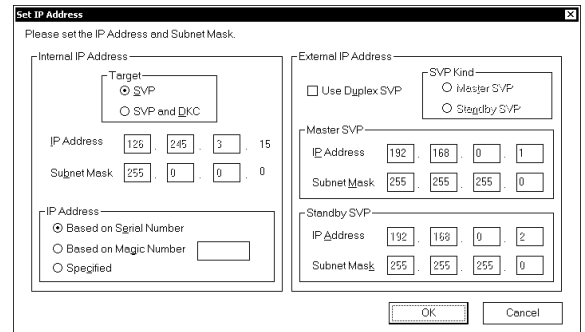

- (4) <Confirming the external IP address setting>
When a message, "When there are directions to set the external IP address, please set the external IP address from the "Control Panel" of Windows after performing this operation." is displayed, select (CL) the [OK] button.

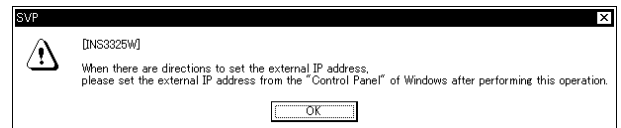

- (5) Inserting the Config FD
Insert the Config FD into the FDD and select (CL) [OK].

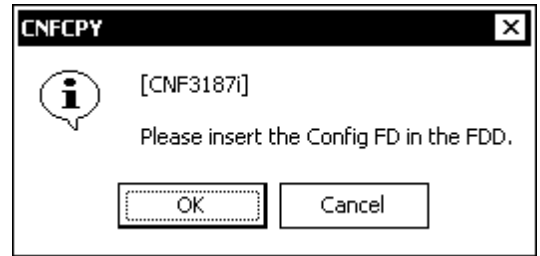

- (6) Removing the Config FD
When the copying of the Config is completed, a message “Please remove the Config FD.” is displayed.
Remove the Config FD from the FDD and select (CL) [OK].

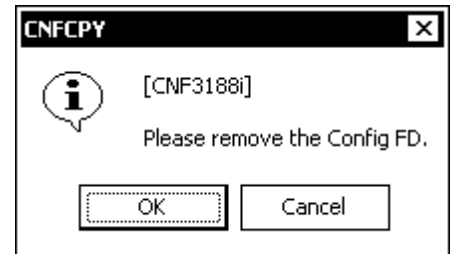

- (7) <Check SVP reboot>
Select (CL) [OK].

* Confirm that LAN cable being connected to External LAN justly, a LAN cable of HUB side are connected justly before selecting OK.

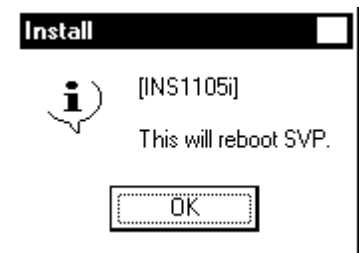

- (8) <Opening the Network and Dial-up Connections window>
When the setting of the external IP address is not required, go to Step 8.
Select (CL) [Settings] and [Network and Dialup Connections] in this order from the [Start].

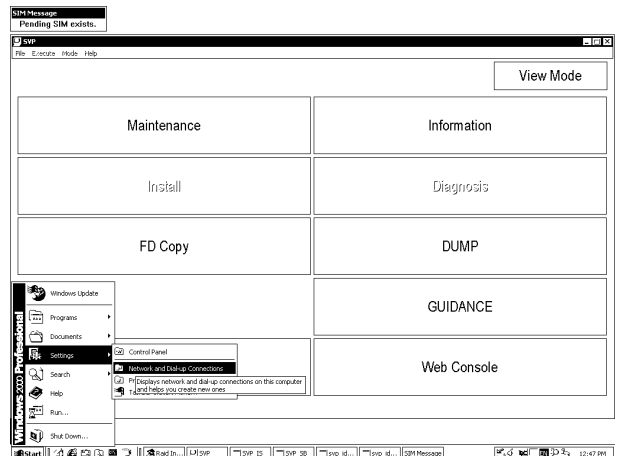

- (9) <Opening the Local Area Connection 2 window>
 Select (CL) [Local Area Connection 2] in the
 Network and Dial-up Connections window.

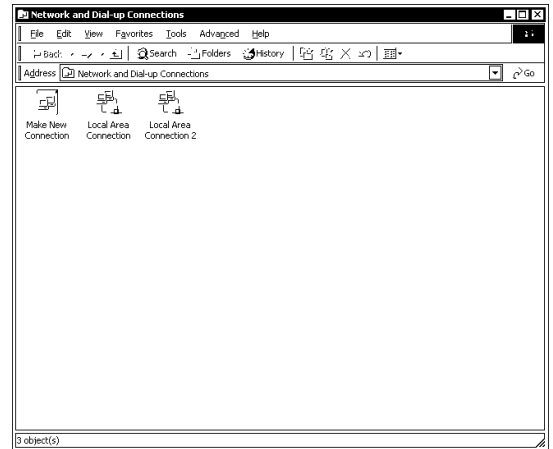

- (10) <Opening the Local Area Connection 2 Properties window>
 Select (CL) [Internal Protocol (TCP/IP)] in the Local Area
 Connection 2 Properties window, and then select the
 [Properties] button.

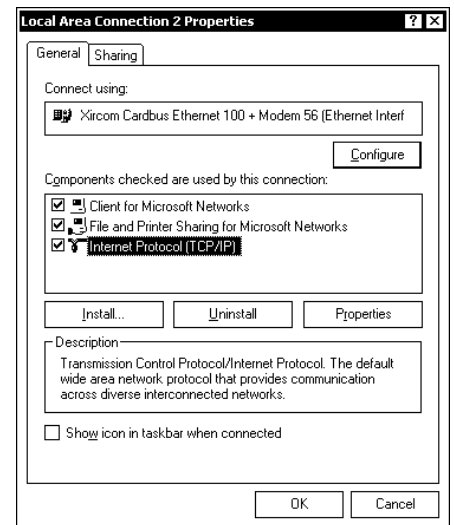

(11) <Setting an external IP address>

Set the IP address and subnet mask, and then select (CL) the [OK] button.

When the setting of the network must be changed after the setting operation is completed, go to Step (12). In the other cases, select (CL) the [OK] button in the 'Local Area Connection 2 Properties' window. Close the 'Network and Dial-up Connection' window.

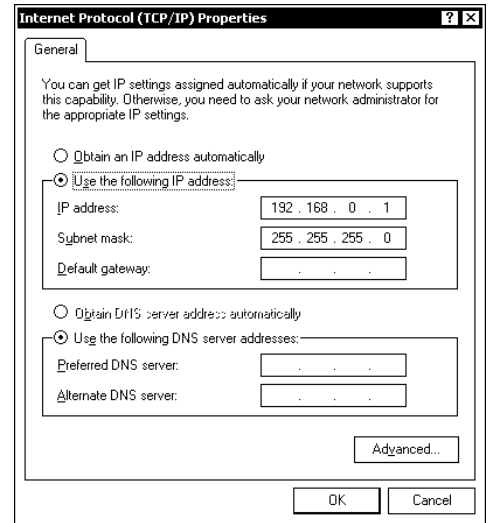

When the SVP is not connected to the LAN, the following window is displayed. Select (CL) the [No].

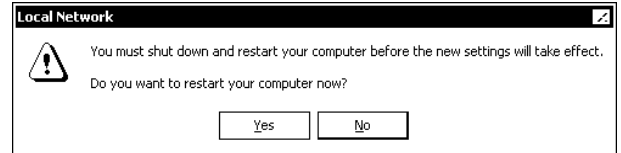

(12) <Opening bus information on the card being used>

Select (CL) the [Configure] button in the 'Local Area Connection 2 Properties' window.

When the Xircom card is used, go to Step (13).

When the 3com card is used, go to Step (16).

[In the case of the Xircom card bus]

(13) <Opening the 'Xircom Cardbus ...' window>

Select (CL) the 'Advanced' tab in the 'Xircom Cardbus ...' window.

The next step must be selected from two kinds of steps depending on the driver. Make a setting instructed in Step (14) or (15).

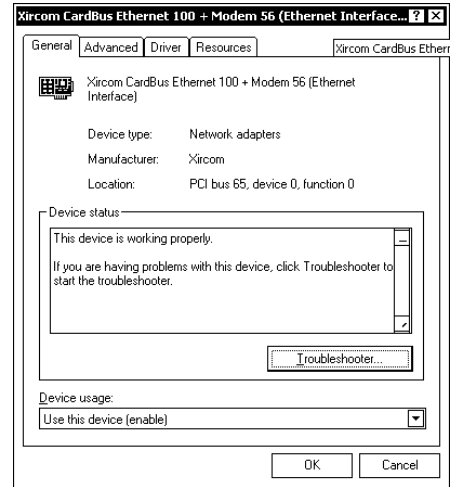

(14)-1 <Setting the speed mode>

Select the 'Line Speed' and change the setting of the 'Value' from 'Auto Detect' to '100 Mbps'.

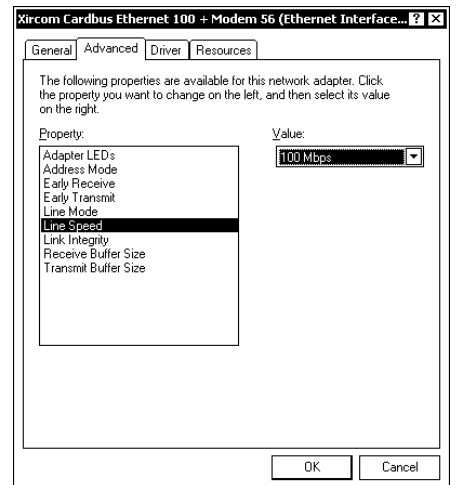

(14)-2 <Setting the line mode>

Select the 'Line Mode' and change the setting of the 'Value' from 'Auto Detect' to 'Full Duplex'.

Return the window to 'Local Area Connection 2 Properties' by pressing (CL) the [OK] button, and close the window by pressing the [OK] button.

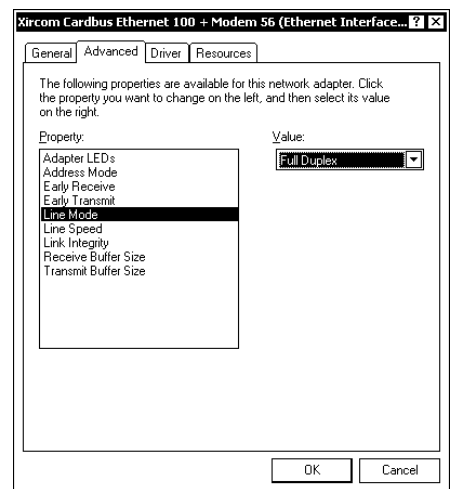

(15)-1 <Setting the Line Configuration>

Select [Line Configuration] and change the setting of the 'Value' to '100Mbps/Full Duplex'.

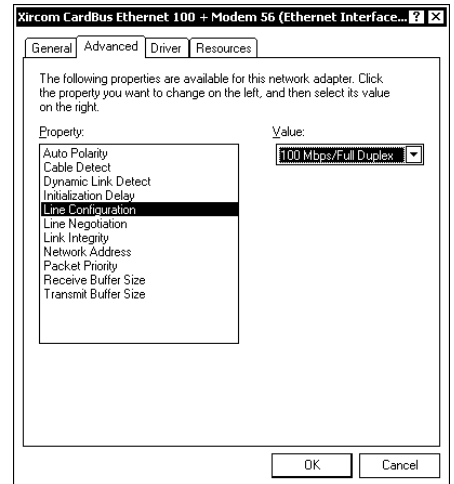

(15)-2 <Setting the Line Negotiation>

Select [Line Negotiation] and change the setting of the 'Value' to 'Off'.

Return the window to the 'Local Area Connection 2 Properties' by selecting (CL) the [OK] button. Then close the window by selecting the [OK] button.

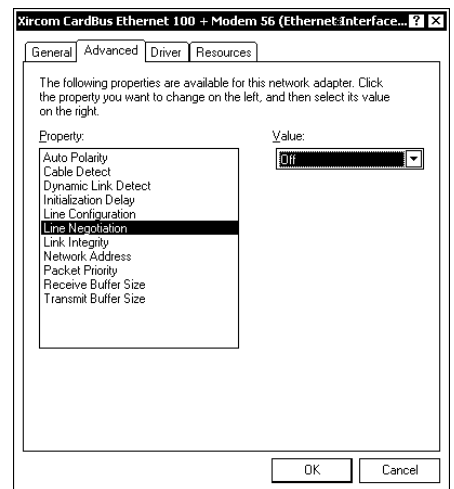

[In the Case of the 3com card bus]

(16) <Opening the 'FEM656C-3Com ...' window>

Select (CL) the 'Advanced' tab in the 'FEM656C-3Com...' window.

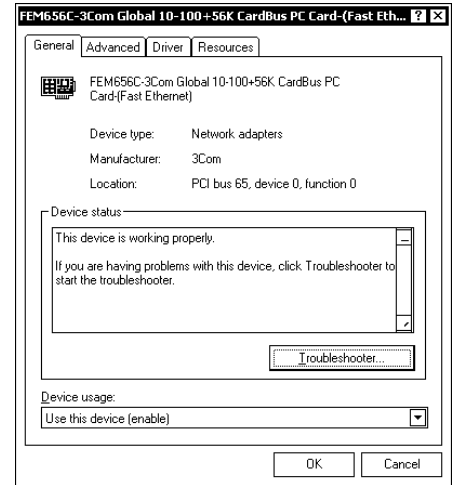

(17) <Setting the network link selection>

Select the 'Network Link Selection' and change the setting of the 'Value' from 'Auto Negotiation' to '100BTX Full Duplex'.

Return the window to 'Local Area Connection 2 Properties' by pressing (CL) the [OK] button, and close the window by pressing the [OK] button.

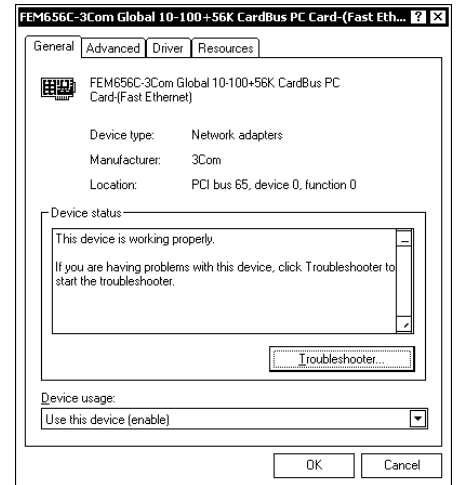

8. TOD Setting

Wait a few minutes, message "Loading SVP Program... SVP requests to DKC can not be performed presently. Please wait..." will be extinguished. Then set TOD.

See [SVP02-10](#).

9. Load the Configuration from the SM to the SVP's HDD

- (1) <Open [Maintenance]>
Select (CL) [Maintenance] form 'SVP'.

- (2) Check "Connection error occurred SVP-DKC." is not displayed.
If "Connection error occurred SVP-DKC" is displayed, see [TRBL05-60](#).

- (3) <Select [Exit]>
Select (CL) [File] from the "Maintenance".
Select (CL) [Exit].

(Multi Cabinet Model)

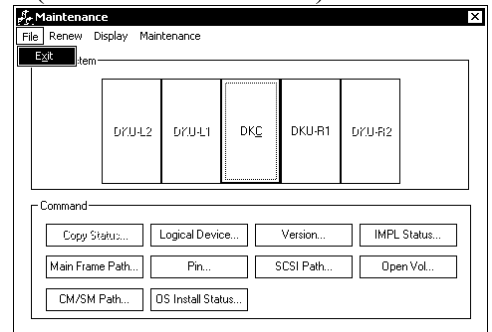

(Single Cabinet Model)

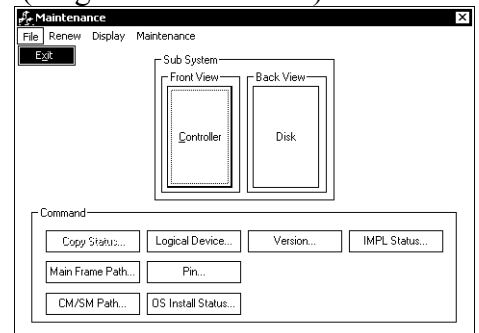

10. Setting Web Console

Make a setting of the Internet Explorer according to [Web Station] section. ([WEB01-10](#))
Remove the CD-ROM.

When you have installed from the backed-up Config FD,

i) Storage list / user list / environment information can be recovered to the backed-up status by copy the following files under c:\program files\apache group\apache\cgi-bin\Utility\CSV.

- USERLIST.CSV
- STRLIST.CSV
- ENV.CSV

ii) Please perform the following procedure, when you use SNMP Agent.

1. Push Web Console button.
2. Open the SNMP Information Tab.
3. Remove the check mark of Extension SNMP and push Apply button.
4. Add the check mark of Extension SNMP and push Apply button again.

iii) Please perform the following procedure, when you don't use SNMP Agent.

1. Push Web Console button.
2. Specify Name, Contact and Location on Information Tab again.

11. Confirm status

Confirm the status display.

If button is valid, go to [12].

If button is blinking, replace the FLASH CARD.

12. Configuration Back

Make a backup copy of the configuration in the CONFIG FD. (See [MICRO-FC08-40](#))

13. Installing Setup on SVP

When the E-NAS is installed, install Setup on SVP in only the SVP that has been replaced through the NAS section. ([NAS03-110](#))

When the E-NAS is not installed, proceed to Chapter 14 SIM Complete.

14. SIM Complete

See [SVP02-580](#).

[End of POST-PROCEDURE]

[11] FLASH CARD

 **CAUTION**

SIM (SIM RC = BFE010 (SVP PS1 Warning) and BFE011 (SVP PS2 Warning)) generates, after power on SVP (PC). Because it was generated in the process which replaces a SVP, and there is no problem.
Please complete SIM before operation.

 **CAUTION**

If the message "Do you want to restart your computer now?" is displayed during the SVP reboot after replacement, select (CL) [Yes]

1. <Confirm status>

Confirm the status display.

If button is blinking, refer to SIM and replace the target part again, or see TROUBLE SHOOTING SECTION.

Go to POST-PROCEDURE z ([REP04-1400](#)).

[12] SVPPS-BOX

1. <Detaching the jumper plug>

Detach the jumper plug from the SVPPS-BOX PS SD pin in response to a message, "Please detach the PS SD jumper plug. Then select OK.". If you have already detached the jumper plug according to HARDWARE T26, go to Step 2.

After making sure that the jumper plug has been detached, select (CL) [OK].

The Optional SVP will be started when the jumper plug is removed. Shutdown the OS.



2. <Checking the environment monitor start processing>

"Processing to enable the environment check..." is displayed.

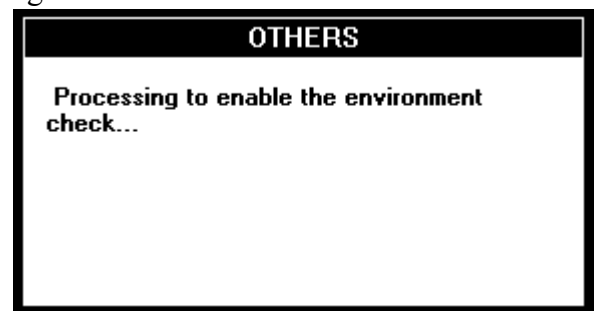

3. <Checking the end of replacement>

Select (CL) [OK] in response to "Replacement of the "SVPPS-BOX" is done.".

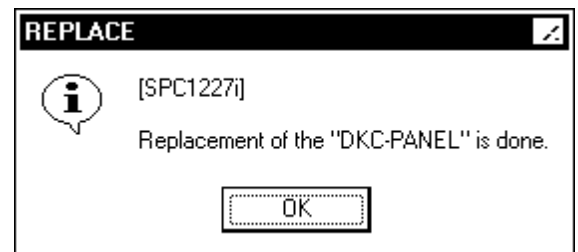

(ex. RS CON)

4. <Checking the status>

- SVPPS-BOX

Check the status display.

If the button is normal (kept on), go to Step 5.

If the button is blinking, perform the replacement again or refer to TROUBLE SHOOTING SECTION.

5. <Complete status of SIM log>
See page [SVP02-580](#).

(Multi Cabinet model)

Close the 'DKC' window.

Close the 'Maintenance' window.

(Single Cabinet model)

Close the 'Controller' window.

Close the 'Maintenance' window.

Go to POST-PROCEDURE z ([REP04-1400](#)).

[13] Switch SVP

1. <Verifying the SVP switching >

The SVP which was the Standby SVP before the switching starts up automatically, and reboots after a setup of Subsystem Configuration.

Check if the SVP is operating normally (without error) after reboot.

In case of liking from NAS section, return to NAS section ([NAS03-200](#)) (5) and perform the following operation.

[14] LAN&MODEM Card

<Appearance>

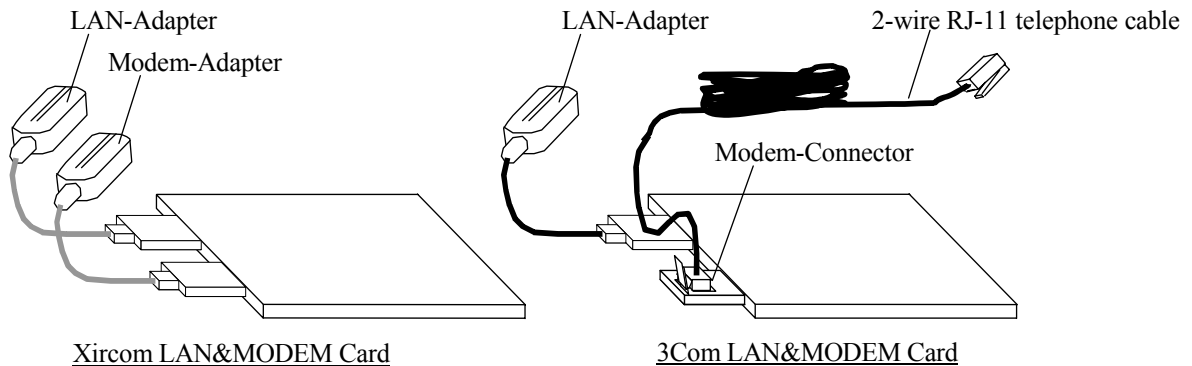

<Procedure of 3Com LAN&MODEM Card driver install>

If the original card is 3com, go to 8.

1. Insert the CD-ROM for 3Com LAN&MODEM Card driver into CD-ROM-Drive.

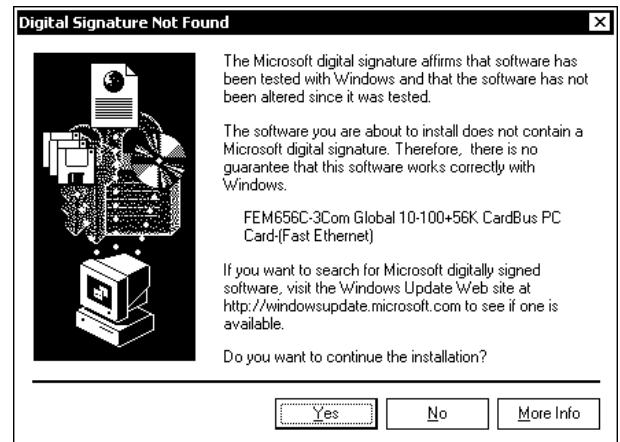

If the below window appears, select (CL) [Cancel], and select (CL) [Yes] in the upper window.

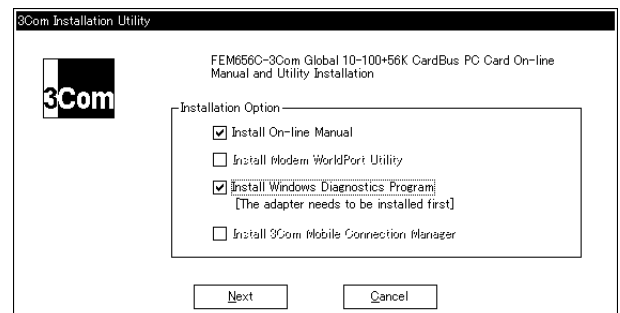

1-1.

If the below window appears, select (CL) [OK].

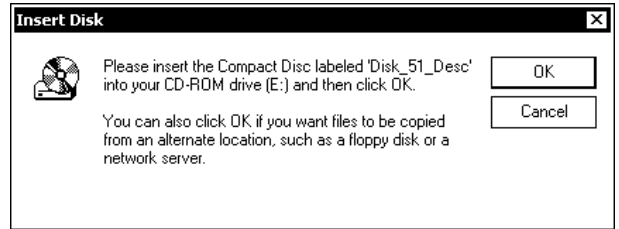

1-2.

Select (CL) [Browse].

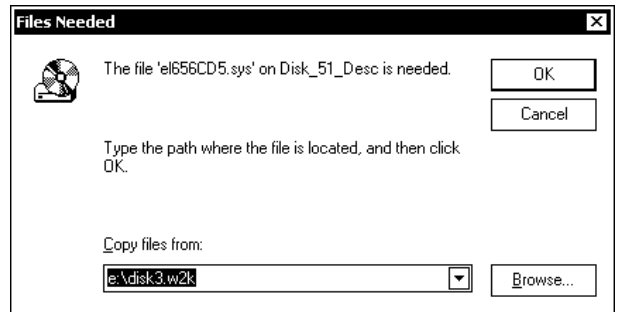

1-3.

Select the file “C:\Program files\3Com\DISK3.W2K\EL656CD5.SY_” or “E:\DISK3.W2K\EL656CD5.SY_” and select (CL) [Open].

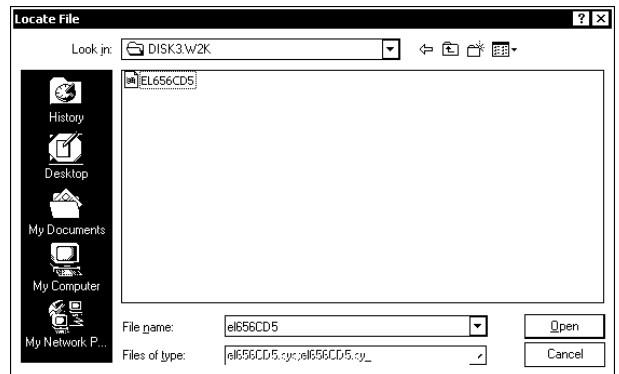

1-4.

Select (CL) [OK].

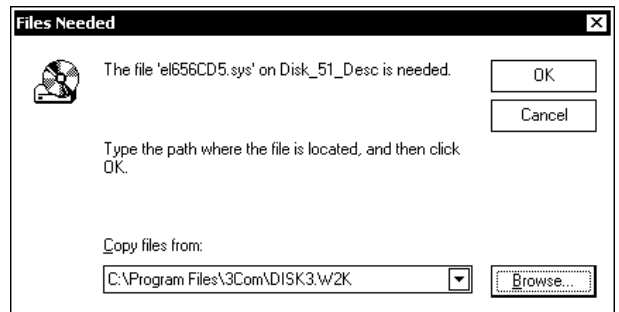

2.

Select (CL) [Yes].

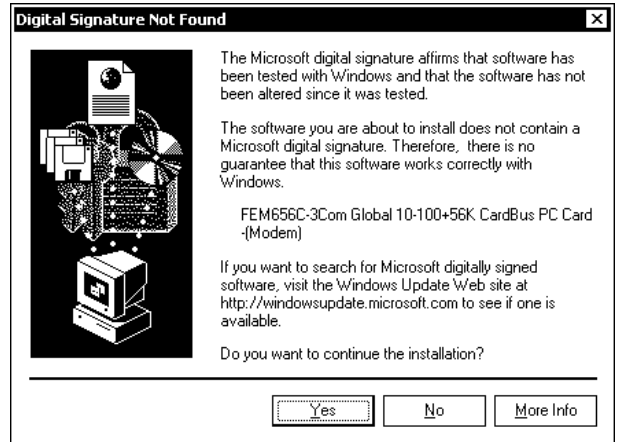

2-1.

If the below window appears, select (CL) [OK].

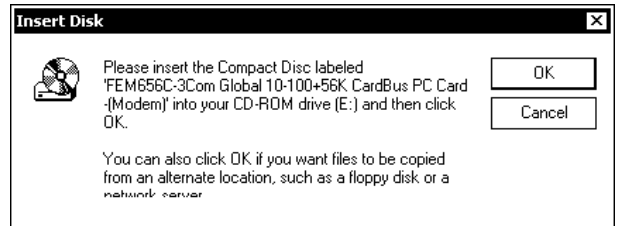

2-2.

Select (CL) [Browse].

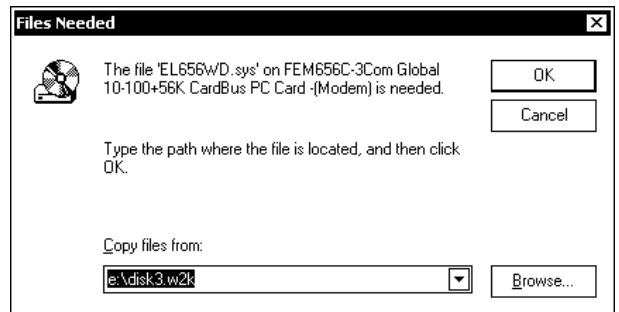

2-3.

Select the file “C:\Program files\3Com\DISK3.W2K\EL656WD.SY_” or “E:\DISK3.W2K\EL656WD.SY_” and select (CL) [Open].

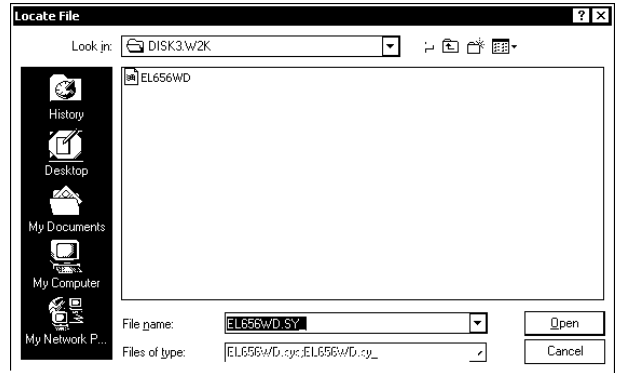

2-4.

Select (CL) [OK].

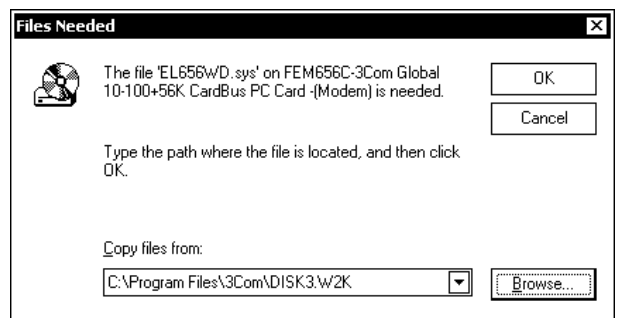

3.

Start “D:\setup.exe”.
When the below window appears, set “Install On-line Manual” and “Install Windows Diagnostics Program”, then select (CL) [Next].

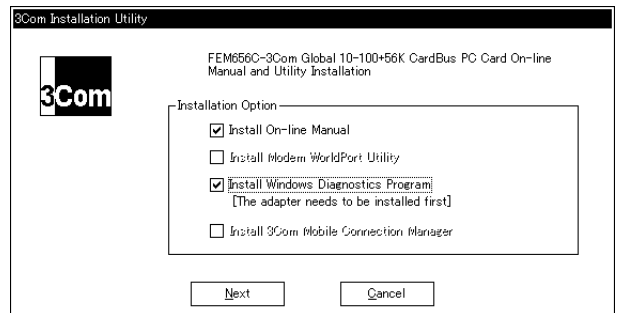

4.

Check “English” and select (CL) [OK].

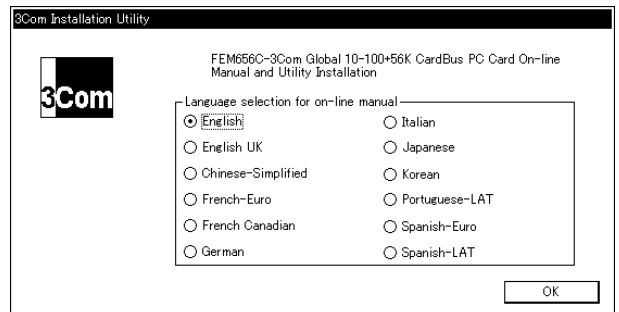

5.
Select (CL) [Start].

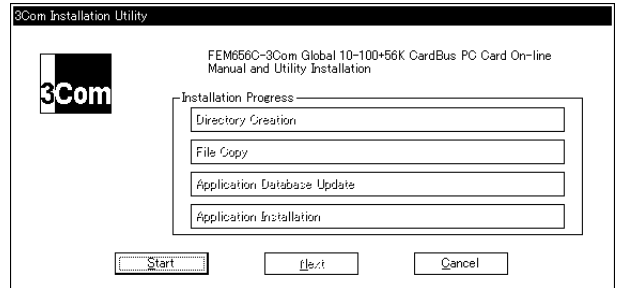

6.
Select (CL) [Next].

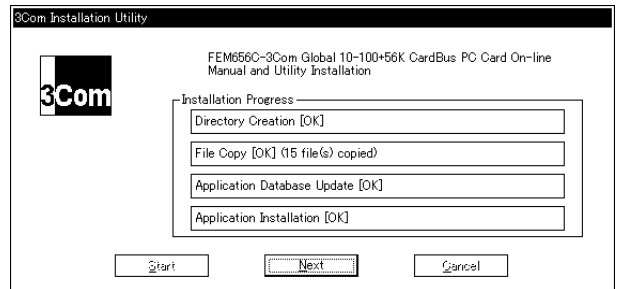

7.
Select (CL) [Finish].

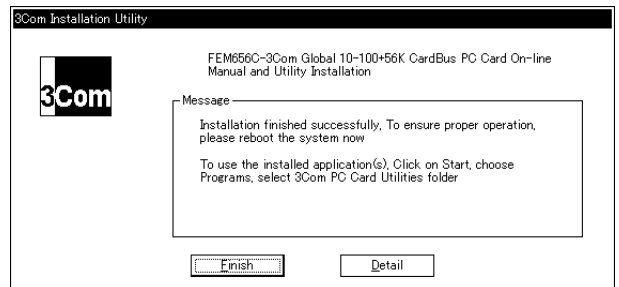

8.
Restart the SVPPC.

9. <Opening the local Area Connection3 window>
Select (CL) [Local Area Connection 3] in the network and Dial-up Connections Window.

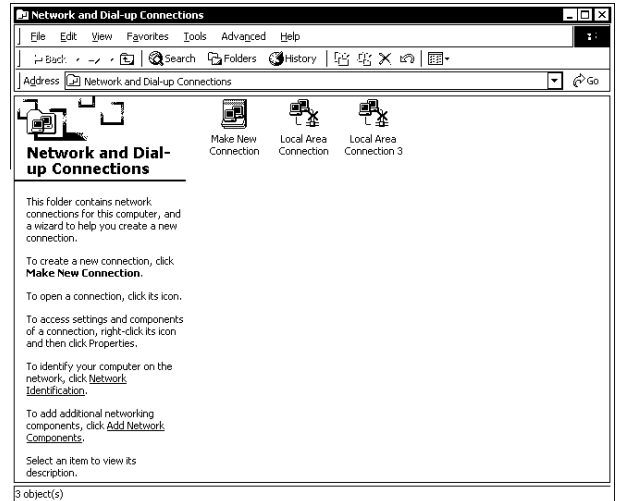

10. <Opening the local Area Connection3 Properties window>
Select (CL) [Internet Protocol (TCP/IP)] in the Local Area Connection3 Properties window, and then select the [Properties] button.

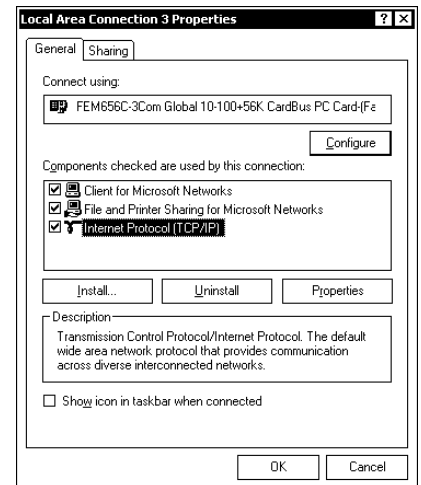

11. <Setting an external IP address>
Set the IP address and subnet mask, and then select (CL) the [OK] button.

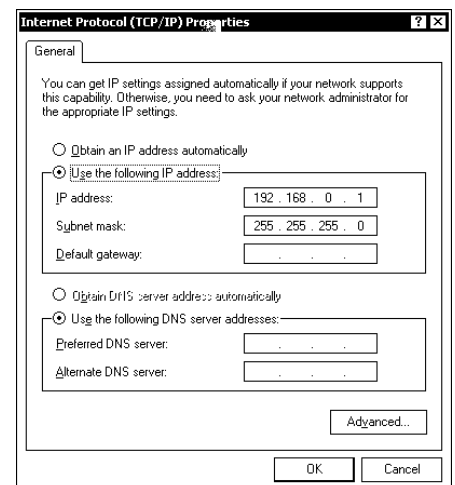

Blank Sheet

REV.0	Jun.2001					
-------	----------	--	--	--	--	--

Blank Sheet

REV.0	Jun.2001					
-------	----------	--	--	--	--	--

Blank Sheet

REV.0	Jun.2001					
-------	----------	--	--	--	--	--

Blank Sheet

REV.0	Jun.2001					
-------	----------	--	--	--	--	--

Blank Sheet

REV.0	Jun.2001					
-------	----------	--	--	--	--	--

Blank Sheet

REV.0	Jun.2001					
-------	----------	--	--	--	--	--

Blank Sheet

REV.0	Jun.2001					
-------	----------	--	--	--	--	--

Blank Sheet

REV.0	Jun.2001					
-------	----------	--	--	--	--	--

Blank Sheet

REV.0	Jun.2001					
-------	----------	--	--	--	--	--

Blank Sheet

REV.0	Jun.2001					
-------	----------	--	--	--	--	--

Blank Sheet

REV.0	Jun.2001					
-------	----------	--	--	--	--	--

Blank Sheet

REV.0	Jun.2001					
-------	----------	--	--	--	--	--

Blank Sheet

REV.0	Jun.2001					
-------	----------	--	--	--	--	--

Blank Sheet

REV.0	Jun.2001					
-------	----------	--	--	--	--	--

Blank Sheet

REV.0	Jun.2001					
-------	----------	--	--	--	--	--

Blank Sheet

REV.0	Jun.2001					
-------	----------	--	--	--	--	--

Blank Sheet

REV.0	Jun.2001					
-------	----------	--	--	--	--	--

Blank Sheet

REV.0	Jun.2001					
-------	----------	--	--	--	--	--

Blank Sheet

REV.0	Jun.2001					
-------	----------	--	--	--	--	--

Blank Sheet

REV.0	Jun.2001					
-------	----------	--	--	--	--	--

Blank Sheet

REV.0	Jun.2001					
-------	----------	--	--	--	--	--

Blank Sheet

REV.0	Jun.2001					
-------	----------	--	--	--	--	--

[POST-PROCEDURE t3]

— OUTLINE —

- ① Specify end of special part replacement.
- ② Reinstall related parts.
- ③ Start environment monitor.
- ④ SIM Complete.

[1] START OF POST-PROCEDURE

1. <Check special part replacement>

Select (CL) [OK] in response to "Please replace the "XXXXX" After replacement, press OK.". Valid "XXXXX" values are listed below.

- 'Fan assembly (DKC)'
----- Go to [2] ([REP04-920](#))
- 'Thermostat assembly'
----- Go to [3] ([REP04-930](#))
- 'BATTERY-x' ----- Go to [4] ([REP04-940](#))
- 'BATCTRL-x' ----- Go to [5] ([REP04-950](#))
- 'SVPPSx' ----- Go to [9] ([REP04-995](#))

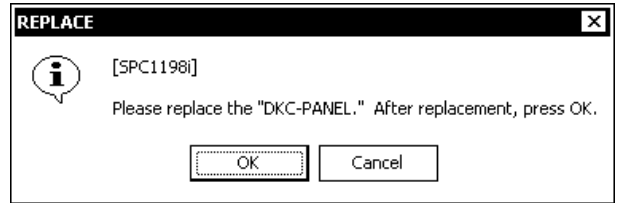

(ex. DKC-PANEL)

Select (CL) [OK] in response to "Please switch "xxPSn" to "DISABLE," and replace it. After replacement, switch it to "ENABLE" and press OK.".

- 'xxPSn' ----- Go to [6] ([REP04-960](#))

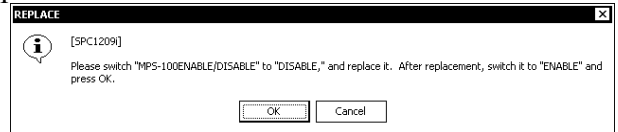

(ex. MPS-R100)

Select (CL) [OK] in response to "Turn off the breaker which supplies power source for AC BOX-x. After that please replace it. When replacement is completed, press OK.".

- 'BREAKER BOX-x'
----- Go to [7] ([REP04-980](#))
- 'AC BOX-Cn' ----- Go to [8] ([REP04-990](#))

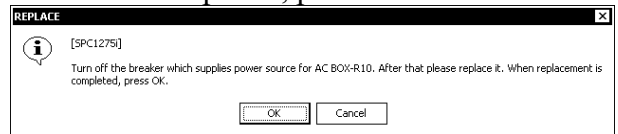

(ex. AC BOX-R10)

[2] Fan assembly

1. <Checking the environment monitor start processing>
 “Processing to enable the environment check...”
 is displayed.

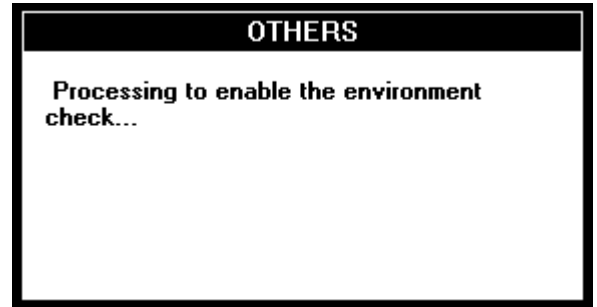

2. <Checking the end of replacement>
 Select (CL) [OK] in response to “Replacement
 of the "Fan assembly" is done.”.

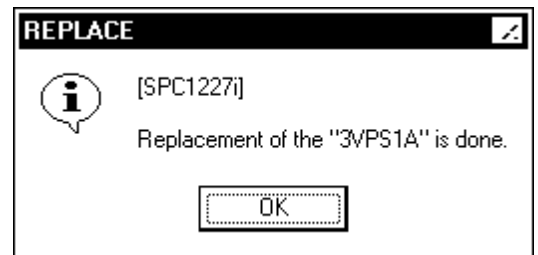

(ex. 3VPS1A)

3. <Confirm status>
 Confirm the status display.
 If button is normal (The string is normally display), go to step 4.
 If button is abnormal (The string is blinking), replace the target part again, or see TROUBLE SHOOTING SECTION.

4. < SIM Complete >
 See [SVP02-580](#).

(Multi Cabinet Model)
 Close ‘Cluster-X’ window.
 Close ‘DKC’ window.
 Close ‘Maintenance’ window.

(Single Cabinet Model)
 Close ‘Cluster-X’ window.
 Close ‘Controller’ window.
 Close ‘Maintenance’ window.

Go to POST-PROCEDURE z ([REP04-1400](#)).

[3] Thermostat assembly

1. <Checking the environment monitor start processing>
“Processing to enable the environment check...”
is displayed.

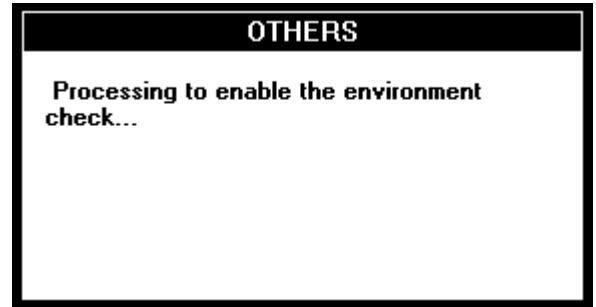

2. <Checking the end of replacement>
Select (CL) [OK] in response to “Replacement
of the "Thermostat assembly" is done.”.

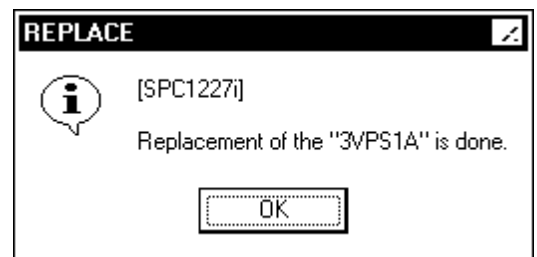

(ex. 3VPS1A)

3. <Confirm status>
Confirm the status display.
If button is normal (The string is normally display), go to step 4.
If button is abnormal (The string is blinking), replace the target part again, or see TROUBLE SHOOTING SECTION.

4. <SIM Complete>
See [SVP02-580](#).

(Multi Cabinet Model)

Close 'Cluster-X' window.

Close 'DKC' window.

Close 'Maintenance' window.

(Single Cabinet Model)

Close 'Cluster-X' window.

Close 'Controller' window.

Close 'Maintenance' window.

Go to POST-PROCEDURE z ([REP04-1400](#)).

[4] BATTERY

1. <Checking the jumper connector of BATCTR>
The following message is displayed.
Confirm that the jumper connector is attached to BATCTR removed at PRE-PROCEDURE T3.
And then press (CL) [OK].

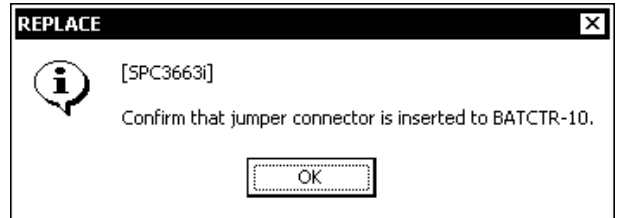

(ex. BATTERY-10)

2. <Attach BATCTR>
“Attach BATCTR-XX to subsystem.” is displayed.
Attach BATCTR removed at PRE-PROCEDURE T3 to the subsystem, and select (CL) [OK].

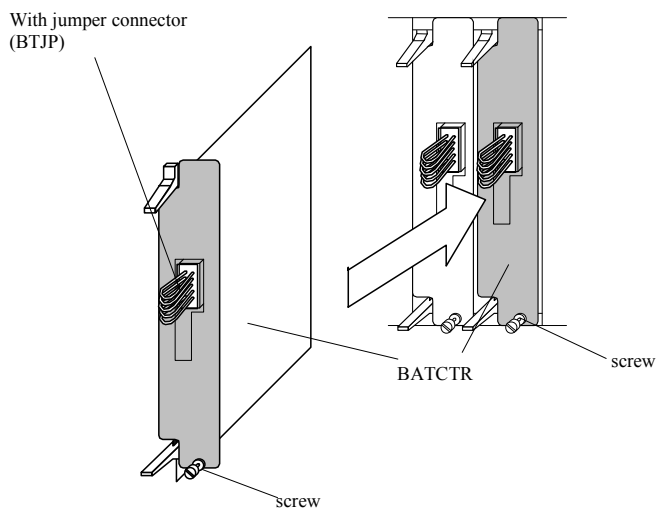

(BAT CTR Insert)
Insert the removed BAT CTR PCB with jumper connector and tighten with the screw.

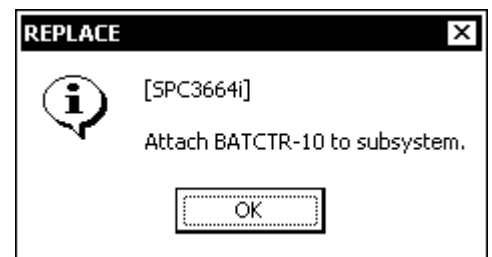

(ex. 3VPS1A)

3. <Checking the environment monitor start processing>
“Processing to enable the environment check...” is displayed.

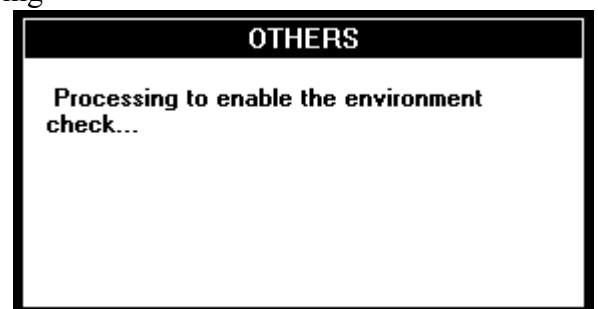

4. <Checking the end of replacement>
Select (CL) [OK] in response to “Replacement of the "BATTERY-x" is done.”.

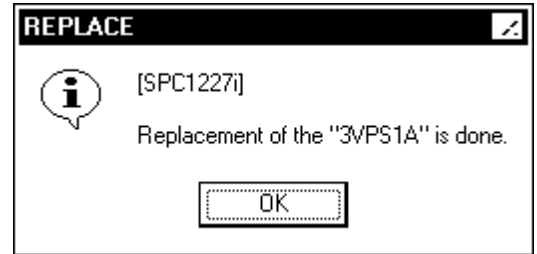

(ex. 3VPS1A)

5. <Setting Battery Warning SIM>
“Select the Setting Battery Life button in the Install panel and then make settings.” is displayed.
If this operation is the preventive maintenance of BATTERY, set the Battery Warning SIM after all BATTERY exchange ends.
(See [SVP02-1290](#))
Otherwise go to step 6.

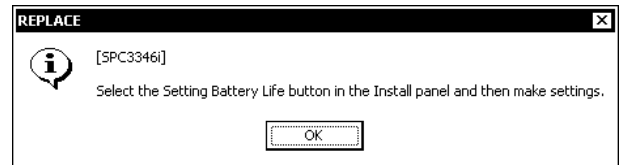

6. <Confirm status>
Confirm the status display.
If button is normal (The string is normally display), go to step 7.
If button is abnormal (The string is blinking), replace the target part again, or see TROUBLE SHOOTING SECTION.

7. <SIM Complete>
See [SVP02-580](#).

(Multi Cabinet Model)
Close ‘Cluster-X’ window.
Close ‘DKC’ window.
Close ‘Maintenance’ window.

(Single Cabinet Model)
Close ‘Cluster-X’ window.
Close ‘Controller’ window.
Close ‘Maintenance’ window.

Go to POST-PROCEDURE z ([REP04-1400](#)).

[5] BATCTR

1. <Checking the environment monitor start processing>
“Processing to enable the environment check...”
is displayed.

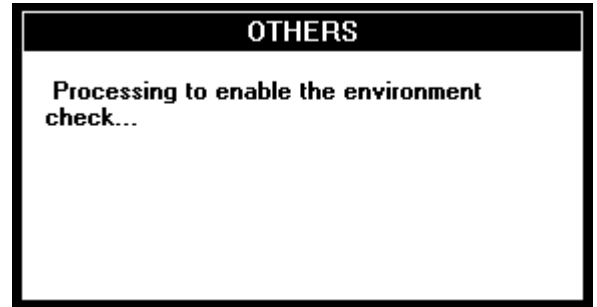

2. <Checking the end of replacement>
Select (CL) [OK] in response to “Replacement
of the "BATCTR-x" is done.”.

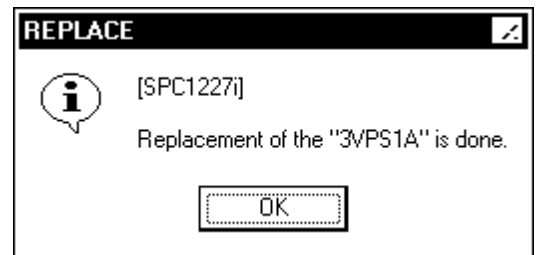

(ex. 3VPS1A)

3. <Confirm status>
Confirm the status display.
If button is normal (The string is normally display), go to step 4.
If button is abnormal (The string is blinking), replace the target part again, or see TROUBLE SHOOTING SECTION.

4. <SIM Complete>
See [SVP02-580](#).

(Multi Cabinet Model)

Close 'Cluster-X' window.

Close 'DKC' window.

Close 'Maintenance' window.

(Single Cabinet Model)

Close 'Cluster-X' window.

Close 'Controller' window.

Close 'Maintenance' window.

Go to POST-PROCEDURE z ([REP04-1400](#)).

[6] PS

1. <Checking the environment monitor start processing>
 “Processing to enable the environment check...”
 is displayed.

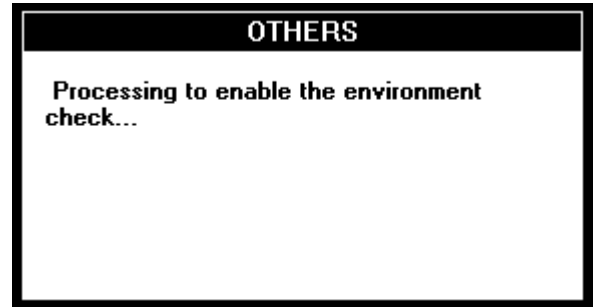

2. <Checking the end of replacement>
 Select (CL) [OK] in response to “Replacement
 of the "PS-X" is done.”.

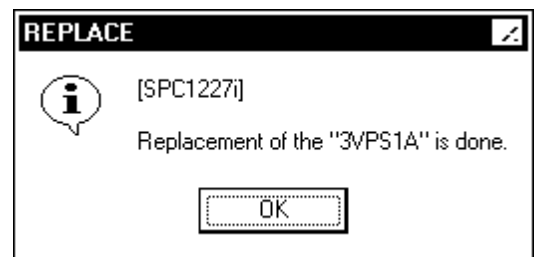

(ex. 3VPS1A)

3. <Confirm status>
 Confirm the status display.
 If button is normal (The string is normally display), go to step 4.
 If button is abnormal (The string is blinking), replace the target part again, or see TROUBLE SHOOTING SECTION.

4. <Confirm Cluster>
 If Cluster is blocked, recover it.
 See [SVP02-1110](#).

5. <SIM Complete>
See [SVP02-580](#).

(Multi Cabinet Model)

Close 'Cluster-X' window.

Close 'DKC' window.

Close 'Maintenance' window.

(Single Cabinet Model)

Close 'Cluster-X' window.

Close 'Controller' window.

Close 'Maintenance' window.

Go to POST-PROCEDURE z ([REP04-1400](#)).

[7] BREAKER BOX

1. <Checking the environment monitor start processing>
“Processing to enable the environment check...”
is displayed.

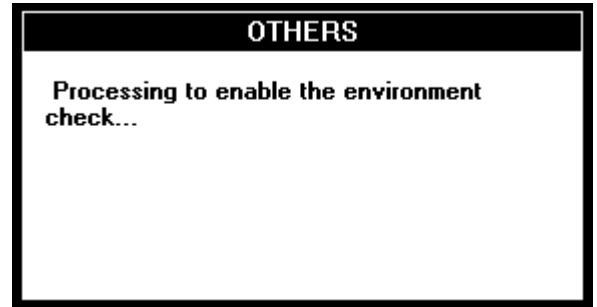

2. <Checking the end of replacement>
Select (CL) [OK] in response to “Replacement
of the "BREAKER BOX-X" is done.”.

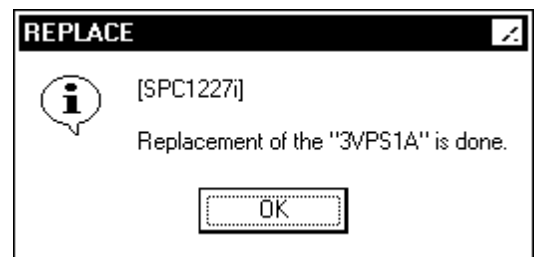

(ex. 3VPS1A)

3. <Confirm Cluster>
If Cluster is blocked, recover it.
See [SVP02-1110](#).

4. <SIM Complete>
See [SVP02-580](#).

(Multi Cabinet Model)

Close 'Cluster-X' window.

Close 'DKC' window.

Close 'Maintenance' window.

(Single Cabinet Model)

Close 'Cluster-X' window.

Close 'Controller' window.

Close 'Maintenance' window.

Go to POST-PROCEDURE z ([REP04-1400](#)).

[8] AC BOX(DKC)

1. <Checking the environment monitor start processing>
“Processing to enable the environment check...”
is displayed.

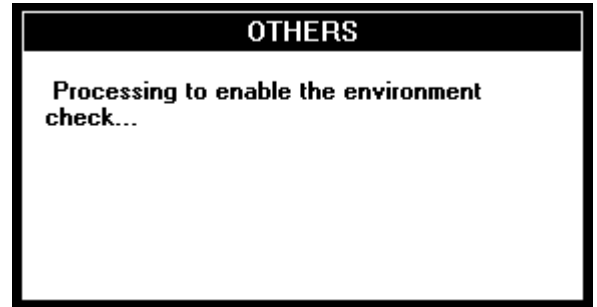

2. <Checking the end of replacement>
Select (CL) [OK] in response to “Replacement
of the "AC BOX-x" is done.”.

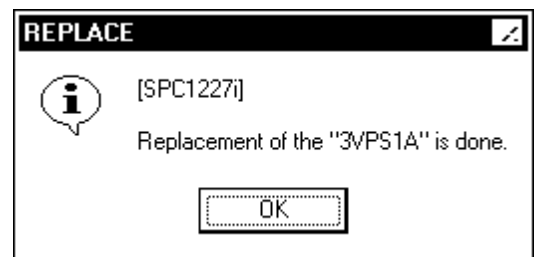

(ex. 3VPS1A)

3. <Confirm Cluster>
If Cluster is blocked, recover it.
See [SVP02-1110](#).

4. <SIM Complete>
See [SVP02-580](#).

(Multi Cabinet Model)

Close 'Cluster-X' window.

Close 'DKC' window.

Close 'Maintenance' window.

(Single Cabinet Model)

Close 'Cluster-X' window.

Close 'Controller' window.

Close 'Maintenance' window.

Go to POST-PROCEDURE z ([REP04-1400](#)).

[9] SVPPS

1. <Detaching a jumper plug>

Detach a jumper plug to the SVPPS following a message, "Please detach the jumper plug of replaced PCB(s)."

After checking that the jumper plug has been detached, select (CL) [OK]. (See [REP03-880](#))

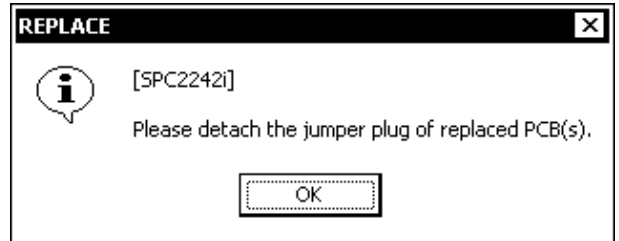

2. <Checking the environment monitor start processing>

"Processing to enable the environment check..." is displayed.

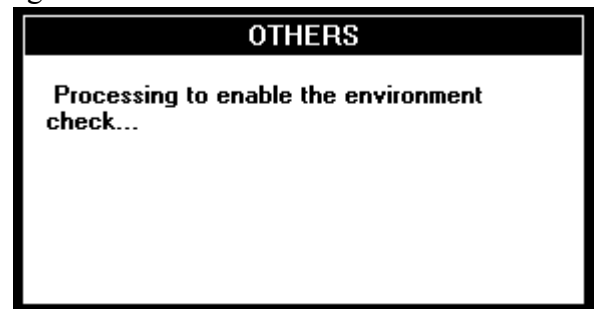

3. <Checking the end of replacement>

Select (CL) [OK] in response to "Replacement of the "SVPPSx" is done."

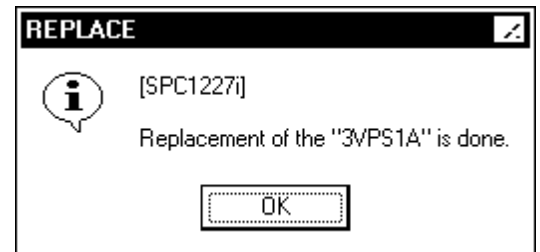

(ex. 3VPS1A)

4. <Confirm Cluster>

If Cluster is blocked, recover it.

See [SVP02-1110](#).

5. <SIM Complete>
See [SVP02-580](#).

(Multi Cabinet Model)

Close 'Cluster-X' window.

Close 'DKC' window.

Close 'Maintenance' window.

(Single Cabinet Model)

Close 'Cluster-X' window.

Close 'Controller' window.

Close 'Maintenance' window.

Go to POST-PROCEDURE z ([REP04-1400](#)).

[POST-PROCEDURE t4]

— OUTLINE —

- ① Specify end of special part replacement.
- ② Reinstall related parts.
- ③ Start environment monitor.
- ④ DKU Path Inline Test.
- ⑤ SIM Complete.

[1] Start of POST-PROCEDURE

1. <Making part replacement check>

• Fan assembly

Select (CL) [OK] in response to “Please replace the "XXXXX" After replacement, press OK.”

‘Fan assembly’ ----- Go to [2] ([REP04-1020](#))

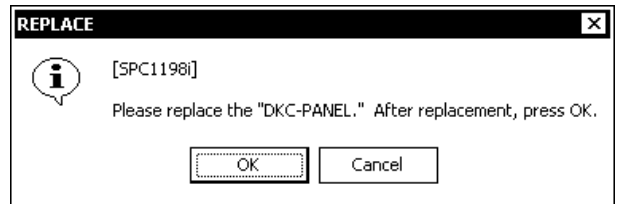

(ex. DKC-PANEL)

• MPS-X, DKUMN-X

Select (CL) [OK] in response to “Please switch "XXXXX" to "DISABLE," and replace it. After replacement, switch it to "ENABLE" and press OK.”.

‘MPS-n’ ----- Go to [3] ([REP04-1030](#))

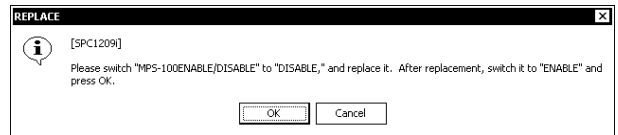

(ex. MPS-R100 of Multi Cabinet Model)

‘DKUMN-R3n’, ‘DKUMN-L3n’ --- Go to [4] ([REP04-1050](#))

Other ‘DKUMN-X’ ----- Go to [5] ([REP04-1060](#))

• AC BOX-X

Select (CL) [OK] in response to “Turn off the breaker which supplies power source for AC BOX-X. After that please replace it. When replacement is completed, press OK.”.

‘AC BOX-X’ ----- Go to [6] ([REP04-1080](#))

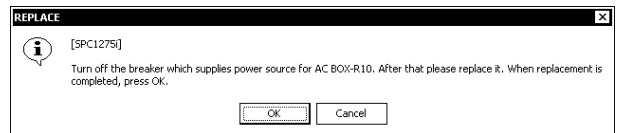

(ex. AC BOX-R10 of Multi Cabinet Model)

• JMP

Select (CL) [OK] in response to “Please replace the "JMPm-n". After replacement, press OK.”.

‘JMPm-n’ ----- Go to [7] ([REP04-1091](#))

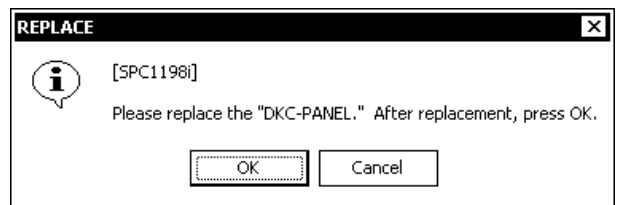

(ex. DKC-PANEL)

[2] Fan assembly

1. <Checking environment monitor start processing>
“Processing to enable the environment check...”
is displayed.

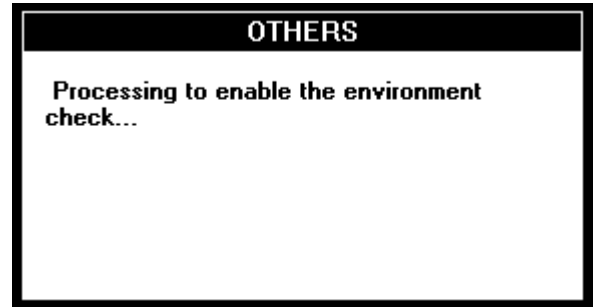

2. <Checking end of replacement>
Select (CL) [OK] in response to
“Replacement of the "Fan assembly" is
done.”.

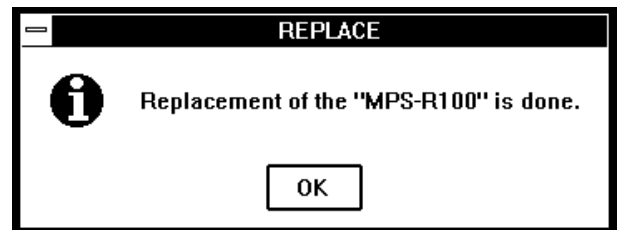

(ex. MPS-R100 of Multi Cabinet Model)

3. <Confirm status>
Confirm the status display.
If button is normal (lighting), go to step 4.
If button is blinking, replace the target part again, or TROUBLE SHOOTING SECTION.

4. <SIM Complete>
See [SVP02-580](#).

(Multi Cabinet Model)
Close ‘HDU-X’ window.
Close ‘DKU-X’ window.
Close ‘Maintenance’ window.

(Single Cabinet Model)
Close ‘Disk’ window.
Close ‘Maintenance’ window.

Go to POST-PROCEDURE z ([REP04-1400](#)).

[3] MPS

1. <Checking environment monitor start processing>
“Processing to enable the environment check...”
is displayed.

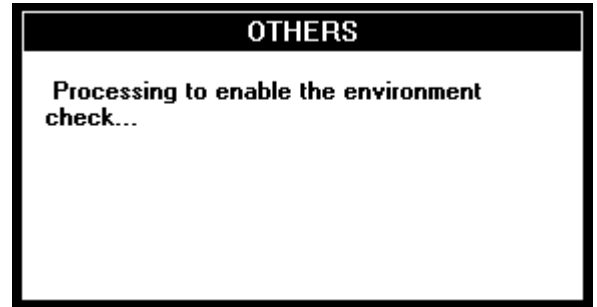

2. <Checking end of replacement>
Select (CL) [OK] in response to
“Replacement of the "MPS-n" is done.”.

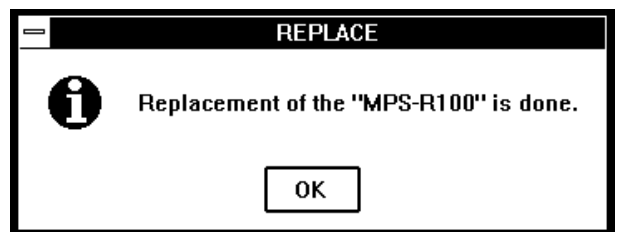

(ex. MPS-R100 of Multi Cabinet Model)

3. <Confirm status>
Confirm the status display.
If button is normal (lighting), go to step 4.
If button is blinking, replace the target part again, or TROUBLE SHOOTING SECTION.

4. <Confirm Cluster>
If Cluster is blocked, recover it.
See [SVP02-1110](#).

5. <SIM Complete>
See [SVP02-580](#).

(Multi Cabinet Model)

Close 'HDU-X' window

Close 'DKU-X' window.

Close 'Maintenance' window.

(Single Cabinet Model)

Close 'HDU-X' window.

Close 'Disk' window.

Close 'Maintenance' window.

Go to POST-PROCEDURE z ([REP04-1400](#)).

[4] DKUMN-R3n, DKUMN-L3n

1. <Checking environment monitor start processing>
“Processing to enable the environment check...”
is displayed.

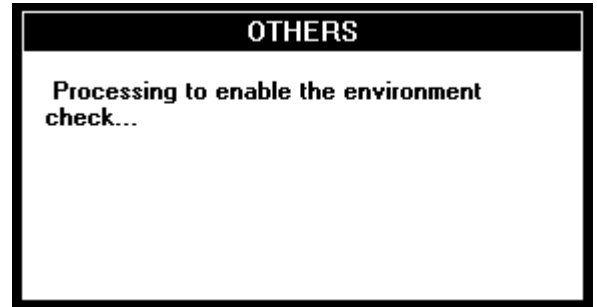

2. <Checking end of replacement>
Select (CL) [OK] in response to
“Replacement of the "DKUMN-X" is done.”.

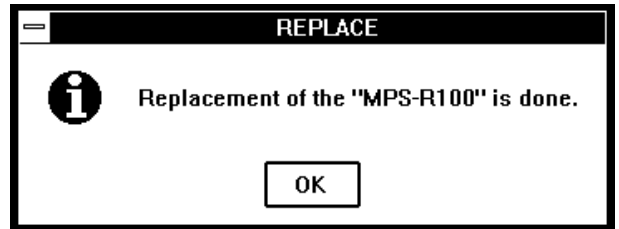

(ex. MPS-R100 of Multi Cabinet Model)

3. <Confirm status>
Confirm the status display.
If button is valid, go to step 4.
If button is blinking, replace the target part again, or TROUBLE SHOOTING SECTION.

4. <SIM Complete>
See [SVP02-580](#).

(Multi Cabinet Model)
Close ‘DKU-X’ window.
Close ‘Maintenance’ window.

Go to POST-PROCEDURE z ([REP04-1400](#)).

[5] Other DKUMN-X

1. <Enabling DKUMN>

When Multi Cabinet Model, if DKUMN-X (listed below) is installed, this message is displayed.

Enable DKUMN in response to "Please switch "DKUMN-X" to "ENABLE".

Then press OK."

After confirming DKUMN-X is enabled, Select (CL) [OK].

DKUMN-X (Multi Cabinet Model):

Replace parts	X
DKUMN-R1F	R2F, R3F
DKUMN-R1R	R2R, R3R
DKUMN-R2F	R3F
DKUMN-R2R	R3R
DKUMN-L1F	L2F, L3F
DKUMN-L1R	L2R, L3R
DKUMN-L2F	L3F
DKUMN-L2R	L3R

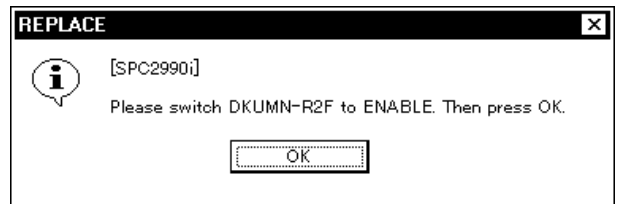

(ex. Replacement of the DKUMN-R1F)

2. <Checking environment monitor start processing>

"Processing to enable the environment check..." is displayed.

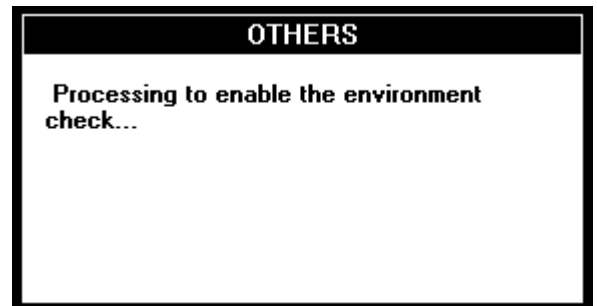

3. <Checking end of replacement>

Select (CL) [OK] in response to "Replacement of the "DKUMN-X" is done."

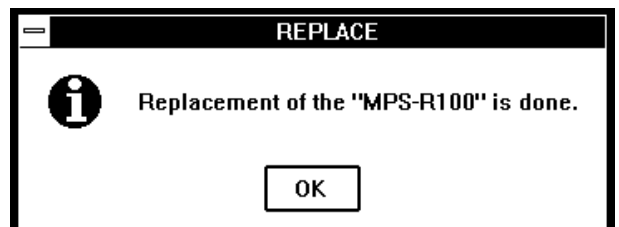

(ex. MPS-R100 of Multi Cabinet Model)

-
4. <Confirm status>
Confirm the status display.
If button is valid, go to step 5.
If button is blinking, replace the target part again, or TROUBLE SHOOTING SECTION.

-
5. <SIM Complete>
See [SVP02-580](#).

(Multi Cabinet Model)

Close 'DKU-X' window.

Close 'Maintenance' window.

Go to POST-PROCEDURE z ([REP04-1400](#)).

[6] AC BOX-X

1. <Checking environment monitor start processing>
“Processing to enable the environment check...”
is displayed.

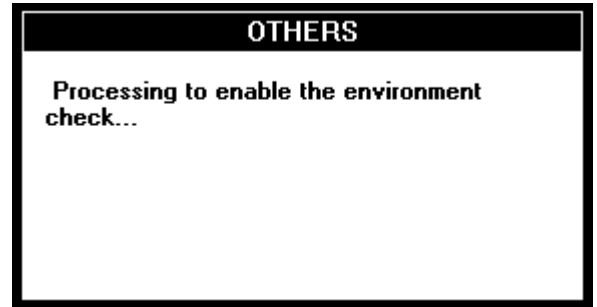

2. <Checking end of replacement>
Select (CL) [OK] in response to
“Replacement of the "AC BOX-X" is done.”.

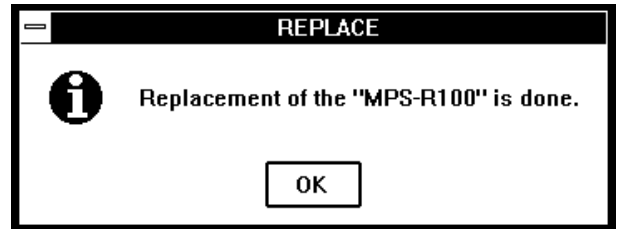

(ex. MPS-R100 of Multi Cabinet Model)

3. <Confirm status>
Confirm the status display.
If button is normal (lighting), go to step 4.
If button is blinking, replace the target part again, or TROUBLE SHOOTING SECTION.

4. <Confirm Cluster>
If Cluster is blocked, recover it.
See [SVP02-1110](#).

5. <SIM Complete>
See [SVP02-580](#).

(Multi Cabinet Model)

Close 'DKU-X' window.

Close 'Maintenance' window.

(Single Cabinet Model)

Close 'Disk' window.

Close 'Maintenance' window.

Go to POST-PROCEDURE z ([REP04-1400](#)).

[7] JMP

1. <Checking environment monitor start processing>
“Processing to enable the environment check...”
is displayed.

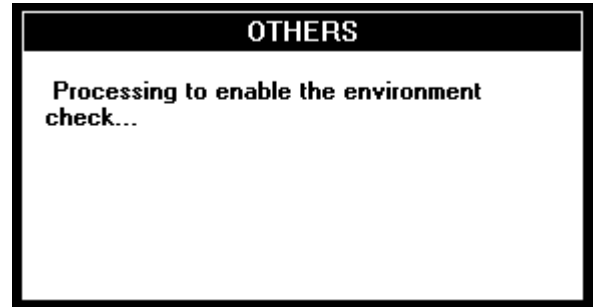

2. <Checking end of replacement>
Select (CL) [OK] in response to “Replacement of the "JMPm-n" is done.”.

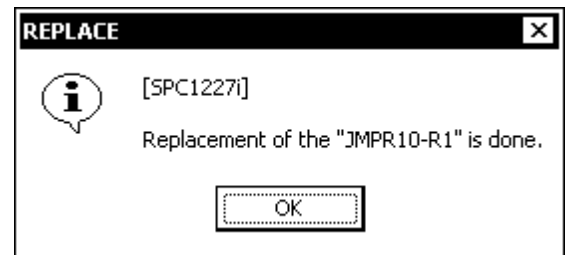

(ex. JMPR10-R1 of Multi Cabinet Model)

3. <Confirm status>
Confirm the status display.
If button is normal (lighting), go to step 4.
If button is blinking, replace the target part again, or TROUBLE SHOOTING SECTION.

4. <SIM Complete>
See [SVP02-580](#).

(Multi Cabinet Model)

Close 'HDU-X' window

Close 'DKU-X' window.

Close 'Maintenance' window.

(Single Cabinet Model)

Close 'HDU-X' window.

Close 'Disk' window.

Close 'Maintenance' window.

Go to POST-PROCEDURE z ([REP04-1400](#)).

[POST-PROCEDURE t5]

— OUTLINE —

- ① Select a part to be replaced.
- ② Reinstall the related parts.
- ③ Complete status of SIM log.

[1] Select a procedure for SVP replacing.

1.

Select a procedure for replacing an SVP and/or a Flash Card according to a part(s) to be replaced.

Procedure for replacing an SVP with or without a Flash Card on the standby SVP

- “SVP” ----- Go to [2] ([REP04-1120](#))
- “SVP & FLASH CARD” Go to [2] ([REP04-1120](#))

Procedure for replacing an SVP and/or a Flash Card on master mode

- “SVP” ----- Go to [3] ([REP04-1240](#))
- “SVP & FLASH CARD” Go to [3] ([REP04-1240](#))
- “FLASH CARD” ----- Go to [4] ([REP04-1350](#))

[2] Replacement of an SVP with or without a Flash Card

Perform the following operation at a replaced SVP.

1. Set Date/Time

(1) <Open [Control Panel]>

Select (DR) [Settings] and then [Control Panel] from [Start].

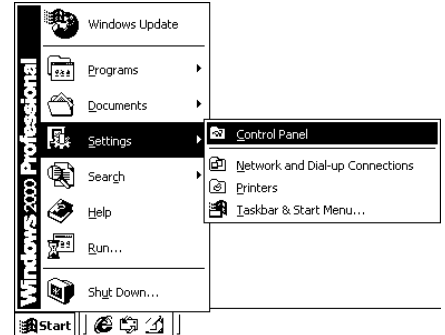

(2) <Open [Date/Time]>

Select (DC) [Date/Time] from [Control Panel].

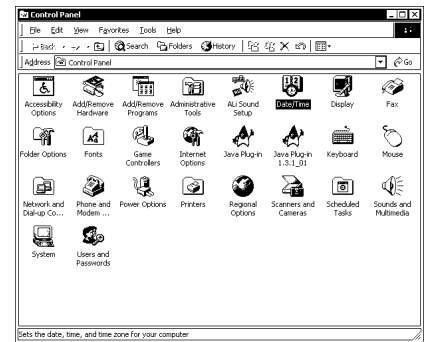

(3) <Select [Time Zone]>

Select (CL) [Time Zone].

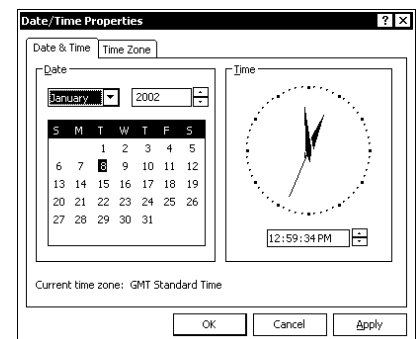

(4) <Check the setting of [Time Zone]>

Make sure that the setting of [Time Zone] is without the relation of a subsystem position “[GMT] Greenwich Mean Time; Dublin, Edinburgh, Lisbon, London”. Also, make sure that a check box on the left of “Automatically adjust clock for daylight saving changes” is (without a check mark). Then, select (CL) [Date/Time].

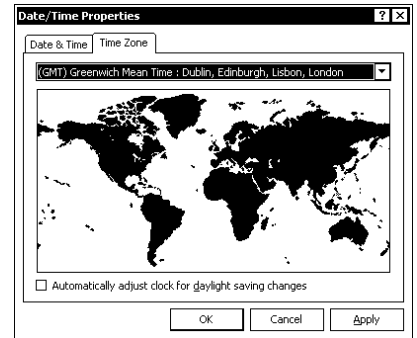

(5) <Set the [Date/Time]>

Check if the [Date/Time] is set to the current time and date. If not, reset it correctly. Then, select (CL) [OK].

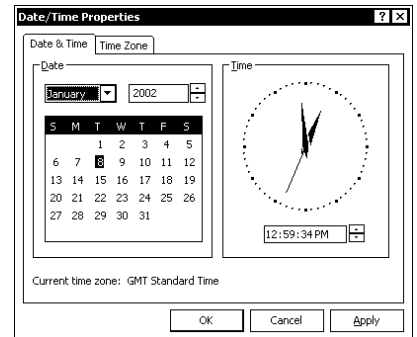

(6) <Close “Control Panel”>

Select (CL) [File] on “Control Panel”.
Select (CL) [Close].

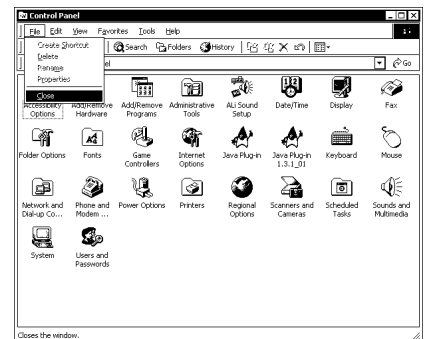

2. Installation of Micro-program

2.1 Preparation

When the SVP program is already installed, perform the following procedure.

2.1.1 Uninstallation of Apache

You need to uninstall the Apache installed in the SVP. Uninstall the Apache by following procedure.

2.1.1.1 Checking Apache version

Use the following procedure and check the version of the Apache currently installed in the SVP.

- (1) Select (DR) [Start]-[Settings]-[Control Panel].

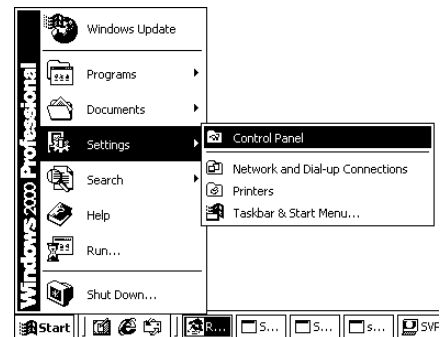

- (2) Select (DC) [Add/Remove Programs], and then press the [Enter] key.

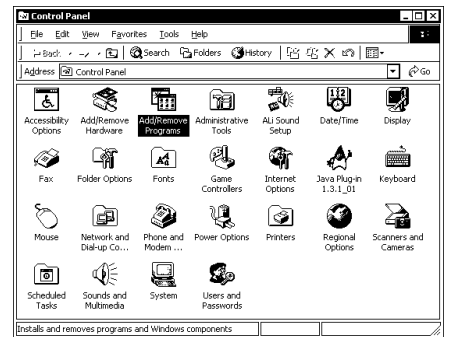

- (3) Check the content of [Currently installed programs] in the 'Add/Remove Programs' panel.

If [Apache Web Server] exists, Apache 1.3.14 is installed. If [Apache HTTP Server 1.3.27] exists, Apache 1.3.27 is installed. In order to uninstall Apache 1.3.14, go to 2.1.1.2. In order to uninstall Apache 1.3.27, go to 2.1.1.3.

When the Apache version check is completed, select (CL) [×] button and close the window.

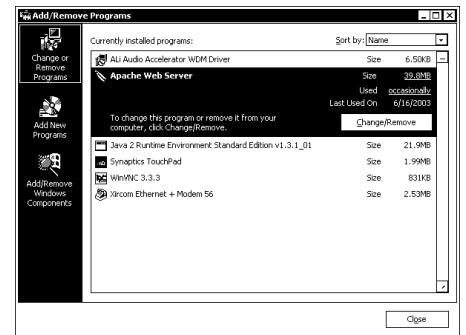

2.1.1.2 Uninstallation of Apache 1.3.14

- (1) Select (DR) [Start]-[Programs]-[Apache Web Server]-[Apache as a service]-[Stop Service]. Service of Apache will stop.

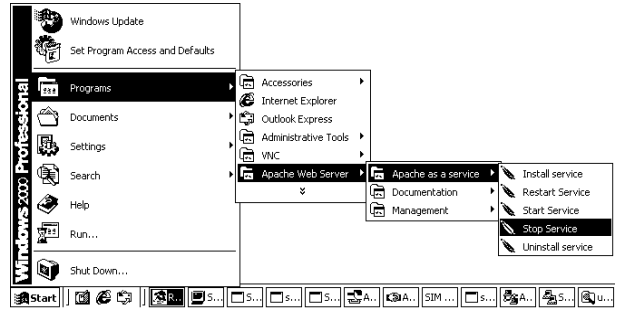

- (2) Select (DR) [Start]-[Programs]-[Apache Web Server]-[Apache as a service]-[Uninstall service].

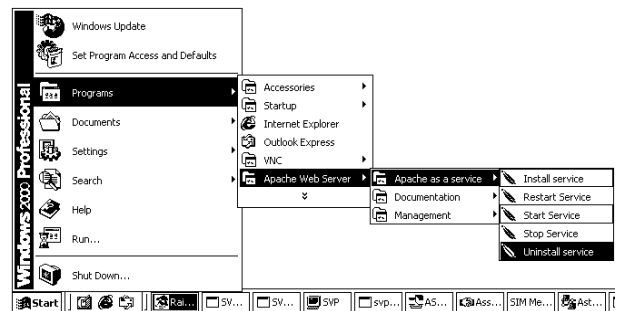

- (3) Select (DR) [Start]-[Shut Down...], and reboot the SVP. Select (CL) [Restart] in the Shut Down Windows panel, and then select (CL) the [OK] button.



- (4) When Windows is rebooted, select (DR) [Start]-[Settings]-[Control Panel].

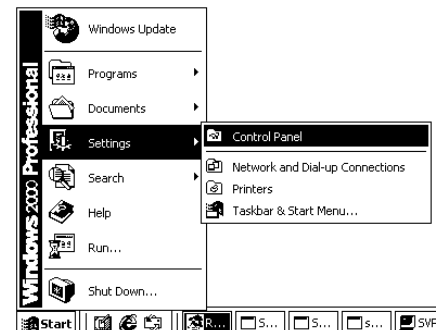

- (5) Select (DC) [Add/Remove Programs], and then press the [Enter] key.

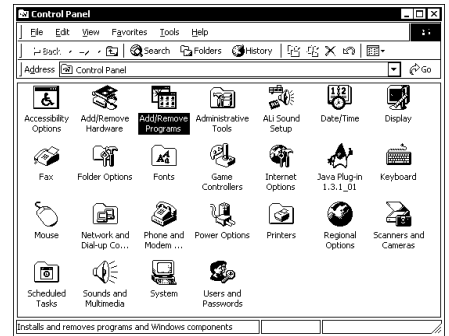

- (6) Select [Apache Web Server], and then select (CL) the [Change/Remove] button.

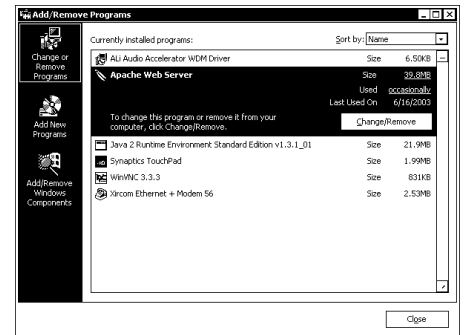

- (7) The message, “Are you sure you want to completely remove ‘Apache Web Server’ and all of its components?” is displayed. Select (CL) the [Yes] button.

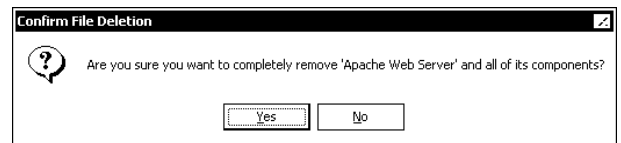

- (8) Uninstallation of Apache starts. When all of the deleted items are checked and the [OK] button becomes selectable, select (CL) the [OK] button.

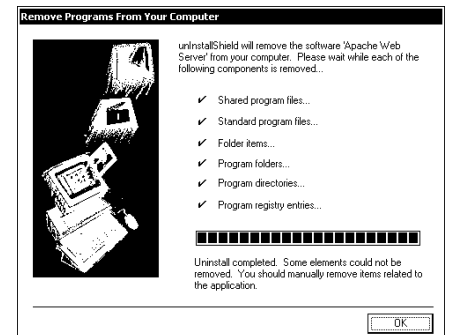

- (9) [Apache Web Server] is removed from the 'Add/Remove Programs' panel.
Select (CL) [×] button, and close this window.

Go to 2.1.2.

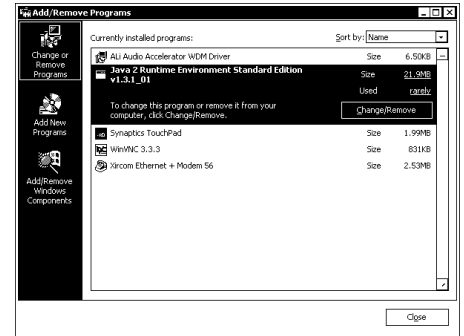

2.1.1.3 Uninstallation of Apache 1.3.27

- (1) Select (DR) [Start]-[Programs]-[Apache HTTP Server]-[Control Apache Server]-[Stop]. Service of Apache will stop.

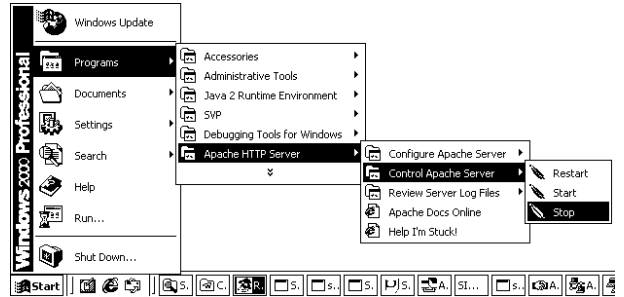

- (2) Select (DR) [Start]-[Settings]-[Control Panel].

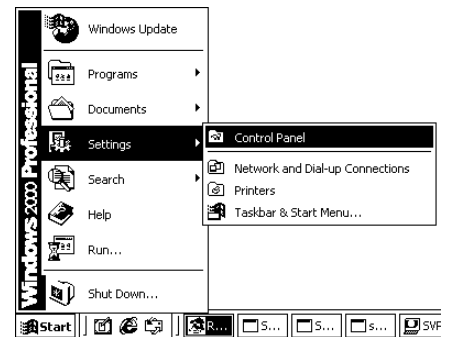

- (3) Select (DC) [Add/Remove Programs], and then press the [Enter] key.

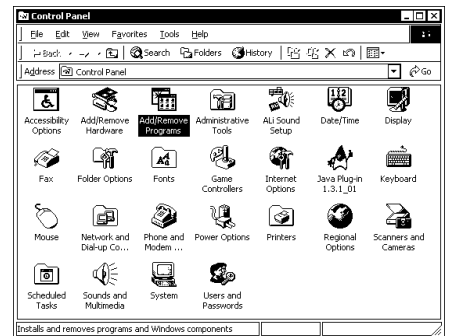

- (4) Select [Apache HTTP Server 1.3.27], and then select (CL) the [Remove] button.

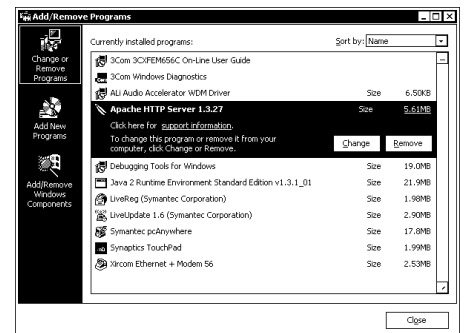

- (5) The message, “Are you sure you want to remove Apache HTTP Server 1.3.27 from your computer?”, is displayed. Select (CL) the [Yes] button.

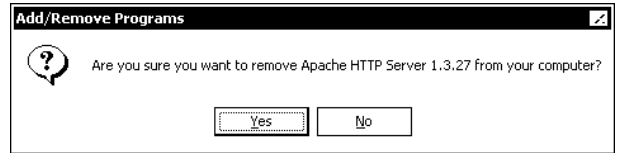

- (6) Uninstallation of Apache 1.3.27 starts.

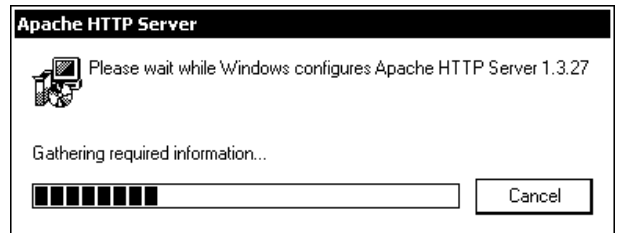

- (7) [Apache HTTP Server 1.3.27] is removed from the ‘Add/Remove Programs’ panel. Select (CL) [×] button, and close this window.

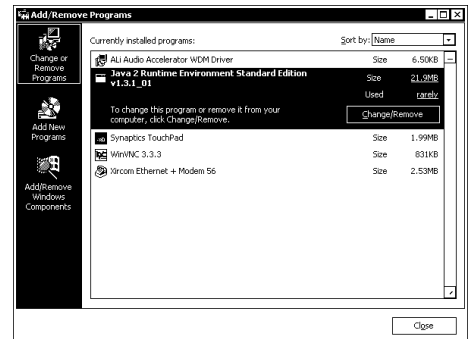

- (8) Select (DR) [Start]-[Shut Down...], and reboot the SVP. Select (CL) [Restart] in the Shut Down Windows panel, and then select (CL) the [OK] button.

When Windows is rebooted, go to 2.1.2.



2.1.2 Uninstallation of Java

(1) Select (DR) [Start]-[Settings]-[Control Panel].

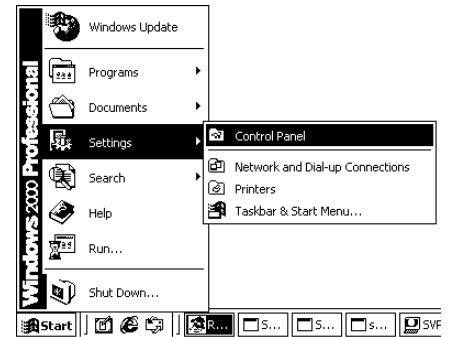

(2) Select (DC) [Add/Remove Programs], and then press the [Enter] key.



(3) Select [Java 2 Runtime Environment Standard Edition v1.3.1_01], and then select (CL) the [Change/Remove] button.

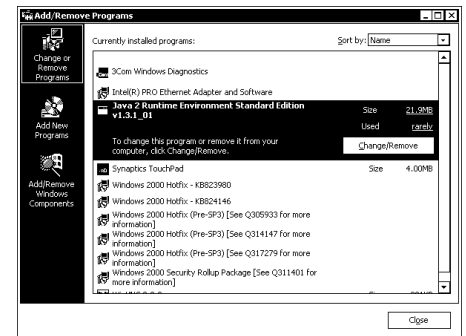

(4) The message, “Are you sure you want to completely remove ‘Java 2 Runtime Environment Standard Edition v1.3.1_01’ and all of its components?”, is displayed. Select (CL) the [Yes] button.

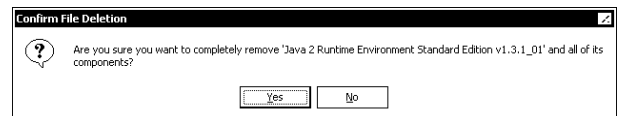

- (5) Uninstallation of Java starts. When all of the deleted items are checked and the [OK] button becomes selectable, select (CL) the [OK] button.

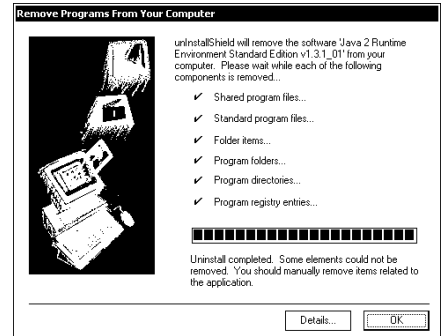

- (6) The message, “Java 2 Runtime Environment Standard Edition v1.3.1_01’ has been removed from your system. It is recommended that you restart your machine to remove files that were in use during uninstall.”, is displayed. Select (CL) the [OK] button.



- (7) [Java 2 Runtime Environment Standard Edition v1.3.1_01] is removed from the ‘Add/Remove Programs’ panel. Select (CL) [x] button, and close this window.

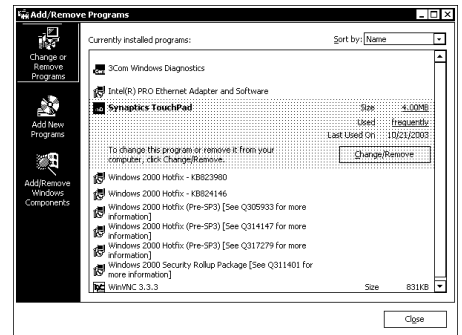

- (8) Select (DR) [Start]-[Shut Down...], and reboot the SVP. Select (CL) [Restart] in the Shut Down Windows panel, and then select (CL) the [OK] button.

When Windows is rebooted, go to 2.1.3.



2.1.3 Performance Monitor Data file delete

- (1) Select (DR) [Start]-[Programs]-[Accessories]-[Windows Explorer].

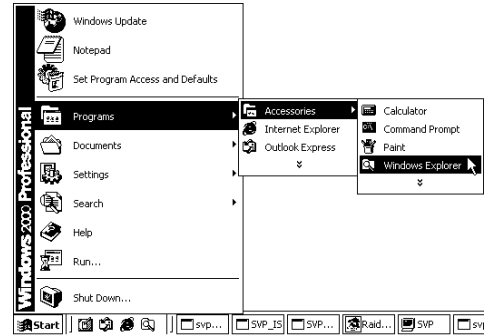

- (2) Select (CL) "D:\Mondat" directory, and delete it.

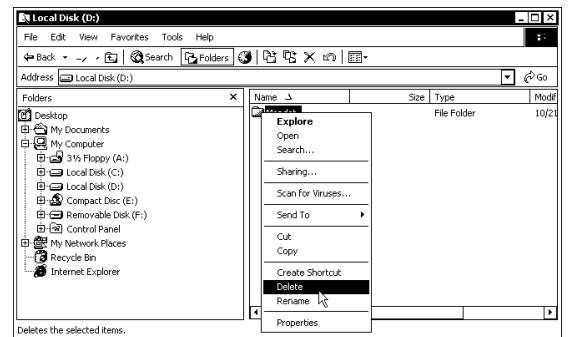

- (3) Select [Yes].

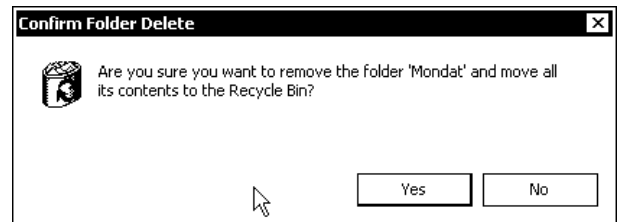

- (4) Finish the Explore.

2.2 Install

- ① Insert the CD-ROM disk into the CD-ROM drive and then wait one minute.
- ② Select (CL) [Run...] from the [Start]. Enter “e:\setup.exe” and select (CL) [OK].

If a message “An old version of Apache has been detected. Please uninstall this version and then perform Setup.exe again.” is displayed, perform again after uninstalling Apache 1.3.14.

The procedure of uninstallation of Apache 1.3.14 is shown 5.2 of WEB CONSOLE SECTION.



3. Installation of Configuration

(1) Inserting the Config FD

- ① A message "Please insert the Config FD into the FDD." is displayed.
- ② Insert the Config FD into the FDD and select (CL) [OK].

If you insert the previously backed-up Config FD, the original configuration is recovered.

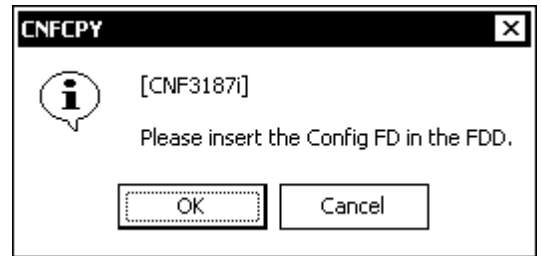

(2) Removing the Config FD

- ① When the copying of the Config is completed, a message "Please remove the Config FD." is displayed.
- ② Remove the Config FD from the FDD and select (CL) [OK].

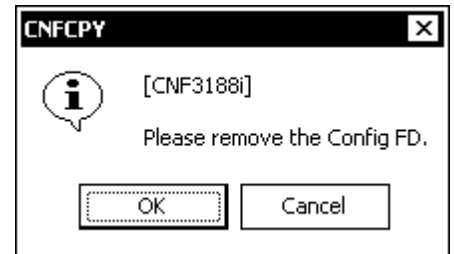

4. JAVA Setup

4-1 JAVA Setup

Setting up of Java is executed. When Java has already been installed, the routine proceeds to Step 4-2.

(1)

Select (CL) [Yes].

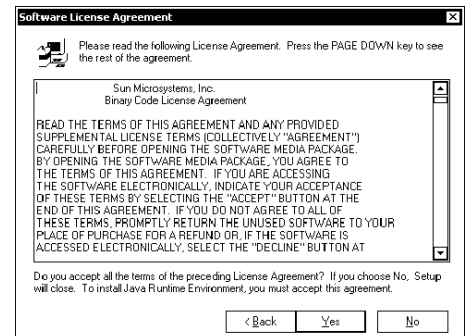

(2)

Select (CL) [Next].

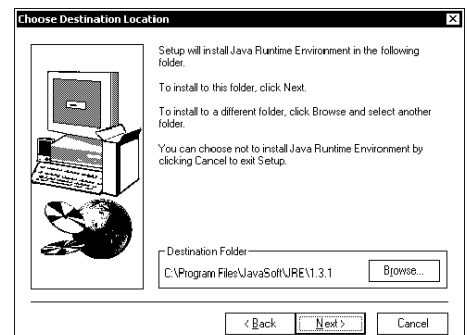

4-2 Setup Process of Apache

Execute Setup of Apache.

If the following panel is not displayed, Apache is already installed. Go to 5. If the SVP version is earlier than 21-06-20/00, Apache 1.3.14 will be installed. Use the following procedure to install it. If the SVP version is 21-06-20/00 or later, Apache 1.3.27 will be installed. Go to 4-3.

- (1)
Select (CL) [Next].

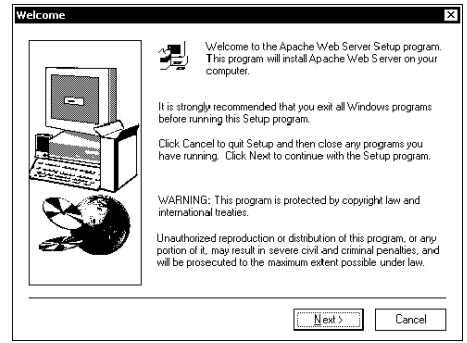

- (2)
Select (CL) [Yes].

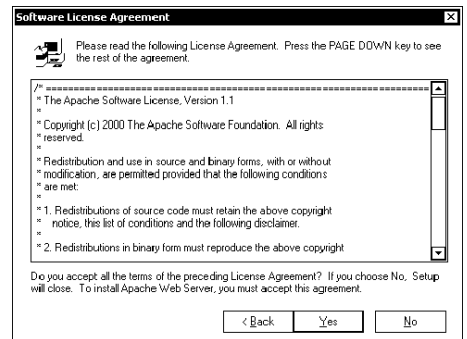

- (3)
Select (CL) [Next].

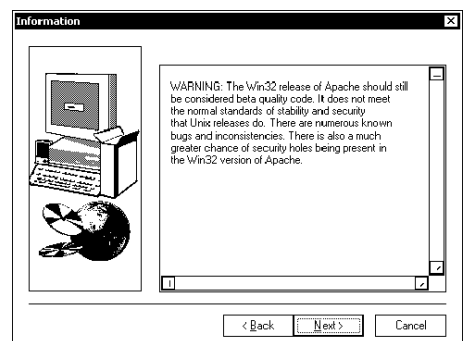

- (4)
Select (CL) [Next].

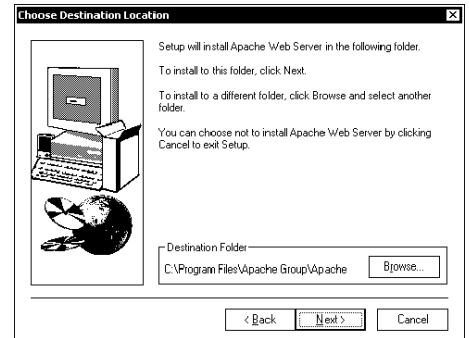

- (5)
Select (CL) [Next].

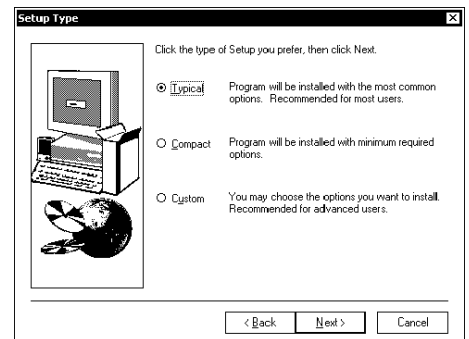

- (6)
Select (CL) [Next].

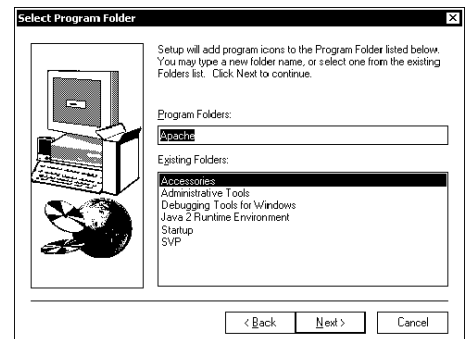

- (7)
Remove the check box of "Yes and I want to view the README file.", and select (CL) [Finish].

Go to Step 5.

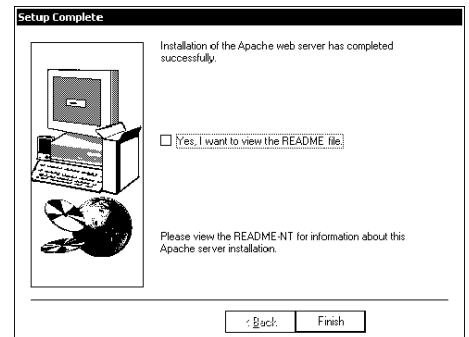

4-3 Setup Process of Apache 1.3.27

- (1) Select (CL) the [Next>] button.

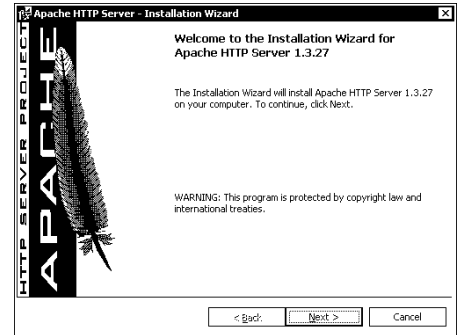

- (2) After selecting (CL) “I accept the terms in the license agreement”, select (CL) the [Next>] button.



- (3) Select (CL) the [Next>] button.

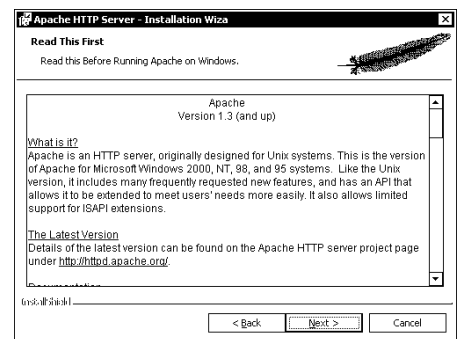

- (4) Enter “domain” to the Network Domain field, “svp” to the Server Name field, and “admin@domain.com” to the Administrator’s Email Address field.
After selecting (CL) “Run as a service for All Users – Recommended”, select (CL) the [Next >] button.

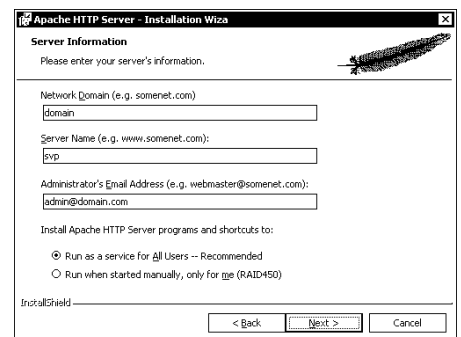

- (5) Select (CL) “Complete,” and then select (CL) the [Next>] button.

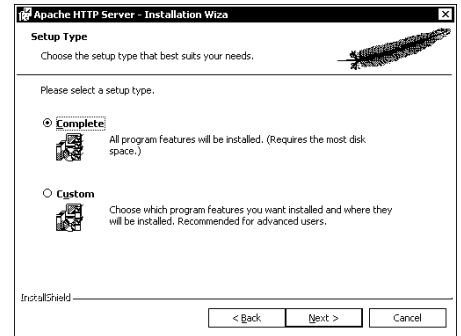

- (6) Select (CL) the [Next>] button.

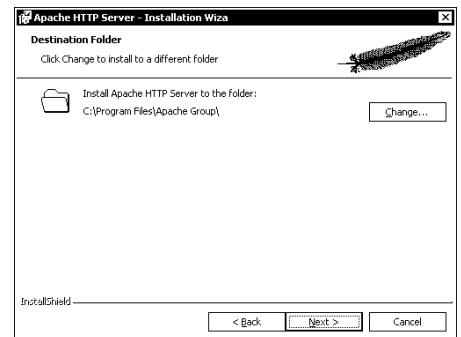

- (7) Select (CL) the [Install] button. Copying of the file will start.

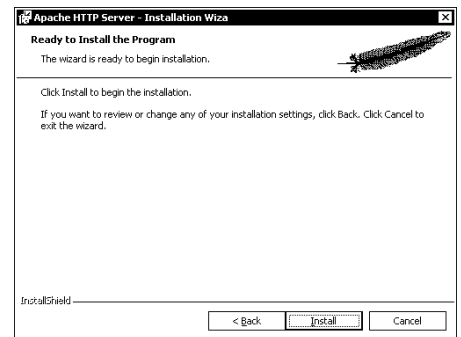

- (8) When copying of the file is completed, this panel is displayed. Select (CL) the [Finish] button.

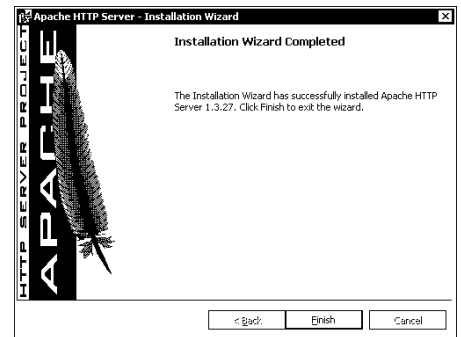

5. Restarting the SVP

When the setup is completed, the SVP restarts automatically.

5-1 < Installation of OpenSA >

If you are going to replace the SVP with OpenSA installed, it is necessary to install OpenSA also in the SVP that has been replaced. ([WEB06-10](#))

If you are going to replace the SVP without OpenSA installed, go to 6.

6. Set IP address of SVP

(1) <Changing the mode>

Change the mode by selecting [Modify Mode].

(2) <Opening the Install window>

Select (CL) [Install] from the [SVP] menu.

(3) <Selecting [Set SVP IP Address]>

Select (CL) [Set IP Address] in the [Install] window.

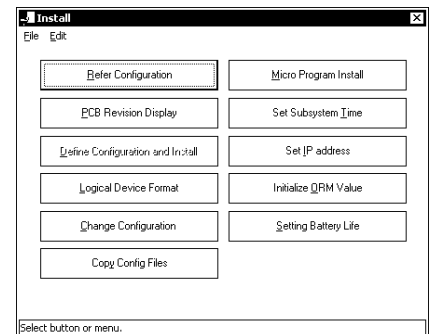

(4) <Setting an IP address>

Select (CL) [SVP] in the Internal IP Address box and enter an IP address and subnet mask of the internal IP address.

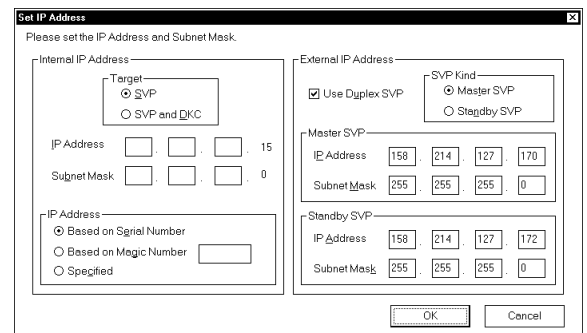

- (5) <Setting the SVP duplication>
- Select (CL) [Use Duplex SVP] in the External IP address box.
 - Select (CL) [Standby SVP] in the SVP Kind box.
 - Enter the IP addresses and subnet masks of the Master and Standby SVPs, and then select (CL) [OK].

- * You do not have to enter the information of Item (c) above when the setting of the external IP address is not required. (External IP Address is required when using Web Console made remote connection or using the SNMP Agent function.)

- (6) <Confirming the external IP address setting>
When a message, “When there are directions to set the external IP address, please set the external IP address from the “Control Panel” of Windows after performing this operation.” is displayed, select (CL) the [OK] button.

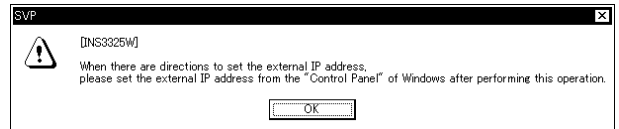

- (7) <Inserting the Config FD>
Insert the Config FD into the FDD and select (CL) [OK].



- (8) <Removing the Config FD>
When the copying of the Config is completed, a message, “Please remove the Config FD.” is displayed. Remove the FD and select (CL) [OK].

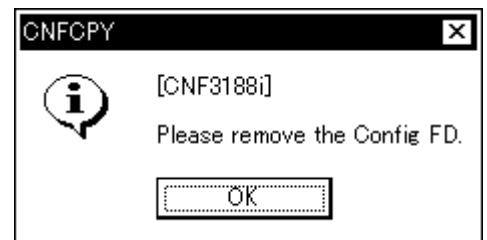

(9) <Confirming rebooting of the SVP>

Select (CL) [OK] in response to a message, “This will reboot SVP.”.



(10) <Opening the Network and Dial-up Connections window>

When the setting of the external IP address is not required, go to Step 7.

Select (CL) [Settings] and [Network and Dialup Connections] in this order from the [Start].

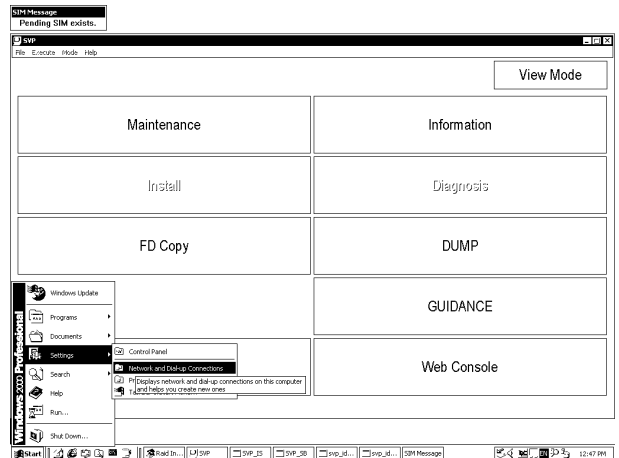

(11) <Opening the Local Area Connection 2 window>

Select (CL) [Local Area Connection 2] in the Network and Dial-up Connections window.

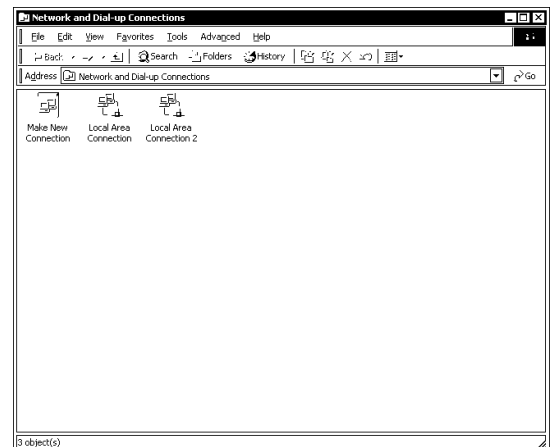

- (12) <Opening the Local Area Connection 2 Properties window>
 Select (CL) [Internal Protocol (TCP/IP)] in the Local Area Connection 2 Properties window, and then select the [Properties] button.

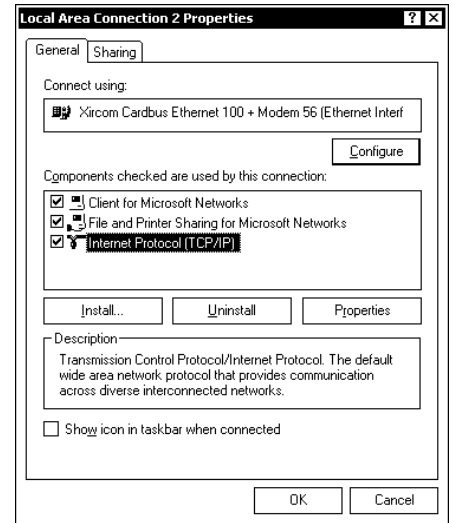

- (13) <Setting an external IP address>
 Set the IP address and subnet mask, and then select (CL) the [OK] button.

When the setting of the network must be changed after the setting operation is completed, go to Step (14). In the other cases, select (CL) the [OK] button in the 'Local Area Connection 2 Properties' window. Close the 'Network and Dial-up Connection' window.

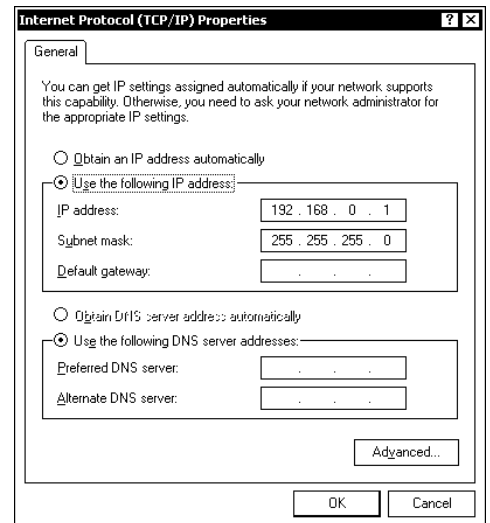

When the SVP is not connected to the LAN, the following window is displayed. Select (CL) the [No].

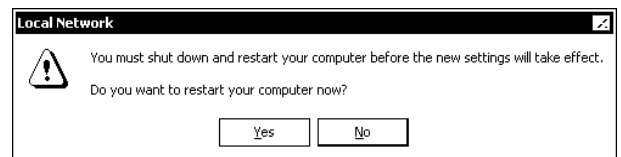

(14) <Opening bus information on the card being used>

Select (CL) the [Configure] button in the 'Local Area Connection 2 Properties' window.

When the Xircom card is used, go to Step (15).

When the 3com card is used, go to Step (18).

[In the case of the Xircom card bus]

(15) <Opening the 'Xircom Cardbus ...' window>

Select (CL) the 'Advanced' tab in the 'Xircom Cardbus ...' window.

The next step must be selected from two kinds of steps depending on the driver. Make a setting instructed in Step (16) or (17).

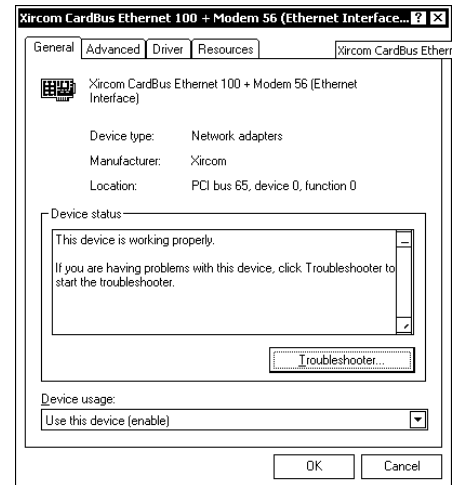

(16)-1 <Setting the speed mode>

Select the 'Line Speed' and change the setting of the 'Value' from 'Auto Detect' to '100 Mbps'.

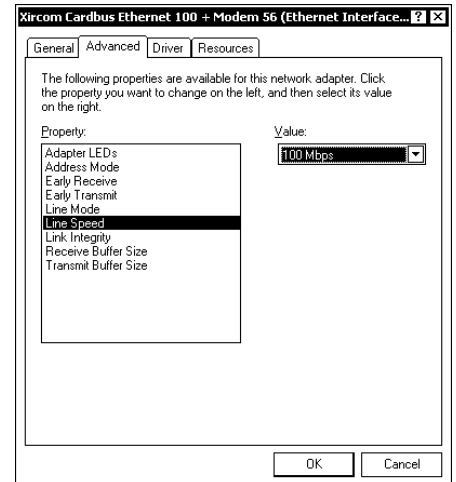

(16)-2 <Setting the line mode>

Select the 'Line Mode' and change the setting of the 'Value' from 'Auto Detect' to 'Full Duplex'.

Return the window to 'Local Area Connection 2 Properties' by pressing (CL) the [OK] button, and close the window by pressing the [OK] button.

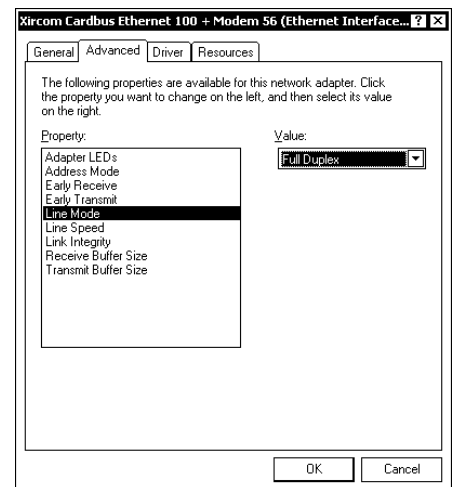

(17)-1 <Setting the Line Configuration>

Select [Line Configuration] and change the setting of the 'Value' to '100Mbps/Full Duplex'.

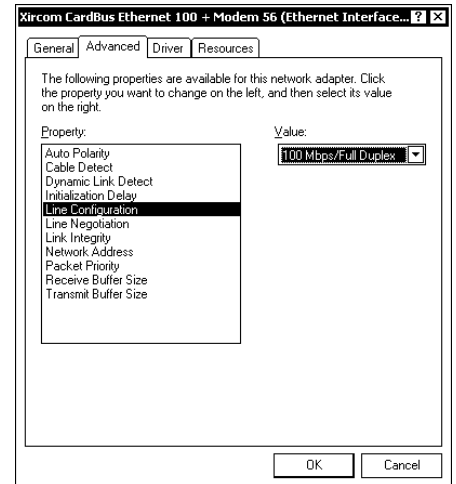

(17)-2 <Setting the Line Negotiation>

Select [Line Negotiation] and change the setting of the 'Value' to 'Off'.

Return the window to the 'Local Area Connection 2 Properties' by selecting (CL) the [OK] button. Then close the window by selecting the [OK] button.

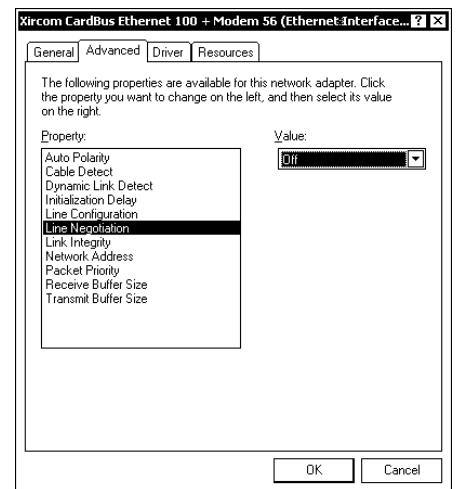

[In the Case of the 3com card bus]

(18) <Opening the 'FEM656C-3Com ...' window>

Select (CL) the 'Advanced' tab in the 'FEM656C-3Com...' window.

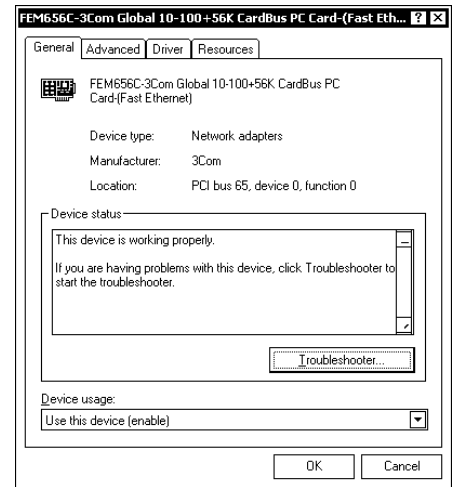

(19) <Setting the network link selection>

Select the 'Network Link Selection' and change the setting of the 'Value' from 'Auto Negotiation' to '100BTX Full Duplex'.

Return the window to 'Local Area Connection 2 Properties' by pressing (CL) the [OK] button, and close the window by pressing the [OK] button.

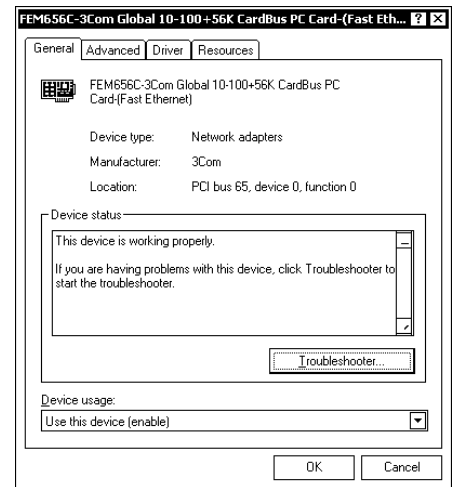

7. Setting Web Console

Make a setting of the Internet Explorer according to [Web Station] section. ([WEB01-10](#))

Remove the CD-ROM.

8. Shutting down the SVP

Power off the SVP (PC) by shutting it down.

9. Removing the SVP PS ON/OFF INH jumper

Remove the jumper plug that was attached in HARDWARE T7 (Step 11 on [REP03-535](#))

Remove the jumper plug from the SVP PS ON/OFF INH pin of the RS CON. When the SVP is an Optional SVP, remove the jumper plug from the PS CTLINH pin of the SVPPS-BOX, too. (See HARDWARE T7 (Step 5 on [REP03-480](#)))

10. Connect the LAN cable

- (1) Connect the LAN cable that was removed in HARDWARE T7 (Step 5 on [REP03-480](#)) to the HUB Box. (See Fig. T7.1-5 ([REP03-480](#)), Fig. T7.1-8 ([REP03-500](#)))

11. Reset the SSVP

Press the SSVP ALARM RESET switch of the SSVP (see LOCATION SECTION ([LOCATION03-40](#) and [LOCATION03-60](#))).

12. Transferring configuration data

- (1) Change the mode to [Modify Mode].
Select (CL) [Maintenance].

- (2) The “Maintenance” window is displayed.

(Multi Cabinet Model)

In the ‘Maintenance’ window, check and select (CL) [DKC] to be replaced.

(Single Cabinet Model)

In the “Maintenance’ window, check and select (CL) [Controller] to be replaced.

(Multi Cabinet Model)

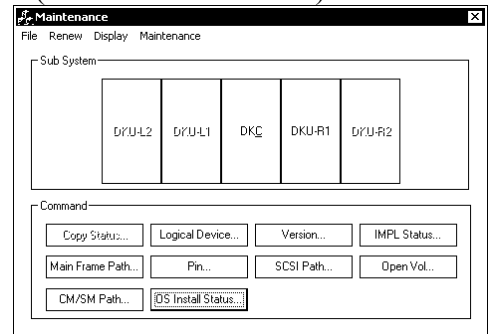

(Single Cabinet Model)

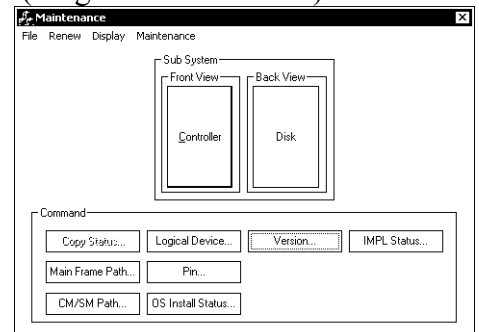

(3)

(Multi Cabinet Model)

In the 'DKC' window, check and select (CL) [SVP] to be replaced.

(Single Cabinet Model)

In the 'Controller' window, check and select (CL) [SVP] to be replaced.

(Multi Cabinet Model)

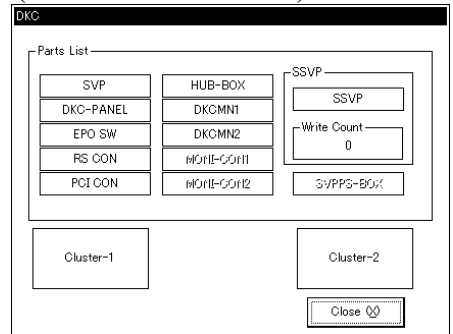

(Single Cabinet Model)

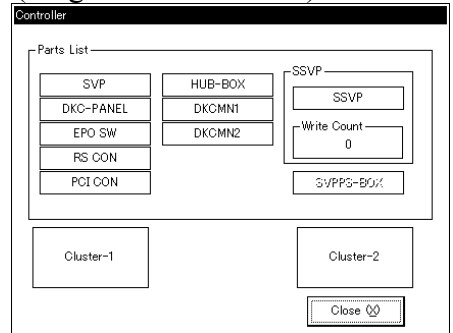

(4) Select (CL) "Transfer Config Data only", and select (CL) [Execute].

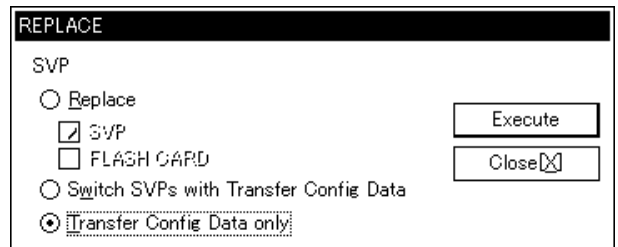

(5) In response to a message "Do you want to transfer configuration data?", select (CL) [Yes].

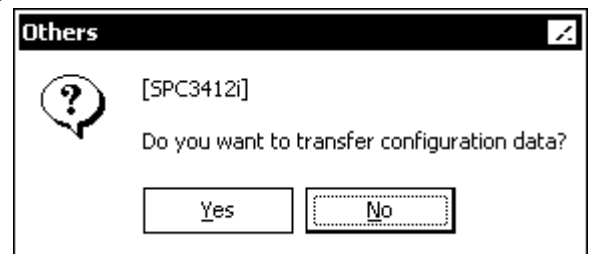

- (6) “Transferring subsystem configuration data...”
is displayed.

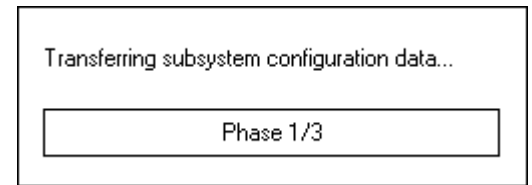

- (7) “Configuration data has been transferred.”
is displayed, when Configuration data has been
transferred. Select (CL) [OK].
If error has occurred while transferring, correct
that a replaced SVP has problem of connecting
and/or setting.

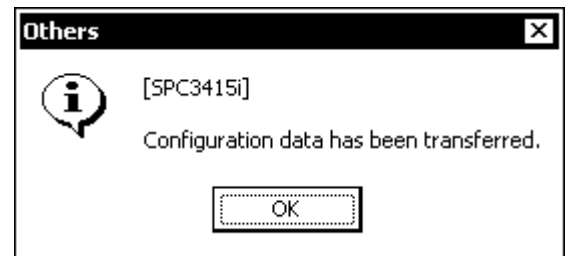

- (8)

(Multi Cabinet Model)
Close 'DKC' window.
Close 'Maintenance' window.

(Single Cabinet Model)
Close 'Controller' window.
Close 'Maintenance' window.

13. Installing Setup on SVP

(1)

When the E-NAS is installed, install Setup on SVP in only the SVP that has been replaced through the NAS section. ([NAS03-110](#))

When the E-NAS is not installed, go to Step (2).

(2)

Go to POST-PROCEDURE z ([REP04-1400](#)).

Blank Sheet

REV.3	Jun.2002	Jul.2002	Sep.2003	Jan.2004		
-------	----------	----------	----------	----------	--	--

[3] Replacement of an SVP with or without a Flash Card (by the side of a Master)

Perform the following operation at a Master SVP.

1. Set Date/Time

(1) <Open [Control Panel]>

Select (DR) [Settings] and then [Control Panel] from [Start].

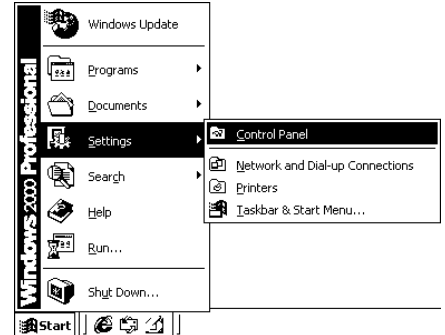

(2) <Open [Date/Time]>

Select (DC) [Date/Time] from [Control Panel].

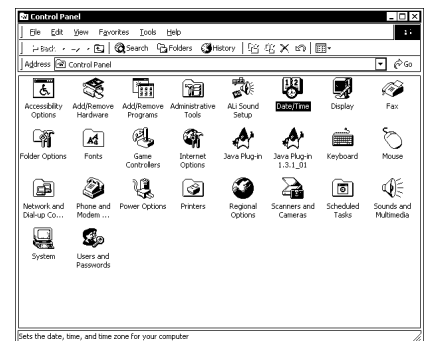

(3) <Select [Time Zone]>

Select (CL) [Time Zone].

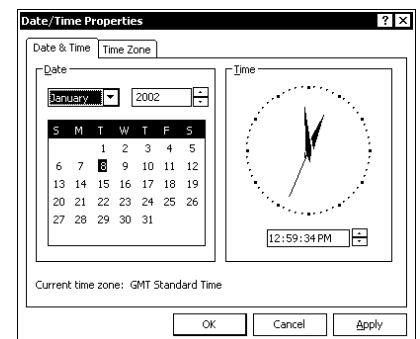

(4) <Check the setting of [Time Zone]>

Make sure that the setting of [Time Zone] is without the relation of a subsystem position “[GMT] Greenwich Mean Time; Dublin, Edinburgh, Lisbon, London”. Also, make sure that a check box on the left of “Automatically adjust clock for daylight saving changes” is (without a check mark). Then, select (CL) [Date/Time].

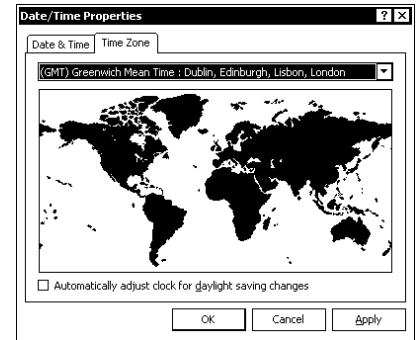

(5) <Set the [Date/Time]>

Check if the [Date/Time] is set to the current time and date. If not, reset it correctly. Then, select (CL) [OK].

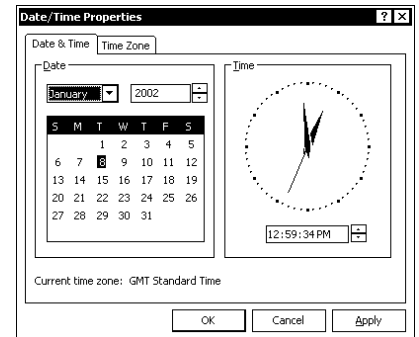

(6) <Close “Control Panel”>

Select (CL) [File] on “Control Panel”.
Select (CL) [Close].

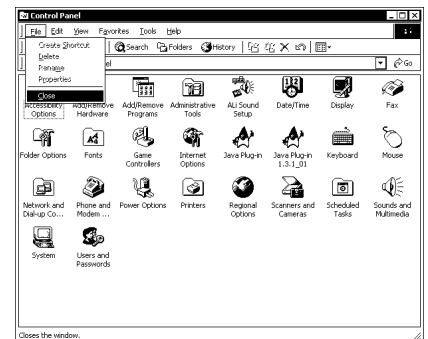

2. Installation of Micro-program

2.1 Preparation

When the SVP program is already installed, perform the following procedure.

2.1.1 Uninstallation of Apache

You need to uninstall the Apache installed in the SVP. Uninstall the Apache by following procedure.

2.1.1.1 Checking Apache version

Use the following procedure and check the version of the Apache currently installed in the SVP.

- (1) Select (DR) [Start]-[Settings]-[Control Panel].

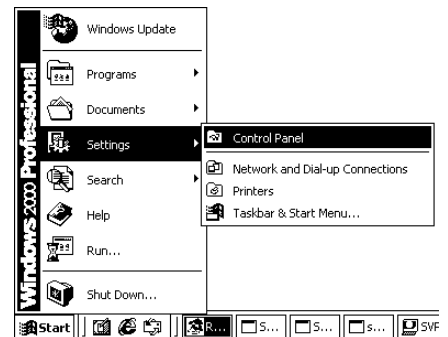

- (2) Select (DC) [Add/Remove Programs], and then press the [Enter] key.

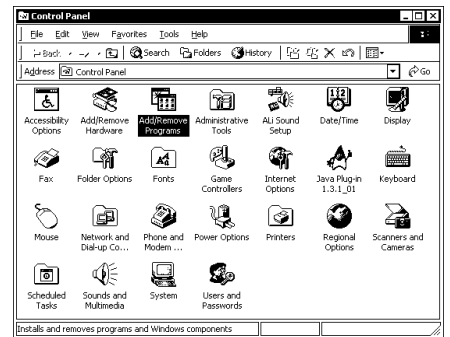

- (3) Check the content of [Currently installed programs] in the 'Add/Remove Programs' panel.

If [Apache Web Server] exists, Apache 1.3.14 is installed.

If [Apache HTTP Server 1.3.27] exists, Apache 1.3.27 is installed. In order to uninstall Apache 1.3.14, go to 2.1.1.2. In order to uninstall Apache 1.3.27, go to 2.1.1.3.

When the Apache version check is completed, select (CL) [×] button and close the window.

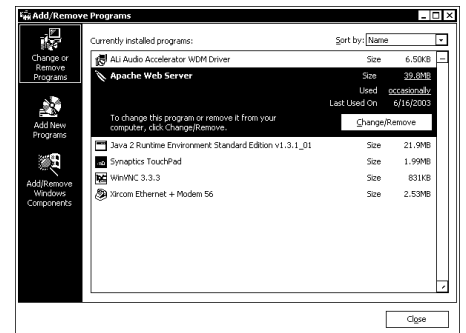

2.1.1.2 Uninstallation of Apache 1.3.14

- (1) Select (DR) [Start]-[Programs]-[Apache Web Server]-[Apache as a service]-[Stop Service]. Service of Apache will stop.

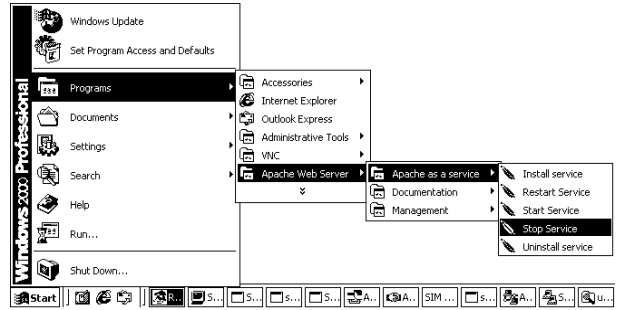

- (2) Select (DR) [Start]-[Programs]-[Apache Web Server]-[Apache as a service]-[Uninstall service].

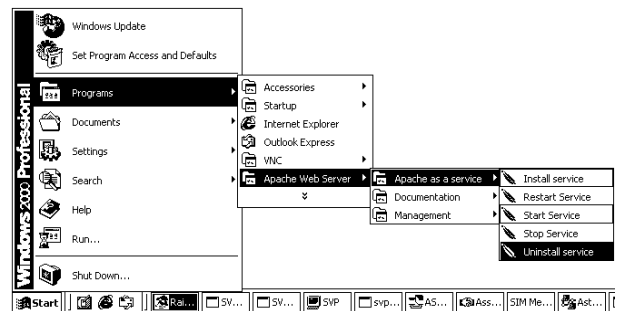

- (3) Select (DR) [Start]-[Shut Down...], and reboot the SVP. Select (CL) [Restart] in the Shut Down Windows panel, and then select (CL) the [OK] button.



- (4) When Windows is rebooted, select (DR) [Start]-[Settings]-[Control Panel].

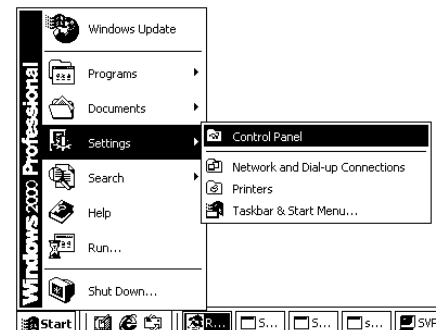

- (5) Select (DC) [Add/Remove Programs], and then press the [Enter] key.

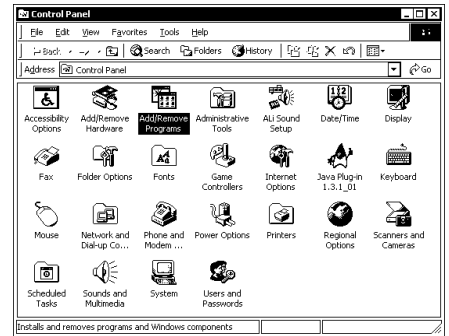

- (6) Select [Apache Web Server], and then select (CL) the [Change/Remove] button.

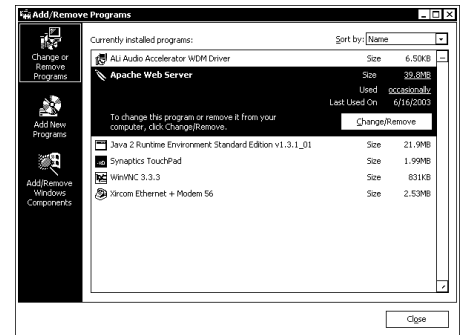

- (7) The message, “Are you sure you want to completely remove ‘Apache Web Server’ and all of its components?” is displayed. Select (CL) the [Yes] button.

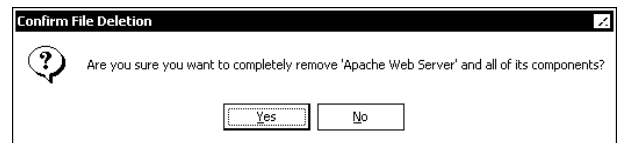

- (8) Uninstallation of Apache starts. When all of the deleted items are checked and the [OK] button becomes selectable, select (CL) the [OK] button.

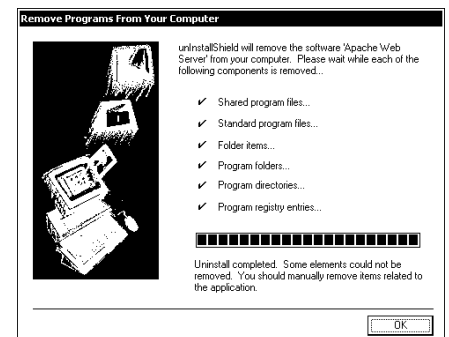

- (9) [Apache Web Server] is removed from the 'Add/Remove Programs' panel.
Select (CL) [×] button, and close this window.

Go to 2.1.2.

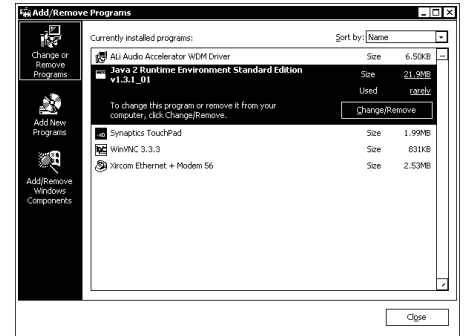

2.1.1.3 Uninstallation of Apache 1.3.27

- (1) Select (DR) [Start]-[Programs]-[Apache HTTP Server]-[Control Apache Server]-[Stop]. Service of Apache will stop.

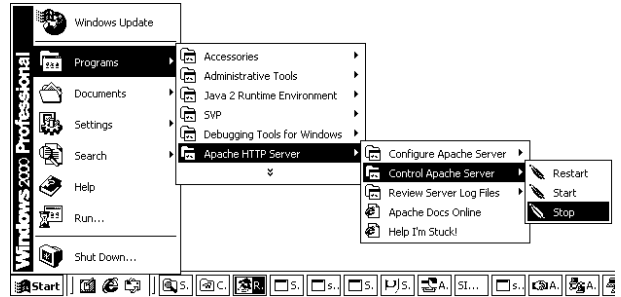

- (2) Select (DR) [Start]-[Settings]-[Control Panel].

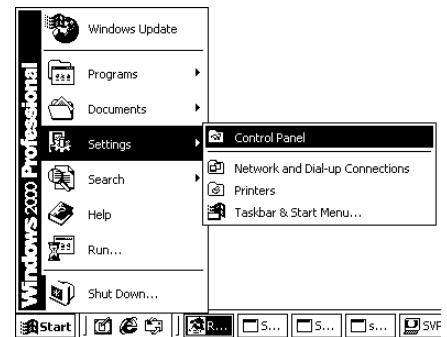

- (3) Select (DC) [Add/Remove Programs], and then press the [Enter] key.

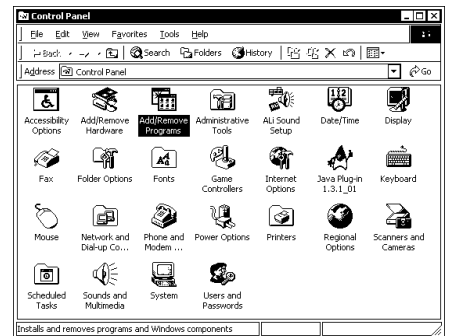

- (4) Select [Apache HTTP Server 1.3.27], and then select (CL) the [Remove] button.

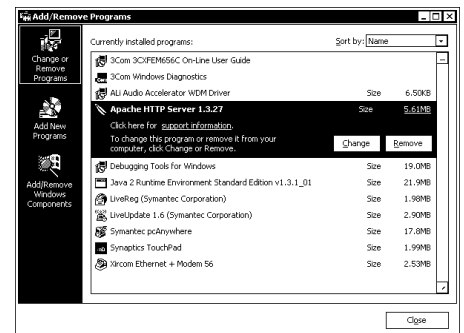

- (5) The message, “Are you sure you want to remove Apache HTTP Server 1.3.27 from your computer?”, is displayed. Select (CL) the [Yes] button.

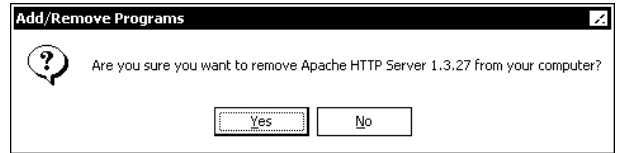

- (6) Uninstallation of Apache 1.3.27 starts.

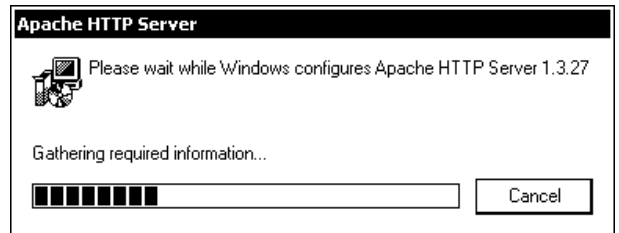

- (7) [Apache HTTP Server 1.3.27] is removed from the ‘Add/Remove Programs’ panel. Select (CL) [×] button, and close this window.

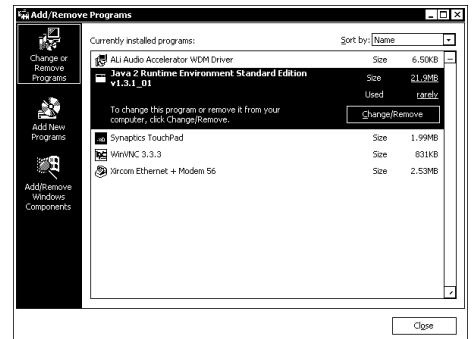

- (8) Select (DR) [Start]-[Shut Down...], and reboot the SVP. Select (CL) [Restart] in the Shut Down Windows panel, and then select (CL) the [OK] button.

When Windows is rebooted, go to 2.1.2.



2.1.2 Uninstallation of Java

(1) Select (DR) [Start]-[Settings]-[Control Panel].

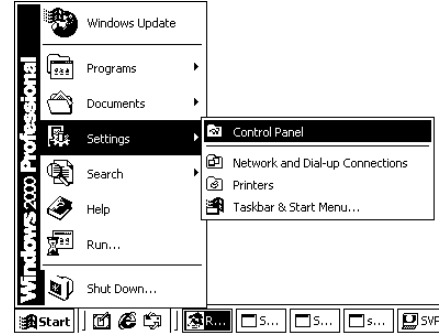

(2) Select (DC) [Add/Remove Programs], and then press the [Enter] key.



(3) Select [Java 2 Runtime Environment Standard Edition v1.3.1_01], and then select (CL) the [Change/Remove] button.

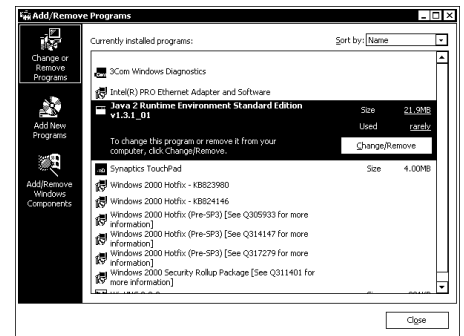

(4) The message, “Are you sure you want to completely remove ‘Java 2 Runtime Environment Standard Edition v1.3.1_01’ and all of its components?”, is displayed. Select (CL) the [Yes] button.

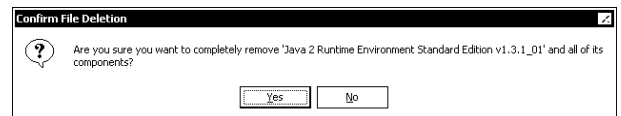

- (5) Uninstallation of Java starts. When all of the deleted items are checked and the [OK] button becomes selectable, select (CL) the [OK] button.

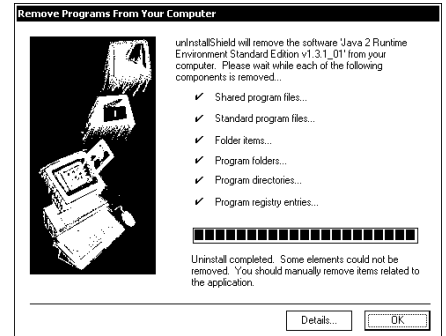

- (6) The message, “Java 2 Runtime Environment Standard Edition v1.3.1_01’ has been removed from your system. It is recommended that you restart your machine to remove files that were in use during uninstall.”, is displayed. Select (CL) the [OK] button.



- (7) [Java 2 Runtime Environment Standard Edition v1.3.1_01] is removed from the ‘Add/Remove Programs’ panel. Select (CL) [x] button, and close this window.

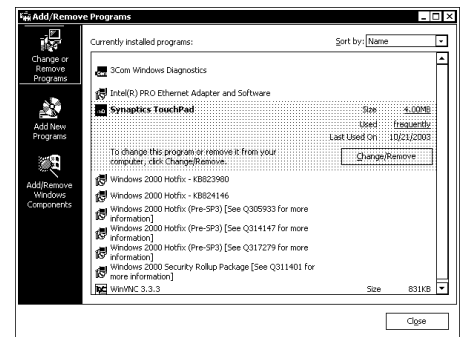

- (8) Select (DR) [Start]-[Shut Down...], and reboot the SVP. Select (CL) [Restart] in the Shut Down Windows panel, and then select (CL) the [OK] button.

When Windows is rebooted, go to 2.1.3.



2.1.3 Performance Monitor Data file delete

- (1) Select (DR) [Start]-[Programs]-[Accessories]-[Windows Explorer].

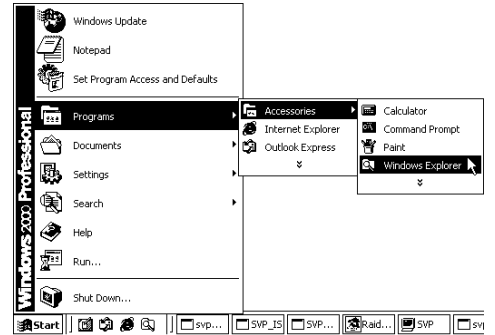

- (2) Select (CL) "D:\Mondat" directory, and delete it.

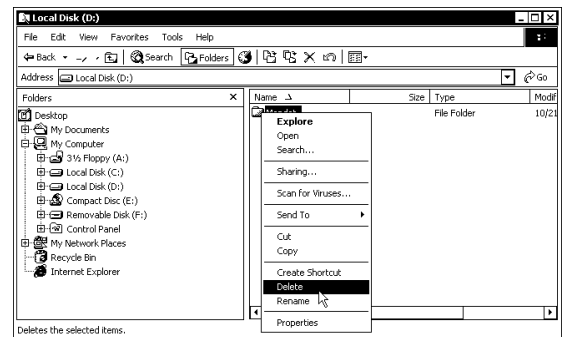

- (3) Select [Yes].

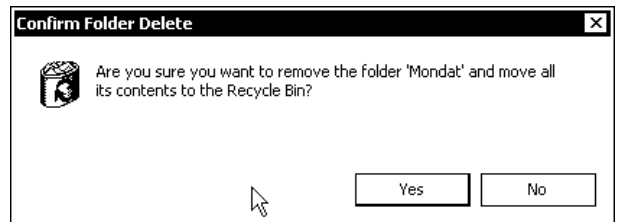

- (4) Finish the Explore.

2.2 Install

- ① Insert the CD-ROM disk into the CD-ROM drive and then wait one minute.
- ② Select (CL) [Run...] from the [Start]. Enter “e:\setup.exe” and select (CL) [OK].

If a message “An old version of Apache has been detected. Please uninstall this version and then perform Setup.exe again.” is displayed, perform again after uninstalling Apache 1.3.14.

The procedure of uninstallation of Apache 1.3.14 is shown 5.2 of WEB CONSOLE SECTION.



3. Installation of Configuration

(1) Inserting the Config FD

- ① A message "Please insert the Config FD into the FDD." is displayed.
- ② Insert the Config FD into the FDD and select (CL) [OK].

If you insert the previously backed-up Config FD, the original configuration is recovered.

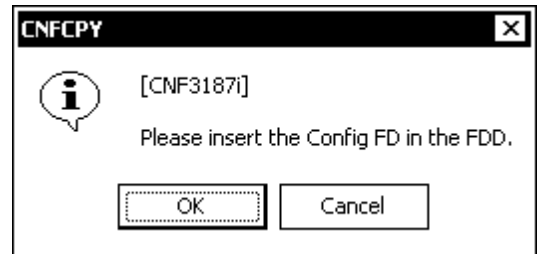

(2) Removing the Config FD

- ① When the copying of the Config is completed, a message "Please remove the Config FD." is displayed.
- ② Remove the Config FD from the FDD and select (CL) [OK].

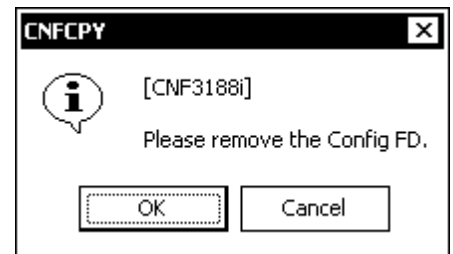

4. JAVA Setup

4-1 JAVA Setup

Setting up of Java is executed. When Java has already been installed, the routine proceeds to Step 4-2.

(1)

Select (CL) [Yes].

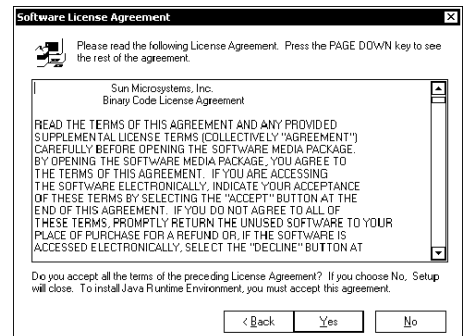

(2)

Select (CL) [Next].

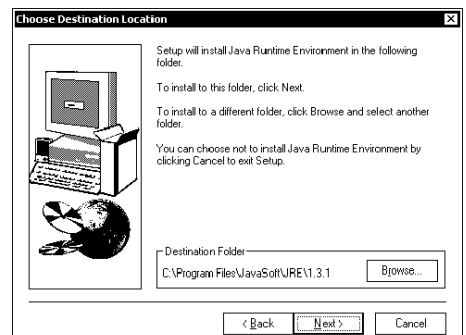

4-2 Setup Process of Apache

Execute Setup of Apache.

If the following panel is not displayed, Apache is already installed. Go to 5. If the SVP version is earlier than 21-06-20/00, Apache 1.3.14 will be installed. Use the following procedure to install it. If the SVP version is 21-06-20/00 or later, Apache 1.3.27 will be installed. Go to 4-3.

- (1)
Select (CL) [Next].

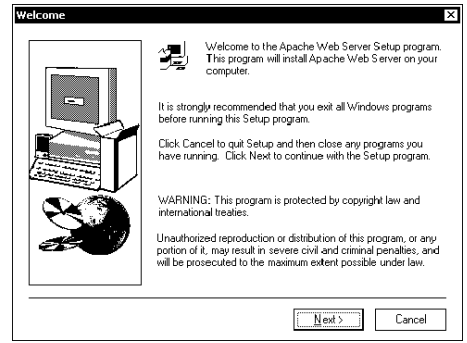

- (2)
Select (CL) [Yes].

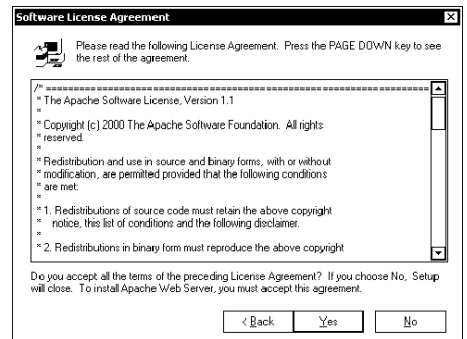

- (3)
Select (CL) [Next].

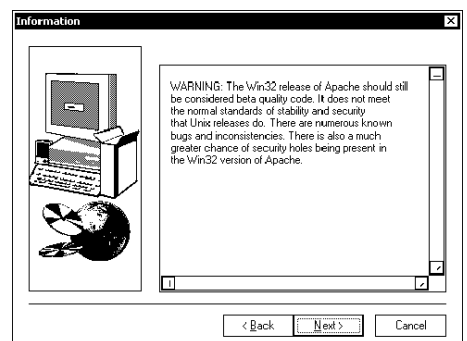

- (4)
Select (CL) [Next].

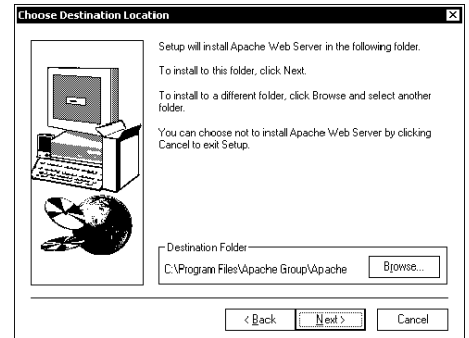

- (5)
Select (CL) [Next].

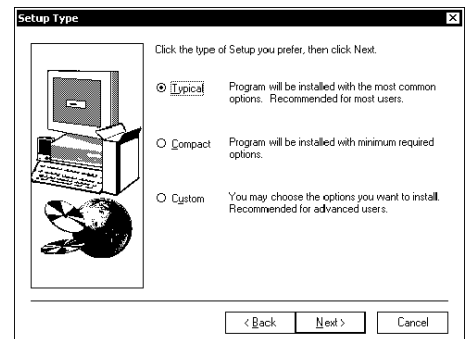

- (6)
Select (CL) [Next].

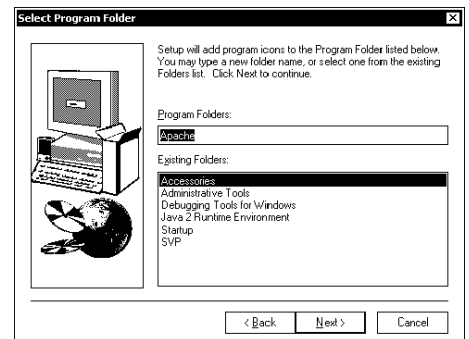

- (7)
Remove the check box of "Yes and I want to view the README file.", and select (CL) [Finish].

Go to Step 5.

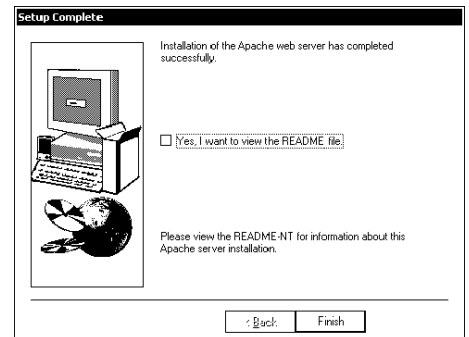

4-3 Setup Process of Apache 1.3.27

- (1) Select (CL) the [Next>] button.

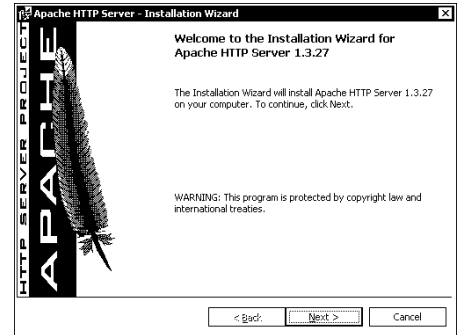

- (2) After selecting (CL) “I accept the terms in the license agreement”, select (CL) the [Next>] button.



- (3) Select (CL) the [Next>] button.

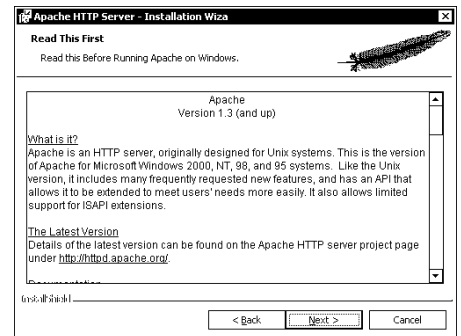

- (4) Enter “domain” to the Network Domain field, “svp” to the Server Name field, and “admin@domain.com” to the Administrator’s Email Address field.
After selecting (CL) “Run as a service for All Users – Recommended”, select (CL) the [Next >] button.

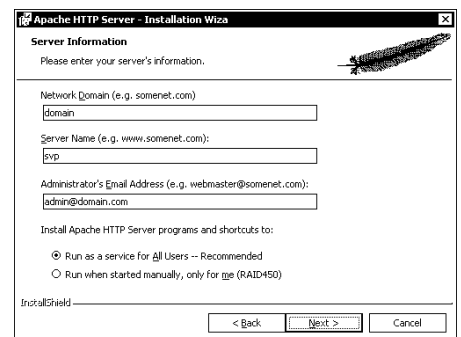

- (5) Select (CL) “Complete,” and then select (CL) the [Next>] button.

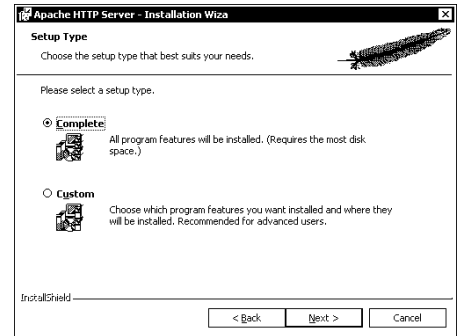

- (6) Select (CL) the [Next>] button.

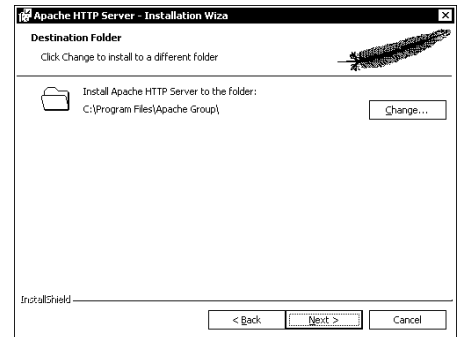

- (7) Select (CL) the [Install] button. Copying of the file will start.

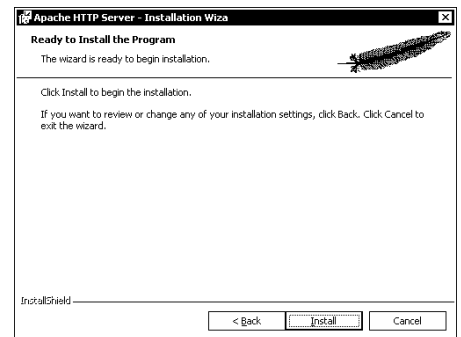

- (8) When copying of the file is completed, this panel is displayed. Select (CL) the [Finish] button.

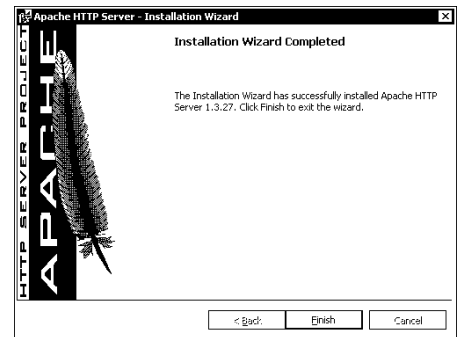

5. Restarting the SVP

When the setup is completed, the SVP restarts automatically.

5-1 < Installation of OpenSA >

If you are going to replace the SVP with OpenSA installed, it is necessary to install OpenSA also in the SVP that has been replaced. ([WEB06-10](#))

If you are going to replace the SVP without OpenSA installed, go to 6.

6. Set IP address of SVP

(1) <Changing the mode>

Change the mode by selecting [Modify Mode].

(2) <Opening the Install window>

Select (CL) [Install] from the [SVP] menu.

(3) <Selecting [Set SVP IP Address]>

Select (CL) [Set IP Address] in the [Install] window.

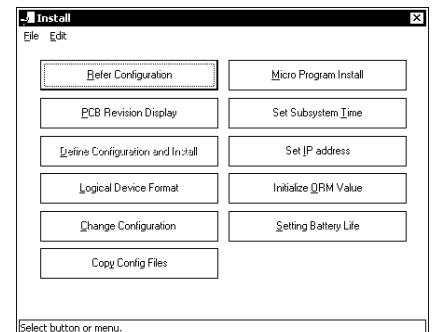

(4) <Setting an IP address>

Select (CL) [SVP] in the Internal IP Address box and enter an IP address and subnet mask of the internal IP address.

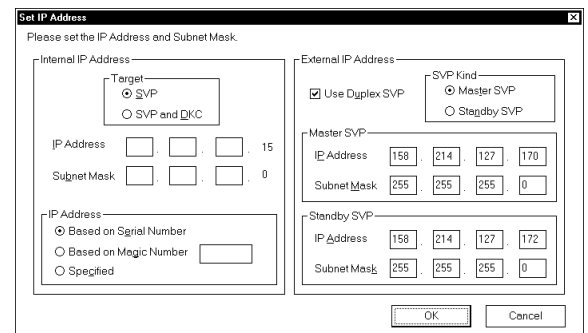

(5) <Setting an IP address>

Select (CL) [SVP] in the Internal IP Address box and enter an IP address and subnet mask of the internal IP address.

(6) <Setting the SVP duplication>

- Select (CL) [Use Duplex SVP] in the External IP address box.
- Select (CL) [Master SVP] in the SVP Kind box.
- Enter the IP addresses and subnet masks of the Master and Standby SVPs, and then select (CL) [OK].

* You do not have to enter the information of

Item (c) above when the setting of the external IP address is not required.

(External IP Address is required when using Web Console made remote connection or using the SNMP Agent function.)

(7) <Confirming the external IP address setting>

When a message, “When there are directions to set the external IP address, please set the external IP address from the “Control Panel” of Windows after performing this operation.” is displayed, select (CL) the [OK] button.

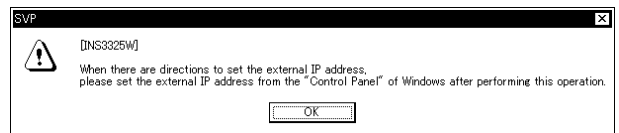

(8) <Inserting the Config FD>

Insert the Config FD into the FDD and select (CL) [OK].



(9) <Removing the Config FD>

When the copying of the Config is completed, a message, “Please remove the Config FD.” is displayed. Remove the FD and select (CL) [OK].



(10) <Confirming rebooting of the SVP>

Select (CL) [OK] in response to a message, “This will reboot SVP.”.



(11) <Opening the Network and Dial-up Connections window>

When the setting of the external IP address is not required, go to Step 7.

Select (CL) [Settings] and [Network and Dialup Connections] in this order from the [Start].

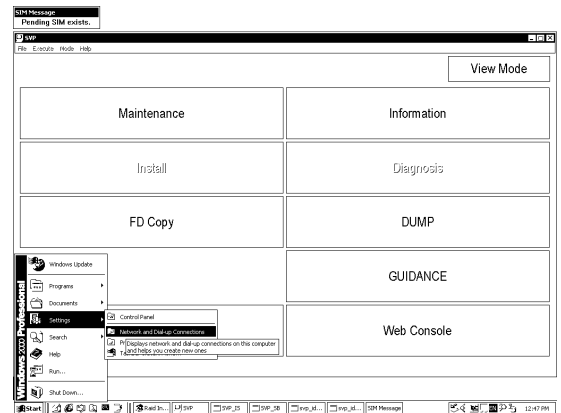

(12) <Opening the Local Area Connection 2 window>

Select (CL) [Local Area Connection 2] in the Network and Dial-up Connections window.

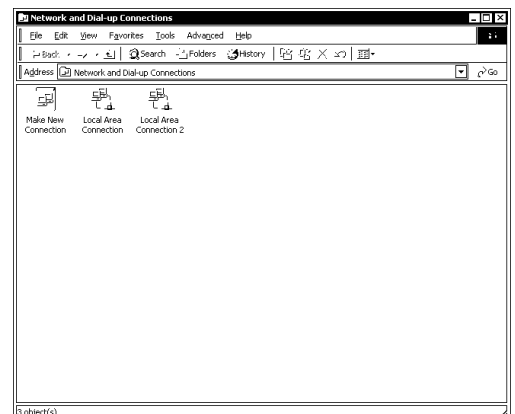

- (13) <Opening the Local Area Connection 2 Properties window>
 Select (CL) [Internal Protocol (TCP/IP)] in the [Local Area Connection 2 Properties] window, and then select (CL) the [Properties] button.

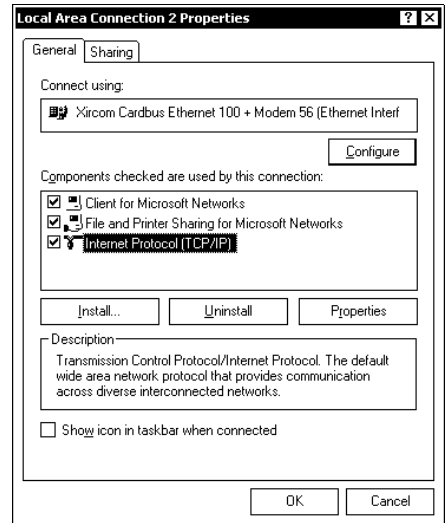

- (14) <Setting an external IP address>
 Set the IP address and subnet mask, and then select (CL) the [OK] button.

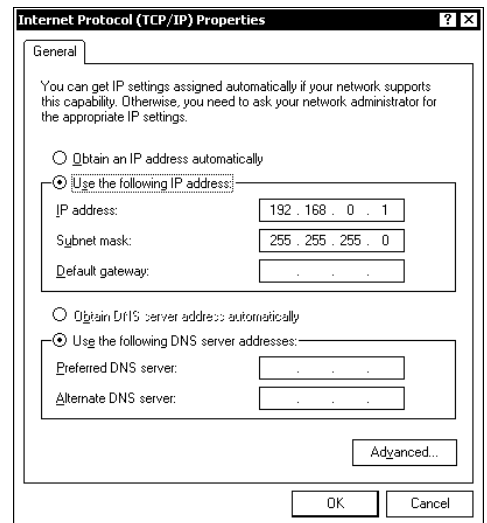

7. Removing the SVP PS ON/OFF INH jumper

Remove the jumper plug that was attached in Step 4 of Item [4] in PRE-PROCEDURE T5.
 Remove the jumper plug from the SVP PS ON/OFF INH pin of the RS CON.
 When the SVP is an Optional SVP, remove the jumper plug from the PS CTLINH pin of the SVPPS-BOX, too.
 (See HARDWARE T7 (Step 5 on [REP03-480](#)))

8. TOD Setting

Wait a few minutes, message “Loading SVP Program... SVP requests to DKC can not be performed presently. Please wait...” will be extinguished. Then set TOD.
 See [SVP02-10](#).

9. Load the Configuration from the SM to the SVP's HDD

- (1) <Open [Maintenance]>
Select (CL) [Maintenance] form 'SVP'.

- (2) Check "Connection error occurred SVP-DKC." is not displayed.
If "Connection error occurred SVP-DKC" is displayed, see [TRBL05-60](#).

- (3) <Select [Exit]>
Select (CL) [File] from the "Maintenance".
Select (CL) [Exit].

(Multi Cabinet Model)

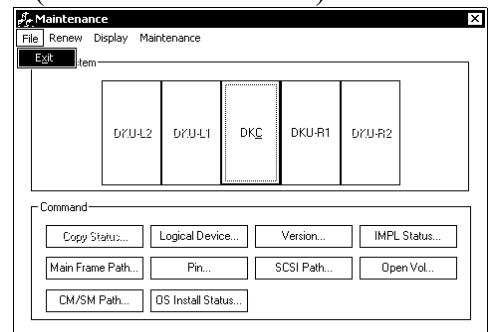

(Single Cabinet Model)

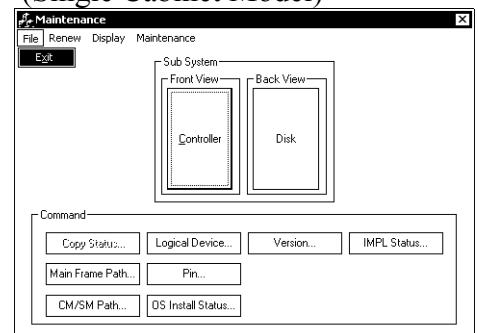

10. Setting Web Console

Make a setting of the Web Console according to [Web Station] section. ([WEB01-10](#))
Remove the CD-ROM.

When you have installed from the backed-up Config FD,

i) Storage list / user list / environment information can be recovered to the backed-up status by copy the following files under c:\program files\apache group\apache\cgi-bin\Utility\CSV.

- USERLIST.CSV
- STRLIST.CSV
- ENV.CSV

ii) Please perform the following procedure, when you use SNMP Agent.

1. Push Web Console button.
2. Open the SNMP Information Tab.
3. Remove the check mark of Extension SNMP and push Apply button.
4. Add the check mark of Extension SNMP and push Apply button again.

iii) Please perform the following procedure, when you don't use SNMP Agent.

1. Push Web Console button.
2. Specify Name, Contact and Location on Information Tab again.

11. Confirm status

Confirm the status display.

If button is valid, go to [12].

If button is blinking, replace the FLASH CARD.

12. Configuration Back

Make a backup copy of the configuration in the CONFIG FD. (See [MICRO-FC08-40](#))

13. Installing Setup on SVP

When the E-NAS is installed, install Setup on SVP in only the SVP that has been replaced through the NAS section. ([NAS03-110](#))

When the E-NAS is not installed, proceed to Chapter 14 SIM Complete.

14. SIM Complete

See [SVP02-580](#).

[End of POST-PROCEDURE]

[4] Replacement of a Flash Card (by the side of a Master)

Perform the following operation at a Master SVP.

1. <Confirm status>
Confirm the status display.

If button is blinking, refer to SIM and replace the target part again, or see TROUBLE SHOOTING SECTION.

[End of POST-PROCEDURE]

[POST-PROCEDURE u]

— OUTLINE —

- ① Execute CUDG on P-DEV.
- ② Specify recovery.
- ③ Correction copy
- ④ Reset ORM Error Count on the P-DEV.
- ⑤ Reset Threshold Counter
- ⑥ SIM Complete.



CAUTION

This processing is a special operation for detecting a cause of a Fibre loop error.
Ask the technical support center about the appropriateness of the operation.

⚠ CAUTION

This processing is a special operation for detecting a cause of a Fibre loop error.
Ask the technical support center about the appropriateness of the operation.

1. <Check the beginning of recovery>
Please insert the floppy disk and select (CL) [OK].
Failure information of the physical device is written to the floppy disk.

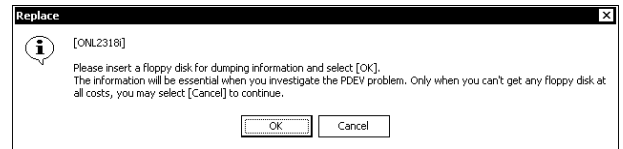

[After the completion of writing failure information:]
“Please remove the FD.” is displayed.
Please remove the floppy disk and select (CL) [OK].



2. <Spin up the Physical Drive>
“Spinning up...” is displayed.

3. <DKU INLINE>
Select (CL) [No] in response to “Are you sure you want to diagnose the physical device?”.

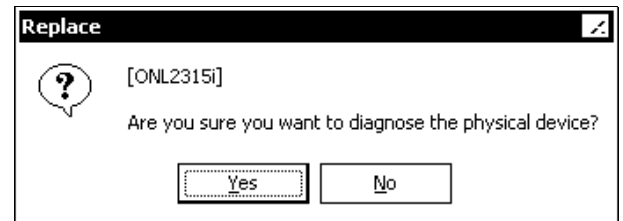

 **CAUTION**

This processing is a special operation for detecting a cause of a Fibre loop error.
Ask the technical support center about the appropriateness of the operation.

4. <Restore Physical Drive>

Select (CL) [Yes] in response to “Are you sure you want to restore the physical device?”.

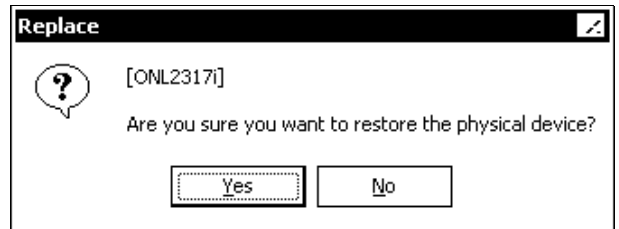

5. <Check the Drive Status>

“Checking...” is displayed.
Device is still blocked.

6. <Check the beginning of correction copy>

Select (CL) [Yes] in response to “Are you sure you want to correct data in the physical device?”.

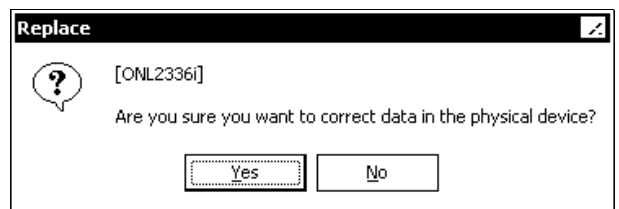

7. <Correct data>

“Correcting...” is displayed.

⚠ CAUTION

This processing is a special operation for detecting a cause of a Fibre loop error.
Ask the technical support center about the appropriateness of the operation.

8. <Check the starting of Correction copy>
Select (CL) [OK] in response to “Correcting data in the physical device has been started.”.

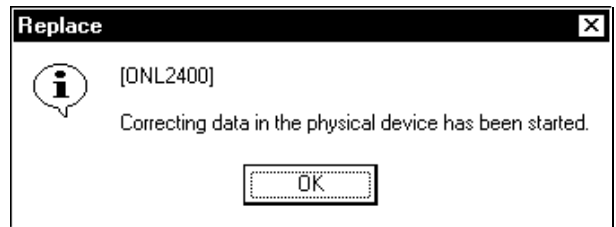

9. <Check the end of P-DEV recovery>
Select (CL) [OK] in response to “Replace finished.”.



10. <SIM Complete>
Refer to [SVP02-580](#).

[POST-PROCEDURE z]

— OUTLINE —

- ① SVP Window
- ② Change the SVP operation mode.

1. <SVP window>

2. <Changing the SVP operation mode>
Change the mode to [View Mode].