

SIM RC SECTION

REV.0	Jan.2000						
-------	----------	--	--	--	--	--	--

Contents

1 Reference Code-----	SIM-RC01-10
2 Reference Codes -----	SIM-RC02-10
2.1 SIM Reference Codes Detected by the Processor -----	SIM-RC02-10
2.2 SIM Reference Codes Detected by the SVP -----	SIM-RC02-220
3 SIM Format -----	SIM-RC03-10

1 Reference Code

A six-byte reference code (RC) is provided for a SIM (service information message) to identify an error and error section. The following shows 32 SIM bytes and reference codes.

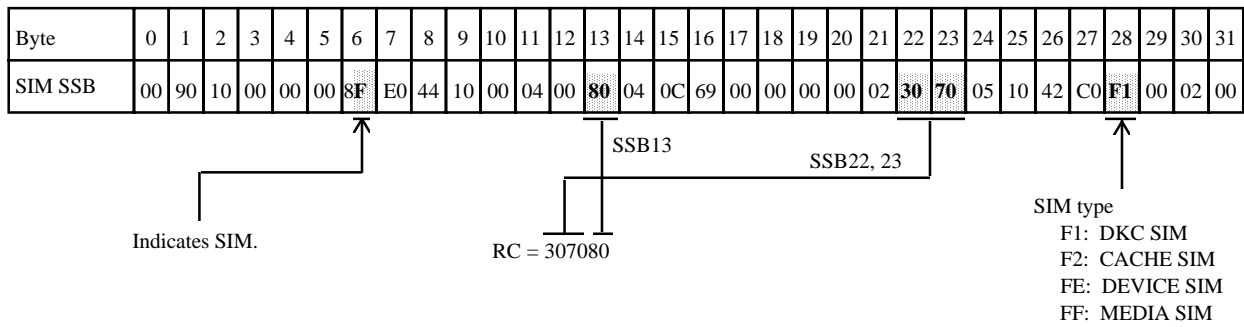

2 Reference Codes

SIMs are roughly classified into two types: SIMs detected by the processor and SIMs detected by the SVP.

2.1 SIM Reference Codes Detected by the Processor

SIM Reference Codes Detected by the Processor (1/7)

Error		REF CODE			SIM 28	Level of error	Host report	Remarks
		22	23	13				
LCP/FCP/ HTP error	LCM Hardware error	21	3Z	XY	F1	Moderate	Yes	X: CHA PCB# (*1) Y: LCP#1 (*3) Z: LCP#2 (*3)
	ADP permanent error	21	70	X0	F1	Moderate	Yes	X: CHA PCB# (*1)
	ADP temporary error	21	71	XY	F1	Service	No	X: CHA PCB# (*1) Y: LCP#0 (*3)
	ADP blocking	21	72	XY	F1	Moderate	Yes	X: CHA PCB# (*1) Y: LCP#0 (*3)
	AL_PA value conflict	21	90	XY	F1	Service	No	X: CHA PCB# (*1) Y: PORT# in PCB
	HTP hard error	21	A0	XY	F1	Moderate	Yes	X: CHA PCB# (*1) Y: HTP PATH# (*33)
	HTP path temporary error	21	A1	XY	F1	Service	No	X: CHA PCB# (*1) Y: HTP PATH# (*33)
	HTP path blocking	21	A2	XY	F1	Moderate	Yes	X: CHA PCB# (*1) Y: HTP PATH# (*33)
	HTP blocking	21	A3	XY	F1	Moderate	Yes	X: CHA PCB# (*1) Y: LCP#1 (*3)
CHA Processor error	ERRN_LUNRECERR	21	91	XY	F1	Serious	Yes	X: CHA P/K# Y: MP# in PCB
	CHK1A threshold over	30	70	XY	F1	Service	No	X: CHA PCB# (*1) Y: MP# in PCB
	CHK1B threshold over	30	71	XY	F1	Service	No	X: CHA PCB# (*1) Y: MP# in PCB
	CHK3 threshold over	30	72	XY	F1	Service	No	X: CHA PCB# (*1) Y: MP# in PCB
	Processor blocking	30	73	XY	F1	Moderate	Yes	X: CHA PCB# (*1) Y: MP# in PCB
	FM threshold over	30	74	XY	F1	Service	No	X: CHA PCB# (*1) Y: MP# in PCB
	FM error	30	75	XY	F1	Moderate	Yes	X: CHA PCB# (*1) Y: MP# in PCB
	Incorrect SUM value of FM	30	76	XY	F1	(*27)	No	X: CHA PCB# (*1) Y: MP# in PCB
	LDEV blockade (Effect of processor blockade)	30	90	XY	F1	Serious	Yes	X: CHA PCB# (*1) Y: MP# in PCB
	P/S OFF impossible	38	8F	00	F1	Moderate	No	
	P/S OFF impossible (Device reserved)	38	9F	00	F1	Moderate	No	

SIM Reference Codes Detected by the Processor (2/7)

Error		REF CODE			SIM 28	Level of error	Host report	Remarks
		22	23	13				
CHA Processor error	Undefined Package is mounted	39	90	XY	F1	Moderate	No	X: CHA PCB# (*1,5) Y: MP# in PCB
	V-R or serial number is inconsistent	39	91	XY	F1	Moderate	No	X: CHA PCB# (*1) Y: MP# in PCB
	Replace failed	39	93	XY	F1	Moderate	No	X: CHA PCB# (*1) Y: MP# in PCB
	Micro-program version up	39	94	X0	F1	Service	No	X: MP version after replacing (*23)
	Micro-program version up impossible	39	95	XY	F1	Service	No	X: Present MP version (*23) Y: reason code (*13)
	CHF PCB exchange (8HSE PCB → 8GSE PCB)	39	99	XY	F1	Service	No	X: CHA P/K# Y: MP# in PCB
	DXBF memory correctable error	39	A0	XY	F1	Service	No	X: CHA P/K# (*1) Y: MP# in PCB
	Warning of SM DISABLE (MPA detected)	39	9A	XY	F1	Moderate	No	X: CHA PCB# (*1) Y: 0 = Side A, 1 = Side B (*2)
	SMA slave error	39	9B	XY	F1	Moderate	No	X: CHA PCB# (*1) Y: MP# in PCB
	MPA slave error	39	9C	XY	F1	Moderate	No	X: CHA PCB# (*1) Y: MP# in PCB
	Injustice DC voltage control	39	9D	X0	F1	Moderate	No	X: CHA PCB# (*1)
	Injustice CE MODE	39	9E	X0	F1	Moderate	No	X: CHA PCB# (*1)
	CHT PCB exchange impossible (4GL ↔ 4GS)	39	9F	X0	F1	Moderate	No	X: CHA PCB# (*1)

[Notes] REF CODE = 213Z

There is another report of SIM (REF CODE = 213Z) in addition to LCP hardware error. It may be reported when a channel cable is drawn out with the connection composition of LCP-LCP. (Connection composition usually has HOST-LCP and RCP-LCP. However, it may be set to LCP-LCP by operation mistake.) In this case, the work by the action code is not performed. The connection state of a cable is corrected.

SIM Reference Codes Detected by the Processor (3/7)

Error	REF CODE			SIM 28	Level of error	Host report	Remarks	
	22	23	13					
DKA Processor error	CHK1A threshold over	31	70	XY	F1	Service	No	X: DKA PCB# (*1) Y: MP# in PCB
	CHK1B threshold over	31	71	XY	F1	Service	No	X: DKA PCB# (*1) Y: MP# in PCB
	CHK3 threshold over	31	72	XY	F1	Service	No	X: DKA PCB# (*1) Y: MP# in PCB
	Processor blocking	31	73	XY	F1	Moderate	Yes	X: DKA PCB# (*1) Y: MP# in PCB
	FM threshold over	31	74	XY	F1	Service	No	X: DKA PCB# (*1) Y: MP# in PCB
	FM error	31	75	XY	F1	Moderate	Yes	X: DKA PCB# (*1) Y: MP# in PCB
	Incorrect SUM value of FM	31	76	XY	F1	(*27)	No	X: DKA PCB# (*1) Y: MP# in PCB
	LDEV blockade (Effect of processor blockade)	31	90	XY	F1	Serious	Yes	X: DKA PCB# (*1) Y: MP# in PCB
	P/S OFF impossible	3C	8F	00	F1	Moderate	No	
	P/S OFF impossible (Device reserved)	3C	9F	00	F1	Moderate	No	
	Undefined Package is mounted	3D	90	XY	F1	Moderate	No	X: DKA PCB# (*1,5) Y: MP# in PCB
	V-R or serial number is inconsistent	3D	91	XY	F1	Moderate	No	X: DKA PCB# (*1) Y: MP# in PCB
	Replace failed	3D	93	XY	F1	Moderate	No	X: DKA PCB# (*1) Y: MP# in PCB
	Micro-program version up	3D	94	X0	F1	Service	No	X: MP version after replacing (*23)
	Micro-program version up impossible	3D	95	XY	F1	Service	No	X: Present MP version (*23) Y: reason code (*13)
	Warning of SM DISABLE (MPA detected)	3D	9A	XY	F1	Moderate	No	X: DKA PCB# (*1) Y: 0 = Side A, 1 = Side B (*2)
	SMA slave error	3D	9B	XY	F1	Moderate	No	X: DKA PCB# (*1) Y: MP# in PCB
	MPA slave error	3D	9C	XY	F1	Moderate	No	X: DKA PCB# (*1) Y: MP# in PCB
	Injustice DC voltage control	3D	9D	X0	F1	Moderate	No	X: DKA PCB# (*1)
	Injustice CE MODE	3D	9E	X0	F1	Moderate	No	X: DKA PCB# (*1)
FSW LED BUS test	3D	AZ	XY	FE	Moderate	No	X: DKA PCB# (*1) Y: MP# in PCB Z: FSW PCB#	
Tachyon error	3D	B0	XY	FE	Service	No	X: DKA PCB# (*1) Y: MP# in PCB	
SHSN error	Logical path blockade (CHA Processor)	32	8Z	XY	F1	Moderate	No	X: CHA PCB# (*1,31) Y: MP# in PCB Z: PATH# 0: A0 PATH 1: A1 PATH 2: B0 PATH 3: B1 PATH

SIM Reference Codes Detected by the Processor (4/7)

Error		REF CODE			SIM 28	Level of error	Host report	Remarks
		22	23	13				
SHSN error	Logical path blockade (DKA Processor)	33	8Z	XY	F1	Moderate	No	X: DKA PCB# (*1,31) Y: MP# in PCB Z: PATH# 0: A0 PATH 1: A1 PATH 2: B0 PATH 3: B1 PATH
CHSN error	Logical path blockade (CHA Processor/CARB0)	32	0Z	XY	F1	Moderate	No	X: CHA PCB# (*1,29) Y: MP# in PCB Z: C path bitmap
	Logical path blockade (CHA Processor/CARB1)	32	1Z	XY	F1	Moderate	No	X: CHA PCB# (*1,29) Y: MP# in PCB Z: C path bitmap
	Logical path blockade (CHA/PMA/CARB0)	32	4Z	XY	F1	Moderate	No	X: CHA PCB# (*1,29) Y: MP# in PCB Z: C path bitmap
	Logical path blockade (CHA/PMA/CARB1)	32	5Z	XY	F1	Moderate	No	X: CHA PCB# (*1,29) Y: MP# in PCB Z: C path bitmap
	Logical path blockade (DKA/DRR/CARB0)	33	0Z	XY	F1	Moderate	No	X: DKA PCB# (*1,29) Y: MP# in PCB Z: C path bitmap
	Logical path blockade (DKA/DRR/CARB1)	33	1Z	XY	F1	Moderate	No	X: DKA PCB# (*1,29) Y: MP# in PCB Z: C path bitmap
	Logical path blockade (DKA/FCA/CARB0)	33	2Z	XY	F1	Moderate	No	X: DKA PCB# (*1,29) Y: MP# in PCB Z: C path bitmap
	Logical path blockade (DKA/FCA/CARB1)	33	3Z	XY	F1	Moderate	No	X: DKA PCB# (*1,29) Y: MP# in PCB Z: C path bitmap
CHA, CHK2 (processor)	RCHA temporary error	3F	84	X0	F1	Service	No	X: CHA PCB# (*1)
	RCHA blocking	3F	85	X0	F1	Serious	Yes	X: CHA PCB# (*1)
DKA CHK2 (processor)	Pinned slot	CF	4X	YY	F1	Moderate	No	X: CU# YY: LDEV#
	DRR temporary error	CF	80	XY	F1	Service	No	X: DKA PCB# (*1) Y: MP# in PCB
	FCA temporary error	CF	81	XY	F1	Service	No	X: DKA PCB# (*1) Y: Port# (*4)
	DRR blocking	CF	82	XY	F1	Moderate	Yes	X: DKA PCB# (*1) Y: MP# in PCB
	FCA blocking (0-3)	CF	83	XY	F1	Moderate	Yes	X: DKA PCB# (*1) Y: Port# (*4)
	Fibre port blocking (Effect of PATH INLINE failed)	CF	84	XY	F1	Moderate	No	X: DKA PCB# (*1) Y: Port# (*4)
	LDEV blockade (Effect of FCA blockade)	CF	90	XY	F1	Serious	Yes	X: DKA PCB# (*1) Y: Port# (*4)

SIM Reference Codes Detected by the Processor (5/7)

Error		REF CODE			SIM 28	Level of error	Host report	Remarks
		22	23	13				
Cache data error	Pinned slot	FF	4X	YY	F2	Moderate	No	X: CU# YY: LDEV#
Cache error	Area is volatiled	FF	CD	0X	F2	Service	No	X: 0 = Side A, 1 = Side B (*2)
	Package is volatiled	FF	CE	0X	F2	Service	No	X: PCB# (*1) Side A:Even, Side B:Odd
	Module group is volatiled	FF	CF	YX	F2	Service	No	X: PCB# (*1) Side A:Even, Side B:Odd Y: Module group# (*10)
	Correctable error	FF	F0	YX	F2	Service	No	X: PCB# (*1) Side A:Even, Side B:Odd Y: Module group# (*10)
	Cache temporary error	FF	F1	YX	F2	Service	Yes	X: PCB# (*1) Side A:Even, Side B:Odd Y: Module group# (*10)
	Module group blocking	FF	F2	YX	F2	Moderate	Yes	X: PCB# (*1) Side A:Even, Side B:Odd Y: Module group# (*10)
	Package blocking	FF	F3	0X	F2	Moderate	Yes	X: PCB# (*1) Side A:Even, Side B:Odd
	Area blocking	FF	F4	0X	F2	Serious	Yes	X: 0 = Side A, 1 = Side B (*2)
	Both area failed	FF	F5	0X	F2	Moderate	No	X: PCB# (*1) Side A:Even, Side B:Odd
	Injustice DC voltage control	FF	F6	0X	F2	Moderate	No	X: PCB# (*1) Side A:Even, Side B:Odd
	Injustice CE MODE	FF	F7	0X	F2	Moderate	No	X: PCB# (*1) Side A:Even, Side B:Odd
	Module group error in On-demand area	FF	FD	YX	F2	Moderate	No	X: PCB# (*1) Y: Module group#
Shared memory error	Loss of duplicated information	FF	DE	XX	F1	Service	No	XX: Lost information type (*25)
	One side Area is volatiled	FF	DF	0X	F1	Service	No	X: 0 = Side A, 1 = Side B (*2)
	Correctable error	FF	E0	YX	F1	Service	No	X: 0 = Side A, 1 = Side B Y: Module# (*2,10)
	Area blocking	FF	E2	0X	F1	Serious	Yes	X: 0 = Side A, 1 = Side B (*2,10)
	Real memory size inconsistent	FF	E3	XY	F1	Serious	No	X: Number of module (side A) Y: Number of module (side B) (*8)
	Replace failed (*20)	FF	E4	0X	F1	Serious	No	X: 0 = Side A, 1 = Side B (*2)
	Both side invalid	FF	E5	00	F1	Acute	No	
	Configuration information compare error (*22)	FF	E6	00	F1	Acute	No	
	Shared memory is volatiled.	FF	E7	00	F1	Serious	No	
	Configration unmatched	FF	E8	00	F1	Acute	No	
	“DKCMAIN” micro lost	FF	E9	00	F1	Serious	No	(*30)
	HPAV micro lost	FF	E9	01	F1	Serious	Yes	
	CHK3 threshold over	FF	EC	0X	F1	Service	No	X: 0 = Side A, 1 = Side B (*2)
	Area temporary blocking (*19)	FF	EE	0X	F1	Service	Yes	X: 0 = Side A, 1 = Side B (*2)
	Rebooted without volatilization after an instantaneous down	FF	EF	00	F1	Service	No	
Module error in On-demand area	FF	ED	YX	F1	Service	No	X: 0 = Side A, 1 = Side B (*2) Y: Module#	

SIM Reference Codes Detected by the Processor (6/7)

Error		REF CODE			SIM 28	Level of error	Host report	Remarks
		22	23	13				
Drive error (normal R/W)	Drive port temporary error (Drive path: Boundary 0)	DF	6X	XX	FE	Service (*32)	No	XXX: Drive number (CDEV#:4b+RDEV#:8b)
	Drive port temporary error (Drive path: Boundary 1)	DF	7X	XX	FE	Service (*32)	No	XXX: Drive number (CDEV#:4b+RDEV#:8b)
	Drive temporary error	EF	AX	XX	FE	Service (*32)	No	XXX: Drive number (CDEV#:4b+RDEV#:8b)
	Drive media error	43	4X	XX	FF	Service (*32)	No	XXX: Drive number (CDEV#:4b+RDEV#:8b)
	Drive port blockade (Drive path: Boundary 0)	DF	8X	XX	FE	Moderate (*32)	Yes **	XXX: Drive number (CDEV#:4b+RDEV#:8b)
	Drive port blockade (Drive path: Boundary 1)	DF	9X	XX	FE	Moderate (*32)	Yes **	XXX: Drive number (CDEV#:4b+RDEV#:8b)
	LDEV blockade (Drive path: Boundary 0/ Effect of SCSI blockade) *15	DF	AX	XX	FE	Serious	Yes **	XXX: Drive number (CDEV#:4b+RDEV#:8b)
	LDEV blockade (Drive path: Boundary 1/ Effect of SCSI blockade) *15	DF	BX	XX	FE	Serious	Yes **	XXX: Drive number (CDEV#:4b+RDEV#:8b)
	Drive blockade (drive)	EF	1X	XX	FE	Serious	Yes **	XXX: Drive number (CDEV#:4b+RDEV#:8b)
	Drive blockade (Effect of Dynamic sparing normal end)	EF	2X	XX	FE	Service	Yes **	XXX: Drive number (CDEV#:4b+RDEV#:8b)
	LDEV blockade (Effect of drive blockade) *15	EF	9X	XX	FE	Serious	Yes **	XXX: Drive number (CDEV#:4b+RDEV#:8b)
	Drive blockade (media)	43	CX	XX	FF	Serious	Yes **	XXX: Drive number (CDEV#:4b+RDEV#:8b)
	Correction copy start *7	45	1X	XX	FE	Service	Yes **	XXX: Drive number (CDEV#:4b+RDEV#:8b) (Source side drive)
	Correction copy normal end *7	45	2X	XX	FE	Service	Yes **	XXX: Drive number (CDEV#:4b+RDEV#:8b) (Source side drive)
	Correction copy abnormal end *7	45	3X	XX	FE	Serious	Yes **	XXX: Drive number (CDEV#:4b+RDEV#:8b) (Source side drive)
	Correction copy discontinued *7	45	4X	XX	FE	Service	No	XXX: Drive number (CDEV#:4b+RDEV#:8b) (Source side drive)
	Correction copy warning end* *7 (With blockade LDEV or some error)	45	5X	XX	FE	Service	Yes **	XXX: Drive number (CDEV#:4b+RDEV#:8b) (Source side drive)
	Dynamic sparing start *7 (Drive copy)	46	1X	XX	FE	Service	Yes **	XXX: Drive number (CDEV#:4b+RDEV#:8b) (Source side drive)
	Dynamic sparing normal end *7 (Drive copy)	46	2X	XX	FE	Service	Yes **	XXX: Drive number (CDEV#:4b+RDEV#:8b) (Source side drive)

SIM Reference Codes Detected by the Processor (7/7)

Error		REF CODE			SIM 28	Level of error	Host report	Remarks	
		22	23	13					
Drive error (normal R/W)	Dynamic sparing abnormal end (Drive copy) *7	46	3X	XX	FE	Moderate	Yes **	XXX: Drive number (CDEV#:4b+RDEV#:8b) (Source side drive)	
	Dynamic sparing discontinued *7	46	4X	XX	FE	Service	No	XXX: Drive number (CDEV#:4b+RDEV#:8b) (Source side drive)	
	Dynamic sparing warning end* (With blockade LDEV or some error) (Drive copy) *7	46	5X	XX	FE	Service	Yes **	XXX: Drive number (CDEV#:4b+RDEV#:8b) (Source side drive)	
	Pinned slot	EF	4X	YY	FE	Moderate	No	X: CU# YY: LDEV#	
Drive error (ORM)	Drive temporary error	50	1X	XX	FE	Service	No	XXX: Drive number (CDEV#:4b+RDEV#:8b)	
	Drive media error	50	2X	XX	FF	Service	No	XXX: Drive number (CDEV#:4b+RDEV#:8b)	
CSW error	Injustice DC voltage control	FF	20	0X	F1	Moderate	No	X: CSW PCB# (*1)	
	Injustice CE MODE	FF	21	0X	F1	Moderate	No	X: CSW PCB# (*1)	
SVP interface error (CHA side)	Ethernet error for SVP	14	00	X0	F1	Moderate	Yes	X: CHA PCB# (*1)	
	SIM transfer failure to SVP	14	01	X0	F1	Serious	Yes	X: CHA PCB# (*1)	
SVP interface error (DKA side)	Ethernet error for SVP	15	00	X0	F1	Moderate	Yes	X: DKA PCB# (*1)	
	SIM transfer failure to SVP	15	01	X0	F1	Serious	Yes	X: DKA PCB# (*1)	
Power error	Separate Model	HDU power off	AC	50	XY	F1	Moderate	Yes	X: DKU number (*12) Y: HDU number (*12)
		HDU power recovered	AC	51	XY	F1	Service	No	X: DKU number (*12) Y: HDU number (*12)
	Single Cabinet Model	HDU power off	AC	50	0X	F1	Moderate	Yes	X: HDU number
		HDU power recovered	AC	51	0X	F1	Service	No	X: HDU number
	DKC was set to power error mode	AC	60	00	F1	Moderate	No		
	DKC was released from power error mode	AC	61	00	F1	Service	No		
	When DKC was set to power error mode, Urgent Destaging start succeeded.	AC	62	00	F1	Service	No		
	When DKC was set to power error mode, Urgent Destaging start failed.	AC	63	00	F1	Moderate	No		
Server error	NAS error (SGI) notice	AC	80	XX	F1	Service	Yes	XX: Error code	

* : Warning end : (1) LDEV blockade status is detected, and copy process for the LDEV is skipped.

(2) Some failure is detected, and copy process is complete.

** : When the drive is 3880 emulation mode, the SIM is not reported to host.

*** : The SIM is not reported to SVP.

SIM Reference Codes Detected by the Processor for HRC/HODM (1/2)

Error		REF CODE			SIM 28	Level of error	Host report	Remarks
		22	23	13				
LCP/FCP error (Remote Control Port)	Logical path(s) on the remote copy connections was logically blocked (Due to an error conditions)	21	80	XY	F1	Moderate	Yes	X: CHA PCB# (*1) Y: LCP#1 or PORT# in PCB (*3, 34)
	The logical path has been recovered from blocked condition on the remote copy conditions.	21	81	XY	F1	Service	Yes (*17)	X: CHA PCB# (*1) Y: LCP#1 or PORT# in PCB (*3, 34)
	MCU has received the notification of communication line error detection from extender.	21	82	XY	F1	Moderate	Yes (*17)	X: CHA PCB# (*1) Y: LCP#1 or PORT# in PCB (*3, 34)
Pair volume status error	HRC started the initial copy or out of sync for this volume.	D0	0X	YY	FE	Service	Yes (*17)	X: CU# YY: LDEV#
	HRC completed the initial copy for this volume.	D0	1X	YY	FE	Service	Yes (*17)	X: CU# YY: LDEV#
	HRC for this volume was deleted. (Operation from an SVP/remote console or a host processor)	D0	2X	YY	FE	Service	Yes (*17)	X: CU# YY: LDEV#
	MCU changed volume pair status. (Operation from an SVP/remote console or a host processor)	D0	3X	YY	FE	Service	No	X: CU# YY: LDEV#
	Status of the R-VOL is changed.	D1	ZX	YY	FE	Service	Yes (*17)	X: CU# YY: LDEV# Z: (*16)
	RCU changed status of R-VOL to suspend. (Operation from an SVP/remote console or a host processor.)	D2	0X	YY	FE	Service	No	X: CU# YY: LDEV#
	Status of the R-VOL was changed from suspend to simplex. (Operation from an SVP/remote console or a host processor.)	D2	1X	YY	FE	Service	No	X: CU# YY: LDEV#
	Status of R-VOL was changed from duplex to simplex. (Operation from an SVP/remote console or a host processor.)	D2	2X	YY	FE	Service	No	X: CU# YY: LDEV#
	Status of the R-VOL was changed from pendingduplex to simplex. (Operation from an SVP/remote console or a host processor.)	D2	3X	YY	FE	Service	No	X: CU# YY: LDEV#
	HODM started the migration copy or out of sync for this volume.	D3	0X	YY	FE	Service	Yes (*17)	X: CU# YY: LDEV#
	HODM completed the migration copy for this volume.	D3	1X	YY	FE	Service	Yes (*17)	X: CU# YY: LDEV#
	HODM for this volume was deleted. (Operation from an SVP/remote console)	D3	2X	YY	FE	Service	Yes (*17)	X: CU# YY: LDEV#
	HODM started the erase operation for the R-VOL.	D3	AX	YY	FE	Service	No (*17)	X: CU# YY: LDEV#
	HODM completed the erase operation for the R-VOL.	D3	BX	YY	FE	Service	No (*17)	X: CU# YY: LDEV#
HRC/HODM for this volume was suspended (Due to an unrecoverable failure on the remote copy connections.)	D4	0X	YY	FE	Serious	Yes (*17)	X: CU# YY: LDEV#	

SIM Reference Codes Detected by the Processor for HRC/HODM (2/2)

Error		REF CODE			SIM 28	Level of error	Host report	Remarks
		22	23	13				
Pair volume status error	HRC/HODM for this volume was suspended (Due to an unrecoverable failure on the M-VOL or the remote copy connections)	D4	1X	YY	FE	Serious	Yes (*17)	X: CU# YY: LDEV#
	HRC/HODM for this volume was suspended (Due to an unrecoverable failure on the R-VOL)	D4	2X	YY	FE	Serious	Yes (*17)	X: CU# YY: LDEV#
	HRC for this volume was suspended (Caused by DFW to the R-VOL was prohibited)	D4	3X	YY	FE	Serious	Yes (*17)	X: CU# YY: LDEV#
	HRC for this volume was suspended (Due to an internal error condition detected by the RCU)	D4	4X	YY	FE	Serious	Yes (*17)	X: CU# YY: LDEV#
	HRC for this volume was suspended (Caused by Delete pair operation was issued to the R-VOL)	D4	5X	YY	FE	Serious	Yes (*17)	X: CU# YY: LDEV#
	Erase operation for this volume was not completed. (Due to an error conditions)	D4	8X	YY	FE	Serious	Yes (*17)	X: CU# YY: LDEV#
	MCU detected a Moderate Level SIM for RCU.	D4	DX	YY	FE	Moderate	Yes (*18)	X: CU# YY: LDEV#
	MCU detected an Acute or Serious Level SIM for RCU.	D4	EX	YY	FE	Serious	Yes (*18)	X: CU# YY: LDEV#
	Status of the M-VOL was not consistent with the R-VOL.	D4	FX	YY	FE	Serious	Yes (*17)	X: CU# YY: LDEV#

Blank Sheet

REV.1	Mar.2000	Apr.2000				
-------	----------	----------	--	--	--	--

Blank Sheet

REV.1	Mar.2000	Apr.2000				
-------	----------	----------	--	--	--	--

SIM Reference Codes Detected by the Processor for HRC/HORC (Asynchronous) (1/2)

Error		REF CODE			SIM 28	Level of error	Host report	Remarks
		22	23	13				
Pair volume status error	HRC started the initial copy or out of sync for this volume.	D5	0X	YY	FE	Service	Yes (*17)	X: CU# YY: LDEV#
	HRC completed the initial copy for this volume.	D5	1X	YY	FE	Service	Yes (*17)	X: CU# YY: LDEV#
	HRC for this volume was accepted delete pair operation. (Operation from an SVP/remote console or a host processor)	D5	2X	YY	FE	Service	Yes (*17)	X: CU# YY: LDEV#
	HRC for this volume was accepted suspend pair operation. (Operation from an SVP/remote console or a host processor)	D5	3X	YY	FE	Service	Yes (*17)	X: CU# YY: LDEV#
	Delete pair operation for this HRC volume has completed.	D5	4X	YY	FE	Service	Yes (*17)	X: CU# YY: LDEV#
	Suspend pair operation for this HRC volume has completed.	D5	5X	YY	FE	Service	Yes (*17)	X: CU# YY: LDEV#
	The R-VOL status has changed as requested by MCU.	D6	ZX	YY	FE	Service	Yes (*17)	X: CU# YY: LDEV# Z: (*16)
	The R-VOL has accepted/completed state change as requested by operation. (Operation from an SVP/remote console or a host processor.)	D7	ZX	YY	FE	Service	No	X: CU# YY: LDEV# Z: (*26)
	The M-VOL has suspended. (Due to an unrecoverable failure on the remote copy connections.)	DB	0X	YY	FE	Serious	Yes (*17)	X: CU# YY: LDEV#
	The M-VOL has suspended. (Due to an unrecoverable failure on the M-VOL or the remote copy connections)	DB	1X	YY	FE	Serious	Yes (*17)	X: CU# YY: LDEV#
	The M-VOL has suspended. (Due to an unrecoverable failure on the R-VOL)	DB	2X	YY	FE	Serious	Yes (*17)	X: CU# YY: LDEV#
	The M-VOL has suspended. (Caused by DFW to the R-VOL was prohibited)	DB	3X	YY	FE	Serious	Yes (*17)	X: CU# YY: LDEV#
	The M-VOL has suspended. (Caused by Suspend pair operation was issued to the R-VOL)	DB	4X	YY	FE	Serious	Yes (*17)	X: CU# YY: LDEV#

SIM Reference Codes Detected by the Processor for HRC/HORC (Asynchronous) (2/2)

Error		REF CODE			SIM 28	Level of error	Host report	Remarks
		22	23	13				
Pair volume status error	The M-VOL has suspended. (Caused by Delete pair operation was issued to the R-VOL)	DB	5X	YY	FE	Serious	Yes (*17)	X: CU# YY: LDEV#
	The R-VOL has suspended. (Due to an unrecoverable failure on the remote copy connections)	DB	6X	YY	FE	Serious	Yes (*17)	X: CU# YY: LDEV#
	The R-VOL has suspended. (Due to an unrecoverable failure on the R-VOL)	DB	7X	YY	FE	Serious	Yes (*17)	X: CU# YY: LDEV#
	The R-VOL has suspended. (Due to an MCU power-off event)	DB	8X	YY	FE	Service	No	X: CU# YY: LDEV#
	MCU detected a Service Level SIM for RCU.	DB	CX	YY	FE	Service	Yes	X: CU# YY: LDEV#
	MCU detected a Moderate Level SIM for RCU.	DB	DX	YY	FE	Moderate	Yes	X: CU# YY: LDEV#
	MCU detected an Acute or Serious Level SIM for RCU.	DB	EX	YY	FE	Serious	Yes	X: CU# YY: LDEV#
	Status of the M-VOL was not consistent with the R-VOL.	DB	FX	YY	FE	Serious	Yes (*17)	X: CU# YY: LDEV#

Notice : SIM which REF.CODE is DB7XXX may be reported in the following case.

- When the Suspend Pair operation with the Drain option is accepted by the MCU/RCU under the host I/O.
- When the Delete Pair operation with the Group option is accepted by the RCU under the host I/O.

SIM Reference Codes Detected by the Processor for HMRCF/HOMRCF/HHSM/HXRC/HRCA (1/1)

Error		REF CODE			SIM 28	Level of error	Host report	Remarks
		22	23	13				
HMRCF error or HOMRCF error	Copy abnormal end	47	DY	XX	FE	Moderate	Yes	XX:T-Vol# Y: CU#
	HCAFE abnormal end	4B	0Y	XX	FE	Moderate	Yes	XX:T-Vol# Y: CU#
	All HCAFE abnormal end by SM volatile	47	E6	00	F1	Moderate	Yes	
HHSM error	HHSM Volume Migration Abnormal End	47	FY	XX	FE	Moderate	No	XX:S-Vol# Y: CU#
HXRC/ HRCA error	Sidefile 'sleep wait' threshold over	49	0X	YY	FE	Service	Yes	X: CU# YY: LDEV#

SIM Reference Codes Detected by the Processor for DCR (1/1)

Error		REF CODE			SIM 28	Level of error	Host report	Remarks
		22	23	13				
DCR Status	PreStaging abnormal end	48	21	XX	FE	Service	No	XX: Reason code *11

(*1)

Separate Model

CHA PCB#: x'0' to x'7' indicates the CHA PCB number. See the figure below.
 DKA PCB#: x'0' to x'7' indicates the DKA PCB number. See the figure below.
 CSW PCB#: x'0' to x'3' indicates the CSW PCB number. See the figure below.
 Cache PCB#: x'0' to x'3' indicates the Cache PCB number. See the figure below.

Single Cabinet Model

CHA PCB#: x'0' to x'6' indicates the CHA PCB number. See the figure below.
 DKA PCB#: x'0' to x'4' indicates the DKA PCB number. See the figure below.
 CSW PCB#: x'0' to x'1' indicates the CSW PCB number. See the figure below.
 Cache PCB#: x'0' to x'1' indicates the Cache PCB number. See the figure below.

(*2) Side A/B: Indicates the side of cache/shared memory. See the figure below.

Separate Model

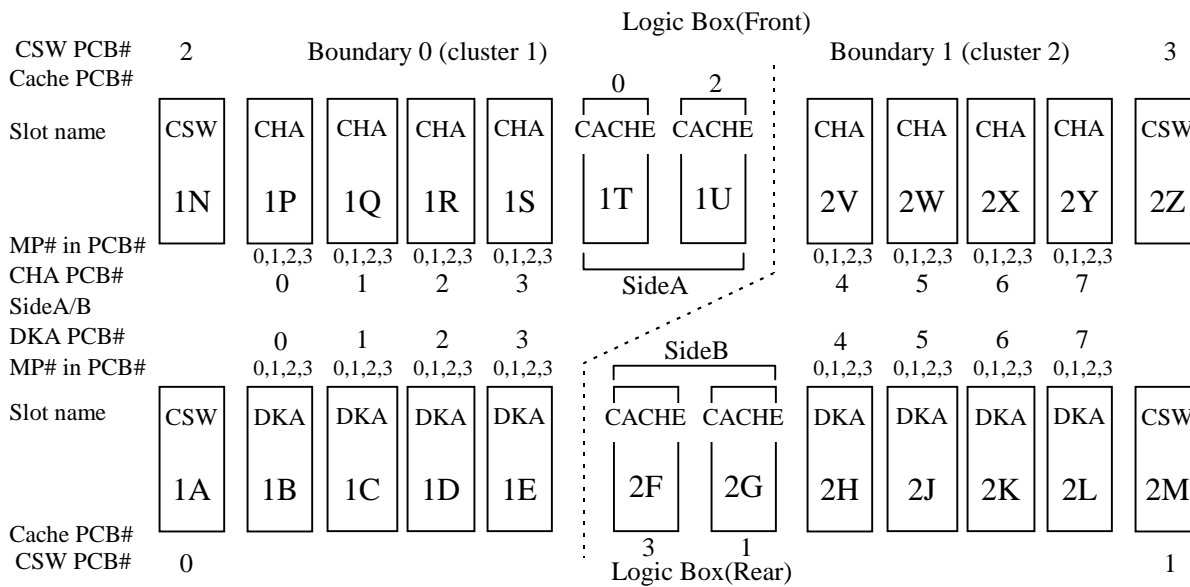

Single Cabinet Model

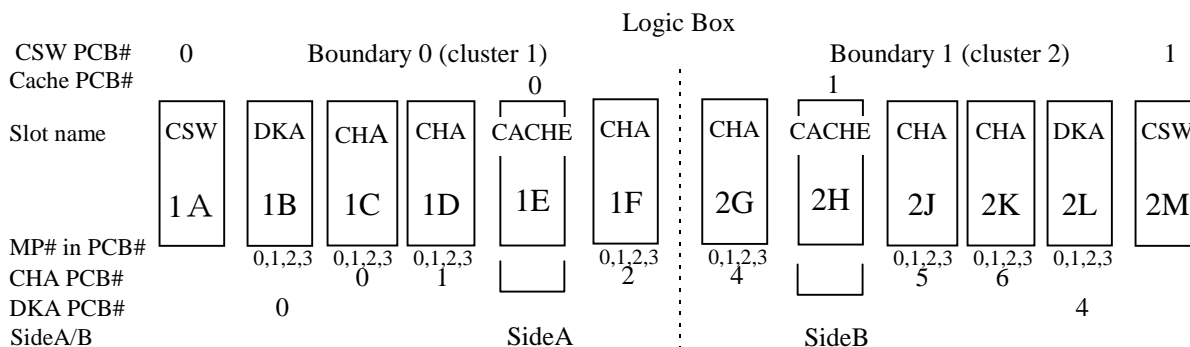

(*3)

Separate Model

LCP #0: x'0' to x'F' indicates the LCP number.

LCP #1: x'0' to x'3' indicates the LCP number.

LCP #2: x'8' to x'F' indicates the LCP number.

-DKC-F410I-8S-

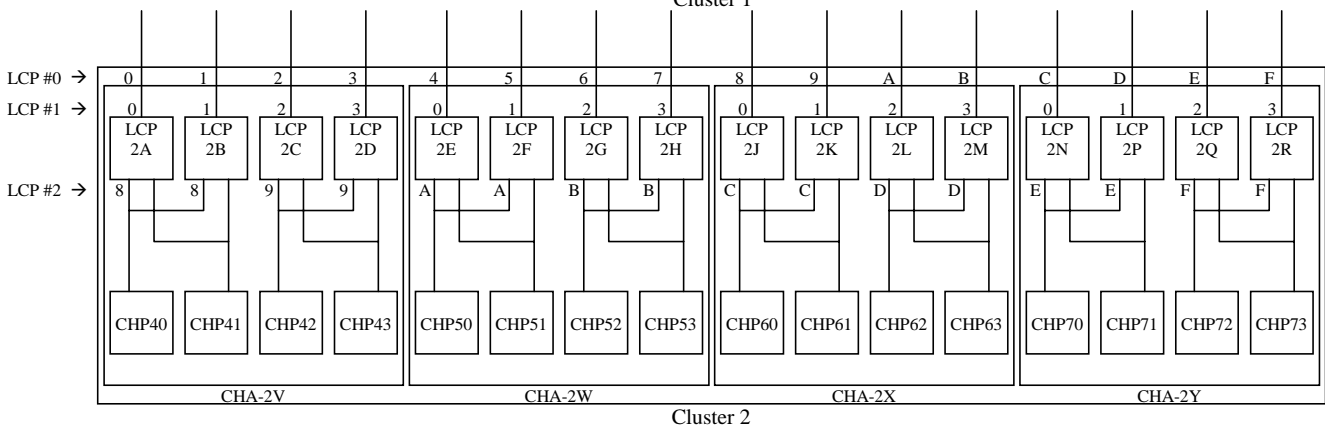
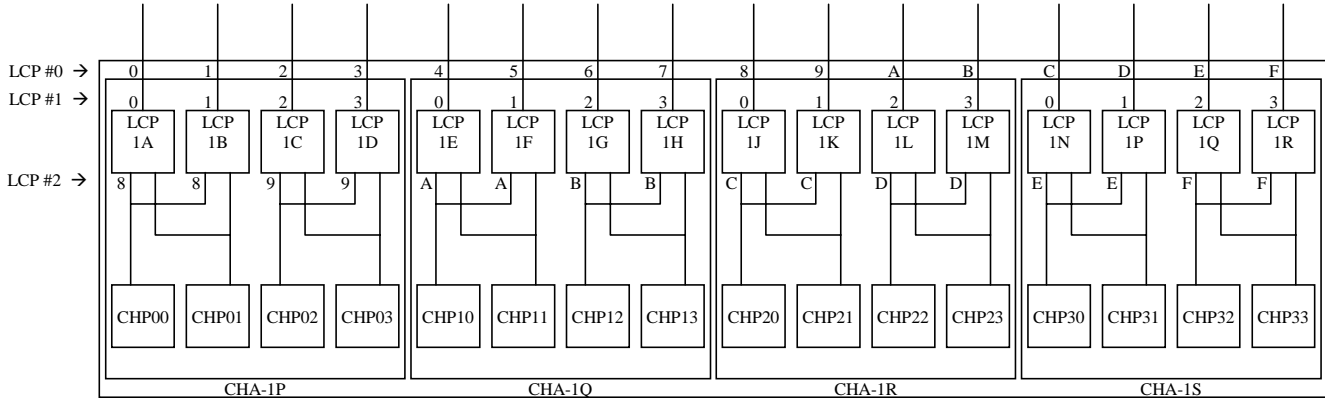

-DKC-F410I-4S-

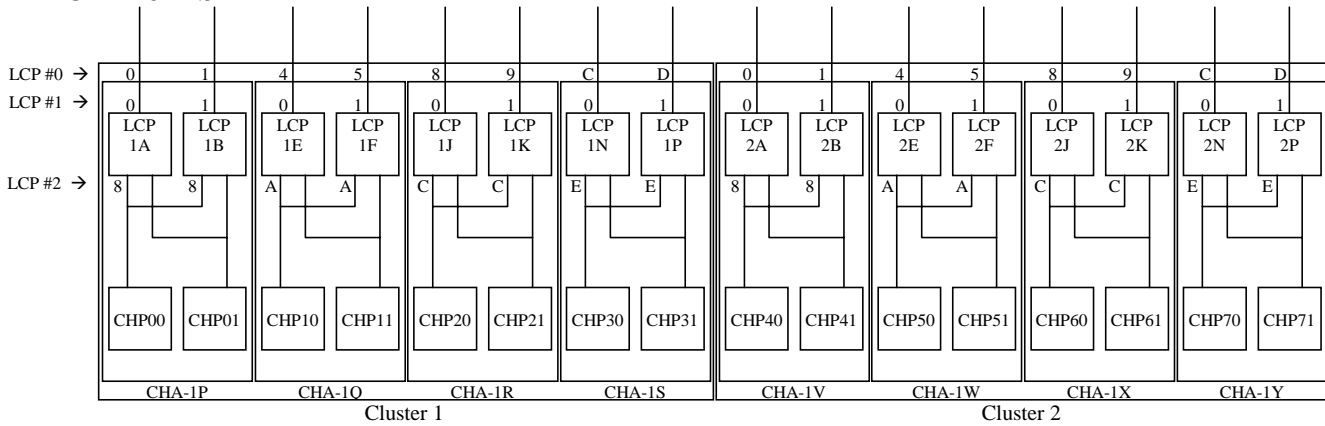

Single Cabinet Model

LCP #0: x'0' to x'D' indicates the LCP number.

LCP #1: x'0' to x'3' indicates the LCP number.

LCP #2: x'8' to x'D' indicates the LCP number.

-DKC-F410I-8S-

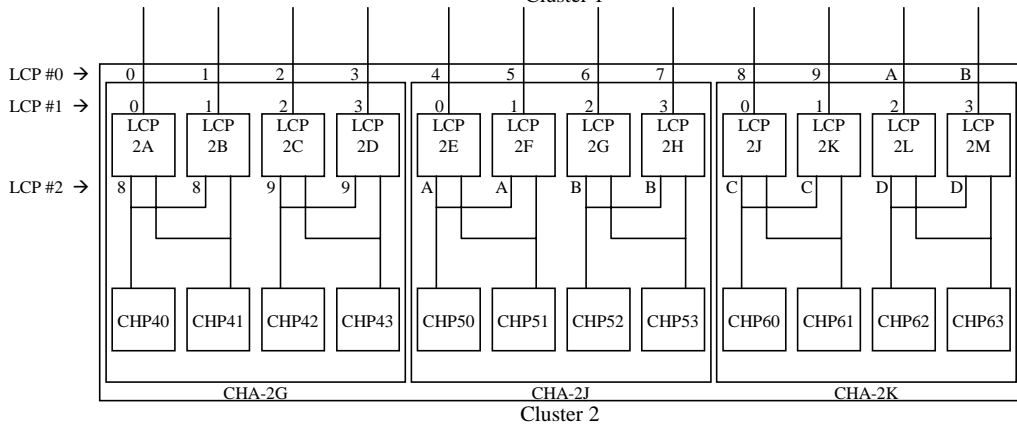
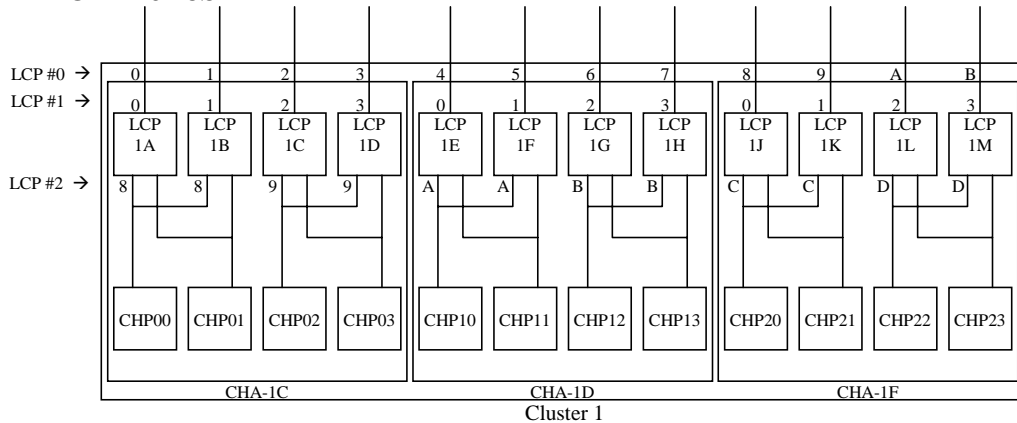

-DKC-F410I-4S-

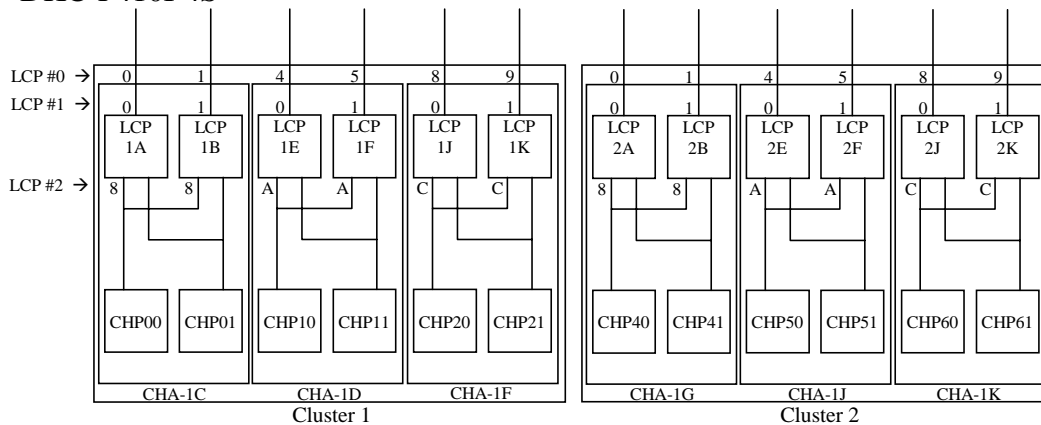

(*4) Port #: x'0' to x'3' indicates the FIBRE port number. See the figure below.

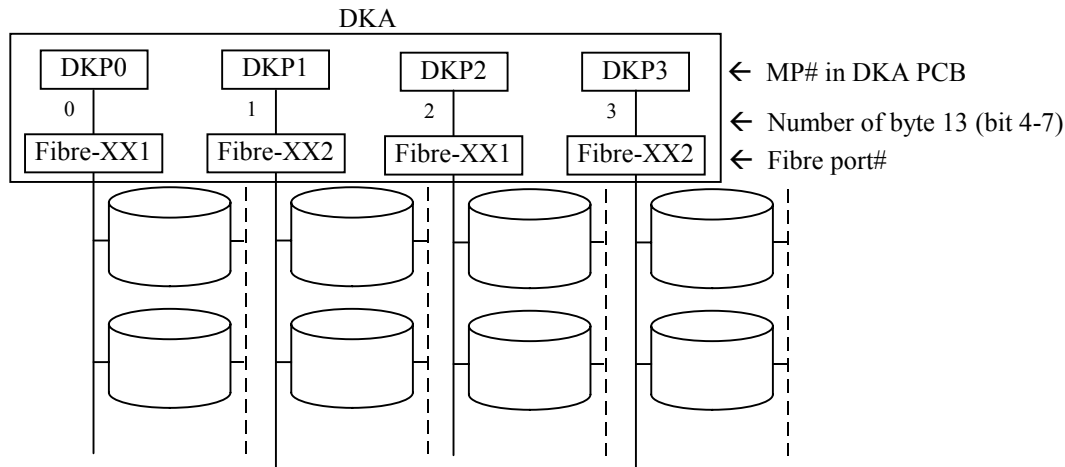

- (*5) The package that is not defined in the configuration information exists.
 If it is prepared for new installation, it is necessary to do the new installation procedure.
 Otherwise it should be pulled out by executing P/S off.
- (*7) Isolate the error according to the procedure shown in [TRBL05-170](#).
- (*8) Recover the error according to the procedure shown in [TRBL05-270](#).
- (*10) Perform error isolation according to the procedure given in the two separate pages attached to [TRBL05-300](#).
- (*11) Reason Code
- x'E1', x'10' : No DCR PP
 - x'E2', x'20' : Subsystem busy
 - x'E4', x'40' : Staging time over
 - x'E5', x'50' : Cache blockade
 - x'E6', x'60' : LDEV Warning
 - x'E7', x'70' : Staging failure
 - x'E8', x'80' : P/S OFF
 - x'90' : PreStaging canceled
 - x'EA', x'A0' : Cache over loaded

(*12) DKU#: x'0' to x'3' indicates DKU number. See the figure below.
 HDU#: x'0' to x'7' indicates HDU number. See the figure below.

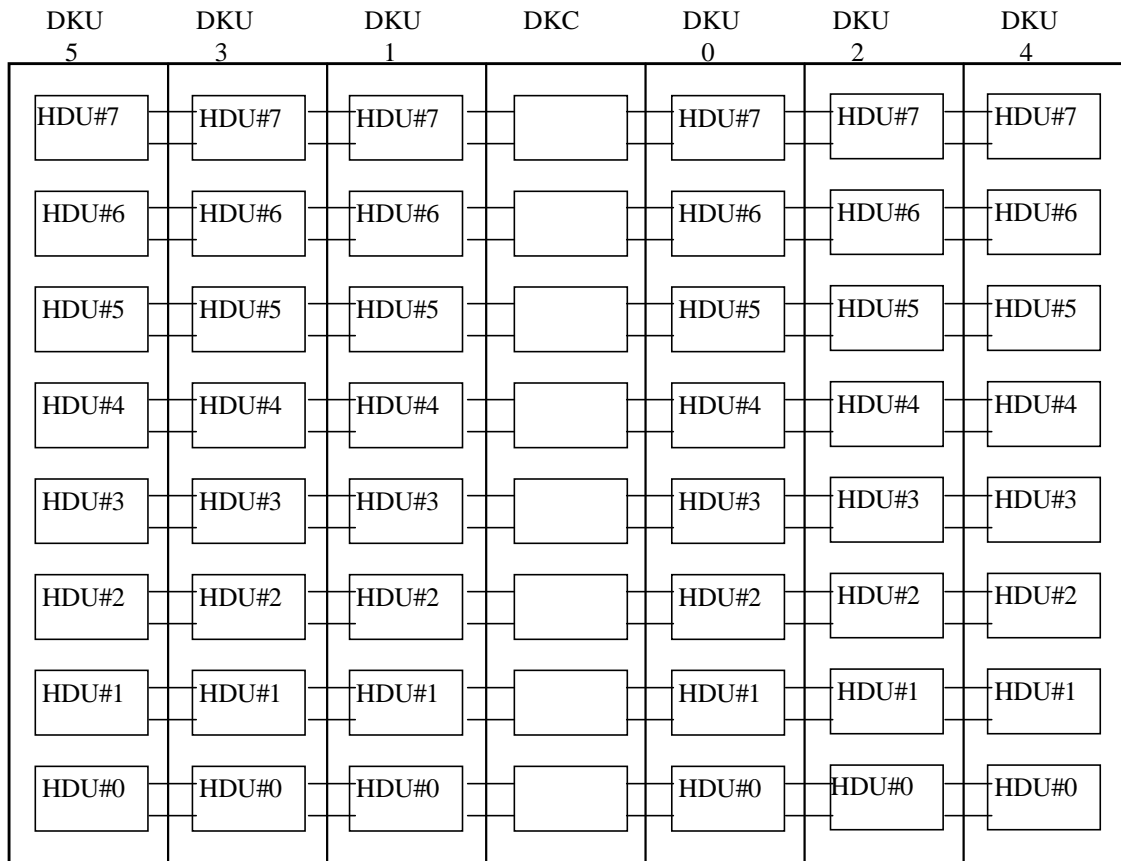

(*13) reason code

- x'0' : Pinned data exist
- x'1' : The shutdown of the power supply was occurred
- x'2' : Invalid Version/Revision exists

(*15) Recover LDEVs according to the procedure shown in [TRBL05-330](#).

(*16) Change pair status number

- x'0': From simplex to duplex pending
- x'1': From simplex to duplex
- x'2': From pending duplex to duplex
- x'3': From pending duplex to suspend
- x'4': From duplex to suspend
- x'5': From duplex to simplex
- x'6': From pending duplex to simplex
- x'7': From suspend to simplex
- x'8': From suspend to duplex pending

(*17) You can suppress reporting the HRC/HODM Service SIM to the HOST by RCU Option operation (PPRC support by HOST and Service SIM of HRC/HODM).

- Service level SIM -

PPRC support by HOST	Service SIM or HRC/HODM	level of error	HRC	HODM
Yes	Report	DKC_SIM	Host Report	Host Report
		DEV_SIM	Not Host Report	Host Report
	Not Report	DKC_SIM	Not Host Report	Not Host Report
		DEV_SIM	Not Host Report	Not Host Report
No	Report	DKC_SIM	Host Report	Host Report
		DEV_SIM	Host Report	Host Report
	Not Report	DKC_SIM	Not Host Report	Not Host Report
		DEV_SIM	Not Host Report	Not Host Report

- Moderate or Serious level SIM -

PPRC support by HOST	level of error	HRC	HODM
Yes	DKC_SIM	Host Report	Host Report
	DEV_SIM	Not Host Report	Host Report
No	DKC_SIM	Host Report	Host Report
	DEV_SIM	Host Report	Host Report

(*18) SIMs which REF.CODE are D4DX, D4EX are reported in case of HODM.
In case of HRC, SIMs reported from RCU are reported to the host by MCU.

Severity Level	RC of reported SIM for HRC	RC of reported SIM for HODM
Acute or Serious	No modification	D4EX
Moderate	No modification	D4DX
Service (Not HRC SIM)	No modification	Not reported
Service (HRC SIM)	Not reported	Not reported

(*19) This temporary blocking is to recover the logical table on SM and be automatically recovered.

(*20) In case of the replacement of the cache memory PCB on the side having blocked SM (see [REP01-160](#) work ID = RCA1), insert the removed cache memory PCB again.

(*21) Isolate the error according to the procedure shown in [TRBL05-200](#).

(*22) The LDEV is blocked because of an error (inconsistency between data on the A and B sides) of configuration information stored in the SM. Recover the error following the instruction of the Technical Support Center.

(*23) X represents the X in a program version “?X-??-??/??”.

(*24) Cache SIMM sizes of sides A and B are different because the replacement of the cache memory has been performed on one side only. Perform the replacement left referring to the description in the remark column.

(*25) Type of the lost information is reported according to the bit position. (There may be the case that two or more bits are set.)

(*26) Change pair status number

x'0': Accepted Suspend Pair operation

x'1': Accepted Delete Pair operation (The R-VOL is in suspended status)

x'2': Accepted Delete Pair operation (The R-VOL is in duplex status)

x'3': Accepted Delete Pair operation (The R-VOL is in pending duplex status)

x'4': Completed Suspend Pair operation

x'5': Completed Delete Pair operation

(*27) In the case that the error is detected in the area of ROM, the level of error is "Moderate" in other case "Service".

(*28) Recover the error according to the procedure shown in [TRBL11-10](#).

(*29) C path bitmap indicates status of C path. See the figure below.

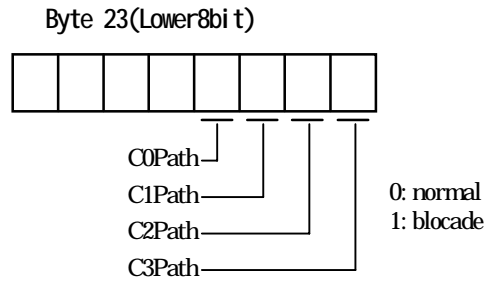

Separate Model

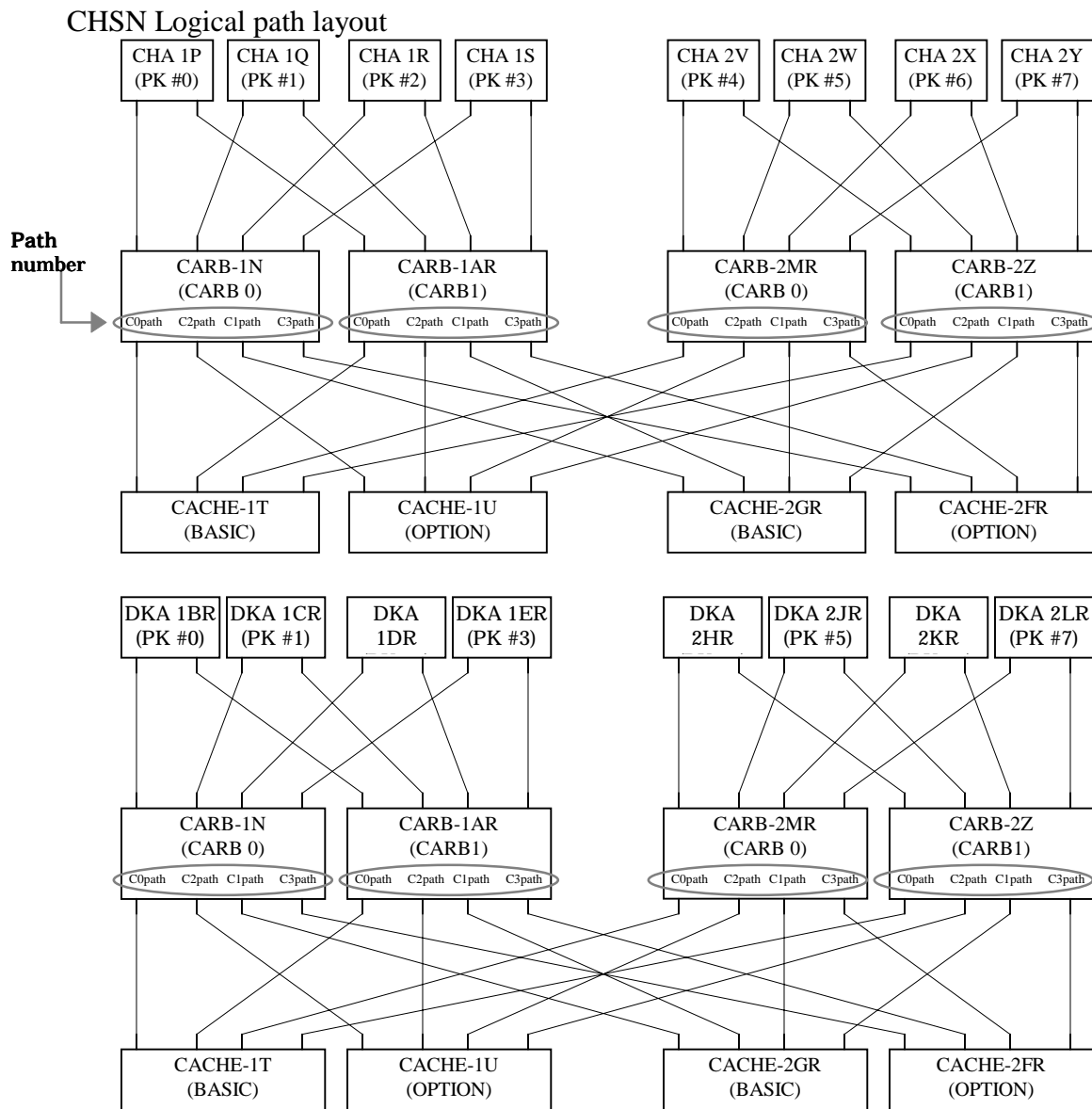

Single Cabinet Model

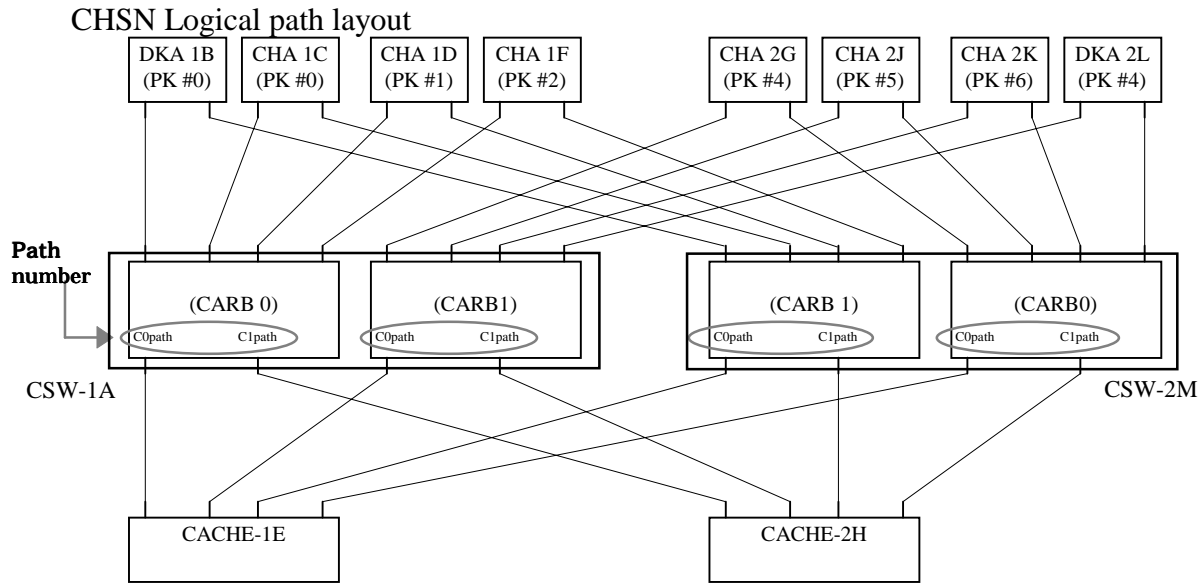

(*30) If this reference code is reported, execute the micro-program exchange procedure (On-line) of the micro type “DKCMAIN”. ([MICRO-FC04-10 to 04-120](#))

(*31) PATH# A0, A1, B0, B1 indicates the SHSN Logical path number. See the figure below.

Separate Model

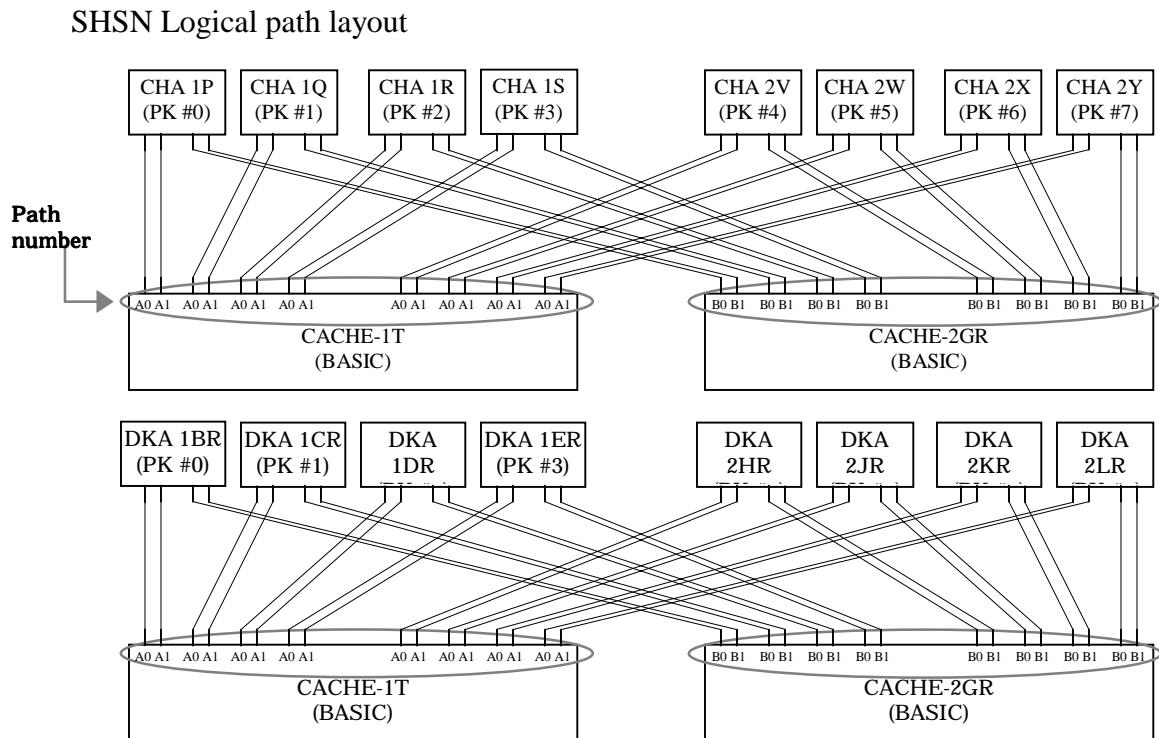

Single Cabinet Model

SHSN Logical path layout

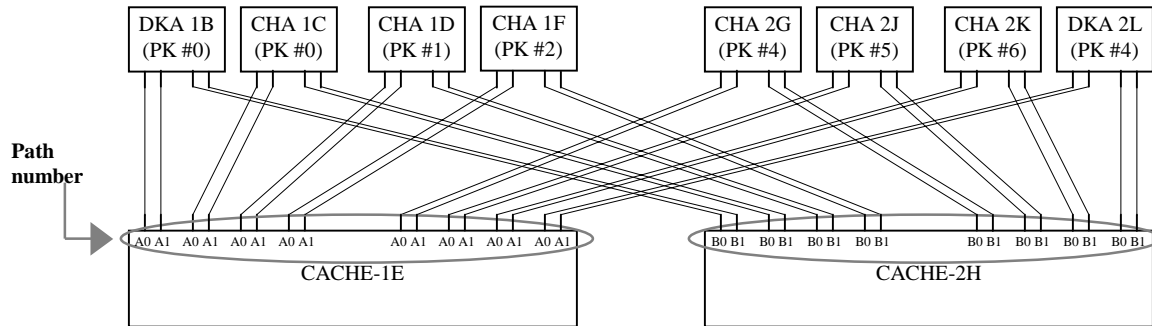

(*32) In the case that there are no redundance of drive the level of error is “Serious”.

(*33) See the figure below about HTP path number.

<< 4MP 2HTP >>

CHA PCB

HTP# in CHA PCB

HTP path# in CHA PCB

MP# in CHA PCB

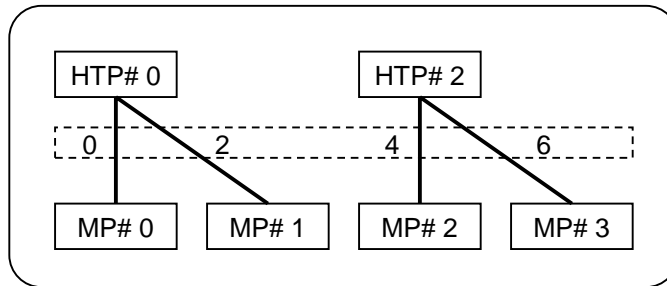

(*34) PORT# in PCB: x‘0’ to x‘3’ in PCB indicates the PORT number in CHA PCB. See the table below.

Separate Model

PORT#	CHA-1P	CHA-1Q	CHA-1R	CHA-1S	CHA-2V	CHA-2W	CHA-2X	CHA-2Y
0	1A	1E	1J	1N	2A	2E	2J	2N
1	1B	1F	1K	1P	2B	2F	2K	2P
2	1C	1G	1L	1Q	2C	2G	2L	2Q
3	1D	1H	1M	1R	2D	2H	2M	2R

Single Cabinet Model

PORT#	CHA-1C	CHA-1D	CHA-1F	CHA-2G	CHA-2J	CHA-2K
0	1A	1E	1J	2A	2E	2J
1	1B	1F	1K	2B	2F	2K
2	1C	1G	1L	2C	2G	2L
3	1D	1H	1M	2D	2H	2M

2.2 SIM Reference Codes Detected by the SVP

Error			REF code			SIM	Level of error	Host report	Remarks
			22	23	13				
AC Fail Detect	Cluster-1	AC1	AC	70	00	F1	Moderate	Yes	
		AC2	AC	70	01	F1	Moderate	Yes	
		AC3	AC	70	02	F1	Moderate	Yes	
		AC4	AC	70	03	F1	Moderate	Yes	
	Cluster-2	AC1	AC	70	10	F1	Moderate	Yes	
		AC2	AC	70	11	F1	Moderate	Yes	
		AC3	AC	70	12	F1	Moderate	Yes	
		AC4	AC	70	13	F1	Moderate	Yes	
AC Recover Fail	Cluster-1	AC1	AC	71	00	F1	Moderate	Yes	
		AC2	AC	71	01	F1	Moderate	Yes	
		AC3	AC	71	02	F1	Moderate	Yes	
		AC4	AC	71	03	F1	Moderate	Yes	
	Cluster-2	AC1	AC	71	10	F1	Moderate	Yes	
		AC2	AC	71	11	F1	Moderate	Yes	
		AC3	AC	71	12	F1	Moderate	Yes	
		AC4	AC	71	13	F1	Moderate	Yes	
UPS Battery Fail	Cluster-1	AC1	AC	72	00	F1	Moderate	Yes	
		AC2	AC	72	01	F1	Moderate	Yes	
		AC3	AC	72	02	F1	Moderate	Yes	
		AC4	AC	72	03	F1	Moderate	Yes	
	Cluster-2	AC1	AC	72	10	F1	Moderate	Yes	
		AC2	AC	72	11	F1	Moderate	Yes	
		AC3	AC	72	12	F1	Moderate	Yes	
		AC4	AC	72	13	F1	Moderate	Yes	
Emergency Destage was started			AC	73	00	F1	Moderate	Yes	
Emergency Destage was finished			AC	74	00	F1	Moderate	Yes	
Environmental error	Temperature Abnormal Front of cabinet(60°C)	Logic 1	BF	10	10	F1	Moderate	Yes	
		Logic 2	BF	10	11	F1	Moderate	Yes	
	Temperature Abnormal Back of cabinet(60°C)	Logic 1	BF	11	10	F1	Moderate	Yes	*13
		Logic 2	BF	11	11	F1	Moderate	Yes	*13
	Temperature Abnormal Front of cabinet(45°C)	Logic 1	BF	12	10	F1	Moderate	Yes	
		Logic 2	BF	12	11	F1	Moderate	Yes	
	Temperature Abnormal Back of cabinet(45°C)	Logic 1	BF	13	10	F1	Moderate	Yes	*13
		Logic 2	BF	13	11	F1	Moderate	Yes	*13
	Voltage alarm(5V) (80% Down)	Logic 1	BF	20	10	F1	Moderate	Yes	
		Logic 2	BF	20	11	F1	Moderate	Yes	
		DKU-XXX (HDU-X ^{*14})	BF	20	XX ^{*1}	F1	Moderate	Yes	
	Voltage alarm(3V) (80% Down)	Logic 1	BF	21	10	F1	Moderate	Yes	
		Logic 2	BF	21	11	F1	Moderate	Yes	
	Voltage alarm(12V) (80% Down)	DKU-XXX (HDU-X ^{*14})	BF	22	XX ^{*1}	F1	Moderate	Yes	
	Voltage warning(3V) (Shared Memory)	Logic 1	BF	30	10	F1	Moderate	Yes	
		Logic 2	BF	30	11	F1	Moderate	Yes	
Voltage warning(3V) (Cache Memory)	Logic 1	BF	31	10	F1	Moderate	Yes		
	Logic 2	BF	31	11	F1	Moderate	Yes		

Error			REF code			SIM 28	Level of error	Host report	Remarks
			22	23	13				
Environmental error	P/S warning	5/3V PS 1A	BF	40	10	F1	Moderate	Yes	
		5/3V PS 2A	BF	40	11	F1	Moderate	Yes	
		5/3V PS 1B	BF	41	10	F1	Moderate	Yes	
		5/3V PS 2B	BF	41	11	F1	Moderate	Yes	
		3V PS 1A	BF	42	10	F1	Moderate	Yes	
		3V PS 2A	BF	42	11	F1	Moderate	Yes	
		3V PS 1B	BF	43	10	F1	Moderate	Yes	
		3V PS 2B	BF	43	11	F1	Moderate	Yes	
		3V PS 1C	BF	44	10	F1	Moderate	Yes	*13
		3V PS 2C	BF	44	11	F1	Moderate	Yes	*13
		3V PS 1D	BF	45	10	F1	Moderate	Yes	*13
		3V PS 2D	BF	45	11	F1	Moderate	Yes	*13
		SUB PS 1	BF	46	10	F1	Moderate	Yes	
	SUB PS 2	BF	46	11	F1	Moderate	Yes		
	P/S warning	DKU-XXX MPS0 (HDU-X MPS0 ^{*14})	BF	4A	XX ^{*1}	F1	Moderate	Yes	
		DKU-XXX MPS1 (HDU-X MPS1 ^{*14})	BF	4B	XX ^{*1}	F1	Moderate	Yes	
	Battery warning	BATTERY-10	BF	50	10	F1	Moderate	Yes	
		BATTERY-20	BF	50	11	F1	Moderate	Yes	
		BATTERY-11	BF	51	10	F1	Moderate	Yes	
		BATTERY-21	BF	51	11	F1	Moderate	Yes	
		BATTERY-12	BF	52	10	F1	Moderate	Yes	*13
		BATTERY-22	BF	52	11	F1	Moderate	Yes	*13
	Battery warning (Diag Mode)	BATTERY-10	BF	5A	10	F1	Moderate	Yes	
		BATTERY-20	BF	5A	11	F1	Moderate	Yes	
		BATTERY-11	BF	5B	10	F1	Moderate	Yes	
		BATTERY-21	BF	5B	11	F1	Moderate	Yes	
		BATTERY-12	BF	5C	10	F1	Moderate	Yes	*13
		BATTERY-22	BF	5C	11	F1	Moderate	Yes	*13
	AC warning	Cluster-1	BF	60	D0	F1	Moderate	Yes	3 Phase Model
		Cluster-2	BF	60	D1	F1	Moderate	Yes	3 Phase Model
		Cluster-1	BF	60	E0	F1	Moderate	Yes	Single Phase Model or Single Cabinet Model
		Cluster-2	BF	60	E1	F1	Moderate	Yes	Single Phase Model or Single Cabinet Model

Error		REF code			SIM 28	Level of error	Host report	Remarks	
		22	23	13					
Environmental error	Fan abnormality	FLGFAN12B	BF	70	10	F1	Moderate	Yes	*13
		FLGFAN21B	BF	70	11	F1	Moderate	Yes	*13
		DKU-XXX (HDU-X ^{*14})	BF	70	XX ^{*1}	F1	Moderate	Yes	
		FLGFAN12A	BF	71	10	F1	Moderate	Yes	*13
		FLGFAN21A	BF	71	11	F1	Moderate	Yes	*13
		FLGFAN11B	BF	72	10	F1	Moderate	Yes	*13
		FLGFAN22B	BF	72	11	F1	Moderate	Yes	*13
		FLGFAN11A	BF	73	10	F1	Moderate	Yes	*13
		FLGFAN22A	BF	73	11	F1	Moderate	Yes	*13
		RLGFAN11B (FLGFAN12B ^{*14})	BF	74	10	F1	Moderate	Yes	
		RLGFAN22B (FLGFAN21B ^{*14})	BF	74	11	F1	Moderate	Yes	
		RLGFAN11A (FLGFAN12A ^{*14})	BF	75	10	F1	Moderate	Yes	
		RLGFAN22A (FLGFAN21A ^{*14})	BF	75	11	F1	Moderate	Yes	
		RLGFAN12B (FLGFAN11B ^{*14})	BF	76	10	F1	Moderate	Yes	
		RLGFAN21B (FLGFAN22B ^{*14})	BF	76	11	F1	Moderate	Yes	
		RLGFAN12A (FLGFAN11A ^{*14})	BF	77	10	F1	Moderate	Yes	
		RLGFAN21A (FLGFAN22A ^{*14})	BF	77	11	F1	Moderate	Yes	
		RPSFAN11B (FPSFAN12B ^{*14})	BF	78	10	F1	Moderate	Yes	
		RPSFAN22B (FPSFAN21B ^{*14})	BF	78	11	F1	Moderate	Yes	
		RPSFAN11A (FPSFAN12A ^{*14})	BF	79	10	F1	Moderate	Yes	
		RPSFAN22A (FPSFAN21A ^{*14})	BF	79	11	F1	Moderate	Yes	
		RPSFAN12B (FPSFAN11B ^{*14})	BF	7A	10	F1	Moderate	Yes	
		RPSFAN21B (FPSFAN22B ^{*14})	BF	7A	11	F1	Moderate	Yes	
		RPSFAN12A (FPSFAN11A ^{*14})	BF	7B	10	F1	Moderate	Yes	
	RPSFAN21A (FPSFAN22A ^{*14})	BF	7B	11	F1	Moderate	Yes		
	JP remains	DKC Alarm	BF	81	A3	F1	Moderate	Yes	*15
		HDU-0-HDU-3	BF	83	BX ^{*2}	F1	Moderate	Yes	*15
		HDU-4-HDU-7	BF	84	BX ^{*2}	F1	Moderate	Yes	*13, *15
		SVP PS Off/On	BF	85	A2	F1	Moderate	Yes	*15
	Environment Monitor failure	Environment monitor error(Access error)	DKCMN1	BF	90	A0	F1	Service	No
DKCMN2			BF	90	A1	F1	Service	No	
DKUMN-XXX (DKUMNX ^{*14})			BF	90	XX ^{*2}	F1	Service	No	

Error		REF code			SIM 28	Level of error	Host report	Remarks	
		22	23	13					
Environment Monitor failure	Environment monitor error(Busy)	BF	91	A2	F1	Service	No		
	Diag mode setting error	Cluster-1	BF	92	A0	F1	Service	No	
		Cluster-2	BF	92	A1	F1	Service	No	
	DKCMN Type Unmatched	DKCMN1	BF	93	A0	F1	Moderate	No	
		DKCMN2	BF	93	A1	F1	Moderate	No	
	Alarm disagreement	DKCMN1	BF	A0	A0	F1	Moderate	No	
		DKCMN2	BF	A0	A1	F1	Moderate	No	
		DKUMN-XXX (DKUMNX ^{*14})	BF	A0	XX ^{*2}	F1	Moderate	No	
	P/S On disagreement	DKCMN1	BF	A1	A0	F1	Moderate	No	
DKCMN2		BF	A1	A1	F1	Moderate	No		
DKUMN-XXX (DKUMNX ^{*14})		BF	A1	XX ^{*2}	F1	Moderate	No		
SVP failure	Logical inconsistency	70	XX ^{*3}	00	F1	Moderate	No		
	HEAP error	71	XX ^{*3}	00	F1	Moderate	No		
	File error	72	XX ^{*3}	00	F1	Moderate	No		
	LAN error	73	XX ^{*3}	00	F1	Moderate	No		
	S-SVP error	74	XX ^{*4}	XX ^{*4}	F1	Moderate	Yes		
	Windows error	75	XX ^{*3}	00	F1	Moderate	No		
	CUDG3 detected error	76	01	XX ^{*5}	F1	Moderate	No		
	LCDG3 detected error	76	10	XX ^{*5}	F1	Moderate	No		
	BOOT detected error(CHA)	79	00	XY ^{*7}	F1	Moderate	No	*11	
	BOOT detected error(DKA)	79	01	XY ^{*8}	F1	Moderate	No	*11	
ISDN Router failure	7B	00	03	F1	Moderate	Yes			
End status of remote microprogram exchange	Normal end	7A	00	00	F1	Service	No		
	Abnormal end (SVP)	7A	01	00	F1	Service	No		
	Abnormal end (MP)	7A	02	XX ^{*10}	F1	Service	No		
	Version check error	7A	03	XX ^{*6}	F1	Service	No		
	Sum check error	7A	04	XX ^{*6}	F1	Service	No		
	LCP patch error	7A	05	XY ^{*9}	F1	Service	No		
	Warning (Configuration inconsistency)	7A	10	00	F1	Service	No		
	Warning (S-SVP busy)	7A	11	00	F1	Service	No		
Warning (LCP busy)	7A	12	XY ^{*9}	F1	Service	No			
Reboot Stop	SVP reboot stop (FD Inserted)	7C	00	00	F1	Moderate	No		
Battery Check	Battery life is over	7C	01	00	F1	Moderate	No		
SVP failure	FLASH Memory (PC card) error	7F	00	00	F1	Moderate	No		
License key	The term of validity is over	7F	F0	00	F1	Serious	Yes	*12	
On-demand	Cache	7F	F0	02	F1	Service	No		
	LUN	7F	F0	03	F1	Service	No		
Pair Failure SIM Reduce	HRC	7F	F1	00	F1	Service	No		
	HRCA	7F	F1	01	F1	Service	No		
	MRCF	7F	F1	02	F1	Service	No		
Dump received	WCHK1 dump(CHA)	30	80	XY ^{*7}	F1	Moderate	No		
	WCHK1 dump(DKA)	31	80	XY ^{*8}	F1	Moderate	No		
	ABEND dump(CHA)	30	81	XY ^{*7}	F1	Moderate	No		
	ABEND dump(DKA)	31	81	XY ^{*8}	F1	Moderate	No		

*1 Error Section(DKU part)

Byte 23	Error Section
20	HDU-R10 (HDU-0 ^{*14})
21	HDU-R11 (HDU-1 ^{*14})
22	HDU-R12 (HDU-2 ^{*14})
23	HDU-R13 (HDU-3 ^{*14})
24 ^{*13}	HDU-R14
25 ^{*13}	HDU-R15
26 ^{*13}	HDU-R16
27 ^{*13}	HDU-R17
30 ^{*13}	HDU-L10
31 ^{*13}	HDU-L11
32 ^{*13}	HDU-L12
33 ^{*13}	HDU-L13
34 ^{*13}	HDU-L14
35 ^{*13}	HDU-L15
36 ^{*13}	HDU-L16
37 ^{*13}	HDU-L17
40 ^{*13}	HDU-R20
41 ^{*13}	HDU-R21
42 ^{*13}	HDU-R22
43 ^{*13}	HDU-R23
44 ^{*13}	HDU-R24
45 ^{*13}	HDU-R25
46 ^{*13}	HDU-R26
47 ^{*13}	HDU-R27
50 ^{*13}	HDU-L20
51 ^{*13}	HDU-L21
52 ^{*13}	HDU-L22
53 ^{*13}	HDU-L23
54 ^{*13}	HDU-L24
55 ^{*13}	HDU-L25
56 ^{*13}	HDU-L26
57 ^{*13}	HDU-L27
60 ^{*13}	HDU-R30
61 ^{*13}	HDU-R31
62 ^{*13}	HDU-R32
63 ^{*13}	HDU-R33
64 ^{*13}	HDU-R34
65 ^{*13}	HDU-R35
66 ^{*13}	HDU-R36
67 ^{*13}	HDU-R37
70 ^{*13}	HDU-L30
71 ^{*13}	HDU-L31
72 ^{*13}	HDU-L32
73 ^{*13}	HDU-L33
74 ^{*13}	HDU-L34
75 ^{*13}	HDU-L35
76 ^{*13}	HDU-L36
77 ^{*13}	HDU-L37

*2 Error Section(DKU MONITOR)

Byte 23	Error Section
B0	DKUMN-R1F (DKUMN1 ^{*14})
B1	DKUMN-R1R (DKUMN2 ^{*14})
B2 ^{*13}	DKUMN-L1F
B3 ^{*13}	DKUMN-L1R
B4 ^{*13}	DKUMN-R2F
B5 ^{*13}	DKUMN-R2R
B6 ^{*13}	DKUMN-L2F
B7 ^{*13}	DKUMN-L2R
B8 ^{*13}	DKUMN-R3F
B9 ^{*13}	DKUMN-R3R
BA ^{*13}	DKUMN-L3F
BB ^{*13}	DKUMN-L3R

*3 Contents of byte 23 when a logical error, a HEEP error, a file error, a LAN error or Windows error occurred

Byte 23	Content
0x00	Dump task
0x01	DKU inline
0x02	Microprogram change (online)
0x03	Information
0x04	LOGOUT
0x05	PATH inline
0x06	Back Ground
0x07	DIAG
0x08	Install
0x09	Online
0x0A	Microprogram change (offline)
0x0B	Special PCB maintenance
0x0C	Common communication function
0xEF	Other AP

*4 Contents of byte 23 and byte 13 when a S-SVP logical error occurred

Byte23	Byte13	Content
00	01	SSVP ROM SUM Check error(Recovered)
00	02	SSVP RAM RD/WR Error(Recovered)
00	50	Software error(Parameter Error)
10	60	Recovering SVP Communication
10	FF	SSVP Failure detected by SVP
50	01	Environment Monitor Register RD/WR error

*5 Contents of byte 13 when a CUDG detection error occurred

Byte13(bit0-bit5)

Byte 13 (bit 0 - bit 5)	MPID	Byte 13 (bit 0 - bit 5)	MPID
000000	CHP00-1P(CHP00-1D ^{*14})	100000	DKP80-1B(DKP80-1C ^{*14})
000001	CHP01-1P(CHP01-1D ^{*14})	100001	DKP81-1B(DKP81-1C ^{*14})
000010	CHP02-1P(CHP02-1D ^{*14})	100010	DKP82-1B(DKP82-1C ^{*14})
000011	CHP03-1P(CHP03-1D ^{*14})	100011	DKP83-1B(DKP83-1C ^{*14})
000100	CHP10-1Q(CHP10-1E ^{*14})	100100 ^{*13}	DKP90-1C
000101	CHP11-1Q(CHP11-1E ^{*14})	100101 ^{*13}	DKP91-1C
000110	CHP12-1Q(CHP12-1E ^{*14})	100110 ^{*13}	DKP92-1C
000111	CHP13-1Q(CHP13-1E ^{*14})	100111 ^{*13}	DKP93-1C
001000	CHP20-1R(CHP20-1G ^{*14})	101000 ^{*13}	DKPA0-1D
001001	CHP21-1R(CHP21-1G ^{*14})	101001 ^{*13}	DKPA1-1D
001010	CHP22-1R(CHP22-1G ^{*14})	101010 ^{*13}	DKPA2-1D
001011	CHP23-1R(CHP23-1G ^{*14})	101011 ^{*13}	DKPA3-1D
001100 ^{*13}	CHP30-1S	101100 ^{*13}	DKPB0-1E
001101 ^{*13}	CHP31-1S	101101 ^{*13}	DKPB1-1E
001110 ^{*13}	CHP32-1S	101110 ^{*13}	DKPB2-1E
001111 ^{*13}	CHP33-1S	101111 ^{*13}	DKPB3-1E
010000	CHP40-2V(CHP40-2H ^{*14})	110000	DKPC0-2H(DKPC0-2M ^{*14})
010001	CHP41-2V(CHP41-2H ^{*14})	110001	DKPC1-2H(DKPC1-2M ^{*14})
010010	CHP42-2V(CHP42-2H ^{*14})	110010	DKPC2-2H(DKPC2-2M ^{*14})
010011	CHP43-2V(CHP43-2H ^{*14})	110011	DKPC3-2H(DKPC3-2M ^{*14})
010100	CHP50-2W(CHP50-2K ^{*14})	110100 ^{*13}	DKPD0-2J
010101	CHP51-2W(CHP51-2K ^{*14})	110101 ^{*13}	DKPD1-2J
010110	CHP52-2W(CHP52-2K ^{*14})	110110 ^{*13}	DKPD2-2J
010111	CHP53-2W(CHP53-2K ^{*14})	110111 ^{*13}	DKPD3-2J
011000	CHP60-2X(CHP60-2L ^{*14})	111000 ^{*13}	DKPE0-2K
011001	CHP61-2X(CHP61-2L ^{*14})	111001 ^{*13}	DKPE1-2K
011010	CHP62-2X(CHP62-2L ^{*14})	111010 ^{*13}	DKPE2-2K
011011	CHP63-2X(CHP63-2L ^{*14})	111011 ^{*13}	DKPE3-2K
011100 ^{*13}	CHP70-2Y	111100 ^{*13}	DKPF0-2L
011101 ^{*13}	CHP71-2Y	111101 ^{*13}	DKPF1-2L
011110 ^{*13}	CHP72-2Y	111110 ^{*13}	DKPF2-2L
011111 ^{*13}	CHP73-2Y	111111 ^{*13}	DKPF3-2L

Byte13(bit6-bit7)

Byte 13 (bit 6 - bit 7)	Section
00	CHA/DKA
01	Shared Memory
10	CSW
11	CACHE

*6 Contents of byte 13 when a version check error or sum check error occurred

Byte 13	Micro-program type
00	RAM BOOT
01	DKC MANI
02	LCP
03	MCP
04	LCDG
05	DKU
06	SVP
07	S-SVP

*7 Contents of byte 13 when a CHP error occurred.

Content of high byte of Byte13(Y)

High byte of Byte 13	Content
0	1 st . CHA of cluster 1
1	2 nd . CHA of cluster 1
2	3 rd . CHA of cluster 1
3 ^{*13}	4 th . CHA of cluster 1 ^{*13}
4	1 st . CHA of cluster 2
5	2 nd . CHA of cluster 2
6	3 rd . CHA of cluster 2
7 ^{*13}	4 th . CHA of cluster 2 ^{*13}

Content of low byte of Byte13(Y)

Low byte of Byte 13	Content
0	1 st . CHP of the CHA
1	2 nd . CHP of the CHA
2	3 rd . CHP of the CHA
3	4 th . CHP of the CHA

In WCHK1 dump and ABEND dump received SIM = 3080XY, 3081XY, the system error code is indicated on the SIM log detail screen in the format [YYYY] as in Reference Code 3080XY[YYYY].

*8 Contents of byte 13 when a DKP error occurred

Content of high byte of Byte13(Y)

High byte of Byte 13	Content
0	1 st . DKA of cluster 2
1 ^{*13}	2 nd . DKA of cluster 2 ^{*13}
2 ^{*13}	3 rd . DKA of cluster 2 ^{*13}
3 ^{*13}	4 th . DKA of cluster 2 ^{*13}
4	1 st . DKA of cluster 2
5 ^{*13}	2 nd . DKA of cluster 2 ^{*13}
6 ^{*13}	3 rd . DKA of cluster 2 ^{*13}
7 ^{*13}	4 th . DKA of cluster 2 ^{*13}

Content of low byte of Byte13(Y)

Low byte of Byte 13	Content
0	1 st . DKP of the DKA
1	2 nd . DKP of the DKA
2	3 rd . DKP of the DKA
3	4 th . DKP of the DKA

In WCHK1 dump and ABEND dump received SIM = 3080XY, 3081XY, the system error code is indicated on the SIM log detail screen in the format [YYYY] as in Reference Code 3080XY[YYYY].

*9 Content of Byte 13 when a LCP error occurred

Contents of high byte 13

High byte of Byte 13	Content
0	1 st . CHA of cluster 1
1	2 nd . CHA of cluster 1
2	3 rd . CHA of cluster 1
3* ¹³	4 th . CHA of cluster 1* ¹³
4	1 st . CHA of cluster 2
5	2 nd . CHA of cluster 2
6	3 rd . CHA of cluster 2
7* ¹³	4 th . CHA of cluster 2* ¹³

Contents of low byte 13

Low byte of Byte 13	Content
0	1 st . LCP of the CHA
1	2 nd . LCP of the CHA
2	3 rd . LCP of the CHA
3	4 th . LCP of the CHA

- *11 Execute the following procedures according to the error code of initialization function which is shown in 5C-5Fth byte of the SSB with error code 3309. Also, the SSB is the relative log of SIM with the reference code 7900xx or 7901xx.

Code (4-bytes)	Procedures	Note
21000041	P/K Replace	Replace the package with another new one.
31000041	MP-Install	Execute it when the P/S OFF is executed with Shut Down Jumpers to install the micro-programs.
	① P/S OFF ② Pull out the Shut Down Jumpers ③ P/S ON	Execute them when you have forgotten to pull out Shut Down Jumpers in the normal P/S ON.
42000041	P/K Replace	Replace the package with another new one.
48000041	Refer to Note(1)	
55000041	P/K Replace	Replace the package with another new one.
56000041	① SVP Replace	Use the same package in ③.
	② MP-Install	
	③ P/K Replace	
others	① MP-Install	Use the same package in ②.
	② P/K Replace	

You never fail to make sure the installed micro program version and the each processor's status by displaying the status (Status display) after the above procedures was finished.

Then, for the micro program version, "Currently running Microprogram Version" and "Stored Microprogram Version per Processor" must be confirmed.

Reference address are as follows.

P/K Replace	REP01-140
SVP Replace	REP01-150 (Work ID : RT10)
MP-Install	MICRO-FC05-10
SSB with the error code 3309	SSBLOG05-2370

[Note(1)]: ① Confirm the PCB name of the package that is set now.

② In the case that the package is the same as the type of the package which you specified in the define configuration.

(a) MP-Install

(b) P/K Replace (Use the same package)

In the case that the package is not same as the type of the package that you specified in the define configuration information.

(a) MP-Install

- *12 Confirm the Program Product Installation status at [Install]-[Refer Configuration].

- *13 Only Separate Model.

- *14 In case of Single Cabinet Model.

- *15 Please improve JP Setting of an indication Port with reference to a LOCATION SECTION 6.2 Other Jumpers.

3 SIM Format

SIM Format (DKC SIM SSB28 = x'F1')

	0	1	2	3	4	5	6	7
0	x'00'							
1	Permanent Error	'0'		'1'	x'0'			
2	'0'			'1'	x'0'			
3	x'000000'							
4								
5								
6								
7	SIM sense record ID (x'E0')							
8	Range subject to the error (Note 1)				Range affected by repair (Note 2)			
9	Level of error (Note 3)		Number of faulty SPs (Note 4)	Number of SPs in SSID (Note 5)	Number of faulty SSIDs (Note 6)	Number of affected SSIDs (Note 7)	Status (Note 8)	0
10	Resend SIM (Note 9)	'0000000'						
11	Hardware level (Note 10)							
12	Hardware level (Note 10)							
13	Isolation code (Note 11)							
14	SSB ID (Note 12)	SIM sequence number (SIM log record #)						SVP ID (Note 13)
15	DKC serial number (x'0C2200'+DKC sequence number)							
16								
17								
18								
19								
20	SSID of self subsystem							
21	Symptom code (Note 14)							
22								
23								
24	Logging and Message Control (Note 15)							
25	Program action code (x'10')							
26	Dual Frame	EDCC Mode	'00'		Nonsynchronous operation	Serial channel	Report output (1)	'0'
27	'0'	'0000'				Extension path configuration	Fenced storage path	
28	x'F1'							
29	Affected SSID							
30	x'00'							
31								

SIM Format (CACHE SIM SSB28 = x'F2')

	0	1	2	3	4	5	6	7
0	x'00'							
1	Permanent Error	'0'		'1'	x'0'			
2	'0'			'1'	x'0'			
3	x'000000'							
4								
5								
6								
6	Serial # valid	Device address valid	Track address valid	'0'	Format (x'F')			
7	SIM sense record ID (x'E0')							
8	Range subject to the error (Note 1)				Range affected by repair (Note 2)			
9	Level of error (Note 3)		Number of faulty SPs (Note 4)	Number of SPs in SSID (Note 5)	Number of faulty SSIDs (Note 6)	Number of affected SSIDs (Note 7)	Status (Note 8)	0
10	Resend SIM (Note 9)	'0000000'						
11	Hardware level (Note 10)							
12	Hardware level (Note 10)							
13	Isolation code (Note 11)							
14	SSB ID (Note 12)	SIM sequence number (SIM log record #)					SVP ID (Note 13)	
15	DKC serial number (x'0C2200'+DKC sequence number)							
16								
17								
18								
19								
20	SSID of self subsystem							
21	Symptom code (Note 14)							
22								
23								
24	Logging and Message Control (Note 15)							
25	Program action code (x'10')							
26	Dual Frame	EDCC Mode	'00'		Nonsynchronous operation	Serial channel	Report output	'0'
27	'0'	'0000'				Extension path configuration	Fenced storage path	
28	x'F2'							
29	Affected SSID							
30	x'00'							
31								

SIM Format (DEVICE SIM SSB28 = x'FE')

	0	1	2	3	4	5	6	7
0	x'0000'							
1								
2	Storage Control Type (x'06')							
3	x'00'							
4	Affected SP			Device Address				
5	Device Type							
6	Serial # valid	Device address valid	Track address valid	'0'	Format (x'F')			
7	SSB ID (Note 12)	SIM Sequence ID					SVP ID (Note 13)	
8	Device Exception (x'1')				Service Message (Note 16)			
9	Level of error (Note 3)			'000000'				
10	Resend SIM (Note 9)	'0000000'						
11	Exception Class Fru List Code (x'80')							
12	Hardware and Microcode Corequisite Indicator (x'01')							
13	Device Address (See reference code)							
14	Action Flag (x'05')							
15								
16								
17	Drive serial number							
18	(x'0C22'+DKU sequence number)							
19								
20	SSID of self subsystem							
21								
22	Symptom code (Note 14)							
23								
24	Logging & Message Control (Note 15)							
25	Program Action Code (x'10')							
26	Dual Frame	EDCC Mode	x'0'	x'0'	Nonsynchro- nous operation	Serial Channel	'1'	'0'
27	x'0'				x'0'	Extention path configuration	Storage path	
28	x'FE'							
29								
30	x'000000'							
31								

SIM Format (MEDIA SIM SSB28 = x'FF')

	0	1	2	3	4	5	6	7
0	x'0000'							
1								
2	Storage Control Type (x'06')							
3	x'00'							
4	Affected SP			Device Address				
5	Device Type							
6	Serial # valid	Device address valid	Track address valid	'0'	Format (x'F')			
7	SSB ID (Note 12)	SIM Sequence ID					SVP ID (Note 13)	
8	Device Exception (x'1')				Service Message (x'1')			
9	Level of error (Note 3)		Media Maintenance Procedure Number (correctable: x'07', uncorrectable: x'05')					
10	Resend SIM (Note 9)	('0000000')						
11	Exception Class Fru List Code (x'80')							
12	Hardware and Microcode Corequisite Indicator (x'01')							
13	Device Address (See reference code)							
14	Correctable: x'87', uncorrectable: x'85'							
15								
16								
17	Drive serial number							
18	(x'0C22'+DKU sequenc number)							
19								
20	SSID of self subsystem							
21								
22	Symptom code (Note 14)							
23								
24	Logging & Message Control (Note 15)							
25	Program Action Code (x'10')							
26	Dual Frame	EDCC Mode	x'0'	x'0'	Nonsynchro- nous operation	Serial Channel	'1'	'0'
27	x'0'				x'0'	Extention path configuration	Storage path	
28	x'FF'							
29	Cylinder Address High							
30	Cylinder Address Low							
31	Head Address							

Notes:

1. Range subject to the error

(1) When byte 28 is x'F1' (DKC SIM)

x'0': Not used
 x'1': Error range not known
 x'2': SP error
 x'3': CHL-I error
 x'4': Not affect performance
 x'5' to x'F': Not used

(2) When byte 28 is x'F2' (CACHE SIM)

x'0': Not used
 x'1': Error range not known
 x'2': Error between SP and CACHE
 x'3': CACHE error
 x'4': DC/FW error
 x'5': FW error
 x'6' to x'F': Not used

2. Range affected by repair

(1) When byte 28 is x'F1' (DKC SIM)

x'0': Not used
 x'1': Repair range not known
 x'2': Repair does not affect performance
 x'3': SP disabled during repair
 x'4': SSID disabled during repair
 x'5' to x'F': Not used

(2) When byte 28 is x'F2' (CACHE SIM)

x'0': Not used
 x'1': Repair range not known
 x'2': Repair does not affect performance
 x'3': CACHE error
 x'4': DC/FW error
 x'5': FW error
 x'6' to x'F': Not used

3. Level of error

B'00': Service SIM
 B'01': Moderate SIM
 B'10': Serious SIM
 B'11': Acute SIM

4. Number of faulty SPs

B'0': 1 SP
 B'1': 2 SPs

5. Number of SPs in SSID

B'0': 2 SPs
 B'1': 4 SPs

6. Number of faulty SSIDs

B'0': 1
 B'1': 2

7. Number of affected SSIDs

B'0': 1
 B'1': 2

8. Status

B'0': Degeneration

B'1': Stop

9. Resend SIM

B'0': Unresent SIM

B'1': Resent SIM

10. Hardware level

Bit 0: ESCON hardware level

When bit 0 is 0:

Bit 1: Not used
 Bits 2-3: Report storage path
 Bits 4-5: Number of channels per cluster
 B'00' = 4
 B'01' = 8
 B'10' = Not used
 B'11' = Not used
 Bit 6: NVS
 B'0' = No NVS
 B'1' = NVS provided
 Bit 7: Not used
 Bits 8-10: Cache size
 000: Non cache
 001: 256MB
 010: 512MB
 011: 768MB
 100: 1024MB
 101: 1280MB
 110: 1536MB
 111: Over 1536MB
 Bits 11-13: Cluster hardware level
 Bits 14-15: Cache/NVS hardware level

When bit 0 is 1:

Bit 1: Not used
 Bits 2-3: Error storage path
 Bits 4-7: Number of channels per cluster
 0000: Metal = 4, ESCON = 0
 0001: Metal = 8, ESCON = 0
 0010: Metal = 4, ESCON = 2
 0100: Metal = 4, ESCON = 4
 0110: Metal = 0, ESCON = 2
 1000: Metal = 0, ESCON = 4
 1010: Metal = 0, ESCON = 8
 1100: Metal = 0, ESCON = 6
 Bit 8: Dual frame
 0: Dual frame
 1: Modular power
 Bits 9-11: Cache size
 000: Non cache
 001: 256MB
 010: 512MB
 011: 768MB
 100: 1024MB
 101: 1280MB
 110: 1536MB
 111: Over 1536MB
 Bits 12-13: Cluster hardware level
 Bits 14-15: Cache/NVS hardware level

11. Isolation code

Byte 13 ≠ X'00' Bytes 22 and 23 are a symptom code.

Byte 13 = X'00' Bytes 22 and 23 are an isolation code. This byte is byte 2 of the association code.

12. SSB ID

B'0' = SVP

B'1' = SP

13. SVP ID

B'0' = SVP1

B'1' = SVP2

14. Symptom code

See bytes 22 and 23 of the reference codes listed in Sections 2.1 and 2.2.

15. Logging and Message control

Bit 0 - 3: Not used

Bit 4 - 5: Logging

B'00': Do not log

B'01': Unconditional log

B'10': Log only once

B'11': Log only if persistent

Bit 6 - 7: Operator message

B'00': No message

B'01': Unconditional message

B'10': Send only once

B'11': Send only if persistent

16. Service Message

x'1': Action

x'C': No action