

DIAGNOSIS SECTION

Contents

DIAGNOSIS

1 Types of Diagnoses	DIAG01-10
2 DIAG Details	DIAG02-10
2.1 CUDG3 (Control Unit Diagnosis3)/LCDG3 (Link Control module Diagnosis3)/ FCDG3 (Fibre Channel module Diagnosis3).....	DIAG02-10
2.2 CUDG4 (Control Unit Diagnosis4)/LCDG4 (Link Control module Diagnosis4)/ FCDG4 (Fibre Channel module Diagnosis4).....	DIAG02-20
2.2.1 CUDG4	DIAG02-20
2.2.2 LCDG4	DIAG02-30
2.2.3 FCDG4	DIAG02-35
2.3 INLINE CUDG(INLINE Control Unit Diagnosis).....	DIAG02-40
2.4 DKU INLINE	DIAG02-40
2.5 DKU PATH INLINE.....	DIAG02-50
2.6 LAN Checker	DIAG02-50
3 DIAG Parts	DIAG03-10
4 DIAG Test Procedures (SVP Operations)	DIAG04-10
4.1 CUDG4/LCDG4/FCDG4 Test Procedures.....	DIAG04-10
4.2 DKU INLINE Test Procedures	DIAG04-100
4.3 DKU PATH INLINE Test Procedures	DIAG04-140
4.3.1 A0 routine Test Procedures	DIAG04-140
4.3.2 A2(A8) routine Test Procedures.....	DIAG04-180
4.3.3 A3 routine Test Procedures	DIAG04-220
4.4 LAN Checker Procedures.....	DIAG04-260
5 DIAG Trouble shooting	DIAG05-10
5.1 CUDG Trouble shooting	DIAG05-10
5.1.1 CUDG3 Trouble shooting	DIAG05-20
5.1.2 CUDG4 Trouble shooting	DIAG05-30
5.1.3 INLINE CUDG Trouble shooting	DIAG05-40
5.1.4 CACHE PCB, CACHE MEMORY MODULE Trouble shooting.....	DIAG05-60
5.2 DKU INLINE Trouble shooting.....	DIAG05-70
5.3 DKU PATH INLINE Trouble shooting	DIAG05-80
6 DIAG Errors	DIAG06-10
6.1 DKU INLINE Error Code List	DIAG06-10
6.2 PATH INLINE Error Code List	DIAG06-70
6.3 CUDG Error Code List.....	DIAG06-230

1 Types of Diagnoses

This subsystem's diagnostics consist of the five types of test routines listed below. They are selected according to the purpose and the part to be tested.

Table 1-1 Diagnostics Test Routines

Item No.	Type	Diagnosis	Part	Timing
1	CUDG3/ LCDG3/ FCDG3	Initial diagnoses	CHA, DKA, CACHE/SHARED MEMORY	When DKC is powered on or CHA or DKA is replaced or installed(automatic)
2	CUDG4/ LCDG4/ FCDG4	Functional diagnoses executed when the unit is offline	CHA, DKA, CACHE/SHARED MEMORY	During installation (as specified by service personnel)
3	INLINE CUDG	Functional diagnoses executed when the unit is online	CACHE/SHARED MEMORY	When Cache or Shared memory is replaced or installed (automatic)
4	DKU INLINE	DKA-HDU functional (connection) check	DKA, FSW, HDD	When an HDD is replaced (automatic) or during installation (as specified by service personnel)
5	DKU PATH INLINE	↑	DKA, FSW, DKUMN	↑
6	LAN	LAN check between DKC and SVP	SVP, SSVP, DKA, CHA	When LAN communication error or communication time-out error is occurred.

2 DIAG Details

2.1 CUDG3 (Control Unit Diagnosis 3)/LCDG3 (Link Control module Diagnosis 3)/FCDG3 (Fibre Channel module Diagnosis 3)

CUDG3/LCDG3/FCDG3 is a collection of test routines that are started at system start time (when the unit power is turned on), prior to the execution of the main program and automatically check the basic functions of the unit to ensure the normal hardware operation of the system. The CUDG3/LCDG3/FCDG3 routines are listed in Table 2.1.

Table 2.1 CUDG3/LCDG3/FCDG3 Test Routines

Item No.	Routine Name	Function
1	CUDG3B	Local memory/RCHK diagnosis
2	CUDG3C1	CHA PCB self-diagnosis
3	CUDG3C2	DKA PCB self-diagnosis
4	CUDG3C3	Shared resource diagnosis by all processors (SMC)
5	CUDG3C4	Shared resource diagnosis by all processors (CACHE)
6	CUDG3C5	Shared resource diagnosis by a delegated processor (SMC)
7	CUDG3C6	Shared resource diagnosis by a delegated processor (CACHE)
8	LCDG3/ FCDG3	CS, for Serial/Parallel port, read/write test, internal diagnostic test, communication diagnostic test

2.2 CUDG4 (Control Unit Diagnosis 4)/LCDG4 (Link Control module Diagnosis 4)/ FCDG4 (Fibre Channel module Diagnosis 4)

CUDG4/LCDG4/FCDG4 supports Cache memory/Shared memory read after full write tests and other tests that cannot be covered by CUDG3/LCDG3/FCDG3. It is executed by the service personnel when the unit is offline. After CUDG4/LCDG4/FCDG4, the subsystem PS OFF/ON is mandatory in order to return to ONLINE status of the subsystem.

2.2.1 CUDG4

The CUDG4 test routines are listed in Table 2.2.1-1 .

The CUDG4 run option are listed in Table 2.2.1-2.

Table 2.2.1-1 CUDG4 Test Routines

Item No.	Routine Name	Function
1	P/K test Group	CHA/DKA diagnosis
2	SMC Normal test Group	SMC, SHARED MEMORY diagnosis (Normal test)
3	Cache Normal test Group	CACHE PCB, CACHE MEMORY diagnosis (Normal test)
4	SMC test Group	SMC, SHARED MEMORY diagnosis
5	Cache test Group	CACHE PCB, CACHE MEMORY diagnosis
6	Heatrun test Group	All the above tests are included.

Note 1: When 'Heatrun test Group' is selected, 'Run Option' settings are invalidated and diagnosis is executed under Heatrun mode.

Heatrun mode : If an error is detected, continuous CUDG test. And Diag log is mode.

Table 2.2.1-2 CUDG Run Option

Item No.	Run Option	If an error is not detected	If an error is detected
1	Normal	CUDG test will be executed only once.	CUDG test will be finished when an error is detected. And the error detail will be displayed on the SVP screen. After finishing the CUDG function, please refer to Diag log. (See 27 of DIAG04-90)
2	Loop	CUDG test will be executed continuously.	CUDG test will be finished when an error is detected. And the error detail will be displayed on the SVP screen. After finishing the CUDG function, please refer to Diag log. (See 27 of DIAG04-90)
3	Error Loop	CUDG test will be executed continuously.	Continuous CUDG test. And an error detail is displayed on the SVP screen. But the CUDG test will be continued testing.
4	Error Log	CUDG test will be executed continuously.	Continuous CUDG test. And an error detail will be displayed on the SVP screen. After finished the CUDG function, refer to Diag log. (See 27 of DIAG04-90)

2.2.2 LCDG4

The LCDG4 test routines are listed in Table 2.2.2-1 .

The LCDG4 run option are listed in Table 2.2.2-2.

Table 2.2.2-1 LCDG4 Test Routines

Item No.	Routine No.	Parameter	Contents of Test
1	10	—	(1) LCP Operation (2) LCP Register Test (3) Data Buffer Read/Write (4) SPS Function
2	20	—	(1) LCP-MP Communication Test (2) Data Transfer Test
3	30	CB750F	(1) Serial Channel Wraparound Test
4	40	—	(1) Optical Signal Defect Test
5	50	—	(1) Optical Signal Error Rate Check

Note 1: Routine 30 is used for running a serial channel wraparound test.

To execute Routine 30, the wraparound test connector is required.

Note 2: Routine 40 and Routine 50 are used for checking optical signals for the serial channel.

Note 3: If Routine 40 or Routine 50 is selected, RUN option will be selected only Normal.

Table 2.2.2-2 LCDG4 Run Option

Item No.	RUN Option	If an error is detected
1	Normal	LCDG test will be executed only once. LCDG test will be finished when an error is detected. And the error detail will be displayed on the SVP screen. After finishing the LCDG function, please refer to Diag log. (See 27 of DIAG04-90)
2	Error Loop	Continuous execution of LCDG test. And an error detail will be displayed on the SVP screen. But the LCDG test will be continued testing.
3	Loop	Continuous execution of LCDG test. LCDG test will be finished when an error is detected. And an error detail will be displayed on the SVP screen. After finishing the LCDG function, please refer to Diag log. (See 27 of DIAG04-90)

2.2.3 FCDG4

The FCDG4 test routines are listed in Table 2.2.3-1 .

The FCDG4 run option are listed in Table 2.2.3-2.

Table 2.2.3-1 FCDG4 Test Routines

Item No.	Routine No.	Parameter	Contents of Test
1	10	—	(1) Processor Test (2) Register Test (3) Internal LINK Test
2	20	—	(1) HTP-MP Communication Test (2) Data Transfer Test
3	30	CB750F	(1) Single Channel Wraparound Test (Note 1)

Note 1: Routine 30 is used for running Fibre Channel wraparound test.
To execute Routine 30, the wraparound test connector is required.

Table 2.2.3-2 FCDG4 Run Option

Item No.	RUN Option	Meaning
1	Normal	FCDG test will be executed once. If an error is detected, error detail will be displayed on the screen . And Diag log is created.
2	Error Loop	Continuous execution of FCDG test. The test is continued even when an error is detected. The error detail will be displayed on the screen.
3	Loop	FCDG test will be executed for the specified times. The test will be terminated when an error is detected. And an error detail will be displayed on the screen.

2.3 INLINE CUDG(INLINE Control Unit Diagnosis)

INLINE CUDG checks the validity of Cache memory and Shared memory when the entire disk subsystem is running normally. The INLINE CUDG test routines are listed in Table 2.3.

Table 2.3 INLINE CUDG Test Routines

Item No.	Routine Name	Function
1	Cache memory system	CACHE PCB, CACHE MEMORY diagnosis
2	Shared memory system	SMC (Shared Memory Control) diagnosis

2.4 DKU INLINE

The DKU INLINE of test routines are used to ensure that the HDD is accessible to the Disk Controller when one is installed (a new or as an additional unit). This INLINE facility is also executed when a HDD is replaced during online processing as part of the recovery procedure to ensure that the HDD is normal. In this case, this INLINE facility runs automatically (with no SVP manipulation). The test routines are listed in Table 2.4.1.

Table 2.4 DKU INLINE Test Routines

Routine ID	Test Name	Function
C1	TEST UNIT READY & REQ.SENSE	Issues the TEST UNIT READY to the HDD and verifies that the status is GOOD or CHECK.
C2	INQUIRY	Checks the HDU-specific information.
C3	START/STOP TEST	Issues the STOP command to the HDD and verifies that the command terminates normally. In 10 seconds, the test routine issues the START command and verifies that normal status is returned.
C4	HDU SELF TEST	Issues the SEND DIAG(Self Test) command to the HDD and verifies that the terminates normally.

- Notes:
1. All logical devices must be in the "BLOCKED" state. If not, the test routine will error-terminate. Refer to from [SVP02-650 to SVP02-740](#) of SVP SECTION for all logical devices blocked.
 2. The previous test routines must have been terminated normally before the pertinent test routine is started.
 3. The Disk Controller should have been powered on normally.

2.5 DKU PATH INLINE

The DKU Path Inline is used to check that the connection between the DKA and the HDU is correct. The DKU path inline test routines are shown in Table 2.5

Table 2.5 DKU PATH INLINE Test Routine

Routine ID	Test Name	Function	Maximum execution time (1 PORT)		
			12HDD	24HDD	32HDD
A0	Path Address TEST1	Checks whether the selected DKA and HDU are correctly connected.	50 sec.	1 min. 40 sec.	2 min. 20 sec.
A2	Failed HDD detection test	Detects the failed HDD and recovers it by using the reset function when an A0 10 or A0 20 error occurs.	1 min.	2 min.	2 min. 40 sec.
A3	HDD READ TEST	Executes the read test of the mounted HDD is executed.	2 min.	4 min.	5 min. 20 sec.
A8	Failed HDD detection test 2	Extension of A2 routine.	2 min.	4 min.	5 min. 20 sec.

- Notes:
1. The routine A2(A8) forcibly blocks the port of the HDD by using the individual SCSI RESET function for the HDD connected to the designated port of the selected DKA. Therefore, you must not do this operation expect for finding the factor of A010/A020 error.
 2. The maximum execution times here is the time when communication is normal. In case of communication time-out, become the time 3 minutes were added to the above time. (Single Cabinet Model become only 12 HDD)
 3. The routine A3 execute Read Test to all equipped HDD. Therefore, you must not execute this operation during ONLINE.
 4. If the target Port (MP) does not block, the routine A8 cannot be executed.

2.6 LAN Checker

LAN checker analyses the LAN connection between DKC and SVP to determine whether the LAN error is caused by the physical connection or the communication software.

Table 2.6 LAN Checker Test

#	Test Name	Function	Maximum execution time
1	Hardware check	Checker executes "Ping" to all MPs. If the result is "no-response", for a MP, the physical connection error has occurred between the MP and SVP.	2 min. (1 MP)
2	Software check	Checker executes the communication between SVP and MPs whose result of #1 is "responded".	

3 DIAG Parts

The parts that are diagnosed by the DIAG test routines are shown in Figs. 3-1 through 3-5.

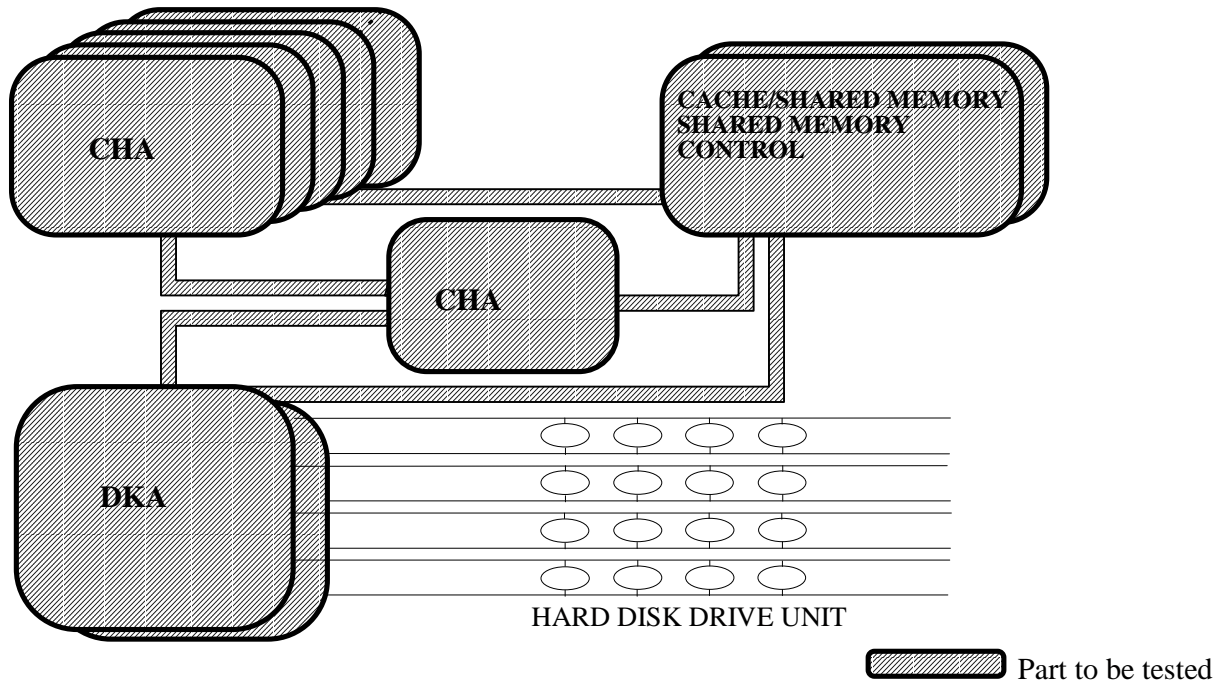

Fig. 3-1 Parts that are Subject to CUDG3/CUDG4 Tests

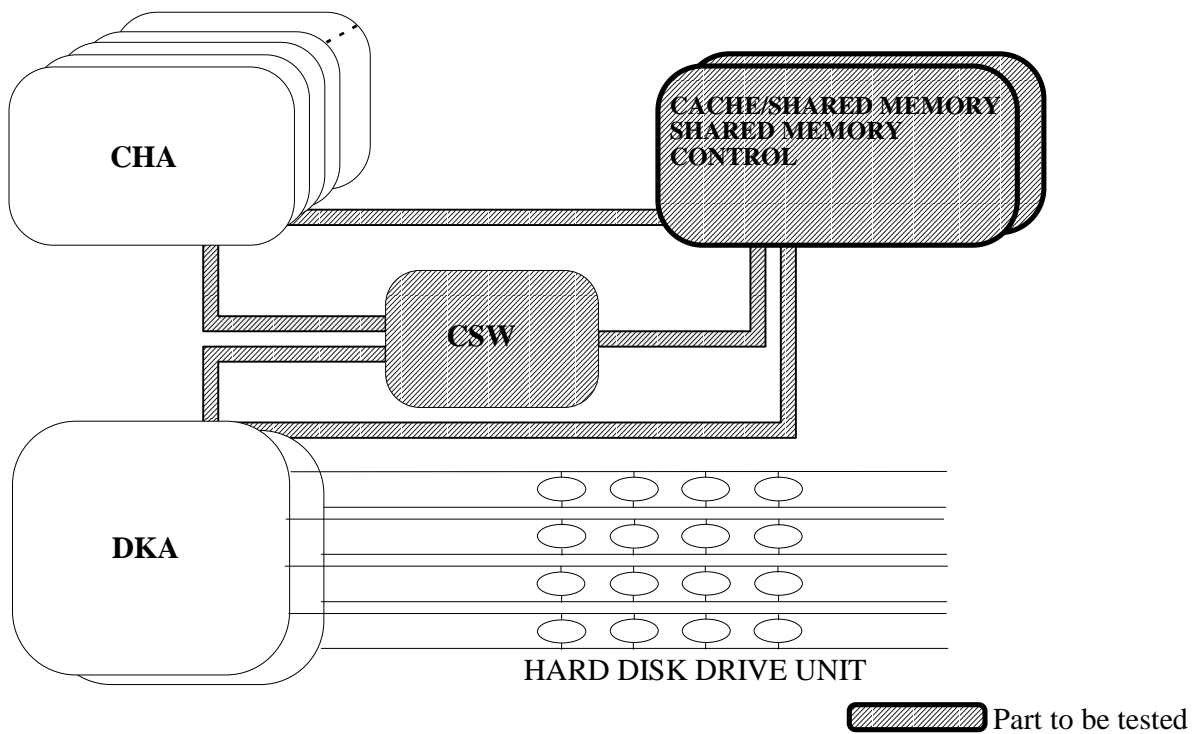

Fig. 3-2 Parts that are Subject to INLINE CUDG Tests

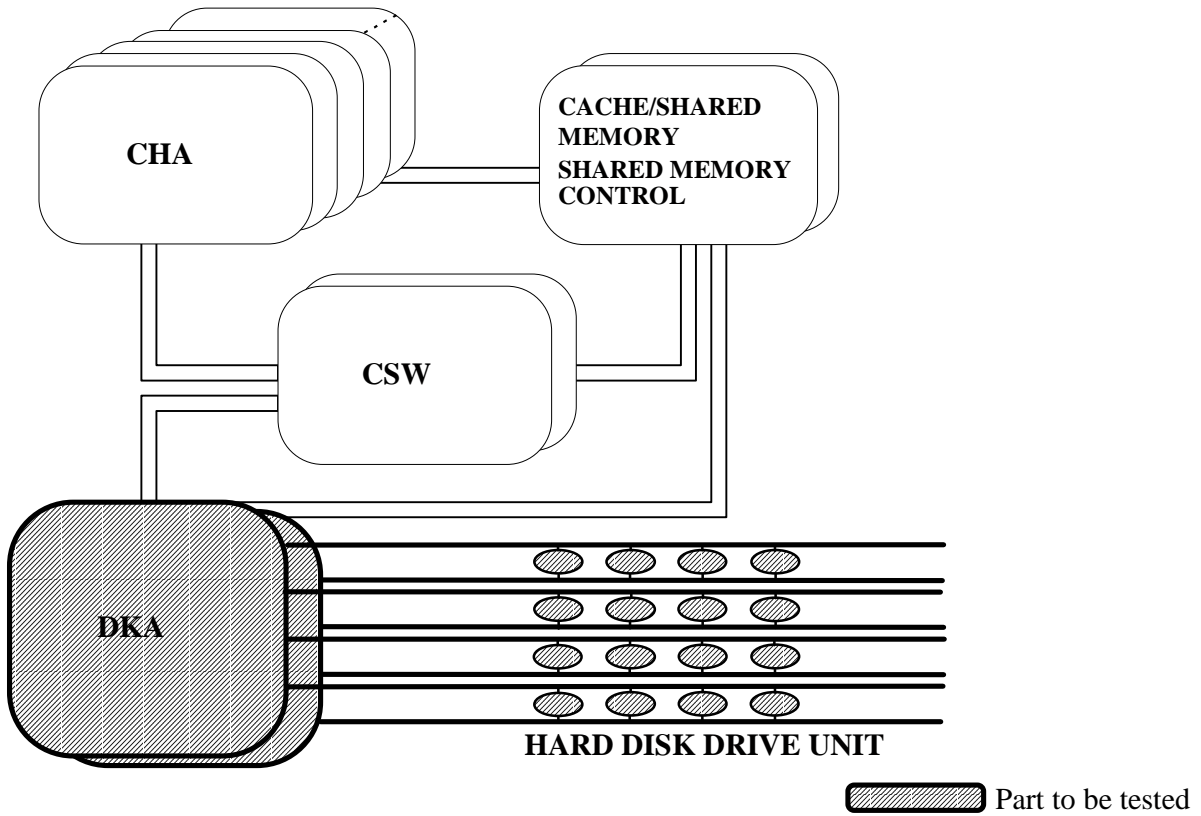

Fig. 3-3 Parts that are Subject to DKU INLINE Tests

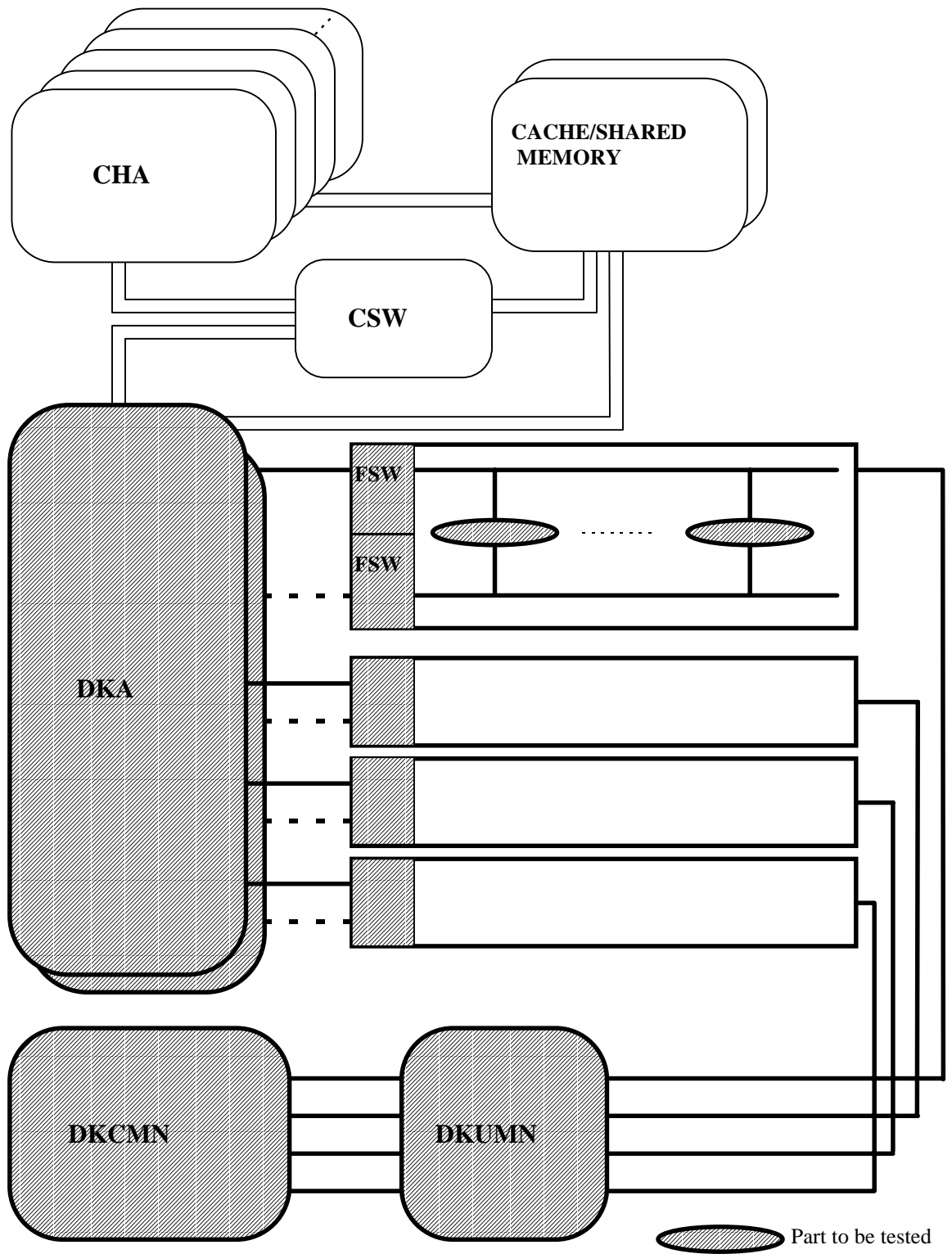

Fig. 3-4 Parts that are Subject to DKU PATH INLINE Tests

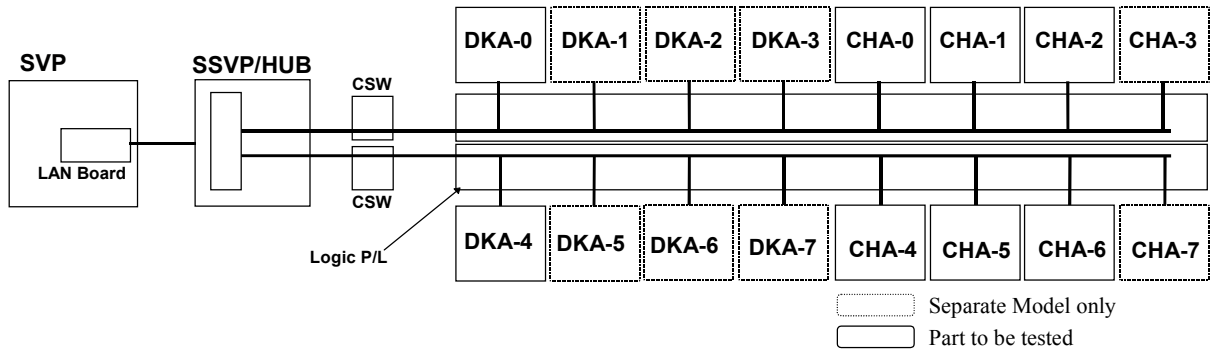

Fig. 3-5 Parts that are Subjects to LAN check

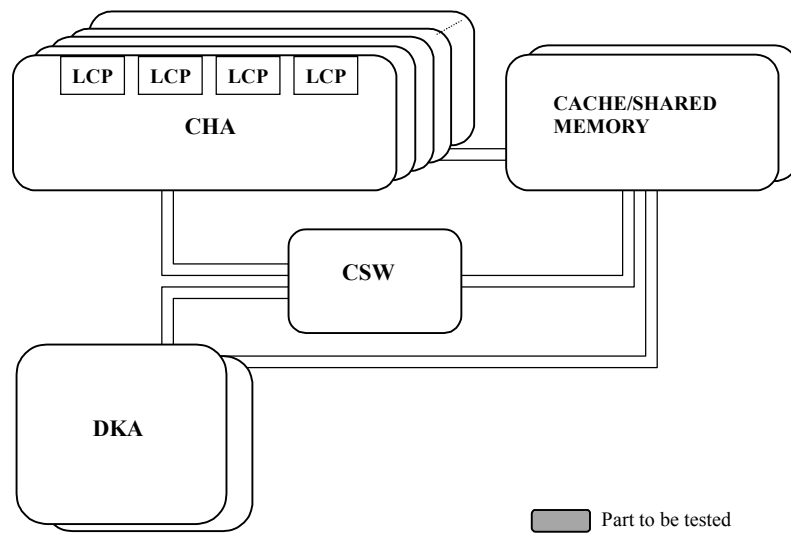

Fig. 3-6 Parts that are Subject to LCDG4 Tests

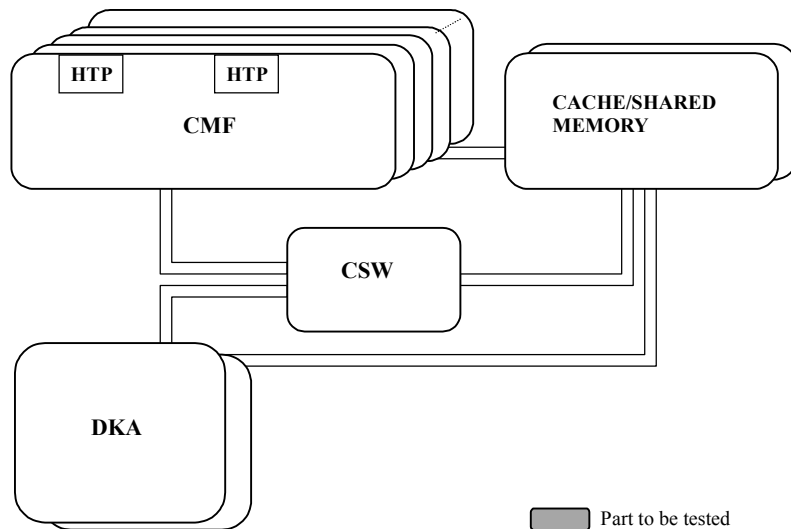

Fig. 3-7 Parts that are Subject to FCDG4 Tests

4 DIAG Test Procedures (SVP Operations)

For the explanation of procedure, the SVP screens of Separate Model are used.
Some screens of Single Cabinet Model have the different location name, but the operations are the same as ones in Separate Model.

4.1 CUDG4/LCDG4/FCDG4 Test Procedures

NOTICE

Powering off/on is required owing to the performance of this operation.

1. <Initial screen>

2. <Operation mode change>
Change the mode to [Modify Mode].
Select (CL) [Diagnosis].

3. <Activating CUDG>
Select (DR) [CUDG4] from [Examination] in
the Diagnosis menu.

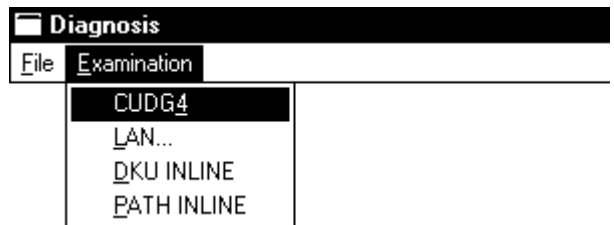

4. <Confirming that the channel path has been varied off>

An inquiry “Have you already varied off all paths?” is displayed.

Vary off the channel path, then select (CL) the [Yes] button.

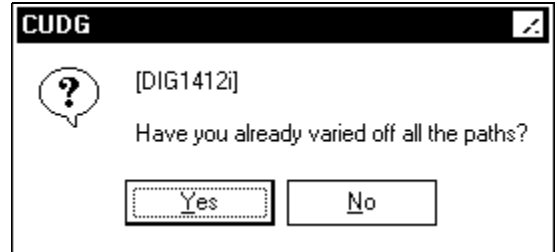

5. <Selection of CUDG4/LCDG4/FCDG4 >

In case of executing CUDG4, go to step 6.

In case of executing LCDG4/FCDG4, go to step 16.

6. <Start of CUDG4 test>

Select (DR) [Start] from [Examine] in the Diagnosis menu.

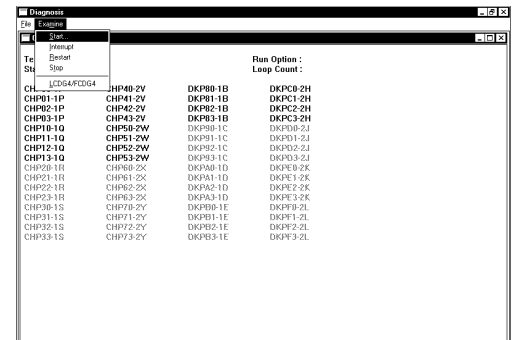

7. <Setting test parameters>

Select a test item, a test execution type, and a test object processor from Test Item, Run Option, and Processor respectively.

Select (CL) the [OK] button after all the selections are made.

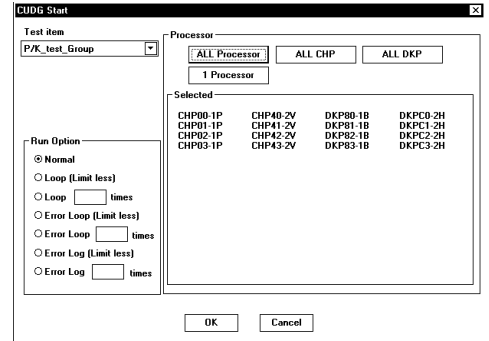

[Test items]

- P/K test Group : Diagnosis on the CHA PCBs or DKA PCBs
- SMC Normal test Group : Diagnosis on the shared memory control (test on the normal system)
- Cache Normal test Group : Diagnosis on the cache platter (test on the normal system)
- SMC test Group : Diagnosis on the shared memory control
- Cache test Group : Diagnosis on the cache platter
- Heatrun test Group : All the above tests are included

Note 1: When 'Heatrun test Group' is selected, 'Run Option' settings are invalidated and diagnosis is executed under Heatrun mode.

[Run option (test execution types)]

Refer to [DIAG01-10](#).

[Test object processors]

- ALL Processor : The test is executed on all the processors exist in the configuration.
- ALL CHP : The test is executed on all the CHPs exist in the configuration.
- ALL DKP : The test is executed on all the DKPs exist in the configuration.
- 1 Processor : The test is executed on specified processor exist in the configuration.

For details, see Item 15.

8. <Displaying CUDG4 loading>

Statuses of INIT, LOAD, and WAIT are displayed on the 'CUDG4' screen.

The illustration on the right shows the screen when the CUDG4 is being loaded.

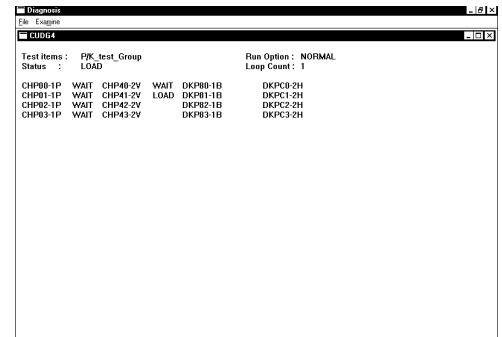

9. <Displaying RUN>

State of the run is displayed on the 'CUDG4' screen.

The illustration on the right shows the screen when the CUDG4 test is being executed.

Normal end ----- Go to step 11.

Abnormal end ----- Go to step 10.

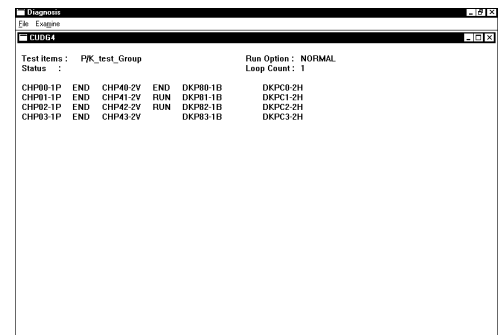

10. <Displaying error>

If an error occurs in CUDG4 test, CUDG Error window is displayed.

Confirm the type of the error, then select (CL) the [OK] button.

Refer to DIAG LOG according to the message.

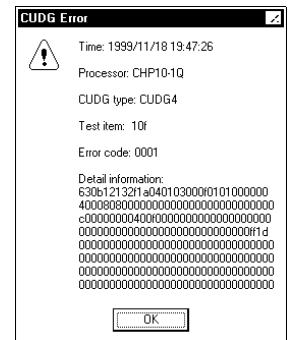

- To display DIAG LOG, see step 27.
- To execute CUDG4 again, go to step 6.
- To terminate CUDG4, go to step 12.

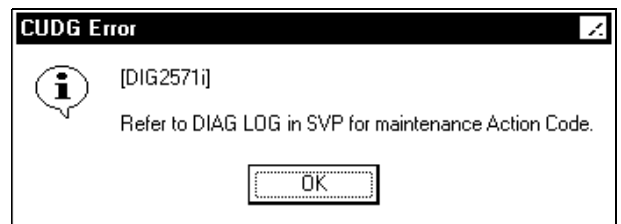

11. <Displaying END>

Status 'END' is displayed for the processor that CUDG4 test ends.

To continue CUDG4, go to step 6.

To terminate CUDG4, go to step 12.

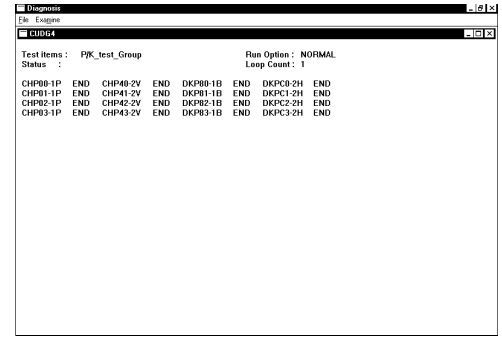

12. <Displaying Exit>

Select (CL) [Exit] from [File] in the Diagnosis menu.

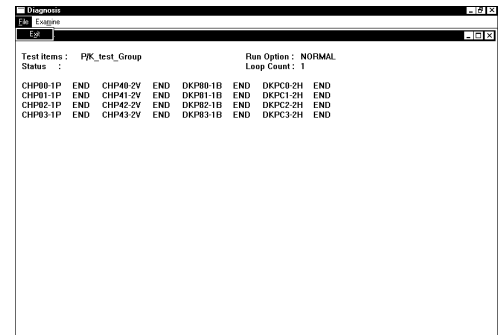

13. <PS-OFF and Reboot the PC>

Turn off the DKC subsystem by performing the PS-OFF operation following the displayed instruction "Turn off the DKC subsystem", then select (CL) the [OK] button.

If the power is not turned off after PS-OFF operation, immediately turn off the breaker.

And reboot the PC.

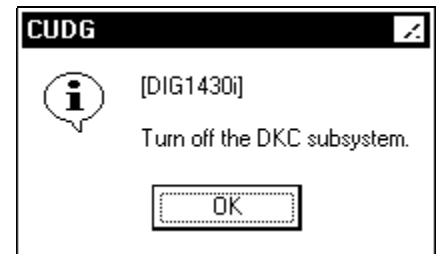

14. <Quitting the diagnosis screen and PS-ON>

The screen is returned to the initial screen.

Turn on the DKC Subsystem by performing the PS-ON operation.

End of CUDG operation.

15. <Specifying a test object processor>

Select a processor on which the test is to be executed.
(Two or more processors can be selected.)

After specifying the processor(s), then select (CL) the [OK] button.

Go to step 7.

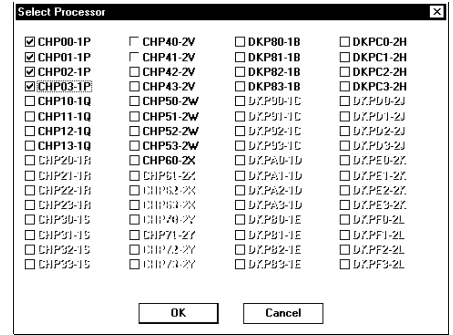

16. <Start of LCDG4/FCDG4 test>

Select (DR) [LCDG4/FCDG4...] from [Examine] on 'Diagnosis'.

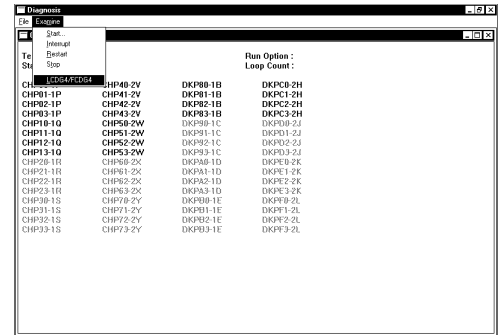

17. <Select [CHA], [LCP/HTP], [Run Option] and [Routine No.]>

Select (CL) [CHA], [LCP/HTP], [Run Option] and [Routine No.] in the 'LCDG4' dialog box.

Select (CL) [Start] button.

Refer to [DIAG02-30](#).

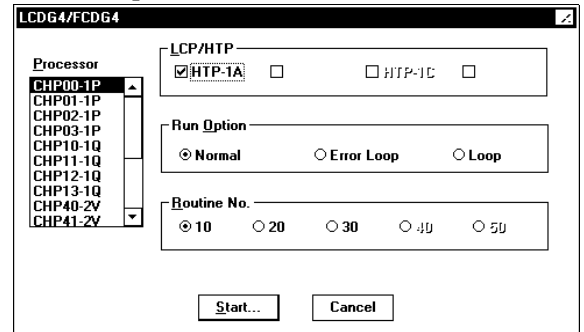

18. <Display of [LOAD]>

Status [INIT], [LOAD], and [WAIT] are displayed in the 'CUDG4' dialog box.

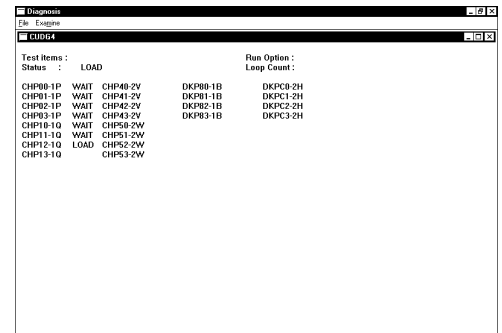

19. <Display of [Running]>

Status [Running] is displayed in the 'LCDG4/FCDG4 Status' dialog box.

Go to 20. in case of Normal End.
Go to 21. in case of Abnormal End.

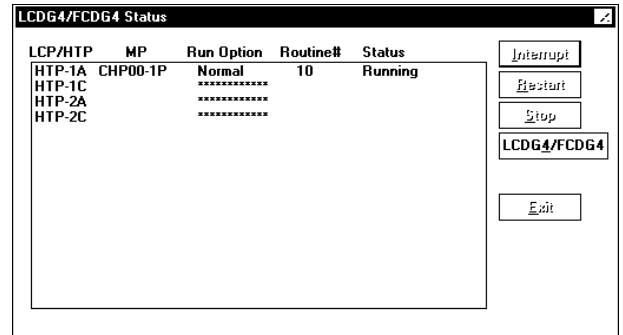

20. <Display of [End]>

Status [End] is displayed in the 'LCDG4/FCDG4 Status' dialog box.

When the routine number is 40, 'Optical Power' is displayed. Select (CL) [OK]. When the routine number is 50, 'Bit Error Rate' is displayed. Select (CL) [OK].

Go to 22.

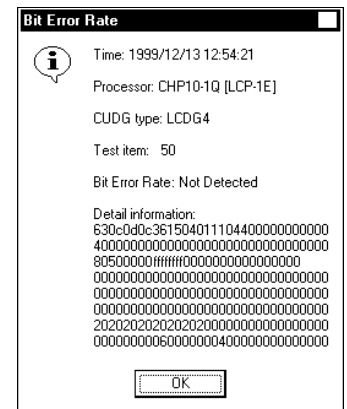
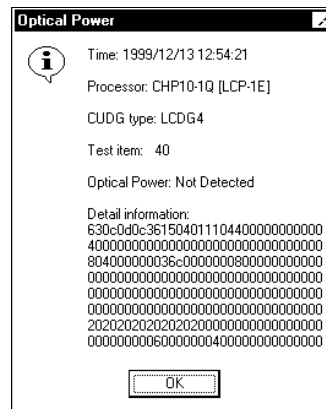
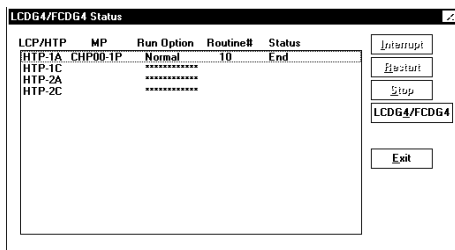

21. <Display of 'CUDG Error'>

After 'CUDG Error' is displayed, select (CL) [OK].

To display DIAG LOG, see step 27.

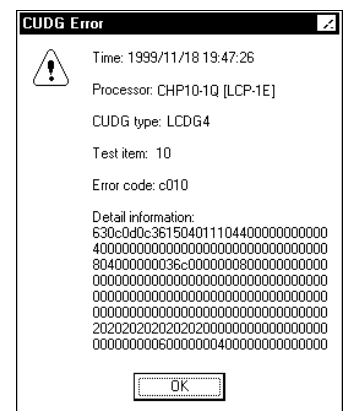
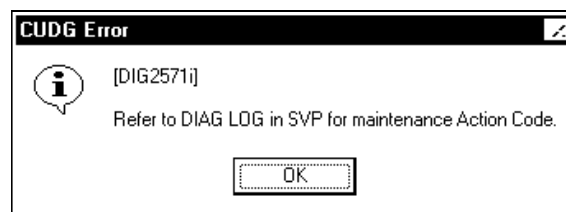

22. <Selection of continuation/termination of LCDG4/FCDG4>

To continue LCDG4/FCDG4, select (CL) [LCDG4] in 'LCDG4/FCDG4 Status' dialog box and go to step 17.

To terminate LCDG4/FCDG4, select (CL) [Exit] in 'LCDG4/FCDG4 Status' dialog box and go to step 23.

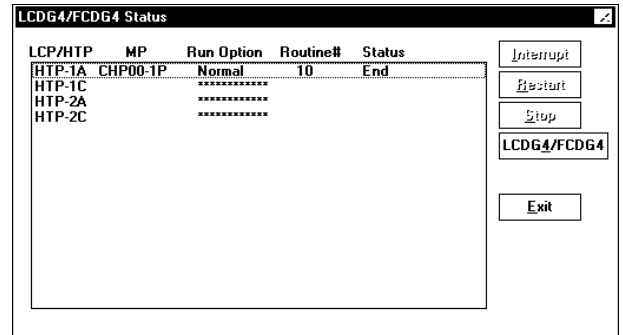

23. <End of LCDG4/FCDG4>

“Are you sure you want to reload the LCP/HTP and end the LCDG4/FCDG4.” is displayed.

Select (CL) [OK].

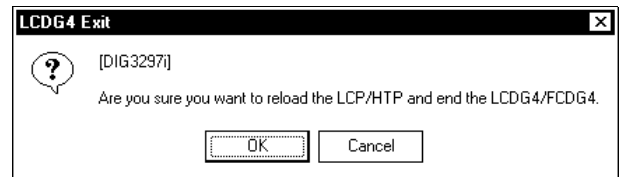

24. <Select [Exit]>

Select (DR) [Exit] from [File] on 'CUDG4'.

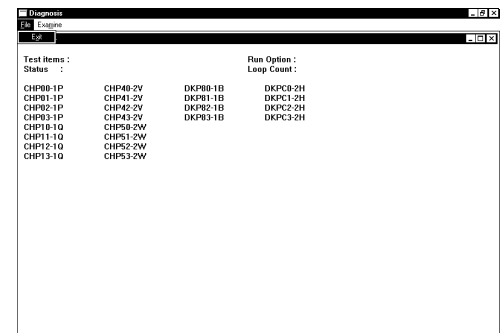

25. <PS-OFF and Reboot the PC>

After “Turn off the DKC subsystem.” is displayed, turn off the DKC subsystem by the PS-OFF operation and then select (CL) [OK].

And reboot the PC.

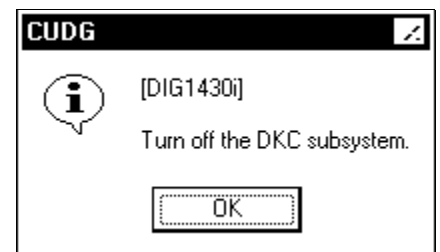

26. <End of the DIAGNOSIS screen>

The Initial screen is displayed.

Turn on the DKC subsystem by performing the PS-ON operation.
In case of error go to 27.

27. <See 'Diag Log'>

If CUDG4/LCDG4/FCDG4 ends with an error, select ACC from the 'Diag Log' dialog box in [INFORMATION] ICON.

See 2.2 Log indication in SVP section.

Note: Refer to ACC (ACTION-CODE) SECTION for ACC analysis.

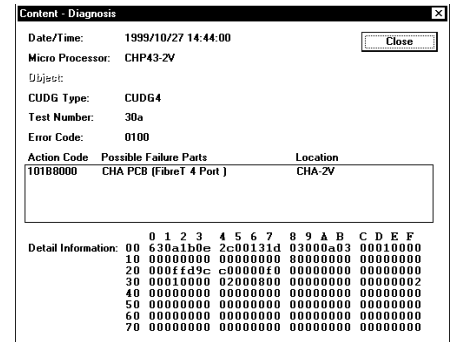

4.2 DKU INLINE Test Procedures

1. <Initial screen>

2. <Operation mode change>
Change the mode to [Modify Mode].
Select (CL) [Diagnosis].

3. <Select 'DKU INLINE'>
'Diagnosis' window is displayed.
And select (DR) [DKU INLINE] from [Examination]
in the Diagnosis menu.

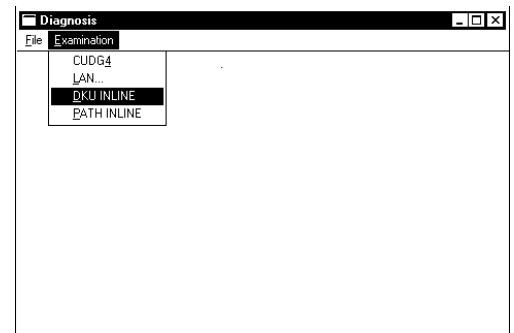

4. <Select [Start]>
Select (DR) [Start] form [Diag].



5. <Select UNIT to be tested>
Select (CL) the UNIT for which the test routine is to be executed from 'Select Unit'.
Then select (CL) [OK] button.

In case of select each 'UNIT' in Separate Model or in case of 'Disk' in Single Cabinet Model, go to 6.

In case of select 'ALL HDD', go to 9.

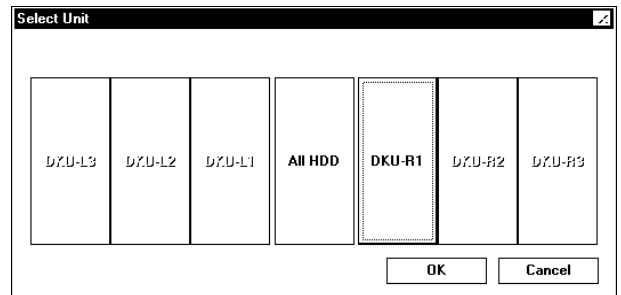

In Single Cabinet Model, "Disk" is displayed instead of "DKU-R1".

6. <Select HDU Group to be tested>
Select (CL) the HDU Group for which the test routine is to be executed from 'UNIT'.
Then select (CL) [OK] button.

In case of select [Select UNIT], go to 5.

(Separate Model)

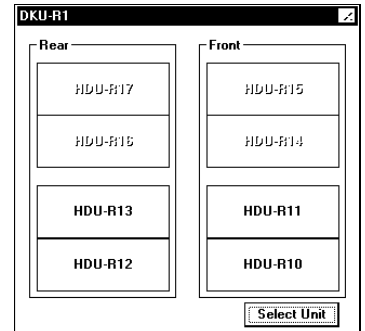

(Single Cabinet Model)

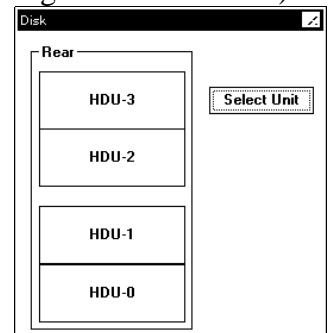

7. <Select HDD to be tested>
 Select (CL) HDD for which the test routine is to be executed from 'HDD SELECT'.
 Then select (CL) [OK] button.



8. <Select [OK]>
 select (CL) [OK] button.

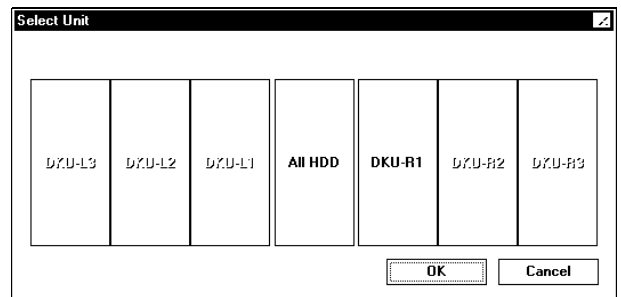

In Single Cabinet Model, "Disk" is displayed instead of "DKU-R1".

9. <Confirm HDD to be tested>
 Confirm HDD to be tested in the 'DRIVE LIST'.
 Then select (CL) [OK].

(Separate Model)

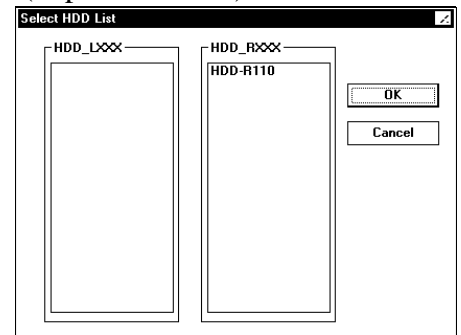

(Single Cabinet Model)

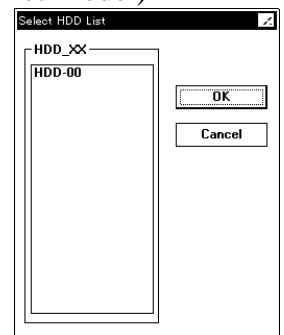

10. <Status Window>

The Status Window is displayed .

Normal end : Go to 11

Abnormal end : Go to 13

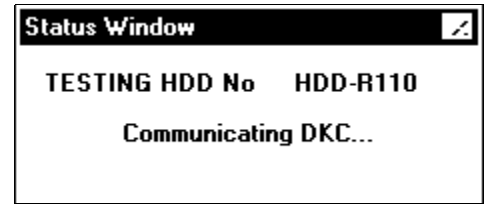

11. <DKU INLINE end>

After the status "INLINE NORMAL END" is displayed, select (DR) [Exit] from [File].

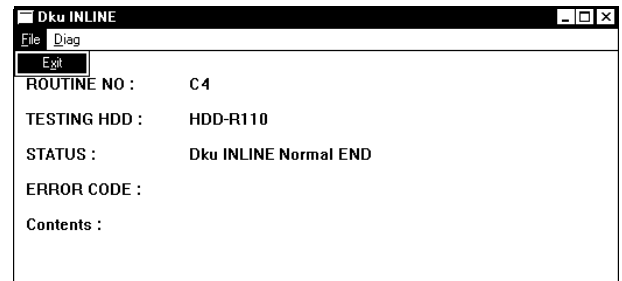

12. <Diagnosis end>

Select (DR) [Exit] from [File] in the Diagnosis menu.

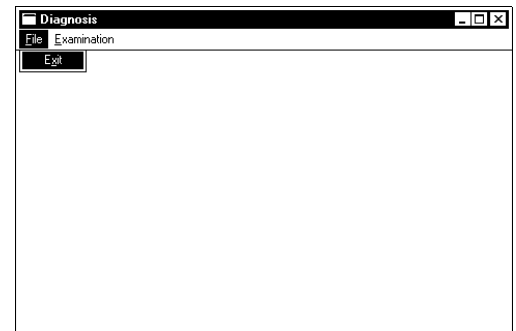

13. <Error End>

"STATUS : Dku INLINE Abnormal END" is displayed.

Refer to Diag Log for details information.

Select (DR) [Exit] from [File].

Go to 12.

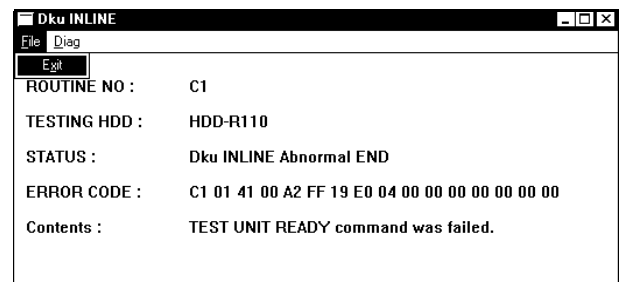

4.3 DKU PATH INLINE Test Procedures

4.3.1 A0 routine Test Procedures

1. <Initial screen>

2. <Operation mode change>
Change the mode to [Modify Mode].
Select (CL) [Diagnosis].

3. <Select 'PATH INLINE'>
'Diagnosis' window is displayed.
And select (DR) [PATH INLINE] from [Examination]
in the Diagnosis menu.

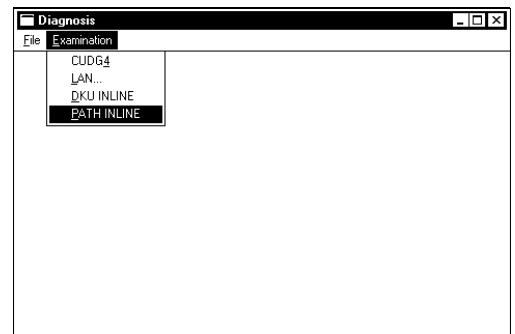

4. <Selecting [Start]>
Select (DR) [Start] from [Diag].



5. <Selecting the DKA to be diagnosed>
Select (CL) the DKA for which the test routine is to be executed.

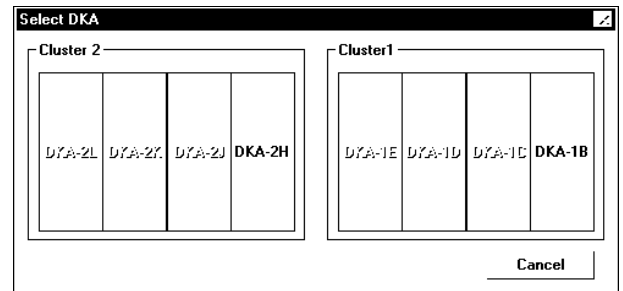

In Single Cabinet Model, the name of DKA is different.

6. <Routine selection>
Select the routine which is to be tested from 'Select Routine'.

And select (CL) the [OK] button.

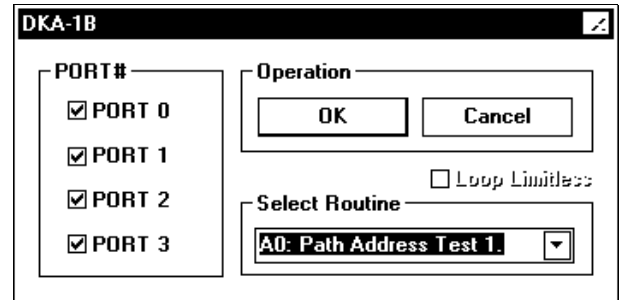

7. <Status Window>
The Status Window is displayed.

Normal end : Go to 8
Abnormal end : Go to 9

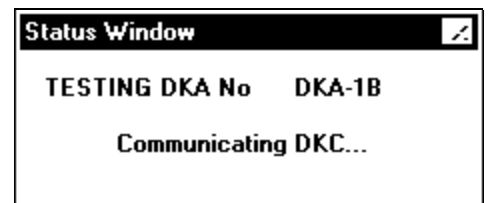

8. <Completing diagnosis>

After "INLINE NORMAL END" is displayed in the STATUS field, select (DR) [Exit] from [File].

Go to 13.

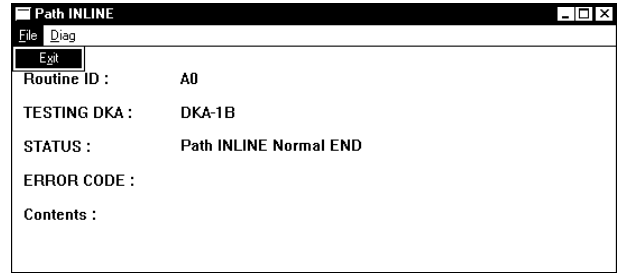

9. <Displaying the error detail>

Select (DR) [List] from [Diag].

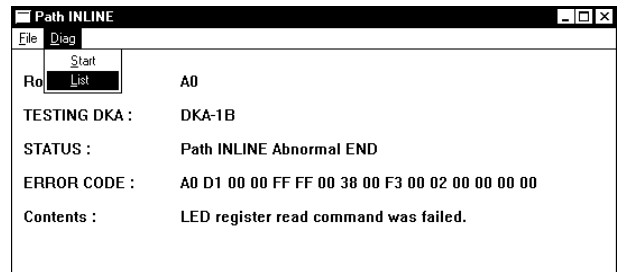

10 <Verification the incorrect part>

Select (CL) the incorrect part from [Path Address].

When [PathAddress] is selected, go to 11.
When [OK] is selected, go to 12.

In Separate Model, if you want to display other DKC, select (CL) [Next UNIT] or [Prev DKU].

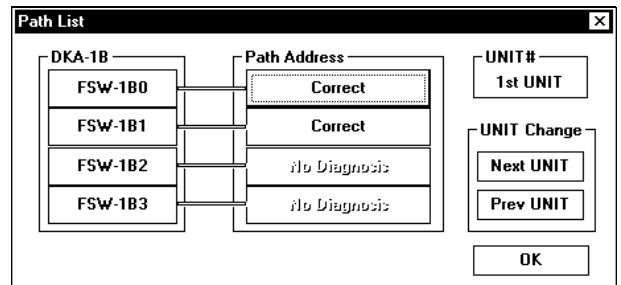

11. <Displaying 'Result'>

'Result' is selected.

Select (CL) the [OK] button.

Go to 10.

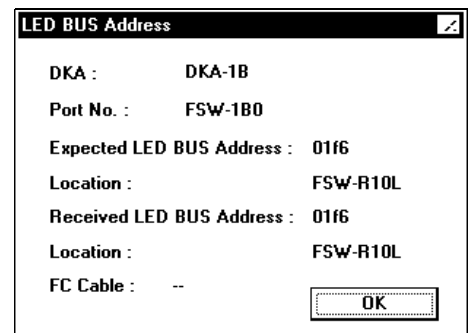

12. <DKU Path inline end>

After "ERROR STOP" is displayed in the Status field, select (DR) [Exit] from [File].

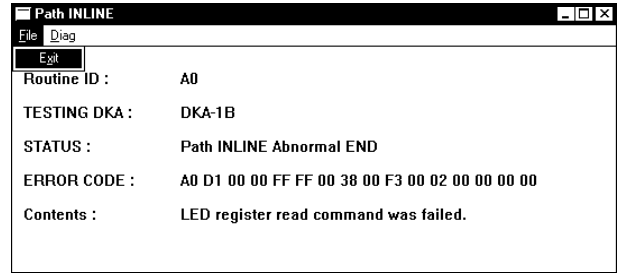

13. <End of [Diagnosis]>

Select (DR) [Exit] from [File] in the Diagnosis menu.

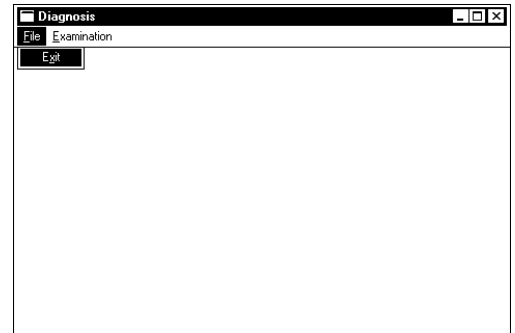

4.3.2 A2(A8) routine Test Procedures

1. <Initial screen>

2. <Operation mode change>
Change the mode to [Test Mode].
Select (CL) [Diagnosis].

<Note>

Please call Technical Support Center for asking how to change the mode to Test Mode.

3. <Select 'PATH INLINE'>
'Diagnosis' window is displayed.
And select (DR) [PATH INLINE] from [Examination]
in the Diagnosis menu.

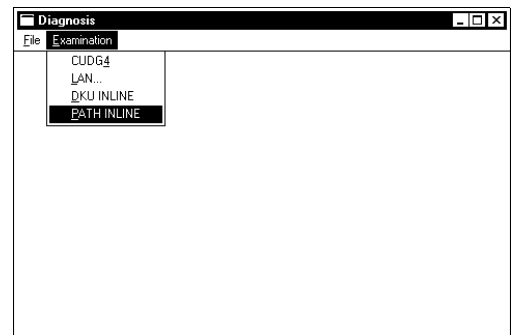

4. <Selecting [Start]>
Select (DR) [Start] from [Diag].



5. <Selecting the DKA to be diagnosed>
Select (CL) the DKA for which the test routine is to be executed.

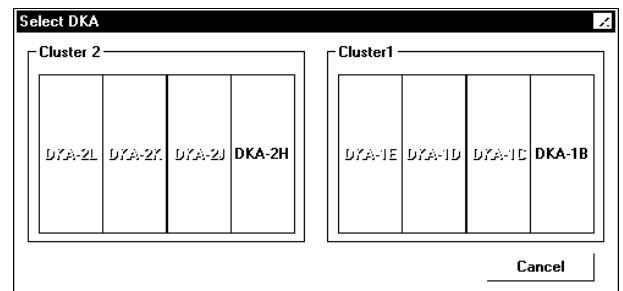

In Single Cabinet Model, the name of DKA is different.

6. <Setting test parameters>
Selecting the PORT and the routine to be executed.

And select (CL) the [OK] button.

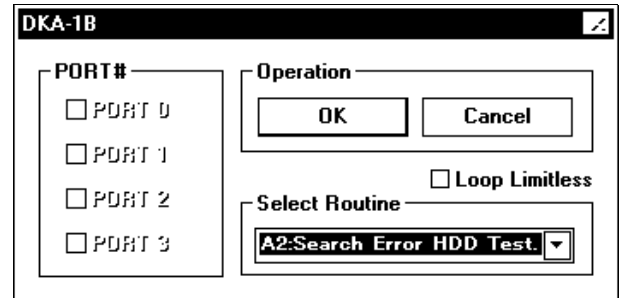

7. <Status Window>
The Status Window is displayed.

Normal end ----- Go to 8
Abnormal end ---- Go to 9

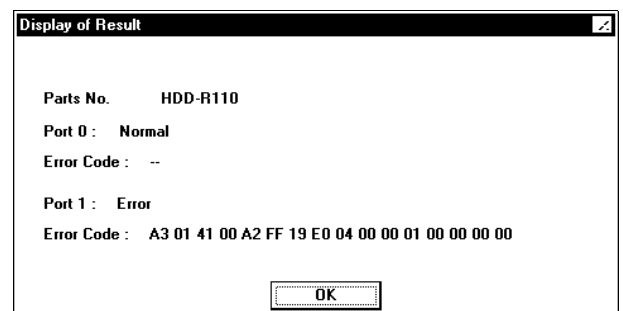

8. <DKU Path INLINE normal end>

After “Path INLINE Normal END” is displayed in the Status field, select (DR) [Exit] from [File].
Go to 13.

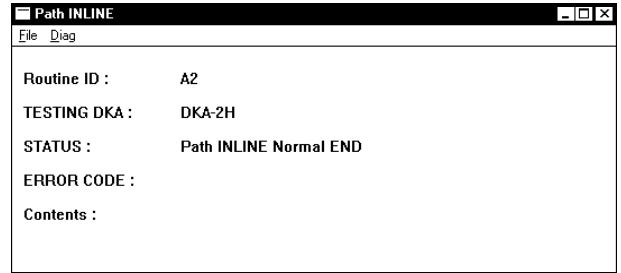

9. <Displaying the error detail>

Select (DR) [List] from [Diag].

In case of A8 routine, go to 14.

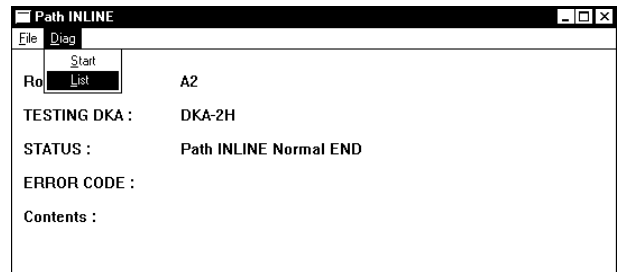

10. <Displaying the Error Devices>

In Separate Model:

“NG” is displayed in the PDEV installing position viewed in the 1st DKU .

If you want to display other DKC, select (CL) [Next DKU] or [Prev DKU].

If you want to refer to more detail information about the “NG” Pdev, select the “NG” button. Go to 11.

(Separate Model)

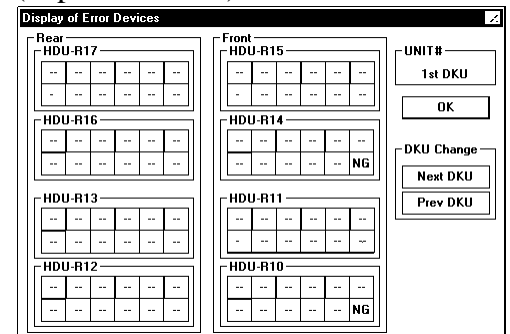

(Single Cabinet Model)

In Single Cabinet Model:

If you want to refer to more detail information about the “NG” Pdev, select the “NG” button. Go to 11.

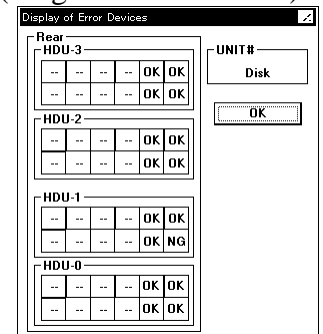

11. <Displaying the Error detail>

Select (CL) the [OK] button after 'Result' is displayed.

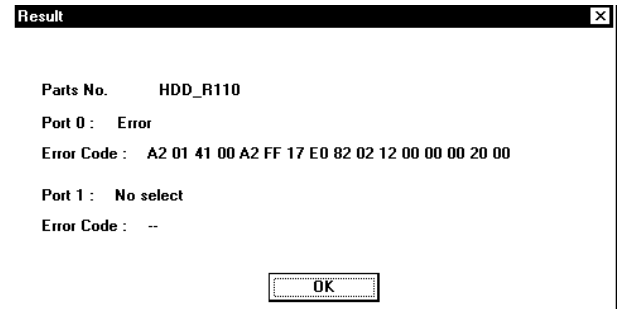

12. <DKU Path inline end>

Select (DR) [Exit] from [File].

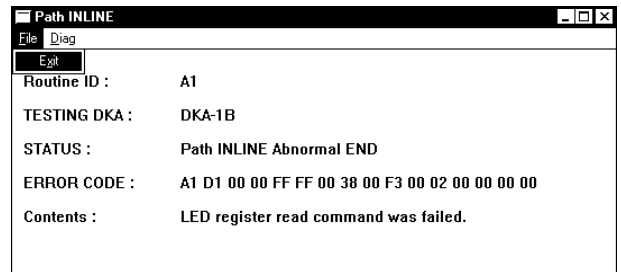

13. <End of [Diagnosis]>

Select (DR) [Exit] from [File] in the Diagnosis menu.

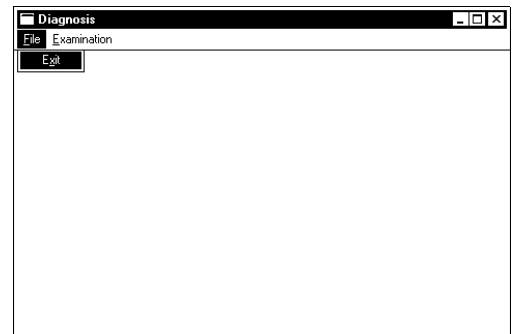

14. <Displaying the Error Devices (A8)>

In Separate Model:

“NG” is displayed in the PDEV installing position viewed in the 1st DKU .

If you want to display other DKC, select (CL) [Next DKU] or [Prev DKU].

If you want to refer to more detail information about the “NG” Pdev, select the “NG” button. Go to 15.

(Separate Model)

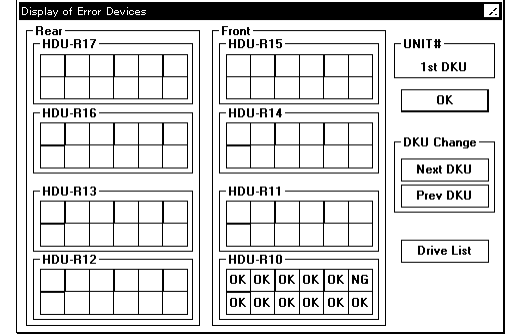

In Single Cabinet Model:

If you want to refer to more detail information about the “NG” Pdev, select the “NG” button. Go to 15.

If you want to refer to Drive List, select the [Drive List] button.

(Single Cabinet Model)

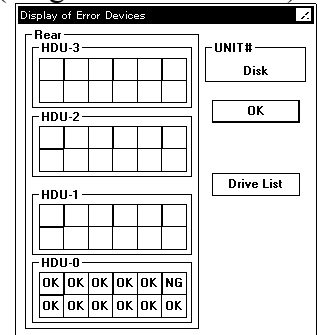

15. <Displaying the Drive List>

Select (CL) the [OK] button after ‘Drive List’ is displayed.

Go to 14.

HDD (C/R#)	STATUS	Read											Check Condition										
		Cnt.	TOV	0	1	2	3	4	5	6	7	8	9	A	B	C	D	E	F	Fibre			
R100(0000)	NORMAL	000	000	000	000	000	000	000	000	000	000	000	000	000	000	000	000	000	000	000	000		
R101(0001)	ERRR	001	000	000	000	000	000	000	000	000	000	000	000	000	000	000	000	000	000	000	000		
R102(0002)	NORMAL	000	000	000	000	000	000	000	000	000	000	000	000	000	000	000	000	000	000	000	000		
R103(0003)	NORMAL	000	000	000	000	000	000	000	000	000	000	000	000	000	000	000	000	000	000	000	000		
R104(0004)	NORMAL	000	000	000	000	000	000	000	000	000	000	000	000	000	000	000	000	000	000	000	000		
R105(0005)	NORMAL	000	000	000	000	000	000	000	000	000	000	000	000	000	000	000	000	000	000	000	000		
R106(0006)	NORMAL	000	000	000	000	000	000	000	000	000	000	000	000	000	000	000	000	000	000	000	000		
R107(0007)	NORMAL	000	000	000	000	000	000	000	000	000	000	000	000	000	000	000	000	000	000	000	000		
R108(0008)	NORMAL	000	000	000	000	000	000	000	000	000	000	000	000	000	000	000	000	000	000	000	000		
R109(0009)	NORMAL	000	000	000	000	000	000	000	000	000	000	000	000	000	000	000	000	000	000	000	000		
R10A(000A)	NORMAL	000	000	000	000	000	000	000	000	000	000	000	000	000	000	000	000	000	000	000	000		
R10B(000B)	NORMAL	000	000	000	000	000	000	000	000	000	000	000	000	000	000	000	000	000	000	000	000		

[HDD (C/R#)]

HDD Name, CDEV Number, RDEV Number

[STATUS]

NORMAL : No Error.

ERROR : Drive Read Error.

TP_ERR : Through Path Error.

[Read Cnt.]

Issue count of Drive Read Command.

[TOV]

Occurrence count of Time over.

[Check Condition 0-F]

Occurrence count of each Check Condition.

(Definition of Check Condition see Sense Key in [SSB04-170.](#))

[Fibre]

Occurrence count of Fibre Error.

4.3.3 A3 routine Test Procedures

1. <Initial screen>

2. <Operation mode change>
Change the mode to [Modify Mode].
Select (CL) [Diagnosis].

3. <Select 'PATH INLINE'>
'Diagnosis' window is displayed.
And select (DR) [PATH INLINE] from [Examination]
in the Diagnosis menu.

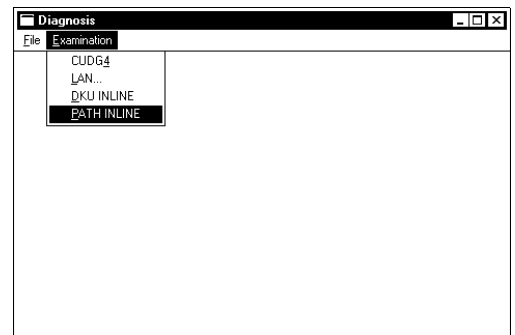

4. <Selecting [Start]>
Select (DR) [Start] from [Diag].



5. <Selecting the DKA to be diagnosed>
Select (CL) the DKA for which the test routine is to be executed.

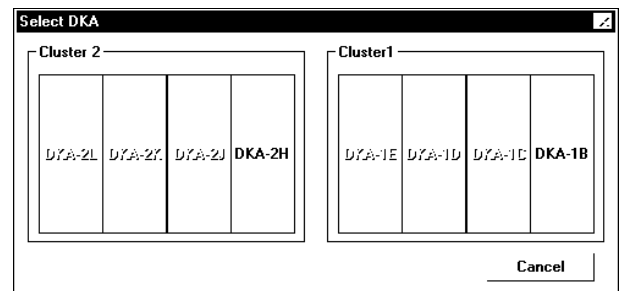

In Single Cabinet Model, the name of DKA is different.

6. <Selecting the routine and Execution>
Select (CL) the [OK] button after A3 routine selected.

In case you loop the diagnosis, check the "Loop Limitless" Check-Box.

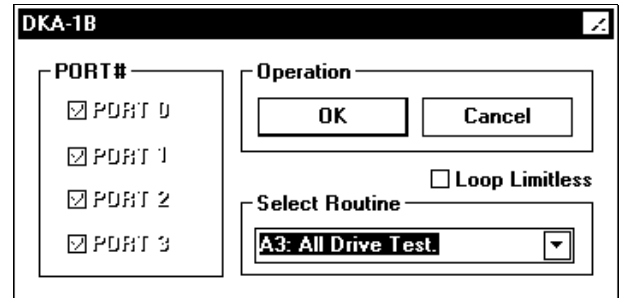

7. <Status Window>
The Status Window is displayed.

Normal end ----- Go to 8
Abnormal end ---- Go to 9

In case you abort the diagnosis, select (CL) the [Stop] button.

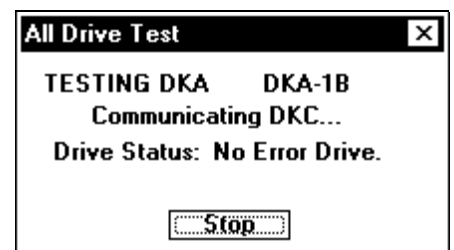

8. <DKU Path inline normal end>

After “Path INLINE NORMAL END” is displayed in the Status field, select (DR) [Exit] from [File].
Go to 13.

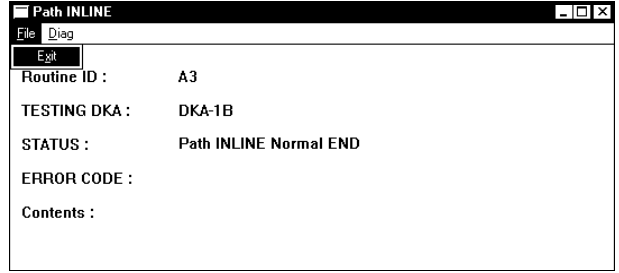

9. <Displaying the error detail>

Select (DR) [List] from [Diag].

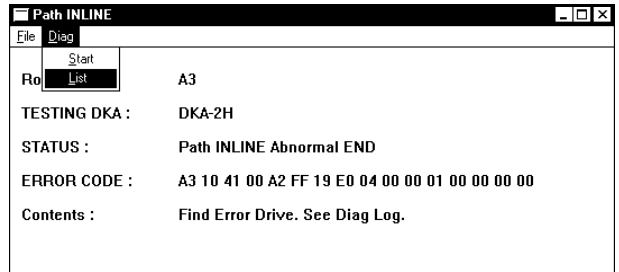

10. <Displaying the Error Devices>

In Separate Model:
“NG” is displayed in the PDEV installing position viewed in the 1st DKU .

If you want to display other DKC, select (CL) [Next DKU] or [Prev DKU].

If you want to refer to more detail information about the “NG” Pdev, select the “NG” button. Go to 11.

(Separate Model)

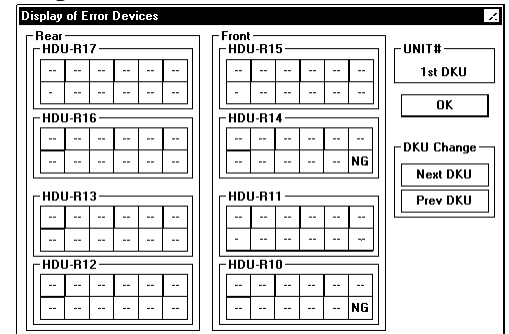

(Single Cabinet Model)

In Single Cabinet Model:

If you want to refer to more detail information about the “NG” Pdev, select the “NG” button. Go to 11.

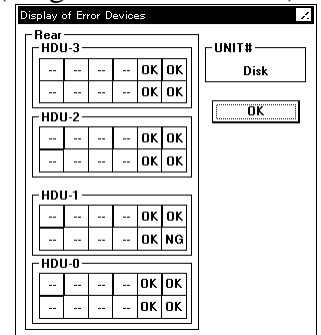

11. <Displaying the Error detail>

Select (CL) the [OK] button after 'Result' is displayed.

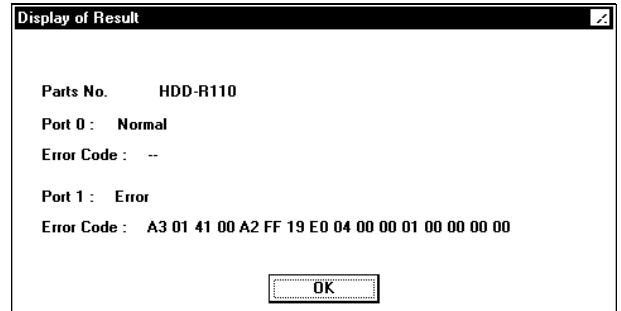

12. <DKU Path inline end>

Select (DR) [Exit] from [File].

Refer to Diag Log for detail information.

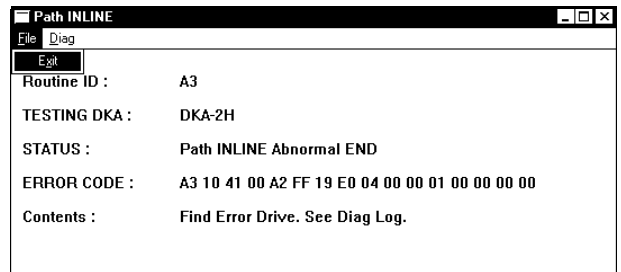

13. <End of [Diagnosis]>

Select (DR) [Exit] from [File] in the Diagnosis menu.

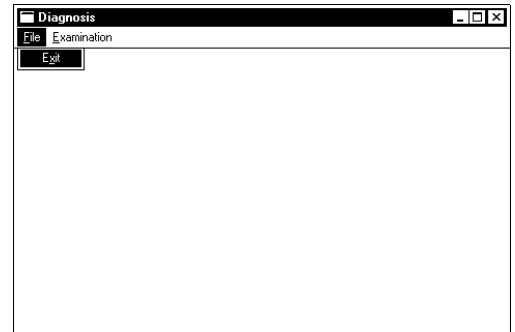

4.4 LAN Check Procedure

1. <Initial screen>

2. <Operation mode change>
Change the mode to [Modify mode].
Select (CL) [Diagnosis].

3. <Activating LAN...>
Select (DR) [LAN...] from Examination in the Diagnosis menu.
(The screen is changed to the LAN Check menu screen.)



4. <Starting LAN Check>

Select (DR) [Start] from Control of the LAN Check menu.

<Supplementary explanation>

Although a default processor to execute a hardware diagnosis is an installed processor, all processors can be selected.

Installed processor : Select (CL) [Target MP] and then select (DR) [Equipped MP].

All processors : Select (CL) [Target MP] and then select (DR) [All MP].

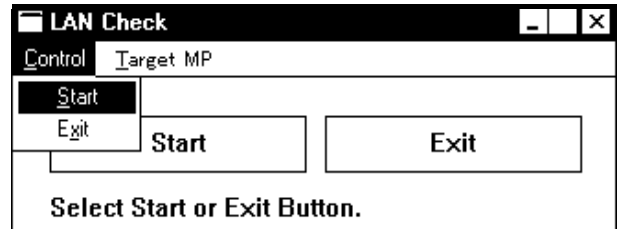

5. <Displaying Wait message>

The Wait message is displayed. It changes to the result display screen a few minutes later.

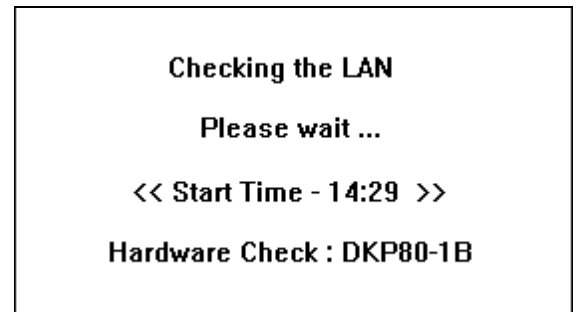

6. <Displaying result>

(1) Adapter status display

When the Adapter button is selected, the screen is changed to that displaying the MP status. The screen is returned to the LAN Check menu screen by selecting (CL) [OK].

[Explanation on statuses]

The status is shown by the appearance of the button as follows:

Black : The test object is normal.

Blinking : The test object is abnormal.

Gray : The test object is not installed.

(Separate Model)

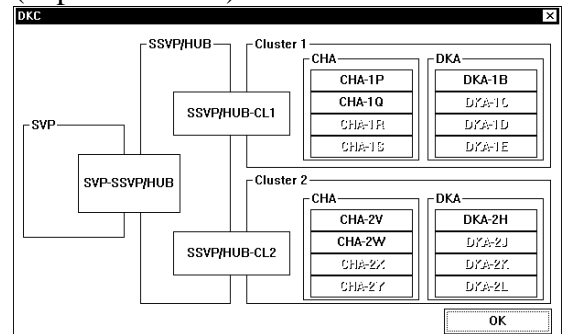

(Single Cabinet Model)

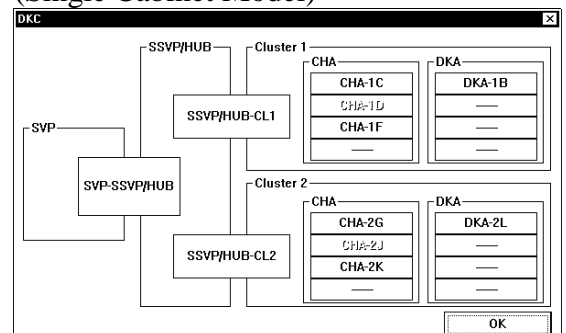

(2) MP status display

When the MP button is selected, the screen is changed to that displaying detailed status. The screen is returned to that displaying the adapter status by selecting (CL) [OK].

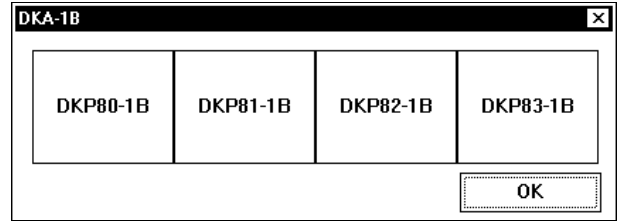

[Explanation on statuses]

The status is shown by the appearance of the MP button as follows:

Black : The concerning MP is normal.

Blinking : The test object is abnormal. However, for the MP which was normal at the time of an FF-Ping, “#” is indicated ahead MP name.

Gray : The test object is not installed.

[Supplemental explanation]

When the test object is not installed in the state that the hardware is abnormal:

The concerning MP is indicated in gray.

When the test object is not installed in the state that the hardware is normal:

The indication of the concerning MP is grayed and blinks.

When the test object is installed by an FF-Ping:

A character “#” is indicated ahead the MP name, and the name indication blinks.

When the test object is connected by an FF-Ping but not installed:

A character ”#” is indicated ahead the MP name, and the name indication is grayed and blinks.

(3) Detailed status display

Detailed information on the concerning MP is displayed.

The screen is returned to that displaying the MP status by selecting (CL) [OK].

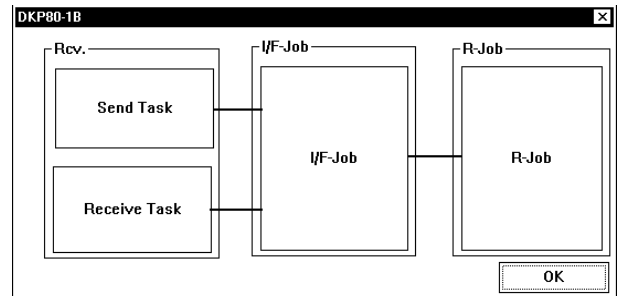

[Explanation on statuses]

The test result is shown by the appearance of the Tusk button as follows:

Black : The MP is normal from the viewpoint of software.

Blinking : The part indication of which is blinking has a problem.

Gray : Not diagnosed yet.

[Supplemental explanation]

There are five types of status as shown below:

When the hardware is abnormal : Rcv., I/F-JOB, and R-JOB are indicated in gray.

When the software is normal : Rcv., I/F-JOB, and R-JOB are indicated in black.

When the Rcv. is abnormal : Rcv. indication blinks, and I/F-JOB and R-JOB are indicated in gray.

When the I/F-JOB is abnormal : Rcv. is indicated in black, I/F-JOB indication blinks, and R-JOB is indicated in gray.

When the R-JOB is abnormal : Rcv. and I/F JOB are indicated in black and R-JOB indication blinks.

7. <Exiting from LAN Check>
Select (DR) [Exit] from Control in the LAN Check menu.

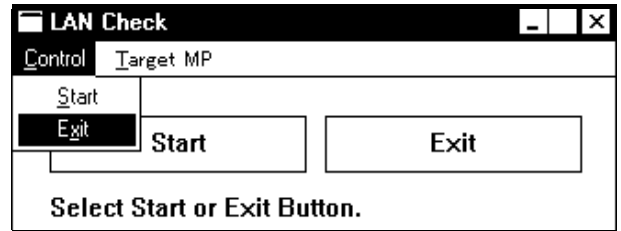

5 DIAG Trouble shooting

5.1 CUDG Trouble shooting

Procedures of CUDG Trouble Shooting vary with CUDG Error Opportunity.
The procedures are listed in Table 5.1 CUDG Trouble shooting Types.

Table 5.1 CUDG Trouble shooting Types

CUDG Error Opportunity	CUDG Trouble shooting Types	Procedure
IMPL, CHA/DKA Replace , CHA/DKA Install	CUDG3 Trouble shooting	Following Subsection 5.1.1
CUDG4	CUDG4 Trouble shooting	Following Subsection 5.1.2
CACHE Replace , CACHE Install	INLINE CUDG Trouble shooting	Following Subsection 5.1.3

Note : If FPC is CACHE PCB or CACHE MEMORY MODULE, see Subsection 5.1.4 ([DIAG05-60](#)).

5.1.1 CUDG3 Trouble shooting

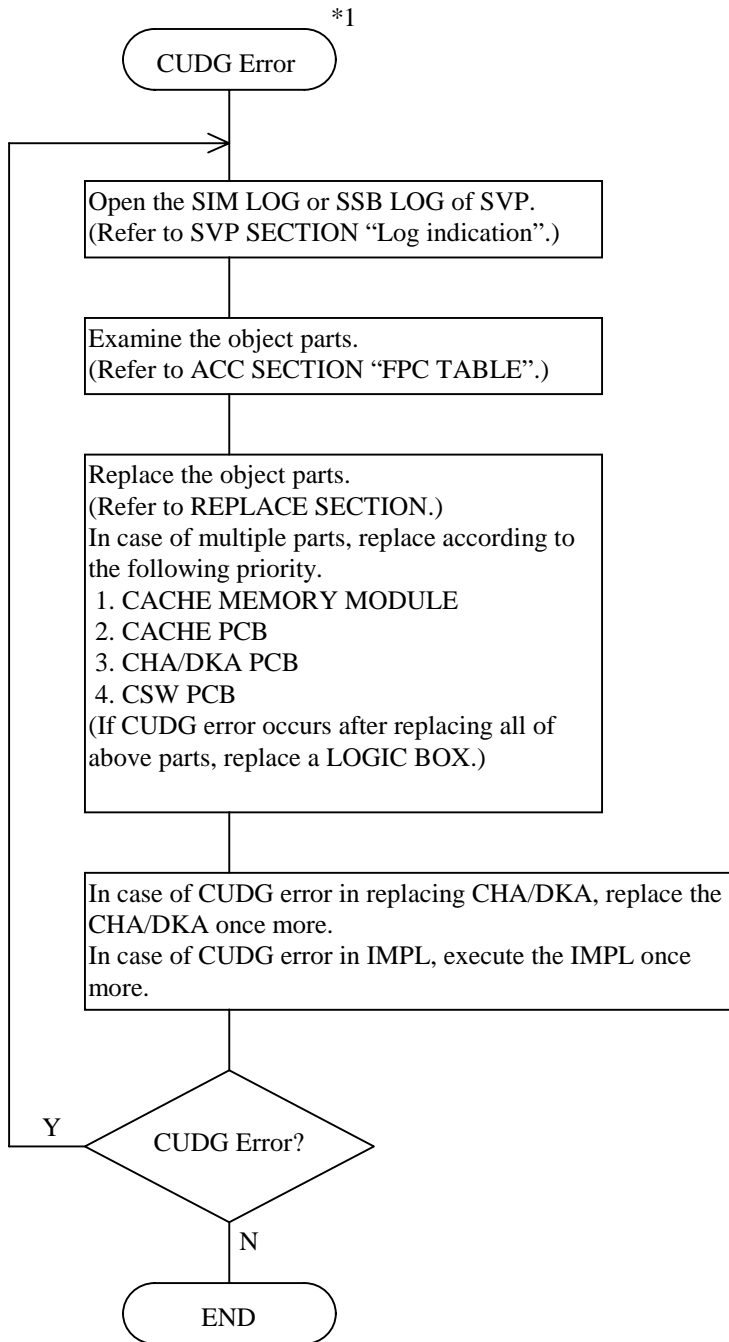

*1 CUDG Error Code is SIM REFERENCE CODE = (7601xx) or SSB ERROR CODE = (3306).

*2 See Subsection 5.1.4 ([DIAG05-60](#)).

5.1.2 CUDG4 Trouble shooting

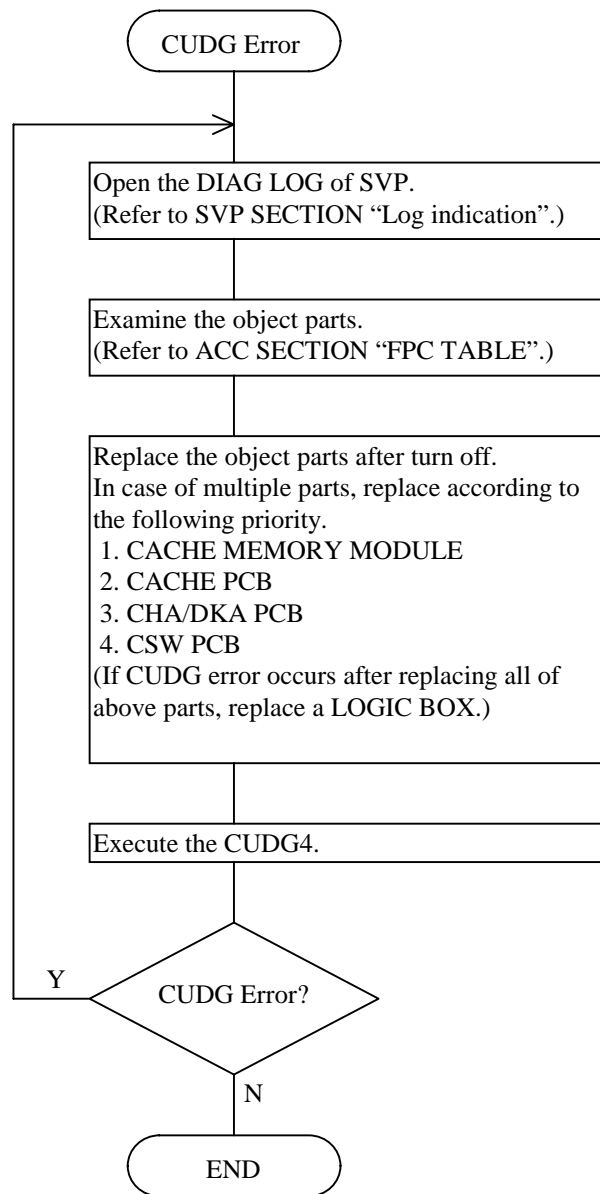

*1 See Subsection 5.1.4 ([DIAG05-60](#)).

5.1.3 INLINE CUDG Trouble shooting

(1) Installation

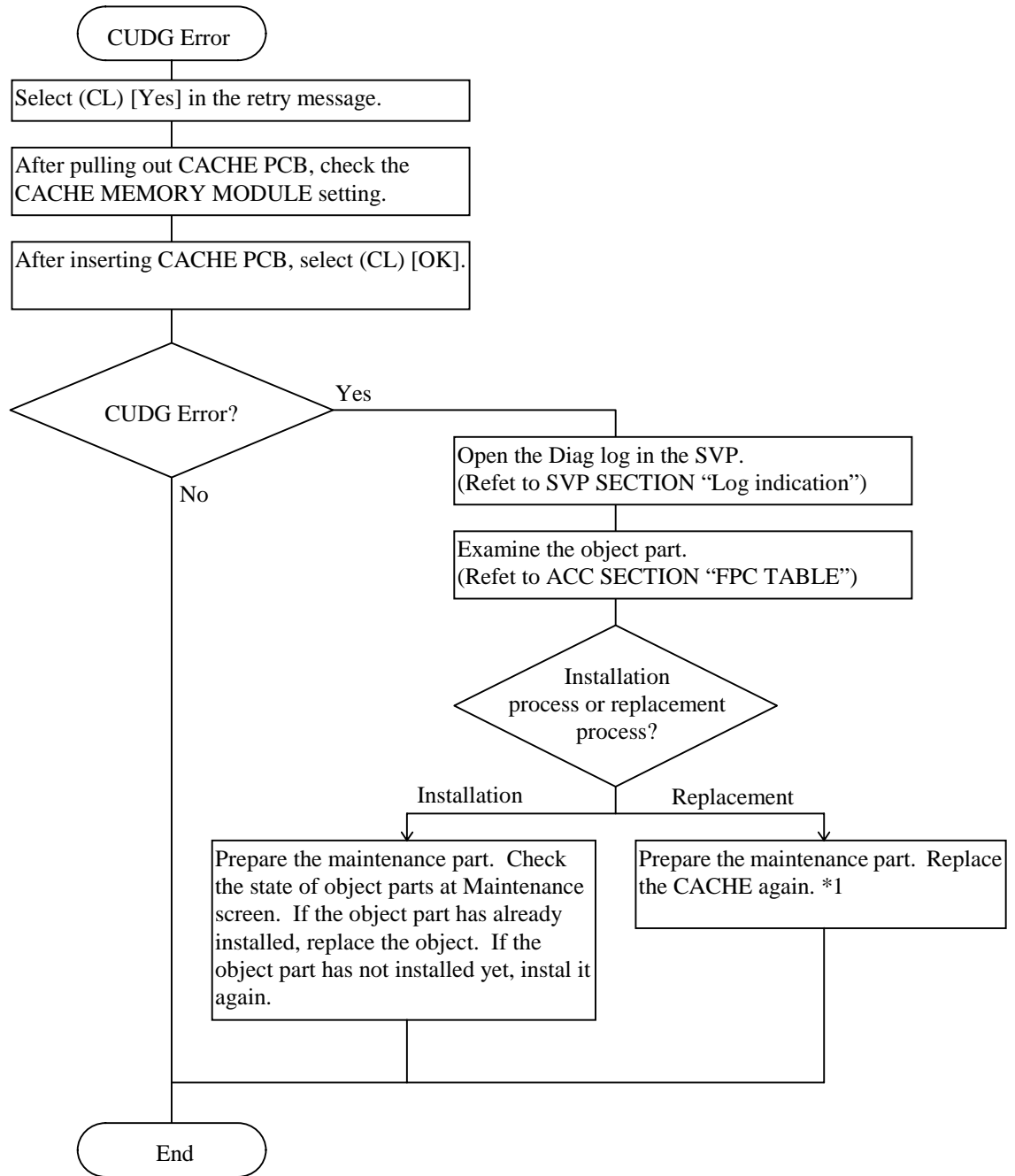

*1 In case of multiple parts, replace according to the following priority.

1. CACHE MEMORY MODULE
2. CACHE PCB
3. CHA/DKA PCB
4. CSW PCB

(If CUDG error occurred after replacing all of above parts, replace LOGIC BOX.)

If error part is CACHE MEMORY MODULE/CACHE PCB, refer to Subsection 5.1.4 ([DIAG05-60](#)).

(2) De-Installation

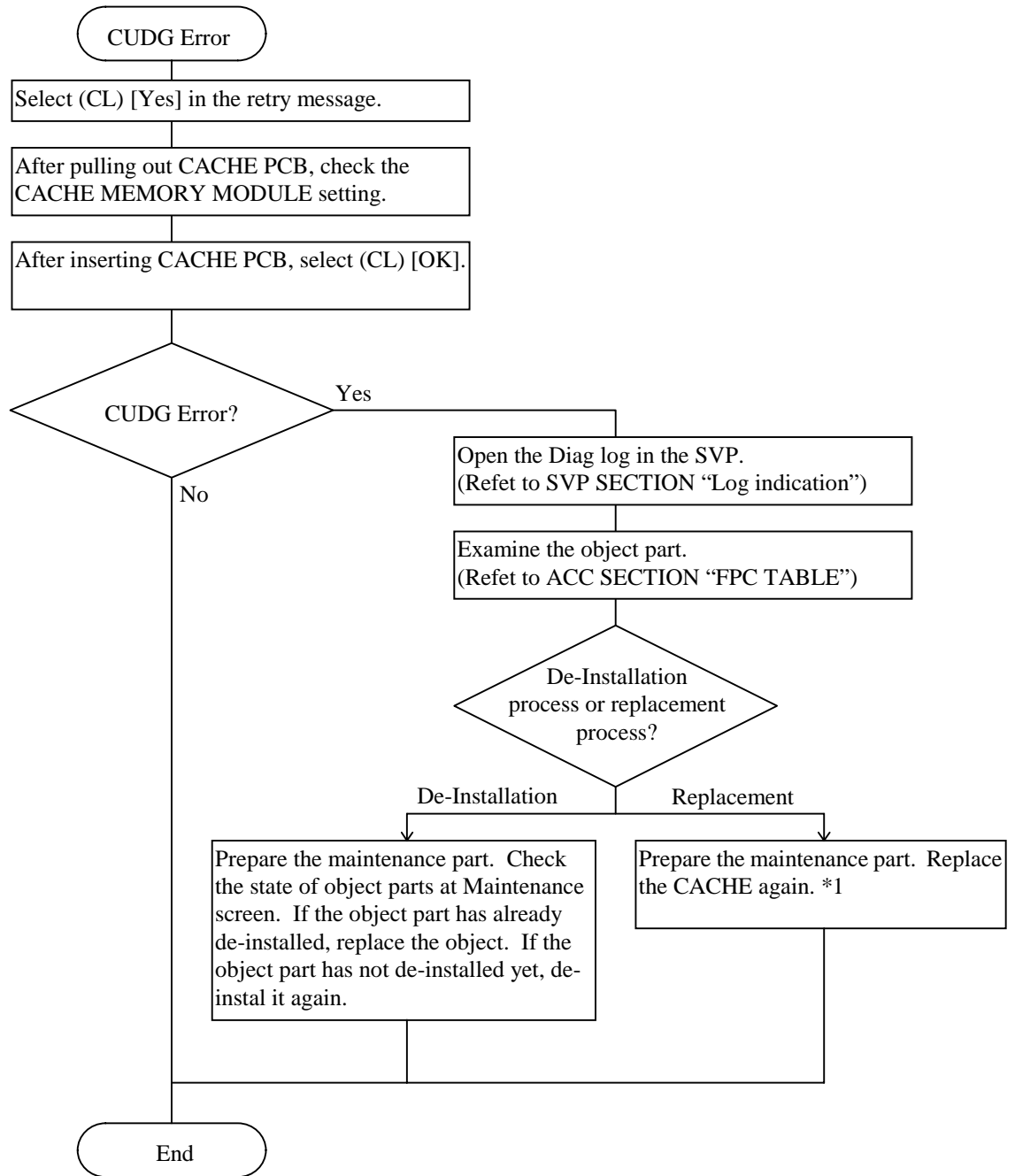

*1 In case of multiple parts, replace according to the following priority.

1. CACHE MEMORY MODULE
2. CACHE PCB
3. CHA/DKA PCB
4. CSW PCB

(If CUDG error occurred after replacing all of above parts, replace LOGIC BOX.)

If error part is CACHE MEMORY MODULE/CACHE PCB, refer to Subsection 5.1.4 (DIAG05-60).

5.1.4 CACHE PCB, CACHE MEMORY MODULE Trouble shooting

If FPC is CACHE PCB, CACHE MEMORY MODULE, execute the following process.

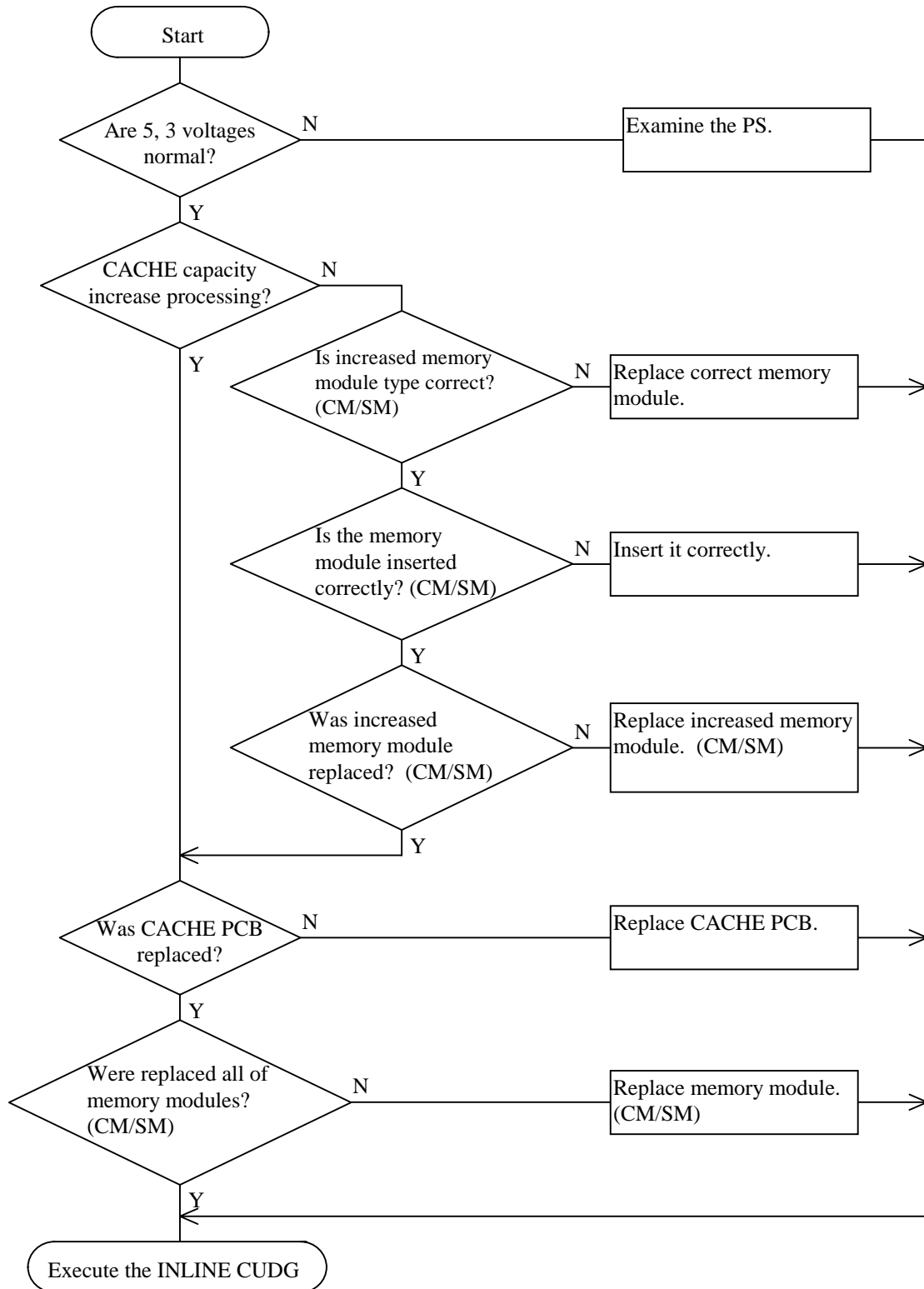

*1 In case of multiple module groups, replace module groups one by one.
If CUDG error occurs after replacing, put them original position.

5.2 DKU INLINE Trouble shooting

Trouble shoot procedures (Except Error Code = "xx e3")

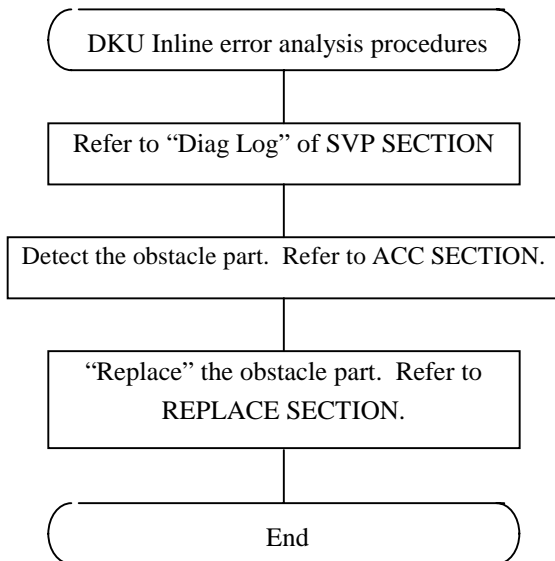

Trouble shoot procedures (In case of Error Code = "xx e3")

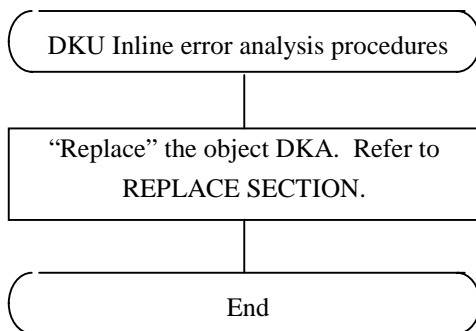

5.3 DKU PATH INLINE Trouble shooting

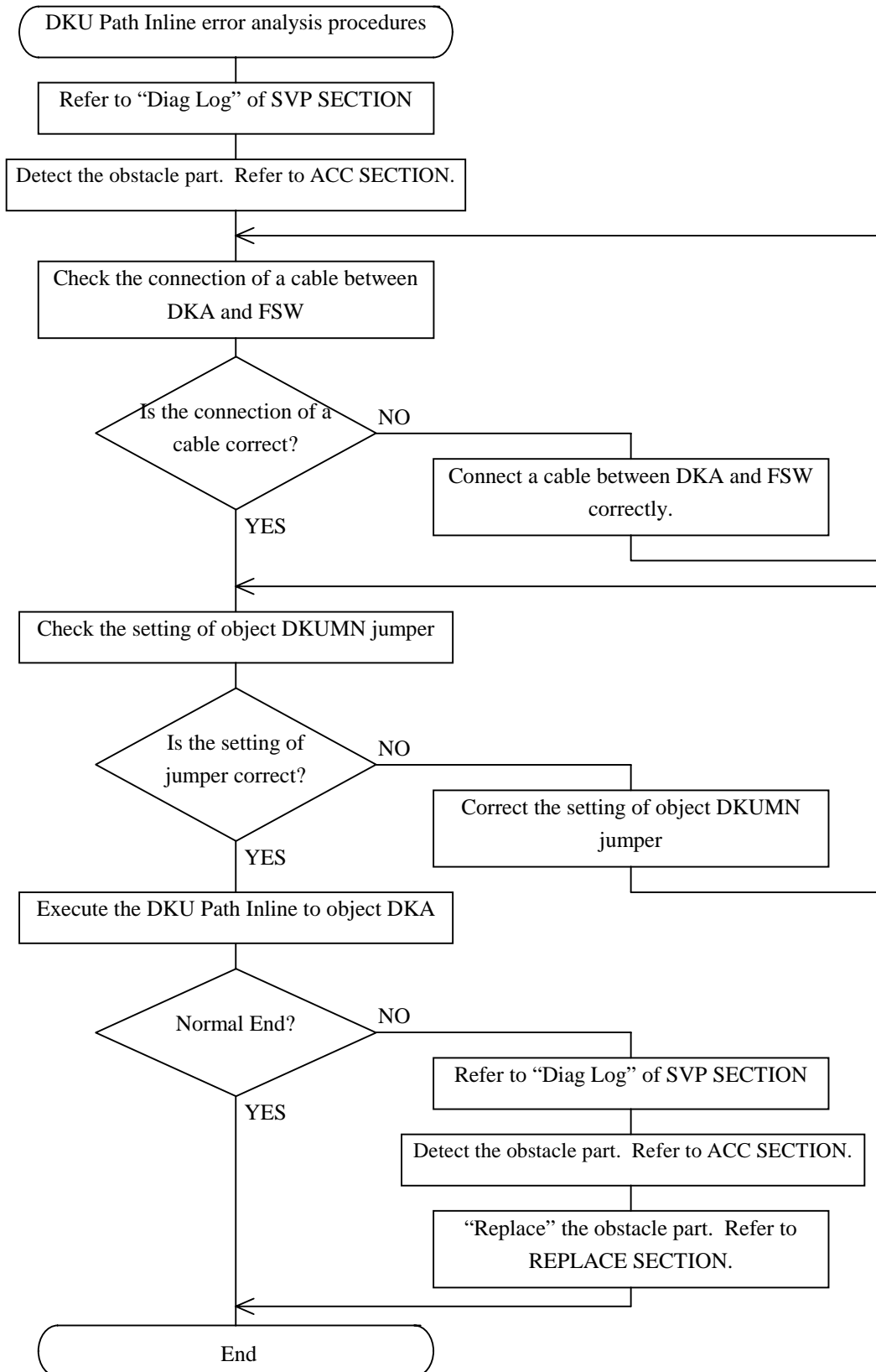

Trouble shoot procedures (Except Error Code = “a0 01”, “a0 02”)

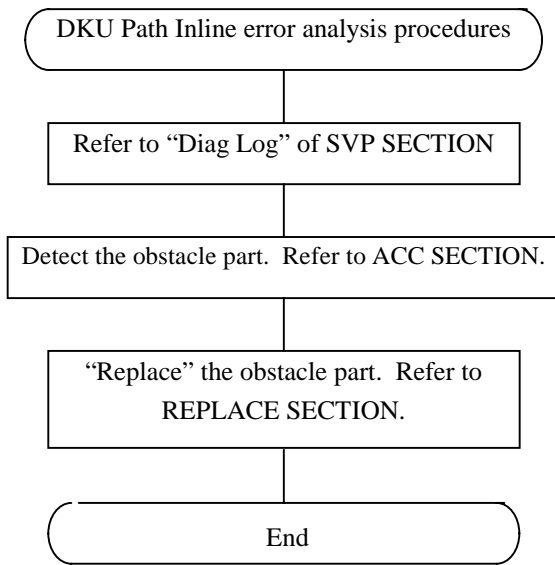

Trouble shoot procedures (In case of Error Code = “xx e3”)

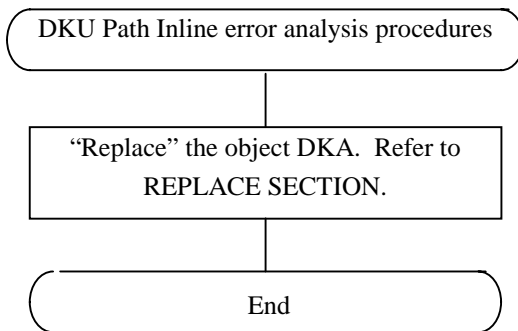

6 DIAG Errors

6.1 DKU INLINE Error Code List

Notes: Replace Error Code on Diagnosis Log of SVP Information since the 8th Byte and after of the Detail Information Byte correspond to Byte 01 and after of Error Byte.

Error Byte										Contents	
01	02	03	04	05	06	07	08	09	10		
XX	E0									The TEST UNIT READ command failed.	
XX	E1									The FC Loop Check command failed.	
XX	E2									The Reset Bypass command failed.	
XX	E3									Communication of between DKC and SVP was TIME OUT.	
XX	E4									Invalid SENSE KEY in TEST UNIT READY. Ev : 0x00	
XX	E5									The LIP command failed.	
XX	E6									The Set Bypass command failed.	
XX	E8	Return Code				FC	FD				Structure Information command was failed.
XX	E9									Dku INLINE Start/End command failed.	
XX	EA	Parameter from ONLINE								The specified HDD does not exist.	
XX	EB									SVP error (Program Error)	
XX	EC									Windows error	
XX	ED									SVP error (DKC-SVP Communication)	

FC: Function code FD: Function detail

Notes: Replace Error Code on Diagnosis Log of SVP Information since the 8th Byte and after of the Detail Information Byte correspond to Byte 01 and after of Error Byte.

Error Byte										Contents
01	02	03	04	05	06	07	08	09	10	
C1	01									The TEST UNIT READY command failed.
C1	02									The REQUEST SENSE command failed.
C1	03									Invalid SENSE KEY. Ev : 0x00
C1	04									Invalid CODE-HI. Ev : 0x00
C1	05									Invalid CODE-LOW. Ev : 0x00
C1	06									The TEST UNIT READY command failed.
C1	07									The REQUEST SENSE command failed.
C1	08									Invalid SENSE KEY. Ev : 0x00
C1	09									Invalid CODE-HI. Ev : 0x00
C1	0A									Invalid CODE-LOW. Ev : 0x00
C1	0B									Invalid SENSE CODE-LOW in TEST UNIT READY. Ev : 0x00
C1	0C									Hard Error of SCSI BUFF has occurred.

Notes: Replace Error Code on Diagnosis Log of SVP Information since the 8th Byte and after of the Detail Information Byte correspond to Byte 01 and after of Error Byte.

Error Byte										Contents
01	02	03	04	05	06	07	08	09	10	
C2	01									The STOP UNIT command failed.
C2	02									The INQUIRY command failed
C2	03									The Vendor ID doesn't agree.

Notes: Replace Error Code on Diagnosis Log of SVP Information since the 8th Byte and after of the Detail Information Byte correspond to Byte 01 and after of Error Byte.

Error Byte										Contents
C3	01									The STOP UNIT command failed.
C3	02									Return Code in TEST UNIT READY Command reported 0x00000000.
C3	03									Return Code in TEST UNIT READY Command reported 0x0f001740.
C3	04									Invalid Error Factor in TEST UNIT READY failed. Ev : 0x17
C3	05									Invalid SENSE KEY in TEST UNIT READY failed. Ev : 0x02
C3	06									Invalid SENSE CODE-HI in TEST UNIT READY failed. Ev : 0x04
C3	07									Invalid SENSE CODE-LOW in TEST UNIT READY failed. Ev : 0x02
C3	08									The Delay function failed.
C3	09									The START UNIT command failed.
C3	0A									The REQUEST SENSE command failed.
C3	0B									Invalid SENSE KEY in TEST UNIT READY. Ev : 0x00
C3	0C									Invalid SENSE CODE-HI in TEST UNIT READY. Ev : 0x00
C3	0D									Invalid SENSE CODE-LOW in TEST UNIT READY. Ev : 0x00

Notes: Replace Error Code on Diagnosis Log of SVP Information since the 8th Byte and after of the Detail Information Byte correspond to Byte 01 and after of Error Byte.

Error Byte										Contents
01	02	03	04	05	06	07	08	09	10	
C4	01									The SELF TEST command failed.
C4	02									The SELF TEST failed.

6.2 PATH INLINE Error Code List

Notes: Replace Error Code on Diagnosis Log of SVP Information since the 8th Byte and after of the Detail Information Byte correspond to Byte 01 and after of Error Byte.

Error Byte										Contents
01	02	03	04	05	06	07	08	09	10	
XX	50									Expected Data comparison error in register read test.
XX	51									Expected Data comparison error in register write and read test.
XX	52									Expected Data comparison error in register bit test.
XX	FC	D#	P#	U#						FC cable connection error.

D# : DKA# P# : PORT# U# : UNIT#
(Note1)

(Note1) DKA#, PORT#, UNIT# mapping

DKA# : 0-7	PORT# : 0-3	UNIT# : 0-2
0 : DKF-1B (DKF-1B)	0 : HDU-R10, R20, R30 (HDU-0) 1 : HDU-R11, R21, R31 (HDU-1)	0 : R1-DKU 1 : R2-DKU
4 : DKF-2H (DKF-2L)	2 : HDU-R12, R22, R32 (HDU-2) 3 : HDU-R13, R23, R33 (HDU-3)	2 : R3-DKU
1 : DKF-1C	0 : HDU-R14, R24, R34 1 : HDU-R15, R25, R35	
5 : DKF-2J	2 : HDU-R16, R26, R36 3 : HDU-R17, R27, R37	
2 : DKF-1D	0 : HDU-L10, L20, L30 1 : HDU-L11, L21, L31	0 : L1-DKU 1 : L2-DKU
6 : DKF-2K	2 : HDU-L12, L22, L32 3 : HDU-L13, L23, L33	2 : L3-DKU
3 : DKF-1E	0 : HDU-L14, L24, L34 1 : HDU-L15, L25, L35	
7 : DKF-2L	2 : HDU-L16, L26, L36 3 : HDU-L17, L27, L37	

(): Single Cabinet Model

Notes: Replace Error Code on Diagnosis Log of SVP Information since the 8th Byte and after of the Detail Information Byte correspond to Byte 01 and after of Error Byte.

Error Byte										Contents
01	02	03	04	05	06	07	08	09	10	
XX	B1									LBS_RW0 read failed in Bypass test.
XX	B2									BYP_HSEL write failed in Bypass test.
XX	B3									BYPSEL read failed in Bypass test.
XX	B4									H_BYP read failed in Bypass test.
XX	B6									PKCTRL read failed in Bypass test.
XX	B7									PKCTRL write failed in Bypass test.
XX	BA									Bypass test compare error.
XX	BB									Structure Information error.

Notes: Replace Error Code on Diagnosis Log of SVP Information since the 8th Byte and after of the Detail Information Byte correspond to Byte 01 and after of Error Byte.

Error Byte										Contents
01	02	03	04	05	06	07	08	09	10	
XX	C0	D#	P#	LED						Register read failed in LED REGISTER READ TEST.
XX	C1	D#	P#	LED						Register read failed in LED REGISTER READ TEST.
XX	C2	D#	P#	LED						Register read failed in LED REGISTER WRITE and READ TEST.
XX	C3	D#	P#	LED						Register write failed in LED REGISTER WRITE and READ TEST.
XX	C4	D#	P#	LED						Register read failed in LED REGISTER WRITE and READ TEST.
XX	C5	D#	P#	LED						Register write failed in LED REGISTER WRITE and READ TEST.
XX	C6	D#	P#	LED						Register write failed in LED REGISTER WRITE and READ TEST.
XX	C7	D#	P#	LED						Register read failed in LED REGISTER WRITE and READ TEST.
XX	C9	D#	P#	LED						Register read failed in LED ERROR RESET.
XX	CA	D#	P#	LED						LBUS_ERR write failed in LED ERROR RESET.
XX	CB	D#	P#	LED						PK_STAT write failed in LED ERROR RESET.
XX	CD	D#	P#	LED						Register read failed in LED ERROR RESET.
XX	CE	D#	P#	LED						LBUS_ERR write failed in LED ERROR RESET.
XX	CF	D#	P#	LED						PK_STAT write failed in LED ERROR RESET.

D# : DKA# P# : PORT# LED : LEDSTAT
(Note1)

(Note1) DKA#, PORT#, UNIT# mapping

DKA# : 0-7	PORT# : 0-3	LEDSTAT
0 : DKF-1B (DKF-1B)	0 : HDU-R10, R20, R30 (HDU-0) 1 : HDU-R11, R21, R31 (HDU-1)	Bit09 : DKU Status Error Bit10 : ACK Error Bit11 : Status Parity Error Bit12 : Read Data Parity Error Bit13 : DKU Output Error Bit14 : Read Busy Bit15 : Write Busy
4 : DKF-2H (DKF-2L)	2 : HDU-R12, R22, R32 (HDU-2) 3 : HDU-R13, R23, R33 (HDU-3)	
1 : DKF-1C	0 : HDU-R14, R24, R34 1 : HDU-R15, R25, R35	
5 : DKF-2J	2 : HDU-R16, R26, R36 3 : HDU-R17, R27, R37	
2 : DKF-1D	0 : HDU-L10, L20, L30 1 : HDU-L11, L21, L31	
6 : DKF-2K	2 : HDU-L12, L22, L32 3 : HDU-L13, L23, L33	
3 : DKF-1E	0 : HDU-L14, L24, L34 1 : HDU-L15, L25, L35	
7 : DKF-2L	2 : HDU-L16, L26, L36 3 : HDU-L17, L27, L37	

() : Single Cabinet Model

Notes: Replace Error Code on Diagnosis Log of SVP Information since the 8th Byte and after of the Detail Information Byte correspond to Byte 01 and after of Error Byte.

Error Byte										Contents
01	02	03	04	05	06	07	08	09	10	
XX	D0	D#	P#	LED						LBS_PADR read failed in ADDRESS CHECK.
XX	D1	D#	P#	LED						PKCTRL read failed in ADDRESS CHECK.
XX	D2	D#	P#	LED						PK_STAT read failed in ADDRESS CHECK.
XX	D4	D#	P#	LED						RWO read succeeded in QUASI-OBSTRUCTION TEST 1.
XX	D6	D#	P#	LED						RWO read succeeded in QUASI-OBSTRUCTION TEST 1.
XX	D8	D#	P#	LED						LFORCE_ERR write failed in INT SIGNAL TEST.
XX	D9	D#	P#	LED						INT SIGNAL isn't been output.
XX	DA	D#	P#	LED						LFORCE_ERR write failed in INT SIGNAL TEST.
XX	DB	D#	P#	LED						INT SIGNAL is been output.
XX	DD	D#	P#	LED						DKULBSERR wasn't been output in LED QUASI-OBSTRUCTION TEST.
XX	DE	D#	P#	LED						PKCTRL read failed in pretreatment.
XX	DF	D#	P#	LED						PKCTRL write failed in pretreatment.

D# : DKA# P# : PORT# LED : LEDSTAT
(Note1)

(Note1) DKA#, PORT#, UNIT# mapping

DKA# : 0-7	PORT# : 0-3	LEDSTAT
0 : DKF-1B (DKF-1B)	0 : HDU-R10, R20, R30 (HDU-0) 1 : HDU-R11, R21, R31 (HDU-1)	Bit09 : DKU Status Error Bit10 : ACK Error
4 : DKF-2H (DKF-2L)	2 : HDU-R12, R22, R32 (HDU-2) 3 : HDU-R13, R23, R33 (HDU-3)	Bit11 : Status Parity Error Bit12 : Read Data Parity Error
1 : DKF-1C	0 : HDU-R14, R24, R34 1 : HDU-R15, R25, R35	Bit13 : DKU Output Error Bit14 : Read Busy
5 : DKF-2J	2 : HDU-R16, R26, R36 3 : HDU-R17, R27, R37	Bit15 : Write Busy
2 : DKF-1D	0 : HDU-L10, L20, L30 1 : HDU-L11, L21, L31	
6 : DKF-2K	2 : HDU-L12, L22, L32 3 : HDU-L13, L23, L33	
3 : DKF-1E	0 : HDU-L14, L24, L34 1 : HDU-L15, L25, L35	
7 : DKF-2L	2 : HDU-L16, L26, L36 3 : HDU-L17, L27, L37	

(): Single Cabinet Model

Notes: Replace Error Code on Diagnosis Log of SVP Information since the 8th Byte and after of the Detail Information Byte correspond to Byte 01 and after of Error Byte.

Error Byte										Contents	
01	02	03	04	05	06	07	08	09	10		
XX	E0									The TEST UNIT READY command failed.	
XX	E1									The RESET CE MODE cannot be done.	
XX	E2									The configuration information acquisition command failed.	
XX	E3									Communication of between DKC and SVP was TIME OUT.	
XX	E4									Communication of between DKC and SVP failed.	
XX	E5									Invalid SENSE CODE-HI in TEST UNIT READY. Ev : 0x00	
XX	E6									Invalid SENSE CODE-LOW in TEST UNIT READY. Ev : 0x00	
XX	E8	Return Code				FC	FD				Structure Information command was failed.
XX	E9									The SET CE MODE cannot be done.	
XX	EA	Parameter from ONLINE								The specified HDD does not exist.	
XX	EB									SVP error (Program Error)	
XX	EC									Windows error	
XX	ED									SVP error (DKC-SVP Communication)	

FC: Function code FD: Function detail

Notes: Replace Error Code on Diagnosis Log of SVP Information since the 8th Byte and after of the Detail Information Byte correspond to Byte 01 and after of Error Byte.

Error Byte										Contents
01	02	03	04	05	06	07	08	09	10	
A0	01									FC cable information read command failed.
A0	02									FC cable abstention indication command failed.
A0	03									The INQUIRY command doesn't failed.
A0	04									FC cable entry indication command doesn't failed.
A0	05									The INQUIRY command failed.
A0	06									The Vender ID doesn't agree.
A0	07									PORT mistake.
A0	08									The LIP command failed.
A0	1X	D#	P0S	P1S	P2S	P3S				Obstruction arise part of the PATH.
A0	2X	D#	P0S	P1S	P2S	P3S				Obstruction arise all the PATH.
A0	AD	D#								Invalid LED BUS address data.
A0	AE	D#	P#	U#	EV ^(Note2)		RV			Invalid LED BUS address data.

D# : DKA# P# : PORT# U# : UNIT# EV : Expected Value

RV : Received Value P(1-3)S : PORT#(1-3) report (FF : Normal, Not FF : Abnormal)
(Note1)

(Note1) DKA#, PORT#, UNIT# mapping

DKA# : 0-7	PORT# : 0-3	LEDSTAT
0 : DKF-1B (DKF-1B)	0 : HDU-R10, R20, R30 (HDU-0) 1 : HDU-R11, R21, R31 (HDU-1)	Bit09 : DKU Status Error Bit10 : ACK Error Bit11 : Status Parity Error Bit12 : Read Data Parity Error Bit13 : DKU Output Error Bit14 : Read Busy Bit15 : Write Busy
4 : DKF-2H (DKF-2L)	2 : HDU-R12, R22, R32 (HDU-2) 3 : HDU-R13, R23, R33 (HDU-3)	
1 : DKF-1C	0 : HDU-R14, R24, R34 1 : HDU-R15, R25, R35	
5 : DKF-2J	2 : HDU-R16, R26, R36 3 : HDU-R17, R27, R37	
2 : DKF-1D	0 : HDU-L10, L20, L30 1 : HDU-L11, L21, L31	
6 : DKF-2K	2 : HDU-L12, L22, L32 3 : HDU-L13, L23, L33	
3 : DKF-1E	0 : HDU-L14, L24, L34 1 : HDU-L15, L25, L35	
7 : DKF-2L	2 : HDU-L16, L26, L36 3 : HDU-L17, L27, L37	

() : Single Cabinet Model

(Note2) Refer to DKA Path Address mapping (DIAG06-180 ~ 220) for Expected Value.

Notes: Replace Error Code on Diagnosis Log of SVP Information since the 8th Byte and after of the Detail Information Byte correspond to Byte 01 and after of Error Byte.

Error Byte										Contents
01	02	03	04	05	06	07	08	09	10	
A1	01									FC cable information read command failed.
A1	02									FC cable abstention indication command failed.
A1	03									The INQUIRY command doesn't failed.
A1	04									FC cable entry indication command doesn't failed.
A1	05									The INQUIRY command failed.
A1	06									The Vender ID doesn't agree.
A1	07									PORT mistake.
A1	08									The LIP command failed.
A1	1X	D#	P0S	P1S	P2S	P3S				Obstruction arise part of the PATH
A1	2X	D#	P0S	P1S	P2S	P3S				Obstruction arise all the PATH.
A1	AD	D#								Invalid LED BUS address data.
A1	AE	D#	P#	U#	EV ^(Note2)		RV			Invalid LED BUS address data.

D# : DKA# P# : PORT# U# : UNIT# EV : Expected Value

RV : Received Value P(1-3)S : PORT#(1-3) report (FF : Normal, Not FF : Abnormal)
(Note1)

(Note1) DKA#, PORT#, UNIT# mapping

DKA# : 0-7	PORT# : 0-3	LEDSTAT
0 : DKF-1B (DKF-1B)	0 : HDU-R10, R20, R30 (HDU-0) 1 : HDU-R11, R21, R31 (HDU-1)	Bit09 : DKU Status Error Bit10 : ACK Error Bit11 : Status Parity Error Bit12 : Read Data Parity Error Bit13 : DKU Output Error Bit14 : Read Busy Bit15 : Write Busy
4 : DKF-2H (DKF-2L)	2 : HDU-R12, R22, R32 (HDU-2) 3 : HDU-R13, R23, R33 (HDU-3)	
1 : DKF-1C	0 : HDU-R14, R24, R34 1 : HDU-R15, R25, R35	
5 : DKF-2J	2 : HDU-R16, R26, R36 3 : HDU-R17, R27, R37	
2 : DKF-1D	0 : HDU-L10, L20, L30 1 : HDU-L11, L21, L31	
6 : DKF-2K	2 : HDU-L12, L22, L32 3 : HDU-L13, L23, L33	
3 : DKF-1E	0 : HDU-L14, L24, L34 1 : HDU-L15, L25, L35	
7 : DKF-2L	2 : HDU-L16, L26, L36 3 : HDU-L17, L27, L37	

() : Single Cabinet Model

(Note2) Refer to DKA Path Address mapping (DIAG06-180 ~ 220) for Expected Value.

Notes: Replace Error Code on Diagnosis Log of SVP Information since the 8th Byte and after of the Detail Information Byte correspond to Byte 01 and after of Error Byte.

Error Byte										Contents
01	02	03	04	05	06	07	08	09	10	
A2	01									LED REGISTER READ command failed.
A2	02									FC cable abstention indication command failed.
A2	03									The INQUIRY command failed.
A2	04									FC cable entry indication command failed.
A2	05									FC LOOP INITIALIZATION command failed.
A2	06									The Vender ID doesn't agree.
A2	07									PORT mistake.
A2	10									ERROR DRIVE exist. (Refer to the Diag Log for detail.)

D# : DKA# P# : PORT# U# : UNIT#

Notes: Replace Error Code on Diagnosis Log of SVP Information since the 8th Byte and after of the Detail Information Byte correspond to Byte 01 and after of Error Byte.

Error Byte										Contents
01	02	03	04	05	06	07	08	09	10	
A3	01									The Drive Read command failed.
A3	02									The Drive Read failed.
A3	10									ERROR DRIVE exist.

D# : DKA# P# : PORT# U# : UNIT#

Notes: Replace Error Code on Diagnosis Log of SVP Information since the 8th Byte and after of the Detail Information Byte correspond to Byte 01 and after of Error Byte.

Error Byte										Contents
01	02	03	04	05	06	07	08	09	10	
A4	01									FC cable information read command failed.
A4	02									FC cable abstention indication command failed.
A4	03									The INQUIRY command doesn't failed.
A4	04									FC cable entry indication command doesn't failed.
A4	05									The INQUIRY command failed.
A4	06									The Vender ID doesn't agree.
A4	07									PORT mistake.
A4	08									The LIP command failed.
A4	1X	D#	P0S	P1S	P2S	P3S				Obstruction arise part of the PATH
A4	2X	D#	P0S	P1S	P2S	P3S				Obstruction arise all the PATH.
A4	AD	D#								Invalid LED BUS address data.
A4	AE	D#	P#	U#	EV ^(Note2)		RV			Invalid LED BUS address data.

D# : DKA# P# : PORT# U# : UNIT# EV : Expected Value

RV : Received Value P(1-3)S : PORT#(1-3) report (FF : Normal, Not FF : Abnormal)
(Note1)

(Note1) DKA#, PORT#, UNIT# mapping

DKA# : 0-7	PORT# : 0-3	LEDSTAT
0 : DKF-1B (DKF-1B)	0 : HDU-R10, R20, R30 (HDU-0) 1 : HDU-R11, R21, R31 (HDU-1)	Bit09 : DKU Status Error Bit10 : ACK Error Bit11 : Status Parity Error Bit12 : Read Data Parity Error Bit13 : DKU Output Error Bit14 : Read Busy Bit15 : Write Busy
4 : DKF-2H (DKF-2L)	2 : HDU-R12, R22, R32 (HDU-2) 3 : HDU-R13, R23, R33 (HDU-3)	
1 : DKF-1C	0 : HDU-R14, R24, R34 1 : HDU-R15, R25, R35	
5 : DKF-2J	2 : HDU-R16, R26, R36 3 : HDU-R17, R27, R37	
2 : DKF-1D	0 : HDU-L10, L20, L30 1 : HDU-L11, L21, L31	
6 : DKF-2K	2 : HDU-L12, L22, L32 3 : HDU-L13, L23, L33	
3 : DKF-1E	0 : HDU-L14, L24, L34 1 : HDU-L15, L25, L35	
7 : DKF-2L	2 : HDU-L16, L26, L36 3 : HDU-L17, L27, L37	

() : Single Cabinet Model

(Note2) Refer to DKA Path Address mapping (DIAG06-180 ~ 220) for Expected Value.

Notes: Replace Error Code on Diagnosis Log of SVP Information since the 8th Byte and after of the Detail Information Byte correspond to Byte 01 and after of Error Byte.

Error Byte										Contents
01	02	03	04	05	06	07	08	09	10	
A5	01									FC cable information read command failed.
A5	02									FC cable abstention indication command failed.
A5	03									The INQUIRY command doesn't failed.
A5	04									FC cable entry indication command doesn't failed.
A5	05									The INQUIRY command failed.
A5	06									The Vender ID doesn't agree.
A5	07									PORT mistake.
A5	08									The LIP command failed.
A5	1X	D#	P0S	P1S	P2S	P3S				Obstruction arise part of the PATH
A5	2X	D#	P0S	P1S	P2S	P3S				Obstruction arise all the PATH.
A5	AD	D#								Invalid LED BUS address data.
A5	AE	D#	P#	U#	EV ^(Note2)		RV			Invalid LED BUS address data.

D# : DKA# P# : PORT# U# : UNIT# EV : Expected Value

RV : Received Value P(1-3)S : PORT#(1-3) report (FF : Normal, Not FF : Abnormal)
(Note1)

(Note1) DKA#, PORT#, UNIT# mapping

DKA# : 0-7	PORT# : 0-3	LEDSTAT
0 : DKF-1B (DKF-1B)	0 : HDU-R10, R20, R30 (HDU-0) 1 : HDU-R11, R21, R31 (HDU-1)	Bit09 : DKU Status Error Bit10 : ACK Error Bit11 : Status Parity Error Bit12 : Read Data Parity Error Bit13 : DKU Output Error Bit14 : Read Busy Bit15 : Write Busy
4 : DKF-2H (DKF-2L)	2 : HDU-R12, R22, R32 (HDU-2) 3 : HDU-R13, R23, R33 (HDU-3)	
1 : DKF-1C	0 : HDU-R14, R24, R34 1 : HDU-R15, R25, R35	
5 : DKF-2J	2 : HDU-R16, R26, R36 3 : HDU-R17, R27, R37	
2 : DKF-1D	0 : HDU-L10, L20, L30 1 : HDU-L11, L21, L31	
6 : DKF-2K	2 : HDU-L12, L22, L32 3 : HDU-L13, L23, L33	
3 : DKF-1E	0 : HDU-L14, L24, L34 1 : HDU-L15, L25, L35	
7 : DKF-2L	2 : HDU-L16, L26, L36 3 : HDU-L17, L27, L37	

() : Single Cabinet Model

(Note2) Refer to DKA Path Address mapping (DIAG06-180 ~ 220) for Expected Value.

Notes: Replace Error Code on Diagnosis Log of SVP Information since the 8th Byte and after of the Detail Information Byte correspond to Byte 01 and after of Error Byte.

Error Byte										Contents	
01	02	03	04	05	06	07	08	09	10		
A8	01	Return Code									Set Bypass command was failed (Multi HDD).
A8	02	Return Code									Reset Bypass command was failed (Multi HDD).
A8	03	Return Code									LIP command was failed (Multi HDD).
A8	04	Return Code									Reset Bypass command was failed (Single HDD).
A8	05	Return Code									LIP command was failed (Single HDD).
A8	06	Return Code									Set Bypass command was failed (Single HDD).
A8	07	Return Code									Drive Read command was failed.
A8	08	Return Code									Inquiry command was failed.
A8	0A	Return Code									Reset Bypass command was failed in Through Path Test.
A8	0B	Return Code									LIP command was failed in Through Path Test.
A8	0C	Return Code									Drive Read command was failed in Through Path Test.
A8	0D	Return Code									Set Bypass command was failed in Through Path Test.
A8	10										Detected Error Drive.

(B) LED BUS Address (Expected Value)

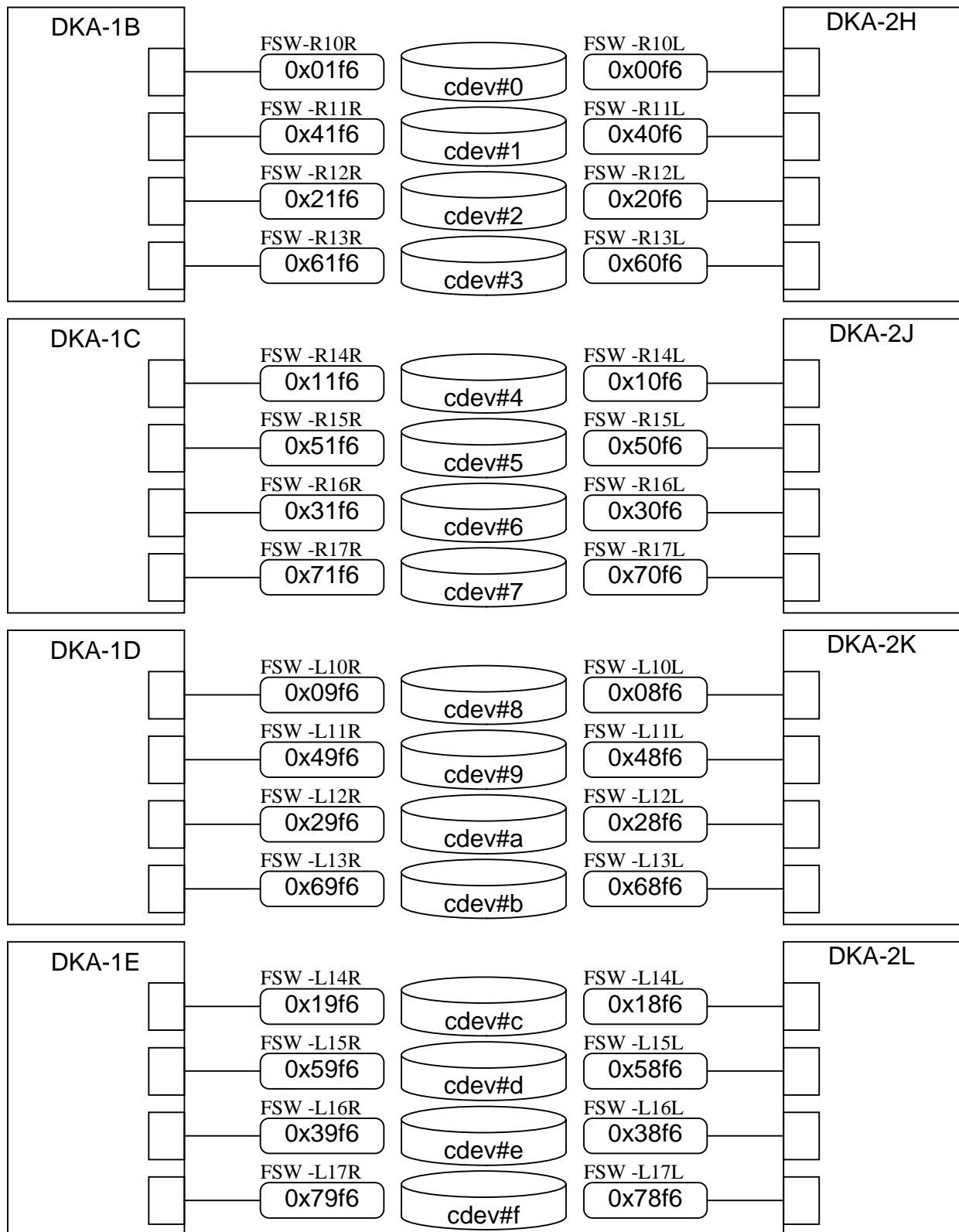

Fig. 6.2-1 DKA Path Address mapping (No Extended Unit : Basic Unit)

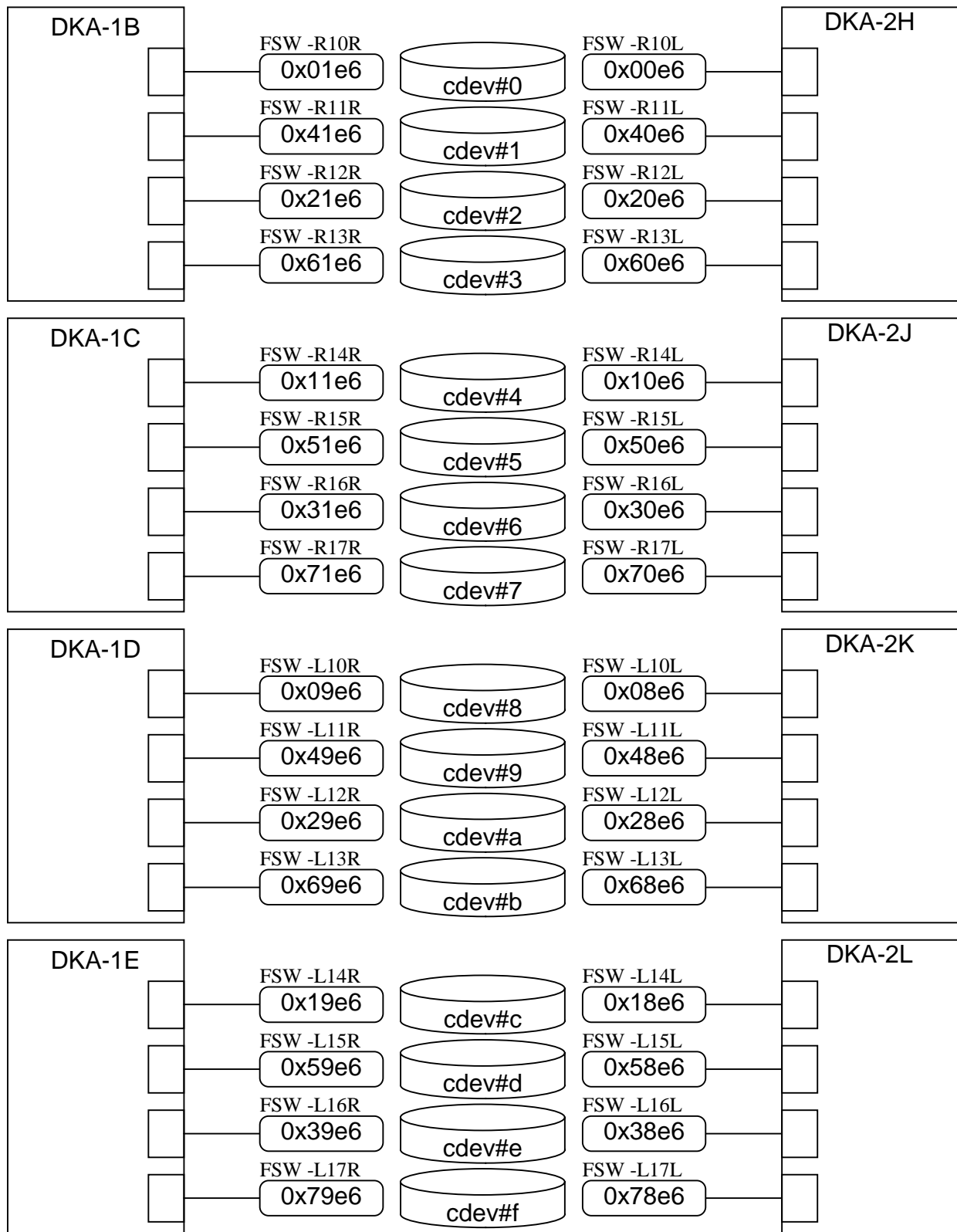

Fig. 6.2-2 DKA Path Address mapping (Equipped Extended Unit : Basic Unit)

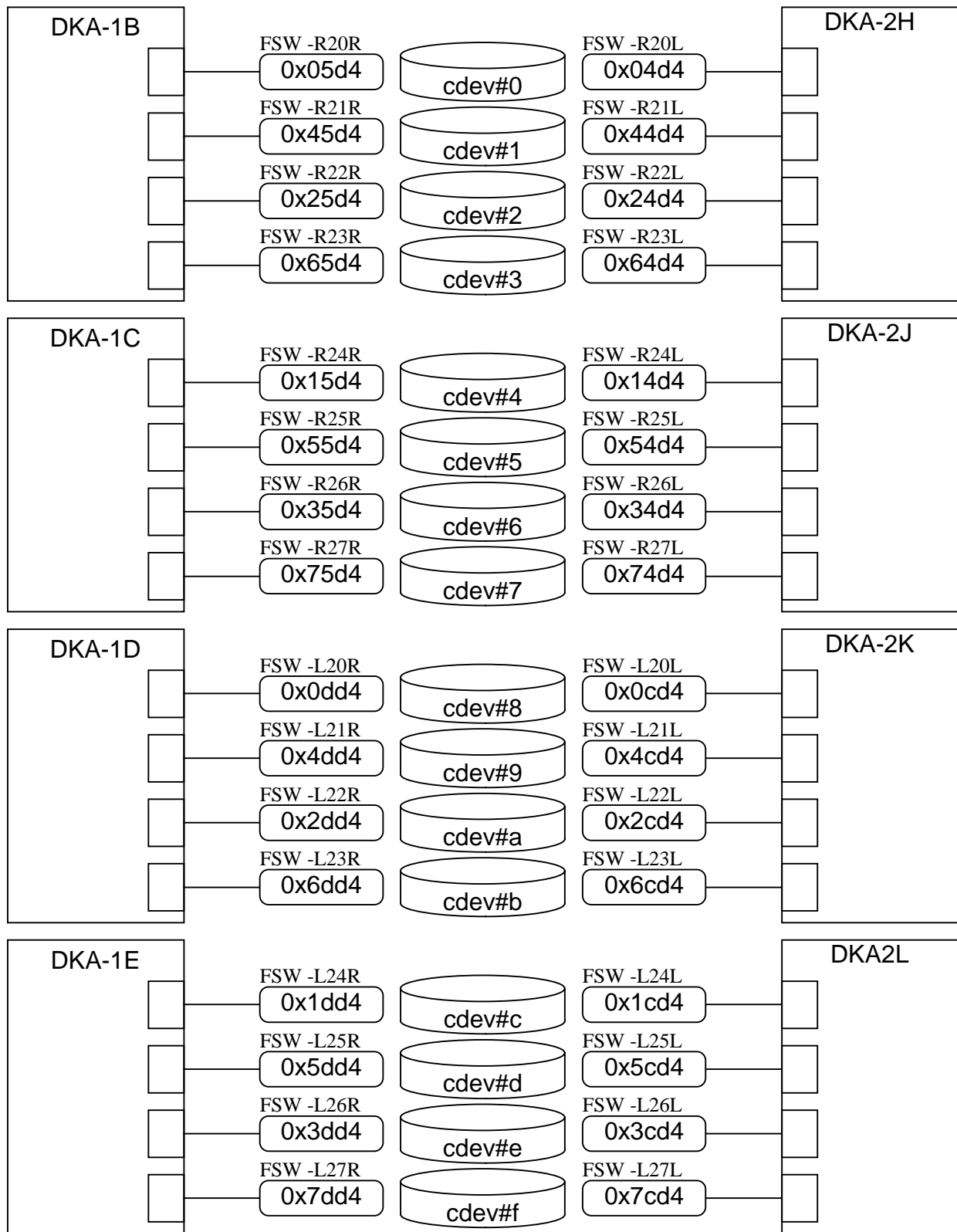

Fig. 6.2-3 DKA Path Address mapping (No Extended Unit 2 : Extended Unit 1)

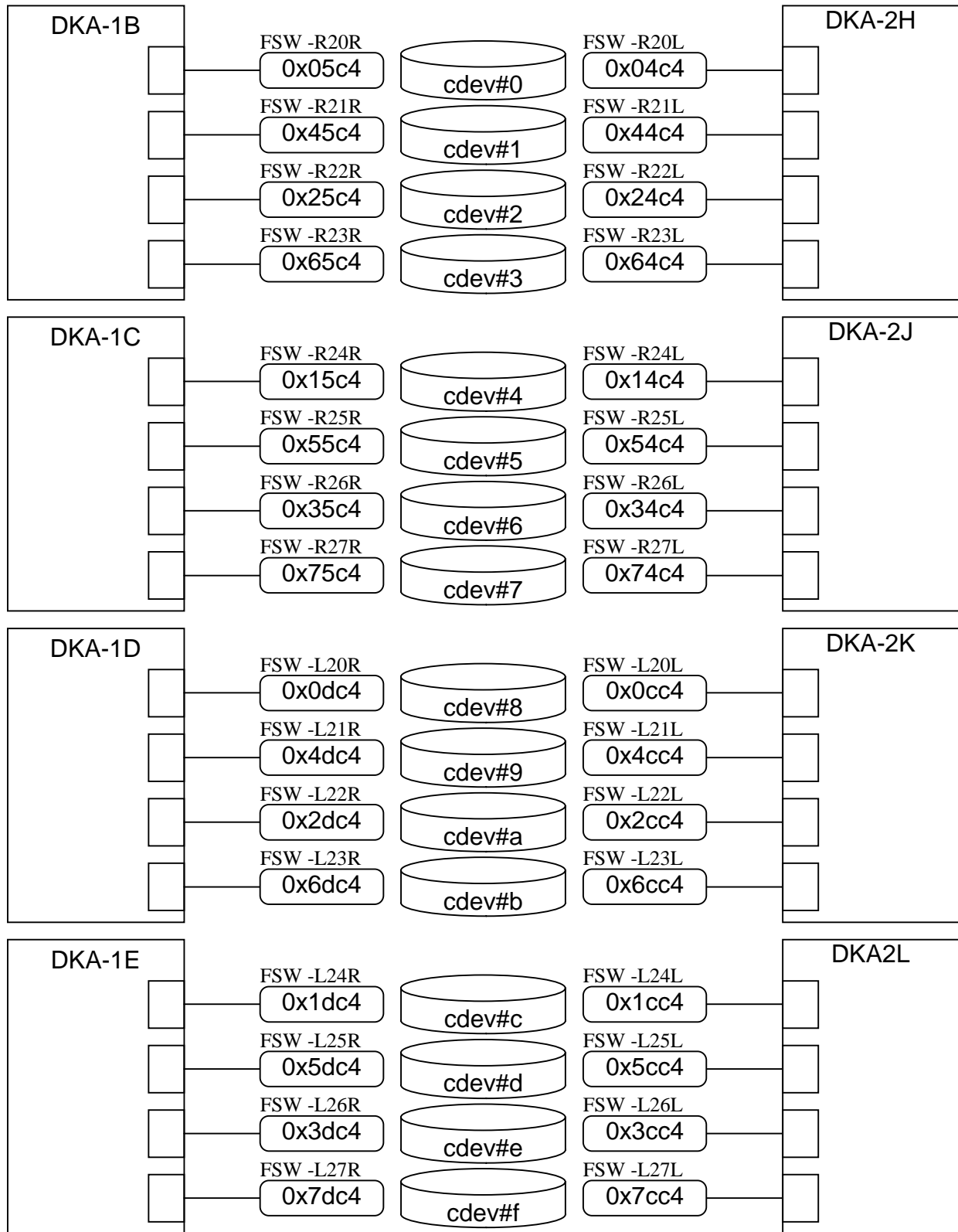

Fig. 6.2-4 DKA Path Address mapping (Equipped Extended Unit 2 : Extended Unit 1)

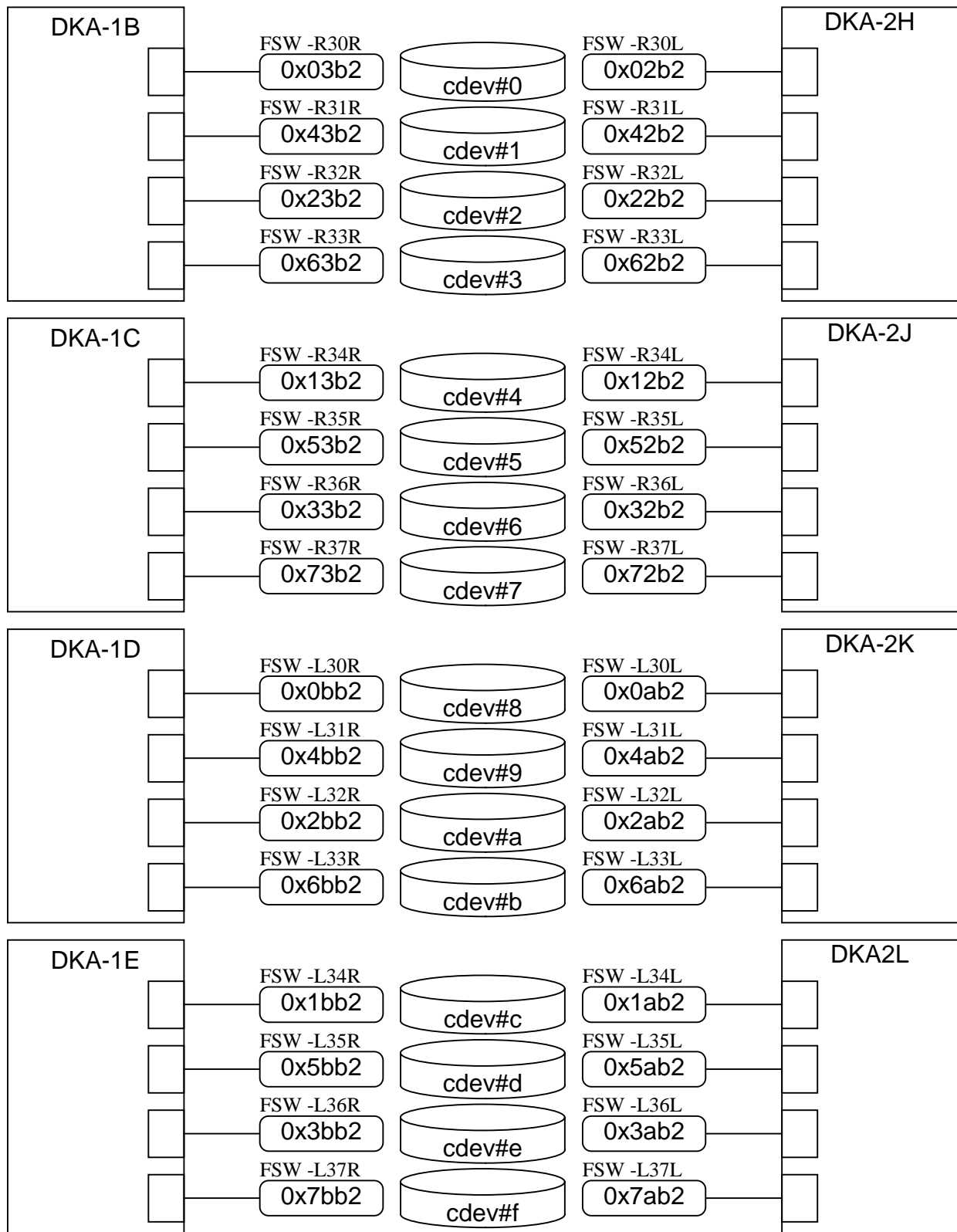

Fig. 6.2-5 DKA Path Address mapping (Extended Unit 2)

6.3 CUDG error code list

LSI classification	Test Item	Error Code	Error Contents	
CMA	0101		Register R/W Test.(Common Part)	
		1000	Error occur in Register Write.	
		2000	Error occur in Register Read.	
		0040	CHK2 Error occur.	
	0102			Memory R/D(A)
		8000	Error occur in Memory Read.	
		4000	Error occur in Memory Write.	
		0002	Data Compare Error occur.	
	0103			Memory R/W(B)
		1000	Error occur in Memory Write.	
		2000	Error occur in Memory Read.	
		8000	Memory Read Error occur.	
	0104			General Memory Test (A)(Write Activation Part)
		4000	Memory Write Error occur.	
		0002	Data Compare Error occur.	
		0040	CHK2 Error occur.	
		1000	Error occur in Register Write.	
		0040	CHK2 Error occur.	
	0105			General Memory Test (A)(Polling Part)
		2000	Error occur in Register Read.	
		0004	Polling Time Out.	
	0106			General Memory Test(A)(Status Confirmation Part after Write)
		0001	Data Compare Error occur.	
		0040	CHK2 Error occur.	
	0107			General Memory Test (A)(Read Activation Part)
		1000	Error occur in TESTADRH/L Write.	
	0108			General Memory Test (A)(Status Confirmation Part after READ)
		0040	CHK2 Error occur.	
		1000	Error occur in Register Write.	
		2000	Error occur in Register Read.	
		0001	Data Compare Error occur.	
		0002	Data Compare Error occur.	
		0040	CHK2 Error occur.	

LSI classification	Test Item	Error Code	Error Contents
CMA	0109		General Memory Test (A)(Write Activation Part)
		1000	Error occur in Register Write.
		0040	CHK2 Error occur.
	010a		General Memory Test (A)(Polling Part)
		2000	Error occur in Register Read.
		0004	Polling Time Out.
		0040	CHK2 Error occur.
	010b		General Memory Test(A)(Status Confirmation Part after Write)
		2000	Error occur in Register Read.
		0001	Data Compare Error occur.
		0040	CHK2 Error occur.
	010c		General Memory Test (A)(Read Activation Part)
		1000	Error occur in TESTADRH/L Write
		0040	CHK2 Error occur.
	010d		General Memory Test(A)(Status Confirmation Part after Read)
		1000	Error occur in Register Write.
		2000	Error occur in Register Read.
		0001	Data Compare Error occur.
		0002	Data Compare Error occur.
		0040	CHK2 Error occur.
	010e		ECC Circuit Test.(A)
		2000	Error occur in Register Read.
		1000	Error occur in Register Write.
		0001	Data Compare Error occur.
		0002	Data Compare Error occur.
		0040	CHK2 Error occur.
		4000	Memory Write Error occur.
	010f		ECC Circuit Test.(B)
		2000	Error occur in Register Read.
		1000	Error occur in Register Write.
		0001	Data Compare Error occur.
		0002	Data Compare Error occur.
		0040	CHK2 Error occur.
		4000	Memory Write Error occur.

LSI classification	Test Item	Error Code	Error Contents
CMA	0110		ECC LOG Register Test
		2000	Error occur in Register Read.
		1000	Error occur in Register Write.
		0001	Data Compare Error occur.
		0002	Data Compare Error occur.
		0040	CHK2 Error occur.
		4000	Memory Write Error occur.
		8000	Memory Read Error occur.
	0111		SLRC Test
		2000	Error occur in Register Read.
		1000	Error occur in Register Write.
		0001	Data Compare Error occur.
		0002	Data Compare Error occur.
		0040	CHK2 Error occur.
	0112		Force Error Test(A)
		2000	Error occur in Register Read.
		1000	Error occur in Register Write.
		0001	Data Compare Error occur.
		0002	Data Compare Error occur.
		0040	CHK2 Error occur.
	0113		Force Error Test(B)
		2000	Error occur in Register Read.
		1000	Error occur in Register Write.
		0001	Data Compare Error occur.
		0002	Data Compare Error occur.
		0040	CHK2 Error occur.
		4000	Memory Write Error occur.
	0114		Self-refresh(Write Activation Part)
		2000	Error occur in Register Read.
		1000	Error occur in Register Write.
		0001	Data Compare Error occur.
		0002	Data Compare Error occur.
		0040	CHK2 Error occur.

LSI classification	Test Item	Error Code	Error Contents
CMA	0115		Self-refresh(Polling Part)
		2000	Error occur in Register Read.
		1000	Error occur in Register Write.
		0001	Data Compare Error occur.
		0002	Data Compare Error occur.
		0040	CHK2 Error occur.
	0116		Self-refresh(Status Confirmation Part after Write)
		2000	Error occur in Register Read.
		1000	Error occur in Register Write.
		0001	Data Compare Error occur.
		0002	Data Compare Error occur.
		0040	CHK2 Error occur.
	0117		Timer Count Up Test
		2000	Error occur in Register Read.
		1000	Error occur in Register Write.
		0001	Data Compare Error occur.
		0002	Data Compare Error occur.
		0040	CHK2 Error occur.
	0118		Self-refresh(Status Confirmation Part after Read)
		2000	Error occur in Register Read.
		1000	Error occur in Register Write.
		0001	Data Compare Error occur.
		0002	Data Compare Error occur.
		0040	CHK2 Error occur.
	0119		Self-refresh (se)
		2000	Error occur in Register Read.
		1000	Error occur in Register Write.
		0001	Data Compare Error occur.
		0002	Data Compare Error occur.
		0040	CHK2 Error occur.

LSI classification	Test Item	Error Code	Error Contents
CMA	011a		PD Check.
		2000	Error occur in Register Read.
		1000	Error occur in Register Write.
		0001	Data Compare Error occur.
		0002	Data Compare Error occur.
		0040	CHK2 Error occur.
	011b		PROM Test.
		2000	Error occur in Register Read.
		1000	Error occur in Register Write.
		0001	Data Compare Error occur.
		0002	Data Compare Error occur.
		0040	CHK2 Error occur.
	011c		GTL Impedance Control.
		2000	Error occur in Register Read.
		0001	Data Compare Error occur.
		0040	CHK2 Error occur.
	011d		Register W/R.
		2000	Error occur in Register Read.
		1000	Error occur in Register Write.
		0001	Data Compare Error occur.
		0002	Data Compare Error occur.
		0040	CHK2 Error occur.
	011e		Timer Count Up Test.
		2000	Error occur in Register Read.
		1000	Error occur in Register Write.
		0001	Data Compare Error occur.
		0002	Data Compare Error occur.
		0040	CHK2 Error occur.
	011f		Timer Count Reset Test.
		2000	Error occur in Register Read.
		1000	Error occur in Register Write.
		0001	Data Compare Error occur.
		0002	Data Compare Error occur.
		0040	CHK2 Error occur.

LSI classification	Test Item	Error Code	Error Contents
CMA	0120		Force Error Test.(A)
		2000	Error occur in Register Read.
		1000	Error occur in Register Write.
		0001	Data Compare Error occur.
		0002	Data Compare Error occur.
		0040	CHK2 Error occur.
	0121		Force Error Test.(B)
		2000	Error occur in Register Read.
		1000	Error occur in Register Write.
		0001	Data Compare Error occur.
		0002	Data Compare Error occur.
		0040	CHK2 Error occur.
	0122		FIFO Memory Test.
		2000	Error occur in Register Read.
		1000	Error occur in Register Write.
		0001	Data Compare Error occur.
		0002	Data Compare Error occur.
		0040	CHK2 Error occur.
		4000	Memory Write Error occur.
		8000	Memory Read Error occur.
	0123		Normal Packet Access.(dw)
		2000	Error occur in Register Read.
		1000	Error occur in Register Write.
		0001	Data Compare Error occur.
		0002	Data Compare Error occur.
		0040	CHK2 Error occur.
		4000	Memory Write Error occur.
		8000	Memory Read Error occur.
	0124		Normal Packet Access.(bcp)
		2000	Error occur in Register Read.
		1000	Error occur in Register Write.
		0001	Data Compare Error occur.
		0002	Data Compare Error occur.
		0040	CHK2 Error occur.
		0200	Cache to Copy Error occur.
		4000	Memory Write Error occur.
		8000	Memory Read Error occur.

LSI classification	Test Item	Error Code	Error Contents
CMA	0125		Normal Packet Access.(icp)
		2000	Error occur in Register Read.
		1000	Error occur in Register Write.
		0001	Data Compare Error occur.
		0002	Data Compare Error occur.
		0040	CHK2 Error occur.
		0400	Cache in Copy Error occur.
		4000	Memory Write Error occur.
		8000	Memory Read Error occur.
	0126		Retry Function Confirmation Test.
		2000	Error occur in Register Read.
		1000	Error occur in Register Write.
		0001	Data Compare Error occur.
		0002	Data Compare Error occur.
		0040	CHK2 Error occur.

LSI classification	Test Item	Error Code	Error Contents
SMA	0201		SM Normal Access Test.
		0100	Read Error occur at 1 word of Test area.
		0040	CHK3 Error occur.
	0202		SM Resources Lock Access Test.
		0100	Write/Read unmatched Error occur at 2 word of Test area.
		0040	CHK3 Error occur.
	0203		Atomic Access Test.
		0040	CHK3 Error occur.
		0100	Write/Read unmatched Error occur of Test area.
	0204		Resources Lock Out Test.
		0040	CHK3 Error occur.
		0100	Write/Read unmatched Error occur of Test area.
	0205		Target Broadcast Test.
		0100	Broadcast Register Data unmatched Error occur.
		0040	CHK3 Error occur.
	0206		Self MP Status Read Test.
		0100	MP_STATUSREG Data unmatched Error occur.
		0040	CHK3 Error occur.
	020c		Configuration Check.
		0040	CHK3 Error occur.
		0100	Error occur in PD Register Read. (CHK3)
		0200	Configuration unmatched Error occur.
	020d		SM Voltage Establish Control routine.
		0100	PS_DETINT Establish Error occur.
		0200	PS_DET_INH Establish.
		0300	Parameter Error occur.
		0040	CHK3 Error occur.
	0211		Register Test 1
		0100	Data Compare Error occur.
		0040	CHK3 Error occur.
	0212		Register Test 2
		0100	Data Compare Error occur.
		0200	Data Compare Error occur.(0 Clear)
		0040	CHK3 Error occur.
	0221		BC Register Test 1
		0100	Data Compare Error occur.
		0200	Data Compare Error occur. (0 Clear)
		0040	CHK3 Error occur.

LSI classification	Test Item	Error Code	Error Contents
SMA	0222		BC Register Test 2
		0100	Data Compare Error occur.
		0200	Data Compare Error occur.(BC Register)
		0300	Status Error occur in BCINT OFF.
		0040	CHK3 Error occur.
	0231		SC Register Test 1.
		0100	Data Compare Error occur.(SCAN_WRITE_DATA Register Test)
		0200	Data Compare Error occur.(0 Clear)
		1100	Data Compare Error occur.(SCAN_READ_DATA Register Test)
		1200	Data Compare Error occur.(0 Clear)
		2100	Data Compare Error occur.(SCAN STATUS Register Test)
		2200	Data Compare Error occur. 0 Clear()
		0040	CHK3 Error occur.
	0232		Scan Time Out Error occur.
		0100	Scan Time Out Error occur.
		0200	Data Compare Error occur.(0 Clear)
		0300	Scan Time Out Error occur.
		0040	CHK3 Error occur.
	0241		MPST Register Test 1.
		0100	Data Compare Error occur.
		0200	Data Compare Error occur.(0 Clear)
		0040	CHK3 Error occur.
	0251		ECC Test 1.
		0100	Status Data Compare Error occur.
		0200	Data Compare Error occur.
		0300	Uncollectable Error occur.
		0400	Data unmatched Error occur.
		0040	CHK3 Error occur.
	0252		ECC Test 2/3
		0100	Uncollectable Error occur.(ECC Test 2)
		0200	Uncollectable Error occur.(ECC Test 3)
		0040	CHK3 Error occur.

LSI classification	Test Item	Error Code	Error Contents
SMA	0261		Single Write/Read Test.
		0100	Data Compare Error occur.
		1100	Data Compare Error occur.
		1300	Data Compare Error occur.
		2100	Data unmatched Error occur.(CHK 3)
		2300	Data unmatched Error occur.(CHK 3)
		0040	CHK3 Error occur.
		3100	Single W/R Compare Error occur.
		3200	Collectable Error occur.
		4100	Double W/R Compare Error occur.(A Side)
		4200	Collectable Error occur.
		4300	Double W/R Compare Error occur.(B Side)
	0262		Read Modify Write Function(Atomic operation Function)Test.
		0100	Read Data Error.
		0040	CHK3 Error occur.
		1100	Read Modify Write Error occur.
		1200	Collectable Error occur.
	0263		Function Test 3.
		0100	Data Compare Error occur.
		0200	Data Compare Error occur.
		0500	Data Compare Error occur.
		0600	Data Compare Error occur.
		0900	Collectable Error occur.
		0a00	Data Compare Error occur.
		0d00	Collectable Error occur.
		0e00	Data Compare Error occur.
		0040	CHK3 Error occur.
	0264		Function Test 4.
		0100	PD_DATA Compare unmatched Error occur.
		0200	Data Compare Error occur.
		0300	Data Compare Error occur.
		0040	CHK3 Error occur.
	0265		Function Test 5.
		0100	Memory Read Error occur.
		0200	Memory not Ready Error occur.
		0300	Memory Data Compare Error occur.
		0400	Memory Data Compare Error occur.
		0040	CHK3 Error occur.

LSI classification	Test Item	Error Code	Error Contents
SMA	0266		Function Test 6.
		0100	Error Status Compare Error occur.
		0200	All Lock Register Read Status Error occur.
		0300	Read Data Compare Error occur.
		0400	Memory Read Compare Error occur.
		0500	Double All Lock Status Compare Error occur.
		0600	All Lock Status Compare Error occur.
		0700	Double All Lock Status Compare Error occur.
		0800	All Lock Status Compare Error occur.
		0900	All Lock Status Compare Error occur.
		0a00	All Lock Status Compare Error occur.
		0b00	All Lock Status Compare Error occur.
		0040	CHK3 Error occur.
	0269		Function Test 9.
		0100	Count Value Status Compare Error occur.
		0200	OUNTER_ERROR_STATUS Register Status Compare Error occur.
		0040	CHK3 Error occur.
	026a		Function Test 10.
		0100	Timer Stop Status Compare Error occur.
		0200	Timer Stop Status Compare Error occur.
		0300	Timer Operation Status Compare Error occur.
		0400	Timer Operation Status Compare Error occur.
		0040	CHK3 Error occur.
	026b		Function Test 11.
		0100	Error Status Compare Error occur.
		1100	Error Status Compare Error occur.
		1200	Error Status Compare Error occur.(detail)
		2100	Error Status Compare Error occur.
		2200	Error Status Compare Error occur.
		2300	Error Status Compare Error occur. (detail)
		0040	CHK3 Error occur.
	0271		Counter Test 1.
		0100	Reset Status Compare Error occur.
		0200	Count Up Status Compare Error occur.(ACK_COUNTER)
		0040	CHK3 Error occur.

LSI classification	Test Item	Error Code	Error Contents
SMA	0272		Counter Test 2
		0100	Reset Status Compare Error occur.
		0200	Count Up Status Compare Error occur.(LOCK_COUNTER)
		0040	CHK3 Error occur.
	0273		Counter Test 3
		0100	Reset Status Compare Error occur.
		0200	Count Up Status Compare Error occur.(SCAN_COUNTER)
		0040	CHK3 Error occur.
	0274		Counter Test 4
		0100	Reset Status Compare Error occur.
		0200	Count Up Status Compare Error occur.(VALID_COUNTER)
		0040	CHK3 Error occur.
	0275		Counter Test 5
		0100	Reset Status Compare Error occur.
		0200	Count Up Status Compare Error occur.(MEM_COUNTER)
		0040	CHK3 Error occur.
	0281		Disconnect 1 Test
		0100	Transfer End Waiting Error occur.
		0200	CHK3 Error occur.
		0300	SM Data Check Error occur.
		0040	CHK3 Error occur.
	0282		Disconnect 2 Test
		0100	Transfer End Waiting Error occur.
		0200	CHK3 Error occur.
		0040	CHK3 Error occur.
	0283		Disconnect 3 Test
		0100	Transfer End Waiting Error occur.
		0200	CHK3 Error occur.
		0040	CHK3 Error occur.

LSI classification	Test Item	Error Code	Error Contents
SMA	0284		Disconnect 4 Test.
		0100	Transfer End Waiting Error occur.
		0200	CHK3 Error occur.
		0300	LOG Address Data Check Error occur.
		0400	LOG Read Data Error occur.
		0500	LOG Read ECC Error occur.
		0700	Board Check Error occur.
		0040	CHK3 Error occur.
	0291		Hard Error Test 1.
		0100	MPA Status Compare Error occur.
		0200	MPA_MSTCHK3 Status Compare Error occur.
		0300	PAHT0 Error Status Compare Error occur.
		0400	PATH1 Error Status Compare Error occur.
		0500	PATH0 Error Detail Status Compare Error occur.
		0600	PATH1 Error Detail Status Compare Error occur.
		0700	BOARD Error Status Error occur.
		0800	BOARD Error Status Error occur.(Detail)
		1100	PATH0 Error Status Error occur.
		1200	PATH1 Error Status Error occur.
		1300	PATH0 Error Detail Status Error occur.
		1400	PATH1 Error Detail Status Error occur.
		1500	BOARD Error Status Error occur.
		1600	BOARD Error Status Error occur.(Detail)
		0040	CHK3 Error occur.
	0292		DIMM Control Line.
		0100	MPA Status Error occur.
		0200	MCTL SINGLE ERROR Status Compare Error occur.
		0300	MCTL SINGLE ERROR Status Compare Error occur.
		0400	Board Error Status Compare Error occur.
		0500	Board Error Status Compare Error occur. (Detail)
		0600	DIMM Status Compare Error occur.
		0700	MPA_STATUS Error occur.
		0800	MCTL SINGLE Status Compare Error occur.
		0040	CHK3 Error occur.

LSI classification	Test Item	Error Code	Error Contents		
SMA	0292		DIMM Control Line.		
		0900	MCTL SINGLE Status Compare Error occur.		
		0a00	PATH0 Status Compare Error occur.		
		0b00	PATH1 Status Compare Error occur.		
	0293			CHK3 Error occur.	
				DIMM Control Line.	
		0100		MPA Status Compare Error occur.	
		0200		PATH0 Common Board Status Compare Error occur.	
		0300		PATH1 Common Board Error Status Error occur.	
		0400		Board Error Status Compare Error occur.	
		0500		Board Error Status Compare Error occur.(Detail)	
		0600		DIAG_MODE REG Status Error occur.	
		0700		DIAG_DATA REG Status Error occur.	
		0800		PATH0 Non-Error Status Error occur.	
	0900		PATH1 Non-Error Status Error occur.		
	02a1			CHK3 Error occur.	
				Memory Test 1.	
		0100		MSA Status Error occur.	
		0200		Transfer End Waiting Status Compare Error occur.	
		0300		Non-Error Status Compare Error occur.	
		0400		MSA Status Error occur.	
		0500		Transfer End Waiting Error occur.	
		0600		Non-Error Status Compare Error occur.	
		0040		CHK3 Error occur.	
		02a2			Memory Test 2.
	0100			Data Compare Error occur.	
	0040			CHK3 Error occur.	
	02a3				Memory Test 3.
			0100		Disconnect Status Compare Error occur.
			0200		Transfer End Waiting Error occur.
			0300		Error Status Compare Error occur.
		0400		MSA Status Error occur.	
		0500		Self Refresh Mode Cancel Check Error occur.	
		0600		Disconnect Finish Check Error occur.	
		0700		Error Status Check Error occur.	
		0040		CHK3 Error occur.	

LSI classification	Test Item	Error Code	Error Contents
SMA	02a4		Memory Test 4.
		0100	Read Data Compare Error occur.
		0200	CHK3 Error occur.
		0300	Collectable Error occur.
		0040	CHK3 Error occur.
	02b1		Lock Test 1.
		0100	SMA Status Register Compare Error occur.
		0200	Data Compare Error occur.
		0300	Data Compare Error occur.
		0400	Read Status Compare Error occur.
		0040	CHK3 Error occur.

LSI classification	Test Item	Error Code	Error Contents
FDTA	0301		Register Test. (Direct Register Test part of PCI/DMA, HSN, HARB.)
		0100	Data Compare Error occur. (0xb0010300 to 0xb00112d4)
		0200	Data Compare Error occur. (0xb00103c to 0xb00112d8)
		0040	CHK2 Error occur.
	0302		Register Test. (Indirect Register Test Part of PCI/DMA.)
		0100	Data Compare Error occur. (0x00000020 to 0x00001063)
		0200	Data Compare Error occur. (0x00000050 to 0x0000005f)
		0300	Data Compare Error occur. (0x00000000 to 0x0000000a)
		0040	CHK2 Error occur.
	0303		Register Test. (Indirect Register Test part of HSN.)
		0100	Data Compare Error occur.
		0040	CHK2 Error occur.
	0304		Register Test. (Indirect Register Test part of HARB.)
		0100	Data Compare Error occur.
		0040	CHK2 Error occur.
	0305		Counter Test (Indirect Register Test part of PCI/DMA.)
		0100	Data Compare Error occur.
		0040	CHK2 Error occur.
	0306		Counter Test (Indirect Register Test part of HSN.)
		0100	Data Compare Error occur.
		0040	CHK2 Error occur.
	0307		DBFLOOP Test.
		0100	Data Compare Error occur.
		0200	Time Out Error occur.
		0300	XFS Register Status Error occur.
		0040	CHK2 Error occur.

LSI classification	Test Item	Error Code	Error Contents
FDTA	0308		DBF Memory Test.
		0100	Bit ON/OFF Data Compare Error occur.
		0200	Address Data Compare Error occur.
		0040	CHK2 Error occur.
	0309		XBF Memory Test.
		0100	Bit ON/OFF Data Compare Error occur in Data Block.
		0200	Bit ON/OFF Data Compare Error occur in Data Block.
		0300	Bit ON/OFF Data Compare Error occur in Data Block.
		0400	Bit ON/OFF Data Compare Error occur in Data Block.
		0500	Bit ON/OFF Data Compare Error occur in Data Block.
		0600	Bit ON/OFF Data Compare Error occur in Data Block.
		0040	CHK2 Error occur.
	030a		Force Error Test.
		0100	Status Compare Error occur.
		0040	CHK2 Error occur.
	030b		Impedance Adjustment Quality Judgment Test.
		0101	IMP_DAH DAL Value Base within the scope Error occur.
		0040	CHK2 Error occur.

LSI classification	Test Item	Error Code	Error Contents	
MMC	0400		MPCHK Circuit Test 1. (Sequence Error force occur.)	
		4000	Initial Data Check Error.	
		4001	Force Sequence Error Test 1 Error.	
		4002	Force Sequence Error Test 2 Error.	
		4003	Force Sequence Error Test 3 Error.	
		4004	Force Sequence Error Test 4 Error.	
		4005	Force Sequence Error Test 5 Error.	
		0401		MPCHK Circuit Test 2. (Countervalue Error Detection.)
			4010	All 0 Data Compare Error.
			4011	All 5 Data Compare Error.
			4012	Increment Data Compare Error.
			4013	Decrement Data Compare Error.
			4014	Force Compare Error Test Error.
		0402		MPCHK Circuit Test 3. (Time out.)
			4020	Normal Case Test 1 Error.
			4021	Normal Case Test 1 Error.
			4022	MRST Cancel Test Error.
			4023	Force Time out occur Test (WCHK1) Error.
			4024	Force Time out occur Test (CHK1A) Error.
		0403		MPCHK Circuit Test 4. (Force Error occur Check.)
			4030	Force Time out Error Test Error.
			4031	Force Timer Parity Error Test Error.
		0404		MPCHK Circuit Test 5. (Error Select Function.)
			4040	MASK Test Error.
			4041	CHK1A Test Error.
			4042	WCHK1 Test Error.
			4043	MASK Test Error.
			4044	CHK1A Test Error.
			4045	WCHK1 Test Error.
			4046	MASK Test Error.
			4047	CHK1A Test Error.
			4048	WCHK1 Test Error.
			4049	MASK Test Error.
			404a	CHK1B Test Error.

LSI classification	Test Item	Error Code	Error Contents	
MMC	0405		SRAM Test 1. (CHK1B Register Test.)	
		4050	Initial Data Check Error.	
		4051	Initial Data Check Error.	
		4052	Initial Data Check Error.	
		4053	Initial Data Check Error.	
		4054	Force Error Test (XBUS Data Parity Set) Error.	
		4055	Force Error Test (XBUS Data Parity Set) Error.	
		4056	Force Error Test (XBUS Data Parity Set) Error.	
		4057	Error Reset Error.	
	0406			SRAM Test 4. (MMC Inside BUS Parity Error Force occur.)
		4060	Initial Data Check Error.	
		4061	Initial Data Check Error.	
		4062	Force Error Test (MMC Parity Set) Error.	
		4063	Force Error Test (MMC Parity Set) Error.	
		4064	Force Error Test (MMC Parity Set) Error.	
		4065	Error Reset Error.	
		4066	Error Reset Error.	
		4067	Error Reset Error.	
	0407			SRAM Test 5. (MMC Inside BUS Parity Error Force occur.)
		4070	Initial Data Check Error.	
		4071	Initial Data Check Error.	
		4072	Force Error Test (WRITE Only Register READ) Error.	
		4073	Force Error Test (WRITE Only Register READ) Error.	
		4074	Force Error Test (WRITE Only Register READ) Error.	
		4075	Error Reset Error.	
		4076	Error Reset Error.	
		4077	Error Reset Error.	
		4078	Error Reset Error.	
		4079	Error Reset Error.	
		407a	Error Reset Error.	
		407b	Error Reset Error.	

LSI classification	Test Item	Error Code	Error Contents
MMC	0409		SRAM Test 16H. (Error Status Reflection Check.)
		4090	Initial Data Check Error.
		4091	WCHK1 (Micro) Test Error.
		4092	Error Reset Error.
		4093	WCHK1 (CHK1A 2 times) Test Error.
		4094	Error Reset Error.
		4095	WCHK1 (MPCHK) Test Error.
		4096	Error Reset Error.
		4097	CHK1A (DRAM) Test Error.
		4098	Error Reset Error.
		409a	CHK1A (MPCHK) Test Error.
		409b	Error Reset Error.
	040a		SRAM Test 18. (MMC Parity Error Mask.)
		40a0	Initial Data Check Error.
		40a1	Initial Data Check Error.
		40a2	Force Error Test (CHK1B) Error.
		40a3	Force Error Test (CHK1B) Error.
		40a4	Force Error Test (CHK1B) Error.
		40a5	Force Error Test (CHK1B) Error.
		40a6	Force Error Test (CHK1B) Error.
		40a7	Force Error Test (CHK1B) Error.
		40a8	Error Reset Error.
		40a9	Error Reset Error.
		40aa	Error Reset Error.
		40ab	Error Reset Error.
	040b		SRAM Test 19H. (CHK1B Status Force occur.)
		40b0	Initial Data Check Error.
		40b2	Force Error Test (WRITE Only Register READ) Error.
		40b3	Force Error Test (MPCHK Timer Parity Error) Error.

LSI classification	Test Item	Error Code	Error Contents
MMC	040f		SRAM Test 15. (A/BREG Byte R/W.)
		40f0	AREG Byte3 R/W Compare Error.
		40f1	AREG Byte2 R/W Compare Error.
		40f2	AREG Byte1 R/W Compare Error.
		40f3	AREG Byte0 R/W Compare Error.
		40f4	BREG Byte3 R/W Compare Error.
		40f5	BREG Byte2 R/W Compare Error.
		40f6	BREG Byte1 R/W Compare Error.
		40f7	BREG Byte0 R/W Compare Error.
	0424		FM Control R/W Register Test
		4240	Register R/W Compare Error.
		4241	No Error Check Error.
		4242	No Error Check Error.
		4243	No Error Check Error.
		4244	No Error Check Error.
	0425		FM Control Error Status Register Test.
		4250	Error Status Register Compare Error.
		4251	FM Register R/W Compare Error.
		4252	No Error Check Error.
		4253	Error Status Register Compare Error.
		4254	Error Status Register Compare Error.
		4255	No Error Check Error.
		4256	FM Register R/W Compare Error.
		4257	No Error Check Error.
		4258	Error Status Register Compare Error.
		4259	No Error Check Error.
		425a	Error Status Register Compare Error.
		425b	Error Status Register Compare Error.

LSI classification	Test Item	Error Code	Error Contents	
MMC	0426		SRAM Test XR3H. (XR Address Parity Error Detection Function.)	
		4260	Initial Data Check Error.	
		4261	Initial Data Check Error.	
		4262	Force Error Test (Address Parity Error Set) Error.	
		4263	Force Error Test (Address Parity Error Set) Error.	
		4264	Force Error Test (Address Parity Error Reset) Error.	
		4265	Force Error Test (Address Parity Error Reset) Error.	
		4266	Error Reset Error.	
		0427		SRAM Test XR5H. (XR Address Decoder Error Detection Function.)
			4270	Initial Data Check Error.
			4271	Force Error Test (LANHOLD/WAIT Time out) Error.
			4272	Force Error Test (LANHOLD/WAIT Time out) Error.
			4273	Error Reset Error.
			4274	Error Reset Error.
			4275	Force Error Test (ADECxx Error) Error.
			4276	Force Error Test (ADECxx Error) Error.
			4277	Error Reset Error.
			4278	Error Reset Error.
			4279	Force Error Test (ADECxx Error) Error.
			427a	Force Error Test (ADECxx Error) Error.
			427b	Error Reset Error.
			427c	Error Reset Error.
		042a		PORT Test
			42a0	0 Output Check Error.
			42a1	1 Output Check Error.
			42a2	0 Output Check Error.
		0430		R/W Register All Bit ON/OFF Test.
			4300	DIAG Mode Set Error.
			4301	Register R/W Compare Error.
		0431		Specify Data Pattern Register R/W Test.
			4310	DIAG Mode Set Error.
			4311	Register R/W Compare Error.

LSI classification	Test Item	Error Code	Error Contents
MMC	0432		READ Only / WRITE Only Register Test.
		4320	DIAG Mode Set Error.
		4321	Register R/W Compare Error.
		4322	Register R/W Compare Error.
		4323	Factor Register Compare Error.
	0433		Threshold Counter Test.
		4330	Force Count up Error.
	0435		LM R/W Test.
		4350	LM R/W Compare Error.
		4351	No Error Check Error.
	0436		ECC Circuit Test 1.(1 Bit Error Detection.)
		4360	WRITE Data Compare Error.
		4361	Syndrome Pattern Compare Error.
		4362	WRITE Data Compare Error.
		4363	Syndrome Pattern Compare Error.
	0437		ECC Circuit Test 2.(1 Bit Error Detection.)
		0100	Count Data Compare Error.
		0300	Count Data Compare Error.
		0400	CHK1B no occurrence Error.
		0500	Error Status Compare Error.
		0600	LM R/W Compare Error.
		0700	Byte Enable Signal Data Compare Error.
		0800	R/W Signal Holding Data Compare Error.
		0900	Before Correction Data Compare Error.
		0a00	Before Correction Check Bit Compare Error.
		0b00	After Correction Data Compare Error.
		0c00	After Correction Check Bit Compare Error.
		0d00	Syndrome Pattern Compare Error.
		0e00	Check Bit Data Compare Error.
		0f00	Before Correction Data Compare Error.
		1000	Error Reset Error.
		1100	Counter Reset Error.

LSI classification	Test Item	Error Code	Error Contents
MMC	0439		ECC Circuit Test 3.(2 Bit Error Detection.)
		4390	Uncorrectable Error no Detection Error.
	043a		ECC Circuit Test 3.(1 Memory Device Error Detection.)
		43a0	Uncorrectable Error no Detection Error.
	0440		Pre-read Control Test.
		4400	Inside RAM R/W Compare Error.
		4401	No Error Check Error.
		4402	Pre-read Buffer R/W Compare Error.
		4403	No Error Check Error.
		4404	Pre-read Buffer R/W Compare Error.
		4405	No Error Check Error.
		4406	Pre-read Buffer R/W Compare Error.
		4407	No Error Check Error.
		4408	Pre-read Buffer R/W Compare Error.
		4409	Pre-read Buffer R/W Compare Error.
		440a	Pre-read Buffer R/W Compare Error.
		440b	Pre-read Buffer R/W Compare Error.
	0441		Hard Monitor Control Test.
		4411	Force Count Up Compare Error.
		4412	No Error Check Error.
		4413	No Error Check Error.
		4414	Count Overflow No Detection Error.
		4415	No Error Check Error.

LSI classification	Test Item	Error Code	Error Contents
MMC	0450		Timer Control Block Test. (Timer 0)
		0108	All 00 Data R/W Compare Error.
		0109	All ff Data R/W Compare Error.
		010a	ON Bit Data R/W Compare Error.
		010b	OFF Bit Data R/W Compare Error.
		0200	Low bit Count up Error.
		0201	High bit Count up Error.
		0300	Over digit Error.
		0400	Interrupt no occurrence Error.
		0401	Interrupt Reset Error.
		0501	Full Count Expect Data Error.
		0502	Interrupt no occurrence Error.
		0040	CHK1B Error occur.
	0451		Timer Control Block Test. (Timer 1)
		0108	All 00 Data R/W Compare Error.
		0109	All ff Data R/W Compare Error.
		010a	ON Bit Data R/W Compare Error.
		010b	OFF Bit Data R/W Compare Error.
		0200	Low bit Count up Error.
		0201	High bit Count up Error.
		0300	Over digit Error.
		0400	Interrupt no occurrence Error.
		0401	Interrupt Reset Error.
		0501	Full Count Expect Data Error.
		0502	Interrupt no occurrence Error.
		0040	CHK1B Error occur.

LSI classification	Test Item	Error Code	Error Contents
MMC	0452		Timer Control Block Test. (Timer 2)
		0108	All 00 Data R/W Compare Error.
		0109	All ff Data R/W Compare Error.
		010a	ON Bit Data R/W Compare Error.
		010b	OFF Bit Data R/W Compare Error.
		0200	Low bit Count up Error.
		0201	High bit Count up Error.
		0300	Over digit Error.
		0400	Interrupt no occurrence Error.
		0401	Interrupt Reset Error.
		0501	Full Count Expect Data Error.
		0502	Interrupt no occurrence Error.
		0040	CHK1B Error occur.
	0453		Timer Control Block Test. (Timer 3)
		0108	All 00 Data R/W Compare Error.
		0109	All ff Data R/W Compare Error.
		010a	ON Bit Data R/W Compare Error.
		010b	OFF Bit Data R/W Compare Error.
		0200	Low bit Count up Error.
		0201	High bit Count up Error.
		0300	Over digit Error.
		0400	Interrupt no occurrence Error.
		0401	Interrupt Reset Error.
		0501	Full Count Expect Data Error.
		0502	Interrupt no occurrence Error.
		0040	CHK1B Error occur.

LSI classification	Test Item	Error Code	Error Contents	
MMC	0454		Timer Control Block Test. (Timer 4)	
		0100	All 00 Data R/W Compare Error.	
		0101	All ff Data R/W Compare Error.	
		0102	All 00 Data R/W Compare Error.	
		0103	All ff Data R/W Compare Error.	
		0104	ON Bit Data R/W Compare Error.	
		0105	OFF Bit Data R/W Compare Error.	
		0106	ON Bit Data R/W Compare Error.	
		0107	OFF Bit Data R/W Compare Error.	
		0202	Low bit Count up Error.	
		0203	High bit Count up Error.	
		0300	Over digit Error.	
		0400	Interrupt no occurrence Error.	
		0401	Interrupt Reset Error.	
		0500	Full Count Expect Data Error.	
		0502	Interrupt no occurrence Error.	
		0040	CHK1B Error occur.	
		0455		Timer Control Block Test. (Timer 5)
			4550	All 00 Data R/W Compare Error.
			4551	All ff Data R/W Compare Error.
			4552	ON Bit Data R/W Compare Error.
			4553	OFF Bit Data R/W Compare Error.
			4554	Low bit Count up Error.
			4555	High bit Count up Error.
			4556	Over digit Error.
			4557	Interrupt no occurrence Error.
			4558	Interrupt Reset Error.
			4559	Full Count Expect Data Error.
			455a	Interrupt no occurrence Error.

LSI classification	Test Item	Error Code	Error Contents
MMC	0456		Timer Control Block Test. (Timer 6)
		4560	All 00 Data R/W Compare Error.
		4561	All ff Data R/W Compare Error.
		4562	ON Bit Data R/W Compare Error.
		4563	OFF Bit Data R/W Compare Error.
		4564	Low bit Count up Error.
		4565	High bit Count up Error.
		4566	Over digit Error.
		4567	Interrupt no occurrence Error.
		4568	Interrupt Reset Error.
		4569	Full Count Expect Data Error.
		456a	Interrupt no occurrence Error.
	0457		Interrupt Test.
		0100	Interrupt Occurrence Register Compare Error occur.
		0200	INT_STS Register Compare Error occur.
		0300	LVLXSTS unmatched Error occur.
		0400	LVL0STS unmatched Error occur.
		0500	SYNCINT unmatched Error occur.
		0600	INT_STS unmatched Error occur.
		0700	LVL#STS unmatched Error occur.
		0800	LVL#STS unmatched Error occur.
		0900	SYNCINT unmatched Error occur.
		0040	CHK1B Error occur.
	0458		Timer 5/6, LANC/SIO Interrupt Test.
		4580	INTEN Register R/W Compare Error.
		4581	Interrupt Requirement no occurrence Error.
		4582	Interrupt Requirement no occurrence Error.
		4583	Interrupt Requirement no occurrence Error.
		4584	Synchronous Circuit Monitor Compare Error.

LSI classification	Test Item	Error Code	Error Contents
MMC	0459		Reset Control Test.
		0100	Reset Factor Cancellation Register Data unmatched Error occur.
		0200	Confirmation Data unmatched Error of Reset Factor Maintenance occur.
		0300	Confirmation Data unmatched Error of Reset Factor Maintenance occur.
		0040	CHK1B Error occur.
	045a		XR Control Test.
		0100	Write Data unmatched Error occur.
		0200	Data unmatched Error occur.
		0040	CHK1B Error occur.
	045b		Synchronous Stop Function Test.
		0040	Synchronous Stop Confirmation Register unmatched Error occur.
		0040	CHK1B Error occur.

LSI classification	Test Item	Error Code	Error Contents
LPA	0601		LPA LSI Test.
		0010	LPA PnVID/PnDID Register Test.
		0020	LPA Register Read Test.
		0030	Communication Mem Data Line Test.
		0040	Communication Mem Address Line Test.
		0050	XFR Memory Data Line Test.
		0060	XFR Memory Address Line Test.
		0040	CHK1B Error occur.
	0602		LPA Initialize Test.
		0010	LPA LSI Initialize Error occur.
		0040	CHK1B Error occur.
	0603		LPA Initialize check Test.
		0010	LPA LSI Initialize Check Error occur.
		0011	LPA LSI Initialize Compare Error occur.
		0040	CHK1B Error occur.
	0604		P/K Exclusive Control Test.
		0100	Lock Time Out.

LSI classification	Test Item	Error Code	Error Contents
MPA	0800		MP resources exclusion in PK.
		0100	Exclusion Time Out.
	0801		Register Test Part of occupational MPA.
			Initial default Read Test.
		0100	Error occur in Initial default Read.
		0200	Data Compare Error occur.
			Counter Test.
		0300	Count Master Data unmatched Error occur.
			Sequencer Test.
		0400	Data Compare Error occur.
		0040	CHK1B Error occur.
	0802		Register Test part of common MPA.
		0500	SCINT_IF Register Initial default Read Test Error occur.
		0600	SCINT_IF Register Write/Read Test Error occur.
		0700	SM_IF Register Initial Read Test Error occur.
		0800	SM_IF Register Write/Read Test Error occur.
		0040	CHK1B Error occur.
	0803		GTL Impedance Adjustment Quality Judgment Test.
		0100	GTL Impedance Error occur.
		0040	CHK1B Error occur.

LSI classification	Test Item	Error Code	Error Contents
QDTA	0901		Register Test.
		0040	CHK1B Error occur.
		0100	Data Compare Error occur.
		0200	Register Reset Error occur.
	0902		Data/Latch Test.
		0040	CHK1B Error occur.
		0100	Data Compare Error occur.
		0200	Register Reset Error occur.
	0903		Sequencer Test.
		0040	CHK1B Error occur.
		0100	Data Compare Error occur.
		0200	Register Reset Error occur.
	0904		Counter Register Test.
		0040	CHK1B Error occur.
		0100	Data Compare Error occur.
		0200	Register Reset Error occur.
	0905		Inside RAM WRITE/READ Test.
		0040	CHK1B Error occur.
		0100	Error occur in Register Read/Write.
		0200	Data Compare Error occur.
	0907		QDTA→CACHE Data Transfer Test.
		0040	CHK1B Error occur.
		0100	Error occur in Register Read/Write.
		0200	Data Compare Error occur.
	0908		LA Change Test.
		0040	CHK1B Error occur.
		0100	Error occur in CACHE Read/Write.
		0200	Data Compare Error occur.

LSI classification	Test Item	Error Code	Error Contents
QDTA	0909		GTL Impedance Test.
		0040	CHK1B Error occur.
		0100	High-order Bit of IMONO Compare Error.
		0200	Error occur in Byte Normal Scope Judgment.
	090a		Force Error Test.
		0040	CHK1B Error occur.
		0100	Error occur in CHK2 Force Error Test.
		0200	Error occur in CHK1B Force Error Test.

LSI classification	Test Item	Error Code	Error Contents
CARB	0c01		P Path Test.
		0100	Error occur in Initial default Read Test.
		0200	Register Read/Write Test.
		0300	Error occur in Counter/Sequencer Test.
		0400	Error occur in Force Error Test.
		0040	CHK2 Error occur.
	0c02		Common Path.
		0100	Error occur in Initial default Read Test.
		0200	Register Read/Write Test.
		0300	Error occur in Counter/Sequencer Test.
		0400	Error occur in Force Error Test.
		0040	CHK2 Error occur.
	0c03		C0 Path Test.
		0100	Error occur in Initial default Read Test.
		0200	Register Read/Write Test.
		0300	Error occur in Counter/Sequencer Test.
		0400	Error occur in Force Error Test.
		0500	Error occur in register restoration.
		0040	CHK2 Error occur.
	0c04		C1 Path Test.
		0100	Error occur in Initial default Read Test.
		0200	Register Read/Write Test.
		0300	Error occur in Counter/Sequencer Test.
		0400	Error occur in Force Error Test.
		0500	Error occur in register restoration.
		0040	CHK2 Error occur.
	0c05		C2 Path Test.
		0100	Error occur in Initial default Read Test.
		0200	Register Read/Write Test.
		0300	Error occur in Counter/Sequencer Test.
		0400	Error occur in Force Error Test.
		0500	Error occur in register restoration.
		0040	CHK2 Error occur.

LSI classification	Test Item	Error Code	Error Contents
CARB	0c06		C3 Path Test.
		0100	Error occur in Initial default Read Test.
		0200	Register Read/Write Test.
		0300	Error occur in Counter/Sequencer Test.
		0400	Error occur in Force Error Test.
		0500	Error occur in register restoration.
		0040	CHK2 Error occur.
	0c0f		Initialze
		0100	REV Register Read Error occur.

LSI classification	Test Item	Error Code	Error Contents
FCA	0f01		Register Initial default Test.
		0100	Initial default Read unmatched Error occur.
		0200	CHK1 occur.
		0040	CHK1B Error occur.
	0f02		Data Register W/R Test.
		0100	Data Compare Error occur.
		0200	CHK1 occur.
		0040	CHK1B Error occur.
	0f03		Slave Register Test.
		0100	Data Compare Error occur.
		0200	CHK1 occur.
		0040	CHK1B Error occur.
	0f04		Counter Test.
		0100	Data Compare Error occur.
		0200	CHK1 occur.
		0040	CHK1B Error occur.
	0f05		Special Register Test.
		0100	Data Compare Error occur.
		0200	CHK1 occur.
		0040	CHK1B Error occur.
	0f06		Inside RAM Test.
		0100	Data Compare Error occur. (Address match Data)
		0200	CHK1 occur.
		0300	Data Compare Error occur. (Fixed Data)
		0400	CHK1 occur.
		0040	CHK1B Error occur.
	0f07		Error Latch Test.
		0100	Test case 1 Data Compare Error occur.
		0200	Test case 2 Data Compare Error occur.
		0300	Test case 3 Data Compare Error occur.
		0400	Test case 4 Data Compare Error occur.
		0040	CHK1B Error occur.

LSI classification	Test Item	Error Code	Error Contents
FCA	0f08		TL Loop Test.
		0100	Initialization Error occur.
		0200	Data Compare Error occur.
		0801	Data Compare Error occur.
		0802	Data Compare Error occur.
		0040	CHK1B Error occur.
	0f09		CHSN Test.
		0100	Data transfer Test Error.
		0010	CM Write Error occur.
		0020	CM Read Error occur.
		0030	Data Compare Error occur.
		0040	CHK1B Error occur.
	0f0a		PAL Test
		0010	CM Write Error occur.
		0040	CHK1B Error occur.
	0f0b		CHSN Test 2
		0010	CM Write Error occur.
		0020	CM Read Error occur.
		0030	Data Compare Error occur.
		0040	CHK1B Error occur.
	0f10		Data Register W/R Test 2.
		0100	Data Compare Error occur.
		0200	CHK1 occur.
		0040	CHK1B Error occur.
	0f11		Data Register W/R Test 3.
		0100	Data unmatched Error occur.
		0200	CHK1 occur.
		0040	CHK1B Error occur.
	0f12		Inside RAM Test 2.
		0100	Data Compare Error in H side.
		0200	CHK1 occur.
		0040	CHK1B Error occur.
	0f13		Inside RAM Test 3.
		0100	Word Access Data Compare Error occur.
		0200	Short Access Data Compare Error occur.
		0300	Byte Access Data Compare Error occur.
		0040	CHK1B Error occur.

LSI classification	Test Item	Error Code	Error Contents
FCA	0f14		Slave Register Test.
		0100	Data Compare Error occur.
		0200	CHK1 occur.
		0040	CHK1B Error occur.
	0f15		LED Register Test.
		0100	Read Compare Error occur.
		0200	CHK1 Status Error occur.
		0300	CHK1 Status Error occur.(End)
		0040	CHK1B Error occur.

LSI classification	Test Item	Error Code	Error Contents
XCLM	1001		Initial default Test.
		0040	CHK1 Error occur.
		0100	Data Compare Error occur.
		0200	CHK1 Error occur.
	1002		Register W/R Test.
		0040	CHK1 Error occur.
		0100	Data Compare Error occur.
		0200	CHK1 Error occur.
	1003		Memory Data Bus Bit Test 1.
		0040	CHK1 Error occur.
		0100	Data Compare Error occur.
		0200	CHK1 Error occur.
	1004		Memory Data Bus Bit Test 2.
		0040	CHK1 Error occur.
		0100	Data Compare Error occur.
		0200	CHK1 Error occur.
	1005		Memory Address Test 1.
		0040	CHK1 Error occur.
		0100	Data Compare Error occur.
		0200	Data Compare Error occur.
		0300	CHK1 Error occur.
	1006		Memory Address Test 2.
		0040	CHK1 Error occur.
		0100	CHK1 Error occur.
		0200	Data Compare Error occur.
		0300	CHK1 Error occur.
		0400	Data Compare Error occur.
		0500	CHK1 Error occur.
	1007		Data Transfer in P/K Test 1.
		0040	CHK1 Error occur.
		0100	CHK2 Error occur.
		0200	Data Compare Error occur.

LSI classification	Test Item	Error Code	Error Contents	
XCLM	1008		Data Transfer in P/K Test 2.	
		0040	CHK1 Error occur.	
		0100	CHK2 Error occur.	
		0200	CHK2 Error occur.	
		0300	Data Compare Error occur.	
	1009		Force Error occur.	
		0040	CHK1 Error occur.	
		0100	CHK2 Error occur.	
	100a		Force Error CHK1 Test.	
		0040	CHK1 Error occur.	
		0100	CHK1 Error occur.	
		0200	Data Compare Error occur.	
		0300	CHK1 Error occur.	
		0400	Data Compare Error occur.	
	100b		Impedance Test.	
		0040	CHK1 Error occur.	
		0100	CHK1 Error occur.	
		0200	Data Compare Error occur.	

LSI classification	Test Item	Error Code	Error Contents
Common			Main.
	0000	0000	Machine Constitution data acquisition function error occur.
	0005	0000	BSA LSI Resource acquisition error occur.
	0006	0000	Noting Valid CHSN.
	0007	0000	Noting Machine Constitution data CMG.
	0127	0000	Cache Register Initialize error occur.

LSI classification	Test Item	Error Code	Error Contents
FDTM	1201		Register Test. (Direct Register Test part of PCI/DMA, HSN, HARB.)
		0100	Data Compare Error occur. (no mask)
		0200	Data Compare Error occur. (mask)
		0040	CHK2 Error occur.
	1202		Register Test. (Indirect Register Test Part of PCI/DMA.)
		0100	Data Compare Error occur. (0x00000020 to 0x00001063)
		0200	Data Compare Error occur. (0x00000050 to 0x0000005f)
		0300	Data Compare Error occur. (0x00000000 to 0x0000000a)
		0040	CHK2 Error occur.
	1203		Register Test. (Indirect Register Test part of HSN.)
		0100	Data Compare Error occur.
		0040	CHK2 Error occur.
	1204		Register Test. (Indirect Register Test part of HARB.)
		0100	Data Compare Error occur.
		0040	CHK2 Error occur.
	1205		Counter Test (Indirect Register Test part of PCI/DMA.)
		0100	Data Compare Error occur.
		0040	CHK2 Error occur.
	1206		Counter Test (Indirect Register Test part of HSN.)
		0100	Data Compare Error occur.
		0040	CHK2 Error occur.
	1207		DBFLOOP Test.
		0100	Data Compare Error occur.
		0200	Time Out Error occur.
		0300	XFS Register Status Error occur.
		0040	CHK2 Error occur.

LSI classification	Test Item	Error Code	Error Contents	
FDTM	1208		DBF Memory Test.	
		0100	Bit ON/OFF Data Compare Error occur.	
		0200	Address Data Compare Error occur.	
		0040	CHK2 Error occur.	
	1209		XBF Memory Test.	
			0100	Bit ON/OFF Data Compare Error occur in Data Block.
			0200	Bit ON/OFF Data LRC Expect Data Compare Error occur in Data Block.
			0300	Address Data Compare Error occur in Data Block.
			0400	Address Data LRC Expect Data Compare Error occur in Data Block.
			0500	Bit ON/OFF Data Compare Error occur in LRC Block.
			0600	Address Data Compare Error occur in LRC Block.
			0040	CHK2 Error occur.
	120a		Force Error Test.	
			0100	Status Compare Error occur.
			0040	CHK2 Error occur.
	120b		Impedance Adjustment Quality Judgment Test.	
			0100	IMP_DAH DAL Value Base within the scope Error occur.
			0040	CHK2 Error occur.

LSI classification	Test Item	Error Code	Error Contents
FDTM	120c		Register Test. (Direct Register Test part of PMA.)
		0100	Data Compare Error occur. (no mask)
		0200	Data Compare Error occur. (mask)
		0300	Enter on PMA Error occur.
		0040	CHK2 Error occur.
	120d		Register Test. (Indirect Register Test Part of PMA.)
		0100	Data Compare Error occur. (no mask.)
		0200	Data Compare Error occur. (mask.)
		0300	Enter on PMA Error occur.
		0040	CHK2 Error occur.
	120e		Counter Test (Indirect Register Test part of PMA.)
		0100	Data Compare Error occur.
		0200	Enter on PMA Error occur.
		0040	CHK2 Error occur.
	120f		PBF Memory Test.
		0100	Bit ON Data Compare Error occur.
		0200	Bit OFF Data Compare Error occur.
		0300	Address Data Compare Error occur.
		0400	Enter on PMA Error occur.
		0040	CHK2 Error occur.
	1210		PMA XBF Memory Test.
		0100	Bit ON Data Compare Error occur.
		0200	0 Data after Bit ON Data Compare Error occur.
		0300	Bit OFF Data Compare Error occur.
		0400	0 Data after Bit OFF Data Compare Error occur.
		0500	Enter on PMA Error occur.
		0040	CHK2 Error occur.
	1211		CRC Calculation Circuit Test.
		0100	Data Compare Error occur.
		0200	CHK2 Error occur.
		0300	CRC Data Compare Error occur.
		0040	CHK2 Error occur.

LSI classification	Test Item	Error Code	Error Contents
FDTM	1212		Force Error Test. (part of PMA.)
		0100	Status Compare Error occur.
		0040	CHK2 Error occur.
	1213		PMA Path Test.
		4000	Memory Write Error occur.
		8000	Memory Read Error occur.
		0002	Memory Compare Error occur.
		0008	Enter on PMA Error occur.
		0040	CHK2 Error occur.
	1214		Detail Force Error Test. (part of PMA.)
		0100	Status Compare Error occur.
		0040	CHK2 Error occur.
	1215		Individual Force Error Test. (part of DMA.)
		0100	Status Compare Error occur.
		0040	CHK2 Error occur.
	1216		Individual Force Error Test. (part of PMA.)
		0100	Status Compare Error occur.
		0040	CHK2 Error occur.
	1217		Force Error Test. (Tachyon transfer part of DMA.)
		0100	Status Compare Error occur.
		0040	CHK2 Error occur.
	1218		Detail Force Error Test. (Tachyon transfer part of DMA.)
		0100	Status Compare Error occur.
		0040	CHK2 Error occur.

LSI classification	Test Item	Error Code	Error Contents
FDTM	1219		Individual Force Error Test. (Tachyon transfer part of DMA.)
		0100	Status Compare Error occur.
		0040	CHK2 Error occur.
	121a		FIFO Error Injection Test. (DBF to HSN.)
		0100	Status Compare Error occur.
		0040	CHK2 Error occur.
	121b		FIFO Error Injection Test. (PBF to HSN.)
		0100	Status Compare Error occur.
		0040	CHK2 Error occur.
	121c		FIFO Error Injection Test. (DBF to PCI 4Byte.)
		0100	Status Compare Error occur.
		0040	CHK2 Error occur.
	121d		FIFO Error Injection Test. (PBF to PCI.)
		0100	Status Compare Error occur.
		0040	CHK2 Error occur.
	121e		FIFO Error Injection Test. (XBF to HSN.)
		0100	Status Compare Error occur.
		0040	CHK2 Error occur.
	121f		FIFO Error Injection Test. (DBF to PCI 8Byte.)
		0100	Status Compare Error occur.
		0040	CHK2 Error occur.

LSI classification	Test Item	Error Code	Error Contents
FDTM	1220		Detail Force Error Test. (Part of DMA.)
		0100	Status Compare Error occur.
		0040	CHK2 Error occur.
	1222		Tachyon Loop Test. (Tachyon to HSN.)
		0100	LPA Setting Error occur.
		0200	Link Up Error occur.
		0300	Data Transfer Error occur.(Single R/W Address Data.)
		0400	Data Transfer Error occur.(Single R/W Specific Data.)
		0500	Data Transfer Error occur.(Single RD after Double WR Address Data.)
		0600	Data Transfer Error occur.(Single CRC R/W All f Data.)
		0700	Data Transfer Error occur.(Single CRC R/W All 0 Data.)
		0040	CHK2 Error occur.
	1223		Tachyon Loop Test .(Tachyon to DBF.)
		0100	LPA Setting Error occur.
		0200	Link Up Error occur.
		0300	Data Transfer Error occur.
		0040	CHK2 Error occur.
	1224		LPA-FDTM(PMA)XFR Test
		0100	Data Transfer Error occur.
		0200	Data Compare Error occur.
		0300	Enter on PMA Error occur.
		0040	CHK2 Error occur.

LSI classification	Test Item	Error Code	Error Contents
FDTM	1225		STATUS Register Test.
		0100	STATUS Register Compare Error Occur.
		0200	CUDG_RDDT Register Compare Error Occur.
		0040	CHK2 Error Occur.
	1226		DBFLOOP Test.(DLRCRGF)
		0100	CUDG_RDDT Register Compare Error Occur.
		0200	Data Compare Error Occur.
		0300	CUDG_RDDT Register Compare Error Occur.
		0400	Time Out Error Occur.
		0500	XFS Register Status Error Occur.
		0040	CHK2 Error Occur.
	1227		HSN Parameter Test.
		0100	Time Out Error Occur.
		0200	HSN Parameter Compare Error Occur.
		0300	CUDG_RDDT Register Compare Error Occur.
		0040	CHK2 Error Occur.
	1228		DMASEQ Register Test.
		0100	CUDG_RDDT Register Compare Error Occur.
		0040	CHK2 Error Occur.
	1229		DMASEQ Timer Test.
		0100	Time Out Error Occur.
		0200	DMATIMEOUT Error Not Occur.
		0300	CUDG_RDDT Register Compare Error Occur.
		0400	CUDG_RDDT Register Compare Error Occur.
		0040	CHK2 Error Occur.
	122a		DBFLOOP Test.(Test Area Extent.)
		0100	Data Compare Error Occur.
		0200	Time Out Error Occur.
		0300	XFS Register Status Error Occur.
		0040	CHK2 Error Occur.