



**Hitachi Freedom Storage™
Thunder 9500™ V Series**

**Resource Manager 9500V User's Guide
Graphical User Interface (GUI)**

© 2003 Hitachi Data Systems Corporation, ALL RIGHTS RESERVED

Notice: No part of this publication may be reproduced or transmitted in any form or by any electronic or mechanical means, including photocopying and recording, or stored in a database or retrieval system for any purpose, without the express written permission of Hitachi Data Systems Corporation.

Hitachi Data Systems reserves the right to make changes to this document at any time without notice and assumes no responsibility for its use. Hitachi Data Systems products or services can only be ordered under the terms and conditions of Hitachi Data Systems' applicable agreements, including license agreements. All of the features described in this document may not be currently available. Refer to the most recent product announcement or contact your local Hitachi Data Systems sales office for information on feature and product availability.

This document contains the most current information available at the time of publication. When new and/or revised information becomes available, this entire document will be updated and distributed to all registered users.

Trademarks

Hitachi Data Systems is a registered trademark and service mark of Hitachi, Ltd., and the Hitachi Data Systems design mark is a trademark and service mark of Hitachi, Ltd.

Freedom Storage and Thunder 9500 are trademarks of Hitachi Data Systems Corporation.

HP and HP-UX are registered trademarks of Hewlett-Packard Company.

Microsoft, Windows, Windows NT, Windows 2000, and the Windows logo are either registered trademarks or trademarks of Microsoft Corporation in the United States and/or other countries.

Sun and Solaris are trademarks or registered trademarks of Sun Microsystems, Inc.

IRIX is a registered trademark of Silicon Graphics, Inc. in the United States.

All other brand or product names are or may be trademarks or service marks of and are used to identify products or services of their respective owners.

The *Java Runtime Environment* document is a copyrighted document of Sun Microsystems, Inc., and it is distributed free of charge.

Notice of Export Controls

Export of technical data contained in this document may require an export license from the United States government and/or the government of Japan. Contact the Hitachi Data Systems Legal Department for any export compliance questions.

Document Revision Level

Revision	Date	Description
MK-92DF605-P	September 2002	Preliminary Release
MK-92DF605-0	November 2002	Initial Release
MK-92DF605-1	January 2003	Revision 1, supersedes and replaces MK-92DF605-0
MK-92DF605-2	January 2003	Revision 2, supersedes and replaces MK-92DF605-1
MK-92DF605-3	January 2003	Revision 3, supersedes and replaces MK-92DF605-2
MK-92DF605-4	February 2003	Revision 4, supersedes and replaces MK-92DF605-3
MK-92DF605-5	April 2003	Revision 5, supersedes and replaces MK-92DF605-4
MK-92DF605-6	July 2003	Revision 6, supersedes and replaces MK-92DF605-5

Source Document for this Revision

The following source documents were used to produce this 9500V user guide:

- *Hitachi Freedom Storage™ Thunder 9500™ V Series Resource Manager 9500V User's Guide Graphical User Interface (GUI)*, RSD-92DF605-5.
- *Disk Array Management Program 2 (for GUI) User's Guide*, K6602895-18.

Changes in this Revision:

- Added a note about connecting to the subsystem via the RS232C interface (9200 only) in section 1.1
- Changed "ArrayManage2-W730-GUI-E.exe" to "ArrayManage2-W740-GUI-E.exe" in the instructions for installing Resource Manager 9500V on Windows® in section 1.4.1
- Changed "ArrayManage2-W730-GUI-E.exe" to "ArrayManage2-W740-GUI-E.exe" in the up instructions for updating Resource Manager 9500V on Windows® in section 1.5.1
- Added the "RAID group deletion," "LU invalidation," "LU reassignment," and "LU restoration," functions to Table 2.1
- Changed Figure 2.1 to reflect screen updates
- Changed Figure 2.5 to reflect screen updates
- Changed the confirmation message screen in step 2 of section 3.1.3.2 to reflect the most recent updates

- Changed Figure 3.11 to reflect screen updates
- Changed the screens in steps 2 and 3 of section 3.1.4.2 to reflect the most recent updates
- Changed the screen in step 1 of section 3.1.4.3 to reflect the most recent updates
- Changed the screens in section 3.1.4.4 to reflect the most recent updates
- Changed the screens in section 3.1.5 to reflect the most recent updates
- Changed Figure 3.17 and Figure 3.18 to reflect screen updates
- Changed the screens in steps 4 and 5 of section 3.2.2 to reflect the most recent updates
- Changed the screens in steps 3 and 6 of section 4.2 to reflect the most recent updates
- Changed the screens in steps 3 and 5 of section 4.8 to reflect the most recent updates
- Changed the screens in steps 9, 13, and 14 of section 4.11 to reflect the most recent updates
- Restructured section 4.13
- Changed Figure 6.1 and Figure 6.2 to reflect screen updates
- Added the “No_RSV_Conf Mode” option to Host Connection Mode 2 in section 6.1
- Changed Figure 7.3 to reflect screen updates
- Added port/host group information to section Figure 7.8
- Changed the microprogram download instructions in step 8 of section 7.9.1
- Changed step 2 of section 7.12
- Changed the system parameters in step 3 of section 7.15
- Changed Figure 8.1, Figure 8.2, Figure 8.3, and Figure 8.4, to reflect screen updates
- Changed the screen in section 12.1.1 to reflect the most recent updates

Referenced Documents

- *Hitachi Thunder 9500™ V Series Password Protection User’s Guide (MK-92DF611).*
- *Hitachi Thunder 9500™ V Series LUN Management User’s Guide (MK-93DF657).*

Preface

The *Hitachi Freedom Storage™ Thunder 9500™ V Series Resource Manager 9500V User's Guide Graphical User Interface (GUI)* describes the operations required to execute the configuration setting and display, information display, and error monitoring of the Hitachi disk array unit subsystem (9200 and 9500V) using the Resource Manager 9500V program via the GUI.

Notes on Use:

- This manual is intended for users with a background in data processing and who understand direct-access storage device subsystems and their basic functions. Specific examples of appropriate users include: system administrators – responsible for operation of systems including array units, system engineers – for construction of systems including array units, and customer support engineers – for maintenance of array units.
- The user needs to be familiar with the Hitachi Freedom Storage™ Thunder 9500™ V Series array subsystem.
- When using the manager, be sure to read this manual and understand the operating procedures and instructions described herein thoroughly before starting your operation. Understand, in particular, the descriptions in the section **Safety Precautions** thoroughly and follow the instructions in this manual.
- The user is presupposed to have thorough knowledge of the basic operation of Windows®, Solaris™, IRIX®, and HP-UX®.
- “Windows® 95”, “Windows® 98”, “Windows® 2000” and “Windows NT® Version 4.0” are abbreviated to “Windows®” in the manual.
- This manual quotes screens that appear when the Resource Manager 9500V program runs with Windows NT® 4.0, and when an array unit is configured from a dual system and is connected to a LAN. When the program runs with Windows® 95, Windows® 98, Windows® 2000, Solaris™, IRIX®, and HP-UX® displays on some screens differ from those on corresponding screens shown in this manual.

For further information on Hitachi Data Systems products and services, please contact your Hitachi Data Systems account team, or visit the Hitachi Data Systems worldwide web site at <http://www.hds.com>. For specific information on the supported host systems and platforms for the 9500, please refer to the user documentation for the product, or contact the vendor's customer support service.

Note 1: The term “9500V” refers to the Hitachi Thunder 9500™ V Series subsystem, unless otherwise noted. Please refer to the *Hitachi Thunder 9500™ V Series User and Reference Guide (MK-92DF601)* for further information on the 9500V disk array subsystem.

Note 2: Throughout this manual, the term “Disk Array Management Program (DAMP)” refers to the Resource Manager 9500V program.

Note 3: The use of Resource Manager 9500V and all other Hitachi Data Systems products is governed by the terms of your license agreement(s) with Hitachi Data Systems.

Note 4: For information on password protection, please refer to the *Hitachi Thunder 9500™ V Series Password Protection User's Guide* (MK-92DF611).

Terminology

Please note the following:

- The term DF600 refers to the Thunder 9500™ V Series subsystem.
- The term DF500 refers to the Thunder 9200™ subsystem.

COMMENTS

Please send us your comments on this document: doc.comments@hds.com.

**Make sure to include the document title, number, and revision.
Please refer to specific page(s) and paragraph(s) whenever possible.**
(All comments become the property of Hitachi Data Systems Corporation.)

Thank you!

Safety Precautions

Note the following when using Resource Manager 9500V:

- Only administrators, system engineers, and field engineers who are familiar with Hitachi Data Systems disk array units are allowed to run Resource Manager 9500V function.
- Make certain you read and fully understand this guide before you operate the Resource Manager 9500V function.
- Carefully follow instructions included with the “CAUTION” label.



Failure to follow these instructions can result in serious system damage and/or the loss of system data.

Cautions to Observe While Starting Your Operation

- While operating Resource Manager 9500V, the contents of array unit errors may be displayed as error messages. Read the User’s Manual or Maintenance Manual to look up the appropriate action to be taken and handle the error accordingly.
- When performing operations in this manual that are preceded by a CAUTION label, read the instructions before starting the operation and follow them carefully during operation.

Contents

Chapter 1	Resource Manager 9500V	1
1.1	Notes on Using Resource Manager 9500V	1
1.2	Operating Environments	4
1.3	Connecting.....	6
1.3.1	RS232C Connection (9200 only)	6
1.3.2	LAN with a Hub	7
1.3.3	LAN without a Hub	7
1.4	Installing	8
1.4.1	Windows®	8
1.4.2	Solaris™	8
1.4.3	IRIX®	9
1.4.4	HP-UX®	10
1.5	Updating	11
1.5.1	Windows®	11
1.5.2	Solaris™	11
1.5.3	IRIX®	11
1.5.4	HP-UX®	12
1.6	Uninstalling.....	13
1.6.1	Windows®	13
1.6.2	Solaris™, IRIX®, and HP-UX®	13
Chapter 2	Functions	15
2.1	Resource Manager 9500V Functions.....	15
2.2	Screens.....	20
2.2.1	Menu Bars and Tool Bars	23
2.2.2	Status Bars.....	25
2.3	Context Menus	25
2.3.1	The Main Screen	26
2.3.2	The Unit Screen.....	28
Chapter 3	Operations.....	33
3.1	Basic Operations	33
3.1.1	Starting	33
3.1.2	Password Setting	39
3.1.3	Changing the Action Mode	41
3.1.4	Registering an Array Unit	44
3.1.5	Version Display.....	53
3.1.6	Terminating	54
3.1.7	Restart an Array Unit	55
3.2	Properties of the Main Screen and Unit Screen.....	57
3.2.1	Displaying the Property of the Main Screen	57
3.2.2	Displaying the Properties of the Unit Screen	57
3.2.3	Displaying the Array Unit Configuration Information	73
3.2.4	Displaying the Information Message	74

Chapter 4	Definition of RAID Group/Logical Unit	75
4.1	Displaying the RAID Group/Logical Unit Definition	76
4.2	Creating a RAID Group.....	79
4.3	Expanding a RAID Group	82
4.4	Deleting a Specified RAID Group.....	85
4.5	Deleting All RAID Groups	88
4.6	Constituting a Logical Unit	90
4.7	Formatting a Logical Unit.....	94
4.8	Expanding a Logical Unit.....	102
4.9	Deleting the Last Defined Logical Unit	104
4.10	Changing the Default Controller in Charge of a Logical Unit.....	107
4.11	Logical Unit Wizard	110
4.11.1	Set Up a Logical Unit in an Existing RAID Group	110
4.11.2	Create a New RAID Group and Set Logical Units	115
4.12	Invalidating a Logical Unit	121
4.13	Reassigning a Logical Unit	122
4.13.1	Assigning Part of a Logical Unit.....	122
4.13.2	Assigning All of a Logical Unit.....	125
4.14	Restoring a Logical Unit.....	127
Chapter 5	System Parameters Setting Wizard	129
5.1	Setting System Parameters	129
Chapter 6	Setting Host Storage Domain (Host Group) Information	157
6.1	Setting Host Storage Domain (Host Group) Options	157
6.2	Specifying Mapping Mode	161
6.3	Setting Mapping Information	163
Chapter 7	Setting System Parameters	167
7.1	Target ID.....	167
7.1.1	Adding Information	167
7.1.2	Adding Mapping information	179
7.1.3	Changing Mapping Information.....	181
7.2	LAN Configuration.....	183
7.3	Setting SCSI Transfer Rate	186
7.4	Spare Drive Setup	189
7.5	Setting the Drive Restoration Control Option	191
7.6	Online Verify Mode.....	193
7.7	Setting Fibre Channel Information	194
7.7.1	Topology Setup	195
7.7.2	Setting the Port Address.....	198
7.7.3	Setting the Transfer Rate.....	201
7.7.4	Setting Port Security	203
7.8	Outputting Configuration Information to a File	205
7.8.1	File Output of the System Parameters	206
7.8.2	Setting System Parameters with a File	213
7.8.3	File Output of the Status of RAID/Logical Units and Constituent Parts of the Configuration	216

7.8.4	Setting the RAID Group/Logical Unit Definition with a File	227
7.8.5	File Output of the Port/Host Storage Domain (Host Group) Information....	230
7.8.6	Setting the Port/Host Storage Domain (Host Group) Information with a File	233
7.9	Replacing the Microprogram	234
7.9.1	Microprogram Download.....	234
7.9.2	Replacing the Microprogram.....	240
7.10	Setting Priced Optional Features	243
7.10.1	Unlock Priced Optional Features.....	243
7.10.2	Lock Priced Optional Features	247
7.10.3	Setting Up Priced Optional Features	250
7.11	Using the Command Device	253
7.11.1	Setting the Command Device.....	253
7.11.2	Changing the Command Device	255
7.11.3	Deleting the Command Device	256
7.11.4	Setting the Serial ID.....	257
7.12	Setting the Port Option.....	258
7.13	Setting the Controller Identifier	261
7.14	Setting RTC	263
7.15	Setting System Parameters	265
Chapter 8	Displaying Statistical Information.....	267
8.1	Displaying Statistical Information in the Array Unit	267
8.2	Displaying the Controller Use Condition	268
8.3	Displaying the Numbers of Host Commands Received	269
8.4	Displaying the Command Execution Condition.....	270
8.5	Displaying the Cache Load Condition.....	271
Chapter 9	Acquiring Performance Information	273
9.1	Outputting Performance Information Manually to a Text File.....	273
9.2	Outputting Performance Information Automatically to Text File.....	276
Chapter 10	Error Monitoring	279
10.1	Setting Error Monitoring Options.....	279
10.1.1	Interval Time.....	280
10.1.2	E-Mail Report.....	280
10.1.2.1	E-Mail Subject.....	281
10.1.2.2	E-Mail Message Text.....	282
10.1.3	Setting Additional Information on E-mail.....	284
10.1.4	Executing Application.....	285
10.2	Outputting Failure Information to Log File.....	287
10.3	Error Monitoring	289
10.4	Checking Status	292
Chapter 11	Automatic Start of Error Monitoring	293
11.1	Automatic Start of Error Monitoring	293
11.1.1	Automatic Start of Windows®.....	293

Chapter 12 Detailed Screen Display.....	295
12.1 Detailed Screen Display	295
12.1.1 Detailed Screen Display on Windows.....	295

List of Figures

Figure 2.1	Resource Manager 9500V Main Screen	20
Figure 2.2	Component Status Tab:9500V (RK)	21
Figure 2.3	Property Screen (Controller)	22
Figure 2.4	Disk Array Subsystem List View Box (when the icon is selected)	26
Figure 2.5	Disk Array Subsystem List View Box (when the icon is not selected)	27
Figure 2.6	RAID Group List View Box (when the icon is selected)	28
Figure 2.7	RAID Group List View Box (when the icon is not selected)	29
Figure 2.8	Logical Unit List View Box (when one icon is selected)	30
Figure 2.9	Logical Unit List View Box (when two or more icons are selected)	31
Figure 2.10	Logical Unit List View Box (when icons are not selected)	32
Figure 3.1	Resource Manager 9500V Main Screen	37
Figure 3.2	Display Details Tool Bar Selection from the Settings Menu	38
Figure 3.3	Unit Screen of an Array Unit.....	38
Figure 3.4	Registering a Password	39
Figure 3.5	Entering a New Password	40
Figure 3.6	Changing the Password	40
Figure 3.7	Changing from Normal Mode to Management Mode.....	42
Figure 3.8	Password-Input Screen	42
Figure 3.9	Changing from Management Mode to Normal Mode.....	43
Figure 3.10	New Registration	44
Figure 3.11	Input Registration Information (TCP/IP).....	45
Figure 3.12	Input Registration Information (RS232C - 9200 only)	45
Figure 3.13	Changing the Registration Contents	48
Figure 3.14	Deleting the Registration Contents.....	50
Figure 3.15	Displaying the Registration Contents.....	52
Figure 3.16	Version Display.....	53
Figure 3.17	Terminating Resource Manager 9500V	54
Figure 3.18	Restarting an Array Unit.....	55
Figure 3.19	Displaying the Properties of the Unit Screen	57
Figure 3.20	Display when Both Controllers are Connected in the Dual System	58
Figure 3.21	Display when a Single Controller is Connected in the Dual System	58
Figure 3.22	Data Drive and Spare Drive	63
Figure 3.23	Enclosure	64
Figure 3.24	Controller 0 and Controller 1.....	65
Figure 3.25	Displaying the Array Unit Configuration Information	73
Figure 3.26	IP Address and Subnet Mask of the LAN Configuration Information	73
Figure 3.27	Displaying the Information Message	74
Figure 4.1	Displaying the Definition Information of All RAID Groups and All Logical Units	76
Figure 4.2	Displaying RAID Group and Drive Information for Defined Logical Units	77
Figure 4.3	Displaying Logical Unit and Drive Information for Defined RAID Groups	78
Figure 4.4	Creating a RAID Group.....	79
Figure 4.5	Expanding a RAID Group.....	82
Figure 4.6	Deleting a Specified RAID Group.....	85
Figure 4.7	Deleting All RAID Groups	88
Figure 4.8	Constituting a Logical Unit.....	90
Figure 4.9	Formatting a Logical Unit.....	94

Figure 4.10	Expanding a Logical Unit.....	102
Figure 4.11	Deleting the Last Defined Logical Unit	104
Figure 4.12	Changing the Default Controller in Charge of a Logical Unit	107
Figure 4.13	Setting the Logical Unit in the Wizard Format	110
Figure 4.14	Invalidation a Logical Unit.....	121
Figure 4.15	Assigning Part of a Logical Unit.....	122
Figure 4.16	Logical Unit Reallocation Panel	123
Figure 4.17	Assigning All of a Logical Unit.....	125
Figure 4.18	Restoring a Logical Unit.....	127
Figure 5.1	Setting the System Parameters in the Wizard Format	129
Figure 5.2	System Startup Settings.....	134
Figure 5.3	Host Connection Mode	135
Figure 5.4	Entering the Serial Number	137
Figure 5.5	Setting the Option 1 Function	138
Figure 5.6	Setting the Option 2 Function	139
Figure 5.7	Setting the Target IDs of Controller 0/1	140
Figure 5.8	Detailed Settings.....	143
Figure 5.9	Data Striping.....	144
Figure 5.10	Inquiry Setting.....	145
Figure 5.11	Setting the Multi-Port Expanding Function	147
Figure 5.12	Setting Port Options	148
Figure 5.13	ROM Response Settings.....	149
Figure 5.14	Setting Controller Options.....	150
Figure 5.15	LAN Settings	151
Figure 5.16	SCSI Settings	152
Figure 5.17	Completing System Parameter Settings	153
Figure 6.1	Setting Host Storage Domain (Host Group) Options	157
Figure 6.2	Host Connection Mode	158
Figure 6.3	Specifying Mapping Mode	161
Figure 6.4	Setting Mapping Information	163
Figure 6.5	Mapping Property	164
Figure 7.1	Adding Target ID Information	168
Figure 7.2	Adding S-TID, M-LUN Target ID Information	170
Figure 7.3	Adding M-TID, S-LUN Target ID Information	171
Figure 7.4	Adding M-TID, M-LUN Target ID Information.....	172
Figure 7.5	Sample File: id00.txt - - - Host LU Independent Access Type	175
Figure 7.6	Sample File: id01.txt - - - Host Alternate Path Access Type	176
Figure 7.7	Adding Mapping Information	179
Figure 7.8	Changing Mapping Information.....	181
Figure 7.9	Setting LAN Configuration Information	183
Figure 7.10	Setting the SCSI Transfer Rate.....	186
Figure 7.11	Setting Up the Spare Drive	189
Figure 7.12	Setting the Drive Restoration Control Option	191
Figure 7.13	Online Verify Mode	193
Figure 7.14	Displaying Fibre Channel Information	194
Figure 7.15	Setting Up the Topology	195
Figure 7.16	Setting the Port Address.....	198
Figure 7.17	Setting the Transfer Rate.....	201

Figure 7.18	Setting Port Security Settings Using File.....	204
Figure 7.19	Outputting the Setting Content of System Parameters to a Specified File	206
Figure 7.20	Format of the System Parameter Output File	208
Figure 7.21	System Parameters: Output Example of Common Parameters.....	209
Figure 7.22	Controller Parameters: Output Example of System Parameters.....	211
Figure 7.23	Output Example for FD Backup Specification.....	212
Figure 7.24	Outputting Configuration Information to File.....	216
Figure 7.25	Format of RAID Group/Logical Unit Configuration Information Output File (1 of 2)	218
Figure 7.26	Format of RAID Group/Logical Unit Configuration Information Output File (2 of 2)	219
Figure 7.27	Outputting the Setting Content of Port/Host Storage Domain (Port/Host Group) Information to a Specified File	230
Figure 7.28	The Outline of the Format of Host Storage Domain (Host Group) Information Output File	232
Figure 7.29	Replacing the Microprogram.....	240
Figure 7.30	Unlocking Priced Optional Features	243
Figure 7.31	Locking Priced Optional Features.....	247
Figure 7.32	Setting Up Priced Optional Features	250
Figure 7.33	Setting the Port Option.....	258
Figure 7.34	Setting the Controller Identifier	261
Figure 7.35	Setting RTC	263
Figure 7.36	Setting System Parameters	265
Figure 8.1	Displaying the Controller Use Condition	268
Figure 8.2	Displaying the Number of Host Command Received	269
Figure 8.3	Displaying the Command Execution Condition.....	270
Figure 8.4	Displaying the Cache Load Condition	271
Figure 10.1	Setting Error Monitoring Options.....	279
Figure 10.2	Setting Additional Information on E-Mail	284
Figure 10.3	Starting Error Monitoring.....	289
Figure 10.4	Checking the Status of Array Unit Components	292

List of Tables

Table 1.1	Restrictions When Multiple Programs are used Concurrently for One Array Unit	3
Table 2.1	Resource Manager 9500V Functions	15
Table 2.2	Status Bar Descriptions	25
Table 2.3	Disk Array Subsystem Menu Options (when the icon is selected)	26
Table 2.4	Disk Array Subsystem Menu Options (when the icon is not selected).....	27
Table 2.5	RAID Group Menu Options (when the icon is selected)	28
Table 2.6	RAID Group Menu Options (when the icon is not selected).....	29
Table 2.7	Logical Unit Menu Options (when one icon is selected)	30
Table 2.8	Logical Unit Menu Options (when two or more icons are selected).....	31
Table 2.9	Logical Unit Menu Options (when icons are not selected).....	32
Table 4.1	Logical Unit Formatting	95
Table 4.2	Interpretation of "Logical Unit Format Results" Window	101
Table 5.1	List of Supported Parameters at the Basic Settings	130
Table 5.1	List of Supported Parameters at the Basic Settings (Continued).....	131
Table 5.2	List of Supported Parameters at the Detailed Settings	132
Table 5.3	Settings when I/O Path Switching Function used in the Sequent NUMA-Q Connection	133
Table 5.4	Settings when the Array Unit used in the WolfPack Mode.....	133
Table 5.5	Settings when the Host uses the VxVM	133
Table 7.1	List of Common Parameters	210
Table 7.2	Parameters of Controller 0	212
Table 10.1	List of E-Mail Subjects.....	281
Table 10.2	List of E-Mail Message Texts	282
Table 10.3	List of Message Texts to be Output	288

Chapter 1 Resource Manager 9500V

This Resource Manager 9500V is used to reference status and set up the configuration of an array unit. This chapter includes the following:

- Notes on Using Resource Manager 9500V
- Operating Environments
- Connecting
- Installing
- Updating
- Uninstalling

Note: The term “Manager” used throughout this manual refers to “Resource Manager 9500V”.

1.1 Notes on Using Resource Manager 9500V

When using Resource Manager 9500V, consider the following:



- When using Resource Manager on “RS232C connection” (9200 only), the “ERROR INF” (a function to specify an error information transfer mode to the RS232C port) must be set to “OFF” (suspension of the error information transfer) by means of the system parameter setting function of the array unit.

The “ERROR INF” is set to “OFF” when shipped from the factory; otherwise, it may result in Resource Manager 9500V failing to connect to the array unit and/or functions of Resource Manager 9500V ending abnormally.

- Certain functions to be executed by Resource Manager 9500V are available and others are not available while the array unit is online with a host. For details, see Chapter 2.
When high I/O load exists, functions that are available while online might cause a command time-out in the host or an abnormal termination in Resource Manager 9500V. It is recommended that these functions be executed while offline.
- When the Resource Manager 9500V is installed in the host connected to the array unit, I/O load from a host might cause a command time-out on the host side or an abnormal termination on the Manager side. It is recommended that the Resource Manager be installed in the host NOT connected to the array unit.
- At least one logical unit must be configured in the array unit, to make all of the Resource Manager 9500V functions available. If no logical unit is defined in the array unit, some functions cannot be executed.

- When the PC enters the suspension state (low power mode) while the Resource Manager 9500V is running, Resource Manager 9500V may not operate correctly after the PC is released from the suspension state.

When you operate Resource Manager 9500V, disable power management by Windows® so that the PC will not enter the suspension state.

- The Resource Manager 9500V can open multiple Unit screens for one array unit. When multiple Unit screens are open, a shortage of memory may occur, depending on the configuration of the system in which the Resource Manager 9500V has been installed; this results in program hang-ups. When opening Unit screens, open only one screen to operate an array unit.
- You can perform error monitoring when a Unit screen is open. When you perform error monitoring with operations of a Unit screen concurrently, error monitoring operation and unit screen operations may terminate abnormally. To start error monitoring, close all unit screens, then perform error monitoring.
- When connecting to the subsystem via the RS232C interface (9200 only), do not execute anything other than the Error Monitoring function online. Executing another function online might cause a command timeout on the host side and terminate other running applications abnormally.
- When Resource Manager 9500V is run with Windows® 98, if MS-IME 98 (Ver.6.00) has been installed in a Windows® 98 system, the initiation of the Resource Manager 9500V program may terminate abnormally. When running Windows® 98, install MSIME 98-98-SRI.
- If the Resource Manager 9500V does not succeed in connecting to the array unit, the following message may appear:

An invalid response was received from the subsystem

This indicates that the Resource Manager 9500V may have been connected to the array unit while the array unit automatically rebooted. Connect to the array unit again after approximately three minutes.

- Resource Manager 9500V may hang up in the following cases.
 - The communication with the connected array unit fails due to controller blockage, array unit failure, or disconnected LAN connection, etc., or the array unit receives a Reset/LIP from the host.
 - Other applications are working concurrently and memory utilization or a CPU use rate is high.

If Resource Manager 9500V hangs up, terminate it forcibly and check the array unit status and the connection status of RS232C (9200 only) or LAN. Reboot Resource Manager 9500V once again.

- Windows® 2000 dynamic disks are not supported.

- If you use the Resource Manager 9500V together with other programs for one array unit, the following restrictions will exist.

Table 1.1 Restrictions When Multiple Programs are used Concurrently for One Array Unit

No.	Program Name	1	2	3	4	5	6	7
1	Disk Array Management Program (LAN)	Δ *1	Δ	×	Δ	×	○	○
2	Disk Array Management Program (RS232C connection – 9200 only)	Δ	×	Δ	×	Δ	○	○
3	Disk Array utility (LAN)	×	Δ	×	Δ	×	○	○
4	Disk Array utility (RS232C connection – 9200 only)	Δ	×	Δ	×	Δ	○	○
5	Disk Array utility for Web	×	Δ	×	Δ	×	○	○
6	SNMP Function	○	○	○	○	○	○	○
7	9500V-built-in Web Server Function	○	○	○	○	○	○	○

○: Concurrent use allowed.

×: Concurrent use not allowed (operations performed with a program terminate abnormally).

Δ: Configuration in which concurrent use is allowed, but is not recommended.

Δ*1: Two Resource Manager 9500Vs can be used concurrently. However, if the identical array subsystem is specified from different Resource Manager 9500Vs while using two Resource Manager 9500Vs concurrently, the setting may not be made correctly.

Additionally, if one Resource Manager 9500V terminates forcibly while using two Resource Manager 9500Vs simultaneously, another Resource Manager 9500V may terminate abnormally. Return the Resource Manager 9500V that terminated abnormally to operational status.

To operate other programs, refer to their respective user's guides provided with the program products.

Note: If any array unit failure is detected, contact Hitachi maintenance personnel.

1.2 Operating Environments

Resource Manager is operated by connecting to the array unit via a LAN (9500V/9200) or RS232C (9200 only). When an array unit is connected to a LAN, a host (personal computer, Sun™ server/workstation, SGI™ server/workstation, HP® server/workstation), in which Resource Manager 9500V is installed, must be connected with the network and operate normally. When an array unit is connected to an RS232C interface (9200 only), an RS232C port of the machine must operate normally.

Note: Windows® 2000 dynamic disks are not supported.

- PC
 - Windows® 95, Windows® 98, Windows® 2000, or Windows NT® 4.0
 - CPU: Pentium-II, III, IV (233 MHz or more is recommended.)
 - Memory: 64 MB (128 MB or more is recommended.)
 - Disk capacity: 23.5 MB max (A free capacity of 100 MB or more is required.)
 - Network adapter
 - Monitor (Resolution 800 × 600, 1,024 × 768 or more is recommended, 256 color or more.)

- Sun™ server/workstation
 - Solaris™ 2.6, 2.8
 - CPU: UltraSPARC or more is recommended.
 - Memory: 64 MB (128 MB or more is recommended.)
 - Disk capacity: 33 MB max (A free capacity of 100 MB or more is required.)
 - Network adapter
 - Monitor (Resolution 800 × 600, 1,024 × 768 or more is recommended, 256 color or more.)

- SGI™ server/workstation
 - IRIX® 6.5
 - CPU: R10000 or more is recommended.
 - Memory: 64 MB (128 MB or more is recommended.)
 - Disk capacity: 6.5 MB max (A free capacity of 100 MB or more is required.)
 - Network adapter
 - Monitor (Resolution 800 × 600, 1,024 × 768 or more is recommended, 256 color or more.)

- HP® server/workstation
 - HP-UX® 11.0
 - CPU: PA8000 or more is recommended.
 - Memory: 64 MB (128 MB or more is recommended.)
 - Disk capacity: 56.5 MB byte max (A free capacity of 100 MB or more is required.)
 - Network adapter
 - Monitor (Resolution 800 × 600, 1,024 × 768 or more is recommended, 256 color or more.)
- JRE
 - Windows®: jre-1_2_2_008
 - Solaris™/IRIX®: JRE1_2_2_06
 - HP-UX®: RTE1.2.2
- RS232C connection (9200 only)
 - Serial port
 - Baud rate: 9600
 - Data bit: 8
 - Parity: none
 - Stop bit: 1
 - Flow control: none
 - Serial cable (9 pin, cross) for RS232C connection: 1 cable/controller
- LAN connection
 - When an array unit is connected directly to a host, a 10BaseT/100BaseT (100BaseT for 9500V only) twisted pair crossover cable is used.
 - When an array unit is connected to a host via a hub, a 10BaseT/100BaseT (100BaseT for 9500V only) twisted pair cable is used.

1.3 Connecting

This section provides examples of connections between a host in which Resource Manager 9500V has been installed and an array unit. These connections include:

- RS232C Connection
- LAN with a Hub
- LAN without a Hub

1.3.1 RS232C Connection (9200 only)

The following diagram is an example of a connection between a host in which Resource Manager 9500V is installed and an array unit.

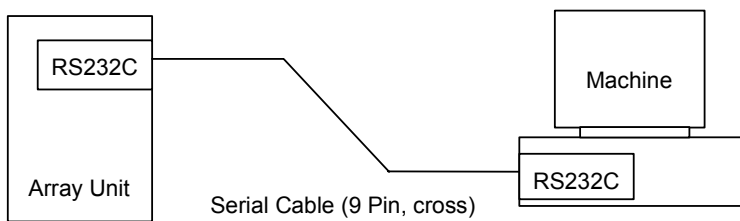

Note: If an array unit is configured from a dual system and a machine is equipped with two RS232C ports, both controller 0 and controller 1 are connected through an RS232C interface.

1.3.2 LAN with a Hub

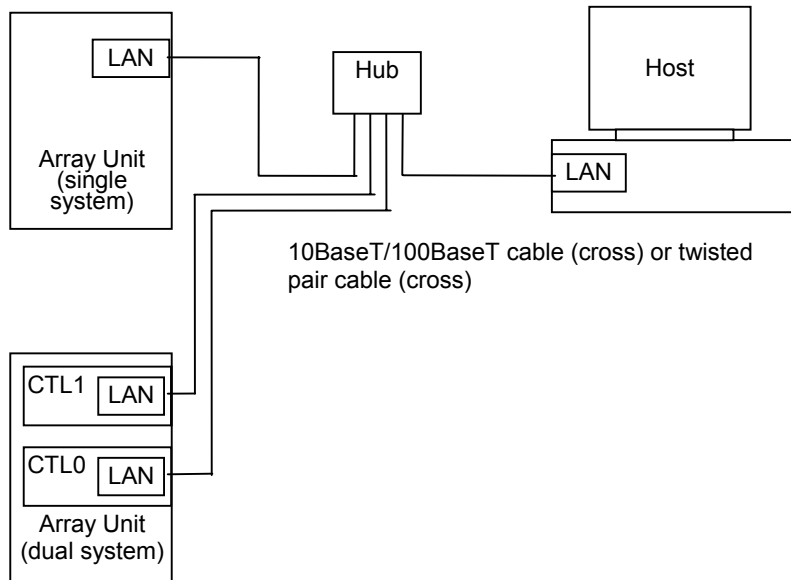

Note: If an array unit is already connected with a LAN, a host is connected to the same network as the array unit.

1.3.3 LAN without a Hub

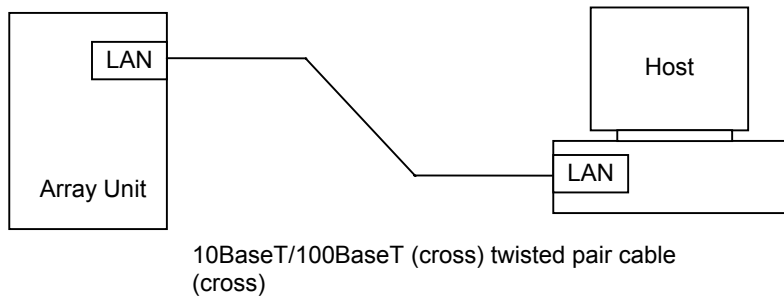

1.4 Installing

The procedures for installing and uninstalling Resource Manager 9500V are described below.

The Resource Manager 9500V GUI program is operated by JAVA. For Windows[®] Solaris[™], HP-UX[®], JRE is packed.

To use IRIX[®], Java Runtime Environment 1.2.2 must be installed on a host and in normal operation. Before installing JRE1.2.2, ensure that it is in normal operation. If JRE1.2.2 is not installed, install JRE1_2_2_06.

This section provides instructions for installing Resource Manager 9500V to the following systems:

- Windows[®]
- Solaris[™]
- IRIX[®]
- HP-UX[®]

1.4.1 Windows[®]

1. Start the PC, then boot up Windows[®].
2. Execute ArrayManage2-W740-GUI-E.exe in the damp_win directory of the provided CD-R.

1.4.2 Solaris[™]

1. Start a Sun[™] server/workstation, and start up a session in the common desktop environment.
2. Create a new directory (Example: /usr/damp) for installing Resource Manager 9500V and copy the ArrayManage2-xSxxx-GUI.tar file in the damp_sol directory of the provided CD-R into the created directory in the hard disk drive.

(The portion "xSxxx" of file names varies with the version of the Resource Manager 9500V, etc.)

3. The ArrayManage2-xSxxx-GUI.tar is the Tar format of a file. Develop the file by referring to the example below.

Example: tar xvf ArrayManage2-xSxxx-GUI.tar

4. Change scripts in the startmgr2 (a shell script used to start the Resource Manager 9500V) in the developed file as follows:

“DEFAULT_JAVAHOME=/usr/java” has been described in the startmgr2 as specification of a path to JRE.

Set up a path to JRE in the DEFAULT_JAVAHOME variable appropriate with the environment in which JRE has been installed. The path to JRE is a path to a place in which JRE has been installed, and a path to a place in which the directories of bin, lib, etc., are placed. Usually, it is named JRE1.2.2, etc.

Example: If JRE has been installed in /usr/local/JRE1.2.2:
DEFAULT_JAVAHOME=/usr/local/JRE1.2.2

5. Log in again.

1.4.3 IRIX®

1. Start an SGI™ server/workstation.
2. Create a new directory (for example: /usr/damp) for installing the Resource Manager 9500V, and copy the ArrayManage2-xxxx-GUI.tar file in the damp_irix directory of the provided CD-R into the created directory in the hard disk drive.

(The portion “xxxx” of file names varies with the version of Resource Manager 9500V.)

3. The ArrayManage2-xxxx-GUI.tar is the Tar format of a file. Develop the file by referring to the example below.

Example: tar xvf ArrayManage2-xxxx-GUI.tar

4. Change scripts in the startmgr2 (a shell script used to start the Resource Manager 9500V) in the developed file as follows:

“DEFAULT_JAVAHOME=/usr/java” has been described in the startmgr2 as specification of a path to JRE.

Set up a path to JRE in the DEFAULT_JAVAHOME variable appropriate with the environment in which JRE has been installed. The path to JRE is a path to a place in which JRE has been installed, and a path to a place in which the directories of bin, lib, etc., are placed. Usually, it is named JRE1.2.2, etc.

Example: If JRE has been installed in /usr/local/JRE1.2.2:
DEFAULT_JAVAHOME=/usr/local/JRE1.2.2

5. Log in again.

1.4.4 HP-UX®

1. Start a HP® server/workstation.
2. Create a new directory (Example: /usr/damp) for installing the Resource Manager 9500V and copy the ArrayManage2-xHxxx-GUI.tar file in the damp_hpux directory of the provided CD-R into the created directory in the hard disk drive.

(The portion "xHxxx" of file names varies with the version of Resource Manager 9500V.)

3. The ArrayManage2-xHxxx-GUI.tar is the Tar format of a file. Develop the file by referring to the example below.

Example: tar xvf ArrayManage2-xHxxx-GUI.tar

4. Log in again.

1.5 Updating

This section provides instructions for updating Resource Manager 9500V on the following systems:

- Windows®
- Solaris™
- IRIX®
- HP-UX®

Note: When you update, terminate Resource Manager 9500V before starting operations.

1.5.1 Windows®

Execute the ArrayManage2-W740-GUI-E.exe in the damp_win directory of the provided CD-R.

The updated Resource Manager 9500V can be run without restarting Windows®.

1.5.2 Solaris™

1. Copy the ArrayManage2-xSxxx-GUI.tar file in the damp_sol directory of the provided CD-R to the hard disk.
(The portion "xSxxx" of file names varies with the version of the Resource Manager 9500V, etc.)
2. The ArrayManage2-xSxxx-GUI.tar is the Tar format of a file. Develop the file by referring to the example below.

Example: tar xvf ArrayManage2-xSxxx-GUI.tar

The updated Resource Manager 9500V can be run without restarting Solaris™.

1.5.3 IRIX®

1. Copy the ArrayManage2-xlxxx-GUI.tar file in the damp_irix directory of the provided CD-R to the hard disk. (The portion "xlxxx" of file names varies with the version of Resource Manager 9500V, etc.)
2. The ArrayManage2-xlxxx-GUI.tar is the Tar format of a file. Develop the file by referring to the example below.

Example: tar xvf ArrayManage2-xlxxx-GUI.tar

The updated Resource Manager 9500V can be run without restarting IRIX®.

1.5.4 HP-UX®

1. Copy the ArrayManage2-xHxxx-GUI.tar file in the damp_hpux directory of the provided CD-R to the hard disk. (The portion "xHxxx" of file names varies with the version of Resource Manager 9500V, etc.)
2. The ArrayManage2-xHxxx-GUI.tar is the Tar format of a file. Develop the file by referring to the example below.

Example: tar xvf ArrayManage2-xHxxx-GUI.tar

The updated Resource Manager 9500V can be run without restarting HP-UX®.

1.6 Uninstalling

This section provides instructions for uninstalling Resource Manager 9500V on the following systems:

- Windows®
- Solaris™, IRIX®, and HP-UX®

1.6.1 Windows®

1. Delete Resource Manager 9500V using the Add and Delete Application icon on the Control Panel.
2. Delete the directory used for Resource Manager 9500V on the hard disk drive.

1.6.2 Solaris™, IRIX®, and HP-UX®

Delete the directory used for Resource Manager 9500V on the hard disk drive.

Chapter 2 Functions

The following table lists all functions of Resource Manager 9500V. Functions that can be used vary, depending on the current Resource Manager 9500V mode. The availability of functions varies, depending on the action mode (monitor mode [Normal] or management mode [Management]). The mode can be changed in the startup screen prior to connecting to the array unit. By default, it is in Monitor mode. Do not operate while online except for item 8: **Error monitoring**; otherwise, your connection may time out.

2.1 Resource Manager 9500V Functions

Table 2.1 Resource Manager 9500V Functions (Continued on next page)

No.	Category	Name of function	Outline of function	Remarks	Usability during operation	Mode	
						Standard	Administrator
1	Configuration display	Component status display	Displays the status of a component such as drive and fan by using an icon.	—	○	○	○
		Property display	Displays the status about system components of an array unit, RAID, logical units, etc.	—	○	○	○
2	RAID group definition	RAID group creation	Used to add a RAID group. You can set a new RAID group by specifying its disk number, RAID level, and group range for the RAID group to be created.	—	○	×	○
		RAID group extension	Used to extend a previously defined RAID group. A previously defined RAID group can be extended by specifying its group number, level, and group range.	Only a drive adjoining a previously defined RAID group can be extended.	○	×	○
		RAID group deletion	Deletes a defined RAID group or a specified RAID group.	Note that this function invalidates user data of the deleted RAID group.	×	×	○

Table 2.1 Resource Manager 9500V Functions (Continued)

No.	Category	Name of function	Outline of function	Remarks	Usability during operation	Mode	
						Standard	Admin-istrator
3	LU definition	LU creation	Used to add a logical unit (LU). A new logical unit is added by specifying its capacity.	A logical unit can be added only in an order of lower to higher numbers.	○	x	○
		LU extension	Used to extend the capacity of a previously defined logical unit (LU). Capacity is increased by specifying a capacity for the logical unit.	Only the LU with the last defined logical unit can be extended.	○	x	○
		LU deletion	Deletes the last defined logical unit (LU).	Note that this function invalidates user data on the deleted logical unit.	x	x	○
		LU formatting	Used to make a defined logical unit (LU) accessible by the host. This function writes null data to the specified logical unit.	This operation is always required to make a logical unit accessible to the host. Note that this function invalidates all user data on disks when the data is already stored on them.	x/○	x	○
		Change of default controller in charge of an LU	Used to change the default controller in charge of an logical unit (LU) as follows: CTL0 → CTL1 and CTL1 → CTL0	Restart the array unit to make the setting valid.	○	x	○
		LU invalidation	Invalidate the specified logical unit so that a host does not recognize it.		○	x	○
		LU reassignment	Make the invalidated logical unit usable by assigning part or all of its area.	The logical units are unformatted after the reassignment is executed.	○	x	○
		LU restoration	Restore the invalidated logical unit to its previous state.		○	x	○

Table 2.1 Resource Manager 9500V Functions (Continued)

No.	Category	Name of function	Outline of function	Remarks	Usability during operation	Mode	
						Standard	Administrator
4	System parameter setting	Setting wizard	Sets a system parameter in the wizard format. There are two types of wizard formats: Basic Settings and Detailed Settings.	<p>To make the setting valid, restart the array unit.</p> <p>I/Os directed from the host cannot be executed after the setting is made, until the array unit is restarted.</p> <p>The function of the Resource Manager 9500V cannot be used with the exception of setting wizard or error monitoring.</p>	x	x	○

Table 2.1 Resource Manager 9500V Functions (Continued)

No.	Category	Name of function	Outline of function	Remarks	Usability during operation	Mode	
						Standard	Administrator
5	Configuration setup	Target ID setting	Sets a combination of the target ID and the LUN.	To make the setting valid, restart the array unit.	○	x	○
		LAN configuration information setting	Sets the IP Address, Sub Net Mask, Default Gateway Address, and the DHCP mode.		○	x	○
		SCSI transfer rate setting	Sets the SCSI I/F transfer rate of the port.		○	x	○
		Setting up spare disk drive	Sets up spare disk drives.	—	○	x	○
		Setting the drive restoration option	Sets a drive restoration mode, automatic or non-automatic start of copy-back, and automatic or non-automatic start of correction copy, time interval, restoring processing unit size, and Dynamic sparing mode.	Optimum time interval and restoring processing unit are set before shipment. Do not change these values unless required; decreased performance could result.	x	x	○
		On-line verify setting	Sets execution or non-execution of the on-line verify function and an interval for it.	Note that an incautious change in the setting may decrease the level of performance.	x	x	○
		Setting and display of the Fibre Channel information	Sets and displays port addresses and security information, etc.	To make the setting valid, restart the array unit.	x	x	○

Table 2.1 Resource Manager 9500V Functions (Continued)

No.	Category	Name of function	Outline of function	Remarks	Usability during operation	Mode	
						Standard	Administrator
5	Configuration setup (continued)	Configuration information file output and its setup by use of a file.	Outputs system parameters and RAID group/logical unit configuration information to a file individually. Sets system parameters and RAID group/logical unit configuration information using a file.	If system parameters are set using a file, restart the array unit in order to validate the settings. When RAID/LU configuration information is set, if setting it with user data stored in the disk drive, the user data is set invalid.	○	○	○
		Microprogram replacement	Downloads and updates the microprogram of the array unit.	To validate the downloaded microprogram, restart the array unit.	×/○	×	○
		Setup and display of the priced optional features	Opens/closes the priced optional features key and sets and displays the enable/disable condition.	—	○	×	○
		Setup and display of RTC	Sets and displays the date and time.	—	○	×	○
6	Statistical information display	Controller use information display	Displays previous statistical information by selecting a related item.	—	○	○	○
7	Performance	Command operation status display	Outputs the command operation status during a certain period or a specified period to the file in the text format.	—	○	○	○
8	Error monitoring	Report when a failure occurs and controller status display	Displays the status of an array unit, and displays the result of monitoring it by polling. When an error is detected while monitoring, outputs the error into a log file, sends it to a specified address by E-Mail, and starts a specified application.	If a failure occurs, contact maintenance personnel.	○	○	○

2.2 Screens

The Resource Manager 9500V operations screen consists of three screens, dialog boxes, and error messages, etc. This section describes the configurations of the three screens.

When you start Resource Manager 9500V, the following screen will be displayed. This screen is the Main screen.

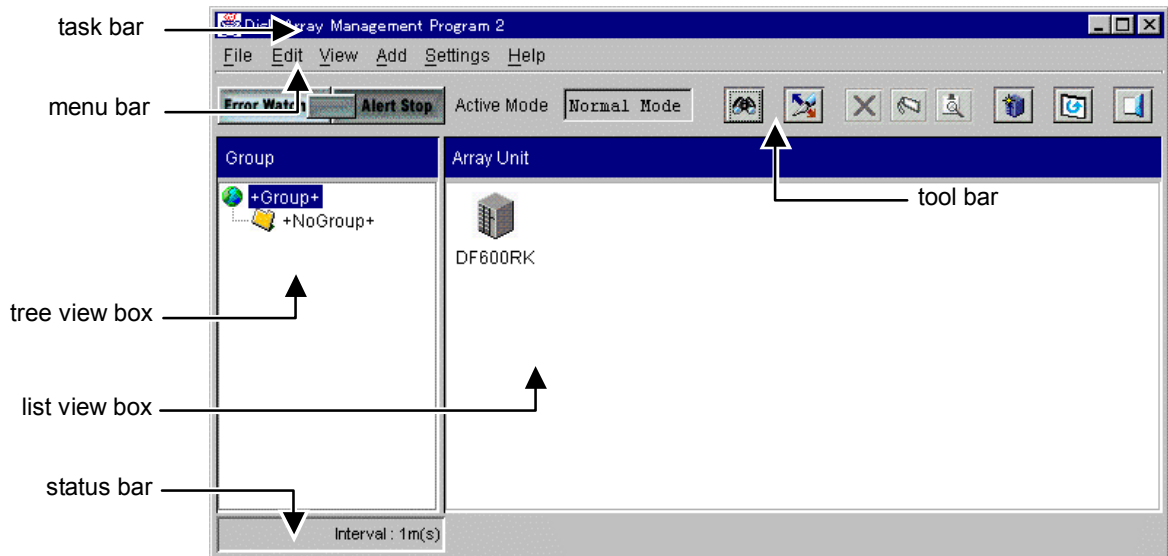

Figure 2.1 Resource Manager 9500V Main Screen

This screen includes the task bar, the menu bar, the tool bar, two view boxes, and the status bar; this is similar to other Windows® applications.

Displayed in the tree view box are group names that have been registered. Displayed in the list view box are array unit names that have been registered in a group.

Double-clicking **+ Group +** enables you to fold a group into its icon and display the group. Clicking a group icon displays only the array units that have been registered in that specific group. Clicking **+ Group +** displays all array units that have been registered.

When you double-click a registered array unit name, a Unit screen will be displayed. On the Unit screen, the status of array unit system components and configuration information of logical units, etc. is displayed selectively by switching the tab. For example, the following screen displays a connection with a 9500V(RK) array unit.

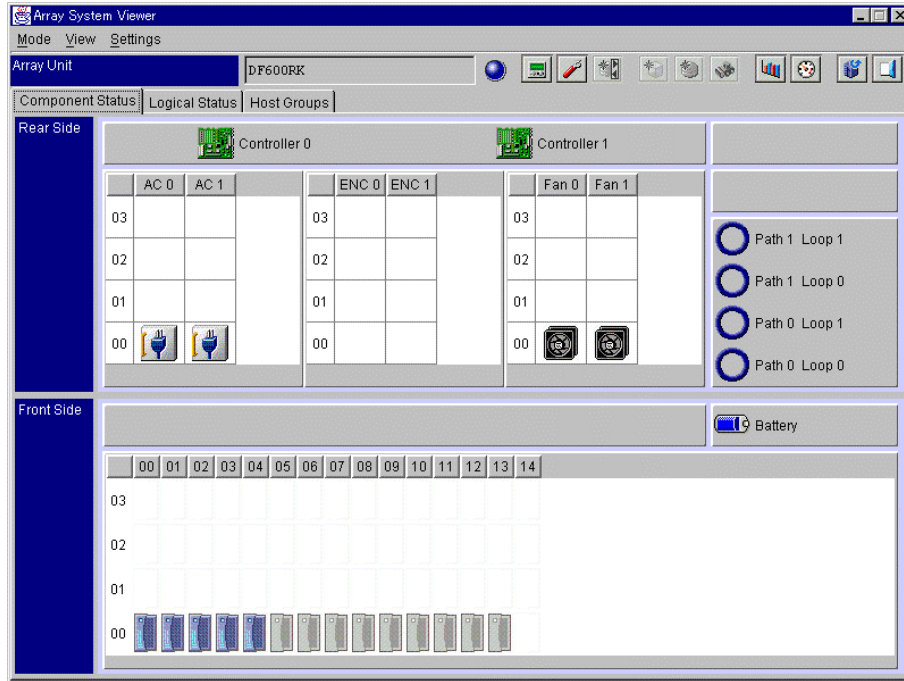

Figure 2.2 Component Status Tab: 9500V (RK)

Double-clicking an icon in the Unit screen displays the Property screen of the double-clicked icon. Even while the Property screen is open, the Unit screen and other operations are allowed.

When you double-click another icon while the Property screen is open, the screen display is switched to information on the icon double-clicked last.

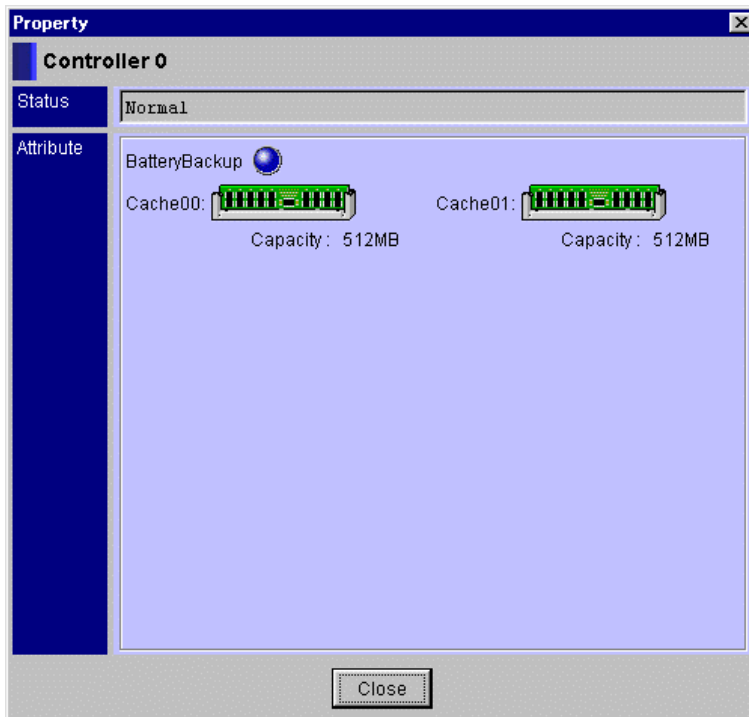



Figure 2.3 Property Screen (Controller)

2.2.1 Menu Bars and Tool Bars

The following shows a list of menu bars and tool bars which are described throughout this User's Guide.

The Main screen



File

Menu	Tool bar	Function
Change Mode		Changes the active mode
Exit		Terminates the Resource Manager 9500V

Edit

Menu	Tool bar	Function
Delete		Deletes the registration of an array unit, which is registered in the Resource Manager 9500V



View

Menu	Tool bar	Function
Refresh		Checks the status of an array unit
Properties		Displays the property of an array unit

Add

Menu	Tool bar	Function
Register Array Unit		Registers the array unit

Settings

Menu	Tool bar	Function
Change Properties	—	Changes the registration contents of the array unit
Monitoring Options		Displays the Monitoring Options screen
Display Details		Displays the Unit screen
Password	—	Changes the password
Reboot	—	Reboot the array unit

Help



Menu	Tool bar	Function
Version	—	Displays the revision of the Resource Manager 9500V

The Unit screen





Mode

Menu	Tool bar	Function
Exit		Terminates the Unit screen

View

Menu	Tool bar	Function
Refresh		Refreshes the Unit screen
Properties	—	Displays the property of an array unit
Performance		Displays the performance of an array unit
Statistical Information		Displays the statistics information of an array unit

Settings

Menu	Tool bar	Function
System Parameter Wizard		Starts the system parameter settings
Configuration Settings		Displays the configuration settings screen
Logical Unit Wizard		Starts the logical unit wizard
RAID Group Settings		Displays the RAID group settings screen
Extend	—	Extends the RAID group
Delete Specified RAID Group	—	Deletes specified RAID group
Delete All	—	Deletes the all RAID group
Logical Unit Settings		Displays the logical unit settings screen
Extend	—	Extends the logical unit
Delete Last Defined Logical Unit	—	Deletes the last defined logical unit
Invalidate	—	Invalidate the logical unit
Restoration	—	Restore the invalidated LU as it was before
Reallocate	—	Make the invalidated LU usable by assigning a part or all of its area

Settings (Continued)

Menu	Tool bar	Function
Online Format		Formats the one logical unit
Offline Format	—	Formats the logical unit (Max.6)
Change Default Controller	—	Changes default controller of logical unit
Select Last Defined Logical Unit	—	Selects the last defined logical unit
Select All Logical Units	—	Selects all logical units
Modify Host Group Option	—	Displays the host connection settings screen
Mapping	—	Displays the LU mapping settings screen
Mapping Mode	—	Specify mapping mode
Modify Mapping	—	Display the LU mapping settings screen

2.2.2 Status Bars

The following table lists status bars which are described throughout this User's Guide.

Table 2.2 Status Bar Descriptions

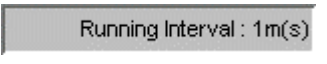
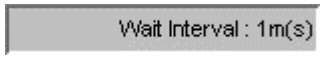
Status Bar	Description
	Error Monitoring is stopped.
	Error Monitoring is running.
	Error Monitoring in the interval.

2.3 Context Menus

A list of the context menus, which are displayed when the right mouse button is clicked while the Main screen or the Unit screen (in the case where the **Logical Status** tab is selected) is displayed, is shown.

2.3.1 The Main Screen

The following context menus are displayed on the Main screen.

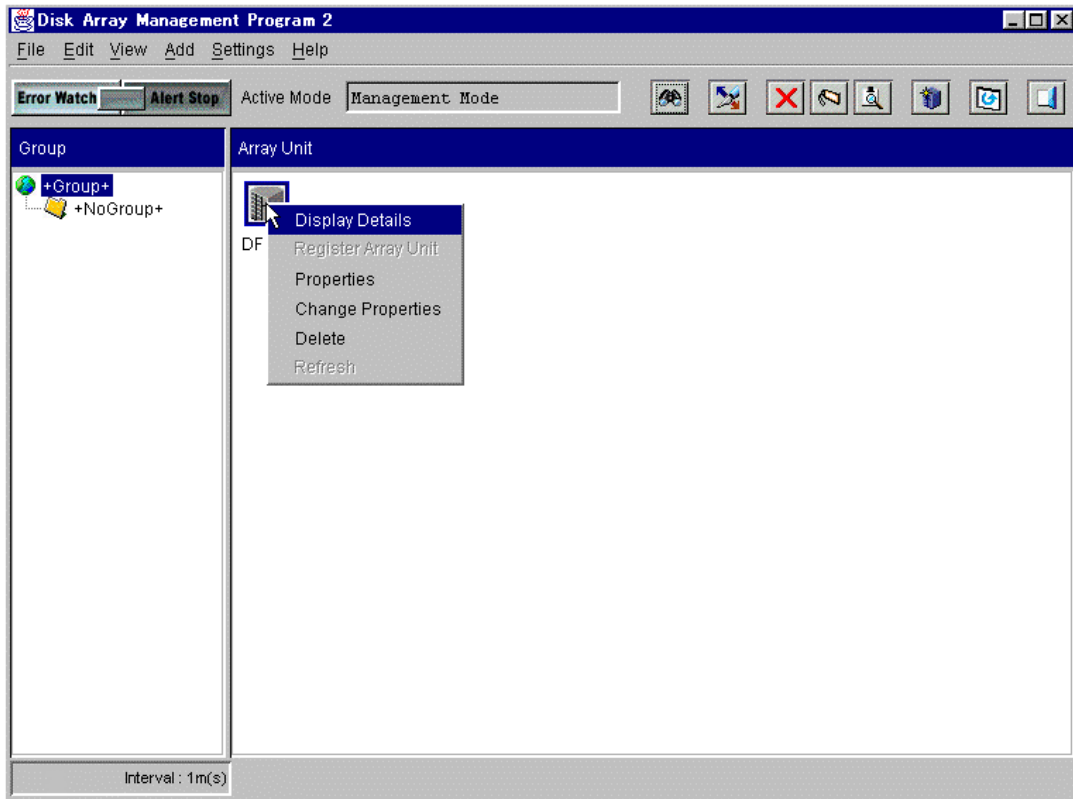

Figure 2.4 Disk Array Subsystem List View Box (when the icon is selected)

Table 2.3 Disk Array Subsystem Menu Options (when the icon is selected)

Pointer	Menu	Function
Disk array subsystem icon is selected.	Display Details	Display the Unit screen.
	Properties	Display the property of an array unit.
	Change Properties	Change the registration contents of the array unit.
	Delete	Delete the registration of an array unit which is registered in the Resource Manager 9500V.

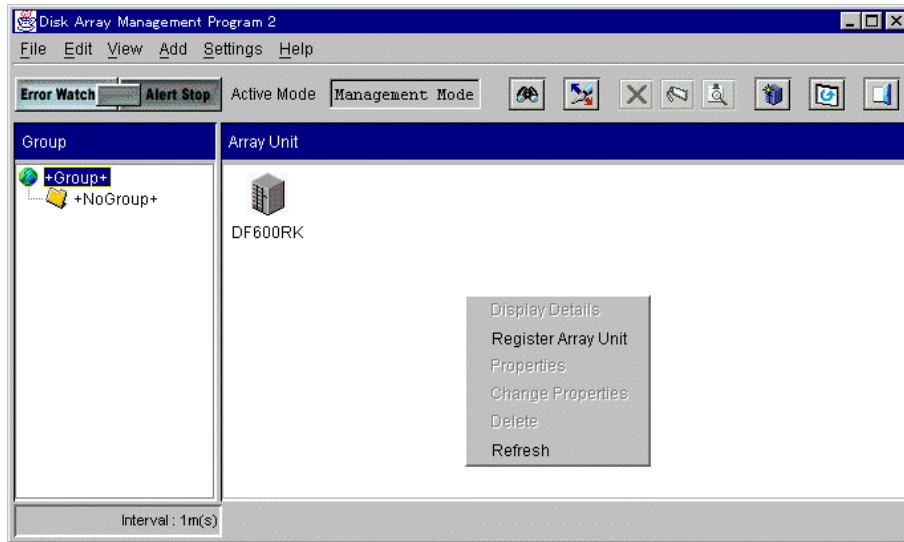

Figure 2.5 Disk Array Subsystem List View Box (when the icon is not selected)

Table 2.4 Disk Array Subsystem Menu Options (when the icon is not selected)

Pointer	Menu	Function
List view box when the icon is not selected.	Register Array Unit	Register the array unit.
	Refresh	The status of an array unit is checked.

2.3.2 The Unit Screen

The following functions can be used when the **Logical Status** tab is selected in the Unit screen. The **Component Status** tab does not provide a context menu.

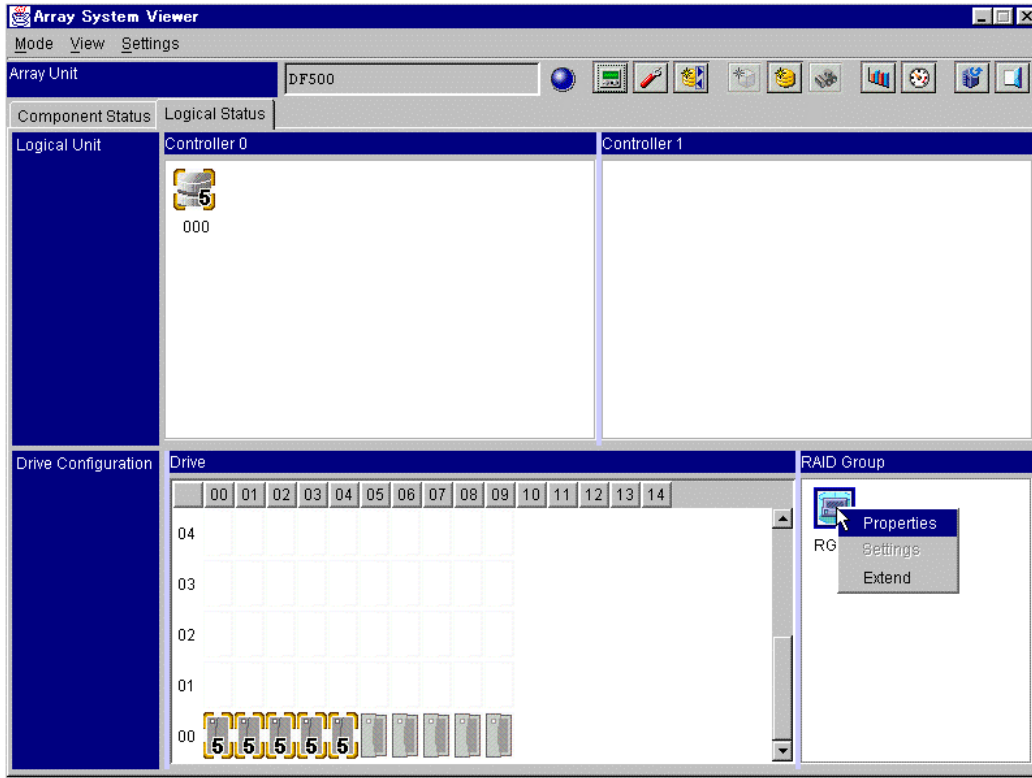

Figure 2.6 RAID Group List View Box (when the icon is selected)

Table 2.5 RAID Group Menu Options (when the icon is selected)

Pointer	Menu	Function
RAID group icon	Properties	Display the property of the RAID group.
	Extend	Extend the RAID group.

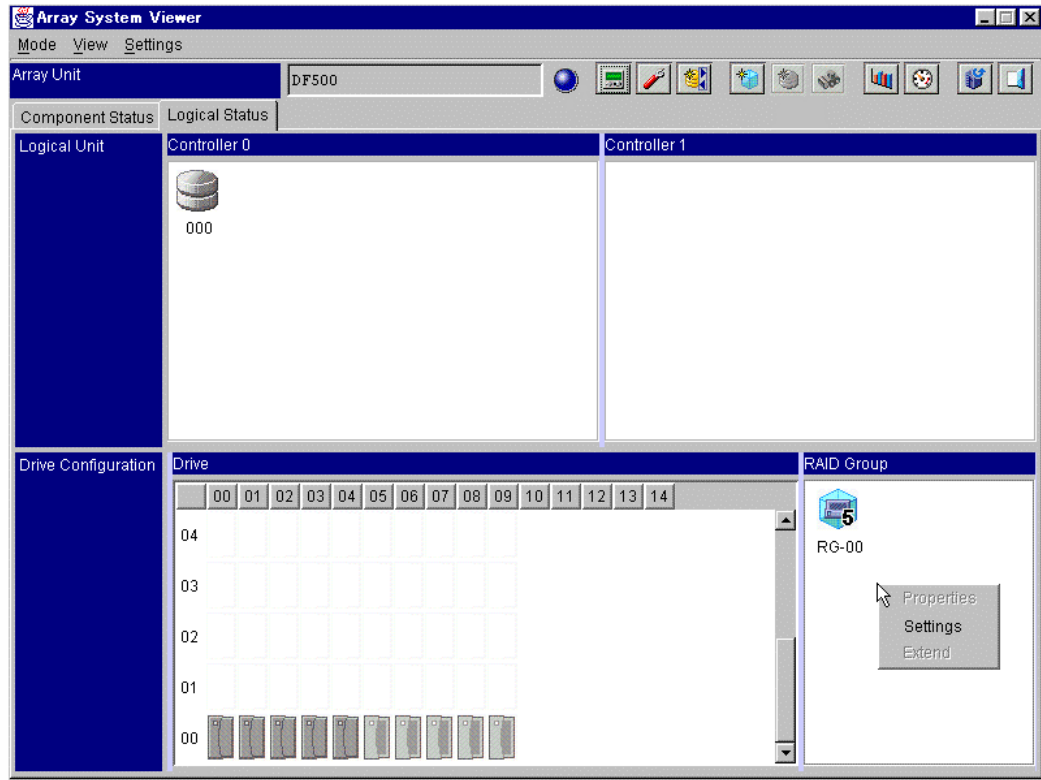

Figure 2.7 RAID Group List View Box (when the icon is not selected)

Table 2.6 RAID Group Menu Options (when the icon is not selected)

Pointer	Menu	Function
RAID Group box list view box when the icon is not selected.	Settings	Display the RAID group settings screen.

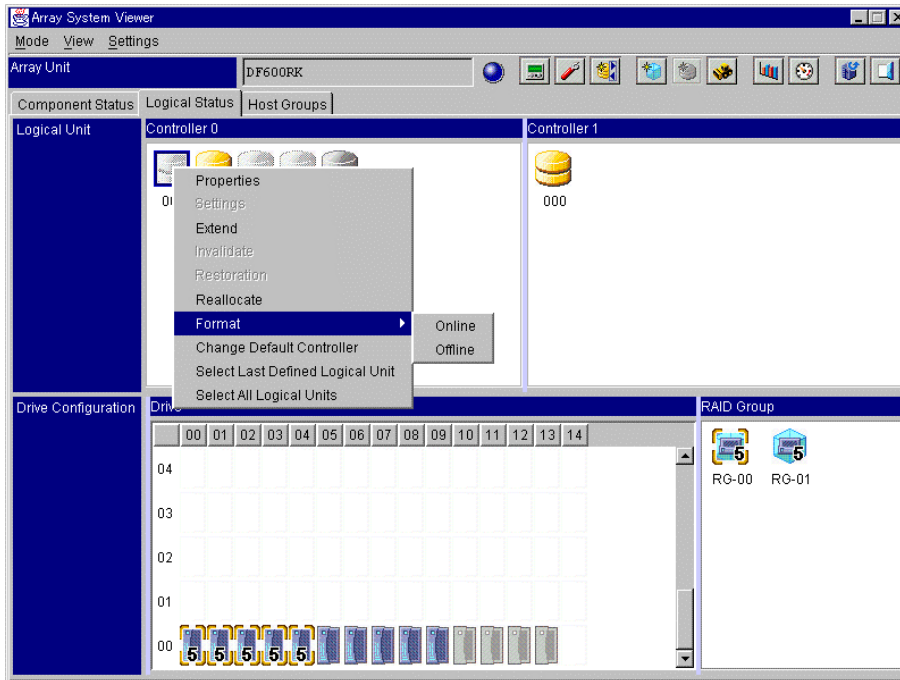

Figure 2.8 Logical Unit List View Box (when one icon is selected)

Table 2.7 Logical Unit Menu Options (when one icon is selected)

Pointer	Menu	Function
Logical unit icons (Select one of them)	Properties	Display the property of the logical unit.
	Extend	Display the dialog box for extending the logical unit
	Invalidate	Invalidate the logical unit
	Restoration	Restore the invalidated LU as it was before
	Reallocate	Make the invalidated LU usable by assigning a part or all of its area
	Online Format	Format the one logical unit
	Offline Format	Format the logical units (Max.6)
	Change Default Controller	Change default controller of logical unit
	Select Last Defined Logical Unit	Select last defined logical unit
	Select All Logical Units	Select all logical units

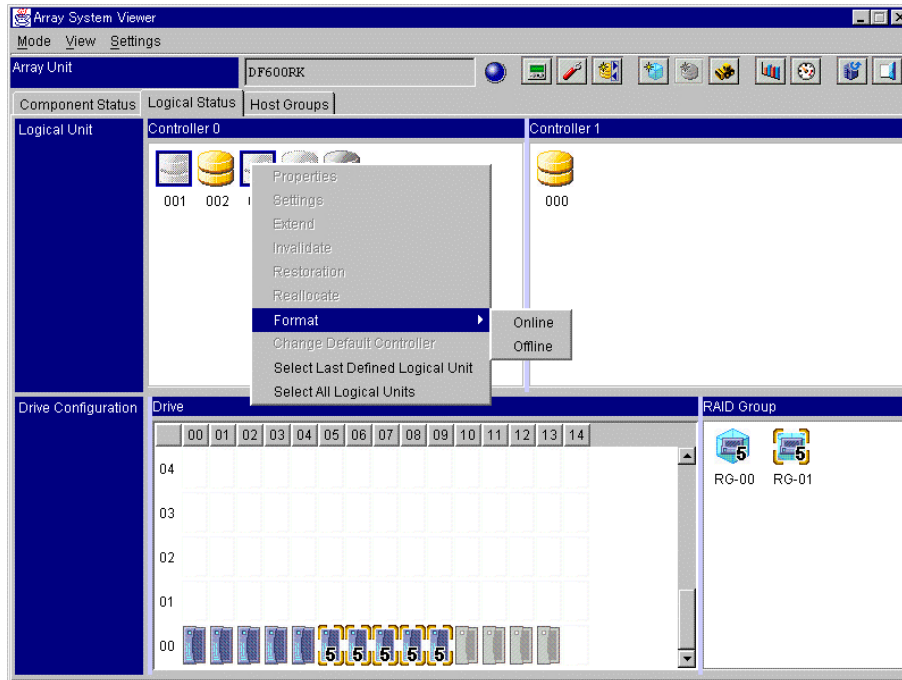

Figure 2.9 Logical Unit List View Box (when two or more icons are selected)

Table 2.8 Logical Unit Menu Options (when two or more icons are selected)

Pointer	Menu	Function
Logical unit icons (Select two or more of them)	Online Format	Format one logical unit
	Offline Format	Format the logical units (Max.6)
	Select Last Defined Logical Unit	Select last defined logical unit
	Select All Logical Units	Select all logical units

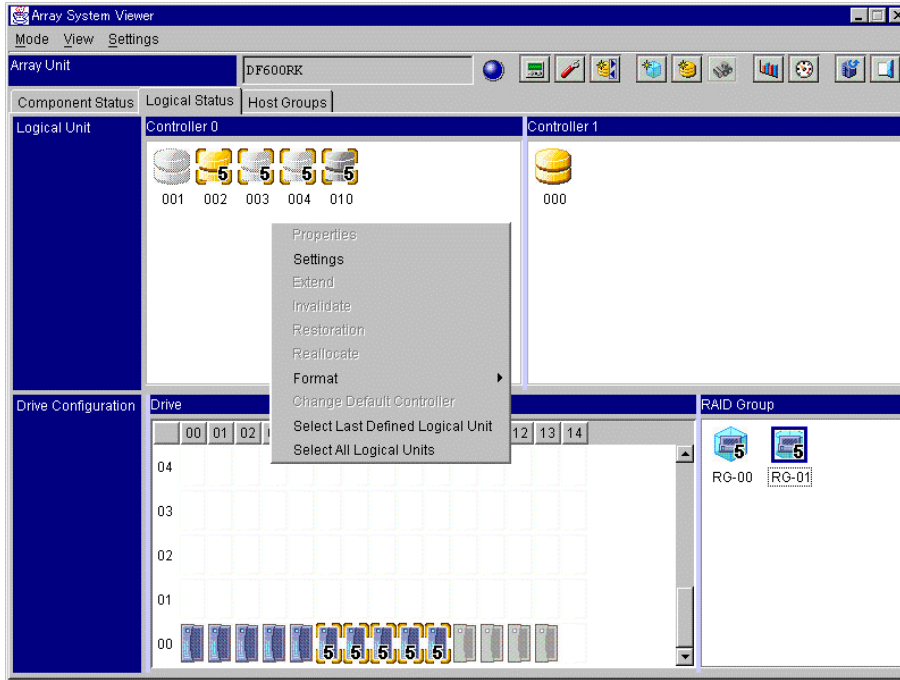

Figure 2.10 Logical Unit List View Box (when icons are not selected)

Table 2.9 Logical Unit Menu Options (when icons are not selected)

	Menu	Function
A region of the Logical Unit Box without icons	Settings	Display the property dialog box for adding the RAID Group. If RAID Group is not selected, this is displayed in gray and cannot be selected.
	Select Last Defined Logical Unit	Select last defined logical unit
	Select All Logical Units	Select all logical units

Chapter 3 Operations

The Resource Manager 9500V Graphical User Interface (GUI) can be used to display the status of array units, set up the configuration of array units, and monitor array units for errors.

The operations in this chapter can be used for Windows[®], Solaris[™], IRIX[®], and HP-UX[®]. This chapter includes:

- Basic Operations
- Properties of the Main Screen and Unit Screen

3.1 Basic Operations

The basic operations described in this section include:

- Starting
- Password Setting
- Changing the Action Mode
- Registering an Array Unit
- Version Display
- Terminating
- Restarting an Array Unit

The operation of these functions conforms to Windows[®], Solaris[™], IRIX[®], and HP-UX[®].

3.1.1 Starting

Use the appropriate Resource Manager 9500V starting procedures. This section includes starting procedures for:

- Windows[®]
- Solaris[™], IRIX[®], and HP-UX[®]

3.1.1.1 Windows®

This section explains how to start Resource Manager 9500V based on location:

- Start the Resource Manager 9500V Program from the Directory where it is Installed.
- Start the Resource Manager 9500V Program from a Directory other than where it is Installed.

Start from the Directory Where the Program is Installed

1. Double click : **Disk Array Management Program 2** (Resource Manager 9500V) on the desktop. The Resource Manager 9500V program will start. Alternatively, on the **Start** menu, point to **Program** and click **Disk Array Management Program 2**.

When the **startmgr2.bat** file (a batch file used to start Resource Manager 9500V) is executed, Resource Manager 9500V starts.

2. **Note:** When Resource Manager 9500V is used on Windows® 95/98/2000, an error may occur in which the menu display is disabled by a menu bar operation with the mouse. If this occurs, disable the pointer trail or the pointer shadow for the **Mouse** properties in the **Control Panel**.

If the menu display is not recovered, disable the **Scheme** for the **Pointers** tab in the **Mouse** properties.

It is also possible that the menu display may be disabled due to erroneous settings. If the menu display remains disabled, set the value to 65536 or less for the **Color pallet** properties in the **Display**.

Example:

If the Resource Manager 9500V has been installed in C:\damp:

```
set DAMP_ROOT_DIR_PATH=C:\damp
java -classpath .\CONFMNG2.JAR jp.co.Hitachi.str.diskarray.gui.ConmanFrame %1
```

For Windows®, the prompt screen is also displayed. The **Prompt** screen is not related to Resource Manager 9500V operations. Closing the Prompt screen terminates the Resource Manager 9500V forcibly. If the display is not necessary, specify “Minimizing icon” with the property of a batch file to “minimize the icon”.

Start from a Directory Other Than Where the Program is Installed

1. Edit the **DAMP_ROOT_DIR_PATH** environment variable of **startmgr2.bat** in the developed file.
2. Set up the install directory of Resource Manager 9500V in the **DAMP_ROOT_DIR_PATH** environment variable.
3. **Note:** When the Resource Manager 9500V program is started from a batch file, execute the batch file by using the same directory as that from which the Resource Manager 9500V program is installed. When Resource Manager 9500V is used on Windows® 95/98, it may terminate abnormally due to an insufficient area for the environmental variable, etc.

If activation fails, change a property of **startmgr2.bat**. To change it, open the property and set the **Initial environment** of the **Memory** tab for 1,024.

3.1.1.2 Solaris™, IRIX®, and HP-UX®

This section explains how to start Resource Manager 9500V based on location:

- Start the Resource Manager 9500V Program from the Directory where it is Installed.
- Start the Resource Manager 9500V Program from a Directory other than where it is Installed.
- Main Screen Functions
- Unit Screen Functions

Start from the Directory Where the Program is Installed

1. Start the **startmgr2** shell script.
2. **Note:** When you start the batch file and the shell script, execute them using the same directory as the one for the Resource Manager 9500V program.

Example:

If the Resource Manager 9500V has been installed in /usr/damp:

```
#DAMP_ROOT_DIR_PATH environment variable
DAMP_ROOT_DIRPATH=/usr/damp
export DAMP_ROOT_DIR_PATH
```

Start from a Directory Other Than Where the Program is Installed

1. Edit the **DAMP_ROOT_DIR_PATH** environment variable of **startmgr2** in the developed file before logging in again (see step 6).
2. Set up the install directory of Resource Manager 9500V in the **DAMP_ROOT_DIR_PATH** environment variable.
3. **Note:** Depending on the environment setting of the server/workstation, correct character fonts may not be displayed on screens. The standard font size is 12. If the characters are not displayed correctly, set the font to a different size. To complete this setting, insert a one space character, following the last line **\$JAVABIN \$EXECJAVA** in **starmgr2**, and add **"-xfont#" (#: a font size)**.

Main Screen Functions

The Resource Manager 9500V program starts in the normal mode and the Main screen appears.

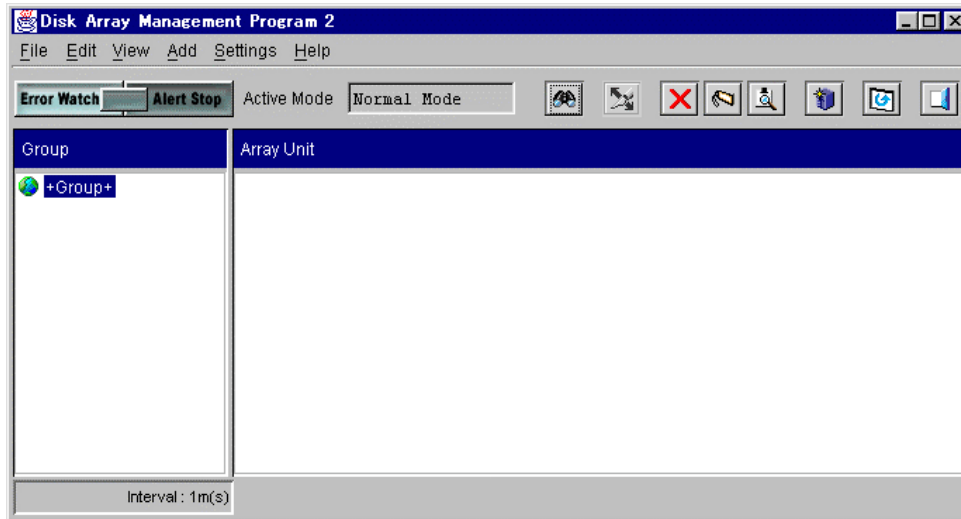



Figure 3.1 Resource Manager 9500V Main Screen

The following functions are performed from the Main screen:

- Registering the array unit (Register, Delete, Change, Refer of the property)
- Executing error monitoring and setting error monitoring option
- Changing the action mode
- Setting and changing the password for logging-in to the management mode
- Displaying the version

Note: When Resource Manager 9500V is first started, the change mode function is disabled. Register the password and the change mode function will be enabled.

1. Click the icon of an array unit on the Main screen.
2. From the **Settings** menu, click **Display Details**. Alternatively, click the : **Display Details** button in the tool bar. The Unit screen of an array unit will be displayed.
This operation can also be done from the context menu of the disk array subsystem icon.

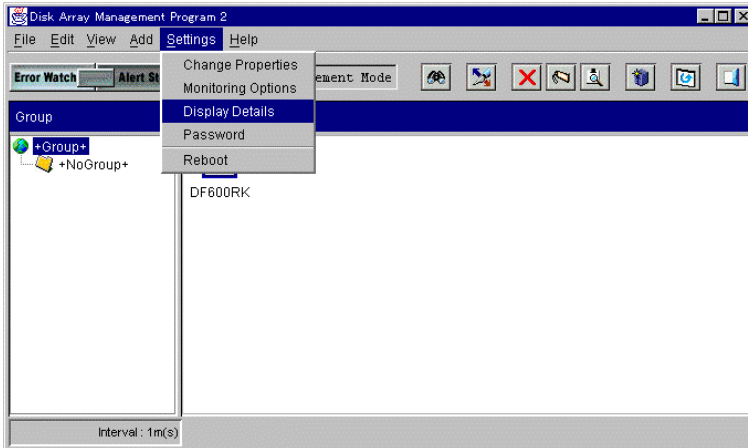

Figure 3.2 Display Details Tool Bar Selection from the Settings Menu

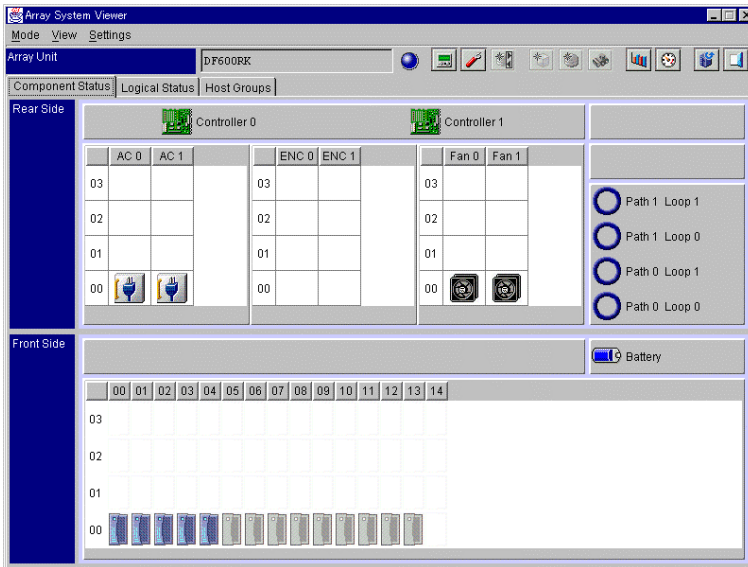

Figure 3.3 Unit Screen of an Array Unit

Unit Screen Functions

The following functions are performed in the Unit screen:

- Displaying the status of the array unit
- Displaying and defining the RAID/logical unit
- Displaying and defining the configuration information (the setting of spare drive)
- Setting the system parameters

3.1.2 Password Setting

When using the Resource Manager 9500V in the management mode, set a password.

3.1.2.1 Registration of a Password

Register a password.

1. On the **Settings** menu, click **Password**.

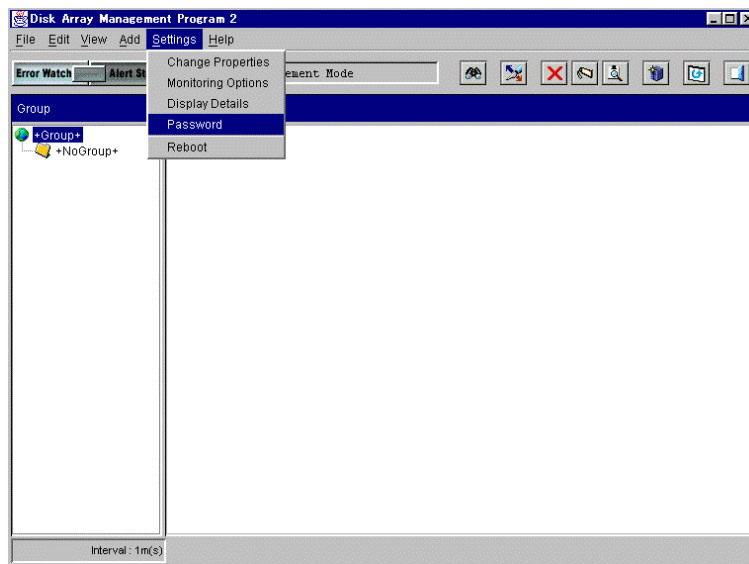

Figure 3.4 Registering a Password

2. Enter New Password and New Password (for confirmation) and click the **OK** button. Specify a password of up to 12 alphanumeric characters.



The screenshot shows a dialog box titled "Password" with a close button (X) in the top right corner. It contains three text input fields: "Old Password", "New Password", and a second "New Password" field. Below the second "New Password" field is the text "Enter the new password for confirmation." At the bottom of the dialog are two buttons: "OK" and "Cancel".

Figure 3.5 Entering a New Password

3.1.2.2 Changing the Password

Change the set password. The password can be changed only in the management mode.

1. On the **Settings** menu, click **Password** on the Main screen.
2. Input **Old Password**, **New Password**, and **New Password (for confirmation)** and click the **OK** button.
3. Specify a password of up to 12 alphanumeric characters.

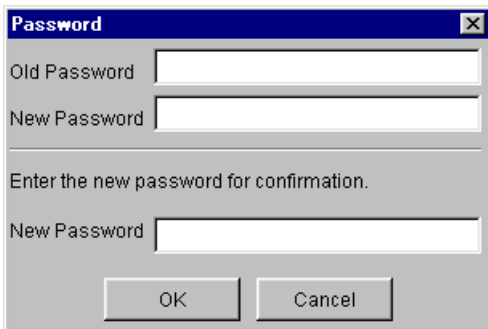

The screenshot shows a dialog box titled "Password" with a close button (X) in the top right corner. It contains three text input fields: "Old Password", "New Password", and a second "New Password" field. Below the second "New Password" field is the text "Enter the new password for confirmation." At the bottom of the dialog are two buttons: "OK" and "Cancel".

Figure 3.6 Changing the Password

3.1.2.3 Deleting the Password

To delete the password, the Resource Manager 9500V must be uninstalled and reinstalled.

1. Delete the directory where the Resource Manager 9500V is installed. Follow the "Uninstalling" directions on page 13.

Note: To save the information of the registered array unit, back up the "utlprm.inf" file in the directory where the Resource Manager 9500V is installed.

2. Create a directory with the same path and the same name as those of the directory deleted in step 1.
3. Re-install Resource Manager 9500V.

Note: When the "utlprm.inf" file has been backed up in step 1, copy this file to the directory created in step 2.

3.1.3 Changing the Action Mode

The Resource Manager 9500V is provided with two action modes: normal mode and management mode. In normal mode, both array unit configuration and status are displayed. In management mode, the array unit configuration can be set in addition to normal mode functions.

Change the action mode in accordance with the operation of the array unit.

3.1.3.1 Changing from Normal Mode to Management Mode

Change the action mode from normal mode to management mode. When logging-in is performed in normal mode, **Normal Mode** is displayed in **Active Mode:** in the upper part of the Main screen.

1. On the **File** menu, click **Change Mode** or click : **Change Mode** in the tool bar.

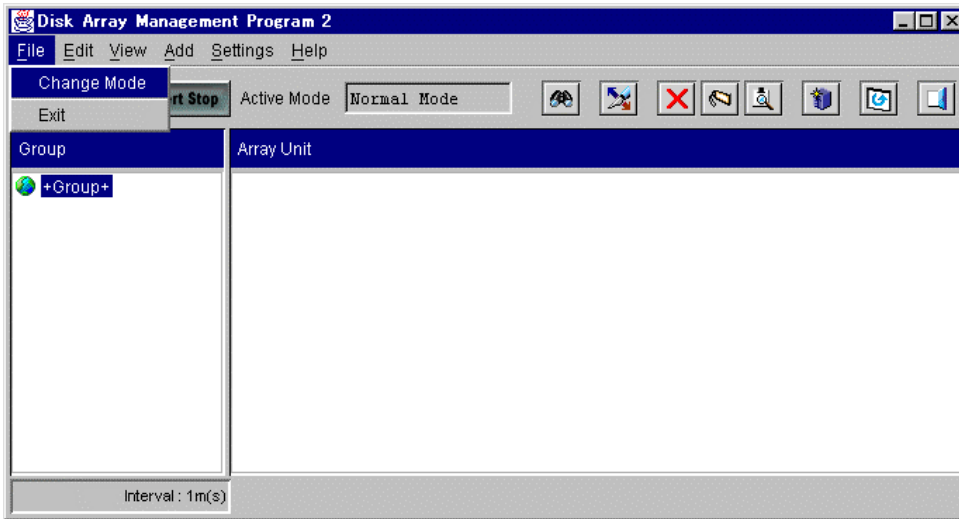

Figure 3.7 Changing from Normal Mode to Management Mode

2. When the password-input screen appears, input a password and click the **OK** button.

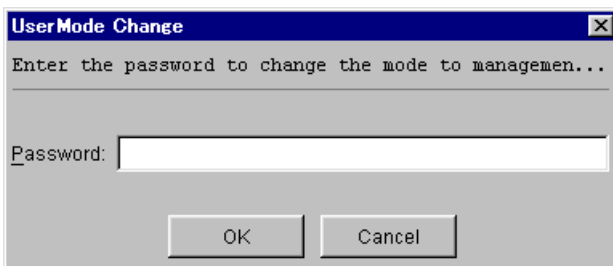



Figure 3.8 Password-Input Screen

Management Mode is displayed in **Active Mode:** in the upper part of the Main screen. The Resource Manager 9500V will operate in Management Mode.

3.1.3.2 Change from Management Mode to Normal Mode

You can change the action mode from Management mode to Normal mode. When logging-in is performed in the Management mode, **Management Mode** is displayed in **Active Mode:** (It appears in the upper part of the Main screen).

1. On the **File** menu, click **Change Mode** or click : **Change Mode** in the tool bar.

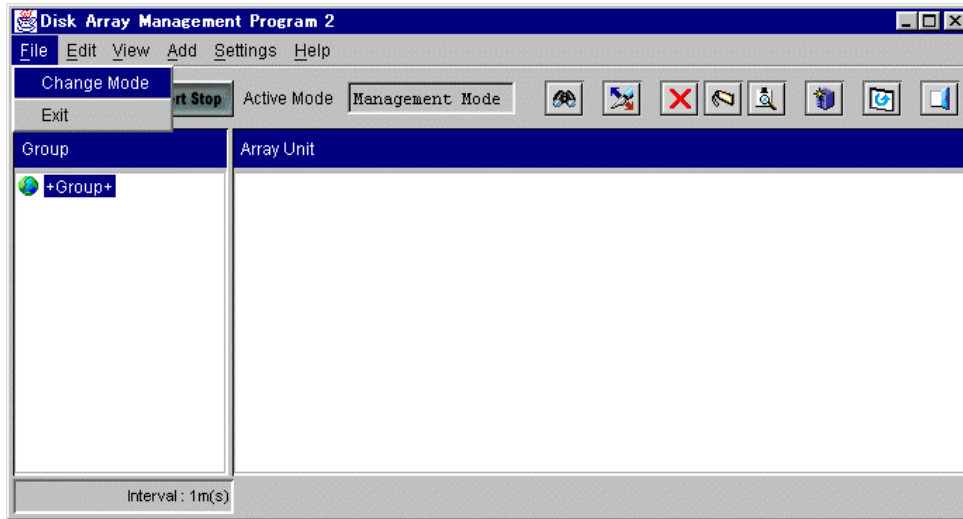
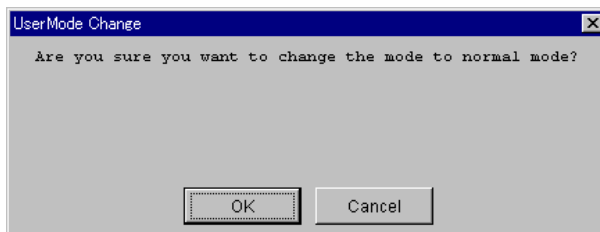

Figure 3.9 Changing from Management Mode to Normal Mode

2. When a confirmation message appears, click the **OK** button.



Normal Mode is displayed in **Active Mode:** in the upper part of the Main screen. The Resource Manager 9500V will operate in Normal mode.

3.1.4 Registering an Array Unit

To operate the array unit from the Resource Manager 9500V, register the array unit. You cannot temporarily register a non-existing array unit.

3.1.4.1 New Registration

1. On the **Add** menu, click the **Register Array Unit** or click : **Register Array Unit** in the tool bar.

This operation can also be completed from the context menu of the list view box.

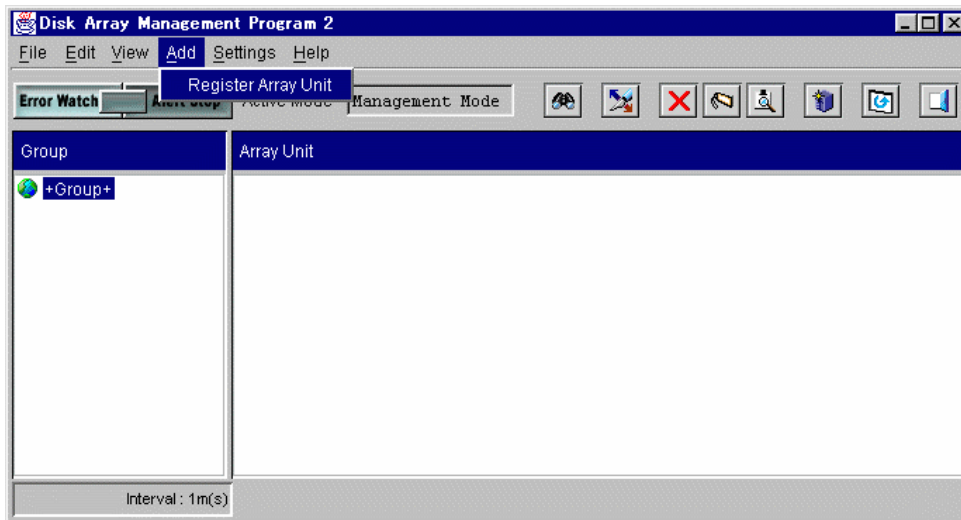

Figure 3.10 New Registration

2. Select either the TCP/IP (9500V/9200) or the RS232C (9200 only) Connection Type. Input the registration information and click the **OK** button.
 - TCP/IP

The screenshot shows a 'Property' dialog box titled 'Array Unit'. It contains several input fields and options:

- Group Name:** An empty text input field.
- Array Unit Name:** An empty text input field.
- Array Unit Type:** A dropdown menu showing 'DF600 Dua1'.
- Connection Type:** Two radio buttons are present: 'TCP/IP(LAN)' (which is selected) and 'RS232C'. Below these are two text input fields labeled 'Controller 0' and 'Controller 1'.
- Error Monitoring:** A checked checkbox labeled 'Monitoring Target' and a button labeled 'Mail Additional Information'.

At the bottom of the dialog are 'OK' and 'Cancel' buttons.

Figure 3.11 Input Registration Information (TCP/IP)

- RS232C (9200 only)

The screenshot shows a 'Property' dialog box titled 'Array Unit'. It contains several input fields and options:

- Group Name:** An empty text input field.
- Array Unit Name:** An empty text input field.
- Array Unit Type:** A dropdown menu showing 'DF500 Dua1'.
- Connection Type:** Two radio buttons are present: 'TCP/IP(LAN)' and 'RS232C' (which is selected). Below these are two text input fields labeled 'Controller 0' and 'Controller 1'.
- Error Monitoring:** A checked checkbox labeled 'Monitoring Target' and a button labeled 'Mail Additional Information'.

At the bottom of the dialog are 'OK' and 'Cancel' buttons.

Figure 3.12 Input Registration Information (RS232C - 9200 only)

- **Group Name:** Group name when array units are controlled as a group. Specify it in up to 16 alphanumeric characters or characters except numbers (-, _). When array units are controlled as a group, input its name. If not, it is not necessary to input the name. The maximum registered number of groups is 200.
- **Array Unit Name:** Registered name of array unit. Specify up to 16 alphanumeric characters or characters (-, _) except numbers.
- **Array Unit Type:** Select a type of array unit.
- **Connection Type:** Select a connection mode with the array unit.

TCP/IP(LAN): Connect LAN.

RS232C: Connect RS232C (9200 Only).

IP Address or Host Name or Port or Device Name: Specify the connection information of controller 0/1. When you select **TCP/IP** in **Connection Type**, specify **IP Address** or **Host Name**. When you select **RS232C** (9200 only), specify **Device Name**.

Specify the RS232C port name or device file name as **Device Name**.
(Example: Windows-COM1, Solaris-ttya)

Error Monitoring: Specify whether or not to perform error monitoring.

Check (ON display): Error monitoring

No check (OFF display): No error monitoring

Note: In the array unit in a dual system, only one controller can be used in the LAN connection mode. **Array Unit Type** is used to select an array unit type to be connected. Specify **IP Address/Host Name/Device Name** for the connected controller side only.

3. When a registration completion message appears, click the **OK** button.

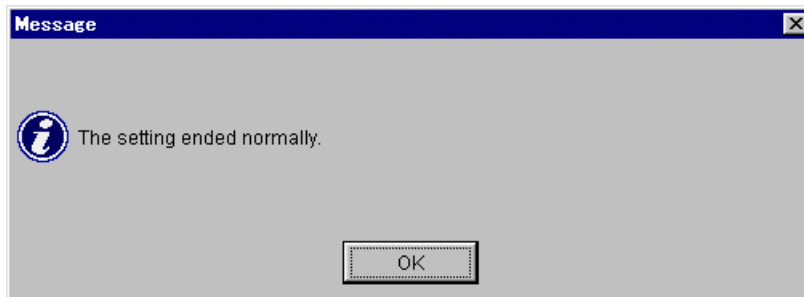

The Main screen is updated and then displayed.

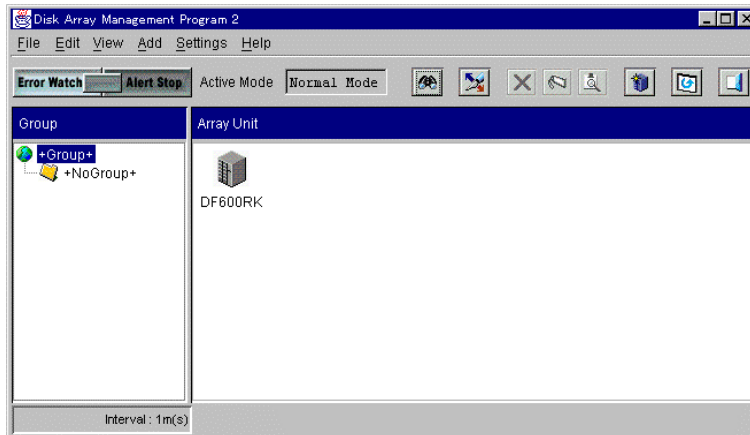

When you input **Group Name**, an array unit icon is displayed in the frame enclosed with the input group. Array unit icons are classified into one for dual system and the other for single system as shown in the following figure.

For dual system



For single system



Array unit icons are displayed in the order of registration.

3.1.4.2 Changing the Registration Contents

Change the registration contents of the array unit, which are registered in the Resource Manager 9500V.

1. Click the icon of an array unit on the Main screen. On the **Settings** menu, click **Change Properties**.

This operation can also be completed from the context menu of the disk array subsystem icon.

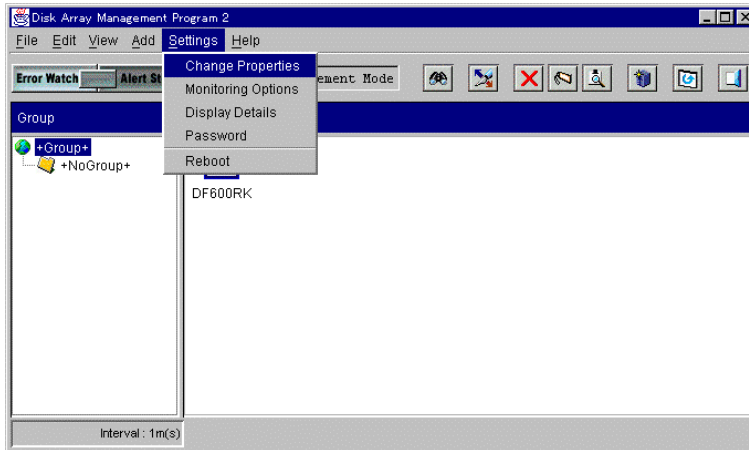
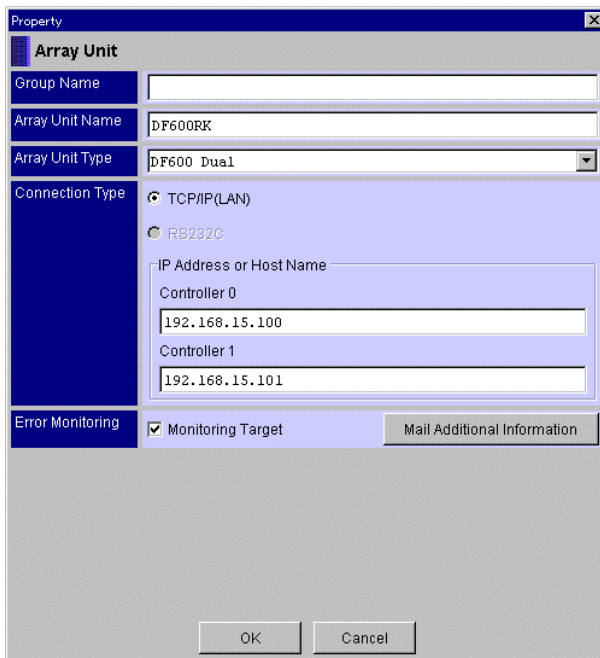
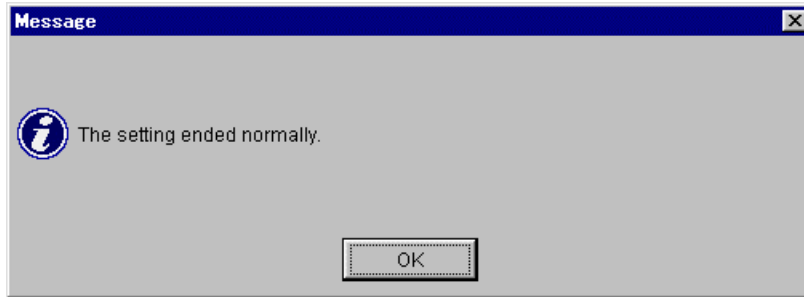

Figure 3.13 Changing the Registration Contents

2. Change the registration contents and click the **OK** button. (The following is an example for a TCP/IP setting.)



3. When a registration change completion message appears, click the OK button.



The Main screen is updated and then displayed.

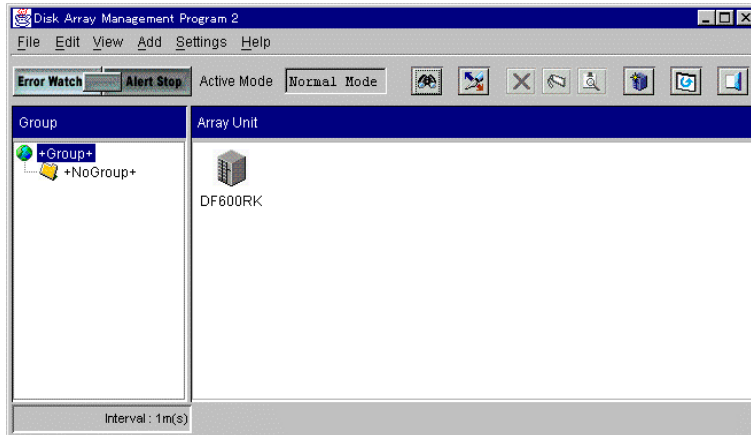

3.1.4.3 Deleting the Registration

Delete the registration of an array unit, that is registered in the Resource Manager 9500V.

1. Click the icon of an array unit on the Main screen. On the **Edit** menu select **Delete** or click  in the tool bar.

This operation can also be completed from the context menu of the disk array subsystem icon.

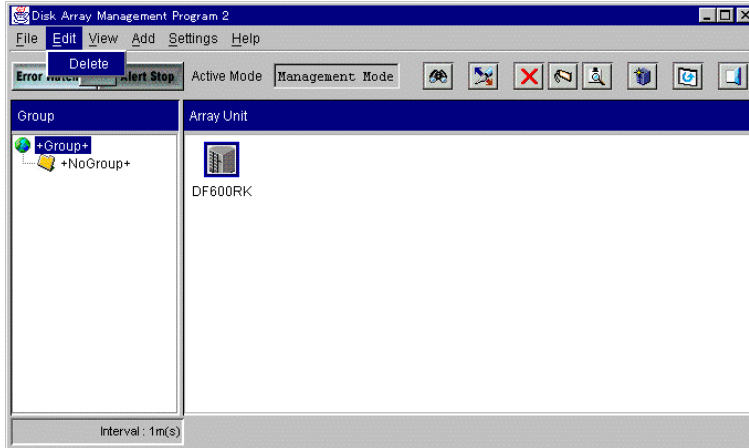
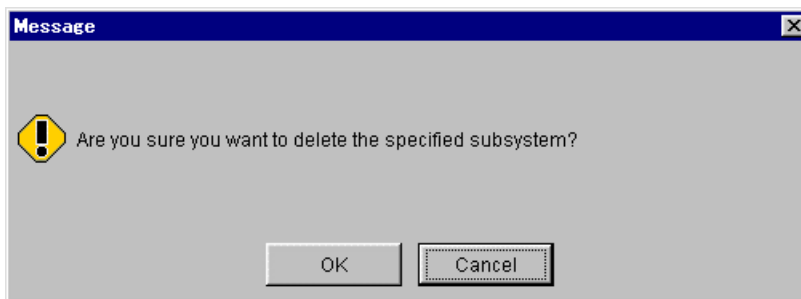
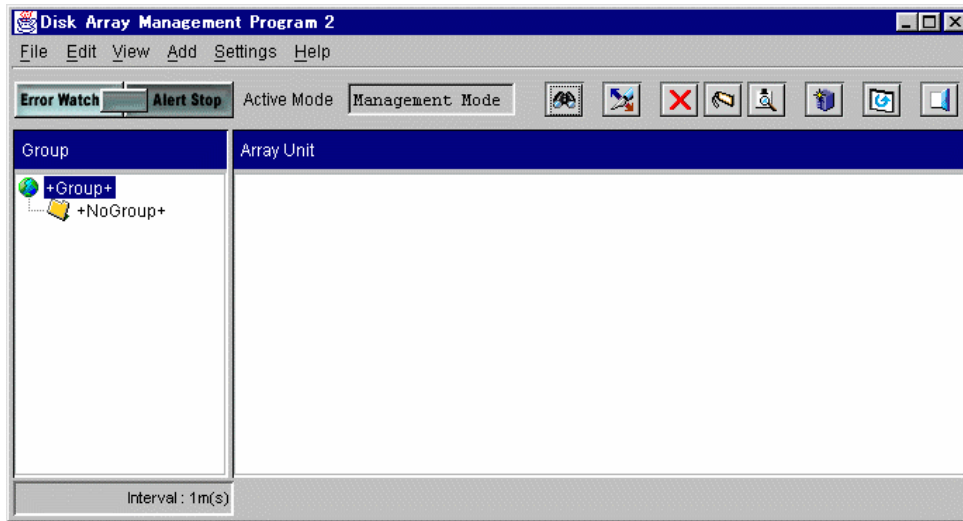

Figure 3.14 Deleting the Registration Contents

2. When a message confirming whether the registration should be deleted or not is displayed, click the **OK** button.



The Main screen is updated and then displayed.



3.1.4.4 Displaying the Registration Contents

Display the registration contents of an array unit, registered in the Resource Manager 9500V.

1. Click the icon of an array unit on the Main screen. On the **View** menu, select **Properties** or click  in the tool bar.

This operation can also be completed from the context menu of the disk array subsystem icon.

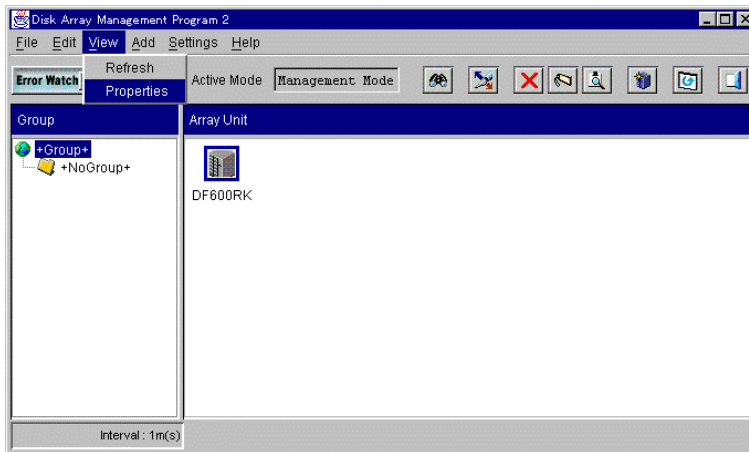
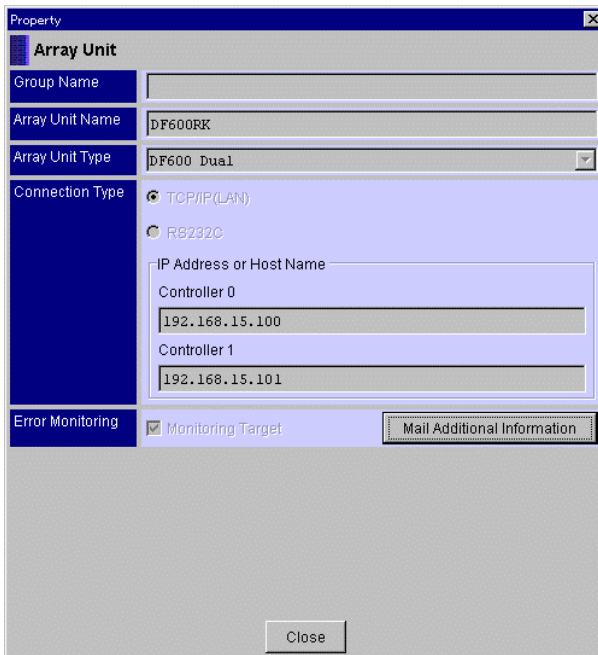

Figure 3.15 Displaying the Registration Contents

The registration contents of the array unit are displayed.



3.1.5 Version Display

Display the version of the Resource Manager 9500V.

1. On the **Help** menu, select **Version**.

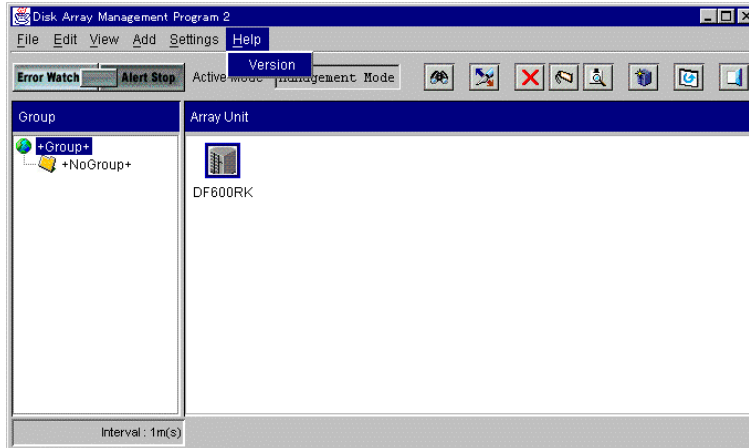

The version of the Resource Manager 9500V is displayed.

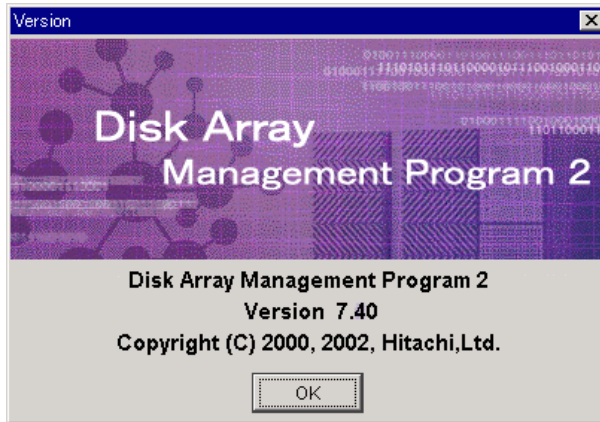



Figure 3.16 Version Display

3.1.6 Terminating

Terminate the Resource Manager 9500V. When the Unit screen is open, close it and terminate the Resource Manager 9500V.

1. Click the icon of an array unit on the Main screen. On the **File** menu, select **Exit** or click  in the tool bar.

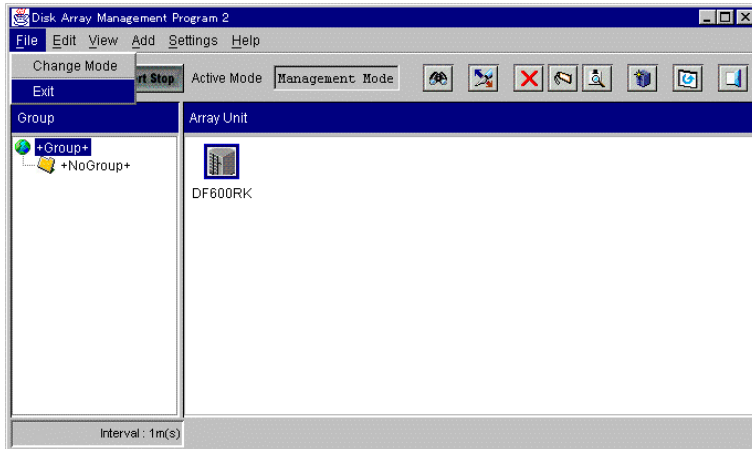

Figure 3.17 Terminating Resource Manager 9500V

The Main screen is closed and Resource Manager 9500V is terminated.

3.1.7 Restart an Array Unit

To restart the array unit:

1. Click the icon of an array unit on the Main screen. On the **Settings** menu, select **Reboot**.

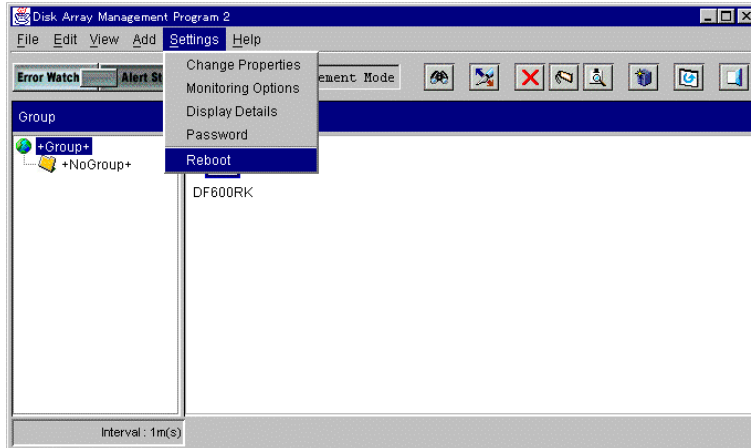
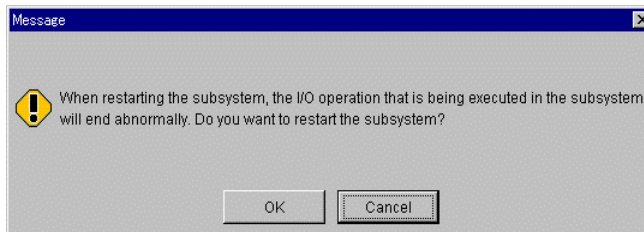
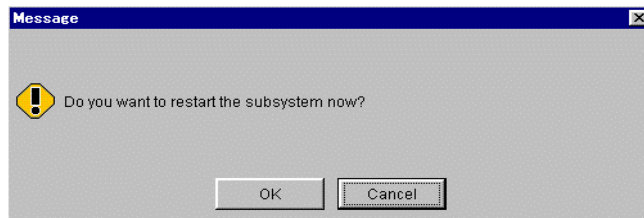
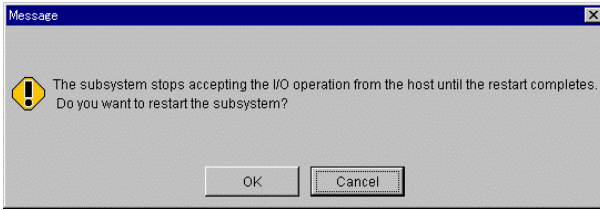

Figure 3.18 Restarting an Array Unit

2. A confirmation message is displayed. Click the **OK** button when restarting.





When restarting an array unit, the restart time is displayed. Restarting takes approximately two to six minutes.

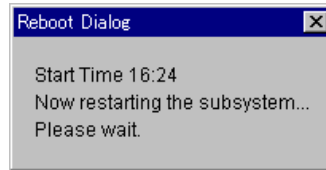
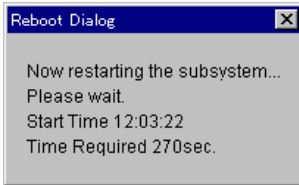

Note: It may take time for an array unit to respond, depending on the condition of the array unit. If it does not respond after 10 minutes or more, check the condition of the array unit.

3. A message indicating that restarting has terminated is displayed. Click the **OK** button.







3.2 Properties of the Main Screen and Unit Screen

3.2.1 Displaying the Property of the Main Screen

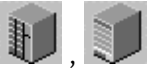
Display the array unit status and information by using icons.

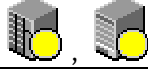
Array Unit Status

 Gray	<ul style="list-style-type: none"> • Initial Main screen when starting Resource Manager 9500V • Out of error monitoring
 Gray + Blue	<ul style="list-style-type: none"> • Normal
 Gray + Yellow	<ul style="list-style-type: none"> • Warning
 Red	<ul style="list-style-type: none"> • Array unit is system down • Array unit is power off • Error in communication with an array unit

3.2.2 Displaying the Properties of the Unit Screen

Display the array unit component status and information by using icons. When you double-click each icon, the information of the component part indicated by the icon is displayed.

1. On the **Settings** menu, select **Display Details** and click the **Component Status** tab. Alternatively, click : **Display Details** in the tool bar and click the **Component Status** tab.

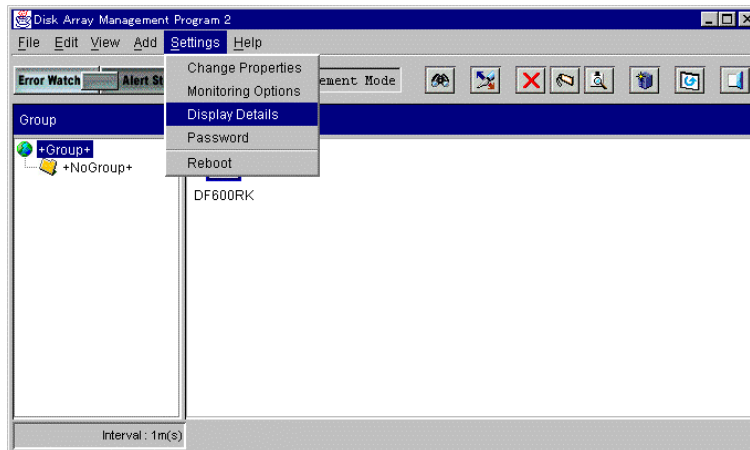



Figure 3.19 Displaying the Properties of the Unit Screen

The array unit component status is displayed.

- To update the component display, on the View menu, select **Refresh** or click  in the tool bar.

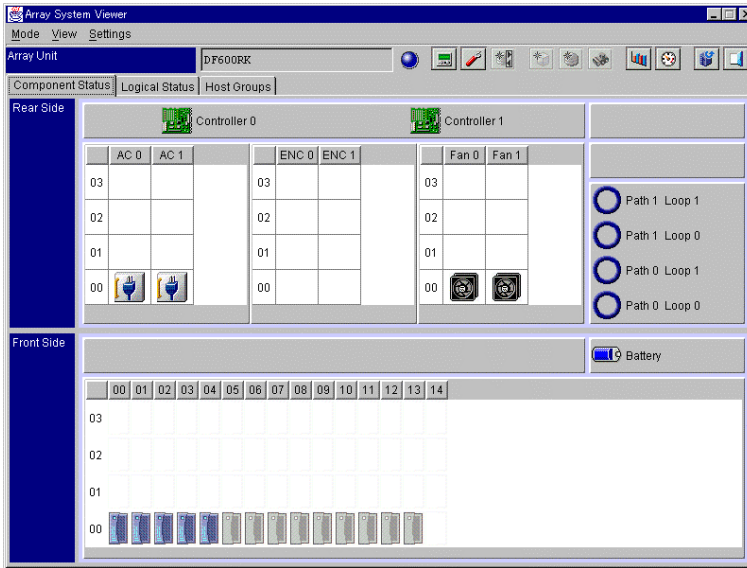

Figure 3.20 Display when Both Controllers are Connected in the Dual System

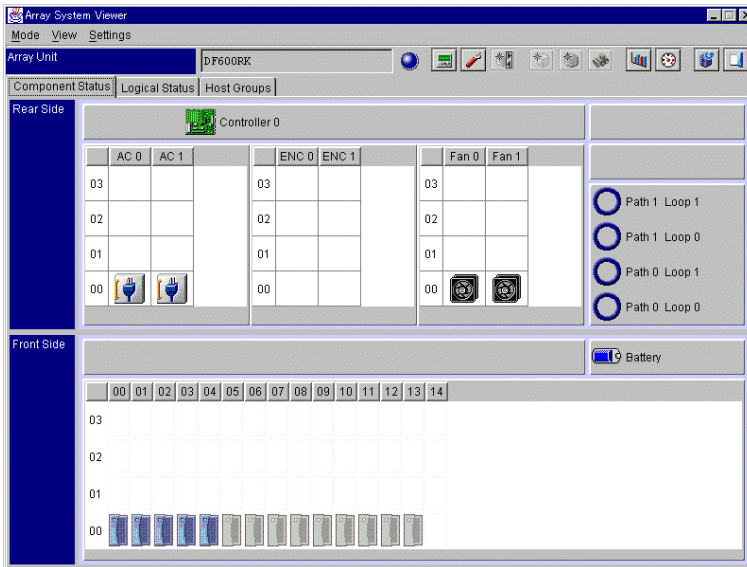















Figure 3.21 Display when a Single Controller is Connected in the Dual System











The controller icon represents only the connected controller side.

3. Display the array unit component status by using icons.



Data Drive

Display	Highlighting	Status
 Purple		<ul style="list-style-type: none"> • Normal (There is a formatted LU.)
 Yellow		<ul style="list-style-type: none"> • Collection reconstruction status • Copy-back status from the spare disk
 Red		<ul style="list-style-type: none"> • Blockade. Disk Drive is blocked.
 Gray		<ul style="list-style-type: none"> • RAID group defined, LU not defined • LU defined, unformatted
 Red + Black		<ul style="list-style-type: none"> • Not mounted in the blockade status
 Purple + Black		<ul style="list-style-type: none"> • RAID group defined, Drive not mounted
 No indication	—	<ul style="list-style-type: none"> • RAID group not defined, Drive mounted
No indication	—	<ul style="list-style-type: none"> • RAID group not defined. Drive not mounted • Not supported location



Spare Drive

Display	Highlighting	Status
 Purple		<ul style="list-style-type: none"> • Spare drive in use
 Yellow		<ul style="list-style-type: none"> • Data reconstruction to spare drive • Copy-back from spare disk to data disk
 Purple + Black		<ul style="list-style-type: none"> • Waiting
 Red		<ul style="list-style-type: none"> • Busy or Disk Drive Detached for Restoring
 Red + Black		<ul style="list-style-type: none"> • Spare disk not mounted though Use of Spare Disk is set as array unit



Enclosure

Display	Status
 Green	<ul style="list-style-type: none">• Normal
 Red	<ul style="list-style-type: none">• Failure



Controller

Display	Status
 Green	<ul style="list-style-type: none">• Normal
 Yellow	<ul style="list-style-type: none">• Failure
 Red	<ul style="list-style-type: none">• Blockade



Battery

Display	Status
 Blue	<ul style="list-style-type: none">• Normal
 Red	<ul style="list-style-type: none">• Failure



Fan

Display	Status
 Black	<ul style="list-style-type: none">• Normal
 Red	<ul style="list-style-type: none">• Failure

Power supply

Display	Status
 Blue	<ul style="list-style-type: none">• Normal
 Red	<ul style="list-style-type: none">• Failure

Loop

Display	Status
 Blue	• Normal
 Red	• Failure

4. On the **View** menu click **Properties**.

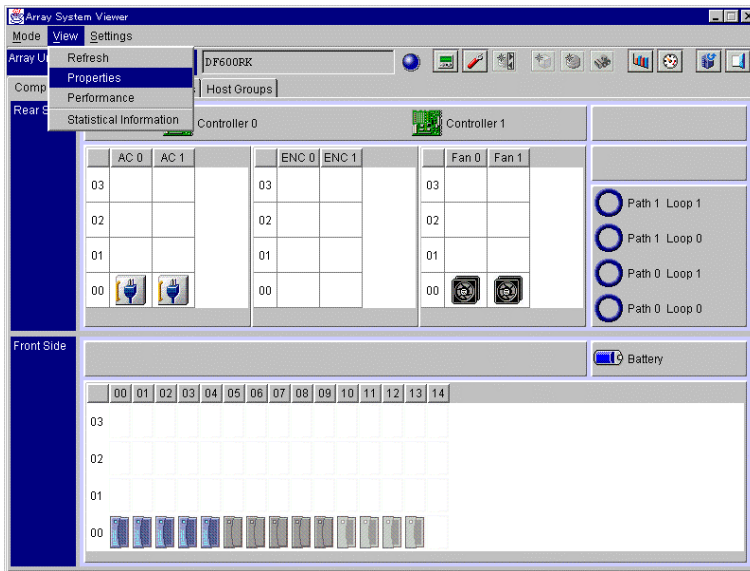

The Property screen of an array unit will be displayed.

Property		
Array Unit		
Microprogram Revision	0650	
Serial Number	65010026	
Connection Type	LAN	
Controller No.	Controller 0	Controller 1
IP Address	192.168.15.100	192.168.15.101
Subnet Mask	255.255.255.0	255.255.255.0
Default Gateway	192.168.15.3	192.168.15.3

Close

- **Microprogram Revision:** Microprogram revision of the array unit
- **Serial Number:** Serial number of the array unit
- **Connection Type:** Connection type of the array unit
- **Controller No.:**
 - IP Address:** IP address of each controller
 - Subnet Mask:** Subnet Mask of each controller
 - Default Gateway:** Default gateway of each controller

- When you double-click each icon, the property screen of the component part is displayed.

For information on data drives and spare drives, click their respective icons. For other components of an array unit, the following information is displayed.

a) Data Drive and Spare Drive

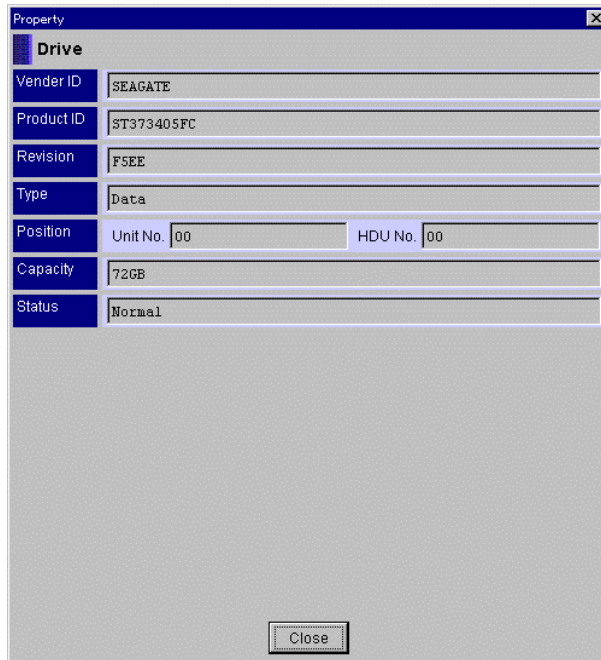

Figure 3.22 Data Drive and Spare Drive

- **Vendor ID:** Vendor ID of drive
- **Product ID:** Product ID of drive
- **Revision:** Firmware revision of drive
- **Type:** Drive using form
 - Data:** Data drive
 - Spare:** Spare drive
- **Position:** Array unit mounting position
 - Unit No.:** Unit No.
 - HDU No.:** HDU No.
- **Capacity:** Storage capacity of a drive
- **Status:** Drive status
 - Normal:** Normal
 - Detached:** Blockade
 - Detached (Unmount):** The drive in the blockade status is not installed.
 - Standby:** Normal (LU not defined)

Out of RG: Normal (RAID not defined)

Undefine: Normal (LU not defined)

Unmount: The drive is not installed.

Recovery: Under recovery (correction copy or copyback in progress)

UnitX HDUY: Position of a corresponding data drive when using spare disk drives.

Waiting: Spare drive not used

Note: **Vendor ID**, **Product ID**, and **Revision** may not be displayed depending on the drive mounting and drive status.

b) Enclosure

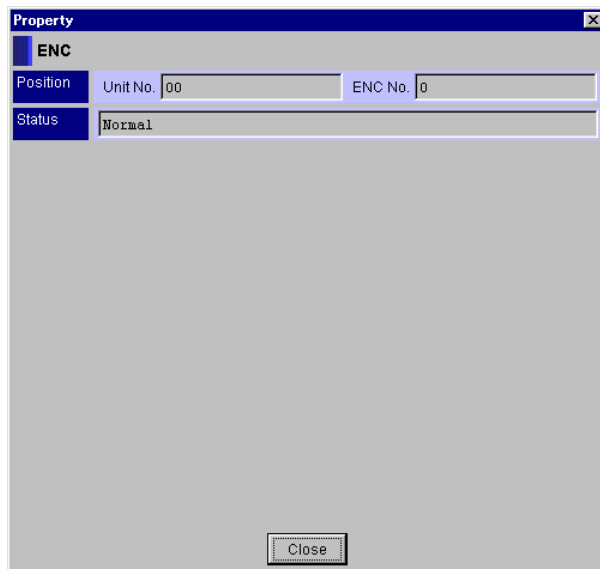

Figure 3.23 Enclosure

- **Position:** Mounting position of an enclosure
 - Unit No.:** Unit No.
 - ENC No.:** ENC No.
- **Status:** Status
 - Normal:** Normal
 - Alarm:** Failure

c) Controller

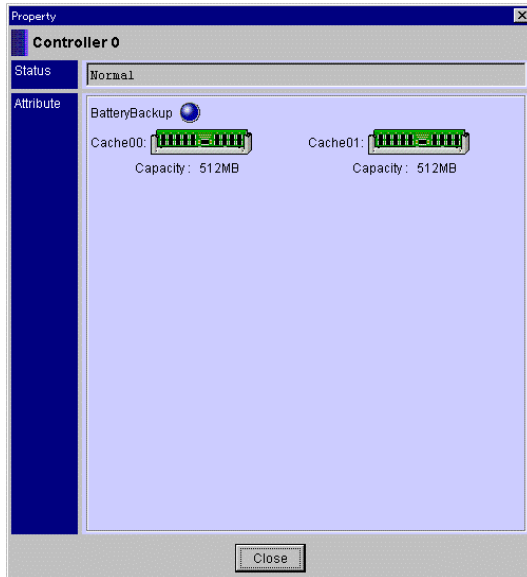



Figure 3.24 Controller 0 and Controller 1



Controller n: Controller n (n: Controller No.)

- **Status:** Status
 - Normal:** Normal
 - Alarm:** Failure
 - Nothing:** Not installed
- **Attribute:** Status of battery backup circuit. Capacity and status of cache memory.
 - BatteryBackup (Blue):** Normal
 - BatteryBackup (Red):** Failure

Battery Backup Circuit

Display	Status
 Blue	• Normal
 Yellow	• Failure

Cache Memory

Display	Status
 Blue	• Normal
 Red	• Failure
	• Not installed

d) Fan

Property	
Fan	
Position	Unit No. 00 Fan No. 0
Status	Normal
Close	

- **Position:** Mounting position
Unit No.: Unit No.
Fan No.: Fan No.
- **Status:** Status
Normal: Normal
Alarm: Failure
Nothing: Not installed

e) Battery

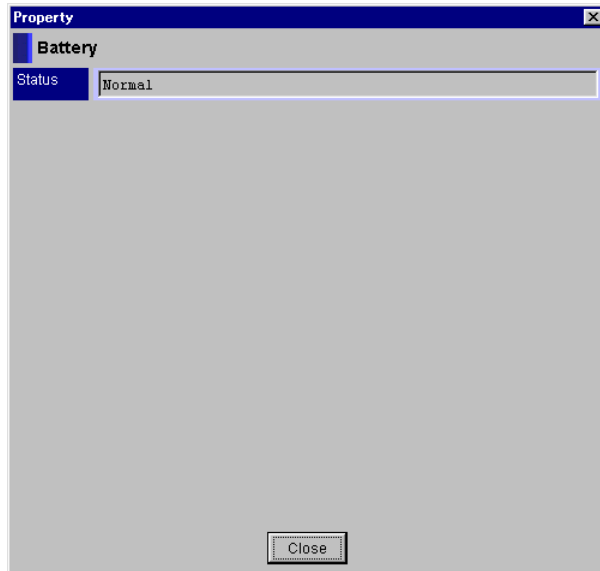

- **Status:** Status
 - Normal:** Normal
 - Alarm:** Failure
 - Nothing:** Not installed

f) AC power supply

Property	
AC Power Supply	
Position	Unit No. 00 AC No. 0
Status	Normal

- **Position:** Mounting position
Unit No.: Unit No.
AC No.: AC No.
- **Status:** Status
Normal: Normal
Alarm: Failure
Nothing: Not installed

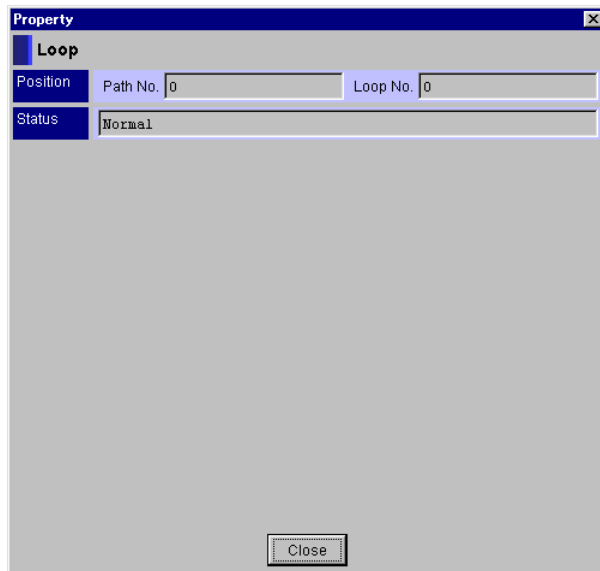

g) Loop

















- **Position:** Mounting position
 - Path No.:** Path No.
 - Loop No.:** Loop No.
- **Status:** Status
 - Normal:** Normal
 - Alarm:** Failure
 - Nothing:** Not installed

Icon and Property of Logical Unit

RAID Group

Display	Highlighting	Status
 Blue		• Normal

Logical unit

Display	Highlighting	Status
 Yellow		• Formatted logical unit
 Gray		• Unformatted logical unit
 Red		• Blockaded logical unit
 Pink		• Regressed logical unit
 Light Yellow		• Invalidated formatted logical unit
 Light Gray		• Invalidated unformatted logical unit
 Light Pink		• Invalidated regressed logical unit

a) RAID Group

RAID Group	
RAID Group	00
RAID Level	RAID 5
HDU Combination	4D+1P
HDU Starting Point	Unit No. 00 HDU No. 00
Size (Number of Drives)	HDUs in the Parity Group 05
	Parity Groups 01

- **RAID Group:** RAID group No.
- **RAID Level:** RAID level
- **HDU Combination:** Parity group configuration
- **HDU Starting Point:** Unit No. and HDU No. defined for the top HDU in a RAID group
- **Size (Number of Drives):** Number of HDUs in parity groups and number of parity groups

b) Logical Unit

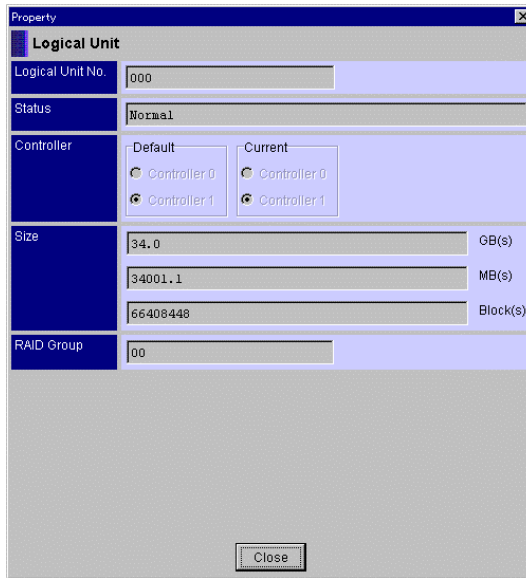

- **Logical Unit No.:** Logical unit No.
- **Status:** Status
 - Normal:** Normal
 - Unformat:** Normal (unformatted)
 - Detached:** Detached
 - Alarm:** Blockade
 - Regression:** Regression
 - Invalidated(Normal):** Invalidated (formatted)
 - Invalidated(Unformatted):** Invalidated (unformatted)
 - Invalidated(Regression):** Invalidated (Regression)
- **Controller:** Controller No. in charge of the default/current LU
- **Size:** Capacity in which the logical unit is defined

Note 1: When the value is expressed in GB, one GB is added per 1,024 MB. A fraction less than 1,024 MB is omitted.

0001 – 1,023 MB = 0 GB
1,024 – 2,047 MB = 1 GB
2,048 – 3,071 MB = 2 GB

Note 2: When the value is expressed in MBs, one MB is added per 2,048 blocks. A fraction less than 2,048 blocks is omitted.

0001 – 2,047 blocks = 0 MB
2,048 – 4,095 blocks = 1 MB
4,096 – 6,143 blocks = 2 MB

- **RAID Group:** RAID group number in which logical units are defined

3.2.3 Displaying the Array Unit Configuration Information

Display the array unit configuration information.

1. Click the icon of an array unit on the Unit screen. On the **Settings** menu, select **Configuration Settings** or click  in the tool bar.

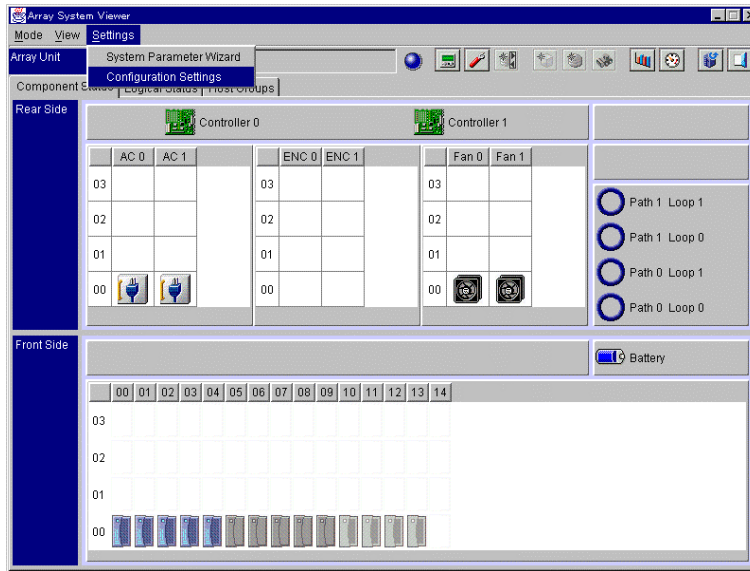

Figure 3.25 Displaying the Array Unit Configuration Information

2. Click the LAN tab.

The IP Address and Subnet Mask of the LAN configuration information validated in the array unit are displayed.

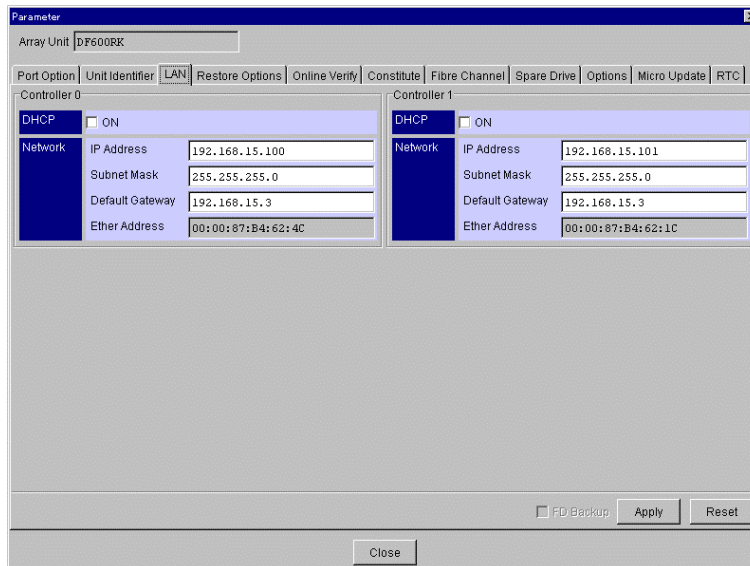

Figure 3.26 IP Address and Subnet Mask of the LAN Configuration Information

3.2.4 Displaying the Information Message

To display the **Information Message** dialog box:

1. Click a patrol lamp icon (🔦) in the Unit Screen.

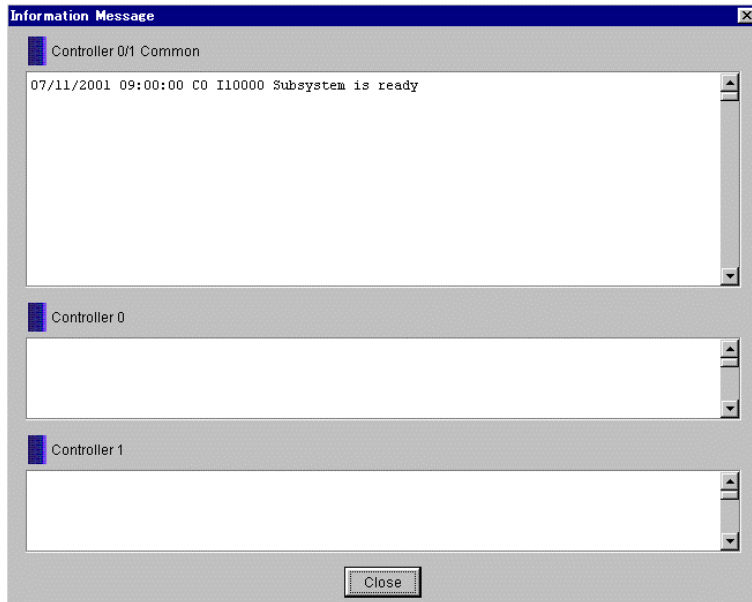

Figure 3.27 Displaying the Information Message

- **Controller 0/1 Common:** After the array unit starts, the fault information and status information are displayed in the Controller 0/1 Common box.
- **Controller 0:** As the array unit starts, the fault information and status information are displayed in the box of Controller 0.
- **Controller 1:** As the array unit starts, the fault information and status information are displayed in the box of Controller 1.

Chapter 4 Definition of RAID Group/Logical Unit

The Resource Manager 9500V Graphical User Interface (GUI) can be used to set, expand, and delete the RAID group. Additionally, the logical unit can be created, expanded, and deleted.

In Monitor mode, the current definition information is displayed but no button for definition is displayed.

This chapter includes the following:

- Displaying the RAID Group/Logical Unit Definition
- Creating a RAID Group
- Expanding a RAID Group
- Deleting a Specified RAID Group
- Deleting All RAID Groups
- Constituting a Logical Unit
- Formatting a Logical Unit
- Expanding a Logical Unit
- Deleting the Last Logical Unit
- Changing the Default Controller in Charge of a Logical Unit
- Logical Unit Wizard
- Invalidating a Logical Unit
- Reassigning a Logical Unit
- Restoring a Logical Unit

4.1 Displaying the RAID Group/Logical Unit Definition

1. Click the **Logical Status** tab on the Unit screen.

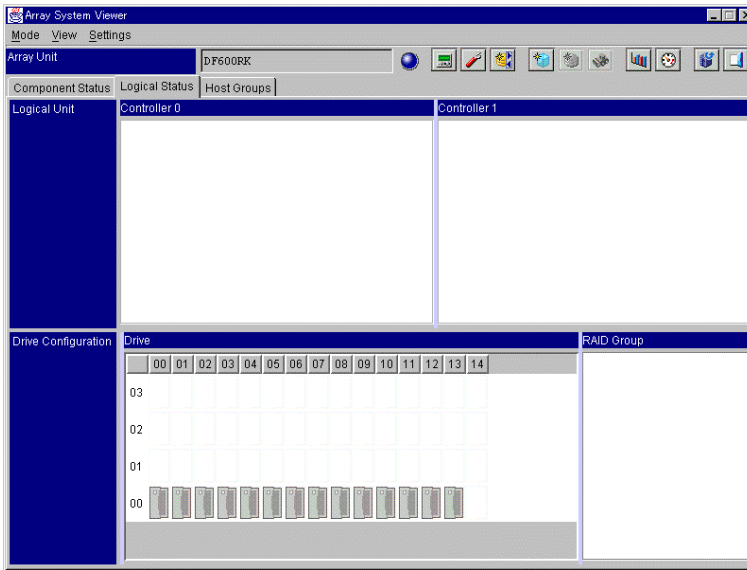

Figure 4.1 Displaying the Definition Information of All RAID Groups and All Logical Units

A screen appears which displays the definition information of all RAID groups and all logical units defined in the array unit.

– **Logical Unit:**

Controller 0: Displays the logical unit number (xxx) of logical units under control of Controller 0, the RAID levels of RAID groups for which logical units have been defined, and the status of logical units.

Controller 1: Displays the logical unit number (xxx) of logical units under control of Controller 1, the RAID levels of RAID groups for which logical units have been defined, and the status of logical units.

– **Drive Configuration:**

Drive: The status of disk drives mounted in an array unit is displayed.

RAID Group: Information about all RAID groups defined for an array unit is displayed.

The following screen displays information related to the RAID groups and drives for which logical units have been defined.

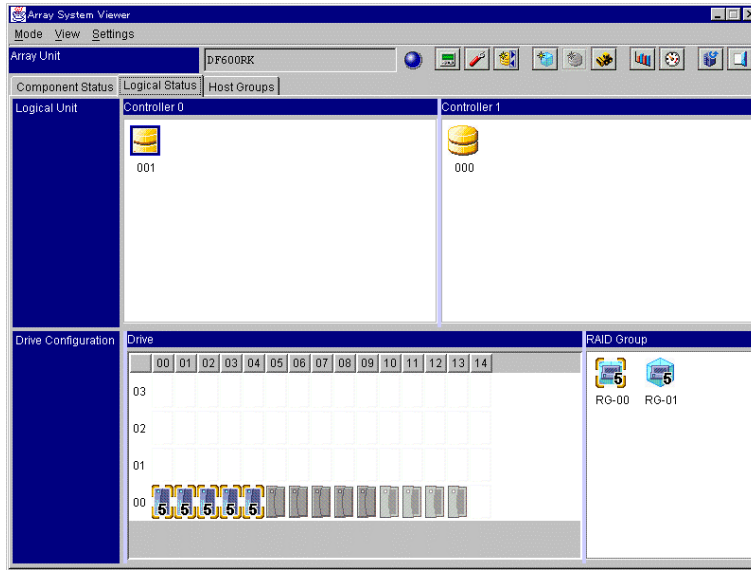

Figure 4.2 Displaying RAID Group and Drive Information for Defined Logical Units

Click the icon of a logical unit displayed in the **Controller Unit** box to display the following information.

- **RAID Group Unit:** Display, by highlighting, the RAID level in the icon of a drive for which logical units have been defined.
- **Drive Configuration:** Display, by highlighting in light blue, the RAID group for which the logical unit has been defined.

The following screen displays information for logical units and drives with defined RAID groups.

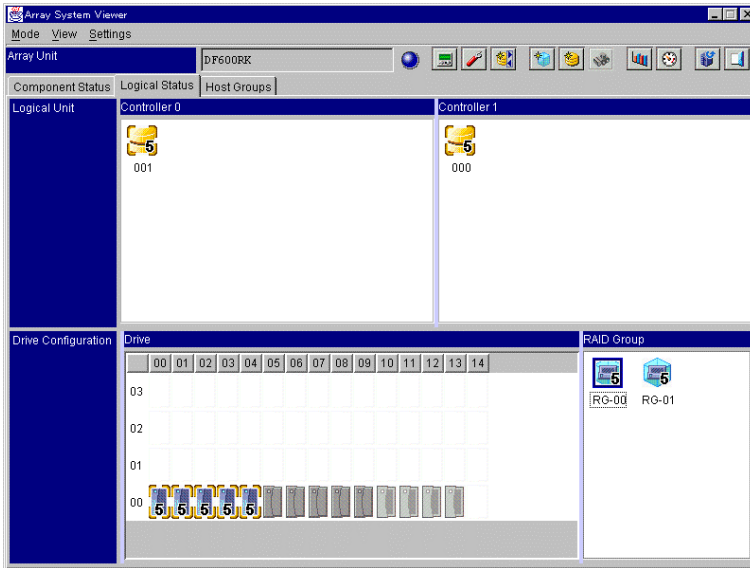

Figure 4.3 Displaying Logical Unit and Drive Information for Defined RAID Groups

Click the icon of a logical unit displayed in the **RAID Group** box to display the following information.

- **Controller Unit:** Displays, by highlighting, all logical units
- **Drive Configuration:** Displays, by highlighting, a RAID level in the icon of the drives for which the RAID group has been defined

4.2 Creating a RAID Group

To create a new RAID group:

1. Click the **Logical Status** tab on the Unit screen.
2. Click the top drive of a selected RAID group. The drive that is clicked is displayed.

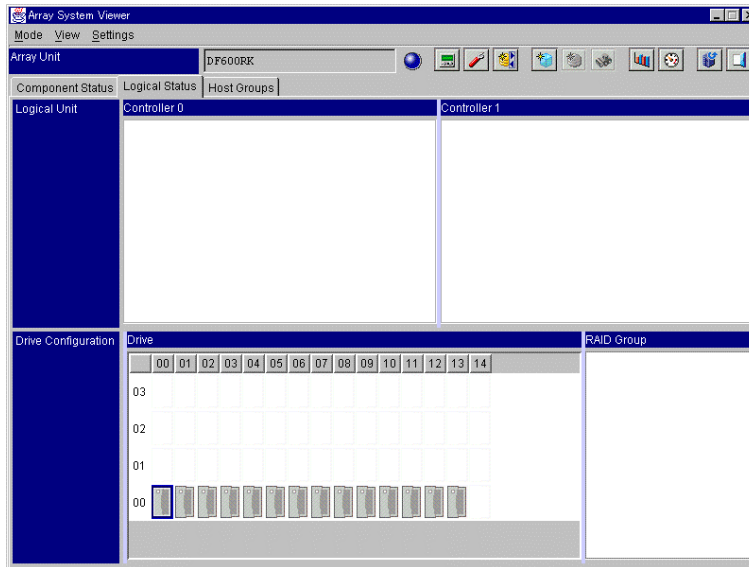
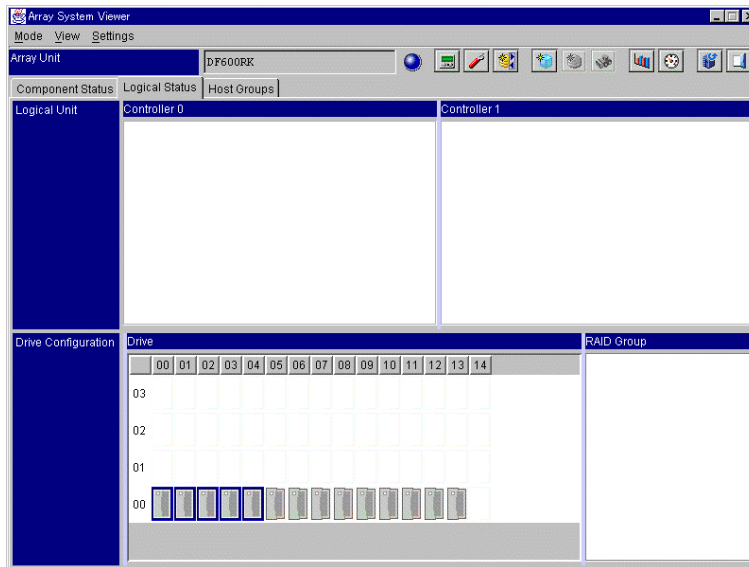



Figure 4.4 Creating a RAID Group

3. Holding down the **shift** key and click the last drive of a RAID group to be created. Drives of the RAID group to be created are enclosed by a rectangular box.



4. On the **Settings** menu, select **RAID Group**, then click **Settings**. Alternatively, click : **RAID Group Settings** in the tool bar.

This operation can also be completed from the context menu of the **RAID Group** box.

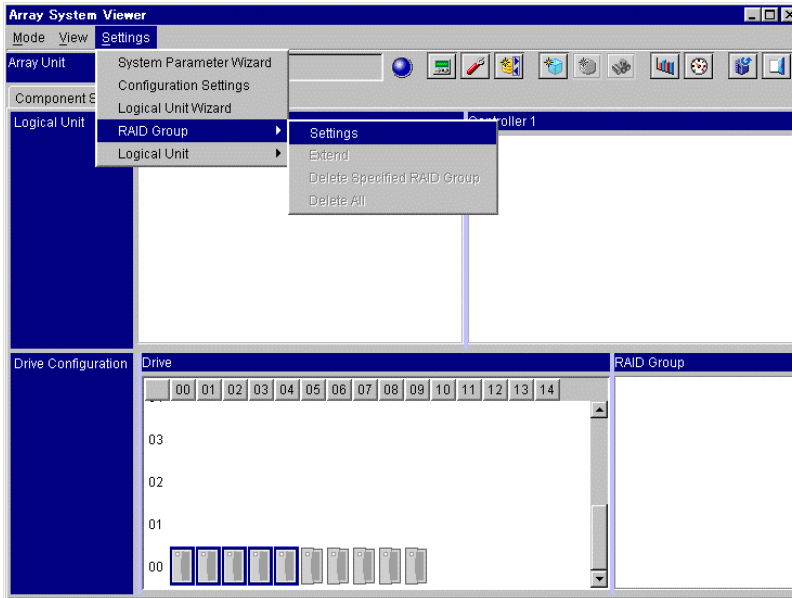

5. Select a RAID level and click the **OK** button.



In **RAID Level**, the RAID level to be added is set.

In **HDU Combination**, RAID level configuration to be added is set.

If you select an option other than **Manual** as **HDU Combination**, the size is automatically set to match the specified level. If you specify any size optionally, select **Manual** from the configuration window.

6. A message appears, stating that the setting is complete. Click the **OK** button.

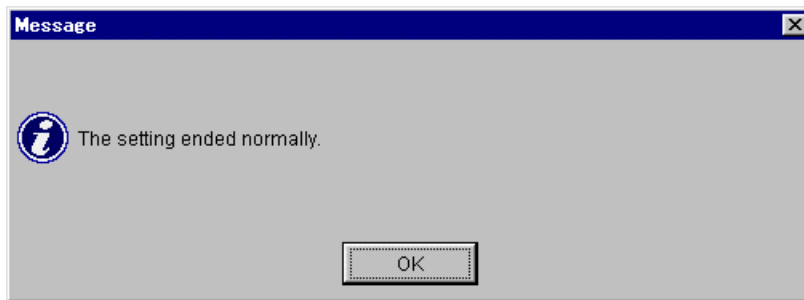

The set RAID group is updated and the following window is displayed.

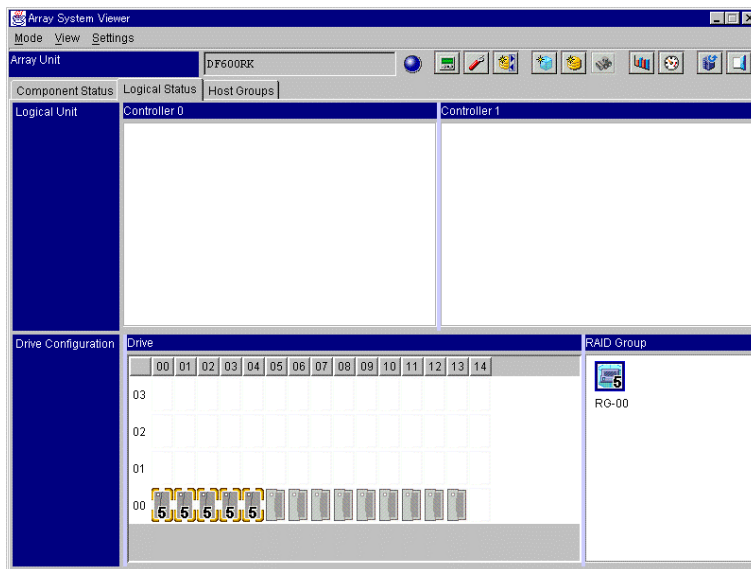

4.3 Expanding a RAID Group

To expand a set RAID group:

1. Click the **Logical Status** tab on the Unit screen.
2. Click the icon of a RAID group on the Unit screen. On the **Settings** menu, select **RAID Group** and click **Extend**.

This operation can be completed from the context menu of the RAID group icon.

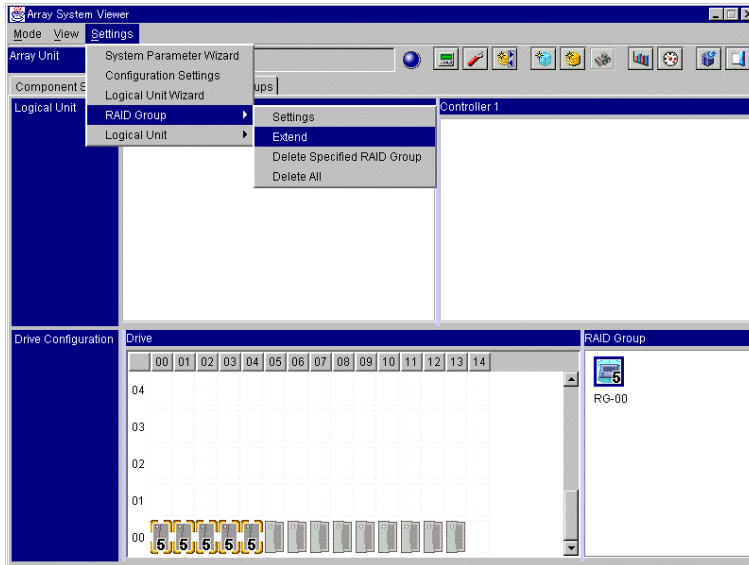
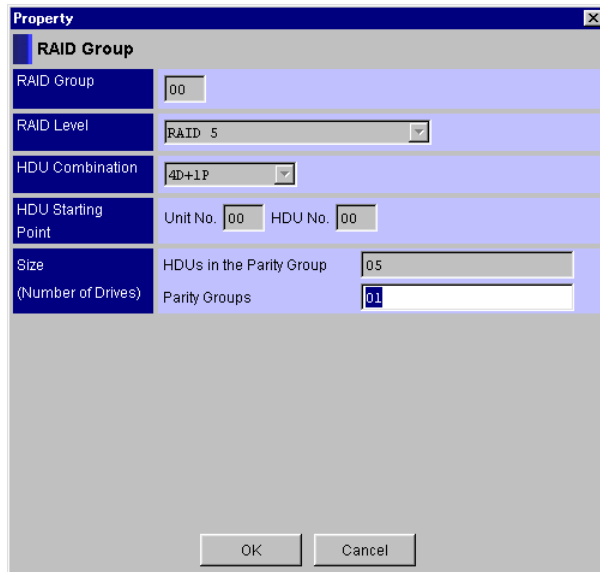

Figure 4.5 Expanding a RAID Group

3. A RAID Group can be expanded by incrementing the number of Parity Groups. Specify the number of parity group after expansion, and then click the **OK** button.



The screenshot shows a 'Property' dialog box with a 'RAID Group' tab. The fields are as follows:

RAID Group	00
RAID Level	RAID 5
HDU Combination	4D+1P
HDU Starting Point	Unit No. 00 HDU No. 00
Size (Number of Drives)	HDUs in the Parity Group: 05 Parity Groups: 01

Buttons: OK, Cancel

In RAID Group, the RAID group number of the RAID group to be expanded is displayed. In RAID Level, the RAID level of the RAID group to be expanded is displayed. In HDU Starting Point, the position of the RAID group to be expanded is displayed.

4. A message indicating completion of setting is displayed. Click the **OK** button.

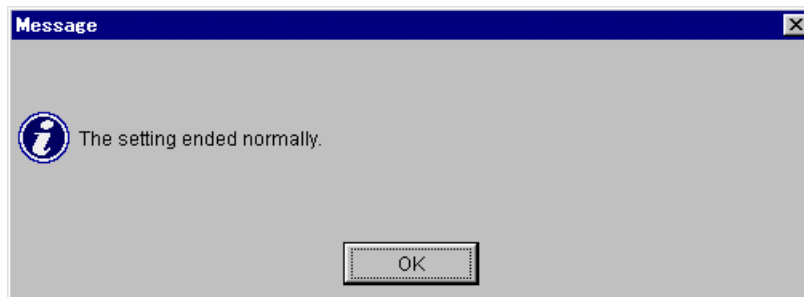

The expanded RAID group is updated and the following window is displayed.

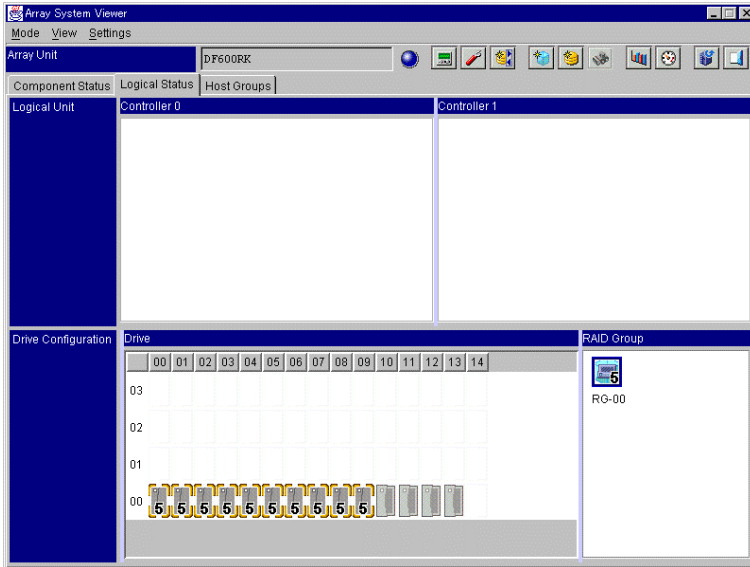

4.4 Deleting a Specified RAID Group

To delete a specified RAID group out of set RAID groups:

1. Click the **Logical Status** tab on the Unit screen.
2. Click the icon of a RAID group on the Unit screen. On the **Settings** menu, select **RAID Group** and click **Delete Specified RAID Group**.

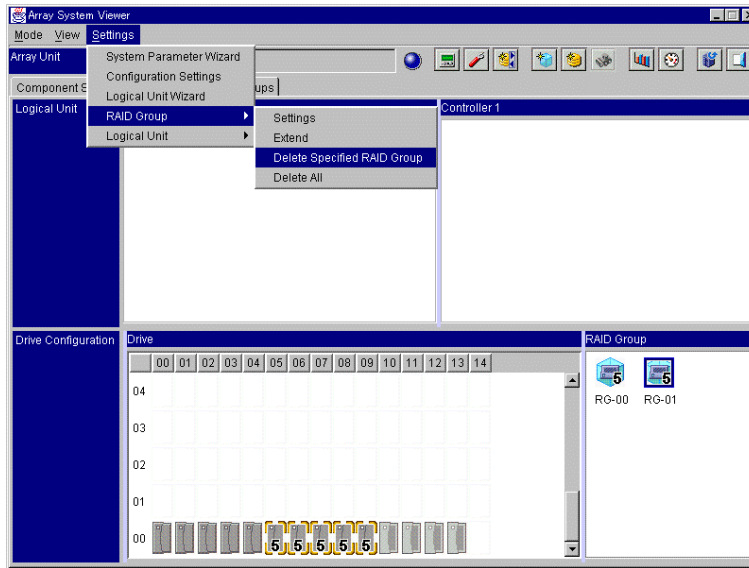
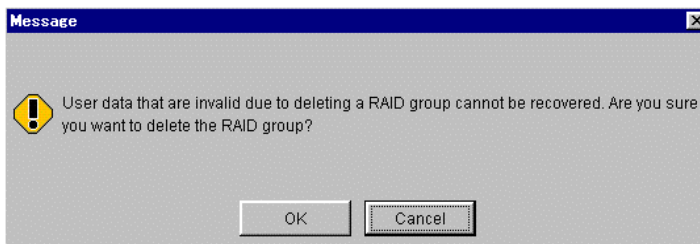
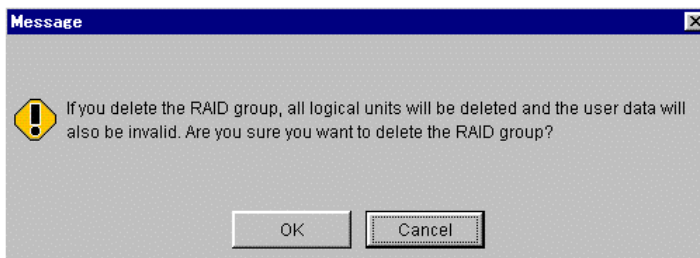
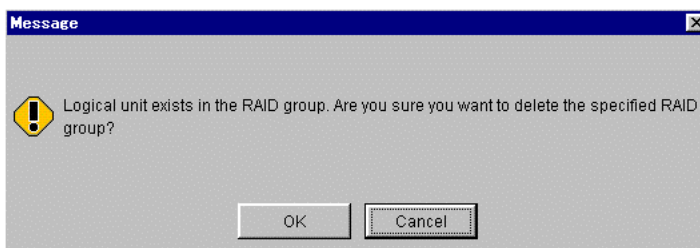

Figure 4.6 Deleting a Specified RAID Group

3. A message appears, requesting confirmation to delete the specified RAID group. Click the **OK** button.
 - a) When no logical unit exists in the RAID Group:



- b) When a logical unit exists in the RAID Group:



Note: If a logical unit is defined in the RAID group, all the user data will be invalidated by deleting the RAID group.

If a logical unit is defined in the specified RAID group, this RAID group cannot be deleted, depending on the disk array subsystem. To delete the specified RAID group, first delete all logical units in the specified RAID group, then delete the RAID group.

4. The deleted RAID group is updated and the following window is displayed.

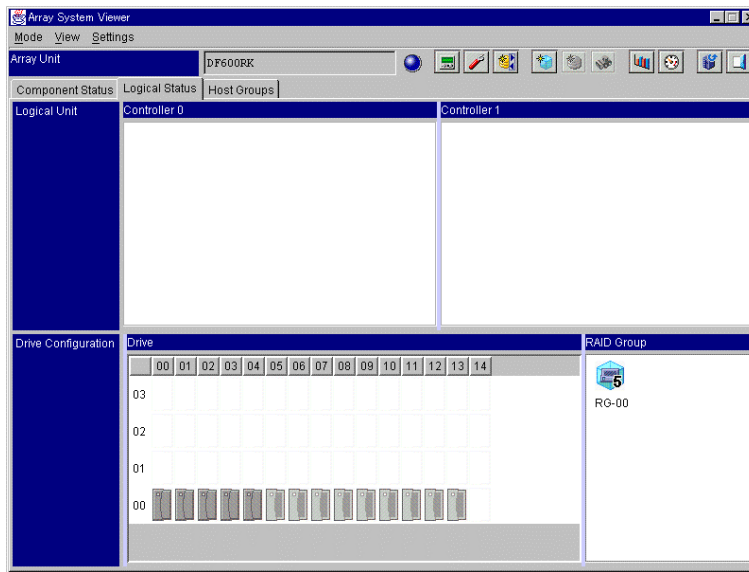

4.5 Deleting All RAID Groups

To delete the entire RAID groups that are set:

1. Click the **Logical Status** tab on the Unit screen.
2. On the **Setting** menu, select **RAID Group** and click **Delete All**.

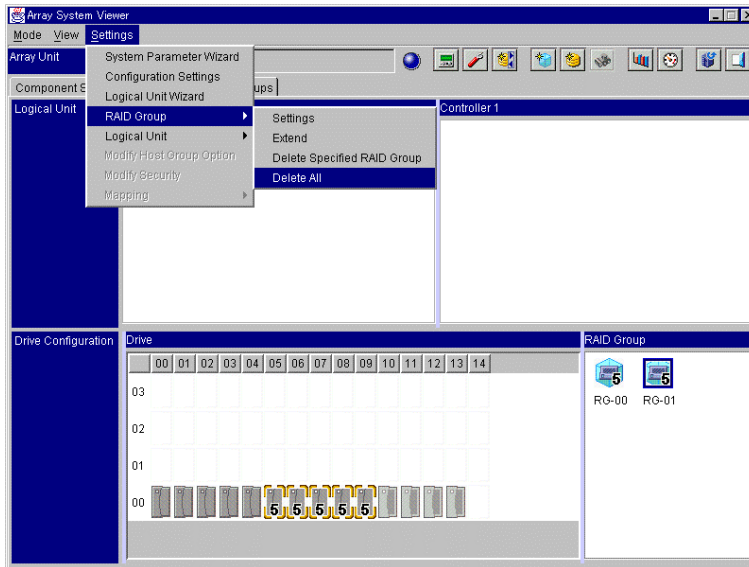
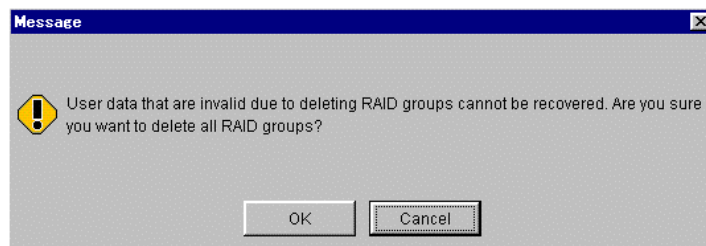
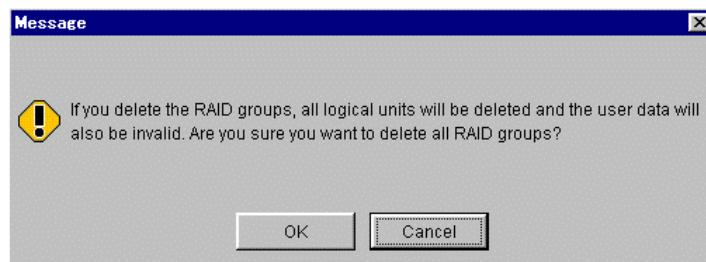
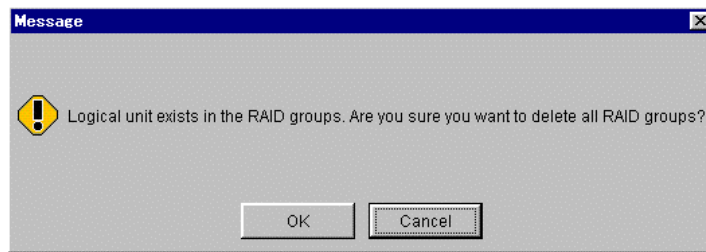

Figure 4.7 Deleting All RAID Groups

3. A message appears, requesting confirmation to delete all RAID groups. Click the **OK** button.
 - a) When there is no Logical Unit in the RAID group:



b) When a Logical Unit exists in the RAID group:



Note: If a logical unit is defined in the RAID group, all user data will be invalidated by deleting that RAID group.

The deleted RAID group is updated and the window in Figure 4.1 appears.

4.6 Constituting a Logical Unit

1. Click the **Logical Status** tab on the Unit screen.
2. Click the icon of a logical unit on the Unit screen. On the **Settings** menu, select **Logical Unit** and click **Settings**. Alternatively, click : **Logical Unit Settings** in the tool bar.

This operation can also be completed from the context menu of the Logical Unit box.

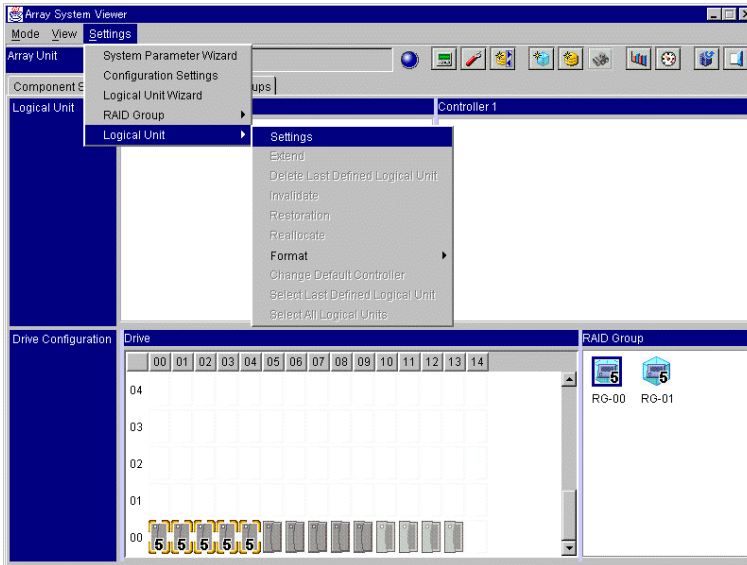

Figure 4.8 Constituting a Logical Unit

3. Select a controller in charge in **Controller** and input **Size**.

The screenshot shows the 'Property' dialog box for a Logical Unit. The 'Logical Unit No.' is 000. The 'Controller' section has 'Controller 0' selected in both 'Default' and 'Current' sub-sections. The 'Size' section has three radio buttons: 'GB' (selected), 'MB', and 'Block'. Each radio button has a text input field set to '1' and a slider below it. The 'GB' section shows '1 GB(s)(1-286)' and a slider from '1GB' to '286GB(s)'. The 'MB' section shows '1 MB(s)(1-286275)' and a slider from '1MB' to '286275MB(s)'. The 'Block' section shows '1 Block(s)(1-559132672)' and a slider from '1Block' to '559132672Block(s)'. The 'RAID Group' is 00 and 'Rest Capacity' is 286.2 GB(s). At the bottom are 'OK' and 'Cancel' buttons.

A created logical unit number is displayed for the **Logical Unit No.** and RAID group number in which logical units are defined for the **RAID Group**. Additionally, a logical unit capacity that can be created is displayed.

- Specify Number of **Block**, **MB**, or **GB** Increased

To specify a value clearly, specify the allocation (number of blocks, MBs or GBs). When you allocate all the remaining capacity of the RAID group concerned, specify a capacity displayed on the screen.

Note: The relation between MBs and blocks is: 1 MB = 2,048 blocks. A fraction less than 2,048 blocks is omitted. The relationship between GB and MB is 1 GB = 1,024 MB. A fraction less than 1,023 is omitted.

Example: 2,048,000 blocks = 1,000 MB
2,049,024 blocks = 1,000 MB

- Specify the **Controller No.**

Click the option button of **CTL0** or **CTL1** to select the controller in charge of the logical unit. (If you select the wrong controller, the logical unit can unexpectedly switch during operation. Performance quality may deteriorate as a result.)

This is necessary with a dual system connection. It is not displayed with a single system connection.

Note: When dual active mode is selected in the dual system, the controller in charge of a logical unit must be selected to set up the logical unit. Perform the logical unit setting, including the selection of the controller referred to in the following diagram. When you change a controller in charge of the logical unit, refer to **Changing the Default Controller in Charge of a Logical Unit** in this chapter.

Example:

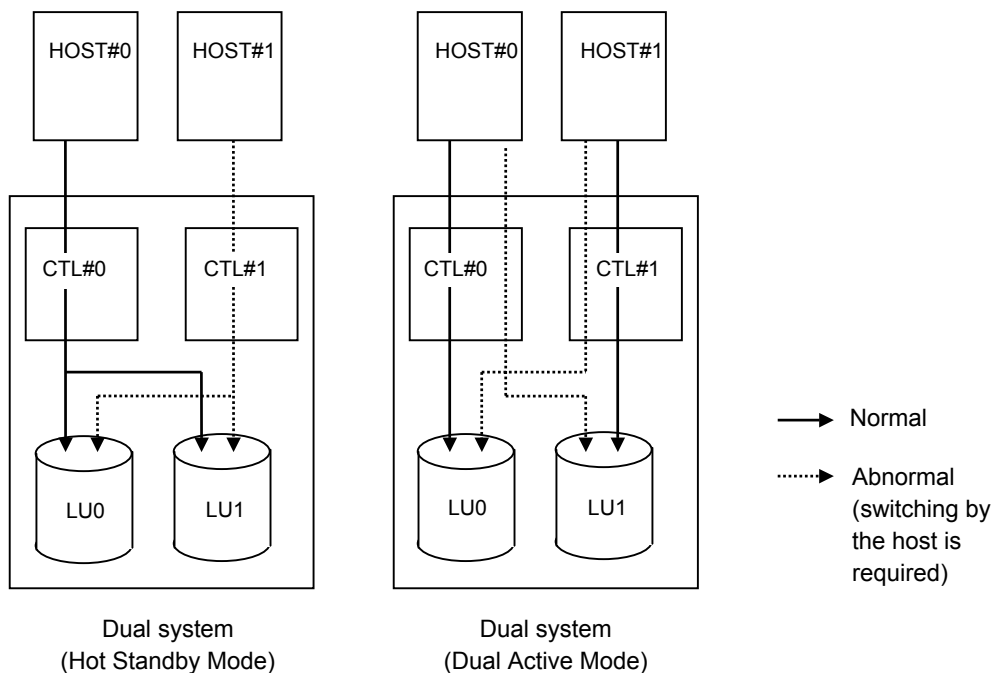

- **Hot Standby Mode:** When a failure in the host or in the controller occurs, processing can be maintained by switching the host command destination to another controller.
- **Dual Active Mode:** Select a controller to access from the host to the logical unit as the controller for the logical unit.

In the above drawing, CTL#0 is in charge of the logical unit0 and CTL#1 is in charge of the logical unit1 respectively. In this example, set up the logical unit by selecting optional button **CTL#0** to select logical unit0 and button **CTL#1** to select logical unit1 respectively.

4. After the logical unit information is set, click the **OK** button.
5. A message appears, stating that the setting is complete. Click the **OK** button.

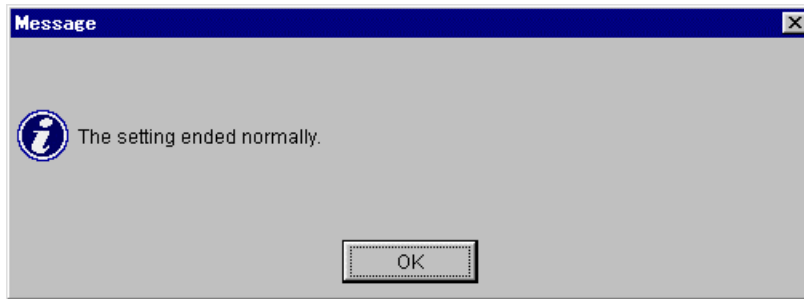

The logical unit information is updated and the window is displayed.

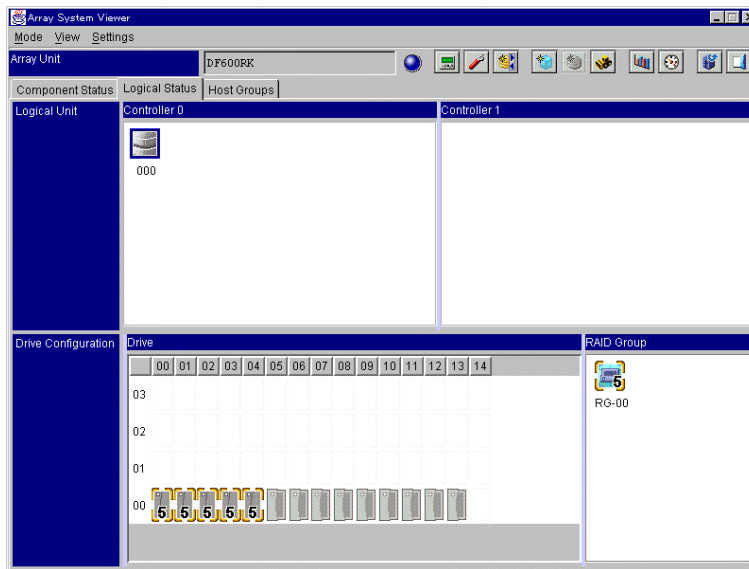

4.7 Formatting a Logical Unit

To format the logical unit:

1. Click the **Logical Status** tab on the Unit screen.

The formatting method includes 2 modes.

- **Online Format:** Specified logical units are formatted one by one and the progress of the formatting is displayed.
- **Offline Format:** If multiple logical units are specified, up to six logical units are formatted concurrently, and the progress of formatting is displayed.

When the logical units are configured for each drive, the time required for the formatting is reduced by 30 to 50 (percent).

- Configuration example: An array unit is configured to form six rows.
Each row is configured as RAID5 and each RAID group is set to one logical unit.

Note: When you format a logical unit whose capacity is less than 100,000 blocks, formatting may be terminated abnormally. When you format a logical unit whose capacity is less than 100,000 blocks, select **Online Format**.

2. Click the icon of a logical unit on the Unit screen. On the **Settings** menu, select **Logical Unit**.
 - a) To Online Format the logical unit, click **Online Format**.
 - b) To Offline Format the logical unit, click **Offline Format**.

This operation can also be completed from the context menu of the logical unit icon.

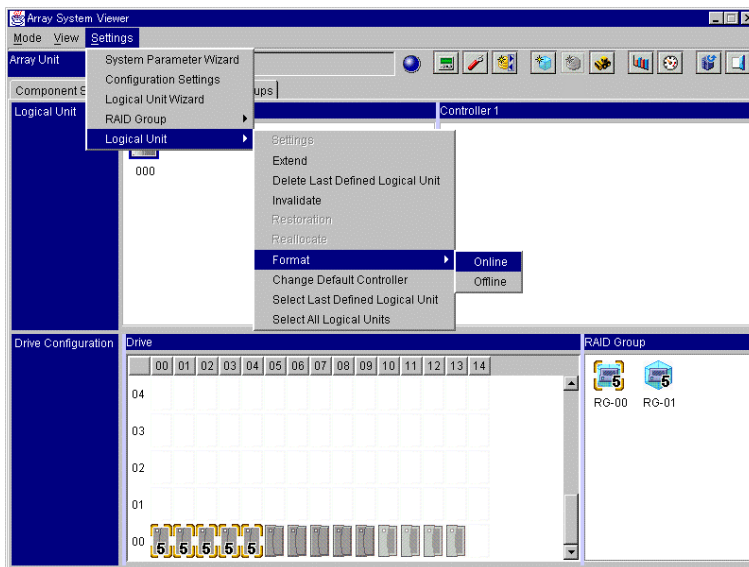

Figure 4.9 Formatting a Logical Unit

When you select multiple logical units, hold down the **Ctrl** key and click the icons of the logical units that you wish to format.

The capability of executing the formatting which corresponds to each logical unit formatting menu item varies with the Resource Manager 9500V connection type and array unit configuration, as shown in the following table.

Table 4.1 Logical Unit Formatting

No.	Logical Unit Formatting Mode	Resource Manager 9500V Connection Type and Array Unit Configuration	
		Single System Dual System + Both connectors are connected to a LAN:	Dual system + RS232C connection (9200 only) Dual system + one of the controllers is connected to a LAN:
1	Online Format	The formatting can be executed in the online status.	The formatting can be executed in the online status. Only the logical unit currently controlled by the controller connected with the PC Resource Manager 9500V can be selected. (When formatting a logical unit not connected by the controller, cable connections must be changed.)
2	Online Format Offline Format	The formatting can be executed in the online status. Online Format is selected. Only one logical unit is selected in Offline Format .	The formatting can be executed in the online status. Online Format is selected and only a logical unit currently controlled by the controller connected with the Resource Manager 9500V is selected. Offline Format is selected and only a logical unit currently controlled by the controller connected with the Resource Manager 9500V is selected.
		The formatting cannot be executed in the online status. Two or more logical units are selected in Offline Format .	The formatting cannot be executed in the online status. A logical unit not controlled by the controller connected with the Resource Manager 9500V is selected. Two or more logical units are selected in Offline Format .

Note: The formatting may be interrupted during the following conditions:

- A host is rebooting
- I/O path switching
- Access to a logical unit of the non-ownership controller

3. A message appears, requesting confirmation to format the selected logical units.
- a) When there is no formatted logical unit online:

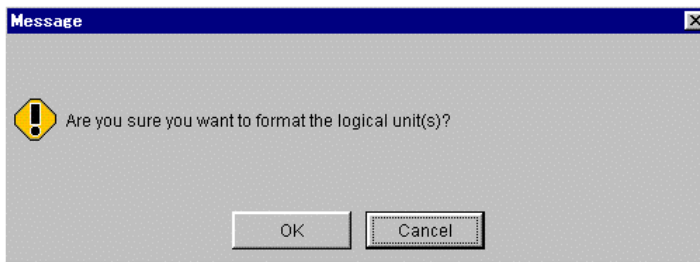

- b) When there is a formatted logical unit online:

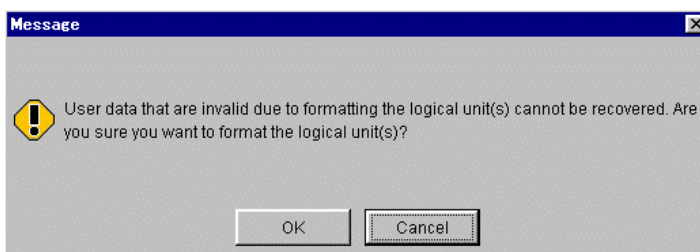
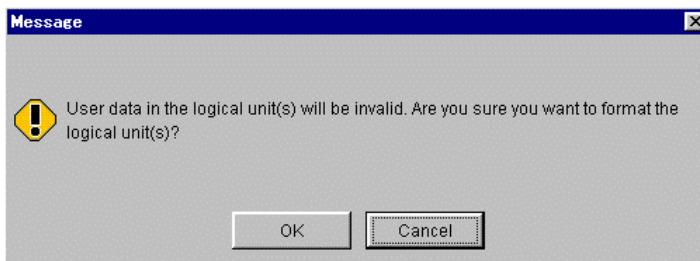
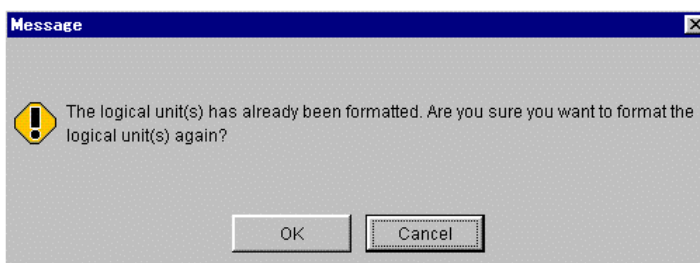

c) When there is no formatted logical unit offline:

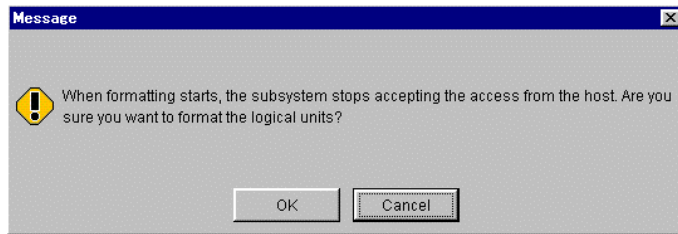
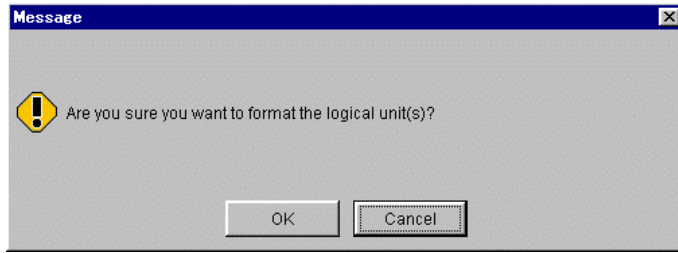

d) When there is a formatted logical unit offline:

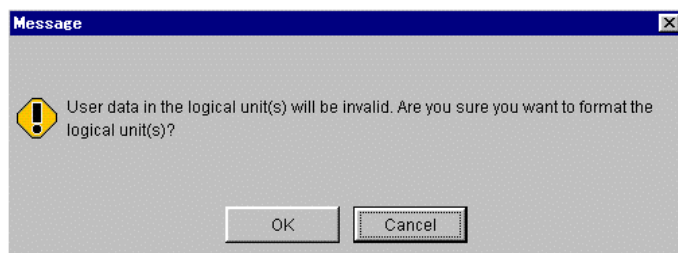
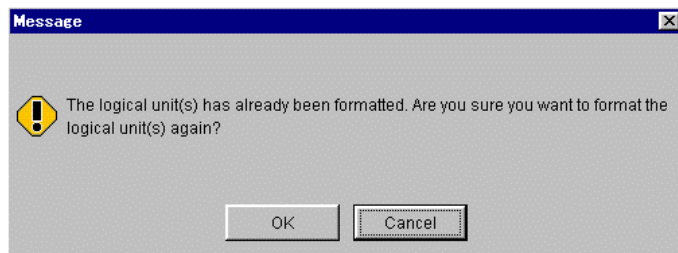

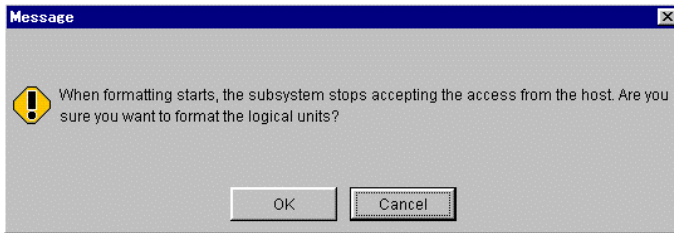
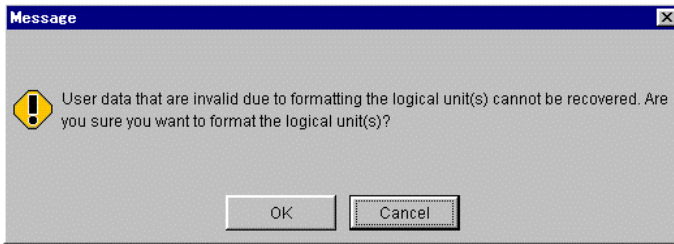

4. Click the **OK** button to format the specified logical units.

a) When **Online Format** is specified:

A screen displays the logical unit number being formatted and the execution progress for the specified logical unit. The progress status indication is renewed every 10 seconds.

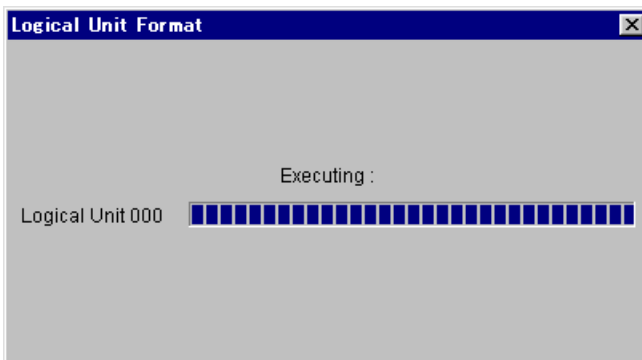

b) When **Offline Format** is specified:

A screen displays the logical unit number being formatted and the execution progress for the specified logical unit. The progress of the formatting is renewed every 10 seconds.

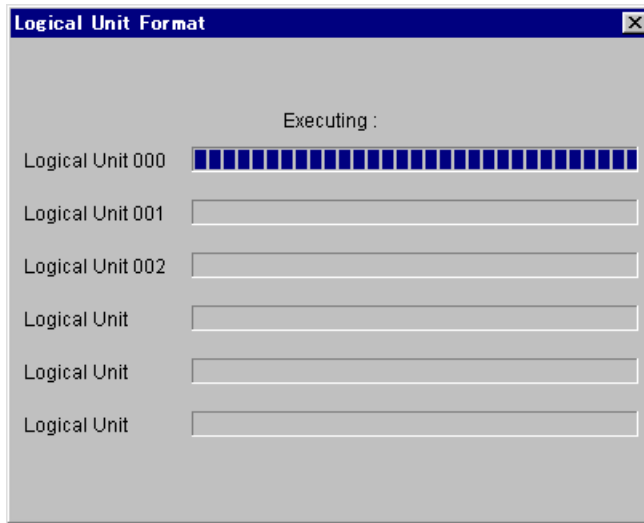

When multiple logical units are specified, up to 6 logical units are formatted in order, starting with the smallest logical unit number; the progress of the formatting is displayed.

After one logical unit is formatted, the next logical unit is formatted; the progress of the formatting is displayed.

5. When a message is displayed indicating that the specified logical unit has been formatted, click the **OK** button.

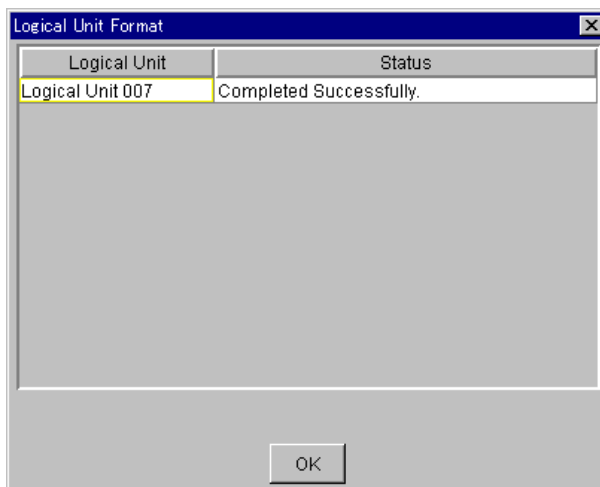

If formatting is terminated abnormally, refer to the contents of the result.

The formatted logical unit information is updated and the following window is displayed.

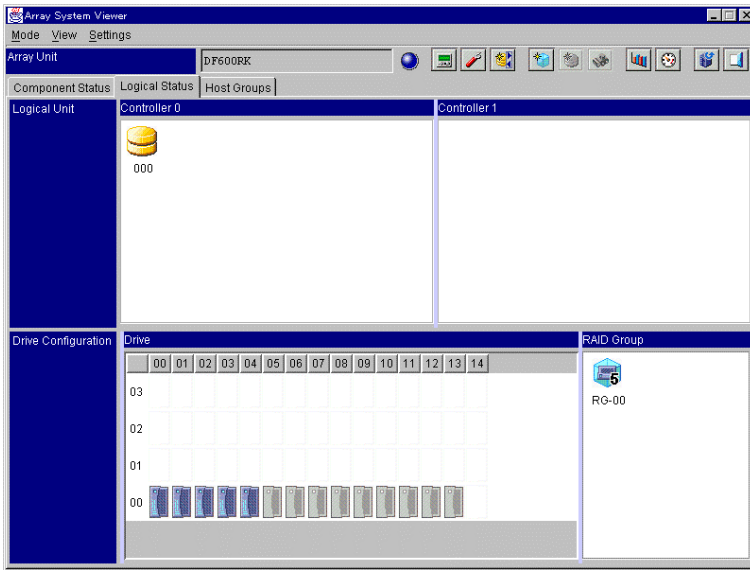
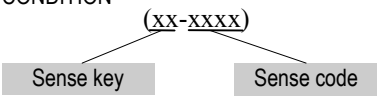

Table 4.2 Interpretation of “Logical Unit Format Results” Window

No.	Result of Logical Unit Formatting	“Status” Column	
1	Succeeded	Completed Successfully	
2	Failed Failure of a FORMAT UNIT command	Abnormal end	# CHK CONDITION (xx-xxxx) 
3	Failed The other error		A message is displayed.

When “Abnormal end” is displayed in the “Status” column, a sense key and a sense code are displayed.

- Sense key - sense code = 02-xxxx, 03-xxxx, 04-xxxx, or 0B-xxxx
The fault may possibly be caused by a hardware failure. Retry. Call maintenance personnel if the problem persists.
- Sense key - sense code = 05-xxxx
The error may possibly be caused by a wrong operation. Check the items below and retry. Call maintenance personnel if the problem persists.
 - **Logical unit #0 defined?**
The related sense-key and sense-code combinations are 05-2500 and 05-2581.
 - **Attempt made to define a logical unit over the capacity of the defined RAID group?**
Related sense-key and sense-code combination is 05-2580.
- Sense key - sense code = 0B-FD01
The controller in charge of the logical unit was switched during formatting. Check the controller in charge of the logical unit and re-execute formatting by the controller.
- Message text = See “Messages”
A message “Failed in a connection with the Array Unit” issued when selecting **Online Format**, is caused by an error (an interface error between the Resource Manager 9500V and array unit) which disables the progress state indication window. The logical unit formatting continues.

4.8 Expanding a Logical Unit

1. Click the **Logical Status** tab on the Unit screen.
2. Click the last logical unit in the Unit screen. On the **Settings** menu, select **Logical Unit** and click **Extend**.

This operation can also be completed from the context menu of the logical unit icon.

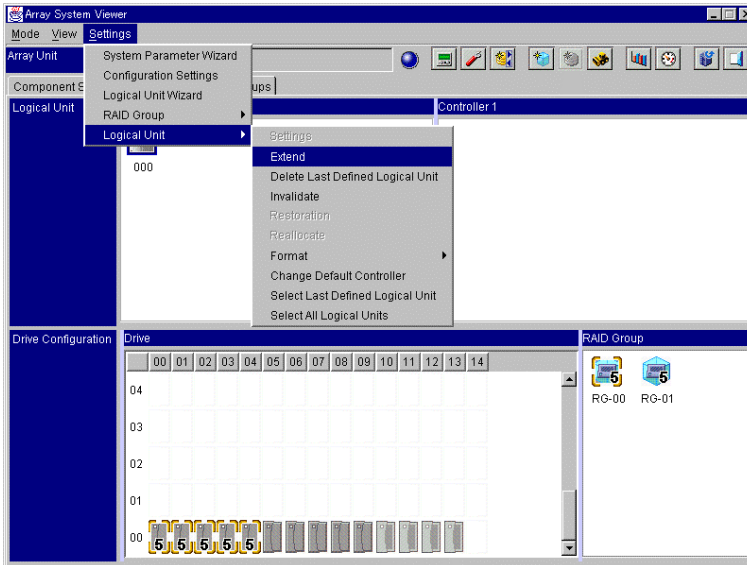
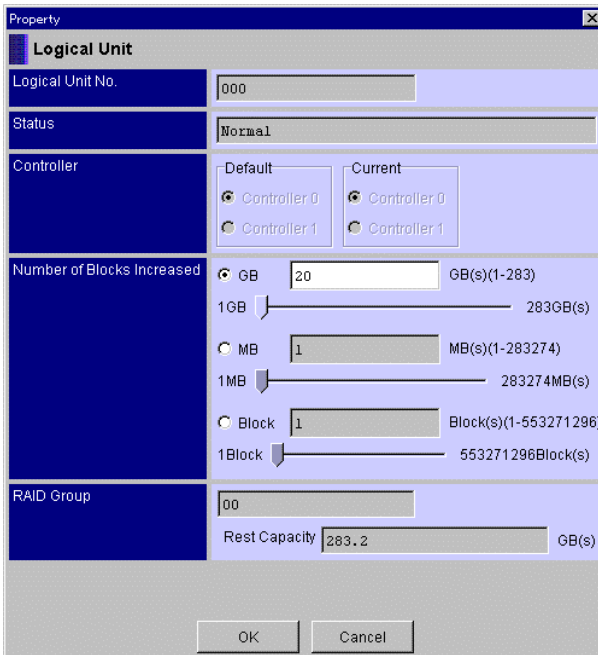
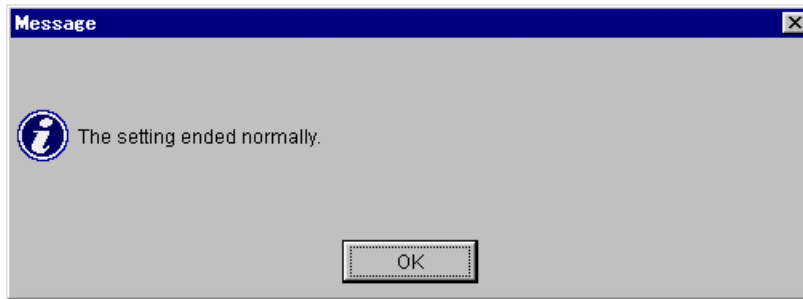

Figure 4.10 Expanding a Logical Unit

3. Specify the capacity in **Number of Blocks Increased**.



4. Complete the setting and click the **OK** button.
5. A message appears, stating that the setting is complete. Click the **OK** button.



The logical unit format is updated and the following window is displayed.

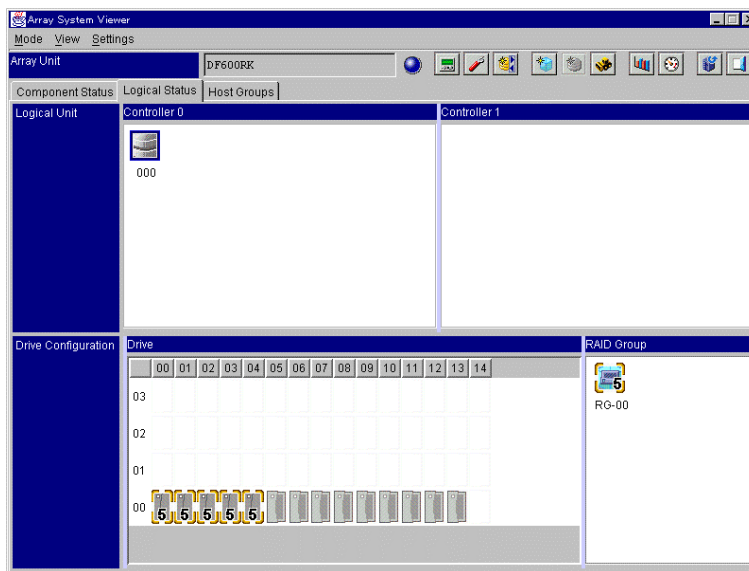

The icons of extended logical units change to unformatted icons.

Though the displayed icons are unformatted, data in logical units before extension is usable. Formatting is performed only on an extended size of an area; the full-size area after extension becomes available for use.

4.9 Deleting the Last Defined Logical Unit

To delete the last defined logical unit:

1. Click the **Logical Status** tab on the Unit screen.
2. On the **Settings** menu, select **Logical Unit** and click **Delete Last Defined Logical Unit**.

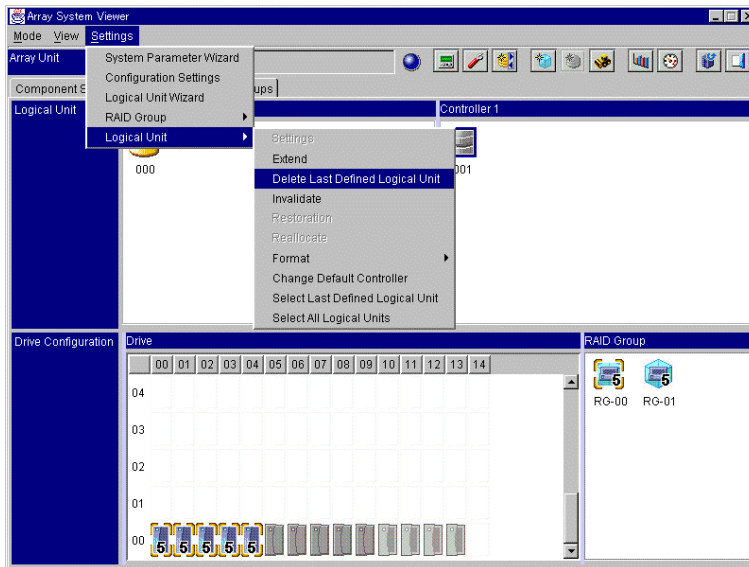
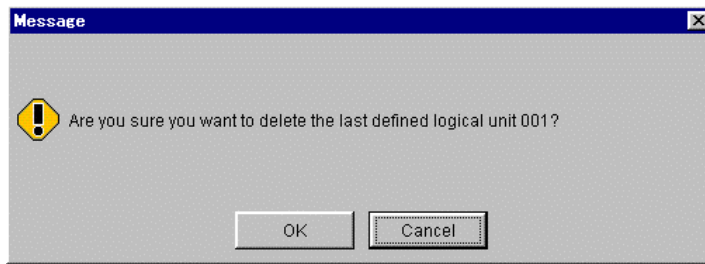

Figure 4.11 Deleting the Last Defined Logical Unit

A message appears, requesting confirmation to delete the last defined logical unit.

a) When the last defined logical unit is not formatted:



b) When the last defined logical unit is formatted:

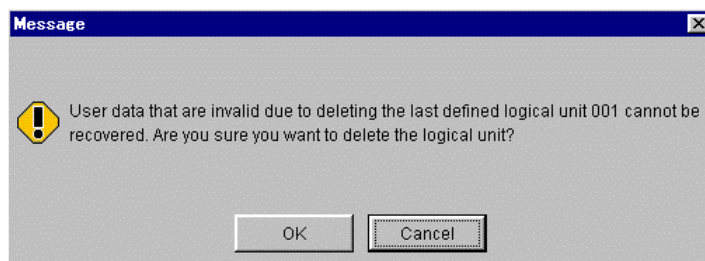
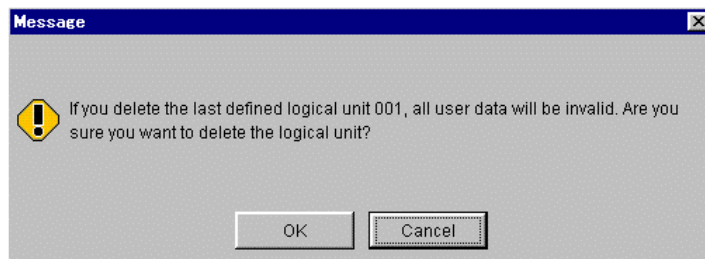
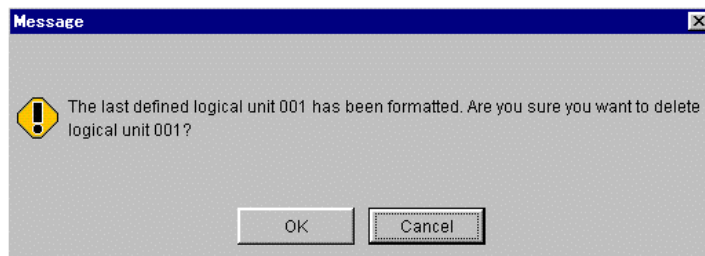

3. Click the **OK** button, and last defined logical units will be deleted. When the last defined logical units have been deleted, the user data in the logical units will be lost.

The logical unit information in which the last defined logical unit is updated and the following window is displayed.

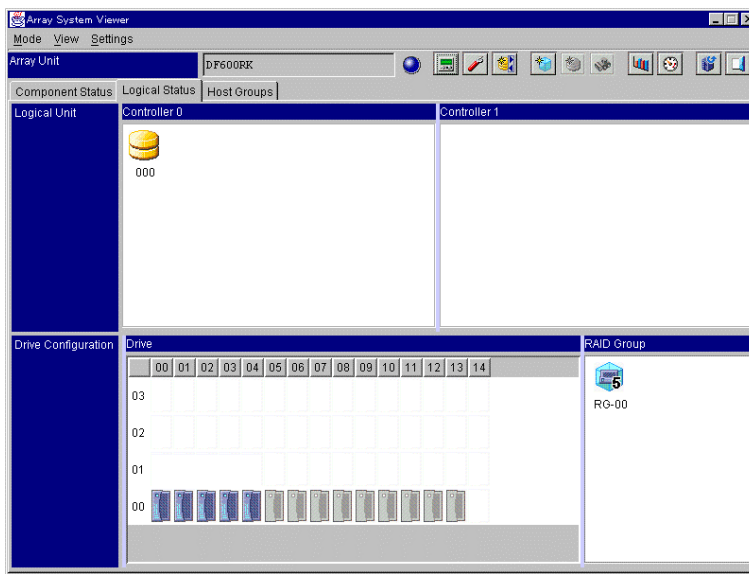

4.10 Changing the Default Controller in Charge of a Logical Unit

Operations vary, depending on the following:

- When an Array Unit Supports a Setup without Restarting
- When an Array Unit does not Support a Setup without Restarting

Note: See step four for information on this variation in operations.

1. Click the **Logical Status** tab on the Unit screen.
2. Click the last logical unit in the Unit screen. On the **Settings** menu, select **Logical Unit** and click **Change Default Controller**.

This operation can be completed from the context menu of the logical unit icon.

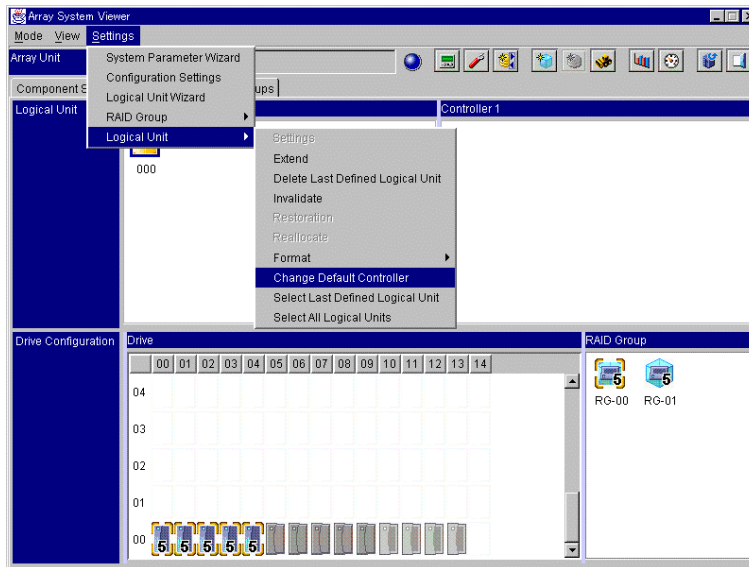
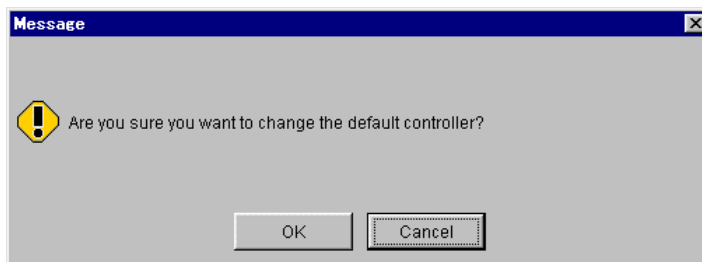

Figure 4.12 Changing the Default Controller in Charge of a Logical Unit

A message is displayed, requesting confirmation to change the default controller in charge of a logical unit.



- Click the **OK** button; the default controller in charge of the logical unit will be changed.

When an Array Unit Supports a Setup without Restarting

- A message appears, stating that the setting is complete. Click the **OK** button. (Resource Manager 9500V goes to screen A.)

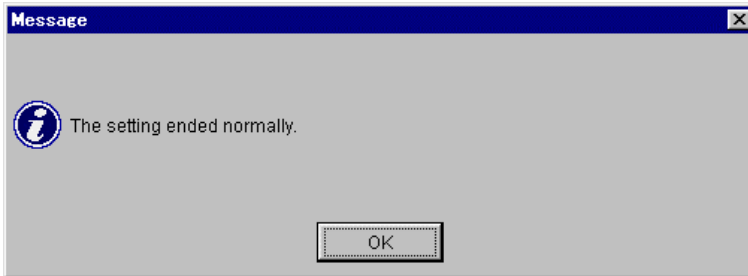

When an Array Unit does not Support a Setup without Restarting

- A message appears, stating that the default controller has been changed. A message is displayed, requesting confirmation to restart the subsystem. Click the **OK** button to restart.

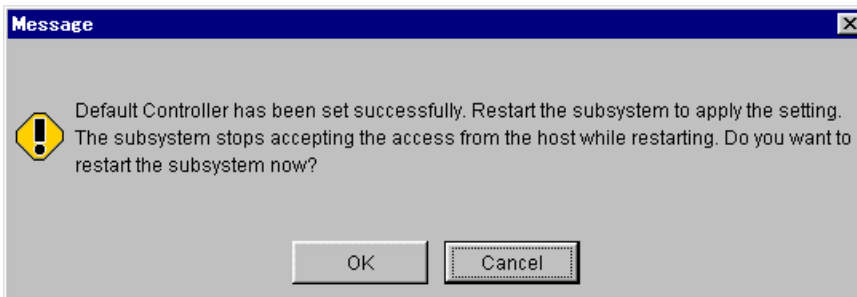

To validate the set-up default controller of a logical unit, restart the array unit. The previous setting stays valid until restarting. The array unit cannot access the host until the reboot is completed and the system restarts. Therefore, be certain the host has stopped accessing data before beginning the restart process.

When you choose to restart the array unit, the time the restart began is displayed. This usually takes approximately two to six minutes.

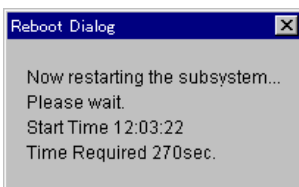

(9500V)

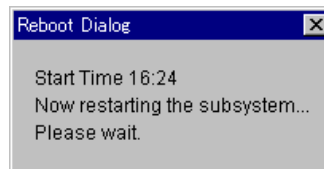

(9200)

Note: It may take time for an array unit to respond, depending on the condition of the array unit. If it does not respond after 10 minutes or more, check the condition of the array unit.

A message appears, stating that the restart is successful. Click the OK button.

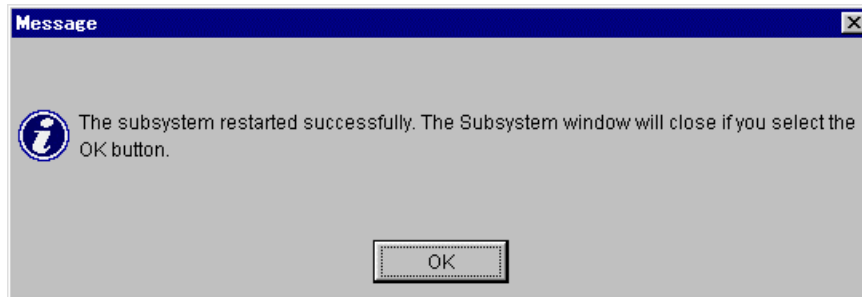

The Unit screen is closed. To perform other operations on the main window, select an array unit from the main window and open the selected Unit screen.

5. When not restarting, logical unit information in which the default controller of a logical unit has been changed is displayed on the screen after being updated.

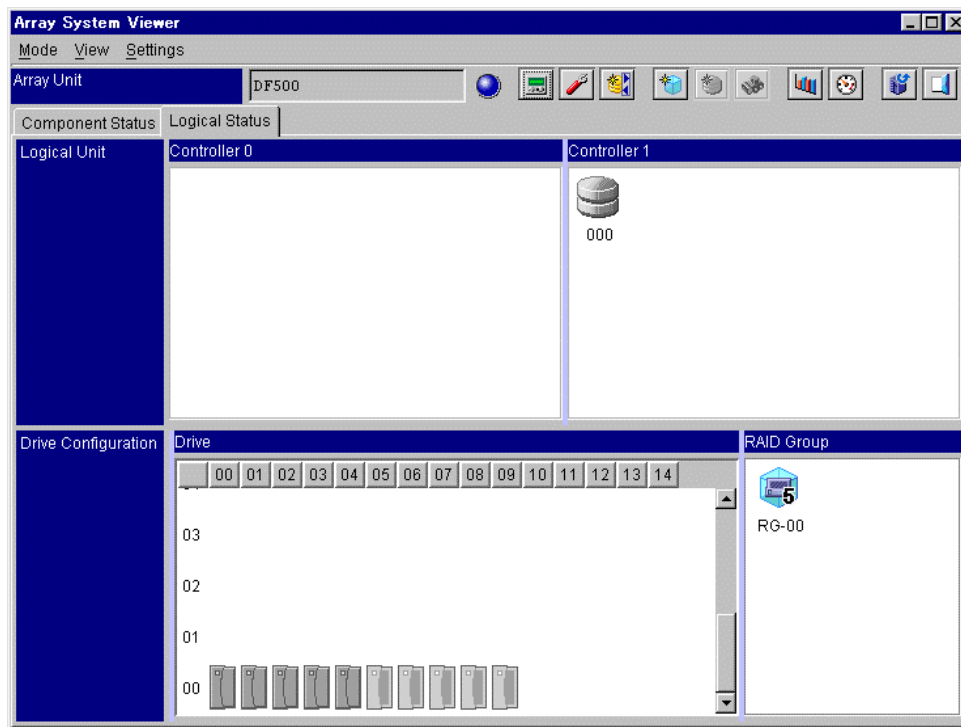

Note: Switching the default controller owning the logical unit changes the default controller currently displayed. When the switching is executed twice, the specified controller is changed to the original default controller controlling the logical unit.

4.11 Logical Unit Wizard

You can set the logical unit in the wizard format using the following methods:

- Set Up a Logical Unit in an Existing RAID Group
- Create a New RAID Group and Set U Logical Units

4.11.1 Set Up a Logical Unit in an Existing RAID Group

1. Click the Logical Status tab on the Unit screen.
2. On the **Settings** menu, select **Logical Unit Wizard** or click : Logical Unit Wizard in the tool bar.

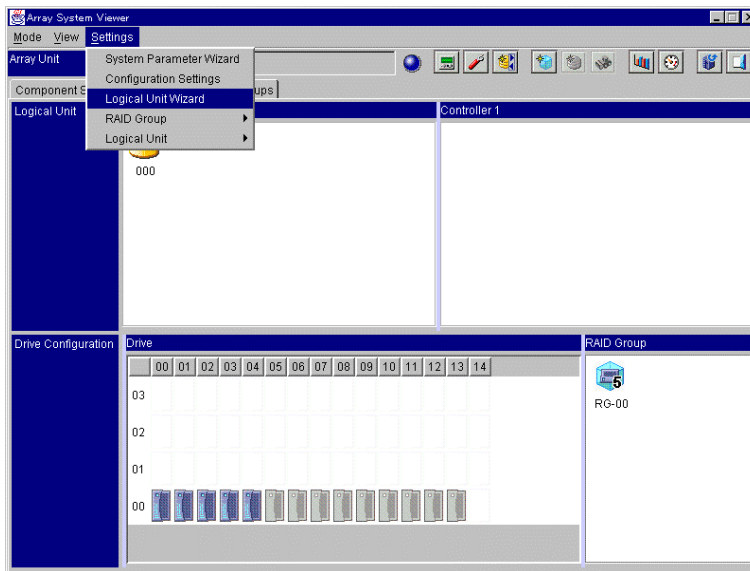
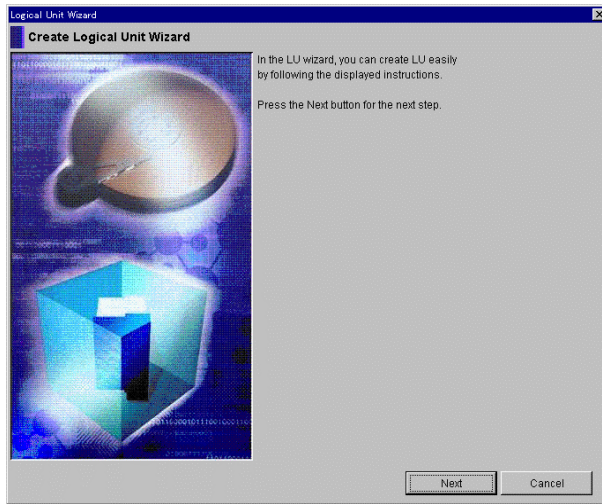
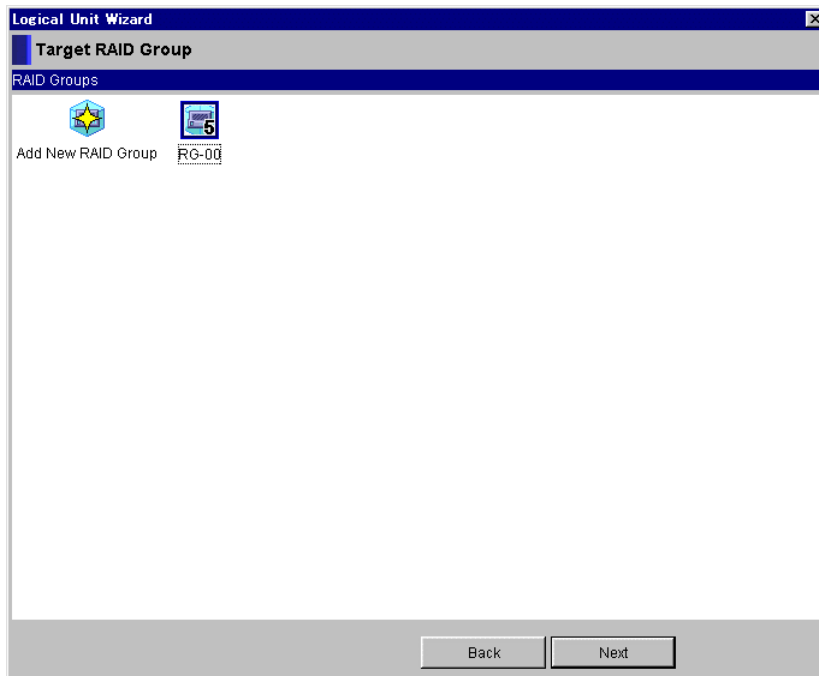

Figure 4.13 Setting the Logical Unit in the Wizard Format

3. When a **Create Logical Unit Wizard** appears, click the **Next** button.



4. Select the RAID group.



5. Click the **Next** button.

6. Select a controller from the **Controller** radio buttons and input the **Size**.

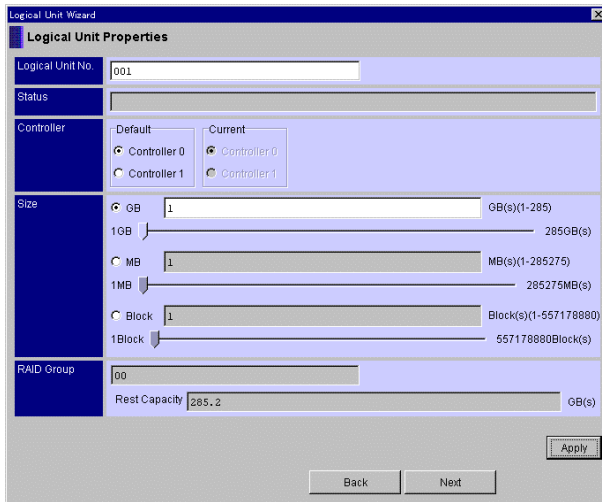

7. Click the **Apply** button to create the logical unit.

8. A message appears, stating that the setting is complete. Click the **OK** button.

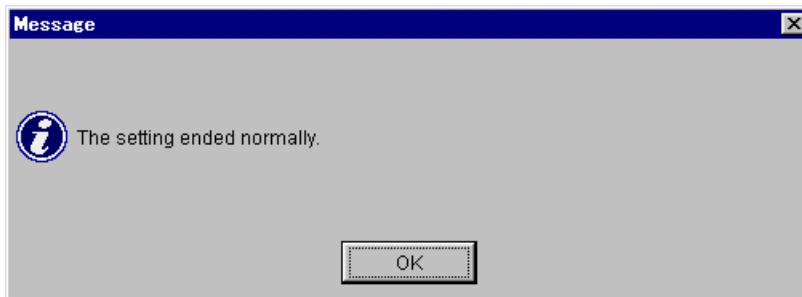

9. Click the **Next** button.

10. The setting of a set-up logical unit is displayed. Check the setting.

To format a logical unit, specify the logical unit to format, and click the **Format** button. If you set up another logical unit in the same RAID group, click the **Add Logical Unit** button.

If you set up a logical unit in another RAID group, click the **Back** button. When you are finished with the settings, click the **Complete** button.

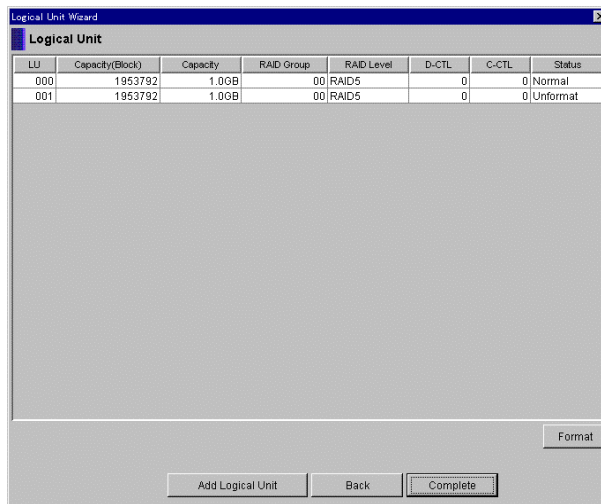

11. When the **Create Logical Unit Wizard** window appears, click the **OK** button.

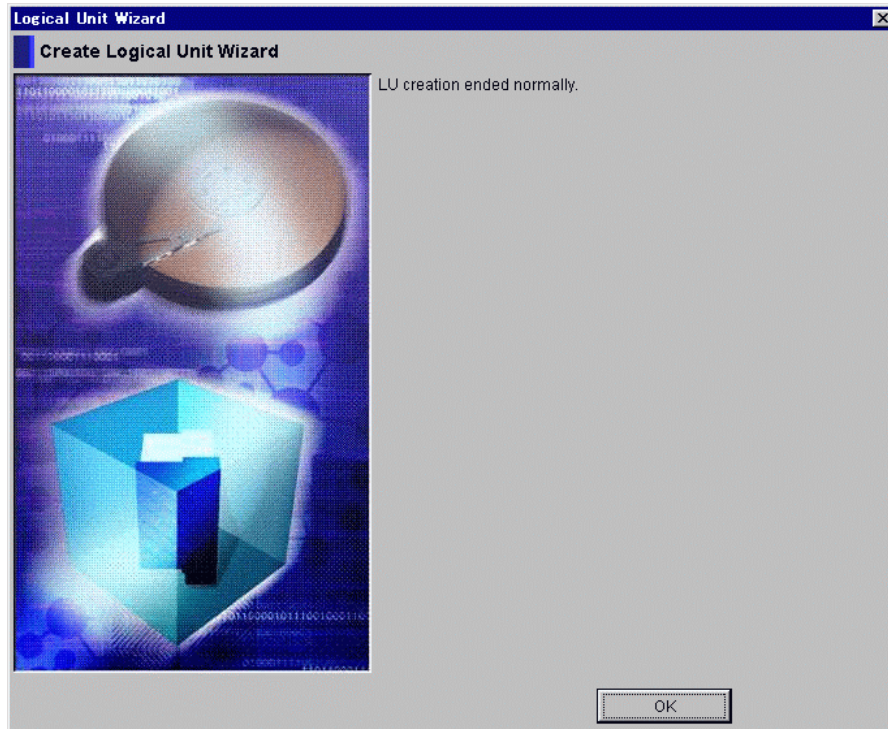

The logical unit information is updated and the window is displayed.

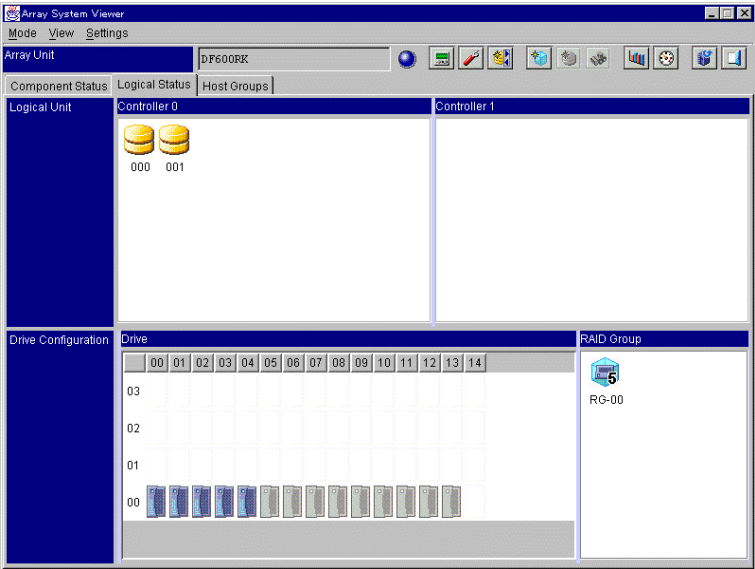

4.11.2 Create a New RAID Group and Set Logical Units

1. Click the **Logical Status** tab on the Unit screen.
2. On the **Settings** menu, select **Logical Unit Wizard** or click  in the tool bar.

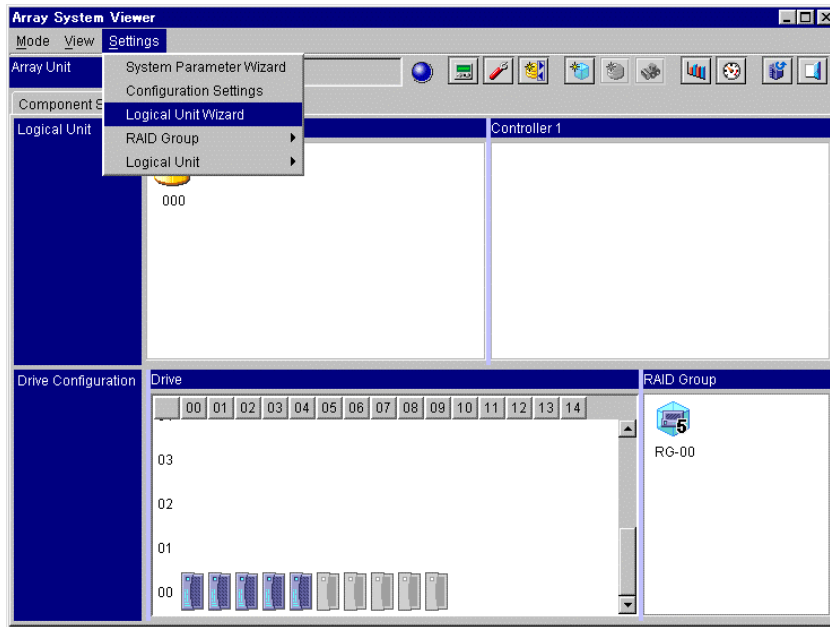

3. When the **Create Logical Unit Wizard** window appears, click the **Next** button.
4. Select the **Add New RAID Group**. Click the **Next** button.

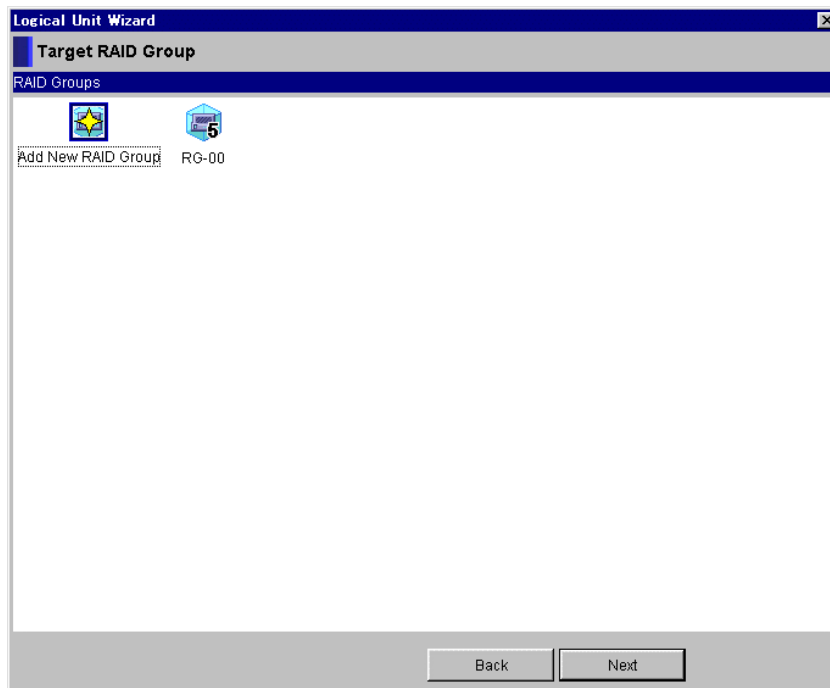

5. Select the RAID group and click the **Next** button.

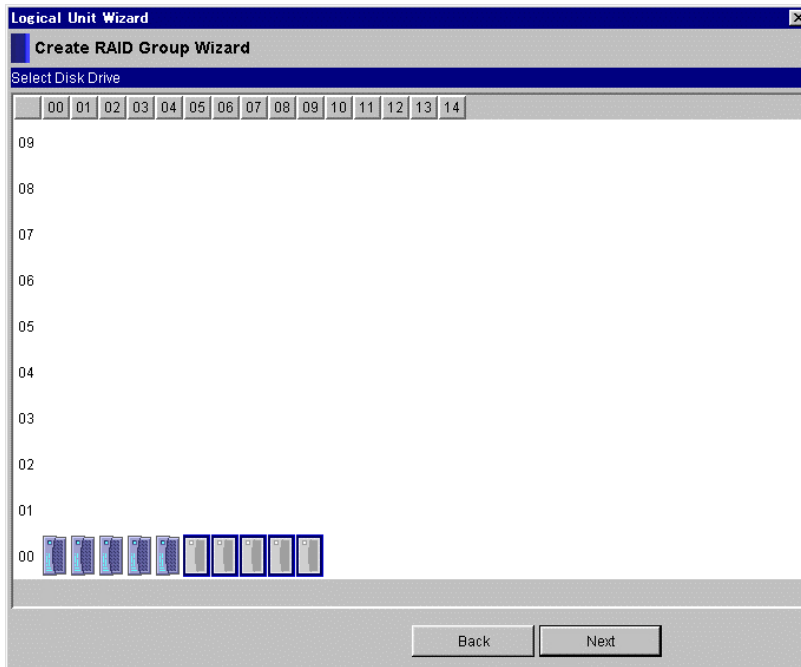

6. Select the **RAID Level** and click the **Apply** button.

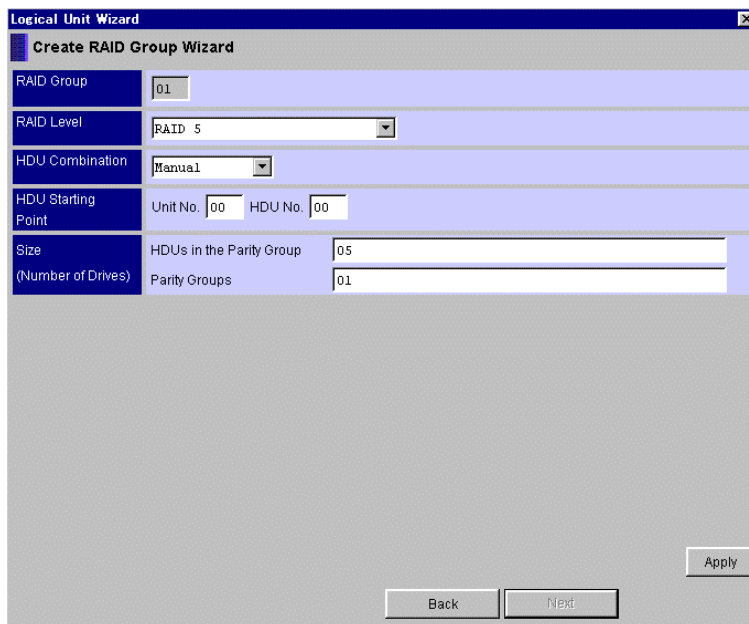

7. A message appears, stating that the setting is complete. Click the **OK** button.

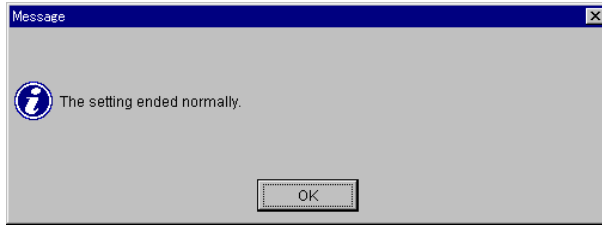

8. Click the **Next** button.

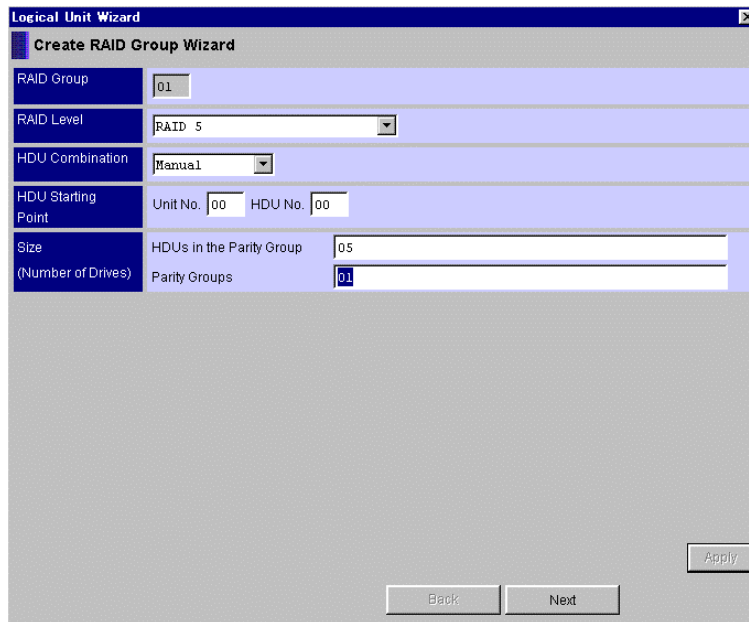

9. Select a controller from the **Controller** radio buttons and input **Size**.

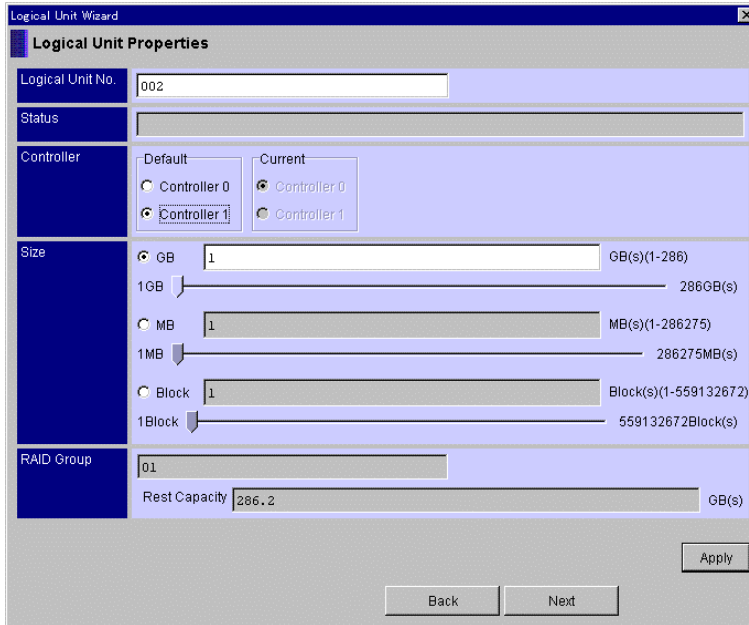

10. Click the **Apply** button.

11. A message appears, stating that the setting is complete. Click the **OK** button.

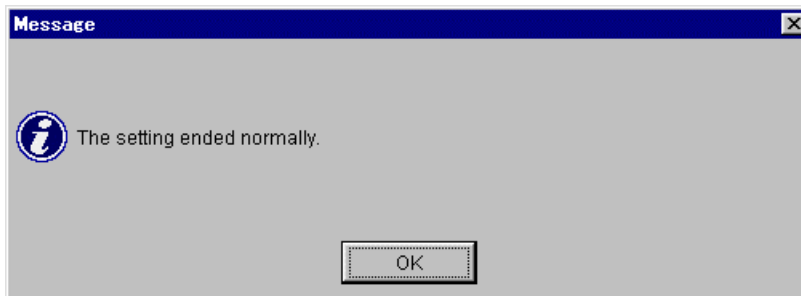

12. Click the **Next** button.

- The setting of a logical unit is displayed; check the setting. To format a logical unit, select the logical unit to format, then click the **Format** button. If you want to set up another logical unit in the same RAID group, click **Add Logical Unit**.

If you set up a logical unit in another RAID group, click the **Back** button. When you are finished, click the **Complete** button.

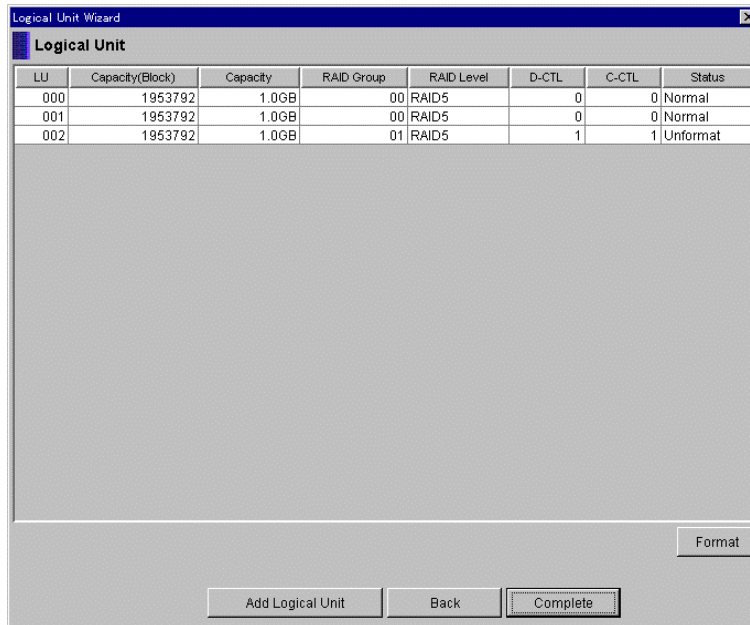

- When a **Create Logical Unit Wizard** window appears, click the **OK** button.

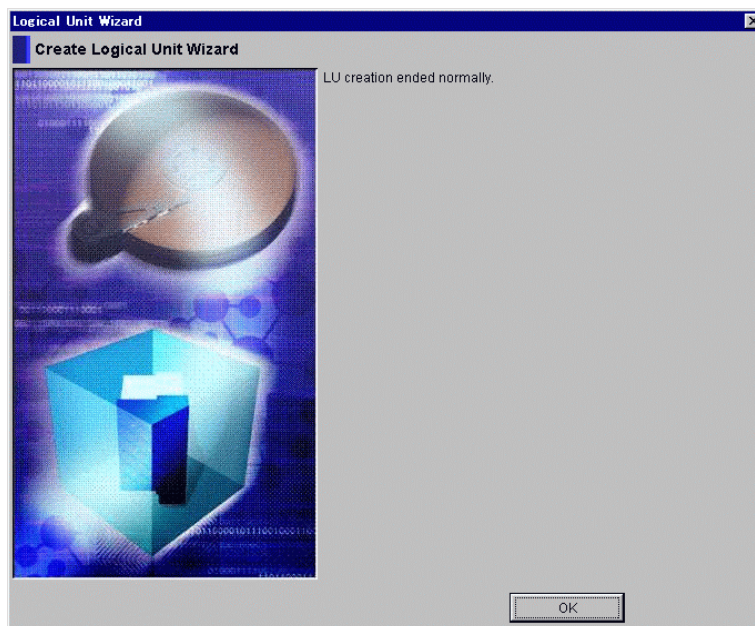

The logical unit information is updated and the following window is displayed.

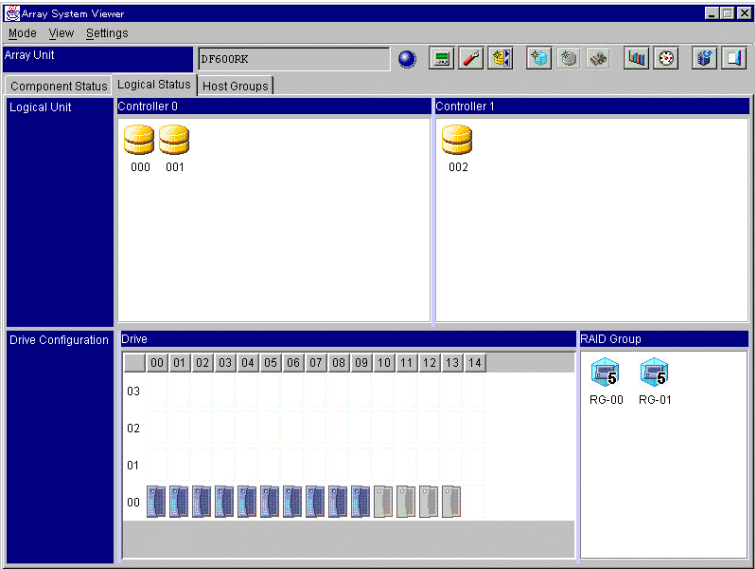

4.12 Invalidating a Logical Unit

Invalidate the specified logical unit so that a host does not recognize it.

1. Click the **Logical Status** tab on the Unit screen.
2. Select the logical unit that you want to invalidate.
3. Select **Logical Unit** in the **Settings** menu and select **Invalidate**.

This operation can be completed from the context menu of the logical unit icon.

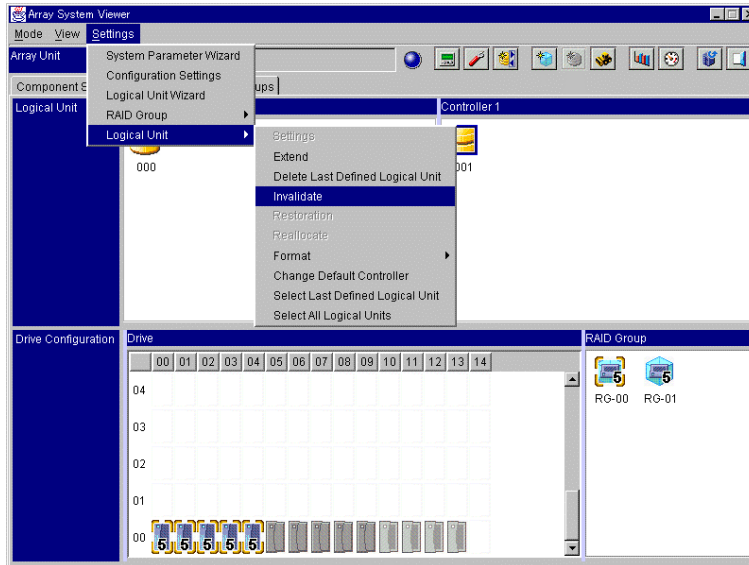
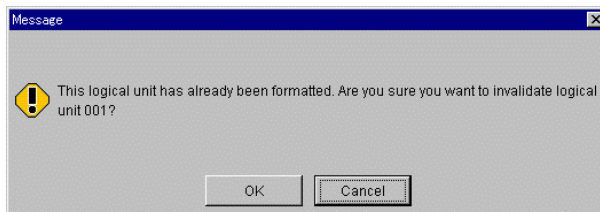
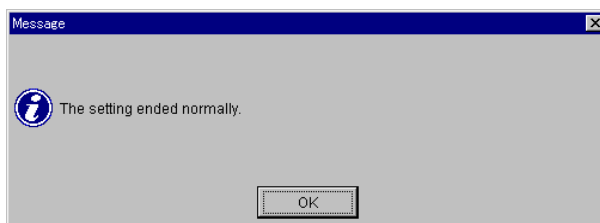

Figure 4.14 Invalidation a Logical Unit

4. A message appears, requesting confirmation to invalidate the specified logical unit. Click the **OK** button.



5. A message appears, stating that the setting is complete. Click the **OK** button.



4.13 Reassigning a Logical Unit

Make the invalidated logical unit usable by assigning part or all of its area. When part of the logical unit is assigned, the rest of the area is set as a new logical unit. The new logical unit is placed in an invalidated state. Both logical units are unformatted after the reassignment is executed.

4.13.1 Assigning Part of a Logical Unit

To assign part of a logical unit:

1. Click the **Logical Status** tab on the Unit screen.
2. Select the logical unit that you want to reassign.
3. Select **Logical Unit** in the **Settings** menu and select **Reallocate**.

This operation can be completed from the context menu of the logical unit icon.

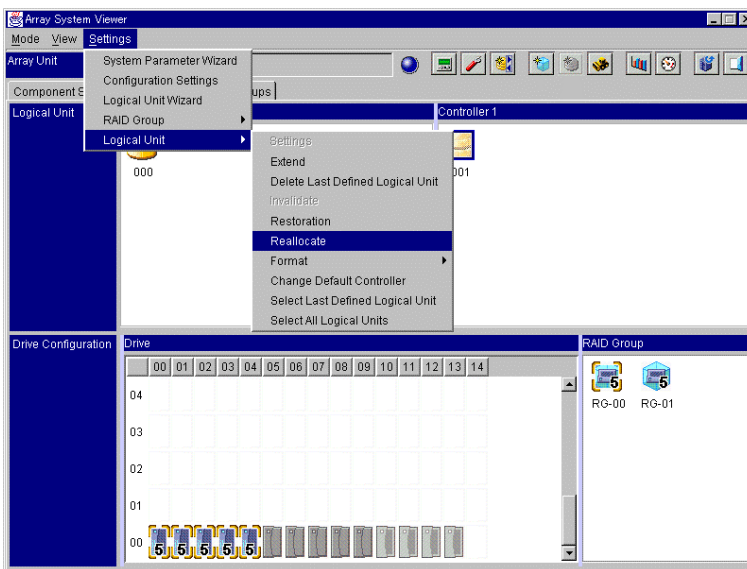

Figure 4.15 Assigning Part of a Logical Unit

- Assign part of the area in units of GB, MB, or block. When you have assigned a part of the area, specify a newly assigned logical unit number for the **New Logical Unit**. When the specification of a logical unit number is omitted, Resource Manager 9500V automatically interprets the number as being the least one of the numbers of unused logical units.

Click the **OK** button.

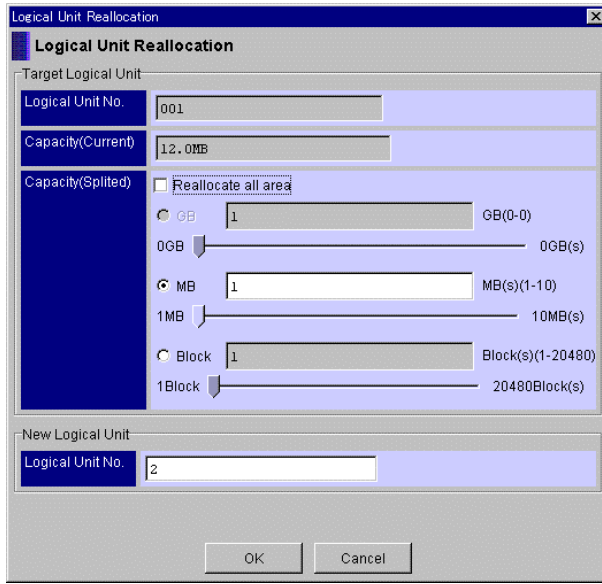
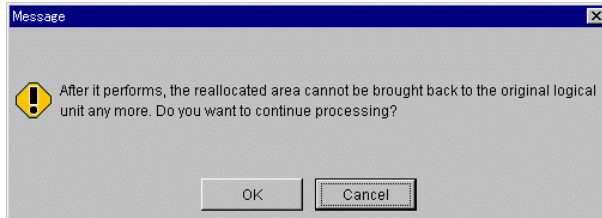
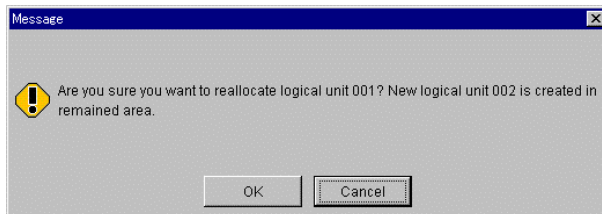
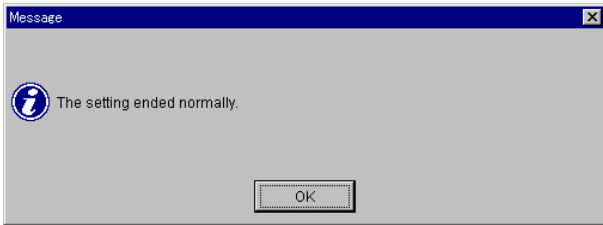
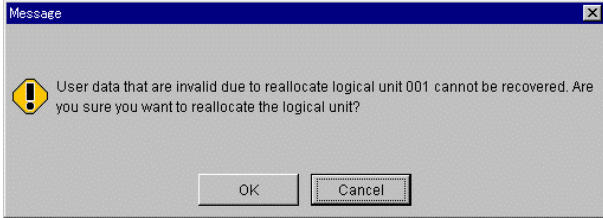
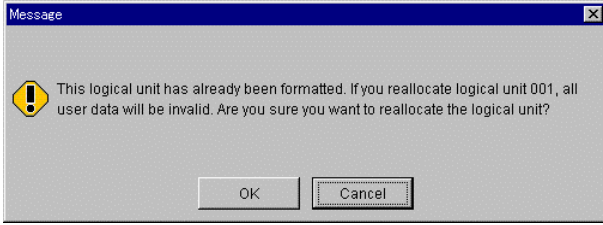

Figure 4.16 Logical Unit Reallocation Panel

The following messages appear:





4.13.2 Assigning All of a Logical Unit

To assign all of a logical unit:

1. Click the **Logical Status** tab on the Unit screen.
2. Select the logical unit that you want to reassign.
3. Select **Logical Unit** in the **Settings** menu and select **Reallocate**.

This operation can be completed from the context menu of the logical unit icon.

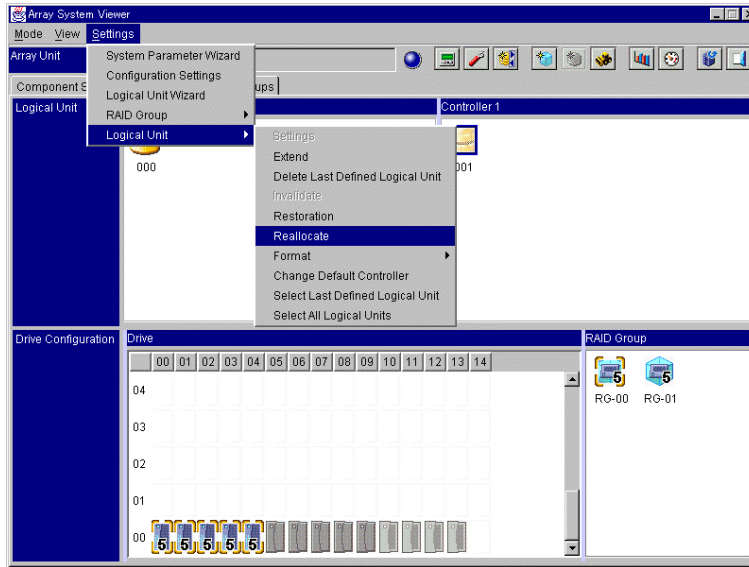
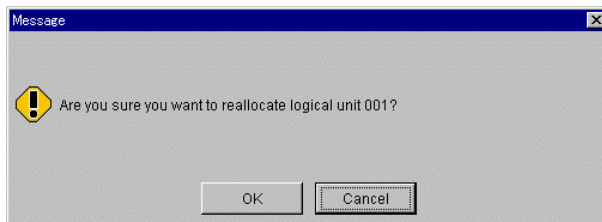
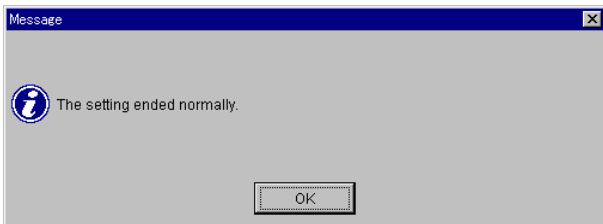
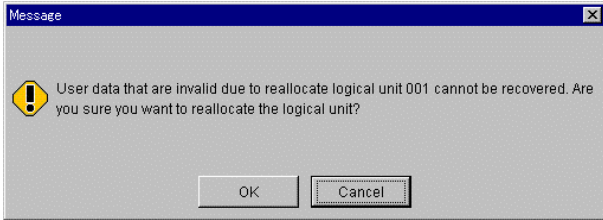
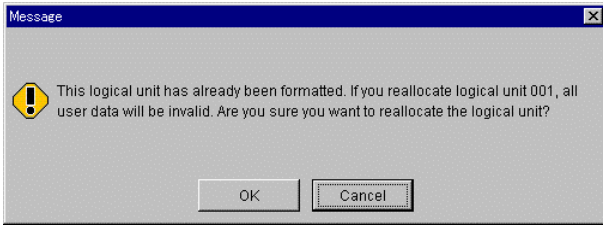

Figure 4.17 Assigning All of a Logical Unit

4. Assign the whole area by selecting **Reallocate all area**.
Click the **OK** button.

The following messages appear:





4.14 Restoring a Logical Unit

To restore the invalidated logical unit to its previous state:

1. Click the **Logical Status** tab on the Unit screen.
2. Select the logical unit that you want to restore. Select **Logical Unit** in the **Settings** menu and select **Restoration**.

This operation can be completed from the context menu of the logical unit icon.

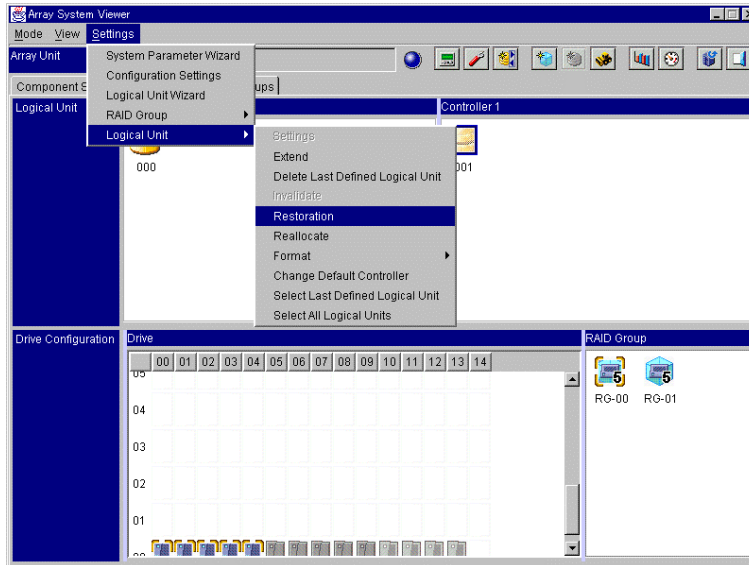
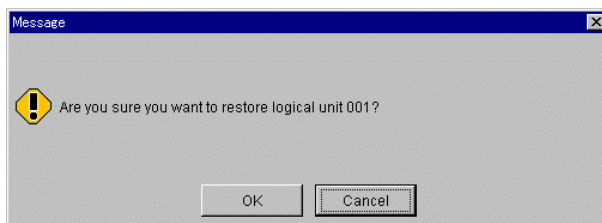
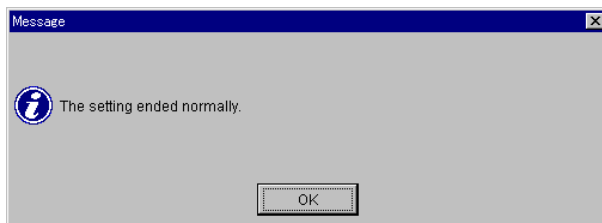

Figure 4.18 Restoring a Logical Unit

3. A message appears, requesting confirmation to restore the specified logical unit. Click the **OK** button.



4. A message appears, stating that the setting is complete. Click the **OK** button.



Chapter 5 System Parameters Setting Wizard

5.1 Setting System Parameters

Set the system parameters of the array unit in the Wizard format.

When connected to the dual system, if the controller on one side is blocked, no setting can be made. Before starting operation, make sure that the array unit is functioning normally. When setting the dual system in the RS232C (9200 only) connection, set the controller 0 side first.

When the system parameters are set, the array unit cannot execute commands from the host. Subsequently, the Resource Manager 9500V Wizard can be used for setting system parameters and error monitoring; other Resource Manager 9500V functions are no longer executable. When the setting is complete, restart the array unit; connect it to the host and the Resource Manager 9500V.

1. On the **Settings** menu, select **System Parameter Wizard** or click : **System Parameter Wizard** in the tool bar.
2. Click the **Basic Settings** or **Detailed Settings**. Click the **Next** button.

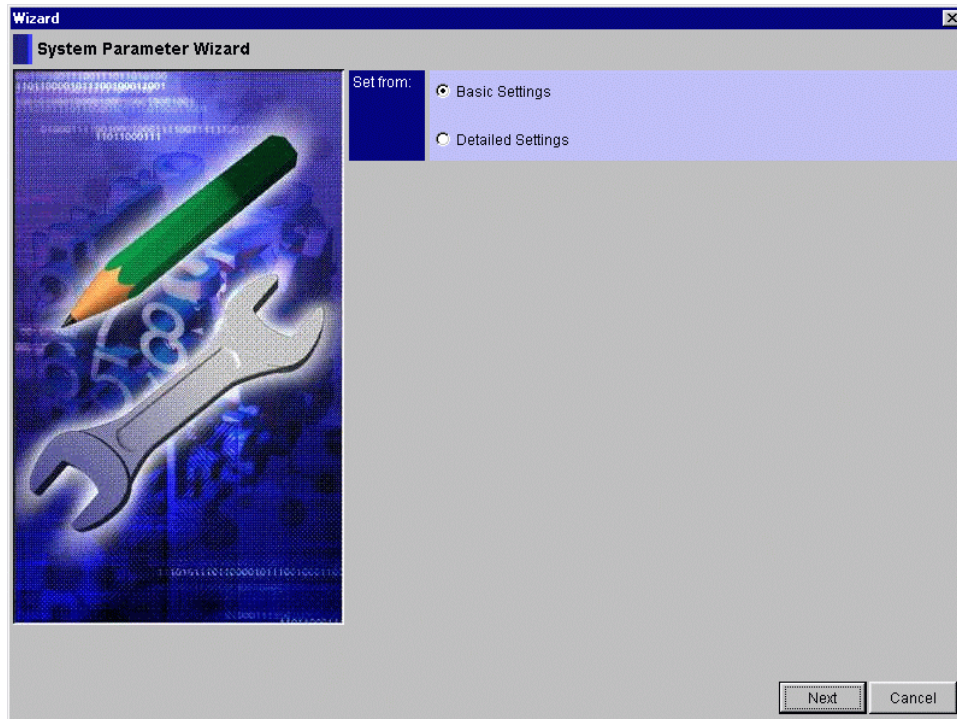

Figure 5.1 Setting the System Parameters in the Wizard Format

- **Basic Settings** can set the basic parameters for use of the array unit.
 - **Detailed Settings** can set the detailed parameters for use of the array unit.
- When you select **Basic Settings**, you can also set the **Detailed Settings** items.

The parameters are displayed in 12 screens. The parameters of the items shown in each screen vary according to of the type of array unit that is connected.

Table 5.1 List of Supported Parameters at the Basic Settings (Continued on next page)

Screen No.	Screen name	Setting item	O: Supported x: Not supported		9500V
			9200 SCSI	Fibre	
1	System Startup Settings	Start Attribute	<input type="radio"/>	<input type="radio"/>	<input type="radio"/>
		SCSI ID/Port ID Take-over Mode	<input type="radio"/>	<input type="radio"/>	<input type="radio"/>
		Default Controller	<input type="radio"/>	<input type="radio"/>	<input type="radio"/>
		Data Share Mode	<input type="radio"/>	<input type="radio"/>	<input type="radio"/>
		Host Connection Mode 1	<input type="radio"/>	<input type="radio"/>	<input checked="" type="checkbox"/>
		Standard Mode	<input type="radio"/>	<input type="radio"/>	<input checked="" type="checkbox"/>
		Open VMS Mode	<input type="radio"/>	<input type="radio"/>	<input checked="" type="checkbox"/>
		TRESPASS Mode	<input type="radio"/>	<input type="radio"/>	<input checked="" type="checkbox"/>
		Wolfpack Mode	<input type="radio"/>	<input type="radio"/>	<input checked="" type="checkbox"/>
		IBM7135 I/O path switch Mode	<input type="radio"/>	<input checked="" type="checkbox"/>	<input checked="" type="checkbox"/>
		NCR I/O path switch Mode	<input type="radio"/>	<input checked="" type="checkbox"/>	<input checked="" type="checkbox"/>
		Host Connection Mode 2	<input type="radio"/>	<input type="radio"/>	<input checked="" type="checkbox"/>
		VxVM DMP Mode	<input type="radio"/>	<input type="radio"/>	<input checked="" type="checkbox"/>
		ODE Mapper Mode	<input type="radio"/>	<input checked="" type="checkbox"/>	<input checked="" type="checkbox"/>
		HP® Connection Mode	<input checked="" type="checkbox"/>	<input type="radio"/>	<input checked="" type="checkbox"/>
		Report inquiry page 83H	<input type="radio"/>	<input type="radio"/>	<input checked="" type="checkbox"/>
		UA (06/2A00) suppress Mode	<input type="radio"/>	<input type="radio"/>	<input checked="" type="checkbox"/>
		HISUP Mode	<input type="radio"/>	<input type="radio"/>	<input checked="" type="checkbox"/>
		CCHS Mode	<input type="radio"/>	<input type="radio"/>	<input checked="" type="checkbox"/>
		Standard INQUIRY data expand Mode	<input type="radio"/>	<input type="radio"/>	<input checked="" type="checkbox"/>
		HP® Connection Mode 2	<input checked="" type="checkbox"/>	<input type="radio"/>	<input checked="" type="checkbox"/>
		Product ID DF400 Mode	<input type="radio"/>	<input type="radio"/>	<input checked="" type="checkbox"/>
		HBA WWN Report Mode	<input type="radio"/>	<input type="radio"/>	<input checked="" type="checkbox"/>
		NACA Mode	<input checked="" type="checkbox"/>	<input type="radio"/>	<input checked="" type="checkbox"/>
		SUN Cluster Connection Mode	<input type="radio"/>	<input type="radio"/>	<input checked="" type="checkbox"/>
		Persistent RSV Cluster Mode	<input type="radio"/>	<input type="radio"/>	<input checked="" type="checkbox"/>
ftServer Connection Mode 1	<input checked="" type="checkbox"/>	<input type="radio"/>	<input checked="" type="checkbox"/>		
ftServer Connection Mode 2	<input checked="" type="checkbox"/>	<input type="radio"/>	<input checked="" type="checkbox"/>		
SRC Read Command Reject Mode	<input checked="" type="checkbox"/>	<input type="radio"/>	<input checked="" type="checkbox"/>		

Table 5.1 List of Supported Parameters at the Basic Settings (Continued)

Screen No.	Screen name	Setting item	9200		9500V
			SCSI	Fibre	
2	Common1	Serial Number	○	○	×
		Delay Planned Shutdown	○	○	○
		Additional Battery Unit Mode	×	×	○
3	Option 1	SCSI/Fibre-Channel Common Options	○	○	○
		Drive Detach Mode	○	○	○
		SCSI Option	○	×	×
		Fibre-Channel Options	×	○	×
4	Option 2	SCSI/Fibre-Channel Common Options	○	○	○
		Multipath (Controller)	○	○	×
		PROCOM Mode	○	○	○
		Report Status (Normal/Warning)	○	○	○
		Multipath (Array Unit)	○	○	×
		Turbo LU Warning	○	○	○
		NX Mode	○	○	○
		Auto Reconstruction Mode	○	○	○
		Forced Write Through Mode	○	○	○
		Changing Logical Unit Mode 1	○	○	○
		Multiple Stream Mode	○	○	○
		Multiple Stream Mode (Write)	×	×	○
		Multiple Stream Mode (Read)	×	×	○
		Fibre-Channel Options	×	○	×
RAID3 Mode	×	○	×		
5	Target ID	Target ID	○	○	×

Table 5.2 List of Supported Parameters at the Detailed Settings

Screen No.	Screen name	Setting item	9200		9500V
			SCSI	Fibre	
6	Data Striping	Data Striping Size	<input type="radio"/>	<input type="radio"/>	<input type="checkbox"/>
		Logical Unit size to be reported to the host	<input type="radio"/>	<input type="checkbox"/>	<input type="checkbox"/>
		Operation if the processor failure occurs	<input type="radio"/>	<input type="radio"/>	<input type="radio"/>
7	INQUIRY Setting	Command Queuing	<input type="radio"/>	<input type="radio"/>	<input type="radio"/>
		ANSI Version	<input type="radio"/>	<input type="checkbox"/>	<input type="checkbox"/>
		Vendor ID	<input type="radio"/>	<input type="radio"/>	<input type="radio"/>
		Product ID	<input type="radio"/>	<input type="radio"/>	<input type="radio"/>
		ROM Microprogram Version	<input type="radio"/>	<input type="radio"/>	<input type="radio"/>
		RAM Microprogram Version	<input type="radio"/>	<input type="radio"/>	<input type="radio"/>
		Web Title	<input type="radio"/>	<input type="radio"/>	<input type="radio"/>
		Cache Mode	<input type="radio"/>	<input type="radio"/>	<input type="checkbox"/>
		Host Connection Mode	<input type="checkbox"/>	<input type="radio"/>	<input type="checkbox"/>
		8	Port Type	Reset/LIP Mode	<input type="radio"/>
Reset/LIP Mode (Signal)	<input type="radio"/>			<input type="radio"/>	<input type="radio"/>
Reset/LIP Mode (Process)	<input type="radio"/>			<input type="radio"/>	<input type="radio"/>
Reset ALL LIP Port Mode	<input type="checkbox"/>			<input type="radio"/>	<input type="radio"/>
Reset Target (Reset Bus Device) Mode	<input type="radio"/>			<input type="radio"/>	<input type="checkbox"/>
Reserve Mode	<input type="radio"/>			<input type="radio"/>	<input type="checkbox"/>
Reset Logical Unit Mode	<input type="checkbox"/>			<input type="radio"/>	<input type="checkbox"/>
Reset Logout of Third Party Process Mode	<input type="checkbox"/>			<input type="radio"/>	<input type="checkbox"/>
9	ROM Response	ROM Pseudo-response command processing	<input type="radio"/>	<input type="checkbox"/>	<input type="checkbox"/>
		Save Data pointer response	<input type="radio"/>	<input type="checkbox"/>	<input type="checkbox"/>
10	Controller Option	Controller Identifier	<input type="radio"/>	<input type="radio"/>	<input type="checkbox"/>
		RS232C Error Information Outflow Mode	<input type="radio"/>	<input type="radio"/>	<input type="radio"/>
		Execute Write & Verify Mode	<input type="radio"/>	<input type="radio"/>	<input type="radio"/>
11	LAN Setting	DHCP	<input type="radio"/>	<input type="radio"/>	<input type="radio"/>
		Network	<input type="radio"/>	<input type="radio"/>	<input type="radio"/>
12	SCSI	Port	<input type="radio"/>	<input type="checkbox"/>	<input type="checkbox"/>
		Board Type	<input type="radio"/>	<input type="checkbox"/>	<input type="checkbox"/>
		Transfer Rate	<input type="radio"/>	<input type="checkbox"/>	<input type="checkbox"/>

The items that are required to be set when the array unit is used in the special mode are shown below. Set items not shown below are to be set according to the environment in which they are used (9200).

Table 5.3 Settings when I/O Path Switching Function used in the Sequent NUMA-Q Connection

No.	Setting Item	Set Value	No. of Windows Displayed
1	Host Connection Mode	TRESPASS Mode	1
2	SCSI/Fibre-Channel Common Options	Multipath (Controller)	4
3	Controller Identifier	Enable	10
	Controller ID	DF500-00C0 (default value)	

Table 5.4 Settings when the Array Unit used in the WolfPack Mode

No.	Setting item	Set value	No. of windows displayed
1	Host Connection Mode	Wolfpack Mode	1
2	Reset/LIP Mode	Reset/LIP Mode (Signal) Reset/LIP Mode (Process) Reset ALL LIP Port Mode	8

Table 5.5 Settings when the Host uses the VxVM

No.	Setting item	Set value	No. of windows displayed
1	Host Connection Mode	VxVM DMP Mode	1
2	Controller Identifier	Enable	10
	Controller ID	DF500-C000 (default value)	

3. The system parameter window is displayed starting with **System Startup Settings**. The window displays the items that are currently set. Check the displayed contents on the window and set each displayed item to the desired configuration. To perform the next setting, click the **Next** button. When you click the **Back** button, the previous window will appear.

To stop the setting, click the **Cancel** button.

The screen that appears when the Fibre version of the 9200 is connected displays the parameters available in every display screen of the Wizard.

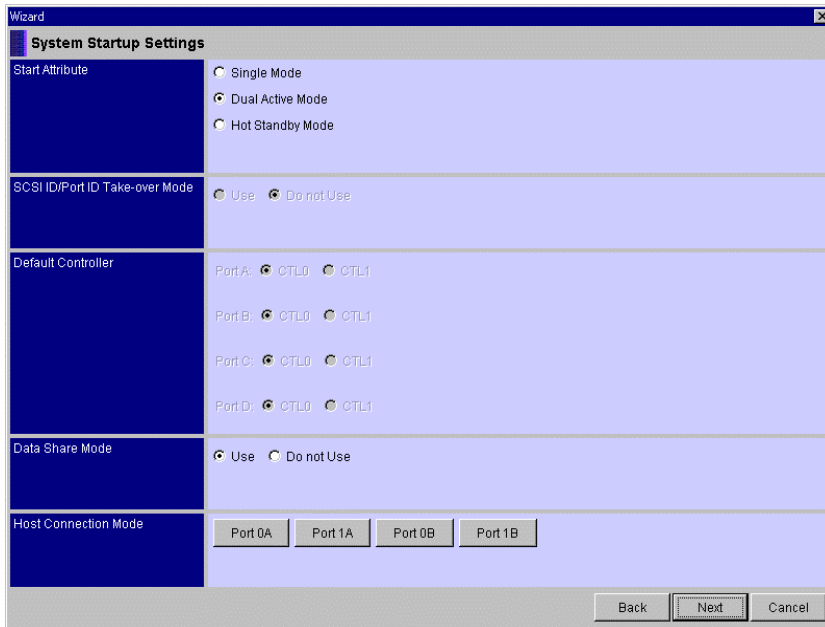

Figure 5.2 System Startup Settings

- **Start Attribute:** Selects the configuration of the array unit
Single Mode: Single configuration
Dual Active Mode: Dual active configuration
Hot Standby Mode: Hot standby configuration
- **SCSI ID/Port ID Take-over Mode:** Specifies the take-over of SCSI ID/port ID
Use: Used the SCSI ID/Port ID Take-over Mode
Do not Use: Not used the SCSI ID/Port ID Take-over Mode
- **Default Controller:** Specifies the controller to be dedicated to the port
This specification is valid only when **Dual Active Mode (connect Host)** is specified.
- **Data Share Mode:** Specifies the attribute of the data share mode
Use: Used in the data share mode
Do not Use: Not used in the data share mode

- **Host Connection Mode:** Specifies the host connection mode of the port
Click the button **Port xx** (xx: 0A, 1A, 0B, 1B) to specify each port.

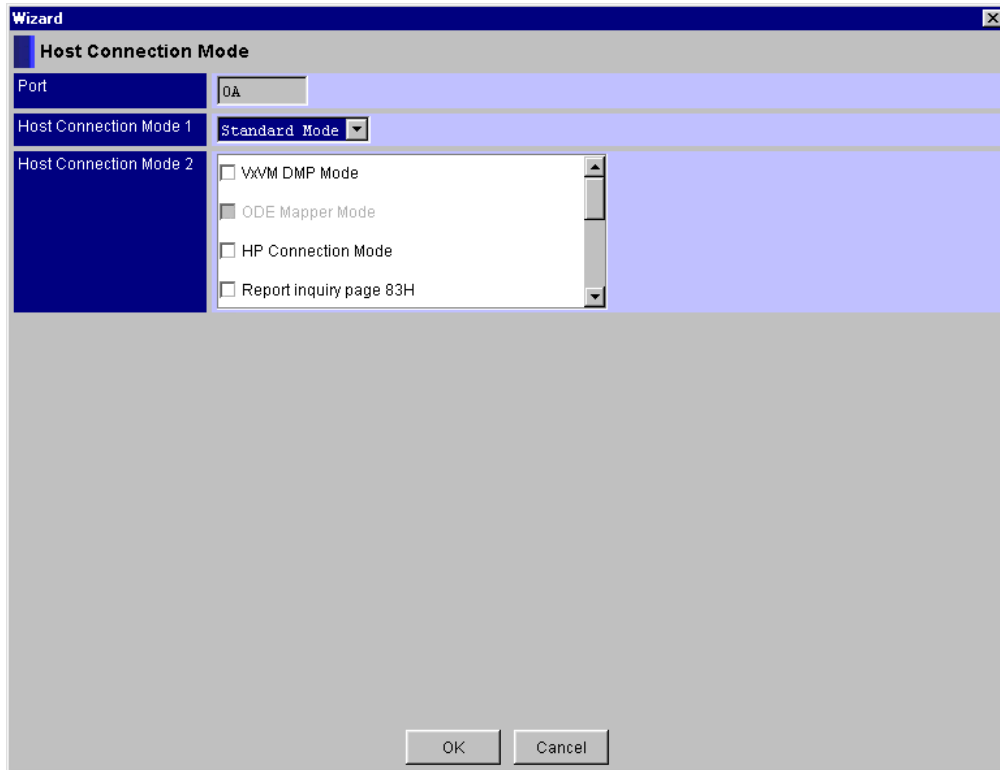

Figure 5.3 Host Connection Mode

- **Host Connection Mode 1**
 - Standard Mode:** Open system emulation mode
 - Open VMS Mode:** Open VMS mode
 - TRESPASS Mode:** TRESPASS mode
 - Wolfpack Mode:** Wolfpack mode
 - IBM 7135 I/O path switch Mode:** IBM 7135 I/O path switch mode
 - NCR I/O path switch Mode:** NCR I/O path switch mode
- **Host Connection Mode 2**
 - VxVM DMP Mode:** VxVM mode
 - ODE Mapper Mode:** ODE Mapper mode
 - HP® Connection Mode:** HP® connection mode
 - Report inquiry page 83H:** Enables the report of Inquiry Page: 83_H
 - UA(60/2A00) Suppress Mode:** Suppresses the unit attention (06/2A00)
 - HISUP Mode:** Enables the HISUP
 - CCHS Mode:** Enables the CCHS convert

Standard INQUIRY data expand Mode: Enables the Standard INQUIRY data expand Mode

HP® Connection Mode 2: Enables the HP® Connection Mode 2

Product ID DF400 Mode: Enables the Product ID DF400 Mode

HBA WWN Report Mode: Enables the HBA WWN Report Mode

NACA Mode: Enables the NACA Mode

SUN Cluster Connection Mode: Enables the SUN Cluster Connection Mode

Persistent RSV Cluster Mode: Enables the Persistent RSV Cluster Mode

ftServer Connection Mode 1: Enables the ftServer Connection Mode 1

ftServer Connection Mode 2: Enables the ftServer Connection Mode 2

SRC Read Command Reject Mode: Enables the SRC Command Reject Mode

Note 1: When the Target ID setting in controller 0 is different than the Target ID setting in controller 1, to change to **SCSI ID/Port ID Take-over Mode**, set the Target IDs of controller 0 and 1 to be the same. After the setting is enabled, change to **SCSI ID/Port ID Take-over Mode**. If it is changed to **SCSI ID/Port ID Take-over Mode**, the Target ID of controller 0 will be automatically mirrored in the Target ID of controller 1. After setting the controller 0 Target ID, change **SCSI ID/Port ID Take-over Mode**.

Note 2: A change from **Single Mode** to another configuration cannot be made for an array unit with a single controller.

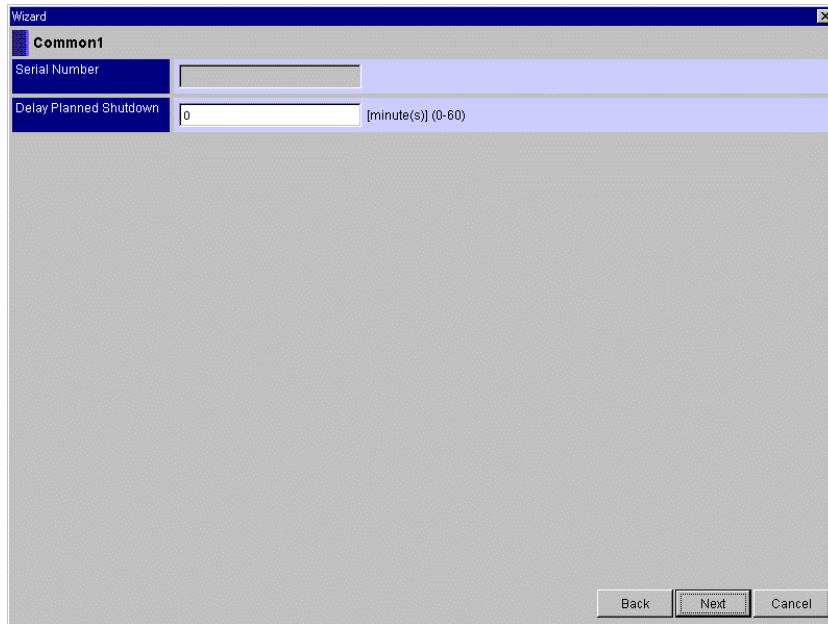

Figure 5.4 Entering the Serial Number

- **Serial Number:** Enter the lower four digits of the manufacturing serial number of an array unit with alphanumeric characters.
The number is reflected in the fiber version of the WWN, so do not set any value except for the lower four digits of the manufacturing serial number. Factory set is the lower four digits of the manufacturing serial number of an array unit.
- **Delay Planned Shutdown:** Specify the time in minutes to delay the execution of the planned shutdown when the main switch has turned off. The applicable range is from 0 to 60 minutes.

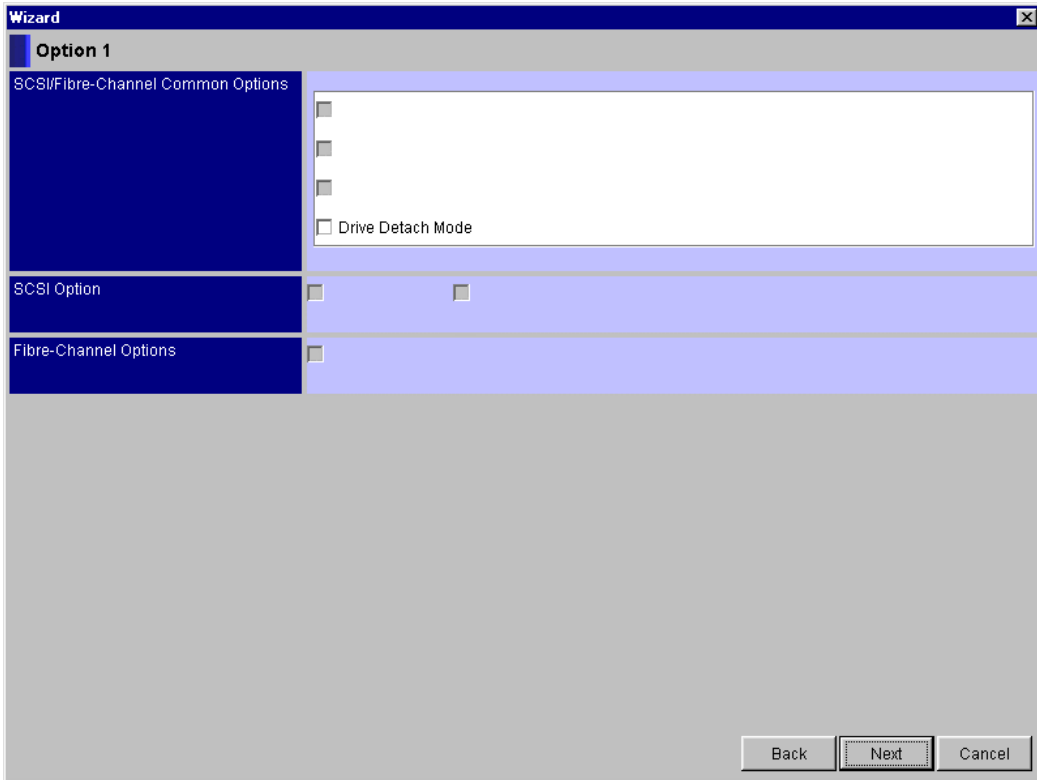

Figure 5.5 Setting the Option 1 Function

Set the Option 1 function of the array unit. Two or more optional functions can be selected.

- **SCSI/Fibre-Channel Common Options:** Options, which can be used by the SCSI and Fibre Channel, interface array units. Set the optional function(s) according to the configuration of the array unit.
 - Drive Detach Mode:** Validates the drive blockade mode
- **SCSI Option:** Options exclusive to the SCSI array unit. Set the optional function (s) according to the configuration of the array unit. When the Fibre Channel interface array unit is connected, this item is displayed in gray and cannot be set.
- **Fibre-Channel Options:** An option exclusive to the Fibre Channel interface array unit. Set the optional function according to the configuration of the array unit. When the SCSI array unit is connected, this item is displayed in gray and cannot be set.

Note: It does not run normally by the setup, although **Option 1** can be set in the plural. When you set it up, set only the applicable item that refers to attaching an array unit in the manual.

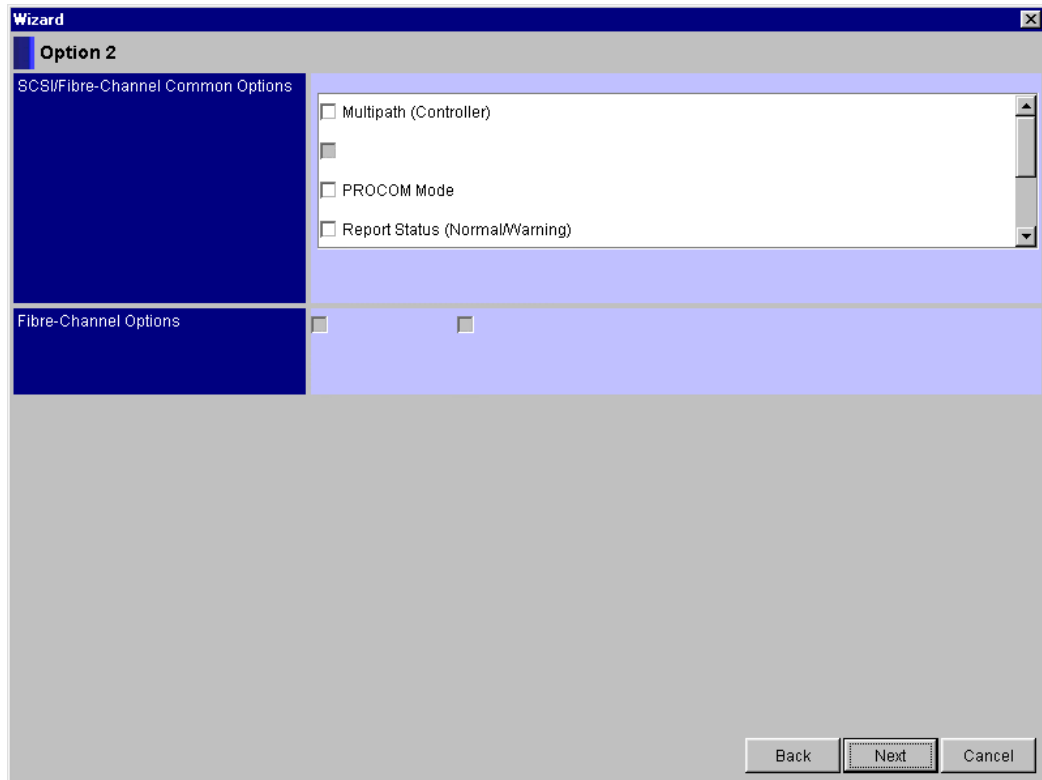

Figure 5.6 Setting the Option 2 Function

Set the Option 2 function (expanded option) of the array unit. Two or more optional functions can be selected.

- **SCSI/Fibre-Channel Common Options:** Options that can be used by the SCSI and Fibre Channel interface array units. Set the optional function(s) according to the configuration of the array unit.

Multipath (Controller): Sets a unit of the sequential judgment to each controller

PROCOM Mode: Validates the PROCOM Mode

Report Status (Normal/Warning): Validates the warning status report mode

Multipath (Array Unit): Sets a unit of the sequential judgment to each array unit

Turbo LU Warning: When the Turbo LU function is invalidated, a warning is reported.

NX Mode: Validates the NX Mode.

Auto Reconstruction Mode: Validates the Auto Reconstruction Mode

Forced Write Through Mode: Validates the Forced Write Through Mode

Changing Logical Unit Mode 1: Validates the Changing Logical Unit Mode 1

Multiple Stream Mode: Validates the Multiple Stream Mode

Multiple Stream Mode (Write): Validates the Multiple Stream Mode (Write)

Multiple Stream Mode (Read): Validates the Multiple Stream Mode (Read)

- **Fibre-Channel Options:** An option exclusive to the Fibre Channel interface array unit. Set the optional function according to the configuration of the array unit. When the SCSI array unit is connected, this item is displayed in gray and cannot be set.
- RAID3 Mode:** Validates the RAID3 Mode.

Note: It does not run normally by the setup though **Option 2** can be set up in the plural. When you set it up, set only the applicable item that refers to attaching an array unit in the manual.

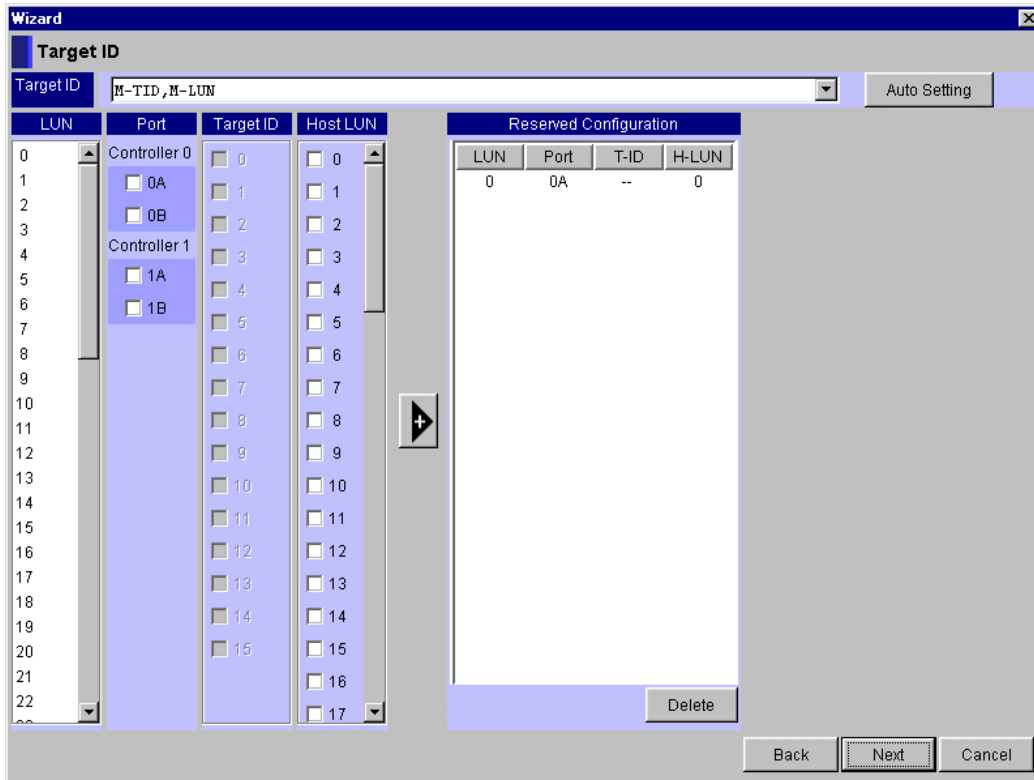



Figure 5.7 Setting the Target IDs of Controller 0/1

Set the target IDs of controller 0/1.

Note 1: If **SCSI ID/Port ID Take-over Mode** is set at **Use**, the setting of controller 0 automatically sets the Target ID for controller 1.

Note 2: The text box for the Host LUN and LUN is displayed on a scroll screen, and LUNs can be selected. When the Resource Manager 9500V runs with IRIX®, all LUNs may not be displayed by scrolling. If all LUNs are not displayed, operate with the arrowdown (▼) key.

Note 3: If the LUN mapping is used for controller 0, LUN mapping is also used for controller 1. Otherwise, all logical units will be available through all ports of the controller that does not use LUN mapping.

- **Target ID:** Specifies configuration types of the target ID and the LUN
 - S-TID, M-LUN:** Sets a target ID for the port and makes the LUN shared by the ports available to be used by a host with an identical LUN
 - M-TID, S-LUN:** Sets a port and a target ID for the LUN and allows the LUN to be used with LUN = '0' and a target ID set by the host
 - M-TID, M-LUN:** Sets a port, a target ID, and a Host LUN for the LUN in a map form and allows the LUN to be used in a configuration set by the host
 - S-TID:** Single Target ID
 - M-TID:** Multi Target ID
 - S-LUN:** Single LUN
 - M-LUN:** Multi LUN
 - LUN:** Logical unit number in the array unit
 - H-LUN:** Logical unit number that the host can recognize
- **LUN:** Specifies the LUN in the array unit
- **Port:** Specifies a port number
- **Target ID:** Specifies a target ID
- **Host LUN:** Specifies a LUN that the host recognizes. When **S-TID, M-LUN** and **M-TID, S-LUN** are selected for **Target ID**, the display appears in gray and the selection is disabled.
- **Reserved Configuration:** Displays the configuration that is set. When **S-TID, M-LUN** is set, **Host LUN** and **LUN** are displayed as “-”. When **M-TID, S-LUN** is set, **H-LUN** is displayed as “-”.
- a) **S-TID, M-LUN mode setting**
 - Select the **S-TID, M-LUN** in **Target ID**.
 - Select one **Port** to be set, select one **Target ID** to be set, and click the  button. The added contents are displayed in **Reserved Configuration**.
- b) **M-TID, S-LUN mode setting**
 - Select the **M-TID, S-LUN** in **Target ID**.
 - Select one **LUN** to be set, select one **Port** and one **Target ID** to be set, and click the  button. The added contents are displayed in **Reserved Configuration**.
 - For deletion, click the line to be deleted in **Reserved Configuration** and click the **Delete** button. The deleted contents disappear from the **Reserved Configuration** display.

c) **M-TID, M-LUN mode setting**

Select the **M-TID, M-LUN** in **Target ID**.

Select one **LUN** to be set, select **Port**, **Target ID**, and **Host LUN** to be set in the mapping setup configuration, and click the  button. The added contents are displayed in **Reserved Configuration**.

Multiple **Port**, **Target ID**, and **Host LUN** can be selected.

For deletion, click the line to be deleted in **Reserved Configuration** and click the **Delete** button.

The deleted contents disappear from the **Reserved Configuration** display.

d) **Auto setting**

Click **Auto Setting**. The target ID configuration file is read and **LUN**, **Port**, **Target ID**, and **Host LUN** are automatically set. The read contents are displayed in **Reserved Configuration**.

Auto setting is performed regardless of **Target ID**.

After execution of auto setting, all of the previous contents are invalidated and changed to the contents of the target ID configuration file.

The file configuration used for executing auto setting is shown in the following figure.

Input "Yes" or "No" in **Target ID** mode. Input the necessary data for **Port**, **Target ID**, **H-LUN**, and **LUN** (the same items as those entered in the setting made on the screen). Put a space between items. If the tabulating function is used, they are regarded as input errors and the inputs are ignored.

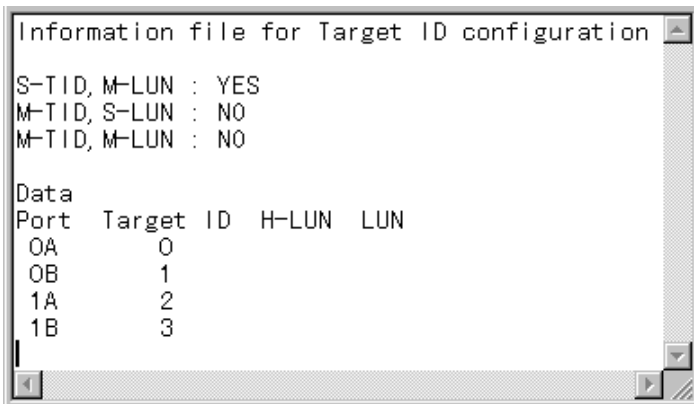

```
Information file for Target ID configuration
S-TID, M-LUN : YES
M-TID, S-LUN : NO
M-TID, M-LUN : NO

Data
Port Target ID H-LUN LUN
OA      0
OB      1
1A      2
1B      3
```

Note: When the Fibre Channel connection is used, set '--' for the **Target ID**.

4. When **Basic Settings** is selected, the window for the **Target ID** setting is the final window. Click the **Next** button, then display **Detailed Settings**.

If you set the **Detailed Settings** items in succession, select **Yes** or select **No**, and then click the **Next** button.

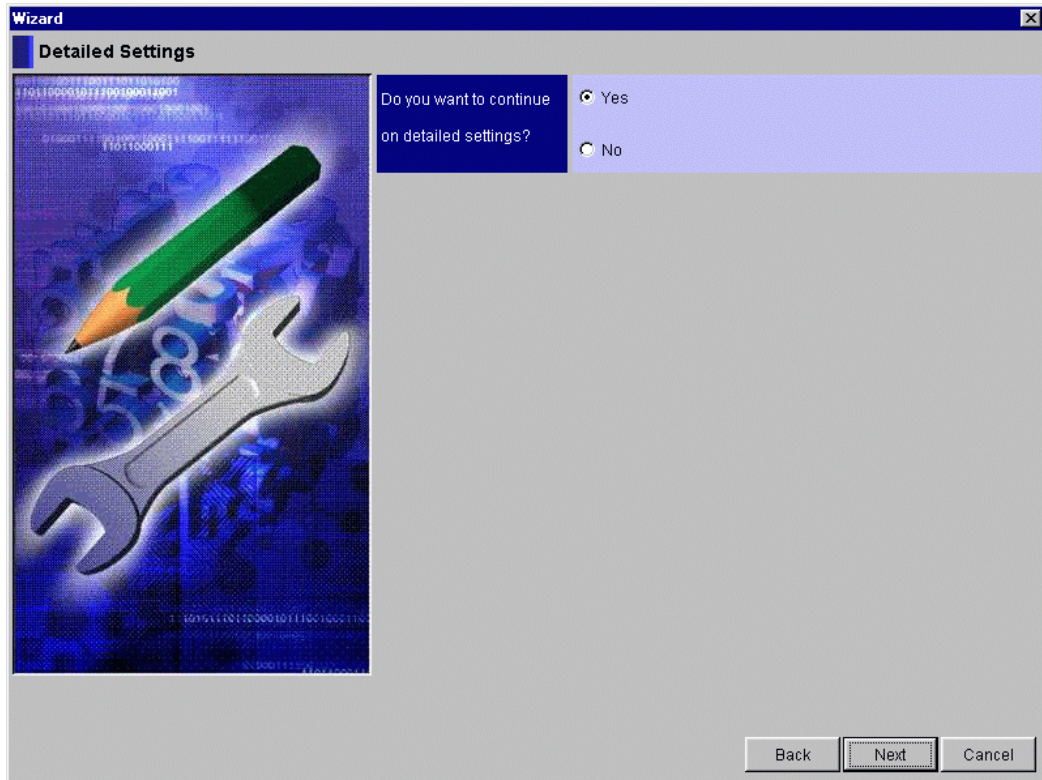

Figure 5.8 Detailed Settings

When you select **No**, the **System Parameter Setting Completed** screen will be displayed. Refer to items from '5' onward and perform a back-up operation.

The following window is displayed when **Detailed Settings** is selected:

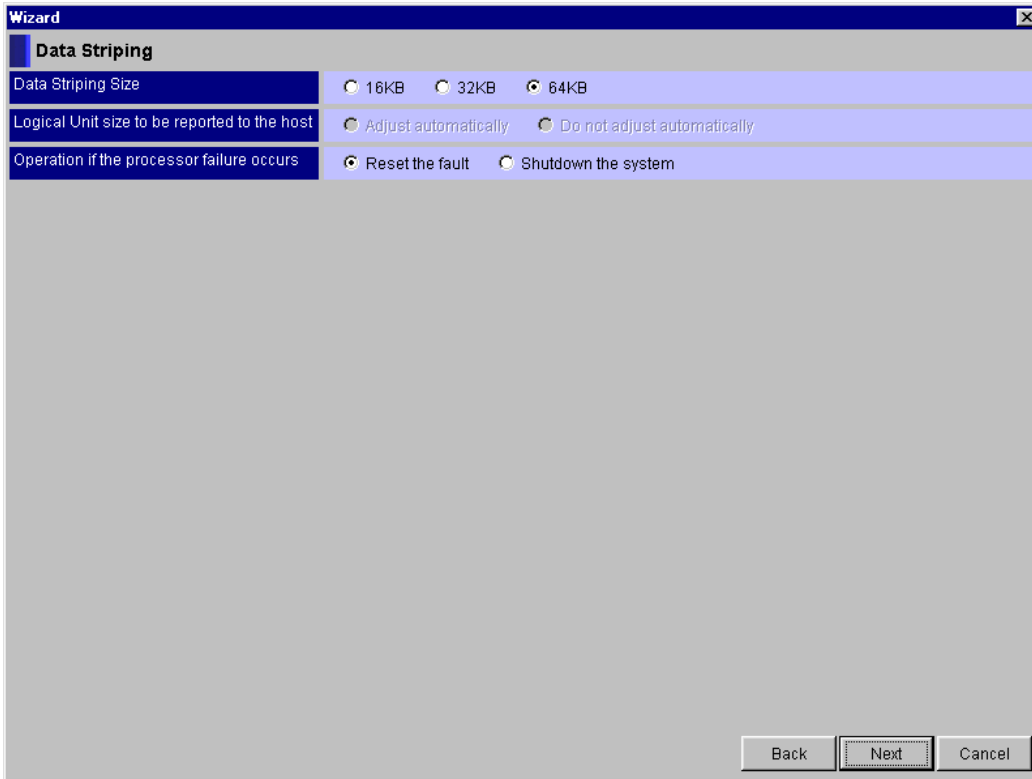

Figure 5.9 Data Striping

- **Data Striping Size:** Sets the striping size. When the RAID group is already defined, it cannot be changed. To change, do so after deleting all the RAID group.
- **Logical Unit size to be reported to the host:** Sets the logical unit size to be reported to the host. When the Fibre Channel interface array unit is connected, this item is displayed in gray and cannot be set.
 - Adjust automatically:** The logical unit size to be reported to the host is determined by the array unit automatically.
 - Do not adjust automatically:** The logical unit size to be reported to the host is set to the consistent value.
- **Operation if the processor failure occurs:** Sets the operation to be performed when a processor failure occurs.
 - Reset the fault:** Resets a failure, and restart the controller
 - Shutdown the system:** Shuts the array unit down

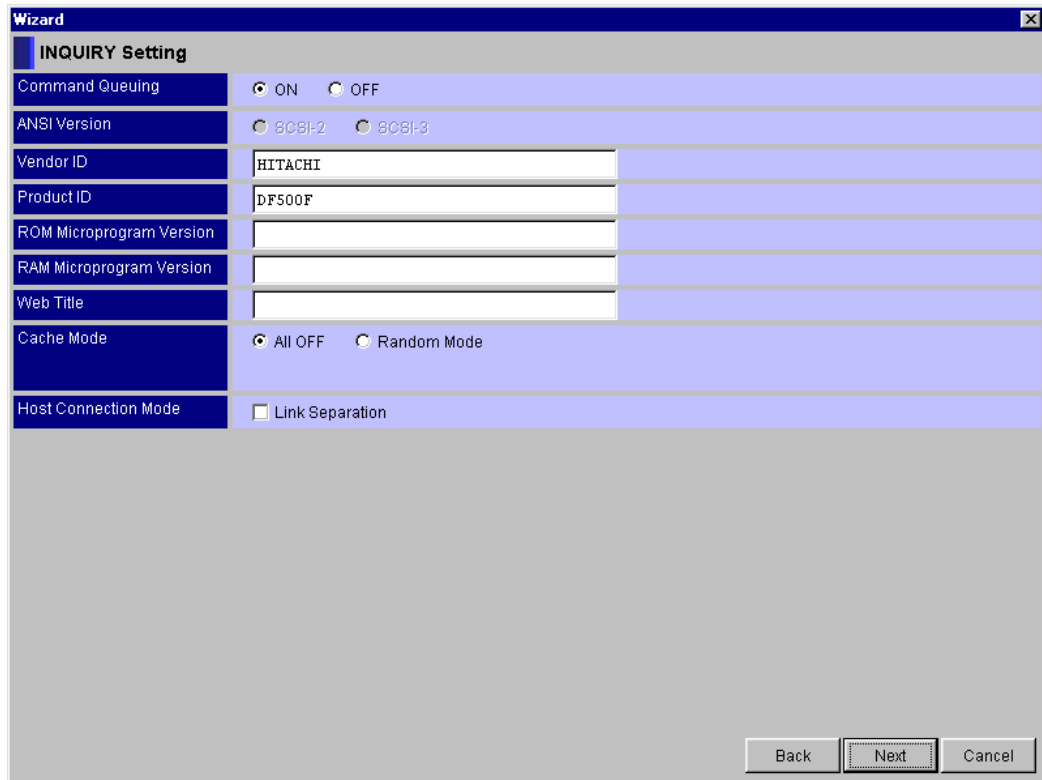

Figure 5.10 Inquiry Setting

- **Command Queuing:** Specifies an execution of a command queuing
 - ON:** Executes a command queuing
 - OFF:** Inhibits a command queuing
- **ANSI Version:** Specifies the SCSI 2/3 reporting mode
 - SCSI-2:** Responds with a setting of “2” for the ANSI version of the standard Inquiry data
 - SCSI-3:** Responds with a setting of “3” for the ANSI version of the standard Inquiry data
- **Vendor ID:** Enter a vendor name with eight characters. When the name consists of less than seven characters, make an eight-character entry by filling the reset with space(s). The default value set in the **Startup Attribute** setting on the **System Startup Settings** is displayed. (△ Denotes a space.)
 - Others:** HITACHI △

- **Product ID:** Enter a model name with 16 characters. When the name consists of less than 16 characters, make a 16-character entry by filling the reset with space(s). In the setting of **Startup Attribute** under **System Startup Settings**, for the cases in which the following modes are specified, the values set by default are shown. (△ Denotes a space.)

IBM 7135 I/O path switch Mode: 7135021000000000

NCR I/O path switch Mode: INF-01-00 △△△△△△△△

Others: other modes (SCSI): DF500 △△△△△△△△△△△△△△

(Fibre): DF500F △△△△△△△△△△△△△△

- **ROM Microprogram Version:** Specifies a microprogram version of a ROM reported by inquiry command
- **RAM Microprogram Version:** Specifies a microprogram version of a RAM reported by inquiry command
- **Web Title:** If the home page of the array unit is displayed with the browser, specifies a character string displayed on the title bar of the browser. Enter up to 32 one-byte coded alphanumeric or characters (except for the ' (single quotation mark), " (double quotation mark), and \ (backslash) symbols) other than numeric.
- **Cache Mode:** Sets the cache memory allocation method
 - All OFF:** Use the cache memory with the ordinary allocation method.
 - Random Mode:** Use the cache memory allocating a buffer for random reading exclusively to it.
- **Host Connection Mode:** Sets up functions necessary for the host to connect
 - Link Separation:** When blocking a controller, shuts down a link

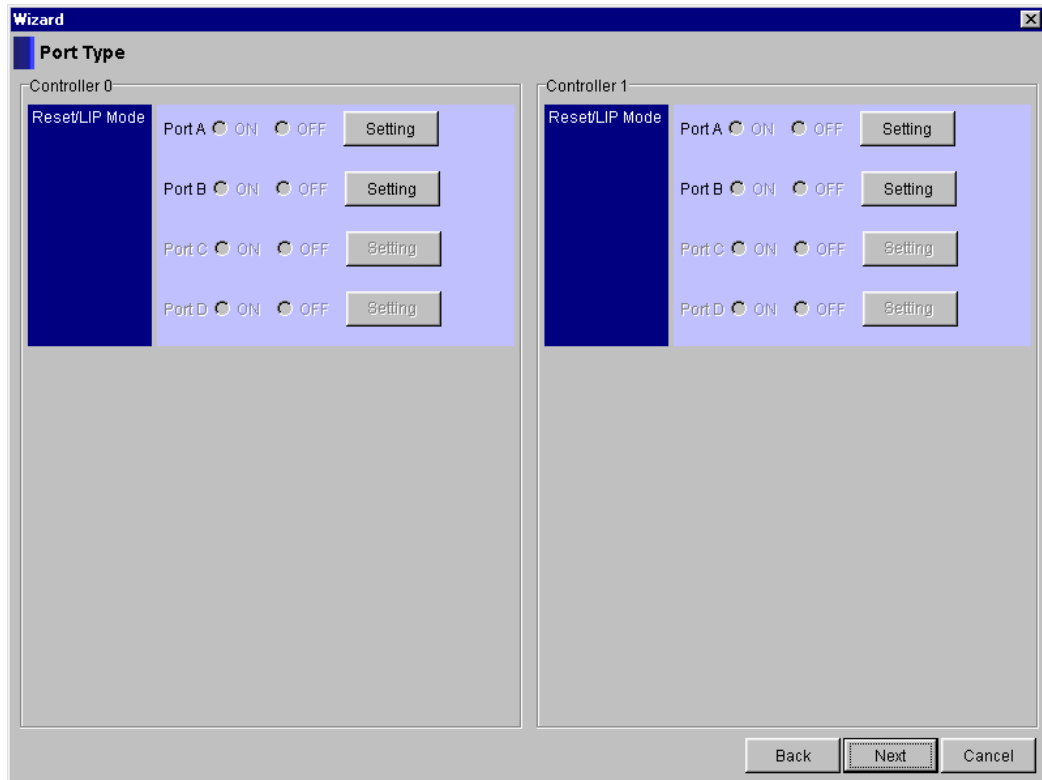

Figure 5.11 Setting the Multi-Port Expanding Function

Sets the multi-port expanding function of the controller 0/1.
When **Multiple** is selected, set the **Reset/LIP Mode**.

- **Reset/LIP Mode:** Specifies the LIP mode from other ports
 - ON:** Validates the LIP mode from other ports
 - OFF:** Invalidates the LIP mode from other ports
 - Setting:** For a connection with the Fibre version, port options can be set. Click **Setting** for each port.

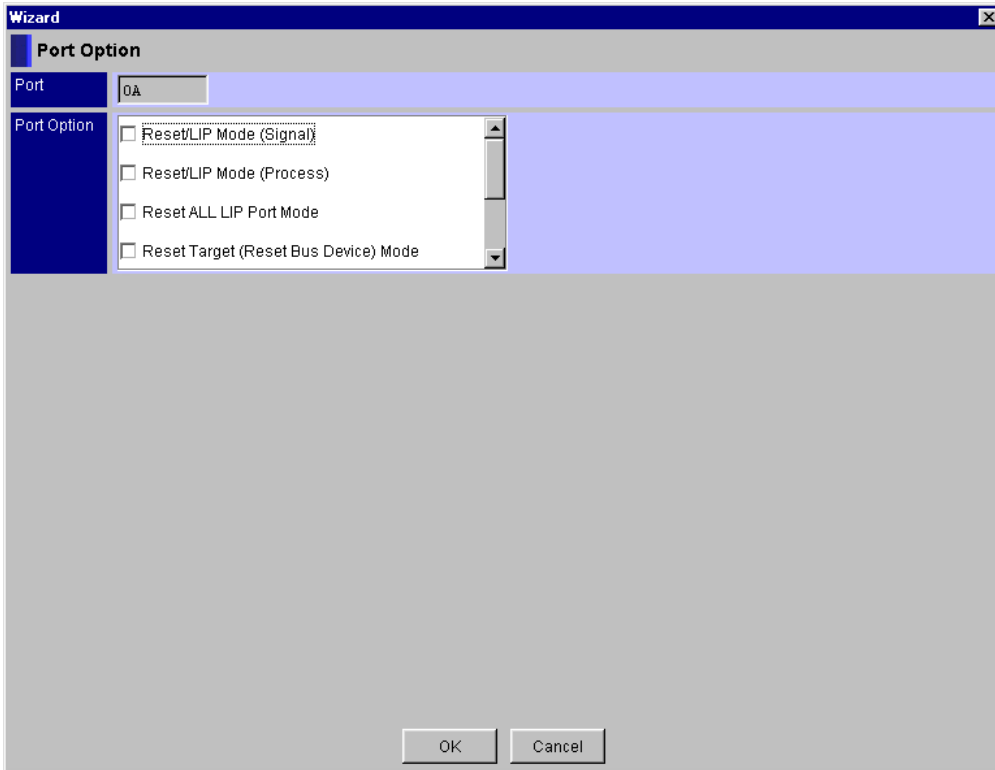

Figure 5.12 Setting Port Options

- **Port:**
- **Port Option:** Sets the port options. If the port option is set and the **OK** button is clicked, it will return to the setting screen of **Port Type**.
 - Reset/LIP Mode (Signal):** The mode to transmit Reset/LIP signals to other ports.
 - Reset/LIP Mode (Process):** The mode to transmit reset processing to other ports.
 - Reset ALL LIP Port Mode:** The mode to execute reset on receiving LIP.
 - Reset Target (Reset Bus Device) Mode:** The mode to transmit Target Reset to other ports.
 - Reserve Mode:** The mode to reserve logical unit in a dual system.
 - Reset Logical Unit Mode:** When the Logical Unit Reset command is issued for a logical unit, all other commands received by that logical unit will be reset, regardless of the port.
 - Reset Logout of Third Party Process Mode:** The mode to transmit Third Party Process Log-out to other ports.

Note: Reset/LIP Mode (signal) is enabled if the Reset/LIP Mode (Process) is set. Port Option can be multiply set, but depending on the setting, it may not function properly. If it is to be set, please refer to the appended manual of the array unit and set only the applicable parameters.

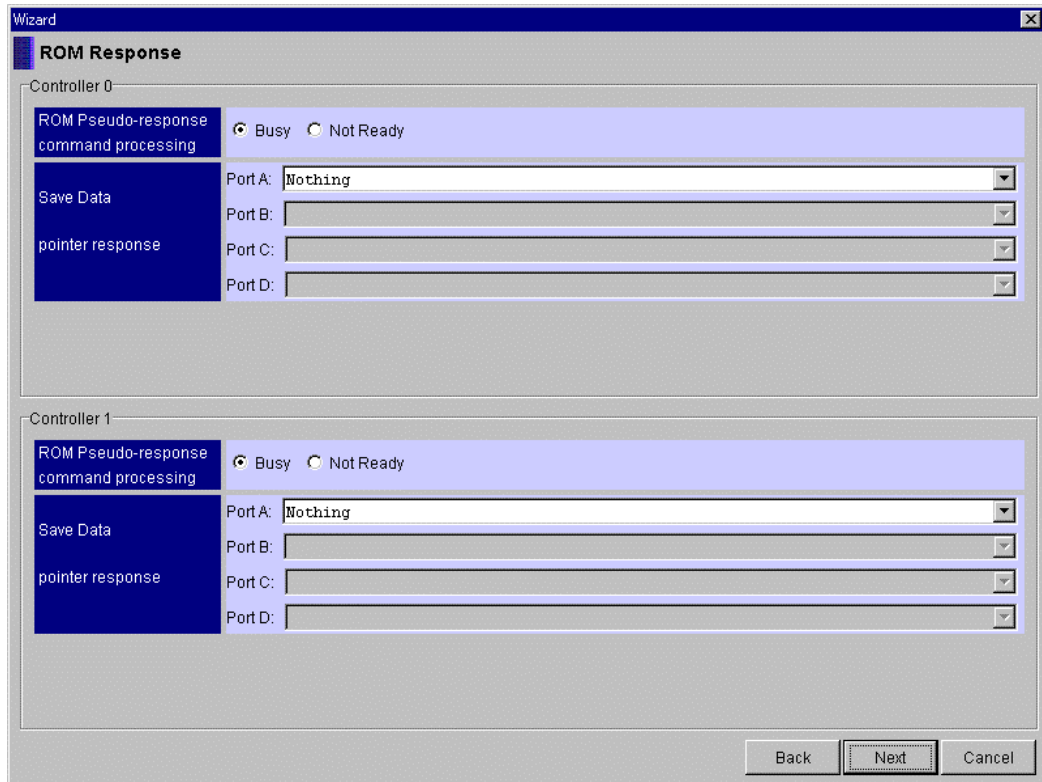

Figure 5.13 ROM Response Settings

- **ROM Pseudo-response command processing:** Sets the mode of response to the host during a period from powering on to the time when the controller 0/1 becomes ready.
 - Busy:** Responds “BUSY”
 - Not Ready:** Responds “Not Ready”
- **Save Data pointer response:** Sets a Save Data Pointer report request to the host by the controller 0/1
 - Nothing:** Does not report
 - After Data:** Reports after receiving data
 - Only After Cmd:** Reports after receiving a command
 - After Data & Cmd:** Reports after receiving data and a command

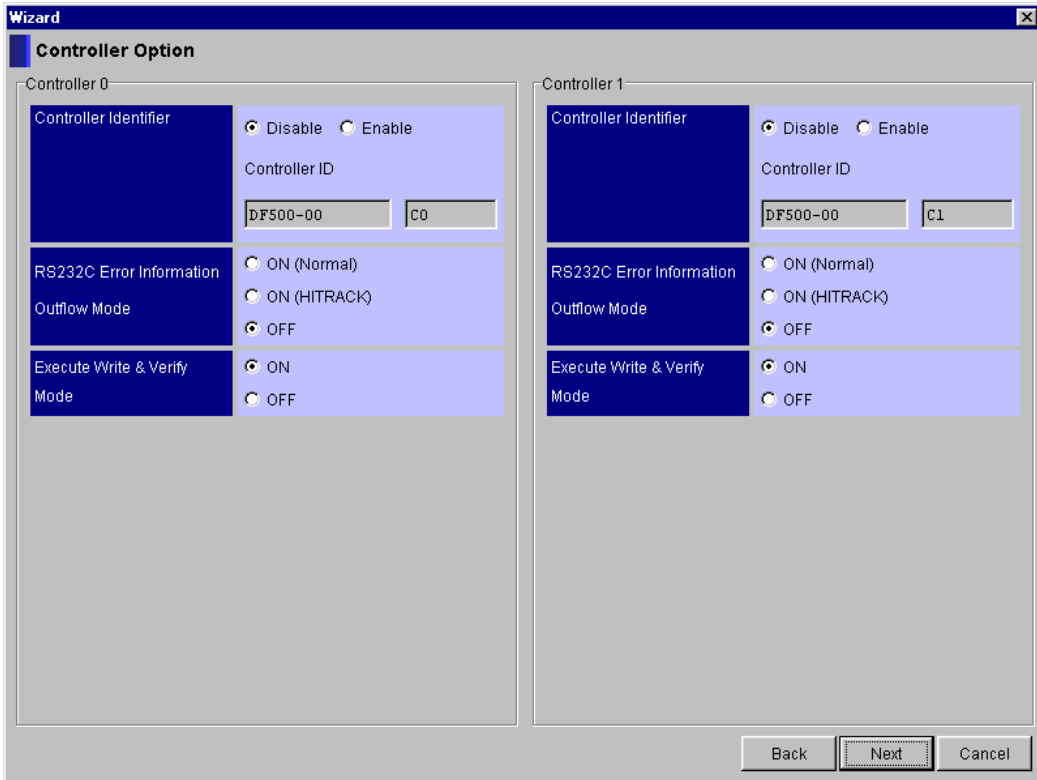

Figure 5.14 Setting Controller Options

- **Controller Identifier:** Sets the controller identifier of the controller 0/1
 - Disable:** Invalidates a setting of the controller identifier
 - Enable:** Validates a setting of the controller identifier
 - Controller ID:** Enter a controller identifier. The controller identifier consists of ten characters; only the top eight characters can be changed but the last two characters cannot be changed. They can be changed when the **Enable** is selected.
- **RS232C Error Information Outflow Mode:** Sets the mode of the error information sending to the RS232C of the controller 0/1 (9200 only)
 - ON (Normal):** Outputs information
 - ON (HITRACK):** Outputs HITRACK mode information
 - OFF:** Inhibits an output of information
- **Execute Write & Verify Mode:** Sets the write & verify execution mode of the controller 0/1
 - ON:** Executes write and verify
 - OFF:** Does not execute write and verify

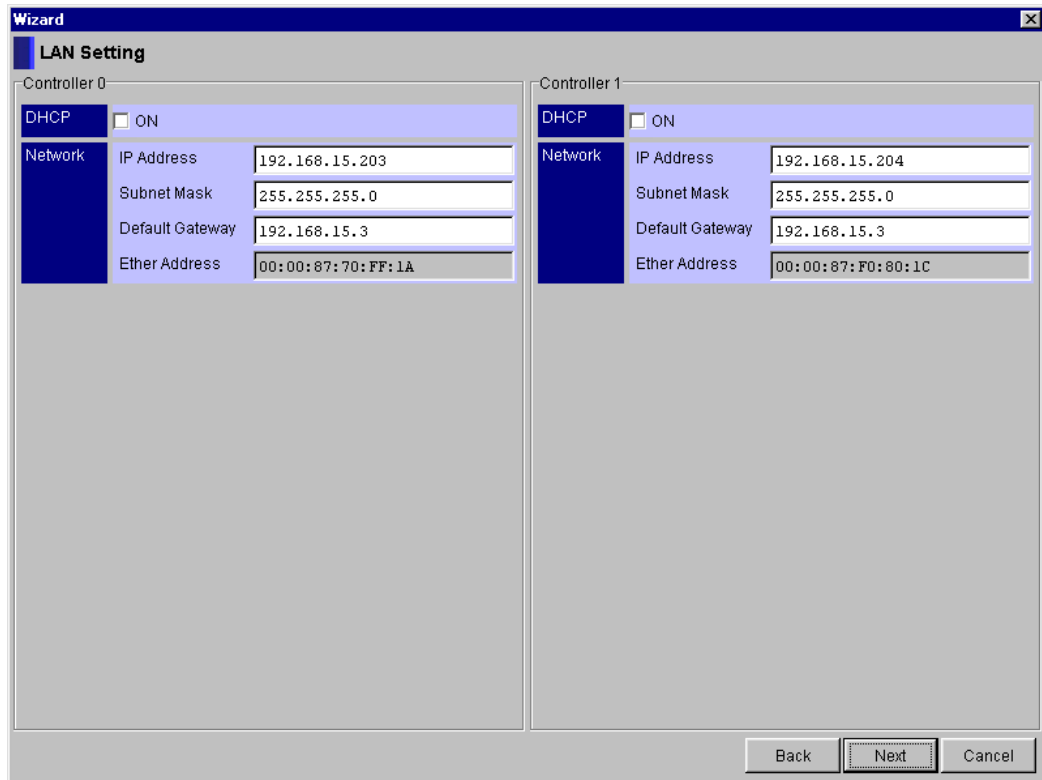

Figure 5.15 LAN Settings

- **DHCP:** Sets the DHCP function
 - **Network:** Sets the LAN parameter. If enable is selected in **DHCP**, gray display will be used
- IP Address:** Sets the IP address
- Subnet Mask:** Sets the subnet mask
- Default Gateway:** Sets the default gateway
- Ether Address:** The Ethernet address (MAC address) is displayed. It cannot be changed.

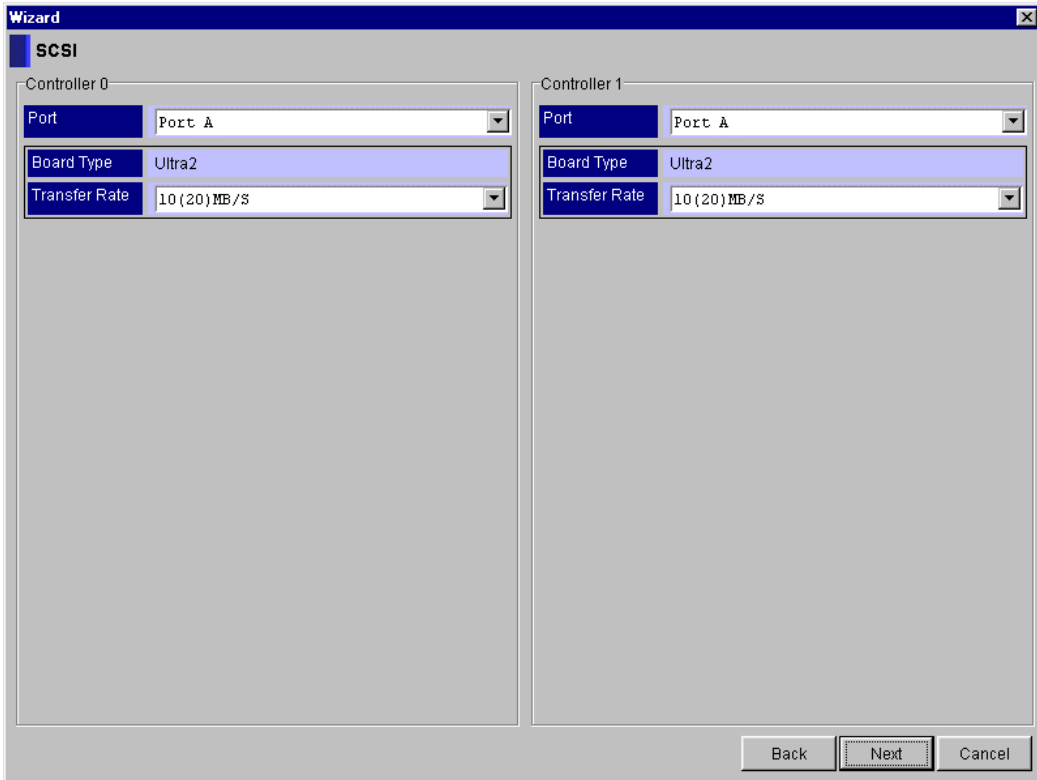

Figure 5.16 SCSI Settings

- **Port:** Selects the port to be set
- **Board Type:** Displays types of I/F board
 - None:** Not installed
 - Single:** Single type
 - Differential:** Differential type
 - Ultra 2:** Ultra 2 type
- **Transfer Rate:** Sets the SCSI transfer rate
 - STANDARD:** Sets the transfer rate automatically according to the I/F board installed
 - ASYNC:** Transfers data in the mode without using the synchronous transfer
 - 5 (10) MB/s:** Sets the maximum transfer rate to 5 MB/s for narrow SCSI and 10 MB/s for wide SCSI
 - 10 (20) MB/s:** Sets the maximum transfer rate to 10 MB/s for narrow SCSI and 20 MB/s for wide SCSI
 - 20 (40) MB/s:** Sets the maximum transfer rate to 20 MB/s for narrow SCSI and 40 MB/s for wide SCSI
 - 40 (80) MB/s:** Sets the maximum transfer rate to 40 MB/s for narrow SCSI and 80 MB/s for wide SCSI

5. Select **Yes** of **FD Backup?**, then click the **OK** button.

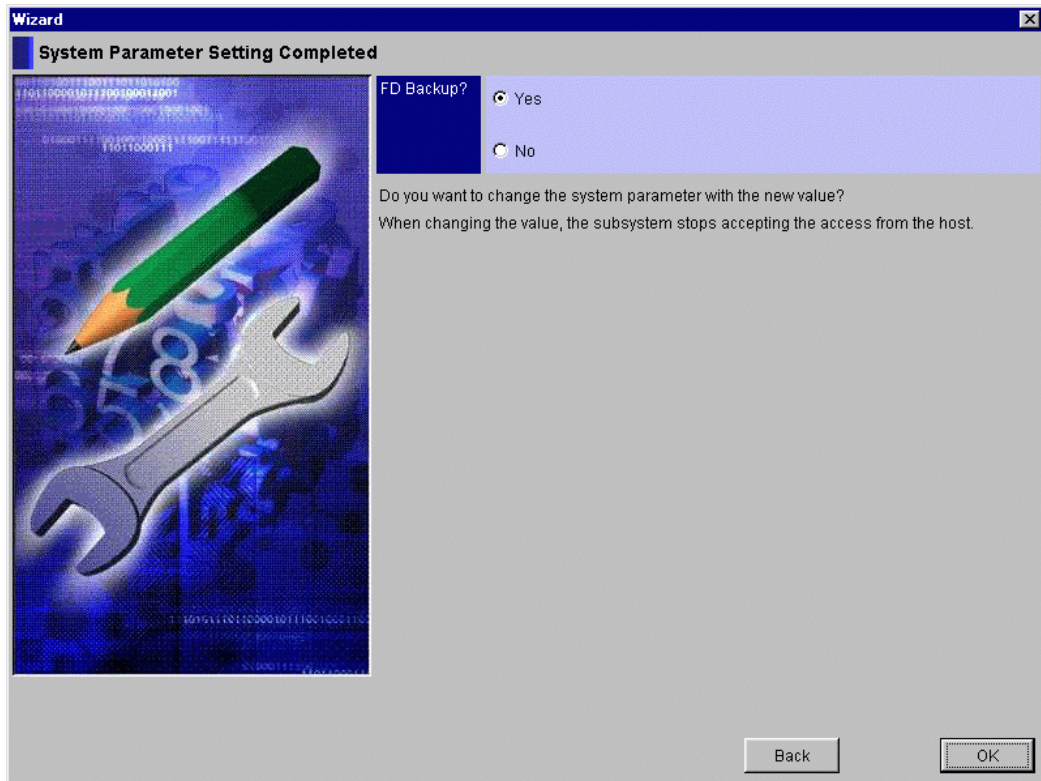

Figure 5.17 Completing System Parameter Settings

- **FD Backup?:** The system parameter information is saved on the backup FD in the array unit. When the setting is changed, it is necessary to save the system parameter information once again. **Select "Yes"** (9200 only).

6. A message appears, stating that the setting is complete. A message is displayed, requesting confirmation to restart the subsystem. Click the **OK** button to restart.



(If the setting does not include changes to the controller configuration.)



(If the setting includes changes to the controller configuration [from a single controller to a dual controller configuration]).

Note: To validate the set system parameters, restart the array unit. The previous settings stay valid until restarting. The array unit cannot access the host until the reboot is completed and the system restarts. Therefore, be certain the host has stopped accessing data before beginning the restart process.

Note: If LAN configuration information is modified, an error message (Interface Error) may be displayed without displaying a restart completion message when restarting is initiated. When modifying LAN configuration information, after closing the Unit window without specifying restart, restart an array unit. After the array unit restarts, modify registered information on the Main screen and open the Unit screen again.

Note: When failing to write onto the FD drive, the message “DMES04EB02: Backup floppy disk write error.” is displayed.

When this message is displayed, writing to a FD has not been finished, but setting the system parameter may be completed.

Check a FD in an array unit, re-confirm the data to set, turn on the **FD Backup?** Check box, and then click the **OK** button once again.

When you choose to restart the array unit, the time the restart began is displayed. This usually takes approximately two to six minutes.

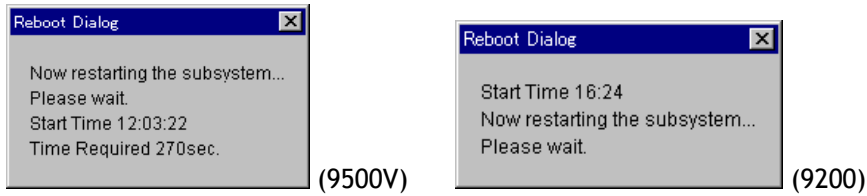

Note: It may take time for an array unit to respond, depending on the condition of the array unit. If it does not respond after 10 minutes or more, check the condition of the array unit.

7. A message appears, stating that the restart is successful. Click the OK button.

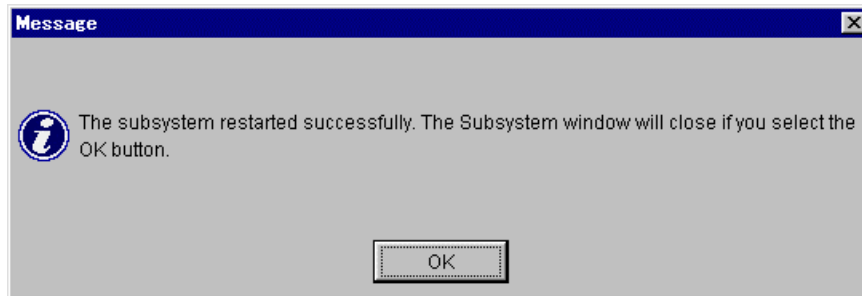

The Unit screen is closed. To perform other operations on the main window, select an array unit from the main window and open the selected Unit screen.

Chapter 6 Setting Host Storage Domain (Host Group) Information

Set Host Storage Domain (Host Group) 0 (000:G000) information, such as a host group option and mapping information.

For information on creating a host storage domain (host group), refer to the *Hitachi Thunder 9500™ V Series LUN Management User's Guide (MK-93DF657)*.

This chapter includes the following:

- Setting Host Storage Domain (Host Group) Options
- Specifying Mapping Mode
- Setting Mapping Information

6.1 Setting Host Storage Domain (Host Group) Options

1. Click the **Host Groups** tab.
2. Click the **Port A** plus signs next to the **000:G000**.
3. Click the **000:G000** plus signs next to the host group options, then select **Option**.
4. On the **Settings** menu, select **Modify Host Group Option**.

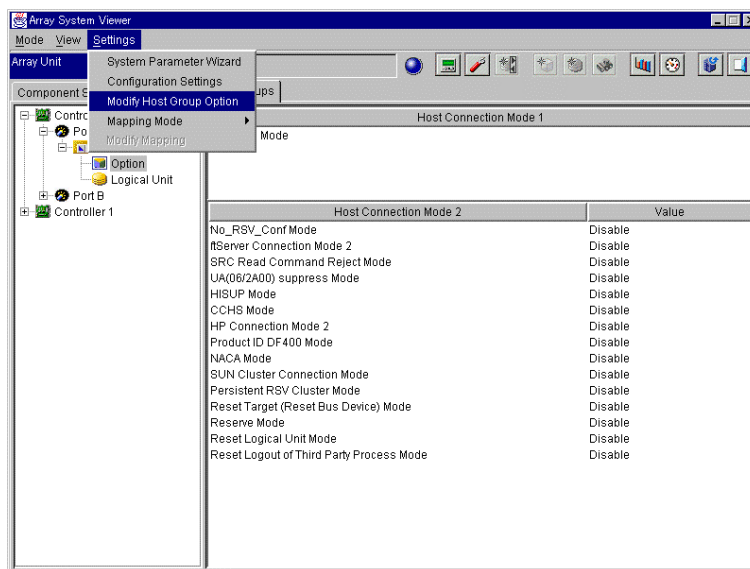

Figure 6.1 Setting Host Storage Domain (Host Group) Options

5. Select **Host Connection Mode 1** and **Host Connection Mode 2**. Click the **OK** button.

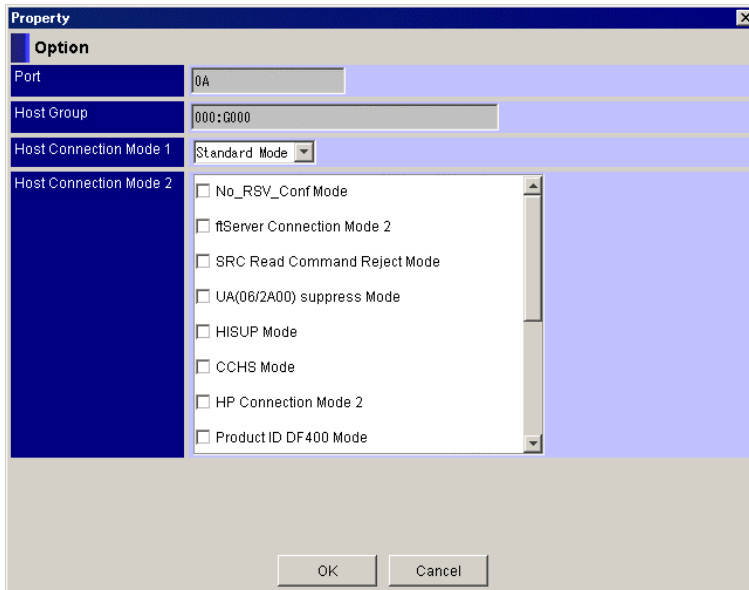

Figure 6.2 Host Connection Mode

- **Host Connection Mode 1**
 - Standard Mode:** Open system emulation mode
 - Open VMS Mode:** Open VMS mode
 - TRESPASS Mode:** TRESPASS mode
 - Wolfpack Mode:** Wolfpack mode

– **Host Connection Mode 2**

No_RSV_Conf Mode: Enables the No_RSV_Conf Mode

ftServer Connection Mode 2: Enables the ftServer Connection Mode 2

SRC Read Command Reject Mode: Enables the SRC Command Reject Mode

UA(60/2A00) Suppress Mode: Suppresses the unit attention (06/2A00)

HISUP Mode: Enables the HISUP

CCHS Mode: Enables the CCHS convert

HP Connection Mode 2: Enables the HP® Connection Mode 2

Product ID DF400 Mode: Enables the Product ID DF400 Mode

NACA Mode: Enables the NACA Mode

SUN Cluster Connection Mode: Enables the SUN Cluster Connection Mode

Persistent RSV Cluster Mode: Enables the Persistent RSV Cluster Mode

Reset Target (Reset Bus Device) Mode: The mode to transmit Target Reset to other ports

Reserve Mode: The mode to reserve logical unit in a dual system

Reset Logical Unit Mode: When the Logical Unit Reset command is issued for a logical unit, all other commands received by that logical unit will be reset, regardless of the port.

Reset Logout of Third Party Process Mode: The mode to transmit Third Party Process Log-out to other ports

6. A confirmation message appears. Click the **OK** button.

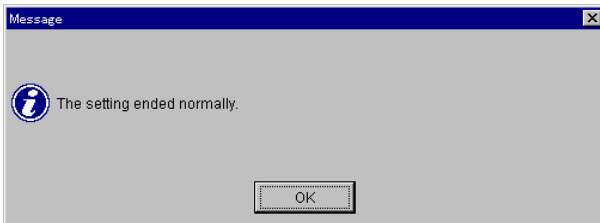
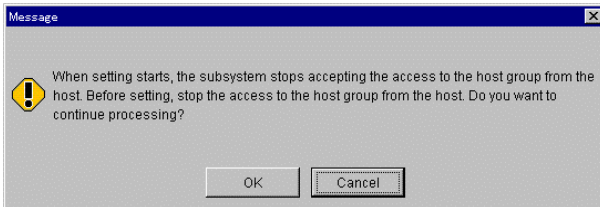
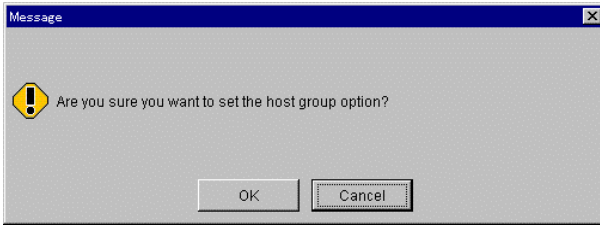

The modified host group options are displayed.

6.2 Specifying Mapping Mode

Set the Mapping Mode effective or ineffective.

1. Click the **Host Groups** tab.
2. On the **Settings** menu, select the **Mapping Mode**, then select **Enable** or **Disable**.

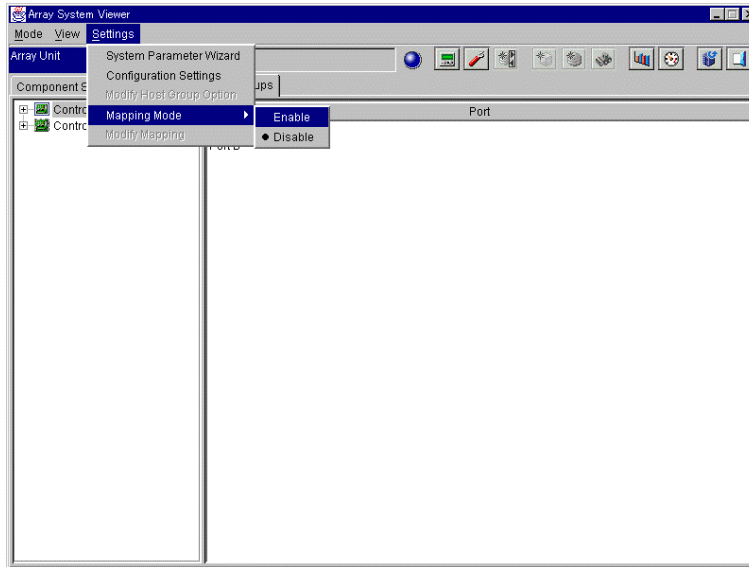
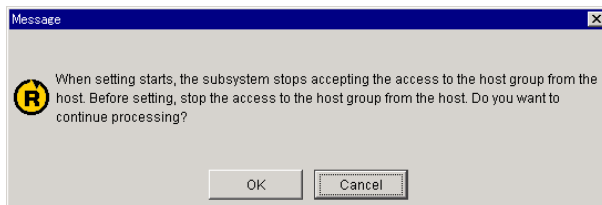
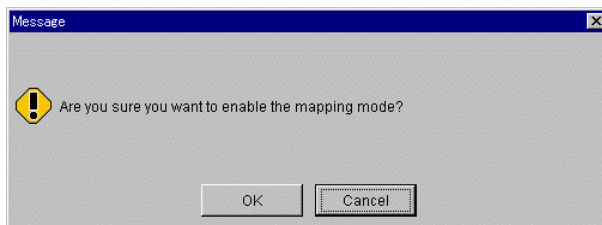
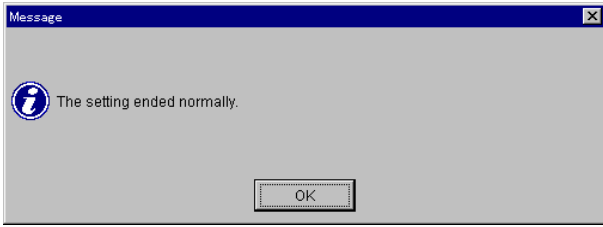

Figure 6.3 Specifying Mapping Mode

3. A confirmation message appears. Click the **OK** button.





6.3 Setting Mapping Information

1. Click the **Host Groups** tab.
2. Click the **Port A** or **Port B** plus signs next to the **000:G000** and select **000:G000**.
3. Select **Logical Unit**.
4. On the **Settings** menu, select **Modify Mapping**.

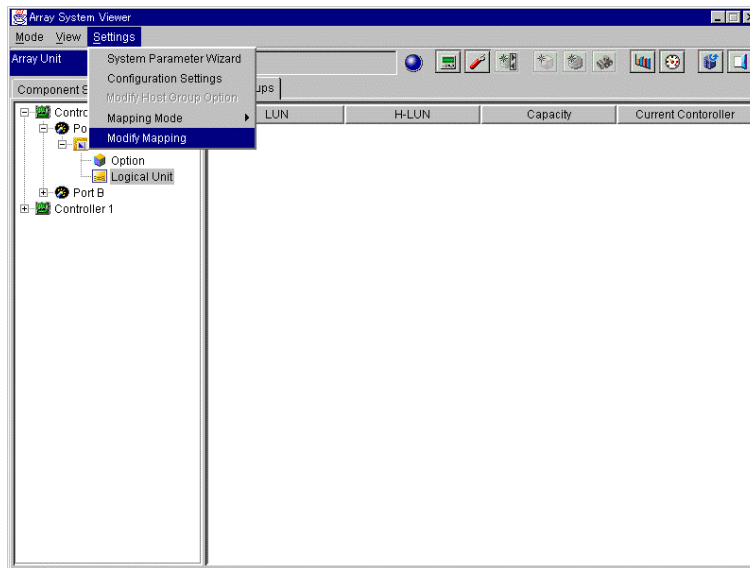



Figure 6.4 Setting Mapping Information

5. Select one **LUN** to be added. Select **Host LUN**, and click the  button. The added contents are displayed in **Reserved Configuration**. Multiple **Host LUN** can be selected.
For deletion, click the line to be deleted in **Reserved Configuration** and click the **Delete** button. The deleted contents disappear from the display of **Reserved Configuration**.
Click **OK** button.

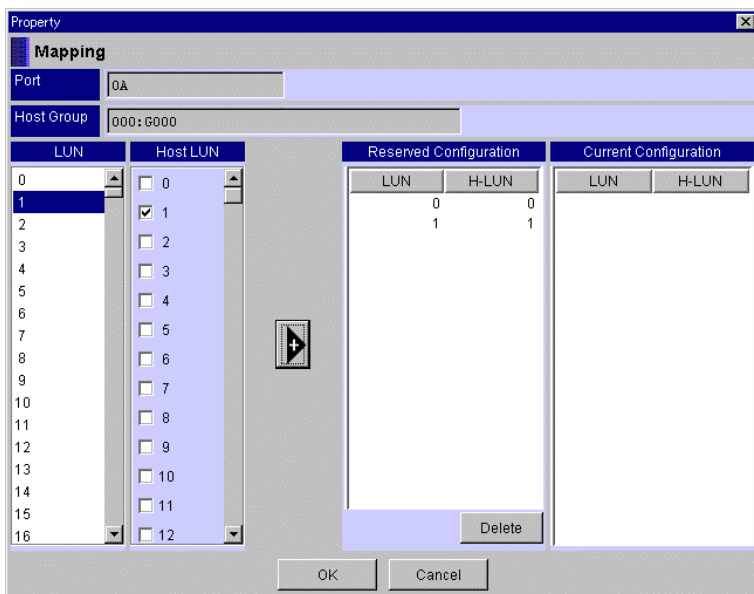
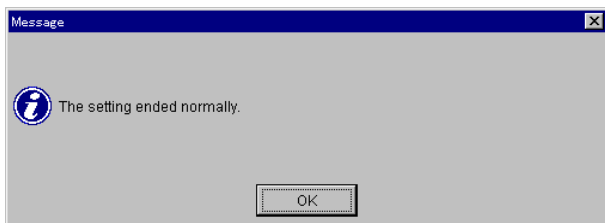
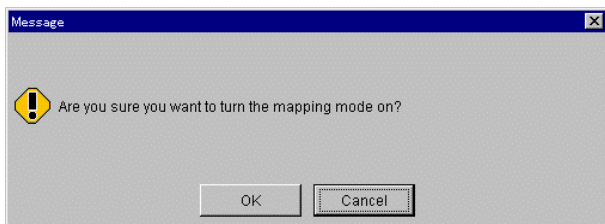
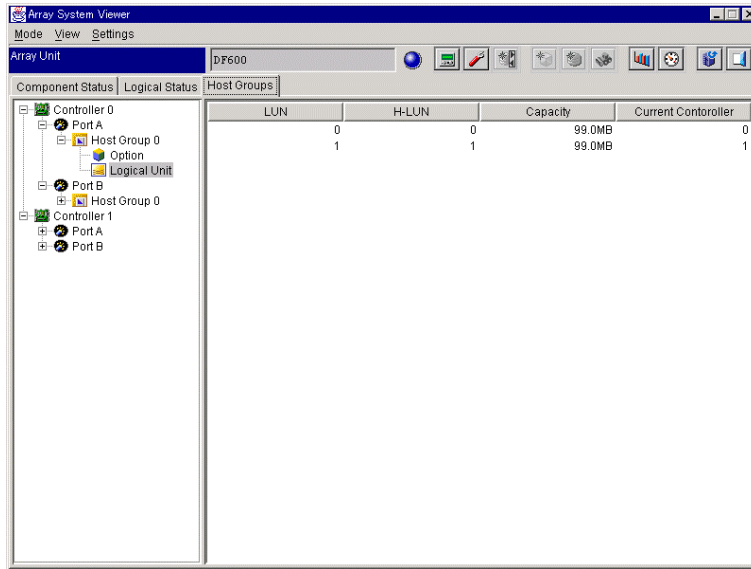

Figure 6.5 Mapping Property

6. A confirmation message appears. Click the **OK** button.



The set mapping information is updated and the following window is displayed.



Chapter 7 Setting System Parameters

Set a system configuration, such as a Target ID and the Fibre information, of an array unit. Individual items to be set are selected by switching the tab screen. Tab screens may not be displayed, depending on the connected array unit and other variables.

This chapter includes the following:

- Target ID (9200 only)
- LAN Configuration
- Setting the SCSI Transfer Rate (9200 only)
- Spare Drive Setup
- Setting the Drive Restoration Control Option
- Online Verify Mode
- Setting Fibre Channel Information
- Outputting Configuration Information to File
- Replacing the Microprogram
- Setting the Priced Optional Features
- Setting Command Devices
- Setting the Port Option
- Setting the Controller Identifier
- Setting RTC
- Setting System Parameters

7.1 Target ID

Set the configuration of the target ID and the LUN which are recognized when the array unit is connected to the host. This section includes the following:

- Adding Information
- Adding Mapping Information
- Changing Mapping Information

7.1.1 Adding Information

1. On the **Settings** menu, select **Configuration Settings** on the Unit screen or click : **Configuration Settings** in the tool bar.

2. Click the **Target ID** tab. And click the **Change (After)** radio button.

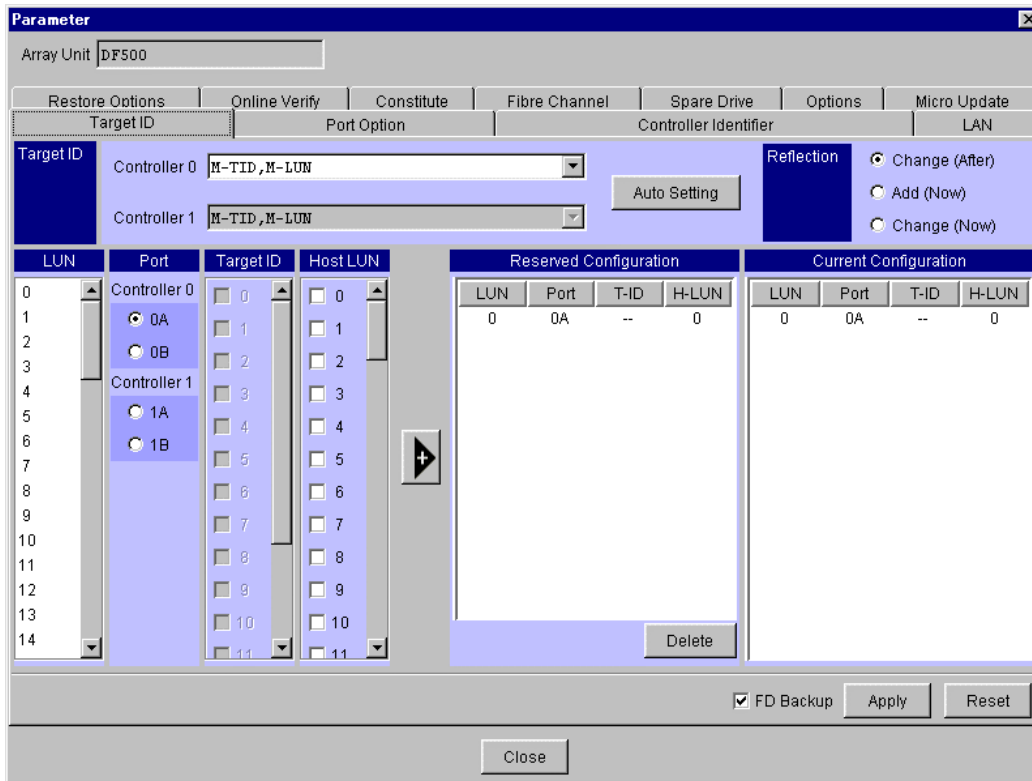

Figure 7.1 Adding Target ID Information

The condition currently set is displayed in **Current Configuration**. When it is displayed once again after the setting, the setting contents are displayed in **Reserved Configuration**.

- **Target ID:** Specifies configuration types of the target ID and the LUN
 - S-TID, M-LUN:** Sets a target ID of the port and makes the LUN, which is shared, by the ports available to be used by the host with an identical LUN
 - M-TID, S-LUN:** Sets a port and a target ID for the LUN and enables the LUN to be used with LUN = '0' and a target ID set by the host
 - M-TID, M-LUN:** Sets a port, a target ID, and a Host LUN for the LUN in a map form and enables the LUN to be used in a configuration set by the host
 - S-TID:** Single Target ID
 - M-TID:** Multi Target ID
 - S-LUN:** Single LUN
 - M-LUN:** Multi LUN
 - LUN:** Logical unit number in the array unit
 - H-LUN:** Logical unit number that the host can recognize
- **LUN:** Specifies the LUN in the array unit. When **S-TID, M-LUN** is selected for **Target ID**, the display is grayed and cannot be selected
- **Port:** Specifies a port number
- **Target ID:** Specifies a target ID
- **Host LUN:** Specifies a LUN that the host recognizes. When **S-TID, M-LUN** and **M-TID, S-LUN** are selected for **Target ID**, the display appears in gray and selection is disabled.
- **Reserved Configuration:** Displays the configuration that is set. When **S-TID, M-LUN** is set, **H-LUN** and **LUN** are displayed as "-". When **M-TID, S-LUN** is set, **H-LUN** is displayed as "-".
- **Current Configuration:** Displays the configuration that is set. When **S-TID, M-LUN** is set, **H-LUN** and **LUN** are displayed as "-". When **M-TID, S-LUN** is set, **H-LUN** is displayed as "-".

Note: The setting of the Target ID varies with the array unit or controller to be connected. When connecting to a single-controller system, only the Controller 0 side can be set up. When connecting to both controllers of a dual-controller system, only the Controller 0 side can be set up, and the settings of the Controller 0 side are reflected on the Controller 1 side. When connecting to either of two controllers of a dual-controller system, only whichever controller side is connected can be set up.

3. Set the target ID and the LUN for each target ID according to the following procedure. When only one controller has been registered for the array unit, the setting of the **Target ID** will be valid only for the registered controller.

In this case, if the **M-TID, M-LUN** is selected in the **Target ID** menu, all logical units will be available through the ports of the non-registered controller.

- a) When **S-TID, M-LUN** mode is specified:

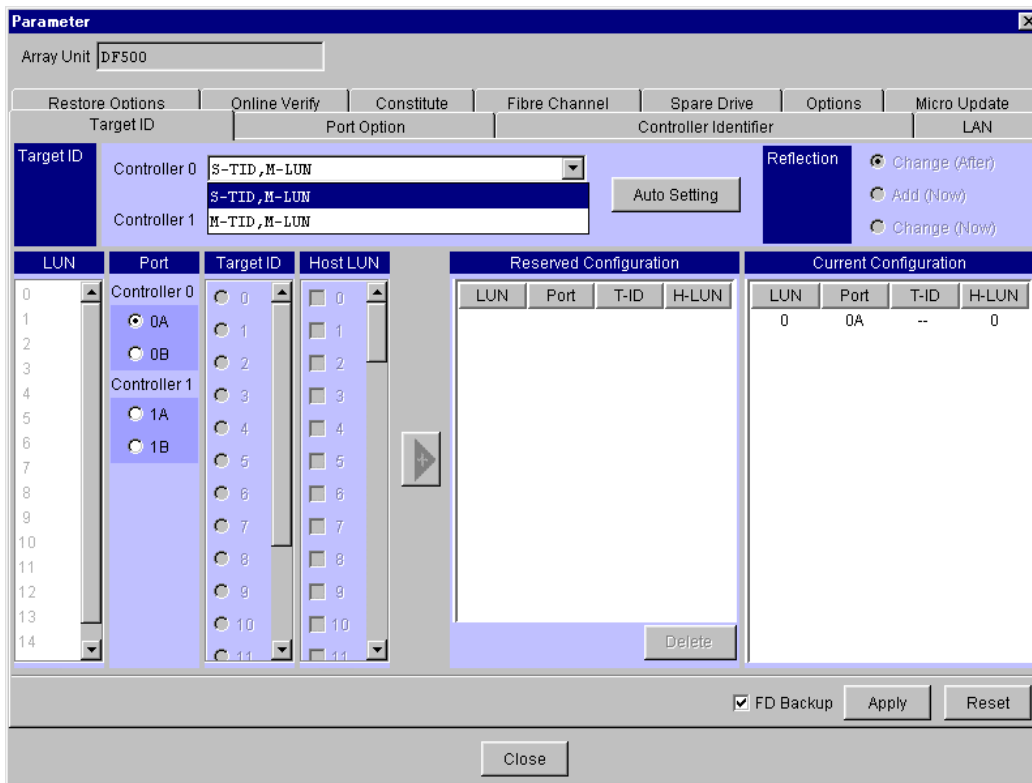



Figure 7.2 Adding S-TID, M-LUN Target ID Information

Select S-TID, M-LUN in Target ID.

For addition, select one **Port** to be added, select one **Target ID** to be set, and click the  button. The added contents are displayed in **Reserved Configuration**.

b) When M-TID, S-LUN mode is specified:

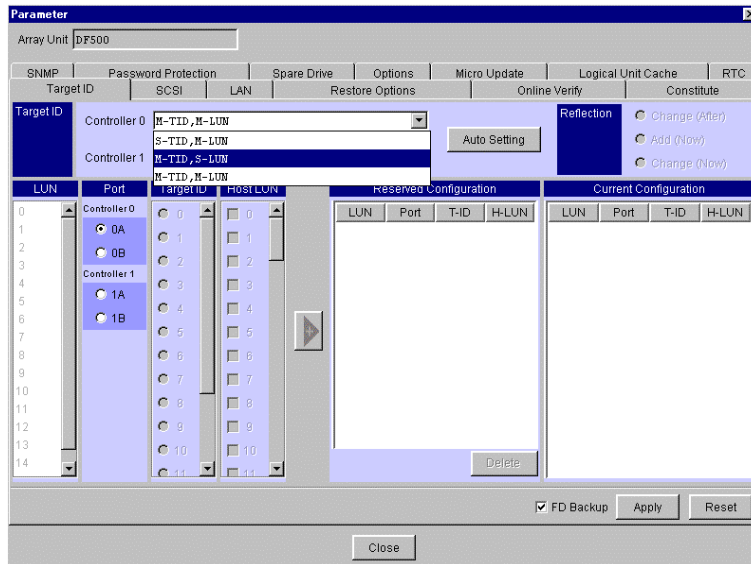



Figure 7.3 Adding M-TID, S-LUN Target ID Information

Select **M-TID, S-LUN** in the Target ID.

Select one **LUN** to be set, select one **Port** and one **Target ID** to be set, and click the  button. The added contents are displayed in **Reserved Configuration**.

Multiple **Port** and **Target ID** can be selected. When you select multiple ones, the item selected in the least significant digit in the table is set.

For deletion, click the line to be deleted in **Reserved Configuration** and click the **Delete** button. The deleted contents disappear from the display of **Reserved Configuration**.

c) When **M-TID, M-LUN** mode is specified:

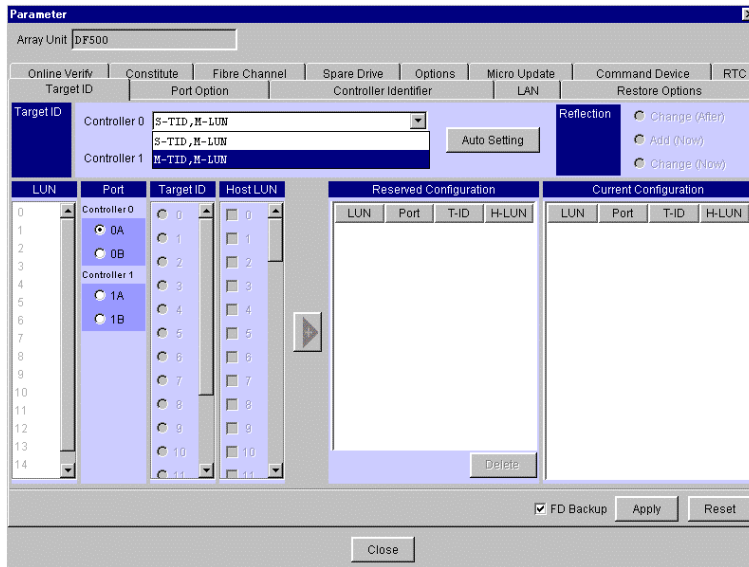



Figure 7.4 Adding M-TID, M-LUN Target ID Information

Click the **M-TID, M-LUN** option button in **Target ID**.

Select one **LUN** to be added. Select **Port**, **Target ID**, and **Host LUN** in the mapping configuration, and click the  button. The added contents are displayed in **Reserved Configuration**.

Multiple **Port**, **Target ID**, and **Host LUN** can be selected.

For deletion, click the line to be deleted in **Reserved Configuration** and click the **Delete** button. The deleted contents disappear from the display of **Reserved Configuration**.

To cancel the setting of the **M-TID, M-LUN**, select the **S-TID, M-LUN**.

d) Auto setting

The target ID configuration file is stored, and **Port**, **Target ID**, **Host LUN**, and **LUN** are set automatically. They can be set regardless of **Target ID**.

When **Auto setting** is set, all configurations that have been set are invalidated and changed to that of the target ID configuration file.

Click the **Auto Setting** button. A window for specifying a file to be stored appears. Specify the file and click the **OK** button, the setting from the file is started and the set information is displayed in **Reserved Configuration**.

The file configuration used for executing the automatic setting is shown below.

Enter the **Target ID** by specifying "Yes" or "No". Input the necessary data, which are the same as those entered in the setting made on the screen, for **Port**, **Target ID**, **H-LUN**, and **LUN**. Put spaces between the items. If the tabulating function is used, they are regarded as input errors and the inputs are ignored.

Example 1: M-TID, M-LUN Mode

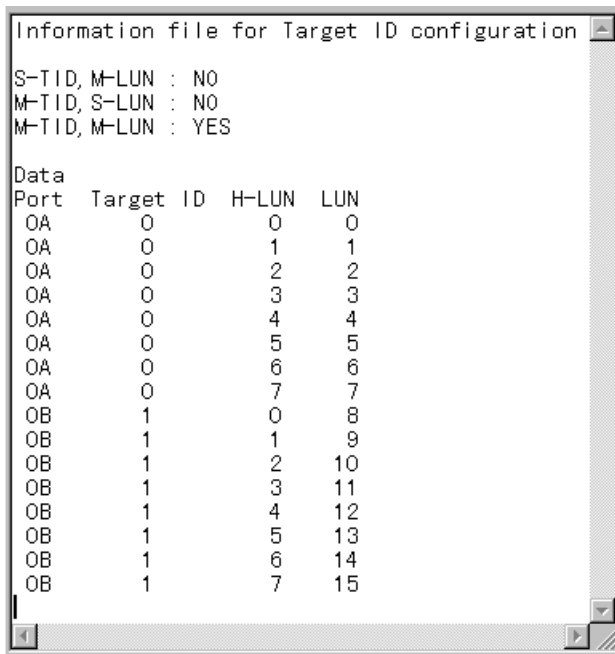

Example 2: S-TID, M-LUN Mode

```
Information file for Target ID configuration
S-TID, M-LUN : YES
M-TID, S-LUN : NO
M-TID, M-LUN : NO

Data
Port Target ID H-LUN LUN
OA      0
OB      1
1A      2
1B      3
```

Note: When the Resource Manager 9500V is connected to the array unit with the Fibre Channel connection, set '--' for the Target ID.

Two types of sample files are provided for automatic setting. The sample file configuration is shown below.

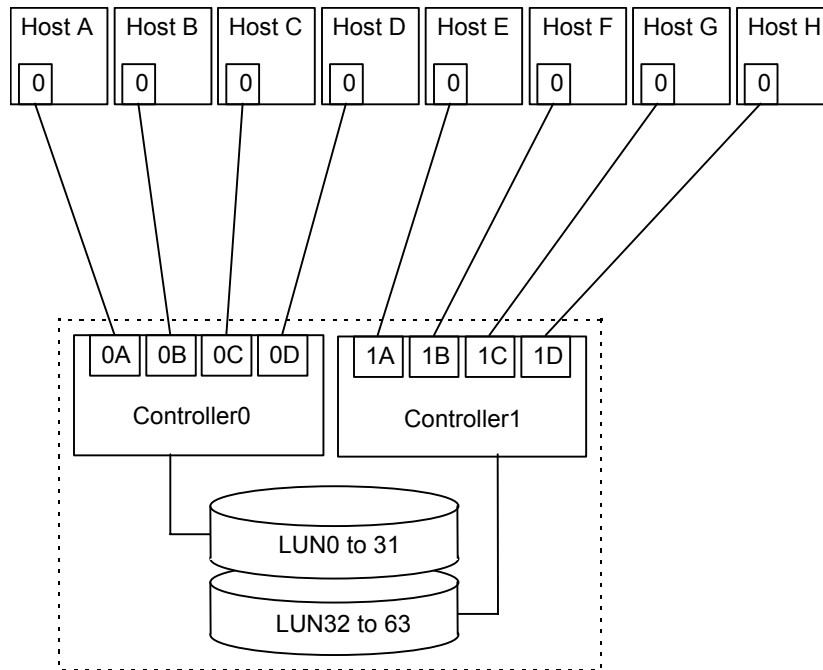

Host	Port	Target ID	H-LUN	LUN
A	0A	0	0 to 7	0 to 7
B	0B	1	0 to 7	8 to 15
C	0C	2	0 to 7	16 to 23
D	0D	3	0 to 7	24 to 31
E	1A	0	0 to 7	32 to 39
F	1B	1	0 to 7	40 to 47
G	1C	2	0 to 7	48 to 55
H	1D	3	0 to 7	56 to 63

Figure 7.5 Sample File: id00.txt --- Host LU Independent Access Type

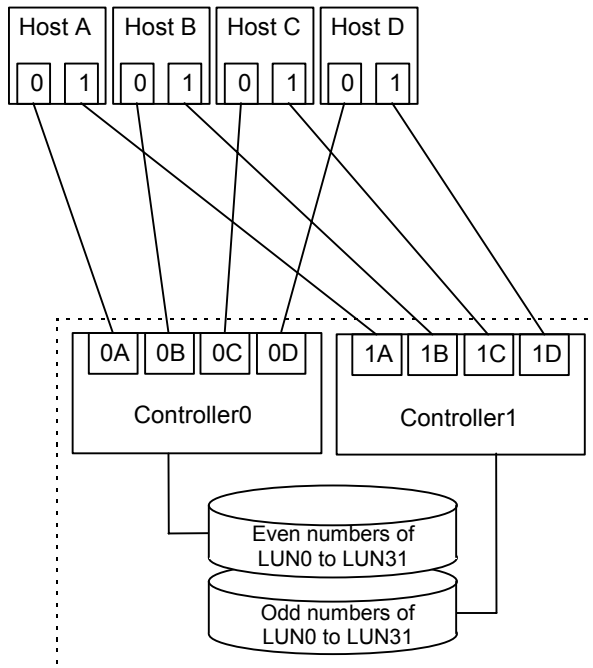

Host	Port	Target ID	H-LUN	LUN
A-Path0	0A	0	0 to 7	0 to 7
A-Path1	0B	1	0 to 7	8 to 15
B-Path0	0C	2	0 to 7	16 to 23
B-Path1	0D	3	0 to 7	24 to 31
C-Path0	1A	0	0 to 7	0 to 7
C-Path1	1B	1	0 to 7	8 to 15
D-Path0	1C	2	0 to 7	16 to 23
D-Path1	1D	3	0 to 7	24 to 31

Figure 7.6 Sample File: id01.txt - - - Host Alternate Path Access Type

4. Click the **Apply** button.
5. A message appears, stating that the Target ID has been changed. A message is displayed, requesting confirmation to restart the subsystem. Click the **OK** button to restart.

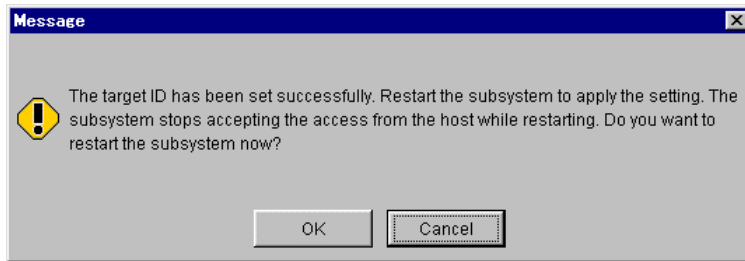

Note: To validate the set Target ID, restart the array unit. The previous settings remain valid until restarting.

The previous setting stays valid until restarting. The array unit cannot access the host until the reboot is completed and the system restarts. Therefore, be certain the host has stopped accessing data before beginning the restart process.

Note: When failing to write onto the FD drive, the message “DMES04EB02: Backup floppy disk write error.” is displayed.

When this message is displayed, writing to a FD has not been finished, but setting the Target ID may be completed.

Check a FD in an array unit, re-confirm the data to set, turn on the **FD Backup** check box, and then click the **Apply** button once again.

6. When you choose to restart the array unit, the time the restart began is displayed. This usually takes approximately two to six minutes.

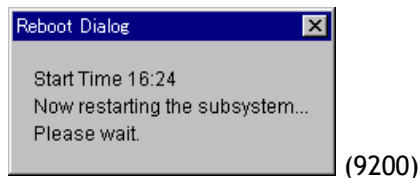
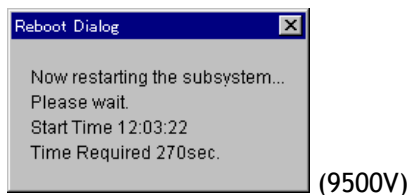

Note: It may take time for an array unit to respond, depending on the condition of the array unit. If it does not respond after 10 minutes or more, check the condition of the array unit.

7. A message appears, stating that the restart is successful. Click the **OK** button.

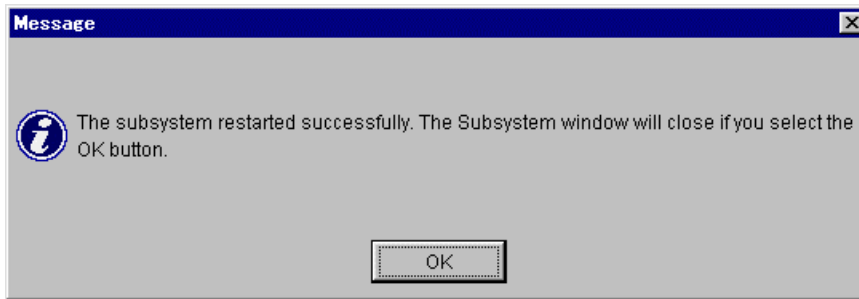

The Unit screen closes. To perform other operations on the main window, select an array unit from the main window and open the selected Unit screen.

7.1.2 Adding Mapping information

Adds mapping information for a set-up Target ID. This setting is allowed only if the Target ID mode of an array unit setup has been set to **M-TID, M-LUN** (mapping).

If the Target ID has been set in advance using **Change (After)**, restart the array unit to reflect the setting, and add mapping information.

The added information becomes valid without restarting the array unit.

1. On the **Settings** menu, select **Configuration Settings** or click : **Configuration Settings** in the tool bar.
2. Click the **Target ID** tab.

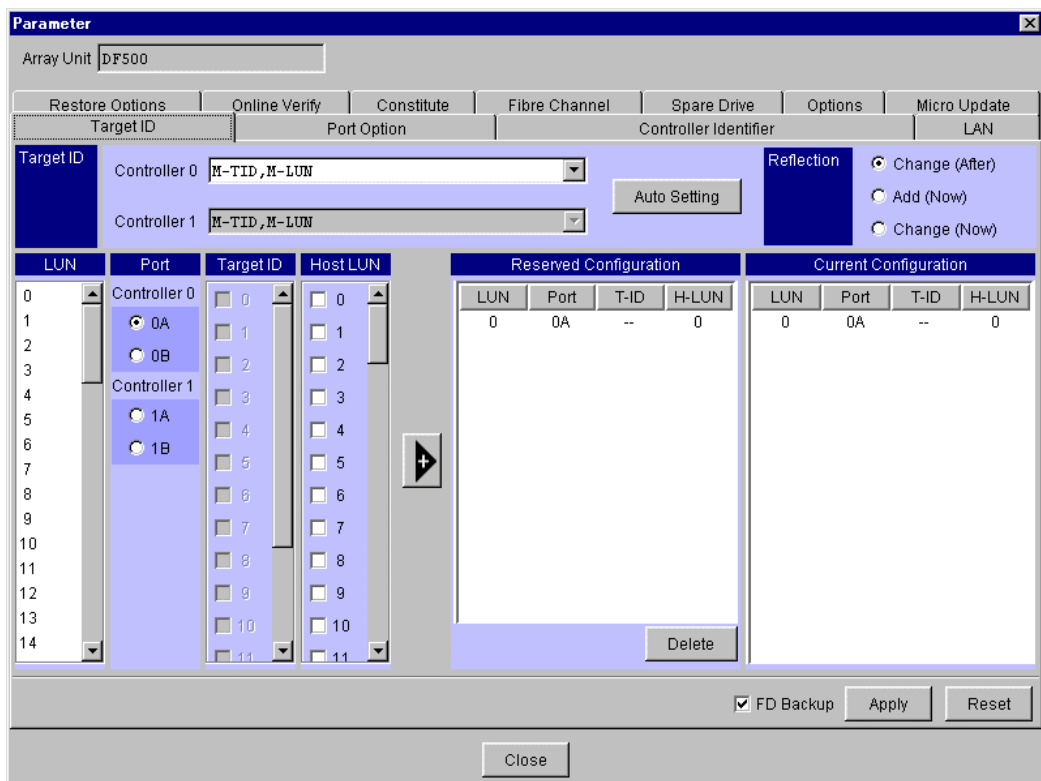
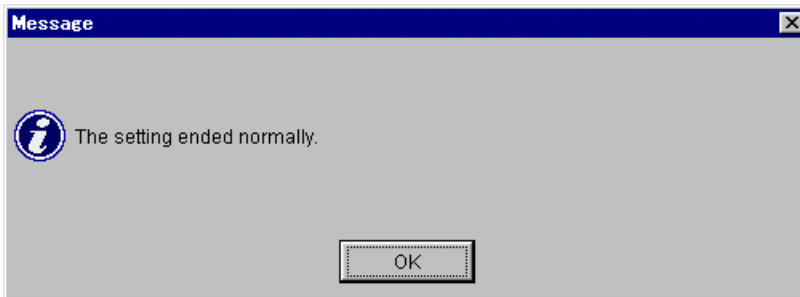

Figure 7.7 Adding Mapping Information

- **FD Backup:** Target ID configuration information has been saved in a backup FD in an array unit as parameter information. When the setting is modified, it is necessary to save it again, so be sure to turn on the check box.
3. Click the **Add (Now)** radio button on **Reflection** box.
 4. Add the information, and click the **Apply** button.

5. A message appears stating that the setting is complete. Click the **OK** button.



The added information is updated and displayed on **Current Configuration**.

Note: When failing to write onto the FD drive, the message “DMES04EB02: Backup floppy disk write error.” is displayed.

When this message is displayed, writing to a FD which has not been finished, but setting the Target ID may be completed.

Check a FD in an array unit, re-confirm the data to set, turn on the **FD Backup** check box, and then click the **Apply** button once again.

7.1.3 Changing Mapping Information

You can change mapping information for a set-up Target ID. This setting is allowed only if the Target ID mode of an array unit for setup has been set to **M-TID,M-LUN** (mapping).

If the Target ID has been set in advance using **Change (After)**, restart an array unit to reflect the setting, then add mapping information. Added information becomes valid without restarting the array unit.

Note: When executing modification, I/O operations on a set-up port may terminate abnormally. When you modify, execute modification after all I/O operations from the host to a port for which to modify settings stops.

1. On the **Settings** menu, select **Configuration Settings** or click : **Configuration Settings** in the tool bar.
2. Click the **Target ID** tab.

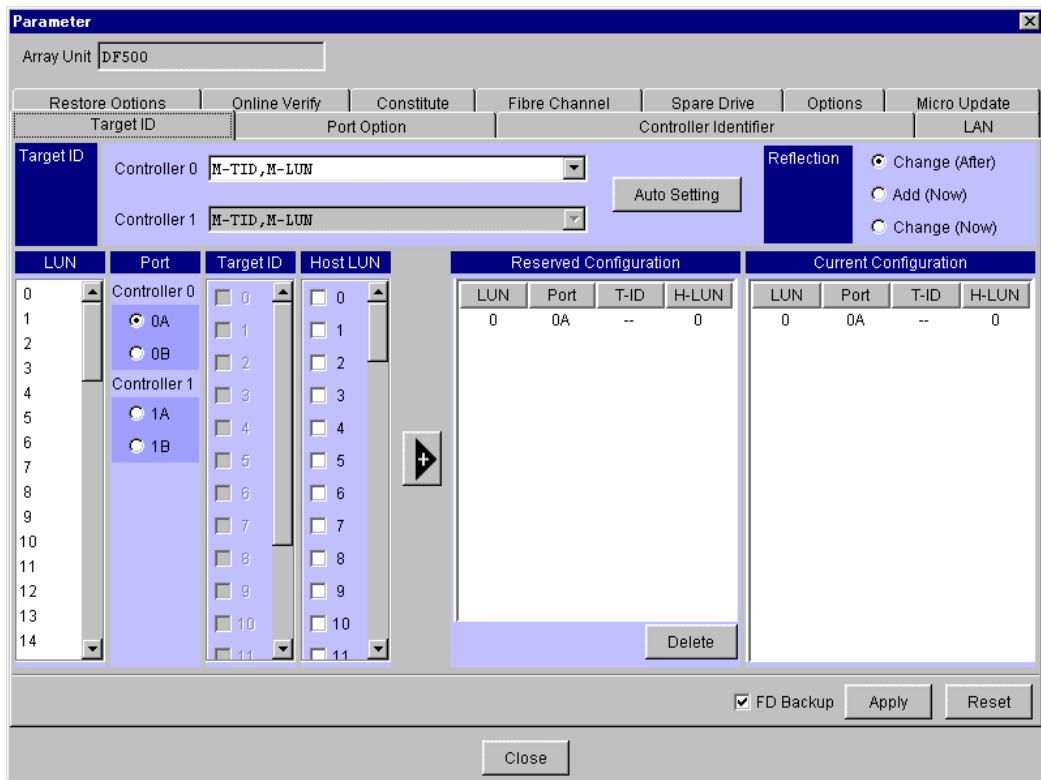
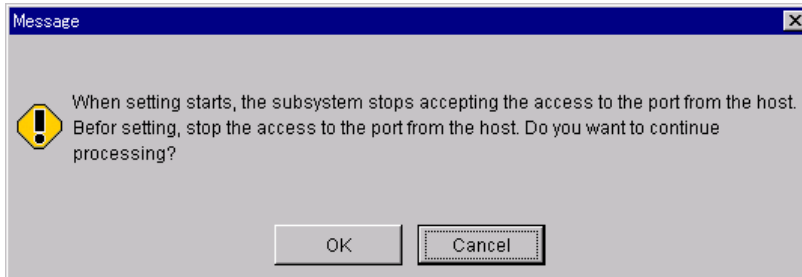

Figure 7.8 Changing Mapping Information

- **FD Backup:** Target ID configuration information has been saved in a backup FD in an array unit as parameter information. When the setting is modified, it is necessary to save it again, so be sure to turn on the check box.

3. Click the Change **(Now)** radio button on **Reflection** box.
4. Add the information, and click the **Apply** button.
5. A confirmation message appears. After making sure that I/O operation initiated by the host has stopped, click the **OK** button.



6. A message indicating completion of setting is displayed. Click the **OK** button.

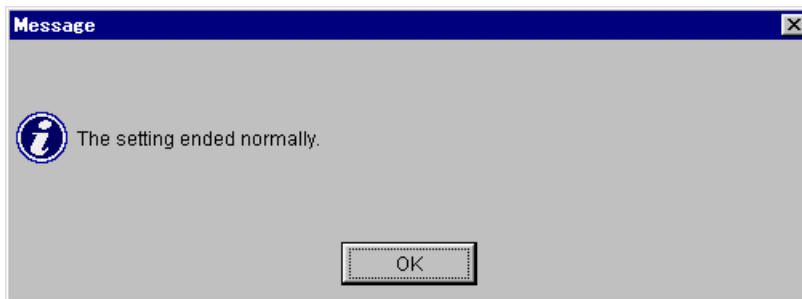

The added information is updated and displayed on **Current Configuration**.

Note: When failing to write onto the FD drive, the message “DMES04EB02: Backup floppy disk write error.” is displayed.

When this message is displayed, writing into a FD has not been finished, but setting the Target ID may be completed.

Check a FD in an array unit, re-confirm the data to set, turn on the **FD Backup** check box, and then click the **Apply** button once again.

7.2 LAN Configuration

To set the LAN configuration information of the array unit:

1. On the **Settings** menu, select **Configuration Settings** or click : **Configuration Settings** in the tool bar.
2. Click the **LAN** tab.

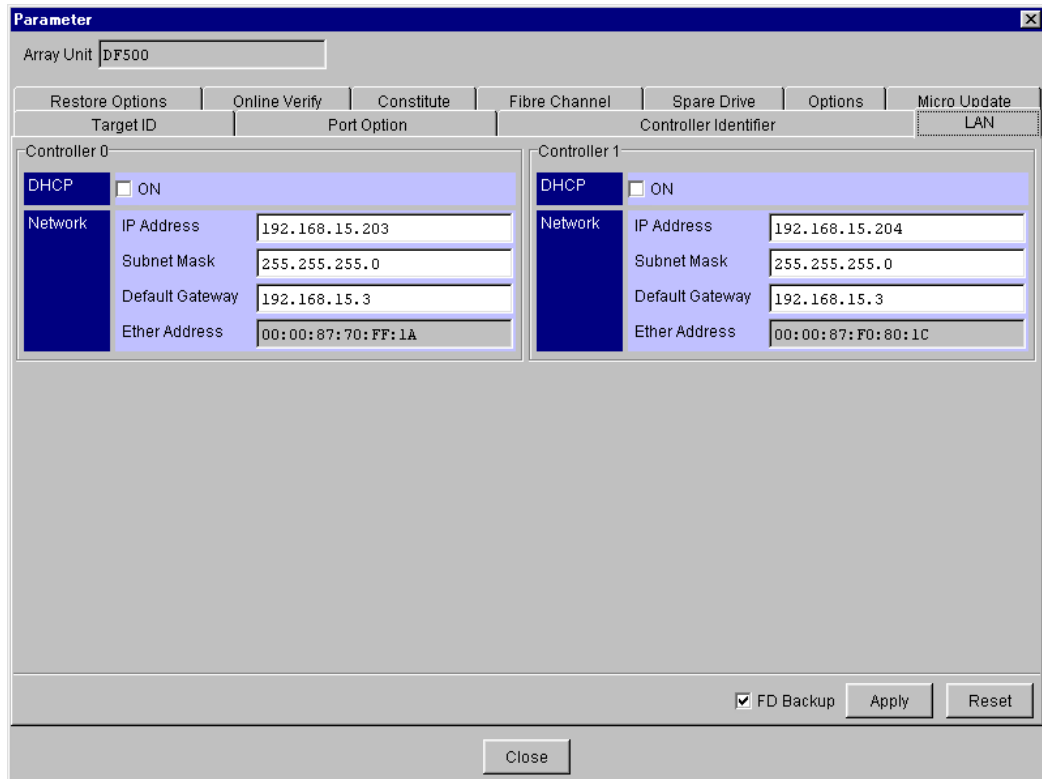

The screenshot shows the 'Parameter' dialog box for an array unit 'DF500'. The 'LAN' tab is selected. The dialog is divided into two sections for 'Controller 0' and 'Controller 1'. Each section has a 'DHCP' checkbox (currently unchecked) and a 'Network' section with fields for IP Address, Subnet Mask, Default Gateway, and Ether Address. At the bottom, there is a checked 'FD Backup' checkbox and 'Apply' and 'Reset' buttons. A 'Close' button is at the very bottom.

Controller	DHCP	IP Address	Subnet Mask	Default Gateway	Ether Address
Controller 0	<input type="checkbox"/>	192.168.15.203	255.255.255.0	192.168.15.3	00:00:87:70:FF:1A
Controller 1	<input type="checkbox"/>	192.168.15.204	255.255.255.0	192.168.15.3	00:00:87:F0:80:1C

Figure 7.9 Setting LAN Configuration Information

- **DHCP:** Specifies whether the DHCP mode will be valid or invalid
- **Network:** Specifies IP Address, Subnet Mask, or Default Gateway, which is part of the LAN information. Ether Address is displayed but cannot be changed.
- **FD Backup:** LAN configuration information is saved onto the backup FD in the array unit as part of the system parameter information. **Check the check box.** If the setting is changed, it will need to be saved again (9200 only).

Note 1: When **ON** is selected in **DHCP**, **LAN Parameter** is displayed in gray and cannot be selected.

3. Click the **Apply** button.
4. A message appears, stating that the setting is complete. A message is displayed, requesting confirmation to restart the subsystem. Click the **OK** button when restarting.

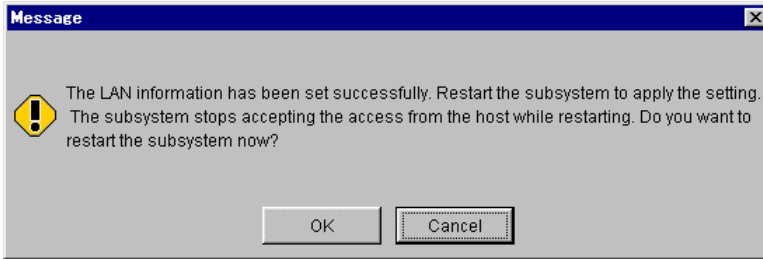

Note: To validate the LAN information, restart the array unit. The previous settings stay valid until restarting. The array unit cannot access the host until the reboot is completed and the system restarts. Therefore, be certain the host has stopped accessing data before beginning the restart process.

Note: When failing to write onto the FD drive, the message “DMES04EB02: Backup floppy disk write error.” is displayed.

When this message is displayed, writing to a FD has not been finished, but setting the LAN configuration information may be completed.

Check the FD in an array unit, re-confirm the data to set, turn on the **FD Backup** check box, and click the **Apply** button again.

5. When you choose to restart the array unit, the time the restart began is displayed. This usually takes approximately two to six minutes.

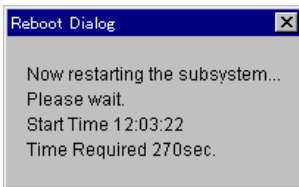

(9500V)

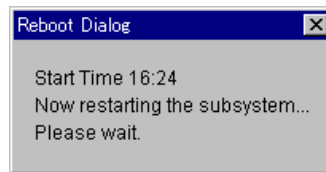

(9200)

Note: It may take time for an array unit to respond, depending on the condition of the array unit. If it does not respond after 10 minutes or more, check the condition of the array unit.

6. A message appears, stating that the restart is successful. Click the **OK** button.

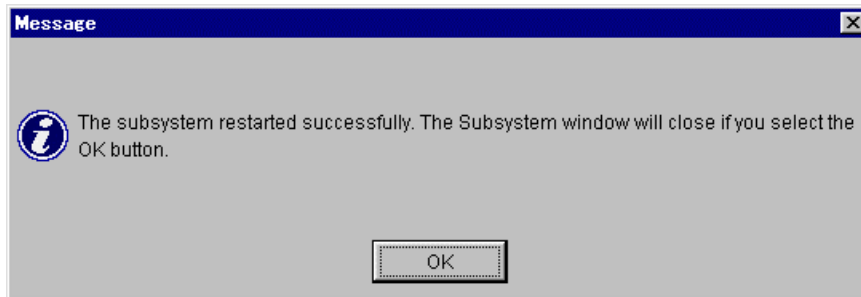

The Unit screen closes. To perform other operations on the main window, select an array unit from the main window and open the selected Unit screen.

7.3 Setting SCSI Transfer Rate

To set the transfer rate for each port of the array unit:

1. On the **Settings** menu, select **Configuration Settings** or click : **Configuration Settings** in the tool bar.
2. Click the **SCSI** tab.

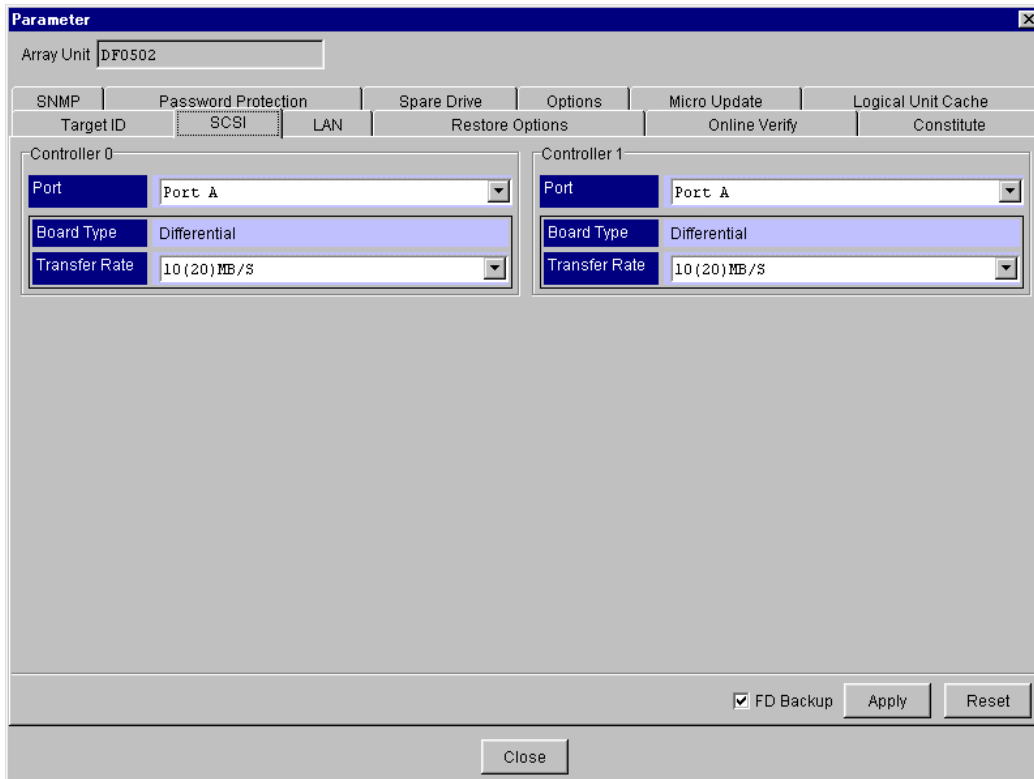

Figure 7.10 Setting the SCSI Transfer Rate

- **Port:** Selects the port number to be set
- **Board Type:** The IF board type installed is displayed
 - None:** Not installed
 - Single:** Single type
 - Differential:** Differential type
 - Ultra2:** Ultra2 type
- **Transfer Rate:** Selects the port transfer rate
 - STANDARD:** Transfers data is automatically according to the IF board installed
 - ASYNC:** Transfers data in the mode without using the synchronous transfer
 - 5(10) MB/s:** Sets the maximum transfer rate to 5 MB/s for narrow SCSI and 10 MB/s for wide SCSI
 - 10(20) MB/s:** Sets the maximum transfer rate to 10 MB/s for narrow SCSI and 20 MB/s for wide SCSI

20(40) MB/s: Sets the maximum transfer rate to 20 MB/s for narrow SCSI and 40 MB/s for wide SCSI

40(80) MB/s: Sets the maximum transfer rate to 40 MB/s for narrow SCSI and 80 MB/s for wide SCSI

Note: When the **Board Type** displays **None**, it is displayed in gray and cannot be set. When the **Board Type** displays **Single** or **Differential**, **40(80) MB/s** is displayed in gray and cannot be selected.

- **FD Backup:** The SCSI I/F transfer rate information is saved on the backup floppy disk in the array unit as system parameter information. **Be sure to check the check box;** it is necessary to save it again when the setting is changed.
3. Click the **Apply** button.
 4. A message appears, stating that the setting is complete. A message is displayed, requesting confirmation to restart the subsystem. Click the **OK** button when restarting.

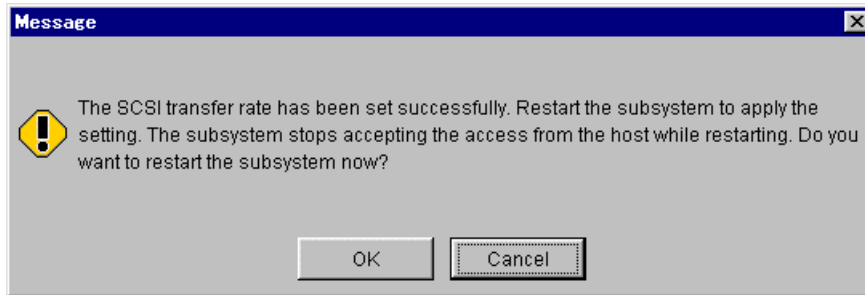

Note: To validate the SCSI Transfer rate information, restart the array unit. The previous settings stay valid until restarting. The array unit cannot access the host until the reboot is completed and the system restarts. Therefore, be certain the host has stopped accessing data before beginning the restart process.

Note: When failing to write onto the FD drive, the message “DMES04EB02: Backup floppy disk write error.” is displayed.

When this message is displayed, writing to a FD has not been finished, but setting the SCSI Transfer rate configuration information may be completed.

Check the FD in an array unit, re-confirm the data to set, turn on the **FD Backup** check box, and click the **Apply** button again.

When you choose to restart the array unit, the time the restart began is displayed. This usually takes approximately two to six minutes.

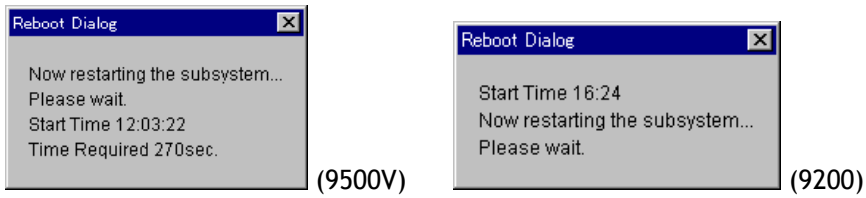

Note: It may take time for an array unit to respond, depending on the condition of the array unit. If it does not respond after 10 minutes or more, check the condition of the array unit.

5. A message appears, stating that the restart is successful. Click the **OK** button.

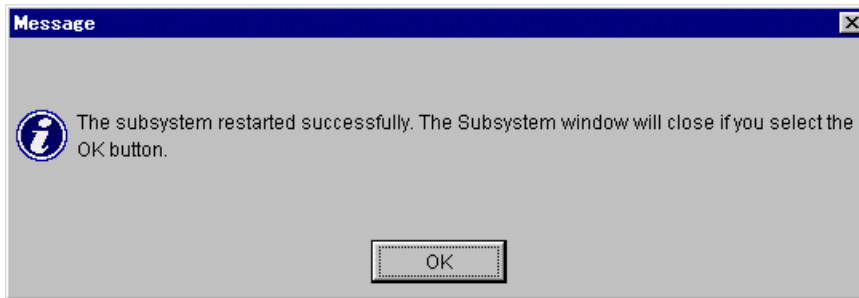

The Unit screen closes. To perform other operations on the main window, select an array unit from the main window and open the selected Unit screen.

7.4 Spare Drive Setup

It is necessary to assign a spare drive to the maximum drive capacity in a subsystem.

To set up and cancel the spare disk:

1. On the **Settings** menu, select **Configuration Settings** or click : **Configuration Settings** in the tool bar.
2. Click the **Spare Drive** tab.

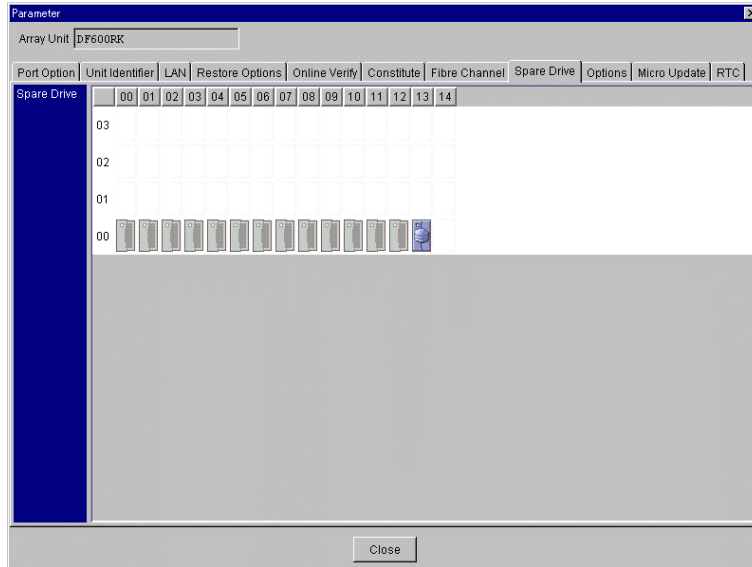

Data disk



Spare disk

Figure 7.11 Setting Up the Spare Drive

Note: To cancel the spare drive setup, click the icon of the HDU to be canceled.

3. A message appears, requesting confirmation to set this drive as a spare. Click the **OK** button.
 - a) When a spare drive is setup:

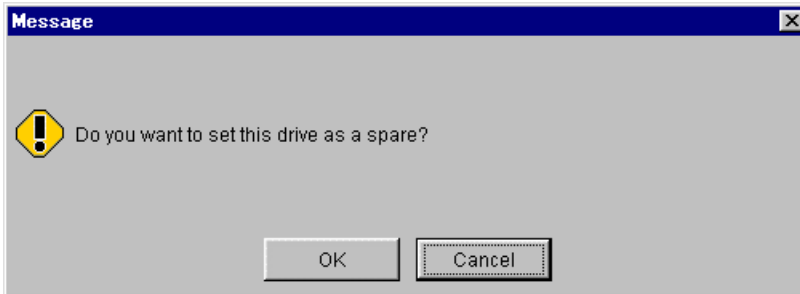

- b) When a spare disk is canceled:



4. A message appears, stating that the setting is complete. Click the **OK** button.

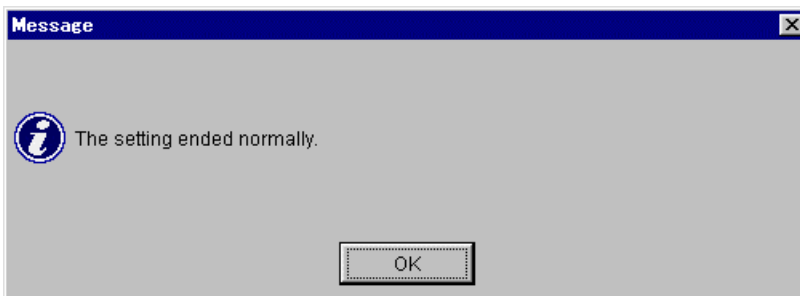

The icon of the HDU, which is setup or canceled is updated and displayed.

7.5 Setting the Drive Restoration Control Option

Selection and setting of this option are not valid when they are made during drive restoration. (Drive restoration is executed according to the option at the start of the processing.) Make certain that the drive is not being restored when changing the option setting.

1. On the Settings menu, select Configuration Settings or click : Configuration Settings in the tool bar.
2. Click the Restore Options tab.

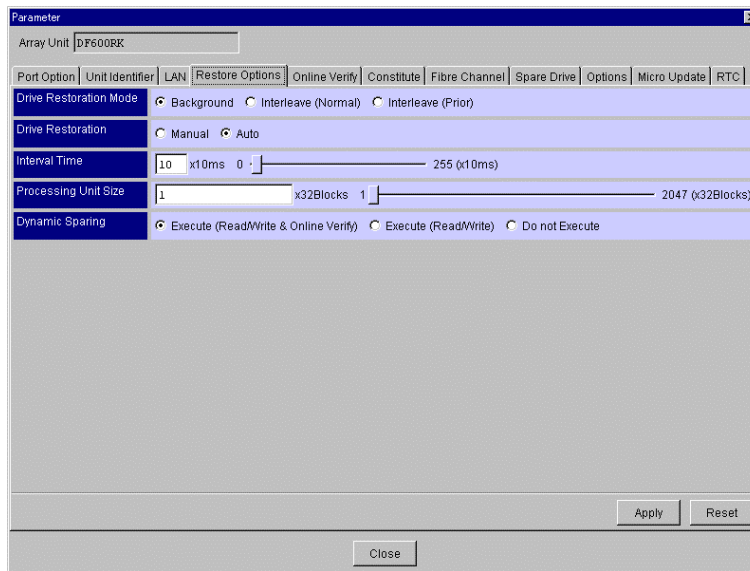

Figure 7.12 Setting the Drive Restoration Control Option

3. Specify Drive Restoration Mode, Drive Restoration, Interval Time, Processing Unit Size, and Dynamic Sparring.
 - **Drive Restoration Mode:** Specify a mode in which drives are to be restored
 - Background:** Executes drive restoration while host I/O processing is not executed
 - Interleave (Normal):** Restores the drive at preset time intervals (specified as “Interval Time”) giving preference to a host command (restores after executing the command)
 - Interleave (Prior):** Restores the drive at preset time intervals (specified as “Interval Time”) taking preference over a host command
 - **Drive Restoration:** Instructs whether to start the following operations automatically or manually. The operations concerned are data restoration to the failed drive or to the spare drive, copy back of the data from the spare drive to the original drive, and dynamic sparing.
 - Manual:** Starts restoring data and copying by manual operations
 - Auto:** Automatically starts restoration of data and copying
 - Note:** Use Auto; the Resource Manager 9500V does not support a manual operation.

- **Interval Time:** Specify a time interval of drive restoration. The default interval time is 10×10 ms and drive restoration is executed at intervals of 100 ms. Specify a multiplication factor 0 to 255 in a unit of 10 ms.
- **Processing Unit Size:** Specify the size of the data block to be restored. The default processing unit size is 32 blocks and data of 16 k byte is restored at a time. When Interleave mode is specified, the function restores data of a processing unit size specified here, waits for a time interval specified here, then starts the next data restoration. Specify a multiplication factor 1 to 2,047 in a unit of 512 bytes.
- **Dynamic Sparing:** Specify a mode for data restoration for the spare drive when the error occurrence count controlled by preventive maintenance exceeds the threshold value.

Execute (Read/Write & Online Verify): When the error occurrence count in **Read/Write Error** or **Online Verify Error**, **Threshold Value Over** and **Start of Dynamic Sparing** are displayed on the panel and data restoration is performed for the spare drive (when the spare drive is not used), and the error disk is blocked.

Execute (Read/Write): When the error occurrence count in **Read/Write Error** exceeds the threshold value, **Threshold Value Over** and **Start of Dynamic Sparing** are displayed on the panel and data restoration is performed for the spare disk in the spare drive (when the spare disk is not used), and the error disk is blocked. When the error occurrence count in **Online Verify Error** exceeds the threshold value, **Threshold Value Over** is displayed on the panel but **Dynamic Sparing** is not performed.

Do not Execute: When the error occurrence count in **Read/Write Error** or **Online Verify Error** exceeds the threshold value, **Threshold Value Over** is displayed on the panel but **Dynamic Sparing** is not performed.

4. After the setting is complete, click the **Apply** button.
5. A message appears, stating that the setting is complete. Click the **OK** button.

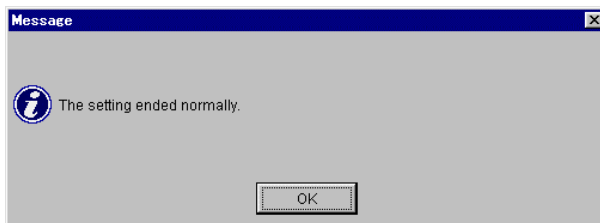

7.6 Online Verify Mode

1. On the **Settings** menu, select **Configuration Settings** or click : **Configuration Settings** in the tool bar.
2. Click the **Online Verify** tab.

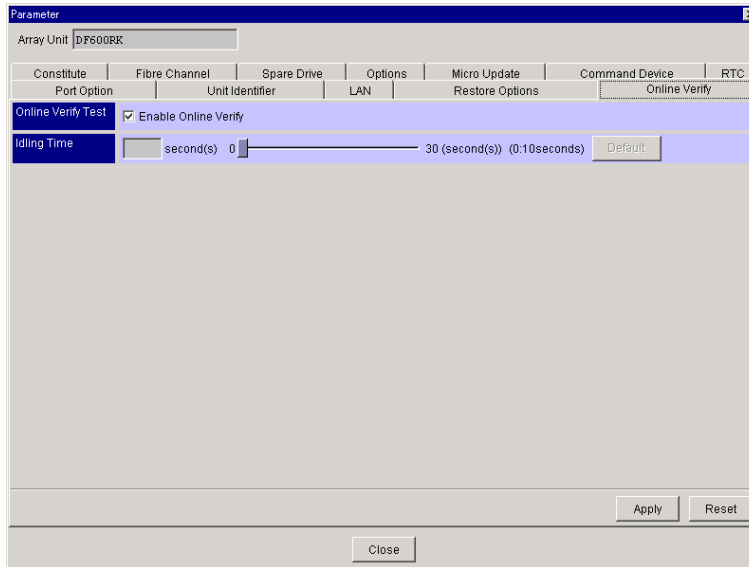
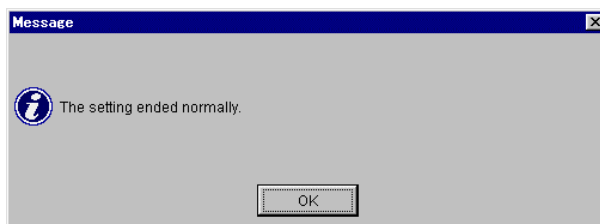

Figure 7.13 Online Verify Mode

3. Select whether or not to execute **Online Verify Test** and specify **Idling Time**.
 - **Online Verify Test:** Specifies whether or not to execute **Online Verify Test**
 - **Idling Time:** Specifies an interval from the end of an I/O operation instructed by the host to the start of the online verify. If “0” is specified, the time is set to 10 [seconds], and hence an online verify operation begins 10 seconds after an I/O operation from the host terminates. Specify a value within a range between 1 and 30 seconds in units of seconds (9200 only).
4. After the setting is complete, click the **Apply** button.
5. A message appears, stating that the setting is complete. Click the **OK** button.



7.7 Setting Fibre Channel Information

This section includes the following:

- Topology Setup
- Setting the Port Address
- Setting the Transfer Rate
- Setting Port Security

To set and display fibre channel information:

1. On the **Settings** menu, select **Configuration Settings** or click : **Configuration Settings** in the tool bar.
2. Click the **Fibre Channel** tab.

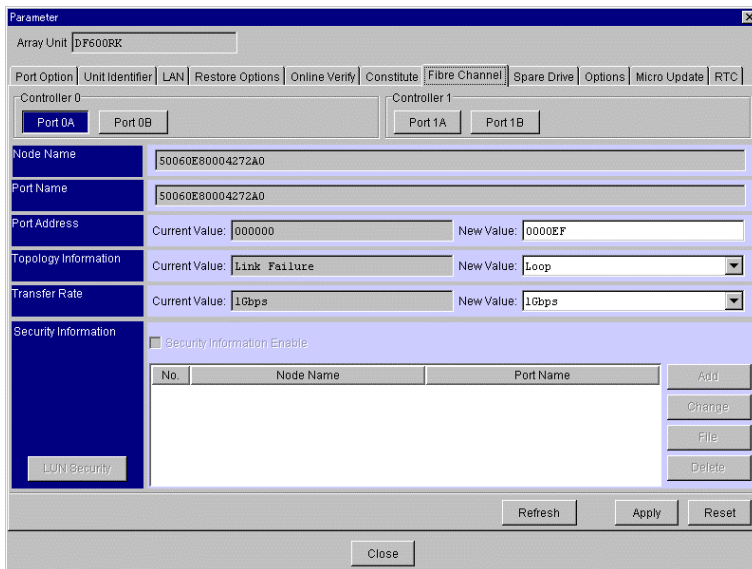

The screenshot shows a 'Parameter' dialog box with the 'Fibre Channel' tab selected. The 'Array Unit' is 'DF600BK'. The 'Fibre Channel' tab is active, showing configuration for Controller 0 and Controller 1. Controller 0 has Port 0A and Port 0B. Controller 1 has Port 1A and Port 1B. The 'Node Name' and 'Port Name' fields are both set to '50060E80004272A0'. The 'Port Address' field shows 'Current Value: 000000' and 'New Value: 0000EF'. The 'Topology Information' field shows 'Current Value: Link Failure' and 'New Value: Loop'. The 'Transfer Rate' field shows 'Current Value: 1Gbps' and 'New Value: 1Gbps'. The 'Security Information' section has a checkbox for 'Security Information Enable' which is unchecked. Below this is a table with columns 'No.', 'Node Name', and 'Port Name', and buttons 'Add', 'Change', 'File', and 'Delete'. At the bottom are 'Refresh', 'Apply', 'Reset', and 'Close' buttons.

Figure 7.14 Displaying Fibre Channel Information

- **Node Name:** Describes 8 bytes of data hexadecimal (with 16 characters)
- **Port Name:** Describes 8 bytes of data hexadecimal (with 16 characters)
- **Port Address:** Port address is displayed as a hexadecimal number.

- **Topology Information:** Indicates the topology status
 - LinkUp (Private Loop):** Arbitrated Loop not connected with Fibre Channel switch
 - LinkUp (Public Loop):** Arbitrated Loop connected with Fibre Channel switch
 - LinkUp (N_Port connection):** Connect Point to Point with host
 - LinkUp (F_Port connection):** Connect Point to Point with Fibre Channel switch
 - Loop Port Bypass:** Bypassed from the loop
 - Standby:** Standby state
 - LinkDown:** Link is down
 - LinkFailure:** Link initialization condition
- **Transfer Rate:** Indicates the fibre transfer rate
- **Security Information:** Setting and displaying LUN security information

7.7.1 Topology Setup

Use the following procedure to set up the topology. The topology is set up on a port basis.

1. On the **Settings** menu, select **Configuration Settings** or click : **Configuration Settings** in the tool bar.
2. Click the **Fibre Channel** tab.
3. Select the **New Value** in the **Topology Information**.

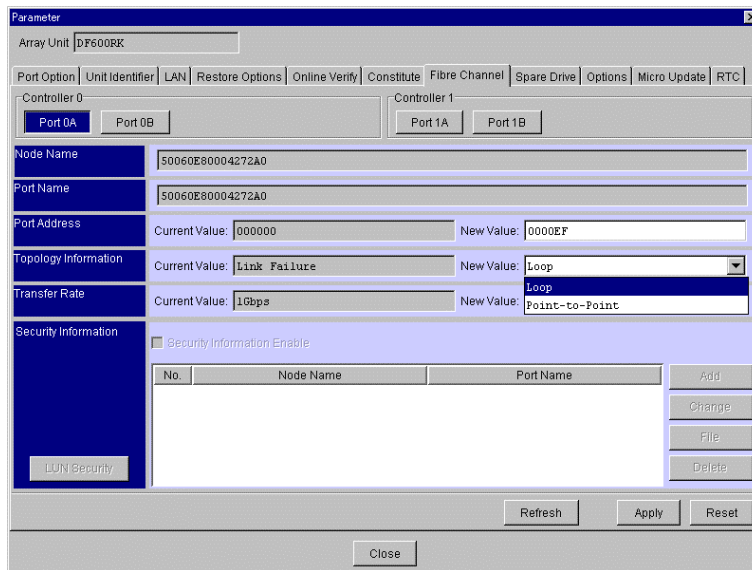

Figure 7.15 Setting Up the Topology

4. Click the **Apply** button.

Operations vary with the array unit being set up. These include:

- When an Array Unit Supports a Setup without Restarting
- When an Array Unit does not Support a Setup without Restarting

7.7.1.1 When an Array Unit Supports a Setup without Restarting

- a) The following message appears. After making sure that I/O operation initiated by the host has stopped, click the **OK** button.

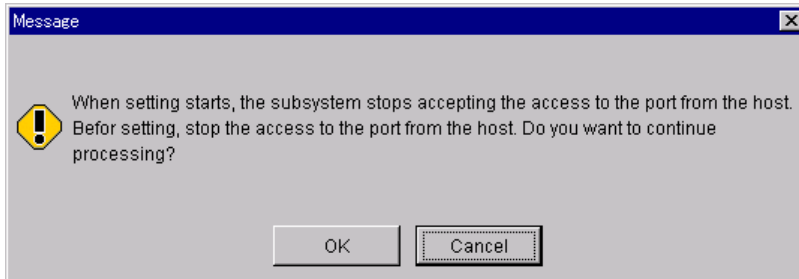

- b) A message indicating completion of setting is displayed. Click the **OK** button.

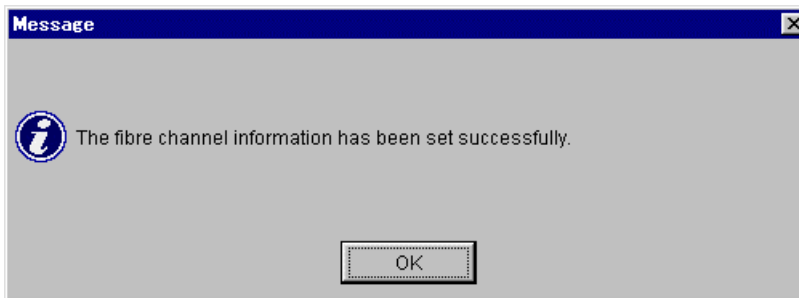

Note: It may take time to complete the setting. Click the **Refresh** button to verify that the correct settings have been made.

7.7.1.2 When an Array Unit does not Support a Setup without Restarting

- a) A message appears, stating that the setting is complete. To validate the topology, restart the array unit. Click the **OK** button to restart.

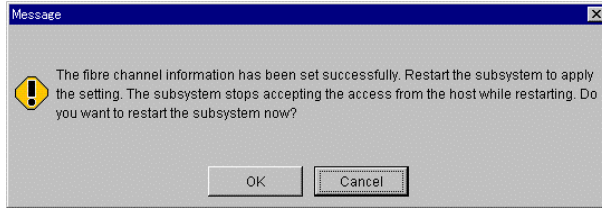

Note: To validate the topology information, restart the array unit. The previous settings stay valid until restarting. The array unit cannot access the host until the reboot is completed and the system restarts. Therefore, be certain the host has stopped accessing data before beginning the restart process.

When you choose to restart the array unit, the time the restart began is displayed. This usually takes approximately two to six minutes.

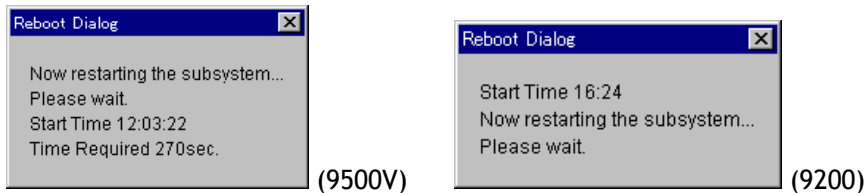

Note: It may take time for an array unit to respond, depending on the condition of the array unit. If it does not respond after 10 minutes or more, check the condition of the array unit.

- b) A message appears, stating that the restart is successful. Click the **OK** button.

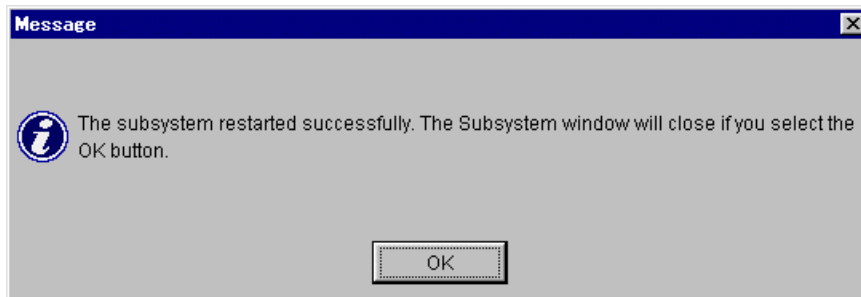

The Unit screen closes. To perform other operations on the main window, select an array unit from the main window and open the selected Unit screen.

7.7.2 Setting the Port Address

To set the port address of the Fibre Port:

1. On the **Settings** menu, select **Configuration Settings** or click : **Configuration Settings** in the tool bar.
2. Click the **Fibre Channel** tab.
3. Select the **New Value** in the **Port Address**.

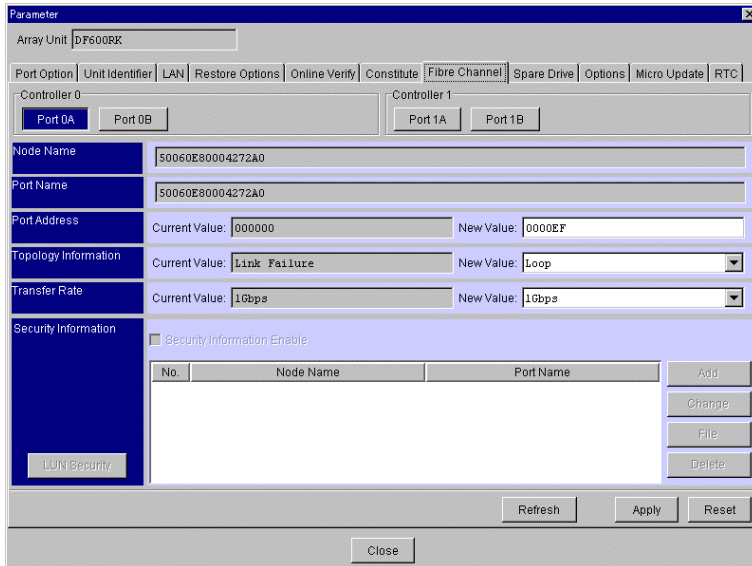

The screenshot shows a 'Parameter' dialog box for an array unit 'DF600BK'. The 'Fibre Channel' tab is selected. Under 'Controller 0', 'Port 0A' is active. The 'Port Address' field shows a 'Current Value' of '000000' and a 'New Value' of '0000EF'. Other fields include 'Node Name' (50060E80004272A0), 'Port Name' (50060E80004272A0), 'Topology Information' (Link Failure to Loop), and 'Transfer Rate' (1Gbps to 1Gbps). A 'Security Information' section has a checkbox for 'Security Information Enable' and a table with columns 'No.', 'Node Name', and 'Port Name'. Buttons for 'Add', 'Change', 'File', and 'Delete' are on the right. At the bottom are 'Refresh', 'Apply', 'Reset', and 'Close' buttons.

Figure 7.16 Setting the Port Address

4. Click the **Apply** button.

Operations vary with the array unit to set up. Refer to individual ways for operations so as to meet their respective array units.

Operations vary with the array unit being set up. These include:

- When an Array Unit Supports a Setup without Restarting
- When an Array Unit does not Support a Setup without Restarting

7.7.2.1 When an Array Unit Supports a Setup without Restarting

- a) The following message appears. After making sure that I/O operation initiated by the host has stopped, click the **OK** button.

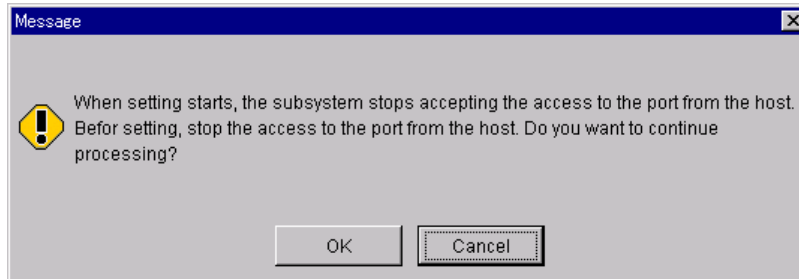

- b) A message indicating completion of setting is displayed. Click the **OK** button.

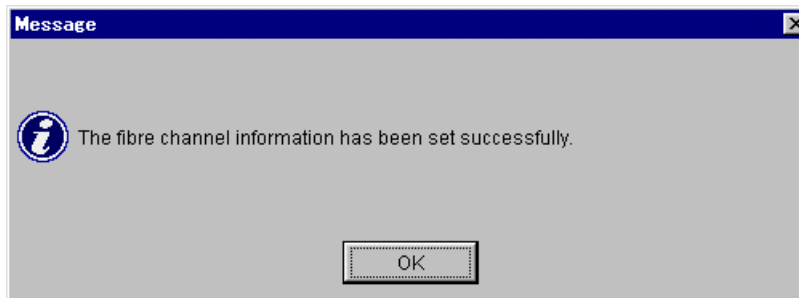

Note: It may take time to complete the setting. Click the **Refresh** button to verify that the correct settings have been made.

7.7.2.2 When an Array Unit does not Support a Setup without Restarting

- a) A message appears, stating that the setting is complete. To validate the port address, restart the array unit. Click the **OK** button to restart.

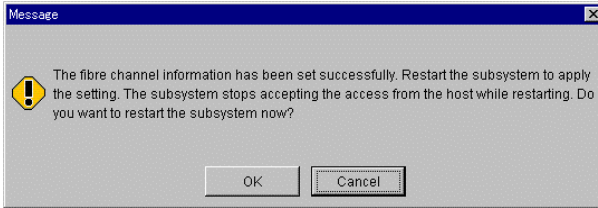

Note: To validate the port address information, restart the array unit. The previous settings stay valid until restarting. The array unit cannot access the host until the reboot is completed and the system restarts. Therefore, be certain the host has stopped accessing data before beginning the restart process.

When you choose to restart the array unit, the time the restart began is displayed. This usually takes approximately two to six minutes.

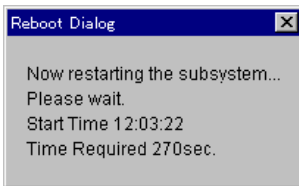

(9500V)

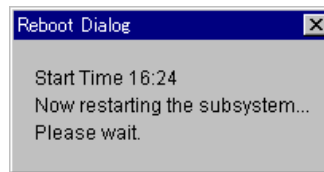

(9200)

Note: It may take time for an array unit to respond, depending on the condition of the array unit. If it does not respond after 10 minutes or more, check the condition of the array unit.

- b) A message appears, stating that the restart is successful. Click the **OK** button.

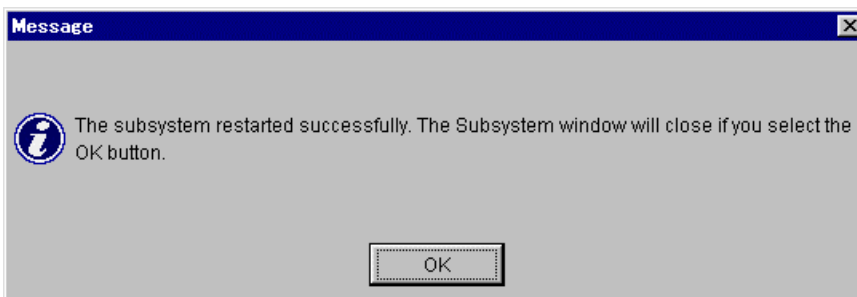

The Unit screen closes. To perform other operations on the main window, select an array unit from the main window and open the selected Unit screen.

7.7.3 Setting the Transfer Rate

To set the transfer rate of the Fibre Port:

1. On the **Settings** menu, select **Configuration Settings** or click : **Configuration Settings** in the tool bar.
2. Click the **Fibre Channel** tab.
3. Select **New Value** in the **Transfer Rate**.

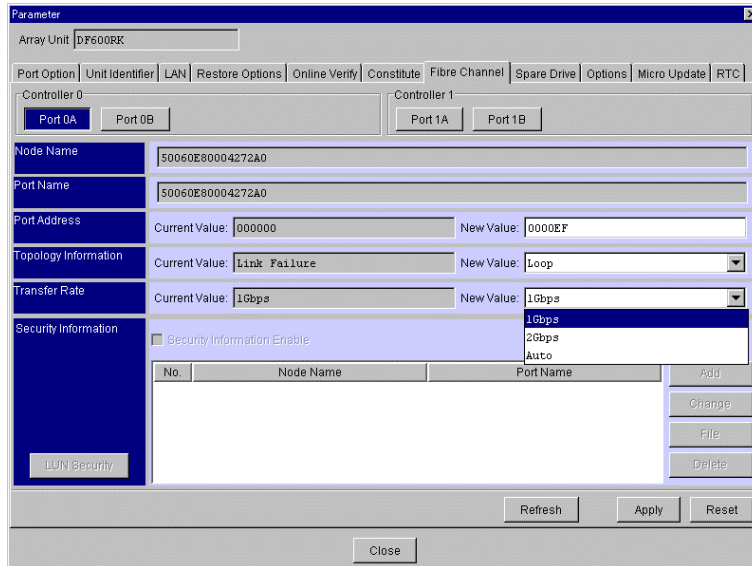
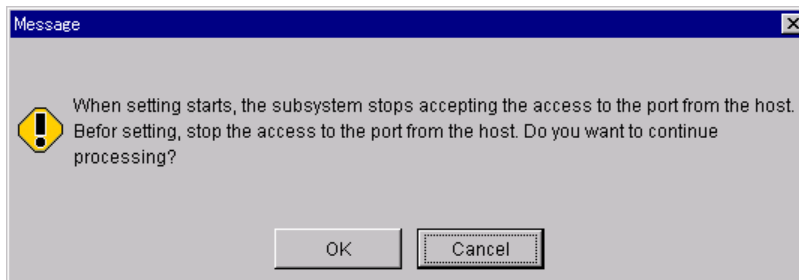
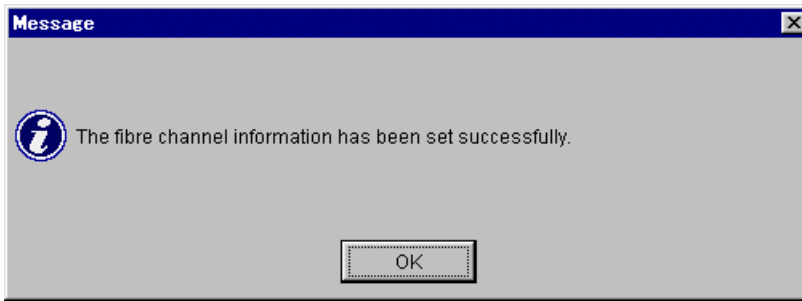

Figure 7.17 Setting the Transfer Rate

4. Click the **Apply** button.
5. The following message appears. After verifying that the I/O operation initiated by the host has stopped, click the **OK** button.



6. A message appears, stating that the setting is complete. Click the **OK** button.



Note: It may take time to complete the setting. Click the **Refresh** button to verify that the correct settings have been made.

7.7.4 Setting Port Security

The port security function specifies another port for which access is permitted for each port. Set the WWN (node name and port name) security information for each port.

1. On the **Settings** menu, select **Configuration Settings** or click : **Configuration Settings** in the tool bar.
 2. Click the **Fibre Channel** tab.
 3. Setting the **WWN**
 - **LUN Security**: Specify whether the LUN security is to be used or not.
 - **WWN**: When using the port security and LUN security, set the host WWN. Specify **Node Name** and **Port Name** using a 16-digit hexadecimal.
- a) For addition, click the **Add** button.

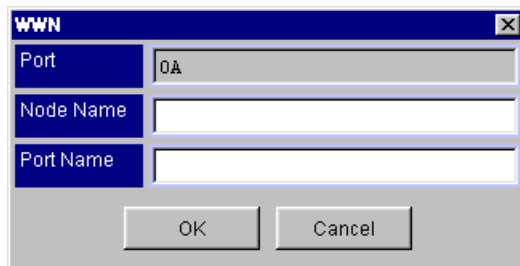

WWN	
Port	0A
Node Name	
Port Name	
OK Cancel	

Specify the **Node Name** and **Port Name** of the WWN of the host and click the **OK** button. The **Parameter** window is updated according to the added WWN.

- b) For deletion, click the **WWN** to be deleted in the **Security Information** box and click the **Delete** button.

The **Parameter** window is updated according to the deleted WWN.

- c) For a change, click the **WWN** to be changed in the **Security Information** box and click the **Change** button.

When the WWN of the host that is set appears, change **Node Name** and **Port Name** and click the **OK** button. The **Parameter** window is updated according to the changed WWN.

- d) When settings are made by using File, click the **File** button.

The WWN information is read from the file and **Node Name**, **Port Name**, and **N_Port_ID** are set.

When a file reference window appears, select the file to be used and click the **OK** button. The **Parameter** window is updated according to the WWN of the read file.

Note: When settings have been made by using **File**, all the contents that are previously set are invalidated and changed to that of the read file.

When you set by use of a file, although multiple pieces of setting information are stated in the file, information about only the selected port is reflected. When you set up all ports, change the port to a port to set up, then read the file.

The following figure shows a file format when settings are performed by using "File". Input the necessary items for each port. Put a space between items. If tabs are used, the setting of the line including "tab" are ignored because it is regarded as an input error.

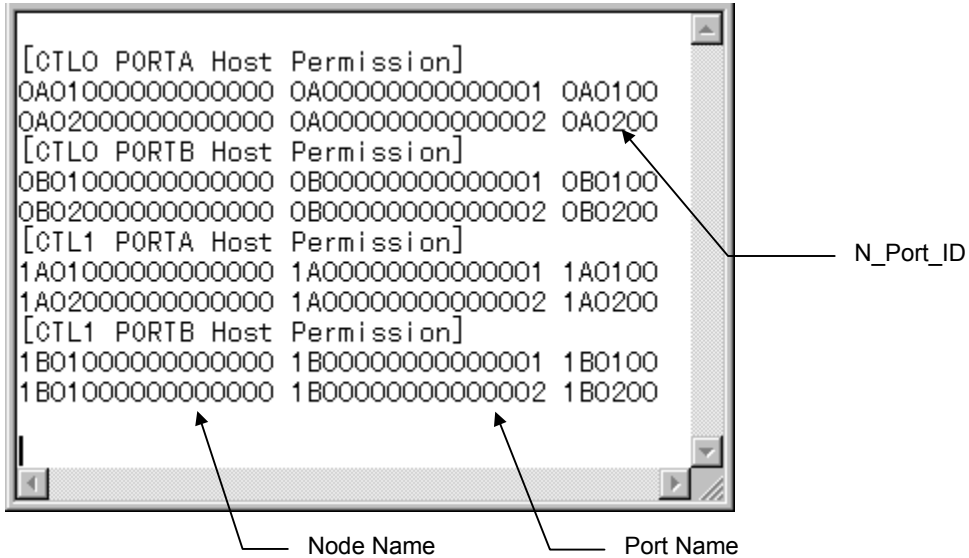
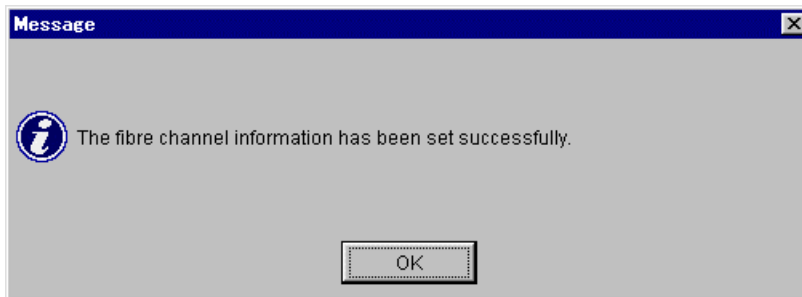

Figure 7.18 Setting Port Security Settings Using File

- **Node Name:** Describes 8 bytes of data hexadecimal (with 16 characters)
- **Port Name:** Describes 8 bytes of data hexadecimal (with 16 characters)
- **N_Port_ID:** Describes 3 bytes of data hexadecimal (with 6 characters). Concerning the host identification information, this data can be omitted. When the data is omitted, it is assumed to be 0X000000.

When “;” is described at the top, the line is regarded as a comment line.

4. Click the **Apply** button on the **Parameter** window.
5. A message appears, stating that the setting is complete. Click the **OK** button.



7.8 Outputting Configuration Information to a File

Output the configuration information of the array unit in a text file or set the configuration using a text file.

The configuration information output in a text file includes the status of the system parameters, RAID group/logical unit port/host group and the constituent parts of the array unit. The configuration to be set includes the system parameters, RAID group/logical unit, and port/host group. The status of the constituent parts of the array unit cannot be set.

The configuration information is handled with separate text files for the system parameters, RAID group/logical unit, and port/host group.

Copying configuration information between array units can be executed by outputting a text file of the configuration from an array unit, then using the output text file to set another array unit.

Editing a text file to set an array unit can be done, but it is recommended that this function be used for the configuration of the same array unit. To change the configuration, use individual functions.

7.8.1 File Output of the System Parameters

To output the settings of the system parameters for an array unit in text form to a specified file:

1. On the **Settings** menu, select **Configuration Settings** or click : **Configuration Settings** in the tool bar.
2. Click the **Constitute** tab.

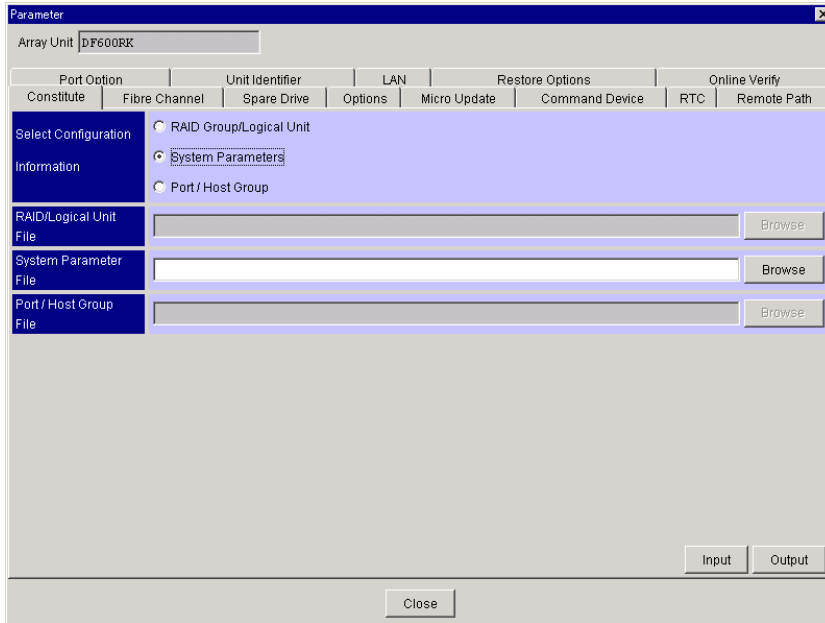
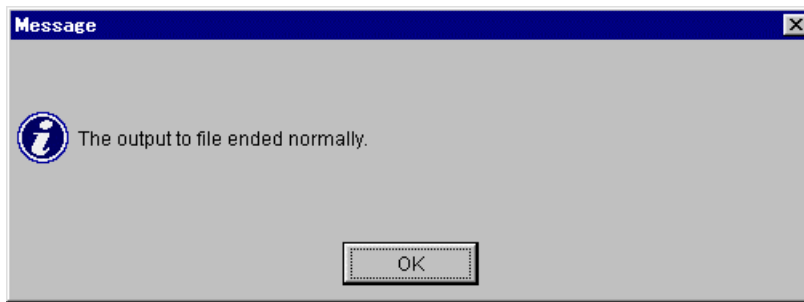

Figure 7.19 Outputting the Setting Content of System Parameters to a Specified File

3. Check the **System Parameters** in the **Select Configuration Information** box.
4. Click the **Browse** button. Specify the directory and file name to which the configuration file will be output.
5. Click the **Output** button.

6. When a message appears, confirming that the system parameter information is output with the specified file name, click the **OK** button.



System parameter information is saved in the form of a text file with the specified file name.

The format of the output file consists of the following items. The outline of the layout of the output file is shown in the following figure.

- File header
- Registration name with the Resource Manager 9500V of the array unit
- Output time (Time of the computer where the Resource Manager 9500V is installed)
- Microprogram revision
- Array unit type
- Common controller parameters
- Controller parameters
- Direction for FD backup (9200 only)

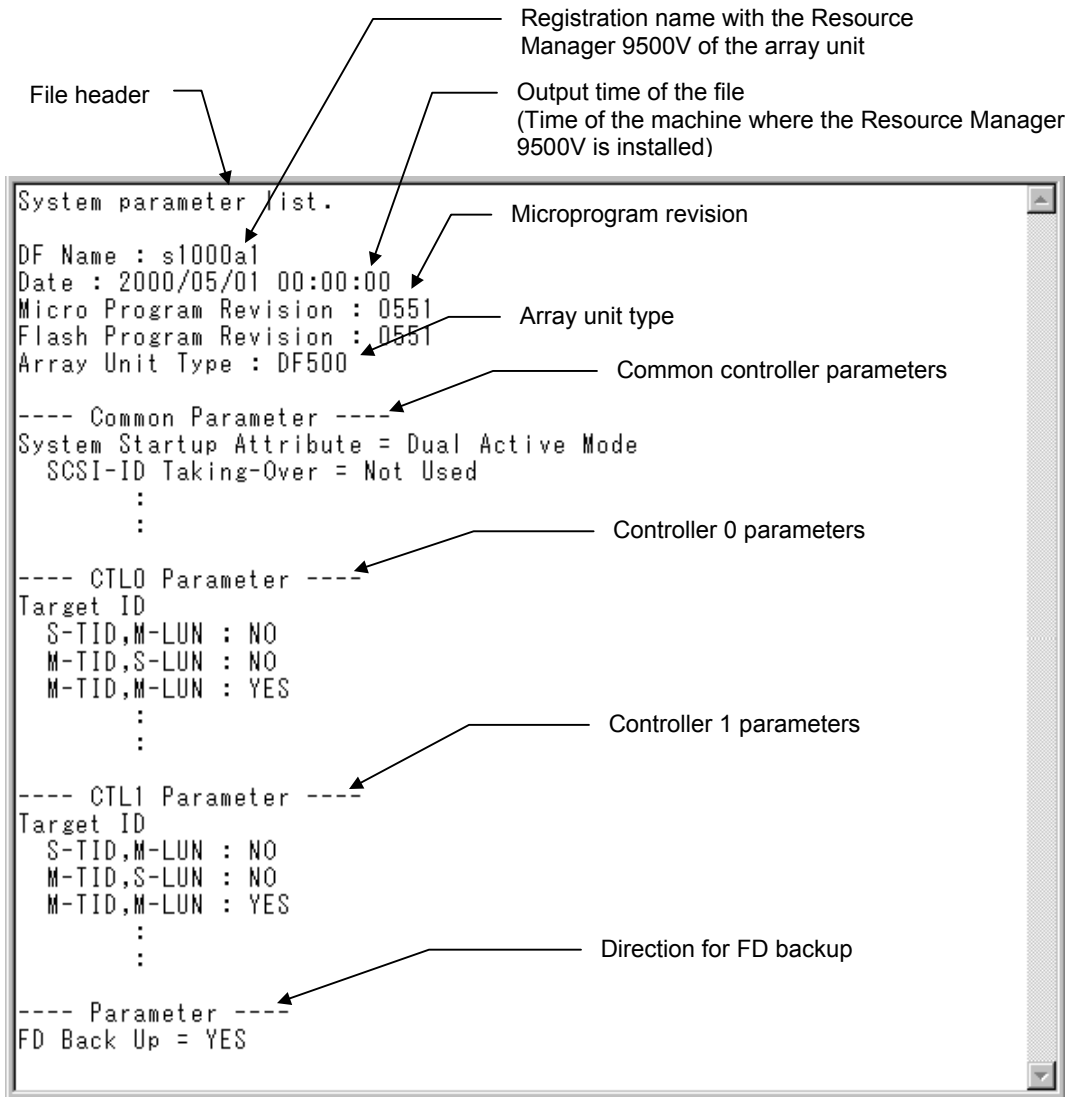

Figure 7.20 Format of the System Parameter Output File

a) Common Controller Parameters

The common system parameters of the array unit are output. An output example of the system parameters of the 9200 is shown in the following figure.

```
---- Common Parameter ----
System Startup Attribute = Dual Active Mode
SCSI ID/Port ID Take-over Mode = ---
Default Controller
  Port A = ---
  Port B = ---
Data Share Mode = Used
Host Connection Mode 1
  Port 0A = Standard Mode
  Port 0B = Standard Mode
  Port 1A = Standard Mode
  Port 1B = Standard Mode
Host Connection Mode 2
  Port 0A
    VxYM DMP mode enable = OFF
    ODE Mapper mode enable = OFF
    HP Connection mode enable = ---
    Report inquiry page 83H = ON
    UA(06/2A00) suppress mode enable = OFF
    HISUP mode enable = OFF
    CCHS convert mode enable = OFF
  Port 0B
    VxYM DMP mode enable = OFF
    ODE Mapper mode enable = OFF
    HP Connection mode enable = ---
    Report inquiry page 83H = ON
    UA(06/2A00) suppress mode enable = OFF
    HISUP mode enable = OFF
    CCHS convert mode enable = OFF
  Port 1A
    VxYM DMP mode enable = OFF
    ODE Mapper mode enable = OFF
    HP Connection mode enable = ---
    Report inquiry page 83H = ON
    UA(06/2A00) suppress mode enable = OFF
    HISUP mode enable = OFF
    CCHS convert mode enable = OFF
  Port 1B
    VxYM DMP mode enable = OFF
    ODE Mapper mode enable = OFF
    HP Connection mode enable = ---
    Report inquiry page 83H = ON
    UA(06/2A00) suppress mode enable = OFF
    HISUP mode enable = OFF
    CCHS convert mode enable = OFF
Serial Number =
Option 1
  Drive Detach mode enable = OFF
Option 2
  Multipath(Controller) = OFF
  PROCOM mode enable = OFF
  Report status (normal / warning) = OFF
  Multipath (Array Unit) = OFF
  Turbo LU Warning = OFF
Data Striping Size = 64KB
Operation if the Processor failures Occurs = Reset a Fault
INQUIRY Information
  Command Queuing = ON
  ANSI Version = ---
  Vendor ID =
  Product ID =
  ROM Microprogram Version =
  RAM Microprogram Version =
Web Title
  Web Title = ""
Cache Mode = All OFF
```

Figure 7.21 System Parameters: Output Example of Common Parameters

The common parameters are the items shown in the following table.

Table 7.1 List of Common Parameters

Item	Setting Item	Wizard Window Title	9200	9500V
1	Start Attribute	System Startup Settings	○	○
2	Host Connection Mode	System Startup Settings	○	×
3	Serial Number	Common 1	○	×
	Delay Planned Shutdown		○	○
	Additional Battery Unit Mode		×	○
4	Option 1	Option 1	○	○
5	Option 2	Option 2	○	○
6	Data Striping Size	Data Striping	○	×
7	Reset ALL LIP Port Mode	Port Type	○	×
8	Operation if the processor failure occurs	Data Striping	○	○
9	Command Queuing	INQUIRY Setting	○	○
10	Web Title	INQUIRY Setting	○	○
11	Cache Mode	INQUIRY Setting	○	×
12	Host Connection Mode	INQUIRY Setting	○	×

○: Supported ×: Not supported

Depending on the array unit in the connection, there are items that do not need to be set; these items will not be output in the file. If the value of an item in the parameters is given as “---” it is an item not supported in the configuration of the array unit.

b) Controller Parameters

The parameters of the Controller in the system parameters of the array unit are output.

```
---- CTL0 Parameter ----
Target ID
S-TID,M-LUN : NO
M-TID,S-LUN : NO
M-TID,M-LUN : YES

Data
Port Target ID H-LUN LUN
0A      0      0      0
0B      0      1      1
Port Type
Port Option
Reset/LIP Mode(Signal)
Port A = OFF
Port B = OFF
Reset/LIP Mode(Process)
Port A = OFF
Port B = OFF
LIP Port All Reset Mode
Port A = OFF
Port B = OFF
Target Reset (Bus Device Reset) Mode
Port A = OFF
Port B = OFF
Reserve Mode
Port A = OFF
Port B = OFF
Logical Unit Reset Mode
Port A = OFF
Port B = OFF
Third Party Process Logout Mode
Port A = OFF
Port B = OFF
ROM Pseudo-response command processing = ---
Save Data pointer response
Port A = ---
Port B = ---
Controller Identifier = Disable
RS232C Error Information Outflow Mode = OFF
Write & Verify Execution Mode = ON
LAN Const
DHCP = OFF
IP Address = 0.0.0.0
Subnet Mask = 0.0.0.0
Default Gateway = 0.0.0.0
Ether Address = 00:00:00:00:00:00
SCSI transfer rate
Port A = ---
Port A = ---
```

Figure 7.22 Controller Parameters: Output Example of System Parameters

The parameters of the Controller are the items shown in the following table.

Table 7.2 Parameters of Controller 0

Item	Setting Item	Wizard Window Title	9200	9500V
1	Target ID	Target ID	<input type="radio"/>	<input checked="" type="checkbox"/>
2	Port Type	Port Type	<input type="radio"/>	<input checked="" type="checkbox"/>
3	ROM Pseudo-response command processing	ROM Response	<input type="radio"/>	<input checked="" type="checkbox"/>
4	Save Data Pointer response	ROM Response	<input type="radio"/>	<input checked="" type="checkbox"/>
5	Controller Identifier	Controller Option	<input type="radio"/>	<input checked="" type="checkbox"/>
6	RS232C Error Information Outflow Mode	Controller Option	<input type="radio"/>	<input type="radio"/>
7	Execute Write & Verify Mode	Controller Option	<input type="radio"/>	<input type="radio"/>
8	LAN Configuration	LAN Setting	<input type="radio"/>	<input type="radio"/>
9	SCSI transfer rate	SCSI	<input type="radio"/>	<input checked="" type="checkbox"/>

Depending on the array unit in the connection, there are items that do not need to be set, and these items will not be output in the file. If the value of an item in the parameters is given as "---" it is an item not supported in the configuration of the array unit.

c) Parameters for Backup Use in the System Parameter Information

The specification of whether the system parameter information is backed up from the FDD of the array unit to FD is shown. The indication is always shown as "YES".



Figure 7.23 Output Example for FD Backup Specification

7.8.2 Setting System Parameters with a File

Set the system parameters in the array unit with the information described in the file. If you set the system parameters using a file that was output when a priced optional feature is in an unlocked state, the setting may terminate abnormally. To set system parameters, use a file that was output when all priced optional features are in a locked state.

For a dual system, setting cannot be executed if one of the controllers is detached. Please confirm that the array unit is operating normally. If the setting of the dual system is executed through an RS232C connection, do it without fail at Controller 0.

When system parameters are set, the array unit cannot execute commands from the host. The functions of the Resource Manager 9500V can no longer work; however, the Wizard sets the system parameters and failure monitoring. After setting, restart the array unit. Confirm that it is operating successfully, then it will connect to the host and the Resource Manager 9500V.

1. Edit the file for setting the system parameters to set the array unit. The file has a specified format. The format of the file is the same as that of the file output by the array unit. Refer to the following sections of this manual for the format and parameters of the file respectively.
 - For the format of the file, refer to **7.8.1 File Output of the System Parameters**.
 - For the parameters, refer to **5.1 Setting System Parameters**.

For the parameters for backup use in the system parameter information, set **Yes** without fail; it is necessary to save the set system parameters in the backup FD in the array unit.

2. On the **Settings** menu, select **Configuration Settings** or click  in the tool bar.
3. Click the **Constitute** tab. (Refer to Figure 7.19.)
4. Click the **System Parameter** radio button.
5. Click the **Browse** button, and specify the directory and file name of the file that describes the system parameters edited in 1. The specified file name will be shown in the text box.
6. Click the **Input** button.
7. The following confirmation screen is displayed. Click the **OK** button.

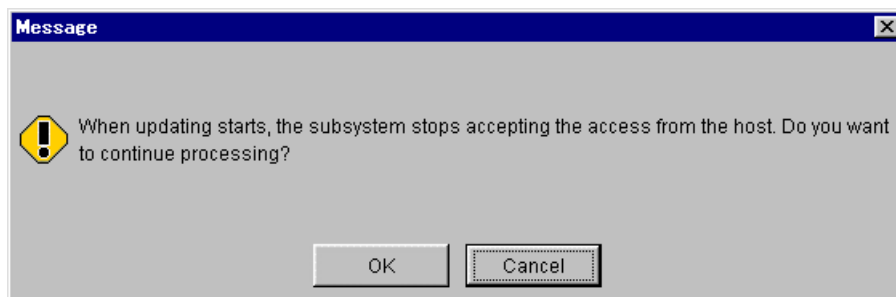

8. A message appears, stating that the system parameter information from a file with specified name has been set. A message is displayed, requesting confirmation to restart the subsystem. Click the **OK** button.

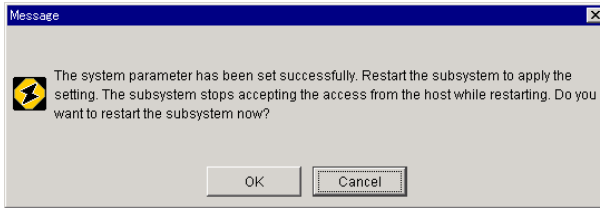

Using the Wizard for setting system parameters verify the configuration parameters.

Note: To validate the set system parameters, restart the array unit. The previous settings stay valid until restarting. The array unit cannot access the host until the reboot is completed and the system restarts. Therefore, be certain the host has stopped accessing data before beginning the restart process.

Note: When failing to write onto the FD drive, the message “DMES04EB02: Backup floppy disk write error.” is displayed.

When this message is displayed, writing to a FD has not been finished, but setting the system parameter may be completed.

Check a FD in an array unit, re-confirm the data to set, turn on the **FD Backup?** Check box, and then click the **OK** button once again.

When you choose to restart the array unit, the time the restart began is displayed. This usually takes approximately two to six minutes.

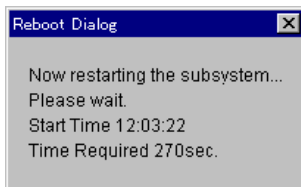

(9500V)

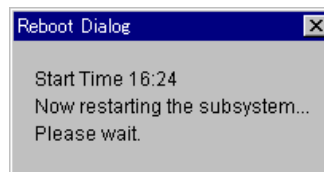

(9200)

Note: It may take time for an array unit to respond, depending on the condition of the array unit. If it does not respond after 10 minutes or more, check the condition of the array unit.

9. A message appears, stating that the restart is successful. Click the **OK** button.

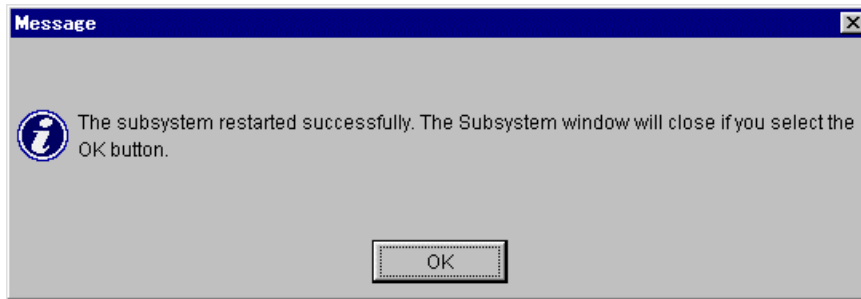

The Unit screen is closed. To perform other operations on the Main screen, select an array unit from the Main screen and open the selected Unit screen.

7.8.3 File Output of the Status of RAID/Logical Units and Constituent Parts of the Configuration

To output RAID group/logical unit definition information already set in an array unit to a specified file in a text format:

1. On the **Settings** menu, select **Configuration Settings** or click : **Configuration Settings** in the tool bar.
2. Click the **Constitute** tab.

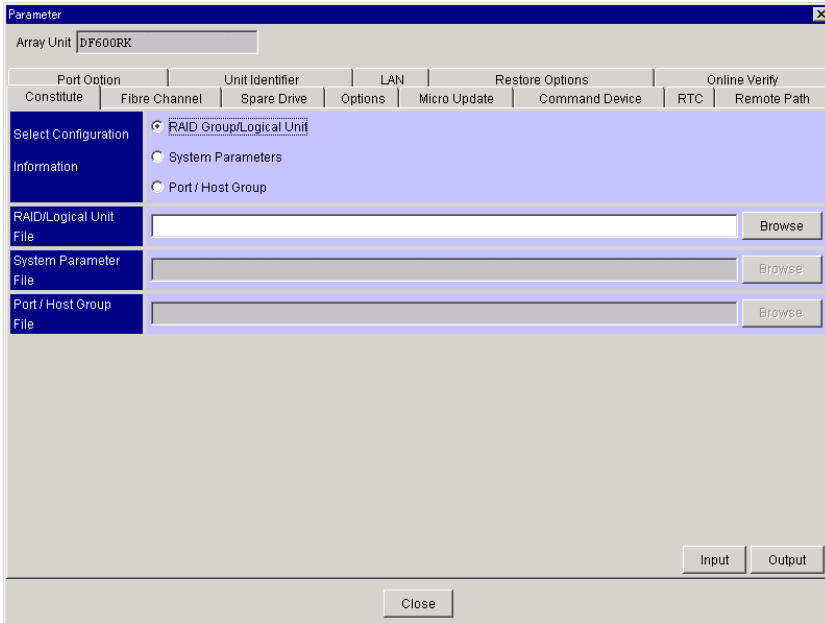
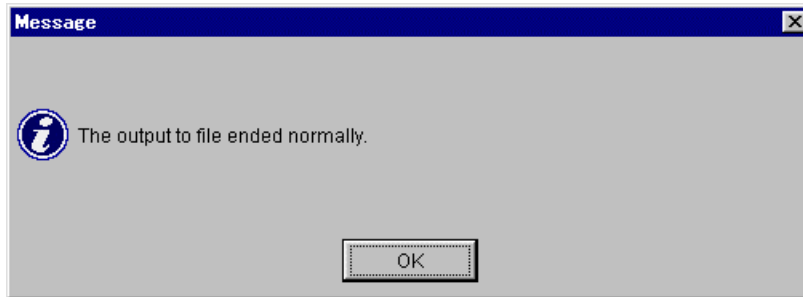

Figure 7.24 Outputting Configuration Information to File

3. Check the **RAID Group/Logical Unit** in the **Select Configuration Information** box.
4. Click the **Browse** button, and specify the directory and file name to output the file of the configuration.
5. Click the **Output** button.

6. A message appears, confirming that the system parameter information is output with the specified file name. Click the **OK** button.



System parameter information is saved in the form of a text file with the specified file name.

The format of the output file consists of the following items. The outline of the layout of the output file is shown in the following figure. This figure outlines the layout of the output file for the 9200.

- File header
- Registration name at the Resource Manager 9500V of the array unit
- Output time (Time of the computer where the Resource Manager 9500V is installed)
- Microprogram revision
- Array unit type
- RAID group/logical unit configuration
- Status of constituent parts

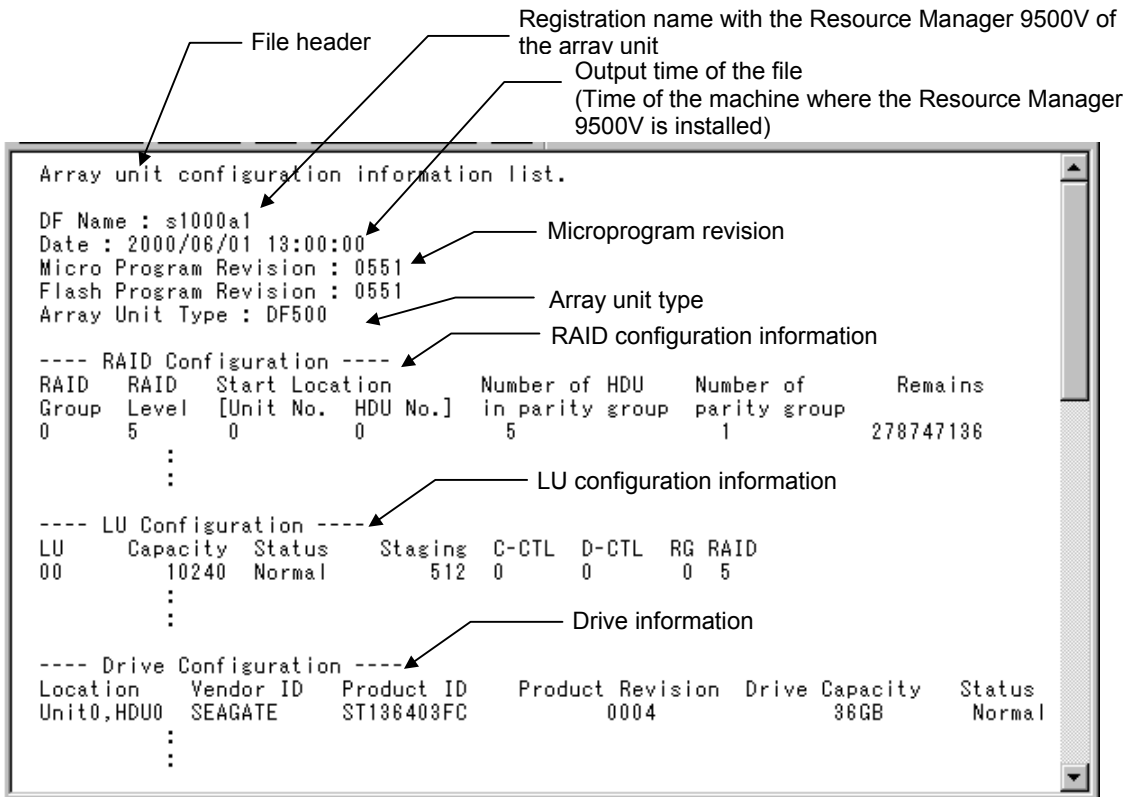

Figure 7.25 Format of RAID Group/Logical Unit Configuration Information Output File (1 of 2)

```

---- Cache Information ----
      Controller 0                Controller 1
Slot   Capacity  Status   Capacity  Status
0      256      Normal
:
:

---- Fan Information ----
Location  Status
0         Normal
:
:

---- Battery Information ----
Location  Status
0         Normal
:
:

---- AC Power Information ----
Location  Status
Unit0,AC0 Normal
:
:

---- Battery Backup Information ----
Location  Status
0         Normal
:
:

---- Loop Information ----
Location  Status
0         Normal
:
:

---- ENC Information ----
Location  Status
Unit0,ENC0 Normal
:
:

```

Cache information

Fan information

Battery information

AC power information

Battery backup information

Loop information

Enclosure information

Figure 7.26 Format of RAID Group/Logical Unit Configuration Information Output File (2 of 2)

a) Format of RAID Configuration Information

This function outputs the RAID configuration of the array unit. RAID groups, which have not been created, are displayed as “-” in the “Level” column.

Example:

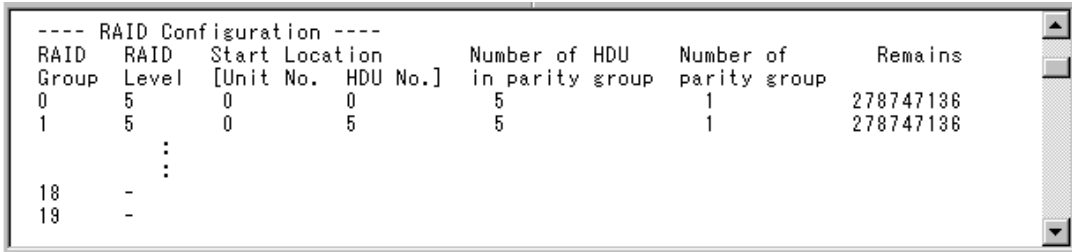

```
---- RAID Configuration ----
RAID  RAID  Start Location      Number of HDU   Number of
Group Level [Unit No.  HDU No.]  in parity group  parity group    Remains
0      5      0          0          5              1              278747136
1      5      0          5          5              1              278747136
      :
18     -
19     -
```

- **RAID Group:** RAID group number
- **RAID Level:** RAID level
When no RAID is set, “-” is displayed. No other information is displayed.
- **Start Location:**
 - Unit No.:** Starting unit number of RAID group
 - HDU No.:** Starting HDU number of RAID group
- **Number of HDU in parity group:** The number of HDU in the parity group of the RAID group
- **Number of parity group:** The number of parity groups in the RAID group
- **Remains:** The capacity (in units of block) that can be defined by logical unit of the RAID group

b) Formatting Logical Unit Configuration Information

This function outputs the logical unit configuration information of the array unit. The information is displayed up to the created logical unit numbers.

Example:

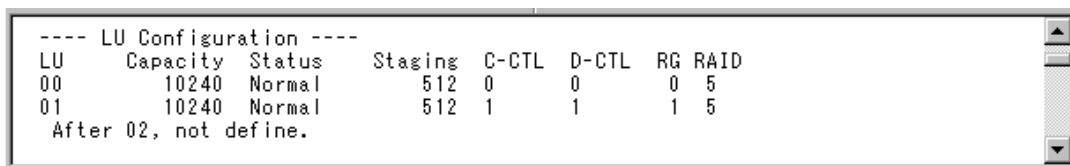

```
---- LU Configuration ----
LU      Capacity  Status   Staging  C-CTL  D-CTL  RG RAID
00      10240    Normal   512      0       0       0  5
01      10240    Normal   512      1       1       1  5
After 02, not define.
```

- **LU:** logical unit number
- **Capacity:** logical unit capacity (in units of block)
- **Status:** The status of the logical unit
 - Normal:** Normal status in which the logical unit is defined and formatted
 - Unformat:** Status in which the logical unit is defined but not formatted
 - Detached:** Status in which the logical unit is blocked
 - Regression:** Status in which the logical unit is regressed
 - Invalidated(Normal):** Status in which the logical unit is invalidated (formatted)
 - Invalidated(Unformat):** Status in which the logical unit is invalidated (not formatted)
 - Invalidated(Regression):** Status in which the logical unit is invalidated (regressed)
- **Staging:** Pre-read data amount (in units of block)
- **C-CTL:** The number of the controller currently in use
- **D-CTL:** Default number of controller controlling the logical unit
- **RG:** The number of the RAID group that creates the logical unit
- **RAID:** The RAID level of the RAID group that creates the logical unit
- **Capacity:** logical unit capacity (in units of MB or GB)

c) Format for Drive Information

The information and status of the drive of the array unit are output.

Example:

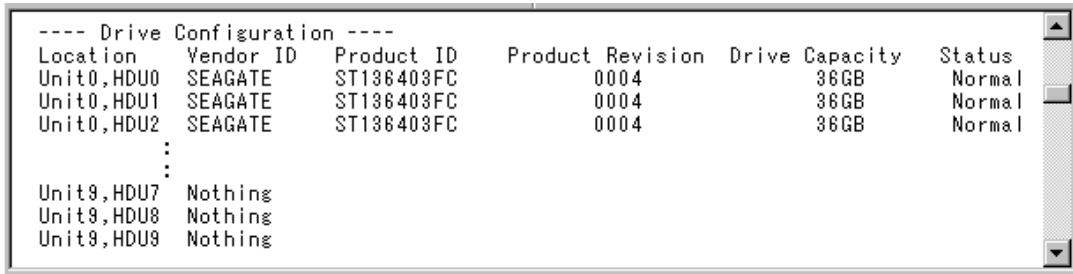

```
---- Drive Configuration ----
Location  Vendor ID  Product ID  Product Revision  Drive Capacity  Status
Unit0,HDU0 SEAGATE    ST136403FC  0004              36GB           Normal
Unit0,HDU1 SEAGATE    ST136403FC  0004              36GB           Normal
Unit0,HDU2 SEAGATE    ST136403FC  0004              36GB           Normal
      :
Unit9,HDU7  Nothing
Unit9,HDU8  Nothing
Unit9,HDU9  Nothing
```

- **Location:** The installation location of the drive
- **Vendor ID:** The vendor ID of the drive
- **Product ID:** The product ID of the drive
- **Product Revision:** Firmware revision of the drive
- **Drive Capacity:** The capacity of the drive
- **Status:** The status of the drive
 - Normal:** Normal (RAID group, logical unit defined)
 - Detached:** Detached
 - Standby:** Normal (Logical unit undefined)
 - Undefine:** Normal (RAID group undefined)
 - Recon.:** Reconfiguring (copying from collection or backup)

“Nothing” is shown after **Location** for the location of an HDU not installed.

d) Format for Cache Information

The configuration information and status of the cache of the array unit are output.

Example:

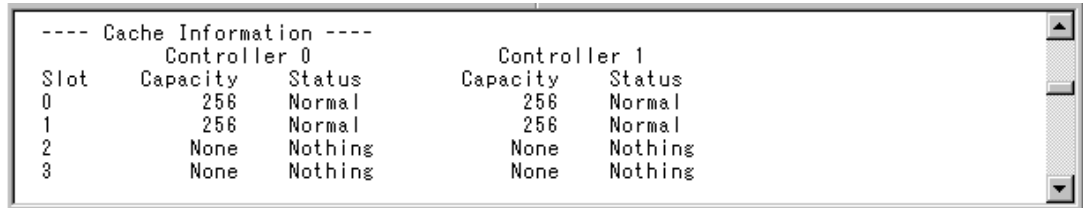

```
---- Cache Information ----
      Controller 0          Controller 1
Slot  Capacity  Status    Capacity  Status
0      256      Normal    256      Normal
1      256      Normal    256      Normal
2      None     Nothing   None     Nothing
3      None     Nothing   None     Nothing
```

- **Slot:** The installation location of the cache
- **Capacity:** The capacity (in units of MB) of the cache of controller 0
- **Status:** The status of the cache of controller 0
 - Normal:** Normal
 - Detached:** Detached
 - Nothing:** Not installed
 - : Slot not supported

e) Format for Fan Information

The status of the fan of the array unit is output.

Example:

```
---- Fan Information ----
Location  Status
0         Normal
```

- **Location:** The installation location of the fan
- **Status:** The status of the fan
 - Normal:** Normal
 - Alarm:** Abnormal
 - Nothing:** Not installed

f) Format for Battery Information

The status of the battery of the array unit is output.

Example:

```
---- Battery Information ----
Location  Status
0         Normal
```

- **Location:** The installation location of the battery
- **Status:** The status of the battery
 - Normal:** Normal
 - Alarm:** Abnormal
 - Nothing:** Not installed

g) Format for AC power Information

The status of the AC power supply of the array unit is output.

Example:

```
---- AC Power Information ----
Location      Status
Unit0,AC0    Normal
Unit0,AC1    Normal
      :
Unit9,AC0    Nothing
Unit9,AC1    Nothing
```

- **Location:** The installation location of the AC power supply
- **Status:** The status of the AC power supply
 - Normal:** Normal
 - Alarm:** Abnormal
 - Nothing:** Not installed

h) Format for Battery Backup Status Information

The status of the battery backup circuit of the array unit is output.

Example:

```
---- Battery Backup Information ----
Location      Status
0             Normal
1             Normal
```

- **Location:** The installation location of the battery backup circuit
- **Status:** The status of the battery backup circuit
 - Normal:** Normal
 - Alarm:** Abnormal

i) Format for Loop Information

The status of the loop of the array unit is output.

Example:

```
---- Loop Information ----
Path Loop Status
0 0 Normal
0 1 Normal
1 0 Normal
1 1 Normal
```

- **Path:** Path number
- **Loop:** Loop number
- **Status:** The status of the loop
 - Normal:** Normal
 - Alarm:** Abnormal
 - Nothing:** Not installed

j) Format for Enclosure Information

The status of the enclosure of the array unit is output.

Example:

```
---- ENC Information ----
Location Status
Unit0,ENC0 Normal
Unit0,ENC1 Normal
Unit1,ENC0 Nothing
Unit1,ENC1 Nothing
:
```

- **Location:** The installation location of the enclosure
- **Status:** The status of the enclosure
 - Normal:** Normal
 - Alarm:** Abnormal
 - Nothing:** Not installed

7.8.4 Setting the RAID Group/Logical Unit Definition with a File

Set the array unit according to the RAID group/logical unit setting information described in a file. If the setup of RAID group/logical unit is configured and completed, all user data previous data will be lost; RAID group/logical unit configuration as specified in the file will be set after deleting the current RAID group/logical unit. If user data is needed, configure the setting after backing up the system.

1. Edit the file to set the RAID group/logical unit information in the array unit. The file has a specified format. The format of the file is the same as that of the file output by the array unit. Refer to section **7.8.3 File Output of the Status of RAID/Logical Units and Constituent Parts of the Configuration** for formatting information.

The parameters in the file are three items: **RAID configuration information**, **LU configuration information**, and **Drive information** in the format of the output file. In the output file, there are items, which give the status of constituent parts, but ignore these while setting up the configuration. The descriptive contents of the parameters are shown below:

- a) **RAID configuration information:** Sets the RAID configuration

Specifies RAID level, RAID group number and RAID size. If the RAID group is not set, “-” is shown after **Level**, and no other parameters are set.

- b) **LU configuration information:** Sets logical unit configuration

Specifies logical unit number, logical unit capacity, pre-read capacity, number of controllers in current use, number of controllers in default use, RAID group number and RAID level, and logical unit status.

In logical unit status, for cases where formatting is to be executed, specify “Normal”. Formatting cannot be executed if another status is specified.

In cases where the full capacity of the RAID group is allocated to one logical unit, specify “All” in **Capacity**.

Even if the number of the controller in current use is specified as “0” or “1”, it will become the same as the number of the controller in default use.

In cases where logical units of less than the maximum logical unit number are created, specify at the end that “After nn, not define” (nn: the last logical unit number + 1).

- c) **Drive information:** Sets the configuration of the HDU installed in the array unit. For an HDU not installed, specify “Nothing”.

When a capacity bigger than that of the installed HDU is specified, it is regarded as an error and not set.

2. On the **Settings** menu, select **Configuration Settings** or click  in the tool bar.
3. Click the **Constitute** tab. (Refer to Figure 7.24.)
4. Click the **RAID Group/Logical Unit** radio button.
5. Click the **Browse** button, and specify the directory and name of the file that describes the RAID group definition and logical unit definition edited in 1. The specified file name will be shown in the text box.

6. Click the **Input** button.
7. The following message appears, stating that a new RAID/LU configuration will be set. This message requests confirmation to restart the subsystem. Click the OK button. All current user data and RAID Group/Logical Unit configuration will be destroyed.

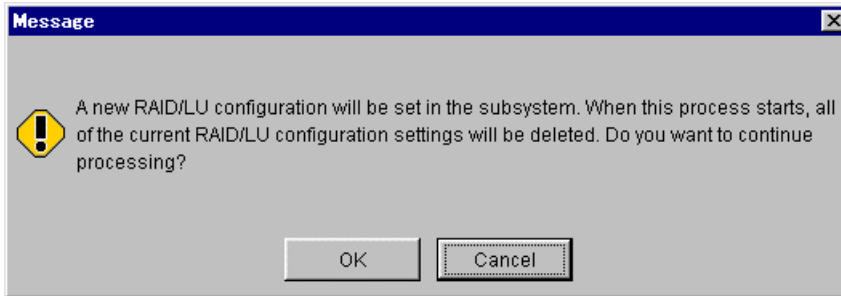

A message appears, stating that the RAID configuration setting has started.

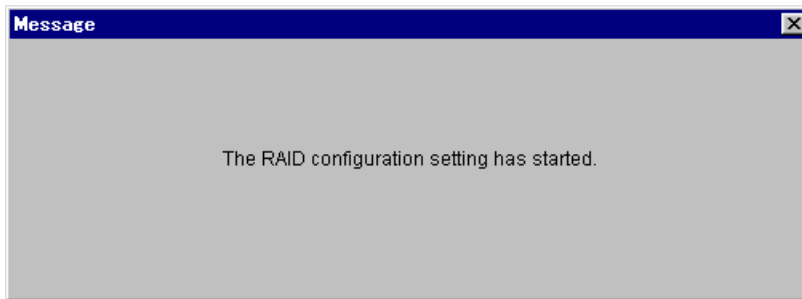

When the setting of the RAID group ends abnormally, an error message will be shown and the processing will be interrupted.

If the setting of the RAID group ends normally, a message that the setting of logical unit has started is shown, and the logical unit setting is executed.

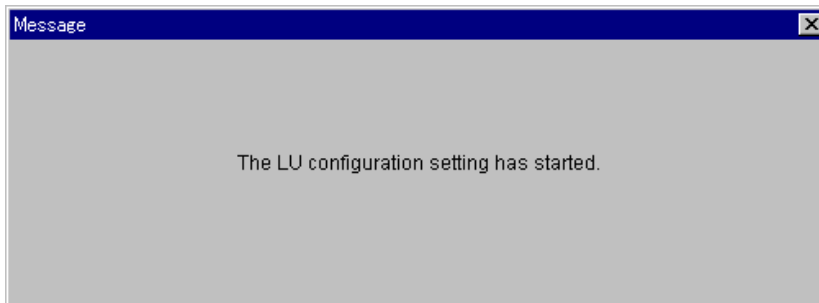

When the logical unit setting ends abnormally, an error message will be shown and processing will be interrupted.

If the logical unit setting ends normally, formatting of the set logical unit will begin. The process of formatting execution will be shown.

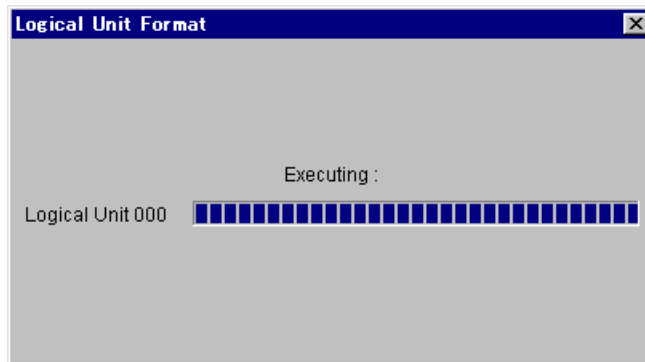

8. When a message appears, indicating that the specified logical unit has been formatted successfully, click the **OK** button.

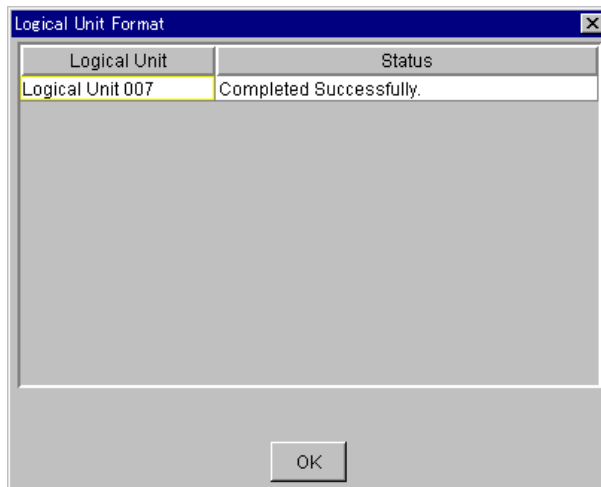

9. A message appears, stating that the setting is complete. Click the **OK** button.

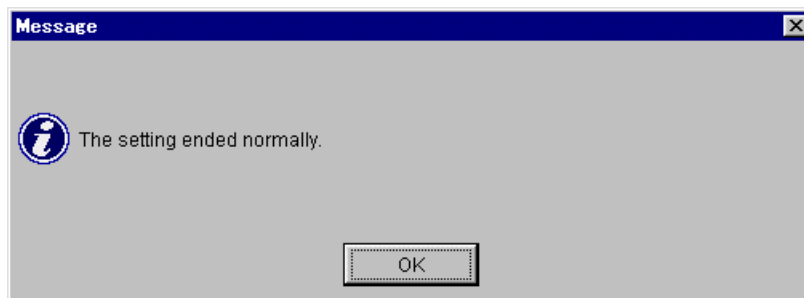

To check the configuration, select the **Logical Status** tab.

7.8.5 File Output of the Port/Host Storage Domain (Host Group) Information

To output the settings of the Port/Host Storage Domain (Port/Host Group) information for an array unit in text form to a specified file:

1. On the **Settings** menu, select **Configuration Settings** or click : **Configuration Settings** in the tool bar.
2. Click the **Constitute** tab.

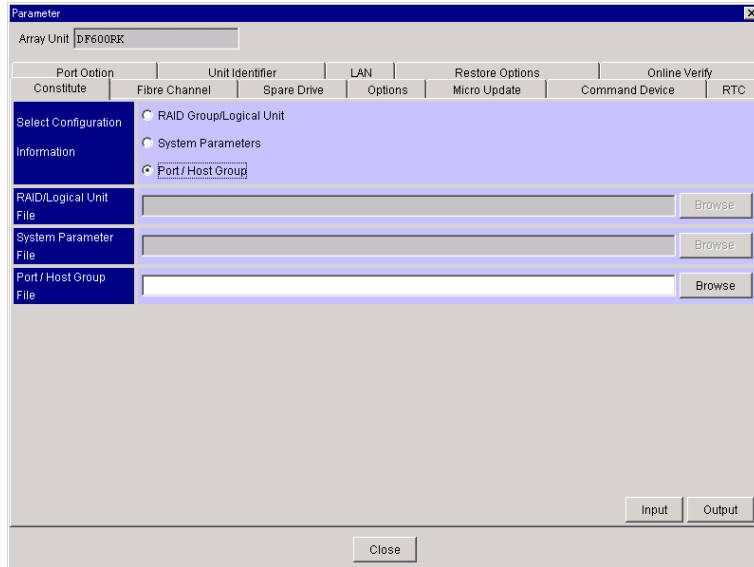
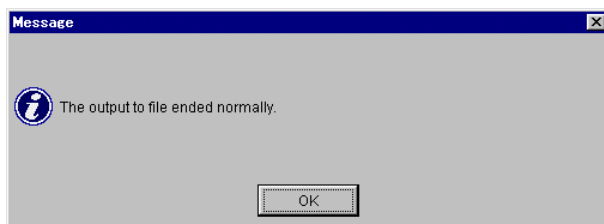

Figure 7.27 Outputting the Setting Content of Port/Host Storage Domain (Port/Host Group) Information to a Specified File

3. Check the **Port/Host Group** in the **Select Configuration Information** box.
4. Click the **Browse** button, and specify the directory and file name to which the host group information file will be output.
5. Click the **Output** button.
6. When a message appears, confirming that the host group information is output with the specified file name, click the **OK** button.



The host storage domain (host group) information is saved in the form of a text file with the specified file name.

The format of the output file consists of the following items. The outline of the layout of the output file is shown in the following figure.

- File header
- Registration name with the Resource Manager 9500V of the array unit
- Output time (Time of the computer where the Resource Manager 9500V is installed)
- Microprogram revision
- Array unit type
- Mapping mode
- Port option
- Host group (Host Storage Domain) option
- Logical unit mapping information
- LUN security information
- Port security information

```

Configuration Information list.

DF Name : df600
Date : 2002/08/28 12:42:02
Micro Program Revision : 0651aa
Array Unit Type : DF600
Serial Number : 65010026

---- CommonInformation ----
MappingMode = ON

---- CTLO ----
---- PortA ----
---- PortOption ----
Reset/LIP Mode(Signal) = ON
Reset/LIP Mode(Process) = ON
LIP Port All Reset Mode = ON

---- HostGroupList ----
---- HostGroupInformation ----
HostGroupNumber = 0

---- HostGroupOption ----
Host Connection Mode 1 = Standard Mode
Host Connection Mode 2
ftServer Connection Mode 2 = OFF
SRC Read Command Reject Mode = OFF
UA(06/2A00) suppress mode enable = ON
HISUP mode enable = ON
CCHS convert mode enable = ON
HP Connection mode2 enable = ON
Product ID DF400 mode = ON
NACA Mode = ON
SUN Cluster Connection Mode = ON
Persistent RSV Cluster Mode = ON
Target Reset (Bus Device Reset) Mode = ON
Reserve Mode = ON
Logical Unit Reset Mode = ON
Third Party Process Logout Mode = ON

---- LuMapping ----
  H-LUN    LUN
    6      0
   15     255
-- HostGroupInformationEnd
-- HostGroupListEnd

---- FibreSecurityInformation ----
Security = ON
SecurityCheckLevel = AllCommand
---- PermissionList ----
NodeName/PortName = 1111111111111111 200000E069402A08
LUN = 0-15,17-143
-- PermissionListEnd

```

Figure 7.28 The Outline of the Format of Host Storage Domain (Host Group) Information Output File

7.8.6 Setting the Port/Host Storage Domain (Host Group) Information with a File

1. On the **Settings** menu, select **Configuration Settings** or click : **Configuration Settings** in the tool bar.
2. Click the **Constitute** tab. (Refer to Figure 7.27.)
3. Check the **Port/Host Group** in the **Select Configuration Information** box.
4. Click the **Browse** button, and specify the directory and file name to which the host group information file will be input.
5. Click the **Input** button.
6. The following confirmation screen is displayed. Click the **OK** button.

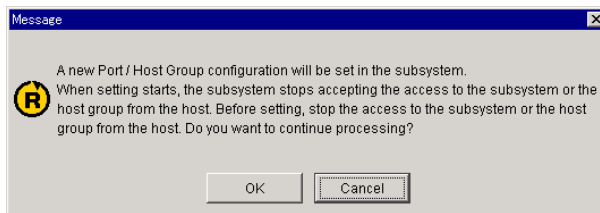

7. A message appears, stating that the setting is complete. Click the **OK** button.

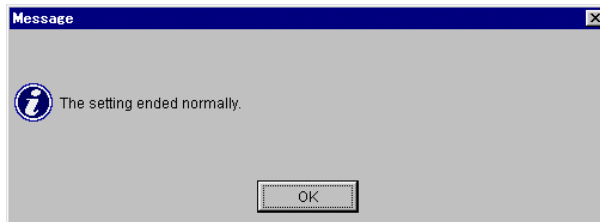

7.9 Replacing the Microprogram

The function downloads and replaces the microprogram in the array unit. When replacing the microprogram, download it, and then replace it.

This section includes the following:

- Microprogram Download
- Replacing the Microprogram

7.9.1 Microprogram Download

Download the microprogram from the FD or CD-R into the array unit. In the download, the microprogram is stored in the array unit; the microprogram of the array unit is not replaced.

1. Copy the microprogram from the floppy disk or CD-R to the hard disk.

When using Windows[®], the microprogram can be stored from the FD or CD-R; the microprogram is not copied when it is stored from the FD or CD-R.

When using Solaris[™], IRIX[®], or HP-UX[®] the microprogram is copied. There are multiple floppy disks of the microprogram; each floppy disk or CD-R is copied to the hard disk using a different directory.

Note: For a directory where the Resource Manager 9500V is installed, do not copy the microprogram directly to the FD or CD-R. Create a sub-directory and copy it under this sub-directory. Specify the name of a directory in the hard disk drive to which the microprogram is copied, with a one-byte coded alphanumeric.

2. On the **Settings** menu, select **Configuration Settings** or click  in the tool bar.

3. Click the **Micro Update** tab.

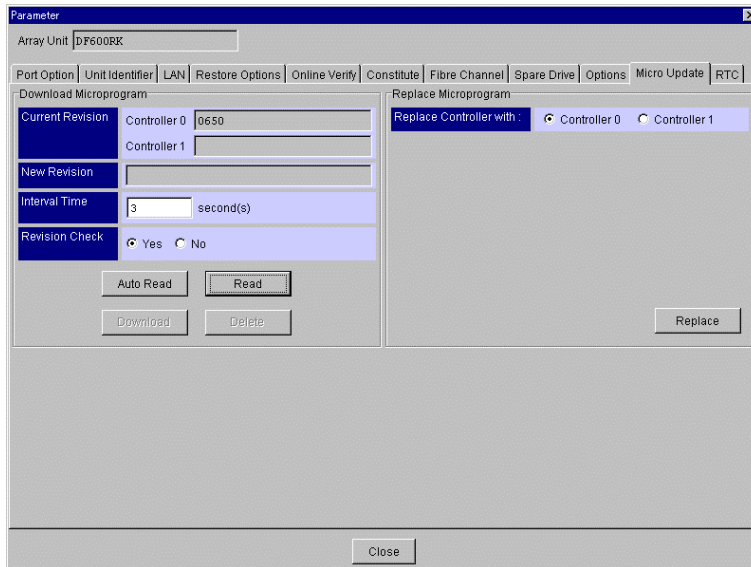

- **Current Revision:** Microprogram revision of each controller of the array unit
- **New Revision:** A microprogram revision stored in the system in which the Resource Manager 9500V is installed. When the microprogram is not read, a blank is displayed.
- **Interval Time:** Interval time for download. Specify the time between one second and 60 seconds. For the LAN connection, when the interval time is specified as 3 seconds, the download requires approximately 9 minutes. The time required for the execution varies with the network status and depends on the I/Os issued by the host. When the interval time is specified as one second longer, the time required for the download is prolonged by 3 minutes.

For the RS232C (9200 only) connection, when the interval time is specified as 3 seconds, the download requires about 4 hours. The time required for the execution varies depending on the I/Os issued by the host. When the interval time is specified as one second longer, the time required for the download is prolonged by 40 minutes. This function can be used during execution of the I/O instructed by the host. However, when the download function is executed, I/O performance of the host is reduced. To enhance performance, specify a longer interval time.

- **Revision Check:** Instructs the revision check of the microprogram to be downloaded. When the download instruction is specified, whether or not a hot replacement is applicable to the microprogram is checked. Select Yes.

When no microprogram is read, the **Download** and **Delete** buttons are displayed in gray and cannot be selected.

4. The microprogram is read into the PC or Sun™ Server/Workstation in which the Resource Manager 9500V is installed. Click the **Auto Read** or the **Read** button. When a revision is displayed in **New Revision**, the microprogram is already read. To download the microprogram that is already read, execute Download.
5. When you have clicked the **Read** button, specify an FD or the directory in which the microprogram is installed; follow the directions given in the window.

When the **Auto Read** button is clicked and the first directory where the microprogram is installed is specified, all the microprograms are read automatically.

Note: When **Auto Read** is executed, an FD or CD-R cannot be read. Specify the name of the directory in which the microprogram is to be stored. The last two figures of the name of the first directory to be read first are '01'; the last two figures of the second directory to be read are '02'. If the directory name is wrongly specified, automatic reading will terminate abnormally.

Designate appropriate numbers at the end of the directory names to indicate the order in which the directories are to be read.

6. When a confirmation message appears, asking whether or not to read the microprogram appears, click the **OK** button.

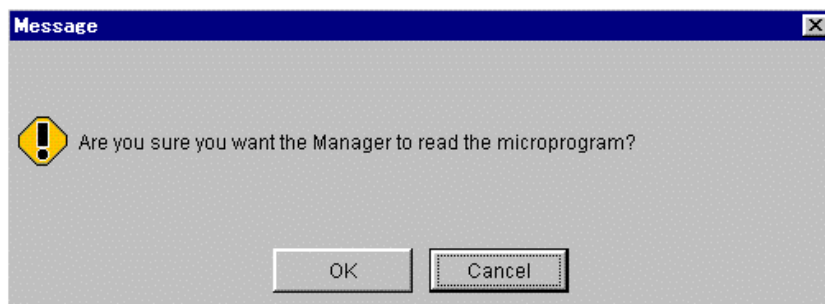

If the microprogram is already read, a confirmation message is displayed. When the **OK** is clicked, the microprogram is overwritten. To stop reading the microprogram, click the **Cancel** button.

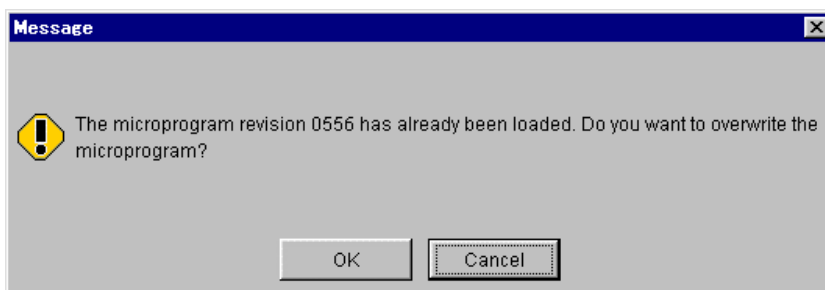

7. To delete the microprogram that is already read in the PC or Server/Workstation, click the **Delete** button. When a confirmation message appears, click the **OK** button.

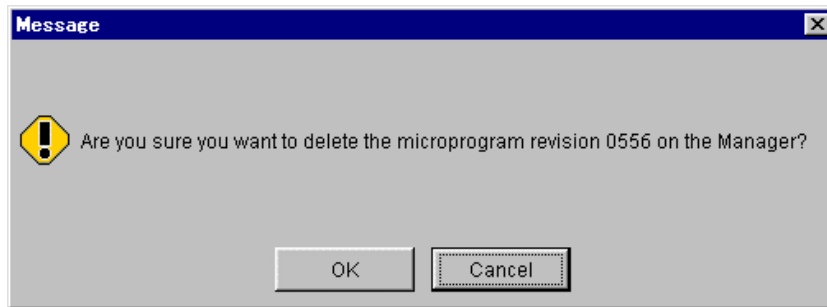

8. When a window for specifying a directory in which the read microprogram exits appears, enter this directory. When the **OK** button is clicked, reading the microprogram is started.

A path-input example is shown below.

When using Windows®: a:

c:/DA Manager GUI/micro/disk1

When using Solaris™, IRIX®, or HP-UX®: /home/usr/DA Manager GUI/micro/disk1

Directory in the hard disk in which the microprogram of the FD is copied.

Multiple floppy disks of the microprogram are supplied. When the **Auto Read** button has been clicked, if a microprogram floppy disk needs to be read, message 5 reappears. In the message, the "No." of the floppy disk to be read is displayed. Read and follow the microprogram according to the display.

9. When a message indicating that the microprogram has been read appears, click the **OK** button.

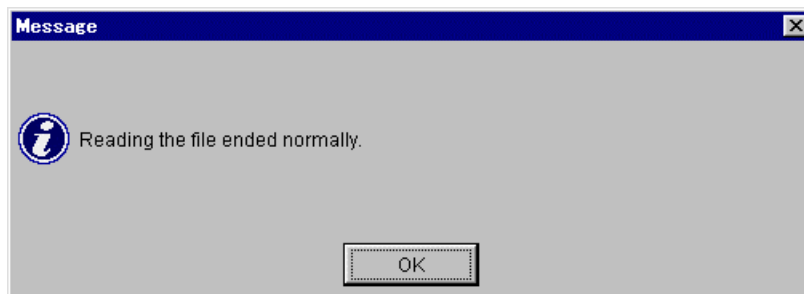

The revision of the read microprogram is displayed in the **New Revision** field.

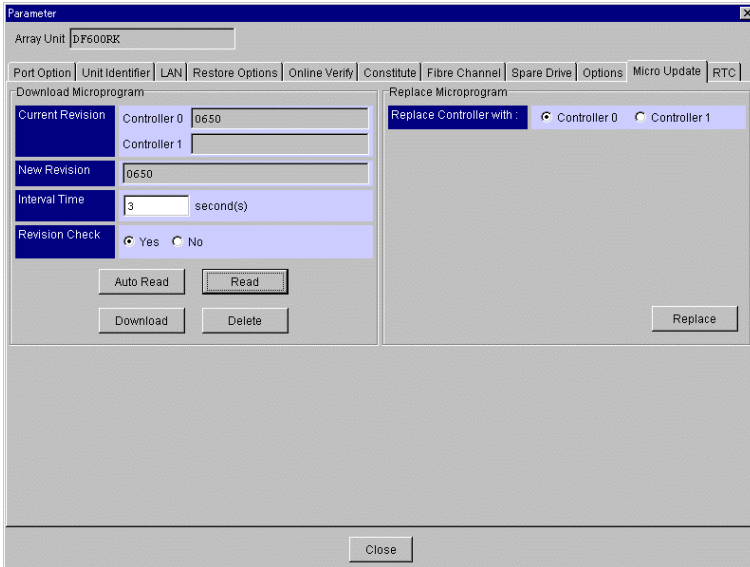

10. To download the microprogram, click the **Download** button.

11. When a confirmation message appears, requesting confirmation to download the microprogram appears, click the **OK** button.

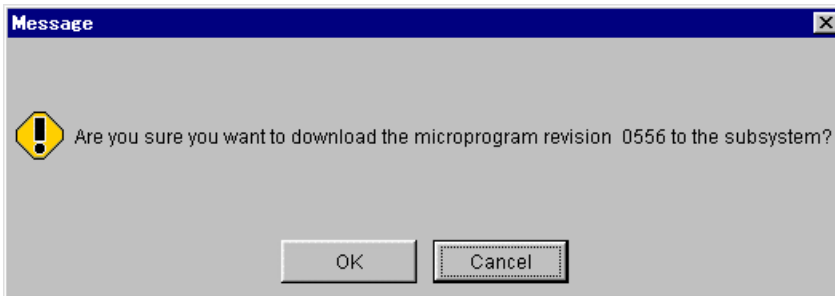

A message appears, stating that the download is being executed. This message displays the revision of the program being downloaded, interval time, and progress.

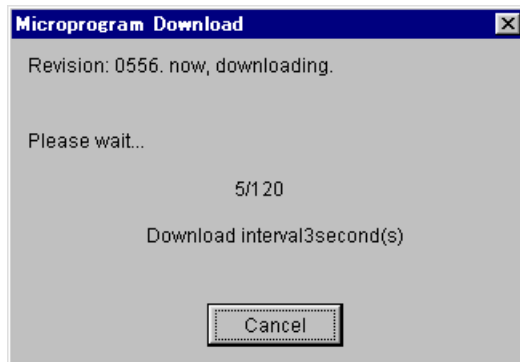

The download can be aborted. To abort the download halfway, click **Cancel**. A confirmation message is displayed. When the **OK** button is clicked, the download is aborted. When the **Cancel** button is clicked, the download is continued.

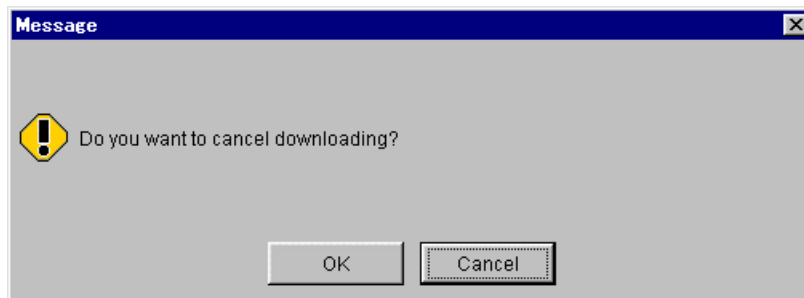

12. When the microprogram is normally downloaded, a confirmation message appears. Click the **OK** button.

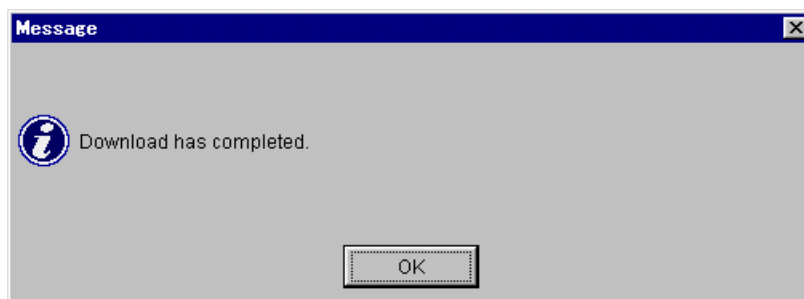

Note: After the microprogram is downloaded, restart the array unit or replace the microprogram. If a hot replacement of the controller board is done before restarting the array unit or the microprogram replacement, the replaced new controller may be blocked. The download may terminate with a DMES05EA03 message when the array unit is heavy host I/Os; perform the download operation again.

7.9.2 Replacing the Microprogram

Replace the microprogram of the controller with the microprogram downloaded in the array unit. When replacing the microprogram, replace both controller 0 and controller 1 microprograms.

1. On the **Settings** menu, select **Configuration Settings** or click : **Configuration Settings** in the tool bar.
2. Click the **Micro Update** tab.

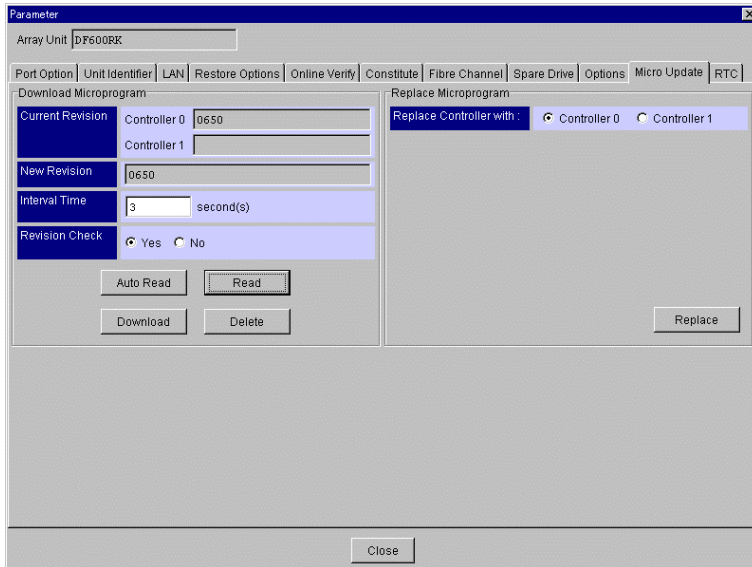
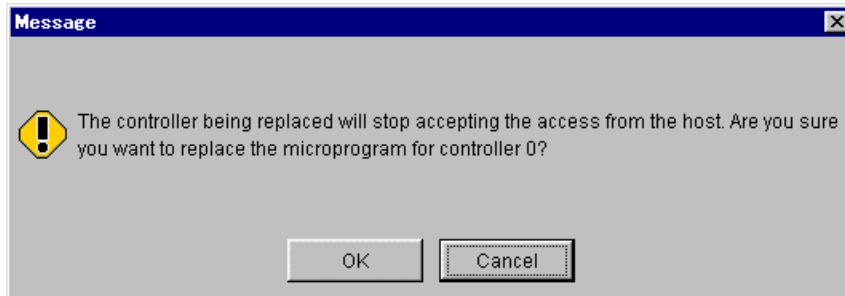

Figure 7.29 Replacing the Microprogram

3. Select the controller whose microprogram is to be replaced and click the **Replace** button.

4. A message is displayed, requesting confirmation to replace the microprogram. The message displays the number of the selected controller. When the **OK** button is clicked, replacement of the microprogram starts.



The following message, stating that the replacement of the microprogram is being executed, is displayed.

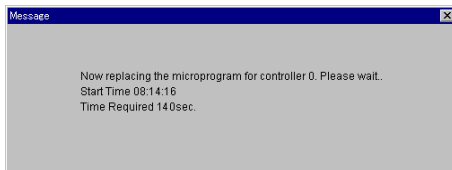

(9500V)

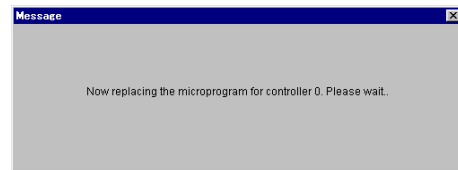

(9200)

5. When the replacement of the microprogram terminates normally, a completion message is displayed. When the **OK** button is clicked, the revision of the replaced microprogram is updated and the window is displayed.



If the downloaded microprogram cannot be replaced, a failure message is displayed. To validate the downloaded microprogram, restart the array unit.

Note: It may take time for an array unit to respond, depending on the condition of the array unit. If it does not respond after 10 minutes or more, check the condition of the array unit.

6. Replace the microprogram of the other controller using the procedure from step 3. When the replacements for both controllers terminate normally, replacement of the array unit microprograms is complete.

Note: When the microprograms are replaced, if the microprogram of only one of the controllers is replaced, the array unit is placed in a warning state. When the microprogram of the other controller is replaced, the array unit recovers from the warning state. When replacing the microprograms, replace the microprograms for both controllers.

7.10 Setting Priced Optional Features

This section includes the following:

- Unlock Priced Optional Features
- Lock Priced Optional Features
- Setting up Priced Optional Features

7.10.1 Unlock Priced Optional Features

The following procedure unlocks the key of priced optional features:

1. On the **Settings** menu, select **Configuration Settings** or click : **Configuration Settings** in the tool bar.
2. Click the **Options** tab.

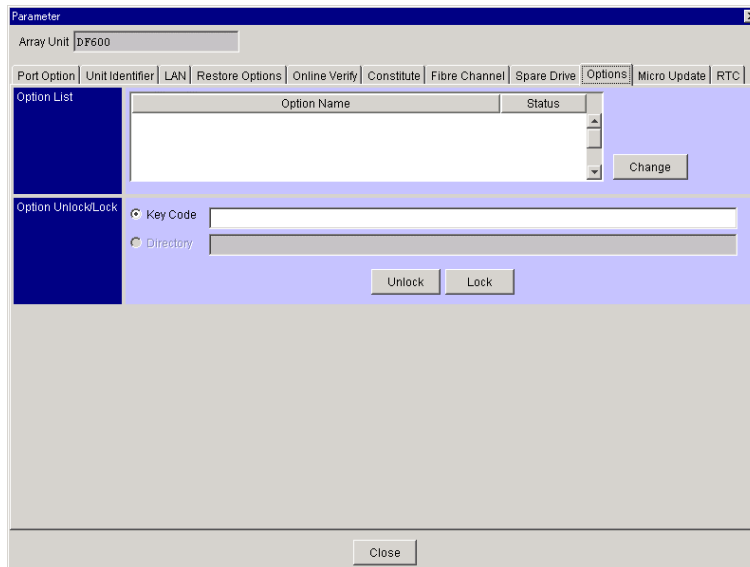

Figure 7.30 Unlocking Priced Optional Features

3. Enter a key code, then click the **Unlock** button (9500V only).

Specify whether you will unlock the priced optional features using the FD with the priced optional features or the key code. Set up the directory path or key code, and then click the **Unlock** button.

When you unlock the option using the key code, click the **Key Code** radio button, then set up the key code. For the key code of the priced optional features, refer to the priced optional features manual. When you unlock the option using the FD, click the **Directory** radio button, then set up the path for the FD (9200 only).

4. When a screen appears, requesting confirmation for unlocking priced optional features, click the **OK** button.

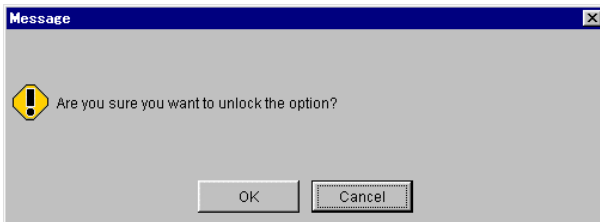

5. A screen confirming that the priced optional features have been unlocked appears. Depending on the option, an array unit may need to be restarted in order to set the unlocking feature effective. Check the manual for the option to be unlocked. All features need to be unlocked.
 - a) When restarting the array unit, and you do not need to set unlocking effective, the following screen is displayed:

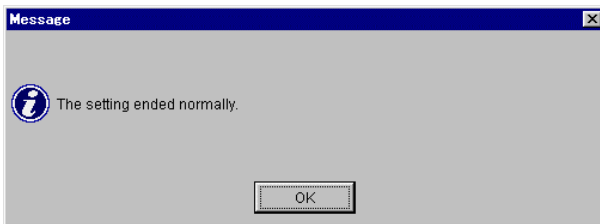

- b) When restarting the array unit is required to set the unlocking feature effective, the following screen is displayed:

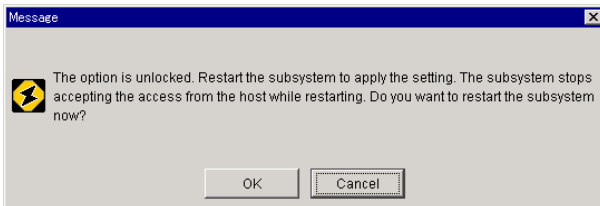

Note: To set effective the unlocking of the option that you have operated, restart the array unit. The feature is not yet closed until restarting. The array unit cannot access the host until the reboot is completed and the system restarts. Therefore, be certain the host has stopped accessing data before beginning the restart process.

After an array unit restarts, the unlocked priced optional features is displayed and Enabled.

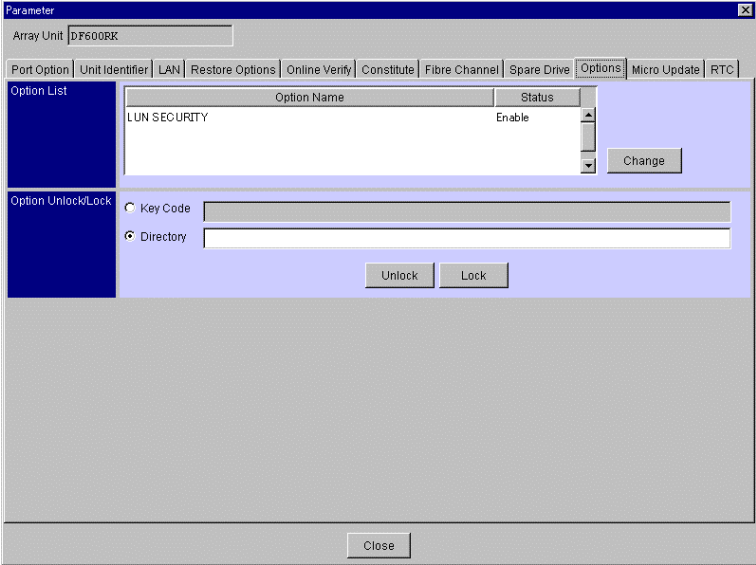

When you choose to restart the array unit, the time the restart began is displayed. This usually takes approximately two to six minutes.

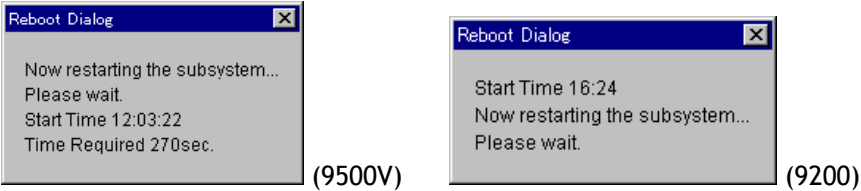

Note: It may take time for an array unit to respond, depending on the condition of the array unit. If it does not respond after 10 minutes or more, check the condition of the array unit.

6. A message appears, stating that the restart is successful. Click the **OK** button.

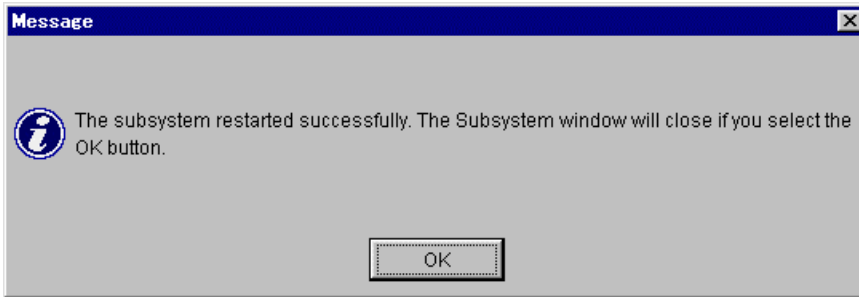

The Unit screen is closed. To perform other operations on the main window, select an array unit from the main window and open the selected Unit screen.

Note: For additional information on priced optional features, refer to the corresponding manual of each feature.

7.10.2 Lock Priced Optional Features

The following procedure locks the key of the priced optional features:

1. On the **Settings** menu, select **Configuration Settings** or click : **Configuration Settings** in the tool bar.
2. Click the **Options** tab.

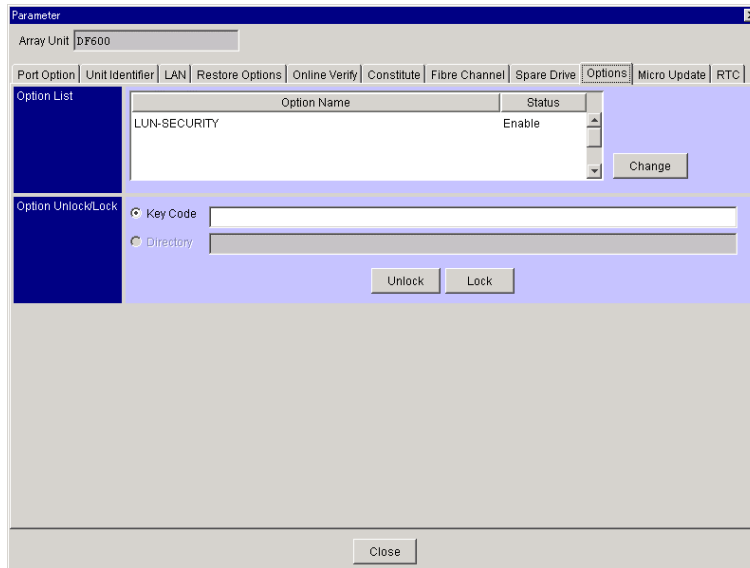

Figure 7.31 Locking Priced Optional Features

3. Enter a key code, then click the **Lock** button (9500V only).

Specify whether you are locking the priced optional features using the FD with the priced optional features, or if you are using the key code. Set up the directory path or key code, and then click the **Lock** button.

When you lock the option using the key code, click the **Key Code** radio button, then set up the key code. For the key code of the priced optional features, refer to the manual of the priced optional features. When you lock the option using the FD, click the **Directory** radio button and then setup the path for the FD (9200 only).

4. When the confirmation screen for priced optional features locking is displayed, click the OK button.

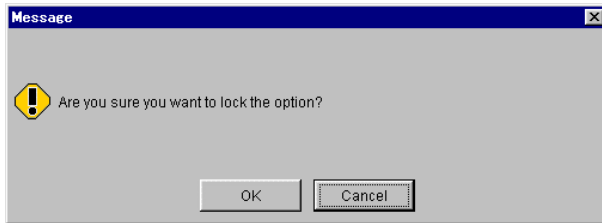

5. A screen, confirming that the priced optional features have been locked, appears. Depending on the option, the array unit needs to be restarted in order to set the locking effective. Check the manual of the option to be unlocked.
 - a) When restarting the array unit, the following screen is displayed:

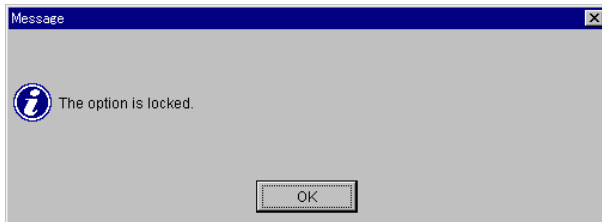

- b) When restarting the array unit, and you do need to set unlocking effective, the following screen is displayed:

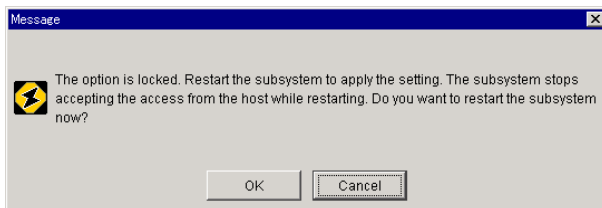

Note: To set the locking of the option that you have operated effective, restart the array unit. The feature is not opened until restarting. The array unit cannot access the host until the reboot is completed and the system restarts. Therefore, be certain the host has stopped accessing data before beginning the restart process.

After an array unit restarts, the locked priced optional features is Disabled.

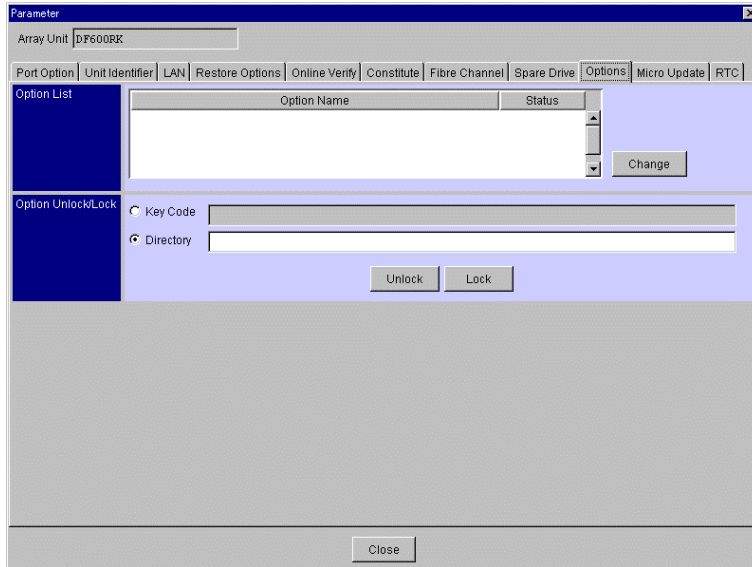

When you choose to restart the array unit, the time the restart began is displayed. This usually takes approximately two to six minutes.

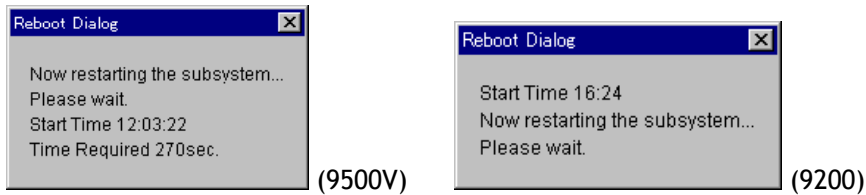

Note: It may take time for an array unit to respond, depending on the condition of the array unit. If it does not respond after 10 minutes or more, check the condition of the array unit.

6. A message appears, stating that the restart is successful. Click the **OK** button.

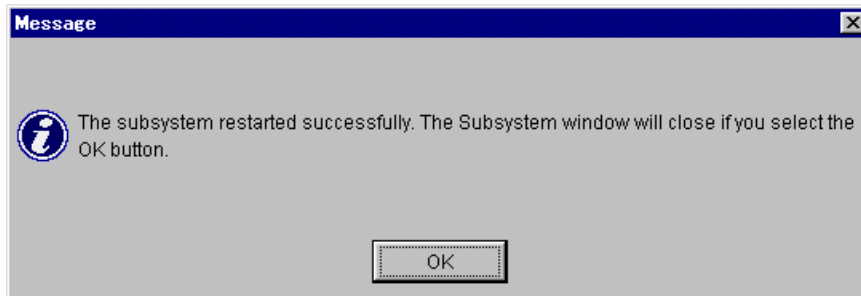

The Unit screen is closed. To perform other operations on the Main screen, select an array unit from the Main screen and open the selected Unit screen.

7.10.3 Setting Up Priced Optional Features

After releasing the key of the priced optional feature, set enable or disable for this feature.

1. On the **Settings** menu, select **Configuration Settings** or click the : **Configuration Settings** in the tool bar.
2. Click the **Options** tab.

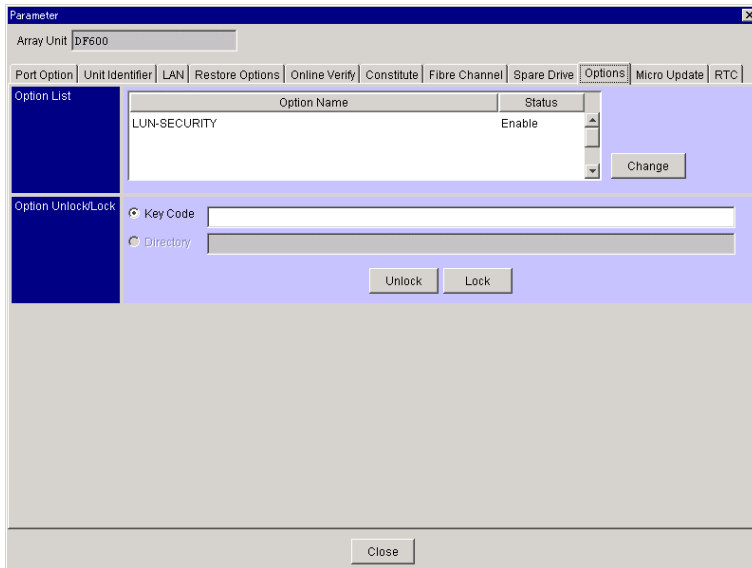
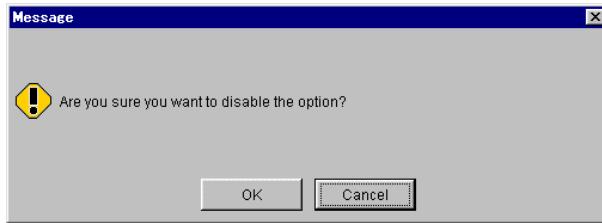

Figure 7.32 Setting Up Priced Optional Features

3. Select the priced optional features to be set up, then click the **Change** button.

4. When the confirmation screen for priced optional features changing is displayed, click the **OK** button.



5. A screen appears, confirming that the priced optional features have been set up. Depending on the option, an array unit needs to be restarted in order to validate the setup. If an array unit supports restarting, a message confirming a restart request will be displayed. Click the **OK** button to restart.
 - a) When restarting the array unit, and you do not need to set unlocking effective, the following screen is displayed:

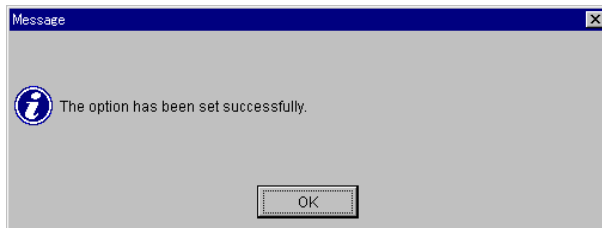

- b) When restarting the array unit, and you do need to set unlocking effective, the following screen is displayed:

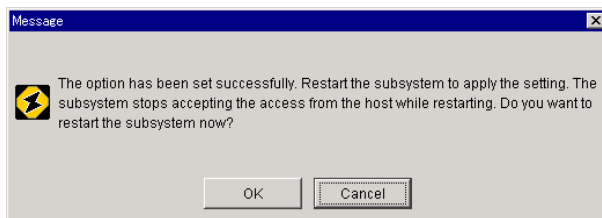

Note: To set the locking of the option that you have operated effective, restart the array unit. The feature is not opened until restarting. The array unit cannot access the host until the reboot is completed and the system restarts. Therefore, be certain the host has stopped accessing data before beginning the restart process.

When not restarting an array unit, a screen appears with the setup priced optional features being updated.

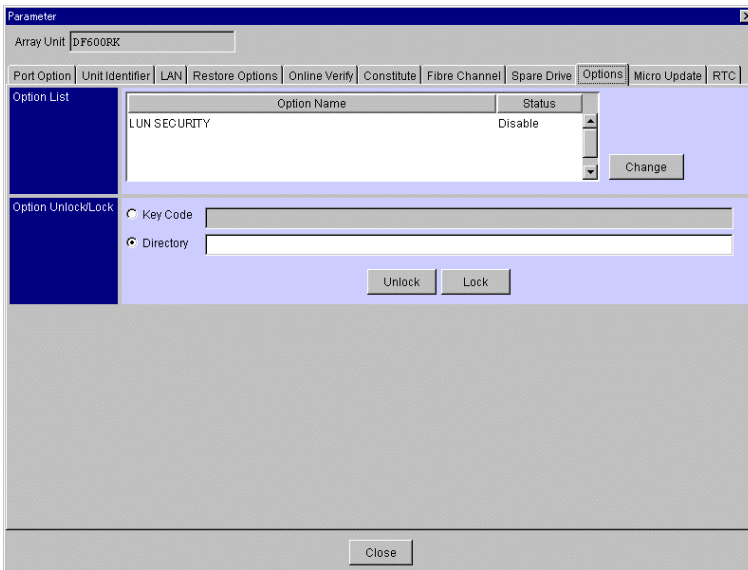

When you choose to restart the array unit, the time the restart began is displayed. This usually takes approximately two to six minutes.

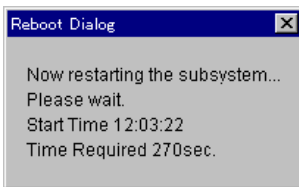

(9500V)

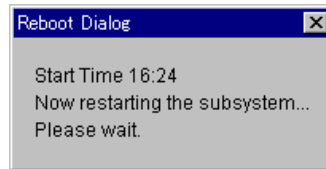

(9200)

Note: It may take time for an array unit to respond, depending on the condition of the array unit. If it does not respond after 10 minutes or more, check the condition of the array unit.

6. A message appears, stating that the restart is successful. Click the **OK** button.

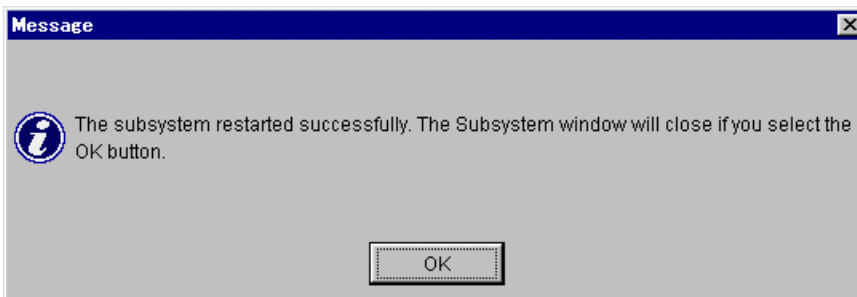

The Unit screen is closed. To perform other operations on the Main screen, select an array unit from the Main screen and open the selected Unit screen.

7.11 Using the Command Device

Set the ID for identifying command devices and array units.

This section includes the following:

- Setting the Command Device
- Changing the Command Device
- Deleting the Command Device
- Setting the Serial ID (9200 only)

7.11.1 Setting the Command Device

When setting the command device, you can specify up to 2 LUs of command devices.

1. On the **Settings** menu, click the **Configuration Settings** or click  in the tool bar.
2. Click the **Command Device** tab.

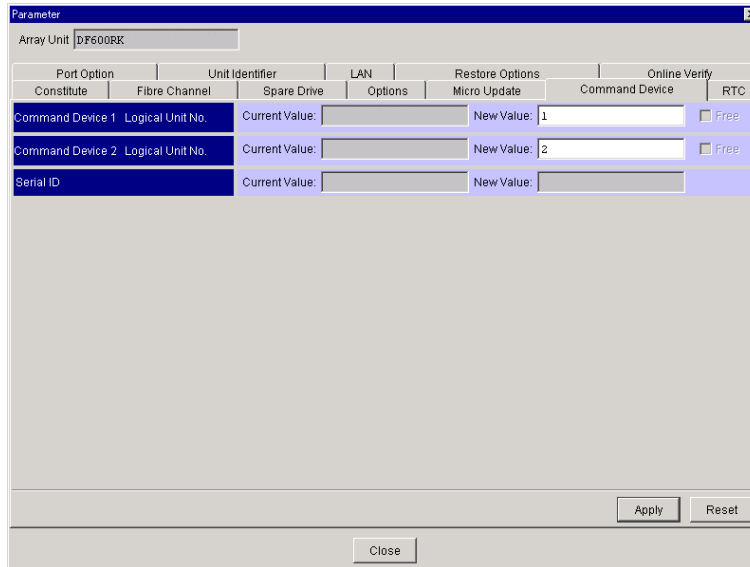

The screenshot shows a 'Parameter' dialog box with the 'Array Unit' set to 'DF600RK'. The 'Command Device' tab is selected, displaying a table with columns for 'Port Option', 'Unit Identifier', 'Current Value', 'New Value', and 'Free'. The table has three rows: 'Command Device 1 Logical Unit No.', 'Command Device 2 Logical Unit No.', and 'Serial ID'. The 'New Value' for 'Command Device 1' is set to '1'. 'Apply', 'Reset', and 'Close' buttons are visible at the bottom.







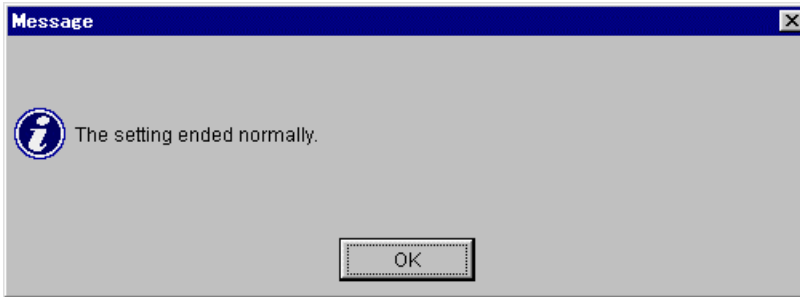

Port Option	Unit Identifier	Current Value	New Value	Free		
Constitute	Fibre Channel	Spare Drive	Options	Micro Update	Command Device	RTC
Command Device 1	Logical Unit No.		1	<input type="checkbox"/>		
Command Device 2	Logical Unit No.		2	<input type="checkbox"/>		
Serial ID						

3. Specify a logical unit in which to set a command device in the **New Value:** text box, then click the Apply button. In the **Current Value:** text box, current information is displayed.
 - **Command Device 1/Command Device 2:**
Logical Unit No.: Specify the logical unit No
 - **Serial ID:** Specify the serial ID of an array unit (9200 only)

4. A message appears, verifying that the setting is complete. Click the **OK** button.



On the **Logical Status** tab screen, the icon of the logical unit is displayed as a command device.

Display	Highlighting	Status
 Yellow		• Normal
 Gray		• Unformatted
 Red		• Blockade
 Pink		• Regression

7.11.2 Changing the Command Device

To change the command device, delete the set command device, then set the command device again.

1. On the **Settings** menu, click **Configuration Settings** in the Unit screen or click  in the tool bar.
2. Click the **Command Device** tab.

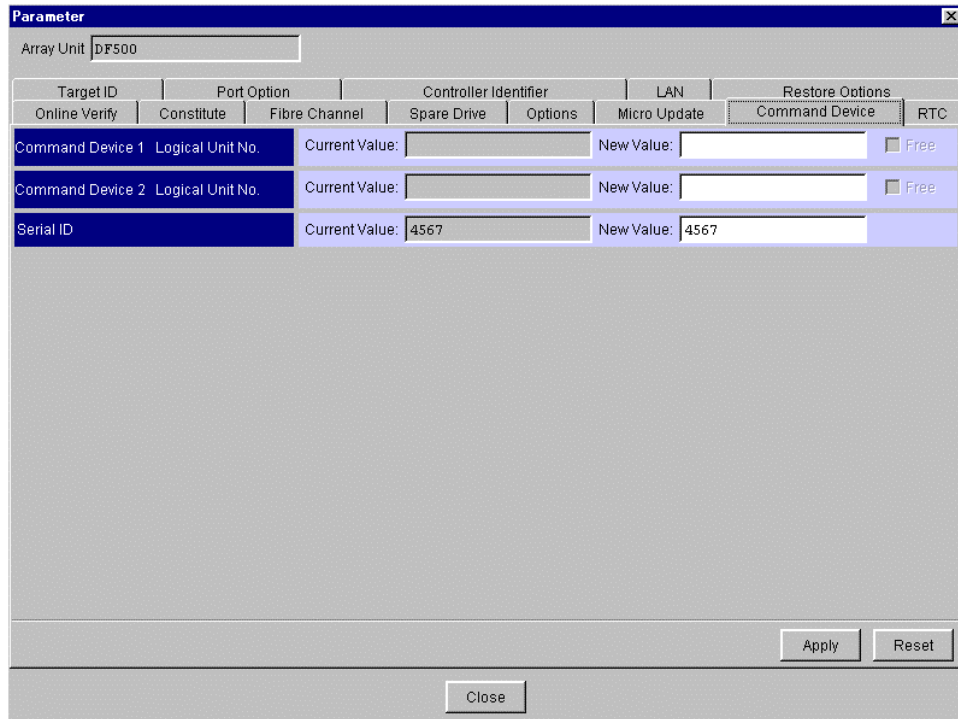

Target ID	Port Option	Controller Identifier		LAN	Restore Options		
Online Verify	Constitute	Fibre Channel	Spare Drive	Options	Micro Update	Command Device	RTC
Command Device 1	Logical Unit No.	Current Value:		New Value:		<input type="checkbox"/> Free	
Command Device 2	Logical Unit No.	Current Value:		New Value:		<input type="checkbox"/> Free	
Serial ID		Current Value:	4567	New Value:	4567		

3. Select the **Free** check button of a command device to change it, then click the **Apply** button.
4. A message verifying that the setting is complete is displayed. Click the **OK** button.

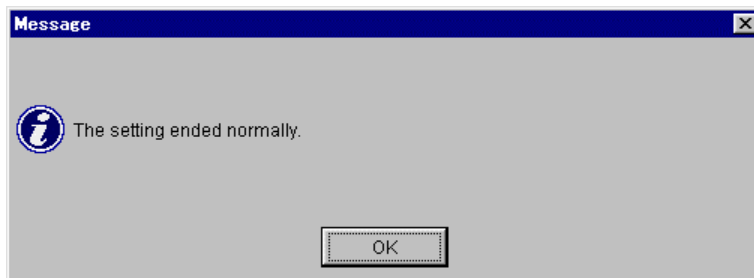

5. In the **Current Value:** entry box, the command device that has been deleted disappears. Change the command device using the same procedure as that for the setting.

7.11.3 Deleting the Command Device

To delete the command device:

1. On the **Settings** menu, click the **Configuration Settings** in the Unit screen or click  in the tool bar.
2. Click the **Command Device** tab.

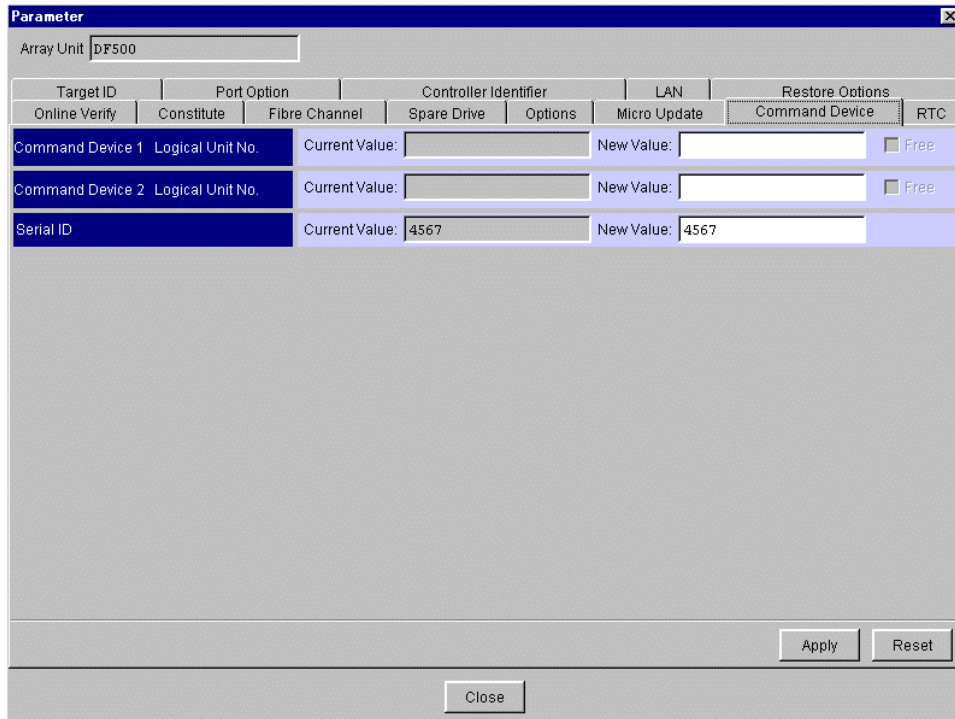

The image shows a 'Parameter' dialog box for an Array Unit 'DF500'. It features a tabbed interface with the 'Command Device' tab selected. The dialog contains a table with columns for 'Current Value' and 'New Value', and a 'Free' checkbox for each command device. The 'Serial ID' is also visible.

Target ID	Port Option	Controller Identifier		LAN	Restore Options		
Online Verify	Constitute	Fibre Channel	Spare Drive	Options	Micro Update	Command Device	RTC
Command Device 1	Logical Unit No.	Current Value:		New Value:		<input type="checkbox"/> Free	
Command Device 2	Logical Unit No.	Current Value:		New Value:		<input type="checkbox"/> Free	
Serial ID		Current Value:	4567	New Value:	4567		

Buttons: Apply, Reset, Close

3. Select the **Free** check button of a command device to delete, and then click the **Apply** button.
4. A message verifying that the setting is complete is displayed. Click the **OK** button.

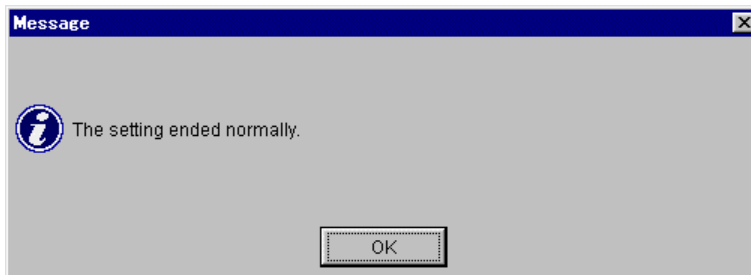

The image shows a 'Message' dialog box with an information icon and the text 'The setting ended normally.' and an 'OK' button.

Message: The setting ended normally.

OK

7.11.4 Setting the Serial ID

To set the serial ID:

1. On the **Settings** menu, click the **Configuration Settings** in the Unit screen. Alternatively, click “: **Configuration Settings**” in the tool bar.
2. Click the **Command Device** tab.

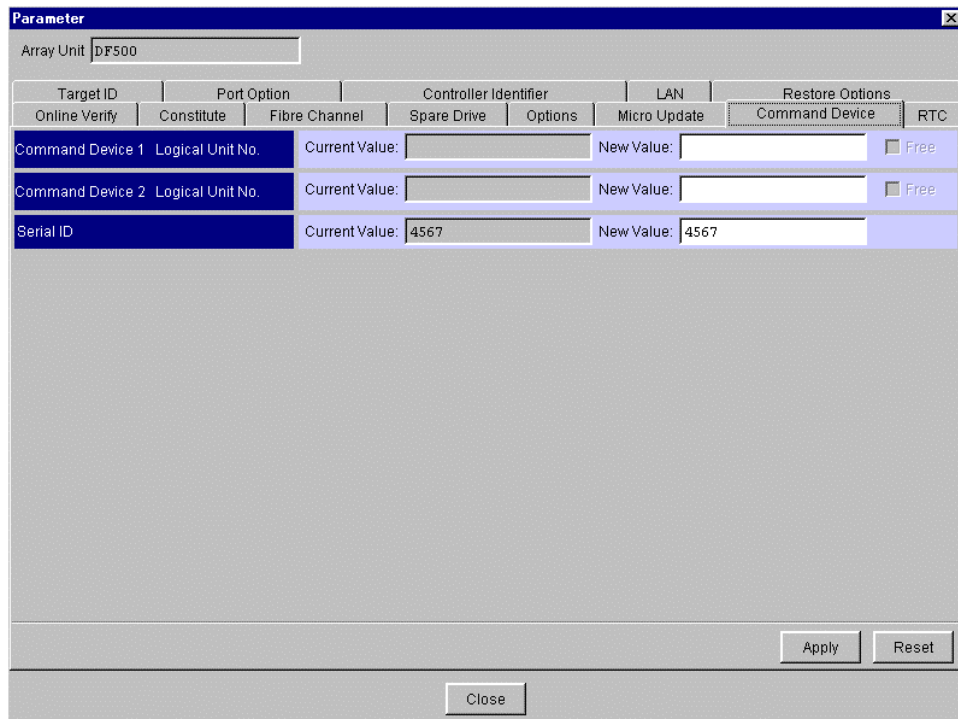

The screenshot shows a 'Parameter' configuration window for an Array Unit 'DF500'. The window has a blue title bar and a close button. Below the title bar, there is a text field for 'Array Unit' containing 'DF500'. A tabbed interface is visible with the following tabs: Target ID, Port Option, Controller Identifier, LAN, and Restore Options. The 'Restore Options' tab is active, showing sub-tabs: Online Verify, Constitute, Fibre Channel, Spare Drive, Options, Micro Update, Command Device (selected), and RTC. The 'Command Device' sub-tab contains a table with three rows:

Command Device 1 Logical Unit No.	Current Value:	New Value:	Free
Command Device 2 Logical Unit No.	Current Value:	New Value:	Free
Serial ID	Current Value: 4567	New Value: 4567	

At the bottom of the window, there are 'Apply' and 'Reset' buttons. Below the window, there is a 'Close' button.

3. Specify a serial ID in the **New Value:** entry box on the **Serial ID** (4 figure decimal number). Click the **Apply** button.
4. A message verifying that the setting is complete is displayed. Click the **OK** button.

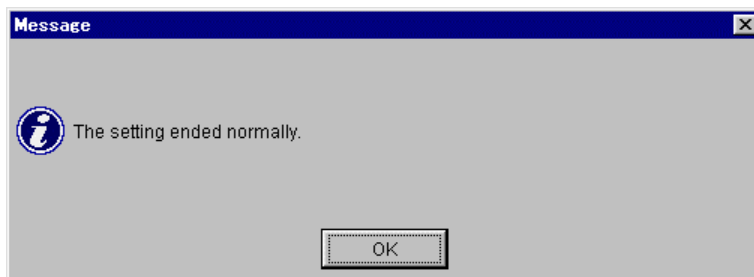

7.12 Setting the Port Option

Sets the port option of the system parameter. The setting information becomes valid without restarting an array unit.

This setting is allowed only if the Target ID mode of an array unit to be set up has been set to **M-TID**, **M-LUN** (mapping), and not setting mapping information. Verify the target ID of the setting port (9200 only).

1. On the **Settings** menu, select **Configuration Settings** or click  in the tool bar.
2. Click the **Port Option** tab.

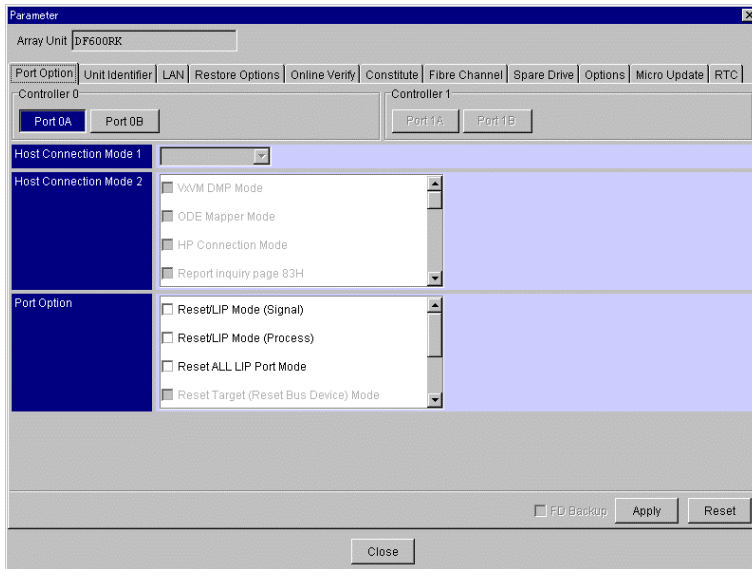

Figure 7.33 Setting the Port Option

- **Host Connection Mode 1** (9200 only)
 - Standard Mode:** Open system emulation mode
 - Open VMS Mode:** Open VMS mode
 - TRESPASS Mode:** TRESPASS mode
 - Wolfpack Mode:** Wolfpack mode
 - IBM 7135 I/O path switch Mode:** IBM 7135 I/O path switch mode
 - NCR I/O path switch Mode:** NCR I/O path switch mode

- **Host Connection Mode 2 (9200 only)**
 - VxVM DMP Mode:** VxVM mode
 - ODE Mapper Mode:** ODE Mapper mode
 - HP® Connection Mode:** HP® connection mode
 - Report inquiry page 83H:** Enables the report of Inquiry Page: 83_H
 - UA(60/2A00) suppress Mode:** Suppresses the unit attention (06/2A00)
 - HISUP Mode:** Enables the HISUP
 - CCHS Mode:** Enables the CCHS convert
 - Standard INQUIRY data expand Mode:** Enables the Standard INQUIRY data expand Mode
 - HP® Connection Mode 2:** Enables the HP® Connection Mode 2
 - Product ID DF400 Mode:** Setting the product ID is DF400
 - HBA WWN Report Mode:** Enables the HBA WWN Report Mode
 - NACA Mode:** Enables the CCHS convert
 - SUN Cluster Connection Mode:** Enables the SUN Cluster Connection Mode
 - Persistent RSV Cluster Mode:** Enables the Persistent RSV Cluster Mode
 - ftServer Connection Mode 1:** Enables the ftServer Connection Mode 1
 - ftServer Connection Mode 2:** Enables the ftServer Connection Mode 2
 - SRC Read Command Reject Mode:** Enables the SRC Read Command Reject Mode
- **Port Option:** Sets the port options
 - If the port option is set and the button **OK** is clicked, it will return to the setting screen of **Port Type**.
 - Reset/LIP Mode (Signal):** The mode to transmit Reset/LIP signals to other ports
 - Reset/LIP Mode (Process):** The mode to transmit reset processing to other ports
 - Reset ALL LIP Port Mode:** The mode to execute reset on receiving LIP
 - Reset Target (Reset Bus Device) Mode:** The mode to transmit Target Reset to other ports
 - Reserve Mode:** The mode to reserve logical unit in a dual system
 - Reset Logical Unit Mode:** When the Logical Unit Reset command is issued for a logical unit, all other commands received by that logical unit will be reset, regardless of the port.
 - Reset Logout of Third Party Process Mode:** The mode to transmit Third Party Process Log-out to other ports
 - Read Frame Min 128 Byte Mode:** The mode that sets the minimum frame size of the read transfer to 128 bytes
 - FD Backup:** Port option information has been saved in a backup FD in an array unit as parameter information. When the setting is modified, it is necessary to save it again, so be sure to turn on the check box (9200 only).

Note: **Reset/LIP Mode (signal)** is enabled if the **Reset/LIP Mode (Process)** is set.
Port Option can be multiply set, but depending on the setting, it may not function properly. If it is to be set, please refer to the appended manual of the array unit and set only the applicable parameters.

3. A message appears, stating that the setting is complete. Click the **OK** button.

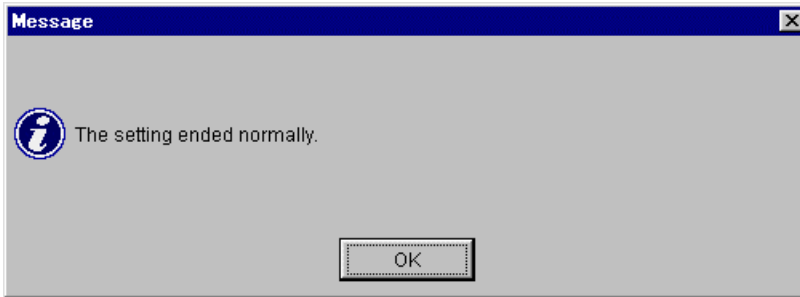

Note: When failing to write onto the FD drive, the message “DMES04EB02: Backup floppy disk write error.” is displayed. When this message is displayed, writing to a FD has not been finished, but setting the port option may be completed. Check a FD in an array unit, re-confirm the data to set, turn on the **FD Backup** check box, and then click the **Apply** button (9200 only).

7.13 Setting the Controller Identifier

Sets the controller identifier of the system parameter. This setting is allowed only if the Target ID mode of an array unit, which is set, has been set to **M-TID**, **M-LUN** (mapping). Mapping information is not set. Confirm the target ID of the port set (9200 only).

Setting information becomes valid without restarting an array unit.

1. On the **Settings** menu, click the **Configuration Settings** or click  in the tool bar.
2. Click the **Controller Identifier** tab (9200 only).
Click the **Unit Identifier** tab (9500V only)

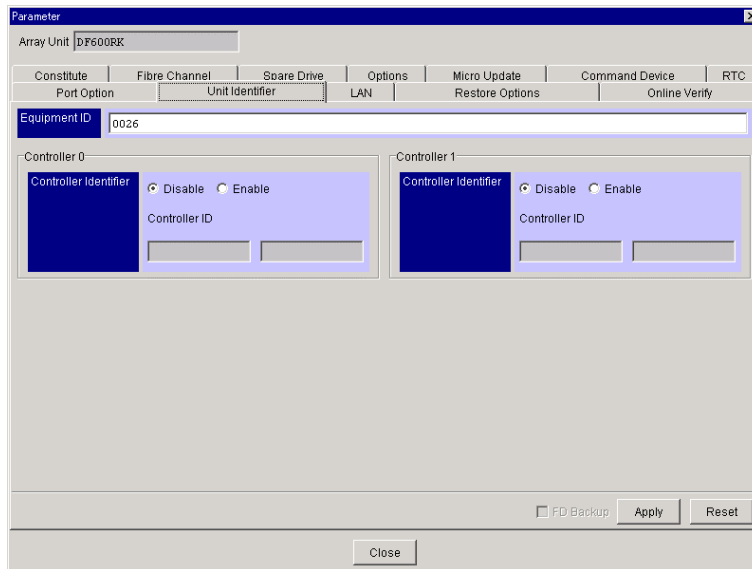
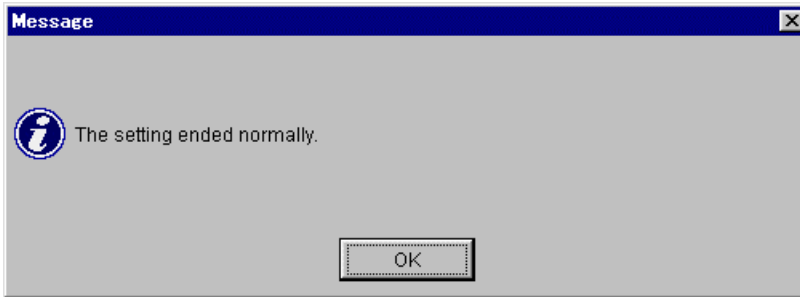

Figure 7.34 Setting the Controller Identifier

3. Set the controller identifier
 - **Equipment ID:** Displays the equipment ID (9500V only)
 - **Controller Identifier:** Enter a controller identifier. The controller identifier consists of ten characters; only the top eight characters can be changed but the last two characters cannot be changed. They can be changed when the **Enable** is selected.
 - **FD Backup:** Controller identifier has been saved in a backup FD in an array unit as parameter information. When the setting is modified, it is necessary to save it again, so turn on the check box (9200 only).

4. A message appears, stating that the setting is complete. Click the **OK** button.



Note: When failing to write onto the FD drive, the message “DMES04EB02: Backup floppy disk write error.” is displayed.

When this message is displayed, writing to a FD has not been finished, but setting the Controller Identifier information may be completed.

Check the FD in an array unit, re-confirm the data to set, turn on the **FD Backup** check box, and click the **Apply** button again.

7.14 Setting RTC

This setting information becomes valid without restarting an array unit.

1. On the **Settings** menu, select **Configuration Settings** or click  in the tool bar.
2. Click the **RTC** tab.

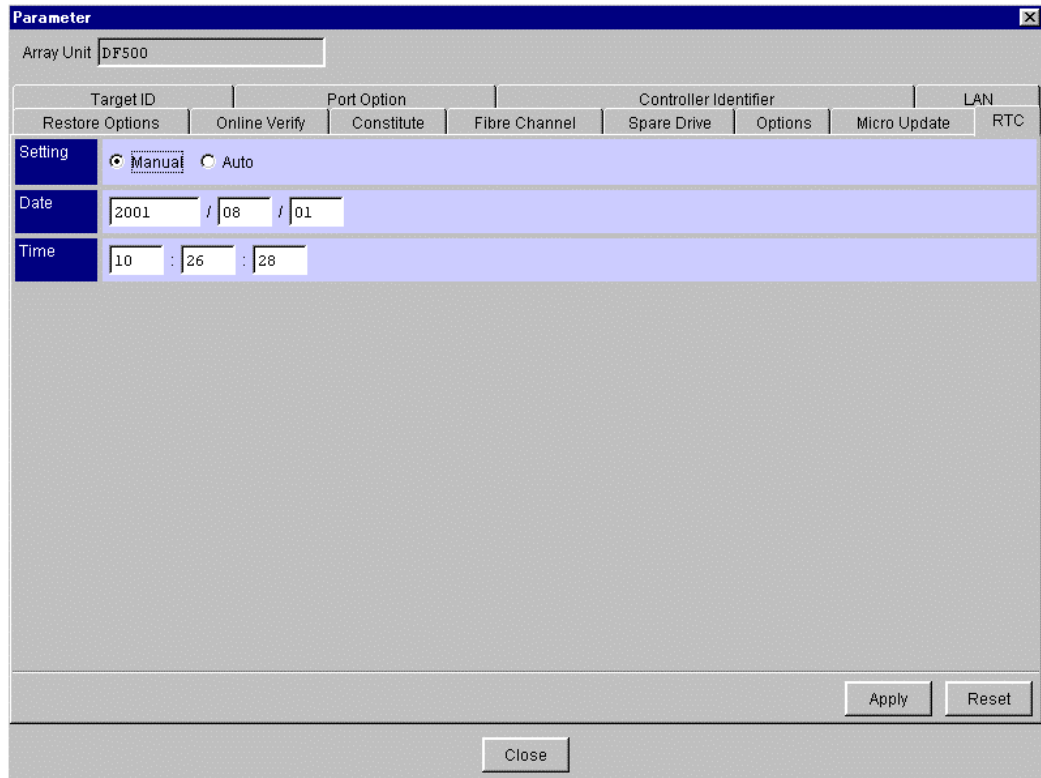

The screenshot shows a 'Parameter' dialog box with the following fields and controls:

- Array Unit: DF500
- Target ID, Port Option, Controller Identifier, LAN, Restore Options, Online Verify, Constitute, Fibre Channel, Spare Drive, Options, Micro Update, RTC (selected tab)
- Setting: Manual, Auto
- Date: 2001 / 08 / 01
- Time: 10 : 26 : 28
- Buttons: Apply, Reset, Close

Figure 7.35 Setting RTC

3. Set the RTC.
 - **Setting:** Select Manual or Auto.
 - Manual:** Sets the date and time
 - Auto:** Sets the time of the PC or Server/Workstation executing the Resource Manager 9500V
 - **Date:** Displays the date
 - **Time:** Displays the time

4. Click the **Apply** button.
5. A message appears, stating that the setting is complete. Click the **OK** button.

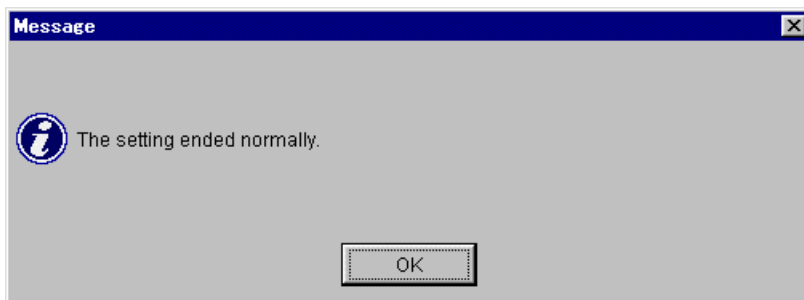

7.15 Setting System Parameters

This setting information becomes valid without restarting an array unit.

1. On the **Settings** menu, click the **Configuration Settings** or click  in the tool bar.
2. Click the **System Parameter** tab.

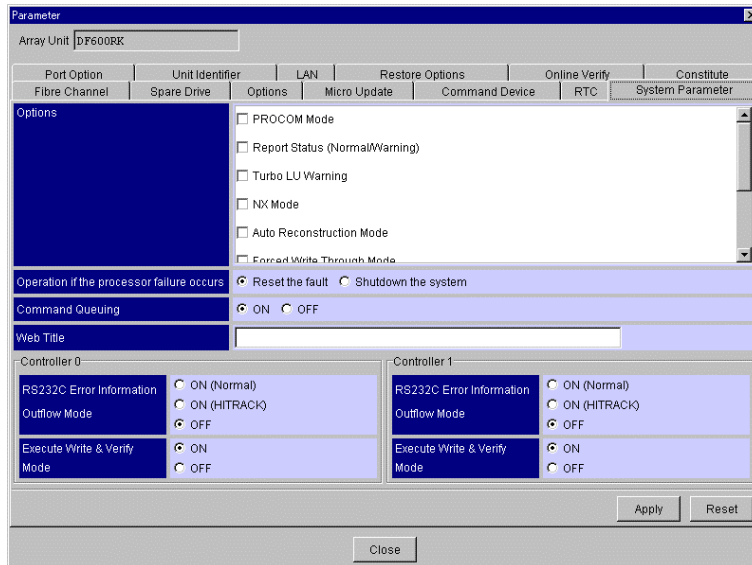
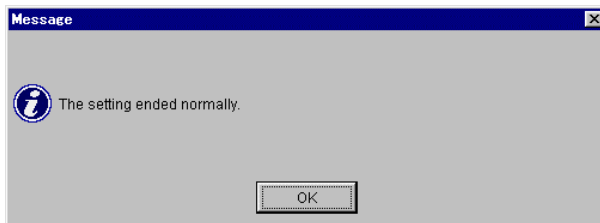

Figure 7.36 Setting System Parameters

3. Set the system parameters.
 - **Options:** Set the optional function(s) according to the configuration of the array unit.
 - PROCOM Mode:** Validates the PROCOM Mode
 - Report Status (Normal/Warning):** Validates the warning status report mode
 - Turbo LU Warning:** When the Turbo LU function is invalidated, a warning is reported.
 - NX Mode:** Validates the NX Mode
 - Auto Reconstruction Mode:** Validates the Auto Reconstruction Mode
 - Forced Write Through Mode:** Validates the Forced Write Through Mode
 - Changing Logical Unit Mode 1:** Validates the Changing Logical Unit Mode 1
 - Multiple Stream Mode:** Validates the Multiple Stream Mode
 - Multiple Stream Mode (Write):** Validates the Multiple Stream Mode (Write)
 - Multiple Stream Mode (Read):** Validates the Multiple Stream Mode (Read)
 - **Operation if the processor failure occurs:** Sets the operation to be performed when a processor failure occurs
 - Reset the fault:** Resets a failure and restarts the controller
 - Shutdown the system:** Shuts the array unit down

- **Command Queuing:** Specifies execution of command queuing
 - ON:** Executes command queuing
 - OFF:** Inhibits command queuing
 - **Web Title:** If the home page of the array unit is displayed with the browser, specifies a character string displayed on the title bar of the browser. Enter up to 32 one-byte coded alphanumeric or characters (except for the ' (single quotation mark), " (double quotation mark), and \ (backslash) symbols) other than numeric.
 - **RS232C Error Information Outflow Mode:** Set the mode of error information sent to the RS232C of controller 0/1.
 - ON (Normal):** Outputs information
 - ON (HITRACK):** Outputs HITRACK mode information
 - OFF:** Inhibits an output of information
 - **Execute Write & Verify Mode:** Set the write & verify execution mode of controller 0/1.
 - ON:** Executes write and verify
 - OFF:** Does not execute write and verify
4. Click the **Apply** button.
 5. A message appears, stating that the setting is complete. Click the **OK** button.



Chapter 8 Displaying Statistical Information

This chapter includes the following:

- Displaying Statistical Information in the Array Unit
- Displaying the Controller Use Condition
- Displaying the Numbers of Host Commands Received
- Displaying the Command Execution Condition
- Displaying the Cache Load Condition

8.1 Displaying Statistical Information in the Array Unit

1. On the **View** menu, select **Statistical Information** or click  in the tool bar.
2. Specify statistical information by **Select**. Click the **OK** button.

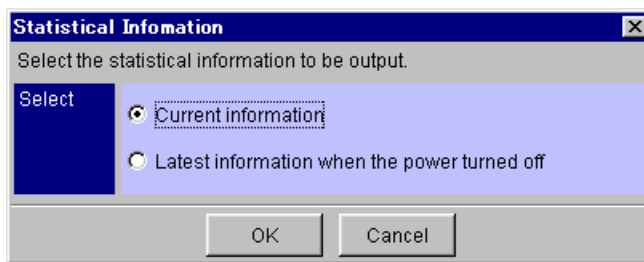

- **Select:** Statistical information to be displayed
- **Current information:** Current information
- **Latest Information when the power turned off:** Information when starting an array unit

8.2 Displaying the Controller Use Condition

1. Click the **Controller** tab.

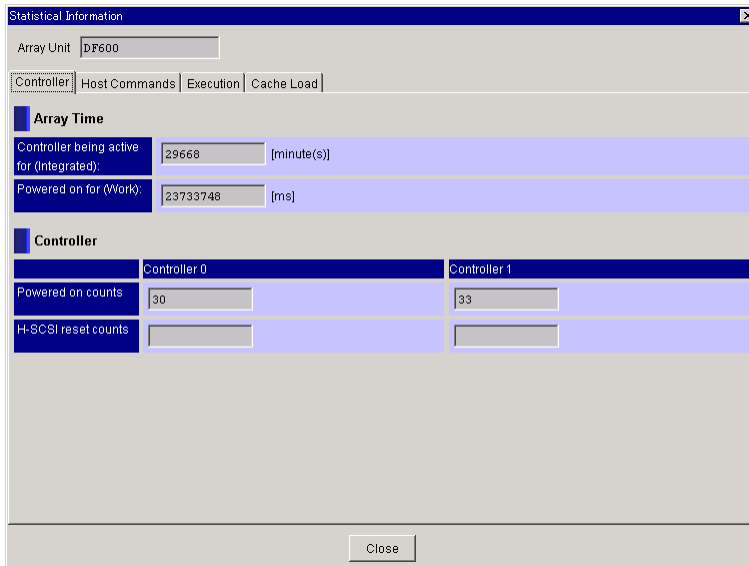
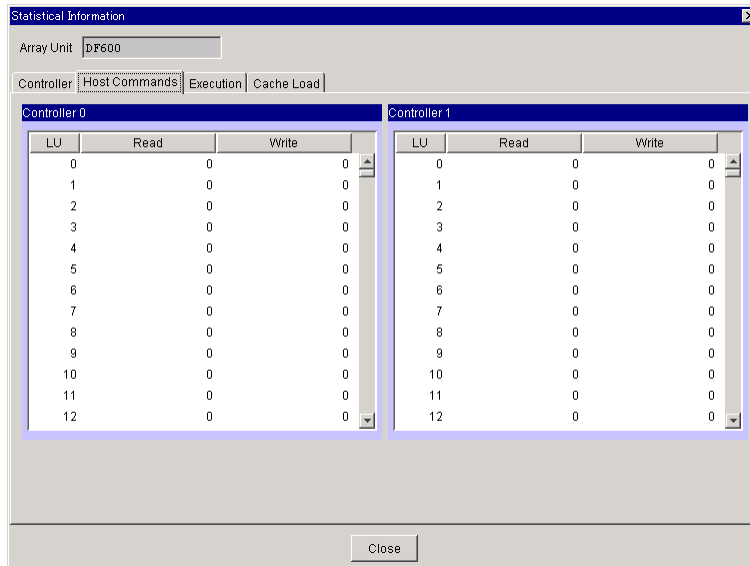

Figure 8.1 Displaying the Controller Use Condition

- **Array Time:**
 - Controller being active for (Integrated):** Integrated acting time of the array unit (minute)
 - Power on for (Work):** Power ON time of the array unit (PS/ON to PS/OFF) time (ms)
- **Controller:**
 - Powered on counts:** Integrated number of power ON times (at interruption) of the controller
 - H-SCSI reset counts:** Integrated number of host bus SCSI reset times (total of interruptions and messages) of the controller (9200 only)

8.3 Displaying the Numbers of Host Commands Received

1. Click the **Host Commands** tab.



The screenshot shows a window titled "Statistical Information" with a close button in the top right corner. Below the title bar, there is a text field for "Array Unit" containing "DF600". Below that, there are three tabs: "Host Commands" (which is selected), "Execution", and "Cache Load". The main area is divided into two panels, "Controller 0" and "Controller 1". Each panel contains a table with columns for "LU", "Read", and "Write". The "LU" column lists logical unit numbers from 0 to 12. The "Read" and "Write" columns show the accumulated number of received read and write commands, respectively. All values in the tables are 0. At the bottom of the window, there is a "Close" button.

Controller 0				Controller 1			
LU	Read	Write		LU	Read	Write	
0	0	0		0	0	0	
1	0	0		1	0	0	
2	0	0		2	0	0	
3	0	0		3	0	0	
4	0	0		4	0	0	
5	0	0		5	0	0	
6	0	0		6	0	0	
7	0	0		7	0	0	
8	0	0		8	0	0	
9	0	0		9	0	0	
10	0	0		10	0	0	
11	0	0		11	0	0	
12	0	0		12	0	0	

Figure 8.2 Displaying the Number of Host Command Received

- **LU:** Logical unit number
- **Read:** Accumulated number of received read commands in each logical unit
- **Write:** Accumulated number of received write commands in each logical unit

8.4 Displaying the Command Execution Condition

1. Click the Execution tab.

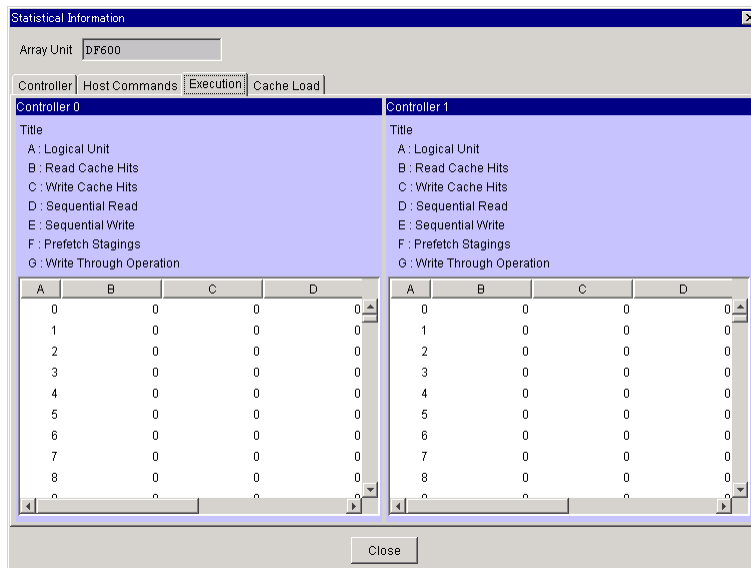

Figure 8.3 Displaying the Command Execution Condition

- **A:Logical Unit:** Logical unit number
- **B:Read Cache Hits:** Total of READ commands (hitting cache or partially hitting cache)
- **C:Write Cache Hits:** Total of WRITE commands (cache read hits)
- **D:Sequential Read:** Total of READ commands (recognized as sequential reading)
- **E:Sequential Write:** Total of WRITE commands (recognized as sequential writing)
- **F:Prefetch Strings:** Total of prefetch jobs executed
- **G:Write Through Operation:** Total of WRITE or WRITE & VERIFY commands (substituted by Write-Through operations)
- **H:Reassigned Blocks:** Number of re-assigned blocks (Not supported)

8.5 Displaying the Cache Load Condition

1. Click the **Cache Load** tab.

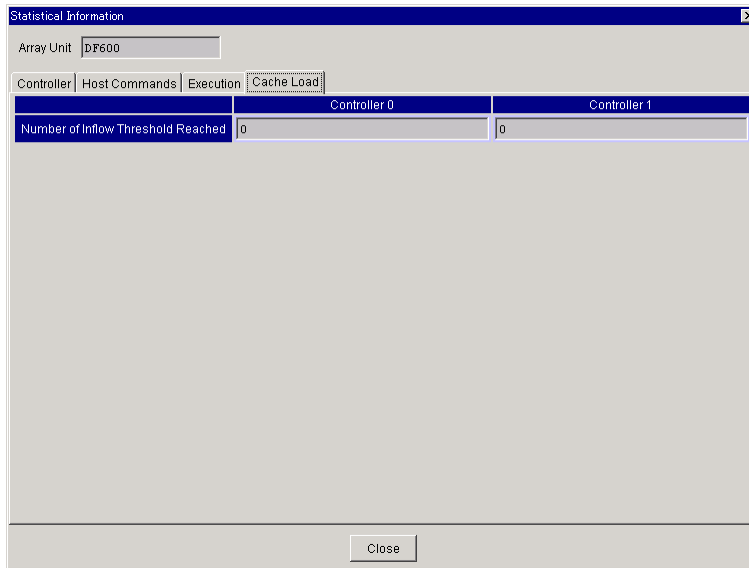

Figure 8.4 Displaying the Cache Load Condition

- **Number of Inflow Threshold Reached:** Total number of occurrences of inflow limitations

This equipment manages the amount of data in cache as an inflow limit. When the host tries to write data exceeding this limit, an inflow limitation occurs. In this case, the write request from the host waits until part of write data is transferred to the drive.

Chapter 9 Acquiring Performance Information

The command operation state is output for each logical unit in the array unit. The command operation state consists of three types of data: the number of received commands, the number of cache-hit commands, and the cache hit rate for each Read or Write command.

This section includes:

- Outputting Performance Information Manually to a Text File
- Outputting Performance Information Automatically to a Text File

9.1 Outputting Performance Information Manually to a Text File

The command operation status for each logical unit in the array unit is output to the file when the **Get Data** button is clicked.

1. On the **View** menu, select **Performance** or click  in the tool bar.

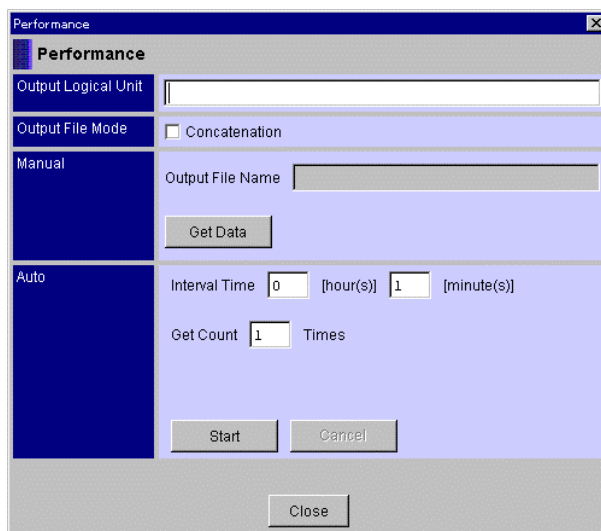

The image shows a dialog box titled "Performance" with a close button (X) in the top right corner. The dialog is divided into two main sections: "Manual" and "Auto".

- Manual Section:**
 - Output Logical Unit:** A text input field.
 - Output File Mode:** A checkbox labeled "Concatenation".
 - Output File Name:** A text input field.
 - Get Data:** A button.
- Auto Section:**
 - Interval Time:** Two input fields: "0" [hour(s)] and "1" [minute(s)].
 - Get Count:** An input field with "1" and the text "Times".
 - Start:** A button.
 - Cancel:** A button.

At the bottom of the dialog is a **Close** button.

2. When outputting performance information of an optional logical unit, specify the number of the logical unit to be output in the **Output Logical Unit**. When doing that, enter the logical unit number using numerals and/or a hyphen(s) (-). If the specification is omitted, the information about all logical units is output.

Example: 0 1 2 3 4 5 8, 0-5 8

3. When you want to make an output as an addition to the information previously output, check the **Concatenation** check box of the **Output File Mode**. Do not check it when you want to overwrite the information previously output.

4. Click the **Get Data** button.

The file names for getting performance information are displayed in the **Output File Name**.

- a) When the **Output File Mode** is not specified:

These files are output to the directory installing the Resource Manager 9500V in the text file format.

Single system: pfms\$\$\$.txt (\$\$: serial number from 00 to 99)

Dual system: pfmd\$\$\$.txt (\$\$: serial number from 00 to 99)

Note: Files are output with the names of pfms00.txt/pfmd00.txt to pfms99.txt/pfmd99.txt. After pfms99.txt/pfmd99.txt, pfms00.txt/pfmd00.txt is overwritten. Transfer necessary information to another directory.

The information is got according to the following timing.

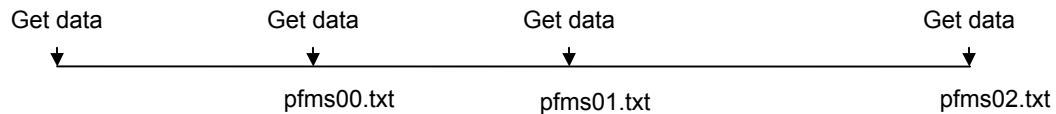

- b) When the **Output File Mode** is specified as **Concatenation**:

These files are output to the directory installing the Resource Manager 9500V in the text file format.

Single system: pfms.txt

Dual system: pfmd.txt

5. After the file processed is terminated, a confirmation message appears. Click the **OK** button.

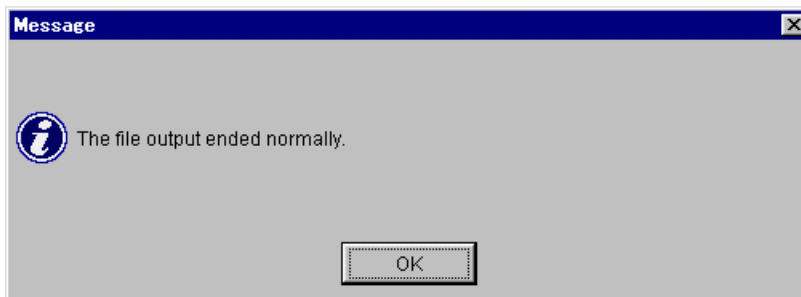

When the single system is connected, only the information of the controller 0 side is collected.

No.1 ← Output number
 2002/08/20 13:47:33 - 2002/08/20 13:50:33 ← Information getting time

LU CTL	Read CMD Count	Read CMD Hit Count	Rate	Write CMD Count	Write CMD Hit Count	Rate
0 0	0	0	0	0	0	0
1 0	0	0	0	0	0	0
2 0	0	0	0	0	0	0
:						
:						
509 0	0	0	0	0	0	0
510 0	0	0	0	0	0	0
511 0	0	0	0	0	0	0
TOTAL 0	0	0	0	0	0	0
LU CTL	Read CMD Count	Read CMD Hit Count	Rate	Write CMD Count	Write CMD Hit Count	Rate
0 1	0	0	0	0	0	0
1 1	0	0	0	0	0	0
2 1	0	0	0	0	0	0
:						
:						
509 1	0	0	0	0	0	0
510 1	0	0	0	0	0	0
511 1	0	0	0	0	0	0
TOTAL 1	0	0	0	0	0	0

- **No.:** Output number
- **Information getting time:** Time and date when the information is got
- **LU:** Logical unit number
- **CTL:** Controller number
- **Read CMD Count:** Number of received Read commands
- **Read CMD Hit Count:** Number of cache-hit Read commands to received Read commands
- **Rate:** Rate (%) of cache-hit Read commands to received Read commands
- **Write CMD Count:** Number of received Write commands
- **Write CMD Hit Count:** Number of cache-hit Write commands to received Write commands
- **Rate:** Rate (%) of cache-hit Write commands to received Write commands
- **Total:** Entire controller

Generally, when the subsystem is structured so that the load on each controller and the load on each disk are leveled, its performance is improved. The higher the cache-hit rate, the higher the performance becomes.

9.2 Outputting Performance Information Automatically to Text File

Command operation state for each logical unit in the array unit is output at the specified intervals by the specified times.

1. On the **View** menu, select **Performance** or click  in the tool bar.

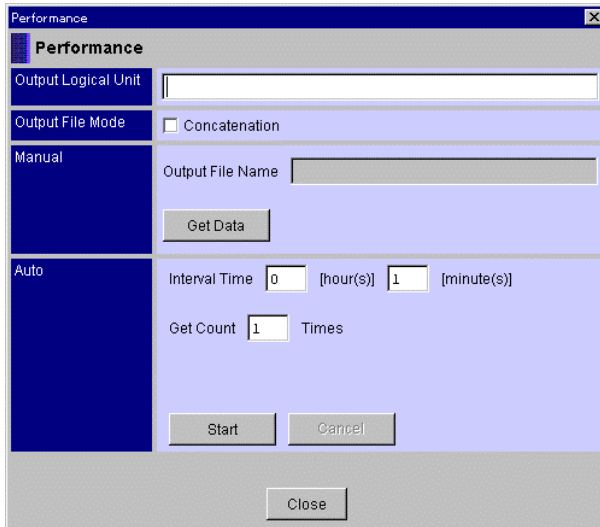

2. When outputting performance information of an optional logical unit, specify the number of the logical unit to be output in the **Output Logical Unit**. When doing that, enter the logical unit number using numerals and/or a hyphen(s) (-). If the specification is omitted, the information about all logical units is output.

Example: 0 1 2 3 4 5 8, 0-5 8

3. When you want to make an output as an addition to the information previously output, check the **Concatenation** check box of the **Output File Mode**. Do not check it when you want to overwrite the information previously output.

4. Specify **Interval Time** (specifies this item in the range of 1 minute to 23 hours 59 minutes) and **Get Count** (specifies this item in the range of 1 to 99), then click the **Start** button.

During file output, the file name for getting performance information is displayed above the **Start** button.

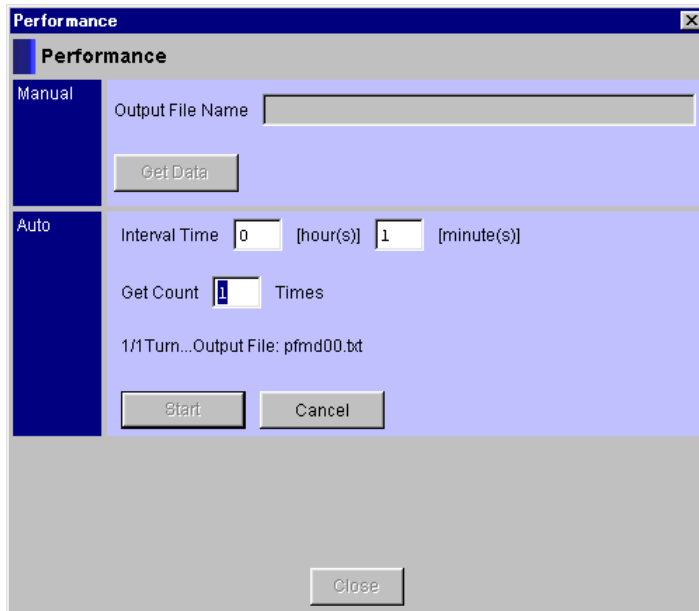

- a) When the **Output File Mode** is not specified:

Files are output with the following file names. The designated files are output to the directory installing the Manager 2 in the text file format.

Single system: pfms\$\$\$.txt (\$\$: serial number from 00 to 98)

Dual system: pfmd\$\$\$.txt (\$\$: serial number from 00 to 98)

Note: Files are output with the names of pfms00.txt/pfmd00.txt to pfms98.txt/pfmd98.txt. When re-executing, the information is overwritten by the same file name (names from pfms00.txt/pfmd00.txt up to pfms98.txt/pfmd98.txt in accordance with the number of times of acquisition). Move the necessary information to another directory.

- b) When the **Output File Mode** is specified as **Concatenation**:

The files to be retrieved are output to the directory installing Resource Manager 9500V in the text file format.

Single system: pfms.txt

Dual system: pfmd.txt

To stop the file output halfway, click the **Cancel** button.

5. When the file processing is terminated, a confirmation message is displayed. Click the **OK** button.

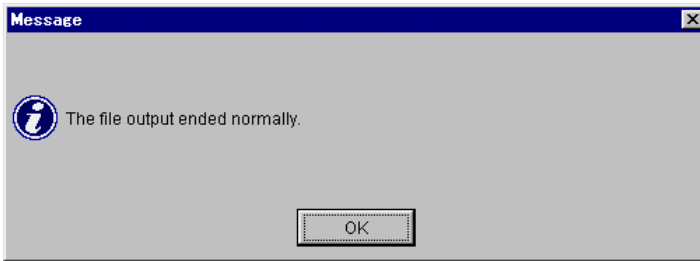

When the single system is connected, only the information of the controller 0 side is collected.

The format to the file to be retrieved is the same as that of the file retrieved manually.

Chapter 10 Error Monitoring

This section includes the following:

- Setting Error Monitoring Options
- Outputting Failure Information to a Log File
- Error Monitoring
- Checking Status

10.1 Setting Error Monitoring Options

During error monitoring, when a failure is detected on the monitored array unit, E-Mail Report or one specified application can be started.

In **Error Alert**, click the **E-Mail Error Report** check box and the **Execute Application** check box to enable them.

1. On the **Settings** menu, select **Monitoring Options** or click  in the tool bar.

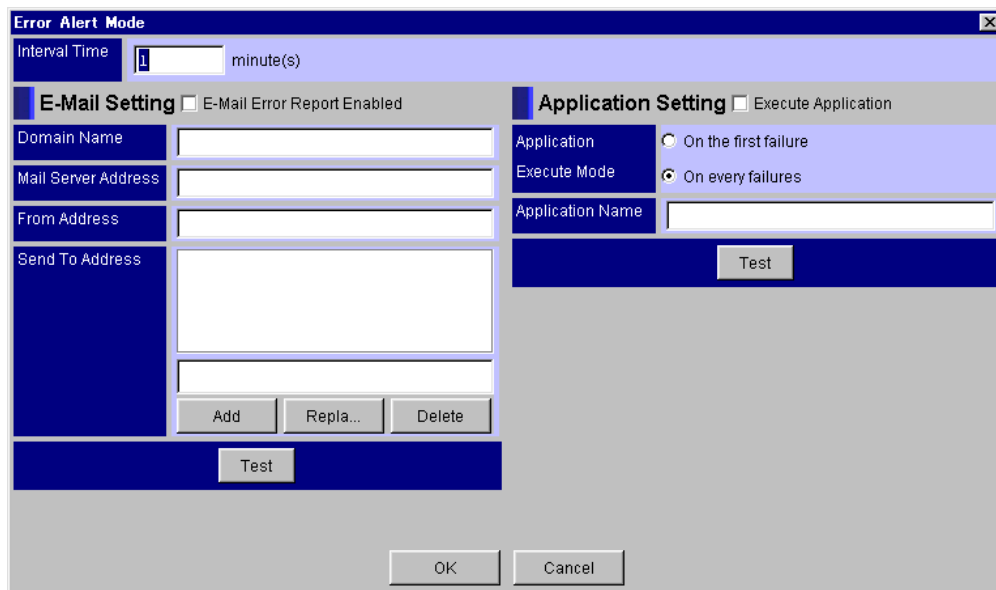

Figure 10.1 Setting Error Monitoring Options

10.1.1 Interval Time

1. Specify the interval time for error monitoring.

Specify **Interval Time** in the range of 1 minute to 720 minutes (12 hours). The interval means the time from an end of all target array unit monitoring until the start of the next monitoring.

2. Click the **OK** button.

The setting is validated without rebooting the Resource Manager 9500V.

10.1.2 E-Mail Report

When an error is detected by error monitoring, the contents of the error are reported.

If an error is detected on the array unit while error monitoring is executed, the following error information will be reported by E-Mail. Usually, the subject is appended before the E-Mail is transmitted.

- E-Mail Subject
- E-Mail Message Text

10.1.2.1 E-Mail Subject

For E-Mail, the failed part can be judged by the subject, so the failed part is appended to the subject as a matter of format. The subject format is shown below. Table 10.1 shows a list of subjects.

Manager/Obstruction (failed part)

Table 10.1 List of E-Mail Subjects

No.	Subject	Meaning
1	Disk	A drive blockade occurred.
2	DC Power	A DC power supply failure occurred.
3	Battery	A battery voltage error occurred.
4	Fan	A fan failure occurred.
5	Controller	A controller blockade occurred. (This occurs only in the dual controller configuration.)
6	AC Power	An AC power supply error occurred.
7	Cache Memory	A cache failure occurred.
8	Cache Backup Circuit	A backup circuit failure occurred.
9	ENC	An enclosure error occurred.
10	Loop	A loop error occurred.
11	Path	A path blockade occurred.
12	Warning	The array unit entered the warning state.
13	Array connection	A failure occurred in the connection with the array unit. A power OFF or a failure occurred in the array unit.

10.1.2.2 E-Mail Message Text

When using E-Mail, the failed part is reported using message text in the subject. The format of the message text is shown below. A list of messages is shown in Table 10.2.

Day, Mon.dd hh:mm:ss yyyy/DF Name/message text

Day: Day of the week **hh:mm:ss:** Hours, minutes, and seconds
Mon: Month **yyyy:** Year
dd: Date

Table 10.2 List of E-Mail Message Texts

No.	Message Text	Meaning of Message
1	ARRAY Drive Detached. ARRAY Detached Drive Position Unit No.X HDU No.Y.	A drive blockade occurred. (The blocked drive is indicated with a set of a Unit No. and an HDU No.)
2	ARRAY DC Power Supply Failure.	A DC power supply failure occurred.
3	ARRAY Battery Alarm.	A battery voltage error occurred.
4	ARRAY Fan Alarm.	A fan failure occurred.
5	ARRAY CONTROLLER Detached.	A controller blockade occurred. (This occurs only in the dual controller configuration.)
6	ARRAY AC Power Supply Failure.	An AC power supply error occurs.
7	ARRAY Cache Memory Alarm.	A cache failure occurred.
8	ARRAY Cache Backup Circuit Alarm.	A backup circuit failure occurred.
9	ARRAY ENC Alarm.	An enclosure error occurs.
10	ARRAY LoopAlarm.	A loop error occurs.
11	ARRAY Path Alarm.	A path blockade occurred.
12	ARRAY Warning.	The array unit entered the warning state.
13	ARRAY Manager Interface error occurred.	A failure occurred in the connection with the array unit. A power OFF or a failure occurred in the array unit.

1. Specify setting items in the E-Mail Report.
 - **E-Mail Error Report Enabled:** Specifies whether or not to execute E-Mail Report when an error is detected by error monitoring. When this item is checked off, E-Mail Report will be executed. ON/OFF is displayed on the right side depending on whether a check mark exists or not.
 - **Domain Name:** Specifies a domain name. Specify it in 39 or less alphanumeric characters or a code.
 - **Mail Server Address:** Specifies the IP address or host name of the mail server. Specify the host name in 99 or less alphanumeric characters.
 - **From Address:** Specifies the mail address of the E-Mail sender. Specify it in 99 or less alphanumeric characters or a code.
 - **Send To Address:** Specifies the mail address of the E-Mail receiver. Specify it in 99 or less alphanumeric characters or a code.
Up to 20 addresses can be set as receivers.
 - Add:** Specify **Send To Address** in the text box above the **Add** button and click **Add**. **Send To Address** added to the **Send To Address** list is displayed.
 - Replace:** Click **Send To Address** to be replaced in the **Send To Address** list, specify **Send To Address** in the text box above the **Add** button, and click **Replace**. The replaced **Send To Address** is displayed in the **Send To Address** list.
 - Delete:** Click **Send To Address** to be deleted in the **Send To Address** list and click **Delete**. The deleted **Send To Address** disappears from the **Send To Address** list.

2. To verify the setting, click the **Test** button.

When the mail has been normally transmitted, a confirmation message appears. Click the **OK** button.

The following mail is transmitted to the set **Send To Address**. Check the receipt of mail by **Send To Address**. If the mail has not been received, check the setting.

Subject: Manager/Obstruction (test)

message: Day, Mon. dd hh:mm:ss yyyy/DF Name /Test message

Day: Day of the week **hh:mm:ss:** Hours, minutes, and seconds

Mon: Month **yyyy:** Year

dd: Date

3. Click the **Close** button.

The setting is validated without rebooting the Resource Manager 9500V.

10.1.3 Setting Additional Information on E-mail

When registering or changing the properties of an array unit, you can add unique information on the e-mail header or on the unit trace information header.

1. In the **Properties** window of the array unit, click the **Mail Additional Information** button.

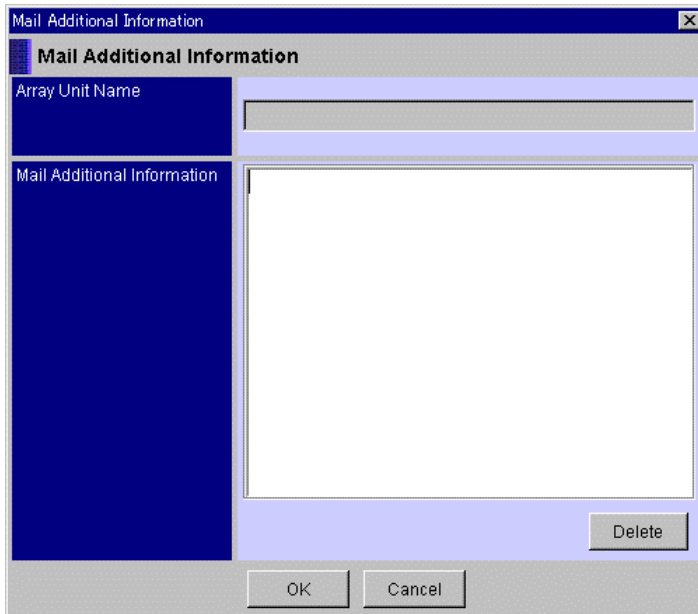

Figure 10.2 Setting Additional Information on E-Mail

2. In the **Mail Additional Information** text box, enter the information in less than or equal to 64-byte characters.

The information set on E-Mail is added to the E-Mail attribute. The format is as follows:

Day, Mon. dd hh:mm:ss yyyy/DF Name/Additional Information/message text

To delete the information, click the **Delete** button.

10.1.4 Executing Application

Execute Application is set so that another application may be started if an array unit error is detected when error monitoring is executed.

The application to be started activates the window; it displays the current size and position.

1. Set the necessary items to start an application.
 - **Execute Application:** Specifies whether or not to activate the application when a failure is detected by the error monitoring. The application is activated when the check box is clicked. ON/OFF is displayed on the right side depending on whether a check mark exists or not.
 - **Application Execute Mode:** Specifies an occasion to activate the application.

On the first failure: The specified application is activated when the first failure is detected after the error monitoring has been activated. When failures are detected continuously, the application is not activated. To activate the application again when a failure is detected after the application has been activated, terminate the error monitoring once and then restart it.

On every failure: The specified application is activated when a failure is detected after the error monitoring has been activated. When the same failure is detected while the error monitoring is executed, the application is not activated at the second and subsequent detections of it.

Note: When you select **On every failures**, the specified application is started upon detection of each error. Consequently, multiple specified applications may be started and the system may hang-up. Select **On the first failure**, and after occurrence of an error, stop error monitoring and restart it after a recovery from the error.

If an error is caused by starting the specified application during error monitoring, a message is displayed and error monitoring is suspended. When the message is closed, this monitoring will be continued.

- **Application Name:** Specifies a path and a file name of the application to be activated. When the file name is long, enclose it with the quotation marks ("). When specifying a data file name of the application, if the data file is not in the same directory in which the manager is, specify the full path.

For Windows®

Example 1: "C: \abc\application.exe"

Example 2: "C: \abc\application.exe (option)"

Example 3: "C: \abc\application.exe (option)" "c: \abc\def\application.dat"



Path and file name of the application



Data file name of the application

For Solaris™, IRIX®, or HP-UX®

Example 1: /home/use/damp/go



Data file name of the application

1. To check the setting, click the **Test** button.
Verify that the specified application is started.
2. Click the **OK** button. The setting will be validated without rebooting the Resource Manager 9500V.

10.2 Outputting Failure Information to Log File

When a failure is detected in the array unit when error monitoring is executed, the function outputs the failure information to a log file.

The log file is output in the text file format with a file name of `errlog.txt` to the same directory in which the Resource Manager 9500V execution file is located. With respect to the file layout, the format for displaying the array unit state transition is shown below as an example. The file format is shown in the following figure. A list of message texts is shown in Table 10.3.

Day, Mon. dd hh:mm:ss yyyy/DF Name/message text

Day: Day of the week	hh:mm:ss: Hours, minutes, and seconds
Mon: Month	yyyy: Year
dd: Date	

Table 10.3 List of Message Texts to be Output

No.	Message Text	Meaning of Message
1	Alert Started.	The error monitoring is started.
2	ARRAY Drive Detached. ARRAY Detached Drive Position Unit No.X HDU No.Y.	A drive blockade occurred. (The blocked drive is indicated with a set of a Unit No. and an HDU No.)
3	ARRAY DC Power Supply Failure.	A DC power supply failure occurred.
4	ARRAY Battery Alarm.	A battery voltage error occurred.
5	ARRAY Fan Alarm.	A fan failure occurred.
6	ARRAY CONTROLLER Detached.	A controller blockade occurred. (This occurs only in the dual controller configuration.)
7	ARRAY AC Power Supply Failure.	An AC power supply error occurs.
8	ARRAY Cache Memory Alarm.	A cache failure occurred.
9	ARRAY Cache Backup Circuit Alarm.	A backup circuit failure occurred.
10	ARRAY ENC Alarm.	An enclosure error occurs.
11	ARRAY Loop Alarm.	A loop error occurs.
12	ARRAY Path Alarm.	A path blockade occurred.
13	ARRAY Warning.	The array unit entered the warning state.
14	ARRAY Manager Interface error occurred.	A failure occurred in the connection with the array unit. A power OFF or a failure occurred in the array unit.
15	ARRAY Manager Interface error occurred. Error Code (nnnn).	When connecting to a LAN, an array unit connection error occurs. nnnn: Winsock error code
16	ARRAY Manager Interface error occurred.	When connecting to an RS232C (9200 only) interface, an array unit connection error occurs.
17	Errinf.Txt File Error (xxxx).	A failure occurred in an access to a work file. xxxx: OPEN : File open failure xxxx: File operation failure

The output size of a log file is up to 520k bytes. When the log information exceeds the limit, the log file is renamed to "errorlog.txt.pre" and a log file "errorlog.txt" is newly created.

The string "--- end ---" comes at the end of log information output. If the log information surpasses its limit again, the existing log file "errorlog.pre.txt" is replaced with "errorlog.txt" and then a new log file "errorlog.txt" is created again.

Note: "Time when a failure is detected" is that of a clock in the system installing the Resource Manager 9500V.

10.3 Error Monitoring

Error monitoring checks the component status of the array unit. This including drives, controller, battery, fan, power supply, and cache. Placing a check in the **Error Watch** box in registered array unit information enables error monitoring at an interval specified for the interval time.

Note: When you perform error monitoring, be sure to close the Unit screen before starting the monitoring. If error monitoring is performed with the Unit screen open, array units may not be monitored normally.

1. Click **Error Watch** **Alert Stop** : **Error Watch** on the Main screen.

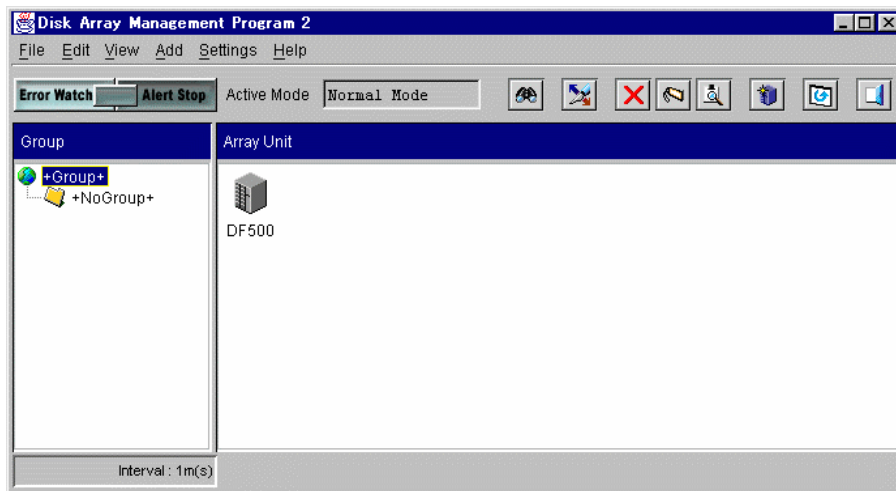

Figure 10.3 Starting Error Monitoring





Monitoring is started for the array unit for which "Error Alert" is specified.

The **Error Watch** button on the Main screen displays **Error Watch** **Alert Stop** .

After the start of error monitoring, the monitoring status is displayed in the status bar. The icon displays a monitoring result of the array unit.





After error monitoring is performed for all the target array units, monitoring will be started again for these target array units after the lapse of the specified interval time.

The error monitoring status is displayed on the left side of the scroll bar in the following three states. In addition, the monitoring result of all the array units subject to monitoring is displayed with icons.





Monitoring Status	Display Characters	Character Color	Array Unit Status
Stop	Stop	 Gray	Error monitoring is not executed.
Monitoring	Monitoring	 Blue	Error monitoring is executed and the all the target array units are normal.
	Monitoring	 Red	Error monitoring is executed and errors are detected in some of the target array units.
Waiting	Waiting	 Blue	Error monitoring is at the interval time and all the target array units that were previously monitored are normal.
	Waiting	 Red	Error monitoring is at the interval time and errors are detected in some of the target array units that were previously monitored.

As an error monitoring result, the status is displayed with the icon color of the array unit in the Main screen.

Array units in the dual system

 Gray	<ul style="list-style-type: none"> • Not monitored
 Gray + Blue	<ul style="list-style-type: none"> • Normal
 Gray + Yellow	<ul style="list-style-type: none"> • An error is detected. • A communication error occurs in a controller.
 Red	<ul style="list-style-type: none"> • A power OFF or a failure of the array unit occurred. • A communication error occurs in both controllers.

Array units in the single system

 Gray	<ul style="list-style-type: none"> • Not monitored
 Gray + Blue	<ul style="list-style-type: none"> • Normal
 Gray + Yellow	<ul style="list-style-type: none"> • An error is detected.
 Red	<ul style="list-style-type: none"> • A power OFF or a failure of the array unit occurred. • A communication error occurred.

- To display the detail information of the array unit, stop error monitoring, click an array unit to be displayed, and click : **Alert Stop**. The contents of display may be different depending on the relationship between **Error Alert** result and “Time” because polling is performed.

When the icon has a Caution symbol displayed, this represents a communication disable status with the array unit; detailed information cannot be displayed.

- Click : **Alert Stop**, and **Error Alert** will be stopped. The icon of the array unit continues to display the last error monitoring result.

Click the icon of an array unit on the Main screen, and then click the “: **Display Details**” in the tool bar.

Note: When the icon has a Caution symbol displayed as an **Error Alert** result, this represents a connection disable status to the array unit or an information get disable status from the array unit. The causes are as follows:

Cause	Contents of Check
Communication line failure	Check the LAN line.
Connected array unit failure	Check the READY status of the array unit.
Too high I/O load from the host	Check the array unit operation status.
Execution of the logical unit format of the connected array unit, wizard setting of system parameter, or SNMP environment information setting	Check the array unit status or restart the array unit.

- Check all of the above. After making sure that connection with the array unit displayed in Caution symbol has been enabled, start error monitoring.

If the icon of the array unit goes yellow because of controller blockage, the same status as that of the Caution symbol icon may be provided.

If error monitoring is performed, though the icon of the array unit is displayed with a Caution symbol, the icon of the normal array unit may be displayed with a Caution symbol. If the cause corresponds to “Too high I/O load from the host”, continue to execute monitoring.

If a drive whose display color is not blue in **Unit Status** in the Unit screen (a drive that is not logical unit-formatted or an undefined spare drive) is pulled out, no error report will be made but it has no effect on the operation. Insert it once again.

If an error occurs, contact maintenance personnel.

10.4 Checking Status

Check the status of array unit components: drives, controllers, batteries, fans, power supply and cache. A status check is done on an array unit for which the check box of the **Error Alert Flag** in “Array Unit Define” is selected.

1. On the **View** menu, select **Refresh** or click  in the tool bar.

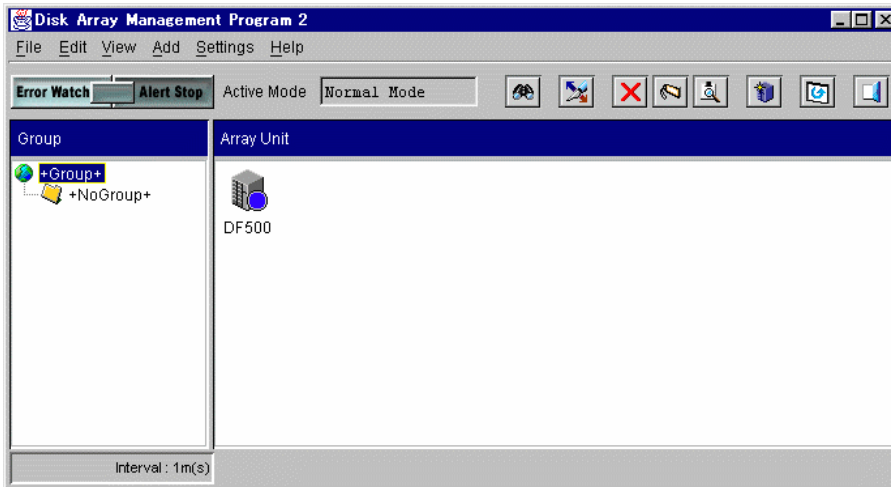

Figure 10.4 Checking the Status of Array Unit Components

The status of an array unit for which error monitoring is specified is checked. When checking begins, the icon of an array unit is displayed with the check result reflected into the icon.

The status check performs functions equivalent to those of error monitoring. When an error is detected in an array unit that has been checked, output of a log, sending of an E-Mail, and restarting of a specified application are performed in accordance with the settings of the monitor options.

Chapter 11 Automatic Start of Error Monitoring

11.1 Automatic Start of Error Monitoring

Error monitoring can be started when Windows® is booted up by specifying an option in the execution file in the Resource Manager 9500V startup file.

The error monitoring function is the same as that provided by clicking the **Error Watch** button.

The automatic start is available only for Windows®.

11.1.1 Automatic Start of Windows®

Error monitoring is started when Windows® is booted up if the error monitoring is set to "startup".

1. Open the bat file to boot the Resource Manager 9500V.
2. Specify an option in the execution file in the bat file.

```
java -classpath .\CONFMNG2.JARjp.co.hitachi.str.diskarray.gui.ConmanFrame -check
```

Parameter for error monitoring 

3. Prepare a shortcut to the Resource Manager 9500V startup bat file for the "Startup".
4. When Windows® is rebooted, the Resource Manager 9500V is started in an error monitoring executing status.

Chapter 12 Detailed Screen Display

12.1 Detailed Screen Display

The detailed display of the array unit is made by specifying options in the execution file in the Resource Manager 9500V startup file.

The detailed display is available only for Windows®.

12.1.1 Detailed Screen Display on Windows

The detailed display of the array unit is made by specifying options in the bat file.

1. When the Resource Manager 9500V is started, the bat file is opened.
2. Specify options in the execution file of the bat file.

There are 3 parameters for screen display.

-unit: Registered name of array unit

-ip: IP address of controller 0 or controller 1 of the registered array unit

-host: Host name of controller 0 or controller 1 of the registered array unit

For the RS232C (9200 only) connection, specify "-unit".

- Example with "-unit" option

```
java -classpath .\CONFMNG2.JARjp.co.hitachi.str.diskarray.gui.ConmanFrame-unit DF600
```

Parameter for screen display → DF600
DF name of the array unit to be displayed → DF600

- Example with "-ip" option

```
java -classpath .\CONFMNG2.JARjp.co.hitachi.str.diskarray.gui.ConmanFrame-ip 192.168.1.100
```

Parameter for screen display → 192.168.1.100
IP address of the array unit to be displayed → 192.168.1.100

- Example with "-host" option

```
java -classpath .\CONFMNG2.JARjp.co.hitachi.str.diskarray.gui.ConmanFrame-host D600
```

Parameter for screen display → D600
Host name of the array unit to be displayed → D600

- The unit window of the array unit specified by option is displayed. The unit window is put into a status provided by logging-in in the normal mode.

