



**Hitachi Freedom Storage™  
Thunder 9530™ V Series  
User and Reference Guide**



**© 2003 Hitachi Data Systems Corporation, ALL RIGHTS RESERVED**

**Notice:** No part of this publication may be reproduced or transmitted in any form or by any electronic or mechanical means, including photocopying and recording, or stored in a database or retrieval system for any purpose, without the express written permission of Hitachi Data Systems Corporation.

Hitachi Data Systems reserves the right to make changes to this document at any time without notice and assumes no responsibility for its use. Hitachi Data Systems products or services can only be ordered under the terms and conditions of Hitachi Data Systems' applicable agreements, including license agreements. All of the features described in this document may not be currently available. Refer to the most recent product announcement or contact your local Hitachi Data Systems sales office for information on feature and product availability.

This document contains the most current information available at the time of publication. When new and/or revised information becomes available, this entire document will be updated and distributed to all registered users.

**Trademarks**

Hitachi Data Systems is a registered trademark and service mark of Hitachi, Ltd. The Hitachi Data Systems design mark is a trademark and service mark of Hitachi, Ltd.

Hi-Track is a registered trademark of Hitachi Data Systems Corporation.

Freedom Storage and Thunder 9500 are trademarks of Hitachi Data Systems Corporation.

Microsoft, Windows, Windows NT, and Windows 2000 are registered trademarks or trademarks of Microsoft Corporation.

Sun and Solaris are trademarks or registered trademarks of SUN Microsystems, Inc.

HP is the registered trademark of Hewlett-Packard Company.

NCR is a registered trademark of NCR Corporation.

All other brand or product names are or may be registered trademarks, trademarks or service marks of and are used to identify products or services of their respective owners.

## Notice of Export Controls

Export of technical data contained in this document may require an export license from the United States government and/or the government of Japan. Contact the Hitachi Data Systems Legal Department for any export compliance questions.

## Document Revision Level

Revision	Date	Description
MK-92DF631-P	January 2003	Preliminary Release
MK-92DF631-P1	January 2003	Preliminary Release. Supersedes and replaces MK-92DF631-P
MK-92DF631-P2	January 2003	Preliminary Release. Supersedes and replaces MK-92DF631-P1
MK-92DF631-0	February 2003	Initial Release. Supersedes and replaces MK-92DF631-P2
MK-92DF631-1	April 2003	Revision 1, supersedes and replaces MK-92DF631-0
MK-92DF631-2	July 2003	Revision 2, supersedes and replaces MK-92DF631-1

## Document Revision Level

The following source documents were used to produce this User and Reference Guide:

- *SANRISE 9530V Series Disk Array Subsystem User's Guide*, 6th Edition.
- *Hitachi Freedom Storage™ Thunder 9530™ V Series User and Reference Guide*, RSD-92DF631-5.

## Changes in this Revision:

- Added **Note 2** for Data capacity after Table 4.1
- Added a Note for Data capacity after Table 4.2
- Added **Note 2** for Data capacity after Table C.1
- Changed the Applicable safety standard/rating in Table E.2 and Table E.3
- Changed Figure E.3
- Changed the screens in steps 2 and 3 of section 7.7.4.2
- Changed the screen in steps 1 and 2 of section 7.7.4.4
- Changed the screen in steps 1 and 2 of section 7.7.4.6
- Changed the screen in steps 1 and 2 of section 7.7.4.7
- Changed the screen in steps 1 and 2 of section 7.7.4.8
- Changed the screen in steps 1 and 2 of section 7.7.4.9
- Added Message Codes I1E000 and I1E100 to Table 8.6
- Deleted Serial Number in Configuration Information for HP and SUN in Table B.1

- Deleted **Note 6** for Table B.1
- Deleted Serial Number in Configuration Information for IBM (AIX) and Sequent in Table B.1
- Deleted **Note 5** for Table B.1
- Deleted Serial Number in Configuration Information for NT/Windows 2000 and Others in Table B.1
- Deleted **Note 4** for Table B.1
- Changed the example of queue\_depth setting in D.3.3
- Changed the Maximum Queue Depth for Initial to 8 in Table D.7
- Changed the Maximum Queue Depth for direct FC-AL and Fabric Switch to Optional in Table D.7
- Deleted \*3 from Remarks for Maximum Number of LUNs in Table D.7
- Changed \*3 for Table D.7
- Changed the value for the Execution Throttle to Optional in Table D.8
- Added \*1 to Note for Execution Throttle in Table D.8
- Changed the value of Execution Throttle to Optional
- Changed the value for the Execution Throttle to Optional in Table D.10
- Added \*1 to Note for Execution Throttle in Table D.10
- Changed the value for the Execution Throttle to Optional in Table D.12
- Added \*1 to Note for Execution Throttle in Table D.12
- Changed the value for the Execution Throttle to Optional in Table D.14
- Added \*1 to Note for Execution Throttle in Table D.12
- Added D.4 Notes on Queue Depth
- Changed Table D.1 OS and HBA Supported by the 9530V (Fibre Channel)
- Added \*3 to Table D.1
- Changed Table D.2 FC Switch Supported by the 9530V
- Changed the title of section D.3.2
- Changed the title of section D.3.3
- Changed the title of section D.3.7
- Changed the title of section D.3.8.
- Changed “Up to 2 GBs (two pair of 512 MB DIMMs) of cache memory can be installed in each controller (or up to 4 GBs per subsystem)” to “Up to 2 GBs (one pair of 512 MB DIMMs) of cache memory can be installed in each controller (or up to 4 GBs per subsystem) in section 1.1.3

- Added a note to section 4.7.4.1, stating “The Additional Battery Unit is available in Japan only”
- Changed “The 9530V supports up to 128 LUNs” to “The 9530V supports up to 512 LUNs” in section 5.4
- Changed the description of open systems configuration in section 6.1.1
- Changed “Maintenance Mode” to Management Mode” in step 1 of section 7.3.11
- Changed step 1 in section 7.7.4.6
- Changed the screen in step 3 of section 7.7.4.6
- Changed Figure 4.1 in section 4.1
- Changed Figure 4.2 in section 4.1
- Changed Figure 4.3 in section 4.1
- Changed Figure 4.4 in section 4.1
- Changed Figure 4.5 in section 4.1
- Changed Figure 4.6 in section 4.1
- Added **Note 3** to the default setting value for the Subnet Mask in Table 8.3
- Deleted Variable IP in Table 8.3
- Added **Note 2** to Steady-state current (A) in Table 2.8
- Added Note to Steady-state current (A) in Table Table 2.10
- Changed the electric current for J2H to 15 A in Table D.1, D.2, and D.3

## Referenced Documents

- *Hitachi Freedom Storage™ Thunder 9500™ V Series FlashAccess 9500V User’s Guide, MK-92DF612*
- *Hitachi Freedom Storage™ Thunder 9500™ V Series Resource Manager 9500V User’s Guide Graphical User Interface (GUI), MK-92DF605*
- *Hitachi Freedom Storage™ Thunder 9500™ V Series Resource Manager 9500V User’s Guide Command Line Interface (CLI), MK-92DF603*
- *Hitachi Freedom Storage™ Thunder 9500™ V Series ShadowImage 9500V User’s Guide, MK-92DF607*

# Preface

The *Hitachi Freedom Storage™ Thunder 9530™ V Series User and Reference Guide* describes the physical, functional, and operational characteristics of the 9530V subsystem. This document also provides operation instructions, installation details, and configuration planning information for the 9530V subsystem.

This User and Reference Guide assumes that:

- The user has a background in data processing and understands direct-access storage device subsystems and their basic functions
- The user is familiar with the Hitachi Freedom Storage™ Thunder 9530™ V Series array subsystem
- The user is familiar with the Windows® 95, Windows® 98, Windows® 2000 or Windows NT® operating systems

For further information on Hitachi Data Systems products and services, please contact your Hitachi Data Systems account team, or visit the Hitachi Data Systems worldwide web site at <http://www.hds.com>. For specific information on the supported host systems and platforms for the 9530V, please refer to the user documentation for the product, or contact the vendor's customer support service.

## Terminology

Please note the following:

- The term DF600 refers to the Thunder 9500™ V Series subsystem.

### COMMENTS

Please send us your comments on this document: [doc.comments@hds.com](mailto:doc.comments@hds.com).

**Make sure to include the document title, number, and revision.**

**Please refer to specific page(s) and paragraph(s) whenever possible.**

(All comments become the property of Hitachi Data Systems Corporation.)

**Thank you!**



# Contents

<b>Chapter 1</b>	<b>Overview of the Thunder 9530™ V Series Subsystem .....</b>	<b>1</b>
1.1	Overview Features .....	1
1.1.1	High Data Availability.....	1
1.1.2	Connectivity.....	1
1.1.3	Enhanced Data Accessibility .....	2
1.1.4	Scalability .....	2
1.1.5	Performance Reporting and Monitoring.....	3
1.1.6	Reliability, Availability, and Serviceability .....	3
1.2	Rack-Mount Model.....	4
1.3	Floor Model .....	4
<b>Chapter 2</b>	<b>Planning for Installation and Operation.....</b>	<b>5</b>
2.1	User Responsibilities .....	6
2.2	Safety Precautions .....	6
2.2.1	Symbol Marks.....	7
2.2.2	Repair, Modification, and Disassembly.....	7
2.2.3	Precautions for Using the Equipment .....	7
2.2.4	Precautions for Inspection and Cleaning .....	10
2.2.5	Emergency Precautions.....	11
2.2.6	Warning Notices .....	12
2.2.7	Locations of Warning Labels on the Equipment .....	12
2.3	General Specifications and Requirements .....	15
2.3.1	Dimensions and Weight.....	15
2.3.2	Floor Load Rating.....	16
2.3.3	Internal Logic Specifications.....	17
2.3.4	Cable Functions.....	17
2.4	Environmental Specifications and Requirements.....	18
2.4.1	Environmental Hazards .....	18
2.4.2	Temperature and Humidity Requirements .....	19
2.4.3	Input Power and Insulation Performance Specifications .....	19
2.4.4	Air Flow Requirements .....	20
2.4.5	Vibration and Shock Tolerances.....	21
2.4.6	Reliability.....	21
<b>Chapter 3</b>	<b>Powering On/Off Procedure.....</b>	<b>23</b>
3.1	9530V Rack-Mount Model .....	23
3.1.1	Subsystem Power On.....	23
3.1.2	Subsystem Power Off .....	23
3.2	9530V Floor Model.....	24
3.2.1	Subsystem Power On.....	24
3.2.2	Subsystem Power Off .....	25

<b>Chapter 4</b>	<b>Subsystem Architecture and Components</b>	<b>27</b>
4.1	Configuration Block Diagrams	27
4.1.1	9530V Rack-Mount Model	28
4.1.2	9530V Floor Model	31
4.2	Redundant Power Supplies	34
4.3	Fibre Channel Interface	34
4.4	Array Frame	35
4.4.1	9530V Rack-Mount Model	35
4.4.2	Floor Model	36
4.5	Disk Array Groups	37
4.6	Service Processor (SVP)	37
4.7	Component Names, Locations, and Functions	38
4.7.1	Front Bezel Component Locations and Functions	38
4.7.2	RKS Component Locations	39
4.7.3	Switch Locations and Functions	40
4.7.4	Connector Locations and Functions	42
4.7.5	LED Locations and Functions	44
4.8	Parts with Limited Lives	49
<b>Chapter 5</b>	<b>Functional and Operational Characteristics</b>	<b>51</b>
5.1	New 9530V Features and Capabilities	51
5.2	RAID Implementations	51
5.3	Cache Management	52
5.4	Logical Units (LUs)	53
5.5	Open Systems Features and Functions	54
5.5.1	Open Systems Middleware	54
5.5.2	LUN Management	54
5.6	Data Management Features and Functions	54
5.6.1	FlashAccess	54
5.6.2	Fibre Security	55
5.7	Copy Solution Features and Functions	55
5.7.1	ShadowImage	55
<b>Chapter 6</b>	<b>Configuring the Thunder 9530™ V Series Subsystem</b>	<b>57</b>
6.1	Overview of Configuration	57
6.1.1	Open Systems Configuration	58
6.1.2	Defining LUNs	58
6.1.3	Fibre Channel Interface Addressing	58
6.1.4	Alternate Pathing	59
6.2	Configuring the LAN Interfaces of the Thunder 9530™ V Series Subsystem	60
6.3	Configuring the Thunder 9530™ V Series Subsystem	60
6.4	Registering the Thunder 9530™ V Series Subsystem for Control by Resource Manager 9500V	61
6.5	Configure the Thunder 9530™ V Series Subsystem for the Desired Application	61
6.6	General Configuration of the Thunder 9530™ V Series Subsystem	61
6.7	Starting the Parameter Wizard in Resource Manager 9500V	62
6.8	Configuring the Basic Parameters for the Thunder 9530™ V Series Subsystem	62

<b>Chapter 7</b>	<b>Configuring Storage on the Thunder 9530™ V Series Subsystem .....</b>	<b>65</b>
7.1	Software Composition .....	65
7.1.1	Microprogram .....	65
7.1.2	System Parameters.....	65
7.1.3	Configuration Information .....	66
7.1.4	SNMP Information .....	66
7.1.5	Storage for Parameters.....	66
7.2	Setting Fibre Channel Information.....	67
7.3	Determining Space and RAID Level Requirements.....	68
7.3.1	Setting a Spare Disk.....	68
7.3.2	Canceling a Spare Disk Setting .....	69
7.3.3	Setting a RAID Group.....	70
7.3.4	Deleting a RAID Group .....	72
7.3.5	Setting a Logical Unit.....	73
7.3.6	Deleting the Last Logical Unit.....	75
7.3.7	Invalidating a Logical Unit .....	75
7.3.8	Restoring a Logical Unit .....	75
7.3.9	Reallocating a Logical Unit .....	76
7.3.10	Formatting a Logical Unit .....	77
7.3.11	Changing the Default Controller in Charge of an LU.....	79
7.4	Setting Host Group Information .....	80
7.4.1	Setting the Mapping Information.....	80
7.5	Transferring Configurations from One Array to Another .....	84
7.6	Storing Configuration Data .....	85
7.6.1	System Parameter Information.....	85
7.6.2	RAID Group/LU information .....	86
7.6.3	Port/Host Group Information.....	87
7.7	Applying Configuration Data to Another Thunder 9530™ V Series Subsystem.....	89
7.7.1	System Parameters.....	89
7.7.2	RAID Group/Logical unit.....	90
7.7.3	Port/Host Group .....	90
7.7.4	Setting the Subsystem When Using Special Mode .....	91
7.8	Changing the Network Parameter.....	111
<b>Chapter 8</b>	<b>Troubleshooting .....</b>	<b>113</b>
8.1	Troubleshooting Based on LED Indications .....	113
8.1.1	The POWER LED does not Turn On.....	113
8.1.2	The POWER LED has Turned Off.....	114
8.1.3	READY LED does not Turn On or the READY LED has Turned On Once, then Turned Off .....	114
8.1.4	The Alarm LED has Turned On.....	115
8.1.5	The WARNING LED has Turned On or Blinks .....	115
8.2	Web Overview.....	116
8.2.1	Operational Environment .....	116
8.2.2	Characteristics of Network Functions .....	117
8.3	Web Operational Procedures .....	119
8.3.1	Connecting to the Network using a LAN Interface .....	119
8.3.2	Screen Outlines .....	120
8.3.3	Main Screen in Normal Mode .....	122

8.3.4	Status Display of Replaceable Components.....	124
8.3.5	Information Message.....	127
8.3.6	Setting the Buzzer Sound Volume .....	128
8.4	Troubleshooting Using a Web Connection .....	129
8.4.1	Checking Subsystem Status.....	129
8.4.2	Checking the Progress Condition Display .....	130
8.4.3	Checking Component Status.....	131
8.4.4	Checking Log Messages.....	132
8.4.5	Troubleshooting Using Messages.....	134
8.4.6	Reading Failure Information.....	138
<b>Chapter 9</b>	<b>Periodic Maintenance .....</b>	<b>141</b>
<b>Appendix A</b>	<b>Glossary.....</b>	<b>143</b>
<b>Appendix B</b>	<b>System Parameter Setting List.....</b>	<b>147</b>
<b>Appendix C</b>	<b>Basic Specifications of the Subsystem.....</b>	<b>153</b>
<b>Appendix D</b>	<b>Power Cables.....</b>	<b>157</b>

# List of Figures

Figure 2.1	Positions and Contents of Labels on Floor Model RKS+H1H.....	13
Figure 2.2	Positions and Contents of Labels on Rack-Mount Model RKS .....	14
Figure 3.1	Subsystem Power On/Off (Example: Floor [RK+RKA+H2H] Model).....	24
Figure 4.1	9531V System Configuration .....	28
Figure 4.2	9532V System Configuration .....	29
Figure 4.3	9533V System Configuration .....	30
Figure 4.4	Floor (RKS+H1H) Model 9531V System Configuration .....	31
Figure 4.5	Floor (RKS+H1H) Model 9532V System Configuration .....	32
Figure 4.6	Floor (RKS+H1H) Model 9533V System Configuration .....	33
Figure 4.7	Front Bezel Component Locations .....	38
Figure 4.8	RKS Component Locations .....	39
Figure 4.9	Panel Assembly Switch Location .....	40
Figure 4.10	Backup Battery Unit Switch Location .....	41
Figure 4.11	Power Unit Switch Locations .....	41
Figure 4.12	Connector Locations for the Power Unit.....	42
Figure 4.13	Connector Locations for the Control Unit .....	43
Figure 4.14	LED Locations for the Disk Drive Display.....	44
Figure 4.15	LED Locations for the Battery Backup Unit.....	45
Figure 4.16	LED Locations for the ENC Unit .....	46
Figure 4.17	LED Locations for the Power Unit.....	47
Figure 4.18	LED Locations for the Fan Assembly.....	47
Figure 4.19	LED Locations for the Control Unit .....	48
Figure 5.1	Logical Units .....	53
Figure 6.1	Fibre Port-to-LUN Addressing .....	58
Figure 6.2	Alternate Pathing .....	59
Figure 7.1	Spare Disk Tub Screen .....	69
Figure 7.2	Select the Disk Drive.....	71
Figure 7.3	Setting the RAID Group Property .....	71
Figure 7.4	Set RAID Group is Updated.....	72
Figure 7.5	Setting the Logical Unit Property .....	74
Figure 7.6	Logical Unit Format screen .....	78
Figure 7.7	Configuration Example (without Port Sharing) .....	109
Figure 7.8	Configuration Example (with Port Sharing) .....	109
Figure 8.1	LAN Connector Location.....	119
Figure 8.2	Main Screen Outline.....	120
Figure 8.3	Subsystem Condition Display .....	122
Figure 8.4	Patrol Lamp Display.....	122
Figure 8.5	Exchange Parts Status Display.....	123
Figure 8.6	Component Status Screen.....	124
Figure 8.7	Information Message Screen .....	127
Figure 8.8	Buzzer Volume Screen .....	128
Figure 8.9	Subsystem Status Screen .....	129
Figure 8.10	Progress Condition Display .....	130
Figure 8.11	Replace Part Summary Screen (HDD) .....	131

Figure 8.12	Information Message Screen.....	132
Figure 8.13	Message Analysis Example .....	139
Figure D.1	Port Extender Dimensions .....	157
Figure D.2	J2H Power Cable .....	158
Figure D.3	J2H5 and J2H10 Power Cables .....	158

## List of Tables

Table 2.1	 Statements .....	12
Table 2.2	Symbols Contained in Warning Labels .....	12
Table 2.3	9530V Dimensions and Weight of the Rack-Mount Model .....	15
Table 2.4	9530V Dimensions and Weight of the Floor Model .....	15
Table 2.5	Internal Logic Specification of the 9530V Rack-Mount Model.....	17
Table 2.6	Principal Functions of 9530V Cables .....	17
Table 2.7	Environmental Specifications .....	19
Table 2.8	Input Power and Insulation Performance Specifications for the Rack-Mount Model .....	19
Table 2.9	Input Power and Insulation Performance Specifications for the Floor Model ...	20
Table 2.10	Vibration and Shock Tolerances .....	21
Table 2.11	Reliability of the 9530V Rack-Mount Model.....	21
Table 2.12	Reliability of the 9530V Floor Model.....	21
Table 4.1	Basic Specifications of the Rack-Mount Model .....	35
Table 4.2	Basic Specifications of the Floor Model .....	36
Table 4.3	Storage Capacity Examples Based on Disk Drive Configuration.....	37
Table 4.4	Front Bezel Component Functions .....	38
Table 4.5	Panel Assembly Switch Functions .....	40
Table 4.6	Backup Battery Unit Switch Functions.....	41
Table 4.7	Power Unit Switch Functions.....	41
Table 4.8	Connector Functions for the Power Unit .....	42
Table 4.9	Connector Functions for the Control Unit .....	43
Table 4.10	LED Functions for the Disk Drive Display .....	44
Table 4.11	LED Functions for the Battery Backup Unit .....	45
Table 4.12	LED Functions for the ENC Unit.....	46
Table 4.13	LED Functions for the Power Unit .....	47
Table 4.14	LED Functions for the Fan Assembly .....	47
Table 4.15	LED Functions for the Control Unit.....	48
Table 4.16	Periodical Replacement Parts and Parts with Limited Lives .....	49
Table 5.1	RAID Specifications of the Rack-Mount and Floor Models .....	51
Table 5.2	Cache Specifications of the Rack-Mount and Floor Models.....	52
Table 7.1	Storage for Parameters .....	66
Table 7.2	Spare Disk Settings .....	68
Table 7.3	RAID Group Setting .....	70
Table 7.4	Logical Unit Setting.....	73
Table 7.5	Formatting Message .....	78
Table 7.6	Model Operations .....	92

Table 8.1	Web Operational Environment .....	116
Table 8.2	Web Operational Requirements .....	117
Table 8.3	Network Parameters .....	118
Table 8.4	Message Code Types .....	134
Table 8.5	Flash Detected Messages .....	135
Table 8.6	Progress Messages .....	136
Table 8.6	Progress Messages (Continued) .....	137
Table 8.7	Warning Messages .....	137
Table 8.8	Failure Messages .....	137
Table 8.9	How to Read Failure Information .....	138
Table B.1	System Parameter Setting List .....	147
Table C.1	Basic Specifications of 9530V .....	153
Table D.1	J1H Power Cable .....	157
Table D.2	J2H Power Cable .....	158
Table D.3	J2H5 and J2H10 Power Cables .....	158



# Chapter 1 Overview of the Thunder 9530™ V Series Subsystem

The Hitachi Freedom Storage™ Thunder 9530™ V Series subsystem is a high-performance, medium-capacity storage array with added features designed to reduce the possibility of data loss due to the failure of any single component. Disk array installation and setup are simplified using the Resource Manager 9500 program (optionally available). Many parts are replaceable while the disk array is online. Cache memory has a battery backup to preserve cache contents in the event of a power failure. For information regarding model types, see sections 1.2 Rack-Mount Model and 1.3 Floor Model.

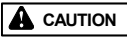
This chapter includes the following:

- Overview Features
- Rack-Mount Model
- Floor Model

## 1.1 Overview Features

The following Hitachi Freedom Storage™ Thunder 9530™ V Series features are discussed in this section:

- High Data Availability
- Connectivity
- Enhanced Data Accessibility
- Scalability
- Performance Reporting and Monitoring
- Reliability, Availability, and Serviceability

### 1.1.1 High Data Availability

The 9530V is designed for high performance and protection of user data. See section 1.2 for additional information on the reliability and availability features of the Hitachi Thunder 9530™ V Series subsystem.

### 1.1.2 Connectivity

The Hitachi Thunder 9530™ V Series subsystem provides connectivity to most open systems through a standard Fibre Channel interface.

- With the Fibre Channel connection, the 9530V subsystem can transfer data between the host computer and the subsystem at a maximum speed of 200 MB/sec. The subsystem can be located up to 300 meters from the host.

- The 9530V subsystem enables you to construct a system which can connect up to 126 fibre channel devices by using the fibre channel interface and connecting the fibre-channel arbitrated loop (FC-AL) and the fibre channel switch (Fabric).
- When the system is configured to connect multiple hosts, a function is provided which rejects a boot by any host except a specified host. This function can prevent access from an illegal host.

### 1.1.3 Enhanced Data Accessibility

The 9530V supports command tag queuing, multi-initiator I/O, and most industry-standard middleware products providing host fail-over capability, I/O path fail-over support, and logical volume management. The 9530V also has many features that increase data accessibility and enable continuous user data access.

- FlashAccess 9500V allows a LUN to reside in cache memory for fastest possible access.
- LUNs can be created to suit customer needs using the Resource Manager 9500V.
- LUN Security 9500V allows the 9530V to control host access to LUNs by host Worldwide Name. Up to 128 Worldwide Names per port can be supported.
- Up to 2 GBs (one pair of 512 MB DIMMs) of cache memory can be installed in each controller (or up to 4 GBs per subsystem) to improve I/O performance.
- ShadowImage 9500V enables you to maintain subsystem-internal copies of all user data on the Thunder 9530™ V Series storage subsystem for purposes such as data backup or duplication.

### 1.1.4 Scalability

The architecture of the 9530V enables the user to scale the subsystem to meet a wide range of capacity and performance requirements.

- One spare disk is set. You can use the system effectively by mounting each spare disk in a disk drive slot left unused as a result of a system construction.

**Note:** Some disk drive slots cannot be used for installation of a spare disk due to restriction of the system configuration. For the details, contact Hitachi Data Systems Customer Support.

- From the host computer, the subsystem can be used as a single large-scale disk drive or as 512 logical disks (LUs) (maximum).

### 1.1.5 Performance Reporting and Monitoring

The Resource Manager 9500V program provides the capability to either monitor the disk array in real time or to collect historical data regarding the performance of the disk array.

### 1.1.6 Reliability, Availability, and Serviceability

The 9530V subsystem is not expected to fail in any way that would interrupt user access to data. The 9530V can sustain single component failures and still continue to provide full access to all stored user data.

**Note:** While access to user data will not normally be compromised, the failure of any single key component may degrade performance.

The reliability, availability, and serviceability features of the 9530V subsystem include:

- **High-Availability capability.** The 9530V subsystem provides high-availability capability for all critical components. The 9530V uses component and function redundancy to provide high availability for many subsystem components.

The Controller of the Thunder 9530™ V Series subsystem increases data reliability by adding original 8-byte data assurance codes to data from a host computer by automatically generating them, writing them in the disk drive together with the data, and checking them when reading the data. On the data bus in the controller, the automatic generation of the data assurance codes and the check are executed to enhance data reliability in data distribution/concentration control, peculiar to the disk array.

This function monitors potential disk failure. Before failure occurs, the data copy operation can be automatically performed in the background. The dynamic sparing feature enables the subsystem to replace the spare disk due to redundancy (excluding RAID 0 configuration) and provides high reliability.

- **Redundant power supply systems.** Each 9530V unit has a set of two power supplies. Each power supply can provide power for the entire subsystem in the unlikely event of power supply failure. The power supplies of each set can be connected across power boundaries so that each set can continue to provide power if a power outage occurs. Each unit of the 9530V can sustain the loss of a single power supply and still continue operation.
- **High capacity cache.** The Thunder 9530™ V Series subsystem supports a maximum of 1 Gb high capacity cache per controller. Writing completion can be reported to the host system when data is written to cache.

## 1.2 Rack-Mount Model

The rack-mount model is composed of an RKS mounted on a rack frame. 9531V, 9532V, and 9533V have 5, 9, and 13 disk drives respectively and each one has a controller that controls them as a RAID system.

**Note:** For additional information about the rack-mount model, refer to the *Hitachi Freedom Storage™ Thunder 9500™ V Series 19-Inch Rack Reference Guide (MK-92DF654)*.

## 1.3 Floor Model

The floor model (RKS+H1H) for 9531V, 9532V, and 9533V have 5, 9, and 13 disk drives respectively and each one has a controller that controls them as a RAID system.

**Note:** For the specifications of the Floor model, refer to Chapter 2 Planning for Installation and Operation.

## Chapter 2 Planning for Installation and Operation

This chapter provides information for planning and preparing a site before and during installation of the Hitachi Thunder 9530™ V Series subsystem. Please read this chapter carefully before beginning your installation planning.

If you would like to use any of the 9530V features or products (e.g., LUN Security 9500V, FlashAccess 9500V), please contact your Hitachi Data Systems account team to obtain the appropriate license(s) and software key files.

**Note:** The general information in this chapter is provided to assist in installation planning and is not intended to be complete. The internal 9530V installation and maintenance documents used by Hitachi Data Systems personnel contain complete specifications. The exact electrical power interfaces and requirements for each site must be determined and verified to meet the applicable local regulations. For further information on site preparation for 9530V installations, contact your Hitachi Data Systems account team or the Hitachi Data Systems Support Center.

This chapter includes the following:

- User Responsibilities
- Safety Precautions
- Dimensions and Weight
- Service Clearance Requirements
- Floor Load Rating
- Internal Logic Specifications
- Cable Requirements
- Environmental Specifications

## 2.1 User Responsibilities

Before the 9530V subsystem arrives for installation, the user must provide the following items to ensure proper installation and configuration.

- Physical space necessary for proper subsystem function and maintenance activity
- Electrical input power
- Connectors and receptacles
- Air conditioning
- Floor ventilation areas (recommended but not required)
- Cable access holes

## 2.2 Safety Precautions

When using the 9530V disk array subsystem, follow these cautionary procedures:

- Perform operations in accordance with the instructions or procedures described in this manual.
- Follow the cautionary notes written on labels affixed to the equipment.
- Follow the cautionary notes written in this manual.

It is impossible to describe every hazard that may exist with this equipment. Please be aware of hazards not described in this manual. Work safely.

The following information is included in this section:

- Symbol Marks
- Repair, Modification, and Disassembly
- Precautions for Using the Equipment
- Precautions for Inspection and Cleaning
- Emergency Precautions
- Warning Notices

## 2.2.1 Symbol Marks

The  symbol followed by the word “CAUTION” in this manual indicates a potential safety hazard. When you see this symbol, observe the safety instructions that follow.



This symbol indicates the existence of a potential hazard which may cause a personal injury or serious damage to the equipment if the written contents are not observed.

## 2.2.2 Repair, Modification, and Disassembly

Users must not repair, remodel, or disassemble the equipment. Such actions may cause hazardous conditions for the user and/or the equipment.

## 2.2.3 Precautions for Using the Equipment

Use special precautions for the following:

- Equipment
- Cables
- Air Vents
- Battery Unit
- Nickel-Hydrate Rechargeable Battery Instructions
- Other

### 2.2.3.1 Equipment

- If you notice unusual heat generation, odors, or smoke emission, shut off the power feed to the equipment and contact the maintenance engineer. Leaving such conditions unattended may result in hazardous physical conditions and equipment failure.
- Avoid physical disruption to the equipment. This may result in hazardous physical conditions and equipment failure.
- Do not place heavy objects on top of the disk array. Avoid using the equipment for any use other than its original purpose; otherwise, an injury or equipment failure may result.

### 2.2.3.2 Cables

- Avoid obstructing walkways when routing cables.
- Do not allow heavy material to be placed on cables. Do not place cables near any apparatus that generates heat. Do not step on or subject cables or connectors to shearing or pulling forces; the cable jacket can be damaged and can break, resulting in an electric shock, fire, or loss of data.
- Make sure that electrical and signal cables are clean before connecting them. Any dirt on a connector should be removed before inserting the connector into a socket.

### 2.2.3.3 Air Vents

- Make certain that the air vents are free of obstruction. They should be inspected periodically.
- Do not place metallic material such as paper clips or any combustible material such as paper into or near the air vents. This may result in electric shock or fire.

### 2.2.3.4 Battery Unit

Observe the following when handling the battery:

- Do not disassemble or tamper with the battery.
- Do not allow the battery to be physically damaged. If the battery is physically damaged, have it replaced as soon as possible.
- Do not connect the two terminals of the battery directly to each other; this will create a short circuit.
- Do not tamper with cable insulation.
- Do not connect the battery to any equipment other than the Thunder 9530™ V Series subsystem.
- Do not expose the battery to high temperatures.
- Use only the specified battery.

### 2.2.3.5 Nickel-Hydrate Rechargeable Battery Instructions

These instructions explain what you must observe when you use a nickel-hydrate rechargeable battery (hereafter it is referred to as the **battery**). If you use the battery incorrectly, it can overheat ignite, burst, or explode, damaging and deteriorating its performance/life. Read and follow the instructions below:



1. Do not disassemble the case; do not modify it or peel off the label. There are high voltage parts inside: if you attempt any of these actions, this can result in electrical shock or burning.
2. Do not disassemble the battery; this can cause short circuits inside or outside of the battery. If the components are exposed to the air, the battery can overheat, burst or ignite. Disassembling the battery can expose you to alkaline solution, which can be dangerous.
3. Do not cut the output cable. Do not modify the connector. If you attempt any of these actions, an electrical shock or burn can result. A short-circuit may cause abnormal chemical reactions inside the battery which leads to overheating, bursting or ignition.
4. Follow the instructions when you recharge the battery pack. If you recharge it in a way different from specified here, it may cause the following problems: The battery may become charged excessively; excessive current may be produced; or the battery cannot be recharged. As a result, the battery may leak, become overheated, burst, or ignite.
5. Do not use excessive force when you connect the battery pack to the charger or other devices. If you cannot connect it easily, check that the positive and negative positions are correct for the connector. If you connect the battery in reverse, it will be charged incorrectly and abnormal chemical reactions may occur inside. As a result, the battery may become overheated, burst or ignite.
6. Do not connect the battery to a power receptacle. If you apply an excessive amount of voltage to the battery, it may produce excessive current making the battery overheat, burst or ignite.
7. Do not use or leave the battery where the temperature can become high, such as, near a fire or a heating element. High temperatures can damage the battery's separator, which may cause short circuit, making it overheat, burst or ignite.
8. Do not incinerate or heat the battery pack. If you do so, the insulator may melt, the safety fuse/mechanism may be damaged, or the electrolyte may gush out. As a result, the battery can burst, explode or ignite.
9. Do not connect the negative terminal to the positive with metal wire. Do not carry or store the battery with other metal parts. This can cause a short circuit or produce an excessive current which can cause the battery to leak, overheat, burst or ignite.
10. Do not let the battery become wet by soaking it in the water or seawater. If the battery becomes wet, a short circuit can occur and an excessive amount of current can be produced, causing abnormal chemical reactions inside. As a result, the battery may become overheated, burst or ignite.
11. Do not nail or hammer the battery. The battery may be broken or dented and a short circuit may occur inside. As a result, the battery may become overheated, burst or ignite.
12. Do not solder directly to the battery. If you do so, heat will melt the insulator and damage the safety fuse/mechanism. As a result, the battery may leak or may become overheated, burst or ignite.

 **Warning**

13. If you find anything strange or unusual with the battery when you use/carry/store it, remove the battery from the device and stop using it. For example, strange smells, strange colors, or deformation are a sign you must stop using the battery.
14. If it takes longer than the specified time to complete recharging, stop recharging the battery; otherwise, the battery may become overheated, burst or ignite.

If the battery leaks and gets into your eyes, immediately flush your eyes with clean water (tap water) and do not rub your eye. Visit the doctor immediately. If you do not seek any treatment for your eyes, problems may occur later. Because the battery uses highly concentrated alkaline as electrolyte, it can burn; you may lose your sight if it makes contacts your eyes. If the battery's liquid contacts your skin or eyes, you must flush them with plenty of clean water and visit a doctor at once.

#### 2.2.3.6 Other

When a failure occurs in the unit, take action according to the procedures recommended in this manual. If the difficulty does not correspond to the corrective measures documented in this manual, contact the maintenance engineer.

#### 2.2.4 Precautions for Inspection and Cleaning

- If a maintenance activity requires that the unit be powered off, make sure that the power-off sequence described in the manual is performed before proceeding with maintenance.
- Do not work on the unit in a damp or flooded environment.
- Do not obstruct access to the unit with parts or tools.
- When performing the work with the door open, take off metal watches or jewelry to prevent electric shock. If you wear metal-frame glasses, do not touch the equipment.
- Ensure that loose clothing, jewelry, or hair do not become tangled in moving components.
- There are high-voltage parts in the equipment. Observe the cautionary statements in the manual to make sure that high-voltage components are not touched during maintenance. Another person should be on alert to shut off the power feed to the equipment.
- After the power feed to the equipment is shut off, electricity remains in the equipment for a period of time. Therefore, do not touch any components other than those indicated in this manual.
- The equipment can become extremely hot. Do not touch any part other than those indicated in this manual.
- When working with the door open, wear cotton gloves to prevent your hands from touching sharp objects.

## 2.2.5 Emergency Precautions

Follow these emergency precautions for the following:

- Electric Shock
- Fire

### 2.2.5.1 Electric Shock

- Do NOT immediately touch the person struck by electricity. You could be the second victim.
- To shut off the electric flow to a victim, disconnect the power feed cable of the equipment. In spite of this action, electricity may not be shut off. Separate the victim from the current source by using a non-conductive material such as dry wooden bar.
- Call an ambulance.
- When the victim has lost consciousness, practice artificial respiration on the victim. To prepare for such a case, learn how to practice artificial respiration.
- When the victim's heart has stopped, give a heart massage. This treatment should only be conducted by a person who has been trained and qualified.

### 2.2.5.2 Fire

- To shut off the electric flow to the equipment, pull out the power feed cable. This will terminate the power supply.
- If a fire cannot be extinguished when the electric flow has been shut off, use fire-fighting procedures and contact the fire department.

## 2.2.6 Warning Notices

### 2.2.6.1 Statements



 statements described in this manual and the pages where they appear are listed below.

Table 2.1  Statements

Warning Statement	Corresponding Page
Cooling fans rotate at a high speed. Keep body parts and loose clothing away from the cooling fans.	10
When cleaning, take care not to touch electrically charged parts. Electric shock may result.	10, 11
Do not touch electrically charged components during parts replacement. Electric shock may result.	11



## 2.2.7 Locations of Warning Labels on the Equipment

Warning labels are pasted on sections of equipment which require special care. Read the messages and observe the warning procedures. They are shown in the following figures:

- Floor Model RKS+H1H
- Rack-Mount Model RKS

Table 2.2 lists and describes the symbols contained in warning labels.

Table 2.2 Symbols Contained in Warning Labels

Symbol Mark	Description
	Caution - electric shock.
	Caution - very hot.

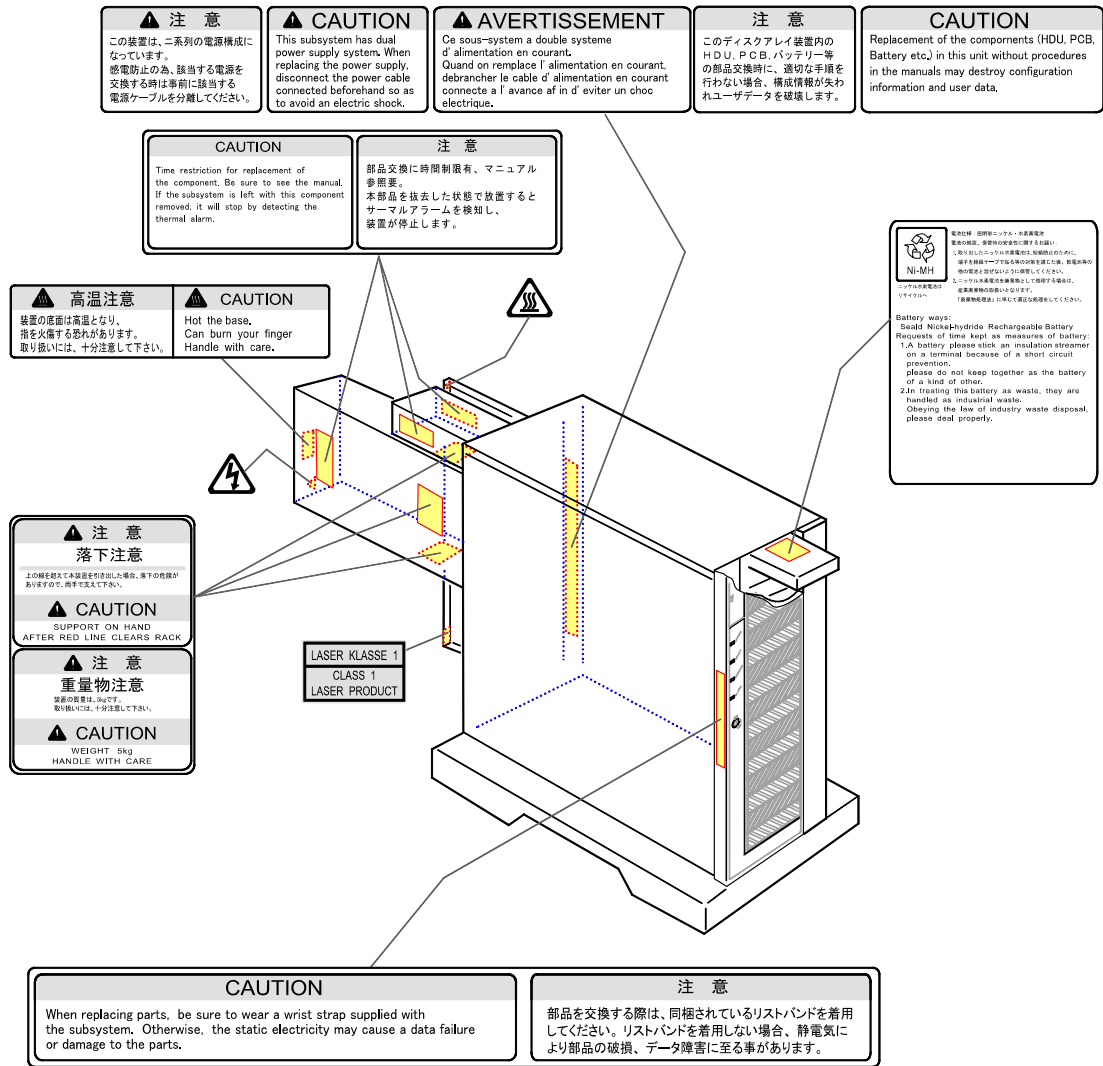

Figure 2.1 Positions and Contents of Labels on Floor Model RKS+H1H

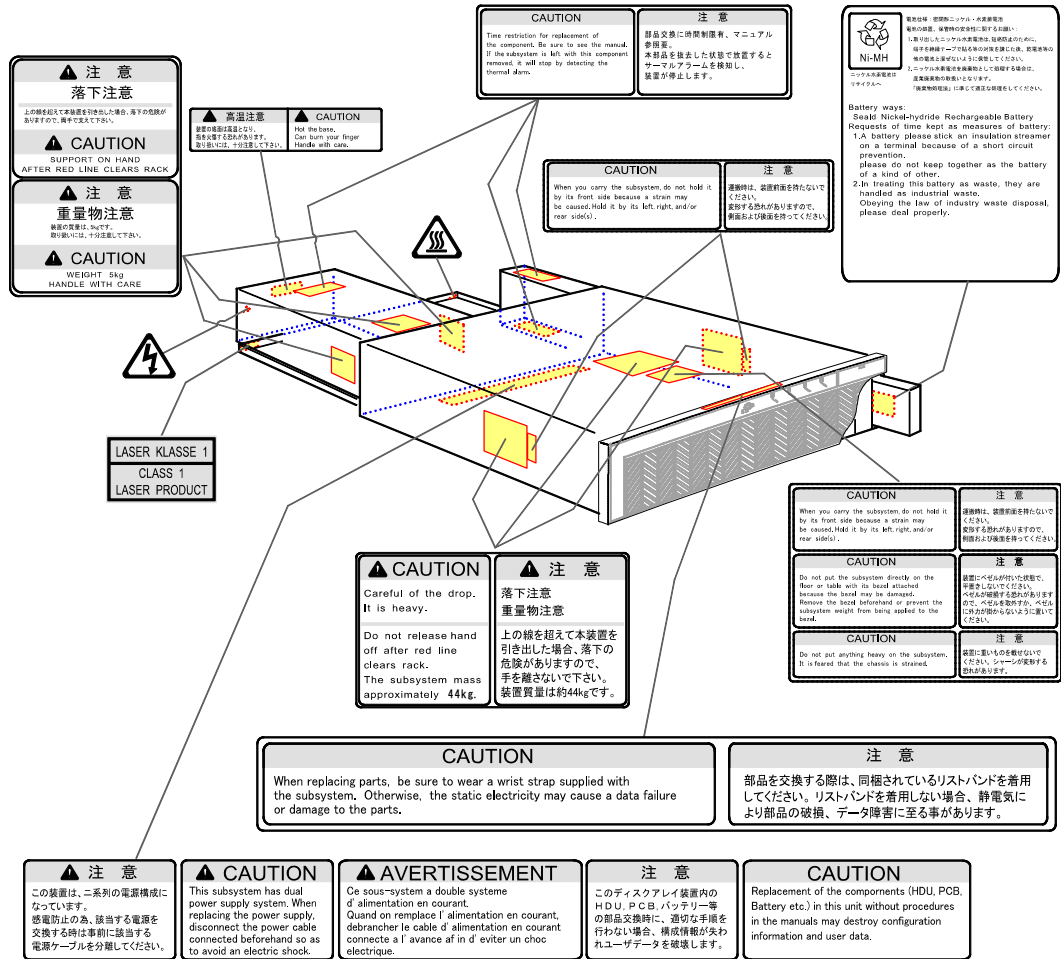

Figure 2.2 Positions and Contents of Labels on Rack-Mount Model RKS

## 2.3 General Specifications and Requirements

This section describes the general specifications and requirements for the Thunder 9530™ V Series subsystem. The following are included:

- Dimensions and Weight
- Service Clearance Requirements
- Floor Load Rating
- Internal Logic Specifications
- Cable Requirements

### 2.3.1 Dimensions and Weight

The following table illustrates the dimensions and weight of the 9530V rack-mount model and the 9530V floor model.

**Table 2.3 9530V Dimensions and Weight of the Rack-Mount Model**

Item		Model	Rack-Mount Model
			RKS
Physical Specifications	Chassis size (W×D×H) (mm)		483×656×129
	Mass (kg)		44 approx
	Acoustic noise (dB)		53 approx
	Required height (EIA unit)		3

**Table 2.4 9530V Dimensions and Weight of the Floor Model**

Item		Model	Floor Model
			Floor (RKS+H1H) Model
Physical Specifications	Chassis size (W×D×H) (mm)		260×737×540
	Mass (kg)		80 approx
	Acoustic noise (dB)		53 approx

## 2.3.2 Floor Load Rating

This section includes:

- Floor Load Rating for the 9530V Rack-Mount Model
- Floor Load Rating for the 9530V Floor Model

### 2.3.2.1 Floor Load Rating for the 9530V Rack-Mount Model

For information about the rack-mount model, refer to the *Hitachi Freedom Storage™ Thunder 9500™ V Series 19-Inch Rack Reference Guide* (MK-92DF654).

### 2.3.2.2 Floor Load Rating for the 9530V Floor Model

The Floor (RKS+H1H) Model contains up to 2 controller boards and up to 14 disk drives. The maximum configuration weighs 80 kg. To assure adequate load-bearing capacity, plan for the maximum configuration.

### 2.3.3 Internal Logic Specifications

The following table lists the internal logic specifications of the 9530V.

**Table 2.5 Internal Logic Specification of the 9530V Rack-Mount Model**

Item		Specification (Note)
Internal logic specification	Control CPU	Power PC7455 (667 MHz)
	Control OS	VxWorks
	Control memory	Flash memory: 2 Mbytes L2 cache memory: 512 Kbytes SRAM: 64 M bytes
	Data bus performance	Cache access: 2.44 Gbytes/s
	Data assurance method	Data bus: Through-parity Cache memory: ECC (1 bit for correction, 2 bits for detection) Disk drive: Data assurance code

**Note:** For additional information about the rack-mount model, refer to the *Hitachi Freedom Storage™ Thunder 9500™ V Series 19-Inch Rack Reference Guide (MK-92DF654)*.

### 2.3.4 Cable Functions

The following table lists the principal functions of the 9530V cable. Fibre channel cables are available from Hitachi Data Systems.

**Table 2.6 Principal Functions of 9530V Cables**

Cable	Function
Fibre Channel cable	Connect with a host or HBA/Switch.
LAN Cross cable	Connect the PCs for user, monitoring and maintenance.

## 2.4 Environmental Specifications and Requirements

To maintain optimal Thunder 9530V performance, the 9530V subsystem must be installed in a proper environment. This section discusses the following necessary environmental specifications and requirements:

- Environmental Hazards
- Temperature and Humidity Requirements
- Input Power and Insulation Performance Specifications
- Air Flow Requirements
- Vibration and Shock Tolerances
- Reliability

### 2.4.1 Environmental Hazards

**Do not** install the subsystem in the places described below; the life of equipment functioning will be shortened and equipment failures will occur. **Avoid** the following:

- Direct sunlight exposure
- Temperature and humidity variation (for example, near an air conditioner)
- Close proximity to a device that generates electrical noise and motion (for example, air conditioner that is not grounded and washing machine motor)
- Close proximity to an apparatus that generates a strong magnetic field
- Excessive dust
- Frequent vibrations
- An inclined floor

## 2.4.2 Temperature and Humidity Requirements

Table 2.7 lists the temperature and humidity requirements for the 9530V subsystem.

**Table 2.7 Environmental Specifications**

Item		Specification
Temperature	In operation (°C)	10 to 40
	In non-operation (°C)	-10 to 50
	In transport/storage (°C)	-30 to 60
	Temperature change rate (°C/h)	10 or less
Humidity	In operation (%)	8 to 80
	In non-operation (%)	8 to 90
	Maximum wet bulb temperature (°C)	29 (non-condensing)
Altitude	In operation (m)	-300 to 3,000
	In non-operation (m)	-300 to 12,000

## 2.4.3 Input Power and Insulation Performance Specifications

The following tables list the input power and insulation performance specifications for the 9530V rack-mount models and the 9530V floor model.

**Table 2.8 Input Power and Insulation Performance Specifications for the Rack-Mount Model**

		Model	Rack-Mount Model
Item		RKS	
Input power specification	Input voltage (V)	AC 100/200 (100-120/200-240)	
	Frequency (Hz)	50/60 ± 1	
	Number of phases, cabling	Single-phase with protective grounding	
	Steady-state current (A) (See <b>Note 1</b> and <b>Note 2</b> )	4.4×2/2.2×2	
	Breaking current (A)	16.00	
	Required power	Steady state (VA)	880 of less
Starting state (VA)		920 of less	
Heat value	Steady state (kJ/h)	3,170 or less	
Insulation performance	Insulation withstand voltage	AC 1,500 V (10 mA, 1 min)	
	Insulation resistance	DC 500 V, 10 M Ω or more	

**Note 1:** This indicates the current consumption in the usual state. When a power supply failure occurs, the power consumption is provided by the single power supply for the subsystem.

**Note 2:** The current value in the operation by a single power supply unit is same as that in the operation by both power supply units.

**Table 2.9 Input Power and Insulation Performance Specifications for the Floor Model**

Item		Model	Floor Model
		Floor (RKS+H1H) Model	
Input power specification	Input voltage (V)	AC 100/200 (100-120/200-240)	
	Frequency (Hz)	50/60 ± 1	
	Number of phases, cabling	Single-phase with protective grounding	
	Steady-state current (A)	4.4×2/2.2×2	
	Breaking current (A) (See <b>Note</b> )	16.0	
	Required power	Steady state (VA)	880 of less
Starting state (VA)		920 of less	
Heat value	Steady state (kJ/h)	3,170 or less	
Insulation performance	Insulation withstand voltage	AC 1,500 V (10 mA, 1 min)	
	Insulation resistance	DC 500 V, 10 M Ω or more	

**Note:** The current value in the operation by a single power supply unit is same as that in the operation by both power supply units.

#### 2.4.4 Air Flow Requirements

The 9530V subsystem is air-cooled. Air must enter the subsystem through the airflow intakes at the back of each subsystem and must be exhausted out of the front, so it is very important that the air intakes and outlets remain clear.

## 2.4.5 Vibration and Shock Tolerances

Table 2.10 lists the vibration and shock tolerance data for the 9530V subsystem. The 9530V can tolerate vibration and shock within these limits and continue to perform normally. The user should consider these requirements if installing the 9530V near large generators located on the floor above or below the 9530V subsystem. Generators or any other source of vibration, if not insulated or shock-mounted, can cause excessive vibration that may affect the subsystem.

**Table 2.10 Vibration and Shock Tolerances**

Item		Specification
Vibration	In operation (m/s <sup>2</sup> )	2.5 or less
	In non-operation (m/s <sup>2</sup> )	5.0 or less
	In transport (packed) (m/s <sup>2</sup> )	5.0 or less
Impact	In operation (m/s <sup>2</sup> )	20 or less
	In non-operation (m/s <sup>2</sup> )	50 or less
	In transport (packed) (m/s <sup>2</sup> )	80 or less
Angle at which the subsystem will turn over (°)		15 or less

## 2.4.6 Reliability

The reliability of the 9530V is described in the following tables.

**Table 2.11 Reliability of the 9530V Rack-Mount Model**

Item	Model	Rack-Mount Model
		RKS
Reliability	Drop in package (JIS Z 0200-1997)	No abnormality must be caused by a free drop of level IV.
	Radio frequency radiation	Conforms to FCC Class A
	Instantaneous power failure	10 ms (100% dip)

**Table 2.12 Reliability of the 9530V Floor Model**

Item	Model	Floor Model
		Floor (RKS+H1H) Model
Reliability	Drop in package (JIS Z 0200-1997)	No abnormality must be caused by a free drop of level IV.
	Radio frequency radiation	Conforms to FCC Class A
	Instantaneous power failure	10 ms (100% dip)



## Chapter 3 Powering On/Off Procedure

The disk drive may emit audible mechanical sounds when the disk drive is started (spun up), immediately after the subsystem is powered on and powered off (spun down). However, this does not indicate a problem if the WARNING or ALARM LED of the basic frame is off; you may use the subsystem.

This section describes power on/off procedures for the following:

- 9530V Rack-Mount Model
- 9530V Floor Model

### 3.1 9530V Rack-Mount Model

The following steps describe power on/off procedures for the 9530V rack-mount model.

**Note:** For additional information about the rack-mount model, refer to the *Hitachi Freedom Storage™ Thunder 9500™ V Series 19-Inch Rack Reference Guide* (MK-92DF654).

#### 3.1.1 Subsystem Power On

**Note:** The EALM lamp (red) of the controller (on the rear side of the subsystem) may come on between subsystem power-on and Ready status. However, it is not a problem if the EALM lamp (red) goes out during this period of time.

1. Verify that the main switch is turned off.
2. Verify that the AC power unit switch of each power unit is turned off.
3. Verify that the circuit breaker (CB1) is turned off.
4. Turn on the circuit breaker (CB1) of the PDB.
5. Turn on the AC power unit switch of the power unit on RKS.
6. Turn on the main switch.
7. Make sure that the READY LED (green) lights within five minutes. If the ALARM LED (red) or WARNING LED (orange) lights, refer to 8.1 Troubleshooting Based on LED Indications.

#### 3.1.2 Subsystem Power Off

1. Turn off the main switch.
2. Verify that the POWER LED (green) on the panel is off.
3. Turn off the AC power unit switch of the power unit.
4. Turn off the circuit breaker (CB1) of the PDB.

**Note:** When storing the subsystem without turning on the power for long periods, request that the maintenance engineer turn off the battery of the subsystem. For details on how to store the subsystem, refer to Chapter 9 Periodic Maintenance.

## 3.2 9530V Floor Model

The following steps describe power on/off procedures for the 9530V floor model.

### 3.2.1 Subsystem Power On

**Note:** The EALM lamp (red) of the controller (on the rear side of the subsystem) may come on between subsystem power-on and Ready status. However, it is not a problem if the EALM lamp (red) goes out during this period of time.

1. Verify that the main switch is turned off.
2. Verify that the AC power unit switch of the power unit is turned off.
3. Turn on the AC power unit switch of the power unit on RKS.
4. Turn on the main switch.
5. Verify that the READY LED (green) lights within five minutes. If the ALARM LED (red) or WARNING LED (orange) lights, refer to 8.1 Troubleshooting Based on LED Indications.

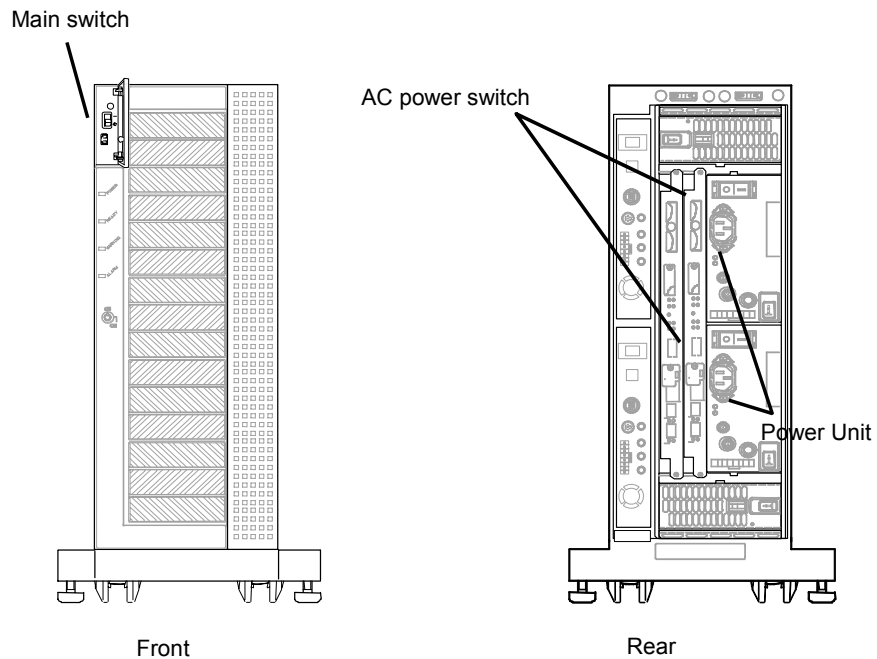

Figure 3.1 Subsystem Power On/Off (Example: Floor [RK+RKA+H2H] Model)

### 3.2.2 Subsystem Power Off

1. Turn off the main switch.
2. Verify that the POWER LED (green) on the panel is off.
3. Turn off the AC power unit switch of the power unit.

**Note:** When storing the subsystem without turning on the power for long periods, request that the maintenance engineer turn off the battery of the subsystem. For details on how to store the subsystem, refer to Chapter 9 Periodic Maintenance.



# Chapter 4 Subsystem Architecture and Components

This chapter includes the following:

- Configuration Block Diagrams
- Redundant Power Supplies
- Fibre Channel Interface
- Array Frames
- Disk Array Groups
- Service Processor (SVP)
- Component Names, Locations, and Functions
- Periodical Replacement Parts and Parts with Limited Lives

## 4.1 Configuration Block Diagrams

This section includes block diagrams for the following:

- 9530V Rack-Mount Model
- 9530V Floor Model

### 4.1.1 9530V Rack-Mount Model

The configuration block diagrams of the RKS (9531V, 9532V, and 9533V) Rack-Mount model is shown below. 9531V, 9532V, and 9533V mount 5, 9, and 13 disk drives respectively.

The disk drives can be assigned to data disk(s), parity disk(s) depending on the RAID level. One spare disk is set.

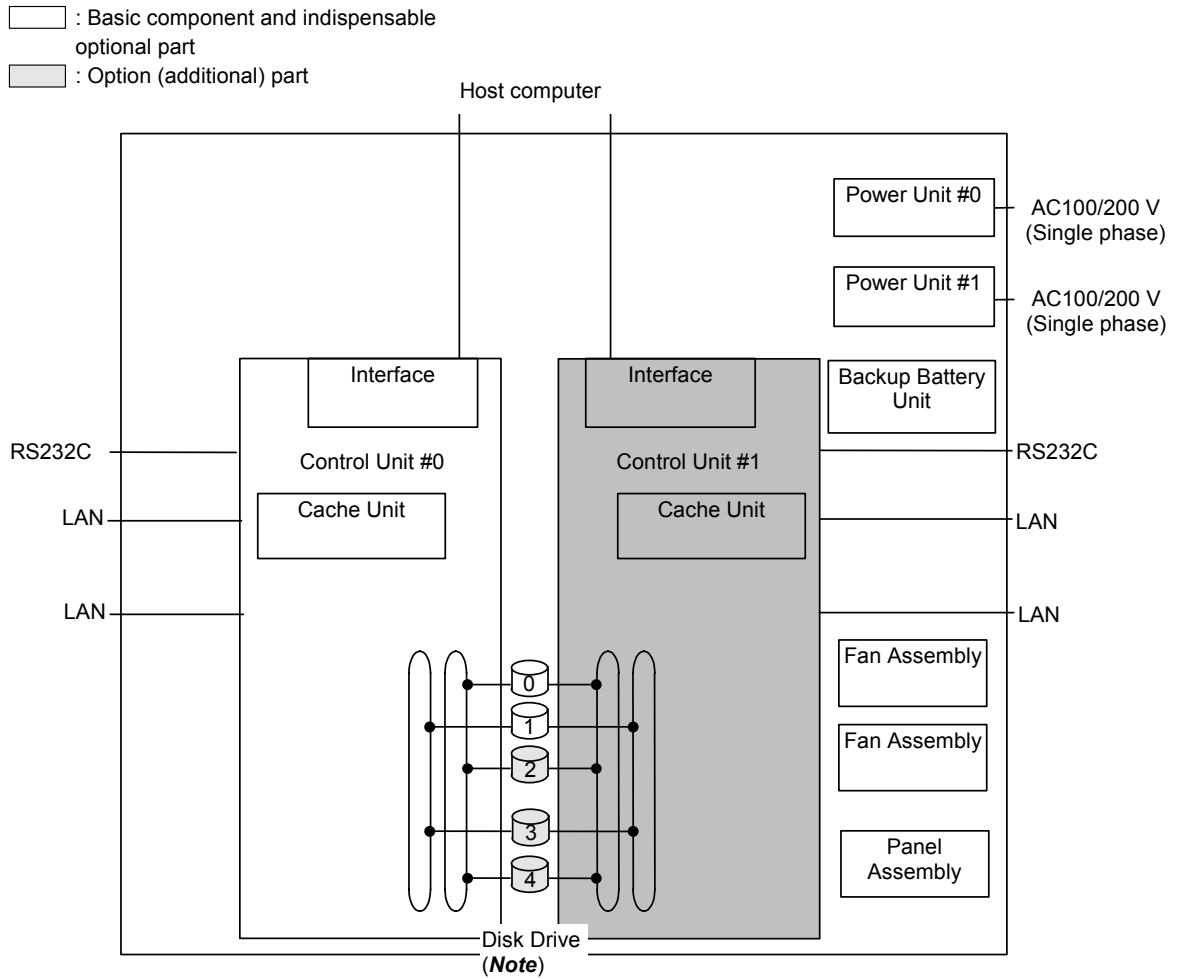

**Note:** Disk drive: DF-F600-AEF72

**Figure 4.1** 9531V System Configuration

- : Basic component and indispensable optional part
- : Option (additional) part

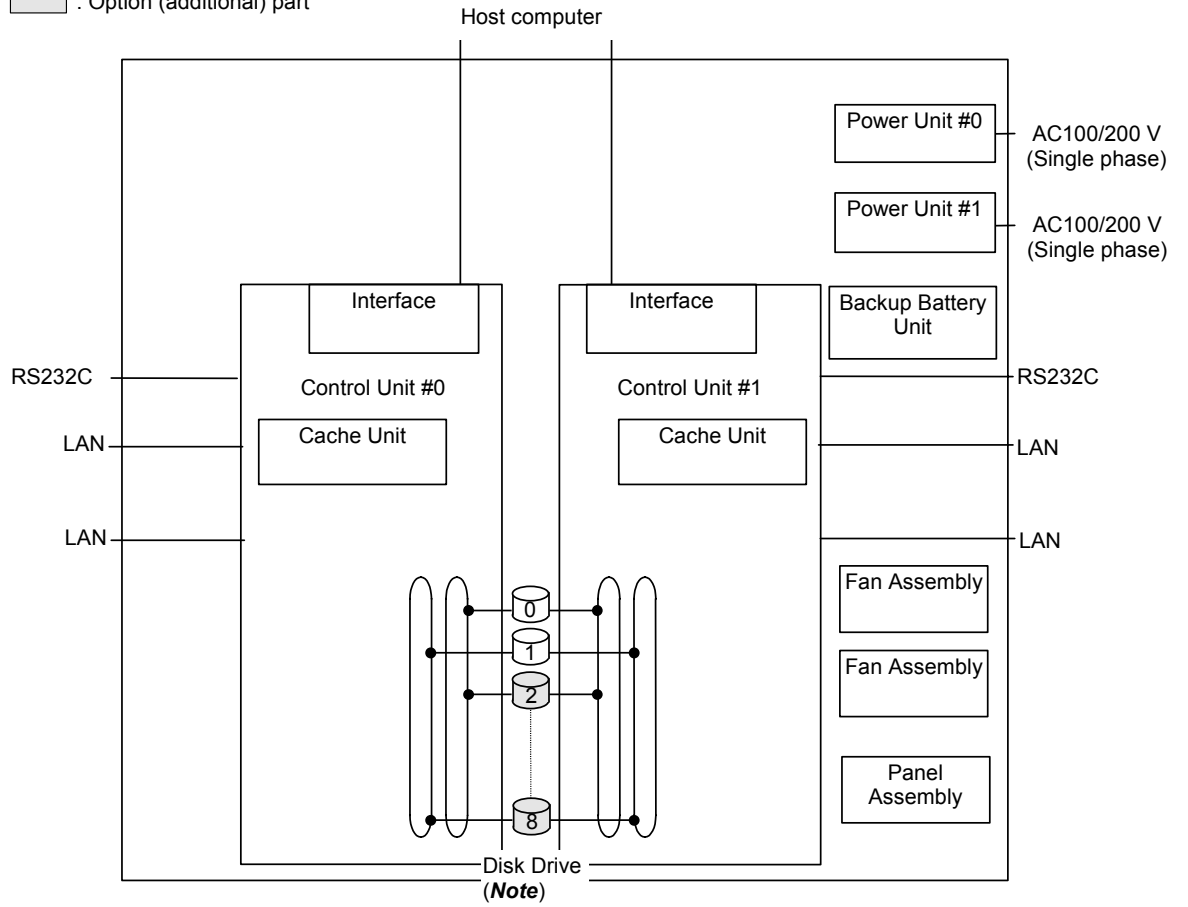

**Note:** Disk drive: DF-F600-AEF72

**Figure 4.2 9532V System Configuration**

- : Basic component and indispensable
- : optional part
- : Option (additional) part

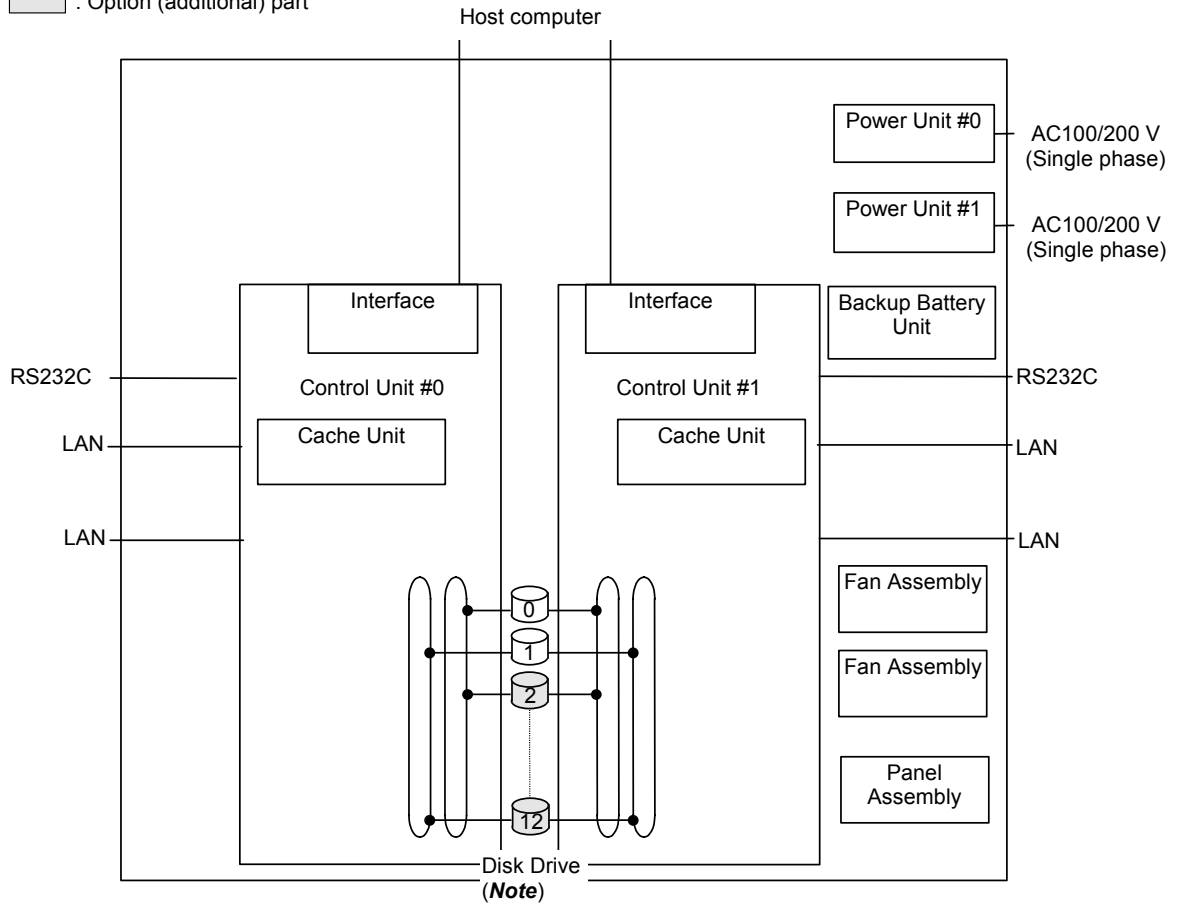

**Note:** Disk drive: DF-F600-AEF72

**Figure 4.3** 9533V System Configuration

## 4.1.2 9530V Floor Model

The configuration block diagrams of the Floor (RKS+H1H) Model (9531V, 9532V, and 9533V) are shown below.

The Floor (RKS+H1H) Model (9531V, 9532V, and 9533V) mount 5, 9, and 13 disk drives respectively.

The disk drives can be assigned to data disk(s), parity disk(s) (mirror disk(s)) depending on the RAID level.

- : Basic component and indispensable optional part
- : Option (additional) part

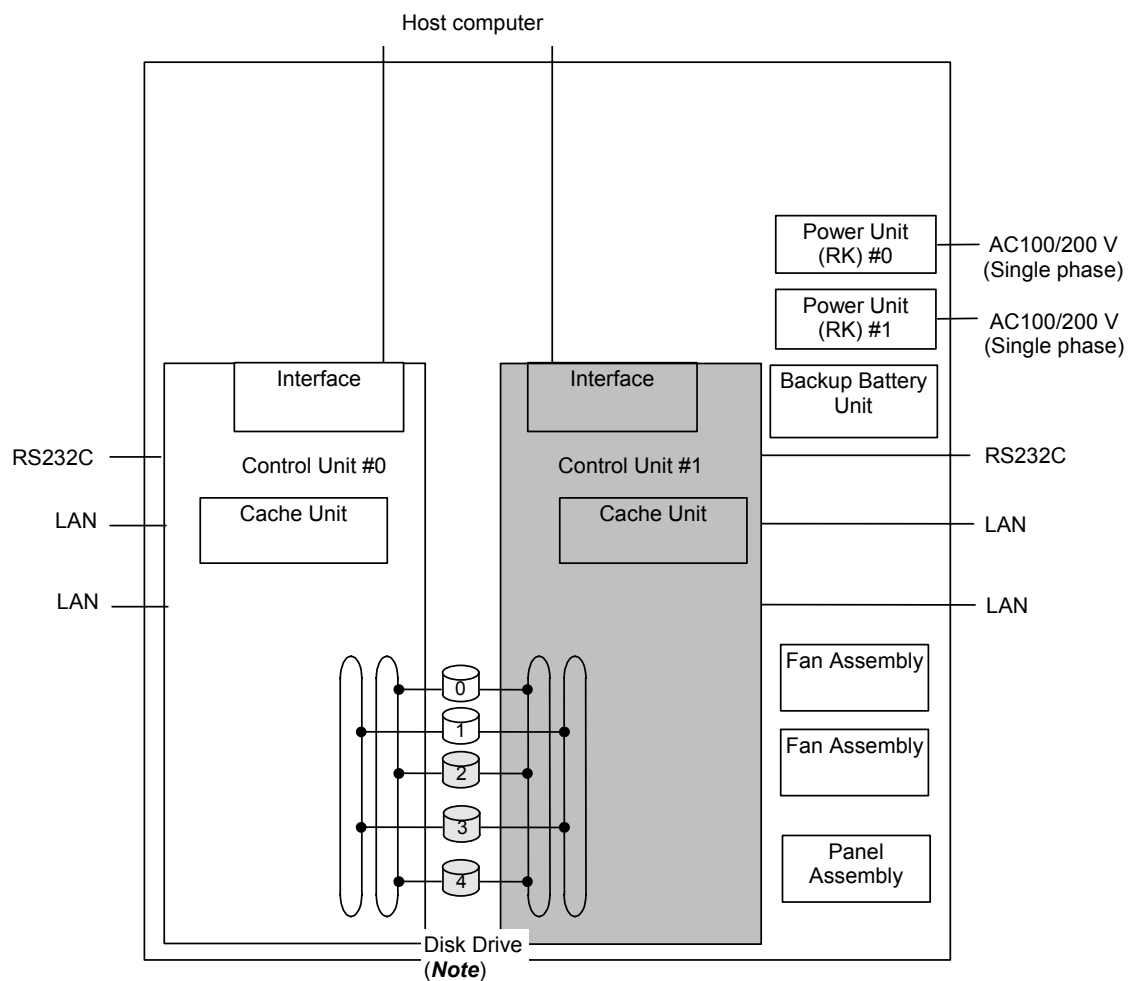

**Note:** Disk drive: DF-F600-AEF72

**Figure 4.4** Floor (RKS+H1H) Model 9531V System Configuration

: Basic component and indispensable optional part  
 : Option (additional) part

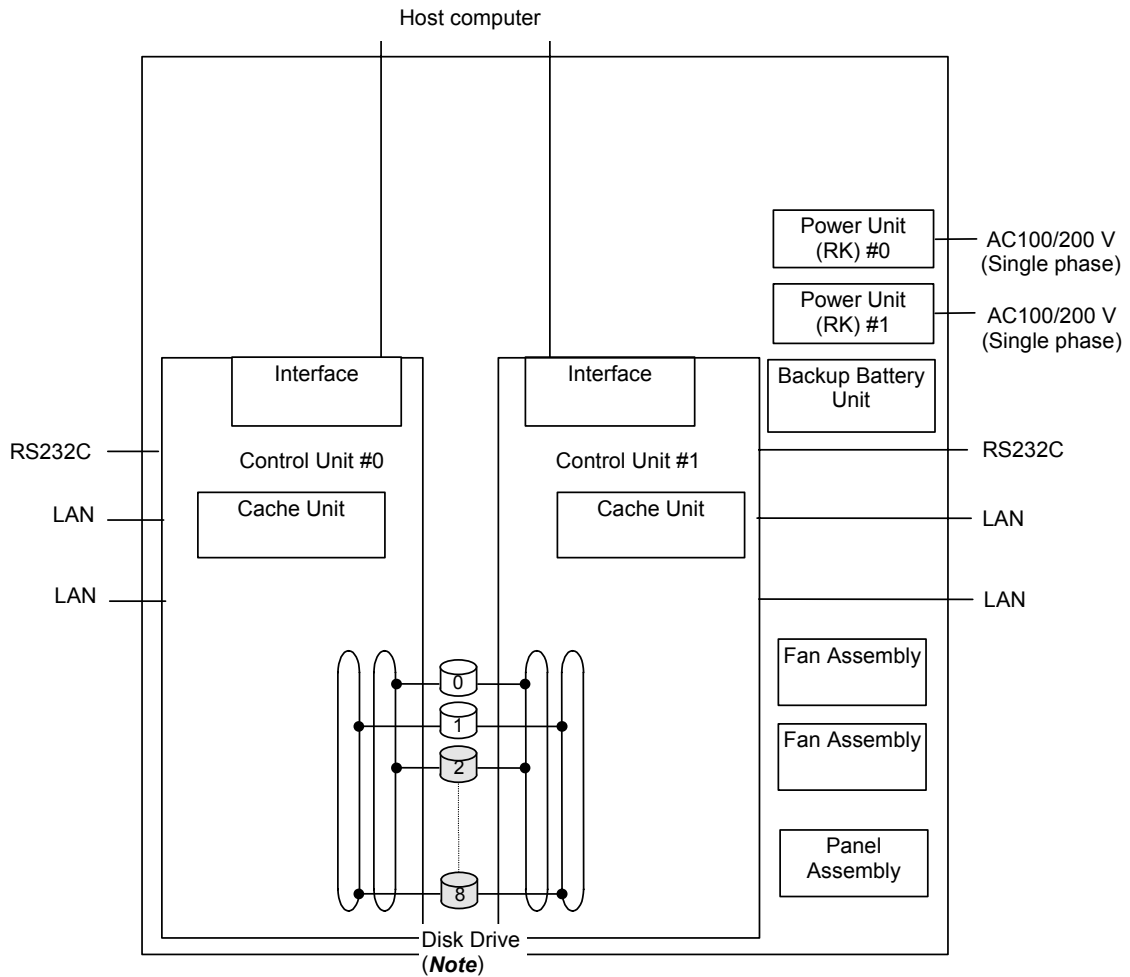

**Note:** Disk drive: DF-F600-AEF72

**Figure 4.5** Floor (RKS+H1H) Model 9532V System Configuration

: Basic component and indispensable optional part  
 : Option (additional) part

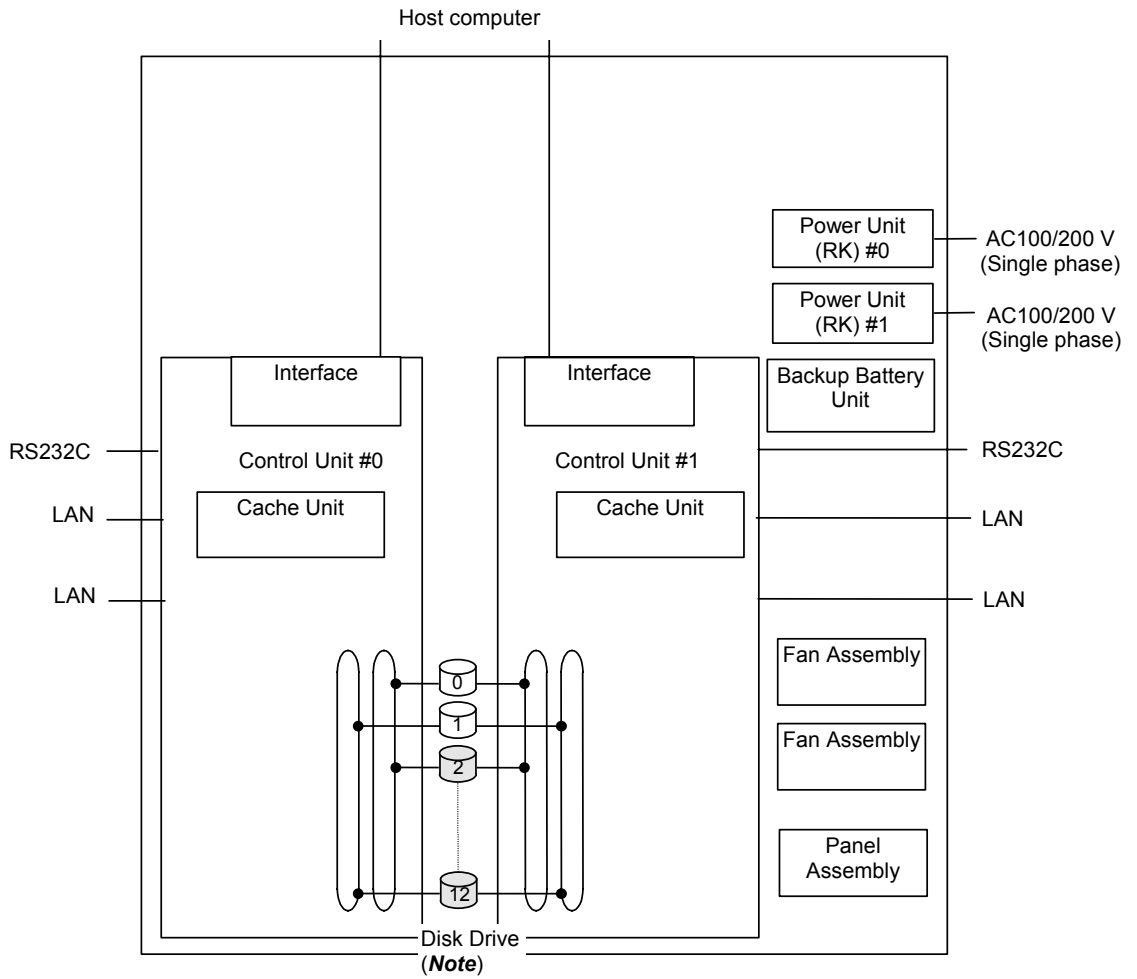

**Note:** Disk drive: DF-F600-AEF72

**Figure 4.6** Floor (RKS+H1H) Model 9533V System Configuration

## 4.2 Redundant Power Supplies

Each 9530V unit is powered by its own set of redundant power supplies, and each power supply is able to provide power for the entire RKS unit, should it become necessary. Because of this redundancy, the Thunder 9530™ V Series subsystem can sustain the loss of multiple power supplies and still continue operation. To make use of this capability, the two power supplies of each 9530V unit should be connected either to dual power sources or to different power panels, so if there is a power failure on one of the sources, the Thunder 9530™ V Series subsystem can continue full operations using power from the alternate source.

## 4.3 Fibre Channel Interface

The Thunder 9530™ V Series subsystem supports open system operations. The Thunder 9530™ V Series subsystem supports up to 2 fibre-channel ports. The 9530V Fibre Channel interface is capable of operating at data transfer speeds of up to 200 MB/sec. The 9530V supports shortwave multimode optical cables. With these shortwave fibre channel cards, the 9530V subsystem can be located up to 300 meters from the open-system host.

## 4.4 Array Frame

The following array frames are described in this section:

- 9530V Rack-Mount Model
- 9530V Floor Model

### 4.4.1 9530V Rack-Mount Model

Each RKS unit contains the physical disk drives, including the disk array groups and the dynamic spare disk drives. Each rack frame has dual AC power plugs, which should be attached to two different power sources or power panels.

**Table 4.1 Basic Specifications of the Rack-Mount Model**

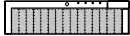
Item		Model	Rackmount model
			1 RKS
Configuration	Configuration		1 RKS
	System appearance		
Disk drive used	Disk drive size (W×D×H) (mm)		101.6×146.1×25.4
	Data capacity (G byte)		72
	Rotational speed (min <sup>-1</sup> )		10,000
	Maximum mountable quantity (unit)	Thunder 9531V	5
		Thunder 9532V	9
Thunder 9533V		13	
Host interface	Interface type		2 G bps Fibre Channel Optical (Non-OFC)
	Data transfer speed (i.e. maximum speed for transfer to host)		200 M bytes/s (Fibre Channel)
	Number of ports	Single controller	Fibre Channel: 1
		Dual controller	Fibre Channel: 2
	Transferred block size (bytes)		512

**Note 1:** For additional information about the rack-mount model, refer to the *Hitachi Freedom Storage™ Thunder 9500™ V Series 19-Inch Rack Reference Guide (MK-92DF654)*.

**Note 2:** This value of storage capacity is calculated as 1 Gbyte = 1,000,000,000 bytes. (This definition is different from 1 Kbyte = 1,024 bytes.)

## 4.4.2 Floor Model

Each floor model contains physical disk drives, including the disk array groups and the dynamic spare disk drives. Additionally, each floor model has dual AC power plugs, which should be attached to two different power sources or power panels.

**Table 4.2 Basic Specifications of the Floor Model**

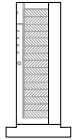
Item	Model	Floor model	
		Floor (RKS+H1H) Model	
Configuration	Configuration	1 RKS+Floor setting kit (DF-F600-H1H)	
	System appearance		
Disk drive used	Disk drive size (W×D×H) (mm)	101.6×146.1×25.4	
	Data capacity (G byte)	72	
	Rotational speed (min <sup>-1</sup> )	10,000	
	Maximum mountable quantity (unit)	Thunder 9531V	5
		Thunder 9532V	9
Thunder 9533V		13	
Host interface	Interface type	2 G bps Fibre Channel Optical (Non-OFC)	
	Data transfer speed (i.e. maximum speed for transfer to host)	200 M bytes/s (Fibre Channel)	
	Number of ports	Single controller	Fibre Channel: 1
		Dual controller	Fibre Channel: 2
	Transferred block size (bytes)	512	

**Note:** This value of storage capacity is calculated as 1 Gbyte = 1,000,000,000 bytes. (This definition is different from 1 Kbyte = 1,024 bytes.)

## 4.5 Disk Array Groups

The RAID group is the basic unit of storage capacity for the Thunder 9530™ V Series subsystem. All disk drives in a RAID group must have the same logical capacity. When a RAID group is configured with drives of different capacity, the RAID group is configured by assuming the minimum capacity of the drives.

The 9530V supports RAID 5 only.

Examples of storage capacities depending on the disk drive configuration are shown below.

**Table 4.3 Storage Capacity Examples Based on Disk Drive Configuration**

Subsystem	Total range of Disk drives	Disk capacity (G bytes)
9531V	3D+1P	202.7
9532V	(3D+1P)×2	405.4
9533V	(5D+1P)×2	694.3

## 4.6 Service Processor (SVP)

The Thunder 9530™ V Series subsystem is controlled by the service processor (SVP). The 9530V subsystem is configured in RAID 5. The SVP is integrated into the controller frame and is accessed through the Resource Manager 9500V program and service utilities. The SVP enables Hitachi Data Systems representatives to configure, maintain, and upgrade the 9530V subsystem.

**Note:** The SVP does not have access to user data stored on the 9530V.

## 4.7 Component Names, Locations, and Functions

This section includes the following:

- Front Bezel Component Locations and Functions
- RK/RKS and RKA Component Locations
- Switch Locations and Functions
- Connector Locations and Functions
- LED Locations and Functions

### 4.7.1 Front Bezel Component Locations and Functions

This section illustrates and describes the locations and functions for the front bezel.

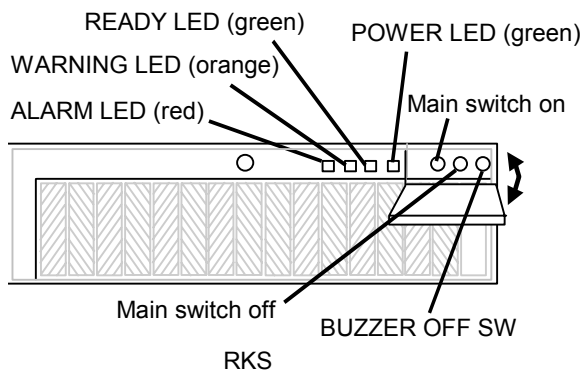

**Figure 4.7 Front Bezel Component Locations**

**Table 4.4 Front Bezel Component Functions**

Name	Function
ALARM LED (red)	Indicates that a failure has occurred which makes the subsystem inoperable
WARNING LED (orange)	Indicates that a failure occurred, but the subsystem is currently operational
READY LED (green)	Indicates that the subsystem is operational
POWER LED(green)	Indicates that the power is supplied to the subsystem
Main switch on	ON: Turns on the power
Main switch off	OFF: Turns off the power
BUZZER OFF SW	Press this switch when the buzzer sounds to stop the beep. When a serious hardware failure occurs, (electrical surges of both power supplies and so on), the buzzer does not stop even when the button is pushed.

## 4.7.2 RKS Component Locations

The locations of the RKS components are shown in the following diagram:

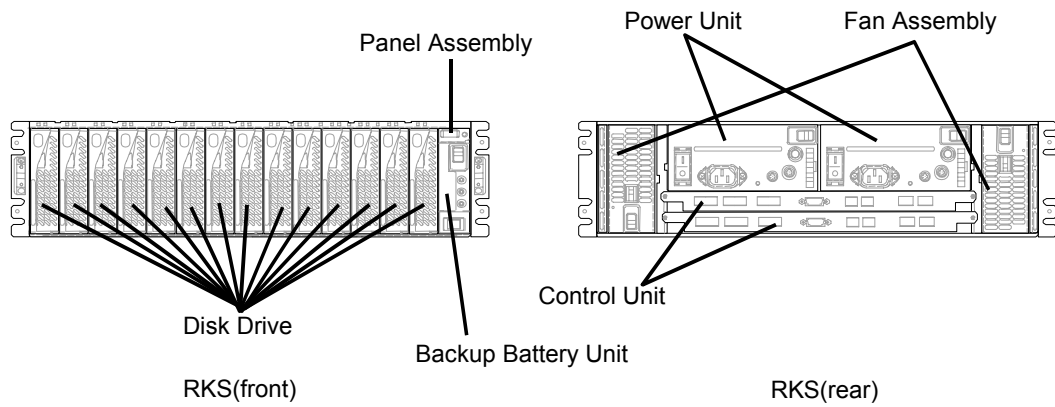

Figure 4.8 RKS Component Locations

### 4.7.3 Switch Locations and Functions

This section illustrates and describes the locations and functions for switches in the following hardware components:

- Panel Assembly
- Backup Battery Unit
- Power Unit

#### 4.7.3.1 Panel Assembly

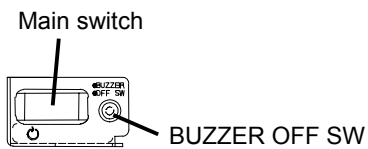

**Figure 4.9** Panel Assembly Switch Location

**Table 4.5** Panel Assembly Switch Functions

Switch	Function
Main switch	Turns on/off the power
BUZZER OFF SW	Pressing this switch while the buzzer sounds stops the beep. When a serious hardware failure occurs, (electrical surges of both power supplies and so on), the buzzer does not stop even when the button is pushed.

### 4.7.3.2 Backup Battery Unit

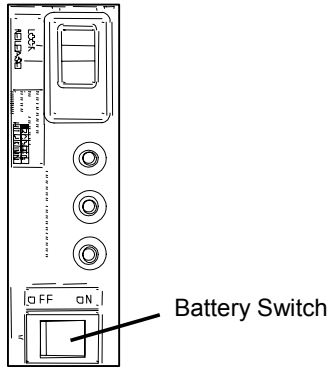

Figure 4.10 Backup Battery Unit Switch Location

Table 4.6 Backup Battery Unit Switch Functions

Switch	Function
Battery Switch	Turns on/off the battery power When this switch is set to the off, the WARN LED comes on and the buzzer sounds.

### 4.7.3.3 Power Unit

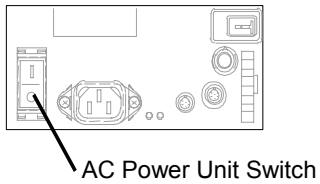

Figure 4.11 Power Unit Switch Locations

Table 4.7 Power Unit Switch Functions

Switch	Function
AC Power Unit Switch	Controls the power applied to the subsystem

## 4.7.4 Connector Locations and Functions

This section illustrates and describes the locations and functions for connectors in the following hardware components:

- Power Unit
- Control Unit

### 4.7.4.1 Power Unit

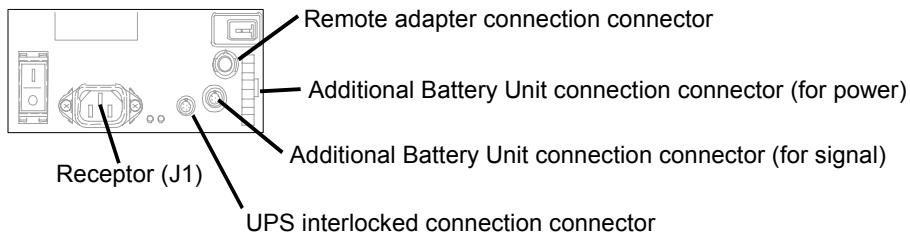

**Figure 4.12 Connector Locations for the Power Unit**

**Note:** The Additional Battery Unit is available in Japan only.

**Table 4.8 Connector Functions for the Power Unit**

Connector	Function
Remote adapter connection connector	Used to connect a Remote adapter
UPS interlocked connection connector	Used to connect an UPS for Thunder 9530V
Receptor (J1)	Power cable receptacle on the unit side

#### 4.7.4.2 Control Unit

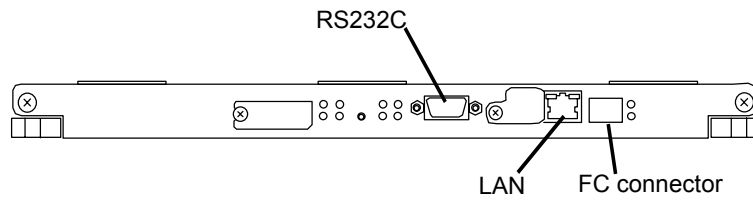

Figure 4.13 Connector Locations for the Control Unit

Table 4.9 Connector Functions for the Control Unit

Connector	Function
RS232C	Connector used to connect an RS232C
FC connector	Connector for a Fibre channel interface cable
LAN	Connector used to connect a LAN cable

## 4.7.5 LED Locations and Functions

This section illustrates and describes the locations and functions of LEDs in the following hardware components:

- Disk Drive Display
- Battery Backup Unit
- ENC Unit
- Power Unit
- Fan Assembly
- Control Unit

### 4.7.5.1 Disk Drive Display

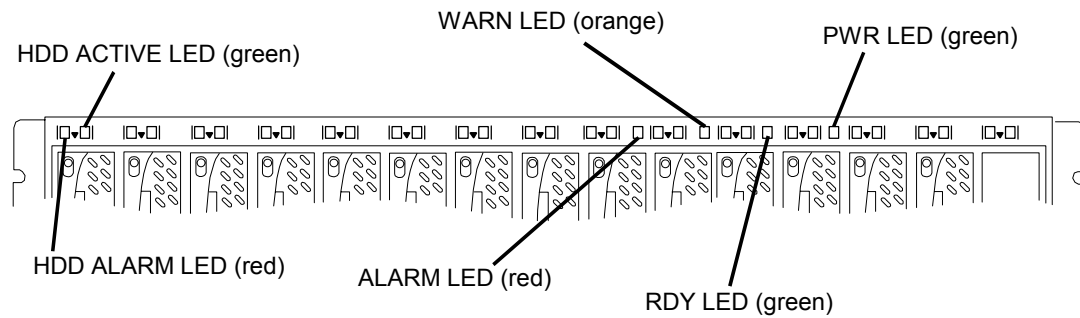

**Figure 4.14** LED Locations for the Disk Drive Display

**Table 4.10** LED Functions for the Disk Drive Display

Connector	Function
HDD ACTIVE LED (green)	When on or flashing, it indicates that the disk drive is operational.
HDD ALARM LED (red)	When on, it indicates that a failure occurred in the disk drive; the disk drive is inoperable.
ALARM LED (red)	When on, it indicates that a failure occurred in the unit; the unit is inoperable.
READY LED (green)	When on, it indicates that the unit is operable.
WARNING LED (orange)	When on, it indicates that a failure occurred in the unit; the unit is inoperable.
POWER LED (green)	When on, it indicates that electricity is supplied to the unit.

## 4.7.5.2 Battery Backup Unit

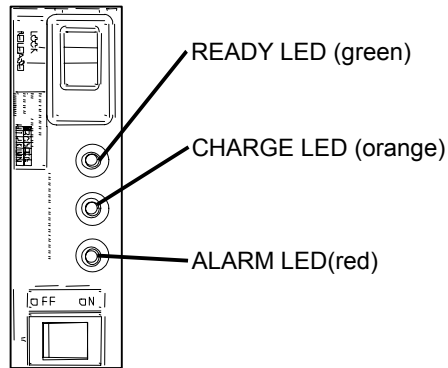

Figure 4.15 LED Locations for the Battery Backup Unit

Table 4.11 LED Functions for the Battery Backup Unit

Connector	Function
READY LED (green)	When on, flashing, or off, it indicates the condition of the battery.
CHARGE LED (orange)	When on or flashing, it indicates the charging status of the battery.
ALARM LED (red)	When on, it indicates that a failure occurs in the battery.

### 4.7.5.3 ENC Unit

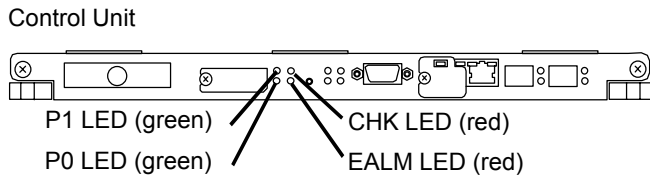

Figure 4.16 LED Locations for the ENC Unit

Table 4.12 LED Functions for the ENC Unit

Connector	Function
P1 LED (green)	When on, it indicates that the link status of FC-AL (loop 1 side) is normal.
P0 LED (green)	When on, it indicates that the link status of FC-AL (loop 0 side) is normal.
EALM LED (red)	When on, it indicates that a failure occurs in the controller (ENC side), so the controller is inoperable.
ALM LED (red)	When on, it indicates that a failure occurs in the ENC Unit, so the ENC Unit is inoperable.
CHK LED (red)	<p>It indicates, according to the number of times the LED flashes, what voltage is abnormal.</p> <p>Once: Logic +5 V voltage is abnormal.            Twice: Drive +12 V voltage is abnormal.            Three times: Logic +3.3 V voltage is abnormal.            Five times: Battery is abnormal.            Six times: Voltage on the controller is abnormal. (Reset of the controller is not canceled)            Seven times: BS 1.8 V, BS 3.3 V, or BS 12 V voltage is abnormal.</p> <p>The following blinking is fast because ENC microprogram detects CUDG error.</p> <p>Once: SRAM error            Twice: ENC hard error            Three times: Microprogram error in flash memory            Not blinking: Boot section error of ENC microprogram, RAM error, or ENC hard configuration error.</p>

#### 4.7.5.4 Power Unit

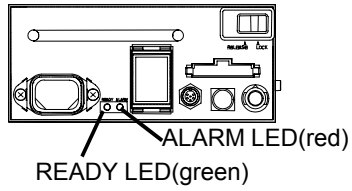

Figure 4.17 LED Locations for the Power Unit

Table 4.13 LED Functions for the Power Unit

Connector	Function
READY LED (green)	When on, it indicates the operating normally.
ALARM LED (red)	When on, it indicates the abnormal or in a stop state.

#### 4.7.5.5 Fan Assembly

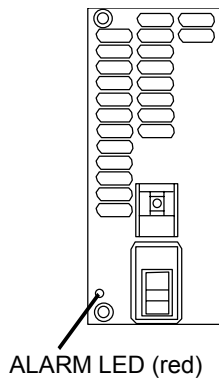
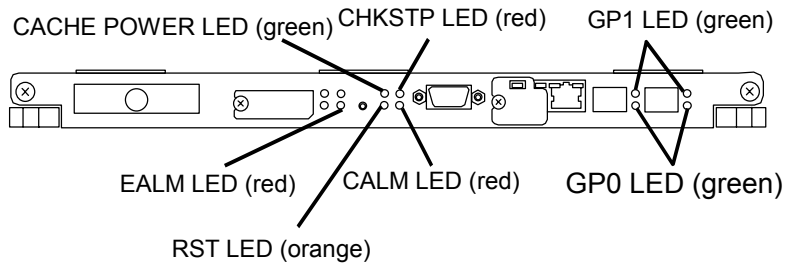

Figure 4.18 LED Locations for the Fan Assembly

Table 4.14 LED Functions for the Fan Assembly

Connector	Function
ALARM LED (red)	When on or off, it indicates the operating status of the fan assembly. on: It is abnormal. off: It is operating normally or in a stop state.

### 4.7.5.6 Control Unit



**Figure 4.19** LED Locations for the Control Unit

**Table 4.15** LED Functions for the Control Unit

Connector	Function
CACHE POWER LED (green)	When on or off, it indicates the status of the cache memory backup operation. on: Backup operation is in execution. off: Backup operation is not in execution.
RST LED (orange)	When on, it indicates that the controller is under resetting.
CALM LED (red)	When on, it indicates that a failure occurs in the controller (CTL side), so the controller is inoperable.
GP0 LED (green)	It indicates the status of the interface installed in the controller as standard.
GP1 LED (green)	It indicates the status of the interface installed in the controller as standard.
CHKSTP LED (red)	When on, it indicates that a failure occurred in the controller (CTL side); the controller is inoperable.

## 4.8 Parts with Limited Lives

In the Thunder 9530™ V Series subsystem, parts with limited lives are used. Part replacement is required to maintain high-quality operation performance.

- Replacement of the designated parts is basically covered by the maintenance service contract. Otherwise, the customer is responsible for purchasing genuine replacement parts periodically and replacing the parts.
- Special maintenance (overhaul) of the subsystem is required to replace parts with limited lives.
- The battery mounted in the subsystem is a periodical replacement part with an indication of the part to be recycled.

**Table 4.16 Periodical Replacement Parts and Parts with Limited Lives**

Classification	Part name	Life	Treatment
Part with limited life	Battery unit	Two years	Periodical replacement is required. When the maintenance service contract is made, periodical replacement is performed as a part of maintenance service. If not, the periodical replacement must be performed by the user. The genuine parts must be used. Follow the given procedure to dispose of the used battery.
Part with limited life	Disk drive	Five years <b>(Note 1)</b>	This part must be replaced through the special maintenance when its life is expires. (After the time limit, the possibility of hardware failure leading to data loss increases.) Life of the subsystem main body is eight years after the shipping from the factory even though special maintenance is performed.

**Note 1:** The expected useful life of the disk drive varies depending on the environment in which the customer uses it. For details, please consult Hitachi Data Systems Customer Service.



## Chapter 5 Functional and Operational Characteristics

This chapter includes a description of the following:

- New 9530V Features and Capabilities
- RAID Implementations
- Cache Management
- Logical Units
- Open System Features and Functions
- Data Management Features and Functions
- Copy Solution Features and Functions

### 5.1 New 9530V Features and Capabilities

The Hitachi Thunder 9530™ V Series subsystem offers the following new or improved features and capabilities, which distinguish the 9530V subsystem from the 9200 subsystem:

- 512 LUNs maximum/45 RAID groups maximum
- The drive interface supports 2 Gbs fibre channel.
- A maximum of 2 Gbs high capacity cache per controller is supported in the dual configuration. This improves the cache percent hit rate.

### 5.2 RAID Implementations

The Thunder 9530™ V Series subsystem supports RAID5.

The RAID specification is shown in the following table:

**Table 5.1 RAID Specifications of the Rack-Mount and Floor Models**

Item	Model		Rackmount Model	Floor Model
			RKS	Floor (RKS+H1H) Model
RAID specifications	RAID level		0/1/5/0+1	
	Thunder 9530V	Thunder 9531V	3D+1P	
		Thunder 9532V	(3D+1P)×2	
		Thunder 9533V	(5D+1P)×2	

**Note:** For additional information about the rack-mount model, refer to the *Hitachi Freedom Storage™ Thunder 9500™ V Series 19-Inch Rack Reference Guide (MK-92DF654)*.

### 5.3 Cache Management

Cache management features include the following:

- Data is stored in cache when reading and writing; it is dynamically managed, depending on the workload read and write I/O characteristics. A high percent cache hit rate is expected, due to transaction processing (data is updated after it is referenced). System throughput is increased by the reduced data writing time.
- Writing completion is reported to the host at the same time the data is written onto the cache; the write operation onto the disk will be asynchronously performed later. The host can perform the next process without waiting for the write operation onto disk.
- The data written onto the cache is saved in the event of an electric power failure due to the nonvolatile cache. The data is assured for 24 hours on the full charge of a standard configuration.
- One specified logical unit on each controller can be resident in cache. High throughput can be realized for the specified logical unit since a 100% cache percent hit rate is expected when reading and writing from the host.

Cache specifications are shown in the following tables:

**Table 5.2 Cache Specifications of the Rack-Mount and Floor Models**

Item	Model	Rackmount Model	Floor Model
		RKS	Floor (RKS+H1H) Model
Cache specifications	Capacity (M bytes/CTL)	1,024	
	Control method	Read LRU/Write after	
	Battery backup	Provided	
	Backup duration (h)	24 (When cache of 1,024 M bytes/CTL is installed)	

**Note:** For additional information about the rack-mount model, refer to the *Hitachi Freedom Storage™ Thunder 9500™ V Series 19-Inch Rack Reference Guide (MK-92DF654)*.

## 5.4 Logical Units (LUs)

The 9530V supports up to 512 LUNs. Each LU is identified by fibre-channel port ID and LUN number.

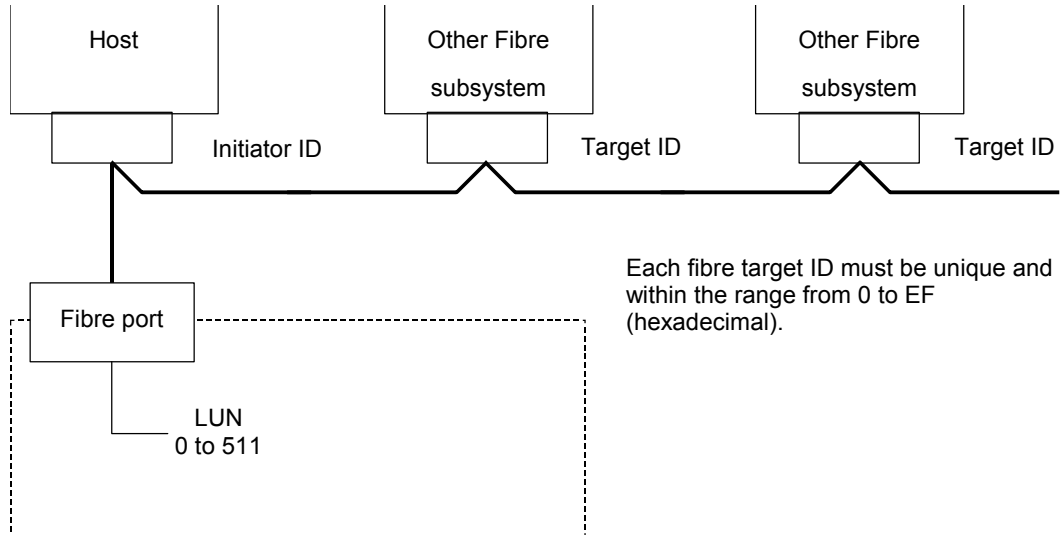

Figure 5.1 Logical Units

## 5.5 Open Systems Features and Functions

The Thunder 9530™ V Series subsystem offers many features and functions specifically for the open-systems environment. The 9530V subsystem also supports important open-system functions such as fibre-channel arbitrated-loop (FC-AL) and fabric topologies, command tag queuing, multi-initiator I/O, and most industry-standard software and middleware products which provide host fail-over, I/O path fail-over, and logical volume management functions.

### 5.5.1 Open Systems Middleware

Open-system middleware products provide host fail-over capability, I/O path fail-over support, and logical volume management in the open-systems environment. Middleware is not usually supplied as part of the basic operating system.

### 5.5.2 LUN Management

Each LUN can be assigned to multiple fibre-channel ports to provide I/O path fail-over with middleware support.

## 5.6 Data Management Features and Functions

These features include:

- Flash Access
- Fibre Security

### 5.6.1 FlashAccess

The FlashAccess function ensures that all data in an LU is stored in cache memory. All read/write commands to the LU can be executed by cache hit 100% without accessing the drive. The system throughput is improved when this function is applied to an LU that contains data accessed frequently because no latency period is needed to access the disk drive.

For additional information, refer to the *Hitachi Freedom Storage™ Thunder 9500™ V Series FlashAccess 9500V User's Guide (MK-92DF612)*.

## 5.6.2 Fibre Security

The Fibre Security function prevents data from being destroyed by illegal accesses. Only specified hosts are permitted to access LUNs (Host Storage Domain).

## 5.7 Copy Solution Features and Functions

The 9530V subsystem provides features and functions which allow you to maintain remote and subsystem internal copies of all user data on the 9530V storage subsystem for data backup or duplication. These include features from the ShadowImage 9530V program.

### 5.7.1 ShadowImage

The Hitachi Data Systems ShadowImage 9530V features enable you to maintain subsystem-internal copies of all user data on the 9530V storage subsystem for purposes such as data backup or duplication. The duplicated volumes are created within the same 9530V subsystem as the primary volume.

ShadowImage 9500V operations are non-disruptive and allow the primary (main) volume of each volume pair to remain online to all hosts for both read and write I/O operations. Once established, ShadowImage 9500V operations continue unattended to provide asynchronous internal data backup. Usability is further enhanced through a resynchronization capability that reduces data duplication requirements and backup time, thereby increasing user productivity.

For additional information, refer to the *Hitachi Freedom Storage™ Thunder 9500™ V Series ShadowImage 9500V User's Guide* (MK-92DF607).



# Chapter 6 Configuring the Thunder 9530™ V Series Subsystem

This chapter includes the following:

- Overview of Configuration
- Configuring the LAN Interface of the Thunder 9530™ V Series Subsystem
- Configuring the Thunder 9530™ V Series Subsystem
- Registering the Thunder 9530™ V Series Subsystem for Control by Resource Manager 9500V
- Configure the Thunder 9530™ V Series Subsystem for the Desired Application
- General Configuration of the Thunder 9530™ V Series Subsystem
- Starting the Parameter Wizard in Resource Manager 9500V
- Configuring the Basic Parameters for the Thunder 9530™ V Series Subsystem

## 6.1 Overview of Configuration

This section includes the following information on configuration:

- Open Systems Configuration
- Defining LUNs
- Fibre Channel Interface Addressing
- Alternate Pathing

### 6.1.1 Open Systems Configuration

The Thunder 9530™ V Series subsystem is compatible with Open Systems Operating Systems including HP9000 series, SUN Fire series, SUN Enterprise series, RS6000 Family, and several x86 PC Operating Systems, including Net Ware 5.0, Linux, Windows NT 4.0, Windows 2000 and XP) as a supported platform.

### 6.1.2 Defining LUNs

The Resource Manager 9500V software enables the user to define the LUN mapping for each device and reconfigure the mapping at any time. For further information on Resource Manager 9500V, please refer to the *Hitachi Freedom Storage™ Thunder 9500™ V Series Resource Manager 9500V User's Guide Graphical User Interface (GUI)*, MK-92DF605, to use a GUI interface. See the *Hitachi Freedom Storage™ Thunder 9500™ V Series Resource Manager 9500V User's Guide Command Line Interface (CLI)*, MK-92DF603, to use the CLI version. You can also contact your Hitachi Data Systems account team.

### 6.1.3 Fibre Channel Interface Addressing

The 9530V subsystem supports a maximum of 4 fibre-channel ports. (Thunder 9530V supports a maximum of 2 fibre-channel ports.) Each fibre-channel port is assigned a unique target ID number. The 9530V can address up to 512 LUNs per port. The following figure illustrates fibre port-to-LUN addressing.

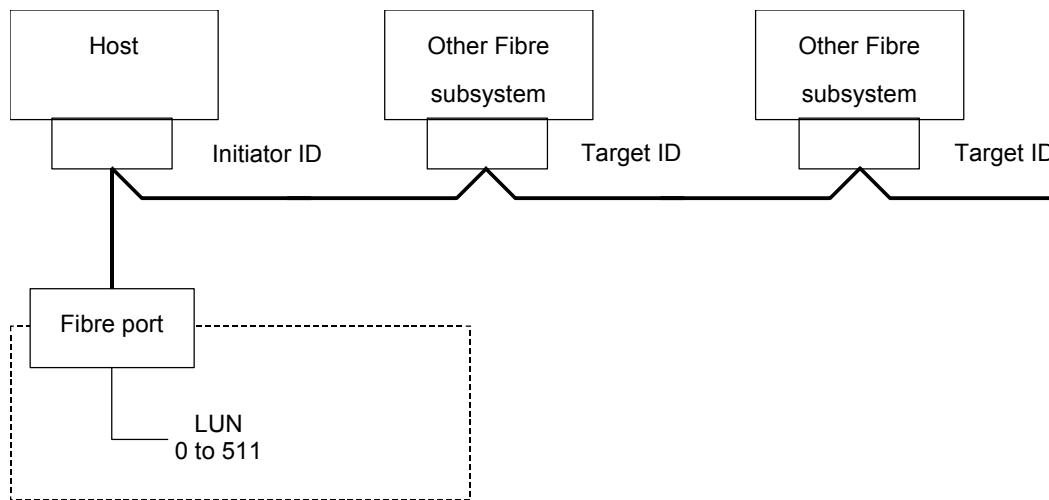

Figure 6.1 Fibre Port-to-LUN Addressing

### 6.1.4 Alternate Pathing

The user should plan for alternate pathing to ensure the highest data availability. The 9530V provides up to 2 fibre channel ports to accommodate alternate pathing for host attachment. The following figure shows a sample of alternate pathing.

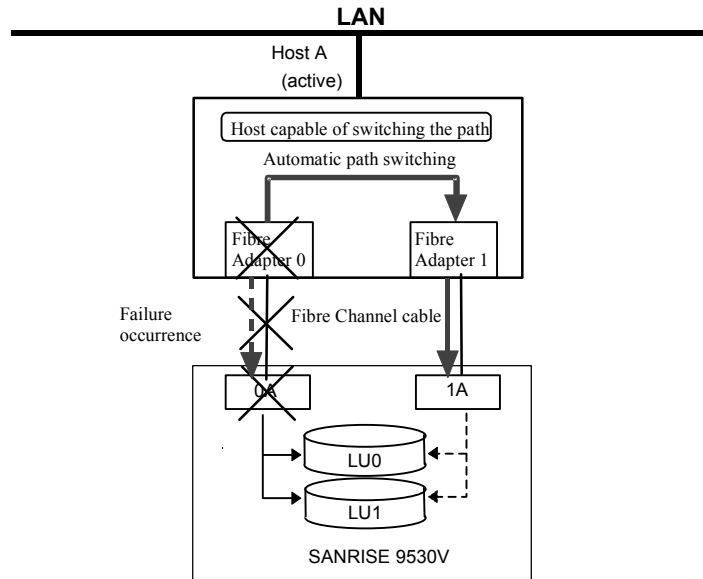

Figure 6.2 Alternate Pathing

## 6.2 Configuring the LAN Interfaces of the Thunder 9530™ V Series Subsystem

Each controller is shipped with a default IP address of 192.168.0.16 and netmask of 255.255.255.0 (the netmask number may differ). The IP address can be set using the Resource Manager 9500V program.

If the Resource Manager 9500V program is used to configure the IP addresses, also refer to the procedure in 7.8 Changing the Network Parameter.

If you wish to use Resource Manager 9500V to configure the IP addresses, please refer to the *Hitachi Freedom Storage™ Thunder 9500™ V Series Resource Manager 9500V User's Guide Graphical User Interface (GUI)*, MK-92DF605, to use a GUI interface. Refer to the *Hitachi Freedom Storage™ Thunder 9500™ V Series Resource Manager 9500V User's Guide Command Line Interface (CLI)*, MK-92DF603, to use the CLI version.

## 6.3 Configuring the Thunder 9530™ V Series Subsystem

The following steps must be performed to configure the disk array:

1. Verify that the subsystem is connected to the LAN.
2. Install Resource Manager 9500V on the system that will be used as the management PC/Server.

See the *Hitachi Freedom Storage™ Thunder 9500™ V Series Resource Manager 9500V User's Guide Graphical User Interface (GUI)*, MK-92DF605, to use a GUI interface. See the *Hitachi Freedom Storage™ Thunder 9500™ V Series Resource Manager 9500V User's Guide Command Line Interface (CLI)*, MK-92DF603, to use the CLI version.

Refer to the section titled "Installing Resource Manager 9500V" for instructions on how to install the program.

3. Register the disk array for control by Resource Manager 9500V.
4. Set the system parameters using the appropriate installation guide for the desired host platform(s).
5. Reboot the disk array to complete the configuration.

## 6.4 Registering the Thunder 9530™ V Series Subsystem for Control by Resource Manager 9500V

To operate the array unit from Resource Manager 9500V, register the array unit. You cannot temporarily register a non-existing array unit.

1. On the **Add** menu, click **Register Array Unit** or click **Register Array Unit** button in the tool bar.
2. Input the **registration information** and click the **OK** button.
3. When a registration completion message appears, click the **OK** button.
4. The Main screen is updated and then displayed.

## 6.5 Configure the Thunder 9530™ V Series Subsystem for the Desired Application

Before configuring the 9530V make sure that you know the following:

- The required RAID level, based on performance and pricing criteria
- The number and size of LUNs you wish to create
- The controller path you wish to use to access the data on the LUNs
- If there are any special options that need to be set that are specific to the host platform(s) being used. These will be detailed in the Host Installation Manual for the host platform being used.

## 6.6 General Configuration of the Thunder 9530™ V Series Subsystem

Activating Management mode in Resource Manager 9500V will enable you to do a general configuration of the 9530V subsystem. Before it is possible to configure the 9530V, management mode must be enabled in Resource Manager 9500V. Otherwise, it is only possible to monitor the status of the 9530V.

To enable Management mode:

1. On the **Settings** menu, click **Password**.
2. Enter **New Password** and **New Password** (for confirmation) and click the **OK** button. Specify a password of up to 12 alphanumeric characters.
3. On the **File** menu, click **Change Mode** or click **Change Mode** button in the tool bar.
4. When the **password-input** screen appears, input a password and click the **OK** button. **Management Mode** is displayed in **Active Mode**: in the upper part of the Main screen. The Resource Manager 9500V program will operate in **Management Mode**.

## 6.7 Starting the Parameter Wizard in Resource Manager 9500V

1. Click the icon of an array unit on the Main screen.
2. Select the **Settings** menu, click **Display Details**. Or, click the **Display Details** button in the tool bar.
3. On the **Settings** menu, select **System Parameter Wizard** or click **System Parameter Wizard** button in the tool bar.

## 6.8 Configuring the Basic Parameters for the Thunder 9530™ V Series Subsystem

Set the system parameters in the Wizard format.

1. On the **Settings** menu, select **System Parameter Wizard** or click **System Parameter Wizard** button in the tool bar.
2. Click the **Basic Settings**. Click the **Next** button.

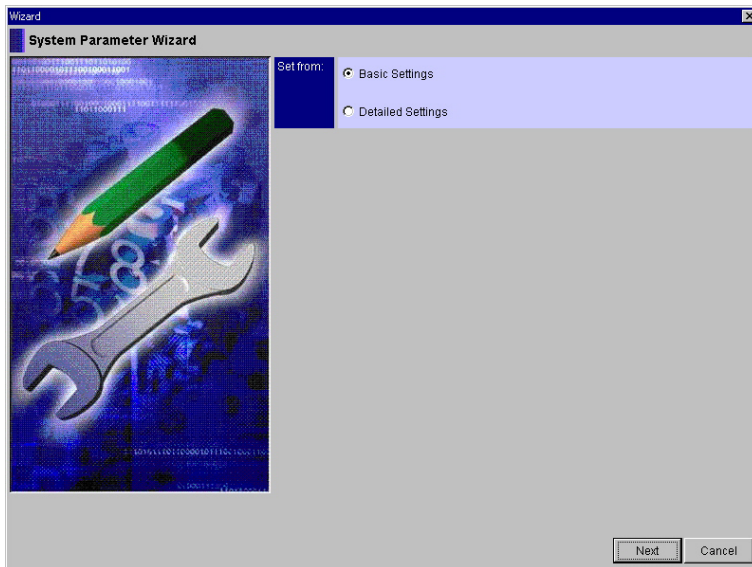

- The system parameter window is displayed, starting with **System Startup Settings**. The window displays the items that are currently set. Check the displayed contents on the window and set each displayed item to the desired configuration.

To perform the next setting, click the **Next** button. When you click the **Back** button, the previous window will appear.

To stop the setting, click the **Cancel** button.

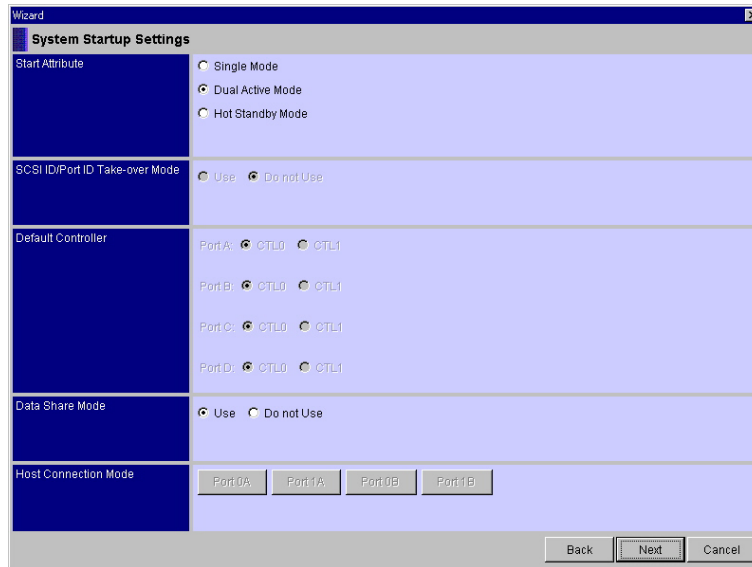

- Common 1, Option 1, and Option 2** screens are shown. Perform the settings for each item. For options, you can make multiple selections.
- The window for the **Option 2** setting is the final window. Click the **Next** button, then displayed **Detailed Settings**.

If you set the **Detailed Settings** items in succession, select **Yes** or select **No**, and then click the **Next** button.

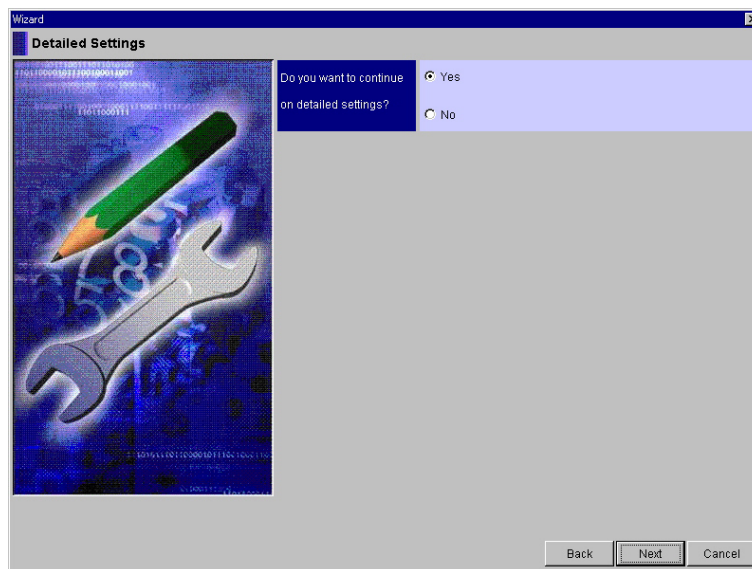

When you select **No**, the **System Parameter Setting Completed** screen will be displayed.

When the setting is completed, restart the array unit; connect it to the host and the Resource Manager 9500V program.

# Chapter 7 Configuring Storage on the Thunder 9530™ V Series Subsystem

The process of configuring storage on the 9530V subsystem involves the following sub-processes:

- Software Composition
- Setting Fibre Channel Information
- Determining Space and RAID Level Requirements
- Setting Host Group Information
- Transferring Configurations from One Array to Another
- Storing Configuration Data
- Applying Configuration Data to an Additional Thunder 9530™ V Series Subsystem
- Setting the Subsystem when Using Special Mode

## 7.1 Software Composition

This section includes the following:

- Microprogram
- System Parameters
- Configuration Information
- SNMP Information
- Storage for Parameters

### 7.1.1 Microprogram

A microprogram controls basic hardware operations which accompany the execution of given instructions performed by a CPU. The version of the microprogram is controlled by the following numerical format: **xxxx/x**.

The microprogram for fibre channel, **065x/x** (x is optional) is available. However, /x may not be included in the microprogram version number or another control system may control the microprograms.

### 7.1.2 System Parameters

System parameters are necessary to start the subsystem (from turning on the main switch to generation of the READY LED (green)). System parameters are stored in flash memory.

### 7.1.3 Configuration Information

The configuration information is a record of customer data on the subsystem, such as the RAID configuration and LU capacity. The configuration information exists in the disk drive when the main switch is turned off; it is transmitted onto the main memory of the controller when the main switch is turned on. When configuration information is changed, the information on the disk drive is updated simultaneously.

### 7.1.4 SNMP Information

The SNMP parameter enables the SNMP function to operate effectively. When SNMP information activates the SNMP function, the template contained in the SNMP information (in the SNMP directory on the provided CD-R) is edited and registered in the subsystem.

### 7.1.5 Storage for Parameters

The storage areas where the parameters on the controller are stored are described in the following table:

**Table 7.1 Storage for Parameters**

No.	Parameter	Storage	Description
1	Fixed Part Program Flash Program System Parameters	Flash Memory (and backup FD)	The parameters are stored in flash memory. No provision of storage against a power shut off is required for the parameters because flash memory can retain information when power is shut off.  Parameters can be backed up to the following: <ul style="list-style-type: none"><li>• Fixed part program: Cannot be backed up program</li><li>• Flash program: Automatically backed up to the system area</li><li>• System parameters: Automatically backed up to the disk drive</li></ul>
2	Microprogram Configuration Information SNMP Information	Disk Drive (System Area)	Generally, information in a RAM is erased when the main switch is turned off. Therefore, the subsystem also stores the parameters used on the RAM on the disk drive. (An area is reserved in the disk drive to store them. This area is called the system area.)  The system area is provided on the disk drives #0 to #4 in the RK frame. Therefore, the system area has redundancy for disk drives #0 to #4 in the RK frame.

## 7.2 Setting Fibre Channel Information

Follow the steps below to set and display fibre channel information:

**Note:** Back up all data before performing this procedure. (If a mistake in operation is made, user data in the subsystem can be lost.)

1. Turn on the power supply.
2. Start the Resource Manager 9500V program and set the operation mode in the **Maintenance Mode**.
3. Click the icon of an array unit on the Main window and select the **Settings** menu. Click **Display Details** or click the **Display Details** button in the tool bar.
4. On the **Settings** menu, click **Configuration Settings** or click the **Configuration Settings** button in the tool bar.
5. Click the **Fibre Channel** tab.
6. Set a **Port Address**, **Topology Information**, **Transfer Rate**.  
**Port Address:** Port address is displayed as a hexadecimal number.  
**Topology Information:** Indicates the topology status.  
**Transfer Rate:** Indicates the fibre transfer rate.
7. Click the **Apply** button.
8. A confirmation message appears. After verifying that the I/O operation initiated by the host has stopped, click the **OK** button.
9. A message appears, stating that the setting is completed. Click the **OK** button.

## 7.3 Determining Space and RAID Level Requirements

This process will depend on the customer requirements, however Hitachi Data Systems recommends certain configuration guidelines that will provide good performance and adequate protection of data integrity in most circumstances.

This function can be used in the device ready state (R/W cannot be executed from the host in operation. When a host command is received, Not Ready is reported to the host computer).

This section includes:

- Setting a Spare Disk
- Setting a RAID Group
- Setting a Logical Unit

### 7.3.1 Setting a Spare Disk

The spare disk has been set at the factory before shipment; it is not necessary to set it. Details of the setting are shown below.

**Table 7.2 Spare Disk Settings**

Unit Name	Number of Spare Disk Drive
Thunder 9531V	Number 13
Thunder 9532V	Number 13
Thunder 9533V	Number 13

To set a spare disk, follow these steps:

**Note:** Disk drives that can be set as spare drives do not yet have a defined RAID group; this excludes disk drive #0 to #4 in Unit 0.

1. Turn on the power supply.
2. Start the Resource Manager 9500V program and set the operation mode in **Maintenance Mode**.
3. Click the icon of an array unit on the Main window, and then select the **Settings** menu. Click **Display Details** or click the **Display Details** button in the tool bar.
4. On the **Settings** menu, select **Configuration Settings** or click **Configuration Settings** button in the tool bar.
5. Click the **Spare Drive** tab.
6. To set up the spare drive, double-click the icon of the disk drive to be setup as a spare drive.
7. The confirmation message for spare drive setup is displayed. Click the **OK** button.

8. A message indicating that the setting is complete is displayed. Click the **OK** button. The icon of the disk drive that is set up is updated and displayed.

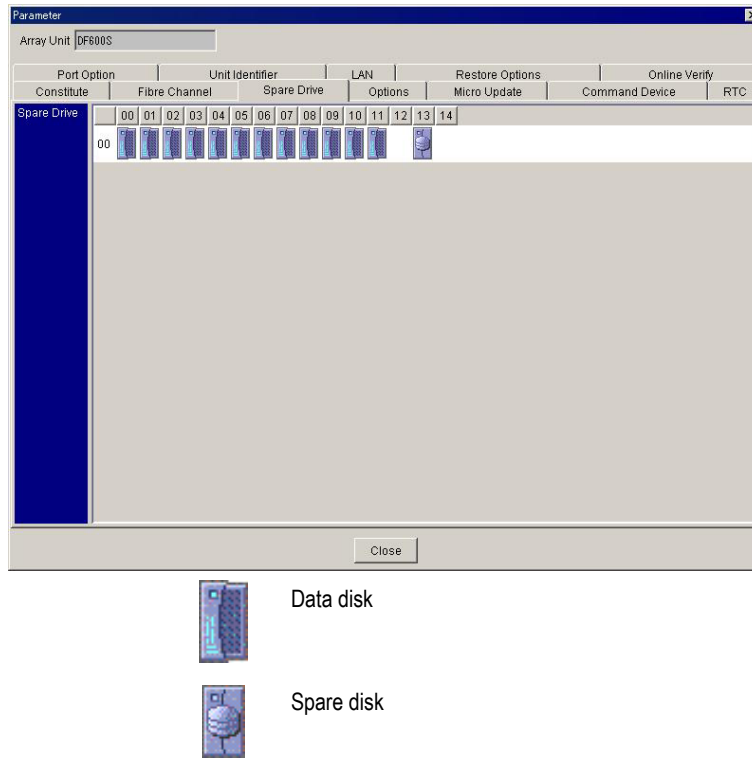

Figure 7.1 Spare Disk Tab Screen

### 7.3.2 Canceling a Spare Disk Setting

To cancel a spare disk setting, follow these steps:

1. On the **Settings** menu, click **Configuration Settings** or click the **Configuration Settings** button in the tool bar.
2. To cancel the spare drive setup, click the icon of the disk drive to be canceled.
3. The confirmation message for spare drive canceled is displayed. Click the **OK** button.
4. A message is displayed, stating that the setting is complete. Click the **OK** button.

### 7.3.3 Setting a RAID Group

The RAID group has been set at the factory before shipment; it is not necessary to set it. Details of the setting are shown below.

Table 7.3 RAID Group Setting

Unit Name	RAID Level	Number of Disk Drive
Thunder 9531V	3D+1P	Number 1 to 4
Thunder 9532V	(3D+1P)×2	Number 1 to 8
Thunder 9533V	(5D+1P)×2	Number 1 to 12

To set a RAID group, follow these steps:

1. Turn on the power supply.
2. Start the Resource Manager 9500V program and set the operation mode in the **Maintenance Mode**.
3. Click the icon of an array unit on the Main window. Select the **Settings** menu and click **Display Details** or click the **Display Details** button in the tool bar.
4. Click the **Logical Status** tab.
5. Click the top drive of a selected RAID. The drive that is selected is displayed.
6. Hold down the **shift** key and click the last drive of the RAID group to be created. The drives of the RAID group to be created are enclosed by a **rectangular** box.
7. On the **Settings** menu, select **RAID Group**, and click the **Settings**. Alternatively, click **RAID Group Settings** button in the tool bar.

This operation can also be completed from the context menu of the **RAID Group** box.

8. Select a RAID level and click the **OK** button.
9. A message appears, stating that the setting is complete. Click the **OK** button. The set RAID group is updated and the window is displayed.

If the RAID group setting is not successful, delete the affected RAID group and try creating the RAID group again.

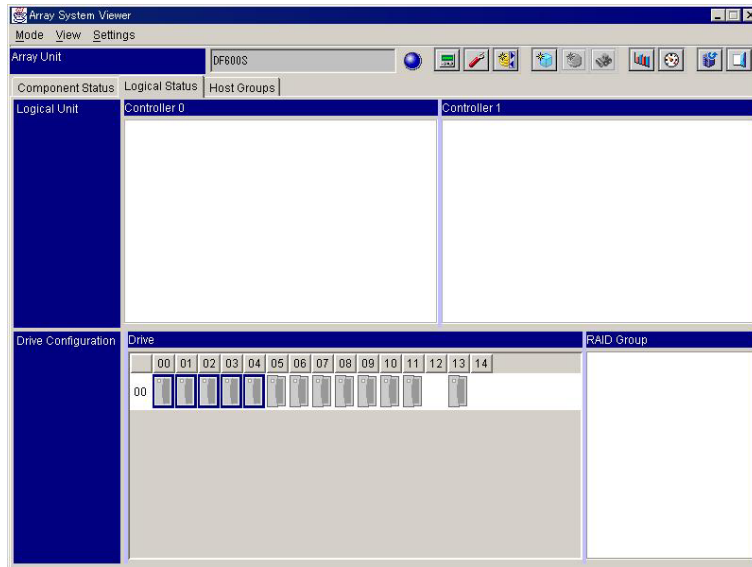

**Figure 7.2** Select the Disk Drive

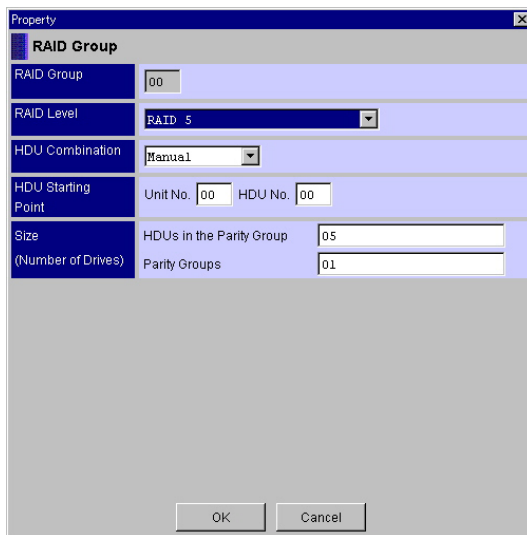

**Figure 7.3** Setting the RAID Group Property

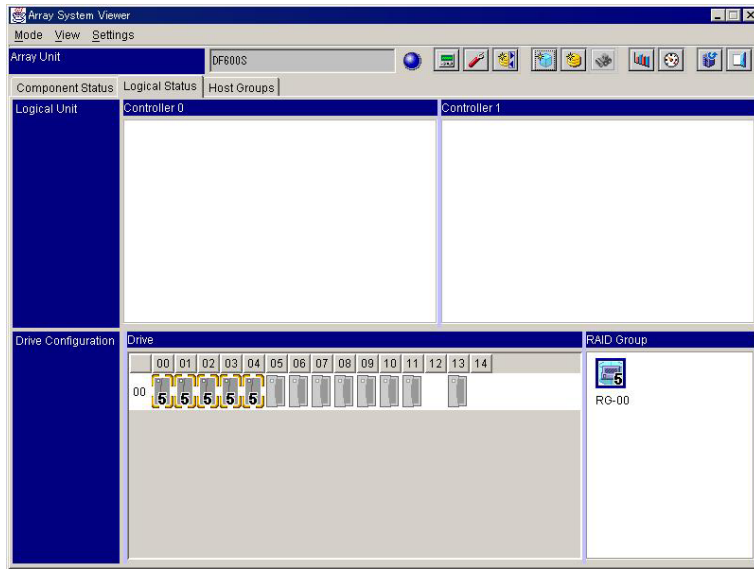

Figure 7.4 Set RAID Group is Updated

## 7.3.4 Deleting a RAID Group

This section includes the following:

- Deleting All RAID Groups
- Deleting a Specified RAID Group

### 7.3.4.1 Deleting All RAID Groups

To delete all RAID groups, follow these steps:

**Note:** All user data on all LUNs will be lost if all RAID groups are deleted. Backup the user data before performing this operation.

The unified LU cannot be unified or split unless the LU unifying function (a priced option) is validated. When a unified LU is defined, the RAID group cannot be deleted. Delete the RAID group after splitting all the unified LUs in the RAID group. For the procedure for splitting a unified LU, refer to the **LU Unifying Function User's Guide**.

1. Click the **Logical Status** tab on the Unit screen.
2. On the **Settings** menu, select **RAID Group** and click the **Delete All**.
3. A message appears, requesting confirmation to delete all RAID groups. Click the **OK** button.

The deleted RAID group is updated and a window is displayed.

### 7.3.4.2 Deleting a Specified RAID Group

**Note:** All user data on all LUNs will be lost if all RAID groups are deleted. Backup the user data before performing this operation.

If the “Unified LU” function has been enabled, make sure that no unified LUs are present in the RAID group to be deleted. It will be impossible to delete a RAID group containing unified LUs until the unified LUs are split.

Delete the RAID group after splitting all the unified LUs in the RAID group. Refer to the **LU Unifying Function User’s Guide** for the procedure for splitting a unified LU.

When a logical unit is deleted, user data is erased. Perform the deletion after verifying the number of the logical unit to be deleted and backing up the data.

To delete a specified RAID group, follow these steps:

1. Click the **Logical Status** tab on the Unit screen.
2. Click the icon of a RAID group on the Unit screen. On the **Settings** menu, select **RAID Group** and click **Delete Specified RAID Group**.
3. A message appears, requesting confirmation to delete the specified RAID group. Click the **OK** button.

The deleted RAID group is updated and the window is displayed.

### 7.3.5 Setting a Logical Unit

The logical unit has been set at the factory before shipment; it is not necessary to set it. Details of the setting are shown below.

**Table 7.4 Logical Unit Setting**

Unit Name	Number of Logical Unit	Size of Logical Unit (Gbytes)
Thunder 9531V	0	202.7
Thunder 9532V	0	202.7
	1	202.7
Thunder 9533V	0	337.8
	1	356.6

To set a logical unit, follow these steps:

1. Turn on the power supply.
2. Start the Resource Manager 9500V program and set the operation mode in the **Maintenance Mode**.
3. Click the icon of an array unit on the Main window. Select the **Settings** menu and click **Display Details** or click the **Display Details** button in the tool bar.

4. Click the **Logical Status** tab on the Unit screen.
5. Click the icon of a logical unit on the Unit screen. On the **Settings** menu, select **Logical Unit** and click the **Settings**. Alternatively, click the **Logical Unit Settings** button in the tool bar.

This operation can also be completed from the context menu of the **Logical Unit** box.

6. Select a controller in charge in the **Default** box and enter the size in Gigabytes, Megabytes or blocks.
7. A created logical unit number is displayed for the **Logical Unit No.** and the RAID group number in which logical units are defined for the **RAID Group**. Additionally, a logical unit capacity that can be created is displayed.

**Note:** To specify a size explicitly in figures, select a unit to specify the size from among the **GB**, **MB**, and **Block**. Specify the size to be allocated in decimal number. The subsystem can be divided into a maximum of 512 logical units.

**Note:** The logical unit number may be set optionally when the logical unit is created. However, logical unit number 0 is assigned to the logical unit created first.

8. After the setting is complete, click the **OK** button.
9. The set logical unit information is updated and the window is displayed.

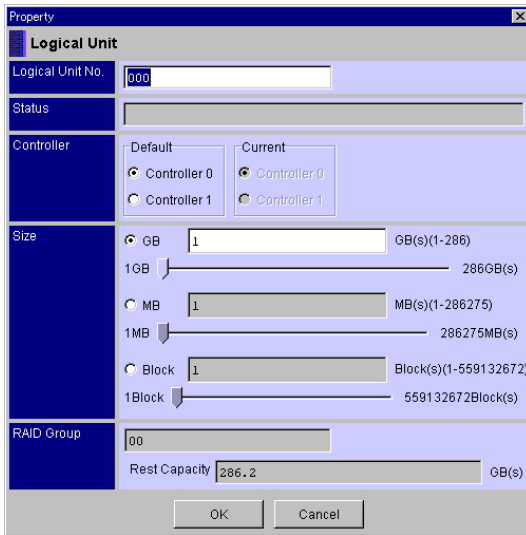

**Figure 7.5** Setting the Logical Unit Property

### 7.3.6 Deleting the Last Logical Unit

To delete the last logical unit, follow these steps:

**Note:** The last logical unit is the final logical unit, which is unified. Delete the final logical unit after verifying its number.

When any logical unit is deleted, the user data in the logical unit will be lost.

1. Click the **Logical Status** tab on the Unit window.
2. On the **Settings** menu, select **Logical Unit** and click **Delete Last Defined Logical Unit**.
3. A confirmation message is displayed indicating whether or not the last logical units should be deleted.

Click the **OK** button, and last logical units will be deleted. When any logical unit is deleted, the user data in the logical unit will be lost.

The logical unit information in which the last logical unit has been deleted is updated and the window is displayed.

### 7.3.7 Invalidating a Logical Unit

To invalidate a logical unit which has already been set, follow these steps:

1. Click the **Logical Status** tab on the Unit window.
2. Click the icon of the logical unit to be invalidated.  
On the **Settings** menu, select **Logical Unit** and click **Invalidate**.
3. A message appears, inquiring whether or not the logical unit should be invalidated.  
Click the **OK** button, and logical unit will be invalidated.
4. On the **View** menu, click **Refresh**.

The logical unit information in which the logical unit has been invalidated is updated and the window is displayed.

### 7.3.8 Restoring a Logical Unit

To restore a logical unit which has already been invalidated, follow these steps:

1. Click the **Logical Status** tab on the Unit window.
2. Click the icon of a logical unit to be restored.  
On the **Settings** menu, select **Logical Unit** and click **Restoration**.
3. A message appears, inquiring whether or not the logical unit should be restored.  
Click the **OK** button, and the logical unit will be restored.
4. On the **View** menu, click **Refresh**.

The logical unit information in which the logical unit has been restored is updated and the window is displayed.

### 7.3.9 Reallocating a Logical Unit

To reallocate a logical unit which has been invalidated, follow these steps:

1. Click the **Logical Status** tab on the Unit window.
2. Click the icon of the logical unit to be reallocated.

On the **Settings** menu, select **Logical Unit** and click **Reallocate**.

The **Logical Unit Reallocation** dialog box is displayed.

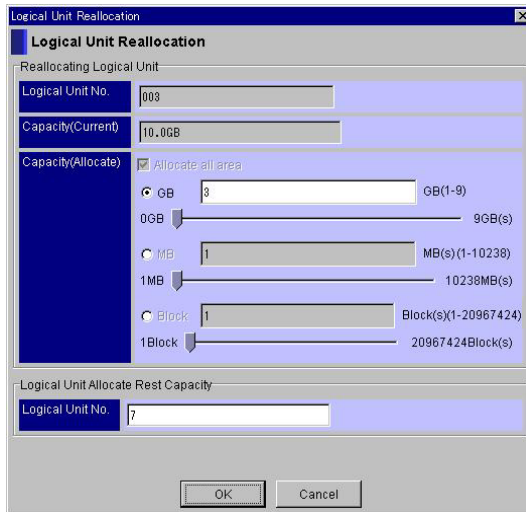

3. Input a capacity to be reassigned.  
**Note:** The capacity to be reassigned can be specified within a range not larger than that of the logical unit invalidated.
4. Click the **OK** button.
5. A message appears inquiring whether or not the logical unit should be reallocated. Click the **OK** button, and logical unit will be reallocated.
6. On the **View** menu, click **Refresh**.  
The logical unit information in which the logical unit has been reallocated is updated and the window is displayed.

### 7.3.10 Formatting a Logical Unit

There are two methods of formatting a logical unit:

- **Online Format**

Specified logical units are formatted one by one and the progress of the formatting is displayed.

- **Offline Format**

If multiple logical units are specified, up to six logical units are formatted concurrently, and the progress of formatting is displayed.

When the logical units are configured for each drive, the time required for the formatting is reduced by 30 to 50 (%).

To format a logical unit, follow these steps:

**Note:** When formatting a logical unit with a logical unit capacity less than 100,000 (blocks), formatting may terminate abnormally. When formatting a logical unit with a logical unit capacity of 100,000 (blocks), select **Online Format**.

1. Click the icon of a logical unit on the Unit window. On the **Settings** menu, select **Logical Unit** and click **Online Format** or **Offline Format**.

When you select multiple logical units, hold down the **Ctrl** key and click the icons of the logical units to format.

2. A confirmation message appears and confirms whether or not the selected logical units may be formatted.

**Note:** When a specified logical unit is formatted, the user data within the specified logical unit is lost. When incorrectly specifying an logical unit, press the **Cancel** button and redo processing by selecting an logical unit to be reformatted.

3. Click the **OK** button to format the specified logical units.
4. When a message is displayed indicating that the specified logical unit has been formatted, click the **OK** button.

If formatting is terminated abnormally, see the contents of the result.

The formatted logical information is updated and the window is displayed.

**Table 7.5 Formatting Message**

Displayed	Action to be taken
02-xxxx, 03-xxxx, 04-xxxx or 0B-xxxx	For the above code, a hardware fault is assumed. If the fault is not recovered after re-execution, contact Hitachi Data Systems.
05-xxxx	For the above code, an operation error is assumed. Upon checking the following items and re-execute processing. If the error is not recovered, contact Hitachi Data Systems.
05-2500 or 05-2581	Is logical unit 0 defined?
05-2600	In spite of none of drive mounted states, is ALL RAID specified and is a logical unit specified for ALL CAPA formatted?
05-2580	Is an attempt made to define a logical unit exceeding the capacity of the defined RAID group?
0B-FD01	Switching of a controller in charge of a logical unit occurred during formatting. Check the controller in charge and re-execute formatting from the controller in charge.
An error occurred in the communication with an array device.	The message indicating that <b>An error occurred in the communication with an array device.</b> at the time when selecting <b>Online Format</b> is output since the progress window cannot be displayed due to the interface failure between the Resource Manager 9500V program and a device. For logical unit formatting, only the logical unit being executed is continuously formatted.

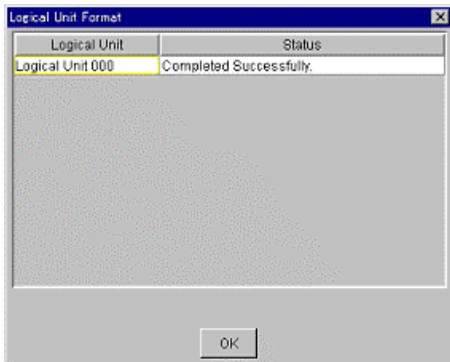

**Figure 7.6 Logical Unit Format screen**

### 7.3.11 Changing the Default Controller in Charge of an LU

**Note:** The controller in charge of a default LU can be changed only for the dual active mode configuration of a dual system.

To change the controller in charge of a default LU, follow these steps:

1. Start the Resource Manager 9500V program and set the operation mode in the **Management Mode**.
2. Click the icon of an array unit on the Main window and select the **Settings** menu. Click **Display Details** or click the **Display Details** button in the tool bar.
3. Click the **Logical Status** tab on the Unit screen.
4. Click the logical unit for which you want to change ownership.  
Resource Manager confirms by highlighting a box around the chosen LU.
5. On the **Settings** menu, select **Logical Unit** and select **Change Default Controller**.  
A message appears, requesting confirmation to change the default controller.
6. Click the **OK** button and default controller in charge of a logical unit will be changed.
7. A message appears, stating that the setting is complete. Click the **OK** button.

## 7.4 Setting Host Group Information

In the 9200, the Host Connection Mode was set for each port, and the port and host to be connected each other were fixed. In the 9530V, the Host Connection Mode, the mapping information of Logical Unit, and LUN security information are set to the group of hosts, not to the host. This enables you to select the host computer to which the subsystem is connected depending on each group of hosts.

For this version, only the Host Group 0 is supported. When only the host group 0 is used, the same functions that can be used in 9200 are available.

### 7.4.1 Setting the Mapping Information

Modify Host Group Option is a function that integrates the Host Connection Mode 1 and 2 on the System Parameter in the 9200.

1. On the unit window, click the **Host Groups** tab.
2. On the unit window, double-click the **Controller** to be set for the connection mode with the host. Display the **Host group 0** by double-clicking the **Port**.

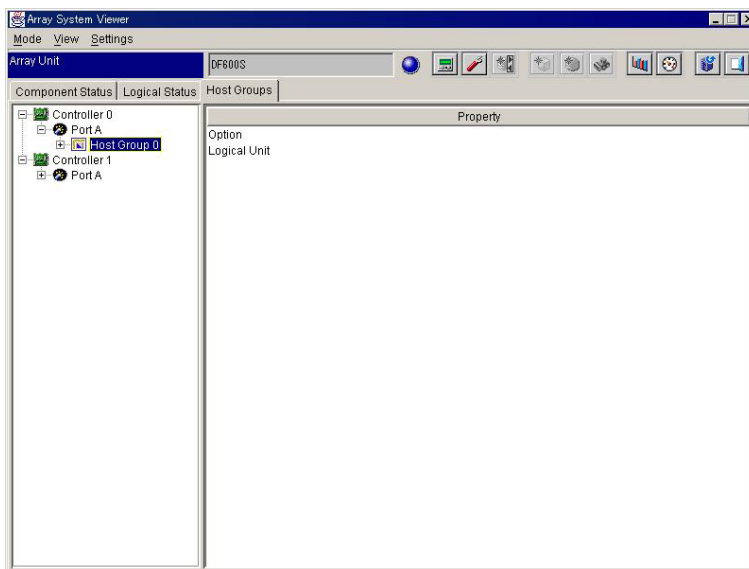

3. On the **Settings** menu, select **Mapping Mode** and click **Enable**.

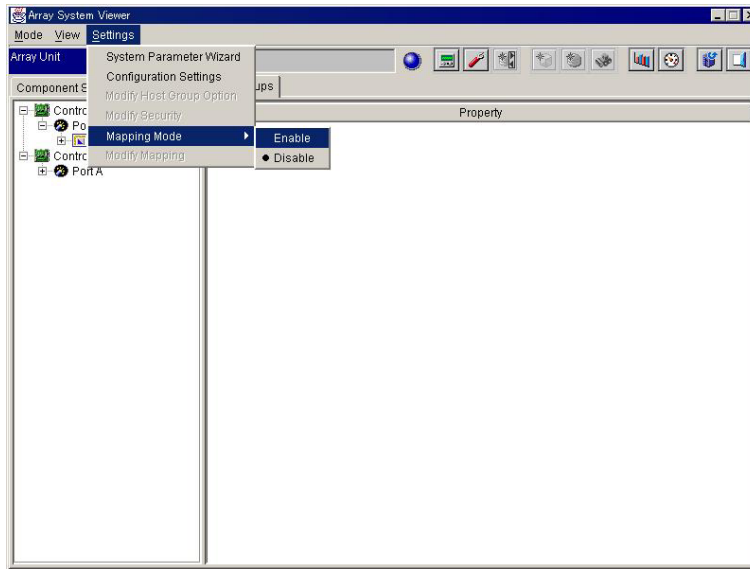

4. A message appears; click the **OK** button.

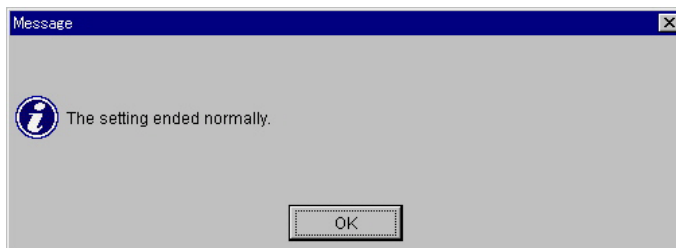
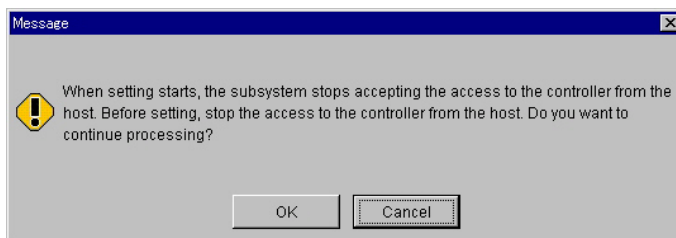
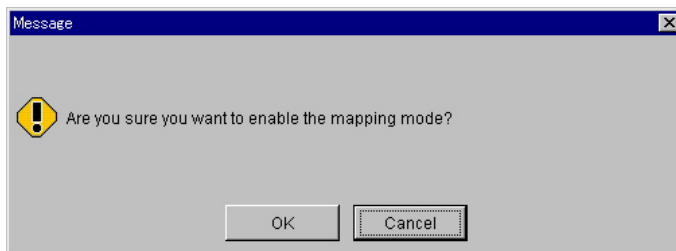

5. Click the Logical Unit.

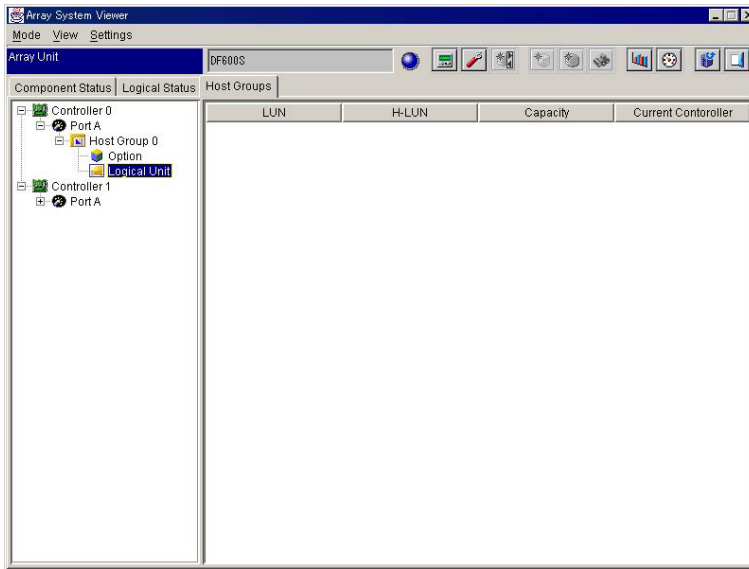

6. On the Settings menu, select Modify Mapping.

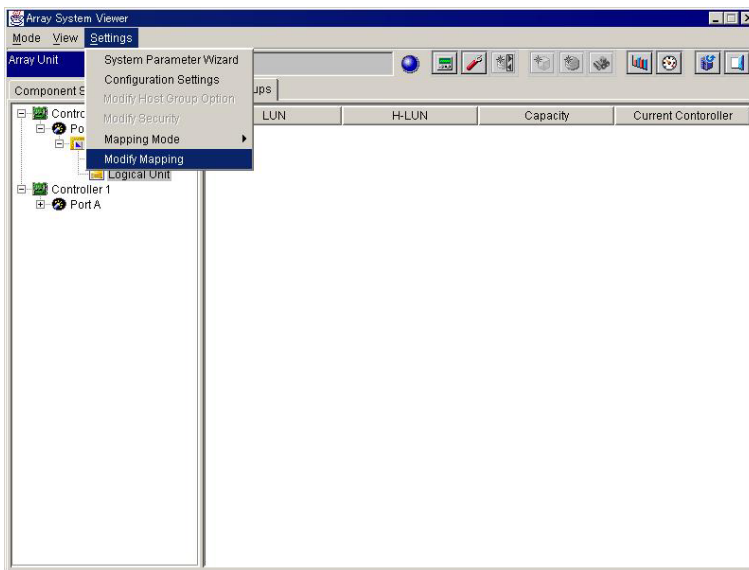

7. Select one **LUN** and one or more **Host LUNs**. Click the  button. The added specification is displayed in the **Reserved Configuration**. For the **Host LUN**, multiple selections can be made.

To delete LUN mapping information, select the line that you want to delete from the **Reserved Configuration**, and click the **Delete** button. The deleted specification disappears from the **Reserved Configuration** display.

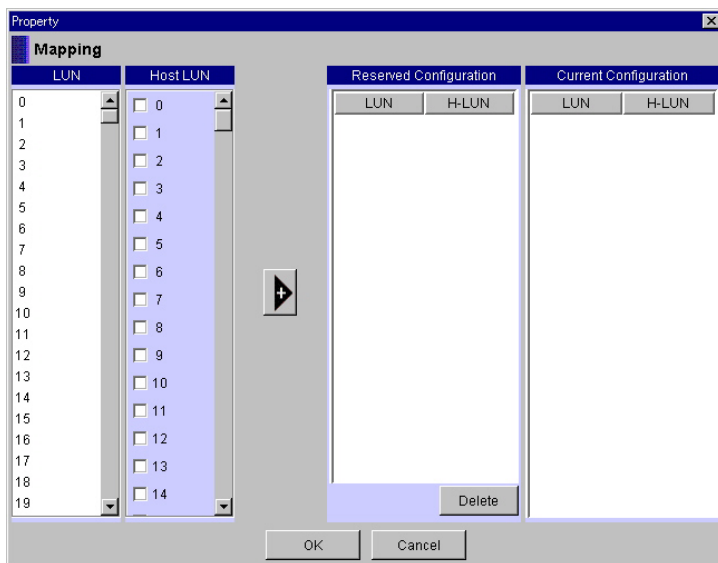

8. A message appears; click the **OK** button.

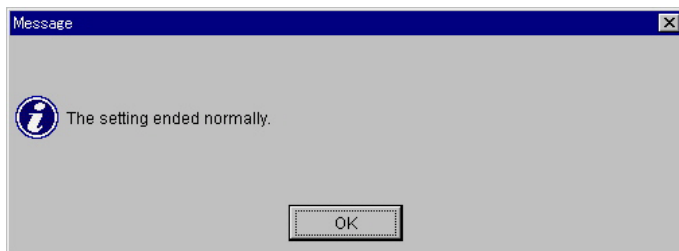
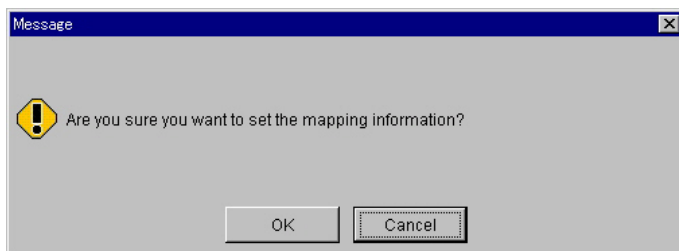

The mapping information is updated and the following window is displayed.

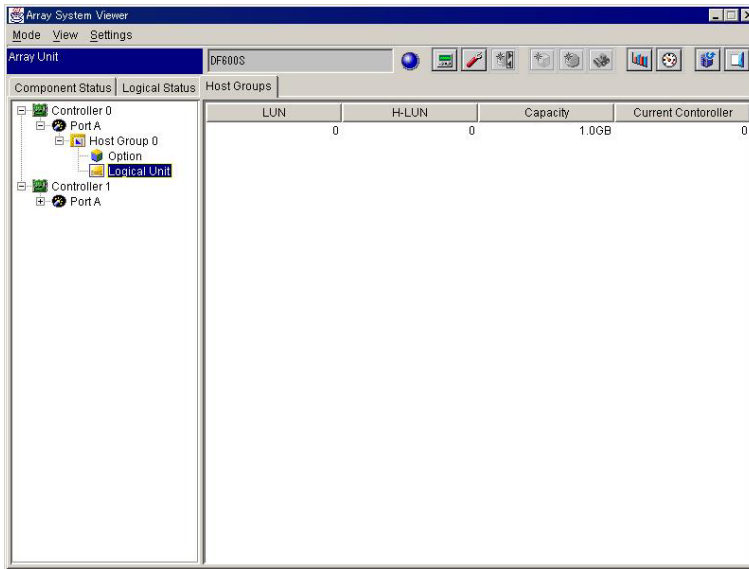

## 7.5 Transferring Configurations from One Array to Another

Output the configuration information of the array unit in a text file or set configuration using a text file. The configuration information output in a text file includes the status of the system parameters, RAID group/logical unit and the constituent parts of the array unit. The configuration to be set includes the system parameters and RAID group/logical unit. The status of the constituent parts of the array unit cannot be set.

Configuration information is handled with separate text files for the system parameters and for RAID group/logical unit.

Copying configuration information between array units can be executed by outputting a text file of the configuration from an array unit, then using the output text file to set another array unit.

**Note:** IP addresses will be reset based on file input. The user must edit the text file to include the correct IP addresses in order to transfer a configuration from one unit to another.

Editing a text file to set an array unit can be executed, but it is recommended that this function be used for the configuration of the same array unit. To change the configuration, use individual functions.

## 7.6 Storing Configuration Data

This section includes the following:

- System Parameter Information
- RAID Group/LU Information
- Port/Host Group Information

### 7.6.1 System Parameter Information

To output the setting of the system parameters for an array unit in text form to a specified file:

1. On the **Settings** menu, select **Configuration Settings** or click **Configuration Settings** button in the tool bar.
2. Click the **Constitute** tab.

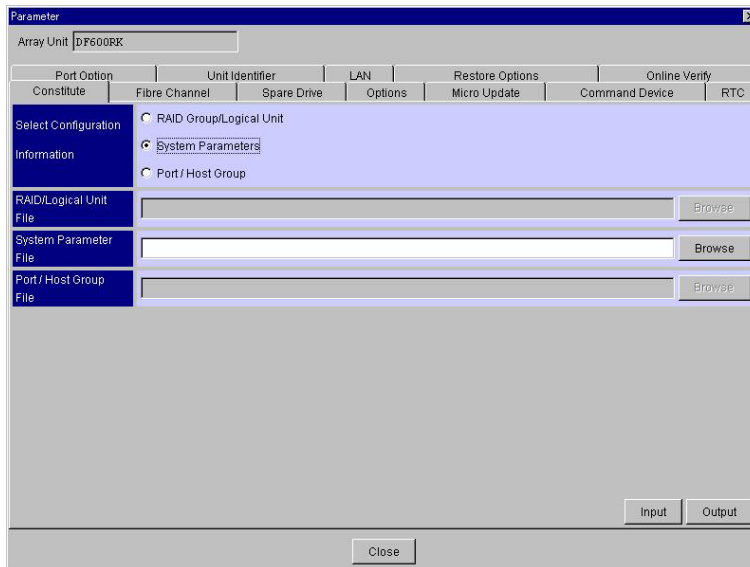

3. Check the **System Parameters** in the **Select Configuration Information** box.
4. Click the **Browse** button. Specify the directory and file name to which the configuration file will be output.
5. Click the **Output** button.

- When a message appears, confirm that the system parameter information is output with the specified file name. Click the **OK** button.

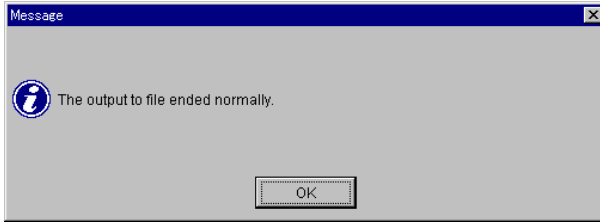

System parameter information is saved in the form of a text file with the specified file name.

## 7.6.2 RAID Group/LU information

To output the RAID group/logical unit definition information already set in an array unit to a specified file in a text format:

- On the **Settings** menu, select **Configuration Settings** or click **Configuration Settings** button in the tool bar.
- Click the **Constitute** tab.

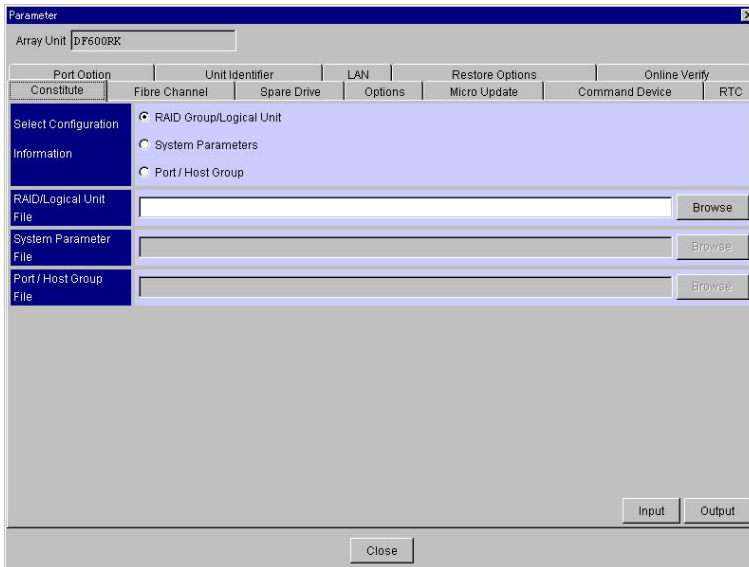

- Check **RAID Group/Logical Unit** in the **Select Configuration Information** box.
- Click the **Browse** button, and specify the directory and file name to output the file of the configuration.
- Click the **Output** button.

- A message appears, confirming that the system parameter information is output with the specified file name. Click the **OK** button.

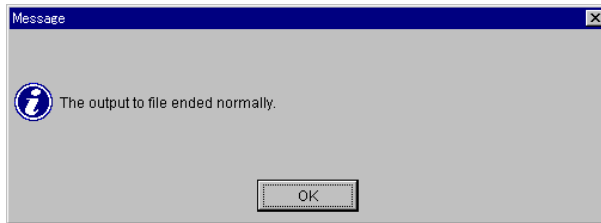

RAID group/LU information is saved in the form of a text file with the specified file name.

### 7.6.3 Port/Host Group Information

To output Port/Host group definition information previously set in an array unit to a specified file in a text format:

- On the **Settings** menu, select **Configuration Settings** or click **Configuration Settings** button in the tool bar.
- Click the **Constitute** tab.
- Check the **Port/Host Group** in the **Select Configuration Information** box.

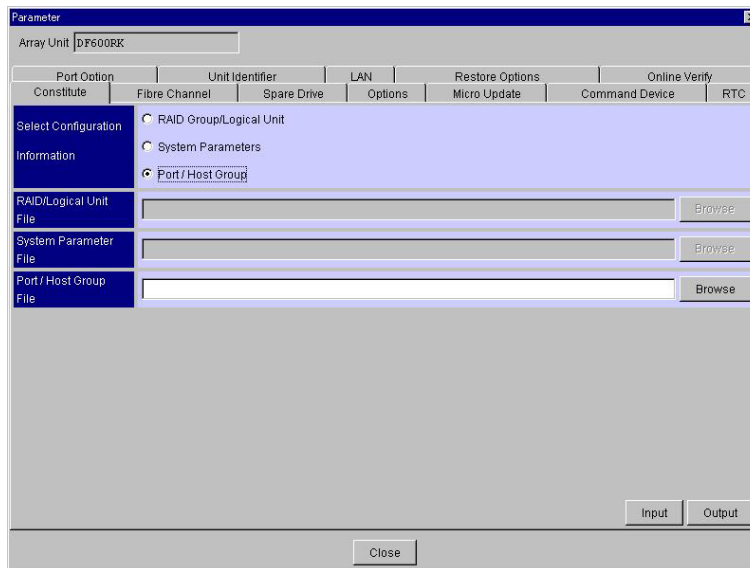

- Click the **Browse** button, and specify the directory and file name to output the file of the configuration.

5. Click the **Output** button.

A message appears, confirming that the system parameter information is output with the specified file name. Click the **OK** button.

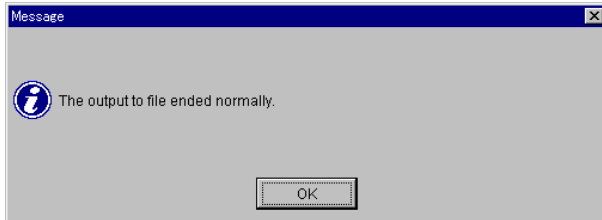

Port/Host group information is saved in the form of a text file with the specified file name.

## 7.7 Applying Configuration Data to Another Thunder 9530™ V Series Subsystem

This section includes the following:

- System Parameters
- RAID Group/Logical Unit
- Port/Host Group

### 7.7.1 System Parameters

Use the modes discussed in this section only when recommended by an Hitachi Data Systems Host or Optional Product installation guide.

Set the system parameters in the array unit with the information described in the file. If you set the system parameters using a file that was output when a priced optional feature is in an unlocked state, the setting may terminate abnormally. To set system parameters, use a file that was output when all priced optional features are in a locked state.

For a dual system, the setting cannot be executed if one of the controllers is detached. Confirm that the array unit is operating normally.

While the system parameters are being set, the array unit cannot execute commands from the host. The functions of Resource Manager 9500V can no longer work with the exception of the Wizard for setting the system parameters and failure monitoring. After setting, restart the array unit. Confirm that it is operating successfully, then connect to the host and the Resource Manager 9500V management program.

1. Edit the file for which you will set system parameters to set the array unit. This file has a specified format. The format of the file is the same as that of the file output by the array unit. To format a file, refer to the file output in 7.6 Storing Configuration Data.
2. On the **Settings** menu, select **Configuration Settings** or click **Configuration Settings** button in the tool bar.
3. Click the **Constitute** tab.
4. Click the **System Parameter** radio button.
5. Click the **Browse** button, and specify the directory and file name of the file that describes the system parameters edited in 1. The specified file name will be shown in the text box.
6. Click the **Input** button.

**Note:** To validate the set system parameters, restart the array unit. The previous settings stay valid until restarting. The array unit cannot access the host until the reboot is completed and the system restarts. Therefore, be certain the host has stopped accessing data before beginning the restart process.

## 7.7.2 RAID Group/Logical unit

**Note:** Back up all data before performing this procedure. All user data is lost when the logical unit is deleted.

Set the array unit according to the RAID group/logical unit setting information described in a file. If the setup of RAID group/logical unit is configured and completed, all user data previous data will be lost; RAID group/logical unit configuration as specified in the file will be set after deleting the current RAID group/logical unit. If user data is needed, configure the setting after backing up the system.

1. Edit the file for which you will set system parameters to set the array unit. This file has a specified format. The format of the file is the same as that of the file output by the array unit. To format a file, refer to the file output in 7.6 Storing Configuration Data.
2. On the **Settings** menu, select **Configuration Settings** or click **Configuration Settings** button in the tool bar.
3. Click the **Constitute** tab.
4. Click the **RAID Group/Logical Unit** radio button.
5. Click the **Browse** button, and specify the directory and name of the file that describes the RAID group definition and logical unit definition edited in 1. The specified file name will be shown in the text box.
6. Click the **Input** button.

To check the configuration, select the **Logical Status** tab.

## 7.7.3 Port/Host Group

1. Edit the file for which you will set system parameters to set the array unit. This file has a specified format. The format of the file is the same as that of the file output by the array unit. To format a file, refer to the file output in 7.6 Storing Configuration Data.
2. On the **Settings** menu, select **Configuration Settings** or click **Configuration Settings** button in the tool bar.
3. Click the **Constitute** tab.
4. Click the **Port/Host Group** radio button.
5. Click the **Browse** button, and specify the directory and name of the file that describes the RAID group definition and logical unit definition edited in 1. The specified file name will be shown in the text box.
6. Click the **Input** button.

## 7.7.4 Setting the Subsystem When Using Special Mode

This section includes the following:

- Using Resource Manager 9500V
- Using the I/O Bus Switching Function in the Sequent NUMA-Q Connection
- Using the Subsystem in LU Blockade Mode
- Using the WolfPack Mode
- Using VxVM (Version 3.2P2+PP or later) on the Host Side
- Making Nine or More LUs Recognized by Using Qlogic HBA or Emulex HBA on Windows 2000/NT
- Making LUs, Numbers 8 - 63 useable when the Subsystem is Connected to the HP Server
- Using the SUN Cluster 3.0
- Using the ftServer
- Using the Microsoft Cluster Server

### 7.7.4.1 Using Resource Manager 9500V

To set the subsystem from the Resource Manager 9500V, perform the following steps:

1. Start the Resource Manager 9500V program and set the operation mode in the **Management Mode**. Refer to the *Hitachi Freedom Storage™ Thunder 9500™ V Series Resource Manager 9500V User's Guide Graphical User Interface (GUI)*, MK-92DF605.
2. Click the icon of an array unit on the Main window, and then select the **Settings** menu. Click **Display Details** or click the **Display Details** button in the tool bar.

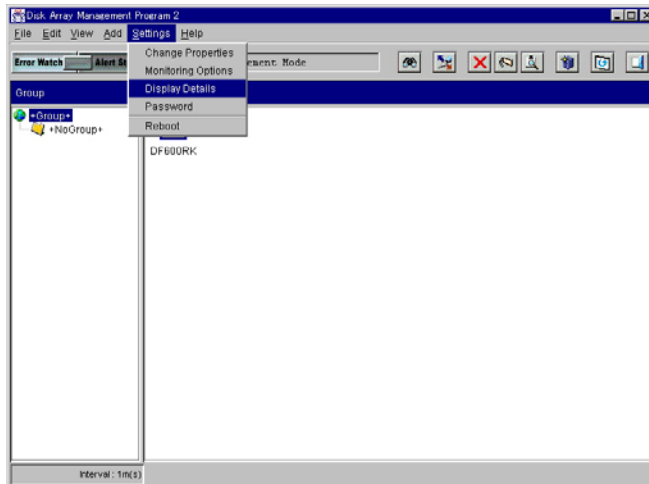

Perform the appropriate operation corresponding to the model to be set.  
For detailed operation, see the following table:

**Note:** The procedure for changing to special mode is performed when the host group setting is in normal mode.

**Table 7.6 Model Operations**

Operations	Page
Using I/O Path Switching Function in the Sequent NUMA-Q Connection	92
Using the Subsystem in LU Blockade Mode	92
Using the WolfPack Mode	97
Using VxVM (Version 3.2P2+PP or later) on the Host Side	100
Making Nine or More LUs Recognized by Using Qlogic HBA or Emulex HBA on Windows 2000	101
Making LUs, Numbers 8 – 63 when the Subsystem is Connected to the HP Server	101
Using the SUN Cluster 3.0	103
Using the ftServer	105
Using the Microsoft Cluster Server	107
Connecting the Subsystem as a Boot Disk or a Dump Device of an HP Server	109

### 7.7.4.2 Using the I/O Path Switching Function in Sequent NUMA-Q Connection

1. On the unit window, double-click the **Controller** to be set for the connection mode with the host. Display **Host group 0** by double-clicking the **Port**.
2. Display the **Option** and **Logical Unit** by double-clicking the **Host group 0**, select the **Option**.

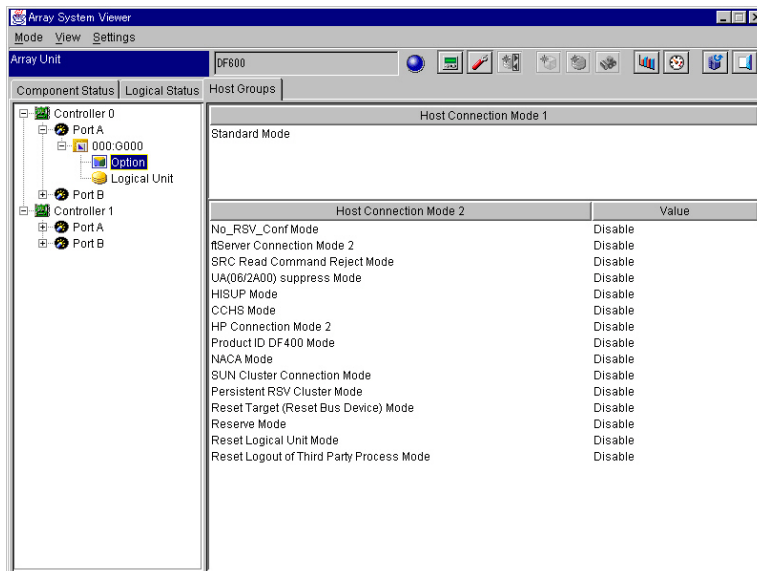

3. On the **Settings** menu, select **Modify Host Group Option**.

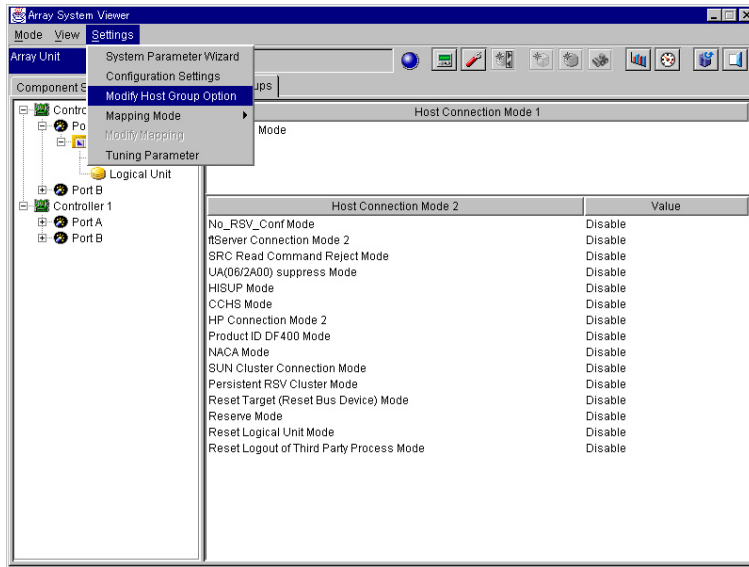

4. Select the **TRESPASS Mode** in **Host Connection Mode 1**. Click the **OK** button.

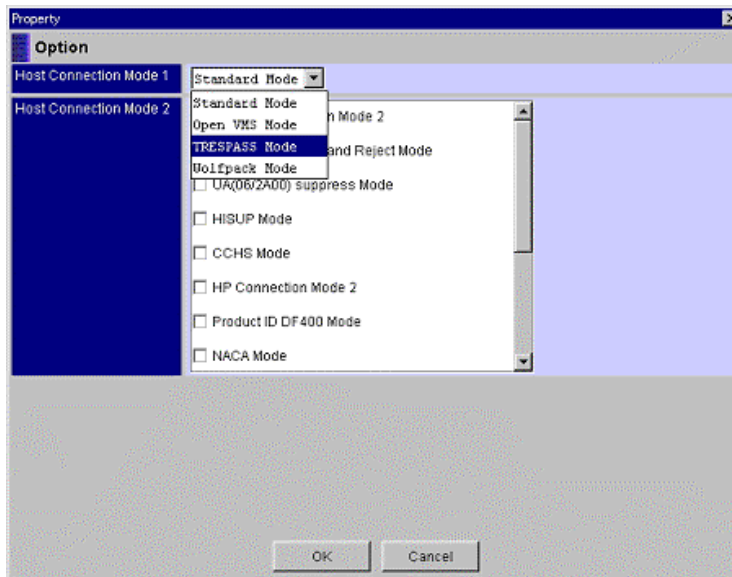

5. A message appears; click the **OK** button.

6. A message appears stating that the setting is complete. Click the **OK** button.

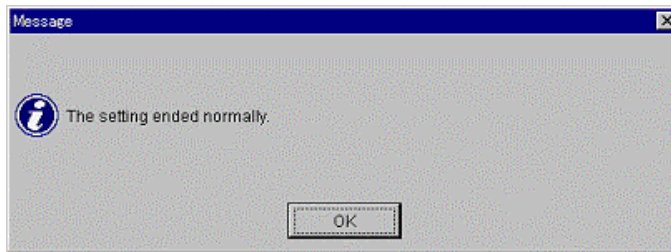

7. On the **Settings** menu, select **Configuration Settings** or click **Configuration Settings** in the tool bar.
8. Click the **Unit Identifier** tab.
9. After **Controller Option** is displayed, click **Enable** in the **Controller Identifier**.  
If nothing is input to a **Controller ID**, **DF600-00** (default value) is reported.

A controller identifier needs to be set for every device. When connecting only one device under control of a host computer, the default value can be used. From the second host computer the controller identifier needs to be changed.

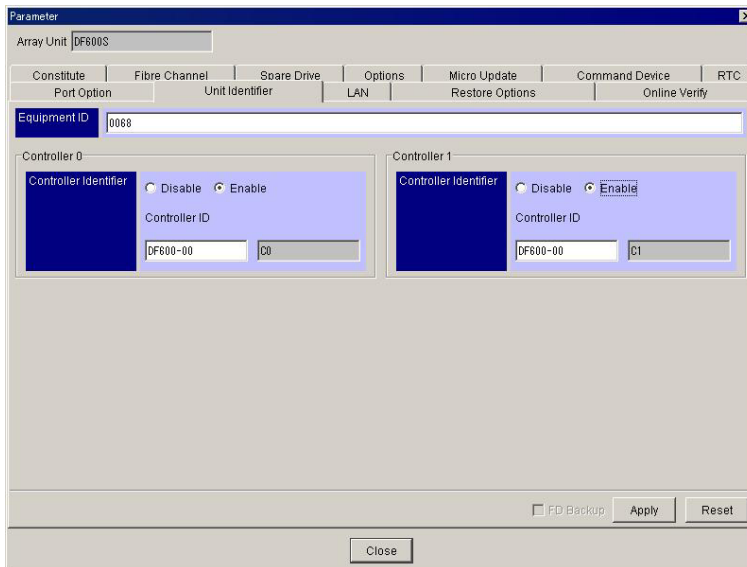

10. Click the **Apply** button.
11. A message appears, stating that the setting is complete. Click the **OK** button.

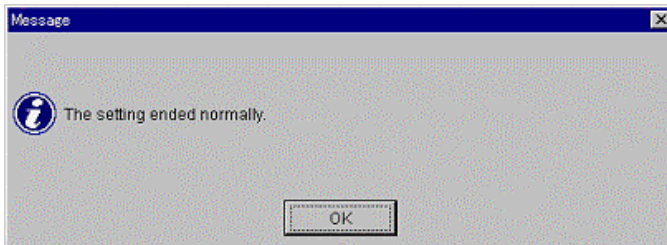

12. Click the **Close** button.

### 7.7.4.3 Using the Subsystem in LU Blockade Mode

1. On the Settings menu, click System Parameter Wizard or click the System Parameter Wizard in the tool bar.

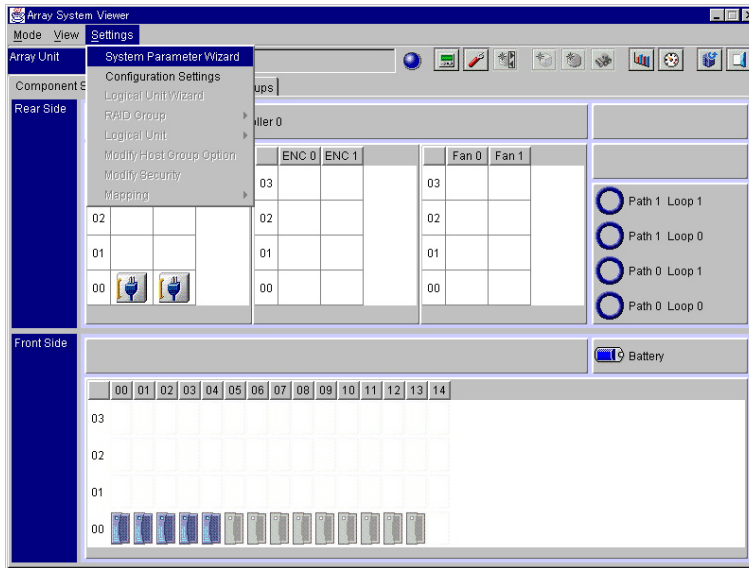

2. Click the Basic Settings, then click the Next button.

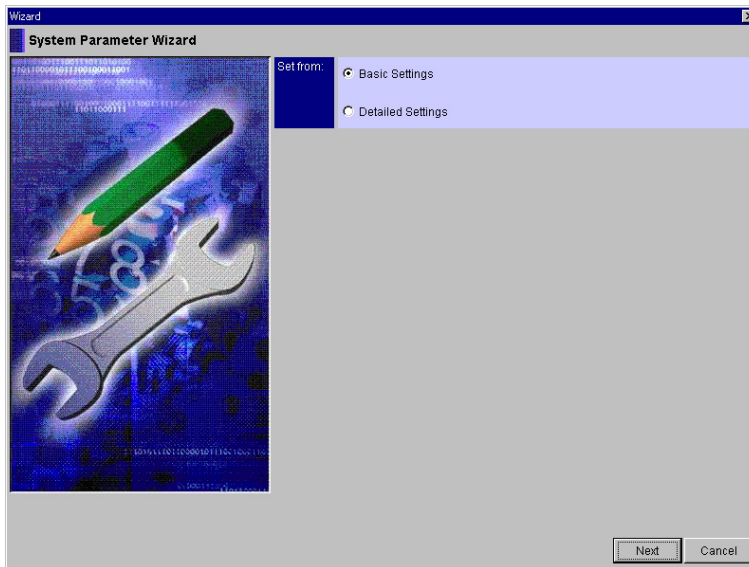

3. Click the Next button until Option 1 is displayed.

4. After **Option 1** has been displayed, click the **Drive Detach Mode** in the **SCSI/Fibre-Channel Common Options**.

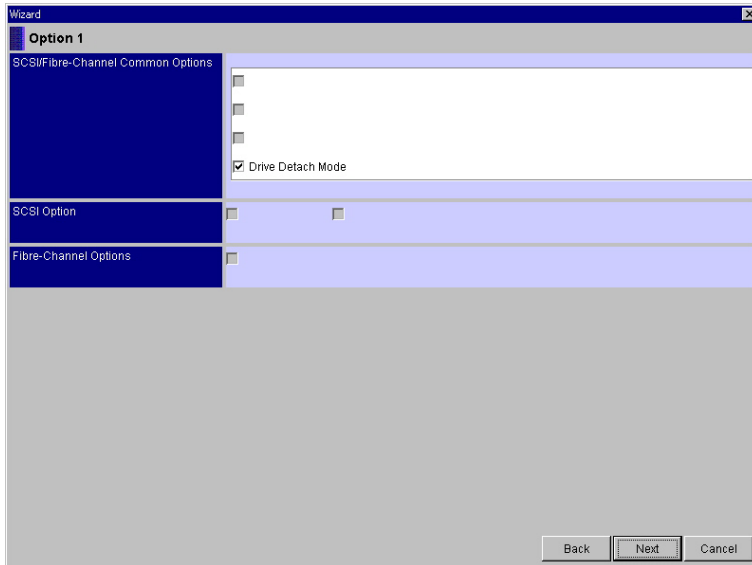

5. Click the **Next** button until **System Parameter Setting Completed** is displayed.
6. Click the **OK** button.
7. When terminated, set the system parameters. The following window is displayed. Click the **OK** button.

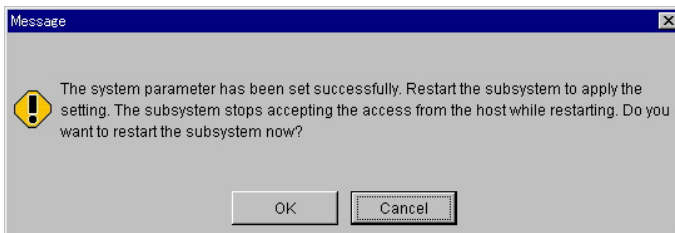

8. Click the **OK** button.
9. A message appears, stating that the restart is successful. Click the **OK** button.

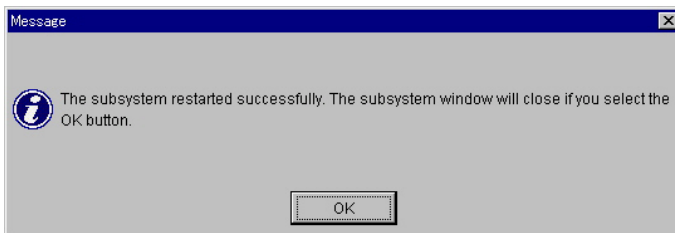

The Unit screen is closed. To perform other operations on the Main screen, select an array unit from the Main screen and open the selected Unit screen.

## 7.7.4.4 Using the WolfPack Mode

1. In the unit window, double-click the **Controller** to be set for the connection mode with the host. Display the **Host group 0** by double-clicking the **Port**.

Display the **Option** and **Logical Unit** by double-clicking the **Host group 0** and select the **Option**.

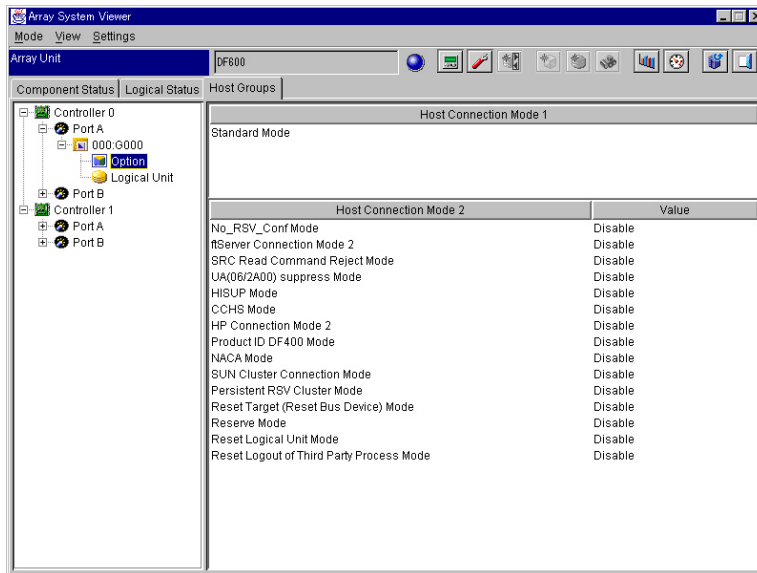

2. On the **Settings** menu, select **Modify Host Group Option**.

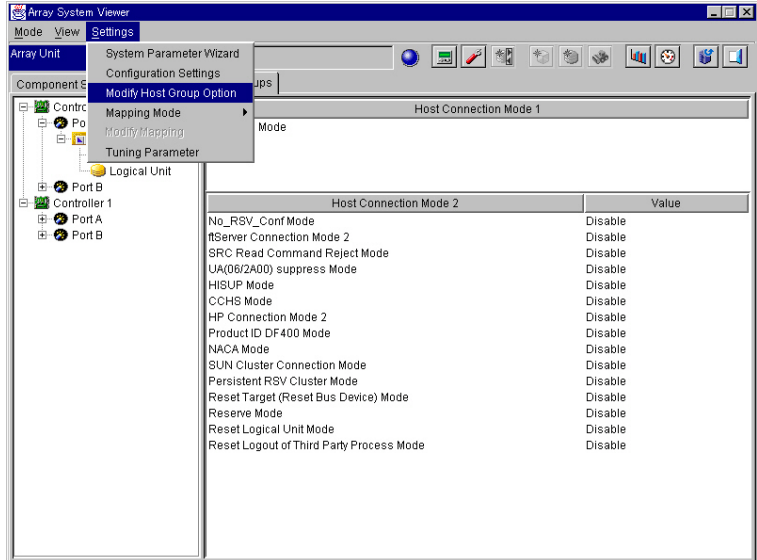

3. Select the **Wolfpack Mode** in the **Host Connection Mode 1**. Click the **OK** button.

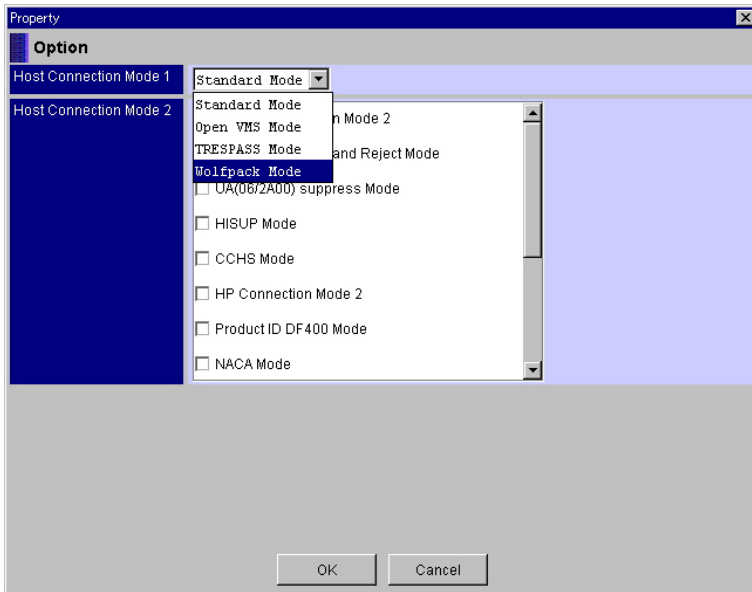

4. A message appears; click the **OK** button.
5. A message appears stating that the setting is complete is displayed. Click the **OK** button.

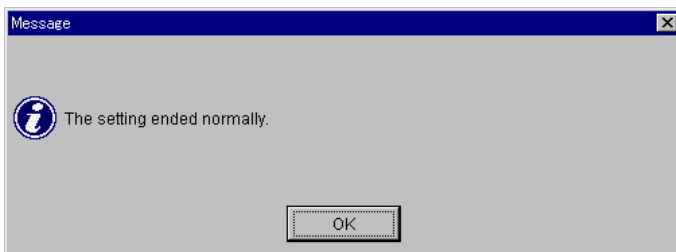

6. On the Settings menu, select **Configuration Settings** or click **Configuration Settings** in the tool bar.
7. Click the **Port Option** tab.

8. Select **Reset ALL LIP Port Mode** of the Port Option.

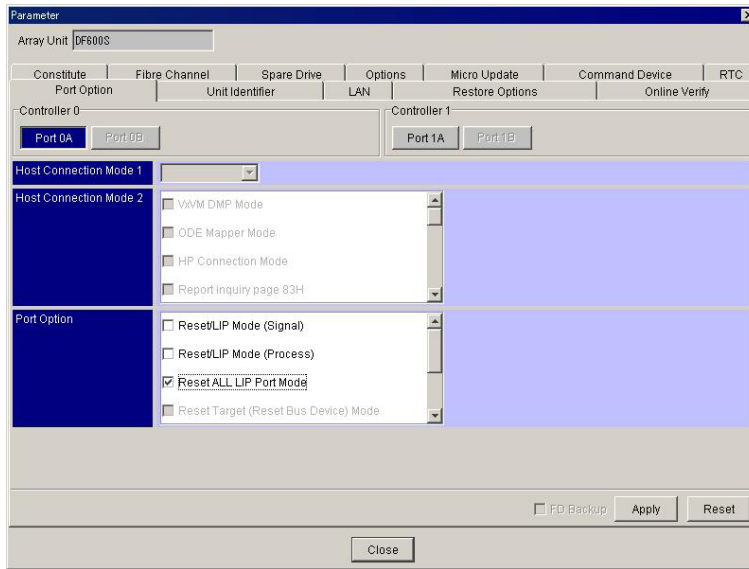

9. Click the **Apply** button.

10. A message appears stating that the setting is complete. Click the **OK** button.

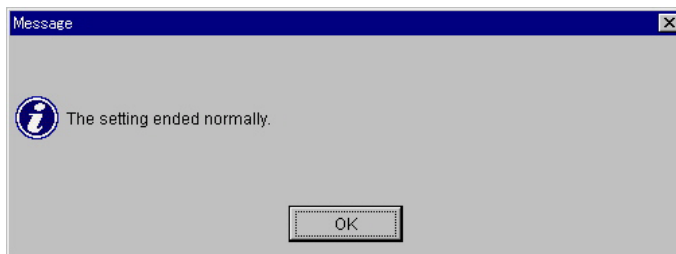

11. Click the **Close** button.

### 7.7.4.5 Using VxVM V3.2P2+PP or later is used on the Host Side

1. On the **Settings** menu, select **Configuration Settings** or click **Configuration Settings** in the tool bar.
2. Click the **Unit Identifier** tab.
3. After **Controller Option** is displayed, click **Enable** in the **Controller Identifier**.

If nothing is input to a **Controller ID**, **DF600-00** (default value) is reported. A controller identifier needs to be set for every device. When connecting only one device under control of a host computer, a default value can be used. From the second host computer, the controller identifier needs to be changed.

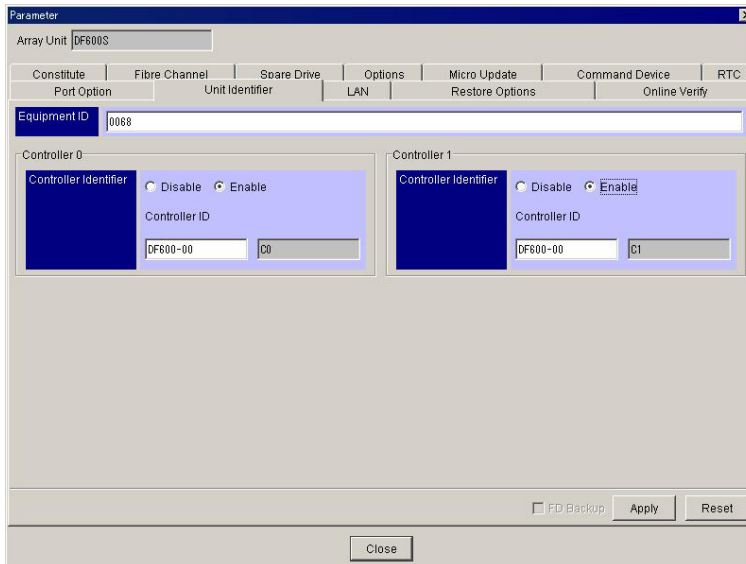

4. Click the **Apply** button.
5. A message appears indicating that the setting is complete. Click the **OK** button.

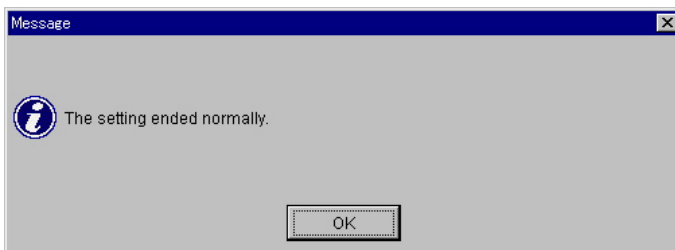

6. Click the **Close** button.

## 7.7.4.6 Making Nine or More LUs Recognized by Using Qlogic HBA or Emulex HBA on Windows 2000

1. On the unit window, double-click the **Controller** to be set for the connection mode with the host, then display the **Host group 0** by double-clicking the **Port**.  
 Display **Option** and **Logical Unit** by double-clicking the **000:G000** and select the **Option**.

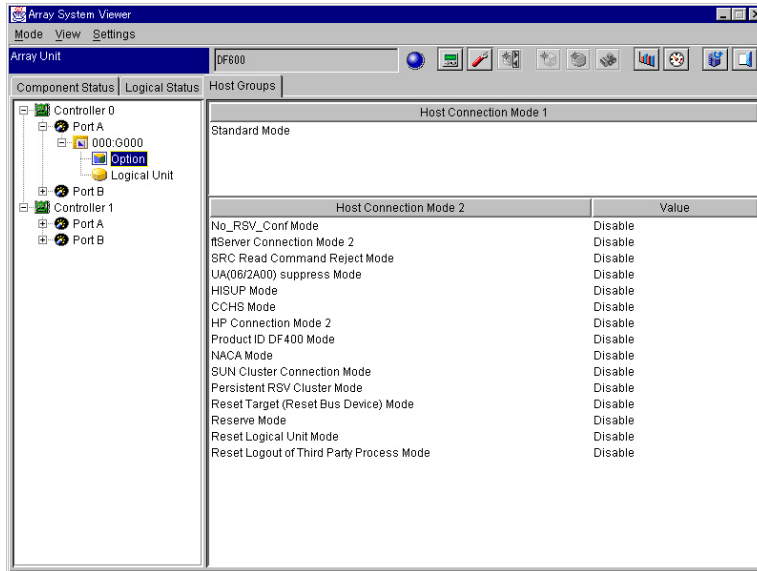

2. On the **Settings** menu, select **Modify Host Group Option**.

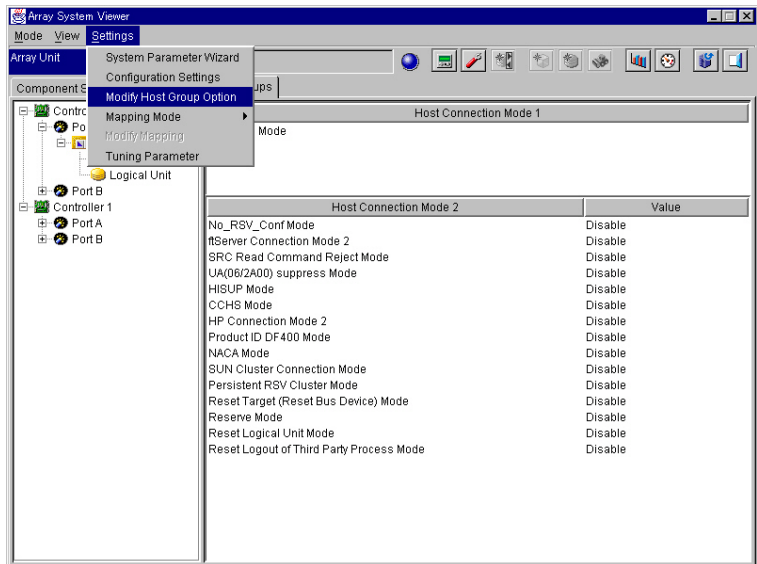

3. Select the **HISUP Mode** in **Host Connection Mode 2**. Click the **OK** button.

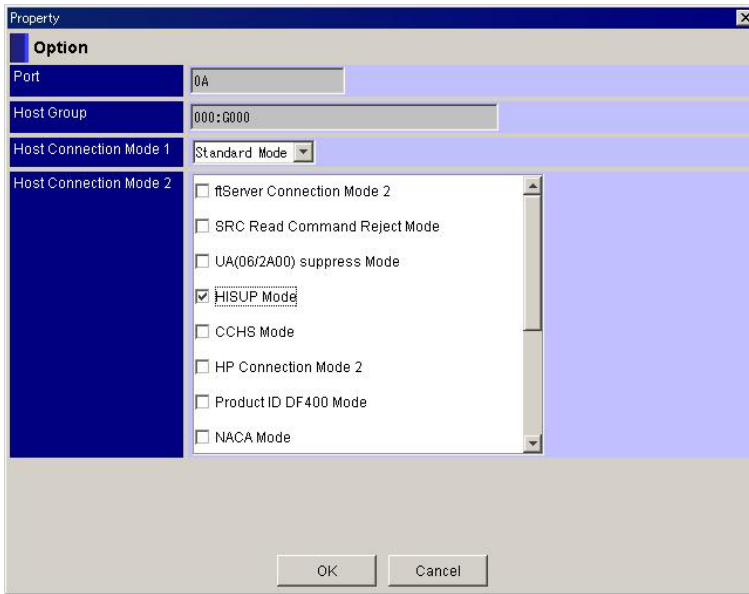

4. A message appears; click the **OK** button.

5. A message appears, stating that the setting is complete. Click the **OK** button.

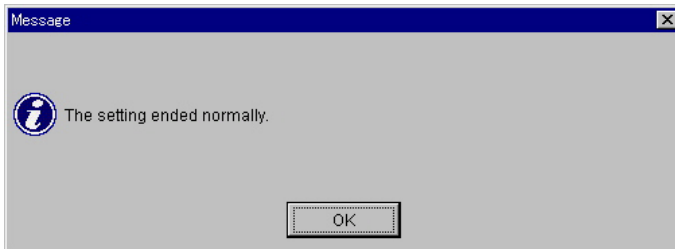

## 7.7.4.7 Making LU Numbers 8 to 63, Recognized when the Subsystem is Connected to the HP Server

1. On the unit window, double-click the **Controller** to be set for the connection mode with the host, then display the **Host group 0** by double-clicking the **Port**.

Display the **Option** and **Logical Unit** by double-clicking **Host group 0** and select the **Option**.

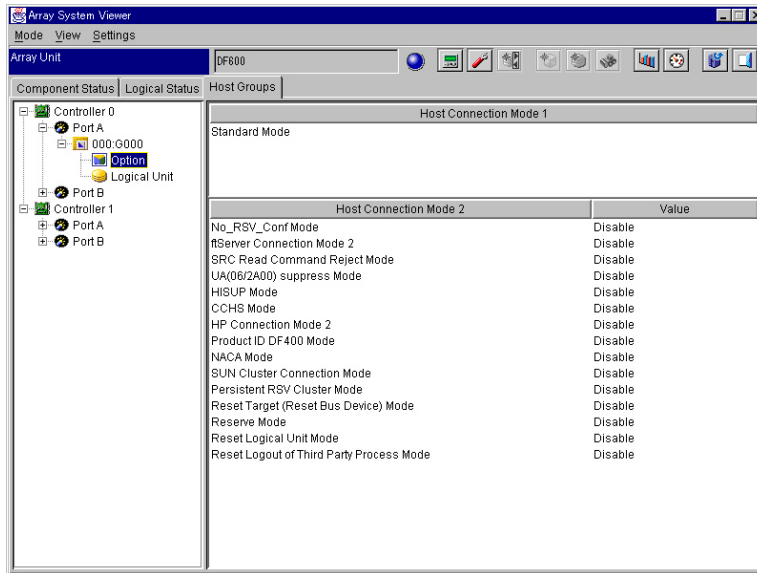

2. On the Settings menu, select **Modify Host Group Option**.

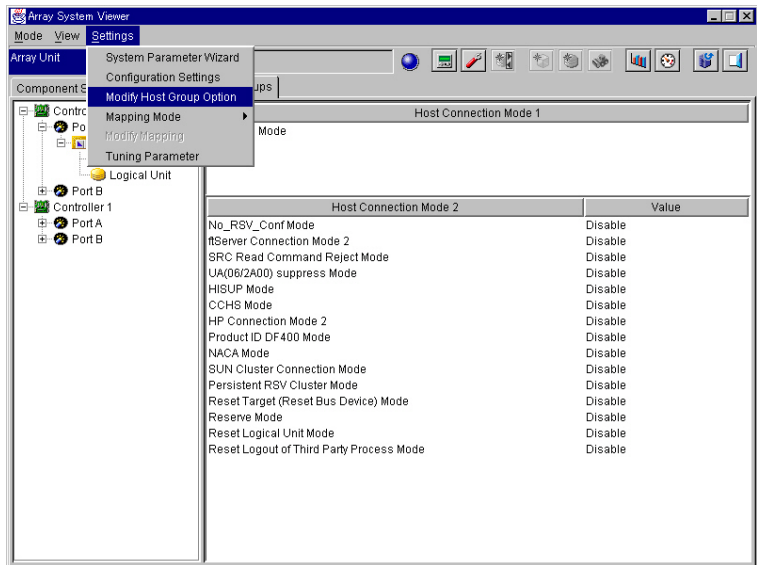

3. Select the **HP Connection Mode 2** in the **Host Connection Mode 2**. Click the **OK** button.

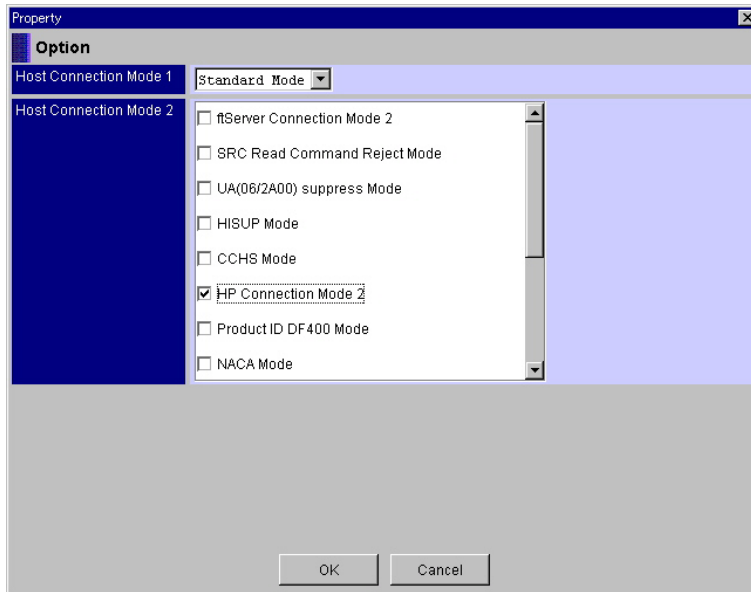

4. A message appears; click the **OK** button.

5. A message appears stating that the setting is complete. Click the **OK** button.

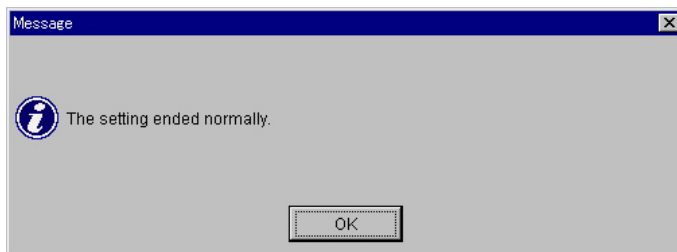

## 7.7.4.8 Using SUN Cluster 3.0

1. On the unit window, double-click the **Controller** to be set for the connection mode with the host, then display the **Host group 0** by double-clicking the **Port**.

Display the **Option** and **Logical Unit** by double-clicking the **Host group 0** and select the **Option**.

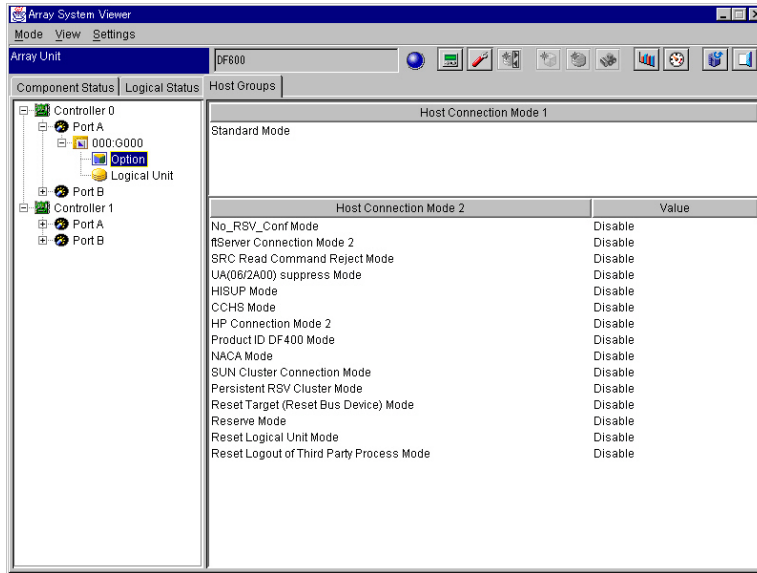

2. On the **Settings** menu, select **Modify Host Group Option**.

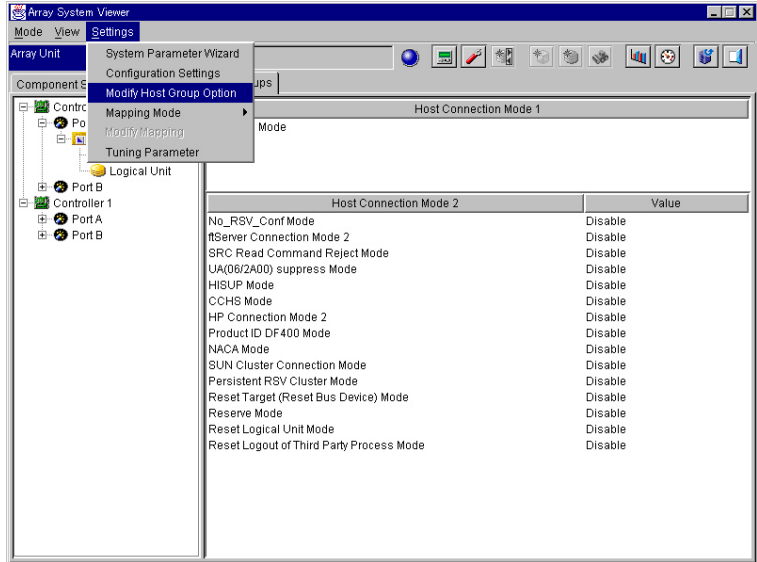

3. Select the **SUN Cluster Connection Mode** in **Host Connection Mode 2**. Click the **OK** button.

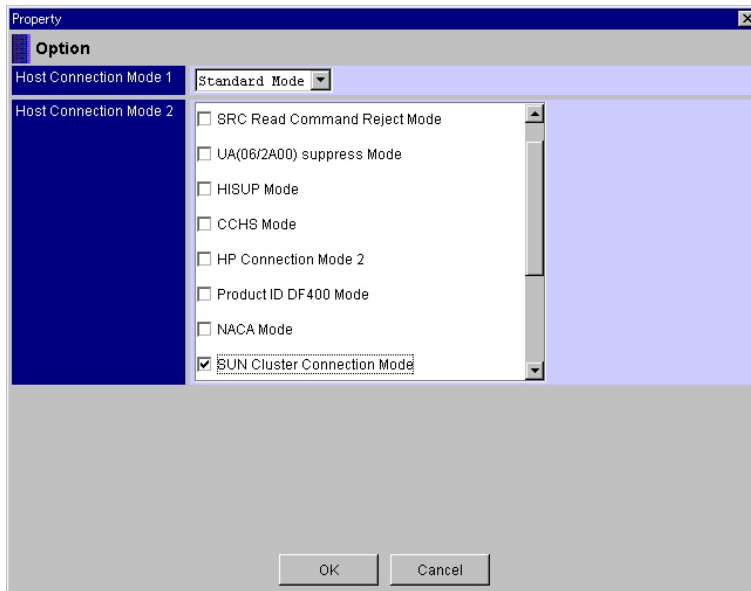

4. A message appears; click the **OK** button.
5. A message appears stating that the setting is complete. Click the **OK** button.

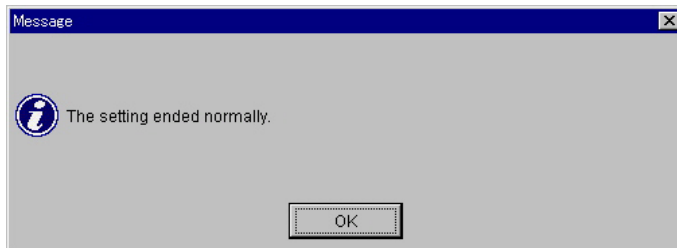

### 7.7.4.9 Using the ftServer

1. On the unit window, double-click the **Controller** to be set for the connection mode with the host. Display the **Host group 0** by double-clicking the **Port**.

Display **Option** and **Logical Unit** by double-clicking **Host group 0**; select the **Option**.

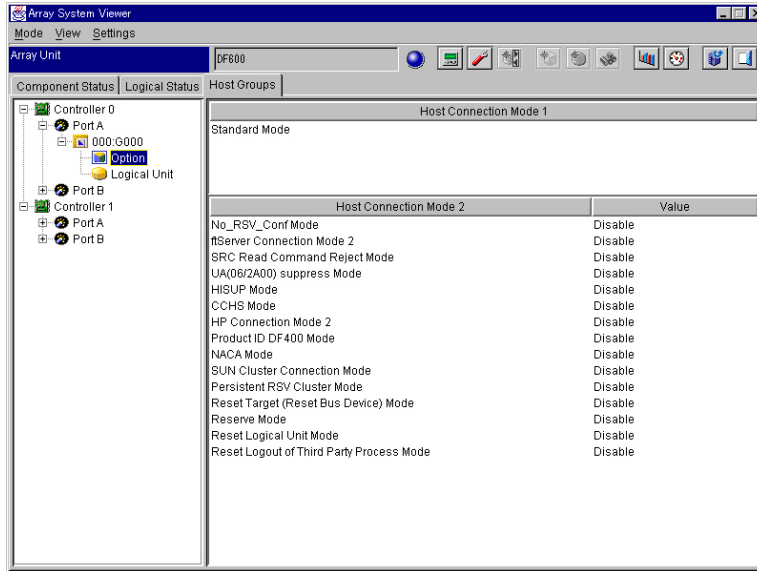

2. On the **Settings** menu, select **Modify Host Group Option**.

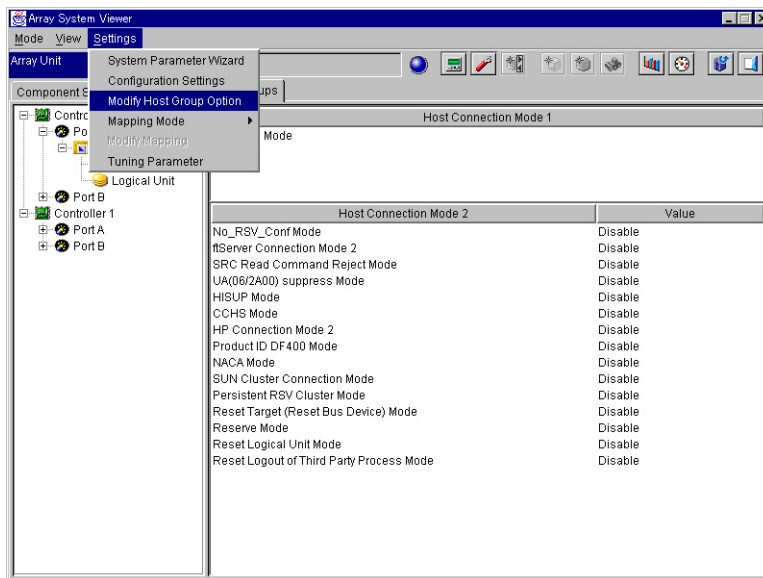

3. Select the **ftServer Connection Mode 2** in the **Host Connection Mode 2**. Click the **OK** button.

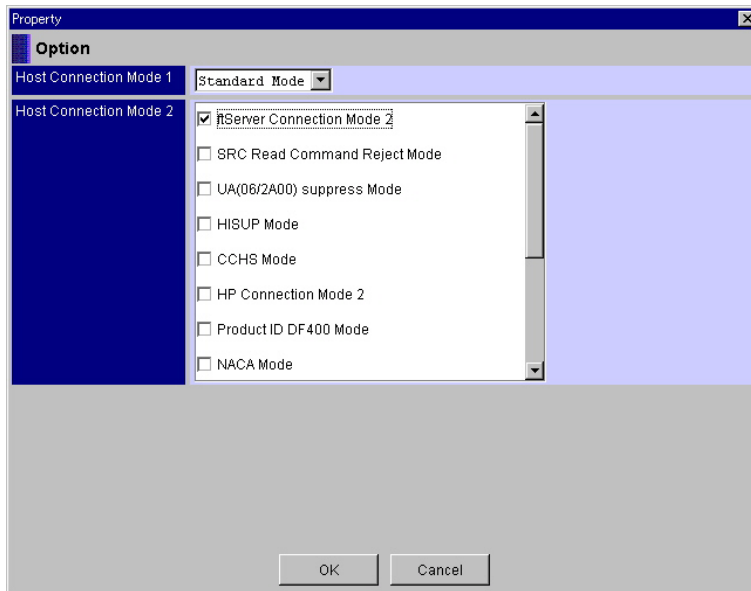

4. A message appears; click the **OK** button.
5. A message appears stating that the setting is complete. Click the **OK** button.

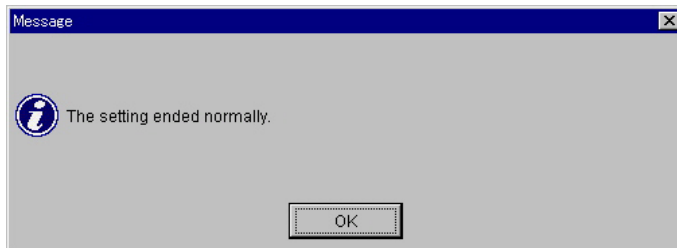

### 7.7.4.10 Using the Microsoft Cluster Server

When connecting to Microsoft Cluster Server via Fabric Switch, Zoning on Fabric Switch must be set for each HBA as shown below:

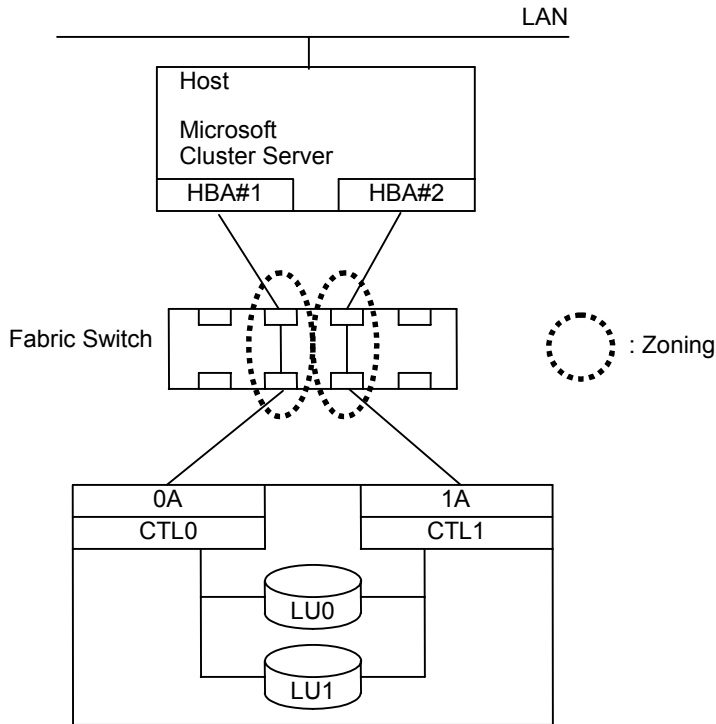

Figure 7.7 Configuration Example (without Port Sharing)

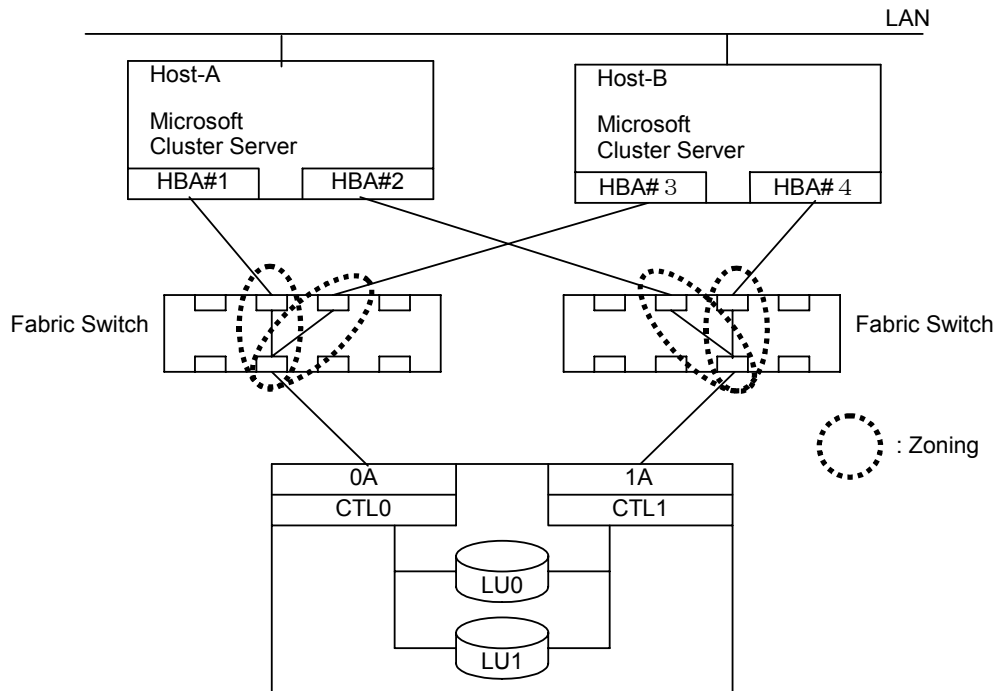
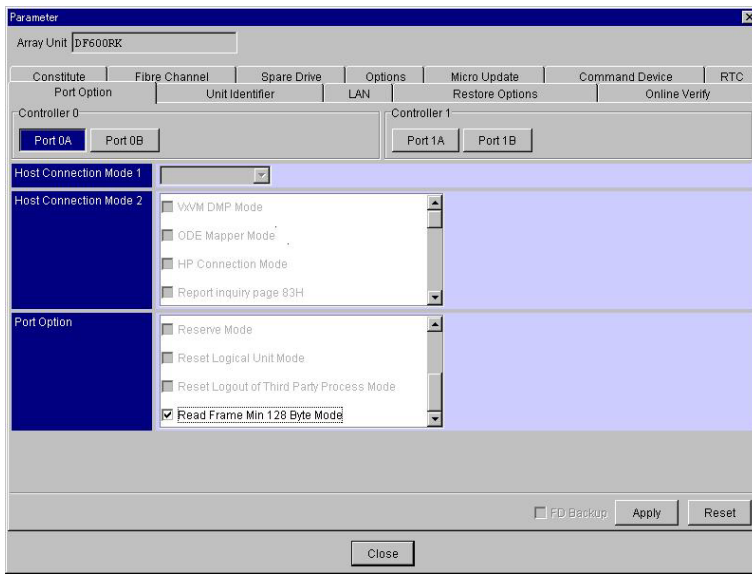

Figure 7.8 Configuration Example (with Port Sharing)

### 7.7.4.11 Connecting the Subsystem as a Boot Disk or a Dump Device of an HP Server

1. On the Settings menu, select Configuration Settings or click Configuration Settings in the tool bar.
2. Click the Port Option tab.
3. Select Read Frame Min 128 Byte Mode of the Port Option.



4. Click the Apply button.
5. A message indicating completion of setting is displayed. Click the OK button.

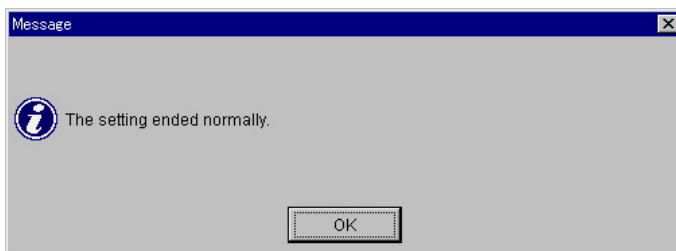

6. Click the Close button.

## 7.8 Changing the Network Parameter

To set a network parameter from the Resource Manager 9500V program, use the following procedure:

1. Turn on the power supply.
2. Start the Resource Manager 9500V program and set the operation mode to Management Mode Refer to the *Hitachi Freedom Storage™ Thunder 9500™ V Series Resource Manager 9500V User's Guide Graphical User Interface (GUI)*, MK-92DF605.
3. Click the icon of an array unit on the Main window, and select the **Settings** menu.
4. Click **Display Details** or click the **Display Details** button in the tool bar.

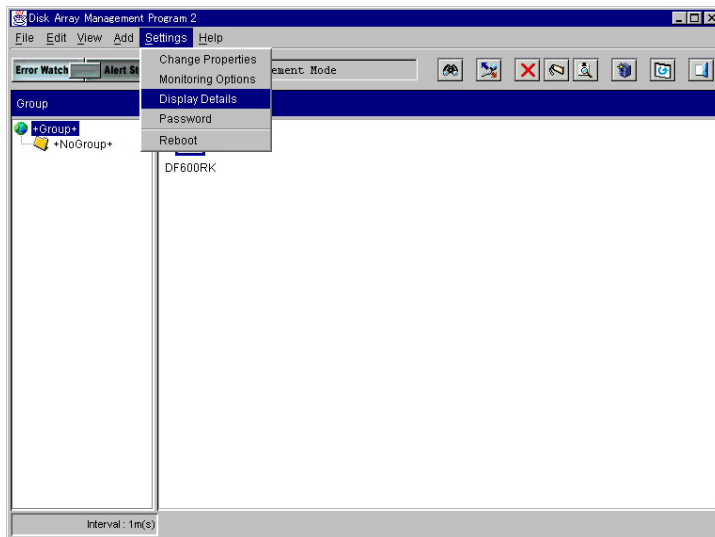

5. On the **Settings** menu, select **Configuration Settings** or click **Configuration Settings** in the tool bar.

- Click the **LAN** tab on the Unit screen.

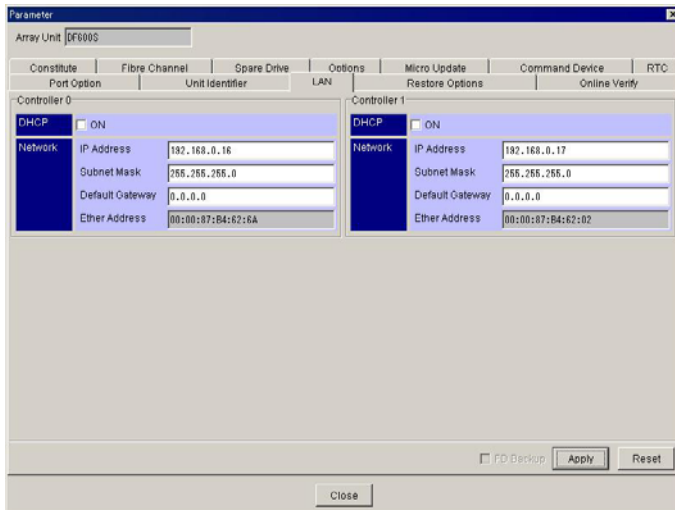

- Set the Network parameter for the **Network**.
- Click the **Apply** button.
- A message appears, stating that the network parameter has been changed. A confirmation message appears, asking you to verify that you wish to restart. Click the **OK** button to restart.

**Note:** When a restart is initiated, the array unit is not ready to access data from the host for duration of this process. Therefore, verify that the host has stopped accessing data before initiating a restart.

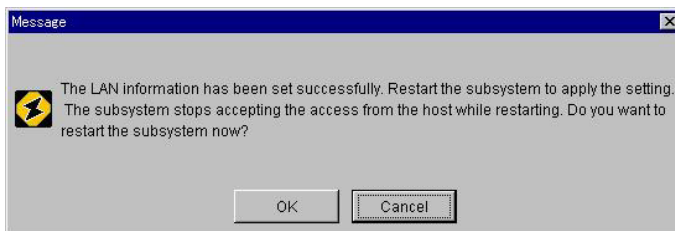

- A message appears, stating that the restart has terminated. Click the **OK** button.  
When the **OK** button is clicked, the unit window is closed. To perform other operations, select an array unit on the main window and open the unit window.

# Chapter 8 Troubleshooting

The Hitachi Freedom Storage™ Thunder 9530™ V Series subsystem provides high data availability and is not expected to fail in any way that would prevent access to user data.

This section includes the following:

- Troubleshooting Based on LED Indications
- Web Overview
- Web Operational Procedures
- Troubleshooting Using a Web Connection

## 8.1 Troubleshooting Based on LED Indications

This section includes the following:

- The POWER LED does not Turn On
- The POWER LED is Turned Off
- The READY LED does not Turn On or the READY LED has Turned On Once, then Turned Off
- The ALARM LED has Turned On
- The WARNING LED has Turned On or Blinks

### 8.1.1 The POWER LED does not Turn On

When the POWER LED does not turn on, follow these steps:

1. Set the AC power unit switch on; set the main switch to on.
2. Has the POWER LED turned on?  
Yes: Go to step 9.  
No: If the power control has been set to **Remote**, power-on the host computer.
3. Has the POWER LED turned on?  
Yes: Go to step 9.  
No: Set the main switch to off; set the AC power unit switch to off.
4. Check the PDB to verify that electricity is supplied to the unit.
5. Verify that the AC cable is correctly connected to the plug socket and the equipment.
6. Set the AC power unit switch to on; set the main switch to on.
7. Has the POWER LED turned on?  
Yes: Go to step 9.  
No: Set the main switch to off; set the AC power unit switch to off.

8. Call your maintenance engineer. Go to step 10.
9. Has the READY LED turned on?  
Yes: Continue to use the equipment as it is.  
No: Verify that the READY LED does not turn on or that the READY LED has turned on once and then turned off.
10. End of the procedure

### 8.1.2 The POWER LED has Turned Off

When the POWER LED has turned off, follow these steps:

1. Electricity is received by the equipment?  
Yes: Remove anything that would prohibit electricity from being supplied to the unit and restart the unit. Go to step 7.  
No: Verify that the AC cable is correctly connected to the plug socket, then restart the unit.
2. Set the main switch to off, then set the AC power unit switch to off.
3. After waiting for more than one minute, set the AC power unit switch to on, then set the main switch to on.
4. Has the POWER LED turned on?  
Yes: Go to step 6.  
No: Set the main switch to off, then set the AC power unit switch to off.
5. Call your maintenance engineer.
6. Has the READY LED turned on?  
Yes: Continue to use the equipment as it is.  
No: Refer to READY LED does not turn on or READY LED has turned on once, then turned off.
7. End of procedure

### 8.1.3 READY LED does not Turn On or the READY LED has Turned On Once, then Turned Off

If the READY LED does not turn on or the READY LED has turned on once, then turned off, follow these steps:

1. Is the POWER LED on?  
Yes: Go to step 2.  
No: Go to step 4 in **POWER LED does not turn on**.
2. Is the ALARM LED on?  
Yes: Refer to **ALARM LED has turn on**.  
No: Go to step 3.
3. Turn off the main switch.

4. After waiting for more than one minute, set the AC power unit switch to on, then set the main switch to on.
5. Has the READY LED turned on?  
Yes: Continue to use the equipment as it is. Go to step 8.  
No: Go to step 6.
6. Set the main switch to off, then set the AC power unit switch to off.
7. Call your maintenance engineer.
8. End of the procedure

#### 8.1.4 The Alarm LED has Turned On

When the ALARM LED has turned on, follow these steps:

1. Identify in which components the failure is resident.

**Note:** Refer to 4.7.5 LED Locations and Functions to identify failed components whose LEDs indicate their respective failures.

2. Set the main switch to off, then set the AC power unit switch to off.
3. Call your maintenance engineer.

#### 8.1.5 The WARNING LED has Turned On or Blinks

When the WARNING LED has turned on or blinks, follow these steps:

1. Does the WARNING LED blink?

Yes: Call your maintenance engineer. Go to step 5

No: Go to step 2.

2. Is the READY LED on?

Yes: Go to step 3.

No: Refer to: READY LED does not turn on or READY LED has turned on once and then turned off.

3. Identify in which components a failure is resident.

**Note:** Refer to 4.7.5 LED Locations and Functions to identify failed components whose LEDs indicate their respective failures.

4. Continue to use the equipment and contact the maintenance engineer.
5. End of the procedure

## 8.2 Web Overview

This section includes the following:

- Operational Environment
- Characteristics of Network Functions
- Connecting to the Network

### 8.2.1 Operational Environment

The Web operational environment and the necessary requirements are shown in the following tables.

**Table 8.1 Web Operational Environment**

No.	Item	Description
1	OS	Microsoft Windows 95/98/2000/Me/XP/NT 4.0, Solaris 2.6/8.0, IRIX 6.4
2	PC	Pentium (Pentium II[233 M Hz or more] is recommended), Memory 40 M bytes or more (64 Mbytes or more is recommended or more)
3	WS	Turbo Sparc 170 M Hz, Memory 256 Mbytes or more R10000 195M Hz, Memory 128 Mbytes or more
4	Disk requirement	50 Mbytes

**Table 8.2 Web Operational Requirements**

No.	Platform	OS	Browser	Ver.	Supported or Not Supported	Microprogram Supported or Not Supported
1	WS	IRIX	Netscape Navigator	4.7	○	X
				4.76	○	X
		Solaris 2.6	Netscape Navigator	4.7	○	X
				4.76	○	X
		Solaris 8.0	Netscape Navigator	4.78	○	X
2	PC	Windows	Internet Explorer	5.0	○	X
				5.5 ( <i>Note 1</i> )	○	○
				6.0	○	○
		Netscape Navigator	4.7	○	X	
			4.73	○	X	
			4.74	○	X	
			4.75	○	X	
			4.76	○	X	
			4.78	○	X	
			6.2	○	X	

**Note 1:** The Service Pack 1 is included.

## 8.2.2 Characteristics of Network Functions

This section discusses the following network function characteristics:

- LAN Interface:  
The connector for 10Base-T/100Base-TX is equipped with the controller. 10Base-T/100Base-TX is selected automatically.
- Network Parameter:  
The 9530V has the following network parameters; they can be set or changed by the Web browser or the Resource Manager 9500V, concerning only port 1 (for users) of each controller.

**Table 8.3 Network Parameters**

Network parameter	Description	Factory Setting Value (Note 1)	
		Controller 0	Controller 1
		For users port: variable IP	For user's port: variable IP
IP Address	The IP Address is changed/set up.	192.168.0.16 (Note 1)	192.168.0.16 (Note 1)
Subnet Mask	The Subnet Mask is changed/set up.	255.255.255.0 (Note 3)	255.255.255.0 (Note 3)
Default Gateway	The Default Gateway is changed/set up.	0.0.0.0	0.0.0.0
DHCP (Note 2)	Enable/Disable of the DHCP function is set up.	Off	Off

**Note 1:** Manage the IP Address after the IP Address is changed from the IP Address of factory setting.

**Note 2:** When the DHCP mode is validated, the IP Address is acquired from the DHCP server.

If the DHCP server is not started up or the DHCP function has been wrongly set, the acquisition of the IP Address will fail and the IP Address of the subsystem will remain **0.0.0.0**. (This is a state in which Disk Array management program 2 or the Web cannot be used via a LAN.)

In this case, you can acquire the IP Address by starting up the DHCP server or by setting the DHCP function correctly when necessary.

**Note 3:**

Microprogram revision 0653/B or earlier

(1) When the user's port address is set to other than 10.x.x.x, 10.x.x.x cannot be used for the IP address for LAN device to be connected to user's port through a gateway. Therefore, set the IP address to other than 10.x.x.x.

(2) When the user's port address is set to 10.x.x.x, 192.168.0.x cannot be used for the IP address for LAN device to be connected to user's port through a gateway. Therefore, set the IP address to other than 192.168.0.x.

Microprogram revision 0653/C or later

(1) When the user's port address is set to other than 10.x.x.x, 10.0.0.(0 to 31) cannot be used for the IP address for LAN device to be connected to user's port through a gateway. Therefore, set the IP address to other than 10.0.0.(0 to 31).

(2) When the user's port address is set to 10.x.x.x, 192.168.0.(0 to 31) cannot be used for the IP address for LAN device to be connected to user's port through a gateway. Therefore, set the IP address to other than 192.168.0.(0 to 31).

## 8.3 Web Operational Procedures

This section contains the following information:

- Connecting to the Network using a LAN Interface
- Screen Outlines
- Main Screen in Normal Mode
- Status Display of Replaceable Components
- Information Message
- Setting the Buzzer Sound Volume

### 8.3.1 Connecting to the Network using a LAN Interface

To use a LAN interface, follow these steps:

1. The connector for 10Base-T/100Base-TX is equipped with the controller. 10Base-T/100Base-TX is selected automatically.
2. Connect the LAN cable with the LAN connector shown in the Figure 8.1.

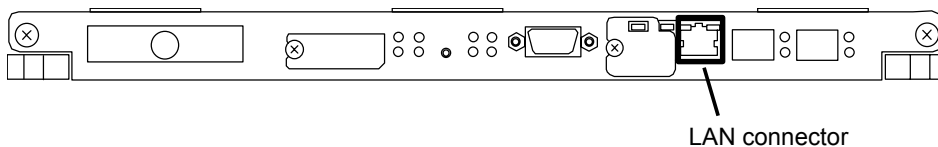

**Figure 8.1 LAN Connector Location**

Change the IP Address of the controller set up to the Address of the Web browser, to enter Normal Mode. Set the IP Address of the controller connected with the network as a dual system configuration. The status of the devices (both controllers) can be monitored from one controller.

### 8.3.2 Screen Outlines

If the Normal Mode function is displayed and clicked in the menu screen, the chosen function can be executed. The following figure displays the main screen outline of Normal Mode.

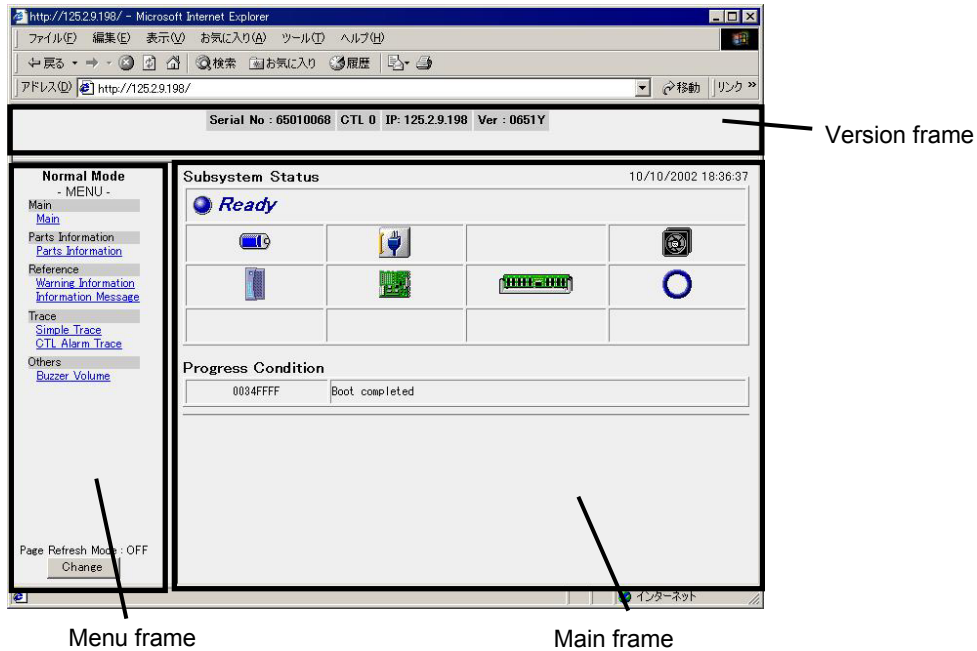

Figure 8.2 Main Screen Outline

This section includes the following:

- Menu Frame
- Main Frame
- Version Frame

### 8.3.2.1 Menu Frame

The main frame displays the following information:

**Main:** The main screen of Normal Mode is displayed.

**Parts Information:** The status of exchange parts is displayed.

**Warning Information:** Fault information that was detected during device information status is displayed.

**Information Message:** Fault information, detected during device operation and device information status is displayed.

**Simple Trace:** A window for collecting the Simple trace is displayed.

**CTL Alarm Trace:** A window for collecting the CTL Alarm trace is displayed.

**Buzzer Volume:** The screen where Buzzer Volume is set up is displayed.

**Page Refresh Mode:** This button sets up an on/off an automatic redisplay function. When clicked, the on/off mode changes.

**OFF display:** This is not refreshed.

**ON display:** The screen of the mainframe is refreshed every 5 seconds. The refresh time currently (RTC) is displayed on the right top.

**Note:** When the PC enters suspension status during operation while the **Page Refresh Mode** is set to **ON**, the Web may not operate correctly after the PC is released from suspension status. When the Web is connected for status monitoring, etc., set the power management of the PC so that the PC does not enter suspension status.

### 8.3.2.2 Main frame

The main frame displays the following information:

**Subsystem Status:** The device status and the exchange parts status are displayed.

**Progress Condition:** The Progress Condition as the device is booting is displayed.

### 8.3.2.3 Version Frame

The version frame displays the following information:

**Web title:** The Web title set by a user is displayed. When it is not set, nothing is displayed.

**Serial No:** The subsystem serial number is displayed.

**CTL:** The connected controller number is shown.

**IP:** The connected IP Address of the controller is shown.

**Rev:** The device version of the microprogram is shown.

### 8.3.3 Main Screen in Normal Mode

The main screen of normal mode consists of the following:

- Patrol Lamp
- Summary of Exchange Parts Status
- Progress Condition Display
- Page Refresh Button

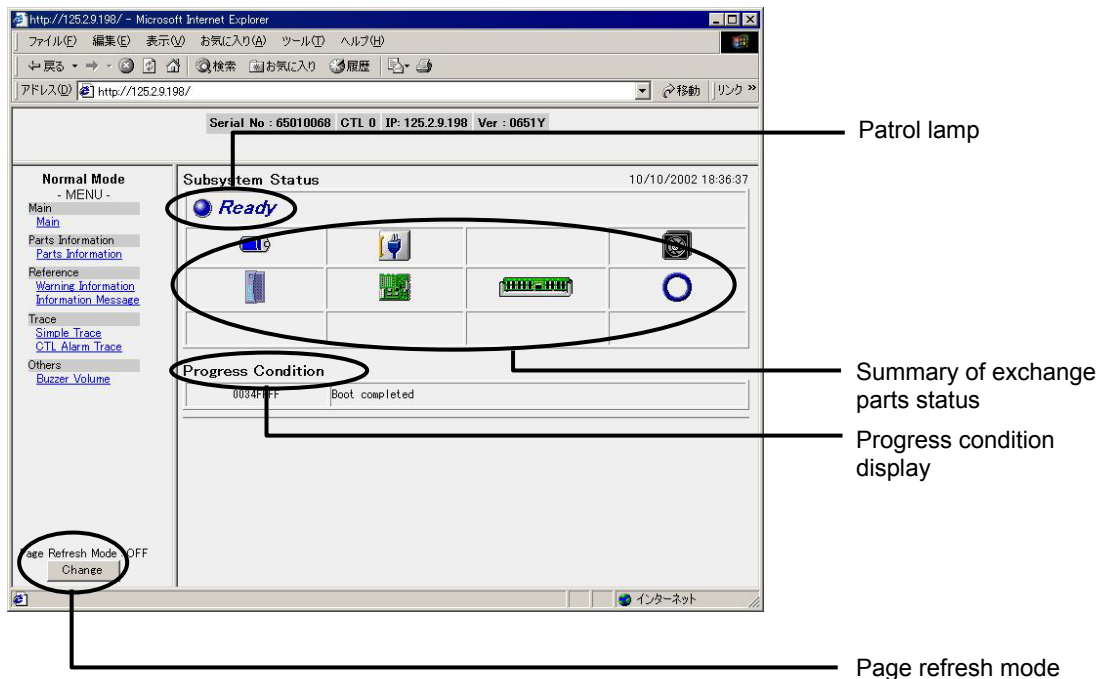

Figure 8.3 Subsystem Condition Display

#### 8.3.3.1 Patrol Lamp

While monitoring the device, the status is displayed.

Image	Status
<i>Booting...</i>	During the start
<b>Ready</b> blue	Normal
<b>Warning</b> yellow	Warning status
<b>Alarm</b> red	Alarm status

Figure 8.4 Patrol Lamp Display

### 8.3.3.2 Summary of Exchange Parts Status

The summary of exchange parts status displays the condition of the exchange parts by changing the color. Detailed information of the specific part is displayed by clicking the part icon.















Parts	Image	
	Normal	Abnormal
Power Unit	 blue	 red
Disk Drive	 blue	 red
Cache Unit	 green	 red
Fan Assembly	 black	 red
Backup Battery Unit	 blue	 red
Control Unit	 green	 red
Fibre Loop	 blue	 red

Figure 8.5 Exchange Parts Status Display

### 8.3.3.3 Progress Condition Display

The progress condition, as the device is booting, is displayed in the progress condition display box.

### 8.3.3.4 Page Refresh Button

This button sets the on/off function of the automatic redisplay function. If clicked, the on/off mode changes.

**OFF** display: The screen is not refreshed.

**ON** display: The screen of the mainframe is refreshed every 5 seconds. The refresh time currently (RTC) is displayed on the right top.

## 8.3.4 Status Display of Replaceable Components

The status display screen of replaceable components displays the status of the Disk Drive, Control Unit, Cache Unit, Fiber Channel Loop, Fan Assembly, Backup Battery Unit, Power Unit/Power Unit (DC), and ENC Unit that are implemented.

This screen is not displayed if the component is not implemented. When the replaceable component has an abnormal status, a red image is displayed.

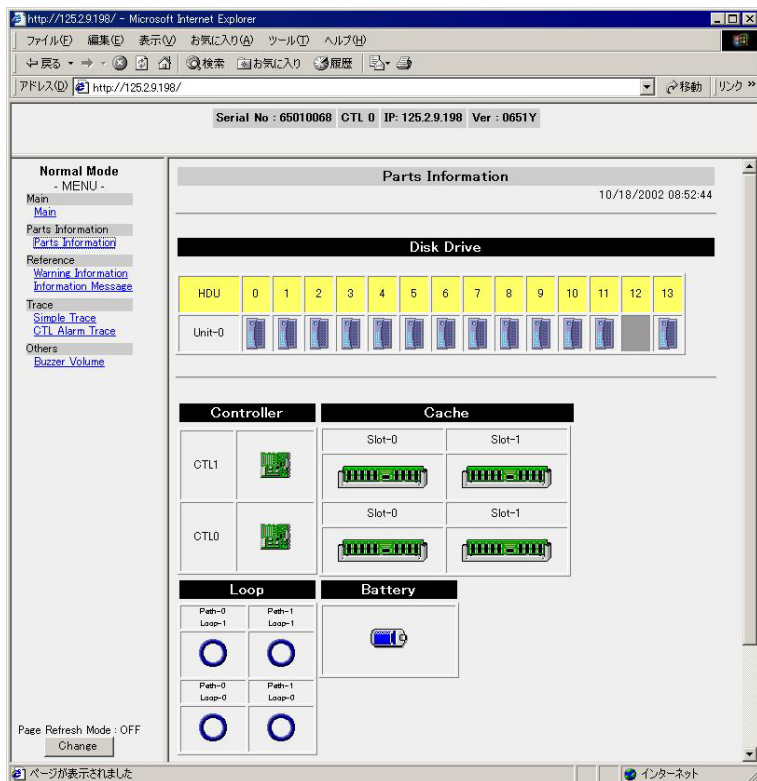







Figure 8.6 Component Status Screen



### Disk Drive

Image	Status
 blue	Normal
 red	A fault has occurred to the disk drive
 red and black	The disk drive port where the fault occurred is not implementing the disk drive
No display	The disk drive is not implemented (the disk drive where the fault occurred was drawn out)

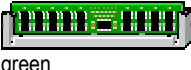

### Control Unit

Image	Status
 green	Normal
 red	Shutdown of the control unit (status where it is not implemented with the setting of the dual system configuration is included)
 yellow	Fault of the battery backup circuit
No display	The fault has not occurred without being implemented with the setting of a single system configuration



### Cache Unit

Image	Status
 green	Normal
 red	Fault (status when the unit is not implemented and the extracted fault cache unit is included)



### Battery Backup Unit

Image	Status
 blue	Normal
 red	There is a fault or the unit is not implemented



### ***Fan Assembly***

<b>Image</b>	<b>Status</b>
 black	Normal
 red	There is a fault or the fan assembly is not implemented (The condition that an AC power supply is not supplied is contained)

### ***Power Unit/Power Unit (DC)***

<b>Image</b>	<b>Status</b>
 blue	Normal
 red	A fault occurred or the unit is not implemented (The condition that an AC power supply/DC power supply is not supplied is contained)

### ***Fibre Loop***

<b>Image</b>	<b>Status</b>
 blue	Normal
 red	Fault

### 8.3.5 Information Message

Fault information and status information of the device that detected it during the device operation are displayed.

Fault information and status information after the device completes a boot are displayed in the **Controller 0/1 Common** box.

Fault information and status information as the device is booting are displayed in the box of **Controller 0** and **Controller 1** for every the controller.

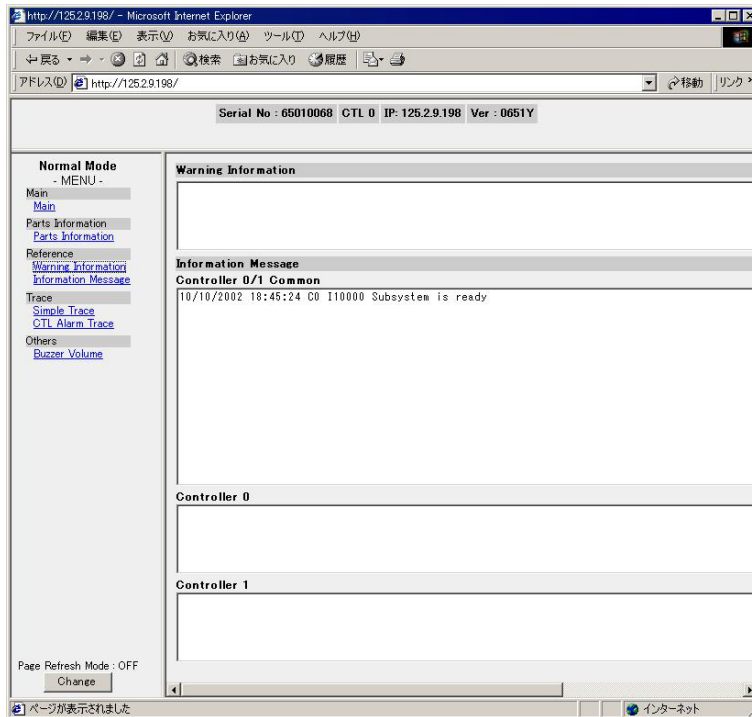

Figure 8.7 Information Message Screen

### 8.3.6 Setting the Buzzer Sound Volume

**Note:** Set the buzzer volume for the environment in which I/Os from a host are not issued while the system is maintained or before the host is started up.

The buzzer volume can be adjusted for 5 stages. Click the **Buzzer Volume** of the menu frame to enter into the buzzer volume-setting screen. If the buzzer volume is designated with the radio button and the **OK** button is clicked, the buzzer volume is changed.

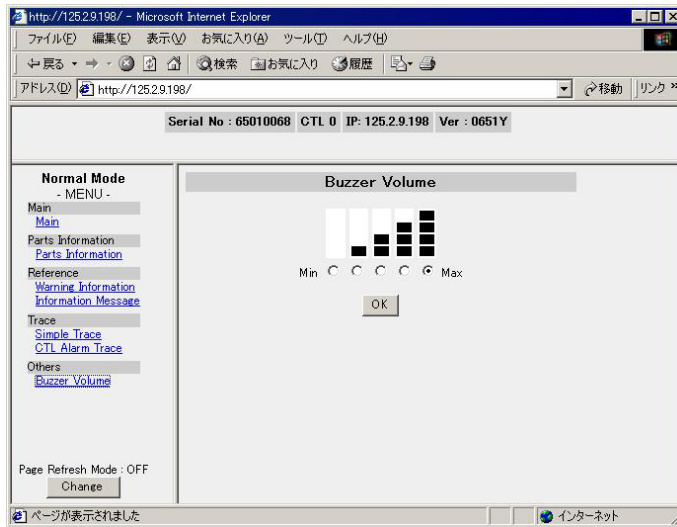

Figure 8.8 Buzzer Volume Screen

## 8.4 Troubleshooting Using a Web Connection

This section includes the following:

- Checking Subsystem Status
- Checking the Progress Condition Display
- Checking Component Status
- Checking Log Messages
- Troubleshooting using Messages
- Reading Failure Information

### 8.4.1 Checking Subsystem Status

Check the position of the failed part of the unit on the main window in the normal mode of the Web.

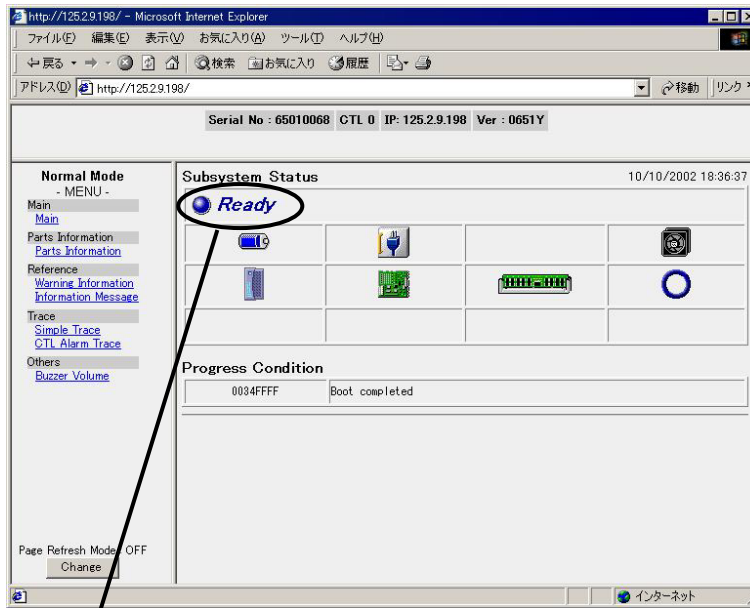

Subsystem Status

Booting	Ready	Warning	Alarm
<i>Booting...</i> black	<i>Ready</i> blue	<i>Warning</i> yellow	<i>Alarm</i> red

Figure 8.9 Subsystem Status Screen

## 8.4.2 Checking the Progress Condition Display

If **Booting...** is indicated in the window (the controller is being started up), the progress of the start-up operation can be confirmed according to the following procedure:

1. Turn on the page refresh mode (click the **ON** button).

The window is updated automatically at 5-second intervals. (If the **OFF** button of the page refresh mode is activated, this operation is not necessary.)

If the page refresh mode is not activated in the main window, press the **update** button of the browser to update the window.

2. Observe the condition-in-progress within the window.

If the start-up operation is completed, **Boot completed** is indicated in this part.

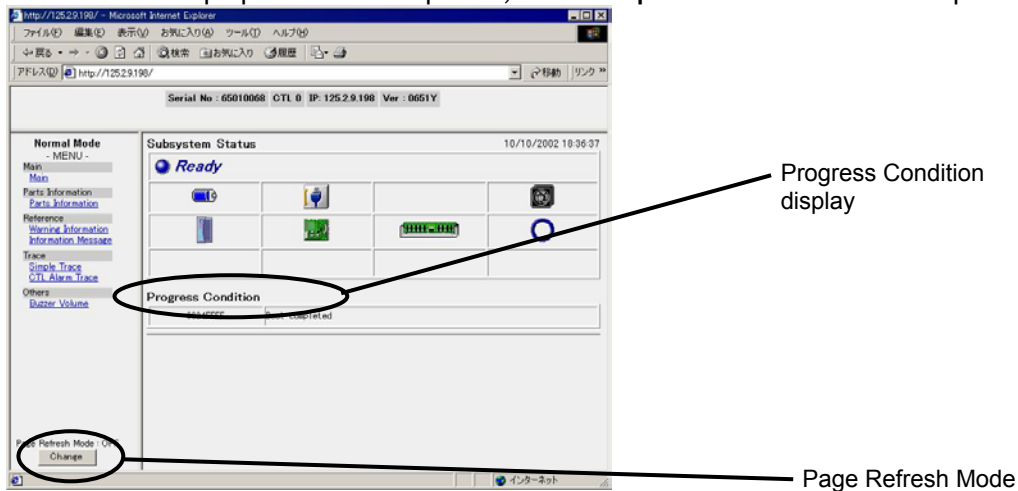

Figure 8.10 Progress Condition Display

### 8.4.3 Checking Component Status

Click each part of Replace Part Summary in the main window; the following window appears and the state of the part is displayed.

In this example, the selected (clicked) part is at the head of the window. You can also select this window by clicking the **Parts Information** menu in the main window. In this window, you can confirm the state of each part in detail. If a part fails, its corresponding icon turns red.

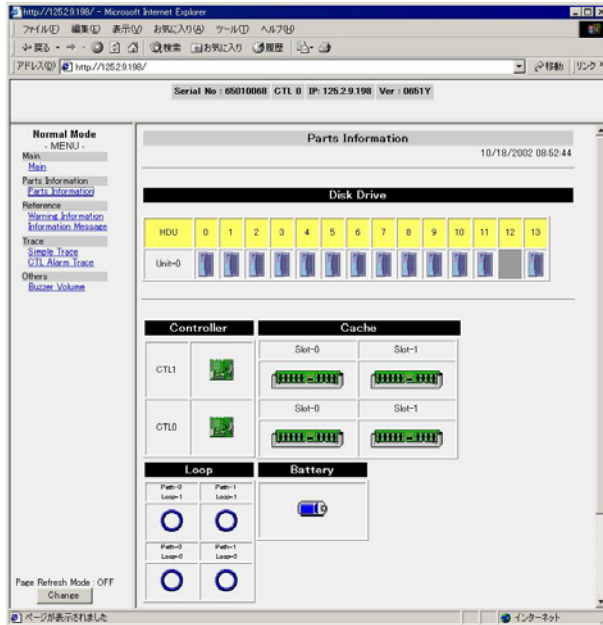

Figure 8.11 Replace Part Summary Screen (HDD)

## 8.4.4 Checking Log Messages

To check log messages:

1. Click the **Information Message** menu in the main window.  
The Information Message window appears.
2. In the Information Message window, identify the cause of the failure and confirm the recovery measures.

The information on the detected failures during operation of the unit and the state of the unit are displayed in the above window.

The information on the failures and the state at the start-up time of the unit is displayed for each Controller in the **Controller 0** and **Controller 1** boxes.

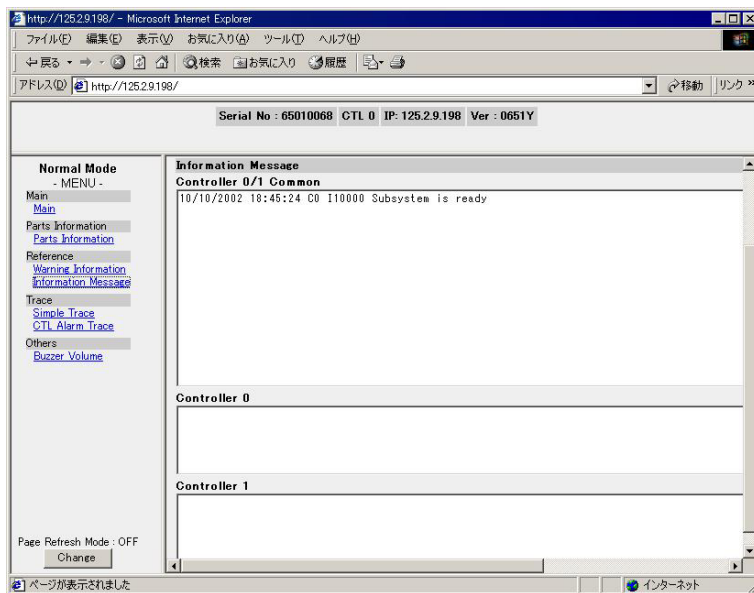

Figure 8.12 Information Message Screen

The contents of each message are shown in the following examples:

- CUDG (Self-test at power-on) Detection Message

The CUDG detection message is displayed in the **Controller 0** or **Controller 1** box as shown in the following example:

**Example:**

MM/DD/YYYY HH:MM:SS Cx	54	◆◆◆◆◆◆◆◆
MM/DD/YYYY HH:MM:SS Cx	50	◆◆◆◆◆◆◆◆
MM/DD/YYYY HH:MM:SS Cx	4C	◆◆◆◆◆◆◆◆
MM/DD/YYYY HH:MM:SS Cx	48	◆◆◆◆◆◆◆◆
MM/DD/YYYY HH:MM:SS Cx	44	◆◆◆◆◆◆◆◆
MM/DD/YYYY HH:MM:SS Cx	40	■ ■ ■ ■ ■ ■ ■ ■
MM/DD/YYYY HH:MM:SS Cx	3C	■ ■ ■ ■ ■ ■ ■ ■
MM/DD/YYYY HH:MM:SS Cx	38	■ ■ ■ ■ ■ ■ ■ ■
MM/DD/YYYY HH:MM:SS Cx	34	■ ■ ■ ■ ■ ■ ■ ■
MM/DD/YYYY HH:MM:SS Cx	30	■ ■ ■ ■ ■ ■ ■ ■
MM/DD/YYYY HH:MM:SS Cx	2C	■ ■ ■ ■ ■ ■ ■ ■
MM/DD/YYYY HH:MM:SS Cx	28	■ ■ ■ ■ ■ ■ ■ ■
MM/DD/YYYY HH:MM:SS Cx	24	■ ■ ■ ■ ■ ■ ■ ■
MM/DD/YYYY HH:MM:SS Cx	20	● ● ● ● ● ● ● ●
MM/DD/YYYY HH:MM:SS Cx		○ ○ ○ ○ ○ ○ ○ ○ ○ ○
MM/DD/YYYY HH:MM:SS Cx	CTLx	

- MM/DD/YYYY: Data of occurrence
- HH:MM:SS: Time of occurrence
- Cx: # of Controller in which failure is detected
- ◆◆◆◆◆◆◆◆: PCI Config information
- ■ ■ ■ ■ ■ ■ ■: Detailed information
- ● ● ● ● ● ● ●: Message code
- ○ ○ ○ ○ ○ ○ ○ ○ ○: Message text (Any number of letters)
- CTLx: CUDG executing controller #

- Flash/RAM Micro Detection Message

The Flash/RAM micro detection message is displayed in the **Controller 0/1 Common**, **Controller 0**, of **Controller 1** box as shown in the following example. The latest one is shown on the top line.

**Note:** The date and time the RTC is set in the detection controller is displayed in this message. If the RTC is different from one control to another, the displayed time of occurrence may differ within messages (the message on the upper line is issued prior to the message on the lower line).

In this example, the latest message is also indicated at the top.

**Example:**

```
MM/DD/YYYY HH:MM:SS Cx ●●●●●● ○○○○○○○○○○○○ : ■■■■■■/◆◆◆◆
MM/DD/YYYY HH:MM:SS Cx ●●●●●● ○○○○○○○○○○○○ : ■■■■■■/◆◆◆◆
      :
```

- MM/DD/YYYY: Confirmed data
- HH:MM:SS: Confirmed times
- Cx: Error detected Controller #
- : Message code (Rxxxxx: Flash detected messages, lxxxxx: Progress messages, Wxxxxx: Warning messages, Hxxxxx: Failure messages)
- : Message text (Any number of letters)
- : Recovery measures code
- ◆◆◆◆: Collecting failure information code

### 8.4.5 Troubleshooting Using Messages

The contents of each failure detected during operation are reported by a message. The failures detected during operation and the state of the unit, after the main switch of this unit is turned on, are reported.

The five types of message codes are displayed in the following table:

**Table 8.4 Message Code Types**

Message code	Measures
018xxxx	Errors detected by CUDG
Rxxxx	Flash detected messages
lxxxx	Progress messages
Wxxxx	Warning messages
Hxxxx	Failure messages

#### 8.4.5.1 Errors Detected by CUDG

When the Errors detected by CUDG are displayed, call your maintenance personnel.

## 8.4.5.2 Flash Detected Messages

When the following Flash detected messages are displayed, follow the instructions to resolve the problem.

**Table 8.5 Flash Detected Messages**

Message code	Message Text	Recovery Measures
RA00xx	Microprogram error [FLS]	Restarting the equipment
RA7000	Microprogram revision mismatch	
RB0000	Upload system error	Check the microprogram you want to install and install it over again.
RB0600	No micro program	Perform the new installation upgrade.
RB0A00	Upload file SUM check error	A sum check error occurred in a read file during a upload. Check the microprogram you want to install and install it over again.
RB0E00	Up grade check NG	The upgrade check of the microprogram failed. (An upgrade version of a microprogram does not conform to the microprogram being upgraded.) Do a new install of the microprogram.
RB3000	File size error	Check the microprogram you wish to install.
RB3100	File open error	
RB3200	File read error	
RB3500	Bad block ID	
RB3600	Bad LBA in START 600 DAT	
RB7000	Program size too large	
RB8000	Old microprogram exists	
RB8300	Empty system retry full install	The update installation cannot be executed because a system does not exist in the disk drive. Execute a new installation.
RBA000	Down grade check NG	The present microprogram version cannot be updated to a specified microprogram version. Check the work procedure. Execute a new installation.

When a Flash detected message other than those shown above is displayed, inform maintenance personnel of the message code.

### 8.4.5.3 Progress Messages

When the following Progress messages are displayed, follow the instructions to resolve the problem.

**Table 8.6 Progress Messages (Continued on next page)**

Message Code	Message Text	Recovery Measures
I031xy	Path recovered automatically	The path recovered automatically. (x: Remote DF# (0), y: Path # (0 or 1))
I10000	Subsystem is ready	The unit is ready.
I11000	All raid group initialized	All RAID groups were deleted.
I111xx	RAID group deleted (RG-xx)	All LUs were deleted. (xx: RAID group# (0-14))
I12000	ALL LU initialized	All LUs were deleted. (This is also displayed when the LU#0 is created.)
I12100	LU deleted (LU-xxx)	LUs were deleted. (xxx: LU# (0-511))
I12200	LU format completed (LU-xxx)	LU formatting was completed. (xxx: LU# (0-511))
I12400	LU format start (LU-xxx)	An LU formatting was started. (xxx: LU# (0-511))
I12500	Unified LUs separated (Uni: LU-xxx)	Dissolution of all LU unification (to dissolve unification of all the unified LUs and to split them into internal LUs) was executed. (xxx: LU# (0 to 511) of a unified LU to be split)
I12600	Last LU separated from unified LU (Uni: LU-xxx)	A separation of a final LU of a unified LU (to separate the last one of the internal LUs which have been combined with a unified LU) was executed. (xxx: LU# (0 to 511) of a unified LU to be split)
I12700	LU reappeared (Uni: LU-xxx)	An internal LU(s) was validated again through splitting of all unified LUs or a separation of a final LU. (xxx: An LU# (0 to 511) of an internal LU which has been separated and validated)
I15Axy	Dynamic sparing start (Unit-x, HDU-y) [zzzzzzzzzz]	Dynamic sparing started. (x: Unit ID# (0-14), y: Disk drive# (RK/RKS=0-13, RKA=0-14), z: Detailed code)
I17002	Default LU-CTL change failed [PS OFF]	Set the equipment in the ready state and turn off the power, then turn on the power again
I17003	Default LU-CTL change failed [HOT]	Use the system as it is
I17004	Default LU-CTL change failed [LU] Permanent LU	
I1A00x	Permanent LU disable (Default CTL-x)	Set the equipment in the ready state and turn off the power, then turn on the power again
I1A10x	Permanent LU deleted (Default CTL-x)	LU residence is deleted. (When RAID group/LU is deleted) (x: Default Controller# (0 or 1))
I1A30x	Permanent LU enable (Default CTL-x)	The FlashAccess function was turned on. (x: Default Controller# (0 or 1))

**Table 8.6 Progress Messages (Continued)**

Message Code	Message Text	Recovery Measures
I1B100	Forced parity correction completed	Forced parity recovery processing was finished.
I1C0xy	Loop diagnostic start (Path-x, Loop-y)	Loop diagnosis was started. (x: Path# (0 or 1), y: Loop# (0 or 1))
I1C1xy	Loop diagnostic end (Path-x, Loop-y)	Loop diagnosis was finished. (x: Path# (0 or 1), y: Loop# (0 or 1))
I1E000	Online verify completed [odd unit]	Check of the frames with even numbers was completed in the online verification.
I1E100	Online verify completed [even unit]	Check of the frames with odd numbers was completed in the online verification.
I61D00	Shutdown warning	Turn off power supply by main switch.

When a Progress message other than those shown above is displayed, inform maintenance personnel of the message code.

#### 8.4.5.4 Warning Messages

When the following Warning messages are displayed, follow the instructions to resolve the problem.

**Table 8.7 Warning Messages**

Message Code	Message Text	Recovery Measures
W03200	Battery SW off	Turn on the battery unit switch.

When a Warning messages other than those shown above is displayed, inform maintenance personnel of the message code.

#### 8.4.5.5 Failure Messages

When the following Failure messages are displayed, follow the instructions and resolve the problem.

**Table 8.8 Failure Messages**

Message Code	Message Text	Recovery Measures
HI0201	PS OFF failed [POFNONCLD]	Turn on PS, then off again.
HI0202	PS OFF failed [POFNOJOB]	

When a Failure message other than those shown above is displayed, inform maintenance personnel of the message code.

## 8.4.6 Reading Failure Information

- The history of the unit, after it is turned on, is displayed in the **Information Message**.
- The **Subsystem is Ready** message displays the time when the unit is ready. Messages sent after the power is turned on until the unit is ready are displayed prior to this message. Messages sent after the unit is ready are displayed after this message.
- Carefully observe the following: **Wxxxxx** (Warning message), **Hxxxxx** (Failure message), and **Rxxxxx** (Flash detection message).
- The following messages are displayed when failures occur and when they are solved. If the recovery message is displayed after a failure occurrence message, the failure has been solved.

**Table 8.9 How to Read Failure Information**

No.	Description	Failure Detection Messages	Failure Recovery Messages
1	Controller error/ recover	<b>W0100x</b> : CTL alarm (CTL-x)	<b>I0010x</b> : CTL recovered (CTL-x)
2	error/recovery	<b>W0D0x0</b> : Cache alarm (CTL-y, CACHE-z)	<b>I0020z</b> : Cache recovered (CACHE-z)
3	Cache memory error/recovery	<b>W03000</b> : Battery alarm	<b>I00300</b> : Battery recovered
		<b>W03100</b> : Battery removed	
		<b>W03200</b> : Battery SW OFF	
		<b>W03300</b> : Battery thermal alarm	
4	Battery backup board error/recovery	<b>W0340x</b> : Battery backup circuit alarm (CTL-x)	<b>I0040x</b> : Battery backup circuit recovered (CTL-x)
5	Fan error/recovery	<b>W04000</b> : FAN alarm (Unit-x, FAN-y)	<b>I00500</b> : FAN recovered (Unit-x, FAN-y)
6	Power supply error/ recovery	<b>W050xy</b> : PS alarm (Unit-x, PS-y)	<b>I006xy</b> : PS recovered (Unit-x, PS-y)
7	Disk drive error/ recovery	<b>W060xy</b> : HDU alarm (Unit-x, HDU-y)	<b>I007xy</b> : HDU recovered (Unit-x, HDU-y)
8	Spare disk error/ recovery	<b>W061xy</b> : Spare HDU alarm (Unit-x, HDU-y)	<b>I009xy</b> : Spare HDU recovered (Unit-x, HDU-y)
9	Loop error/recovery	<b>W080xy</b> : Loop alarm (Path-x, Loop-y)	<b>I00Axy</b> : Loop recovered (Path-x, Loop-y)
10	UPS error/recovery	<b>W0C000</b> : UPS alarm (UPS-x)	<b>I00D00</b> : UPS recovered (UPS-x)

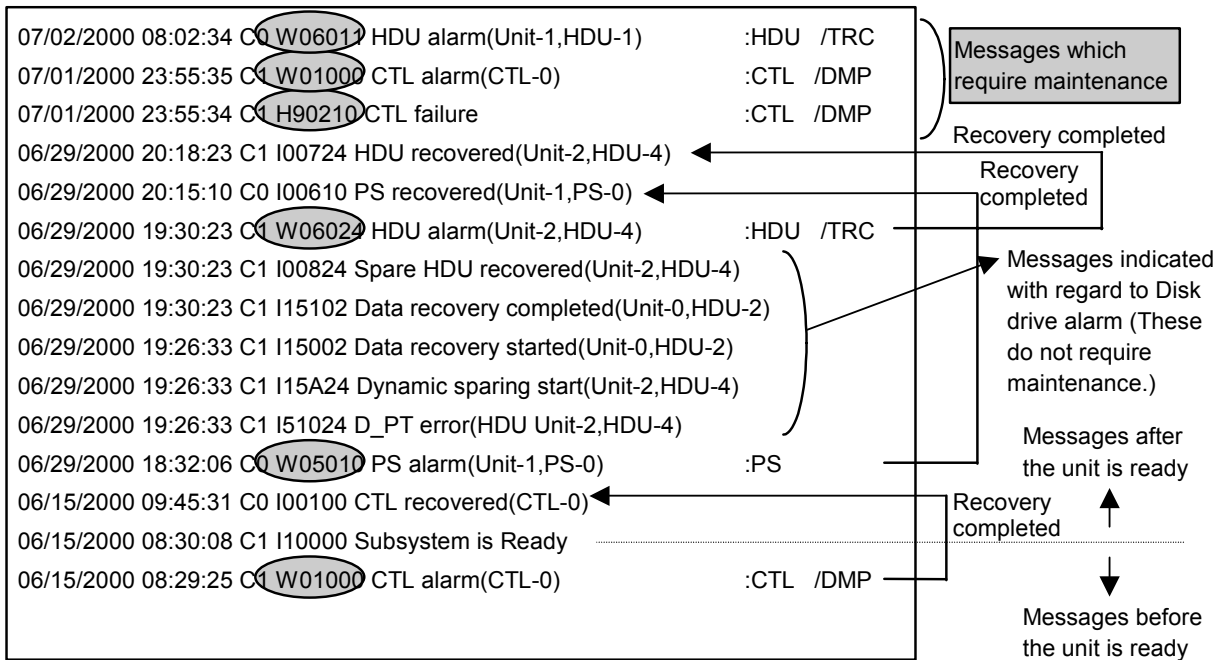

Figure 8.13 Message Analysis Example



## Chapter 9 Periodic Maintenance

If the subsystem is not energized for more than 18 days, the battery may over-discharge and unrecoverable damage may result. The battery must be energized more than 2 hours at least once every 18 days; alternatively, the subsystem can be stored with the AC Power Unit Switch/DC Power Unit Switch of the battery turned off. However, when the AC Power Unit Switch/DC Power Unit Switch is turned off, the battery discharges naturally. In this case, the battery should be charged once every six months for longer than 2 hours because spontaneous discharge occurs.



## Appendix A Glossary

- **Cache backup:**  
Because a cache memory uses DRAM, information stored in it is lost when the subsystem power is shut off. To provide against unexpected power failure, the subsystem has an setup to maintain data in the cache memory by batteries.  
Cache backup is a state in which the data is protected by the batteries.
- **CTL:**  
Controller
- **CUDG:**  
Control Unit Diagnosis
- **Destage:**  
Automatically writes data in cache memory, not yet written on the disk drive, on the disk drive when the main switch is turned off.
- **DHCP:**  
DHCP is an abbreviation for Dynamic Host Configuration Protocol; it is a client/server type protocol according to which a server automatically assigns an IP address when each client has started.
- **ECC:**  
Error Checking and Correcting
- **EIA:**  
Electronic Industries Alliance  
EIA standard (1 EIA unit = 44.45 mm)
- **FC-AL:**  
Fibre Channel Arbitrated Loop
- **FC-SW:**  
Fibre Channel-Switch Topology
- **Fibre channel:**  
A set of standards of interfaces that are connected through optical fibre, etc. to achieve high-speed data transfer between devices.
- **Fibre Channel HBA:**  
Fibre Channel Host bus Adapter
- **Fibre Channel HUB:**  
An apparatus to connect and relay Fibre Channel cables, each connected to a Fibre Channel device in order to form an arbitrated loop of the Fibre Channel.

- **Flash memory:**  
ROM that can be electrically erased and reprogrammed. A type of EEPROM (Electrically Erasable and Programmable). It can retain information without electricity and is widely used as an external storage, etc.
- **Host computer:**  
A computer which manages devices. For the disk array, it is a computer which enables the disk array store data.
- **Hot replacement:**  
Used to replace an installed part with the subsystem power on. Usually, the major part is duplicated so that when one of the parts fails, the subsystem function is maintained by another part.
- **I/F:**  
Interface
- **IP address:**  
IP address is an abbreviation for Internet Protocol Address; it is a numeral string which shows an address of a computer connected to a network.
- **LA:**  
Logical Address
- **LBA:**  
Logical Block Address
- **LED:**  
Light-Emitting Diode
- **LRC:**  
Longitudinal Redundancy Check
- **LSI:**  
Large-service Interface
- **LU:**  
Logical Unit
- **LVD:**  
Low Voltage Differential
- **Microprogram:**  
A program that controls the basic hardware operation
- **Parity disk:**  
When configuring RAID 5, one disk drive in a RAID group is designated as the parity disk and the other disk drives are designated as data disks. On the parity disk, parity data calculated from those of data disks is stored. When one of the disk drives in a RAID group fails, the subsystem can still be used and its data will not be damaged, by virtue of the parity data.
- **PDB:**  
Power Distribution Box

- **Rack frame:**  
A frame on which electronic equipment is mounted (using rails, etc.). Most rack frames have a width of 19 inches and are called 19-inch rack frames. The height of the equipment to be mounted is regulated by the EIA standard. The rack frame has screw holes to fasten equipment with bolts, etc.
- **RAID:**  
**Redundant Array of Independent (Inexpensive) Disks**  
A concept proposed in 1987 by a research group of the University of California, Berkeley. RAID distributes accesses among multiple disk drives, and thereby realizes a storage subsystem with high-speed accessibility, a large capacity, and high reliability. The University of California defined six levels of configurations from RAID 0 through RAID 5, and one of the levels is selected based on the trade-off in terms of cost and speed to meet the user's need.
- **Remote Maintenance Function (SNMP):**  
The SNMP agent support function reports failures to the workstation which monitors the network via the SNMP of the open platform.
- **R/W:**  
Read/Write
- **SNMP:**  
SNMP is an abbreviation for Simple Network Management Protocol, and it is one of the network protocols developed to manage a network.
- **Spare disk:**  
A disk drive which is mounted separately from the disk drives for usual write and read operation; when a failure occurs in a disk drive, data stored in the failed drive is copied to the spare disk drive so that the disk subsystem can continue to be available equivalently to the original subsystem.
- **UPS:**  
**Uninterrupted Power Supply**  
A backup power supply which is mounted on the Thunder 9530 unit to prevent shutdown of the unit even when power stoppage or momentary power interruption occurs.
- **Write cache:**  
When data is written from a host computer onto a disk array subsystem, it is not written directly on the disk drive but written in cache memory. In this way, the disk array subsystem can return a writing completion report promptly. This writing method using cache memory is called write cache.



## Appendix B System Parameter Setting List

Table B.1 System Parameter Setting List

	Platforms		HP			SUN				
	HA	Alternate Path	None	Alternate Link	None	None	HPM (Note 11)/ HDLM (Note 12)	VxVM V3.2P2+PP or later (Note 14)		
	Fail Over	None	MC/ Service Guard	None	SC (Note 7)	VCS (Note 5)	None	First Watch/ VCS (Note 5)		
<b>System Parameter</b>										
1	System Startup Attribute	Depends on System Configuration (Note 1)								
2	Data Share Mode	Depends on System Configuration (Note 2)								
3	Drive Detach mode enable	Disable (Standard setting)								
4	Report status (normal/warning)	Enable (Standard setting)								
5	Turbo LU Warning	Disable (Standard setting)								
6	Operation if the Processor failures Occurs	Reset a Fault (Standard setting)								
7	Command Queuing Mode	On (Standard setting)								
8	Vendor ID	HITACHI (Standard setting)								
9	Product ID	DF600F (Standard setting)								
10	ROM Microprogram Version	No change is needed								
11	RAM Microprogram Version	No change is needed								
12	RS232C Error Information Outflow Mode	When RS232C is used: On When RS232C is not used: Off (Standard setting)								
13	Write & Verify Executing Mode	On (Standard setting)								
14	DHCP (Note 8)	OFF (Standard setting)								
15	IP Address	To be set according to the network setting								
16	Subnet Mask	To be set according to the network setting								
17	Default Gateway	To be set according to the network setting								
<b>Host Group</b>										
1	Host Connection Mode (Option 2)	Without setting								
2	Host Connection Mode1	Standard Mode								
3	Host Connection Mode2	HP Connection mode 2 enable (Note 6)	(Note 9)	SUN Cluster Connection Mode	Persistent RSV Cluster Mode (Note 10)	(Note 9)	Persistent RSV Cluster Mode (Note 10)			
4	LU Mapping Mode	Depends on System Configuration (Note 3)								
<b>Configuration Information</b>										
1	Reset/LIP Mode (Process)	Reset within the port (Standard setting)								
2	Reset/LIP Mode (Signal)	Reset within the port (Standard setting)								
3	LIP Reset Mode	Target Authentication (Standard setting)								
5	Controller Identifier	Disable (Standard setting)						Enable		
6	Controller ID	-						DF600-00 (Standard setting (Note 4))		
7	Read Frame Min 128 Byte Mode (Note 13)	OFF (Standard setting)								

**Note 1:** Hot Standby mode is used when only one of the two Controllers is normal.

**Note 2:** Data Share mode is used to prevent performance deterioration which results from LU ownership that is switched when a host computer issues commands frequently to a Controller to which the computer has no ownership, in the normal or regression status (owing to a path or host computer failure).

It is recommended that the subsystem in the Data Share mode be used when LU ownership switching may occur.

**Note 3:** When the 9530V is connected, the LU not intended to be accessed by the port must be masked by means of LU mapping mode.

**Note 4:** Make the controller IDs of the CTL-00 and CTL-01 of the 9530V identical. When two or more 9530Vs are connected to the system, set the Controller IDs which are not duplications of each other.

When one of the host computers connected to the 9530V requires a Controller ID, set the Controller identifier to Enabled.

**Note 5:** Veritas Cluster Server

**Note 6:** Set the HP Connection Mode 2 when LUs, whose LU numbers are 8 to 63, are recognized if the subsystem is connected to the HP server.

**Note 7:** SUN Cluster 3.0

**Note 8:** When the DHCP mode is validated, the IP Address is acquired from the DHCP server.

If the DHCP server is not started or the DHCP function has been incorrectly set, the acquisition of the IP Address will fail and the IP Address of the subsystem will remain "0.0.0.0". (When this occurs, the Resource Manager 9500V program or the Web cannot be used via a LAN.) In this case, acquire the IP Address by starting the DHCP server or by setting the DHCP function correctly when necessary.

**Note 9:** Without setting

**Note 10:** Set the Persistent RSV Cluster mode when using the "VERITAS Database Edition/Advanced Cluster for Oracle8i".

**Note 11:** Hitachi Path Manager

**Note 12:** Hitachi Dynamic Link Manager

When using HDLM, please note the following:

Data Share Mode: Indispensable selection

Vendor ID: If this text is changed, it cannot be managed by HDLM. Do not change this text.

Serial Number: When multiple storages of same type exist, allocate a different Serial Number for each disk array subsystem.

**Note 13:** Set this mode when connecting the subsystem as a boot disk or a dump device of an HP server. No operation problem occurs if a device other than a boot disk or a dump device is connected to a port for which this mode is set. However, when lowering of the subsystem performance is not allowed, connect the boot disk/dump device of an HP server to a port separate from devices.

**Note 14:** Array Support Library (ASL): Indispensable selection

**Table B.1 System Parameter Setting List (Continued)**

Platforms		IBM (AIX)			Sequent
HA	Alternate Path	None	HPM ( <b>Note 7</b> )/HDLM ( <b>Note 8</b> )		MP Driver
	Fail Over	None	HACMP	None	None
<b>System Parameter</b>					
1	System Startup Attribute	Depends on System Configuration ( <b>Note 1</b> )			
2	Data Share Mode	Depends on System Configuration ( <b>Note 2</b> )			
3	Drive Detach mode enable	Disable (Standard setting)			
4	Report status (normal/warning)	Enable (Standard setting)			
5	Turbo LU Warning	Disable (Standard setting)			
6	Operation if the Processor failures Occurs	Reset a Fault (Standard setting)			
7	Command Queuing Mode	On (Standard setting)			
8	Vendor ID	HITACHI (Standard setting)			
9	Product ID	DF600F (Standard setting)			
10	ROM Microprogram Version	No change is needed			
11	RAM Microprogram Version	No change is needed			
12	RS232C Error Information Outflow Mode	When RS232C is used: On When RS232C is not used: Off (Standard setting)			
13	Write & Verify Executing Mode	On (Standard setting)			
14	DHCP ( <b>Note 6</b> )	OFF (Standard setting)			
15	IP Address	To be set according to the network setting			
16	Subnet Mask	To be set according to the network setting			
17	Default Gateway	To be set according to the network setting			
<b>Host Group</b>					
1	Host Connection Mode (Option 2)	Without setting			
2	Host Connection Mode1	Standard Mode			TRESPASS Mode
3	Host Connection Mode2	UA(06/2A00) suppress mode enable NACA mode enable ( <b>Note 5</b> )			Without setting
4	LU Mapping Mode	Depends on System Configuration ( <b>Note 3</b> )			
<b>Configuration Information</b>					
1	Reset/LIP Mode (Process)	Reset within the port (Standard setting)			
2	Reset/LIP Mode (Signal)	Reset within the port (Standard setting)			
3	LIP Reset Mode	Target Authentication (Standard setting)			
5	Controller Identifier	Disable (Standard setting)			Enable
6	Controller ID	-			DF600-00 (Standard setting ( <b>Note 4</b> ))
7	Read Frame Min 128 Byte Mode	OFF (Standard setting)			

**Note 1:** Hot Standby mode is used when only one of the two Controllers is normal.

**Note 2:** Data Share mode is used to prevent performance deterioration which results from LU ownership that is switched when a host computer issues commands frequently to a Controller to which the computer has no ownership, in the normal or regression status (owing to a path or host computer failure).

It is recommended that the subsystem in the Data Share mode be used when LU ownership switching may occur.

**Note 3:** When the 9530V is connected, the LU not intended to be accessed by the port must be masked by means of LU mapping mode.

**Note 4:** Set the controller ID's of the CTL-00 and CTL-01 of the 9530V to be identical. When two or more 9530Vs are connected to the system, set the Controller IDs which are not duplications of each other.

When one of the host computers connected to the 9530V requires a Controller ID, set the Controller identifier to Enabled.

**Note 5:** Set the NACA mode when the subsystem is connected to an AIX server where the IBM genuine HBA (FC6227 or later) is installed.

[When LUN Management is not used (when LUN Security is used)]

Do not connect a server other than the AIX server where the IBM genuine HBA (FC6227 or later) is installed, to a port of the 9530V for which the NACA mode has been set. (In the Fibre Channel Loop connection or Fabric connection, do not connect the AIX server, in which the IBM genuine HBA (FC6227 or later) is installed, together with another type server, to a port of the 9530V for which the NACA mode has been set.)

[When LUN Management is used]

By registering the AIX server and the other servers at the separate host groups, you can connect the each server to the same port.

**Note 6:** When the DHCP mode is validated, the IP Address is acquired from the DHCP server.

If the DHCP server is not started or the DHCP function has been incorrectly set, the acquisition of the IP Address will fail and the IP Address of the subsystem will remain "0.0.0.0". (When this occurs, the Resource Manager 9500V program or the Web cannot be used via a LAN.) In this case, acquire the IP Address by starting the DHCP server or by setting the DHCP function correctly when necessary.

**Note 7:** Hitachi Path Manager

**Note 8:** Hitachi Dynamic Link Manager

When using HDLM, note the following:

Data Share Mode: Indispensable selection

Vendor ID: If this text is changed, it cannot be managed by HDLM. Do not change this text.

Serial Number: When multiple storages of same type exist, a different Serial Number needs to be allocated for each disk array subsystem.

**Table B.1 System Parameter Setting List (Continued)**

Platforms		NT/Windows 2000				Others
HA	Alternate Path	None	HPM ( <b>Note 5</b> )/ HDL7 ( <b>Note 6</b> )	None	VVM V3.0SP1/ V3.1 ( <b>Note 7</b> )	None
	Fail Over	None	MSCS		None	None
<b>System Parameter</b>						
1	System Startup Attribute	Depends on System Configuration ( <b>Note 1</b> )				
2	Data Share Mode	Depends on System Configuration ( <b>Note 2</b> )				
3	Drive Detach mode enable	Disable (Standard setting)				
4	Report status (normal/warning)	Enable (Standard setting)				
5	Turbo LU Warning	Disable (Standard setting)				
6	Operation if the Processor failures Occurs	Reset a Fault (Standard setting)				
7	Command Queuing Mode	On (Standard setting)				
8	Vendor ID	HITACHI (Standard setting)				
9	Product ID	DF600F (Standard setting)				
10	ROM Microprogram Version	No change is needed				
11	RAM Microprogram Version	No change is needed				
12	RS232C Error Information Outflow Mode	When RS232C is used: On When RS232C is not used: Off (Standard setting)				
13	Write & Verify Executing Mode	On (Standard setting)				
14	DHCP ( <b>Note 4</b> )	OFF (Standard setting)				
15	IP Address	To be set according to the network setting				
16	Subnet Mask	To be set according to the network setting				
17	Default Gateway	To be set according to the network setting				
<b>Host Group</b>						
1	Host Connection Mode (Option 2)	Without setting				
2	Host Connection Mode1	Standard Mode	Wolfpack Mode	Trespass Mode	Standard Mode	
3	Host Connection Mode2	Without setting	Reset Target (Reset Bus Device) Mode Reset Logout of Third Party Process Mode	Without setting		
4	LU Mapping Mode	Depends on System Configuration ( <b>Note 3</b> )				
<b>Configuration Information</b>						
1	Reset/LIP Mode (Process)	Reset within the port (Standard setting)				
2	Reset/LIP Mode (Signal)	Reset within the port (Standard setting)				
3	LIP Reset Mode	Target Authentication (Standard setting)	LIP Port ALL Reset Mode	Target Authentication (Standard setting)		
5	Controller Identifier	Disable (Standard setting)			Enable	Disable (Standard setting)
6	Controller ID	-			DF500F	-
7	Read Frame Min 128 Byte Mode	OFF (Standard setting)				

**Note 1:** Hot Standby mode is used when only one of the two Controllers is normal.

**Note 2:** Data Share mode is used to prevent performance deterioration which results from LU ownership that is switched when a host computer issues commands frequently to a Controller to which the computer has no ownership, in the normal or regression status (owing to a path or host computer failure).

It is recommended that the subsystem in the Data Share mode be used when LU ownership switching may occur.

**Note 3:** When the 9530V is connected, the LU not intended to be accessed by the port must be masked by means of LU mapping mode.

**Note 4:** When the DHCP mode is validated, the IP Address is acquired from the DHCP server.

If the DHCP server is not started or the DHCP function has been incorrectly set, the acquisition of the IP Address will fail and the IP Address of the subsystem will remain "0.0.0.0". (When this occurs, the Resource Manager 9500V program or the Web cannot be used via a LAN.) In this case, acquire the IP Address by starting the DHCP server or by setting the DHCP function correctly when necessary.

**Note 5:** Hitachi Path Manager

**Note 6:** Hitachi Dynamic Link Manager

When using HDLM, note the following:

Data Share Mode: Indispensable selection

Vendor ID: If this text is changed, it cannot be managed by HDLM. Do not change this text.

Serial Number: When multiple storages of same type exist, a different Serial Number needs to be allocated for each disk array subsystem.

**Note 7:** VERITAS Volume Manager for Windows

# Appendix C Basic Specifications of the Subsystem



This appendix includes the following:

- Basic Specifications of the 9530

## C.1 Basic Specifications of the 9530V

The basic specifications of the Thunder 9530V are described in this section.

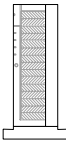
**Table C.1 Basic Specifications of 9530V**

Item	Model	Floor Model	Rack-Mount Model	
		Floor (RKS+H1H) Model	RKS	
Configuration	Configuration	-	1 RKS	
	Subsystem appearance			
Disk drive used	Disk drive size(W×D×H) (mm)	101.6×146.1×25.4		
	Data capacity (G byte)	72		
	Rotational speed (min <sup>-1</sup> )	10,000		
	Maximum mountable quantity (unit)	14		
Host interface	Interface type	2 Gbps Fibre Channel Optical (Non-OFC)	-	
	Data transfer speed (i.e. maximum speed for transfer to host)	200 Mbytes/s (Fibre Channel)	-	
	Number of ports	Single controller	Fibre Channel: 1	-
		Dual controller	Fibre Channel: 2	-
	Transferred block size (bytes)	512 bytes		

**Note 1:** For additional information about the rack-mount model, refer to the *Hitachi Freedom Storage™ Thunder 9500™ V Series 19-Inch Rack Reference Guide* (MK-92DF654).

**Note 2:** This value of storage capacity is calculated as 1 Gbyte = 1,000,000,000 bytes. (This definition is different from 1 Kbyte = 1,024 bytes.)

**Table C.1 Basic Specifications of 9530V (Continued)**

Item I	Model		Floor Model	Rack-Mount Model
			Floor (RKS+H1H) Model	RKS
RAID specifications ( <b>Note 1</b> )	RAID level ( <b>Note 2</b> )		0/1/5/0+1	
	RAID configuration (unit of addition)	RAID 0	2D to 14D	
		RAID 1	1D+1M	
		RAID 5	2D+1P to 13D+1P	
		RAID 0+1	2D+2M to 7D+7M	
Internal logic specifications	Control CPU		Power PC7455 (667 MHz)	
	Control OS		VxWorks	
	Control memory		Flash memory: 2 Mbytes L2 Cache memory: 512 kbytes SRAM: 64 M bytes	
	Data bus performance		Cache access 610 M bytes/s	
	Data assurance method		Data bus: Through-parity Cache memory: ECC(1 bit for correction, 2 bits for detection) Disk drive: Data assurance code	
Physical Specifications	Start-up time (min)		Standard 3 ( <b>Note 9</b> )	
	Chassis size (W×D×H) (mm)		260×737×540	483×656×129
	Mass (kg) ( <b>Note 3</b> )		80 approx.	44 approx.
	Acoustic noise (dB) ( <b>Note 8</b> )		56 or less	57 or less
	Required height (EIA) ( <b>Note 4</b> )		-	3
Input power specifications	Input voltage (V)		AC 100/200 (100 to 120/200 to 240)	
	Frequency (Hz)		50/60 ±1	
	Number of phases, cabling		Single-phase with protective grounding	
	Steady-state current 100V/200V (A) ( <b>Note 6</b> ) ( <b>Note 7</b> )		4.4×2/2.2×2	
	Breaking current (A)		16.0	
	Required power	Steady state (VA)	880 or less	
Starting state (VA) ( <b>Note 5</b> )		920 or less		
Heat value		Steady state (kJ/h)	3,170 or less	

**Note 1:** D: Data disk, P: Parity disk

**Note 2:** Although the subsystem with a configuration of RAID 5, RAID 1, or RAID 0+1 provides data reliability enhanced by means of redundancy, a possibility remains that user data is lost owing to an unexpected failure of a host computer or hardware/software of the subsystem itself. Therefore, users are requested to back up all data for restoration in case where the original data is lost.

**Note 3:** Value of maximum configuration (in the case where all the mountable Disk drives and Controller are mounted).

**Note 4:** Can be mounted on the Hitachi special rack frame (U6). For the mounting, special rails for the rack frame and decoration panel(s) are required separately depending on the number of the mounted subsystem(s).

**Note 5:** Power requirement in the case of the maximum configuration is shown. When planning facilities such as the uninterrupted power supply (UPS), specify the power factor as 100% for calculation. Value at 100 V/200 V is shown. (Example: 300 W=300 VA)

The actual required power may exceed the value shown in the table when the tolerance is included.

**Note 6:** The current value in the operation by a single power supply unit is same as that in the operation by both power supply units.

**Note 7:** When one of the two power supply units fails, another power supply unit requires electric current for the two power supply units. Therefore, plan for a power supply facility in which the current carrying capacity of one of the power supply units is a total capacity of the two power supply units.

**Note 8:** A noise emitted at the time of start is not included.

**Note 9:** The start-up time may be longer than three minutes depending on the configuration.

**Table C.1 Basic Specifications of 9530V (Continued)**

Item	Model	Floor Model	Rack-Mount Model
		Floor (RKS+H1H) Model	RKS
Cache specifications	Capacity (M bytes/CTL)	1,024	
	Control method	Read LRU/Write after	
	Battery backup	Provided	
	Backup duration (h) ( <b>Note 1</b> )	24 (Cache 1,024 M bytes/CTL)	
Maintenance specifications/ anti-fault specifications	Spare disk	Up to fifteen of mounted Disk drives can be set to Spare disks	
	Display function	Status LEDs (POWER/READY/WARNING/ALARM) LED of maintenance part	
Insulation performance	Insulation withstand voltage	AC 1,500 V (10 mA to 1 min)	
	Insulation resistance	DC 500 V、10 M Ω or more	

**Note 1:** Non-volatility of data in the cache memory is ensured against power trouble such as a sudden power failure. It transfers data in the Cache memory to Disk drives by turning off the power normally, and prevents the battery charge from being wasted.

When the subsystem enters the Cache Backup mode, a warning (lighting of the orange LED) informing of a voltage drop of the battery may be issued when the subsystem is started. It shows that the remaining capacity of the battery is not sufficient, and in this state, the subsystem operates disabling the Write Cache function automatically.

When the battery is charged, the warning indication disappears, and the subsystem continues the operation enabling the Write Cache function.

The warning indication disappears within 24 hours at the latest. Even when the warning is being indicated, normal functional operation is assured although the operation is performed in the Write-Through mode and the R/W performance is lowered because the Write Cache function is disabled.

Since the battery is subject to the effect of the environmental temperature, avoid using a battery in unnecessarily continuous operation at a high temperature.

If the subsystem is not energized for more than a month, the over discharging of the battery occurs and it may cause the battery an unrecoverable damage. In this case, the battery must be energized more than 24 hours at least once a month, or store the subsystem with the switch of the battery turned off. Even when the switch is turned off, the battery discharges naturally. Even in this case, however, charge the battery once per three months for longer than 24 hours because spontaneous discharge is done.



## Appendix D Power Cables

This section includes descriptions of the following power cables:

- J1H
- J2H
- J2H5
- J2H10
- DC Power Cable

**Table D.1 J1H Power Cable**

Cable name	Part No.	Name	Quantity	Model	Applicable safety standard/ rating
DF-F600-J1H Power cable	1	Cable	-	PVC code	UL and CSA
	2	Connector A	1	NEMA Standard 5-15 P	For AC 125 V (13 A or 15 A)
	3	Connector B	1	EN60320-C13	For standard use

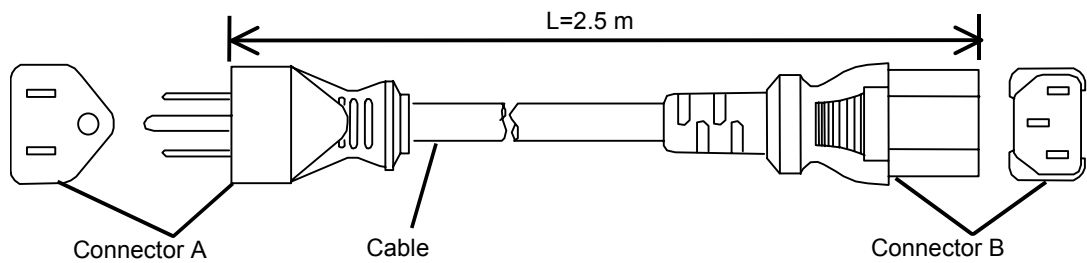

**Figure D.1 Port Extender Dimensions**

**Table D.2 J2H Power Cable**

Cable name	Part No.	Name	Quantity	Model	Applicable safety standard/ rating
DF-F600-J2H	1	Cable	-	PVC code	UL and CSA
Power cable	2	Connector A	1	EN60324-C14	For AC 250 V (13 A or 15 A)
	3	Connector B	1	EN60324-C13	For rack frame

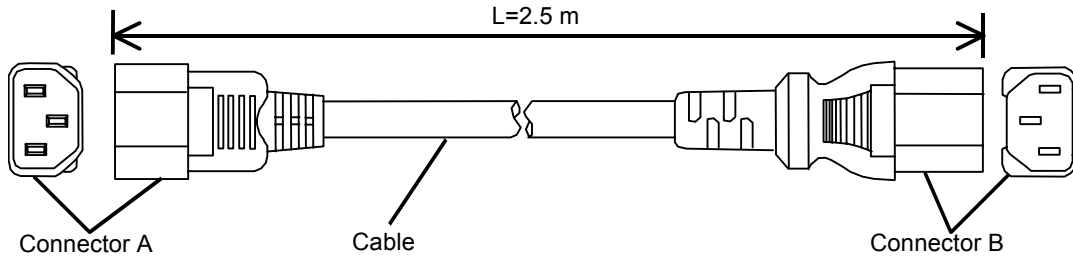

**Figure D.2 J2H Power Cable**

**Table D.3 J2H5 and J2H10 Power Cables**

Cable name	Part No.	Name	Quantity	Model	Applicable safety standard/ rating
DF-F600-	1	Cable	-	GENELEC	UL and CSA
J2H5/J2H10	2	Connector A	1	EN60320-C14	For AC 250 V (13 A or 15 A)
Power cable	3	Connector B	1	EN60320-C13	For rack frame

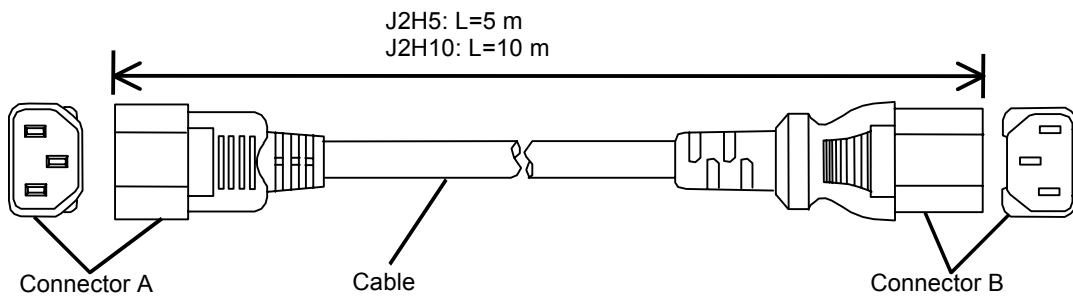

**Figure D.3 J2H5 and J2H10 Power Cables**