



**Hitachi Freedom Storage™  
Thunder 9500™ V Series**

**FlashAccess 9500V  
User's Guide**



© 2003 Hitachi Limited, ALL RIGHTS RESERVED

**Notice:** No part of this publication may be reproduced or transmitted in any form or by any electronic or mechanical means, including photocopying and recording, or stored in a database or retrieval system for any purpose, without the express written permission of Hitachi Limited.

Hitachi reserves the right to make changes to this document at any time without notice and assumes no responsibility for its use. Hitachi products or services can only be ordered under the terms and conditions of Hitachi's applicable agreements, including license agreements. All of the features described in this document may not be currently available. Refer to the most recent product announcement or contact your local Hitachi sales office for information on feature and product availability.

This document contains the most current information available at the time of publication. When new and/or revised information becomes available, this entire document will be updated and distributed to all registered users.

## Trademarks

Hitachi Data Systems is a registered trademark and service mark of Hitachi, Ltd., and the Hitachi Data Systems design mark is a trademark and service mark of Hitachi, Ltd.

Freedom Storage and Thunder 9500 are trademarks of Hitachi Data Systems Corporation.

All other brand or product names are or may be trademarks or service marks of and are used to identify products or services of their respective owners.

## Notice of Export Controls

Export of technical data contained in this document may require an export license from the United States government and/or the government of Japan. Contact the Hitachi Legal Department for any export compliance questions.

## Document Revision Level

Revision	Date	Description
MK-92DF612-P	September 2002	Preliminary Release
MK-92DF612-0	November 2002	Revision 0, supersedes and replaces MK-92DF612-P
MK-92DF612-1	December 2002	Revision 1, supersedes and replaces MK-92DF612-0
MK-92DF612-2	January 2003	Revision 2, supersedes and replaces MK-92DF612-1
MK-92DF612-3	April 2003	Revision 3, supersedes and replaces MK-92DF612-2

## Source Documents Used in this Revision

The following source documents were used to produce this users guide:

- FlashAccess 9470 User's Guide (FlashAccess\_0E) dated 08/01/02.
- FlashAccess User's Guide (DF600)(FlashAccess\_0E) dated 08/01/02.
- FlashAccess User's Guide (DF600)(RSD-92df612-3) dated 03/31/03.

## Changes in this Revision

- Revised Table 2.1, item 2 (changed 0+1 to 1+0).
- Updated Figure 4.3, Parameter Panel capture.

## Referenced Documents

- *9500V User and Reference Manual (MK-92DF601)*
- *Resource Manager 9500V (for GUI) User's Guide (MK-92DF605)*
- *Resource Manager 9500V (for CLI) User's Guide (MK-92DF603)*

# Preface

Before using FlashAccess 9500V, read the operating procedures and notices included in this guide.

The *FlashAccess 9500V User's Guide* assumes that:

- The user has a background in data processing and understands direct-access storage device subsystems and their basic functions.
- The user is familiar with the Disk array subsystem.
- The user is familiar with the *Hitachi Resource Manager 9500V (for GUI) User's Guide* (MK-92DF605) and/or the *Hitachi Resource Manager 9500V (for CLI) User's Guide* (MK-92DF603).

**Note:** For additional information on the 9500V subsystem features and functions, please contact your Hitachi Data Systems account team, or visit Hitachi Data Systems online at <http://www.hds.com>.

**Note:** The use of Hitachi Resource Manager, the FlashAccess 9500V software, and all other Hitachi Data Systems products is governed by the terms of your license agreement(s) with Hitachi Data Systems.

**Note:** The screens shown in this document were captured on a Windows® system with the Internet Explorer web browser. The screens may display differently on other operating systems and browsers. Please refer to the *Resource Manager 9500 User's Guide for GUI* (MK-92DF605) for further information on other operating systems and browsers.

**Note:** The term "9500V" refers to the entire Hitachi Freedom Storage™ Thunder 9500™ V Series subsystem family, unless otherwise noted.

**Note:** FlashAccess is an abbreviation for Flash Data Access.

**Note:** FlashAccess is not supported on the 9531V subsystem.

## COMMENTS

Please send us your comments on this document: [doc.comments@hds.com](mailto:doc.comments@hds.com).

**Make sure to include the document title, number, and revision.  
Please refer to specific page(s) and paragraph(s) whenever possible.**  
(All comments become the property of Hitachi Data Systems Corporation.)

**Thank you!**



# Contents

<b>Chapter 1</b>	<b>Introducing FlashAccess 9500V</b> .....	<b>1</b>
<b>Chapter 2</b>	<b>FlashAccess 9500V Functions</b> .....	<b>3</b>
	2.1 FlashAccess 9500V Characteristics.....	3
	2.2 Conditions Necessary for FlashAccess 9500V Operation .....	4
	2.3 Conditions that Terminate FlashAccess 9500V Operation.....	5
	2.4 Conditions that Disable FlashAccess 9500V Operation.....	6
<b>Chapter 3</b>	<b>Installing and Uninstalling FlashAccess 9500V (GUI)</b> .....	<b>7</b>
	3.1 Installing FlashAccess 9500V .....	8
	3.2 Uninstallation .....	12
<b>Chapter 4</b>	<b>Enabling/Disabling FlashAccess 9500V (GUI)</b> .....	<b>15</b>
<b>Chapter 5</b>	<b>Setting/Referring/Canceling LUs with FlashAccess 9500V (GUI)</b> .....	<b>17</b>
<b>Chapter 6</b>	<b>Capacity of the LU with FlashAccess 9500V</b> .....	<b>21</b>
<b>Chapter 7</b>	<b>Troubleshooting</b> .....	<b>23</b>
	7.1 Troubleshooting.....	23
	7.2 Calling the Hitachi Data Systems Technical Support Center.....	23
<b>Appendix A</b>	<b>FlashAccess 9500V Operations Using CLI</b> .....	<b>25</b>
	A.1 Installing FlashAccess 9500V .....	25
	A.2 Uninstallation .....	27
	A.3 Enabling/Disabling FlashAccess 9500V .....	28
	A.4 Setting/Referring/Canceling LUs with FlashAccess 9500V .....	29
	<b>Acronyms and Abbreviations</b> .....	<b>31</b>
	<b>Index</b> .....	<b>33</b>

## List of Figures

Figure 1.1	FlashAccess 9500V Overview .....	1
Figure 3.1	Array System Viewer Panel.....	8
Figure 3.2	Parameter Panel (Options tab: No Option) .....	9
Figure 3.3	The Unlock Confirmation Request Message .....	9
Figure 3.4	The Unlock Confirmation Message .....	9
Figure 3.5	Parameter Panel (Options tab: FlashAccess Enable) .....	10
Figure 3.6	The Reboot Message .....	10
Figure 3.7	Restart Successful Message.....	11
Figure 3.8	The Lock Confirmation Request Message .....	12
Figure 3.9	The Lock Confirmation Message .....	13
Figure 4.1	Enable/Disable Confirmation Request Message .....	15
Figure 4.2	Confirmation Message .....	15
Figure 4.3	Parameter Panel (Options tab: FlashAccess Disable) .....	16
Figure 5.1	Parameter Panel (Logical Unit Cache tab).....	17
Figure 5.2	LU Cache Confirmation Message.....	18
Figure 5.3	Reboot Message .....	18
Figure 5.4	Restart Terminated Message .....	19

## List of Tables

Table 2.1	Conditions Necessary for FlashAccess 9500V .....	4
Table 2.2	Conditions that Terminate FlashAccess 9500V .....	5
Table 2.3	Conditions that Terminate FlashAccess 9500V .....	6
Table 6.1	Maximum Capacity of LU with FlashAccess 9500V (Number of Logical Blocks).....	21

# Chapter 1 Introducing FlashAccess 9500V

The FlashAccess 9500V function ensures that all data in an LU (Logical Unit) is stored in cache memory. All read/write commands to the LU can be executed at a 100% cache hit rate without accessing the drive. The system throughput is improved when this function is applied to an LU that contains data accessed frequently because no latency period is needed to access the disk drive.

As shown in Figure 1.1 below, part of cache memory installed in the controller is used for the FlashAccess 9500V function. Cache memory utilizes a battery backup on both controllers, and the data is duplicated on each controller for safety against power failure and cache package failure, etc.

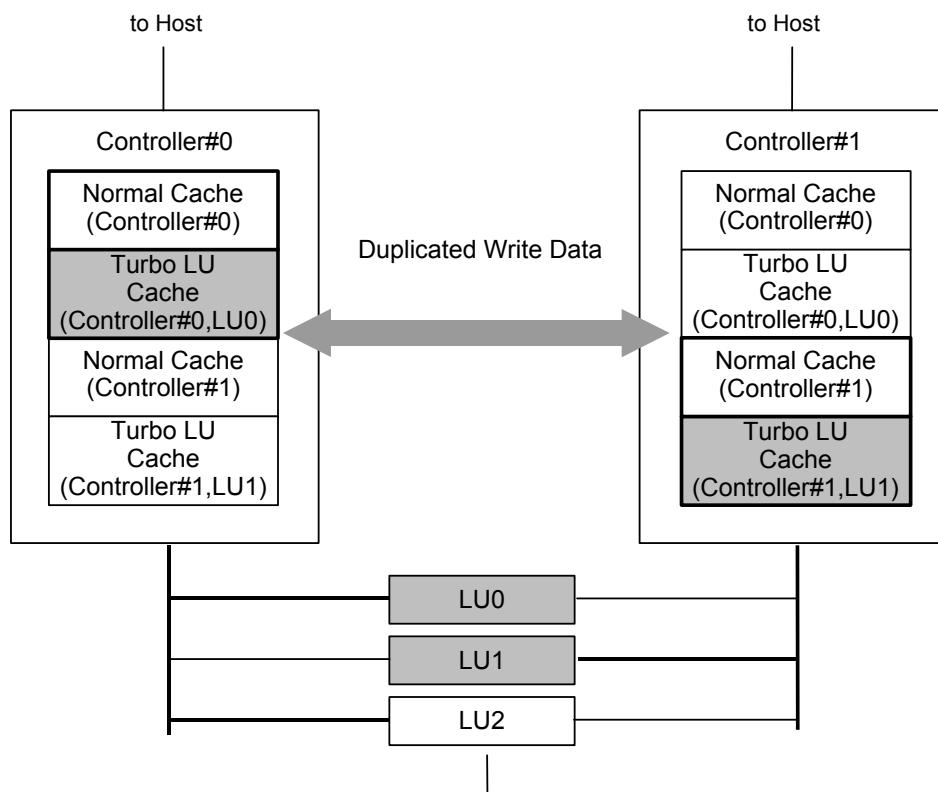

Figure 1.1 FlashAccess 9500V Overview

**Note:** FlashAccess 9500V requires initial preplanning due to rules regarding cache capacity (see Chapter 6).

This document includes the following information:

- FlashAccess 9500V Functions
- Installing and Uninstalling FlashAccess 9500V (GUI)
- Enabling/Disabling FlashAccess 9500V (GUI)
- Setting/Referring/Canceling LU with Turbo Cache Function (GUI)
- Capacity of LU with Turbo Cache Function
- Operations Using Command Line Interface (CLI)

## Chapter 2 FlashAccess 9500V Functions

This section contains the following:

- FlashAccess 9500V Characteristics
- Conditions Necessary for FlashAccess 9500V Operation
- Conditions that Terminate FlashAccess 9500V Operation
- Conditions that Disable FlashAccess 9500V Operation

### 2.1 FlashAccess 9500V Characteristics

The controller executes read/write commands to the LU using the FlashAccess 9500V function as follows:

- Read data accessed by the host is stored in the cache memory until the array unit is turned off. Therefore, subsequent host access to the previously accessed area is guaranteed to be transferred from the cache memory without accessing the disk drives.
- Write data from the host is stored in the cache memory, and not written to disk drives until the array unit is turned off.
- The cache memory utilizes a battery backup and the write data is duplicated (stored in the cache memory on both controllers).
- Write data stored in the cache memory is written to disk drives when the array unit is turned off and when the FlashAccess 9500V operation is stopped by failures.

As described previously, read/write commands to the LU with the FlashAccess 9500V function can be processed without a substantial delay. However, the internal controller operation is the same as that of commands issued to other LUs, except that the read/write command to the LU with the FlashAccess 9500V function can be transferred from/to the cache memory without accessing the disk drives.

A delay may be observed in the following cases even if the FlashAccess 9500V function is applied to the LU.

- The command execution may wait for the completion of commands issued to other LUs.
- The command execution may wait for the completion of commands other than read/write commands (such as the Mode Select command) issued to the same LU.
- The command execution may wait for the completion of processing for internal operation such as data reconstruction, etc.

The following sections detail the conditions that permit or prevent (halt) FlashAccess 9500V operations.

## 2.2 Conditions Necessary for FlashAccess 9500V Operation

To use FlashAccess 9500V, all of the conditions listed in Table 2.1 must be met. Verify these conditions are present before you use FlashAccess 9500V.

**Table 2.1 Conditions Necessary for FlashAccess 9500V**

No.	Item	Conditions	Remarks
1	Controller Configuration	<ul style="list-style-type: none"><li>• Dual Controller configuration</li></ul>	
2	RAID Level	<ul style="list-style-type: none"><li>• RAID 5, or RAID 1+0</li></ul>	
3	LU Size	<ul style="list-style-type: none"><li>• Hot Standby Configuration Less than (available Cache Capacity - 256MB)</li><li>• Dual Active Configuration Less than (available Cache Capacity - 256MB)/2</li></ul>	See Chapter 6
4	Number of LUs with Turbo Cache Function	<ul style="list-style-type: none"><li>• Hot Standby Configuration 1/Subsystem</li><li>• Dual Active Configuration 1/Controller</li></ul>	

## 2.3 Conditions that Terminate FlashAccess 9500V Operation

When the array unit is working without failures, the FlashAccess 9500V operation continues until the array unit is powered-off. However, the configuration changes or failures listed in Table 2.2 will halt FlashAccess 9500V operation.

**Table 2.2 Conditions that Terminate FlashAccess 9500V**

No.	Conditions	Remarks
1	When the array unit is powered off.	Normal case
2	When the cache capacity is changed and the available capacity of the cache memory is less than LU size.	Cache uninstallation
3	When a controller failure occurs.	Failures Battery alarm immediately disables any FlashAccess LUN as the battery backs up all user cache. When the battery fails, the subsystem goes into a "write through" to disk mode and does not use cache at all.
4	When one of the cache packages has failed.	
5	When the battery alarm occurs.	
6	When a battery backup circuit failure occurs.	
7	When the number of PIN data (data unable to be written to disk drives because of some failures) exceeded the threshold value.	

FlashAccess 9500V operation will be restarted when the failures are corrected.

## 2.4 Conditions that Disable FlashAccess 9500V Operation

The FlashAccess 9500V operation is disabled under the conditions listed in Table 2.3.

**Note:** Pay special attention when you change the configuration of the array unit and reset the LU with FlashAccess 9500V.

**Table 2.3** Conditions that Terminate FlashAccess 9500V

No.	Conditions	Remarks
1	When the setting of FlashAccess 9500V is cleared.	All of these conditions are caused by the operator.
2	When FlashAccess 9500V is disabled or uninstalled (locked).	
3	When the default ownership of FlashAccess 9500V is changed.	
4	When the LU with FlashAccess 9500V is deleted or the RAID group of the LU is deleted.	
5	When the controller configuration is changed (Dual Active mode to/from Hot Standby mode).	

The changes created by conditions 1-3 in Table 2.3 above will be valid at the next power-on of the array unit. Therefore, the FlashAccess 9500V function will be disabled at the next power-on of the array unit.

## Chapter 3 Installing and Uninstalling FlashAccess 9500V (GUI)

This chapter provides instructions for installing and uninstalling FlashAccess 9500V using the GUI version of the Resource Manager 9500V. This section includes the following:

- Installing FlashAccess 9500V
- Uninstalling FlashAccess 9500V

For details on installing FlashAccess 9500V using CLI, see Appendix A.

To make FlashAccess 9500V available, you must install the feature and make its functions selectable (unlocked).

**Note:** To install this function, the key code provided with the optional feature is required.

FlashAccess 9500V is installed and uninstalled using Resource Manager 9500V.

**Note:** Before installing and uninstalling, make sure that the array unit is in normal operating mode. If a failure (such as a controller blockade) has occurred, installation and uninstallation operations cannot be performed.

### 3.1 Installing FlashAccess 9500V

To install FlashAccess 9500V using the GUI version of Resource Manager 9500V:

1. Start the Resource Manager 9500V and change the mode of operation to **Management Mode**. For details, refer to the *Resource Manager 9500V (for GUI) User's Guide* (MK-92DF605).
2. Register the subsystem (array unit) in which you will install FlashAccess 9500V and connect to the subsystem. For details, refer to *Resource Manager 9500V (for GUI) User's Guide* (MK-92DF605).

The Array System Viewer panel appears and displays the connected subsystem (see Figure 3.1).

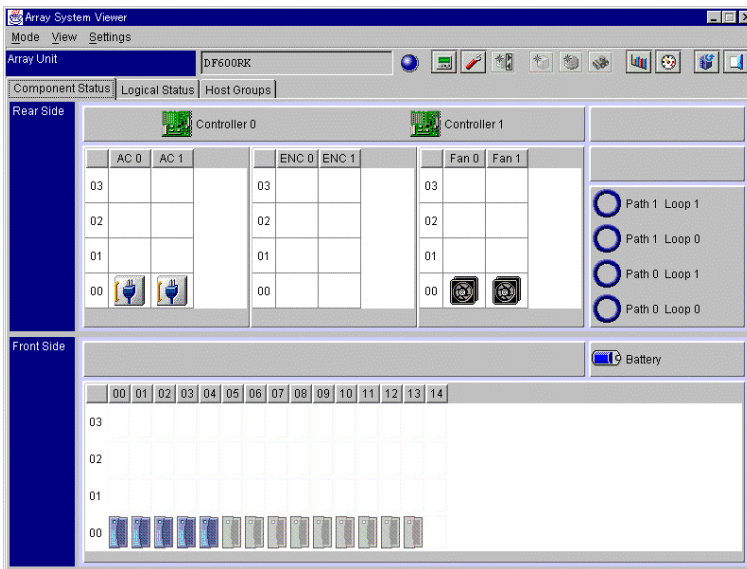

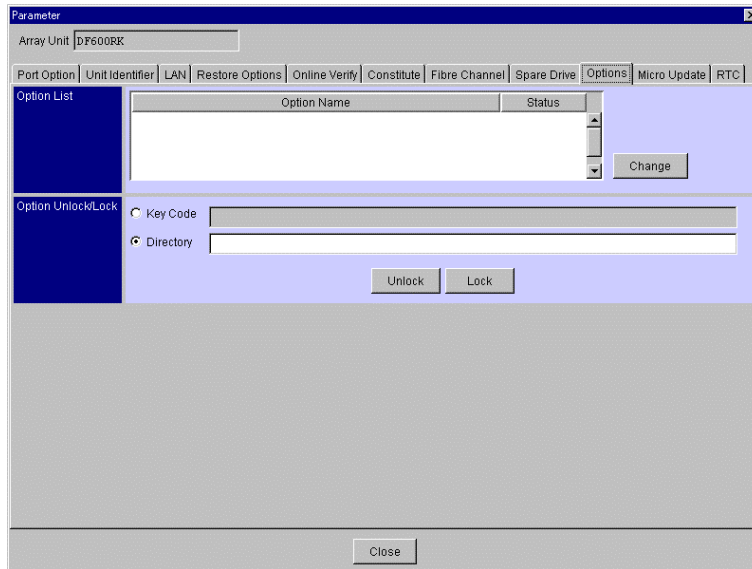

Figure 3.1 Array System Viewer Panel

3. From the **Settings** menu, select **Configuration Settings**. Alternatively, from the tool bar, select the **Configuration Settings**  button.
4. On the resulting Parameter panel, click the **Options** tab (see Figure 3.2).



**Figure 3.2 Parameter Panel (Options tab: No Option)**

5. Enter a **key code** in the text box and click the **Unlock** button.
6. A message appears requesting a confirmation to unlock the FlashAccess 9500V option. Click the **OK** button (see Figure 3.3).

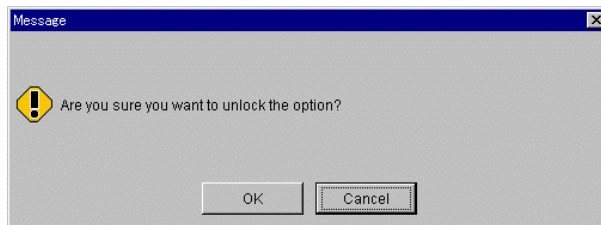

**Figure 3.3 The Unlock Confirmation Request Message**

7. A message appears confirming that this optional feature is unlocked. It also requests confirmation to restart the subsystem. Click the **OK** button to restart (see Figure 3.4).

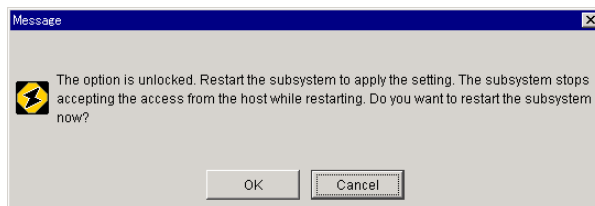

**Figure 3.4 The Unlock Confirmation Message**

**Note:** To validate the unlocking of this optional feature, restart the array unit. The previous setting stays valid until restarting. The array unit cannot access the host until the restart is completed. Therefore, be certain the host has stopped accessing data before beginning the restart process.

When a restart is not in process, this set-up optional feature will be updated and displayed (see Figure 3.5).

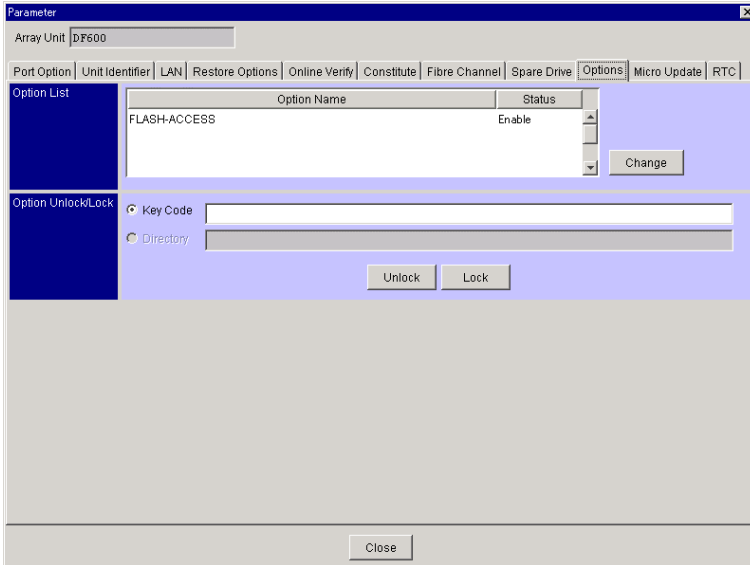

Figure 3.5 Parameter Panel (Options tab: FlashAccess Enable)

When you choose to restart the array unit, the time the restart began is displayed. Restarting takes approximately two to six minutes (see Figure 3.6).

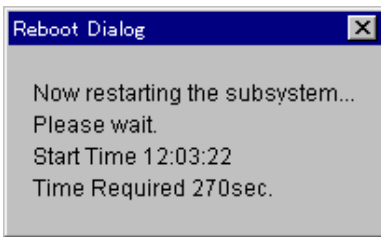
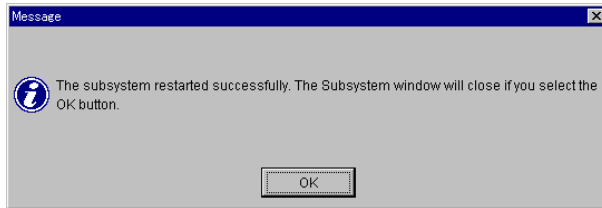

Figure 3.6 The Reboot Message

**Note:** It may take up to six minutes for an array unit to respond, depending on the configuration of the array unit.

8. A message appears stating that the restart was successful. Click the **OK** button (see Figure 3.7).



**Figure 3.7 Restart Successful Message**

The Array System Viewer panel closes. To perform other operations, select the desired operation from the Array System Viewer panel.

## 3.2 Uninstallation

To uninstall FlashAccess 9500V using the GUI version of Resource Manager 9500V:

1. Start the Resource Manager 9500V and switch the mode of operation to **Management Mode**. For details, refer to the *Resource Manager 9500V (for GUI) User's Guide* (MK-92DF605).
2. Register the array unit in which you will uninstall the FlashAccess function and connect to the registered array unit. A unit window for the connected array unit will be displayed (refer to Figure 3.1).
3. From the **Settings** menu, select **Configuration Settings**. Alternatively, from the tool bar, select the **Configuration Settings**  button.
4. On the resulting Parameter panel, click the **Options** tab (refer to Figure 3.5).
5. Enter a **key code** in the text box and click the **Lock** button.
6. A message appears requesting a confirmation to lock the FlashAccess 9500V option. Click the **OK** button (see Figure 3.8).

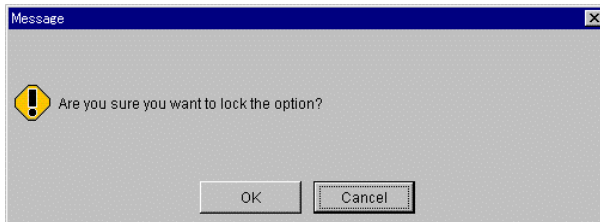

**Figure 3.8** The Lock Confirmation Request Message

7. A message appears confirming that this optional feature is locked. It also requests confirmation to restart the subsystem. Click the **OK** button to restart (see Figure 3.9).

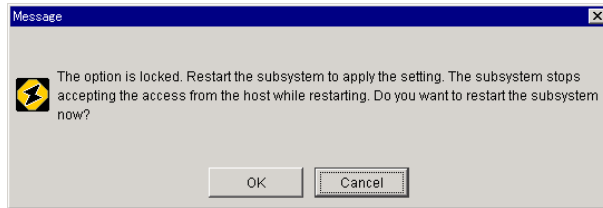

**Figure 3.9** The Lock Confirmation Message

**Note:** To validate the locking of this optional feature, restart the array unit. The previous setting stays valid until restarting. The array unit cannot access the host until the restart is completed. Therefore, be certain the host has stopped accessing data before beginning the restart process.

When a restart is not in process, this set-up optional feature will be updated and displayed (refer to Figure 3.2).

When you choose to restart the array unit, the time the restart began is displayed. Restarting takes approximately two to six minutes.

**Note:** It may take up to six minutes for an array unit to respond, depending on the configuration of the array unit.

8. A message appears stating that the restart was successful. Click the **OK** button.

The Array System Viewer panel closes. To perform other operations, select the desired operation from the Main screen.



## Chapter 4 Enabling/Disabling FlashAccess 9500V (GUI)

To enable or disable FlashAccess 9500V (without uninstalling this function) using the GUI version of Resource Manager 9500V:

1. Start the Resource Manager 9500V and switch to **Management Mode**. For details, refer to the *Resource Manager 9500V (for GUI) User's Guide* (MK-92DF605).
2. Register the array unit in which you will set FlashAccess 9500V. A unit window for the connected array unit appears (refer to Figure 3.1).
3. From the **Settings** menu, select **Configuration Settings**. Alternatively, from the tool bar, select the **Configuration Settings**  button.
4. On the resulting Parameter panel, click the **Options** tab (refer to Figure 3.5).
5. Click **FLASH-ACCESS** in the **Option Name** text box, and then click the **Change** button.
6. In the resulting message, click **OK** button (see Figure 4.1).

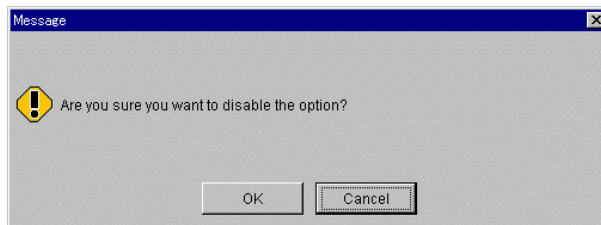

Figure 4.1 Enable/Disable Confirmation Request Message

7. A message appears confirming that this optional feature is set. It also requests confirmation to restart the subsystem. Click the **OK** button to restart (see Figure 4.2).

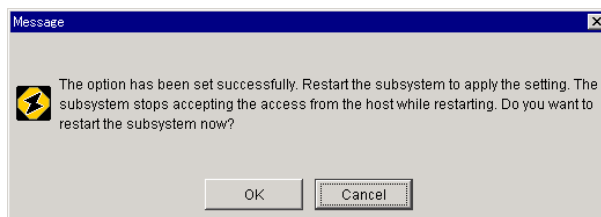

Figure 4.2 Confirmation Message

**Note:** This setting is not active until the system is restarted. The subsystem cannot access the host until the restart is completed. Therefore, be certain the host has stopped accessing data before beginning the restart process.

When a restart is not in process, this set-up optional feature will be updated and displayed (see Figure 4.3).

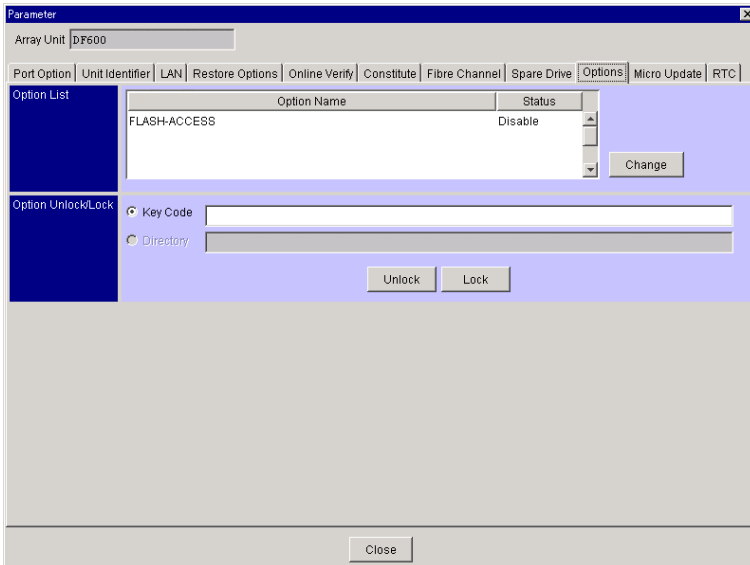

Figure 4.3 Parameter Panel (Options tab: FlashAccess Disable)

When you choose to restart the array unit, the time the restart began is displayed. Restarting takes approximately two to six minutes.

**Note:** It may take up to six minutes for an array unit to respond, depending on the configuration of the array unit.

8. A message appears stating that the restart was successful. Click the **OK** button (refer to Figure 3.7).

The Array System Viewer panel closes. To perform other operations, select the desired operation from the Main screen.

## Chapter 5 Setting/Referring/Canceling LUs with FlashAccess 9500V (GUI)

You can set an LU using Resource Manager 9500V by installing the FlashAccess 9500V function. The LU that is set for the FlashAccess 9500V function must be previously defined. If the LU is not defined, define the LU (choose an LU that already exists that you would like to be a FlashAccess LU). Confirm that the conditions required for FlashAccess 9500V operations are present before performing the operation (refer to Table 2.1).

1. From the Array System Viewer panel **Settings** menu, select **Configuration Settings**. Alternatively, from the tool bar, select the **Configuration Settings**  button.
2. On the resulting Parameter panel, click the **Logical Unit Cache** tab.

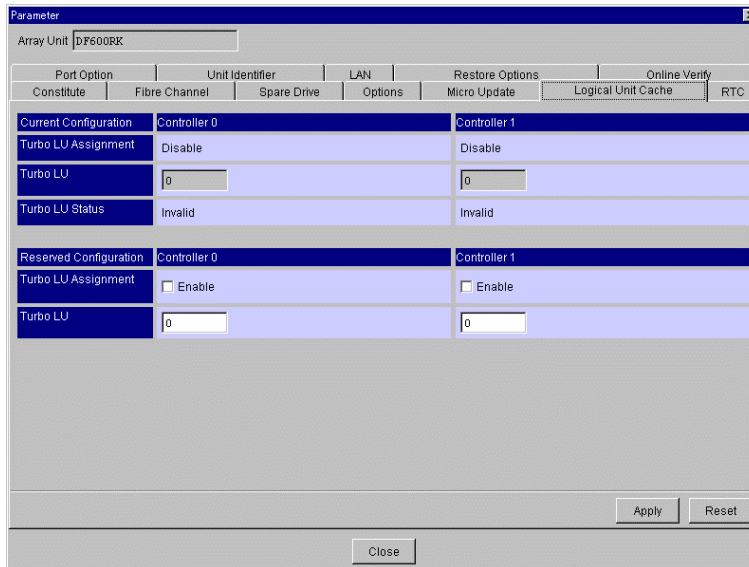

The screenshot shows the 'Parameter' dialog box for Array Unit DF600RK. The 'Logical Unit Cache' tab is selected. The dialog is divided into two main sections: 'Current Configuration' and 'Reserved Configuration', each with columns for Controller 0 and Controller 1.

	Controller 0	Controller 1
<b>Current Configuration</b>		
Turbo LU Assignment	Disable	Disable
Turbo LU	0	0
Turbo LU Status	Invalid	Invalid
<b>Reserved Configuration</b>		
Turbo LU Assignment	<input type="checkbox"/> Enable	<input type="checkbox"/> Enable
Turbo LU	0	0

Buttons: Apply, Reset, Close

Figure 5.1 Parameter Panel (Logical Unit Cache tab)

3. Enter the options for the **Reserved Configuration**. You can check the setup information by viewing the **Current Configuration** after restarting the array unit.

The Logical Unit Cache tab contains the following:

- **Current Configuration:** The current configuration setup is displayed.
  - **LU cache resident mode:** Displays the LU cache resident state (enabled or disabled).
    - Enable:** The LU cache resident function is set.
    - Disable:** The LU cache resident function is canceled.

- **Designated LU:** The number of an LU in which LU cache is resident.
- **LU cache resident status:** Displays the status of an LU in which LU cache is resident. If the LU cache resident mode is disabled, LU information is not displayed.
  - Available:** The LU in which LU cache is resident is available.
  - Unavailable:** The LU in which LU cache is resident is unavailable.
- **Reserved Configuration:** A configuration to be reserved is displayed.
  - **LU cache resident mode:** Displays the LU cache resident state (enabled or disabled).
    - Enable:** The LU cache resident function is set.
    - Disable:** The cache resident function is canceled.
  - **Designated LU:** The number of an LU in which LU cache is resident.

**Note:** If an array unit has a standby configuration, only one setup can be specified for Controller 0. If a setup is specified for Controller 1, it is ignored.

4. From the Array System Viewer panel, click the **Apply** button.
5. A message appears confirming that LU cache is set. The message also asks you to restart the system. Click the **OK** button (see Figure 5.2).

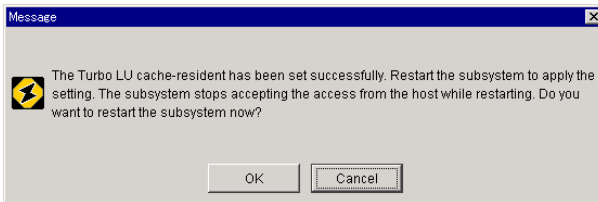

**Figure 5.2 LU Cache Confirmation Message**

**Note:** To validate the LU cache resident condition, restart the array unit. The previous setting remains valid until the system is restarted. The subsystem cannot access the host until the restart is completed. Therefore, be certain the host has stopped accessing data before beginning the restart process.

When you choose to restart the array unit, a message appears displaying the time the restart began (see Figure 5.3). Restarting takes approximately two to six minutes.

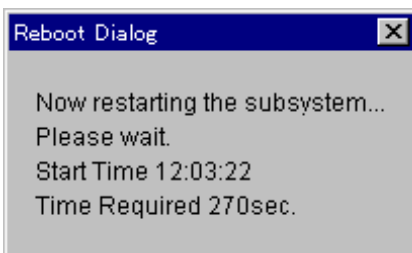

**Figure 5.3 Reboot Message**

**Note:** It may take time for an array unit to respond. Do not manually power off the array unit. However, if it does not respond after 10 minutes or more, check the condition of the array unit.

6. A message appears stating that the restart has terminated (see Figure 5.4). Click the **OK** button. The Array System Viewer panel closes. To perform other operations on the Main screen, select an array unit from the Main screen and open the selected unit.

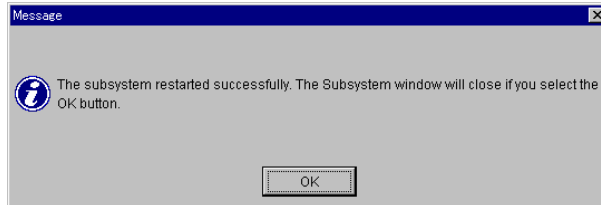

**Figure 5.4** Restart Terminated Message

**Note:** The Flash Access 9500V function is available as a separately purchased optional feature. If the Flash Access 9500V function is not installed or the priced optional feature is not validated, LU cache cannot be set resident.



## Chapter 6 Capacity of the LU with FlashAccess 9500V

The maximum size of the LU that is used for the FlashAccess 9500V function depends on the capacity of the installed cache memory. FlashAccess 9500V uses part of the cache memory. Table 6.1 shows the maximum size (number of blocks) of the LU that is used for the FlashAccess 9500V function.

**Table 6.1 Maximum Capacity of LU with FlashAccess 9500V (Number of Logical Blocks)**

Installed Cache Capacity (MB/Controller)	1024	2048
Hot Standby mode	1,132,992	3,161,088
Dual Active mode	566,496	1,580,544

The number of blocks specified at the LU definition is rounded up to the boundary fixed for each RAID configuration. Therefore, when you use the number of blocks to define an LU for the FlashAccess 9500V function, the capacity of the LU may exceed the value (as specified in Table 6.1).

**Note:** When you define an LU for the FlashAccess 9500V function, specify the number of blocks which are a multiple of the boundary value, and less than or equal to the value in Table 6.1. The following is the LU definition formula:

Number of data disks × 1024 data blocks = Number of boundary blocks



# Chapter 7 Troubleshooting

## 7.1 Troubleshooting

The 9500V subsystem provides continuous data availability and is not expected to fail in any way that would interrupt access to user data. For troubleshooting information on the 9500V subsystem or Resource Manager, please refer to the *9500V User and Reference Manual* (MK-92DF601), the *Resource Manager 9500V User's Guide for GUI* (MK-92DF605), or the *Resource Manager 9500V User's Guide for CLI* (MK-92DF603).

## 7.2 Calling the Hitachi Data Systems Technical Support Center

If you need to call the Hitachi Data Systems Technical Support Center, be sure to provide as much information about the problem as possible. Include the circumstances surrounding the error or failure and the exact content of any error codes and/or messages displayed. The worldwide Hitachi Data Systems Technical Support Centers are:

- Hitachi Data Systems North America/Latin America  
San Diego, California, USA  
1-800-348-4357
- Hitachi Data Systems Europe  
Contact Hitachi Data Systems Local Support
- Hitachi Data Systems Asia Pacific  
North Ryde, Australia  
011-61-2-9325-3300



## Appendix A FlashAccess 9500V Operations Using CLI

This section includes the following:

- Installing FlashAccess 9500V
- Uninstalling FlashAccess 9500V
- Enabling/Disabling FlashAccess 9500V
- Setting/Referring/Canceling LUs with FlashAccess 9500V

### A.1 Installing FlashAccess 9500V

The FlashAccess 9500V feature is usually unselectable (locked); to make it available, you must install the FlashAccess 9500V feature and make its functions selectable (unlocked). **To install this function, the key code provided with the optional feature is required.**

FlashAccess 9500V is installed and uninstalled using Resource Manager 9500V.

**Note:** Before installing and uninstalling, make sure that the array unit is in normal operating mode. If a failure such as a controller blockade has occurred, installation and uninstallation operations cannot be performed.

To install FlashAccess 9500V using the CLI version of Resource Manager 9500V:

1. From the command prompt, register the subsystem (array unit) in which you will install FlashAccess 9500V and connect to the subsystem. For details, refer to *Resource Manager 9500V (for CLI) User's Guide (MK-92DF603)*.
2. Unlock the optional features by using the following:

**Example 1:**

```
% auopt -unit df600 -lock off -keycode Key code
Password:
Option was opened.
Restart the subsystem to apply the setting.
The subsystem stops accepting the access from the host while restarting.
Also, if you are logging in, the login status will be cancelled when restarting
begins.
Do you want to restart the subsystem now? (y/n [n]): y
Now restarting the subsystem. Start Time HH:MM:SS Time Required nnnsec.
The subsystem restarted successfully.
%
```

**Example 2:**

```
% auopt -unit df600 -refer
Password:
Option name          Status
FLASH-ACCESS        Enable
%
```

**Note:** To validate the unlocking of this optional feature, restart the array unit. The previous setting stays valid until restarting. The array unit cannot access the host until the restart is completed. Therefore, be certain the host has stopped accessing data before beginning the restart process.

**Note:** It may take up to six minutes for an array unit to respond, depending on the configuration of the array unit.

## A.2 Uninstallation

To uninstall FlashAccess 9500V using the CLI version of Resource Manager 9500V:

1. From the command prompt, register the subsystem (array unit) in which you will uninstall FlashAccess 9500V and connect to the subsystem.
2. Register the array unit in which you will uninstall FlashAccess 9500V and connect to the array unit (subsystem). For details, refer to *Resource Manager 9500V (for CLI) User's Guide (MK-92DF603)*.
3. Lock the optional features by using the following:

### Example 1:

```
% auopt -unit df600 -lock on -keycode Key code
Password:
Option was closed.
Restart the subsystem to apply the setting.
The subsystem stops accepting the access from the host while restarting.
Also, if you are logging in, the login status will be cancelled when restarting
begins.
Do you want to restart the subsystem now? (y/n [n]): y
Now restarting the subsystem. Start Time HH:MM:SS Time Required nnnsec.
The subsystem restarted successfully.
%
```

### Example 2:

```
% auopt -unit df600 -refer
Password:
DMEC002015:No information displayed.
%
```

**Note:** To validate the locking of this optional feature, restart the array unit. The previous setting stays valid until restarting. The array unit cannot access the host until the restart is completed. Therefore, be certain the host has stopped accessing data before beginning the restart process.

**Note:** It may take up to six minutes for an array unit to respond, depending on the configuration of the array unit.

### A.3 Enabling/Disabling FlashAccess 9500V

FlashAccess 9500V can be enabled or disabled without uninstalling this function.

To enable or disable FlashAccess 9500V (without uninstalling this function) using the CLI version of Resource Manager 9500V:

1. From the command prompt, register the subsystem (array unit) in which you will change the status of the FlashAccess 9500V and connect to the subsystem.
2. Execute the **auopt** command to change the status (enable or disable) of the FlashAccess feature.

The following is an example of how to change the status from enable to disable. To change the status from disable to enable, enter enable after the -st option.

#### Example 1:

```
% auopt -unit df600 -option FLASH-ACCESS -st disable
Password:
The option has been set successfully.
Restart the subsystem to apply the setting.
The subsystem stops accepting the access from the host while restarting.
Also, if you are logging in, the login status will be cancelled when restarting
begins.
Do you want to restart the subsystem now? (y/n [n]): y
Now restarting the subsystem. Start Time HH:MM:SS Time Required nnnsec.
The subsystem restarted successfully.
%
```

#### Example 2:

```
% auopt -unit df600 -refer
Password:
Option name      Status
FLASH-ACCESS    Disable
%
```

**Note:** This setting is not active until the system is restarted. The subsystem cannot access the host until the restart is completed. Therefore, be certain the host has stopped accessing data before beginning the restart process.

**Note:** It may take up to six minutes for an array unit to respond, depending on the configuration of the array unit.

## A.4 Setting/Referring/Canceling LUs with FlashAccess 9500V

You can set an LU using Resource Manager 9500V by installing the FlashAccess 9500V Function. The LU that is set for the FlashAccess 9500V function must be previously defined. If the LU is not defined, define the LU (choose an LU that already exists that you would like to be a FlashAccess LU). Confirm that the conditions required for FlashAccess 9500V operations are present before performing the operation (refer to Table 2.1).

1. From the command prompt, register the subsystem (array unit) in which you will set FlashAccess 9500V and connect to the array unit (subsystem). For details, refer to *Resource Manager 9500V (for CLI) User's Guide (MK-92DF603)*.
2. Execute the **auturbolu** command to specify the subsystem.

### Example:

```
% auturbolu -unit df600 -set -ctl1_assign enable -ctl1_lu 0
Password:
The Turbo LU cache-resident has been set successfully.
Restart the subsystem to apply the setting.
The subsystem stops accepting the access from the host while restarting.
Also, if you are logging in, the login status will be cancelled when restarting
begins.
Do you want to restart the subsystem now? (y/n [n]): y
Now restarting the subsystem. Start Time HH:MM:SS Time Required mnmsec.
The subsystem restarted successfully.
%
```

3. Specify as shown in the following example. Check the information that has been set.

### Example:

```
% auturbolu -unit df600 -refer

Password:
Controller 0
Current Configuration
  Turbo LU Assignment      : off
  Turbo LU                 :
  Turno LU Status         : off
Reserved Configuration
  Turbo LU Assignment      : off
  Turbo LU                 :

Controller 1
Current Configuration
  Turbo LU Assignment      : on
  Turbo LU                 : 0
  Turno LU Status         : enable
Reserved Configuration
  Turbo LU Assignment      : on
  Turbo LU                 : 0

%
```

**Note 1:** If an array unit has a standby configuration, only one setup can be specified for the Controller 0 side. If a setup has been specified for the Controller 1 side, it is ignored.

**Note 2:** To validate the LU cache resident condition, restart the array unit. The previous setting remains valid until the system is restarted. The subsystem cannot access the host until the restart is completed. Therefore, be certain the host has stopped accessing data before beginning the restart process.

**Note 3:** It may take time for an array unit to respond. Do not manually power off the array unit. However, if it does not respond after 10 minutes or more, check the condition of the array unit.

## Acronyms and Abbreviations

CLI	command line interface
FDD	floppy disk drive
GUI	graphical user interface
LU	logical unit
RAID	redundant array of inexpensive (independent) disks



# Index

## C

cache memory size, 21  
characteristics of FlashAccess 9500, 3

## D

defining an LU, 21  
designated LU, 18  
disabling FlashAccess 9500 operations, 6

## E

enabled/disabled, 17

## F

FlashAccess 9500  
characteristics, 3  
enabling/disabling  
CLI, 28  
GUI, 15  
installing  
CLI, 25  
GUI, 8  
introduction, 1  
operational requirements, 4  
uninstalling  
CLI, 27  
GUI, 12  
FlashAccess 9500 operations  
disabling, 6  
halting, 5

## H

halting FlashAccess 9500 operations, 5

## I

installing FlashAccess 9500  
CLI, 25  
GUI, 8  
introduction to FlashAccess 9500, 1

## L

locking optional features, 12, 27  
locking validation, 13, 27  
LU cache resident condition validation, 30  
LU cache resident condition validation, 18  
LU cache resident state, 17  
LU cache resident status, 18  
LU size, 21

## N

number of logical blocks, 21

## R

registering the subsystem (array unit)  
using CLI, 25, 27, 29  
using GUI, 8, 12, 15  
requirements  
for FlashAccess 9500 operations, 4  
Resource Manager 9500V  
starting, 8

## S

size  
cache memory, 21  
LU, 21  
starting  
Resource Manager 9500V, 8  
state of LU cache resident, 17

## T

technical support, 23  
time required to restart, 10, 13, 16, 18  
troubleshooting, 23

## U

uninstall  
FlashAccess 9500  
CLI, 27  
GUI, 12  
unlocking  
validate, 10  
validate, 26  
unlocking optional features, 9, 25

## V

validate  
locking, 13, 27  
LU cache resident condition, 30  
LU cache resident condition, 18  
unlocking, 10, 26

