

# Disk Array management program 2 (for GUI) User's Guide

## Considerations

Before using this Disk Array management program 2, read safety instructions described in this guide carefully. Be sure to observe precautions in individual chapters. Keep this guide at hand for reference at any time.

# HITACHI



© 2001 Hitachi Limited, ALL RIGHTS RESERVED

All or any part of this guide may not be reproduced in any form or by any means without permission in writing from the publisher.

The contents of this guide may be revised without prior notice.

Hitachi would appreciate any comments such as questions or errors in descriptions you have about this guide. Please remember that Hitachi assumes no responsibility or liability for any losses that are caused by or result from improper use of this product, or the handling, repairs, and modifications carried out with willful neglect or negligence of instructions in this guide.

The copyright of the guide belongs to Hitachi. All or a part of the guide may not be used or may not be copied without permission.

## Trademarks

“Microsoft”, “Windows”, and “Windows NT” are registered trademarks of Microsoft Corporation (U.S.A.).

Solaris is a registered trademark of SUN Corporation (U.S.A.).

IRIX is a registered trademark of Silicon Graphics, Inc..

Company names and product names appeared in the guide are trademarks or registered trademarks of each enterprises.

The “Java Runtime Environment” is a copyrighted document of SUN Microsystems Corporation, and they are distributed free of charge.

## Notice of Export Controls

Export of technical data contained in this document may require an export license from the United States government and/or the government of Japan. Contact the Hitachi Legal Department for any export compliance questions.

## Document Revision Level

| Revision | Date      | Description   |
|----------|-----------|---------------|
|          | May, 2001 | Third edition |



# Preface

This guide describes the operation to execute the configuration setting and display, information display, and error monitoring of the Hitachi disk array units (DF500, DF500L, collectively called the array unit below) using the Disk Array management program 2 (called the manager 2 below).

When you operate a Hitachi disk array units (DF350, DF350F, and DF400), you do it by using the Manager together with the Disk Array Management Program 2. On how to operate the Manager, refer to guides provided with the Manager. The bundle version of the Manager does not include the Manager.

For the specifications of the array unit, see the guide attached to the array unit.

This guide is common to the product and bundle versions of the Manager 2. If you use the bundle version of the Manager 2, some functions are not available. The unavailable functions are displayed in a shaded background in the table of contents and a list of functions.

## **Notes on use:**

- This guide is intended for system administrators responsible for operation of systems including array units, system engineers for construction of systems including array units, and customer support engineer for maintenance of array units.
- When using the manager 2, be sure to read this guide and understand the operating procedures and instructions described herein thoroughly before starting your operation. Understand, in particular, the descriptions in the Chapter **Safety Precautions** thoroughly and follow the instructions in this guide.
- The user is presupposed to have thorough knowledge of the basic operation of Windows, Solaris, and IRIX.
- “Windows 95”, “Windows 98”, “Windows 2000”, and “Windows NT Version 4.0” are abbreviated to “Windows” in the guide.
- This guide quotes screens that appears when the product version of the Manager 2 runs with Windows NT 4.0, and when an array unit (DF500(RK)) is configured from a dual system and is connected to a LAN. When the Manager 2 runs with Windows 95, Windows 98, Windows 2000, Solaris, and IRIX, displayed on some screens differ from those shown in this guide, but ways for operations are the same. In addition, when the bundle version’s is used, the menus of functions not supported on the main screen and the unit screen, etc. are not displayed.



# Safety Precaution

When using this manager 2, read the following notes carefully, and follow the instructions to operate the manager 2.

## Precautions before starting your operation

- Do not operate an array unit except system administrators responsible for operation of systems including array units, system engineers for construction of systems including array units, and qualified service personnel for maintenance of array units.
- Read and understand this guide thoroughly before starting your operation.
- The following attention mark heading appears in this guide to indicate a safety precaution.

## Cautions while starting your operation

- While operating the manager 2, the contents of an error, which occurs in an array unit, may be displayed as an error message. In this case, read the user's guide or maintenance guide to look up action on the error message and handle the error according to the action.
- When performing operations in this guide with a caution attention mark indicated, be sure to read precautions before starting the operation, and follow them to operate.



# Contents

|  |    |
|--|----|
| Chapter 1 Outline .....  | 1  |
| 1.1 Outline .....  | 1  |
| 1.2 Notes on Using the Manager 2 .....                             | 1  |
| 1.3 Operating Environments .....                                   | 4  |
| 1.4 Connection .....   | 6  |
| 1.5 Installing the manager 2 .....                                 | 7  |
| 1.5.1 Installing the manager 2 .....                               | 7  |
| 1.5.1.1 Windows .....  | 7  |
| 1.5.1.2 Solaris .....  | 8  |
| 1.5.1.3 IRIX .....   | 9  |
| 1.5.2 Updating .....   | 10 |
| 1.5.2.1 Windows .....  | 10 |
| 1.5.2.2 Solaris .....  | 10 |
| 1.5.2.3 IRIX .....   | 10 |
| 1.5.3 Uninstalling .....   | 11 |
| 1.5.3.1 Windows .....  | 11 |
| 1.5.3.2 Solaris and IRIX .....                                     | 11 |
| 1.6 How to cooperate with the Manager .....                        | 12 |
| Chapter 2 Functions .....  | 13 |
| 2.1 Manager 2 Functions .....                                      | 13 |
| 2.2 Applying Support Functions of Microprograms .....              | 19 |
| 2.3 Screens .....  | 21 |
| 2.3.1 Menu bars and tool bars .....                                | 25 |
| 2.3.2 Status bar .....   | 27 |
| Chapter 3 Operations .....   | 29 |
| 3.1 Basic Operations .....   | 29 |
| 3.1.1 Starting .....   | 29 |
| 3.1.2 Password setting .....                                       | 32 |
| 3.1.2.1 Registration of a password .....                           | 32 |
| 3.1.2.2 Changing the password .....                                | 33 |
| 3.1.2.3 Deleting the password .....                                | 33 |
| 3.1.3 Changing the action mode .....                               | 34 |
| 3.1.3.1 Changing from the normal mode to the management mode ..... | 34 |
| 3.1.3.2 Change from the management mode to the normal mode .....   | 35 |
| 3.1.4 Registering an array unit .....                              | 36 |
| 3.1.4.1 New registration .....                                     | 36 |
| 3.1.4.2 Changing the registration contents .....                   | 39 |
| 3.1.4.3 Deleting the registration .....                            | 41 |
| 3.1.4.4 Displaying the registration contents .....                 | 43 |

|                  |   |            |
|------------------|---|------------|
| 3.1.5            | Version display .....   | 44         |
| 3.1.6            | Terminating .....   | 45         |
| 3.2              | Displaying the property .....   | 46         |
| 3.2.1            | Displaying the property of the main screen.....   | 46         |
| 3.2.2            | Displaying the property of the unit screen .....  | 47         |
| 3.2.3            | Displaying the array unit configuration information.....  | 59         |
| <b>Chapter 4</b> | <b>Definition of RAID Group/Logical Unit.....</b>   | <b>61</b>  |
| 4.1              | Creating a RAID group .....   | 64         |
| 4.2              | Expanding a RAID group.....   | 67         |
| 4.3              | Deleting a specified RAID group.....  | 69         |
| 4.4              | Deleting all RAID groups.....   | 71         |
| 4.5              | Constituting a logical unit .....   | 73         |
| 4.6              | Formatting a logical unit .....   | 77         |
| 4.7              | Expanding a logical unit.....   | 83         |
| 4.8              | Deleting the last logical unit.....   | 85         |
| 4.9              | Deleting all logical units.....   | 87         |
| 4.10             | Changing the default controller in charge of an logical unit .....                                | 89         |
| 4.11             | Logical unit Wizard .....   | 92         |
| <b>Chapter 5</b> | <b>System Parameters Setting Wizard .....</b>   | <b>101</b> |
| 5.1              | Setting system parameters .....   | 101        |
| <b>Chapter 6</b> | <b>Setting System Parameters .....</b>  | <b>129</b> |
| 6.1              | Target ID.....  | 129        |
| 6.1.1            | Added information becomes valid with restarting an array unit. ....                               | 129        |
| 6.1.2            | Adds mapping information.....   | 139        |
| 6.1.3            | Change mapping information.....   | 141        |
| 6.2              | LAN configuration .....   | 143        |
| 6.3              | Setting SCSI transfer rate .....  | 145        |
| 6.4              | Spare Drive Setup.....  | 148        |
| 6.5              | Setting the drive restoration control option .....  | 150        |
| 6.6              | Online verify mode.....   | 152        |
| 6.7              | Setting Fibre Channel Information.....  | 153        |
| 6.7.1            | Topology Setup.....   | 154        |
| 6.7.2            | Setting of Port Address .....   | 157        |
| 6.7.3            | Setting of transfer rate .....  | 160        |
| 6.7.4            | Setting port security .....   | 162        |
| 6.7.5            | Setting LUN security.....   | 164        |
| 6.8              | Outputting Configuration Information to File .....  | 166        |
| 6.8.1            | File Output of Configuration : System Parameters .....  | 167        |
| 6.8.2            | Outputting configuration information to file : RAID group/logical unit and component status ..... | 176        |
| 6.8.3            | Setting the Configuration With a File: System Parameters .....                                    | 186        |
| 6.8.4            | Setting the Configuration With a File: RAID group/Logical unit Definition .....                   | 190        |

Portions in a shaded background of functions are not available in the bundle version.

|   |   |            |
|---|---|------------|
| 6.9   | Replacing the microprogram .....                                    | 194        |
| 6.9.1   | Microprogram download .....   | 194        |
| 6.9.2   | Replacing the microprogram .....                                    | 200        |
| 6.10  | Setting priced optional features .....                              | 202        |
| 6.10.1  | Unlock priced optional features .....                               | 202        |
| 6.10.2  | Lock priced optional features .....                                 | 205        |
| 6.10.3  | Setting up priced optional features .....                           | 208        |
| 6.11  | Setting and outputting SNMP environmental information file .....    | 211        |
| 6.11.1  | Setting SNMP environmental information file .....                   | 211        |
| 6.11.2  | Outputting SNMP environmental information file .....                | 213        |
| 6.12  | Array Unit Management by Password protection function .....         | 215        |
| 6.12.1  | Setting User ID .....   | 216        |
| 6.12.2  | Changing User ID .....  | 218        |
| 6.12.3  | Deleting User ID .....  | 220        |
| 6.12.4  | Changing Password .....   | 222        |
| 6.12.5  | Logging into Array Unit .....                                       | 224        |
| 6.12.6  | Logging into Array Unit Forcibly .....                              | 225        |
| 6.12.7  | Logging Out from Array Unit .....                                   | 228        |
| 6.13  | Setting Turbo LU .....  | 229        |
| 6.14  | Setting MRCF-Lite .....   | 231        |
| 6.14.1  | Setting command device .....  | 231        |
| 6.14.2  | Changing command device .....                                       | 233        |
| 6.14.3  | Delete command device .....   | 234        |
| 6.14.4  | Displaying the coupled logical unit .....                           | 235        |
| 6.15  | Setting port option .....   | 236        |
| 6.16  | Setting controller identifier .....                                 | 238        |
| <b>Chapter 7 Displaying Statistical Information .....</b> |   | <b>241</b> |
| 7.1   | Displaying the controller use condition .....                       | 242        |
| 7.2   | Displaying the numbers of host commands received .....              | 243        |
| 7.3   | Displaying the command execution condition .....                    | 244        |
| 7.4   | Displaying the cache load condition .....                           | 245        |
| <b>Chapter 8 Acquiring Performance Information .....</b>  |   | <b>247</b> |
| 8.1   | Outputting performance information manually to text file .....      | 247        |
| 8.2   | Outputting performance information automatically to text file ..... | 250        |
| <b>Chapter 9 Error Monitoring .....</b>                   |   | <b>253</b> |
| 9.1   | Setting Error Monitoring Options .....                              | 253        |
| 9.1.1   | Interval time .....   | 253        |
| 9.1.2   | E-Mail Report .....   | 254        |
| 9.1.3   | Executing application .....   | 257        |
| 9.2   | Outputting failure information to log file .....                    | 259        |
| 9.3   | Error Monitoring .....  | 261        |
| 9.4   | Checking Status .....   | 264        |

Portions in a shaded background of functions are not available in the bundle version.

|  |     |
|--|-----|
| Chapter 10 Automatic Start of Error Monitoring ..... | 265 |
| 10.1 Automatic Start of Error Monitoring .....       | 265 |
| 10.1.1 Automatic Start of Windows .....              | 265 |
| Chapter 11 Detailed Screen Display .....             | 267 |
| 11.1 Detailed Screen Display .....                   | 267 |
| 11.1.1 Detailed screen display on Windows .....      | 267 |

Portions in a shaded background of functions are not available in the bundle version.

## List of Figures

|              |   |     |
|--------------|---|-----|
| Figure 6.8.1 | Outline of the format of the system parameter output file .....                                     | 169 |
| Figure 6.8.2 | System parameters: output example of common parameters .....  | 170 |
| Figure 6.8.3 | System parameters: output example of controller 0 parameters.....                                   | 172 |
| Figure 6.8.4 | System parameters: output example of the parameters of controller 1 .....                           | 174 |
| Figure 6.8.5 | Output example for FD backup specification.....   | 175 |
| Figure 6.8.6 | The outline of the format of RAID group/logical unit<br>configuration information output file ..... | 178 |

## List of Tables

|             |  |     |
|-------------|--|-----|
| Table 2.1   | Manager 2 Functions.....   | 13  |
| Table 2.2   | Microprogram Revision Numbers and Their Supports for Manager 2 Functions.. | 19  |
| Table 4.6.1 | Interpretation of “Logical Unit Format Results” Screen.....                | 82  |
| Table 5.1.1 | List of supported parameters at the Basic Settings.....                    | 102 |
| Table 5.1.2 | List of supported parameters at the Detailed Settings .....                | 103 |
| Table 6.8.1 | List of common parameters.....   | 171 |
| Table 6.8.2 | List of parameters of controller 0 .....                                   | 173 |
| Table 6.8.3 | List of parameters of controller 1 .....                                   | 175 |
| Table 9.1.1 | List of E-Mail Subjects .....  | 254 |
| Table 9.1.2 | List of E-Mail Message Texts .....   | 255 |
| Table 9.2.1 | List of Message Texts to Be Output .....                                   | 260 |



# Chapter 1 Outline

## 1.1 Outline

The manager 2 is used to perform such operations on an array unit as referencing the status of an array unit and setting up the configuration of an array unit.

## 1.2 Notes on Using the Manager 2

When using this manager 2, take the following considerations.

- When using the manager 2 on “RS232C connection”, the “ERROR INF” (a function to specify an error information transfer mode to the RS232C) must be set to “OFF” (suspension of an error information transfer) by means of the system parameter setting function of the array unit.  
(The “ERROR INF” is set to “OFF” when shipped from the factory.) Otherwise, it may be caused that the manager 2 fails to be connected to the array unit or that functions of the manager 2 end abnormally.
- Regarding the functions to be executed by the manager 2, some are available and others are not available during an on-line. For details, see chapter 2.  
For a case of high I/O load, functions that are available in the on-line might cause a command time-out in the host or a recovering fault in the manager 2. A use during off-line is recommended.
- A logical unit, at least, must be in the array unit, to make available all of manager 2 functions. If no logical unit are in the array unit, some functions selected can not be operated.
- When the PC enters the suspension status during operation while the manager 2, the manager 2 may not operate correctly after the PC is released from the suspension status. When you operate the manager 2, set the power management of the PC so that the PC should not enter the suspension status.
- The Manager 2 allows to open multiple unit screens. When multiple unit screens are open, a shortage of memory may occur depending on the configuration of a machine in which the Manager 2 has been installed, resulting in hang-up of programs. When opening unit screens, open only one unit screen to operate an array unit.
- The Manager 2 allows to open multiple unit screens for one array unit. When doing operations by opening multiple unit screens for one array unit, operations may terminate abnormally. Open only one unit screen for one array unit to operate an array unit.

- When you perform error monitoring, it can be done in the condition in which a unit screen is open. When performing error monitoring together with operations of a unit screen concurrently, error monitoring operation and unit screen operations may terminate abnormally. When starting error monitoring, close all unit screens, and then perform error monitoring.
- When the Manager 2 is run with Windows 98, if MS-IME 98(Ver. 6.00.0) has been installed in a Windows 98 system, the starting of the Manager 2 may terminate abnormally. When running with Windows 98, install MSIME 98-SR1.
- When the manager 2 is in operation, it may hang-up in the following cases. If the manager 2 hangs up, terminate it forcibly and check the array unit status and the connection status of RS232C or LAN. Then, boot up the manager 2 once again. And start the manager 2 again after you finish other application.
  - In case that the communication with the connected array unit fails due to controller blockage, array unit failure, or disconnected LAN connection, etc., or in case that the array unit receives a Reset/LIP from the host.
  - Other application works at the same time, and a CPU use rate is high.

- If you use the manager together other programs for one array unit, the following restrictions are placed.

| No. | Program name                                      | 1 | 2 | 3 | 4 | 5 | 6 | 7 |
|-----|---|---|---|---|---|---|---|---|
| 1   | Disk Array management program (LAN)               | × | Δ | × | Δ | × | ○ | ○ |
| 2   | Disk Array management program (RS232C connection) | Δ | × | Δ | × | Δ | ○ | ○ |
| 3   | Disk Array utility (LAN)                          | × | Δ | × | Δ | × | ○ | ○ |
| 4   | Disk Array utility (RS232C connection)            | Δ | × | Δ | × | Δ | ○ | ○ |
| 5   | Disk Array utility for Web                        | × | Δ | × | Δ | × | ○ | ○ |
| 6   | SNMP Agent Support Function                       | ○ | ○ | ○ | ○ | ○ | ○ | ○ |
| 7   | DF500-built-in Web Server Function                | ○ | ○ | ○ | ○ | ○ | ○ | ○ |

○ :Concurrent use allowed.

×

Δ :Configuration in which concurrent use is allowed, but which is not recommended.

If you run a combination of programs of which concurrent use is not allowed, when a program with a usage restriction placed on it has been started, start another program of the combination after terminating the running program. On how to operate other programs, refer to their respective user's guides provided with the program products.

- If any array unit failure is detected, contact with maintenance personnel.

## 1.3 Operating Environments

The manager 2 is operated by connecting between the array unit and a LAN or RS232C. When an array unit is connected to a LAN, a machine (personal computer, SUN server/workstation, SGI server/workstation), in which the manager 2 is installed, must be connected with the LAN and operate normally.

When an array unit is connected to an RS232C interface, an RS232C port of the machine must operate normally.

- PC
  - Windows 95, Windows 98, Windows 2000, or Windows NT 4.0
  - CPU : Pentium-II (Pentium-II 233 MHz or more is recommended.)
  - Memory : 64 M byte (128 M byte or more is recommended.)
  - Disk capacity : 3 M byte max. (A free capacity of 100 M byte or more is required.)
  - Network adapter
  - Monitor (Resolution 800 × 600, 1,024 × 768 or more is recommended.)
  
- SUN server/workstation
  - Solaris 2.6, 2.7, 2.8
  - CPU : UltraSPARC or more is recommended.
  - Memory : 64 M byte (128 M byte or more is recommended.)
  - Disk capacity : 4.5 M byte max. (A free capacity of 100 M byte or more is required.)
  - Network adapter
  - Monitor (Resolution 800 × 600, 1,024 × 768 or more is recommended.)
  
- SGI server/workstation
  - IRIX 6.5
  - CPU : R10000 or more is recommended.
  - Memory : 64 M byte (128 M byte or more is recommended.)
  - Disk capacity : 4 M byte max. (A free capacity of 100 M byte or more is required.)
  - Network adapter
  - Monitor (Resolution 800 × 600, 1,024 × 768 or more is recommended.)

- JRE
  - Windows : JRE1.2.2-006
  - Solaris : JRE1.2.2\_06
  
- RS232C connection
  - Serial port
    - baud rate : 9600
    - data bit : 8
    - parity : non
    - stop bit : 1
    - flow control : non
  - Serial cable (9 pin, cross) for RS232C connection : 1 cable/controller
  
- LAN connection
  - When an array unit is connected to a machine directly, a 10BaseT/100BaseT cable (cross) or a twisted pair cable (cross) is used.  
When an array unit is connected to a machine via a hub, a 10BaseT/100BaseT cable or a twisted pair cable is used.

## 1.4 Connection

Shown below is an example of connections between a machine in which the manager 2 has been installed and an array unit.

- RS232C connection

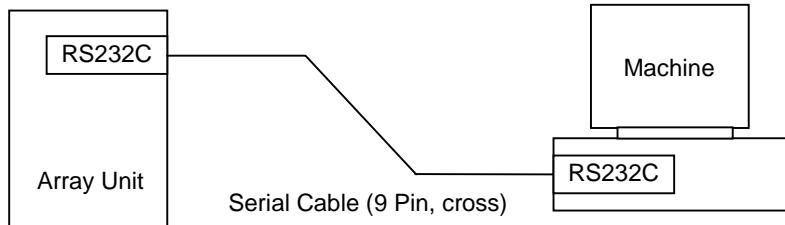

**Note:** If an array unit is configured from a dual system and a machine is equipped with two RS232C ports, both controller 0 and controller 1 are connected through an RS232C interface.

- LAN (with a Hub)

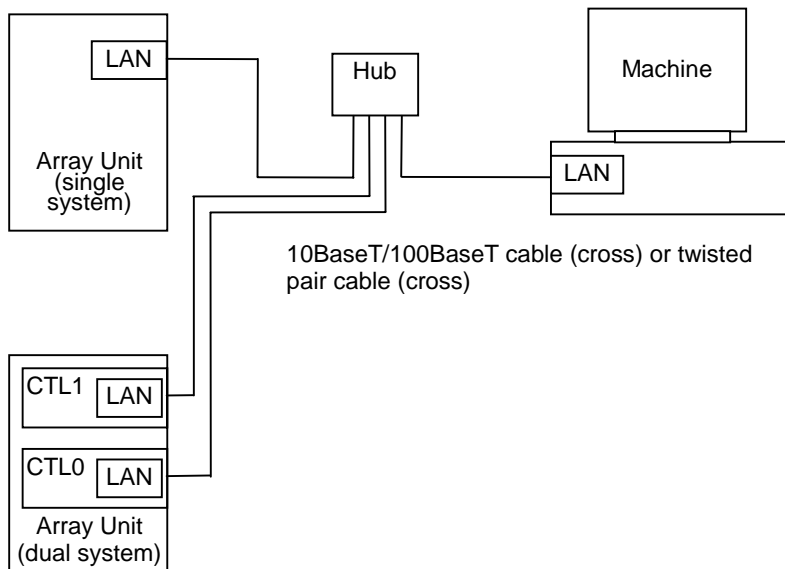

**Note:** If an array unit is already connected with a LAN, a machine is connected to the same network as the one to which the array unit connects.

- LAN (without Hub)

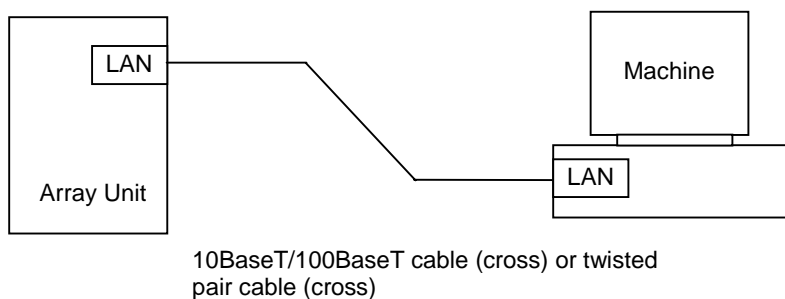

## 1.5 Installing the manager 2

The procedures for installing and uninstalling the manager 2 are described below. For using the manager 2, JRE1.2.2 is installed on a machine and is in normal operation. Before installing JRE1.2.2, check if it is in normal operation. If JRE1.2.2 is not installed, install JRE1.2.2-006 or JRE1.2.2\_06.

### 1.5.1 Installing the manager 2

Installs the manager 2 by the following procedure.

#### 1.5.1.1. Windows

1. Start the PC, then boot up Windows.
2. If JRE1.2.2-006 is not yet installed, installs JRE1.2.2-006 contained in the provided CD-R.
3. Executes the setup.exe in the GUI directory of the provided CD-R.
4. When executing the startmgr2.bat (a batch file used to start the manager 2), the manager 2 starts.

**Note:** When starting the manager 2 from other than a directory in which the manager 2 has been installed, edits the DAMP\_ROOT\_DIR\_PATH environment variable of the startmgr2.bat in the developed file. Sets up the install directory of the manager 2 in the DAMP\_ROOT\_DIR\_PATH environment variable.

**Example :** If the manager 2 has been installed in C:\damp,  
set DAMP\_ROOT\_DIR\_PATH=C:\damp  
java -classpath .\CONFMNG2.JAR jp.co.hitachi.str.diskarray.gui.ConmanFrame %1

### 1.5.1.2. Solaris

1. Starts a SUN server/workstation, and starts up a session in the common desk-top environment.
2. If JRE1.2.2\_06 is not yet installed, installs JRE1.2.2\_06 contained in the provided CD-R. When installing JRE1.2.2\_06, OS patches need to be applied, and hence applies the patch in the provided CD-R.
3. Creates a new directory(Example: /usr/damp) for installing the manager 2, and copies the ArrayManage2-xSxxx-GUI.tar file in the provided CD-R into the created directory in the hard disk drive.  
(The portion “xSxxx” of file names varies with the version of the Manager 2, etc.)
4. The ArrayManage2-xSxxx-GUI.tar is the Tar format of a file. Develops the file by referring to the example below.

**Example :** tar xvf ArrayManage2-xSxxx-GUI.tar

5. Changes scripts in the startmgr2 (a shell script used to start the manager 2) in the developed file as follows.  
“DEFAULT\_JAVAHOME=/usr/java” has been described in the startmgr2 as specification of a path to JRE.  
Sets up a path to JRE in the DEFAULT\_JAVAHOME variable so as to suit the environment in which JRE has been installed. The path to JRE is a path to a place in which JRE has been installed, and a path to a place in which the directories of bin, lib, etc., are placed. Usually, it is named JRE1.2.2, etc.
6. Logs in again.
7. After logging in again, when executing the startmgr2 (a shell script used to start the manager 2), the manager 2 starts.

**Example :** If the manager 2 has been installed in /usr/damp,  
# DAMP\_ROOT\_DIR\_PATH environment variable  
DAMP\_ROOT\_DIR\_PATH=/usr/damp  
export DAMP\_ROOT\_DIR\_PATH

**Note:** When starting the manager 2 from other than a directory in which the manager 2 has been installed, edits the DAMP\_ROOT\_DIR\_PATH environment variable of the startmgr2 in the developed file before logging in again at Step 6. Sets up the install directory of the manager 2 in the DAMP\_ROOT\_DIR\_PATH environment variable.  
Correct character fonts may not be displayed on screens, depending on the environment setting of a server/workstation that is installed. The font size is set to 12 as standard. If characters are not displayed correctly, set the font size to another. To set it, insert one space character following the last line \$JAVABIN \$EXECJAVA in startmgr2, and add “-xfont#” (#: a font size).

### 1.5.1.3. IRIX

1. Starts a SGI server/workstation.
2. Creates a new directory(Example: /usr/damp) for installing the manager 2, and copies the ArrayManage2-xIxxx-GUI.tar file in the provided CD-R into the created directory in the hard disk drive.  
(The portion “xIxxx” of file names varies with the version of the Manager 2, etc.)
3. The ArrayManage2-xIxxx-GUI.tar is the Tar format of a file. Develops the file by referring to the example below.

**Example :** tar xvf ArrayManage2-xIxxx-GUI.tar

4. Changes scripts in the startmgr2 (a shell script used to start the manager 2) in the developed file as follows.  
“DEFAULT\_JAVAHOME=/usr/java” has been described in the startmgr2 as specification of a path to JRE.  
Sets up a path to JRE in the DEFAULT\_JAVAHOME variable so as to suit the environment in which JRE has been installed. The path to JRE is a path to a place in which JRE has been installed, and a path to a place in which the directories of bin, lib, etc., are placed. Usually, it is named JRE1.2.2, etc.

**Example :** If JRE has been installed in /usr/local/JRE1.2.2,  
DEFAULT\_JAVAHOME=/usr/local/JRE1.2.2

5. Logs in again.
6. After logging in again, when executing the startmgr2 (a shell script used to start the manager 2), the manager 2 starts.

**Example :** If the manager 2 has been installed in /usr/damp,  
# DAMP\_ROOT\_DIR\_PATH environment variable  
DAMP\_ROOT\_DIR\_PATH=/usr/damp  
export DAMP\_ROOT\_DIR\_PATH

**Note:** When starting the manager 2 from other than a directory in which the manager 2 has been installed, edits the DAMP\_ROOT\_DIR\_PATH environment variable of the startmgr2 in the developed file before logging in again at Step 5. Sets up the install directory of the manager 2 in the DAMP\_ROOT\_DIR\_PATH environment variable.

Correct character fonts may not be displayed on screens, depending on the environment setting of a server/workstation that is installed. The font size is set to 10 as standard. If characters are not displayed correctly, set the font size to another. To set it, insert one space character following the last line \$JAVABIN \$EXECJAVA in startmgr2, and add “-xfont#” (#: a font size).

## 1.5.2 Updating

Updates the manager 2 by the following procedure. If you update, be sure to terminate the manager 2 before starting operations.

### 1.5.2.1. Windows

1. Executes the setup.exe in the GUI directory of the provided CD-R.

The updated manager 2 can be run without restarting Windows.

### 1.5.2.2. Solaris

1. Copies the ArrayManage2-xSxxx-GUI.tar file in the provided CD-R to the hard disk. (The portion “xSxxx” of file names varies with the version of the Manager 2, etc.)
2. The ArrayManage2-xSxxx-GUI.tar is the Tar format of a file. Develops the file by referring to the example below.

**Example :** tar xvf ArrayManage2-xSxxx-GUI.tar

The updated manager 2 can be run without restarting Solaris.

### 1.5.2.3. IRIX

1. Copies the ArrayManage2-xIxxx-GUI.tar file in the provided CD-R to the hard disk. (The portion “xIxxx” of file names varies with the version of the Manager 2, etc.)
2. The ArrayManage2-xIxxx-GUI.tar is the Tar format of a file. Develops the file by referring to the example below.

**Example :** tar xvf ArrayManage2-xIxxx-GUI.tar

The updated manager 2 can be run without restarting IRIX.

### 1.5.3 Uninstalling

Uninstalls the manager 2 by the following procedure.

#### 1.5.3.1. Windows

1. Deletes the manager 2 using the Add and Delete Application icon on the Control Panel.
2. Deletes the directory, for installing the manager 2, on the hard disk drive.

#### 1.5.3.2. Solaris and IRIX

1. Deletes the directory, for installing the manager 2, on the hard disk drive.

## 1.6 How to cooperate with the Manager

When you operate DF350, DF350F, and DF400 array units, you must install the Manager. Install the Manager in the same directory as for the Manager 2. On how to install the Manager, refer to the Manager User's Guide.

You register DF650, DF350F, and DF400 array units on the main screen of the Manager 2. When you operate DF350, DF350F, and DF400 array units, click a registered array unit on the main screen of the Manager 2 to display a unit screen, then a unit screen of the Manager appears. On how to operate on the unit screen, refer to the Manager User's Guide.

**Note:** When you run cooperation between Windows2000 and Windows NT 4.0, you edit the PATH environment variable of the startmgr2 batch file for starting the Manager 2. Set "%PATH%" of the PATH environment variable to the directory where JRE1.1.8 has been installed. When running the cooperation without setting the PATH, an error is displayed on a unit screen of the Manager 2.

**Example :** If JRE1.1.8 has been installed in "c:\Program Files\JavaSoft\JRE\1.1\bin" (standard installation of JRE1.1.8).

# Chapter 2 Functions

## 2.1 Manager 2 Functions

Table 2.1 lists functions of the manager 2. Available or Not Available on-line depends on the respective functions. Functions that can be used vary depending on the action mode (normal mode or management mode). Therefore, change the mode according to the function you want to use.

Don't operate during on-line except for item 9 : **Error monitoring**, in the case of RS232C connection.

Table 2.1 Manager 2 Functions

| No. | Category              | Name of function         | Outline of function  | Remarks  | Usability during operation | Mode     |               |
|-----|-----------------------|--------------------------|--|--|----------------------------|----------|---------------|
|     |                       |                          |  |  |                            | Standard | Administrator |
| 1   | Configuration display | Component status display | Displays the status of a component such as drive and fan by using an icon.   | —  | ○                          | ○        | ○             |
|     |                       | Property display         | Displays the status about system components of an array unit, RAID, logical units, etc.  | —  | ○                          | ○        | ○             |
| 2   | RAID group definition | RAID group institution   | Used to adds a RAID group. You can set a new RAID group by specifying its disk number, RAID level, and group range for the RAID group to be created.     | —  | ○                          | ×        | ○             |
|     |                       | RAID group extension     | Used to extend an previously defined RAID group. A previously defined RAID group can be extended by specifying its group number, level, and group range. | Only a drive adjoining a previously defined RAID group can be extended.  | ○                          | ×        | ○             |
|     |                       | RAID group deletion      | Delete a defined RAID group or a specified RAID group.   | Note that this function invalidates user data of the deleted RAID group. No specified RAID group can be deleted, when a logical unit is defined. | ×                          | ×        | ○             |

Table 2.1 Manager 2 Functions (Continued)

| No. | Category      | Name of function                                | Outline of function   | Remarks  | Usability during operation | Mode     |               |
|-----|---------------|---|---|--|----------------------------|----------|---------------|
|     |               |   |   |  |                            | Standard | Administrator |
| 3   | LU definition | LU institution                                  | Used to add a logical unit (LU). A new logical unit is added by specifying its capacity.  | Logical unit can be added only in an order of lower to higher number.  | ○                          | ×        | ○             |
|     |               | LU extension                                    | Used to extend the capacity of a previously defined logical unit (LU). Capacity is increased by specifying a capacity for the logical unit. | Only the LU with the greatest LU number can be extended.   | ○                          | ×        | ○             |
|     |               | LU deletion                                     | Deletes all defined local units (LU) or the last logical unit.  | Note that this function invalidates user data on the deleted logical unit.   | ×                          | ×        | ○             |
|     |               | LU formatting                                   | Used to make a defined logical unit (LU) accessible by the host. This function writes null data to the specified logical unit.              | This operation is always required to make a logical unit accessible to the host. Note that this function invalidates all user data on disks when the data is already stored on them. | ×/○                        | ×        | ○             |
|     |               | Change of default controller in charge of an LU | Used to change the default controller in charge of an logical unit (LU) as follows :<br>CTL0 → CTL1 and<br>CTL1 → CTL0                      | Restart the array unit to make the setting valid.  | ○                          | ×        | ○             |
|     |               | Setting TURBO LU Assignment                     | Can set the logical unit (LU) to be resident in the cache.  |  | ○                          | ×        | ○             |

Table 2.1 Manager 2 Functions (Continued)

| No. | Category                 | Name of function | Outline of function   | Remarks   | Usability during operation | Mode     |               |
|-----|--------------------------|------------------|---|---|----------------------------|----------|---------------|
|     |                          |                  |   |   |                            | Standard | Administrator |
| 4   | System parameter setting | Setting wizard   | Sets a system parameter in the wizard format. There are two types of wizard formats : Basic Settings and Detailed Settings. | To make the setting valid, restart the array unit.<br>I/Os directed from the host cannot be executed after the setting is made until the array unit is restarted.<br>Besides, the function of the manager 2 cannot be used except the setting wizard, SNMP environmental information setting or error monitoring. | ×                          | ×        | ○             |

Table 2.1 Manager 2 Functions (Continued)

| No. | Category            | Name of function                                     | Outline of function   | Remarks   | Usability during operation | Mode     |               |
|-----|---------------------|--|---|---|----------------------------|----------|---------------|
|     |                     |  |   |   |                            | Standard | Administrator |
| 5   | Configuration setup | Target ID setting                                    | Sets a combination of the target ID and the LUN.  | To make the setting valid, restart the array unit.  | ○                          | ×        | ○             |
|     |                     | LAN configuration information setting                | Sets the IP Address, Sub Net Mask, Default Gateway Address, and the DHCP mode.  |   | ○                          | ×        | ○             |
|     |                     | SCSI transfer rate setting                           | Sets the SCSI I/F transfer rate of the port.  |   | ○                          | ×        | ○             |
|     |                     | Setting up spare disk drive                          | Sets up spare disk drives.  | —   | ○                          | ×        | ○             |
|     |                     | Setting the drive restoration option                 | Sets a drive restoration mode, automatic or non-automatic start of copy-back, and automatic or non-automatic start of correction copy, time interval, restoring processing unit size, and Dynamic sparing mode. | Optimum time interval and restoring processing unit are set before shipment. Do not change these values unless required for fear of giving bad effect to the performance. | ×                          | ×        | ○             |
|     |                     | On-line verify setting                               | Whether or not to execute the on-line verify function and an interval for it.   | Note that an incautious change in the setting may give a bad effect on the performance.   | ×                          | ×        | ○             |
|     |                     | Setting and display of the Fibre Channel information | Sets and displays port addresses and security information, etc.   | To make the setting valid, restart the array unit.  | ×                          | ×        | ○             |

Portions in a shaded background of functions are not available in the bundle version.

Table 2.1 Manager 2 Functions (Continued)

| No. | Category                        | Name of function   | Outline of function  | Remarks   | Usability during operation | Mode     |               |
|-----|---------------------------------|--|--|---|----------------------------|----------|---------------|
|     |                                 |  |  |   |                            | Standard | Administrator |
| 6   | Priced optional features        | Configuration information file output and its setup by use of a file | Outputs system parameters and RAID group/logical unit configuration information to a file individually.<br>Sets system parameters and RAID group/logical unit configuration information using a file | If system parameters are set using a file, restart the array unit in order to validate the settings.<br>When RAID/LU configuration information is set, if setting it with user data stored in the disk drive, the user data is set invalid. | ○                          | ○        | ○             |
|     |                                 | Microprogram replacement   | Downloads and updates the microprogram of the array unit.  | To validate the downloaded microprogram, restart the array unit.  | ×/○                        | ×        | ○             |
|     |                                 | Setting SNMP environment information and outputting its file         | Sets the SNMP environmental information file and outputs the set contents in it.   | To make the setting valid, restart the array unit.  | ×/○                        | ×        | ○             |
|     |                                 | Setup and display of the priced optional features                    | Opens/closes the priced optional features key and sets and displays the enable/disable condition.  | —   | ○                          | ×        | ○             |
|     |                                 | Password protection  | Sets the password protection function for an array unit.   | —   |                            |          |               |
| 7   | Statistical information display | Controller use information display                                   | Displays previous statistical information by selecting a related item.   | —   | ○                          | ○        | ○             |

Portions in a shaded background of functions are not available in the bundle version.

Table 2.1 Manager 2 Functions (Continued)

| No. | Category         | Name of function   | Outline of function   | Remarks  | Usability during operation | Mode                  |                       |
|-----|------------------|--|---|--|----------------------------|-----------------------|-----------------------|
|     |                  |  |   |  |                            | Standard              | Administrator         |
| 8   | Performance      | Command operation status display                           | Outputs the command operation status during a certain period or a specified period to the file in the text format.  | —  | <input type="radio"/>      | <input type="radio"/> | <input type="radio"/> |
| 9   | Error monitoring | Report when a failure occurs and controller status display | Displays the status of an array unit, and displays the result of monitoring it by polling.<br>When an error is detected while monitoring, outputs the error into a log file, sends it to a specified address by E-Mail, and starts a specified application. | If a failure occurs, contact with maintenance personnel. | <input type="radio"/>      | <input type="radio"/> | <input type="radio"/> |

Portions in a shaded background of functions are not available in the bundle version.

## 2.2 Applying Support Functions of Microprograms

Functions of the manager 2 may be disabled depending on the revision number of the microprogram of the array unit connected. Table 2.2 shows the revision numbers of the microprogram which support the manager 2 functions and the manager 2 operations when the microprogram does not support the manager 2 functions.

Table 2.2 Microprogram Revision Numbers and Their Supports for Manager 2 Functions

| No. | Function                         | Revision Nos. of microprogram which support the manager 2 | Remarks |
|-----|----------------------------------|---|---------|
| 1   | Expanding RAID group             | 0552, and later   |         |
| 2   | SCSI transfer rate setting       | 0503, and later   |         |
| 3   | Array unit management by user ID | 0552, and later   |         |

**Note:** Revision numbers of the microprogram are classified as shown below according to the function of the array unit.

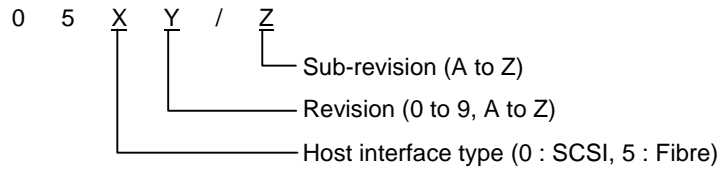

- Host interface : SCSI
  - 050V (050V/Z) : Version for the DF500 single/dual system used in the open system
- Host interface : Fibre Channel
  - 055V (055V/Z) : Version for the DF500 single/dual system used in the open system

Update of revision is made for each of nine revisions listed above. An example is shown below.

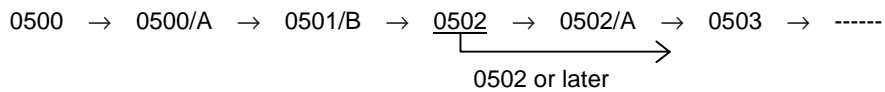

Sub-revision is updated in alphabetic order, however, some sub-revisions may be skipped.

## 2.3 Screens

The Manager 2 operations screen consists of three screens, dialog boxes that are used by invoking from the screens, and error messages, etc. This section describes the configurations of the three screens. For details, see chapters from Chapter 3 onward.

When you start the Manager 2, the following screen will be displayed. This screen is called the Main screen.

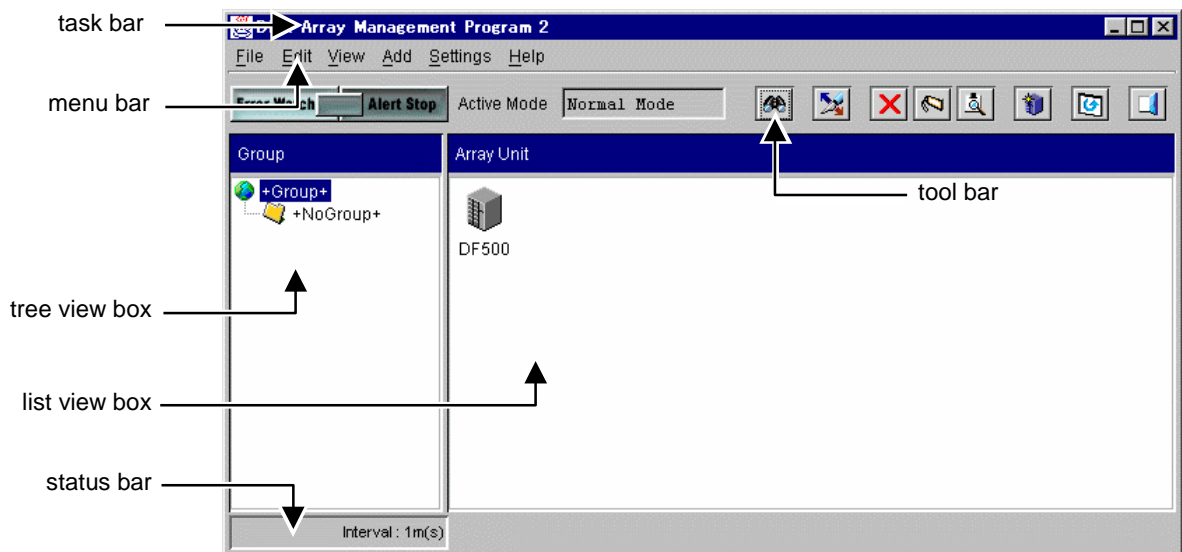

The screen consists of the task bar, the menu bar, the tool bar, two view boxes, and the status bar in the same way as other Windows applications.

Displayed in the tree view box are group names that have been registered. Displayed in the list view box are array unit names that have been registered in a group.

Double-clicking + **Group** + enables to fold a group into its icon and display the group.

Clicking a group icon displays only the array units that have been registered in the group concerned. Clicking + **Group** + displays all array units that have been registered.

When you double-click a registered array unit name, a Unit screen will be displayed. On the Unit screen, the status of array unit system components and configuration information of logical units, etc. is displayed selectively by switching the tab. For example, shown is a screen in the case of connection with a DF500(RK)/500L(RKL) array unit.

Component Status tab : DF500(RK)

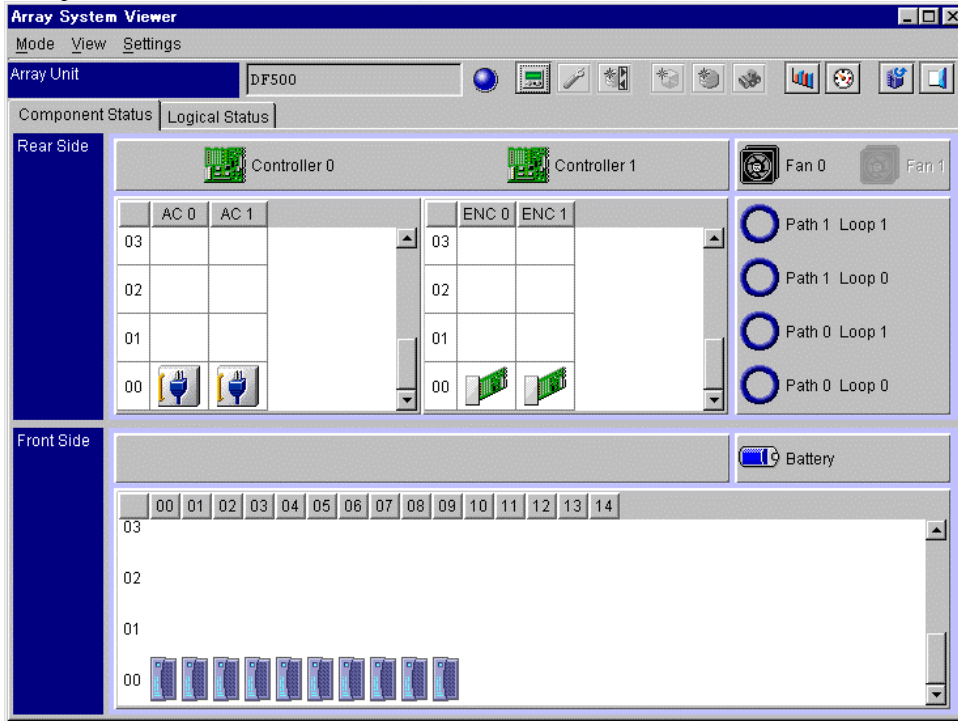

Component Status tab : DF500(RKL)

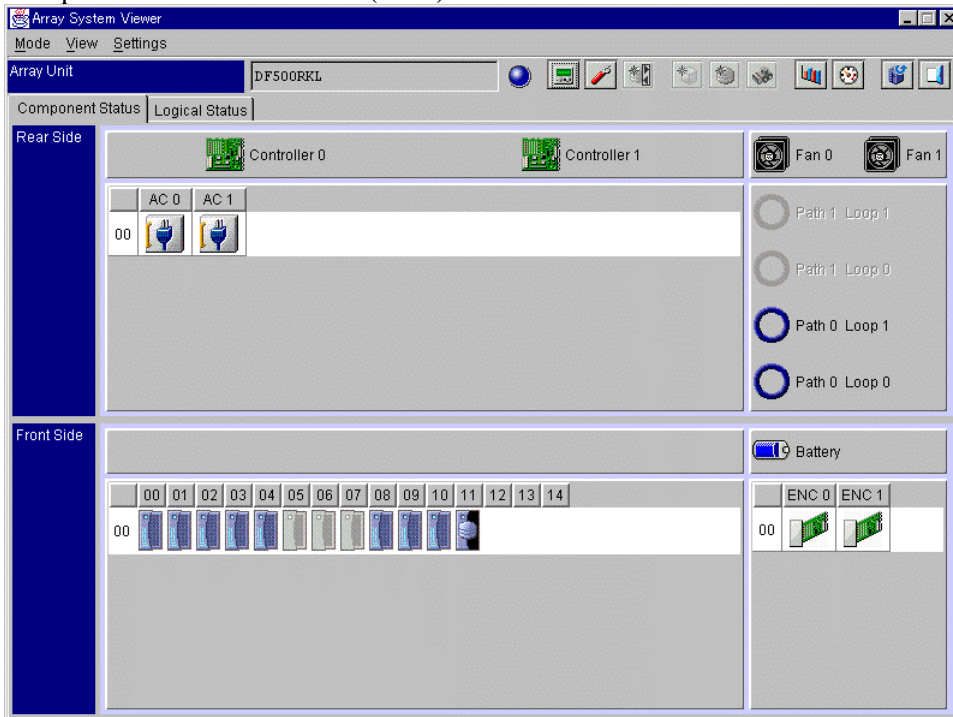

Logical Status tab : DF500(RK)

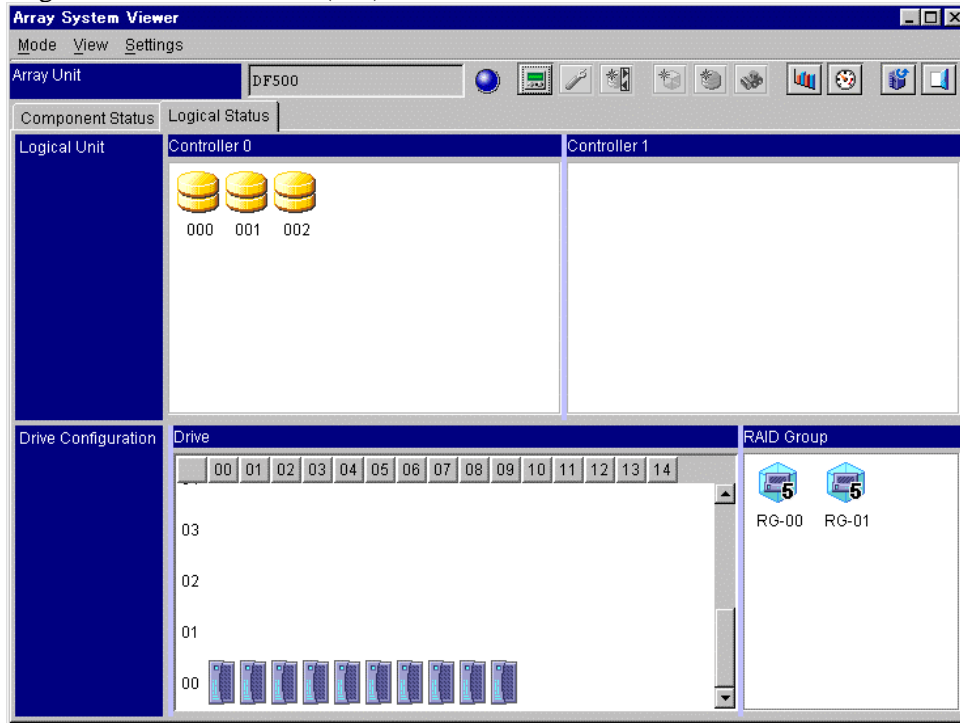

Logical Status tab : DF500(RKL)

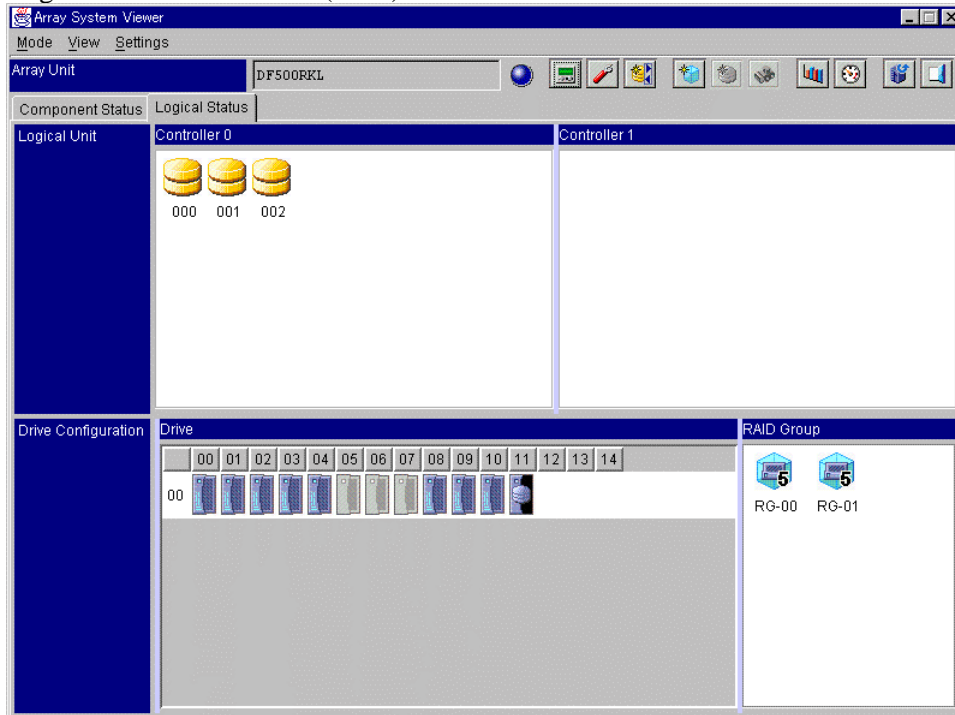

Double-clicking an icon in the Unit screen displays the Property screen of the double-clicked icon. Even while the Property screen is open, Unit screen and other operations are allowed. When you double-click another icon while the Property screen is open, the screen display is switched to information on the icon double-clicked last.

Property screen (controller)

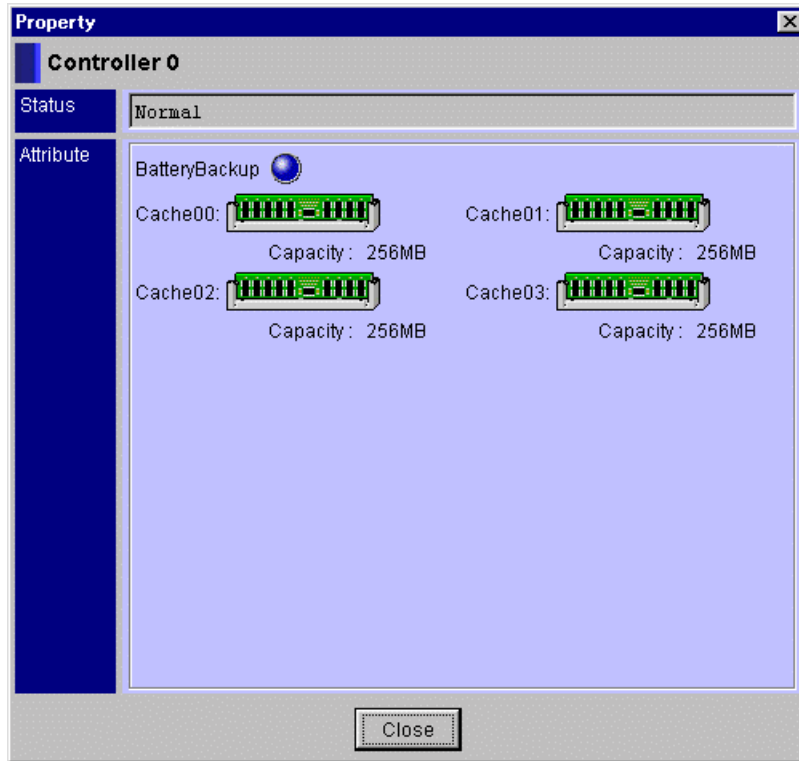



### 2.3.1 Menu bars and tool bars

The following shows a list of menu bars and tool bars, which are described in chapters from Chapter 3 onward.

#### The Main screen



##### File

| Menu        | Tool bar  | Function                  |
|-------------|---|---------------------------|
| Change Mode |  | Changing the active mode. |
| Exit        |  | Terminate the Manager 2.  |

##### Edit

| Menu   | Tool bar  | Function   |
|--------|---|--|
| Delete |  | Delete the registration of an array unit which is registered in the Manager 2. |



##### View

| Menu       | Tool bar  | Function                                |
|------------|---|---|
| Refresh    |   | The status of an array unit is checked. |
| Properties |  | Display the property of an array unit.  |

##### Add

| Menu                | Tool bar  | Function                 |
|---------------------|---|--------------------------|
| Register Array Unit |  | Register the array unit. |

##### Settings

| Menu               | Tool bar  | Function  |
|--------------------|---|---|
| Change Properties  | —   | Change the registration contents of the array unit. |
| Monitoring Options |  | Display the Monitoring Options screen.              |
| Display Details    |  | Display the Unit screen.                            |
| Password           | —   | Change the password.                                |

##### Help

| Menu    | Tool bar | Function                               |
|---------|----------|--|
| Version | —        | Display the revision of the Manager 2. |







The Unit screen  
Mode

| Menu | Tool bar  | Function                   |
|------|---|----------------------------|
| Exit |  | Terminate the Unit screen. |

View



| Menu    | Tool bar  | Function                 |
|---------|---|--------------------------|
| Refresh |  | Refresh the Unit screen. |

Settings

| Menu                        | Tool bar  | Function                                   |
|-----------------------------|---|--|
| System Parameter Wizard     |    | Start the system parameter settings.       |
| Configuration Settings      |    | Display the configuration settings screen. |
| Logical Unit Wizard         |    | Start the logical unit wizard.             |
| RAID Group Settings         |    | Display the RAID group settings screen.    |
| Extend                      | —   | Extend the RAID group.                     |
| Delete Specified RAID Group | —   | Delete specified RAID group.               |
| Delete All                  | —   | Delete the all RAID group.                 |
| Logical Unit Settings       |  | Display the logical unit settings screen.  |
| Extend                      | —   | Extend the logical unit.                   |
| Delete Last Logical Unit    | —   | Delete last logical unit.                  |
| Delete All                  | —   | Delete the all logical unit.               |
| Format (Single)             |  | Format the one logical unit.               |
| Format (Multiple)           | —   | Format the logical unit (Max.6).           |
| Change Default Controller   | —   | Change default controller of logical unit. |

### 2.3.2 Status bar

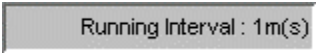
The following shows a list of menu bars and tool bars, which are described in chapters from Chapter 3 onward.

| Status bar   | Description                       |
|--|-----------------------------------|
|  Interval : 1m(s)         | Error Monitoring is stopped.      |
|  Running Interval : 1m(s) | Error Monitoring is running.      |
|  Wait Interval : 1m(s)    | Error Monitoring in the interval. |



# Chapter 3 Operations

Functions of displaying the status of array units, setting up the configuration of array units, monitoring array units for errors, etc are achieved by using the GUI (Graphical User Interface) on Windows, Solaris, and IRIX.

This guide quotes screens that appears when the manager 2 runs with Windows 2000, and when an DF500 array unit.

## 3.1 Basic Operations

Operations of these functions conform to those of Windows, Solaris, and IRIX.

### 3.1.1 Starting

1. Execute the batch file or shell script for starting the manager 2.
  - For Windows, start the batch file : startmgr2.bat.
  - For Solaris and IRIX, start the shell script : startmgr2.

**Note:** When starting the batch file and the shell script, execute them by using the same directory as that of the manager 2 program.

The manager 2 is started in the normal mode and the main screen appears.

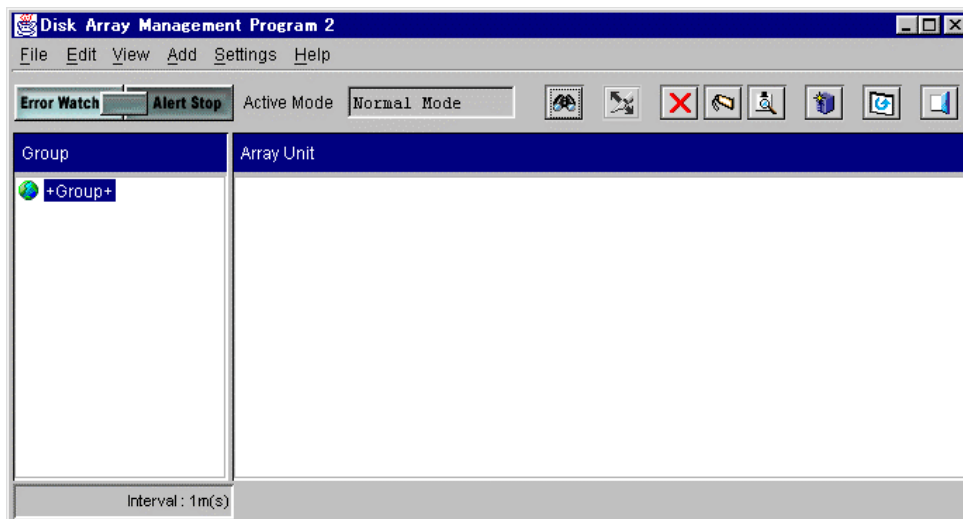

In the case of Windows, the prompt screen is also displayed.

The Prompt screen has nothing to do with Manager 2 operations. Closing the Prompt screen terminates the Manager 2 program forcibly. If the display is not necessary, specify “Minimizing icon” with the property of a batch file to “minimize the icon.”

In the main screen, the following functions are performed. The operation for each function, see the page pertaining to the explanation of each function.

- Registering the array unit (Register, Delete, Change, Refer of the property)
- Executing error monitoring and setting error monitoring option
- Changing the action mode
- Setting and changing the password for logging-in to the management mode
- Displaying the version

**Note:** When the manager 2 is first started, the change mode function is disabled. Register the password, and the change mode function will be enabled.

- Click the icon of an array unit on the Main screen, and then select “**Settings—Display Details**”. Or, when you click the “ : **Display Details**” in the tool bar, the Unit screen of an array unit will be displayed.

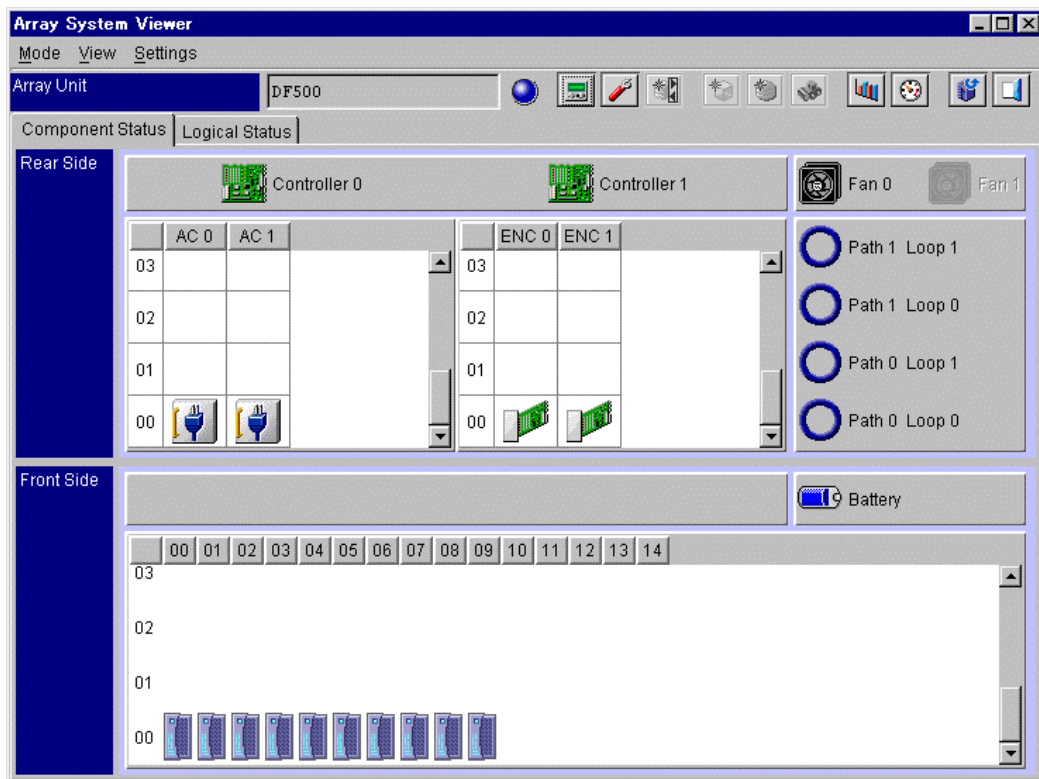
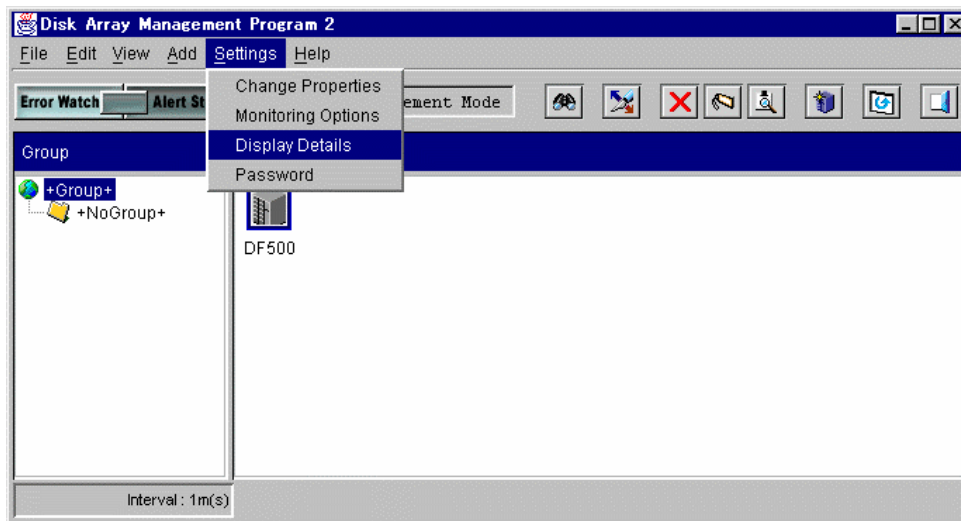

In the unit screen, the following functions are performed. The operation for each function, see the page pertaining to the explanation of each function.

- Registering the array unit (Register, Delete, Change, Refer of the property)
- Executing error monitoring and setting error monitoring option
- Changing the action mode
- Setting and changing the password for logging-in to the management mode

### 3.1.2 Password setting

When using the manager 2 in the management mode, set a password.

#### 3.1.2.1. Registration of a password

Register a password.

1. Select “**Settings—Password**” on the Main screen.

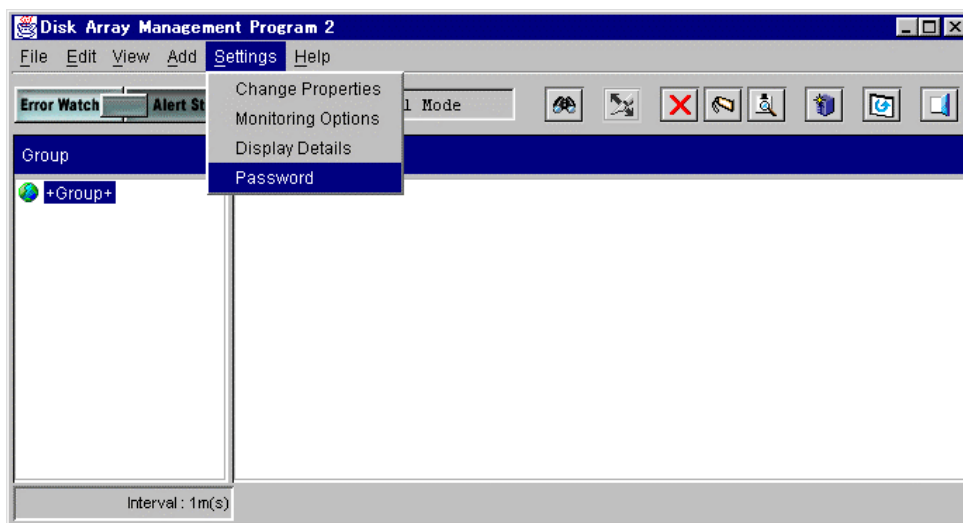

2. Input **New Password** and **New Password (for confirmation)** and click the **OK** button. Specify a password of up to 12 alphanumeric characters.

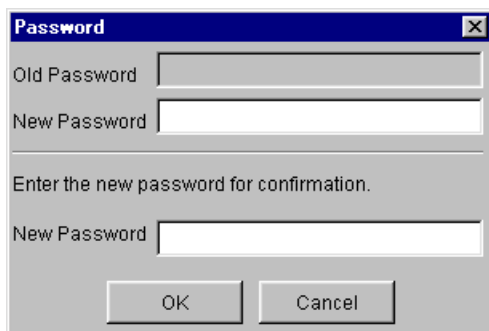

### 3.1.2.2. Changing the password

Change the set password. The password can be changed only in the management mode.

1. Select “**Settings—Password**” on the Main screen.
2. Input **Old Password**, **New Password**, and **New Password (for confirmation)** and click the **OK** button.  
Specify a password of up to 12 alphanumeric characters.

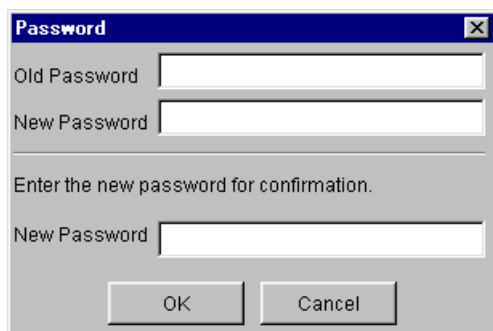

The image shows a standard Windows-style dialog box titled "Password". It features a blue title bar with a close button (X) on the right. The dialog contains three text input fields. The first is labeled "Old Password", the second "New Password", and the third "New Password". Below the second and third fields, there is a line of text that reads "Enter the new password for confirmation." At the bottom of the dialog, there are two buttons: "OK" and "Cancel".

### 3.1.2.3. Deleting the password

To delete the password, the manager 2 must be uninstalled and reinstalled.

1. Delete the directory where the manager 2 is installed.  
**Note:** To save the information of the registered array unit, back up the “utlprm.inf” file in the directory where the manager 2 is installed.
2. Re-install the manager 2.  
**Note:** When the “utlprm.inf” file has been backed up in 1, copy this file to the directory created in 2.

### 3.1.3 Changing the action mode

The manager 2 is provided with two action modes, namely, normal mode and management mode. In the normal mode, both array unit configuration and status are displayed. In the management mode, the array unit configuration can be set in addition to the normal mode functions.

Change the action mode in accordance with the operation of the array unit.

#### 3.1.3.1. Changing from the normal mode to the management mode

Change the action mode from the normal mode to the management mode. When logging-in is performed in the normal mode, **Normal Mode** is displayed in **Active Mode:** in the upper part of the main screen.

1. Select “**File—Change Mode**” on the Main screen. Or, when you click the “ : **Change Mode**” in the tool bar.

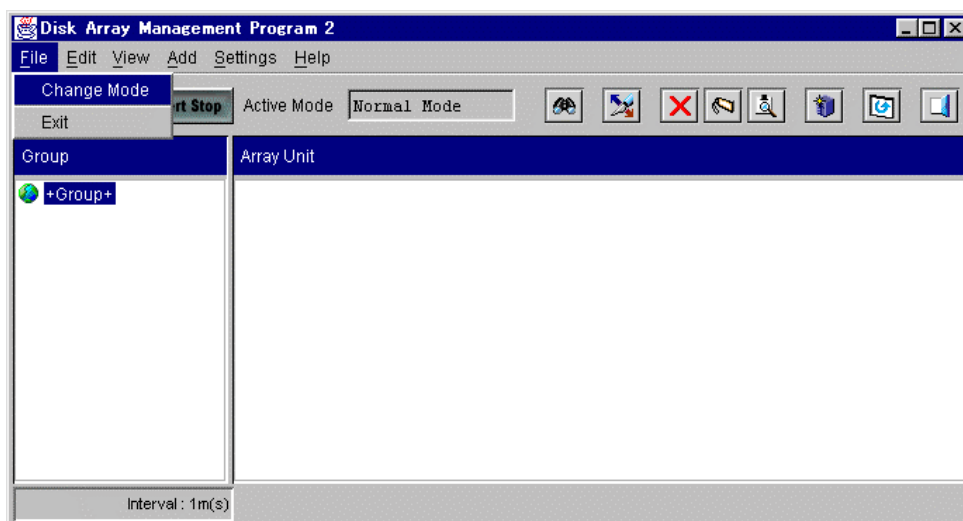

2. When the password input screen appears, input a password and click the **OK** button.

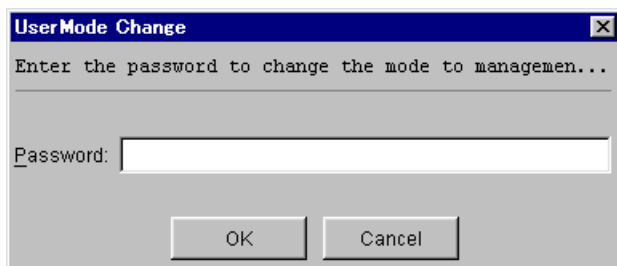

**Management Mode** is displayed in **Active Mode:** in the upper part of the main screen and the manager 2 will operate in the management mode.

### 3.1.3.2. Change from the management mode to the normal mode

Change the action mode from the management mode to the normal mode. When logging-in is performed in the management mode, **Management Mode** is displayed in **Active Mode:** in the upper part of the main screen.

1. Select “**File—Change Mode**” on the Main screen. Or, when you click the  : **Change Mode**” in the tool bar.

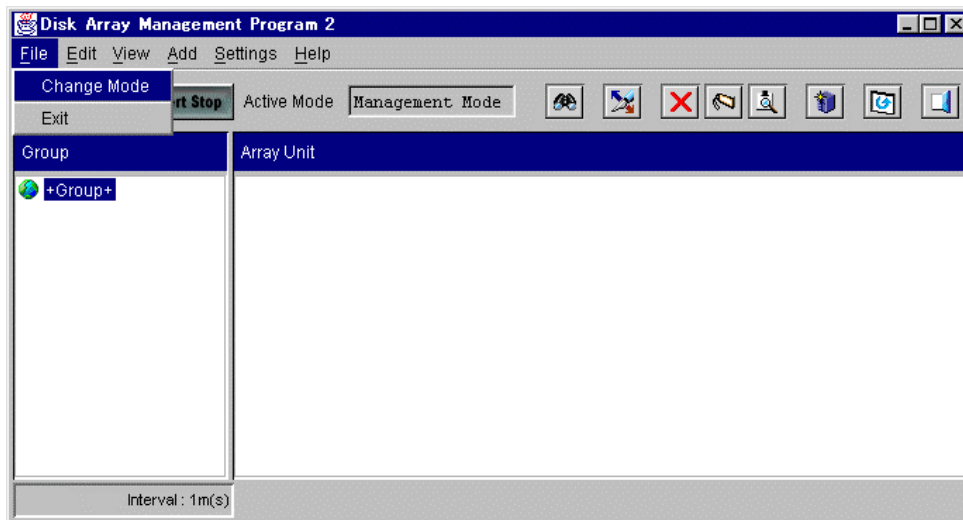

2. When a confirmation message appears, click the **OK** button.

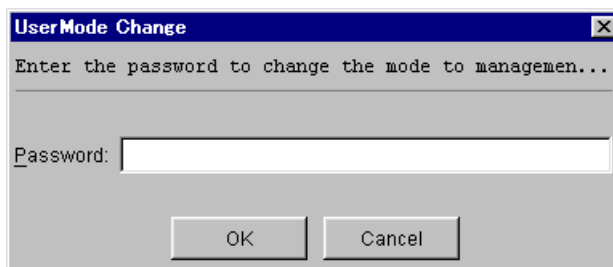

**Normal Mode** is displayed in **Active Mode:** in the upper part of the main screen and the manager 2 will operate in the normal mode.

### 3.1.4 Registering an array unit

To operate the array unit from the manager 2, register the array unit to be operated. For a non-existing array unit, it is impossible to temporarily register it.

#### 3.1.4.1. New registration

1. Select “**Add—Register Array Unit**” on the Main screen. Or, when you click the “ : **Register Array Unit**” in the tool bar.

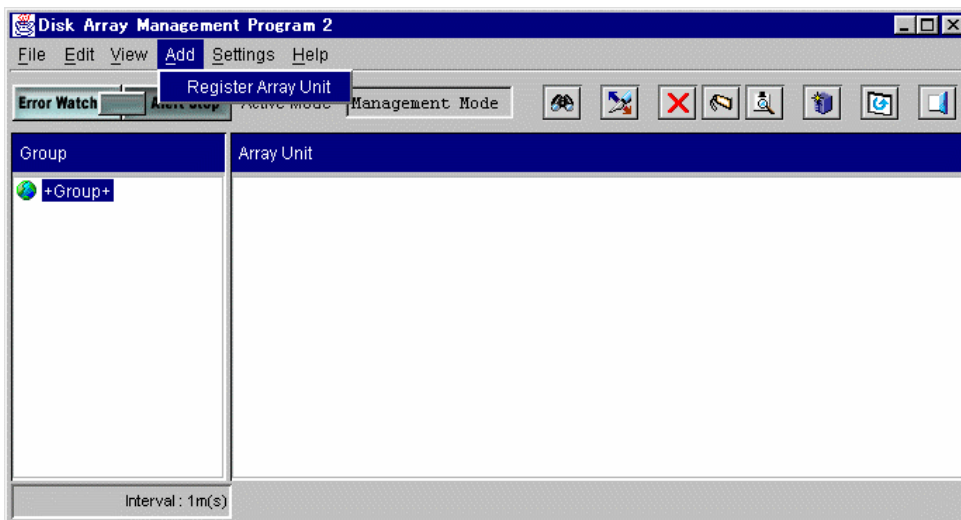

2. Input the registration information and click the **OK** button.

- **Group Name:** Group name when array units are controlled as a group. Specify it in up to 16 alphanumeric characters or characters except numbers (-, \_) . When array units are controlled as a group, input its name. If not, it is not necessary to input the name. The maximum registered number of groups is 200.
- **Array Unit Name:** Registered name of array unit. Specify it in up to 16 alphanumeric characters or characters (-, \_) except numbers.
- **Array Unit Type:** Select a type of array unit.
- **Connection Type:** Select a connection mode with the array unit.

**TCP/IP(LAN):** Connect LAN.

**RS232C:** Connect RS232C.

**IP Address,Host Name or Device Name:** Specify the connection information of controller 0/1. When you select **TCP/IP** in **Connection Type**, specify **IP Address** or **Host Name**. When you select **RS232C**, specify **Device Name**. Specify the RS232C port name or device file name as **Device Name**. (Example : Windows-COM1, Solaris-ttya)

**Error Monitoring:** Specify whether or not to perform error monitoring.

**Check (ON display):** Error monitoring

**No check (OFF display):** No error monitoring

**Note:** In the array unit in the dual system, only one controller can be used in the LAN connection mode. **Array Unit Type** is used to select an array unit type to be connected. Specify **IP Address/Host Name/Device Name** for the connected controller side only.

3. When a registration completion message appears, click the **OK** button.

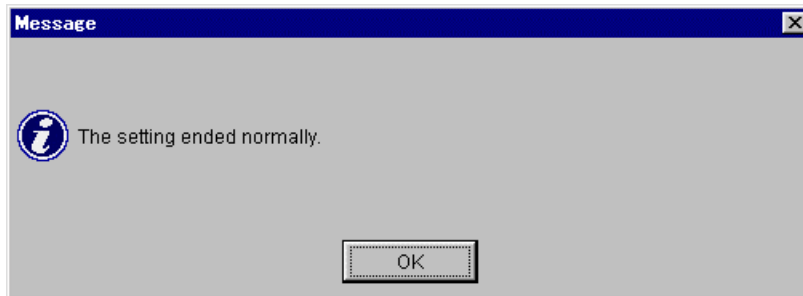

The main screen is updated and then displayed.

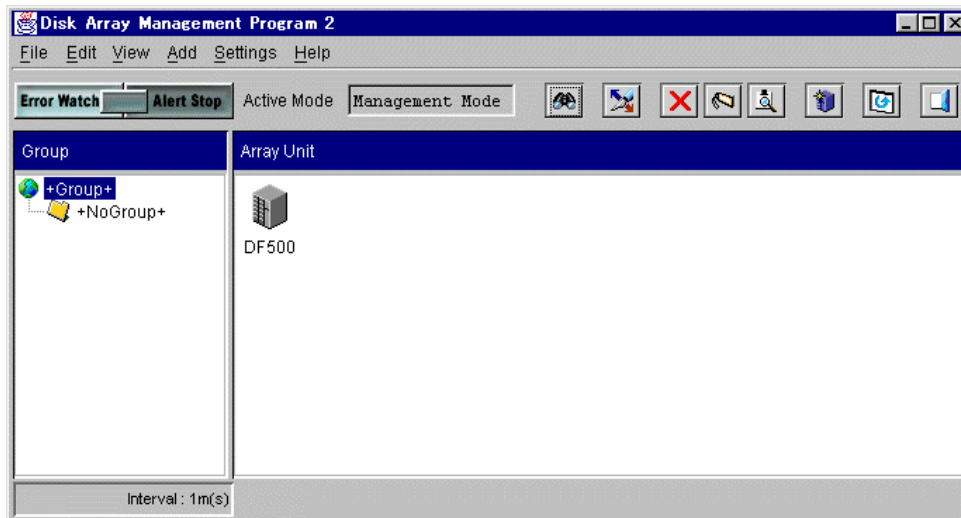

When you input in **Group Name**, an array unit icon is displayed in the frame enclosed with the input group. Array unit icons are classified into one for dual system and the other for single system as shown in the following figure.

For dual system 

For single system 

Array unit icons are displayed in the order of registration.

### 3.1.4.2. Changing the registration contents

Change the registration contents of the array unit which are registered in the manager 2.

1. Click the icon of an array unit on the Main screen, and then select “**Settings—Properties**”.

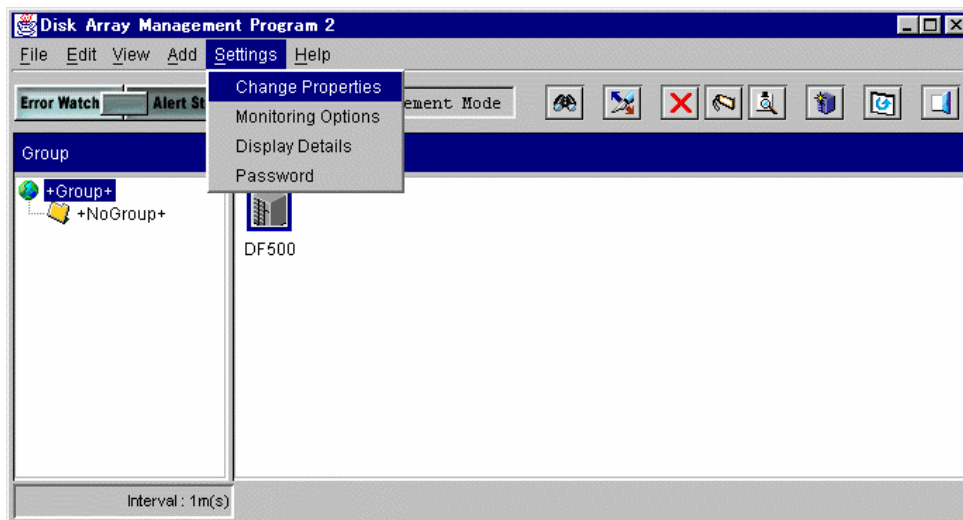

2. The registration contents are displayed. Change the registration contents and click the **OK** button.

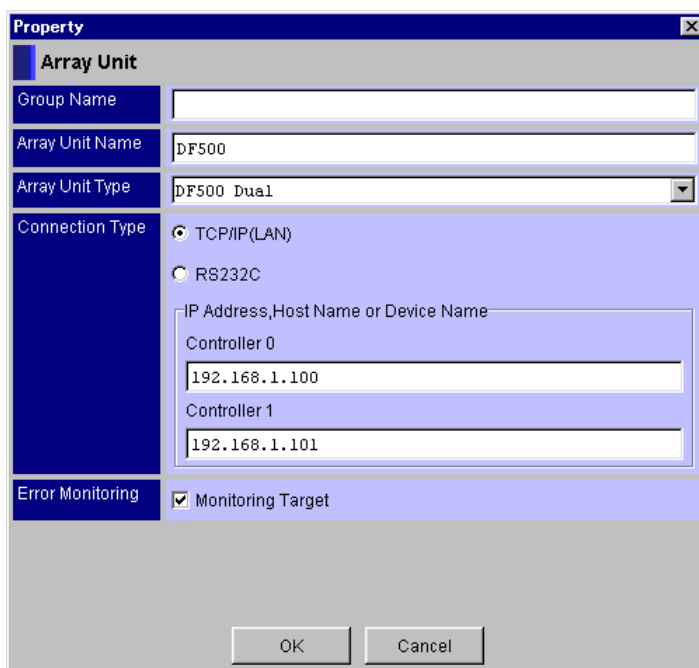

3. When a registration change completion message appears, click the **OK** button.

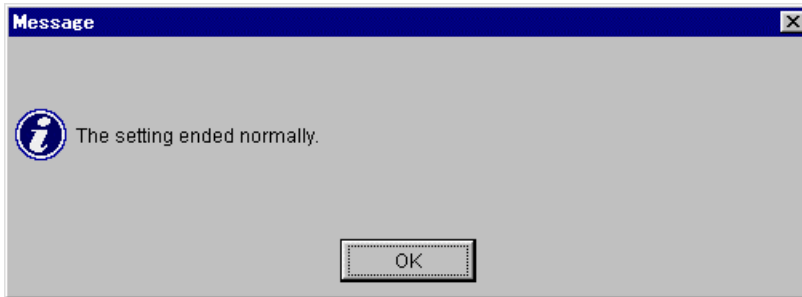

The main screen is updated and then displayed.

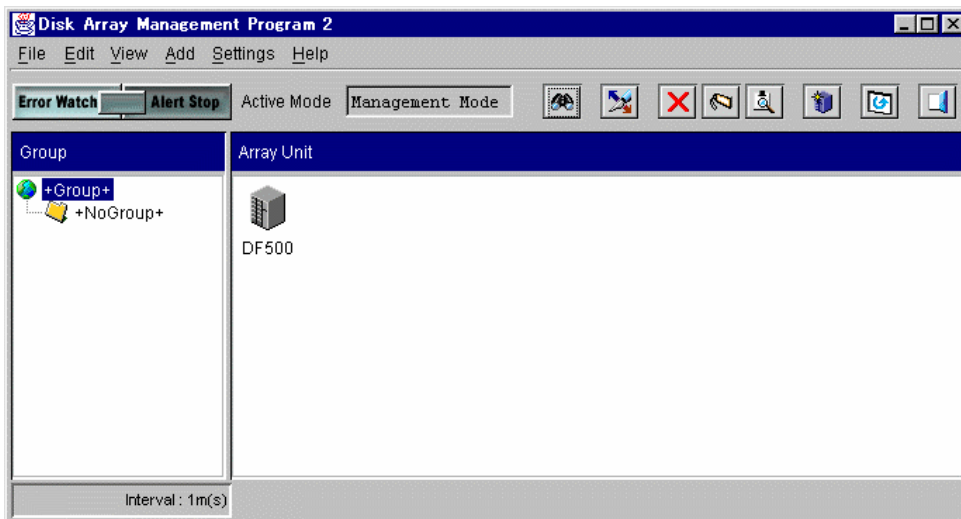

### 3.1.4.3. Deleting the registration

Delete the registration of an array unit which is registered in the manager 2.

1. Click the icon of an array unit on the Main screen, and then select “**Edit—Delete**”. Or, when you click the “ : **Delete**” in the tool bar.

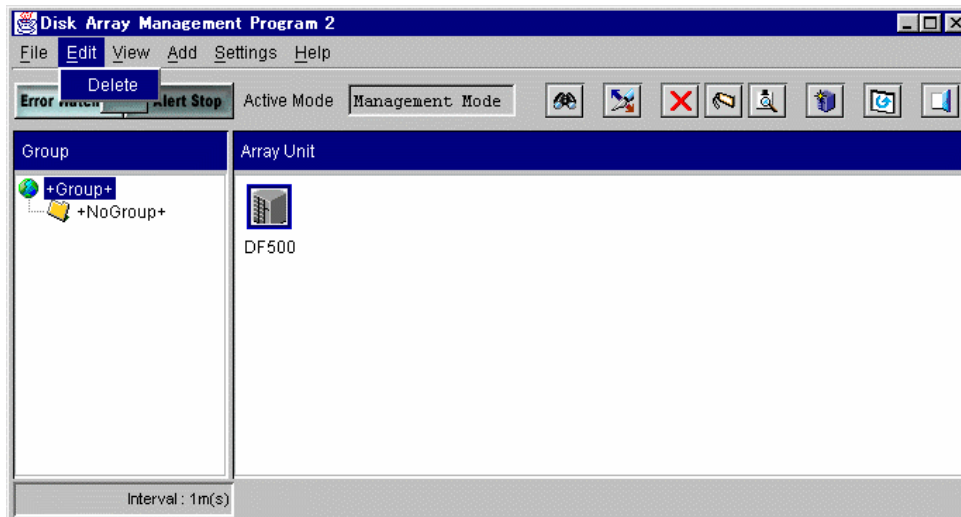

2. When a message confirming whether the registration should be deleted or not is displayed, click the **OK** button.

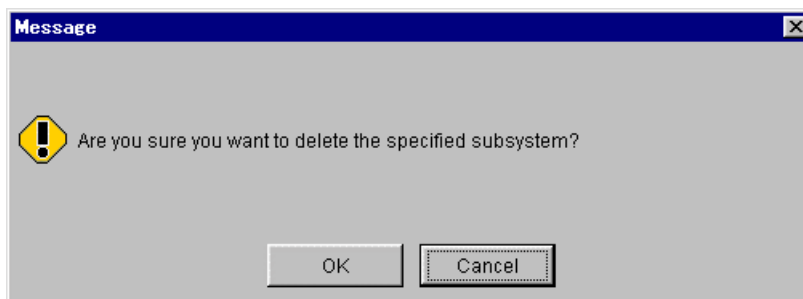

The main screen is updated and then displayed.

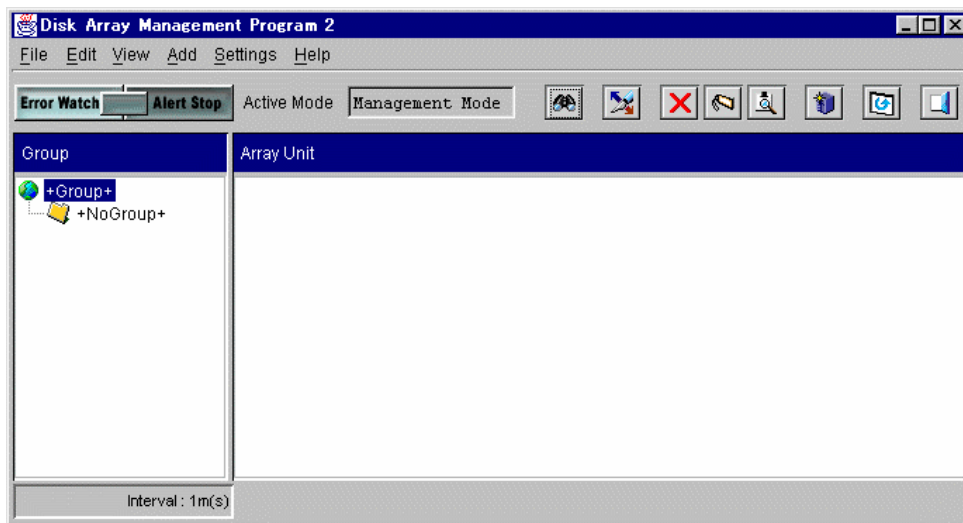

### 3.1.4.4. Displaying the registration contents

Display the registration contents of an array unit which is registered in the manager 2.

1. Click the icon of an array unit on the Main screen, and then select “**View—Properties**”.  
Or, when you click the “ : **Properties**” in the tool bar.

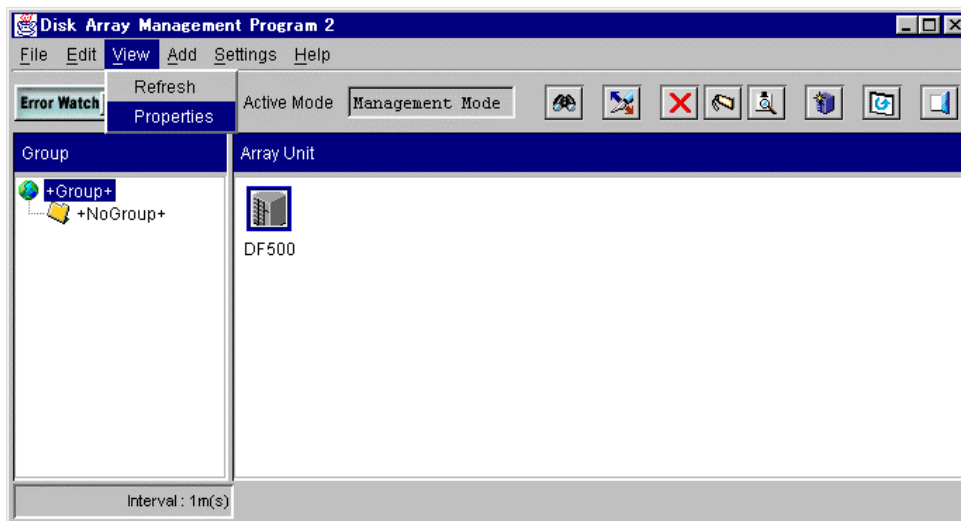

The registration contents of the array unit are displayed.

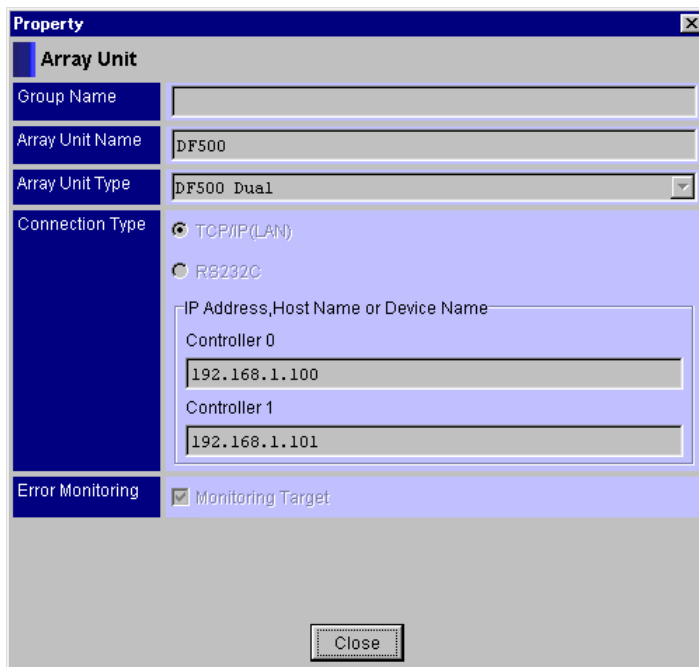

### 3.1.5 Version display

Display the version of the manager 2.

1. Select “**Help—Version**” on the Main screen.

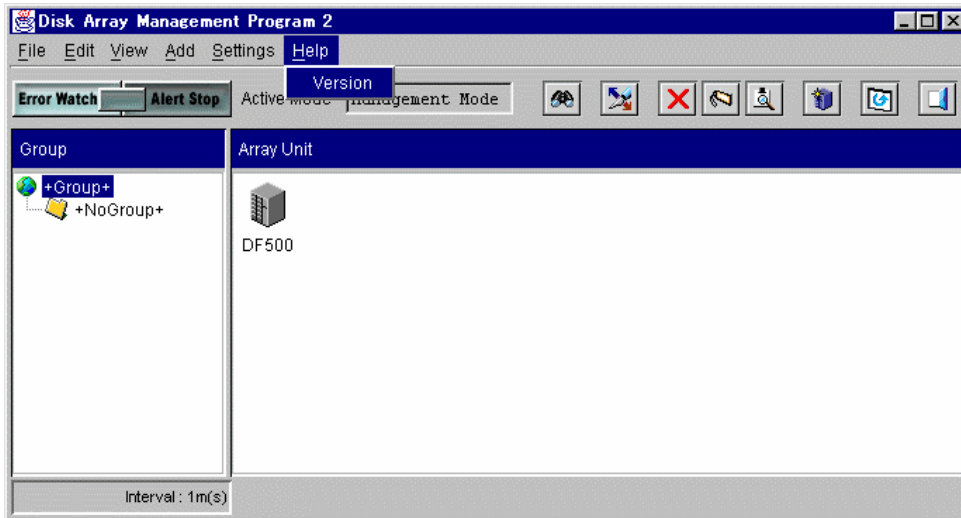

The version of the manager 2 is displayed.

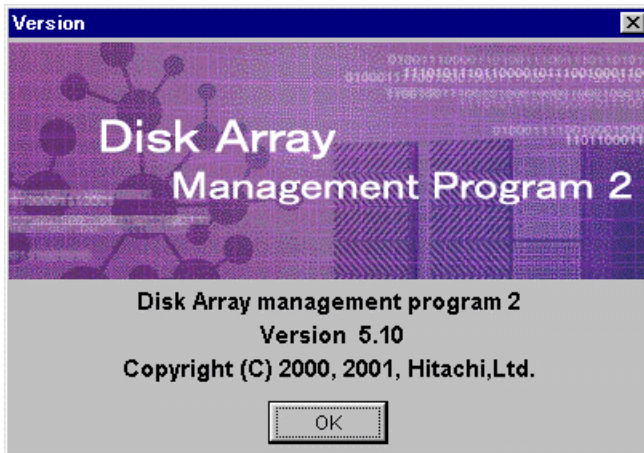

### 3.1.6 Terminating

Terminate the manager 2. When the unit screen is open, close it and terminate the manager 2.

1. Click the icon of an array unit on the Main screen, and then select “**File—Exit**”. Or, when you click the “ : **Exit**” in the tool bar.

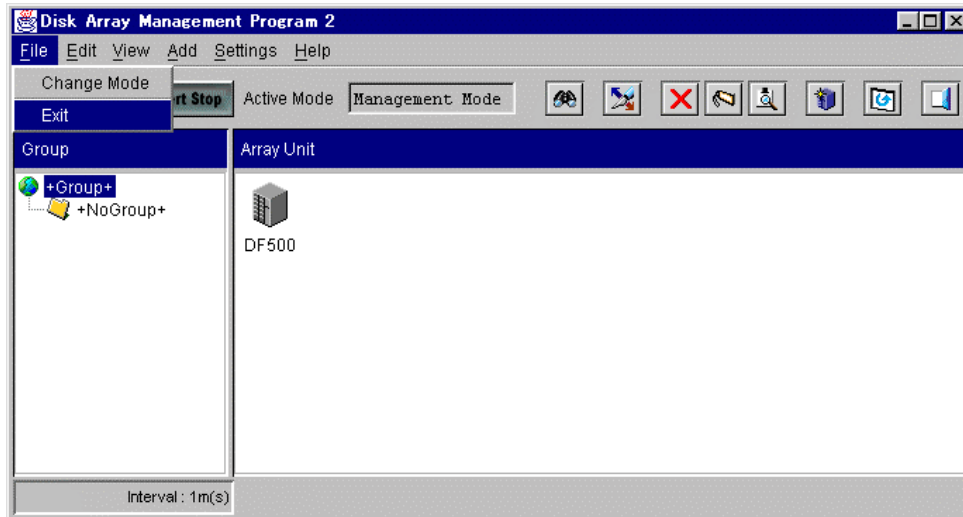



The Main screen is closed and the manager 2 is terminated.  
When you run with Windows, close the prompt screen too.

## 3.2 Displaying the property

### 3.2.1 Displaying the property of the main screen

Display the array unit status and information by using icons.

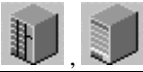
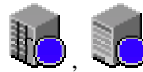
#### a) Array unit status

|   |  |
|---|--|
|  Gray          | <ul style="list-style-type: none"><li>• Initial main screen when starting Manager 2.</li><li>• Out of error monitoring.</li></ul>                                    |
|  Gray + Blue   | <ul style="list-style-type: none"><li>• Normal</li></ul>   |
|  Gray + Yellow | <ul style="list-style-type: none"><li>• Warning</li></ul>  |
|  Red           | <ul style="list-style-type: none"><li>• Array unit is system down.</li><li>• Array unit is power off.</li><li>• Error in communication with an array unit.</li></ul> |

### 3.2.2 Displaying the property of the unit screen

Display the array unit component status and information by using icons. When you double-click each icon, the information of the component part indicated by the icon is displayed.

1. Select “**Settings—Display Details**”, and then click the “**Component Status**” tab. Or, when you click the “ : **Display Details**” in the tool bar, and then click the “**Component Status**” tab.

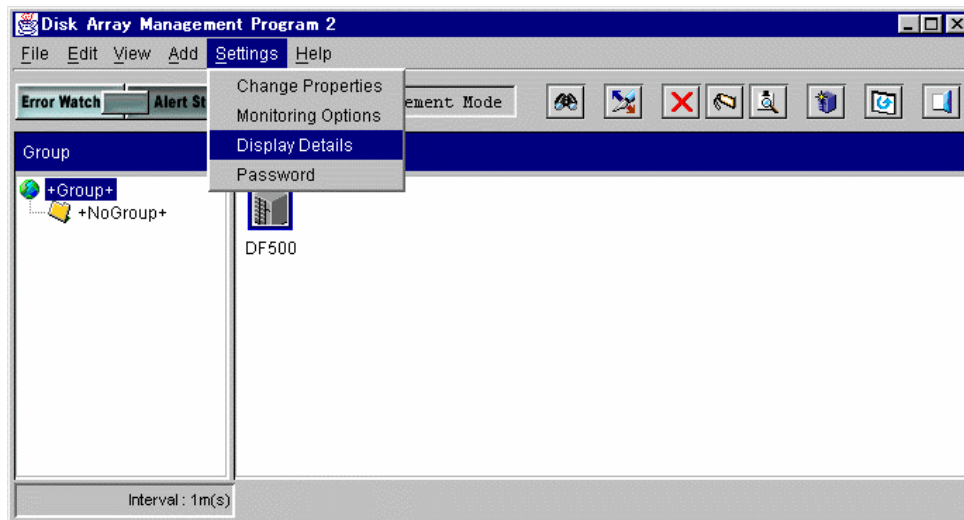

Display the array unit component status.

To update the component display, select “**View—Refresh**”. Or, when you click the “ : **Refresh**” in the tool bar.

- Display when both controllers are connected in the dual system

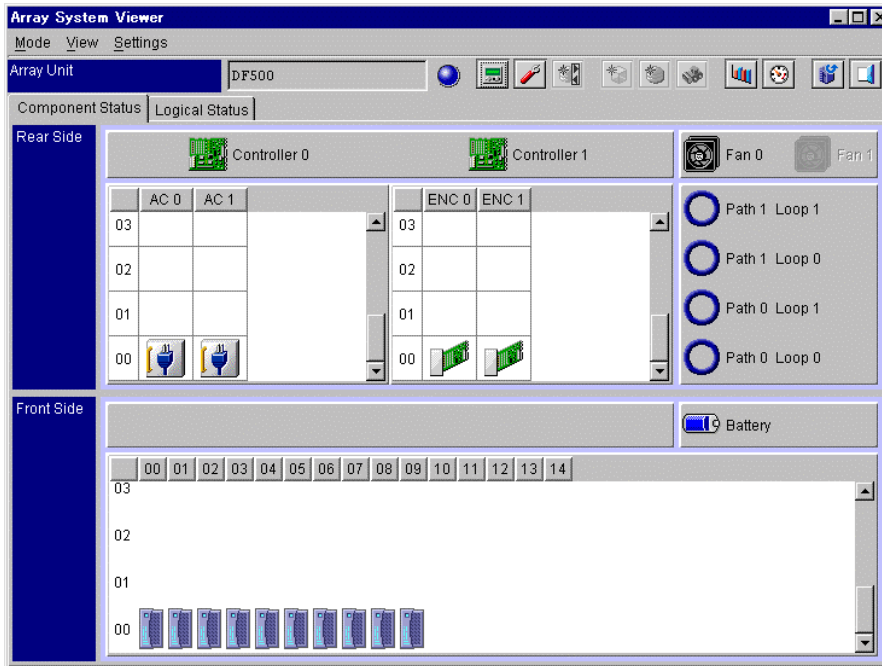



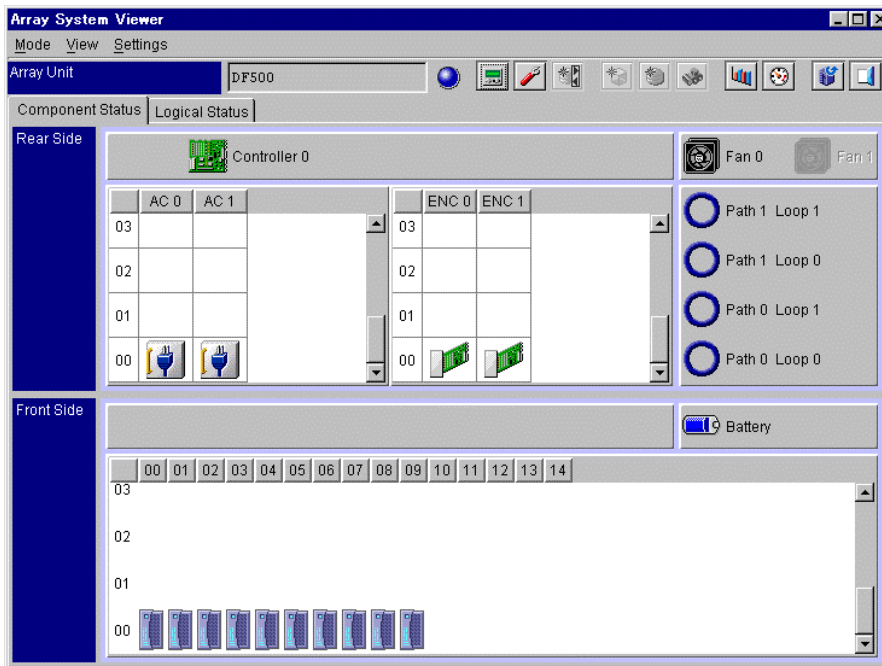









- Display when a single controller is connected in the dual system/single system is connected













Regarding the display of the controller icon, only the connected controller side is displayed.

Display the array unit component status by using icons.



b) Data drive

| Display  | Highlighting  | Status   |
|--|---|--|
|  Purple         |  | <ul style="list-style-type: none"> <li>• Normal (There is a formatted LU.)</li> </ul>  |
|  Yellow         |  | <ul style="list-style-type: none"> <li>• Collection reconstruction status</li> <li>• Copy-back status from the spare disk</li> </ul> |
|  Red            |  | <ul style="list-style-type: none"> <li>• Blockade</li> </ul>   |
|  Gray           |  | <ul style="list-style-type: none"> <li>• RAID group defined, LU not defined</li> <li>• LU defined, unformatted</li> </ul>            |
|  Red + Black    |  | <ul style="list-style-type: none"> <li>• Not mounted in the blockade status</li> </ul>   |
|  Purple + Black |  | <ul style="list-style-type: none"> <li>• RAID group defined, Drive not mounted</li> </ul>  |
|  No indication  | —   | <ul style="list-style-type: none"> <li>• RAID group not defined, Drive mounted</li> </ul>  |
| No indication  | —   | <ul style="list-style-type: none"> <li>• RAID group not defined, Drive not mounted</li> <li>• Not supported location</li> </ul>      |



c) Data drive

| Display  | Highlighting  | Status   |
|--|---|--|
|  Purple         |  | <ul style="list-style-type: none"> <li>• Spare drive in use</li> </ul>   |
|  Yellow         |  | <ul style="list-style-type: none"> <li>• Data reconstruction to spare drive</li> <li>• Copy-back from spare disk to data disk</li> </ul> |
|  Purple + Black |  | <ul style="list-style-type: none"> <li>• Waiting</li> </ul>  |
|  Red            |  | <ul style="list-style-type: none"> <li>• Busy or Disk Drive Detached for Restoring</li> </ul>  |
|  Red + Black    |  | <ul style="list-style-type: none"> <li>• Spare disk not mounted though Use of Spare Disk is set as array unit</li> </ul>                 |



d) Enclosure

| Display   | Status  |
|---|---|
|  Green | <ul style="list-style-type: none"> <li>• Normal</li> </ul>  |
|  Red   | <ul style="list-style-type: none"> <li>• Failure</li> </ul> |



e) Controller

| Display  | Status   |
|--|--|
|  Green  | <ul style="list-style-type: none"> <li>• Normal</li> </ul>   |
|  Yellow | <ul style="list-style-type: none"> <li>• Failure</li> </ul>  |
|  Red    | <ul style="list-style-type: none"> <li>• Blockade</li> </ul> |



f) Battery

| Display   | Status  |
|---|---|
|  Blue  | <ul style="list-style-type: none"> <li>• Normal</li> </ul>  |
|  Red | <ul style="list-style-type: none"> <li>• Failure</li> </ul> |



g) Fan

| Display   | Status  |
|---|---|
|  Black | <ul style="list-style-type: none"> <li>• Normal</li> </ul>  |
|  Red   | <ul style="list-style-type: none"> <li>• Failure</li> </ul> |

h) Power supply

| Display  | Status  |
|--|---|
|  Blue | <ul style="list-style-type: none"> <li>• Normal</li> </ul>  |
|  Red  | <ul style="list-style-type: none"> <li>• Failure</li> </ul> |

i) Loop

| Display  | Status  |
|--|---|
|  Blue | <ul style="list-style-type: none"> <li>• Normal</li> </ul>  |
|  Red  | <ul style="list-style-type: none"> <li>• Failure</li> </ul> |

2. When you double-click each icon, displayed property screen of the component part indicated.  
For data drives and spare drives, information when clicking their respective icons is displayed. For other components of an array unit, information when displaying a screen is displayed.

a) Data drive and spare drive

| Property   |                        |
|------------|------------------------|
| Drive      |                        |
| Vendor ID  | SEAGATE                |
| Product ID | ST136403FC             |
| Revision   | FF78                   |
| Type       | Data                   |
| Position   | Unit No. 00 HDU No. 00 |
| Capacity   | 36GB                   |
| Status     | Normal                 |

- **Vendor ID:** Vendor ID of drive
- **Product ID:** Product ID of drive
- **Revision:** Firmware revision of drive
- **Type:** Drive using form
  - Data:** Data drive
  - Spare:** Spare drive
- **Position:** Array unit mounting position
  - Unit No.:** Unit No.
  - HDU No.:** HDU No.
- **capacity:** Storage capacity of a drive

- **Status:** Drive status
    - Normal:** Normal
    - Detached:** Blockade
    - Detached (Unmount):** The drive in the blockade status is not installed.
    - Standby:** Normal (LU not defined)
    - Out of RG:** Normal (RAID not defined)
    - Undefine:** Normal (LU not defined)
    - Unmount:** The drive is not installed.
    - Recovery:** Under recovery (correction copy or copyback in progress)
    - UnitX HDUY:** Position of a corresponding data drive when using spare disk drives.
    - Waiting:** Spare drive not used
- Note:** **Vendor ID**, **Product ID**, and **Revision** may not be displayed depending on the drive mounting and drive status.

b) Enclosure

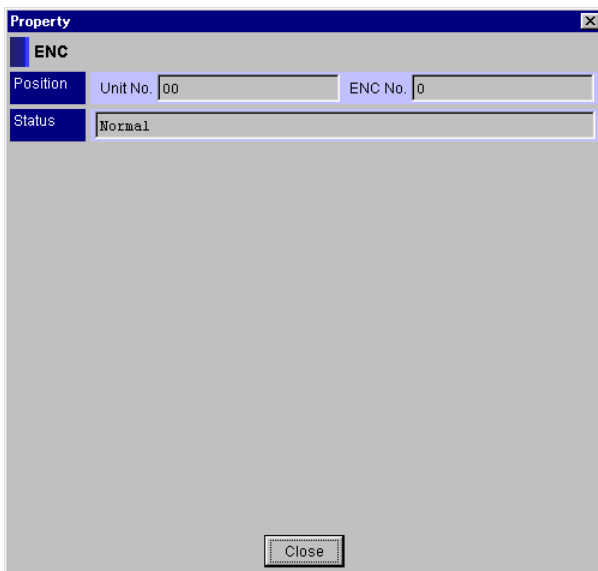

- **Position:** Mounting position of an enclosure
  - Unit No.:** Unit No.
  - ENC No.:** ENC No.
- **Status:** Status
  - Normal:** Normal
  - Alarm:** Failure

c) Controller

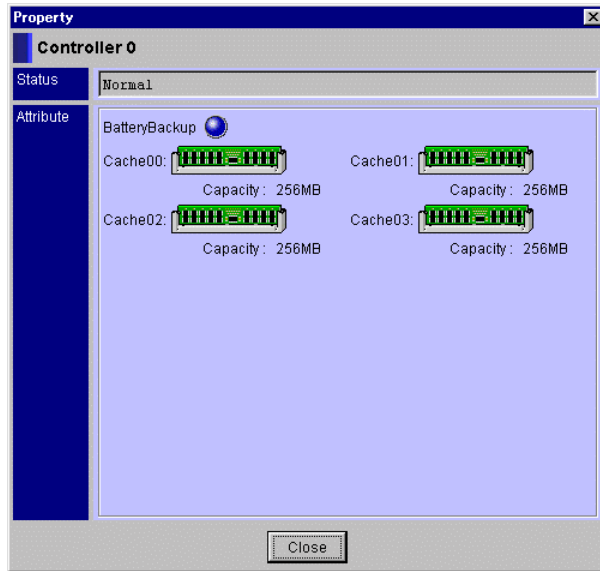

**Controller n:** Controller n (n : Controller No.)

- **Status:** Status
  - Normal:** Normal
  - Alarm:** Failure
  - Nothing:** Not installed
- **Attribute:** Status of battery backup circuit. Capacity of cache memory.
  - BatteryBackup (Blue):** Normal
  - BatteryBackup (Red):** Failure

d) Fan

Property

Fan

Position Fan No. 0

Status Normal

Close

- **Position:** Mounting position  
**Fan No.:** Fan No.
- **Status:** Status  
**Normal:** Normal  
**Alarm:** Failure  
**Nothing:** Not installed

e) Battery

Property

Battery

Status Normal

Close

- **Status:** Status  
**Normal:** Normal  
**Alarm:** Failure  
**Nothing:** Not installed

f) AC power supply

The screenshot shows a 'Property' dialog box with a title bar containing a close button. The dialog has a tab labeled 'AC Power Supply'. Below the tab, there are two sections: 'Position' and 'Status'. The 'Position' section contains two input fields: 'Unit No.' with the value '00' and 'AC No.' with the value '0'. The 'Status' section contains a text field with the value 'Normal'. At the bottom center of the dialog is a 'Close' button.

- **Position:** Mounting position  
**Unit No.:** Unit No.  
**AC No.:** AC No.
- **Status:** Status  
**Normal:** Normal  
**Alarm:** Failure  
**Nothing:** Not installed



g) Loop

The screenshot shows a 'Property' dialog box with a title bar containing a close button. The dialog has a tab labeled 'Loop'. Below the tab, there are two sections: 'Position' and 'Status'. The 'Position' section contains two input fields: 'Path No.' with the value '0' and 'Loop No.' with the value '0'. The 'Status' section contains a text field with the value 'Normal'. At the bottom center of the dialog is a 'Close' button.









- **Position:** Mounting position  
**Path No.:** Path No.  
**Loop No.:** Loop No.
- **Status:** Status  
**Normal:** Normal  
**Alarm:** Failure  
**Nothing:** Not installed

- Icon and property of logical unit

- h) RAID group

| Display   | Highlighting  | Status   |
|---|---|--|
| <br>Blue |  | <ul style="list-style-type: none"> <li>• Normal</li> </ul> |

- i) Logical unit

| Display   | Highlighting  | Status   |
|---|---|--|
| <br>Yellow |  | <ul style="list-style-type: none"> <li>• Normal (formatted logical unit.)</li> </ul>   |
| <br>Gray   |  | <ul style="list-style-type: none"> <li>• Normal (unformatted logical unit.)</li> </ul> |
| <br>Red    |  | <ul style="list-style-type: none"> <li>• Blockade</li> </ul>                           |
| <br>Pink   |  | <ul style="list-style-type: none"> <li>• Regression</li> </ul>                         |

j) RAID group

The screenshot shows a 'Property' dialog box titled 'RAID Group'. It contains several configuration fields:

- RAID Group:** A text input field containing '00'.
- RAID Level:** A dropdown menu set to 'RAID 5'.
- HDU Combination:** A dropdown menu set to '4D+1P'.
- HDU Starting Point:** Two text input fields: 'Unit No.' containing '00' and 'HDU No.' containing '00'.
- Size (Number of Drives):** Two text input fields: 'HDUs in the Parity Group' containing '05' and 'Parity Groups' containing '01'.

A 'Close' button is located at the bottom center of the dialog box.

- **RAID Group:** RAID group No.
- **RAID Level:** RAID level
- **HDU Combination:** Parity group configuration
- **HDU Starting Point:** Unit No. and HDU No. defined for the top HDU in a RAID group.
- **Size (Number of Drives):** Number of HDUs in parity groups and number of parity groups.

k) Logical unit

The screenshot shows a 'Property' dialog box for a 'Logical Unit'. The fields are as follows:

| Field                | Value                                |
|----------------------|--------------------------------------|
| Logical Unit No.     | 000                                  |
| Status               | Normal                               |
| Controller (Default) | Controller 0 (selected)              |
| Controller (Current) | Controller 0 (selected)              |
| Size                 | 128000 Block(s) (range: 1-277628928) |
| RAID Group           | 00                                   |

- **Logical Unit No.:** Logical unit No.
- **Status:** Status
  - Normal:** Normal
  - Unformat:** Normal (unformatted)
  - Alarm:** Blockade
  - Regression:** Regression
- **Controller:** Controller No. in charge of the default/current LU
- **Size:** Capacity in which the logical unit is defined
- **RAID Group:** RAID group number in which logical units are defined

### 3.2.3 Displaying the array unit configuration information

Display the array unit configuration information.

1. Click the icon of an array unit on the Unit screen, and then select “**Settings—Configuration Settings**”. Or, when you click the : **Configuration Settings**” in the tool bar.

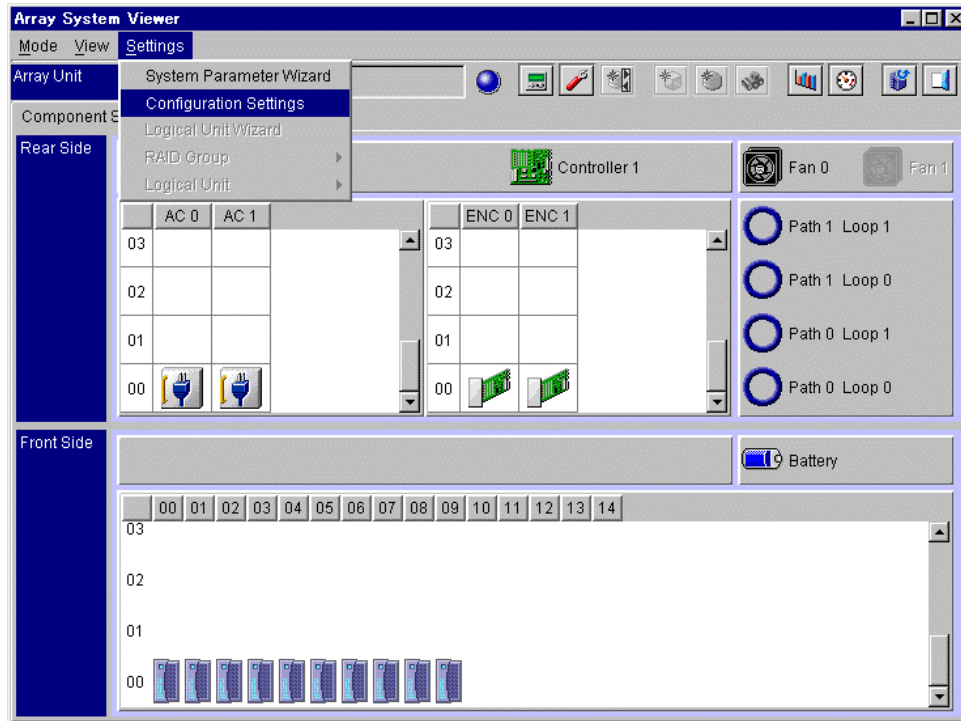

2. Click the **LAN** tab.  
The IP Address and Subnet Mask of the LAN configuration information that is validated in the array unit are displayed.

The screenshot shows a 'Parameter' window for Array Unit DF500. The 'LAN' tab is selected. The window is divided into two sections: 'Controller 0' and 'Controller 1'. Each section has a 'DHCP' checkbox (unchecked) and a 'Network' section with four fields: IP Address, Subnet Mask, Default Gateway, and Ether Address. At the bottom right, there is a checked 'FD Backup' checkbox and 'Apply' and 'Reset' buttons. At the bottom center, there is a 'Close' button.

| Controller   | DHCP                     | IP Address    | Subnet Mask   | Default Gateway | Ether Address     |
|--------------|--------------------------|---------------|---------------|-----------------|-------------------|
| Controller 0 | <input type="checkbox"/> | 192.168.1.100 | 255.255.255.0 | 192.168.15.3    | 00:00:87:70:FF:1A |
| Controller 1 | <input type="checkbox"/> | 192.168.1.101 | 255.255.255.0 | 192.168.15.3    | 00:00:87:F0:80:1C |

# Chapter 4 Definition of RAID Group/Logical Unit

Setting, expanding and deleting the RAID group, and creating, expanding, and deleting etc. the logical unit are executed.

In the monitor mode, the current definition information is displayed but no button for definition is displayed.

- **Displaying the RAID group/logical unit definition**

Click the **Logical Status** tab on the Unit screen.

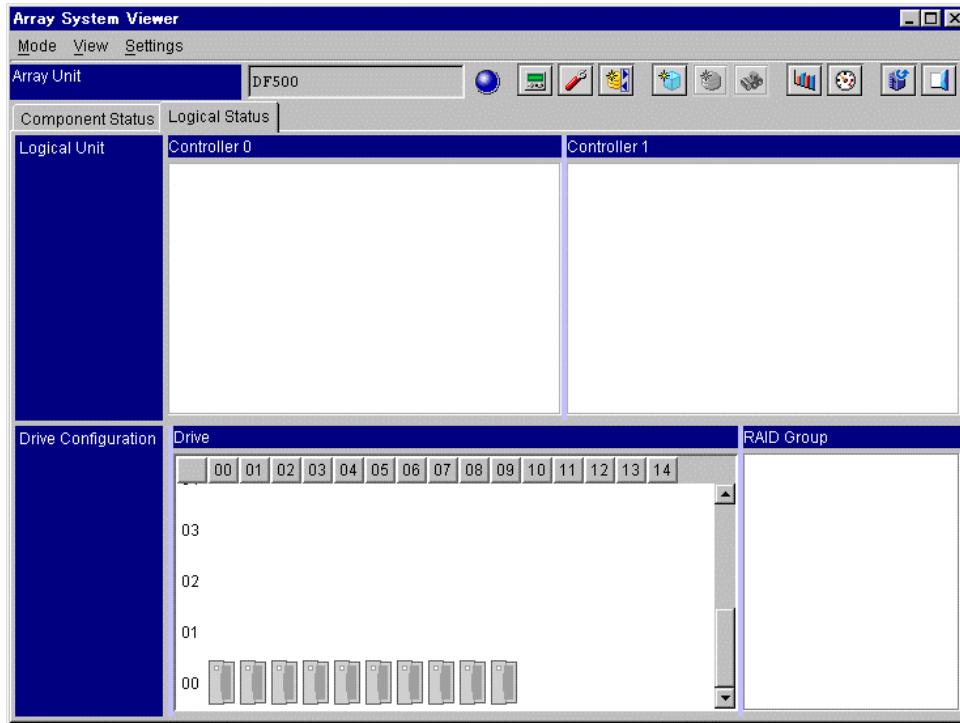

Displays the definition information of all RAID groups and all logical units defined in the array unit.

- **Logical Unit:**

**Controller 0:** Displaying logical unit number (xxx) of logical units under control of Controller 0, the RAID levels of RAID groups for which logical units have been defined, and the status of logical units.

**Controller 1:** Displaying logical unit number (xxx) of logical units under control of Controller 1, the RAID levels of RAID groups for which logical units have been defined, and the status of logical units.

- **Drive Configuration:**

**Drive:** The status of disk drives mounted in an array unit is displayed.

**RAID Group:** Information about all RAID groups defined for an array unit is displayed.

Displaying information related to the RAID groups and drives for which logical units have been defined.

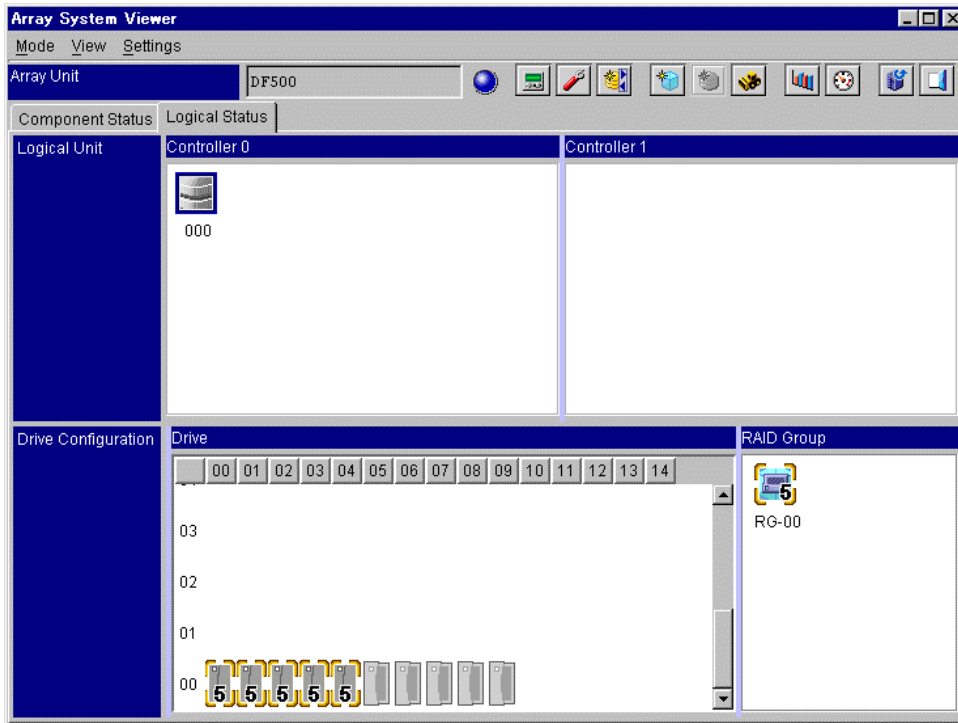

Clicking the icon of a logical unit displayed in the **Logical Unit** box displays the following information.

- **Logical Unit:** Displays, by highlighting, a RAID level in the icon of a drive for which logical units have been defined.
- **Drive Configuration:** Displays, by highlighting in light blue, a RAID group for which logical units have been defined.

Displaying information related to the logical units and drives for which RAID groups have been defined.

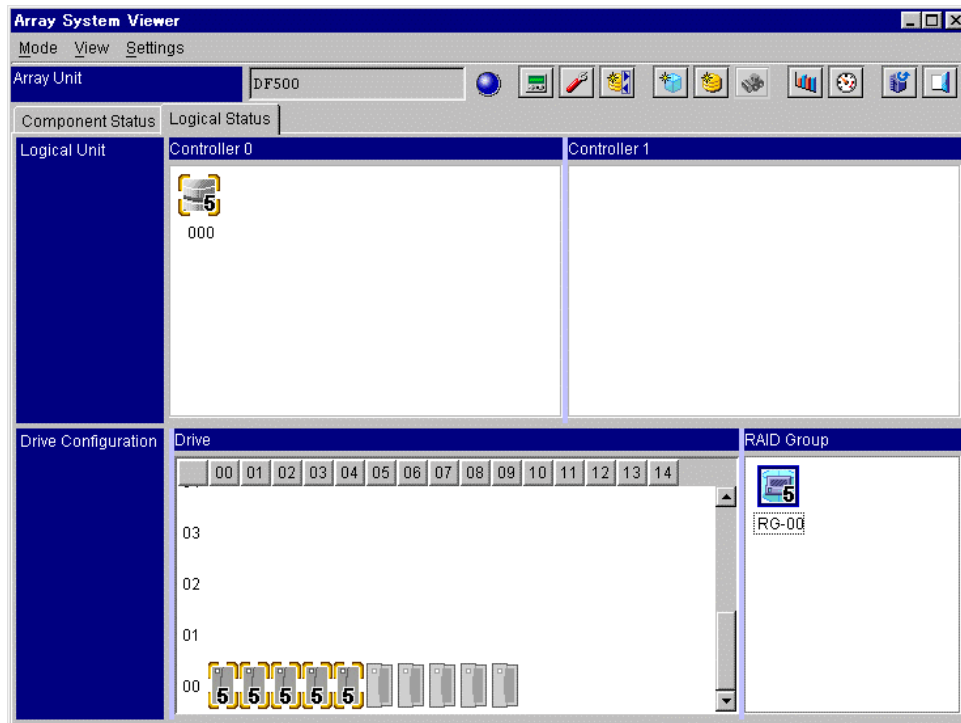

Clicking the icon of a logical unit displayed in the **RAID Group** box displays the following information.

- **Logical Unit:** Displays, by highlighting, a all logical units.
- **Drive Configuration:** Displays, by highlighting, a RAID level in the icon of a drive for which RAID groups have been defined.

## 4.1 Creating a RAID group

Create a new RAID group.

1. Click the **Logical Status** tab on the Unit screen.
2. Clicks the top drive of which an RAID group is comprised. The drive that is clicked is displayed with a selected appearance.

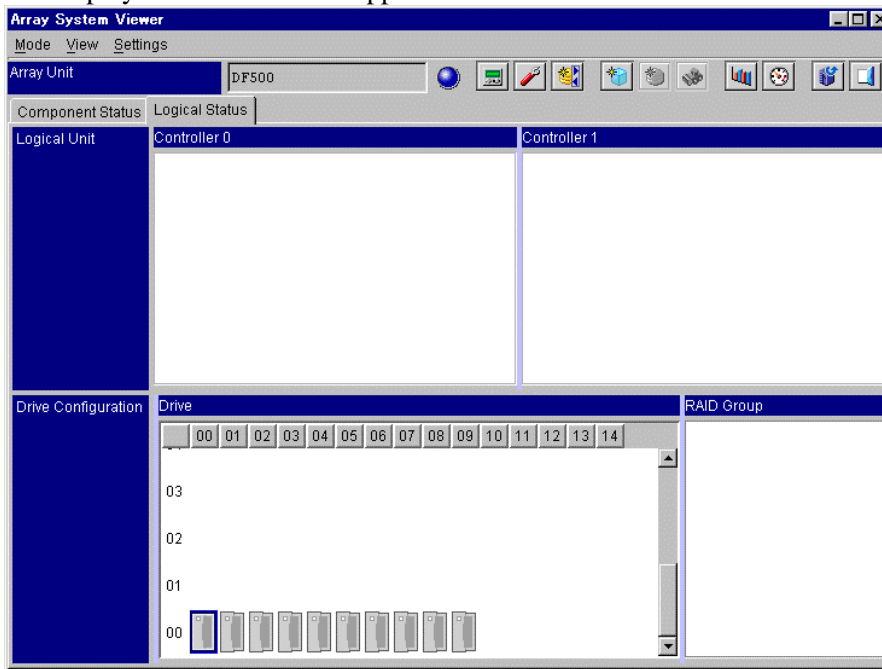

3. Holding down the **shift** key, clicks the last drive of an RAID group which to create. Drives of the RAID group which to create are enclosed by a rectangular box.

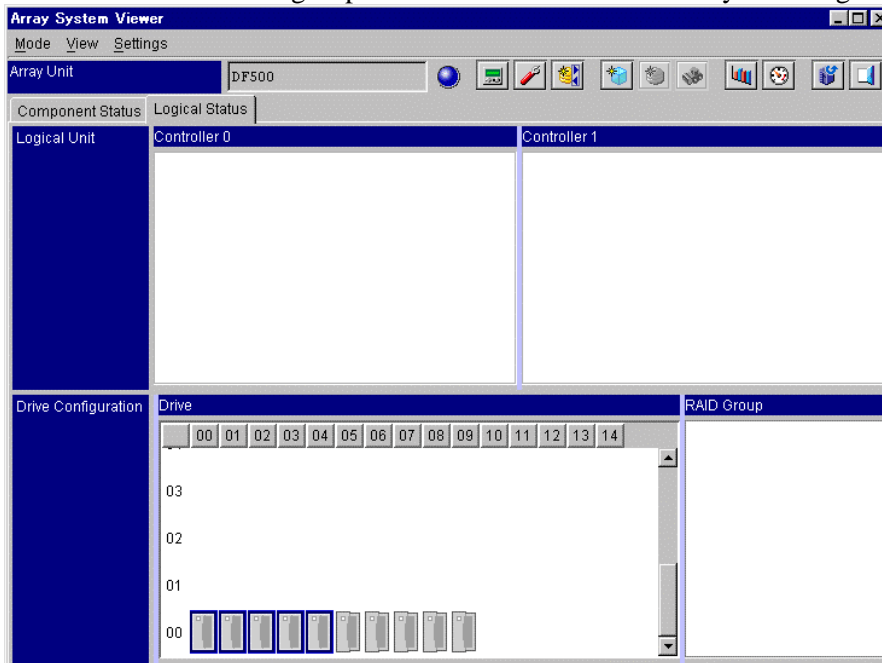

4. Select “**Settings—RAID Group—Settings**” on the Unit screen. Or, when you click the “ : **RAID Group Settings**” in the tool bar.

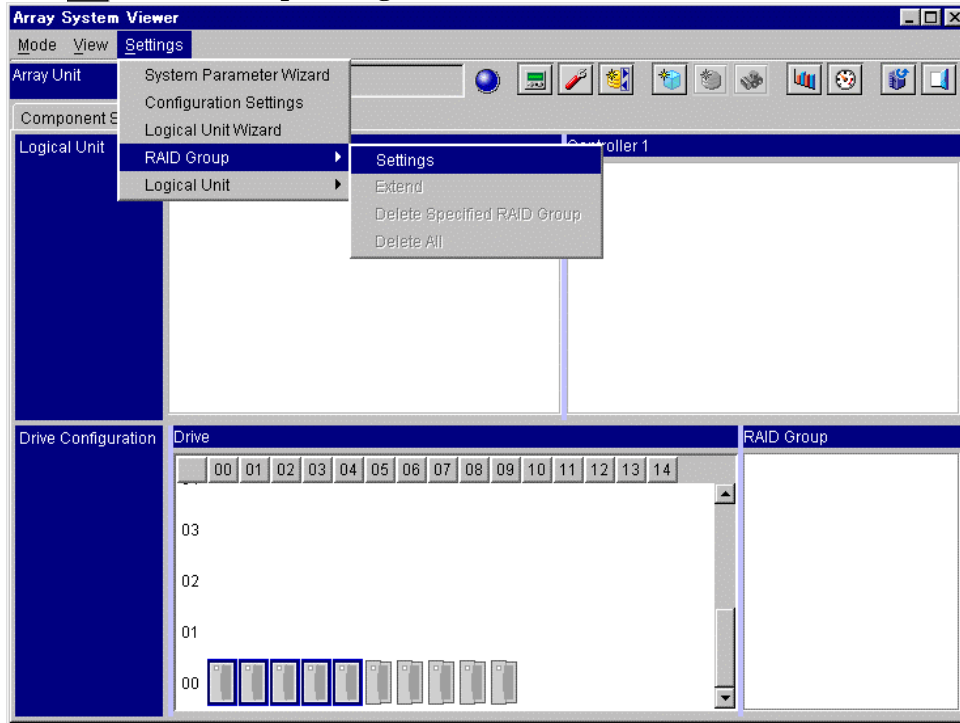

5. Select a RAID level and click the **OK** button.

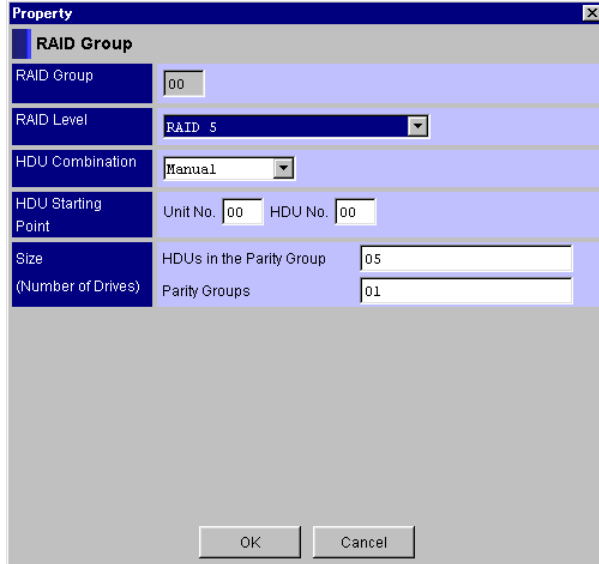

In **RAID Level**, RAID level to be added is set.

In **HDU Configuration**, RAID level configuration to be added is set.

If you select an option other than **Manual** as HDU Configuration, the size is automatically set so as to match with the specified level. If you specify any size optionally, specify **Manual** by the configuration specification.

6. A message indicating completion of setting is displayed, click the **OK** button.

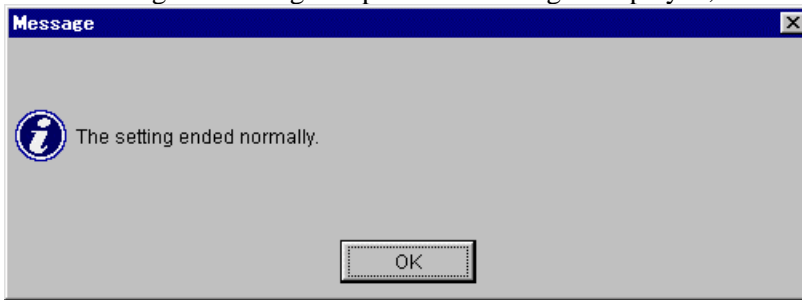

The set RAID group is updated and then the window is displayed.

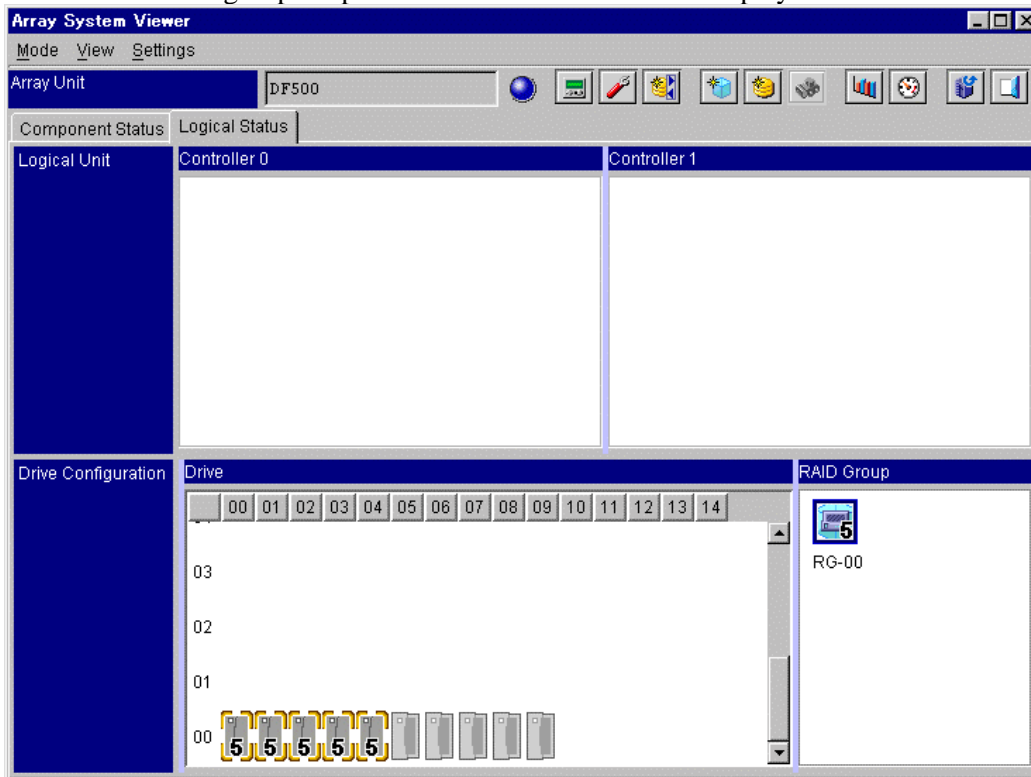

## 4.2 Expanding a RAID group

Expand a set RAID group.

1. Click the **Logical Status** tab on the Unit screen.
2. Click the icon of a RAID group on the Unit screen, and then select “**Settings—RAID Group—Extend**”.

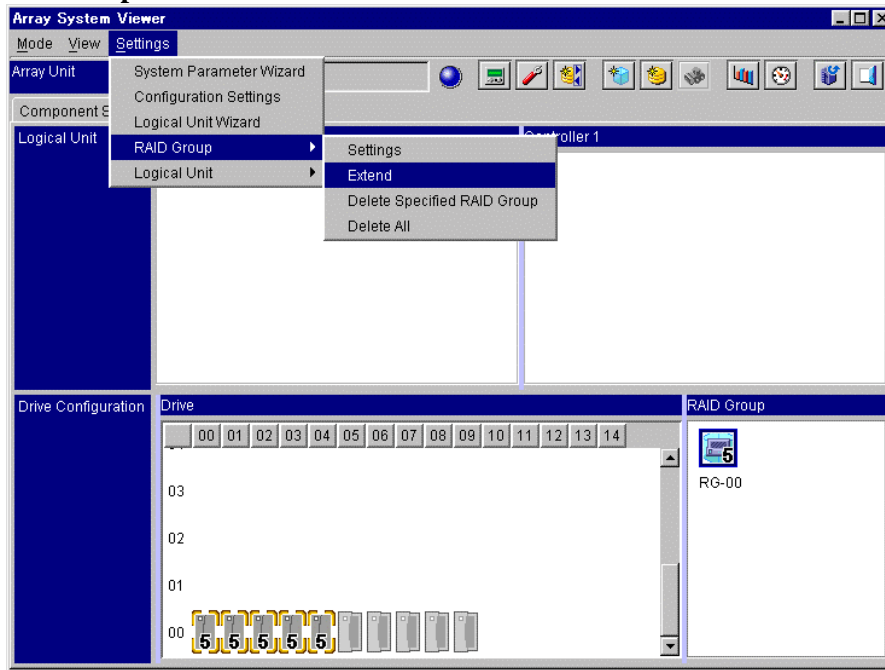

3. Specify the number of parity group after expansion, then click the **OK** button.

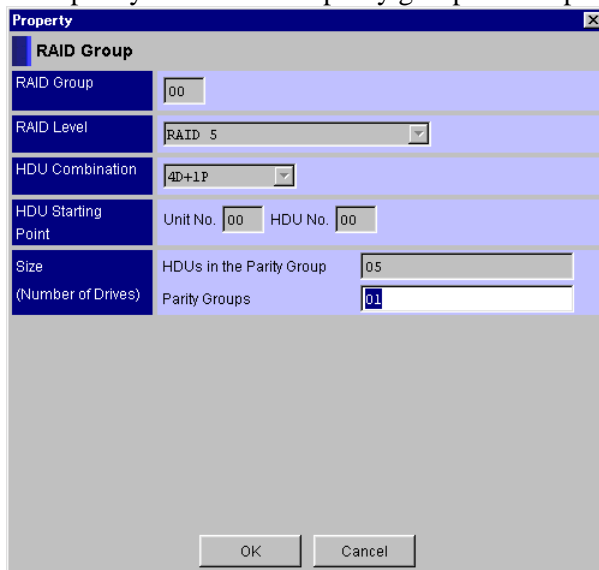

In RAID Level, the RAID level of RAID group to be expanded is displayed. In HDU Starting Point, the position of the RAID group to be expanded is displayed.

4. A message indicating completion of setting is displayed, click the **OK** button.

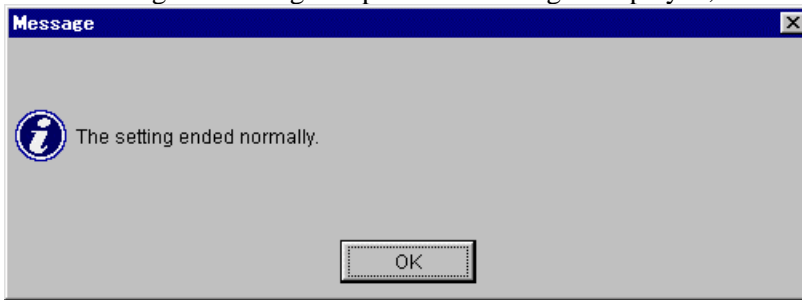

The expanded RAID group is updated and then the window is displayed.

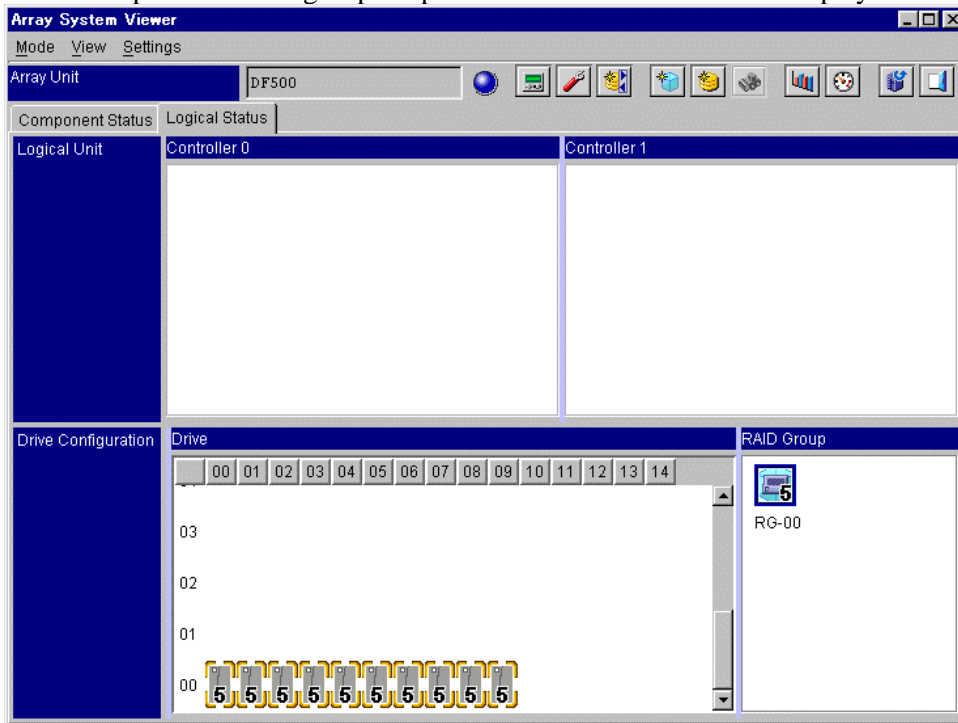

### 4.3 Deleting a specified RAID group

Delete a specified RAID group out of set RAID groups.

1. Click the **Logical Status** tab on the Unit screen.
2. Click the icon of a RAID group on the Unit screen, and then select “**Settings—RAID Group—Delete Specified RAID Group**”.

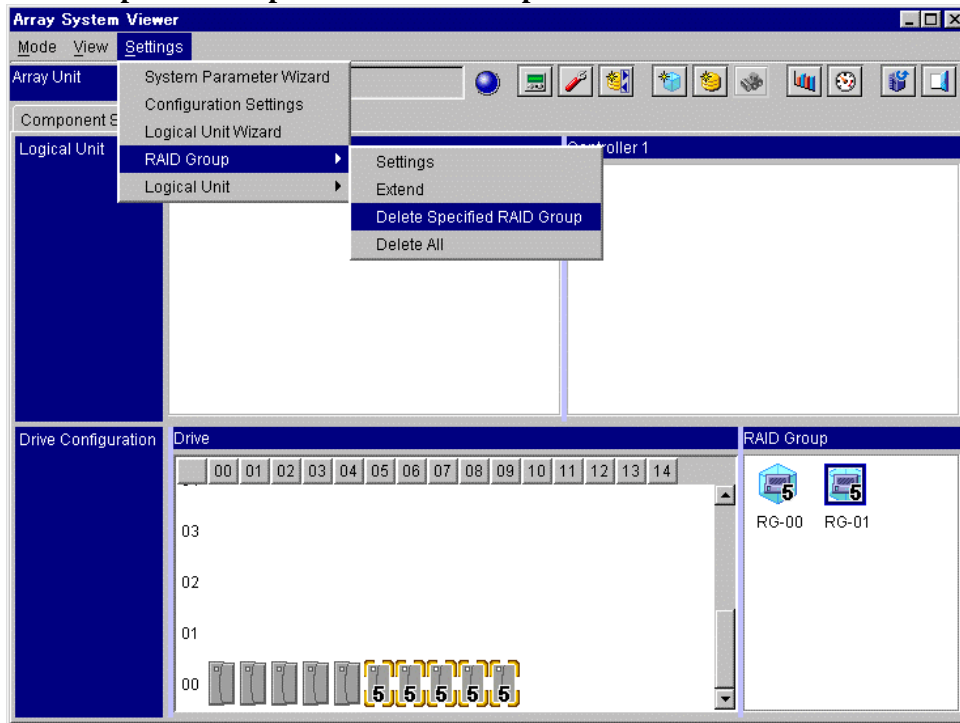

3. When a confirmation message appears, click the **OK** button.



**Note:** If an logical unit is defined in the specified RAID group, this RAID group cannot be deleted. To delete the specified RAID group, first delete all logical units in the specified RAID group, and then perform it.

The expanded RAID group is updated and then the window is displayed.

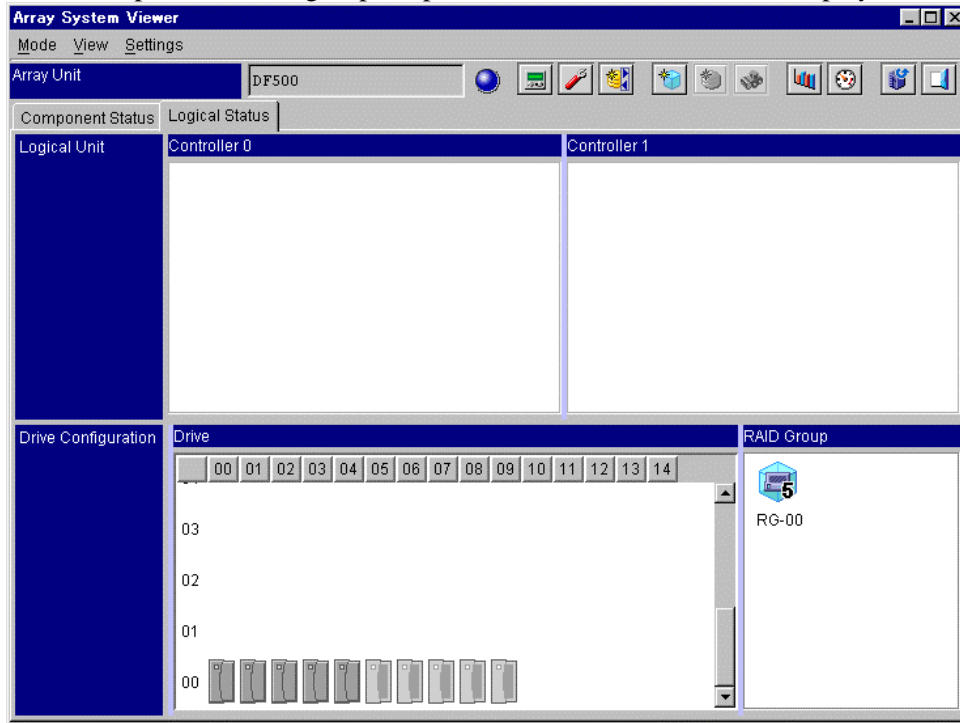

## 4.4 Deleting all RAID groups

Delete all the RAID groups that are set.

1. Click the **Logical Status** tab on the Unit screen.
2. Select “**Settings—RAID Group—Delete All**”.

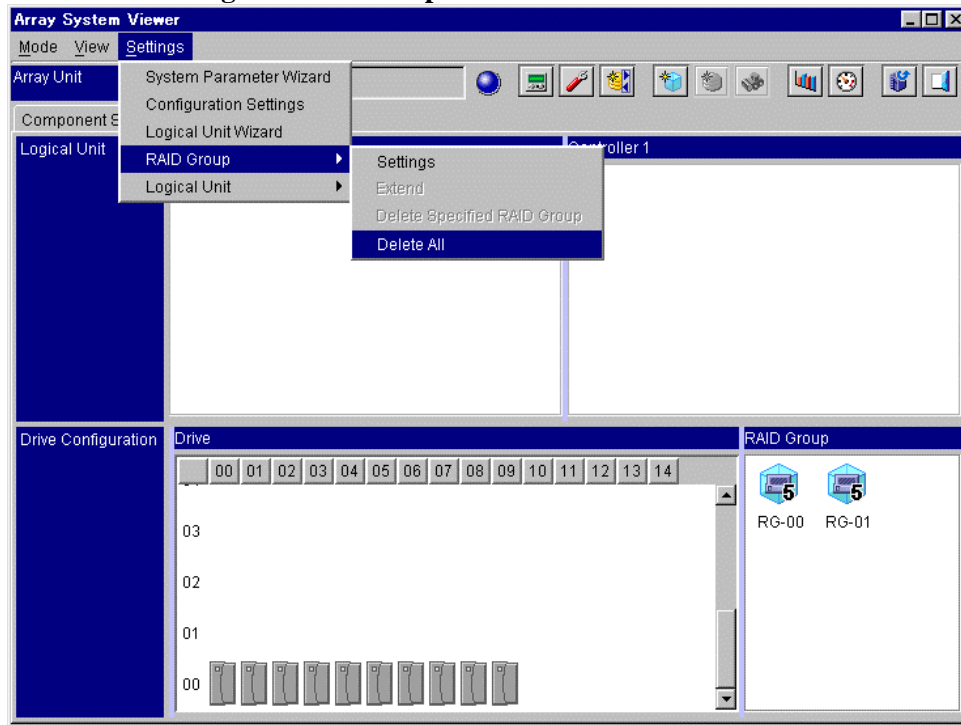

3. When a confirmation message appears, click the **OK** button.

- 1) When there is no formatted LU in the RAID group



- m) When there is any formatted LU in the RAID group

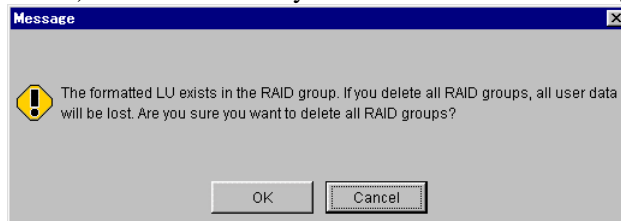

**Note:** If any logical unit is defined in the RAID group, all the user data will be invalidated by deleting the RAID group.

The deleted RAID group is updated and the window is displayed.

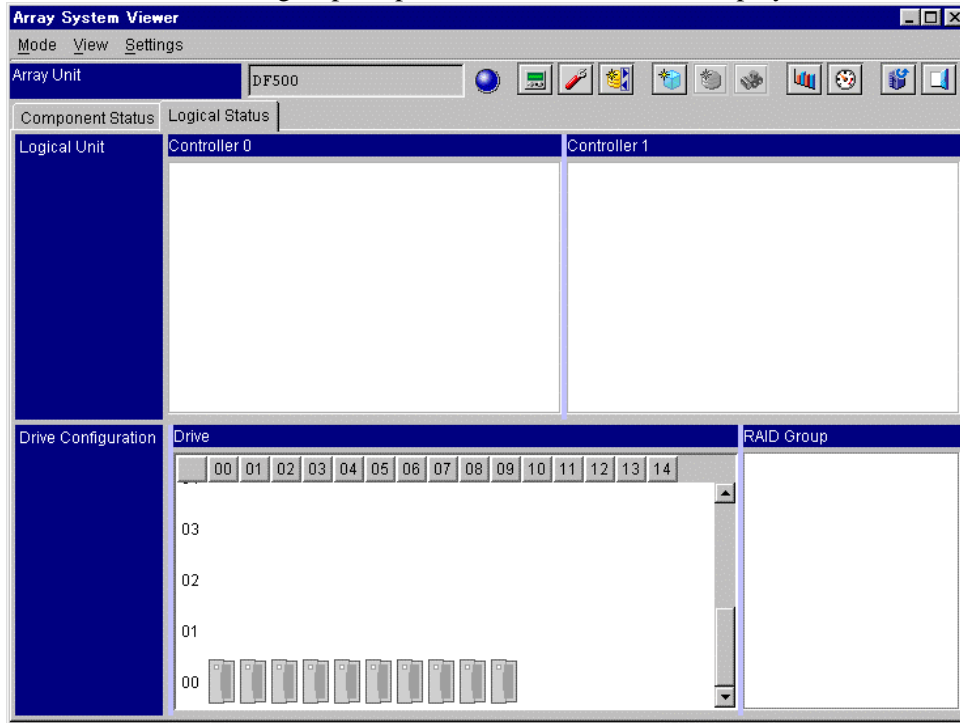

## 4.5 Constituting a logical unit

1. Click the **Logical Status** tab on the Unit screen.
2. Click the icon of a logical unit on the Unit screen, and then select “**Settings—Logical Unit—Settings**”. Or, when you click the “ : **Logical Unit Settings**” in the tool bar.

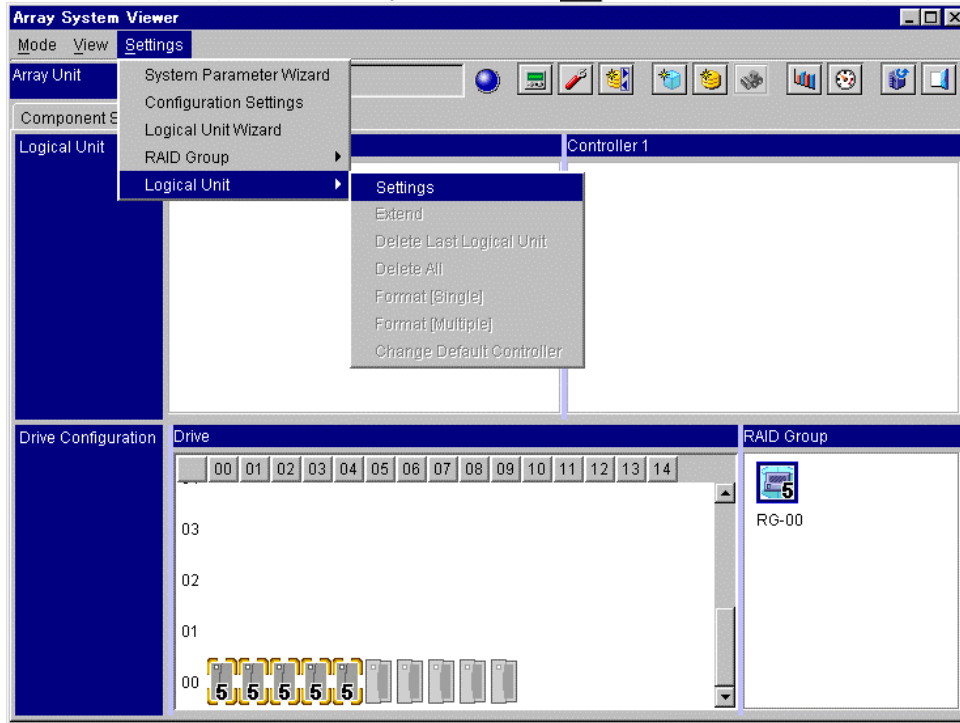

3. Select a controller in charge in **Controller** and input **Size**.

The screenshot shows a 'Property Logical Unit' dialog box. It has several sections: 'Logical Unit No.' with a text box containing '000'; 'Status' with an empty text box; 'Controller' with two sub-sections, 'Default' and 'Current', each containing radio buttons for 'Controller 0' and 'Controller 1'; 'Size' with a text box containing '0' and a label 'Block(s)(1-278757376)', and a slider bar below it ranging from '1Block' to '278757376Block(s)'; and 'RAID Group' with a text box containing '00'. At the bottom are 'OK' and 'Cancel' buttons.

A created logical unit No. is displayed for the **Logical Unit No.**, and a created RAID group No. for the **RAID Group**. In addition, an logical unit capacity that can be created is displayed.

- **Specifying Number of Block Increased**

To specify a value clearly, specify the allocation (number of blocks).

When you allocate all the remaining capacity of the RAID group concerned, specify a capacity (the number of blocks) displayed on the screen.

- Specifying the **controller No.**

Click the option button of **CTL0** or **CTL1** to select the controller in charge of the logical unit. (If you wrongly select a controller, logical unit may unexpectedly switch when it is operating, causing to deteriorate the performance.)

This is a specification necessary in the case of the dual system connection. Accordingly, it is not displayed in the case of the single system connection.

**Note:** When a dual active mode is selected in the dual system, a controller in charge of an logical unit must be selected to setup an logical unit. Perform the logical unit setting including the selection of the controller referring the following drawing. When you change a controller in charge of the logical unit, see “Changing the default controller in charge of an logical unit”.

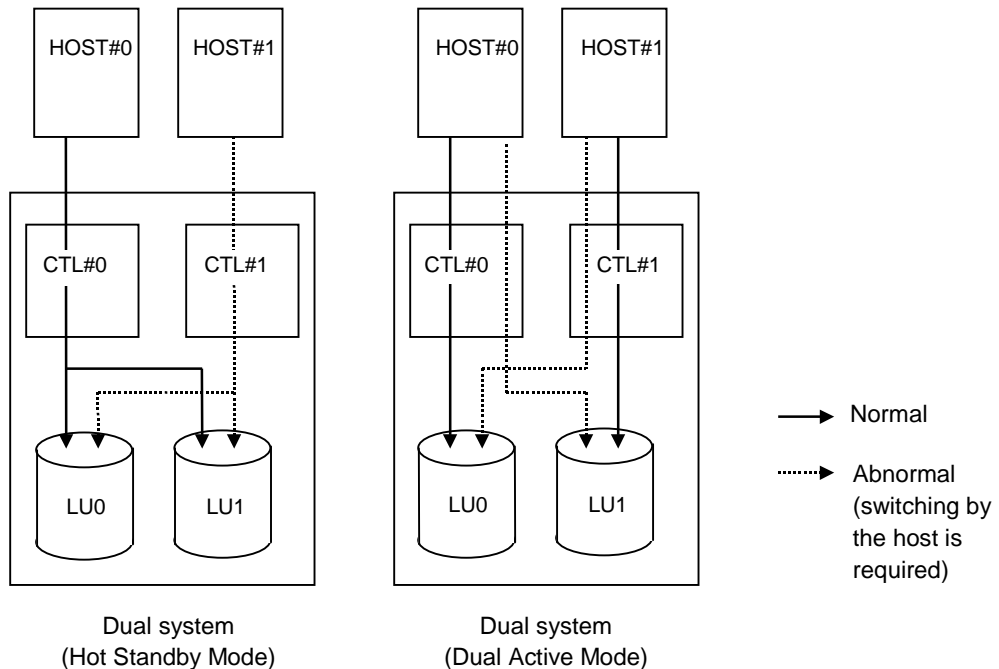

- **Hot Standby Mode:** When a failure in the host or in the controller occurred, process can be continued by switching host command destination to another controller.
- **Dual Active Mode:** Select a controller to access from the host to the logical unit as the controller for the logical unit.

In the above drawing, CTL#0 is in charge of the logical unit0 and CTL#1 is in charge of the logical unit1 respectively. In this example, setup the logical unit selecting an optional button of **CTL#0** to select logical unit0 and **CTL#1** to select logical unit1 respectively.

4. After completion of the setting, click the **OK** button.
5. A message indicating completion of setting is displayed, click the **OK** button.

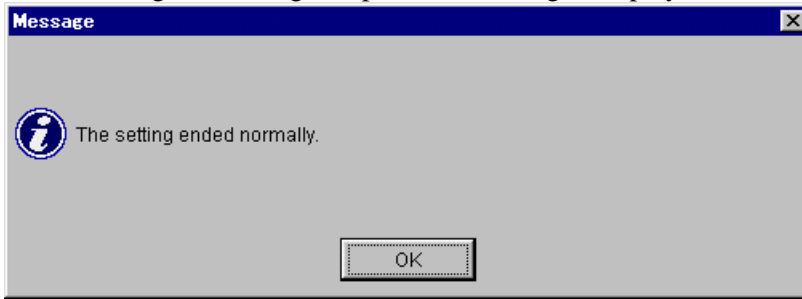

The set logical unit information is updated and the window is displayed.

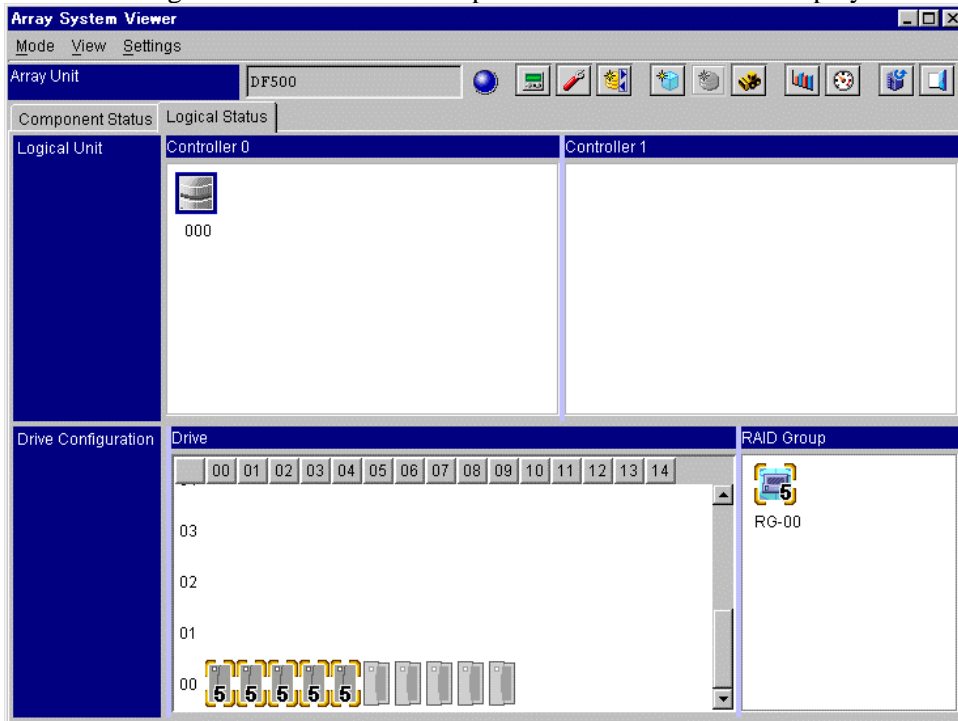

## 4.6 Formatting a logical unit

Format the logical unit.

1. Click the **Logical Status** tab on the Unit screen.

The executing method for formatting includes 2 modes.

- **Format (Single):** Specified logical units are formatted one by one and the progress of the formatting is displayed.
- **Format (Multiple):** If multiple logical units are specified, up to six logical units are formatted concurrently, and the progress of formatting is displayed.  
When the logical units are configured for each drive, the time required for the formatting is reduced by 30 to 50 (%).
  - Configuration example : An array unit configured to form six rows  
Each row is configured as RAID5 and each RAID group is set to one logical unit.

**Note:** When you format an logical unit whose capacity is less than 100,000 blocks, formatting may be terminated abnormally. When you format an logical unit whose capacity is less than 100,000 blocks, select **Format (Single)**.

2. Click the icon of a logical unit on the Unit screen, and then select “**Settings—Logical Unit—Format[Single]**” or “**Settings—Logical Unit—Format[Multiple]**”.

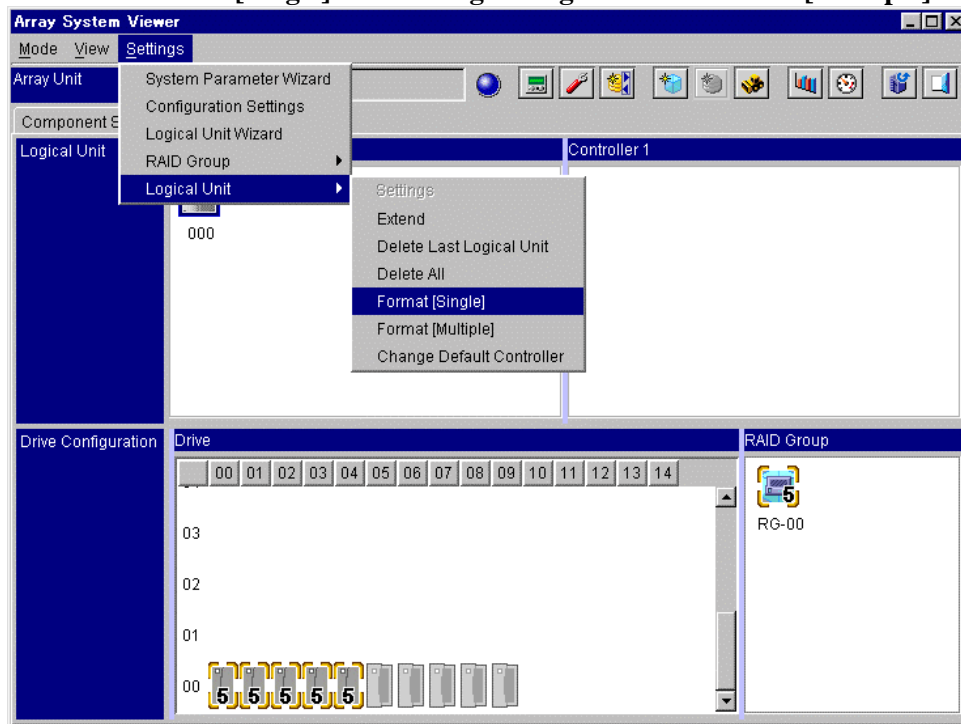

When you select multiple logical units, holding down the **Ctrl** key, clicks the icons of logical units which to format.

The executability of the formatting corresponding to each logical unit formatting menu item varies with the manager 2 connection type and array unit configuration as shown in the following table.

| No. | logical unit formatting mode         | manager 2 connection type and array unit configuration   |  |
|-----|--------------------------------------|--|--|
|     |                                      | Single system<br>Dual system + Both connectors are connected to a LAN:   | Dual system + RS232C connection<br>Dual system + one of the controllers is connected to a LAN:   |
| 1   | Format (Single)                      | The formatting can be executed in the online status.   | The formatting can be executed in the online status.<br>Only the logical unit currently controlled by the controller connected with the PC manager can be selected.<br>(When formatting an logical unit not connected by the controller, cable connections must be changed.)   |
| 2   | Format (Single)<br>Format (Multiple) | The formatting can be executed in the online status.<br><b>Format (Single)</b> is selected.<br>Only one logical unit is selected in <b>Format (Multiple)</b> . | The formatting can be executed in the online status.<br><b>Format (Normal)</b> or <b>Format (Single)</b> is selected and only an logical unit currently controlled by the controller connected with the manager is selected.<br><b>Format (Multiple)</b> is selected and only an logical unit currently controlled by the controller connected with the manager is selected. |
|     |                                      | The formatting cannot be executed in the online status.<br>Two or more logical units are selected in <b>Format (Multiple)</b> .                                | The formatting cannot be executed in the online status.<br>An logical unit not controlled by the controller connected with the manager is selected. Two or more logical units are selected in <b>Format (Multiple)</b> .   |

**Note:** The formatting may be interrupted if a host rebooting, I/O path switching, or an access to the logical unit by the host which is not controlling it occurs while a formatting executable in the online status is executed.

3. A confirmation message appears to confirm whether the selected logical units may be formatted or not.

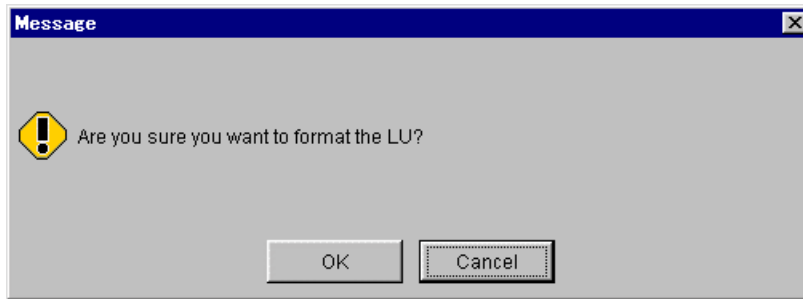

Click the **OK** button to format the specified logical units.

- n) When **Format (Single)** is specified

The logical unit number being formatted of execution progress are displayed for the specified logical unit. The progress status indication is renewed every 10 seconds.

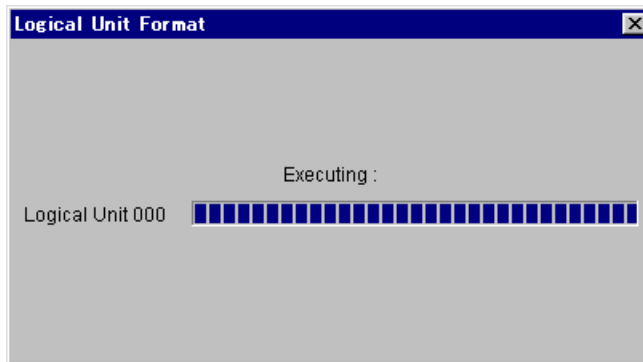

- o) When **Format (Multiple)** is specified

The logical unit number being formatted of the formatting are displayed for the specified logical unit. The progress of the formatting is renewed every 10 seconds.

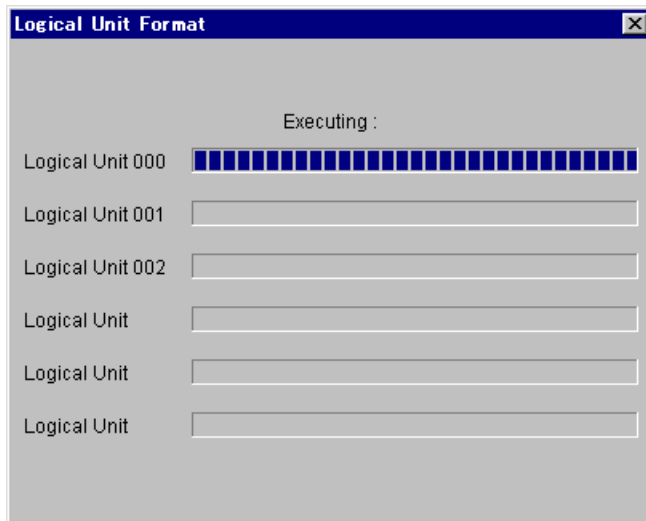

When multiple logical units are specified, up to 6 logical units are formatted in the order starting with the smallest logical unit number and the progress of the formatting is displayed. After one logical unit is formatted, the next logical unit is formatted and the progress of the formatting is displayed.

4. When a message is displayed indicating that the specified logical unit has been formatted, click the **OK** button.

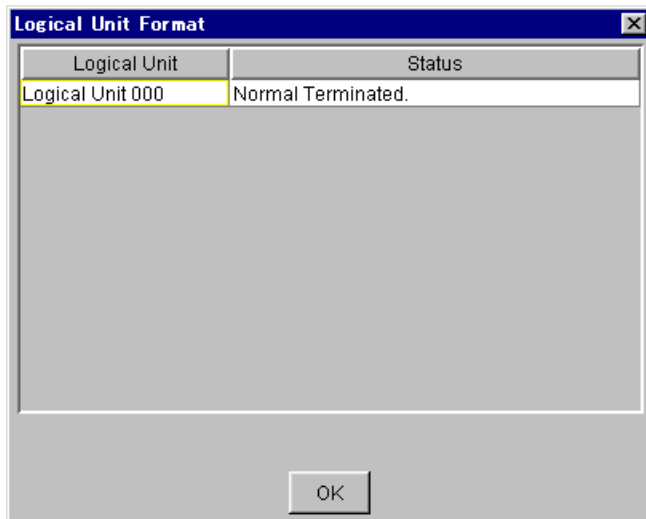

If formatting is terminated abnormally, see the contents of the result.

The formatted logical unit information is updated and then the window is displayed.

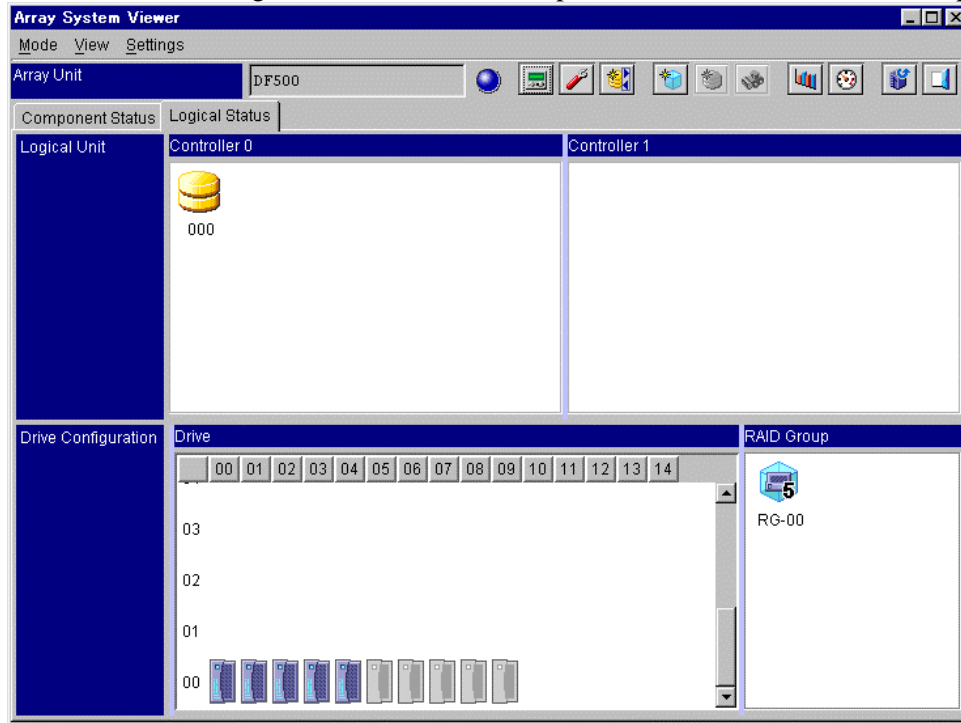

Table 4.6.1 Interpretation of “Logical Unit Format Results” Window

| No. | Result of logical unit formatting                    | “Status” column   |   |
|-----|--|-------------------|---|
| 1   | Succeeded  | Normal Terminated |   |
| 2   | Failed (02-xxxx)<br>Failure of a FORMAT UNIT command | Abnormal end      | # CHK CONDITION<br><br>* This function internally uses a FORMAT UNIT command. A sense key and a sense code for the case the command returns the CHECK CONDITION status are displayed. |
| 3   | Failed<br>The other error                            |                   | A message is displayed.   |

When “Abnormal end” is displayed in the “Status” column, a sense key and a sense code are displayed.

- Sense key - sense code = 02-xxxx, 03-xxxx, 04-xxxx, or 0B-xxxx  
The fault may possibly be caused by a hardware failure. Retry. Call maintenance personnel if the problem persists.
- Sense key - sense code = 05-xxxx  
The error may possibly be caused by a wrong operation. Check the items below and retry. Call maintenance personnel if the problem persists.
  - **Logical unit #0 defined?**  
The related sense-key and sense-code combinations are 05-2500 and 05-2581.
  - **logical unit formatting by ALL RAID and ALL CAPA although not all drives installed?**  
Related sense-key and sense-code combination is 05-2600.
  - **Attempt made to define an logical unit over the capacity of the defined RAID group?**  
Related sense-key and sense-code combination is 05-2580.
- Sense key - sense code = 0B-FD01  
A switching of the controller in charge of the logical unit occurred during a formatting. Check the controller in charge of the logical unit and reexecute the formatting by the controller.
- Message text = See “Messages”.  
A message “Failed in a connection with the Array Unit” issued when selecting **Format (Single)** is caused by an error (an interface error between the manager 2 and array unit) which disables the progress state indication window to be displayed. The logical unit formatting is continued nevertheless.

## 4.7 Expanding a logical unit

1. Click the **Logical Status** tab on the Unit screen.
2. Click the last logical unit in the Unit screen, then select “**Settings—Logical Unit—Extend**”.

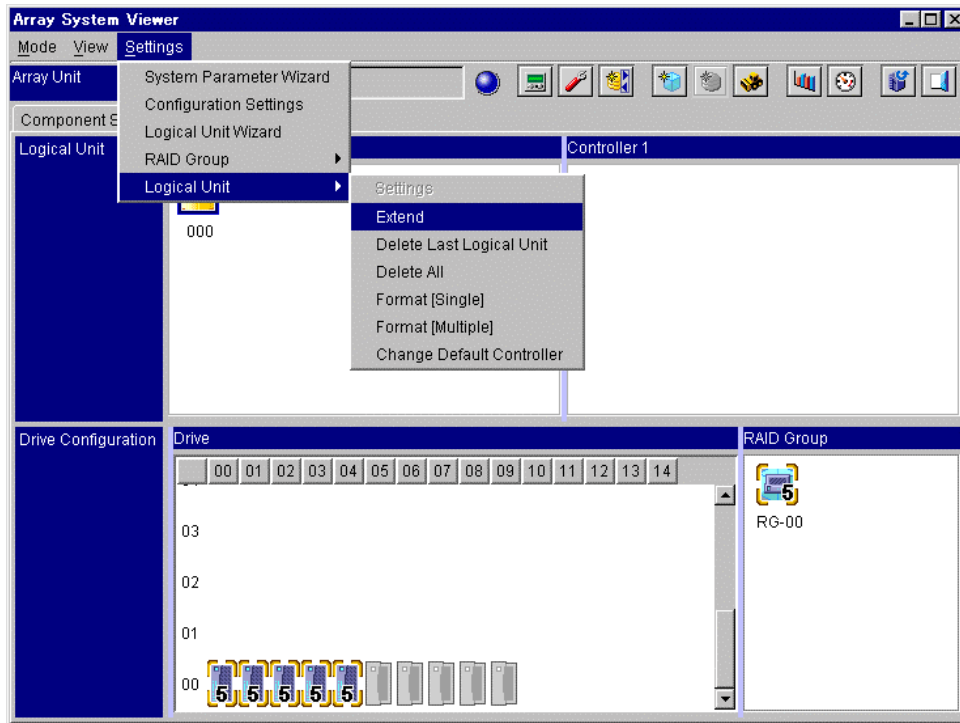

3. Specify the capacity in **Number of Blocks Increased**.

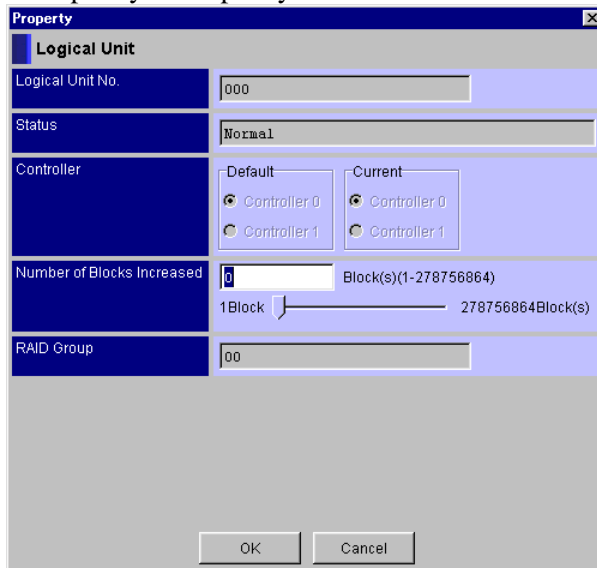

4. After completion of the setting, click the **OK** button.
5. A message indicating completion of setting is displayed, click the **OK** button.

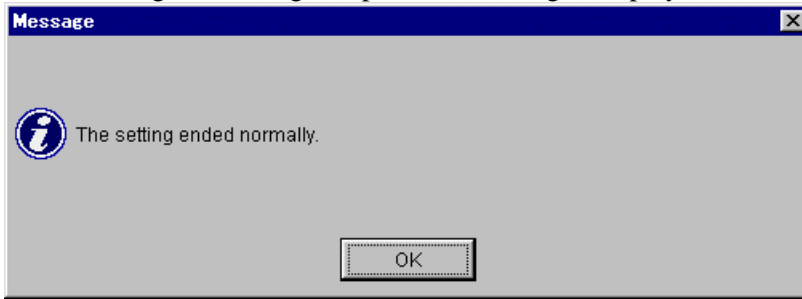

The logical unit information in which the last logical unit has been deleted is updated and the window is displayed.

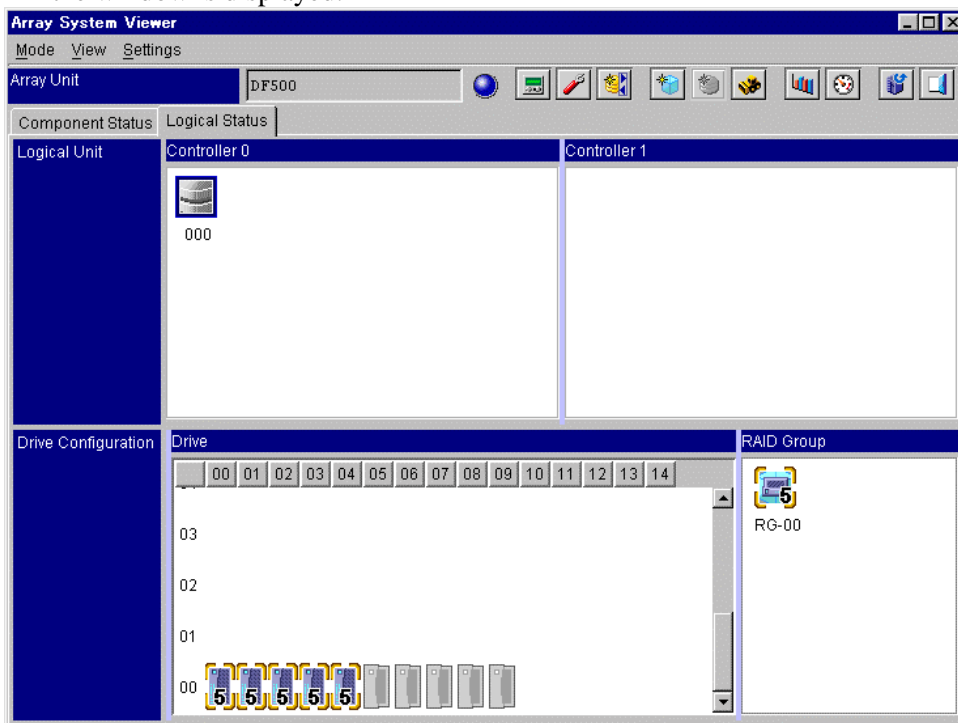

The icons of extended logical units change to a not-yet-formatted icon. Though the displayed icons are a not-yet-formatted icon, data in logical units before extension is usable. Formatting is performed only on an extended size of an area, and then the full-size area after extension becomes available for use.

## 4.8 Deleting the last logical unit

Delete the last logical unit.

1. Click the **Logical Status** tab on the Unit screen.
2. Select “**Settings—Logical Unit—Delete Last Logical Unit**”.

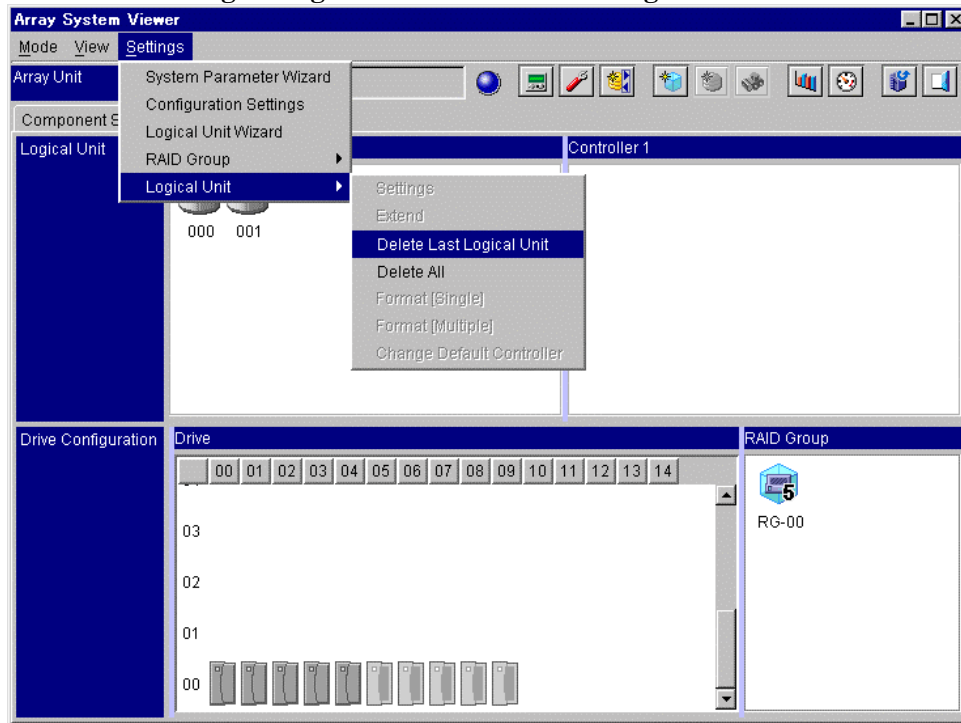

A confirmation message is displayed indicating whether last logical units should be deleted or not.

p) When no formatted logical unit exists

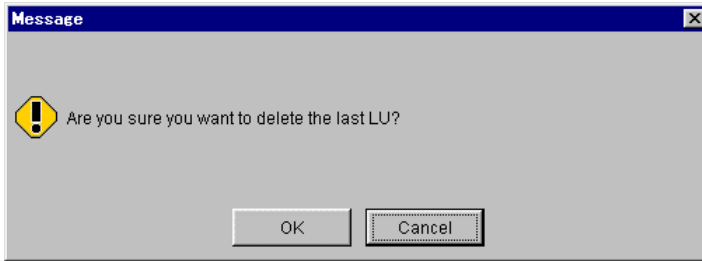

q) When any formatted logical unit exists

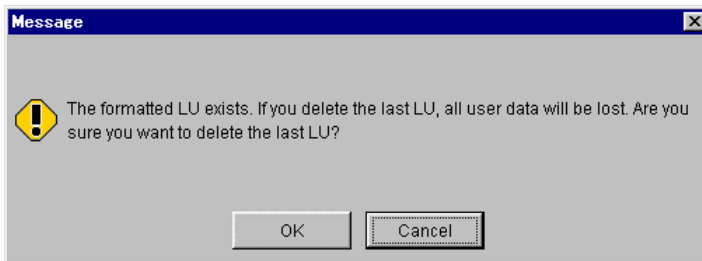

3. Click the **OK** button, and last logical units will be deleted. When the last logical units have been deleted, the user data in the logical units will be lost. The logical unit information in which the last logical unit has been deleted is updated and the window is displayed.

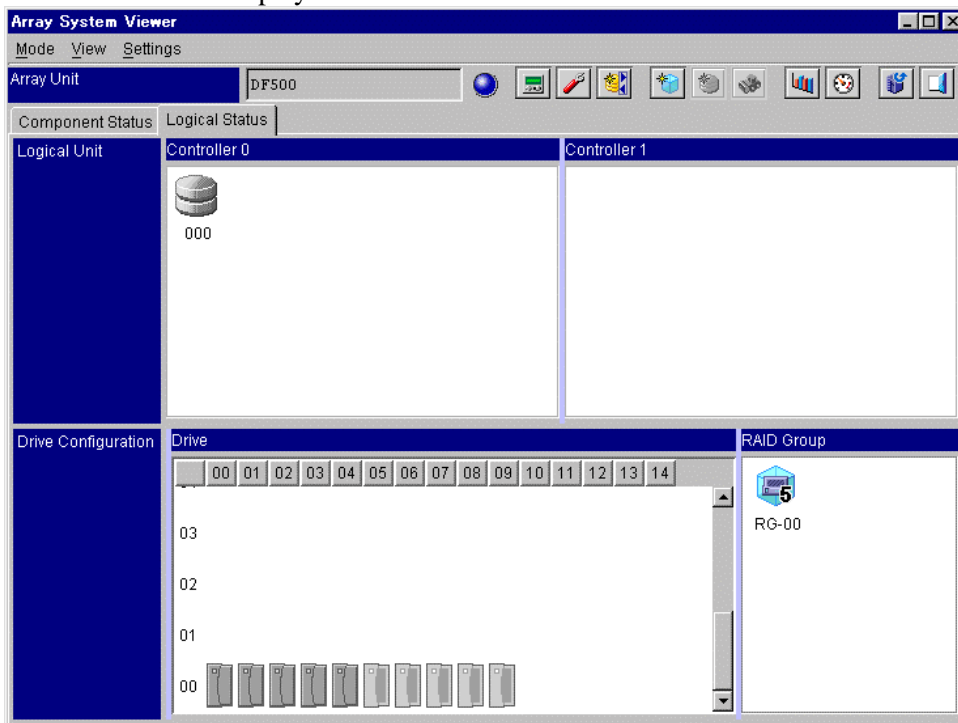

## 4.9 Deleting all logical units

Delete all logical units.

1. Click the **Logical Status** tab on the Unit screen.
2. Select “**Settings—Logical Unit—Delete All**”.

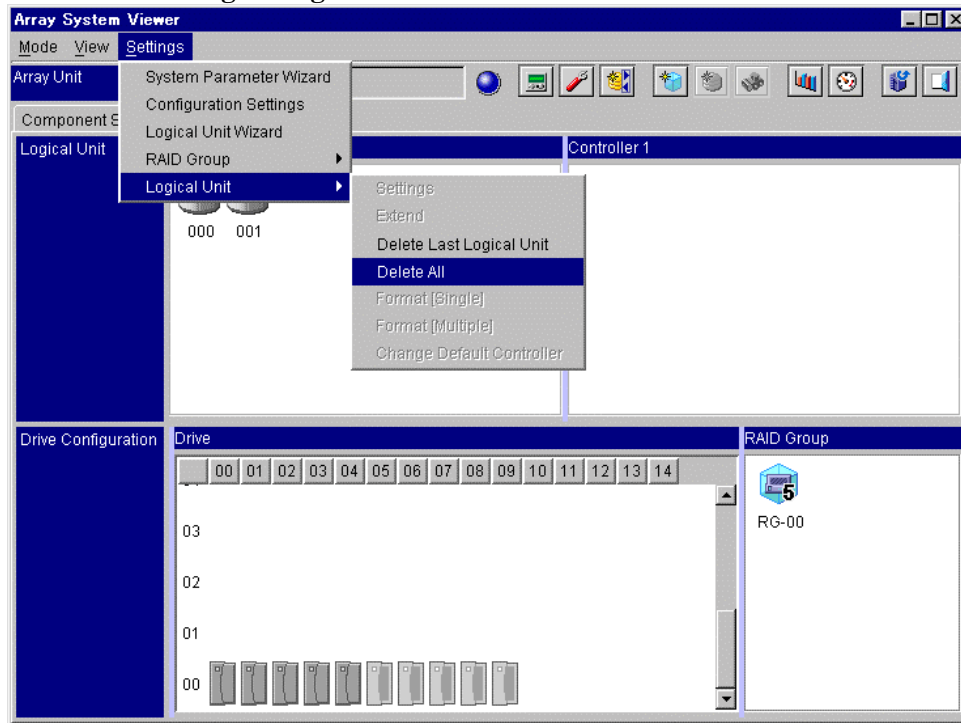

A confirmation message is displayed indicating whether all logical units should be deleted or not.

r) When no formatted logical unit exists

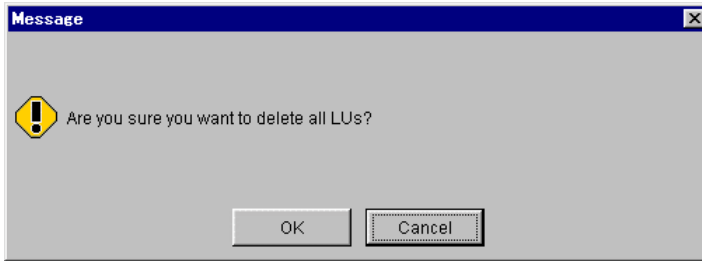

s) When any formatted logical unit exists

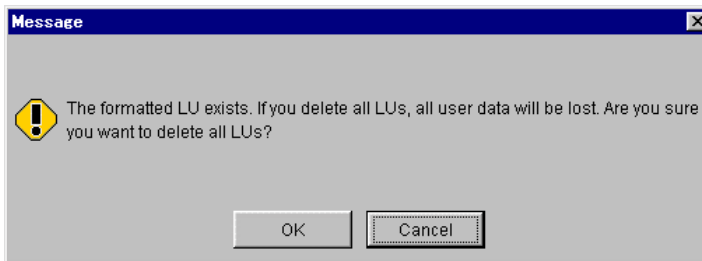

3. Click the **OK** button, and all logical units will be deleted. When all the logical units have been deleted, the user data in the logical units will be lost. The logical unit information in which all the logical units have been deleted is updated and the window is displayed.

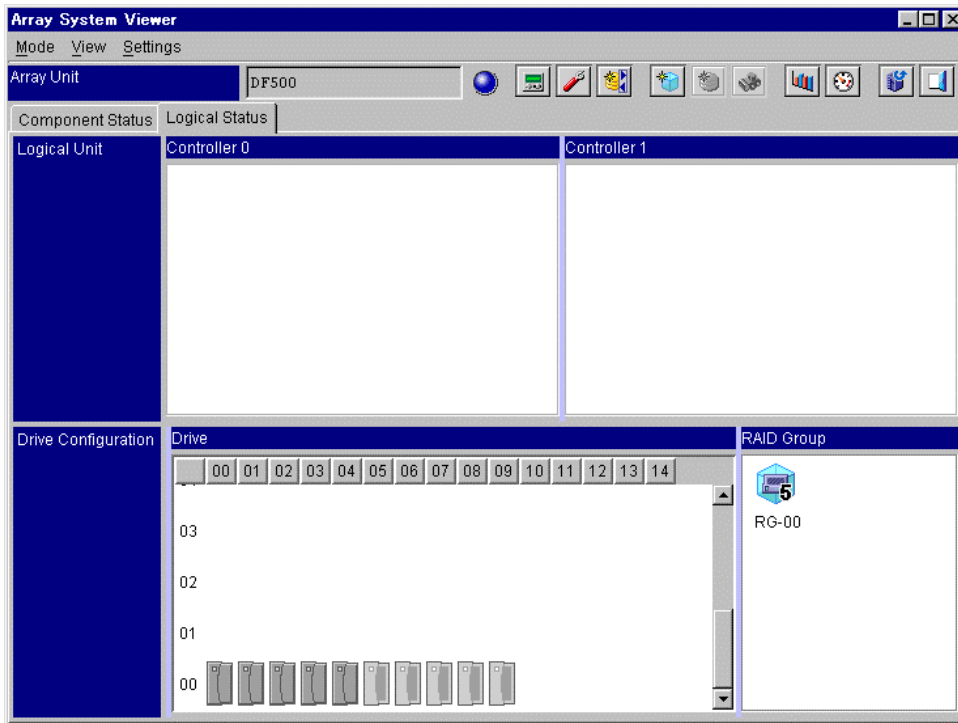

#### 4.10 Changing the default controller in charge of an logical unit

1. Click the **Logical Status** tab on the Unit screen.
2. Click the last logical unit in the Unit screen, then select “**Settings—Logical Unit—Change Default Controller**”.

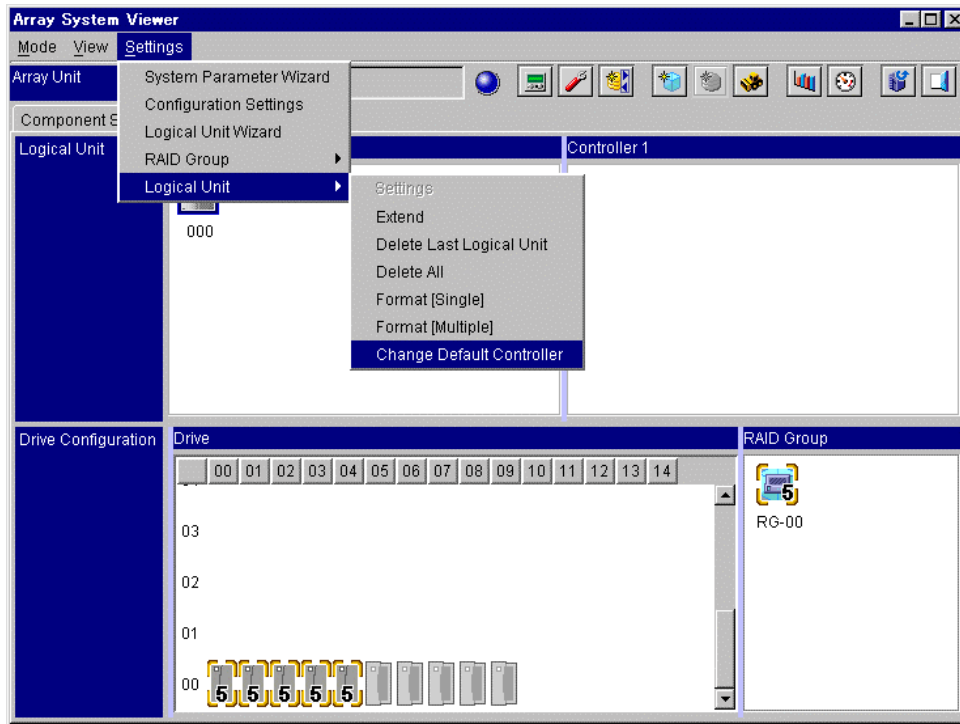

A confirmation message is displayed indicating whether default controller in charge of an logical unit should be changed or not.

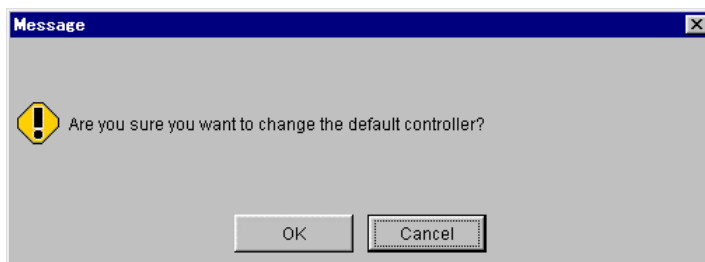

3. Click the **OK** button, and default controller in charge of an logical unit will be changed.
4. A message indicating that the default controller with which an logical unit is connected has been changed. A confirmation message indicating a request for restarting is displayed, so clicks the **OK** button when restarting.



To validate the setup default controller of an logical unit, restart the array unit. The previous setting stays valid until restarting. When restarting is initiated, the array unit is not ready to accept an access from the host for duration from initiation until the restarting terminates. Therefore, after making sure that the host has stopped accessing, initiate restarting.

When instructing to restart an array unit, the time the restarting has began is displayed. The restarting takes about two to six minutes.

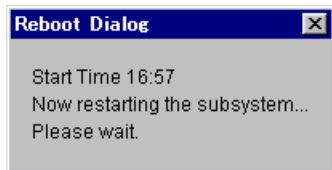

**Note:** It may take time for an array unit to respond, depending on the condition of the array unit. If it does not still respond after 10 minutes or more pass, check the condition of the array unit.

5. A message indicating that the restarting has terminated is displayed, so clicks the **OK** button.

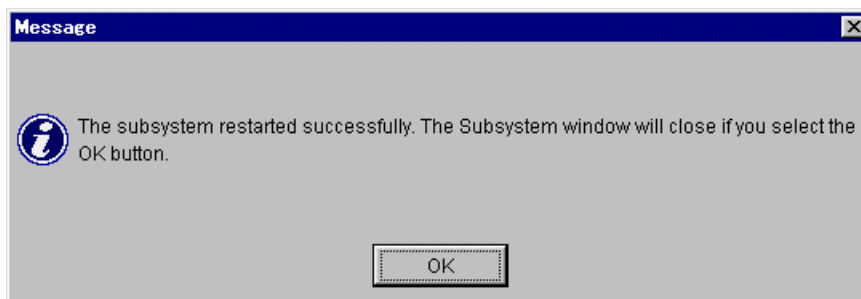

When clicking the **OK** button, the unit screen is closed. To perform other operations, select again on the main screen an array unit which to operate, and open the unit screen.

When not restarting, logical unit information, in which the default controller of an logical unit has been changed, is displayed on the screen after being updated.

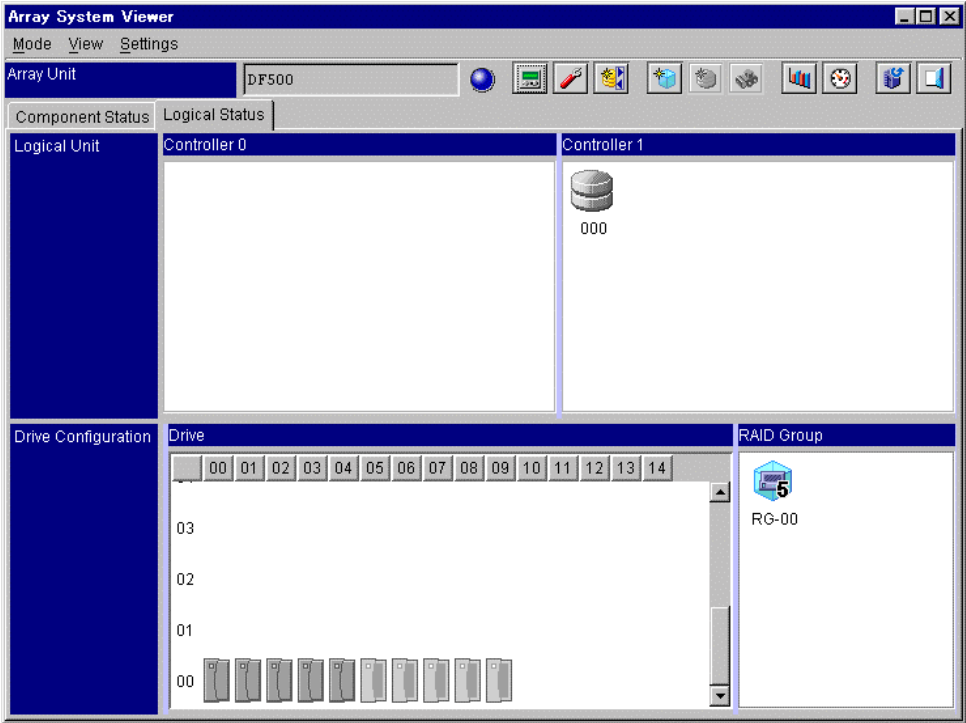

**Note:** Execution of a switching of the default controller controlling the logical unit changes the default controller currently displayed. When the switching is continuously executed twice, the specified controller is changed to the original default controller controlling the logical unit.

## 4.11 Logical unit Wizard

Set the logical unit in the wizard format.

- If you set up a logical unit in an existing RAID group
  1. Click the **Logical Status** tab on the Unit screen.
  2. Select “**Settings—Logical Unit Wizard**”. Or, when you click the “ : **Logical Unit Wizard**” in the tool bar.

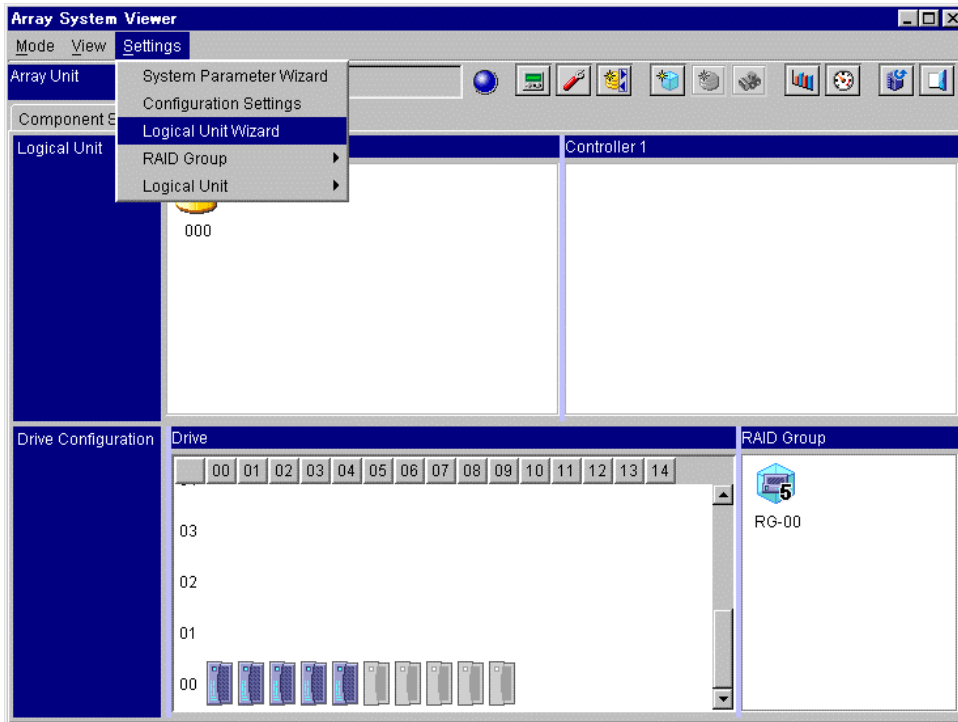

3. When a **Create Logical Unit Wizard** appears, click the **Next** button.

4. Specify the RAID group.

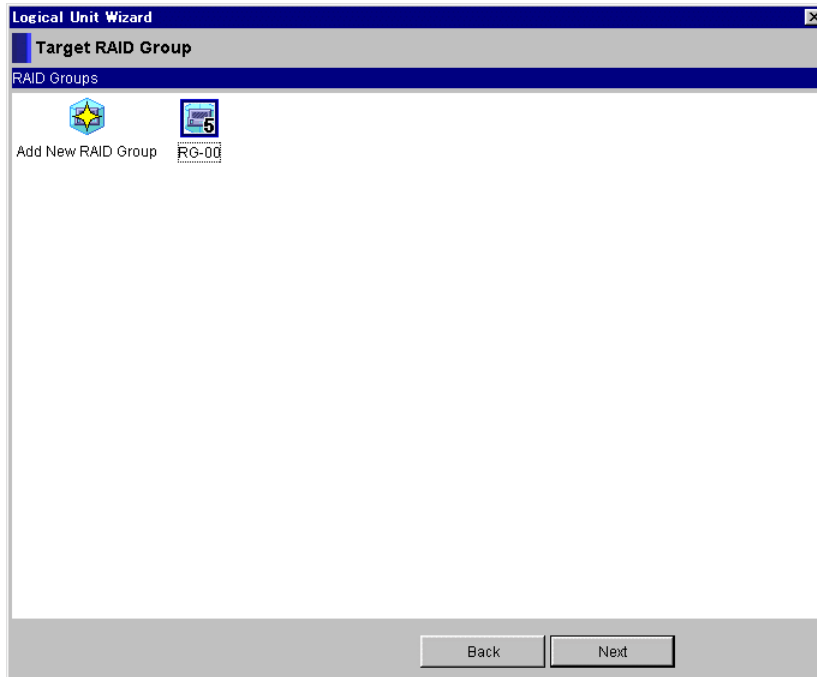

5. Click the **Next** button.

6. Select a controller in charge in **Controller** and input **Size**.

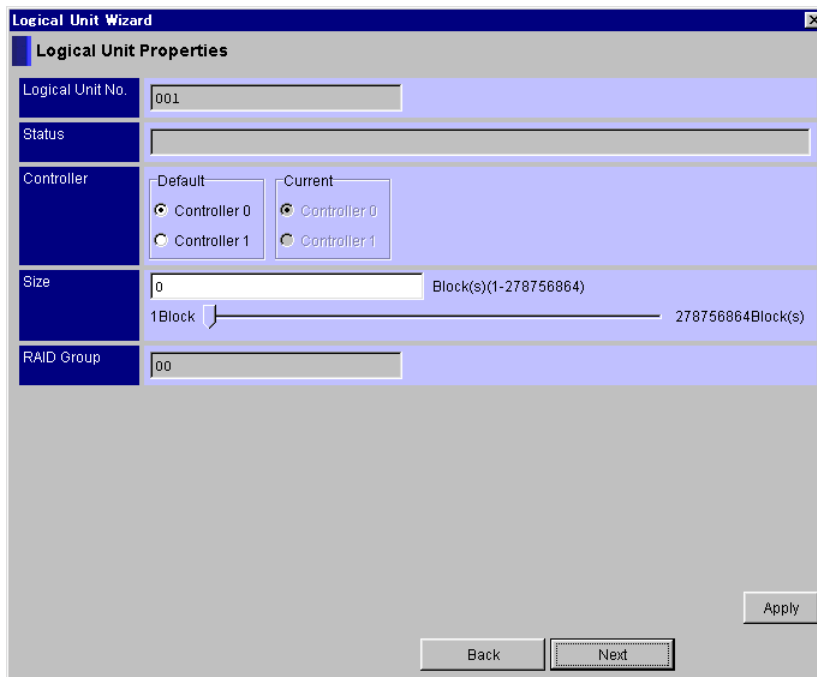

7. Click the **Apply** button.  
If not clicked the **Apply** button, the logical unit is not created.
8. A message indicating completion of setting is displayed, click the **OK** button.

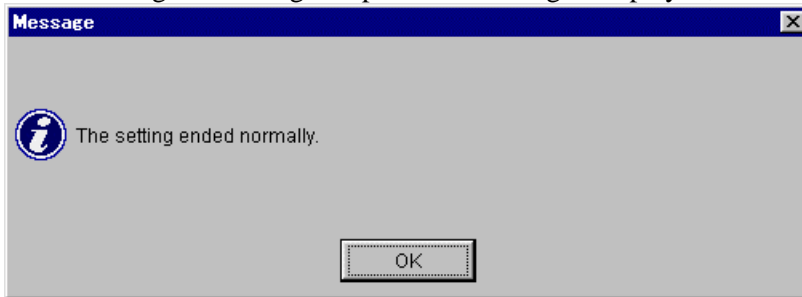

9. Click the **Next** button.
10. The setting of a set-up logical unit is displayed, so you check the setting. If you format a set-up logical unit, specify the logical unit to format, and then click the **Format** button. Further, if you set up another logical unit in the same RAID group, click **Add Logical Unit**. In addition, if you set up a logical unit in another RAID group, click the **Back** button. When you are finished setting up, click the **Complete** button.

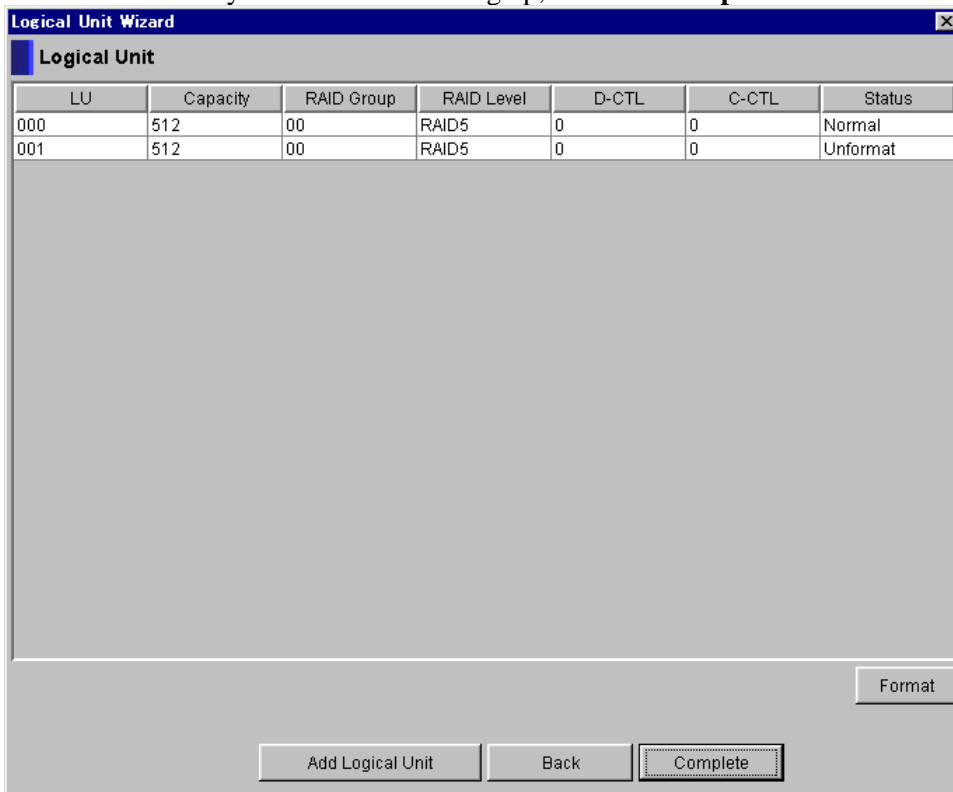

11. When a **Create Logical Unit Wizard** appears, click the **OK** button.

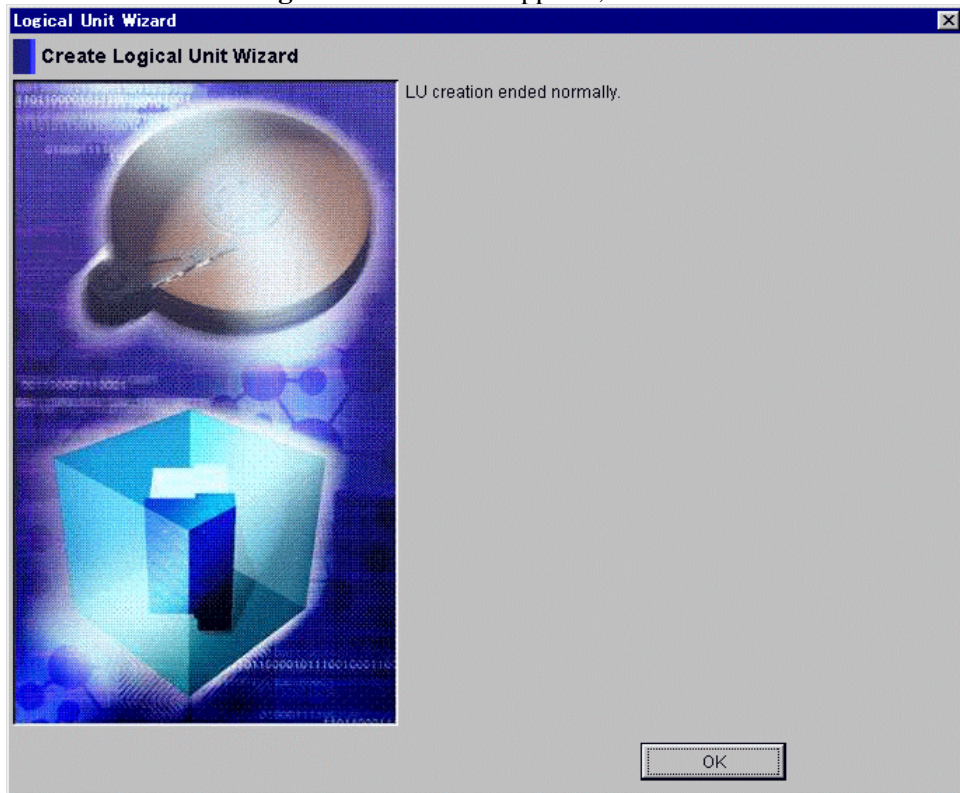

The set logical unit information is updated and the window is displayed.

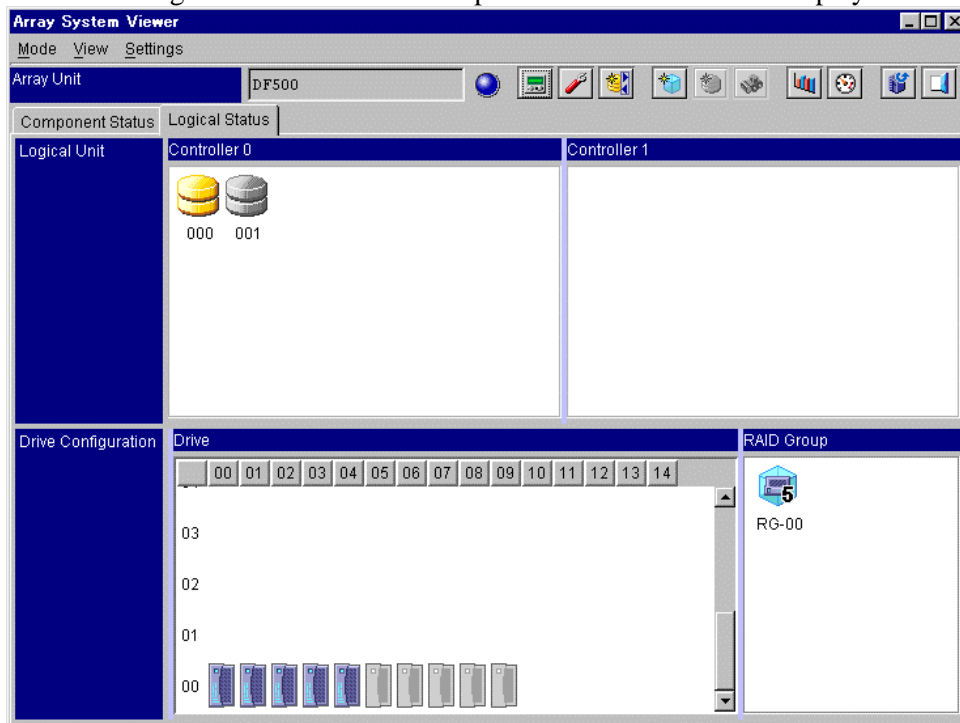

- If you create a new RAID group and set u logical units
  1. Click the **Logical Status** tab on the Unit screen.
  2. Select “**Settings—Logical Unit Wizard**”. Or, when you click the “ : **Logical Unit Wizard**” in the tool bar.

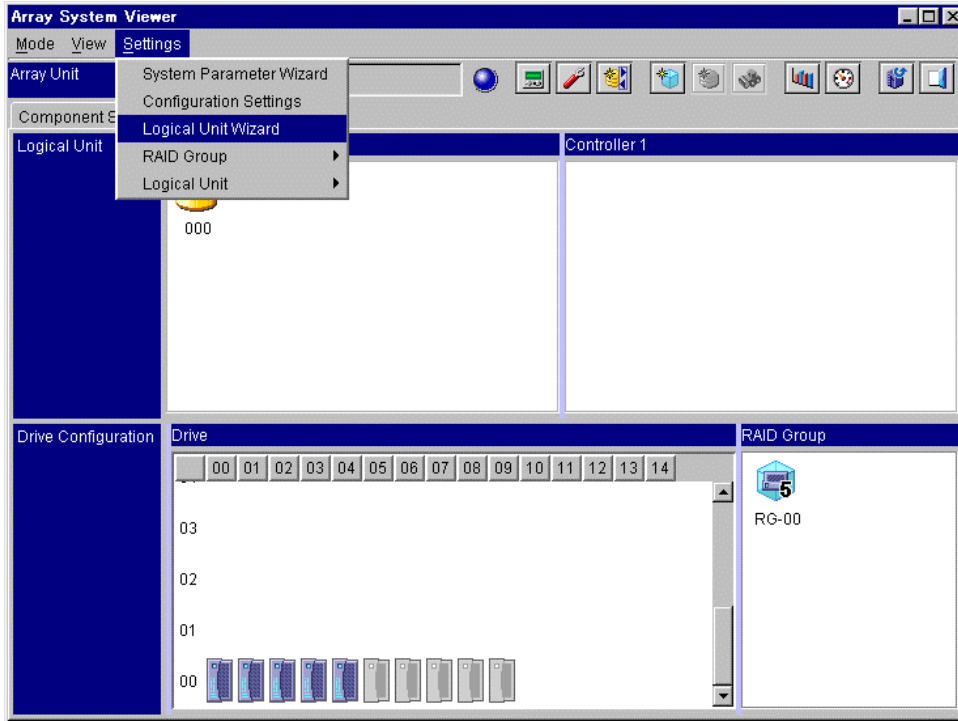

3. When a **Create Logical Unit Wizard** appears, click the **Next** button.

4. Specify the **Add New RAID Group**, click the **Next** button.

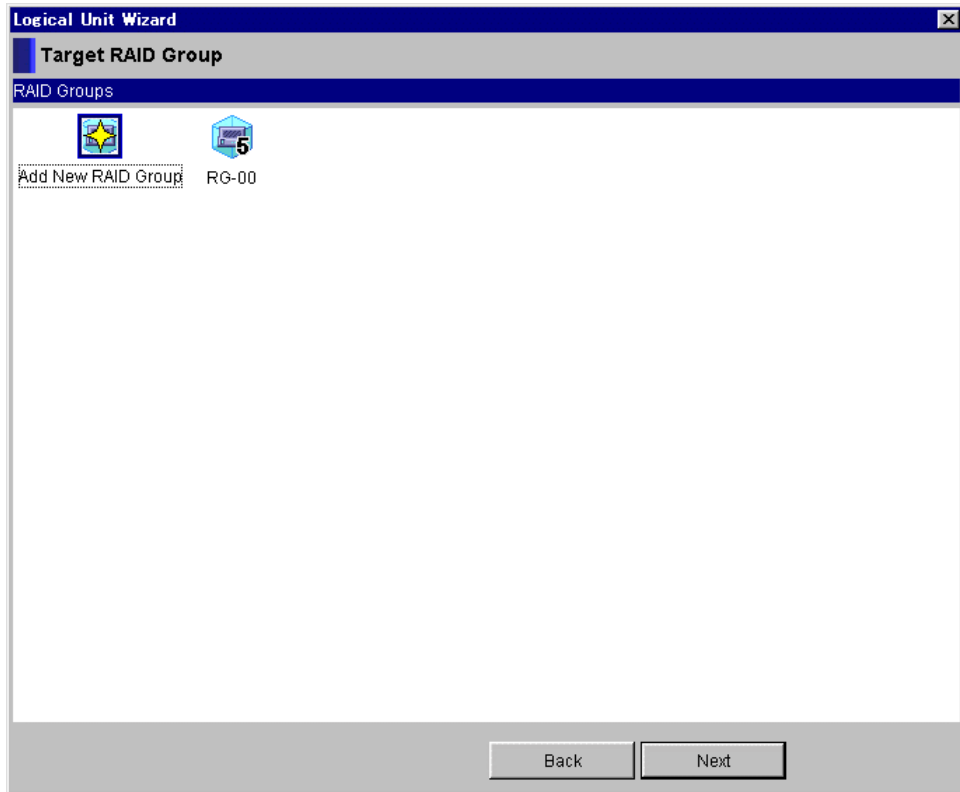

5. Specify the RAID group, click the **Next** button.

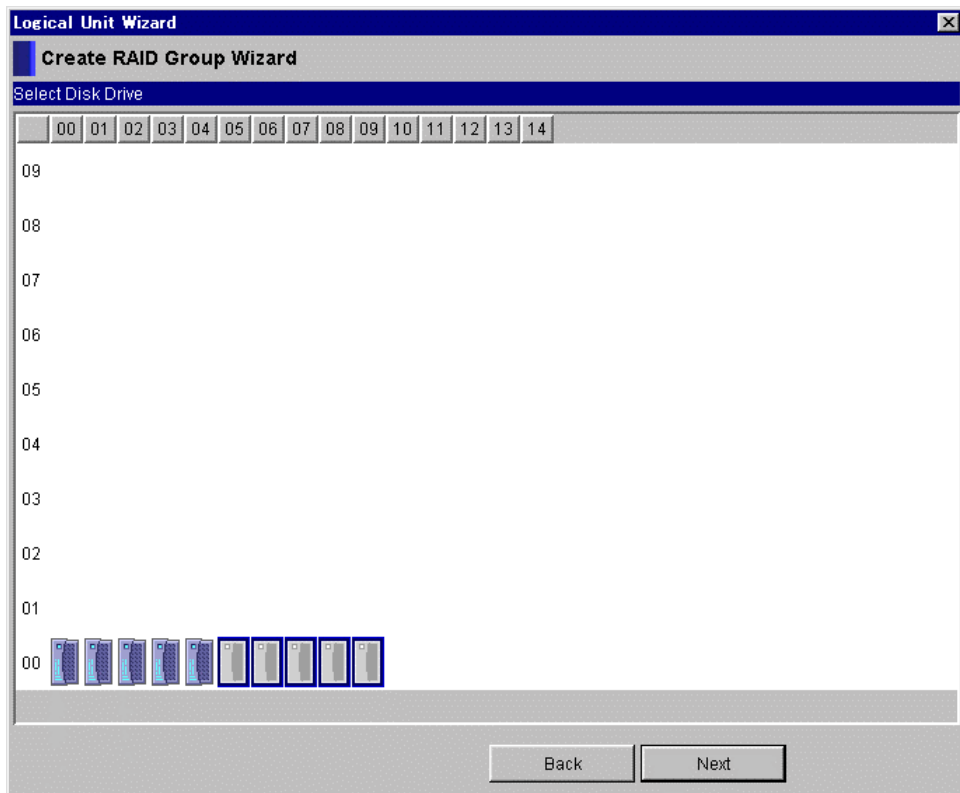

6. Specify the **RAID Level**, click the **Next** button.

The screenshot shows the 'Logical Unit Wizard' window with the 'Create RAID Group Wizard' tab selected. The fields are as follows:

|                         |                          |            |
|-------------------------|--------------------------|------------|
| RAID Group              | 01                       |            |
| RAID Level              | RAID 5                   |            |
| HDU Combination         | Manual                   |            |
| HDU Starting Point      | Unit No. 00              | HDU No. 05 |
| Size (Number of Drives) | HDUs in the Parity Group | 05         |
|                         | Parity Groups            | 01         |

Buttons: Back, Next

7. Select a controller in charge in **Controller** and input **Size**.

The screenshot shows the 'Logical Unit Wizard' window with the 'Logical Unit Properties' tab selected. The fields are as follows:

|                  |   |  |
|------------------|---|--|
| Logical Unit No. | 001   |  |
| Status           |   |  |
| Controller       | Default: Controller 0 (selected), Controller 1              | Current: Controller 0 (selected), Controller 1 |
| Size             | 0 Block(s)(1-278757376)<br>1Block  -----  278757376Block(s) |  |
| RAID Group       | 01  |  |

Buttons: Apply, Back, Next

8. Click the **Apply** button.
9. A message indicating completion of setting is displayed, click the **OK** button.

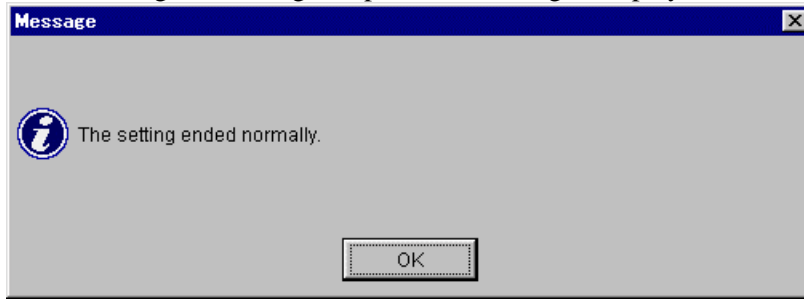

10. Click the **Next** button.
11. The setting of a set-up logical unit is displayed, so you check the setting. If you format a set-up logical unit, specify the logical unit to format, and then click the **Format** button. Further, if you set up another logical unit in the same RAID group, click **Add Logical Unit**. In addition, if you set up a logical unit in another RAID group, click the **Back** button. When you are finished setting up, click the **Complete** button.

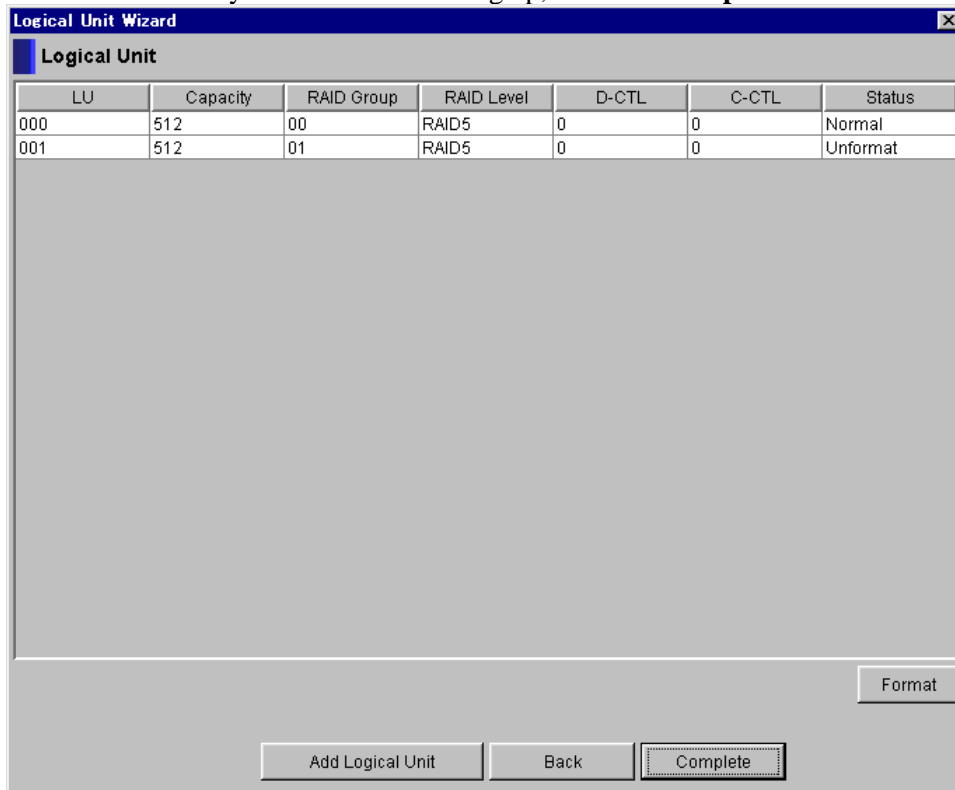

12. When a **Create Logical Unit Wizard** appears, click the **OK** button.

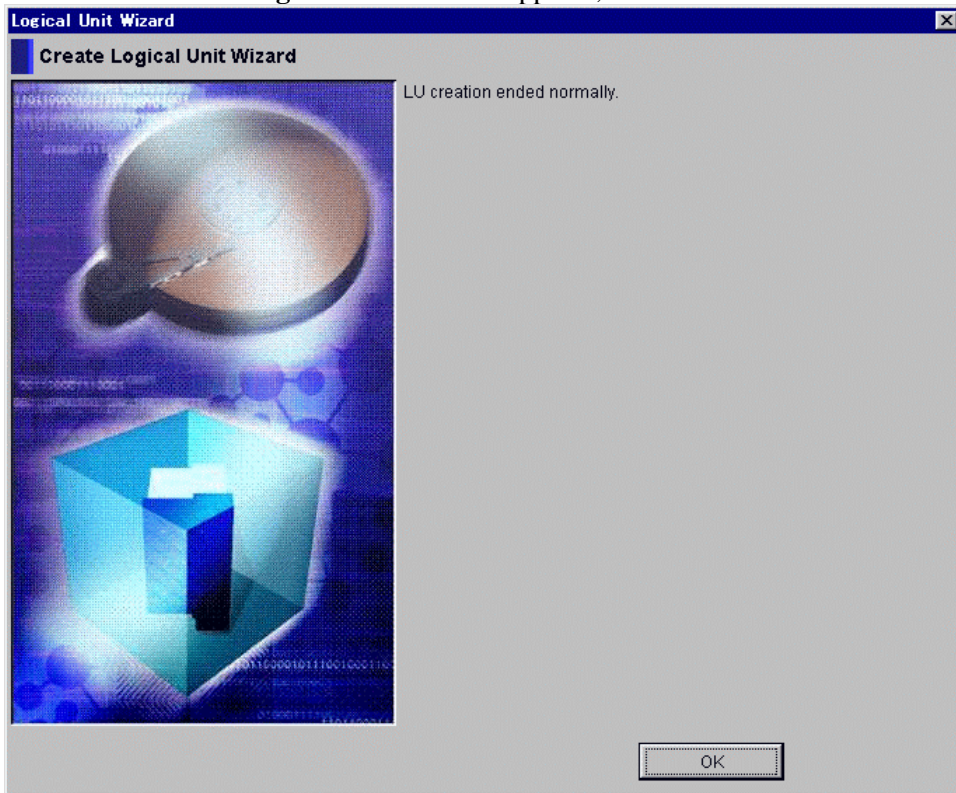

The set logical unit information is updated and the window is displayed.

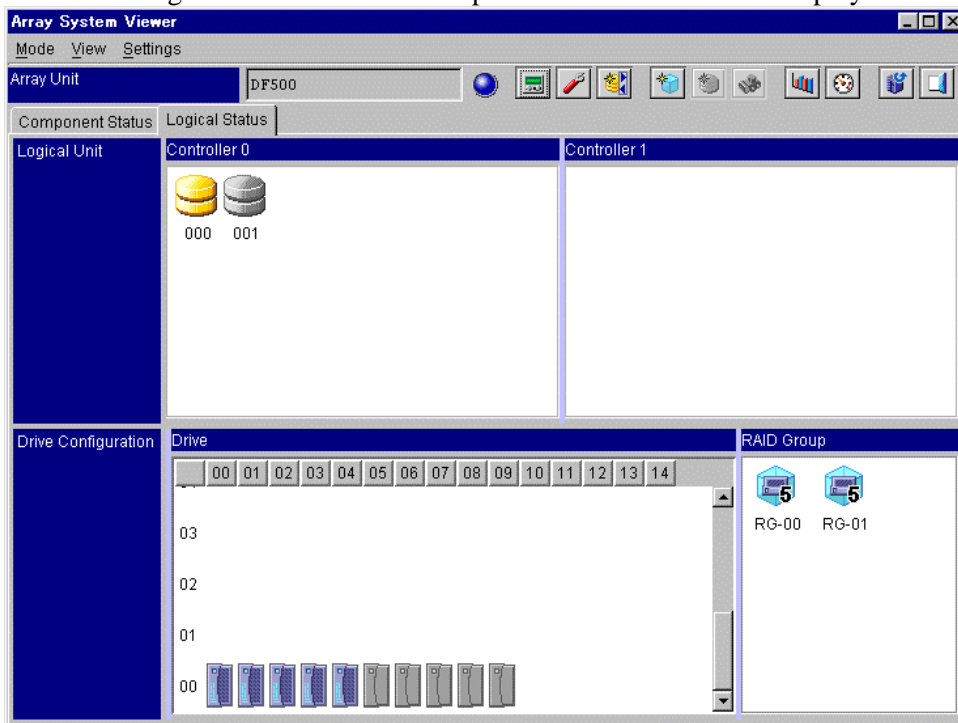

# Chapter 5 System Parameters Setting Wizard

## 5.1 Setting system parameters

Set the system parameters of the array unit in the wizard format.

When connected to the dual system, if the controller on one side is blocked, no setting can be made. Before starting operation, make sure that the array unit is not in a warning status.

When setting the dual system in the RS232C connection, be sure to set the controller 0 side first.

When the system parameter is set, the array unit cannot execute any command from the host. After this, the functions of the manager 2 can no longer work, except the wizard for setting system parameters and error monitoring. After the setting is completed, restart the array unit, make sure that the array unit has been started up, and then connect it to the host and the manager 2.

1. Select “**Settings—System Parameter Wizard**” on the Unit screen. Or, when you click the “ : **System Parameter Wizard**” in the tool bar.
2. Click the **Basic Settings** or **Detailed Settings**, click the **Next** button.



- **Basic Settings** can set the basic parameters for use of the array unit.
  - **Detailed Settings** can set the detailed parameters for use of the array unit.
- When you select **Basic Settings**, you can go on to set the **Detailed Settings** items as well.

The parameters are displayed in 18 screens in wizard form. As for the items shown in each screen, the parameters vary according to of the type of array unit that is connected. The correspondence of the parameters in each screen with array units is shown in Table 5.1.1 and 5.1.2.

Table 5.1.1 List of supported parameters at the Basic Settings

| Screen No.                        | Screen name             | Setting item                      | SCSI                     | Fibre                    |
|-----------------------------------|-------------------------|-----------------------------------|--------------------------|--------------------------|
| 1                                 | System Startup Settings | Start Attribute                   | <input type="radio"/>    | <input type="radio"/>    |
|                                   |                         | SCSI ID/Port ID Take-over Mode    | <input type="radio"/>    | <input type="radio"/>    |
|                                   |                         | Default Controller                | <input type="radio"/>    | <input type="radio"/>    |
|                                   |                         | Data Share Mode                   | <input type="radio"/>    | <input type="radio"/>    |
|                                   |                         | Host Connection Mode              | <input type="radio"/>    | <input type="radio"/>    |
|                                   |                         | Host Connection Mode 1            | <input type="radio"/>    | <input type="radio"/>    |
|                                   |                         | Standard Mode                     | <input type="radio"/>    | <input type="radio"/>    |
|                                   |                         | Open VMS Mode                     | <input type="radio"/>    | <input type="radio"/>    |
|                                   |                         | TRESPASS Mode                     | <input type="radio"/>    | <input type="radio"/>    |
|                                   |                         | Wolfpack Mode                     | <input type="radio"/>    | <input type="radio"/>    |
|                                   |                         | IBM7135 I/O path switch Mode      | <input type="radio"/>    | <input type="checkbox"/> |
|                                   |                         | NCR I/O path switch Mode          | <input type="radio"/>    | <input type="checkbox"/> |
|                                   |                         | Host Connection Mode 2            | <input type="radio"/>    | <input type="radio"/>    |
|                                   |                         | VxVM DMP Mode                     | <input type="radio"/>    | <input type="radio"/>    |
|                                   |                         | ODE Mapper Mode                   | <input type="radio"/>    | <input type="checkbox"/> |
|                                   |                         | HP Connection Mode                | <input type="checkbox"/> | <input type="radio"/>    |
|                                   |                         | Report inquiry page 83H           | <input type="radio"/>    | <input type="radio"/>    |
|                                   |                         | UA (06/2A00) suppress Mode        | <input type="radio"/>    | <input type="radio"/>    |
|                                   |                         | HISUP Mode                        | <input type="radio"/>    | <input type="radio"/>    |
|                                   |                         | CCHS Mode                         | <input type="radio"/>    | <input type="radio"/>    |
| Standard INQUIRY data expand Mode | <input type="radio"/>   | <input type="radio"/>             |                          |                          |
| Product ID DF400 Mode             | <input type="radio"/>   | <input type="radio"/>             |                          |                          |
| Serial Number                     | <input type="radio"/>   | <input type="radio"/>             |                          |                          |
| 2                                 | Option 1                | SCSI/Fibre-Channel Common Options | <input type="radio"/>    | <input type="radio"/>    |
|                                   |                         | Drive Detach Mode                 | <input type="radio"/>    | <input type="radio"/>    |
|                                   |                         | SCSI Option                       | <input type="radio"/>    | <input type="checkbox"/> |
|                                   |                         | Fibre-Channel Options             | <input type="checkbox"/> | <input type="radio"/>    |

Table 5.1.1 List of supported parameters at the Basic Settings (Continued)

| Screen No. | Screen name | Setting item                      | SCSI | Fibre |
|------------|-------------|-----------------------------------|------|-------|
| 3          | Option 2    | SCSI/Fibre-Channel Common Options | ○    | ○     |
|            |             | Multipath (Controller)            | ○    | ○     |
|            |             | PROCOM Mode                       | ○    | ○     |
|            |             | Report Status (Normal/Warning)    | ○    | ○     |
|            |             | Multipath (Array Unit)            | ○    | ○     |
|            |             | Turbo LU Warning                  | ○    | ○     |
| 4          | Target ID   | Target ID                         | ○    | ○     |

Table 5.1.2 List of supported parameters at the Detailed Settings

| Screen No. | Screen name     | Setting item                                 | SCSI | Fibre |
|------------|-----------------|--|------|-------|
| 5          | Data Striping   | Data Striping Size                           | ○    | ○     |
|            |                 | Logical Unit size to be reported to the host | ○    | ×     |
|            |                 | Operation if the processor failure occurs    | ○    | ○     |
| 6          | INQUIRY Setting | Command Queuing                              | ○    | ○     |
|            |                 | ANSI Version                                 | ○    | ×     |
|            |                 | Vendor ID                                    | ○    | ○     |
|            |                 | Product ID                                   | ○    | ○     |
|            |                 | ROM Microprogram Version                     | ○    | ○     |
|            |                 | RAM Microprogram Version                     | ○    | ○     |
|            |                 | Web Title                                    | ○    | ○     |
|            |                 | Cache Mode                                   | ○    | ○     |
|            |                 | Host Connection Mode                         | ×    | ○     |
| 7          | Port Type       | Reset/LIP Mode                               | ○    | ○     |
|            |                 | Reset/LIP Mode (Signal)                      | ○    | ○     |
|            |                 | Reset/LIP Mode (Process)                     | ○    | ○     |
|            |                 | Reset ALL LIP Port Mode                      | ×    | ○     |
|            |                 | Reset Target (Reset Bus Device) Mode         | ○    | ○     |
|            |                 | Reserve Mode                                 | ○    | ○     |
|            |                 | Reset Logical Unit Mode                      | ×    | ○     |
|            |                 | Reset Logout of Third Party Process Mode     | ×    | ○     |

Table 5.1.2 List of supported parameters at the Detailed Settings (Continued)

| Screen No. | Screen name       | Setting item                           | SCSI | Fibre |
|------------|-------------------|--|------|-------|
| 8          | ROM Response      | ROM Pseudo-response command processing | ○    | ×     |
|            |                   | Save Data pointer response             | ○    | ×     |
| 9          | Controller Option | Controller Identifier                  | ○    | ○     |
|            |                   | RS232C Error Information Outflow Mode  | ○    | ○     |
|            |                   | Execute Write & Verify Mode            | ○    | ○     |
| 10         | LAN Setting       | DHCP                                   | ○    | ○     |
|            |                   | Network                                | ○    | ○     |
| 11         | SCSI              | Port                                   | ○    | ×     |
|            |                   | Board Type                             | ○    | ×     |
|            |                   | Transfer Rate                          | ○    | ×     |
| 12         | RTC Setting       | Setting                                | ○    | ○     |
|            |                   | Date                                   | ○    | ○     |
|            |                   | Time                                   | ○    | ○     |

Items required to be set when the array unit is used in the special mode are shown below. Setting items not shown below are to be set according to the environment in which they are used.

t) When the I/O path switching function is used in the Sequent NUMA-Q connection

| No. | Setting item                      | Set value                  | No. of windows displayed |
|-----|-----------------------------------|----------------------------|--------------------------|
| 1   | Host Connection Mode              | TRESPASS Mode              | 1                        |
| 2   | SCSI/Fibre-Channel Common Options | Multipath (Controller)     | 3                        |
| 3   | Controller Identifier             | Enable                     | 9                        |
|     | Controller ID                     | DF500-00C0 (default value) |                          |

u) When the array unit is used in the WolfPack mode

| No. | Setting item         | Set value  | No. of windows displayed |
|-----|----------------------|--|--------------------------|
| 1   | Host Connection Mode | Wolfpack Mode  | 1                        |
| 2   | Reset/LIP Mode       | Reset/LIP Mode (Signal)<br>Reset/LIP Mode (Process)<br>Reset ALL LIP Port Mode | 7                        |

v) When the host uses the VxVM DMP

| No. | Setting item          | Set value                  | No. of windows displayed |
|-----|-----------------------|----------------------------|--------------------------|
| 1   | Host Connection Mode  | VxVM DMP Mode              | 1                        |
| 2   | Controller Identifier | Enable                     | 9                        |
|     | Controller ID         | DF500-C000 (default value) |                          |

- The system parameter window is displayed starting with **System Startup Setting**. The window displays the items currently set. Check the displayed contents on the window and set each displayed item to the configuration you want to set. When making the next setting, click the **Next** button. When you click the **Back** button, the previous window will appear.

To stop the setting, click the **Cancel** button.

Below, using the screen display when the Fibre version of DF500 is connected, the parameters in every display screen of the wizard will be displayed.

- **Start Attribute:** Selects the configuration of the array unit.  
**Single Mode:** Single configuration  
**Dual Active Mode:** Dual active configuration  
**Hot Standby Mode:** Hot standby configuration
- **SCSI ID/Port ID Take-over Mode:** Specifies the take-over of SCSI ID/port ID.  
**Use:** Used the SCSI ID/Port ID Take-over Mode.  
**Do not Use:** Not used the SCSI ID/Port ID Take-over Mode.
- **Default Controller:** Specifies the controller to be positioned at the port.  
This specification is valid only when **Dual Active Mode (connect Host)** is specified.
- **Data Share Mode:** Specifies the attribute of the data share mode.  
**Use:** Used in the data share mode.  
**Do not Use:** Not used in the data share mode.

- **Host Connection Mode:** Specifies the host connection mode of the port. Click the button **Port xx** (xx : 0A, 1A, 0B, 1B) to specify each port.

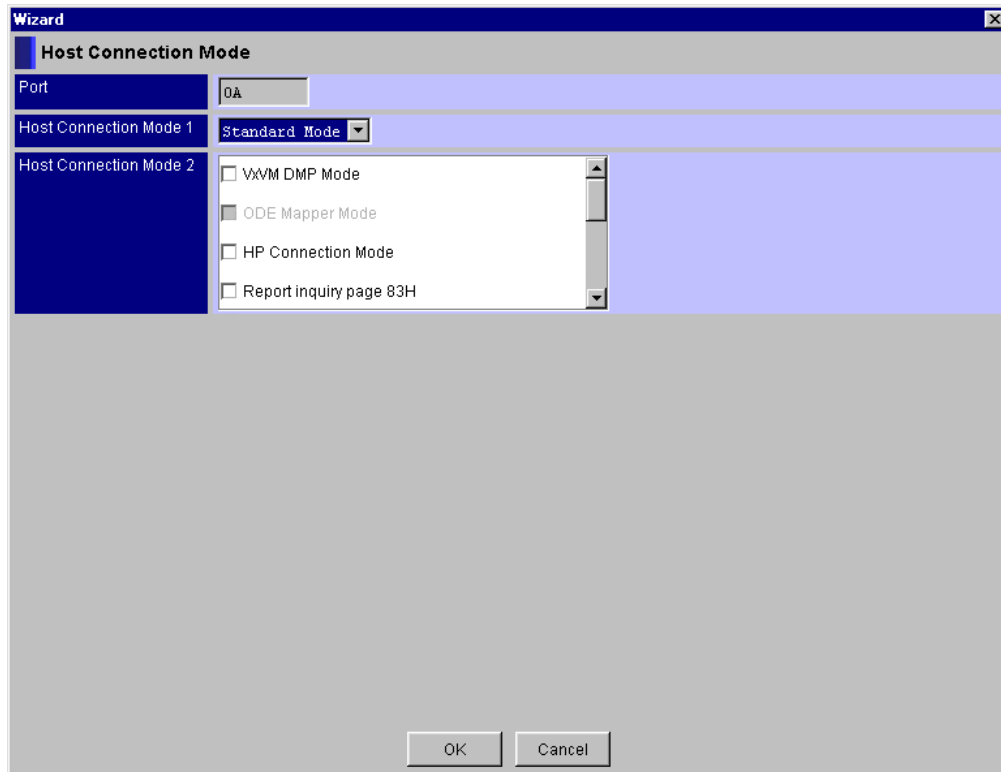

- **Host Connection Mode 1**
  - Standard Mode:** Open system emulation mode
  - Open VMS Mode:** Open VMS mode
  - TRESPASS Mode:** TRESPASS mode
  - Wolfpack Mode:** Wolfpack mode
  - IBM 7135 I/O path switch Mode:** IBM 7135 I/O path switch mode
  - NCR I/O path switch Mode:** NCR I/O path switch mode
- **Host Connection Mode 2**
  - VxVM DMP Mode:** VxVM mode
  - ODE Mapper Mode:** ODE Mapper mode
  - HP Connection Mode:** HP connection mode
  - Report inquiry page 83H:** Enables the report of Inquiry Page : 83<sub>H</sub>.
  - UA(60/2A00) suppress Mode:** Suppresses the unit attention (06/2A00).
  - HISUP Mode:** Enables the HISUP
  - CCHS Mode:** Enables the CCHS convert
  - Standard INQUIRY data expand Mode:** Enables the Standard INQUIRY data expand Mode.
  - Product ID DF400 Mode:** Enables the Product ID DF400 Mode.

- **Serial Number:** Enters the lower four digits of the manufacturing serial number of an array unit with alphanumeric characters.  
**The number is reflected on the fiber version of the WWN, so do not set any value except for the lower four digits of the manufacturing serial number.** Factory set is the lower four digits of the manufacturing serial number of an array unit.

**Note 1:** When DF350 or DF400 is connected, to change to **SCSI ID/Port ID Take-over Mode**, please do so when the Target ID's of controller 0 and controller 1 are set to be the same. It cannot be changed when the settings of the Target ID's are different. When the setting of Target ID's are different in controller 0 and controller 1, to change to **SCSI ID/Port ID Take-over Mode**, set the Target ID's of controller 0 and controller 1 to be the same. After the setting is enabled, please change to **SCSI ID/Port ID Take-over Mode**. When DF500 is connected, if it is changed to **SCSI ID/Port ID Take-over Mode**, the Target ID of controller 0 will be automatically mirrored in the Target ID of controller 1. After setting the Target ID to be set in controller 0, please change **SCSI ID/Port ID Take-over Mode**.

**Note 2:** Concerning the array unit with a single controller, a change from the **Single Mode** to the other configuration cannot be made.

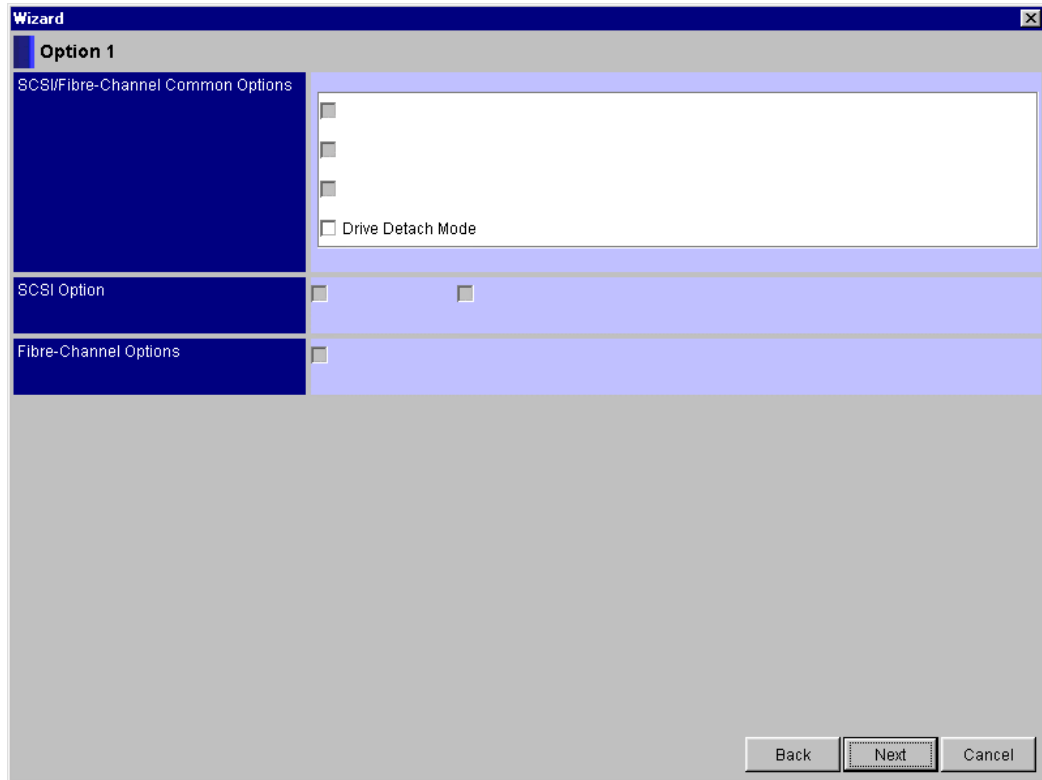

Sets the optional functions 1 of the array unit. The two or more optional functions can be selected.

- **SCSI/Fibre-Channel Common Options:** Options which can be used by the SCSI and Fibre Channel interface array units. Set the optional function(s) according to the configuration of the array unit.

**Drive Detach Mode:** Validates the drive blockade mode.

- **SCSI Option:** Options exclusive to the SCSI array unit. Set the optional function (s) according to the configuration of the array unit. When the Fibre Channel interface array unit is connected, this item is displayed in gray and cannot be set.
- **Fibre-Channel Options:** An option exclusive to the Fibre Channel interface array unit. Set the optional function according to the configuration of the array unit. When the SCSI array unit is connected, this item is displayed in gray and cannot be set.

**Note:** It does not normally by the setup though **Option 1** can be setup in the plural. When you set it up, setup only an applicable item referring to the manual of attaching array unit.

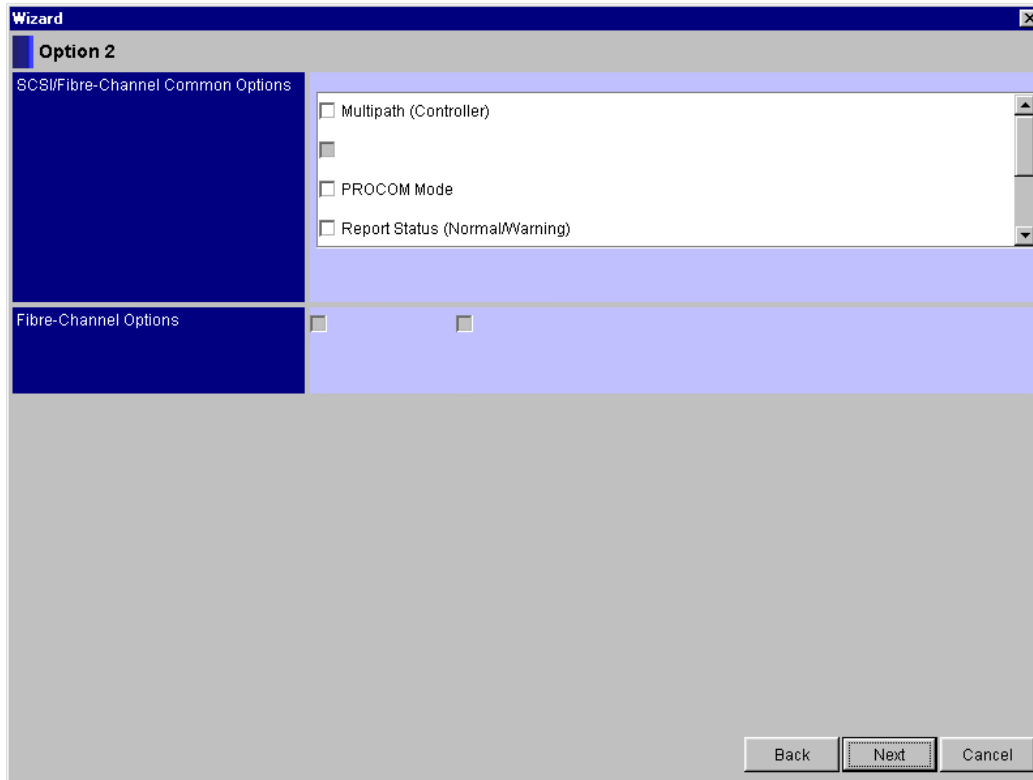

Sets the optional functions 2 (expanded option) of the array unit. The two or more optional functions can be selected.

- **SCSI/Fibre-Channel Common Options:** Options which can be used by the SCSI and Fibre Channel interface array units. Set the optional function(s) according to the configuration of the array unit.

**Multipath (Controller):** Sets a unit of the sequential judgment to each controller.

**PROCOM Mode:** Validates the PROCOM Mode.

**Report Status:** Validates the warning status report mode.

**Multipath (Array Unit):** Sets a unit of the sequential judgment to each array unit.

**Turbo LU Warning:** When the Turbo LU function is invalidated, a warning is reported.

- **Fibre-Channel Options:** An option exclusive to the Fibre Channel interface array unit. Set the optional function according to the configuration of the array unit. When the SCSI array unit is connected, this item is displayed in gray and cannot be set.

**Note:** It does not normally by the setup though **Option 2** can be setup in the plural. When you set it up, setup only an applicable item referring to the manual of attaching array unit.

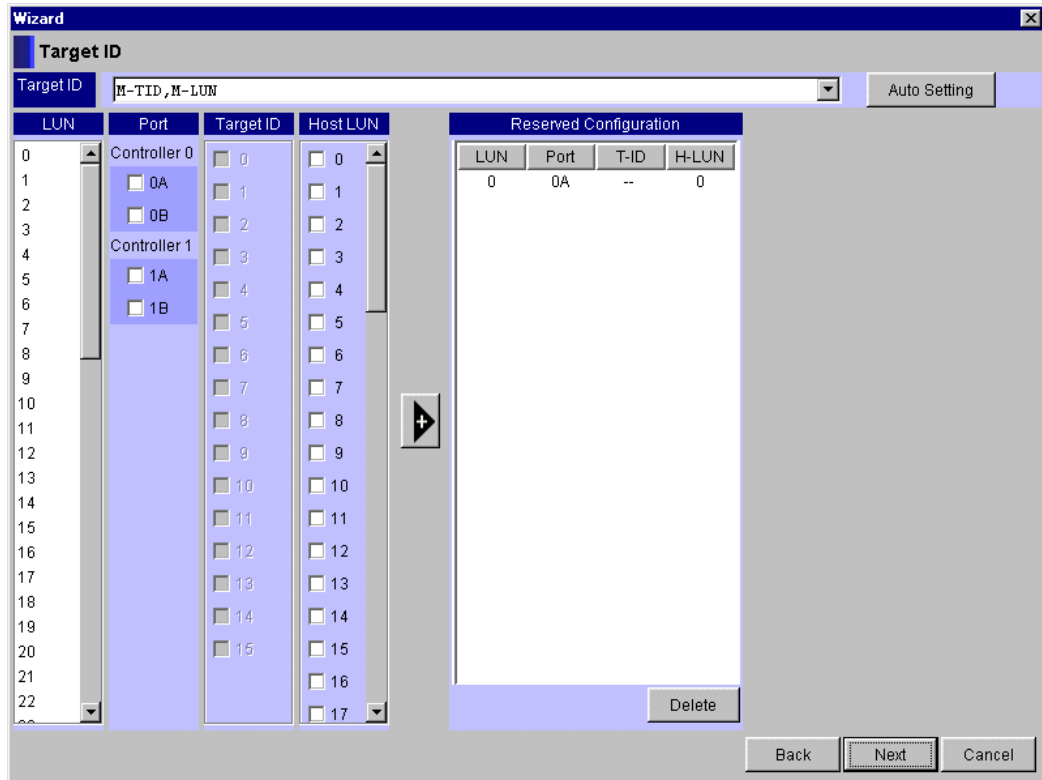



Sets the target IDs of controller 0/1.

**Note 1:** If **SCSI ID/Port ID Take-over Mode** is set at **Use**, the setting of controller 0 automatically sets the Target ID for controller 1.

**Note 2:** The text box for the Host LUN and LUN is displayed on a scroll screen, and LUNs from 0 to 63 can be selected. When the manager 2 runs with IRIX, all LUNs may not be displayed by scrolling. If LUNs are not displayed up to 63, operate with the arrowdown (▼) key.

**Note 3:** In case that the LUN mapping is used for the controller 0, the LUN mapping shall be also used for the controller 1. Otherwise, all logical unit will be available through all ports of the controller that does not use the LUN mapping.

- **Target ID:** Specifies configuration types of the target ID and the LUN.
  - S-TID, M-LUN:** Sets a target ID of the port and makes the LUN which shared by the ports can be used by the host with an identical LUN.
  - M-TID, S-LUN:** Sets a port and a target ID for the LUN and makes the LUN can be used with LUN = '0' and a target ID set by the host.
  - M-TID, M-LUN:** Sets a port, a target ID, and an Host LUN for the LUN in a map form and makes the LUN can be used in a configuration set by the host.
  - S-TID:** Single Target ID
  - M-TID:** Multi Target ID
  - S-LUN:** Single LUN
  - M-LUN:** Multi LUN
  - LUN:** Logical unit number in the array unit.
  - H-LUN:** Logical unit number that the host can recognize.
- **LUN:** Specifies the LUN in the array unit.
- **Port:** Specifies a port number.
- **Target ID:** Specifies a target ID.
- **Host LUN:** Specifies an LUN that the host recognizes. When **S-TID, M-LUN** and **M-TID, S-LUN** are selected for **Target ID**, the display appears in gray and selection is disabled.
- **Reserved Configuration:** Displays the configuration that is set. When **S-TID, M-LUN** is set, **Host LUN** and **LUN** are displayed as “-”. When **M-TID, S-LUN** is set, **H-LUN** is displayed as “-”.
- w) **S-TID, M-LUN** mode setting
  - Select the **S-TID, M-LUN** in **Target ID**.
  - Select one **Port** to be set, select one **Target ID** to be set, and click the  button. The added contents are displayed in **Reserved Configuration**.
- x) **M-TID, S-LUN** mode setting
  - Select the **M-TID, S-LUN** in **Target ID**.
  - Select one **LUN** to be set, select one **Port** and one **Target ID** to be set, and click the  button.
  - The added contents are displayed in **Reserved Configuration**.
  - For deletion, click the line to be deleted in **Reserved Configuration** and click the **Delete** button.
  - The deleted contents disappear from the **Reserved Configuration** display.

y) **M-TID, M-LUN** mode setting

Select the **M-TID, M-LUN** in **Target ID**.

Select one **LUN** to be set, select **Port, Target ID**, and **Host LUN** to be set in the mapping setup configuration, and click the  button. The added contents are displayed in **Reserved Configuration**.

Multiple **Port, Target ID**, and **Host LUN** can be selected.

For deletion, click the line to be deleted in **Reserved Configuration** and click the **Delete** button.

The deleted contents disappear from the **Reserved Configuration** display.

z) **Auto setting**

Click **Auto Setting**. The target ID configuration file is read and **LUN, Port, Target ID**, and **Host LUN** are automatically set. The read contents are displayed in **Reserved Configuration**.

Auto setting is performed regardless of **Target ID**.

After execution of auto setting, all of the previous contents are invalidated and changed to the contents of the target ID configuration file.

The file configuration used for executing auto setting is shown in the following figure.

Input “Yes” or “No” in **Target ID** mode. Input necessary data for **Port, Target ID, H-LUN**, and **LUN** (the same items as those entered in the setting made on the screen).

Put a space between items. If the tabulating function is used, they are regarded as input errors and the inputs are ignored.

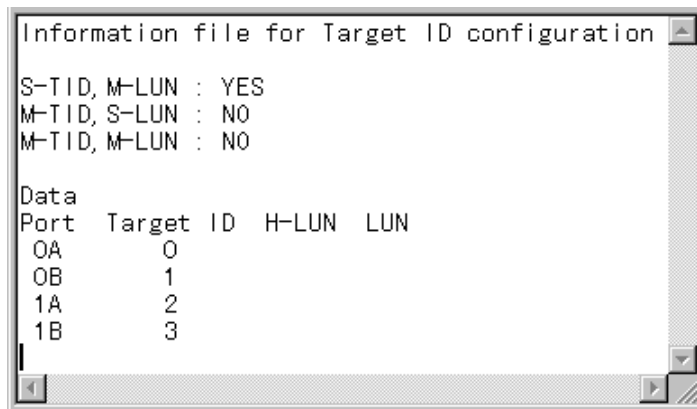

```
Information file for Target ID configuration
S-TID, M-LUN : YES
M-TID, S-LUN : NO
M-TID, M-LUN : NO

Data
Port  Target ID  H-LUN  LUN
OA      0
OB      1
1A      2
1B      3
```

**Note:** When the Fibre Channel connection, set ‘--’ for the **Target ID**.

- When the **Basic Settings** is selected, the window for the **Target ID** setting is the final window. Click the **Next** button, then displayed **Detailed Settings**. If you set the **Detailed Settings** items in succession, select **Yes**, or if not, select **No**, and then click the **Next** button.

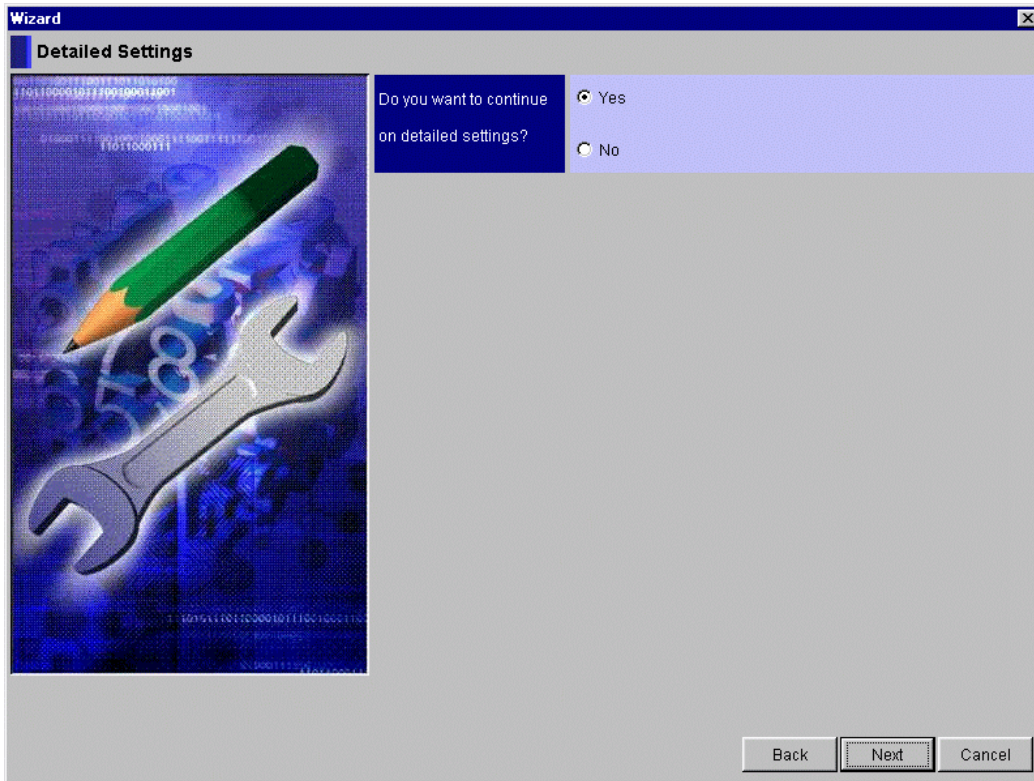

When you select **No**, the **System Parameter Setting Completed** screen will be displayed. Refer to items from '5' onward, perform a back-up operation.

The window displayed when the **Detailed Settings** is selected

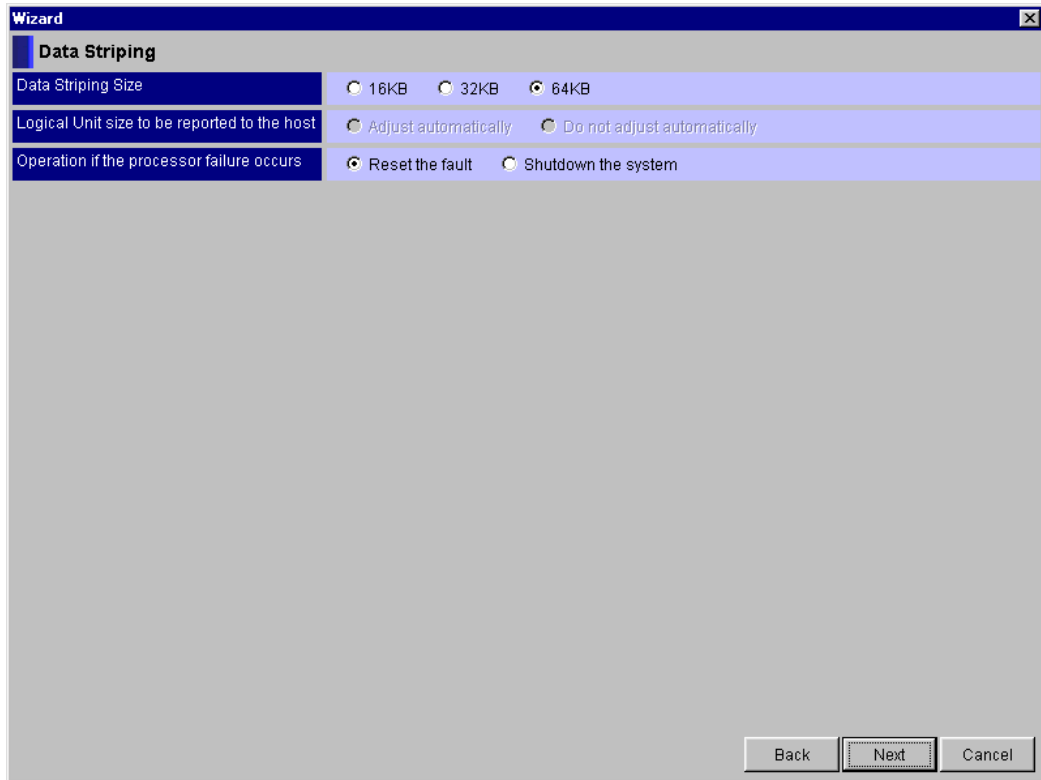

- **Data Striping Size:** Sets the striping size. In cases in which logical unit is already defined, it cannot be changed. In case of change, please do so after deleting all the logical unit.
- **Logical Unit size to be reported to the host:** Sets the logical unit size to be reported to the host. When the Fibre Channel interface array unit is connected, this item is displayed in half-tone and cannot be set.  
**Adjust automatically:** The logical unit size to be reported to the host is determined by the array unit automatically.  
**Do not adjust automatically:** The logical unit size to be reported to the host is set to the consistent value.
- **Operation if the processor failure occurs:** Sets the operation to be performed when a processor failure occurs.  
**Reset the fault:** Resets a failure, and restart the controller.  
**Shutdown the system:** Make the array unit go down.

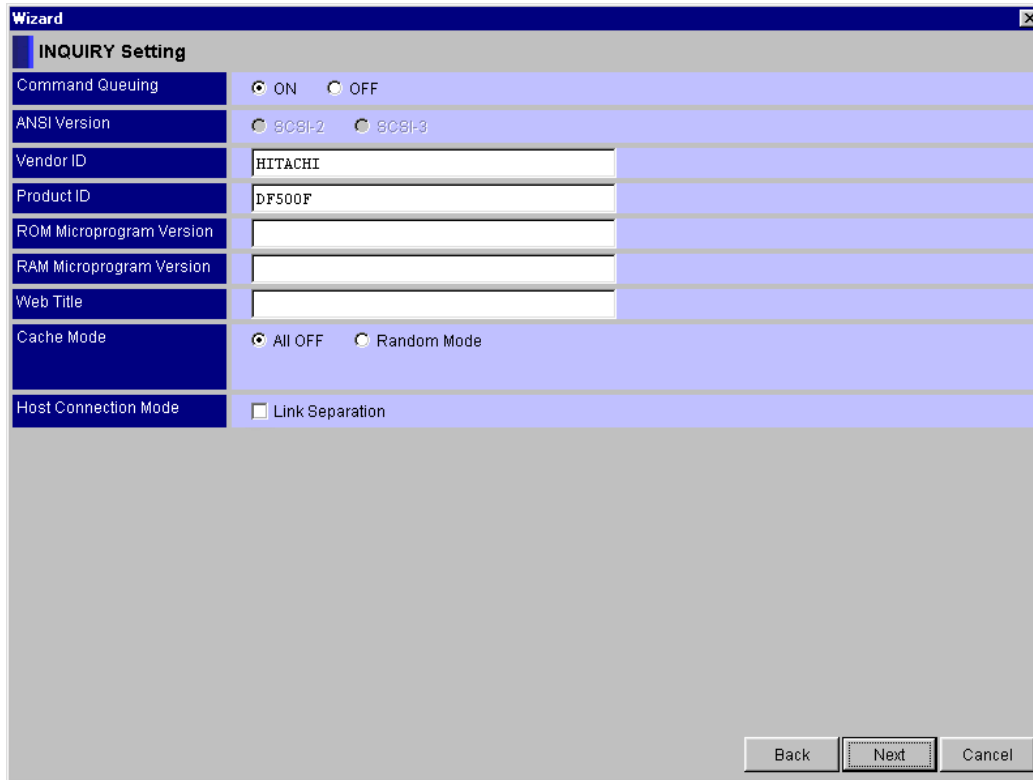

- **Command Queuing:** Specifies an execution of a command queuing.  
**ON:** Executes a command queuing.  
**OFF:** Inhibits a command queuing.
- **ANSI Version:** Specifies the SCSI 2/3 reporting mode.  
**SCSI-2:** Responds with a setting of “2” for the ANSI version of the standard Inquiry data.  
**SCSI-3:** Responds with a setting of “3” for the ANSI version of the standard Inquiry data.
- **Vendor ID:** Enter a vendor name with eight characters. When the name consists of less than seven characters, make a eight-character entry by filling the reset with space(s).  
The default value set in the **Startup Attribute** setting on the **System Startup Settings** is displayed. (“△ ” denotes a space.)  
**Others:** HITACHI △

- **Product ID:** Enter a model name with 16 characters. When the name consists of less than 16 characters, make a 16-character entry by filling the rest with space(s). In the setting of **Startup Attribute** under **System Startup Settings**, for the cases in which the following modes are specified, the values set by default are shown. (“△” denotes a space.)
  - IBM 7135 I/O path switch Mode:** 7135021000000000
  - NCR I/O path switch Mode:** INF-01-00 △△△△△△△△
  - Others:** other modes (SCSI) : DF500△△△△△△△△△△△△△△  
(Fibre) : DF500F△△△△△△△△△△△△△△
- **ROM Microprogram Version:** Specifies a microprogram version of a ROM reported by inquiry command.
- **RAM Microprogram Version:** Specifies a microprogram version of a RAM reported by inquiry command.
- **Web Title:** If the home page of the array unit is displayed with the browser, specifies a character string displayed on the title bar of the browser. Enter up to 32 one-byte coded alphanumeric or characters (except for the ‘ (single quotation mark), “ (double quotation mark), and \ (backslash) symbols) other than numeric.
- **Cache Mode:** Sets the cache memory allocation method.
  - All OFF:** Use the cache memory with the ordinary allocation method.
  - Random Mode:** Use the cache memory allocating a buffer for random reading exclusively to it.
- **Host Connection Mode:** Sets up functions necessary for the host to which to connect.
  - Link Separation:** When blocking a controller, shuts down a link.

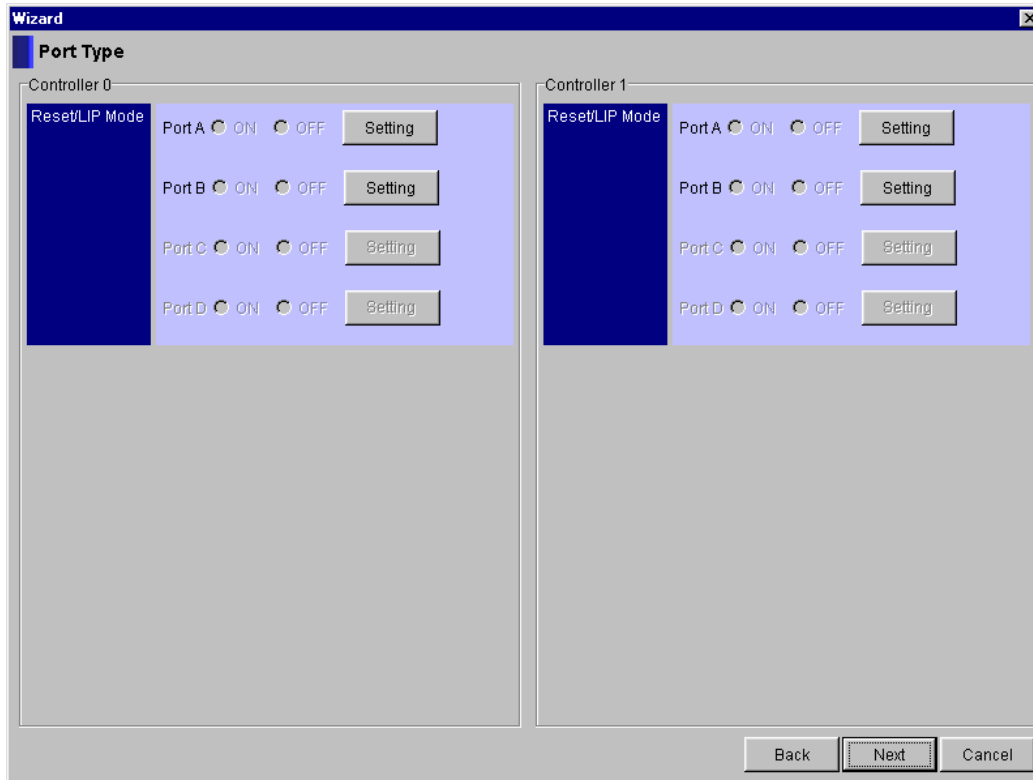

Sets the multi-port expanding function of the controller 0/1.

When **Multiple** is selected, set the **Reset/LIP Mode**.

- **Reset/LIP Mode:** Specifies the LIP mode from other ports.

**ON:** Validates the LIP mode from other ports.

**OFF:** Invalidates the LIP mode from other ports.

**Setting:** For the case of connection with Fibre version, port options can be set. Click **Setting** for each port.

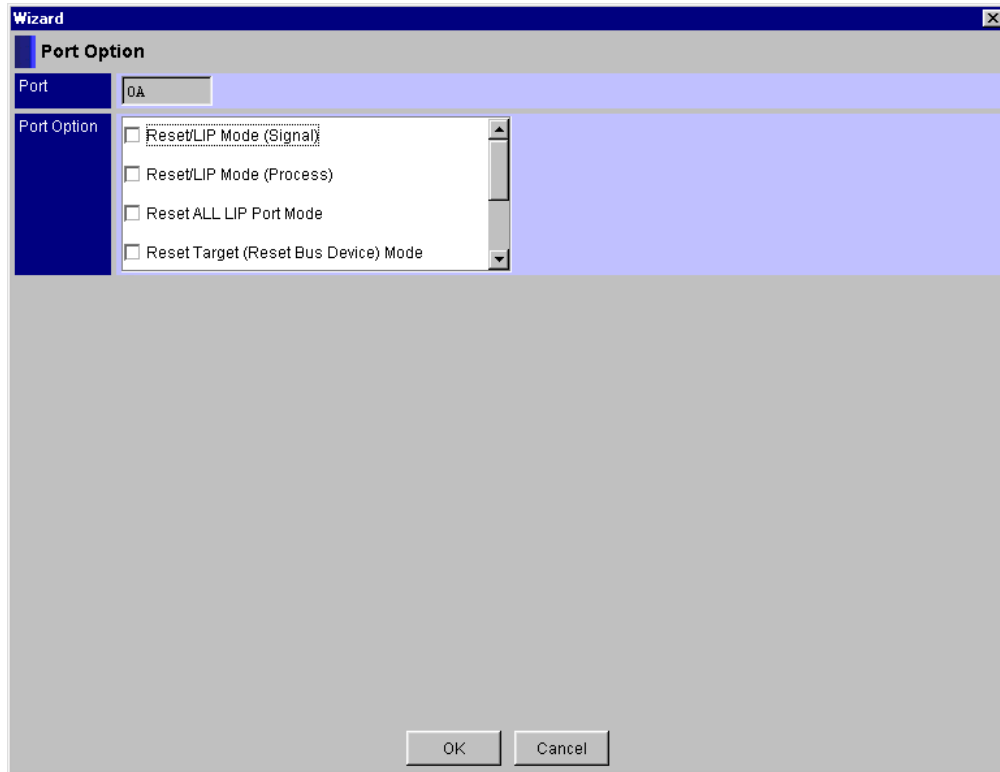

- **Port:**
- **Port Option:** Sets the port options.  
If the port option is set and the **OK** button is clicked, it will return to the setting screen of **Port Type**.
  - Reset/LIP Mode (Signal):** The mode to transmit Reset/LIP signals to other ports.
  - Reset/LIP Mode (Process):** The mode to transmit reset processing to other ports.
  - Reset ALL LIP Port Mode:** The mode to execute reset on receiving LIP.
  - Reset Target (Reset Bus Device) Mode:** The mode to transmit Target Reset to other ports.
  - Reserve Mode:** The mode to reserve logical unit in a dual system.
  - Reset Logical Unit Mode:** When the Logical Unit Reset command is issued for an logical unit, all other commands received by that logical unit will be reset, regardless of the port.
  - Reset Logout of Third Party Process Mode:** The mode to transmit Third Party Process Log-out to other ports.

**Note:** Reset/LIP Mode (signal) is enabled if the **Reset/LIP Mode (Process)** is set.  
**Port Option** can be multiply set, but depending on the setting, it may not function properly. If it is to be set, please refer to the appended manual of the array unit and set only the applicable parameters.

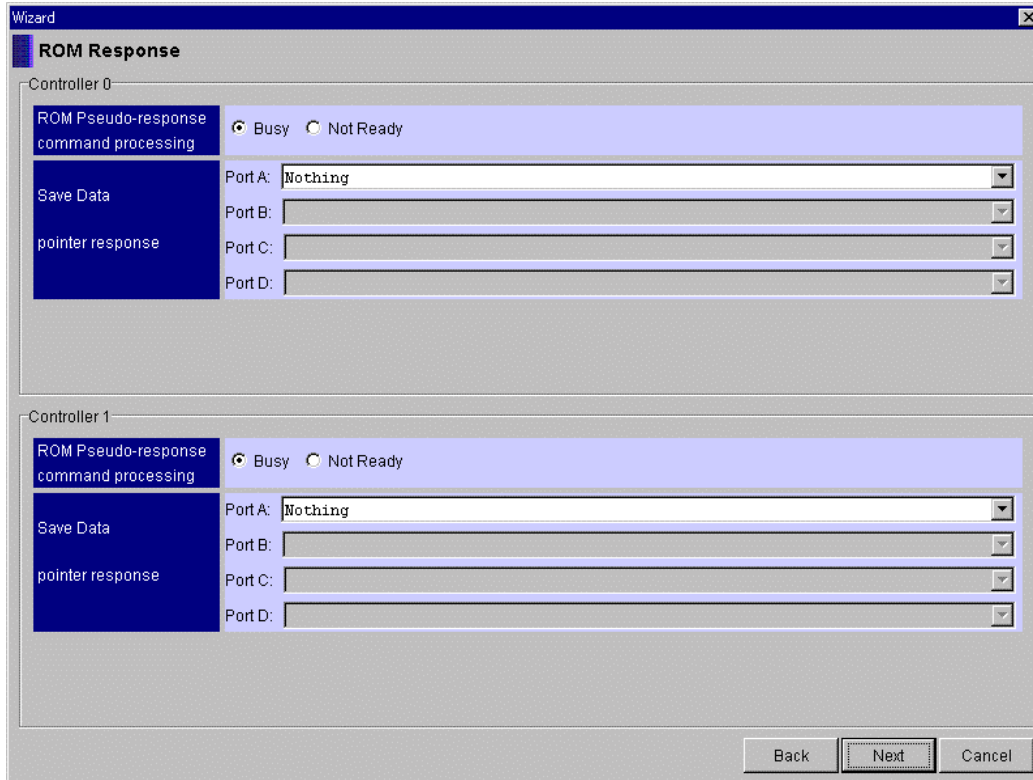

- **ROM Pseudo-response command processing:** Sets the mode of response to the host during a period from powering on to the time when the controller 0/1 becomes ready.
  - Busy:** Responds “BUSY”.
  - Not Ready:** Responds “Not Ready”.
- **Save Data pointer response:** Sets a Save Data Pointer report request to the host by the controller 0/1.
  - Nothing:** Does not report.
  - After Data:** Reports after receiving data.
  - Only After Cmd:** Reports after receiving a command.
  - After Data & Cmd:** Reports after receiving data and a command.

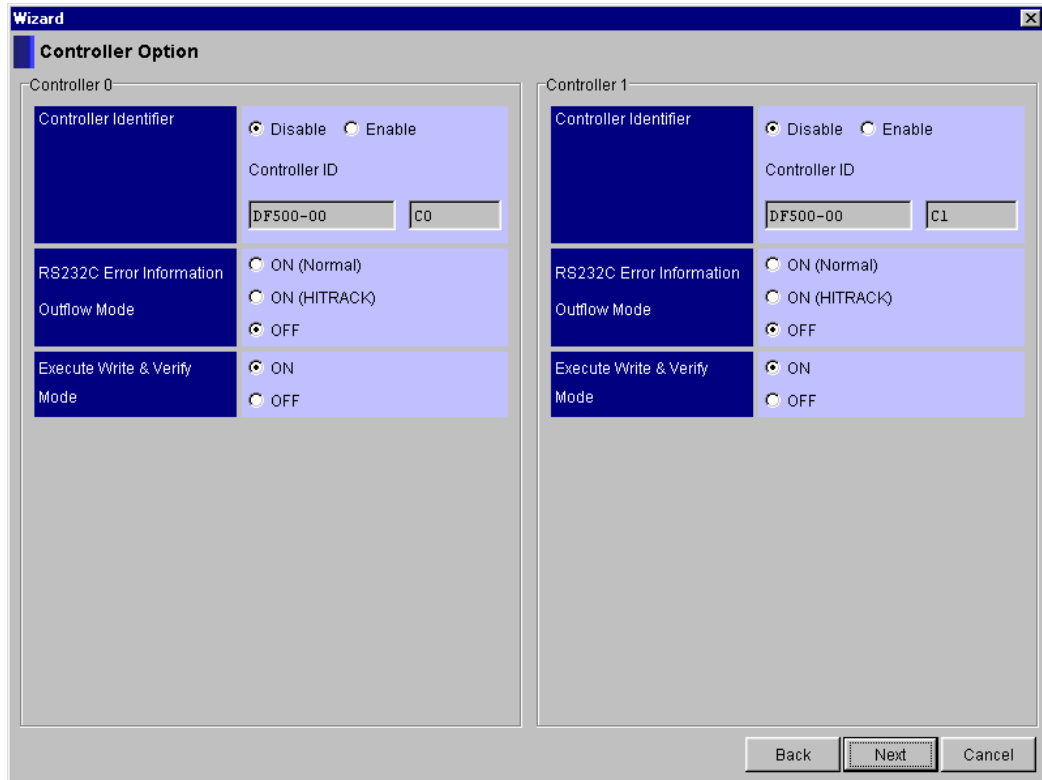

- **Controller Identifier:** Sets the controller identifier of the controller 0/1.  
**Disable:** Invalidates a setting of the controller identifier.  
**Enable:** Validates a setting of the controller identifier.  
**Controller ID:** Enter a controller identifier. The controller identifier consists of ten characters; only the top eight characters can be changed but the last two characters cannot be changed. They can be changed when the **Enable** is selected.
- **RS232C Error Information Outflow Mode:** Sets the mode of the error information sending to the RS232C of the controller 0/1.  
**ON (Normal):** Outputs information.  
**ON (HITRACK):** Outputs HITRACK mode information.  
**OFF:** Inhibits an output of information.
- **Execute Write & Verify Mode:** Sets the write & verify execution mode of the controller 0/1.  
**ON:** Executes write and verify.  
**OFF:** Dose not execute write and verify.

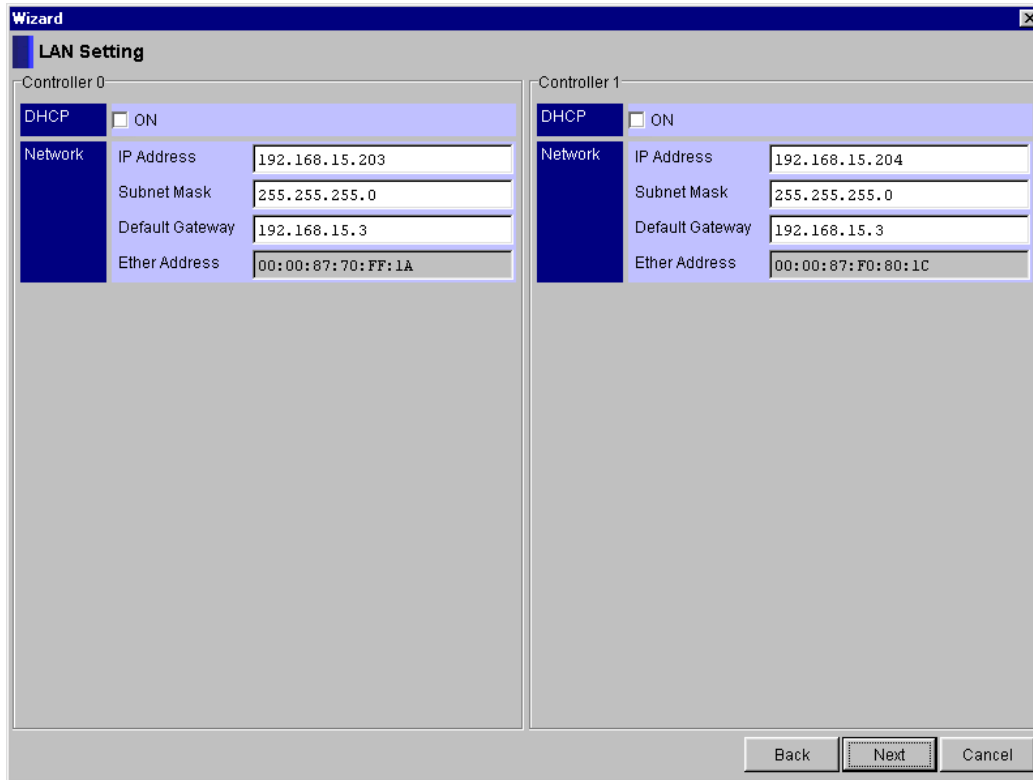

- **DHCP:** Sets the DHCP function.
- **Network:** Sets the LAN parameter. If enable is selected in **DHCP**, gray display will be used.

**IP Address:** Sets the IP address.

**Subnet Mask:** Sets the sub net mask.

**Default Gateway:** Sets the default gateway.

**Ether Address:** The Ethernet address (MAC address) is displayed. It cannot be changed.

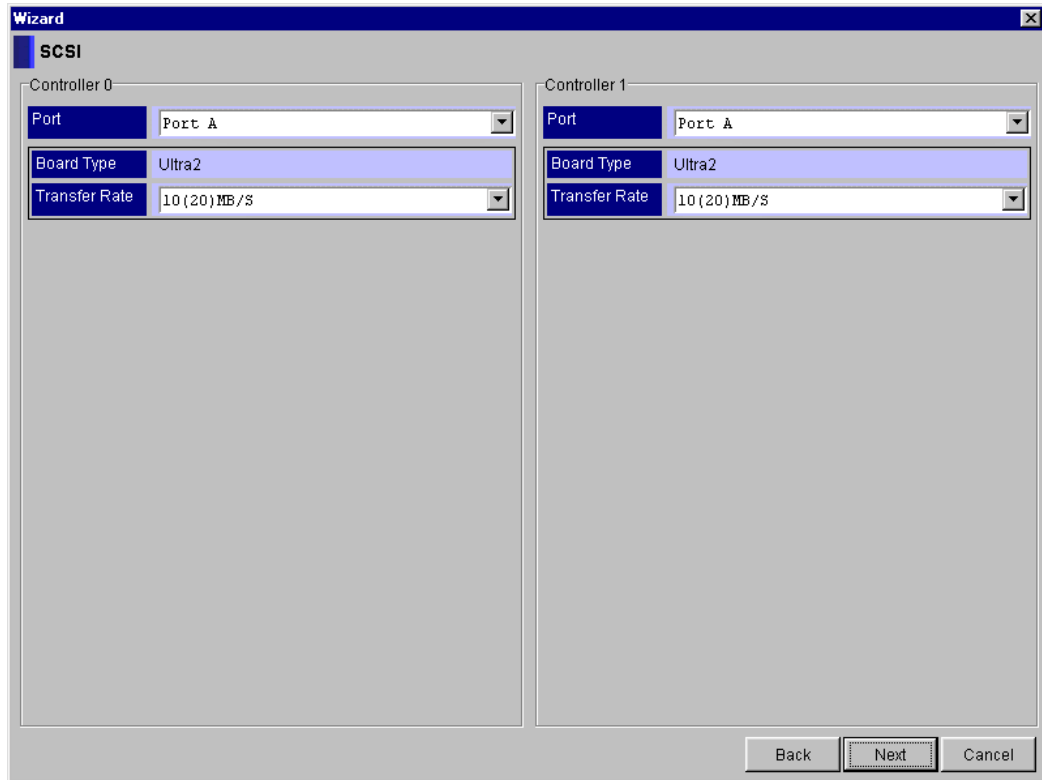

- **Port:** Selects the port to be set.
- **Board Type:** Displays types of I/F board.
  - None:** Not installed
  - Single:** Single type
  - Differential:** Differential type
  - Ultra 2:** Ultra 2 type
- **Transfer Rate:** Sets the SCSI transfer rate.
  - STANDARD:** Sets the transfer rate automatically according to the I/F board installed.
  - ASYNC:** Transfers data in the mode without using the synchronous transfer.
  - 5 (10) MB/S:** Sets the maximum transfer rate to 5 M byte/s for narrow SCSI and 10 M byte/s for wide SCSI.
  - 10 (20) MB/S:** Sets the maximum transfer rate to 10 M byte/s for narrow SCSI and 20 M byte/s for wide SCSI.
  - 20 (40) MB/S:** Sets the maximum transfer rate to 20 M byte/s for narrow SCSI and 40 M byte/s for wide SCSI.
  - 40 (80) MB/S:** Sets the maximum transfer rate to 40 M byte/s for narrow SCSI and 80 M byte/s for wide SCSI.

The image shows a 'Wizard' dialog box titled 'RTC Setting'. It has a blue header bar with the title 'RTC Setting'. Below the header, there are three sections: 'Setting', 'Date', and 'Time'. The 'Setting' section has two radio buttons: 'Manual' (which is selected) and 'Auto'. The 'Date' section has three input fields containing the values '2001', '03', and '26'. The 'Time' section has three input fields containing the values '17', '49', and '22'. At the bottom right of the dialog, there are three buttons: 'Back', 'Next', and 'Cancel'.

- **Setting:** Select **Manual/Auto**.  
**Manual:** Sets the date and time to be set.  
**Auto:** Sets the time of the PC or SUN server/workstation executing the manager 2.
- **Date:** Displays date.
- **Time:** Displays time.

5. Select **Yes** of **FD Backup?**, then click the **OK** button.

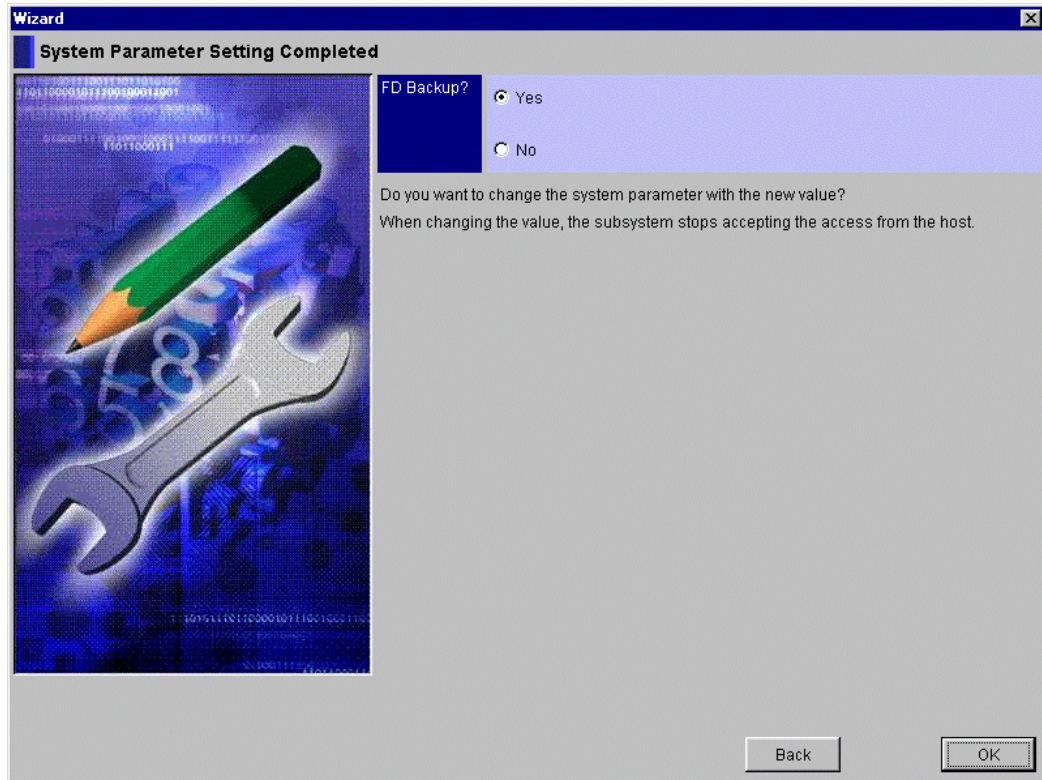

- **FD Backup?:** The system parameter information is saved on the backup FD in the array unit. When the setting is changed, it is necessary to save the system parameter information once again. **Be sure to select “Yes”**

6. A message indicating completion of setting is displayed. A confirmation message indicating a request for restarting is displayed, so click the **OK** button when restarting.

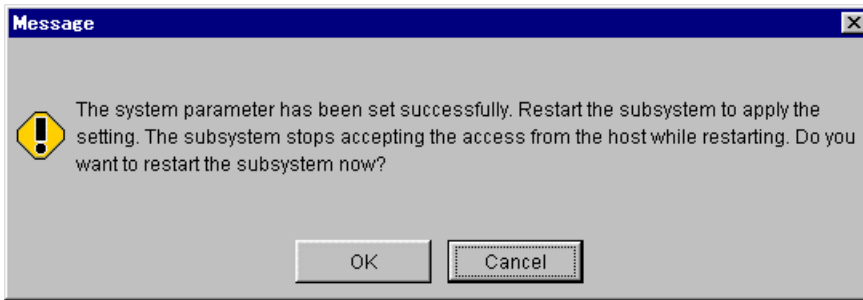

**Note:** To validate the set system parameters, restart the array unit. The previous settings stay valid until restarting.

Commands from the host and part of the manager functions cannot be executed until the array unit is restarted.

When restarting is initiated, the array unit is not ready to accept an access from the host for duration from initiation until the restarting terminates. Therefore, after making sure that the host has stopped accessing, initiate restarting.

**Note:** If LAN configuration information is modified, an error message (Interface Error) may be displayed without displaying a restart completion message when restarting is initiated. When modifying LAN configuration information, after closing the unit window without specifying restart, restart an array unit. After the array unit restarts, modify registered information on the main window, and then open the unit window again.

**Note:** When failing to write onto the FD drive, the message “DMES04EB02 : Backup floppy disk write error.” is displayed.

When this message is displayed, writing into an FD has not been finished, but setting the system parameter may be completed.

Check an FD in an array unit, re-confirm the data to set, turn on the **FD Backup?** check box, and then click the **OK** button once again.

7. When instructing to restart an array unit, the time the restarting has began is displayed. The restarting takes about two to six minutes.

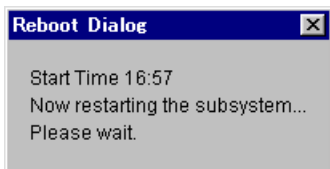

**Note:** It may take time for an array unit to respond, depending on the condition of the array unit. If it does not still respond after 10 minutes or more pass, check the condition of the array unit.

8. A message indicating that the restarting has terminated is displayed, so click the **OK** button.

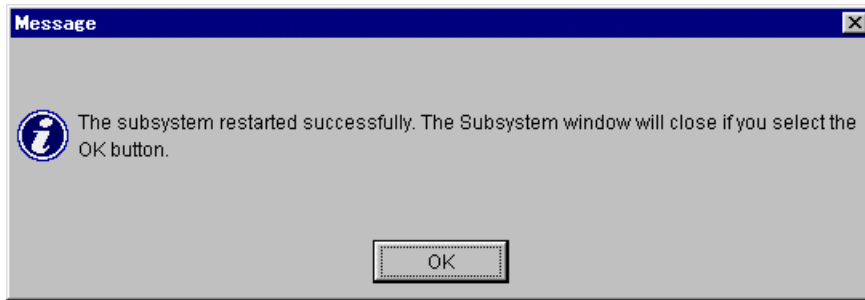

When clicking the **OK** button, the unit screen is closed. To perform other operations, select again on the main screen an array unit which to operate, and open the unit screen.



# Chapter 6 Setting System Parameters

Sets a system configuration, such as a Target ID and fibre information, of an array unit. Individual items to be set are selected by switching the tab screen. Some tab screens may not be displayed depending on the connected array unit, etc.

## 6.1 Target ID

Set the configuration of the target ID and the LUN which are recognized when the array unit is connected to the host.

### 6.1.1 Added information becomes valid with restarting an array unit.

1. Select “**Settings—Configuration Settings**” on the Unit screen. Or, when you click the “ : **Configuration Settings**” in the tool bar.
2. Click the **Target ID** tab. And click the **Change (After)** radio button.

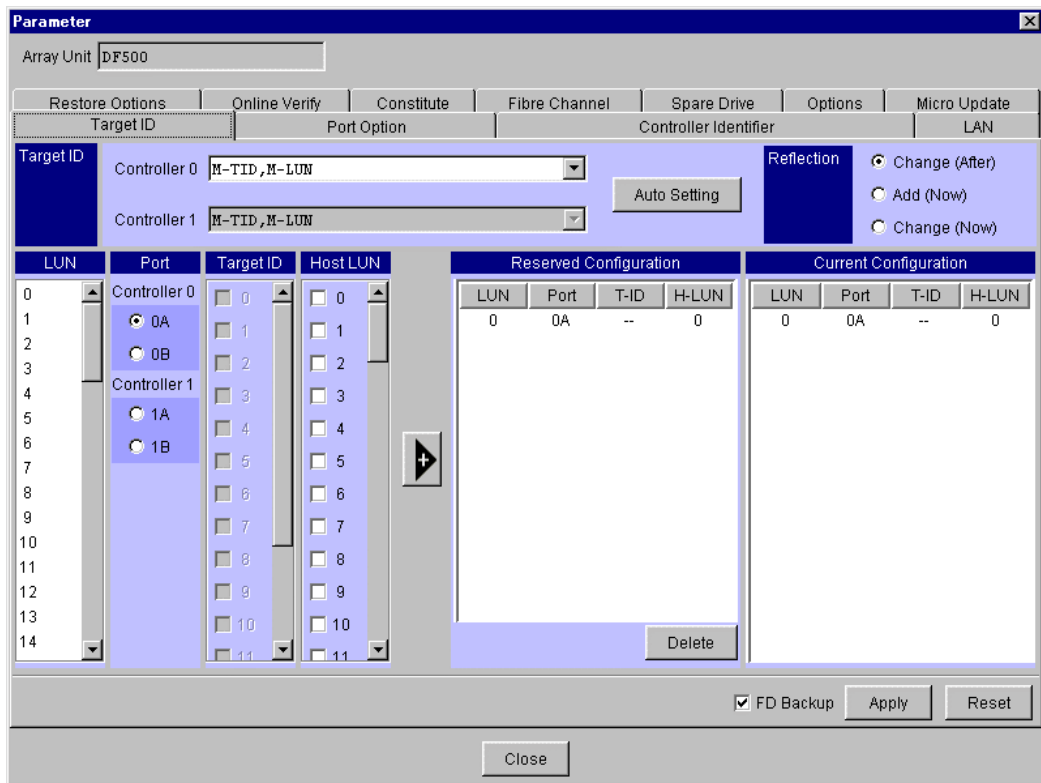

The condition currently set is displayed in **Current Configuration**. When it is displayed once again after the setting, the setting contents are displayed in **Reserved Configuration**.

- **Target ID:** Specifies configuration types of the target ID and the LUN.
  - S-TID, M-LUN:** Sets a target ID of the port and makes the LUN which shared by the ports can be used by the host with an identical LUN.
  - M-TID, S-LUN:** Sets a port and a target ID for the LUN and makes the LUN can be used with LUN = '0' and a target ID set by the host.
  - M-TID, M-LUN:** Sets a port, a target ID, and an Host LUN for the LUN in a map form and makes the LUN can be used in a configuration set by the host.
  - S-TID:** Single Target ID
  - M-TID:** Multi Target ID
  - S-LUN:** Single LUN
  - M-LUN:** Multi LUN
  - LUN:** Logical unit number in the array unit.
  - H-LUN:** Logical unit number that the host can recognize.
- **LUN:** Specifies the LUN in the array unit. When **S-TID, M-LUN** is selected for **Target ID**, the display is grayed and cannot be selected.
- **Port:** Specifies a port number.
- **Target ID:** Specifies a target ID.
- **Host LUN:** Specifies an LUN that the host recognizes. When **S-TID, M-LUN** and **M-TID, S-LUN** are selected for **Target ID**, the display appears in gray and selection is disabled.
- **Reserved Configuration:** Displays the configuration that is set. When **S-TID, M-LUN** is set, **Host LUN** and **LUN** are displayed as “-”. When **M-TID, S-LUN** is set, **H-LUN** is displayed as “-”.
- **Current Configuration:** Displays the configuration that is set. When **S-TID, M-LUN** is set, **Host LUN** and **LUN** are displayed as “-”. When **M-TID, S-LUN** is set, **H-LUN** is displayed as “-”.

**Note:** The setting of the Target ID varies with the array unit or controller to be connected. When connecting to a single-controller system, only the Controller 0 side can be set up. When connecting to both controllers of a dual-controller system, only the Controller 0 side can be set up, and the settings of the Controller 0 side are reflected on the Controller 1 side. When connecting to either of two controllers of a dual-controller system, only whichever controller side is connected can be set up.

3. Set the target ID and the LUN for each target ID according to the following procedure. When only one controller has been registered for the array unit, the setting of the **Target ID** will be valid only for the registered controller. In this case, if the **M-TID, M-LUN** is selected in the **Target ID** menu, all logical units will be available through the ports of the non-registered controller.

aa) When **S-TID, M-LUN** mode is specified

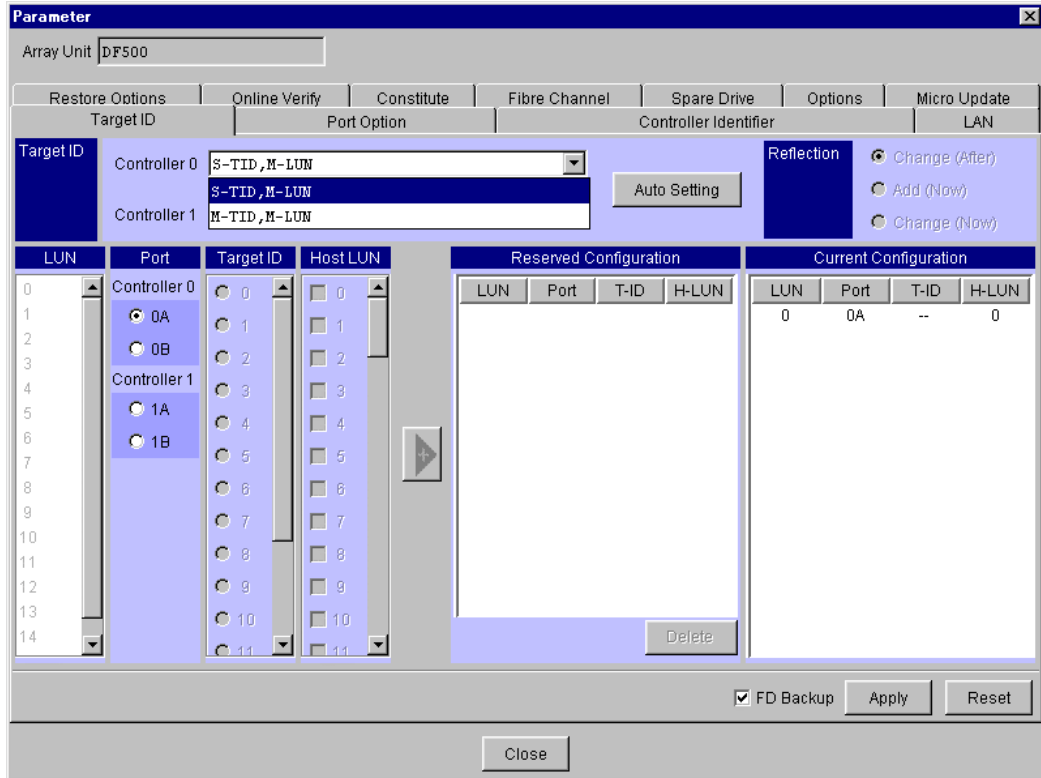

Select **S-TID, M-LUN** in **Target ID**.

For addition, select one **Port** to be added, select one **Target ID** to be set, and click the  button. The added contents are displayed in **Reserved Configuration**.

bb) When **M-TID, S-LUN** mode is specified

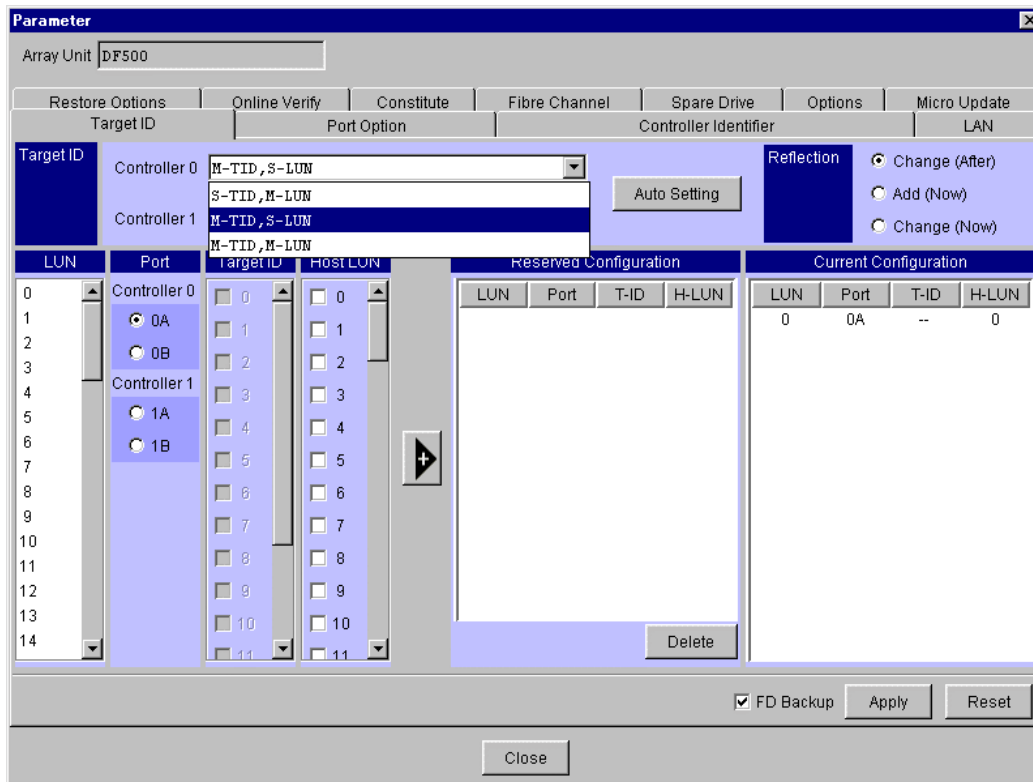

Select **M-TID, S-LUN** in the **Target ID**.

Select one **LUN** to be set, select one **Port** and one **Target ID** to be set, and click the  button. The added contents are displayed in **Reserved Configuration**.

Multiple **Port** and **Target ID** can be selected. When you select multiple ones, the item selected in the least significant digit in the table is set.

For deletion, click the line to be deleted in **Reserved Configuration** and click the **Delete** button. The deleted contents disappear from the display of **Reserved Configuration**.

c) When **M-TID, M-LUN** mode is specified

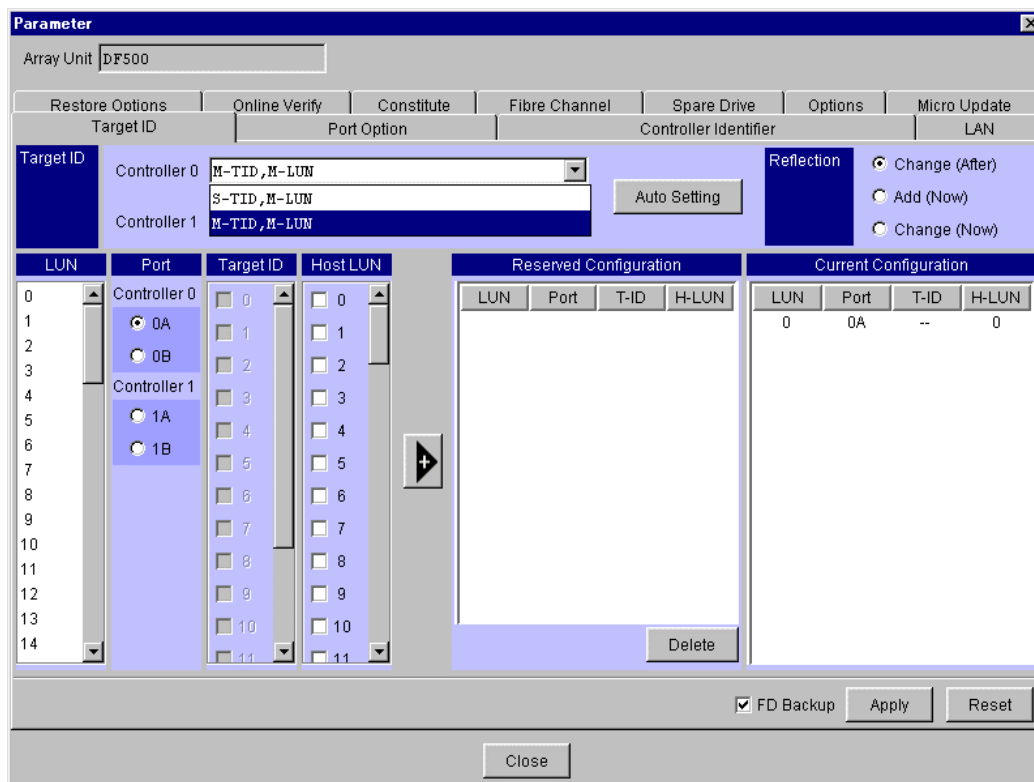

Click the **M-TID, M-LUN** option button in **Target ID**.

Select one **LUN** to be added, select **Port**, **Target ID**, and **Host LUN** in the mapping configuration, and click the  button. The added contents are displayed in **Reserved Configuration**.

Multiple **Port**, **Target ID**, and **Host LUN** can be selected.

For deletion, click the line to be deleted in **Reserved Configuration** and click the **Delete** button. The deleted contents disappear from the display of **Reserved Configuration**.

To cancel the setting of the **M-TID, M-LUN**, delete all of the **Reserved Configuration**.

dd) Auto setting

The target ID configuration file is stored, and **Port**, **Target ID**, **Host LUN**, and **LUN** are set automatically.

They can be set regardless of **Target ID**.

When **Auto setting** is set, all configurations that have been set are invalidated and changed to that of the target ID configuration file.

Click the **Auto Setting** button. A window for specifying a file to be stored appears. Specify the file and click the **OK** button, the setting from the file is started and the set information is displayed in **Reserved Configuration**.

The file configuration used for executing the automatic setting is shown below.

Enter the **Target ID** by specifying “Yes” or “No”. Input necessary data, which are the same as those entered in the setting made on the screen, for **Port**, **Target ID**, **H-LUN**, and **LUN**. Put spaces between the items. If the tabulating function is used, they are regarded as input errors and the inputs are ignored.

#### Example 1 M-TID, M-LUN Mode

```
Information file for Target ID configuration
S-TID, M-LUN : NO
M-TID, S-LUN : NO
M-TID, M-LUN : YES

Data
Port Target ID H-LUN LUN
OA 0 0 0
OA 0 1 1
OA 0 2 2
OA 0 3 3
OA 0 4 4
OA 0 5 5
OA 0 6 6
OA 0 7 7
OB 1 0 8
OB 1 1 9
OB 1 2 10
OB 1 3 11
OB 1 4 12
OB 1 5 13
OB 1 6 14
OB 1 7 15
```

#### Example 2 S-TID, M-LUN Mode

```
Information file for Target ID configuration
S-TID, M-LUN : YES
M-TID, S-LUN : NO
M-TID, M-LUN : NO

Data
Port Target ID H-LUN LUN
OA 0
OB 1
1A 2
1B 3
```

**Note:** When the manager 2 is connected to the array unit with the Fibre Channel connection, set ‘--’ for the **T-ID**.

Two types of sample files are provided for automatic setting. The sample file configuration is shown below.

Sample file : id00.txt --- Host LU independent access type

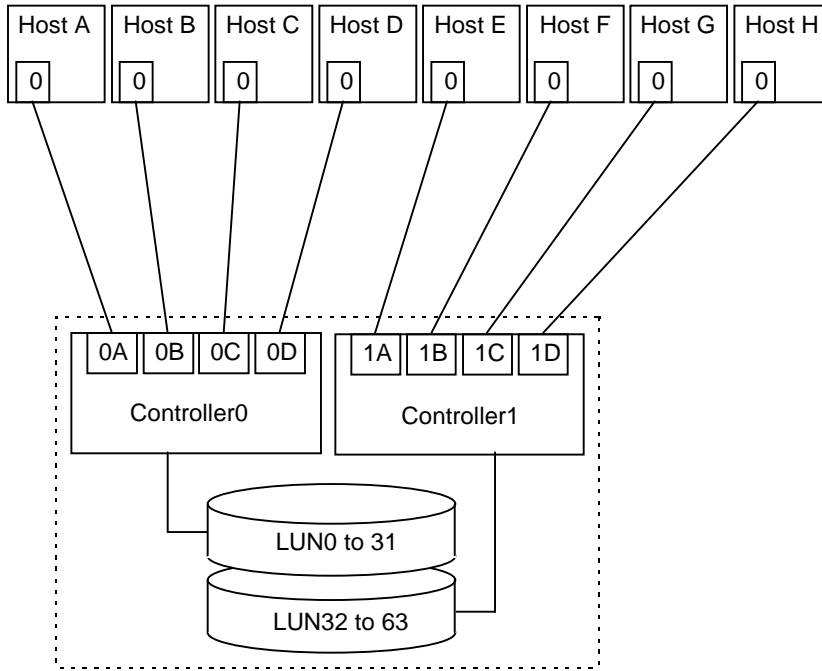

| Host | Port | Target ID | H-LUN  | LUN      |
|------|------|-----------|--------|----------|
| A    | 0A   | 0         | 0 to 7 | 0 to 7   |
| B    | 0B   | 1         | 0 to 7 | 8 to 15  |
| C    | 0C   | 2         | 0 to 7 | 16 to 23 |
| D    | 0D   | 3         | 0 to 7 | 24 to 31 |
| E    | 1A   | 0         | 0 to 7 | 32 to 39 |
| F    | 1B   | 1         | 0 to 7 | 40 to 47 |
| G    | 1C   | 2         | 0 to 7 | 48 to 55 |
| H    | 1D   | 3         | 0 to 7 | 56 to 63 |

Sample file : id01.txt --- Host alternate path access type

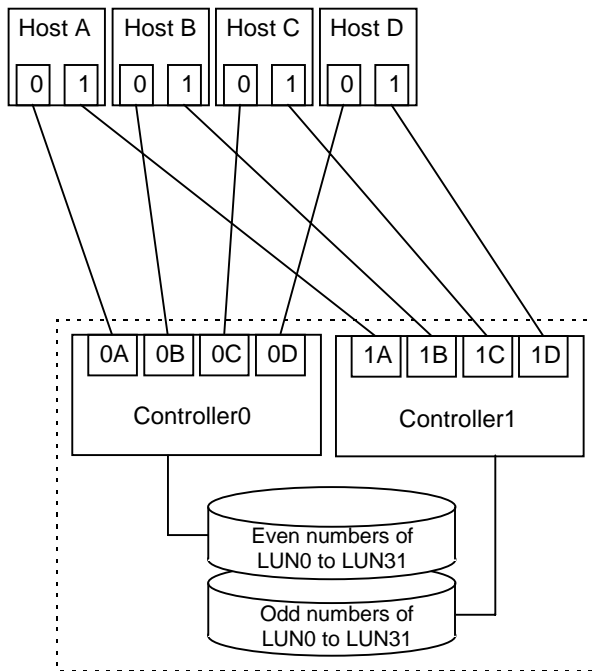

| Host    | Port | Target ID | H-LUN  | LUN      |
|---------|------|-----------|--------|----------|
| A-Path0 | 0A   | 0         | 0 to 7 | 0 to 7   |
| A-Path1 | 0B   | 1         | 0 to 7 | 8 to 15  |
| B-Path0 | 0C   | 2         | 0 to 7 | 16 to 23 |
| B-Path1 | 0D   | 3         | 0 to 7 | 24 to 31 |
| C-Path0 | 1A   | 0         | 0 to 7 | 0 to 7   |
| C-Path1 | 1B   | 1         | 0 to 7 | 8 to 15  |
| D-Path0 | 1C   | 2         | 0 to 7 | 16 to 23 |
| D-Path1 | 1D   | 3         | 0 to 7 | 24 to 31 |

4. Click the **Apply** button.
5. A message indicating completion of setting is displayed. A confirmation message indicating a request for restarting is displayed, so click the **OK** button when restarting.

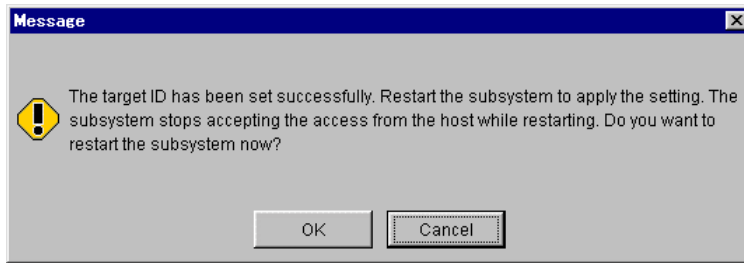

**Note:** To validate the set Target ID, restart the array unit. The previous settings stay valid until restarting.

When restarting is initiated, the array unit is not ready to accept an access from the host for duration from initiation until the restarting terminates. Therefore, after making sure that the host has stopped accessing, initiate restarting.

**Note:** When failing to write onto the FD drive, the message “DMES04EB02 : Backup floppy disk write error.” is displayed.

When this message is displayed, writing into an FD has not been finished, but setting the Target ID may be completed.

Check an FD in an array unit, re-confirm the data to set, turn on the **FD Backup** check box, and then click the **Apply** button once again.

6. When instructing to restart an array unit, the time the restarting has began is displayed. The restarting takes about two to six minutes.

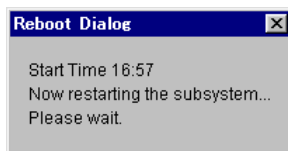

**Note:** It may take time for an array unit to respond, depending on the condition of the array unit. If it does not still respond after 10 minutes or more pass, check the condition of the array unit.

7. A message indicating that the restarting has terminated is displayed, so click the **OK** button.

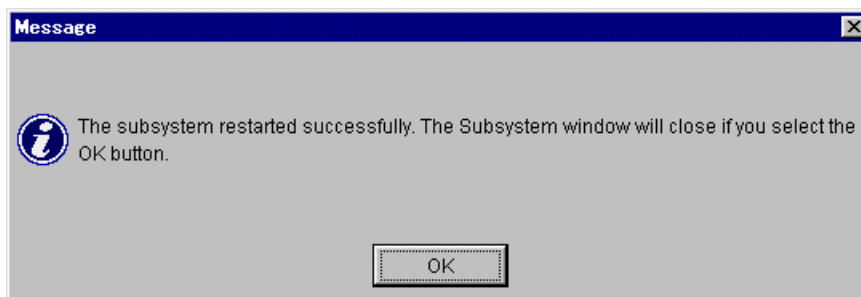

When clicking the **OK** button, the unit screen is closed. To perform other operations, select again on the main screen an array unit which to operate, and open the unit screen.

## 6.1.2 Adds mapping information

Adds mapping information for an set-up Target ID. Setting is allowed only if the Target ID mode of an array unit which to set up has been set to **M-TID,M-LUN** (mapping).

If the Target ID has been set in advance using the **Change (After)**, restart an array unit to reflect the setting on the array unit, and then add mapping information.

Added information becomes valid without restarting an array unit.

1. Select “**Settings—Configuration Settings**” on the Unit screen. Or, when you click the : **Configuration Settings**” in the tool bar.
2. Click the **Target ID** tab.

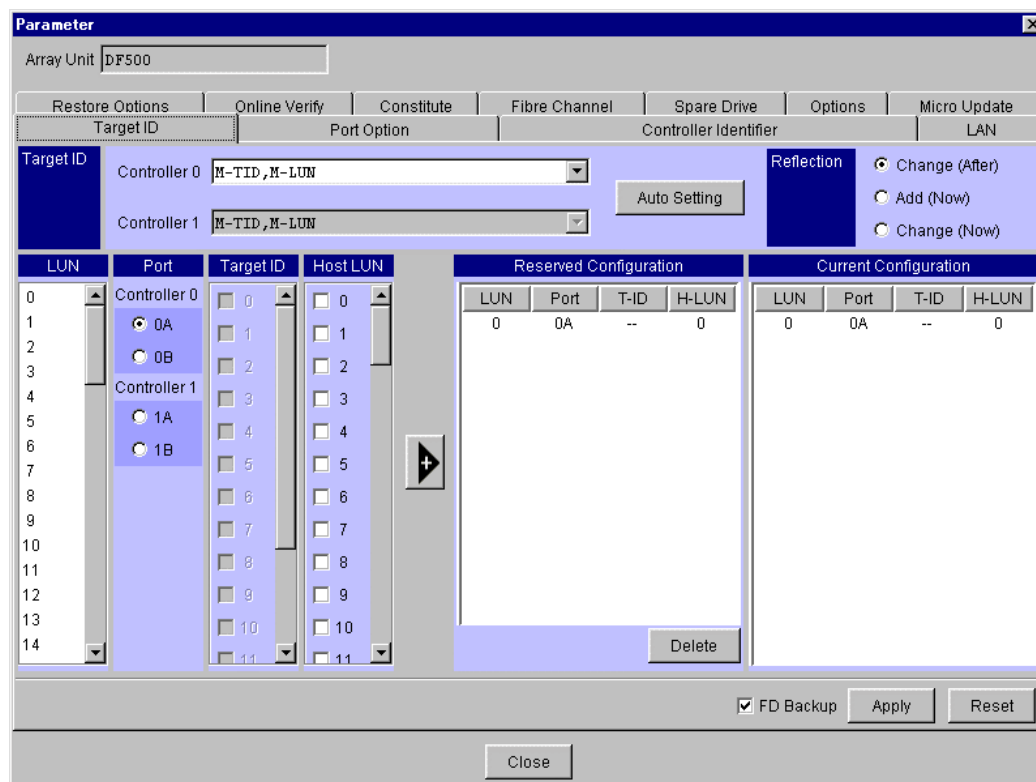

- **FD Backup:** Target ID configuration information has been saved in a backup FD in an array unit as parameter information. When the setting is modified, it is necessary to save it again, so be sure to turn on the check box.

3. Click the **Add (Now)** radio button on **Reflection** box.
4. Add the information, and click the **Apply** button.

5. A message indicating completion of setting is displayed, click the **OK** button.

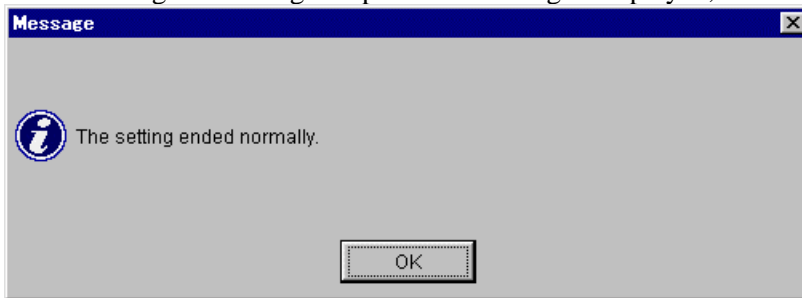

The added information is updated and displayed on **Current Configuration**.

**Note:** When failing to write onto the FD drive, the message “DMES04EB02 : Backup floppy disk write error.” is displayed.

When this message is displayed, writing into an FD has not been finished, but setting the Target ID may be completed.

Check an FD in an array unit, re-confirm the data to set, turn on the **FD Backup** check box, and then click the **Apply** button once again.

### 6.1.3 Change mapping information

Change mapping information for an set-up Target ID. Setting is allowed only if the Target ID mode of an array unit which to set up has been set to **M-TID,M-LUN** (mapping).

If the Target ID has been set in advance using the **Change (After)**, restart an array unit to reflect the setting on the array unit, and then add mapping information.

Added information becomes valid without restarting an array unit.

**Note:** When executing modification, I/O operations on a set-up port may terminate abnormally. When you modify, execute modification after all I/O operations from the host to a port for which to modify settings stop.

1. Select “**Settings—Configuration Settings**” on the Unit screen. Or, when you click the : **Configuration Settings**” in the tool bar.
2. Click the **Target ID** tab.

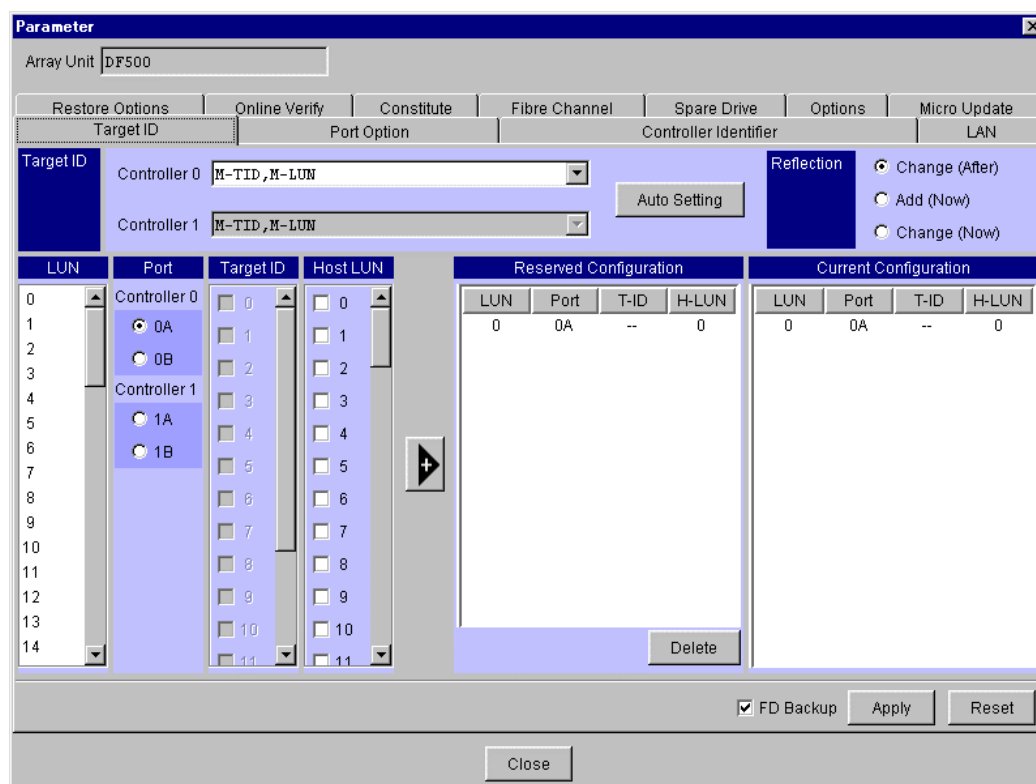

- **FD Backup:** Target ID configuration information has been saved in a backup FD in an array unit as parameter information. When the setting is modified, it is necessary to save it again, so be sure to turn on the check box.

3. Click the **Change (Now)** radio button on **Reflection** box.
4. Add the information, and click the **Apply** button.

5. A confirmation message indicating. After making sure that I/O operation initiated by the host has stopped, click the **OK** button.

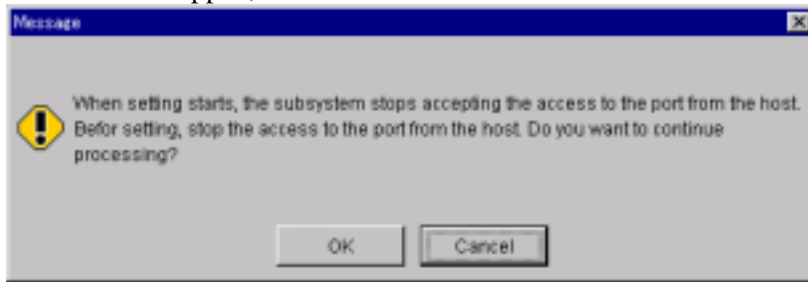

6. A message indicating completion of setting is displayed, click the **OK** button.

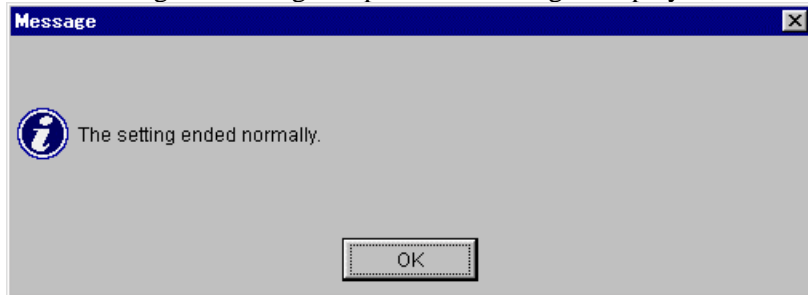

The added information is updated and displayed on **Current Configuration**.

**Note:** When failing to write onto the FD drive, the message “DMES04EB02 : Backup floppy disk write error.” is displayed.

When this message is displayed, writing into an FD has not been finished, but setting the Target ID may be completed.

Check an FD in an array unit, re-confirm the data to set, turn on the **FD Backup** check box, and then click the **Apply** button once again.

## 6.2 LAN configuration

The LAN configuration information of the array unit is set.

1. Select “**Settings—Configuration Settings**” on the Unit screen. Or, when you click the “ : **Configuration Settings**” in the tool bar.
2. Click the **LAN** tab.

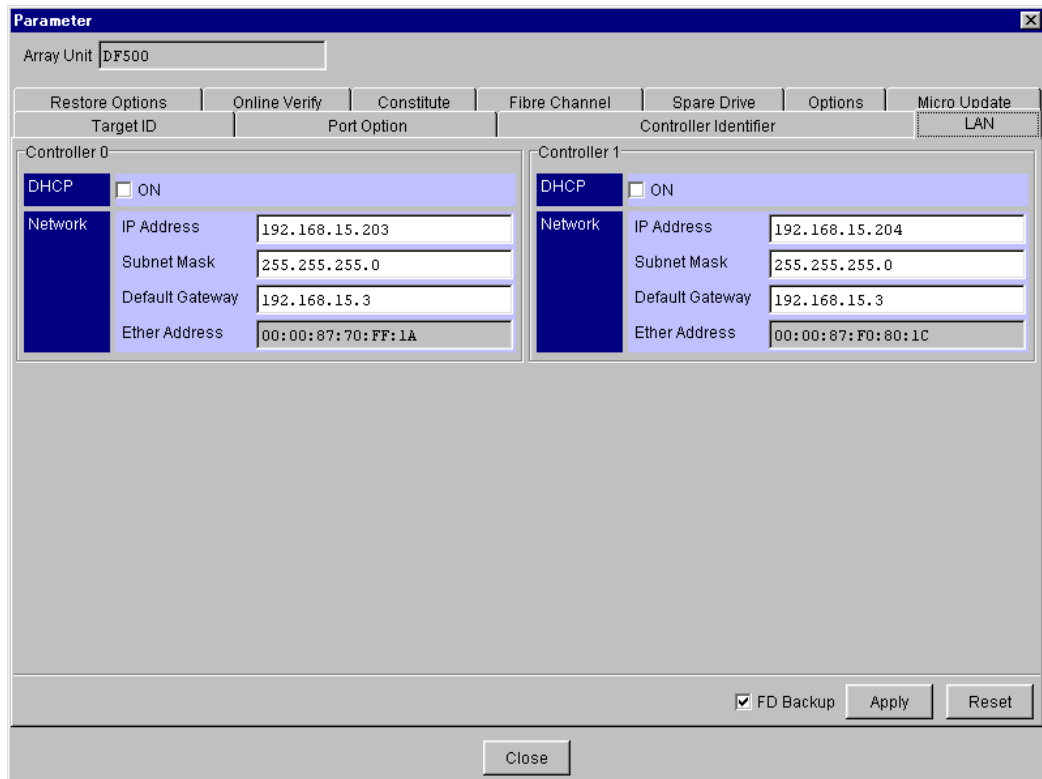

The screenshot shows the 'Parameter' configuration window for an array unit. The window title is 'Parameter' and the array unit is identified as 'DF500'. The interface includes several tabs: 'Restore Options', 'Online Verify', 'Constitute', 'Fibre Channel', 'Spare Drive', 'Options', and 'Micro Update'. The 'LAN' tab is selected, showing configuration for two controllers, Controller 0 and Controller 1. Each controller has a 'DHCP' section with a checkbox for 'ON' (currently unchecked) and a 'Network' section with fields for 'IP Address', 'Subnet Mask', 'Default Gateway', and 'Ether Address'. The 'Ether Address' field is grayed out, indicating it is read-only. At the bottom of the window, there is a checked checkbox for 'FD Backup' and buttons for 'Apply', 'Reset', and 'Close'.

| Controller   | DHCP                        | IP Address     | Subnet Mask   | Default Gateway | Ether Address     |
|--------------|-----------------------------|----------------|---------------|-----------------|-------------------|
| Controller 0 | <input type="checkbox"/> ON | 192.168.15.203 | 255.255.255.0 | 192.168.15.3    | 00:00:87:70:FF:1A |
| Controller 1 | <input type="checkbox"/> ON | 192.168.15.204 | 255.255.255.0 | 192.168.15.3    | 00:00:87:F0:80:1C |

- **DHCP:** Specifies whether the DHCP mode is to be valid or invalid.
- **Network:** Specifies IP Address, Subnet Mask, or Default Gateway which is a piece of the LAN information. Ether Address is only displayed and cannot be changed.
- **FD Backup:** LAN configuration information is saved onto the backup FD in the array unit as a piece of the system parameter information. **Be sure to check the check box** because a saving of it is required again if the setting is changed

**Note 1:** When selected **ON** in **DHCP**, **LAN Parameter** is displayed in gray and can not be selected.

3. Click the **Apply** button.
4. A message indicating completion of setting is displayed. A confirmation message indicating a request for restarting is displayed, so click the **OK** button when restarting.

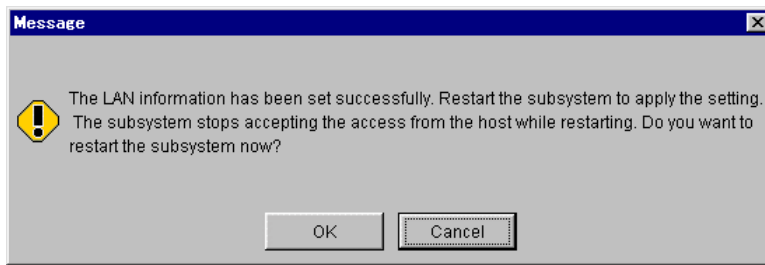

**Note:** To validate the set LAN information, restart the array unit. The previous settings stay valid until restarting.

When restarting is initiated, the array unit is not ready to accept an access from the host for duration from initiation until the restarting terminates. Therefore, after making sure that the host has stopped accessing, initiate restarting.

**Note:** When failing to write onto the FD drive, the message “DMES04EB02 : Backup floppy disk write error.” is displayed.

When this message is displayed, writing into an FD has not been finished, but setting the LAN configuration information may be completed.

Check an FD in an array unit, re-confirm the data to set, turn on the **FD Backup** check box, and then click the **Apply** button once again.

5. When instructing to restart an array unit, the time the restarting has began is displayed. The restarting takes about two to six minutes.

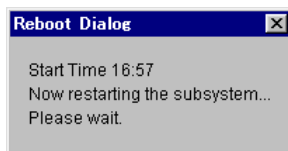

**Note:** It may take time for an array unit to respond, depending on the condition of the array unit. If it does not still respond after 10 minutes or more pass, check the condition of the array unit.

6. A message indicating that the restarting has terminated is displayed, so click the **OK** button.

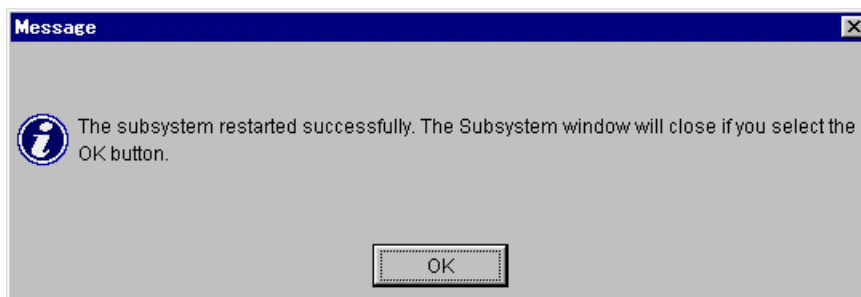

When clicking the **OK** button, the unit screen is closed. To perform other operations, select again on the main screen an array unit which to operate, and open the unit screen.

## 6.3 Setting SCSI transfer rate

The transfer rate for each port of the array unit is set.

1. Select “**Settings—Configuration Settings**” on the Unit screen. Or, when you click the “ : **Configuration Settings**” in the tool bar.
2. Click the **SCSI** tab.

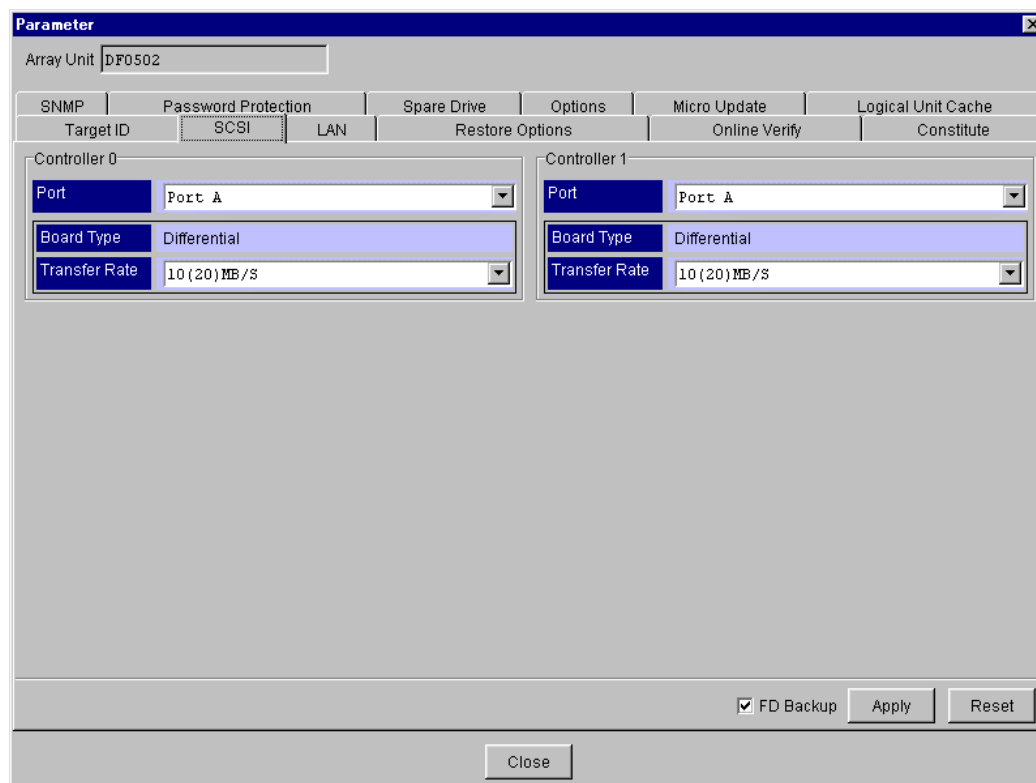

- **Port:** Selects the port number to be set.
- **Board Type:** The IF board type installed is displayed.
  - None:** Not installed
  - Single:** Single type
  - Differential:** Differential type
  - Ultra2:** Ultra2 type
- **Transfer Rate:** Selects the port transfer rate.
  - STANDARD:** Transfers data is automatically according to the IF board installed.
  - ASYNC:** Transfers data in the mode without using the synchronous transfer.
  - 5(10) MB/S:** Sets the maximum transfer rate to 5 M byte/s for narrow SCSI and 10 M byte/s for wide SCSI.
  - 10(20) MB/S:** Sets the maximum transfer rate to 10 M byte/s for narrow SCSI and 20 M byte/s for wide SCSI.
  - 20(40) MB/S:** Sets the maximum transfer rate to 20 M byte/s for narrow SCSI and 40 M byte/s for wide SCSI.
  - 40(80) MB/S:** Sets the maximum transfer rate to 40 M byte/s for narrow SCSI and 80 M byte/s for wide SCSI.

**Note:** When the **Board Type** is displayed **None**, it is displayed in gray and cannot be set. When the **Board Type** is displayed **Single** or **Differential**, **40(80) MB/S** are displayed in gray and cannot be selected.

- **FD Backup:** The SCSI I/F transfer rate information is saved on the backup floppy disk in the array unit as system parameter information. **Be sure to check the check box** because it becomes necessary to save it once again when the setting is changed.
3. Click the **Apply** button.
  4. A message indicating completion of setting is displayed. A confirmation message indicating a request for restarting is displayed, so click the **OK** button when restarting.

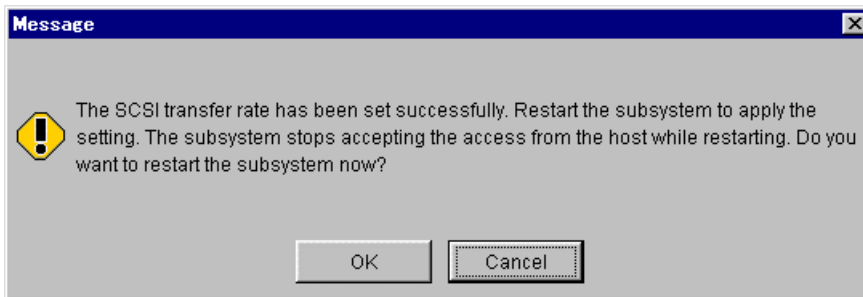

**Note:** To validate the set SCSI transfer rate, restart the array unit. The previous settings stay valid until restarting.

When restarting is initiated, the array unit is not ready to accept an access from the host for duration from initiation until the restarting terminates. Therefore, after making sure that the host has stopped accessing, initiate restarting.

**Note:** When failing to write onto the FD drive, the message “DMES04EB02 : Backup floppy disk write error.” is displayed.

When this message is displayed, writing into an FD has not been finished, but setting the SCSI transfer rate may be completed.

Check an FD in an array unit, re-confirm the data to set, turn on the **FD Backup** check box, and then click the **Apply** button once again.

5. When instructing to restart an array unit, the time the restarting has began is displayed. The restarting takes about two to six minutes.

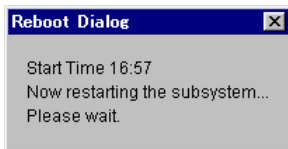

**Note:** It may take time for an array unit to respond, depending on the condition of the array unit. If it does not still respond after 10 minutes or more pass, check the condition of the array unit.

6. A message indicating that the restarting has terminated is displayed, so click the **OK** button.

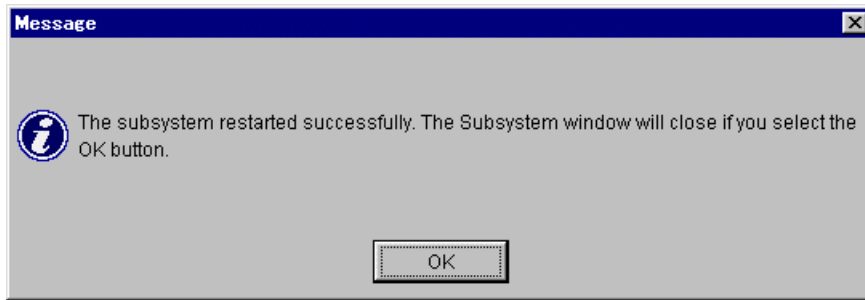

When clicking the **OK** button, the unit screen is closed. To perform other operations, select again on the main screen an array unit which to operate, and open the unit screen.

## 6.4 Spare Drive Setup

The following procedure sets up and cancels the spare disk.

1. Select “**Settings—Configuration Settings**” on the Unit screen. Or, when you click the : **Configuration Settings**” in the tool bar.
2. Click the **Spare Drive** tab.

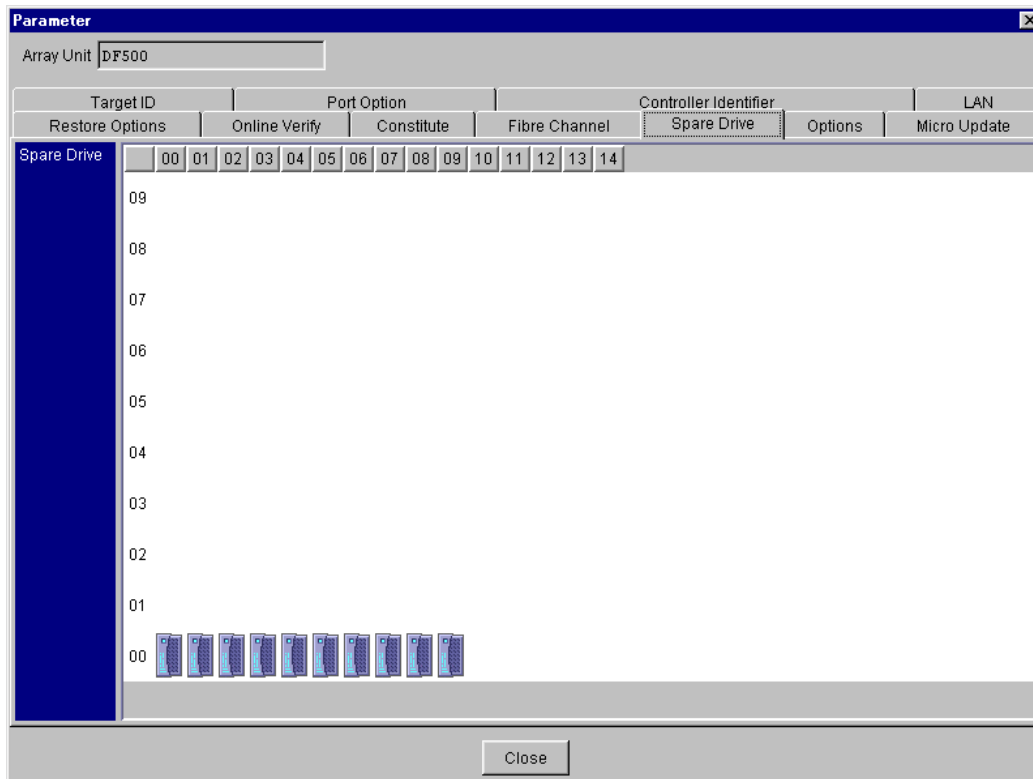

Data disk



Spare disk

3. To setup the spare drive, double-click the icon of the HDU to be setup as a spare drive. HDUs that can be set to a spare drive drive are data disk drives for which an RAID group is not yet defined, excluding HDUs 0 and 1 in Unit 0. To cancel the spare drive setup, click the icon of the HDU to be canceled.

4. The confirmation message for spare drive setup or canceled is displayed. Click the **OK** button.

ee) When a spare disk is setup

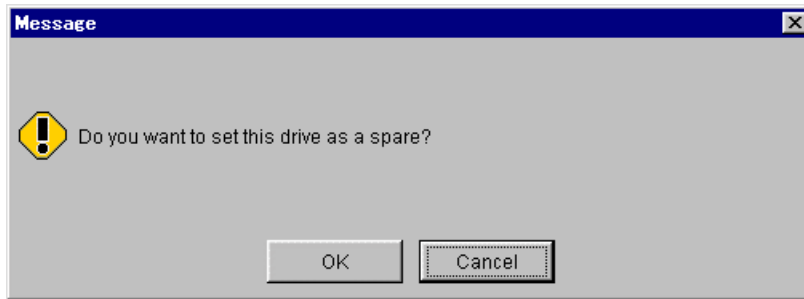

ff) When a spare disk is canceled

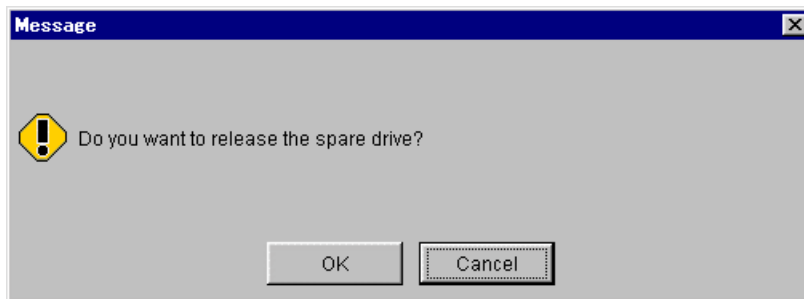

5. A message indicating completion of setting is displayed, click the **OK** button.

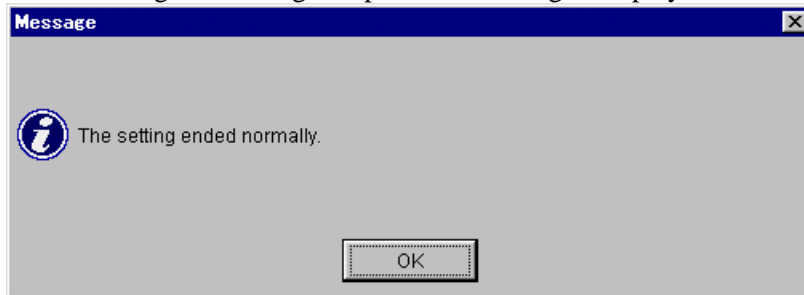

The icon of the HDU which is setup or canceled is updated and displayed.

## 6.5 Setting the drive restoration control option

Selection and setting of this option are not valid when they are made during drive restoration. (Drive restoration is executed according to the option at the start of the processing.) Make sure that the drive is not being restored when changing the option setting.

1. Select “**Settings—Configuration Settings**” on the Unit screen. Or, when you click the “ : **Configuration Settings**” in the tool bar.
2. Click the **Restore Options** tab.

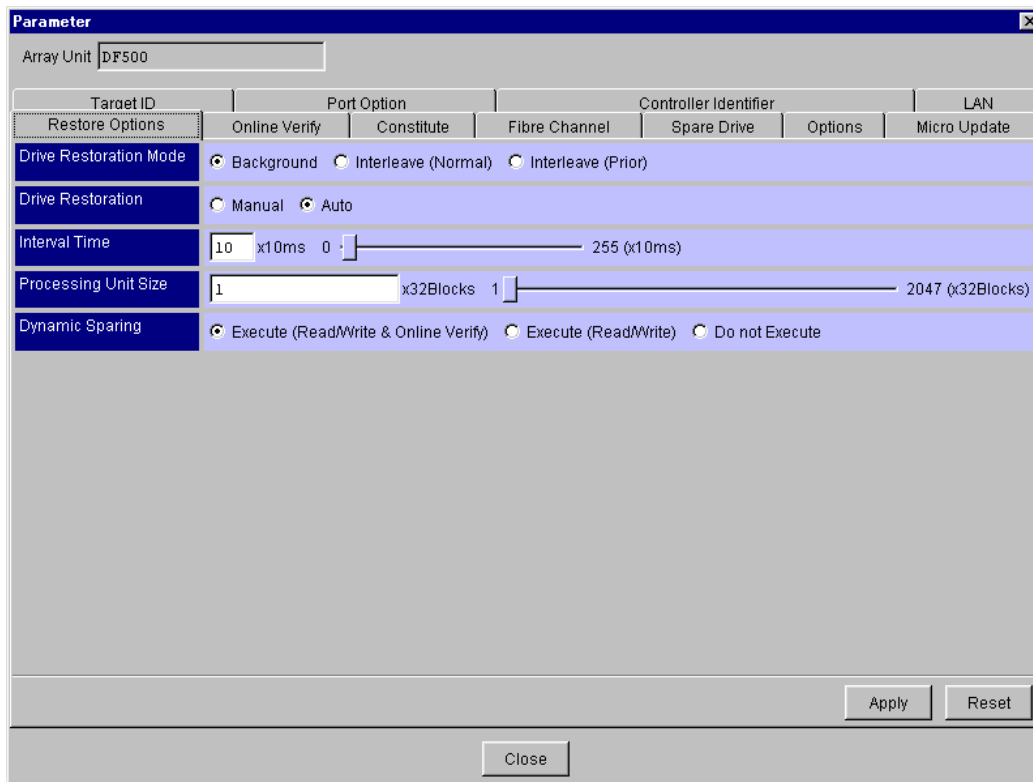

| Target ID              | Port Option   | Controller Identifier | LAN           |             |         |              |
|------------------------|---|-----------------------|---------------|-------------|---------|--------------|
| Restore Options        | Online Verify   | Constitute            | Fibre Channel | Spare Drive | Options | Micro Update |
| Drive Restoration Mode | <input checked="" type="radio"/> Background <input type="radio"/> Interleave (Normal) <input type="radio"/> Interleave (Prior)                        |                       |               |             |         |              |
| Drive Restoration      | <input type="radio"/> Manual <input checked="" type="radio"/> Auto  |                       |               |             |         |              |
| Interval Time          | 10 x10ms 0 255 (x10ms)  |                       |               |             |         |              |
| Processing Unit Size   | 1 x32Blocks 1 2047 (x32Blocks)  |                       |               |             |         |              |
| Dynamic Sparring       | <input checked="" type="radio"/> Execute (Read/Write & Online Verify) <input type="radio"/> Execute (Read/Write) <input type="radio"/> Do not Execute |                       |               |             |         |              |

3. Specify **Drive Restoration Mode**, **Drive Restoration**, **Interval Time**, **Processing Unit Size**, and **Dynamic Sparring**.

- **Drive Restoration Mode:** Specify a mode in which drives are to be restored.

**Background:** Executes drive restoration while host I/O processing is not executed.

**Interleave (Normal):** Restores the drive at preset time intervals (specified as “Interval Time”) giving preference to a host command (restores after executing the command).

**Interleave (Prior):** Restores the drive at preset time intervals (specified as “Interval Time”) taking preference over a host command.

- **Drive Restoration:** Instructs whether to start the following operations automatically or manually. The operations concerned are data restoration to the failed drive or to the spare drive, copy back of the data from the spare drive to the original drive, and dynamic sparing.

**Manual:** Starts restoring data and copying by manual operations.

**Auto:** Automatically starts restoration of data and copying.

**Note:** Use **Auto**, as the manager 2 does not support a manual operation.

- **Interval Time:** Specify a time interval of drive restoration. The default interval time is  $10 \times 10$  ms and drive restoration is executed at intervals of 100 ms. Specify a multiplication factor 0 to 255 in a unit of 10 ms.
- **Processing Unit Size:** Specify the size of the data block to be restored. The default processing unit size is 32 blocks and data of 16 k byte is restored at a time. When Interleave mode is specified, the function restores data of a processing unit size specified here, waits for a time interval specified here, then starts the next data restoration. Specify a multiplication factor 1 to 2,047 in a unit of 512 bytes.
- **Dynamic Sparing:** Specify a mode for data restoration for the spare drive when the error occurrence count controlled by preventive maintenance exceeds the threshold value.

**Execute (Read/Write & Online Verify):** When the error occurrence count in **Read/Write Error** or **Online Verify Error**, Threshold Value Over and Start of Dynamic Sparing are displayed on the panel and data restoration is performed for the spare drive (when the spare drive is not used), and the error disk is blocked.

**Execute (Read/Write):** When the error occurrence count in **Read/Write Error** exceeds the threshold value, Threshold Value Over and Start of Dynamic Sparing are displayed on the panel and data restoration is performed for the spare disk in the spare drive (when the spare disk is not used), and the error disk is blocked. When the error occurrence count in **Online Verify Error** exceeds the threshold value, Threshold Value Over is displayed on the panel but Dynamic Sparing is not performed.

**Do not Execute:** When the error occurrence count in **Read/Write Error** or **Online Verify Error** exceeds the threshold value, Threshold Value Over is displayed on the panel but Dynamic Sparing is not performed.

4. After completion of the setting, click the **Apply** button.

## 6.6 Online verify mode

1. Select “**Settings—Configuration Settings**” on the Unit screen. Or, when you click the “ : **Configuration Settings**” in the tool bar.
2. Click the **Online Verify** tab.

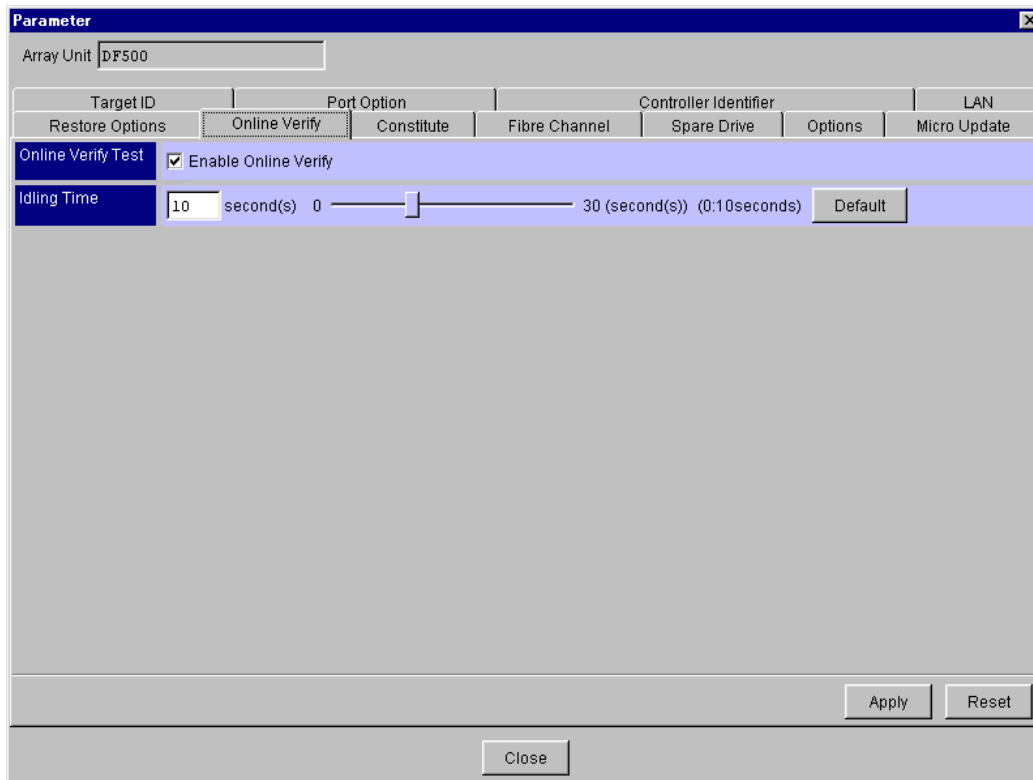

3. Select whether or not to execute **Online Verify Test** and specify **Idling Time**.
  - **Online Verify Test:** Specifies whether or not to execute **Online Verify Test**.
  - **Idling Time:** Specifies an interval from the end of an I/O operation instructed by the host to the start of the online verify. If “0” is specified, the time is set to 10 [seconds], and hence an online verify operation begins 10 [seconds] after an I/O operation from the host terminates. Specify a value within a range between 1 and 30 seconds in units of seconds.
4. After completion of the setting, click the **Apply** button.

## 6.7 Setting Fibre Channel Information

The fibre channel information is displayed and set.

1. Select “**Settings—Configuration Settings**” on the Unit screen. Or, when you click the “ : **Configuration Settings**” in the tool bar.
2. Click the **Fibre Channel** tab.

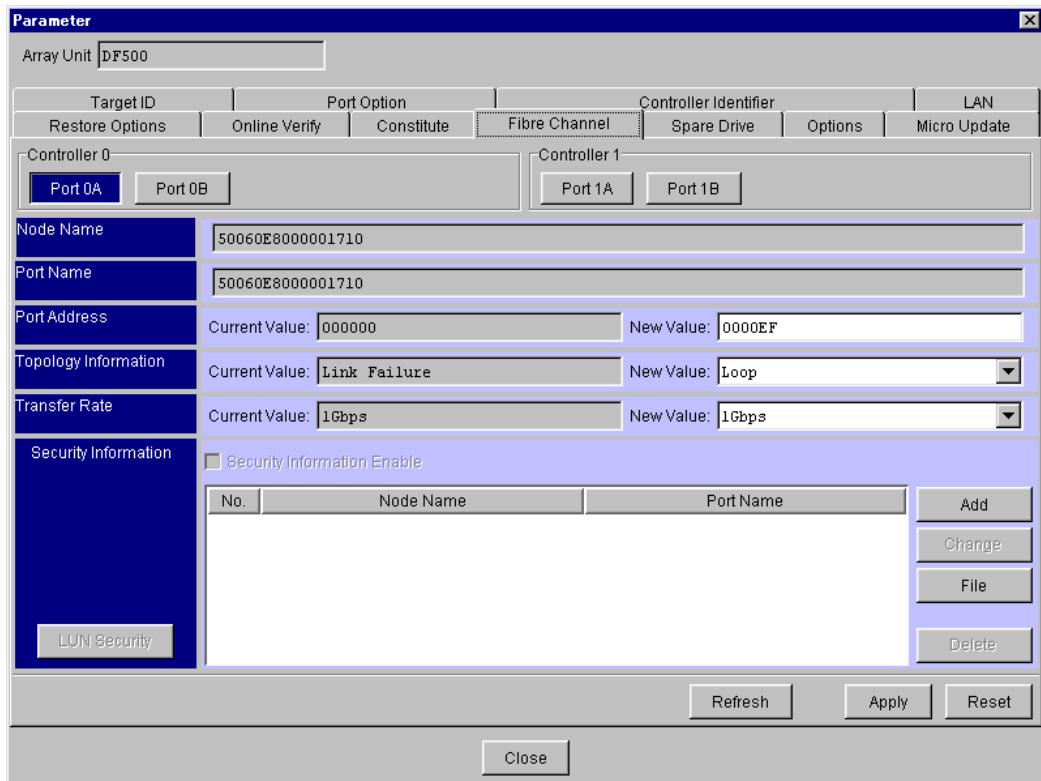

The screenshot shows a software window titled "Parameter" with a close button in the top right corner. The "Array Unit" is set to "DF500". A navigation bar at the top includes tabs for "Target ID", "Port Option", "Controller Identifier", and "LAN". Below this, a secondary bar contains "Restore Options", "Online Verify", "Constitute", "Fibre Channel" (the active tab), "Spare Drive", "Options", and "Micro Update". The main area is divided into "Controller 0" and "Controller 1". Under "Controller 0", there are buttons for "Port 0A" and "Port 0B". Under "Controller 1", there are buttons for "Port 1A" and "Port 1B". The configuration fields are as follows:

- Node Name:** 50060E8000001710
- Port Name:** 50060E8000001710
- Port Address:** Current Value: 000000, New Value: 0000EF
- Topology Information:** Current Value: Link Failure, New Value: Loop (dropdown menu)
- Transfer Rate:** Current Value: 1Gbps, New Value: 1Gbps (dropdown menu)
- Security Information:**  Security Information Enable

Below the Security Information section is a table with columns "No.", "Node Name", and "Port Name". To the right of the table are buttons for "Add", "Change", "File", and "Delete". At the bottom of the window are "Refresh", "Apply", "Reset", and "Close" buttons.

- **Node Name:** Describes 8 bytes of data hexadecimal (with 16 characters).
- **Port Name:** Describes 8 bytes of data hexadecimal (with 16 characters).
- **Port Address:** Port address is displayed as a hexadecimal number.
- **Topology Information:** Indicate the topology status.
- **Transfer Rate:** Indicate the fiber transfer rate.
- **Security Information:** Setting and displaying at the LUN security information.

## 6.7.1 Topology Setup

The following procedure sets up the topology. The topology is setup on a port basis.

1. Select “**Settings—Configuration Settings**” on the Unit screen. Or, when you click the “: **Configuration Settings**” in the tool bar.
2. Click the **Fibre Channel** tab.
3. Select the **New Value** in the **Topology Information**.

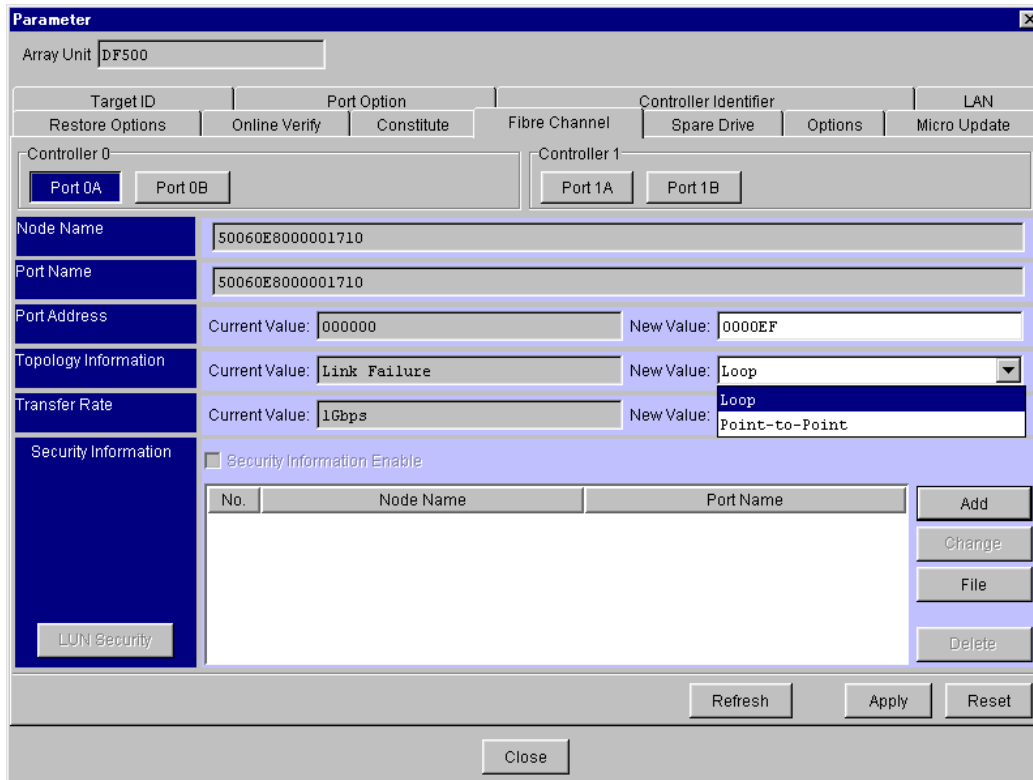

The screenshot shows the 'Parameter' window for Array Unit DF500. The 'Fibre Channel' tab is selected. The window is divided into two controllers: Controller 0 and Controller 1. Controller 0 has ports Port 0A and Port 0B. Controller 1 has ports Port 1A and Port 1B. The 'Node Name' and 'Port Name' fields are both set to '50060E8000001710'. The 'Port Address' section shows 'Current Value: 000000' and 'New Value: 0000EF'. The 'Topology Information' section shows 'Current Value: Link Failure' and 'New Value: Loop'. The 'Transfer Rate' section shows 'Current Value: 1Gbps' and 'New Value: Loop'. The 'Security Information' section has a checkbox for 'Security Information Enable' which is unchecked. Below this is a table with columns 'No.', 'Node Name', and 'Port Name', and buttons 'Add', 'Change', 'File', and 'Delete'. At the bottom of the window are 'Refresh', 'Apply', 'Reset', and 'Close' buttons.

4. Click the **Apply** button.

Operations vary with the array unit to set up. Refer to individual ways for operations so as to meet their respective array units.

- If an array unit supports a setup without restarting
5. A confirmation message indicating. After making sure that I/O operation initiated by the host has stopped, click the **OK** button.

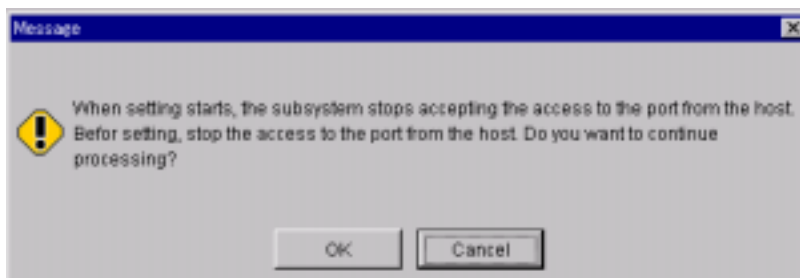

6. A message indicating completion of setting is displayed, click the **OK** button.

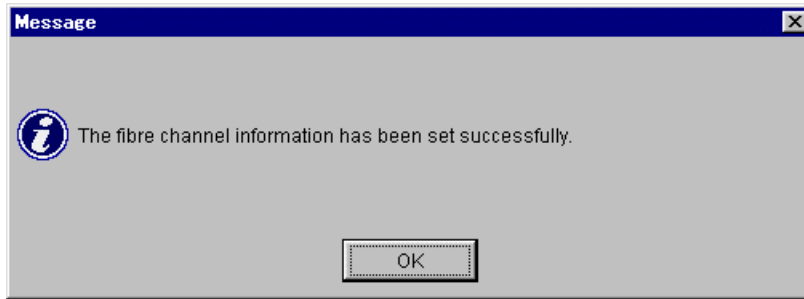

**Note:** It may take time to complete setting.

Click the **Refresh** button, and then check if correct settings has been made.

- If an array unit not supports a setup without restarting

5. A message indicating completion of setting is displayed. To validate the set topology, restart the array unit. So clicks the **OK** button when restarting.

**Note:** To validate the set topology, restart the array unit. The previous settings stay valid until restarting.

When restarting is initiated, the array unit is not ready to accept an access from the host for duration from initiation until the restarting terminates. Therefore, after making sure that the host has stopped accessing, initiate restarting.

6. When instructing to restart an array unit, the time the restarting has began is displayed. The restarting takes about two to six minutes.

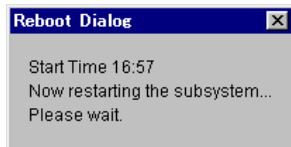

**Note:** It may take time for an array unit to respond, depending on the condition of the array unit. If it does not still respond after 10 minutes or more pass, check the condition of the array unit.

7. A message indicating that the restarting has terminated is displayed, so click the **OK** button.

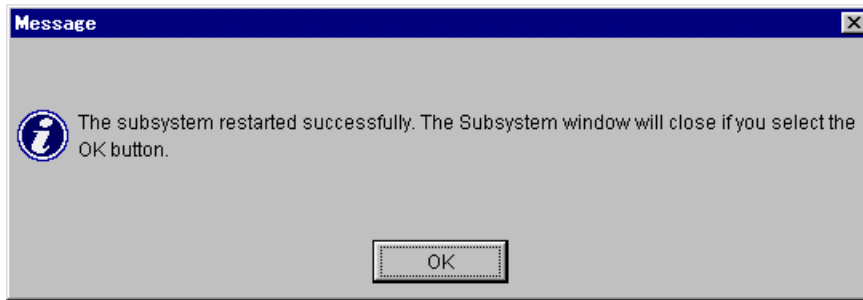

When clicking the **OK** button, the unit screen is closed. To perform other operations, select again on the main screen an array unit which to operate, and open the unit screen.

## 6.7.2 Setting of Port Address

Set the port address of the Fibre Port.

1. Select “**Settings—Configuration Settings**” on the Unit screen. Or, when you click the “: **Configuration Settings**” in the tool bar.
2. Click the **Fibre Channel** tab.
3. Select the **New Value** in the **Port Address**.

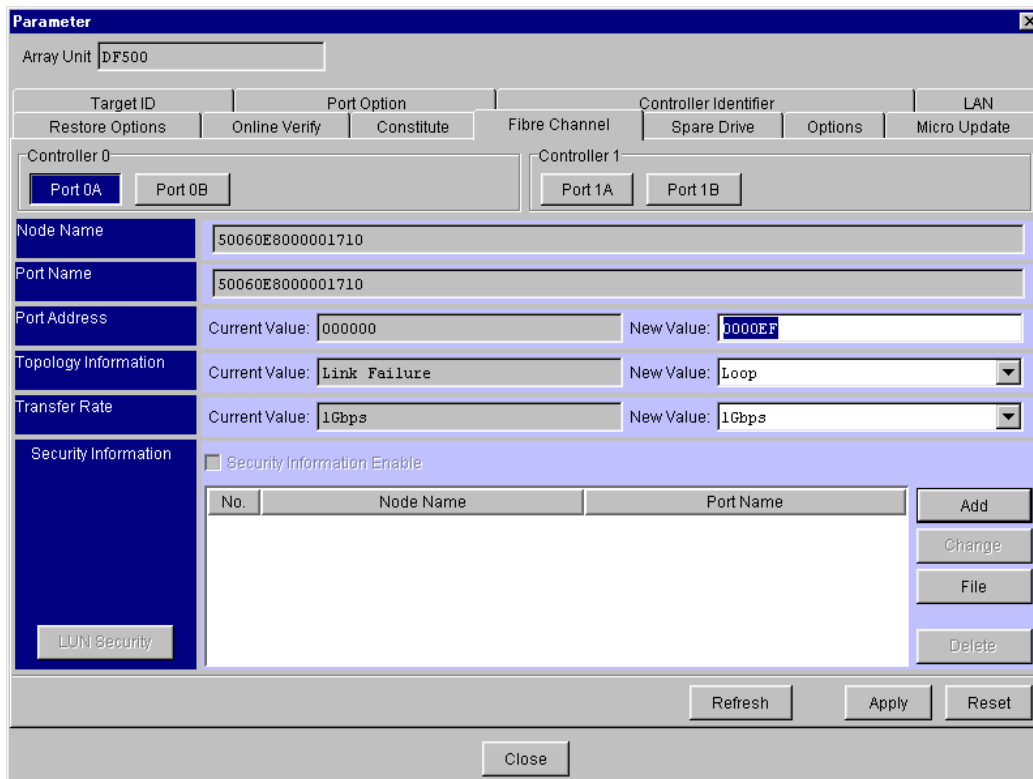

The screenshot shows the 'Parameter' configuration window for an array unit 'DF500'. The window is divided into several sections:

- Target ID:** DF500
- Port Option:** Fibre Channel (selected)
- Controller 0:** Port 0A (selected)
- Controller 1:** Port 1A (selected)
- Node Name:** 50060E8000001710
- Port Name:** 50060E8000001710
- Port Address:** Current Value: 000000, New Value: 0000EF
- Topology Information:** Current Value: Link Failure, New Value: Loop
- Transfer Rate:** Current Value: 1Gbps, New Value: 1Gbps
- Security Information:** Security Information Enable (checkbox)
- Table:** A table with columns 'No.', 'Node Name', and 'Port Name'. It is currently empty.
- Buttons:** Add, Change, File, Delete, Refresh, Apply, Reset, Close.

4. Click the **Apply** button.

Operations vary with the array unit to set up. Refer to individual ways for operations so as to meet their respective array units.

- If an array unit supports a setup without restarting
5. A confirmation message indicating. After making sure that I/O operation initiated by the host has stopped, click the **OK** button.

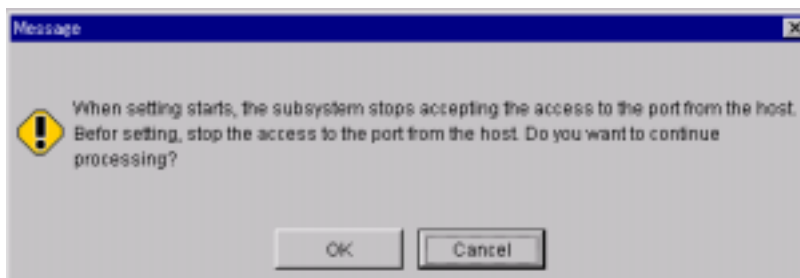

6. A message indicating completion of setting is displayed, click the **OK** button.

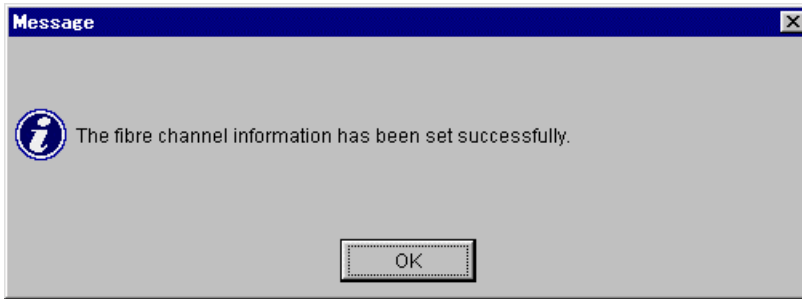

**Note:** It may take time to complete setting.

Click the **Refresh** button, and then check if correct settings has been made.

- If an array unit not supports a setup without restarting

5. A message indicating completion of setting is displayed. To validate the set topology, restart the array unit. So clicks the **OK** button when restarting.

**Note:** To validate the set port address, restart the array unit. The previous settings stay valid until restarting.

When restarting is initiated, the array unit is not ready to accept an access from the host for duration from initiation until the restarting terminates. Therefore, after making sure that the host has stopped accessing, initiate restarting.

6. When instructing to restart an array unit, the time the restarting has began is displayed. The restarting takes about two to six minutes.

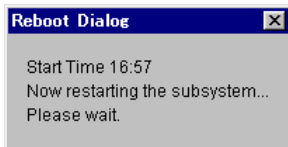

**Note:** It may take time for an array unit to respond, depending on the condition of the array unit. If it does not still respond after 10 minutes or more pass, check the condition of the array unit.

7. A message indicating that the restarting has terminated is displayed, so click the **OK** button.

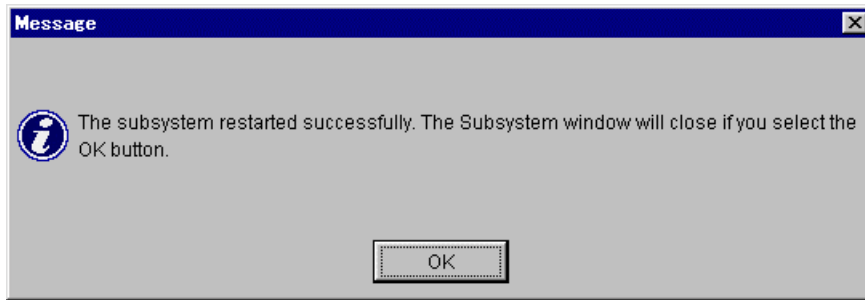

When clicking the **OK** button, the unit screen is closed. To perform other operations, select again on the main screen an array unit which to operate, and open the unit screen.

### 6.7.3 Setting of transfer rate

Set the transfer rate of the Fibre Port.

1. Select “**Settings—Configuration Settings**” on the Unit screen. Or, when you click the “ : **Configuration Settings**” in the tool bar.
2. Click the **Fibre Channel** tab.
3. Select the **New Value** in the **Transfer Rate**.

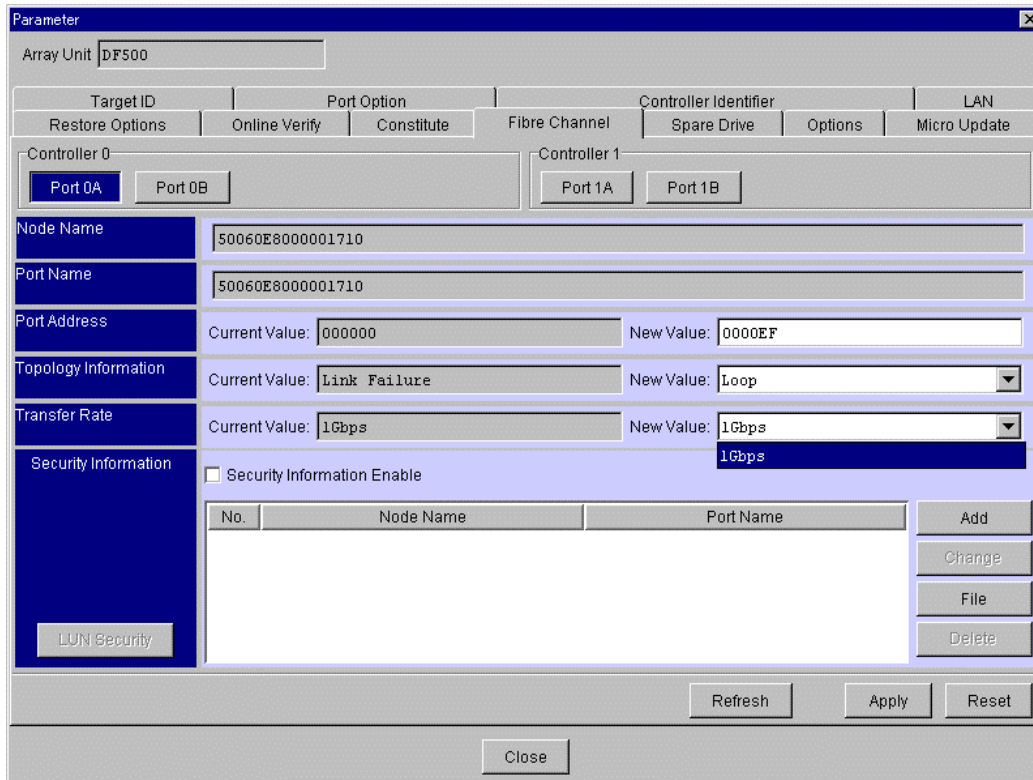

The screenshot shows the 'Parameter' configuration window for Array Unit DF500. The 'Fibre Channel' tab is selected. Under 'Controller 0', 'Port 0A' is selected. The 'Transfer Rate' field shows a 'Current Value' of '1Gbps' and a 'New Value' of '1Gbps'. The 'Topology Information' field shows a 'Current Value' of 'Link Failure' and a 'New Value' of 'Loop'. The 'Security Information' section has 'Security Information Enable' unchecked. At the bottom, there are 'Refresh', 'Apply', and 'Reset' buttons.

4. Click the **Apply** button.
5. A confirmation message indicating. After making sure that I/O operation initiated by the host has stopped, click the **OK** button.

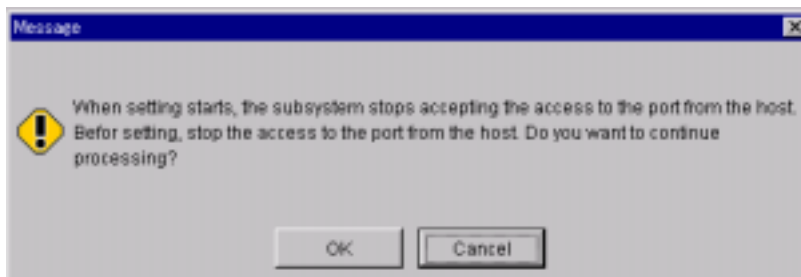

6. A message indicating completion of setting is displayed, click the **OK** button.

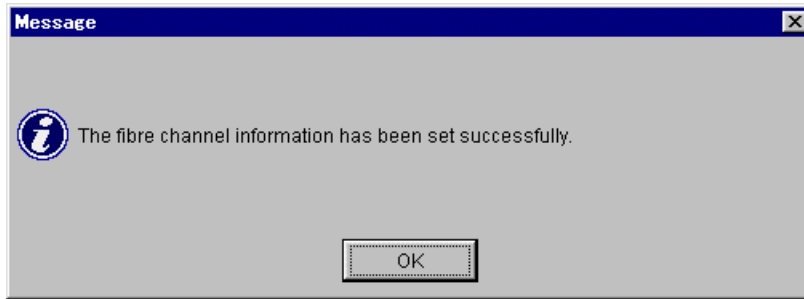

**Note:** It may take time to complete setting.  
Click the **Refresh** button, and then check if correct settings has been made.

## 6.7.4 Setting port security

The port security function specifies another port for which access is permitted for each port. Set the WWN (node name and port name) being security information for each port.

1. Select “**Settings—Configuration Settings**” on the Unit screen. Or, when you click the : **Configuration Settings**” in the tool bar.
2. Click the **Fibre Channel** tab.
3. Setting the **WWN**.
  - **LUN Security**: Specify whether the LUN security is to be used or not.
  - **WWN**: When using the port security and LUN security, setup the host WWN. Specify **Node Name** and **Port Name** using a 16-digit hexadecimal.

gg) For addition, click the **Add** button.

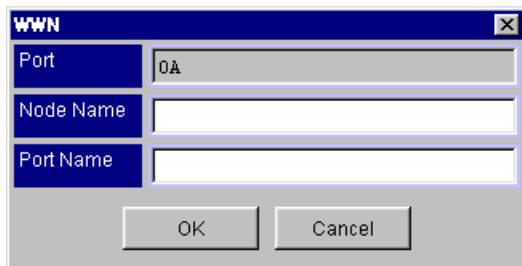

| WWN       |    |
|-----------|----|
| Port      | 0A |
| Node Name |    |
| Port Name |    |
| OK Cancel |    |

Specify **Node Name** and **Port Name** of the WWN of the host and click the **OK** button. The **Parameter** window is updated according to the added WWN.

hh) For deletion, click the **WWN** to be deleted in the **Security Information** box and click the **Delete** button.

The **Parameter** window is updated according to the deleted WWN.

ii) For a change, click the **WWN** to be deleted in the **Security Information** box and click the **Change** button.

When the WWN of the host that is set appears, change **Node Name** and **Port Name** and click the **OK** button. The **Parameter** window is updated according to the added WWN.

jj) When settings are made by using File, click the **File** button.

The WWN information is read from the file and **Node Name**, **Port Name**, and **N\_Port\_ID** are set.

When a file reference window appears, select a file to be used and click the **OK** button.

The **Parameter** window is updated according to the WWN of the read file.

**Note:** When settings have been made by using **File**, all the contents that are previously set are invalidated and changed to that of the read file.

When you set by use of a file, though multiple pieces of setting information are stated in the file, information about only selected port is reflected. When you set up all ports, change the port to a port which to set up, and then read the file.

The following figure shows a file format for the case where settings are performed by using “File”. Input necessary items for each port. Put a space between items. If tabs are used, the setting of the line including “tab” are ignored because it is regarded as an input error.

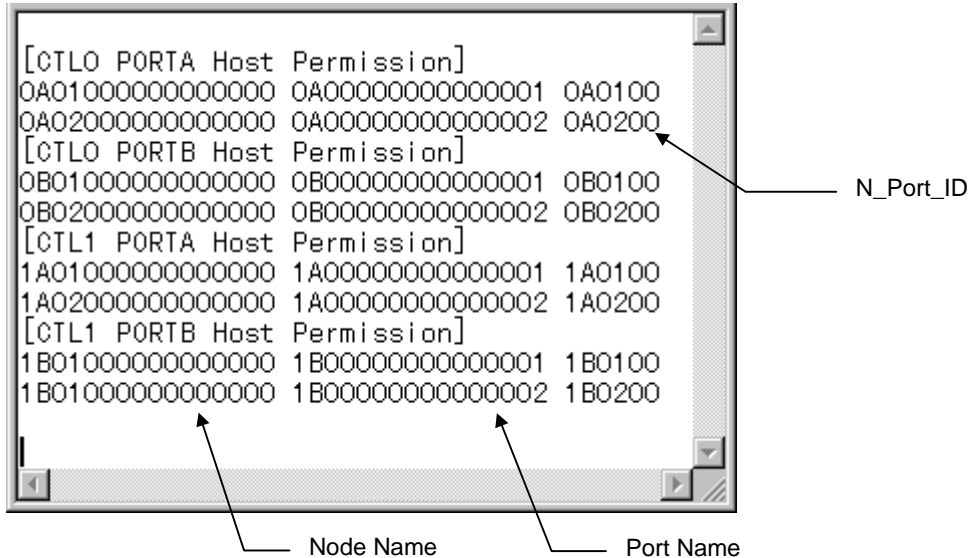

- **Node Name:** Describes 8 bytes of data hexadecimal (with 16 characters).
- **Port Name:** Describes 8 bytes of data hexadecimal (with 16 characters).
- **N\_Port\_ID:** Describes 3 bytes of data hexadecimal (with 6 characters). Concerning the host identification information, this data can be omitted. When the data is omitted, it is assumed to be 0X000000.

When “;” is described at the top, the line is regarded as a comment line.

4. Click the **Apply** button on the **Parameter** window.
5. A message indicating completion of setting is displayed, click the **OK** button.

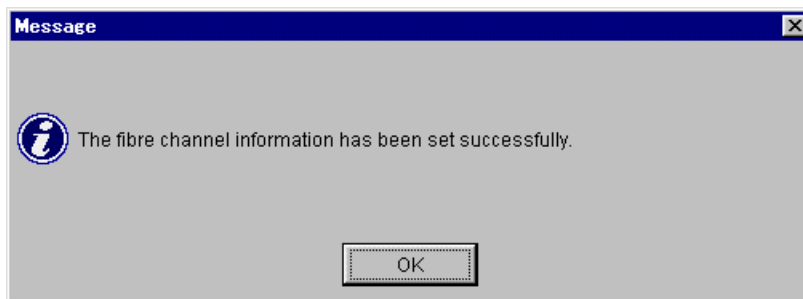

### 6.7.5 Setting LUN security

The LUN security function specifies another port for which access is permitted for each port and each LUN.

Set the WWN (node name and port name) being security information for each port and for each LUN.

1. Select “**Settings—Configuration Settings**” on the Unit screen. Or, when you click the “ : **Configuration Settings**” in the tool bar.
2. Click the **Fibre Channel** tab.
3. Turn on the **Security Information Enable** check box in the **Security Information** box. The **LUN Security** is enabled, so click the **LUN Security** button. Displayed **LUN Security** window.

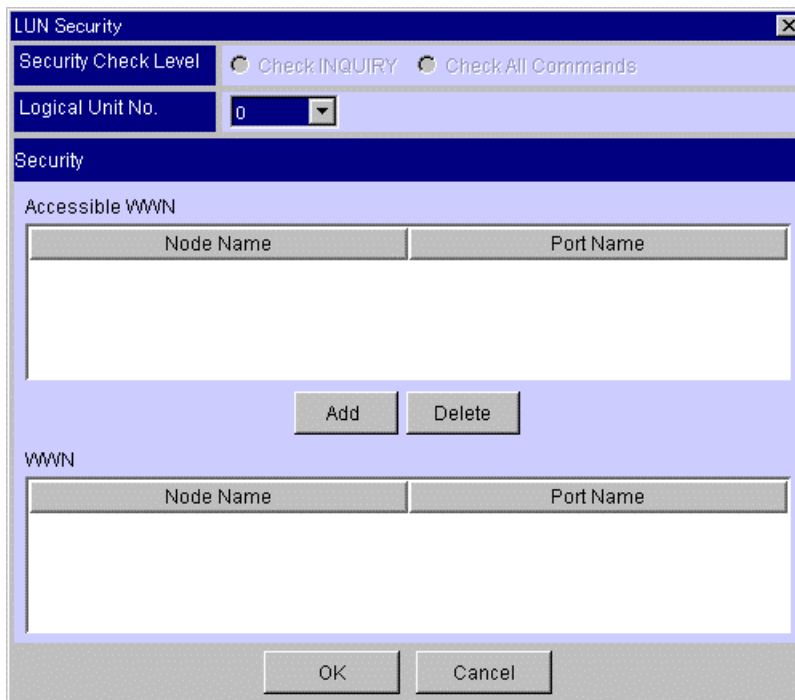

The screenshot shows the LUN Security configuration window. At the top, there's a title bar 'LUN Security'. Below it, the 'Security Check Level' section has two radio buttons: 'Check INQUIRY' (selected) and 'Check All Commands'. The 'Logical Unit No.' is set to '0'. The 'Security' section is expanded, showing two tables. The 'Accessible WWN' table has columns for 'Node Name' and 'Port Name'. Below this table are 'Add' and 'Delete' buttons. The 'WWN' table also has columns for 'Node Name' and 'Port Name'. At the bottom of the window are 'OK' and 'Cancel' buttons.

If the HP connection mode is specified with system parameters, you cannot specify **Logical Unit No.**

In this case, LUN-based setting is not possible and only port-based setting is possible.

4. Select **Check INQUIRY** or **Check All Commands** on the **Security Check Level** box.  
Select the **Logical Unit No.** an logical unit No. to set.  
The logical unit No. to set is displayed in the **Logical Unit No.**, and WWN information in the logical unit No. is displayed  
For addition, click the WWN to be added in the **WWN** box and click the **Add** button. For deletion, click the WWN to be deleted in the **Accessible WWN** box and click **Delete**. The WWN to be set is displayed in the **Access Enable WWN** box.  
To setup the security for all logical units, specify **ALL** for **Logical Unit No.**
5. Clicks the **OK** button, and then clicks the **OK** button on the **Parameter** screen.
6. A message indicating completion of setting is displayed, click the **OK** button.

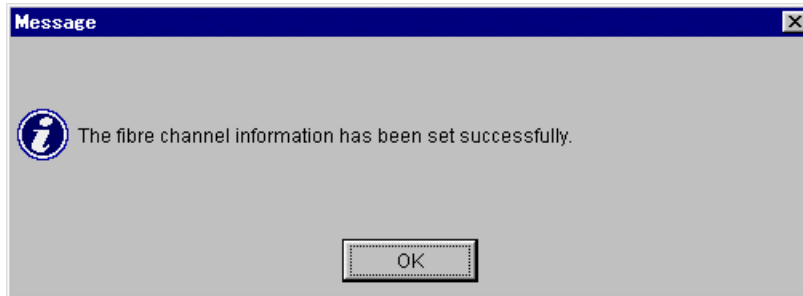

## 6.8 Outputting Configuration Information to File

Output in a text file the configuration information of the array unit, or set configuration using a text file.

The configuration information output in a text file is the status of the system parameters, RAID group/logical unit and the constituent parts of the array unit. The configuration to be set is the system parameters and RAID group/logical unit. The status of the constituent parts of the array unit cannot be set.

The configuration information is handled with separate text files for the system parameters and for RAID group/logical unit.

The copying of configuration between array units can be carried out, by outputting a text file of the configuration from an array unit, and then by using the output text file to set another array unit.

Editing a text file to set an array unit can be carried out, but it is recommended that this function be used for the configuration of the same array unit. As for a change in the configuration, please carry out using individual functions.

## 6.8.1 File Output of Configuration : System Parameters

Output in text form to a specified file the setting content of the system parameters set in an array unit.

1. Select “**Settings—Configuration Settings**” on the Unit screen. Or, when you click the “ : **Configuration Settings**” in the tool bar.
2. Click the **Constitute** tab.

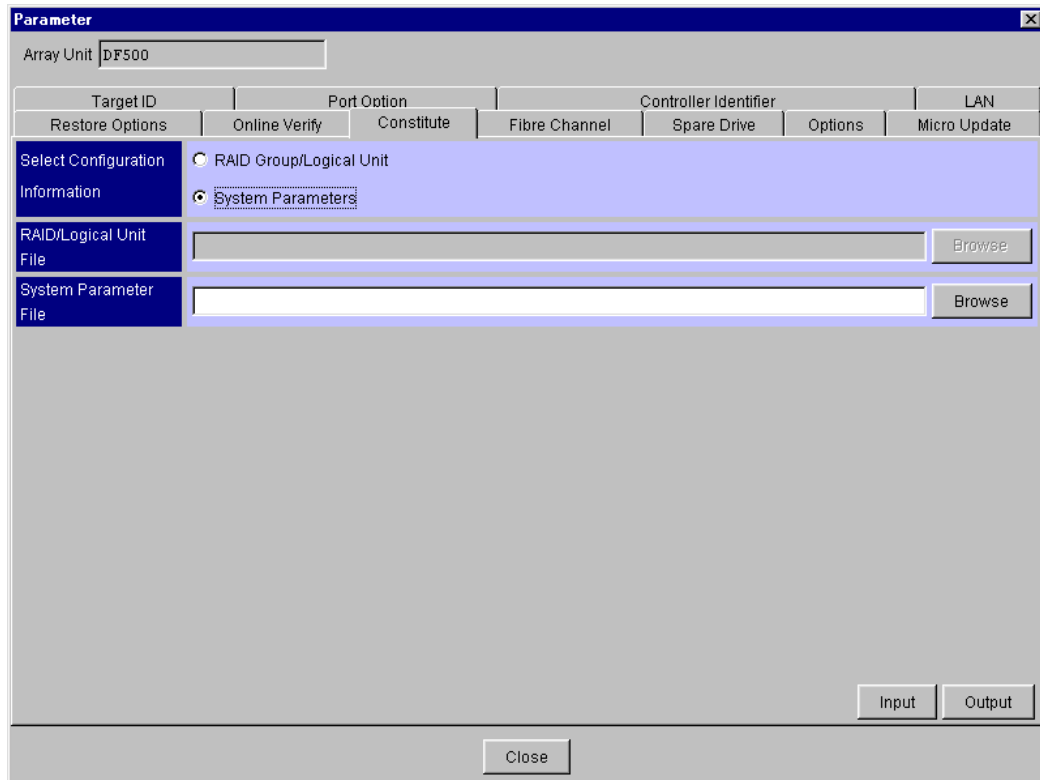

3. Check the **System Parameters** in the **Select Configuration Information** box.
4. Click the **Browse** button, and specify the directory and file name to output the file of the configuration.
5. Click the **Output** button.

6. When a confirmation message displaying that the system parameter information is output with the specified file name shown, click the **OK** button.

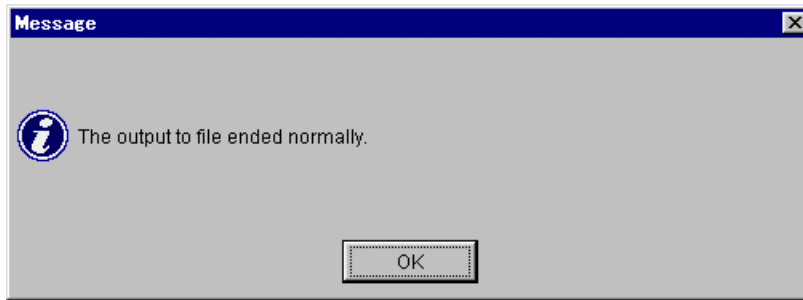

System parameter information is saved in the form of a text file with the specified file name.

The format of the output file consists of the following items. The outline of the layout of the output file is shown in Figure 6.8.1

- File header
- Registration name with the manager 2 of the array unit
- Output time (Time of the machine where the manager 2 is installed)
- Microprogram revision
- Array unit type
- Common controller parameters
- Controller 0 parameters
- Controller 1 parameters
- Direction for FD backup

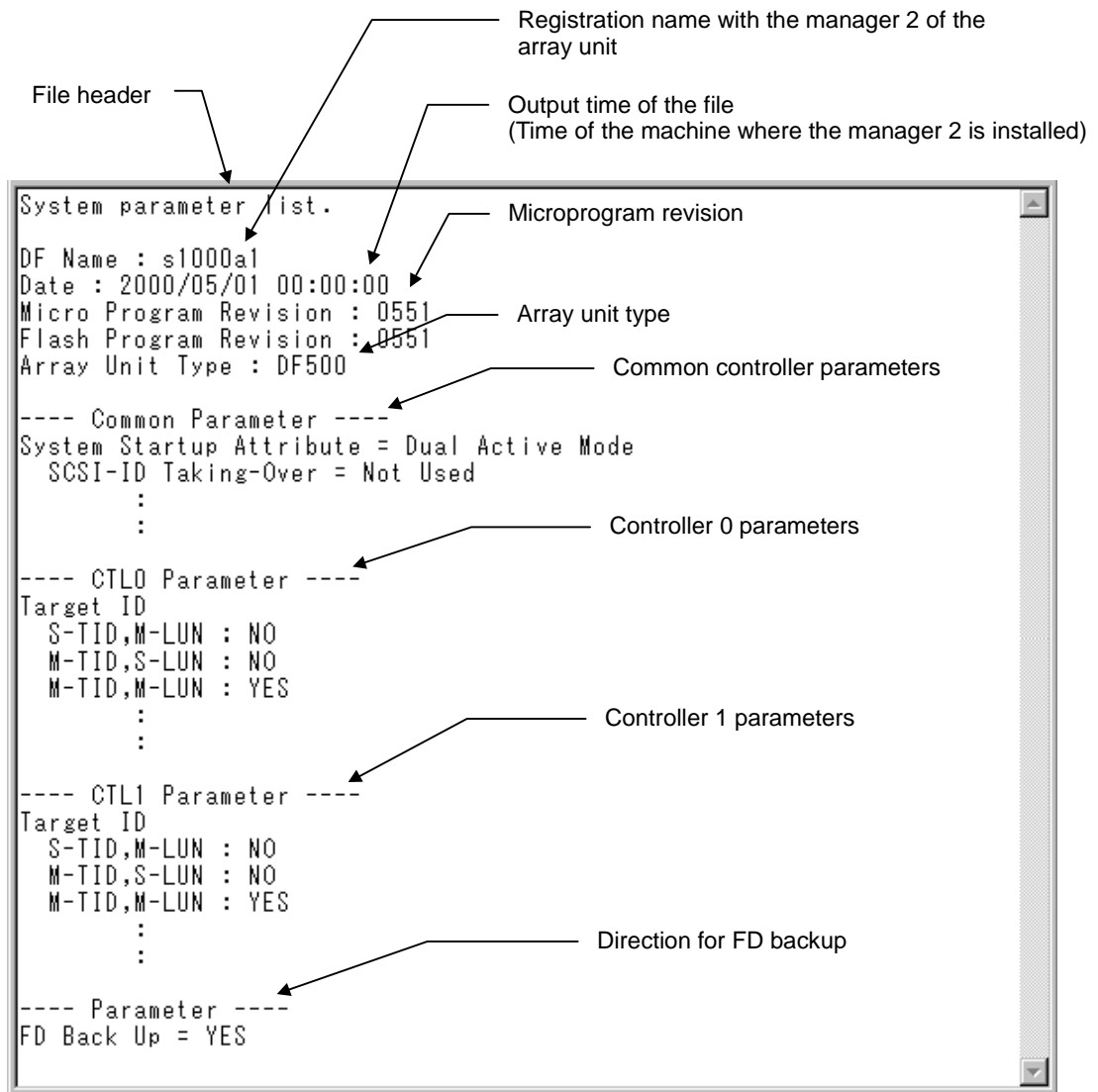

Figure 6.8.1 Outline of the format of the system parameter output file

## kk) Common Controller Parameters

The common system parameters of the array unit are output. An output example of the system parameters of DF500 is shown in Figure 6.8.2.

```
---- Common Parameter ----
System Startup Attribute = Dual Active Mode
SCSI ID/Port ID Take-over Mode = ---
Default Controller
  Port A = ---
  Port B = ---
Data Share Mode = Used
Host Connection Mode 1
  Port 0A = Standard Mode
  Port 0B = Standard Mode
  Port 1A = Standard Mode
  Port 1B = Standard Mode
Host Connection Mode 2
  Port 0A
    VxVM DMP mode enable = OFF
    ODE Mapper mode enable = OFF
    HP Connection mode enable = ---
    Report inquiry page 83H = ON
    UA(06/2A00) suppress mode enable = OFF
    HISUP mode enable = OFF
    CCHS convert mode enable = OFF
  Port 0B
    VxVM DMP mode enable = OFF
    ODE Mapper mode enable = OFF
    HP Connection mode enable = ---
    Report inquiry page 83H = ON
    UA(06/2A00) suppress mode enable = OFF
    HISUP mode enable = OFF
    CCHS convert mode enable = OFF
  Port 1A
    VxVM DMP mode enable = OFF
    ODE Mapper mode enable = OFF
    HP Connection mode enable = ---
    Report inquiry page 83H = ON
    UA(06/2A00) suppress mode enable = OFF
    HISUP mode enable = OFF
    CCHS convert mode enable = OFF
  Port 1B
    VxVM DMP mode enable = OFF
    ODE Mapper mode enable = OFF
    HP Connection mode enable = ---
    Report inquiry page 83H = ON
    UA(06/2A00) suppress mode enable = OFF
    HISUP mode enable = OFF
    CCHS convert mode enable = OFF
Serial Number =
Option 1
  Drive Detach mode enable = OFF
Option 2
  Multipath(Controller) = OFF
  PROCOM mode enable = OFF
  Report status (normal / warning) = OFF
  Multipath (Array Unit) = OFF
  Turbo LU Warning = OFF
Data Striping Size = 64KB
Operation if the Processor failures Occurs = Reset a Fault
INQUIRY Information
  Command Queuing = ON
  ANSI Version = ---
  Vendor ID =
  Product ID =
  ROM Microprogram Version =
  RAM Microprogram Version =
Web Title
  Web Title = ""
Cache Mode = All OFF
```

Figure 6.8.2 System parameters: output example of common parameters

The common parameters are the items shown in Table 6.8.1.

Table 6.8.1 List of common parameters

| Item | Setting item                              | Wizard window title     |
|------|---|-------------------------|
| 1    | Start Attribute                           | System Startup Settings |
| 2    | Host Connection Mode                      | System Startup Settings |
| 3    | Serial Number                             | System Startup Settings |
| 4    | Option 1                                  | Option 1                |
| 5    | Option 2                                  | Option 2                |
| 6    | Data Striping Size                        | Data Striping           |
| 7    | Reset ALL LIP Port Mode                   | Port Type               |
| 8    | Operation if the processor failure occurs | Data Striping           |
| 9    | Command Queuing                           | INQUIRY Setting         |
| 10   | Cache Mode                                | INQUIRY Setting         |

Depending on the array unit in connection, there are items that do not need to be set, and these items will not be output in the file. Moreover, if the value of an item in the parameters is given as “---” it is an item not supported in the configuration of the array unit.

## II) Controller 0 Parameters

The parameters of controller 0 in the system parameters of the array unit that make the output are output.

```
---- CTL0 Parameter ----
Target ID
S-TID,M-LUN : NO
M-TID,S-LUN : NO
M-TID,M-LUN : YES

Data
Port Target ID H-LUN LUN
0A      0      0    0
0B      0      1    1
Port Type
Port Option
Reset/LIP Mode(Signal)
Port A = OFF
Port B = OFF
Reset/LIP Mode(Process)
Port A = OFF
Port B = OFF
LIP Port All Reset Mode
Port A = OFF
Port B = OFF
Target Reset (Bus Device Reset) Mode
Port A = OFF
Port B = OFF
Reserve Mode
Port A = OFF
Port B = OFF
Logical Unit Reset Mode
Port A = OFF
Port B = OFF
Third Party Process Logout Mode
Port A = OFF
Port B = OFF
ROM Pseudo-response command processing = ---
Save Data pointer response
Port A = ---
Port B = ---
Controller Identifier = Disable
RS232C Error Information Outflow Mode = OFF
Write & Verify Execution Mode = ON
LAN Const
DHCP = OFF
IP Address = 0.0.0.0
Subnet Mask = 0.0.0.0
Default Gateway = 0.0.0.0
Ether Address = 00:00:00:00:00:00
SCSI transfer rate
Port A = ---
Port B = ---
```

Figure 6.8.3 System parameters: output example of controller 0 parameters

The parameters of controller 0 are the items shown in Table 6.8.2.

Table 6.8.2 List of parameters of controller 0

| Item | Setting item                          | Wizard window title |
|------|---------------------------------------|---------------------|
| 1    | Target ID                             | Target ID           |
| 2    | Port Type                             | Port Type           |
| 3    | Controller Identifier                 | Controller Option   |
| 4    | RS232C Error Information Outflow Mode | Controller Option   |
| 5    | Execute Write & Verify Mode           | Controller Option   |
| 6    | LAN Configuration                     | LAN Setting         |

Depending on the array unit in connection, there are items that do not need to be set, and these items will not be output in the file. Moreover, if the value of an item in the parameters is given as “---” it is an item not supported in the configuration of the array unit.

mm) Controller 1 Parameters

The parameters of controller 1 in the system parameters of the array unit that make the output are output.

```
---- CTL1 Parameter ----
Target ID
S-TID,M-LUN : NO
M-TID,S-LUN : NO
M-TID,M-LUN : YES

Data
Port Target ID H-LUN LUN
0A 0 0 0
0B 0 1 1
Port Type
Port Option
Reset/LIP Mode(Signal)
Port A = OFF
Port B = OFF
Reset/LIP Mode(Process)
Port A = OFF
Port B = OFF
LIP Port All Reset Mode
Port A = OFF
Port B = OFF
Target Reset (Bus Device Reset) Mode
Port A = OFF
Port B = OFF
Reserve Mode
Port A = OFF
Port B = OFF
Logical Unit Reset Mode
Port A = OFF
Port B = OFF
Third Party Process Logout Mode
Port A = OFF
Port B = OFF
ROM Pseudo-response command processing = ---
Save Data pointer response
Port A = ---
Port B = ---
Controller Identifier = Disable
RS232C Error Information Outflow Mode = OFF
Write & Verify Execution Mode = ON
LAN Const
DHCP = OFF
IP Address = 0.0.0.0
Subnet Mask = 0.0.0.0
Default Gateway = 0.0.0.0
Ether Address = 00:00:00:00:00:00
SCSI transfer rate
Port A = ---
Port B = ---
```

Figure 6.8.4 System parameters: output example of the parameters of controller 1

The parameters of controller 1 are the items shown in Table 6.8.3.

Table 6.8.3 List of parameters of controller 1

| Item | Setting item                          | Wizard window title |
|------|---------------------------------------|---------------------|
| 1    | Target ID                             | Target ID           |
| 2    | Port Type                             | Port Type           |
| 3    | Controller Identifier                 | Controller Option   |
| 4    | RS232C Error Information Outflow Mode | Controller Option   |
| 5    | Execute Write & Verify Mode           | Controller Option   |
| 6    | LAN Configuration                     | LAN Setting         |

Depending on the array unit in connection, there are items that do not need to be set, and these items will not be output in the file. Moreover, if the value of an item in the parameters is given as “---” it is an item not supported in the configuration of the array unit.

nn) Parameters for Backup Use in the System Parameter Information

The specification of whether the system parameter information is backed up from the FDD of the array unit to FD is shown. The indication is always shown as “YES”.

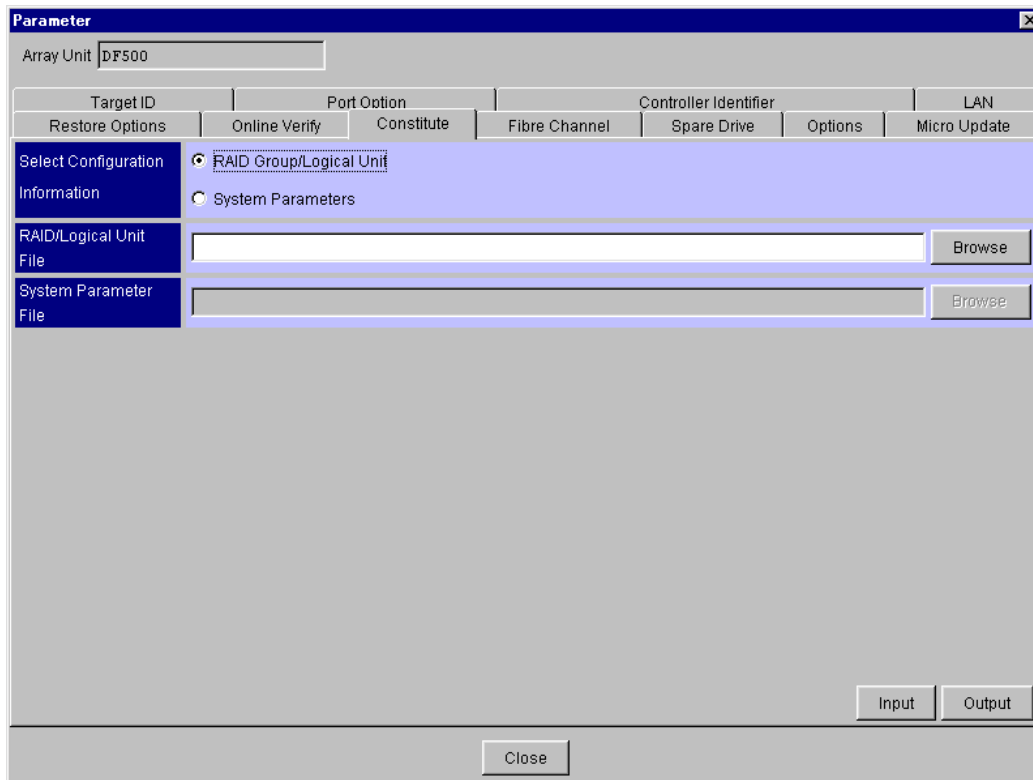

Figure 6.8.5 Output example for FD backup specification

## 6.8.2 Outputting configuration information to file : RAID group/logical unit and component status

The RAID group/logical unit definition information already set in an array unit is output to a specified file in a text format.

1. Select “**Settings—Configuration Settings**” on the Unit screen. Or, when you click the “ : **Configuration Settings**” in the tool bar.
2. Click the **Constitute** tab.



3. Check the **System Parameters** in the **Select Configuration Information** box.
4. Click the **Browse** button, and specify the directory and file name to output the file of the configuration.
5. Click the **Output** button.

6. When a confirmation message that the system parameter information is output with the specified file name is shown, click the **OK** button.

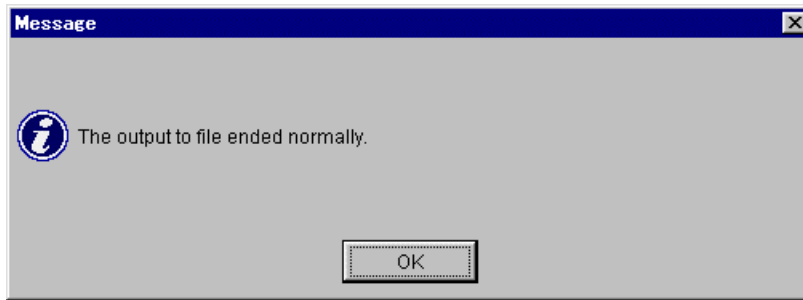

System parameter information is saved in the form of a text file with the specified file name.

The format of the output file consists of the following items. The outline of the layout of the output file is shown in Figure 6.8.6. Figure 6.8.6 is the outline of the layout of the output file for the case of DF500.

- File header
- Registration name at the manager 2 of the array unit
- Output time (Time of the machine where the manager 2 is installed)
- Microprogram revision
- Array unit type
- RAID group/logical unit configuration
- Status of constituent parts

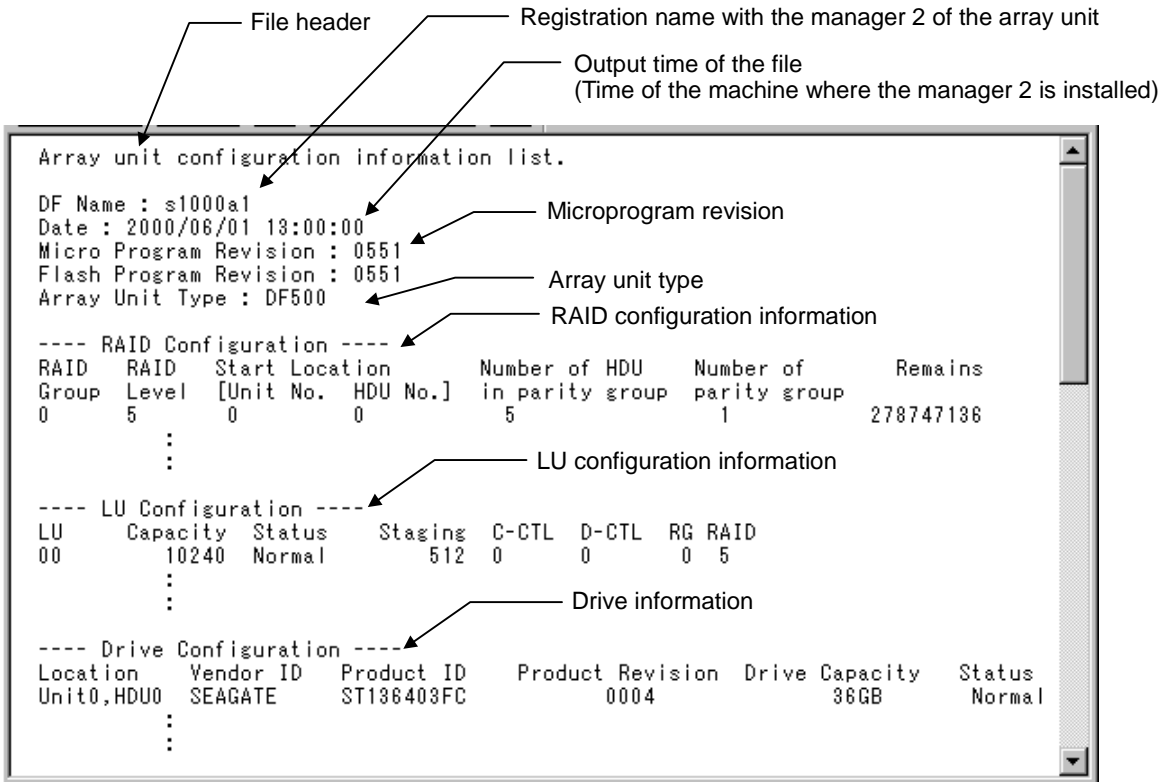

Figure 6.8.6 The outline of the format of RAID group/logical unit configuration information output file

```

----- Cache Information -----
      Controller 0
Slot  Capacity  Status
0      256      Normal
      :
      :

----- Fan Information -----
Location  Status
0         Normal
      :
      :

----- Battery Information -----
Location  Status
0         Normal
      :
      :

----- AC Power Information -----
Location  Status
Unit0,AC0 Normal
      :
      :

----- Battery Backup Information -----
Location  Status
0         Normal
      :
      :

----- Loop Information -----
Location  Status
0         Normal
      :
      :

----- ENC Information -----
Location  Status
Unit0,ENC0 Normal
      :
      :

```

Cache information

Fan information

Battery information

AC power information

Battery backup information

Loop information

Enclosure information

Figure 6.8.6 The outline of the format of RAID group/logical unit configuration information output file

oo) Format of RAID configuration information

The function outputs the RAID configuration of the array unit. RAID groups which have not been created are displayed as “-” in the “Level” column.

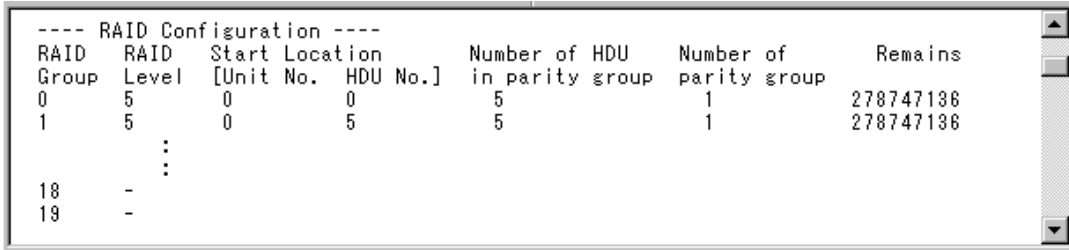

```
---- RAID Configuration ----
RAID  RAID  Start Location      Number of HDU   Number of      Remains
Group Level [Unit No. HDU No.] in parity group parity group
0      5      0          0          5             1             278747136
1      5      0          5          5             1             278747136
      :
18     -
19     -
```

- **RAID Group:** RAID group number
- **RAID Level:** RAID level  
When no RAID is set, “-” is displayed. No other information is displayed.
- **Start Location:**  
**Unit No.:** Starting unit number of RAID group  
**HDU No.:** Starting HDU number of RAID group
- **Number of HDU in parity group:** The number of HDU in the parity group of the RAID group
- **Number of parity group:** The number of parity groups in the RAID group
- **Remains:** The capacity (in units of block) that can be defined by logical unit of the RAID group

pp) Formatting logical unit configuration information

The function outputs the logical unit configuration information of the array unit. The information is displayed up to the created logical unit numbers .

```
---- LU Configuration ----
LU   Capacity  Status   Staging  C-CTL  D-CTL  RG  RAID
00   10240    Normal   512      0       0       0  5
01   10240    Normal   512      1       1       1  5
After 02, not define.
```

- **LU:** logical unit number
- **Capacity:** logical unit capacity (in units of block)
- **Status:** The status of the logical unit
  - Normal:** Normal status in which the logical unit is defined and formatted
  - Unformat:** Status in which the logical unit is defined but not formatted
  - Detached:** Status in which the logical unit is blocked
  - Regressed:** Status in which the logical unit is regressed
- **Staging:** Preread data amount (in units of block)
- **C-CTL:** The number of the controller currently in use
- **D-CTL:** Default number of controller controlling the logical unit
- **RG:** The number of the RAID group that creates the logical unit
- **RAID:** The RAID level of the RAID group that creates the logical unit

qq) Format for Drive Information

The information and status of the drive of the array unit are output.

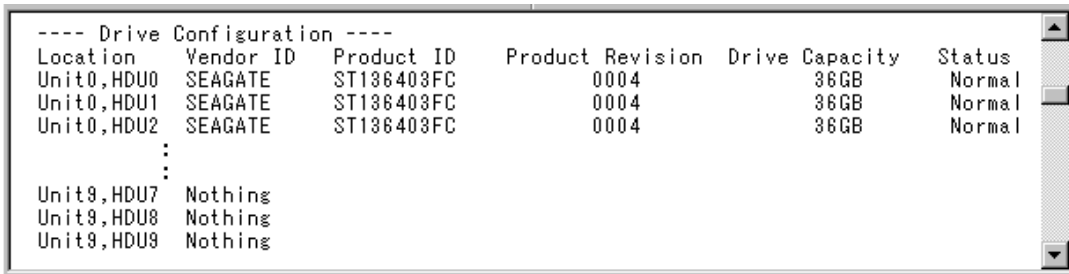

```
---- Drive Configuration ----
Location  Vendor ID  Product ID  Product Revision  Drive Capacity  Status
Unit0,HDU0 SEAGATE    ST136403FC    0004             36GB           Normal
Unit0,HDU1 SEAGATE    ST136403FC    0004             36GB           Normal
Unit0,HDU2 SEAGATE    ST136403FC    0004             36GB           Normal
      :
Unit9,HDU7  Nothing
Unit9,HDU8  Nothing
Unit9,HDU9  Nothing
```

- **Location:** The installation location of the drive
- **Vendor ID:** The vendor ID of the drive
- **Product ID:** The product ID of the drive
- **Product Revision:** Firmware revision of the drive
- **Drive Capacity:** The capacity of the drive
- **Status:** The status of the drive
  - Normal:** Normal (RAID group, logical unit defined)
  - Detached:** Detached
  - Standby:** Normal (Logical unit undefined)
  - Undefine:** Normal (RAID group undefined)
  - Recon.:** Re-configuring (copying from collection or backup)

“Nothing” is shown after **Location** for the location of a HDU not installed.

rr) Format for Cache Information

The configuration information and status of the cache of the array unit are output.

```
---- Cache Information ----
                          Controller 0          Controller 1
Slot  Capacity  Status      Capacity  Status
0     256       Normal      256      Normal
1     256       Normal      256      Normal
2     None      Nothing     None      Nothing
3     None      Nothing     None      Nothing
```

- **Slot:** The installation location of the cache

Controller 0

- **Capacity:** The capacity (in units of M byte) of the cache of controller 0
- **Status:** The status of the cache of controller 0

**Normal:** Normal

**Detached:** Detached

**Nothing:** Not installed

---: Slot not supported

Controller 1

- **Capacity:** The capacity (in units of M byte) of the cache of controller 1
- **Status:** The status of the cache of controller 1

**Normal:** Normal

**Detached:** Detached

**Nothing:** Not installed

---: Slot not supported

ss) Format for Fan Information

The status of the fan of the array unit is output.

```
---- Fan Information ----
Location  Status
0         Normal
```

- **Location:** The installation location of the fan

- **Status:** The status of the fan

**Normal:** Normal

**Alarm:** Abnormal

**Nothing:** Not installed

tt) Format for Battery Information

The status of the battery of the array unit is output.

```
---- Battery Information ----
Location  Status
0         Normal
```

- **Location:** The installation location of the battery
- **Status:** The status of the battery
  - Normal:** Normal
  - Alarm:** Abnormal
  - Nothing:** Not installed

uu) Format for AC power Information.

The status of the AC power supply of the array unit is output.

```
---- AC Power Information ----
Location  Status
Unit0,AC0 Normal
Unit0,AC1 Normal
      :
Unit9,AC0 Nothing
Unit9,AC1 Nothing
```

- **Location:** The installation location of the AC power supply
- **Status:** The status of the AC power supply
  - Normal:** Normal
  - Alarm:** Abnormal
  - Nothing:** Not installed

vv) Format for Battery Backup Status Information.

The status of the battery backup circuit of the array unit is output.

```
---- Battery Backup Information ----
Location  Status
0         Normal
1         Normal
```

- **Location:** The installation location of the battery backup circuit
- **Status:** The status of the battery backup circuit
  - Normal:** Normal
  - Alarm:** Abnormal

ww) Format for Loop Information.

The status of the loop of the array unit is output.



```
Location  Status
0         Normal
1         Normal
2         Normal
3         Normal
```

- **Location:** The installation location of the loop
- **Status:** The status of the loop
  - Normal:** Normal
  - Alarm:** Abnormal
  - Nothing:** Not installed

xx) Format for Enclosure Information.

The status of the enclosure of the array unit is output.



```
---- ENC Information ----
Location  Status
Unit0,ENC0 Normal
Unit0,ENC1 Normal
      :
Unit9,ENC0 Nothing
Unit9,ENC1 Nothing
```

- **Location:** The installation location of the enclosure
- **Status:** The status of the enclosure
  - Normal:** Normal
  - Alarm:** Abnormal
  - Nothing:** Not installed

### 6.8.3 Setting the Configuration With a File: System Parameters

Set the array unit with the setting information for the system parameters described in the file. If you set by use of a file that was output under the condition in which any priced optional feature is in an unlocked state, setting may terminate abnormally. For a file for setting, use a file that was output under the condition in which all priced optional features are in a locked state.

In the case of connection with a dual system, setting cannot be carried out if one of the controllers is detached. Please confirm that the array unit is not in warning status.

If the setting of the dual system is carried out through RS232C connection, please do it without fail at controller 0.

In the case that system parameters are set, the array unit cannot execute commands from the host. Moreover, the functions of the manager 2 can no longer work, except the Wizard for setting the system parameters and failure monitoring. After the setting, please restart the array unit, and after confirming that it is up and running, connect to the host and the manager 2.

1. Edit the file for setting the system parameters to set the array unit. The file has a specified format. The format of the file is the same as that of the file output by the array unit. Please refer to the following for the format and parameters of the file respectively.

- For the format of the file : **6.8.1 File Output of Configuration : System Parameters**

- For the parameters : **5.1 Setting system parameters**

As for the parameters for backup use in the system parameter information, please set **Yes** without fail, as it is necessary to save the set system parameters in the backup FD in the array unit.

2. Select “**Settings—Configuration Settings**” on the Unit screen. Or, when you click the  : **Configuration Settings**” in the tool bar.

3. Click the **Constitute** tab.

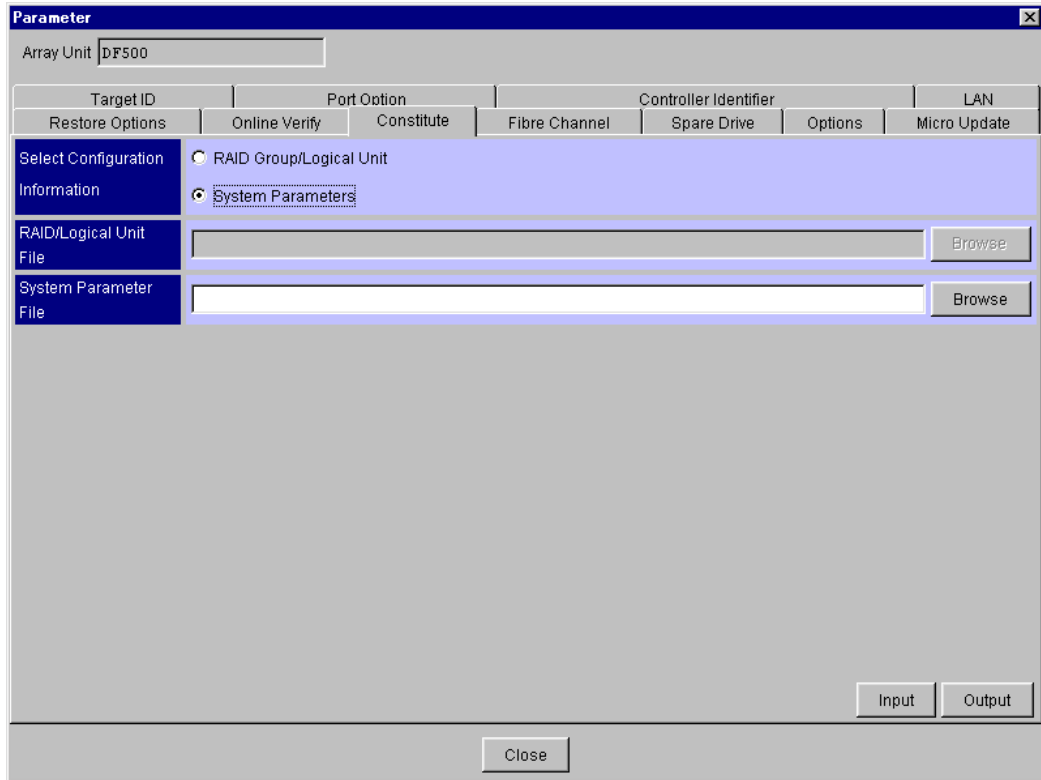

4. Click the **System Parameter** radio button.
5. Click the **Browse** button, and specify the directory and file name of the file that describes the system parameters edited in 1. The specified file name will be shown in the text box.
6. Click the **Input** button.
7. As a confirmation screen for whether to carry out the setting is displayed, click the **OK** button.

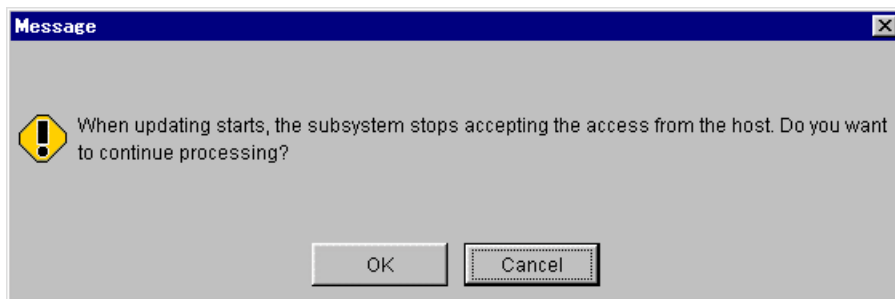

8. Now that a confirmation message that the system parameter information from a file with specified name has been set is shown, click the **OK** button.

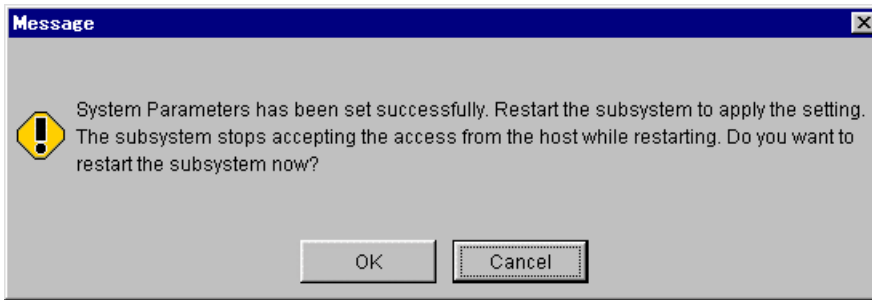

For the set configuration, please confirm the parameters using the Wizard for setting system parameters.

**Note:** To validate the set system parameters, restart the array unit. The previous settings stay valid until restarting.

Until restart, commands from the host and part of the functions of the manager 2 cannot be executed.

When restarting is initiated, the array unit is not ready to accept an access from the host for duration from initiation until the restarting terminates. Therefore, after making sure that the host has stopped accessing, initiate restarting.

**Note:** In case where writing onto FD fails, the message : “DMES04EB02 : Backup floppy disk write error.” is shown.

When this message is displayed, writing into an FD has not been finished, but setting the system parameter may be completed.

Check an FD in an array unit, re-confirm the data to set, turn on the **FD Backup** check box, and then click the **Apply** button once again.

When instructing to restart an array unit, the time the restarting has began is displayed. The restarting takes about two to six minutes.

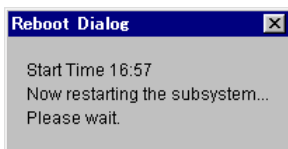

**Note:** It may take time for an array unit to respond, depending on the condition of the array unit. If it does not still respond after 10 minutes or more pass, check the condition of the array unit.

9. A message indicating that the restarting has terminated is displayed, so click the **OK** button.

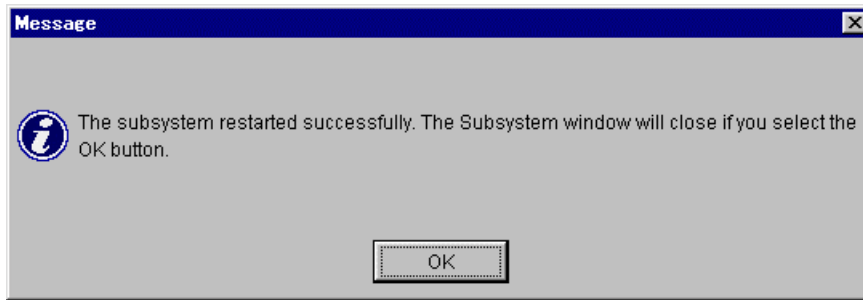

When clicking the **OK** button, the unit screen is closed. To perform other operations, select again on the main screen an array unit which to operate, and open the unit screen.

## 6.8.4 Setting the Configuration With a File: RAID group/Logical unit Definition

Setting the array unit according to the RAID group/logical unit setting information described in a file.

If the setup of RAID group/logical unit is carried out, all the user data before setting up will be lost as RAID group/logical unit configuration as specified in the file will be set after deleting the current RAID group/logical unit. If the user data is needed, please do the setting after carrying out a backup.

1. Edit the file for setting the RAID group/logical unit to be set in the array unit. The file has a specified format. The format of the file is the same as that of file output by the array unit. Please refer to the following for the format of the file :

– **6.8.2 Outputting configuration information to file : RAID group/Logical unit and component status**

The parameters in the file are the three items of **RAID configuration information**, **LU configuration information**, and **Drive information** in the format of the output file. In the output file, there are items for the status of the constituent parts, but they are ignored while setting up the configuration. The descriptive contents of the parameters are shown below :

yy) **RAID configuration information** : Sets the RAID configuration.

Specifies RAID level, RAID group number and RAID size.

If RAID group is not set, “-” is shown after **Level**, and no other parameters are set.

zz) **LU configuration information** : Sets logical unit configuration.

Specifies logical unit number, logical unit capacity, pre-read capacity, number of controllers in current use, number of controllers in default use, RAID group number and RAID level, and logical unit status.

In logical unit status, in cases where formatting is to be executed, specify “Normal”.

Formatting cannot be carried out if other status is specified.

In cases where the full capacity of the RAID group is allocated to one logical unit, specify “All” in **Capacity**.

Even if the number of the controller in current use is specified as “0” or “1”, it will become the same as the number of the controller in default use.

A maximum of 64 LU can be created. In cases where logical unit of less than the maximum logical unit number are created, specify at the end that “After nn, not define” (nn : the last logical unit number + 1).

aaa) **Drive information** : Sets the configuration of the HDU installed in the array unit to be set.

For HDU not installed, specify “Nothing”.

In the case that a capacity bigger than that of the installed HDU is specified, it is regarded as an error and not set.

2. Select “**Settings—Configuration Settings**” on the Unit screen. Or, when you click the  : **Configuration Settings**” in the tool bar.
3. Click the **Constitute** tab.

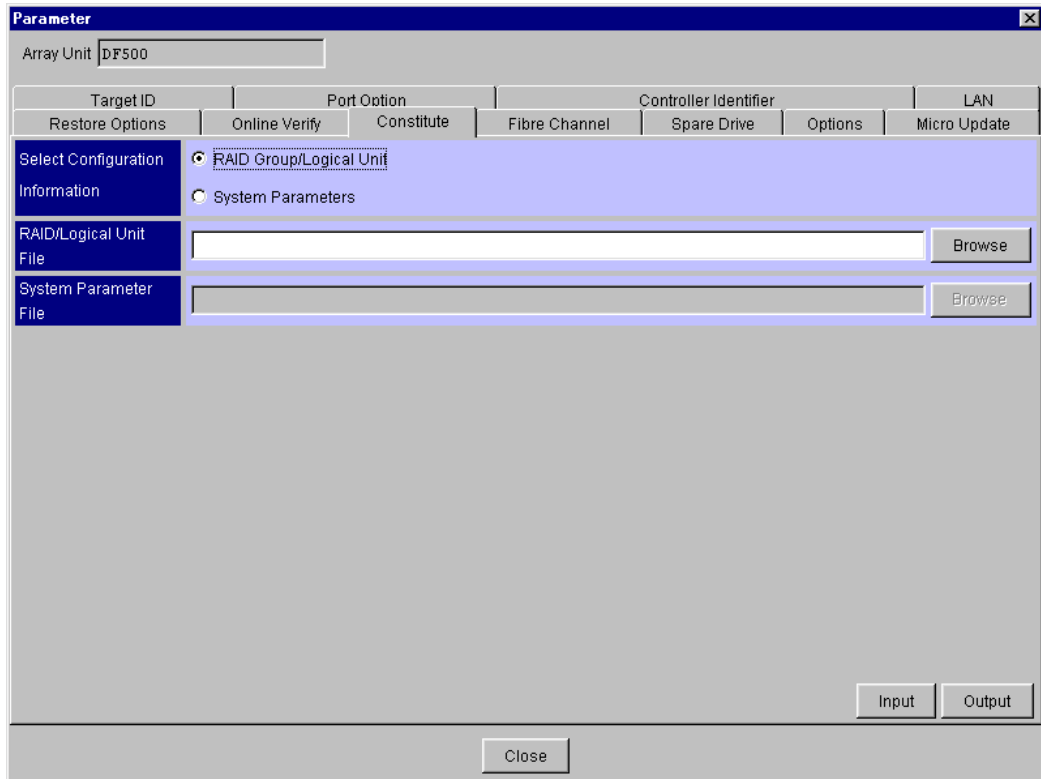

4. Click the **RAID Group/Logical Unit** radio button.
5. Click the **Browse** button, and specify the directory and name of the file that describes the RAID group definition and logical unit definition edited in 1. The specified file name will be shown in the text box.
6. Click the **Input** button.
7. As a confirmation screen for whether to carry out the setting is displayed, click the **OK** button.

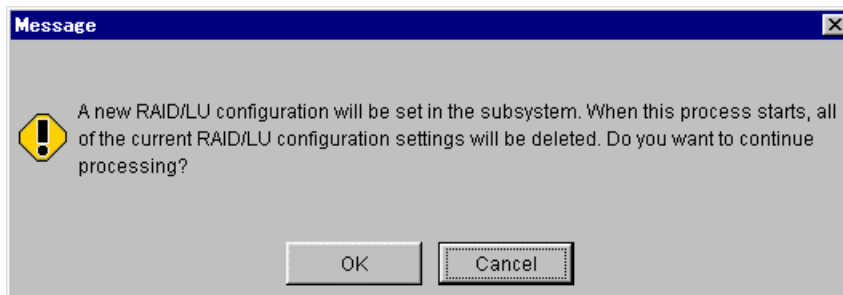

A message that the setting of the RAID group has started is shown, and the setting of RAID group is carried out.

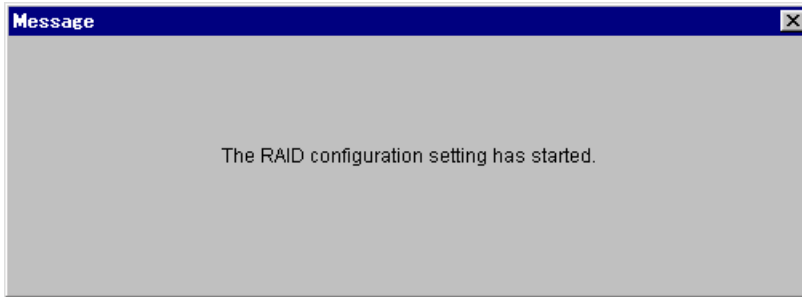

In the case that the setting of the RAID group ends abnormally, an error message will be shown and the processing will be interrupted.

If the setting of the RAID group ends normally, a message that the setting of logical unit has started is shown, and the setting of logical unit is carried out.

In the case that the setting of the logical unit ends abnormally, an error message will be shown and the processing will be interrupted.

If the setting of the logical unit ends normally, the formatting of the set logical unit will begin. The process of formatting execution will be shown.

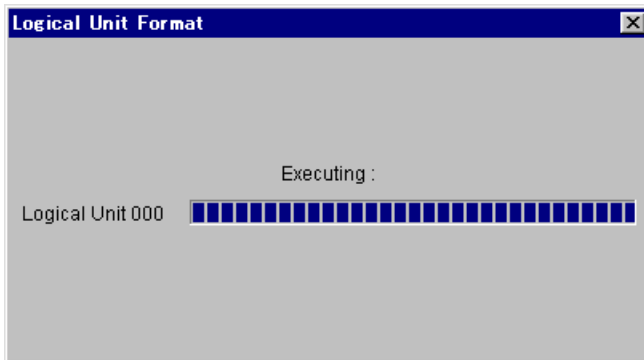

In the case that the setting of the RAID group ends abnormally, an error message will be shown and the processing will be interrupted.

8. When a message is displayed indicating that the specified logical unit has been formatted, click the **OK** button.

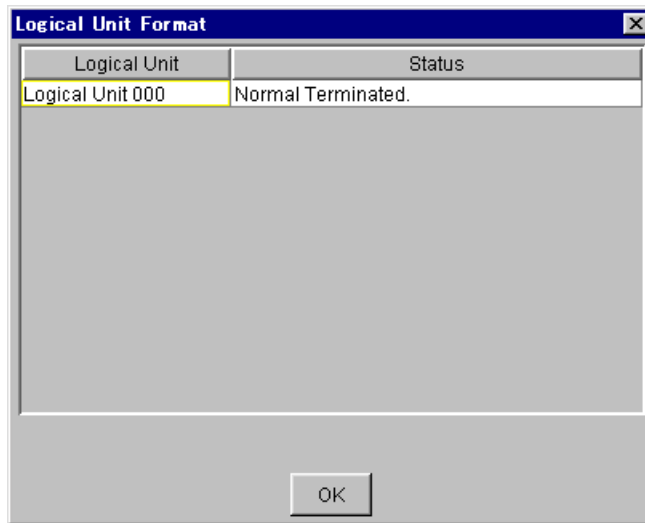

9. A message indicating completion of setting is displayed, click the **OK** button.

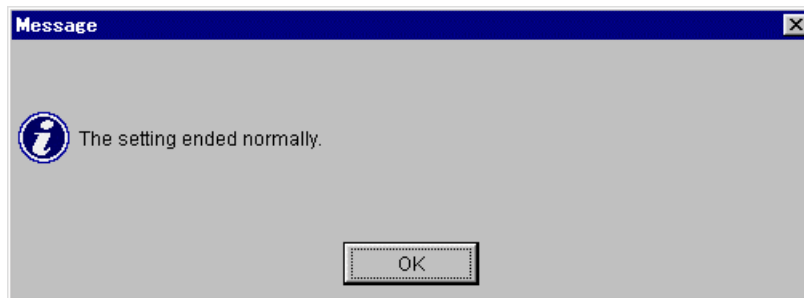

For the set configuration, please confirm the **Logical Status** tab.

## 6.9 Replacing the microprogram

The function downloads and replaces the microprogram in the array unit. When replacing the microprogram, download it and then replace it.

### 6.9.1 Microprogram download

Download the microprogram from the FD into the array unit. In the download, the microprogram is only stored in the array unit and the microprogram of the array unit is not replaced.

1. Copy the microprogram from the floppy disk to the hard disk.  
When using Windows, it can store the microprogram from the FD, so that the microprogram is not copied when it is stored from the FD.  
When using Solaris, the microprogram is surely copied. As there are multiple floppy disks of the microprogram, each floppy disk is copied to the hard disk using a different directory.  
**Note:** To a directory where the manager 2 is installed, don't copy the microprogram directly to the FD but create a sub-directory and copy it under this sub-directory. Specify the name of a directory in the hard disk drive to which the microprogram is copied, with one-byte coded alphanumeric.
2. Select “**Settings—Configuration Settings**” on the Unit screen. Or, when you click the : **Configuration Settings**” in the tool bar.

3. Click the **Micro Update** tab.

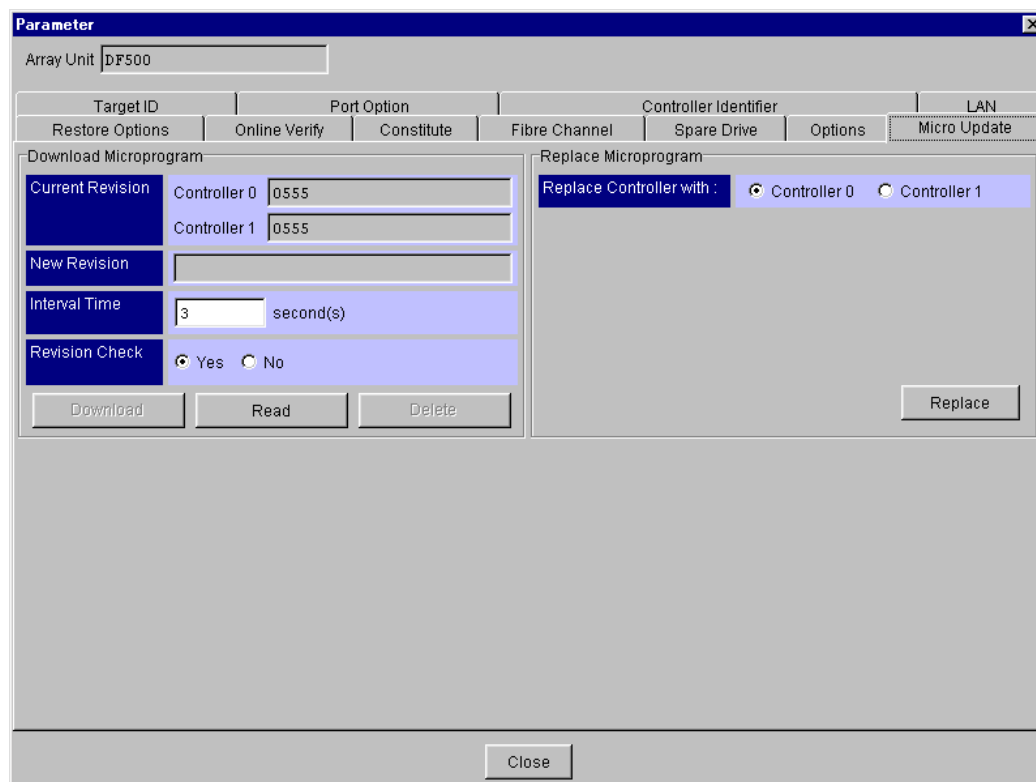

- **Current Revision:** Microprogram revision of each controller of the array unit.
- **New Revision:** A microprogram revision stored in the machine in which the manager 2 is installed. When the microprogram is not read, a blank is displayed.
- **Interval Time:** Interval time for download. Specify the time between one second and 60 seconds. In the case of the LAN connection, when the interval time is specified as 3 seconds, the download requires about 9 minutes. The time required for the execution varies with the network status and depending on the I/Os issued by the host. When the interval time is specified as one second longer, the time required for the download is prolonged by 3 minutes. In the case of the RS232C connection, when the interval time is specified as 3 seconds, the download requires about 4 hours. The time required for the execution varies depending on the I/Os issued by the host. When the interval time is specified as one second longer, the time required for the download is prolonged by 40 minutes. The function can be used during execution of the I/O instructed by the host. However, when the download function is executed, the I/O performance of the host is reduced. To restrain the reduction of the performance, specify a longer interval time.
- **Revision Check:** Instructs the check of the revision of the microprogram to be downloaded. When the download instruction is specified, whether a hot replacement is applicable to the microprogram is checked. Select Yes.

When no microprogram is read, the **Download** and **Delete** buttons are displayed in gray and cannot be selected.

4. The microprogram is read into the PC or SUN server/workstation in which the manager is installed. Click the **Read** button. When a revision is displayed in **New Revision**, the microprogram is already read. To download the microprogram that is already read, execute Download.
5. When a confirmation message as to whether or not to read the microprogram appears, click the **OK** button.

If the microprogram is already read, a confirmation message is displayed. When the **OK** is clicked, the microprogram is overwritten. To stop reading the microprogram, click the **Cancel** button.

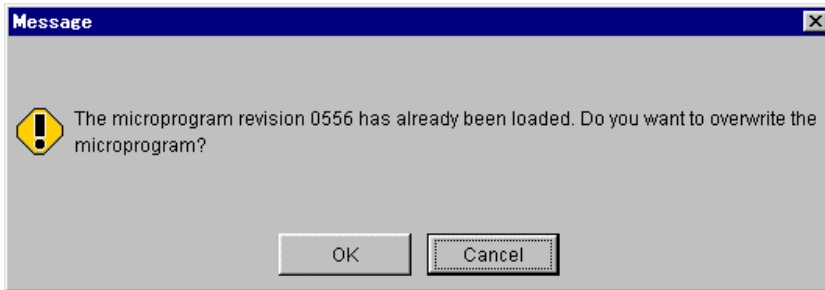

To delete the microprogram that is already read in the PC or SUN server/workstation, click the **Delete** button. When a confirmation message appears, click the **OK** button.

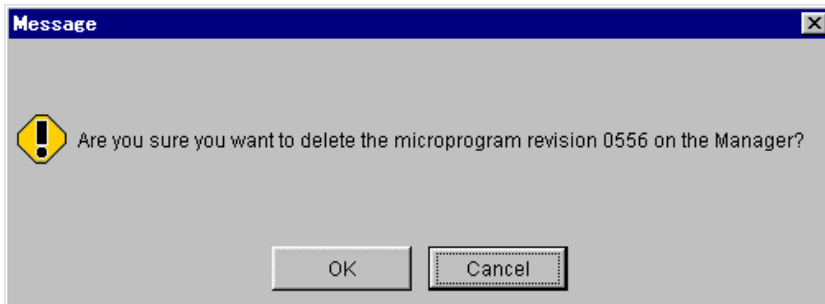

- When a window for specifying a directory in which the read microprogram exits appears, specify this directory. When the **OK** button is clicked, reading the microprogram is started.

A path input example is shown below.

When using Windows : a:

c:\manager2\mp0557\disk1

When using Solaris or IRIX: /home/usr/manager2/mp0557/disk1

Directory in the hard disk in which the microprogram of the FD is copied.

Multiple floppy disks of the microprogram are supplied. If there is a floppy disk of the microprogram to be read next, the message of 5 reappears. In the message, “No.” of the floppy disk to be read is displayed. Read the microprogram according to the display.

- When a message indicating that all the microprogram has been read appears, click the **OK** button.

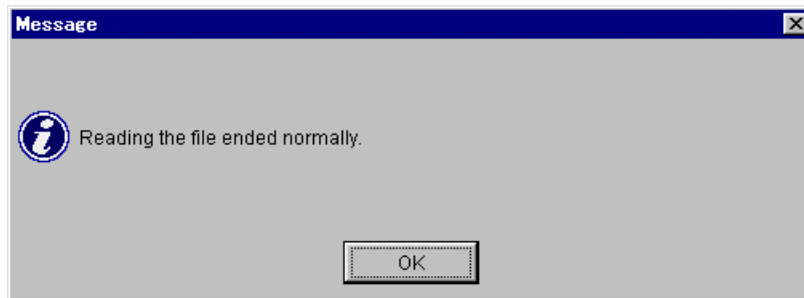

The revision of the read microprogram is displayed in the **New Revision** field.

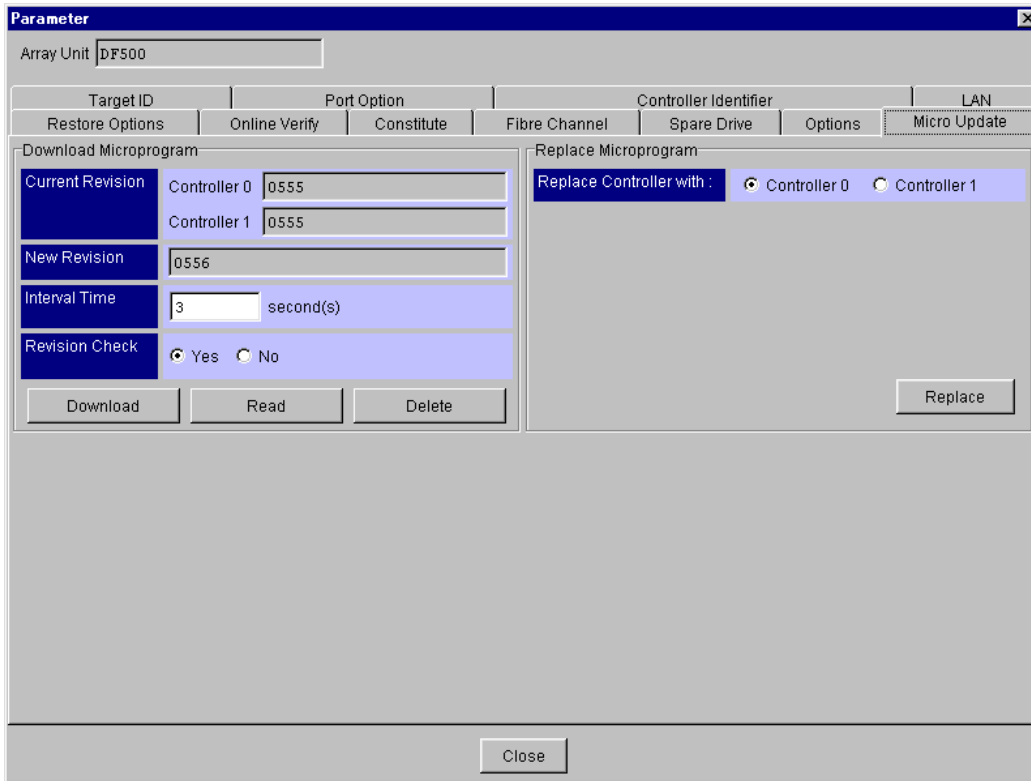

8. When downloading the microprogram, click the **Download** button.
9. When a confirmation message as to whether or not to download the microprogram appears, click the **OK** button.

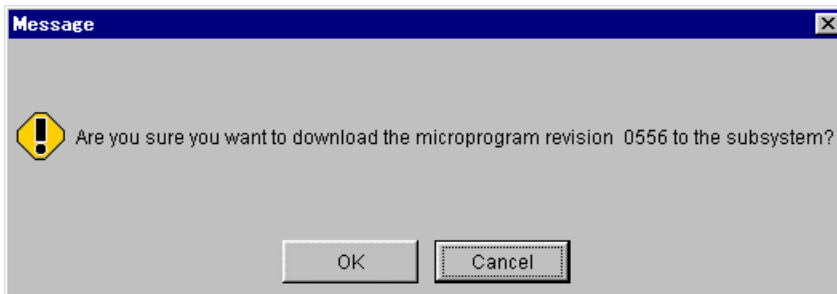

The message informing that the download is being executed is displayed. The message shows the revision of the program being downloaded, interval time, and progress.

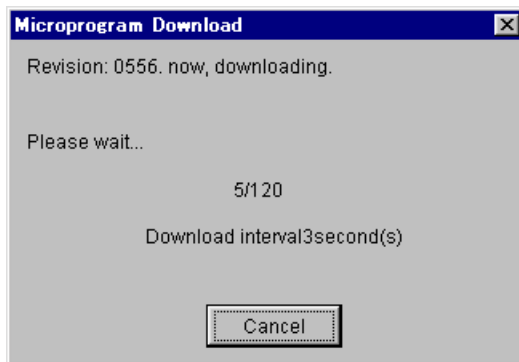

The download can be aborted. When aborting the download halfway, click **Cancel**. The confirmation message is displayed. When the **OK** button is clicked, the download is aborted. When the **Cancel** button is clicked, the download is continued.

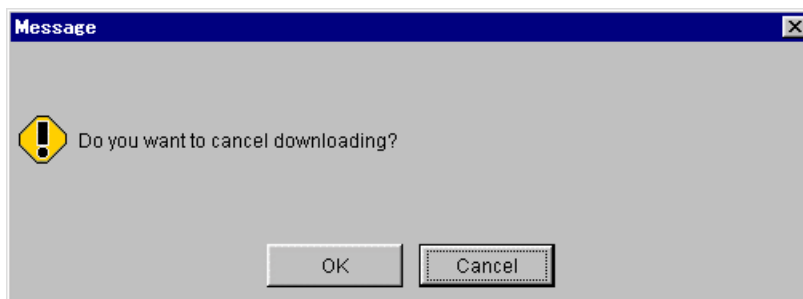

10. When the microprogram is normally downloaded, a confirmation message appears. Click the **OK** button.

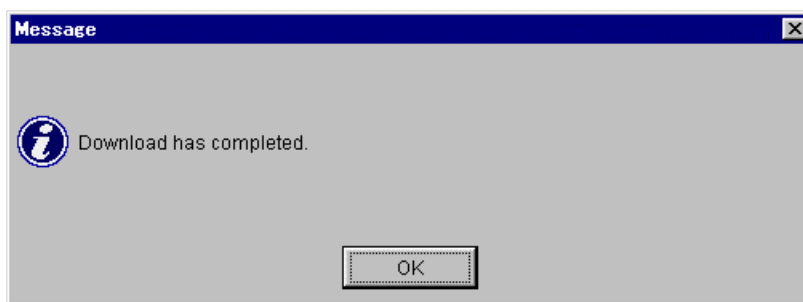

**Note:** After the download of the microprogram, be sure to restart the array unit or replace the microprogram. If a hot replacement of the controller board is done before the restart of the array unit or the microprogram replacement, the replaced new controller may be blocked. The download may terminate with a DMES05EA03 message when the array unit is heavy host I/Os. In the case, please perform the download operating again.

## 6.9.2 Replacing the microprogram

Replace the microprogram of the controller with the microprogram downloaded in the array unit. When replacing the microprogram, be sure to replace those of the both controller 0 and controller 1.

1. Select “**Settings—Configuration Settings**” on the Unit screen. Or, when you click the  : **Configuration Settings**” in the tool bar.
2. Click the **Micro Update** tab.

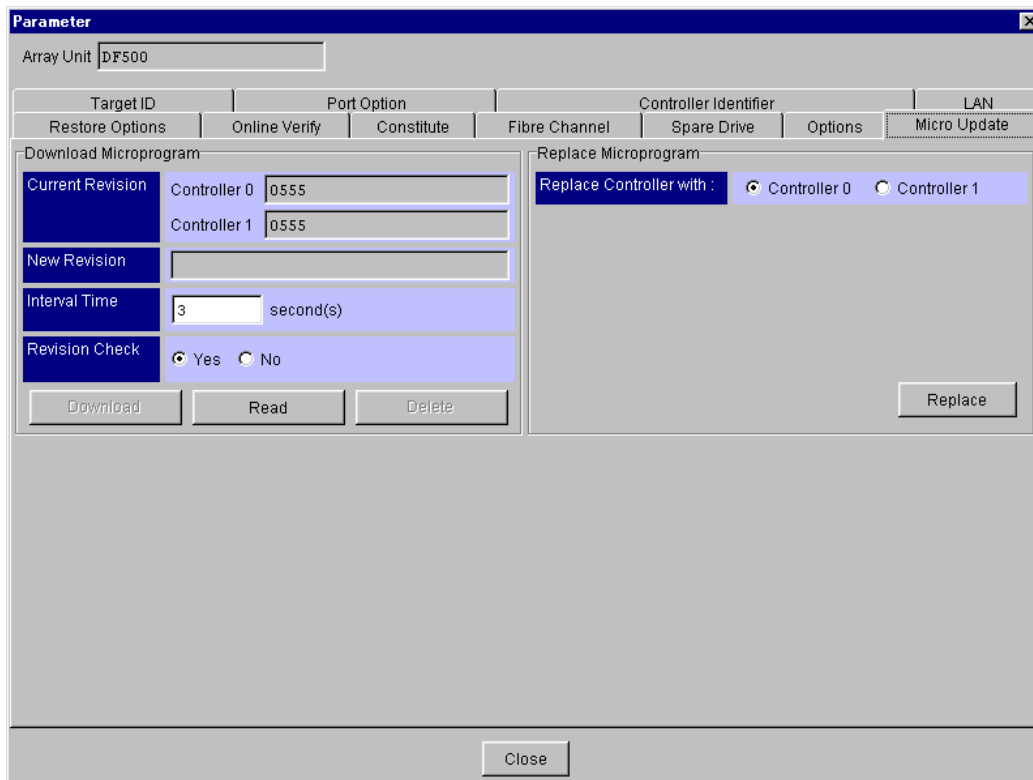

3. Select the controller whose microprogram is to be replaced and click the **Replace** button.
4. The message confirming whether to replace the microprogram is displayed. The message shows the number of the selected controller. When the **OK** button is clicked, the replacement of the microprogram starts.

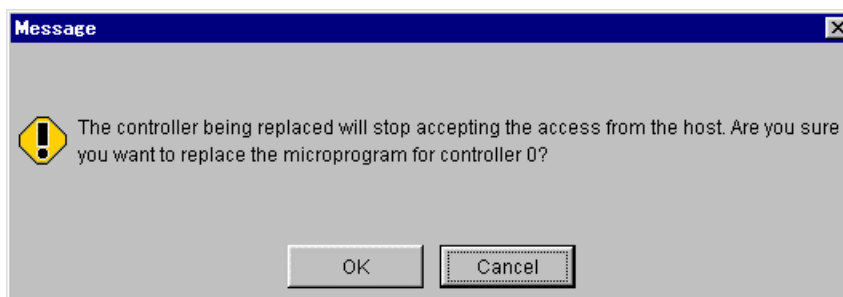

The message informing that the replacement of the microprogram is being executed is displayed.

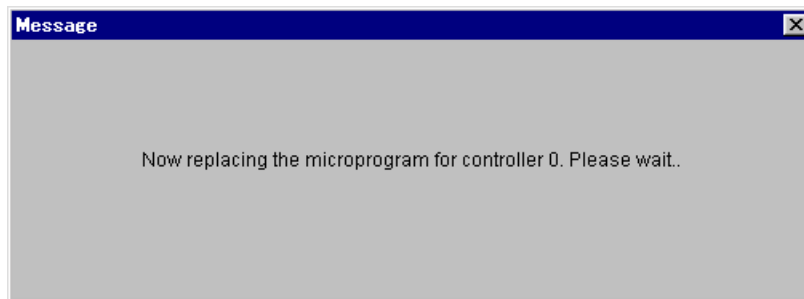

5. When the replacement of the microprogram terminates normally, the completion message is displayed. When the **OK** button is clicked, the revision of the replaced microprogram is updated and the window is displayed.



If downloaded microprogram cannot be replaced, a failure message is displayed. To validate the downloaded microprogram, restart the array unit.

6. Replace the microprogram of the other controller according to the procedure from 3. When the replacements for the both controllers terminate normally, the replacement of the microprograms of the array unit is completed.

**Note:** In the replacement of the microprograms, if the microprogram of only one of the controllers is replaced, the array unit is placed in the state that it is warned. When the microprogram of the other controller is replaced, the array unit is recovered from the above state. When replacing the microprograms, be sure to replace the microprograms of the both controllers continuously.

## 6.10 Setting priced optional features

### 6.10.1 Unlock priced optional features

The following procedure unlock the key of the priced optional features.

1. Select “**Settings—Configuration Settings**” on the Unit screen. Or, when you click the “ : **Configuration Settings**” in the tool bar.
2. Click the **Options** tab.

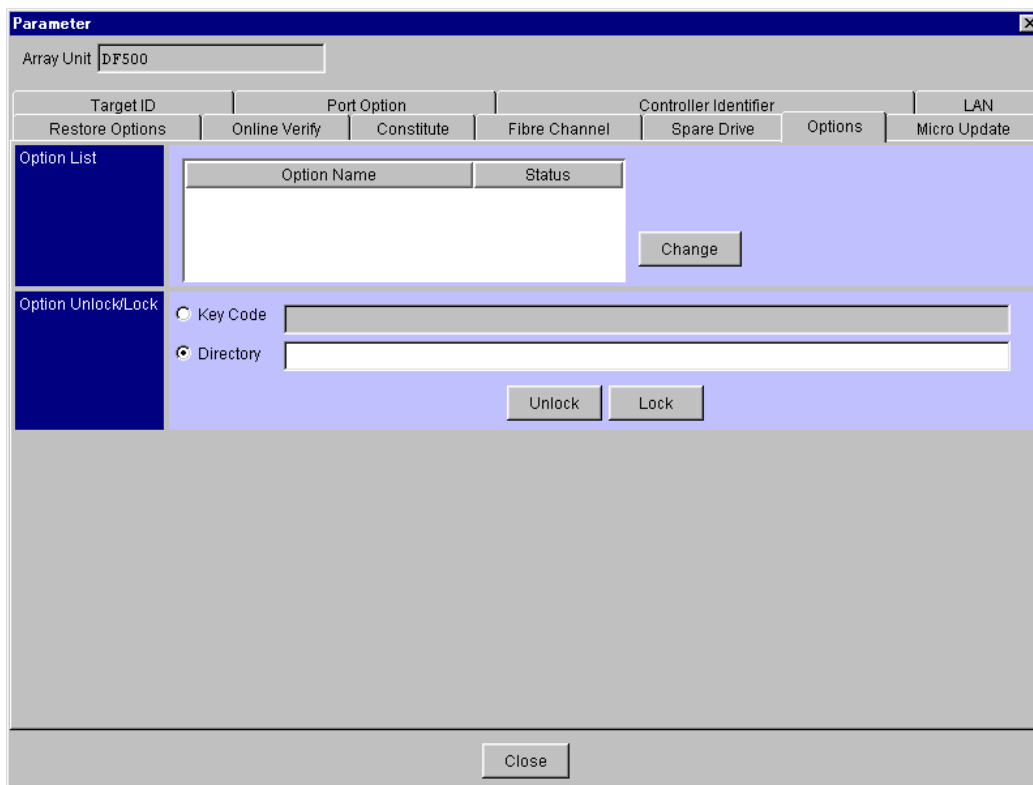

The screenshot shows a window titled "Parameter" with a close button in the top right corner. The "Array Unit" is set to "DF500". Below this is a navigation bar with tabs: "Target ID", "Port Option", "Controller Identifier", and "LAN". Underneath these are sub-tabs: "Restore Options", "Online Verify", "Constitute", "Fibre Channel", "Spare Drive", "Options" (which is selected), and "Micro Update". The main area is divided into two sections. The top section, "Option List", has a table with columns "Option Name" and "Status", and a "Change" button. The bottom section, "Option Unlock/Lock", has two radio buttons: "Key Code" (unselected) and "Directory" (selected). Below the radio buttons are two text input fields. At the bottom of this section are "Unlock" and "Lock" buttons. A "Close" button is located at the very bottom of the window.

3. Specify whether you are unlock the priced optional features using the FD with the priced optional features, or if you are using the key code, then setup the directory path or key code, then click the **Unlock** button.  
When you unlock the option using the key code, click the **Key Code** radio button and then setup the key code. For the key code of the priced optional features, refer to the manual of the priced optional features. When you unlock the option using the FD, click the **Directory** radio button and then setup the path for the FD.

4. When the confirmation screen for priced optional features unlock is displayed, click the **OK** button.

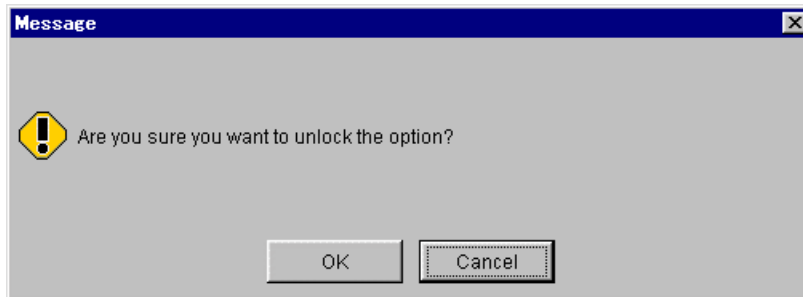

5. A screen confirming that the priced optional features has been unlocked appears. Depending on the option, an array unit needs to be restarted in order to set the unlocking effective. If an array unit supports restarting, a message confirming a restart request will be displayed, click the **OK** button when restarting.

bbb) Option that does not require to restart an array unit in order to set the unlocking effective.

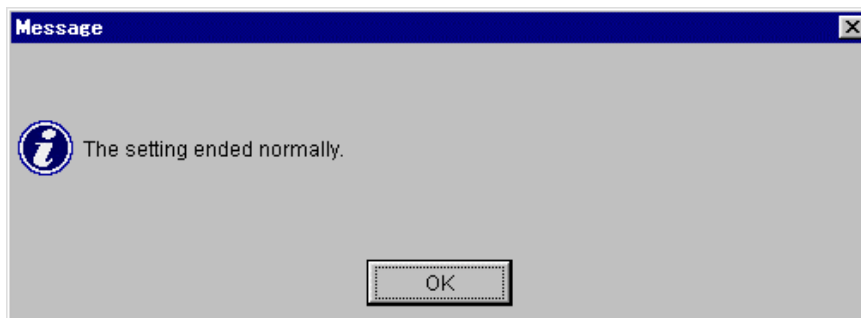

ccc) Option for which the unlocking is set effective by restarting an array unit

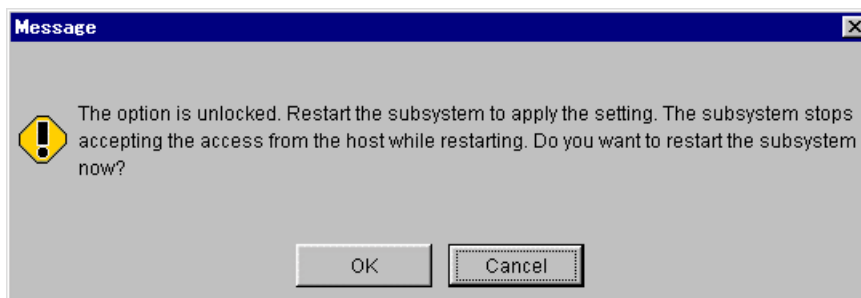

**Note:** To set effective the unlocking of the option that you have operated, restart the array unit. The feature is not yet closed until restarting.

When restarting is initiated, the array unit is not ready to accept an access from the host for duration from initiation until the restarting terminates. Therefore, after making sure that the host has stopped accessing, initiate restarting.

If an array unit fails to restart, the unlocked priced optional features is displayed.

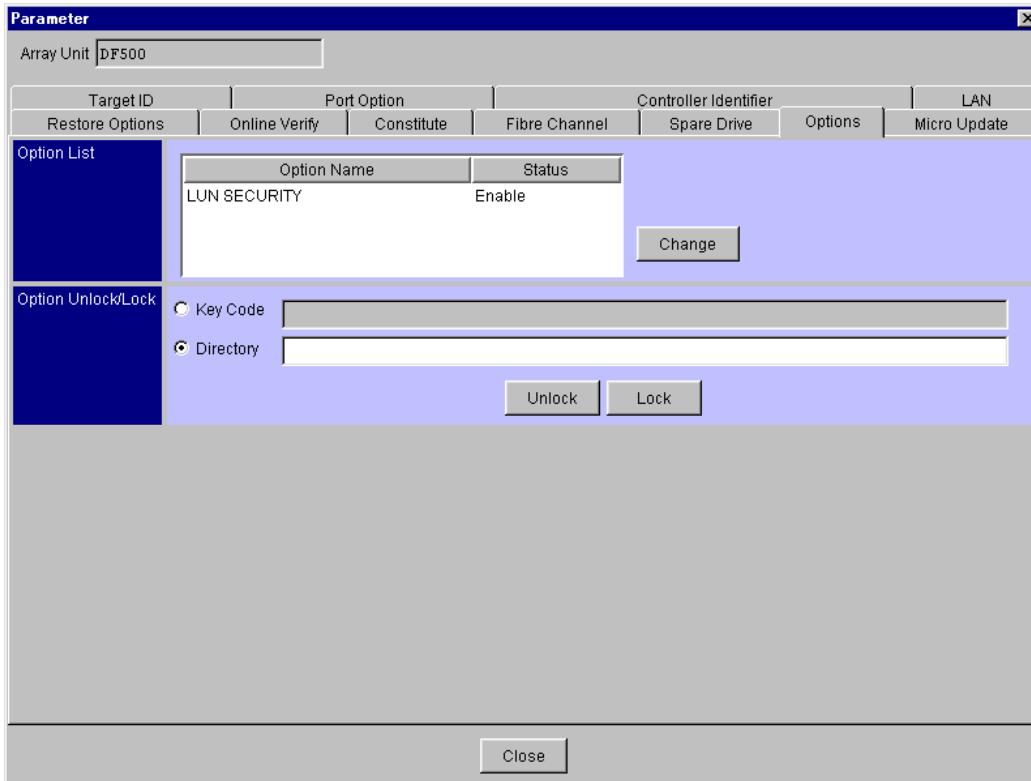

When instructing to restart an array unit, the time the restarting has began is displayed. The restarting takes about two to six minutes.

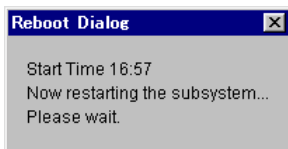

**Note:** It may take time for an array unit to respond, depending on the condition of the array unit. If it does not still respond after 10 minutes or more pass, check the condition of the array unit.

6. A message indicating that the restarting has terminated is displayed, so click the **OK** button.

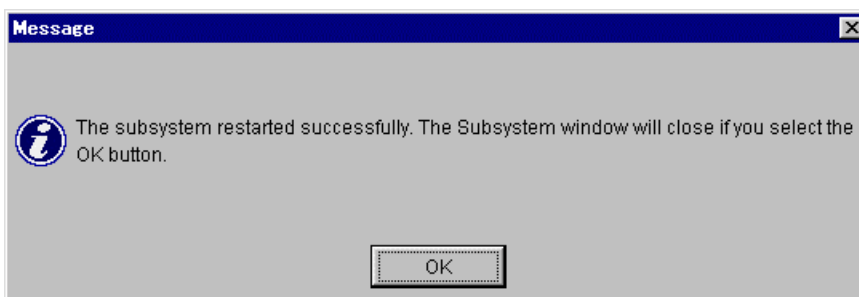

When clicking the **OK** button, the unit screen is closed. To perform other operations, select again on the main screen an array unit which to operate, and open the unit screen.

## 6.10.2 Lock priced optional features

The following procedure lock the key of the priced optional features.

1. Select “**Settings—Configuration Settings**” on the Unit screen. Or, when you click the “ : **Configuration Settings**” in the tool bar.
2. Click the **Options** tab.

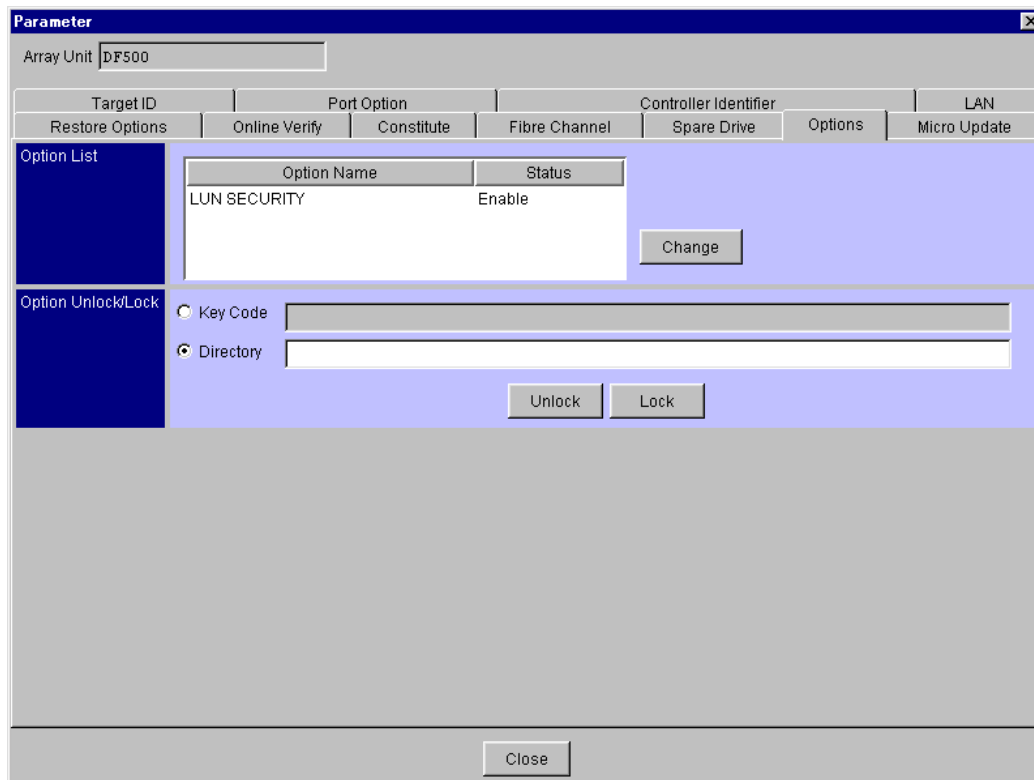

3. Specify whether you are locking the priced optional features using the FD with the priced optional features, or if you are using the key code, then setup the directory path or key code, then click the **Lock** button.  
When you lock the option using the key code, click the **Key Code** radio button and then setup the key code. For the key code of the priced optional features, refer to the manual of the priced optional features. When you lock the option using the FD, click the **Directory** radio button and then setup the path for the FD.

4. When the confirmation screen for priced optional features locking is displayed, click the **OK** button.

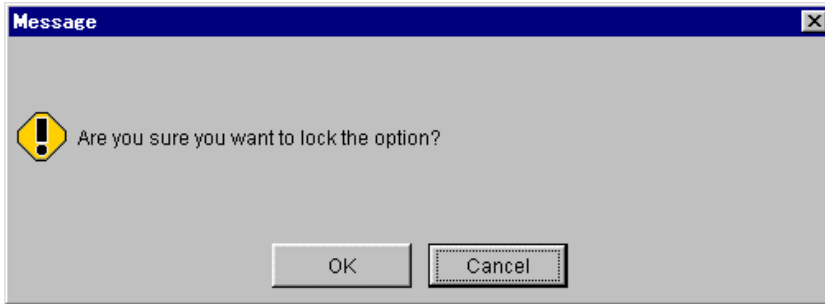

5. A screen confirming that the priced optional features has been locked appears. Depending on the option, an array unit needs to be restarted in order to set the locking effective. If an array unit supports restarting, a message confirming a restart request will be displayed, clicks the **OK** button when restarting.

ddd) Option that does not require to restart an array unit in order to set the locking effective.

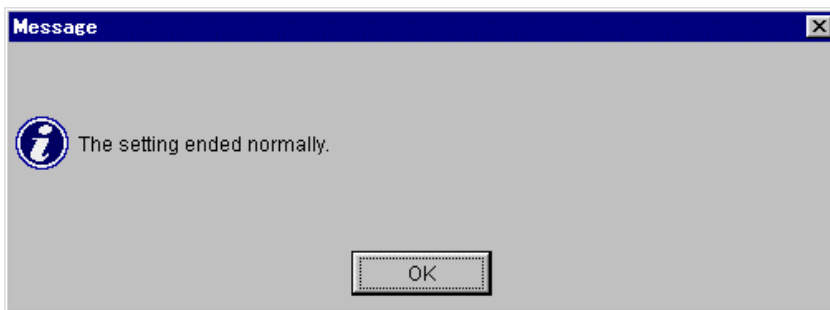

eee) Option for which the closing is set effective by restarting an array unit

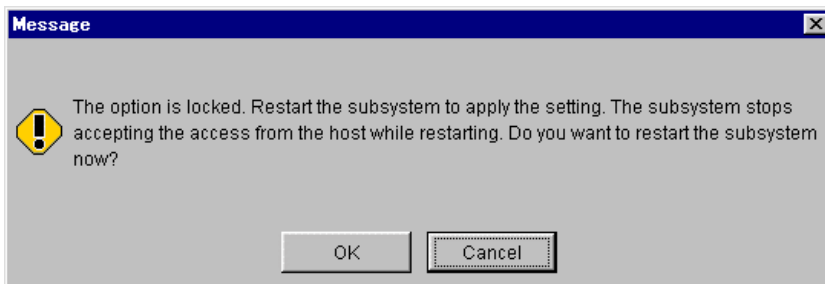

**Note:** To set effective the locking of the option that you have operated, restart the array unit. The feature is not yet opened until restarting. When restarting is initiated, the array unit is not ready to accept an access from the host for duration from initiation until the restarting terminates. Therefore, after making sure that the host has stopped accessing, initiate restarting.

If an array unit fails to restart, the locked priced optional features is not displayed.

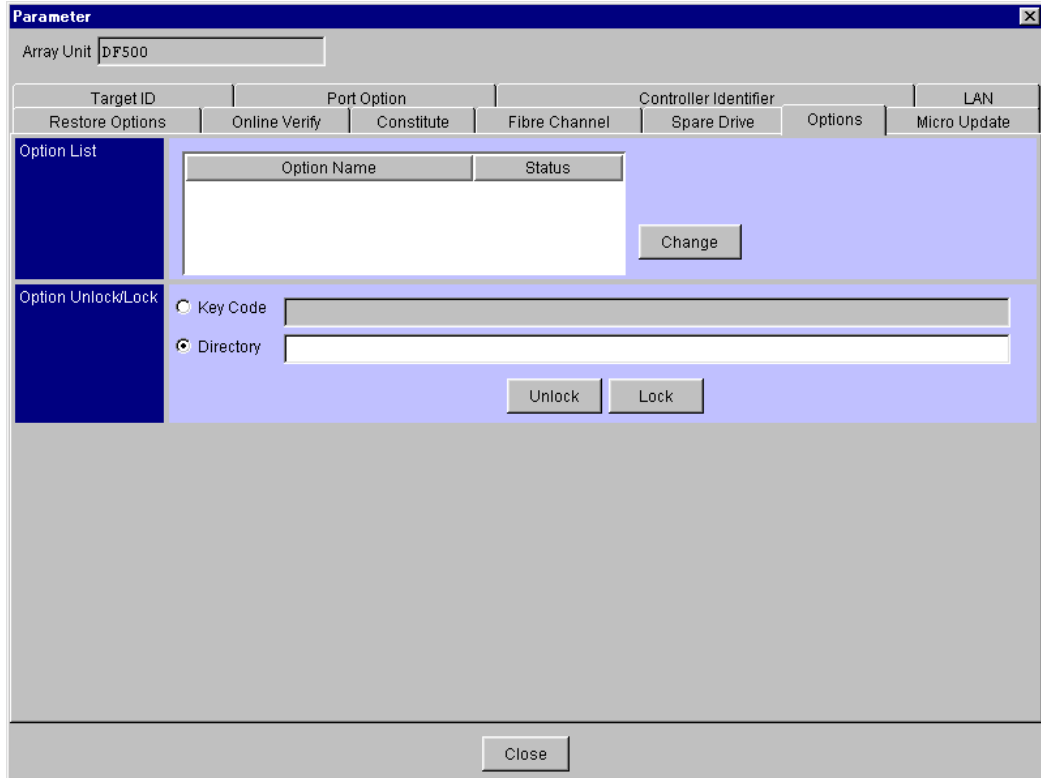

When instructing to restart an array unit, the time the restarting has began is displayed. The restarting takes about two to six minutes.

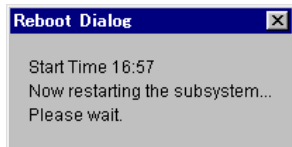

**Note:** It may take time for an array unit to respond, depending on the condition of the array unit. If it does not still respond after 10 minutes or more pass, check the condition of the array unit.

6. A message indicating that the restarting has terminated is displayed, so click the **OK** button.

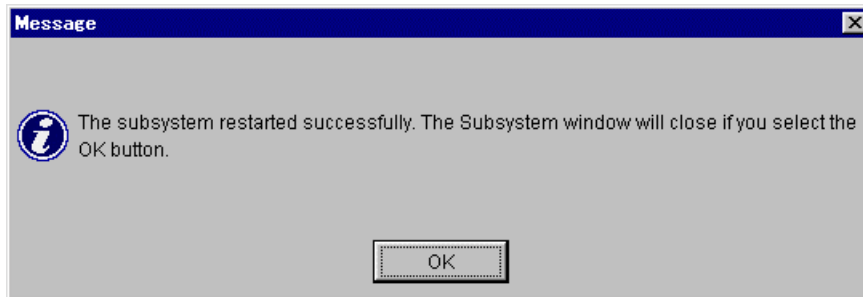

When clicking the **OK** button, the unit screen is closed. To perform other operations, select again on the main screen an array unit which to operate, and open the unit screen.

### 6.10.3 Setting up priced optional features

After releasing the key of priced optional feature, sets whether to enable or disable the priced optional feature.

1. Select “**Settings—Configuration Settings**” on the Unit screen. Or, when you click the “ : **Configuration Settings**” in the tool bar.
2. Click the **Options** tab.

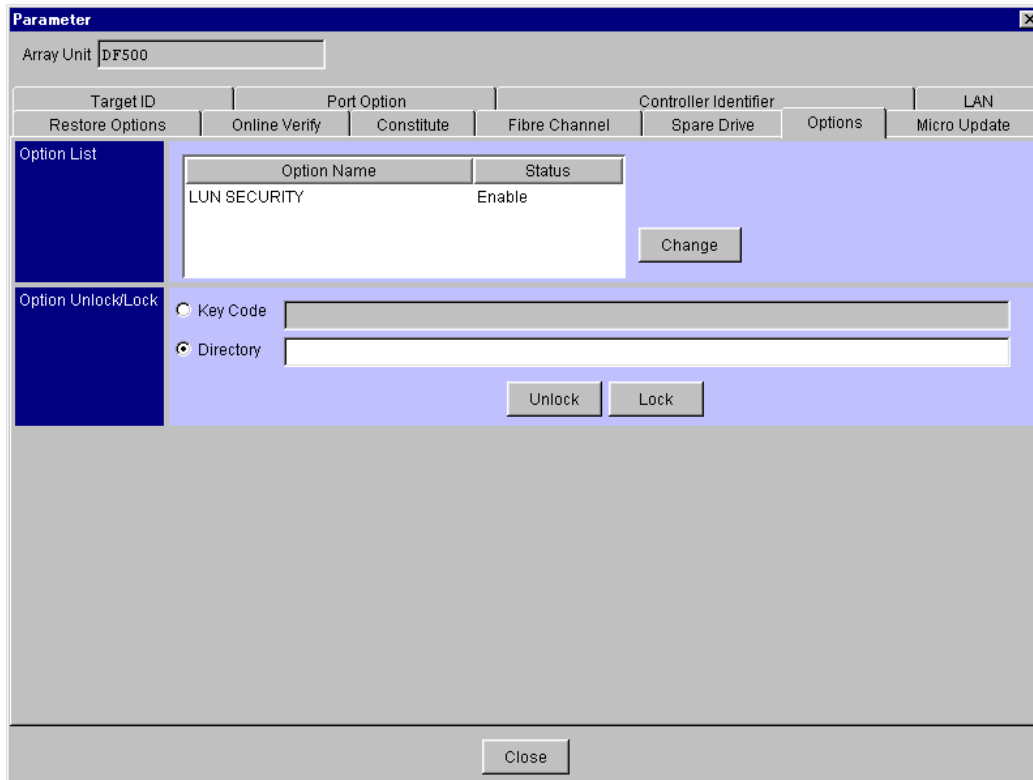

3. Select the priced optional features to be setup and then click the **Change** button.
4. When the confirmation screen for priced optional features changing is displayed, click the **OK** button.

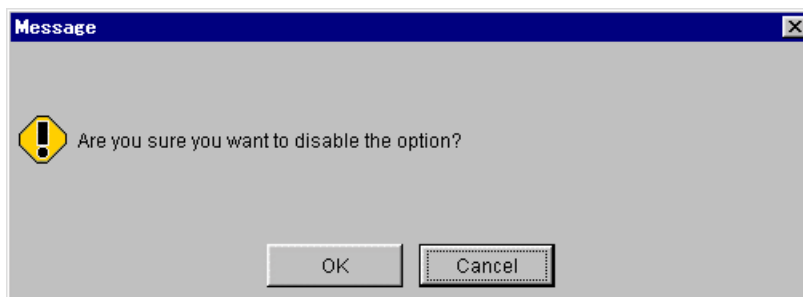

5. A screen confirming that the priced optional features has been setup appears. Depending on the option, an array unit needs to be restarted in order to set the setup effective. If an array unit supports restarting, a message confirming a restart request will be displayed, clicks the **OK** button when restarting.

fff) Option that does not require to restart an array unit in order to set the setup effective.

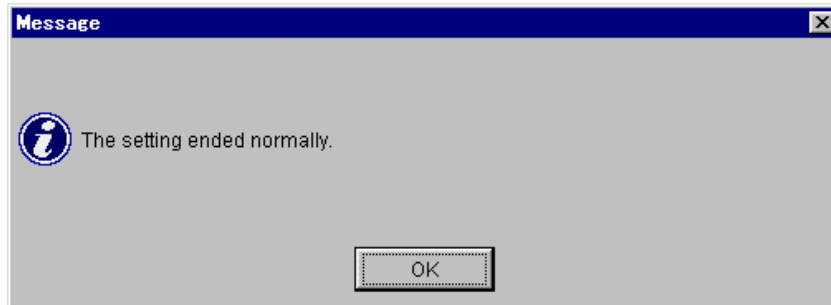

ggg) Option for which the setup is set effective by restarting an array unit.

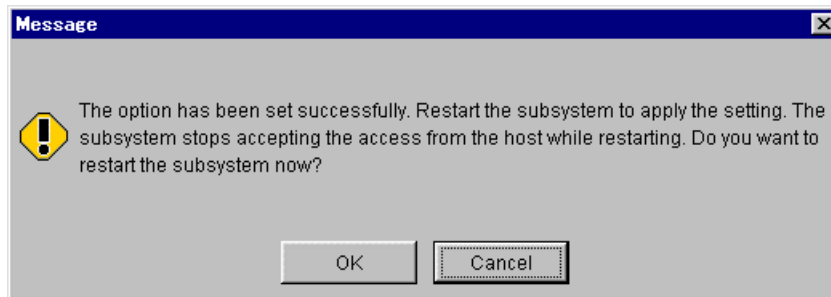

**Note:** To set effective the setup of the option that you have operated, restart the array unit. The setup is not yet reflected until restarting. When restarting is initiated, the array unit is not ready to accept an access from the host for duration from initiation until the restarting terminates. Therefore, after making sure that the host has stopped accessing, initiate restarting.

When not restarting an array unit, a screen appears with the setup priced optional features being updated.

When instructing to restart an array unit, the time the restarting has began is displayed. The restarting takes about two to six minutes.

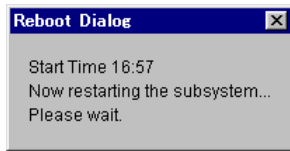

**Note:** It may take time for an array unit to respond, depending on the condition of the array unit. If it does not still respond after 10 minutes or more pass, check the condition of the array unit.

7. A message indicating that the restarting has terminated is displayed, so click the **OK** button.

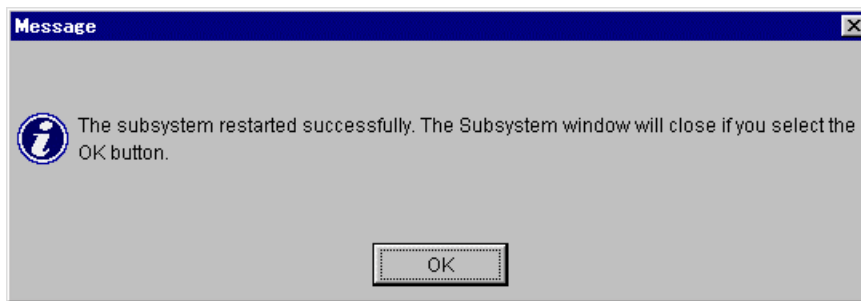

When clicking the **OK** button, the unit screen is closed. To perform other operations, select again on the main screen an array unit which to operate, and open the unit screen.

## 6.11 Setting and outputting SNMP environmental information file

The SNMP configuration information file is set to the array unit and the SNMP configuration information that is set in the array unit is output to the file.

If one of the controllers is blocked, no setting can be made. Before using the function, make sure that the array unit is not in the state in which a warning has been given to it.

If the SNMP environmental information file is set, the array unit cannot execute a command issued from the host. Neither can it execute any functions other than the setting wizard function of the manager, function for the SNMP configuration information file setting and outputting, and the error monitoring function. After the setting is completed, restart the array unit, make sure that the array unit has started up, and then connect it to the host and the manager.

The registered SNMP configuration information file is not validated unless the array unit is restarted.

### 6.11.1 Setting SNMP environmental information file

Set the SNMP environmental information file into the array unit from the FD or hard disk.

1. Select “**Settings—Configuration Settings**” on the Unit screen. Or, when you click the : **Configuration Settings**” in the tool bar.
2. Click the **SNMP** tab.

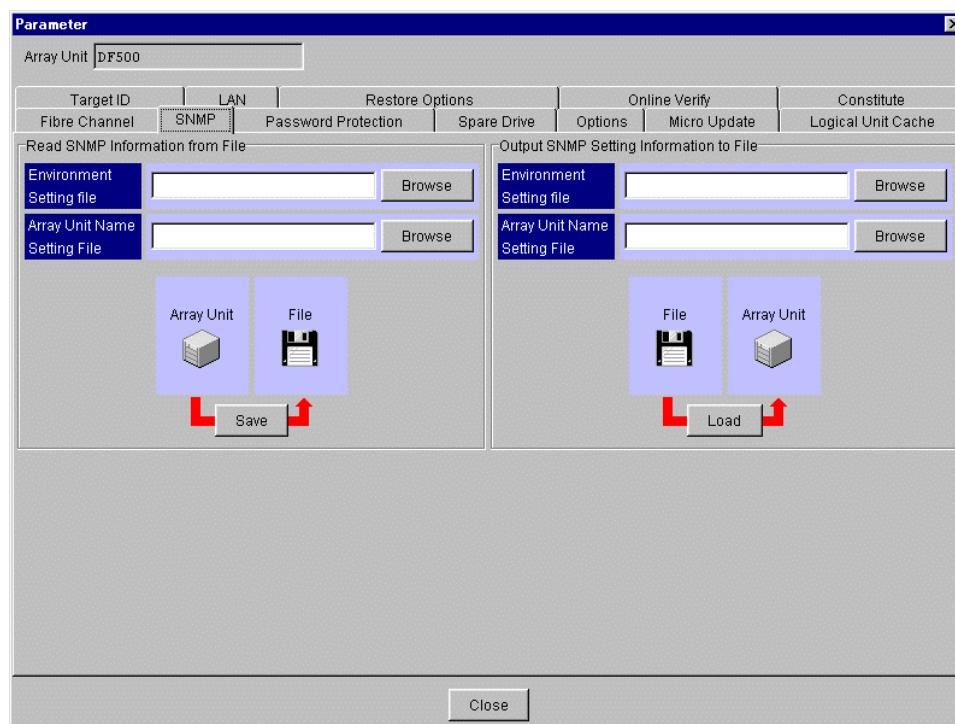

- **Environment Setting File:** Specifies environment setting file.
- **Array Unit Name Setting File:** Specifies array unit name setting file.

- Specify the paths to the “**Environment Setting File**”(Output SNMP Setting Information to File) and “**Array Unit Name Setting File**”(Output SNMP Setting Information to File) and click the **Load** button. When you set only one file, specify only the path of the target file.
- A message indicating completion of setting is displayed. A confirmation message indicating a request for restarting is displayed, so clicks the **OK** button when restarting.

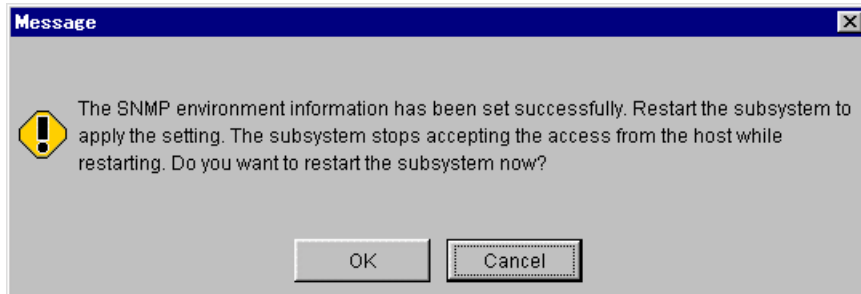

**Note:** To validate the set SNMP environment information, restart the array unit. The previous settings stay valid until restarting.

Commands from the host cannot be executed until the array unit is restarted. The manager 2 functions cannot be also executed.

When restarting is initiated, the array unit is not ready to accept an access from the host for duration from initiation until the restarting terminates. Therefore, after making sure that the host has stopped accessing, initiate restarting.

When instructing to restart an array unit, the time the restarting has began is displayed. The restarting takes about two to six minutes.

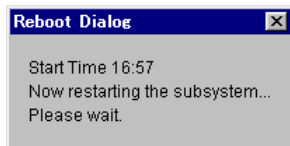

**Note:** It may take time for an array unit to respond, depending on the condition of the array unit. If it does not still respond after 10 minutes or more pass, check the condition of the array unit.

- A message indicating that the restarting has terminated is displayed, so click the **OK** button.

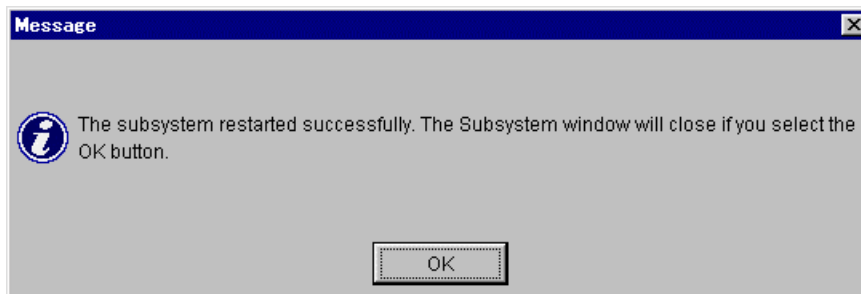

When clicking the **OK** button, the unit screen is closed. To perform other operations, select again on the main screen an array unit which to operate, and open the unit screen.

## 6.11.2 Outputting SNMP environmental information file

Output the SNMP environmental information file from the array unit in the text file format.

1. Select “**Settings—Configuration Settings**” on the Unit screen. Or, when you click the : **Configuration Settings**” in the tool bar.
2. Click the **SNMP** tab.

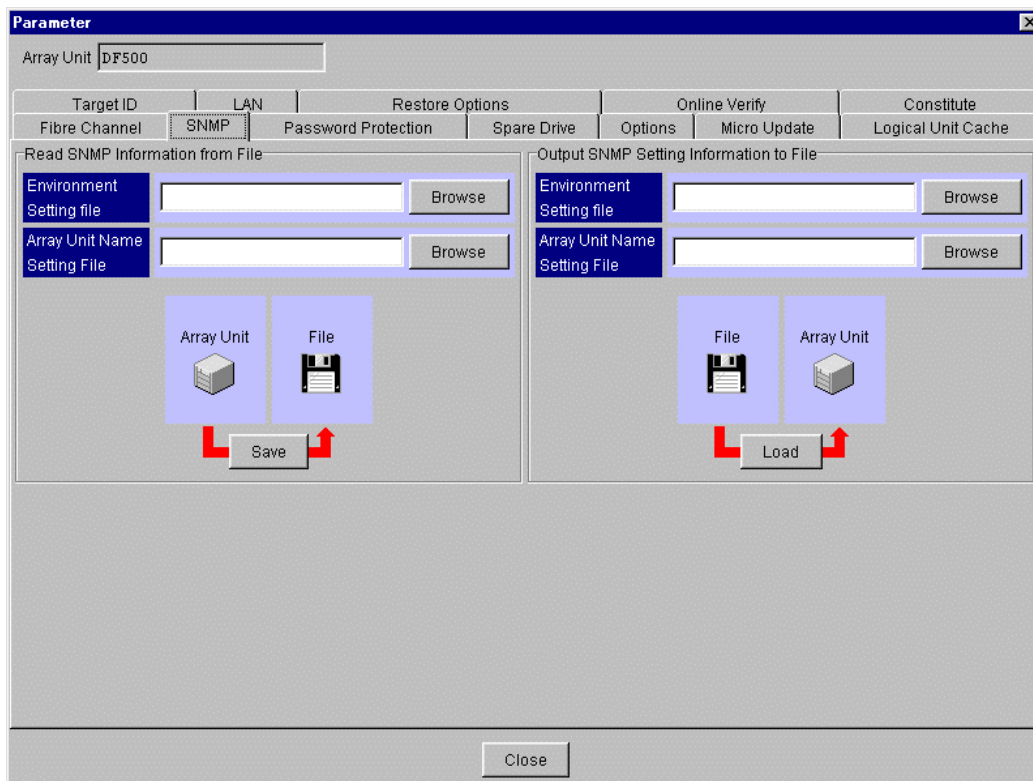

3. Specify the paths of the directory for storing the “**Environment Setting File**”(Read SNMP Information from File) and the “**Array Unit Name Setting File**”(Read SNMP Information from File) file and click the **Save** button. To output only one file, specify only the path of the target file.

**Note:** Specify the name of a directory in the hard disk drive to which the microprogram is copied and the file name, with one-byte coded alphanumerics.

4. When the file output is normally terminated, the message shown in the following figure is displayed. Then, click the **OK** button.

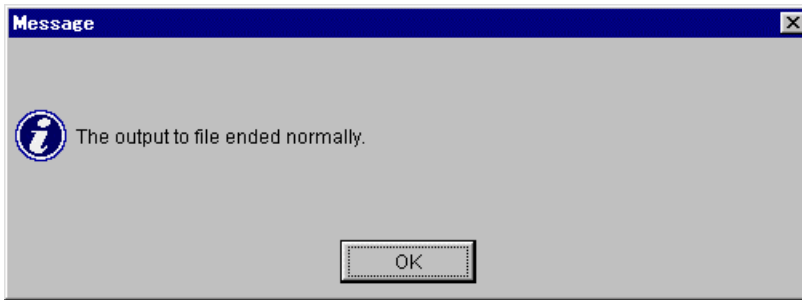

## 6.12 Array Unit Management by Password protection function

Operators who operate an array unit are managed by setting user IDs in the array unit. If no user ID has been set, anyone may operate. If a user ID has been set, the set user ID must be entered.

The User ID screen is displayed if a priced optional feature of the array unit, “Password Security,” has been installed. When you have unlocked/locked the priced optional feature of the array unit, “Password Security” using the **Options** tab, operations of the “Password Security” priced optional feature are enabled by displaying the Unit screen again.

If no user ID has been registered, “0” is displayed in the **User IDs** field.

The screenshot shows a software window titled "Parameter" for an "Array Unit DF500". The window has a tabbed interface with several tabs: "Target ID", "LAN", "Restore Options", "Online Verify", and "Constitute". The "Restore Options" tab is active, and within it, the "Password Protection" sub-tab is selected. Below the tabs is an "Operation menu" with four radio buttons: "Register User ID" (which is selected), "Change User ID", "Delete User ID", and "Change Password". Below the menu is a "User IDs" field containing the value "0". There are two main sections: "User ID" and "Password". The "User ID" section contains "Old User ID" and "New User ID" input fields. The "Password" section contains "Old Password", "New Password", and "Check Password" input fields. At the bottom right of the window are "Apply" and "Reset" buttons, and at the bottom center is a "Close" button.

Management of operators by user ID is effective when operating the manager 2 in management mode. When operating the manager 2 in normal mode, the manager 2 may be operated regardless of whether a user ID has been registered or not.

## 6.12.1 Setting User ID

Sets a user ID in an array unit.

1. Select “**Settings—Configuration Settings**” on the Unit screen. Or, when you click the “ : **Configuration Settings**” in the tool bar.
2. Click the **Password Protection** tab.

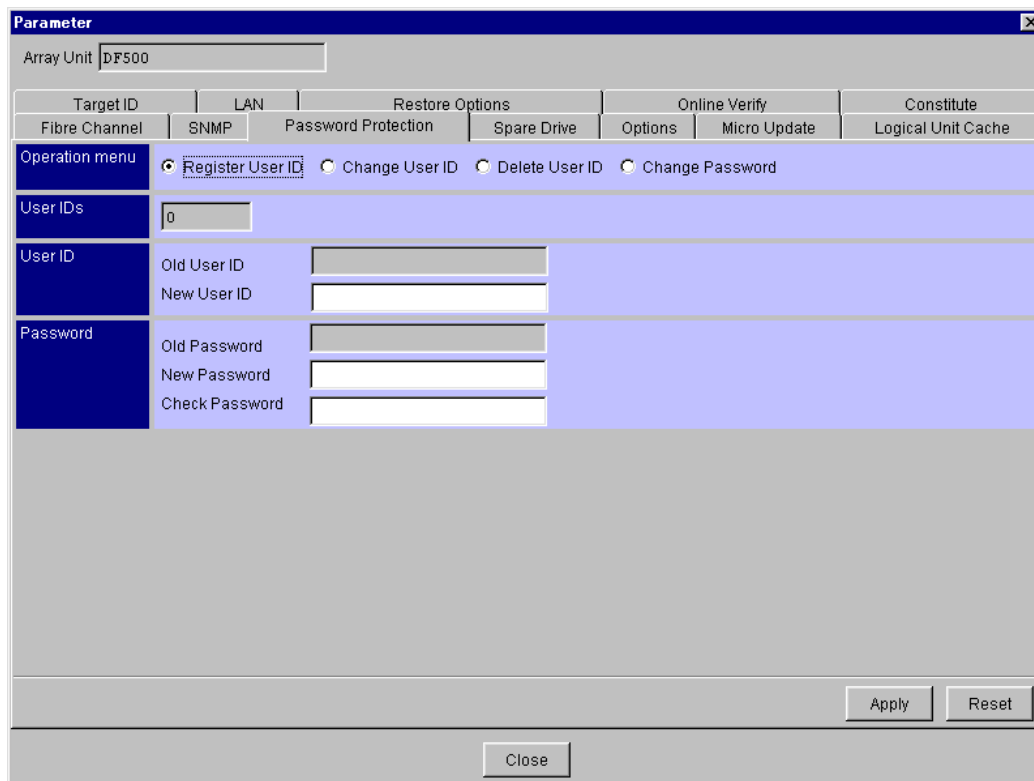

The screenshot shows a window titled "Parameter" for Array Unit "DF500". The window has a tabbed interface with the following tabs: Target ID, LAN, Restore Options, Online Verify, and Constitute. The "Restore Options" tab is active, and within it, the "Password Protection" sub-tab is selected. The "Operation menu" shows four radio buttons: "Register User ID" (selected), "Change User ID", "Delete User ID", and "Change Password". Below the menu, there are input fields for "User IDs" (containing "0"), "User ID" (with "Old User ID" and "New User ID" sub-fields), and "Password" (with "Old Password", "New Password", and "Check Password" sub-fields). At the bottom right, there are "Apply" and "Reset" buttons, and at the bottom center, a "Close" button.

3. From the **Operation menu**, clicks the **Register User ID** option button. Enters into the **New User ID**, **New Password**, and **Check Password** fields their respective data, and then clicks the **Apply** button.
  - **New User ID:** Specifies a user ID to register. Specifies with alphanumeric and special symbols “- (minus)” and “\_(underline)” of 4 to 12 characters long.
  - **New Password:** Specifies the password of a user ID to register. Specifies with alphanumeric and special symbols “- (minus)” and “\_(underline)” of 4 to 12 characters long.
  - **Check Password:** Specifies the same password as that of a user ID to register. Specifies with alphanumeric and special symbols “- (minus)” and “\_(underline)” of 4 to 12 characters long.

4. A message indicating completion of registering is displayed, so click the **OK** button.

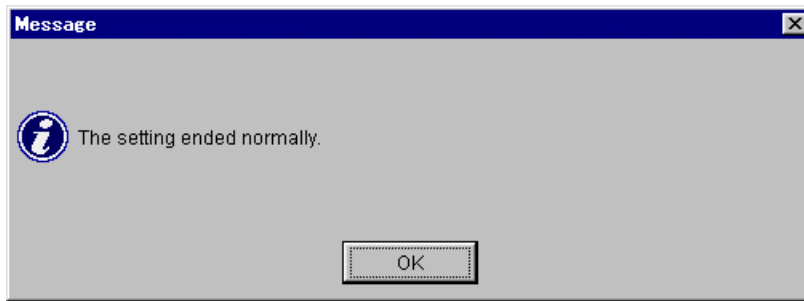

The number of user IDs registered is updated, and is displayed.

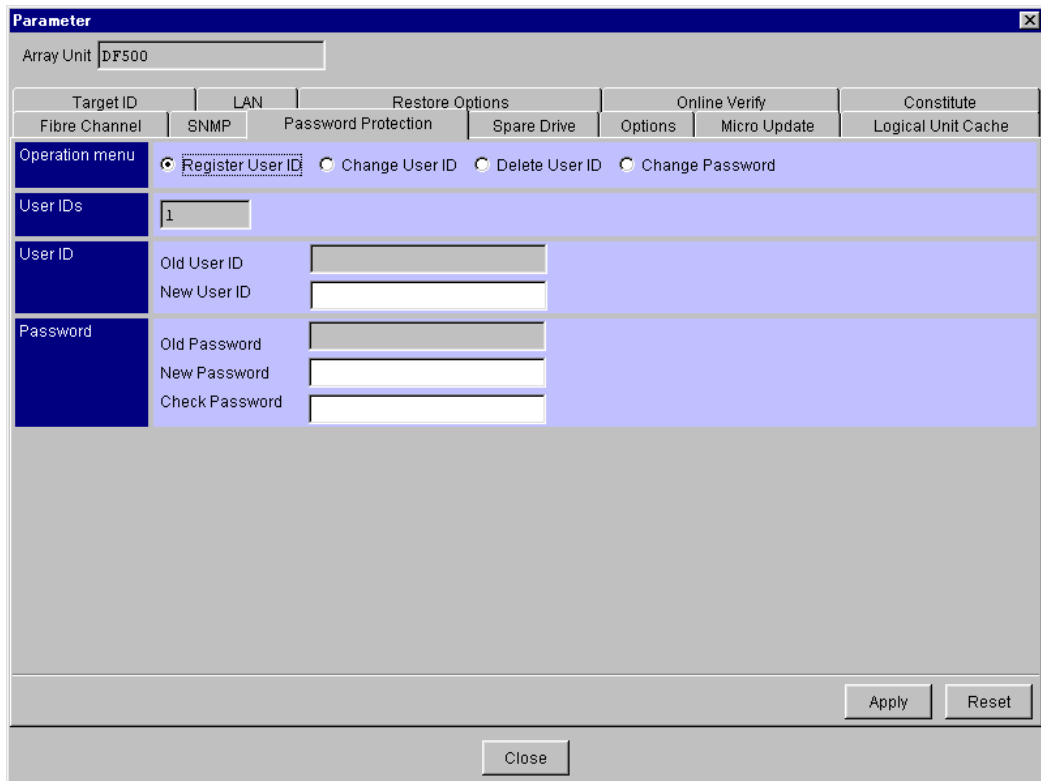

## 6.12.2 Changing User ID

Changes a user ID already registered in an array unit.

1. Select “**Settings—Configuration Settings**” on the Unit screen. Or, when you click the : **Configuration Settings**” in the tool bar.
2. Click the **Password Protection** tab.

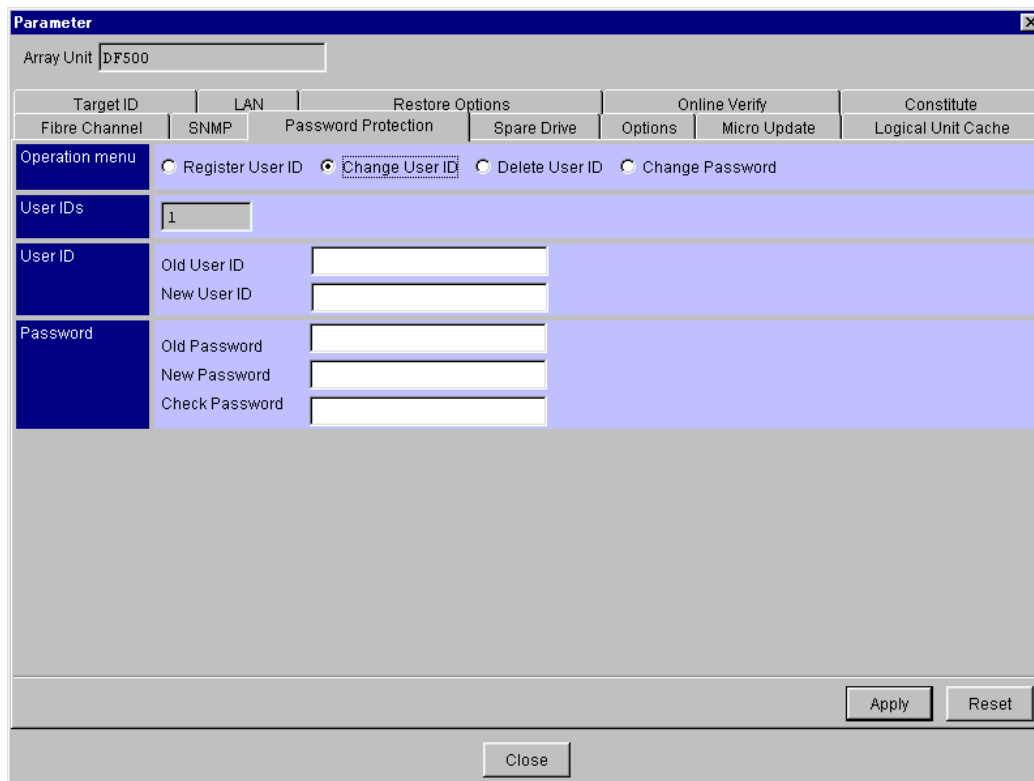

The screenshot shows a software window titled "Parameter" for Array Unit "DF500". The window has a tabbed interface with the following tabs: Target ID, LAN, Restore Options, Online Verify, and Constitute. The "Restore Options" tab is active, and within it, the "Password Protection" sub-tab is selected. In the "Operation menu", four radio buttons are present: "Register User ID", "Change User ID" (which is selected), "Delete User ID", and "Change Password". Below the menu, there is a "User IDs" list containing the number "1". Underneath, there are input fields for "Old User ID", "New User ID", "Old Password", "New Password", and "Check Password". At the bottom right, there are "Apply" and "Reset" buttons, and at the bottom center, there is a "Close" button.

3. From the **Operation menu**, clicks the **Change User ID** option button. Enters into the **Old User ID**, **New User ID**, **Old Password**, **New Password**, and **Check Password** fields their respective data, and then clicks the **Apply** button.
  - **Old User ID:** Specifies a user ID to change.
  - **New User ID:** Specifies a user ID to register. Specifies with alphanumeric and special symbols “- (minus)” and “\_(underline)” of 4 to 12 characters long.
  - **Old Password:** Specifies the password of a user ID to change.
  - **New Password:** Specifies the password of a user ID to register. Specifies with alphanumeric and special symbols “- (minus)” and “\_(underline)” of 4 to 12 characters long.
  - **Check Password:** Specifies the same password as that of a user ID to register. Specifies with alphanumeric and special symbols “- (minus)” and “\_(underline)” of 4 to 12 characters long.

4. A message indicating completion of changing is displayed, then click the **OK** button.

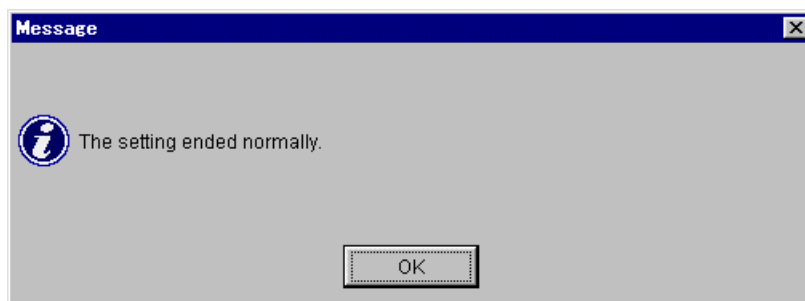

### 6.12.3 Deleting User ID

Deletes a user ID already registered in an array unit.

1. Select “**Settings—Configuration Settings**” on the Unit screen. Or, when you click the : **Configuration Settings**” in the tool bar.
2. Click the **Password Protection** tab.

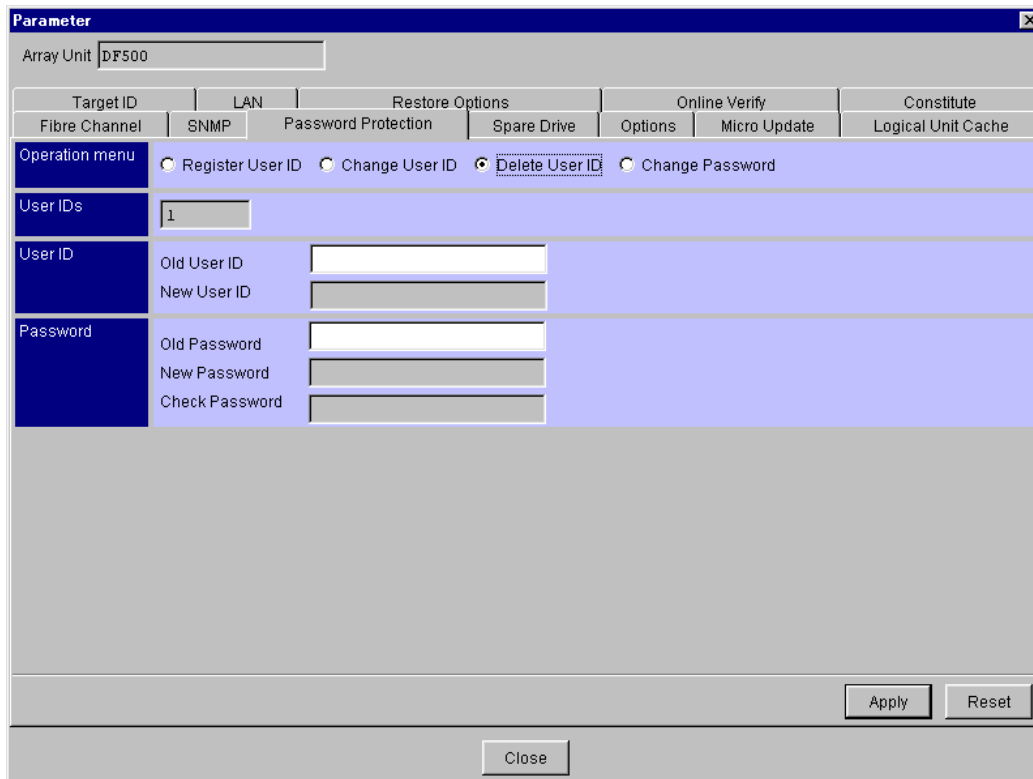

The screenshot shows a dialog box titled "Parameter" with a close button (X) in the top right corner. The "Array Unit" field contains "DF500". Below this is a tabbed interface with several tabs: "Target ID", "LAN", "Restore Options", "Online Verify", and "Constitute". The "Restore Options" tab is active, showing sub-tabs for "Fibre Channel", "SNMP", "Password Protection", "Spare Drive", "Options", "Micro Update", and "Logical Unit Cache". The "Password Protection" sub-tab is selected, displaying an "Operation menu" with four radio buttons: "Register User ID", "Change User ID", "Delete User ID" (which is selected), and "Change Password". Below the menu, the "User IDs" field contains the number "1". The "User ID" section has two input fields: "Old User ID" and "New User ID". The "Password" section has three input fields: "Old Password", "New Password", and "Check Password". At the bottom right of the dialog are "Apply" and "Reset" buttons, and a "Close" button is centered at the very bottom.

3. From the **Operation menu**, clicks the **Delete User ID** option button. Enters into the **Old User ID** and **Old Password** fields their respective data, and then clicks the **Apply** button.
  - **Old User ID:** Specifies a user ID to change.
  - **Old Password:** Specifies the password of a user ID to change.
4. A message indicating completion of deleting is displayed, then click the **OK** button.

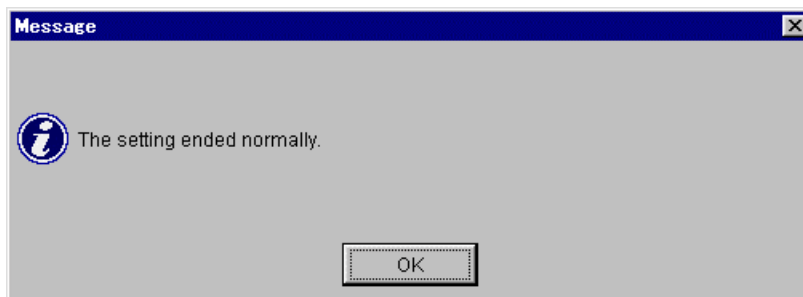

The screenshot shows a "Message" dialog box with a close button (X) in the top right corner. It features an information icon (i) on the left and the text "The setting ended normally." in the center. At the bottom center, there is an "OK" button.

The number of user IDs registered is updated, and is displayed.

The screenshot shows a window titled "Parameter" with a close button in the top right corner. The "Array Unit" is set to "DF500". Below this is a tabbed interface with the following tabs: Target ID, LAN, Restore Options, Online Verify, and Constitute. Under the "Restore Options" tab, there are sub-tabs: Fibre Channel, SNMP, Password Protection, Spare Drive, Options, Micro Update, and Logical Unit Cache. The "Operation menu" is currently selected, showing four radio button options: "Register User ID" (which is selected), "Change User ID", "Delete User ID", and "Change Password". Below the operation menu, the "User IDs" field displays the number "0". The "User ID" section contains two input fields: "Old User ID" and "New User ID". The "Password" section contains three input fields: "Old Password", "New Password", and "Check Password". At the bottom right of the window are "Apply" and "Reset" buttons, and at the very bottom center is a "Close" button.

## 6.12.4 Changing Password

Changes the password of a user ID already registered in an array unit.

1. Select “**Settings—Configuration Settings**” on the Unit screen. Or, when you click the “: **Configuration Settings**” in the tool bar.
2. Click the **Password Protection** tab.

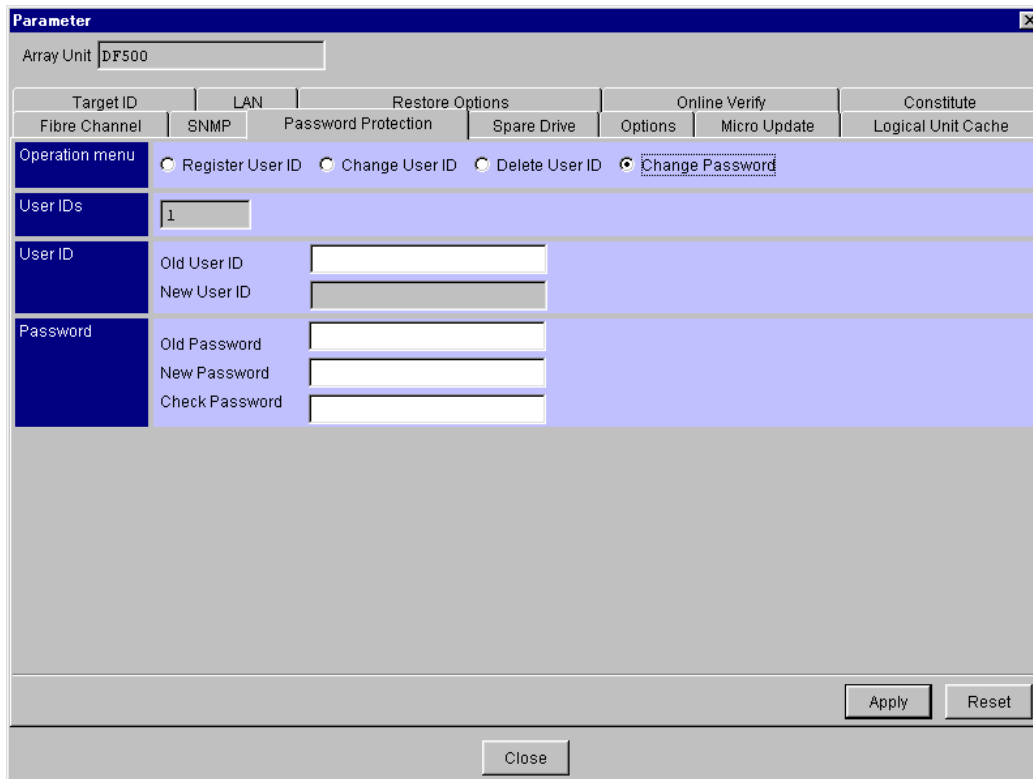

The screenshot shows a window titled "Parameter" for Array Unit "DF500". The window has a tabbed interface with the following tabs: Target ID, LAN, Restore Options, Online Verify, and Constitute. The "Restore Options" tab is active, and within it, the "Password Protection" sub-tab is selected. The "Operation menu" shows four radio buttons: "Register User ID", "Change User ID", "Delete User ID", and "Change Password", with "Change Password" selected. Below the menu, the "User IDs" section shows a list with "1" selected. The "User ID" section has fields for "Old User ID" and "New User ID". The "Password" section has fields for "Old Password", "New Password", and "Check Password". At the bottom right, there are "Apply" and "Reset" buttons, and at the bottom center, a "Close" button.

3. From the **Operation menu**, clicks the **Change Password** option button. Enters into the **Old User ID**, **Old Password**, **New Password**, and **Check Password** fields their respective data, and then clicks the **Apply** button.
  - **Old User ID:** Specifies a user ID to change.
  - **Old Password:** Specifies the password of a user ID to change.
  - **New Password:** Specifies the password of a user ID to register. Specifies with one-byte coded alphanumerics and special symbols “- (minus)” and “\_(underline)” of 4 to 12 characters long.
  - **Check Password:** Specifies the same password as that of a user ID to register. Specifies with one-byte coded alphanumerics and special symbols “- (minus)” and “\_(underline)” of 4 to 12 characters long.

4. A message indicating completion of changing is displayed, then click the **OK** button.

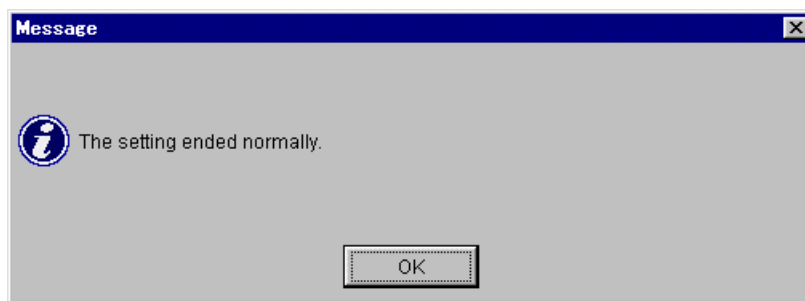

## 6.12.5 Logging into Array Unit

Logs into an array unit in which a user ID has been already registered.

If the mode of operating has been set in the “Normal Mode”, you can log in to an array unit in which user IDs are already registered.

1. Change the Active Mode to **Management Mode**.
2. Click the icon of an array unit on the Main screen, and then select “**Settings—Display Details**”. Or, when you click the “ : **Display Details**” in the tool bar, the Unit screen of an array unit will be displayed.
3. Enters a registered user ID and its password, then clicks the **OK** button.

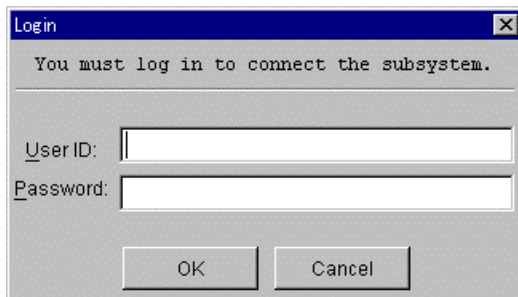

Logs in with the registered user ID, and the unit window is displayed.

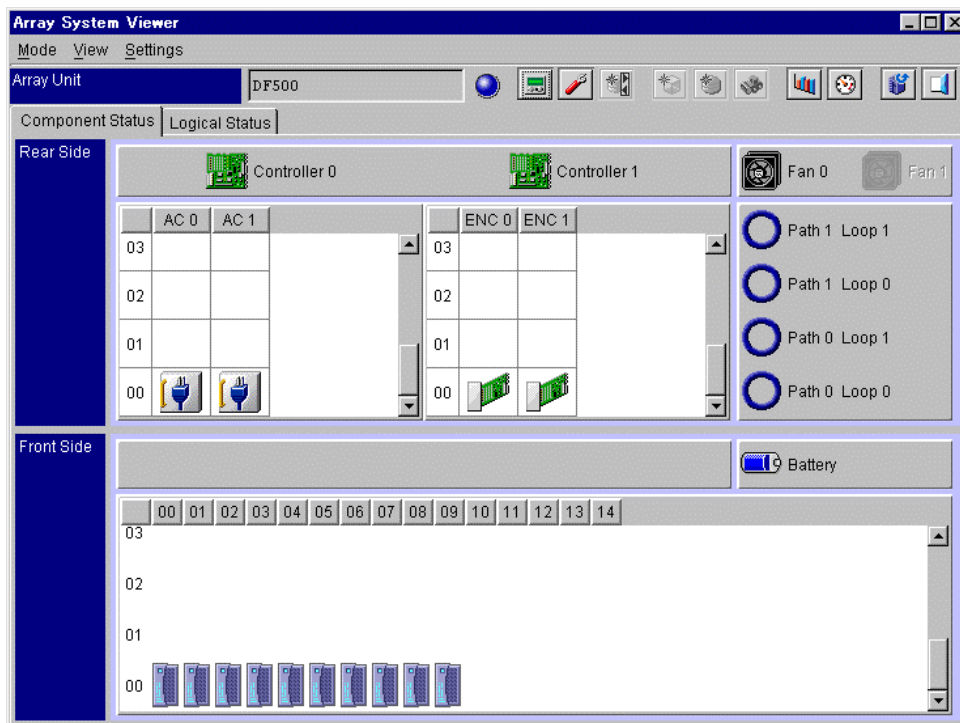

### 6.12.6 Logging into Array Unit Forcibly

Logs out a user ID forcibly from an array unit to which a user has already logged in with the user ID, then logs in forcibly with another registered user ID.

When clicking the icon of an array unit to which a user has already logged in and then select “**Settings—Display Details**” or when you click the “ : **Display Details**” in the tool bar, a message indicating that a user has already logged in is displayed. The message indicates the user ID of an already logged-in user and connection information..



1. Terminates the manager 2, and restarts the manager 2 by appending the “-discon” option of the Forcibly Logging In command.

hhh) With Windows, edits the description contents of startmgr2.bat (a batch file used to start the manager 2) and adds the “-discon” option.

**Example :**

```
java -classpath.\CONFMNG2.JARjp.co.hitachi.str.diskarray.gui.ConmanFrame%1 -discon
```

- iii) With Solaris and IRIX, it is started with the “-discon” option appended when starting the manager 2.

**Example :** ./startmgr2 -discon

2. Restarts the manager 2, and sets the mode of operation to management mode.
3. Click the icon of an array unit on the Main screen, and then select “**Settings—Display Details**”. Or, when you click the “ : **Display Details**” in the tool bar, the Unit screen of an array unit will be displayed.
4. Enters a registered user ID and its password, then click the **OK** button.

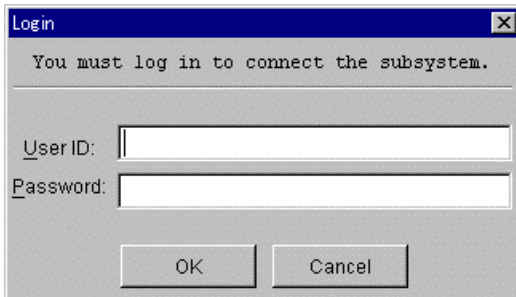

5. A user ID with which a user has logged in and its password are displayed. When logging in forcibly, click the **OK** button.

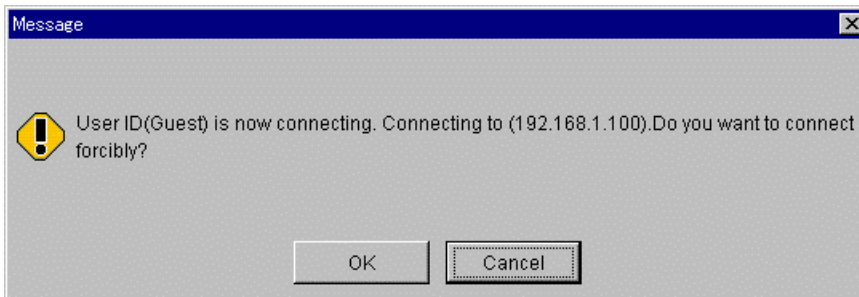

Logging in with an entered user ID is done, and the unit window is displayed.

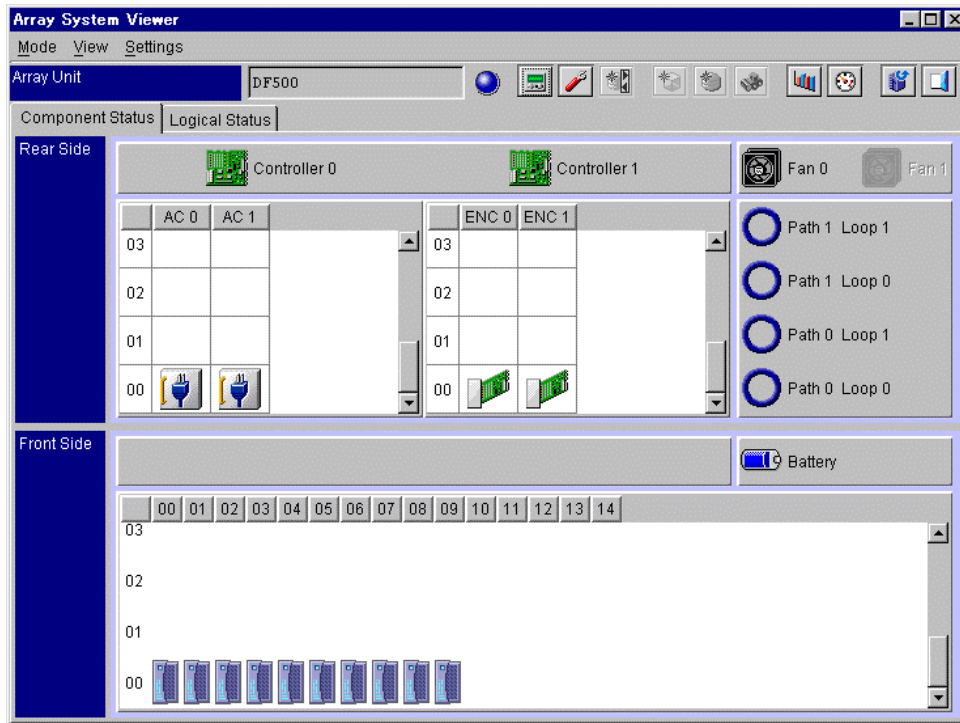

### 6.12.7 Logging Out from Array Unit

1. Select “**Mode—Exit**”. Or, when you click the “ : **Exit**” in the tool bar, the Unit screen of an array unit will be displayed.

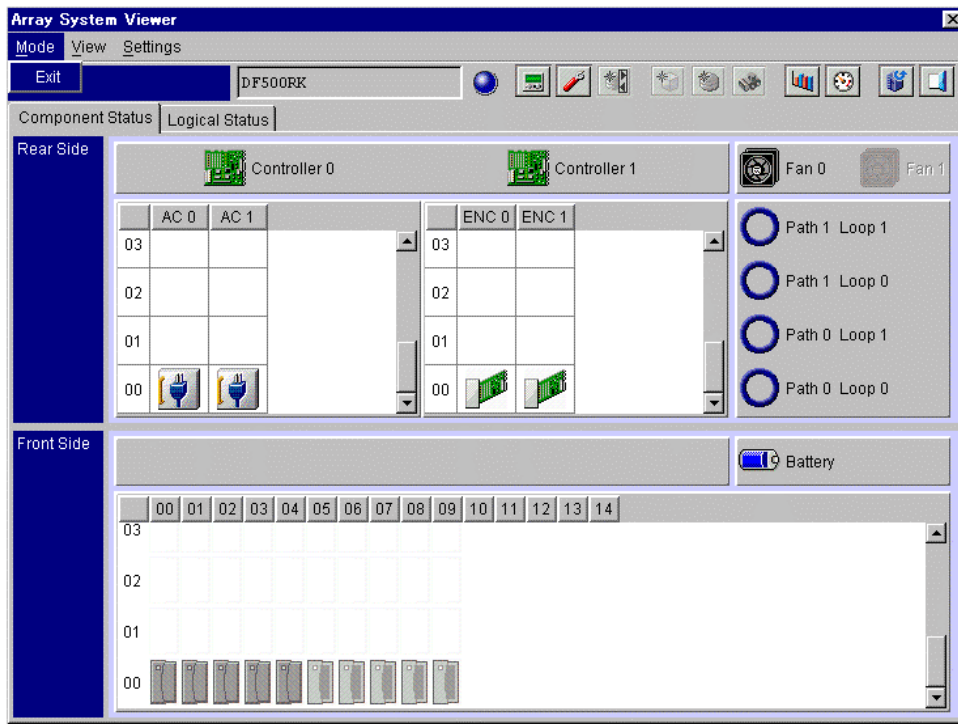

Logging out is done, and the unit window is closed.

## 6.13 Setting Turbo LU

This function sets an logical unit to be resident in the cache.

1. Select “**Settings—Configuration Settings**” on the Unit screen. Or, when you click the “ : **Configuration Settings**” in the tool bar.
2. Click the **Logical Unit Cache** tab.

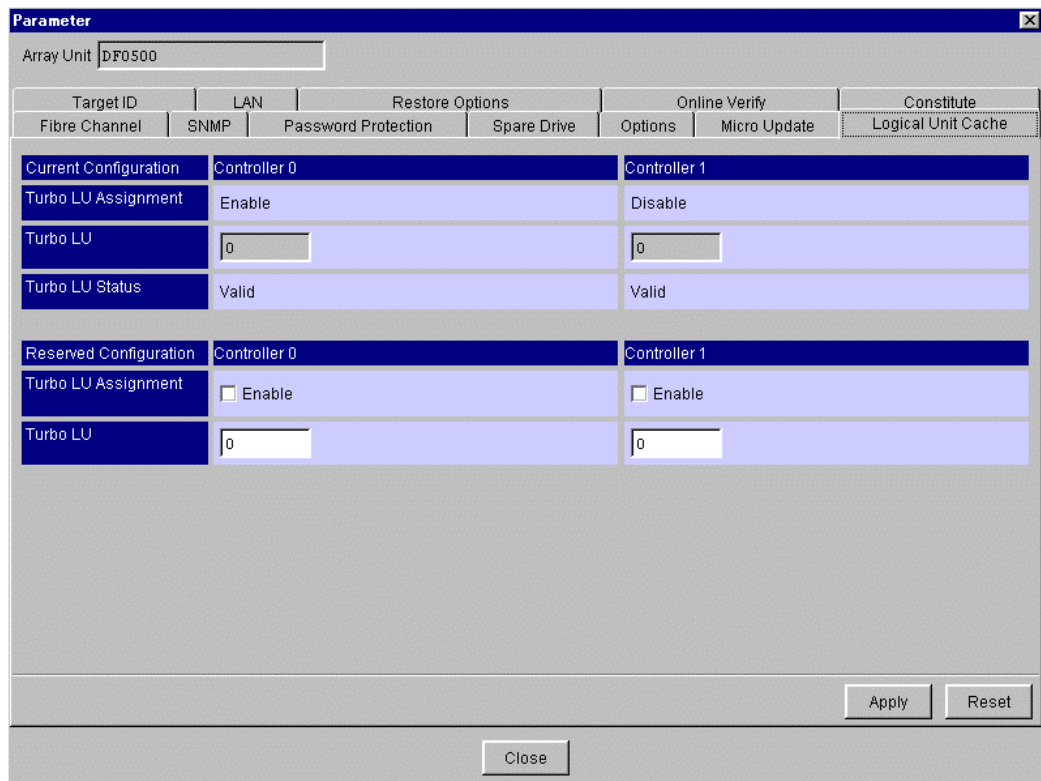

| Parameter                     |  | Array Unit: DF0500              |              |
|-------------------------------|--|---------------------------------|--------------|
|                               |  | Target ID                       | LAN          |
|                               |  | Restore Options                 |              |
|                               |  | Online Verify                   |              |
|                               |  | Constitute                      |              |
|                               |  | Fibre Channel                   | SNMP         |
|                               |  | Password Protection             | Spare Drive  |
|                               |  | Options                         | Micro Update |
|                               |  | Logical Unit Cache              |              |
| <b>Current Configuration</b>  |  | <b>Controller 0</b>             |              |
| <b>Turbo LU Assignment</b>    |  | Enable                          |              |
| <b>Turbo LU</b>               |  | 0                               |              |
| <b>Turbo LU Status</b>        |  | Valid                           |              |
| <b>Reserved Configuration</b> |  | <b>Controller 0</b>             |              |
| <b>Turbo LU Assignment</b>    |  | <input type="checkbox"/> Enable |              |
| <b>Turbo LU</b>               |  | 0                               |              |
|                               |  | <b>Controller 1</b>             |              |
| <b>Turbo LU Assignment</b>    |  | Disable                         |              |
| <b>Turbo LU</b>               |  | 0                               |              |
| <b>Turbo LU Status</b>        |  | Valid                           |              |

Apply    Reset

Close

- **Current Configuration:** Indicates the currently set configuration.
  - **Turbo LU Assignment:** Setting status of whether to validate or invalidate the Turbo LU function.
    - Enable:** Valid
    - Disable:** Invalid
  - **Turbo LU:** Turbo LU number
  - **Turbo LU Status:** Status of the Turbo LU. This status is not displayed when the **Turbo LU Assignment** is set to DISABLE.
    - Valid:** Usable
    - Invalid:** Unusable

- **Reserve Configuration:** Indicates the configuration to be reserved.
  - **Turbo LU Assignment:** Specifies the setting of whether to validate or invalidate the Turbo LU function.
    - Enable:** Valid
    - Disable:** Invalid
  - **Turbo LU:** Specifies the Turbo LU number.

3. Click the **Apply** button.
4. A message indicating that LU cache has been set resident is displayed. A confirmation message indicating a request for restarting is displayed, so clicks the **OK** button when restarting.

**Note:** To validate the set LU cache resident condition, restart the array unit. The previous setting stays valid until restarting. When restarting is initiated, the array unit is not ready to accept an access from the host for duration from initiation until the restarting terminates. Therefore, after making sure that the host has stopped accessing, initiate restarting.

When instructing to restart an array unit, the time the restarting has began is displayed. The restarting takes about two to six minutes.

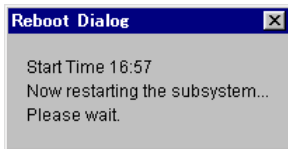

**Note:** It may take time for an array unit to respond, depending on the condition of the array unit. If it does not still respond after 10 minutes or more pass, check the condition of the array unit.

5. A message indicating that the restarting has terminated is displayed, so click the **OK** button.

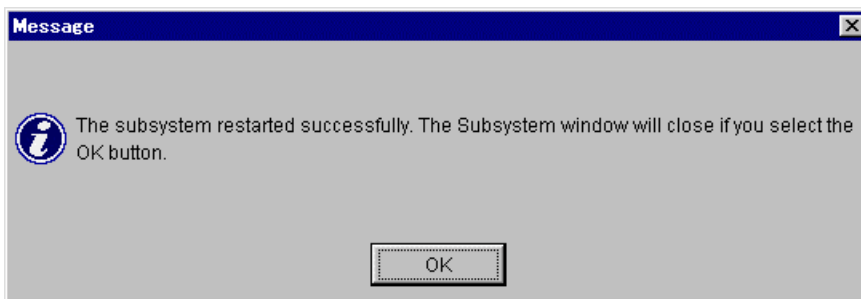

When clicking the **OK** button, the unit screen is closed. To perform other operations, select again on the main screen an array unit which to operate, and open the unit screen.

**Note:** The LU cache resident function is available as a priced optional feature. If the LU cache resident function is not yet installed or the priced optional feature is not yet made effective, LU cache cannot be set resident.

## 6.14 Setting MRCF-Lite

Sets the ID for identifying command devices and array units in order to use MRCF-Lite. For details on how to set up MRCF-Lite, refer to the MRCF-Lite User's Guide.

### 6.14.1 Setting command device

Sets the command device. You can specify up to 2 LUs of command devices.

1. Select “**Settings—Configuration Settings**” on the Unit screen. Or, when you click the  : **Configuration Settings**” in the tool bar.
2. Click the **MRCF-Lite** tab.

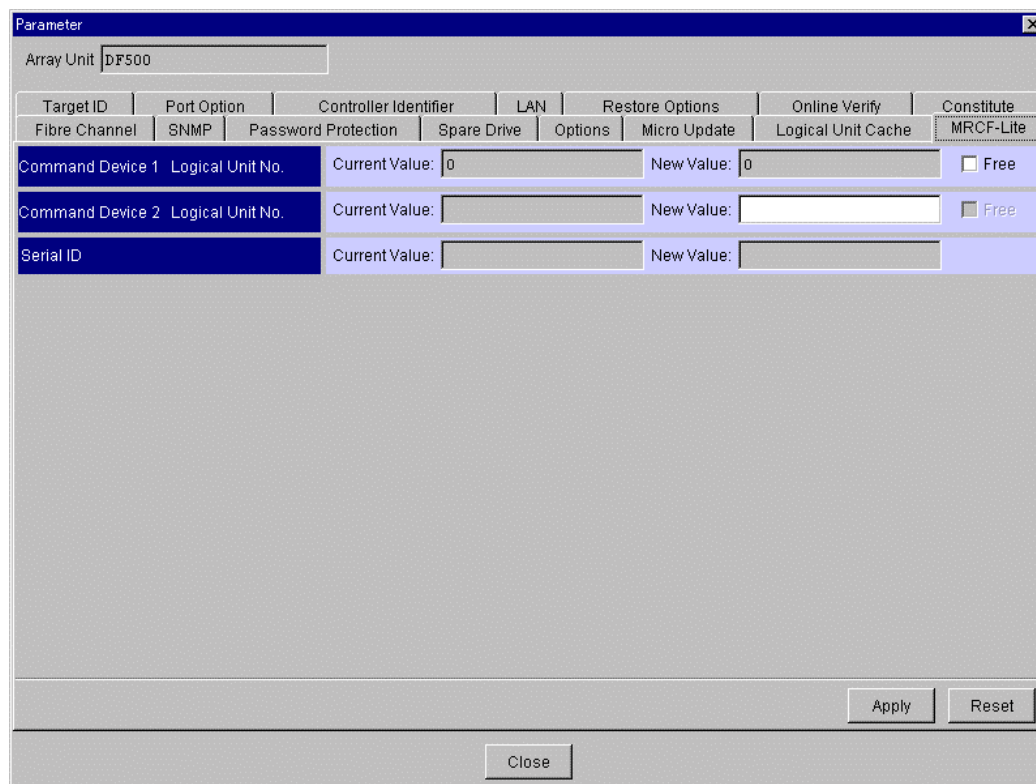

The screenshot shows a 'Parameter' dialog box with a title bar and a close button. The 'Array Unit' field is set to 'DF500'. Below this is a tabbed interface with the following tabs: Target ID, Port Option, Controller Identifier, LAN, Restore Options, Online Verify, and Constitute. The 'Constitute' tab is active, showing sub-tabs: Fibre Channel, SNMP, Password Protection, Spare Drive, Options, Micro Update, Logical Unit Cache, and MRCF-Lite. The 'MRCF-Lite' sub-tab is selected, displaying a table with three rows: 'Command Device 1 Logical Unit No.', 'Command Device 2 Logical Unit No.', and 'Serial ID'. Each row has 'Current Value' and 'New Value' text boxes, and a 'Free' checkbox. The 'Current Value' for 'Command Device 1' is '0', and its 'New Value' is also '0'. The 'Free' checkbox for 'Command Device 1' is unchecked. The 'Free' checkbox for 'Command Device 2' is checked. At the bottom right of the dialog are 'Apply' and 'Reset' buttons, and at the bottom center is a 'Close' button.







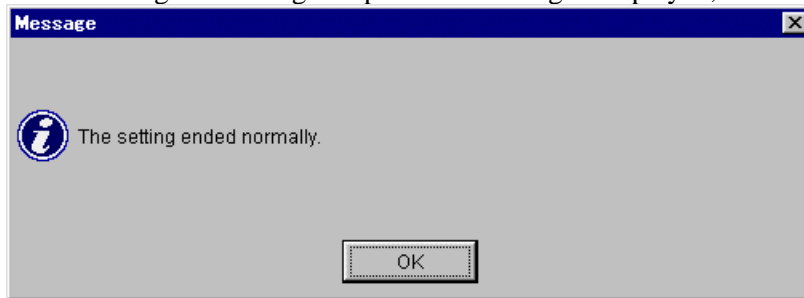

| Parameter                         | Current Value | New Value | Free                                |
|-----------------------------------|---------------|-----------|-------------------------------------|
| Command Device 1 Logical Unit No. | 0             | 0         | <input type="checkbox"/>            |
| Command Device 2 Logical Unit No. |               |           | <input checked="" type="checkbox"/> |
| Serial ID                         |               |           |                                     |

3. Specify an logical unit which to set to a command device in the **New Value** text box, and then click the **Apply** button. In the Current: text box, current information is displayed.
  - **Command Device 1/Command Device 2:**  
**Logical Unit No.:** Specify the logical unit No.
  - **Serial ID:** Specify the serial ID of an array unit.

4. A message indicating completion of setting is displayed, click the **OK** button.



On the **Logical Status** tab screen, a logical unit that has been set up as a command device is displayed in such a way that the icon of the logical unit is displayed as a command device.

| Display  | Highlighting  | Status         |
|--|---|----------------|
|  Yellow |    | • Normal       |
|  Gray   |    | • Unformatted. |
|  Red    |    | • Blockade     |
|  Pink |  | • Regression   |

## 6.14.2 Changing command device

Change the command device. When you change the command device, delete the set command device, and then set the command device again.

1. Select “**Settings—Configuration Settings**” on the Unit screen. Or, when you click the “ : **Configuration Settings**” in the tool bar.
2. Click the **MRCF-Lite** tab.

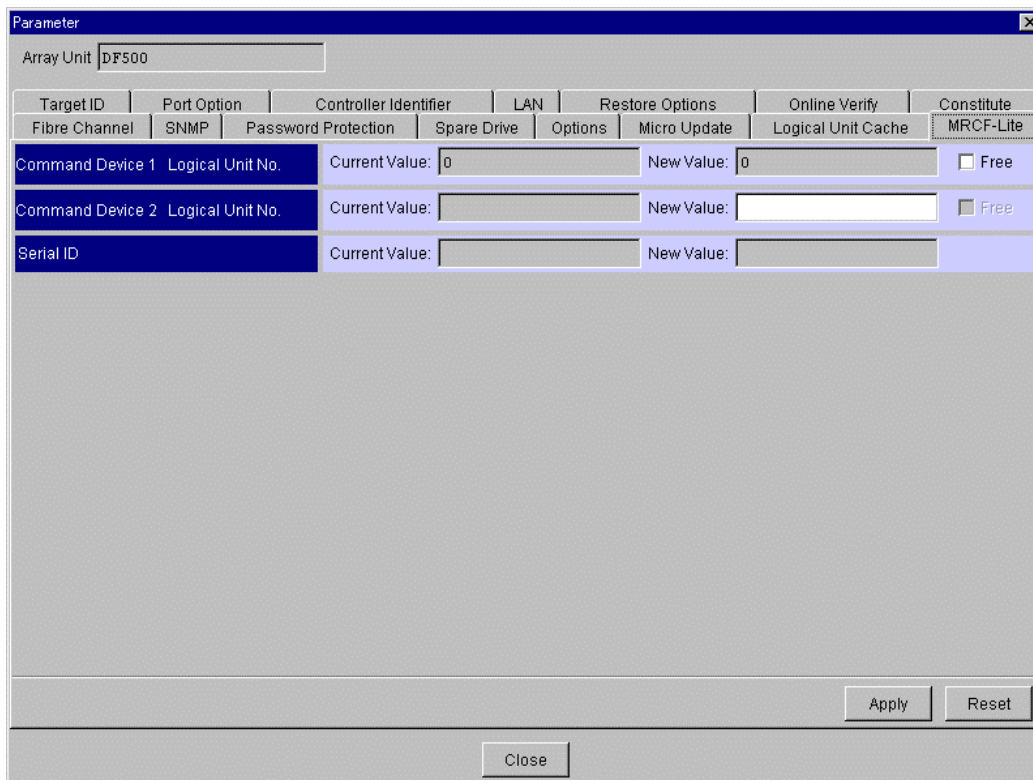

3. Select the **Free** check button of a command device to change, and then click the **Apply** button.
4. A message indicating completion of setting is displayed, click the **OK** button.

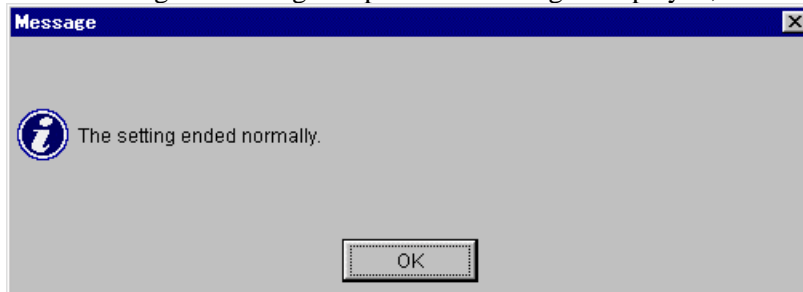

5. The **Current** show of the command device that has been deleted disappears. Set up a new one to which you want to change the command device in the same procedure as for setting.

### 6.14.3 Delete command device

Delete the command device.

1. Select “**Settings—Configuration Settings**” on the Unit screen. Or, when you click the “ : **Configuration Settings**” in the tool bar.
2. Click the **MRCF-Lite** tab.

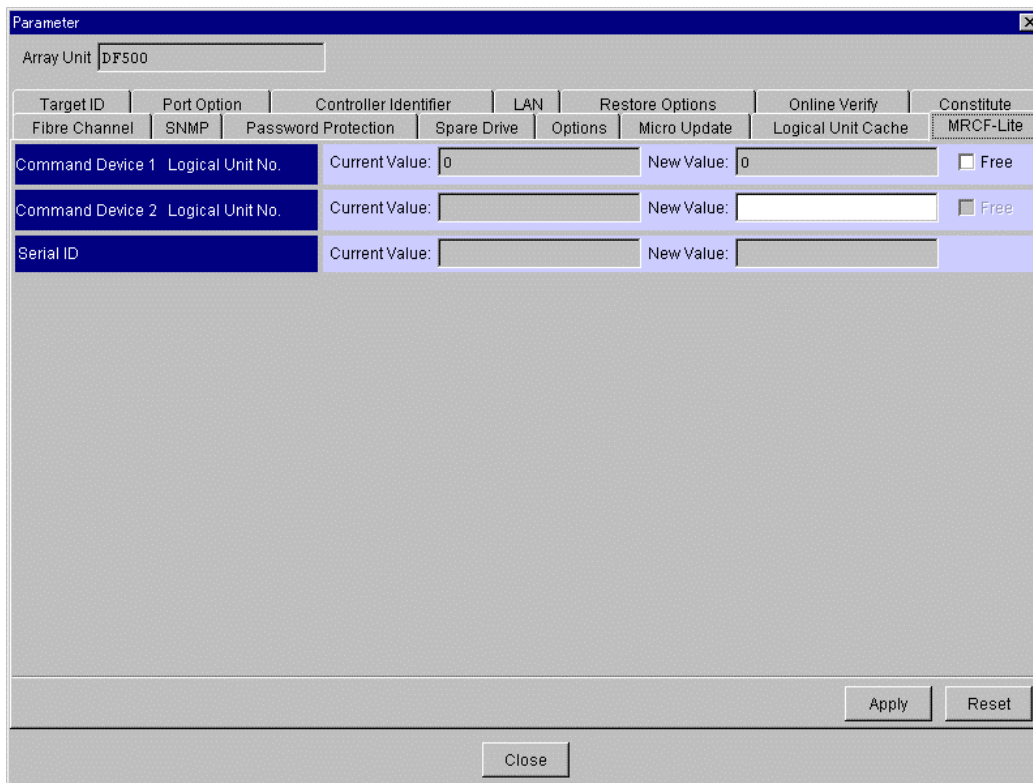

The screenshot shows a 'Parameter' window for 'Array Unit DF500'. It features a tabbed interface with the following tabs: Target ID, Port Option, Controller Identifier, LAN, Restore Options, Online Verify, and Constitute. The 'Constitute' tab is active, showing sub-tabs: Fibre Channel, SNMP, Password Protection, Spare Drive, Options, Micro Update, Logical Unit Cache, and MRCF-Lite. The MRCF-Lite sub-tab is selected, displaying three rows of configuration fields:

| Parameter                         | Current Value | New Value | Free                                |
|-----------------------------------|---------------|-----------|-------------------------------------|
| Command Device 1 Logical Unit No. | 0             | 0         | <input checked="" type="checkbox"/> |
| Command Device 2 Logical Unit No. |               |           | <input type="checkbox"/>            |
| Serial ID                         |               |           |                                     |





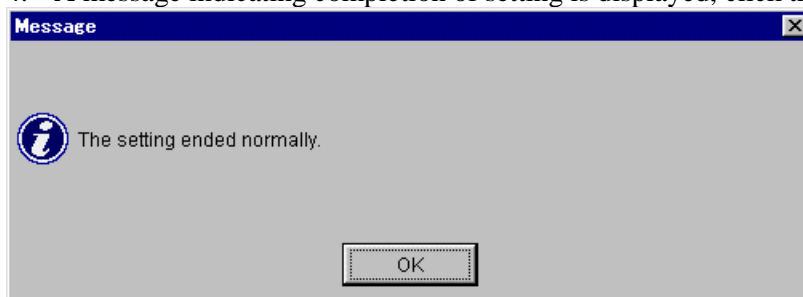



Buttons for 'Apply', 'Reset', and 'Close' are visible at the bottom of the window.

3. Select the **Free** check button of a command device to delete, and then click the **Apply** button.
4. A message indicating completion of setting is displayed, click the **OK** button.



#### 6.14.4 Displaying the coupled logical unit

The status of coupled logical units is displayed in the **Logical Status** tab screen on the Unit screen.

| Display  | Highlighting  | Status |
|--|---|--------|
|  Yellow |  | • PAIR |
|  Gray   |  | • COPY |
|  Red    |  | • PSUS |
|  Red    |  | • PSUE |

When you double-click icon, the information of the coupled logical unit is displayed.

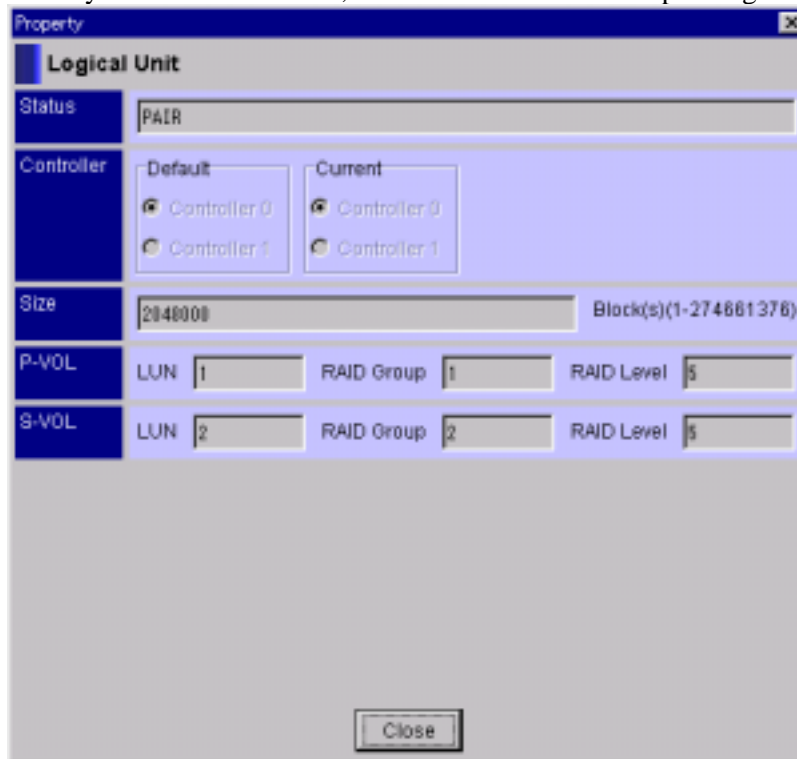

## 6.15 Setting port option

Sets the port option of the system parameter. Setting is allowed only if the Target ID mode of an array unit which to set up has been set to **M-TID,M-LUN** (mapping). And not setting mapping information.

Confirmation the target ID of setting port.

Setting information becomes valid without restarting an array unit.

1. Select “**Settings—Configuration Settings**” on the Unit screen. Or, when you click the : **Configuration Settings**” in the tool bar.
2. Click the **Port Option** tab.

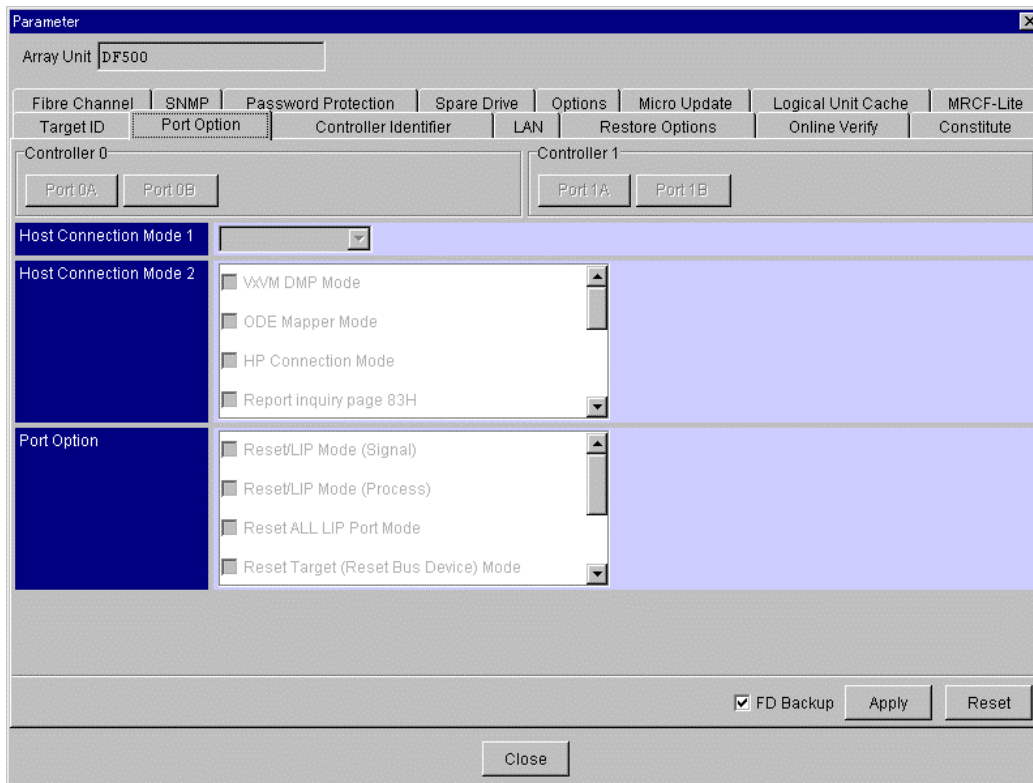

3. Select a port to set up, select **Host Connection Mode 1** to set, and then specify **Host Connection Mode 2** and the **Port Option**.
  - **Host Connection Mode 1**
    - Standard Mode:** Open system emulation mode
    - Open VMS Mode:** Open VMS mode
    - TRESPASS Mode:** TRESPASS mode
    - Wolfpack Mode:** Wolfpack mode
    - IBM 7135 I/O path switch Mode:** IBM 7135 I/O path switch mode
    - NCR I/O path switch Mode:** NCR I/O path switch mode

- **Host Connection Mode 2**  
**VxVM DMP Mode:** VxVM mode  
**ODE Mapper Mode:** ODE Mapper mode  
**HP Connection Mode:** HP connection mode  
**Report inquiry page 83H:** Enables the report of Inquiry Page : 83<sub>H</sub>.  
**UA(60/2A00) suppress Mode:** Suppresses the unit attention (06/2A00).  
**HISUP Mode:** Enables the HISUP  
**CCHS Mode:** Enables the CCHS convert  
**Standard INQUIRY data expand Mode:** Enables the Standard INQUIRY data expand Mode.  
**Product ID DF400 Mode:** Setting the product ID is DF400.
- **Port Option:** Sets the port options.  
 If the port option is set and the button **OK** is clicked, it will return to the setting screen of **Port Type**.  
**Reset/LIP Mode (Signal):** The mode to transmit Reset/LIP signals to other ports.  
**Reset/LIP Mode (Process):** The mode to transmit reset processing to other ports.  
**Reset ALL LIP Port Mode:** The mode to execute reset on receiving LIP.  
**Reset Target (Reset Bus Device) Mode:** The mode to transmit Target Reset to other ports.  
**Reserve Mode:** The mode to reserve logical unit in a dual system.  
**Reset Logical Unit Mode:** When the Logical Unit Reset command is issued for an logical unit, all other commands received by that logical unit will be reset, regardless of the port.  
**Reset Logout of Third Party Process Mode:** The mode to transmit Third Party Process Log-out to other ports.  
**FD Backup:** Port option information has been saved in a backup FD in an array unit as parameter information. When the setting is modified, it is necessary to save it again, so be sure to turn on the check box.

**Note:** **Reset/LIP Mode (signal)** is enabled if the **Reset/LIP Mode (Process)** is set.  
**Port Option** can be multiply set, but depending on the setting, it may not function properly. If it is to be set, please refer to the appended manual of the array unit and set only the applicable parameters.

4. A message indicating completion of setting is displayed, click the **OK** button.

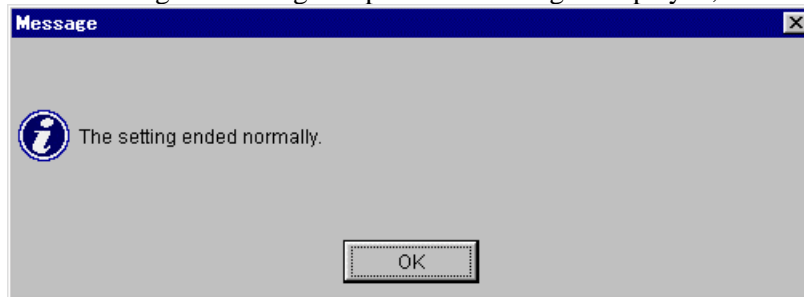

**Note:** When failing to write onto the FD drive, the message “DMES04EB02 : Backup floppy disk write error.” is displayed.  
 When this message is displayed, writing into an FD has not been finished, but setting the port option may be completed.  
 Check an FD in an array unit, re-confirm the data to set, turn on the **FD Backup** check box, and then click the **Apply** button once again.

## 6.16 Setting controller identifier

Sets the controller identifier of the system parameter. Setting is allowed only if the Target ID mode of an array unit which to set up has been set to **M-TID,M-LUN** (mapping). And not setting mapping information.

Confirmation the target ID of setting port.

Setting information becomes valid without restarting an array unit.

1. Select “**Settings—Configuration Settings**” on the Unit screen. Or, when you click the : **Configuration Settings**” in the tool bar.
2. Click the **Controller Identifier** tab.

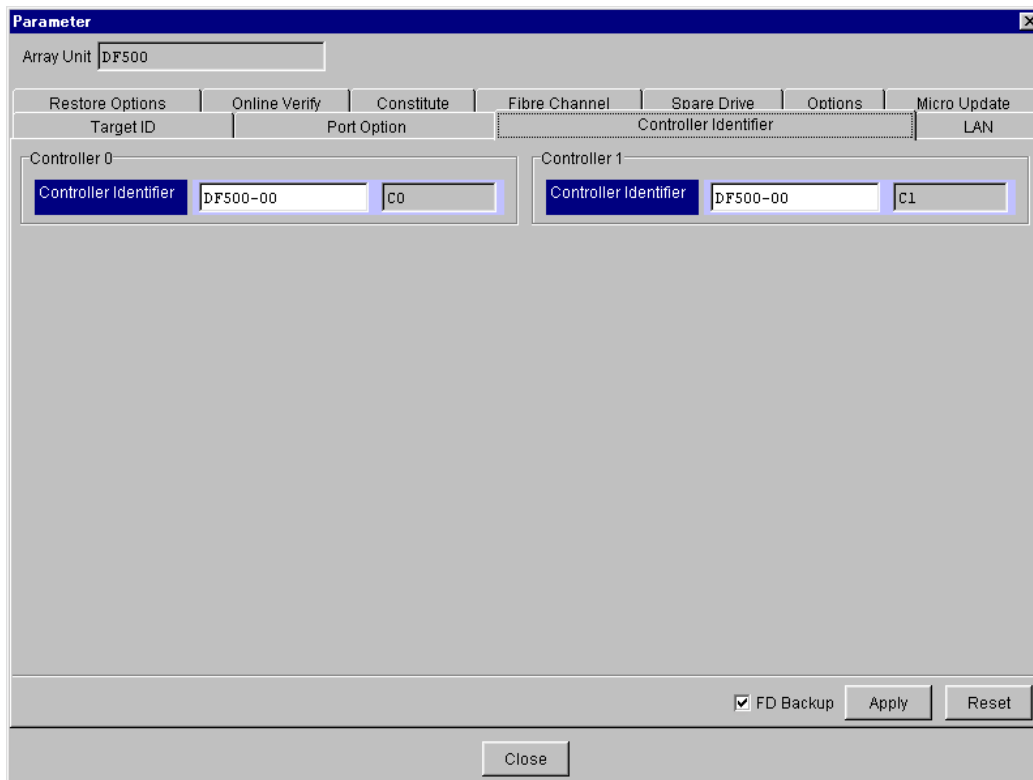

The screenshot shows a software window titled "Parameter" with a close button in the top right corner. At the top, there is a text field for "Array Unit" containing "DF500". Below this is a horizontal menu with several tabs: "Restore Options", "Online Verify", "Constitute", "Fibre Channel", "Spare Drive", "Options", and "Micro Update". Underneath the menu, there are four sub-tabs: "Target ID", "Port Option", "Controller Identifier" (which is currently selected), and "LAN". The main area of the window is divided into two sections: "Controller 0" and "Controller 1". Each section contains a "Controller Identifier" label, a text input field with "DF500-00", and a dropdown menu with "C0" for Controller 0 and "C1" for Controller 1. At the bottom right of the window, there is a checked checkbox labeled "FD Backup", followed by "Apply" and "Reset" buttons. A "Close" button is located at the bottom center of the window.

3. Sets the controller identifier.
  - **Controller Identifier:** Enter a controller identifier. The controller identifier consists of ten characters; only the top eight characters can be changed but the last two characters cannot be changed. They can be changed when the **Enable** is selected.
  - **FD Backup:** Controller identifier has been saved in a backup FD in an array unit as parameter information. When the setting is modified, it is necessary to save it again, so be sure to turn on the check box.

4. A message indicating completion of setting is displayed, click the **OK** button.

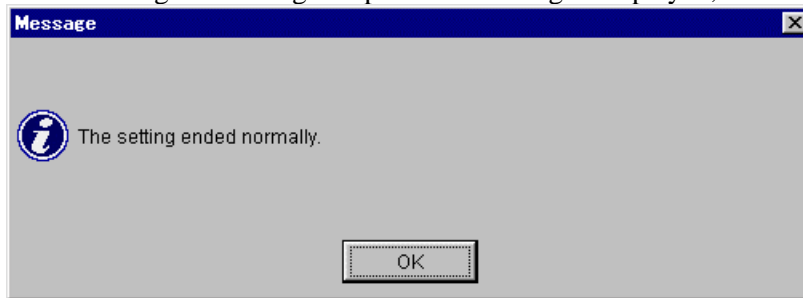

**Note:** When failing to write onto the FD drive, the message “DMES04EB02 : Backup floppy disk write error.” is displayed.

When this message is displayed, writing into an FD has not been finished, but setting the controller identifier may be completed.

Check an FD in an array unit, re-confirm the data to set, turn on the **FD Backup** check box, and then click the **Apply** button once again.



## Chapter 7 Displaying Statistical Information

You can display the statistical information in the array unit.

1. Select “**View—Statistical Information**” on the Unit screen. Or, when you click the “ : **Statistical Information**” in the tool bar.
2. Specifies statistical information which to display by **Select**, and clicks the **OK** button.

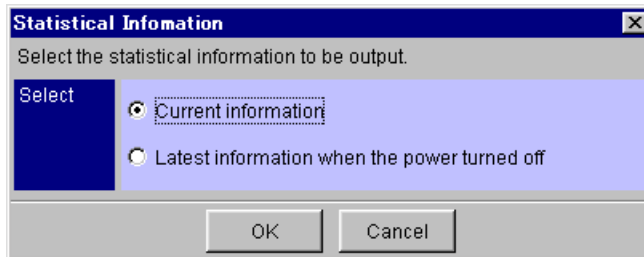

- **Select:** Statistical information to be displayed
  - Current Information:** Current information
  - Latest Information when the power turned off:** Information when starting up an array unit

## 7.1 Displaying the controller use condition

1. Click the **Controller** tab.

The screenshot shows a window titled "Statistical Information" with a close button in the top right corner. The "Array Unit" is set to "DF500". There are four tabs: "Controller" (selected), "Host Commands", "Execution", and "Cache Load".

**Array Time**

|   |         |             |
|---|---------|-------------|
| Controller being active for (Integrated): | 8124    | [minute(s)] |
| Power on for (Work):                      | 1473711 | [ms]        |

**Controller**

|                     | Controller 0 | Controller 1 |
|---------------------|--------------|--------------|
| Powered on counts   | 22           | 22           |
| H-SCSI reset counts | 0            | 0            |

A "Close" button is located at the bottom center of the window.

- **Array Time:**
  - Controller being active for (Integrated):** Integrated acting time of the array unit (minute)
  - Power on for (Work):** Power ON time of the array unit (PS/ON to PS/OFF) time (ms)
- **Controller:**
  - Powered on counts:** Integrated number of power ON times (at interruption) of the controller
  - H-SCSI reset counts:** Integrated number of host bus SCSI reset times (total of interruptions and messages) of the controller

## 7.2 Displaying the numbers of host commands received

1. Click the **Host Commands** tab.

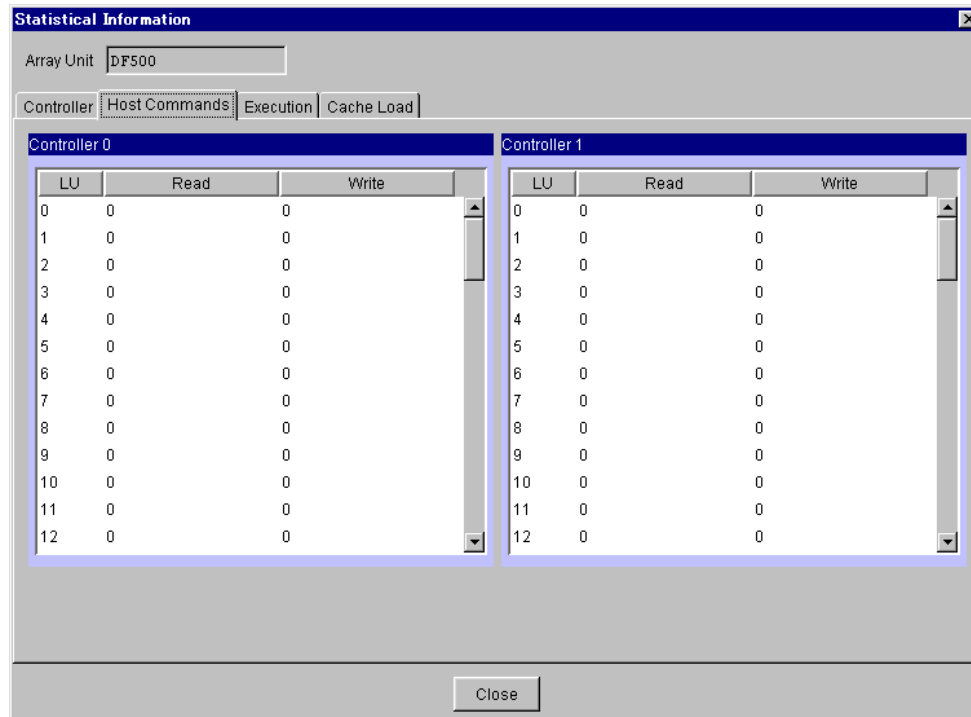

The screenshot shows a window titled "Statistical Information" with a close button in the top right corner. Below the title bar, there is a text field for "Array Unit" containing "DF500". Below that, there are three tabs: "Host Commands" (which is selected), "Execution", and "Cache Load". The main area of the window is divided into two panels, "Controller 0" and "Controller 1". Each panel contains a table with three columns: "LU", "Read", and "Write". The data in both tables is as follows:

| LU | Read | Write |
|----|------|-------|
| 0  | 0    | 0     |
| 1  | 0    | 0     |
| 2  | 0    | 0     |
| 3  | 0    | 0     |
| 4  | 0    | 0     |
| 5  | 0    | 0     |
| 6  | 0    | 0     |
| 7  | 0    | 0     |
| 8  | 0    | 0     |
| 9  | 0    | 0     |
| 10 | 0    | 0     |
| 11 | 0    | 0     |
| 12 | 0    | 0     |

At the bottom center of the window, there is a "Close" button.

- **LU:** Logical unit number
- **Read:** Accumulated number of received read commands in each logical unit
- **Write:** Accumulated number of received write commands in each logical unit

### 7.3 Displaying the command execution condition

1. Click the **Execution** tab.

The screenshot shows a window titled "Statistical Information" with a sub-tab "Execution". It displays data for two controllers, Controller 0 and Controller 1. Each controller has a table with columns A, B, C, and D, representing different command execution metrics. The data shows that for all logical units (0-7) on both controllers, the values for all metrics are 0.

| Controller   | A | B | C | D |
|--------------|---|---|---|---|
| Controller 0 | 0 | 0 | 0 | 0 |
| Controller 0 | 1 | 0 | 0 | 0 |
| Controller 0 | 2 | 0 | 0 | 0 |
| Controller 0 | 3 | 0 | 0 | 0 |
| Controller 0 | 4 | 0 | 0 | 0 |
| Controller 0 | 5 | 0 | 0 | 0 |
| Controller 0 | 6 | 0 | 0 | 0 |
| Controller 0 | 7 | 0 | 0 | 0 |
| Controller 1 | 0 | 0 | 0 | 0 |
| Controller 1 | 1 | 0 | 0 | 0 |
| Controller 1 | 2 | 0 | 0 | 0 |
| Controller 1 | 3 | 0 | 0 | 0 |
| Controller 1 | 4 | 0 | 0 | 0 |
| Controller 1 | 5 | 0 | 0 | 0 |
| Controller 1 | 6 | 0 | 0 | 0 |
| Controller 1 | 7 | 0 | 0 | 0 |

- **A:Logical Unit:** Logical unit number
- **B:Read Cache Hits:** Total of READ commands (hitting cache or partially hitting cache)
- **C:Write Cache Hits:** Total of WRITE commands (cache read hits)
- **D:Sequential Read:** Total of READ commands (recognized as sequential reading)
- **E:Sequential Write:** Total of WRITE commands (recognized as sequential writing)
- **F:Prefetch Strings:** Total of prefetch jobs executed
- **G:Write Through Operation:** Total of WRITE or WRITE & VERIFY commands (substituted by Write-Through operations)
- **H:Reassigned Blocks:** Number of re-assigned blocks (Not supported)

## 7.4 Displaying the cache load condition

1. Click the **Cache Load** tab.

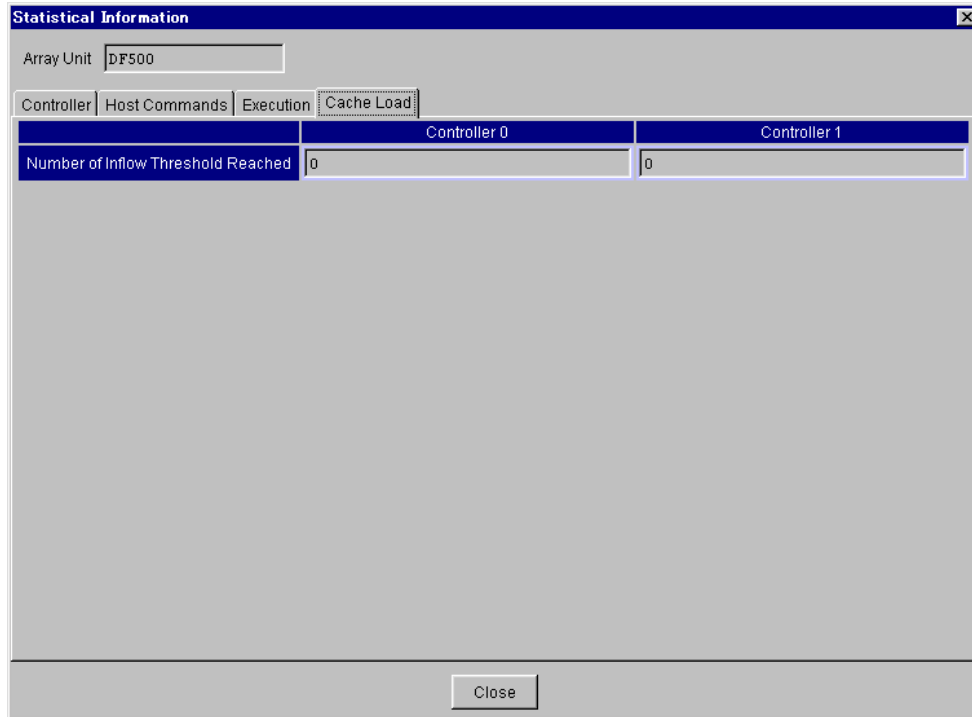

- **Number of Inflow Threshold Reached:** Total number of occurrences of inflow limitations.

This equipment manages the amount of data in cache as an inflow limit. When the host tries to write data exceeding this limit, an inflow limitation occurs. In this case, the write request from the host is made to wait until part of write data is transferred to the drive.



# Chapter 8 Acquiring Performance Information

Command operation state is outputted for each logical unit in the array unit. The command operation state consists of three types of data; the number of received commands, the number of cache-hit commands, and the cache hit rate for each Read or Write command.

## 8.1 Outputting performance information manually to text file

The command operation status for each logical unit in the array unit is output to the file when the **Get Data** button is clicked.

1. Select “**View—Performance**” on the Unit screen. Or, when you click the “ : **Performance**” in the tool bar.

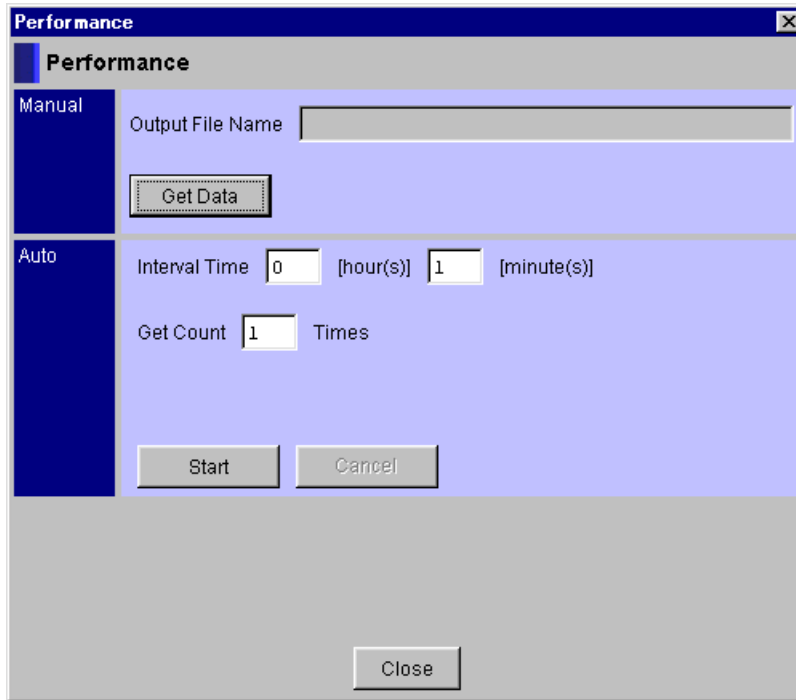

**Note:** Specify the file name with alphanumerics.



Refer to the created text file by means of Excel using “SAMPLEPM.xls” on the supplied FD. The text file is created in the manner that it is tabulated in the format shown below when it is opened on Excel by using a delimiter “;”. In the case of signal connection, only information on the controller 0 side is collected

|       | CTL0 |          |               |       |           |                | CTL1 |          |               |       |           |                |
|-------|------|----------|---------------|-------|-----------|----------------|------|----------|---------------|-------|-----------|----------------|
|       | Read | Read Hit | Read Hit Rate | Write | Write Hit | Write Hit Rate | Read | Read Hit | Read Hit Rate | Write | Write Hit | Write Hit Rate |
| LU0   |      |          |               |       |           |                |      |          |               |       |           |                |
| LU1   |      |          |               |       |           |                |      |          |               |       |           |                |
| LU2   |      |          |               |       |           |                |      |          |               |       |           |                |
| LU3   |      |          |               |       |           |                |      |          |               |       |           |                |
| LU4   |      |          |               |       |           |                |      |          |               |       |           |                |
| LU5   |      |          |               |       |           |                |      |          |               |       |           |                |
| LU6   |      |          |               |       |           |                |      |          |               |       |           |                |
| LU7   |      |          |               |       |           |                |      |          |               |       |           |                |
| LU8   |      |          |               |       |           |                |      |          |               |       |           |                |
| LU9   |      |          |               |       |           |                |      |          |               |       |           |                |
| LU10  |      |          |               |       |           |                |      |          |               |       |           |                |
| LU11  |      |          |               |       |           |                |      |          |               |       |           |                |
| LU12  |      |          |               |       |           |                |      |          |               |       |           |                |
| LU13  |      |          |               |       |           |                |      |          |               |       |           |                |
| LU14  |      |          |               |       |           |                |      |          |               |       |           |                |
| LU15  |      |          |               |       |           |                |      |          |               |       |           |                |
| Total |      |          |               |       |           |                |      |          |               |       |           |                |

- **CTL0 and CTL1:** Controller number
- **LU0 to LU15:** Logical unit number
- **Total:** Entire controller
- **Read:** Number of received Read commands
- **Read Hit:** Number of cache-hit Read commands to received Read commands
- **Read Hit Rate:** Rate (%) of cache-hit Read commands to received Read commands
- **Write:** Number of received Write commands
- **Write Hit:** Number of cache-hit Write commands to received Write commands
- **Write Hit Rate:** Rate (%) of cache-hit Write commands to received Write commands

Generally, when the subsystem is structured so that the load on each controller and the load on each disk are leveled, its performance is improved. The higher the cache-hit rate is, the higher the performance becomes.

## 8.2 Outputting performance information automatically to text file

Command operation state for each logical unit in the array unit is output at the specified intervals by the specified times.

1. Select “**View—Performance**” on the Unit screen. Or, when you click the “ : **Performance**” in the tool bar.

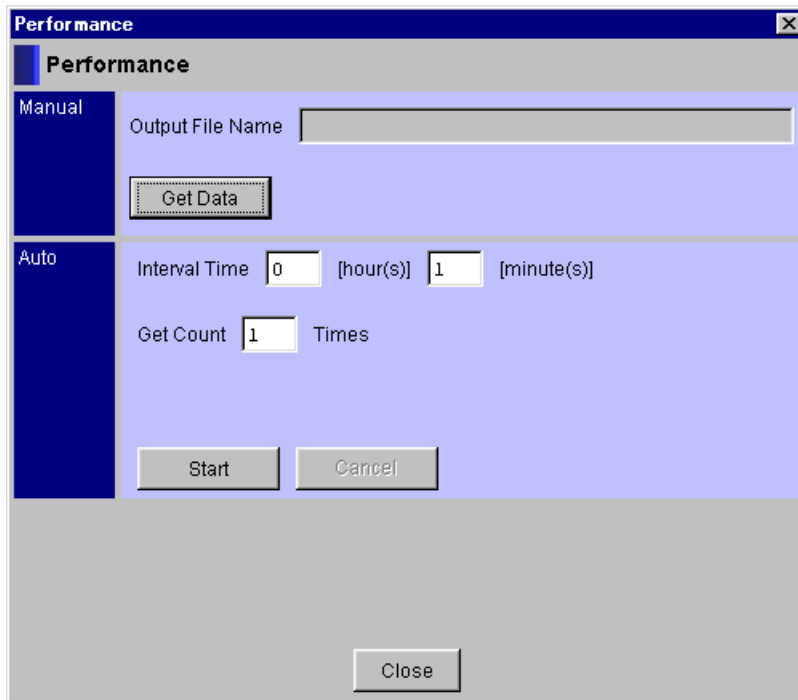

The image shows a dialog box titled "Performance" with a close button in the top right corner. The dialog is divided into two sections: "Manual" and "Auto".

- Manual Section:** Contains an "Output File Name" text input field and a "Get Data" button.
- Auto Section:** Contains two input fields for "Interval Time" (0 [hour(s)] 1 [minute(s)]) and "Get Count" (1 Times). Below these are "Start" and "Cancel" buttons.

At the bottom center of the dialog is a "Close" button.

- **Interval Time:** Specifies this item in the range of 1 minute to 23 hours 59 minutes.
- **Get Count:** Specifies this item in the range of 1 to 99.

- Specify **Interval Time** and **Get Count**, then click the **OK** button.  
During file output, the file name for getting performance information is displayed above the **Start** button.

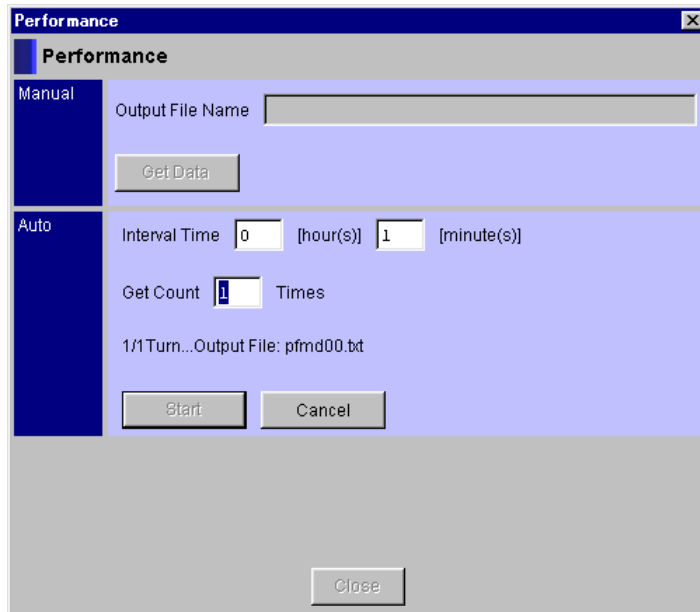

Files are output with the following file names. The files to be got are output to the directory installing the manager 2 in the text file format.

Single system : pfms\$\$\$.txt (\$\$ : serial number from 00 to 98)

Dual system : pfmd\$\$\$.txt (\$\$ : serial number from 00 to 98)

**Note:** Files are output with the names of pfms00.txt/pfmd00.txt to pfms98.txt/pfmd98.txt. When re-executing, information is overwritten by the same file name (names from pfms00.txt/pfmd00.txt up to pfms98.txt/pfmd98.txt in accordance with the number of times of acquisition). Move necessary information to another directory.

To stop the file output halfway, click the **Cancel** button.

- When the file get processing is terminated, a confirmation message is displayed. Then, click the **OK** button.

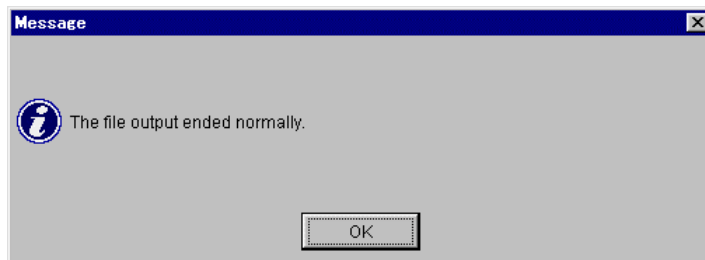

Refer to created text files on Excel by using 'SAMPLEPM.xls' in the supplied FD. Test files are created in the following format when they are opened by ',' on Excel. When the single system is connected, only the information of the controller 0 side is collected. The format to the file to be got is the same as that of the file got manually.



# Chapter 9 Error Monitoring

## 9.1 Setting Error Monitoring Options

During error monitoring, when a failure is detected on the monitored array unit, E-Mail Report or specified one application can be started.

In **Error Alert**, click the **E-Mail Error Report** check box and the **Execute Application** check box to enable them, so that the function is validated.

1. Select “**Settings—Monitoring Options**” on the Main screen. Or, when you click the “ : **Monitoring Options**” in the tool bar.

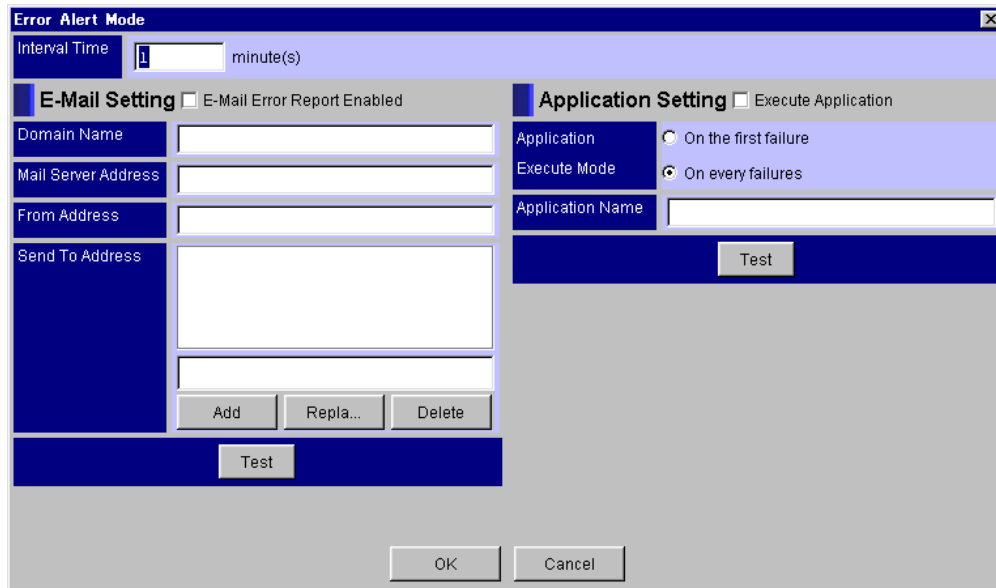

### 9.1.1 Interval time

1. Specify the interval time for error monitoring.  
Specify **Interval Time** in the range of 1 minute to 720 minutes (12 hours). The interval means the time from an end of all target array unit monitoring till a start of the next monitoring.
2. Click the **OK** button.  
The setting is validated without rebooting the manager 2.

## 9.1.2 E-Mail Report

When an error is detected by error monitoring, reporting the contents of the error is set.

If an error is detected on the array unit while error monitoring is executed, the following error information will be reported by E-Mail.

Usually, the subject is appended before E-Mail is transmitted.

- E-Mail subject

In the case of E-Mail, the failed part can be judged by the subject, so the failed part is appended to the subject as a matter of format. The subject format is shown below. Table 9.1.1 shows a list of subjects.

Manager/Obstruction (failed part)

Table 9.1.1 List of E-Mail Subjects

| No. | Subject              | Meaning   |
|-----|----------------------|---|
| 1   | Disk                 | A drive blockade occurred.  |
| 2   | DC Power             | A DC power supply failure occurred.   |
| 3   | Battery              | A battery voltage error occurred.   |
| 4   | Fan                  | A fan failure occurred.   |
| 5   | Controller           | A controller blockade occurred.<br>(This occurs only in the dual controller configuration.)                       |
| 6   | AC Power             | An AC power supply error occurs.  |
| 7   | Cache Memory         | A cache failure occurred.   |
| 8   | Cache Backup Circuit | A backup circuit failure occurred.  |
| 9   | ENC                  | An enclosure error occurs.  |
| 10  | Loop                 | A loop error occurs.  |
| 11  | Warning              | The array unit entered the warning state.   |
| 12  | Array connection     | A failure occurred in the connection with the array unit.<br>A power OFF or a failure occurred in the array unit. |

- E-Mail message text

When using E-Mail, the failed part is reported using a message text in the subject. The format of the message text is shown below. A list of message texts is shown in Table 9.1.2.

Day, Mon.dd hh:mm:ss yyyy/DF Name/ARRAY message text

**Day** : Day of the week            **hh:mm:ss** : Hours, minutes, and seconds

**Mon** : Month                            **yyyy** : Year

**dd** : Date

Table 9.1.2 List of E-Mail Message Texts

| No. | Message text   | Meaning of message  |
|-----|--|---|
| 1   | ARRAY Drive Detached.<br>ARRAY Detached Drive Position Unit No.X HDU No.Y. | A drive blockade occurred.<br>(The blocked drive is indicated with a set of a Unit No. and a HDU No.)             |
| 2   | ARRAY DC Power Supply Failure.   | A DC power supply failure occurred.   |
| 3   | ARRAY Battery Alarm.   | A battery voltage error occurred.   |
| 4   | ARRAY Fan Alarm.   | A fan failure occurred.   |
| 5   | ARRAY CONTROLLER Detached.   | A controller blockade occurred.<br>(This occurs only in the dual controller configuration.)                       |
| 6   | ARRAY AC Power Supply Failure.   | An AC power supply error occurs.  |
| 7   | ARRAY Cache Memory Alarm.  | A cache failure occurred.   |
| 8   | ARRAY Cache Backup Circuit Alarm.  | A backup circuit failure occurred.  |
| 9   | ARRAY ENC Alarm.   | An enclosure error occurs.  |
| 10  | ARRAY LoopAlarm.   | A loop error occurs.  |
| 11  | ARRAY Warning.   | The array unit entered the warning state.   |
| 12  | ARRAY Manager Interface error occurred.                                    | A failure occurred in the connection with the array unit.<br>A power OFF or a failure occurred in the array unit. |

1. Specify setting items in E-Mail Report.
  - **E-Mail Error Report Enabled:** Specifies whether or not to execute E-Mail Report when an error is detected by error monitoring. When this item is check off, E-Mail Report will be executed. ON/OFF is displayed on the right side depending on whether a check mark exists or not.
  - **Domain Name:** Specifies a domain name. Specify it in 39 or less alphanumeric characters or a code.
  - **Mail Server Address:** Specifies the IP address or host name of the mail server. Specify the host name in 99 or less alphanumeric characters.
  - **From Address:** Specifies the mail address of the E-Mail sender. Specify it in 99 or less alphanumeric characters or a code.
  - **Send To Address:** Specifies the mail address of the E-Mail receiver. Specify it in 99 or less alphanumeric characters or a code. Up to 20 addresses can be set as receivers.
    - Add:** Specify **Send To Address** in the text box above the **Add** button and click **Add**. **Send To Address** added to the **Send To Address** list is displayed.
    - Replace:** Click **Send To Address** to be replaced in the **Send To Address** list, specify **Send To Address** in the text box above the **Add** button, and click **Replace**. The replaced **Send To Address** is displayed in the **Send To Address** list.
    - Delete:** Click **Send To Address** to be deleted in the **Send To Address** list and click **Delete**. The deleted **Send To Address** disappears from the **Send To Address** list.
  
2. For confirming the setting, click the **Test** button.  
 When the mail has been normally transmitted, a confirmation message appears. Then, click the **OK** button.

The following mail is transmitted to the set **Send To Address**. Check the receipt of mail by **Send To Address**. If the mail has not been received, check the setting.

**Subject:** Manager/Obstruction (test)

**message:** Day, Mon. dd hh:mm:ss yyyy/DF Name /Test message

**Day:** Day of the week    **hh:mm:ss:** Hours, minutes, and seconds

**Mon:** Month                    **yyyy:** Year

**dd:** Date

3. Click the **Close** button.  
 The setting is validated without rebooting the manager 2.

### 9.1.3 Executing application

“Execute Application” is set so that another application may be started if an array unit error is detected when error monitoring is executed.

The application to be started make the window active so as to be displayed with the current size and position.

1. Set the setting items for starting an application.

- **Execute Application:** Specifies whether or not to activate the application when a failure is detected by the error monitoring. The application is activated when the check box is checked by a clicking. ON/OFF is displayed on the right side depending on whether a check mark exists or not.
- **Application Execute Mode:** Specifies an occasion to activate the application.
  - **On the first failure:** The specified application is activated when the first failure is detected after the error monitoring has been activated. When failures are detected continuously, the application is not activated. To activate the application again when a failure is detected after the application has been activated, terminate the error monitoring once and then restart it.
  - **On every failures:** The specified application is activated when a failure is detected after the error monitoring has been activated. When the same failure is detected while the error monitoring is executed, the application is not activated at the second and subsequent detections of it.

**Note:** When you select **On every failures**, the specified application is started upon detection of each error. Consequently, multiple specified applications may be started with the result that the machine will result in a hang-up status. Select **On the first failure**, and after occurrence of an error, stop error monitoring and restart it after a recovery from the error.

If an error is caused by starting the specified application during error monitoring, a message is displayed and error monitoring is suspended. When the message is closed, this monitoring will be continued.

- **Application Name:** Specifies a path and a file name of the application to be activated. When the file name is long, enclose it with the quotation marks ( " "). When specifying a data file name of the application, if the data file is not in the same directory in which the manager is, specify the full path.

- For Windows

Example 1: "C: \abc\application.exe"

Example 2: "C: \abc\application.exe (option)"

Example 3: "C: \abc\application.exe (option)" "c: \abc\def\application.dat"

Path and file name of the application

Data file name of the application

- For Solaris or IRIX

Example 1: /home/use/damp/go

Data file name of the application

2. To check the setting, click the **Test** button.  
Check that the specified application is started.
3. Click the **OK** button. The setting will be validated without rebooting the manager 2.

## 9.2 Outputting failure information to log file

When a failure is detected in the array unit in the case where the error monitoring is executed, the function outputs the failure information to a log file.

The log file is output in the text file format with a file name of `errlog.txt` to the same directory in which a manager execution file is. With respect to the file layout, the format for displaying the array unit state transition is shown below as an example. The file format is shown in the following figure. A list of message texts is shown in Table 9.2.1.

Day, Mon. dd hh:mm:ss yyyy/DF Name/ARRAY message text

**Day:** Day of the week

**hh:mm:ss:** Hours, minutes, and seconds

**Mon:** Month

**yyyy:** Year

**dd:** Date

Table 9.2.1 List of Message Texts to Be Output

| No. | Message text   | Meaning of message  |
|-----|--|---|
| 1   | Alert Started.   | The error monitoring is started.  |
| 2   | ARRAY Drive Detached.<br>ARRAY Detached Drive Position Unit No.X HDU No.Y. | A drive blockade occurred.<br>(The blocked drive is indicated with a set of a Unit No. and a HDU No.)             |
| 3   | ARRAY DC Power Supply Failure.   | A DC power supply failure occurred.   |
| 4   | ARRAY Battery Alarm.   | A battery voltage error occurred.   |
| 5   | ARRAY Fan Alarm.   | A fan failure occurred.   |
| 6   | ARRAY CONTROLLER Detached.   | A controller blockade occurred.<br>(This occurs only in the dual controller configuration.)                       |
| 7   | ARRAY AC Power Supply Failure.   | An AC power supply error occurs.  |
| 8   | ARRAY Cache Memory Alarm.  | A cache failure occurred.   |
| 9   | ARRAY Cache Backup Circuit Alarm.  | A backup circuit failure occurred.  |
| 10  | ARRAY ENC Alarm.   | An enclosure error occurs.  |
| 11  | ARRAY Loop Alarm.  | A loop error occurs.  |
| 12  | ARRAY Warning.   | The array unit entered the warning state.   |
| 13  | ARRAY Manager Interface error occurred.                                    | A failure occurred in the connection with the array unit.<br>A power OFF or a failure occurred in the array unit. |
| 14  | ARRAY Manager Interface error occurred.<br>Error Code (nnnn).              | When connecting to an LAN, an array unit connection error occurs.<br>nnnn : Winsoc error code                     |
| 15  | ARRAY Manager Interface error occurred.                                    | When connecting to an RS232C interface, an array unit connection error occurs.                                    |
| 16  | Errinf.Txt File Error (xxxx).  | A failure occurred in an access to a work file.<br>xxxx : OPEN: File open failure<br>xxxx: File operation failure |

The log file is output up to 223 k byte or up to 2,000 events. When the log information exceeds the limit, the log information is overwritten from the top of the file and output. At the end of the log information, “--- end ---” is output. Search for “--- end ---” and identify the latest information.

**Note:** “Time when a failure is detected” is that of a clock in the machine installing the manager 2.

### 9.3 Error Monitoring

Error monitoring is performed about the component status of the array unit including drive, controller, battery, fan, power supply, and cache in the array unit. Placing a check in the **Error Watch** box in registered array unit information performs error monitoring at an interval specified for the interval time.

**Note:** When you perform error monitoring, be sure to close the Unit screen before starting the monitoring. If performed with the Unit screen remaining open, array units may not be monitored normally.

1. Click the “ **Error Watch**  **Alert Stop** : **Error Watch**” on the Main screen.

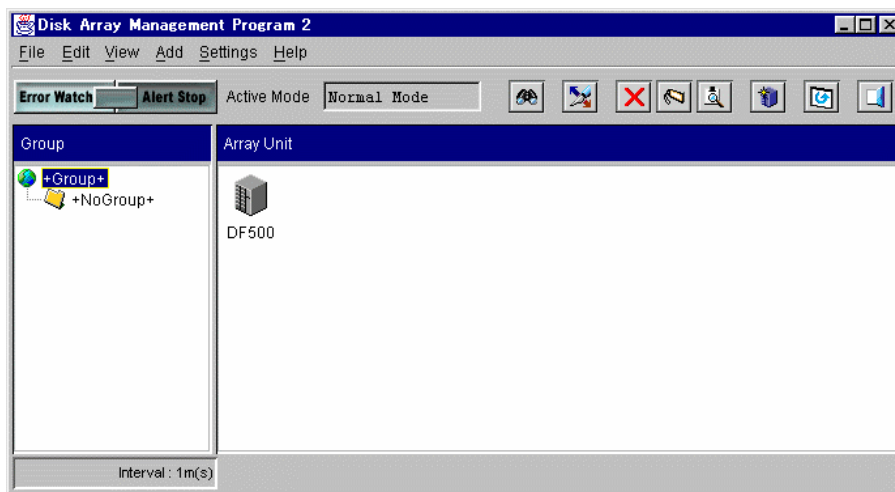





Monitoring is started for the array unit for which “Error Alert” is specified.

The **Error Watch** button on the Main screen comes to indicate “ **Error Watch**  **Alert Stop**”.

After the start of error monitoring, the monitoring status is displayed in the status bar. The icon with a monitoring result of the array unit is displayed.





After error monitoring is performed for all the target array units, monitoring will be started again for these target array units after the lapse of the specified interval time.

The error monitoring status is displayed on the left side of the scroll bar in the following three states. In addition, the monitoring result of all the array units subject to monitoring is displayed with icons.





| Monitoring status | Display characters | Character color  | Array unit status  |
|-------------------|--------------------|--|--|
| Stop              | Stop               |  Gray | Error monitoring is not executed.  |
| Monitoring        | Monitoring         |  Blue | Error monitoring is executed and the all the target array units are normal.  |
|                   | Monitoring         |  Red  | Error monitoring is executed and errors are detected in some of the target array units.  |
| Waiting           | Waiting            |  Blue | Error monitoring is at the interval time and all the target array units that were previously monitored are normal.                 |
|                   | Waiting            |  Red  | Error monitoring is at the interval time and errors are detected in some of the target array units that were previously monitored. |

As a error monitoring result, the status is displayed with the icon color of the array unit in the main screen.

jjj) Array units in the dual system

|   |   |
|---|---|
|  Gray          | <ul style="list-style-type: none"> <li>• Not monitored</li> </ul>   |
|  Gray + Blue   | <ul style="list-style-type: none"> <li>• Normal</li> </ul>  |
|  Gray + Yellow | <ul style="list-style-type: none"> <li>• An error is detected.</li> <li>• A communication error occurs in a controller.</li> </ul>                                    |
|  Red           | <ul style="list-style-type: none"> <li>• A power OFF or a failure of the array unit occurred.</li> <li>• A communication error occurs in both controllers.</li> </ul> |

kkk) Array units in the single system

|   |   |
|---|---|
|  Gray          | <ul style="list-style-type: none"> <li>• Not monitored</li> </ul>   |
|  Gray + Blue   | <ul style="list-style-type: none"> <li>• Normal</li> </ul>  |
|  Gray + Yellow | <ul style="list-style-type: none"> <li>• An error is detected.</li> </ul>   |
|  Red           | <ul style="list-style-type: none"> <li>• A power OFF or a failure of the array unit occurred.</li> <li>• A communication error occurred.</li> </ul> |

- To display the detail information of the array unit, stop error monitoring, click an array unit to be displayed, and click  : **Alert Stop**. The contents of display may be different depending on the relationship between **Error Alert** result and “Time” because polling is performed.

In the case where the icon has a Caution symbol displayed, this represents a communication disable status with the array unit and detail information cannot be displayed.

- Click  : **Alert Stop**, and **Error Alert** will be stopped. The icon of the array unit continues to display the last error monitoring result.

Click the icon of an array unit on the Main screen, and then click the “ : **Display Details**” in the tool bar.

**Note:** In the case where the icon has a Caution symbol displayed as a **Error Alert** result, this represents a connection disable status to the array unit or a information get disable status from the array unit. The causes are the following items.

| Cause   | Contents of check                                      |
|---|--|
| Communication line failure  | Check the LAN line.                                    |
| Connected array unit failure  | Check the READY status of the array unit.              |
| Too high I/O load from the host   | Check the array unit operation status.                 |
| Execution of the logical unit format of the connected array unit, wizard setting of system parameter, or SNMP environment information setting | Check the array unit status or restart the array unit. |

Make the above checks. After making sure that connection with the array unit displayed in Caution symbol has been enabled, start error monitoring.

If the icon of the array unit goes yellow because of controller blockage, the same status as that of the Caution symbol icon may be provided.

If error monitoring is performed though the iron of the array unit is displayed in Caution symbol, the icon of the normal array unit may be displayed in Caution symbol. If the cause corresponds to “Too high I/O load from the host”, continue to execute monitoring.

If a drive whose display color is not blue in **Unit Status** in the unit screen (a drive that is not logical unit-formatted or an undefined spare drive) is pulled out, no error report will be made but it has no effect on the operation. Insert it once again.

If an error occurs, contact with maintenance personnel.

## 9.4 Checking Status

Checks the status of such components of an array unit as drives, controllers, batteries, fans, power supply and cache. Checks is done on an array unit for which the check box of the **Error Alert Flag** in “Array Unit Define” is selected.

1. Select “**View—Refresh**” on the Main screen. Or, when you click the “ : **Refresh**” in the tool bar.

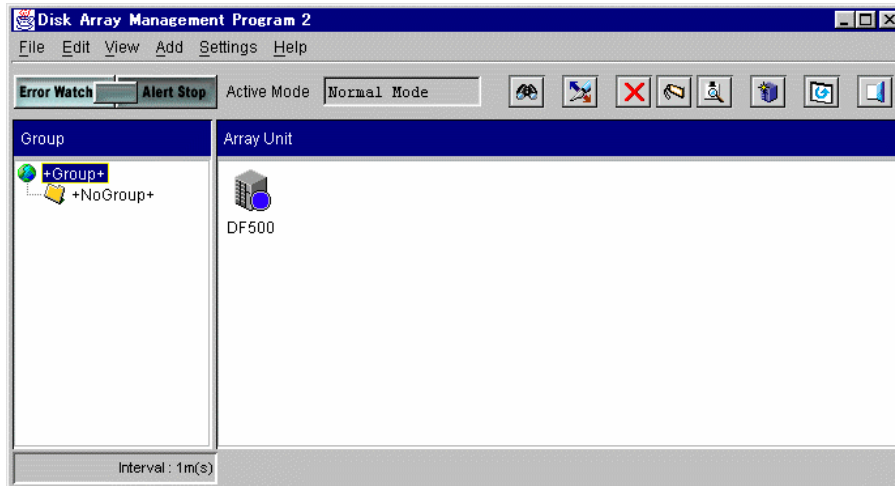

The status of an array unit for which error monitoring is specified is checked. When checking begins, the icon of an array unit is displayed with the check result reflected into the icon.

The status check performs functions equivalent to those of error monitoring. When an error is detected in an array unit that has been checked, outputting of a log, sending of an E-Mail, and restarting of a specified application are done in accordance with the settings of the monitor options.

# Chapter 10 Automatic Start of Error Monitoring

## 10.1 Automatic Start of Error Monitoring

Error monitoring can be started when Windows is booted up by specifying an option in the execution file in the manager 2 startup file.

The error monitoring function is the same as that provided by clicking the **Error Watch** button.

The automatic start is available only for Windows.

### 10.1.1 Automatic Start of Windows

Error monitoring is started when Windows is booted up if the error monitoring is set to “startup”.

1. Open the bat file to boot the manager 2.
2. Specify an option in the execution file in the bat file.

```
java -classpath .\CONFMNG2.JARjp.co.hitachi.str.diskarray.gui.ConmanFrame -check  
>> exclog
```

Parameter for error monitoring 

3. Prepare a shortcut to the manager 2 startup bat file for the “Startup”.
4. When Windows is rebooted, the manager 2 is started in an error monitoring executing status.



# Chapter 11 Detailed Screen Display

## 11.1 Detailed Screen Display

The detailed display of the array unit is made by specifying options in the execution file in the manager 2 startup file.

The detailed display is available only for Windows.

### 11.1.1 Detailed screen display on Windows

The detailed display of the array unit is made by specifying options in the bat file.

1. When the manager 2 is start up, the bat file is opened.
2. Specify options in the execution file of the bat file.

There are 3 parameters for screen display.

**-unit:** Registered name of array unit

**-ip:** IP address of controller 0 or controller 1 of the registered array unit

**-host:** Host name of controller 0 or controller 1 of the registered array unit

In the case of RS232C connection, specify “-unit”.

- Example with “-unit” option

```
java -classpath .\CONFMNG2.JAR jp.co.hitachi.str.diskarray.gui.ConmanFrame -unit  
DF500
```

Parameter for screen display —————>

—————> DF name of the array unit to be display

- Example with “-ip” option

```
java -classpath .\CONFMNG2.JAR jp.co.hitachi.str.diskarray.gui.ConmanFrame -ip  
192.168.1.100
```

Parameter for screen display —————>

—————> IP address of the array unit to be display

- Example with “-host” option

```
java -classpath .\CONFMNG2.JAR jp.co.hitachi.str.diskarray.gui.ConmanFrame -host  
DF500
```

Parameter for screen display —————>

—————> Host name of the array unit to be display

- The unit window of the array unit specified by option is displayed. The unit window is put into a status provided by logging-in in the normal mode.

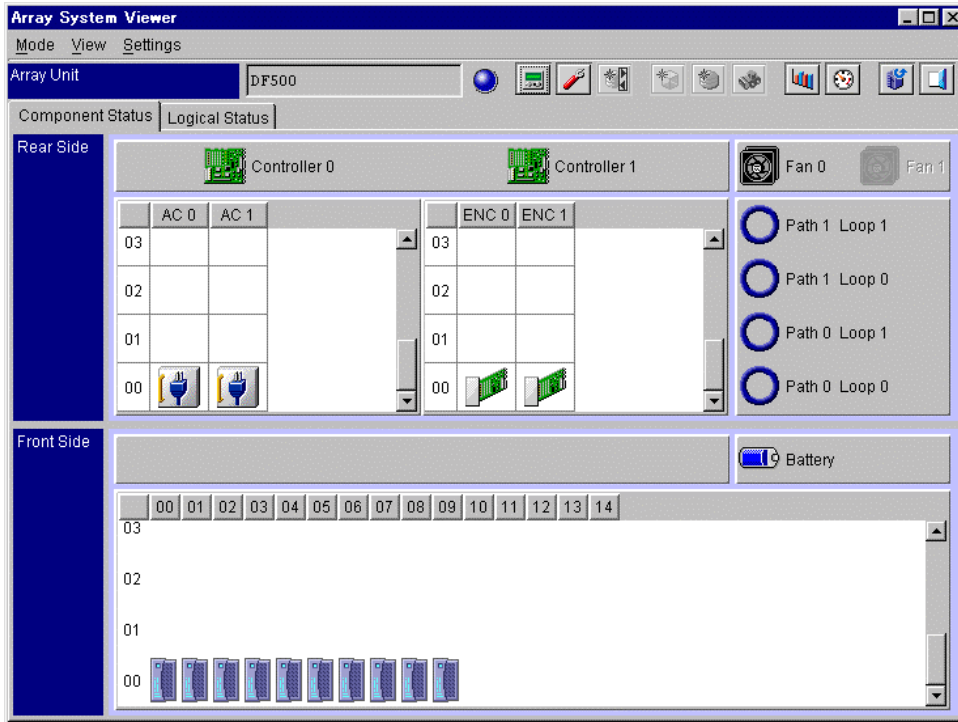

---

Disk Array management program 2  
(for GUI)

User's Guide

Third edition May, 2001

---

**HITACHI**