

Disk Array management program (for CLI) User's Guide Vol. 1

Considerations

Before using this Disk Array management program, read safety instructions described in this manual carefully. Be sure to observe precautions in individual chapters. Keep this manual at hand for reference at any time.

HITACHI

© 2000, 2001 Hitachi Limited, ALL RIGHTS RESERVED

All or any part of this manual may not be reproduced in any form or by any means without permission in writing from the publisher.

The contents of this manual may be revised without prior notice.

Hitachi would appreciate any comments such as questions or errors in descriptions you have about this manual.

Please remember that Hitachi assumes no responsibility or liability for any losses that are caused by or result from improper use of this product, or the handling, repairs, and modifications carried out with willful neglect or negligence of instructions in this manual.

The copyright of the manual belongs to Hitachi. All or a part of the manual may not be used or may not be copied without permission.

Trademarks

“Microsoft”, “Windows”, and “Windows NT” are registered trademarks of Microsoft Corporation (U.S.A.).

Solaris is a registered trademark of SUN Corporation (U.S.A.).

IRIX is a registered trademark of Silicon Graphics, Inc..

HP is a trademark of Hewlett - Packard Company, HP-UX is a product name of Hewlett - Packard Company.

Company names and product names appeared in the manual are trademarks or registered trademarks of each enterprises.

Notice of Export Controls

Export of technical data contained in this document may require an export license from the United States government and/or the government of Japan. Contact the Hitachi Legal Department for any export compliance questions.

Document Revision Level

Revision	Date	Description
	February, 2001	Ninth edition

Preface

This manual describes the operation to execute the configuration setting and display, information display, and error monitoring of the Hitachi disk array units (DF350, DF350F, DF400, and DF500, collectively called the array unit below) using the Disk Array management program (called the manager below).

For the specifications of the array unit, see the manual attached to the array unit.

Notes on use:

- This manual is intended for system administrators responsible for operation of systems including array units, system engineers for construction of systems including array units, and customer support engineer for maintenance of array units.
- When using the manager, be sure to read this manual and understand the operating procedures and instructions described herein thoroughly before starting your operation. Understand, in particular, the descriptions in the Chapter **Safety Precautions** thoroughly and follow the instructions in this manual.
- The user is presupposed to have thorough knowledge of the basic operation of Windows, Solaris, IRIX, and HP-UX.
- “Windows 95”, “Windows 98”, Windows 2000, and “Windows NT Version 4.0” are abbreviated to “Windows” in the manual.

Safety Precaution

When using this manager, read the following notes carefully, and follow the instructions to operate the manager.

Precautions before starting your operation

- Do not operate an array unit except system administrators responsible for operation of systems including array units, system engineers for construction of systems including array units, and qualified service personnel for maintenance of array units.
- Read and understand this manual thoroughly before starting your operation.
- The following attention mark heading appears in this manual to indicate a safety precaution.



Indicates a potentially serious situation which, if continuing operation with negligence of the instructions where this alert appears, can cause loss of the user data stored in the Hitachi disk array subsystem. Be sure to read the instructions described in a precaution item carefully and follow them to start your operation.

Cautions while starting your operation

- While operating the manager, the contents of an error, which occurs in an array unit, may be displayed as an error message. In this case, read the user's manual or maintenance manual to look up action on the error message and handle the error according to the action.
- When performing operations in this manual with a caution attention mark indicated, be sure to read precautions before starting the operation, and follow them to operate.

Contents

Vol. 1

Chapter 1	Outline	1
1.1	Outline	1
1.2	Notes on Using the Manager	1
1.3	Operating Environments	3
1.4	Connection	5
1.5	Installing the manager	6
1.5.1	Installing the manager	6
1.5.1.1	Windows	6
1.5.1.2	Solaris	7
1.5.1.3	IRIX	8
1.5.1.4	HP-UX	9
1.5.2	Update	10
1.5.2.1	Windows	10
1.5.2.2	Solaris	10
1.5.2.3	IRIX	11
1.5.2.4	HP-UX	11
1.5.3	Uninstalling	12
1.5.3.1	Windows	12
1.5.3.2	Solaris, IRIX, and HP-UX	12
Chapter 2	Command List	13
2.1	Command List	13
2.2	Applying Support Functions of Microprograms	16
Chapter 3	Command Specifications	19
3.1	Command Format	19
3.1.1	Standard command	19
3.1.2	Administration command	20
3.1.3	Referencing command syntax	20
3.2	Registering Array Unit	21
3.2.1	Displaying Registration Information	21
3.2.2	Registering	22
3.2.3	Changing Registration Information	24
3.2.4	Deleting Registration Information	26
3.2.5	Setting Password in Administration Mode	27

3.3	Array Unit Management by User ID	28
3.3.1	Setting User ID	28
3.3.2	Changing User ID	29
3.3.3	Deleting User ID	30
3.3.4	Changing Password	31
3.3.5	Logging In and Forcibly Logging In to Array Unit	32
3.3.6	Logging Out from Array Unit	33
3.3.7	Checking Login	34
3.4	Displaying Array Unit Status	35
3.4.1	Displaying Microprogram Revision	35
3.4.2	Displaying Drive Configuration Information	36
3.4.3	Displaying Cache Configuration Information	40
3.4.4	Displaying Status of Power Supply/Fan/Battery	42
3.4.5	Displaying Current IP Address	44
3.5	RAID/LU	45
3.5.1	Referencing RAID Group	45
3.5.2	Setting Up RAID Group	46
3.5.3	Expanding RAID Group	48
3.5.4	Deleting RAID Group	50
3.5.5	Referencing LU	51
3.5.6	Setting Up LU	52
3.5.7	Formatting LU	53
3.5.8	Displaying Progress of LU Formatting	55
3.5.9	Expanding LU	56
3.5.10	Deleting LU	57
3.5.11	Changing Default Controller of LU	58
3.5.12	Setting Turbo LU	59
3.6	Setting Up Configuration	61
3.6.1	Referencing/Setting Fibre Channel Information	61
3.6.2	Spare HDU Setup	71
3.6.3	Fee-Basis Option Reference/Setup	72
3.6.4	Referencing/Setting Drive Restoration Control Information	74
3.6.5	Referencing/Setting Online Verify Information	76

Vol. 2

3.7	System Parameters	77
3.7.1	Referencing/Setting System Parameters	77
3.7.2	Referencing/Setting RTC	97
3.7.3	Referencing/Setting Target Information	99
3.7.4	Referencing/Setting LAN Information	107
3.7.5	Referencing/Setting SCSI Transfer Rate	110
3.8	File Output of Configuration and Configuration Setting by File	113
3.8.1	File Output of the Configuration : System Parameters	113
3.8.2	File output of the configuration : the status of RAID/LU and constituent parts	123
3.8.3	Setting the configuration with a file : System parameters	134
3.8.4	Setting the configuration with a file : RAID/LU definition	136
3.9	Microprogram Replacement	138
3.9.1	Downloading/Replacing Microprogram	138
3.10	SNMP Environment Information	141
3.10.1	Setting SNMP Environment Information and Outputting Its File	141
3.11	Displaying Statistical Information	143
3.11.1	Displaying Statistical Information	143
3.12	Obtaining Performance Information	145
3.12.1	Outputting Performance Information File	145
3.13	Monitoring Errors	147
3.13.1	Setting Up E-Mail Reports	147
3.13.2	Setting the Starting of Application	151
3.13.3	Monitoring Errors	152
Chapter 4	Manager Operation Procedure	155
4.1	Executing commands by setting administrator mode	155
4.2	Executing commands using a user ID	156
Chapter 5	Examples of Using Command	157

List of Figures

Figure 3.1	Command Format of Manager	19
Figure 3.2	Format of Standard Command (when terminating normally)	19
Figure 3.3	Format of Standard Command (when an error is detected)	19
Figure 3.4	Format 1 of Administration Command	20
Figure 3.5	Format 2 of Administration Command	20
Figure 3.6	Example of Referencing Command Syntax	20
Figure 3.7	Outline of the format of the system parameter output file	115
Figure 3.8	System parameters: output example of common parameters	116
Figure 3.9	System parameters: output example of controller 0 parameters	119
Figure 3.10	System parameters: output example of the parameters of controller 1	121
Figure 3.11	Output example for FD backup specification	122
Figure 3.12	The outline of the format of RAID/LU configuration information output file	124

List of Tables

Table 2.1	List of Manager Commands	13
Table 2.2	Microprogram Revision Numbers and Their Supports for Manager Functions ...	16
Table 3.1	List of common parameters	117
Table 3.2	List of parameters of controller 0	120
Table 3.3	List of parameters of controller 1	122
Table 3.4	List of E-Mail Subjects	149
Table 3.5	List of E-Mail Message Texts	150
Table 3.6	List of Message Texts to Be Output	154

Chapter 1 Outline

1.1 Outline

The manager is a summary of the commands (to execute in line mode) for the sake of managing the array unit, referring to its status and setting its configuration, etc. The user operates these commands in a prompt state by selecting a command having the function appropriate for a user's purpose.

1.2 Notes on Using the Manager

When using this manager, take the following considerations.



- When using the manager on “RS232C connection”, the “ERROR INF” (a function to specify an error information transfer mode to the RS232C) must be set to “OFF” (suspension of an error information transfer) by means of the system parameter setting function of the array unit.
(The “ERROR INF” is set to “OFF” when shipped from the factory.) Otherwise, it may be caused that the manager fails to be connected to the array unit or that functions of the manager end abnormally.
- Regarding the functions to be executed by the manager, some are available and others are not available during an on-line. For details, see chapter 2.
For a case of high I/O load, functions that are available in the on-line might cause a command time-out in the host or a recovering fault in the manager. A use during off-line is recommended.
- A logical unit, at least, must be in the array unit, to make available all of manager functions. If no logical unit are in the array unit, some functions selected can not be operated.
- The manager can operate up to 1,024 array units. When setting configuration (setting of RAID groups, logical units, etc.), set the controllers one by one, after quitting the device status failure monitoring.
- When the PC enters the suspension status during operation while the manager, the manager may not operate correctly after the PC is released from the suspension status.
When you operate the manager, set the power management of the PC so that the PC should not enter the suspension status.

- When the manager is in operation, it may hang up in the following cases. If the manager hangs up, terminate it forcibly and check the array unit status and the connection status of RS232C or LAN. Then, boot up the manager once again. And start the manager again after you finish other application.
 - In case that the communication with the connected array unit fails due to controller blockage, array unit failure, or disconnected LAN connection, etc., or in case that the array unit receives a Reset/LIP from the host.
 - Other application works at the same time, and a CPU use rate is high.
- If any array unit failure is detected, contact with maintenance personnel.

1.3 Operating Environments

The manager is operated by connecting between the array unit and a LAN or RS232C.

When a LAN is connected, the machine (PC, UNIX server/workstation, SGI server/workstation, or HP server/workstation) to install the manager are connected to the network and must be in correct operation.

When an RS232C is connected, the machine to install the manager require the correct operation of the RS232C port.

- PC
 - Windows 95, Windows 98, Windows 2000, or Windows NT 4.0
 - CPU: Pentium
 - Memory: 16 M byte
 - Disk capacity: 6.5 M byte max.
 - Network adapter

- SUN server/workstation
 - Solaris 2.6, 2.7, 2.8
 - CPU: UltraSPARC or more is recommended.
 - Memory: 16 M byte
 - Disk capacity: 12.5 M byte max.
 - Network adapter

- SGI server/workstation
 - IRIX 6.4, 6.5
 - CPU: R10000 or more is recommended.
 - Memory: 16 M byte
 - Disk capacity: 21.5 M byte max.
 - Network adapter

- HP server/workstation
 - HP-UX 10.20, 11.0
 - CPU: HA8000 or more is recommended.
 - Memory: 16 M byte
 - Disk capacity: 13.5 M byte max.
 - Network adapter

- RS232C connection
 - Serial port
 - baud rate: 9600
 - data bit: 8
 - parity: non
 - stop bit: 1
 - flow control: non
 - Serial cable (9 pin, cross) for RS232C connection : 1 cable/controller

- LAN connection
 - In cases in which the array unit and the machine are connected directly, use 10BaseT/100BaseT (for the case of DF500) cable (cross) or twisted pair cable (cross).
In case in which the array unit and machine are connected through a hub, use 10BaseT/100BaseT (for the case of DF500) cable or twisted pair cable.

1.4 Connection

An example of connection between the machine that installed the manager and the array unit is shown in the following drawing.

- RS232C connection

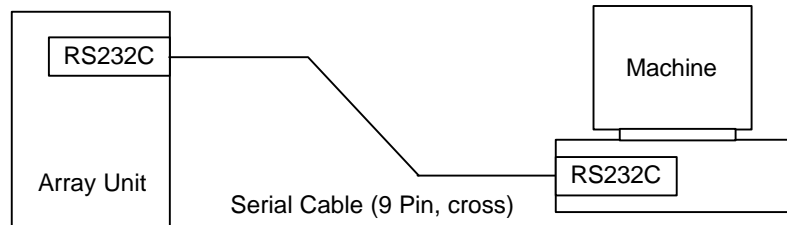

Note: In the dual system where two RS232C ports are in the machine, connect the RS232C to both of controller 0 and controller 1.

- LAN (with a Hub)

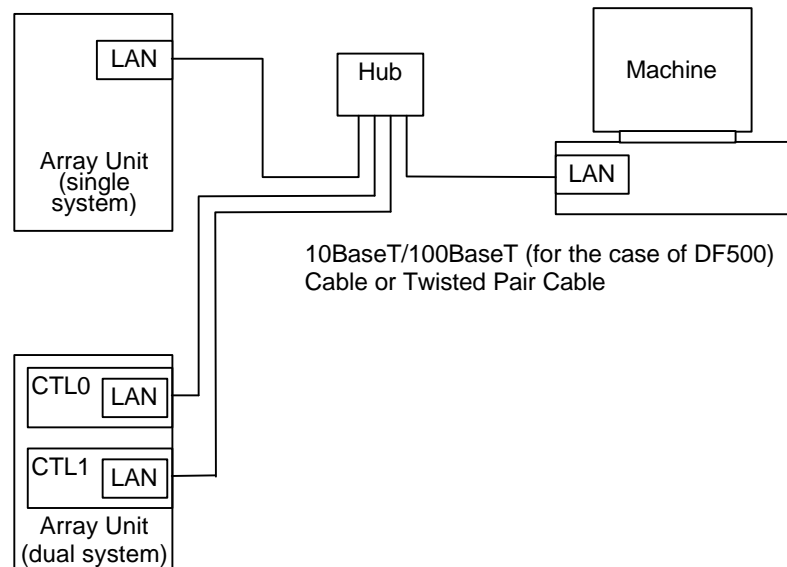

Note: When the array unit has been already LAN connected, connect the machine through the same LAN.

- LAN (without Hub)

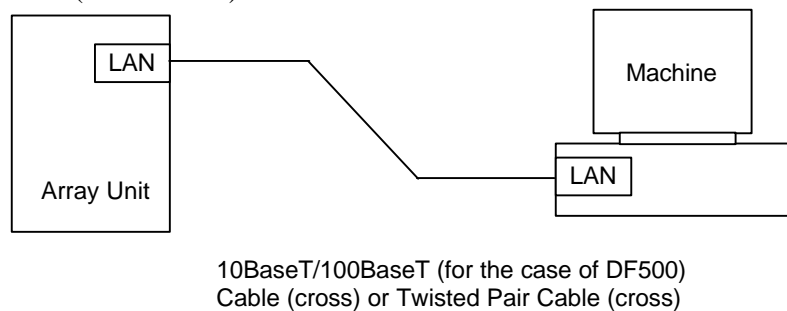

1.5 Installing the manager

The procedures for installing and uninstalling the manager are described below.

1.5.1 Installing the manager

Installs the manager by the following procedure.

1.5.1.1 Windows

1. Start the PC, then boot up Windows.
2. Executes the setup.exe in the CLI directory of the provided CD-R.
3. Upon completion of executing the startmgr.bat (a batch file used to start the manager), a prompt screen will be displayed. Executes commands on the displayed screen.
Or a prompt screen is displayed, the program moves to a directory in which the manager has been installed, and after the following are executed, executes commands.

```
set CMDF_PATH=.
```

```
set LANG=ja
```

Note :When executing commands from other than a directory in which the manager has been installed, edits the CMDF_PATH environment variable of the startmgr.bat in the developed file. Sets up the install directory of the manager in the CMDF_PATH environment variable. However, if the LANG environment variable is not specified, the manager operates in English language mode.

Example : If the manager has been installed in C:\manage.

```
set CMDF_PATH=C:\manage
```

```
set LANG=ja
```

```
command.com
```

1.5.1.2 Solaris

1. Start the SUN server/workstation.
2. Create a new directory for installing the manager. Copy the ArrayManage-S350-CLI.tar file in the supplied CD-R to the directory created in the hard disk.

Required disk capacities are approx: 13 M byte for the main program storage area, 512 k byte for the work area, and 6 M byte when executing the microprogram replacement.

3. The ArrayManage-S350-CLI.tar file is a Tar format file. Expand the file referring to the example.

Example: tar xvf ArrayManage-S350-CLI.tar

When setting /usr/manage for the install directory, the following file structure is developed.

```
/usr/manage/          : command and message file of manager
|
└── /lib/             : common library used when running manager
```

4. Adds a path to the common library to the LD_LIBRARY_PATH environment variable. Example when setting DFHOME for the install directory

If the LD_LIBRARY_PATH environment variable not yet defined (example of C shell) :

```
% setenv LD_LIBRARY_PATH ${DFHOME}/lib
```

If the LD_LIBRARY_PATH environment variable already defined (example of C shell) :

```
% setenv LD_LIBRARY_PATH $LD_LIBRARY_PATH:${DFHOME}/lib
```

5. Sets up a path to the directory, in which the manager has been installed, in the CMDF_PATH environment variable.

Example: when setting DFHOME for the install directory (example of C shell) :

```
% setenv CMDF_PATH ${DFHOME}
```

It is recommended that statements 4 and 5 should be described in the initial setting file (in the case of C shell : log in) of log in shell, of a user who uses the manager.

6. Logs in again.

1.5.1.3 IRIX

1. Start the SGI server/workstation.
2. Create a new directory for installing the manager. Copy the ArrayManage-I350-CLI.tar file in the supplied CD-R to the directory created in the hard disk.

Required disk capacities are approx: 21 M byte for the main program storage area, 512 k byte for the work area, and 6 M byte when executing the microprogram replacement.

3. The ArrayManage-I350-CLI.tar file is a Tar format file. Expand the file referring to the example.

Example: tar xvf ArrayManage-I350-CLI.tar

When setting /usr/manage for the install directory, the following file structure is developed.

```
/usr/manage/          : Command and message file of manager
|
└── /lib/             : Common library used when running manager
```

4. Adds a path to the common library to the LD_LIBRARY_PATH environment variable. Example when setting DFHOME for the install directory

If the LD_LIBRARY_PATH environment variable not yet defined (example of C shell) :

```
% setenv LD_LIBRARY_PATH ${DFHOME}/lib
```

If the LD_LIBRARY_PATH environment variable already defined (example of C shell) :

```
% setenv LD_LIBRARY_PATH $LD_LIBRARY_PATH:${DFHOME}/lib
```

5. Sets up a path to the directory, in which the manager has been installed, in the CMDF_PATH environment variable.

Example: when setting DFHOME for the install directory (example of C shell) :

```
% setenv CMDF_PATH ${DFHOME}
```

It is recommended that statements 4 and 5 should be described in the initial setting file (in the case of C shell : log in) of log in shell, of a user who uses the manager.

6. Logs in again.

1.5.1.4 HP-UX

1. Start the HP server/workstation.
2. Create a new directory for installing the manager. Copy the ArrayManage-H350-CLI.tar file in the supplied CD-R to the directory created in the hard disk.

Required disk capacities are approx: 13 M byte for the main program storage area, 512 k byte for the work area, and 6 M byte when executing the microprogram replacement.

3. The ArrayManage-H350-CLI.tar file is a Tar format file. Expand the file referring to the example.

Example: tar xvf ArrayManage-H350-CLI.tar

When setting /usr/manage for the install directory, the following file structure is developed.

```
/usr/manage/           : Command and message file of manager
|
└── /lib/              : Common library used when running manager
```

4. Adds a path to the common library to the SHLIB_PATH environment variable. Example when setting DFHOME for the install directory

If the SHLIB_PATH environment variable not yet defined (example of C shell) :

```
% setenv SHLIB_PATH ${DFHOME}/lib
```

If the SHLIB_PATH environment variable already defined (example of C shell) :

```
% setenv SHLIB_PATH $SHLIB_PATH:${DFHOME}/lib
```

5. Sets up a path to the directory, in which the manager has been installed, in the CMDF_PATH environment variable.

Example: when setting DFHOME for the install directory (example of C shell) :

```
% setenv CMDF_PATH ${DFHOME}
```

It is recommended that statements 4 and 5 should be described in the initial setting file (in the case of C shell : log in) of log in shell, of a user who uses the manager.

6. Logs in again.

1.5.2 Update

Updates the manager by the following procedure. If you update, be sure to terminate the manager before starting operations.

1.5.2.1 Windows

1. Executes the setup.exe in the CLI directory of the provided CD-R.

The updated manager will be executed without restarting Windows.

1.5.2.2 Solaris

1. Copy the ArrayManage-S350-CLI.tar file in the attached CD-R to the hard disk.
2. The ArrayManage-S350-CLI.tar file is a Tar type file. Open the file as described in the following example.

Example : `tar xvf ArrayManage-S350-CLI.tar`

The updated manager will be executed without restarting Solaris.

1.5.2.3 IRIX

1. Copy the ArrayManage-I350-CLI.tar file in the attached CD-R to the hard disk.
2. The ArrayManage-I350-CLI.tar file is a Tar type file. Open the file as described in the following example.

Example : tar xvf ArrayManage-I350-CLI.tar

The updated manager will be executed without restarting IRIX.

1.5.2.4 HP-UX

1. Copy the ArrayManage-H350-CLI.tar file in the attached CD-R to the hard disk.
2. The ArrayManage-H350-CLI.tar file is a Tar type file. Open the file as described in the following example.

Example : tar xvf ArrayManage-H350-CLI.tar

The updated manager will be executed without restarting HP-UX.

1.5.3 Uninstalling

Uninstalls the manager by the following procedure.

1.5.3.1 Windows

1. Deletes the manager using the Add and Delete Application icon in the Control Panel.
2. Deletes the directory generated in the hard disk for installing the manager.

1.5.3.2 Solaris, IRIX, and HP-UX

1. Deletes the directory generated in the hard disk for installing the manager.
2. Deletes the statement of a path to the common library from the set contents of the LD_LIBRARY_PATH environment variable.
3. Invalidates the CMDF_PATH environment variable.

Chapter 2 Command List

2.1 Command List

Table 2.1 shows a list of manager commands.

There are two types of manager's commands : one type is the standard command that is used in standard mode, and the other the administration command that is used in administration mode. When executing an administration command, a password must be set and entered. Of the administration commands, the commands that require password entry are shown with symbols "O" marked in the password column of Table 2.1. These commands can be either used or not during on-line. Commands that can be used during on-line are shown each with symbols "O" marked in the on-line use column in Table 2.1.

In addition, some commands, unless logging in, cannot be executed when a user ID has been registered by using the Password Security function. The commands that require log in if a user ID has been registered are shown with symbols "O" marked in the log in column of Table 2.1.

Table 2.1 List of Manager Commands

Classification	Function	Command	On-line use	Password	Log in
Array unit registration	Referencing array unit information	auunitref	O	x	x
	Adding array unit information	auunitadd	O	x	x
	Changing array unit information	auunitchg	O	x	x
	Deleting array unit information	auunitdel	O	x	x
	Setting password	aupasswd	O	O	x
Array unit management by user ID	Setting user ID	auuidadd	O	O	O
	Changing user ID	auuidchg	O	O	O
	Deleting user ID	auuiddel	O	O	O
	Changing password	aupwdchg	O	O	O
	Logging into array unit	aulogin	O	O	x
	Logging out from array unit	aulogout	O	O	O
	Checking log in	auchkuid	O	x	O
Array unit status	Displaying microprogram revision	aurev	O	x	x
	Displaying drive configuration information	audrive	O	x	x
	Displaying cache configuration information	aucache	O	x	x
	Displaying status of power supply/fan/battery	ausupply	O	x	x
	Displaying current IP address	aucrlan	O	x	x

Table 2.1 List of Manager Commands (Continued)

Classification	Function	Command	On-line use	Password	Log in
RAID /LU	Referencing RAID group	aurgref	○	×	×
	Setting up RAID group	aurgadd	○	○	○
	Expanding RAID group	aurgexp	○	○	○
	Deleting RAID group	aurgdel	×	○	○
	Referencing LU	auluref	○	×	×
	Setting up LU	auluadd	○	○	○
	Formatting LU	auformat	○	○	○
	Displaying progress of LU formatting	auformatst	○	○	×
	Expanding LU	auluexp	○	○	○
	Deleting LU	auludel	×	○	○
	Changing default controller of LU	auluchg	○	○	○
	Setting turbo LU (See Note 1.)	auturbolu	○	○	○
System parameters	Referencing/setting system parameters (See Note 1.)	ausysparam	×	○	○
	Referencing/setting RTC (See Note 1.)	aurtc	×	○	○
	Referencing/setting target information (See Note 1.)	autarget	○	○	○
	Referencing/setting LAN information (See Note 1.)	aulan	○	○	○
	Referencing/setting SCSI transfer rate (See Note 1.)	ausync	○	○	○
Setting up configuration	Referencing/setting fibre channel information	aufibre aufibrel	×	○	○
	Spare HDU setup	auspare	○	○	○
	Fee-Basis option reference/setup	auopt	○	○	○
	Referencing/setting drive restoration control information	audrecopt	×	○	○
	Referencing/setting online verify information	auonlineverify	×	○	○
File output of the RAID/LU configuration information	File output of the RAID/LU configuration information and component conditions	auconfigout	○	×	×

Table 2.1 List of Manager Commands (Continued)

Classification	Function	Command	On-line use	Password	Log in
RAID/LU configuration setup in file	RAID/LU configuration setup from file	auconfigset	○	○	○
File output of system parameter	File output of system parameter	ausyspout	○	×	×
System parameter setup in file	System parameter setup from file	ausyspset	○	○	○
Microprogram replacement	Downloading/replacing microprogram	aumicro	×/○ See Note 2.	○	○
SNMP environment information	Setting SNMP environment information and outputting its file (See Note 1.)	ausnmp	×/○ See Note 3.	○	○
Displaying statistical information	Displaying statistical information	austatistics	○	×	×
Obtaining performance information	Outputting performance information file	auperform	○	×	×
Monitoring errors	Setting up E-Mail reports	aumail	○	×	×
	Setting the starting of application	auextprog	○	×	×
	Monitoring errors	auerroralert	○	×	×

Note 1: Set items do not become effective unless restarting the array unit.

Note 2: When connecting the DF400, the function is available during on-line.

Note 3: When connecting the DF350, the function is available during on-line.

Commands that require log in, if reference is specified by the option, can be executed without logging in.

2.2 Applying Support Functions of Microprograms

Functions of the manager may be disabled depending on the revision number of the microprogram of the array unit connected. Table 2.2 shows the revision numbers of the microprogram which support the manager functions and the manager operations when the microprogram does not support the manager functions.

Table 2.2 Microprogram Revision Numbers and Their Supports for Manager Functions

No.	Function	Revision Nos. of microprogram which support the manager			Remarks
		DF350/DF350F	DF400	DF500	
1	Current IP address display	Not supported	0404, 4404, 0454, 4454, and later respectively	All	
2	RAID group expansion	All	All	0552, and later respectively	
3	LU expansion				
	LU formatting : (Single)	0304, 1304, 4304, 0354, 4354, and later respectively		All	
	LU formatting : (Multi)	Not supported	0406, 4406, 0456, 4456, and later respectively		
	Setting of TURBO LU Assignment		0404, 4404, 0454, 4454, and later respectively	0552, and later respectively	
4	Setting and display of the Fibre Channel information		0450, 4450, and later respectively	All	
5	Referencing/ setting system parameters		0406, 4406, 0456, 4456, and later respectively		
6	Setting target information	0304, 1304, 4304, and later respectively	All		DF350F is not supported.
7	Setting spare disk	Not supported	Not supported		
8	Setting LAN information	0307/P, 4307/P, and later respectively	0401/A, 4401/A, 0451/A, 4451/A, and later respectively		DF350F is not supported.
	DHCP mode setting	Not supported	0404, 4404, 0454, 4454, and later respectively		
9	SCSI transfer rate setting		All	0503, and later respectively	

Table 2.2 Microprogram Revision Numbers and Their Supports for Manager Functions
(Continued)

No.	Function	Revision Nos. of microprogram which support the manager			Remarks
		DF350/DF350F	DF400	DF500	
10	Setting drive restoration control information Interleave (priority mode)	Not supported	0406, 4406, 0456, 4456, and later respectively	All	
11	Dynamic sparing setting	0304, 1304, 4304, 0354, 4354, and later respectively	All		
12	Microprogram replacement	All	0404, 4404, 0454, 4454, and later respectively		DF350F is not supported.
13	Setting SNMP environment information and outputting its file	4307/P and later respectively	4406, 4456, and later respectively		DF350F is not supported.
14	Array unit management by user ID	Not supported	040A, 440A, 045A, 445A, and later respectively (Revision of flash program: B15 or later)	0552, and later respectively	
15	Instruction to reboot				
16	Fee-Basis option setup		Not supported	All	

Note: Revision numbers of the microprogram are classified as shown below according to the function of the array unit.

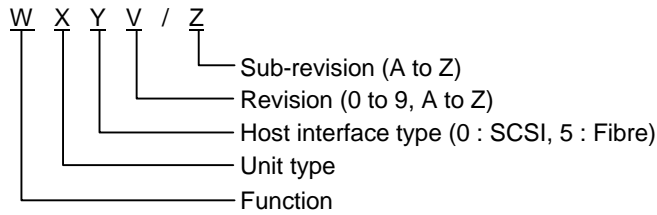

■ Host interface : SCSI

- **030V (030V/Z)**: Version for the DF350 single/dual system used in the open system
- **130V (130V/Z)**: Version for the DF350 single/dual system used in the open system and connected to the AS/400
- **430V (430V/Z)**: Version for the DF350 single/dual system used in the open system and supports the SNMP
- **040V (040V/Z)**: Version for the DF400 single/dual system used in the open system
- **440V (440V/Z)**: Version for the DF400 single/dual system used in the open system and supports the SNMP

■ Host interface : Fibre Channel

- **035V (035V/Z)**: Version for the DF350F single/dual system used in the open system
- **435V (435V/Z)**: Version for the DF350F single/dual system used in the open system and supports the SNMP
- **045V (045V/Z)**: Version for the DF400 single/dual system used in the open system
- **445V (445V/Z)**: Version for the DF400 single/dual system used in the open system and supports the SNMP
- **055V (055V/Z)**: Version for the DF500 single/dual system used in the open system

Update of revision is made for each of nine revisions listed above. An example is shown below.

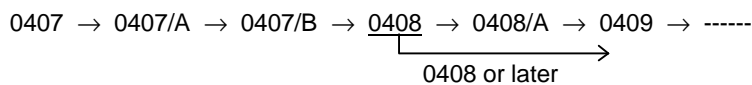

Sub-revision is updated in alphabetic order, however, some sub-revisions may be skipped.

Chapter 3 Command Specifications

3.1 Command Format

The command format of the manager is specified with a command name and succeeding options as shown in Figure 3.1. When specifying multiple options, the order in which options are specified does not matter. In addition, options may be omitted depending the kind of commands.

```
Command Option 1 Option 2 Option 3 .....
```

Figure 3.1 Command Format of Manager

Commands of the manager are classified mainly into the standard command and the administrator command. The following describes specifications of each type of commands.

3.1.1 Standard command

The standard command is a command used mainly for reference. Figure 3.2 and Figure 3.3 show the formats of the standard command. When executing a standard command, the execution result will be displayed following its execution. If an error is detected in specification of options or while processing, you are notified of an error message.

```
%Command Option 1 Option 2 Option 3  
Result  
%
```

Figure 3.2 Format of Standard Command (when terminating normally)

```
%Command Option 1 Option 2 Option 3  
Error message  
%
```

Figure 3.3 Format of Standard Command (when an error is detected)

3.1.2 Administration command

The administration command is a command used to setup a configuration for the array unit. Taking into consideration the integrity and security of data, this command prompts you to enter a password when executing it, and is executed if the password can be authenticated. When reference is specified by the option, a password must be also entered.

Figure 3.4 and Figure 3.5 show the formats of the administration command. When entering an administrator command, this command prompts you to enter a password following the entry. This time, when you enter a preset password, the command will be executed. When, in particular, performing operations associated with data configurations such as deletion of a RAID group or logical unit, commands prompt you to confirm whether or not to execute the function itself before entering a password (see Figure 3.5).

```
%Command Option 1 Option 2 Option 3 .....  
Password : (Entering a already-set password)  
%
```

Figure 3.4 Format 1 of Administration Command

```
%Command Option 1 Option 2 Option 3 .....  
Are you executing ...? (y/n [n])  
Password : (Entering a already-set password)  
%
```

Figure 3.5 Format 2 of Administration Command

3.1.3 Referencing command syntax

When you want to reference the syntax of a command, specify the `-help` option in the command, then the **Usage** information will be displayed, as shown in Figure 3.6.

The **Usage** display is the same in the description of each command as [Synopsis].

```
% auunitadd -help  
Configuration Manager  
Version 3.50  
Copyright (C) 2000, 2001, Hitachi, Ltd.  
  
Usage :  
auunitadd -unit unit_name [ -group group_name ] -DF350 | -DF400 -single |  
-dual -RS232C | -LAN [ -ct10 device | address ]  
[ -ct11 device | address ] [ -watch ]  
%
```

Figure 3.6 Example of Referencing Command Syntax

3.2 Registering Array Unit

3.2.1 Displaying Registration Information

- Command name

auunitref

- Synopsis

auunitref [-unit unit_name]

- Description

Displays registration information of an array unit registered in the manager.

When omitting the option of an array unit name, displays a list of information registered in the manager.

When specifying an array unit name for the option, displays information about a specified array unit.

- Options

Options	Description
-unit unit_name	Specifies the name of an array unit whose registration information to reference. Specifies with one-byte coded alphanumerics and special symbols "-" (minus)" and "_" (underline)" of up to 16 characters long.

- Examples of using command

References all registered information.

```
% auunitref
Unit      Group  Array  Type  Watch  Comm  Device/IP addresses
df350a    hsp    DF350  Dual  on     LAN   192.168.33.120 192.168.33.130
df400a    hsp    DF400  Dual  on     LAN   192.168.0.50  192.168.0.51
df400a0   hsp    DF400  Single on     LAN   192.168.0.60
df400a1   hsp    DF400  Dual  off    LAN   192.168.0.62  192.168.0.63
df400b1   hsp1   DF400  Dual  on     LAN   192.168.1.100 192.168.1.101
df400b2   hsp1   DF400  Dual  off    LAN   192.168.1.102 192.168.1.103
df400c1   hsp1   DF400  Single off    232C  COM1
df500a1   hsp1   DF500  Dual  on     LAN   192.168.2.100 192.168.2.101
df500a2   hsp1   DF500  Dual  on     LAN   192.168.2.102 192.168.2.103
%
```

References registration information of an array unit whose name is df500a1.

```
% auunitref -unit df500a1
Unit      Group  Array  Type  Watch  Comm  Device/IP addresses
df500a1   hsp    DF500  Dual  on     LAN   192.168.0.100 192.168.0.101
```

3.2.2 Registering

- **Command name**

auunitadd

- **Synopsis**

```
auunitadd -unit unit_name [ -group group_name ] -DF350 | -DF400 | -DF500
          -single | -dual
          -RS232C | -LAN
          [ -ct10 device | address ] [ -ct11 device | address ] [ -watch ]
```

- **Description**

Registers an array unit into the manager. Registration information consists of an array unit name, a group name, a type, an configuration, an connection interface, and device.

- **Options**

Options	Description
-unit unit_name	Specifies the name of an array unit whose registration information to reference. Specifies with one-byte coded alphanumerics and special symbols "-" (minus)" and "_" (underline)" of up to 16 characters long.
-group group_name	Specifies the name of a group in which multiple array units are managed all together. If this option is omitted, array units are not managed in a group all together. The maximum number of groups registered is 200. Specifies with one-byte coded alphanumerics and special symbols "-" (minus)" and "_" (underline)" of up to 16 characters long.
-DF350 -DF400 -DF500	Specifies the type of an array unit.
-single -dual	Specifies the configuration (single system or dual system) of an array unit.
-RS232C -LAN	Specifies the connection interface (RS232C or LAN) to an array unit.
-ct10 device address	Specifies the device or address used to connect to Controller 0. If "LAN" is selected as the [connection interface], specifies an "IP address" or "host name". If "RS232C", specifies a "device name". Specifies a host name with up to 15 one-byte coded characters. Specifies a device name with a RS232C port name or a device file name. (Example : Windows - COM1, Solaris - /dev/ttya)
-ct11 device address	Specifies the device or address used to connect to Controller 1. If "LAN" is selected as the [connection interface], specifies an "IP address" or "host name". If "RS232C", specifies a "device name". Specifies a host name with up to 15 one-byte coded characters. Specifies a device name with a RS232C port name or a device file name. (Example : Windows - COM1, Solaris - ttya)
-watch	Specifies that an array unit registered is monitored for errors. If omitted, an array unit is not monitored for errors.

Note: In the array unit in the dual system, only one controller can be used in the LAN connection mode. **Array Unit Type** is used to select an array unit type to be connected. Specify **Controller 0 IP Address/Host Name/Device Name** and **Controller 1 IP Address/ Host Name/Device Name** for the connected controller side only. When registering the array unit in the dual system, confirm the controller to be connected to before specifying **Controller 0 IP Address/Host Name/Device Name** and **Controller 1 IP Address/Host Name/Device Name**. If you specified the wrong controller, depending on the specified contents the controller configuration may be set as the opposite controller side.

- Examples of using command

Registers an DF400 with a dual system configuration and a LAN connection interface by an array unit name of df400d1.

```
% auunitadd -unit df400d1 -DF400 -dual -LAN -ctl0 192.168.1.100 -ctl1  
192.168.1.101  
%
```

Registers an DF400 with a single system configuration and an RS232C connection interface by an array unit name of df400s1, and additionally subjects it to monitoring for errors.

```
% auunitadd -unit df400s1 -DF400 -single -RS232C -ctl0 /dev/ttya -watch  
%
```

Registers a DF500 with a dual system configuration and a LAN connection interface by an array unit name of df500a1.

```
% auunitadd -unit-df500a1 -DF500 -dual -LAN -ctl0 192.168.1.100 -ctl1  
192.168.1.101  
%
```

3.2.3 Changing Registration Information

- **Command name**

auunitchg

- **Synopsis**

```
auunitchg -unit unit_name
[ -newunit unit_name ] [ -group group_name ]
[ -DF350 | -DF400 | -DF500 ] [ -single | -dual ]
[ -RS232C | -LAN ]
[ -ct10 device | address ] [ -ct11 device | address ]
[ -watch | -ignore ] [ -f ]
```

- **Description**

Changes registration information (array unit name, group name, type, configuration, connection interface, and device) of an already-registered array unit.

However, items of array unit information, if their options are omitted, are not changed.

- **Options**

Options	Description
-unit unit_name	Specifies the name of a registered array unit. Specifies with one-byte coded alphanumerics and special symbols "-" (minus)" and "_"(underline)" of up to 16 characters long.
-newunit unit_name	Specifies the array unit name to change. Specifies an array unit name after change, with one-byte coded alphanumerics and special symbols "-" (minus)" and "_"(underline)" of up to 16 characters long.
-group group_name	Specifies the group name to change. Specifies with one-byte coded alphanumerics and special symbols "-" (minus)" and "_"(underline)" of up to 16 characters long.
-DF350 -DF400 -DF500	Specifies the type of an array unit to change.
-single -dual	Specifies the configuration (single system or dual system) of an array unit to change.
-RS232C -LAN	Specifies the connection interface (RS232C or LAN) of an array unit to change.
-ct10 device address	Specifies the device or address to change, which address is used to connect to Controller 0. If the [connection interface] is "LAN", specifies an "IP address" or "host name". If "RS232C", specifies a "device name". Specifies a host name with up to 15 one-byte coded characters. Specifies a device name with a RS232C port name or a device file name. (Example : Windows - COM1, Solaris - /dev/ttya)

(Continued)

Options	Description
-ctl1 device address	Specifies the device or address to change, which address is used to connect to Controller 1. Specifies in the same way as for Controller 0.
-watch	Specifies that an array unit is monitored for errors.
-ignore	Specifies that an array unit is not monitored for errors.
-f	The confirmation message at command execution is omitted.

- Examples of using command

Displays registration information of an array unit whose name is df500a1, and goes on to change it. Then, checks if changes have been made to the registration information of the array unit.

```
% auunitref -unit df500a1
Unit      Group  Array  Type   Watch  Comm   Device/IP addresses
df500a1   hsp    DF500  Dual   on     232C   /dev/ttya
%
% auunitchg -unit df500a1 -LAN -ctl0 192.168.1.100 -ctl1 192.168.1.101
change df500a1? (y/n [n]) y
%
% auunitref -unit df500a1
Unit      Group  Array  Type   Watch  Comm   Device/IP addresses
df500a1   hsp    DF500  Dual   on     LAN    192.168.1.100 192.168.1.101
%
```

If a specified array unit name is not yet registered, the following message is displayed.

```
% auunitchg -unit df500b1
DMEA001003 : Specified Unit name is not registered.
%
```

3.2.4 Deleting Registration Information

- **Command name**
auunitdel
- **Synopsis**
auunitdel -unit unit_name [-f]
- **Description**
Deletes registration information of an already-registered array unit.
- **Options**

Options	Description
-unit unit_name	Specifies the name of a registered array unit whose registration information to delete. Specifies with one-byte coded alphanumerics and special symbols "-" (minus)" and " <u>" (underline)" of up to 16 characters long.</u>
-f	Specifies that confirmation of deletion is omitted.

- **Examples of using command**

Deletes registration information of an already-registered array unit whose name is df500a1.

```
% auunitdel -unit df500a1  
remove df500a1? (y/n [n]) y  
%
```

Checks the information registered by an array unit name that has been deleted.

```
% auunitdel -unit df500b1  
DMEA001003 : Specified Unit name is not registered.  
%
```

3.2.5 Setting Password in Administration Mode

- Command name

apasswd

- Synopsis

apasswd

- Description

Sets a new password used in administration mode to execute administration commands. In addition, changes an already-set password.

If a new password is set, enters the same password twice. If changed, enters an already-set password, and then enters a new password again.

- Examples of using command

Sets a new password used in administration mode.

```
% apasswd
```

```
New password : (Enters a password to be set newly.)
```

```
Retype new password : (Enters the same password as above.)
```

```
%
```

Changes a password used in administration mode.

```
% apasswd
```

```
Old password : (Enters an already-set password.)
```

```
New password : (Enters a new password.)
```

```
Retype new password : (Enters the same password as above.)
```

```
%
```

3.3 Array Unit Management by User ID

3.3.1 Setting User ID

- Command name

auuidadd

- Synopsis

auuidadd -unit unit_name [-num]

- Description

Registers a user ID and its password into an array unit. Up to 20 users can be registered. Specifies the user ID and its password individually with one-byte coded alphanumerics and special symbols “- (minus)” and “_(underline)” of 4 to 12 characters long. After registering, displays the number of user IDs setup in the array unit.

- Options

Options	Description
-unit unit_name	Specifies the name of an array unit into which to register a user ID. Specifies with one-byte coded alphanumerics and special symbols “- (minus)” and “_(underline)” of up to 16 characters long.
-num	Displays the number of already-registered user IDs.

- Examples of using command

Adds a user ID into an array unit whose name is df400a1.

```
% auuidadd -unit df400a1
Password :
User ID for array unit : (User ID to set)
Password for array unit : (Password of a user ID to set)
Retype New Password for array unit : (Same password as that of a user ID to set)
Number of registered User ID : n
%
```

Displays the number of user IDs already-registered in an array unit whose name is df400a1.

```
% auuidadd -unit df400a1 -num
Password :
Number of registered User ID : n
%
```

3.3.2 Changing User ID

- **Command name**

auuidchg

- **Synopsis**

auuidchg -unit unit_name

- **Description**

Changes a user ID that has been setup in an array unit.
After changing, displays the number of user IDs setup in the array unit.

- **Options**

Options	Description
-unit unit_name	Specifies the name of an array unit in which to change a user ID. Specifies with one-byte coded alphanumerics and special symbols "-" (minus)" and "_" (underline)" of up to 16 characters long.

- **Examples of using command**

Changes a user ID that has been registered in an array unit whose name is df400a1.

```
% auuidchg -unit df400a1
Password :
Old User ID for array unit : (Already-set user ID)
Old Password for array unit : (Password of an already-set user ID)
New User ID for array unit : (User ID to set)
New Password for array unit : (Password of a user ID to set)
Retype New Password for array unit : (Same password as that of a user ID to
set)
Number of registered User ID : n
%
```

3.3.3 Deleting User ID

- Command name

auiddel

- Synopsis

auiddel -unit unit_name

- Description

Deletes a user ID that has been setup in an array unit.
After deleting, displays the number of user IDs setup in the array unit.

- Options

Options	Description
-unit unit_name	Specifies the name of an array unit in which to delete a user ID. Specifies with one-byte coded alphanumerics and special symbols "-" (minus)" and " <u>" (underline)" of up to 16 characters long.</u>

- Examples of using command

Deletes a user ID that has been registered in an array unit whose name is df400a1.

```
% auiddel -unit df400a1
Password :
User ID for array unit : (Already-set user ID)
Password for array unit : (Password of an already-set user ID)
Number of registered User ID : n
%
```

3.3.4 Changing Password

- Command name

`aupwdchg`

- Synopsis

`aupwdchg -unit unit_name`

- Description

Changes the password of a user ID that has been setup in an array unit.
After changing, displays the number of user IDs setup in the array unit.

- Options

Options	Description
<code>-unit unit_name</code>	Specifies the name of an array unit in which to change the password of a user ID. Specifies with one-byte coded alphanumerics and special symbols "-" (minus)" and "_" (underline)" of up to 16 characters long.

- Examples of using command

Changes the password of a user ID that has been registered in an array unit whose name is `df400a1`.

```
% aupwdchg -unit df400a1
Password :
User ID for array unit : : (Already-set user ID)
Old Password for array unit : (Password of an already-set user ID)
New Password for array unit : (Password of a user ID to set)
Retype New Password for array unit : (Same password as that of a user ID to
set)
Number of registered User ID : n
%
```

3.3.5 Logging In and Forcibly Logging In to Array Unit

- Command name

aulogin

- Synopsis

aulogin -unit unit_name [-discon]

- Description

Declares an intention to log into an array unit with a user ID registered in the array unit. This log in disables to log in with any other user ID.

When forcibly logging into an array unit to which another user has already logged in, specifies the -discon option. When forcibly logging in, the user ID of an already logged-in user is logged out.

- Options

Options	Description
-unit unit_name	Specifies the name of an array unit to which to log in. Specifies with one-byte coded alphanumerics and special symbols "-" (minus) and "_" (underline) of up to 16 characters long.
-discon	Specifies this option when forcibly logging into an array unit to which another user has already logged in.

- Examples of using command

Logs in, with a registered user ID, to an array unit whose name is df400a1.

```
% aulogin -unit df400a1
Password :
User ID for array unit : (Already-set user ID)
Password for array unit : (Password of an already-set user ID)
%
```

Logs in, with a registered user ID, to an array unit, whose name is df400a1 and to which another user has logged in.

```
% aulogin -unit df400a1 -discon
Password :
User ID for array unit : (Already-set user ID)
Password for array unit : (Password of an already-set user ID)
User ID (xxxxxxxxxxxx) has been logged in.
Connected with (xxx.xxx.xxx.xxx). (See Note)
Do you want to forcibly log in ? (y/n [n])
%
```

Note: Destination of connection is indicated as “Connected with (xxx.xxx.xxx.xxx).” (an item in parentheses is an IP address)” in the case of a connection via a LAN, or “Connected with (RS232C).” in the case of a connection via RS232C.

3.3.6 Logging Out from Array Unit

- **Command name**
alogout
- **Synopsis**
alogout -unit unit_name
- **Description**
Logs out a user ID with which a user has already logged into an array unit.

- **Options**

Options	Description
-unit unit_name	Specifies the name of an array unit from which to log out. Specifies with one-byte coded alphanumerics and special symbols "-" (minus)" and " <u>_</u> (underline)" of up to 16 characters long.

- **Examples of using command**

Logs out a user ID with which a user has logged into an array unit whose name is df400a1.

```
% alogout -unit df400a1
Password :
%
```

3.3.7 Checking Login

- Command name

auchkuid

- Synopsis

auchkuid -unit unit_name

- Description

Checks the user ID and connected unit of a user who has already logged in an array unit. Information about the connected unit is an IP address for LAN connection, and “RS232C” for RS232C connection.

This command is allowed for reference only with a user ID other than that of a user who has already logged in. Though this command is issued with the user ID of a user who has already logged in, the user information cannot be referenced.

- Options

Options	Description
-unit unit_name	Specifies the name of an array unit whose log in status to check. Specifies with one-byte coded alphanumerics and special symbols “- (minus)” and “_ (underline)” of up to 16 characters long.

- Examples of using command

Checks a user ID with which a user has logged into an array unit whose name is df400a1.

```
% auchkuid -unit df400a1
User ID (xxxxxxxxxxxx) has been logged in.
Connected with (xxx.xxx.xxx.xxx). (See Note)
%
```

Note: Destination of connection is indicated as “Connected with (xxx.xxx.xxx.xxx).” (an item in parentheses is an IP address)” in the case of a connection via a LAN, or “Connected with (RS232C).” in the case of a connection via RS232C.

3.4 Displaying Array Unit Status

3.4.1 Displaying Microprogram Revision

- Command name

aurev

- Synopsis

aurev -unit unit_name [-ct10 | -ct11]

- Description

Displays the microprogram revision of a specified unit.

- Options

Options	Description
-unit unit_name	Specifies the name of an array unit for which to display its microprogram revision. Specifies with one-byte coded alphanumerics and special symbols "-" (minus) and " <u>_</u> " (underline) of up to 16 characters long.
-ct10 -ct11	Specifies the controller No. of an array unit for which to display its microprogram revision.

- Examples of using command

Displays the microprogram revision of an array unit whose name is df500a1.

```
% aurev -unit df500a1
micro revision : 0501
%
```

3.4.2 Displaying Drive Configuration Information

- Command name

audrive

- Synopsis

- In the case of DF350, DF400

audrive -unit unit_name -status

- In the case of DF500

audrive -unit unit_name -status [-uno unit_no -hno hdu_no]

- In the case of DF350, DF400, and DF500

audrive -unit unit_name -vendor

- Description

Displays the status and type of drives in a specified array unit.

If an HDU on which data restoration is in progress is specified, a process of restoring is displayed.

- Options

Options	Description
-unit unit_name	Specifies the name of an array unit for which to display its drive configuration information. Specifies with one-byte coded alphanumerics and special symbols "-" (minus) and "_" (underline) of up to 16 characters long.
-status -vendor	The drive information is displayed. -status: The drive condition is displayed. -vendor: The vendor ID, product ID, and revision of the mounted drive are displayed. For the DF500, the storage capacity of drives is displayed.

For the exclusive use of DF500

Options	Description
-uno unit_no -hno hdu_no	<p>Displays the operating status of the drive at a specified position. In addition, if the drive is a data drive subject to data recovery, the following information is displayed additionally.</p> <p>When recovery is in progress, "(nn%)" is displayed to indicate the progress rate of recovery.</p> <p>When no recovery is performed, "(0%)" is displayed.</p> <p>When recovery terminates normally or recovery is terminated forcibly, "(100%)" or "Normal" is displayed.</p> <p>When recovery terminates abnormally, "(nn% Aborted)" is displayed to indicate the progress rate of the recovery already processed until an abnormal termination and the resulting abnormal termination.</p>

- Examples of using command

Displays the status of drives in an array unit whose name is df400a1.

```
% audrive -unit df400a1 -status
Port  Row    Type    Physics  Status
  0     0    Data    Mount    Normal
  1     0    Data    Mount    Normal
  2     0    Data    Mount    Normal
  3     0    Data    Mount    Normal
  4     0    Data    Mount    Normal
  5     0    Spare   Mount    Standby
  0     1    Data    Mount    Normal
  1     1    Data    Mount    Standby
  2     1    Undefine Mount    Out of RG
  3     1    Undefine Mount    Out of RG
  4     1    Undefine Mount    Out of RG
%
```

Displays the status of drives in an array unit whose name is df500a1 (CK, RK model).

```
% audrive -unit df500a1 -status
Unit No.  HDU No.  Type    Physics  Status
  0         0    Data    Mount    Normal
  0         1    Data    Mount    Normal
  0         2    Data    Mount    Normal
  :         :
  :         :
  0         8    Data    Mount    Normal
  0         9    Spare   Mount    Standby
  1         0    Undefine Mount    Out of RG
  1         1    Undefine Mount    Out of RG
  :         :
  :         :
  1         8    Undefine Mount    Out of RG
  1         9    Undefine Mount    Out of RG
  :         :
  :         :
```

Displays the status of drives in an array unit whose name is df500a2 (MK, RKL model).

```
% audrive -unit df500a2 -status
Unit No.  HDU No.  Type      Physics  Status
          0         0   Data      Mount   Normal
          0         1   Data      Mount   Normal
          0         2   Data      Mount   Normal
          :
          :
          0         9   Data      Mount   Normal
          0        10   Spare     Mount   Standby
          0        11   Spare     Mount   Standby
```

%

Displays the status of drive HDU No. 7 in UNIT No. 0 of an array unit whose name is df500a1.

```
% audrive -unit df500a1 -status uno 0 hno 7
Unit No.  HDU No.  Type      Physics  Status
          0         7   Data      Mount   Reconst
                                   (75%)
```

Displays the drive information of an array unit whose name is df400a1.

```
% audrive -unit df400a1 -status
Port  Row   Vendor      Product      Revision
     0    0   HITACHI    DK328-43    D0D4
     1    0   HITACHI    DK328-43    D0D4
     2    0   HITACHI    DK328-43    D0D4
     3    0   HITACHI    DK328-43    D0D4
     4    0   HITACHI    DK328-43    D0D4
```

%

Displays the drive information of an array unit whose name is df500a1 (CK, RK model).

```
% audrive -unit df500a1 -status
Unit No.  HDU No.  Vendor      Product      Revision  Capacity
          0         0   HITACHI    DK328-43    D0D4     18GB
          0         1   HITACHI    DK328-43    D0D4     18GB
          0         2   HITACHI    DK328-43    D0D4     18GB
          :
          :
          0         8   HITACHI    DK328-43    D0D4     18GB
          0         9   HITACHI    DK328-43    D0D4     18GB
          1         0   HITACHI    DK328-43    D0D4     18GB
          1         1   HITACHI    DK328-43    D0D4     18GB
          :
          :
```

%

Displays the drive information of an array unit whose name is df500a2 (MK, RKL model).

```
% audrive -unit df500a2 -status
Unit No.  HDU No.  Vendor      Product      Revision    Capacity
      0      0      HITACHI    DK328-43     D0D4       18GB
      0      1      HITACHI    DK328-43     D0D4       18GB
      :
      :
      0      9      HITACHI    DK328-43     D0D4       18GB
      0     10      HITACHI    DK328-43     D0D4       18GB
      0     11      HITACHI    DK328-43     D0D4       18GB
%
```

Displays the drive information of an array unit whose name is df400a1.

```
% audrive -unit df400a1 -vendor
Port  Row  Vendor      Product      Revision
  0    0  HITACHI    DK328H-43    D0D4
  1    0  HITACHI    DK328H-43    D0D4
  2    0  HITACHI    DK328H-43    D0D4
  3    0  HITACHI    DK328H-43    D0D4
  4    0  HITACHI    DK328H-43    D0D4
  5    0  HITACHI    DK328H-43    D0D4
  0    1  HITACHI    DK328H-43    D0D4
  1    1  HITACHI    DK328H-43    D0D4
  2    1  HITACHI    DK328H-43    D0D4
  3    1  HITACHI    DK328H-43    D0D4
  4    1  HITACHI    DK328H-43    D0D4
%
```

Displays the drive information of an array unit whose name is df500a1 (CK, RK model).

```
% audrive -unit df500a1 -vendor
Unit No.  HDU No.  Vendor      Product      Revision
      0      0      HITACHI    DK32CJ-18FC  F6A6
      0      1      HITACHI    DK32CJ-18FC  F6A6
      0      2      HITACHI    DK32CJ-18FC  F6A6
      :
      :
      0      8      HITACHI    DK32CJ-18FC  F6A6
      0      9      HITACHI    DK32CJ-18FC  F6A6
      :
      :
%
```

Displays the drive information of an array unit whose name is df500a2 (MK, RKL model).

```
% audrive -unit df500a2 -vendor
Unit No.  HDU No.  Vendor      Product      Revision
      0      0      HITACHI    DK32CJ-18FC  F6A6
      0      1      HITACHI    DK32CJ-18FC  F6A6
      :
      :
      0      8      HITACHI    DK32CJ-18FC  F6A6
      0      9      HITACHI    DK32CJ-18FC  F6A6
%
```

3.4.3 Displaying Cache Configuration Information

- **Command name**
aucache

- **Synopsis**
aucache -unit unit_name

- **Description**
Displays the status and capacity of cache memory.

- **Options**

Options	Description
-unit unit_name	Specifies the name of an array unit for which to display cache configuration information. Specifies with one-byte coded alphanumerics and special symbols "-" (minus)" and "_ (underline)" of up to 16 characters long.

- Examples of using command

Displays the cache memory configuration information of an array unit whose name is df400a1.

```
% aucache -unit df400a1
Ctl    Slot    Status          Size (MB)
  0      0    normal          32
  0      1    detached        -----
  0      2    normal          -----
  0      3    not installed   -----
  0      4    not installed   -----
  0      5    not installed   -----
  0      6    not installed   -----
  0      7    not installed   -----
  0      8    not installed   -----
  0      9    not installed   -----
  0     10    not installed   -----
  0     11    not installed   -----
  0     12    not installed   -----
  0     13    not installed   -----
  0     14    not installed   -----
  0     15    not installed   -----
  1      0    normal          32
  1      1    detached        -----
  1      2    normal          -----
  1      3    not installed   -----
  1      4    not installed   -----
  1      5    not installed   -----
  1      6    not installed   -----
  1      7    not installed   -----
  1      8    not installed   -----
  1      9    not installed   -----
  1     10    not installed   -----
  1     11    not installed   -----
  1     12    not installed   -----
  1     13    not installed   -----
  1     14    not installed   -----
  1     15    not installed   -----
%
```

3.4.4 Displaying Status of Power Supply/Fan/Battery

- Command name

ausupply

- Synopsis

ausupply -unit unit_name

- Description

Displays the status of DC power supplies, AC power supplies, batteries, fans, and backup circuits individually.

- Options

Options	Description
-unit unit_name	Specifies the name of an array unit for which to display information. Specifies with one-byte coded alphanumerics and special symbols "-" (minus) and "_" (underline) of up to 16 characters long.

- Examples of using command

Displays the status of power supplies, batteries, and fans of an array unit whose name is df400a1 individually.

```
% ausupply -unit df400a1
```

```
DC PS Information
```

```
No. Status
0 normal
1 normal
2 normal
3 normal
4 alarm
5 normal
6 normal
7 nothing
```

```
FAN Information
```

```
No. Status
0 normal
1 normal
2 normal
3 normal
4 normal
5 alarm
6 normal
```

Battery Information

No.	Status
0	normal
1	normal

Battery Backup Information

No.	Status
0	normal
1	normal

AC PS Information

No.	Status
0	alarm
1	normal

%

3.4.5 Displaying Current IP Address

- Command name

aucrlan

- Synopsis

aucrlan -unit unit_name

- Description

The LAN information with the enabled array unit is displayed.

For the DF350 and DF400, the IP address and the subnet mask are displayed; for the

DF500, the IP address, the subnet mask, and the default gateway address are displayed.

- Options

Options	Description
-unit unit_name	Specifies the name of an array unit for which to display LAN information. Specifies with one-byte coded alphanumerics and special symbols "-" (minus) and "_" (underline)" of up to 16 characters long.

- Examples of using command

Display the LAN information with enabled array unit name df400a1.

```
% aucrlan -unit df400a1
CTL  IP address  Net mask
  0  125.0.9.98  255.255.255.0
  1  125.0.9.99  255.255.255.0
%
```

Display the LAN information with enabled array unit name df500a1.

```
% aucrlan -unit df500a1
CTL  IP address  Net mask      Default gateway
  0  125.0.9.98  255.255.255.0  125.0.9.5
  1  125.0.9.99  255.255.255.0  125.0.9.5
%
```

3.5 RAID/LU

3.5.1 Referencing RAID Group

- Command name

aurgref

- Synopsis

aurgref -unit unit_name

- Description

The definition of the RAID groups set to the array unit is displayed in list form. The display contents include the RAID group number, the RAID level, the definition frame of the RAID group.

- Options

Options	Description
-unit unit_name	Specify the name of the array unit which references the definition of the RAID group. Specifies with one-byte coded alphanumeric and special symbols "-" (minus)" and "_"(underline)" of up to 16 characters long.

- Examples of using command

Reference the definition of the RAID group of the array unit name df400a1.

```
% aurgref -unit df400a1
RG   Level  Port  Width  Row  Depth
  0     5    0     5     0    1
  2     0    0     3     1    1
  3     1    0     4     2    1
%
```

Reference the definition of the RAID group of the array unit name df500a1.

```
% aurgref -unit df500a1
RAID      RAID  Start Location      Number of HDU      Number of      Remains
Group No.  Level  [Unit No, HDU No.]  in parity group  parity group
          0     5           0           5           0           1  10000000
%
```

3.5.2 Setting Up RAID Group

- **Command name**

aurgadd

- **Synopsis**

– In the case of DF350, DF400

```
aurgadd -unit unit_name -rg rg_no
        -RAID0 | -RAID1 | -RAID5 | -RAID01 | -RAIDB | -RAIDC
        -row row_no -port port_no -width width_num -depth depth_num
```

– In the case of DF500

```
aurgadd -unit unit_name -rg rg_no
        -RAID0 | -RAID1 | -RAID5 | -RAID01
        -uno unit_no -hno hdu_no -hnum hdu_num -pnum pty_num
```

- **Description**

Sets up a RAID group in a specified array unit.

- **Options**

Options	Description
-unit unit_name	Specifies the name of an array unit in which to setup a RAID group. Specifies with one-byte coded alphanumerics and special symbols "-" (minus)" and "_" (underline)" of up to 16 characters long.
-rg rg_no	Specifies the RAID group No.
-RAID0, -RAID1, -RAID5, -RAID01, -RAIDB, -RAIDC	Specifies the RAID level.

For the exclusive use of DF350, DF400

Options	Description
-row row_no	Specifies the row No. of the top HDU in a RAID group.
-port port_no	Specifies the port No. of the top HDU in a RAID group.
-width width_num	Specifies the number of HDU arranged horizontally in a RAID group (width). Sets the value of 2 or more.
-depth depth_num	Specifies the number of HDU arranged vertically in a RAID group (depth).

For the exclusive use of DF500

Options	Description
-uno unit_no	Specifies the Unit No. of the top drive in a RAID group.
-hno hdu_no	Specifies the HDU No. of the top drive in a RAID group.
-hnum hdu_num	Specify the number of HDUs in the parity group of the RAID group.
-pnum pty_num	Specify the number of parity groups of the RAID group.

- Examples of using command

Setup a RAID group in an array unit whose name is df400a1 (DF400). Set RAID group number to 2, RAID level to RAID5, starting drive Port to 0, Row to 2, Width to 5, and Height to 1.

```
% aurgadd -unit df400a1 -rg 2 -RAID5 -port 0 -row 2 -width 5 -depth 1
Password :
%
```

Setup the RAID group of array unit name df500a1. Set RAID group number to 2, RAID level to RAID5, starting drive Unit number to 0, HDU number to 2, number of HDUs in the parity group to 5, number of parity groups to 1.

```
% aurgadd -unit df500a1 -rg 2 -RAID5 -uno 0 -hno 0 -hnum 5 -pnum 1
Password :
%
```

3.5.3 Expanding RAID Group

- Command name

`aurgexp`

- Synopsis

– In the case of DF350, DF400

`aurgexp -unit unit_name -rg rg_no -width width_num`

`aurgexp -unit unit_name -rg rg_no -depth depth_num`

– In the case of DF500

`aurgexp -unit unit_name -rg rg_no -pnum pty_num`

- Description

Expands the already-defined size of a RAID group.

For DF350 and DF400, only either the width or the height is specified for the expansion direction, and specification depends on each RAID level.

- Options

Options	Description
<code>-unit unit_name</code>	Specifies the name of an array unit in which a RAID group whose size to expand has been defined. Specifies with one-byte coded alphanumerics and special symbols "-" (minus) and "_" (underline) of up to 16 characters long.
<code>-rg rg_no</code>	Specifies the RAID group No. of a RAID group for which to expand its already-defined size.

For the exclusive use of DF350, DF400

Options	Description
<code>-width width_num</code>	Specifies the number of drives arranged horizontally in a RAID group (width) after expansion.
<code>-depth depth_num</code>	Specifies the number of drives arranged vertically in a RAID group (depth) after expansion.

For the exclusive use of DF500

Options	Description
<code>-pnum pty_num</code>	Specifies the number of parity groups after expansion.

- Examples of using command

Expands the depth of RAID group 2, which has been setup in an array unit whose name is df400a1, from 1 to 3.

```
% aurgref -unit df400a1
RG Level Port Width Row Depth
 2   5   0    5   0    1
%
% aurgexp -unit df400a1 -rg 2 -depth 3
Password :
%
% aurgref -unit df400a1
RG Level Port Width Row Depth
 2   5   0    5   0    3
%
%
```

Expands the number of parity groups of RAID group 0, which number has been set in an array unit whose name is df500a1, from 1 to 3.

```
% aurgref -unit df500a1
RAID RAID Start Location Number of HDU Number of Remains
Group No. Level [Unit No. HDU No.] in parity group parity group
 0     5     0     5           0           1 10000000
%
% aurgexp -unit df500a1 -rg 0 -pnum 3
Password :
%
% aurgref -unit df500a1
RAID RAID Start Location Number of HDU Number of Remains
Group No. Level [Unit No. HDU No.] in parity group parity group
 0     5     0     5           0           3 30000000
%
%
```

3.5.4 Deleting RAID Group

- Command name

`aurgdel`

- Synopsis

`aurgdel -unit unit_name -rg rg_no [-f]`

`aurgdel -unit unit_name -ALL [-f]`

- Description

Deletes a specified RAID group or all RAID groups in an array unit.

- Options

Options	Description
<code>-unit unit_name</code>	Specifies the name of an array unit in which RAID groups to be deleted have been defined. Specifies with one-byte coded alphanumerics and special symbols "-" (minus) and "_" (underline) of up to 16 characters long.
<code>-rg rg_no</code>	Specifies the RAID group No. of a RAID group which to delete.
<code>-ALL</code>	Specifies to delete all RAID groups.
<code>-f</code>	The confirmation message at command execution is omitted.

- Examples of using command

Deletes RAID group 1 that has been defined in an array unit whose name is `df400a1`.

```
% aurgdel -unit df400a1 -rg 1
remove RAID group 1? (y/n [n]) y
Password :
%
```

An attempt was made to delete all RAID groups that have been defined in an array unit whose name is `df400a1`, but the deletion was canceled.

```
% aurgdel -unit df400a1 -ALL
This function invalidates user data of the deleted RAID groups.
remove all RAID groups? (y/n [n]) n
Terminate execution.
%
```

3.5.5 Referencing LU

- Command name

auluref

- Synopsis

auluref -unit unit_name [-lu lun ...]

- Description

Displays already-defined LU information (capacity, status, pre-read staging amount, current controller No., default controller No., RAID group No. of a RAID group to which to belong, and its RAID level).

- Options

Options	Description
-unit unit_name	Specifies the name of an array unit for which to reference LU information. Specifies with one-byte coded alphanumeric and special symbols "-" (minus) and "_" (underline) of up to 16 characters long.
-lu lun ...	When you want to reference LU information, specifies an LU No. If omitted, all already-defined LU information is displayed.

- Examples of using command

Displays all LU information in an array unit whose name is df400a1.

```
% auluref -unit df400a1
LU Capacity Status Staging C-CTL D-CTL RG RAID
0 100352 Normal 512 0 0 0 5
1 100352 Normal 512 0 0 0 5
2 100352 Normal 512 0 0 0 5
3 100352 Normal 512 0 0 0 5
%
```

Displays information about LU 0 in an array unit whose name is df400a1.

```
% auluref -unit df400a1 -lu 0
LU Capacity Status Staging C-CTL D-CTL RG RAID
0 100352 Normal 512 0 0 0 5
%
```

3.5.6 Setting Up LU

- Command name

au luadd

- Synopsis

– In the case of dual system

```
au luadd -unit unit_name [ -lu lun ] -rg rg_no -size num | lest
        -ct10 | -ct11
```

– In the case of single system

```
au luadd -unit unit_name [ -lu lun ] -rg rg_no -size num | lest
```

- Description

Sets up an LU.

- Options

Options	Description
-unit unit_name	Specifies the name of an array unit to which to add an LU. Specifies with one-byte coded alphanumerics and special symbols "-" (minus) and "_" (underline) of up to 16 characters long.
-lu lun	Specifies the LU No. of an LU to add. An LU No. to be specified must be the next number to the last of already-set numbers. If omitted, the manager automatically determines an LU No. For connection of the DF350 and DF400, the determination processing is performed with the increase in the number of set LUs, resulting in inferior response. If the LU number to be added is known, specification of the LU number is recommended.
-rg rg_no	Specifies the RAID group No. of a RAID group to which to add an LU.
-size num lest	Specifies the capacity (number of blocks) of an LU. If "lest" is specified for the capacity, all remaining capacity of the RAID group is assigned.
-ct10 -ct11	Specifies the default controller No. of an LU. This option is specified when array unit is dual system.

- Examples of using command

Adds LU 3 to RAID group 2 in an array unit with a dual system configuration, whose name is df400a1. The capacity shall be 1,024,000, and the default controller be no. 0.

```
% au luadd -unit df400a1 -lu 3 -size 1024000 -ct10 -rg 2
Password :
%
```

3.5.7 Formatting LU

- **Command name**

auformat

- **Synopsis**

auformat -unit unit_name -N | -I | -Im -lu lun ... [-f]

- **Description**

Formats a specified LU.

If multiple LUs are specified, LUs are formatted in the ascending order of LUNs regardless of formatting methods.

- **Options**

Options	Description
-unit unit_name	Specifies the name of an array unit in which an LU to format has been defined. Specifies with one-byte coded alphanumerics and special symbols "-" (minus)" and "_" (underline)" of up to 16 characters long.
-N -I -Im	Specifies the formatting method. -N: Formats in the Normal mode in units of LUs. Formatting is executed from the current controller controlling an LU. In registering unit information, the current controller controlling an LU that formats LUs must be registered. -I: Formats in the Immediate mode in units of LUs. Formatting is executed from the current controller controlling an LU. In registering unit information, the current controller controlling an LU that formats LUs must be registered. -Im: Formats up to six LUs concurrently in the Immediate mode. If this mode is specified, LUs are formatted from their respective controllers with which they are connected regardless of the current controller controlling an LU.
-lu lun ...	Specifies the LU Nos. of LUs which to format. When specifying, a single LU No. or multiple LU Nos. can be specified. Single specification: Specifies a single LU No.. Example: -lu 3 Multiple specification: Specifies multiple LU Nos.. Example: -lu 0 1 2 3 4 5 8 -lu 0-5 8
-f	The confirmation message at command execution is omitted.

- Examples of using command

Formats LU 3 in an array unit, whose name is df400a1, in Normal mode.

```
% auformat -unit df400a1 -N -lu 3
format LU 3? (y/n [n]) y
Password :
%
```

Formats, in the Immediate mode, LUs from LUNs 4 to 7 in an array unit whose name is df400a1.

In addition, confirmation of whether or not to format is not done.

```
% auformat -unit df400a1 -I -lu 4-7 -f
Password :
%
```

3.5.8 Displaying Progress of LU Formatting

- Command name

auformatst

- Synopsis

auformatst -unit unit_name -lu lun

- Description

Displays the progress of formatting LUs for which to specify formatting in the Immediate mode.

When a specified LU is under formatting, the progress (in percent) of formatting is displayed. When not under formatting in such a case as immediately after an LU has been setup or its size has been expanded, or the formatting has been completed, the following indication is displayed:

- “100%” is displayed when the LU is normal.
- “0%” is displayed when the LU is in condition other than above.

- Options

Options	Description
-unit unit_name	Specifies the name of an array unit in which LUs have been defined. Specifies with one-byte coded alphanumerics and special symbols “- (minus)” and “_(underline)” of up to 16 characters long.
-lu lun	Specifies the LU No. of an LU for which to check the progress.

- Examples of using command

After specifying to format LU 4 in an array unit, whose name is df400a1, in Immediate mode, checks the progress of formatting.

```
% auformat -unit df400a1 -lu 4 -I -f
Password :
%
% auformatst -unit df400a1 -lu 4
df400a1 LU 4 17 %
% auformatst -unit df400a1 -lu 4
df400a1 LU 4 50 %
% auformatst -unit df400a1 -lu 4
df400a1 LU 4 81 %
% auformatst -unit df400a1 -lu 4
df400a1 LU 4 94 %
% auformatst -unit df400a1 -lu 4
df400a1 LU 4 100 %
%
```

3.5.9 Expanding LU

- Command name

auluexp

- Synopsis

auluexp -unit unit_name -lu lun -incr size | lest

- Description

Expands the size of an LU. Note that an LU whose size can be expanded is the last LU in each RAID group (LU with the largest LU No. assigned within each RAID group).

- Options

Options	Description
-unit unit_name	Specifies the name of an array unit in which an LU whose size to expand has been defined. Specifies with one-byte coded alphanumerics and special symbols "-" (minus) and "_" (underline) of up to 16 characters long.
-lu lun	Specifies the LU No. of an LU for which to expand its size.
-incr size lest	Specifies the increment (in the number of blocks) by which to expand. size: Specifies the number of blocks. lest: Assigns all remaining capacity of an RAID group.

- Examples of using command

Expands the capacity of LU 3 in an array unit, whose name is df400a1, by an increment of 3072 blocks.

```
% auluexp -unit df400a1 -lu 3 -incr 3072
Password :
%
```

Assigns to LU 3 in an array unit, whose name is df400a1, all remaining capacity of an RAID group to which this LU belongs.

```
% auluexp -unit df400a1 -lu 3 -incr lest
Password :
%
```

3.5.10 Deleting LU

- Command name

auludel

- Synopsis

auludel -unit unit_name -last | -ALL [-f]

- Description

Deletes the last of already-defined LUs or all LUs.

- Options

Options	Description
-unit unit_name	Specifies the name of an array unit in which LUs have been defined. Specifies with one-byte coded alphanumerics and special symbols "-" (minus)" and "_" (underline)" of up to 16 characters long.
-last -ALL	Specifies LUs to delete. -last: Deletes the last LU. -ALL: Deletes all LUs.
-f	The confirmation message at command execution is omitted.

- Examples of using command

Deletes the last LU in an array unit whose name is df400a1.

```
% auludel -unit df400a1 -last
This function invalidate data on the deleted logical unit.
remove the last LU? (y/n [n]) y
Password :
%
```

An attempt was made to delete all LUs in an array unit whose name is df400a1, but the deletion was canceled.

```
% auludel -unit df400a1 -ALL
This function invalidate data on the deleted logical unit.
remove all LU? (y/n [n]) n
Aborts the processing.
%
```

3.5.11 Changing Default Controller of LU

- Command name

auluchg

- Synopsis

auluchg -unit unit_name -lu lun

- Description

Changes the default controller, with which an LU is connected, to another controller.

- Options

Options	Description
-unit unit_name	Specifies the name of an array unit in which LUs have been defined. Specifies with one-byte coded alphanumerics and special symbols "-" (minus)" and "_" (underline)" of up to 16 characters long.
-lu lun	Specifies the LU No. of an LU whose default controller is changed.

- Examples of using command

Changes the default controller with which LU 2 is connected in an array unit whose name is df400a1.

```
% auluchg -unit df400a1 -lu 2
Password :
Default controller for the LU settings finished normally.
You need reboot the array unit to avail settings.
%
```

Changes the default controller with which LU 2 is connected in an array unit, whose name is df400a2 and which supports restarting.

```
% auluchg -unit df400a2 -lu 2
Password :
Default controller for the LU settings finished normally.
You need reboot the array unit to avail settings.
Array unit stops accepting input and output while rebooting.
And if you already logged in, login status is canceled when the reboot starts.
Do you reboot the array unit now (y/n [n]) : y
Now reboot the array unit. Start Time HH : MM
Reboot has been completed.
%
```

3.5.12 Setting Turbo LU

- **Command name**

auturbolu

- **Synopsis**

auturbolu -unit unit_name -refer

auturbolu -unit unit_name -set
 [-ct10_assign enable | disable -ct10_lu lun]
 [-ct11_assign enable | disable -ct11_lu lun]

- **Description**

References the status of whether turbo LU is resident or not, and sets the turbo LU.

- **Options**

Options	Description
-unit unit_name	Specifies the name of an array unit for which to reference the LU cache residence state and in which to set LU cache resident. Specifies with one-byte coded alphanumerics and special symbols "-" (minus)" and "_" (underline)" of up to 16 characters long.
-refer	References the status of whether turbo LU is resident or not.
-set	Sets turbo LU.
-ct10_assign enable disable -ct11_assign enable disable	Specifies to validate or invalidate that turbo LU of Controllers 0 and 1 is resident individually.
-ct10_lu lun -ct11_lu lun	Specifies the LU No. of an LU for which turbo LU is set resident.

- Examples of using command

References the state of whether LU cache of an array unit, whose name is df400a1, is resident or not.

```
% auturbolu -unit df400a1 -refer
Password :
Controller 0
Current Configuration
  Turbo LU Assignment      : disable
  Turbo LU                 :
  Turbo LU Status         :
Reserved Configuration
  Turbo LU Assignment      : disable
  Turbo LU                 :

Controller 1
Current Configuration
  Turbo LU Assignment      : disable
  Turbo LU                 :
  Turbo LU Status         :
Reserved Configuration
  Turbo LU Assignment      : disable
  Turbo LU                 :
%
```

Sets LU cache resident for an array unit whose name is df400a1.

```
% auturbolu -unit df400a1 -set -ctl0_assign enable -ctl0_lu 3 \
-ctl1_assign disable -ctl1_lu 4
Password :
Turbo LU settings finished normally.
You need reboot the array unit to avail settings.
%
```

Sets LU cache resident for an array unit, whose name is df400a2 and which supports restarting.

```
% auturbolu -unit df400a2 -set -ctl0_assign enable -ctl0_lu 3 \
-ctl1_assign disable -ctl1_lu 4
Password :
Turbo LU settings finished normally.
You need reboot the array unit to avail settings.
Array unit stops accepting input and output while rebooting.
And if you already logged in, login status is canceled when the reboot starts.
Do you reboot the array unit now (y/n [n]) : y
Now reboot the array unit. Start Time HH:MM
Reboot has been completed.
%
```

3.6 Setting Up Configuration

3.6.1 Referencing/Setting Fibre Channel Information

- Command name

aufibre

- Synopsis

```
aufibre -unit unit_name -refer
```

```
aufibre -unit unit_name -set -ctl0 | -ctl1 -port A | B
[ -FC-AL | -Fabric ]
[ -portinfo n_port_id ] [ -access-guard on | off ]
[ -permission node_name port_name [ -permission-lu lun ... ] ]
```

```
aufibre -unit unit_name -set -ctl0 | -ctl1 -port A | B
[ -FC-AL | -Fabric ]
[ -portinfo n_port_id ] [ -access-guard on | off ]
[ -file filename ]
```

```
aufibre -unit unit_name -rm -ctl0 | -ctl1 -port A | B
-permission node_name port_name [ -permission-lu lun ... ]
```

- Description

References and sets fibre channel information.

- Options

Options	Description
-unit unit_name	Specifies the name of an array unit for which to reference, set, and delete fibre channel information. Specifies with one-byte coded alphanumerics and special symbols "-" (minus) and "_" (underscore) of up to 16 characters long.
-refer	Displays all already-set fibre channel information.
-set	Sets fibre channel information.
-rm	Deletes port security information and LUN security information.
-ctl0 -ctl1	Specifies a controller for which to set and delete fibre channel information.
-port A B	Specifies a port for which to set and delete fibre channel information.
-FC-AL -Fabric	Sets the topology of a specified port in a specified controller. -FC-AL: Sets the topology to FC_AL. -Fabric: Sets the topology to Fabric.

(Continued)

Options	Description
<code>-portinfo n_port_id</code>	Specifies the N_port ID of a specified port in a specified controller. Specifies <code>n_port_id</code> with six hexadecimal characters.
<code>-access-guard on off</code>	Specifies whether to validate or invalidate port security of a specified port in a specified controller. on: Validates port security (a port specified by <code>-port</code> option accepts security from only a host specified by <code>-permission</code> option). off: Invalidates port security (does not limit the host that accesses a port specified by <code>-port</code> option).
<code>-permission node_name port_name</code>	[<code>-set</code> option specified] When using port security, specifies access permission host information (node name, port name). node_name: Node name of a host (character string of 16 hexadecimal characters) port_name: Port name of a host (character string of 16 hexadecimal characters)
<code>-permission-lu lun ...</code>	[<code>-set</code> option specified] When using LUN security, specifies access permission LUNs (multiple LUNs can be specified). When specifying <code>-permission-lu</code> option, host information must be specified by <code>-permission</code> option. If host information specified by <code>-permission</code> is not yet set, access permission host information and LUN security information are set together at the same time. If host information specified by <code>-permission</code> option is already set, LUN security information is set additionally.
<code>-file filename</code>	When setting host security all together by file input, specifies the host permission information file.
<code>-permission node_name port_name</code>	[<code>-rm</code> option specified] Specifies host information (node name, port name) which to exclude from host security. node_name: Node name of a host (character string of 16 hexadecimal characters) port_name: Port name of a host (character string of 16 hexadecimal characters)
<code>-permission-lu lun ...</code>	[<code>-rm</code> option specified] When using LUN security, specifies LUNs (multiple LUNs can be specified) which to exclude from access permission LUs. When specifying <code>-permission-lu</code> option, host information must be specified by <code>-permission</code> option.

- Examples of using command

References the fibre channel information of an array unit whose name is df400a1.

```
% aufibre -unit df400a1 -refer
Password :
LUN security
  CTL 0  on
  CTL 1  on
```

Topology Information

CTL	Port	Topology
0	A	FC-AL
0	B	FC-AL
1	A	FC-AL
1	B	FC-AL

Port Information

CTL	Port	Node name	Port name	N port_ID
0	A	50000E100000232F	50000E100000232F	0000EF
0	B	0000000000000000	0000000000000000	0000EF
1	A	0000000000000000	0000000000000000	0000EF
1	B	0000000000000000	0000000000000000	777777

SFC Firmware Revision

CTL	Port	BIU	Sequence Manager	Operational Firmware	PowOnSelf TestFirm	ENDEC+	FC-PH
0	A	00000004	10020193	02125805	01102000	3001506D	09/09
0	B	00000000	00000000	00000000	00000000	00000000	00/00
1	A	00000000	00000000	00000000	00000000	00000000	00/00
1	B	00000000	00000000	00000000	00000000	00000000	00/00

Security Information

CTL	Port	Access Guard	Node name	Port name	N port_ID
0	A	disable	AAAAAAAAAAAA0A00 25 30 50 60 63	0AAAAAAAAAAAAA00	000000
0	B	disable	0B01000000000000	0B00000000000001	0B0100
1	A	disable	AAAAAAAAAAAA1A00 6 12 34 43	1AAAAAAAAAAAAA00	000000
1	B	disable	BBBBBBBBBBBB1B00 15 23 31 34 55	1BBBBBBBBBBBB00	000000

%

Sets to Fabric the topology of Port A on controller 0 of an array unit whose name is df400a1.

```
% aufibre -unit df400a1 -set -ctl0 -port A -Fabric
Password :
Fibre channel information settings finished normally.
You need reboot the array unit to avail settings.
%
```

Sets to Fabric the topology of Port A on controller 0 of an array unit, whose name is df400a2 and which supports restarting.

```
% aufibre -unit df400a2 -set -ctl0 -port A -Fabric
Password :
Fibre channel information settings finished normally.
You need reboot the array unit to avail settings.
Array unit stops accepting input and output while rebooting.
And if you already logged in, login status is canceled when the reboot starts.
Do you reboot the array unit now (y/n [n]) : y
Now reboot the array unit. Start Time HH : MM
Reboot has been completed.
%
```

The following figure shows a file format for the case where settings are performed by using “File”. Input necessary items for each port. Put a space between items. If tabs are used, the setting of the line including “tab” are ignored because it is regarded as an input error.

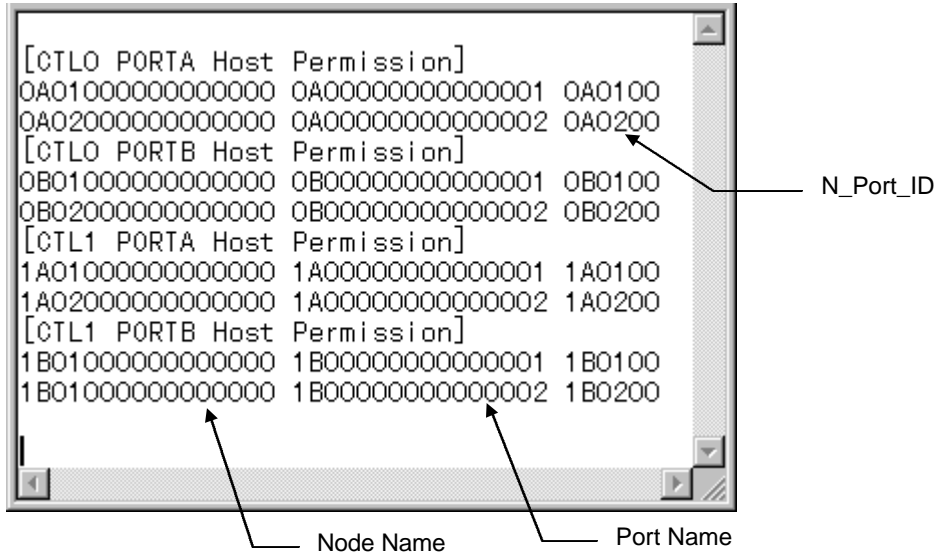

- **Node Name:** Describes 8 bytes of data hexadecimal (with 16 characters).
- **Port Name:** Describes 8 bytes of data hexadecimal (with 16 characters).
- **N_Port_ID:** Describes 3 bytes of data hexadecimal (with 6 characters). Concerning the host identification information, this data can be omitted. When the data is omitted, it is assumed to be 0X000000.

When “;” is described at the top, the line is regarded as a comment line.

- Command name

aufibre1

- Synopsis

– In the case of DF450, DF400, and DF500

```
aufibre1 -unit unit_name -refer
```

– In the case of DF400

```
aufibre1 -unit unit_name -set  
[ -topo ctl_no topology1 ]  
[ -portaddr ctl_no port_no port_address ]  
[ -accguard ctl_no port_no on | off ]  
[ -perm ctl_no port_no node_name port_name ]  
[ -permlu ctl_no port_no node_name port_name lun... ]  
[ -permluall ctl_no port_no node_name port_name ]  
[ -file ctl_no port_no filename ]
```

– In the case of DF500

```
aufibre1 -unit unit_name -set  
[ -topo ctl_no topology2 ]  
[ -portaddr ctl_no port_no port_address ]  
[ -lus ctl_no port_no on | off ]  
[ -perm ctl_no port_no node_name port_name ]  
[ -permlu ctl_no port_no node_name port_name lun... ]  
[ -permluall ctl_no port_no node_name port_name ]  
[ -file ctl_no port_no filename ]
```

– In the case of DF400, DF500

```
aufibre1 -unit unit_name -rm  
[ -perm ctl_no port_no node_name port_name ]  
[ -permlu ctl_no port_no node_name port_name lun... ]  
[ -permluall ctl_no port_no node_name port_name ]
```

- Description

References and sets fibre channel information.

■ Option

Options	Description
-unit unit_name	Specifies the name of an array unit for which to reference, set, and delete fibre channel information. Specifies with one-byte coded alphanumerics and special symbols "-" (minus) and "_" (underline) of up to 16 characters long.
-refer	Displays all already-set fibre channel information.
-set	Sets fibre channel information.
-rm	Deletes port security information and LUN security information.
-topo ctl_no topology1	Specifies the topology of the specified controller. ctl_no : Controller number (0 or 1) topology1 : Type of topology FC-AL : FC-AL Fabric : Fabric Point-to-Point
-topo ctl_no port_no topology2	Specifies the topology of the specified port. ctl_no : Controller number (0 or 1) port_no : Port name (A or B) topology2 : Type of topology loop : loop ptop : Point-to-Point
-portaddr ctl_no port_no port-address	Specifies the port address of the specified port. ctl_no : Controller number (0 or 1) port_no : Port name (A or B) port-address : Port address (6 hexadecimal characters)
-accguard ctl_no port_no on off	Specifies whether the port security of the specified port is enabled or disabled. ctl_no : Controller number (0 or 1) port_no : Port name (A or B) on : Enables the port security. off : Disables the port security.
-lus ctl_no port_no on off	Specifies whether the LUN security of the specified port is enabled or disabled. ctl_no : Controller number (0 or 1) port_no : Port name (A or B) on : Enables the LUN security. off : Disables the LUN security.

(Continued)

Options	Description
<code>-perm</code> <code>ctl_no port_no</code> <code>node_name</code> <code>port_name</code>	[-set option specification] Specifies host information (node name and port name) that can be accessed by the specified port. [-rm option specification] Specifies the host information to be deleted from the host information (node name and port name) that can be accessed by the specified port. ctl_no : Controller number (0 or 1) port_no : Port name (A or B) node_name : Node name of the host (16 hexadecimal characters) port_name : Port name of the host (16 hexadecimal characters)
<code>-permlu</code> <code>ctl_no port_no</code> <code>node_name</code> <code>port_name lun..</code>	[-set option specification] When using the LUN security function at a specified port, specifies LUs, to which the host is permitted to access, into host information registered with the -perm option (multiple LUs can be specified). Host information and LUN security are not allowed to be registered at the same time. [-rm option specification] Specifies the LUNs whose access permission is to be deleted from the LUN security set by the specified port. (Multiple LUs can be specified.) ctl_no : Controller number (0 or 1) port_no : Port name (A or B) node_name : Node name of the host (16 hexadecimal characters) port_name : Port name of the host (16 hexadecimal characters) lun.. : LU number
<code>-permluall</code> <code>ctl_no port_no</code> <code>node_name</code> <code>port_name</code>	[-set option specification] When using the LUN security function at a specified port, specifies host information that is already registered with the -perm option, which specifies permission to access to all LUs. Host information and LUN security are not allowed to be registered at the same time. [-rm option specification] Specifies the host information whose access permission is to be deleted from the LUN security set by the specified port. ctl_no : Controller number (0 or 1) port_no : Port name (A or B) node_name : Node name of the host (16 hexadecimal characters) port_name : Port name of the host (16 hexadecimal characters)
<code>-file</code> <code>ctl_no port_no</code> <code>filename</code>	When setting host security all together by file input, specifies the host permission information file. ctl_no : Controller No. (0 or 1) port_no : Port name (A or B) filename : File name which to input

- Examples of using command

Reference the fiber channel information of the array unit name df400a1. Same as aufibre.

Reference the fiber channel information of array unit name df500a1. Same as aufibre.

Set the topology of Port A of controller 0 of the array unit name df400a1 to Fabric.

```
% aufibre1 -unit df400a1 -set -topo 0 Fabric
Password :
Fibre channel information settings finished normally.
You need reboot the array unit to avail settings.
%
```

Set the topology of Port A of controller 0 of array unit name df400a2 supporting re-activation: to Fabric.

```
% aufibre1 -unit df400a2 -set -topo 0 Fabric
Password :
Fibre channel information settings finished normally.
You need reboot the array unit to avail settings.
Array unit stops accepting input and output while rebooting.
And if you already logged in, login status is canceled when the reboot starts.
Do you reboot the array unit now (y/n [n]) : y
Now reboot the array unit. Start Time HH : MM
Reboot has been completed.
%
```

Set the topology of Port A of controller 0 of array unit name df500a1 to loop.

```
% aufibre1 -unit df500a1 -set -topo 0 A loop
Password :
Fibre channel information settings finished normally.
You need reboot the array unit to avail settings.
%
```

The following figure shows a file format for the case where settings are performed by using “File”. Input necessary items for each port. Put a space between items. If tabs are used, the setting of the line including “tab” are ignored because it is regarded as an input error.

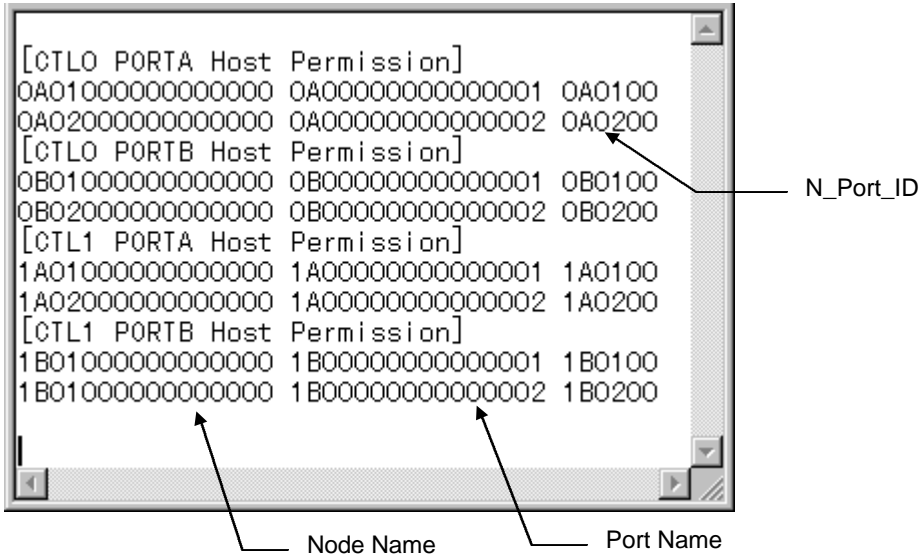

- **Node Name:** Describes 8 bytes of data hexadecimal (with 16 characters).
- **Port Name:** Describes 8 bytes of data hexadecimal (with 16 characters).
- **N_Port_ID:** Describes 3 bytes of data hexadecimal (with 6 characters). Concerning the host identification information, this data can be omitted. When the data is omitted, it is assumed to be 0X000000.

When “;” is described at the top, the line is regarded as a comment line.

3.6.2 Spare HDU Setup

- **Command name**

auspare

- **Synopsis**

```
auspare -unit unit_name -set -uno unit_no -hno hdu_no
auspare -unit unit_name -rm -uno unit_no -hno hdu_no
```

- **Description**

The specified HDU is setup as a spare HDU. The spare HDU attribute of the specified spare HDU is canceled.

Not installed HDU cannot be set as spare HDU.

- **Options**

Options	Description
-unit unit_name	Specifies the name of the array unit to set or cancel the spare HDU. Specifies with one-byte coded alphanumeric and special symbols "-" (minus)" and "_" (underline)" of up to 16 characters long.
-set	Sets up the spare HDU.
-rm	Cancels the spare HDU.
-uno unit_no	Specifies the Unit number of the spare HDU.
-hno hdu_no	Specifies the HDU number of the spare HDU.

- **Examples of using command**

Setup the spare HDU of array unit name df500a1. The position of the spare HDU is the HDU position with Unit number of 0 and HDU number of 9.

```
% auspare -unit df500a1 -set -uno 0 -hno 9
Password :
%
```

Checks, with an audrive command, settings of the spare HDU in an array unit whose name is df500a1. "Spare" is displayed in the "Type" field for HDUs that are set to "Spare".

```
% audrive -unit df500a1 -status -uno 0 -hno 9
Unit No.  HDU No.  Type    Status    Physics
          0         9  Spare  Standby   Mount
%
```

3.6.3 Fee-Basis Option Reference/Setup

- Command name

auopt

- Synopsis

auopt -unit unit_name -refer

- Case of used key-FD

auopt -unit unit_name -lock off | on [-keyfd fd-path]

- Case of used key-code

auopt -unit unit_name -lock off | on [-keycode key-code]

auopt -unit unit_name -option option_name -st enable | disable

- Description

Locks or unlocks the specified fee-basis option. Unlocks or locks can be carried out by the key FD or the key code described in key FD appended in the option.

Enables or disables the fee-basis option after unlocking.

- Options

Options	Description
-unit unit_name	Specifies the name of the array unit to setup or reference the fee-basis option. Specifies with one-byte coded alphanumerics and special symbols "-" (minus) and "_" (underline) of up to 16 characters long.
-refer	The unlocked fee-basis option is displayed.
-lock off on	Specifies locking or unlocking of the fee-basis option. off: Unlocks the fee-basis option. on: Locks the fee-basis option.
-keyfd fd-path	Specifies the directory storing the key FD when it is used to unlock or lock the fee-basis option. fd-path: Directory in which the key FD exists
-keycode key-code	Specifies the key code when used to unlock or lock the fee-basis option. key-code: Key code
-option option-name	Specifies the option name when enabling or disabling the unlocked fee-basis option. option-name: Option name For the option name, refer to the manual for each individual fee-basis option.

(Continued)

Options	Description
-st enable disable	Specifies whether the fee-basis option is enabled or disabled. enable: Enables the fee-basis option. disable: Disables the fee-basis option.

- Examples of using command

Display the unlocked fee-basis option of array unit name df500a1.

```
% auopt -unit df500a1 -refer
Password :
Option name      Status
SNMP             enable
%
```

Unlocks the SNMP fee-basis option that requires to restart an array unit name df500a1, using the key FD.

```
% auopt -unit df500a1 -lock off -keyfile a :
Password :
Option was opened.
You need reboot the array unit to avail setting.
Array unit stops accepting input and output while rebooting.
And if you already logged in, login status is canceled when the reboot starts.
Do you reboot the array unit now (y/n [n]) : y
Now reboot the array unit. Start Time HH : MM
Reboot has been completed.
%
```

Enables the SNMP fee-basis option that requires to restart an array unit name df500a1.

```
% auopt -unit df500a1 -option SNMP -st enable
Password :
Option setting ended normally.
You need reboot the array unit to avail setting.
Array unit stops accepting input and output while rebooting.
And if you already logged in, login status is canceled when the reboot starts.
Do you reboot the array unit now (y/n [n]) : y
Now reboot the array unit. Start Time HH : MM
Reboot has been completed.
%
```

Unlocks the LUN security fee-basis option that does not require to restart an array unit name df500a1, using the key FD.

```
% auopt -unit df500a1 -lock off -keyfile a :
Password :
Option was opened.
You need reboot the array unit to avail setting.
%
```

3.6.4 Referencing/Setting Drive Restoration Control Information

- Command name

audrecopt

- Synopsis

```
audrecopt -unit unit_name -refer
audrecopt -unit unit_name -set
          [ -restor back | normal | priority ] [ -auto enable | disable ]
          [ -sparing rwv | rw | not ] [ -interval interval_time ]
          [ -size n ]
```

- Description

References and sets drive restoration control information.

- Options

Options	Description
-unit unit_name	Specifies the name of an array unit for which to reference and set drive restoration control information. Specifies with one-byte coded alphanumerics and special symbols "-" (minus) and "_" (underline) of up to 16 characters long.
-refer	References drive restoration control information.
-set	Sets drive restoration control information.
-restor back normal priority	Specifies the drive restoration mode. back: Execute the restoration processing in the intervals of the host command processing. normal: Gives priority to the processing of commands from the host, and executes the restoration processing at a certain interval after a host command terminates. priority: Executes the restoration processing at a certain interval with higher priority than that of the processing of commands from the host.
-auto enable disable	Specifies whether or not to automatically start copying back.
-sparing rwv rw not	Specifies the operating mode of dynamic sparing. rwv: When the count of either Read/Write errors or On-line Verify errors exceeds a predetermined threshold value, starts dynamic sparing. rw: When the count of Read/Write errors exceeds a predetermined threshold value, starts dynamic sparing. not: Although the count of either Read/Write errors or On-line Verify errors exceeds a predetermined threshold value, does not start dynamic sparing.

(Continued)

Options	Description
-interval interval_time	Specifies the interval at which to execute the restoration processing. Specifies it with a value from 0 to 255 in units of 10 ms. The default value is 10, and hence executes the restoration processing at an interval of 100 ms.
-size n	Specifies the unit of restored data per single operation in the restoration processing. Specifies a value of a multiple of 32 between 32 and 65,504 in units of 512 bytes. The default value is 32, and hence restores 16 k byte data in a single operation.

- Examples of using command

Displays the drive restoration control information of an array unit whose name is df400a1.

```
% audrecopt -unit df400a1 -refer
Password :
Drive restoration mode      : Background
Drive restoration          : Automatically
Dynamic spare mode         : Executing (Read, Write, Online Verify)
Interval time [10msec]     : 10
Restore data size [blocks] : 32
%
```

Sets drive restoration control information for an array unit whose name is df400a1.

```
% audrecopt -unit df400a1 -set -restor normal -auto enable -interval 10
-size 64 -sparing rw
Password :
%
% audrecopt -unit df400a1 -refer
Password :
Drive restoration mode      : Interleave (standard)
Drive restoration          : Automatically
Dynamic spare mode         : Execution (Read/Write & Online Verify)
Interval time [10msec]     : 10
Restore data size [blocks] : 64
%
```

3.6.5 Referencing/Setting Online Verify Information

- Command name

auonlineverify

- Synopsis

auonlineverify -unit unit_name -refer

auonlineverify -unit unit_name -set
 [-verify enable | disable] [-time time]

- Description

References and sets on-line verify information.

- Options

Options	Description
-unit unit_name	Specifies the name of an array unit for which to reference and set on-line verify information. Specifies with one-byte coded alphanumerics and special symbols "-" (minus) and "_" (underline) of up to 16 characters long.
-refer	References on-line verify information.
-set	Sets on-line verify information.
-verify enable disable	Specifies whether or not to perform an on-line verify test.
-time time	Specifies the idling time (0 to 30 seconds). If "0" is specified, the idling time is set to 10 seconds.

- Examples of using command

References the on-line verify information of an array unit whose name is df400a1.

```
% auonlineverify -unit df400a1 -refer
Password :
Online verify test : Yes
Idling time [sec] : 0
%
```

Sets on-line verify information for an array unit whose name is df400a1, then references it.

```
% auonlineverify -unit df400a1 -set -verify enable -time 5
Password :
%
% auonlineverify -unit df400a1 -refer
Password :
Online verify test : Yes
Idling time [sec] : 5
%
```

3.7 System Parameters

3.7.1 Referencing/Setting System Parameters

- Command name

ausysparam

- Synopsis

– In the case of DF350, DF400, and DF500

```
ausysparam -unit unit_name -refer
```

– In the case of DF400 (SCSI version)

```
ausysparam -unit unit_name -set  
[ -SystemStartup single | DualIDTake | DualNotIDTake |  
HotIDTake | HotNotIDTake ]  
[ -TakingID Port_no ctl_no ]  
[ -DataShare used | notUsed ]  
[ -SpareDisk one | two | not ]  
[ -HostConnection standard | OpenVMS | TRESPASS | WolfPack |  
IBM7135 | NCR ]  
[ -SerialNumber string ]  
[ -DriveCapacity row_no disk_size ]  
[ -VxVM enable | disable ]  
[ -CLAM enable | disable ]  
[ -Solaris enable | disable ]  
[ -DriveDetach enable | disable ]  
[ -MP5400 enable | disable ]  
[ -OdeMapper enable | disable ]  
[ -MultipathController enable | disable ]  
[ -ReportInquiry enable | disable ]  
[ -PROCOCOM enable | disable ]  
[ -ReportStatus enable | disable ]  
[ -MultipathArrayUnit enable | disable ]  
[ -LuCacheWarning enable | disable ]  
[ -UASuppress enable | disable ]  
[ -DataStriping 16 | 32 | 64 ]  
[ -Buzzer on | off ]
```

```

[ -LuSizeReport auto | not ]
[ -ScsiResetLip on | off ]
[ -ProcessorFailures reset | shutdown ]
[ -inquiryCommandQueue on | off ]
[ -inquiryAnsiVersion 2 | 3 ]
[ -inquiryVendor string ]
[ -inquiryProduct string ]
[ -inquiryRomMicro string ]
[ -inquiryRamMicro string ]
[ -CacheMode off | random | sequential | randseq ]
[ -PortType normal | multiple ]
[ -PortTypeResetLip ctl_no port_no on | off ]
[ -PseudoResponse ctl_no busy | notReady ]
[ -SaveDataPointer ctl_no port_no
    nothing | data | cmd | datacmd ]
[ -ControllerIdentifer ctl_no enable | disable ]
[ -ControllerID ctl_no string1 ]
[ -Rs232cOutflow ctl_no off | normal | hitrac ]
[ -WriteVerifyExecution ctl_no on | off ]
[ -ConnectLAN ctl_no on | off ]
[ -dhcp ctl_no enable | disable ]
[ -IPAddress ctl_no inet_addr ]
[ -SubnetMask ctl_no netmask ]
[ -DefaultGateway ctl_no gateway ]
[ -setSM ctl_no port_no tid ]
[ -mSM ctl_no port_no tid ]
[ -setMS ctl_no port_no tid lu ]
[ -mMS ctl_no port_no tid lu ]
[ -setMM ctl_no port_no tid hlu lu ]
[ -mMM ctl_no port_no tid hlu lu ]
[ -sync ctl_no port_no atandard | async | N5 | N10 | N13 | N20 |
    N33 | N40 | W10 | W20 | W26 | W40 | W66 | W80 ]
[ -fd on | off ]

```

– In the case of DF400 (Fibre version)

```

ausysparam -unit unit_name -set
[ -SystemStartup single | Dual | DualIDTake | DualNotIDTake |
    HotIDTake | HotNotIDTake ]
[ -TakingID Port_no ctl_no ]
[ -DataShare used | notUsed ]
[ -SpareDisk one | two | not ]
[ -HostConnection standard | OpenVMS | TRESPASS | WolfPack ]
[ -SerialNumber string ]
[ -DriveCapacity row_num disk_size ]
[ -VxVM enable | disable ]
[ -CLAM enable | disable ]
[ -Solaris enable | disable ]
[ -DriveDetach enable | disable ]
[ -HPUX enable | disable ]
[ -MultipathController enable | disable ]
[ -ReportInquiry enable | disable ]
[ -PROCOM enable | disable ]
[ -ReportStatus enable | disable ]

[ -MultipathArrayUnit enable | disable ]
[ -LuCacheWarning enable | disable ]
[ -UASuppress enable | disable ]
[ -SGI enable | disable ]
[ -PortIdTaking enable | disable ]
[ -DataStriping 16 | 32 | 64 ]
[ -Buzzer on | off ]
[ -ScsiResetLip on | off ]
[ -ProcessorFailures reset | shutdown ]
[ -inquiryCommandQueue on | off ]
[ -inquiryVendor string ]
[ -inquiryProduct string ]
[ -inquiryRomMicro string ]
[ -inquiryRamMicro string ]
[ -CacheMode off | random | sequential | randseq ]
[ -PortType normal | multiple ]
[ -PortTypeResetLip ctl_no port_no on | off ]
[ -PortTypeOption ctl_no port_no SGI | HP enable | disable ]
[ -ControllerIdentifer ctl_no enable | disable ]
[ -ControllerID ctl_no string1 ]
[ -Rs232cOutflow ctl_no off | normal | hitrac ]
[ -WriteVerifyExecution ctl_no on | off ]
[ -ConnectLAN ctl_no on | off ]
[ -dhcp ctl_no enable | disable ]
[ -IPAddress ctl_no inet_addr ]
[ -SubnetMask ctl_no netmask ]
[ -DefaultGateway ctl_no gateway ]
[ -setMM ctl_no port_no hlu lu ]
[ -mMM ctl_no port_no hlu lu ]
[ -fd on | off ]

```

– In the case of DF500 (SCSI version)

```

ausysparam -unit unit_name -set
[ -SystemStartup Single | DualIDTake | DualNotIDTake |
    HotIDTake | HotNotIDTake ]
[ -TakingID port_no ctl_no ]
[ -DataShare used | notUsed ]
[ -HostConnection ctl_no port_no
    standard | OpenVMS | TRESPASS | WolfPack |
    IBM7135 | NCR ]
[ -SerialNumber string ]
[ -VxVM ctl_no port_no enable | disable ]
[ -DriveDetach enable | disable ]
[ -OdeMapper ctl_no port_no enable | disable ]
[ -ReportInquiry ctl_no port_no enable | disable ]
[ -MultipathController enable | disable ]
[ -PROCOM enable | disable ]
[ -ReportStatus enable | disable ]
[ -MultipathArrayUnit enable | disable ]
[ -LuCacheWarning enable | disable ]
[ -UASuppress ctl_no port_no enable | disable ]
[ -HISUP ctl_no port_no enable | disable ]
[ -CCHS ctl_no port_no enable | disable ]
[ -DataStriping 16 | 32 | 64 ]
[ -LuSizeReport auto | not ]
[ -ProcessorFailures reset | shutdown ]
[ -inquiryCommandQueue on | off ]
[ -inquiryAnsiVersion 2 | 3 ]
[ -inquiryVendor string ]
[ -inquiryProduct string ]
[ -inquiryRomMicro string ]
[ -inquiryRamMicro string ]
[ -WebTitle string ]
[ -CacheMode off | random ]
[ -PortTypeOption ctl_no port_no
    ResetLipSignal | ResetLipProcess |
    TargetReset | Reserve enable | disable ]
[ -PseudoResponse ctl_no busy | notReady ]
[ -SaveDataPointer ctl_no port_no
    nothing | data | cmd | datacmd ]
[ -ControllerIdentifier ctl_no enable | disable ]
[ -ControllerID ctl_no string ]
[ -Rs232cOutflow ctl_no off | normal | hitrack ]
[ -WriteVerifyExecution ctl_no on | off ]
[ -dhcp ctl_no enable | disable ]
[ -IPAddress ctl_no inet_addr ]
[ -SubnetMask ctl_no netmask ]
[ -DefaultGateway ctl_no gateway ]
[ -setSM ctl_no port_no tid ]
[ -mSM ctl_no port_no tid ]
[ -setMS ctl_no port_no tid lu ]
[ -mMS ctl_no port_no tid lu ]
[ -setMM ctl_no port_no tid hlu lu ]
[ -mMM ctl_no port_no tid hlu lu ]
[ -sync ctl_no port_no standard | async |
    N5 | N10 | N20 | N40 | W10 | W20 | W40 | W80 ]
[ -fd on | off ]

```

– In the case of DF500 (Fibre version)

```

ausysparam -unit unit_name -set
[ -SystemStartup Single | DualIDTake | DualNotIDTake |
    HotIDTake | HotNotIDTake ]
[ -TakingID Port_no ctl_no ]
[ -DataShare used | notUsed ]
[ -HostConnection ctl_no port_no
    standard | OpenVMS | TRESPASS | WolfPack ]
[ -SerialNumber string ]
[ -VxVM ctl_no port_no enable | disable ]
[ -DriveDetach enable | disable ]
[ -HPUX ctl_no port_no enable | disable ]
[ -ReportInquiry ctl_no port_no enable | disable ]
[ -MultipathController enable | disable ]
[ -PROCUM enable | disable ]
[ -ReportStatus enable | disable ]
[ -MultipathArrayUnit enable | disable ]
[ -LuCacheWarning enable | disable ]
[ -UASuppress ctl_no port_no enable | disable ]
[ -HISUP ctl_no port_no enable | disable ]
[ -CCHS ctl_no port_no enable | disable ]
[ -LinkSeparation enable | disable ]
[ -DataStriping 16 | 32 | 64 ]
[ -ProcessorFailures reset | shutdown ]
[ -inquiryCommandQueue on | off ]
[ -inquiryVendor string ]
[ -inquiryProduct string ]
[ -inquiryRomMicro string ]
[ -inquiryRamMicro string ]
[ -WebTitle string ]
[ -CacheMode off | random ]
[ -PortTypeOption ctl_no port_no
    ResetLipSignal | ResetLipProcess |
    LipPortAllReset | TargetReset |
    Reserve | LUReset | TPRLO
    enable | disable ]
[ -ControllerIdentifier ctl_no enable | disable ]
[ -ControllerID ctl_no string1 ]
[ -Rs232cOutflow ctl_no off | normal | hitrac ]
[ -WriteVerifyExecution ctl_no on | off ]
[ -dhcp ctl_no enable | disable ]
[ -IPAddress ctl_no inet_addr ]
[ -SubnetMask ctl_no netmask ]
[ -DefaultGateway ctl_no gateway ]
[ -setMM ctl_no port_no hlu lu ]
[ -mMM ctl_no port_no hlu lu ]
[ -fd on | off ]

```

- Description

References the contents of system parameters or set the parameters.

- Options

Options	Description
-unit unit_name	Specifies the name of an array unit for which to reference and set system parameters. Specifies with one-byte coded alphanumerics and special symbols "-" (minus) and "_" (underline) of up to 16 characters long.
-refer	References system parameters.
-set	Sets system parameters.
-SystemStartup Single DualIDTake DualNotIDTake HotIDTake HotNotIDTake	Specifies the configuration of an array unit. Single: Single DualIDTake: Dual active (with the taking over of SCSI ID) DualNotIDTake: Dual active (without the taking over of SCSI ID) HotIDTake: Hot standby (with the taking over of SCSI ID) HotNotIDTake: Hot standby (without the taking over of SCSI ID)
-TakingID port_no ctl_no	Specifies the default controller of each port when specifying a dual active configuration in which the taking over of SCSI IDs is used. port_no: Port number (A, B, C, D) ctl_no: Controller number (0, 1)
-DataShare used notUsed	Specifies the data share mode. used: Uses the data share mode. notUsed: Does not use the data share mode.
-SerialNumber string	Specifies the lower four digits of the manufacturing serial number of an array unit with numeric characters. The number is reflected on the fiber version of WWN, so do not set any value except for the lower four digits of the manufacturing serial number. Factory set is the lower four digits of the manufacturing serial number of an array unit.
-DriveDetach enable disable	Specifies whether to set the drive blockade mode effective or ineffective. enable: Enables the drive blockade mode. disable: Disables the drive blockade mode.
-MultipathController enable disable	Specifies whether or not to perform sequential judgment for each controller. enable: Sequential decision at the controller unit. disable: Sequential decision at the port unit.
-PROCOM enable disable	Specifies whether to set the PROCOM mode effective or ineffective. enable: Enables the PROCOM mode. disable: Disables the PROCOM mode.
-ReportStatus enable disable	Specifies whether to set the warning status reporting mode effective or ineffective. enable: Enables the warning status report. disable: Disables the warning status report.

(Continued)

Options	Description
<code>-MultipathArrayUnit</code> enable disable	Specifies whether or not to perform sequential judgment for each array unit. enable: Sequential decision at array unit. disable: Sequential decision at port unit.
<code>-LuCacheWarning</code> enable disable	Specifies whether or not to report a warning when the turbo LU function is set effective. enable: Reports the warning. disable: Dose not report the warning.
<code>-DataStriping</code> 16 32 64	Specifies the data striping size. 16 : To treat as 16 k byte. 32 : To treat as 32 k byte. 64 : To treat as 64 k byte.
<code>-ProcessorFailures</code> reset shutdown	Specifies action when a processor failure occurs. reset: Resets the failure and restarts the controller. shutdown: Shuts down the array unit.
<code>-inquiryAnsiVersion</code> 2 3	Sets the ANSI version of standard INQUIRY data. 2: SCSI2 3: SCSI3
<code>-inquiryCommandQueue</code> on off	Specifies execution of command queuing of INQUIRY response information. on: Executes command queuing. off: Suppresses command queuing.
<code>-inquiryVendor</code> string	Specifies the vendor name of Inquiry response information with up to eight characters.
<code>-inquiryProduct</code> string	Specifies the product type of Inquiry response information with up to sixteen characters.
<code>-inquiryRomMicro</code> string	Specifies the ROM microprogram version of Inquiry response information with up to two characters.
<code>-inquiryRamMicro</code> string	Specifies the RAM microprogram version of Inquiry response information with up to two characters.
<code>-CacheMode</code> off random sequential randseq	Specifies the method of allocating cache memory. off: Uses cache memory by the common allocation method. random: Uses it by allocating to the buffer for random read only. sequential: Uses it by allocating to the buffer for sequential read only. randseq: Uses it by allocating to the buffers for both random read and sequential read only.
<code>-ControllerIdentifer</code> ctl_no enable disable	Specifies whether the controller identifier is valid or invalid. ctl: 0, 1 enable/disable: Valid/Invalid

(Continued)

Options	Description
-ControllerID ctl string1	Specifies the controller ID. ctl: 0, 1 string1: Controller ID (up to eight characters)
-LuSizeReport auto not	Specifies the LU size to be reported to the host. Valid for the SCSI version only. auto: The LU size is automatically determined by the array unit. not: The LU size is set to an identical value.
-PseudoResponse ctl_no busy notReady	Sets the response mode for duration from power on until the controller gets ready (in the case of SCSI version). ctl_no: Controller number (0, 1) busy: Responds with Busy. notReady: Respond with Not Ready.
-SaveDataPointer ctl port nothing data cmd datacmd	Specifies the request for the controller to report a Save Data Pointer to the host. ctl_no: Controller number (0, 1) port_no: Port number (A, B, C, D) nothing: Does not report. data: Reports after transferring data. cmd: Reports after receiving a command. datacmd: Reports after transferring data and after receiving a command.
-sync ctl_no port_no standard async N5 N10 N13 N20 N33 N40 W10 W20 W26 W40 W66 W80	Specifies the SCSI transfer rate of a port. When connecting the DF500, do not specify N13 , W26 , N33 , and W66 , because they are all not supported. standard: Sets to a value so as to match the transfer rate of an interface board mounted. async: Transfers in the mode in which synchronous transfer is not used. N5: Sets the maximum transfer rate to Narrow 5 [MB/s]. N10: Sets the maximum transfer rate to Narrow 10 [MB/s]. N13: Sets the maximum transfer rate to Narrow 13 [MB/s]. N20: Sets the maximum transfer rate to Narrow 20 [MB/s]. N33: Sets the maximum transfer rate to Narrow 33 [MB/s]. N40: Sets the maximum transfer rate to Narrow 40 [MB/s]. W10: Sets the maximum transfer rate to Wide 10 [MB/s]. W20: Sets the maximum transfer rate to Wide 20 [MB/s]. W26: Sets the maximum transfer rate to Wide 26 [MB/s]. W40: Sets the maximum transfer rate to Wide 40 [MB/s]. W66: Sets the maximum transfer rate to Wide 66 [MB/s]. W80: Sets the maximum transfer rate to Wide 80 [MB/s].

(Continued)

Options	Description
<code>-WriteVerifyExecution</code> <code>ctl_no</code> <code>on off</code>	Specifies execution of a write & verify operation ctl_no : Controller No. (0, 1) on : Executes a write & verify operation. off : Does not execute a write & verify operation.
<code>-Rs232cOutflow</code> <code>ctl_no</code> <code>off normal hitrac</code>	Sets the mode of sending out error information onto RS232C. ctl_no : Controller No. (0, 1) off : Does not send out information. normal : Sends out information. hitrac : Sends out information in the HITRAC mode.
<code>-dhcp</code> <code>ctl_no</code> <code>enable disable</code>	Specifies whether the DHCP mode is enable or disable. ctl_no : Controller number (0, 1) enable : Enables the DHCP mode disable : Disables the DHCP mode.
<code>-IPAddress</code> <code>ctl_no inet_addr</code>	Specifies the IP address. ctl_no : Controller number (0, 1) inet_addr : IP address (format xxx.xxx.xxx.xxx)
<code>-SubnetMask</code> <code>ctl_no netmask</code>	Specifies the subnet mask. ctl_no : Controller number (0, 1) netmask : Subnet mask (format xxx.xxx.xxx.xxx)
<code>-DefaultGateway</code> <code>ctl_no gateway</code>	Specifies the default gateway. ctl_no : Controller number (0, 1) gateway : Default gateway (format xxx.xxx.xxx.xxx)
<code>-setSM</code> <code>ctl_no port_no</code> <code>tid</code>	Sets the target ID by S-TID, M-LUN modes. ctl_no : Controller number (0, 1) port_no : Port number (A, B, C, D) tid : Target ID
<code>-rmSM</code> <code>ctl_no port_no</code> <code>tid</code>	Deletes the target ID by S-TID, M-LUN modes. ctl_no : Controller number (0, 1) port_no : Port number (A, B, C, D) tid : Target ID

Note: If LAN configuration information (such as an IP Address) is modified, an error message (Interface Error) may be displayed without displaying a restart completion message when restarting an array unit. When modifying LAN configuration information, restart an array unit by not specifying restart.

(Continued)

Options	Description
<code>-setMS</code> <code>ctl_no port_no</code> <code>tid lu</code>	Sets the target ID by M-TID, S-LUN modes. ctl_no : Controller number (0, 1) port_no : Port number (A, B, C, D) tid : Target ID lu : LU number
<code>-mMS</code> <code>ctl_no port_no</code> <code>tid lu</code>	Deletes the target ID by M-TID, S-LUN modes. ctl_no : Controller number (0, 1) port_no : Port number (A, B, C, D) tid : Target ID lu : LU number
<code>-setMM</code> <code>ctl_no port_no</code> <code>tid hlu lu</code>	Sets the target ID by M-TID, M-LUN modes. (for the case of SCSI version) ctl_no : Controller number (0, 1) port_no : Port number (A, B, C, D) tid : Target ID hlu : LU number recognized by the host lu : LU number
<code>-mMM</code> <code>ctl_no port_no</code> <code>tid hlu lu</code>	Delete the target ID by M-TID, M-LUN modes. (for the case of SCSI version) ctl_no : Controller number (0, 1) port_no : Port number (A, B, C, D) tid : Target ID hlu : LU number recognized by the host lu : LU number
<code>-setMM</code> <code>ctl_no port_no</code> <code>hlu lu</code>	Sets the target ID by M-TID, M-LUN modes. (for the case of Fibre version) ctl_no : Controller number (0, 1) port_no : Port number (A, B) hlu : LU number recognized by the host lu : LU number
<code>-mMM</code> <code>ctl_no port_no</code> <code>hlu lu</code>	Deletes the target ID by M-TID, M-LUN modes. (for the case of Fibre version) ctl_no : Controller number (0, 1) port_no : Port number (A, B) hlu : LU number recognized by the host lu : LU number

(Continued)

Options	Description
-fd on off	Specifies whether or not to make a backup copy to the FD. System parameter information is already saved in the backup FD in an array unit. When settings are modified, the information must be saved again, and hence be sure to specify on. on: Makes a backup copy. off: Does not make a backup copy.

In case of the DF400

Options	Description
-SpareDisk one two not	Specifies the configuration of spare disk drives. one: Uses one spare disk drive. two: Uses two spare disk drives. not: Dose not use spare disk drive.
-HostConnection standard OpenVMS TRESPASS WolfPack IBM7135 NCR	Specifies the mode to be emulated. standard: Open system emulation mode OpenVMS: Open VMS mode TRESPASS: TRESPASS mode WolfPack: WolfPack mode IBM7135: IBM7135 I/O path switching emulation mode NCR: NCR I/O path switching emulation mode
-DriveCapacity row_num disk_size	Specifies the capacity of installed drives in units of rows. ROW 0 cannot be specified. row_num: 1, 2, 3, 4, 5 disk_size: 4, 9, 18, 36, 72 (G byte) 0XXXXXXXX (user-specified value : hex. value)
-VxVM enable disable	Specifies whether to set the VxVM mode effective or ineffective. enable: Enables the VxVM mode. disable: Disables the VxVM mode.
-OdeMapper enable disable	Specifies whether to set the ODE Mapper mode effective or ineffective. enable: Enables the ODE Mapper mode. disable: Disables the ODE Mapper mode.
-HPUX enable disable	Specifies whether to set the HP connection mode effective or ineffective. enable: Enables the HP connection mode. disable: Disables the HP connection mode.
-ReportInquiry enable disable	Specifies whether to set the Inquiry Page : 83 reporting mode effective or ineffective. enable: Enables the report of Inquiry Page : 83. disable: Disables the report of Inquiry Page : 83.

(Continued)

Options	Description
<code>-UASuppress</code> enable disable	Specifies whether or not to suppress a unit attention (06/2A00). enable: Suppress the unit attention. disable: Dose not suppress the unit attention.
<code>-Buzzer</code> on off	Specifies whether to set the buzzer in the sounding mode or silent mode. on: Turn on the buzzer. off: Turn off the buzzer.
<code>-PortTypeOption</code> ctl_no port_no SGI HP enable disable	For the fibre version of the array unit, options can be specified for each port. ctl_no: Controller number (0, 1) port: Port number (A, B, C, D) SGI: Sets the SGI mode. HP: Sets the HP connection mode. enable: Enables the setting of SGI mode and HP connection mode. disable: Disables the setting of SGI mode and HP connection mode.
<code>-CLAM</code> enable disable	Specifies whether to set the CLAM mode effective or ineffective. enable: Enables the CLAM mode. disable: Disables the CLAM mode.
<code>-Solaris</code> enable disable	Specifies whether to set the SUN Solaris2.5.1 mode effective or ineffective. enable: Enables the SUN Solaris2.5.1 mode. disable: Disables the SUN Solaris2.5.1 mode.
<code>-MP5400</code> enable disable	Specifies whether to set the MP5400 mode effective or ineffective. enable: Enables the MP5400 mode. disable: Disables the MP5400 mode.
<code>-OdeMapper</code> enable disable	Specifies whether to enable or disable the ODE Mapper mode. enable: Enables the ODE Mapper mode. disable: Disables the ODE Mapper mode.
<code>-SGI</code> enable disable	Specifies whether to set the SGI mode effective or ineffective. enable: Enables the SGI mode. disable: Disables the SGI mode.
<code>-PortIdTaking</code> enable disable	Specifies whether to set the taking over of port IDs effective or ineffective. enable: Enables the taking over of port ID. disable: Disables the taking over of port ID.
<code>-ScsiResetLip</code> on off	For the SCSI version, sets the reset mode when receiving a SCSI reset from other ports. For the fibre version, sets the LIP mode when receiving an LIP from other ports. When the -PortType option is multiple, the setting is invalid. on: Sets a SCSI reset/LIP from other ports effective. off: Sets a SCSI reset/LIP from other ports ineffective.

(Continued)

Options	Description
-PortType normal multiple	Sets the multi-port expansion function. normal: Validates the setting specified with -ScsiResetLip option. multiple: Sets the SCSI reset/LIP mode for each port.
-PortTypeResetLip ctl_no port_no on off	Sets the SCSI reset/LIP mode for each controller and each port. ctl_no: Controller number (0, 1) port_no: Port number (A, B, C, D) on: Sets a SCSI reset/LIP from other ports effective. off: Sets a SCSI reset/LIP from other ports ineffective.
-ConnectLAN ctl_no on off	Specifies the validity/invalidity of interface with applications through LAN ctl_no: Controller number (0, 1) on: Enable. off: Disable

In case of the DF500

Options	Description
-HostConnection ctl_no port_no standard OpenVMS TRESPASS WolfPack	Specifies the mode to be emulated. ctl_no : Controller number (0, 1) port_no : Port number (A, B) standard : Open system emulation mode OpenVMS : Open VMS mode TRESPASS : TRESPASS mode WolfPack : WolfPack mode
-VxVM ctl_no port_no enable disable	Specifies whether to set the VxVM mode effective or ineffective. ctl_no : Controller number (0, 1) port_no : Port number (A, B) enable : Enables the VxVM mode. disable : Disables the VxVM mode.
-OdeMapper ctl_no port_no enable disable	Specifies whether to set the ODE Mapper mode effective or ineffective. ctl_no : Controller number (0, 1) port_no : Port number (A, B) enable : Enables the ODE Mapper mode. disable : Disables the ODE Mapper mode.
-HPUX ctl_no port_no enable disable	Specifies whether to set the HP connection mode effective or ineffective. ctl_no : Controller number (0, 1) port_no : Port number (A, B) enable : Enables the HP connection mode. disable : Disables the HP connection mode.
-HISUP ctl_no port_no enable disable	Specifies whether to set the HISUP mode effective or ineffective. ctl_no : Controller number (0, 1) port_no : Port number (A, B) enable : Enables the HISUP mode. disable : Disables the HISUP mode.
-CCHS ctl_no port_no enable disable	Specifies whether to set the CCHS convert mode effective or ineffective. ctl_no : Controller number (0, 1) port_no : Port number (A, B) enable : Enables the CCHS convert mode. disable : Disables the CCHS convert mode.
-WebTitle string	If the home page of the array unit is displayed with the browser, specifies a character string displayed on the title bar of the browser. Enter up to 32 one-byte coded alphanumerics or characters (except for the ' (single quotation mark), " (double quotation mark), and \ (backslash) symbols) other than numeric.

(Continued)

Options	Description
-LinkSeparation enable disable	Specifies whether to set the Link Separation effective or ineffective. enable: Enables the Link Separation. disable: Disables the Link Separation.
-ReportInquiry ctl_no port_no enable disable	Specifies whether to set the Inquiry Page : 83 reporting mode effective or ineffective. ctl_no: Controller number (0, 1) port_no: Port number (A, B) enable: Enables the report of Inquiry Page : 83. disable: Disables the report of Inquiry Page : 83.
-UASuppress ctl_no port_no enable disable	Specifies whether or not to suppress a unit attention (06/2A00). ctl_no: Controller number (0, 1) port_no: Port number (A, B) enable: Suppress the unit attention. disable: Dose not suppress the unit attention.
-PortTypeOption ctl_no port_no ResetLipSignal ResetLipProcess LipPortAllReset TargetReset Reserve LUReset TPRLO enable disable	For the Fibre Channel version of array units, sets options for individual ports. ctl_no: Controller No. (0, 1) port_no: Port No. (A, B, C, D) ResetLipSignal: Sets ResetLip (signal). ResetLipProcess: Sets ResetLip (processing). LipPortAllReset: Sets the resetting of all ports by an LIP. TargetReset: Enables the Target rest. Reserve: Enables the Reserve. LUReset: Enables the LU reset. TPRLO: Sets Third Party Process Logout Mode. enable: Enables the settings described above. disable: Disables the settings described above.

- Examples of using command

References the system parameters of an array unit whose name is df500a1.

```
% ausysparam -unit df500a1 -refer
Password :
System parameter list.
```

```
DF Name : df500a1
Date : 2000/06/01 13:00:00
Micro Program Revision : 0551
Flash Program Revision : 0551
Array Unit Type : DF500
--- Common Parameter ---
System Startup Attribute = Dual Active Mode
  SCSI ID/Port ID Take-over Mode = ----
  Default Controller
    Port A = ---
    Port B = ---
  Data Share Mode = Not Used
Host Connection Mode 1
  Port 0A = Standard Mode
  Port 0B = Standard Mode
  Port 1A = Standard Mode
  Port 1B = Standard Mode
Host Connection Mode 2
  Port 0A
    VxVM DMP mode enable = OFF
    ODE Mapper mode enable = ---
    HP Connection mode enable = OFF
    Report Inquiry page 83H = OFF
    UA (06/2A00) suppress mode enable = OFF
    HISUP mode enable = OFF
    CCHS convert mode enable = OFF
  Port 0B
    VxVM DMP mode enable = OFF
    ODE Mapper mode enable = ---
    HP Connection mode enable = OFF
    Report Inquiry page 83H = OFF
    UA (06/2A00) suppress mode enable = OFF
    HISUP mode enable = OFF
    CCHS convert mode enable = OFF
  Port 1A
    VxVM DMP mode enable = OFF
    ODE Mapper mode enable = ---
    HP Connection mode enable = OFF
    Report Inquiry page 83H = OFF
    UA (06/2A00) suppress mode enable = OFF
    HISUP mode enable = OFF
    CCHS convert mode enable = OFF
  Port 1B
    VxVM DMP mode enable = OFF
    ODE Mapper mode enable = ---
    HP Connection mode enable = OFF
    Report Inquiry page 83H = OFF
    UA (06/2A00) suppress mode enable = OFF
    HISUP mode enable = OFF
    CCHS convert mode enable = OFF
```

```
Serial Number =  
Option 1  
  Drive Detach mode enable = OFF  
Option 2  
  Multipath (Controller) = OFF  
  PROCOM mode enable = OFF  
  Report Status (normal / warning) = OFF  
  Multipath (Array Unit) = OFF  
  Turbo LU Warning = OFF  
Data Striping Size = 64KB  
Operation if the Processor failures Occurs = Reset a Fault  
INQUIRY information  
  Command Queuing = ON  
  ANSI Version = ---  
  Vendor ID = HITACHI  
  Product ID = DF500F  
  ROM Microprogram Version =  
  RAM Microprogram Version =  
Web Title  
  Web Title = ""  
Cache Mode = All OFF  
Host Connection Mode  
  Link Separation
```

```

--- CTL0 Parameter ---
Target ID
  S-TID, M-LUN : NO
  M-TID, S-LUN : NO
  M-TID, M-LUN : YES

Data
Port Target ID H-LUN LUN
Port Type
Port Option
  Reset/LIP Mode (Signal)
    Port A = OFF
    Port B = OFF
  Reset/LIP Mode (Process)
    Port A = OFF
    Port B = OFF
  LIP Port All Reset Mode
    Port A = OFF
    Port B = OFF
  Target Reset (Bus Device Reset) Mode
    Port A = OFF
    Port B = OFF
  Reserve Mode
    Port A = OFF
    Port B = OFF
  Logical Unit Reset Mode
    Port A = OFF
    Port B = OFF
  Third Party Process Logout Mode
    Port A = OFF
    Port B = OFF
ROM Pseudo-response command processing = ---
Save Data pointer response
  Port A = ---
  Port B = ---
Controller Identifier = Disable
RS232C Error Information Outflow Mode = OFF
Write & Verify Execution Mode = ON
LAN Const
  DHCP = OFF
  IP Address = 0.0.0.0
  Subnet Mask = 0.0.0.0
  Default Gateway = 0.0.0.0
  Ether Address = 00:00:87:70:9F:F3
SCSI transfer rate
  Port A = ---
  Port B = ---

```

```

--- CTL1 Parameter ---
Target ID
  S-TID, M-LUN : NO
  M-TID, S-LUN : NO
  M-TID, M-LUN : YES

Data
Port Target ID H-LUN LUN
Port Type
Port Option
  Reset/LIP Mode (Signal)
    Port A = OFF
    Port B = OFF
  Reset/LIP Mode (Process)
    Port A = OFF
    Port B = OFF
  LIP Port All Reset Mode
    Port A = OFF
    Port B = OFF
  Target Reset (Bus Device Reset) Mode
    Port A = OFF
    Port B = OFF
  Reserve Mode
    Port A = OFF
    Port B = OFF
  Logical Unit Reset Mode
    Port A = OFF
    Port B = OFF
  Third Party Process Logout Mode
    Port A = OFF
    Port B = OFF
ROM Pseudo-response command processing = ---
Save Data pointer response
  Port A = ---
  Port B = ---
Controller Identifier = Disable
RS232C Error Information Outflow Mode = OFF
Write & Verify Execution Mode = ON
LAN Const
  DHCP = OFF
  IP Address = 0.0.0.0
  Subnet Mask = 0.0.0.0
  Default Gateway = 0.0.0.0
  Ether Address = 00:00:87:70:9F:F3
SCSI transfer rate
  Port A = ---
  Port B = ---
%
```

Sets a system parameter (to suppress the mode in which to send error information to an RS232C interface) of an array unit whose name is df500a1.

```
% ausysparam -unit df500a1 -set -Rs232cOutflow off
Execute this command, then access from the host will stop.
Continue (y/n [n]) : y
Password :
System Parameter settings finished normally.
You need reboot the array unit to avail settings.
%
```

Sets a system parameter (to set the buzzer in the sounding mode) of an array unit, whose name is df400a1 and which supports restarting.

```
%ausysparam -unit df400a1 -set -Buzzer on
Execute this command, then access from the host will stop.
Continue (y/n [n]) : y
Password :
System Parameter settings finished normally.
You need reboot the array unit to avail settings.
Array unit stops accepting input and output while rebooting.
And if you already logged in, login status is canceled when the reboot starts.
Do you reboot the array unit now (y/n [n]) : y
Now reboot the array unit. Start Time HH : MM
Reboot has been completed.
%
```

Note: When setting all system parameters with Windows, you cannot set them on a prompt screen because of a limitation on the number of characters. Create the contents of settings on a Bat file, then execute appropriate commands.

3.7.2 Referencing/Setting RTC

- Command name

aurtc

- Synopsis

aurtc -unit unit_name -refer

aurtc -unit unit_name -set -auto [-f]

aurtc -unit unit_name -set -manual -date yyyy/mm/dd -time HH:MM:SS [-f]

- Description

References and sets RTC.

- Options

Options	Description
-unit unit_name	Specifies the name of an array unit for which to reference and set RTC. Specifies with one-byte coded alphanumerics and special symbols "-" (minus) and "_" (underline) of up to 16 characters long.
-refer	References RTC.
-set	Sets RTC.
-auto	Sets RTC by the date and time of the machine on which the manager is running.
-manual	Sets to RTC the date and time specified by -date and -time options, respectively.
-date yyyy/mm/dd	Specifies the date to set. yyyy : in A.D. (1900 to 2089) mm : month (01 to 12) dd : day (01 to 31)
-time HH:MM:SS	Specifies the time to set. HH : hour (00 to 23) MM : minute (00 to 59) SS : second (00 to 59)

- Examples of using command

References RTC of an array unit whose name is df500a1.

```
% aurtc -unit df500a1 -refer
Password :
Date 1999/1/9   Time 18:14:28
%
```

Automatically sets RTC of an array unit whose name is df500a1.

```
% aurtc -unit df500a1 -set -auto
Execute this command, then access from the host will stop.
Continue (y/n [n]) : y
Password :
RTC settings finished normally.
You need reboot the array unit to avail settings.
%
```

Sets RTC of an array unit, whose name is df500a1, by specifying the date and time.

```
% aurtc -unit df500a1 -set -manual -date 2000/01/01 -time 12:34:56
Execute this command, then access from the host will stop.
Continue (y/n [n]) : y
Password :
RTC settings finished normally.
You need reboot the array unit to avail settings.
%
```

By specifying the date and time, sets RTC of an array unit, whose name is df400a1 and which supports restarting.

```
% aurtc -unit df400a1 -set -manual -date 2000/01/01 -time 12:34:56
Execute this command, then access from the host will stop.
Continue (y/n [n]) : y
Password :
RTC settings finished normally.
You need reboot the array unit to avail settings.
Array unit stops accepting input and output while rebooting.
And if you already logged in, login status is canceled when the reboot starts.
Do you reboot the array unit now (y/n [n]) : y
Now reboot the array unit. Start Time HH : MM
Reboot has been completed.
%
```

3.7.3 Referencing/Setting Target Information

- Command name

autarget

- Synopsis

– In the case of DF350, DF400, and DF500

```
autarget -unit unit_name -refer
```

– In the case of DF350

```
autarget -unit unit_name -set -rm -mode SM  
-ctl0 | -ctl1 -tid n [ -fd on | off ]
```

```
autarget -unit unit_name -set | -rm -mode MS  
-ctl0 | -ctl1 -tid n -lu num [ -fd on | off ]
```

– In the case of DF400 (SCSI version)

```
autarget -unit unit_name -set | -rm -mode SM  
-ctl0 | -ctl1 -port A | B | C | D -tid n [ -fd on | off ]
```

```
autarget -unit unit_name -set | -rm -mode MS  
-ctl0 | -ctl1 -port A | B | C | D -tid n -lu lun  
[ -fd on | off ]
```

```
autarget -unit unit_name -set | -rm -mode MS  
-ctl0 | -ctl1 -port A | B | C | D -tid num -hlu lun -lu lun  
[ -fd on | off ]
```

– In the case of DF400 (Fibre Channel version), DF500 (Fibre Channel version)

```
autarget -unit unit_name -set | -rm -mode MM  
-ctl0 | -ctl1 -port A | B -hlu lun -lu lun [ -fd on | off ]
```

– In the case of DF500 (SCSI version)

```
autarget -unit unit_name -set | -rm -mode SM  
-ctl0 | -ctl1 -port A -tid n [ -fd on | off ]
```

```
autarget -unit unit_name -set | -rm -mode MS  
-ctl0 | -ctl1 -port A -tid n -lu lun [ -fd on | off ]
```

```
autarget -unit unit_name -set | -rm -mode MM  
-ctl0 | -ctl1 -port A -tid n -hlu lun -lu lun [ -fd on | off ]
```

– In the case of DF400, DF500

```
autarget -unit unit_name -file filename [ -fd on | off ]
```

- Description

References and sets target ID information.

DF350F has not been supported.

■ Options

Options	Description
-unit unit_name	Specifies the name of an array unit for which to reference and set target ID information. Specifies with one-byte coded alphanumerics and special symbols "-" (minus) and "_" (underline) of up to 16 characters long.
-refer	References target ID information.
-set	Adds target ID information.
-rm	Deletes target ID information.
-mode SM MS MM	Specifies individual types of a target ID and a LUN configuration. SM: Single target ID and multi-LUN (Sets the target ID for a port, and the host uses an LUN shared by the port for the same LUN.) MS: Multi-target ID and single LUN (Sets the port and target ID for an LUN, and the host uses with a set target ID as LUN="0".) MM: LU mapping (Sets the port, target ID, and H-LUN for an LUN by mapping, and the host uses with a set configuration)
-ctl0 -ctl1	Specifies the controller No.
-port A B C D -port A B	Specifies the port No.
-tid n	Specifies the target ID for the SCSI version. Cannot specify it for the fibre version.
-hlu n	Specifies the LUN recognized from the host.
-lu n	Specifies the internal LUN in the array unit.
-file filename	Specifies the target ID configuration file. If this option is specified, reads a target ID configuration file, and sets according to its contents.
-fd on off	Specifies whether or not to make a backup copy of the FD. Target ID information has been saved in the backup FD in the array unit as system parameter information. When changing settings, target ID information needs to be saved again, so be sure to specify "on".

- Examples of using command

Displays target ID information in an array unit (SCSI version) whose name is df400a1.

[S-TID, M-LUN]

```
% autarget -unit df400a1 -refer
Password :
Current target ID mode : S-TID, M-LUN
CTL      PORT  T-ID  H-LUN  LUN
  0       A    0     --     --
  0       B    1     --     --
  1       A    2     --     --
  1       B    3     --     --

Reserved target ID mode : S-TID, M-LUN
CTL      PORT  T-ID  H-LUN  LUN
  0       A    0     --     --
  0       B    0     --     --
  1       A    0     --     --
  1       B    0     --     --

%
```

Displays target ID information in an array unit (SCSI version) whose name is df400b1.

[M-TID, S-LUN]

```
% autarget -unit df400b1 -refer
Password :
Current target ID mode : M-TID, S-LUN
CTL      PORT  T-ID  H-LUN  LUN
  0       A    0     --     0
  0       A    1     --     0
  0       B    2     --     1
  0       B    3     --     1
  1       A    0     --     2
  1       A    1     --     2
  1       B    2     --     3
  1       B    3     --     3

Reserved target ID mode : M-TID, S-LUN
CTL      PORT  T-ID  H-LUN  LUN
  0       A    0     --     0
  0       A    2     --     0
  0       B    4     --     1
  0       B    6     --     1
  1       A    1     --     2
  1       A    3     --     2
  1       B    5     --     3
  1       B    7     --     3

%
```

Displays target ID information in an array unit (SCSI version) whose name is df400c1.

[LU mapping]

```
% autarget -unit df400c1 -refer
Password :
Current target ID mode : M-TID, M-LUN
CTL      PORT    T-ID    H-LUN    LUN
  0       A      0       0       0
  0       B      1       2       4
  1       A      2       0       1
  1       B      3       2       5

Reserved target ID mode : M-TID, M-LUN
CTL      PORT    T-ID    H-LUN    LUN
  0       A      0       1       2
  0       B      1       3       6
  1       A      2       1       3
  1       B      3       3       7

%
```

Displays target ID information in an array unit (Fibre version) whose name is df500a1.

[LU mapping]

```
% autarget -unit df500a1 -refer
Password :
Current target ID mode : M-TID, M-LUN
CTL      PORT    T-ID    H-LUN    LUN
  0       A      --      0       0
  0       B      --      2       4
  1       A      --      0       1
  1       B      --      2       5

Reserved target ID mode : M-TID, M-LUN
CTL      PORT    T-ID    H-LUN    LUN
  0       A      --      1       2
  0       B      --      3       6
  1       A      --      1       3
  1       B      --      3       7

%
```

Sets target ID information in an array unit (SCSI version) whose name is df400a1. Sets the target ID of Controller 0, Port A to 0 with a single target ID and multi-LUN configuration.

```
% autarget -unit df400a1 -set -mode SM -ctl0 -port A -tid 0 -fd on
Password :
Target ID settings finished normally.
You need reboot the array unit to avail settings.
%
```

Sets target ID information in an array unit (SCSI version), whose name is df400a2 and which supports restarting. Sets the target ID of Controller 0, Port A to 0 with a single target ID and multi-LUN configuration.

```
% autarget -unit df400a2 -set -mode SM -ctl0 -port A -tid 0 -fd on
Password :
Target ID settings finished normally.
You need reboot the array unit to avail settings.
Array unit stops accepting input and output while rebooting.
And if you already logged in, login status is canceled when the reboot.
Do you reboot the array unit now (y/n [n]) : y
Now reboot the array unit. Start Time HH : MM
Reboot has been completed.
%
```

The format of the target ID configuration file when setting by file input is shown in the figure below.

Enter the **Target ID** by specifying “Yes” or “No”. Input necessary data for **Port**, **Target ID**, **H-LUN**, and **LUN**. Put spaces between the items. If the tabulating function is used, they are regarded as input errors and the inputs are ignored.

Example 1 LU mapping mode

```
Information file for Target ID configuration
S-TID, M-LUN : NO
M-TID, S-LUN : NO
M-TID, M-LUN : YES

Data
Port Target ID H-LUN LUN
OA 0 0 0
OA 0 1 1
OA 0 2 2
OA 0 3 3
OA 0 4 4
OA 0 5 5
OA 0 6 6
OA 0 7 7
OB 1 0 8
OB 1 1 9
OB 1 2 10
OB 1 3 11
OB 1 4 12
OB 1 5 13
OB 1 6 14
OB 1 7 15
```

Example 2 Single target ID and multi-LUN mode

```
Information file for Target ID configuration
S-TID, M-LUN : YES
M-TID, S-LUN : NO
M-TID, M-LUN : NO

Data
Port Target ID H-LUN LUN
OA 0
OB 1
1A 2
1B 3
```

Note: When the manager is connected to array unit with the Fibre Channel connection, set ‘--’ for the **T-ID**.

Two types of the sample files when setting by file input are provided. The sample file configuration is shown below.

Sample file : id00.txt --- Host LU independent access type

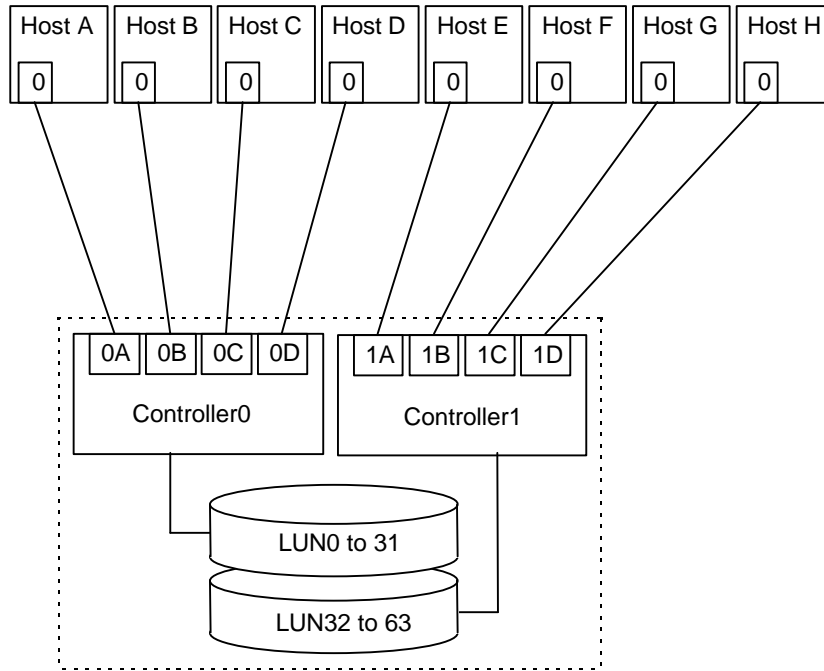

Host	Port	Target ID	H-LUN	LUN
A	0A	0	0 to 7	0 to 7
B	0B	1	0 to 7	8 to 15
C	0C	2	0 to 7	16 to 23
D	0D	3	0 to 7	24 to 31
E	1A	0	0 to 7	32 to 39
F	1B	1	0 to 7	40 to 47
G	1C	2	0 to 7	48 to 55
H	1D	3	0 to 7	56 to 63

Sample file : id01.txt --- Host alternate path access type

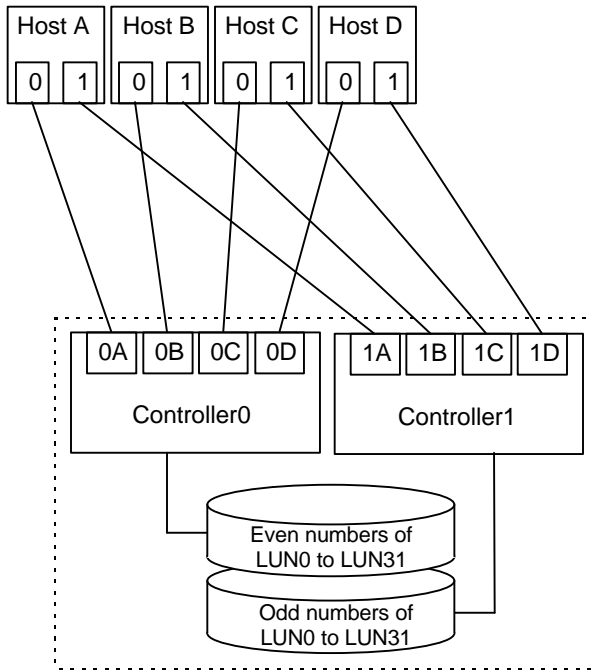

Host	Port	Target ID	H-LUN	LUN
A-Path0	0A	0	0 to 7	0 to 7
A-Path1	0B	1	0 to 7	8 to 15
B-Path0	0C	2	0 to 7	16 to 23
B-Path1	0D	3	0 to 7	24 to 31
C-Path0	1A	0	0 to 7	0 to 7
C-Path1	1B	1	0 to 7	8 to 15
D-Path0	1C	2	0 to 7	16 to 23
D-Path1	1D	3	0 to 7	24 to 31

3.7.4 Referencing/Setting LAN Information

- **Command name**

aulan

- **Synopsis**

- In the case of DF350, DF400, and DF500

```
aulan -unit unit_name -refer
```

- In the case of DF350

```
aulan -unit unit_name -set -ctl0 | -ctl1
      [ -addr inet_addr ] [ -mask netmask ] [ -gate gateway ]
      [ -fd on | off ]
```

- In the case of DF400

```
aulan -unit unit_name -set -ctl0 | -ctl1
      [ -addr inet_addr ] [ -mask netmask ] [ -gate gateway ]
      [ -link enable | disable ] [ -dhcp enable | disable ]
      [ -fd on | off ]
```

- In the case of DF500

```
aulan -unit unit_name -set -ctl0 | -ctl1
      [ -addr inet_addr ] [ -mask netmask ] [ -gate gateway ]
      [ -dhcp enable | disable ] [ -fd on | off ]
```

- **Description**

Displays and sets LAN information of the array unit.
DF350F has not been supported.

- **Options**

Options	Description
-unit unit_name	Specifies the name of an array unit for which to reference and set LAN information. Specifies with one-byte coded alphanumeric and special symbols "-" (minus) and "_" (underline) of up to 16 characters long.
-refer	References LAN information.
-set	Sets LAN information.
-ctl0 -ctl1	Specifies the controller.
-addr inet_addr	Specifies individual IP addresses.
-mask netmask	Specifies individual subnet masks.

(Continued)

Options	Description
-gate gateway	Specifies individual default gateways.
-link enable disable	Specifies whether LAN connection is valid or invalid.
-dhcp enable disable	Specifies whether the DHCP mode is set enable or disable.
-fd on off	Specifies whether or not to make a backup copy of the FD. LAN information has been saved in the backup FD in the array unit as system parameter information. When changing settings, LAN information needs to be saved again, so be sure to specify "on".

■ Examples of using command

References LAN information of an array unit whose name is df500a1.

```
% aulan -unit df500a1 -refer
Password :
CTL   IP address      Net mask      Gateway      Ethernet address  Conn  DHCP
  0   125.0.9.98    255.255.255.0 125.0.9.15   00:00:87:50:78:AF enable NO
  1   125.0.9.99    255.255.255.0 125.0.9.15   00:00:87:50:78:9F enable NO
%
```

References LAN information of an array unit (DF350) whose name is df350a1.

```
% aulan -unit df350a1 -refer
Password :
CTL   IP address      Net mask      Gateway      Ethernet address
  0   125.0.9.98    255.255.255.0 125.0.9.15   00:00:87:50:78:AF
  1   125.0.9.99    255.255.255.0 125.0.9.15   00:00:87:50:78:9F
%
```

Sets LAN information for the Controller 0 side of an array unit (DF350) whose name is df350b1.

```
% aulan -unit df350b1 -set -ct10
-addr 192.168.100.100 -mask 255.255.255.0 -gate 192.168.100.3
Password :
%
```

Sets LAN information for the Controller 0 side of an array unit whose name is df500a1.

```
% aulan -unit df500a1 -set -ct10
-addr 192.168.100.100 -mask 255.255.255.0 -gate 192.168.100.5
Password :
LAN information settings finished normally.
You need reboot the array unit to avail settings.
%
```

Sets LAN information for the Controller 0 side of an array unit whose name is df400a1 and which supports restarting.

```
% aulan -unit df400a1 -set -ct10  
-addr 192.168.100.100 -mask 255.255.255.0 -gate 192.168.100.5
```

Password :

LAN information settings finished normally.

You need reboot the array unit to avail settings.

Array unit stops accepting input and output while rebooting.

And if you already logged in, login status is canceled when the reboot starts.

Do you reboot the array unit now (y/n [n]) : y

Now reboot the array unit. Start Time HH : MM

Reboot has been completed.

```
%
```

3.7.5 Referencing/Setting SCSI Transfer Rate

- Command name

ausync

- Synopsis

– In the case of DF400, DF500

```
ausync -unit unit_name -refer
```

– In the case of DF400

```
ausync -unit unit_name -set -ctl0 | -ctl1 -port A | B | C | D  
-sync standard | async | N5 | N10 | N13 | N20 | N33 | N40 | W10 |  
W20 | W26 | W40 | W66 | W80  
[ -fd on | off ]
```

– In the case of DF500

```
ausync -unit unit_name -set -ctl0 | -ctl1 -port A  
-sync standard | async | N5 | N10 | N20 | N40 |  
W10 | W20 | W40 | W80  
[ -fd on|off ]
```

- Description

Displays and sets the SCSI transfer rate of each port. When setting, one entry of the command can set the transfer rate only for one port.

■ Options

Options	Description
-unit unit_name	Specifies the name of an array unit for which to reference and set the SCSI transfer rate. Specifies with one-byte coded alphanumerics and special symbols "-" (minus) and " <u>_"</u> (underline)" of up to 16 characters long.
-refer	References SCSI transfer rate information.
-set	Sets SCSI transfer rate information.
-ctl0 -ctl1	Specifies the controller for which to set information.
-port A B C D	Specifies the port for which to set information.
-sync standard async N5 N10 N13 N20 N33 N40 W10 W20 W26 W40 W66 W80	Specifies the transfer rate of a port. When connecting the DF500, do not specify N13 , W26 , N33 , and W66 , because they are all not supported. standard : Sets the transfer rate so as to match that of a mounted interface board. async : Transfers in a mode in which synchronous transfer is not used. N5, W10 : Maximum transfer rate: Narrow 5 [MB/s], Wide 10 [MB/s] N10, W20 : Maximum transfer rate: Narrow 10 [MB/s], Wide 20 [MB/s] N13, W26 : Maximum transfer rate: Narrow 13 [MB/s], Wide 26 [MB/s] N20, W40 : Maximum transfer rate: Narrow 20 [MB/s], Wide 40 [MB/s] N33, W66 : Maximum transfer rate: Narrow 33 [MB/s], Wide 66 [MB/s] N40, W80 : Maximum transfer rate: Narrow 40 [MB/s], Wide 80 [MB/s]
-fd on off	Specifies whether or not to make a backup copy of the FD. SCSI transfer rate information has been saved in the backup FD in the array unit as system parameter information. When changing settings, SCSI transfer rate information needs to be saved again, so be sure to specify "on".

- Examples of using command

References the SCSI transfer rate information of an array unit whose name is df400a1.

```
% ausync -unit df400a1 -refer
Password :
CTL  Port  I/F board type  Velocity
  0    A    no set          standard
  0    B    no set          standard
  0    C    no set          standard
  0    D    differential  async
  1    A    no set          standard
  1    B    differential  5 (10) MB
  1    C    no set          standard
  1    D    no set          standard
%
```

Sets SCSI transfer rate information for port A on Controller 0 side of an array unit whose name is df400a1.

```
% ausync -unit df400a1 -set -ctl0 -port A -sync standard -fd on
Password :
SYNC CONTROL settings finished normally.
You need reboot the array unit to avail settings.
%
```

Sets SCSI transfer rate information for port A on Controller 0 side of an array unit, whose name is df400a2 and which supports restarting.

```
% ausync -unit df400a2 -set -ctl0 -port A -sync standard -fd on
Password :
SYNC CONTROL settings finished normally.
You need reboot the array unit to avail settings.
Array unit stops accepting input and output while rebooting.
And if you already logged in, login status is canceled when the reboot starts.
Do you reboot the array unit now (y/n [n]) : y
Now reboot the array unit. Start Time HH : MM
Reboot has been completed.
%
```

3.8 File Output of Configuration and Configuration Setting by File

To output in a text file the configuration information of the array unit, or to set its configuration using a text file.

The configuration information output in the text file is the status of the system parameters, and those of the constituent parts of the RAID/LU and the array unit. The configuration to be set is the system parameters and RAID/LU. The status of the constituent parts of the array unit cannot be set.

The configuration information is handled with separate text files for the system parameters and for RAID/LU.

The copying of configuration between array units can be carried out, by outputting a text file of the configuration from an array unit, and then by using the output text file to set another array unit.

Editing a text file to set an array unit can be carried out, but it is requested that this function be used for the configuration of the same array unit. As for a change in the configuration, please carry it out by the individual functions.

3.8.1 File Output of the Configuration : System Parameters

- Command name

`ausyspout`

- Synopsis

`ausyspout -unit unit_name -file file_name`

- Description

Output in text form to a specified file the setting content of the system parameters set in the array unit.

- Options

Options	Description
<code>-unit unit_name</code>	Specifies the name of an array unit whose system parameters are to be output into the file. Specifies with one-byte coded alphanumerics and special symbols "-" (minus) and "_" (underline) of up to 16 characters long.
<code>-file file_name</code>	Specifies the name the file (path) to output the system parameters.

- Examples of using command

Output the setting information of the system parameters of the array unit with the name :
df500a1 in a file with the name : sysprm.txt in the directory where the manager is installed.

```
% ausysypout -unit df500a1 -file sysprm.txt  
Password :  
%
```

The format of the output file consists of the following items. The outline of the layout of the output file is shown in Figure 3.7.

- File header
- Registration name with the manager of the array unit
- Output time (Time of the machine where the manager is installed)
- Microprogram revision
- Array unit type
- Common controller parameters
- Controller 0 parameters
- Controller 1 parameters
- Direction for FD backup

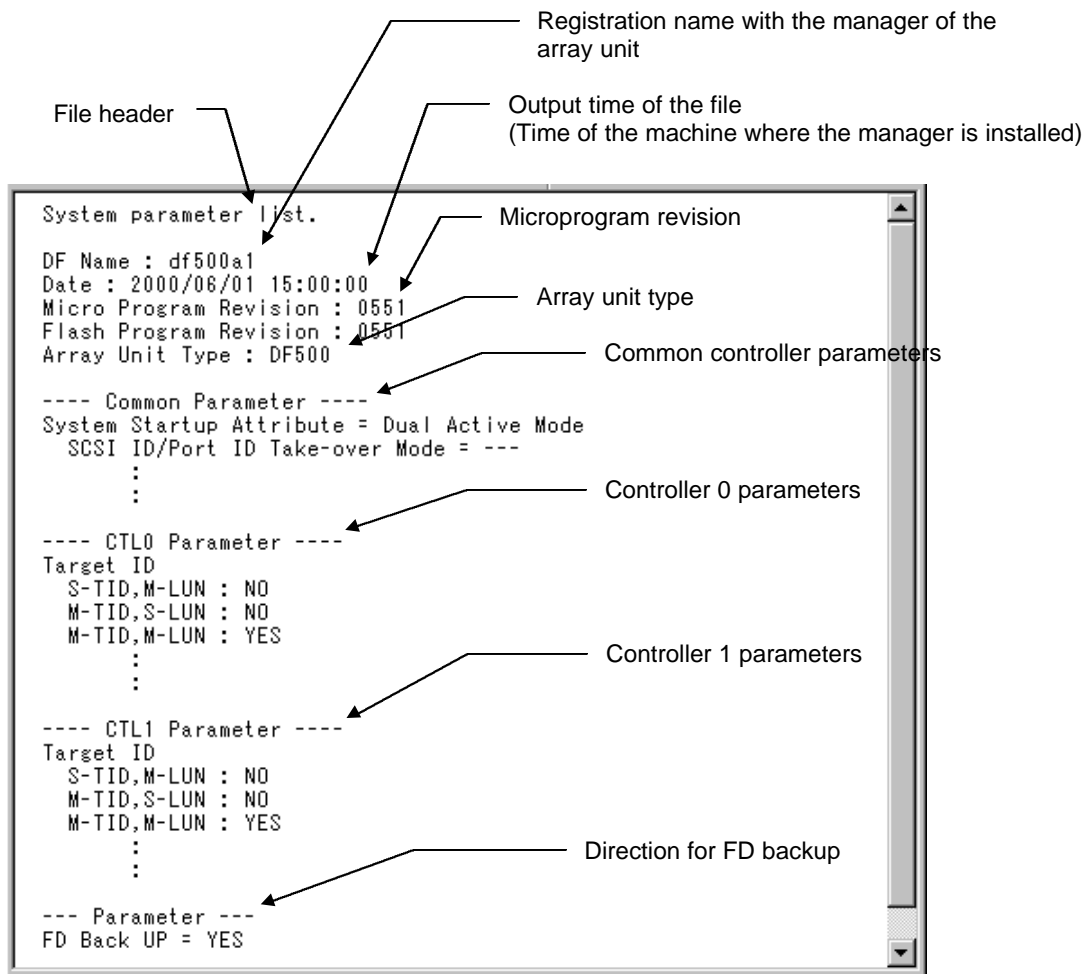

Figure 3.7 Outline of the format of the system parameter output file

If DF300, DF350, and DF350F units are connected, the item of the revision of the flash program is displayed as “---”. In addition, the type of array units is not displayed.

- Common Controller Parameters

The common system parameters of the array unit are output. An output example of the system parameters of DF500 is shown in Figure 3.8.

```

---- Common Parameter ----
System Startup Attribute = Dual Active Mode
SCSI ID/Port ID Take-over Mode = ---
Default Controller
  Port A = ---
  Port B = ---
Data Share Mode = Used
Host Connection Mode 1
  Port 0A = Standard Mode
  Port 0B = Standard Mode
  Port 1A = Standard Mode
  Port 1B = Standard Mode
Host Connection Mode 2
  Port 0A
    VxVM DMP mode enable = OFF
    ODE Mapper mode enable = OFF
    HP Connection mode enable = ---
    Report inquiry page 83H = ON
    UA(06/2A00) suppress mode enable = OFF
    HISUP mode enable = OFF
    CCHS convert mode enable = OFF
  Port 0B
    VxVM DMP mode enable = OFF
    ODE Mapper mode enable = OFF
    HP Connection mode enable = ---
    Report inquiry page 83H = ON
    UA(06/2A00) suppress mode enable = OFF
    HISUP mode enable = OFF
    CCHS convert mode enable = OFF
  Port 1A
    VxVM DMP mode enable = OFF
    ODE Mapper mode enable = OFF
    HP Connection mode enable = ---
    Report inquiry page 83H = ON
    UA(06/2A00) suppress mode enable = OFF
    HISUP mode enable = OFF
    CCHS convert mode enable = OFF
  Port 1B
    VxVM DMP mode enable = OFF
    ODE Mapper mode enable = OFF
    HP Connection mode enable = ---
    Report inquiry page 83H = ON
    UA(06/2A00) suppress mode enable = OFF
    HISUP mode enable = OFF
    CCHS convert mode enable = OFF
Serial Number =
Option 1
  Drive Detach mode enable = OFF
Option 2
  Multipath(Controller) = OFF
  PROCOM mode enable = OFF
  Report status (normal / warning) = OFF
  Multipath (Array Unit) = OFF
  Turbo LU Warning = OFF
Data Striping Size = 64KB
Operation if the Processor failures Occurs = Reset a Fault
INQUIRY Information
  Command Queuing = ON
  ANSI Version = ---
  Vendor ID =
  Product ID =
  ROM Microprogram Version =
  RAM Microprogram Version =
Web Title
  Web Title = ""
Cache Mode = All OFF

```

Figure 3.8 System parameters: output example of common parameters

The common parameters are the items shown in Table 3.1.

Table 3.1 List of common parameters

No.	Parameter	Option
1	System Startup Attribute Single Mode Dual Active Mode Hot Standby Mode SCSI ID/Port ID Take-over Mode Used Not Used Default Controller Data Share Mode	-SystemStartup Single DualIDTake DualNotIDTake HotIDTake HotNotIDTake -TakingID -DataShare
2	Spare Disk One spare disk is valid Two spare disk is valid Spare disk not mounted	-SpareDisk one two not
3	Host Connection Mode 1 Standard Mode Open VMS Mode TRESSPASS Mode Wolfpack Mode IBM7135 I/O path switch emulation Mode NCR I/O path switch emulation Mode	-HostConnenction standard OpenVMS TRESSPASS WolfPack IBM7135 NCR
4	Host Connection Mode 2 VxVM DMP mode enable ODE Mapper mode enable HP Connection mode enable Report inquiry page 83H UA (06/2A00) suppress mode enable HISUP mode enable CCHS convert mode enable	-VxVM -OdeMappar -HPUX -ReportInquiry -UASuppress -HISUP -CCHS
5	Serial Number	-SerialNumber
6	Drive Capacity (ROW LAST LBA)	-DriveCapacity
7	Option 1 VxVM DMP mode enable CLAM mode enable SUN Solaris2.5.1 mode enable Drive Detach mode enable MP5400 mode enable ODE Mapper mode enable	-VxVM -CLAM -Solaris -DriveDetach -MP5400 -OdeMappar

No.	Parameter	Option
	HP Connection mode enable	-HPUX

Table 3.1 List of common parameters (Continued)

No.	Parameter	Option
8	Option 2 Multi path (Controller) Report inquiry page 83H PROCOM mode enable Report status (normal/warning) Multi path (Array Unit) Turbo LU Warning UA (06/2A00) suppress mode enable SGI mode enable Port-ID Taking-over enable	-MultipathController -ReportInquiry -PROCOM -ResetStatus -MultipathArrayUnit -LuCacheWarning -UASuppress -SGI -PortIdTaking
9	Data Striping Size	-DataStriping
10	Buzzer	-Buzzer
11	LU size Report to the Host	-LuSizeReport
12	SCSI Reset/LIP Mode for all Ports	-ScsiResetLip
13	Operation if the Processor failures Occurs	-ProcessorFailures
14	INQUIRY Information Command Queuing ANSI Version Vendor ID Product ID ROM Microprogram Version RAM Microprogram Version	-inquiryCommandQueue -inquiryAnsiVersion -inquiryVendor -inquiryProduct -inquiryRomMicro -inquiryRammicro
15	Cache Mode All OFF Random mode Sequential mode Random & Sequential mode	-CacheMode off random sequential randseq
16	Web Title	-WebTitle
17	Host Connection Mode Link Separation	-LinkSeparation

Depending on the array unit in connection, there are items that do not need to be set, and these items will not be output in the file. Moreover, if the value of an item in the parameters is given as “---” it is an item not supported in the configuration of the array unit.

- Controller 0 Parameters

The parameters of controller 0 in the system parameters of the array unit that make the output are output.

```

---- CTL0 Parameter ----
Target ID
S-TID,M-LUN : NO
M-TID,S-LUN : NO
M-TID,M-LUN : YES

Data
Port Target ID H-LUN LUN
0A      0      0      0
0B      0      1      1
Port Type
Port Option
Reset/LIP Mode(Signal)
Port A = OFF
Port B = OFF
Reset/LIP Mode(Process)
Port A = OFF
Port B = OFF
LIP Port All Reset Mode
Port A = OFF
Port B = OFF
Target Reset (Bus Device Reset) Mode
Port A = OFF
Port B = OFF
Reserve Mode
Port A = OFF
Port B = OFF
Logical Unit Reset Mode
Port A = OFF
Port B = OFF
Third Party Process Logout Mode
Port A = OFF
Port B = OFF
ROM Pseudo-response command processing = ---
Save Data pointer response
Port A = ---
Port B = ---
Controller Identifier = Disable
RS232C Error Information Outflow Mode = OFF
Write & Verify Execution Mode = ON
LAN Const
DHCP = OFF
IP Address = 0.0.0.0
Subnet Mask = 0.0.0.0
Default Gateway = 0.0.0.0
Ether Address = 00:00:00:00:00:00
SCSI transfer rate
Port A = ---
Port A = ---

```

Figure 3.9 System parameters: output example of controller 0 parameters

The parameters of controller 0 are the items shown in Table 3.2.

Table 3.2 List of parameters of controller 0

No.	Parameter	Option
1	Target ID	-setSM -rmSM -setMS -rmMS -setMM -rmMM
2	Port Type	-PortType -PortTypeResetLp
3	ROM Pseudo-response command processing	-PseudoResponse
4	Save Data pointer resource	-SaveDataPointer
5	Controller Identifier	-ControllerIdentifier -ControllerID
6	RS232C Error Information Outflow Mode	-Rs232cOutflow
7	Write & Verify Execution Mode	-WriteVerifyExecution
8	LAN Const	-ConnectLAN -dhcp -IPAddress -SubnetMask -DefaultGateway
9	SCSI transfer rate	-sync

Depending on the array unit in connection, there are items that do not need to be set, and these items will not be output in the file. Moreover, if the value of an item in the parameters is given as “---” it is an item not supported in the configuration of the array unit.

- Controller 1 Parameters

The parameters of controller 1 in the system parameters of the array unit that make the output are output.

```

---- CTL1 Parameter ----
Target ID
S-TID,M-LUN : NO
M-TID,S-LUN : NO
M-TID,M-LUN : YES

Data
Port Target ID H-LUN LUN
0A      0      0      0
0B      0      1      1
Port Type
Port Option
Reset/LIP Mode(Signal)
Port A = OFF
Port B = OFF
Reset/LIP Mode(Process)
Port A = OFF
Port B = OFF
LIP Port All Reset Mode
Port A = OFF
Port B = OFF
Target Reset (Bus Device Reset) Mode
Port A = OFF
Port B = OFF
Reserve Mode
Port A = OFF
Port B = OFF
Logical Unit Reset Mode
Port A = OFF
Port B = OFF
Third Party Process Logout Mode
Port A = OFF
Port B = OFF
ROM Pseudo-response command processing = ---
Save Data pointer response
Port A = ---
Port B = ---
Controller Identifier = Disable
RS232C Error Information Outflow Mode = OFF
Write & Verify Execution Mode = ON
LAN Const
DHCP = OFF
IP Address = 0.0.0.0
Subnet Mask = 0.0.0.0
Default Gateway = 0.0.0.0
Ether Address = 00:00:00:00:00:00
SCSI transfer rate
Port A = ---
Port B = ---

```

Figure 3.10 System parameters: output example of the parameters of controller 1

The parameters of controller 1 are the items shown in Table 3.3.

Table 3.3 List of parameters of controller 1

No.	Parameter	Option
1	Target ID	-setSM -rmSM -setMS -rmMS -setMM -rmMM
2	Port Type	-PortType -PortTypeResetLp
3	ROM Pseudo-response command processing	-PseudoResponse
4	Save Data pointer resource	-SaveDataPointer
5	Controller Identifier	-ControllerIdentifier -ControllerID
6	RS232C Error Information Outflow Mode	-Rs232cOutflow
7	Write & Verify Execution Mode	-WriteVerifyExecution
8	LAN Const	-ConnectLAN -dhcp -IPAddress -SubnetMask -DefaultGateway
9	SCSI transfer rate	-sync

Depending on the array unit in connection, there are items that do not need to be set, and these items will not be output in the file. Moreover, if the value of an item in the parameters is given as “---” it is an item not supported in the configuration of the array unit.

- Controller 1 Parameters

The parameters of controller 1 in the system parameters of the array unit that make the output are output.

```

---- Parameter ----
FD Back Up = YES
  
```

Figure 3.11 Output example for FD backup specification

3.8.2 File output of the configuration : the status of RAID/LU and constituent parts

- Command name

auconfigout

- Synopsis

auconfigout -unit unit_name -file file_name

- Description

RAID/LU configuration information already set in an array unit is output to a specified file in a text format.

- Options

Options	Description
-unit unit_name	Specifies the name of the array unit that outputs the RAID/LU information file. Specifies with one-byte coded alphanumerics and special symbols "-" (minus)" and " <u>" (underline)" of up to 16 characters long.</u>
-file file_name	Specifies the name of a file (path) into which to output configuration information.

- Examples of using command

Outputs RAID/LU configuration information of an array unit, whose name is df500a1, by a file name of config.txt into a directory in which the manager has been installed.

```
% auconfigout -unit df500a1 -file config.txt  
%
```

The format of the output file consists of the following items. The outline of the layout of the output file is shown in Figure 3.12. Figure 3.12 is the outline of the layout of the output file for the case of DF500.

- File header
- Registration name at the manager of the array unit
- Output time (Time of the machine where the manager is installed)
- Microprogram revision
- Array unit type
- RAID/LU configuration
- Status of constituent parts

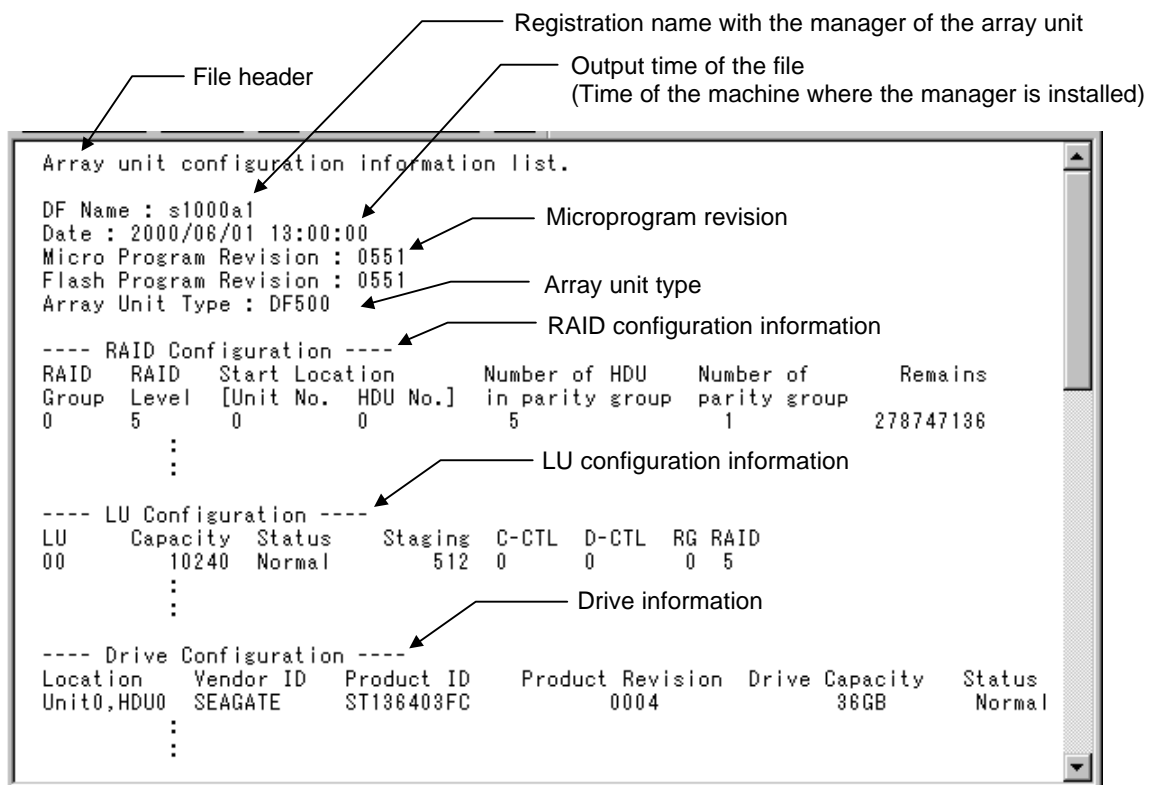

Figure 3.12 The outline of the format of RAID/LU configuration information output file

If DF300, DF350, and DF350F units are connected, the item of the revision of the flash program is displayed as "---". In addition, the type of array units is not displayed.

```

---- Cache Information ----
      Controller 0
Slot  Capacity  Status
0      256      Normal
      :
      :

---- Fan Information ----
Location  Status
0         Normal
      :
      :

---- Battery Information ----
Location  Status
0         Normal
      :
      :

---- AC Power Information ----
Location  Status
Unit0,AC0 Normal
      :
      :

---- Battery Backup Information ----
Location  Status
0         Normal
      :
      :

---- Loop Information ----
Location  Status
0         Normal
      :
      :

---- ENC Information ----
Location  Status
Unit0,ENC0 Normal
      :
      :

```

Cache information

Fan information

Battery information

AC power information

Battery backup information

Loop information

Enclosure information

Figure 3.12 The outline of the format of RAID/LU configuration information output file
(Continued)

- Format of RAID configuration information

The function outputs the RAID configuration of the array unit. RAID groups which have not been created are displayed as “-” in the “Level” column.

For the case of DF350, DF400

```

---- RAID Configuration ----
RAID  RAID
Group Level Row Port Width Depth
0     5     0   0   5     1
1     5     1   0   5     1
2     -
3     -
4     -
5     -

```

- **RAID Group:** RAID group number
- **RAID Level:** RAID level
When no RAID is set, “-” is displayed. No other information is displayed.
- **Row:** Starting row number of RAID group
- **Port:** Starting port number of RAID group
- **Width:** Width of RAID group
- **Depth:** Depth of RAID group

For the case of DF500

```

---- RAID Configuration ----
RAID  RAID  Start Location  Number of HDU  Number of  Remains
Group Level [Unit No. HDU No.] in parity group parity group
0     5     0     0     5     1  278747136
1     5     0     5     5     1  278747136
      :
18    -
19    -

```

- **RAID Group:** RAID group number
- **RAID Level:** RAID level
When no RAID is set, “-” is displayed. No other information is displayed.
- **Start Location:**
Unit No.: Starting unit number of RAID group
HDU No.: Starting HDU number of RAID group
- **Number of HDU in parity group:** The number of HDU in the parity group of the RAID group
- **Number of parity group:** The number of parity groups in the RAID group
- **Remains:** The capacity [Block] that can be defined by LU of the RAID group

- Formatting LU configuration information

The LU configuration of the array unit is output. The information is displayed up to the created LU numbers .

```

---- LU Configuration ----
LU      Capacity  Status   Staging  C-CTL  D-CTL  RG RAID
00      10240    Normal   512      0       0       0  5
01      10240    Normal   512      1       1       1  5
After 02, not define.

```

- **LU:** LU number
- **Capacity:** LU capacity (in units of block)
- **Status:** The status of the LU
 - Normal:** Normal status in which the LU is defined and formatted
 - Unformat:** Status in which the LU is defined but not formatted
 - Detached:** Status in which the LU is blocked
 - Regressed:** Status in which the LU is regressed
- **Staging Size:** Preread data amount (in units of block)
- **C-CTL:** The number of the controller currently in use
- **D-CTL:** Default number of controller controlling the LU
- **RG:** The number of the RAID group that creates the LU
- **RAID:** The RAID level of the RAID group that creates the LU

- **Format for Drive Information**

The information and status of the drive of the array unit are output.

For the case of DF400

```

---- Drive Configuration ----
Location  Vendor ID  Product ID  Product Revision  Drive Capacity  Status
Row0,Port0  HITACHI  DK319H-18WS  APY6  4GB  Normal
Row0,Port1  HITACHI  DK319H-18WS  APY6  4GB  Normal
Row0,Port2  HITACHI  DK319H-18WS  APY6  4GB  Normal
:
Row5,Port3  Nothing
Row5,Port4  Nothing
Row5,Port5  Nothing
  
```

For the case of DF500

```

---- Drive Configuration ----
Location  Vendor ID  Product ID  Product Revision  Drive Capacity  Status
Unit0,HDU0  SEAGATE  ST136403FC  0004  36GB  Normal
Unit0,HDU1  SEAGATE  ST136403FC  0004  36GB  Normal
Unit0,HDU2  SEAGATE  ST136403FC  0004  36GB  Normal
:
Unit9,HDU7  Nothing
Unit9,HDU8  Nothing
Unit9,HDU9  Nothing
  
```

- **Location:** The installation location of the drive
- **Vendor ID:** The vendor ID of the drive
- **Product ID:** The product ID of the drive
- **Product Revision:** Firmware revision of the drive
- **Drive Capacity:** The capacity of the drive
- **Status:** The status of the drive

Normal: Normal (RAID, LU defined)

Detached: Detached

Standby: Normal (LU undefined)

Undefine: Normal (RAID undefined)

Recon.: Reconfiguring (copying from collection or backup)

“Nothing” is shown after **Location** for the location of a HDU not installed.

- **Format for Cache Information**

The configuration information and status of the cache of the array unit are output.

```

---- Cache Information ----
      Controller 0              Controller 1
Slot   Capacity  Status      Capacity  Status
0      256      Normal      256      Normal
1      256      Normal      256      Normal
2      None     Nothing     None     Nothing
3      None     Nothing     None     Nothing
  
```

- **Slot:** The installation location of the cache

Controller 0

- **Capacity:** The capacity [M byte] of the cache of controller 0

- **Status:** The status of the cache of controller 0

Normal: Normal

Detached: Detached

Nothing: Not installed

---: Slot not supported

Controller 1

- **Capacity:** The capacity [M byte] of the cache of controller 1

- **Status:** The status of the cache of controller 1

Normal: Normal

Detached: Detached

Nothing: Not installed

---: Slot not supported

- **Format for Fan Information**

The status of the fan of the array unit is output.

```

---- Fan Information ----
Location  Status
0         Normal
  
```

- **Location:** The installation location of the fan

- **Status:** The status of the fan

Normal: Normal

Alarm: Abnormal

Nothing: Not installed

- **Format for Battery Information**

The status of the battery of the array unit is output.

```
---- Battery Information ----
Location  Status
0         Normal
```

- **Location:** The installation location of the battery

- **Status:** The status of the battery

Normal: Normal

Alarm: Abnormal

Nothing: Not installed

- **Format for DC power (Controller) Information : for connection with DF400**

The status of the DC power supply (controller) of the array unit is output.

```
---- DC Power Information(Controller) ----
Location      Status
Ct11-0       Normal
Ct11-1       Normal
Ct11-0       Normal
Ct11-1       Normal
```

- **Location:** The installation location of the DC power supply (controller)

- **Status:** The status of the DC power supply (controller)

Normal: Normal

Alarm: Abnormal

Nothing: Not installed

- Format for DC power (Driver) Information : for connection with DF400
The status of the DC power supply (driver) of the array unit is output.

```

---- DC Power Information(Driver) ----
Location      Status
0             Normal
1             Normal
2             Normal
3             Normal

```

- **Location:** The installation location of the DC power supply (driver)
- **Status:** The status of the DC power supply (driver)
 - Normal:** Normal
 - Alarm:** Abnormal
 - Nothing:** Not installed

- Format for DC power Information : for connection with DF350 or DF350F
The status of the DC power supply of the array unit is output.

```

---- DC Power Information ----
Location      Status
0             Normal
1             Normal
2             Normal
3             Normal
4             Normal

```

- **Location:** The installation location of the DC power supply
- **Status:** The status of the DC power supply
 - Normal:** Normal
 - Alarm:** Abnormal
 - Nothing:** Not installed

- Format for AC power Information : for connection with DF400 or DF500
The status of the AC power supply of the array unit is output.

For the case of DF400

```

---- AC Power Information ----
Location      Status
0             Normal
1             Normal

```

For the case of DF500

```

---- AC Power Information ----
Location      Status
Unit0,AC0     Normal
Unit0,AC1     Normal
              :
              :
Unit9,AC0     Nothing
Unit9,AC1     Nothing

```

- **Location:** The installation location of the AC power supply
- **Status:** The status of the AC power supply
 - Normal:** Normal
 - Alarm:** Abnormal
 - Nothing:** Not installed

- Format for Battery Backup Status Information : for connection with DF400 or DF500
The status of the battery backup circuit of the array unit is output.

```

---- Battery Backup Information ----
Location      Status
0             Normal
1             Normal

```

- **Location:** The installation location of the battery backup circuit
- **Status:** The status of the battery backup circuit
 - Normal:** Normal
 - Alarm:** Abnormal

- Format for Loop Information : for connection with DF500
The status of the loop of the array unit is output.

Location	Status
0	Normal
1	Normal
2	Normal
3	Normal

- **Location:** The installation location of the loop
- **Status:** The status of the loop
 - Normal:** Normal
 - Alarm:** Abnormal
 - Nothing:** Not installed
- Format for Enclosure Information : for connection with DF500
The status of the enclosure of the array unit is output.

---- ENC Information ----	
Location	Status
Unit0,ENC0	Normal
Unit0,ENC1	Normal
	⋮
Unit9,ENC0	Nothing
Unit9,ENC1	Nothing

- **Location:** The installation location of the enclosure
- **Status:** The status of the enclosure
 - Normal:** Normal
 - Alarm:** Abnormal
 - Nothing:** Not installed

3.8.3 Setting the configuration with a file : System parameters

- Command name

ausyspset

- Synopsis

ausyspset -unit unit_name -file file_name

- Description

To set the array unit with the setting information for the system parameters described in the file.

If you set by use of a file that was output under the condition in which any priced optional feature is in an unlocked state, setting may terminate abnormally. For a file for setting, use a file that was output under the condition in which all priced optional features are in a locked state.

Files have a standard format. The format of files is the same as that of files that are output from an array unit. For the file format and the contents of settings in files, see the following individually:. When specifying individual items of a file, insert one space character after a “=”.

- For the file format, see Subsection **3.8.1 File Output of the Configuration : System Parameters**.
- For setting items, see Subsection **3.7.1 Referencing/Setting System Parameters**, and Subsection **3.8.1 File Output of the Configuration : System Parameters**.

For setting items for backup in system parameter information, the set system parameters must be saved into the backup FD in an array unit, and hence be sure to specify “Yes”.

In the case of connection with a dual system, setting will not be carried out if one of the controllers is detached. Please confirm that the array unit is not in warning status before using it.

When executing the command, an array unit is disabled to execute commands from both the host and the Manager. In addition, to make the set system parameters effective, restart an array unit. Until the unit is restarted up, the previous settings remain effective.

After setting is finished, restart an array unit, make sure that the unit has started up, and then connect the unit to the host and the Manager.

After initiating the restarting of an array unit, the unit is not ready to accept access from the host until restarting is complete. After making sure that the host has stopped accessing, restart the unit.

- Options

Options	Description
-unit unit_name	Specifies the name of the array unit to be set with the configuration information for the system parameters. Specifies with one-byte coded alphanumerics and special symbols “- (minus)” and “_(underline)” of up to 16 characters long.
-file file_name	Specifies the name of the file (path) to output the configuration information.

- Examples of using command

Sets the array unit with name : df400a1 according to the configuration system parameters described in the text file with name : sysprm.txt.

```
% ausyspset -unit df400a1 -file sysprm.txt
Execute this command, then access from the host will stop.
Continue (y/n [n]) : y
Password :
System parameter settings finished normally.
You need reboot the array unit to avail settings.
Array unit stops accepting input and output while rebooting.
And if you already logged in, login status is canceled when the reboot starts.
Do you reboot the array unit now (y/n [n]) : y
Now reboot the array unit. Start Time HH : MM
Reboot has been completed.
%
```

Sets the array unit with name: df500a1 according to the configuration system parameters described in the text file with name : sysprm.txt.

```
% ausyspset -unit df500a1 -file sysprm.txt
Execute this command, then access from the host will stop.
Continue (y/n [n]) : y
Password :
System parameter settings finished normally.
You need reboot the array unit to avail settings.
%
```

3.8.4 Setting the configuration with a file : RAID/LU definition

- Command name

auconfigset

- Synopsis

auconfigset -unit unit_name -file file_name

- Description

To set the array unit according to the RAID/LU setting information described in the file. In the case of setting RAID/LU, as the current RAID/LU will all be first deleted, all the user data before setting will be lost. If the user data is needed, please do the setting after carrying out a backup.

Files have a standard format. The format of files is the same as that of files that are output from an array unit. For the file format, see the following:

- Subsection **3.8.2 File output of the configuration : the status of RAID/LU and constituent parts.**

Setting items in files are “RAID configuration information”, “LU configuration information”, and “drive information” in the format of output files. The output files include items about the status of configuration components, but the items are ignored at the time of setting. The contents of setting items are described below.

RAID configuration information : Sets up an RAID configuration.

Specifies the RAID level, the RAID group No., and the RAID size.

For RAID groups that are not setup, enter “-” for “Level”, and other items are not set.

LU configuration information : Sets up an LU configuration.

Specifies the LU No., the LU capacity, the amount of data pre-read, the No. of the current controller controlling an LU, the No. of the default controller controlling an LU, the RAID group No., the RAID level, and the status of an LU.

When formatting, specifies “Normal” for the LU status. If other status is specified, formatting is not executed.

If all capacity contained in an RAID group is allocated to one LU in the group, specifies “All” for “Capacity”.

Although “0” or “1” is specified for the No. of the current controller controlling an LU, the current controller No. is set to the same as the No. of the default controller controlling an LU.

Up to 64 LUs can be setup for the DF400 and the DF500, and up to 16 LUs for the DF300, the DF350 and the DF350F. When setting up LUs less than the maximum, specifies “After nn, not define” (nn : the last LU No. + 1) at the end.

Drive information : Sets up the configuration of HDUs mounted in array unit for which to set drive information.

Specifies the drive capacity. Other items are not set, but the items are listed.

Specifies “Nothing” for not-mounted HDUs.

If a capacity larger than a total capacity of mounted HDUs is specified, it is handled as an error, and an HDU configuration is not setup.

- Options

Options	Description
-unit uniat_name	Specifies the name of the array unit to be set with the RAID/LU configuration. Specifies with one-byte coded alphanumerics and special symbols "-" (minus)" and " <u>" (underline)" of up to 16 characters long.</u>
-file file_name	Specifies the name of the file (path) to output the configuration information.

- Examples of using command

Sets the array unit with name : df500a1 according to the RAID/LU configuration described in the text file with name : config.txt.

```
% auconfigset -unit df500a1 -file config.txt
```

The new RAID/LU configuration will be set in array unit.

When setup process starts, current RAID/LU configuration will be deleted.

Are you sure (y/n [n]) : y

Password :

RAID configuration setting start.

RAID configuration setting complete.

LU configuration setting start.

LU configuration setting complete.

LUX format start

LUY format start

LUX format end : Normally terminated

LUZ format start

LUX format end : CHECK CONDITION : xx-xxxx

:

:

```
%
```

3.9 Microprogram Replacement

3.9.1 Downloading/Replacing Microprogram

- Command name

aumicro

- Synopsis

– In the case of DF350, DF400, and DF500

```
aumicro -unit unit_name -read -path disk01 disk02 disk03 ...
```

```
aumicro -revision
```

```
aumicro -clean
```

– In the case of DF350

```
aumicro -unit unit_name -upload |
```

– In the case of DF400, DF500

```
aumicro -unit unit_name -upload -time time -check on | off
```

```
aumicro -unit unit_name -change -ctl0 | -ctl1
```

- Description

Downloads a microprogram into the array unit. In addition, replaces the current microprogram with a downloaded microprogram.

- Options

Options	Description
-unit unit_name	Specifies the name of an array unit whose microprogram to download and replace. Specifies with one-byte coded alphanumerics and special symbols "-" (minus)" and " <u>" (underline)" of up to 16 characters long.</u>
-read	Reads a microprogram onto the manager.
-path disk01 disk02 disk03 ...	Specifies sequentially the path names to individual directories in which each FD file of a microprogram to be downloaded is stored.
-upload	Downloads a microprogram into an array unit.
-time time	Specifies the time interval (1 to 60 seconds) at which to download a microprogram. When downloading into the DF350, specification of the interval time is ignored. See Note.
-check on off	Specifies whether or not to check the revision of a microprogram.

(Continued)

Options	Description
-change	Replaces a microprogram.
-ctl0 -ctl1	Specifies the controller whose microprogram to replace.
-revision	Displays the revision of a microprogram with which to replace.
-clean	Deletes the microprogram read in.

Note: the time interval can be specified from 0 second, however, values over 3 seconds are recommended if execution is carried out while ON.

- Examples of using command

Downloads a microprogram into an array unit whose name is df500a1, and afterward performs microprogram replacement.

Checks the revision of a microprogram of an array unit, whose name is df500a1, when downloading it.

```
% aurev -unit df500a1
micro revision : 0500
%
```

First reads in a microprogram to be downloaded. The microprogram is provided in a multiple number of floppy disks, the contents in every floppy disk have operation examples, in the case that they are stored under each of the directories disk01, disk02, disk03, disk04, disk05.

```
% amicro -unit df500a1 -read -path disk01 disk02 disk03 disk04 disk05
%
```

Checks the revision of the microprogram read in.

```
% amicro -revision
Version      : 0501
%
```

Downloads the read-in microprogram into an array unit whose name is df500a1. Sets the time interval to 3 seconds, and specifies checking of the microprogram revision. While downloading, the number of files already downloaded: mmm and the total number of files to be downloaded: nnn are shown.

```
% amicro -unit df500a1 -upload -time 3 -check on
Password :
df500a1 : mmm/nnn done.
%
```

Replaces the current microprogram with the downloaded microprogram. Replaces the microprogram on the controller 0 side and controller 1 side, in that order.

```
% aumicro -unit df500a1 -change -ct10
Password :
%
% aumicro -unit df500a1 -change -ct11
Password :
%
```

Because micro-program downloading and replacing were completed, the microprogram read in manager is removed.

```
% aumicro -clean
%
```

Downloads a microprogram into an array unit whose name is df350a1.

Checks the revision of the microprogram of an array unit, whose name is df350a1, in advance when downloading it.

```
% aurev -unit df350a1
micro revision : 0307
```

A microprogram to download is read in manager. Though a microprogram is stored in several floppy disks, the operation example when the contents of each floppy disk are stored under each directory of disk01, disk02, disk03, and disk04 is shown.

```
% aumicro -unit df350a1 -read -path disk01 disk02 disk03 disk04
%
```

Revision of the read microprogram is confirmed.

```
% aumicro -revision
micro revision : 0308
%
```

Downloads the read-in microprogram into an array unit whose name is df350a1. While downloading, the number of files already downloaded: mmm and the total number of files to be downloaded: nnn are shown.

```
% aumicro -unit df350a1 -upload
Password :
df350a1 : mmm/nnn done.
%
```

Because microprogram downloading was completed, the microprogram read in manager is removed.

```
% aumicro -clean
%
```

3.10 SNMP Environment Information

3.10.1 Setting SNMP Environment Information and Outputting Its File

- Command name

ausnmp

- Synopsis

```
ausnmp -unit unit_name -get [ -config config.txt ] [ -name name.txt ]
```

```
ausnmp -unit unit_name -set [ -config config.txt ] [ -name name.txt ]
```

- Description

Reads and sets up the SNMP environment file.

- Options

Options	Description
-unit unit_name	Specifies the name of an array unit for which to read and setup an SNMP environment file. Specifies with one-byte coded alphanumerics and special symbols "-" (minus) and "_" (underline) of up to 16 characters long.
-get	Reads SNMP environment information and outputs it into a specified file.
-set	Sets up the contents of a specified SNMP environment information file in the array unit.
-config config.txt	Specifies the file name of SNMP config information.
-name name.txt	Specifies the file name of SNMP name information.

- Examples of using command

Acquires config.txt information and name.txt information from an array unit whose name is df500a1.

```
% ausnmp -unit df500a1 -refer -config config.txt -name name.txt
%
```

Sets up config.txt information and name.txt information in an array unit (DF350) whose name is df350a1.

```
% ausnmp -unit df350a1 -set -config config.txt -name name.txt
Password :
%
```

Sets config.txt and name.txt information individually for an array unit, whose name is df400a1 and that does not support the restart.

```
% ausnmp -unit df400a1 -set -config config.txt -name name.txt
Execute this command, then access from the host will stop.
Continue (y/n [n]) : y
Password :
SNMP Configuration settings finished normally.
You need reboot the array unit to avail settings.
%
```

Sets up config.txt information and name.txt information in an array unit whose name is df500a1.

```
% ausnmp -unit df500a1 -set -config config.txt -name name.txt
Execute this command, then access from the host will stop.
Continue (y/n [n]) : y
Password :
SNMP Configuration settings finished normally.
You need reboot the array unit to avail settings.
Array unit stops accepting input and output while rebooting.
And if you already logged in, login status is canceled when the reboot starts.
Do you reboot the array unit now (y/n [n]) : y
Now reboot the array unit. Start Time HH : MM
Reboot has been completed.
%
```

3.11 Displaying Statistical Information

3.11.1 Displaying Statistical Information

- Command name

austatistics

- Synopsis

austatistics -unit unit_name -memory | -drive

- Description

Displays statistical information that has been accumulated in the array unit. Items to be displayed are as follows:

- Controller use condition
- Number of host commands received
- Command execution condition
- Cache load condition

- Options

Options	Description
-unit unit_name	Specifies the name of an array unit for which to display statistical information. Specifies with one-byte coded alphanumerics and special symbols "-" (minus) and "_" (underline) of up to 16 characters long.
-memory -drive	Specifies the location of the statistical information to be displayed. -memory: The statistical information (the current information) in the current memory is displayed. -drive: The statistical information stored in the system drive (the information at the time of activation of the array unit) is displayed.

- Examples of using command

Displays statistical information of an array unit whose name is df500a1.

```
% austatistics -unit df500a1 -memory
Controller Use Condition
Controller acting time (integrated)      :          4676
Controller acting time (work)           : 256969390
                                           CTL 0   CTL 1
Power on time                           :           22      22
Host SCSI reset time                     :          4676   4676
```

Number of Host Commands

CTL	LU	READ	WRITE
0	0	2677	3261
0	1	2752	2835
0	2	2506	2860
0	3	2614	2829
0	4	0	0
:	:	:	:
0	61	0	0
0	62	0	0
0	63	0	0
1	0	0	0
1	1	0	0
1	2	0	0
1	3	0	0
1	4	0	0
:	:	:	:
1	61	0	0
1	62	0	0
1	63	0	0

Command Execution Condition

CTL	LU	Read Cache Hits	Write Cache Hits	Sequential Reads	Sequential Writes	Prefetch Stagings	Write through Operation	Reassign Blocks
0	0	1067	2904	384	424	31229	0	0
0	1	969	2651	387	386	30291	0	0
0	2	937	2664	374	371	26475	0	0
0	3	846	2629	360	368	24916	0	0
0	4	0	0	0	0	0	0	0
:	:	:	:	:	:	:	:	:

Cache Load Condition

		CTL 0	CTL 1
Number of inflow threshold reached	:	0	0
%			

3.12 Obtaining Performance Information

3.12.1 Outputting Performance Information File

- Command name

`auperform`

- Synopsis

`auperform -unit unit_name -manual`

`auperform -unit unit_name -auto time [-count nn]`

- Description

Acquires the command operational condition of each LU in an array unit, and outputs their respective information in a text-file format into the current directory.

Items to be acquired are the following six ones.

- Number of Read commands received
- Number of the cache-hitting ones of Read commands received
- Rate of the number of the cache-hitting ones to the number of Read commands received
- Number of Write commands received
- Number of the cache-hitting ones of Write commands received
- Rate of the number of the cache-hitting ones to the number of Write commands received

The output file names are as follows:

For acquiring manually: “pfms???.txt” for a single configuration, and “pfmd???.txt” for a dual configuration (“??” is a number from 00 to 99.)

For acquiring automatically: “pfmsing.txt” for a single configuration, and “pfmdual.txt” for a dual configuration

- Options

Options	Description
-unit unit_name	Specifies the name of an array unit for which to acquire performance information. Specifies with one-byte coded alphanumerics and special symbols "-" (minus) and " <u> </u> " (underline) of up to 16 characters long.
-manual	Acquires performance information manually.
-auto time	Automatically acquires performance information at an interval of time (1 to 1439 minutes) specified for this option.
-count nn	If automatical acquisition is specified, specifies the number of times acquisition is repeated (1 to 99).

- Examples of using command

Acquires the performance information of an array unit, whose name is df500a1, only once at an interval of 10 minutes.

```
% auperform -unit df500a1 -auto 10
%
```

3.13 Monitoring Errors

3.13.1 Setting Up E-Mail Reports

- Command name

aumail

- Synopsis

aumail -refer

aumail -set [-domain domain_name] [-srv mail_server_addr]
[-from from_addr] [-add to_addr] [-rm to_addr]

aumail -test

- Description

Sets E-Mail information that is transmitted when an error is detected while monitoring errors.

- Options

Options	Description
-refer	Displays the E-Mail information set currently.
-set	Sets E-Mail information.
-domain domain_name	Specifies the domain name. Specify it in 39 or less alphanumeric characters or a code.
-srv mail_server_addr	Specifies the IP address or host name of a mail server. Specify the host name in 99 or less alphanumeric characters.
-from from_addr	Specifies the mail address of an E-Mail sender. Specify it in 99 or less alphanumeric characters or a code.
-add to_addr	Adds the mail address of an E-Mail receiver. Specify it in 99 or less alphanumeric characters or a code. Up to 20 addresses can be set as receivers.
-rm to_addr	Deletes the mail address of an E-Mail receiver.
-test	Performs a test of originating an E-Mail.

- Examples of using command

Displays the contents of an E-Mail information setup.

```
% aumail -refer
Domain name : abc.hitachi.co.jp
Mail server  : server1.abc.hitachi.co.jp
From address : sender1@str.hitachi.co.jp
To address   : receiver1@abc.hitachi.co.jp
%
```

Sets E-Mail information

```
% aumail -set -domain abc.hitachi.co.jp -srv server1.abc.hitachi.co.jp
-from sender2@abc.hitachi.co.jp -add receiver2@abc.hitachi.co.jp
%
```

Adds a receiver address.

```
% aumail -set -add receiver3@abc.hitachi.co.jp
%
```

If an error is detected on the array unit while error monitoring is executed, the following error information will be reported by E-Mail.

Usually, the subject is appended before E-Mail is transmitted.

- E-Mail subject

In the case of E-Mail, the failed part can be judged by the subject, so the failed part is appended to the subject as a matter of format. The subject format is shown below. Table 3.4 shows a list of subjects.

Manager/Obstruction (failed part)

Table 3.4 List of E-Mail Subjects

No.	Subject	Meaning
1	Disk	A drive blockade occurred.
2	DC Power	A DC power supply failure occurred.
3	Battery	A battery voltage error occurred.
4	Fan	A fan failure occurred.
5	Controller	A controller blockade occurred. (This occurs only in the dual controller configuration.)
6	AC Power	An AC power supply error occurs.
7	Cache Memory	A cache failure occurred.
8	Cache Backup Circuit	A backup circuit failure occurred.
9	ENC	An enclosure error occurs.
10	loop	A loop error occurs.
11	Warning	The array unit entered the warning state.
12	Array connection	A failure occurred in the connection with the array unit. A power OFF or a failure occurred in the array unit.

- E-Mail message text

The E-mail reports a failed section with a message text. The format of the message text is shown below. A list of message texts is shown in Table 3.5.

Day, Mon.dd hh:mm:ss yyyy/DF Name/ARRAY message text

Day: Day of the week **hh:mm:ss:** Hours, minutes, and seconds

Mon: Month **yyyy:** Year

dd: Date

Table 3.5 List of E-Mail Message Texts

No.	Message text	Meaning of message
1	ARRAY Drive Detached ARRAY Detached Drive Position Port No.X Row No.Y	A drive blockade occurred. (The blocked drive is indicated with a set of a Port No. and a Row No.)
2	ARRAY DC Power Supply Failure	A DC power supply failure occurred.
3	ARRAY Battery Alarm	A battery voltage error occurred.
4	ARRAY Fan Alarm	A fan failure occurred.
5	ARRAY CONTROLLER Detached	A controller blockade occurred. (This occurs only in the dual controller configuration.)
6	ARRAY AC Power Supply Failure	An AC power supply error occurs.
7	ARRAY Cache Memory Alarm	A cache failure occurred.
8	ARRAY Cache Backup Circuit Alarm	A backup circuit failure occurred.
9	ARRAY ENC Alarm	An enclosure error occurs.
10	ARRAY Loop Alarm	A loop error occurs.
11	ARRAY Warning	The array unit entered the warning state.
12	ARRAY Manager Interface error occurred	A failure occurred in the connection with the array unit. A power OFF or a failure occurred in the array unit.

3.13.2 Setting the Starting of Application

- Command name

auextprog

- Synopsis

auextprog -refer

auextprog -set command

auextprog -test

- Description

Sets up an external program that is started when an error is detected while monitoring errors.

- Options

Options	Description
-refer	Displays (references) the external program setup.
-set command	Sets up an external program that is started when an error is detected while monitoring errors.
-test	Starts an external program specified by the -set option.

- Examples of using command

Sets up the application “go” to be started.

```
% auextprog -set go
%
```

Displays an application setup to be started.

```
% auextprog -refer
Program name      : go
%
```

3.13.3 Monitoring Errors

- **Command name**

auerroralert

- **Synopsis**

auerroralert [-time uptime] [-mail] [-prog every | once]

- **Description**

Monitors an array unit subject to monitoring (an array unit registered by specifying the `-watch` option) for errors. While monitoring errors, the word “Execution” indicating that monitoring is in execution, and information on failures that are detected by the error monitor are displayed. The contents of failure information displayed are the same as those of messages output to a log file. The word “Execution” indicating that monitoring is in execution is displayed repeatedly on a line, and the time for which monitoring is in execution is updated and displayed.

Terminates forcibly to stop monitoring for errors (for example, press “ctl” + “c”).

- **Options**

Options	Description
<code>-time uptime</code>	Specifies the time interval at which to monitor errors. Specifies a value from 1 to 720 (minutes). If omitted, monitors only once.
<code>-mail</code>	Originates an E-Mail when an error is detected.
<code>-prog every once</code>	Starts an external program when an error is detected. every: After error monitoring is started, a specified application is started when an error is detected. If the same error is detected while monitoring errors, the application is no longer started from the second detection onward. once: After error monitoring is started, a specified application is started when an error is detected for the first time. If errors are detected continuously, the application is not started. After a specified application is started, in order to start the application again when an error is detected, terminate and then restart error monitoring.

- **Examples of using command**

Monitors errors at an interval of 10 minutes. During error monitoring, a battery failure is detected in an array unit whose name is df400a1.

```
% auerroralert -time 1
Mon, May 01 10:10:00 2000 Executing
Mon, May 01 10:30:00 2000/df400a1/ARRAY Battery Alarm
Mon, May 01 10:40:00 2000 Executing
```

When a failure is detected in the array unit in the case where the error monitoring is executed, the function outputs the failure information to a log file.

The log file is output, with a file name: errlog.txt and in a text file format, onto a path setup by the CMDF_PATH environmental variable. The file format is shown in the following figure.

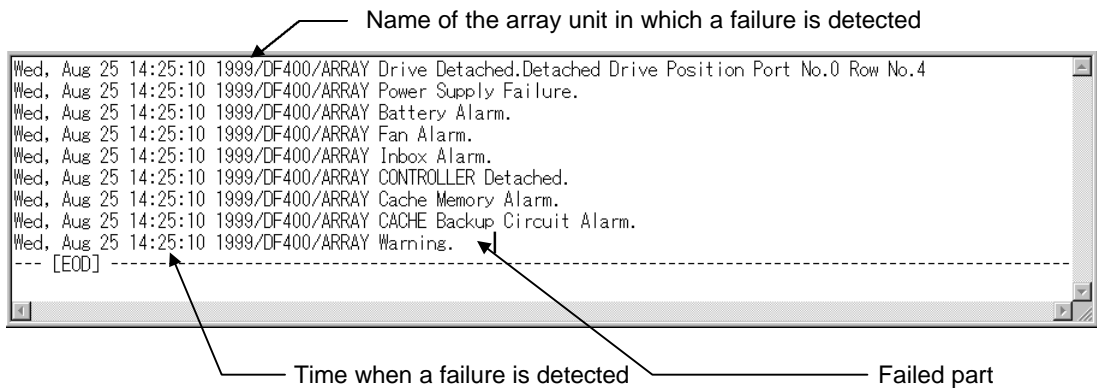
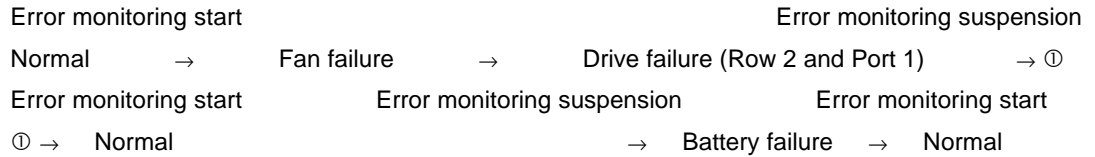

The log file is output up to 223 k byte or up to 2,000 events. When the log information exceeds the limit, the log information is overwritten from the top of the file and output.

“--- end ---” is output is at the end of log information, and hence search for “--- end ---” to determine the latest information.

Note: The failure detection time is a time of the clock on a personal computer or SUN server/workstation in which the Manager has been installed.

The log information to be output reports the failed part using a message text. The format of message text is shown below. A list of message texts is shown in Table 3.6.

Day, Mon. dd hh:mm:ss yyyy/DF Name/ARRAY message text

Day: Day of the week **hh:mm:ss:** Hours, minutes, and seconds

Mon: Month **yyyy :** Year

dd: Date

Table 3.6 List of Message Texts to Be Output

No.	Message text	Meaning of message
1	Alert Started.	The error monitoring is started.
2	ARRAY Drive Detached. Detached Drive Position Port No.X Row No.Y	A drive blockade occurred. (The blocked drive is indicated with a set of a port No. and a row No.)
3	ARRAY DC Power Supply Failure	A DC power supply failure occurred.
4	ARRAY Battery Alarm	A battery voltage error occurred.
5	ARRAY Fan Alarm	A fan failure occurred.
6	ARRAY CONTROLLER Detached	A controller blockade occurred. (This occurs only in the dual controller configuration.)
7	ARRAY AC Power Supply Failure	An AC power supply error occurs.
8	ARRAY Cache Memory Alarm	A cache failure occurred.
9	ARRAY Cache Backup Circuit Alarm	A backup circuit failure occurred.
10	ARRAY ENC Alarm	An enclosure error occurs.
11	ARRAY Loop Alarm	A loop error occurs.
12	ARRAY Warning	The array unit entered the warning state.
13	ARRAY Manager Interface error occurred	A failure occurred in the connection with the array unit. A power OFF and a failure occurred in the array unit.
14	ARRAY Manager Interface error occurred. Error Code (nnnnn).	When the array unit was connected via an LAN, a connection disability occurred. nnnnn: Winsoc error code
15	ARRAY Manager Interface error occurred.	When the array unit was connected via RS232C, a connection disability occurred.
16	Errinf.Txt File Error (xxxx).	A failure occurred in an access to a work file. xxxx: OPEN : File open failure xxxx: File operation failure

Chapter 4 Manager Operation Procedure

The following describes basic operation procedures of the manager after installation.

4.1 Executing commands by setting administrator mode

1. Setting password

When, as an administrator of the array unit, performing operations on the manager such as setting up the configuration of an array unit, a password is required. For this, first sets a password. Use an `aupasswd` command to set a password. A password, if set once, is saved in the workstation, so a password does not need setting at every operation.

Note that changing a password at regular intervals is recommended. An `aupasswd` command is also used to change a password.

2. Registering array unit

Registers in the manager an array unit that you operate. Uses an `auunitadd` command to register an array unit. When registering, gives a unique unit name (up to 16 alphanumeric characters) to one array unit, and registers information such as the unit type (DF350, DF400), a configuration (Single, Dual), and a connection interface (LAN, RS232C). This time, a registered array unit name is used as a key word to specify an array unit with individual commands of the manager. Array unit information, if registered once, is kept under control of the manager, so array unit information does not need registering at every operation.

In addition, uses an `auunitchg` command to change the registered contents. In such a case as when a unit no longer needs to be controlled by the manager, registered unit information can be deleted with an `auunitdel` command.

3. Operations with various commands

After an array unit is placed under control of the manager by registering the unit, performs operations on the array unit such as referencing, setting, and monitoring by use of various manager commands.

4.2 Executing commands using a user ID

1. Setting user ID

Registers the user ID of a user who manages an array unit that has been registered in the Manager. Uses an `auuidadd` command to setup a user ID.

Note that once a user ID is registered, commands cannot be executed on the relevant array units without entering the user ID (log in : `aulogin`).

2. Logging into array unit

Logs into an array unit with a registered user ID. Uses an `aulogin` command.

When forcibly logging into an array unit to which another user has already logged in, uses an `aulogin` command with the `-discon` option appended.

3. Operations with various commands

After an array unit is placed under control of the Manager by registering the array unit, performs operations on the array unit such as referencing, setting, and monitoring by use of various Manager commands. When executing commands after logged in, you are not prompted to enter the user ID used for logging in and the password.

4. Logging out from array unit

Logs out from an array unit to which you have logged in. Uses an `aulogout` command.

Chapter 5 Examples of Using Command

The following shows an example in which one RAID group is setup in an array unit, and then one logical unit is setup.

```
% aupasswd -----For registering a password.
New password : -----Enters a password.
Retype new password : -----Enters the password again.
%
% auunitadd -unit array01 -DF400 -dual -LAN -ct10 125.0.9.98 -ct11 125.0.9.99
-----Registers a DF400 array unit with a dual
configuration by unit name array01. The connection
interface is LAN connection for both unit.

% auunitref -----Checks that registration is complete.
Unit Group Array Type Watch Comm Device/IP addresses
array01 DF400 Dual off LAN 125.0.9.98 125.0.9.99
%
% aurgadd -unit array01 -rg 0 -RAID5 -row 0 -port 0 -width 5 -depth 1
-----Adds a RAID group with a RAID5 level.

Password : -----Enters a already-registered password.
%
% auluadd -unit array01 -----Checks that a RAID group has been configured.
RG Level Port Width Row Depth
0 5 0 5 0 1
%
% auliadd -unit array01 -lu 0 -rg 0 -size 100352 -ct10--- Adds LU0.
Password : -----Enters a already-registered password.
%
% auluref -unit array01 -----Checks that an LU has been configured.
LU Capacity Status Staging C-CTL D-CTL RG RAID
0 100352 Unformat 512 0 0 0 5
```

Disk Array management program
(for CLI)

User's Guide

Ninth edition February, 2001

HITACHI