

3.3 Hardware Installation

3.3.1 How to open/close the Cover.

SVP Cover	INST03-20
Movable Rack Cover 1	INST03-30
Movable Rack Cover 2	INST03-40
Movable Rack Cover 3	INST03-50
Logic Box Cover 1	INST03-60
Logic Box Cover 2	INST03-70
Logic PS Box Cover 1	INST03-80
Logic PS Box Cover 2	INST03-90
Cache Box Cover 1	INST03-100
Cache Box Cover 2	INST03-110

3.3.1.1 SVP Cover

- a. Loosen the two screws.
- b. Open the SVP Cover.
- c. Open the SVP screen.

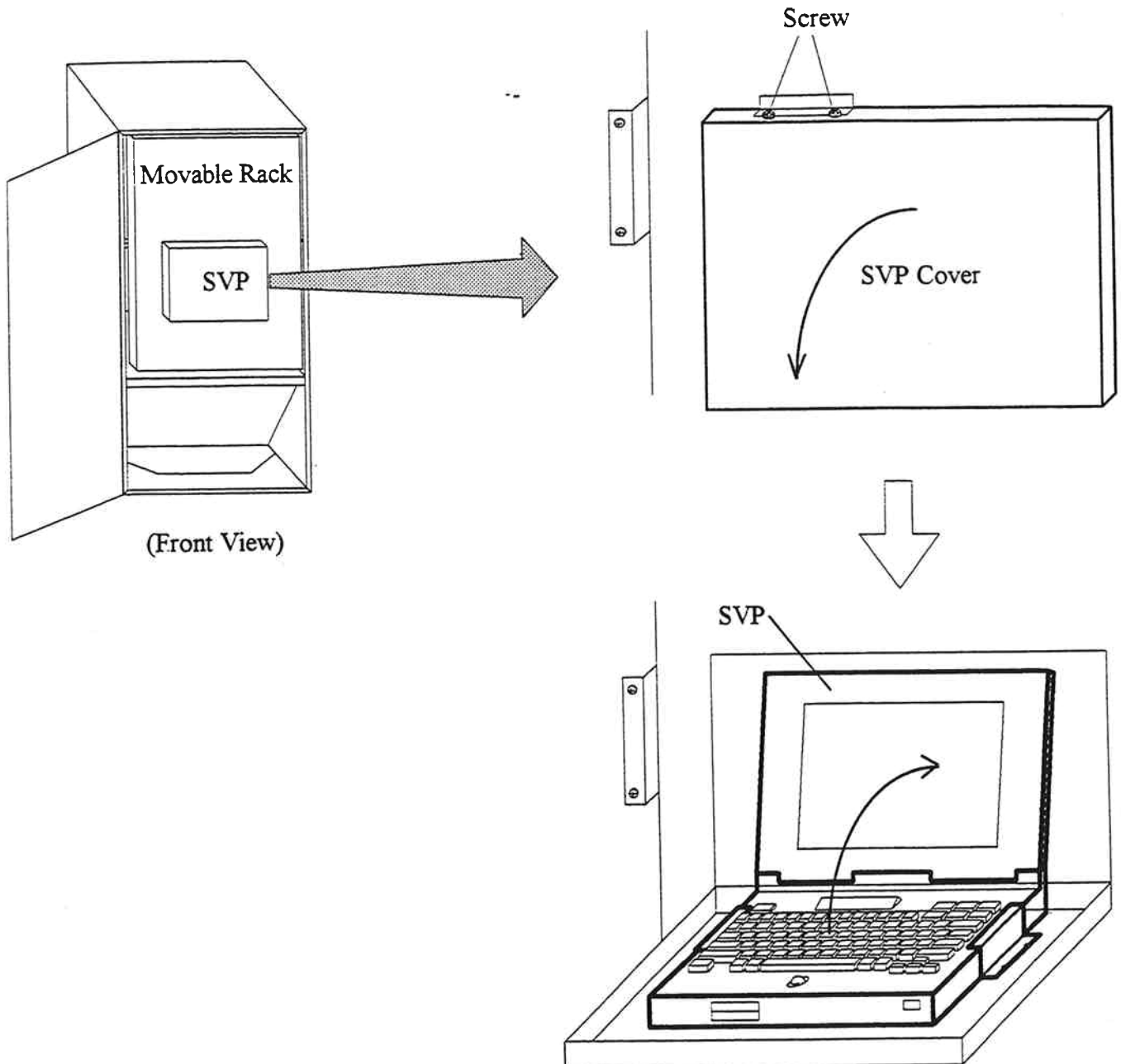

3.3.1.2 Movable Rack Cover 1

Attachment

- a. Attach Movable Rack Cover 1 to the Movable Rack.
- b. Tighten the four screws.

Removal

- a. Loosen the four screws.
- b. Remove Movable Rack Cover 1 from the Movable Rack.

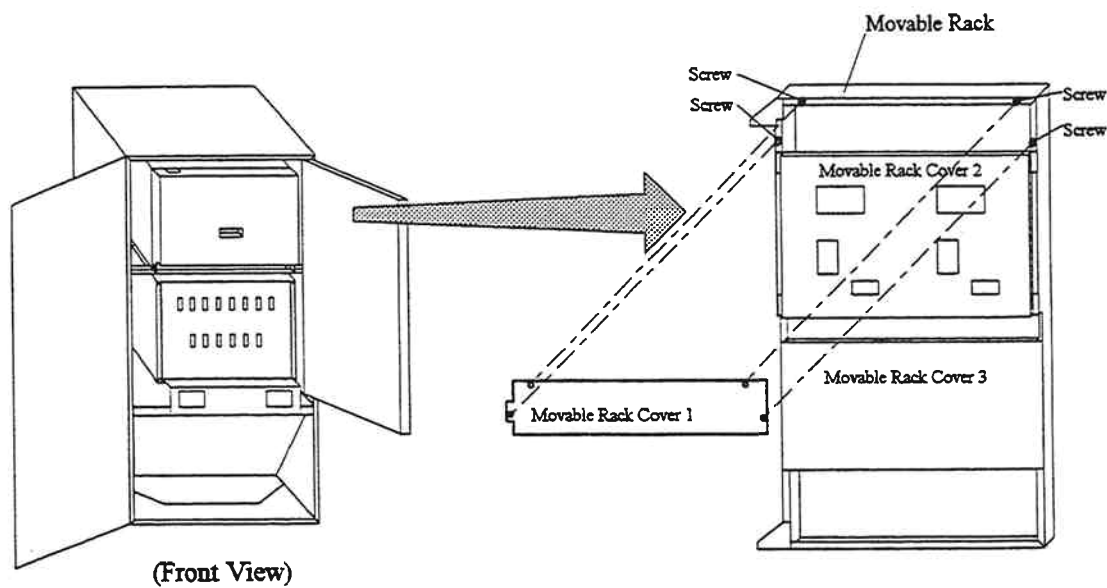

3.3.1.3 Movable Rack Cover 2

Attachment

- a. Attach Movable Rack Cover 2 to the Movable Rack.
- b. Tighten the four screws.

Removal

- a. Loosen the four screws.
- b. Remove Movable Rack Cover 2 from the Movable Rack.

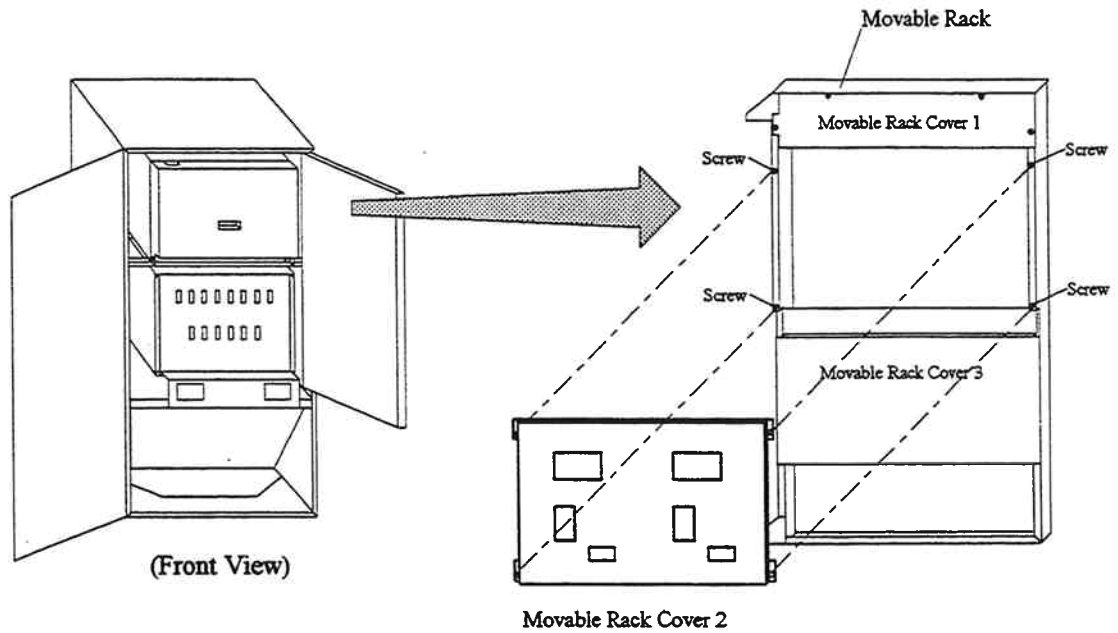

3.3.1.4 Movable Rack Cover 3

Attachment

- a. Attach Movable Rack Cover 3 to the Movable Rack.
- b. Tighten the four screws.

Removal

- a. Loosen the four screws.
- b. Remove Movable Rack Cover 3 from the Movable Rack.

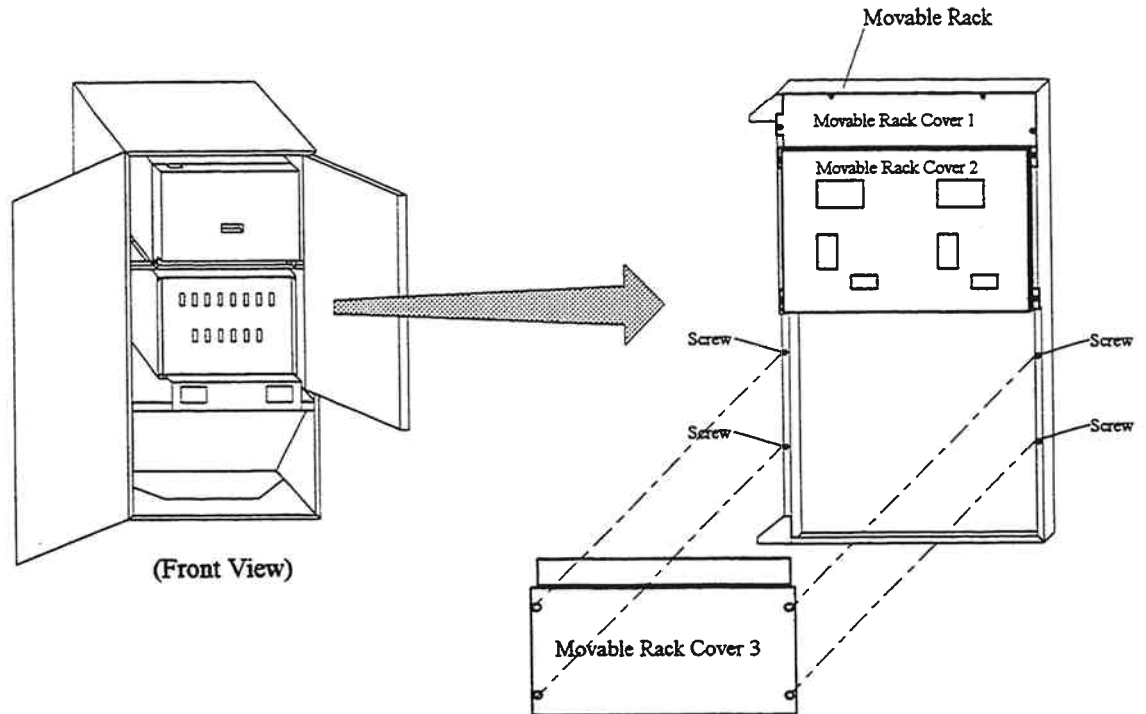

3.3.1.5 Logic Box Cover 1

Attachment

- a. Attach Logic Box Cover 1 to the Logic Box.
- b. Tighten the three screws.

Removal

- a. Loosen the three screws.
- b. Remove Logic Box Cover 1 from the Logic Box.

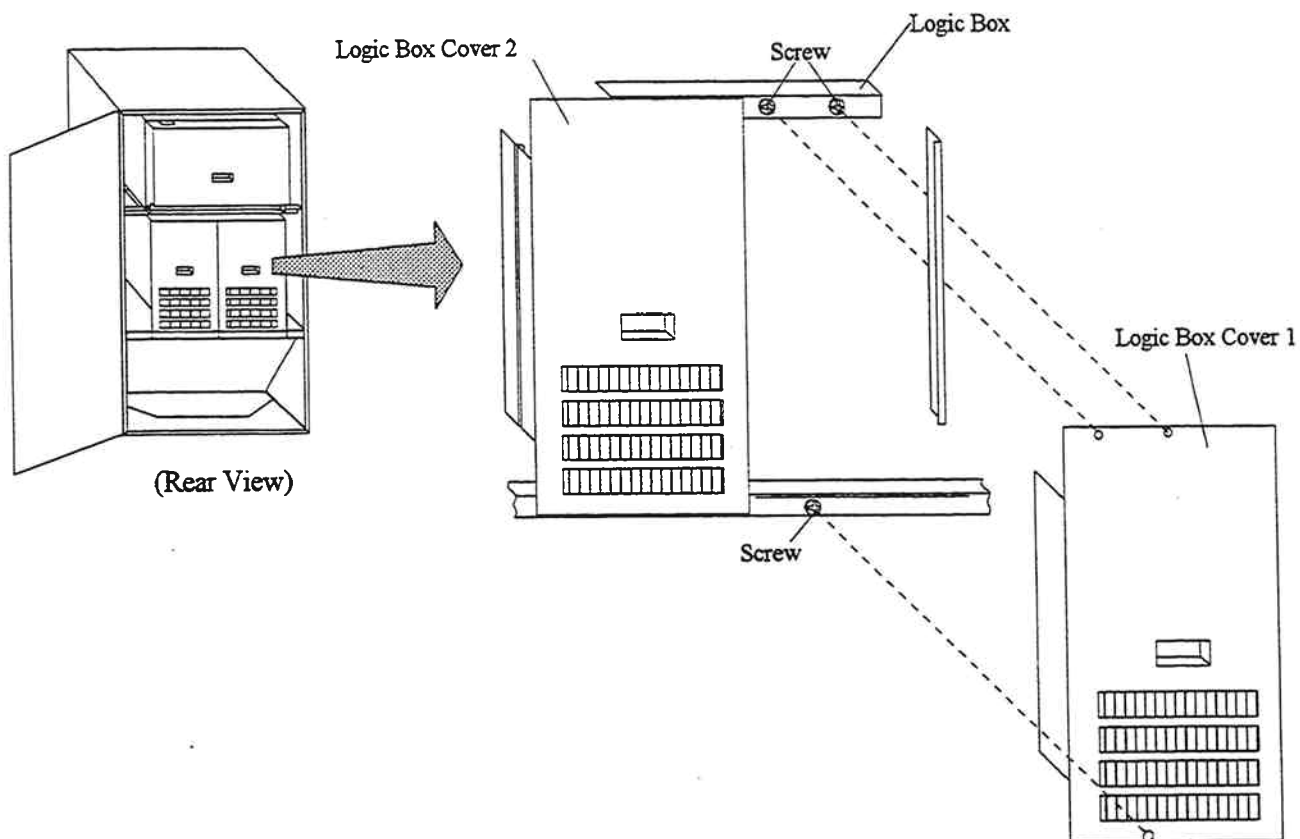

3.3.1.6 Logic Box Cover 2

Attachment

- a. Attach Logic Box Cover 2 to the Logic Box.
- b. Tighten the three screws.

Removal

- a. Loosen the three screws.
- b. Remove Logic Box Cover 2 from the Logic Box.

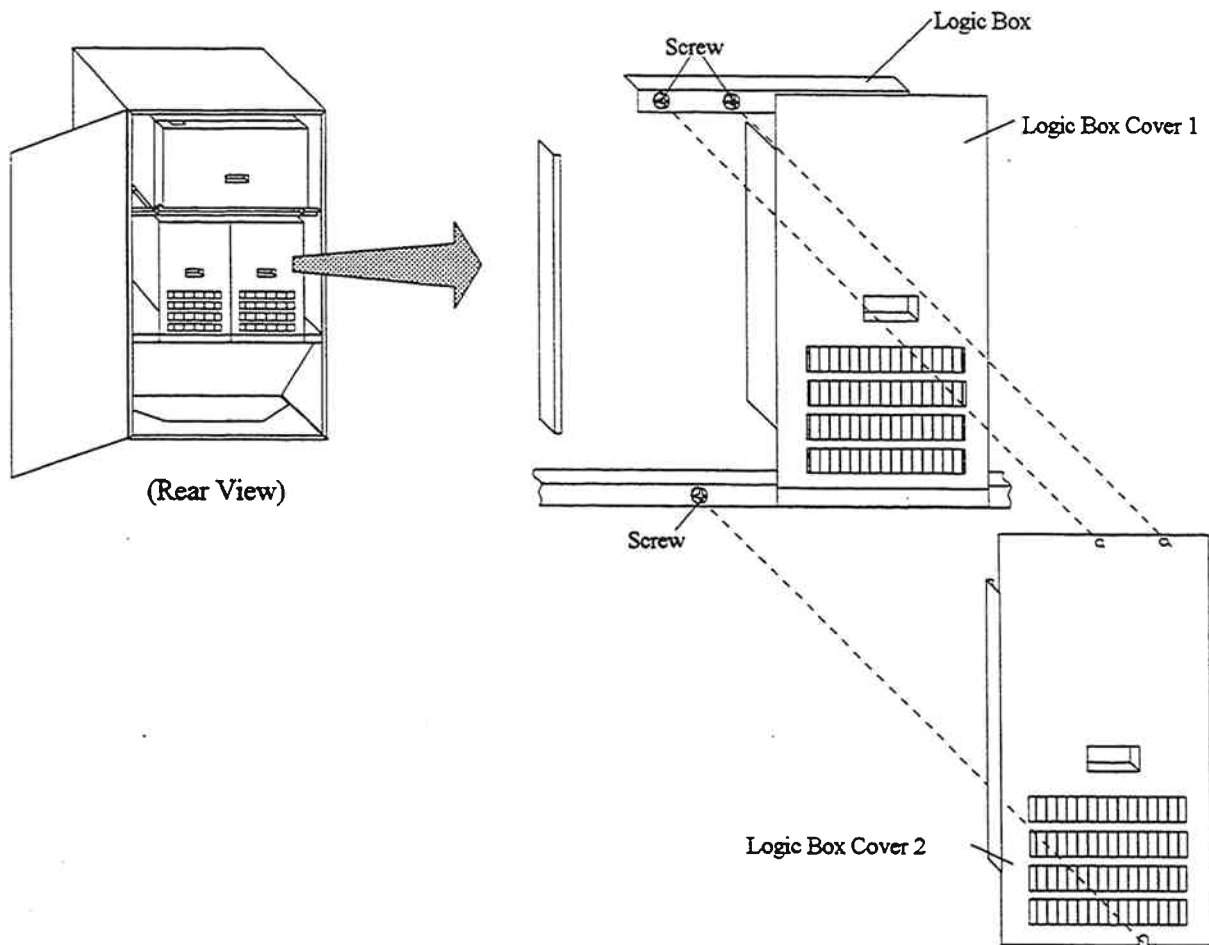

3.3.1.7 Logic PS Box Cover 1

Attachment

- a. Attach Logic PS Box Cover 1 to the Logic PS Box.
- b. Tighten the four screws.

Removal

- a. Loosen the four screws.
- b. Remove Logic PS Box Cover 1 from the Logic PS Box.

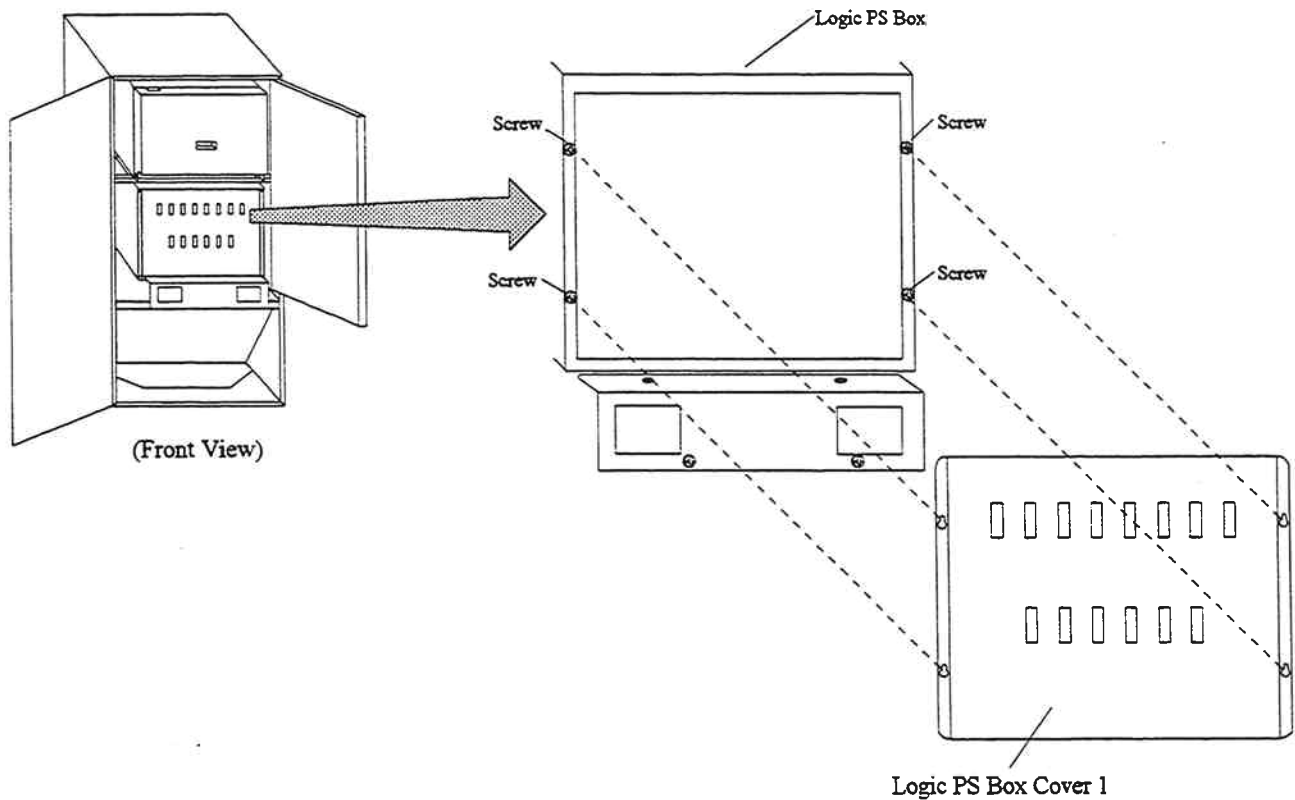

- Logic PS Box Cover 1 (Type 1)
In case of DKC210I S/N 30001-30434,
40001-40218,
50001-50175

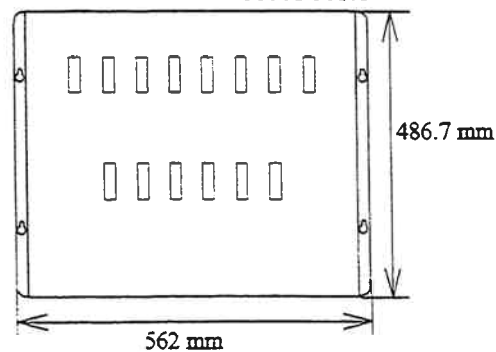

- Logic PS Box Cover 1 (Type 2)
In case of DKC210I S/N 30435-, 40219-,
50176-

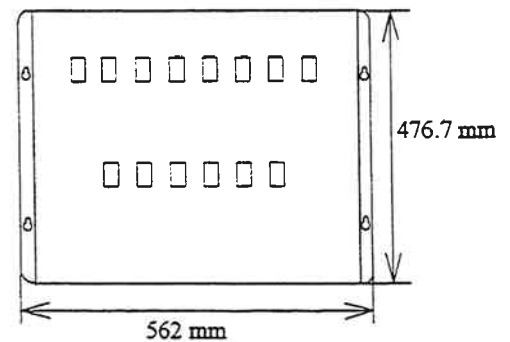

3.3.1.8 Logic PS Box Cover 2

Attachment

- a. Attach Logic PS Box Cover 2 to the Logic PS Box.
- b. Tighten the four screws.

Removal

- a. Loosen the four screws.
- b. Remove Logic PS Box Cover 2 from the Logic PS Box.

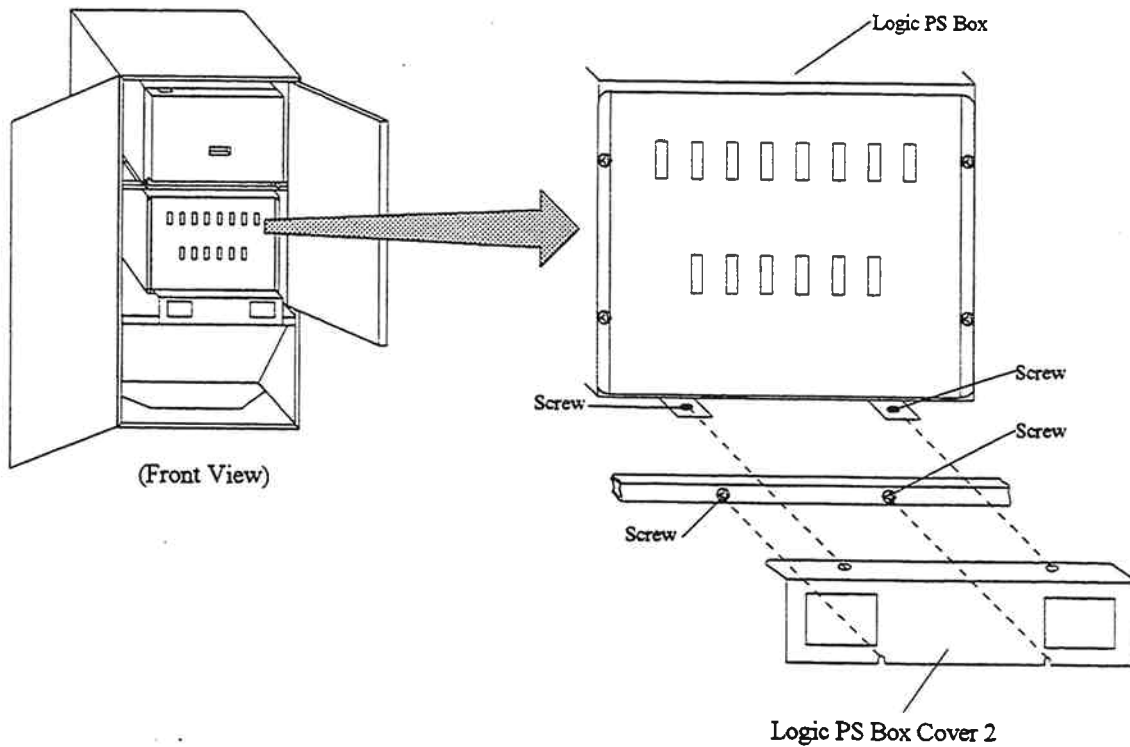

• Logic PS Box Cover 2 (Type 1)

In case of DKC210I S/N 30001-30434,
40001-40218,
50001-50175

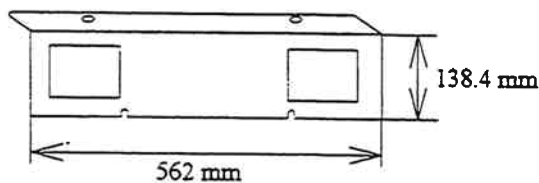

• Logic PS Box Cover 2 (Type 2)

In case of DKC210I S/N 30435-, 40219-,
50176-

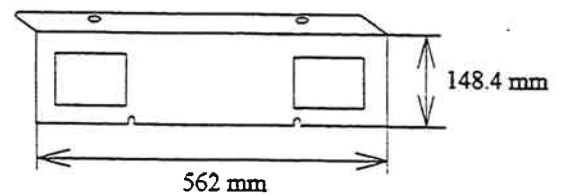

3.3.1.9 Cache Box Cover 1

Attachment

- a. Attach Cache Box Cover 1 to the Cache Box-1.
- b. Tighten the four screws.

Removal

- a. Loosen the four screws.
- b. Remove Cache Box Cover 1 from the Cache Box-1.

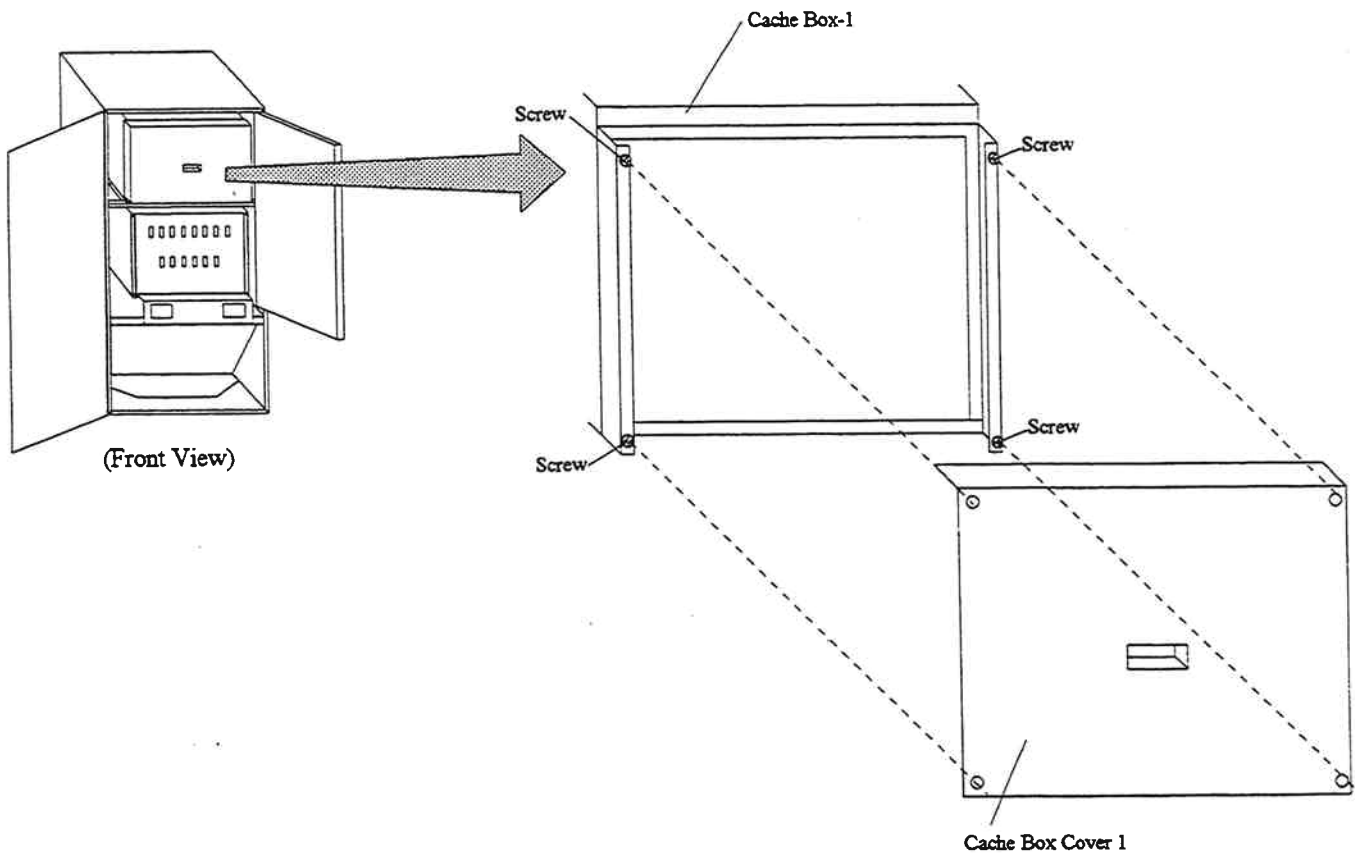

3.3.1.10 Cache Box Cover 2

Attachment

- a. Attach Cache Box Cover 2 to the Cache Box-2.
- c. Tighten the four screws.

Removal

- a. Loosen the four screws.
- b. Remove Cache Box Cover 2 from the Cache Box-2.

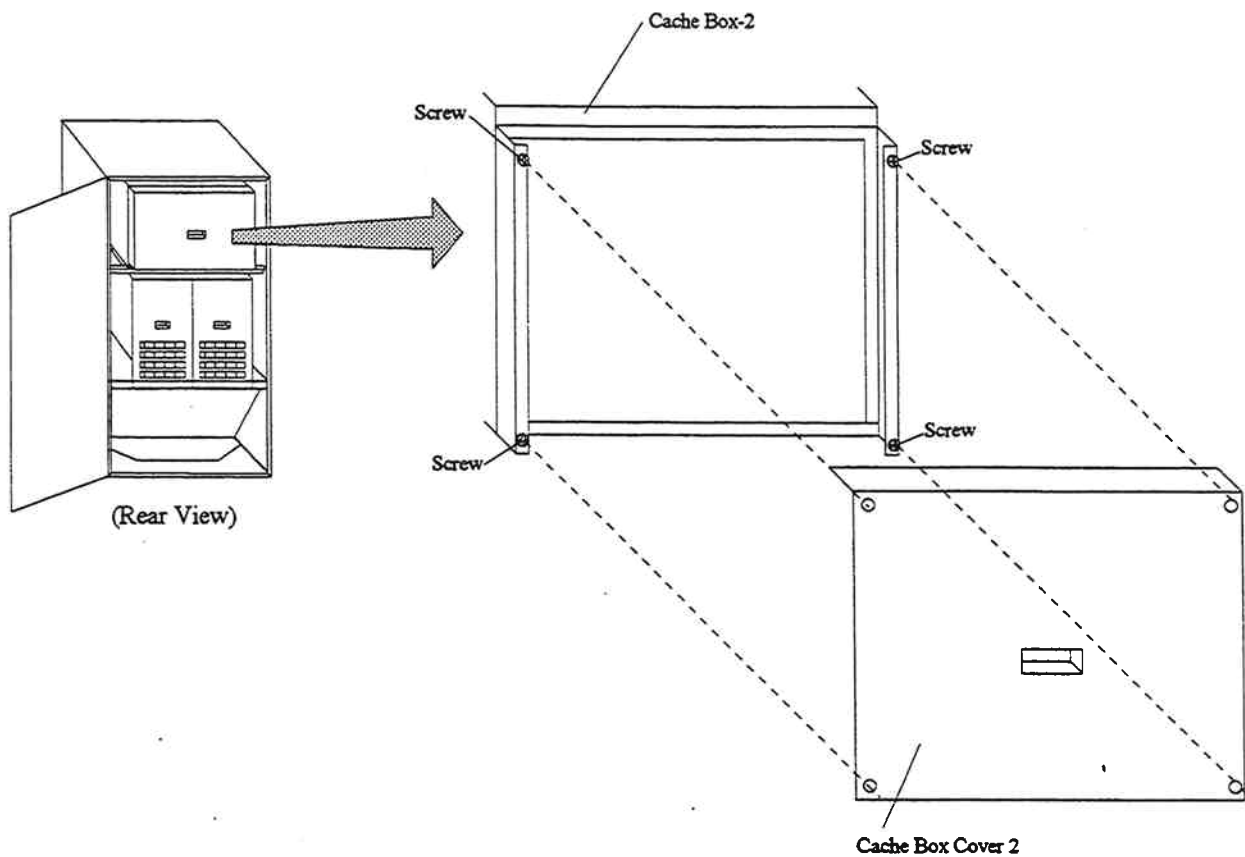

3.3.2 UNPACKING AND INSPECTION

Receiving and Inspection

Before unpacking the unit, check the physical condition of the packed unit.

1. Prior to unpacking, check the container for visible damage or any indication of excessive shock, tilt or anything else abnormal during transportation and handling.
2. Obtain and check shipping manifest for missing units.
3. If anything abnormal is found, appropriate action should be taken before starting an installation.

Unpacking Procedure

NOTICE:

- Be very careful when handling the equipment.
- Do not drop the equipment from a height more than 5mm(0.2in.)high.
- Floor unevenness must be less than 10mm(0.4in.). Move slowly and lift the four screw jacks at the bottom of each frame to the highest position to prevent contact with the ramp.

3.3.2.1 Unpacking

3.3.2.1.1 Disk Controller (DKC210)

1. Card board crate overview is shown in Fig. 3.3.2.1.1-1.
2. Cut the polyester bands.
3. Remove the nails.

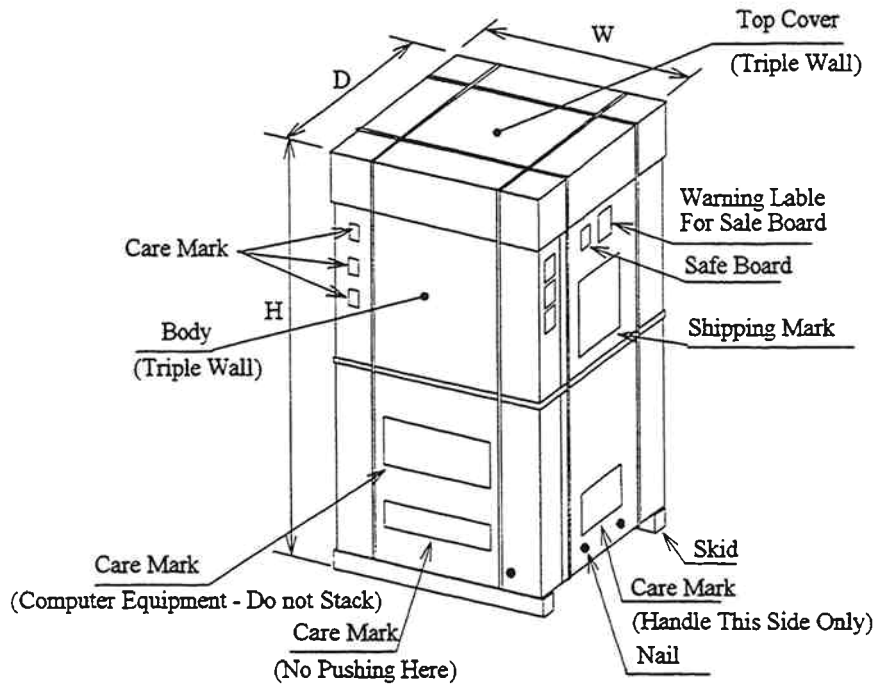

Fig. 3.3.2.1.1-1 Card Board Crate Overview

4. Remove Top Cover and Side Covers.

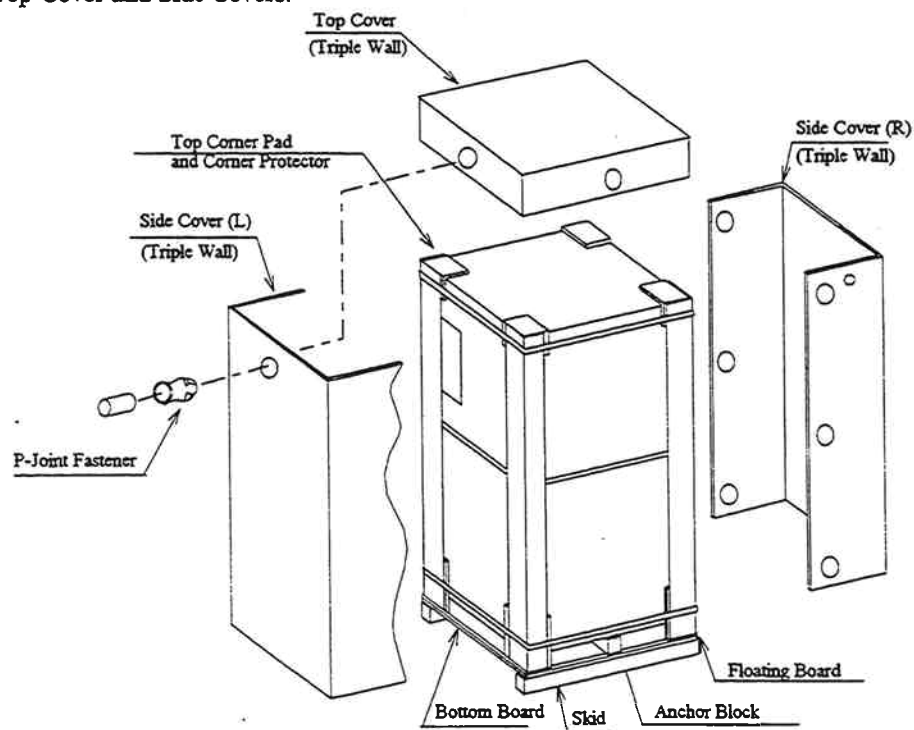

Fig. 3.3.2.1.1-2 Breakdown of CARD BOARD Crate

5. Take the equipment down from FLOATER by lifting the equipment with forklift a minimum amount needed to remove the FLOATER/DECK/SKID assembly.
6. Gently lower the equipment onto floor.
7. Remove adhesive tape and corner protectors.

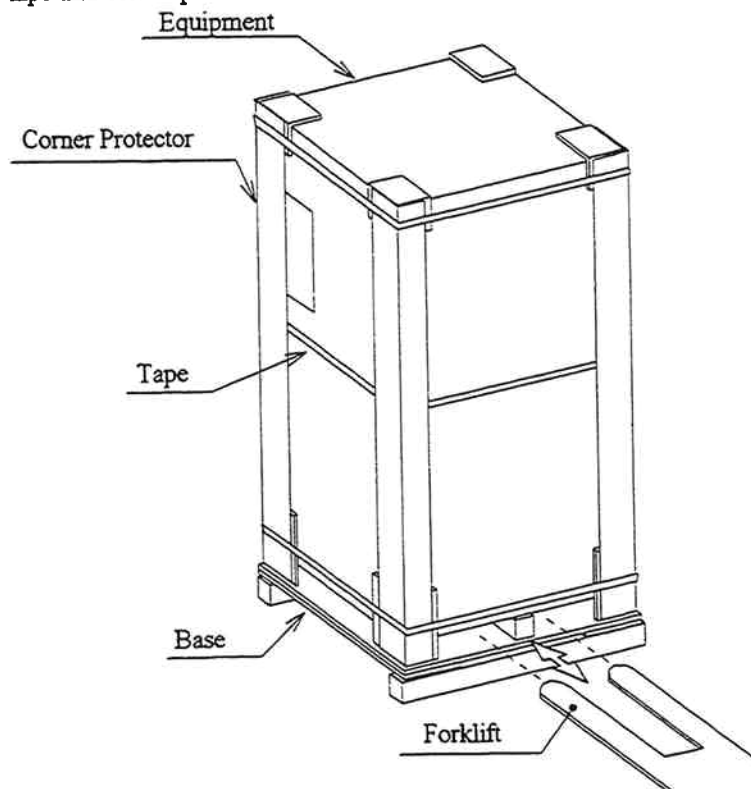

Fig. 3.3.2.1.1-3 Lift of Equipment.

8. Remove the polyethylene bag and adhesive tape.

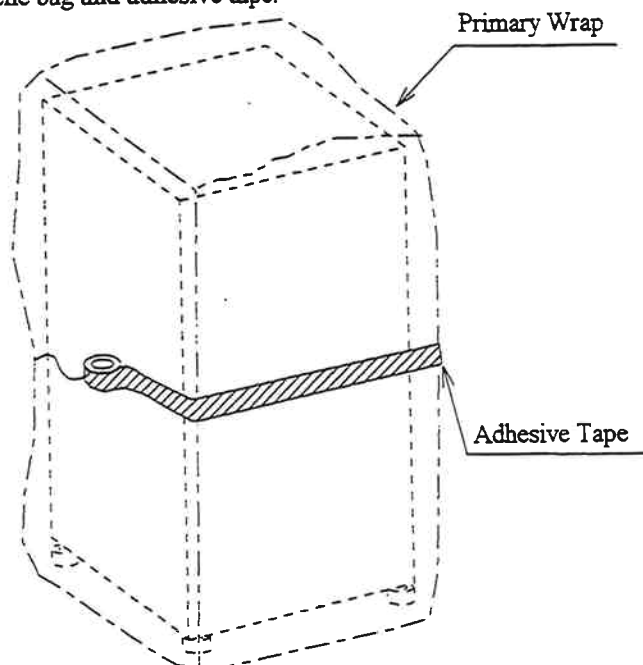

Fig. 3.3.2.1.1-4 Removal of Wrap Material.

9. Remove the band.

10. Remove the adhesive tape and cushions from Operator Panel Cover.

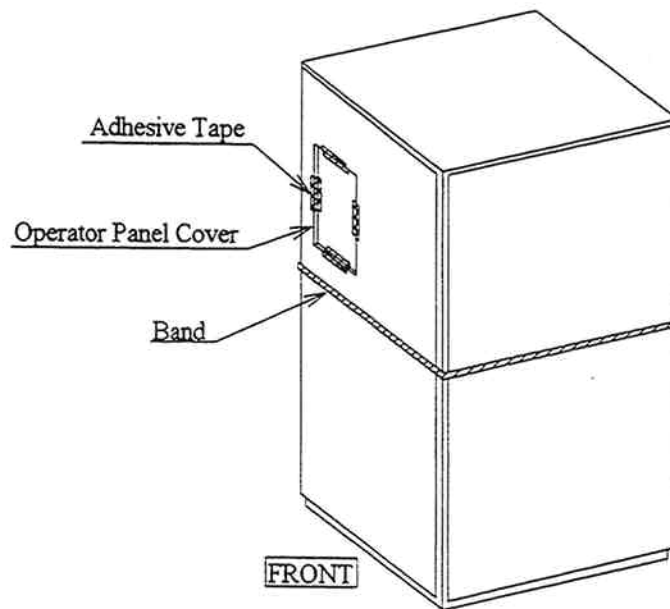

Fig. 3.3.2.1.1-5 Surface Unpacking

11. Open the front and rear door, remove the shipping cushions and tapes from the container.

12. Visually check the unit for any damage.

3.3.2.1.2 Disk Unit (DKU205I-14)

1. The container overview is shown in Fig. 3.3.2.1.2-1.
2. Cut the polyester bands.
3. Remove the nails and washers on the lower part of the crate.
4. The container breakdown is shown in Fig. 3.3.2.1.2-2
5. Unfasten P-JOINT Fasteners.
6. Remove the cap by lifting.
7. Remove the sleeves.
8. Cut polypropylene tapes.
9. Remove the corner protectors.
10. Break the seal of polyethylene bag and open it
11. Take the unit down from the FLOATER by lifting the unit with forklift a minimum amount needed to remove FLOATER/DECK/SKID assembly.
11. Gently lower the equipment onto floor.
13. Remove adhesive tape and cushions from the unit.
14. Visually check the unit for any damage.

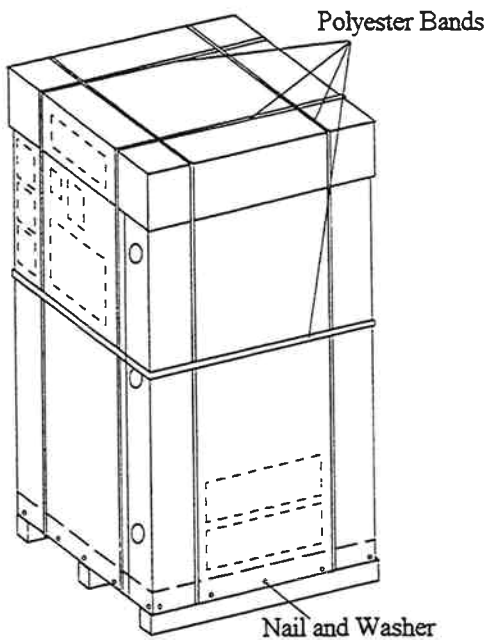

Fig. 3.3.2.1.2-1 Container Overview

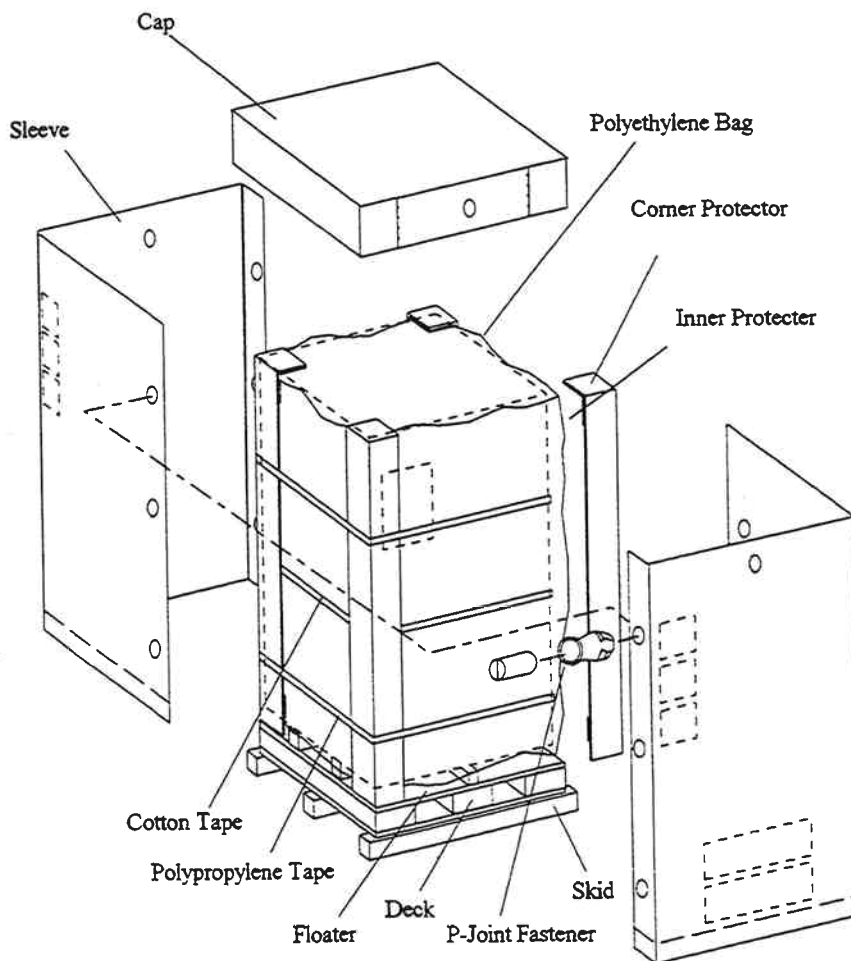

Fig. 3.3.2.1.2-2 Breakdown of Container

3.3.2.1.3 Platform for Additional Cache Assembly (DKC-F210I-40)

1. The container overview is shown in Fig. 3.3.2.1.3-1.
2. Cut the polyester bands.
3. Open the container.
4. Break the seal of polyethylene bag and open it
5. Gently lower the equipment onto floor.
6. Visually check the unit for any damage.

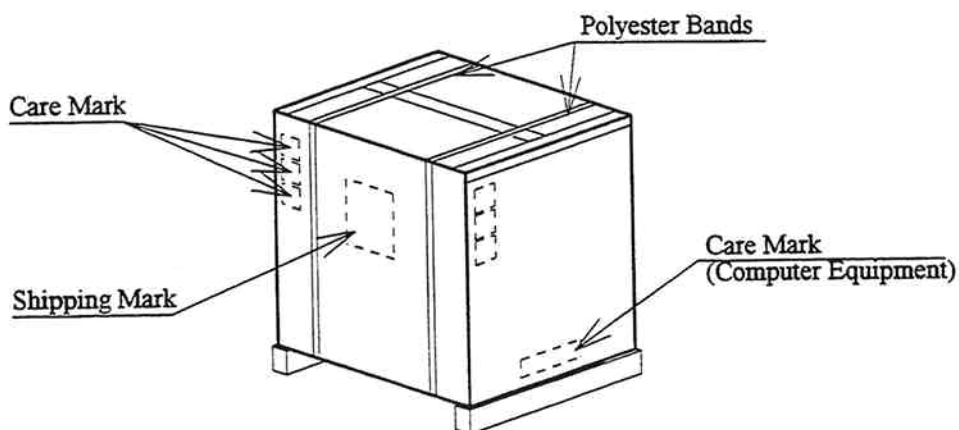

Fig. 3.3.2.1.3-1 Container Overview

3.3.2.1.4 Platform for Canister Mount (DKU-F205I-B4)

1. The container overview is shown in Fig. 3.3.2.1.4-1.
2. Cut the polyester bands.
3. Open the container.
4. Break the seal of polyethylene bag and open it
5. Gently lower the equipment onto floor.
6. Visually check the unit for any damage.

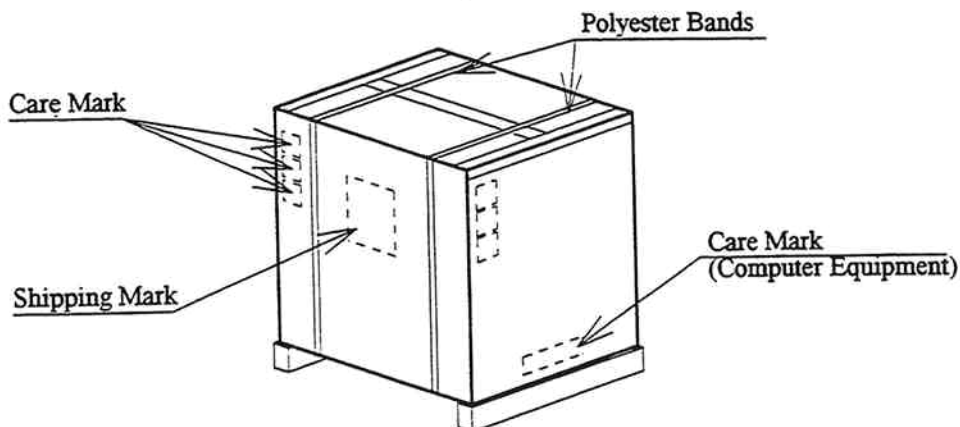

Fig. 3.3.2.1.4-1 Container Overview

3.3.2.2 Inspection of Packaged Parts and Accessories.

1. Match the unpacked parts against the parts lists in Tables 3.3.2.2-1 through 3.3.2.2-4 to verify that all parts are supplied.

DKC210IU

Table 3.3.2.2-1 List of Packaged Parts and Accessories (Disk Controller)

(Basic)

No.	Name of parts	Parts number	Quantity/Unit	Remarks
1	Disk Controller	-----	1	
2	Kick Plate (Side)	3236815-1	2	
3	Kick Plate (F/R)	3236816-1	2	
4	Screw (Black)	5411531-2	4	
5	Jumper Connector (P/S)	3240062-D	1	P311(230V)
6	Jumper Connector	3240204-A	2	P15
7	Jumper Connector	3240272-A	2	SD
8	Side Cover	3236770-C	1	
9	Screw (M5x36)	SB536	4	
10	LL-Washer	2051001-532	4	

DKC210IE

Table 3.3.2.2-2 List of Packaged Parts and Accessories (Disk Controller)

(Basic)

No.	Name of parts	Parts number	Quantity/Unit	Remarks
1	Disk Controller	-----	1	
2	Kick Plate (Side)	3236815-1	2	
3	Kick Plate (F/R)	3236816-1	2	
4	Screw (Black)	5411531-2	4	
5	Jumper Connector	3240204-A	2	P15
6	Jumper Connector	3240272-A	2	SD
7	Side Cover	3236770-C	1	
8	Screw (M5x36)	SB536	4	
9	LL-Washer	2051001-532	4	

DKC210IE (CPX)

Table 3.3.2.2-3 List of Packaged Parts and Accessories (Disk Controller)

(Basic)

No.	Name of parts	Parts number	Quantity/Unit	Remarks
1	Disk Controller	-----	1	
2	Kick Plate (Side)	3236815-1	2	
3	Kick Plate (F/R)	3236816-1	2	
4	Screw (Black)	5411531-2	4	
5	Jumper Connector	3240204-A	2	P15
6	Jumper Connector	3240272-A	2	SD
7	Maintenance Manual (1/10)	-----	1	
8	Maintenance Manual (2/10)	-----	1	
9	Maintenance Manual (3/10)	-----	1	
10	Maintenance Manual (4/10)	-----	1	
11	Maintenance Manual (5/10)	-----	1	
12	Maintenance Manual (6/10)	-----	1	
13	Maintenance Manual (7/10)	-----	1	
14	Maintenance Manual (8/10)	-----	1	
15	Maintenance Manual (9/10)	-----	1	
16	Maintenance Manual (10/10)			
17	Side Cover	3236770-C	1	
18	Screw (M5x36)	SB536	4	
19	LL-Washer	2051001-532	4	
20	Setup Installer (Floppy Disk)	5486291-11	1	
21	DKC Main (Floppy Disk)	5486291-12	1	
22	DKC Main (Floppy Disk)	5486291-13	1	
23	DKC Main (Floppy Disk)	5486291-14	1	
24	DKC Main (Floppy Disk)	5486291-15	1	
25	SVP (Floppy Disk)	5486291-16	1	
26	SVP (Floppy Disk)	5486291-17	1	
27	SVP (Floppy Disk)	5486291-18	1	
28	LCP/MPC/LCDG (Floppy Disk)	5486291-19	1	
29	CUDG4 (Floppy Disk)	5486291-20	1	
30	DKU (Floppy Disk)	5486291-21	1	
31	S-SVP (Floppy Disk)	5486291-22	1	
32	Ramboot (Floppy Disk)	5486291-23	1	
33	Config (Floppy Disk)	5486291-24	1	
34	Dump (Floppy Disk)	5486291-25	16	

DKU205IE/U

Table 3.3.2.2-4 List of Packaged Parts and Accessories (Disk Unit)

No.	Name of parts	Parts number	Quantity/Unit	Remarks
1	Disk Unit	-----	1	
2	Kick Plate	3239219-1	2	Note 1
3	Connecting Bolt Assy	5437962-A	4	
4	Screw (Black)	5409006-1	4	
5	Connecting Screw Assy	5487372-A	2	
6				

Note 1: This is packed with drive unit.

2. Return to General Flow.

New Installation: Go to INST02-10 step (2).

Non-Disruptive Installation: Go to INST02-20 step (2).

Disruptive Installation: Go to INST02-35 step (2).

3.3.3 Basic Subsystem Installation

See SECTION 3.3.4 INSTALLATION OF DISK UNIT (DKU205I-14) when there are two or more Disk Units. [INST03-307]

3.3.3.1 Flowchart

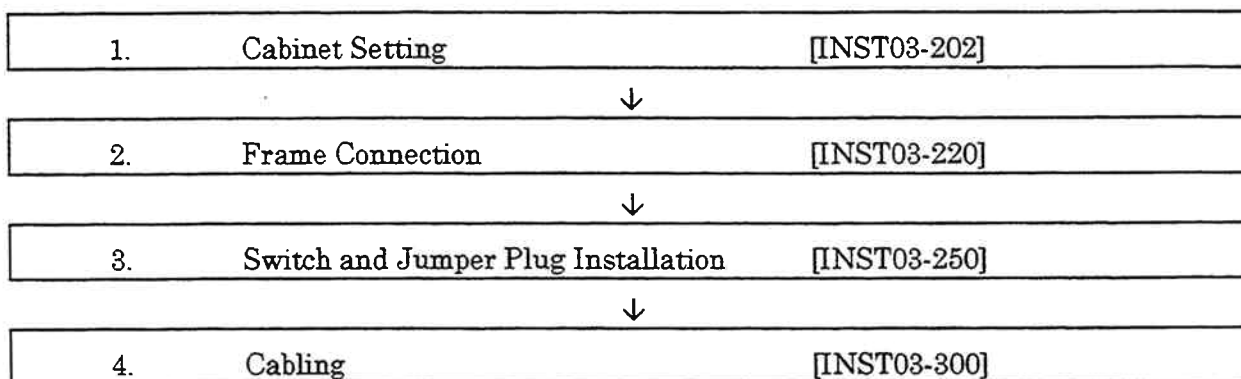

3.3.3.2 Cabinet Setting

- ♦ Refer to Table 3.3.3.2-1 when laying out the Basic Disk Unit with respect to the Disk Controller and relocating the side cover.

1. Place the Disk Controller and Disk Unit in the required position.

Table 3.3.3.2-1 Removal and Re-installation of Side Cover

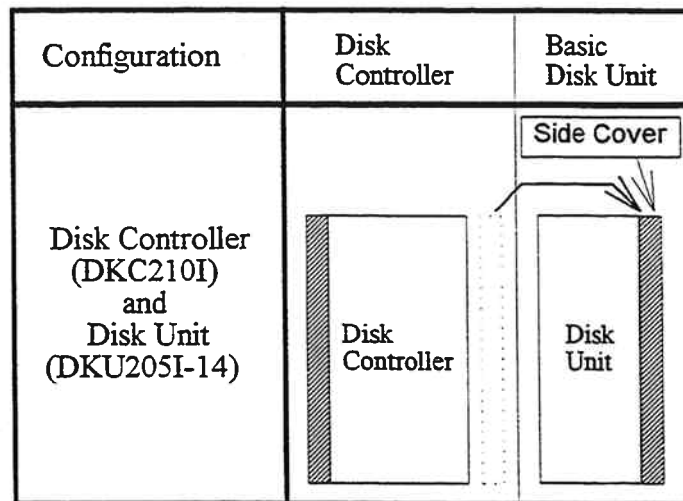

- Remove the fall proof adapters from the Disk Unit.

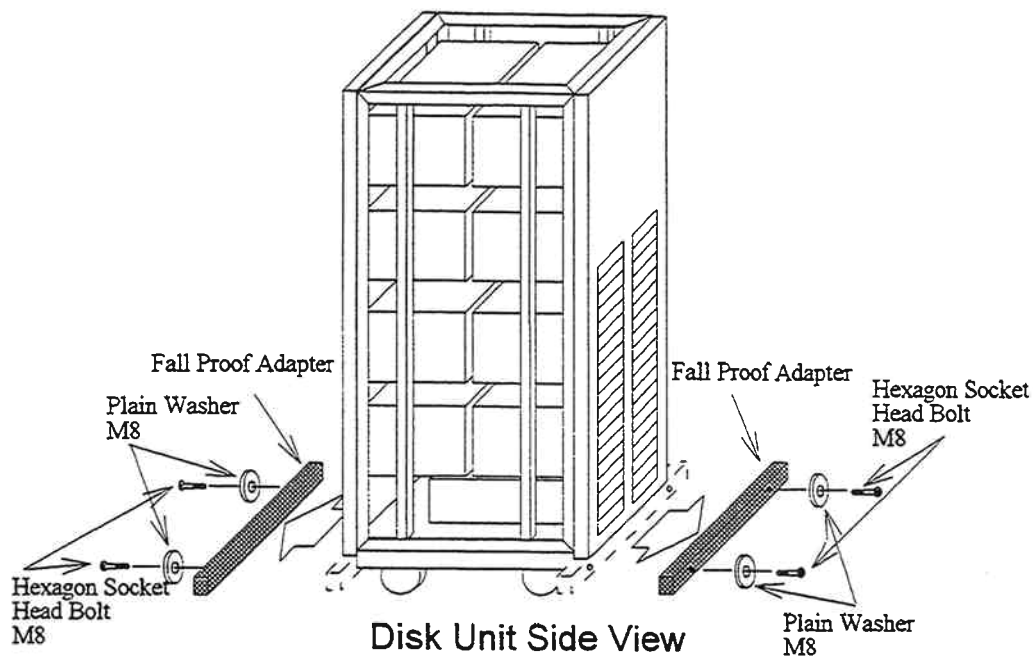

Fig. 3.3.3.2-1 Removal of Fall Proof Adapter

Note: The fall proof adapters, hexagon socket head bolt M8s, and plain washer M8s should be stored in the place of installation for future use in moving or taking out the unit.

- Open the front and rear doors on the Disk Controller and the Disk Unit.
- Remove the screws for transporting the movable rack.

Remove the three screws which secure the movable rack.

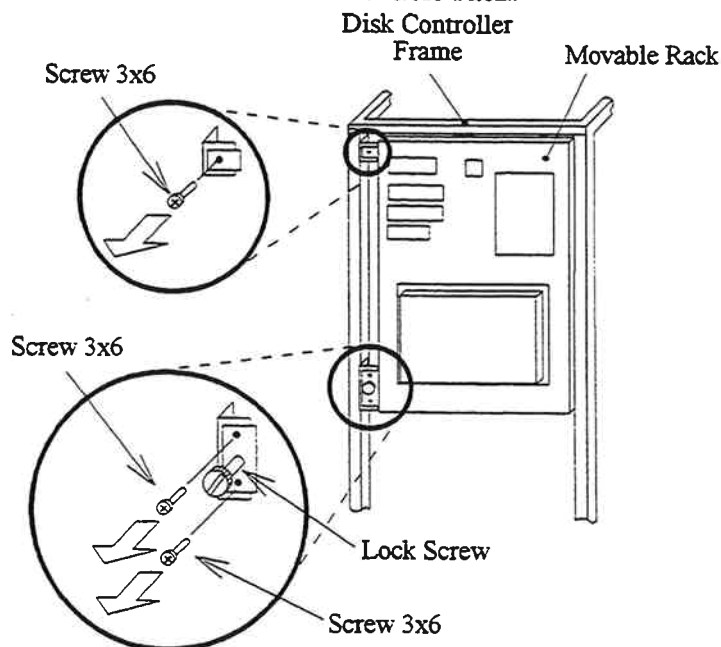

Fig. 3.3.3.2-2 Removal of Screws for Transporting the Movable Rack

Note: The screws for transporting the movable rack (screws 3x6) should be stored in the place of installation for future use in taking out and transporting the unit.

5. Exchange of a fixed plate of SVP (PC) case.

- (1) Referring to figure 3.3.2 - 3, loosen a screw ① and a screw ② that fixes SVP (PC) case ③.
- (2) As removing a fixed plate ④ of SVP (PC) case ③, attach it for an opposite.
- (3) Fix a fixed plate ④ of SVP (PC) in a screw ①.

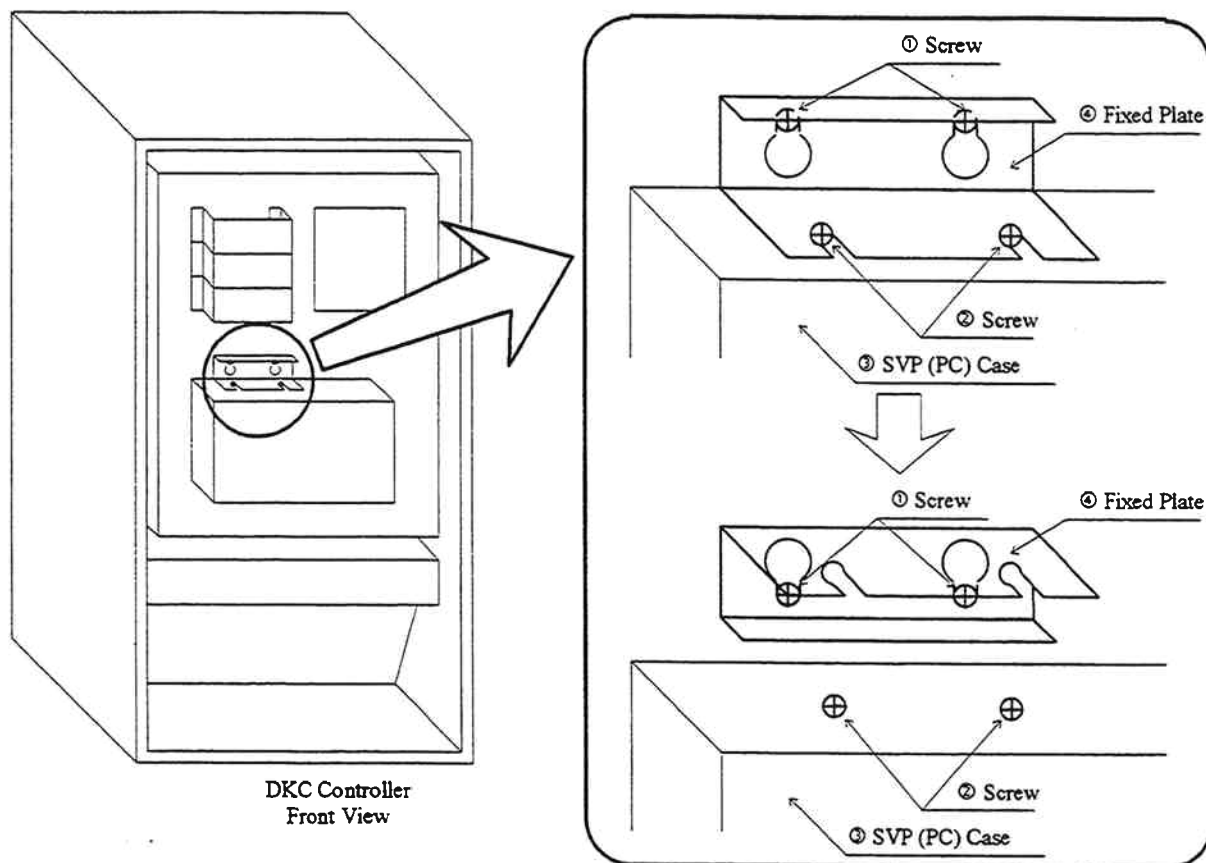

Fig. 3.3.3.2-3 Exchange of a Fixed Plate of SVP (PC) Case

6. Loosen the repeat binders which secure the DKUMN cables, the SCSI interface cables and the AC power cables for the Disk Controller

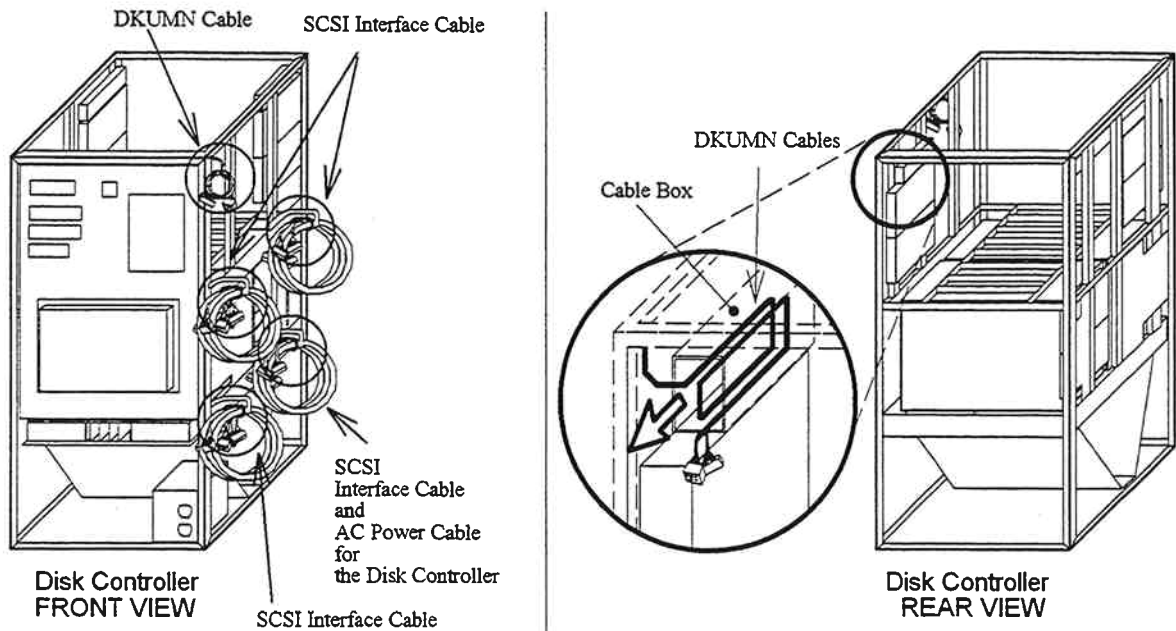

Fig. 3.3.3.2-4

7. Pass the DKUMN cables, the SCSI interface cables and the AC power cables for the Disk Controller through the Basic Disk Unit frame. Refer to Fig. 3.3.3.2-5. See enlarged view A to pass the DKUMN cable through the DKU frame from behind the cable duct. Be extremely careful not to pinch the inter-frame cable when coupling the frames to each other. Especially, be careful it not to clip a cable with an enlarged view B.

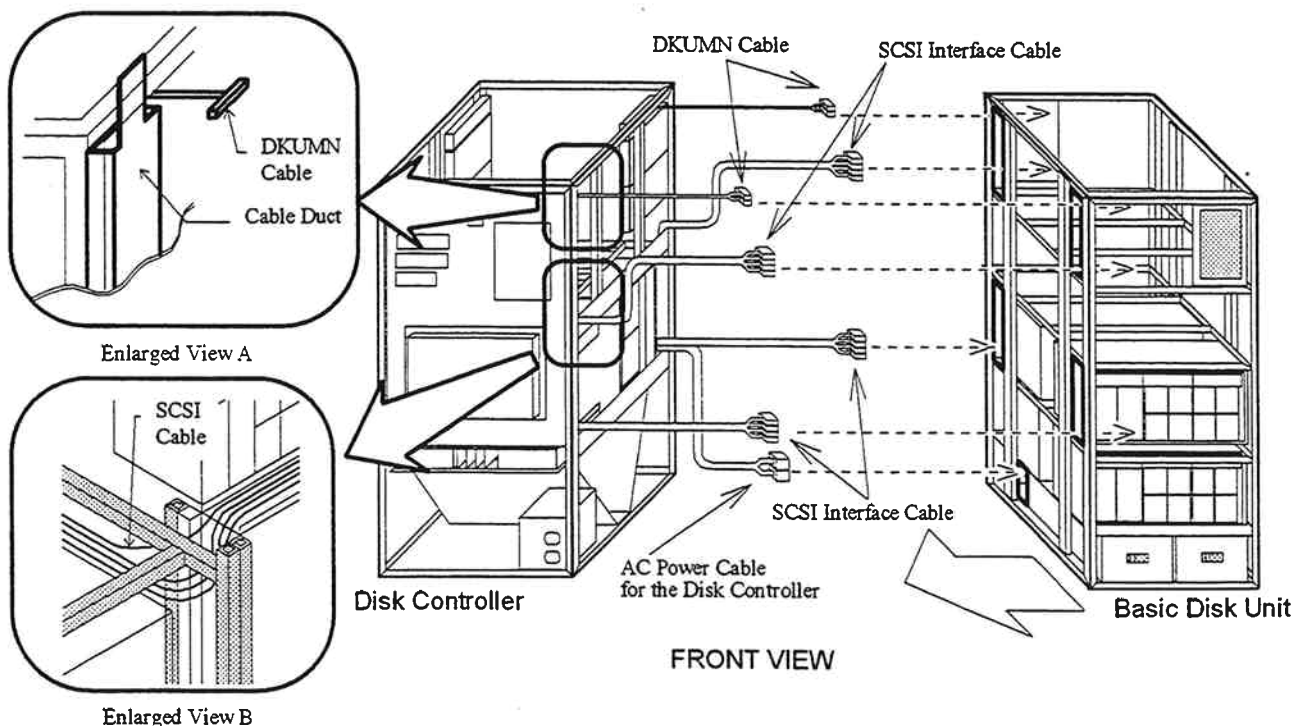

Fig. 3.3.3.2-5

9. Lower the screw jacks until frame is 57mm (2.25in.) from the floor before connecting frames.
10. Level the device as shown Fig. 3.3.3.2-6.

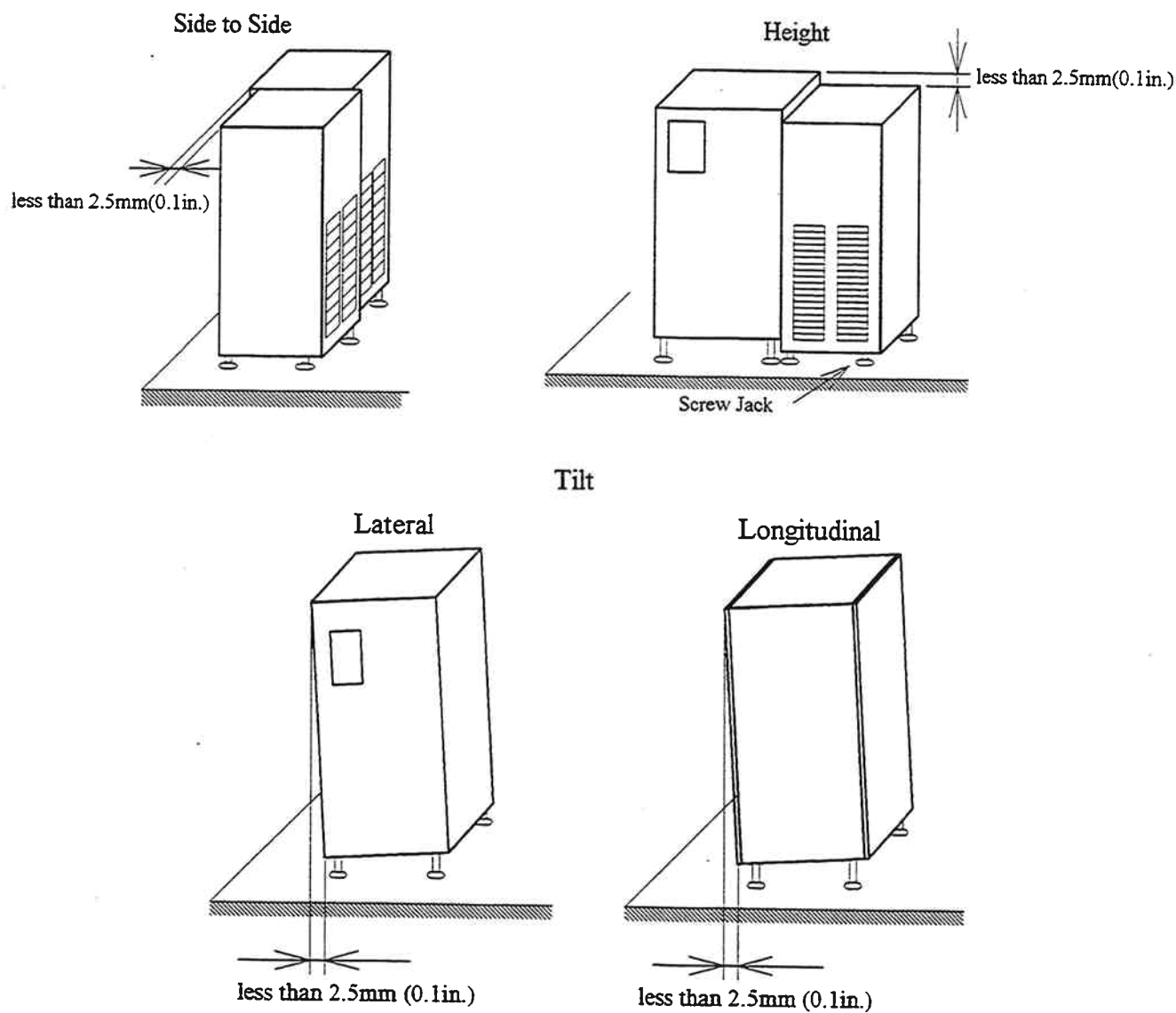

Fig. 3.3.3.2-6 Unit Layout, Height, and Tilt

3.3.3.3 Frame Connection

3.3.3.3.1 Frame Connection

Connect the devices together using six of Connecting Bolt assemblies, three in front and three in rear.

See Fig. 3.3.3.3.1-1.

The direction of hexagon socket head bolts, binding screws and connecting nuts must be the same as shown in the figure.

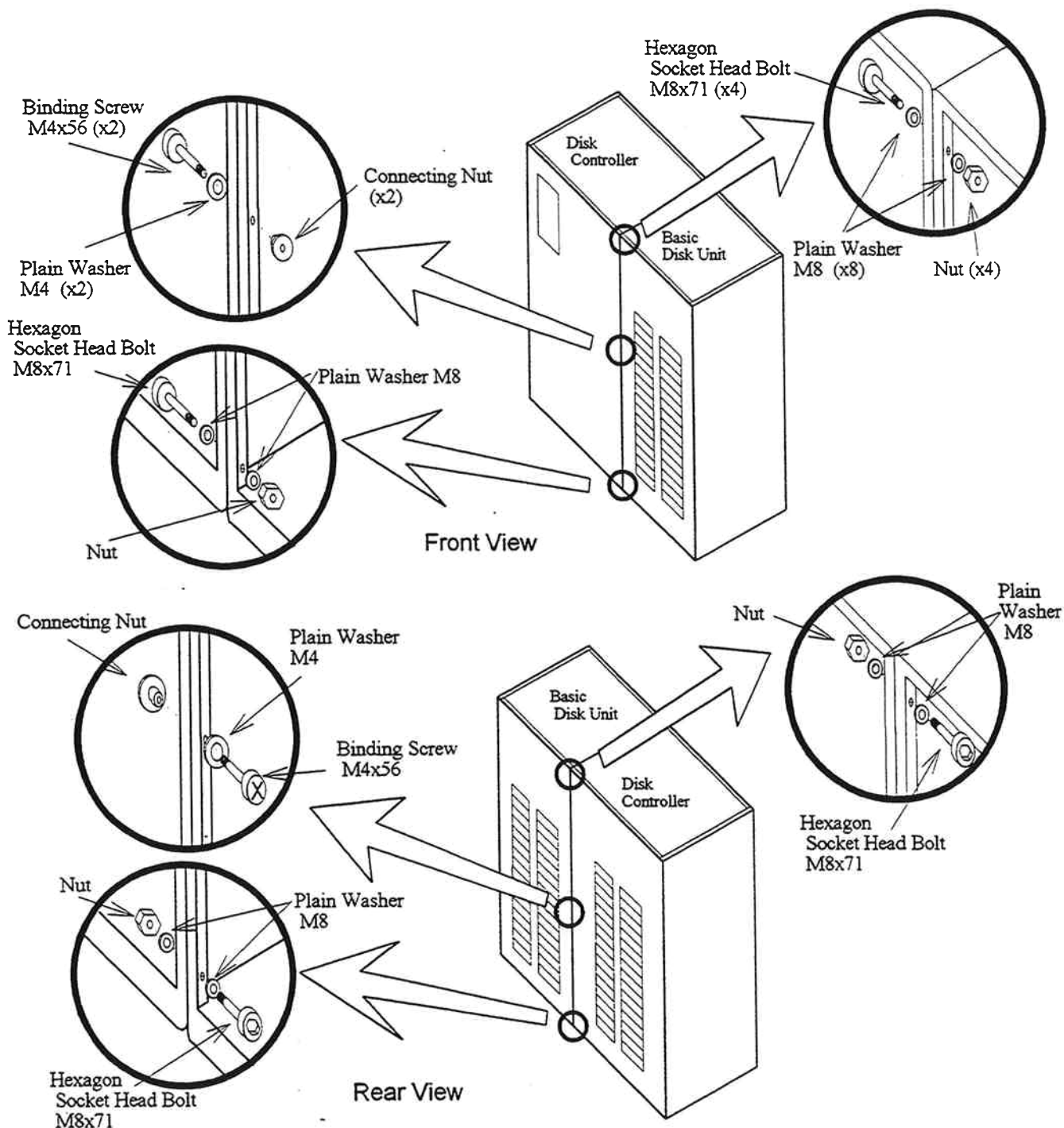

Fig. 3.3.3.3.1-1 Frame Connection

3.3.3.3.2 Frame Ground Cable Attachment

Note

- : Frame ground cable
 ● : Screw and washer (lock washer)
 ⊙ : Thread

1. Remove the right side cover of the Disk Controller.
2. Connect the cabinets.

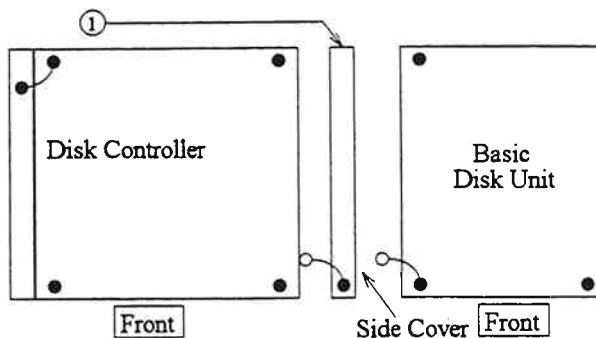

3. Attach the side cover to the Disk Unit. Refer to SECTION 3.3.3.3.3 Side Cover Re-installation.
4. Attach the frame ground cable with the screw and lock washer.

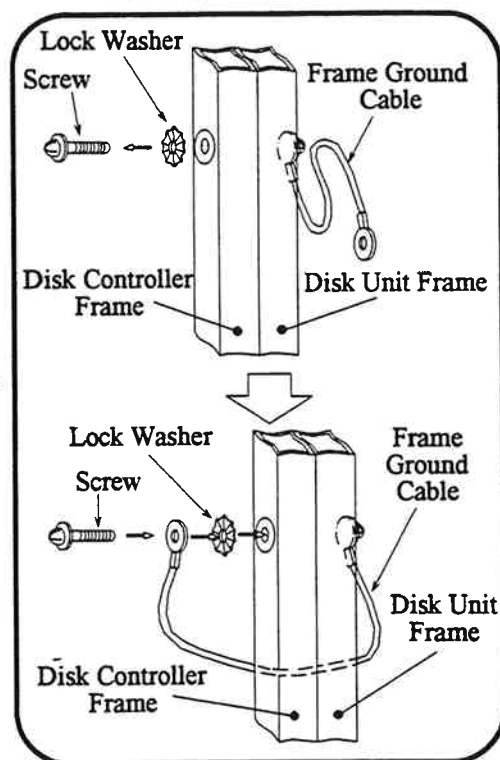
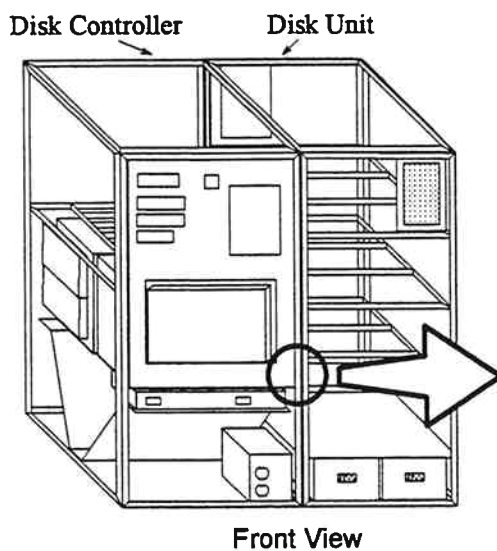
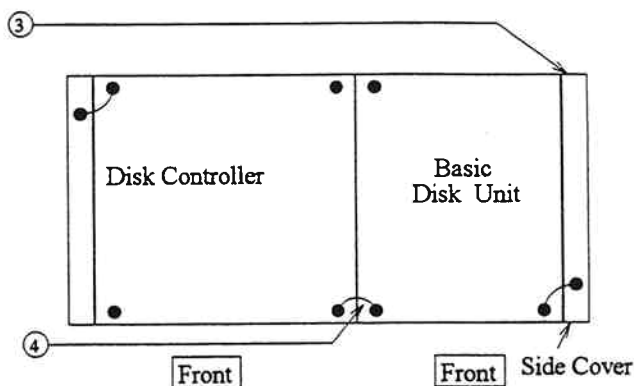

Fig. 3.3.3.3.2-1 Attachment of Frame Ground Cable

3.3.3.3.3

Side Cover Re-installation

Attach the side cover to the end of the string with the four binding screws and washers.

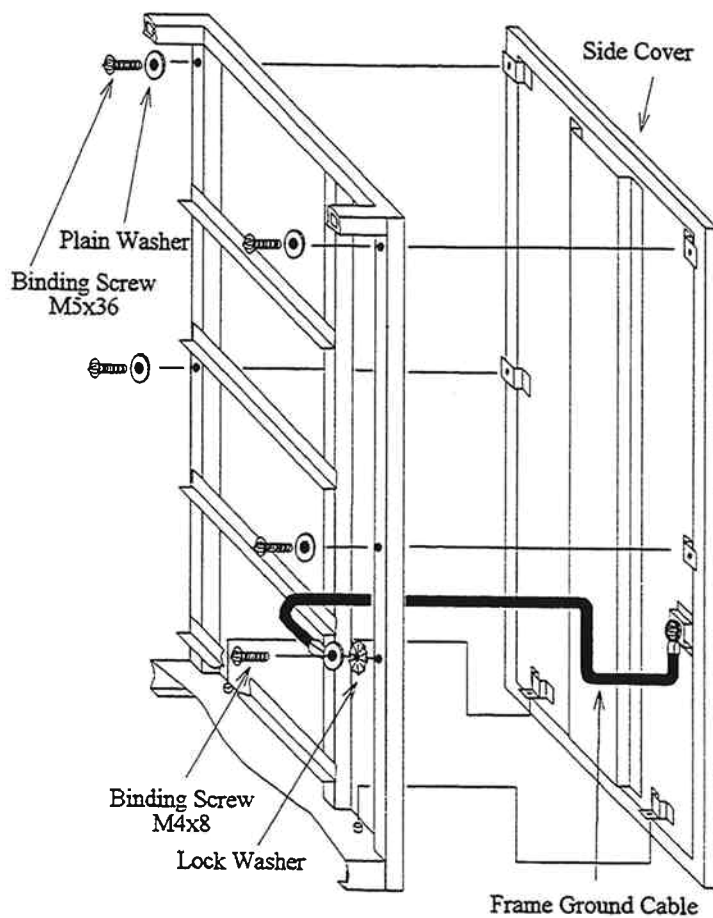

Fig. 3.3.3.3.3-1 Re-installation of Side Cover

3.3.3.3.4 Installation of Kick Plate

Attach the kick plates with the binding screws. See Fig. 3.3.3.4.1.

NOTICE

Contact the Kick Plate to the floor to prevent static electricity.

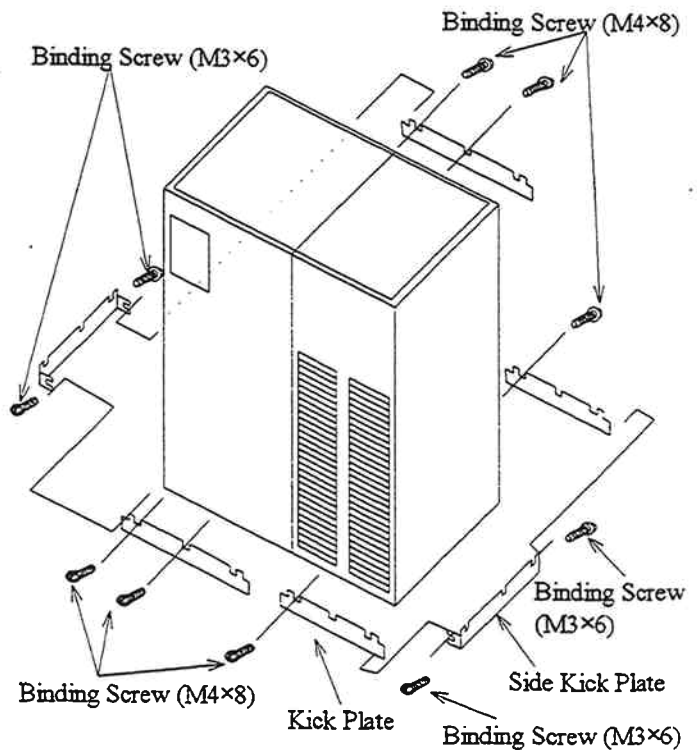

Fig. 3.3.3.3.4-1 Installation of Kick Plate

3.3.3.4 Installation of Switches and Jumper Plugs

Be sure to wear your wrist strap and attach to ground prior to performing the following work. This will insure that the IC and LSI on the PCB are protected from static electricity.

3.3.3.4.1 Installation of Jumper Plugs in PWRCTL PCB

Install the jumper plugs in the PWRCTL-1 and PWRCTL-2 as indicated in the table below. This following shows the settings for the unit containing no Platform for Additional Cache Assembly (DKC-F210I-40). For the settings for the unit containing the Platform for Additional Cache Assembly (DKC-F210I-40), see [INST03-1660]

Table 3.3.3.4.1-1 Jumper plug installation in the PWRCTL PCB

Location No.	JP1	JP2	JP3 (#1 - #3)	JP3 (#4 - #6)	JP3 (#7 - #9)	JP3 (#10 - #12)	Remarks
PWRCTL-1	#2-#3	Not used	#1-#2	#4-#5	#8-#9	#11-#12	
PWRCTL-2	#1-#2	Not used	#1-#2	#4-#5	#8-#9	#11-#12	

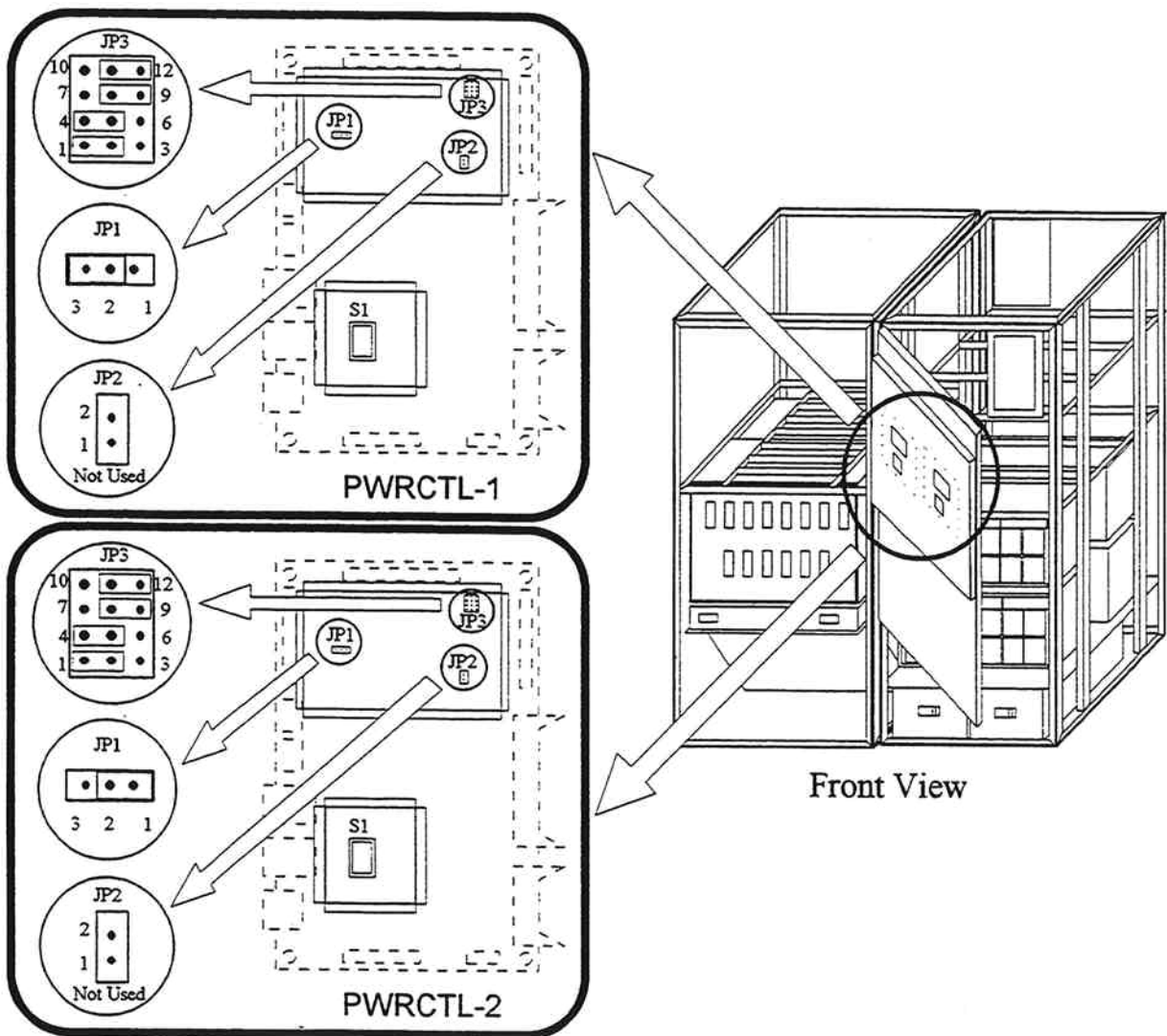

Fig. 3.3.3.4.1-1 Installation of Jumper Plugs in PWRCTL PCB

3.3.3.4.2 Installation of Switches and Jumper Plugs in DKUMN PCB

Set the switches and install the jumper plugs in the DKUMN PCBs as indicated in the table below.

This following shows the settings for the unit containing no Platform for canister mount (DKU-F205I-B4) (containing four HDU boxes)
 For the settings for the unit containing the Platform for canister mount (DKU F205I-B4) (containing eight HDU boxes), see [INST03-1940]

Table 3.3.3.4.2-1 SWITCH and JUMPER PLUG installation of the DKUMN PCB

Location No.	S1	JP1 (#1 - #3)	JP1 (#4 - #6)	JP1 (#7 - #9)	JP1 (#10-#12)	JP2	JP3 (#1 - #3)	JP3 (#4 - #6)	Remarks
DKUMN-R1F	ENABLE	#1-#2	#4-#5	#7-#8	#10-#11 Reserved	Not used	#1-#2	#5-#6	
DKUMN-R1R	ENABLE	#2-#3	#4-#5	#7-#8	#10-#11 Reserved	Not used	#2-#3	#4-#5	

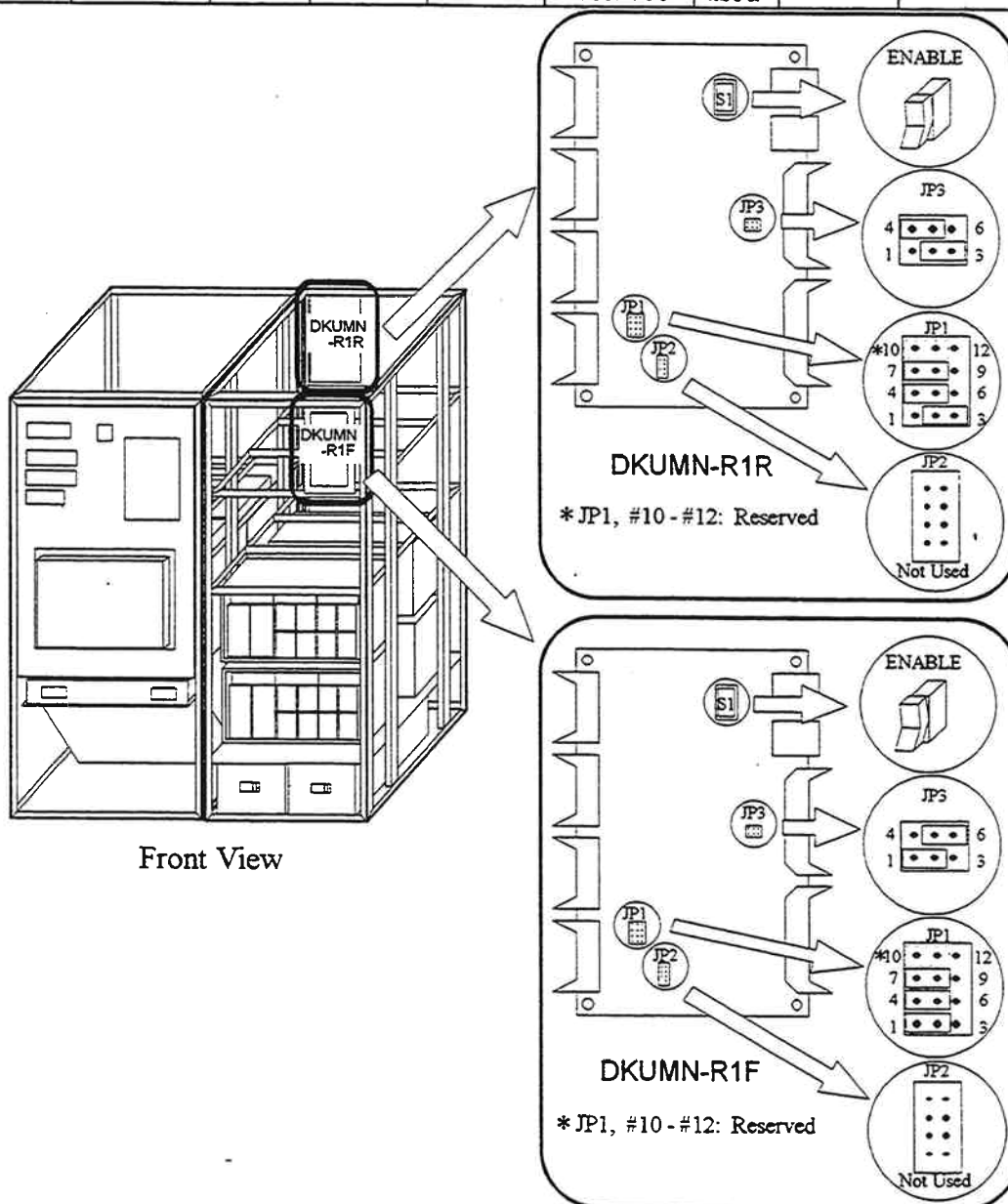

Fig. 3.3.3.4.2-1 Installation of Switches and Jumper Plugs in DKUMN PCB

3.3.3.4.3 Installation of Jumper Plugs in CE PANEL PCB.

Install the jumper plugs in the CE PANEL PCB as indicated in the table below.

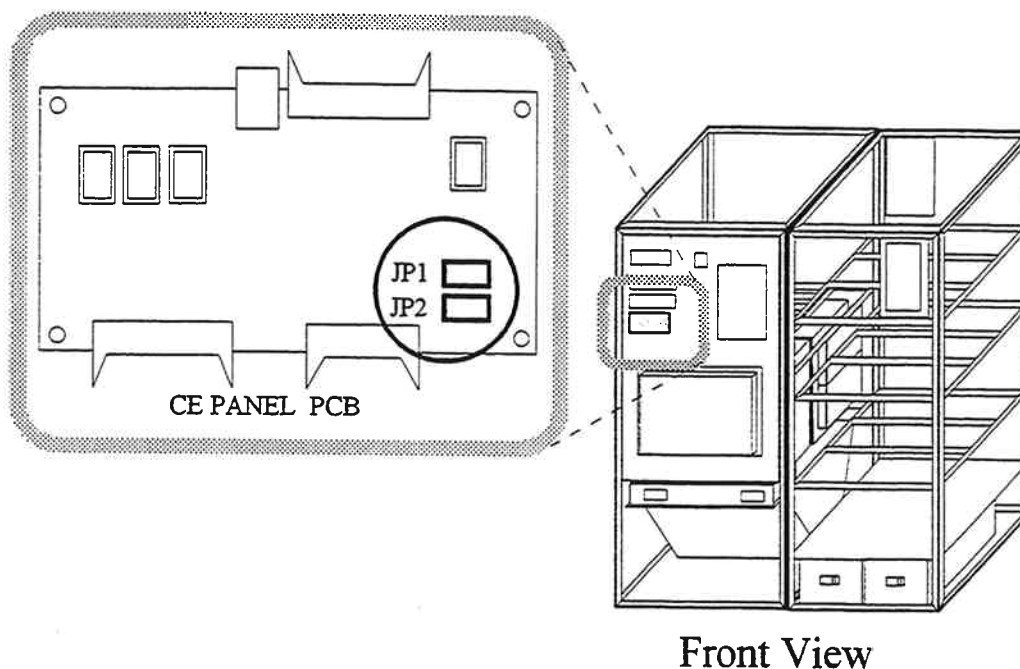
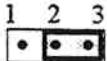
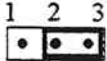
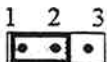
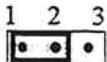

Fig. 3.3.3.4.3-1 Installation of Jumper Plugs in CE PANEL PCB

Table 3.3.3.4.3-1 Installation of Jumper Plugs in CE PANEL PCB

<p>Enables PCI At least one PCI Cable attached to JP1 - JP8 on PCI CONN PCB.</p>	<p>JP1 </p> <p>JP2 </p>
<p>Disables PCI or No PCI Cable attached to JP1 - JP8 PCI CONN PCB.</p>	<p>JP1 </p> <p>JP2 </p>

3.3.3.4.4 Installation of Jumper Plugs in RS CONN PCB.

Install the jumper plugs in the RS CONN PCB as indicated in the table below.

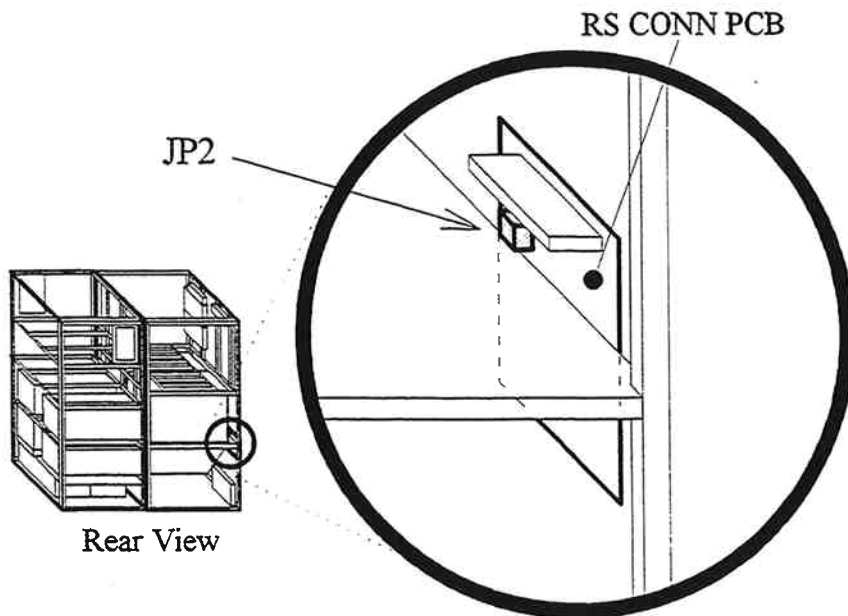
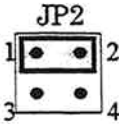
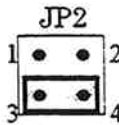

Fig. 3.3.3.4.4-1 Installation of Jumper Plugs in RS CONN PCB

Table 3.3.3.4.4-1 Installation of Jumper Plugs in RS CONN PCB

<p>This setting attaches terminator to RS-422</p>	 <p>JP2</p> <p>1 2 3 4</p>
<p>This setting detaches terminator to RS-422</p>	 <p>JP2</p> <p>1 2 3 4</p>

3.3.3.4.5 Installation of Jumper Connectors in BATT CTR PCB.

1. Check the Battery output Voltage.

a. Disconnect the cables (CDX1) of the battery controller PCB that corresponds to the battery box.

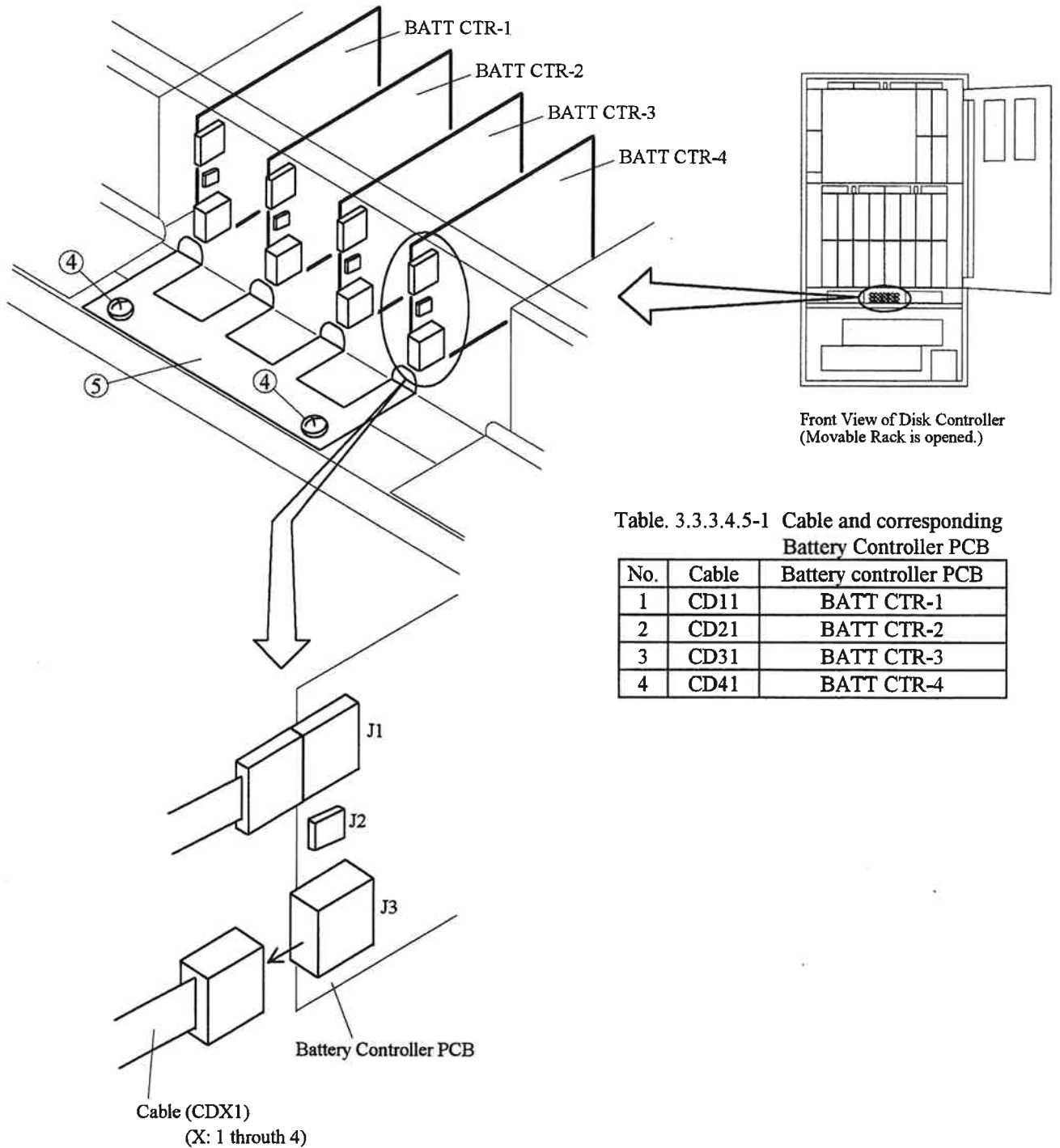

Fig. 3.3.3.4.5-1 Disconnection of the Cables

- b. Insert the pins of the digital voltmeter into the cable (CDX1) connector to make sure that battery voltage is within the allowable voltage.

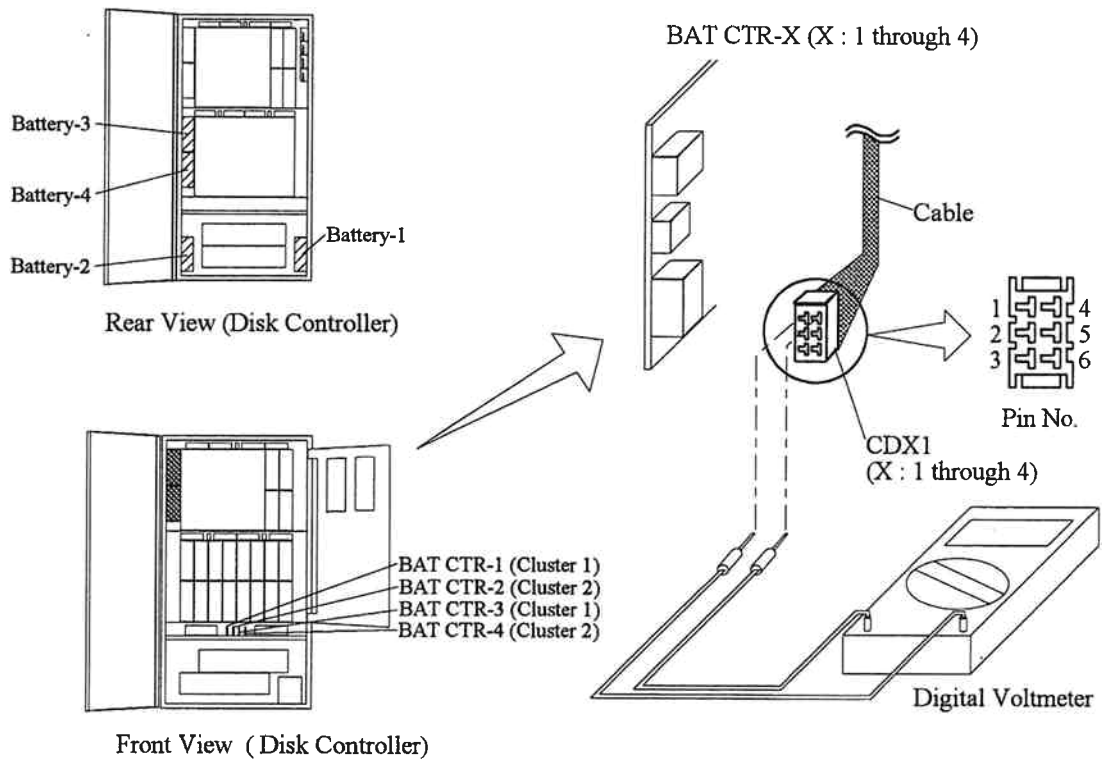

Fig. 3.3.3.4.5-2 Battery Voltmeter Check

Table 3.3.3.4.5-2 Voltage Checkpoint and Allowable Voltage

No.	PIN No. (CDX1)		Allowable battery voltage
	-	+	
1	④	①	3.0V through 5.0V
2	⑤	②	3.0V through 5.0V

- c. If the Battery voltage is not within the allowable voltage, replace the battery assembly seeing Table 3.3.3.4.5-3 and Fig. 3.3.3.4.5-2. For replacement, loosen the two screws locking the battery assembly and replace the battery assembly with a new one. Then recheck the battery voltage in step b.

Table 3.3.3.4.5-3 Cable and corresponding Battery Assembly

No.	Cable	Replacement Battery Assembly
1	CD11	Battery-1
2	CD21	Battery-2
3	CD31	Battery-3
4	CD41	Battery-4

d. Connect the cables (CDX1) to the Battery Controller PCBs (BATT CTR-1, 2, 3, 4).

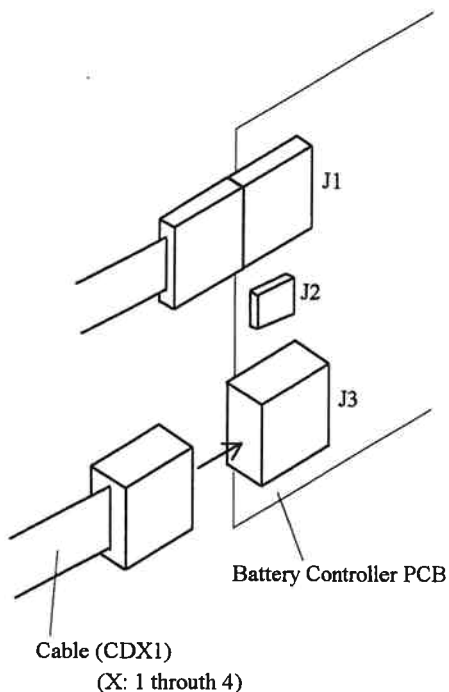

Fig. 3.3.3.4.5-3 Connection of the Cables

2. Install the jumper connectors in the BATT CTR PCBs as indicated in the figure below.

This following shows the settings for the unit containing no Platform for Additional Cache Assembly (DKC-F210I-40).
For the settings for the unit containing the Platform for Additional Cache Assembly (DKC-F210I-40), see [INST03-1590]

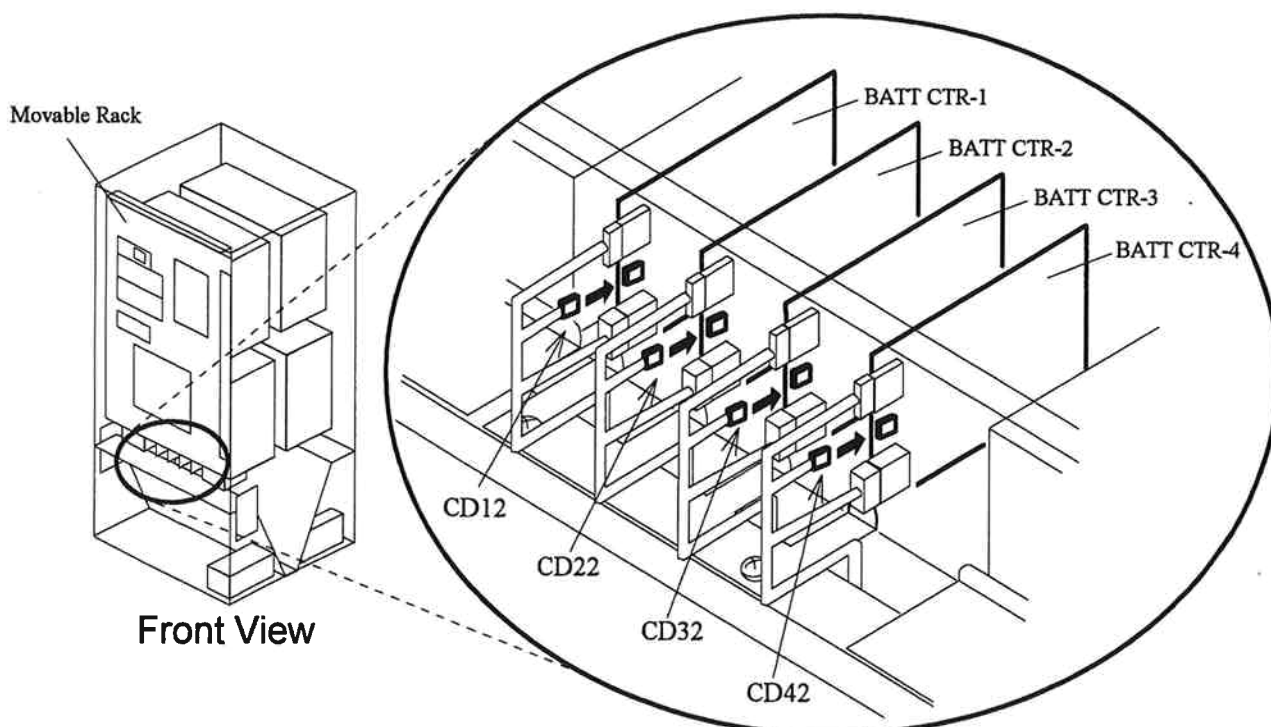

Fig. 3.3.3.4.5-4 Installation of Jumper Connectors in BATT CTR PCB

3.3.3.5 Cabling

Table 3.3.3.5-1 Cabling Index

No.	Description	Reference Page	Remarks
1	AC Power Cable for Disk Controller	INST03-300	Basic Disk Unit only
2	DKUMN cable	INST03-340	
3	SCSI Interface cable	INST03-360	

3.3.3.5.1 Cabling Procedure of AC Power Cables for Disk Controller

Connect the AC Power cables for Disk Controller. Refer to Table 3.3.3.6.1-1 and Fig. 3.3.3.5.1-1.

No.	Basic Disk Unit			Disk Controller			Remarks
	Location No.	Connector No.	Cable No.	Location No.	Connector No.	Cable No.	
1	AC BOX-R10	J103	P103-1	BREAKER BOX-1	J200	P200-1	
2	AC BOX-R11	J103	P103-2	BREAKER BOX-2	J200	P200-2	

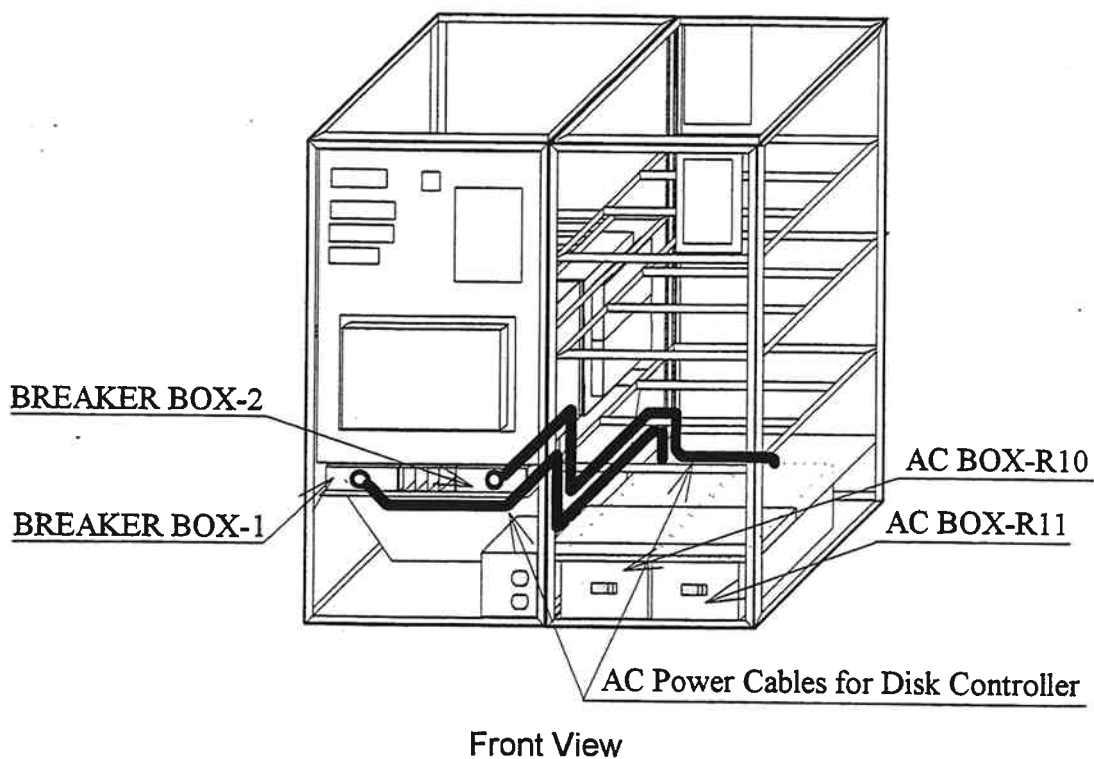

Fig. 3.3.3.5.1-1 Connection of AC Power Cables for Disk Controller

1. Loosen the two repeat binders which fasten the AC Power cables for Disk Controller to the frame.

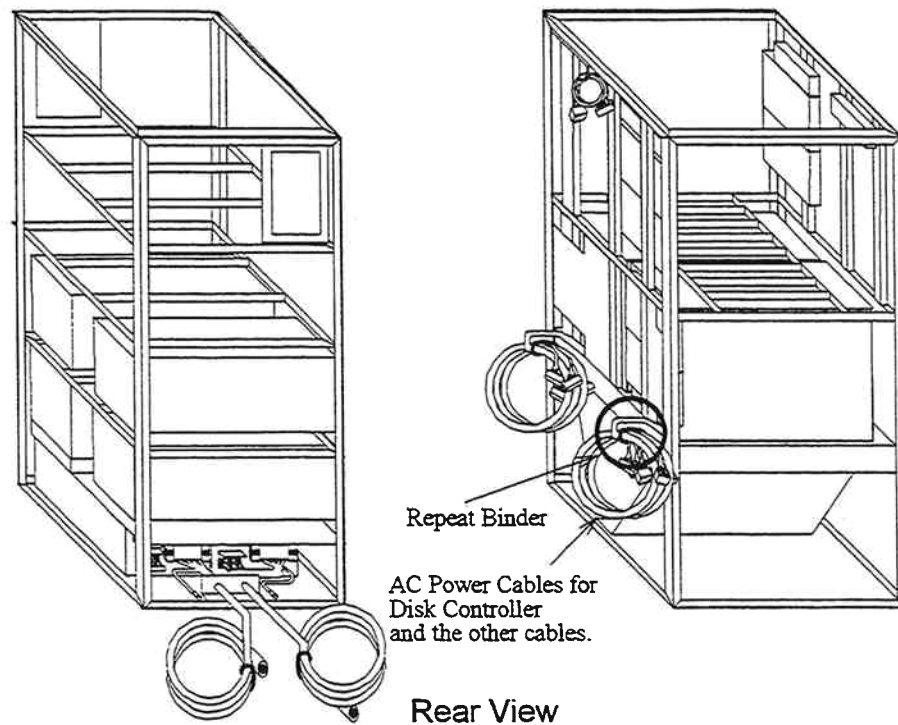
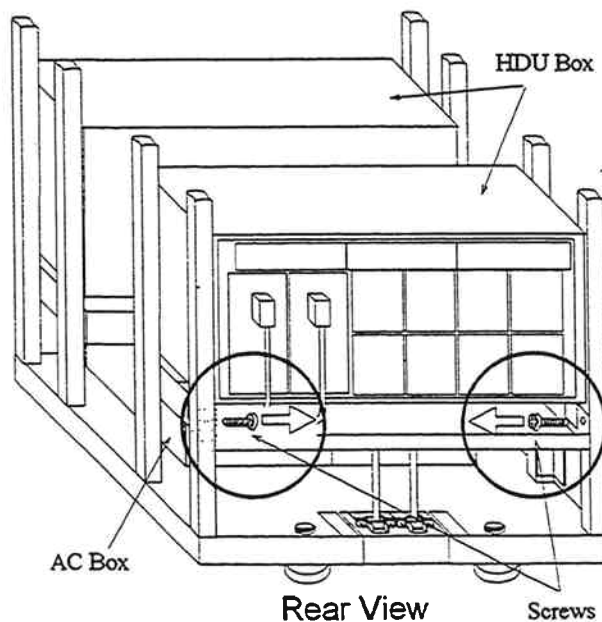

Fig. 3.3.3.5.1-12 AC Power Cable for Disk Controller

2. Remove the plate. Refer to Fig. 3.3.3.5.1-3.

a. Loosen the two screws.



b. Remove the plate.

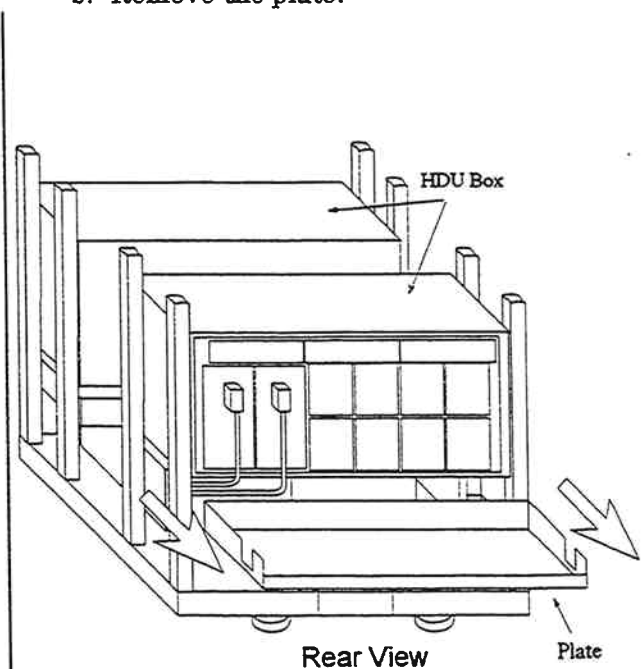

Fig. 3.3.3.5.1-3 Removal of Plate

3. Fix the Power Cable Assy.

a. Loose the four screws

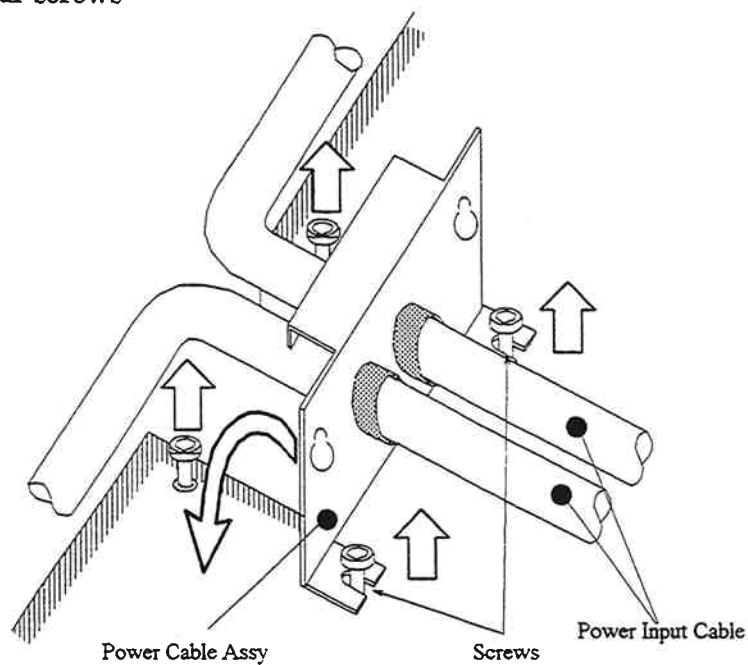

Fig. 3.3.3.5.1-4 Fixation of Power Cable Assy

b. Fix the power cable Assy with screws.

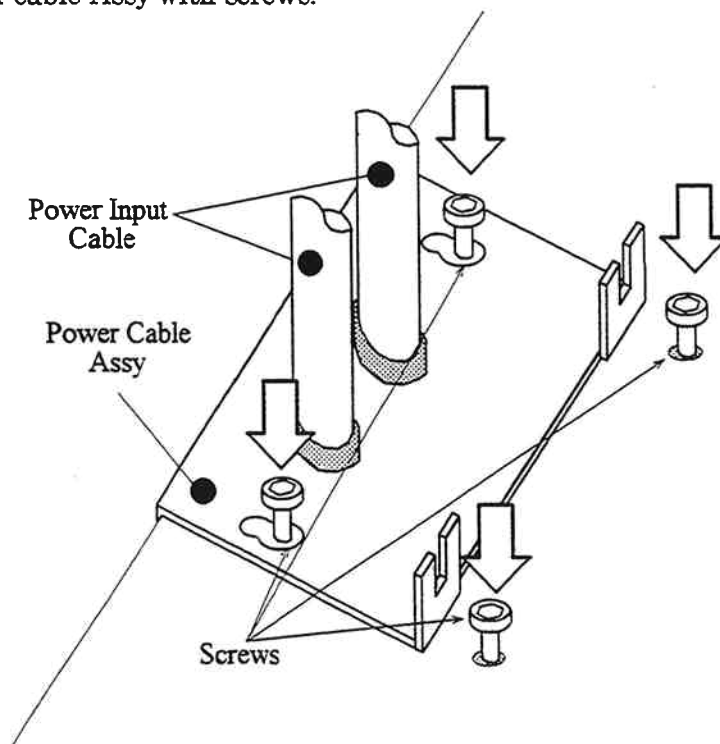

Fig. 3.2.3.5.1-5 Fixation of Power Cable Assy

4. Connect the AC Power Cables for Disk Controller Refer to Fig. 3.3.3.5.1-6

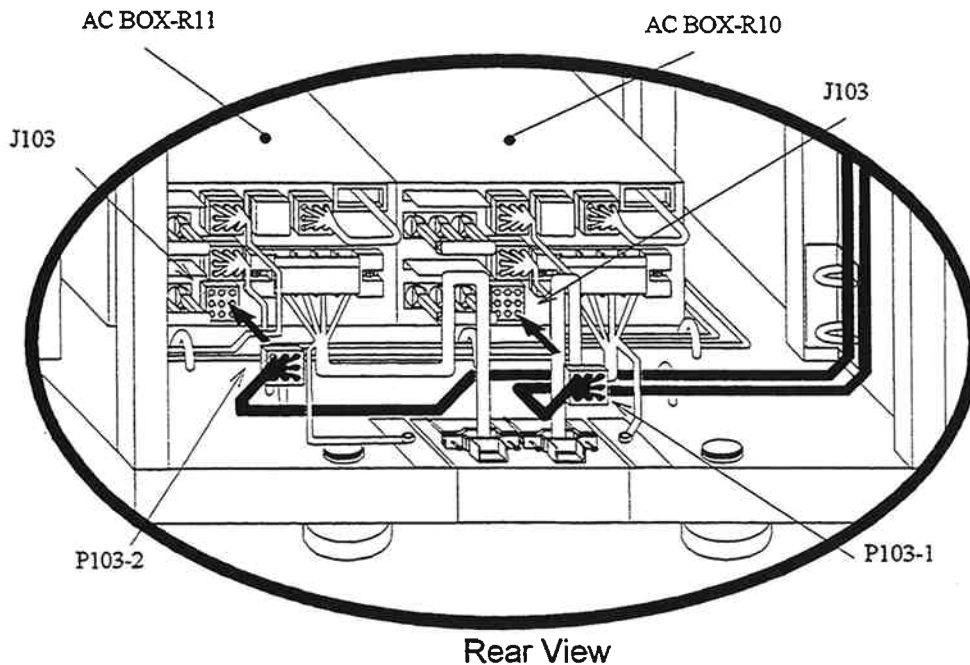

Fig. 3.3.3.5.1-6 Connection of AC Power Cables for Disk Controller

5. Bind the cables with the repeat binders. Refer to Fig. 3.3.3.5.1-7.

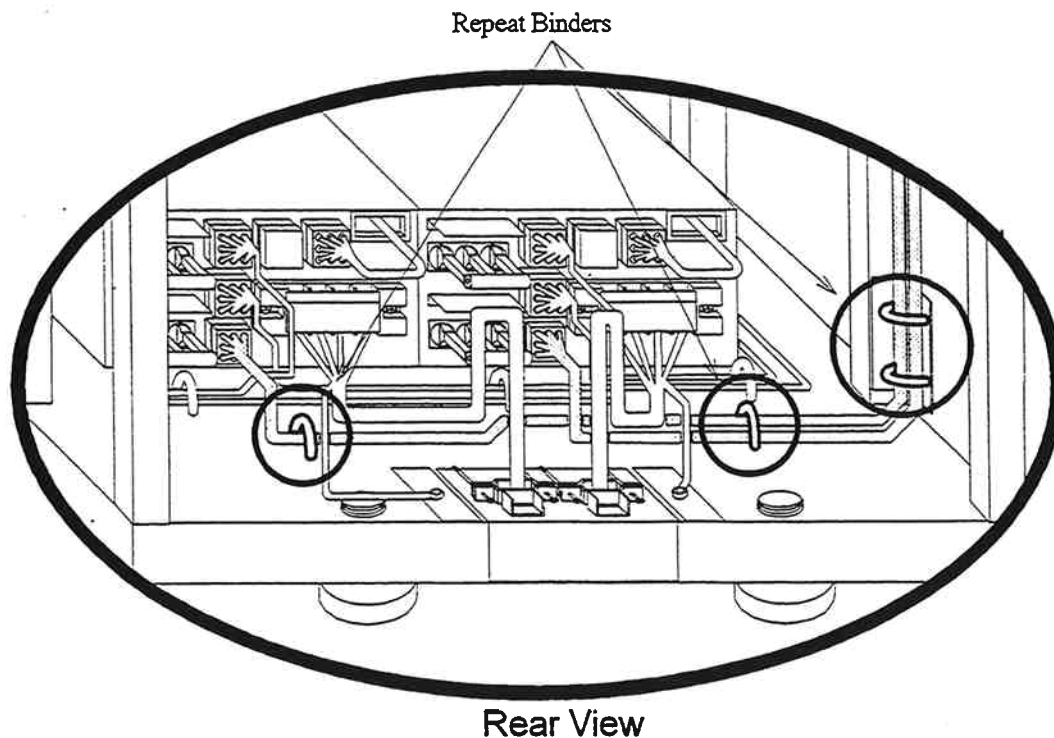

Fig. 3.3.3.5.1-7 Fastening of AC Power Cables for the Disk Controller

6. Re-Install the plate. Refer to Fig. 3.3.3.5.1-8

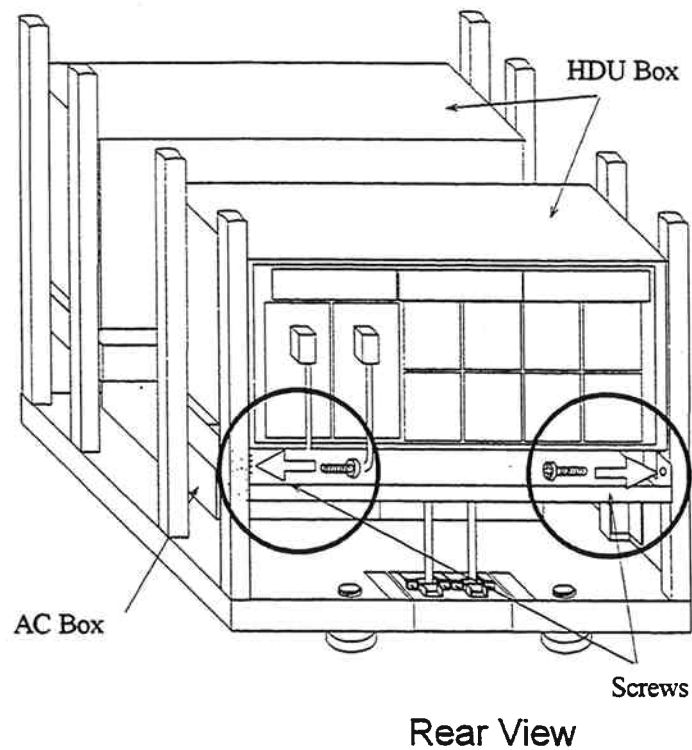
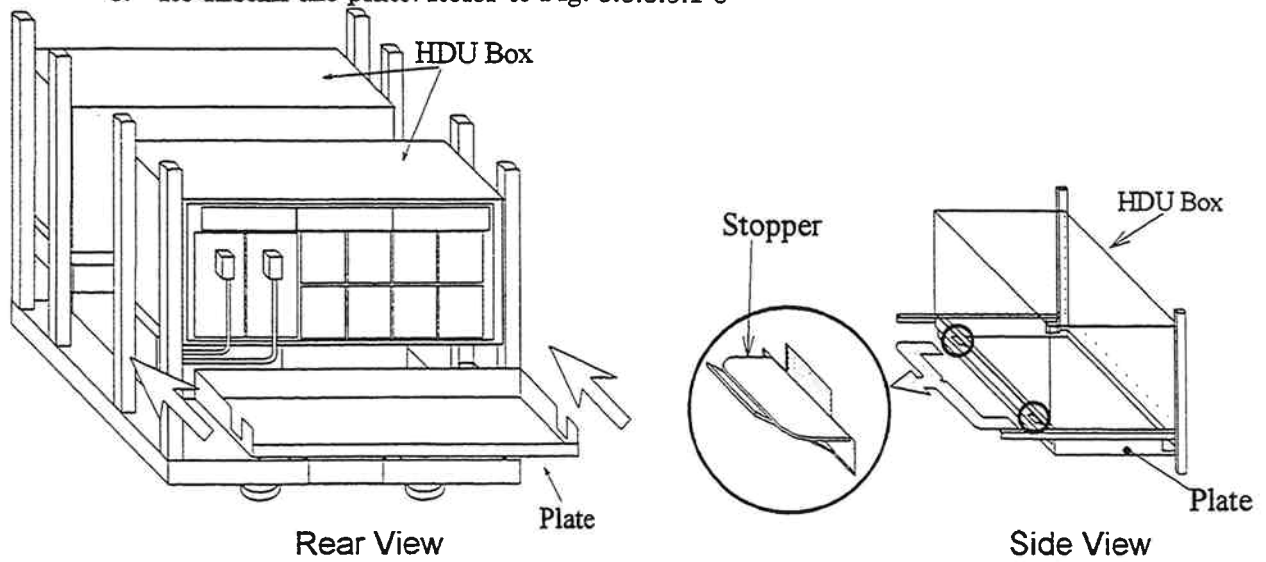

Fig. 3.3.3.5.1-8 Re-Installation of Plate

3.3.3.5.2 Cabling Procedure of the DKUMN Cables

Be sure to wear your wrist strap and attach to ground prior to performing the following work. This will insure that the IC and LSI on the PCB are protected from static electricity.

1. Connect the PWRCTL PCBs or Logic PS BB and the DKUMN PCBs as summarized in the table below.

Table 3.3.3.5.2-1 Connection of DKUMN Cables

No.	Disk Controller			Basic Disk Unit			Remarks
	Location No.	Connector No.	Cable No.	Location No.	Connector No.	Cable No.	
1	PWRCTL-1	J12	P12-1	DKUMN-R1F	J04	P4-1	
2	Logic PS BB	3AE3	3AE3	DKUMN-R1F	J02	P2-1	
3	PWRCTL-2	J12	P12-2	DKUMN-R1R	J04	P4-2	
4	Logic PS BB	3BE3	3BE3	DKUMN-R1R	J02	P2-2	

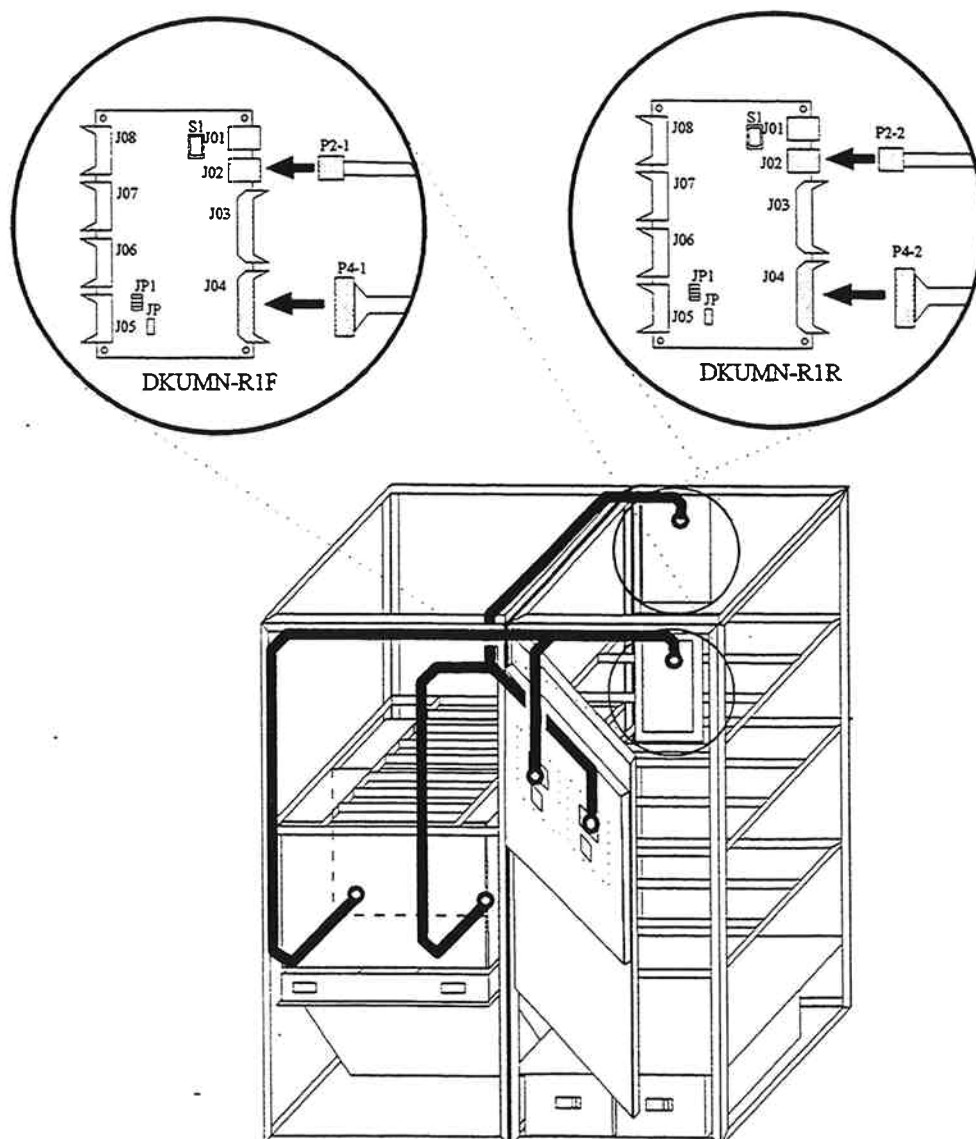
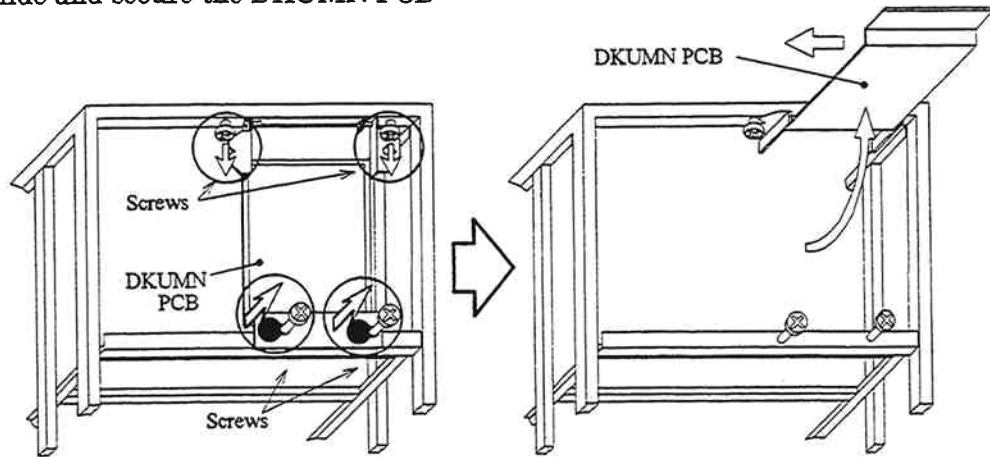

Fig. 3.3.3.5.2-1 Connection of DKUMN Cables

2. Before binding the DKUMN cables. Secure the DKUMN PCB. Refer to Fig. 3.3.3.5.2-3
 - a. Loosen the four screws.
 - b. Lift the DKUMN PCB.
 - c. Slide and secure the DKUMN PCB



Disk Unit Front View

Fig. 3.3.3.5.2-2 Lift of DKUMN PCB

3. Bind the cables with binders to prevent them from sagging.

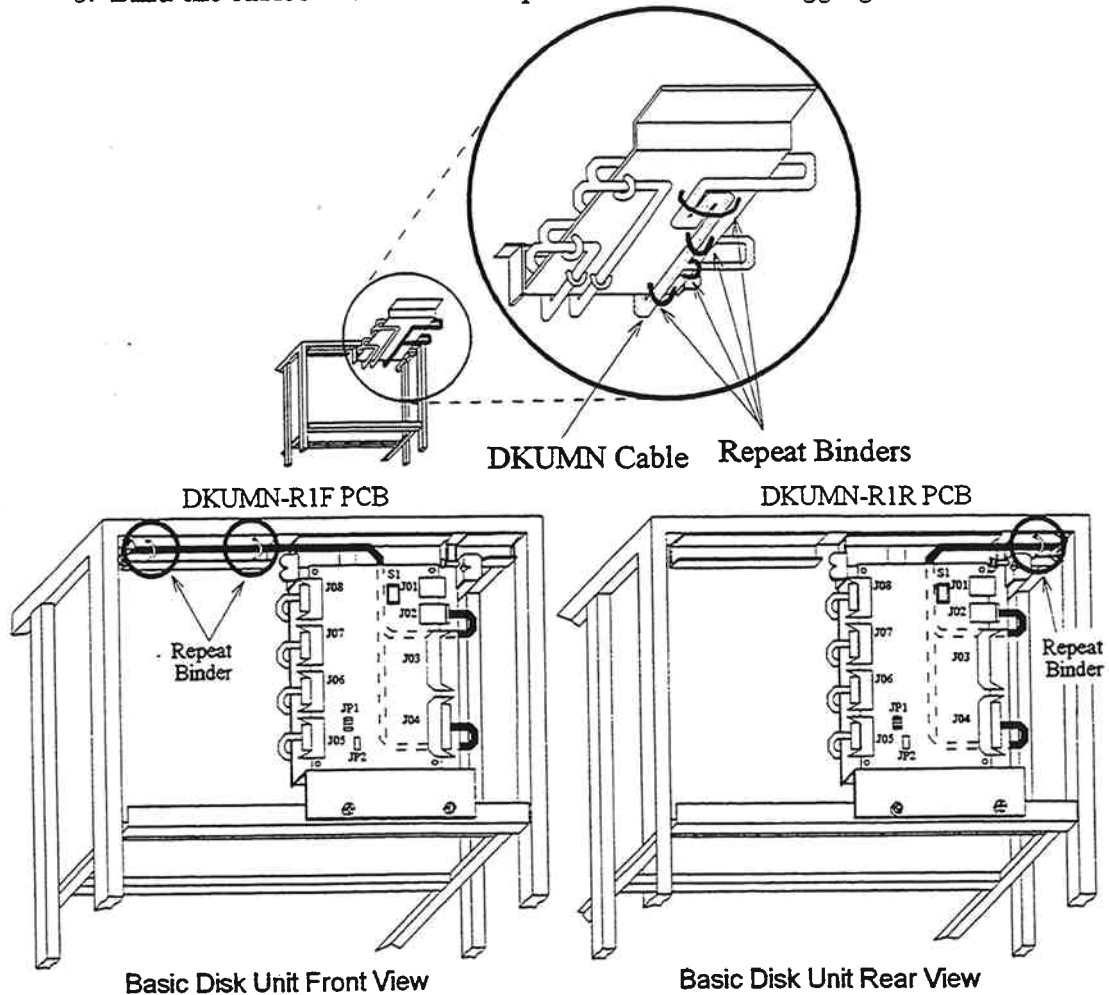

Fig. 3.2.3.5.2-3 Binding of DKUMN Cables

Blank sheet

REV.7	Jun.1995	Sep.1995	Nov.1995	Mar.1996		
-------	----------	----------	----------	----------	--	--

3.3.3.5.3 Cabling Procedure of SCSI Interface Cables

1. Connect the SCSI interface cables to the sub-edges on the SCSI BFR PCBs located in the HDU box.

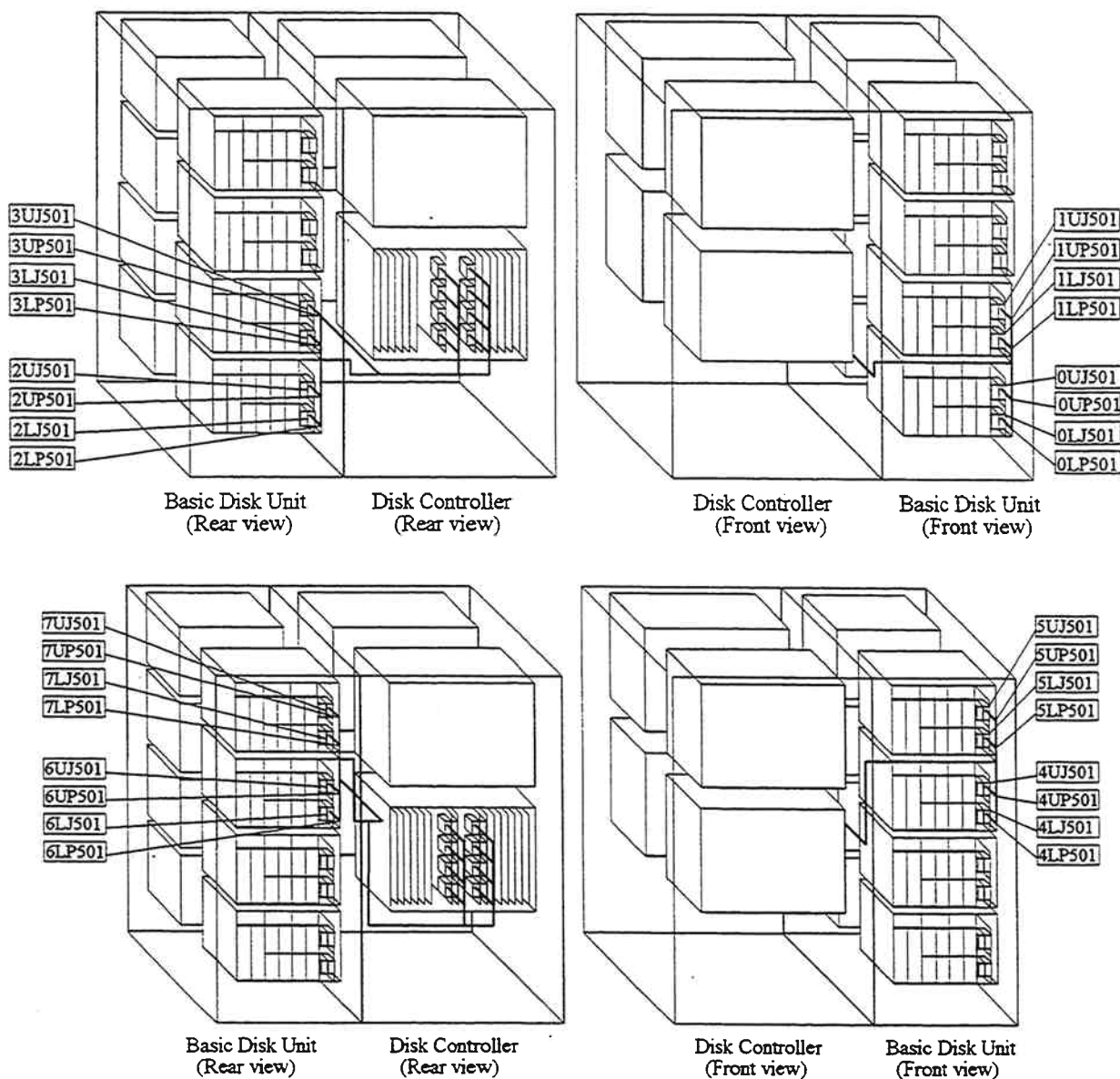

Fig. 3.3.3.5.3-1 SCSI Interface Cabling Diagram (SCSI BFR PCB Side)

2. Secure the SCSI interface cables to the cable conduit with cable fixing wire and repeat binder. If the SCSI interface cables are too long, fold them over inside the cable conduit and secure them with cable fixing wire and repeat binder.

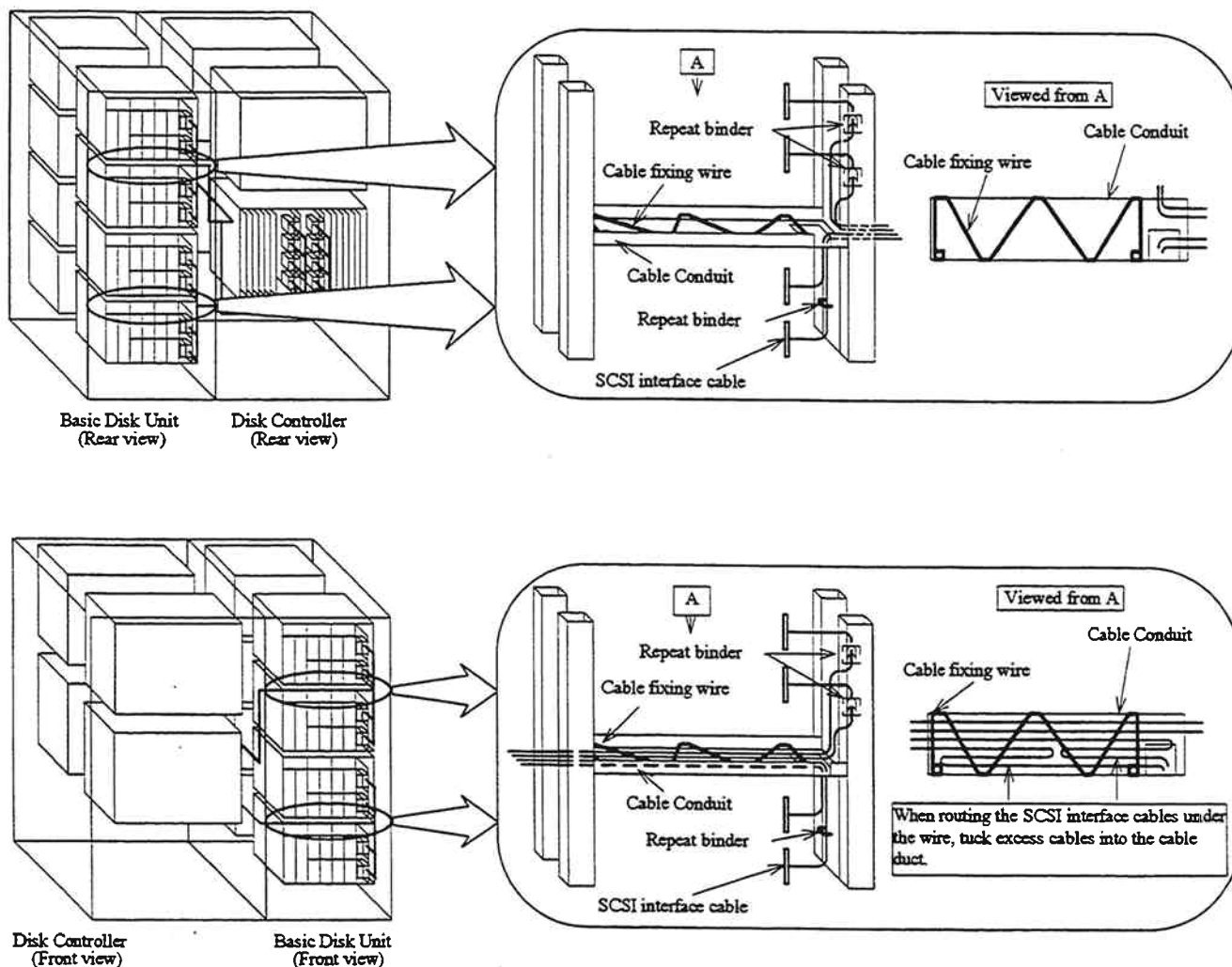

Fig. 3.3.3.5.3-2 Fixing of SCSI Interface Cables

3. Return to General Flow.

New Installation: Go to INST02-10 Step (3).

3.3.4 Installation of Disk Unit (DKU2051-14)

3.3.4.1 Flowchart

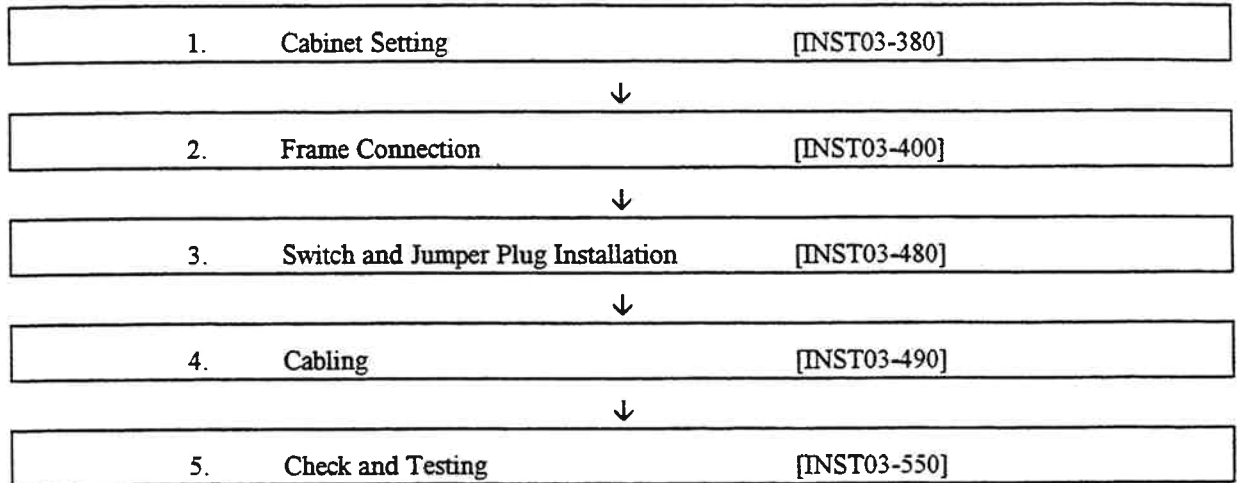

3.3.4.2 Cabinet Setting (Adjusting the Cabinet Height)

3.3.4.2.1 Flowchart

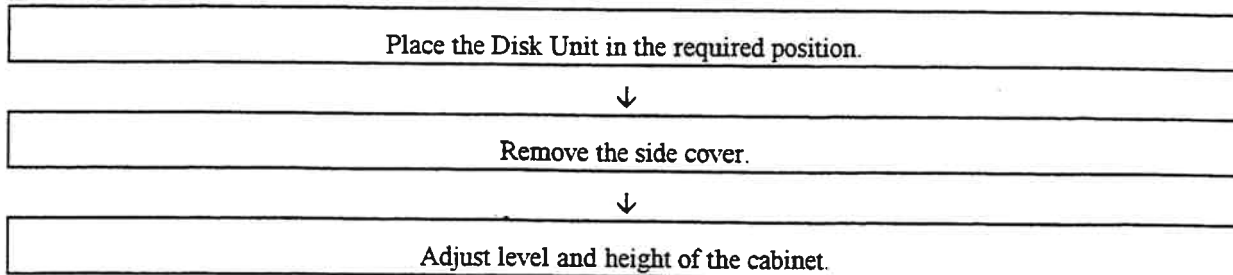

3.3.4.2.2 Disk Unit(s) Layout

Refer to Table 3.2.3.2-1 when laying out the Basic Disk Unit with respect to the Disk Controller and relocating the side cover.

Install the Disk Unit(s) in one of the locations shown in Table 3.3.4.2.2-1.

Table 3.3.4.2.2-1 Removal and Re-installation of Side Cover

Configuration	Fourth Disk Unit	Second Disk Unit	Disk Controller	Basic Disk Unit	Third Disk Unit
Disk Controller and Two Disk Units	Side Cover	Second Disk Unit	Disk Controller	Basic Disk Unit	Side Cover
Disk Controller and Three Disk Units		Second Disk Unit	Disk Controller	Basic Disk Unit	Third Disk Unit
Disk Controller and Four Disk Units	Fourth Disk Unit	Second Disk Unit	Disk Controller	Basic Disk Unit	Third Disk Unit

3.3.4.2.3 Side Cover Removal

Remove the side covers shown in Table 3.3.4.2.2-1 from the installed Disk Controller or Disk Unit(s).

3.3.4.2.4 Remove the Fall Proof Adapter

Remove the fall proof adapters from the Disk Unit(s).

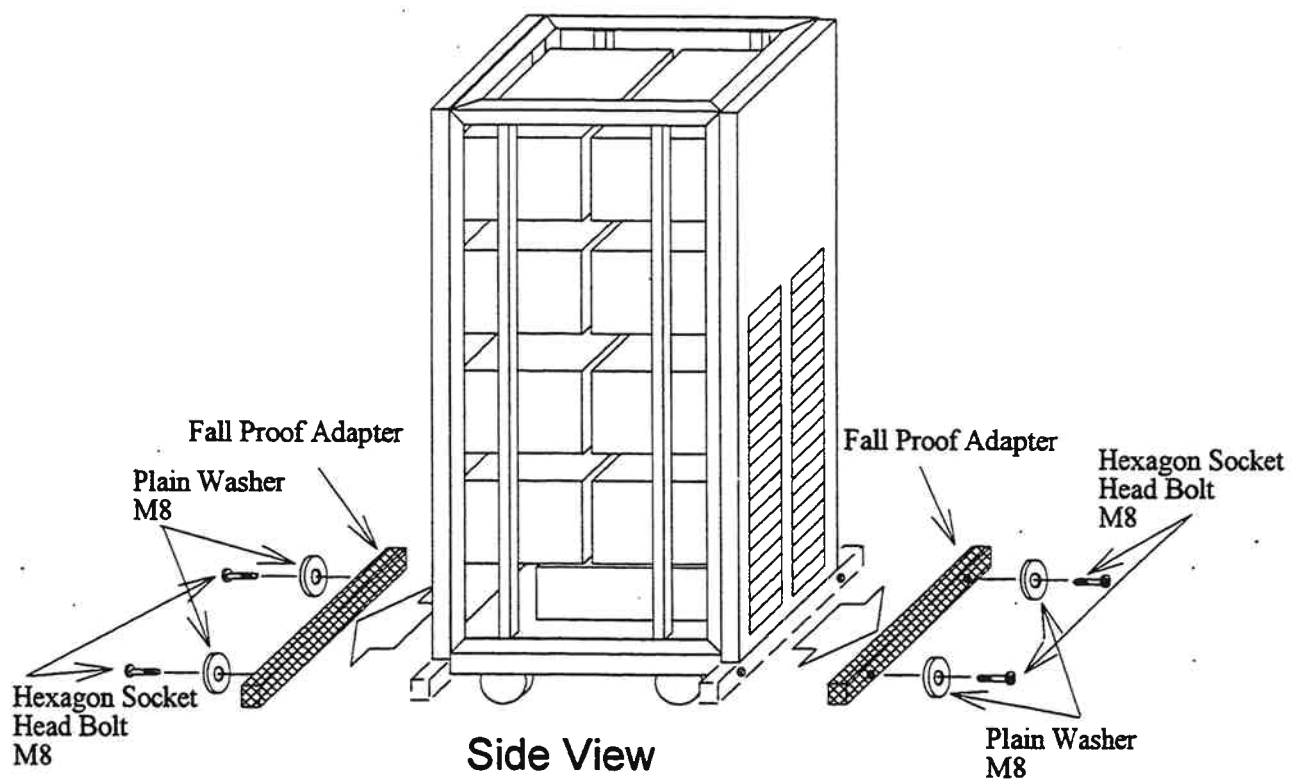

Fig. 3.3.4.2.4-1 Removal of Fall Proof Adapter

Note: The fall proof adapters, hexagon socket head bolt M8s, and plain washer M8s should be stored in the place of installation for future use in moving or taking out the unit.

3.3.4.2.5 Adjusting the Cabinet Height and Level

1. Lower the screw jacks until the frame is 57mm (2.25in.) from the floor before connecting the frames.
2. Level the device as shown on Fig. 3.3.4.2.5-1.
3. When adjusting the cabinet height, make sure that there is a clearance of approximately 2.5 mm (0.1 in.) between the casters and the floor.

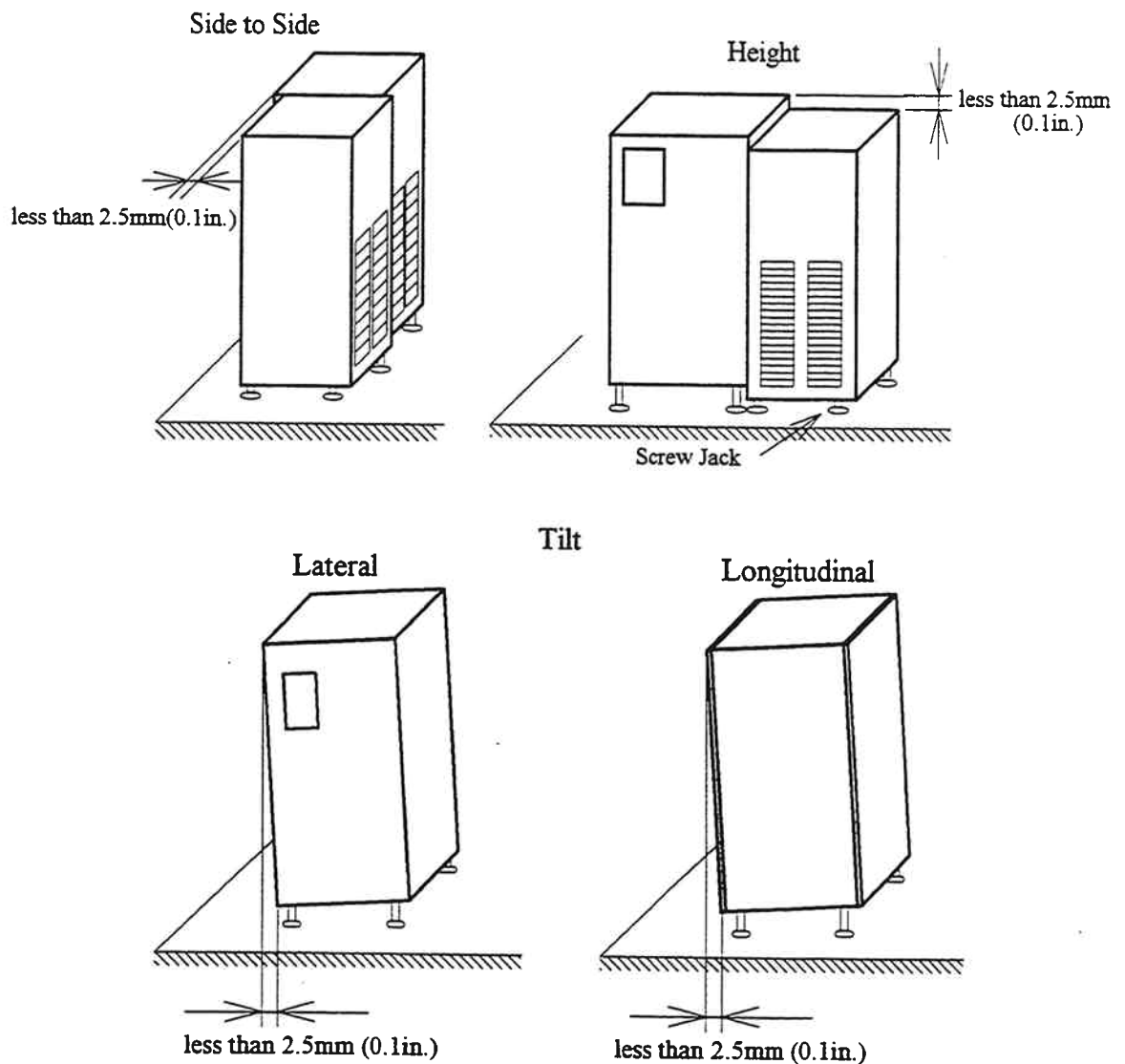
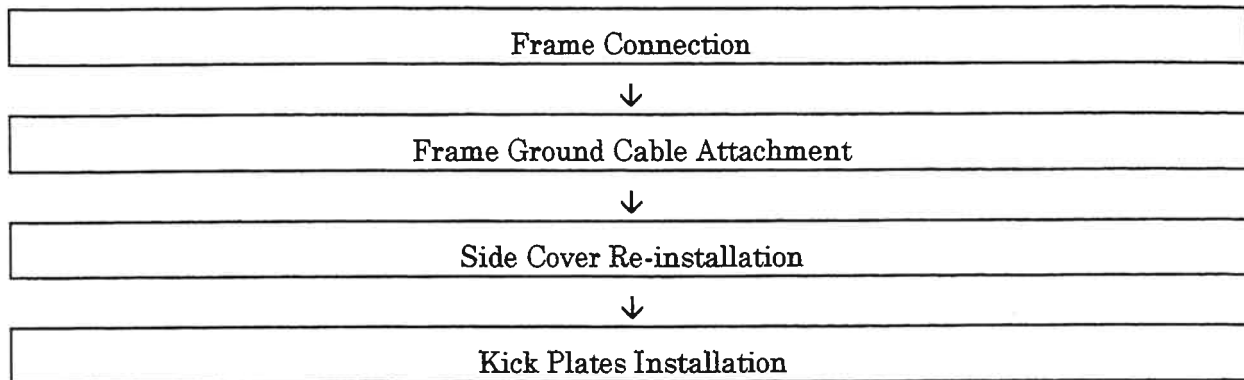

Fig. 3.3.4.2.5-1 Cabinet Setting

3.3.4.3 Frame Connection

3.3.4.3.1 Flowchart



3.3.4.3.2 Frame Connection

Connect the devices together using four of the Connecting Bolt Assy. Place two at the front and two at the rear. See figures 3.3.4.3.2-1 and 3.3.4.3.2-2. The direction of the hexagon socket head bolts must be the same as shown in the figure.

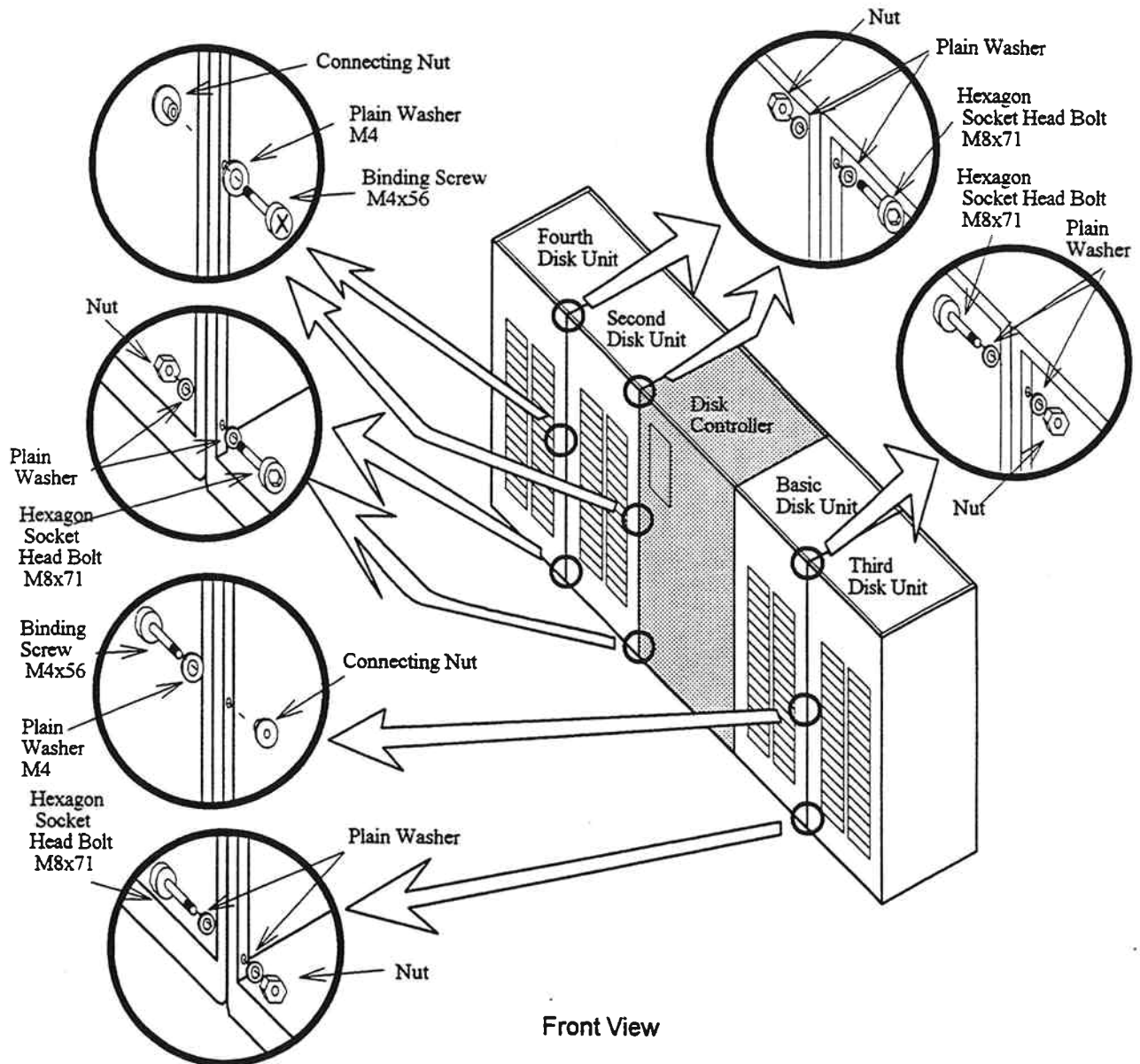

Fig. 3.3.4.3.2-1 Connection of Frame

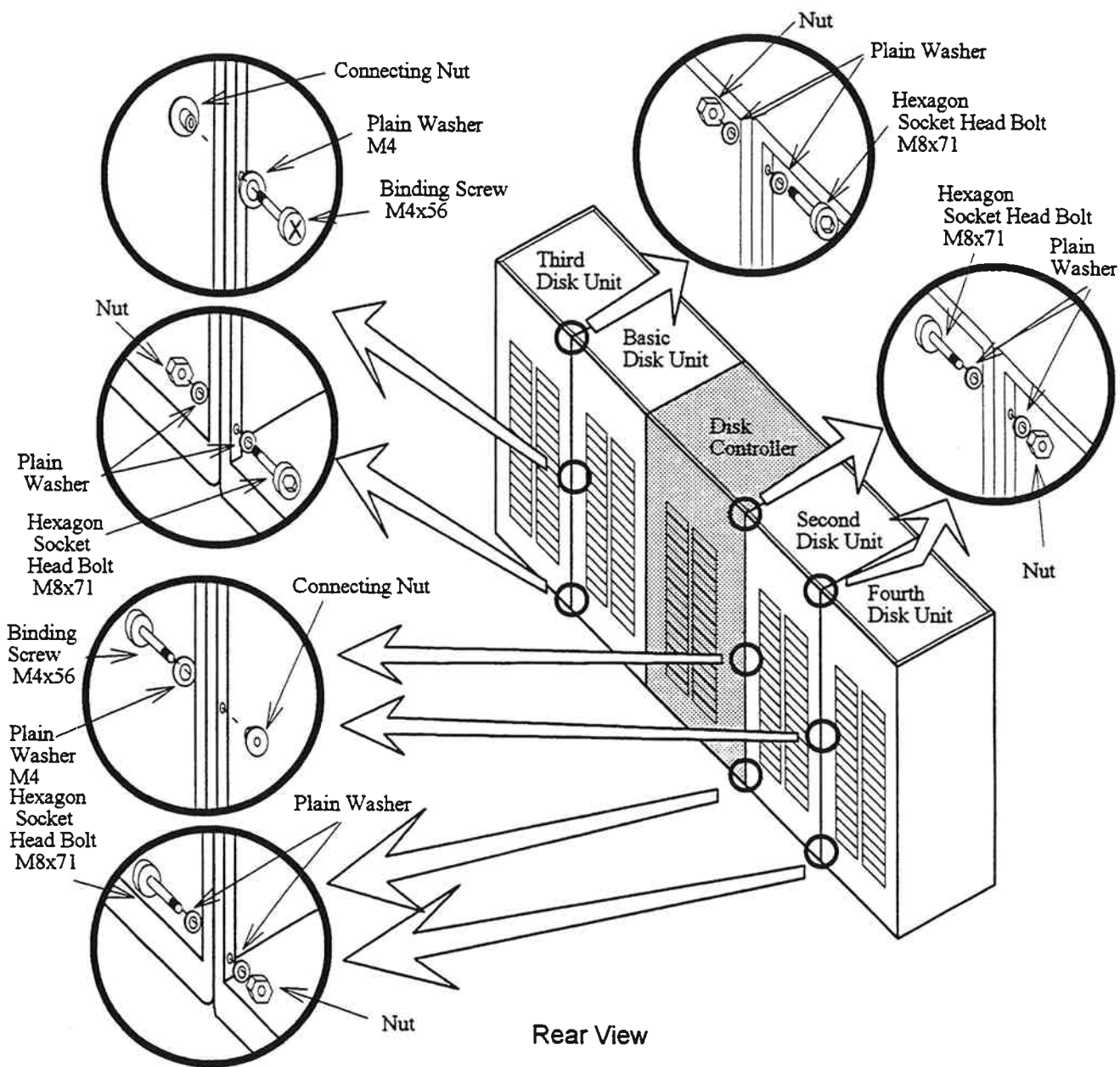
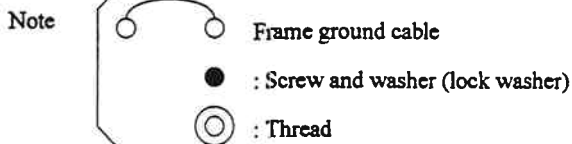

Fig. 3.3.4.3.2-2 Connection of Frame

3.3.4.3.3 Frame Ground Cable Attachment



Second Disk Unit

1. Remove the left side cover of the Disk Controller with the frame ground cable.
2. Remove the frame ground cable from the Second Disk Unit.
3. Connect the cabinets.
4. Attach the side cover to the Second Disk Unit. Refer To Section 3.3.4.3.4 Side Cover Re-Installation [INST03-460].
5. Attach frame ground cable with the screw and lock washer.

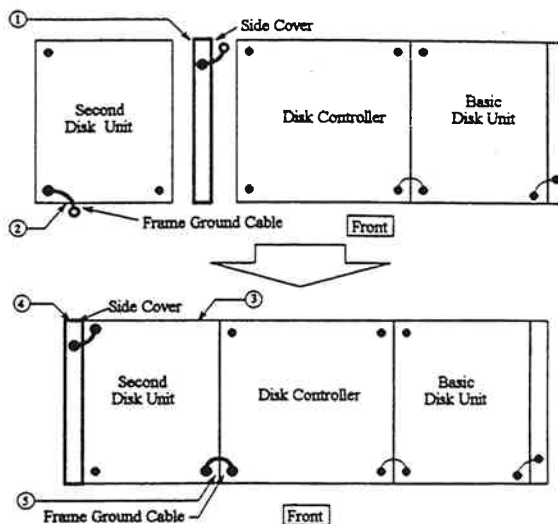

Fig. 3.3.4.3.3-1 Attachment of Frame Ground Cable

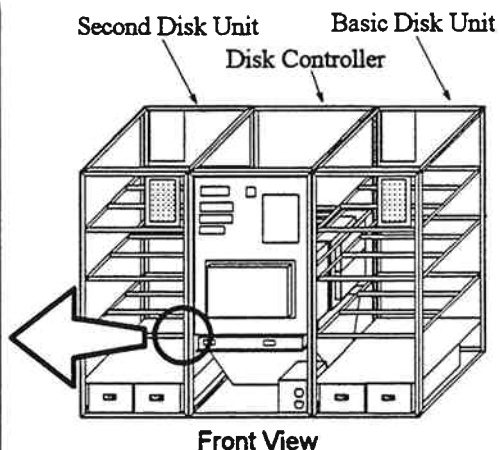
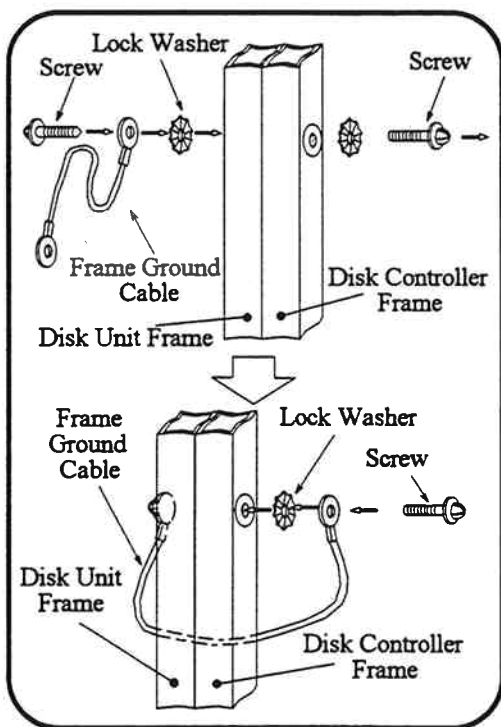

Fig. 3.3.4.3.3-2 Attachment of Frame Ground Cable

Third Disk Unit

1. Remove the right side cover together with the frame ground cable from the Disk Controller or Basic Disk Unit.
2. Connect the cabinet.
3. Attach the side cover to the Third Disk Unit. Refer to SECTION 3.3.4.3.4 Side Cover Re-Installation [INST03-460].
4. Attach the frame ground cable with the screw and lock washer.

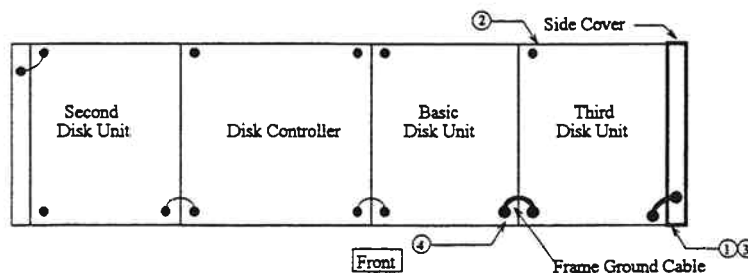

Fig. 3.3.4.3.3-3 Attachment of Frame Ground Cable

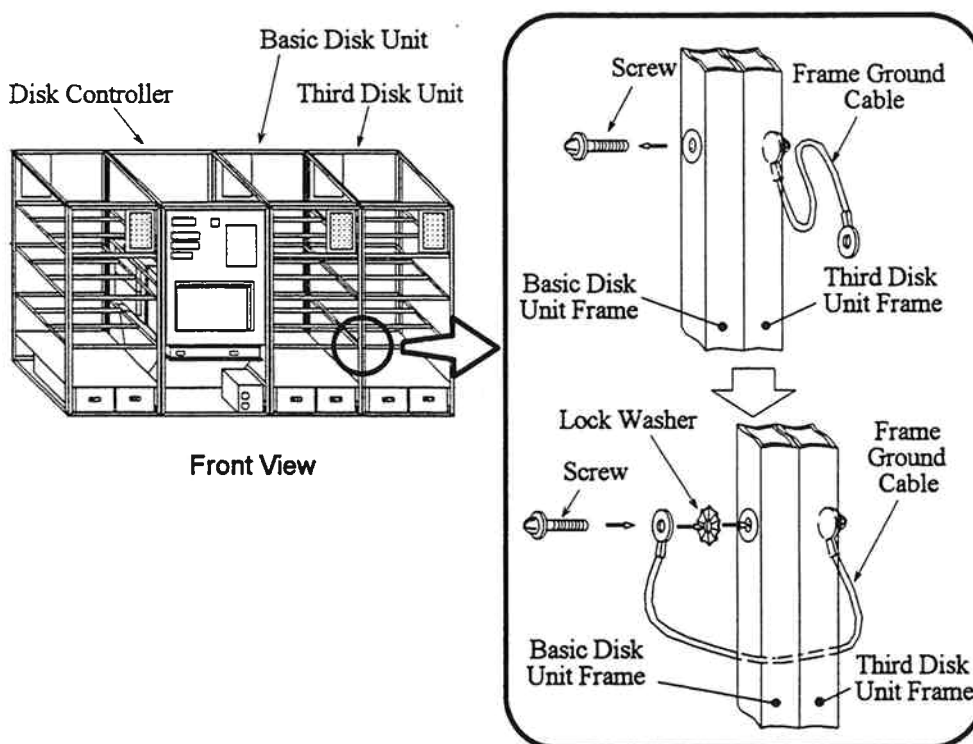

Fig. 3.3.4.3.3-4 Attachment of Frame Ground Cable

Fourth Disk Unit

1. Remove the left side cover together with the frame ground cable from the Disk Controller or Second Disk Unit.
2. Remove the frame ground cable from the Fourth Disk Unit.
3. Connect the cabinet.
4. Attach the side cover to the Fourth Disk Unit. Refer To Section 3.3.4.3.4 Side Cover Re-Installation [INST03-460].
5. Attach the frame ground cable with the screw and lock washer.

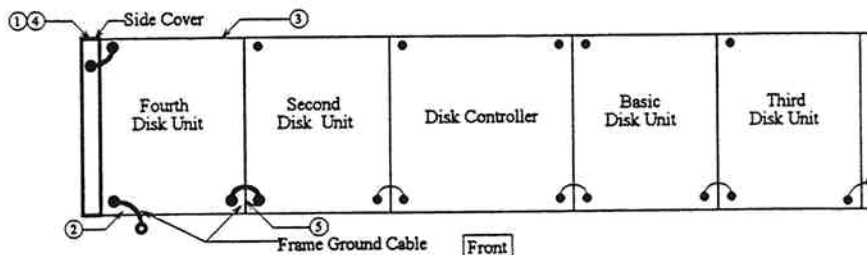

Fig. 3.3.4.3.3-5 Attachment of Frame Ground Cable

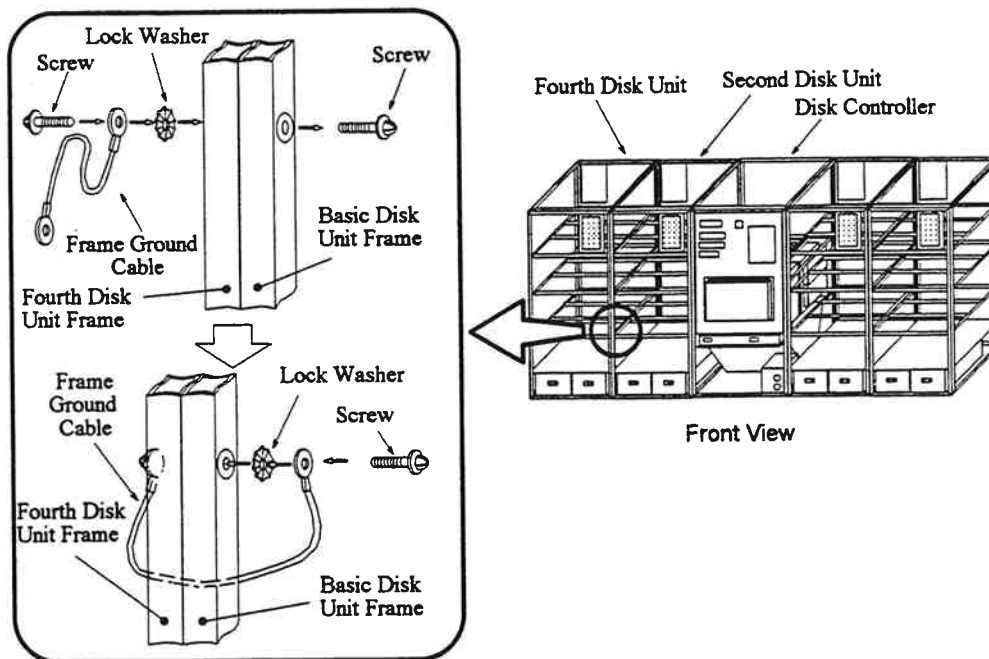

Fig. 3.3.4.3.3-6 Attachment of Frame Ground Cable

3.3.4.3.4 Side Cover Re-Installation

Attach the side cover to the end of the string with the four binding screws and washers.

See Fig. 3.3.4.3.4-1 and Table 3.3.4.2.2-1.

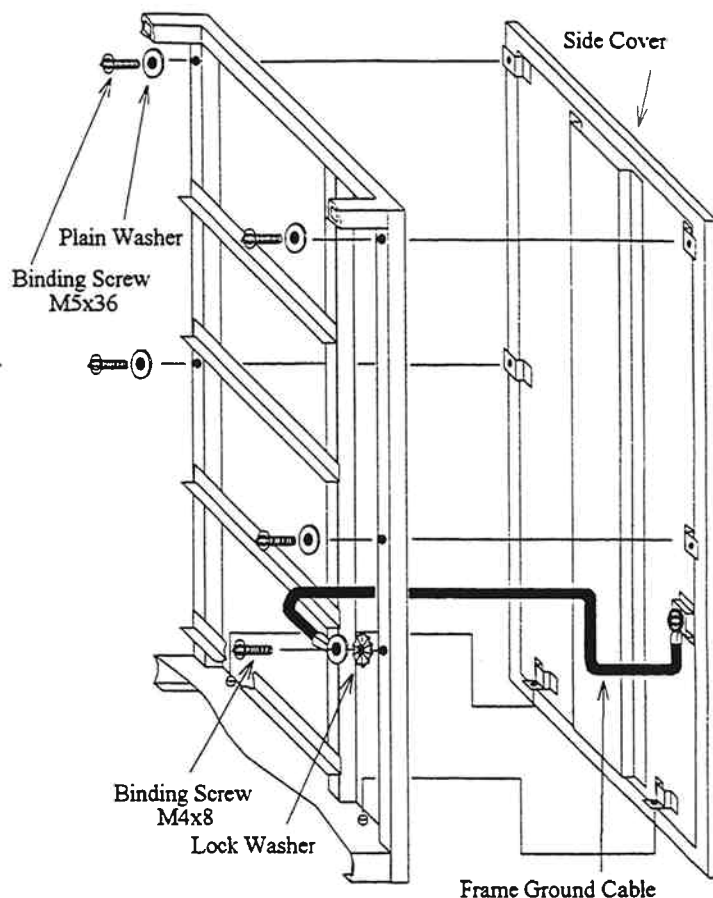

Fig. 3.3.4.3.4-1 Re-Installation of Side Cover

3.3.4.3.5 Kick Plate Installation

Secure the kick plates with screws, as shown in figures 3.3.4.3.5-1, 3.3.4.3.5-2, and 3.3.4.3.5-3

Remove the side kick plates from the Disk Controller and replace them on the cabinets at both ends.

NOTICE

Contact the Kick Plate to the floor to prevent static electricity.

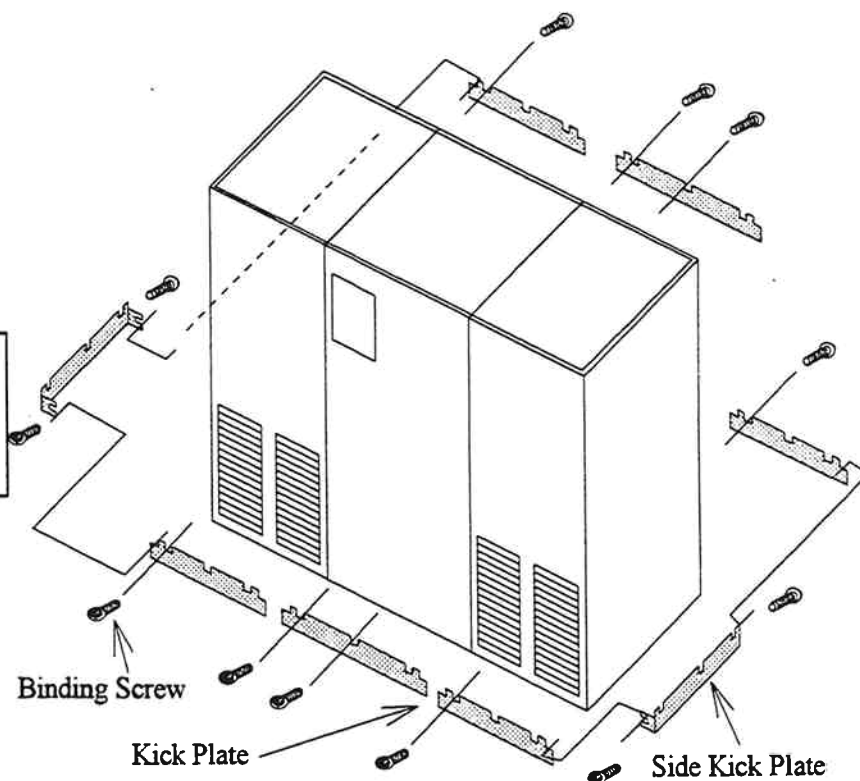

Fig. 3.3.4.3.5-1 Installation of Kick Plate (Two Disk Units)

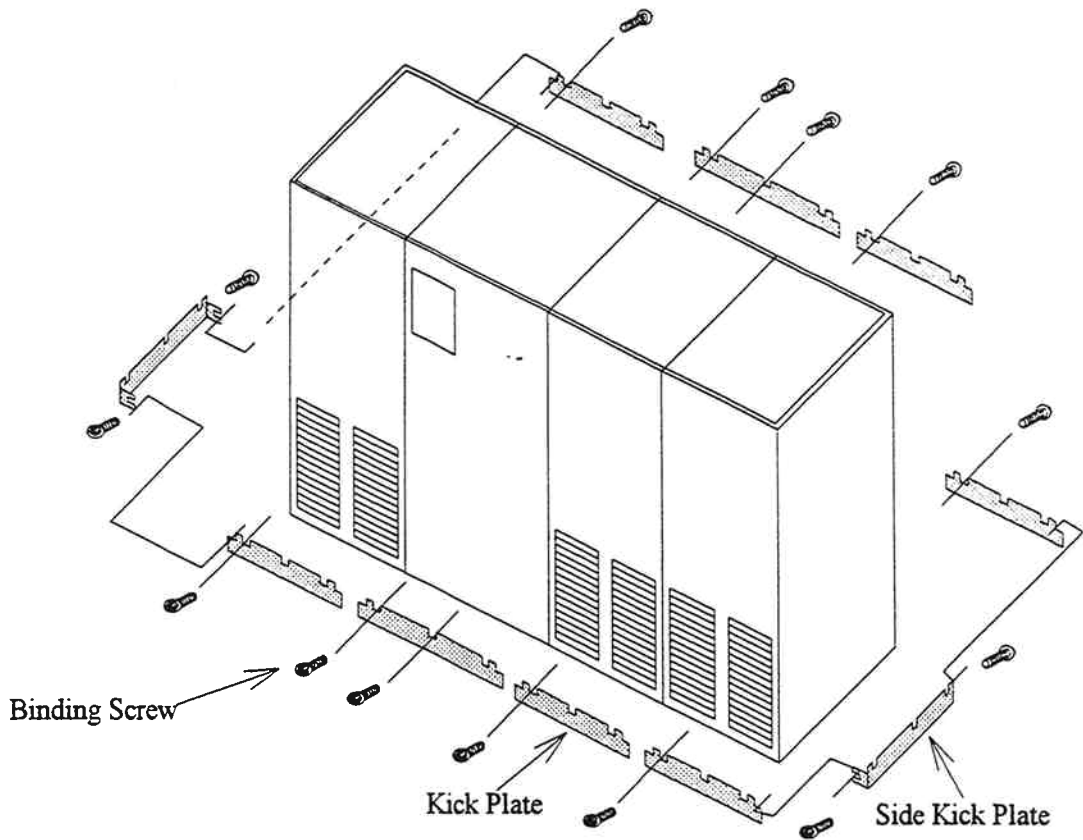

Fig. 3.3.4.3.5-2 Installation of Kick Plate(Three Disk Units)

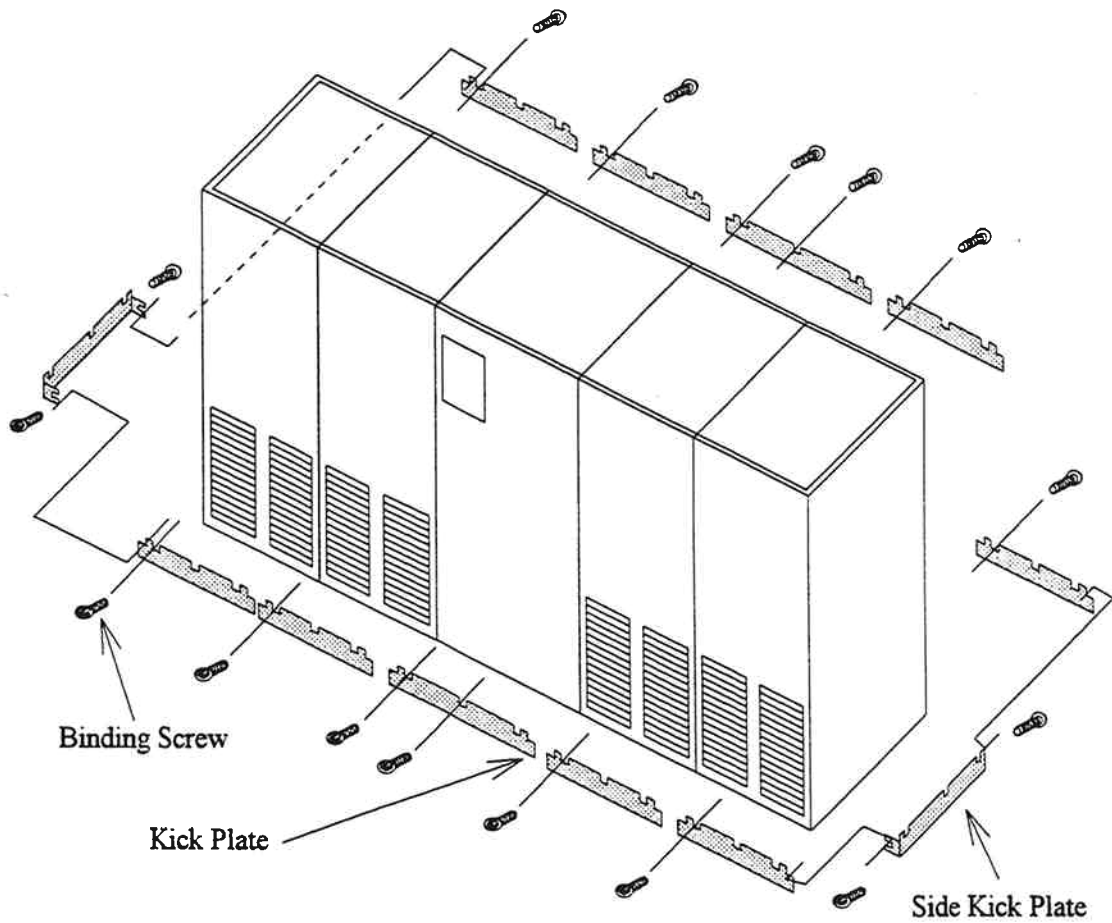

Fig. 3.3.4.3.5-3 Installation of Kick Plate (Four Disk Units)

3.3.4.4 Switch and Jumper Plug Installation

Be sure to wear your wrist strap and attach to ground prior to performing the following work. This will insure that the IC and LSI on the PCB are protected from static electricity.

3.3.4.4.1 DKUMN Setting

Set the switches and install the jumper plugs in the DKUMN PCBs as indicated in the table below.

This following shows the settings for the unit containing no Platform for canister mount (DKU-F205I-B4) (containing four HDU boxes).
 For the settings for the unit containing the Platform for canister mount (DKU F205I-B4) (containing eight HDU boxes), change JP3 as seeing [INST03-1940].

Table 3.3.4.4.1-1 DKUMN PCB Jumper Plug Positions

	1	2	3	4	5	6	Remarks
	DKUMN-L1F	DKUMN-L1R	DKUMN-R2F	DKUMN-R2R	DKUMN-L2F	DKUMN-L2R	
	front	rear	front	rear	front	rear	
S1	DISABLE	DISABLE	DISABLE	DISABLE	DISABLE	DISABLE	
JP1							* #10 - #12: Reserved
JP2							
JP3							
	Second Disk Unit		Third Disk Unit		Fourth Disk Unit		

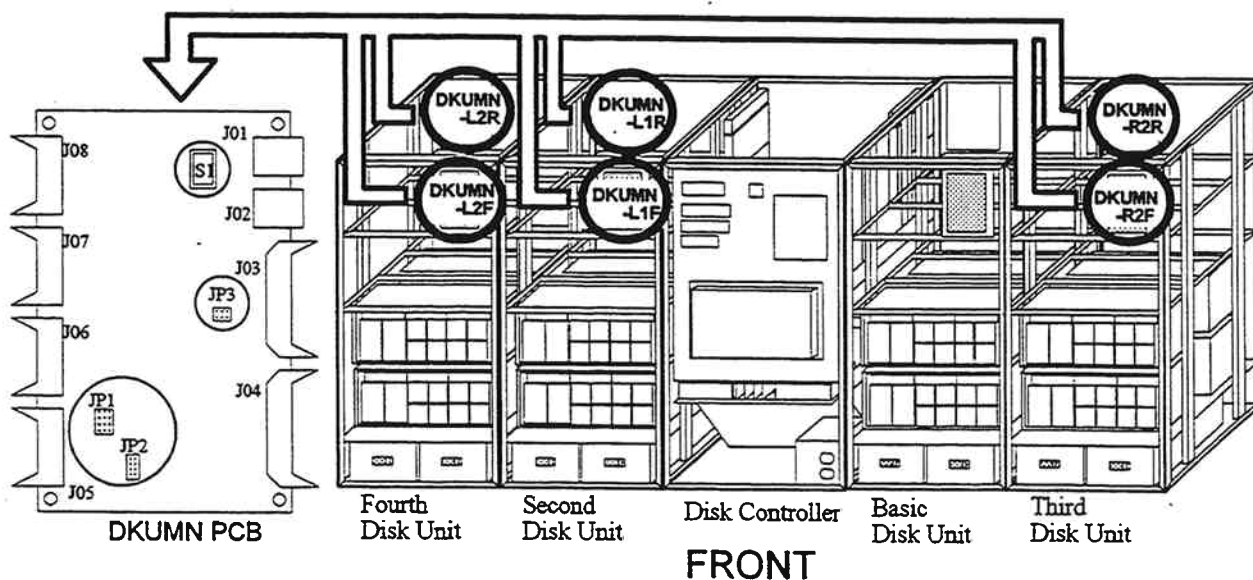

3.3.4.4.2 SCSI ID Setting

1. If a HDD Canister has been installed when setting SCSI ID jumper plugs, move the HDD canister from ① to ② seeing Figs. 3.3.4.4.2-1 and 3.4.4.2-2.
 - (1) For de-installation of the HDD canister, see 3.4.5 De-installation of HDD Canister (Pages INST04-1090 to 1110).
 - (2) For installation of the HDD canister, see 3.3.10 Installation of HDD Canister (Pages INST03-1950 to 1970).

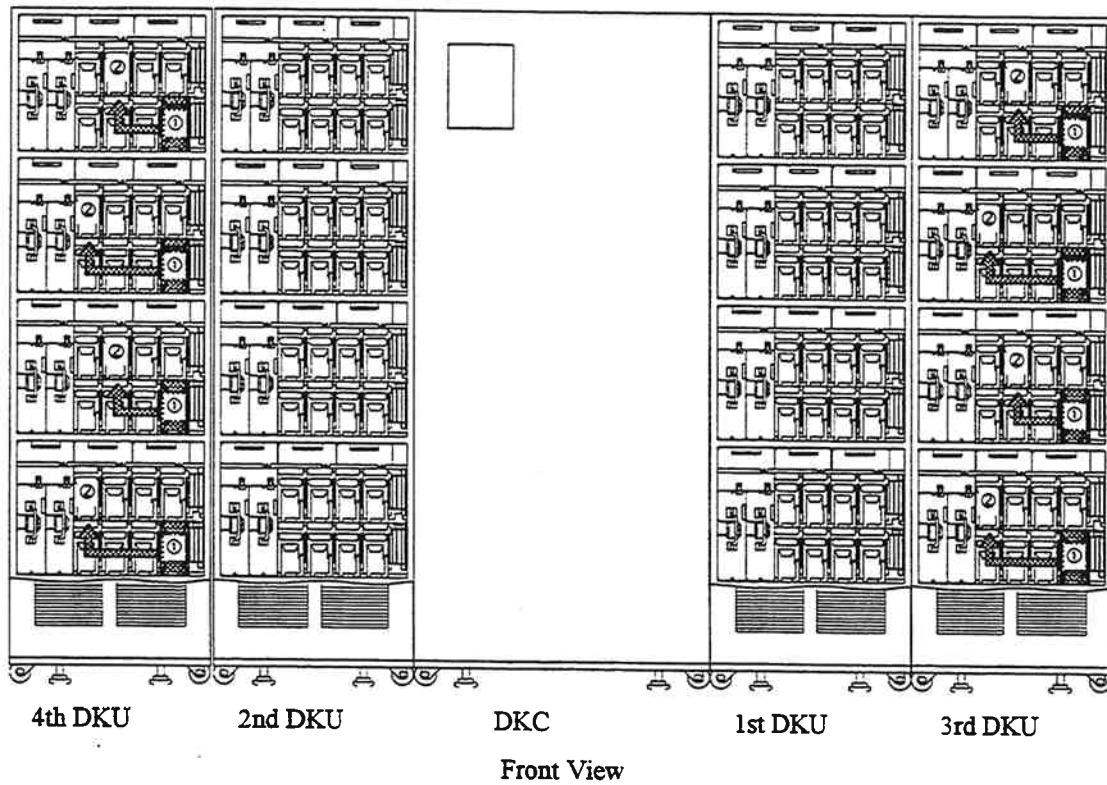

Fig. 3.3.4.4.2-1 Moving HDD Canister

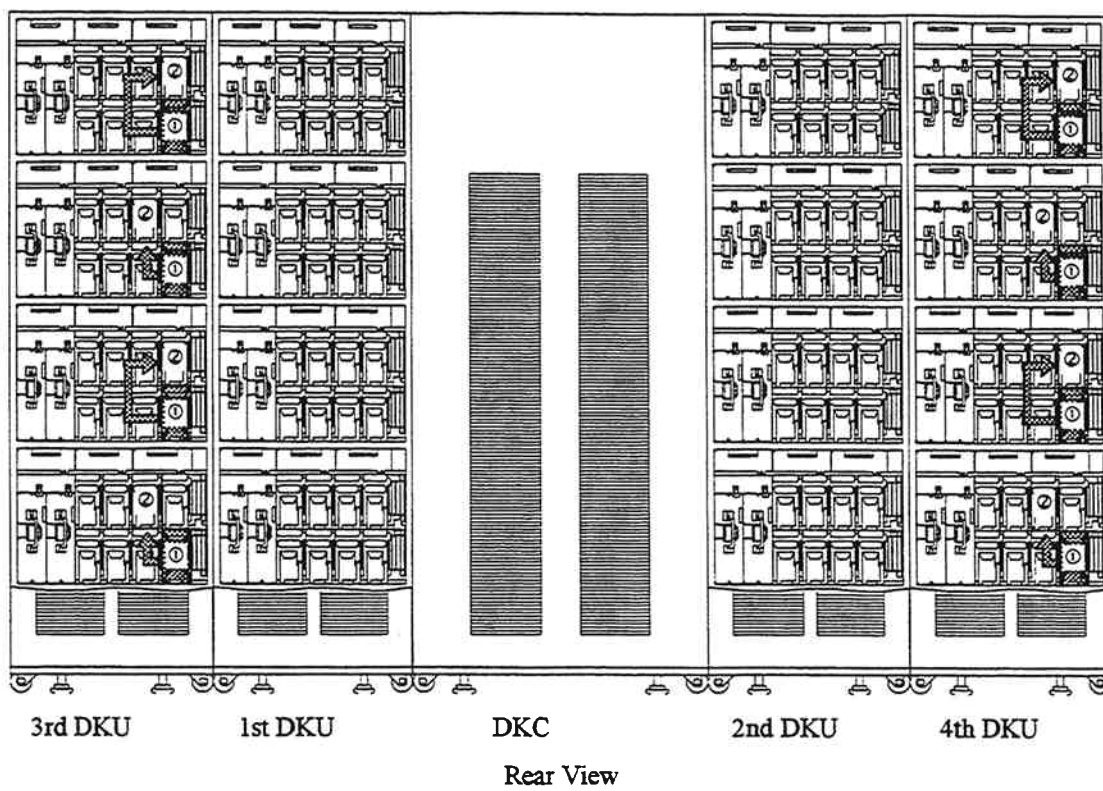

Fig. 3.3.4.4.2-2 Moving HDD Canister

Notice

Wrong setting of SCSI ID jumper plugs may cause DKU failures during operation. Be extremely careful in setting the SCSI ID jumper plugs.

2. Seeing Figs. 3.3.4.4.2-3 and 3.3.4.4.2-4, set the jumper plugs on HDU box.

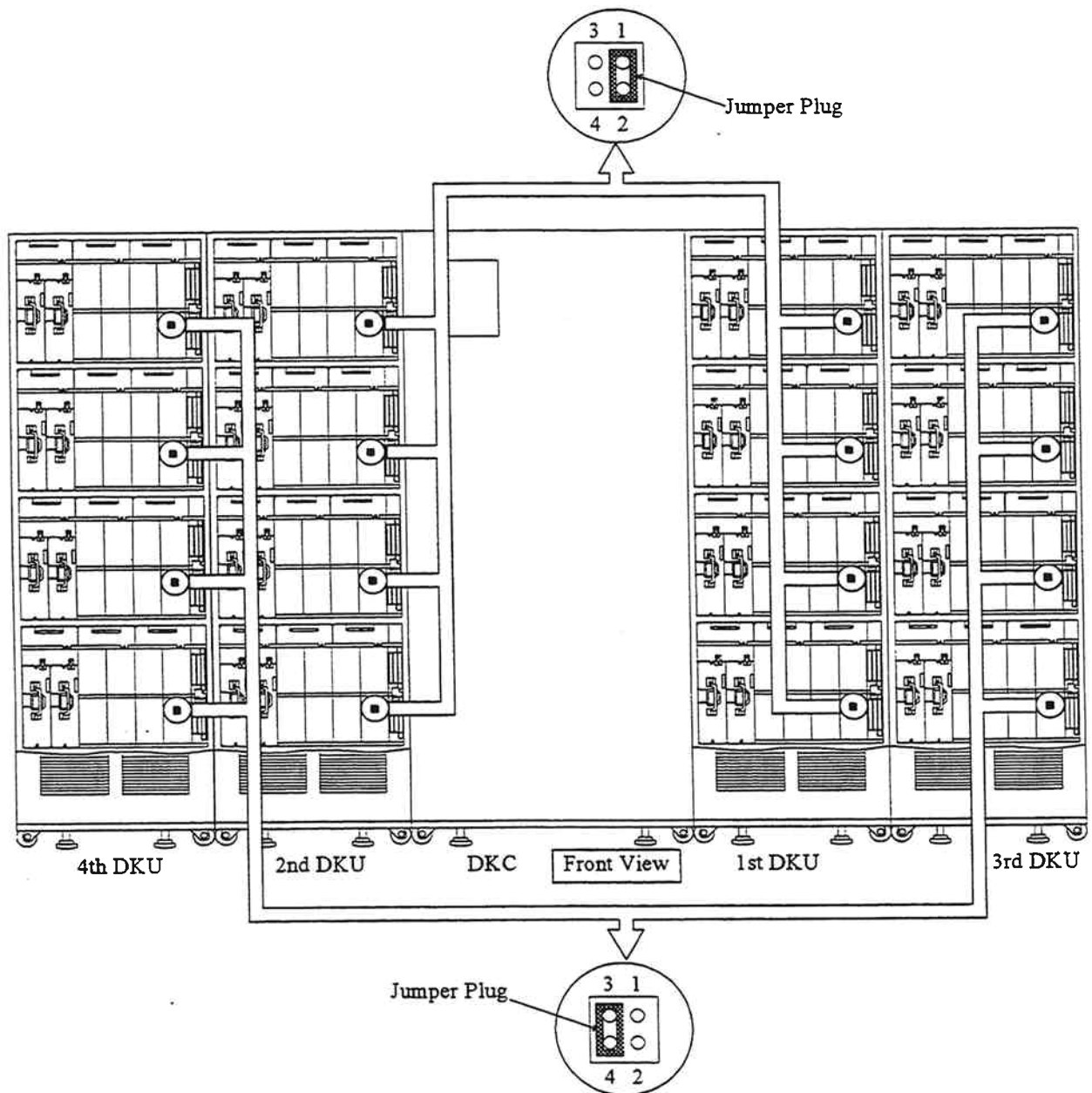

Fig. 3.3.4.4.2-3 Setting the SCSI ID Jumper Plugs

Notice

Wrong setting of SCSI ID jumper plugs may cause DKU failures during operation. Be extremely careful in setting the SCSI ID jumper plugs.

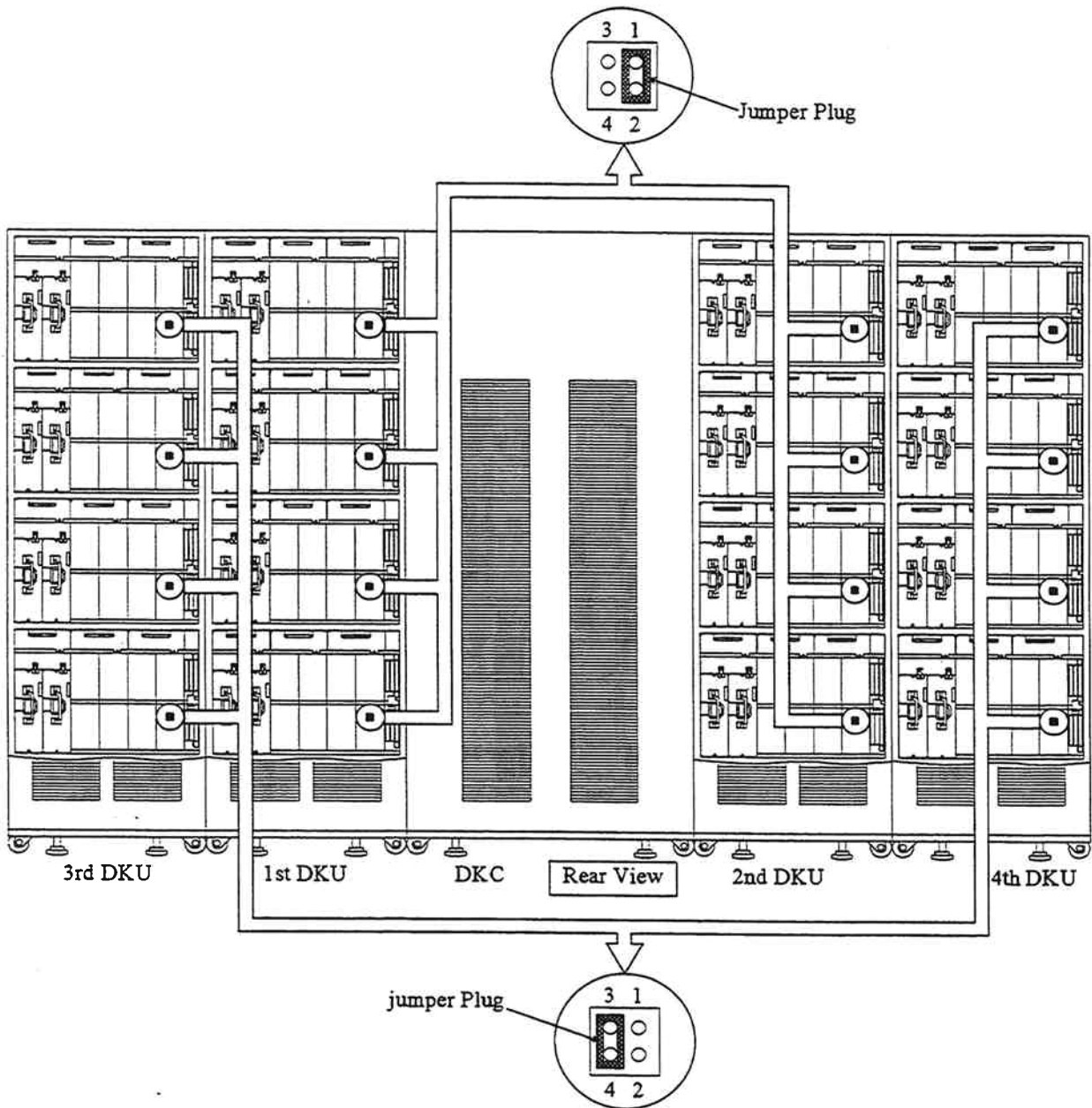

Fig. 3.3.4.4.2-4 Setting the SCSI ID Jumper Plugs

3.3.4.5 Cabling

3.3.4.5.1 Connection of DKUMN Cable

1. Loosen the repeat binders which secure the DKUMN cables.

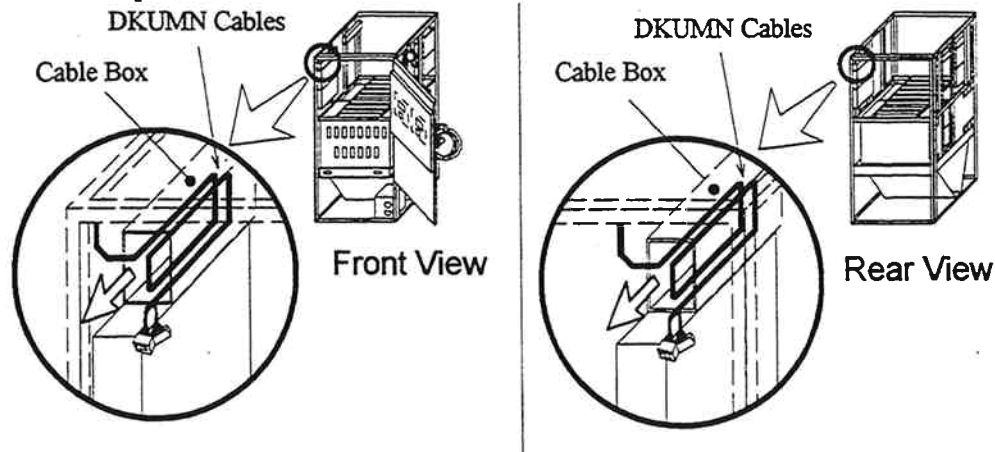

Fig. 3.3.4.5.1-1 Binding of DKUMN Cables

2. Before binding the DKUMN cables, secure the DKUMN PCB. Refer to Fig. 3.3.4.5.1-2.
 - a. Loosen the screws.
 - b. Lift the DKUMN PCB.
 - c. Slide and secure the DKUMN PCB.

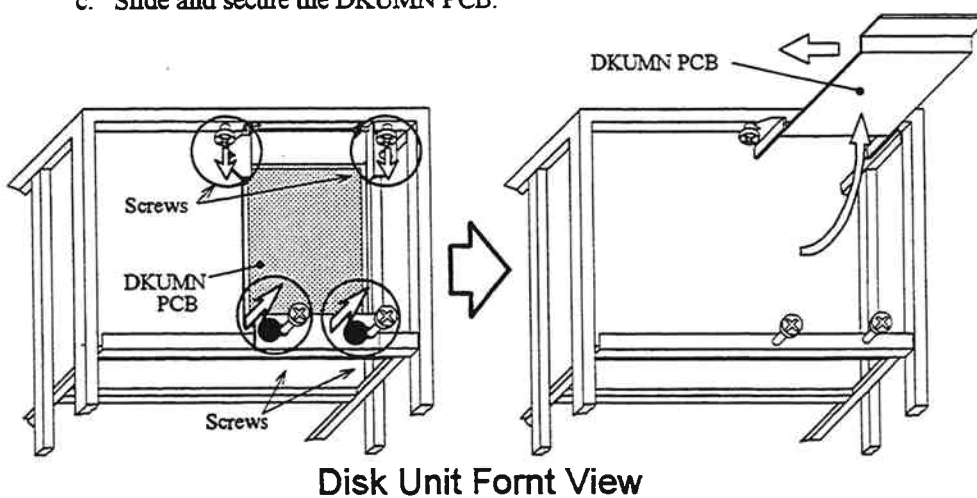

Fig. 3.3.4.5.1-2 Lift of DKUMN PCB

3. Bind the cables with repeat binders to prevent them from sagging.

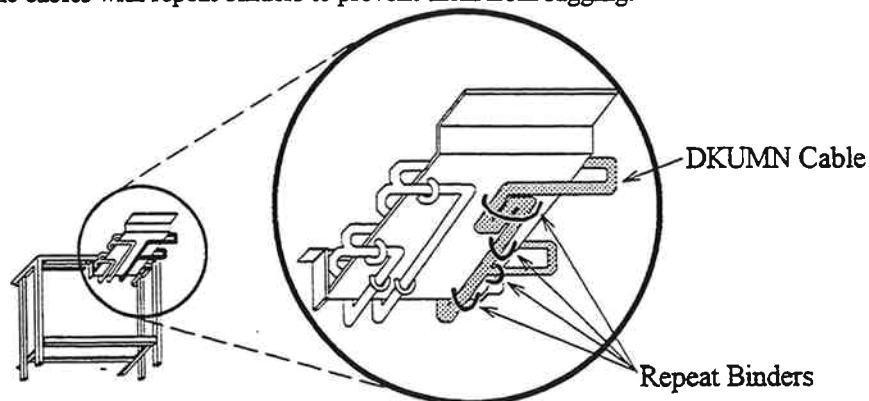

Fig. 3.3.4.5.1-3 Binding of DKUMN Cables

Second Disk Unit

Be sure to wear your wrist strap and attach to ground prior to performing the following work. This will insure that the IC and LSI on the PCB are protected from static electricity.

1. Connect the PWRCTL PCBs or Logic PS Back Board and DKUMN PCBs as summarized in the table below.
2. Bind the cables with repeat binders to prevent them from sagging.

Table 3.3.4.5.1-1 Connection of DKUMN Cable

No.	Disk	Controller	Cable No.	Second	Disk Unit	REMARKS
	Location No.	Connector No.		Location No.	Connector No.	
1	PWRCTL-1	J22	P22-1	DKUMN-L1F	J04	P4-1
2	Logic PS BB	3AE3	3AE3	DKUMN-L1F	J02	P2-1
3	PWRCTL-2	J22	P22-2	DKUMN-L1R	J04	P4-2
4	Logic PS BB	3BE3	3BE3	DKUMN-L1R	J02	P2-2

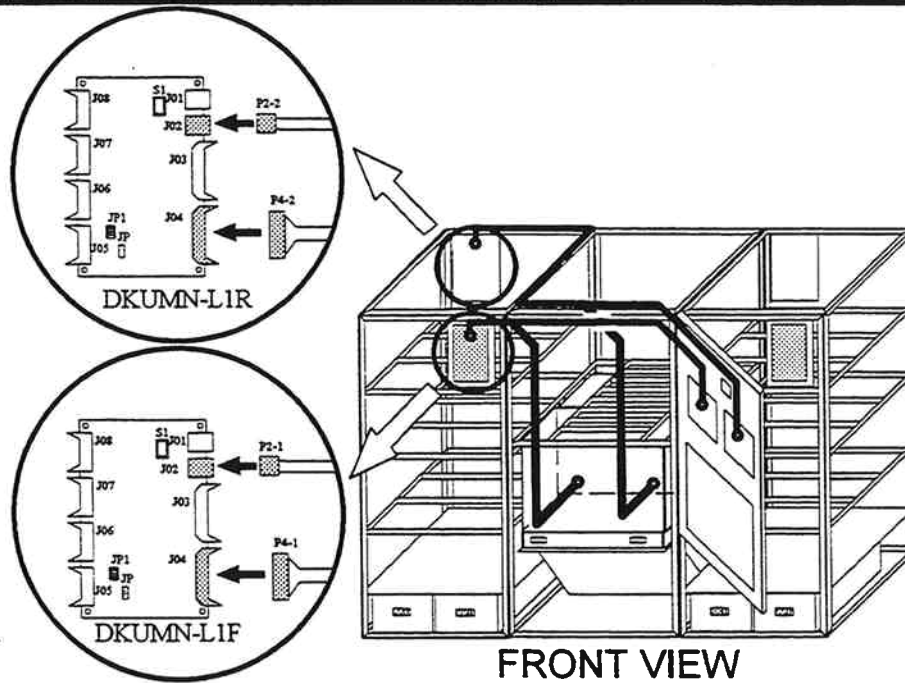

Fig. 3.3.4.5.1-4 Connection of DKUMN Cables

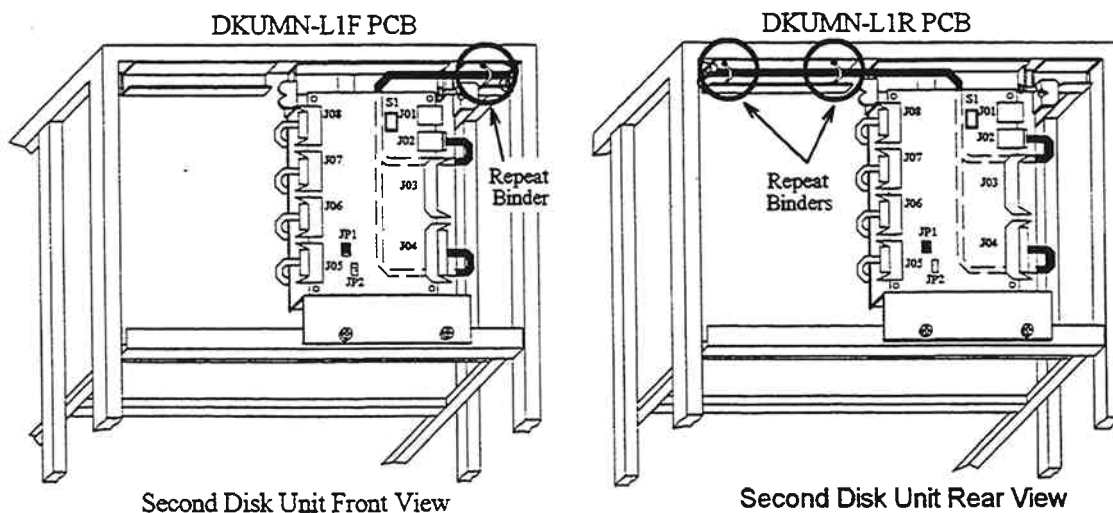

Fig. 3.3.4.5.1-5 Binding of DKUMN Cables

Third Disk Unit

Be sure to wear your wrist strap and attach to ground prior to performing the following work. This will insure that the IC and LSI on the PCB are protected from static electricity.

1. Connect the DKUMN cables between the Basic Disk Unit and the Third Disk Unit as indicated in the table below.
2. Bind the cables with repeat binders to prevent them from sagging.

Table 3.3.4.5.1-2 Connection of DKUMN Cables

No.	Basic Disk Unit			Third Disk Unit			Remarks
	Location No.	Connector No.	Cable No.	Location No.	Connector No.	Cable No.	
1	DKUMN-R1F	J03	P3-1	DKUMN-R2F	J04	P4-1	
2	DKUMN-R1F	J01	P1-1	DKUMN-R2F	J01	P1-1	
3	DKUMN-R1R	J03	P3-2	DKUMN-R2R	J04	P4-2	
4	DKUMN-R1R	J01	P1-2	DKUMN-R2R	J01	P1-2	

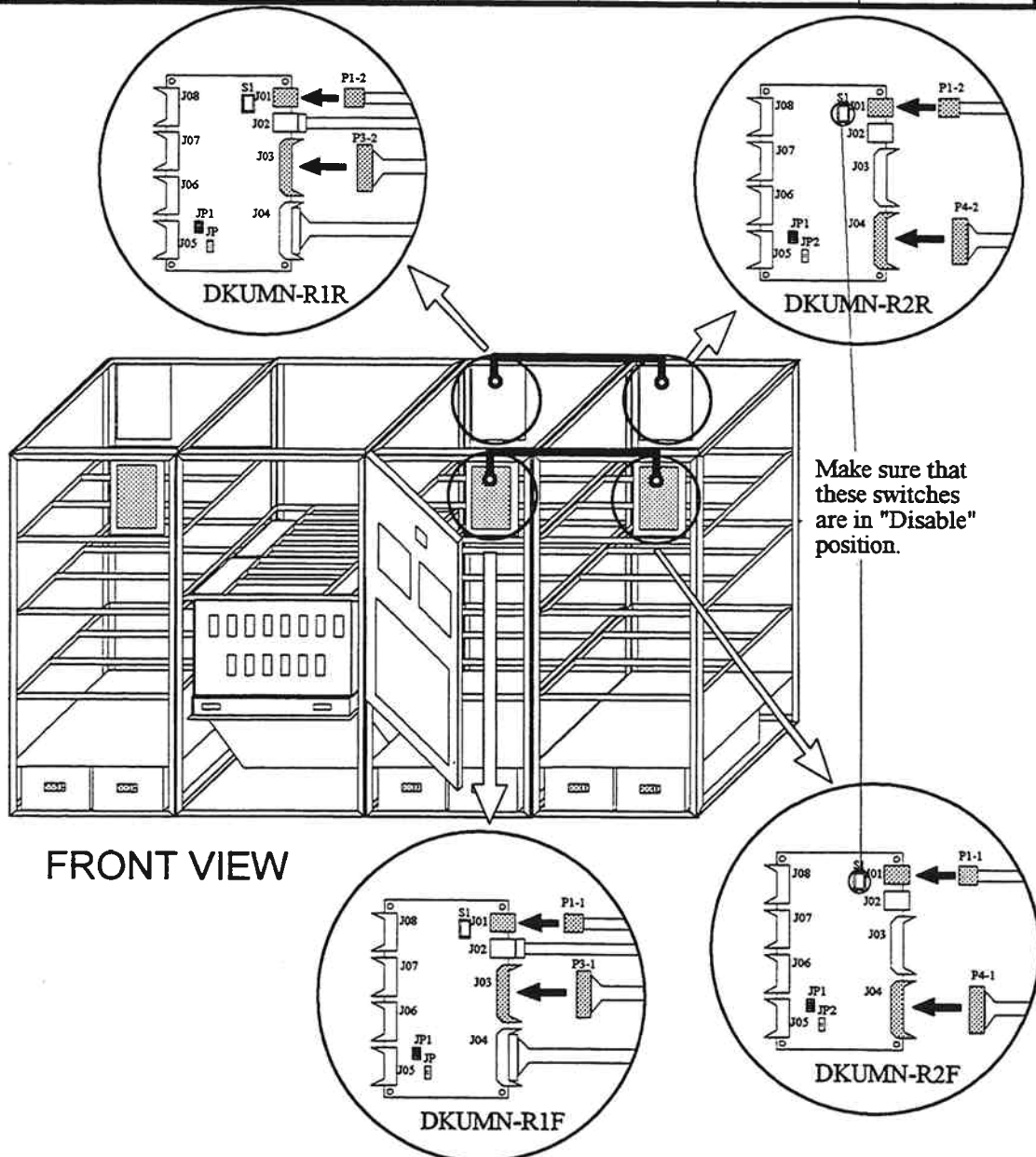

Fig. 3.3.4.5.1-6 Connection of DKUMN Cables

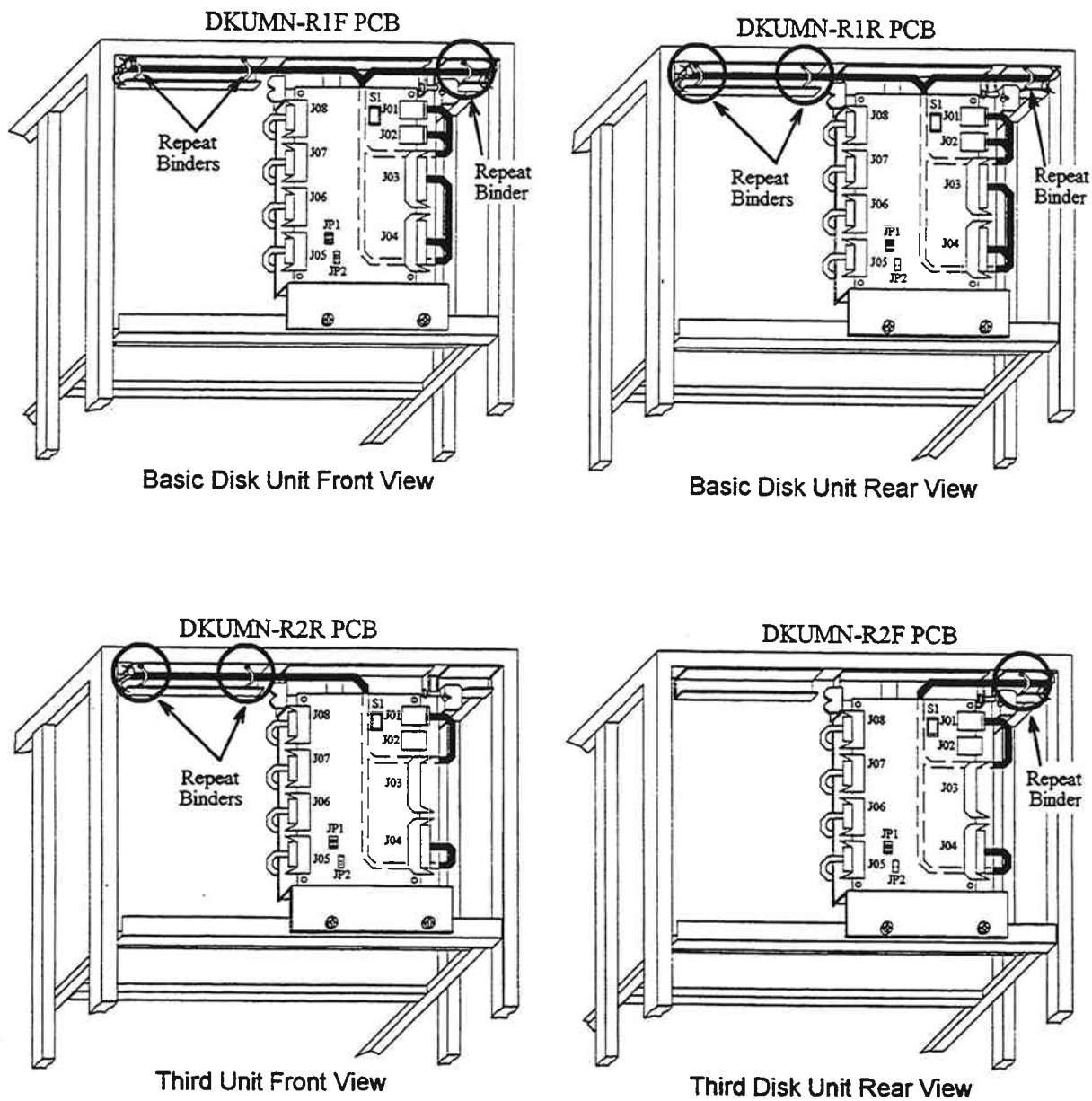

Fig. 3.3.4.5.1-7 Binding of DKUMN Cables

Fourth Disk Unit

Be sure to wear your wrist strap and attach to ground prior to performing the following work. This will insure that the IC and LSI on the PCB are protected from static electricity.

1. Connect the DKUMN cables between the Second Disk Unit and the Fourth Disk Unit as indicated in the table below.
2. Bind the cables with repeat binders to prevent them from sagging.

Table 3.3.4.5.1-3 Connection of DKUMN Cables

No.	Second Disk Unit			Fourth Disk Unit			REMARKS
	Location No.	Connector No.	Cable No.	Location No.	Connector No.	Cable No.	
1	DKUMN-L1F	J03	P3-1	DKUMN-L2F	J04	P4-1	
2	DKUMN-L1F	J01	P1-1	DKUMN-L2F	J01	P1-1	
3	DKUMN-L1R	J03	P3-2	DKUMN-L2R	J04	P4-2	
4	DKUMN-L1R	J01	P1-2	DKUMN-L2R	J01	P1-2	

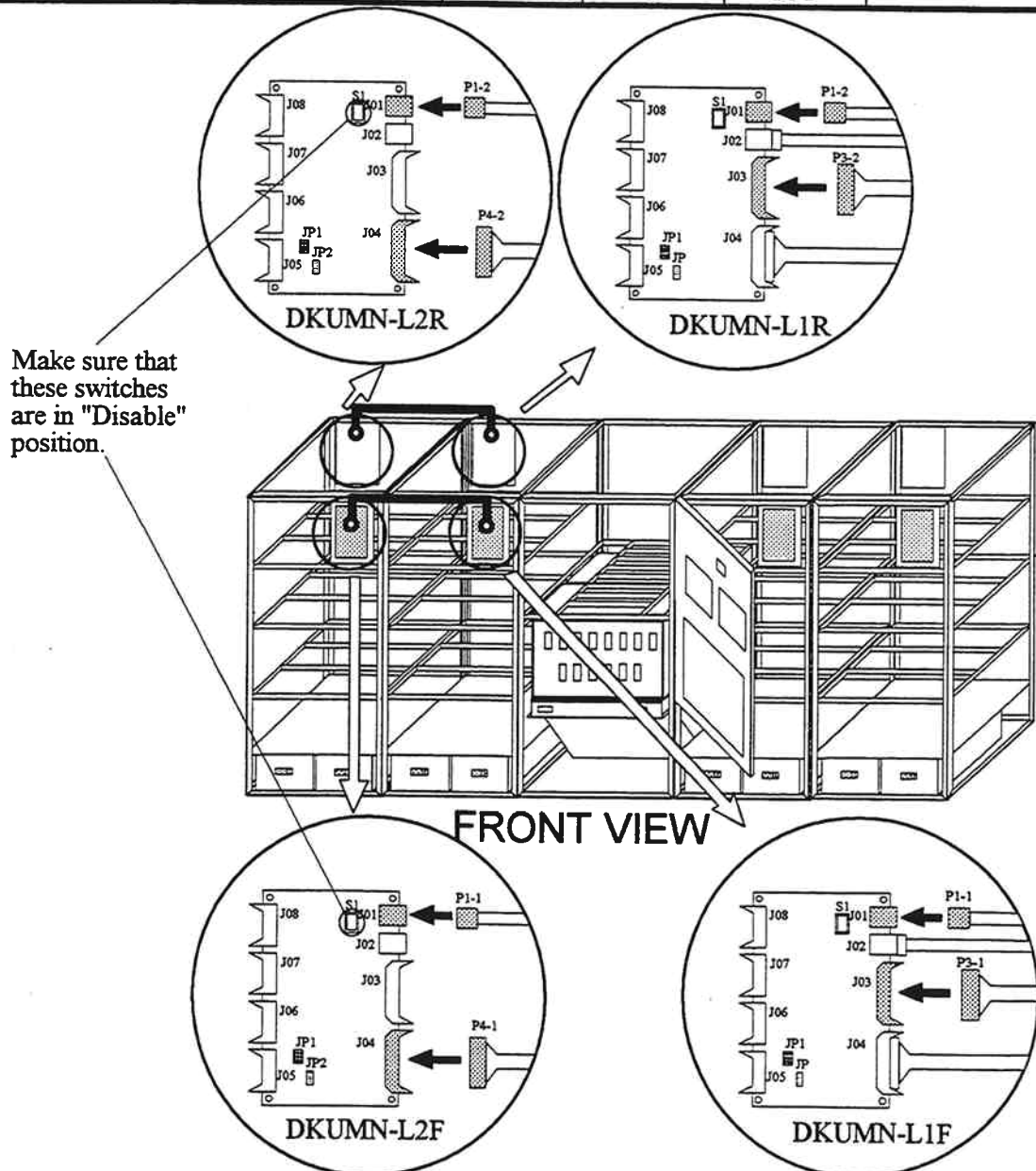

Fig. 3.3.4.5.1-8 Connection of DKUMN cables

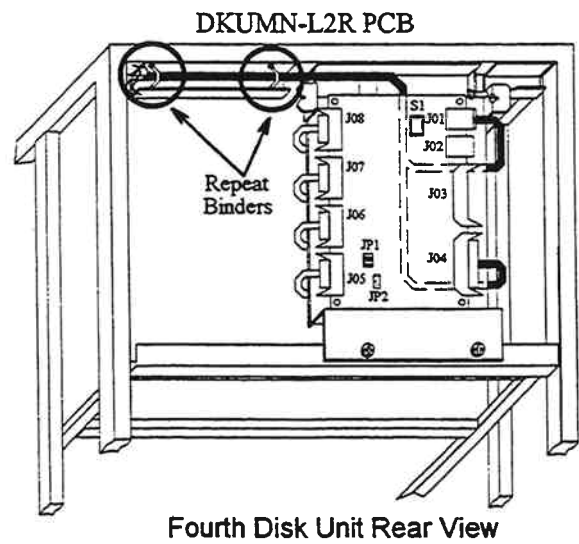
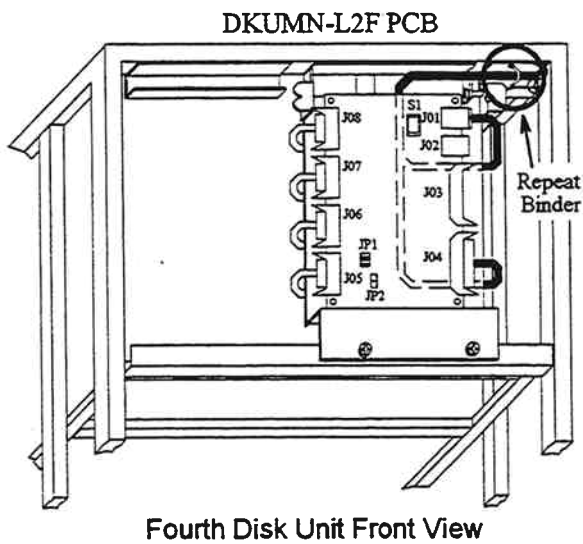
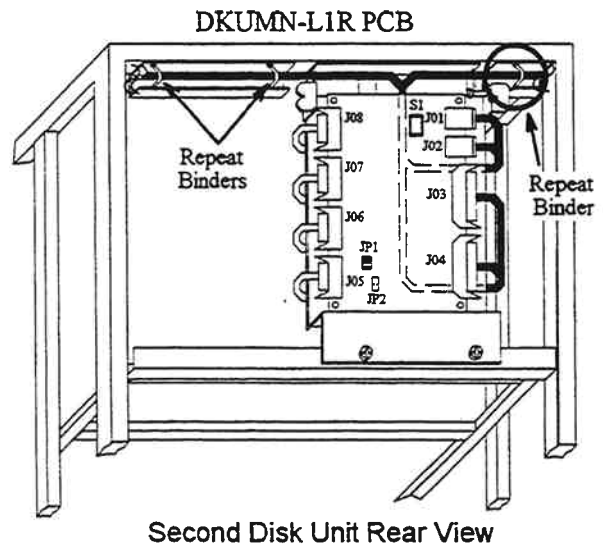
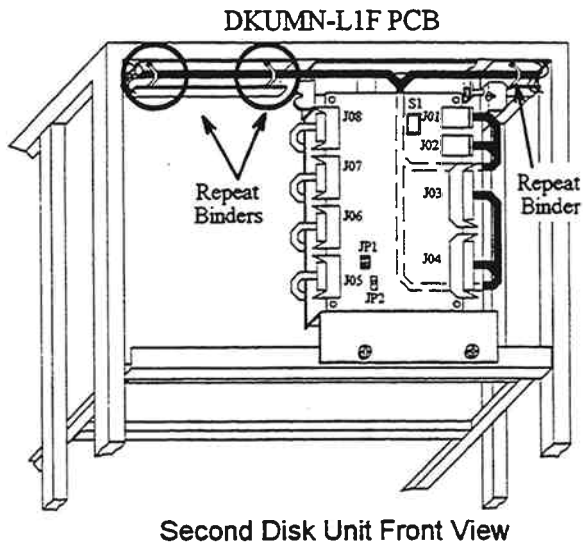

Fig. 3.3.4.5.1-9 Binding of DKUMN Cables

3.3.4.6 Check and Testing

3.3.4.6.1 AC Input Voltage Check

 **WARNING**

Do not touch the internal parts of the AC power cable, the AC Box, or the Breaker Box.

Line voltage is present even if the circuit breaker is off.

1. Check the AC input voltage using a voltmeter at the customer's AC power source (at the distribution board or receptacle for R & S connectors).

3.3.4.6.2 Checking the AC Input Cable, and AC Input Voltage Select Jumper Cable

1. Check the input power cable and jumper cable (P104) at the AC Boxes in Disk Units.

See Table 3.3.4.6.2-1, Fig. 3.3.4.6.2-1, and Fig. 3.3.4.6.2-2 for items.

Table 3.3.4.6.2-1 AC Input Cable Conditions and Jumper Cable (P104) Positions

Input Voltage	AC Input Cable Conditions	Jumper Cable (P104) Position	Remarks
200-240Vac	4 conductors (R,S,T,FG)	J104-1	DKU205IU-14 J104-2 dummy connector
380-415Vac	5 conductors (R,S,T,N,FG)	J104-2	DKU205IE-14 J104-1 dummy connector

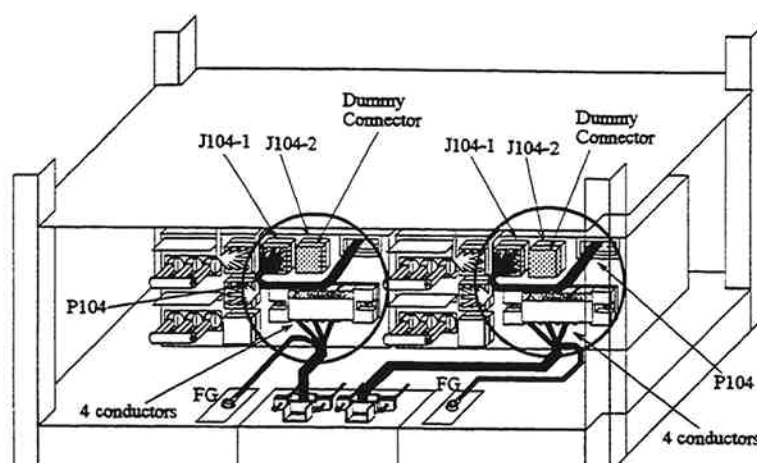

Fig. 3.3.4.6.2-1 AC Input Cable Conductors and Jumper Cable (P104) Positions 200-240Vac

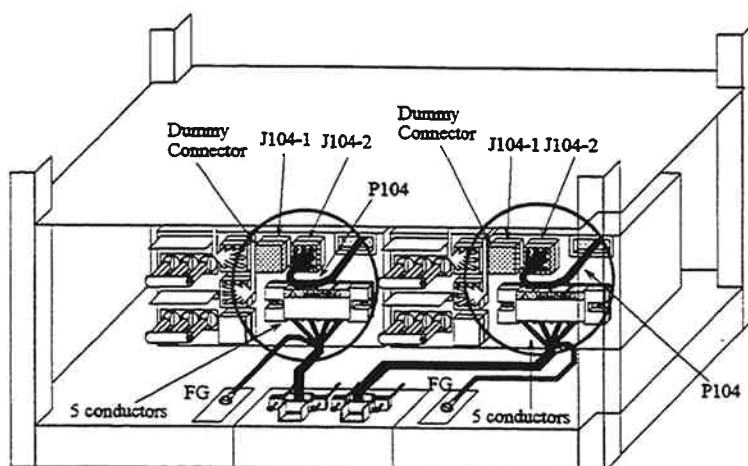

Fig. 3.3.4.6.2-2 AC Input Cable Conductors and Jumper Cable (P104) Positions 380-415Vac

2. Return to General Flow.

New Installation: Go to INST02-11 Step (9)-3.

Non-Disruptive Installation: Go to INST02-21 Step (9)-3.

Disruptive Installation: Go to INST02-40 Step (8)-3.

3.3.5 Installation of Hz Conversion Kit

3.3.5.1 Installation of Hz Conversion Kit for Disk Controller (DKC-F210I-56, DKC-F210I-65)

DKC-F210I-56 DKC210IE(50Hz) to DKC210IU(60Hz)

DKC-F210I-65 DKC210IU(60Hz) to DKC210IE(50Hz)



Perform The Hz Conversion with care.

This Hz Conversion is concerned with Primary Circuit.

Perform this procedure before connecting the Disk Unit to the frame and the Power Cable Assy.

Be sure to mind your head during operation, or you might hit your head against the movable rack, which causes injury.

3.3.5.1.1 Flowchart

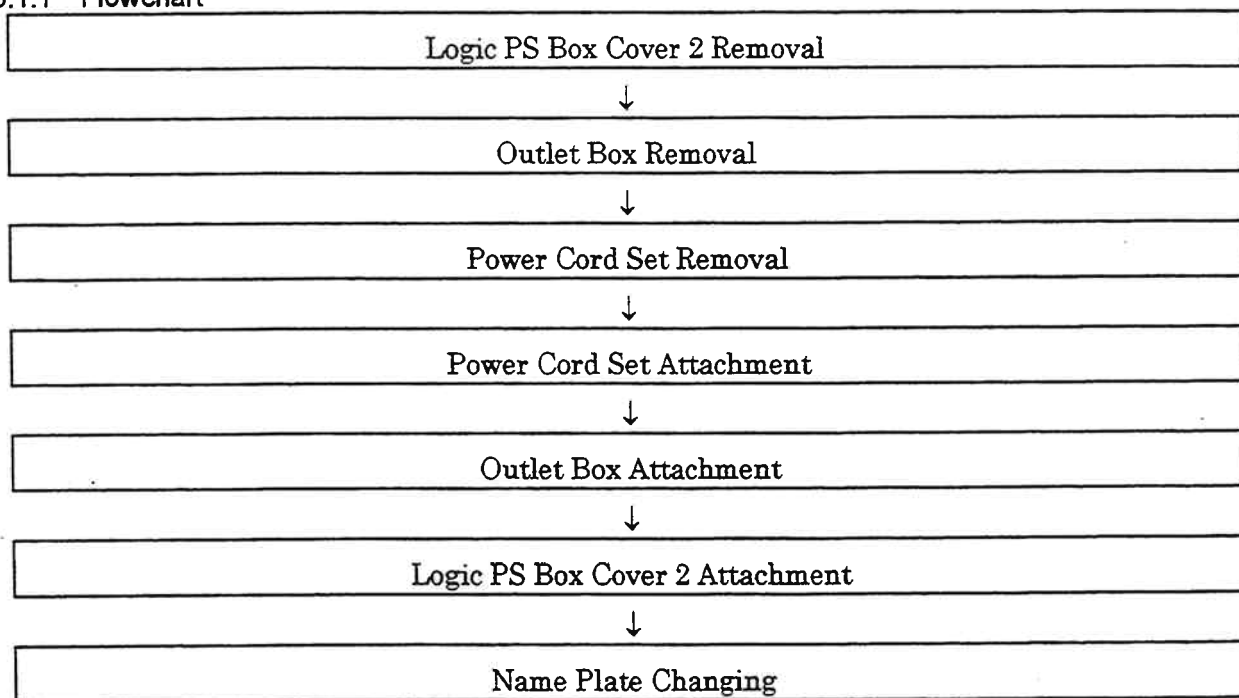

3.3.5.1.2 Parts List

DKC-F210I-56 DKC210IE(50Hz) to DKC210IU(60Hz)

No.	Name of Part	Part Number	Quantity/Unit	Remarks
1	Outlet Box (IU type)	5483817-A	1	(2098674-A)
2	Jumper Plug (P311:208V)	3240062-B	1	
3	Jumper Plug (P311:230V)	3240062-D	1	
4	Jumper Plug (P312:115V)	3240062-G	1	
5	Name Plate (IU-5)	3243051-1	1	For DKC210IU-5
	Name Plate (IU-5E)	3244901-1		For DKC210IU-5E
	Name Plate (IU-0E)	3247028-1		For DKC210IU-0E
6	Label (FCC)	3183097-1	1	
7	Power Cord Set (IU)	5485511-2	1	
8	Label (220V)	3221432-1	1	

DKC-F210I-65 DKC210IU(60Hz) to DKC210IE(50Hz)

No.	Name of Part	Part Number	Quantity/Unit	Remarks
1	Outlet Box (IE type)	5483817-B	1	(2098675-A)
2	Name Plate (IE-5)	3243052-1	1	For DKC210IE-5
	Name Plate (IE-5E)	3244902-1		For DKC210IE-5E
	Name Plate (IE-0E)	3247029-1		For DKC210IE-0E
3	Label (IN)	3228038-1	1	
4	Power Cord Set (IE)	5485511-1	1	
5	Label (380V)	3221432-1	1	
6	Label (CE Mark)	3240543-1	1	

3.3.5.1.3 Procedure of Hz Conversion Kit Installation

1. Logic PS Box Cover 2 removal

Remove the Logic PS Cover 2. Refer to SECTION 4.3.1.8 LOGIC PS BOX COVER 2 [INST03-90].

2. Outlet Box removal

a. Detach the connectors from the Outlet Box.

Loosen the three repeat binders that fasten the OLB power cable (P203).

Table 3.3.5.1.3- 1 Detachment of Connectors

Connector No. Model Name	Breaker Box-1 J203	Outlet Box J311	Outlet Box J312	Outlet Box J313-1	Outlet Box J313-2	Remarks
DKC-F210I-56	○	—	—	○	◆	
DKC-F210I-65	○	×	×	○	◆	
	OLB power cable (Breaker Box- 1)	For setting the input voltage (only for DKC-F210I- 65)	For setting the output voltage (only for DKC-F210I- 65)	power cord set		

Symbols) ○: Detach the connectors, ×: Do not detach the connectors,

◆: Detach the connector if it is connected.

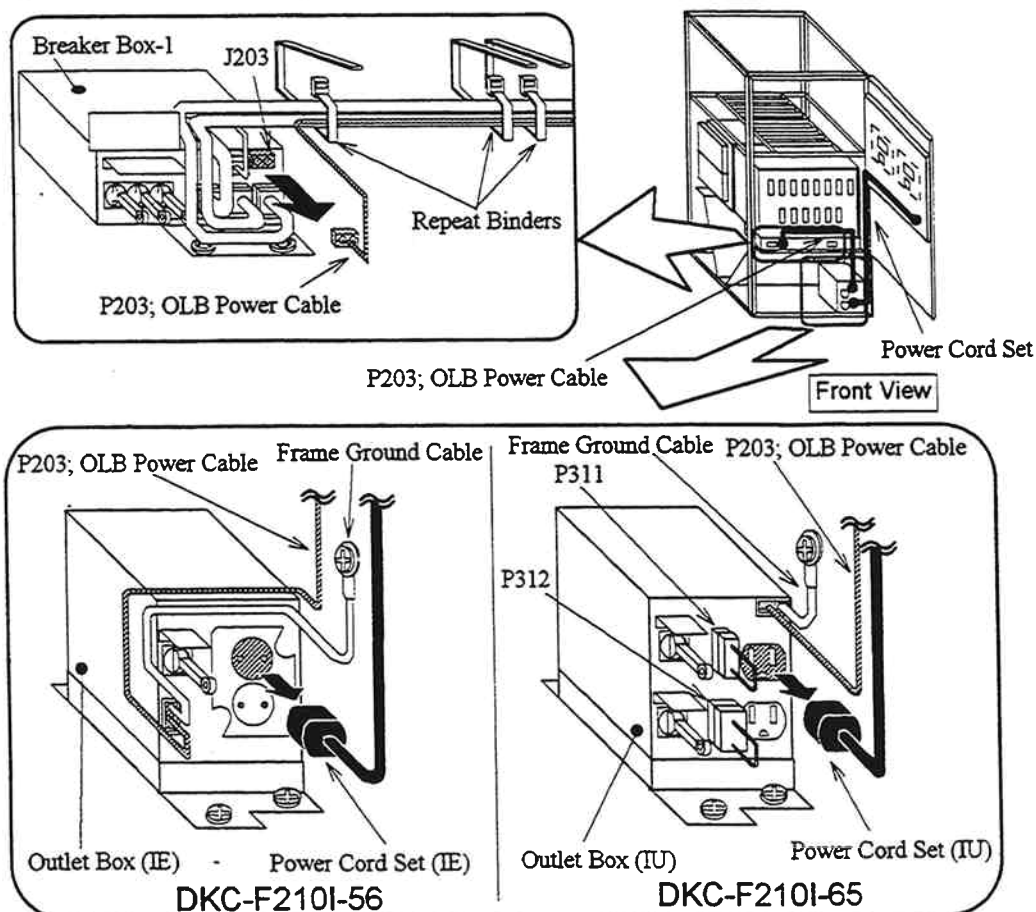

Fig. 3.3.5.1.3-1 Removal of Outlet Box

- b. Detach the frame ground cable of the Outlet Box from Disk Controller frame.
- c. Remove the two screws that fasten the Outlet Box.

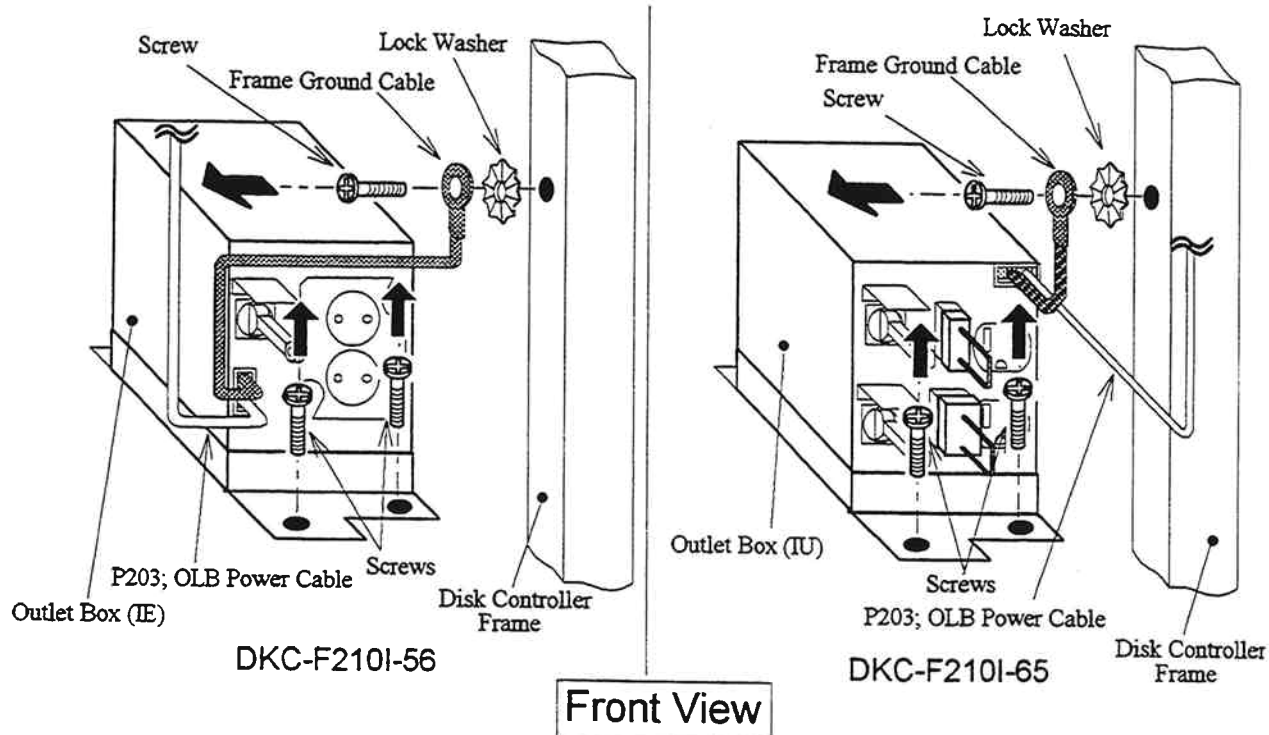

Fig. 3.3.5.1.3-2 Removal of Outlet Box

- d. Remove the Outlet Box.

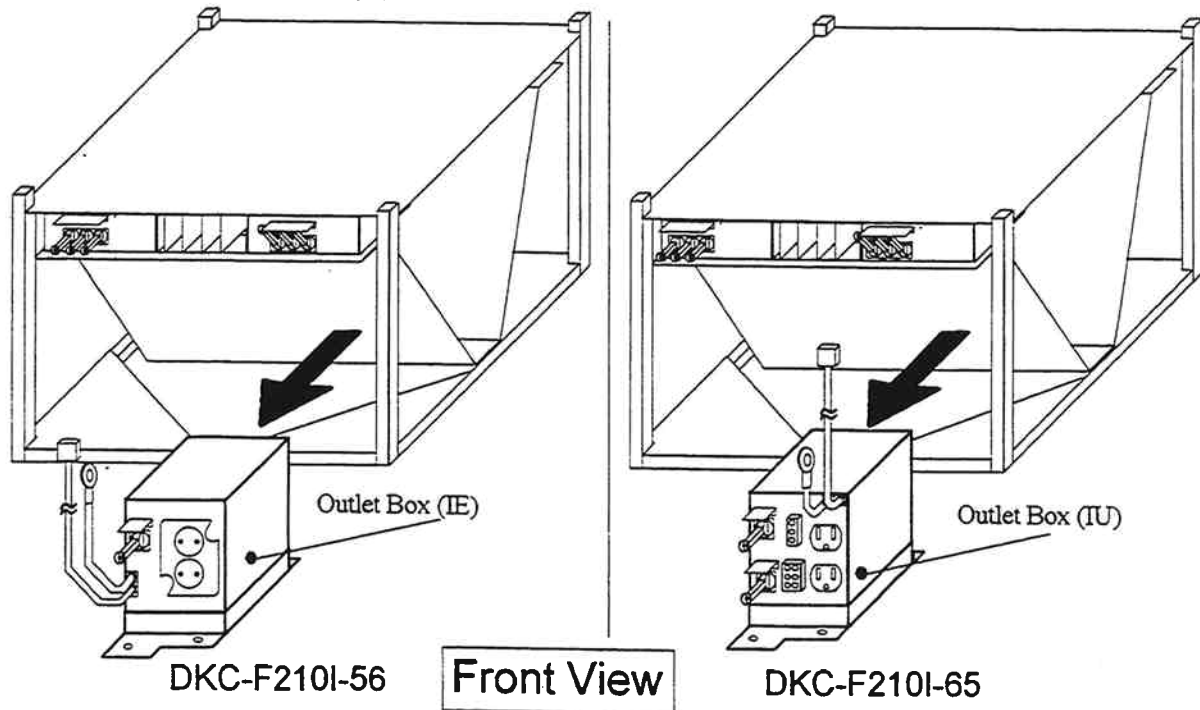

Fig. 3.3.5.1.3-3 Removal of Outlet Box

3. Power Cord Set Removal

- a. Remove the plate from the Movable Rack
- b. Disconnect the power cord set from AC adapter.
- c. Remove the power cord set from the cable clamps.
- d. Remove the power cord set from the Movable Rack.

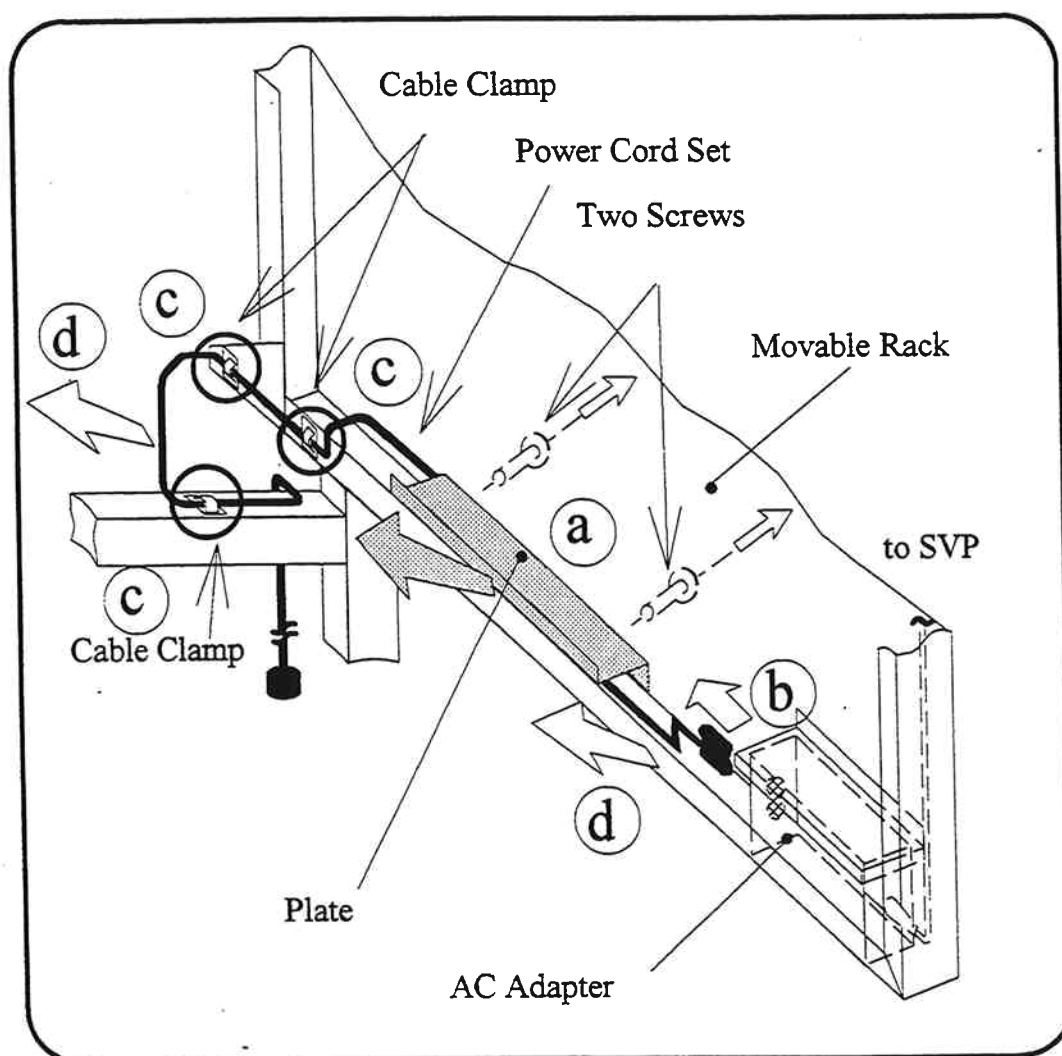
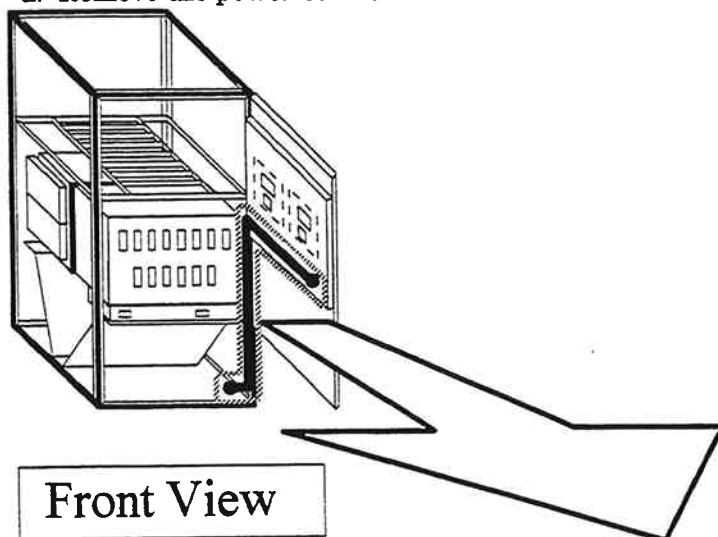

Fig. 3.3.5.1.3-4 Removal of Power Cord Set

4. Power Cord Set Attachment

- a. Connect the power cord set to the AC adapter.
- b. Fasten the power cord set with the cable clamp.
- c. Attach the plate to the Movable Rack

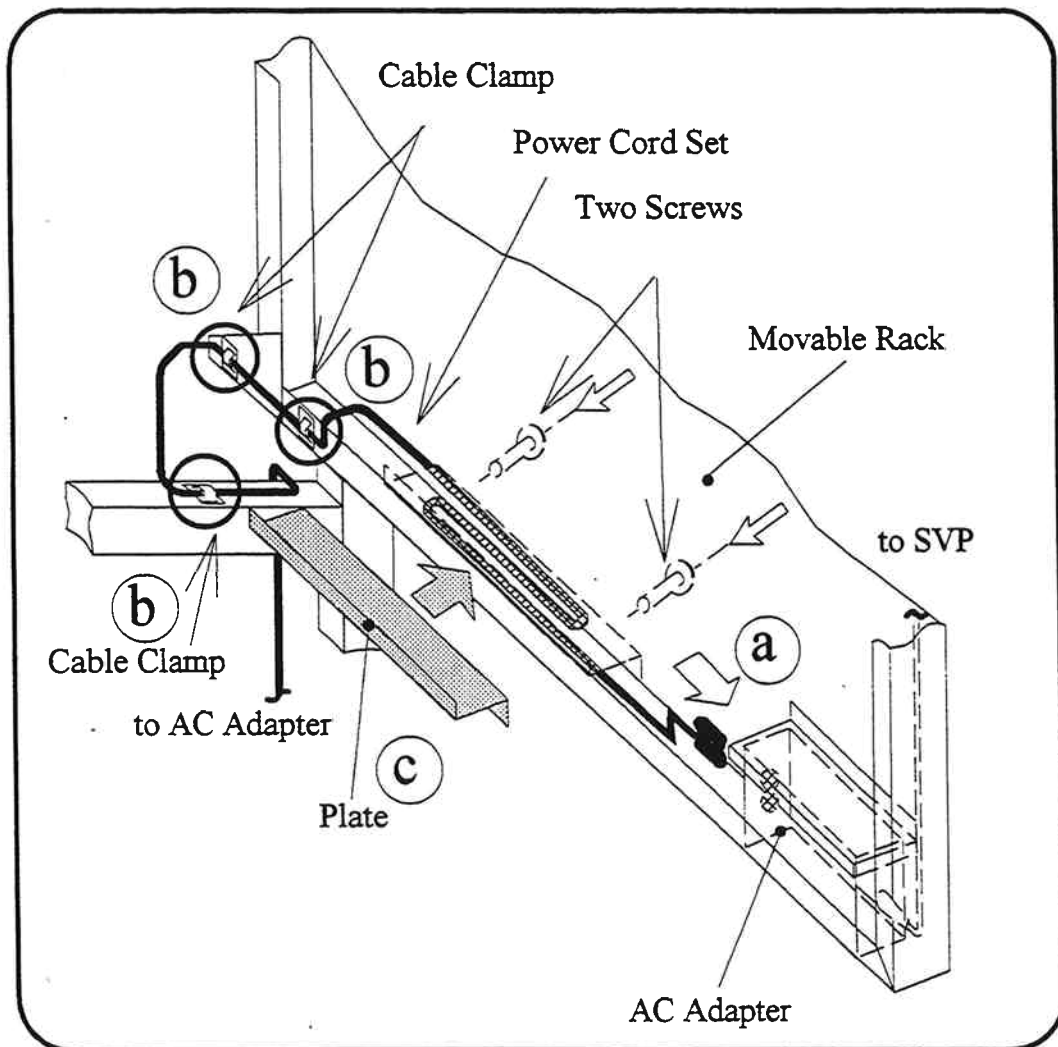
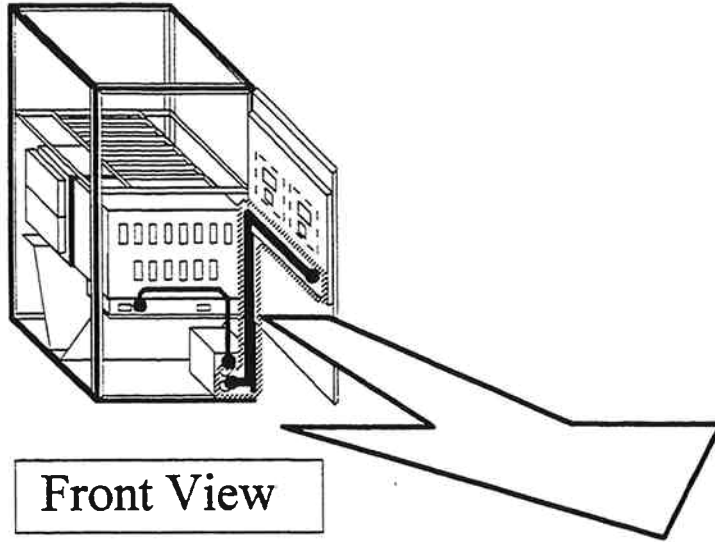

Fig. 3.3.5.1.3-5 Attachment of Power Cord Set

5. Outlet Box attachment

a. Insert the Outlet Box to the stopper position located at the bottom of the Disk Controller.

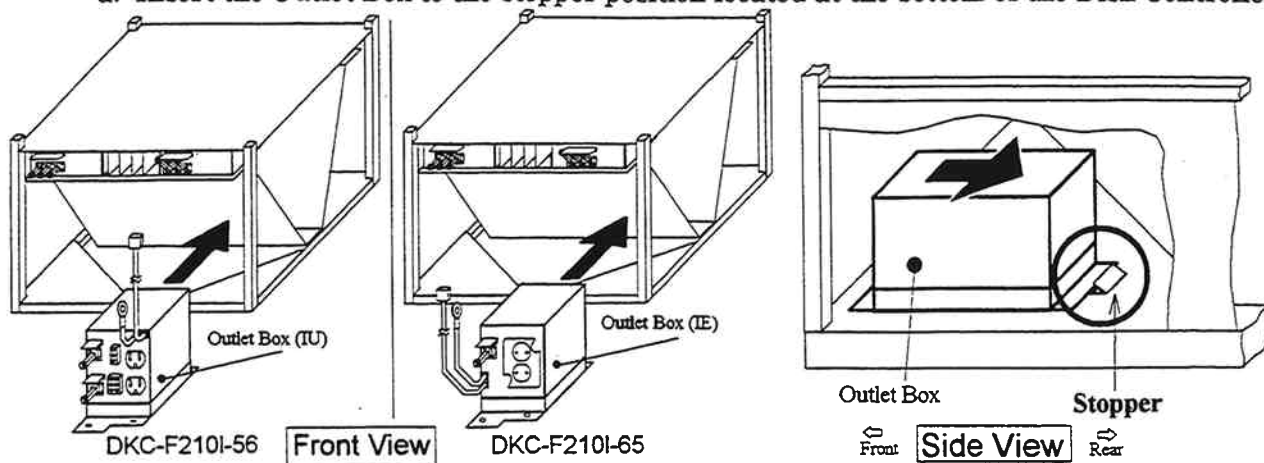

Fig. 3.3.5.1.3-6 Attachment of Outlet Box

b. Attach the Outlet Box with two screws.

Attach the frame ground cable to the Disk Controller frame using the screw and lock washer.

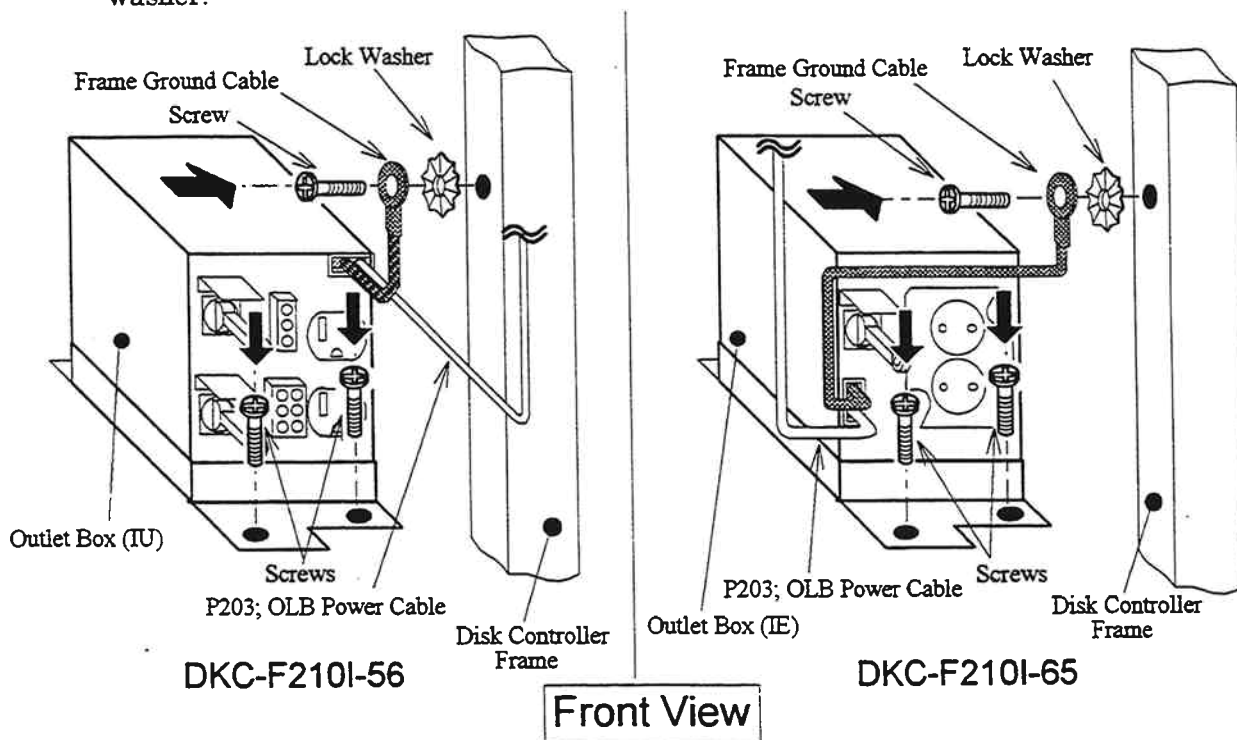

Fig. 3.3.5.1.3-7 Attachment of Outlet Box

c. Insert the Outlet Box connector as it was.

Attach the OLB power cable (P203) with three repeat binders.

Table 3.3.5.1.3- 2 Outlet Box Connectors

Connector No.	P203	P311	P312	J313	Remarks
Model Name					
DKC-F210I-56	○	○	○	○	◆
DKC-F210I-65	○	—	—	○	◆
	OLB power cable (Breaker Box-1)	For setting the input voltage (only for DKC-F210I-56)	For setting the output voltage (only for DKC-F210I-65)	Power cord set	

Symbols) ○: Insert the connector. ×: Do not insert the connector.
◆: Insert the connector as needed

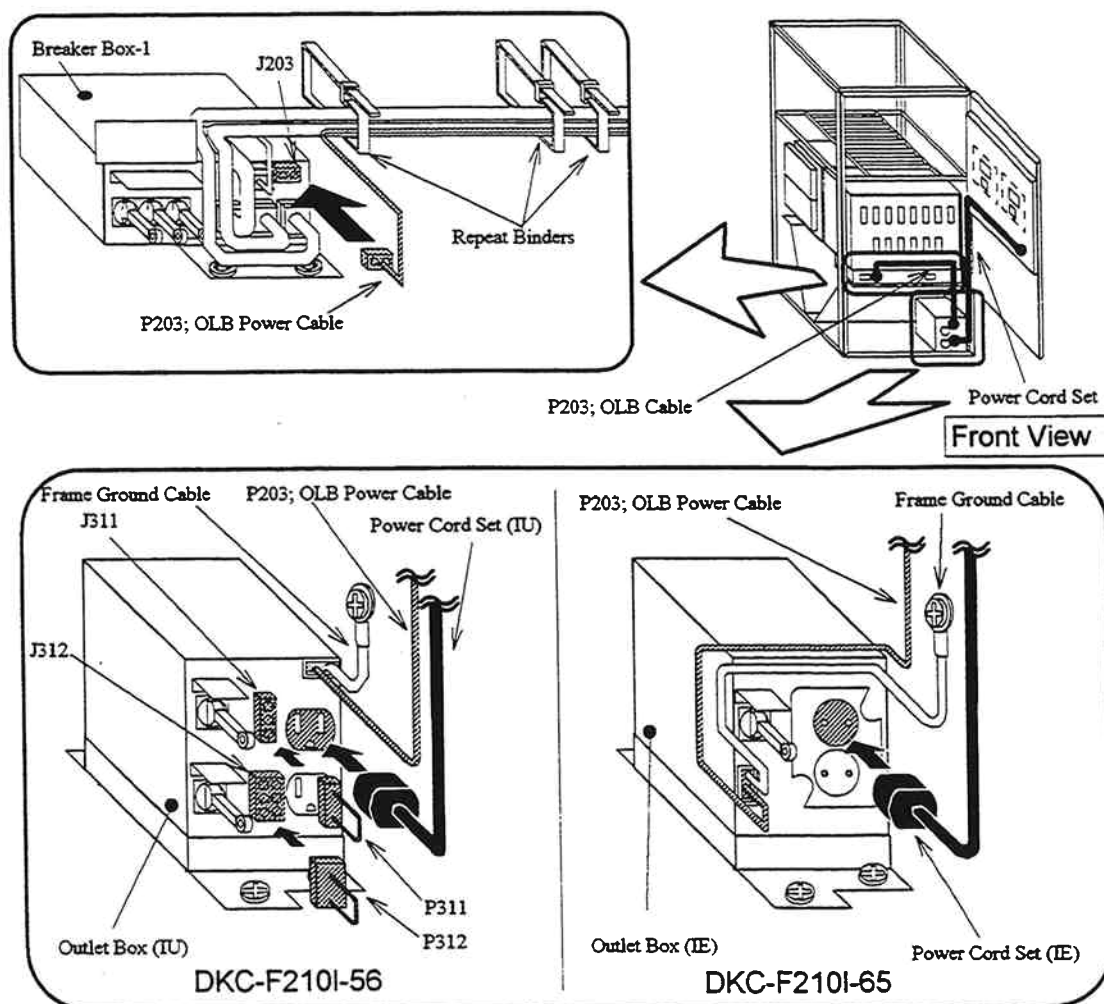

Fig. 3.3.5.1.3-8 Outlet Box Reattachment

6. Logic PS Cover Attachment

Attach the Logic PS Cover 2. Refer to SECTION 4.3.1.8 LOGIC PS BOX COVER 2 [INST03-90].

7. Name Plate Changing

DKC-F210I-56

- Change the Name Plate.
- Put the Label (220V) and the Label (FCC).
- Remove the Label (CE) and the Label (IN).

DKC-F210I-65

- Change the Name Plate.
- Put the Label (380V), the Label (CE) and Label (IN).
- Remove the Label (FCC).

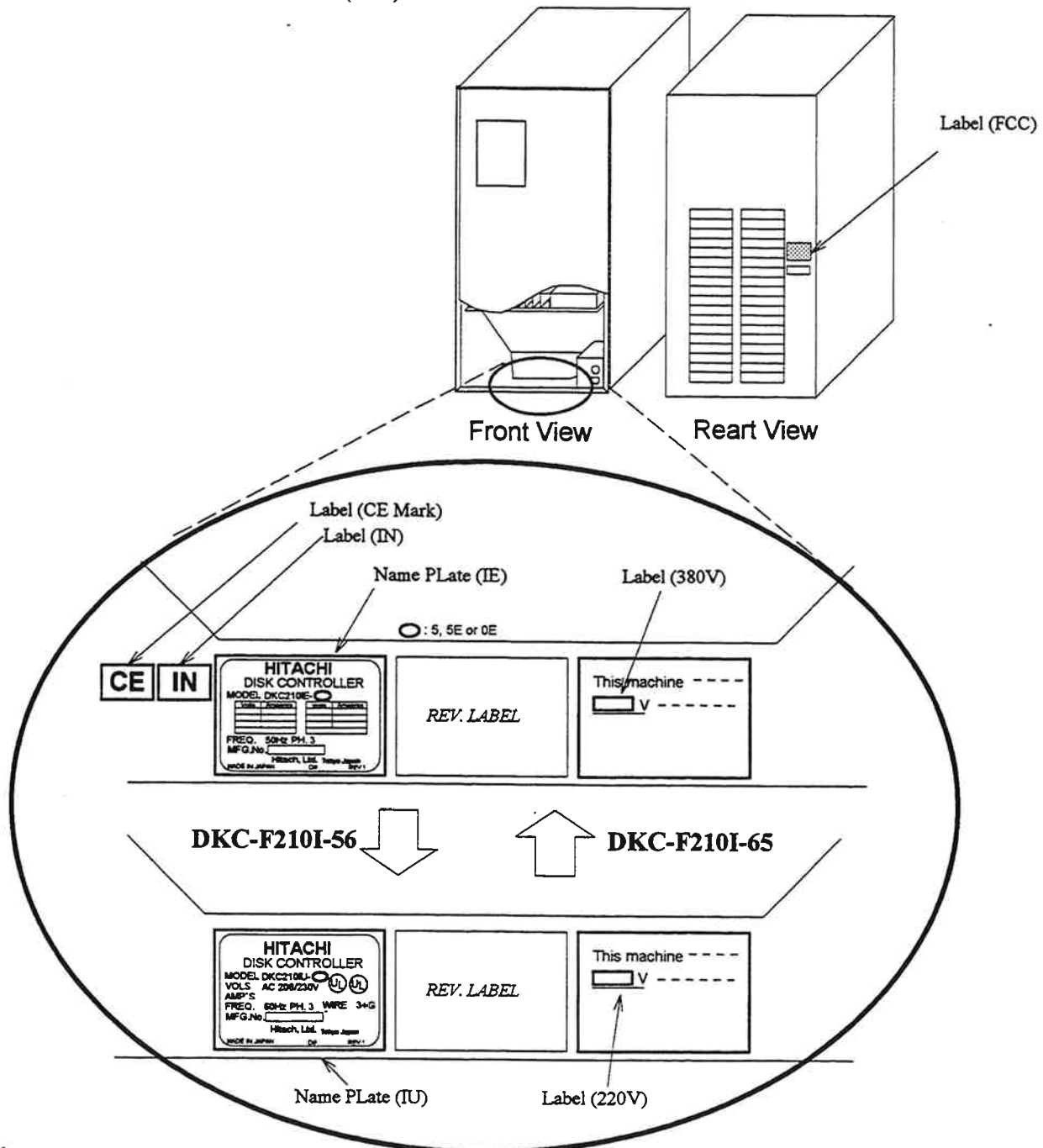

Fig. 3.3.5.1.3-9 Location of Name Plate

Checking the Voltage Select Jumper Connector at the Outlet Box

DKC-F210-56 ONLY

1. Check the P311 and P312 jumper connectors at the Outlet Box.

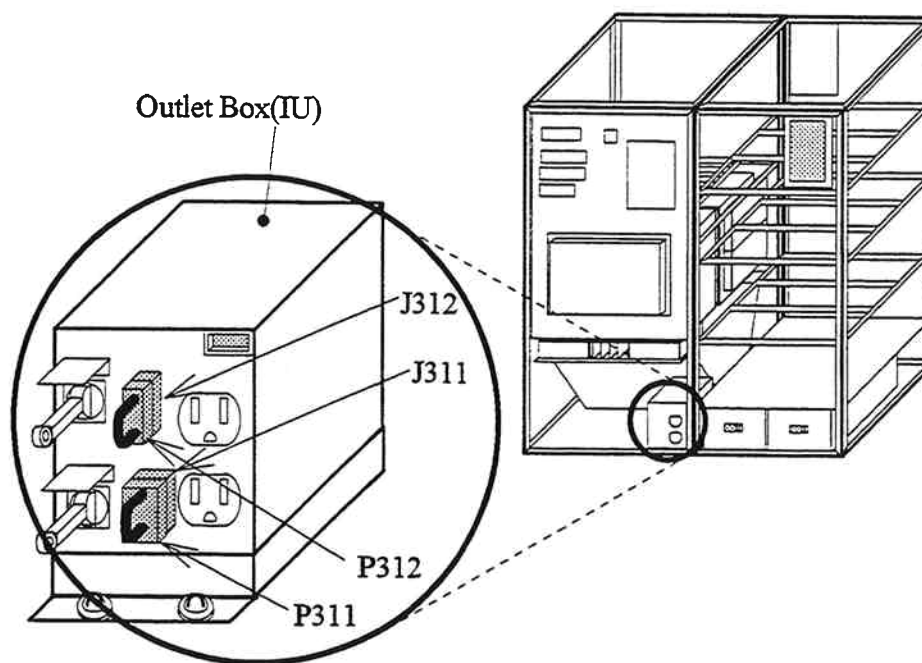

Fig. 3.3.5.1.3-10 Voltage Select Jumper Connectors

Table 3.3.5.1.3- 3 Voltage Select Jumper Connector Setting

Input		Jumper Connectors		Output Voltage
Input Voltage	Frequency	J311	J312	
208 Vac	60 Hz	P311	P312	115 Vac
		208V	115V	
230 Vac		P311	P312	
		230V	115V	

2. Return to General Flow.

New Installation: Go to INST02-10 Step (2)-2.

3.3.5.2 Installation of Hz Conversion Kit for Disk Unit (DKU-F205I-56, DKU-F205I-65)

DKU-F205I-56 DKU205IE-14 (50Hz) to DKU205IU-14 (60Hz)

DKU-F205I-65 DKU205IU-14 (60Hz) to DKU205IE-14 (50Hz)

CAUTION

Perform The Hz Conversion with care.

This Hz Conversion is concerned with Primary Circuit.

Perform this procedure before connecting the Power Cable Assy.

(Turn off the circuit breakers on the power distribution panel)

Turn off the main circuit breaker CB101 located in the AC Box.

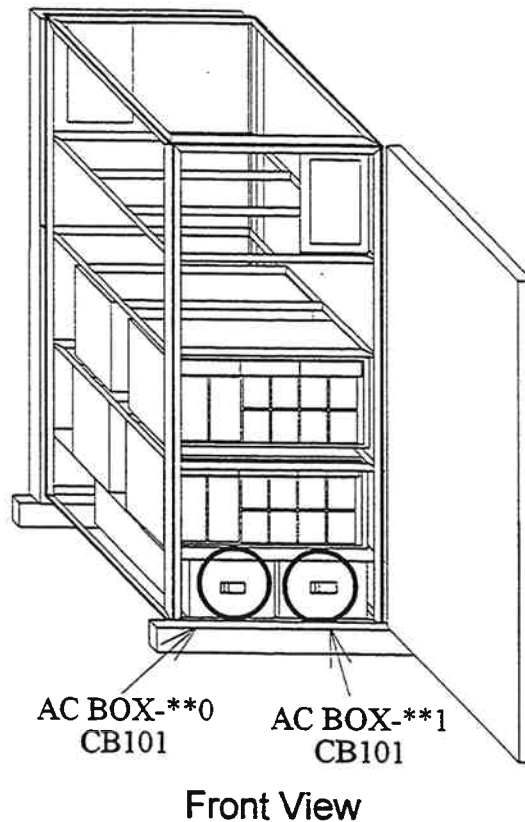
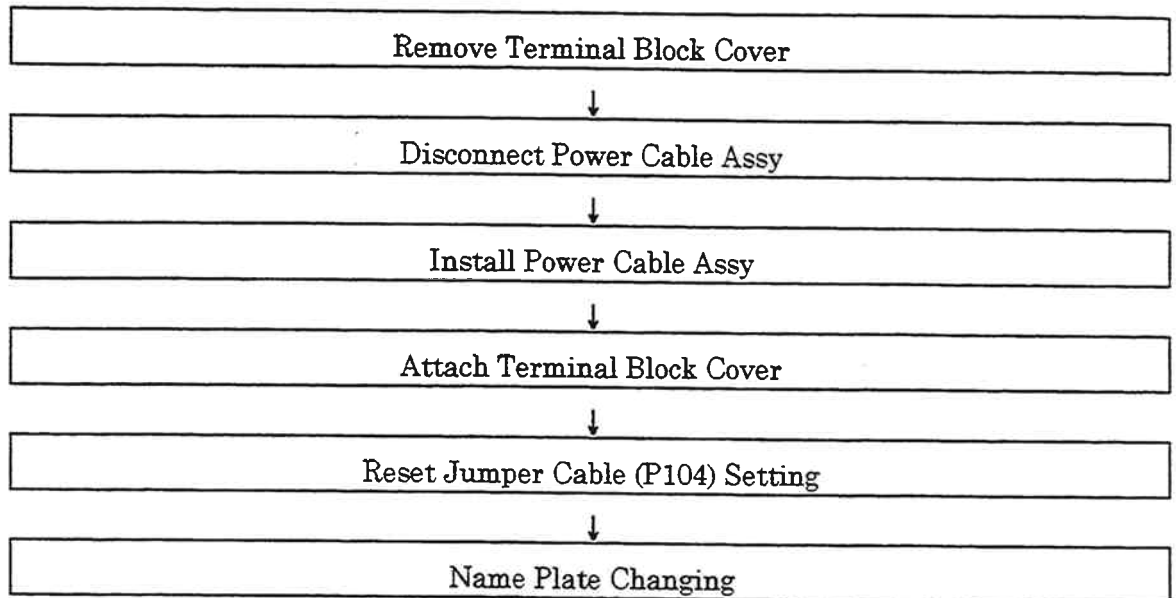

Fig. 3.3.5.2-1 Location of the Disk Unit Circuit Breakers

Table 3.3.5.2-1 Disk Unit Circuit Breakers

No.	Location No.	Breaker No.	Remarks
1	AC BOX-**0	CB101	
2	AC BOX-**1	CB101	

3.3.5.2.1 Flowchart



3.3.5.2.2 Parts List

DKU-F205I-56 DKU205IE-10(50Hz) to DKU205IU-10(60Hz)

No.	Name of Part	Part number	Quantity/Unit	Remarks
1	Power Cable Assy (IU type)	3239396-A	1	
2	Nameplate (IU)	2099649-1	1	
3	Label (V. Hz)	3213180-1	1	
4	Label (CSA)	5409086-1	1	
5	Label Noise (FCC/CSA)	3183097-1	1	
6	Label (UL/CUL)	3243606-3	1	

DKU-F205I-65 DKU205IU-10(60Hz) to DKU205IE-10(50Hz)

No.	Name of Part	Part number	Quantity/Unit	Remarks
1	Power Cable Assy (IE type)	3239396-B	1	
2	Nameplate (IE)	2099649-2	1	
3	Label (V. Hz)	3213180-1	1	
4	Label (CSA)	5409086-1	1	
5	Label (IN)	3228038-1	1	
6	Label (UL3)	5466323-1	1	
7	Label (CE Mark)	3240543-1	1	

3.3.5.2.3 Changing Input Power Cables

1. Remove the fall proof adapter (only for rear side).

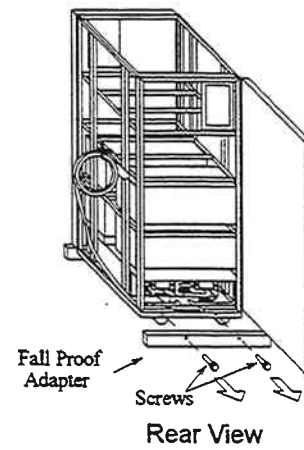

Fig. 3.3.5.2.3-1 Removal of Fall Proof Adapter

2. Remove the plate of the back side of the Disk Unit as illustrated in fig. 3.3.5.2-3.
 - a. Remove the two screws.
 - b. Slide the plate toward the rear side to remove.

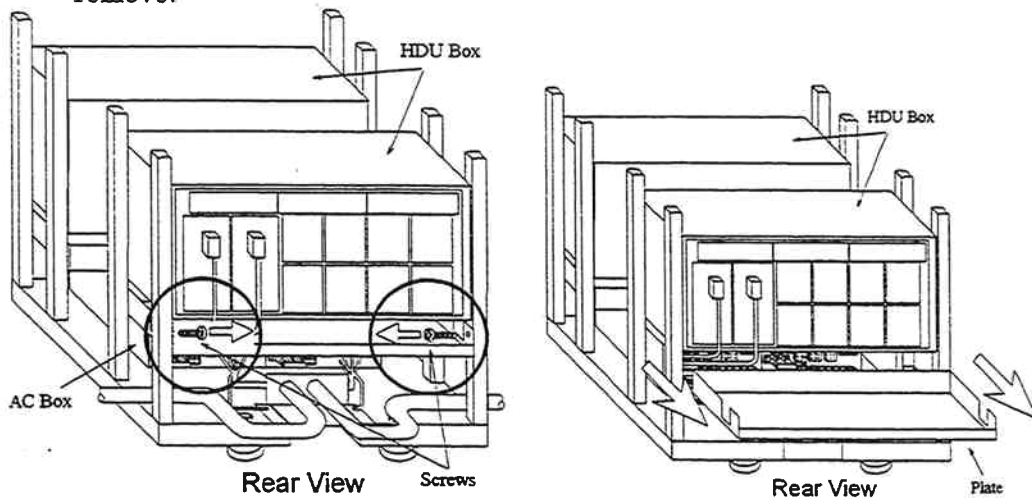

Fig. 3.3.5.2-2 Removal of Plate

3. Remove the terminal block cover and disconnect the power cable Assy.

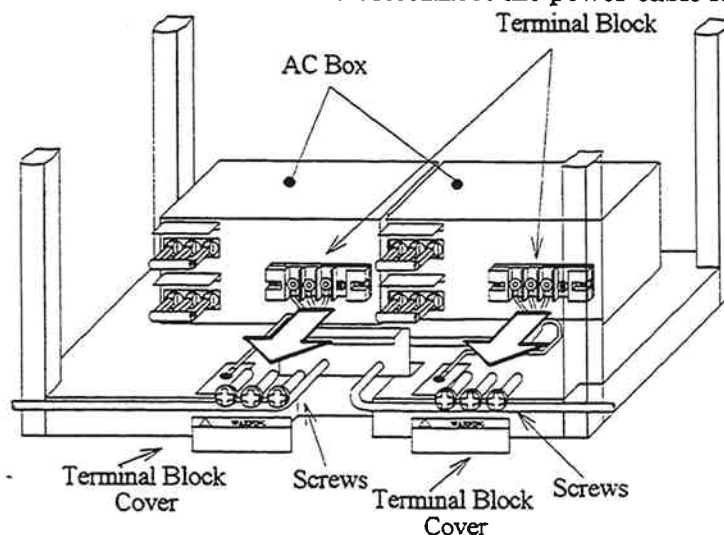

Fig. 3.3.5.2-3 Removal of Power Cable Assy (DKU-F205I-65)

4. Remove the frame ground cable for each input power cable from the frame.

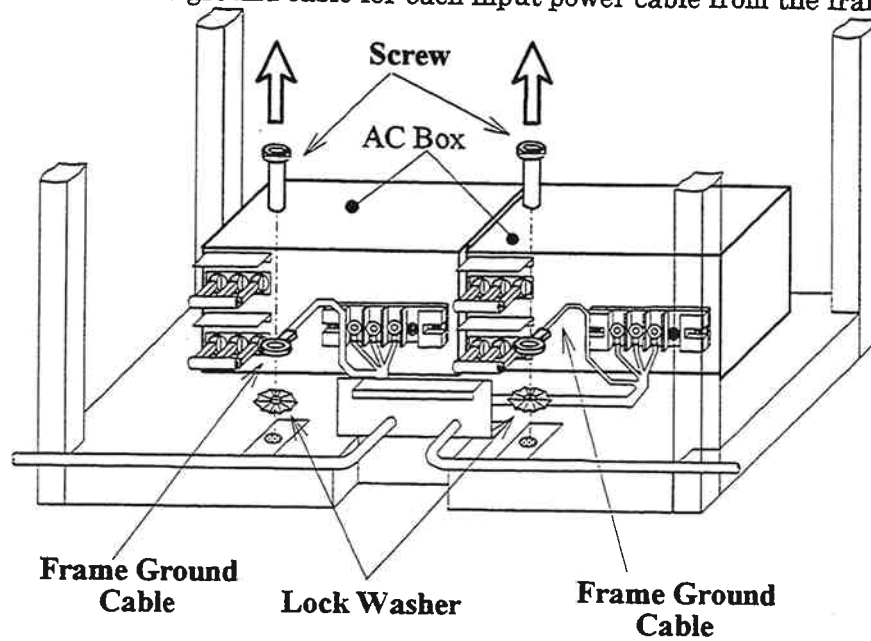

Fig. 3.3.5.2-4 Removal of Frame Ground Cable (DKU-F205I-65)

5. Loosen the screws and remove the Power Cable Assy.

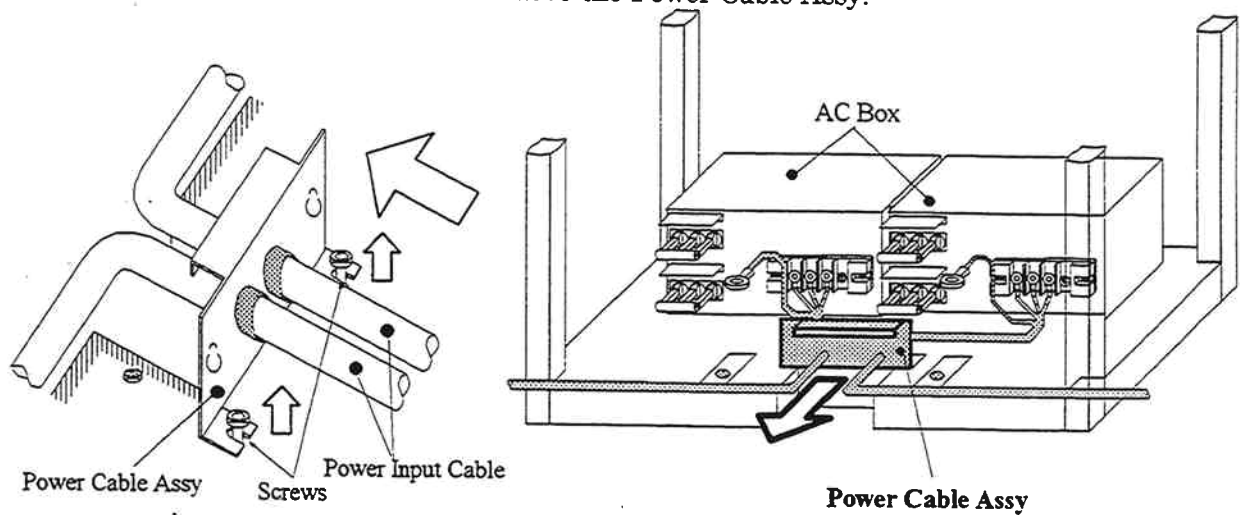

Fig. 3.3.5.2-5 Removal of Power Cable Assy (DKU-F205I-65)

6. Attach the Power Cable Assy and secure two screws.

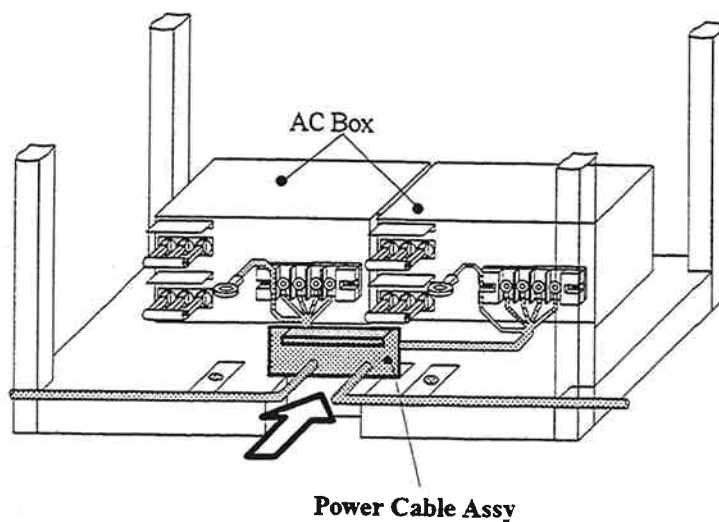

Fig. 3.3.5.2-6 Installation of Power Cable Assy (DKU-F205I-65)

7. Attach frame ground cable with the screw and lock washer.

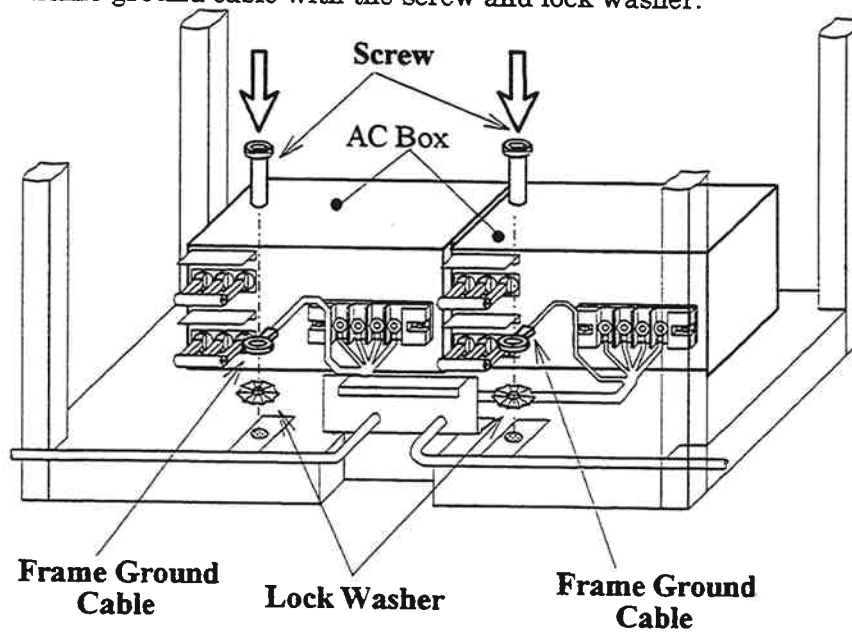

Fig. 3.3.5.2-7 Attachment of Frame Ground Cable (DKU-F205I-65)

- Connect the input power cables to the terminal block and attach terminal block cover.

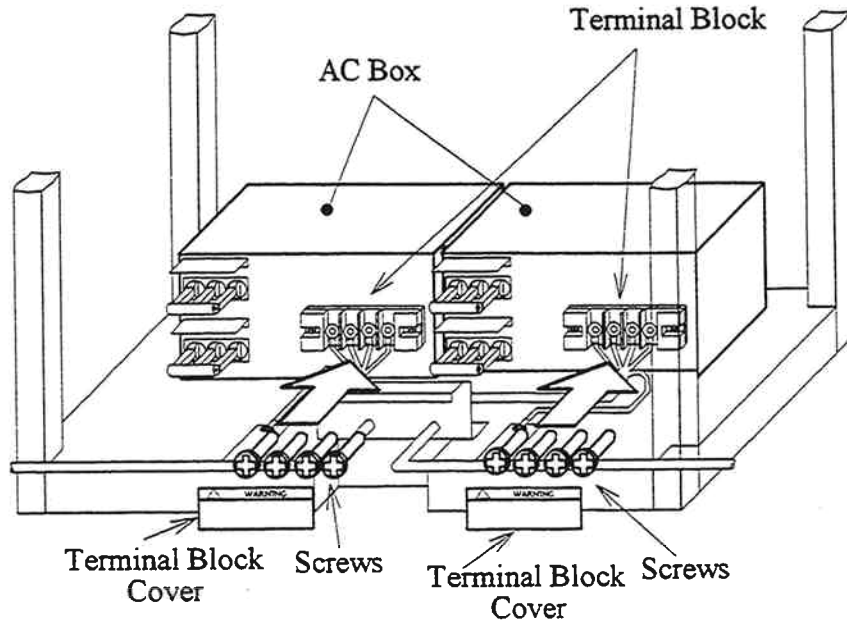

Fig. 3.3.5.2-8 Connection of Power Cable Assy (DKU-F205I-65)

Table 3.3.5.2-2 Input Power Cable Conductors Numbers and Jumper Cable (P104) Locations

No.	Model Number	Input Voltage	Input Power Cable Conductors	Remarks
1	DKU-F205I-56	200-240Vac	4 conductors (L1, L2, L3, FG)	50Hz → 60Hz
2	DKU-F205I-65	380-415Vac	5 conductors (L1, L2, L3, N, FG)	60Hz → 50Hz

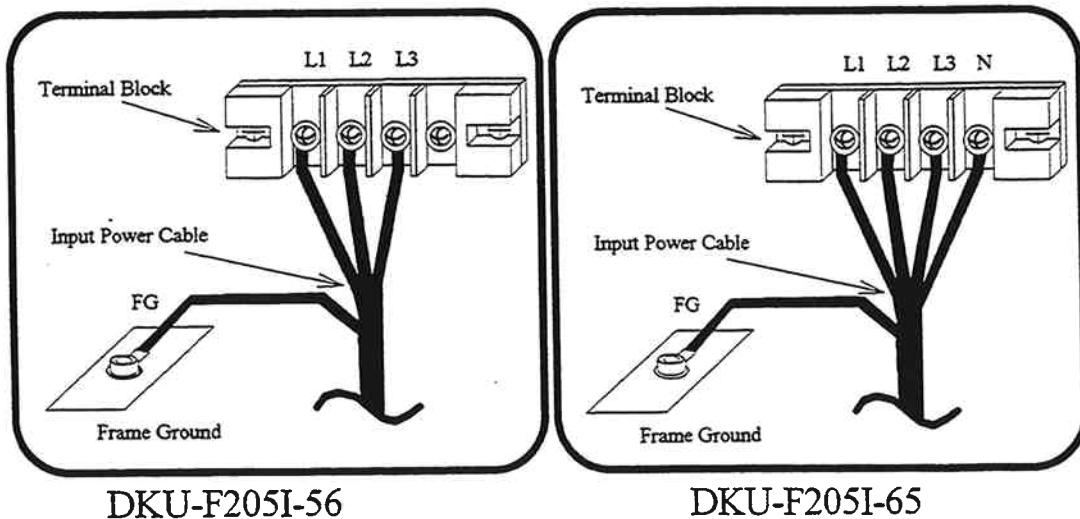

Fig. 3.3.5.2-9 Connection of Input Power Cables to the Terminal Block

9. Install the jumper cable (P104) as indicated in the table below.

Table 3.3.5.2-3 Jumper Cable (P104) Locations

No.	Model Number	Input Voltage	Jumper Cable (P104) Location	Remarks
1	DKU-F205I-56	200-240Vac	J104-1	(J104-2: Dummy Connector) 50Hz → 60Hz
2	DKU-F205I-65	380-415Vac	J104-2	(J104-1: Dummy Connector) 60Hz → 50Hz

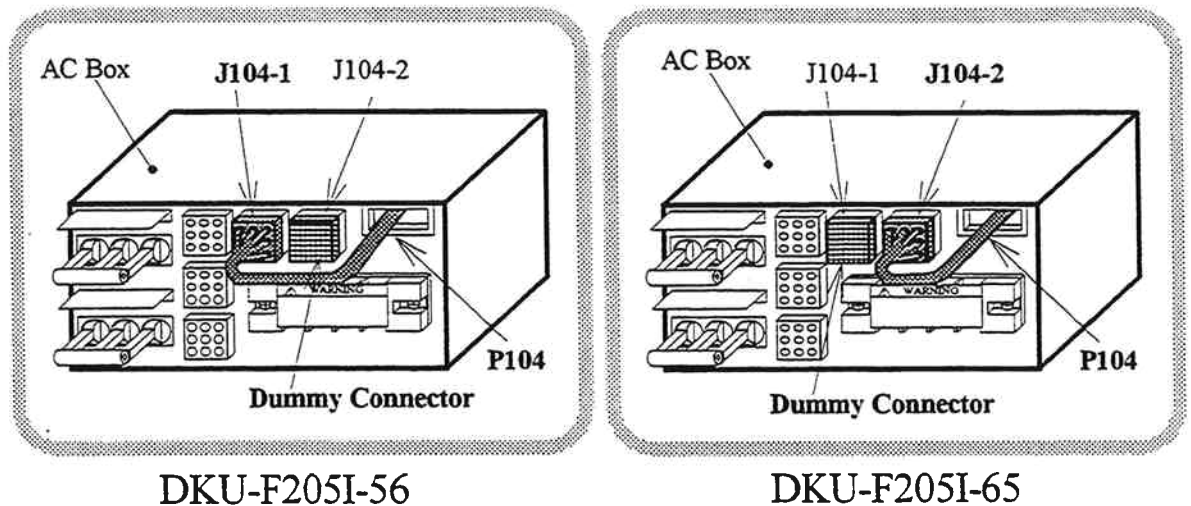

Fig. 3.3.5.2-10 Jumper Cable P104 Setting

10. Re-Install the plate.

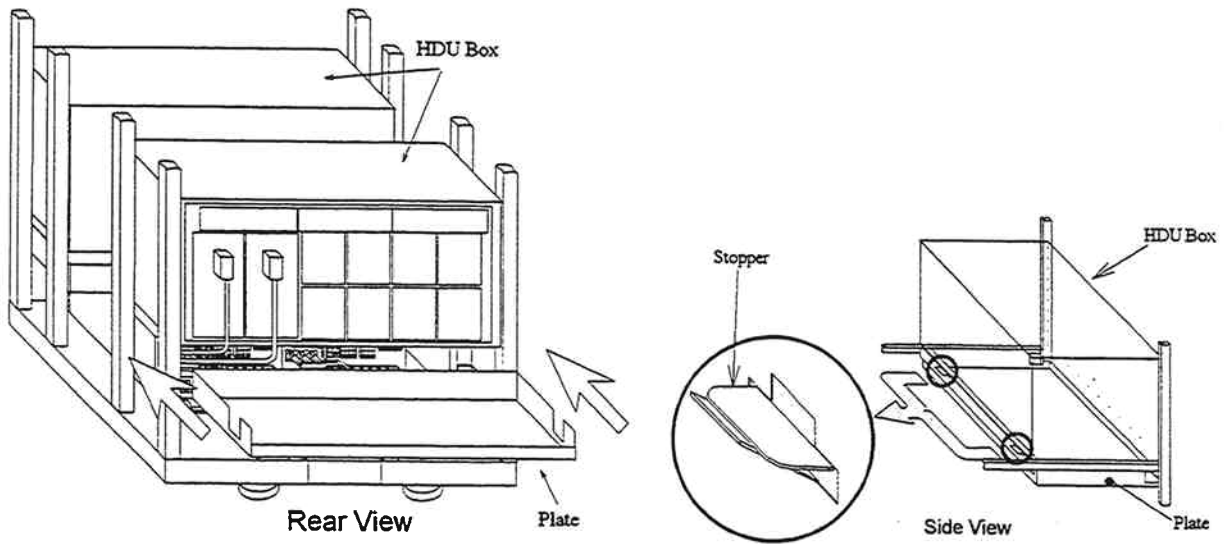

Fig. 3.3.5.2-11 Attachment of Plate

11. Secure the plate with screws.

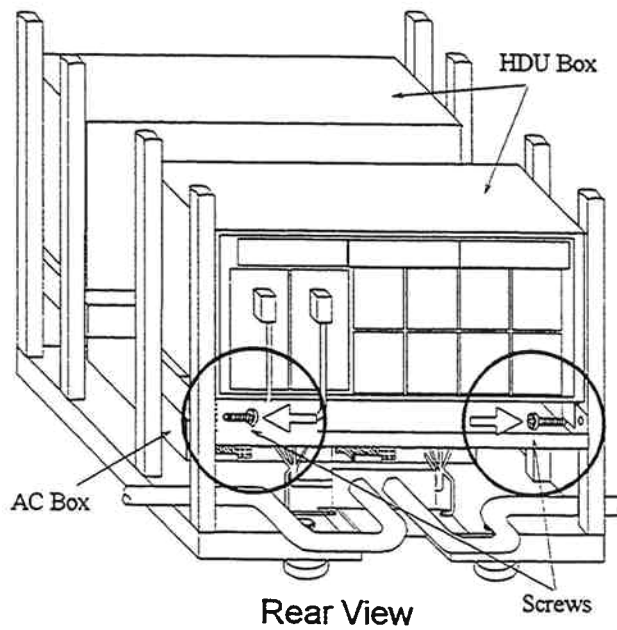

Fig. 3.3.5.2-12 Attachment of Plate

12. Change the Nameplate.

Refer to Fig. 3.3.5.2-15 and Fig. 3.3.5.2-16 "Location of Nameplate and Labels".

DKU-F205I-56

a. Change the Nameplate , Label (V. Hz) and Label (CSA).

Engrave the manufacturing number and so forth on the new nameplate and labels.

b. Remove the Label (IN), Label (CE Mark) and Label (UL3).

c. Put the Label (UL/CUL) and Label Noise (FCC/CSA).

DKU-F205I-65

a. Change the Nameplate , Label (V. Hz) and Label (CSA).

Engrave the manufacturing number and so forth on the new nameplate and labels.

b. Remove the Label (UL/CUL) and Label Noise (FCC/CSA).

c. Put the Label (IN), Label (CE Mark) and Label (UL3).

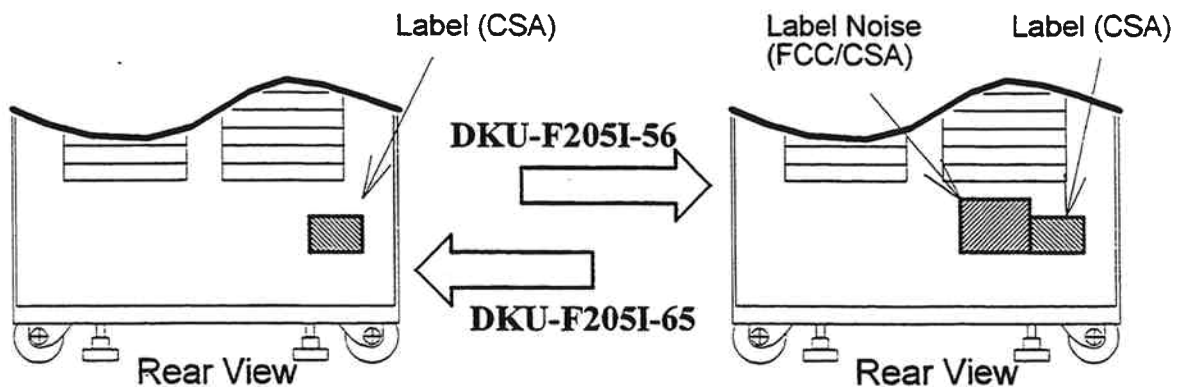

Fig. 3.3.5.2-13 Location of Nameplate and Labels

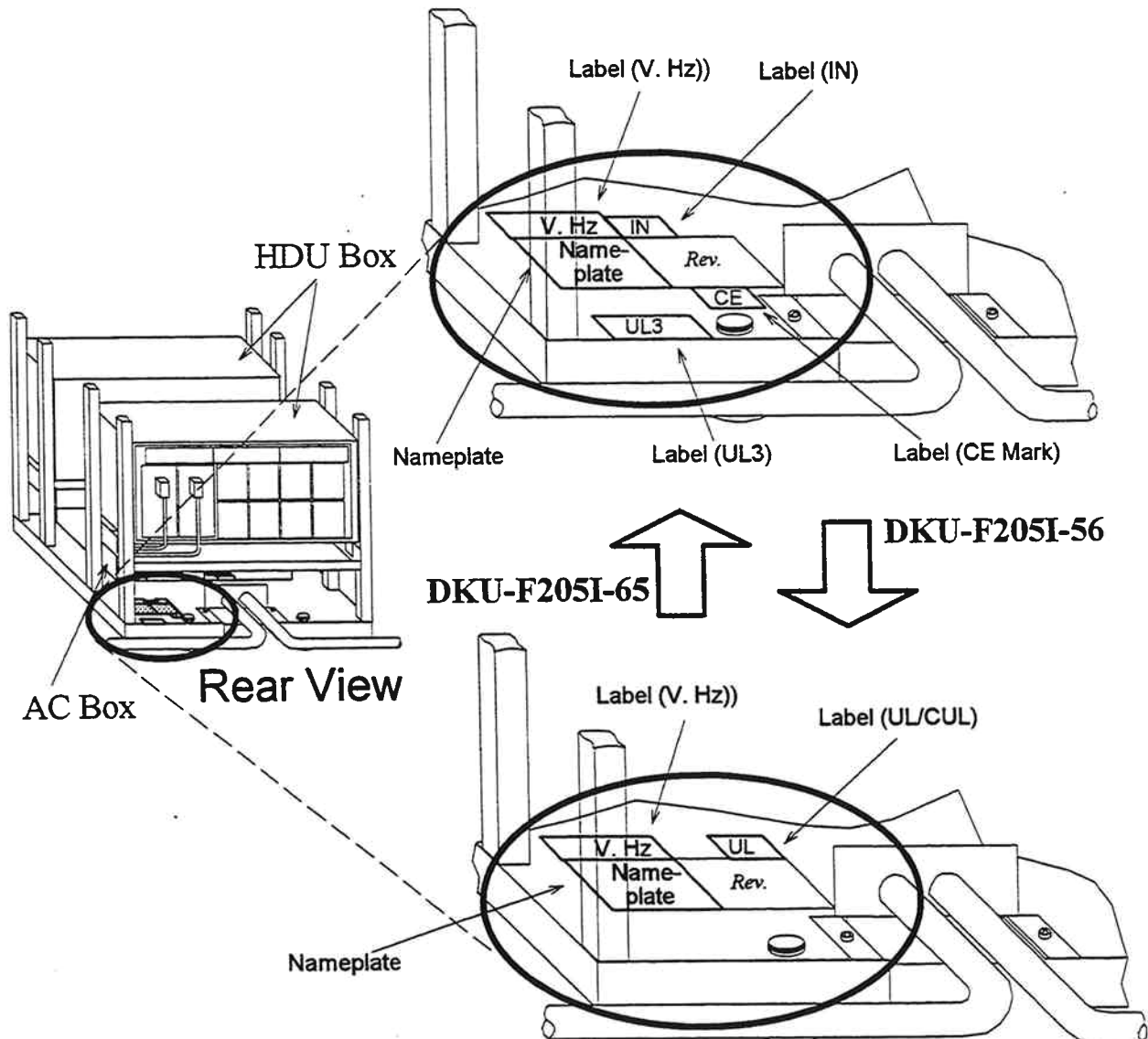

Fig. 3.3.5.2-14 Location of Nameplate and Labels

13. Return to General Flow.

New Installation

Basic Disk Unit Installation : Go to INST02-10 Step (2)-3.

Additional Disk Units : Go to INST02-11 Step (9)-2.

Non-Disruptive Installation: Go to INST02-21 Step (9)-2.

Disruptive Installation: Go to INST02-40 Step (8)-2.

3.3.6 Installation of Channel Switch

3.3.6.1 Flowchart

3.3.6.1.1 Installation of Parallel 8 Channel Switch (DKC-F210I-8P/8PE)[INST03-760]

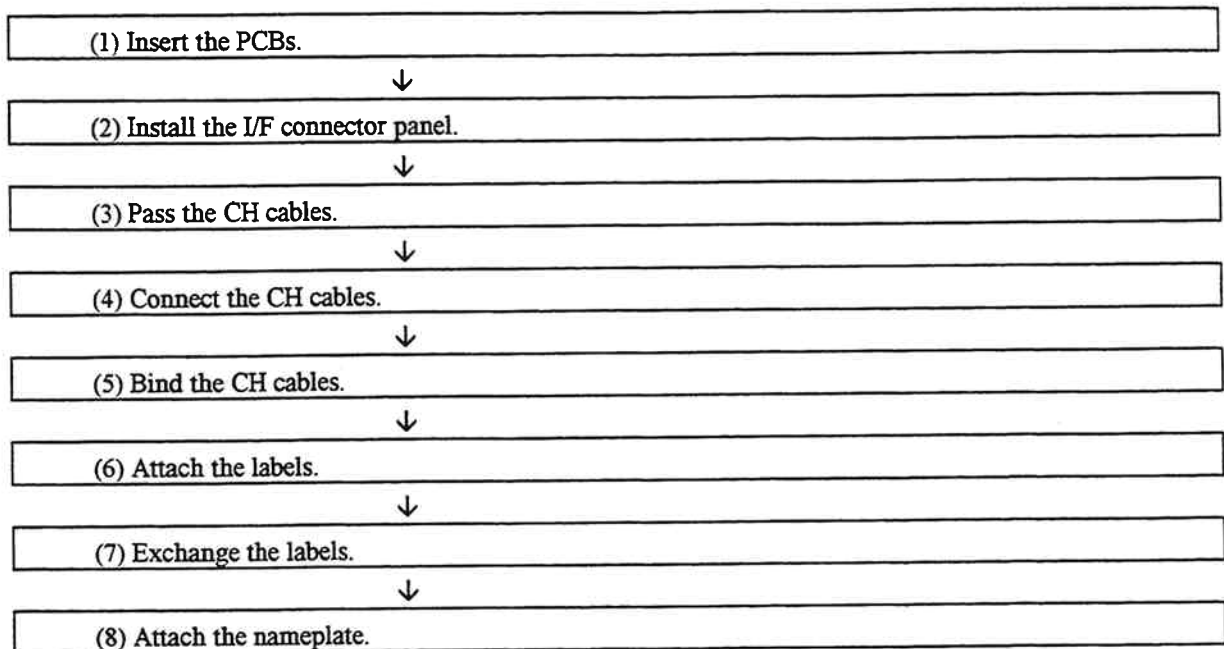

3.3.6.1.2 Installation of Serial 4 Port Adapter (DKC-F210I-4S/4SE)[INST03-840]

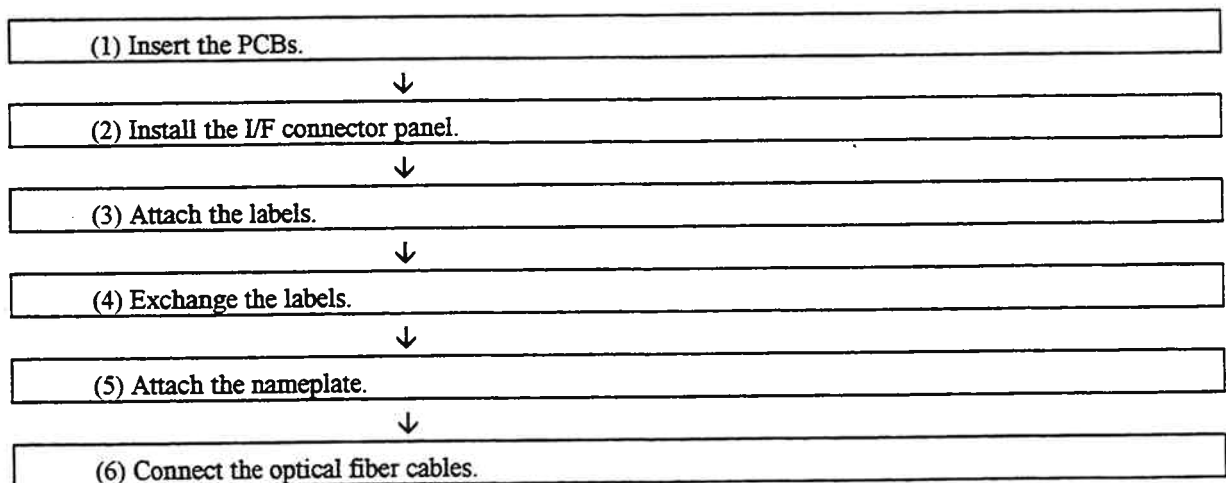

3.3.6.1.3 Installation of Serial 8 Port Adapter (DKC-F210I-8S/8SE)[INST03-900]

(1) Insert the PCBs.



(2) Install the I/F connector panel.



(3) Attach the labels.



(4) Exchange the labels.



(5) Attach the nameplate.



(6) Connect the optical fiber cables.

3.3.6.1.4 Installation of SCSI 8 Port Adapter (DKC-F210I-8C)[INST03-951]

(1) Insert the PCBs.



(2) Install the I/F connector panel.



(3) Pass the SCSI cables.



(4) Connect the SCSI cables.



(5) Bind the SCSI cables.



(6) Attach the labels.



(7) Attach the nameplate.

3.3.6.1.5 Installation of SCSI 8 Port Adapter (Dual Processor) (DKC-F210I-8CD)[INST03-959A]

(1) Insert the PCBs.



(2) Install the I/F connector panel.



(3) Pass the SCSI cables.



(4) Connect the SCSI cables and bind the SCSI cables.



(5) Attach the labels.



(6) Attach the nameplate.

3.3.6.2.2 Installation Procedure of Parallel 8 Channel Switch

Basic Location(CH A-D)

Be sure to wear your wrist strap and attach to ground prior to performing the following work. This will insure that the IC and LSI on the PCB are protected from static electricity.

1. Insertion of the PCBs
 - a. Set the jumper plugs(JP1-JP4) referring to Fig. 3.3.6.2.2-1.
 - b. Insert the PCBs to the correct locations in the Logic Box referring to Table 3.3.6.2.2-1.
 - c. Fasten the two screws referring to Fig. 3.3.6.2.2-1.

Table 3.3.6.2.2-1 Inserting Location

No.	Part name	Slot No.	Location No.	Remarks
1	Channel Adapter PCB	E and Q	CHA-1E and CHA-2Q	in Logic Box

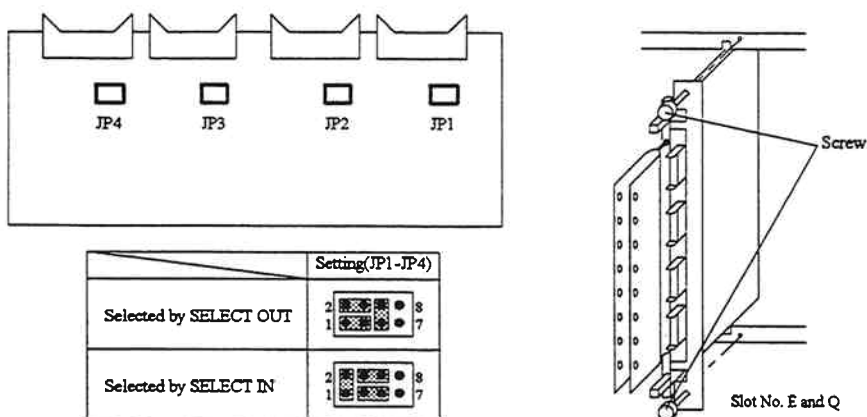
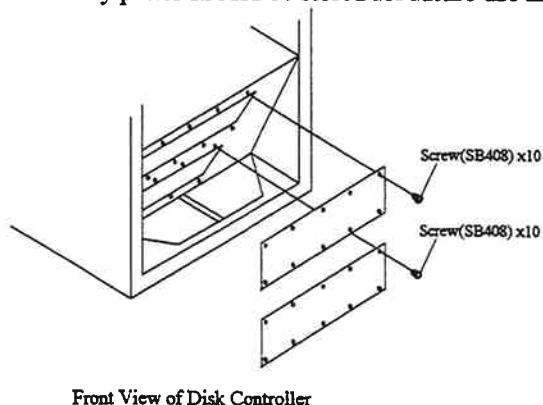

Fig. 3.3.6.2.2-1 Insertion of PCB

2. Installation of the I/F connector panel
 - a. Remove the dummy plate referring to Fig. 3.3.6.2.2-2.
 - b. Install the I/F connector panel referring Fig. 3.3.6.2.2-3.

Note: Dummy plates should be stored for future use in De-installation.



Front View of Disk Controller

Fig. 3.3.6.2.2-2 Removal of Dummy Plate

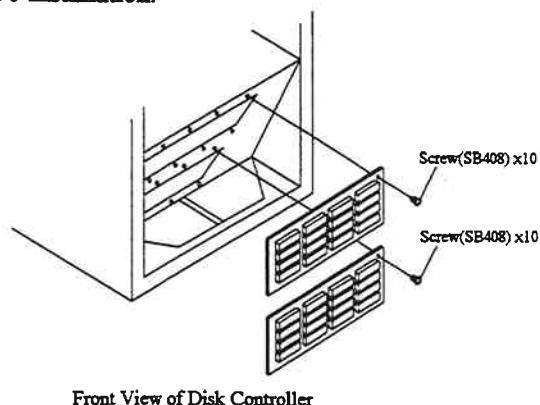

Front View of Disk Controller

Fig. 3.3.6.2.2-3 Installation of I/F Connector Panel

3. Cabling

- a. Pass the CH cables through the cable guide referring to Fig. 3.3.6.2.2-4.

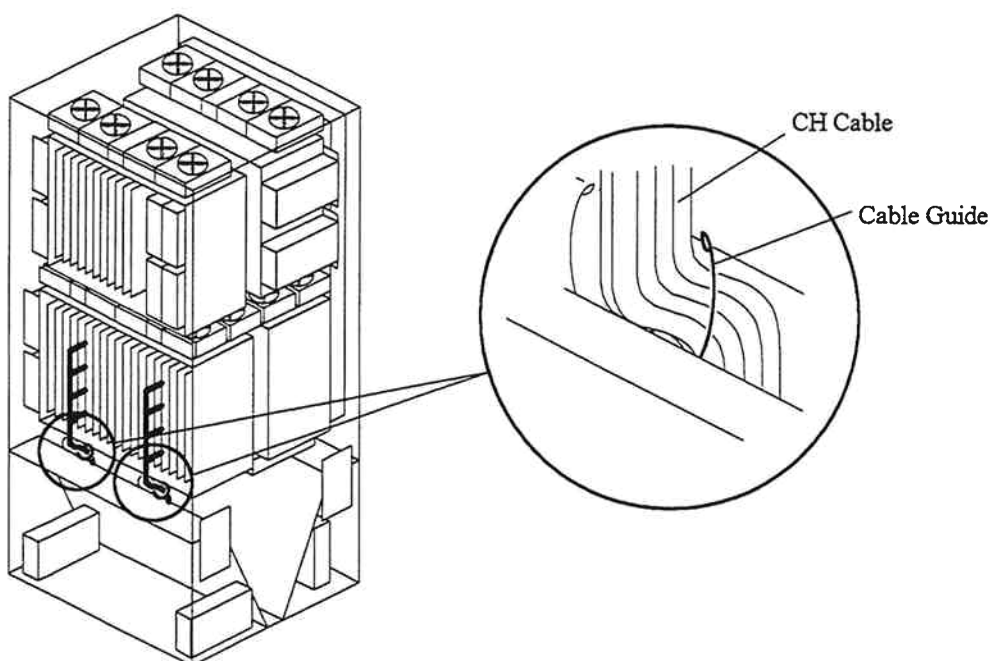
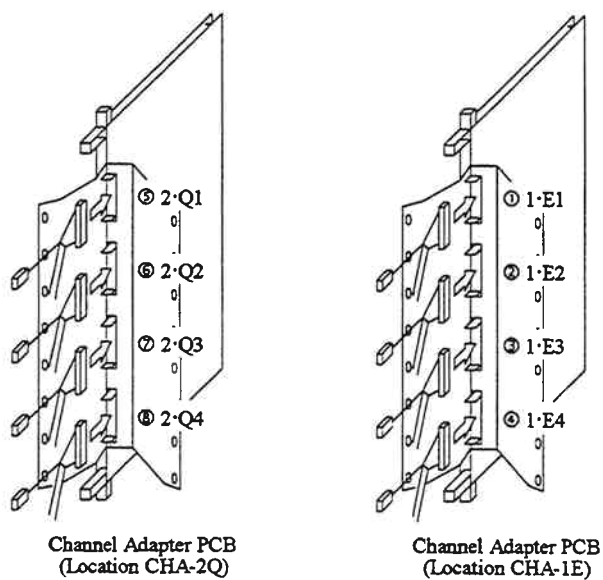

Fig. 3.3.6.2.2-4 Cabling

4. Connection of the CH cables

- a. Connect the CH cables to the sub-edge connectors on PCB. Refer to Fig. 3.3.6.2.2-5 and Table 3.3.6.2.2-2.



Channel Adapter PCB
(Location CHA-2Q)

Channel Adapter PCB
(Location CHA-1E)

Fig. 3.3.6.2.2-5 Connection of CH Cables

Table 3.3.6.2.2-2 CH Cable Connection

No.	CH cable	Sub-edge connector on PCB
1	1•E1/1•F1	1•E1
2	1•E2/1•F2	1•E2
3	1•E3/1•F3	1•E3
4	1•E4/1•F4	1•E4
5	2•Q1/2•R1	2•Q1
6	2•Q2/2•R2	2•Q2
7	2•Q3/2•R3	2•Q3
8	2•Q4/2•R4	2•Q4

5. Binding of the CH cables

- a. Bind the CH cables referring to Fig. 3.3.6.2.2-6.
- b. Button up the cable cover referring to Fig. 3.3.6.2.2-7.

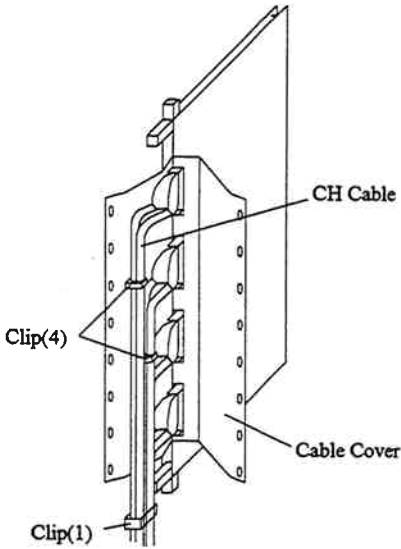

Fig. 3.3.6.2.2-6 Binding

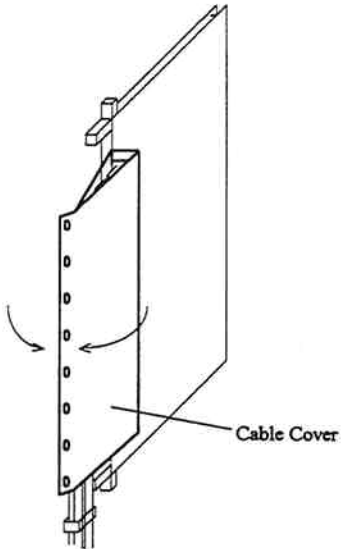

Fig. 3.3.6.2.2-7 Cable Cover

6. Labeling

- a. Attach the labels "PARALLEL PORT" to ① and ② referring to Fig. 3.3.6.2.2-8.

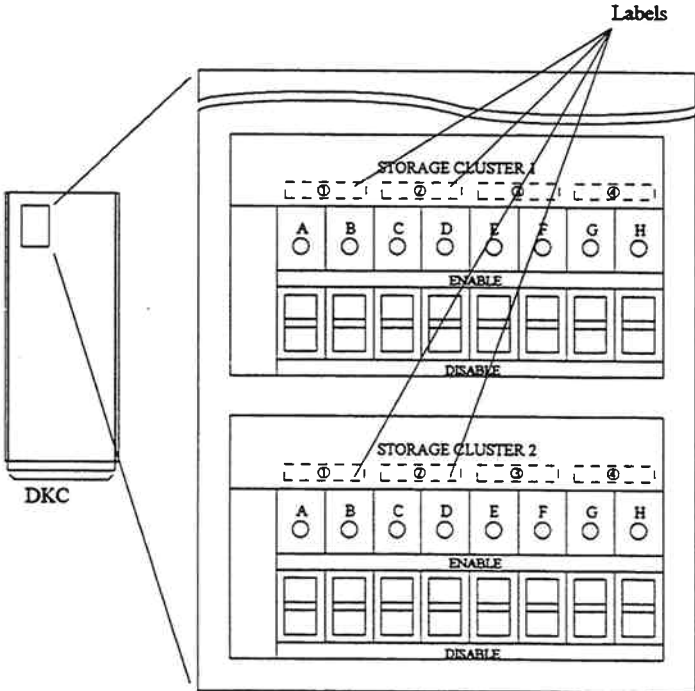
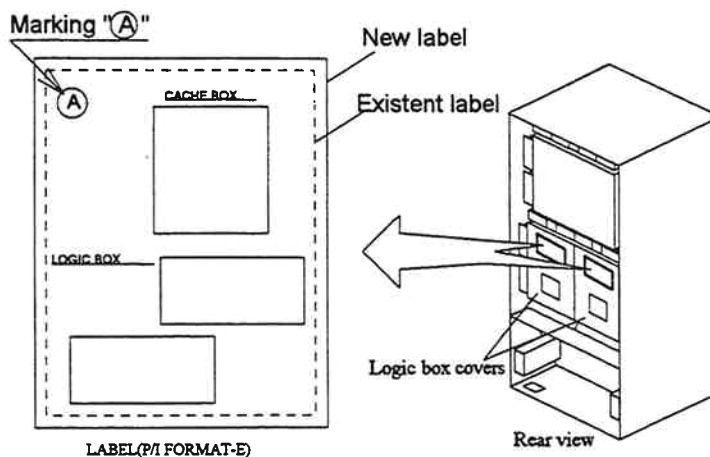

Fig. 3.3.6.2.2-8 Attachment of Labels

7. Exchange of Labels

- a. Stick the new labels (marking Ⓐ) over the existent labels on Logic box covers.

Note: If a new labels with a marking Ⓐ printed was already attached, this work is not required.



8. Attachment of the nameplate

- a. Attach the nameplate referring to Fig. 3.3.6.2.2-9.

• DKC-F210I-8P

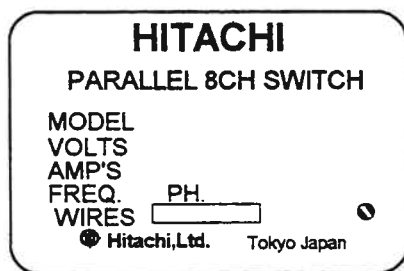

• DKC-F210I-8PE

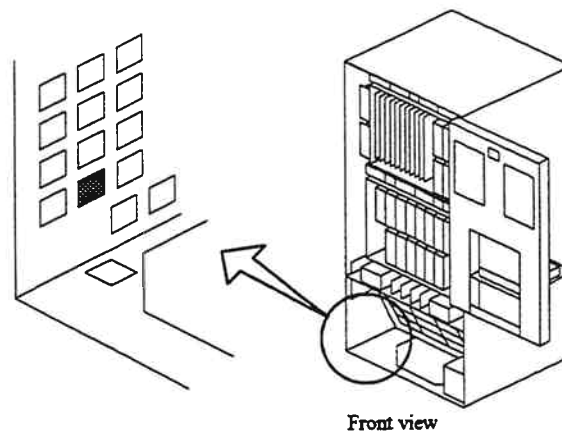
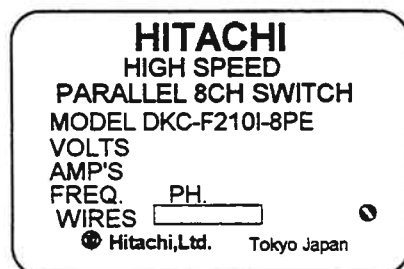

Fig. 3.3.6.2.2-9 Attachment of Nameplate

9. Return to General Flow.

New Installation: Go to INST02-10 Step (8). But if CHA must be installed in additional location, perform the hardware procedure for CHA additional location.

Non-disruptive Installation: Go to INST02-20A Step (4)-2.

Disruptive Installation: Go to INST02-40 Step (7).

Additional Location(CH E-H)

Be sure to wear your wrist strap and attach to ground prior to performing the following work. This will insure that the IC and LSI on the PCB are protected from static electricity.

1. Insertion of the PCBs

- a. Set the jumper plugs(JP1-JP4) referring to Fig. 3.3.6.2.2-10.
- b. Insert the PCBs to the correct locations in the Logic Box referring to Table 3.3.6.2.2-3.
- c. Fasten the two screws referring to Fig. 3.3.6.2.2-10.

Table 3.3.6.2.2-3 Inserting Location

No.	Part name	Slot No.	Location No.	Remarks
1	Channel Adapter PCB	F and R	CHA-1F and CHA-2R	in Logic Box

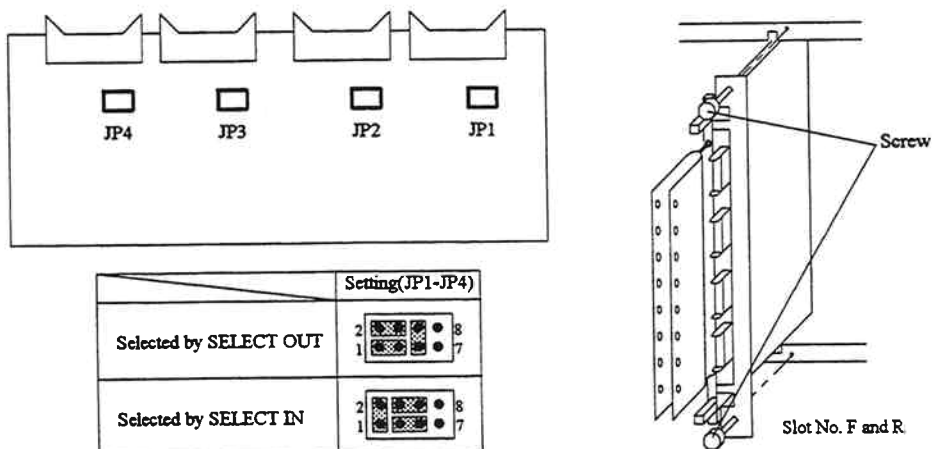
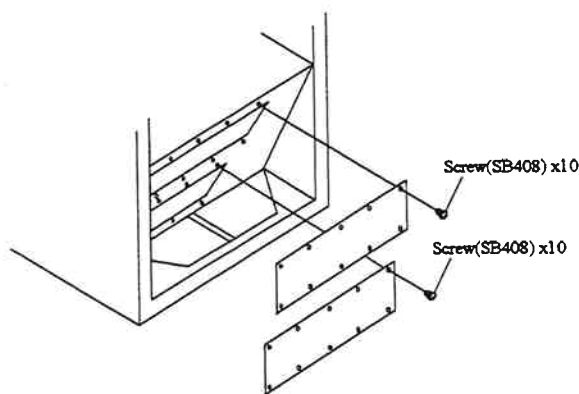

Fig. 3.3.6.2.2-10 Insertion of PCB

2. Installation of the I/F connector panel

- a. Remove the dummy plate referring to Fig. 3.3.6.2.2-11.
- b. Install the I/F connector panel referring to Fig. 3.3.6.2.2-12.

Note: Dummy plates should be stored for future use in De-installation.



Rear View of Disk Controller

Fig. 3.3.6.2.2-11 Removal of Dummy Plate

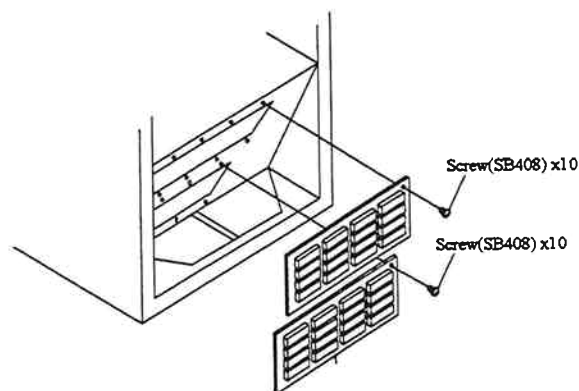

Rear View of Disk Controller

Fig. 3.3.6.2.2-12 Installation of I/F Connector Panel

3. Cabling

- a. Pass the CH cables through the cable guide referring to Fig. 3.3.6.2.2-13.

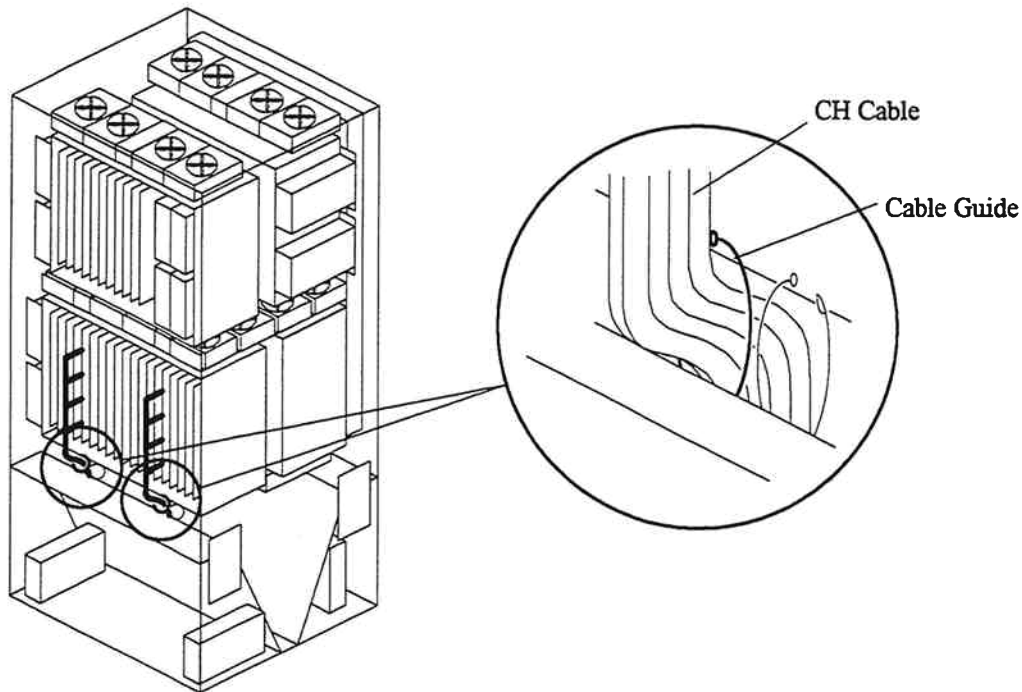

Fig. 3.3.6.2.2-13 Cabling

4. Connection of the CH cables

- a. Connect the CH cables to the sub-edge connectors on PCB. Refer to Fig. 3.3.6.2.2-14 and Table 3.3.6.2.2-4.

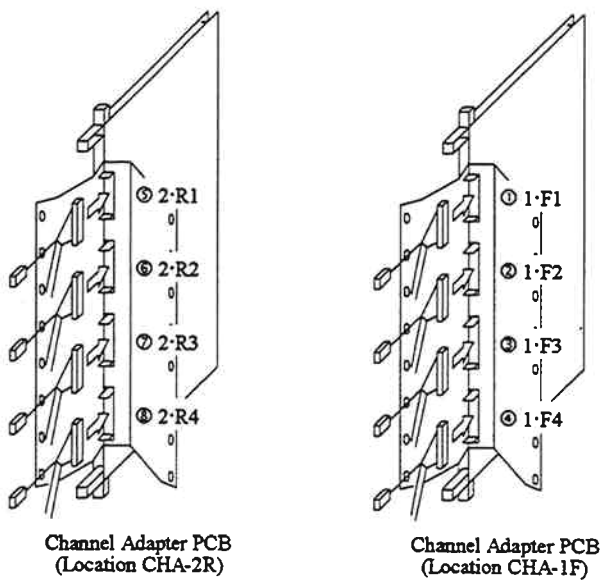

Table 3.3.6.2.2-4 CH Cable Connection

No.	CH cable	Sub-edge connector on PCB
1	1·E1/1·F1	1·F1
2	1·E2/1·F2	1·F2
3	1·E3/1·F3	1·F3
4	1·E4/1·F4	1·F4
5	2·Q1/2·R1	2·R1
6	2·Q2/2·R2	2·R2
7	2·Q3/2·R3	2·R3
8	2·Q4/2·R4	2·R4

Fig. 3.3.6.2.2-14 Connection of CH Cables