

# DF300 DK/MK/CK/RK/RKH/RKWH USER'S OPERATING MANUAL

Rev. 0

Read this manual carefully and keep it.

- Before starting operation, read the safety instructions carefully and fully understand them.
- After reading this manual, keep it at hand for your reference.

HITACHI

All Right Reserved, Copyright © 1996, Hitachi, Ltd.

K6601275	SHEET NO.	REV NO.	0
	1/21	Dec.1.'96	

## Preface

- This manual explains the procedures necessary for an operator who operates the Hitachi DF-300-DK/MK/RK/CK/RKH/RKWH disk array subsystem to handle it appropriately. Before starting operation, read this manual carefully.
- After reading this manual, keep it at hand for your reference..
- Hitachi, Ltd. reserves all copyrights for this manual. No part of this manual may be reproduced without the prior permission of Hitachi, Ltd.
- Precautions to be taken and matters to be duly considered for using the equipment safely will be explained hereunder. Take the following precautions for safety.
- Keep the front and rear covers of the equipment closed. (The covers are used to operate the equipment safely and quietly and furthermore to prevent an accumulation of static electricity and radiation of radio noise.)
- Do not put articles on the top and near the front and side covers of the equipment. The reason is that the equipment may be damaged when a heavy article is put on its top, and cooling air is discharged from the side covers.
- When the front and side covers are to be opened, do not touch the parts other than those designated in this manual. A high voltage is applied to the equipment. Never touch the components of the power supply.
- Before turning on or off the equipment or operating it, make sure that the equipment is not under maintenance.
- When a trouble occurs, take only the measures against it which is described in this manual. If such a trouble that the measures against which is not found in this manual, contact our trained service personnel for taking measures.
- When a fatal error occurs, report the details of the problem to our service personnel. When the report is more in detail, it is more useful for solution.
- When the DF300 disk array subsystem is used in the USA, the following warning is applied.

K6601275	SHEET NO.	REV NO.	0
	I/	Dec.1.'96	

**Warning:** This equipment generates and uses radio frequency energy. Moreover, there are some possibility that the equipment can radiate the energy. So if this equipment is not installed or not used in accordance with the instruction manual, it may cause interference to radio communications. It has been tested and found to comply with the limits for a Class A computing device pursuant to Subpart J of Part 15 of FCC Rules, which are designed to provide reasonable protection against such interference when operated in a commercial environment. Operation of this equipment in a residential area is likely to cause interference in which case the user at his own expense will be required to take whatever measures may be required to correct the interference.

Acoustic noise according to GSGV Regulation 3:

Sound pressure level < 55 db (A) (Measured according to ISO7779)

Use a plug which can be operated easily to supply power to the equipment.

- The contents of this manual are subject to change without previous notice.

K6601275	SHEET NO.	REV NO.	0
	II/	Dec.1.'96	

DF300 DK/MK/CK/RK/RKH/RKWH USER'S OPERATING MANUAL

REVISION CONTROL LIST

Correction Code AD : Added CH : Changed CR : Corrected DL : Deleted

REV.	Date	DRW.	CHKD.	APPD.	Sheet No.	Description	Code
0	Dec.1.'96	M.Hori			All	Issued	

## Contents

Preface .....	I
⚠ SAFETY SUMMARY .....	SAFE-1
1. Operation of the Operator Panel .....	4
2. Operation Procedures .....	13
3. Troubleshooting.....	15
Appendix .....	18

K6601275	SHEET NO.	REV NO.	0
	3/	Dec.1.'96	

---

 SAFETY SUMMARY





---

1.  General Safety Guidelines

Read the following safety guidelines carefully and follow them when you conduct maintenance of the machine.

Before starting maintenance

- Maintenance of the machine must be done only by trained and qualified engineers.
- Read and follow the safety guidelines and procedures in this manuals.
- In this manual and on the machine, hazard warnings are provided to aid you in preventing or reducing the risk of death, personal injury, or product damage. Understand and follow these hazard warnings fully.
- The hazard warning which appear on the warning labels on the machine or in the manual have one of the following alert headings WARNING, or CAUTION.

 <b>DANGER:</b>	indicates an imminently hazardous situation which, if not avoided, will result in death or serious injury.
 <b>WARNING:</b>	indicates a potentially hazardous situation which, if not avoided, can result in death or serious injury.
 <b>CAUTION:</b>	indicates a potentially hazardous situation which, if not avoided, will or can result in minor or moderate injury, or serious damage of product.
	The alert symbol shown left precedes every signal word for hazard warnings, and appears in safety related descriptions in the manual.

The signal word 'NOTICE' is used to present warnings which are not directly related to personal injury hazards.

- Keep in mind that the hazard warnings in this manual or on the machine cannot cover every possible case, as it is impossible to predict and evaluate all circumstances beforehand.

Be alert and use your common sense.

2. ⚠ Hazard Warning Statements

The following are the hazard warning statements contained in this manual.

2.1 ⚠ DANGER statement

No DANGER statement

2.2 ⚠ WARNING Statement

Never touch the inside of the power supply.

Electricity remains in the power supply, even if the main switch has been turned off.

(p5,7,9)

2.3 ⚠ CAUTION statements

The HDU assembly is a precise part. Be sure to keep it away from shock and vibration.

(p18)

K6601275	SHEET NO.	REV NO.	0
	SAFE-2/	Dec.1.'96	

1. Operation of the operator panel

(1) Appearance of the SVP

(Desk-top type)

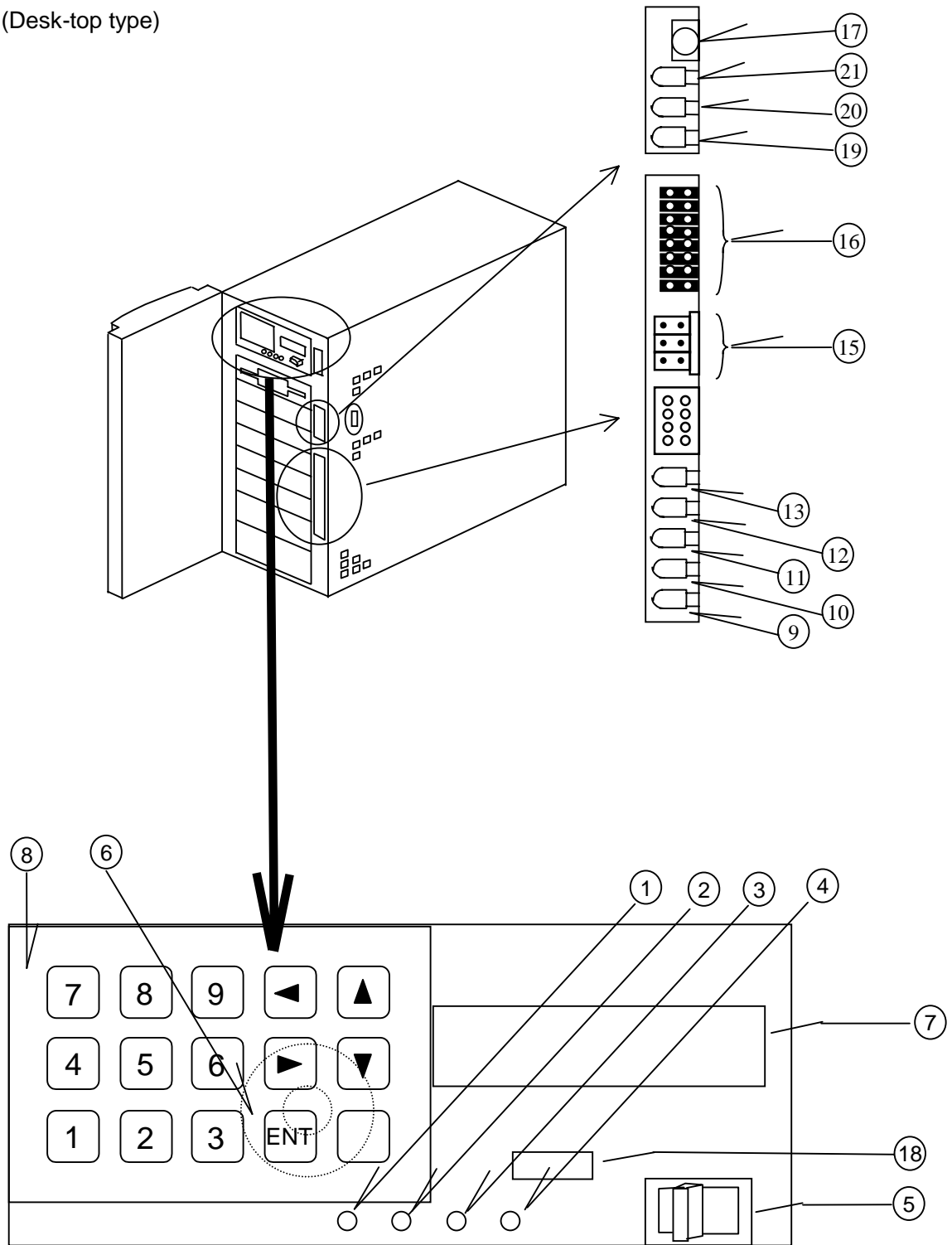

K6601275	SHEET NO.	REV NO.	0
	4/	Dec.1.'96	

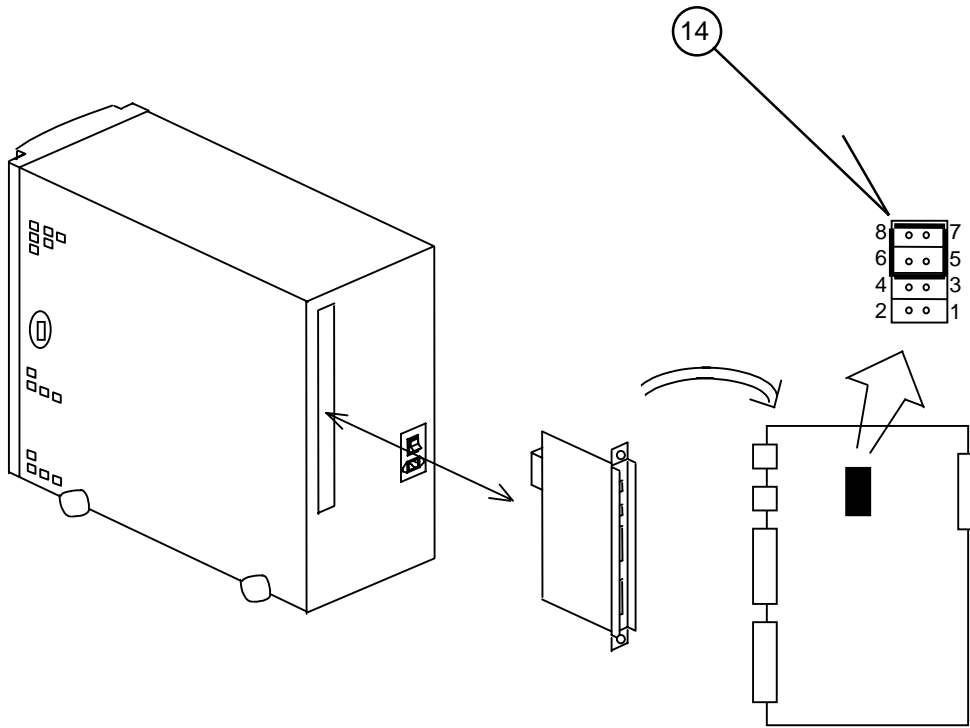

**⚠ WARNING**

Never touch the inside of the power supply.  
Electricity remains in the power supply, even if the main switch has been turned off.

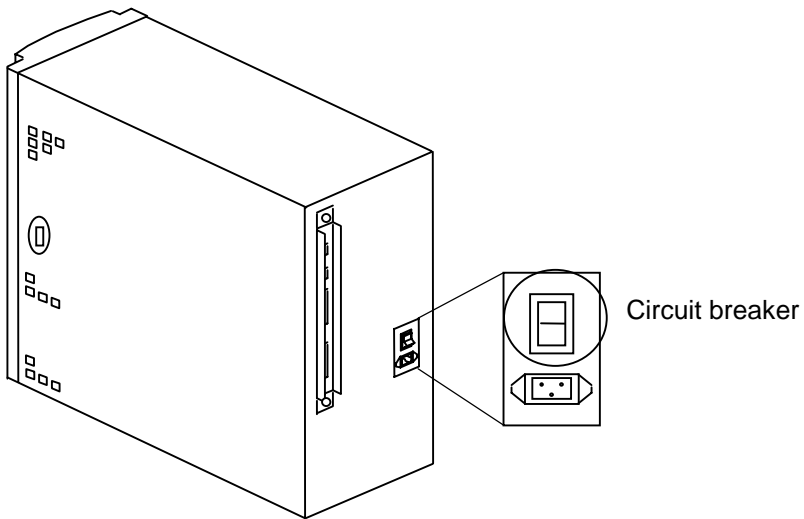

K6601275	SHEET NO.	REV NO.	0
	5/	Dec.1.'96	

(Mini-tower and cabinet types)

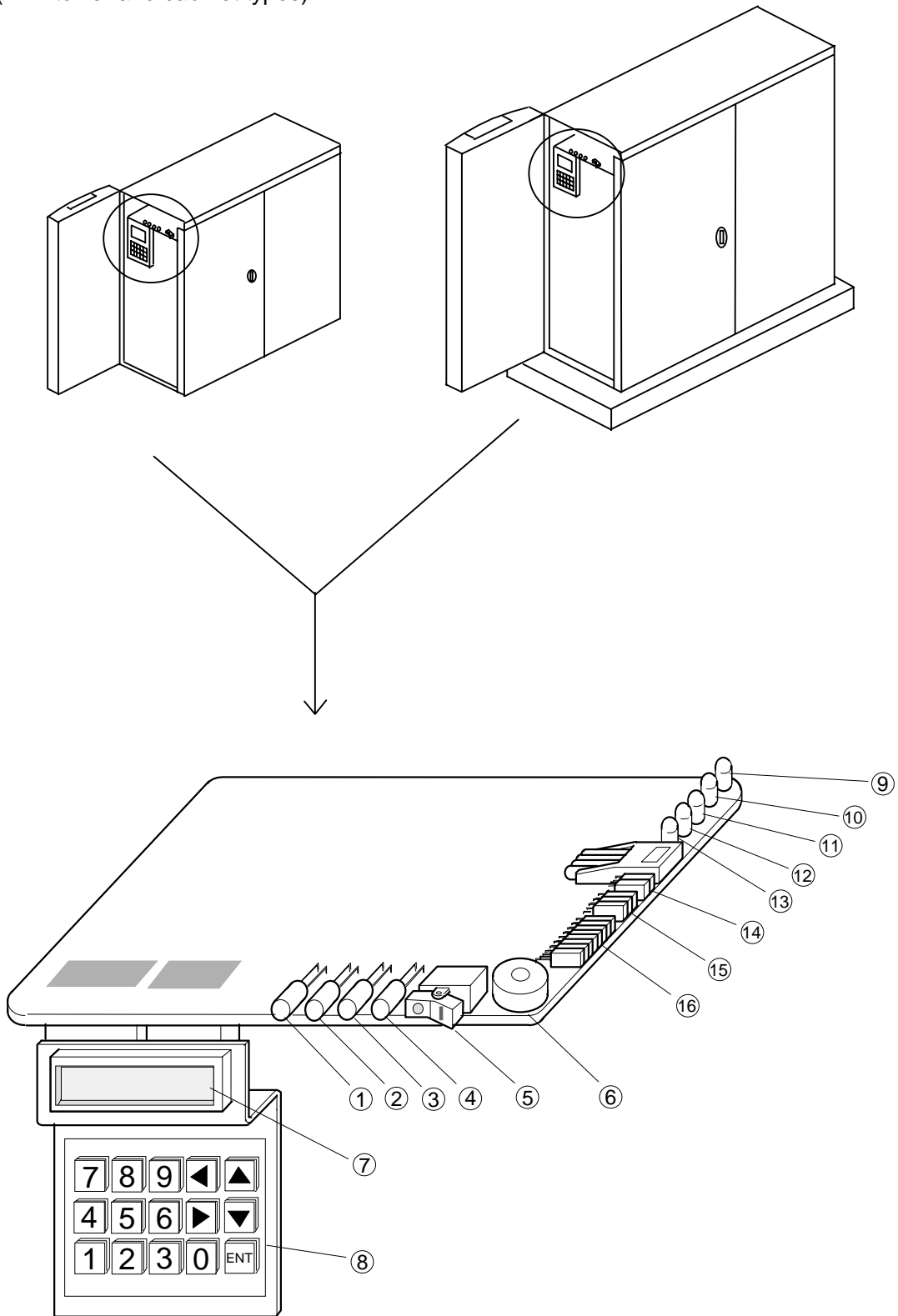

K6601275	SHEET NO.	REV NO.	0
	6/	Dec.1.'96	

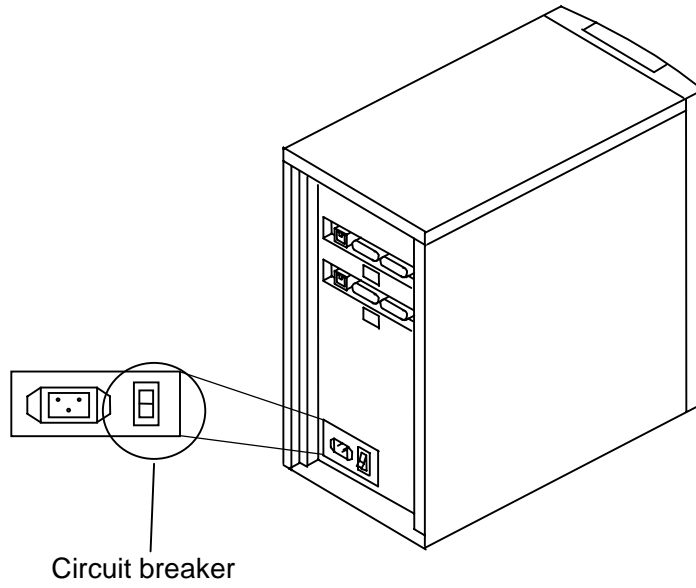

 **WARNING**

Never touch the inside of the power supply.  
Electricity remains in the power supply, even if the main switch has been turned off.

K6601275	SHEET NO.	REV NO.	0
	7/	Dec.1.'96	

(Rack mount type)

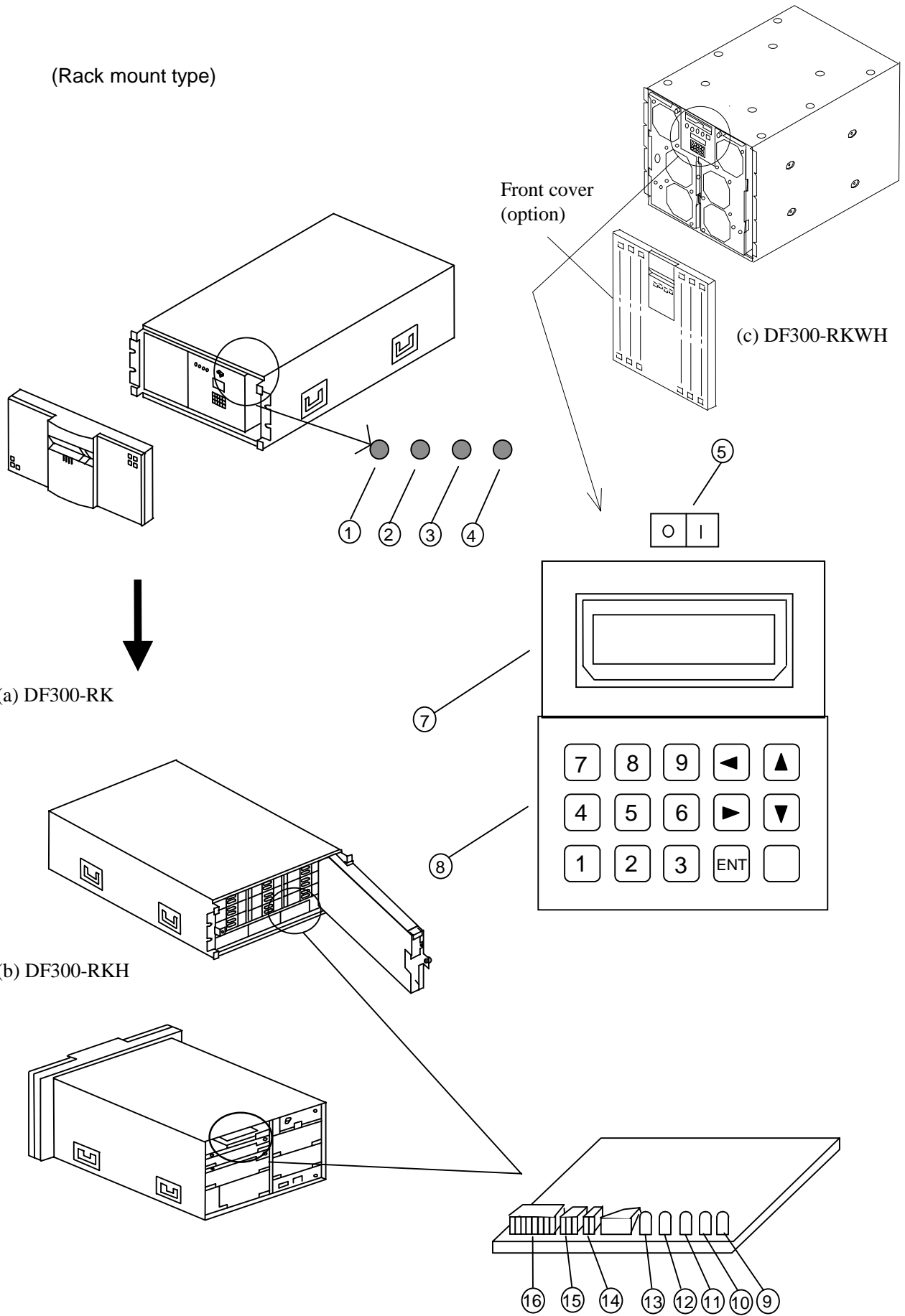

K6601275	SHEET NO.	REV NO.	0
	8/	Dec.1.'96	

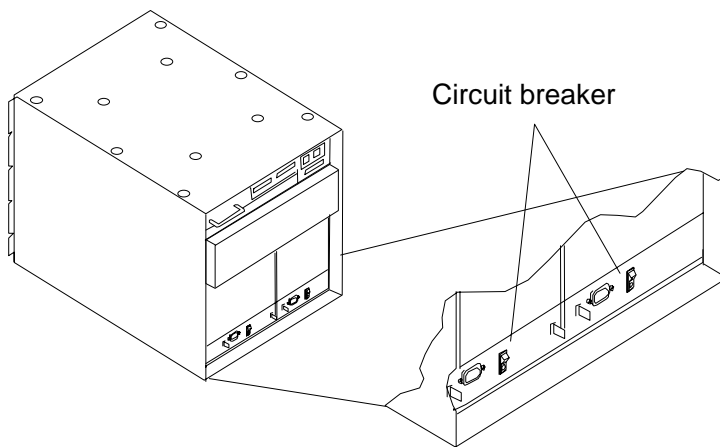
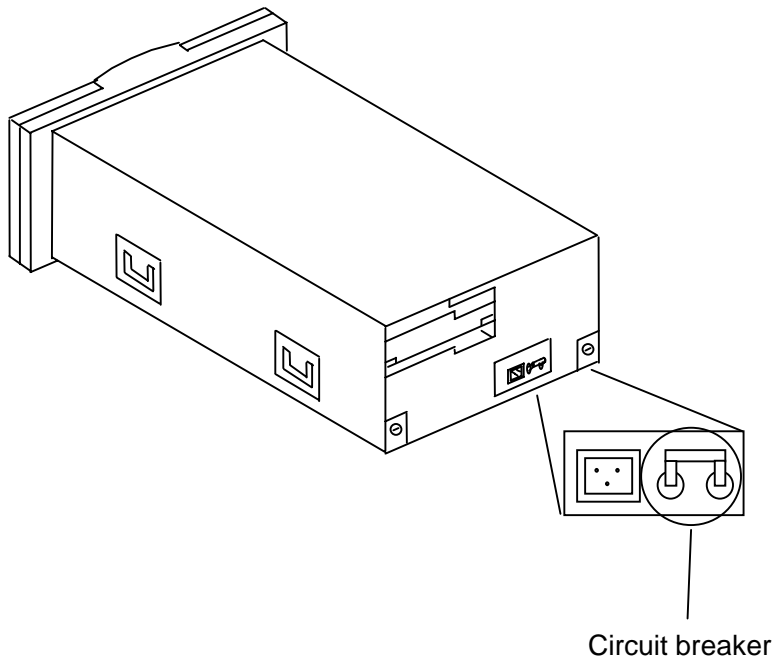

 **WARNING**

Never touch the inside of the power supply.

Electricity remains in the power supply, even if the main switch has been turned off.

K6601275	SHEET NO.	REV NO.	0
	9/	Dec.1.'96	

(2) Description of SVP

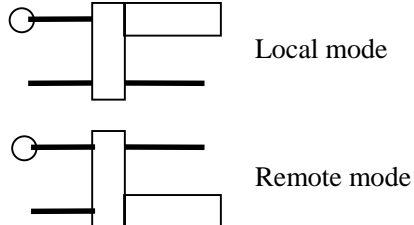
No.	Name	Category	Color	Function
1	READY	LED	Green	Indicates that the power is turned on and the subsystem is operable.
2	WARNING	LED	Yellow	Indicates that the subsystem is operable but an internal failure has been occurred.
3	ALARM	LED	Red	Indicates that an inoperable failure has occurred in the subsystem.
4	POWER	LED	Green	Indicates that the power is supplied to drives and PCBs.
5	Main switch	Switch	-	Turns the power on/off. Press the "1" side to turn the subsystem on. Press the "0" side to turn the subsystem off.
6	Buzzer	Buzzer	-	Sounds an alarm when a failure occurs.
7	LCD	LCD	-	Displays a status of the subsystem and an error code.
8	Numeric keypad	Switch	-	Used to set the subsystem.
9	SVP CHECK1	LED	Red	Indicates whether or not a cause of abnormal voltage is displayed.
10	SVP ALARM	LED	Red	Indicates a cause of abnormal voltage with the number of times that this LED blinks.
11	CHARGE	LED	Yellow	Indicates whether the battery is in charge (lighted up) or not (lighted out), or that the voltage is unstable (blinking).
12	BATTERY OK	LED	Green	Indicates that the battery has been charged.
13	SVP READY	LED	Green	Indicates that the SVP is operable.
14	SW4	Jumper socket	Green	Used to set the Local/Remote mode. <sup>*1</sup> 

\*1 When the setting of LOCAL/REMOTE mode is changed, turn off the main switch and the switch on the rear side of the unit to turn off the power and then turn on the power again.

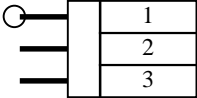
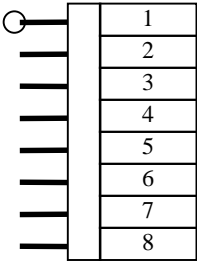
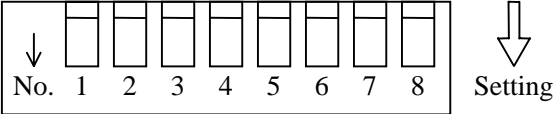
No.	Name	Category	Color	Function																		
15	SW3 * <sup>1</sup>	Jumper socket	Black	 <table border="1"> <thead> <tr> <th>#</th> <th>Meaning</th> </tr> </thead> <tbody> <tr> <td>1</td> <td>On : Reset</td> </tr> <tr> <td>2</td> <td>DC failure detection level On : 4.2V Off : 4.6V</td> </tr> <tr> <td>3</td> <td>Buzzer On : Controlled by the host Off : Continues to sound</td> </tr> </tbody> </table>	#	Meaning	1	On : Reset	2	DC failure detection level On : 4.2V Off : 4.6V	3	Buzzer On : Controlled by the host Off : Continues to sound										
#	Meaning																					
1	On : Reset																					
2	DC failure detection level On : 4.2V Off : 4.6V																					
3	Buzzer On : Controlled by the host Off : Continues to sound																					
16	SW2	Jumper socket	Black	 <table border="1"> <thead> <tr> <th>#</th> <th>Meaning</th> </tr> </thead> <tbody> <tr> <td>1</td> <td>Off : LED test</td> </tr> <tr> <td>2</td> <td>Off : LCD test</td> </tr> <tr> <td>3</td> <td>Off : Buzzer test</td> </tr> <tr> <td>4</td> <td>Off : Battery charge</td> </tr> <tr> <td>5</td> <td>Off : Battery discharge</td> </tr> <tr> <td>6</td> <td>Off : Unused</td> </tr> <tr> <td>7</td> <td>Off : Unused</td> </tr> <tr> <td>8</td> <td>Off : Unused</td> </tr> </tbody> </table> <p>* : Insert all the sockets for normal operation.</p>	#	Meaning	1	Off : LED test	2	Off : LCD test	3	Off : Buzzer test	4	Off : Battery charge	5	Off : Battery discharge	6	Off : Unused	7	Off : Unused	8	Off : Unused
#	Meaning																					
1	Off : LED test																					
2	Off : LCD test																					
3	Off : Buzzer test																					
4	Off : Battery charge																					
5	Off : Battery discharge																					
6	Off : Unused																					
7	Off : Unused																					
8	Off : Unused																					
17	RESET switch	Switch	-	Collects the memory dump information.																		
18	DIP switch	Switch	-	 <table border="1"> <thead> <tr> <th>#</th> <th>Meaning</th> </tr> </thead> <tbody> <tr> <td>1</td> <td>Microprogram installation</td> </tr> <tr> <td>2</td> <td>Memory dump</td> </tr> <tr> <td>3</td> <td>EEPROM clear</td> </tr> <tr> <td>4</td> <td>System parameter test</td> </tr> <tr> <td>5</td> <td></td> </tr> <tr> <td>6</td> <td>CUDG skip</td> </tr> <tr> <td>7</td> <td>System installation (overwritten)</td> </tr> <tr> <td>8</td> <td>N.U.</td> </tr> </tbody> </table>	#	Meaning	1	Microprogram installation	2	Memory dump	3	EEPROM clear	4	System parameter test	5		6	CUDG skip	7	System installation (overwritten)	8	N.U.
#	Meaning																					
1	Microprogram installation																					
2	Memory dump																					
3	EEPROM clear																					
4	System parameter test																					
5																						
6	CUDG skip																					
7	System installation (overwritten)																					
8	N.U.																					

No.	Name	Category	Color	Function
19	CACHE PWR	LED	Green	Indicates that the power is supplied to the CACHE memory.
20	FAIL	LED	Red	Indicates that the error has occurred in the CTL ASSY and it is not operable.
21	RESET	LED	Yellow	Indicates that the CTL ASSY is being reset.

#### LOCAL mode

The subsystem can be turned on/off using its main switch regardless of the terminator power setting described in Subsection 4.6 in "Installation".

#### REMOTE mode

The host can remotely control the subsystem startup when the terminator power is set so that the power is supplied using the host SCSI bus. (For this mode, the main switch on the subsystem must have been turned on.)

#### LED TEST

Lights up all the LEDs on the panel.

#### LCD TEST

This mode tests the LCD module by displaying the test characters. If a key is pressed during this test, the value being pressed is displayed on the LCD.

#### BUZZER TEST

This mode tests the buzzer.

The buzzer sounds by setting the buzzer (bit 6) of the CTRL Reg. (0X02).

#### BATTERY CHARGE

This mode is for charging the battery regardless of the battery voltage.

2. Operation Procedures

Equipment power on/off

2-1-1

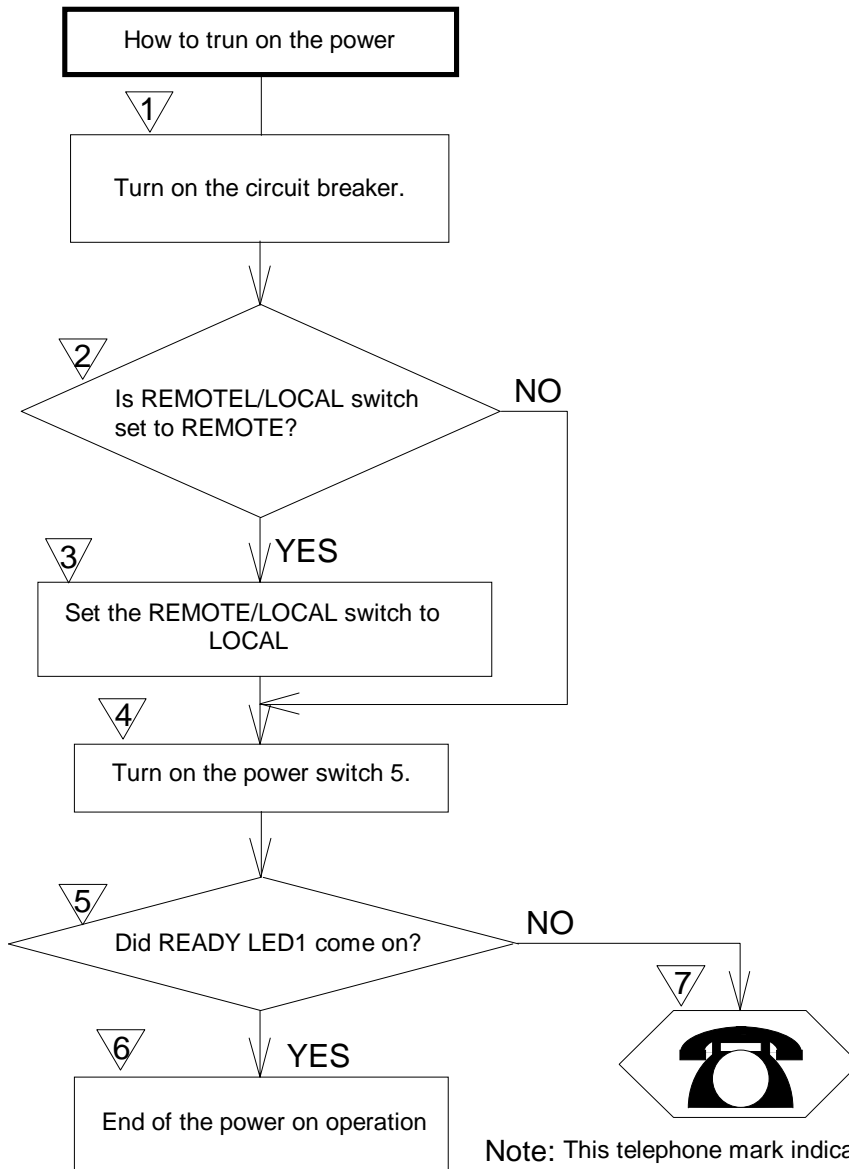

Note: This telephone mark indicates that the operator should contact a service personnel. The same for the following procedures.

K6601275	SHEET NO.	REV NO.	0
	13/	Dec.1.'96	

2-1-2

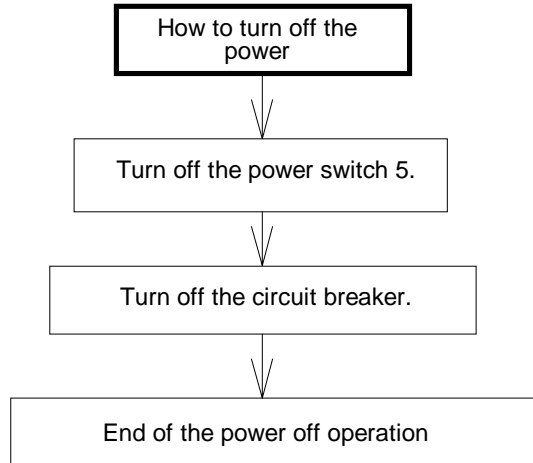

K6601275	SHEET NO.	REV NO.	0
	14/	Dec.1.'96	

### 3. Troubleshooting

3-1

#### Guidance for failure recovery

To allow the system to enter the operable status, the READY lamp on the operator panel must be on after the power is turned on as specified in Section 2.1.1 (on page 11) and a preparation for starting the system operation is made. It is also necessary that no error occurs when the read or write command from the host system is executed.

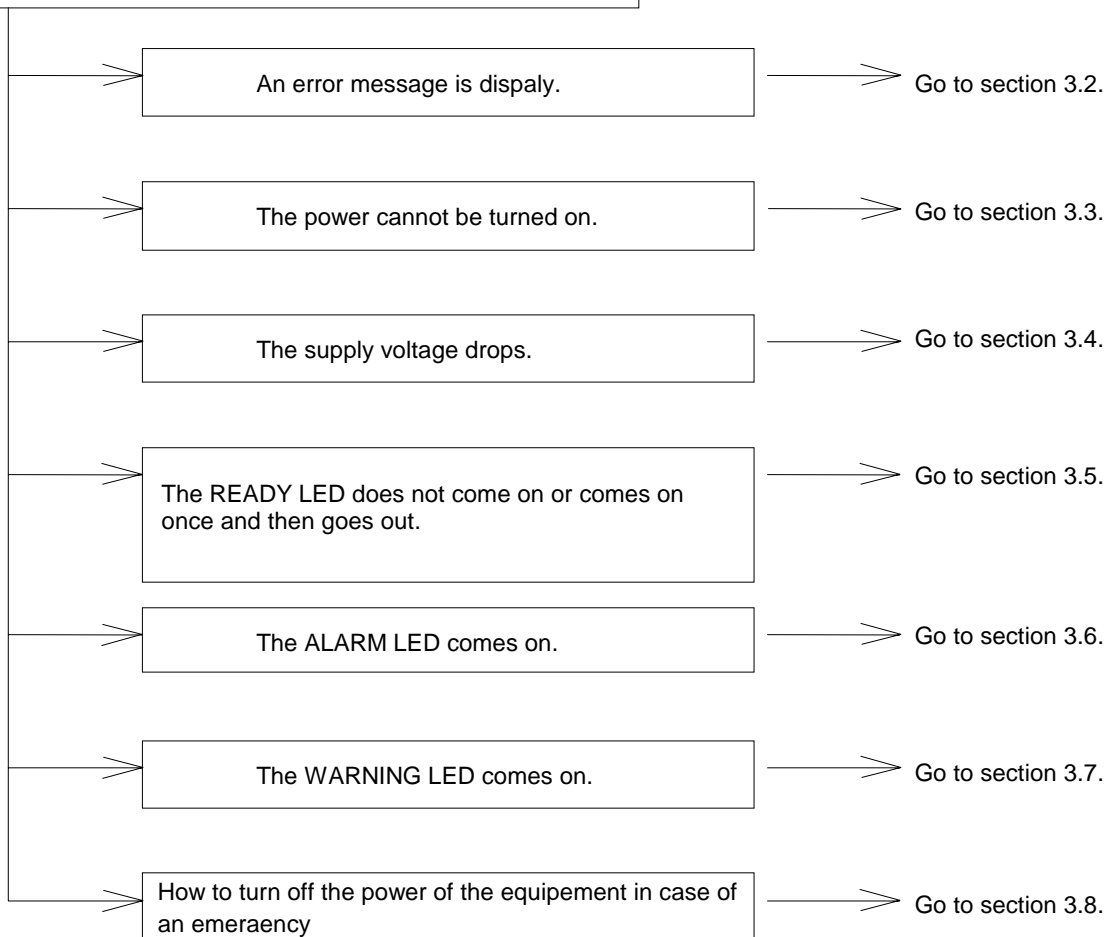

3-2

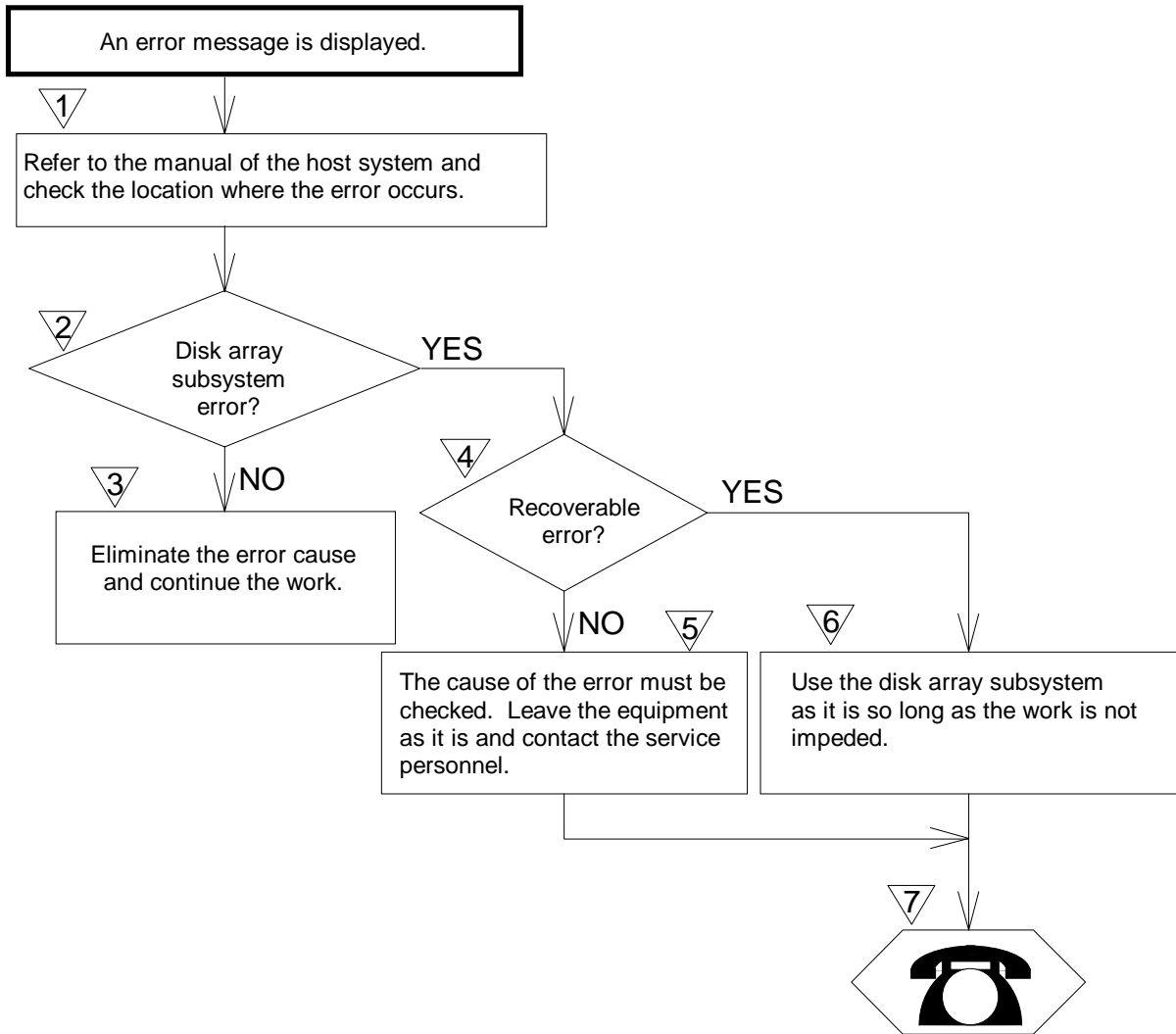

3-3

The power cannot be turned on.

3-4

The supply voltage drops.

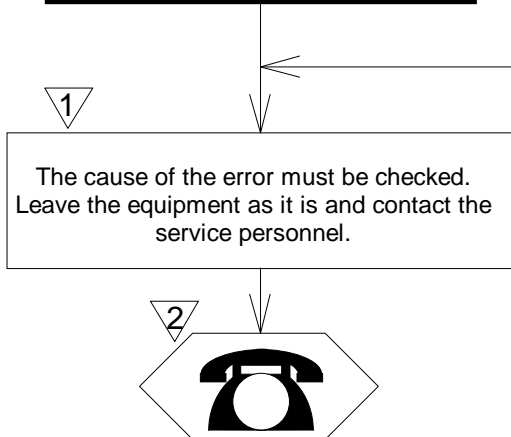

K6601275	SHEET NO.	REV NO.	0
	16/	Dec.1.'96	

3-5

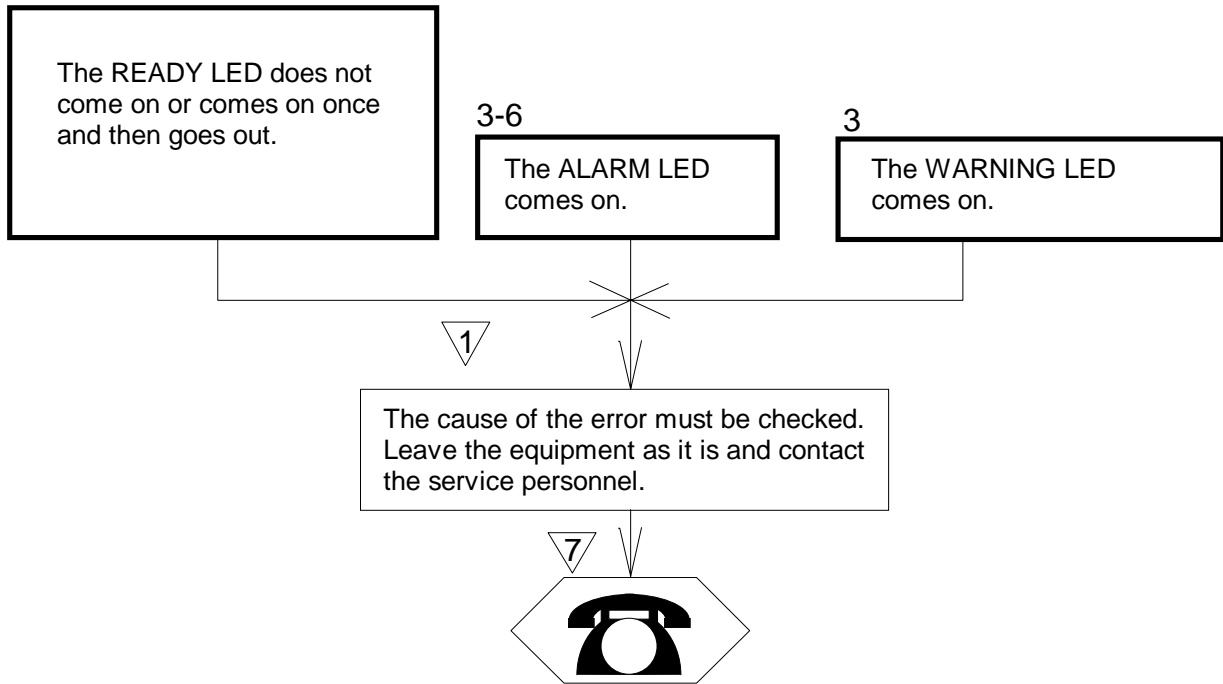

3-8

How to turn off the power in case of an emergency.

1

Turn off the power by the power switch on the operator panel and turn off the main breaker of the power supply of the equipment.

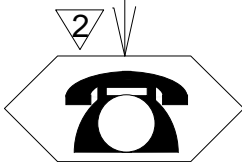

Note: When an error such as overheating, a smell, smoking, noise or abnormal vibration occurs in the equipment, or it is feared that the equipment might be damaged due to a power supply error, perform an emergency power shut down operation for the equipment and an AC power off operation on the distribution board.

K6601275	SHEET NO.	REV NO.	0
	17/	Dec.1.'96	

Appendix: Disk drive replacement procedures

Replace the disk drive according to the following procedures.

NOTE
------

The HDU assembly is a precise part. Be sure to keep it away from shock and vibration.

Procedures:

1. - Open the front cover (for desktop type).
  - Open the side cover (for mini-tower type or a cabinet type)
  - Remove the front cover and open the front panel (for rack mount type).
2. Pull the lever of the faulty HDU assembly in the equipment toward you.
3. Remove the faulty HDU assembly from the equipment.
4. Pull the lever of the new HDU assembly toward you.
5. Install the new HDU assembly in the equipment.
6. Return the lever of the new HDU assembly to the normal position.
7. Close the cover and panel.

K6601275	SHEET NO.	REV NO.	0
	18/	Dec.1.'96	

(Desktop type)

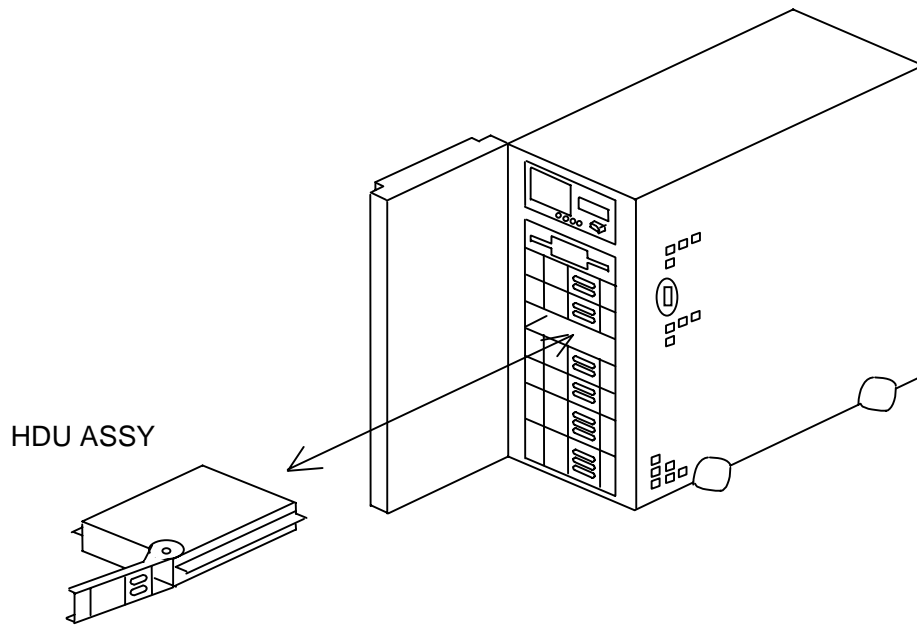

K6601275	SHEET NO.	REV NO.	0
	19/	Dec.1.'96	

(Mini-tower type)

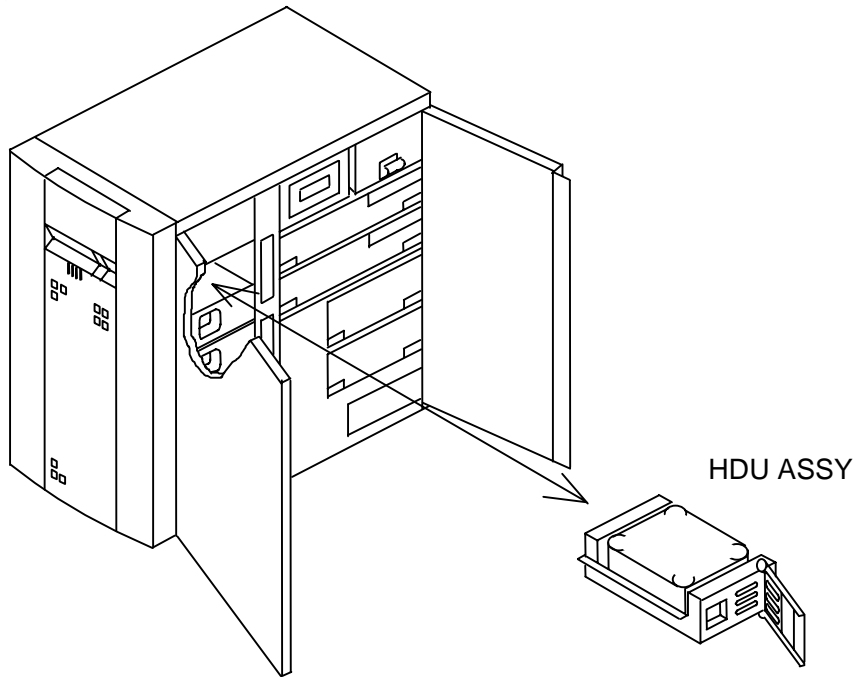

(Cabinet type)

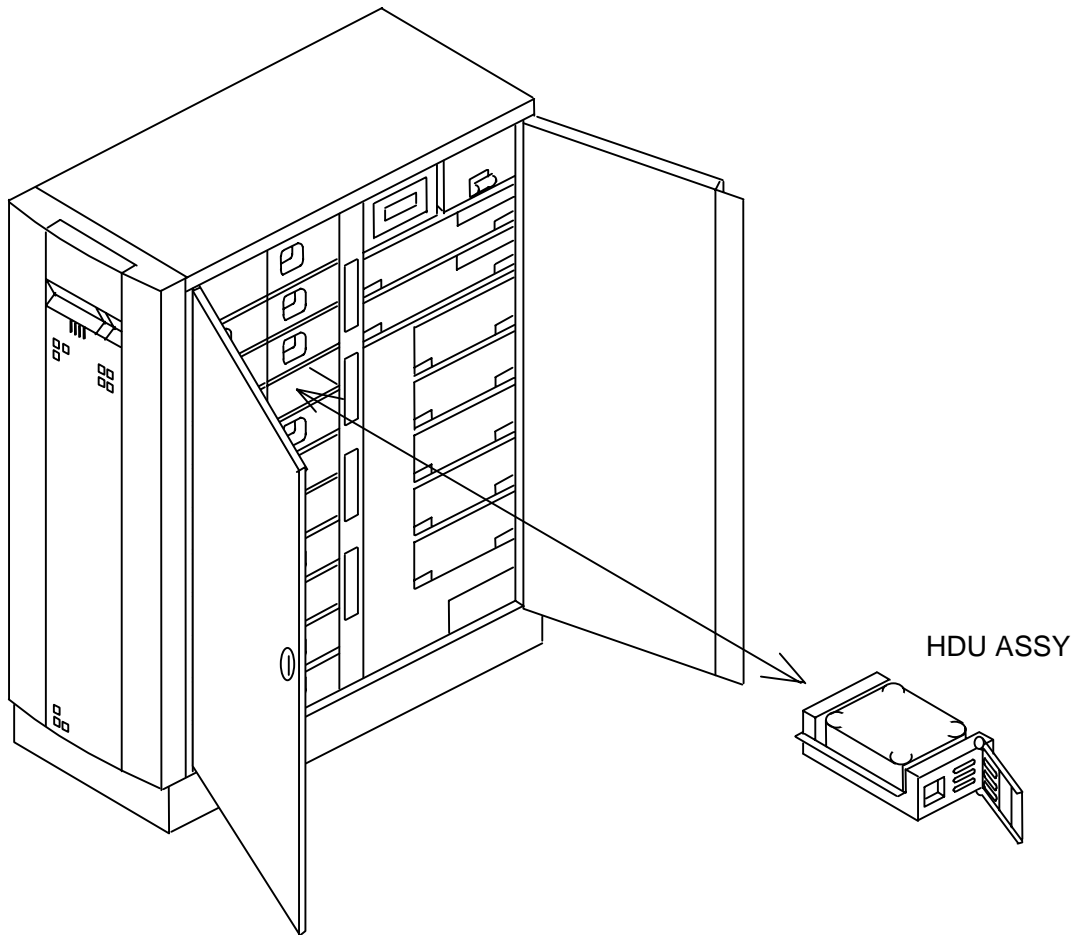

K6601275	SHEET NO.	REV NO.	0
	20/	Dec.1.'96	

(Rack mount type)

DF300-RK

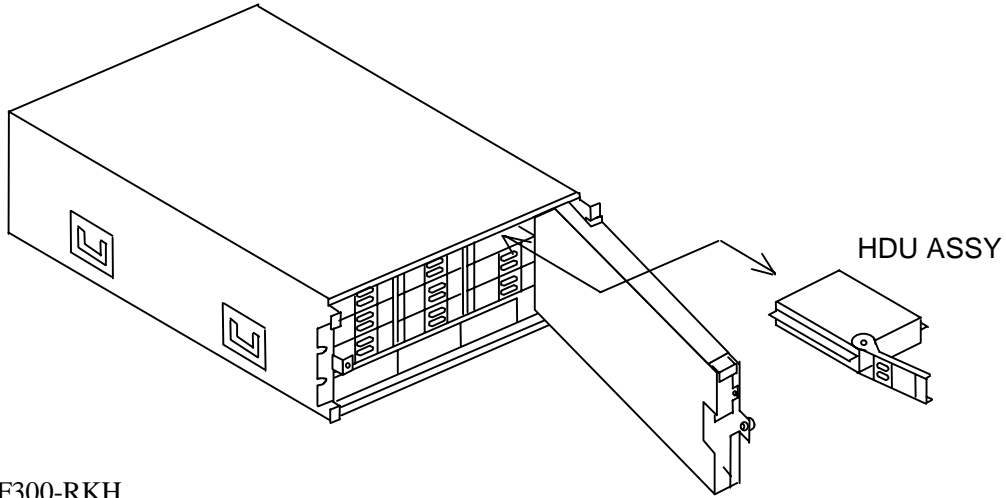

DF300-RKH

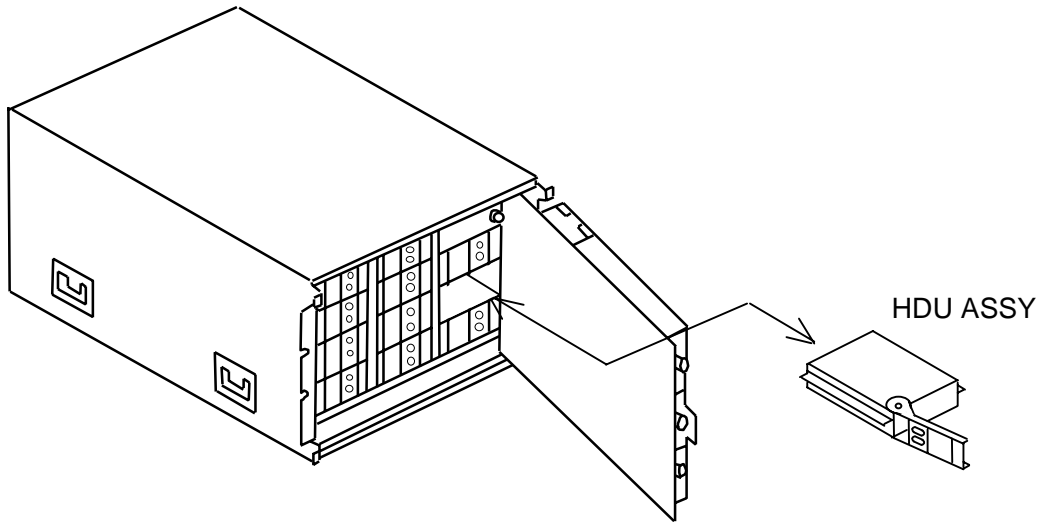

DF300-RKWH

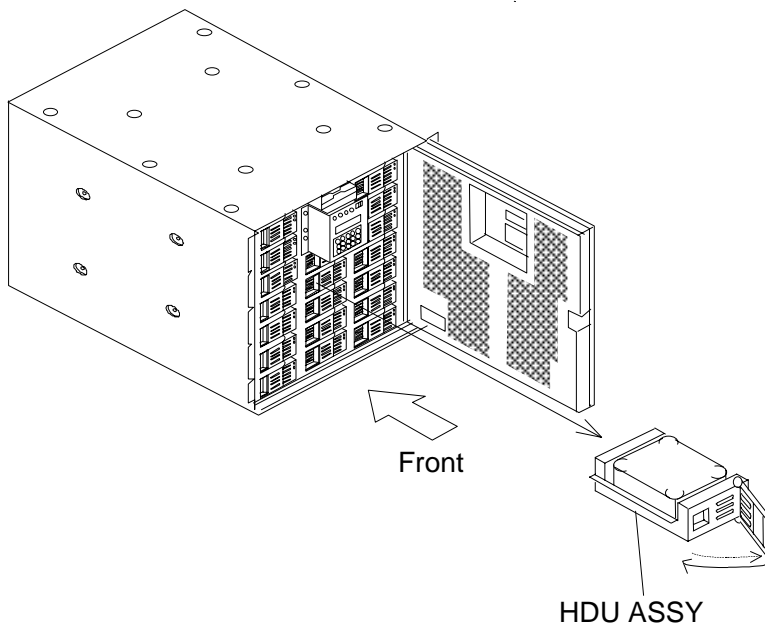

K6601275	SHEET NO.	REV NO.	1
	21/21	Nov.29.'96	