



Hitachi Virtual Storage Platform G200

Hardware Reference Guide

© 2015, 2016 Hitachi, Ltd. All rights reserved.

No part of this publication may be reproduced or transmitted in any form or by any means, electronic or mechanical, including copying and recording, or stored in a database or retrieval system for commercial purposes without the express written permission of Hitachi, Ltd., or Hitachi Data Systems Corporation (collectively "Hitachi"). Licensee may make copies of the Materials provided that any such copy is: (i) created as an essential step in utilization of the Software as licensed and is used in no other manner; or (ii) used for archival purposes. Licensee may not make any other copies of the Materials. "Materials" mean text, data, photographs, graphics, audio, video and documents.

Hitachi reserves the right to make changes to this Material at any time without notice and assumes no responsibility for its use. The Materials contain the most current information available at the time of publication.

Some of the features described in the Materials might not be currently available. Refer to the most recent product announcement for information about feature and product availability, or contact Hitachi Data Systems Corporation at https://support.hds.com/en_us/contact-us.html.

Notice: Hitachi products and services can be ordered only under the terms and conditions of the applicable Hitachi agreements. The use of Hitachi products is governed by the terms of your agreements with Hitachi Data Systems Corporation.

By using this software, you agree that you are responsible for:

1. Acquiring the relevant consents as may be required under local privacy laws or otherwise from authorized employees and other individuals to access relevant data; and
2. Verifying that data continues to be held, retrieved, deleted, or otherwise processed in accordance with relevant laws.

Notice on Export Controls. The technical data and technology inherent in this Document may be subject to U.S. export control laws, including the U.S. Export Administration Act and its associated regulations, and may be subject to export or import regulations in other countries. Reader agrees to comply strictly with all such regulations and acknowledges that Reader has the responsibility to obtain licenses to export, re-export, or import the Document and any Compliant Products.

Hitachi is a registered trademark of Hitachi, Ltd., in the United States and other countries.

AIX, AS/400e, DB2, Domino, DS6000, DS8000, Enterprise Storage Server, eServer, FICON, FlashCopy, IBM, Lotus, MVS, OS/390, PowerPC, RS/6000, S/390, System z9, System z10, Tivoli, z/OS, z9, z10, z13, z/VM, and z/VSE are registered trademarks or trademarks of International Business Machines Corporation.

Active Directory, ActiveX, Bing, Excel, Hyper-V, Internet Explorer, the Internet Explorer logo, Microsoft, the Microsoft Corporate Logo, MS-DOS, Outlook, PowerPoint, SharePoint, Silverlight, SmartScreen, SQL Server, Visual Basic, Visual C++, Visual Studio, Windows, the Windows logo, Windows Azure, Windows PowerShell, Windows Server, the Windows start button, and Windows Vista are registered trademarks or trademarks of Microsoft Corporation. Microsoft product screen shots are reprinted with permission from Microsoft Corporation.

iPad is a trademark of Apple Inc., registered in the U.S. and other countries.

All other trademarks, service marks, and company names in this document or website are properties of their respective owners.



Contents

Preface.....	7
Safety and environmental notices.....	8
Equipment with Network Equipment-Building System specifications.....	9
General safety guidelines.....	10
Handling of heavy parts.....	10
Preventing electric shock.....	10
Avoiding rotating or moving parts.....	11
Preventing machine damage.....	11
Working when the storage system is turned on.....	11
Precautions when using the storage system.....	11
Procedures in an emergency.....	12
For electric shock.....	12
For fire.....	12
Intended audience.....	13
Product version.....	13
Release notes.....	13
Changes in this revision.....	13
Document conventions.....	13
Conventions for storage capacity values.....	14
Accessing product documentation.....	15
Getting help.....	15
Comments.....	16
1 Product overview.....	17
Block configuration.....	18
Hitachi Virtual Storage Platform G200 model.....	18
Features.....	19
Scalability.....	20
Examples of supported Hitachi Virtual Storage Platform G200 configurations.....	20
Maximum number of mounted drive trays.....	20

2	Hardware description.....	25
	Storage system controllers.....	26
	CBSS controller.....	26
	CBSS with front panel bezel.....	26
	CBSS front panel without bezel.....	27
	CBSS rear panel.....	28
	CBSL controller.....	29
	CBSL with front panel bezel.....	29
	CBSL front panel without bezel.....	30
	CBSL rear panel.....	31
	Controller interfaces.....	33
	Front end module descriptions.....	33
	8 Gbps Fibre Channel board LEDs and connectors.....	33
	16 Gbps Fibre Channel board LEDs and connectors.....	34
	10 Gbps iSCSI board LEDs and connectors (optical).....	36
	10 Gbps iSCSI board LEDs and connectors (copper).....	36
	LAN blade LEDs and connectors.....	37
	Back end module LEDs and connectors.....	38
	CBSS/CBSL AC power supply unit LEDs and connectors.....	39
	CBSSD/CBSLD DC power supply unit LEDs and connectors.....	39
	Storage system drive trays.....	40
	Small form factor (SFF) drive tray.....	40
	SFF with front panel bezel.....	40
	SFF front panel without bezel.....	40
	SFF rear panel.....	41
	Large form factor (LFF) drive tray.....	42
	LFF with front panel bezel.....	42
	LFF front panel without bezel.....	43
	LFF rear panel.....	43
	Flash module drive (FMD) tray.....	44
	FMD with front panel bezel.....	44
	FMD front panel without bezel.....	45
	FMD rear panel.....	46
	Dense intermix drive tray.....	47
	Dense intermix drive tray with front panel bezel.....	47
	Dense intermix drive tray display LEDs.....	48
	Dense intermix drive tray rear panel.....	49
	SFF and LFF AC power supply unit LEDs and connectors.....	50
	SFF and LFF DC power supply unit LEDs and connectors.....	50
	Hitachi Virtual Storage Platform SVP server.....	51
	Service processor description.....	51
	SVP front panel.....	52
	SVP rear panel.....	53
3	System option modes.....	55
	System Option Modes.....	56
4	Maintaining the storage system.....	85
	Storing the storage system.....	86

Using flash module drives.....	86
Powering off the storage system.....	87
Removing cables.....	87
5 User administration for maintenance utility.....	89
Required roles for operating Maintenance Utility.....	90
Setting up user accounts.....	91
Disabling user accounts.....	93
Removing user accounts.....	97
Backing up user accounts.....	100
Restoring user account information.....	100
A Storage system specifications.....	103
Model lists.....	104
Hitachi Virtual Storage Platform G200 controller model list.....	104
Drive tray model lists.....	109
Other model list.....	113
Replacement parts.....	114
Battery unit.....	114
Hitachi Virtual Storage Platform G200 mechanical specifications (AC power supply model).....	115
Hitachi Virtual Storage Platform G200 mechanical specifications (DC power supply model).....	119
Electrical specifications.....	123
VSP G200 electrical specifications (DC power supply).....	124
Environmental specifications.....	125
VSP G200 environmental specifications (DC power supply).....	128
Battery specifications.....	130
RAID specifications.....	130
iSCSI specifications.....	131
iSCSI standards.....	133
Regulatory compliance.....	134
Dense intermix drive tray connection restrictions.....	135
SVP hardware specifications.....	135
Index.....	137



Preface

This guide describes the VSP Gx00 models.

- [Safety and environmental notices](#)
- [Equipment with Network Equipment-Building System specifications](#)
- [General safety guidelines](#)
- [Intended audience](#)
- [Product version](#)
- [Release notes](#)
- [Changes in this revision](#)
- [Document conventions](#)
- [Conventions for storage capacity values](#)
- [Accessing product documentation](#)
- [Getting help](#)
- [Comments](#)

Safety and environmental notices

Equipment warranty

The term of guarantee of normal operation of the storage system and free service is one year from date of purchase.

If a failure occurs multiple times, the storage system might shut off to avoid a serious accident.

Notice of export controls

Export of technical data contained in this document might require an export license from the United States government, the government of Japan, or both. Contact the Hitachi Legal Department for guidance about any export compliance questions.

Backup

Hitachi cannot guarantee against data loss due to failures. Therefore, back up your data to minimize chances for data loss.

Data backup is also critical when hardware components are added or replaced, because performing such hardware procedures restores parameter settings that can affect how data is managed on the storage systems.

Disposal



This symbol on the product or on its packaging means that your electrical and electronic equipment should be disposed at the end of life separately from your household wastes.

There are separate collection systems for recycling in the European Union. For more information, contact the local authority or the dealer where you purchased the product.

Recycling

A nickel-metal hydride battery is used in the Cache Backup Battery.

A nickel-metal hydride battery is a resource that can be recycled. When you want to replace the Cache Backup Battery, call the service personnel. They will dispose of it for you. This nickel-metal hydride battery, which is designated as recycling product by a recycling promotion law, must be recycled.

The mark posted on the Cache Backup Battery is a three-arrow mark that indicates a recyclable part.



UEFI Development Kit 2010

This product includes UEFI Development Kit 2010 written by the UEFI Open Source Community. For more information, see the UEFI Development Kit website:

<http://sourceforge.net/apps/mediawiki/tianocore/index.php?title=UDK2010>

© 2004, Intel Corporation.

All rights reserved.

Redistribution and use in source and binary forms, with or without modification, are permitted provided that the following conditions are met:

Redistributions of source code must retain the above copyright notice, this list of conditions and the following disclaimer.

Redistributions in binary form must reproduce the above copyright notice, this list of conditions and the following disclaimer in the documentation and/or other materials provided with the distribution.

Neither the name of the Intel Corporation nor the names of its contributors might be used to endorse or promote products derived from this software without specific prior written permission.

THIS SOFTWARE IS PROVIDED BY THE COPYRIGHT HOLDERS AND CONTRIBUTORS "AS IS" AND ANY EXPRESS OR IMPLIED WARRANTIES, INCLUDING, BUT NOT LIMITED TO, THE IMPLIED WARRANTIES OF MERCHANTABILITY AND FITNESS FOR A PARTICULAR PURPOSE ARE DISCLAIMED. IN NO EVENT SHALL THE COPYRIGHT OWNER OR CONTRIBUTORS BE LIABLE FOR ANY DIRECT, INDIRECT, INCIDENTAL, SPECIAL, EXEMPLARY, OR CONSEQUENTIAL DAMAGES (INCLUDING, BUT NOT LIMITED TO, PROCUREMENT OF SUBSTITUTE GOODS OR SERVICES; LOSS OF USE, DATA, OR PROFITS; OR BUSINESS INTERRUPTION) HOWEVER CAUSED AND ON ANY THEORY OF LIABILITY, WHETHER IN CONTRACT, STRICT LIABILITY, OR TORT (INCLUDING NEGLIGENCE OR OTHERWISE) ARISING IN ANY WAY OUT OF THE USE OF THIS SOFTWARE, EVEN IF ADVISED OF THE POSSIBILITY OF SUCH DAMAGE.

Notes on use

When using the Hitachi storage system, be sure to read this guide and understand the operating procedures and instructions described herein thoroughly before starting your operation.

The array complies with FDA radiation performance standard 21 CFR subchapter J.

EMI regulation

This equipment has been tested and found to comply with the limits for a Class A digital device, pursuant to Part 15 of the FCC Rules. These limits are designed to provide reasonable protection against harmful interference when the equipment is operated in a commercial environment. This equipment generates, uses, and can radiate radio frequency energy and, if not installed and used in accordance with the instruction manual, may cause harmful interference in which case the user will be required to correct the interference at his own expense. Testing was done with shielded cables. Therefore, in order to comply with the FCC regulations, you must use shielded cables with your installation.

The electromagnetic interference (EMI) test was done in the following configuration.

If trouble occurs in another configuration, a user might be requested to take appropriate preventative measures:

- RKU + CBSS + dense intermix drive tray + flash module drive tray + 2 small form factor drive trays + 1 large form factor drive tray.
- RKU + CBSL + 1 small form factor drive tray + 1 large form factor drive.

This product must not be used in residential areas.

This is a class A product. In a domestic environment this product can cause radio interference in which case the user can be required to take adequate measures.

Equipment with Network Equipment-Building System specifications

Within the midrange storage systems of the Hitachi VSP family, the Hitachi Virtual Storage Platform G200 is the equipment with the Network Equipment-Building System (NEBS) specifications.

The equipment with the NEBS specifications is suitable for use in Telecommunications Facilities. The equipment with the NEBS specifications is suitable for use in the CBN (Common Bonding Network).

General safety guidelines

Before starting maintenance:

- Maintenance must be performed by trained and qualified engineers only.
- The safety guidelines and procedures in this manual must be read and followed.
- In this manual and on the storage system, hazard warnings are provided to aid you in preventing or reducing the risk of death, personal injury, or product damage. Understand and follow these hazard warnings fully.
- If warning labels on the storage system become dirty or start peeling off, replace them.
- If an anomaly such as an unusual noise, smell, or smoke occurs on the storage system while it is running, power off or remove the power cables immediately.
- Hazard warnings in this manual or on the storage system cannot cover every possible case, because it is impossible to predict and evaluate all circumstances beforehand. Be alert and use common sense.
- To ensure normal operation, operate the storage system according to the information in this manual.

Read the following safety guidelines carefully and follow them when you conduct maintenance of the machine:

- Do not use materials that are outside the specifications for the storage system.
- Use the spare parts, consumables, and materials for maintenance that are specified in this manual; otherwise, personal injury, system damage, and degradation in system quality can occur.
- Keep the maintenance area neat.
- Always put away parts, materials, and tools when not in use.

Handling of heavy parts

- When lifting a heavy object, hold it close to yourself and keep your back erect to prevent back injury.
- When lifting an object designated with a caution in this manual, use a proper lifting tool or have somebody assist you.

Preventing electric shock

- Before starting work, be sure that, unless otherwise specifically instructed, there is no potential electric hazard in the maintenance area such as insufficient grounding or a wet floor.
- Before starting work, know where the emergency power-off switches are located and be sure you know how to operate them.

- Unless otherwise specifically instructed, remove all power sources to the machine before starting maintenance. Switching off the storage system power supplies is usually not sufficient.
- Do not touch any uninsulated conductor or surface that remains charged for a limited time after the external power supply to the storage system is disconnected.
- Do not replace parts during a thunderstorm.

Avoiding rotating or moving parts

- Do not supply power to any device with rotating or moving parts that are not properly covered.
- Tuck in your tie, scarf, shirt, or any other loose clothing to prevent it from getting caught by a rotating or moving part.

Preventing machine damage

- Use the tools and instruments, as instructed in this manual, or equivalent commercially available tools and instruments suited for the purpose.
- Use measurement instruments and powered tools that are properly calibrated or periodically inspected.
- Before finishing your work, be sure all parts removed during maintenance have been installed in their original positions in the storage system. Do not leave any tools or foreign material in the storage system.

Working when the storage system is turned on

Observe the following safety measures when working on the storage system with the system power turned on. When you perform maintenance, do not touch live electric parts to prevent an electric shock.

- Do not touch heat sinks immediately after a board is removed because the heat sinks are extremely hot.
- While performing maintenance, do not drop tools, screws, or other items into the storage system, because doing so can cause a short circuit.
- While performing maintenance, do not damage or pinch wires.
- When moving a heavy object, have at least two people move the object after confirming there are no obstacles nearby.

Precautions when using the storage system

- Use the supplied power cords included with the storage system. Do not use the supplied power cords for other products. Do not use other power cords with the storage system.
- Shut off the power feed to the equipment and inform the system administrator immediately if you notice an unusual smell, abnormal heat generation, or smoke emission. Leaving such conditions unattended can cause electric shock or fire.

- Exercise care when handling the storage system and its parts. Do not drop the equipment or parts.
- Do not stand on the storage system. Avoid using the storage system for any use other than the one for which it was originally designed.
- Do not place heavy objects on the storage system, near the vents on the front and rear panels, or on the cables attached to the storage system.
- Do not put a container with water, paper clips, or the like on the storage system or near the power supply.
- Route cables in a way to prevent people from tripping over them.
- Do not operate the storage system in a moist or dusty place.
- Keep these vents open and be sure they are not blocked to keep the storage system ventilated. Cool air enters the storage system from the air vent on the front panel and exits through the vent on the rear panel.
- If a failure occurs in the storage system, follow the instructions in this manual. If the problem is not covered by this manual, contact your system administrator.

Procedures in an emergency

For electric shock

- Before performing maintenance, be sure that there is no potential electric hazard in the maintenance area, such as insufficient grounding or a wet floor.
- Before performing maintenance, observe where the emergency poweroff switches are located and be sure you know how to operate them.
- Unless otherwise instructed, remove all power sources to the storage system before starting work. Switching off the storage system power supplies is not sufficient. When power is fed from a wall or floor outlet, unplug the power supply cord, or turn off the switch on the power distribution panel or board.
- If the power supply has a lockout device, lock the device after powering off the storage system and retain the key. Attach a notice on the panel or board prohibiting the use of the switch.
- If the machine power has been already turned off, confirm that these conditions have been satisfied.

For fire

- Shut off all the power to the machine.
- Turn off the emergency power switch or stop the power supply to the storage system.
- If the fire continues to burn after the power is shut off, take suitable actions, including the use of a fire extinguisher, or call the fire department.

Intended audience

This document is intended for system administrators, Hitachi Data Systems representatives, and authorized service providers who install, configure, or operate VSP Gx00 models .

Readers of this document should be familiar with the following:

- Data processing and RAID storage systems and their basic functions.
- One of the VSP Gx00 models .
- The operating system and web browser software on the system hosting the storage management software.

Product version

This document revision applies to the following:

- VSP G200 firmware 83-03-2x or later
- SVOS 6.4.1 or later

Release notes

Read the release notes before installing and using this product. They may contain requirements or restrictions that are not fully described in this document or updates or corrections to this document. Release notes are available on Hitachi Data Systems Support Connect: https://support.hds.com/en_us/documents.html.

Changes in this revision

Some of the features described in this document might not be currently available.

- Added support for a virtual service processor.
- Made editorial changes to content.





Document conventions

This document uses the following typographic conventions:

Convention	Description
Bold	<ul style="list-style-type: none">• Indicates text in a window, including window titles, menus, menu options, buttons, fields, and labels. Example: Click OK.

Convention	Description
	<ul style="list-style-type: none"> Indicates emphasized words in list items.
<i>Italic</i>	<ul style="list-style-type: none"> Indicates a document title or emphasized words in text. Indicates a variable, which is a placeholder for actual text provided by the user or for output by the system. Example: <code>pairdisplay -g group</code> <p>(For exceptions to this convention for variables, see the entry for angle brackets.)</p>
Monospace	Indicates text that is displayed on screen or entered by the user. Example: <code>pairdisplay -g oradb</code>
< > angle brackets	Indicates variables in the following scenarios: <ul style="list-style-type: none"> Variables are not clearly separated from the surrounding text or from other variables. Example: <code>Status-<report-name><file-version>.csv</code> Variables in headings.
[] square brackets	Indicates optional values. Example: [a b] indicates that you can choose a, b, or nothing.
{ } braces	Indicates required or expected values. Example: { a b } indicates that you must choose either a or b.
vertical bar	Indicates that you have a choice between two or more options or arguments. Examples: [a b] indicates that you can choose a, b, or nothing. { a b } indicates that you must choose either a or b.

This document uses the following icons to draw attention to information:

Icon	Label	Description
	Note	Calls attention to important or additional information.
	Tip	Provides helpful information, guidelines, or suggestions for performing tasks more effectively.
	Caution	Warns the user of adverse conditions and/or consequences (for example, disruptive operations, data loss, or a system crash).
	WARNING	Warns the user of a hazardous situation which, if not avoided, could result in death or serious injury.

Conventions for storage capacity values

Physical storage capacity values (for example, disk drive capacity) are calculated based on the following values:

Physical capacity unit	Value
1 kilobyte (KB)	1,000 (10 ³) bytes
1 megabyte (MB)	1,000 KB or 1,000 ² bytes
1 gigabyte (GB)	1,000 MB or 1,000 ³ bytes
1 terabyte (TB)	1,000 GB or 1,000 ⁴ bytes
1 petabyte (PB)	1,000 TB or 1,000 ⁵ bytes
1 exabyte (EB)	1,000 PB or 1,000 ⁶ bytes

Logical storage capacity values (for example, logical device capacity) are calculated based on the following values:

Logical capacity unit	Value
1 block	512 bytes
1 cylinder	Mainframe: 870 KB Open-systems: <ul style="list-style-type: none"> • OPEN-V: 960 KB • Others: 720 KB
1 KB	1,024 (2 ¹⁰) bytes
1 MB	1,024 KB or 1,024 ² bytes
1 GB	1,024 MB or 1,024 ³ bytes
1 TB	1,024 GB or 1,024 ⁴ bytes
1 PB	1,024 TB or 1,024 ⁵ bytes
1 EB	1,024 PB or 1,024 ⁶ bytes

Accessing product documentation

Product user documentation is available on Hitachi Data Systems Support Connect: https://support.hds.com/en_us/documents.html. Check this site for the most current documentation, including important updates that may have been made after the release of the product.

Getting help

[Hitachi Data Systems Support Connect](https://support.hds.com/en_us/documents.html) is the destination for technical support of products and solutions sold by Hitachi Data Systems. To contact technical support, log on to Hitachi Data Systems Support Connect for contact information: https://support.hds.com/en_us/contact-us.html.

[Hitachi Data Systems Community](#) is a global online community for HDS customers, partners, independent software vendors, employees, and prospects. It is the destination to get answers, discover insights, and make

connections. **Join the conversation today!** Go to community.hds.com, register, and complete your profile.

Comments

Please send us your comments on this document to doc.comments@hds.com. Include the document title and number, including the revision level (for example, -07), and refer to specific sections and paragraphs whenever possible. All comments become the property of Hitachi Data Systems Corporation.

Thank you!

Product overview

Hitachi Virtual Storage Platform G200 is a modular, rack-mountable, storage system.

The storage systems have dual controllers that provide the interface to a data host. Each controller contains its own processor, dual in-line cache memory modules (DIMMs), cache flash memory (CFM), battery, and fans. Each controller also has an Ethernet connection for out-of-band management using Hitachi Device Manager - Storage Navigator. If the data path through one controller fails, all hard drives remain available to data hosts using a redundant data path through the other controller. The storage system allows a defective controller to be replaced.

All storage system models allow defective drives to be replaced without interruption of data availability to host computers. A hot spare drive can be configured to replace a failed drive automatically, securing the fault-tolerant integrity of the logical drive. Self-contained, hardware-based RAID logical drives provide maximum performance in compact external enclosures.

Key components are implemented with a redundant configuration, so that the storage system can remain operational in the unlikely event that a component should fail. Adding and replacing components, along with firmware upgrades, can be conducted while the storage system is operating.

- [Block configuration](#)
- [Hitachi Virtual Storage Platform G200 model](#)
- [Features](#)
- [Scalability](#)

Block configuration

A block configuration supports the Fibre Channel and Internet Small Computer System Interface (iSCSI) protocols, and consists of:

- Two controllers with onboard drives
- One or more optional drive trays
- One 1U block service processor server (SVP)

Hitachi Virtual Storage Platform G200 model

The Hitachi Virtual Storage Platform G200 consists of:

- A 2U enclosure that includes two controllers, and either 24 small form factor (SFF) disk drives or 12 large form factor (LFF) disk drives.
- An associated number of drive trays.

The Hitachi Virtual Storage Platform G200 supports 64 GB of high-speed memory cache, arranged as 32 GB per controller.

The Hitachi Virtual Storage Platform G200 interfaces consist of:

- **8 GB Fibre Channel:** 16 ports per system.
- **16 GB Fibre Channel:** 8 ports per system.
- **10 GB iSCSI:** 8 ports per system.



Note: Some controllers and drive trays are available with AC or DC power supplies (see the following tables). AC and DC controllers and drive trays are functionally identical, except for power.

Controller	Power supply	Controller chassis	Height	Number of drives supported	Drive type
CBSS	AC	DW800-CBSS	2U (86 mm)	24	2.5 inch
CBSSD	DC	DW800-CBSSD	2U (86 mm)	24	2.5 inch
CBSL	AC	DW800-CBSL	2U (86 mm)	12	3.5 inch
CBSLD	DC	DW800-CBSLD	2U (86 mm)	12	3.5 inch

Drive tray	Drive tray model name	Supported drive types	Number of drives supported	Height
SFF drive tray	<ul style="list-style-type: none">• DW-F800-DBS (AC power supply, contains BNST)	2.5-inch SFF	24	2U (86.2 mm)

Drive tray	Drive tray model name	Supported drive types	Number of drives supported	Height
	<ul style="list-style-type: none"> DW-F800-DBSD (DC power supply) DW-F800-DBSC 			
LFF drive tray	<ul style="list-style-type: none"> DW-F800-DBL (power supply, contains BNST) DW-F800-DBLD (DC power supply) DW-F800-DBLC 	3.5-inch LFF	12	2U (86.2 mm)
FMD drive tray	<ul style="list-style-type: none"> DW-F800-DBF 	Flash module drive (FMD)	12	2U (86.2 mm)
Dense intermix drive tray	<ul style="list-style-type: none"> DW-F800-DB60 (power supply, contains BNST) DW-F800-DB60C 	3.5-inch LFF	60	4U (174.3 mm)

Related references

- [Examples of supported Hitachi Virtual Storage Platform G200 configurations](#) on page 20

Features

Feature	Value
Maximum cache memory supported	64 GB
Maximum number of spare drives	16
Maximum number of RAID groups	75
Maximum volume size	128 TB
Maximum number of volumes per host groups	2,047
Maximum number of volumes per RAID group	1,024
Maximum number of DP pool volumes	4,095
Maximum number of DP pools	64
Maximum number of Fibre Channel devices connected through a Fibre Channel switch	128
Maximum number of iSCSI hosts connected through a network switch	255

Scalability

All storage systems offer pay-as-you-grow scalability by allowing you to hot-add drives as you need them.

Examples of supported Hitachi Virtual Storage Platform G200 configurations

Controller	Drive tray	Maximum number of drive trays supported	Maximum number of drives supported
CBSS	SFF drive tray	7	192 HDDs or SSDs
	LFF drive tray	7	108 HDDs or SSDs
	FMD drive tray	7	108 FMDs
	Dense intermix drive tray	4	264 HDDs or SSDs

Controller	Drive tray	Maximum number of drive trays supported	Maximum number of drives supported
CBSL	SFF drive tray	7	180 HDDs or SSDs
	LFF drive tray	7	96 HDDs or SSDs
	FMD drive tray	7	96 FMDs
	Dense intermix drive tray	4	252 HDDs or SSDs



Note: The Hitachi Virtual Storage Platform G200 includes the drive to be installed in the controller chassis.

Related references

- [Hitachi Virtual Storage Platform G200 model](#) on page 18

Maximum number of mounted drive trays

The following table shows the maximum number of mountable drive trays and a maximum number of mountable drives for each drive type.

The values below include drives installed in the controller.

Controller	Maximum drive trays		Maximum number of drives	
	Drive trays	Maximum number		
CBSS	SFF	7	192 HDDs or SSDs	
	LFF	7	108 HDDs or SSDs	
	FMD	7	108 FMDs	
	Dense intermix drive tray	4	264 HDDs or SSDs	
CBSL	7	SFF	7	180 HDDs or SSDs
	5	LFF	7	96 HDDs or SSDs
	3	FMD	7	96 FMDs
	1	Dense intermix drive tray	4	252 HDDs or SSDs

Controller	Number of mounted drive trays (up to 7 per path)		Maximum number of mounted drives	
	SFF, LFF drives	Dense intermix drive tray	SFF drive + dense intermix drive tray	LFF drive + dense intermix drive tray
CBSS	7	0	192	108
	5	1	204	144
	3	2	216	180
	1	3	228	216
	0	4	264	264
The maximum number of drive trays that can be installed per path is 7.				

Controller	Number of mounted drive trays (up to 8 per path)		Maximum number of mounted drives	
	SFF, LFF drives	Dense intermix drive tray	SFF drive + dense intermix drive tray	LFF drive + dense intermix drive tray
CBSL	7	0	180	96
	5	1	192	132
	3	2	204	168
	1	3	216	204

Controller	Number of mounted drive trays (up to 8 per path)		Maximum number of mounted drives	
	SFF, LFF drives	Dense intermix drive tray	SFF drive + dense intermix drive tray	LFF drive + dense intermix drive tray
	0	4	252	252

The maximum number of drive trays that can be installed per path is 7.

Number of mounted drive trays (up to 10 per path)		Maximum number of mounted drives (up to 240 per path - see Note below)	
SFF, LFF drives	Dense intermix drive tray	SFF drive + dense intermix drive tray	LFF drive + dense intermix drive tray
48	0	1152	576
45	1	1140	600
44	2	1176	648
41	3	1164	672
40	4	1200	720
37	5	1188	744
36	6	1224	792
33	7	1212	816
32	8	1248	864
29	9	1236	888
28	10	1272	936
25	11	1260	960
24	12	1296	1008
21	13	1284	1032
20	14	1320	1080
17	15	1308	1104
16	16	1344	1152
13	17	1332	1176
12	18	1368	1224
9	19	1356	1248
8	20	1392	1296
5	21	1380	1320
4	22	1416	1368
1	23	1404	1392

Number of mounted drive trays (up to 10 per path)		Maximum number of mounted drives (up to 240 per path - see Note below)	
SFF, LFF drives	Dense intermix drive tray	SFF drive + dense intermix drive tray	LFF drive + dense intermix drive tray
0	24	1440	1440
The maximum number of drive trays that can be installed per path is 8.			

Hardware description

The following sections describe the storage system hardware.

- [Storage system controllers](#)
- [Controller interfaces](#)
- [Storage system drive trays](#)
- [Hitachi Virtual Storage Platform SVP server](#)

Storage system controllers

Every storage system has two controllers. The controllers contain fans and power supplies, and provide the interfaces between a host and the storage system.

A controller manages the I/O between the host system and data volumes.

CBSS controller

CBSS with front panel bezel

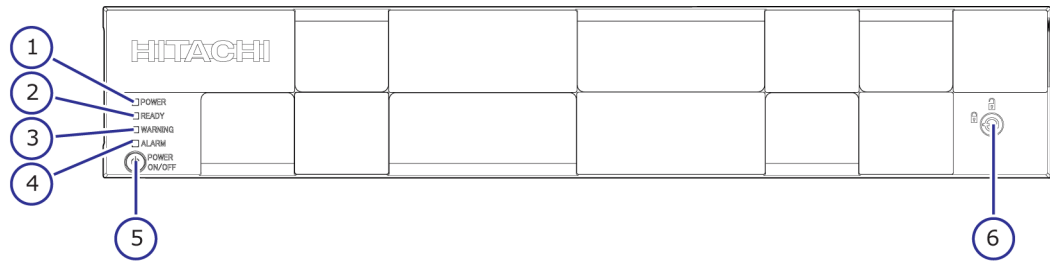

Number	Item	Description
1	POWER LED	Green: Storage system is powered on. Amber: Storage system is receiving power.
2	READY LED	Green: Normal operation.
3	WARNING LED	Off: Normal operation. Amber: Component requires maintenance. Blink: Failure requires maintenance. Note: When System Option Mode 1097 is set to ON, the WARNING LED does not blink even if the following failure information issues SIM: Failure information SIM: 452xxx, 462xxx, 3077xy, 4100xx and 410100.

Number	Item	Description
		LED might go OFF during user maintenance.
4	ALARM LED	Off: Normal operation. Red: Processor failure (system may be down). Go to the Customer Contact Us page at https://support.hds.com/en_us/contact-us.html .
5	POWER ON/OFF (main switch)	Powers the storage system.
6	Lock	Locks and unlocks the front panel bezel by using the supplied key.



Note: Removing a controller can cause the POWER, READY, WARNING, and ALARM LEDs on the front panel to go off. These LEDs return to their on state after the storage system recovers from the controller replacement.

CBSS front panel without bezel

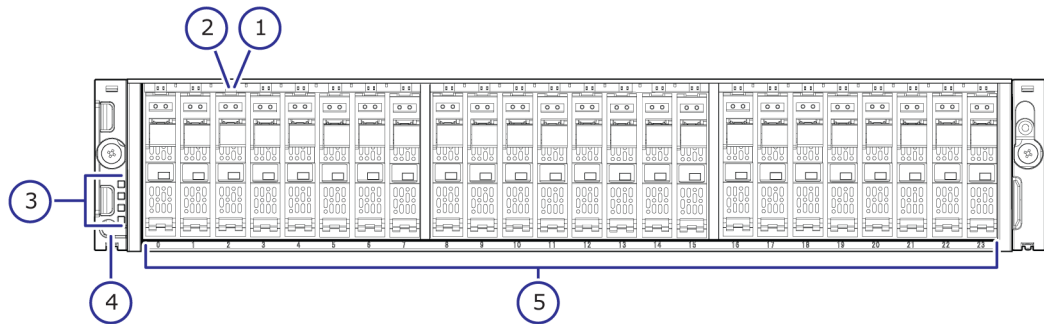

Number	Item	Description
1	ACT LED	Green: Normal operation. Blink green: Drive is being accessed.
2	ALM LED	Red: drive stopped due to a failure and can be replaced.
3	POWER, READY, WARNING, ALARM LEDs	See the previous table.
4	POWER ON/OFF (main switch)	Powers the storage system.
5	Small form factor drives	There are 24 2.5-inch small form factor drives oriented

Number	Item	Description
		vertically. Slots are designated 0-23 (left to right).

CBSS rear panel

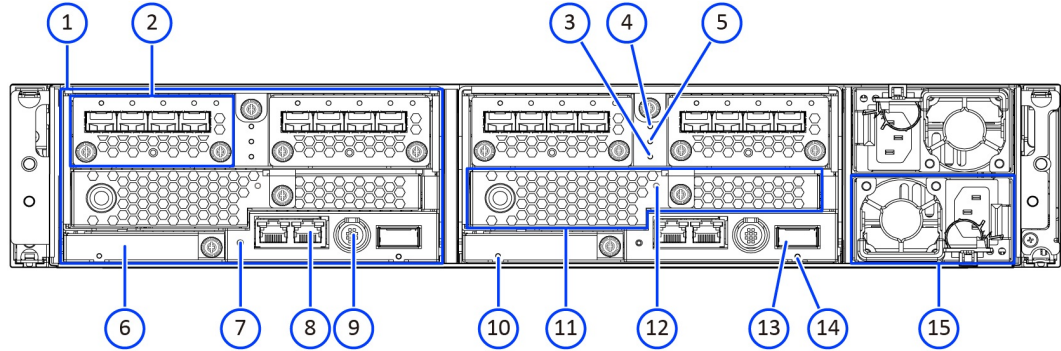



Number	Item	Description
1	Controllers	Controller 1 (left) and Controller 2 (right).
2	Front end module	N/A
3	CTL ALM LED	Red: Controller can be removed. Blink red: Failure with the controller's power supply unit. Amber: LAN reset switch was pressed.
4	BACKUP STTS LED	Green: Power restoration in progress following power outage. Fast blink green: Restoring. Slow blink green: Restoring or sequential shutdown in progress.
5	CTL WARN LED	Amber blink one time: Failure with fan 0. Amber blink two times: Failure with fan 1.
6	Cache flash memory	N/A
7	LAN-RST switch	Use only when instructed by Hitachi Support.

Number	Item	Description
8	LAN port	Maintenance LAN port (left) and user LAN port (right).
9	Uninterruptible power supply port	N/A
10	ALARM LED (for cache flash memory)	Red: Cache flash memory can be removed.
11	Backup module	N/A
12	STATUS	Green: Charging of the battery in the backup module is complete. Blink green: Battery in the backup module is charging or discharging. Red: Backup module can be removed. Blink red: Backup module can be removed. Blink red one time: Battery failure Off: battery is not installed, failure occurred, or firmware is being upgraded.
13	SAS port	N/A
14	Port LED	Blue: port link has been made.
15	Power supply unit	N/A

CBSL controller

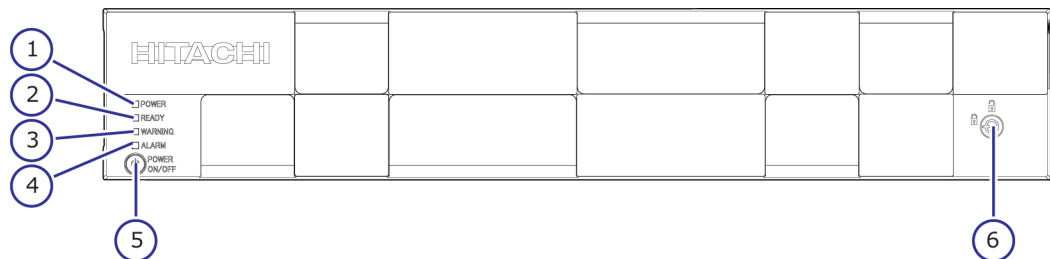
CBSL with front panel bezel



Number	Item	Description
1	POWER LED	Green: Storage system is powered on. Amber: Storage system is receiving power.
2	READY LED	Green: Normal operation.
3	WARNING LED	Off: Normal operation. Amber: Component requires maintenance. Blink: Failure requires maintenance.  Note: When System Option Mode 1097 is set to ON, the WARNING LED does not blink even if the following failure information issues SIM: Failure information SIM: 452xxx, 462xxx, 3077xy, 4100xx and 410100. LED might go OFF during user maintenance.
4	ALARM LED	Off: Normal operation. Red: Processor failure (system may be down). Go to the Customer Contact Us page at https://support.hds.com/en_us/contact-us.html .
5	POWER ON/OFF (main switch)	Powers the storage system.
6	Lock	Locks and unlocks the front panel bezel by using the supplied key.

 **Note:** Removing a controller can cause the POWER, READY, WARNING, and ALARM LEDs on the front panel to go off. These LEDs return to their on state after the storage system recovers from the controller replacement.

CBSL front panel without bezel

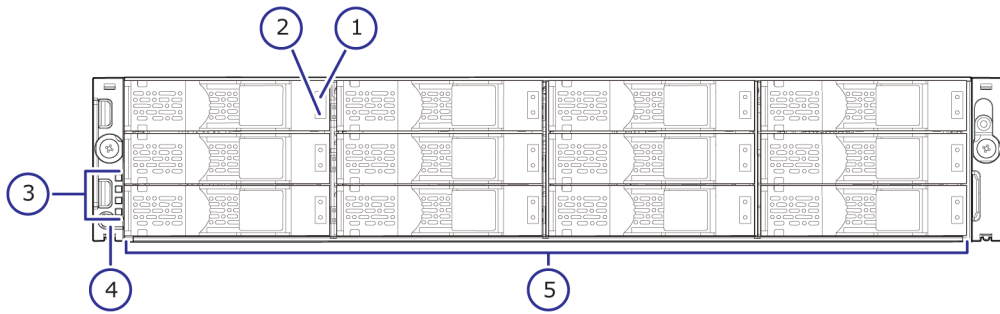

Number	Item	Description												
1	ACT LED	Green: Normal operation. Blink green: Drive is being accessed.												
2	ALM LED	Red: drive stopped due to a failure and can be replaced.												
3	POWER, READY, WARNING, ALARM LEDs	See the previous table.												
4	POWER ON/OFF (main switch)	Powers the storage system.												
5	Large Form Factor Drives	There are 12 3.5-inch large form factor drives stacked horizontally. Slots are designated the following way: <table style="margin-left: 20px;"> <tr> <td>8</td><td>9</td><td>10</td><td>11</td> </tr> <tr> <td>4</td><td>5</td><td>6</td><td>7</td> </tr> <tr> <td>0</td><td>1</td><td>2</td><td>3</td> </tr> </table>	8	9	10	11	4	5	6	7	0	1	2	3
8	9	10	11											
4	5	6	7											
0	1	2	3											

CBSL rear panel

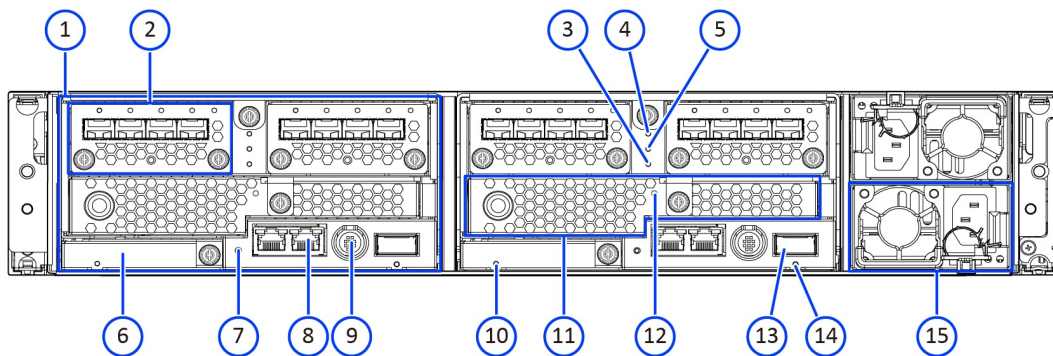

Number	Item	Description
1	Controllers	Controller 1 (left) and Controller 2 (right).
2	Front end module	N/A
3	CTL ALM LED	Red: Controller can be removed. Blink red: Failure with the controller's power supply unit. Amber: LAN reset switch was pressed.
4	BACKUP STTS LED	Green: Power restoration in progress following power outage. Fast blink green: Restoring. Slow blink green: Restoring or sequential shutdown in progress.
5	CTL WARN LED	Amber blink one time: Failure with fan 0. Amber blink two times: Failure with fan 1.
6	Cache flash memory	N/A
7	LAN-RST switch	Use only when instructed by Hitachi Support.
8	LAN port	Maintenance LAN port (left) and user LAN port (right).
9	Uninterruptible power supply port	N/A
10	ALARM LED (for cache flash memory)	Red: Cache flash memory can be removed.
11	Backup module	N/A
12	STATUS	Green: Charging of the battery in the backup module is complete. Blink green: Battery in the backup module is charging or discharging. Red: Backup module can be removed. Blink red: Backup module can be removed. Blink red one time: Battery failure

Number	Item	Description
		Off: battery is not installed, failure occurred, or firmware is being upgraded.
13	SAS port	N/A
14	Port LED	Blue: port link has been made.
15	Power supply unit	N/A

Controller interfaces

Controllers provide interfaces for connecting, powering, and configuring and managing the storage system. They also have LEDs to show the status of the storage system.

Front end module descriptions

8 Gbps Fibre Channel board LEDs and connectors

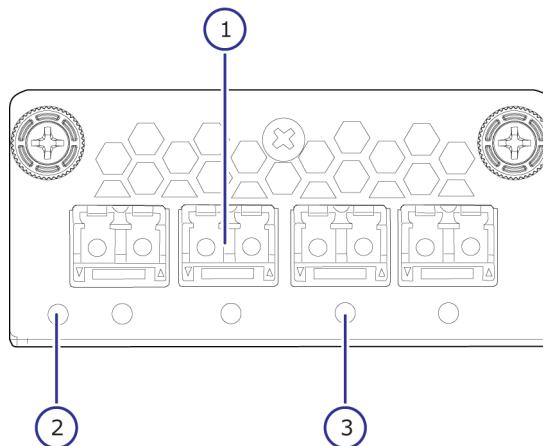

Number	Item	Description
1	Fibre Channel connectors	Connect to Fibre Channel cables.
2	STATUS LED	Green: front end module is in power-on state. Red: front end module can be removed safely.

Number	Item	Description
3	PORT LED	Red: Small form-factor pluggable can be removed. Blue: Normal link status at 8 Gbps. Green: Normal link status at 2 Gbps or 4 Gbps.

Port Assignments

CHB#	8 Gbps Fibre Channel Ports (left to right)			
	Port 1	Port 2	Port 3	Port 4
CHB-1A	1A	3A	5A	7A
CHB-1B	1B	3B	5B	7B
CHB-1C	1C	3C	5C	7C
CHB-1D	1D	3D	5D	7D
CHB-1E	1E	3E	5E	7E
CHB-1F	1F	3F	5F	7F
CHB-1G	1G	3G	5G	7G
CHB-1H	1H	3H	5H	7H
CHB-2A	2A	4A	6A	8A
CHB-2B	2B	4B	6B	8B
CHB-2C	2C	4C	6C	8C
CHB-2D	2D	4D	6D	8D
CHB-2E	2E	4E	6E	8E
CHB-2F	2F	4F	6F	8F
CHB-2G	2G	4G	6G	8G
CHB-2H	2H	4H	6H	8H

16 Gbps Fibre Channel board LEDs and connectors

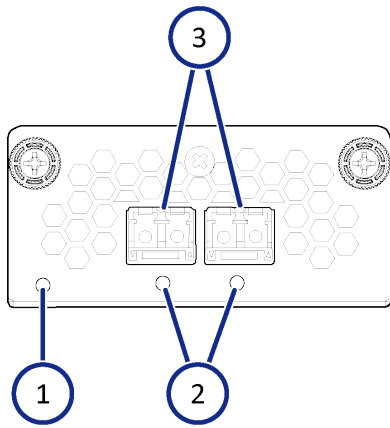

Number	Item	Description
1	STATUS LED	Green: front end module is in the power-on state. Red: front end module can be removed safely.
2	PORT LED	Red: Small form-factor pluggable can be removed. Blue: normal link status at 16 Gbps. Green: normal link status at 4 or 8 Gbps.
3	Fibre Channel connectors	Connect to Fibre Channel cables.

Port Assignments

CHB#	16 Gbps Fibre Channel Ports (left to right)	
	Port 1	Port 2
CHB-1A	1A	3A
CHB-1B	1B	3B
CHB-1C	1C	3C
CHB-1D	1D	3D
CHB-1E	1E	3E
CHB-1F	1F	3F
CHB-1G	1G	3G
CHB-1H	1H	3H
CHB-2A	2A	4A
CHB-2B	2B	4B
CHB-2C	2C	4C

CHB#	16 Gbps Fibre Channel Ports (left to right)	
	Port 1	Port 2
CHB-2D	2D	4D
CHB-2E	2E	4E
CHB-2F	2F	4F
CHB-2G	2G	4G
CHB-2H	2H	4H

10 Gbps iSCSI board LEDs and connectors (optical)

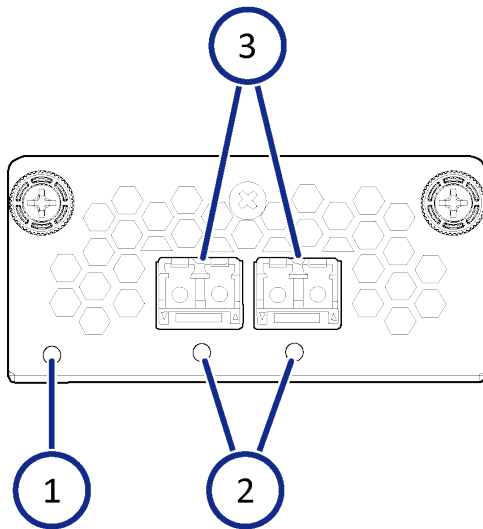

Number	Item	Description
1	STATUS LED	Green: front end module is in the power-on state. Red: front end module can be removed safely.
2	PORT LED	Red: Small form-factor pluggable can be removed. Blue: Normal link status. Blink blue: Front end module is in communication status.
3	iSCSI connectors	Connect to Ethernet LAN cables.

10 Gbps iSCSI board LEDs and connectors (copper)

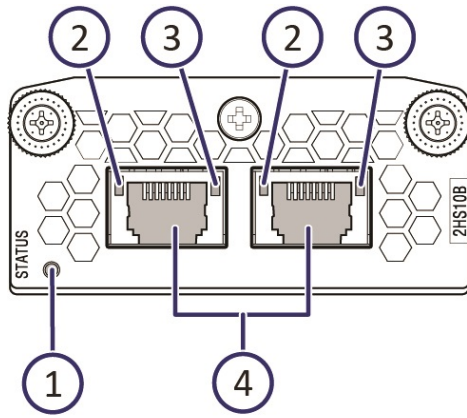

Number	Item	Description
1	STATUS LED	Green: front end module is in the power-on state. Red: front end module can be removed safely.
2	PORT (Link/Speed) LED	Yellow: 1 Gbps link. Green: 10 Gbps link. Off: no link.
3	PORT LED	Green: link has been made. Blinking: communication is occurring. Off: no link or not ready to communicate.
4	iSCSI connectors	Connect to Ethernet LAN cables.

LAN blade LEDs and connectors

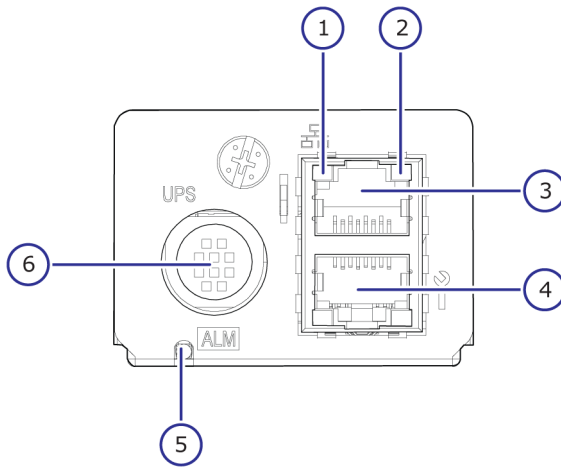

Number	LED or connector	Description
1	ACT LED	Green: data is being transferred.
2	LINK LED	Green: link status is normal.
3	LAN 2	LAN port used by the user.
4	LAN 1	Maintenance LAN port used by service personnel.
5	LAN ALARM LED	Red: LAN blade can be removed.
6	Uninterruptible power supply port	N/A

Back end module LEDs and connectors

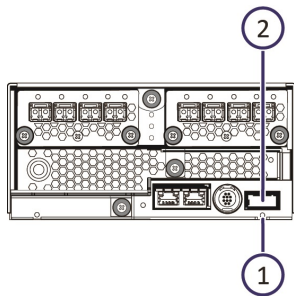

Number	Item	Description
1	PATH 1 connector	Connect to a drive tray.
2	PORT LED	Blue: Normal link status.

CBSS/CBSL AC power supply unit LEDs and connectors

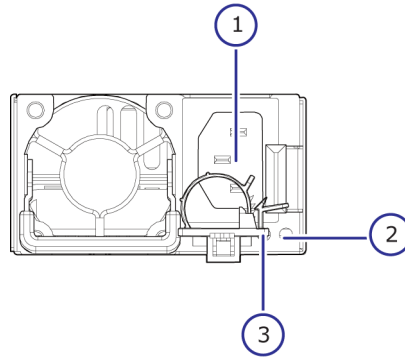

Number	LED or connector	Description
1	Receptacle	Connect to the power cable supplied with the storage system.
2	AC IN LED	Blue: AC input is normal.
3	ALM/RDY LED	Red: Power supply unit can be replaced. Green: Normal operation.

CBSSD/CBSLD DC power supply unit LEDs and connectors

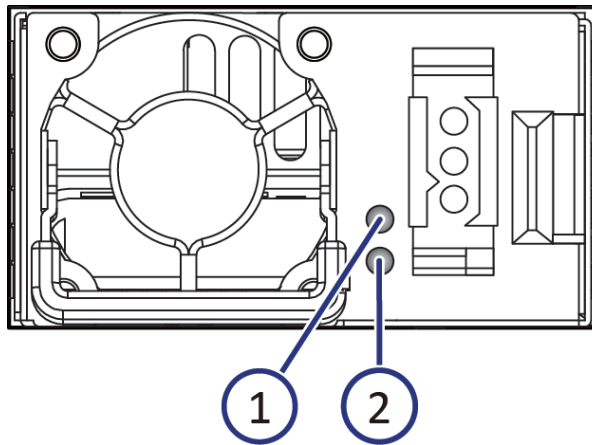

Number	Item	Description
1	ALM/RDY LED	Red: Power supply unit can be replaced. Green: Normal operation.
2	DC IN LED	Blue: DC input is normal.

Storage system drive trays

Drive trays contain drives, power supplies, fans, and status LEDs. They also provide interfaces for connecting to controllers and other drive trays.

Small form factor (SFF) drive tray

SFF with front panel bezel

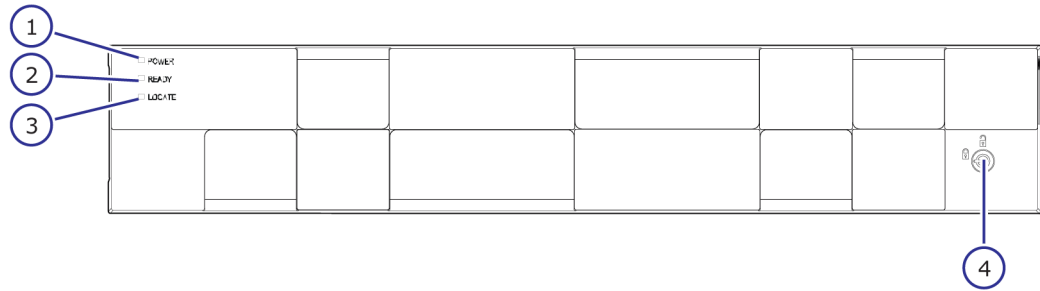

Number	Item	Description
1	POWER LED	Green: Drive tray is powered on.
2	READY LED	Green: Drive tray is operational.
3	LOCATE LED	Amber: <ul style="list-style-type: none"> This LED indicates the location of the chassis that detects a failure. The LED can be lit/turned off by Maintenance Utility to specify the chassis location.
4	Lock	Locks and unlocks the front panel bezel by using the supplied key.

SFF front panel without bezel

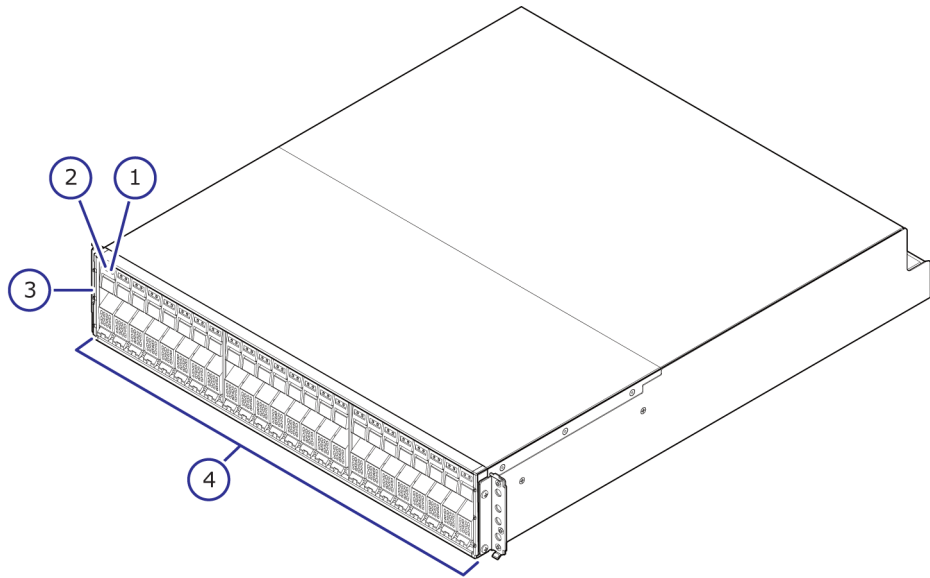

Number	Item	Description
1	ACT LED	Green: Normal operation. Blink green: Drive is being accessed.
2	ALM LED	Red: drive stopped due to a failure and can be replaced.
3	POWER, READY, LOCATE LEDs	See the previous table.
4	Small form factor drives	There are 24 2.5-inch small form factor drives oriented vertically. Slots are designated 0-23 (left to right).

SFF rear panel

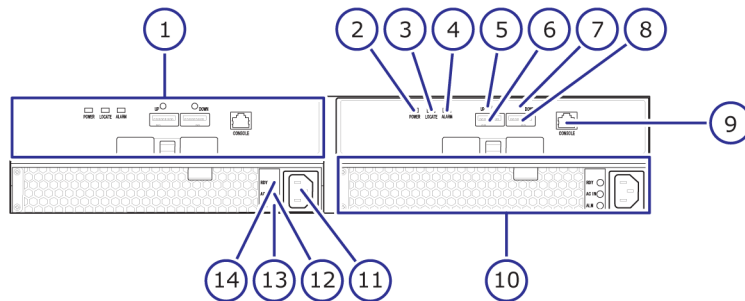

Number	Item	Description
1	ENC	N/A
2	POWER LED	Green: ENC is in the power-on state.
3	LOCATE LED	<ul style="list-style-type: none"> This LED indicates the location of the chassis. The LED can be lit or turned off by the maintenance utility.
4	ALARM LED	Red: ENC can be replaced.
5	PATH (IN) LED	Blue: IN side port is linked up.
6	PATH (IN) connector	Connect to a controller or drive tray.
7	PATH (OUT) LED	Blue: OUT side port is linked up.
8	PATH (OUT) connector	Connect to a drive tray.
9	Console	This port is reserved.
10	Power supply unit	N/A
11	Receptacle	Connect to the power cable supplied with the storage system.
12	AC IN LED	Green: Normal operation.
13	ALM LED	Red: Power supply unit can be replaced.
14	RDY LED	Green: Normal operation.

Large form factor (LFF) drive tray

LFF with front panel bezel

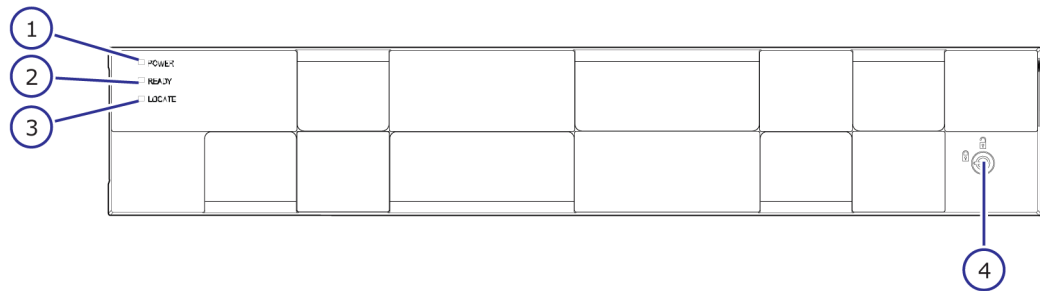

Number	Item	Description
1	POWER LED	Green: Drive tray is powered on.

Number	Item	Description
2	READY LED	Green: Drive tray is operational.
3	LOCATE LED	Amber: <ul style="list-style-type: none"> This LED indicates the location of the chassis. The LED can be lit/turned off by Maintenance Utility.
4	Lock	Locks and unlocks the front panel bezel by using the supplied key.

LFF front panel without bezel

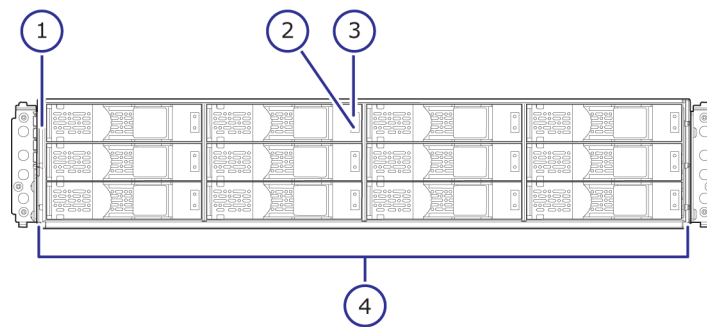

Number	Item	Description
1	POWER, READY, LOCATE LEDs	See the previous table.
2	ACT LED	Green: Normal operation. Blink green: Drive is being accessed.
3	ALM LED	Red: drive stopped due to a failure and can be replaced.
4	Large Form Factor Drives	There are 12 3.5-inch large form factor drives stacked horizontally. Slots are designated the following way: <pre> 8 9 10 11 4 5 6 7 0 1 2 3 </pre>

LFF rear panel

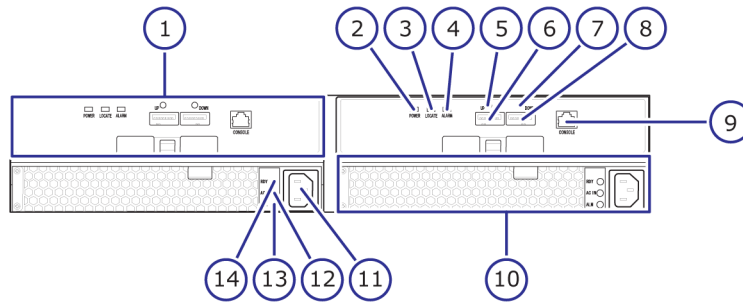

Number	Item	Description
1	ENC	N/A
2	POWER LED	Green: ENC is in the power-on state.
3	LOCATE LED	Amber: <ul style="list-style-type: none"> This LED indicates the location of the chassis. The LED can be lit or turned off by the maintenance utility.
4	ALARM LED	Red: ENC can be replaced.
5	PATH (IN) LED	Blue: IN side port is linked up.
6	PATH (IN) connector	Connect to a controller or drive tray.
7	PATH (OUT) LED	Blue: OUT side port is linked up.
8	PATH (OUT) connector	Connect to a drive tray.
9	Console	This port is reserved.
10	Power supply unit	N/A
11	Receptacle	Connect to the power cable supplied with the storage system.
12	AC IN LED	Green: Normal operation.
13	ALM LED	Red: Power supply unit can be replaced.
14	RDY LED	Green: Normal operation.

Flash module drive (FMD) tray

FMD with front panel bezel

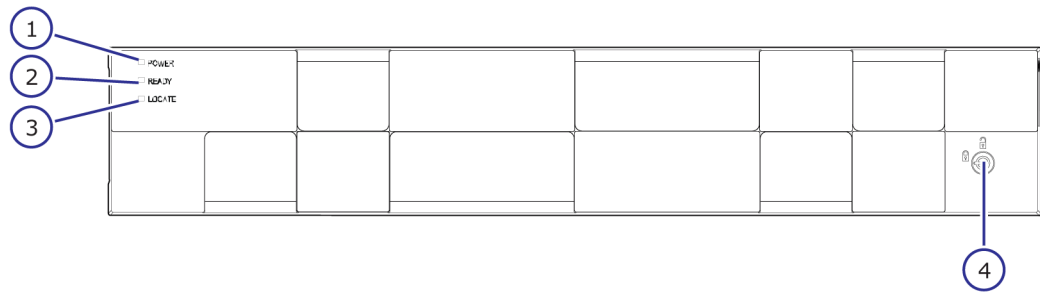

Number	Item	Description
1	POWER LED	Green: Drive tray is powered on.
2	READY LED	Green: Drive tray is operational.
3	LOCATE LED	Amber: <ul style="list-style-type: none"> This LED indicates the location of the chassis. The LED can be lit or turned off by the maintenance utility.
4	Lock	Locks and unlocks the front panel bezel by using the supplied key.

FMD front panel without bezel

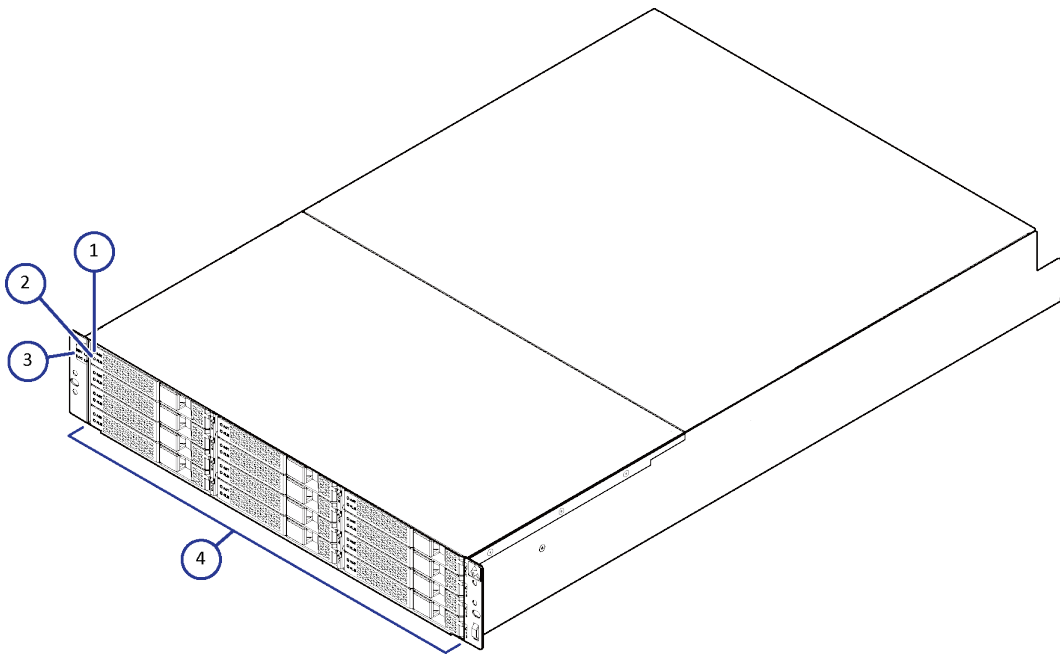

Number	Item	Description
1 2	ACT LED	Green: Normal operation. Blink: drive is being accessed. Slow blink: <ul style="list-style-type: none"> DKC-F710I-1R6FM/3R2FM: insufficient battery capacity in the flash module drive. DKC-F810I-1R6FN/3R2FN/6R4FN: flash module drive built-in capacitor is charged. If the storage system is turned on, the LED stops blinking when the capacitor is charged completely (about two minutes).
	ALM LED	Red: Drive stopped due to a failure and can be replaced.
3	POWER, READY, LOCATE LEDs	See the previous table.
4	Flash module drives	Twelve flash module drives. Slots are designated the following way: 9, 10, 11 6, 7, 8 3, 4, 5 0, 1, 2

FMD rear panel

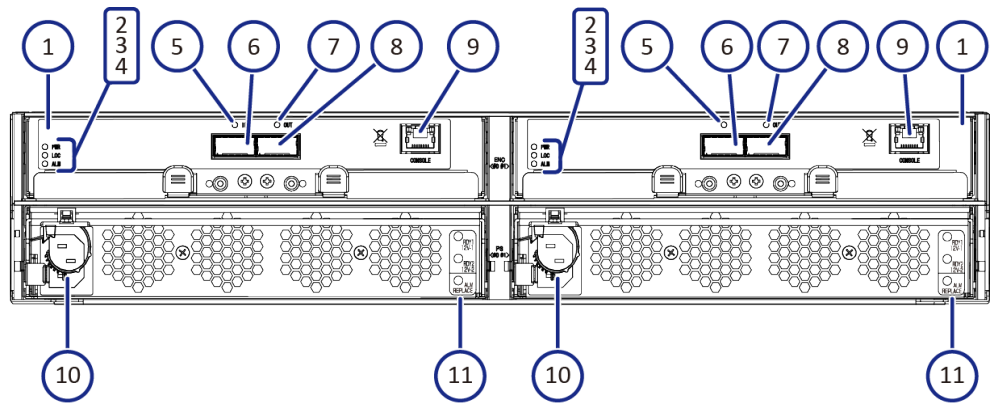

Number	Item	Description
1	ENC	N/A

Number	Item	Description
2	POWER LED	Green: ENC is in the power-on state.
3	LOCATE LED	Amber: <ul style="list-style-type: none"> This LED indicates the location of the chassis. The LED can be lit or turned off by the maintenance utility.
4	ALARM LED	Red: ENC can be replaced.
5	PATH (IN) LED	Blue: IN side port is linked up.
6	PATH (IN) connector	Connect to a controller or drive tray.
7	PATH (OUT) LED	Blue: OUT side port is linked up.
8	PATH (OUT) connector	Connect to a drive tray.
9	Console	This port is reserved.
10	Receptacle	Connect to the power cable supplied with the storage system.
11	Three LEDs, top to bottom:	
	RDY LED	Green: power supply unit is operating normally.
	AC IN LED	Green: power supply unit is operating normally.
	ALM REPLACE LED	Red: power supply unit can be replaced.

Dense intermix drive tray

Dense intermix drive tray with front panel bezel

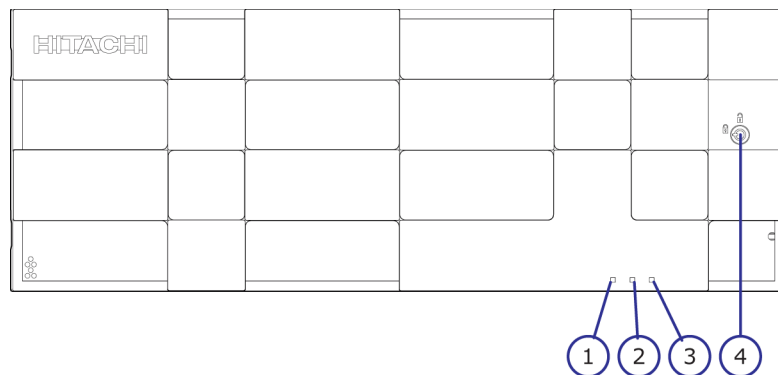

Number	Item	Description
1	POWER LED	Green: Drive tray is powered on.
2	READY LED	Green: Drive tray is operational.
3	LOCATE LED	Amber: <ul style="list-style-type: none"> This LED indicates the location of the chassis. The LED can be lit or turned off by the maintenance utility.
4	Lock	Locks and unlocks the front panel bezel by using the supplied key.

Dense intermix drive tray display LEDs

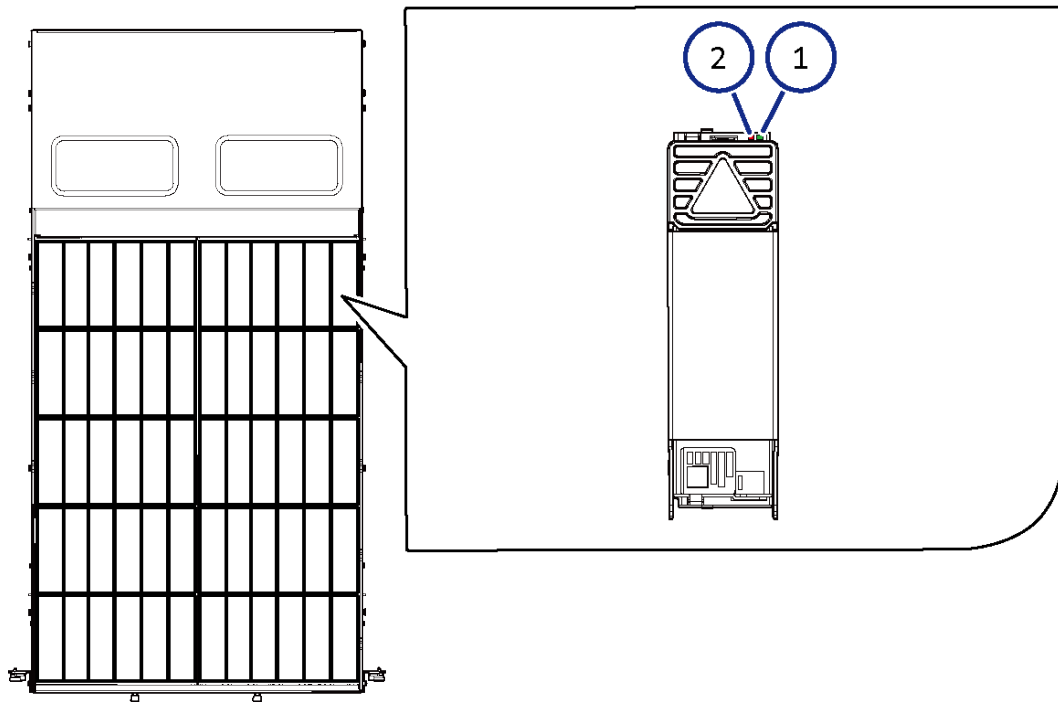

Number	Item	Description
1	ACT	Green: Normal operation. Blink green: Drive is being accessed.
2	ALM LED	Red: Drive stopped due to a failure and can be replaced.



Note: Drives are organized as follows, starting from the rear of the drive tray and moving left to right. In the above figure on the left, the rear of the drive tray is at the top.

- Rear of drive tray: 48 - 59
- 36 - 47
- 24 - 35
- 12 - 23
- Front of drive tray: 00 - 11

Dense intermix drive tray rear panel

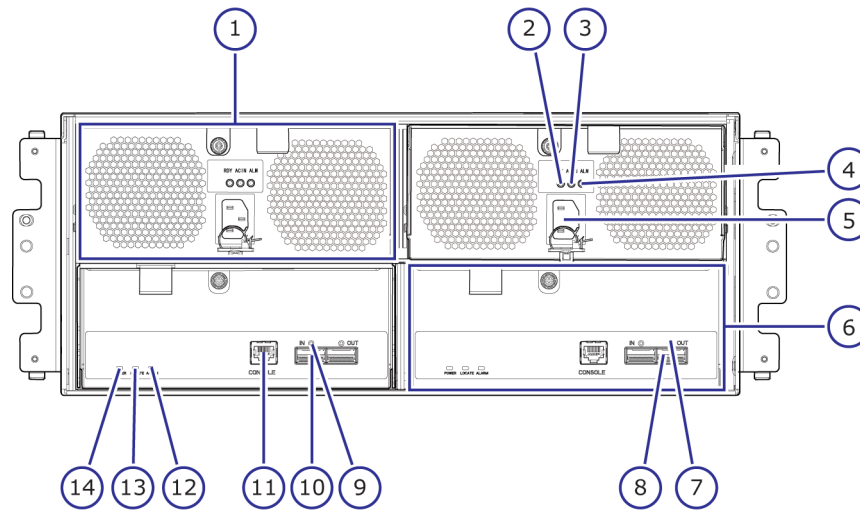

Number	Item	Description
1	Power supply unit	N/A
2	RDY LED	Green: Normal operation.
3	AC IN LED	Green: Normal operation.
4	ALM LED	Red: Power supply unit can be replaced.
5	Receptacle	Connect to the power cable supplied with the storage system.
6	ENC	N/A
7	PATH (OUT) LED	Blue: OUT side port is linked up.
8	PATH (OUT) connector	Connect to a drive tray.
9	PATH (IN) LED	Blue: IN side port is linked up.
10	PATH (IN) connector	Connect to a controller or drive tray.

Number	Item	Description
11	Console	This port is reserved.
12	ALARM LED	Red: ENC can be replaced.
13	LOCATE LED	<ul style="list-style-type: none"> This LED indicates the location of the chassis. The LED can be lit or turned off by the maintenance utility.
14	POWER LED	Green: ENC is in the power-on state.

SFF and LFF AC power supply unit LEDs and connectors

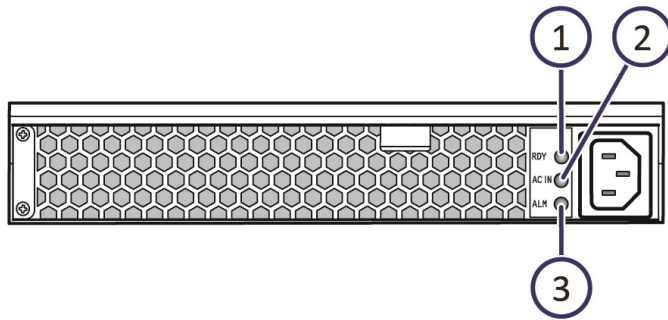

Number	Item	Description
1	RDY LED	Green: Normal operation.
2	AC IN LED	Green: AC input is operating normally.
3	ALM LED	Red: Power supply unit can be replaced.

SFF and LFF DC power supply unit LEDs and connectors

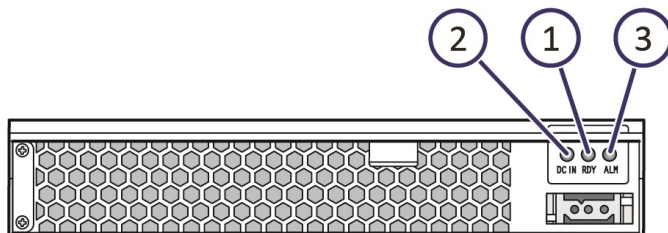

Number	Item	Description
1	RDY LED	Green: Normal operation.
2	DC IN LED	Green: DC input is operating normally.
3	ALM LED	Red: Power supply unit can be replaced.

Hitachi Virtual Storage Platform SVP server

The following sections describe the physical SVP. A virtual SVP is also available.

Service processor description

VSP Gx00 models include a separate, dedicated 1U service processor (SVP) to host an element manager (Hitachi Device Manager - Storage Navigator). The SVP (model number 3919435.P) operates independently from the storage system's CPU and operating system, and provides out-of-band configuration and management of the storage system. It also collects performance data for key components of the storage system to enable diagnostic testing and analysis.



Note: This product is also designed for IT power distribution systems with phase-to-phase voltage.

The SVP runs Microsoft Windows Embedded Standard 7. This operating system provides the same look and feel and desktop environment as Microsoft Windows 7 Professional.

The SVP provides four RJ-45 ports:

- Two ports connect to the storage system controllers (one port for each controller).
- One port connects to the user's IP network.
- One port connects to a user-supplied management console PC.

Three of the four RJ-45 ports (the ones that connect to the controllers and the IP network) are configured as a bridge. The SVP can be addressed using the default IP address 192.168.0.15.

In the unlikely event you cannot connect to the SVP using the default IP address, use the following emergency login: `http://<default SVP IP address>/dev/storage/<model number><system serial number>/emergency.do`. For example:

Storage system model number	Storage system serial number	URL

8320004	456789	http://192.168.0.15/dev/storage/8320004456789/emergency.do
8340004	456789	http://192.168.0.15/dev/storage/8340004456789/emergency.do
8360004	456789	http://192.168.0.15/dev/storage/8360004456789/emergency.do

Users are responsible for adopting the appropriate security procedures with the SVP, including:

- Applying Windows security patches.
- Turning on automatic Windows updates or using the manual Windows update method.
- Installing antivirus software that has been tested and approved by Hitachi.
- Installing the latest SVP firmware releases from Hitachi.

SVP front panel

The SVP front panel has LEDs, a reset button, and a power button.

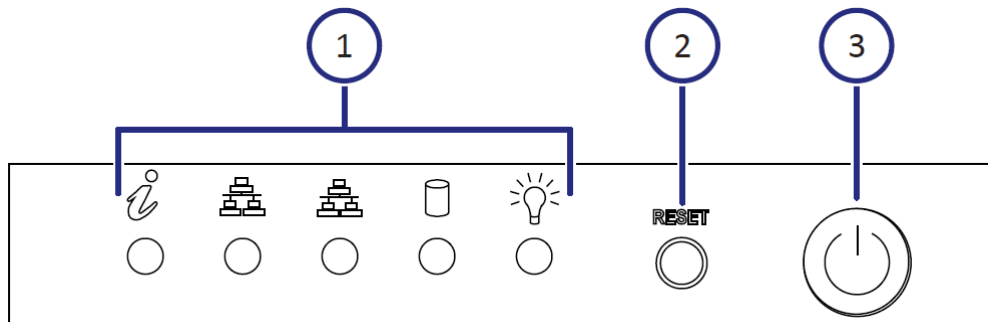

Number	Description
1	LEDs. From left to right, the LEDs are: <ul style="list-style-type: none"> • BMC Heartbeat • LAN card 2 • LAN card 1 • Hard drive • System standby power
2	Reset button.
3	Power button. Applies power to or removes power from the SVP.

SVP rear panel

The only ports used on the rear panel of the SVP are the power socket and the four LAN ports.

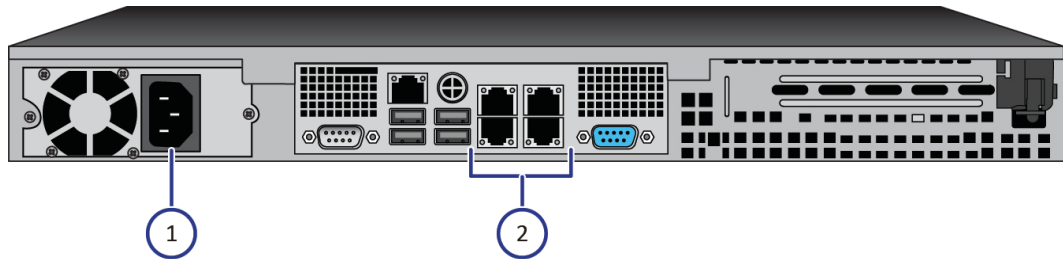

Number	Description
1	Power socket. Attach the power cable supplied with the SVP.
2	Four LAN ports arranged as follows: LAN3 LAN4 LAN1 LAN2 These ports connect to your IP network, the management console PC, and the user LAN port on each storage system controller.



Note: After the Initial Startup Wizard is run, the SVP can be used in non-bridge mode. In this mode, the cables can be removed from SVP ports LAN3 and LAN4 and attached to switches. For more information, contact customer support.

System option modes

- [System Option Modes](#)

System Option Modes

System Option Modes allow VSP Gx00 models to be configured to specific customer operating requirements.

At installation, the modes are set to their default values, as shown in the following table. If you think these mode settings should be changed, discuss these settings with your Hitachi Data Systems team. The System Option Modes can be changed by a Hitachi Data Systems representative only.

The following table was up to date at the time this manual was published. However, the System Option Mode information might change in firmware releases that precede the next release of this manual. Contact your Hitachi Data Systems team for the latest information about System Option Modes.

The System Option Mode information includes:

- Mode = specifies the System Option Mode number
- Description = describes the action or function that the mode provides.
- Default = specifies the default setting (ON or OFF) of the mode.



Note: These modes are supported by all firmware versions.

Mode	Description	Default
15	<p>The mode can improve the host response time to be about within 6 seconds.</p> <p>Note:</p> <ol style="list-style-type: none"> 1. The mode applies when a drive response delay may affect business operations. 2. If Dynamic Sparing or Auto Correction Mode is used due to host I/O conflicts with copy processing, I/O watching time is 30 seconds even the mode is set to ON. 3. Even though System Option Mode 015 is set to ON, the function does not apply to SATA or NL-SAS drives. 	ON
22	<p>Regarding the correction copy or the drive copy, in case ECCs/LRC PINs are set on the track of copy source HDD, mode 22 can be used to interrupt the copy processing (default) or to create ECCs/LRC PINs on the track of copy target HDD to continue the processing.</p> <p>Mode 22 = ON:</p> <p>If ECCs/LRC PINs (up to 16*1) have been set on the track of copy source HDD, ECCs/LRC PINs (up to 16*1) will be created on the track of copy target HDD so that the copy processing will continue.</p>	OFF

	<p>If the number of ECCs/LRC PINs exceeds the maximum, the corresponding copy processing will be interrupted.</p> <p>*1: The maximum number of ECCs/LRC PINs is as follows.</p> <p>< For HUS VM></p> <p>73-03-01-00/00 or higher: 64</p> <p>Earlier than 73-03-01-00/00: 16</p> <p>Mode 22 = OFF:</p> <p>If ECCs/LRC PINs have been set on the track of copy source HDD, the copy processing will be interrupted.</p> <p>(first recover ECCs/LRC PINs by using the PIN recovery flow, and then perform the correction copy or the drive copy again)</p> <p>One of the controlling option for correction/drive copy.</p>	
80	<p>For HUS VM (SI for OPEN)</p> <p>In response to the Restore instruction from the host, if neither Quick nor Normal is specified, the following operation is performed.</p> <p>Mode 80 = ON:</p> <p>Normal Restore (Reverse Copy) is performed.</p> <p>Mode 80 = OFF:</p> <p>Quick Restore is performed.</p> <p>Notes:</p> <p>1. This mode is applied when the specification for Restore of SI is switched between Quick (default) and Normal.</p> <p>2. The performance of Restore differs depending on the Normal or Quick specification.</p>	OFF
87	<p>HUS VM: Determining which of NormalCopy or QuickResync, if not specified, is performed at the execution of pairresync by RAID Manager. If ON, QuickResync, or if OFF, NormalCopy is performed.</p>	OFF
122	<p>For Split or Resync request from the Mainframe host and Storage Navigator,</p> <p>Mode 122 = ON:</p> <p>By specifying Split or Resync, Steady/Quick Split or Normal/Quick Resync is respectively executed in accordance with Normal/Quick setting.</p> <p>Mode 122 = OFF :</p> <p>By specifying Split or Resync, Steady/Quick Split or Normal/Quick Resync is respectively executed in accordance with Normal/Quick setting.</p> <p>For details, see the System Option Mode 122 sheet.</p>	OFF

	<p>Notes:</p> <p>(1) For HUS VM, this mode is applied to use scripts etc that are used on Lightning 9900 and Lightning 9900 V.</p> <p>(2) Executing the pairresync command from RAID Manager may be related to the System Option Mode 087 setting.</p> <p>(3) When performing At-Time Split from RAID Manager, Set this mode to OFF or specify the environment variable HORCC_SPLT for Quick.</p> <p>Otherwise, Pairsplit may turn timeout.</p> <p>(4) The mode becomes effective after specifying Split/Resync following the mode setting. The mode function does not work if it is set during the Split/Resync operation.</p>	
292	<p>Issuing OLS when Switching Port</p> <p>In case the mainframe host (FICON) is connected with the CNT-made FC switch (FC9000 etc.), and is using along with the TrueCopy S/390 with Open Fibre connection, the occurrence of Link Incident Report for the mainframe host from the FC switch will be deterred when switching the CHT port attribute (including automatic switching when executing CESTPATH and CDELPATH in case of Mode 114=ON).</p> <p>Mode 292=ON:</p> <p>When switching the port attribute, issue the OLS (100 ms) first, and then reset the Chip.</p> <p>Mode 292=OFF:</p> <p>When switching the port attribute, reset the Chip without issuing the OLS.</p>	OFF
310	<p>Mode 310 = ON:</p> <p>The monitoring timer for MP hang-up is 6 seconds and returning a response to the host within 8 is guaranteed.</p> <p>Mode 310 = OFF:</p> <p>The monitoring timer for MP hang-up remains 15 seconds (USP/NSC / USP V/VM) or 8 seconds (VSP/ VSP G1000).</p> <p>Notes:</p> <p>(1) This mode applies to a site where strict host response performance is required.</p> <p>(2) If a hardware failure occurs when the mode is set to ON, the time until MPB blockage is determined is shorter than usual.</p>	OFF
448	<p>Mode 448 = ON: (Enabled)</p> <p>If the SVP detects a blocked path, the SVP assumes that an error occurred, and then immediately splits (suspends) the mirror.</p> <p>Mode 448 = OFF: (Disabled)</p>	N/A

	<p>If the SVP detects a blocked path and the path does not recover within the specified period of time, the SVP assumes that an error occurred, and then splits (suspends) the mirror.</p> <p>Note:</p> <p>The mode 448 setting takes effect only when mode 449 is set to OFF.</p>	
449	<p>This mode is used to enable and disable detection of communication failures between MCU and RCU.</p> <p>Mode 449 = ON</p> <p>On MCU side, checking read journal disruption from RCU is disabled, and monitoring read journal failures is disabled on RCU side.</p> <p>Mode 449 = OFF</p> <p>Detecting communication failures between MCU and RCU is enabled.</p> <p>Notes:</p> <p>(1) The mode applies at sites where disabling the detection of communication failures between MCU and RCU in UR configuration is required.</p> <p>(2) For USP/NSC, the default setting is OFF with versions from 50-03-95-00/00 to 50-04-31-00/00, and is ON with versions 50-04-40-00/00 and later.</p> <p>(3) When the mode is set to ON, System Option Mode 448 does not work.</p> <p>(4) The mode setting is not changed by microcode upgrade.</p> <p>(5) The mode is not effective for remote paths between Initiator port on MCU and Target port on RCU.</p> <p>(6) While a path from RCU to MCU is disconnected, if the UR pair remains in Suspending or Deleting status, recover it in accordance with the procedure in Recovery from UR Failure in TROUBLE SHOOTING section of the Maintenance Manual.</p>	ON
454	<p>CLPR (Function of Virtual Partition Manager) partitions the cache memory in the disk subsystem into multiple virtual cache and assigns the partitioned virtual cache for each use. If a large amount of cache is required for a specific use, it can minimize the impact on other uses. The CLPR function works as follows depending on whether System Option Mode 454 is set to ON or OFF.</p> <p>Mode 454 = OFF:</p> <p>The amount of the entire destage processing is periodically determined by using the highest workload of all CLPRs (*a). (The larger the workload is, the larger the amount of the entire destage processing becomes.)</p> <p>*a: (for HUS VM)</p>	OFF

	<p>(Write Pending capacity of CLPR#x of concerned MPB) ÷ (Cache capacity of CLPR#x of concerned MPB), x=0 to 31 CLPR whose value above is the highest of all CLPRs</p> <p>Because the destage processing would be accelerated depending on CLPR with high workload, when the workload in a specific CLPR increases, the risk of host I/O halt would be reduced.</p> <p>Therefore, set Mode 454 to OFF in most cases.</p> <p>Mode 454 = ON:</p> <p>The amount of the entire destage processing is periodically determined by using the workload of the entire system (*b). (The larger the workload is, the larger the amount of the entire destage processing becomes.)</p> <p>*b: (for HUS VM)</p> <p>(Write Pending capacity of the entire system of concerned MPB) ÷ (Cache capacity of the entire system of concerned MPB)</p> <p>Because the destage processing would not be accelerated even if CLPR has high workload, when the workload in a specific CLPR increases, the risk of host I/O halt would be increased. Therefore, it is limited to set Mode 454 to ON only when a CLPR has constant high workload and it gives priority to I/O performance in a CLPR with low workload than host I/O halt in the CLPR with high workload.</p> <p>Notes:</p> <p>(1) When this System Option Mode is set to ON, even if there is an overloaded CLPR (CLPR with large Write Pending capacity), the amount of destage processing would not increase easily. Therefore TOV(MIH) may occur in the overloaded CLPR. Set this System Option Mode to ON only when the overloaded state of a specific CLPR would not affect other CLPRs.</p> <p>In the case where the HUR function is used, if user volumes and journal volumes are defined in different CLPRs, when the CLPR to which the journal volumes are assigned overflows, the user volumes become inaccessible either. Therefore it is recommended to set this System Option Mode to OFF.</p> <p>(2) Because the destage processing will have a lower priority in the overloaded CLPR, the overloaded state of the overloaded CLPR is not removed, and TOV(MIH) may occur.</p>	
457	<p>(1) High Speed LDEV Format for External Volumes</p> <p>The high speed LDEV format for external volumes is available by setting System Option Mode 457 to ON. If System Option Mode 457 is ON, when selecting the external volume group and performing the LDEV format, any Write processing on the external LUs will be skipped. However, if</p>	OFF

	<p>the emulation type of the external LDEV is a mainframe system, the Write processing for mainframe control information only will be performed after the write skip.</p> <p>(2) Support for Mainframe Control Block Write GUI</p> <p>In case of System Option Mode 457 On, the high speed LDEV format for external volumes was supported at V03. Since V04, Control Block Write of the external LDEVs in Mainframe emulation has been supported by Storage Navigator (GUI).</p> <ul style="list-style-type: none"> - In case the LDEV is not written with data "0" before performing the function, the LDEV format may fail. - After the format processing, make sure to set System Option Mode 457 to OFF. 	
459	<p>PAIR → PSUS(SP) → PSUS: System Option Mode 459 function is running at copy pending from P-VOL to S-VOL such as PSUS(SP) → PSUS. Please refer additional TAB of mode list.</p> <p>Mode 459 = ON:</p> <p>Waits for cache memory to completely destage the DKC S-Vol to the External Volume S-Vol before changing pair status to SUSPEND.</p> <p>Mode 459 = OFF:</p> <p>The status changes to SUSPEND as soon as all the delta data is copied to S-Vol cache. The status does not wait for cache to destage to the S-Vol external volume.</p>	OFF
466	<p>Universal Replicator recommends the line band of 100 Mbps or more for the path between Main and Remote. However, when a customer uses the line band of around 10 Mbps, operation on UR cannot be properly processed. As a result, many retries occur and UR may suspend. This mode is provided to guarantee the line band of at least 10 Mbps for proper system operation.</p> <p>Mode 466 = ON:</p> <p>The line band of 10 Mbps or more is available. The JNL read is performed with 4-multiplexed read size of 256 KB.</p> <p>Mode 466 = OFF:</p> <p>The same as the conventional operation. The line band of 100 Mbps or more is available. The JNL read is performed with 32-multiplexed read size of 1 MB by default.</p> <p>Note that the line band can be changed from the window for changing JNL group options.</p>	OFF
467	<p>In case of using the following features, the current copy processing slows down if the dirty percentage is 60% or larger, and it stops if the dirty percentage is 75% or larger. Mode 467 is to prevent the dirty percentage from over 60% so that the host performance is not affected.</p>	ON

	<p>The default setting is different according to models and versions. For details, see spreadsheet "Default Setting of Mode 467".</p> <p>Mode 467 = ON:</p> <p>The copy processing stops if the dirty percentage is 60% or larger. If the dirty percentage becomes lower than 60%, the copy processing restarts.</p> <p>Mode 467 = OFF:</p> <p>The copy processing slows down if the dirty percentage is 60% or larger, and it stops if the dirty percentage is 75% or larger.</p> <p>Notes:</p> <ol style="list-style-type: none"> 1. This mode must always be set to ON when using an external volume as the secondary volume of any of the above-mentioned PPs for copy. 2. It takes longer to finish the copy processing because it stops for prioritizing the host I/O performance. 3. This mode supports background copy only. The processing to copy the pre-update data to the S-VOL, which occurs when overwriting data to un-copied slots of P-VOL in Split processing or reading or writing data to un-copied slots of S-VOL, is not supported. 4. Check the write pending rate of each CLPR per MP blade. Even though there is some free cache capacity in the entire system, if the write pending rate of an MP blade where ShadowImage / ShadowImage for z/OS / FCV2 / Copy-on-Write Snapshot / Volume Migration pairs belong to exceeds the threshold, the copy operation is stopped. 	
471	<p>Since the SIM-RC(*) that are generated when the usage rate of Pool used by Snapshot exceeds the threshold value can be resolved by users, basically they are not reported to the maintenance personnel.</p> <p>This option is used to inform maintenance personnel of these SIMs that are basically not reported to maintenance personnel in case these SIMs must be reported to them.</p> <p>* SIMs reported by setting the mode to ON are as follows.</p> <p>- HUS VM:</p> <p>SIM-RC 601xxx (Pool utilization threshold excess)/ 603000 (SM Space Warning)</p> <p>Mode 471 = ON:</p> <p>This kind of SIMs is reported to maintenance personnel.</p> <p>Mode 471 = OFF:</p> <p>This kind of SIMs is not reported to maintenance personnel.</p> <p>Notes:</p>	OFF

	<p>Set this mode to ON when it is required to inform maintenance personnel of the SIM-RC(*).</p> <p>* SIMs reported by setting the mode to ON are as follows.</p> <ul style="list-style-type: none"> - HUS VM: <p>SIM-RC 601xxx (Pool utilization threshold excess)/ 603000 (SM Space Warning)</p>	
474	<p>UR initial copy performance can be improved by issuing a command from Raid Manager/BC Manager to execute a dedicated script consists of UR initial copy (Nocopy), UR suspend, TC (Sync) initial copy, TC (Sync) delete, and UR resync.</p> <p>Mode 474 = ON:</p> <p>For a suspended UR pair, a TC-Sync pair can be created with the same P-VOL/S-VOL so that UR initial copy time can be reduced by using the dedicated script.</p> <p>Mode 474 = OFF:</p> <p>For a suspended UR pair, a TC-Sync pair cannot be created with the same P-VOL/S-VOL. For this, the dedicated script cannot be used.</p> <p>Notes:</p> <ol style="list-style-type: none"> 1. Set this mode for both MCU and RCU. 2. When the mode is set to ON; <ul style="list-style-type: none"> - Execute all of pair operations from Raid Manager/ BCM. - Use a dedicated script. - Initial copy operation is prioritized over update I/O. Therefore, the processing speed of the update I/O slows down by about 15μs per command. 3. If this mode is set to ON, the processing speed of update I/O slows down by about 15μs per command, version downgrade is disabled, and Take Over is not available. 4. If the mode is not set to ON for both or either sides, the behavior is as follows. <ul style="list-style-type: none"> - Without setting on both sides: Normal UR initial copy performance. - With setting on MCU/without setting on RCU: TC Sync pair creation fails. - Without setting on MCU/with setting on RCU: The update data for P-VOL is copied to the S-VOL in synchronous manner. 5. While the mode is set to ON, make sure not to perform micro-program downgrade to an unsupported version. 6. While the mode is set to ON, make sure not to perform the Take Over function. 	OFF

	7. The mode cannot be applied to a UR pair that is the 2nd mirror in URxUR multi-target configuration or URxUR cascade configuration. If applied, TC pair creation is rejected with SSB=CBEE output.	
506	<p>This option is used to enable Delta Resync with no host update I/O by copying only differential JNL instead of copying all data.</p> <p>The HUR Differential Resync configuration is required.</p> <p>Mode 506 = ON:</p> <p>Without update I/O: Delta Resync is enabled.</p> <p>With update I/O: Delta Resync is enabled.</p> <p>Mode 506 = OFF:</p> <p>Without update I/O: Total data copy of Delta Resync is performed.</p> <p>With update I/O: Delta Resync is enabled.</p> <p>Note:</p> <p>Even when mode 506 is set to ON, the Delta Resync may fail and only the total data copy of the Delta Resync function is allowed if the necessary journal data does not exist on the primary subsystem used for the Delta Resync operation.</p>	OFF
561	<p>This option is used to allow Quick Restore for external volumes with different Cache Mode settings.</p> <p>Mode 561 = ON:</p> <p>Quick Restore for external volumes with different Cache Mode settings is prevented.</p> <p>Mode 561 = OFF:</p> <p>Quick Restore for external volumes with different Cache Mode settings is allowed.</p>	OFF
589	<p>When this option is ON, the frequency of progress update of disconnection is changed.</p> <p>Mode 589 = ON:</p> <p>For each external volume, progress is updated only when the progress rate is 100%.</p> <p>Mode 589 = OFF:</p> <p>Progress is updated when the progress rate exceeds the previous level.</p> <p>Notes:</p> <ol style="list-style-type: none"> 1. Set this option to ON when disconnecting an external volume while the specific host IO operation is online and its performance requirement is severe. 2. Whether the disconnecting status for each external volume is progressed or not cannot be confirmed on 	OFF

	Storage Navigator (It indicates "--" until just before the completion and at the last it changes to 100%).	
689	<p>This option is used to slow down the initial copy and resync copy operations when the Write Pending rate on RCU exceeds 60%.</p> <p>Mode 689 = ON:</p> <p>The initial copy and resync copy operations are slowed down when the Write Pending rate on RCU exceeds 60%.</p> <p>*: From VSP, if the Write Pending rate of CLPR where the initial copy target secondary volume belongs to is not over 60% but that of MP PCB where the S-VOL belongs to is over 60%, the initial copy operation is slowed down.</p> <p>Mode 689 = OFF:</p> <p>The initial copy and resync copy operations are not slowed down when the Write Pending rate on RCU exceeds 60% (the same as before).</p> <p>Notes:</p> <ol style="list-style-type: none"> 1. This mode can be set online. 2. The micro-programs on both MCU and RCU must support this mode. 3. This mode should be set per customer's requests. 4. If the Write Pending status long keeps 60% or more on RCU, it takes extra time for the initial copy and resync copy to be completed by making up for the slowed down copy operation. 5. From VSP, if the Write Pending rate of CLPR where the initial copy target secondary volume belongs to is not over 60% but that of MP PCB where the S-VOL belongs to is over 60%, the initial copy operation is slowed down. 6. When the mode is applied while an unsupported model (USP V/VM (earlier than V02), USP/NSC and earlier models) is connected as MCU, if the Write Pending rate reaches 60%, pair suspend may occur. 	OFF
690	<p>This option is used to prevent Read JNL or JNL Restore when the Write Pending rate on RCU exceeds 60% as follows:</p> <ul style="list-style-type: none"> - When CLPR of JNL-Volume exceeds 60%, Read JNL is prevented. - When CLPR of Data (secondary)-Volume exceeds 60%, JNL Restore is prevented. <p>Mode 690 = ON:</p> <p>Read JNL or JNL Restore is prevented when the Write Pending rate on RCU exceeds 60%.</p> <p>Mode 690 = OFF:</p> <p>Read JNL or JNL Restore is not prevented when the Write Pending rate on RCU exceeds 60% (the same as before).</p>	OFF

	<p>Notes:</p> <ol style="list-style-type: none"> 1. This mode can be set online. 2. This mode should be set per customer's requests. 3. If the Write Pending status long keeps 60% or more on RCU, it takes extra time for the initial copy to be completed by making up for the prevented copy operation. 4. If the Write Pending status long keeps 60% or more on RCU, the pair status may become Suspend due to the JNL-Vol being full. 5. When RAID 500 is used on P-VOL side, the mode cannot be used. If the mode is set to ON, SSB=8E08 on P-VOL side and SSB=C8D1 on S-VOL side may frequently be output. 	
696	<p>This mode is available to enable or disable the QoS function.</p> <p>Mode 696 = ON:</p> <p>QoS is enabled. (In accordance with the Share value set to SM, I/Os are scheduled. The Share value setting from RMLIB is accepted.)</p> <p>Mode 696 = OFF:</p> <p>QoS is disabled. (The Share value set to SM is cleared. I/O scheduling is stopped. The Share value setting from host is rejected.)</p> <p>Note:</p> <ol style="list-style-type: none"> 1. Set this mode to ON when you want to enable the QoS function. 	OFF
701	<p>This option is used to issue the Read command at the LU discovery operation using UVM.</p> <p>Mode 701 = ON:</p> <p>The Read command is issued at the LU discovery operation.</p> <p>Mode 701 = OFF:</p> <p>The Read command is not issued at the LU discovery operation.</p> <p>Notes:</p> <ol style="list-style-type: none"> 1. When the external storage is USP/NSC and the Open LDEV Guard attribute (VMA) is defined on an external device, set the mode to ON. 2. When this option is set to ON, it takes longer time to complete the LU discovery. The amount of time depends on external storages. 3. With this system option OFF, if searching for external devices with VMA set, the VMA information cannot be read. 4. When the mode is set to ON while the following conditions are met, the external volume is blocked. 	OFF

	<p>(a) HUS VM is used on the storage system.</p> <p>(b) An external volume to which Nondisruptive Migration (NDM) attribute is set exists.</p> <p>(c) The external volume is reserved by the host.</p> <p>5. As the VMA information is USP/NSC specific, this mode does not need to be ON when the external storage is other than USP/NSC.</p> <p>6. Set the mode to OFF when the following conditions are met.</p> <p>(a) HUS VM is used on the storage system.</p> <p>(b) An external volume to which Nondisruptive Migration (NDM) attribute is set exists.</p>	
704	<p>To reduce the chance of MIH, this option can reduce the priority of SI, VM, CoW Snapshot, Flash Copy or Resync copy internal IO requests so that host IO has a higher priority. This mode creates new work queues where these jobs can be assigned with a lower priority.</p> <p>Mode 704 = ON:</p> <p>Copy processing requested is registered into a newly created queue so that the processing is scheduled with lower priority than host I/O.</p> <p>Mode 704 = OFF:</p> <p>Copy processing requested is not registered into a newly created queue. Only the existing queue is used.</p> <p>Note:</p> <p>If the PDEV is highly loaded, the priority of Read/Write processing made by SI, VM, CoW Snapshot, Flash Copy or Resync may become lower. As a consequence the copy speed may be slower</p>	N/A
721	<p>When a parity group is uninstalled or installed, the following operation is performed accordingly.</p> <p>Mode 721 = ON:</p> <p>When a parity group is uninstalled or installed, neither the LED of the HDD for uninstallation lights up, nor the instruction message for removing the HDD appears. Also, the windows other than that of parity group, such as DKA or DKU, are unavailable to select.</p> <p>Mode 721 = OFF:</p> <p>When a parity group is uninstalled or installed, the operation is as before; the LED of the HDD lights up, and the HDD must be unmounted and remounted.</p> <p>Notes:</p> <p>1. When the RAID level or emulation type is changed for the existing parity group, this option should be applied only if</p>	OFF

	<p>the HDD mounted position remains the same at the time of the parity group uninstallation or installation.</p> <p>2. After the operation using this option is completed, the mode must be set back to Off; otherwise, the LED of the HDD to be removed will not light up at subsequent parity group uninstalling operations</p>	
725	<p>This option determines an action when Not Ready is returned from the external volume.</p> <p>Mode 725 = ON:</p> <p>When Not Ready is returned, the external path is blocked and the path status can be automatically recovered (Not Ready blockade). Note that the two behaviors, automatic recovery and blockade, may be repeated.</p> <p>From version 60-05-06-00/00, the following is added.</p> <p>For the device of Not Ready blockade, the Device Health Check is executed after 30 seconds.</p> <p>Mode 725 = OFF:</p> <p>When Not Ready is returned 3 times in 3 minutes, the path is blocked and the path status cannot be automatically recovered (Response error blockade).</p> <p>Notes:</p> <p>1. For HUS VM:</p> <p>(1) Applying this System Option Mode is prohibited when USP V/VM is used as an external subsystem and its external volume is DP-VOL.</p> <p>(2) Applying this System Option Mode is recommended when the above condition (1) is not met and SUN storage is used as an external storage.</p> <p>(3) Applying this System Option Mode is recommended when the above condition (1) is not met and EMC CX series, VNX series, or Fujitsu Fibre CAT CX series is used as an external storage.</p> <p>(4) Applying this System Option Mode is recommended if the above condition (1) is not met and a maintenance operation such as firmware update causing controller reboot is executed on the external storage side while a storage system other than Hitachi product is used as an external subsystem.</p> <p>2. While USP V/VM is used as an external subsystem and its volume is DP-VOL, if some Pool-VOLs constituting the DP-VOL are blocked, a phenomenon of external path blockade and recovery occurs repeatedly.</p> <p>3. In the case that a virtual volume mapped by UVM is set to pool-VOL and used as DP-VOL in local subsystem, this System Option Mode can be applied without problem.</p>	OFF
729	<p>To set the Protect attribute for the target DP-VOL using the DRU, when any Write operation is requested to the area</p>	OFF

	<p>where the page allocation is not provided at a time when the HDP Pool is full.</p> <p>Mode 729 = ON:</p> <p>To set the Protect attribute for the target DP-VOL using the DRU, when any Write operation is requested to the area where the page allocation is not provided at a time when the HDP Pool is full. (Not to set in the case of Read request).</p> <p>Mode 729 = OFF:</p> <p>Not to set the Protect attribute for the target DP-VOL using the DRU, when any Write operation is requested to the area where the page allocation is not provided at a time when HDP Pool is full.</p> <p>Notes:</p> <ol style="list-style-type: none"> 1. This System Option Mode is applied when; <ul style="list-style-type: none"> -The threshold of Pool is high (e.g., 95%) and the Pool may be full. -DP V-VOL uses file system. -Data Retention Utility is installed. 2. Since the Protect attribute is set for V-VOL, the Read operation cannot be allowed as well. 3. When the Data Retention Utility is not installed, the desired effect is not achieved. 4. Protect attribute can be released from the Data Retention window of Storage Navigator after releasing the full status of the Pool by adding a Pool-VOL. 5. With VSP Gx00/Fx00 V01+1 and later, do not change the mode setting but use the virtual volume protection function when the pool is full to change the setting. 6. With VSP Gx00/Fx00 V01+1 and later, when HM 063 or 73 is set to ON, the setting of the HMO is prioritized over the System Option Mode 729 setting so that the behavior remains as that of setting the mode to OFF even when the System Option Mode is set to ON. 	
733	<p>This option enables to suspend Volume Migration or Quick Restore operation during LDEV-related maintenance.</p> <p>USP V/VM:</p> <p>Mode 733 = ON:</p> <p>Volume Migration or Quick Restore operation during LDEV-related maintenance is suspended.</p> <p>Mode 733 = OFF:</p> <p>Volume Migration or Quick Restore operation during LDEV-related maintenance is not suspended.</p> <p>VSP and later models, HUS VM and later models:</p>	OFF

	<p>Mode 733 = ON:</p> <p>Volume Migration or Quick Restore operation during LDEV-related maintenance is not suspended</p> <p>Mode 733 = OFF:</p> <p>Volume Migration or Quick Restore operation during LDEV-related maintenance is suspended.</p> <p>Notes:</p> <ol style="list-style-type: none"> 1. (USP V/VM) This option is recommended as functional improvement to avoid maintenance failures. In some cases of a failure in LDEV-related maintenance without setting the option, Storage Navigator operations may be unavailable. 2. (USP V/VM) There is the potential for LDEV-related maintenance activities to fail when Volume Migration and Quick Restore is active without setting the option. 3. Note that behavior when the mode is set to ON and OFF is reversed between USP V/VM and VSP and later/HUS VM and later. 4. (USP V/VM) This option should be applied when Volume Migration or Quick Restore operation can be suspended during LDEV-related maintenance. 5. (USP V/VM) If virtual volume capacity expansion operation conflicts with Volume Migration or Quick Restore operation, the virtual volume capacity expansion operation may fail. 6. (VSP and later/HUS VM and later) This mode should be applied to perform Volume Migration or Quick Restore during maintenance operation. 7. (VSP and later/HUS VM and later) Set mode 733 to ON if you want to prioritize the Volume Migration or Quick Restore operation over maintenance activities. In this case, maintenance activities may fail when the Volume Migration or Quick Restore operation works during the maintenance activities. 8. (VSP and later/HUS VM and later) An LDEV-related maintenance operation such as LDEV installation/removal may fail when Volume Migration or Quick Restore takes place. 	
734	<p>When exceeding the pool threshold, the SIM is reported as follows.</p> <p>Mode 734 = ON:</p> <p>A SIM is reported at the time when the pool usage rate exceeds the pool threshold (warning, system, or depletion). Once the pool usage rate falls below the pool threshold, and then exceeds again, the SIM is reported again. If the pool usage rate continues to exceed the warning threshold and the depletion threshold, the SIM (SIM-RC625000) is repeatedly reported every eight (8) hours until the pool usage rate falls below the depletion threshold.</p>	OFF

	<p>Mode 734 = OFF:</p> <p>A SIM is reported at the time when the pool usage rate exceeds the pool threshold (warning, system, or depletion). Once the pool usage rate falls below the pool threshold, and then exceeds again, the SIM is reported again. The SIM is not reported while the pool usage rate continues to exceed the warning threshold and the depletion threshold.</p> <p>Notes:</p> <ol style="list-style-type: none"> 1. This option is turned ON to prevent the Write I/O operation from being unavailable due to pool full. 2. If the pool threshold exceeding SIM occurs frequently, other SIMs may not be reported. 3. Though turning on this option can increase the warning effect, if measures such as adding a pool fail to be done in time so that the pool becomes full, system option mode 729 can be used to prevent file systems from being destroyed. 4. Turning on system option mode 741 can provide the SIM report to not only the users but also the service personnel. 	
741	<p>The option enables to switch over whether to report the following SIM for users to the service personnel.</p> <p>SIM-RC 625000 (DP Pool usage rate continues to exceed the threshold)</p> <p>Mode 741 = ON:</p> <p>SIM is reported to the service personnel</p> <p>Mode 741 = OFF:</p> <p>SIM is not reported to the service personnel</p> <p>Notes:</p> <ol style="list-style-type: none"> 1. This option is set to ON to have SIM for users reported to the service personnel, <ul style="list-style-type: none"> - for the system where SNMP and E-mail notification are not set. - if Storage Navigator isn't periodically activated. 2. When Mode 734 is turned OFF, SIM-RC625000 is not reported; accordingly the SIM is not reported to the service personnel even though this option is ON. 	OFF
745	<p>This option enables to change the area where the information is obtained as the Characteristic1 item from SYMMETRIX.</p> <p>Mode 745 = ON:</p> <p>(1) The area where the information is obtained as the Characteristic1 item from SYMMETRIX is changed.</p> <p>(2) When CheckPaths or Device Health Check (1/hour) is performed, the information of an already-mapped external volume is updated to the one after change.</p>	OFF

	<p>Mode 745 = OFF:</p> <p>(1) The area where the information is obtained as the Characteristic1 item from SYMMTRIX is set to the default.</p> <p>(2) When CheckPaths or Device Health Check (1/hour) is performed, the information of an already-mapped external volume is updated to the default.</p> <p>Notes:</p> <p>1. This option is applied when the SYMMETRIX of EMC is connected using UVM.</p> <p>2. Enable the setting of EMC SCSI Flag SC3 for the port of the SYMMETRIX storage of EMC connected with USP V/VM and disable the setting of Flag SPC2. If the setting of EMC SCSI Flag SC3 is not enabled or the setting of Flag SPC2 is enabled, the effect of this mode may not be achieved.</p> <p>3. If you want to enable this mode immediately after setting, perform Check Paths on each path one by one for all the external ports connected to the SYMMETRIX storage of EMC. But, without doing Check Paths, the display of Characteristic1 can automatically be changed by the Device Health Check to be performed once an hour. If SSB=AD02 occurs and a path is blocked, perform Check Paths on this path again.</p> <p>4. If the Check Paths is performed while ShadowImage for z/OS pair and FlashCopy Mirror pair are defined in the specified volume, the Check Paths operation is rejected with a message, "605 2518". If ShadowImage for z/OS pair and FlashCopy Mirror pair are defined in the specified volume, do not perform Check Paths but wait until the display is automatically changed.</p>	
749	<p>This mode disables the DP Rebalance function and the DT Tier relocation function which allow the HDDs of all ECC Groups in the pool to share the load.</p> <p>Mode 749 = ON:</p> <p>The DP Rebalance function and the DT Tier relocation functions are disabled.</p> <p>Mode 749 = OFF:</p> <p>The DP Rebalance function and the DT Tier relocation functions are activated.</p> <p>Notes:</p> <p>1. This option is applied when no change in performance characteristic is desired.</p> <p>2. When a pool is newly installed, the load may be concentrated on the installed pool volumes.</p> <p>3. When 0 data discarding is executed, load may be unbalanced among pool volumes.</p> <p>4. Pool VOL deletion while the mode is set to ON fails. To delete pool VOLs, set the mode to OFF.</p>	OFF

757	<p>Setting this mode to ON or OFF to disable or enable outputting In-band audit logs.</p> <p>Mode 757 = ON:</p> <p>In-band audit log is not output.</p> <p>Mode 757 = OFF:</p> <p>In-band audit log is output.</p> <p>Notes:</p> <p>(1) Mode 757 applies to the sites where outputting the In-band audit logs is not needed.</p> <p>(2) When this option is set to ON,</p> <ul style="list-style-type: none"> - There is no access to SM for the In-band audit logs, which can avoid the corresponding performance degradation. - SM is not used for the In-band audit logs. <p>(3) If outputting the In-band audit log is desired, set this mode to OFF.</p>	OFF
784	<p>This mode can reduce the MIH watch time of RI/O for a TC Sync or GAD pair internally so that update I/Os can continue by using an alternate path without time-out occurrence in the environment where Open host time-out time is short (15 seconds or less). The mode is effective at initial pair creation or Resync operation for TC Sync or GAD. (Not effective by just setting this mode to ON)</p> <p>The mode is applied to TC Sync (83-01-01-x0/00 and higher) and GAD (83-01-21-x0/00 and higher).</p> <p>Mode 784 = ON:</p> <p>The MIH time of RIO is internally reduced so that, even though a path failure occurs between DKCs in the environment where host MIH time is set to 15 seconds, update I/Os can be processed by using an alternate path promptly, lowering the possibility of host MIH occurrence.</p> <p>Mode 784 = OFF:</p> <p>The operation is processed in accordance with the TC Sync specification.</p> <p>Notes:</p> <p>(1) The mode is applied to the environment where OPEN host time-out time is set to 15 seconds or less.</p> <p>(2) The mode is applied to reduce RI/O MIH time to 5 seconds.</p> <p>(3) This function is available for all the TC Sync and GAD pairs on the subsystem, unable to specify the pairs that are using this function or not.</p> <p>(4) To apply the mode to TC Sync, both MCU and RCU must be HUS VM and micro-program must be the support version</p>	OFF

	<p>on both sides. If either one of MCU or RCU is USP V/VM, the function cannot be applied.</p> <p>(5) For a TC Sync or GAD pair with the mode effective (RI/O MIH time is 5 seconds), the setting of RI/O MIH time made at RCU registration (default is 15 seconds, which can be changed within range from 10 to 100 seconds) is invalid. However, RI/O MIH time displayed on Storage Navigator and CCI is not "5 seconds" but is what set at RI/O registration.</p> <p>(6) If a failure occurs on the switched path between DKCs, Open server time-out may occur.</p> <p>(7) If an MP to which the path between DKCs belongs is overloaded, switching to an alternate path delays and time-out may occur.</p> <p>(8) If an RI/O retry occurs due to other factors than RI/O MIH (5 sec), such as a check condition report issued from RCU to MCU, the RI/O retry is performed on the same path instead of an alternate path. If a response delay to the RI/O occurs constantly on this path due to path failure or link delay, time-out may occur due to response time accumulation for each RI/O retried within 5 seconds.</p> <p>(9) Even though the mode is set to ON, if Open host time-out time is set to 10 seconds or less, time-out may occur due to a path failure between DKCs.</p> <p>(10) Operation commands are not available for promptly switching to an alternate path.</p> <p>(11) The mode works for the pair for which initial pair creation or Resync operation is executed.</p> <p>(12) Micro-program downgrade to an unsupported version cannot be executed unless all the TC Sync pairs are suspended or deleted.</p> <p>(13) See System Option Mode 784 sheet for operational specifications in each combination of MCU and RCU of TC.</p> <p>(14) For GAD pairs, the mode is effective if the microcode is in a version that supports GAD.</p> <p>(15) The mode does not support paths between DKCs using iSCSI in VSP Gx00/Fx00. (Configuration where DKC paths of Fibre and iSCSI coexist is not supported.)</p>	
803	<p>While a DP pool VOL is blocked, if a read or write I/O is issued to the blocked pool VOL, this mode can enable the Protect attribute of DRU for the target DP-VOL.</p> <p>Mode 803 = ON:</p> <p>While a DP pool VOL is blocked, if a read or write I/O is issued to the blocked pool VOL, the DRU attribute is set to Protect.</p> <p>Mode 803 = OFF:</p> <p>While a DP pool VOL is blocked, if a read or write I/O is issued to the blocked pool VOL, the DRU attribute is not set to Protect.</p>	OFF

	<p>See the System Option Mode 729 and 803 sheet for more details.</p> <p>Notes:</p> <ol style="list-style-type: none"> 1. This mode is applied when <ul style="list-style-type: none"> - a file system using DP pool VOLs is used. - Data Retention Utility is installed. 2. Because the DRU attribute is set to Protect for the V-VOL, a read I/O is also disabled. 3. If Data Retention Utility is not installed, the expected effect cannot be achieved. 4. The Protect attribute of DRU for the HDP V-VOL can be released on the Data Retention window of Storage Navigator after recovering the blocked pool VOL. 5. With HM800 V01+1 and later, do not change the mode setting but use the virtual volume protection function when the pool volume is blocked to change the setting. 	
855	<p>By switching the mode to ON/OFF when ShadowImage is used with System Option Mode 467 set to ON, copy processing is continued or stopped as follows.</p> <p>Mode 855 = ON:</p> <p>When the amount of dirty data is within the range from 58% to 63%, the next copy processing is continued after the dirty data created in the previous copy is cleared to prevent the amount of dirty data from increasing (copy after destaging). If the amount of dirty data exceeds 63%, the copy processing is stopped.</p> <p>Mode 855 = OFF:</p> <p>The copy processing is stopped when the amount of dirty data is over 60%.</p> <p>For details, see the System Option Mode 855 sheet.</p> <p>Notes:</p> <ol style="list-style-type: none"> 1. This mode is applied when all the following conditions are met. <ul style="list-style-type: none"> - ShadowImage is used with System Option Mode 467 set to ON. - Write pending rate of an MP blade that has LDEV ownership of the copy target is high. - Usage rate of a parity group to which the copy target LDEV belongs is low. - ShadowImage copy progress is delayed. 2. This mode is available only when System Option Mode 467 is set to ON. 	OFF

	3. If workload of the copy target parity group is high, the copy processing may not be improved even if this mode is set to ON.	
857	<p>This option enables or disables to limit the cache allocation capacity per MPB (VSP / VSP G1000) or MPU (HUS VM) to within the prescribed capacity (*) except for Cache Residency.</p> <p>*: 128 GB (VSP/HUS VM), 256 GB (VSP G1000).</p> <p>Mode 857 = ON:</p> <p>The cache allocation capacity is limited to within the prescribed capacity.</p> <p>Mode 857 = OFF:</p> <p>The cache allocation capacity is not limited to within the prescribed capacity.</p> <p>Notes:</p> <p>(1) This mode is applied to stabilize the performance by preventing paging of PM control information from occurring. For details, refer to the section of Virtual Partition Manager in the guideline.</p> <p>(2) The cache hit rate may decrease.</p> <p>(3) The cache allocation capacity per MPB/MPU is limited to within the prescribed capacity.</p>	OFF
867	<p>All-page reclamation (discarding all mapping information between DP pool and DP volumes) is executed in DP-VOL LDEV format. This new method is enabled or disabled by setting the mode to ON or OFF.</p> <p>Mode 867 = ON:</p> <p>LDEV format of the DP-VOL is performed with page reclamation.</p> <p>Mode 867 = OFF:</p> <p>LDEV format of the HDP-VOL is performed with 0 data writing.</p> <p>Notes:</p> <p>1. The mode is applied from factory shipment.</p> <p>2. Do not change the setting of the mode during DP-VOL format.</p> <p>3. If the setting of the mode is changed during DP-VOL format, the change is not reflected to the format of the DP-VOL being executed but the format continues in the same method.</p>	ON
896	<p>The mode enables or disables the background format function performed on an unformatted area of a DP/DT/TI*1 pool.</p> <p>*1: The background format function for a TI pool is only available for V01+1 (73-01-31-00/00) or higher.</p>	ON

	<p>* For the information of operating conditions, refer to Provisioning Guide for Open Systems.</p> <p>Mode 896 = ON:</p> <p>The background format function is disabled.</p> <p>Mode 896 = OFF:</p> <p>The background format function is enabled.</p> <p>Notes:</p> <ol style="list-style-type: none"> 1. <HUS VM> The mode is applied when a customer requires disabling the background format for a DP/DT/TI*1 pool due to a concern of performance degradation of other functions in an environment where a DP-VOL is used by other functions. 2. When the background format function is enabled, because up to 42MB/s of ECCG performance is used, local copy performance may degrade by about 10%. Therefore, confirm whether the 10% performance degradation is acceptable or not before enabling the function. 3. When a Dynamic Provisioning VOL on an external storage system, which is used as an external VOL, is used as a pool VOL, if the external pool on the external storage side becomes full due to the background format, the external VOL may be blocked. <p>If the external pool capacity is smaller than the external VOL capacity (Dynamic Provisioning VOL of external storage system), do not enable the background format function.</p> <ol style="list-style-type: none"> 4. If the background format function is disabled by changing the mode setting, the format progress is initialized and the entire area become unformatted. 	
897	<p>By the combination of System Option Mode 897 and 898 setting, the expansion width of Tier Range upper I/O value (IOPH) can be changed as follows.</p> <p>Mode 897 = ON:</p> <p>System Option Mode 898 is OFF: 110%+0IO</p> <p>System Option Mode 898 is ON: 110%+2IO</p> <p>Mode 897 = OFF (Default)</p> <p>System Option Mode 898 is OFF: 110%+5IO (Default)</p> <p>System Option Mode 898 is ON: 110%+1IO</p> <p>By setting the System Option Modes to ON to lower the upper limit for each tier, the gray zone between other tiers becomes narrow and the frequency of page allocation increases.</p> <p>Notes:</p> <ol style="list-style-type: none"> 1. Apply the mode when the usage of upper tier is low and that of lower tier is high. 	OFF

	<p>2. The mode must be used with System Option Mode 898.</p> <p>3. Narrowing the gray zone increases the number of pages to migrate between tiers per relocation.</p> <p>4. When Tier1 is SSD while System Option Mode 901 is set to ON, the effect of System Option Mode 897 and 898 to the gray zone of Tire1 and Tier2 is disabled and the System Option Mode 901 setting is enabled instead. In addition, the settings of System Option Mode 897 and 898 are effective for Tire2 and Tier3.</p> <p>Please also see spreadsheet "System Option Mode_897_898_901" for more details about the relations between Mode 897, 898 and 901.</p>	
898	<p>By the combination of System Option Mode 898 and 897 setting, the expansion width of Tier Range upper I/O value (IOPH) can be changed as follows.</p> <p>Mode 898 = ON:</p> <p>System Option Mode 897 is OFF: 110%+1IO</p> <p>System Option Mode 897 is ON: 110%+2IO</p> <p>Mode 898 = OFF (Default):</p> <p>System Option Mode 897 is OFF: 110%+5IO (Default)</p> <p>System Option Mode 897 is ON: 110%+0IO</p> <p>By setting the System Option Modes to ON to lower the upper limit for each tier, the gray zone between other tiers becomes narrow and the frequency of page allocation increases.</p> <p>Notes:</p> <ol style="list-style-type: none"> 1. Apply the mode when the usage of upper tier is low and that of lower tier is high. 2. The mode must be used with System Option Mode 897. 3. Narrowing the gray zone increases the number of pages to migrate between tiers per relocation. 4. When Tier1 is SSD while Mode 901 is set to ON, the effect of system option mode 897 and 898 to the gray zone of Tire1 and Tier2 is disabled and the Mode 901 setting is enabled instead. In addition, the settings of Mode 897 and 898 are effective for Tire2 and Tier3. <p>Please also see spreadsheet "System Option Mode_897_898_901" for more details about the relations between System Option Mode 897, 898 and 901.</p>	OFF
899	<p>In combination with the system option mode 900 setting, whether to execute and when to start the I/O synchronous copy change as follows.</p> <p>Mode 899 = ON:</p> <p>System option mode 900 is ON: I/O synchronous copy starts without retrying Volume Migration.</p>	OFF

	<p>System option mode 900 is OFF: I/O synchronous copy starts when the threshold of Volume Migration retry is exceeded. (Recommended).</p> <p>Mode 899 = OFF:</p> <p>System option mode 900 is ON: I/O synchronous copy starts when the number of retries reaches half of the threshold of Volume Migration retry.</p> <p>System option mode 900 is OFF: Volume Migration is retired and I/O synchronous copy is not executed.</p> <p>Notes:</p> <ol style="list-style-type: none"> 1. This mode is applied when improvement of Volume Migration success rate is desired under the condition that there are many updates to a migration source volume of Volume Migration. 2. During I/O synchronous copy, host I/O performance degrades. 	
900	<p>In combination with system option mode 899 setting, whether to execute and when to start the I/O synchronous copy change as follows.</p> <p>Mode 900 = ON:</p> <p>System option mode 899 is ON: I/O synchronous copy starts without retrying Volume Migration.</p> <p>System option mode 899 is OFF: I/O synchronous copy starts when the number of retries reaches half of the threshold of Volume Migration retry.</p> <p>Mode 900 = OFF:</p> <p>System option mode 899 is ON: I/O synchronous copy starts when the threshold of Volume Migration retry is exceeded. (Recommended)</p> <p>System option mode 899 is OFF: Volume Migration is retired and I/O synchronous copy is not executed.</p> <p>Notes:</p> <ol style="list-style-type: none"> 1. This mode is applied when improvement of Volume Migration success rate is desired under the condition that there are many updates to a migration source volume of Volume Migration. 2. During I/O synchronous copy, host I/O performance degrades. 	OFF
901	<p>By setting the mode to ON or OFF, the page allocation method of Tier Level ALL when the drive type of tier1 is SSD changes as follows.</p> <p>Mode 901 = ON:</p> <p>For tier1 (drive type is SSD), pages are allocated until the capacity reaches the limit.</p>	OFF

	<p>(Without consideration of exceeding performance limitation, allocation is done from highly loaded pages until reaching the capacity limit.</p> <p>When the capacity of the tier1 reaches the threshold value, the minimum value of the tier range is set to the starting value of the lower IOPH zone, and the maximum value of the lower tier range is set to the boundary value.</p> <p>Mode 901 = OFF (default):</p> <p>For tier1 (drive type is SSD), page allocation is performed based on performance potential limitation.</p> <p>(With consideration of exceeding performance limitation, allocation is done from highly loaded pages but at the point when the performance limitation is reached, pages are not allocated any more even there is free space)</p> <p>When the capacity of the tier1 reaches the threshold value, the minimum value of the tier range is set to the boundary value, and the maximum value of the lower tier range is set to a value of boundary value x 110% + 5 [IOPH].</p> <p>Notes:</p> <ol style="list-style-type: none"> 1. This mode is applied when pages with the maximum capacity need to be allocated to tier1 (drive type is SSD) with DT or DTz. 2. When Tier1 is SSD while System Option Mode 901 is set to ON, the effect of System Option Mode 897 and 898 to the gray zone of Tire1 and Tier2 is disabled and the System Option Mode 901 setting is enabled instead. In addition, the settings of System Option Mode 897 and 898 are effective for Tire2 and Tier3. 3. The following is recommended when applying System Option Mode 901. <p>The actual I/O value (total number of I/Os of all tiering policies) < the performance potential value of Tier 1*1 x 0.6</p> <p>*1: The performance potential value of Tier 1 displayed on Monitor information by using Dx-ray.</p> <p>Please also see spreadsheet "System Option Mode 897_898_901" for more details about the relations between System Option Mode 897, 898 and 901.</p>	
904	<p>By setting the mode to ON or OFF, the number of pages to be migrated per unit time at tier relocation is changed.</p> <p>Mode 904 = ON:</p> <p>The number of pages to be migrated at tier relocation is set to up to one page per second.</p> <p>Mode 904 = OFF:</p> <p>No restriction on the number of pages to be migrated at tier relocation (existing specification).</p> <p>Notes:</p>	OFF

	<p>1. This mode is applied when</p> <ul style="list-style-type: none"> - Dynamic Tiering for Mainframe is used (including multi platforms configuration). - the requirement for response time is severe. <p>2. The number of pages to be migrated per unit time at tier relocation decreases.</p>	
908	<p>The mode can change CM capacity allocated to MPBs with different workload.</p> <p>Mode 908 = ON:</p> <p>Difference in CM allocation capacity among MPBs with different workload is large.</p> <p>Mode 908 = OFF:</p> <p>Difference in CM allocation capacity among MPBs with different workload is small. (Existing operation)</p> <p>Notes:</p> <p>1. If a CLPR is used by only some MPBs among all the installed MPBs, set the mode to ON for the CLPR to increase CM capacity allocated to the MPBs that use the CLPR.</p> <p>Example:</p> <p>(a) A CLPR only for UR JNLG</p> <p>(b) A configuration where MPBs and CLPRs are separately used for Open and Mainframe systems.</p> <p>2. Since CM capacity allocated to MPBs with low load is small, the performance is affected by a sudden increase in load.</p> <p>3. System option mode 908 cannot be used with system option mode 933. When system option mode 933 is set to ON, the function of system option mode 908 is canceled even though system option mode 908 is ON.</p> <p>4. This mode is effective for a CLPR. Therefore, when setting the mode to ON/OFF, select target "LPRXX (XX=00 to 31)". For example, even when CLPR0 is defined (any of CLPR1 to 31 are not defined), select "LPR00" first and then set the mode to ON/OFF.</p>	OFF
930	<p>When the mode is set to ON, all of the zero data page reclamation operations in processing are stopped. (Also the zero data page reclamation cannot be started.)</p> <p>* Zero data page reclamation by WriteSame and UNMAP functions, and IO synchronous page reclamation are not disabled.</p> <p>Mode 930 = ON:</p> <p>All of the zero data page reclamation operations in processing are stopped at once. (Also the zero data reclamation cannot be newly started.)</p> <p>Mode 930 = OFF:</p>	OFF

	<p>The zero data page reclamation is performed.</p> <p>See the system option mode 930 sheet for relationship with system option mode 755.</p> <p>Notes:</p> <p>(1) The mode is applied when stopping or disabling zero data page reclamation by user request is required.</p> <p>(2) When the mode is set to ON, the zero data page reclamation does not work at all.</p> <p>* Zero data page reclamation by Write Same and UNMAP, and IO synchronous page reclamation can work.</p> <p>(3) When downgrading micro-program to a version that does not support the mode while the mode is set to ON, set the mode to OFF after the downgrade.</p> <p>* Because the zero data page reclamation does not work at all while the mode is set to ON.</p>	
937	<p>By setting the mode to ON, DT monitoring data is collected even if the pool is a DP pool.</p> <p>Mode 937 = ON:</p> <p>DT monitoring data is collected even if the pool is a DP pool.</p> <p>Only Manual execution mode and Period mode are supported.</p> <p>Mode 937 = OFF:</p> <p>DT monitoring data is not collected if the pool is a DP pool</p> <p>Notes:</p> <ol style="list-style-type: none"> 1. The mode is applied when DT monitoring data collection is required in DP environment. 2. When DT is already used, do not set the mode to ON. 3. For DT monitoring data collection, shared memory for DT must be installed. For details, see the system option mode 937 sheet. 4. If monitoring data collection is performed without shared memory for DT installed, an error is reported and the monitoring data collection fails. 5. Before removing the shared memory for DT, set the mode to OFF and wait for 30 minutes. 6. Tier relocation with monitoring data collected when the mode is set to ON is disabled. 7. When DP is converted into DT (after purchase of PP license), the collected monitoring data is discarded. 8. Before downgrading the micro-program to an unsupported version, set system option mode 937 to OFF and wait for at least 30 minutes. 	OFF

1021	<p>The mode can enable or disable the auto-recovery for external volumes of an EMC storage system.</p> <p>Mode 0121 = ON:</p> <p>An external volume that is blocked due to Not Ready status can be recovered automatically regardless of the type of external storage system.</p> <p>Mode 1021 = OFF (default):</p> <p>An external volume that is blocked due to Not Ready status might not be recovered automatically depending on the type of external storage system.</p> <p>Notes:</p> <p>(1) The mode is applied when the auto-recovery of external volumes that are blocked due to Not Ready status is desired in UVM connection using an ECM storage system as an external storage system.</p> <p>(2) When the mode is set to ON and the connected external storage system is not in stable status (such as failure and recovery from failure), a blockage due to Not Ready status and auto-recovery may occur repeatedly.</p>	OFF
1070	<p>The mode changes the processing for a group operation with GAD CTG.</p> <p>Mode 1070 = ON:</p> <p>The status change of all pairs in a CTG is performed for 50 msec.</p> <p>Mode 1070 = OFF (default):</p> <p>The status change of all pairs in a CTG is performed for 1 msec.</p> <p>Notes:</p> <p>(1) The mode is applied when reducing the time to complete status change of all pairs in a CTG at a group operation (suspension and resync operation) with the GAD CTG function. In a system configuration where host I/O performance is prioritized, do not use the mode because setting the mode may affect the host I/O performance.</p> <p>(2)The MP usage rate increases during status change of all pairs in a CTG. For approximate percentage increase in MP usage rate, see sheet "System Option Mode 1070".</p>	OFF
1093	<p>This mode is used to disable background unmap during microcode downgrade from a version that supports pool reduction rate correction to a version that does not support the function.</p> <p>Mode 1093 = ON:</p> <p>Background unmap cannot work.</p> <p>Mode 1093 = OFF (default):</p> <p>Background unmap can work.</p>	OFF

	<p>Notes:</p> <p>The mode is applied when downgrading microcode from a version that supports pool reduction rate correction to a version that does not support the function is disabled.</p>	
1097	<p>This mode disables the warning LED to blink when specific SIMs are reported.</p> <p>Mode 1097 = ON:</p> <p>When SIM=452XXX, 462XXX, 3077XY, 4100XX, or 410100 is reported, the warning LED does not blink.</p> <p>Mode 1097 = OFF (default):</p> <p>When SIM=452XXX, 462XXX, 3077XY, 4100XX, or 410100 is reported, the warning LED blinks.</p> <p>Note:</p> <p>The mode disables the warning LED to blink when specific SIMs are reported.</p>	Inactive

Maintaining the storage system

Maintenance covers a broad spectrum of activity with the goal of keeping a storage system operational and available to all hosts. This chapter describes topics for performing storage system maintenance.

Maintenance covers a broad spectrum of activity with the goal of keeping a storage system operational and available to all hosts. This chapter describes topics for performing storage system maintenance.

- [Storing the storage system](#)
- [Using flash module drives](#)
- [Powering off the storage system](#)
- [Removing cables](#)

Storing the storage system

If the storage system does not receive power for more than six months, the battery can become discharged and possibly damaged. To avoid this situation, charge the battery for more than three hours at least once every six months.



Note: Do not store the equipment in an environment with temperatures of 104°F (40°C) or higher because battery life will be shortened.

Using flash module drives

Observe the following guidelines when handling the listed flash module drives (FMDs). The types of FMDs are equipped with a battery or capacitor.

Power up the flash module drives using power from the storage system for at least 90 minutes every month. Failing to do so may render a flash module drive unusable and will abrogate replacement under the terms of the warranty.

Model Name	Drive type	Battery	Capacitor
DKC-F710I-1R6FM	NFH1A-P1R6SS	yes	N/A
	NFH1C-P1R6SS	yes	N/A
	NFH1D-P1R6SS	N/A	Yes
DKC-F710I-3R2FM	NFH1B-P3R2SS	yes	N/A
	NFH1C-P3R2SS	yes	N/A
	NFH1D-P3R2SS	N/A	yes
DKC-F810I-1R6FN	NFHAE-Q1R6SS	N/A	yes
	NFH1D-P1R6SS	N/A	yes
DKC-F810I-3R2FN	NFHAE-Q3R2SS	N/A	yes
	NFH1D-P3R2SS	N/A	yes
DKC-F810I-6R4FN	NFHAE-Q6R4SS	N/A	yes
	NFH1D-P6R4SS	N/A	yes

Guidelines for handling the FMDs

Follow the guidelines to avoid damaging the components when handling FMDs.

- Check the main edge connector of the drive for any damage, deformation, dust or debris before installing.

- Check for floats or position gaps in the connector. Mark the identified location.
- To prevent any damages to the FMD, avoid touching the connector or handling the ends of the FMD. Use both hands to hold the middle area of the FMD.
- Avoid installing or removing the FMD at an angled position.

Powering off the storage system

Procedure

1. Press the main switch for three seconds until the **POWER** LED blinks.
2. Verify that the **POWER** LED on the front of the storage system changes from green to amber.
It can take from 25 minutes to 4 hours for the **POWER** LED to turn amber, depending on the configuration of the system (check after 33 minutes).
3. To stop the power supply from supplying power, remove the power cables from the power supply units on the controller chassis and drive box.
If the storage system is connected to a PDU, you can stop the power supply by turning off the PDU breaker.



Note: If the storage system does not receive power for more than six months, the battery can become discharged and possibly damaged. To avoid this situation, charge the battery for more than three hours at least once every six months.

Removing cables

Observe the following instructions when removing cables from the storage system.

To remove a SAS cable, pull the tab of the SAS cable (1) to release the latch and remove the SAS cable (2).

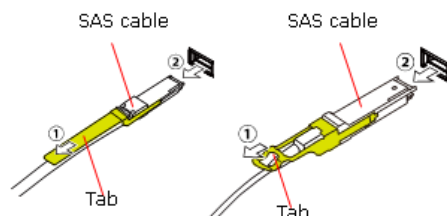

To remove an optical cable, push the top of the connector of the optical cable (1) to release the latch and remove the SAS cable (2).

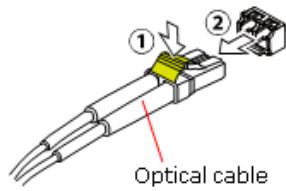

To remove a LAN cable, push the top of the LAN cable connector (1) to release the latch and remove the LAN cable (2).

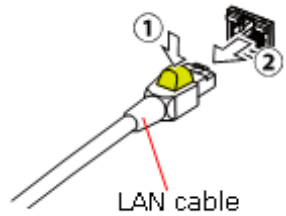

User administration for maintenance utility

The maintenance utility allows you to set up and manage user accounts.

- [Required roles for operating Maintenance Utility](#)
- [Setting up user accounts](#)
- [Disabling user accounts](#)
- [Removing user accounts](#)
- [Backing up user accounts](#)
- [Restoring user account information](#)

Required roles for operating Maintenance Utility

You can control the availability of using each operation window of Maintenance Utility for a user by registering the user in the user group and assigning them with the appropriate role.

The following table lists the required roles for using specific Maintenance Utility operation windows.

Maintenance Utility operation window	Required role name
Initial Setting Wizard	Storage Administrator (Initial Configuration)
Set Up System Information	Storage Administrator (Initial Configuration)
Firmware	Support Personnel or User Maintenance*
User Administration	Security Administrator (View & Modify)
Alert Notifications	Storage Administrator (Initial Configuration)
Set Up Date & Time	Storage Administrator (Initial Configuration)
Set Up Network Settings	Storage Administrator (Initial Configuration)
Licenses	Storage Administrator (Initial Configuration)
Audit Log Settings	Audit Log Administrator (View & Modify)
Turn on/off Locate LEDs	Support Personnel or User Maintenance*
Power on Storage System	Support Personnel or User Maintenance*
Power off Storage System	Support Personnel or User Maintenance*
Edit UPS Mode	Support Personnel or User Maintenance*
Edit Login Message	Storage Administrator (Initial Configuration)
Select Cipher Suite	Security Administrator (View & Modify)
Update Certificate Files	Security Administrator (View & Modify)
Force Release System Lock	Storage Administrator (Initial Configuration)
Reboot GUM	Support Personnel or User Maintenance
Change Password	No role is required.
Boot System Safe Mode	Support Personnel*
Alert Display	Support Personnel or User Maintenance*
Alert Display Related to FRU	Support Personnel or User Maintenance*
Administration Menu	N/A
Power Management	N/A
System Management	N/A

Maintenance Utility operation window	Required role name
Resetting GUM	N/A
* <ul style="list-style-type: none"> Support Personnel: Operations performed by the service personnel User Maintenance: Operations performed by the user 	

Setting up user accounts

This procedure describes how to create a user account and register the account to a user group with appropriate roles. You can create up to 20 users, including the built-in user.

Procedure

1. In the Maintenance Utility window, click **Administration > User Administration**.
2. In the **User Groups** tab, click **Create User**.

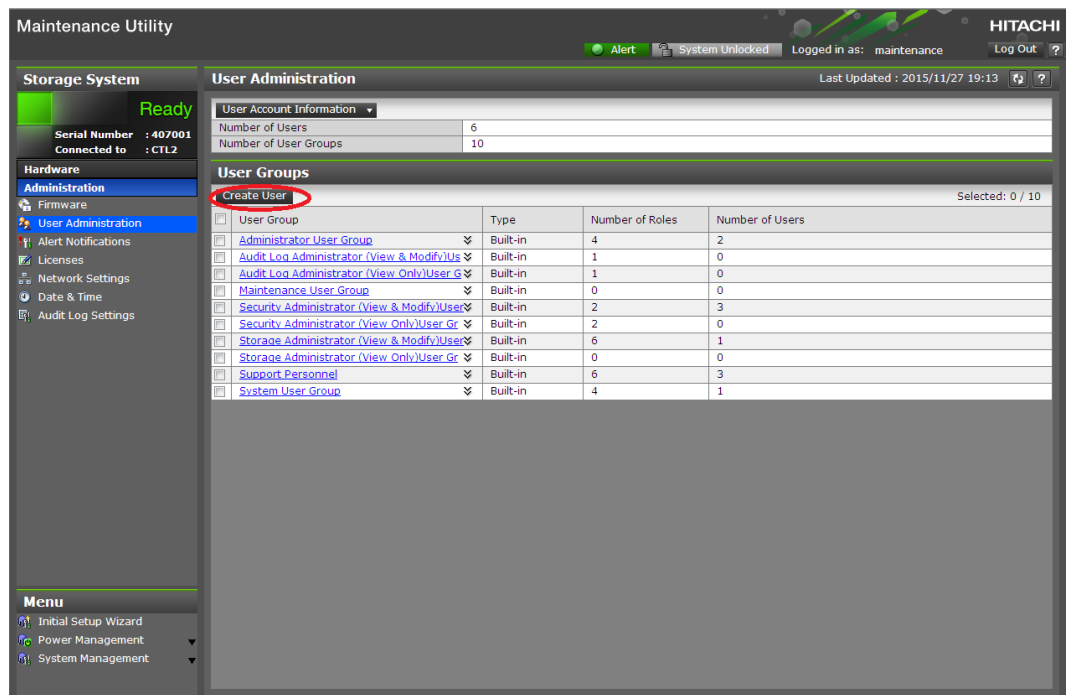

3. Create a new user account. Specify the User Name, Account Status, Authentication and User Group. Click **Finish**.

Create User

To create a new user account, specify the User Name, Account Status, Authentication, and User Group. When the settings are complete, click [Finish].

User Name:
(Max. 256 characters)

Account Status: Enable Disable

Authentication: Local: Password:
(6 - 256 characters)

Re-enter Password:

External

User Groups			
<input type="checkbox"/>	User Group Name	Type	Number of Roles
<input type="checkbox"/>	Administrator User Group	Built-in	8
<input type="checkbox"/>	Audit Log Administrator (View ...	Built-in	2
<input type="checkbox"/>	Audit Log Administrator (View ...	Built-in	2
<input type="checkbox"/>	Maintenance User Group	Built-in	2
<input type="checkbox"/>	Security Administrator (View &...	Built-in	3
<input type="checkbox"/>	Security Administrator (View O...	Built-in	2

Selected: 0 of 10

Finish Cancel ?

Item	Description
User Name	
Account Status	<p>The following statuses are available:</p> <p>Enable = user can use the account.</p> <p>Disable = user cannot use the account or log in to the storage management software.</p>
Authentication	<p>The following methods are available:</p> <p>Local = does not use authentication server. Uses a dedicated password for storage management software.</p> <p>External = uses an authentication server.</p>

4. Confirm the settings, and then click **Apply**.

Create User

Verify the settings, and then click [Apply].

Added User	
User Name	maintenance
Account Status	Enable
Authentication	Local
Password	*****
Number of User Groups	1

Selected User Groups		
User Group Name	Type	Number of Roles
Administrator User Group	Built-in	8
		Total: 1

5. When the completion message appears, click **Close**.

Disabling user accounts

The following procedure describes how to disable user accounts.

Observe the following guideline:

- Log into an account that is different from the user whose account that you want to disable (you cannot disable the current login user account).
- To disable the user account specified by the registered storage system in the **Storage Device List** window, click Stop Service for the registered storage system. After disabling the user account, click Edit to enable the user account.

Procedure

1. In the Maintenance Utility window, click **Administration > User Administration**.
2. In the **User Groups** tab, click the user group to which the user belongs.

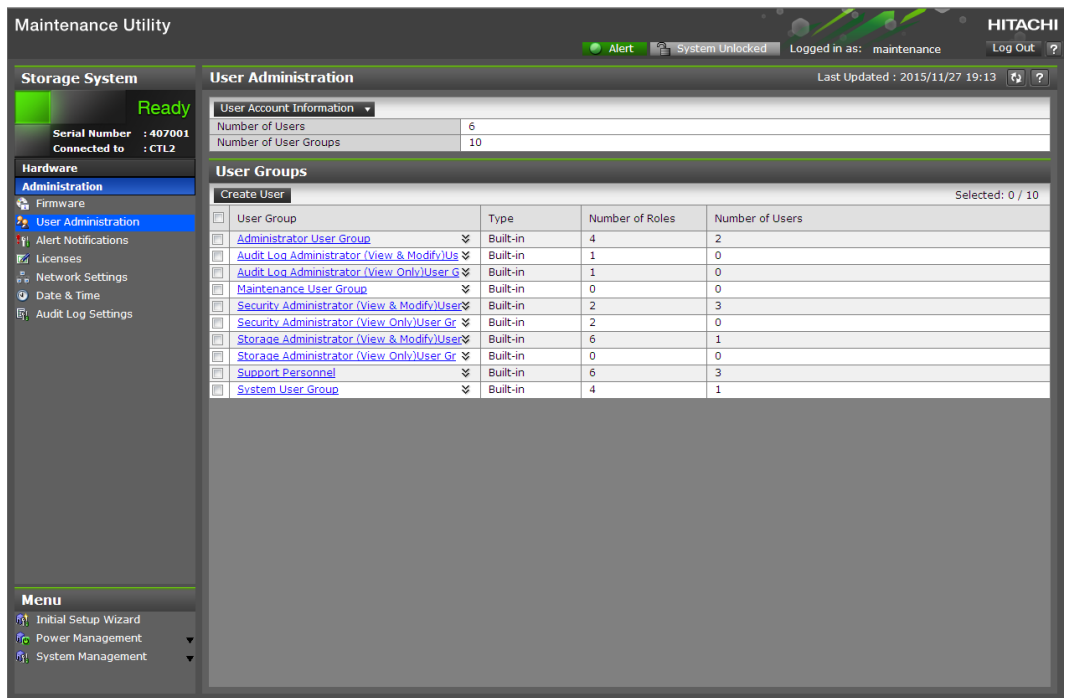

3. Click the **Users** tab, and then select the user that you want to disable.

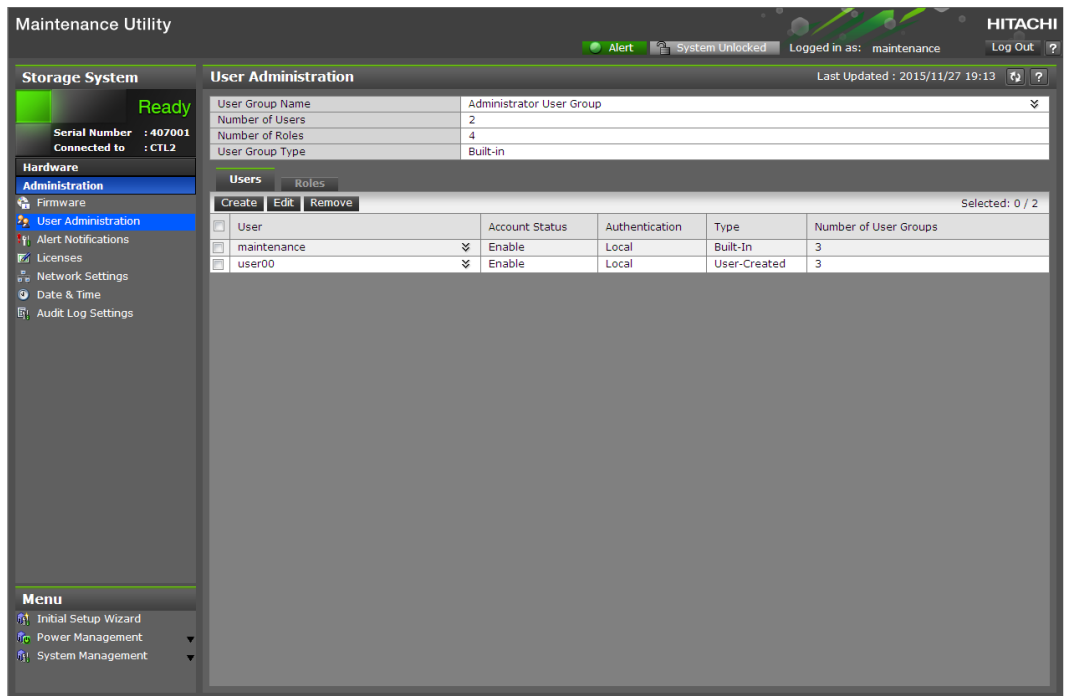

4. Click **Edit**.
5. For **Account Status**, click **Disable**, and then click **Finish**.

Create User

To create a new user account, specify the User Name, Account Status, Authentication, and User Group. When the settings are complete, click [Finish].

User Name:
(Max. 256 characters)

Account Status: Enable **Disable**

Authentication: Local: Password:
(6 - 256 characters)

Re-enter Password:

External

User Groups			
<input type="checkbox"/>	User Group Name	Type	Number of Roles
<input checked="" type="checkbox"/>	Administrator User Group	Built-in	8
<input type="checkbox"/>	Audit Log Administrator (View ...	Built-in	2
<input type="checkbox"/>	Audit Log Administrator (View ...	Built-in	2
<input type="checkbox"/>	Maintenance User Group	Built-in	2
<input type="checkbox"/>	Security Administrator (View &...	Built-in	3
<input type="checkbox"/>	Security Administrator (View O...	Built-in	2

Selected: 1 of 10

Finish Cancel ?

- Confirm the settings, and then click **Apply**.

Edit User

Verify the edited settings, and then click [Apply].

Edited User	
User Name	maintenance
Account Status	Disable
Authentication	Local
Password	
Number of User Groups	4

Selected User Groups		
User Group Name	Type	Number of Roles
Administrator User Group	Built-in	16
Support Personnel	Built-in	16
		Total: 4

- When a completion message appears, click **Close**.

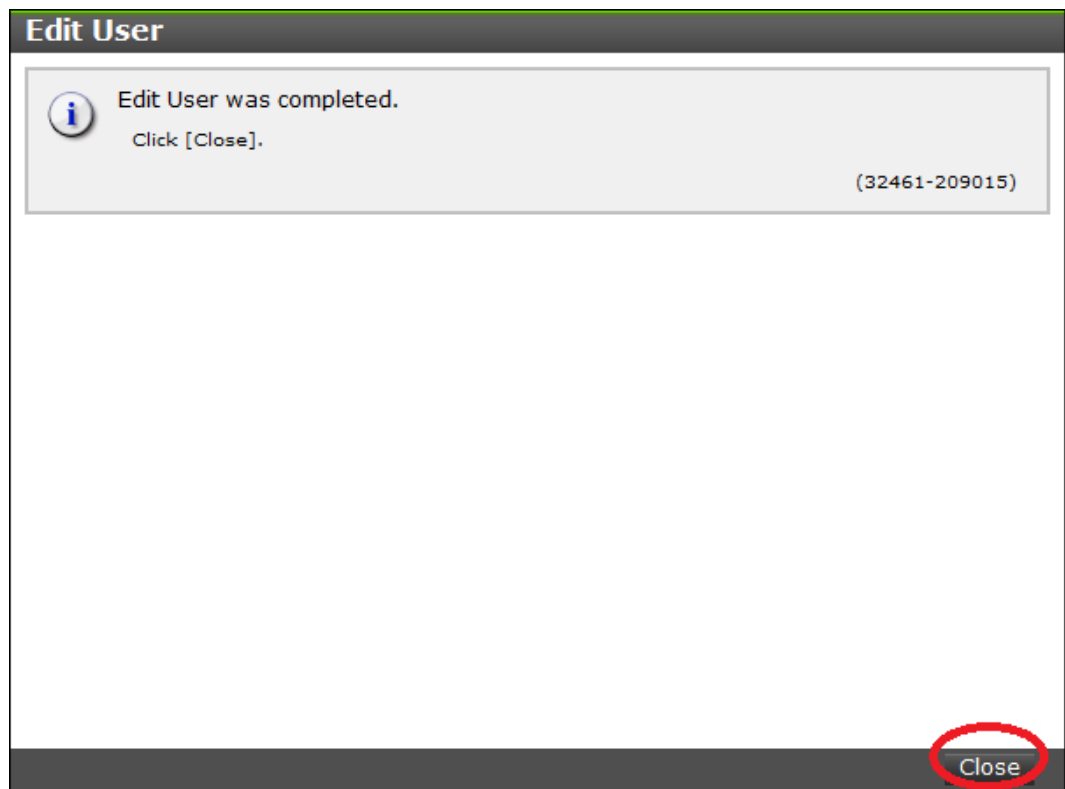

Removing user accounts

Security administrators can remove a user account when the account is no longer in use. Built-in user accounts cannot be deleted. If deleting the current login user account, you can continue the storage management software operation until you log out.

 **Note:** To delete the user account specified by the registered storage system in the **Storage Device List** window, click **Stop Service** of the registered storage system. After deletion, click Edit to enable the user account.

Procedure

1. In the Maintenance Utility window, click **Administration > User Administration**.
2. In the **User Groups** tab, click the user group to which the user belongs.

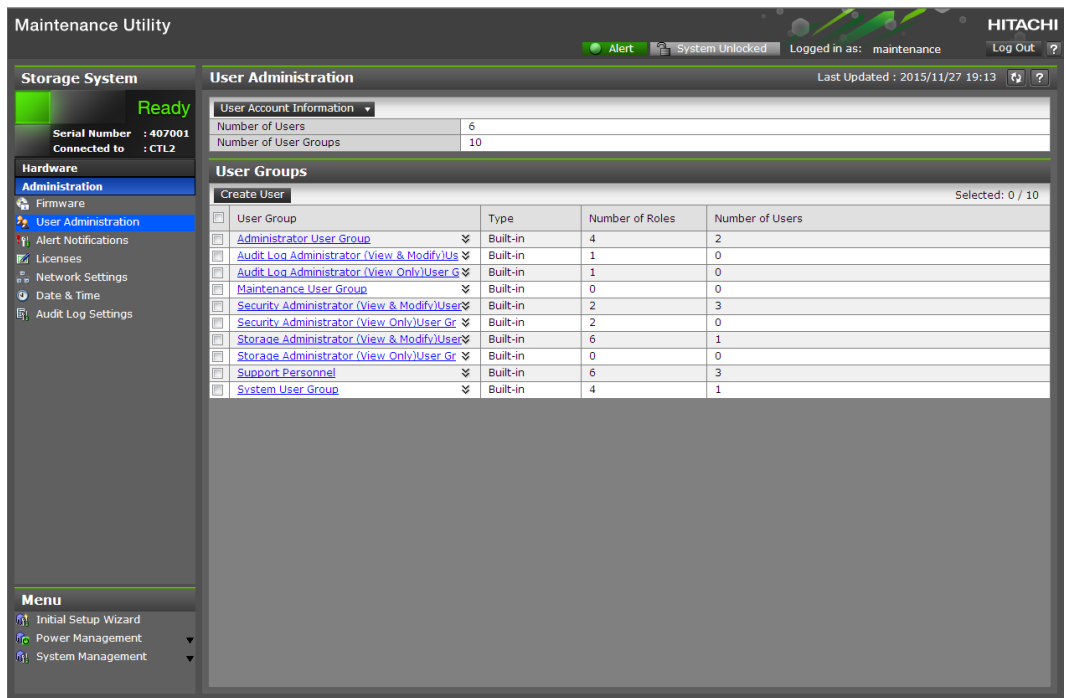

3. Click the **Users** tab, and then select the user you want to remove.

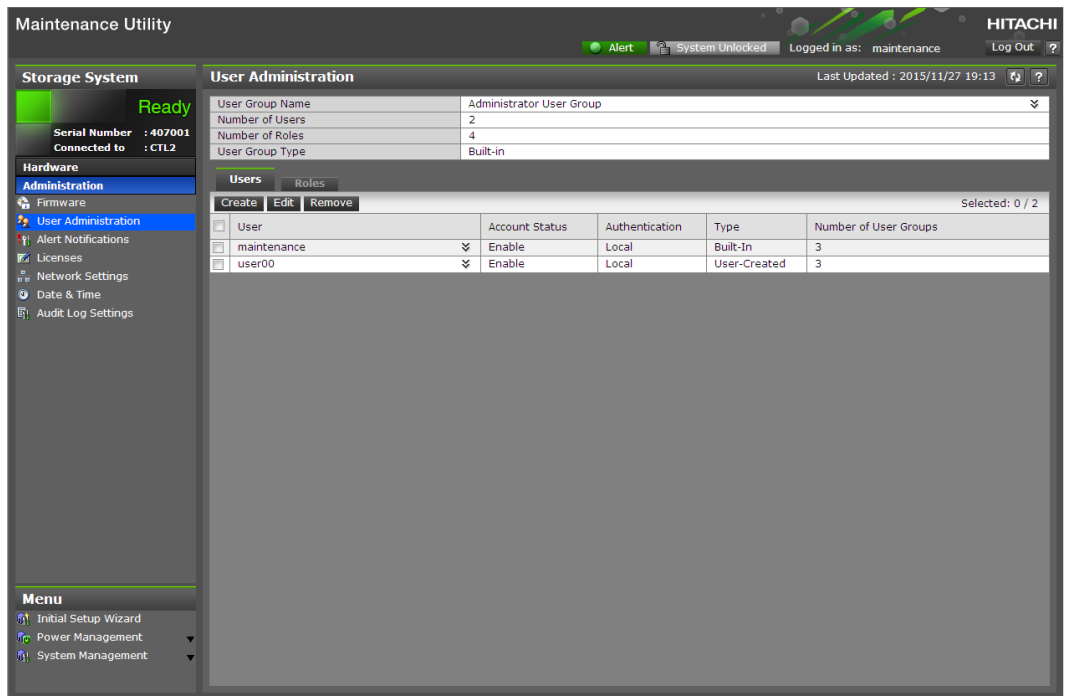

4. Click **Remove**.
The **Confirm** window opens.

5. In the **Confirm** window, confirm the settings and specify the task name, and then click **Apply**.

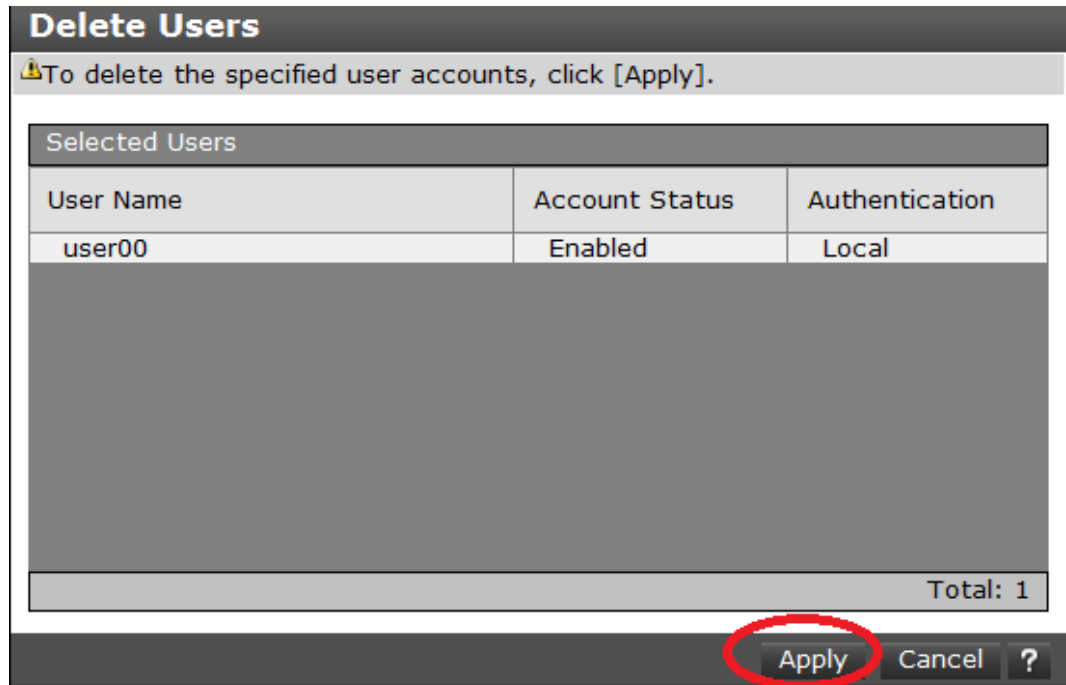

6. At the completion message, click **Close**.

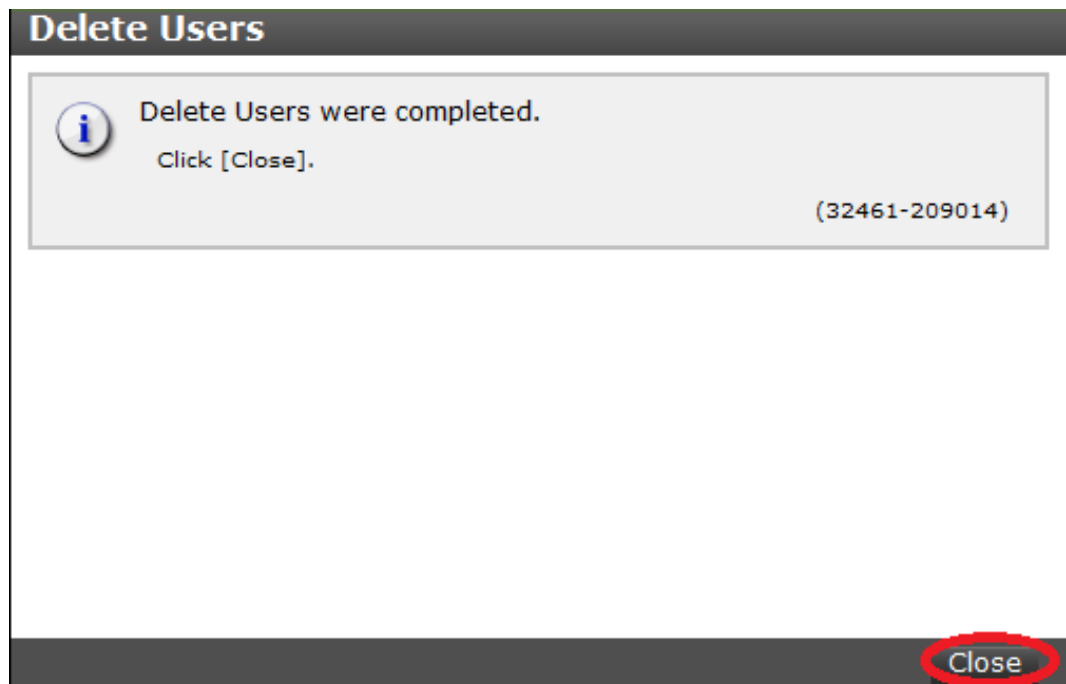

Backing up user accounts

Procedure

1. Click **User Account Information > Backup**.
2. Specify a storage destination and a file name in the displayed window and download a file.
3. When a message asks whether you want to remove the selected item, click **Close**.

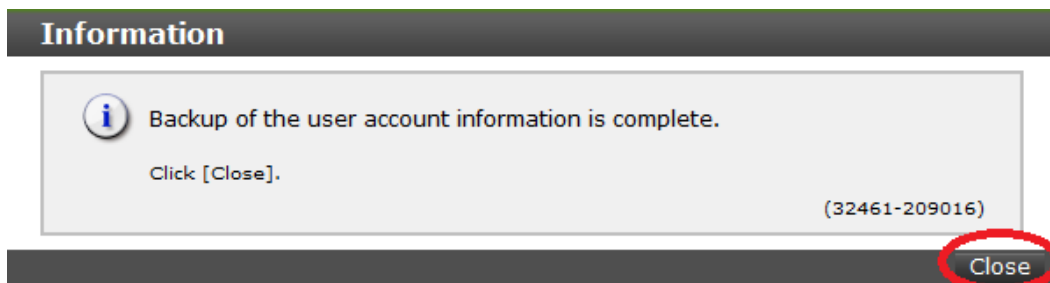

Restoring user account information

Procedure

1. Click **User Account Information > Restore**
The **Restore User Account** window opens.
2. Specify file names to be restored, and then click **Apply**.

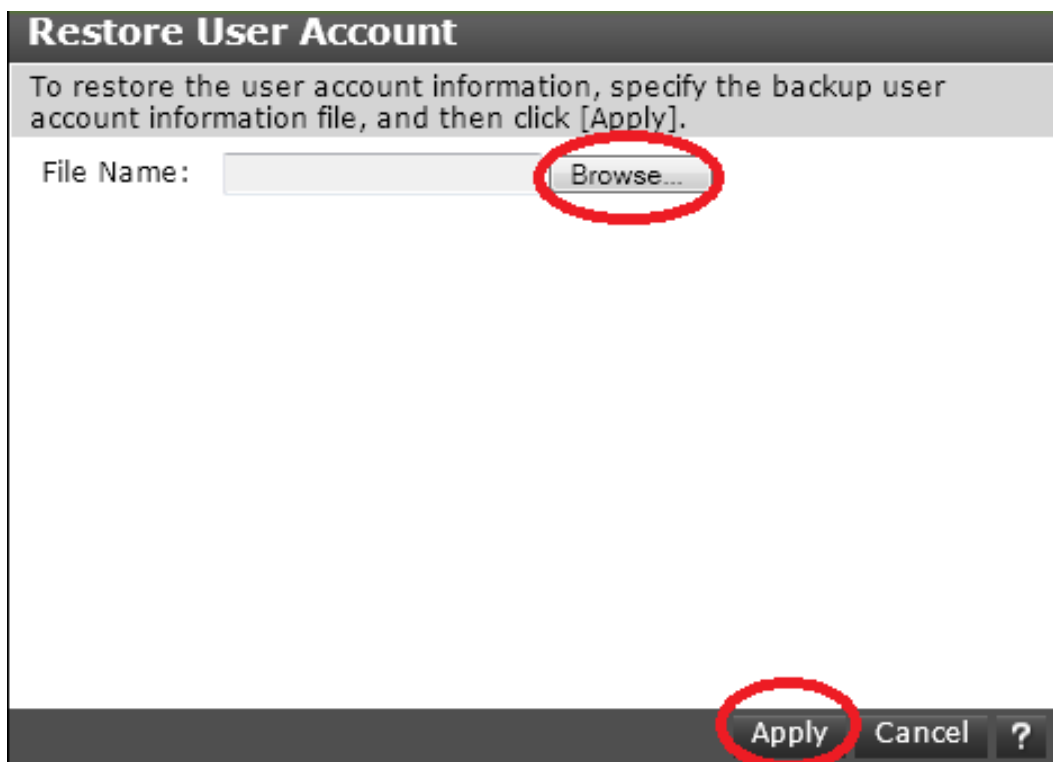

3. When a completion message appears, click **Close**.

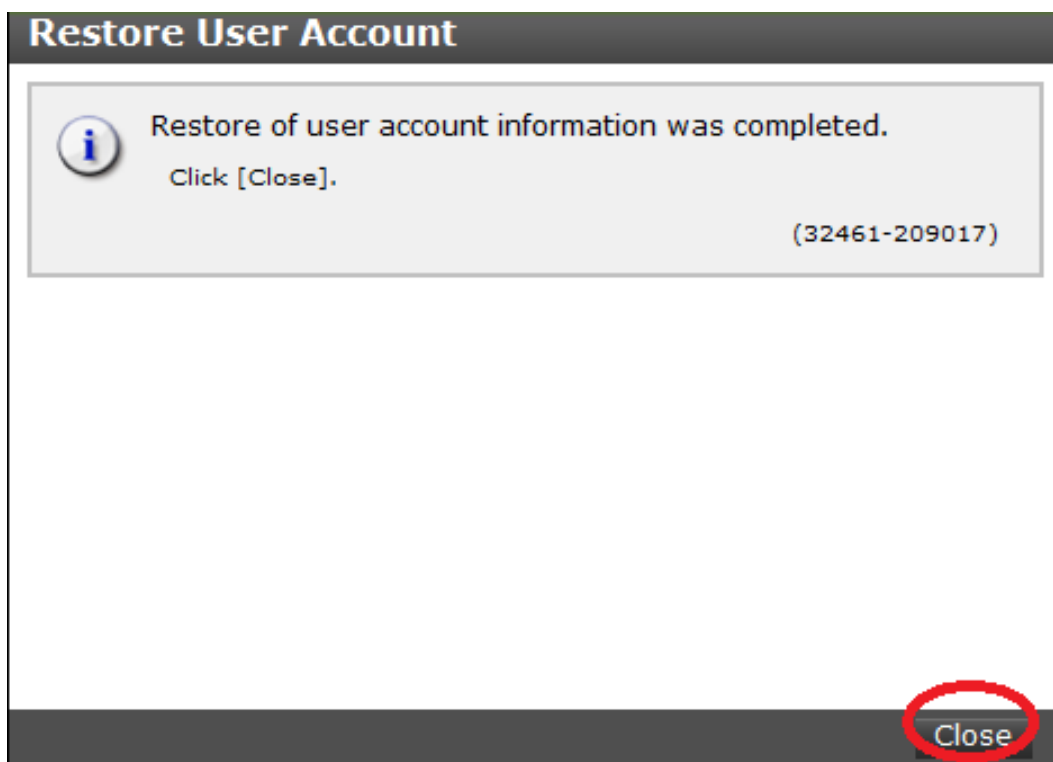

Storage system specifications

- [Model lists](#)
- [Replacement parts](#)
- [Hitachi Virtual Storage Platform G200 mechanical specifications \(AC power supply model\)](#)
- [Hitachi Virtual Storage Platform G200 mechanical specifications \(DC power supply model\)](#)
- [Electrical specifications](#)
- [VSP G200 electrical specifications \(DC power supply\)](#)
- [Environmental specifications](#)
- [VSP G200 environmental specifications \(DC power supply\)](#)
- [Battery specifications](#)
- [RAID specifications](#)
- [iSCSI specifications](#)
- [iSCSI standards](#)
- [Regulatory compliance](#)
- [Dense intermix drive tray connection restrictions](#)
- [SVP hardware specifications](#)

Model lists

Hitachi Virtual Storage Platform G200 controller model list

CBSS controller components

Part number	Part name	Quantity
DW800-CBSS	2U chassis	1
	AC power supply unit	2
	Power cable (0.9 m)	2
	Power cable (2.5 m)	2
	Backup module (BKM)	2
	Front bezel (2U)	1
	Binder	1
	SAS cable label	2
	Controller	2
DW-F800-BM10	Cache flash memory	2

CBSS controller optional components

Part number	Part name	Quantity
DW-F800-CTLS	Controller Board	2
DW-F800-CTLSE	Controller Board (Encryption)	2
DW-F800-4HF8	Front end module (8-Gbps - FC)	2-4
DW-F800-2HF16	Front end module (16-Gbps - FC)	2-4
DW-F800-2HS10S	Front end module (10-Gbps SFP - iSCSI)	2-4
DW-F800-2HS10B	Front end module (10-Gbps copper - iSCSI)	2-4
DKC-F810I-CM8G	Cache memory (8 GB)	4
DKC-F810I-CM16G	Cache memory (16 GB)	4
DW-F800-BM10	Cache Flash Memory (CFM)	2
DKC-F810I-200MEM	200-GB, 2.5-inch, MLC, 12-Gbps flash drive	0-24
DKC-F810I-300KCM	300-GB, 2.5-inch, 15kmin ⁻¹ 6-Gbps SAS drive (contains BNST)	0-24

Part number	Part name	Quantity
DKC-F810I-300KCMC	300-GB, 2.5-inch, 15kmin ⁻¹ , 6-Gbps SAS drive	0-24
DKC-F810I-400MEM	400-GB, 2.5-inch, MLC, 12-Gbps SAS drive	0-24
DKC-F810I-600JCM	600-GB, 2.5-inch, 10kmin ⁻¹ , 6-Gbps SAS drive (contains BNST)	0-24
DKC-F810I-600JCMC	600-GB, 2.5-inch, 10kmin ⁻¹ , 6-Gbps SAS drive	0-24
DKC-F810I-600KGM	600-GB, 2.5-inch, 15kmin ⁻¹ 12-Gbps SAS drive	0-24
DKC-F810I-1R2JCM	1.2-TB, 2.5-inch, 10kmin ⁻¹ , 6-Gbps SAS drive (contains BNST)	0-24
DKC-F810I-1R2JCMC	1.2-TB, 2.5-inch, 10kmin ⁻¹ , 6-Gbps SAS drive	0-24
DKC-F810I-1R8JGM	1.8-TB, 2.5-inch, 10kmin ⁻¹ , 6-Gbps SAS drive	0-24
DW-F800-1PS8	SFP for 8-Gbps shortwave	0-8
DW-F800-1PL8	SFP for 8-Gbps longwave	0-8
DW-F800-1PS16	SFP for 16-Gbps shortwave	0-4
DW-F800-1PL16	SFP for 16-Gbps longwave	0-4

CBSSD controller components

Part number	Part name	Quantity
DW800-CBSSD	2U chassis	1
	DC power supply unit	2
	Power cable (1.5 m)	2
	Power cable (3 m)	2
	Backup module (BKM)	2
	Front bezel (2U)	1
	Air filter	1
	Binder	1
	SAS cable label	2
	Controller	2
DW-F800-BM10	Cache flash memory	2

CBSSD controller optional components

Part number	Part name	Quantity
DW-F800-CTLS	Controller Board	2
DW-F800-CTLSE	Controller Board (Encryption)	2
DW-F800-4HF8	Front end module (8 Gbps - FC)	2-4
DW-F800-2HF16	Front end module (16 Gbps - FC)	2-4
DW-F800-2HS10S	Front end module (10 Gbps SFP - iSCSI optical)	2-4
DW-F800-2HS10B	Front end module (10 Gbps iSCSI (copper))	2-4
DKC-F810I-CM8G	Cache memory (8 GB)	4
DKC-F810I-CM16G	Cache memory (16 GB)	4
DW-F800-BM10	Cache Flash Memory (CFM)	2
DKC-F810I-200MEM	200-GB, 2.5-inch, MLC, 12 Gbps flash drive	0-24
DKC-F810I-300KCM	300-GB, 2.5-inch, 15kmin ⁻¹ 6-Gbps SAS drive (contains BNST)	0-24
DKC-F810I-300KCMC	300-GB, 2.5-inch, 15kmin ⁻¹ , 6-Gbps SAS drive	0-24
DKC-F810I-400MEM	400-GB, 2.5-inch, MLC, 12-Gbps SAS drive	0-24
DKC-F810I-600JCM	600-GB, 2.5-inch, 10kmin ⁻¹ , 6-Gbps SAS drive (contains BNST)	0-24
DKC-F810I-600JCMC	600-GB, 2.5-inch, 10kmin ⁻¹ , 6-Gbps SAS drive	0-24
DKC-F810I-600KGM	600-GB, 2.5-inch, 15kmin ⁻¹ 12-Gbps SAS drive	0-24
DKC-F810I-1R2JCM	1.2-TB, 2.5-inch, 10kmin ⁻¹ , 6-Gbps SAS drive (contains BNST)	0-24
DKC-F810I-1R2JCMC	1.2-TB, 2.5-inch, 10kmin ⁻¹ , 6-Gbps SAS drive	0-24
DKC-F810I-1R8JGM	1.8-TB, 2.5-inch, 10kmin ⁻¹ , 6-Gbps SAS drive	0-24
DKC-F810I-1PS8	SFP for 8-Gbps shortwave	0-16
DKC-F810I-1PL8	SFP for 8-Gbps longwave	0-16
DKC-F810I-1PS16	SFP for 16-Gbps shortwave	0-8
DKC-F810I-1PL16	SFP for 16-Gbps longwave	0-8

CBSL controller components

Part number	Part name	Quantity
DW800-CBSL	2U chassis	1
	AC power supply unit	2
	Power cable (0.9 m)	2
	Power cable (2.5 m)	2
	Backup module	2
	Front bezel (2U)	1
	Binder	1
	SAS cable label	2
	Controller	2
DW-F800-BM10	Cache flash memory	2

CBSL controller optional components

Part number	Part name	Quantity
DW-F800-CTLS	Controller Board	2
DW-F800-CTLSE	Controller Board (Encryption)	2
DW-F800-4HF8	Front end module (8-Gbps - FC)	2-4
DW-F800-2HF16	Front end module (16-Gbps - FC)	2-4
DW-F800-2HS10S	Front end module (10-Gbps SFP - iSCSI optical)	2-4
DW-F800-2HS10B	Front end module (10-Gbps copper - iSCSI copper)	2-4
DKC-F810I-CM8G	Cache memory (8 GB)	4
DKC-F810I-CM16G	Cache memory (16 GB)	4
DW-F800-BM10	Cache Flash Memory (CFM)	2
DKC-F810I-400M6M	400 GB, Flash drive, 3.5-inch*	0-12
DKC-F810I-1R2J5M	1.2-TB, 3.5-inch, 10kmin ⁻¹ , 6-Gbps SAS drive (contains BNST)	0-12
DKC-F810I-1R2J5MC	1.2 TB, SAS, 3.5-inch*	0-12
DKC-F810I-1R8J6M	1.8-TB, 3.5-inch, 10kmin ⁻¹ , 6-Gbps SAS drive	0-12
DKC-F810I-4R0H3M	4-TB, 7.2K 3.5-inch, 7200min ⁻¹ , 6-Gbps SAS drive (contains BNST)	0-12
DKC-F810I-4R0H3MC	4-TB, 7.2K 3.5-inch, 7200min ⁻¹ 6-Gbps SAS drive	0-12

Part number	Part name	Quantity
DKC-F810I-6R0H9M	6-TB, 7.2K 3.5-inch, 7200min ⁻¹ 12-Gbps SAS drive	0-12
DKC-F810I-1PS8	SFP for 8-Gbps shortwave	0-16
DKC-F810I-1PL8	SFP for 8-Gbps longwave	0-16
DKC-F810I-1PS16	SFP for 16-Gbps shortwave	0-8
DKC-F810I-1PL16	SFP for 16-Gbps longwave	0-8
<p>*Note: The drive capacity values are calculated as 1 G byte =1,000,000,000 bytes. This definition is different from that calculated as 1 k byte =1,024 bytes, which are actually displayed on PCs that you are using. The parity group capacity values displayed in the storage management software are calculated as 1 k byte =1,024 bytes.</p>		

CBSLD controller components

Part number	Part name	Quantity
DW800-CBSLD	2U chassis	1
	DC power supply unit	2
	Power cable (1.5 m)	2
	Power cable (3 m)	2
	Backup module	2
	Front bezel (2U)	1
	Binder	1
	Air filter	1
	SAS cable label	2
	Controller	2
DW-F800-BM10	Cache flash memory	2

CBSLD controller optional components

Part number	Part name	Quantity
DW-F800-CTLS	Controller Board	2
DW-F800-CTLSE	Controller Board (Encryption)	2
DW-F800-4HF8	Front end module (8-Gbps - FC)	2-4
DW-F800-2HF16	Front end module (16-Gbps - FC)	2-4
DW-F800-2HS10S	Front end module (10-Gbps SFP - iSCSI optical)	2-4
DW-F800-2HS10B	Front end module (10-Gbps copper - iSCSI copper)	2-4

Part number	Part name	Quantity
DKC-F810I-CM8G	Cache memory (8 GB)	4
DKC-F810I-CM16G	Cache memory (16 GB)	4
DW-F800-BM10	Cache Flash Memory (CFM)	2
DKC-F810I-1R2J5M	1.2-TB, 3.5-inch, 10kmin ⁻¹ , 6-Gbps SAS drive (contains BNST)	0-12
DKC-F810I-1R8J6M	1.8-TB, 3.5-inch, 10kmin ⁻¹ , 6-Gbps SAS drive	0-12
DKC-F810I-4R0H3M	4-TB, 7.2K 3.5-inch, 7200min ⁻¹ , 6-Gbps SAS drive (contains BNST)	0-12
DKC-F810I-4R0H3MC	4-TB, 7.2K 3.5-inch, 7200min ⁻¹ 6-Gbps SAS drive	0-12
DKC-F810I-6R0H9M	6-TB, 7.2K 3.5-inch, 7200min ⁻¹ 12-Gbps SAS drive	0-12
DKC-F810I-6R0HLM	6-TB, 7.2K 3.5-inch, 7200min ⁻¹ 12-Gbps SAS drive	0-12
DKC-F810I-1PS8	SFP for 8-Gbps shortwave	0-16
DKC-F810I-1PL8	SFP for 8-Gbps longwave	0-16
DKC-F810I-1PS16	SFP for 16-Gbps shortwave	0-8
DKC-F810I-1PL16	SFP for 16-Gbps longwave	0-8

Drive tray model lists

SFF drive tray components (AC power)

Model number	Part name	Quantity
DW-F800-DBS and DW-F800-DBSC	2U chassis	1
	ENC	2
	AC power supply unit	2
	Power cable (0.9 m)	2
	Power cable (2.5 m)	2
	Front bezel (2U)	1

SFF drive tray components (DC power)

Model number	Part name	Quantity
DW-F800-DBSD	2U chassis	1
	ENC	2

Model number	Part name	Quantity
	DC power supply unit	2
	Power cable (1.5 m)	2
	Power cable (3 m)	2
	Front bezel (2U)	1
	Air filter	1

SFF drive tray optional components

Model number	Part name	Quantity
DKC-F810I-200MEM	200-GB, 2.5-inch, MLC, 12-Gbps flash drive	0-24
DKC-F810I-300KCM	300-GB, 2.5-inch, 15kmin ⁻¹ , 6-Gbps SAS drive (contains BNST)	0-24
DKC-F810I-400MEM	400-GB, 2.5-inch, MLC, 12-Gbps flash drive	0-24
DKC-F810I-600JCM	600-GB, 2.5-inch, 10kmin ⁻¹ , 6-Gbps SAS drive (contains BNST)	0-24
DKC-F810I-600KGM	600-GB, 2.5-inch, 15kmin ⁻¹ , 6-Gbps SAS drive	0-24
DKC-F810I-1R2JCM	1.2-TB, 2.5-inch, 10kmin ⁻¹ , 6-Gbps SAS drive (contains BNST)	0-24

LFF drive tray components (AC power)

Model number	Part name	Quantity
DW-F800-DBL and DW-F800-DBLC	2U chassis	1
	ENC	2
	AC power supply unit	2
	Power cable (0.9 m)	2
	Power cable (2.5 m)	2
	Front bezel (2U)	1

LFF drive tray components (DC power)

Model number	Part name	Quantity
DW-F800-DBLD	2U chassis	1
	ENC	2
	DC power supply unit	2

Model number	Part name	Quantity
	Power cable (1.5 m)	2
	Power cable (3 m)	2
	Front bezel (2U)	1
	Air filter	1

Optional LFF drive tray components

Model number	Part name	Quantity
DKC-F810I-400M6M	400 GB, Flash drive, 3.5-inch*	0-12
DKC-F810I-1R2J5M	1.2-TB, 3.5-inch, 10kmin ⁻¹ , 6-Gbps SAS drive (contains BNST)	0-12
DKC-F810I-1R2J5MC	1.2 TB, SAS, 3.5-inch*	0-12
DKC-F810I-1R8J6M	1.8-TB, 3.5-inch, 10kmin ⁻¹ , 6-Gbps SAS drive	0-12
DKC-F810I-4R0H3M	4-TB, 7.2K 3.5-inch, 7200min ⁻¹ , 6-Gbps SAS drive (contains BNST)	0-12
DKC-F810I-6R0H9M	6-TB, 7.2K 3.5-inch, 7200min ⁻¹ , 12-Gbps SAS drive	0-12

***Note:** The drive capacity values are calculated as 1 G byte =1,000,000,000 bytes. This definition is different from that calculated as 1 k byte =1,024 bytes, which are actually displayed on PCs that you are using. The parity group capacity values displayed in the storage management software are calculated as 1 k byte =1,024 bytes.

FMD drive tray components

Model number	Part name	Quantity
DW-F800-DBF	2U chassis	1
	ENC	2
	Power supply unit	2
	Power cable (0.9 m)	2
	Power cable (2.5 m)	2
	Front bezel (2U)	1

FMD drive tray optional components

Model number	Part name	Quantity
DKC-F710I-1R6FM	1.6-TB, MLC, 6-Gbps Flash Module Drive	0-12

Model number	Part name	Quantity
DKC-F710I-3R2FM	3.2-TB, MLC, 6-Gbps Flash Module Drive	0-12
DKC-F810I-1R6FN	1.6-TB, Flash Module Drive	0-12
DKC-F810I-3R2FN	3.2-TB, Flash Module Drive	0-12
DKC-F810I-6R4FN	6.4-TB, Flash Module Drive	0-12

Dense intermix drive tray components

Model number	Part name	Quantity
DW-F800-DB60 and DW-F800-DB60C	4U box	1
	ENC	2
	Power supply unit	2
	Power cable (0.9 m)	2
	Power cable (2.5 m)	2
	Front bezel (dense intermix drive tray)	1
DW-F800-SCQ3	SAS cable (3 m), including 2 omega clips (DW-F800-SCQ3)	2

Dense intermix drive tray optional components

Model number	Part name	Quantity
DKC-F810I-400M8M	1.6-GB, MLC, 12-Gbps flash drive	0-60
DKC-F810I-1R2J7M	1.2-TB, 2.5-inch, 10kmin ⁻¹ , 6-Gbps SAS drive (contains BNST)	0-60
DKC-F810I-1R2J7MC	1.2-TB, 2.5-inch, 10kmin ⁻¹ , 6-Gbps SAS drive	0-60
DKC-F810I-1R8J8M	1.8-TB, 3.5-inch, 10kmin ⁻¹ , 6-Gbps SAS drive	0-60
DKC-F810I-4R0H4M	4-TB, 7.2K 3.5-inch, 7200min ⁻¹ , 6-Gbps SAS drive (contains BNST)	0-60
DKC-F810I-4R0H4MC	4-TB, 7.2K 3.5-inch, 7200min ⁻¹ , 6-Gbps SAS drive	0-60
DKC-F810I-6R0HLM	6-TB, 7.2K 3.5-inch, 7200min ⁻¹ , 12 Gbps SAS drive	0-60

Other model list

Numbers in parentheses show the quantities of the components.

Power cables

Model number	Specification
DW-F800-J1K	2.5 m, 2-pole power cable with grounding terminal (AC 125 V, 13 A or 15 A)
DW-F800-J2H	2.5 m, 2-pole power cable with grounding terminal (AC 250 V, 13 A or 15 A)
DW-F800-J2H5	5.0 m, 2-pole power cable with grounding terminal (AC 250 V, 13 A or 15 A)
DW-F800-J2H10	10.0 m, 2-pole power cable with grounding terminal (AC 250 V, 13 A or 15 A)
A-F6516-P620	Power cable for PDU (1)
A-F6516-P630	Power cable for PDU (1)

SAS cables

Model number	Specification
DW-F800-SCQ1	1 m SAS cable, including omega clips (2)
DW-F800-SCQ1F	1.5 m SAS cable, including omega clips (2)
DW-F800-SCQ3	3 m SAS cable, including omega clips (2)
DW-F800-SCQ5	5 m SAS cable, including omega clips (2)
DW-F800-SCQ10A	10 m SAS optical cable
DW-F800-SCQ30A	30 m SAS optical cable
DW-F800-SCQ1HA	100 m SAS optical cable

Optical cables

Model number	Specification
A-6515-GM5L	5 m LC-LC optical cable for optical
A-6515-GM10L	10 m LC-LC optical cable for optical
A-6515-GM20L	20 m LC-LC optical cable for optical
A-6515-GM30L	30 m LC-LC optical cable for optical
A-6515-GM40L	40 m LC-LC optical cable for optical
A-6515-GM50L	50 m LC-LC optical cable for optical
A-6515-GM1JL	100 m LC-LC optical cable for optical

Model number	Specification
A-6515-GS10L	10 m LC-LC optical cable for optical
A-6515-GS20L	20 m LC-LC optical cable for optical
A-6515-GS30L	30 m LC-LC optical cable for optical
A-6515-GS50L	50 m LC-LC optical cable for optical
A-6515-GS1JL	100 m LC-LC optical cable for optical
A-6515-HM5L	5 m LC-LC optical cable for optical
A-6515-HM10L	10 m LC-LC optical cable for optical
A-6515-HM20L	20 m LC-LC optical cable for optical
A-6515-HM30L	30 m LC-LC optical cable for optical
A-6515-HM50L	50 m LC-LC optical cable for optical
A-6515-HM100L	100 m LC-LC optical cable for optical
A-6515-HM200L	200 m LC-LC optical cable for optical
A-6515-HM300L	300 m LC-LC optical cable for optical
A-6515-JM5L	5 m LC-LC optical cable for optical
A-6515-JM10L	10 m LC-LC optical cable for optical
A-6515-JM20L	20 m LC-LC optical cable for optical
A-6515-JM30L	30 m LC-LC optical cable for optical
A-6515-JM50L	50 m LC-LC optical cable for optical
A-6515-JM100L	100 m LC-LC optical cable for optical
A-6515-JM200L	200 m LC-LC optical cable for optical
A-6515-JM300L	300 m LC-LC optical cable for optical

Replacement parts

Part replacement is required to maintain high performance. Replacement of parts is covered by the maintenance service contract.

Battery unit

Replacement period

Three years.

Treatment

Use the storage system in a place where the ambient temperature is 86°F (30°C) or less on average.

Periodic parts replacement is required. For customers with maintenance service contracts, parts are replaced periodically in keeping with the terms of the contract.



Note: The battery is designed to protect the data in the cache memory in an emergency, such as a sudden power failure. In these situations, follow the normal power down procedure. If not, the battery might reach its lifespan earlier than expected and become unusable within three years. When replacing the battery, follow the given procedure for disposing a used battery.

Hitachi Virtual Storage Platform G200 mechanical specifications (AC power supply model)

Configuration

Controller

- 1 CBSS
- 1 CBSL

Drive trays

- 1 SFF drive tray (DBS)
- 1 LFF drive tray (DBL)
- 1 FMD drive tray
- 1 dense intermix drive tray

Drive

Item	Component	Specification
Drive size (WxDxH)	CBSS, SFF drive tray	2.5-type: 3.21 x 8.10 x 0.74 inches (81.6 x 205.7 x 18.7 mm)
	CBSL, LFF drive tray	3.5-type: 4 x 5.78 x 1.02 inches (101.6 x 147.0 x 26.1 mm)
	FMD drive tray	Flash module drive: 5.74 x 14.44 x 0.78 inches (146 x 366.8 x 19.8 mm)
Data capacity (GB)	CBSS, SFF drive tray	2.5-type: 196.92, 288.20, 393.85, 576.39, 1152.79, 1729.29
	CBSL, LFF drive tray, dense intermix drive tray	3.5-type: 393.85, 1152.79, 1729.29, 3916.14, 5874.22
	FMD drive tray	Flash module drive: 1759.21, 3518.43, 7036.87

Item	Component	Specification
Rotational speed (min ⁻¹)	CBSS, SFF drive tray	Flash drive, 2.5-type: 196.92 GB, 393.85 GB 2.5-type: 288.20 GB, 15,000 RPM 2.5-type: 576.39 GB, 10,000 or 15,000 RPM 2.5-type: 1152.79 GB, 10,000 RPM 2.5-type: 1729.29 GB, 10,000 RPM
	CBSL, LFF drive tray	Flash drive, 3.5-type: 393.85 GB 3.5-type: 1152.79 GB, 10,000 RPM 3.5-type: 1729.29 GB, 10,000 RPM 3.5-type: 3916.14 GB, 7,200 RPM 3.5-type: 5874.22 GB, 7,200 RPM
	FMD drive tray	Flash module drive: 1759.21 GB, 3518.43 GB, 7036.87 GB
Maximum number of drives that can be mounted	CBSS	24 drives
	CBSL	12 drives
	SFF drive tray	24 drives
	LFF drive tray	12 drives
	FMD drive tray	12 drives
	Dense intermix drive tray	60 drives
Maximum number of spare drives		16

Host interface

Item	Component	Specification
Interface type	Fibre Channel optical	8 Gbps, 16 Gbps
	iSCSI optical	10 Gbps
	Copper iSCSI	10 Gbps
Data transfer speed (maximum speed for transfer to host)	Fibre Channel optical	800 Mbps (Fibre Channel)
	Fibre Channel optical	1600 Mbps (Fibre Channel)
	iSCSI optical	10 Gbps (iSCSI optical)
	Copper iSCSI	10 Gbps (copper iSCSI)
Number of ports	8-Gbps Fibre Channel optical	16
	16-Gbps Fibre Channel optical	4

Item	Component	Specification
	10-Gbps optical iSCSI	8
	10-Gbps copper iSCSI	8
Transferred block size		512 bytes
Maximum number of hosts using a Fibre Channel switch		255
Maximum number of hosts using a network switch		255

RAID specifications

D: Data drive, P: Parity drive.

Although the storage system with a configuration of RAID 1, RAID 5, or RAID 6 provides data reliability enhanced by redundancy, there is a chance that user data could be lost due to an unexpected host, storage system hardware, or software failure. Therefore, users are requested to back up all data.

Item	Drive tray
RAID Level	SAS, SAS 7.2k, flash drives mounted
RAID 1	2D+2D, 4D+4D
RAID 5	3D+1P, 4D+1P, 6D+1P, 7D+1P
RAID 6	6D+2P, 12D+2P, 14D+2P

Item	Specification
Maximum number of parity groups	88
Maximum volume size	60 TB (or 4 TB if using the LDEVs of other storage systems)
Maximum volumes/host groups and iSCSI targets	2,048
Maximum volumes/parity groups	2,048

Internal logic specifications

Item	Component	Specifications
Shared memory	Flash memory	32 MB
	L3 cache memory	4 MB
	SDRAM	1 GB
Data assurance method	Data bus	Parity
	Cache memory	ECC (1 bit for correction, 2 bits for detection)
	Drive	Data assurance code

Physical specifications

Item	Component	Specifications
Start-up time (min) ¹	Controller	Standard: 5 to 8
	Drive trays	Standard: 5 to 8
Chassis size	Controller	WxDxH: 19 x 32 x 3.5 inches (483 x 813 x 88 mm)
	SFF drive tray	WxDxH: 19 x 22.2 x 3.5 inches (483 x 565 x 88.2 mm)
	LFF drive tray	WxDxH: 19 x 22.2 x 3.5 inches (483 x 565 x 88.2 mm)
	FMD drive tray	WxDxH: 19 x 30 x 3.4 inches (483 x 762 x 87 mm)
	Dense intermix drive tray	WxDxH: 19 x 40.5 x 7 inches (482 x 1029 x 176 mm)
Mass (approximate) ²	CBSS	97 lbs (44 kg)
	CBSL	101.4 lbs (46 kg)
	SFF drive tray	51 lbs (23 kg)
	LFF drive tray	59.5 lbs (27 kg)
	FMD drive tray	84 lbs (38 kg)
	Dense intermix drive tray	198 lbs (90 kg)
Required height	CBSS, CBSL	2
	SFF drive tray	2
	LFF drive tray	2
	FMD drive tray	2
	Dense intermix drive tray	4
Notes <ol style="list-style-type: none"> The startup time might be longer in proportion to the number of drive trays connected. With a maximum configuration of 1 controller and 19 drive trays, startup time is approximately 8 minutes. Value of maximum configuration when all controllers and drives are mounted. Mixing SFF, LFF, FMD, and dense intermix drive trays might affect the maximum number of drives that can be mounted. 		

Cache specifications

Item	Specifications
Capacity (GB)	64 GB
Control method	Read LRU, Write after

Item	Specifications
Battery backup	Provided
Backup duration	Unrestricted (saving to a nonvolatile memory)

Data in the cache memory is preserved against power failures. If a power outage occurs, data in cache memory is written to drives.

When the storage system enters Cache Backup mode, the amber **WARNING** LED goes on to when the system starts. This warning indicates that the battery charge has dropped significantly and the remaining battery capacity is not sufficient; the storage system will continue operating with the Write Cache function disabled.

When the battery is charged, the warning indication disappears, and the storage system continues the operation in the Write Cache function.

The warning indication disappears within six hours. Even when the warning is shown, normal operation is assured in Write-Through. Read and write performance is lowered because the Write Cache function is disabled.

If the storage system is not charged for more than six months, the battery can become overcharged and sustain unrecoverable damage. To avoid this situation, charge the battery more than 3 hours every six months.

Insulation performance

Item	Specifications
Insulation withstand voltage	AC 1,500 V (100 mA, 1 min)
Insulation resistance	DC 500 V, 10 M Ω or more

Hitachi Virtual Storage Platform G200 mechanical specifications (DC power supply model)

Configuration

Controller

- 1 CBSSD
- 1 CBSLD

Drive trays

- 1 SFF drive tray (DBSD)
- 1 LFF drive tray (DBLD)

Item	Component	Specification
Drive size (WxDxH)	CBSSD, SFF drive tray	2.5-type: 3.21 x 8.10 x 0.74 inches (81.6 x 205.7 x 18.7 mm)
	CBSLD, LFF drive tray	3.5-type: 4 x 5.78 x 1.02 inches (101.6 x 147.0 x 26.1 mm)
Data capacity (GB)	CBSSD, SFF drive tray	2.5-type: 196.92, 288.20, 393.85, 576.39, 1152.79, 1729.29
	CBSLD, LFF drive tray	3.5-type: 393.85, 1152.79, 1729.29, 3916.14, 5874.22
Rotational speed (min ⁻¹)	CBSSD, SFF drive tray	Flash drive, 2.5-type: 196.92 GB, 393.85 GB 2.5-type: 288.20 GB, 15,000 RPM 2.5-type: 576.39 GB, 10,000 or 15,000 RPM 2.5-type: 1152.79 GB, 10,000 RPM 2.5-type: 1729.29 GB, 10,000 RPM
	CBSLD, LFF drive tray	Flash drive, 3.5-type: 393.85 GB 3.5-type: 1152.79 GB, 10,000 RPM 3.5-type: 1729.29 GB, 10,000 RPM 3.5-type: 3916.14 GB, 7,200 RPM 3.5-type: 5874.22 GB, 7,200 RPM
Maximum number of drives that can be mounted	CBSSD, SFF drive tray	24 drives
	CBSLD, LFF drive tray	12 drives
Maximum number of spare drives		16

Host interface

Item	Component	Specification
Interface type	Fibre Channel optical	8 Gbps, 16 Gbps
	iSCSI optical	10 Gbps
	Copper iSCSI	10 Gbps
Data transfer speed (maximum speed for transfer to host)	Fibre Channel optical	800 Mbps (Fibre Channel)
	Fibre Channel optical	1600 Mbps (Fibre Channel)
	iSCSI optical	10 Gbps (iSCSI optical)
	Copper iSCSI	10 Gbps (copper iSCSI)

Item	Component	Specification
Number of ports	8-Gbps Fibre Channel optical	16
	16-Gbps Fibre Channel optical	4
	10-Gbps optical iSCSI	8
	10-Gbps copper iSCSI	8
Transferred block size		512 bytes
Maximum number of hosts using a Fibre Channel switch		255
Maximum number of hosts using a network switch		255

RAID specifications

D: Data drive, P: Parity drive.

Although the storage system with a configuration of RAID 1, RAID 5, or RAID 6 provides data reliability enhanced by redundancy, there is a chance that user data could be lost due to an unexpected host, storage system hardware, or software failure. Therefore, users are requested to back up all data.

Item	Drive tray
RAID Level	SAS, SAS 7.2k, flash drives mounted
RAID 1	2D+2D, 4D+4D
RAID 5	3D+1P, 4D+1P, 6D+1P, 7D+1P
RAID 6	6D+2P, 12D+2P, 14D+2P

Item	Specification
Maximum number of parity groups	88
Maximum volume size	60 TB (or 4 TB if using the LDEVs of other storage systems)
Maximum volumes/host groups and iSCSI targets	2,048
Maximum volumes/parity groups	2,048

Internal logic specifications

Item	Component	Specifications
Shared memory	Flash memory	32 MB
	L3 cache memory	4 MB
	SDRAM	1 GB
Data assurance method	Data bus	Parity

Item	Component	Specifications
	Cache memory	ECC (1 bit for correction, 2 bits for detection)
	Drive	Data assurance code

Physical specifications

Item	Component	Specifications
Start-up time (min) ¹	Controller	Standard: 5 to 8
	Drive trays	Standard: 5 to 8
Chassis size	Controller	WxDxH: 19 x 32 x 3.5 inches (483 x 813 x 88 mm)
	SFF drive tray	WxDxH: 19 x 22.2 x 3.5 inches (483 x 565 x 88.2 mm)
	LFF drive tray	WxDxH: 19 x 22.2 x 3.5 inches (483 x 565 x 88.2 mm)
Mass (approximate) ²	CBSSD	97 lbs (44 kg)
	CBSLD	101.4 lbs (46 kg)
	SFF drive tray	51 lbs (23 kg)
	LFF drive tray	59.5 lbs (27 kg)
Required height	CBSSD, CBSLD	2
	SFF drive tray	2
	LFF drive tray	2
Notes		
<ol style="list-style-type: none"> 1. The startup time might be longer in proportion to the number of drive trays connected. With a maximum configuration of 1 controller and 19 drive trays, startup time is approximately 8 minutes. 2. Value of maximum configuration when all controllers and drives are mounted. 3. Mixing DBSD and DBLD drive trays might affect the maximum number of drives that can be mounted. 		

Cache specifications

Item	Specifications
Capacity (GB)	64 GB
Control method	Read LRU, Write after
Battery backup	Provided
Backup duration	Unrestricted (saving to a nonvolatile memory)

Data in the cache memory is preserved against power failures. If a power outage occurs, data in cache memory is written to drives.

When the storage system enters Cache Backup mode, the amber **WARNING** LED goes on to when the system starts. This warning indicates that the battery charge has dropped significantly and the remaining battery capacity is not sufficient; the storage system will continue operating with the Write Cache function disabled.

When the battery is charged, the warning indication disappears, and the storage system continues the operation in the Write Cache function.

The warning indication disappears within six hours. Even when the warning is shown, normal operation is assured in Write-Through. Read and write performance is lowered because the Write Cache function is disabled.

If the storage system is not charged for more than six months, the battery can become overcharged and sustain unrecoverable damage. To avoid this situation, charge the battery more than 3 hours every six months.

Insulation performance

Item	Specifications
Insulation withstand voltage	AC 1,500 V (100 mA, 1 min)
Insulation resistance	DC 500 V, 10 M Ω or more

Electrical specifications

Item	Controller	Drive tray
Input voltage (operable voltage range) (V)	AC 100-120/200-240 +6%/-11%	SFF, LFF, FMD, and dense intermix drive tray: AC 200-240 +6%/-11%
Frequency (Hz)	50/60 \pm 1	
Number of phases, cabling	Single-phase with protective grounding	
Steady-state current 100V/ 200V ^{1, 2}	CBSS: 4.0x2/2.0x2 CBSL: 4.0x2/2.0x2	SFF drive tray: 2.4x2/1.2x2 LFF drive tray: 1.9x2/1.0x2 FMD drive tray: 2.6x2/1.3x2 Dense intermix drive tray: -/ 3.0x2
Current rating of breaker/fuse (A)	16.0	
Heat value (normal) (kJ/h)	CBSS: 1800 or less CBSL 1550 or less	SFF drive tray: 1120 or less LFF drive tray: 940 or less

Item	Controller	Drive tray
		FMD drive tray: 1300/1520 or less Dense intermix drive tray: 3460 or less
Steady-state power (VA/W) ³	CBSS: 800/760 or less CBSL: 800/760 or less	SFF drive tray: 480/460 or less LFF drive tray: 380/350 or less FMD drive tray: 520/490 or less Dense intermix drive tray: 1200/1160 or less
Power consumption (VA/W)	CBSS: 520/500 or less CBSL: 450/430 or less	SFF drive tray: 320/310 or less LFF drive tray: 280/260 or less FMD drive tray: 440/420 or less Dense intermix drive tray: 1000/960 or less
Notes: <ol style="list-style-type: none"> 1. The power current of Nx2 described in this table is required for a single power unit. 2. If one power unit fails, another power unit requires electric current for the two power units. Therefore, plan the power supply facility so that the current-carrying capacity for one power unit can provide the total capacity for two power units. 3. This table shows the power requirement (100 V or 200 V) for the maximum configuration . The actual required power might exceed the value shown in the table when the tolerance is included. 		

VSP G200 electrical specifications (DC power supply)

Input power specifications

Item	CBSSD	CBSLD	DBSD	DBLD
Rated input voltage (v)	DC -60 to -48			
Input voltage fluctuation (v)	DC -72 to -40			
Input voltage instant fluctuation (v)	DC -75 to -36			
Inrush current (v)	35 (Ta = 25°C, in the range of rated input voltage, except when voltage fluctuates)			
Input shape	Connection by connector. Connect the terminal by the dedicated cable with terminal. Connector: Positronic Industries Inc., PCS Series			
Heat value (kJ/h)	1800	1550	1120	940

Item	CBSSD	CBSLD	DBSD	DBLD
Steady-state power (W)	760	760	460	350
Power consumption (W)	500	430	310	260
Input current (A)	15.9	15.9	9.6	7.3
UPS	No connection			
Remote adapter	No connection			

Environmental specifications

Temperature



Caution: The following VSP Gx00/Fx00 storage system components are not supported in high-temperature environments. Do not operate the following components at temperatures of 40°C or higher:

- DB60 dense drive tray
- HDS provided service processor (SVP) server
- First-generation FMDs (non-DC2 FMDs)

State	Controller	SFF, LFF drive trays	Dense intermix drive tray
Operating	50°F to 104°F (10°C to 40°C)	50°F to 104°F (10°C to 40°C)	50°F to 95°F (10°C to 35°C)
Non-operating	14°F to 122°F (-10°C to 50°C)	14°F to 122°F (-10°C to 50°C)	14°F to 122°F (-10°C to 50°C)
Transport, storage	-22°F to 140°F (-30°C to 60°C)	-22°F to 140°F (-30°C to 60°C)	-22°F to 140°F (-30°C to 60°C)
Temperature change rate (°C/h)	10 or less		

State	Controller	FMD drive trays
Operating	50°F to 104°F (10°C to 40°C)	DKC-F710I-1R6FM or DKC-F710I-3R2FM drive is installed: 50°F to 95°F (10°C to 35°C)
Operating	50°F to 104°F (10°C to 40°C)	DKC-F810I-1R6FN, DKC-F810I-3R2FN, or DKC-F810I-6R4FN drive is installed: 50°F to 104°F (10°C to 40°C)

State	Controller	FMD drive trays
Non-operating	14°F to 122°F (-10°C to 50°C)	14°F to 95°F (-10°C to 35°C)
Transport, storage	-22°F to 140°F (-30°C to 60°C)	-22°F to 122°F (-30°C to 50°C)
Temperature change rate (°C/h)	10 or less	

Humidity

State	Percentage
Operating	8 to 80
Non-operating	8 to 90
Transport, storage (%)	5 to 95
Maximum wet bulb temperature (°C)	29 (non-condensing)

Vibration

State	m/s ²
Operating	2.5 or less Within 5 seconds (resonance point: 10 Hz or less)
Non-operating	5.0 or less at 5 Hz to 300 Hz (no damage to product) 9.8 (1.0 G) Within 5 seconds (resonance point: 10 Hz or less)
Transport (packed)	5.0 or less

Impact

State	m/s ²
Operating	20 or less (10 ms, half sine wave)
Non-operating	50 or less (10 ms, half sine wave)
Transport (packed)	80 or less

Altitude

State	Controller	FMD drive
Operating (m)	3,000 (Environmental temperature: 10°C to 32°C) 900 (Environmental temperature: 10°C to 40°C)	3,000 (Environmental temperature 10°C to 32°C) OR 900 (Environmental temperature: 10°C to 35°C) when DKC-F710I-1R6FM or DKC-F710I-3R2FM drive is installed.
Operating (m)	3,000 (Environmental temperature: 10°C to 32°C) 900 (Environmental temperature: 10°C to 40°C)	3,000 (Environmental temperature: 10°C to 32°C) OR 900 (Environmental temperature: 10°C to 40°C) when DKC-F810I-1R6FN, DKC-F810I-3R2FN, or DKC-F810I-6R4FN drive is installed.
Non-operating (m)	-60 to 12,000	N/A

State	Controller	SFF and LFF drives	Dense intermix drive tray
Operating (m)	3,000 (Environmental temperature: 10°C to 32°C)	3,000 (Environmental temperature: 10°C to 32°C)	3,000 (Environmental temperature: 10°C to 28°C)
	900 (Environmental temperature: 10°C to 40°C)	900 (Environmental temperature: 10°C to 40°C)	1,000 (Environmental temperature: 10°C to 35°C)
Non-operating (m)		N/A	

Atmosphere

Avoid areas exposed to corrosive gas and salty air.

Acoustic Noise

State	Controller	SFF, LFF	Dense intermix drive tray
Operating	60 dB (Environmental temperature 32°C or less) ¹	60 dB (Environmental temperature 32°C or less) ¹	71 dB (Environmental temperature 32°C or less) ^{1, 2, 3, 4}

State	Controller	SFF, LFF	Dense intermix drive tray
Non-operating	55 dB	55 dB	71 dB (Environmental temperature 32°C or less) ^{1, 2, 3, 4}
Notes: <ol style="list-style-type: none"> 1. The system's internal temperature controls the rotating speed of the fan module. Therefore, this standard value might be exceeded if the maximum load continues under high-temperature environment or if a failure occurs in the system. 2. Sound pressure level (LA) changes from 66 dB or 75 dB, according to the ambient temperature, drive configuration, and operating status. Maximum volume can reach 79 dB during maintenance procedure for a failed ENC or power supply. 3. Acoustic power level (LWA) measured by the ISO 7779 standard is 7.2 B. This value changes from 7.2 B to 8.1 B, according to the ambient temperature, drive configuration, and operating status. 4. When accessing the dense intermix drive tray, do not work for long times at the rear of the rack. 			

State	Controller	FMD	
Operating	60 dB (Environmental temperature 32°C or less) ¹	60 dB (Environmental temperature 32°C or less) ^{1, 2, 3} (When accessing the dense intermix drive tray, do not work for long times at the rear of the rack.)	
Non-operating	55 dB (Environmental temperature 32°C or less) ^{1, 2, 3, 4} 55 dB		
Notes: <ol style="list-style-type: none"> 1. The system's internal temperature controls the rotating speed of the fan module. Therefore, this standard value might be exceeded if the maximum load continues under high-temperature environment or if a failure occurs in the system. 2. Sound pressure level (LA) changes from 66 dB or 75 dB, according to the ambient temperature, drive configuration, and operating status. Maximum volume can reach 79 dB during maintenance procedure for a failed ENC or power supply. 3. Acoustic power level (LWA) measured by the ISO 7779 standard is 7.2 B. This value changes from 7.2 B to 8.1 B, according to the ambient temperature, drive configuration, and operating status. 			

VSP G200 environmental specifications (DC power supply)

Item		CBSSD/CBSLD/ DBSD/DBLD	Notes
Temperature	Operating	41°F to 104°F (5°C to 40°C)	
	Non-operating	23°F to 131°F	

Item		CBSSD/CBSLD/ DBSD/DBLD	Notes
		(-5 to 55°C) in 16 hours	
	Transport/storage)	-22°F to 140°F (-30°C to 60°C)	
Humidity	Operating	5% to 85% (non-condensing)	
	Transportation/storage	5% to 95% (non-condensing)	
Vibration	Operating (m/s ²)	2.5 or less (5 to 300 Hz)	Within 5 seconds (Resonance point:10 Hz or less)
	Non-operating (m/s ²)	5.0 or less (5 to 300 Hz): No critical damage for product. 9.8 (1.0 G) Adopt fall-prevention safety measures.	
	Transport (packed) (m/s ²)	5.0 or less	
Impact	Operating (m/s ²)	20 or less	10 ms, half sine wave
	Non-operating (m/s ²)	50 or less	
	Transport (packed) (m/s ²)	80 or less	
Angle at which the storage system turns over		15° or less	To be measured when installed on leveling bolts.
Altitude	Operating (m)	-60 to 1,800 above sea level Environmental temperature: 41°F to 104°F (5°C to 40°C)	
		-1,800 to 4,000 above sea level Environmental temperature: 41°F to 86°F (5°C to 30°C)	
Atmosphere		No corrosive gas and salty air must be found.	
Acoustic Noise	Operating	60 dB Environmental temperature: 89.6°F (32°C) or less The system's internal temperature controls the rotating speed of the fan. Therefore, this standard value	Measured at the position 1.5 meter away from the storage system, at a height of 1.5 meters.

Item		CBSSD/CBSLD/ DBSD/DBLD	Notes
		might be exceeded if the maximum load continues under high-temperature environment or if a system failure occurs.	
	Standby	55 dB	

Battery specifications

The following table shows the lifetime expectancy of the batteries installed in the storage system.

Storage system intake temperature	CBSS	CBSL
Up to 75.2° F (24° C)	5 years	5 years
Up to 86° F (30° C)	5 years	4 years
Up to 93.2° (34° C)	4 years	3 years
Up to 104° (40° C)	3 years	2 years

RAID specifications

Item		Controller	SFF, LFF, dense intermix drive trays (range for setup)
RAID level		SAS, SAS 7.2k, flash drives mounted: 1, 5, 6	
RAID configuration (unit of addition)	RAID 1	2D+2D, 4D+4D	
	RAID 5	3D+1P, 4D+1P, 6D+1P, 7D+1P	
	RAID 6	6D+2P, 12D+2P, 14D+2P	

Item		Controller	FMD drive tray (range for setup)
RAID level		N/A	SAS, SAS 7.2 krpm, flash drives mounted: 0, 1, 5, 6, 1+0 (DBW supports SAS 7.2k drives)

Item		Controller	FMD drive tray (range for setup)
RAID configuration (unit of addition)	RAID 1	N/A	2D+2D, 4D+4D
	RAID 5	N/A	3D+1P, 4D+1P, 6D+1P, 7D+1P
	RAID 6	N/A	6D+2P, 12D+2P, 14D+2P



Note: Although certain RAID configurations support redundancy in the event of a drive failure, best practices dictate that you back up data on a regular basis.

iSCSI specifications

Item	Specification	Comments
iSCSI target function	Supported	N/A
iSCSI target function	Supported	TrueCopy® only
iSCSI ports	2 per interface board	VSP Gx00 models: Maximum 32 per iSCSI system
Connection methods	Direct and switch connections	
Host connections	255 (maximum per iSCSI port)	With Linux software initiator, the maximum number decreases.
Path failover	HDLM ¹	Supports Microsoft MPIO (Multi Path I/O)
Link	10 Gbps SFP+	N/A
Transfer speed	10 Gbps	N/A
Connector type	LC	N/A
Cable	Optical OM3, OM2 MMF cable	N/A
Network switch	L2 or L3 switch	Should comply with IEEE802.3ae
Switch cascading	Maximum: 5 switches or fewer	Minimum number of cascading switches is recommended.
MAC address	Per port (fixed value)	Factory setting: World Wide Unique value. Cannot be changed.
Maximum transfer unit (MTU)	1,500, 4,500, 9,000 bytes (Ethernet frame)	Jumbo frame, MTU size greater than 1500
Link aggregation	Not supported	N/A

Item	Specification	Comments
Tagged VLAN	Supported	N/A
IPv4	Supported	N/A
IPv6	Supported	Note the following precautions: <ul style="list-style-type: none"> When iSCSI Port IPv6 is set to Enabled, if the IPv6 global address is set to automatic, the address is determined by acquiring a prefix from an IPv6 router. If the IPv6 router does not exist in the network, the address cannot be determined. As a result, an iSCSI connection might be delayed. When an iSCSI Port IPv6 is set to Enabled, verify the IPv6 router is connected to the same network, and then set IPv6 global address automatically.
Subnet mask	Supported	N/A
Gateway address	Supported	N/A
DHCP	N/A	N/A
DNS	N/A	N/A
Ping (ICMP ECHO) Transmit, Receive	Supported	N/A
IPsec ²	N/A	N/A
TCP port number	3260	Changeable among 1 to 65,535. Observe the following if changing values: <ul style="list-style-type: none"> The setting of the corresponding host should also be changed to log in the new port number. The new port number might conflict with other network communication or be filtered on some network equipment, preventing the storage system from communicating through the new port number.
iSCSI name	Both iqn ³ and eui ⁴ types are supported	The unique iqn value is automatically set when a target is made. iSCSI name is configurable.

Item	Specification	Comments
Error recovery level	0 (zero)	Error recovery by retrying from host. Does not support Level 1 and Level 2.
Header digest	Supported	Detects header error or data error with iSCSI communication. The storage system follows the host's digest setting. If digest is enabled, the performance degrades. The amount of the degradation depends on factors such as host performance of host and transaction pattern.
Data digest	Supported	
Maximum iSCSI connections at one time	255 per iSCSI port	N/A
CHAP	Supported	Authentication: login request is sent properly from host to storage. CHAP is not supported during discovery session.
Mutual (2-way) CHAP	Supported (not available if connected to Linux software initiator)	Authentication: login request is sent properly from host to storage.
CHAP user registration	Max 512 users per iSCSI port	N/A
iSNS	Supported	With iSNS (name service), a host can discover a target without knowing the target's IP address.
<p>Note:</p> <ol style="list-style-type: none"> 1. JP1, HiCommand Dynamic Link Manager. Pass switching is achieved. Not supported on Microsoft Windows Vista and Windows 7 operating systems. 2. IP Security. Authentication and encryption of IP packets. The storage system does not support IPsec. 3. iqn: iSCSI Qualified Name. The iqn consists of a type identifier, "iqn," a date of domain acquisition, a domain name, and a character string given by the individual who acquired the domain. Example: iqn.1994-04.jp.co.hitachi:rsd.d7m.t.10020.1b000.tar 4. eui: 64-bit Extended Unique Identifier. The eui consists of a type identifier, "eui," and an ASCII-coded, hexadecimal, EUI-64 identifier. Example: eui.0123456789abcdef 		

iSCSI standards

The following standards apply to the management, maintenance, and iSCSI data ports. To configure this system, use switches that comply with the following standards:

- IEEE 802.1D STP
- IEEE 802.1w RSTP
- IEEE 802.3 CSMA/CD

- IEEE 802.3u Fast Ethernet
- IEEE 802.3z 1000 BASE-X
- IEEE 802.1Q Virtual LANs
- IEEE 802.3ad Dynamic LACP
- IEEE 802.3ae 10 Gigabit Ethernet
- RFC 768 UDP
- RFC 783 TFTP
- RFC 791 IP
- RFC 793 TCP
- RFC 1157 SNMP v1
- RFC 1231 MIB II
- RFC 1757 RMON
- RFC 1901 SNMPv2

Regulatory compliance

This equipment has been tested and certified for compliance with the following standards.

Standard	Specification	Mark on the product	Country regulation
Electronic emission controls	FCC part 15 Subpart B: 2013	FCC	USA and Canada
	ICES-003 Issue 5:2012	ICES-003	USA and Canada
	AS/NZS CISPR 22:2009+A1	RCM	Australia and New Zealand
	TP TC 020/2011	EAC	Russia, Belarus, and Kazakhstan
	CNS 13438	BSMI	Taiwan
	KN22	KC	Korea
	KN24	KC	Korea
Electronic emission certifications	EN5522: 2010	CEmarking	EU
	EN5524: 2010	CEmarking	EU
	EN61000-3.2:2006+A1+A2	CEmarking	EU
	EN61000-3.3:2008	CEmarking	EU
Safety certifications	UL and CSA 60950-1:2007	cTUVus	USA and Canada
	EN60950-1:2006+A1	TUV	Germany
	IEC60950-1:2005+A1	N/A	All CB countries
	IEC60950-1:2005+A1	S_Mark	Argentina
	TP TC 004/2011	EAC	Russia

Standard	Specification	Mark on the product	Country regulation
	CNS 14336-1	BSMI	Taiwan
	EN60950-1:2006+A1	CEmarking	EU
Radio interference voluntary control	VCCI V-3/2013.04	VCCI	Japan

Dense intermix drive tray connection restrictions

If a drive is inserted into a slot of a dense intermix drive tray when the installed number of drives exceeds 240 slots per path, the drive is blocked.

SVP hardware specifications

The following table lists the hardware specifications for the physical service processor (SVP) server.



Caution: The HDS supplied SVP server is not supported in high temperature environments. Do not operate the SVP server at temperatures of 40°C or higher.

Item	Specification
Dimensions	Height: 1.7 inches (43 mm) Width: 17.2 inches (437 mm) Depth: 14.5 inches (369 mm) Weight: 14 lbs (6.4 kg)
Processor	Celeron G1820 2.7 GHz 2M, 2C, 2T <ul style="list-style-type: none"> • Cores: 2 • Instruction set: 64-bit • SmartCache: 2 MB • Maximum memory size: 32 GB • Memory types: DDR3-1333, DDR3L-1333 @ 1.5V
Memory	8 GB RAM DDR3
Hard drive	2 TB
Network interface card	x4 ports (on-board NIC) + x1 IPMI (BMC) port
Rated AC voltage	100-240 V, 50-60 Hz, 4.2 - 1.8A

Item	Specification
Power supply	350 Watt AC power supply w/ PFC
AC voltage	100-240 V, 50-60 Hz, 4.2-1.8 Amp
Power supply safety / EMC	<ul style="list-style-type: none"> • USA - UL listed, FCC • Canada - CUL listed • Germany - TUV Certified • Europe/CE Mark • EN 60950/IEC 60950-Compliant
Fans	2x 4cm 4-pin PWM fans
Operating system	Microsoft Windows Embedded Standard 7

Index

Numerics

- 10 Gbps iSCSI board (copper) 36
- 10 Gbps iSCSI board (optical) 36
- 16 Gbps Fibre Channel board 34
- 8 Gbps Fibre Channel board 33

A

- AC electrical specifications 124
- AC mechanical specifications 115
- AC power supply units
 - CBSL controller 39
 - CBSS controller 39
 - large form factor drive tray 50
 - small form factor drive tray 50

B

- back end module
 - LEDs and connectors 38
- backing up user accounts 100
- battery specifications 130
- bezels
 - CBSL controller 29
 - CBSS controller 26
 - dense intermix drive tray 47
 - flash module drive tray 44
 - large form factor drive tray 42
 - service processor 52
 - small form factor drive tray 40

C

- cables
 - removing 87
- CBSL controller 29
 - AC power supply unit 39
 - CBSL controller 29
 - front panel bezel 29
 - rear panel 31
 - without front panel bezel 30
- CBSLD power supply unit 39
- CBSS controller 26
 - AC power supply unit 39

- rear panel 28
 - with front panel bezel 26
 - without front panel bezel 27
- CBSSD power supply unit 39
- compliance 134
- configurations 20
- connection restrictions for dense intermix drive tray 135
- connections
 - dense intermix drive tray restrictions 135
- controllers
 - CBSL 29
 - CBSS 26

D

- DC environmental specifications 128
- DC mechanical specifications 119
- DC power supply units
 - CBSLD 39
 - CBSSD 39
 - large form factor drive tray 50
 - small form factor drive tray 50
- dense intermix drive tray 47
 - display LEDs 48
 - rear panel 49
 - with front panel bezel 47
- dense intermix drive tray connection restrictions 135
- disabling user accounts 93
- display LEDs on dense intermix drive tray 48
- drive trays
 - dense intermix 47
 - flash module 44
 - large form factor 42
 - maximum number 20
 - small form factor 40

E

- electrical specifications 123
 - AC 124
- environmental specifications 125
 - DC 128

F

- features 19
- Fibre Channel
 - cable removal 87
- flash module drive tray 44
 - rear panel 46
 - with front panel bezel 44
 - without front panel bezel 45
- front end modules
 - 10 Gbps iSCSI board (copper) 36
 - 10 Gbps iSCSI board (optical) 36
 - 16 Gbps Fibre Channel board 34
 - 8 Gbps Fibre Channel board 33
- front panel bezels
 - CBSL controller 29
 - CBSS controller 26
 - dense intermix drive tray 47
 - flash module drive tray 44
 - large form factor drive tray 42
 - service processor 52
 - small form factor drive tray 40

I

- iSCSI
 - cable removal 87
 - specifications 131
 - standards 133

L

- LAN blade LEDs and connectors 37
- large form factor drive tray 42
 - AC power supply unit 50
 - DC power supply units 50
 - rear panel 43
 - with front panel bezel 42
 - without bezel 43

M

- maintaining the storage system 85
- maximum
 - number of mounted drives 20
- mechanical specifications
 - AC 115
 - DC 119
- model lists 104
- mounted drive trays 20

N

- number of mounted drive trays 20

P

- parts, replacement 114

- power supply units
 - CBSL controller 39
 - CBSLD 39
 - CBSS controller 39
 - CBSSD 39
- powering off the storage system 87

R

- RAID specifications 130
- rear panels
 - CBSL controller 31
 - CBSS controller 28
 - dense intermix drive tray 49
 - flash module drive tray 46
 - large form factor drive tray 43
 - service processor 53
 - small form factor drive tray 41
- regulatory compliance 134
- removing cables 87
- removing user accounts 97
- replacement parts 114
- restoring user account information 100
- roles 90

S

- SAS cables
 - removing 87
- scalability 20
- service processor
 - front panel 52
 - rear panel 53
 - specifications 135
- setting up user accounts 91
- small form factor drive tray 40
 - AC power supply unit 50
 - DC power supply units 50
 - rear panel 41
 - with front panel bezel 40
 - without bezel 40
- specifications
 - AC 115
 - battery 130
 - electrical 123
 - electrical (AC) 124
 - environmental 125
 - environmental (DC) 128
 - iSCSI 131
 - mechanical (DC) 119
 - RAID 130
 - service processor 135
- standards for iSCSI 133
- storage system
 - maintenance 85
 - power off 87
 - regulatory compliance 134
 - storing 86

- storage system controllers
 - CBSL 29
 - CBSS 26
- storing the storage system 86
- supported configurations 20
- System Option Modes 56

U

- user administration 89

Hitachi Data Systems

Corporate Headquarters

2845 Lafayette Street
Santa Clara, California 95050-2639
U.S.A.
www.hds.com

Regional Contact Information

Americas

+1 408 970 1000
info@hds.com

Europe, Middle East, and Africa

+44 (0) 1753 618000
info.emea@hds.com

Asia Pacific

+852 3189 7900
hds.marketing.apac@hds.com



MK-94HM8020-05

June 2016