

Troubleshooting

This “Troubleshooting” volume describes the trouble analysis of the subsystem, etc.

Contents

Chapter 1. Flowchart for Troubleshooting	TRBL 01-0000
Chapter 2. Before Maintenance Work	TRBL 02-0000
2.1 Precautions	TRBL 02-0000
2.2 Confirming and Setting RTC (Real Time Clock)	TRBL 02-0010
2.3 Indications and their Functions.....	TRBL 02-0030
Chapter 3. Before Starting WEB Connection	TRBL 03-0000
3.1 Procedure to WEB Connection	TRBL 03-0000
3.2 When the WEB has Already been Connected	TRBL 03-0070
3.3 Note on WEB Connecting	TRBL 03-0080
3.4 Procedure for Specifying Maintenance Port IP Address	TRBL 03-0130
3.5 Procedure to Search IP Address of Maintenance Port	TRBL 03-0140
Chapter 4. Trouble Analysis by WEB Connection	TRBL 04-0000
4.1 Confirm State of Unit	TRBL 04-0010
4.2 Confirm State of Each Part	TRBL 04-0040
4.3 Confirm Log Messages	TRBL 04-0100
4.4 TrueCopy remote replication/ TrueCopy Extended Distance Path Confirm State.....	TRBL 04-0170
4.5 The Priority Error Messages when “CTL alarm” is Displayed.....	TRBL 04-0180
Chapter 5. Procedure for Investigating Disk Array System Regarding Fibre Channel Failure	TRBL 05-0000
Chapter 6. Details of Recovery Methods	TRBL 06-0000
6.1 Error Recovery Methods.....	TRBL 06-0000
6.1.1 System Down.....	TRBL 06-0020
6.1.2 The Subsystem does not Become Ready : Case 1 >Loading Failure)	TRBL 06-0050
6.1.3 The Failure Occurred Immediately after Being Ready >Forced Parity Correction).....	TRBL 06-0110
6.1.4 The Power cannot be Turned Off : Case 1 >The Number of PIN Data is Too Large).....	TRBL 06-0550
6.1.5 The Power cannot be Turned Off : Case 2 (Hardware Failure)	TRBL 06-0580
6.1.6 The Power cannot be Turned Off : Case 3 >Control Unit Failure).....	TRBL 06-0600
6.1.7 The Power cannot be Turned Off : Case 4 >Cache Memory Failure).....	TRBL 06-0620
6.1.8 Data Recovery does not Terminate Normally : Case 1 >Read Error).....	TRBL 06-0640

6.1.9 Data Recovery does not Terminate Normally : Case 2 (Disk Drive Failure)	TRBL 06-0650
6.1.10 Data Recovery does not Terminate Normally : Case 3 (Spare Disk Drive Failure)	TRBL 06-0670
6.1.11 A Failure Occurred during Operation : Case 1 (PIN Over)	TRBL 06-0690
6.1.12 A Failure Occurred during Operation : Case 2 (LA/LRC Error)	TRBL 06-0720
6.1.13 A Failure Occurred during Operation : Case 3 (LU Blockade)	TRBL 06-0740
6.1.14 A Failure Occurred during Operation : Case 4 (Incomplete Writing)	TRBL 06-0760
6.1.15 The Incomplete Write Area was Registered in the Restored VOL..	TRBL 06-0770
6.1.16 Recovery Method of the Modular Volume Migration which Terminated Abnormally	TRBL 06-0790
6.1.17 Path Blockade Occurs in the TrueCopy remote replication/ TrueCopy Extended Distance Function	TRBL 06-0820
6.1.18 Recovery Method for Disk Drives which Skipped Drive Firmware Replacement	TRBL 06-0920
6.1.19 Recovery Method when the Subsystem Down of the Array Occurred due to the Incorrect ENC Cable Connection ..	TRBL 06-0930
6.1.20 Recovery Method when a Power Unit Failure of the Additional Chassis Occurred	TRBL 06-0950
6.1.21 Recovery Method when the Creation of the SSL User Certificate File Failed	TRBL 06-0960
6.1.22 Recovery Method when Detecting the Mismatch of the Control Unit Model Names between the Control Units..	TRBL 06-0980
6.1.23 Recovery Method when an Error of the Additional Battery Box Connection was Detected	TRBL 06-1010
6.1.24 Recovery Method when the Spin-up of the System Drive Failed ...	TRBL 06-1030
6.1.25 Recovery Method when the Subsystem went Down because the Load of the DP Management Information.....	TRBL 06-1060
6.1.26 Recovery Method when the Firmware Detected an Error of the DP Management Information and the Control Unit was Blocked ...	TRBL 06-1120
6.1.27 Recovery Method when the Disk Drive Serial Number Acquired at the time of Starting the Subsystem and the Serial Number of the Configuration Information do not Match	TRBL 06-1140
6.1.28 Procedure for Starting the Subsystem by Removing the Failed Disk Drive when the Subsystem is not Ready	TRBL 06-1160
6.1.29 Failure Determination and Recovery Methods of Fibre Channel Port Path	TRBL 06-1200
6.1.30 Recovery Method when the Multiple Suspected Failed Parts were Detected in the Backend.....	TRBL 06-1340
6.1.31 Recovery Method when Write to the Cache Data (Pseudo Planned Shutdown) Failed in the LT Short Version SELF HEATRAN System .	TRBL 06-1380
6.1.32 Recovery Method when the Version Downgrade to the Firmware which does not Support the SATA Drives Failed	TRBL 06-1430

6.1.33 The Recovery Method when the Copy-Back Operates Regardless of the Copy-Back-Less Setting if Power Saving is Enabled and Performs the Drive Restoration	TRBL 06-1470
Chapter 7. Collecting Error Information.....	TRBL 07-0000
7.1 Time to Collect Failure Information	TRBL 07-0010
7.2 Judge Collection of Failure Information	TRBL 07-0020
7.3 Collecting Simple Trace.....	TRBL 07-0040
7.4 Collecting CTL Alarm Trace	TRBL 07-0090
7.5 Collecting Full Dump	TRBL 07-0140
Chapter 8. Trouble Analysis by LED Indication	TRBL 08-0000
8.1 Trouble Analysis by LED Indication of Front Bezel.....	TRBL 08-0000
8.2 Trouble Analysis by LED Indication of Each Part.....	TRBL 08-0150
Chapter 9. Data Collection when a Failure Occurs in Program Product (P.P.) ...	TRBL 09-0000
9.1 Locating Failed Part	TRBL 09-0000
9.1.1 When a Failure Occurs in the DF800 Main Body.....	TRBL 09-0020
9.1.2 When a Failure Occurs in a Host System Server.....	TRBL 09-0020
9.1.3 When a Failure Occurs in a Server for Monitoring and Setting.....	TRBL 09-0020
9.2 List of Data to be Collected when a P.P. Failure Occurs.....	TRBL 09-0030
Chapter 10. Trouble Analysis by Failure Monitoring Function.....	TRBL 10-0000
10.1 Trouble Analysis by SNMP Agent Support Function.....	TRBL 10-0000
10.1.1 Maintenance with TRAP Codes	TRBL 10-0000
10.1.2 Maintenance with MIB (df Regression) Values.....	TRBL 10-0050
10.2 Trouble Analysis by Hitachi Storage Navigator Modular 2.....	TRBL 10-0080
10.2.1 Maintenance with the Hitachi Storage Navigator Modular 2 (GUI Version).....	TRBL 10-0080
10.2.2 Hitachi Storage Navigator Modular 2 Maintenance Function	TRBL 10-0090
10.2.3 Displaying Logical Unit Failure Data Information.....	TRBL 10-0100
10.2.4 Setting Pre-fetch Information	TRBL 10-0120
10.2.5 Setting a Threshold for Preventive Maintenance	TRBL 10-0150
10.2.6 Drive Maintenance.....	TRBL 10-0180
10.2.7 Setting a Mode for Reporting to the Host Using an SSB.....	TRBL 10-0200
10.2.8 Setting SATA Drive Options	TRBL 10-0230
10.2.9 Setting SATA Drive Restore Options	TRBL 10-0260
10.2.10 Replacing the Online ENC Firmware	TRBL 10-0280
10.2.11 Drive Performance Delay Diagnostic Function.....	TRBL 10-0310
10.2.12 Setting the Drive Firmware Download	TRBL 10-0350
10.2.13 Displaying Temperature in the Basic Unit.....	TRBL 10-0380
10.2.14 Setting the Host Reservation Forced Release Function	TRBL 10-0410

Chapter 11. Procedure for the iSCSI System Failure Determination on the Disk Array System Side	TRBL 11-0000
Chapter 12. Procedure for Online ENC Firmware Download	TRBL 12-0000
12.1 Outline of Online ENC Firmware Download	TRBL 12-0000
12.2 Preconditions for Online ENC Firmware Download.....	TRBL 12-0010
12.3 Restriction and Notes of Online ENC Firmware Download	TRBL 12-0020
12.3.1 Restriction	TRBL 12-0020
12.3.2 Precautions	TRBL 12-0030
12.4 Time Required for Online ENC Firmware Download	TRBL 12-0040
12.5 Before Starting Online ENC Firmware Download	TRBL 12-0050
12.5.1 Hierarchy of ENC Firmware Storage Directories	TRBL 12-0060
12.6 Procedure for Online ENC Firmware Download.....	TRBL 12-0070
12.6.1 Flowchart	TRBL 12-0080
12.6.2 Connecting the PC Used for Maintenance	TRBL 12-0090
12.6.3 Online ENC Firmware Download.....	TRBL 12-0120
12.7 Procedure for Displaying ENC Firmware Revision Using Web.....	TRBL 12-0240
Chapter 13. Procedure for Offline ENC Firmware Download	TRBL 13-0000
13.1 Offline ENC Firmware Download Overview.....	TRBL 13-0000
13.2 Offline ENC Firmware Download Prerequisites	TRBL 13-0010
13.3 Restriction and Notes of Offline ENC Firmware Download.....	TRBL 13-0040
13.4 Offline ENC Firmware Download Time	TRBL 13-0050
13.5 Before Beginning an Offline ENC Firmware Download.....	TRBL 13-0070
13.5.1 Hierarchy of ENC Firmware Storage Directories	TRBL 13-0100
13.6 Offline ENC Firmware Download Procedure (Dual Controller)	TRBL 13-0110
13.6.1 Flowchart (General).....	TRBL 13-0120
13.6.2 Flowchart (Detailed)	TRBL 13-0140
13.6.3 Connecting the PC Used for Maintenance	TRBL 13-0150
13.6.4 Deleting Browser History Information	TRBL 13-0180
13.6.5 Downloading Offline ENC Firmware	TRBL 13-0210
13.7 Offline ENC Firmware Download Procedure (Single Controller)	TRBL 13-0320
13.7.1 Flowchart (General).....	TRBL 13-0330
13.7.2 Flowchart (Detailed)	TRBL 13-0350
13.7.3 Offline ENC Firmware Download Procedure Screen (Single Controller)	TRBL 13-0360
13.8 Offline ENC Firmware Download Web Display Screen	TRBL 13-0370
13.8.1 URLs.....	TRBL 13-0370
13.8.2 Web Screen Image.....	TRBL 13-0380
13.8.3 Side Frame and Top Frame Image Screen Details	TRBL 13-0390
13.8.4 Select Frame Image Screen Details.....	TRBL 13-0400

13.9	Procedure for Invalidating the Automatic ENC Firmware Downloading Function	TRBL 13-0410
Chapter 14.	Procedure for Replacing the Online Drive Firmware	TRBL 14-0000
14.1	Overview of the Online Drive Firmware Replacement Function	TRBL 14-0000
14.2	Prerequisites	TRBL 14-0010
14.3	Restrictions	TRBL 14-0020
14.4	Online Drive Firmware Replacement Time	TRBL 14-0020
14.5	Before Replacing the Online Drive Firmware	TRBL 14-0030
14.6	Procedure for Replacing the Online Drive Firmware.....	TRBL 14-0040
14.6.1	Replacing Procedure	TRBL 14-0040
14.6.2	Procedure Screen	TRBL 14-0070
14.7	Web Screen of the Drive Firmware	TRBL 14-0100
14.7.1	URL.....	TRBL 14-0100
14.7.2	Web Screen Image	TRBL 14-0100
14.8	Method of Checking the Drive Firmware Revision.....	TRBL 14-0130
14.8.1	The Check Method by WEB Connection	TRBL 14-0130
14.8.2	The Check Method by Trace Analysis.....	TRBL 14-0150
14.8.3	The Procedure to Check the Drive Firmware Revision Using the Hitachi Storage Navigator Modular 2.....	TRBL 14-0160
Chapter 15.	Procedure for Replacing the Offline Drive Firmware.....	TRBL 15-0000
15.1	Overview of the Offline Drive Firmware Replacement Function	TRBL 15-0000
15.2	Prerequisites	TRBL 15-0020
15.3	Restrictions.....	TRBL 15-0040
15.4	Offline Drive Firmware Replacement Time	TRBL 15-0041
15.5	Before Replacing the Offline Drive Firmware.....	TRBL 15-0050
15.6	Procedure for Replacing the Offline Drive Firmware	TRBL 15-0070
15.6.1	Replacing Procedure	TRBL 15-0070
15.6.2	Procedure Screen	TRBL 15-0170
15.7	Web Screen of the Drive Firmware	TRBL 15-0240
15.7.1	URL.....	TRBL 15-0240
15.7.2	Web Screen Image	TRBL 15-0240
15.8	Method of Checking the Drive Firmware Revision.....	TRBL 15-0270
15.8.1	The Check Method by WEB Connection	TRBL 15-0270
15.8.2	The Check Method by Trace Analysis.....	TRBL 15-0290
15.8.3	The Procedure to Check the Drive Firmware Revision Using the Hitachi Storage Navigator Modular 2.....	TRBL 15-0300

Chapter 1. Flowchart for Troubleshooting

This chapter contains information on troubleshooting to be used when failures occur in the unit.

The following is the flow of troubleshooting to be used when a failure occurs in the unit.

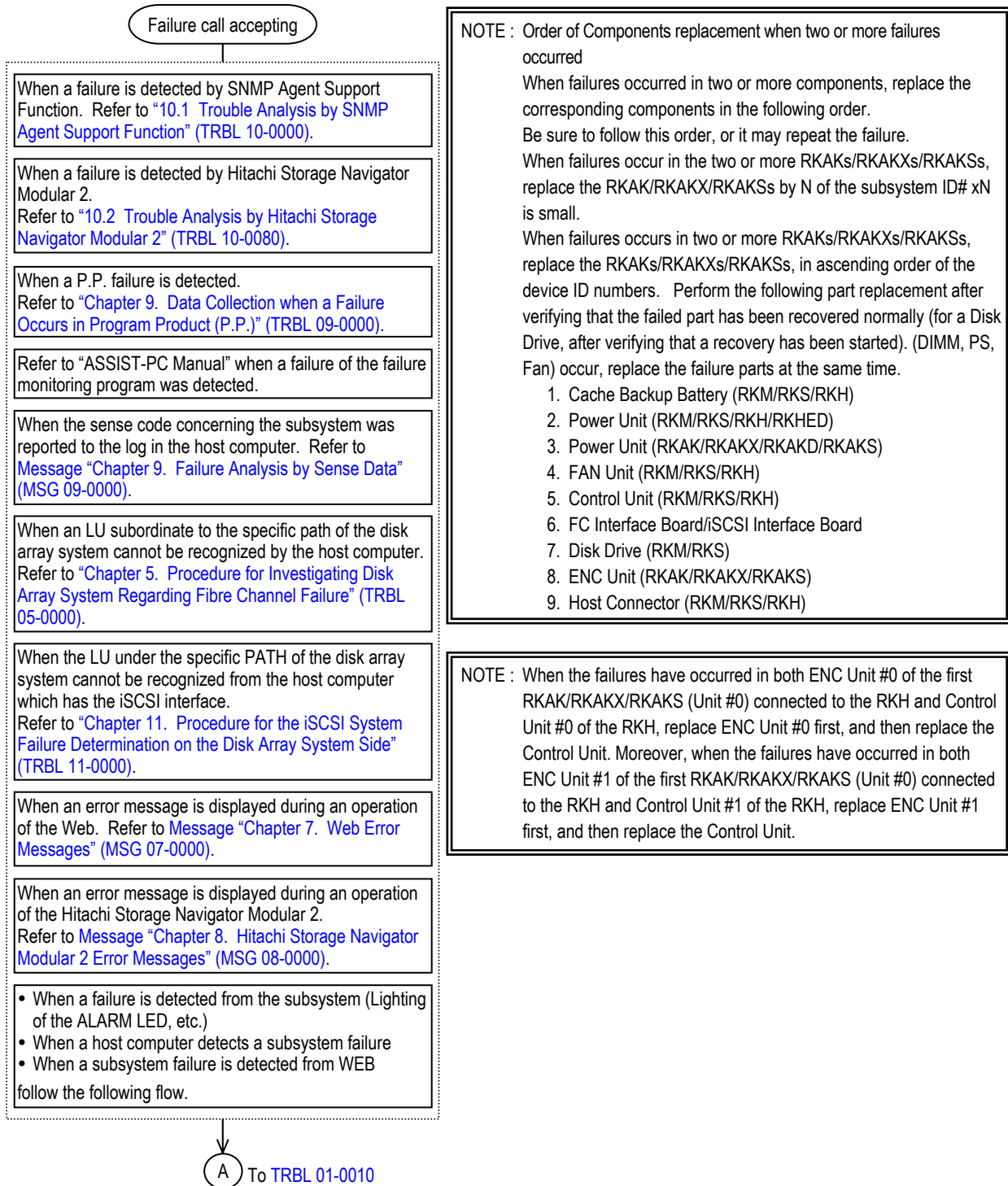

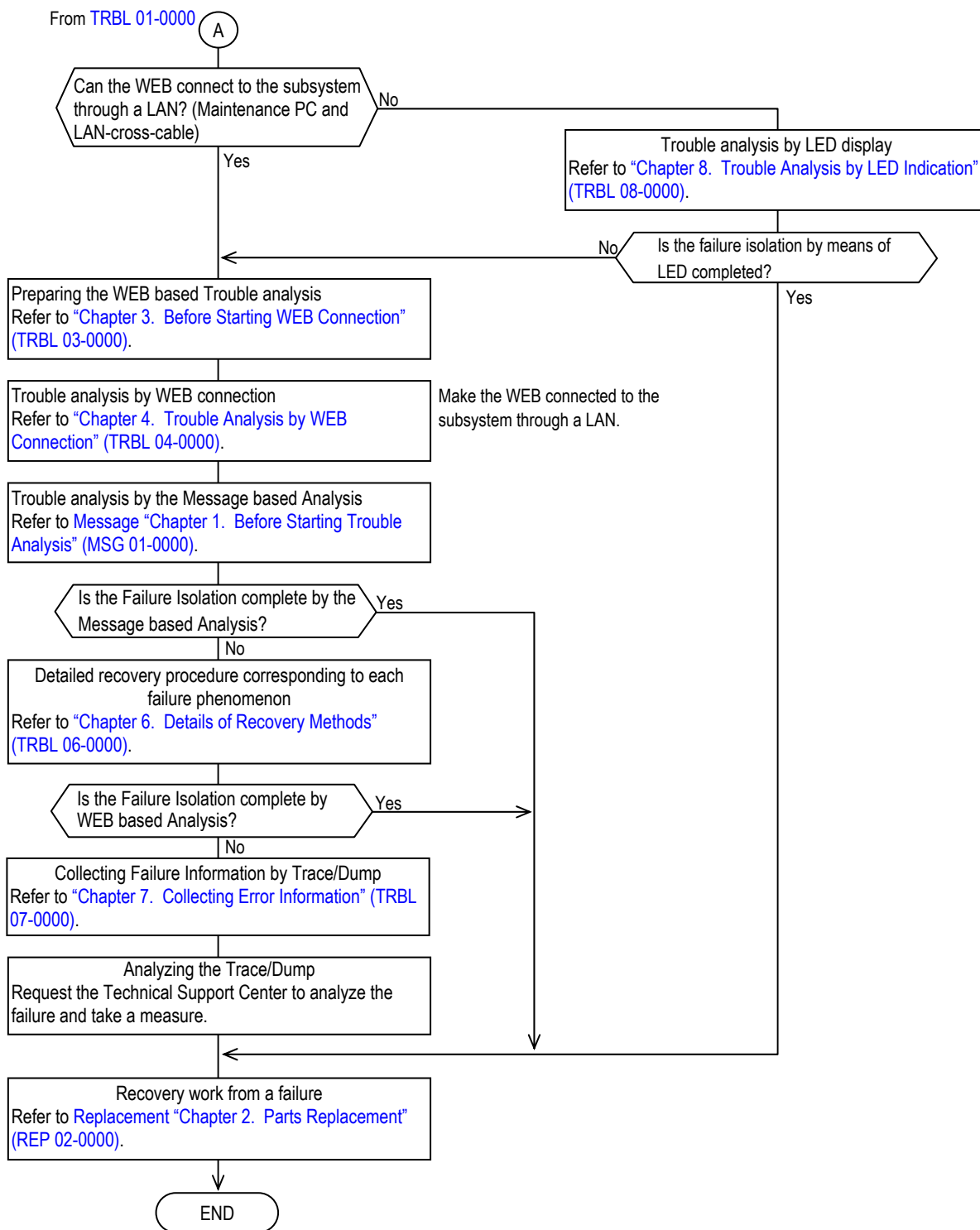

Chapter 2. Before Maintenance Work

2.1 Precautions

(1) Note on restarting

When restarting the subsystem, turn on the main switch after waiting more than one minute after the main switch is turned off (after the POWER LED goes out).

- If the array subsystem used for a remote side of TrueCopy remote replication/TrueCopy Extended Distance restarts in the status that TrueCopy remote replication/TrueCopy Extended Distance is enabled, the following phenomena occur.
 - The paths of TrueCopy remote replication/TrueCopy Extended Distance are both blocked. The notice of E-mail Alert Function, SNMP Agent Support Function, and TRAP occur at the time of the path blockade.
Perform the notice and the check to the Failure Monitoring Department in advance. The path blockade automatically recovers after restarting.
 - When the status of the pair of TrueCopy remote replication/TrueCopy Extended Distance is PAIR or COPY, the pair changes to PSUE.
If the Pair status of TrueCopy remote replication/TrueCopy Extended Distance is either PAIR or COPY, suspend the pairs before restarting the array subsystem.
- When Power Saving of the priced option is used, if you restart the subsystem after executing the spin-down and before completing it, the spin-down may fail because of the recognition processing of the host immediately after the subsystem starts.
Check that there is no RAID Group whose power saving status is “Normal (command monitoring)” after executing the spin-down, and then restart the subsystem.
If the spin-down fails, execute the spin-down again.
- If the NAS Unit is connected and the NAS service is in operation, ask the NAS Unit administrator for planned shutdown of the NAS Unit.
After rebooting the array device, ask the NAS Unit administrator to reboot the NAS Unit and check the status of the FC path (Fibre Channel path). Refer to [“Recovering from FC path errors”](#) in [“Hitachi NAS Manager User’s Guide”](#) to check the status of the FC path, and if there is a failure in the FC path, ask the NAS Unit administrator to recover the FC path.

(2) Notes while the array subsystem is being started

Because the status where the array subsystem is being started is in the middle of the transition to the status of the subsystem power turned on (Ready status) from the status of the subsystem power turned off, do not perform the following work while the array subsystem is being started.

- Isolating the Fibre system failure in the disk array system side
- Trouble analysis by LED indication
- Part replacement
- Data collection when a failure occurs in Program Product (P.P.)
- Troubleshooting of the failure of the failure monitoring program
- Troubleshooting of the WEB error message

Also, the setting function or the reference function using the Hitachi Storage Navigator Modular 2 cannot be executed to the array subsystem which is being started.

2.2 Confirming and Setting RTC (Real Time Clock)

RTC (Real Time Clock) is a built-in clock in the Controller. It is used to record the time information of messages and trace/dump when an error occurred. Even if the RTC is out of order, the host system may not be affected. However, the time information of messages and trace/dump is not correct. Accordingly, the failure analysis with synchronizing to the host may be affected.

In the following cases, check the RTC and reset it if it varies.

- When the controller was replaced while the subsystem power was turned off.
- When there is something wrong with the time on messages, traces and dump.

Set the time on the Japanese Standard Time basis

Set RTC using Hitachi Storage Navigator Modular 2. Refer to [System Parameter “1.1 Procedure for Connecting Hitachi Storage Navigator Modular 2 with the Subsystem” \(SYSPR 01-0020\)](#) to connect Hitachi Storage Navigator Modular 2.

The setting of RTC can be made without rebooting the array unit.

NOTE: If data inconsistency happens with all data in the cache memory gone due to a problem such as system down and the combination of power outage and battery failure, the setting done from the start of the array to the occurrence of data inconsistency will return to where it was before the start of the array. So it is necessary to check and reconfigure the Date & Time setting after maintenance work for a failure that leads to data inconsistency.

- (1) Put a checkmark in one of the array subsystems on the main window, and press the [Ctrl] key, [Shift] key and the [E] key at the same time.

It is displayed as “maintenance mode” in [Operation Mode] of the upper part of the window, and Hitachi Storage Navigator Modular 2 is operated in the maintenance mode.

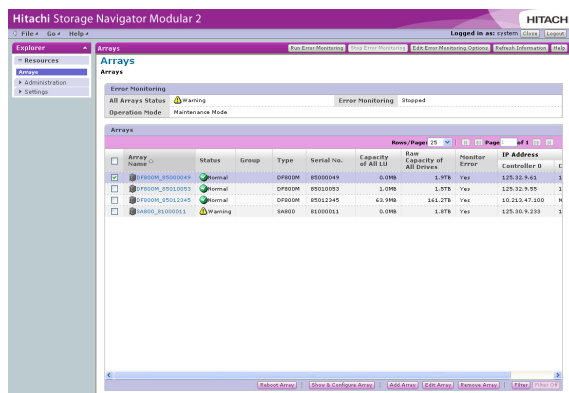

NOTE : There is a case that the LAN Port Number is changed. When the main screen is not displayed even though the name of the array subsystem is clicked, use the changed LAN Port Number, and execute it again. (Refer to [System Parameter “1.2 LAN Port Number Change by Hitachi Storage Navigator Modular 2” \(SYSPR 01-0120\)](#).)

- (2) Click the array subsystem to set the parameter from [Subsystem Name].

(3) Select [Settings] - [Date & Time] in the unit window.

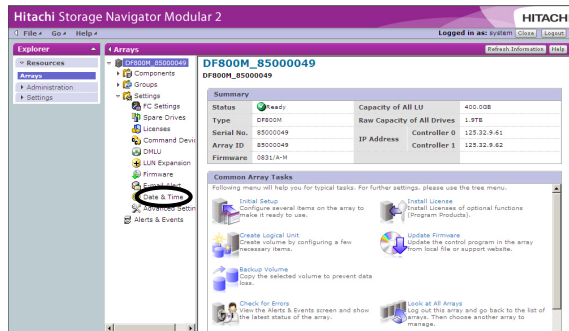

(4) Click the [Edit Date & Time] button in the unit window.

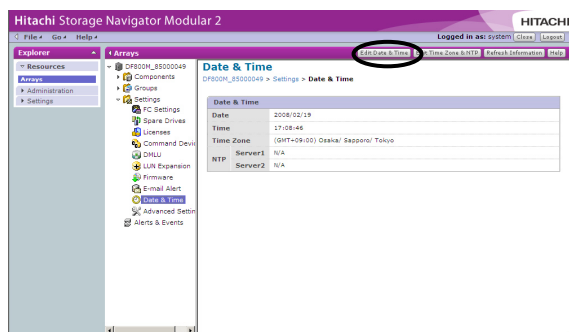

(5) The Edit Date and Time window is displayed.

Specify the setting method and click the [OK] button.

[Date and Time] : Specifies the setting method.

- Select “Set Automatically” unless it is especially required to set it manually.
- When you have selected “Set Manually”, enter [Date] (you can display or set the date that is set now) and [Time] (you can display or set the time that is set now).

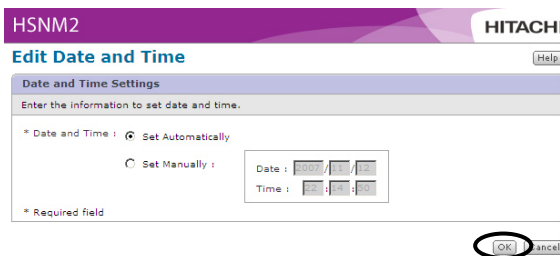

(6) The completion message is displayed. Click the [Close] button.

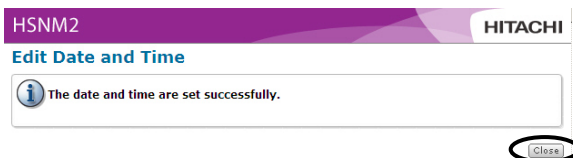

2.3 Indications and their Functions

(1) Indication positions and their functions of RKM

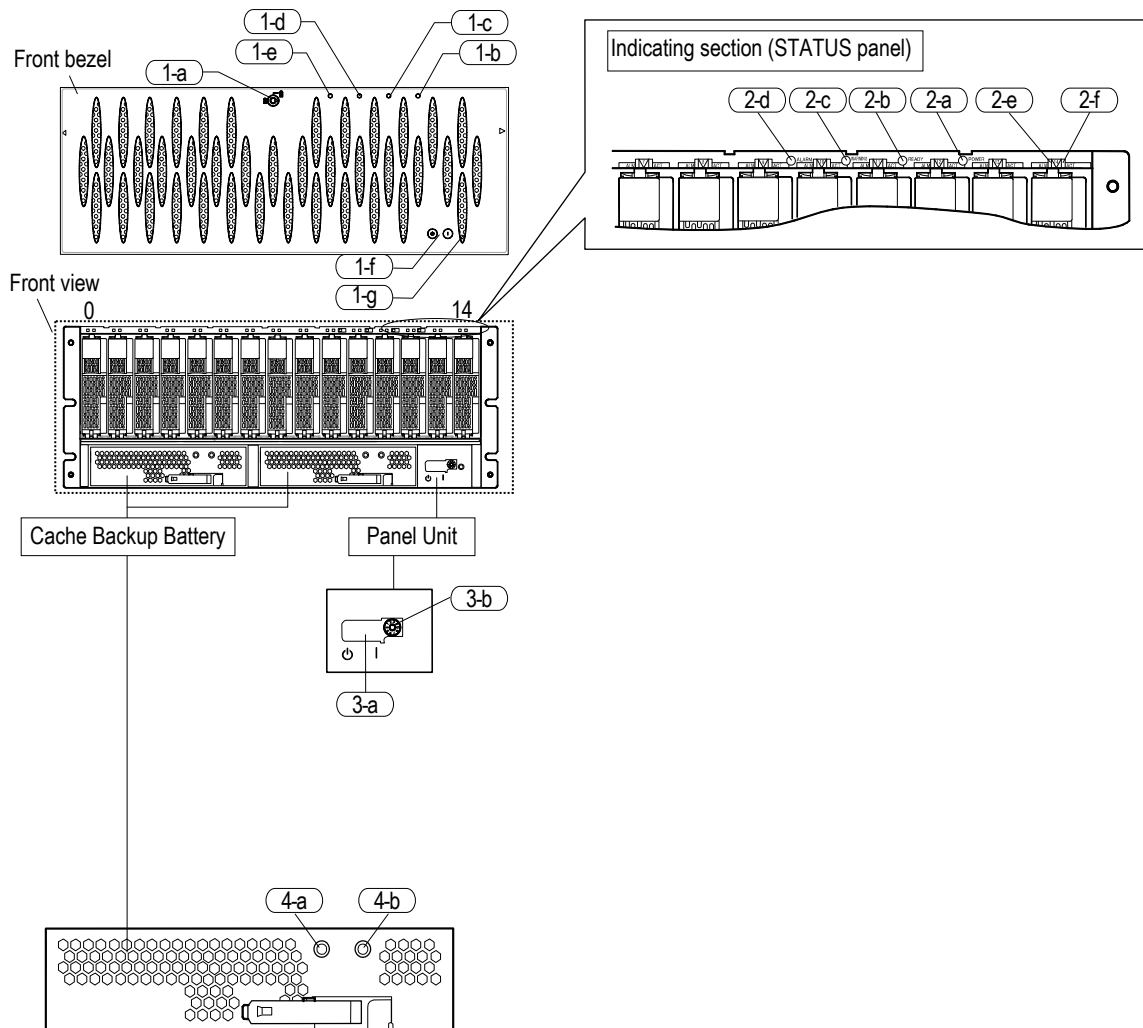

Figure 2.3.1 Indication Locations of Functional Components (Front View)

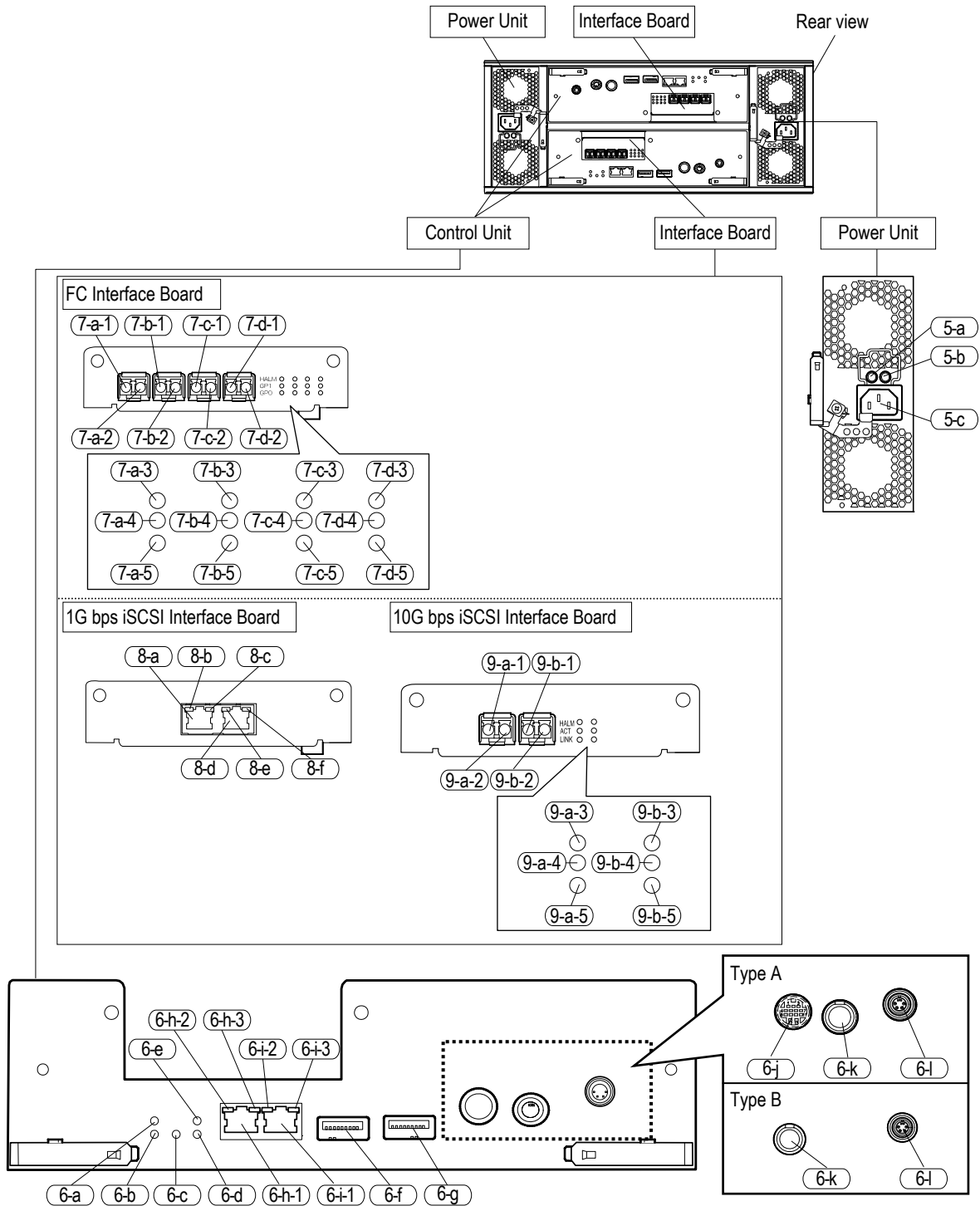

Figure 2.3.1.1 Indication Locations of Functional Components (Rear View)

Table 2.3.1 Functions of Indications

No.	Section	Name	Classification	Color	Function	
1-a	Front Bezel	KEY	Key	—	Locks the front bezel.	
1-b		POWER	LED	Green	Indicates that the power supply is supplied to the subsystem.	
1-c		READY	LED	Green	On Indicates that the subsystem can be operated. Blinking High-speed blinking : Indicates that the automatic download of the ENC firmware is being executed in the dual controller configuration. Low-speed blinking : Indicates that the download processing of the ENC firmware is completed online.	
1-d		WARNING	LED	Orange	On Indicates that a failure, which allows the subsystem to operate, occurred. Blinking High-speed blinking : Indicates that the most recent revision maintenance function of the flash program or the automatic download of the ENC firmware at the time of turning the power on in the single controller configuration is being executed. Low-speed blinking : Indicates that a failure, which does not stop operation occurred in unit (It must be detected with WEB).	
1-e		ALARM	LED	Red	On Indicates that a failure, which does not allow the subsystem to operate, occurred. Blinking Low-speed blinking : Indicates that a serious failure occurred while power on.	
1-f			Main switch (OFF)	Switch	—	OFF : Presses off the power.
1-g			Main switch (ON)	Switch	—	ON : Presses on the power.
2-a	STATUS Panel (RKM)	POWER	LED	Green	Indicates that the power supply is supplied to the subsystem.	
2-b		READY	LED	Green	On Indicates that the subsystem can be operated. Blinking High-speed blinking : Indicates that the automatic download of the ENC firmware is being executed in the dual controller configuration. Low-speed blinking : Indicates that the download processing of the ENC firmware is completed online.	
2-c		WARNING	LED	Orange	On Indicates that a failure, which allows the subsystem to operate, occurred. Blinking High-speed blinking : Indicates that the most recent revision maintenance function of the flash program or the automatic download of the ENC firmware at the time of turning the power on in the single controller configuration is being executed. Low-speed blinking : Indicates that a failure, which allows the subsystem to operate, occurred. (It must be detected with WEB).	

No.	Section	Name	Classification	Color	Function											
2-d	STATUS Panel (RKM)	ALARM	LED	Red	On Indicates that a failure occurred which makes the subsystem unable to operate. Blinking Low-speed blinking : Indicates that a serious failure occurred while power on.											
2-e		ALM	LED	Red	Indicates that a failure which makes the unable to operate occurred.											
2-f		ACT	LED	Green	<table border="1"> <thead> <tr> <th>No.</th> <th>LED status</th> <th>Meaning</th> </tr> </thead> <tbody> <tr> <td>1</td> <td>Blinking</td> <td>Shows that the Disk Drive is being accessed.</td> </tr> <tr> <td>2</td> <td>On</td> <td>Spin up state. (SAS/SAS(SED))/ Power on. (SATA/Flash Drive)</td> </tr> <tr> <td>3</td> <td>Off</td> <td>Spin down state. (SAS/SAS(SED))/ Power off. (SATA/Flash Drive)</td> </tr> </tbody> </table>	No.	LED status	Meaning	1	Blinking	Shows that the Disk Drive is being accessed.	2	On	Spin up state. (SAS/SAS(SED))/ Power on. (SATA/Flash Drive)	3	Off
No.	LED status	Meaning														
1	Blinking	Shows that the Disk Drive is being accessed.														
2	On	Spin up state. (SAS/SAS(SED))/ Power on. (SATA/Flash Drive)														
3	Off	Spin down state. (SAS/SAS(SED))/ Power off. (SATA/Flash Drive)														
3-a	Panel Unit	Main switch	Switch	—	Turns on/off the power. : Power on ⏻ : Power off											
3-b		Mode switch	Switch	—	Sets the local/remote power unit control mode. In the Ready status, sets the Web special window display permission.											
4-a	Cache Backup Battery	ALM	LED	Red	Lights when the Cache Battery unit is in trouble. • Battery voltage is abnormal. • Battery temperature abnormal.											
4-b		RDY	LED	Green	Shows the state of the battery. On : Battery is in the normal condition. Blinking : Charged up when start-up Off : Abnormal • The battery is not installed. • Battery voltage is abnormal. • Temperature of the battery is abnormal.											
5-a	Power Unit	ALM	LED	Red	Lights when the Power Unit is in trouble.											
5-b		RDY	LED	Green	Shows the operation state of the Power Unit. On : Normal operation Off : Abnormal operation or out of operation											
5-c		Receptor (J1)	Connector	—	Connector on the subsystem side to connect the power cable.											
6-a	Control Unit	ALM	LED	Red	• Indicates that a failure which makes in the Controller unable to operate occurred in it. • Does not light up when the Control Unit is in the reset status.											
6-b		LOC	LED	Orange	Indicate the Chassis location • A factor of the error is indicated by the blinking count. Six times : Voltage on the Controller is abnormal. (Reset of the Controller is not canceled.) • The CUDG error detected by the ENC firmware is indicated. On: CUDG error detected by ENC firmware (BOOT section) RAM error detected by ENC firmware ENC hard configuration error High-speed blinking: Once : SRAM error. Twice : CUDG error in ENC hard. Three times : Firmware error in flash memory. Four times : The hardware error of the ENC part was detected. • When adding the chassis with the power turned on, it lights up to indicate the addition source (this is not an error).											

No.	Section	Name	Classification	Color	Function	
6-c	Control Unit	RST SW	Switch	—	Used to perform a Full Dump.	
6-d		RST	LED	Orange	Indicates that the Controller is being reset. <ul style="list-style-type: none"> • During power-on reset • During reset for doing a dump • During reset for a reboot at the time of a firmware down load • The DC-DC converter or the reset circuit on the Control Unit fails. 	
6-e		C-PWR	LED	Green	You can check if the Cache memory is being backed up by the indication status of this LED. It is valid when the power cables are connected to the Power Units. On : Indicates that the cache is being backed up. (The power is supplied from the battery to the Cache memory.) Off : The Cache memory is not backed up.	
6-f		PATH0	Connector	—	Connection connector for ENC cable (PATH 0 side).	
6-g		PATH1	Connector	—	Connection connector for ENC cable (PATH 1 side).	
6-h-1		LAN0	LAN0	Connector	—	Connects the LAN0 cable. (For maintenance)
6-h-2			ACT	LED	Yellow	Indicates that data is being transferred via a LAN 0.
6-h-2			LINK	LED	Green	Indicates that the link status of the LAN 0 is normal.
6-i-1		LAN1	LAN1	Connector	—	Connects the LAN1 cable. (For User Management)
6-i-2			ACT	LED	Yellow	Indicates that data is being transferred via a LAN 1.
6-i-3			LINK	LED	Green	Indicates that the link status of the LAN 1 is normal.
6-j		Connector for connecting the Additional Battery Box (BATTERY)	Connector	—	Not used.	
6-k		Connector for connecting the UPS interlocking cable (UPS)	Connector	—	Used to connect the UPS for the DF800.	
6-l	Connector for connecting the Remote adapter (REMOTE ADAPTER)	Connector	—	Used to connect the Remote Adapter.		
7-a-1	FC Interface Board	Port 0A/ Port 1A	Tx	Connector	—	Connector on the signal output side to connect the Fibre Channel interface cable in the Port 0A/Port 1A side.
7-a-2			Rx	Connector	—	Connector on the signal input side to connect the Fibre Channel interface cable in the Port 0A/Port 1A side.
7-a-3			HALM	LED	Red	Lights when the Port 0A/Port 1A is in trouble.
7-a-4			GP1	LED	Green	Shows status of the standard Interface Board mounted on the Controller in the Port 0A/Port 1A side.
7-a-5			GP0	LED	Green	Shows status of the standard Interface Board mounted on the Controller in the Port 0A/Port 1A side.
7-b-1		Port 0B/ Port 1B	Tx	Connector	—	Connector on the signal output side to connect the Fibre Channel interface cable in the Port 0B/Port 1B side.
7-b-2			Rx	Connector	—	Connector on the signal input side to connect the Fibre Channel interface cable in the Port 0B/Port 1B side.
7-b-3			HALM	LED	Red	Lights when the Port 0B/Port 1B is in trouble.
7-b-4			GP1	LED	Green	Shows status of the standard Interface Board mounted on the Controller in the Port 0B/Port 1B side.
7-b-5			GP0	LED	Green	Shows status of the standard Interface Board mounted on the Controller in the Port 0B/Port 1B side.

No.	Section	Name	Classification	Color	Function	
7-c-1	FC Interface Board	Port 0C/ Port 1C	Tx	Connector	—	Connector on the signal output side to connect the Fibre Channel interface cable in the Port 0C/Port 1C side.
7-c-2			Rx	Connector	—	Connector on the signal input side to connect the Fibre Channel interface cable in the Port 0C/Port 1C side.
7-c-3			HALM	LED	Red	Lights when the Port 0C/Port 1C is in trouble.
7-c-4			GP1	LED	Green	Shows status of the standard Interface Board mounted on the Controller in the Port 0C/Port 1C side.
7-c-5			GP0	LED	Green	Shows status of the standard Interface Board mounted on the Controller in the Port 0C/Port 1C side.
7-d-1		Port 0D/ Port 1D	Tx	Connector	—	Connector on the signal output side to connect the Fibre Channel interface cable in the Port 0D/Port 1D side.
7-d-2			Rx	Connector	—	Connector on the signal input side to connect the Fibre Channel interface cable in the Port 0D/Port 1D side.
7-d-3			HALM	LED	Red	Lights when the Port 0D/Port 1D is in trouble.
7-d-4			GP1	LED	Green	Shows status of the standard Interface Board mounted on the Controller in the Port 0D/Port 1D side.
7-d-5			GP0	LED	Green	Shows status of the standard Interface Board mounted on the Controller in the Port 0D/Port 1D side.
8-a	1G bps iSCSI Interface Board	Port 0A/ Port 1A	iSCSI	Connector	—	Connects the iSCSI cable (Port 0A/Port 1A side).
8-b			Active	LED	Yellow	Indicates that data is being transferred via a Port 0A/Port 1A side.
8-c			Link	LED	Green	Indicates that the link status of the Port 0A/Port 1A side is normal.
8-d		Port 0B/ Port 1B	iSCSI	Connector	—	Connects the iSCSI cable (Port 0B/Port 1B side).
8-e			Active	LED	Yellow	Indicates that data is being transferred via a Port 0B/Port 1B side.
8-f			Link	LED	Green	Indicates that the link status of the Port 0B/Port 1B side is normal.
9-a-1	10G bps iSCSI Interface Board	Port 0A/ Port 1A	Tx	Connector	—	Connector on the signal output side to connect the 10G iSCSI interface cable in the Port 0A/Port 1A side.
9-a-2			Rx	Connector	—	Connector on the signal input side to connect the 10G iSCSI interface cable in the Port 0A/Port 1A side.
9-a-3			HALM	LED	Red	Lights when the Port 0A/Port 1A is in trouble.
9-a-4			Active	LED	Green	Indicates that data is being transferred via a Port 0A/Port 1A side.
9-a-5			Link	LED	Green	Indicates that the link status of the Port 0A/Port 1A side is normal.
9-b-1		Port 0B/ Port 1B	Tx	Connector	—	Connector on the signal output side to connect the 10G iSCSI interface cable in the Port 0B/Port 1B side.
9-b-2			Rx	Connector	—	Connector on the signal input side to connect the 10G iSCSI interface cable in the Port 0B/Port 1B side.
9-b-3			HALM	LED	Red	Lights when the Port 0B/Port 1B is in trouble.
9-b-4			Active	LED	Green	Indicates that data is being transferred via a Port 0B/Port 1B side.
9-b-5			Link	LED	Green	Indicates that the link status of the Port 0B/Port 1B side is normal.

(2) Indication positions and their functions of RKEM

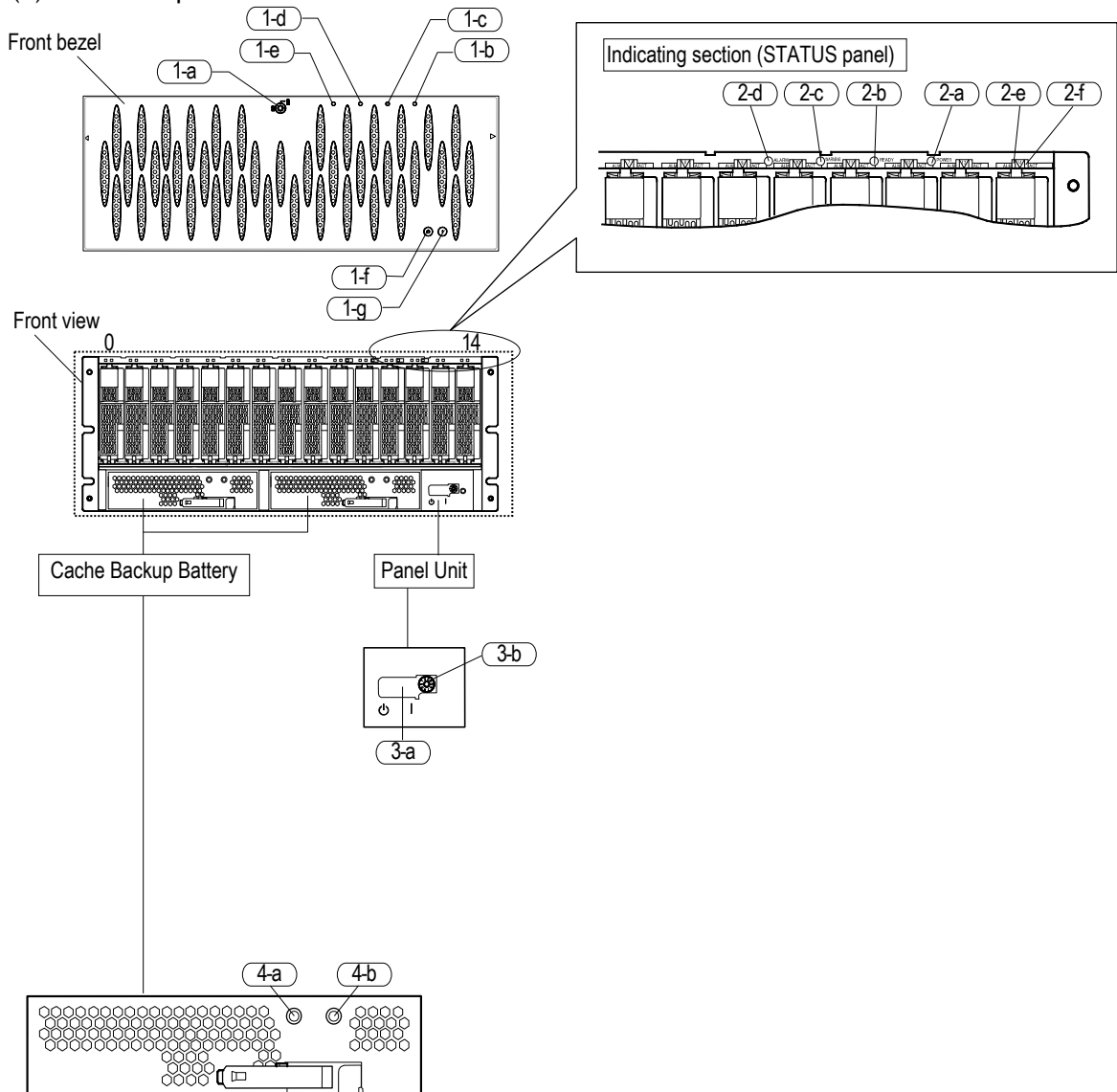

Figure 2.3.1.2 Indication Locations of Functional Components (Front View)

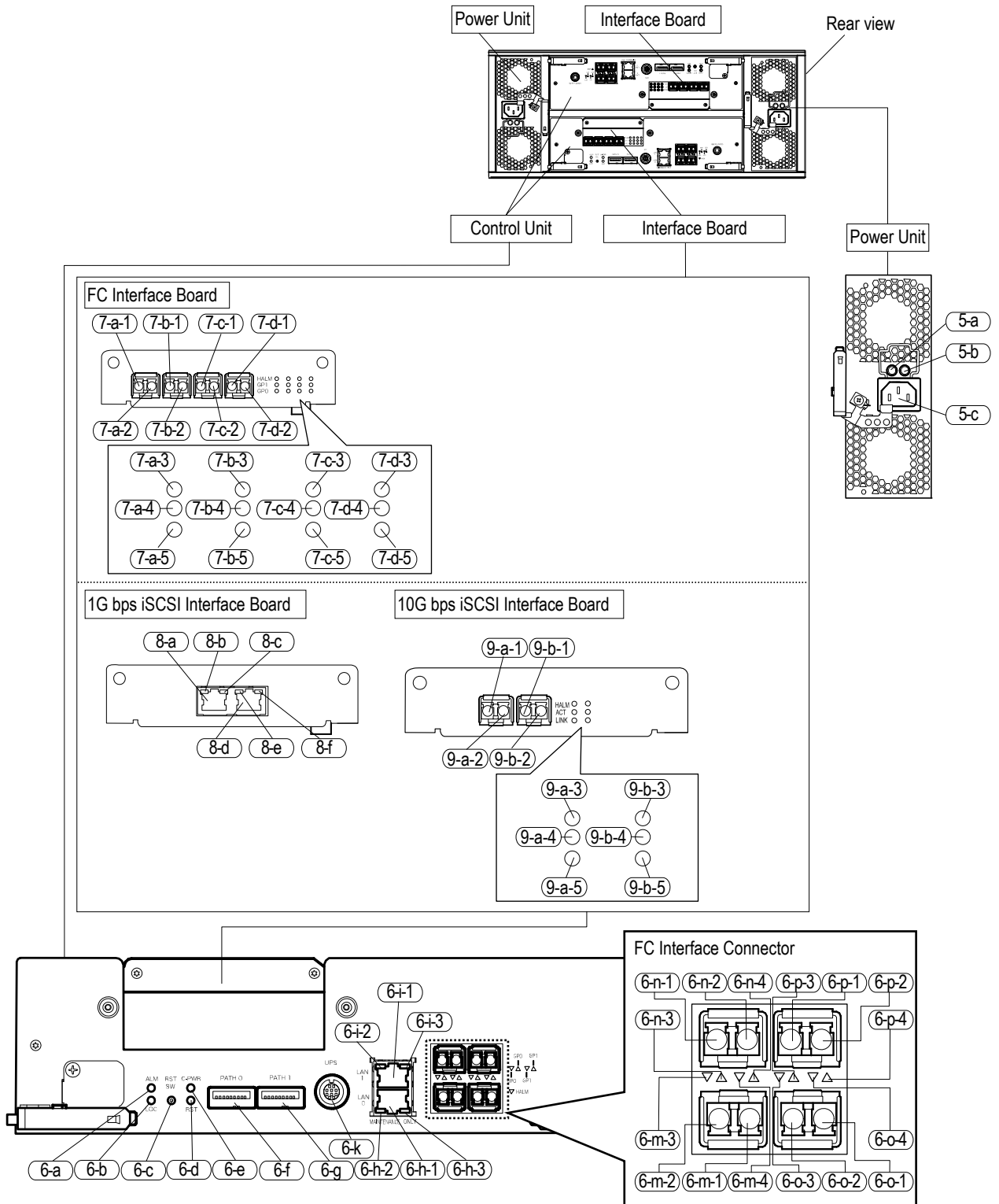

Figure 2.3.1.3 Indication Locations of Functional Components (Rear View)

Table 2.3.1.1 Functions of Indications

No.	Section	Name	Classification	Color	Function
1-a	Front Bezel	KEY	Key	—	Locks the front bezel.
1-b		POWER	LED	Green	Indicates that the power supply is supplied to the subsystem.
1-c		READY	LED	Green	On Indicates that the subsystem can be operated. Blinking High-speed blinking : Indicates that the automatic download of the ENC firmware is being executed in the dual controller configuration. Low-speed blinking : Indicates that the download processing of the ENC firmware is completed online.
1-d		WARNING	LED	Orange	On Indicates that a failure, which allows the subsystem to operate, occurred. Blinking High-speed blinking : Indicates that the most recent revision maintenance function of the flash program or the automatic download of the ENC firmware at the time of turning the power on in the single controller configuration is being executed. Low-speed blinking : Indicates that a failure, which does not stop operation occurred in unit (It must be detected with WEB).
1-e		ALARM	LED	Red	On Indicates that a failure, which does not allow the subsystem to operate, occurred. Blinking Low-speed blinking : Indicates that a serious failure occurred while power on.
1-f		Main switch (OFF)	Switch	—	OFF : Presses off the power.
1-g		Main switch (ON)	Switch	—	ON : Presses on the power.
2-a	STATUS Panel (RKEM)	POWER	LED	Green	Indicates that the power supply is supplied to the subsystem.
2-b		READY	LED	Green	On Indicates that the subsystem can be operated. Blinking High-speed blinking : Indicates that the automatic download of the ENC firmware is being executed in the dual controller configuration. Low-speed blinking : Indicates that the download processing of the ENC firmware is completed online.
2-c		WARNING	LED	Orange	On Indicates that a failure, which allows the subsystem to operate, occurred. Blinking High-speed blinking : Indicates that the most recent revision maintenance function of the flash program or the automatic download of the ENC firmware at the time of turning the power on in the single controller configuration is being executed. Low-speed blinking : Indicates that a failure, which allows the subsystem to operate, occurred. (It must be detected with WEB).

No.	Section	Name	Classification	Color	Function											
2-d	STATUS Panel (RKEM)	ALARM	LED	Red	On Indicates that a failure occurred which makes the subsystem unable to operate. Blinking Low-speed blinking : Indicates that a serious failure occurred while power on.											
2-e		ALM	LED	Red	Indicates that a failure which makes the unable to operate occurred.											
2-f		ACT	LED	Green	<table border="1"> <thead> <tr> <th>No.</th> <th>LED status</th> <th>Meaning</th> </tr> </thead> <tbody> <tr> <td>1</td> <td>Blinking</td> <td>Shows that the Disk Drive is being accessed.</td> </tr> <tr> <td>2</td> <td>On</td> <td>Spin up state. (SAS/SAS(SED))/ Power on. (SATA/Flash Drive)</td> </tr> <tr> <td>3</td> <td>Off</td> <td>Spin down state. (SAS/SAS(SED))/ Power off. (SATA/Flash Drive)</td> </tr> </tbody> </table>	No.	LED status	Meaning	1	Blinking	Shows that the Disk Drive is being accessed.	2	On	Spin up state. (SAS/SAS(SED))/ Power on. (SATA/Flash Drive)	3	Off
No.	LED status	Meaning														
1	Blinking	Shows that the Disk Drive is being accessed.														
2	On	Spin up state. (SAS/SAS(SED))/ Power on. (SATA/Flash Drive)														
3	Off	Spin down state. (SAS/SAS(SED))/ Power off. (SATA/Flash Drive)														
3-a	Panel Unit	Main switch	Switch	—	Turns on/off the power. : Power on ⏻ : Power off											
3-b		Mode switch	Switch	—	Sets the local/remote power unit control mode. In the Ready status, sets the Web special window display permission.											
4-a	Cache Backup Battery	ALM	LED	Red	Lights when the Cache Battery unit is in trouble. • Battery voltage is abnormal. • Battery temperature abnormal.											
4-b		RDY	LED	Green	Shows the state of the battery. On : Battery is in the normal condition. Blinking : Charged up when start-up Off : Abnormal • The battery is not installed. • Battery voltage is abnormal. • Temperature of the battery is abnormal.											
5-a	Power Unit	ALM	LED	Red	Lights when the Power Unit is in trouble.											
5-b		RDY	LED	Green	Shows the operation state of the Power Unit. On : Normal operation Off : Abnormal operation or out of operation											
5-c		Receptor (J1)	Connector	—	Connector on the subsystem side to connect the power cable.											
6-a	Control Unit	ALM	LED	Red	• Indicates that a failure which makes in the Controller unable to operate occurred in it. • Does not light up when the Control Unit is in the reset status.											
6-b		LOC	LED	Orange	Indicate the Chassis location • A factor of the error is indicated by the blinking count. Six times : Voltage on the Controller is abnormal. (Reset of the Controller is not canceled.) • The CUDG error detected by the ENC firmware is indicated. On: CUDG error detected by ENC firmware (BOOT section) RAM error detected by ENC firmware ENC hard configuration error High-speed blinking: Once : SRAM error. Twice : CUDG error in ENC hard. Three times : Firmware error in flash memory. Four times : The hardware error of the ENC part was detected. • When adding the chassis with the power turned on, it lights up to indicate the addition source (this is not an error).											

No.	Section	Name	Classification	Color	Function	
6-c	Control Unit	RST SW	Switch	—	Used to perform a Full Dump.	
6-d		RST	LED	Orange	Indicates that the Controller is being reset. <ul style="list-style-type: none"> • During power-on reset • During reset for doing a dump • During reset for a reboot at the time of a firmware down load • The DC-DC converter or the reset circuit on the Control Unit fails. 	
6-e		C-PWR	LED	Green	You can check if the Cache memory is being backed up by the indication status of this LED. It is valid when the power cables are connected to the Power Units. On : Indicates that the cache is being backed up. (The power is supplied from the battery to the Cache memory.) Off : The Cache memory is not backed up.	
6-f		PATH0	Connector	—	Connection connector for ENC cable (PATH 0 side).	
6-g		PATH1	Connector	—	Connection connector for ENC cable (PATH 1 side).	
6-h-1		LAN0	LAN0	Connector	—	Connects the LAN0 cable. (For maintenance)
6-h-2			ACT	LED	Yellow	Indicates that data is being transferred via a LAN 0.
6-h-2			LINK	LED	Green	Indicates that the link status of the LAN 0 is normal.
6-i-1		LAN1	LAN1	Connector	—	Connects the LAN1 cable. (For User Management)
6-i-2			ACT	LED	Yellow	Indicates that data is being transferred via a LAN 1.
6-i-3			LINK	LED	Green	Indicates that the link status of the LAN 1 is normal.
6-k		Connector for connecting the UPS interlocking cable (UPS)		Connector	—	Used to connect the UPS for the DF800.
6-m-1		Control Unit (FC Interface Connector)	Port 0A/ Port 1A	Tx	Connector	—
6-m-2	Rx			Connector	—	Connector on the signal input side to connect the Fibre Channel interface cable in the Port 0A/Port 1A side.
6-m-3	GP0			LED	Green/ Red	•Shows status of the standard Interface Board mounted on the Controller in the Port 0A/Port 1A side. (Green)
6-m-4	GP1			LED	Green/ Red	•When the Port 0A/Port 1A is abnormal, the GP0 and GP1 light up at the same time, and it indicates the HALM. (Red)
6-n-1	Port 0B/ Port 1B		Tx	Connector	—	Connector on the signal output side to connect the Fibre Channel interface cable in the Port 0B/Port 1B side.
6-n-2			Rx	Connector	—	Connector on the signal input side to connect the Fibre Channel interface cable in the Port 0B/Port 1B side.
6-n-3			GP0	LED	Green/ Red	•Shows status of the standard Interface Board mounted on the Controller in the Port 0B/Port 1B side. (Green)
6-n-4			GP1	LED	Green/ Red	•When the Port 0B/Port 1B is abnormal, the GP0 and GP1 light up at the same time, and it indicates the HALM. (Red)

No.	Section	Name	Classification	Color	Function	
6-o-1	Control Unit (FC Interface Connector)	Port 0C/ Port 1C	Tx	Connector	—	Connector on the signal output side to connect the Fibre Channel interface cable in the Port 0C/Port 1C side.
6-o-2			Rx	Connector	—	Connector on the signal input side to connect the Fibre Channel interface cable in the Port 0C/Port 1C side.
6-o-3			GP0	LED	Green/ Red	•Shows status of the standard Interface Board mounted on the Controller in the Port 0C/Port 1C side. (Green) •When the Port 0C/Port 1C is abnormal, the GP0 and GP1 light up at the same time, and it indicates the HALM. (Red)
6-o-4			GP1	LED	Green/ Red	
6-p-1		Port 0D/ Port 1D	Tx	Connector	—	Connector on the signal output side to connect the Fibre Channel interface cable in the Port 0D/Port 1D side.
6-p-2			Rx	Connector	—	Connector on the signal input side to connect the Fibre Channel interface cable in the Port 0D/Port 1D side.
6-p-3			GP0	LED	Green/ Red	•Shows status of the standard Interface Board mounted on the Controller in the Port 0D/Port 1D side. (Green) •When the Port 0D/Port 1D is abnormal, the GP0 and GP1 light up at the same time, and it indicates the HALM. (Red)
6-p-4			GP1	LED	Green/ Red	
7-a-1	FC Interface Board	Port 0E/ Port 1E	Tx	Connector	—	Connector on the signal output side to connect the Fibre Channel interface cable in the Port 0E/Port 1E side.
7-a-2			Rx	Connector	—	Connector on the signal input side to connect the Fibre Channel interface cable in the Port 0E/Port 1E side.
7-a-3			HALM	LED	Red	Lights when the Port 0E/Port 1E is in trouble.
7-a-4			GP1	LED	Green	Shows status of the standard Interface Board mounted on the Controller in the Port 0E/Port 1E side.
7-a-5			GP0	LED	Green	Shows status of the standard Interface Board mounted on the Controller in the Port 0E/Port 1E side.
7-b-1		Port 0F/ Port 1F	Tx	Connector	—	Connector on the signal output side to connect the Fibre Channel interface cable in the Port 0F/Port 1F side.
7-b-2			Rx	Connector	—	Connector on the signal input side to connect the Fibre Channel interface cable in the Port 0F/Port 1F side.
7-b-3			HALM	LED	Red	Lights when the Port 0F/Port 1F is in trouble.
7-b-4			GP1	LED	Green	Shows status of the standard Interface Board mounted on the Controller in the Port 0F/Port 1F side.
7-b-5			GP0	LED	Green	Shows status of the standard Interface Board mounted on the Controller in the Port 0F/Port 1F side.
7-c-1	FC Interface Board	Port 0G/ Port 1G	Tx	Connector	—	Connector on the signal output side to connect the Fibre Channel interface cable in the Port 0G/Port 1G side.
7-c-2			Rx	Connector	—	Connector on the signal input side to connect the Fibre Channel interface cable in the Port 0G/Port 1G side.
7-c-3			HALM	LED	Red	Lights when the Port 0G/Port 1G is in trouble.
7-c-4			GP1	LED	Green	Shows status of the standard Interface Board mounted on the Controller in the Port 0G/Port 1G side.
7-c-5			GP0	LED	Green	Shows status of the standard Interface Board mounted on the Controller in the Port 0G/Port 1G side.
7-d-1		Port 0H/ Port 1H	Tx	Connector	—	Connector on the signal output side to connect the Fibre Channel interface cable in the Port 0H/Port 1H side.
7-d-2			Rx	Connector	—	Connector on the signal input side to connect the Fibre Channel interface cable in the Port 0H/Port 1H side.
7-d-3			HALM	LED	Red	Lights when the Port 0H/Port 1H is in trouble.
7-d-4			GP1	LED	Green	Shows status of the standard Interface Board mounted on the Controller in the Port 0H/Port 1H side.
7-d-5			GP0	LED	Green	Shows status of the standard Interface Board mounted on the Controller in the Port 0H/Port 1H side.

No.	Section	Name	Classification	Color	Function	
8-a	1G bps iSCSI Interface Board	Port 0E/ Port 1E	iSCSI	Connector	—	Connects the iSCSI cable (Port 0E/Port 1E side).
8-b			Active	LED	Yellow	Indicates that data is being transferred via a Port 0E/Port 1E side.
8-c			Link	LED	Green	Indicates that the link status of the Port 0E/Port 1E side is normal.
8-d		Port 0F/ Port 1F	iSCSI	Connector	—	Connects the iSCSI cable (Port 0F/Port 1F side).
8-e			Active	LED	Yellow	Indicates that data is being transferred via a Port 0F/Port 1F side.
8-f			Link	LED	Green	Indicates that the link status of the Port 0F/Port 1F side is normal.
9-a-1	10G bps iSCSI Interface Board	Port 0E/ Port 1E	Tx	Connector	—	Connector on the signal output side to connect the 10G iSCSI interface cable in the Port 0E/Port 1E side.
9-a-2			Rx	Connector	—	Connector on the signal input side to connect the 10G iSCSI interface cable in the Port 0E/Port 1E side.
9-a-3			HALM	LED	Red	Lights when the Port 0E/Port 1E is in trouble.
9-a-4			Active	LED	Green	Indicates that data is being transferred via a Port 0A/Port 1A side.
9-a-5			Link	LED	Green	Indicates that the link status of the Port 0E/Port 1E side is normal.
9-b-1		Port 0F/ Port 1F	Tx	Connector	—	Connector on the signal output side to connect the 10G iSCSI interface cable in the Port 0F/Port 1F side.
9-b-2			Rx	Connector	—	Connector on the signal input side to connect the 10G iSCSI interface cable in the Port 0F/Port 1F side.
9-b-3			HALM	LED	Red	Lights when the Port 0F/Port 1F is in trouble.
9-b-4			Active	LED	Green	Indicates that data is being transferred via a Port 0F/Port 1F side.
9-b-5			Link	LED	Green	Indicates that the link status of the Port 0F/Port 1F side is normal.

(3) Indication positions and their functions of RKS

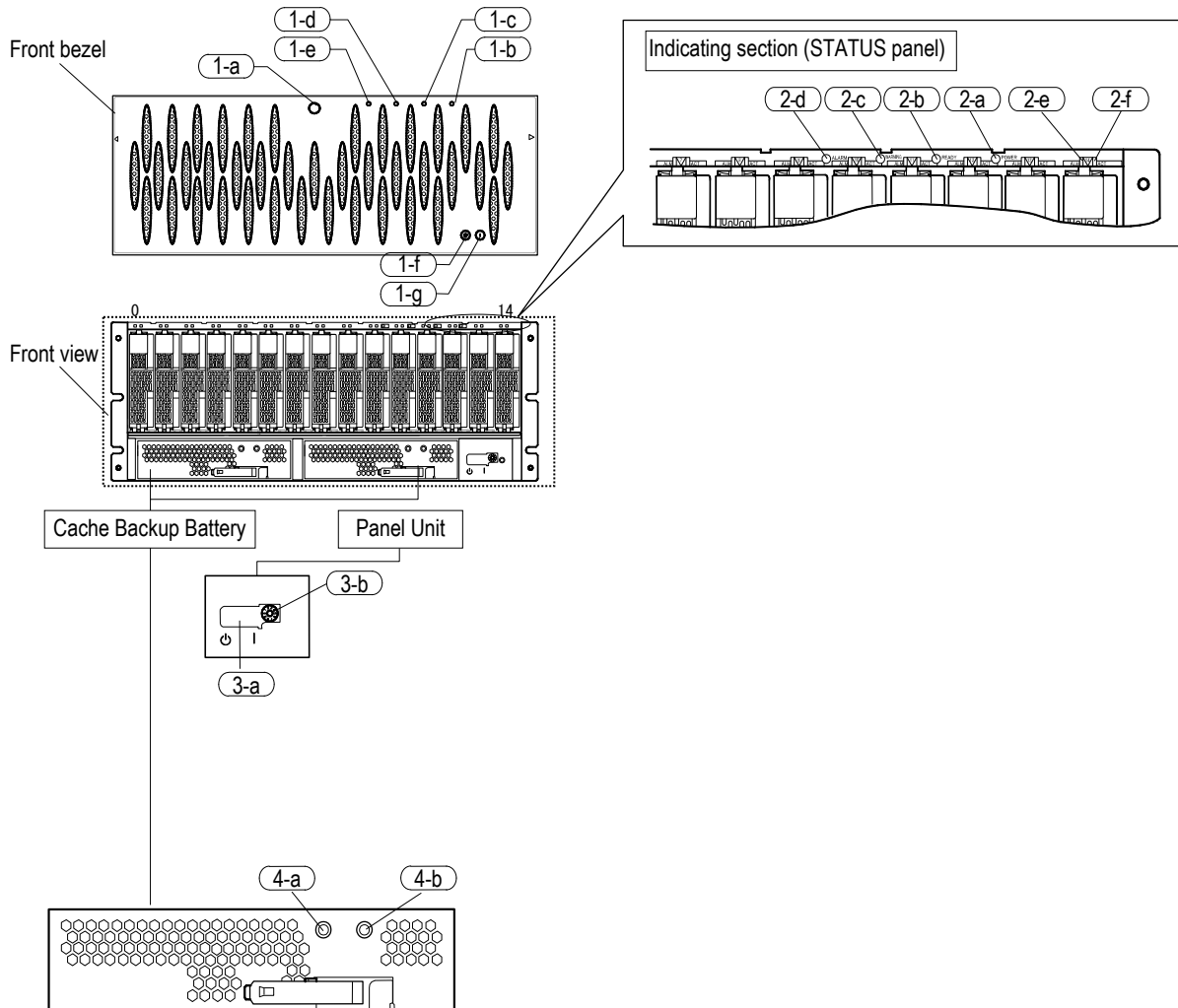

Figure 2.3.2 Indication Locations of Functional Components (Front View)

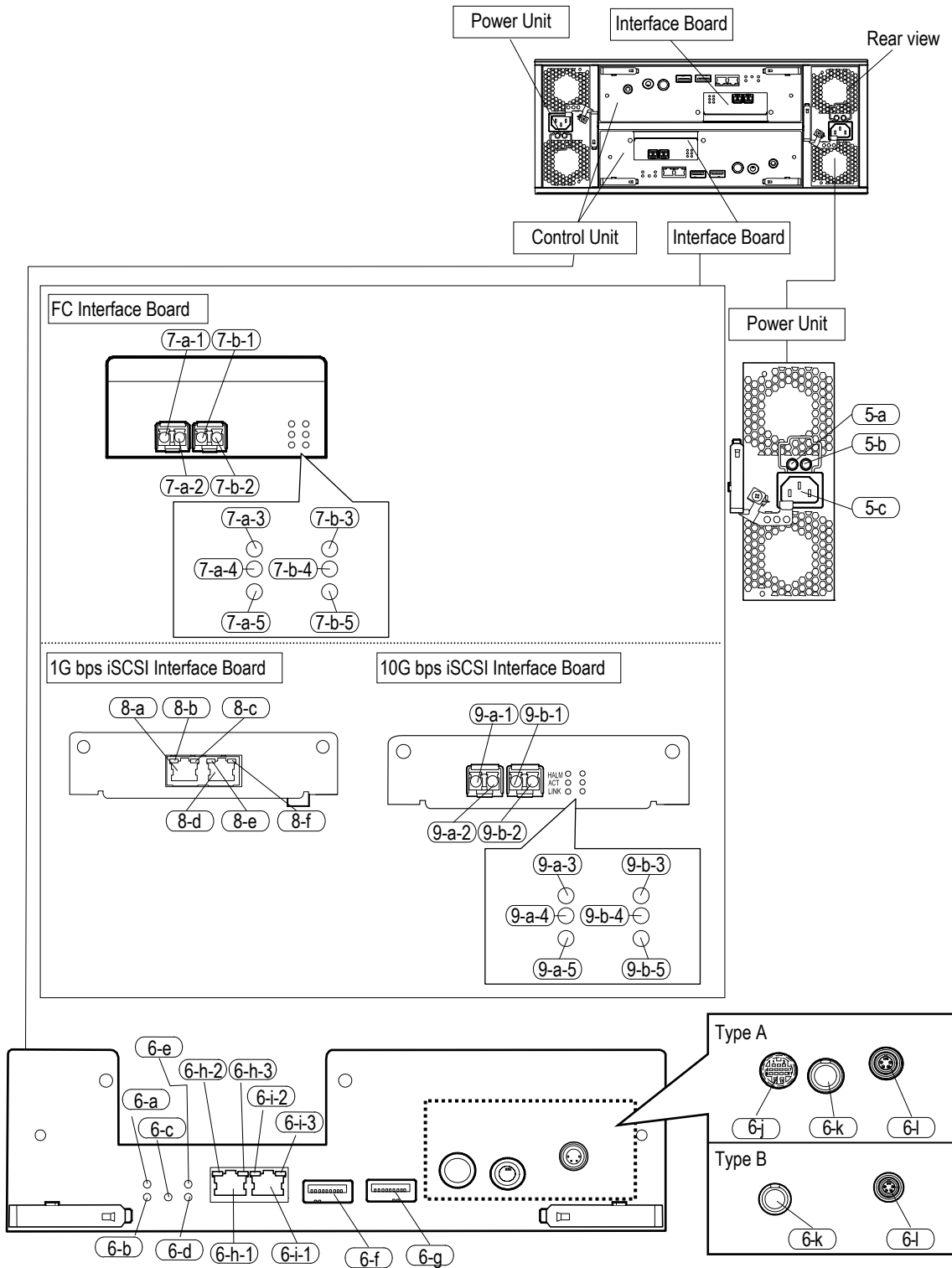

Figure 2.3.2.1 Indication Locations of Functional Components (Rear View)

Table 2.3.2 Functions of Indications

No.	Section	Name	Classification	Color	Function
1-a	Front Bezel	KEY	Key	—	Locks the front bezel.
1-b		POWER	LED	Green	Indicates that the power supply is supplied to the subsystem.
1-c		READY	LED	Green	On Indicates that the subsystem can be operated. Blinking High-speed blinking : Indicates that the automatic download of the ENC firmware is being executed in the dual controller configuration. Low-speed blinking : Indicates that the download processing of the ENC firmware is completed online.
1-d		WARNING	LED	Orange	On Indicates that a failure, which allows the subsystem to operate, occurred. Blinking High-speed blinking : Indicates that the most recent revision maintenance function of the flash program or the automatic download of the ENC firmware at the time of turning the power on in the single controller configuration is being executed. Low-speed blinking : Indicates that a failure, which does not stop operation occurred in unit (It must be detected with WEB).
1-e		ALARM	LED	Red	On Indicates that a failure, which does not allow the subsystem to operate, occurred. Blinking Low-speed blinking : Indicates that a serious failure occurred while power on.
1-f		Main switch (OFF)	Switch	—	OFF : Presses off the power.
1-g		Main switch (ON)	Switch	—	ON : Presses on the power.
2-a	STATUS Panel (RKS)	POWER	LED	Green	Indicates that the power supply is supplied to the subsystem.
2-b		READY	LED	Green	On Indicates that the subsystem can be operated. Blinking High-speed blinking : Indicates that the automatic download of the ENC firmware is being executed in the dual controller configuration. Low-speed blinking : Indicates that the download processing of the ENC firmware is completed online.
2-c		WARNING	LED	Orange	On Indicates that a failure, which allows the subsystem to operate, occurred. Blinking High-speed blinking : Indicates that the most recent revision maintenance function of the flash program or the automatic download of the ENC firmware at the time of turning the power on in the single controller configuration is being executed. Low-speed blinking : Indicates that a failure, which allows the subsystem to operate, occurred. (It must be detected with WEB).

No.	Section	Name	Classification	Color	Function											
2-d	STATUS Panel (RKS)	ALARM	LED	Red	On Indicates that a failure occurred which makes the subsystem unable to operate. Blinking Low-speed blinking : Indicates that a serious failure occurred while power on.											
2-e		ALM	LED	Red	Indicates that a failure which makes the unable to operate occurred.											
2-f		ACT	LED	Green	<table border="1"> <thead> <tr> <th>No.</th> <th>LED status</th> <th>Meaning</th> </tr> </thead> <tbody> <tr> <td>1</td> <td>Blinking</td> <td>Shows that the Disk Drive is being accessed.</td> </tr> <tr> <td>2</td> <td>On</td> <td>Spin up state. (SAS/SAS(SED))/ Power on. (SATA/Flash Drive)</td> </tr> <tr> <td>3</td> <td>Off</td> <td>Spin down state. (SAS/SAS(SED))/ Power off. (SATA/Flash Drive)</td> </tr> </tbody> </table>	No.	LED status	Meaning	1	Blinking	Shows that the Disk Drive is being accessed.	2	On	Spin up state. (SAS/SAS(SED))/ Power on. (SATA/Flash Drive)	3	Off
No.	LED status	Meaning														
1	Blinking	Shows that the Disk Drive is being accessed.														
2	On	Spin up state. (SAS/SAS(SED))/ Power on. (SATA/Flash Drive)														
3	Off	Spin down state. (SAS/SAS(SED))/ Power off. (SATA/Flash Drive)														
3-a	Panel Unit	Main switch	Switch	—	Turns on/off the power. : Power on ⏻ : Power off											
3-b		Mode switch	Switch	—	Set the local/remote power unit control mode. In the Ready status, sets the Web special window display permission.											
4-a	Cache Backup Battery	ALM	LED	Red	Lights when the Cache Backup Battery is in trouble. • Battery voltage is abnormal. • Battery temperature abnormal.											
4-b		RDY	LED	Green	Shows the state of the battery. On : Battery is in the normal condition. Blinking : Charged up when start-up Off : Abnormal • The battery is not installed. • Battery voltage is abnormal. • Temperature of the battery is abnormal.											
5-a	Power Unit	ALM	LED	Red	Lights when the Power Unit is in trouble.											
5-b		RDY	LED	Green	Shows the operation state of the Power Unit. On : Normal operation Off : Abnormal operation or out of operation											
5-c		Receptor (J1)	Connector	—	Connector on the subsystem side to connect the power cable.											
6-a	Control Unit	ALM	LED	Red	Indicates that a failure which makes in the Controller unable to operate occurred in it.											
6-b		LOC	LED	Orange	Indicate the Chassis location • A factor of the error is indicated by the blinking count. Six times : Voltage on the Controller is abnormal. (Reset of the Controller is not canceled.) • The CUDG error detected by the ENC firmware is indicated. On: CUDG error detected by ENC firmware (BOOT section) RAM error detected by ENC firmware ENC hard configuration error High-speed blinking: Once : SRAM error. Twice : CUDG error in ENC hard. Three times : Firmware error in flash memory. Four times : The hardware error of the ENC part was detected. • When adding the chassis with the power turned on, it lights up to indicate the addition source (this is not an error).											
6-c		RST SW	Switch	—	Used to perform a Full Dump.											

No.	Section	Name	Classification	Color	Function	
6-d	Control Unit	RST	LED	Orange	Indicates that the Controller is being reset. <ul style="list-style-type: none"> • During power-on reset • During reset for doing a dump • During reset for a reboot at the time of a firmware down load 	
6-e		C-PWR	LED	Green	You can check if the Cache memory is being backed up by the indication status of this LED. It is valid when the power cables are connected to the Power Units. On : Indicates that the cache is being backed up. (The power is supplied from the battery to the Cache memory.) Off : The Cache memory is not backed up.	
6-f		PATH0	Connector	—	Connection connector for ENC cable (PATH 0 side).	
6-g		PATH1	Connector	—	Connection connector for ENC cable (PATH 1 side).	
6-h-1		LAN0	LAN0	Connector	—	Connects the LAN0 cable. (For maintenance)
6-h-2			ACT	LED	Yellow	Indicates that data is being transferred via a LAN 0.
6-h-3			LINK	LED	Green	Indicates that the link status of the LAN 0 is normal.
6-i-1		LAN1	LAN1	Connector	—	Connects the LAN1 cable. (For User Management)
6-i-2			ACT	LED	Yellow	Indicates that data is being transferred via a LAN 1.
6-i-3			LINK	LED	Green	Indicates that the link status of the LAN 1 is normal.
6-j		Connector for connecting the Additional Battery Box (BATTERY)	Connector	—	Not used.	
6-k		Connector for connecting the UPS interlocking cable (UPS)	Connector	—	Used to connect the UPS for the DF800.	
6-l		Connector for connecting the Remote adapter (REMOTE ADAPTER)	Connector	—	Used to connect the Remote Adapter.	
7-a-1		FC Interface Board	Port 0A/ Port 1A	Tx	Connector	—
7-a-2	Rx			Connector	—	Connector on the signal input side to connect the Fibre Channel interface cable in the Port 0A/Port 1A side.
7-a-3	HALM			LED	Red	Lights when the Port 0A/Port 1A is in trouble.
7-a-4	GP1			LED	Green	Shows status of the standard Interface Board mounted on the Controller in the Port 0A/Port 1A side.
7-a-5	GP0			LED	Green	Shows status of the standard Interface Board mounted on the Controller in the Port 0A/Port 1A side.
7-b-1	Port 0B/ Port 1B		Tx	Connector	—	Connector on the signal output side to connect the Fibre Channel interface cable in the Port 0B/Port 1B side.
7-b-2			Rx	Connector	—	Connector on the signal input side to connect the Fibre Channel interface cable in the Port 0B/Port 1B side.
7-b-3			HALM	LED	Red	Lights when the Port 0B/Port 1B is in trouble.
7-b-4			GP1	LED	Green	Shows status of the standard Interface Board mounted on the Controller in the Port 0B/Port 1B side.
7-b-5			GP0	LED	Green	Shows status of the standard Interface Board mounted on the Controller in the Port 0B/Port 1B side.
8-a	1G bps iSCSI Interface Board	Port 0A/ Port 1A	iSCSI	Connector	—	Connects the iSCSI cable (Port 0A/Port 1A side).
8-b			Active	LED	Yellow	Indicates that data is being transferred via a Port 0A/Port 1A side.
8-c			Link	LED	Green	Indicates that the link status of the Port 0A/Port 1A side is normal.
8-d		Port 0B/ Port 1B	iSCSI	Connector	—	Connects the iSCSI cable (Port 0B/Port 1B side).
8-e			Active	LED	Yellow	Indicates that data is being transferred via a Port 0B/Port 1B side.
8-f			Link	LED	Green	Indicates that the link status of the Port 0B/Port 1B side is normal.

No.	Section	Name	Classification	Color	Function	
9-a-1	10G bps iSCSI Interface Board	Port 0A/ Port 1A	Tx	Connector	—	Connector on the signal output side to connect the 10G iSCSI interface cable in the Port 0A/Port 1A side.
9-a-2			Rx	Connector	—	Connector on the signal input side to connect the 10G iSCSI interface cable in the Port 0A/Port 1A side.
9-a-3			HALM	LED	Red	Lights when the Port 0A/Port 1A is in trouble.
9-a-4			Active	LED	Green	Indicates that data is being transferred via a Port 0A/Port 1A side.
9-a-5			Link	LED	Green	Indicates that the link status of the Port 0A/Port 1A side is normal.
9-b-1	Port 0B/ Port 1B	Port 0B/ Port 1B	Tx	Connector	—	Connector on the signal output side to connect the 10G iSCSI interface cable in the Port 0B/Port 1B side.
9-b-2			Rx	Connector	—	Connector on the signal input side to connect the 10G iSCSI interface cable in the Port 0B/Port 1B side.
9-b-3			HALM	LED	Red	Lights when the Port 0B/Port 1B is in trouble.
9-b-4			Active	LED	Green	Indicates that data is being transferred via a Port 0B/Port 1B side.
9-b-5			Link	LED	Green	Indicates that the link status of the Port 0B/Port 1B side is normal.

(4) Indication positions and their functions of RKES

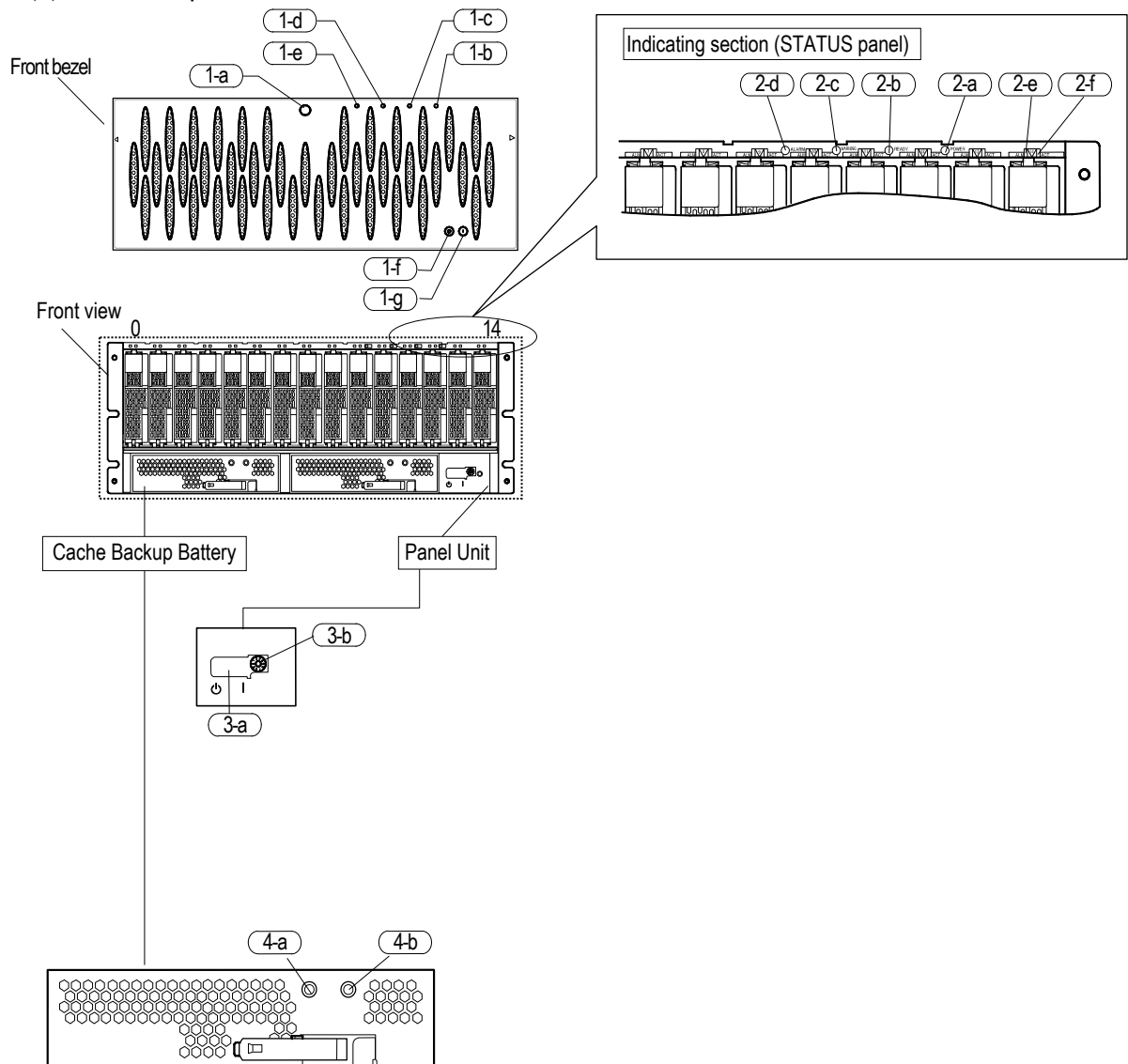

Figure 2.3.2.2 Indication Locations of Functional Components (Front View)

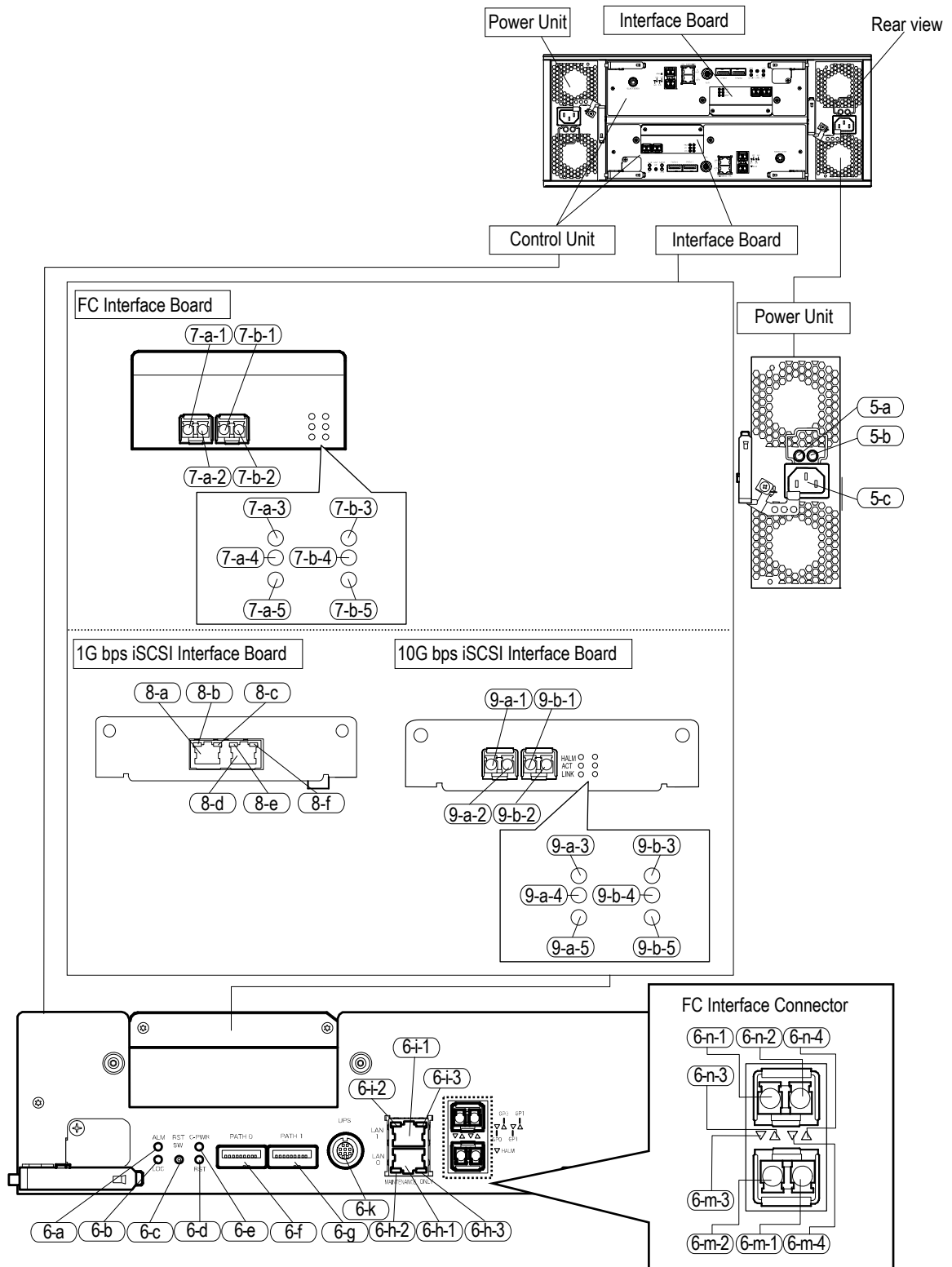

Figure 2.3.2.3 Indication Locations of Functional Components (Rear View)

Table 2.3.2.1 Functions of Indications

No.	Section	Name	Classification	Color	Function
1-a	Front Bezel	KEY	Key	—	Locks the front bezel.
1-b		POWER	LED	Green	Indicates that the power supply is supplied to the subsystem.
1-c		READY	LED	Green	On Indicates that the subsystem can be operated. Blinking High-speed blinking : Indicates that the automatic download of the ENC firmware is being executed in the dual controller configuration. Low-speed blinking : Indicates that the download processing of the ENC firmware is completed online.
1-d		WARNING	LED	Orange	On Indicates that a failure, which allows the subsystem to operate, occurred. Blinking High-speed blinking : Indicates that the most recent revision maintenance function of the flash program or the automatic download of the ENC firmware at the time of turning the power on in the single controller configuration is being executed. Low-speed blinking : Indicates that a failure, which does not stop operation occurred in unit (It must be detected with WEB).
1-e		ALARM	LED	Red	On Indicates that a failure, which does not allow the subsystem to operate, occurred. Blinking Low-speed blinking : Indicates that a serious failure occurred while power on.
1-f		Main switch (OFF)	Switch	—	OFF : Presses off the power.
1-g		Main switch (ON)	Switch	—	ON : Presses on the power.
2-a	STATUS Panel (RKES)	POWER	LED	Green	Indicates that the power supply is supplied to the subsystem.
2-b		READY	LED	Green	On Indicates that the subsystem can be operated. Blinking High-speed blinking : Indicates that the automatic download of the ENC firmware is being executed in the dual controller configuration. Low-speed blinking : Indicates that the download processing of the ENC firmware is completed online.
2-c		WARNING	LED	Orange	On Indicates that a failure, which allows the subsystem to operate, occurred. Blinking High-speed blinking : Indicates that the most recent revision maintenance function of the flash program or the automatic download of the ENC firmware at the time of turning the power on in the single controller configuration is being executed. Low-speed blinking : Indicates that a failure, which allows the subsystem to operate, occurred. (It must be detected with WEB).

No.	Section	Name	Classification	Color	Function											
2-d	STATUS Panel (RKES)	ALARM	LED	Red	On Indicates that a failure occurred which makes the subsystem unable to operate. Blinking Low-speed blinking : Indicates that a serious failure occurred while power on.											
2-e		ALM	LED	Red	Indicates that a failure which makes the unable to operate occurred.											
2-f		ACT	LED	Green	<table border="1"> <thead> <tr> <th>No.</th> <th>LED status</th> <th>Meaning</th> </tr> </thead> <tbody> <tr> <td>1</td> <td>Blinking</td> <td>Shows that the Disk Drive is being accessed.</td> </tr> <tr> <td>2</td> <td>On</td> <td>Spin up state. (SAS/SAS(SSED))/ Power on. (SATA/Flash Drive)</td> </tr> <tr> <td>3</td> <td>Off</td> <td>Spin down state. (SAS/SAS(SSED))/ Power off. (SATA/Flash Drive)</td> </tr> </tbody> </table>	No.	LED status	Meaning	1	Blinking	Shows that the Disk Drive is being accessed.	2	On	Spin up state. (SAS/SAS(SSED))/ Power on. (SATA/Flash Drive)	3	Off
No.	LED status	Meaning														
1	Blinking	Shows that the Disk Drive is being accessed.														
2	On	Spin up state. (SAS/SAS(SSED))/ Power on. (SATA/Flash Drive)														
3	Off	Spin down state. (SAS/SAS(SSED))/ Power off. (SATA/Flash Drive)														
3-a	Panel Unit	Main switch	Switch	—	Turns on/off the power. : Power on ⏻ : Power off											
3-b		Mode switch	Switch	—	Set the local/remote power unit control mode. In the Ready status, sets the Web special window display permission.											
4-a	Cache Backup Battery	ALM	LED	Red	Lights when the Cache Backup Battery is in trouble. • Battery voltage is abnormal. • Battery temperature abnormal.											
4-b		RDY	LED	Green	Shows the state of the battery. On : Battery is in the normal condition. Blinking : Charged up when start-up Off : Abnormal • The battery is not installed. • Battery voltage is abnormal. • Temperature of the battery is abnormal.											
5-a	Power Unit	ALM	LED	Red	Lights when the Power Unit is in trouble.											
5-b		RDY	LED	Green	Shows the operation state of the Power Unit. On : Normal operation Off : Abnormal operation or out of operation											
5-c		Receptor (J1)	Connector	—	Connector on the subsystem side to connect the power cable.											
6-a	Control Unit	ALM	LED	Red	Indicates that a failure which makes in the Controller unable to operate occurred in it.											
6-b		LOC	LED	Orange	Indicate the Chassis location • A factor of the error is indicated by the blinking count. Six times : Voltage on the Controller is abnormal. (Reset of the Controller is not canceled.) • The CUDG error detected by the ENC firmware is indicated. On: CUDG error detected by ENC firmware (BOOT section) RAM error detected by ENC firmware ENC hard configuration error High-speed blinking: Once : SRAM error. Twice : CUDG error in ENC hard. Three times : Firmware error in flash memory. Four times : The hardware error of the ENC part was detected. • When adding the chassis with the power turned on, it lights up to indicate the addition source (this is not an error).											
6-c		RST SW	Switch	—	Used to perform a Full Dump.											

No.	Section	Name	Classification	Color	Function		
6-d	Control Unit	RST	LED	Orange	Indicates that the Controller is being reset. <ul style="list-style-type: none"> • During power-on reset • During reset for doing a dump • During reset for a reboot at the time of a firmware down load 		
6-e		C-PWR	LED	Green	You can check if the Cache memory is being backed up by the indication status of this LED. It is valid when the power cables are connected to the Power Units. On : Indicates that the cache is being backed up. (The power is supplied from the battery to the Cache memory.) Off : The Cache memory is not backed up.		
6-f		PATH0	Connector	—	Connection connector for ENC cable (PATH 0 side).		
6-g		PATH1	Connector	—	Connection connector for ENC cable (PATH 1 side).		
6-h-1		LAN0	LAN0	Connector	—	Connects the LAN0 cable. (For maintenance)	
6-h-2			ACT	LED	Yellow	Indicates that data is being transferred via a LAN 0.	
6-h-3			LINK	LED	Green	Indicates that the link status of the LAN 0 is normal.	
6-i-1		LAN1	LAN1	Connector	—	Connects the LAN1 cable. (For User Management)	
6-i-2			ACT	LED	Yellow	Indicates that data is being transferred via a LAN 1.	
6-i-3			LINK	LED	Green	Indicates that the link status of the LAN 1 is normal.	
6-k			Connector for connecting the UPS interlocking cable (UPS)	Connector	—	Used to connect the UPS for the DF800.	
6-m-1		Control Unit (FC Interface Connector)	Port 0A/ Port 1A	Tx	Connector	—	Connector on the signal output side to connect the Fibre Channel interface cable in the Port 0A/Port 1A side.
6-m-2				Rx	Connector	—	Connector on the signal input side to connect the Fibre Channel interface cable in the Port 0A/Port 1A side.
6-m-3	GP0			LED	Green/ Red	•Shows status of the standard Interface Board mounted on the Controller in the Port 0A/Port 1A side. (Green)	
6-m-4	GP1			LED	Green/ Red	• When the Port 0A/Port 1A is abnormal, the GP0 and GP1 light up at the same time, and it indicates the HALM. (Red)	
6-n-1	Port 0B/ Port 1B		Tx	Connector	—	Connector on the signal output side to connect the Fibre Channel interface cable in the Port 0B/Port 1B side.	
6-n-2			Rx	Connector	—	Connector on the signal input side to connect the Fibre Channel interface cable in the Port 0B/Port 1B side.	
6-n-3			GP0	LED	Green/ Red	•Shows status of the standard Interface Board mounted on the Controller in the Port 0B/Port 1B side. (Green)	
6-n-4			GP1	LED	Green/ Red	•When the Port 0B0/Port 1B is abnormal, the GP0 and GP1 light up at the same time, and it indicates the HALM. (Red)	
7-a-1	FC Interface Board	Port 0E/ Port 1E	Tx	Connector	—	Connector on the signal output side to connect the Fibre Channel interface cable in the Port 0E/Port 1E side.	
7-a-2			Rx	Connector	—	Connector on the signal input side to connect the Fibre Channel interface cable in the Port 0E/Port 1E side.	
7-a-3		HALM	LED	Red	Lights when the Port 0E/Port 1E is in trouble.		
7-a-4		GP1	LED	Green	Shows status of the standard Interface Board mounted on the Controller in the Port 0E/Port 1E side.		
7-a-5		GP0	LED	Green	Shows status of the standard Interface Board mounted on the Controller in the Port 0E/Port 1E side.		

No.	Section	Name	Classification	Color	Function	
7-b-1	FC Interface Board	Port 0F/ Port 1F	Tx	Connector	—	Connector on the signal output side to connect the Fibre Channel interface cable in the Port 0F/Port 1F side.
7-b-2			Rx	Connector	—	Connector on the signal input side to connect the Fibre Channel interface cable in the Port 0F/Port 1F side.
7-b-3			HALM	LED	Red	Lights when the Port 0F/Port 1F is in trouble.
7-b-4			GP1	LED	Green	Shows status of the standard Interface Board mounted on the Controller in the Port 0F/Port 1F side.
7-b-5			GP0	LED	Green	Shows status of the standard Interface Board mounted on the Controller in the Port 0F/Port 1F side.
8-a	1G bps iSCSI Interface Board	Port 0E/ Port 1E	iSCSI	Connector	—	Connects the iSCSI cable (Port 0E/Port 1E side).
8-b			Active	LED	Yellow	Indicates that data is being transferred via a Port 0E/Port 1E side.
8-c			Link	LED	Green	Indicates that the link status of the Port 0E/Port 1E side is normal.
8-d		Port 0F/ Port 1F	iSCSI	Connector	—	Connects the iSCSI cable (Port 0F/Port 1F side).
8-e			Active	LED	Yellow	Indicates that data is being transferred via a Port 0F/Port 1F side.
8-f			Link	LED	Green	Indicates that the link status of the Port 0F/Port 1F side is normal.
9-a-1	10G bps iSCSI Interface Board	Port 0E/ Port 1E	Tx	Connector	—	Connector on the signal output side to connect the 10G iSCSI interface cable in the Port 0E/Port 1E side.
9-a-2			Rx	Connector	—	Connector on the signal input side to connect the 10G iSCSI interface cable in the Port 0E/Port 1E side.
9-a-3			HALM	LED	Red	Lights when the Port 0E/Port 1E is in trouble.
9-a-4			Active	LED	Green	Indicates that data is being transferred via a Port 0A/Port 1A side.
9-a-5			Link	LED	Green	Indicates that the link status of the Port 0E/Port 1E side is normal.
9-b-1		Port 0F/ Port 1F	Tx	Connector	—	Connector on the signal output side to connect the 10G iSCSI interface cable in the Port 0F/Port 1F side.
9-b-2			Rx	Connector	—	Connector on the signal input side to connect the 10G iSCSI interface cable in the Port 0F/Port 1F side.
9-b-3			HALM	LED	Red	Lights when the Port 0F/Port 1F is in trouble.
9-b-4			Active	LED	Green	Indicates that data is being transferred via a Port 0F/Port 1F side.
9-b-5			Link	LED	Green	Indicates that the link status of the Port 0F/Port 1F side is normal.

This page is for editorial purpose only.

(5) Indication positions and their functions of RKEXS

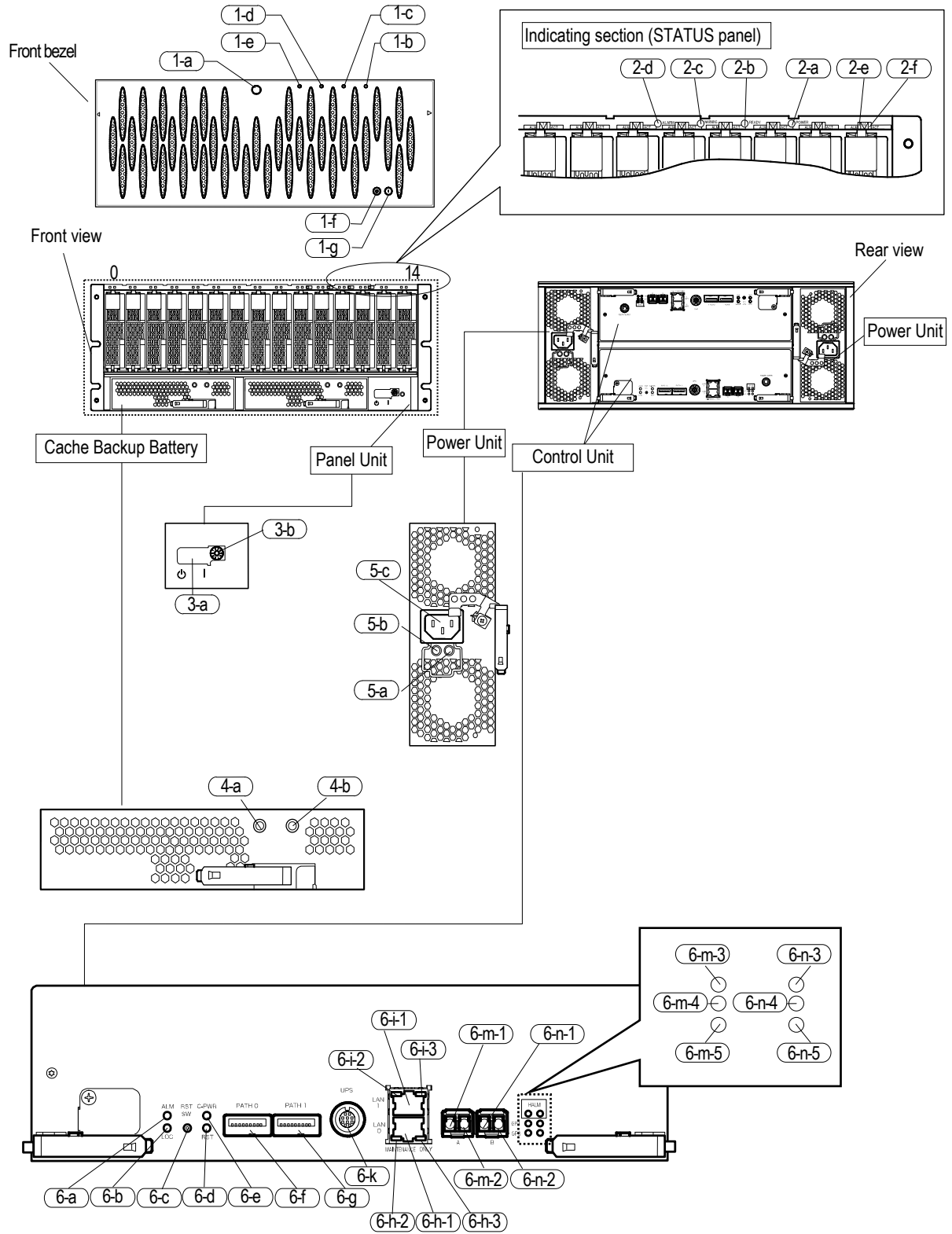

Figure 2.3.2.4 Indication Locations of Functional Components

Table 2.3.2.2 Functions of Indications

No.	Section	Name	Classification	Color	Function
1-a	Front Bezel	KEY	Key	—	Locks the front bezel.
1-b		POWER	LED	Green	Indicates that the power supply is supplied to the subsystem.
1-c		READY	LED	Green	On Indicates that the subsystem can be operated. Blinking High-speed blinking : Indicates that the automatic download of the ENC firmware is being executed in the dual controller configuration. Low-speed blinking : Indicates that the download processing of the ENC firmware is completed online.
1-d		WARNING	LED	Orange	On Indicates that a failure, which allows the subsystem to operate, occurred. Blinking High-speed blinking : Indicates that the most recent revision maintenance function of the flash program or the automatic download of the ENC firmware at the time of turning the power on in the single controller configuration is being executed. Low-speed blinking : Indicates that a failure, which does not stop operation occurred in unit (It must be detected with WEB).
1-e		ALARM	LED	Red	On Indicates that a failure, which does not allow the subsystem to operate, occurred. Blinking Low-speed blinking : Indicates that a serious failure occurred while power on.
1-f		Main switch (OFF)	Switch	—	OFF : Presses off the power.
1-g		Main switch (ON)	Switch	—	ON : Presses on the power.
2-a	STATUS Panel (RKEXS)	POWER	LED	Green	Indicates that the power supply is supplied to the subsystem.
2-b		READY	LED	Green	On Indicates that the subsystem can be operated. Blinking High-speed blinking : Indicates that the automatic download of the ENC firmware is being executed in the dual controller configuration. Low-speed blinking : Indicates that the download processing of the ENC firmware is completed online.
2-c		WARNING	LED	Orange	On Indicates that a failure, which allows the subsystem to operate, occurred. Blinking High-speed blinking : Indicates that the most recent revision maintenance function of the flash program or the automatic download of the ENC firmware at the time of turning the power on in the single controller configuration is being executed. Low-speed blinking : Indicates that a failure, which allows the subsystem to operate, occurred. (It must be detected with WEB).

No.	Section	Name	Classification	Color	Function											
2-d	STATUS Panel (RKEXS)	ALARM	LED	Red	On Indicates that a failure occurred which makes the subsystem unable to operate. Blinking Low-speed blinking : Indicates that a serious failure occurred while power on.											
2-e		ALM	LED	Red	Indicates that a failure which makes the unable to operate occurred.											
2-f		ACT	LED	Green	<table border="1"> <thead> <tr> <th>No.</th> <th>LED status</th> <th>Meaning</th> </tr> </thead> <tbody> <tr> <td>1</td> <td>Blinking</td> <td>Shows that the Disk Drive is being accessed.</td> </tr> <tr> <td>2</td> <td>On</td> <td>Spin up state. (SAS/SAS(SED))/ Power on. (SATA/Flash Drive)</td> </tr> <tr> <td>3</td> <td>Off</td> <td>Spin down state. (SAS/SAS(SED))/ Power off. (SATA/Flash Drive)</td> </tr> </tbody> </table>	No.	LED status	Meaning	1	Blinking	Shows that the Disk Drive is being accessed.	2	On	Spin up state. (SAS/SAS(SED))/ Power on. (SATA/Flash Drive)	3	Off
No.	LED status	Meaning														
1	Blinking	Shows that the Disk Drive is being accessed.														
2	On	Spin up state. (SAS/SAS(SED))/ Power on. (SATA/Flash Drive)														
3	Off	Spin down state. (SAS/SAS(SED))/ Power off. (SATA/Flash Drive)														
3-a	Panel Unit	Main switch	Switch	—	Turns on/off the power. : Power on ⏻ : Power off											
3-b		Mode switch	Switch	—	Set the local/remote power unit control mode. In the Ready status, sets the Web special window display permission.											
4-a	Cache Backup Battery	ALM	LED	Red	Lights when the Cache Backup Battery is in trouble. • Battery voltage is abnormal. • Battery temperature abnormal.											
4-b		RDY	LED	Green	Shows the state of the battery. On : Battery is in the normal condition. Blinking : Charged up when start-up Off : Abnormal • The battery is not installed. • Battery voltage is abnormal. • Temperature of the battery is abnormal.											
5-a	Power Unit	ALM	LED	Red	Lights when the Power Unit is in trouble.											
5-b		RDY	LED	Green	Shows the operation state of the Power Unit. On : Normal operation Off : Abnormal operation or out of operation											
5-c		Receptor (J1)	Connector	—	Connector on the subsystem side to connect the power cable.											
6-a	Control Unit	ALM	LED	Red	Indicates that a failure which makes in the Controller unable to operate occurred in it.											
6-b		LOC	LED	Orange	Indicate the Chassis location • A factor of the error is indicated by the blinking count. Six times : Voltage on the Controller is abnormal. (Reset of the Controller is not canceled.) • The CUDG error detected by the ENC firmware is indicated. On: CUDG error detected by ENC firmware (BOOT section) RAM error detected by ENC firmware ENC hard configuration error High-speed blinking: Once : SRAM error. Twice : CUDG error in ENC hard. Three times : Firmware error in flash memory. Four times : The hardware error of the ENC part was detected. • When adding the chassis with the power turned on, it lights up to indicate the addition source (this is not an error).											
6-c		RST SW	Switch	—	Used to perform a Full Dump.											

No.	Section	Name	Classification	Color	Function	
6-d		RST	LED	Orange	Indicates that the Controller is being reset. <ul style="list-style-type: none"> • During power-on reset • During reset for doing a dump • During reset for a reboot at the time of a firmware down load 	
6-e	Control Unit	C-PWR	LED	Green	You can check if the Cache memory is being backed up by the indication status of this LED. It is valid when the power cables are connected to the Power Units. On : Indicates that the cache is being backed up. (The power is supplied from the battery to the Cache memory.) Off : The Cache memory is not backed up.	
6-f		PATH0	Connector	—	Connection connector for ENC cable (PATH 0 side).	
6-g		PATH1	Connector	—	Connection connector for ENC cable (PATH 1 side).	
6-h-1		LAN0	LAN0	Connector	—	Connects the LAN0 cable. (For maintenance)
6-h-2	ACT		LED	Yellow	Indicates that data is being transferred via a LAN 0.	
6-h-3	LINK		LED	Green	Indicates that the link status of the LAN 0 is normal.	
6-i-1		LAN1	LAN1	Connector	—	Connects the LAN1 cable. (For User Management)
6-i-2	ACT		LED	Yellow	Indicates that data is being transferred via a LAN 1.	
6-i-3	LINK		LED	Green	Indicates that the link status of the LAN 1 is normal.	
6-k		Connector for connecting the UPS interlocking cable (UPS)	Connector	—	Used to connect the UPS for the DF800.	
6-m-1	Control Unit (FC Interface Connector)	Port 0A/ Port 1A	Tx	Connector	—	Connector on the signal output side to connect the Fibre Channel interface cable in the Port 0A/Port 1A side.
6-m-2			Rx	Connector	—	Connector on the signal input side to connect the Fibre Channel interface cable in the Port 0A/Port 1A side.
6-m-3			HALM	LED	Red	Lights when the Port 0A/Port 1A is in trouble.
6-m-4			GP1	LED	Green	Shows status of the standard Interface Board mounted on the Controller in the Port 0A/Port 1A side.
6-m-5			GP0	LED	Green	Shows status of the standard Interface Board mounted on the Controller in the Port 0A/Port 1A side.
6-n-1		Port 0B/ Port 1B	Tx	Connector	—	Connector on the signal output side to connect the Fibre Channel interface cable in the Port 0B/Port 1B side.
6-n-2			Rx	Connector	—	Connector on the signal input side to connect the Fibre Channel interface cable in the Port 0B/Port 1B side.
6-n-3			HALM	LED	Red	Lights when the Port 0B/Port 1B is in trouble.
6-n-4			GP1	LED	Green	Shows status of the standard Interface Board mounted on the Controller in the Port 0B/Port 1B side.
6-n-5			GP0	LED	Green	Shows status of the standard Interface Board mounted on the Controller in the Port 0B/Port 1B side.

This page is for editorial purpose only.

(6) Indication positions and their functions of RKEXSA

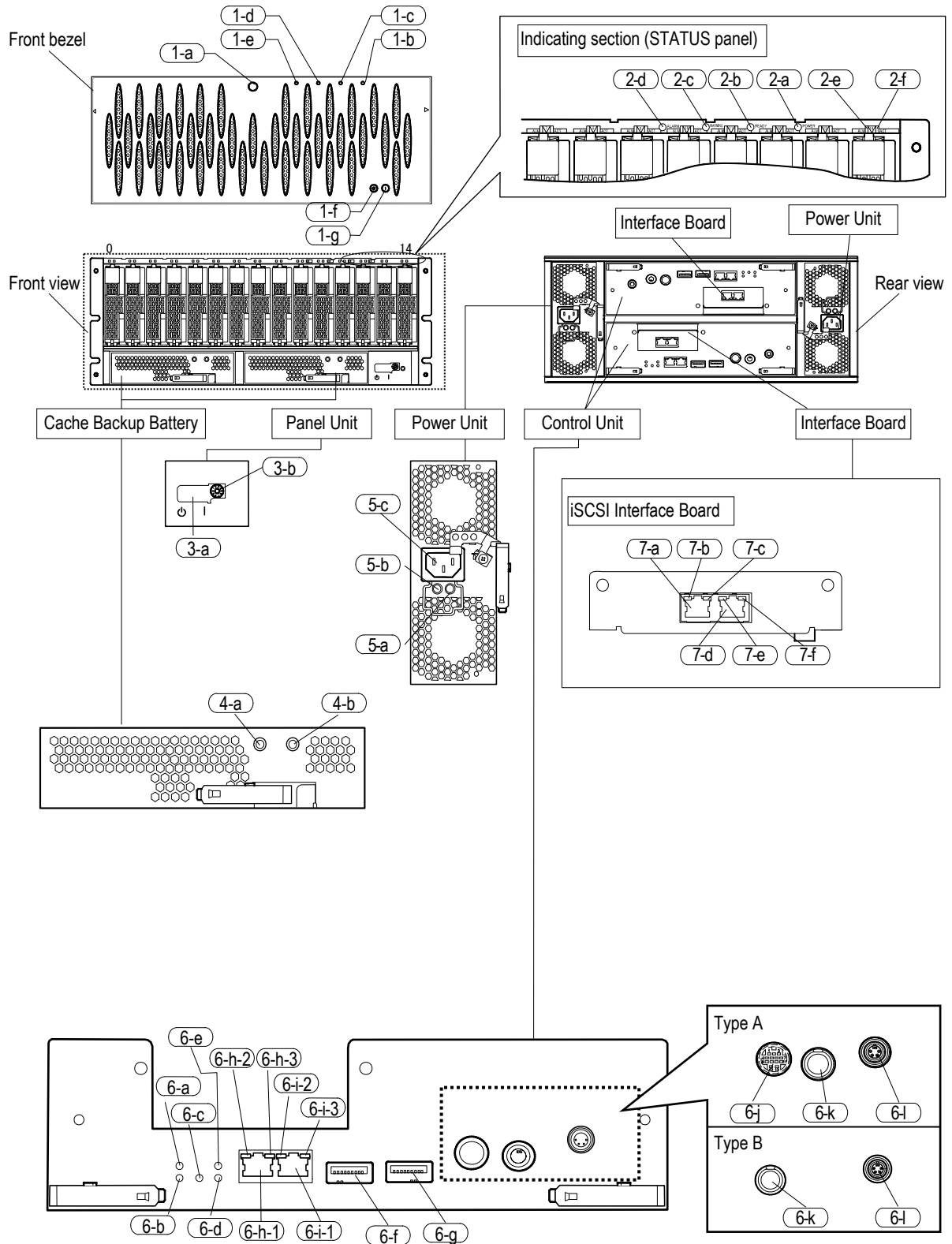

Figure 2.3.2.5 Indication Locations of Functional Components

Table 2.3.2.3 Functions of Indications

No.	Section	Name	Classification	Color	Function
1-a	Front Bezel	KEY	Key	—	Locks the front bezel.
1-b		POWER	LED	Green	Indicates that the power supply is supplied to the subsystem.
1-c		READY	LED	Green	On Indicates that the subsystem can be operated. Blinking High-speed blinking : Indicates that the automatic download of the ENC firmware is being executed in the dual controller configuration. Low-speed blinking : Indicates that the download processing of the ENC firmware is completed online.
1-d		WARNING	LED	Orange	On Indicates that a failure, which allows the subsystem to operate, occurred. Blinking High-speed blinking : Indicates that the most recent revision maintenance function of the flash program or the automatic download of the ENC firmware at the time of turning the power on in the single controller configuration is being executed. Low-speed blinking : Indicates that a failure, which does not stop operation occurred in unit (It must be detected with WEB).
1-e		ALARM	LED	Red	On Indicates that a failure, which does not allow the subsystem to operate, occurred. Blinking Low-speed blinking : Indicates that a serious failure occurred while power on.
1-f		Main switch (OFF)	Switch	—	OFF : Presses off the power.
1-g		Main switch (ON)	Switch	—	ON : Presses on the power.
2-a	STATUS Panel (RKEXSA)	POWER	LED	Green	Indicates that the power supply is supplied to the subsystem.
2-b		READY	LED	Green	On Indicates that the subsystem can be operated. Blinking High-speed blinking : Indicates that the automatic download of the ENC firmware is being executed in the dual controller configuration. Low-speed blinking : Indicates that the download processing of the ENC firmware is completed online.
2-c		WARNING	LED	Orange	On Indicates that a failure, which allows the subsystem to operate, occurred. Blinking High-speed blinking : Indicates that the most recent revision maintenance function of the flash program or the automatic download of the ENC firmware at the time of turning the power on in the single controller configuration is being executed. Low-speed blinking : Indicates that a failure, which allows the subsystem to operate, occurred. (It must be detected with WEB).

No.	Section	Name	Classification	Color	Function											
2-d	STATUS Panel (RKEXSA)	ALARM	LED	Red	On Indicates that a failure occurred which makes the subsystem unable to operate. Blinking Low-speed blinking : Indicates that a serious failure occurred while power on.											
2-e		ALM	LED	Red	Indicates that a failure which makes the unable to operate occurred.											
2-f		ACT	LED	Green	<table border="1"> <thead> <tr> <th>No.</th> <th>LED status</th> <th>Meaning</th> </tr> </thead> <tbody> <tr> <td>1</td> <td>Blinking</td> <td>Shows that the Disk Drive is being accessed.</td> </tr> <tr> <td>2</td> <td>On</td> <td>Spin up state. (SAS/SAS(SED))/ Power on. (SATA/Flash Drive)</td> </tr> <tr> <td>3</td> <td>Off</td> <td>Spin down state. (SAS/SAS(SED))/ Power off. (SATA/Flash Drive)</td> </tr> </tbody> </table>	No.	LED status	Meaning	1	Blinking	Shows that the Disk Drive is being accessed.	2	On	Spin up state. (SAS/SAS(SED))/ Power on. (SATA/Flash Drive)	3	Off
No.	LED status	Meaning														
1	Blinking	Shows that the Disk Drive is being accessed.														
2	On	Spin up state. (SAS/SAS(SED))/ Power on. (SATA/Flash Drive)														
3	Off	Spin down state. (SAS/SAS(SED))/ Power off. (SATA/Flash Drive)														
3-a	Panel Unit	Main switch	Switch	—	Turns on/off the power. : Power on ⏻ : Power off											
3-b		Mode switch	Switch	—	Set the local/remote power unit control mode. In the Ready status, sets the Web special window display permission.											
4-a	Cache Backup Battery	ALM	LED	Red	Lights when the Cache Backup Battery is in trouble. • Battery voltage is abnormal. • Battery temperature abnormal.											
4-b		RDY	LED	Green	Shows the state of the battery. On : Battery is in the normal condition. Blinking : Charged up when start-up Off : Abnormal • The battery is not installed. • Battery voltage is abnormal. • Temperature of the battery is abnormal.											
5-a	Power Unit	ALM	LED	Red	Lights when the Power Unit is in trouble.											
5-b		RDY	LED	Green	Shows the operation state of the Power Unit. On : Normal operation Off : Abnormal operation or out of operation											
5-c		Receptor (J1)	Connector	—	Connector on the subsystem side to connect the power cable.											
6-a	Control Unit	ALM	LED	Red	Indicates that a failure which makes in the Controller unable to operate occurred in it.											
6-b		LOC	LED	Orange	Indicate the Chassis location • A factor of the error is indicated by the blinking count. Six times : Voltage on the Controller is abnormal. (Reset of the Controller is not canceled.) • The CUDG error detected by the ENC firmware is indicated. On: CUDG error detected by ENC firmware (BOOT section) RAM error detected by ENC firmware ENC hard configuration error High-speed blinking: Once : SRAM error. Twice : CUDG error in ENC hard. Three times : Firmware error in flash memory. Four times : The hardware error of the ENC part was detected. • When adding the chassis with the power turned on, it lights up to indicate the addition source (this is not an error).											
6-c		RST SW	Switch	—	Used to perform a Full Dump.											

No.	Section	Name	Classification	Color	Function	
6-d		RST	LED	Orange	Indicates that the Controller is being reset. <ul style="list-style-type: none"> • During power-on reset • During reset for doing a dump • During reset for a reboot at the time of a firmware down load 	
6-e	Control Unit	C-PWR	LED	Green	You can check if the Cache memory is being backed up by the indication status of this LED. It is valid when the power cables are connected to the Power Units. On : Indicates that the cache is being backed up. (The power is supplied from the battery to the Cache memory.) Off : The Cache memory is not backed up.	
6-f		PATH0	Connector	—	Connection connector for ENC cable (PATH 0 side).	
6-g		PATH1	Connector	—	Connection connector for ENC cable (PATH 1 side).	
6-h-1		LAN0	LAN0	Connector	—	Connects the LAN0 cable. (For maintenance)
6-h-2			ACT	LED	Yellow	Indicates that data is being transferred via a LAN 0.
6-h-3			LINK	LED	Green	Indicates that the link status of the LAN 0 is normal.
6-i-1		LAN1	LAN1	Connector	—	Connects the LAN1 cable. (For User Management)
6-i-2			ACT	LED	Yellow	Indicates that data is being transferred via a LAN 1.
6-i-3			LINK	LED	Green	Indicates that the link status of the LAN 1 is normal.
6-j			Connector for connecting the Additional Battery Box (BATTERY)	Connector	—	Not used.
6-k			Connector for connecting the UPS interlocking cable (UPS)	Connector	—	Used to connect the UPS for the DF800.
6-l			Connector for connecting the Remote adapter (REMOTE ADAPTER)	Connector	—	Used to connect the Remote Adapter.
7-a		iSCSI Interface Board	Port A	iSCSI	Connector	—
7-b	Active			LED	Yellow	Indicates that data is being transferred via a Port A side.
7-c	Link			LED	Green	Indicates that the link status of the Port A side is normal.
7-d	Port B		iSCSI	Connector	—	Connects the iSCSI cable (Port B side). (For User Management)
7-e			Active	LED	Yellow	Indicates that data is being transferred via a Port B side.
7-f			Link	LED	Green	Indicates that the link status of the Port B side is normal.

(7) Indication positions and their functions of RKEXSB

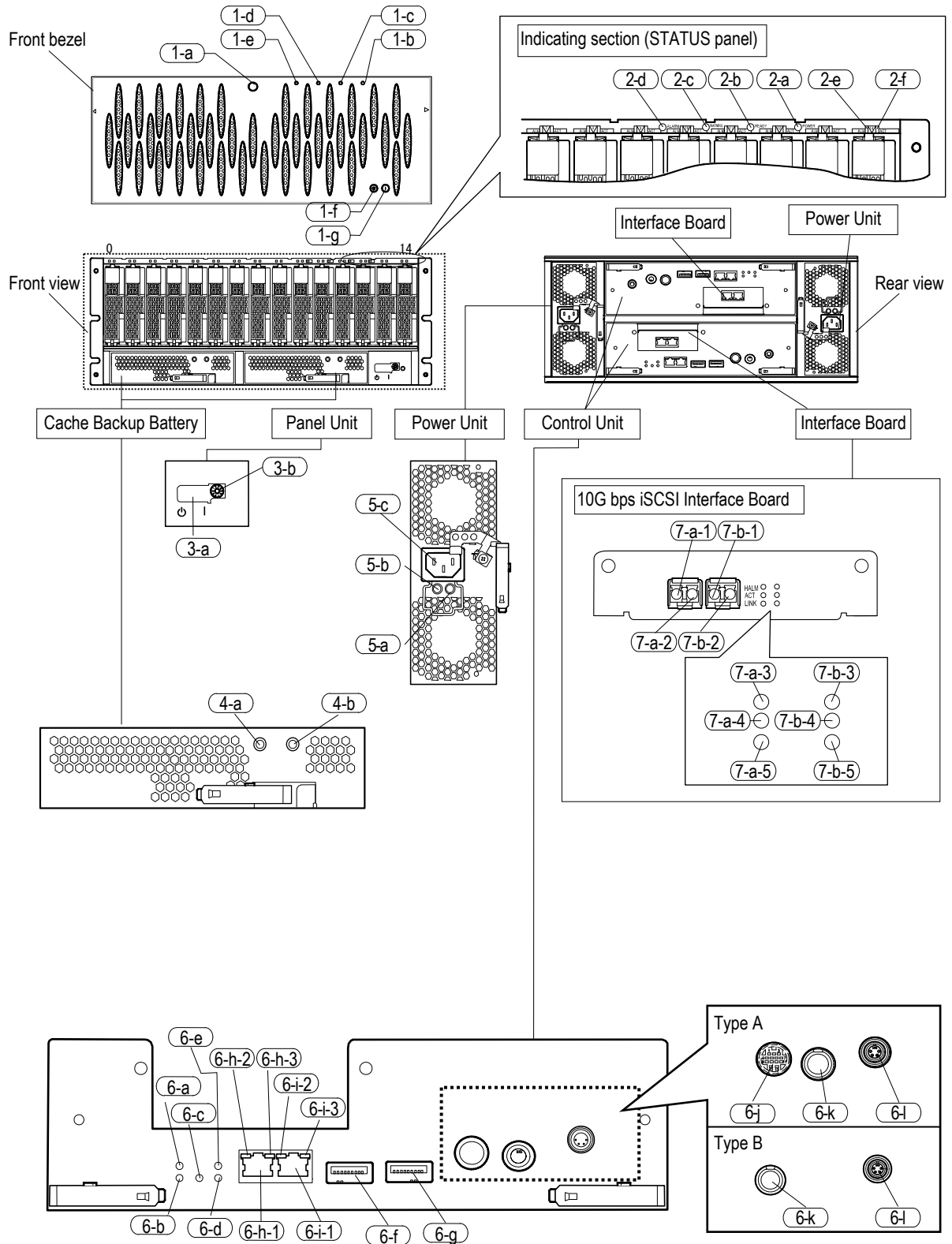

Figure 2.3.2.6 Indication Locations of Functional Components

Table 2.3.2.4 Functions of Indications

No.	Section	Name	Classification	Color	Function
1-a	Front Bezel	KEY	Key	—	Locks the front bezel.
1-b		POWER	LED	Green	Indicates that the power supply is supplied to the subsystem.
1-c		READY	LED	Green	On Indicates that the subsystem can be operated. Blinking High-speed blinking : Indicates that the automatic download of the ENC firmware is being executed in the dual controller configuration. Low-speed blinking : Indicates that the download processing of the ENC firmware is completed online.
1-d		WARNING	LED	Orange	On Indicates that a failure, which allows the subsystem to operate, occurred. Blinking High-speed blinking : Indicates that the most recent revision maintenance function of the flash program or the automatic download of the ENC firmware at the time of turning the power on in the single controller configuration is being executed. Low-speed blinking : Indicates that a failure, which does not stop operation occurred in unit (It must be detected with WEB).
1-e		ALARM	LED	Red	On Indicates that a failure, which does not allow the subsystem to operate, occurred. Blinking Low-speed blinking : Indicates that a serious failure occurred while power on.
1-f		Main switch (OFF)	Switch	—	OFF : Presses off the power.
1-g		Main switch (ON)	Switch	—	ON : Presses on the power.
2-a	STATUS Panel (RKEXSB)	POWER	LED	Green	Indicates that the power supply is supplied to the subsystem.
2-b		READY	LED	Green	On Indicates that the subsystem can be operated. Blinking High-speed blinking : Indicates that the automatic download of the ENC firmware is being executed in the dual controller configuration. Low-speed blinking : Indicates that the download processing of the ENC firmware is completed online.
2-c		WARNING	LED	Orange	On Indicates that a failure, which allows the subsystem to operate, occurred. Blinking High-speed blinking : Indicates that the most recent revision maintenance function of the flash program or the automatic download of the ENC firmware at the time of turning the power on in the single controller configuration is being executed. Low-speed blinking : Indicates that a failure, which allows the subsystem to operate, occurred. (It must be detected with WEB).

No.	Section	Name	Classification	Color	Function											
2-d	STATUS Panel (RKEXSB)	ALARM	LED	Red	On Indicates that a failure occurred which makes the subsystem unable to operate. Blinking Low-speed blinking : Indicates that a serious failure occurred while power on.											
2-e		ALM	LED	Red	Indicates that a failure which makes the unable to operate occurred.											
2-f		ACT	LED	Green	<table border="1"> <thead> <tr> <th>No.</th> <th>LED status</th> <th>Meaning</th> </tr> </thead> <tbody> <tr> <td>1</td> <td>Blinking</td> <td>Shows that the Disk Drive is being accessed.</td> </tr> <tr> <td>2</td> <td>On</td> <td>Spin up state. (SAS/SAS(SED))/ Power on. (SATA/Flash Drive)</td> </tr> <tr> <td>3</td> <td>Off</td> <td>Spin down state. (SAS/SAS(SED))/ Power off. (SATA/Flash Drive)</td> </tr> </tbody> </table>	No.	LED status	Meaning	1	Blinking	Shows that the Disk Drive is being accessed.	2	On	Spin up state. (SAS/SAS(SED))/ Power on. (SATA/Flash Drive)	3	Off
No.	LED status	Meaning														
1	Blinking	Shows that the Disk Drive is being accessed.														
2	On	Spin up state. (SAS/SAS(SED))/ Power on. (SATA/Flash Drive)														
3	Off	Spin down state. (SAS/SAS(SED))/ Power off. (SATA/Flash Drive)														
3-a	Panel Unit	Main switch	Switch	—	Turns on/off the power. : Power on ⏻ : Power off											
3-b		Mode switch	Switch	—	Set the local/remote power unit control mode. In the Ready status, sets the Web special window display permission.											
4-a	Cache Backup Battery	ALM	LED	Red	Lights when the Cache Backup Battery is in trouble. • Battery voltage is abnormal. • Battery temperature abnormal.											
4-b		RDY	LED	Green	Shows the state of the battery. On : Battery is in the normal condition. Blinking : Charged up when start-up Off : Abnormal • The battery is not installed. • Battery voltage is abnormal. • Temperature of the battery is abnormal.											
5-a	Power Unit	ALM	LED	Red	Lights when the Power Unit is in trouble.											
5-b		RDY	LED	Green	Shows the operation state of the Power Unit. On : Normal operation Off : Abnormal operation or out of operation											
5-c		Receptor (J1)	Connector	—	Connector on the subsystem side to connect the power cable.											
6-a	Control Unit	ALM	LED	Red	Indicates that a failure which makes in the Controller unable to operate occurred in it.											
6-b		LOC	LED	Orange	Indicate the Chassis location • A factor of the error is indicated by the blinking count. Six times : Voltage on the Controller is abnormal. (Reset of the Controller is not canceled.) • The CUDG error detected by the ENC firmware is indicated. On: CUDG error detected by ENC firmware (BOOT section) RAM error detected by ENC firmware ENC hard configuration error High-speed blinking: Once : SRAM error. Twice : CUDG error in ENC hard. Three times : Firmware error in flash memory. Four times : The hardware error of the ENC part was detected. • When adding the chassis with the power turned on, it lights up to indicate the addition source (this is not an error).											
6-c		RST SW	Switch	—	Used to perform a Full Dump.											

No.	Section	Name	Classification	Color	Function	
6-d		RST	LED	Orange	Indicates that the Controller is being reset. <ul style="list-style-type: none"> • During power-on reset • During reset for doing a dump • During reset for a reboot at the time of a firmware down load 	
6-e	Control Unit	C-PWR	LED	Green	You can check if the Cache memory is being backed up by the indication status of this LED. It is valid when the power cables are connected to the Power Units. On : Indicates that the cache is being backed up. (The power is supplied from the battery to the Cache memory.) Off : The Cache memory is not backed up.	
6-f		PATH0	Connector	—	Connection connector for ENC cable (PATH 0 side).	
6-g		PATH1	Connector	—	Connection connector for ENC cable (PATH 1 side).	
6-h-1		LAN0	LAN0	Connector	—	Connects the LAN0 cable. (For maintenance)
6-h-2			ACT	LED	Yellow	Indicates that data is being transferred via a LAN 0.
6-h-3			LINK	LED	Green	Indicates that the link status of the LAN 0 is normal.
6-i-1		LAN1	LAN1	Connector	—	Connects the LAN1 cable. (For User Management)
6-i-2			ACT	LED	Yellow	Indicates that data is being transferred via a LAN 1.
6-i-3			LINK	LED	Green	Indicates that the link status of the LAN 1 is normal.
6-j			Connector for connecting the Additional Battery Box (BATTERY)	Connector	—	Not used.
6-k			Connector for connecting the UPS interlocking cable (UPS)	Connector	—	Used to connect the UPS for the DF800.
6-l			Connector for connecting the Remote adapter (REMOTE ADAPTER)	Connector	—	Used to connect the Remote Adapter.
7-a-1		10G bps iSCSI Interface Board	Port 0A/ Port 1A	Tx	Connector	—
7-a-2	Rx			Connector	—	Connector on the signal input side to connect the 10G iSCSI interface cable in the Port 0A/Port 1A side.
7-a-3	HALM			LED	Red	Lights when the Port 0A/Port 1A is in trouble.
7-a-4	Active			LED	Green	Indicates that data is being transferred via a Port 0A/Port 1A side.
7-a-5	Link			LED	Green	Indicates that the link status of the Port 0A/Port 1A side is normal.
7-b-1	Port 0B/ Port 1B		Tx	Connector	—	Connector on the signal output side to connect the 10G iSCSI interface cable in the Port 0B/Port 1B side.
7-b-2			Rx	Connector	—	Connector on the signal input side to connect the 10G iSCSI interface cable in the Port 0B/Port 1B side.
7-b-3			HALM	LED	Red	Lights when the Port 0B/Port 1B is in trouble.
7-b-4			Active	LED	Green	Indicates that data is being transferred via a Port 0B/Port 1B side.
7-b-5			Link	LED	Green	Indicates that the link status of the Port 0B/Port 1B side is normal.

(8) Indication positions and their functions of RKEXS8F

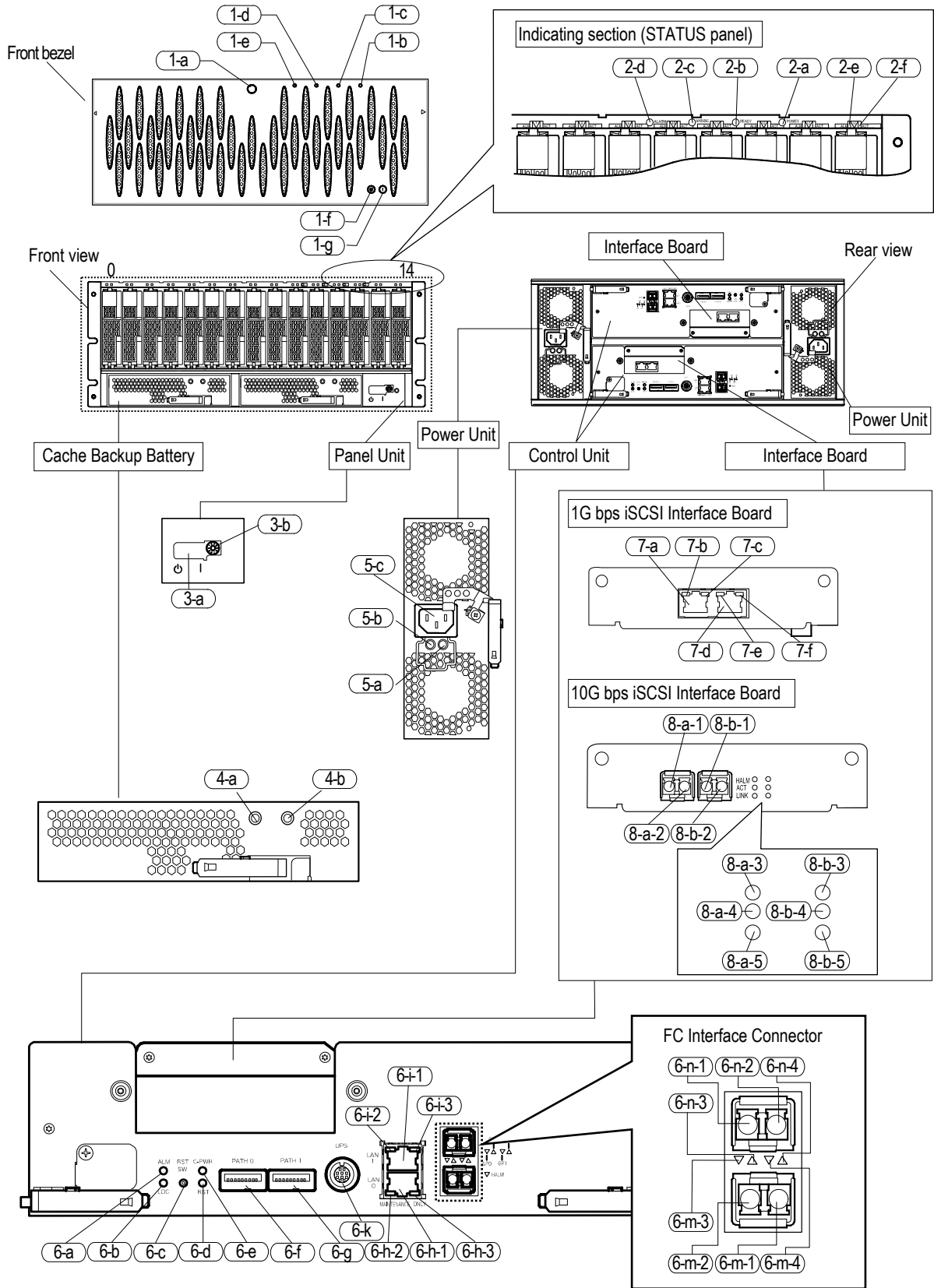

Figure 2.3.2.7 Indication Locations of Functional Components

Table 2.3.2.5 Functions of Indications

No.	Section	Name	Classification	Color	Function	
1-a	Front Bezel	KEY	Key	—	Locks the front bezel.	
1-b		POWER	LED	Green	Indicates that the power supply is supplied to the subsystem.	
1-c		READY	LED	Green	On Indicates that the subsystem can be operated. Blinking High-speed blinking : Indicates that the automatic download of the ENC firmware is being executed in the dual controller configuration. Low-speed blinking : Indicates that the download processing of the ENC firmware is completed online.	
1-d		WARNING	LED	Orange	On Indicates that a failure, which allows the subsystem to operate, occurred. Blinking High-speed blinking : Indicates that the most recent revision maintenance function of the flash program or the automatic download of the ENC firmware at the time of turning the power on in the single controller configuration is being executed. Low-speed blinking : Indicates that a failure, which does not stop operation occurred in unit (It must be detected with WEB).	
1-e		ALARM	LED	Red	On Indicates that a failure, which does not allow the subsystem to operate, occurred. Blinking Low-speed blinking : Indicates that a serious failure occurred while power on.	
1-f			Main switch (OFF)	Switch	—	OFF : Presses off the power.
1-g			Main switch (ON)	Switch	—	ON : Presses on the power.
2-a		STATUS Panel (RKEXS8F)	POWER	LED	Green	Indicates that the power supply is supplied to the subsystem.
2-b			READY	LED	Green	On Indicates that the subsystem can be operated. Blinking High-speed blinking : Indicates that the automatic download of the ENC firmware is being executed in the dual controller configuration. Low-speed blinking : Indicates that the download processing of the ENC firmware is completed online.
2-c	WARNING		LED	Orange	On Indicates that a failure, which allows the subsystem to operate, occurred. Blinking High-speed blinking : Indicates that the most recent revision maintenance function of the flash program or the automatic download of the ENC firmware at the time of turning the power on in the single controller configuration is being executed. Low-speed blinking : Indicates that a failure, which allows the subsystem to operate, occurred. (It must be detected with WEB).	
2-d	ALARM		LED	Red	On Indicates that a failure occurred which makes the subsystem unable to operate. Blinking Low-speed blinking : Indicates that a serious failure occurred while power on.	

No.	Section	Name	Classification	Color	Function												
2-e	STATUS Panel (RKEXS8F)	ALM	LED	Red	Indicates that a failure which makes the unable to operate occurred.												
2-f		ACT	LED	Green													
<table border="1"> <thead> <tr> <th>No.</th> <th>LED status</th> <th>Meaning</th> </tr> </thead> <tbody> <tr> <td>1</td> <td>Blinking</td> <td>Shows that the Disk Drive is being accessed.</td> </tr> <tr> <td>2</td> <td>On</td> <td>Spin up state. (SAS/SAS(SSED)) Power on. (SATA)</td> </tr> <tr> <td>3</td> <td>Off</td> <td>Spin down state. (SAS/SAS(SSED)) Power off. (SATA)</td> </tr> </tbody> </table>						No.	LED status	Meaning	1	Blinking	Shows that the Disk Drive is being accessed.	2	On	Spin up state. (SAS/SAS(SSED)) Power on. (SATA)	3	Off	Spin down state. (SAS/SAS(SSED)) Power off. (SATA)
No.	LED status	Meaning															
1	Blinking	Shows that the Disk Drive is being accessed.															
2	On	Spin up state. (SAS/SAS(SSED)) Power on. (SATA)															
3	Off	Spin down state. (SAS/SAS(SSED)) Power off. (SATA)															
3-a	Panel Unit	Main switch	Switch	—	Turns on/off the power. : Power on ⊖ : Power off												
3-b		Mode switch	Switch	—	Set the local/remote power unit control mode. In the Ready status, sets the Web special window display permission.												
4-a	Cache Backup Battery	ALM	LED	Red	Lights when the Cache Backup Battery is in trouble. • Battery voltage is abnormal. • Battery temperature abnormal.												
4-b		RDY	LED	Green	Shows the state of the battery. On : Battery is in the normal condition. Blinking : Charged up when start-up Off : Abnormal • The battery is not installed. • Battery voltage is abnormal. • Temperature of the battery is abnormal.												
5-a	Power Unit	ALM	LED	Red	Lights when the Power Unit is in trouble.												
5-b		RDY	LED	Green	Shows the operation state of the Power Unit. On : Normal operation Off : Abnormal operation or out of operation												
5-c		Receptor (J1)	Connector	—	Connector on the subsystem side to connect the power cable.												
6-a	Control Unit	ALM	LED	Red	Indicates that a failure which makes in the Controller unable to operate occurred in it.												
6-b		LOC	LED	Orange	Indicate the Chassis location • A factor of the error is indicated by the blinking count. Six times : Voltage on the Controller is abnormal. (Reset of the Controller is not canceled.) • The CUDG error detected by the ENC firmware is indicated. On: CUDG error detected by ENC firmware (BOOT section) RAM error detected by ENC firmware ENC hard configuration error High-speed blinking: Once : SRAM error. Twice : CUDG error in ENC hard. Three times : Firmware error in flash memory. Four times : The hardware error of the ENC part was detected. • When adding the chassis with the power turned on, it lights up to indicate the addition source (this is not an error).												
6-c		RST SW	Switch	—	Used to perform a Full Dump.												
6-d		RST	LED	Orange	Indicates that the Controller is being reset. • During power-on reset • During reset for doing a dump • During reset for a reboot at the time of a firmware down load												

No.	Section	Name	Classification	Color	Function	
6-e	Control Unit	C-PWR	LED	Green	You can check if the Cache memory is being backed up by the indication status of this LED. It is valid when the power cables are connected to the Power Units. On : Indicates that the cache is being backed up. (The power is supplied from the battery to the Cache memory.) Off : The Cache memory is not backed up.	
6-f		PATH0	Connector	—	Connection connector for ENC cable (PATH 0 side).	
6-g		PATH1	Connector	—	Connection connector for ENC cable (PATH 1 side).	
6-h-1		LAN0	LAN0	Connector	—	Connects the LAN0 cable. (For maintenance)
6-h-2			ACT	LED	Yellow	Indicates that data is being transferred via a LAN 0.
6-h-3			LINK	LED	Green	Indicates that the link status of the LAN 0 is normal.
6-i-1		LAN1	LAN1	Connector	—	Connects the LAN1 cable. (For User Management)
6-i-2			ACT	LED	Yellow	Indicates that data is being transferred via a LAN 1.
6-i-3			LINK	LED	Green	Indicates that the link status of the LAN 1 is normal.
6-k			Connector for connecting the UPS interlocking cable (UPS)	Connector	—	Used to connect the UPS for the DF800.
6-m-1		Control Unit (FC Interface Connector)	Port 0A/ Port 1A	Tx	Connector	—
6-m-2	Rx			Connector	—	Connector on the signal input side to connect the Fibre Channel interface cable in the Port 0A/Port 1A side.
6-m-3	GP0			LED	Green/ Red	•Shows status of the standard Interface Board mounted on the Controller in the Port 0A/Port 1A side. (Green)
6-m-4	GP1			LED	Green/ Red	• When the Port 0A/Port 1A is abnormal, the GP0 and GP1 light up at the same time, and it indicates the HALM. (Red)
6-n-1	Port 0B/ Port 1B		Tx	Connector	—	Connector on the signal output side to connect the Fibre Channel interface cable in the Port 0B/Port 1B side.
6-n-2			Rx	Connector	—	Connector on the signal input side to connect the Fibre Channel interface cable in the Port 0B/Port 1B side.
6-n-3			GP0	LED	Green/ Red	•Shows status of the standard Interface Board mounted on the Controller in the Port 0B/Port 1B side. (Green)
6-n-4			GP1	LED	Green/ Red	•When the Port 0B0/Port 1B is abnormal, the GP0 and GP1 light up at the same time, and it indicates the HALM. (Red)
7-a	1G bps iSCSI Interface Board	Port 0E/ Port 1E	iSCSI	Connector	—	Connects the iSCSI cable (Port 0E/Port 1E side).
7-b			Active	LED	Yellow	Indicates that data is being transferred via a Port 0E/Port 1E side.
7-c			Link	LED	Green	Indicates that the link status of the Port 0E/Port 1E side is normal.
7-d		Port 0F/ Port 1F	iSCSI	Connector	—	Connects the iSCSI cable (Port 0F/Port 1F side).
7-e			Active	LED	Yellow	Indicates that data is being transferred via a Port 0F/Port 1F side.
7-f			Link	LED	Green	Indicates that the link status of the Port 0F/Port 1F side is normal.
8-a-1	10G bps iSCSI Interface Board	Port 0E/ Port 1E	Tx	Connector	—	Connector on the signal output side to connect the 10G iSCSI interface cable in the Port 0E/Port 1E side.
8-a-2			Rx	Connector	—	Connector on the signal input side to connect the 10G iSCSI interface cable in the Port 0E/Port 1E side.
8-a-3			HALM	LED	Red	Lights when the Port 0E/Port 1E is in trouble.
8-a-4			Active	LED	Green	Indicates that data is being transferred via a Port 0A/Port 1A side.
8-a-5			Link	LED	Green	Indicates that the link status of the Port 0E/Port 1E side is normal.
8-b-1			Port 0F/ Port 1F	Tx	Connector	—
8-b-2		Rx		Connector	—	Connector on the signal input side to connect the 10G iSCSI interface cable in the Port 0F/Port 1F side.
8-b-3		HALM		LED	Red	Lights when the Port 0F/Port 1F is in trouble.
8-b-4		Active		LED	Green	Indicates that data is being transferred via a Port 0F/Port 1F side.
8-b-5		Link		LED	Green	Indicates that the link status of the Port 0F/Port 1F side is normal.

(9) Indication positions and their functions of RKH/RKHED

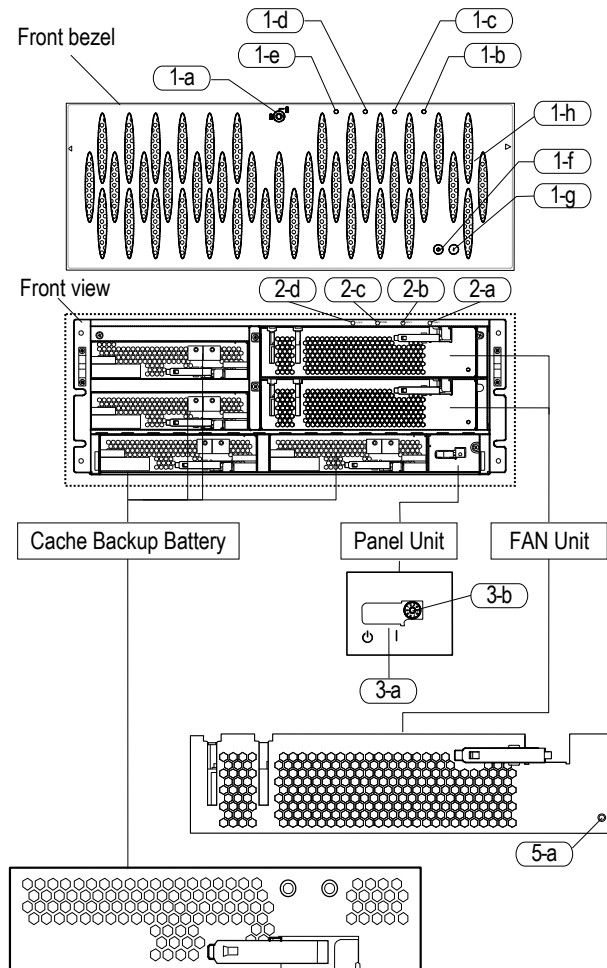

Figure 2.3.3 Indication Locations of Functional Components (Front View)

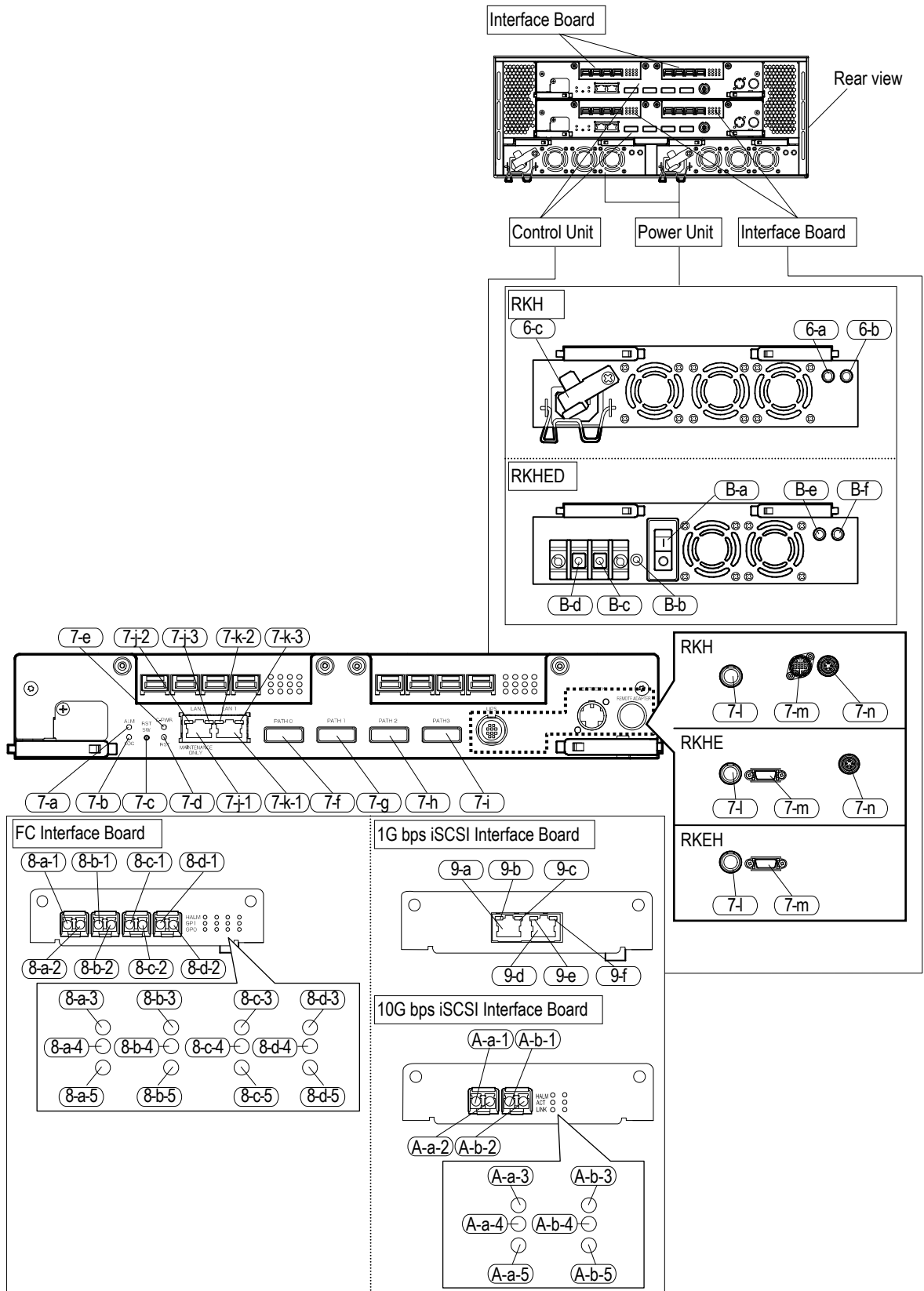

Figure 2.3.3.1 Indication Locations of Functional Components (Rear View)

Table 2.3.3 Functions of Indications

No.	Section	Name	Classification	Color	Function
1-a	Front Bezel	KEY	Key	—	Locks the front bezel.
1-b		POWER	LED	Green	Indicates that the power supply is supplied to the subsystem.
1-c		READY	LED	Green	On Indicates that the subsystem can be operated. Blinking High-speed blinking : Indicates that the automatic download of the ENC firmware is being executed in the dual controller configuration. Low-speed blinking : Indicates that the download processing of the ENC firmware is completed online.
1-d		WARNING	LED	Orange	On Indicates that a failure, which allows the subsystem to operate, occurred. Blinking High-speed blinking : Indicates that the most recent revision maintenance function of the flash program or the automatic download of the ENC firmware at the time of turning the power on in the single controller configuration is being executed. Low-speed blinking : Indicates that a failure, which does not stop operation occurred in unit (It must be detected with WEB).
1-e		ALARM	LED	Red	On Indicates that a failure, which does not allow the subsystem to operate, occurred. Blinking Low-speed blinking : Indicates that a serious failure occurred while power on.
1-f		Main switch (OFF)	Switch	—	OFF : Presses off the power.
1-g		Main switch (ON)	Switch	—	ON : Presses on the power.
2-a	STATUS Panel (RKH)	POWER	LED	Green	Indicates that the power supply is supplied to the subsystem.
2-b		READY	LED	Green	On Indicates that the subsystem can be operated. Blinking High-speed blinking : Indicates that the automatic download of the ENC firmware is being executed in the dual controller configuration. Low-speed blinking : Indicates that the download processing of the ENC firmware is completed online.
2-c		WARNING	LED	Orange	On Indicates that a failure, which allows the subsystem to operate, occurred. Blinking High-speed blinking : Indicates that the most recent revision maintenance function of the flash program or the automatic download of the ENC firmware at the time of turning the power on in the single controller configuration is being executed. Low-speed blinking : Indicates that a failure, which allows the subsystem to operate, occurred. (It must be detected with WEB).

No.	Section	Name	Classification	Color	Function
2-d	STATUS Panel (RKH)	ALARM	LED	Red	On Indicates that a failure occurred which makes the subsystem unable to operate. Blinking Low-speed blinking : Indicates that a serious failure occurred while power on.
3-a	Panel Unit	Main switch	Switch	—	Turns on/off the power. : Power on ⊖ : Power off
3-b		Mode switch	Switch	—	Set the local/remote power unit control mode. In the Ready status, sets the Web special window display permission.
4-a	Cache Backup Battery	ALM	LED	Red	Lights when the Cache Backup Battery is in trouble. • Battery voltage is abnormal. • Battery temperature abnormal.
4-b		RDY	LED	Green	Shows the state of the battery. On : Battery is in the normal condition. Blinking : Charged up when start-up Off : Abnormal • The battery is not installed. • Battery voltage is abnormal. • Temperature of the battery is abnormal.
5-a	FAN Unit	ALM	LED	Red	Shows the state of the FAN Unit On : Abnormal Off : Normal
6-a	Power Unit (RKH)	ALM	LED	Red	Lights when the Power Unit is in trouble.
6-b		RDY	LED	Green	Shows the operation state of the Power Unit. On : Normal operation Off : Abnormal operation or out of operation
6-c		Receptor (J1)	Connector	—	Connector on the subsystem side to connect the power cable.
7-a	Control Unit	ALM	LED	Red	• Indicates that a failure which makes in the Controller unable to operate occurred in it. • Does not light up when the Control Unit is in the reset status.
7-b		LOC	LED	Orange	Indicate the Chassis location • A factor of the error is indicated by the blinking count. Six times : Voltage on the Controller is abnormal. (Reset of the Controller is not canceled.) • The CUDG error detected by the ENC firmware is indicated. On: CUDG error detected by ENC firmware (BOOT section) RAM error detected by ENC firmware ENC hard configuration error High-speed blinking: Once : SRAM error. Twice : CUDG error in ENC hard. Three times : Firmware error in flash memory. Four times : The hardware error of the ENC part was detected. • When adding the chassis with the power turned on, it lights up to indicate the addition source (this is not an error).
7-c		RST SW	Switch	—	Used to perform a Full Dump.

No.	Section	Name	Classification	Color	Function		
7-d	Control Unit	RST	LED	Orange	Indicates that the Controller is being reset. <ul style="list-style-type: none"> • During power-on reset • During reset for doing a dump • During reset for a reboot at the time of a firmware down load • The DC-DC converter or the reset circuit on the Control Unit fails. 		
7-e		C-PWR	LED	Green	You can check if the Cache memory is being backed up by the indication status of this LED. It is valid when the power cables are connected to the Power Units. On : Indicates that the cache is being backed up. (The power is supplied from the battery to the Cache memory.) Off : The Cache memory is not backed up.		
7-f		PATH0	Connector	—	Connection connector for ENC cable (PATH 0 side).		
7-g		PATH1	Connector	—	Connection connector for ENC cable (PATH 1 side).		
7-h		PATH2	Connector	—	Connection connector for ENC cable (PATH 2 side).		
7-i		PATH3	Connector	—	Connection connector for ENC cable (PATH 3 side).		
7-j-1		LAN0	LAN0	Connector	—	Connects the LAN0 cable. (For maintenance)	
7-j-2			ACT	LED	Yellow	Indicates that data is being transferred via a LAN 0.	
7-j-3			LINK	LED	Green	Indicates that the link status of the LAN 0 is normal.	
7-k-1		LAN1	LAN1	Connector	—	Connects the LAN1 cable. (For User Management)	
7-k-2			ACT	LED	Yellow	Indicates that data is being transferred via a LAN 1.	
7-k-3			LINK	LED	Green	Indicates that the link status of the LAN 1 is normal.	
7-l		Connector for connecting the UPS interlocking cable (UPS)	Connector	—	Used to connect the UPS for the DF800.		
7-m		Connector for connecting the Additional Battery Box (BATTERY)	Connector	—	Used to connect the Additional Battery Box.		
7-n		Connector for connecting the Remote adapter (REMOTE ADAPTER)	Connector	—	Used to connect the Remote Adapter. Not exist on the RKEH.		
8-a-1		FC Interface Board	Port 0A/ Port 1A/ Port 0E/ Port 1E	Tx	Connector	—	Connector on the signal output side to connect the Fibre Channel interface cable in the Port 0A/Port 1A/Port 0E/Port 1E side.
8-a-2				Rx	Connector	—	Connector on the signal input side to connect the Fibre Channel interface cable in the Port 0A/Port 1A/Port 0E/Port 1E side.
8-a-3	HALM			LED	Red	Lights when the Port 0A/Port 1A/Port 0E/Port 1E is in trouble.	
8-a-4	GP1			LED	Green	Shows status of the standard Interface Board mounted on the Controller in the Port 0A/Port 1A/Port 0E/Port 1E side.	
8-a-5	GP0			LED	Green	Shows status of the standard Interface Board mounted on the Controller in the Port 0A/Port 1A/Port 0E/Port 1E side.	
8-b-1	Port 0B/ Port 1B/ Port 0F/ Port 1F		Tx	Connector	—	Connector on the signal output side to connect the Fibre Channel interface cable in the Port 0B/Port 1B/Port 0F/Port 1F side.	
8-b-2			Rx	Connector	—	Connector on the signal input side to connect the Fibre Channel interface cable in the Port 0B/Port 1B/Port 0F/Port 1F side.	
8-b-3			HALM	LED	Red	Lights when the Port 0B/Port 1B/Port 0F/Port 1F is in trouble.	
8-b-4			GP1	LED	Green	Shows status of the standard Interface Board mounted on the Controller in the Port 0B/Port 1B/Port 0F/Port 1F side.	
8-b-5			GP0	LED	Green	Shows status of the standard Interface Board mounted on the Controller in the Port 0B/Port 1B/Port 0F/Port 1F side.	

No.	Section	Name	Classification	Color	Function	
8-c-1	FC Interface Board	Port 0C/ Port 1C/ Port 0G/ Port 1G	Tx	Connector	—	Connector on the signal output side to connect the Fibre Channel interface cable in the Port 0C/Port 1C/Port 0G/Port 1G side.
8-c-2			Rx	Connector	—	Connector on the signal input side to connect the Fibre Channel interface cable in the Port 0C/Port 1C/Port 0G/Port 1G side.
8-c-3			HALM	LED	Red	Lights when the Port 0C/Port 1C/Port 0G/Port 1G is in trouble.
8-c-4			GP1	LED	Green	Shows status of the standard Interface Board mounted on the Controller in the Port 0C/Port 1C/Port 0G/Port 1G side.
8-c-5			GP0	LED	Green	Shows status of the standard Interface Board mounted on the Controller in the Port 0C/Port 1C/Port 0G/Port 1G side.
8-d-1		Port 0D/ Port 1D/ Port 0H/ Port 1H	Tx	Connector	—	Connector on the signal output side to connect the Fibre Channel interface cable in the Port 0D/Port 1D/Port 0H/Port 1H side.
8-d-2			Rx	Connector	—	Connector on the signal input side to connect the Fibre Channel interface cable in the Port 0D/Port 1D/Port 0H/Port 1H side.
8-d-3			HALM	LED	Red	Lights when the Port 0D/Port 1D/Port 0H/Port 1H is in trouble.
8-d-4			GP1	LED	Green	Shows status of the standard Interface Board mounted on the Controller in the Port 0D/Port 1D/Port 0H/Port 1H side.
8-d-5			GP0	LED	Green	Shows status of the standard Interface Board mounted on the Controller in the Port 0D/Port 1D/Port 0H/Port 1H side.
8-a	1G bps iSCSI Interface Board	Port 0A/ Port 1A/ Port 0E/ Port 1E	iSCSI	Connector	—	Connects the iSCSI cable (Port 0A/Port 1A/Port 0E/Port 1E side).
8-b			Active	LED	Yellow	Indicates that data is being transferred via a Port 0A/Port 1A/Port 0E/Port 1E side.
8-c			Link	LED	Green	Indicates that the link status of the Port 0A/Port 1A/Port 0E/Port 1E side is normal.
8-d		Port 0B/ Port 1B/ Port 0F/ Port 1F	iSCSI	Connector	—	Connects the iSCSI cable (Port 0B/Port 1B/Port 0F/Port 1F side).
8-e			Active	LED	Yellow	Indicates that data is being transferred via a Port 0B/Port 1B/Port 0F/Port 1F side.
8-f			Link	LED	Green	Indicates that the link status of the Port 0B/Port 1B/Port 0F/Port 1F side is normal.
A-a-1	10G bps iSCSI Interface Board	Port 0A/ Port 1A/ Port 0E/ Port 1E	Tx	Connector	—	Connector on the signal output side to connect the 10G iSCSI interface cable in the Port 0A/Port 1A/Port 0E/Port 1E side.
A-a-2			Rx	Connector	—	Connector on the signal input side to connect the 10G iSCSI interface cable in the Port 0A/Port 1A/Port 0E/Port 1E side.
A-a-3			HALM	LED	Red	Lights when the Port 0A/Port 1A/Port 0E/Port 1E side is in trouble.
A-a-4			Active	LED	Green	Indicates that data is being transferred via a Port 0A/Port 1A/Port 0E/Port 1E side.
A-a-5			Link	LED	Green	Indicates that the link status of the Port 0A/Port 1A/Port 0E/Port 1E side is normal.
A-b-1		Port 0B/ Port 1B/ Port 0F/ Port 1F	Tx	Connector	—	Connector on the signal output side to connect the 10G iSCSI interface cable in the Port 0B/Port 1B/Port 0F/Port 1F side.
A-b-2			Rx	Connector	—	Connector on the signal input side to connect the 10G iSCSI interface cable in the Port 0B/Port 1B/Port 0F/Port 1F side.
A-b-3			HALM	LED	Red	Lights when the Port 0B/Port 1B/Port 0F/Port 1F is in trouble.
A-b-4			Active	LED	Green	Indicates that data is being transferred via a Port 0B/Port 1B/Port 0F/Port 1F side.
A-b-5			Link	LED	Green	Indicates that the link status of the Port 0B/Port 1B/Port 0F/Port 1F side is normal.

No.	Section	Name	Classification	Color	Function
B-a	Power Unit (RKHED)	Power Unit Switch	Switch	—	Controls the power applied to the subsystem. : Power on O: Power off
B-b		Terminal (FG)	Terminal	—	Connector on the subsystem side to connect the power cable.
B-c		Terminal (-)	Terminal	—	Connector on the subsystem side to connect the power cable.
B-d		Terminal (+)	Terminal	—	Connector on the subsystem side to connect the power cable.
B-e		ALM	LED	Red	Lights when the Power Unit is in trouble.
B-f		RDY	LED	Green	Shows the operation state of the Power Unit. On : Normal operation Off : Abnormal operation or out of operation

(10) Indication positions and their functions of RKAK/RKAKD

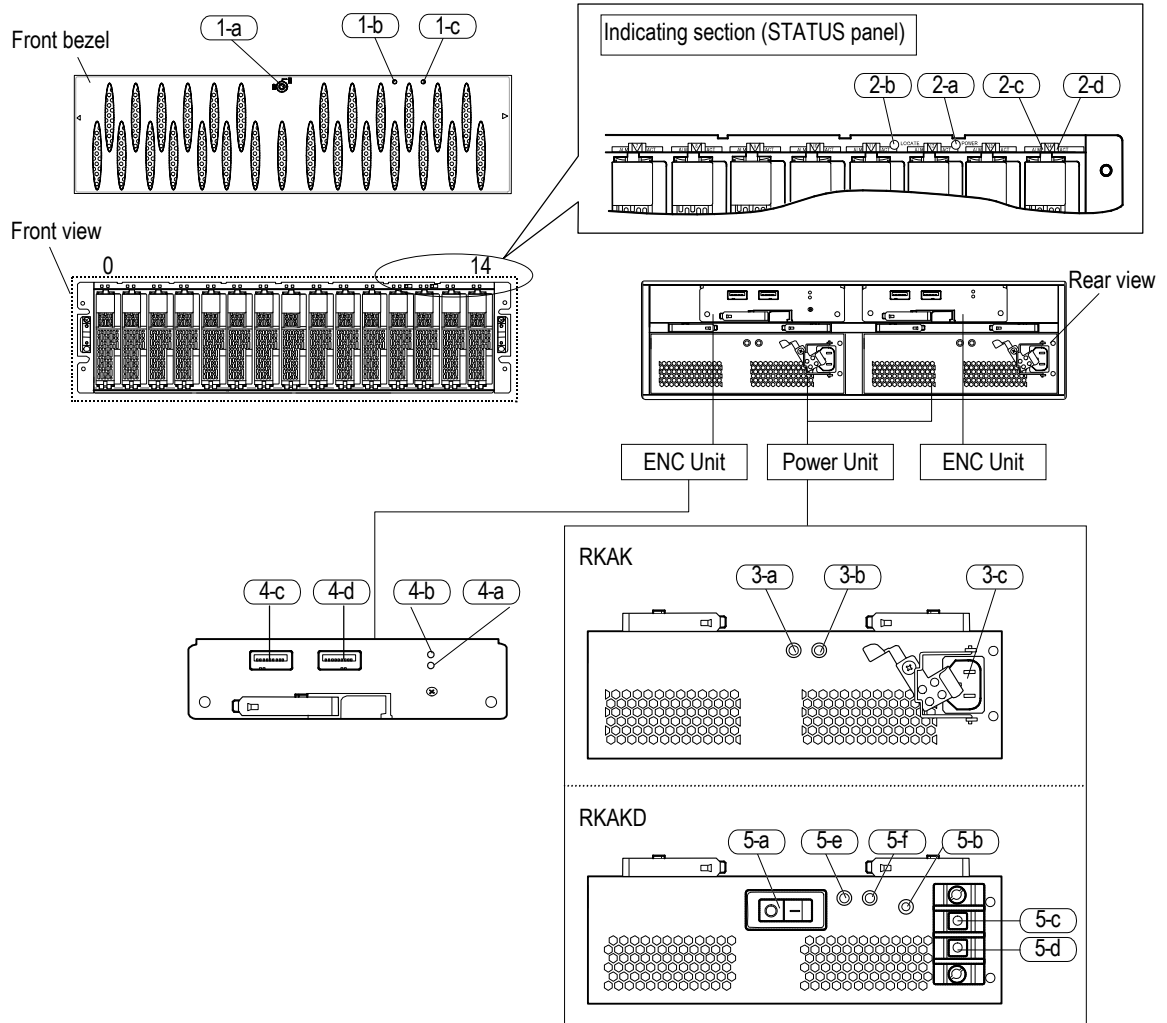

Figure 2.3.4 Indication Locations of Functional Components

Table 2.3.4 Functions of Indications

No.	Section	Name	Classification	Color	Function											
1-a	Front Bezel	KEY	Key	—	Locks the front bezel.											
1-b		POWER	LED	Green	Indicates that the power supply is supplied to RKAK.											
1-c		LOCATE	LED	Orange	<ul style="list-style-type: none"> Indicates that a failure which allows the RKAK operation occurred. When adding the chassis with the power turned on, it lights up to indicate the addition source (this is not an error). 											
2-a	STATUS Panel	POWER	LED	Green	Indicates that the power is supplied to the RKAK.											
2-b		LOCATE	LED	Orange	<ul style="list-style-type: none"> Indicates that a failure which allows the RKAK operation occurred. When adding the chassis with the power turned on, it lights up to indicate the addition source (this is not an error). 											
2-c		ALM	LED	Red	Indicates that a failure which makes the unable to operate occurred.											
2-d		ACT	LED	Green	<table border="1"> <thead> <tr> <th>No.</th> <th>LED status</th> <th>Meaning</th> </tr> </thead> <tbody> <tr> <td>1</td> <td>Blinking</td> <td>Shows that the Disk Drive is being accessed.</td> </tr> <tr> <td>2</td> <td>On</td> <td>Spin up state. (SAS/SAS(SSED))/ Power on. (SATA/Flash Drive)</td> </tr> <tr> <td>3</td> <td>Off</td> <td>Spin down state. (SAS/SAS(SSED))/ Power off. (SATA/Flash Drive)</td> </tr> </tbody> </table>	No.	LED status	Meaning	1	Blinking	Shows that the Disk Drive is being accessed.	2	On	Spin up state. (SAS/SAS(SSED))/ Power on. (SATA/Flash Drive)	3	Off
No.	LED status	Meaning														
1	Blinking	Shows that the Disk Drive is being accessed.														
2	On	Spin up state. (SAS/SAS(SSED))/ Power on. (SATA/Flash Drive)														
3	Off	Spin down state. (SAS/SAS(SSED))/ Power off. (SATA/Flash Drive)														
3-a	Power Unit (RKAK)	ALM	LED	Red	Lights when the Power Unit is in trouble.											
3-b		RDY	LED	Green	Shows the operation state of the Power Unit. On : Normal operation Off : Abnormal operation or out of operation											
3-c		Receptor (J1)	Connector	—	Connector on the subsystem side to connect the power cable.											
4-a	ENC Unit	ALM	LED	Red	Indicates error factors by means of lighting. Lighting Indicates that a failure, which makes the ENC Unit unable to operate, occurred.											
4-b		LOC	LED	Orange	Indicate the Chassis location <ul style="list-style-type: none"> The CUDG error detected by the ENC firmware is indicated. On: <ul style="list-style-type: none"> CUDG error detected by ENC firmware (BOOT section) RAM error detected by ENC firmware ENC hard configuration error High-speed blinking: <ul style="list-style-type: none"> Once : SRAM error. Twice : CUDG error in ENC hard. Three times : Firmware error in flash memory. When adding the chassis with the power turned on, it lights up to indicate the addition source (this is not an error). 											
4-c		PATH0 (IN side)	Connector	—	Connection (for input) connector for ENC cable (PATH0 side).											
4-d		PATH0 (OUT side)	Connector	—	Connection connector (for output) for ENC cable (PATH 0 side).											
5-a	Power Unit (RKAKD)	Power Unit Switch	Switch	—	Controls the power applied to the subsystem. : Power on O : Power off											
5-b		Terminal (FG)	Terminal	—	Connector on the subsystem side to connect the power cable.											
5-c		Terminal (–)	Terminal	—	Connector on the subsystem side to connect the power cable.											
5-d		Terminal (+)	Terminal	—	Connector on the subsystem side to connect the power cable.											
5-e		ALM	LED	Red	Lights when the Power Unit is in trouble.											
5-f		RDY	LED	Green	Shows the operation state of the Power Unit. On : Normal operation Off : Abnormal operation or out of operation											

(11) Indication positions and their functions of RKAKX

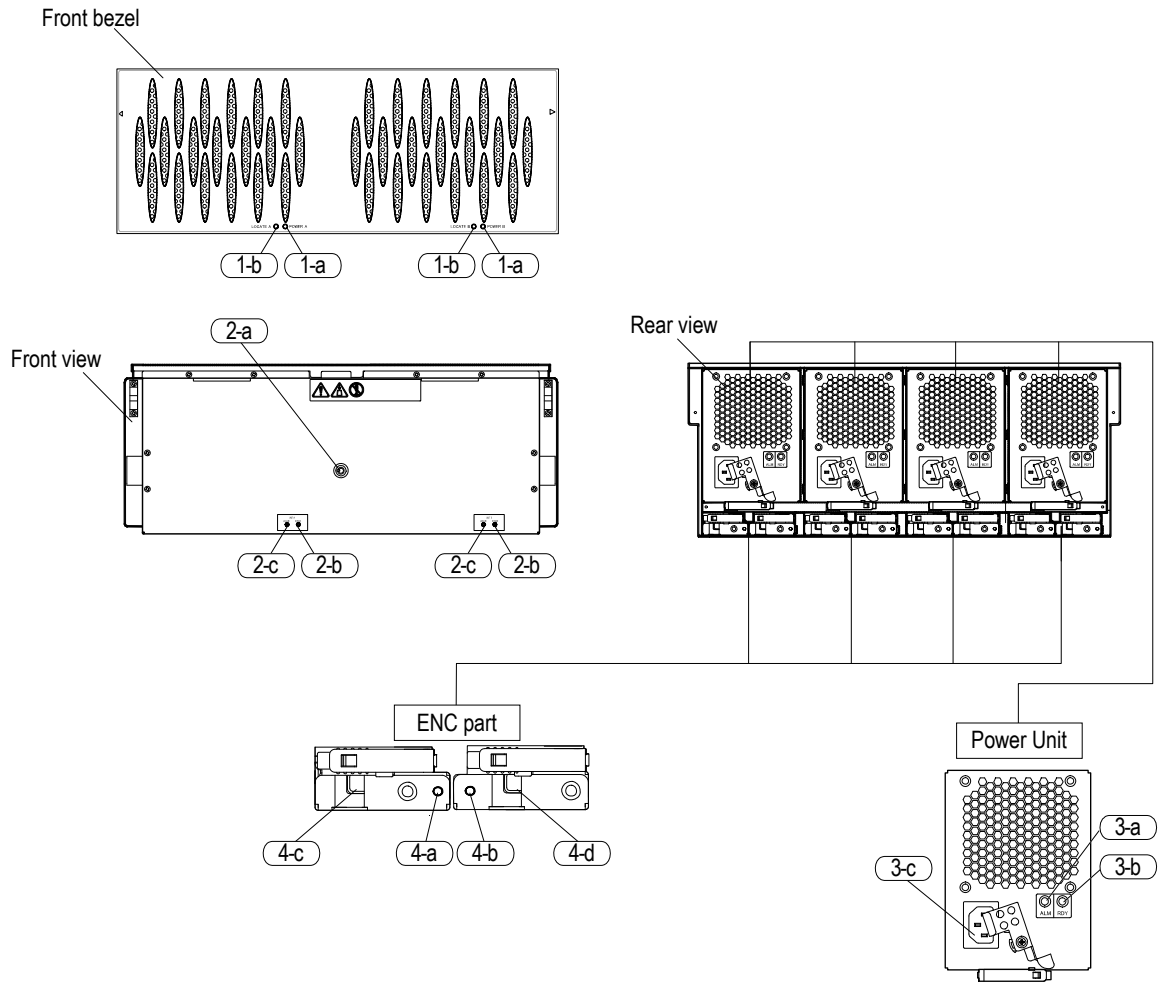

Figure 2.3.5 Indication Locations of Functional Components

Table 2.3.5 Functions of Indications

No.	Section	Name	Classification	Color	Function
1-a	Front Bezel	POWER	LED	Green	Indicates that the power supply is supplied to RKAKX.
1-b		LOCATE	LED	Orange	<ul style="list-style-type: none"> Indicates that a failure which allows the RKAKX operation occurred. When adding the chassis with the power turned on, it lights up to indicate the addition source (this is not an error).
2-a	STATUS Panel	KEY	Key	—	Locks the front bezel.
2-b		POWER	LED	Green	Indicates that the power is supplied to the RKAKX.
2-c		LOCATE	LED	Orange	<ul style="list-style-type: none"> Indicates that a failure which allows the RKAKX operation occurred. When adding the chassis with the power turned on, it lights up to indicate the addition source (this is not an error).
3-a	Power Unit	ALM	LED	Red	Lights when the Power Unit is in trouble.
3-b		RDY	LED	Green	Shows the operation state of the Power Unit. On : Normal operation Off : Abnormal operation or out of operation
3-c		Receptor (J1)	Connector	—	Connector on the subsystem side to connect the power cable.
4-a	ENC Unit	ALM	LED	Red	Indicates error factors by means of lighting. Lighting Indicates that a failure, which makes the ENC Unit unable to operate, occurred.
4-b		LOC	LED	Orange	Indicate the Chassis location <ul style="list-style-type: none"> The CUDG error detected by the ENC firmware is indicated. On: <ul style="list-style-type: none"> CUDG error detected by ENC firmware (BOOT section) RAM error detected by ENC firmware ENC hard configuration error High-speed blinking: <ul style="list-style-type: none"> Once : SRAM error. Twice : CUDG error in ENC hard. Three times : Firmware error in flash memory. When adding the chassis with the power turned on, it lights up to indicate the addition source (this is not an error).
4-c		PATH0 (IN side)	Connector	—	Connection (for input) connector for ENC cable (PATH0 side).
4-d	PATH0 (OUT side)	Connector	—	Connection connector (for output) for ENC cable (PATH 0 side).	

(12) Indication positions and their functions of RKAKS

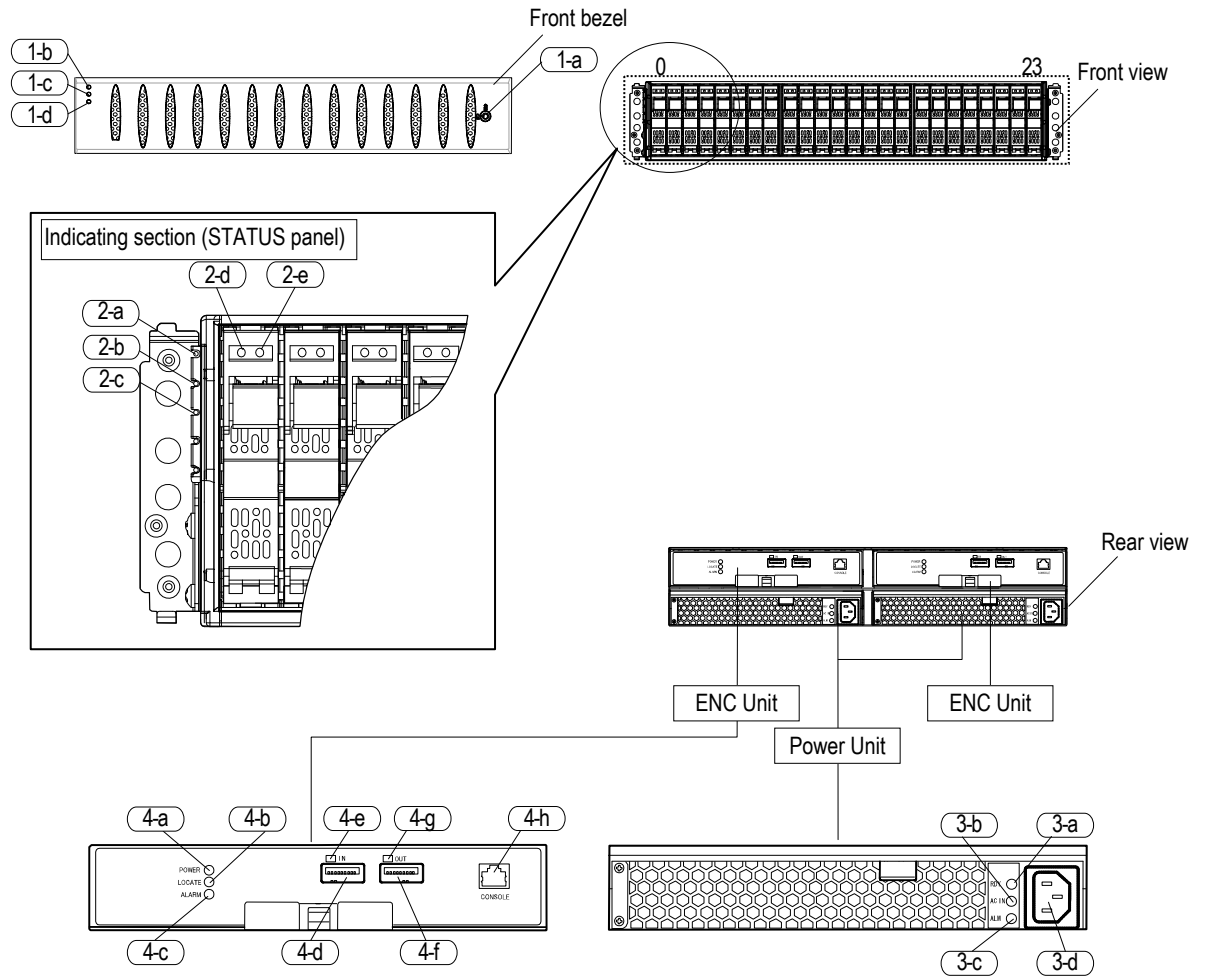

Figure 2.3.5.1 Indication Locations of Functional Components

Table 2.3.5.1 Functions of Indications

No.	Section	Name	Classification	Color	Function											
1-a	Front Bezel	KEY	Key	—	Locks the front bezel.											
1-b		POWER	LED	Green	Indicates that the power supply is supplied to RKAKS.											
1-c		READY	LED	Green	Indicates that the subsystem can be operated.											
1-d		LOCATE	LED	Orange	<ul style="list-style-type: none"> Indicates that a failure which allows the RKAKS operation occurred. When adding the chassis with the power turned on, it lights up to indicate the addition source (this is not an error). 											
2-a	STATUS Panel	POWER	LED	Green	Indicates that the power is supplied to the RKAKS.											
2-b		READY	LED	Green	Indicates that the subsystem can be operated.											
2-c		LOCATE	LED	Orange	<ul style="list-style-type: none"> Indicates that a failure which allows the RKAKS operation occurred. When adding the chassis with the power turned on, it lights up to indicate the addition source (this is not an error). 											
2-d		ALM	LED	Red	Indicates that a failure which makes the unable to operate occurred.											
2-e		ACT	LED	Green	<table border="1"> <thead> <tr> <th>No.</th> <th>LED status</th> <th>Meaning</th> </tr> </thead> <tbody> <tr> <td>1</td> <td>Blinking</td> <td>Shows that the Disk Drive is being accessed.</td> </tr> <tr> <td>2</td> <td>On</td> <td>Spin up state. (SAS)</td> </tr> <tr> <td>3</td> <td>Off</td> <td>Spin down state. (SAS)</td> </tr> </tbody> </table>	No.	LED status	Meaning	1	Blinking	Shows that the Disk Drive is being accessed.	2	On	Spin up state. (SAS)	3	Off
No.	LED status	Meaning														
1	Blinking	Shows that the Disk Drive is being accessed.														
2	On	Spin up state. (SAS)														
3	Off	Spin down state. (SAS)														
3-a	Power Unit (RKAKS)	RDY	LED	Green	Shows the operation state of the Power Unit. On : Normal operation Off : Abnormal operation or out of operation											
3-b		AC_IN	LED	Green	On : Indicates that the AC input is normal.											
3-c		ALM	LED	Red	Lights when the Power Unit is in trouble.											
3-d		Receptor (J1)	Connector	—	Connector on the subsystem side to connect the power cable.											
4-a	ENC Unit (RKAKS)	POWER	LED	Green	Indicates that the power supply is supplied to ENC Unit.											
4-b		LOCATE	LED	Orange	Indicate the Chassis location <ul style="list-style-type: none"> The CUDG error detected by the ENC firmware is indicated. On: <ul style="list-style-type: none"> CUDG error detected by ENC firmware (BOOT section) RAM error detected by ENC firmware ENC hard configuration error High-speed blinking: <ul style="list-style-type: none"> Once : SRAM error. Twice : CUDG error in ENC hard. Three times : Firmware error in flash memory. <ul style="list-style-type: none"> When adding the chassis with the power turned on, it lights up to indicate the addition source (this is not an error). 											
4-c		ALARM	LED	Red	Indicates error factors by means of lighting. Lighting Indicates that a failure, which makes the ENC Unit unable to operate, occurred.											
4-d		PATH0	(IN side)	Connector	—	Connection connector (for input)for ENC cable (PATH0 side).										
4-e			(IN side)	LED	Green	Indicates that the IN side is linked up.										
4-f		PATH0	(OUT side)	Connector	—	Connection connector (for output) for ENC cable (PATH 0 side).										
4-g			(OUT side)	LED	Green	Indicates that the OUT side is linked up.										
4-h		CONSOLE	Connector	—	Use prohibited because of the use for factory productivity.											

(13) Indication positions and their functions of Additional Battery Box

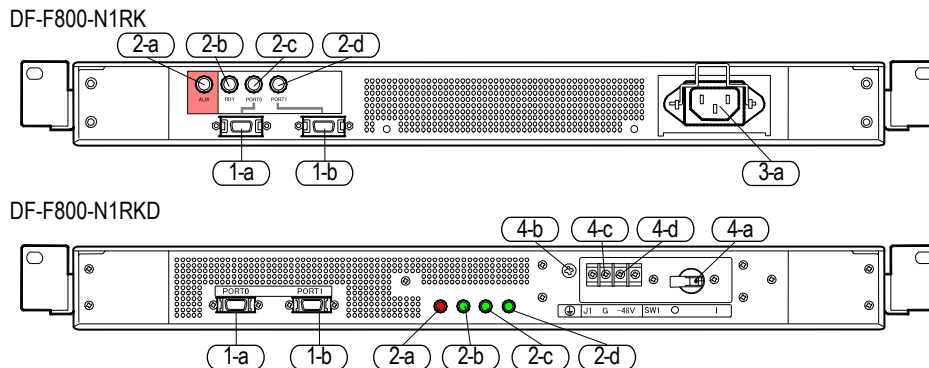

Figure 2.3.6 Indication Locations of Functional Components

Table 2.3.6 Functions of Indications

No.	Section	Name	Classification	Color	Function
1-a	Connector	PORT 0	Connector	—	For the connecting cable is connected.
1-b	Connector	PORT 1	Connector	—	For the connecting cable is connected.
2-a	STATUS Panel	ALM	LED	Red	ON Lights when the Battery is in trouble. <ul style="list-style-type: none"> Battery Circuit is abnormal. Battery voltage is abnormal. OFF <ul style="list-style-type: none"> During operating usually. During out of operation During backup.
2-b		RDY	LED	Green	ON <ul style="list-style-type: none"> Charge is completed. Supplementation charge. Low-speed blinking : Charged up when start-up High-speed blinking : Abnormal <ul style="list-style-type: none"> Battery Circuit is abnormal. Battery voltage is abnormal. OFF <ul style="list-style-type: none"> Out of operation. Battery voltage is abnormal. Trouble occurred.
2-c		PORT 0	LED	Green	ON <ul style="list-style-type: none"> During operating normally. (can be backup) OFF <ul style="list-style-type: none"> During out of operation (after sequential shutdown) Connector is abnormal condition (The cable is not connected. etc.) During backup.
2-d		PORT 1	LED	Green	ON <ul style="list-style-type: none"> During operating normally. (can be backup) OFF <ul style="list-style-type: none"> During out of operation (after sequential shutdown) Connector is abnormal condition (The cable is not connected. etc.) During backup.

No.	Section	Name	Classification	Color	Function
3-a	Power Unit (DF-F800-N1RK)	Receptor (J1)	Connector	—	Connector on the subsystem side to connect the power cable.
4-a	Power Unit (DF-F800-N1RKD)	Power Unit Switch	Switch	—	Controls the power applied to the subsystem from outside. : Power on ○: Power off
4-b		Terminal (FG)	Terminal	—	Connector on the subsystem side to connect the power cable.
4-c		Terminal (+)	Terminal	—	Connector on the subsystem side to connect the power cable.
4-d		Terminal (—)	Terminal	—	Connector on the subsystem side to connect the power cable.

This page is for editorial purpose only.

Chapter 3. Before Starting WEB Connection

3.1 Procedure to WEB Connection

(1) Points to be confirmed before connecting WEB

Unless the subsystem is activated, the subsystem cannot be connected to WEB.

Confirming the following LEDs before connecting to WEB.

- Confirming the power status (POWER LED).

Check if the POWER LED on the Front Bezel lights up.

If the Power LED does not light up, see [“Chapter 8. Trouble Analysis by LED Indication” \(TRBL 08-0000\)](#).

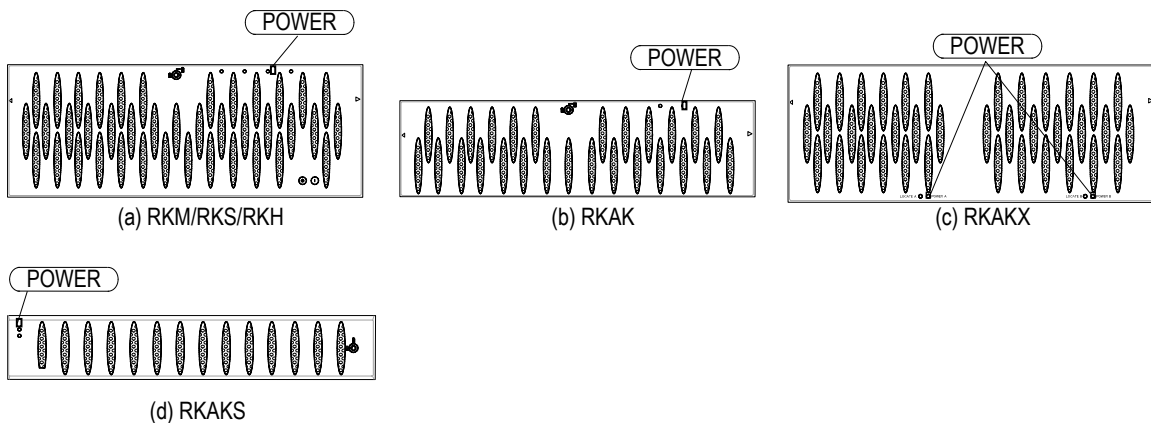

Figure 3.1.1 Locations and Name of LED

(2) Preparation of maintenance terminal to be used

Table 3.1.1 Decision and Preparation of Maintenance Terminal

Item	Customer's environment	Maintenance terminal used	Preparation	Connection procedure reference destination
1	Using LAN connectors for maintenance of the Control Unit	Connect the portable Maintenance PC via a LAN.	<ul style="list-style-type: none"> • PC for maintenance^{(*)1} • LAN cross cable 	“3.1 (4) Procedure to connect portable maintenance PC to WEB” (TRBL 03-0010) .

*1 : Refer to [“3.3 Note on WEB Connecting” \(TRBL 03-0080\)](#) for recommended PC.

(3) Control Unit to be connection

If a system has a dual Control Unit, connect to either Control Unit to connect to the WEB.

First, connect to Control Unit#0.

If Control Unit #0 is blocked, however, information after the blockage of Control Unit #0 is referenced on only Control Unit #1 side. Accordingly, if Control Unit #0 is blocked, connect to Control Unit #1.

(4) Procedure to connect portable maintenance PC to WEB

- (a) Remove the cover on the Control Unit. Connect the LAN-Connector for maintenance and the LAN-Connector of Maintenance PC with a LAN-cross-cable.

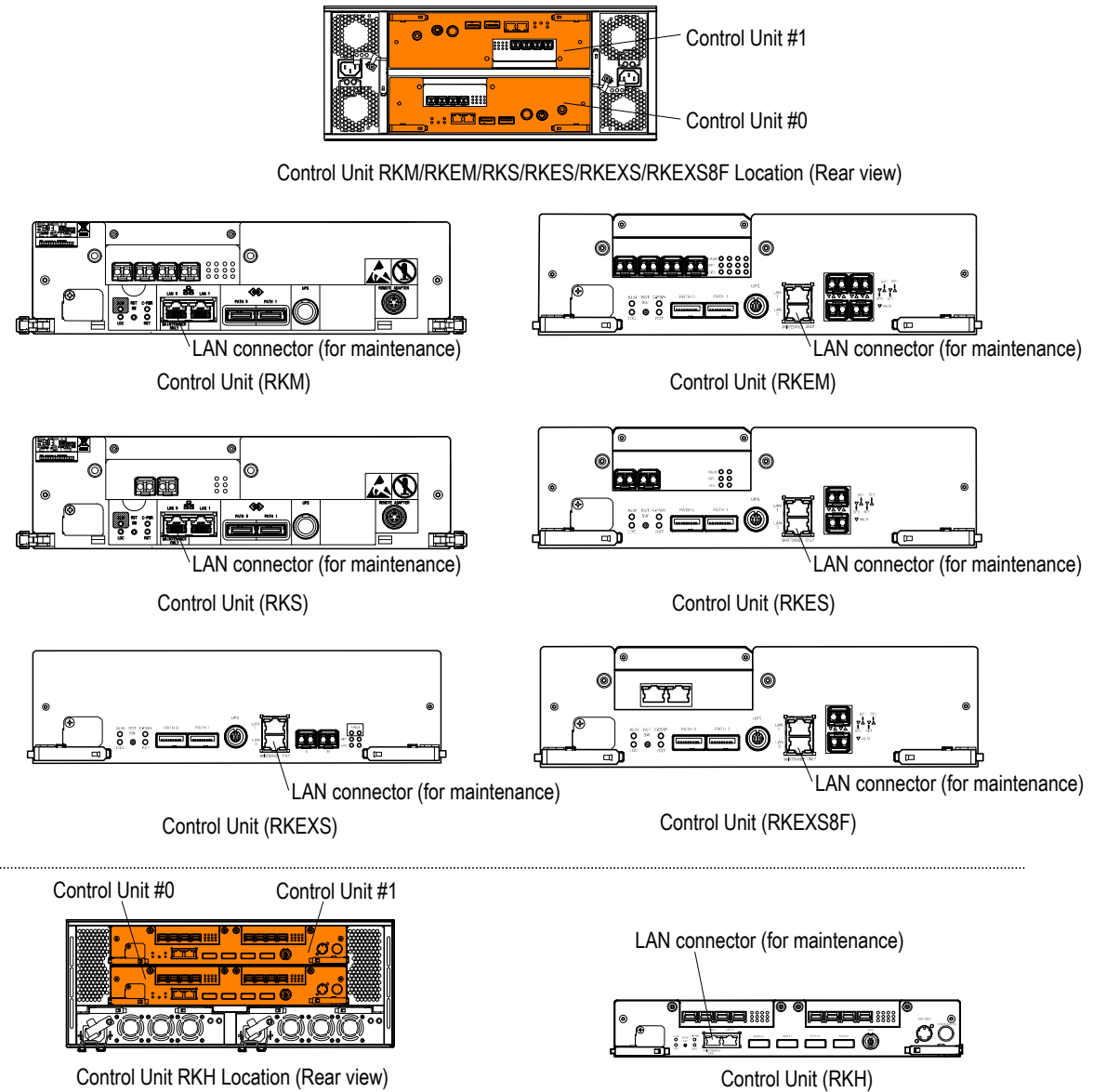

Figure 3.1.2 LAN Connector Position

- (b) Start up the maintenance PC.
- (c) Change the IP address of the network parameter for the maintenance PC.
- (c-1) In case of the IPv4 environment
- (i) Make the setting of the IP Address to be set to the PC as Item 1 in [Table 3.1.2](#).
 - CTL0: 10.0.0.16 (Input example : http://10.0.0.16/)
 - (ii) If it is not connectable, by setting the values of Item 2 to Item 5 in [Table 3.1.2](#), specify the connectable value and perform the WEB connection.
 - According to the setting value of “Maintenance PC” of Items 2 to 5 on [Table 3.1.2](#), set the IP Address and the Subnet Mask of the Maintenance PC.
 - According to the “Array (LAN port for maintenance)” information of Items 2 to 5 on [Table 3.1.2](#), enter into “Address” of the WEB browser and connect with the array.
 - (iii) If not connected yet, refer to [“3.4 Procedure for Specifying Maintenance Port IP Address” \(TRBL 03-0130\)](#).

Table 3.1.2 Operational Environment (IPv4)

No.	Subsystem (LAN port for maintenance)		Maintenance PC	
	IP Address	Subnet Mask	IP Address	Subnet Mask
1	CTL 0: 10.0.0.16 CTL 1: 10.0.0.17 (At the time of shipment)	255.255.255.0 (At the time of shipment)	10.0.0.2 to 0.0.0.9	255.255.255.0
2	CTL 0: 192.168.0.16 CTL 1: 192.168.0.17	255.255.255.0	192.168.0.2 to 192.168.0.9	255.255.255.0
3	CTL 0: 192.168.233.16 CTL 1: 192.168.233.17	255.255.255.0	192.168.233.2 to 192.168.233.9	255.255.255.0
4	CTL 0: 172.23.211.16 CTL 1: 172.23.211.17	255.255.255.0	172.23.211.2 to 172.23.211.9	255.255.255.0
5	CTL 0: 10.197.181.16 CTL 1: 10.197.181.17	255.255.255.0	10.197.181.2 to 10.197.181.9	255.255.255.0

- (b-2) In case of the IPv6 environment
- (i) Make the setting of the IP Address to be set to the PC as Item 1 in [Table 3.1.3](#).
- CTL0: fe80::16 (Input example : http://[fe80::16]/)
- When connecting on WEB by the IPv6 address, put the address in brackets ([]).
- (ii) If it is not connectable, set the value of Item 2 in [Table 3.1.3](#), and perform the WEB connection.
- According to the setting value of “Maintenance PC” of Item 2 on [Table 3.1.3](#), set the IP Address and the Subnet Mask of the Maintenance PC.
 - According to the “Array (LAN port for maintenance)” information of Item 2 on [Table 3.1.3](#), enter into “Address” of the WEB browser and connect with the array.
- (iii) If not connected yet, refer to [“3.4 Procedure for Specifying Maintenance Port IP Address” \(TRBL 03-0130\)](#).

Table 3.1.3 Operational Environment (IPv6)

No.	Subsystem (LAN port for maintenance)		Maintenance PC	
	IP Address	Length of Subnet Prefix	IP Address	Subnet Mask
1	CTL0: fe80::16 CTL1: fe80::17 (At the time of shipment)	64 (At the time of shipment)	Automatic	Automatic
2	CTL 0: fe80::f6 CTL 1: fe80::f7	64	Automatic	Automatic

- Manual change of the network parameter of the Maintenance port
- When the User management port is set as the same network address as the Maintenance port, the communication cannot be made normally. Prepare five patterns of the network parameter fixed values to be used in the Maintenance port, and change the network parameter fixed values to be used in the Maintenance port manually by the network parameter of the User management port. Therefore, in the work other than the installation work of the array at shipment, the maintenance LAN Port for the WEB connection is set to any of Items 1 to 5 in [Table 3.1.2](#) in case of the IPv4 environment and set to either Item 1 or 2 in [Table 3.1.3](#) in case of the IPv6 environment.

NOTE : When the network address of the LAN device, which is connected via the Gateway in the extension of the User management port, is the same as that of the Maintenance port, the communication cannot be made normally because of the conflict between them.

Therefore, use a value other than the network address set to the maintenance port for the LAN device connected to the port for the user management via Gateway. Or change the IP address of the maintenance port to a value other than the network address of the LAN device connected via Gateway by Hitachi Storage Navigator Modular 2. (Refer to [System Parameter “4.2 \(4\) Setting of Maintenance LAN” \(SYSPR 04-0160\)](#).)

- (d) Make sure that negotiation of Maintenance PC is set to auto negotiation.
- To check negotiation of Maintenance PC, refer to [“3.1 \(6\) Procedure for setting negotiation” \(TRBL 03-0050\)](#).

This page is for editorial purpose only.

(5) Setting method of IP Address on Windows 95

The procedure for setting an IP Address of the PC in Windows 95 is shown below.

Also in Windows 98, Windows 2000 and Windows XP, the IP Address of the PC can be set by the similar operation.

(a) Select [Start]-[Set]-[Control Panel]-[Network].

(b) Select [Configuration]-[The following network components are installed]-[TCP/IP] and click the [Properties] button to open [TCP/IP].

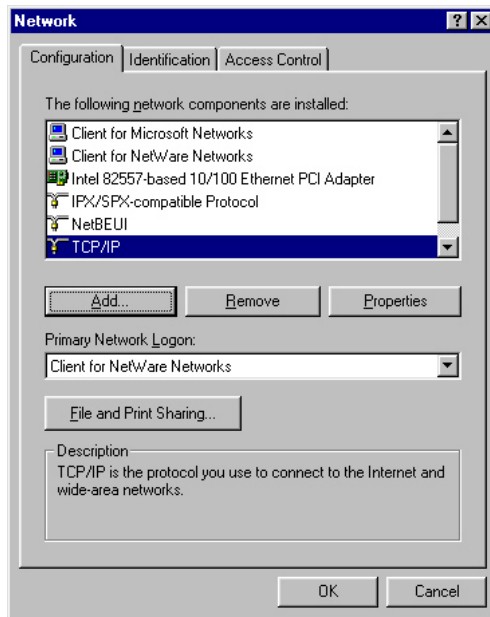

(c) Select [TCP/IP Properties]-[IP Address]-[Specify an IP address] and set the [IP Address] and press the [OK] button.

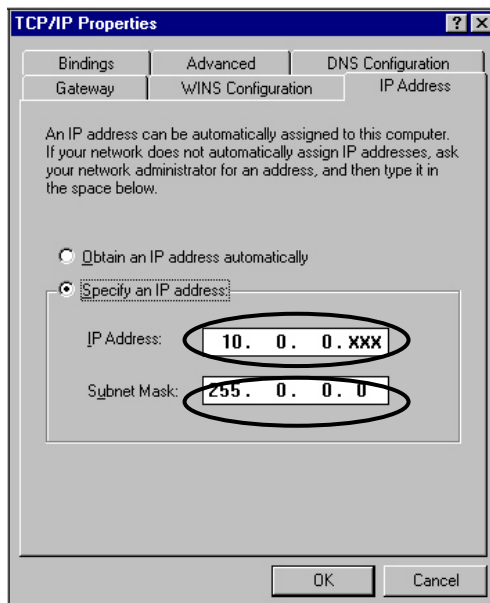

- (d) Set the TCP/IP to “Disable DNS” because the connection takes a long time when the TCP/IP of the network is set to the condition in which the DNS is used.

For the setting procedure, refer to the instruction manual of the PC to be used.

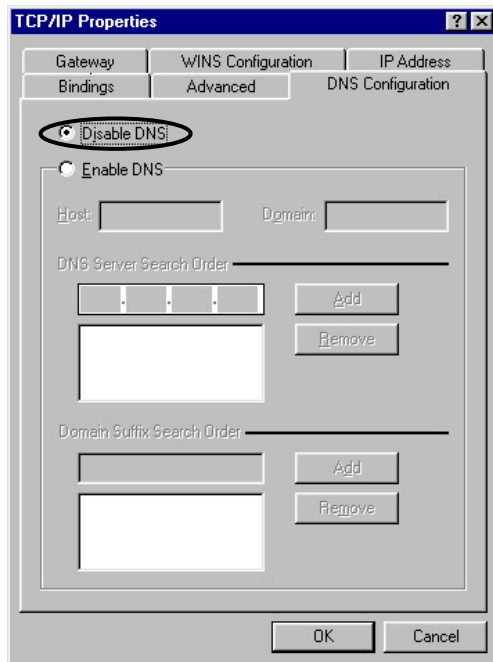

- (e) When confirming message appears whether to reboot the Maintenance PC, press [OK].
- (f) The maintenance PC is rebooted and the changed IP Address and Subnet Mask become effective.
- (g) Start up the Browser. Enter the URL window with the IP address of maintenance port to which the maintenance PC is connected. When WEB screen appears, the connection is complete.

- NOTE :
- When the Control Unit to be connected to WEB is blocked, the WEB connection may not be performed for ten minutes usually (for the maximum of 60 minutes) from the time when the Control Unit was blocked because the CTL alarm trace is being created.
 - When entering IPv6 address in URL, you need to put the IP address in square brackets ([]) and specify it as URL (e.g. [http://\[fe80::16\]](http://[fe80::16])). Not all OS and browsers can be connected to IPv6. Refer to [“3.3 Note on WEB Connecting” \(TRBL 03-0080\)](#) for the detail.

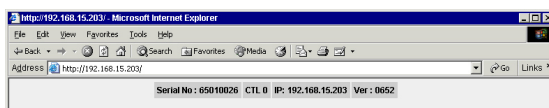

- (h) Make sure that the browser is set to the condition in which the proxy server is not used because the connection cannot be done if the proxy server is set to be used.
To make sure the setting, refer to the instruction manual of the browser to be used.
If you cannot connect, the negotiation of Maintenance PC may be changed.
Refer to “[\(6\) Procedure for setting negotiation](#)” (TRBL 03-0050), and set negotiation of Maintenance PC to auto negotiation.

This page is for editorial purpose only.

(6) Procedure for setting negotiation

The procedure for setting negotiation of the PC is shown below.

(a) Select [Start]-[Set]-[Control Panel]-[Network].

(b) If Windows 95 or Windows 98, select [Configuration]-[The following network components are installed]-Network Interface Card, and click the [Properties] button to open Network Interface Card.

If Windows 2000 or Windows XP, click the [Configure] button in [Connect using]

Windows95, Windows98

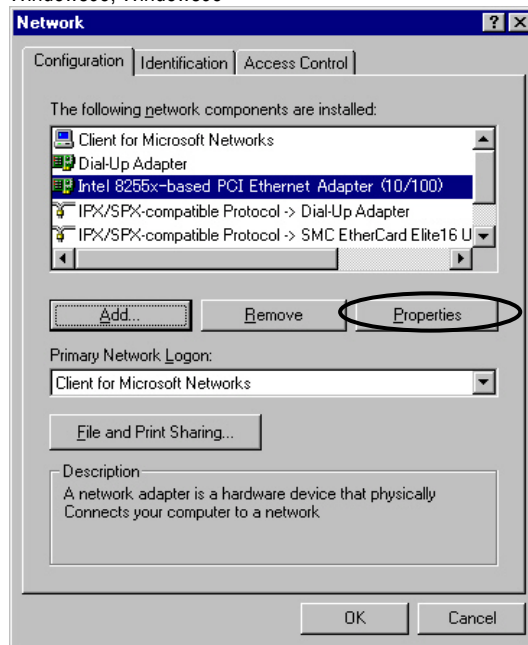

Windows2000, Windows XP

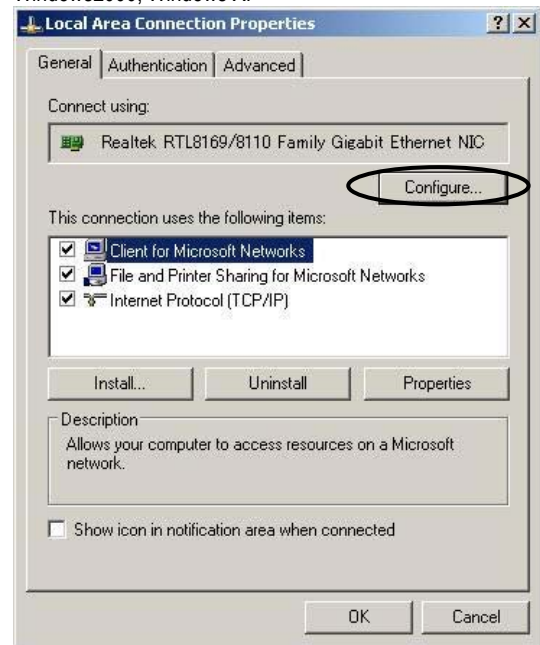

(c) Select [Advanced] tab, click Link speed and duplex mode in [Property].

And set [Value] to auto negotiation.

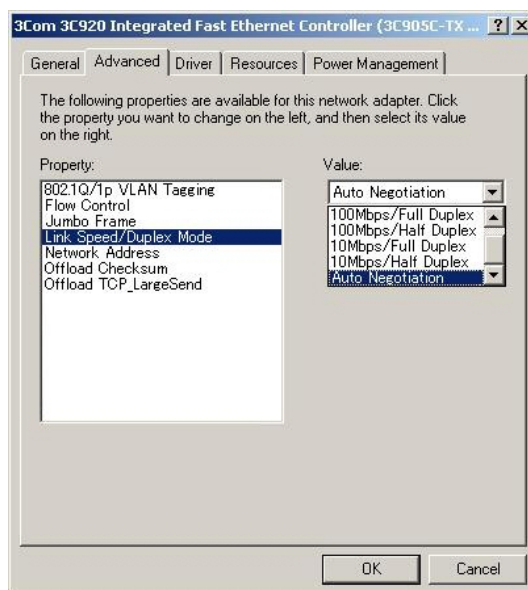

- (d) After reboot maintenance PC, start up the Browser. Enter the URL window with the IP address of maintenance port to which the maintenance PC is connected. When WEB screen appears, the connection is complete.

NOTE : When the Control Unit to be connected to WEB is blocked, the WEB connection may not be performed for ten minutes usually (for the maximum of 60 minutes) from the time when the Control Unit was blocked because the CTL alarm trace is being created.

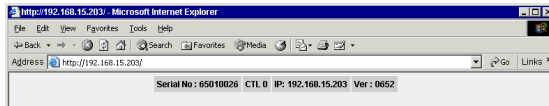

- (e) Make sure that the browser is set to the condition in which the proxy server is not used because the connection cannot be done if the proxy server is set to be used. To make sure the setting, refer to the instruction manual of the browser to be used. If you cannot connect, change the LAN-cross-cable.

3.2 When the WEB has Already been Connected

If the WEB has been connected, information displayed before may be still displayed. Before starting trouble analysis based on the WEB connection, [Refresh] the WEB window. The time when the WEB window is displayed is referenced as shown below. Window display differs depending on firmware revision.

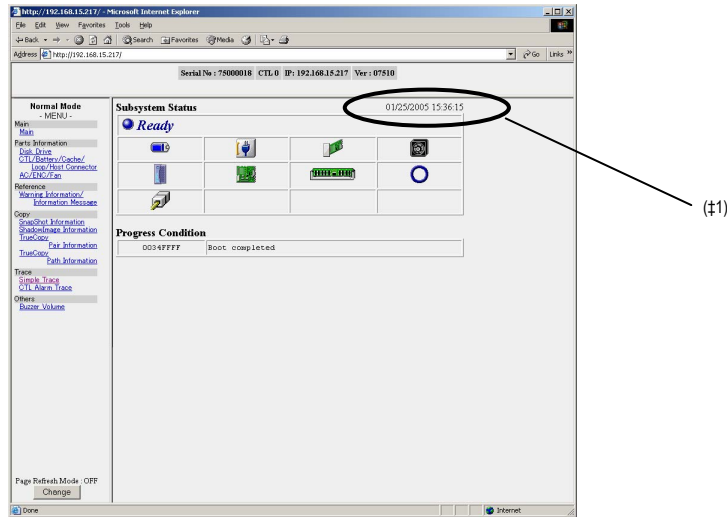

¶1 : The time determined by the Device Controller RTC (Real Time Clock) is indicated here. (It is not consistent with the main PC clock.)

For setting the Device Controller RTC, refer to “2.2 Confirming and Setting RTC (Real Time Clock)” (TRBL 02-0010).

3.3 Note on WEB Connecting

(1) Note on WEB using

- (a) The LAN function may become temporarily unable to be connected when the update of the WEB display is repeated frequently. In this case, wait for a short time (at least one minute), then update again.
- (b) When connecting the WEB of DF800, use the following browsers.

Table3.3.1 Recommended WEB Hardware

No.	Item	Description	Remark
1	OS	Microsoft Windows 2000, XP, 2003, Vista, 2008, 7, Solaris 8, 9, 10, IRIX 6.5, AIX 5.1	When connecting with IPv6, Windows Vista, 2008
2	PC	Pentium 4 1 G Hz (2 G Hz or more is recommended), Memory 1 G bytes or more (2 G bytes or more is recommended)	—
3	WS	Turbo Sparc 170 M Hz, Memory 256 M bytes or more R10000 195 M Hz, Memory 128 M bytes or more	—
4	Disk requirement	<ul style="list-style-type: none"> • 60 M bytes, under ordinary maintenance work • 2.4 G bytes per one Controller, under Full Dump collection^(*1) <ul style="list-style-type: none"> { Storing temporary file of Browser : 1.2 G bytes } { Storing Full Dump: 1.2 G bytes } 	<ul style="list-style-type: none"> • Data compression tool is required for Full Dump. • Refer to WEB "3.5.3 Collecting Full Dump" (WEB 03-0460) or WEB "3.5.4 Collecting Full Dump (Full Dump(SnapShot/TCE))" (WEB 03-0500) for the capacity of Full Dump when it is uncompressed.

*1 : Full Dump collection may be requested by the Technical Support Center at the time of a tough failure.

Table3.3.2 Support Browser List

(○ : support × : not support)

No.	Platform	OS		Browser		Supported or not supported	Java Applet supported or not supported (*2)(*3)	Supported or not supported (IPv6)	
		Type	Ver.	Type	Ver. (*1)				
1	WS	IRIX	6.5	Netscape Navigator	4.76(*4)	○	×	×	
		Solaris	8, 9	Netscape Navigator	4.76(*4)	○	×	×	
			10	Mozilla	1.7	○	×	○	
		AIX	5.1	Mozilla	1.7	○	×	×	
2	PC	Windows	2000	Internet Explorer	6.0	○	○	×	
			XP	6.0, 7.0	Internet Explorer	6.0, 7.0	○	○	×
				2003 (32 bit)	Internet Explorer	6.0, 7.0	○	○	×
			2003 (64 bit)	Internet Explorer	6.0	○	○	×	
				6.0 (64 Bit)	Internet Explorer	6.0	○	×	×
			Vista	Internet Explorer	7.0, 9.0	○	○	○	
				7.0 (64 Bit)	Internet Explorer	7.0, 9.0	○	×	○
			2008	Internet Explorer	7.0, 9.0	○	○	○	
				7.0 (64 Bit)	Internet Explorer	7.0, 9.0	○	×	○
			7 (32 bit)	Internet Explorer	8.0, 9.0, 10.0	○	○	○	
		7 (64 bit)	Internet Explorer	8.0, 9.0 (64 bit)	○	×	○		
			10.0 (64 Bit)	Internet Explorer	8.0, 9.0 (64 bit)	○	○(*5)	○	
		Windows	2000/XP	Netscape Navigator	7.1 (J)	○	×	×	
				Netscape Navigator	7.2 (E)	○	×	×	
			2003	Netscape Navigator	7.1 (J)	○	×	×	
				Netscape Navigator	7.2 (E)	○	×	×	
Vista	Netscape Navigator		7.1 (J)	○	×	×			
	Netscape Navigator		7.2 (E)	○	×	×			

*1 : Service Pack 1 is included. (except Internet Explorer 8.0, 9.0 and 10.0)

*2 : When installing the firmware, the Maintenance PC must be started by the OS from the drive C in order to prevent a problem of security from occurring.

*3 : Java Applet is used for the following cases.

- Firmware installation
- Host command trace download
- Online ENC firmware download
- Offline Drive Firmware download
- Online Drive Firmware download

*4 : Netscape Navigator 4.76 causes the following problems because the release is old. However, there is no problem in the operation.

- If you cancel in the file save window when saved by the simple trace collection, WEB may not be connected for a while. Leave the interval for about 20 minutes and connect it again.
- The java script error may occur in some windows, but there is no problem in the operation.
- Since the sub-window is closed soon in the initialization window of the SSL certificate and the complete window is not displayed, the initialization is completed normally.

*5 : The extended protection mode of the Internet options newly installed in Internet Explorer 10.0 should be disabled (default is disabled).

Notices on (restriction of) the support browser

In the case of Windows2003, because the strict data security is the default setting, the Web function cannot work.

In order to solve the above problem, change the setting of the browser as follows.

- Select [Tools] - [Internet Options ...] - [Security] - [Custom Level ...] - [Custom Setting Reset] of the browser in this order and select the setting of the security level from Medium or lower and click the “Reset” button.

The making of the setting as Medium solves the problem. However, if you want to use Win2003 leaving the security level as High, make the following settings for the detailed items of the [Custom Level ...].

- Enable the [Active scripting] of the [Scripting].
- Enable the [Allow META REFRESH] of the [Miscellaneous].
- Enable the [File download] of the [Downloads].
- Enable the [Run ActiveX controls and plug-ins] of the [ActiveX controls and plug-ins].

- In Windows Vista, Server 2008, the value that security is more strengthened than Windows Server 2003 is default, so that the WEB function does not operate as is. To solve this, change the browser setting as shown below.

- Register is as the reliable WEB site from [Tool] - [Internet Option] - [Security] - [Reliable Site] - [Site].

- When entering IPv6 address in URL in Windows Vista, Server 2008, you need to put the IP address in square brackets ([]) and specify it as URL. (e.g.: http://[fe80::16]/).

- The WEB function operates normally in other Windows because the security level is being [Medium]. However, set the following items in [Settings] of [Tools] - [Internet Options ...] - [Security] - [Custom Level ...] to [Enable].

- Enable the [Active scripting] of the [Scripting].
- Enable the [File download] of the [Downloads].

- There may be a case where a new line is started in a window depending on a setting of the browser. In such a case, make the character size smaller.

< Method of character size change >

In the case of IE

Select “Middle” or smaller size for the “Character Size” in the “Display”.

In the case of Netscape

Select the “Reduction of Font Size” in the “Display” and keep it being selected until paragraphs become easy to be read.

- There may be a case where an empty dialog box is displayed during operation in the Maintenance mode. In such a case, close the window by clicking on the mark of “X” in the upper left corner of the dialog box, restart the browser, and then make a retry from the entry of the URL.

- When a window size is changed while a page is displayed by Netscape, the succeeding operation in the Refresh mode may not be done normally. In such a case, display the page over again by clicking the Re-Display button.
- In the case of using Netscape
Memory cache: 1024 kbytes (default) or larger
Disk cache: 7680 kbytes (default) or larger

< Method of cache size setting >

Select the “Edition”, “Setting”, “Details”, and “Cache” in this order.

Specify sizes of the memory cache and disk cache.

- When obtaining trace information etc. with Netscape, there are cases that a sub-screen to specify the file download destination does not automatically close. In such a case, press a close button at the upper right corner of the sub-screen to close the sub-screen after download complete.
- When using Netscape Navigator 7.x, select [Edit]-[Preference...]-[Advanced]-[HTTP Networking], and set “Use HTTP 1.0” in the “Direct Connection Options” and “Proxy Connection Options”. When this setting is not made, the summary window is not displayed correctly.
- When collecting Full Dump using Netscape Navigator 4.7x, pay attention to free space in PC because information to be downloaded won’t be compressed.

	Installed cache per Control Unit	Free Capacity needed on PC
RKM	1 G bytes (Minimum)	1,825 M bytes
	8 G bytes (Maximum)	6,187 M bytes
RKS	1 G bytes (Minimum)	1,461 M bytes
	4 G bytes (Maximum)	3,387 M bytes
RKH	2 G bytes (Minimum)	3,734 M bytes
	16 G bytes (Maximum)	12,087 M bytes
RKEXS/RKEXSA/RKEXSB	2 G bytes	2,103 M bytes

NOTE : When using IE 8.0, IE 9.0 or IE 10.0, the WEB window display may slow down and the collection of the trace from the WEB window may not complete. Uncheck the checkbox of “Enable SmartScreen Filter” in the Internet Options Advanced Settings. If the issue still occurs, please cancel the DNS Server’s settings of the PC’s LAN.

(2) The procedure for connecting to another subsystem having the same IP address via a LAN.

In the case of connecting and maintaining two or more controllers, whose IP addresses are the same, using a Maintenance PC and cross cable of a LAN, when one of the Controllers is connected to the PC, the PC memorizes the IP address and physical address of the Controller making a pair of them. Therefore, if another Controller is connected to the PC via a LAN, the IP address is not accepted because the physical address is different.

To make the above connection via a LAN, execute the following command from the MS-DOS prompt of Windows PC in order to delete the information on the IP address stored in the arp table in the PC.

```
arp -d IP address
```

- IP address : IP address stored in the arp table

Example : When deleting an IP address 10.0. 0.16 (default) from the table

```
arp -d 10.0.0.16
```

To make sure that the IP address stored in the arp table has been deleted, execute the following command from the MS-DOS prompt of Windows PC.

```
arp -a
```

The IP address has been deleted when a message, “No ARP Entries Found” or the one informing that the specified IP address could not be found is returned from the subsystem.

(3) User authentication when connecting the Web

A [User Name] and a [Password] may be requested at the time of Web connection or Web operation. In that case, input “maintenance” for the [User Name] and “hosyu9500” for the [Password].

3.4 Procedure for Specifying Maintenance Port IP Address

When the connection cannot be made even with the five patterns of the maintenance port IP addresses, the host address of the maintenance port IP address may have been changed. In this case, specify the maintenance port IP address as shown below.

NOTE : When the subsystem can not communicate with Hitachi Storage Navigator Modular 2, (for example, the controller is blockade, the subsystem is in Maintenance Mode and so on), this procedure is can not work.

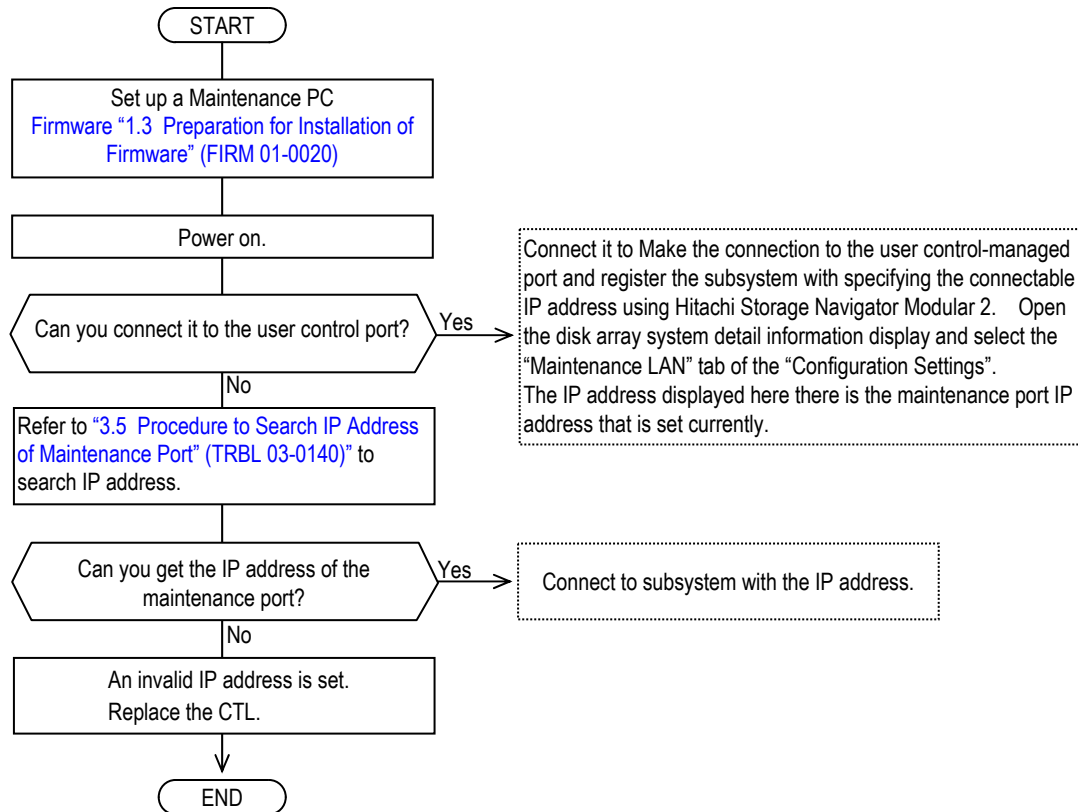

3.5 Procedure to Search IP Address of Maintenance Port

(1) Activating the Hitachi Storage Navigator Modular 2

(a) Check if “SNM2 Server” of the service PC is started from “Services” of “Administrative Tools” of the Control Panel of the Windows.

If not started, make it “Start”.

(b) Start the browser, and specify an address as follows.

<When connecting with http>

“http://xxx:23015/StorageNavigatorModular/”

<When connecting with https>

“https://xxx:23016/StorageNavigatorModular/”

xxx : IP address of the service PC.

NOTE : • The https is invalid in the status immediately after the installation. Refer to the [“Hitachi Storage Navigator Modular 2 Graphical User Interface \(GUI\) User’s Guide”](#) for the method to enable https.

• When the display of the menu, etc. on the window is broken, select the color palette from the property of the window, and make it other than True Color and 65536 or less.

• When entering IPv6 address in the address column of the WEB browser, you need to put xxx in square brackets ([]) and specify it as URL.
(e.g.: ”http://[xxx]:23015/StorageNavigatorModular/”)

(c) Two windows, a title window and a login window, are displayed automatically.

When the user is registered in Hitachi Storage navigator Modular 2, enter the registered contents in the user ID and the password, and click the login button.

NOTE : • When Hitachi Storage Navigator Modular 2 was newly installed, enter the temporarily registered user ID “system” and password “manager”.

• If the login window is not displayed automatically, the popup may be blocked. Cancel the popup block.

Usually, “Popup is blocked” is displayed on the top of the browser. Click this display and select “Popup in this site is always allowed”.

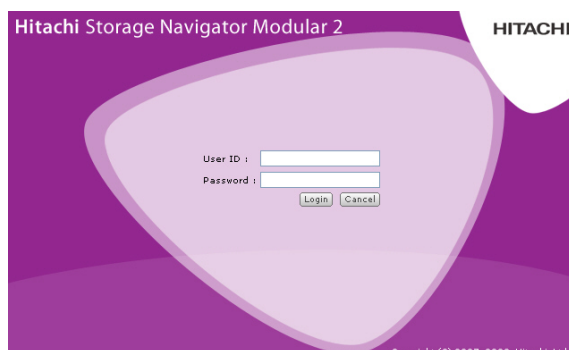

- (d) The Hitachi Storage Navigator Modular 2 is activated in the Normal Mode and the main window is displayed^(†1).

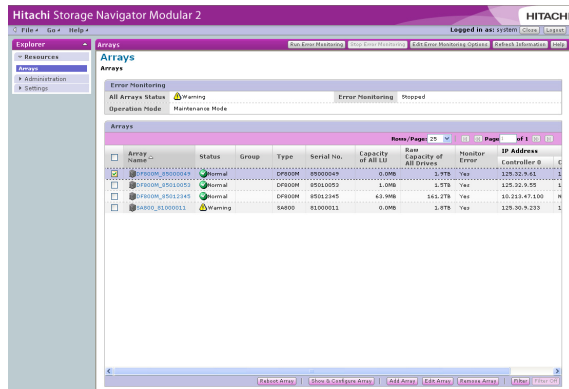

You can execute the display of the Hitachi Storage Navigator Modular 2 Operation Mode and state of the failure monitoring and the following functions in the main window.

For the operation of each function, refer to the page explaining each function.

- Registration of the disk array system (registration, deletion, change, and properties display)
- Execution of the failure monitoring and setting of the failure monitoring option
- Change of the Operation Mode
- Display of the version

†1 : The mode change cannot be done at the time of the initial activation of the Hitachi Storage Navigator Modular 2.
A registration of a password validates the mode change.

(2) Changing the Maintenance Mode

Hitachi Storage Navigator Modular 2 has two Active Modes, that is, the Normal Mode, and Maintenance Mode. In the Normal Mode, the program displays the configuration and statuses of the disk array. In the Maintenance Mode, it can set the configuration of the disk array in addition to the function in the Normal Mode.

(a) Changing the Normal Mode to the Maintenance Mode

Change the Operation Mode from the Normal Mode to the Maintenance Mode.

(i) Check that the “mode” file exists in the following directory.

If it exists, go to Procedure (iv).

\HiCommand\StorageNavigatorModular\conf

(ii) If there is no mode file, create a mode file (without extension) and write the following letters in one line. However, do not insert line feeds.

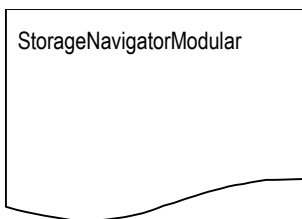

Figure 3.5.1 Mode File

(iii) Store the created mode file in the following place.

\HiCommand\StorageNavigatorModular\conf

(iv) Put a checkmark in the array subsystem to operate on the main window, and press the [Ctrl] key, [Shift] key and the [E] key at the same time.^(†1)

It is displayed as “maintenance mode” in [Operation Mode] of the upper part of the main window, and Hitachi Storage Navigator Modular 2 is operated in the maintenance mode.

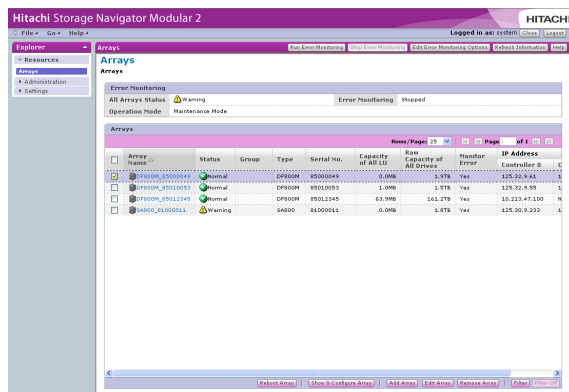

†1 : When the array subsystem to operate is not registered, click the blank area (other than buttons and characters) in the “Arrays” window, and press the [Ctrl] key, [Shift] key and [E] key at the same time.

(3) Searching for IP address of the disk array system

Search for IP address of the disk array system to be operated in order to operate it from the Hitachi Storage Navigator Modular 2.

(a) Click the [Add Array] in the main window.

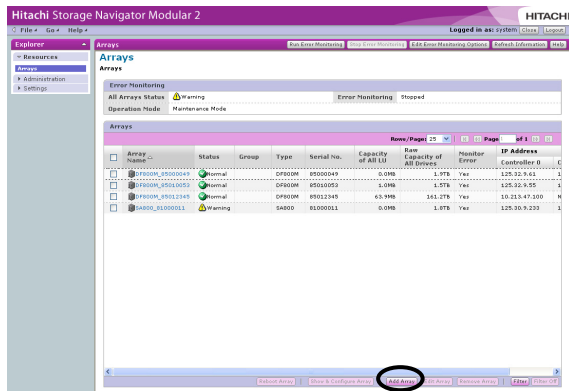

(b) [HSNM2 _ Add Array Wizard] is displayed. Click the [Next] button.

(c) When connecting with IPv4, check the [Scope Search] radio button, check the [Scope of IPv4 Address], and enter the scope of the IP address to search. Then, uncheck the [Scope of IPv6 Address] checkbox.

In the textbox of [From] and [To], input following combination in #1 in Table 3.5.1.

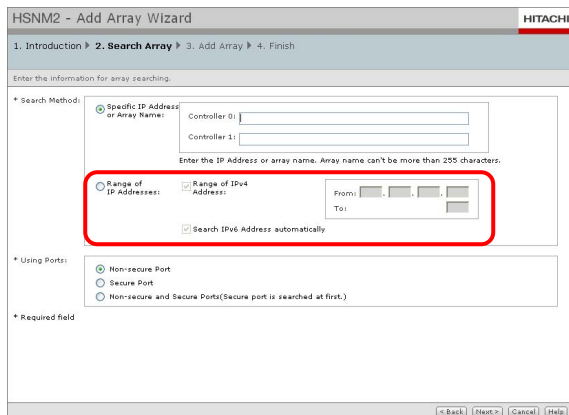

[From] : Input a start IP address of the search range

[To] : Input a end IP address (only host address) of the search range

Table 3.5.1 Combination of Input to Search IP Address (IPv4)

No.	From				To
1	10	0	0	16	247
2	192	168	0	16	247
3	192	168	233	16	247
4	172	23	211	16	247
5	10	197	181	16	247

When connecting with IPv6, check the [Scope Search] radio button and check the [Scope of IPv6 Address] checkbox. Then, uncheck the [Scope of IPv4 Address] checkbox.

(d) Press [Next], and the searching is start.

(e) The result of searching is displayed in “Search Results”.

If IP address is not displayed, retry searching with another combination in Table 3.5.1. (When you retry, change network setting of maintenance PC.)

When IP address is displayed

Array Name	Type	Controller 0	Controller 1	Serial No.
DF800M_85000049	DF800M	125.32.9.61	125.32.9.62	85000049

When IP address is not displayed

Array Name	Type	Controller 0	Controller 1	Serial No.
No Object				

This page is for editorial purpose only.

Chapter 4. Trouble Analysis by WEB Connection

Trouble analysis by WEB connection to locate a failed part in the unit and how to repair that trouble are shown below.

The flow of the trouble analysis by WEB connection is as follows.

Determine the failed part following the procedure below.

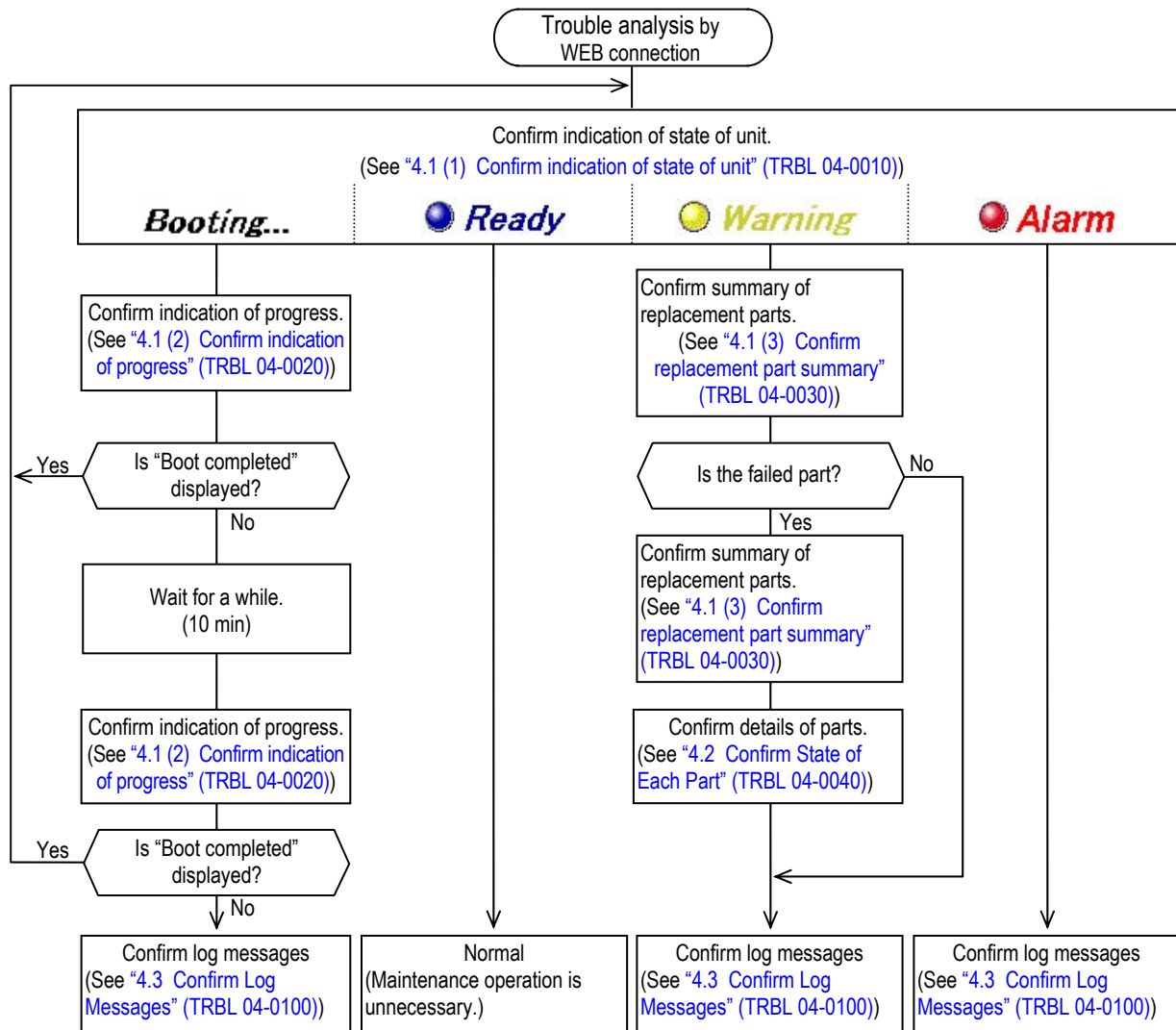

NOTE : When the log messages are checked while the WARNING LED (orange) on the front of the Basic Chassis is blinking at low speed, the WARNING LED (orange) goes out if the subsystem is not in the Warning status. If the subsystem is in the Warning status, the WARNING LED (orange) lights up.

While this WARNING LED (orange) is blinking at high speed, the update of the flash program or the automatic download of the ENC firmware at the time of turning the power on in the single controller configuration is being executed. The WARNING LED (orange) on the front of the Basic Chassis goes off in the maximum of 30 to 85 minutes, and the READY LED (green) lights up.

4.1 Confirm State of Unit

Check the failed part of the unit on the main window in the normal mode of the WEB.
 For the replacement of the parts and recovery method, see the log messages. (Refer to “4.3 Confirm Log Messages” (TRBL 04-0100).)

(1) Confirm indication of state of unit

The state of the unit can be confirmed in the following window.
 When the unit is RKEXSA/RKEXSB, the (E-XSi) is displayed of right side of version display (maintenance mode is not displayed).

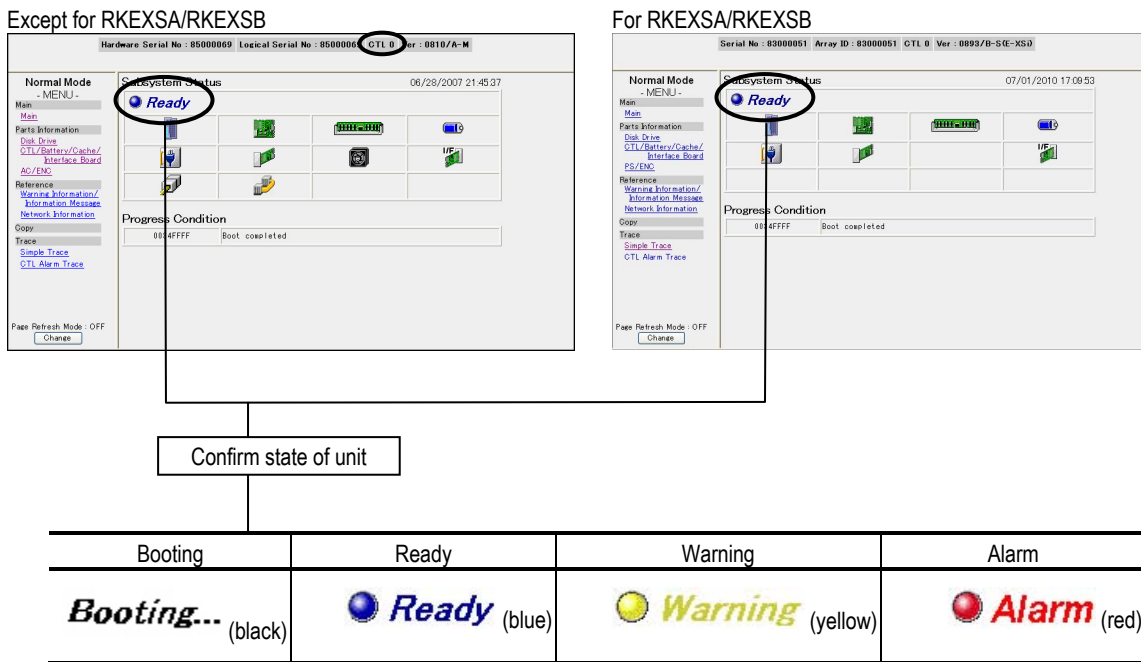
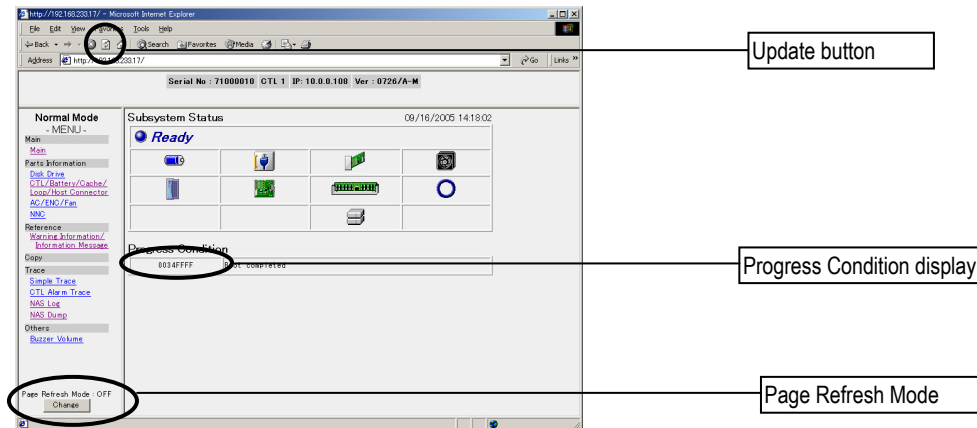

Figure 4.1.1 Main Window in the Normal Mode

(2) Confirm indication of progress

If “Booting...” is indicated in the window of (1) (the Controller is being started up), the progress of start-up operation can be confirmed according to the following procedure.



(a) Turn on the page refresh mode (Click the [Change] button).

The window is updated automatically at the interval of 5 seconds. (If the [ON] button of the page refresh mode is indicated, the above operation is not necessary.)

If the page refresh mode is not indicated in the main window, press the update button of the browser to update the window.

(b) See the indication of progress of the window.







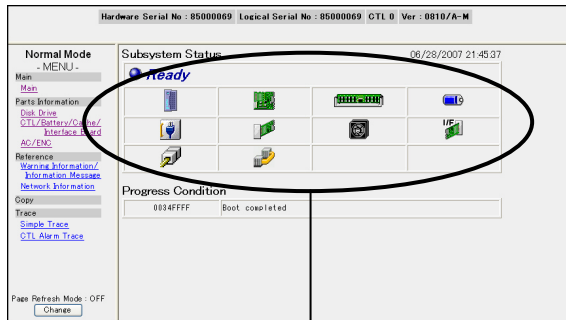



If the start-up operation is completed, “Boot completed” is indicated in this part.

(3) Confirm replacement part summary

The state of each replacement parts can be confirmed with the replacement part summary.



Summary of exchange parts status

Cache Backup Battery	Power Unit	FAN Unit	Disk Drive	Control Unit
				
Cache Unit	ENC Unit	Interface Board	Host Connector	Remote Path
				

If any part fails, its summary becomes red.

If the red part summary is clicked, the state confirmation window of the part appears and the position of the failed part is confirmed more in detail. (Refer to [“4.2 Confirm State of Each Part” \(TRBL 04-0040\)](#).)

Also, when the menu frame “Warning Information” is clicked, status of each component is displayed (Refer to [“4.2 Confirm State of Each Part” \(TRBL 04-0040\)](#).) and the status of each component can be checked.

4.2 Confirm State of Each Part

When checking the status of a component through an image, a clicking on each component of the “Summary of replacement component statuses” in the main window changes the window to that shown in Item (1) below and a detailed component status is displayed.

In this case, the window is changed in the state in which the selected (clicked) component is positioned at the top of the window. Also, a clicking on the “Parts Information” menu in the main window changes the window.

When checking the status of a component through a message, a clicking on the “Warning Information” of the menu frame in the main window changes the window to that shown in Item “(2) Procedure of the status checking by messages” (TRBL 04-0090) and displays a detailed component status as a message. In this case, detailed status of each component can be checked. For the replacement for maintenance or recovery procedure, refer to a log message (See “4.3 Confirm Log Messages” (TRBL 04-0100)) and perform a recovery action following the procedure given by the each log message.

(1) Checking the status through an image



The display screen of exchange part status displays the status of the Disk Drive, Control Unit, Cache Unit, FAN Unit, Cache Backup Battery, Power Unit, ENC Unit that are implemented. Furthermore, this is not displayed, if it is not implemented.

Also, the exchange part of abnormal status displays a red image. The Parts Information screen is shown below.

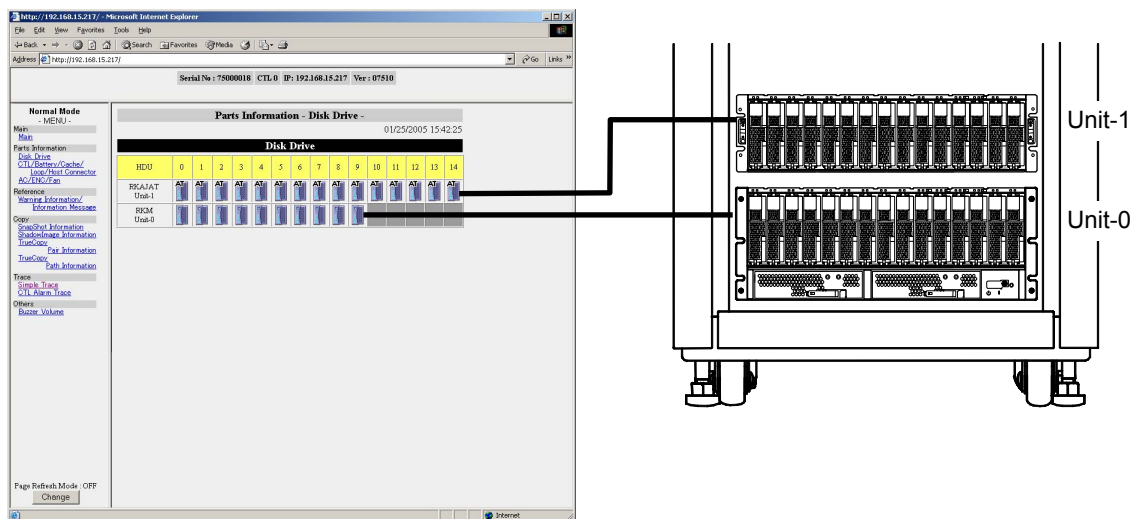
(a) Disk Drive





• Disk Drive

Image	Status
 Blue	• Normal
 Red	• Fault has occurred to the Disk Drive
 Red and Black	• Disk Drive port that the fault occurred is not implementing the Disk Drive
No display	• Disk Drive is not implemented (Except for the status where the Disk Drive that the fault occurred was drawn out), or although a failure occurs in the Disk Drive, the Disk Drive type cannot be determined.

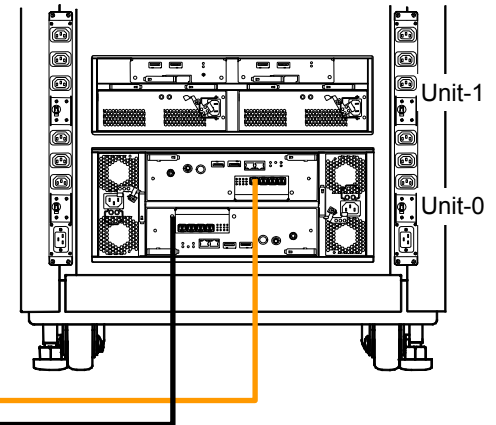
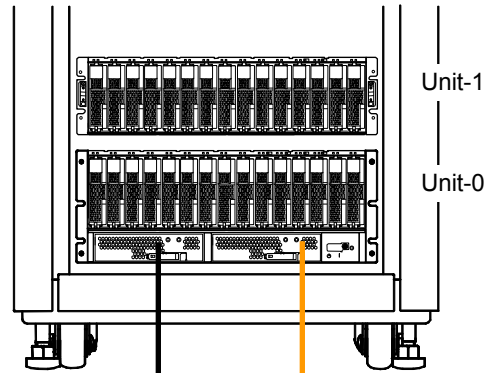
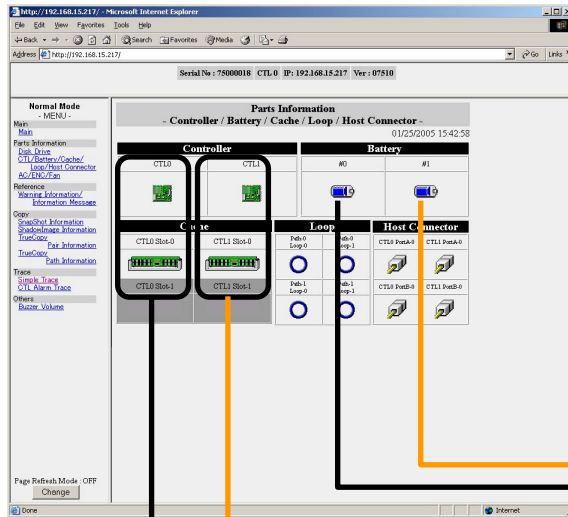

(b) Controller/Battery/Cache/Interface Board/Host Connector





• Control Unit

Image	Status
 Green	• Normal
 Red	• Shutdown of the Control Unit (Status where it is not implemented with the setting of the dual system configuration is included)
 Yellow	• Fault of the battery backup circuit
No display	• Even the fault has not occurred without being implemented with the setting of single system configuration

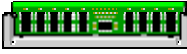

• Cache Backup Battery

Image	Status
 Green	• Normal
 Red	• There is a fault or not implemented



• Cache Unit

Image	Status
 Green	<ul style="list-style-type: none"> • Normal
 Red	<ul style="list-style-type: none"> • Fault (Status where is not implemented and extracted the fault cache memory is included)
No display	<ul style="list-style-type: none"> • It is not implemented and there is not a fault

• Interface Board

Image	Status
 Green	<ul style="list-style-type: none"> • Normal
 Red	<ul style="list-style-type: none"> • Fault

• Host Connector

Image	Status
 Gray	<ul style="list-style-type: none"> • Normal
 Red	<ul style="list-style-type: none"> • Fault

(c) AC/ENC/Fan

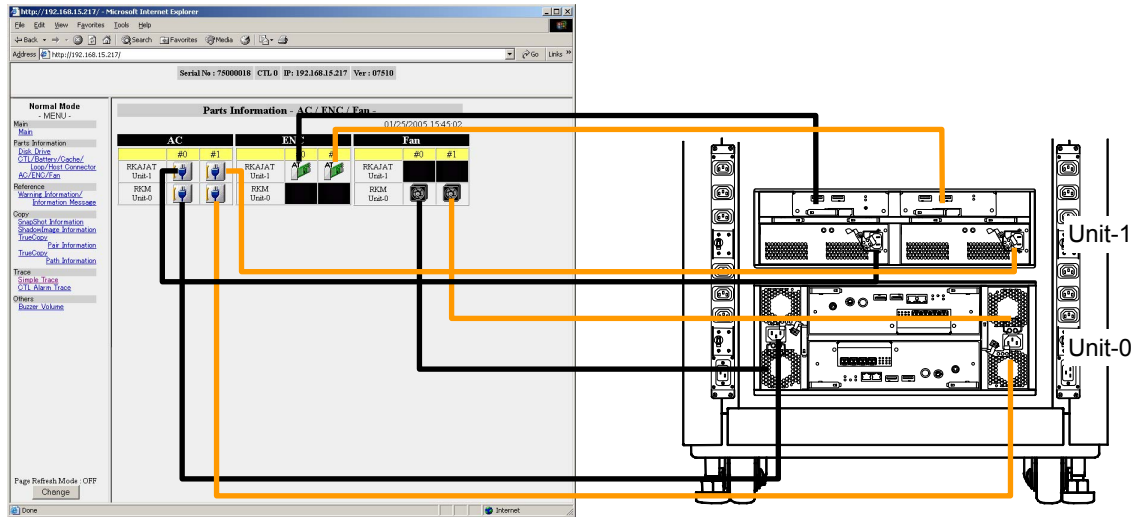

• Power Unit

Image	Status
Blue	• Normal
Red	• It is fault occurred or not implemented

• ENC Unit

Image	Status
Green	• Normal
Red	• It is fault occurred or not implemented

• FAN Unit

Image	Status
Black	• Normal
Red	• There is a fault or not implemented

(2) Procedure of the status checking by messages

A warning message about the failed part is displayed.

Refer to “4.3 Confirm Log Messages” (TRBL 04-0100) for the details of the warning messages.

When checking the status of a component through a message, a clicking on the “Warning Information” of the menu frame in the main window changes the screen to the one shown below and a detailed message explaining the component status is displayed.

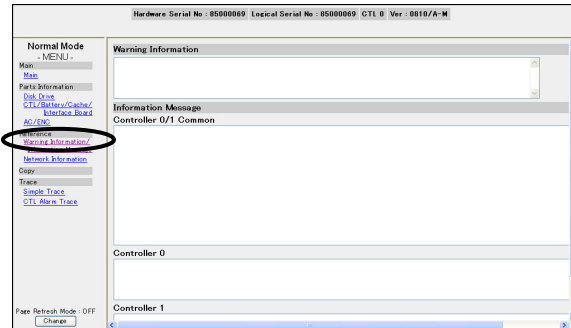

4.3 Confirm Log Messages

(1) Procedure for confirming log messages

Click the [Information Message] menu in the main window, and the “Information Message window” appears.

In the “Information Message window”, you can identify the cause of the failure and confirm the recovery method.

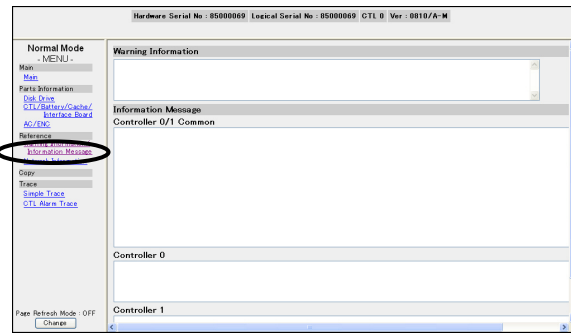

The information on the failures which were detected during operation of the unit and state of the unit is indicated in the above window.

The information on the failures and state after the unit starts up is indicated in the [Controller 0/1 Common] box.

The information on the failures and state at the time of start-up of the unit is indicated for each Controller in the [Controller 0] and [Controller 1] boxes.

The contents of each message are shown below.

(b) Flash/RAM firmware detection message

(i) Indicated message

The Flash/RAM firmware detection message is indicated in the [Controller 0/1 Common], [Controller 0], or [Controller 1] box as shown below.

The latest one is indicated at the top line.

NOTE : As the date and time of occurrence indicated by the message, the RTC set in the detection controller is used.

If the RTC is different from one control to another, the indicated time of occurrence may be different from one message to another (the message on the upper line is indicated earlier than the one on the lower line).

In this case, the actually latest message is indicated at the top, too.

```
MM/DD/YYYY hh:mm:ss xy □□□□□□ ○○○○○○○○○○○○ : △△△△△△/◆◆◆◆◆◆
MM/DD/YYYY hh:mm:ss xy □□□□□□ ○○○○○○○○○○○○ : △△△△△△/◆◆◆◆◆◆
:
```

MM/DD/YYYY : Confirmed date

hh:mm:ss : Confirmed times

xy : Detect Controller #/Detect Core #

□□□□□□□□ : Message Code^(†1)

Hxxxxx : Failure messages (See [Message “Chapter 3. Failure Messages” \(MSG 03-0000\)](#))

Ixxxxx : Progress messages (See [Message “Chapter 4. Progress Messages” \(MSG 04-0000\)](#))

Rxxxxx : Flash detected messages (See [Message “Chapter 5. Flash Detected Messages” \(MSG 05-0000\)](#))

Wxxxxx : Warning messages (See [Message “Chapter 6. Warning Messages” \(MSG 06-0000\)](#))

○○○○○○○○○○○○○ : Message text (Optional font number)

△△△△△△△△△ : Recovery method code (see (ii))

◆◆◆◆◆ : Collecting failure information code (see (ii))

†1 : For the message in which no recovery method is written, follow the recovery method shown in another message issued at the same time.

(ii) Recovery method

- ① Collect the failure information according to “(◆◆◆◆)”.

Table 4.3.1 Collecting Failure Information List

Display code	Error information you must collect
STRC	Collect Simple Trace
CTRC	Collect CTL Alarm Trace
FDMP	Collect Full Dump
PLOG	Collect Service PC Log, and Simple Trace
No display	None

Refer to “[Chapter 7. Collecting Error Information](#)” (TRBL 07-0000) for the details.

- ② Recover from the failure according to “Recovery method code (△△△△△△△)”.

Refer to the [Message “Chapter 1. Before Starting Trouble Analysis”](#) (MSG 01-0000) for the details of the messages.

Table 4.3.2 Recovery Method Code List

Display code	Recovery methods	Reference page
CTL	① Replace the Control Unit, the ALM LED of which is on. ② If the system is still abnormal, replace the other Control Unit.	Replacement “2.2.5 Replacing Control Unit” (REP 02-0450)
BAT	Replace the Cache Backup Battery.	Replacement “2.2.2 Replacing Cache Backup Battery” (REP 02-0280)
CACHE	Replace the Cache Unit indicated in the message text.	Replacement “2.2.6 Replacing Cache Unit” (REP 02-0640)
ENC	Replace the ENC Unit indicated in the message text.	Replacement “2.2.9 Replacing ENC Unit” (REP 02-1020)
FAN	Replace the FAN Unit.	Replacement “2.2.3 Replacing FAN Unit” (REP 02-0350)
HDU	Replace the Disk Drive indicated in the message text.	Replacement “2.2.1 Replacing Disk Drive” (REP 02-0030)
MANUAL	Refer to the manual, and recover from the failure according to the recovery methods for each message code. Hxxxx : Failure messages (See Message “Chapter 3. Failure Messages (MSG 03-0000)”) Ixxxx : Progress messages (See Message “Chapter 4. Progress Messages (MSG 04-0000)”) Rxxxx : Flash detected messages (See Message “Chapter 5. Flash Detected Messages (MSG 05-0000)”) Wxxxx : Warning messages (See Message “Chapter 6. Warning Messages (MSG 06-0000)”)	Message “Chapter 1. Before Starting Trouble Analysis” (MSG 01-0000)
PON	Turn on the power again.	—
PS	Replace the Power Unit indicated in the message text.	Replacement “2.2.4 Replacing Power Unit” (REP 02-0390)

Display code	Recovery methods	Reference page
RETRY	① Retry the operation. ② If the same failure still occurs, refer to the message list in the manual, and recover from the failure according to the recovery methods for each message code.	Message "Chapter 1. Before Starting Trouble Analysis" (MSG 01-0000)
SYSPM	Set the system parameter in the WEB maintenance mode correctly.	WEB "Chapter 3. The Maintenance Mode Operation Procedure" (WEB 03-0000)
UPS	When a UPS is connected, take a recovery action referring to the UPS manual.	—
No display	This is not a problem. Recovery operation is not necessary.	—

(iii) How to read failure information

- The history of the unit after it is turned on is indicated in the Information Message.
- The message of Subsystem is Ready indicates the time when the unit is ready. The messages made after the power is turned on until the unit is ready are indicated before this message. The messages made after the unit is ready are indicated after this message.
- Particularly pay attention to Wxxxxx (Warning message), Hxxxxx (Failure messages), and Rxxxxx (Flash detection message).
- The following messages are indicated when failures occur and when they are solved. (See [Table 4.3.3.](#)) If the recovery message is indicated after a failure occurrence message, the failure has been solved and you do not need to solve it.

Table 4.3.3 Failure Message List

No.	Description	Failure detected messages		Failure recovery messages	
1	Controller error/recovery	W00100	CTL alarm (CTL-x)	I0010x	CTL recovered (CTL-x)
2	Battery error/recovery	W03z0x	Battery alarm	I00300	Battery recovered
		W3Tzxy	Battery alarm (Additional Battery-y)	I0030x	Battery recovered (Battery-x)
3	Battery backup circuit error/recovery	W0400x	Battery backup circuit alarm (CTL-x)	I0040x	Battery backup circuit recovered (CTL-x)
4	FAN error/recovery	W05z00	FAN alarm (Unit-x, FAN-y)	I00500	FAN recovered (Unit-x, FAN-y)
		W06z00	FAN alarm (CTL-Unit, FAN-x)	I00500	FAN recovered (CTL-Unit, FAN-y)
5	Power supply error/ recovery	W07zy0	PS alarm (Unit-w, PS-x)	I006z0	PS recovered (Unit-x, PS-y)
		W08zy0	PS alarm (CTL-Unit, PS-x)		PS recovered (CTL-Unit, PS-y)
6	Disk Drive error/recovery	W09zab	HDU alarm (Unit-x, HDU-y, Type-c)	I007ab	HDU recovered (Unit-x, HDU-y)
		W0Azab	SATA HDU alarm (Unit-x, HDU-y, Type-c)		
7	Spare Disk error/recovery	W0Bzab	Spare HDU alarm (Unit-x, HDU-y, Type-c)	I009ab	Spare HDU recovered (Unit-x, HDU-y)
		W0Czab	SATA Spare HDU alarm (Unit-x, HDU-y, Type-c)		
8	ENC Unit error/recovery	W0Fze0	ENC alarm (Unit-x, ENC-y)	I00Be0	ENC recovered (Unit-x, ENC-y)
		W0Gze0	SENC alarm (Unit-x, ENC-y)		
9	UPS	W0Hz0x	UPS alarm (UPS-x)	I00D00	UPS recovered (UPS-x)
10	Path failure (detachment)/ recovery	W0K0xy	Path alarm (Remote-x, Path-y)	I030xy	Path recovered by web operation (Remote-x, Path-y)
				I031xy	Path recovered automatically
11	Occurrence/ rectification of an incomplete writing	W0L000	Unreadable PIN detected (Unit-x, HDU-y)	I04000	Unreadable PIN recovered
		W0M000	Unreadable PIN detected (Unit-*, HDU-*)		
12	Issue/callback of a resident LU off warning	W390xy	Permanent LU warning (CTL-x, ERR-y)	I1A2xy	Permanent LU warning recovered (CTL-x, ERR-y)
13	Excess/rectification of the threshold value of the number of pinned sub-segments	W3G000	PIN is over directory threshold [write through] (DIR-x)	I6EG00	PIN over recovered [directory threshold] (DIR-x)
		W3J000	PIN is over partition threshold [write through] (DIR-x, PTT-y)	I6EH00	PIN over recovered [partition threshold] (DIR-x, PTT-y)
		W3L000	PIN is over RAID group threshold [write through] (DIR-x, RG-y)	I6EJ00	PIN over recovered [RAID group threshold] (DIR-x, RG-y)
14	The DM-LU failure/recovery	W3N000	DM-LU write disable (LU-x)	I6EM00	DM-LU recovered (LU-x)
		W3P000	All DM-LU write disabled		
15	The host connector failure/ recovery	W0Pz0f	Host connector alarm (Portxy-z)	I53A0f	Host connector recovered (Portxy-z)
16	Backend route failure /recovery	W40000	Backend route warning has been detected (Path-x, Route-y)	I5JBxy	Backend route recovered (Path-x, Route-y)

Example of message analysis :

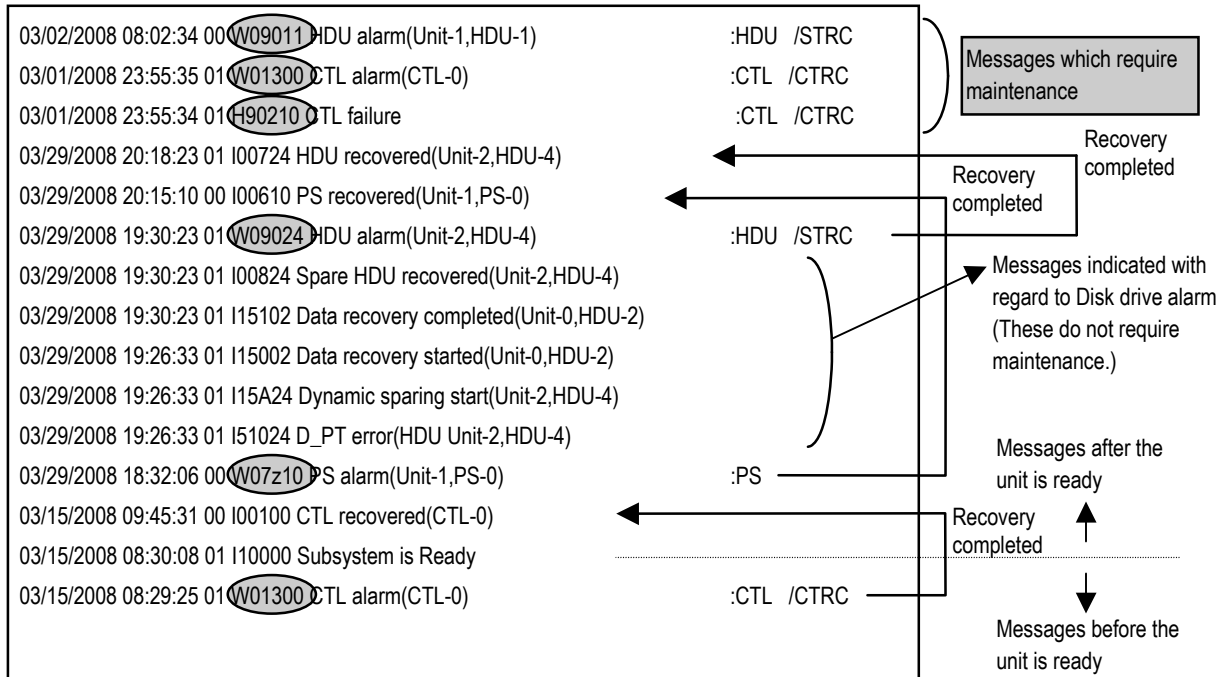

4.4 TrueCopy remote replication/TrueCopy Extended Distance Path Confirm State

(1) Procedure for confirming log messages

By clicking the path of [Summary of the replacement parts state] in the main window, the window is changed to the following one. And the details about the path state are displayed. Also by clicking [TrueCopy Path Information] on the menu frame in the main screen, the window is changed to the following window. And the details about the path state are displayed.

Perform the maintenance operation for replacement and the recovery operation referring to “6.1.17 Path Blockade Occurs in the TrueCopy remote replication/TrueCopy Extended Distance Function” (TRBL 06-0820).

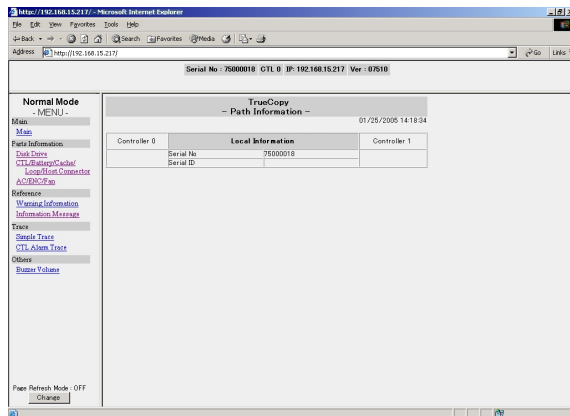

4.5 The Priority Error Messages when “CTL alarm” is Displayed

When the “W01z0x CTL alarm” message is displayed, if the following message is displayed before “W01z0x CTL alarm” message, follow the recovery method of the message.

- (1) Failure Messages. (Refer to [Message “Chapter 3. Failure Messages” \(MSG 03-0000\)](#) for the recovery method.)

Message code	Message text
H0AHxy	EDC error was detected (CTL-x, I/F-y)
H0F900	SED Authentication key error was detected
H21700	EDC error (Port-xy)
H303xy	ECC uncorrectable error was detected (CTL-x, CACHE-y)
H306xy	Please replace cache memory to recover from cache uncorrectable error (CTL-x, CACHE-y)
H30B0x	CACHE uncorrectable ERR [OTH_CTL] (CTL-x)
H30Bxy	CACHE uncorrectable ERR [OTH_CTL] (CTL-x, CACHE-y)
H30Gxy	ECC uncorrectable error (CACHE-x/y)
H90320	Watch-dog time-out
HB0Cxx	H-FPC is not detected (Port-xy)
HB0E00	Fatal iSCSI protocol chip error was detected (CTL-x, I/F-y, Code-z)
HD220x	CACHE error over (CACHE-x) [CRECT]
HE21xy	I/F board type error (CTL-x, I/F board-y)
HF0100	Data transfer check error [SEGPOSERR]
HF0103	Data transfer check error [RDSEGERR]
HF0105	Data transfer check error [WSEGPDEV]
HF0106	Data transfer check error [WSEGLOCK]
HF0107	Data transfer check error [CCPLUNERR]
HF0108	Data transfer check error [CCPLBAERR]
HF0109	Data transfer check error [PARLUNERR]
HF010A	Data transfer check error [PARLBAERR]
HF010B	Data transfer check error [QUEUEERR]
HF010C	Data transfer check error [COWDRVERR]
HF010E	Data transfer check error [DSTPOSERR]
HF0117	Data transfer check error [BUFSGQATERR]
HF0118	Data transfer check error [WRBUFTODTY]
HF020x	Directory check error (CTL-x)
HF0300	Data transfer check error [STGLUNERR]
HF0400	Data transfer check error [NTMPRD]
HH0E0x	CACHE access error (CACHE-x) [PON]
HH270x	I/F Board is not installed (CTL-x)
HH2900	Cache capacity reduced although copy function enable
HH7C0x	H-IPC firmware boot up failed (CTL-x)
HH7Gxy	H-IPC soft reset has ended in failure (Port-xy)
HH7Hxy	H-IPC hardware error (Port-xy)
HH7I0x	iSCSI firmware load failed (CTL-x)
HH7J00	H-IPC is not detected (Port-xy)
HH7N00	H-IPC PCI STS REG error [OPE]
HH7P00	H-IPC PCI STS REG error [ILE]
HH7Q00	H-IPC PCI STS REG error [ICE]
HH7R00	H-IPC PCI STS REG error [OCE]

Message code	Message text
HH7S00	H-IPC PCI STS REG error [DPE]
HH7U00	H-IPC PCI ECC error
HH7Wxy	H-IPC firmware initialization failed (CTL-x, I/F-y)
HH8100	Product number error was detected [discrepancy between ENC's of RKAKX] (RKAKX- (xx-y))
HH9N0x	ENC recovery failed [Cable error] (CTL-x)
HH9Y0x	ENC recovery failed [linkup error in the other route] (CTL-x)
HHA0xy	H-IPC hardware error was detected (CTL-x, I/F-y)
HHA1xy	iSCSI firmware load failed (CTL-x, I/F-y)
HHA2xy	H-IPC is not detected (CTL-x, I/F-y)
HHA4xy	H-IPC ECC error was detected (CTL-x, I/F-y)
HI0100	PS OFF failed [DSTG HUNG]
HI0201	PS OFF failed [POFNONCLD]
HI0202	PS OFF failed [POFNOJOB]
HI0310	OTHPs OFF time-out
HI0420	System down selected [PS OFF]
HI050x	CACHE access error (CACHE-x) [POFF]
HI0600	PS OFF failed [PIN]
HJ4Nxx	Microprogram error was detected [DIR] (CTL-y)
HZ0H0x	Directory reinitialization failed (CTL-x)
HZ0Pxx	Cache capacity reduced although Cache Partition Manager enable

- (2) Progress Messages. (Refer to [Message “Chapter 4. Progress Messages” \(MSG 04-0000\)](#) for the recovery method.)

Message code	Message text
I5FE00	Connectivity path failure of SENC occurred

- (3) Flash Detected Messages. (Refer to [Message “Chapter 5. Flash Detected Messages” \(MSG 05-0000\)](#) for the recovery method.)

Message code	Message text
R20M00	DCTL CACHE uncorrectable ERR [REG82001238, Bit29](CTL-x, CACHE-y)
R312xy	ECC uncorrectable error (CTL-z)
RA30xy	CACHE size mismatch b/w. CTL (CACHE-x/y)
RA7A00	CACHE installation error (CACHE-0/1)
RA7B0x	CACHE size get error (CACHE-x)
RB0Cxy	CACHE pair check error (CACHE-x/y)

Chapter 5. Procedure for Investigating Disk Array System Regarding Fibre Channel Failure

When a failure occurs in a Fibre Channel Link between a host computer and the subsystem, judge whether or not the failure has occurred in the interface portion of the subsystem following the flowchart shown below.

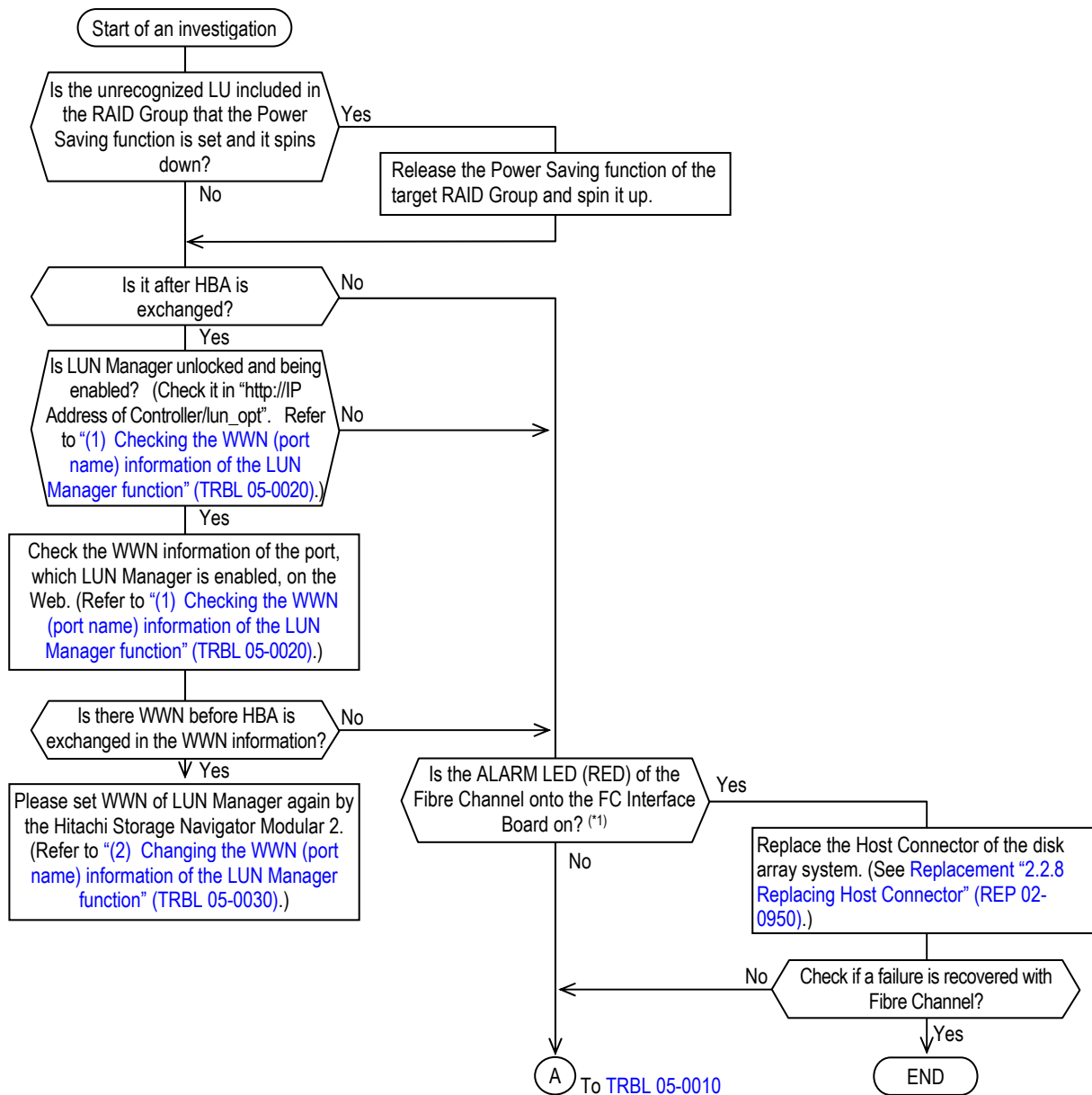

*1 : Refer to Table 8.2.7 of "8.2 (6) LED Indication Patterns on FC Interface Board" (TRBL 08-0240).

From TRBL 05-0000

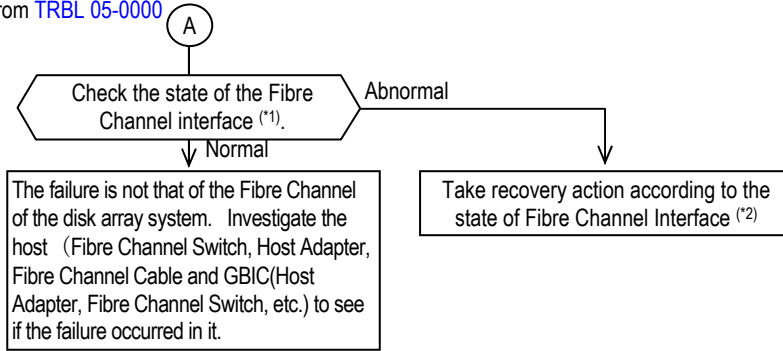

*1 : Refer to Table 8.2.7 of “8.2 (6) LED Indication Patterns on FC Interface Board” (TRBL 08-0240).

(1) Checking the WWN (port name) information of the LUN Manager function

- (a) A [User Name] and a [Password] may be requested at the time of Web connection or Web operation. In that case, input “maintenance” for the [User Name] and “hosyu9500” for the [Password].

http://IP address of controller/lun_opt

unlock and lock state display
enable and disable state display

Display of state of security of each port, name of node, name of port, and host group

Option Name	Unlock/Lock	Status
LUN Manager	Unlock	Enable

Port	Security	Port Name	Host Group
0A	Enable	AAAAAAAAAAAAAAAA	000
0A	Enable	BBBBBBBBBBBBBBBB	000
0E	Disable		
1A	Enable	DDDDDDDDDDDDDDDD	001
1A	Enable	FFFFFFFFFFFFFFFF	001
1E	Disable		

[To Normal Mode Top](#)

NOTE : If you enter http://IP address/lun_opt for URL and display the window, the URL changes.

When displaying the WWN (port information) of the LUN Manager function by http://IP address/lun_opt, specify this URL every time. If you operate with the “Update” button, etc. without specifying http://IP address/lun_opt, the most recent information is not displayed.

(2) Changing the WWN (port name) information of the LUN Manager function

When replacing the Fibre Channel host bus adaptor card (HBA) installed in the host computer connected by the array subsystem and Fibre Channel, if using the LUN Manager function in the array subsystem, it is required to change the setting of LUN Manager on the array subsystem side.

Since the LUN Manager function decides which host can access which LU, it sets a WWN (port name) of the HBA which allows the access to the host group defined for each port of the array subsystem. Therefore, if replacing the HBA, it is required to change the setting which allows the access to the WWN (port name) after the replacement.

<Advance preparation>

The following preparation is required before starting this work.

- Acquiring the WWN (port name) of the old (before replacement) HBA
- Acquiring the WWN (port name) of the new (after replacement) HBA

The above-mentioned information is generally attached on the HBA as a label.

(a) Turn on the power supply.

(b) Start Hitachi Storage Navigator Modular 2, check the array subsystem to set, and change the operation mode to “Maintenance mode”.

(Refer to [System Parameter “1.1 \(4\)\(b\) Changing the Maintenance Mode” \(SYSPR 01-0080\)](#).)

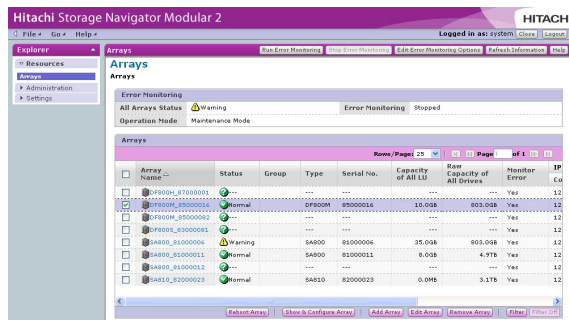

(c) Click the array subsystem name, and open the unit window.

NOTE : When the main window is not displayed even if you select the array subsystem, check that the LAN port number is not changed. (Refer to [System Parameter “1.2 LAN Port Number Change by Hitachi Storage Navigator Modular 2” \(SYSPR 01-0120\).](#)) Use the changed LAN Port Number, and execute it again.

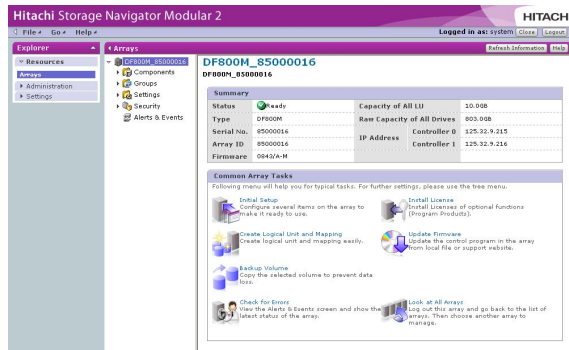

(d) Select [Groups] - [Host Groups] from the tree in the unit window.

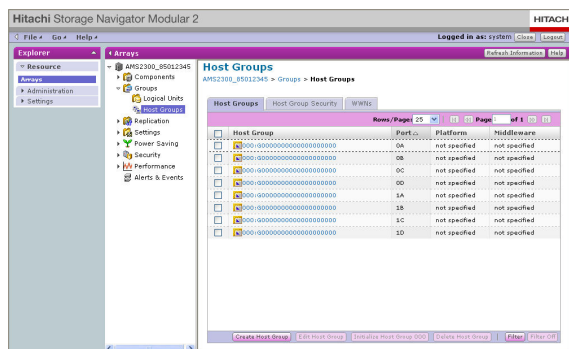

(e) Select the host group to change, and click the [Edit Host Group] button.

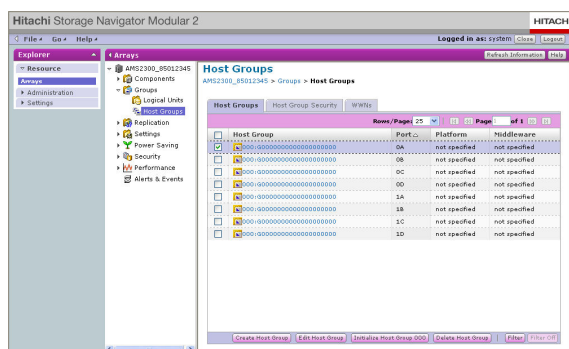

(f) Select the WWN (port name) before the HBA replacement, and click the [Remove] button.

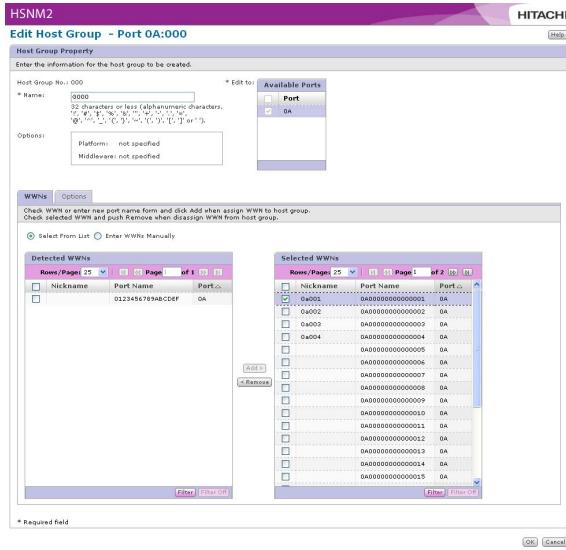

(g) Check that the deleted WWN (port name) moved to the list of [Detected WWNs], and click the [OK] button. Then, the confirmation message is displayed. Click the [Close] button.

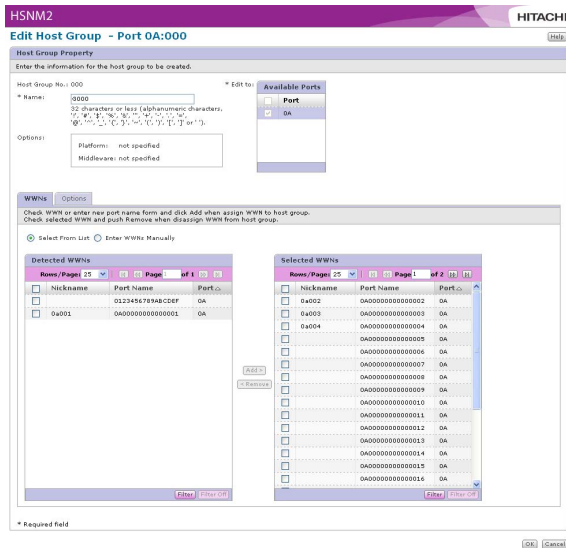

(h) When deleting the WWN (port name) before the HBA replacement, select the [WWNs] tab.

NOTE : • You cannot set the same nickname for the different WWN (port name) in the same port. When setting the nickname which was set for the WWN (port name) before the HBA replacement to the WWN (port name) after the replacement, it is required to change the nickname which was set for the WWN (port name) before the replacement (refer to “(4) Setting nicknames” <TRBL 05-0110>).

• If not deleting the WWN (port name), go to the procedure (j).

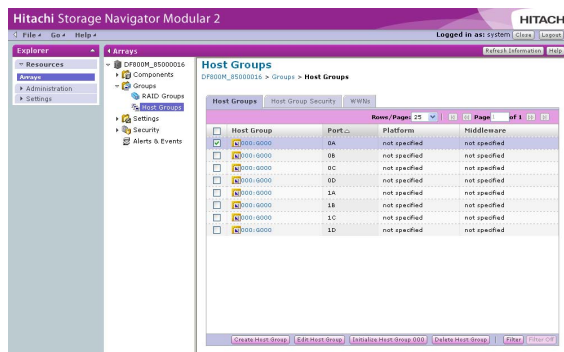

(i) Select the WWN (port name) before the HBA replacement, and click the [Delete WWN] button. Then, the confirmation message is displayed. Click the [Close] button.

NOTE : When setting the nickname which was set for the WWN (port name) before the HBA replacement to the WWN (port name) after the replacement, write down the nickname before deleting the WWN (port name) before the replacement.

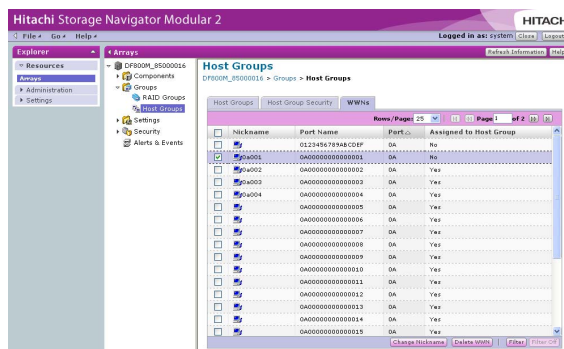

- (j) Select the [Host Groups] tab. After that, select the host group to change, and click the [Edit Host Groups] button.

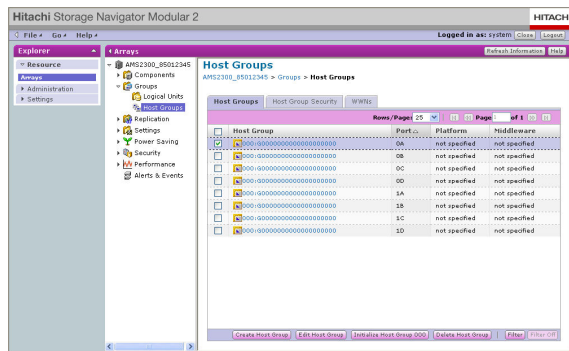

- (k) If the WWN (port name) of the HBA after the replacement is on the list of [Detected WWNs], select this WWN (port name), and click the [Add] button.

NOTE : When the WWN (port name) of the HBA before the replacement is not on the list of [Detected WWNs], click the [Enter WWNs Manually] button, and enter the WWN (port name). (Refer to “(3) Changing the WWN (port name) information by manual input” <TRBL 05-0090>.)

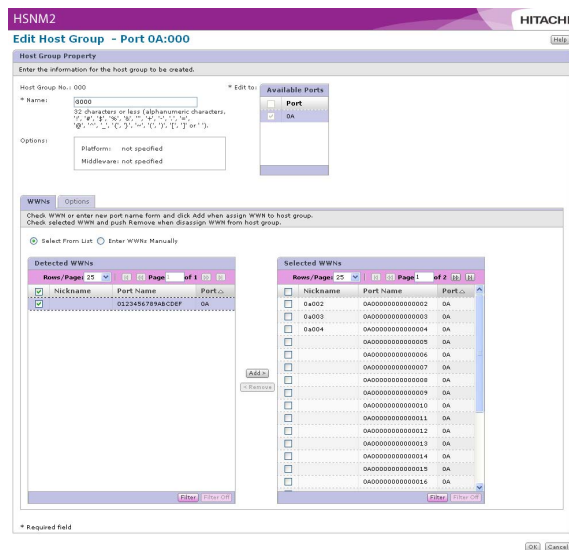

- (l) Check that the WWN (port name) of the HBA after the replacement moved to [Selected WWNs] from the list of [Detected WWNs], and click [OK]. Then, the confirmation message is displayed. Click the [Close] button.

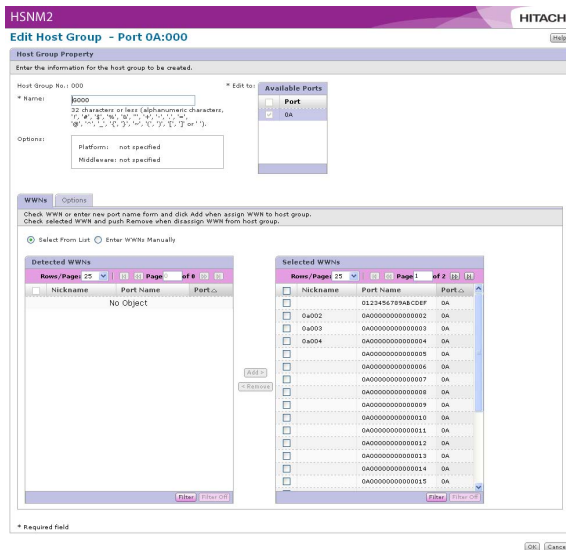

- (m) Select the [WWNs] tab, and check that [Assigned to Host Group] of the assigned WWN (port name) became “Yes”.

NOTE : When setting a nickname to the WWN (port name) of the HBA after the replacement, select the WWN (port name), click the [Change Nickname] button, and enter the nickname (refer to “(4) Setting nicknames” <TRBL 05-0110>”).

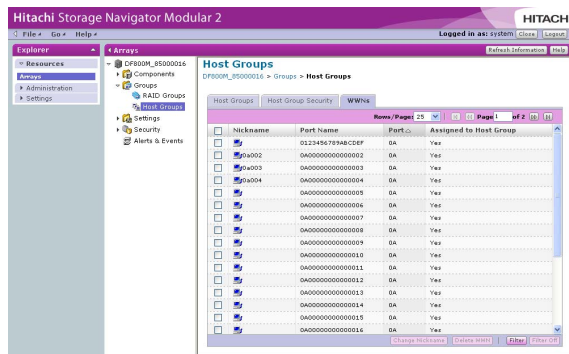

- (n) Recognize the device from the host computer again and check that the host computer can recognize the same LU as the one before the HBA replacement.

NOTE : The host computer may not be able to recognize the LU only by recognizing the device again depending on the host computer. In that case, remove the Fibre Channel cable once and insert it again.

(3) Changing the WWN (port name) information by manual input

- (a) Display the host group edit window in the procedure (a) to (e) of “(2) Changing the WWN (port name) information of the LUN Manager function”, and check that there is no WWN (port name) to enter manually on the list of [Detected WWNs].

HSNM2 HITACHI

Edit Host Group - Port 0A:000

Host Group Property

Enter the information for the host group to be created.

Host Group No.: 000 * Edit to: Available Ports

* Name: 0000 Port: 0A

Options: Platform: not specified Middlewares: not specified

WWNs Options

Check WWN or enter new port name form and click Add when assign WWN to host group.
Check selected WWN and push Remove when disassign WWN from host group.

Select From List Enter WWNs Manually

Detected WWNs		
Row	Page	25 of 8
Nickname	Port Name	Port Co.
No Object		

Selected WWNs		
Row	Page	25 of 8
Nickname	Port Name	Port Co.
<input type="checkbox"/>	0a002	GA00000000000002 0A
<input type="checkbox"/>	0a003	GA00000000000003 0A
<input type="checkbox"/>	0a004	GA00000000000004 0A
<input type="checkbox"/>		GA00000000000005 0A
<input type="checkbox"/>		GA00000000000006 0A
<input type="checkbox"/>		GA00000000000007 0A
<input type="checkbox"/>		GA00000000000008 0A
<input type="checkbox"/>		GA00000000000009 0A
<input type="checkbox"/>		GA00000000000010 0A
<input type="checkbox"/>		GA00000000000011 0A
<input type="checkbox"/>		GA00000000000012 0A
<input type="checkbox"/>		GA00000000000013 0A
<input type="checkbox"/>		GA00000000000014 0A
<input type="checkbox"/>		GA00000000000015 0A
<input type="checkbox"/>		GA00000000000016 0A

* Required field

- (b) Click [Enter WWNs Manually], enter the WWN (port name) to assign to the host group in the [Port Name] column, and then click the [Add] button.

HSNM2 HITACHI

Edit Host Group - Port 0A:000

Host Group Property

Enter the information for the host group to be created.

Host Group No.: 000 * Edit to: Available Ports

* Name: 0000 Port: 0A

Options: Platform: not specified Middlewares: not specified

WWNs Options

Check WWN or enter new port name form and click Add when assign WWN to host group.
Check selected WWN and push Remove when disassign WWN from host group.

Select From List Enter WWNs Manually

Port Name: 0123456789abcd

Enter 16 character (from 0 to F) when add new port name.

Selected WWNs		
Row	Page	25 of 8
Nickname	Port Name	Port Co.
<input type="checkbox"/>	0a002	GA00000000000002 0A
<input type="checkbox"/>	0a003	GA00000000000003 0A
<input type="checkbox"/>	0a004	GA00000000000004 0A
<input type="checkbox"/>		GA00000000000005 0A
<input type="checkbox"/>		GA00000000000006 0A
<input type="checkbox"/>		GA00000000000007 0A
<input type="checkbox"/>		GA00000000000008 0A
<input type="checkbox"/>		GA00000000000009 0A
<input type="checkbox"/>		GA00000000000010 0A
<input type="checkbox"/>		GA00000000000011 0A
<input type="checkbox"/>		GA00000000000012 0A
<input type="checkbox"/>		GA00000000000013 0A
<input type="checkbox"/>		GA00000000000014 0A
<input type="checkbox"/>		GA00000000000015 0A
<input type="checkbox"/>		GA00000000000016 0A

* Required field

- (c) Check that the input WWN (port name) moved to [Selected WWNs], and click [OK]. Then, the confirmation message is displayed. Click the [Close] button.

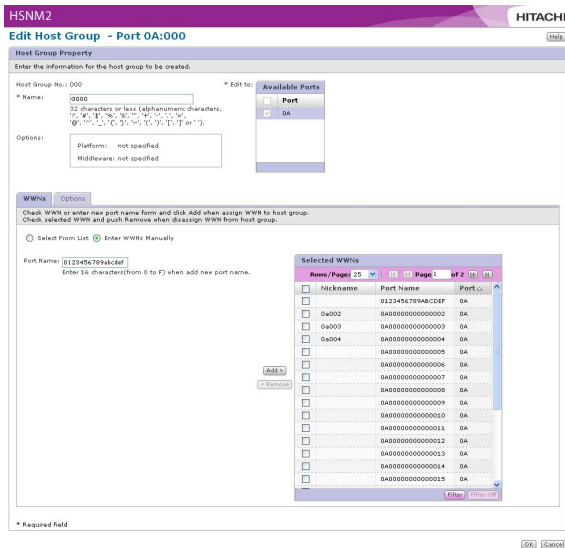

- (d) Select the [WWNs] tab, and check that [Assigned to Host Group] of the assigned WWN (port name) became “Yes”.

NOTE : When setting a nickname to the WWN (port name) of the HBA after the replacement, select the WWN (port name), click the [Change Nickname] button, and enter the nickname (refer to “(4) Setting nicknames” <TRBL 05-0110>”).

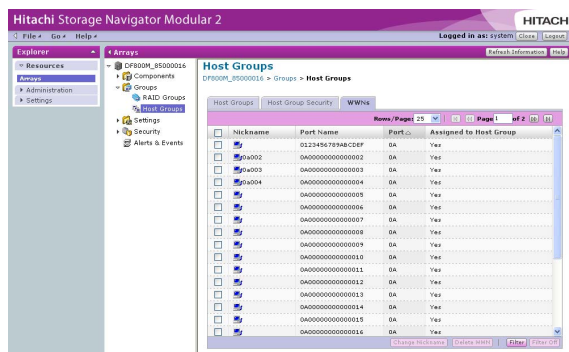

(4) Setting nicknames

(a) Display the select host group window in the procedure (a) to (e) of “(2) Changing the WWN (port name) information of the LUN Manager function”.

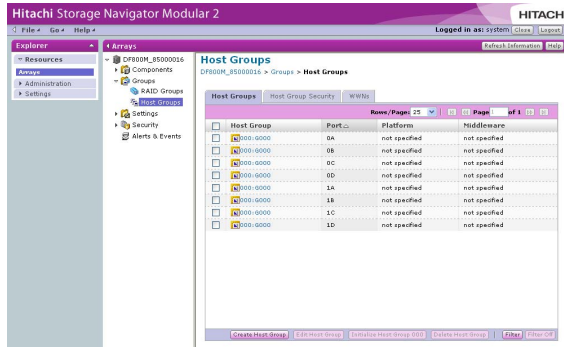

(b) Select the [WWNs] tab.

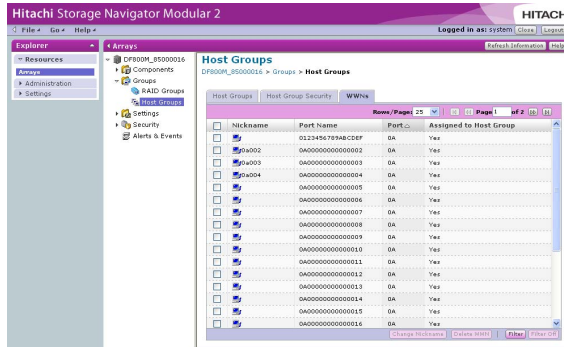

(c) Select the WWN (port name) to set a nickname, and click the [Change Nickname] button.

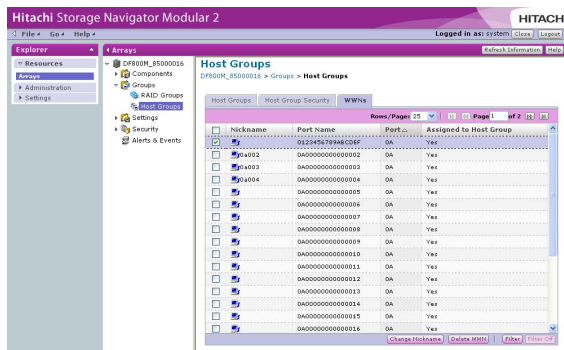

This page is for editorial purpose only.

Chapter 6. Details of Recovery Methods

6.1 Error Recovery Methods

Table 6.1.1 shows error recovery methods^(†1).

Table 6.1.1 Error Recovery Methods for Each Error

No.	Classification	Description	Reference page
1	The subsystem goes down.	Both controllers are blocked in the dual controller configuration. Only one controller is blocked in the single or dual controller configuration.	"6.1.1 System Down" (TRBL 06-0020)
2		The load of the DP management information from the Disk Drive failed at the time of starting the subsystem.	"6.1.25 Recovery Method when the Subsystem went Down because the Load of the DP Management Information" (TRBL 06-1060)
3		POWER LED on the subsystem lighted off because a Drive short-circuit failure (on the Basic Chassis or the Additional Chassis) occurred.	"Chapter 8. Trouble Analysis by LED Indication" (TRBL 08-0000)
4		The subsystem down occurred because the subsystem does not become Ready due to a Disk Drive failure. Start the subsystem and perform the failure maintenance by removing the failed Disk Drive when the subsystem is not Ready.	"6.1.28 Procedure for Starting the Subsystem by Removing the Failed Disk Drive when the Subsystem is not Ready" (TRBL 06-1160)
5	The subsystem does not become ready.	A loading of information from a Disk Drive failed.	"6.1.2 The Subsystem does not Become Ready : Case 1 (Loading Failure)" (TRBL 06-0050)
6		POWER LED on the subsystem lighted off because a Drive short-circuit failure (on the Basic Chassis or the Additional Chassis) occurred.	"Chapter 8. Trouble Analysis by LED Indication" (TRBL 08-0000)
7		The subsystem down occurred because the subsystem does not become Ready due to a Disk Drive failure. Start the subsystem and perform the failure maintenance by removing the failed Disk Drive when the subsystem is not Ready.	"6.1.28 Procedure for Starting the Subsystem by Removing the Failed Disk Drive when the Subsystem is not Ready" (TRBL 06-1160)
8	The failure occurred immediately after being ready.	The user data in the cache memory was lost because data stored in the cache memory volatilized. (A forced parity correction is required ^(†1) .)	"6.1.3 The Failure Occurred Immediately after Being Ready (Forced Parity Correction)" (TRBL 06-0110)
9	The power cannot be turned off.	Planned shutdown cannot be performed because the number of PIN data is too large. (due to Disk Drive and Controller error.)	"6.1.4 The Power cannot be Turned Off : Case 1 (The Number of PIN Data is Too Large)" (TRBL 06-0550)
10		An attempt was made to save PIN data to the Disk Drive during planned shutdown but failed because a hardware error occurred.	"6.1.5 The Power cannot be Turned Off : Case 2 (Hardware Failure)" (TRBL 06-0580)

*1 : When user data is lost because of volatilization of data in the cache memory, restore it in the procedure given in No.5.

- †1 : • Since the latest state of the unit is always referenced in this recovery operation, turn on the Page Refresh Mode of the WEB. (Click the [ON] button to indicate [OFF].)
- In the recovery operation, when turning on the power again, the WEB connection between the subsystem and the browser are turned off. Perform the WEB connection again (press the refresh button of the browser).

No.	Classification	Description	Reference page
11	The power cannot be turned off.	Planned shutdown cannot be performed because all the Disk Drives to which inheritance information is to be saved disappeared due to a DMA double error or a Disk Drive quintuple error.	"6.1.6 The Power cannot be Turned Off : Case 3 (Control Unit Failure)" (TRBL 06-0600)
12		Planned shutdown cannot be performed because PIN data cannot be saved due to a Cache memory error, etc.	"6.1.7 The Power cannot be Turned Off : Case 4 (Cache Memory Failure)" (TRBL 06-0620)
13	Data recovery does not terminate normally.	<ul style="list-style-type: none"> A read error occurred in the copy source during the correction copy or copy back, and the forced recovery is executed. A read error occurred in the copy source during the correction copy or copy back, and the data recovery terminated abnormally. 	"6.1.8 Data Recovery does not Terminate Normally : Case 1 (Read Error)" (TRBL 06-0640)
14		Data recovery terminated abnormally because a Disk Drive error occurred in the copy source during a correction copy or copy back.	"6.1.9 Data Recovery does not Terminate Normally : Case 2 (Disk Drive Failure)" (TRBL 06-0650)
15		Data recovery terminated abnormally because a Spare Disk error occurred during a copyback.	"6.1.10 Data Recovery does not Terminate Normally : Case 3 (Spare Disk Drive Failure)" (TRBL 06-0670)
16	A failure occurred during operation.	The number of PIN segments exceeded its threshold value. (Actions to be taken when PIN OVER occurs)	"6.1.11 A Failure Occurred during Operation : Case 1 (PIN Over)" (TRBL 06-0690)
17		Data containing a LA/LRC error was detected.	"6.1.12 A Failure Occurred during Operation : Case 2 (LA/LRC Error)" (TRBL 06-0720)
18		Actions to be taken when a LU blockade occurs.	"6.1.13 A Failure Occurred during Operation : Case 3 (LU Blockade)" (TRBL 06-0740)
19		<ul style="list-style-type: none"> The command for reassignment was sent from a host computer to an LU of RAID 0. The write uncompleted area was registered because a read impossible area was found during the RAID group expansion. 	"6.1.14 A Failure Occurred during Operation : Case 4 (Incomplete Writing)" (TRBL 06-0760)
20	The incomplete write area was registered in the restored VOL.	<ul style="list-style-type: none"> The incomplete write area was registered in the P-VOL because there was the unreadable area in the pool LU during restoring the P-VOL of Copy-on-write SnapShot. The incomplete write was registered in the S-VOL because there was the unreadable area in the pool LU when restoring the S-VOL due to S-VOL-Takeover as a result of executing the [horctakeover] command with TrueCopy Extended Distance. 	"6.1.15 The Incomplete Write Area was Registered in the Restored VOL" (TRBL 06-0770)
21	The Modular Volume Migration terminated abnormally.	One Modular Volume Migration or two or more Modular Volume Migrations terminated abnormally.	"6.1.16 Recovery Method of the Modular Volume Migration which Terminated Abnormally" (TRBL 06-0790)
22	PATH blockade occurred in the TrueCopy remote replication/TrueCopy Extended Distance function.	Actions to be taken when the PATH blockade occurs.	"6.1.17 Path Blockade Occurs in the TrueCopy remote replication/TrueCopy Extended Distance Function" (TRBL 06-0820)"
23	The drive firmware conversion was skipped for some Disk Drives.	Although the drive firmware conversion was executed, "IZ0EE HDU firmware update was skipped (Unit-x, HDU-y)" was displayed in the Information Message on WEB, and the drive firmware conversion was skipped for some Disk Drives.	"6.1.18 Recovery Method for Disk Drives which Skipped Drive Firmware Replacement" (TRBL 06-0920)

No.	Classification	Description	Reference page
24	The subsystem down of the array occurred due to the incorrect ENC cable connection.	When the array started, an error of the ENC cable connection for the array was detected and the subsystem down occurred.	"6.1.19 Recovery Method when the Subsystem Down of the Array Occurred due to the Incorrect ENC Cable Connection" (TRBL 06-0930)
25	A Power Unit failure of the Additional Chassis occurred.	The Additional Chassis was unable to be recognized temporarily or constantly due to a Power Unit failure and the subsystem down occurred. Or, the power of the Additional Chassis was turned off when the subsystem was Ready.	"6.1.20 Recovery Method when a Power Unit Failure of the Additional Chassis Occurred" (TRBL 06-0950)
26	The update of the SSL user certificate failed.	The creation of the SSL user certificate file failed	"6.1.21 Recovery Method when the Creation of the SSL User Certificate File Failed" (TRBL 06-0960)
27	The mismatch of the Control Unit model names between the Control Units was detected.	The firmware judged that the Control Unit model names between the Control Units differ due to the hardware failure.	"6.1.22 Recovery Method when Detecting the Mismatch of the Control Unit Model Names between the Control Units" (TRBL 06-0980)
28	An error of the Additional Battery Box connection was detected.	An error of the Additional Battery Box connection for the array was detected.	"6.1.23 Recovery Method when an Error of the Additional Battery Box Connection was Detected" (TRBL 06-1010)
29	The spin-up of the system drive failed.	The spin-up of the system drive failed at the time of starting the subsystem or changing to the maintenance mode.	"6.1.24 Recovery Method when the Spin-up of the System Drive Failed" (TRBL 06-1030)
30	An error of the DP management information was detected.	The firmware detected an error of the DP management information, and either or both Control Units were blocked.	"6.1.26 Recovery Method when the Firmware Detected an Error of the DP Management Information and the Control Unit was Blocked" (TRBL 06-1120)
31	It was detected that the Disk Drive serial number acquired at the time of starting the subsystem and the serial number of the configuration information do not match.	It was detected that the serial number acquired at the time of starting the subsystem and the serial number of the configuration information do not match in two or more Disk Drives.	"6.1.27 Recovery Method when the Disk Drive Serial Number Acquired at the time of Starting the Subsystem and the Serial Number of the Configuration Information do not Match" (TRBL 06-1140)
32	A failure occurred in the path of the Fibre Channel port, and the failure detection count exceeded the threshold value.	The threshold value was set for an error on the Fibre Channel signal in the path of the Fibre Channel port between the host and the subsystem, but the failure detection count exceeded the threshold value.	"6.1.29 Failure Determination and Recovery Methods of Fibre Channel Port Path" (TRBL 06-1200)
33	Multiple suspected failed parts were detected in the backend.	Actions to be taken when a failed part could not be identified by backend automatic diagnostic and the suspected failed parts were narrowed down only up to two parts.	"6.1.30 Recovery Method when the Multiple Suspected Failed Parts were Detected in the Backend" (TRBL 06-1340)
34	In the SATA Disk Drive test of the LT short version SELF HEATRAN system, write to the cache data (pseudo planned shutdown) failed.	In the SATA Disk Drive test of the LT short version SELF HEATRAN system, write to the cache data (pseudo planned shutdown) to the Disk Drive to be executed before the test of the test pattern 121 failed.	"6.1.31 Recovery Method when Write to the Cache Data (Pseudo Planned Shutdown) Failed in the LT Short Version SELF HEATRAN System" (TRBL 06-1380)

No.	Classification	Description	Reference page
35	The version downgrade to the firmware which does not support the SATA drives exceeding 2 TB capacity failed.	Since the RAID groups and the DP pools configured of the SATA drives exceeding 2 TB capacity exist, the version downgrade to the firmware which does not support the SATA drives exceeding 2 TB capacity cannot be performed.	“6.1.32 Recovery Method when the Version Downgrade to the Firmware which does not Support the SATA Drives Failed” (TRBL 06-1430)
36	This becomes the copy-back operation regardless of the copy-back-less setting at the time of the Drive failure restoration.	The action to be taken when the copy-back operates regardless of the copy-back-less setting because Power Saving is enabled and all the Spare Drives are set for the system drives.	“6.1.33 The Recovery Method when the Copy-Back Operates Regardless of the Copy-Back-Less Setting if Power Saving is Enabled and Performs the Drive Restoration” (TRBL 06-1470)

6.1.1 System Down

[WEB Information Message display]

MM/DD/YYYY	hh:mm:ss	xy	Hxxxxxx	○○○○○○○	:	△△△△△△/□□□□
Date	Time	x : Detect Controller #	y : Detect Core #			

xxxxx, ○○○○○○○ : △△△△△△/□□□□ Optional

- NOTE :
- When the READY LED (green) on the front side of the Basic Chassis is lights off, refer to [“Chapter 8. Trouble Analysis by LED Indication” \(TRBL 08-0000\)](#) to recover the failures.
 - The recovery method shown below is for the case where blockades of both Controllers in a dual Controller configuration occur.
 - The ALARM LED (red) on the front side of the Basic Chassis comes on and the both controllers are detached. As to the ALM LED (red) on the controller PCBA, only the ALM LED (red) on one of the controllers, in which the failure was detected earlier, comes on.
Make sure on which controller the ALM LED (red) is on because the recovery work is to be done starting from the controller whose ALM LED (red) is on.

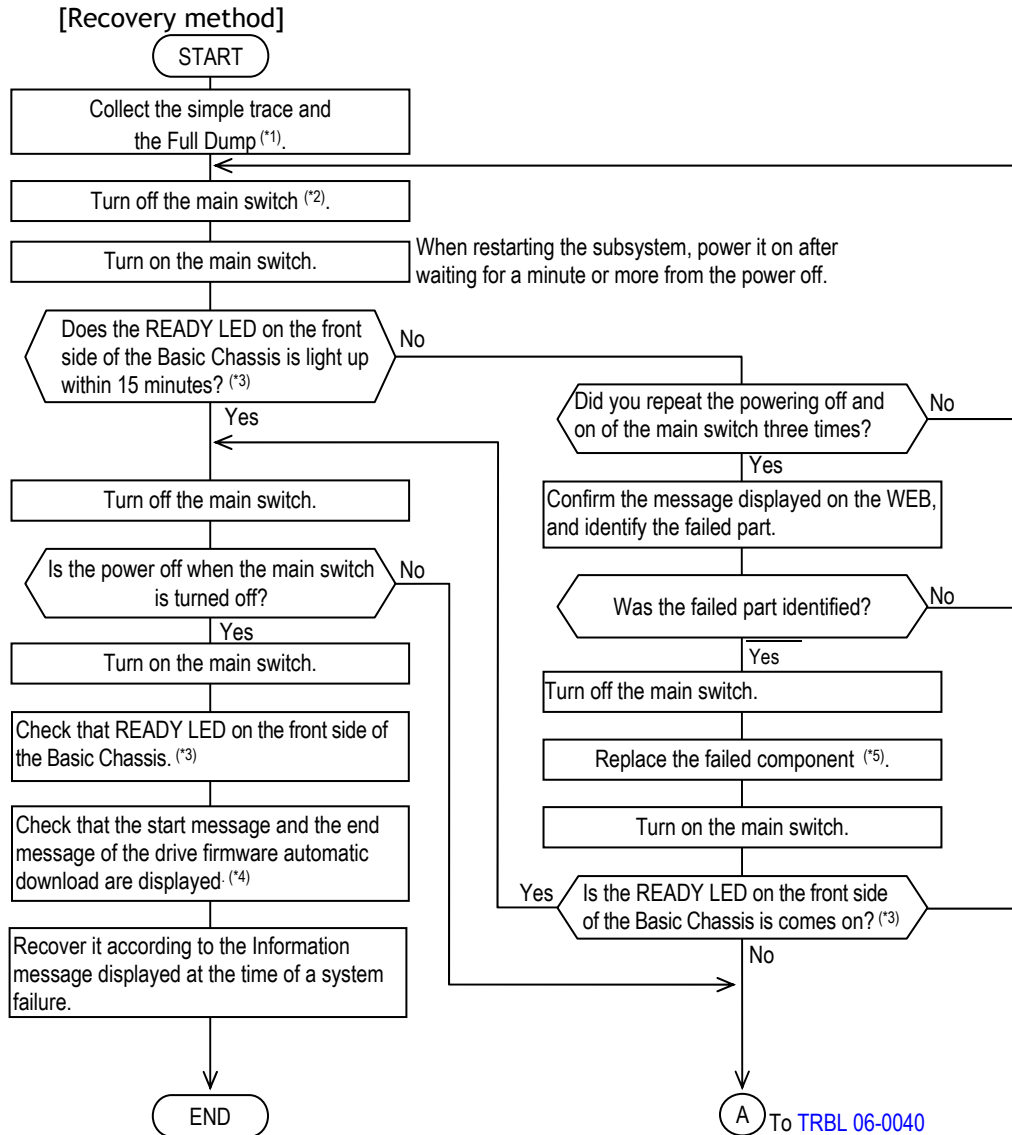

*1 : For Simple Trace Collection, refer to “7.3 Collecting Simple Trace” (TRBL 07-0040), for Full Dump Collection, refer to “7.5 Collecting Full Dump” (TRBL 07-0140).

*2 : When the ALARM LED (red) on the front of the Basic Chassis does not go out even if five minutes passed after turning off the main switch, remove the power cables from the Power Units.

*3 : Wait if the READY LED (green) on the front of the Basic Chassis is blinking at high speed (for the maximum of 30 to 50 minutes, or 40 to 60 minutes in case of the RKH), or the WARNING LED (orange) is blinking at high speed (for the maximum of 30 to 85 minutes).

*4 : When the drive firmware version of the disk drive is new, the start message and completion message of the drive firmware automatic download are not displayed. To check the drive firmware automatic download, refer to [Firmware “1.6 \(4\) Checking the start message and end message of the automatic download \(FIRM 01-0890\)”](#).

*5 : For the replacement of the failed component, refer to [Replacement “Chapter 2. Parts Replacement” \(REP 02-0000\)](#).

From TRBL 06-0030

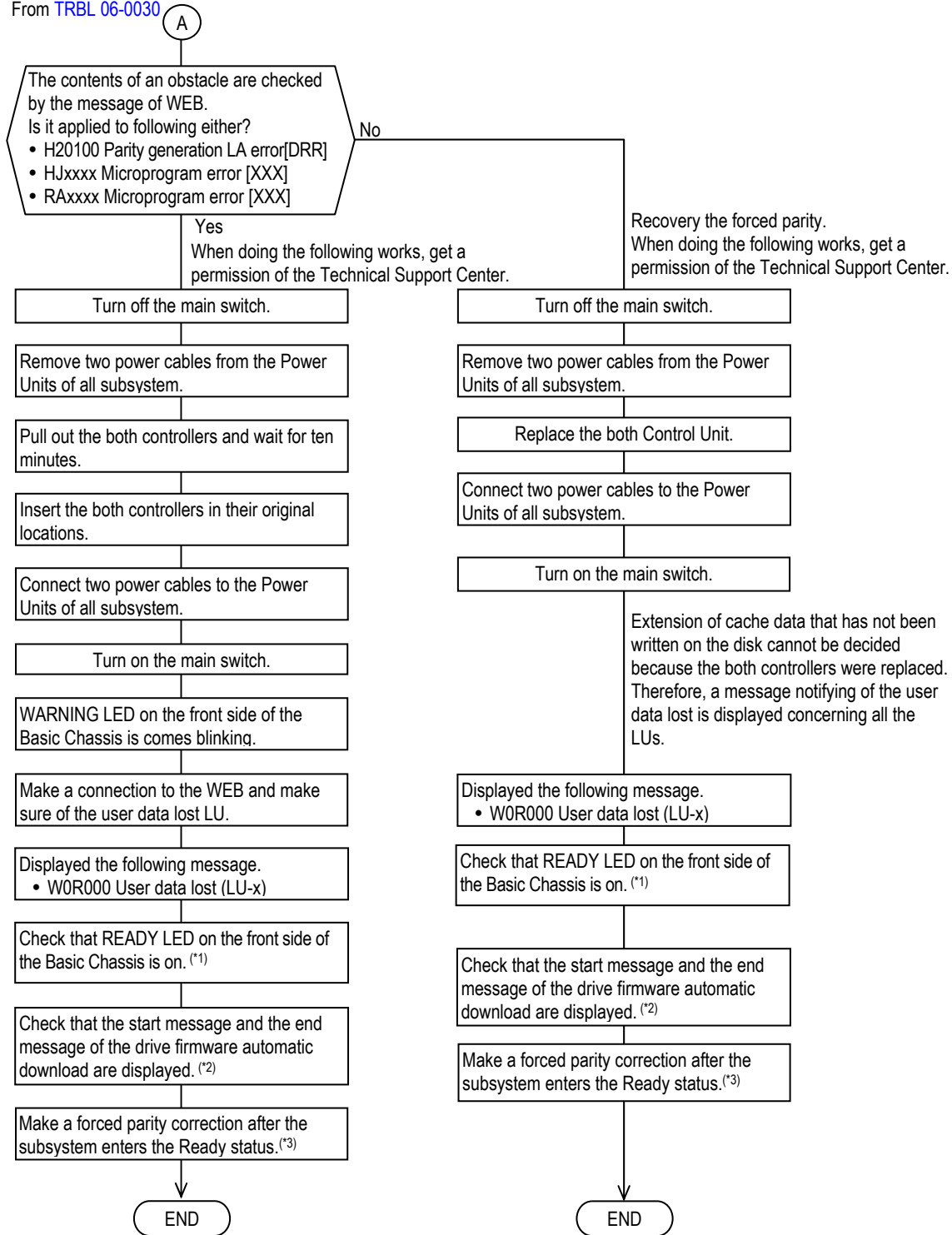

*1 : Wait if the READY LED (green) on the front of the Basic Chassis is blinking at high speed (for the maximum of 30 to 50 minutes, or 40 to 60 minutes in case of the RKH), or the WARNING LED (orange) is blinking at high speed (for the maximum of 30 to 85 minutes).

*2 : When the drive firmware version of the disk drive is new, the start message and completion message of the drive firmware automatic download are not displayed. To check the drive firmware automatic download, refer to [Firmware “1.6 \(4\) Checking the start message and end message of the automatic download \(FIRM 01-0890\)”](#).

*3 : For the forced parity correction, refer to Item [“6.1.3 The Failure Occurred Immediately after Being Ready \(Forced Parity Correction\)” \(TRBL 06-0110\)](#).

6.1.2 The Subsystem does not Become Ready : Case 1 (Loading Failure)

(Information could not be loaded from the Disk Drive.)

[WEB Information Message display]

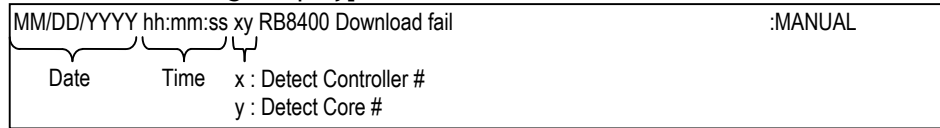

[Recovery method]

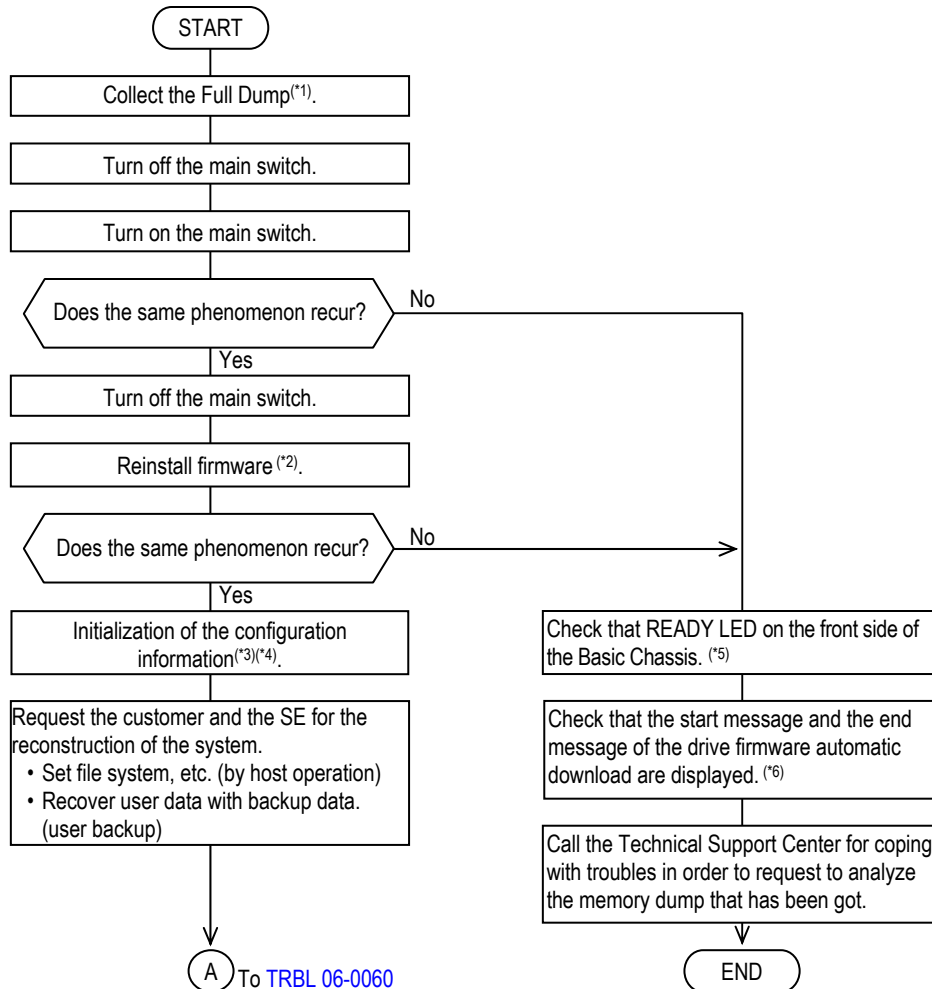

*1 : For the collection Full Dump, refer to “7.5 Collecting Full Dump” (TRBL 07-0140).

*2 : Make the subsystem in the maintenance mode referring to WEB “Chapter 3. The Maintenance Mode Operation Procedure” (WEB 03-0000), and refer to WEB “3.3.1 Microprogram” (WEB 03-0270) for the installation procedure of the firmware.

*3 : If this operation is executed, all the data in the Disk Drive are deleted (the RAID group and LU definition are initialized).

*4 : For initialization of the information on configuration, refer to “(1) Initialization procedure for configuration information” (TRBL 06-0070).

*5 : Wait if the READY LED (green) on the front of the Basic Chassis is blinking at high speed (for the maximum of 30 to 50 minutes, or 40 to 60 minutes in case of the RKH), or the WARNING LED (orange) is blinking at high speed (for the maximum of 30 to 85 minutes).

*6 : When the drive firmware version of the disk drive is new, the start message and completion message of the drive firmware automatic download are not displayed. To check the drive firmware automatic download, refer to Firmware “1.6 (4) Checking the start message and end message of the automatic download (FIRM 01-0890)”.

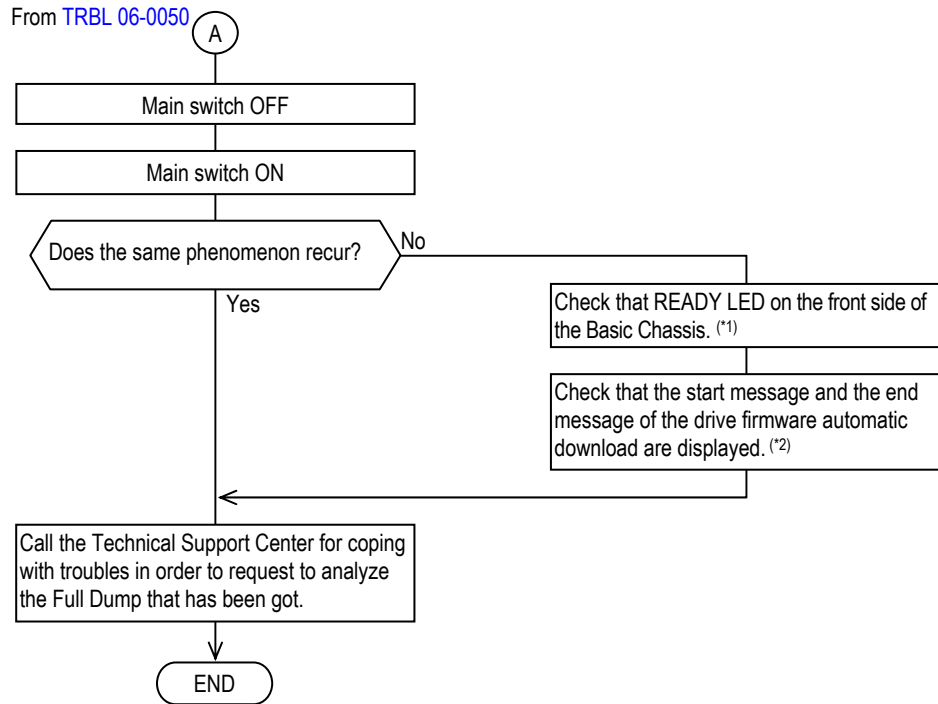

*1 : Wait if the READY LED (green) on the front of the Basic Chassis is blinking at high speed (for the maximum of 30 to 50 minutes, or 40 to 60 minutes in case of the RKH), or the WARNING LED (orange) is blinking at high speed (for the maximum of 30 to 85 minutes).

*2 : When the drive firmware version of the disk drive is new, the start message and completion message of the drive firmware automatic download are not displayed. To check the drive firmware automatic download, refer to [Firmware "1.6 \(4\) Checking the start message and end message of the automatic download \(FIRM 01-0890\)"](#).

(1) Initialization procedure for configuration information

- NOTE :
- Be careful that the whole data on the disk will be erased (RAID groups and LU definitions will be initialized.) when this operation is performed. Even if the configuration information is initialized, the Boot Options and the System Parameter maintain the present setting value.
 - Be careful that if there is a LU whose access attribute is set by Data Retention Utility, initialization of configuration information is not possible.

- (a) Turn on the main switch of the subsystem.
- (b) Entering the Maintenance mode by WEB is required to initialize Configuration Information. The method for entering the Maintenance mode varies depending on statuses of the READY LED (green) and ALARM LED (red) on the front side of the Basic Chassis.
- When the READY LED (green) is on, proceed to the procedure starting from the step (e).
 - When the ALARM LED (red) is on, wait for three minutes after making sure of the lighting of it, proceed to the procedure starting from the step (f).
 - Also proceed to the procedure starting from the step (c) in the case where the READY LED (green) and ALARM LED (red) do not come on after waiting for ten minutes when the power is turned on.
- (c) Check that the READY LED (green) on the front of the Basic Chassis is not blinking at high speed.
- When the READY LED (green) on the front of the Basic Chassis is blinking at high speed, wait for the maximum of 30 to 50 minutes (or 40 to 60 minutes in case of the RKH) until the READY LED (green) lights up because the automatic download of the ENC firmware is being executed.
- (d) Check that the WARNING LED (orange) on the front of the Basic Chassis (RKM/RKS/RKH) is not blinking at high speed. When the WARNING LED (orange) on the front of the Basic Chassis is blinking at high speed, wait for the maximum of 30 to 85 minutes until the WARNING LED (orange) on the front of the Basic Chassis goes out and the READY LED (green) lights up because the update of the flash program or the automatic download of the ENC firmware at the time of turning the power on in the single controller configuration is being executed.
- (e) Check that the start message and the end message of the drive firmware automatic download are displayed. When the drive firmware version of the disk drive is new, the start message and completion message of the drive firmware automatic download are not displayed. When the message indicating the abnormal termination is displayed, perform the maintenance according the recovery method in the message code (refer to [Firmware “1.6 \(4\) Checking the start message and end message of the automatic download \(FIRM 01-0890\)”](#)).
- (f) Changing the Maintenance Mode.
- Single Controller
Press the RST SW of the single Control Unit. (While pressing RST SW, the RST LED (orange) is on.) Use a tool with a thin tip (a precise screwdriver, etc.) because the hole of RST SW is small (3 mm in diameter).
 - Dual Controller
- (i) Press the RST SW of the Control Unit #0. (While pressing RST SW, the RST LED (orange) is on.) Use a tool with a thin tip (a precise screwdriver, etc.) because the hole of RST SW is small (3 mm in diameter).

(ii) Wait for a while (about ten seconds) and check that the ALM LED (red) of the Control Unit lights up. Within ten seconds after the ALM LED (red) lights up, press the RST SW of the other Control Unit.

When the ALM LED (red) of the Control Unit #0 does not go out in spite of the above operation, power off the subsystem, return to step (1) without pulling out nor insert the Controller, and execute the procedure over again.

NOTE : Because the Control Unit is shutdown status for the Maintenance Mode, the command from the host is impossible execution. Please change it to the Maintenance Mode after the confirmation of separation of the device from the host or shutdown of the host.

When ALM LED (red) on Control Unit #0 turns off and READY LED (green) on the front side of the Basic Chassis is turns off, it transfers to Maintenance mode.

(a) Rackmount model of RKH/RKM/RKS

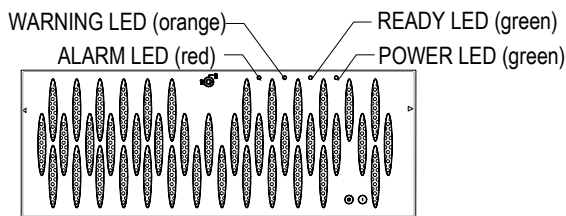

(b) Control Unit Location

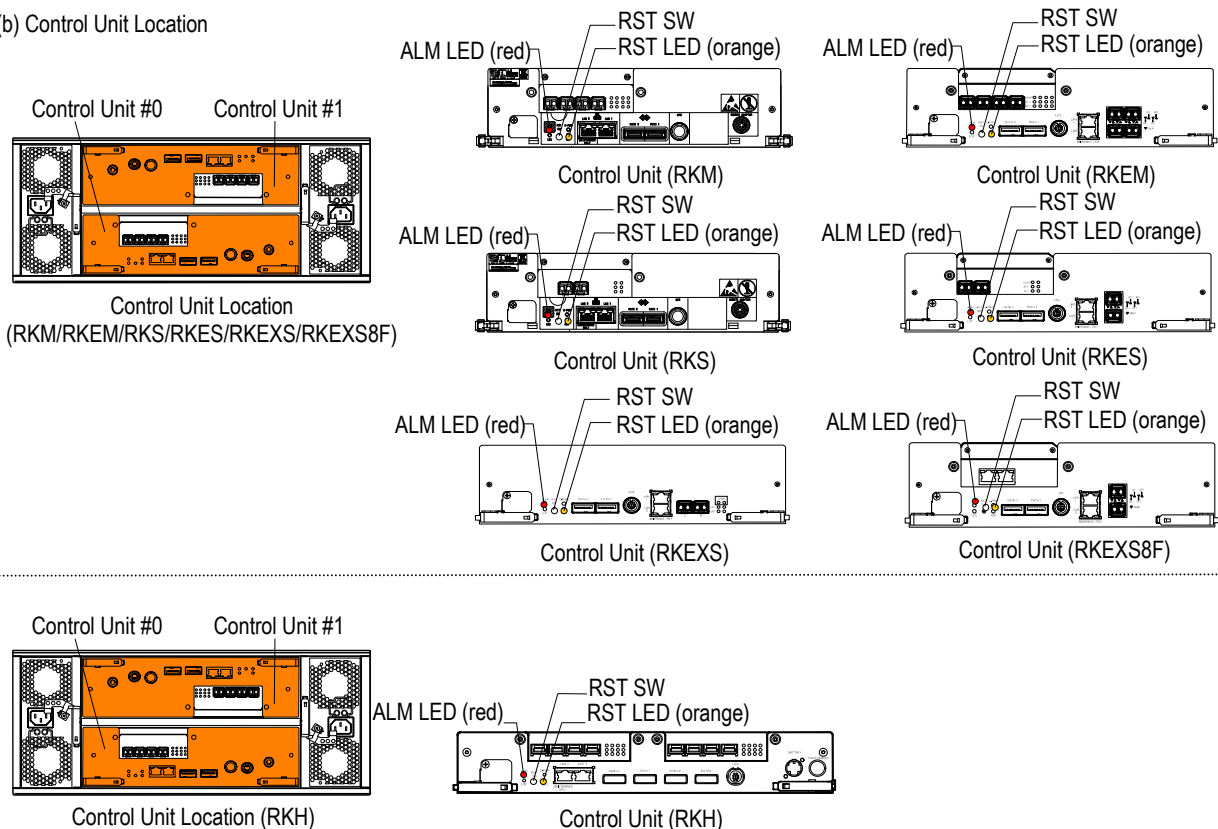
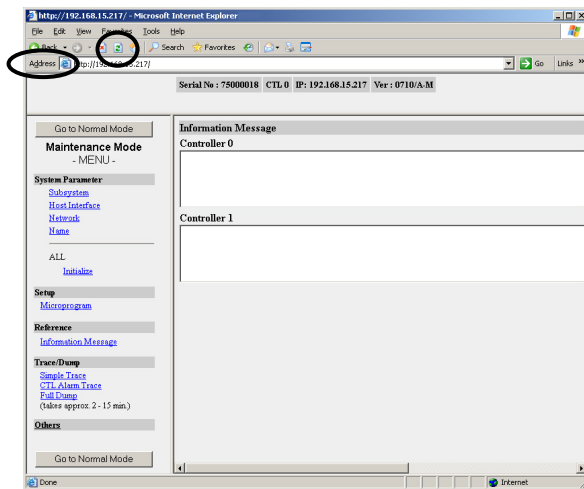

Figure 6.1.1 Indication Locations of LED

- (g) Enter the IP address of the LAN connector for maintenance, to which the service PC is connected, from the browser. When the Web has already been connected, update the page by pressing the Update button. (For the procedure for connecting the Web, refer to “Chapter 3. Before Starting WEB Connection” (TRBL 03-0000).)

A [User Name] and a [Password] may be requested at the time of Web connection or Web operation. In that case, input “maintenance” for the [User Name] and “hosyu9500” for the [Password].



- (h) Click “Others” in the menu frame.
The following window appears.

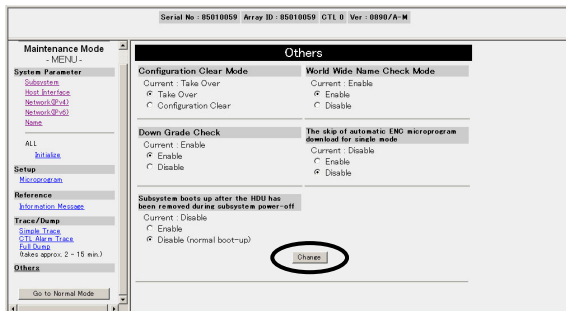

- (i) Select the “Configuration Clear” radio button of [Configuration Clear Mode], then click the “Change” button.
“Current” of the “Configuration Clear Mode” is displayed as “Configuration Clear.”

- (j) Click “Go To Normal Mode”. There are two “Go To Normal Mode” buttons, one at the top of the menu frame and the other at the bottom. Select either of them.

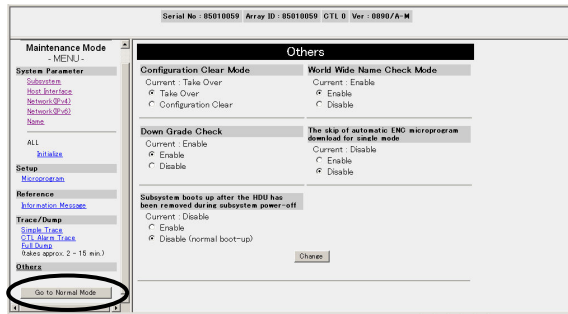

The following window is displayed while the above operation is executed.

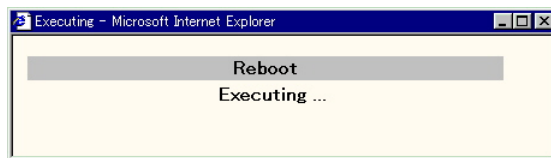

- (k) The following confirmation message is displayed at the later time for a while. Please click [OK] for the continuation.

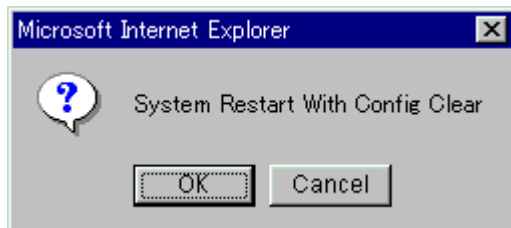

The following window is displayed while the above operation is executed.

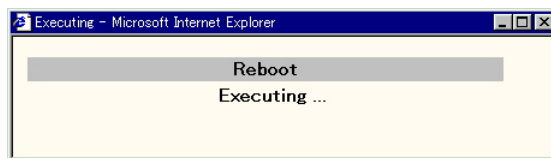

- (l) If rebooting is finished, the subsystem is ready. (It usually takes about four minutes to become the READY status (about five minutes in case of the RKH).)
At this time, check that the READY LED (green) lights up after waiting for the maximum of 30 to 50 minutes (or 40 to 60 minutes in case of the RKH) when the READY LED (green) is blinking at high speed, or waiting for the maximum of 30 to 85 minutes when the WARNING LED (orange) is blinking at high speed.

- (m) Check that the start message and the end message of the drive firmware automatic download are displayed. When the drive firmware version of the disk drive is new, the start message and completion message of the drive firmware automatic download are not displayed. When the message indicating the abnormal termination is displayed, perform the maintenance according the recovery method in the message code (refer to [Firmware “1.6 \(4\) Checking the start message and end message of the automatic download \(FIRM 01-0890\)”](#)).

This page is for editorial purpose only.

6.1.3 The Failure Occurred Immediately after Being Ready (Forced Parity Correction)

A failure occurred immediately after the subsystem had been started up. The user data in the cache memory was lost because data stored in the cache memory volatilized.

[WEB Information Message display]

MM/DD/YYYY	hh:mm:ss	xy	W3D000	Forced parity correction LU is detected	:MANUAL
Date		Time	x : Detect Controller #	y : Detect Core #	

< Explanation >

A forced parity correction is made in order to synchronize parities in the disk array system when data is lost because of volatilization of data in the cache memory caused by a power failure, etc. (when the subsystem cannot execute the deliberate shutdown).

The forced parity correction is made for each LU. Each LU can be in the following statuses. There are the actions to be taken of “Execution of the Forced Parity Correction” and “Skip of the Forced Parity Correction” for the LU that the subsystem determined the need for the forced parity correction.

Execute the forced parity correction basically for the LU that the subsystem determined the need for the forced parity correction.

However, the forced parity correction can be skipped in the following cases.

- In the case where the customer/SE can recognize that the system does not access the LU concerned, so that there is no data loss for the LU concerned even if the data on the Cache memory is volatilized.
- In the case where the backup data of the customer is restored in the subsystem after discarding the data of this LU when creating the LU concerned again by executing the LU format or deleting the LU.
- In the case where the status of the forced parity correction of the LU concerned is “Correction Aborted” and the drive restoration of the blocked Disk Drive which configures this LU is completed normally afterwards (the consistency of the parity data of this LU is assured due to the drive restoration, so that if the forced parity correction is skipped after completing the drive restoration normally, the status of the forced parity correction of this LU is changed to “Restored”).^(#1)

#1 : When the status of the forced parity correction of the LU concerned is “Correction Aborted”, the consistency of the parity data is assured at the time when the drive restoration of the blocked Disk Drive which configures this LU is completed normally, and the status of the forced parity correction is changed to “Restored”. However, this LU can be accessed by the host computer at the time of skipping the forced parity correction for the LU, so that the host computer may access the data whose consistency of the parity data is not taken (the data generated only from the data part and the data generated including the parity data may differ, so that the read data which the subsystem returns to the host computer may be changed when the host computer reads this area).

< Notes on making forced parity correction >

- The restoration is made using the maintenance function of Hitachi Storage Navigator Modular 2. For the procedure concerned, refer to [“10.2.3 Displaying Logical Unit Failure Data Information” \(TRBL 10-0100\)](#).
- For a failure of a part other than the drive that occurs during forced parity correction, refer to the [Replacement “2.1 Locations of Replacement Components” \(REP 02-0000\)](#). For a drive failure, refer to the [Replacement “2.2.1 Replacing Disk Drive” \(REP 02-0030\)](#).
- The dynamic sparing cannot be instructed in the Hitachi Storage Navigator Modular 2 during the forced parity correction. When the dynamic sparing is required because the threshold value is exceeded, the dynamic sparing is not performed but the correction copy is made through a detachment of the drive concerned.
- The copy back cannot be instructed in the Hitachi Storage Navigator Modular 2 during the forced parity correction. When the copy back is required, the copy back is started automatically after the forced parity correction is completed.
- When a drive failure, PIN Over or incomplete write occurs during the forced parity correction, the data check and the operation using the Hitachi Storage Navigator Modular 2 are required again.
- For the LU status or its transfer in the forced parity correction described in the maintenance operation flow, refer to [“< Change of the status in the forced parity correction >” \(TRBL 06-0470\)](#). Also, for the standard time required for the recovery, refer to [“< Standard time required for the forced parity correction >” \(TRBL 06-0490\)](#).
- The forced parity correction recovers one LU per Control Unit. Therefore, if there are multiple LUs that need forced parity correction, the order of the forced parity correction should be determined by checking the Control Unit in charge of each LU (Refer to [“\[Execution of forced parity correction\]” \(TRBL 06-0340\)](#)).
- If the data on the Cache memory is volatilized due to a power failure within one minute after performing the following work, all LUs may be required for the forced parity correction.
 - ① Setting of the configuration information such as the system parameter by the Hitachi Storage Navigator Modular 2
 - ② The pair operation by RAID Manager
- When there is the LU executing the forced parity correction, if the data on the Cache memory is volatilized due to the power failure, all the LUs become the target of the forced parity correction afterwards.
- If the data on the Cache memory is volatilized due to a power failure within one minute after performing the setting of such as the system parameter configuration information in the Hitachi Storage Navigator Modular 2, the set contents may not be reflected. Check the configuration. Be sure to check the configuration when a power failure occurs. If the configuration is not reflected, set the configuration information again.
- For the LU that the RAID group expansion is performed, if a drive blockade occurs when the forced parity correction status is “Parity Correction”, “Waiting Parity Correction” or “Uncorrected”, the user data cannot recover and the LU concerned becomes unformatted. If this status occurs, restore the drive, format the LU concerned, and then recover the user data from the backup.
- Check with the user whether the LU to be restored from the backup data is using the Dynamic Provisioning function, and if it is used, restore the backup data according to the user’s instruction.

(1) Data reading/writing instructed by a host

- The LU whose status of the forced parity correction is “Parity Correction”, “Waiting Parity Correction”, or “Waiting Drive Reconstruction” can read from and write to the host, but the host performance may be deteriorated during the forced parity correction.
- For the LU that the RAID group expansion processing is performed, when the forced parity correction status is “Parity Correction”, “Waiting Parity Correction” or “Waiting Drive Reconstruction”, it cannot read/write from/to the host.
- When an LU, a status of which concerning the forced parity correction is “Parity Correction”, exists in the disk array system, performance of host I/Os is lowered.

(2) Relations between statuses of forced parity correction and operations of the other functions

- The operation of other functions for the LU concerned is partially restricted depending on the status of the LU which is performing the forced parity correction.

No.	Instruction function	Status of forced parity correction		
		Parity Correction / Waiting Parity Correction / Waiting Drive Reconstruction	Uncorrected / Uncorrected and Drive Detached / Correction Aborted	Correction Skipped / Restored
1	The delete of LU	×	×	○
2	LU Unification	×	×	○
3	The change of the controller in charge of a default LU	○	○	○
4	Instruction to make an LU resident	○	○	○
5	LU mapping	○	○	○
6	Setting a prefetch size	○	○	○
7	ShadowImage in-system replication pair formation	○ ^(*1)	×	○
8	ShadowImage in-system replication pair restoration	○ ^(*2)	×	○
9	TrueCopy remote replication pair formation	○ ^(*1)	×	○
10	TrueCopy Extended Distance pair formation	○ ^(*1)	×	○
11	TrueCopy remote replication restoration	○ ^(*2)	×	○
12	TrueCopy Extended Distance restoration	○ ^(*2)	×	○
13	Copy-on-write SnapShot pair formation ^(*3)	○	×	○
14	Copy-on-write SnapShot pair restoration ^(*4)	×	×	○
15	Command device registration	○	×	○
16	LUN Manager setting	○	○	○
17	Password protection	○	○	○
18	Format instruction	×	×	○
19	Hot replacement of the firmware	×	×	○
20	Pseudo deliberate shutdown	○	○	○
21	Data Retention Utility	○	○	○

*1 : When a status of an LU concerning the forced parity correction for a secondary LU is “Waiting Parity Correction” or “Parity Correction”, a pair cannot be formed.

*2 : When a status of an LU concerning the forced parity correction for a primary LU is “Waiting Parity Correction” or “Parity Correction”, a pair cannot be formed.

*3 : When a status of either a P-VOL or a POOL (when two or more P-VOLs/POOLS exist, any one of them) is “Uncorrected”, “Uncorrected and Drive Detached” or “Correction Aborted”, a pair cannot be formed. When a POOL (when two or more POOLS exist, any one of them) is in the “Waiting Parity Correction” or “Parity Correction” status, a pair cannot be formed.

*4 : The restoration cannot be made unless a status of a P-VOL and a POOL (when two or more P-VOLs/POOLS exist, all of them) is “Correction Skipped” or “Restored”.

No.	Instruction function	Status of forced parity correction		
		Parity Correction / Waiting Parity Correction / Waiting Drive Reconstruction	Uncorrected / Uncorrected and Drive Detached / Correction Aborted	Correction Skipped / Restored
22	Instruction to make forced parity correction	×	○(*1)	○
23	Instruction to skip forced parity correction	×	○	○
24	Instruction to abort forced parity correction	○	×	×
25	RAID Group deletion	×	×	○
26	RAID Group expansion	×	×	○
27	LU capacity change (expansion/reduction)	×	×	○

*1 : For "Correction Aborted".

- A part of the execution of the forced parity correction to the LU and the instruction of the skip is restricted while the other functions are operating or depending on the status of the LU.

No.	Function in operation	Possibility of forced parity correction	Description
1	Unification LU	Partially impossible	Though an instruction to make the restoration for a child LU cannot be issued, the restoration instructed to be made for a parent LU is also applied to a child LU.
2	Format instruction	Impossible	An instruction to make the restoration cannot be issued to an LU being formatted.
3	Firmware hot replacement	Impossible	An instruction to make the parity correction cannot be issued during replacement of the firmware.
4	Pseudo deliberate shutdown	Impossible	An instruction to make the restoration cannot be issued because the disk array system is shut down deliberately.
5	Unformatted	Impossible	The execution of the forced parity correction and the instruction of the skip cannot be performed to the unformatted LU.
6	V-VOL of Copy-on-write SnapShot	Impossible	The execution of the forced parity correction and the instruction of the skip cannot be performed to the V-VOL of Copy-on-write SnapShot.

(3) Process of forced parity correction

- When the subsystem cannot perform the planned shutdown again due to the power failure, etc., the subsystem power is turned off, and the data on the Cache memory volatilizes during the forced parity correction, all LUs become the target of the forced parity correction.
- When a failure occurs in a Control Unit that is making the forced parity correction, the restoration is taken over by a mate Control Unit and continued. However, when the mate Control Unit is making the forced parity correction, it stands by for the restoration taken over. Also, when the Control Unit is recovered, perform the parity processing with the recovered Control Unit.

< Forced Parity Collection Maintenance Flow >

Perform the maintenance operation for the forced parity collection following the flow shown below.

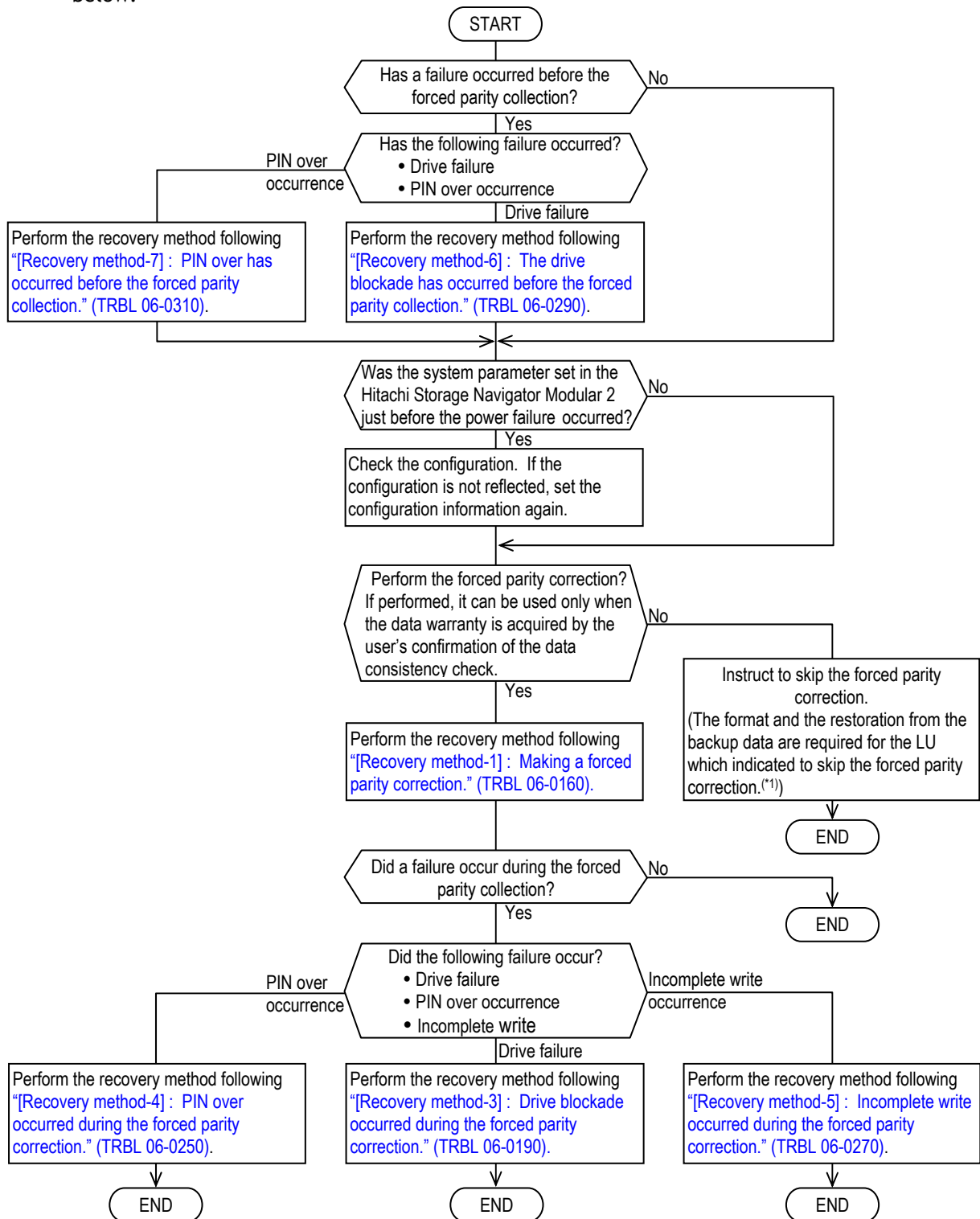

*1: Check with the user whether the LU to be restored from the backup data is using the Dynamic Provisioning function.

If it is used, restore the backup data according to the user's instruction.

[Recovery methods]

[Recovery method-1] : Making a forced parity correction.

The forced parity correction resynchronizes data in Disk Drives, however, it cannot restore the data completely. Ask a user to verify the data and restore data that could not be restored using the backup data.

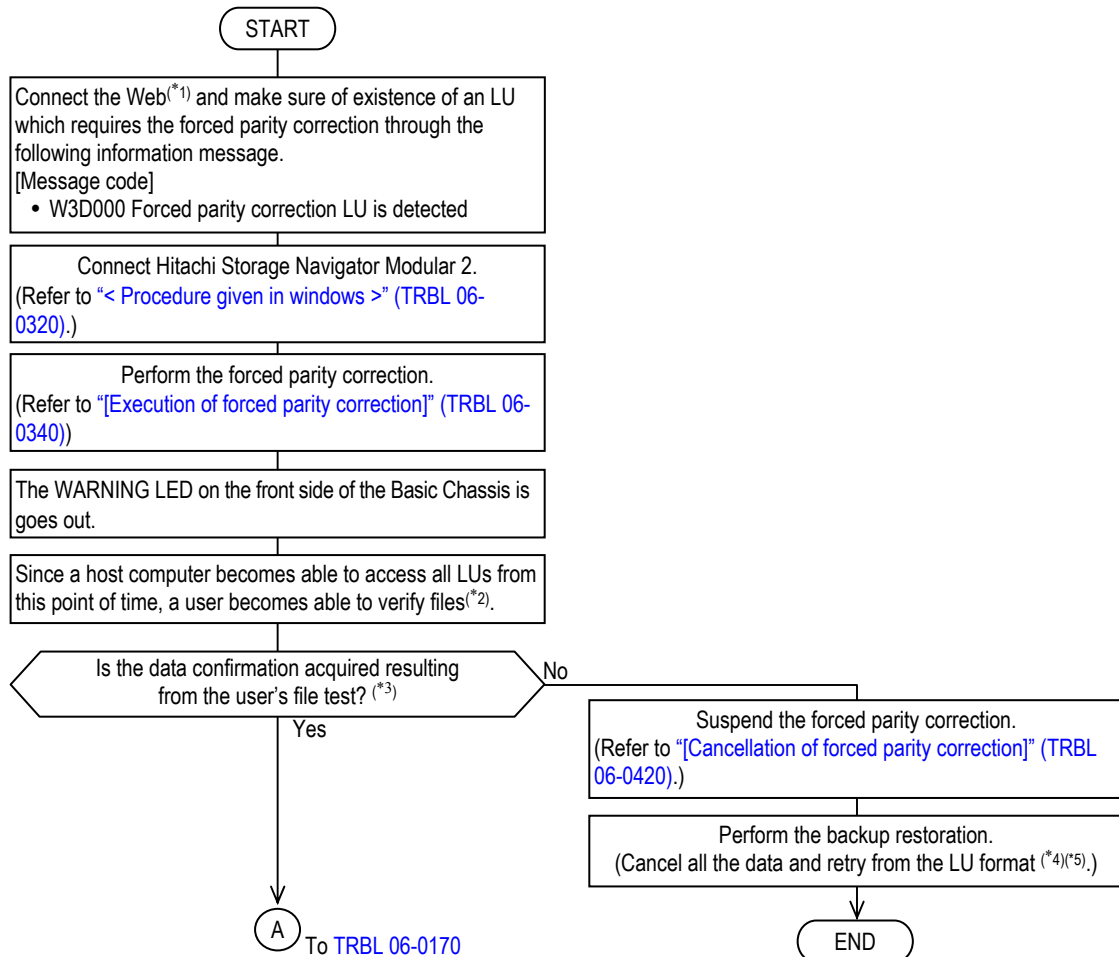

*1 : For the connection of the WEB, refer to "Chapter 3. Before Starting WEB Connection" (TRBL 03-0000).

*2 : When a drive detachment, pin over, or incomplete writing occurs during a period from the verification of files by a user to the completion of the forced parity correction, the verification of files by the user must be done again. When a failure occurs, take recovery actions referring to "[Recovery method-3] : Drive blockade occurred during the forced parity correction." (TRBL 06-0190), "[Recovery method-4] : PIN over occurred during the forced parity correction." (TRBL 06-0250), "[Recovery method-5] : Incomplete write occurred during the forced parity correction." (TRBL 06-0270).

*3 : Request the customer and the SE for the work.

*4 : There may be a case that the LU formatting fails. In this case, request a user to check if a sense code is reported in the log of a host computer. When the reported sense code is "05-9552" or "05-9577", the LU concerned is an object of ShadowImage in-system replication, TrueCopy remote replication, TrueCopy Extended Distance or Copy-on-write SnapShot. Therefore, request a user to release the pair and execute the LU formatting again after it is released. (Refer to System Parameter "3.3 [Procedure ③-F] Formatting LU" (SYSPR 03-0290).)

Also, the backup restoration cannot be done for the LU whose access attribute is set as other than Read/Write by Data Retention Utility because it cannot be formatted or written.

*5: Check with the user whether the LU to be restored from the backup data is using the Dynamic Provisioning function. If it is used, restore the backup data according to the user's instruction.

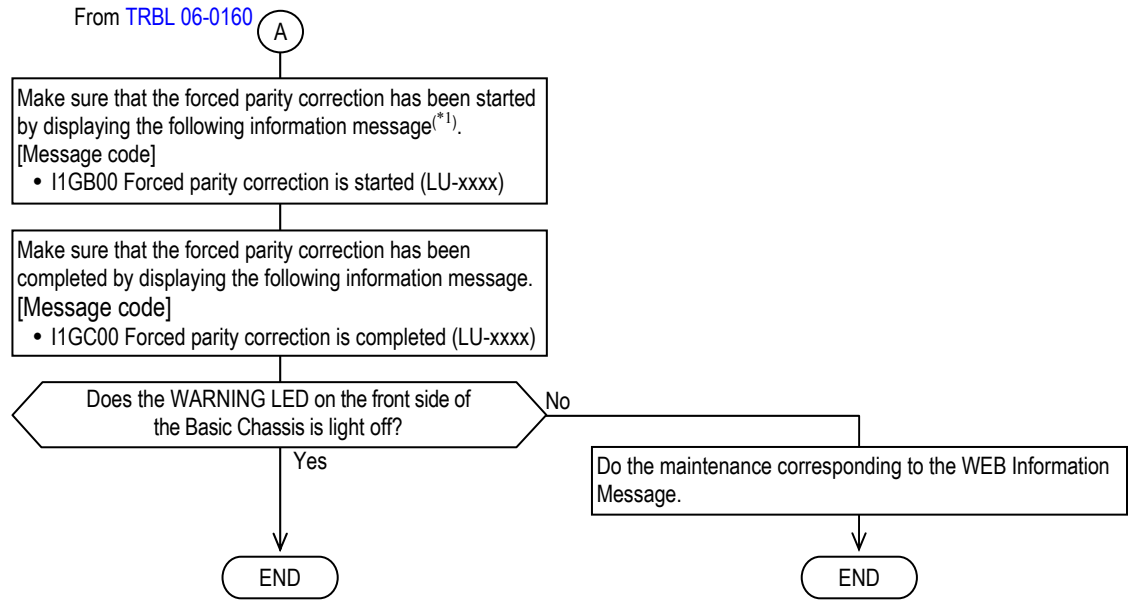

*1 : For a standard time required for the forced parity correction, refer to “< Standard time required for the forced parity correction >” (TRBL 06-0490).

[Recovery method-2] : A forced parity correction is not made (a forced parity correction is skipped).

Because a forced parity correction is not made, data in a Disk Drive are not synchronized and an LA error, etc. may occur. Issue an instruction to skip the forced parity correction from Hitachi Storage Navigator Modular 2, format the LU, and then make a backup restoration.

However, for the LU that the RAID group expansion is performed, do not skip the forced parity correction. Even when restoring the backup data, be sure to perform a forced parity correction before performing the LU formatting, and then restore the backup data.

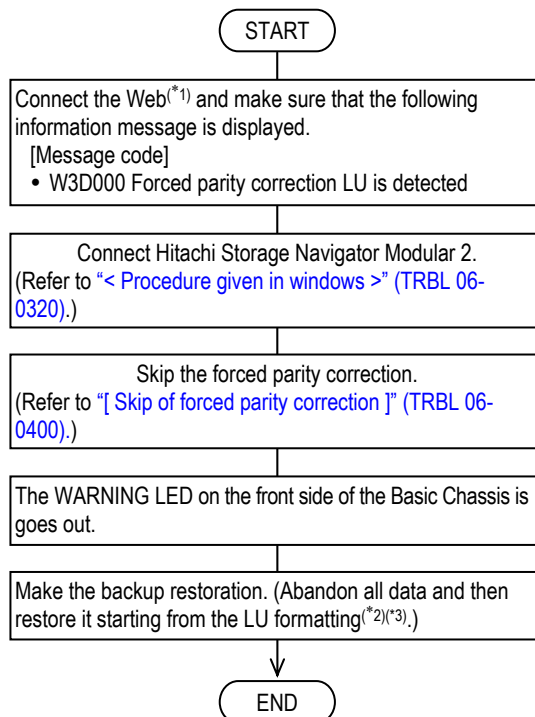

*1 : For the connection of the WEB, refer to "Chapter 3. Before Starting WEB Connection" (TRBL 03-0000).

*2 : There may be a case that the LU formatting fails. In this case, request a user to check if a sense code is reported in the log of a host computer. When the reported sense code is "05-9552" or "05-9577", the LU concerned is an object of ShadowImage in-system replication, TrueCopy remote replication, TrueCopy Extended Distance or Copy-on-write SnapShot. Therefore, request a user to release the pair and execute the LU formatting again after it is released. (Refer to System Parameter "3.3 [Procedure ③-F] Formatting LU" (SYSPR 03-0290).)

Also, the backup restoration cannot be done for the LU whose access attribute is set as other than Read/Write by Data Retention Utility because it cannot be formatted or written.

*3: Check with the user whether the LU to be restored from the backup data is using the Dynamic Provisioning function.

If it is used, restore the backup data according to the user's instruction.

[Recovery method-3] : Drive blockade occurred during the forced parity correction.

When a Disk Drive is detached during forced parity correction, the restoration is interrupted and a drive recovery action is taken.

When the Disk Drive including the LU that performs the forced parity correction instruction is blocked in the RAID Group, the status of the LU concerned changes to “Uncorrected and Drive Detached” or “Correction Aborted”.

The status is also changes for the LU that unifies the LU including the blocked Disk Drive in the RAID Group. The status is not changed for the LU other than this.

However, for the LU that the RAID group expansion is performed, if a drive blockade occurs during the forced parity correction the LU concerned becomes unformatted. If this status occurs, restore the drive, format the LU concerned, and then recover the user data from the backup.

[WEB Information Message display]

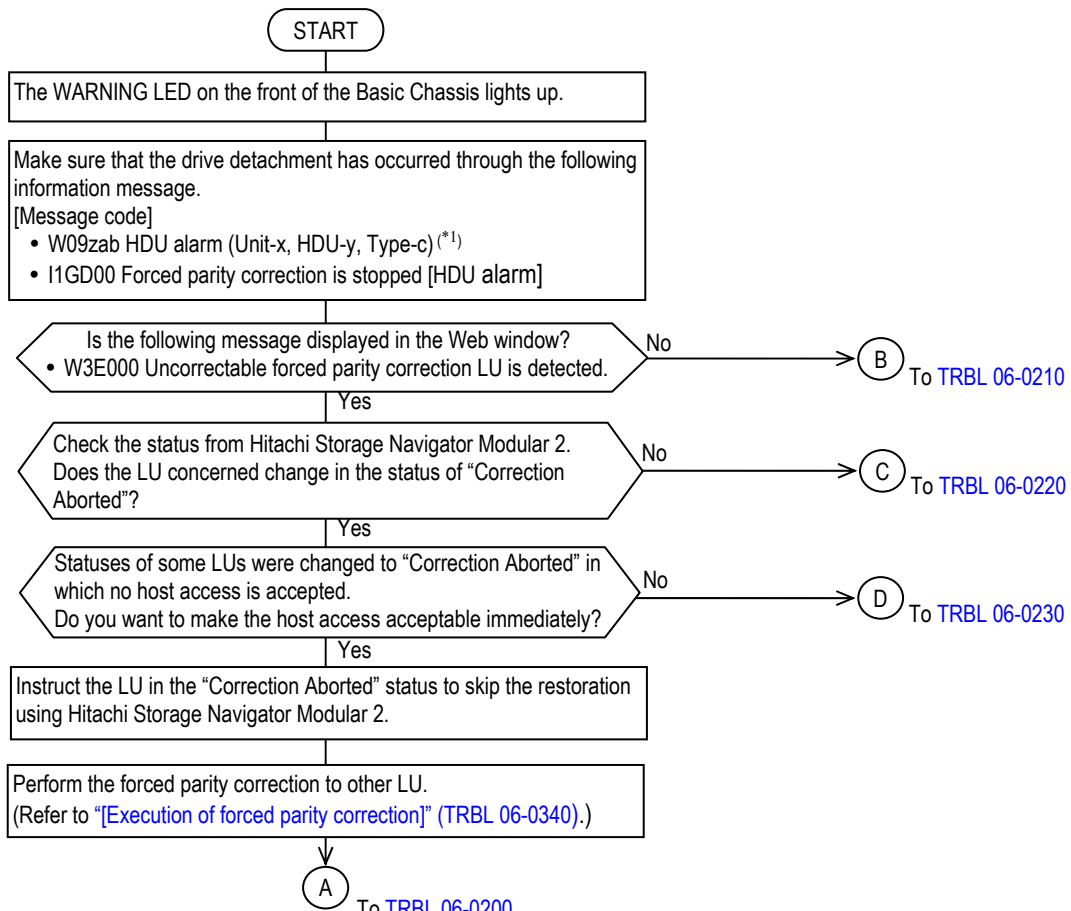
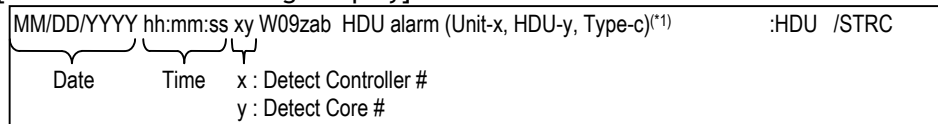

*1 : Any of W0Azab may be displayed other than W09zab. Also, when the Spare Disk Drive in use is blocked, any of W0Bzab and W0Czab is displayed.

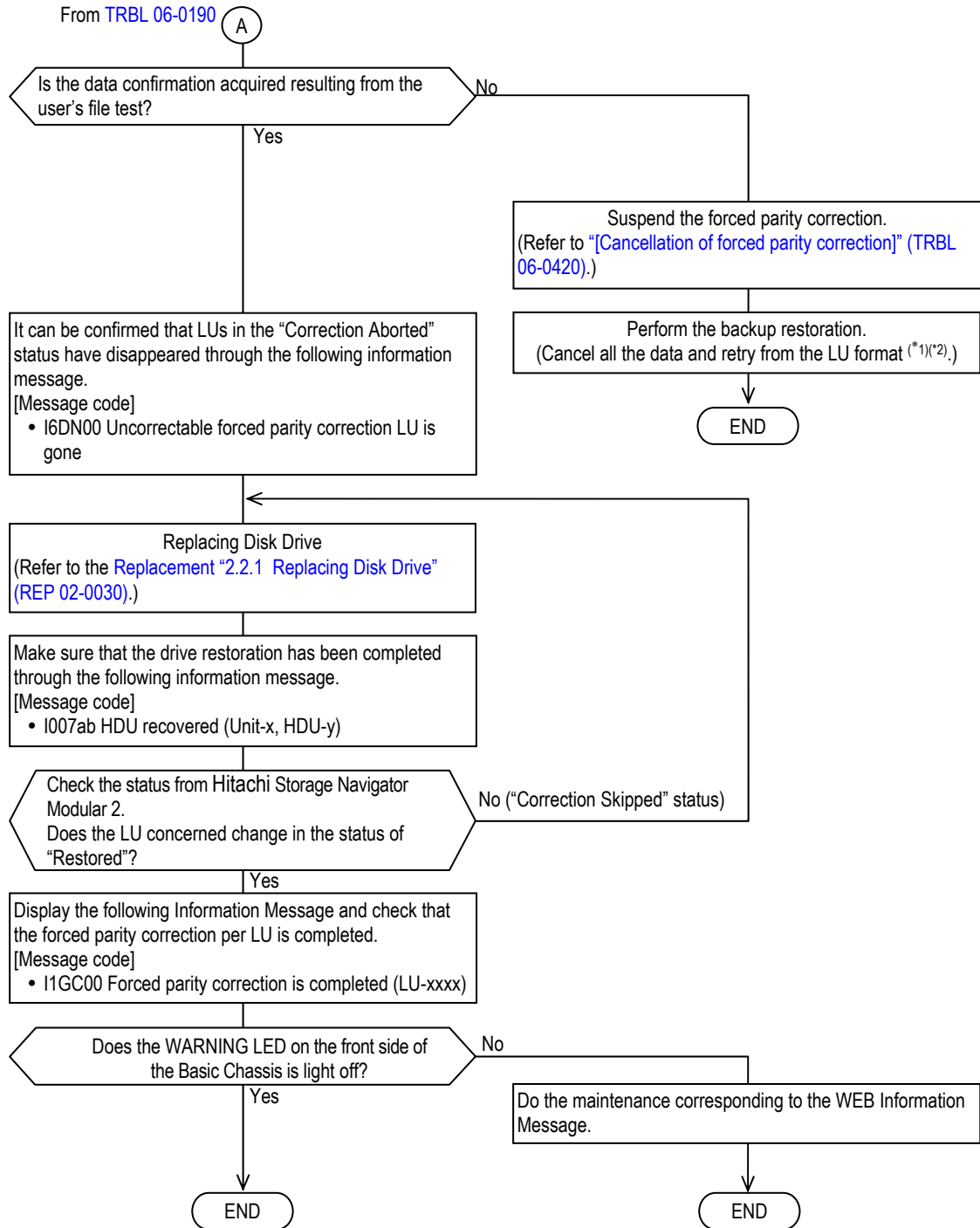

*1 : There may be a case that the LU formatting fails. In this case, request a user to check if a sense code is reported in the log of a host computer. When the reported sense code is "05-9552" or "05-9577", the LU concerned is an object of ShadowImage in-system replication, TrueCopy remote replication, TrueCopy Extended Distance or Copy-on-write SnapShot. Therefore, request a user to release the pair and execute the LU formatting again after it is released. (Refer to System Parameter "3.3 [Procedure ③-F] Formatting LU" (SYSPR 03-0290).)

Also, the backup restoration cannot be done for the LU whose access attribute is set as other than Read/Write by Data Retention Utility because it cannot be formatted or written.

*2: Check with the user whether the LU to be restored from the backup data is using the Dynamic Provisioning function.

If it is used, restore the backup data according to the user's instruction.

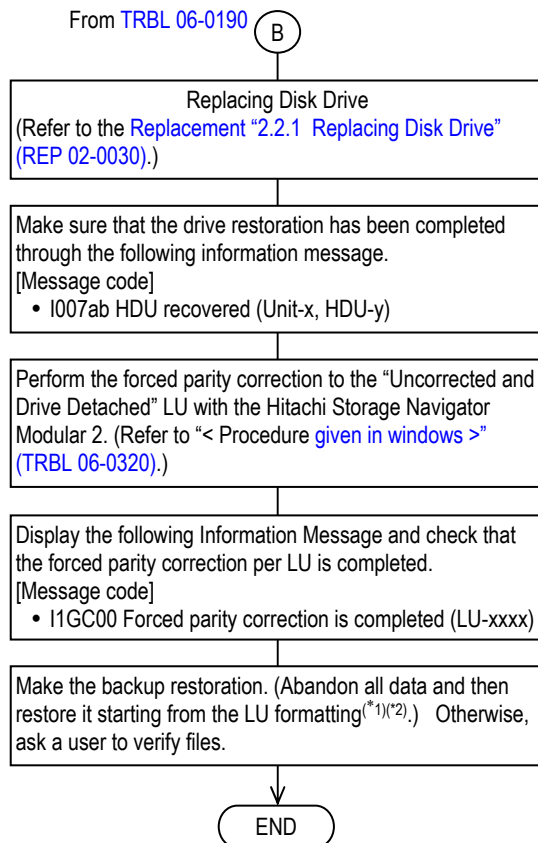

*1 : There may be a case that the LU formatting fails. In this case, request a user to check if a sense code is reported in the log of a host computer. When the reported sense code is "05-9552" or "05-9577", the LU concerned is an object of ShadowImage in-system replication, TrueCopy remote replication, TrueCopy Extended Distance or Copy-on-write SnapShot. Therefore, request a user to release the pair and execute the LU formatting again after it is released. (Refer to [System Parameter "3.3 \[Procedure ③-F\] Formatting LU"](#) (SYSPR 03-0290).)

Also, the backup restoration cannot be done for the LU whose access attribute is set as other than Read/Write by Data Retention Utility because it cannot be formatted or written.

*2: Check with the user whether the LU to be restored from the backup data is using the Dynamic Provisioning function.

If it is used, restore the backup data according to the user's instruction.

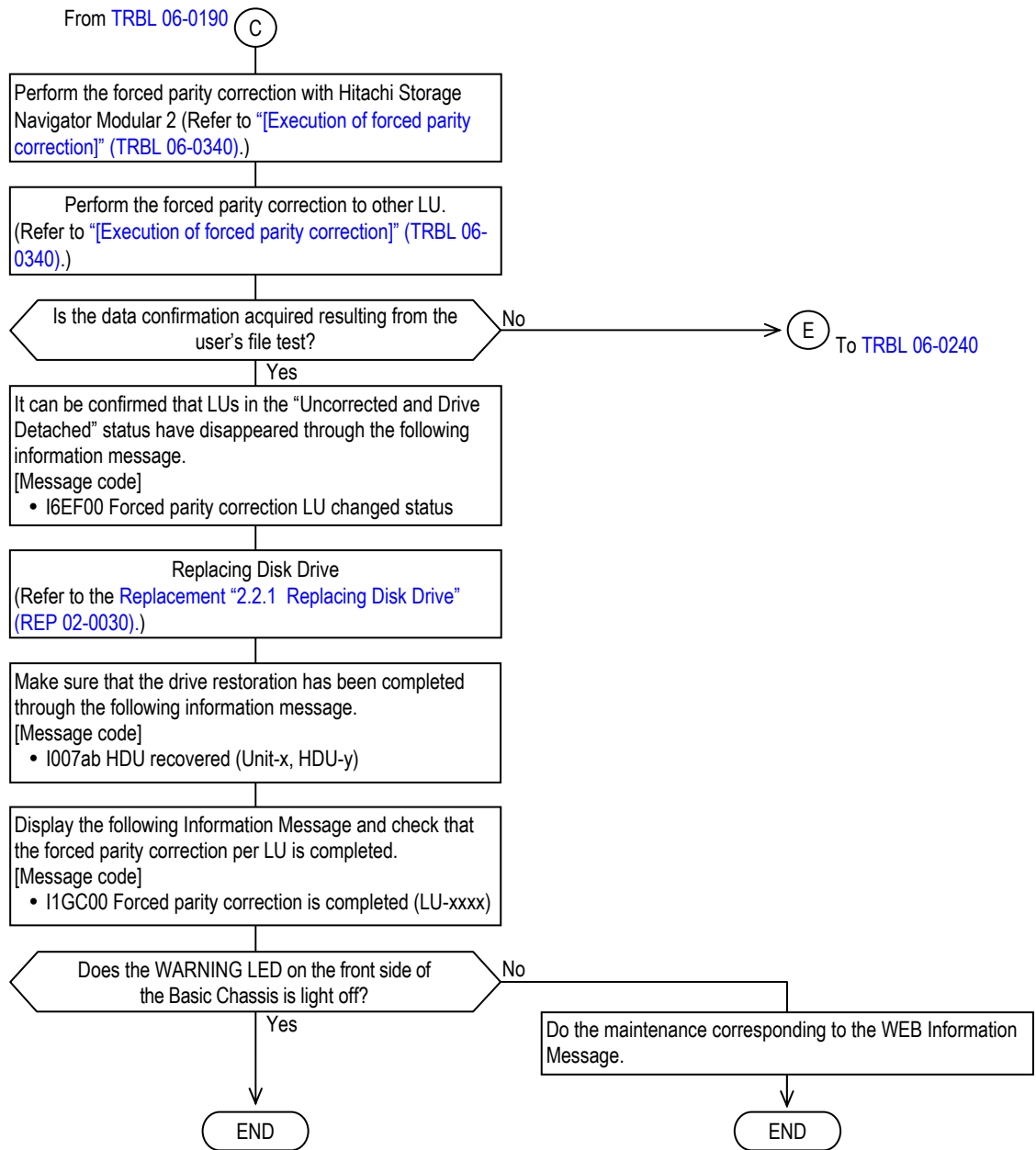

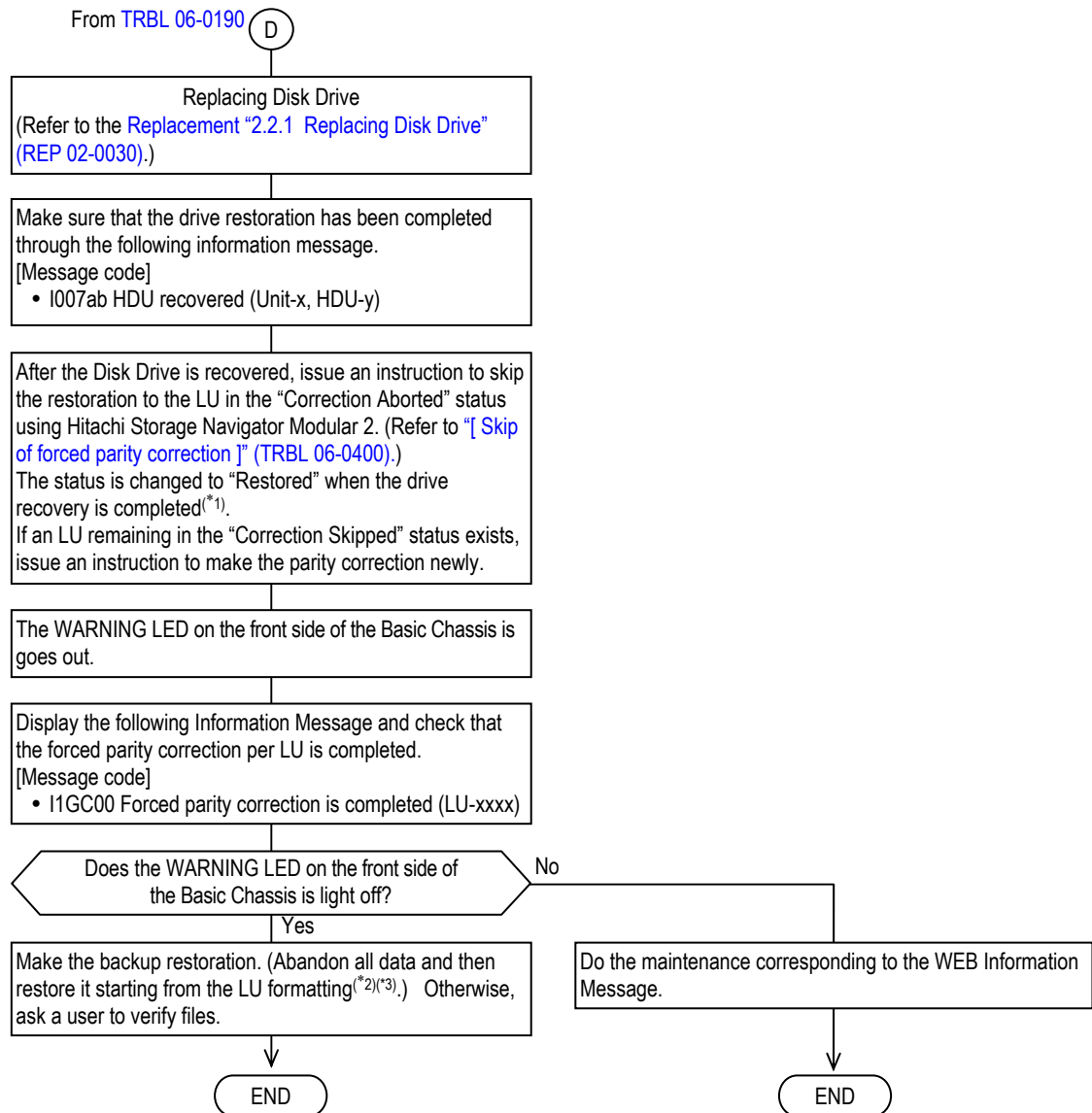

*1 : An LU that conforms to any of the following conditions does not enter the "Restored" status and remains in the "Correction Skipped" status.

If an LU remaining in the "Correction Skipped" status exists, issue an instruction to make the forced parity correction newly.

- An LU of RAID 1+0, RAID 6.
- A unified LU a part of which is included in a RAID group having a drive detachment
- An LU whose parity group is deeper than 1

*2 : There may be a case that the LU formatting fails. In this case, request a user to check if a sense code is reported in the log of a host computer. When the reported sense code is "05-9552" or "05-9577", the LU concerned is an object of ShadowImage in-system replication, TrueCopy remote replication, TrueCopy Extended Distance or Copy-on-write SnapShot. Therefore, request a user to release the pair and execute the LU formatting again after it is released. (Refer to System Parameter "3.3 [Procedure ③-F] Formatting LU" (SYSPR 03-0290).)

Also, the backup restoration cannot be done for the LU whose access attribute is set as other than Read/Write by Data Retention Utility because it cannot be formatted or written.

*3: Check with the user whether the LU to be restored from the backup data is using the Dynamic Provisioning function.

If it is used, restore the backup data according to the user's instruction.

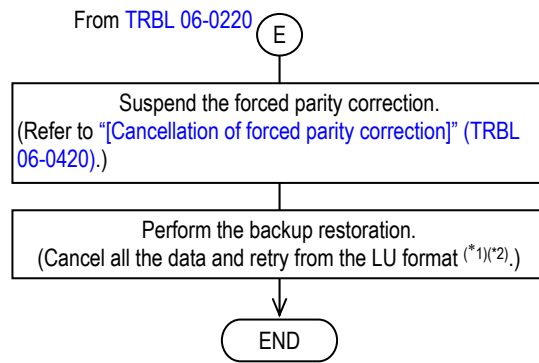

*1 : There may be a case that the LU formatting fails. In this case, request a user to check if a sense code is reported in the log of a host computer. When the reported sense code is "05-9552" or "05-9577", the LU concerned is an object of ShadowImage in-system replication, TrueCopy remote replication, TrueCopy Extended Distance or Copy-on-write SnapShot. Therefore, request a user to release the pair and execute the LU formatting again after it is released. (Refer to [System Parameter "3.3 \[Procedure ③-F\] Formatting LU" \(SYSPR 03-0290\)](#).)

Also, the backup restoration cannot be done for the LU whose access attribute is set as other than Read/Write by Data Retention Utility because it cannot be formatted or written.

*2: Check with the user whether the LU to be restored from the backup data is using the Dynamic Provisioning function.

If it is used, restore the backup data according to the user's instruction.

[Recovery method-4] : PIN over occurred during the forced parity correction.

When a pin over occurs, the status of the LU, the forced parity correction for which has been instructed to be made, is changed to “Uncorrected”.

[WEB Information Message display]

MM/DD/YYYY	hh:mm:ss	xy	I1GH00	Forced parity correction is stopped by too many PINs (RG-x, LU-y)
MM/DD/YYYY	hh:mm:ss	xy	I1GJ00	Forced parity correction is stopped by too many PINs(PTT-x, LU-y)
MM/DD/YYYY	hh:mm:ss	xy	I1GK00	Forced parity correction is stopped by too many PINs(DIR-x, LU-y)
MM/DD/YYYY	hh:mm:ss	xy	I6GQ00	Forced parity correction stopped by too many PINs (POOL-x, LU-y)
Date		Time	x : Detect Controller #	
			y : Detect Core #	

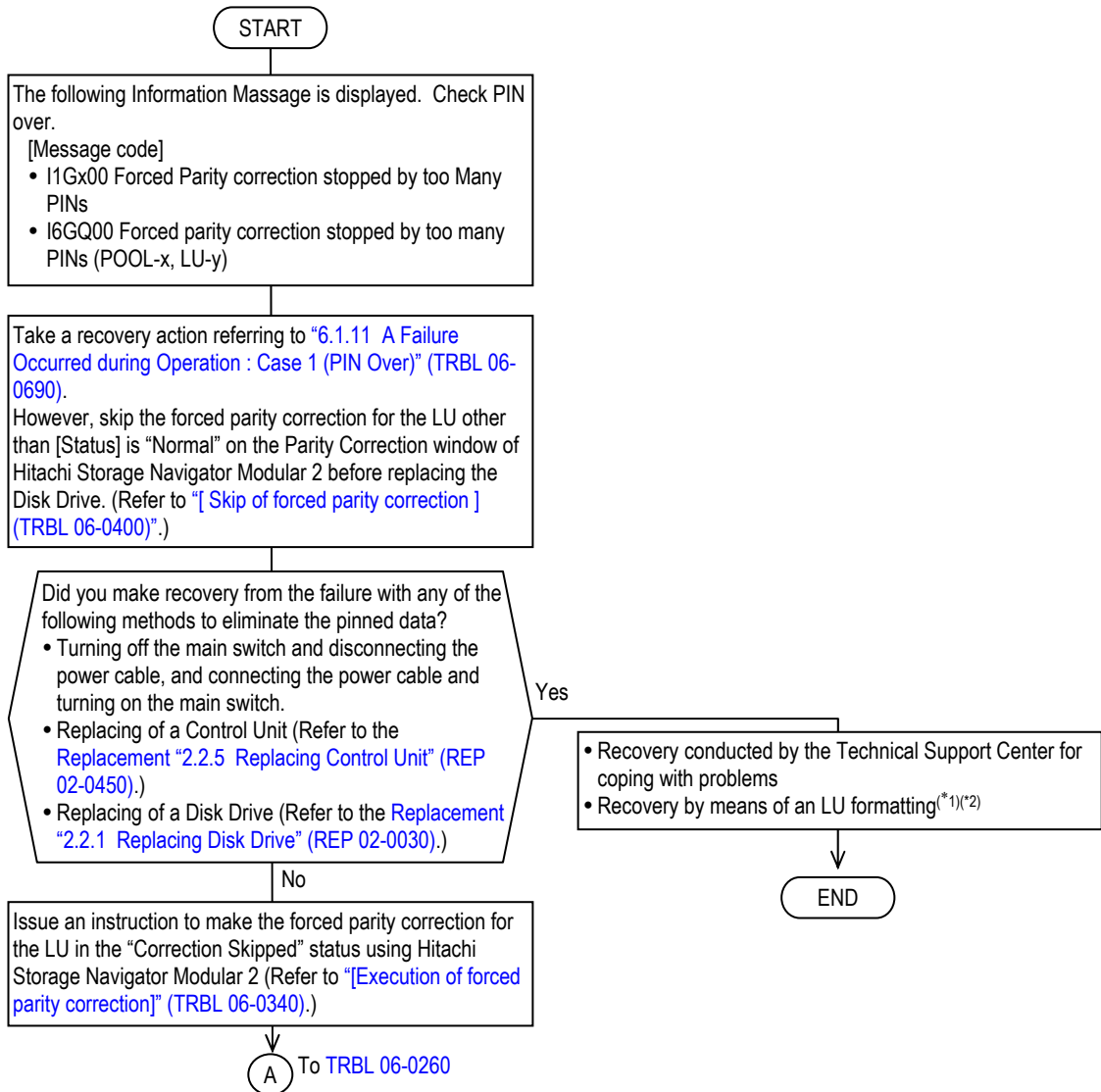

*1 : To perform recovery by the LU format, skip the LU which is in the “Uncorrected” status in the Hitachi Storage Navigator Modular 2 before the LU format.

*2: Check with the user whether the LU to be restored from the backup data is using the Dynamic Provisioning function.

If it is used, restore the backup data according to the user’s instruction.

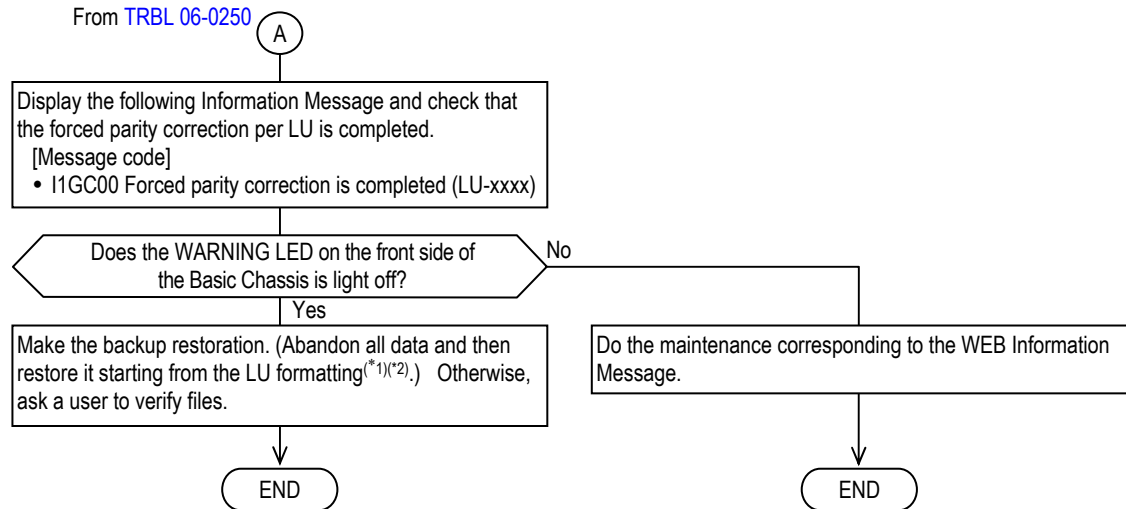

*1 : There may be a case that the LU formatting fails. In this case, request a user to check if a sense code is reported in the log of a host computer. When the reported sense code is "05-9552" or "05-9577", the LU concerned is an object of ShadowImage in-system replication, TrueCopy remote replication, TrueCopy Extended Distance or Copy-on-write SnapShot. Therefore, request a user to release the pair and execute the LU formatting again after it is released. (Refer to [System Parameter "3.3 \[Procedure ©-F\] Formatting LU" \(SYSPR 03-0290\).](#))

Also, the backup restoration cannot be done for the LU whose access attribute is set as other than Read/Write by Data Retention Utility because it cannot be formatted or written.

*2: Check with the user whether the LU to be restored from the backup data is using the Dynamic Provisioning function.

If it is used, restore the backup data according to the user's instruction.

[Recovery method-5] : Incomplete write occurred during the forced parity correction.

In the part where the data cannot be restored such as the data on Disk Drive cannot be read out during the forced parity correction, an incomplete writing occurs.

When many incomplete writings occur, the status of the LU, the forced parity correction for which has been instructed to be made, is changed to “Correction Aborted”, and then the forced parity correction will be stopped.

[WEB Information Message display]

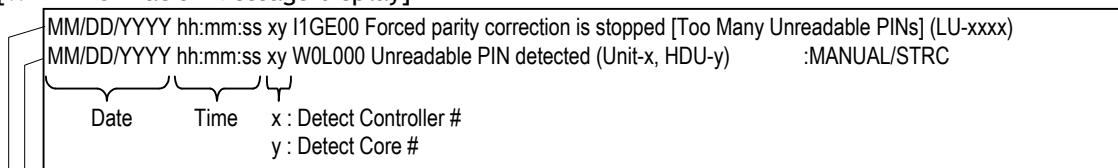

An incomplete writing occurs.
 Forced parity correction is stopped because many incomplete writings occur.

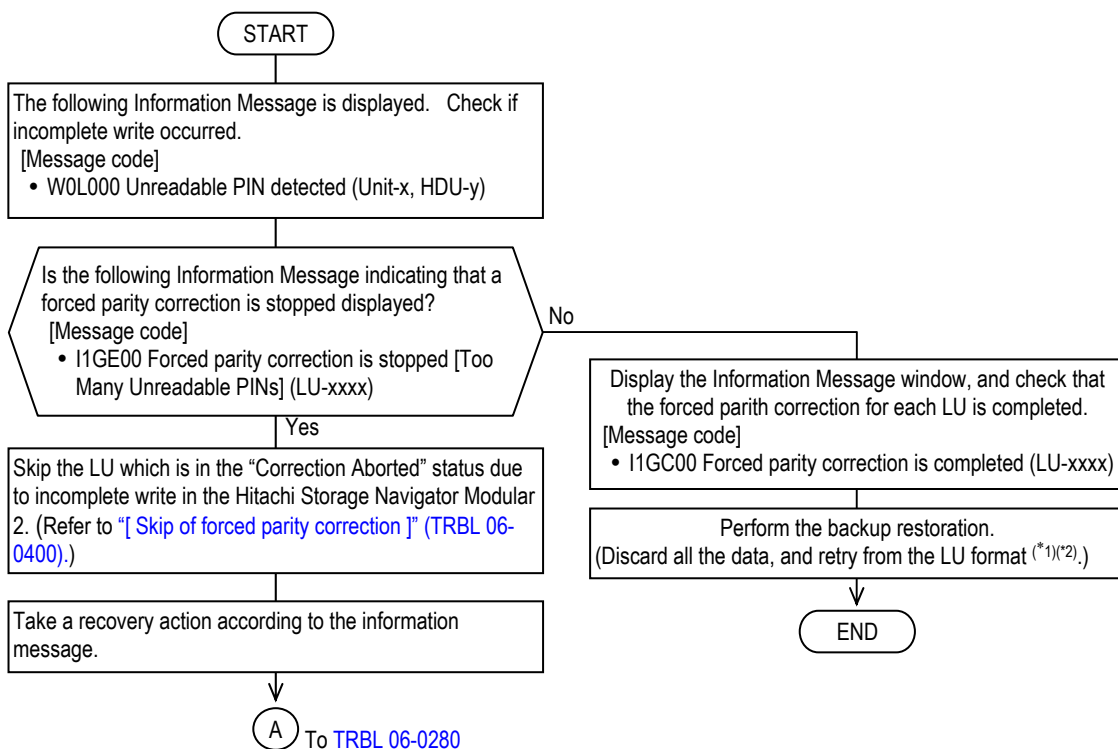

*1 : There may be a case that the LU formatting fails. In this case, request a user to check if a sense code is reported in the log of a host computer. When the reported sense code is “05-9552” or “05-9577”, the LU concerned is an object of ShadowImage in-system replication, TrueCopy remote replication, TrueCopy Extended Distance or Copy-on-write SnapShot. Therefore, request a user to release the pair and execute the LU formatting again after it is released. (Refer to [System Parameter “3.3 \[Procedure ©-F\] Formatting LU” \(SYSPR 03-0290\)](#).)

Also, the backup restoration cannot be done for the LU whose access attribute is set as other than Read/Write by Data Retention Utility because it cannot be formatted or written.

*2: Check with the user whether the LU to be restored from the backup data is using the Dynamic Provisioning function.

If it is used, restore the backup data according to the user’s instruction.

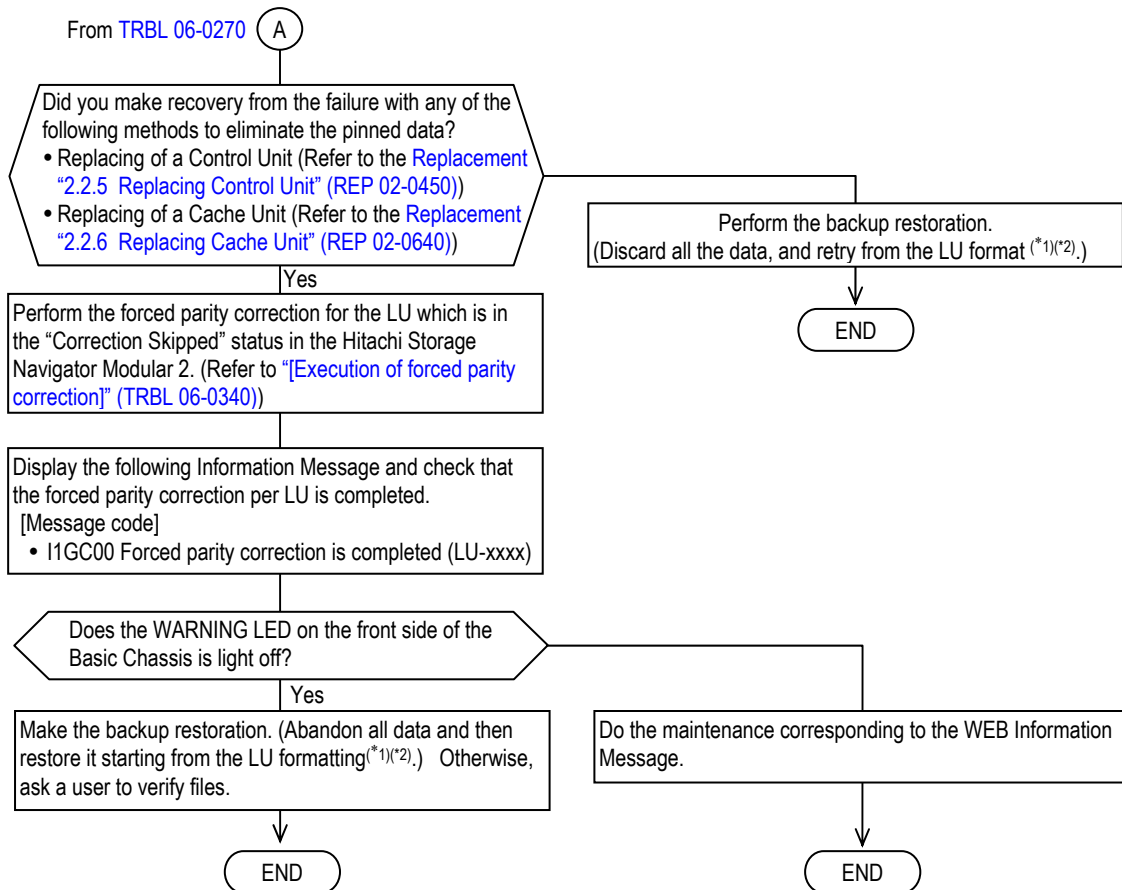

*1 : There may be a case that the LU formatting fails. In this case, request a user to check if a sense code is reported in the log of a host computer. When the reported sense code is "05-9552" or "05-9577", the LU concerned is an object of ShadowImage in-system replication, TrueCopy remote replication, TrueCopy Extended Distance or Copy-on-write SnapShot. Therefore, request a user to release the pair and execute the LU formatting again after it is released. (Refer to System Parameter "3.3 [Procedure ©-F] Formatting LU" (SYSPR 03-0290).)

Also, the backup restoration cannot be done for the LU whose access attribute is set as other than Read/Write by Data Retention Utility because it cannot be formatted or written.

*2: Check with the user whether the LU to be restored from the backup data is using the Dynamic Provisioning function.

If it is used, restore the backup data according to the user's instruction.

[Recovery method-6] : The drive blockade has occurred before the forced parity collection.
 If the Disk Drive has been blocked before the forced parity collection, the drive restoration is already operated.
 The LU status in which the drive restoration has already operated is changed to “Correction Aborted”. The other LU status is changed to “Uncorrected”.

[WEB Information Message display]

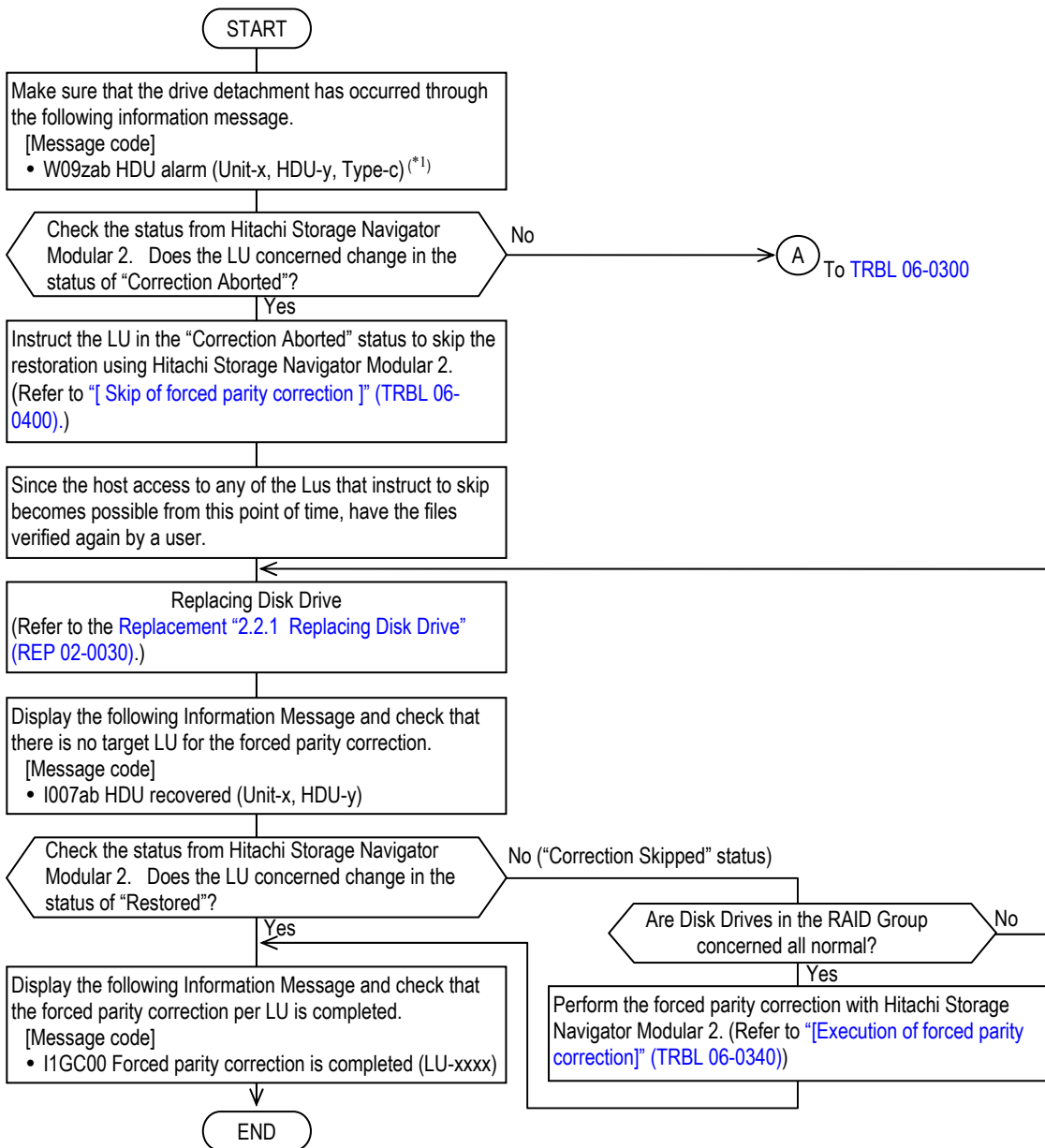
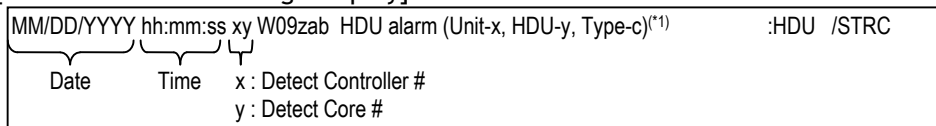

*1 : Any of W0Azab may be displayed other than W09zab. Also, when the Spare Disk Drive in use is blocked, any of W0Bzab and W0Czab is displayed.

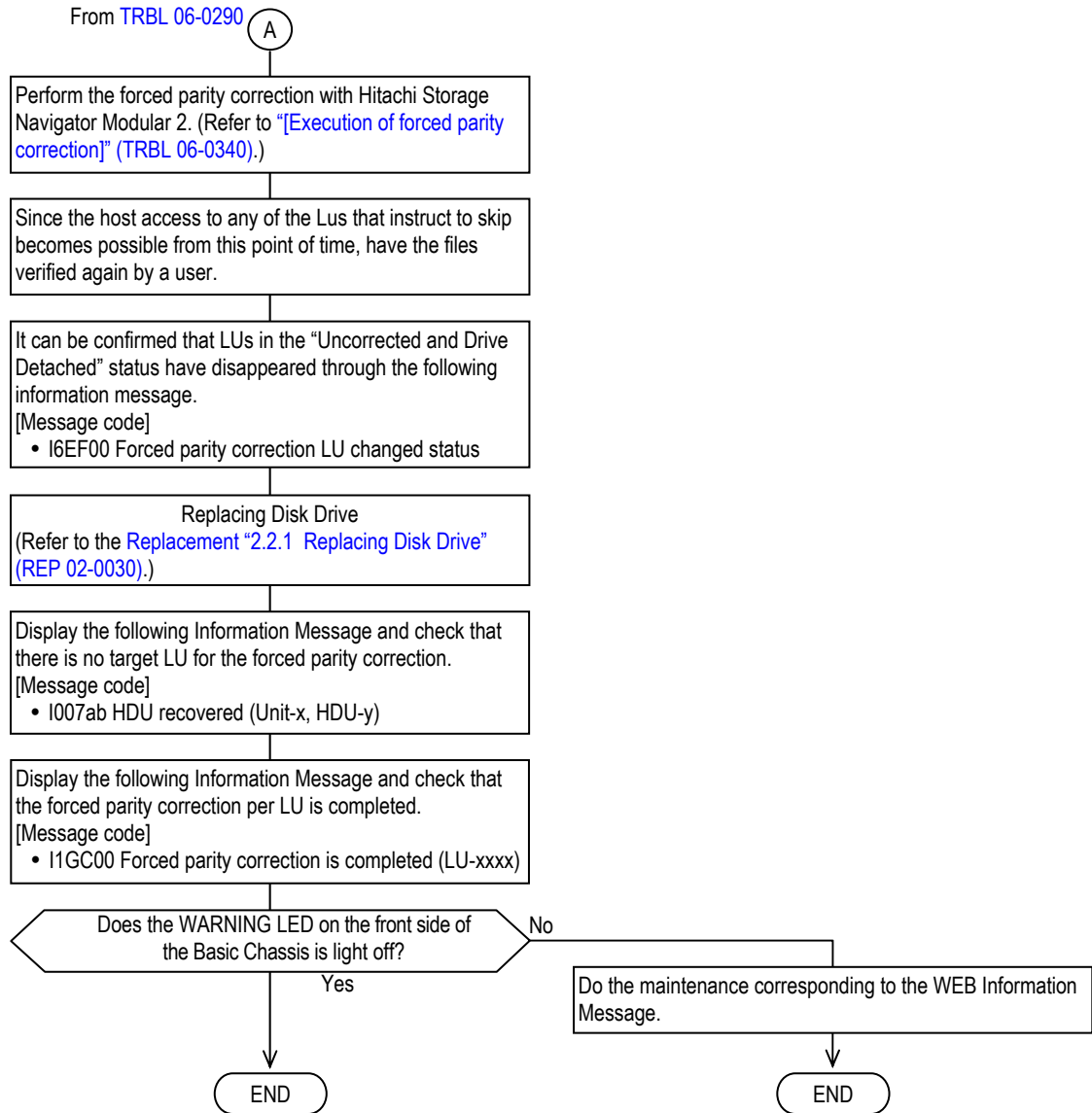

[Recovery method-7] : PIN over has occurred before the forced parity collection.
 If PIN over occurred, change the LU in which PIN over occurred to
 “Uncorrected” status.

[WEB Information Message display]

```
MM/DD/YYYY hh:mm:ss xy W3G000 PIN is over directory threshold[write through](DIR-x)
MM/DD/YYYY hh:mm:ss xy W3H000 PIN is over directory threshold[write will not run](DIR-x)
MM/DD/YYYY hh:mm:ss xy W3J000 PIN is over partition threshold[write through](DIR-x,PTT-xx)
MM/DD/YYYY hh:mm:ss xy W3K000 PIN is over partition threshold[write will not run](DIR-x,PTT-xx)
MM/DD/YYYY hh:mm:ss xy W3L000 PIN is over RAID group threshold[write through](DIR-x,RG-xx)
MM/DD/YYYY hh:mm:ss xy W3M000 PIN is over RAID group threshold[write will not run](DIR-x,RG-xx)
```

} Date } Time } x : Detect Controller #
} y : Detect Core #

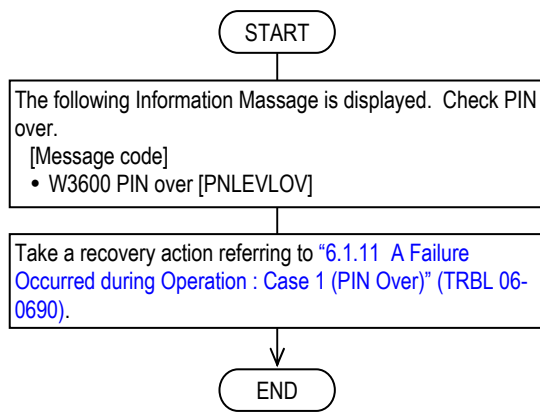

< Procedure given in windows >

- (a) Connect the Web. (Refer to “Chapter 3. Before Starting WEB Connection” (TRBL 03-0000).)
- (b) Check that there is LU for which the forced parity correction is necessary by the “W3D000” message in the WEB window.

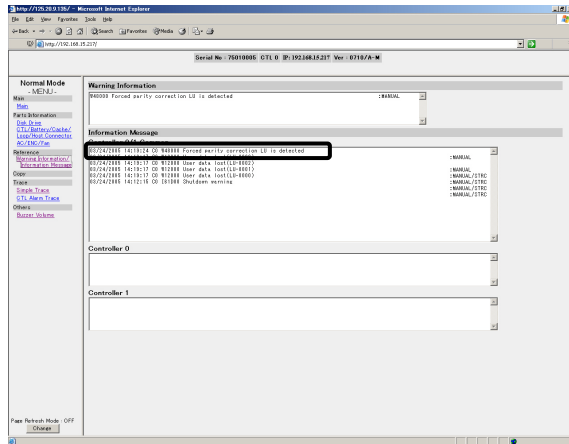

- (c) Connect Hitachi Storage Navigator Modular 2.
 - (i) Start the Hitachi Storage Navigator Modular 2, put a checkmark to the array subsystem to set, press the [Ctrl] key, [Shift] key and [E] key at the same time, and change the operation mode to “Maintenance Mode”. Check that “Maintenance Mode” is displayed in [Operation Mode] on the top of the main window.

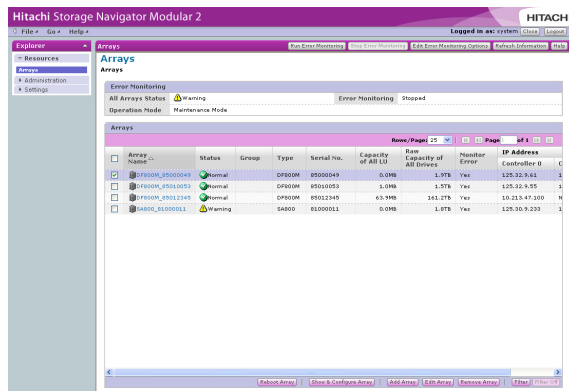

(ii) Click the name of the array subsystem to be set from the unit window.

NOTE : There is a case that the LAN Port Number is changed. When the main screen is not displayed even though the icon of the array subsystem is clicked, use the changed LAN Port Number, and execute it again. (Refer to [System Parameter "1.2 LAN Port Number Change by Hitachi Storage Navigator Modular 2" \(SYSPR 01-0120\).](#))

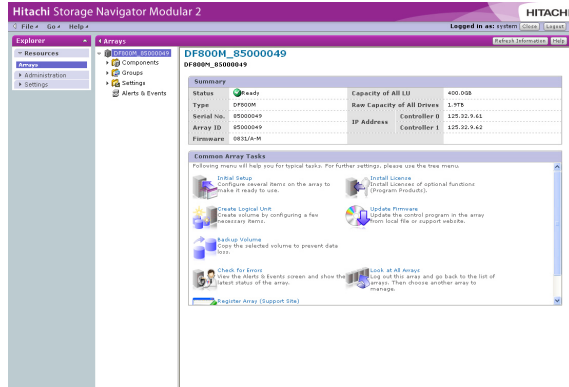

[Execution of forced parity correction]

- When the Hitachi Storage Navigator Modular 2 is version 08B0/A or more

(a) Select [Settings] - [Parity Correction] from the tree.

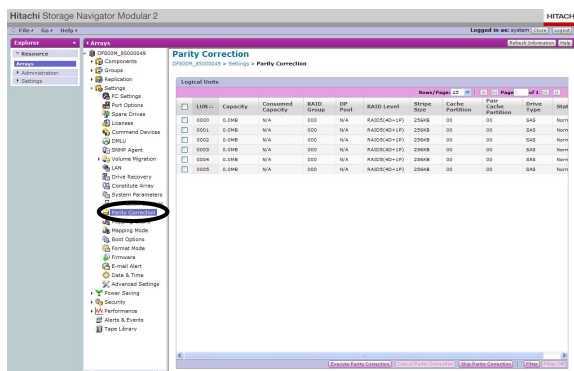

(b) Click the [Execute Parity Correction] button.

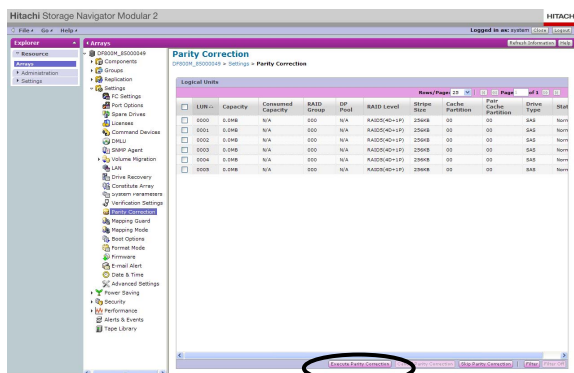

No.	Status Symbol of Hitachi Storage Navigator Modular 2	Meaning	Status seen from a host	Recovery method
1	Uncorrected	A status in which the subsystem is waiting for an instruction to make or skip the forced parity correction issued by Hitachi Storage Navigator Modular 2.	A status in which a host cannot instruct the LU to read or write.	Perform the forced parity correction or skip in the Hitachi Storage Navigator Modular 2 according to < Procedure given in windows > (TRBL 06-0320).
2	Parity Correcting (n%)	A status in which Hitachi Storage Navigator Modular 2 has issued an instruction to make the forced parity correction and restoration is "Parity Correction".	A status in which a host can instruct the LU to read or write. However, it is impossible for the LU that the RAID Group is under expansion.	—
3	Waiting Parity Correction(o) (n%)	A status in which Hitachi Storage Navigator Modular 2 has issued an instruction to make the forced parity correction and is waiting for making of the restoration.	A status in which a host can instruct the LU to read or write. However, it is impossible for the LU that the RAID Group is under expansion.	—

No.	Status Symbol of Hitachi Storage Navigator Modular 2	Meaning	Status seen from a host	Recovery method
4	Waiting Drive Reconstruction	Waiting Drive Reconstruction: The forced parity correction is instructed from Hitachi Storage Navigator Modular 2, and waiting for the replacement of the Disk Drive.	Reading and writing data from the host are enabled. However, it is impossible for the LU that the RAID Group is under expansion.	① Connect WEB (Refer to “Chapter 3. Before Starting WEB Connection” (TRBL 03-0000).) ② Replace the blocked Disk Drive referring to the Information Message on WEB (refer to Replacement “2.2.1 Replacing Disk Drive” (REP 02-0030).).
5	Correction Skipped	A status in which Hitachi Storage Navigator Modular 2 has issued an instruction to “Correction Skipped” the forced parity correction.	A status in which a host can instruct the LU to read or write.	Make an LU formatting (refer to System Parameter “3.3 [Procedure ③-F] Formatting LU (SYSPR 03-0290”).) and backup restoration. However, check with the user whether the LU to be restored from the backup data is using the Dynamic Provisioning function, and if it is used, restore the backup data according to the user’s instruction.
6	—	Restored : A status in which Hitachi Storage Navigator Modular 2 issued an instruction to make the forced parity correction and the restoration has been completed.	A status in which a host can instruct the LU to read or write.	—
7	Uncorrected and Drive Detached	The forced parity recovery is aborted due to the Disk Drive blockade although the forced parity recovery was instructed from Hitachi Storage Navigator Modular 2. However, the forced parity recovery is required.	Reading and writing data from the host are disabled.	① Connect the WEB (Refer to “Chapter 3. Before Starting WEB Connection” (TRBL 03-0000).) ② Replace the blocked Disk Drive referring to the Information Message on the WEB (Refer to Replacement “2.2.1 Replacing Disk Drive” (REP 02-0030).) ③ Skip the forced parity correction according to < Procedure given in windows > (TRBL 06-0320) (Refer to “[Skip of forced parity correction]” (TRBL 06-0400).).
8	Correction Aborted	A status in which the forced parity correction is interrupted because of a drive detachment although Hitachi Storage Navigator Modular 2 has issued an instruction to make the restoration.	A status in which a host cannot instruct the LU to read or write.	① Connect the WEB (Refer to “Chapter 3. Before Starting WEB Connection” (TRBL 03-0000).) ② Replace the blocked Disk Drive referring to the Information Message on the WEB (Refer to Replacement “2.2.1 Replacing Disk Drive” (REP 02-0030).) ③ Skip the forced parity correction according to < Procedure given in windows > (TRBL 06-0320) (Refer to “[Skip of forced parity correction]” (TRBL 06-0400).) ④ Execute the forced parity correction according to < Procedure given in windows > (TRBL 06-0320).

- (c) Status checking and execution of the logical unit for the forced parity correction
 - When “Uncorrected” exists in the logical unit status
 - (i) An “Execute Parity Correction” window is displayed.
Check the logical units whose status is “Uncorrected” are registered in the right list (the registered logical units).

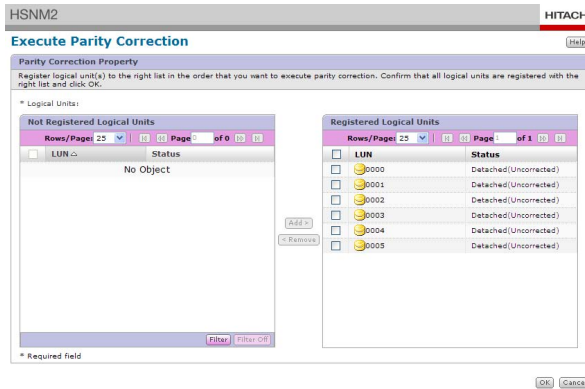

- (ii) List the logical units in order of executing the forced parity correction.
Select the logical units from the right list (registered logical unit), and click the [Remove] button to move them to the left list (unregistered logical unit). Select the logical unit in the left list in order of executing the forced parity correction, and then click the [Add] button to move it to the right list.

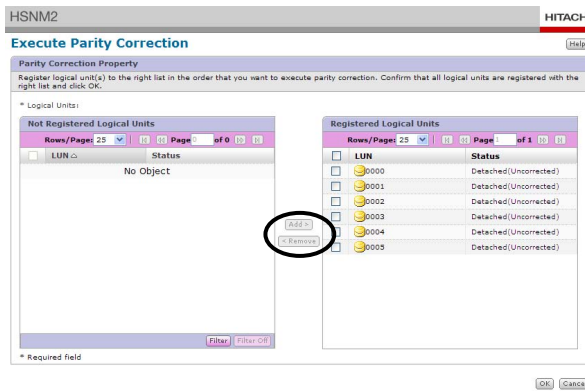

(iii) Verify that the logical units in the right list are listed in order of executing the forced parity correction, and click the [OK] button.

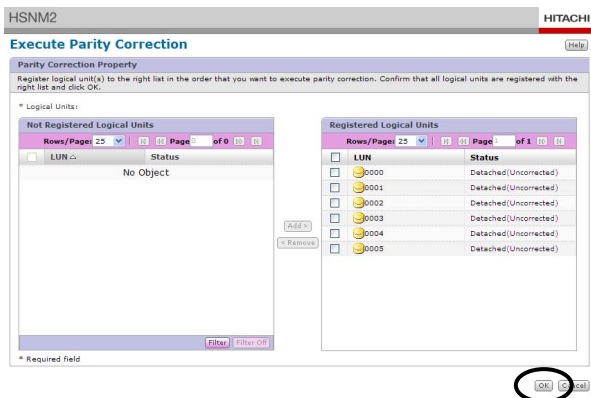

(iv) Click the [Close] button.

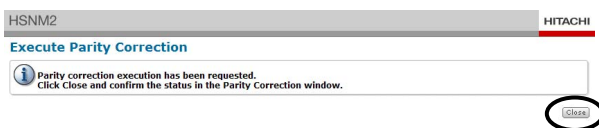

- When the status of the logical unit is other than “Uncorrected”
 - (i) Because the dialog, indicating that the logical unit for the forced parity correction target does not exist, is displayed, click the [Close] button.



(ii) Select the logical units which needs to execute the forced parity correction referring to the status of the logical unit, and click the [Execute Parity Correction] button.

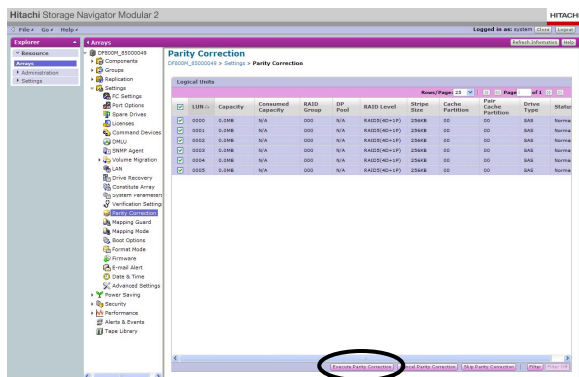

- (iii) List the logical units in order of executing the forced parity correction.
 Select the logical units from the right list, and click the [Remove] button to move them to the left list (unregistered logical unit). Select the logical unit in the left list in order of executing the forced parity correction, and then click the [Add] button to move it to the right list.

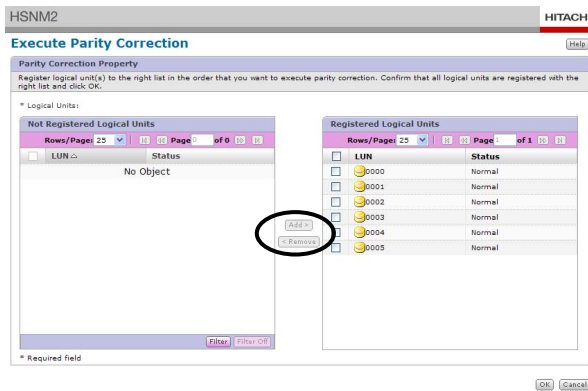

- (iv) Verify that the logical units in the right list are listed in order of executing the forced parity correction, and click the [OK] button.

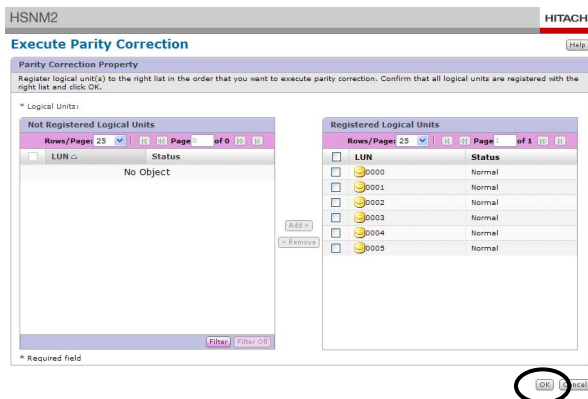

- (v) Click the [Close] button.

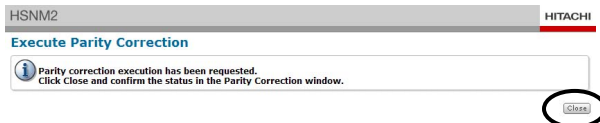

(d) Refer to a message in the Web window.

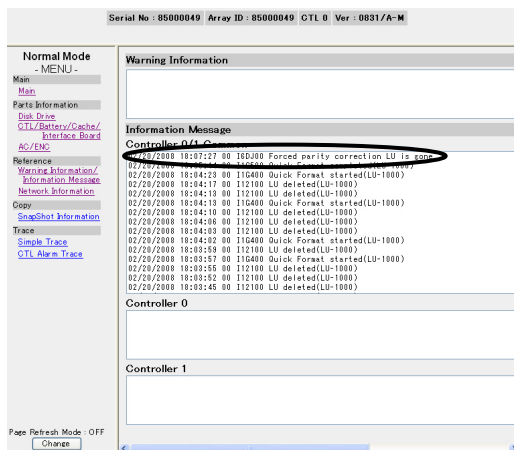

(e) Displaying a progress rate of the forced parity correction

For the LU, the forced parity correction for which has been instructed to be made, rate of progress of the restoration is displayed in the “Status” column of the LU concerned.

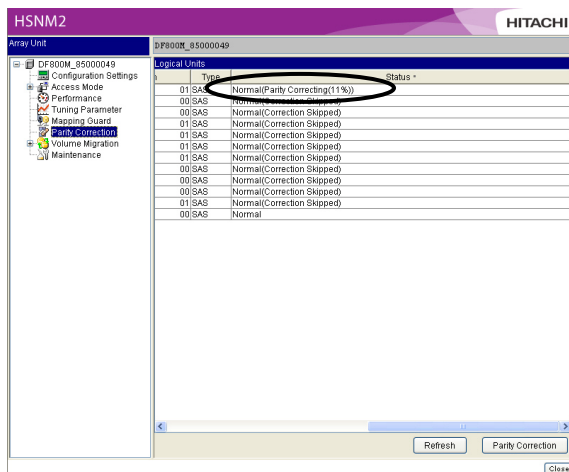

LU statuses concerning a forced parity correction and display of statuses by Hitachi Storage Navigator Modular 2.

No.	Status	Remarks
1	Parity Correction (n%)	n: Progress rate
2	Waiting Parity Correction(o) (n%)	o: Waiting order n: Rate of progress
3	Waiting Drive Reconstruction	—
4	Uncorrected	—
5	Uncorrected and Drive Detached	—
6	Correction Aborted	—
7	Restored	—
8	Correction Skipped	—

- (f) Make sure that the forced parity correction has been completed in the Web window.

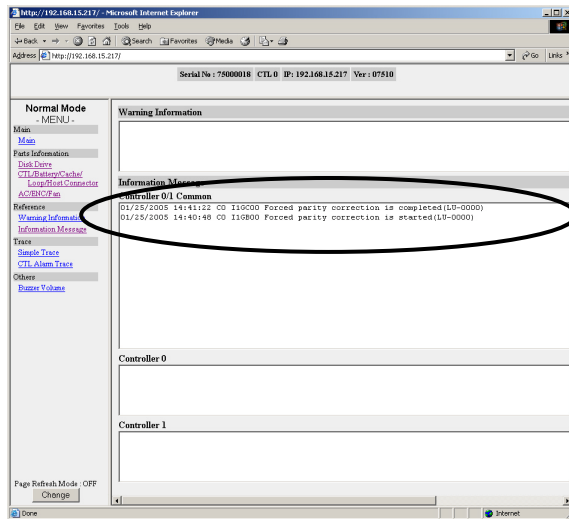

When making the forced parity correction for an LU in the “Correction Skipped” or “Restored” status, refer to “[[Instruction to make a forced parity correction for an LU in the “Correction Skipped” or “Restored” status](#)]” (TRBL 06-0450).

- (g) Make sure that the WARNING LED on the front side of the Basic Chassis has gone out.
- (h) Make the backup restoration. (Abandon all data and then restore it starting from the LU formatting.) Otherwise, ask a user to verify files.
- However, check with the user whether the LU to be restored from the backup data is using the Dynamic Provisioning function, and if it is used, restore the backup data according to the user’s instruction.

- When the Hitachi Storage Navigator Modular 2 is less than version 08B0/A
 - (a) Select [Settings] - [Advanced Settings] from the tree, and click the [Open Advanced Settings] button.

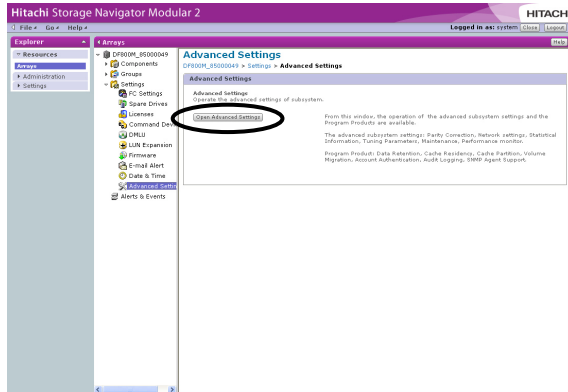

- (b) Click [Parity Correction].

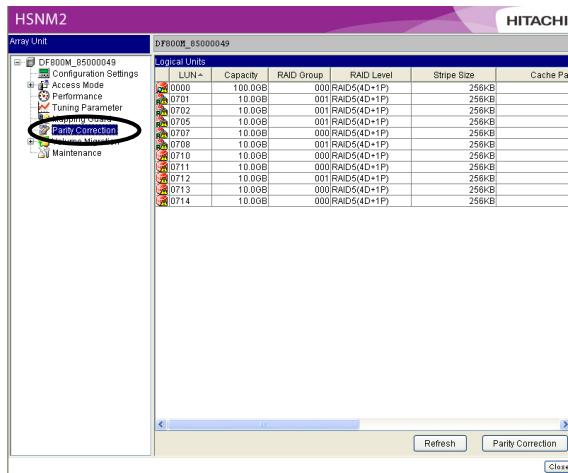

- (c) Select the [Parity Correction] button in the lower right. The parity correction instruction window is displayed.

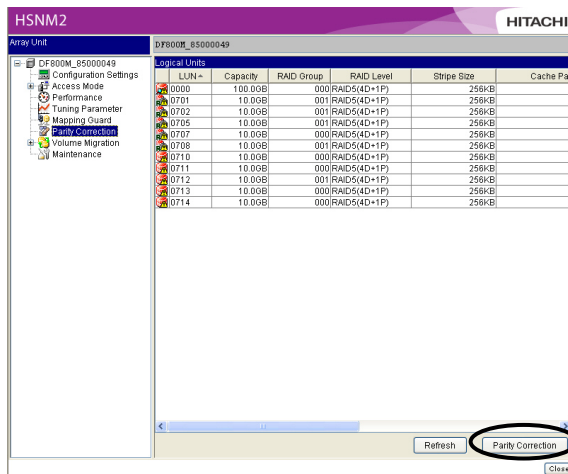

No.	Status Symbol of Hitachi Storage Navigator Modular 2	Meaning	Status seen from a host	Recovery method
1	Uncorrected	A status in which the subsystem is waiting for an instruction to make or skip the forced parity correction issued by Hitachi Storage Navigator Modular 2.	A status in which a host cannot instruct the LU to read or write.	Perform the forced parity correction or skip in the Hitachi Storage Navigator Modular 2 according to < Procedure given in windows > (TRBL 06-0320).
2	Parity Correcting (n%)	A status in which Hitachi Storage Navigator Modular 2 has issued an instruction to make the forced parity correction and the restoration is "Parity Correction".	A status in which a host can instruct the LU to read or write. However, it is impossible for the LU that the RAID Group is under expansion.	—
3	Waiting Parity Correction(o) (n%)	A status in which Hitachi Storage Navigator Modular 2 has issued an instruction to make the forced parity correction and is waiting for making of the restoration.	A status in which a host can instruct the LU to read or write. However, it is impossible for the LU that the RAID Group is under expansion.	—
4	Waiting Drive Reconstruction	Waiting Drive Reconstruction: The forced parity correction is instructed from Hitachi Storage Navigator Modular 2, and waiting for the replacement of the Disk Drive.	Reading and writing data from the host are enabled. However, it is impossible for the LU that the RAID Group is under expansion.	① Connect WEB (Refer to " Chapter 3. Before Starting WEB Connection " (TRBL 03-0000).) ② Replace the blocked Disk Drive referring to the Information Message on WEB (refer to Replacement "2.2.1 Replacing Disk Drive" (REP 02-0030).).
5	Correction Skipped	A status in which Hitachi Storage Navigator Modular 2 has issued an instruction to "Correction Skipped" the forced parity correction.	A status in which a host can instruct the LU to read or write.	Make an LU formatting (refer to System Parameter "3.3 [Procedure ③-F] Formatting LU (SYSPR 03-0290).") and backup restoration. However, check with the user whether the LU to be restored from the backup data is using the Dynamic Provisioning function, and if it is used, restore the backup data according to the user's instruction.
6	—	Restored : A status in which Hitachi Storage Navigator Modular 2 issued an instruction to make the forced parity correction and the restoration has been completed.	A status in which a host can instruct the LU to read or write.	—

No.	Status Symbol of Hitachi Storage Navigator Modular 2	Meaning	Status seen from a host	Recovery method
7	Uncorrected and Drive Detached	The forced parity recovery is aborted due to the Disk Drive blockade although the forced parity recovery was instructed from Hitachi Storage Navigator Modular 2. However, the forced parity recovery is required.	Reading and writing data from the host are disabled.	<ol style="list-style-type: none"> ① Connect the WEB (Refer to “Chapter 3. Before Starting WEB Connection” (TRBL 03-0000)). ② Replace the blocked Disk Drive referring to the Information Message on the WEB (Refer to Replacement “2.2.1 Replacing Disk Drive” (REP 02-0030)). ③ Skip the forced parity correction according to < Procedure given in windows > (TRBL 06-0320) (Refer to “[Skip of the forced parity correction]” (TRBL 06-0400)).
8	Correction Aborted	A status in which the forced parity correction is interrupted because of a drive detachment although Hitachi Storage Navigator Modular 2 has issued an instruction to make the restoration.	A status in which a host cannot instruct the LU to read or write.	<ol style="list-style-type: none"> ① Connect the WEB (Refer to “Chapter 3. Before Starting WEB Connection” (TRBL 03-0000)). ② Replace the blocked Disk Drive referring to the Information Message on the WEB (Refer to Replacement “2.2.1 Replacing Disk Drive” (REP 02-0030)). ③ Skip the forced parity correction according to < Procedure given in windows > (TRBL 06-0320) (Refer to “[Skip of forced parity correction]” (TRBL 06-0400)). ④ Execute the forced parity correction according to < Procedure given in windows > (TRBL 06-0320).

(d) Status checking of the logical unit for the forced parity correction.

- When the status of the logical unit is “Uncorrected”
 - (i) Because the dialog, indicating that the LU which needs the forced parity correction exists, is displayed, click the [OK] button. The parity correction process is interrupted by clicking the [Cancel] button.

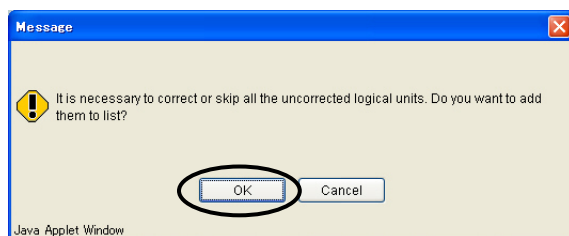

- When the status of the logical unit is other than “Uncorrected”
 - (i) Because the dialog, indicating that the logical unit for the forced parity correction target does not exist, is displayed, click the [OK] button.

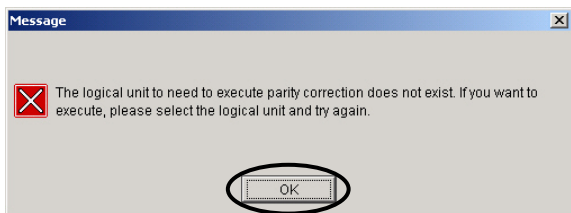

- (ii) Check the LU which needs to execute the forced parity correction referring to the status of the logical unit.

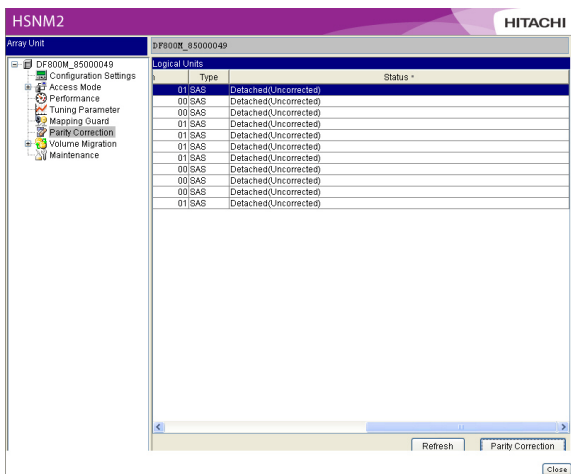

- (iii) If LUs executed by forced parity correction exist, specify the target logical unit and click the [Parity Correction] button.

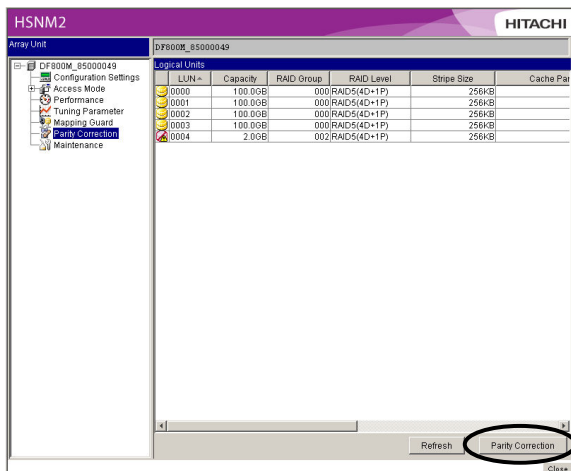

(e) Execution of the forced parity correction

When skipping the forced parity correction, refer to “[Execution of forced parity correction]” (TRBL 06-0340).

When aborting the forced parity correction while it is in progress, refer to “[Cancellation of forced parity correction]” (TRBL 06-0420).

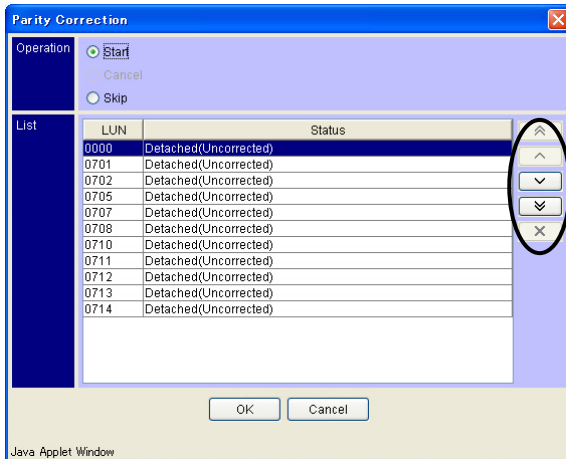
(i) Sort the LUs in order of making forced parity correction. ^{(#1)(#2)}

(ii) When the sort is completed, select the [Start] radio button and click the [OK] button.

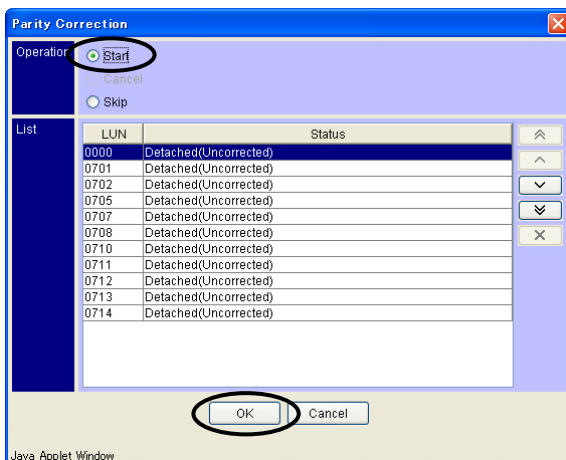

#1 : The forced parity correction operates LU one by one in order for each Control Unit in charge of LU. Therefore, the Control Unit in charge of the LU which performs the forced parity correction should be considered to decide the sorting order.

#2 : The forced parity correction is performed in order of the sorted LU.

However, if the LU belongs in the same RAID Group, it may not be executed in the sorted order because the process is not performed in each Control Unit.

If the forced parity correction order of the LU which belongs in the same RAID Group needs to be assured, select one LU following the step (e). For the remaining LU, follow the procedure for the “[Instruction to make a forced parity correction for an LU in the “Correction Skipped” or “Restored” status]” (TRBL 06-0450), and indicate the addition of the forced parity correction LU.

(iii) Click the [OK] button.

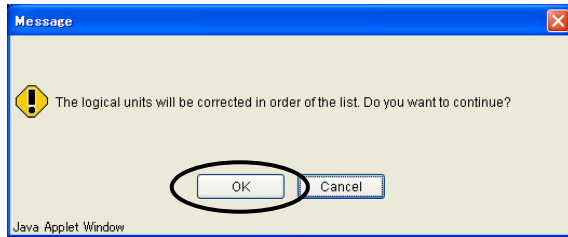

(iv) Click the [OK] button.

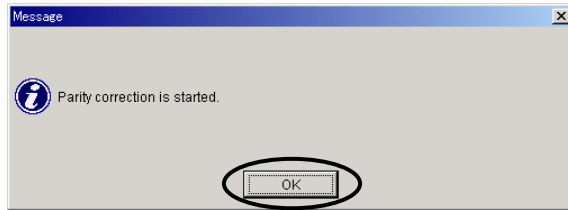

(f) Refer to a message in the Web window.

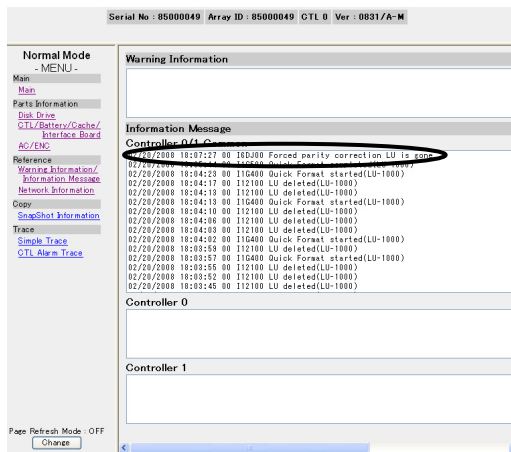

(g) Displaying a progress rate of the forced parity correction

For the LU, the forced parity correction for which has been instructed to be made, rate of progress of the restoration is displayed in the “Status” column of the LU concerned.

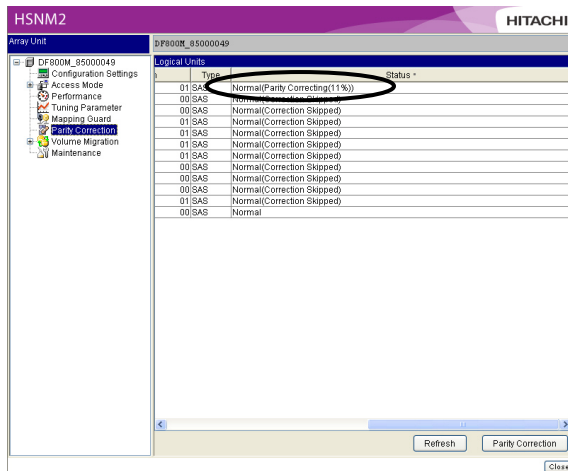

LU statuses concerning a forced parity correction and display of statuses by Hitachi Storage Navigator Modular 2.

No.	Status	Remarks
1	Parity Correction (n%)	n: Progress rate
2	Waiting Parity Correction(o) (n%)	o: Waiting order n: Rate of progress
3	Waiting Drive Reconstruction	—
4	Uncorrected	—
5	Uncorrected and Drive Detached	—
6	Correction Aborted	—
7	Restored	—
8	Correction Skipped	—

(h) Make sure that the forced parity correction has been completed in the Web window.

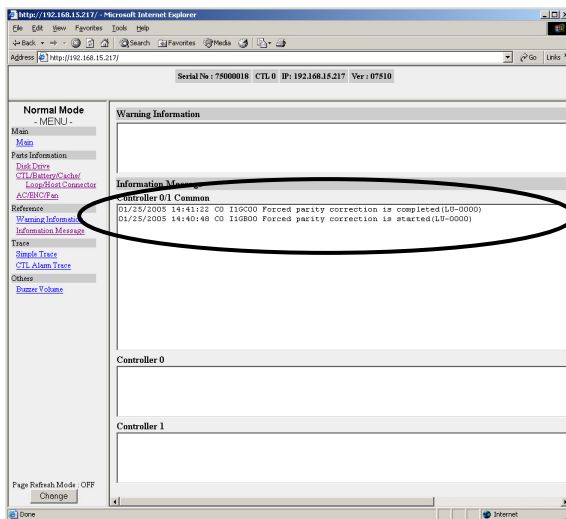

When making the forced parity correction for an LU in the “Correction Skipped” or “Restored” status, refer to “[[Instruction to make a forced parity correction for an LU in the “Correction Skipped” or “Restored” status](#)]” (TRBL 06-0450).

- (i) Make sure that the WARNING LED on the front side of the Basic Chassis has gone out.
- (j) Make the backup restoration. (Abandon all data and then restore it starting from the LU formatting.) Otherwise, ask a user to verify files.

However, check with the user whether the LU to be restored from the backup data is using the Dynamic Provisioning function, and if it is used, restore the backup data according to the user’s instruction.

- [Skip of forced parity correction]
- When the Hitachi Storage Navigator Modular 2 is version 08B0/A or more
 - (a) Select the logical unit for which you want to execute the forced parity correction, and click the [Skip Parity Correction] button.

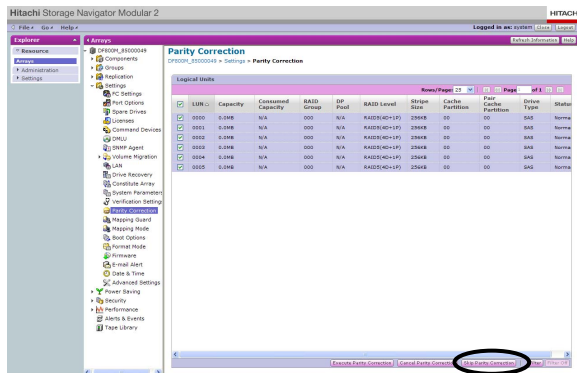

- (b) The list of logical units to be skipped is displayed. Click the [Confirm] button.

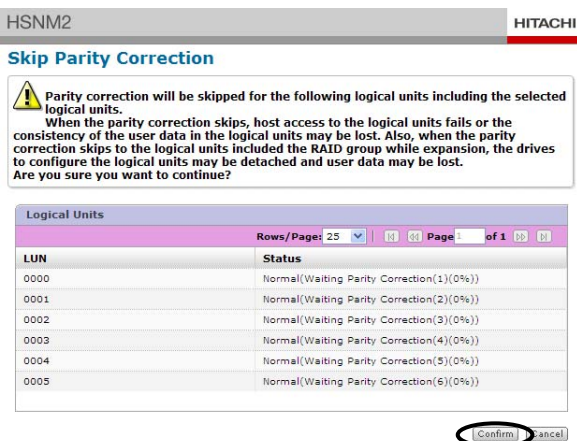

- (c) Click the [Close] button.



- When the Hitachi Storage Navigator Modular 2 is less than version 08B0/A
 - (a) Select the [Skip] radio button and click the [OK] button.

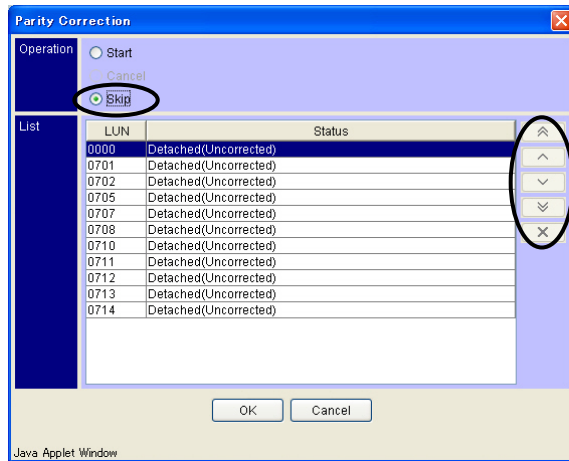

- (b) Click the [OK] button.

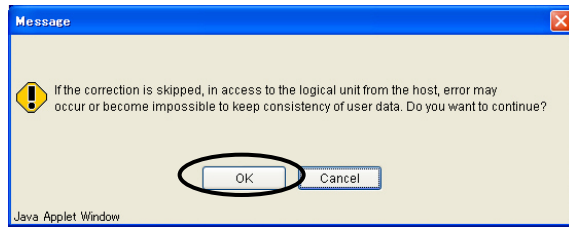

- (c) Click the [OK] button.

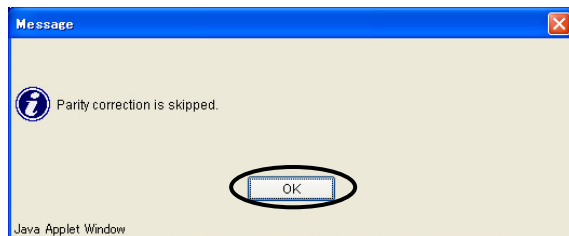

[Cancellation of forced parity correction]

The forced parity correction can be cancelled while the LU is in progress or after the correction is instructed.

- When the Hitachi Storage Navigator Modular 2 is version 08B0/A or more
 - (a) Select an LU whose status displayed in the logical unit status column is “Parity Correction” or “Waiting Parity Correction”, and click the [Cancel Parity Correction] button.

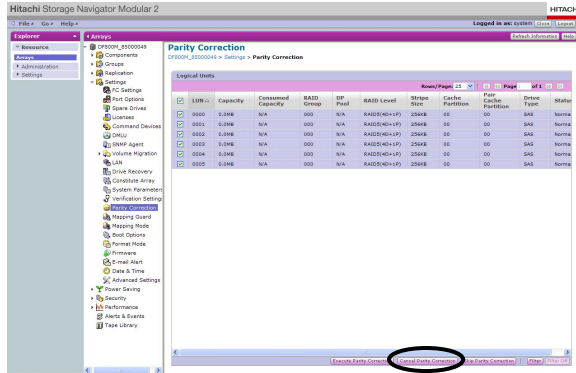

- (b) Click the [Confirm] button.

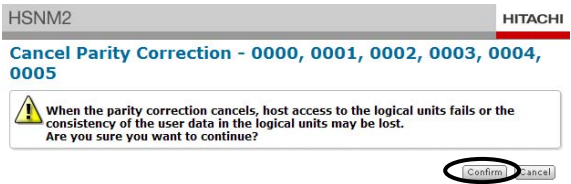

- (c) Click the [Close] button.

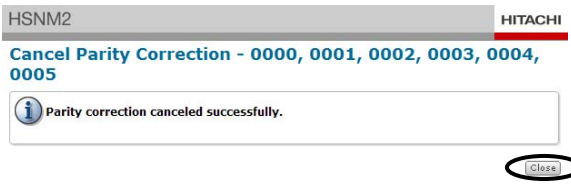

- When the Hitachi Storage Navigator Modular 2 is less than version 08B0/A
 - (a) Select an LU whose status displayed in the Logical unit status column is “Parity Correction” or “Waiting Parity Correction”.

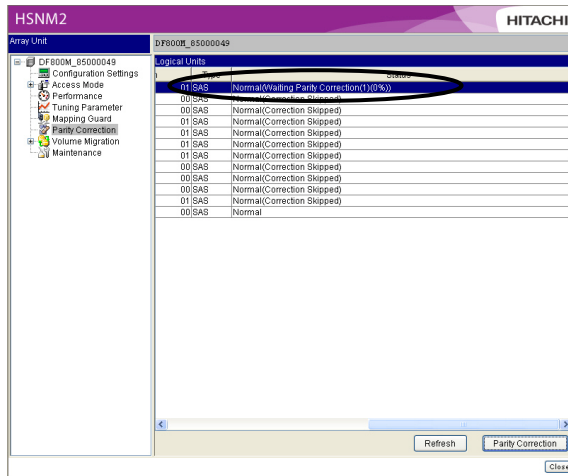

- (b) Click the [Parity Correction] button.

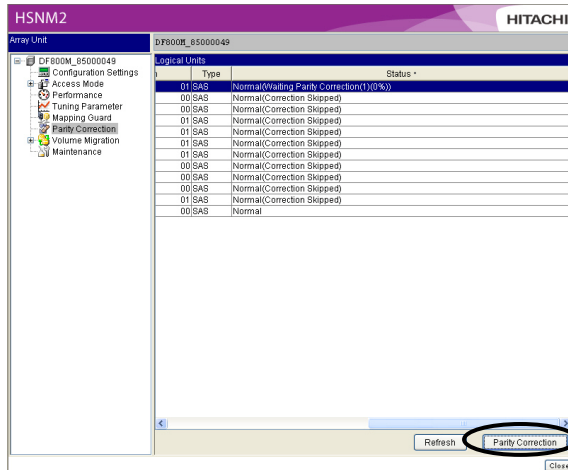

- (c) Select [Cancel] and press the [OK] button.

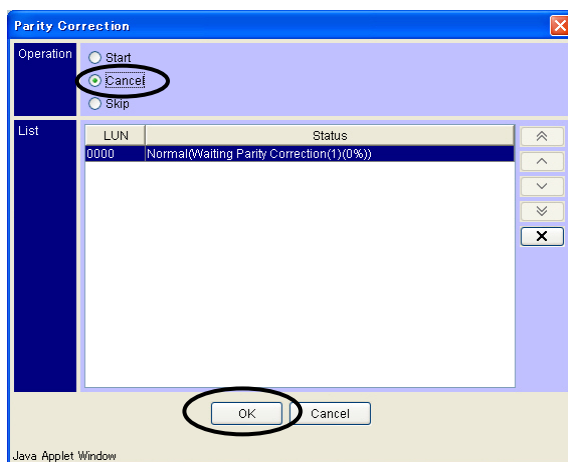

(d) Click the [OK] button.

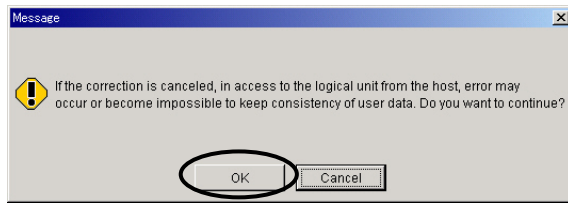

(e) Click the [OK] button.

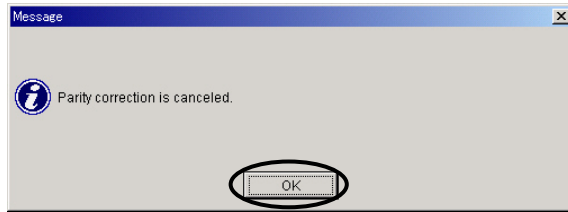

[Instruction to make a forced parity correction for an LU in the “Correction Skipped” or “Restored” status]

A forced parity correction can be made for an LU in the “Correction Skipped” status or for an LU for which the forced parity correction has been made.

- When the Hitachi Storage Navigator Modular 2 is version 08B0/A or more
 - (a) Select an LU to execute forced parity correction in the status column of the logical unit. Click the [Execute Parity Correction] button.

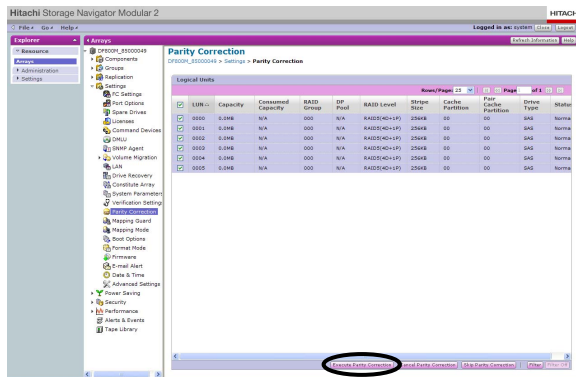

- (b) List the logical units in order of executing the forced parity correction. Select the logical units from the right list (registered logical unit), and click the [Remove] button to move them to the left list (unregistered logical unit). Select the logical unit in the left list in order of executing the forced parity correction, and then click the [Add] button to move it to the right list.

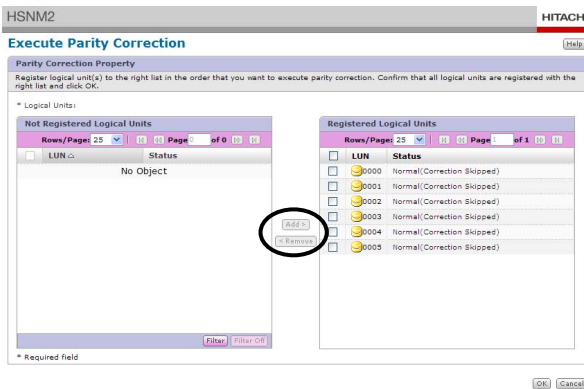

- (c) Verify that the logical units in the right list are listed in order of executing the forced parity correction, and click the [OK] button.

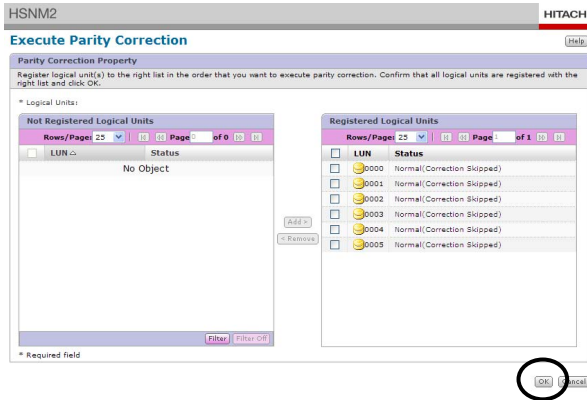

- (d) Click the [Close] button.

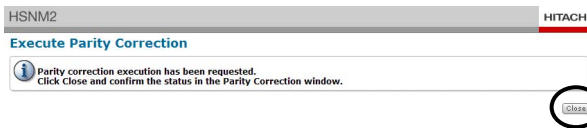

- When the Hitachi Storage Navigator Modular 2 is less than version 08B0/A
 - (a) Select an LU to execute forced parity correction in the status column of the logical unit.

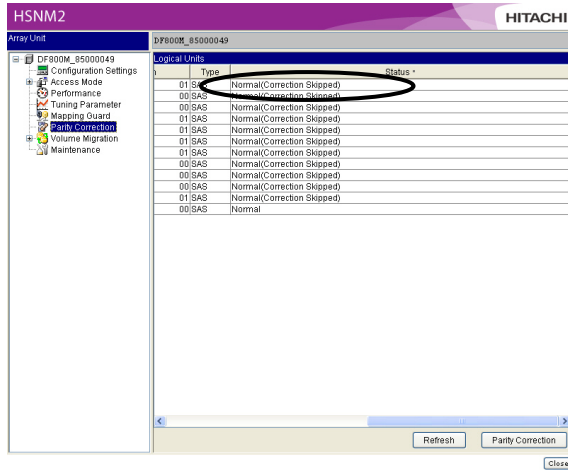

- (b) Click the [Parity Correction] button while selecting it.

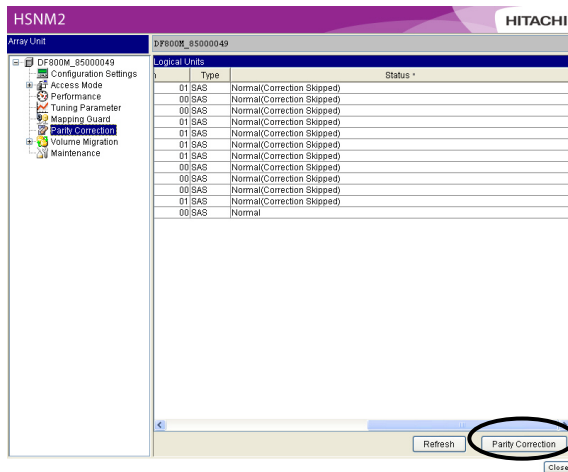

- (c) Click the [OK] button.

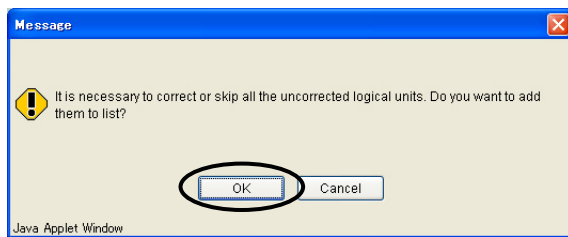

(d) Select [Start], specify an order of making the forced parity correction, and press the [OK] button.

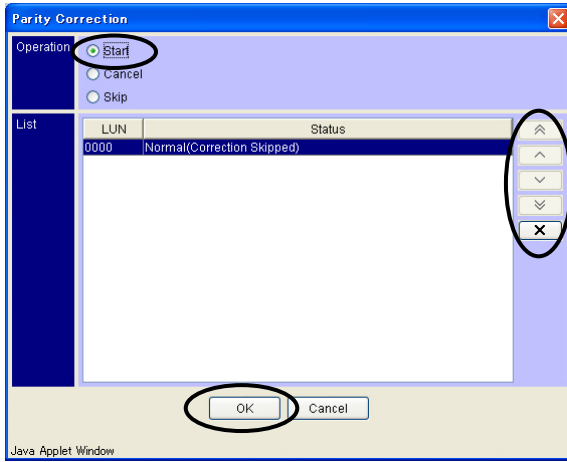

(e) Click the [OK] button.

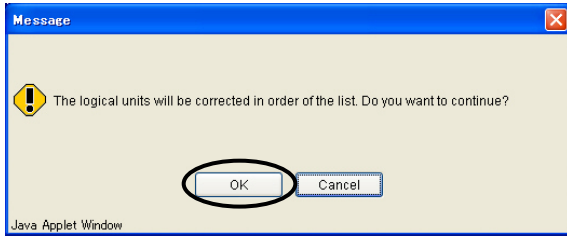

(f) Click the [OK] button.

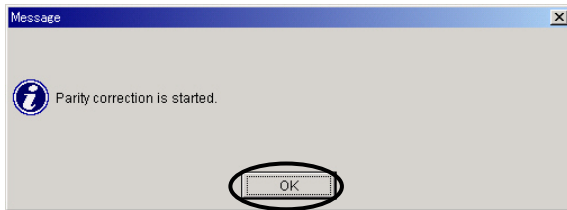

< Change of the status in the forced parity correction >

The status of the forced parity correction changes as shown below. The status and progress rate of the restoration can be referred to for each LU using Hitachi Storage Navigator Modular 2. (Hitachi Storage Navigator Modular 2 is abbreviated to HSNM2 in the status transition chart of the forced parity recovery.)

(a) Change of the status after user data is lost

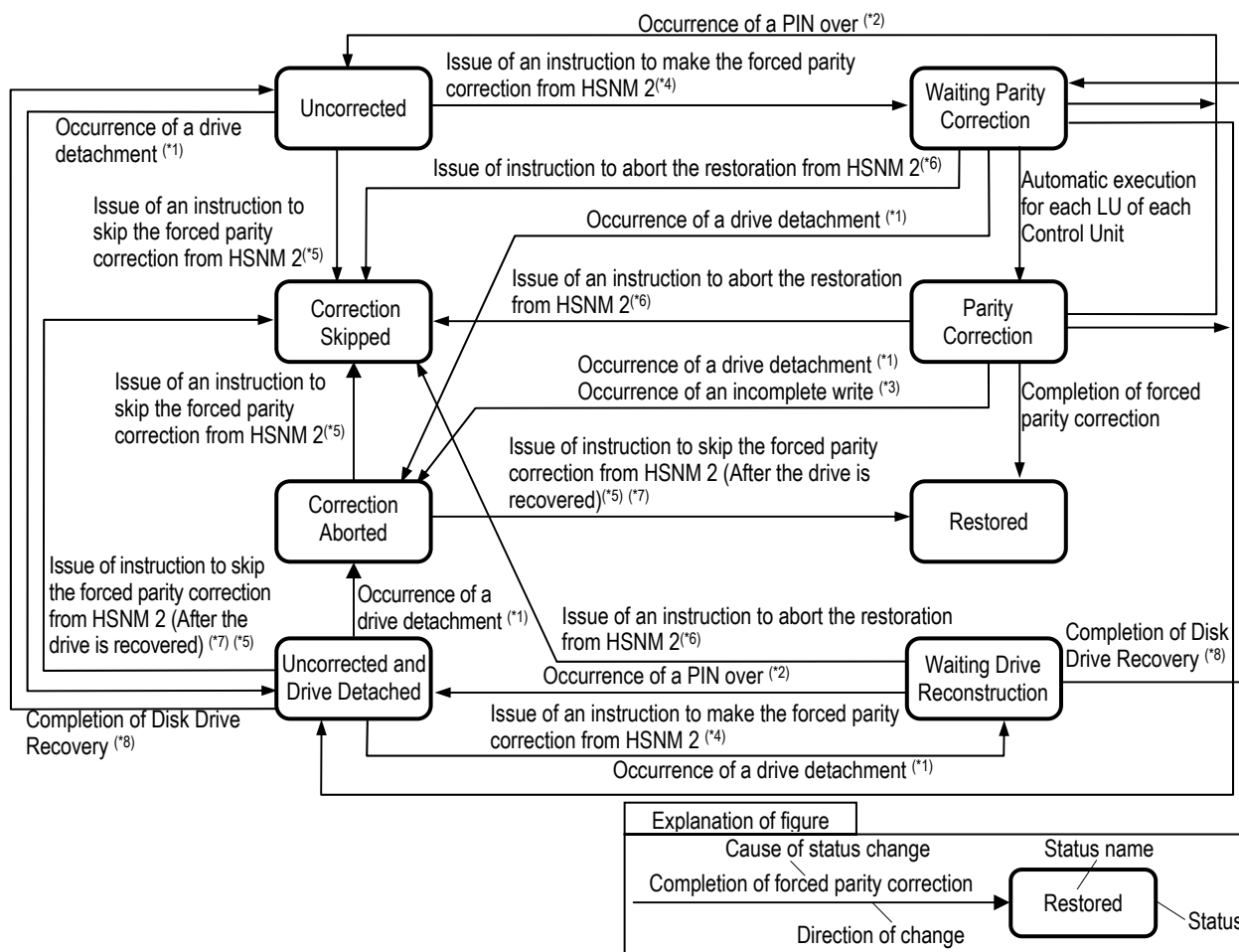

- *1 : Refer to “[Recovery method-3] : Drive blockade occurred during the forced parity correction.” (TRBL 06-0190).
- *2 : Refer to “[Recovery method-4] : PIN over occurred during the forced parity correction.” (TRBL 06-0250).
- *3 : Refer to “[Recovery method-5] : Incomplete write occurred during the forced parity correction.” (TRBL 06-0270).
- *4 : Refer to “[Execution of forced parity correction]” (TRBL 06-0340).
- *5 : Refer to “[Skip of forced parity correction]” (TRBL 06-0400)
- *6 : Refer to “[Cancellation of forced parity correction]” (TRBL 06-0420).
- *7 : An LU that conforms to any of the following conditions does not enter the “Restored” status and remains in the “Correction Skipped” status.
 In this case, issue an instruction to skip the forced parity correction and then issue an instruction to make the restoration.
 - An LU of RAID 1+0, RAID 6
 - A unified LU a part of which is included in a RAID group having a drive detachment
 - An LU whose parity group is deeper than 1
- *8 : The LU concerned to any of the following conditions does not change to “Disk Drive Restored”. In this case, instruct the force parity correction.
 - LU whose Disk Drive of a part of the unified LU is blocked and included in the RAID Group
 - LU whose depth of the parity group is larger than one

(b) Forced parity correction for an LU in the “Restored” status

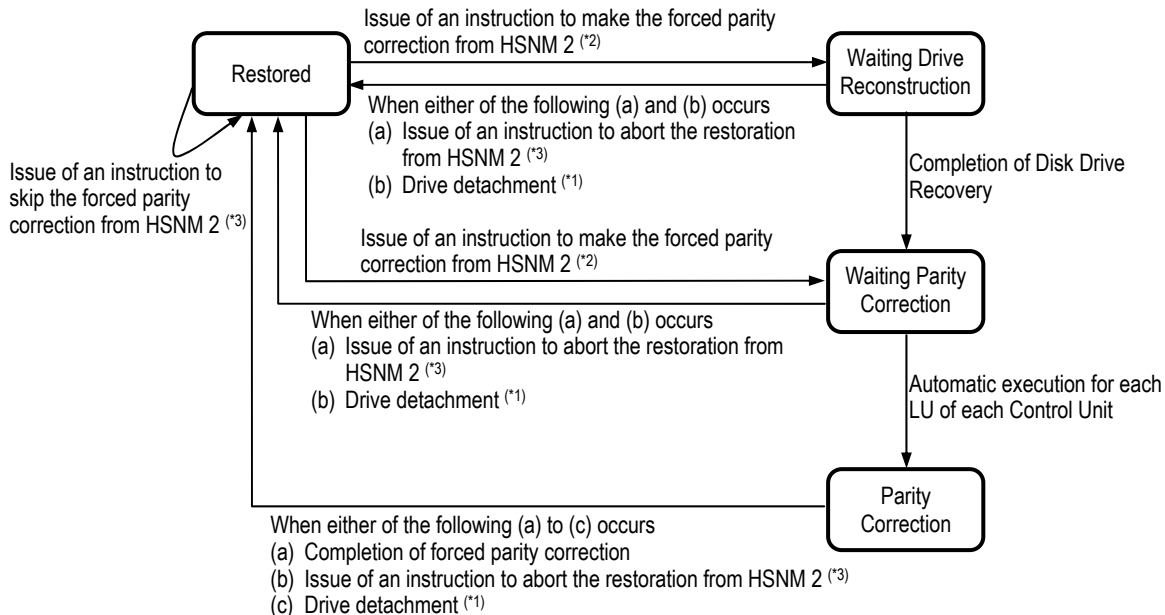

(c) Forced parity correction for an LU in the “Correction Skipped” status

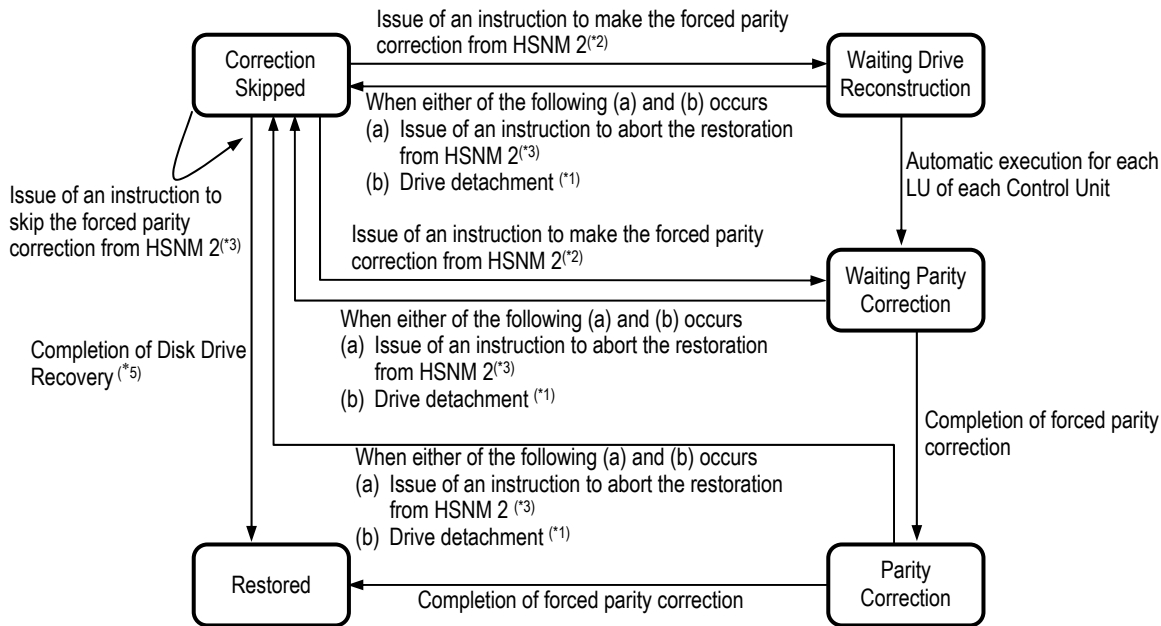

*1 : Refer to “[Recovery method-3] : Drive blockade occurred during the forced parity correction.” (TRBL 06-0190).

*2 : Refer to “[Execution of forced parity correction]” (TRBL 06-0340).

*3 : Refer to “[Skip of forced parity correction]” (TRBL 06-0400)

*4 : Refer to “[Cancellation of forced parity correction]” (TRBL 06-0420).

*5 : An LU that conforms to any of the following conditions does not enter the “Restored” status and remains in the “Correction Skipped” status.

- An LU of RAID 1+0
- A unified LU a part of which is included in a RAID group having a drive detachment
- An LU whose parity group is deeper than 1

< Standard time required for the forced parity correction >

A forced parity correction takes a long time from start to completion. (Refer from [Table 6.1.2](#) to [Table 6.1.4.4.](#))

Standard times required for the forced parity correction are shown below.

NOTE : • The data above are standard times required for a forced parity correction for one or two RAID groups.

Further, the times required for the restoration vary depending on the Disk Drive capacity, number of Disk Drives, and RAID configuration.

Also, the time when the forced parity correction processing takes becomes short about 10 to 20 % depending on the type even by the Disk Drives of the same capacity.

The forced parity correction operates one LU at a time per Control Unit.

Therefore, when one Control Unit recovered the parity of two or more LUs (n LUs), the time that it takes to complete recovering all the parities of the n LUs becomes n times the standard time.

- When using the Dynamic Provisioning function, the recovery time differs depending on the write status to the Disk Drive because the format of the DP pool operates. The recovery time also differs depending on the capacity that uses the DP volume.

**Table 6.1.2 Standard Times Required for Forced Parity Correction for One RAID Group
(3.5-type SAS Disk Drive) (When No Host I/O Is Executed) (‡1)**

			Unit : min				
		Disk Drives (G byte) (‡1)	142.61	287.62	392.73	439.44	575.30
Item							
AMS2300 AMS2100 AMS2010(‡2)	4 Disk Drives	RAID 6 (2D+2P)	200	400	550	610	800
	6 Disk Drives	RAID 6 (4D+2P)	220	440	600	670	880
	10 Disk Drives	RAID 6 (8D+2P)	260	520	710	790	1040
	14 Disk Drives	RAID 6 (12D+2P)	300	590	800	900	1180
	18 Disk Drives	RAID 6 (16D+2P)	330	650	890	1000	1300
	30 Disk Drives	RAID 6 (28D+2P)	390	790	1080	1200	1580
	3 Disk Drives	RAID 5 (2D+1P)	110	230	310	340	460
	5 Disk Drives	RAID 5 (4D+1P)	130	260	360	400	520
	9 Disk Drives	RAID 5 (8D+1P)	170	330	450	510	660
	11 Disk Drives	RAID 5 (10D+1P)	190	370	510	570	740
	13 Disk Drives	RAID 5 (12D+1P)	210	410	560	630	820
	16 Disk Drives	RAID 5 (15D+1P)	230	460	620	690	920
	4 Disk Drives	RAID 1+0 (2D+2D)	210	420	570	640	840
	8 Disk Drives	RAID 1+0 (4D+4D)	420	840	1150	1290	1680
	16 Disk Drives	RAID 1+0 (8D+8D)	870	1760	2400	2680	3520
2 Disk Drives	RAID 1 (1D+1D)	110	210	290	320	420	
AMS2500	4 Disk Drives	RAID 6 (2D+2P)	230	450	620	690	900
	6 Disk Drives	RAID 6 (4D+2P)	240	490	670	740	980
	10 Disk Drives	RAID 6 (8D+2P)	290	570	780	870	1140
	14 Disk Drives	RAID 6 (12D+2P)	320	640	870	980	1280
	18 Disk Drives	RAID 6 (16D+2P)	350	700	950	1070	1400
	30 Disk Drives	RAID 6 (28D+2P)	420	840	1140	1280	1680
	3 Disk Drives	RAID 5 (2D+1P)	130	250	340	380	500
	5 Disk Drives	RAID 5 (4D+1P)	150	290	390	440	580
	9 Disk Drives	RAID 5 (8D+1P)	180	360	490	540	720
	11 Disk Drives	RAID 5 (10D+1P)	200	400	540	610	800
	13 Disk Drives	RAID 5 (12D+1P)	220	430	580	650	860
	16 Disk Drives	RAID 5 (15D+1P)	240	470	650	720	940
	4 Disk Drives	RAID 1+0 (2D+2D)	230	470	630	710	940
	8 Disk Drives	RAID 1+0 (4D+4D)	470	940	1280	1430	1880
	16 Disk Drives	RAID 1+0 (8D+8D)	960	1930	2640	2950	3860
2 Disk Drives	RAID 1 (1D+1D)	120	230	320	350	460	

*1 : The drive capacity values are calculated as 1 G byte =1,000,000,000 bytes. This definition is different from that calculated as 1 k byte =1,024 bytes, which are actually displayed on PCs that you are using.

The RAID group capacity values displayed in the Hitachi Storage Navigator Modular 2 are calculated as 1 k byte =1,024 bytes.

*2 : AMS 2010 does not support 142.61 G bytes, 287.62 G bytes, and 392.73 G bytes Disk Drives.

‡1 : The standard of the forced parity correction time when the parity of one LU was recovered.

**Table 6.1.2.1 Standard Times Required for Forced Parity Correction for One RAID Group
(2.5-type SAS Disk Drive) (When No Host I/O Is Executed) (‡1)**

				Unit : min		
Item	Disk Drives (G byte) (‡1)			287.62	575.30	
	AMS2300 AMS2100 AMS2010	4 Disk Drives	RAID 6	(2D+2P)	420	830
6 Disk Drives		(4D+2P)		450	900	
10 Disk Drives		(8D+2P)		540	1070	
14 Disk Drives		(12D+2P)		600	1200	
18 Disk Drives		(16D+2P)		670	1340	
30 Disk Drives		(28D+2P)		810	1620	
3 Disk Drives		RAID 5	(2D+1P)	240	470	
5 Disk Drives			(4D+1P)	270	540	
9 Disk Drives			(8D+1P)	340	680	
11 Disk Drives			(10D+1P)	390	770	
13 Disk Drives			(12D+1P)	420	840	
16 Disk Drives			(15D+1P)	470	930	
		4 Disk Drives	RAID 1+0	(2D+2D)	430	860
		8 Disk Drives		(4D+4D)	870	1730
		16 Disk Drives		(8D+8D)	1800	3600
		2 Disk Drives	RAID 1	(1D+1D)	220	440
AMS2500	4 Disk Drives	RAID 6	(2D+2P)	470	930	
	6 Disk Drives		(4D+2P)	510	1010	
	10 Disk Drives		(8D+2P)	590	1170	
	14 Disk Drives		(12D+2P)	660	1310	
	18 Disk Drives		(16D+2P)	720	1430	
	30 Disk Drives		(28D+2P)	860	1710	
	3 Disk Drives	RAID 5	(2D+1P)	260	510	
	5 Disk Drives		(4D+1P)	300	590	
	9 Disk Drives		(8D+1P)	370	740	
	11 Disk Drives		(10D+1P)	410	810	
	13 Disk Drives		(12D+1P)	440	870	
	16 Disk Drives		(15D+1P)	490	980	
		4 Disk Drives	RAID 1+0	(2D+2D)	480	950
		8 Disk Drives		(4D+4D)	960	1920
		16 Disk Drives		(8D+8D)	1980	3960
		2 Disk Drives	RAID 1	(1D+1D)	240	480

*1 : The drive capacity values are calculated as 1 G byte =1,000,000,000 bytes. This definition is different from that calculated as 1 k byte =1,024 bytes, which are actually displayed on PCs that you are using.

The RAID group capacity values displayed in the Hitachi Storage Navigator Modular 2 are calculated as 1 k byte =1,024 bytes.

‡1 : The standard of the forced parity correction time when the parity of one LU was recovered.

Table 6.1.2.2 Standard Times Required for Forced Parity Correction for One RAID Group (SAS(SED) Disk Drive) (When No Host I/O Is Executed) (‡1)

Unit : min

Item		Disk Drives (G byte) (*1)	575.30
AMS2300 AMS2100	4 Disk Drives	RAID 6 (2D+2P)	800
	6 Disk Drives	(4D+2P)	880
	10 Disk Drives	(8D+2P)	1040
	14 Disk Drives	(12D+2P)	1180
	18 Disk Drives	(16D+2P)	1300
	30 Disk Drives	(28D+2P)	1580
	3 Disk Drives	RAID 5 (2D+1P)	460
	5 Disk Drives	(4D+1P)	520
	9 Disk Drives	(8D+1P)	660
	11 Disk Drives	(10D+1P)	740
	13 Disk Drives	(12D+1P)	820
	16 Disk Drives	(15D+1P)	920
	4 Disk Drives	RAID 1+0 (2D+2D)	840
	8 Disk Drives	(4D+4D)	1680
	16 Disk Drives	(8D+8D)	3520
2 Disk Drives	RAID 1 (1D+1D)	420	
AMS2500	4 Disk Drives	RAID 6 (2D+2P)	900
	6 Disk Drives	(4D+2P)	980
	10 Disk Drives	(8D+2P)	1140
	14 Disk Drives	(12D+2P)	1280
	18 Disk Drives	(16D+2P)	1400
	30 Disk Drives	(28D+2P)	1680
	3 Disk Drives	RAID 5 (2D+1P)	500
	5 Disk Drives	(4D+1P)	580
	9 Disk Drives	(8D+1P)	720
	11 Disk Drives	(10D+1P)	800
	13 Disk Drives	(12D+1P)	860
	16 Disk Drives	(15D+1P)	940
	4 Disk Drives	RAID 1+0 (2D+2D)	940
	8 Disk Drives	(4D+4D)	1880
	16 Disk Drives	(8D+8D)	3860
2 Disk Drives	RAID 1 (1D+1D)	460	

*1 : The drive capacity values are calculated as 1 G byte =1,000,000,000 bytes. This definition is different from that calculated as 1 k byte =1,024 bytes, which are actually displayed on PCs that you are using.
 The RAID group capacity values displayed in the Hitachi Storage Navigator Modular 2 are calculated as 1 k byte =1,024 bytes.

‡1 : The standard of the forced parity correction time when the parity of one LU was recovered.

Table 6.1.2.3 Standard Times Required for Forced Parity Correction for One RAID Group (SATA Disk Drive) (When No Host I/O Is Executed) (‡1)

				Unit : min				
Item		Disk Drives (G byte) (*1)		491.25	737.49	983.69	1,968.52	2,953.31
AMS2300 AMS2100 AMS2010(*2)	4 Disk Drives	RAID 6	(2D+2P)	700	1060	1410	2820	4230
	6 Disk Drives		(4D+2P)	770	1150	1540	3080	4620
	10 Disk Drives		(8D+2P)	930	1390	1850	3700	5550
	14 Disk Drives		(12D+2P)	1000	1580	2100	4200	6300
	18 Disk Drives		(16D+2P)	1070	1740	2320	4640	6960
	30 Disk Drives		(28D+2P)	1400	2080	2770	5540	8310
	3 Disk Drives	RAID 5	(2D+1P)	400	590	790	1580	2370
	5 Disk Drives		(4D+1P)	460	690	920	1840	2760
	9 Disk Drives		(8D+1P)	590	890	1190	2380	3570
	11 Disk Drives		(10D+1P)	660	1000	1350	2700	4050
	13 Disk Drives		(12D+1P)	690	1050	1400	2800	4200
	16 Disk Drives		(15D+1P)	740	1150	1500	3000	4500
	4 Disk Drives	RAID 1+0	(2D+2D)	730	1100	1460	2920	4380
	8 Disk Drives		(4D+4D)	1490	2230	2980	5960	8940
	16 Disk Drives		(8D+8D)	3080	4650	6200	12400	18600
2 Disk Drives	RAID 1	(1D+1D)	370	550	730	1460	2190	
AMS2500	4 Disk Drives	RAID 6	(2D+2P)	790	1190	1580	3160	4740
	6 Disk Drives		(4D+2P)	860	1290	1720	3440	5160
	10 Disk Drives		(8D+2P)	1000	1510	2010	4020	6030
	14 Disk Drives		(12D+2P)	1080	1620	2150	4300	6450
	18 Disk Drives		(16D+2P)	1170	1760	2340	4680	7020
	30 Disk Drives		(28D+2P)	1460	2210	2940	5880	8820
	3 Disk Drives	RAID 5	(2D+1P)	440	660	880	1760	2640
	5 Disk Drives		(4D+1P)	500	750	1000	2000	3000
	9 Disk Drives		(8D+1P)	630	940	1260	2520	3780
	11 Disk Drives		(10D+1P)	700	1060	1410	2820	4230
	13 Disk Drives		(12D+1P)	730	1100	1460	2920	4380
	16 Disk Drives		(15D+1P)	770	1170	1550	3100	4650
	4 Disk Drives	RAID 1+0	(2D+2D)	830	1240	1650	3300	4950
	8 Disk Drives		(4D+4D)	1670	2500	3340	6680	10020
	16 Disk Drives		(8D+8D)	3510	5270	7020	14040	21060
2 Disk Drives	RAID 1	(1D+1D)	410	620	820	1640	2460	

*1 : The drive capacity values are calculated as 1 G byte =1,000,000,000 bytes. This definition is different from that calculated as 1 k byte =1,024 bytes, which are actually displayed on PCs that you are using.

The RAID group capacity values displayed in the Hitachi Storage Navigator Modular 2 are calculated as 1 k byte =1,024 bytes.

*2 : AMS 2010 does not support 491.25 G bytes and 737.49 G bytes Disk Drives.

‡1 : The standard of the forced parity correction time when the parity of one LU was recovered.

Table 6.1.2.4 Standard Times Required for Forced Parity Correction for One RAID Group (SAS7.2K Disk Drive) (When No Host I/O Is Executed) (‡1)

				Unit : min	
Item	Disk Drives (G byte) (*1)			1,956.94	
AMS2300 AMS2100 AMS2010	4 Disk Drives	RAID 6	(2D+2P)	2740	
	6 Disk Drives		(4D+2P)	3020	
	10 Disk Drives		(8D+2P)	3570	
	14 Disk Drives		(12D+2P)	4050	
	18 Disk Drives		(16D+2P)	4460	
	30 Disk Drives		(28D+2P)	5420	
	3 Disk Drives	RAID 5	(2D+1P)	1580	
	5 Disk Drives		(4D+1P)	1780	
	9 Disk Drives		(8D+1P)	2260	
	11 Disk Drives		(10D+1P)	2540	
	13 Disk Drives		(12D+1P)	2810	
	16 Disk Drives		(15D+1P)	3160	
		4 Disk Drives	RAID 1+0	(2D+2D)	2880
		8 Disk Drives		(4D+4D)	5770
		16 Disk Drives		(8D+8D)	12090
		2 Disk Drives	RAID 1	(1D+1D)	1440
AMS2500	4 Disk Drives	RAID 6	(2D+2P)	3090	
	6 Disk Drives		(4D+2P)	3360	
	10 Disk Drives		(8D+2P)	3910	
	14 Disk Drives		(12D+2P)	4390	
	18 Disk Drives		(16D+2P)	4810	
	30 Disk Drives		(28D+2P)	5770	
	3 Disk Drives	RAID 5	(2D+1P)	1710	
	5 Disk Drives		(4D+1P)	1990	
	9 Disk Drives		(8D+1P)	2470	
	11 Disk Drives		(10D+1P)	2740	
	13 Disk Drives		(12D+1P)	2950	
	16 Disk Drives		(15D+1P)	3220	
		4 Disk Drives	RAID 1+0	(2D+2D)	3220
		16 Disk Drives		(8D+8D)	13260
	2 Disk Drives	RAID 1	(1D+1D)	1580	

*1 : The drive capacity values are calculated as 1 G byte =1,000,000,000 bytes. This definition is different from that calculated as 1 k byte =1,024 bytes, which are actually displayed on PCs that you are using.
The RAID group capacity values displayed in the Hitachi Storage Navigator Modular 2 are calculated as 1 k byte =1,024 bytes.

‡1 : The standard of the forced parity correction time when the parity of one LU was recovered.

**Table 6.1.2.5 Standard Times Required for Forced Parity Correction for One RAID Group (Flash Drive)
(When No Host I/O Is Executed) (‡1)**

				Unit : min	
Item	Disk Drives (G byte) (*1)			195.82	
AMS2300 AMS2100	4 Disk Drives	RAID 6	(2D+2P)	300	
	6 Disk Drives		(4D+2P)	320	
	10 Disk Drives		(8D+2P)	380	
	14 Disk Drives		(12D+2P)	420	
	18 Disk Drives		(16D+2P)	480	
	30 Disk Drives		(28D+2P)	580	
	3 Disk Drives	RAID 5	(2D+1P)	180	
	5 Disk Drives		(4D+1P)	200	
	9 Disk Drives		(8D+1P)	240	
	11 Disk Drives		(10D+1P)	280	
	13 Disk Drives		(12D+1P)	300	
	16 Disk Drives		(15D+1P)	340	
		4 Disk Drives	RAID 1+0	(2D+2D)	300
		8 Disk Drives		(4D+4D)	600
16 Disk Drives		(8D+8D)		1260	
2 Disk Drives		RAID 1	(1D+1D)	160	
AMS2500	4 Disk Drives	RAID 6	(2D+2P)	340	
	6 Disk Drives		(4D+2P)	360	
	10 Disk Drives		(8D+2P)	420	
	14 Disk Drives		(12D+2P)	460	
	18 Disk Drives		(16D+2P)	500	
	30 Disk Drives		(28D+2P)	600	
	3 Disk Drives	RAID 5	(2D+1P)	180	
	5 Disk Drives		(4D+1P)	220	
	9 Disk Drives		(8D+1P)	260	
	11 Disk Drives		(10D+1P)	300	
	13 Disk Drives		(12D+1P)	320	
	16 Disk Drives		(15D+1P)	340	
		4 Disk Drives	RAID 1+0	(2D+2D)	340
		16 Disk Drives		(8D+8D)	1380
2 Disk Drives		RAID 1	(1D+1D)	180	

*1 : The drive capacity values are calculated as 1 G byte =1,000,000,000 bytes. This definition is different from that calculated as 1 k byte =1,024 bytes, which are actually displayed on PCs that you are using.
The RAID group capacity values displayed in the Hitachi Storage Navigator Modular 2 are calculated as 1 k byte =1,024 bytes.

‡1 : The standard of the forced parity correction time when the parity of one LU was recovered.

Table 6.1.3 Standard Times Required for Forced Parity Correction for Two RAID Groups (3.5-type SAS Disk Drive) (without Host I/O, Two RAID Group) (‡1)

				Unit : min					
		Disk Drives (G byte) (*1)		142.61	287.62	392.73	439.44	575.30	
Item									
AMS2300 AMS2100 AMS2010(*2)	4 Disk Drives x2	RAID 6	(2D+2P)x2	210	410	560	620	820	
	6 Disk Drives x2		(4D+2P)x2	230	450	610	680	900	
	10 Disk Drives x2		(8D+2P)x2	270	530	720	800	1060	
	14 Disk Drives x2		(12D+2P)x2	310	600	810	910	1200	
	18 Disk Drives x2		(16D+2P)x2	340	660	900	1010	1320	
	30 Disk Drives x2		(28D+2P)x2	400	800	1090	1210	1600	
	3 Disk Drives x2	RAID 5	(2D+1P)x2	120	240	320	350	480	
	5 Disk Drives x2		(4D+1P)x2	140	270	370	410	540	
	9 Disk Drives x2		(8D+1P)x2	180	340	460	520	680	
	11 Disk Drives x2		(10D+1P)x2	200	380	520	580	760	
	13 Disk Drives x2		(12D+1P)x2	220	420	570	640	840	
	16 Disk Drives x2		(15D+1P)x2	240	470	630	700	940	
	4 Disk Drives x2	RAID 1+0	(2D+2D)x2	220	430	580	650	860	
	8 Disk Drives x2		(4D+4D)x2	430	850	1160	1300	1700	
	16 Disk Drives x2		(8D+8D)x2	880	1770	2410	2690	3540	
	2 Disk Drives x2	RAID 1	(1D+1D)x2	120	220	300	330	440	
	AMS2500	4 Disk Drives x2	RAID 6	(2D+2P)x2	240	460	630	700	920
		6 Disk Drives x2		(4D+2P)x2	250	500	680	750	1000
10 Disk Drives x2		(8D+2P)x2		300	580	790	880	1160	
14 Disk Drives x2		(12D+2P)x2		330	650	880	990	1300	
18 Disk Drives x2		(16D+2P)x2		360	710	960	1080	1420	
30 Disk Drives x2		(28D+2P)x2		430	850	1150	1290	1700	
3 Disk Drives x2		RAID 5	(2D+1P)x2	140	260	350	390	520	
5 Disk Drives x2			(4D+1P)x2	160	300	400	450	600	
9 Disk Drives x2			(8D+1P)x2	190	370	500	550	740	
11 Disk Drives x2			(10D+1P)x2	210	410	550	620	820	
13 Disk Drives x2			(12D+1P)x2	230	440	590	660	880	
16 Disk Drives x2			(15D+1P)x2	250	480	660	730	960	
4 Disk Drives x2		RAID 1+0	(2D+2D)x2	240	480	640	720	960	
8 Disk Drives x2			(4D+4D)x2	480	950	1290	1440	1900	
16 Disk Drives x2			(8D+8D)x2	970	1940	2650	2960	3880	
2 Disk Drives x2		RAID 1	(1D+1D)x2	130	240	330	360	480	

*1 : The drive capacity values are calculated as 1 G byte =1,000,000,000 bytes. This definition is different from that calculated as 1 k byte =1,024 bytes, which are actually displayed on PCs that you are using.

The RAID group capacity values displayed in the Hitachi Storage Navigator Modular 2 are calculated as 1 k byte =1,024 bytes.

*2 : AMS 2010 does not support 142.61 G bytes, 287.62 G bytes, and 392.73 G bytes Disk Drives.

‡1 : Two RAID groups = one RAID group/controller0 and one RAID group/controller1.

Table 6.1.3.1 Standard Times Required for Forced Parity Correction for Two RAID Groups (2.5-type SAS Disk Drive) (without Host I/O, Two RAID Group) (‡1)

				Unit : min	
		Disk Drives (G byte) (‡1)		287.62	575.30
Item					
AMS2300 AMS2100 AMS2010	4 Disk Drives x2	RAID 6	(2D+2P)x2	420	840
	6 Disk Drives x2		(4D+2P)x2	460	920
	10 Disk Drives x2		(8D+2P)x2	540	1080
	14 Disk Drives x2		(12D+2P)x2	610	1220
	18 Disk Drives x2		(16D+2P)x2	680	1350
	30 Disk Drives x2		(28D+2P)x2	820	1640
	3 Disk Drives x2	RAID 5	(2D+1P)x2	240	480
	5 Disk Drives x2		(4D+1P)x2	280	560
	9 Disk Drives x2		(8D+1P)x2	350	690
	11 Disk Drives x2		(10D+1P)x2	390	780
	13 Disk Drives x2		(12D+1P)x2	430	860
	16 Disk Drives x2		(15D+1P)x2	480	950
	4 Disk Drives x2	RAID 1+0	(2D+2D)x2	440	870
	8 Disk Drives x2		(4D+4D)x2	870	1740
	16 Disk Drives x2		(8D+8D)x2	1810	3620
2 Disk Drives x2	RAID 1	(1D+1D)x2	230	450	
AMS2500	4 Disk Drives x2	RAID 6	(2D+2P)x2	480	950
	6 Disk Drives x2		(4D+2P)x2	510	1020
	10 Disk Drives x2		(8D+2P)x2	600	1190
	14 Disk Drives x2		(12D+2P)x2	660	1320
	18 Disk Drives x2		(16D+2P)x2	720	1440
	30 Disk Drives x2		(28D+2P)x2	870	1730
	3 Disk Drives x2	RAID 5	(2D+1P)x2	270	530
	5 Disk Drives x2		(4D+1P)x2	300	600
	9 Disk Drives x2		(8D+1P)x2	380	750
	11 Disk Drives x2		(10D+1P)x2	420	830
	13 Disk Drives x2		(12D+1P)x2	450	890
	16 Disk Drives x2		(15D+1P)x2	500	990
	4 Disk Drives x2	RAID 1+0	(2D+2D)x2	480	960
	8 Disk Drives x2		(4D+4D)x2	970	1940
	16 Disk Drives x2		(8D+8D)x2	1990	3980
2 Disk Drives x2	RAID 1	(1D+1D)x2	250	500	

*1 : The drive capacity values are calculated as 1 G byte =1,000,000,000 bytes. This definition is different from that calculated as 1 k byte =1,024 bytes, which are actually displayed on PCs that you are using.
The RAID group capacity values displayed in the Hitachi Storage Navigator Modular 2 are calculated as 1 k byte =1,024 bytes.

‡1 : Two RAID groups = one RAID group/controller0 and one RAID group/controller1.

Table 6.1.3.2 Standard Times Required for Forced Parity Correction for Two RAID Groups (SAS(SED) Disk Drive) (without Host I/O, Two RAID Group) (‡1)

Unit : min

Item		Disk Drives (G byte) (‡1)	575.30	
AMS2300 AMS2100	4 Disk Drives x2	RAID 6	(2D+2P)x2	820
	6 Disk Drives x2		(4D+2P)x2	900
	10 Disk Drives x2		(8D+2P)x2	1060
	14 Disk Drives x2		(12D+2P)x2	1200
	18 Disk Drives x2		(16D+2P)x2	1320
	30 Disk Drives x2		(28D+2P)x2	1600
	3 Disk Drives x2	RAID 5	(2D+1P)x2	480
	5 Disk Drives x2		(4D+1P)x2	540
	9 Disk Drives x2		(8D+1P)x2	680
	11 Disk Drives x2		(10D+1P)x2	760
	13 Disk Drives x2		(12D+1P)x2	840
	16 Disk Drives x2		(15D+1P)x2	940
	4 Disk Drives x2	RAID 1+0	(2D+2D)x2	860
	8 Disk Drives x2		(4D+4D)x2	1700
	16 Disk Drives x2		(8D+8D)x2	3540
2 Disk Drives x2	RAID 1	(1D+1D)x2	440	
AMS2500	4 Disk Drives x2	RAID 6	(2D+2P)x2	920
	6 Disk Drives x2		(4D+2P)x2	1000
	10 Disk Drives x2		(8D+2P)x2	1160
	14 Disk Drives x2		(12D+2P)x2	1300
	18 Disk Drives x2		(16D+2P)x2	1420
	30 Disk Drives x2		(28D+2P)x2	1700
	3 Disk Drives x2	RAID 5	(2D+1P)x2	520
	5 Disk Drives x2		(4D+1P)x2	600
	9 Disk Drives x2		(8D+1P)x2	740
	11 Disk Drives x2		(10D+1P)x2	820
	13 Disk Drives x2		(12D+1P)x2	880
	16 Disk Drives x2		(15D+1P)x2	960
	4 Disk Drives x2	RAID 1+0	(2D+2D)x2	960
	8 Disk Drives x2		(4D+4D)x2	1900
	16 Disk Drives x2		(8D+8D)x2	3880
2 Disk Drives x2	RAID 1	(1D+1D)x2	480	

*1 : The drive capacity values are calculated as 1 G byte =1,000,000,000 bytes. This definition is different from that calculated as 1 k byte =1,024 bytes, which are actually displayed on PCs that you are using.
The RAID group capacity values displayed in the Hitachi Storage Navigator Modular 2 are calculated as 1 k byte =1,024 bytes.

‡1 : Two RAID groups = one RAID group/controller0 and one RAID group/controller1.

**Table 6.1.3.3 Standard Times Required for Forced Parity Correction for Two RAID Groups (SATA Disk Drive)
(without Host I/O, Two RAID Group) (‡1)**

				Unit : min					
			Disk Drives (G byte) (*1)	491.25	737.49	983.69	1,968.52	2,953.31	
Item									
AMS2300 AMS2100 AMS2010(*2)	4 Disk Drives x2	RAID 6	(2D+2P)x2	710	1070	1420	2840	4260	
	6 Disk Drives x2		(4D+2P)x2	780	1160	1550	3100	4650	
	10 Disk Drives x2		(8D+2P)x2	940	1400	1860	3720	5580	
	14 Disk Drives x2		(12D+2P)x2	1010	1590	2110	4220	6330	
	18 Disk Drives x2		(16D+2P)x2	1080	1750	2330	4660	6990	
	30 Disk Drives x2		(28D+2P)x2	1410	2090	2780	5560	8340	
	3 Disk Drives x2	RAID 5	(2D+1P)x2	410	600	800	1600	2400	
	5 Disk Drives x2		(4D+1P)x2	470	700	930	1860	2790	
	9 Disk Drives x2		(8D+1P)x2	600	900	1200	2400	3600	
	11 Disk Drives x2		(10D+1P)x2	670	1010	1360	2720	4080	
	13 Disk Drives x2		(12D+1P)x2	700	1060	1410	2820	4230	
	16 Disk Drives x2		(15D+1P)x2	750	1160	1510	3020	4530	
	4 Disk Drives x2	RAID 1+0	(2D+2D)x2	740	1110	1470	2940	4410	
	8 Disk Drives x2		(4D+4D)x2	1500	2240	2990	5980	8970	
	16 Disk Drives x2		(8D+8D)x2	3090	4660	6210	12420	18630	
	2 Disk Drives x2	RAID 1	(1D+1D)x2	380	560	740	1480	2220	
	AMS2500	4 Disk Drives x2	RAID 6	(2D+2P)x2	800	1200	1590	3180	4770
		6 Disk Drives x2		(4D+2P)x2	870	1300	1730	3460	5190
10 Disk Drives x2		(8D+2P)x2		1010	1520	2020	4040	6060	
14 Disk Drives x2		(12D+2P)x2		1090	1630	2160	4320	6480	
18 Disk Drives x2		(16D+2P)x2		1180	1770	2350	4700	7050	
30 Disk Drives x2		(28D+2P)x2		1470	2220	2950	5900	8850	
3 Disk Drives x2		RAID 5	(2D+1P)x2	450	670	890	1780	2670	
5 Disk Drives x2			(4D+1P)x2	510	760	1010	2020	3030	
9 Disk Drives x2			(8D+1P)x2	640	950	1270	2540	3810	
11 Disk Drives x2			(10D+1P)x2	710	1070	1420	2840	4260	
13 Disk Drives x2			(12D+1P)x2	740	1110	1470	2940	4410	
16 Disk Drives x2			(15D+1P)x2	780	1180	1560	3120	4680	
4 Disk Drives x2		RAID 1+0	(2D+2D)x2	840	1250	1660	3320	4980	
8 Disk Drives x2			(4D+4D)x2	1680	2510	3350	6700	10050	
16 Disk Drives x2			(8D+8D)x2	3520	5280	7030	14060	21090	
2 Disk Drives x2		RAID 1	(1D+1D)x2	420	630	830	1660	2490	

*1 : The drive capacity values are calculated as 1 G byte =1,000,000,000 bytes. This definition is different from that calculated as 1 k byte =1,024 bytes, which are actually displayed on PCs that you are using.

The RAID group capacity values displayed in the Hitachi Storage Navigator Modular 2 are calculated as 1 k byte =1,024 bytes.

*2 : AMS 2010 does not support 491.25 G bytes and 737.49 G bytes Disk Drives.

‡1 : Two RAID groups = one RAID group/controller0 and one RAID group/controller1.

Table 6.1.3.4 Standard Times Required for Forced Parity Correction for Two RAID Groups (SAS7.2K Disk Drive) (without Host I/O, Two RAID Group) (‡1)

				Unit : min	
Item	Disk Drives (G byte) (‡1)			1,956.94	
AMS2300 AMS2100 AMS2010	4 Disk Drives x2	RAID 6	(2D+2P)x2	2810	
	6 Disk Drives x2		(4D+2P)x2	3090	
	10 Disk Drives x2		(8D+2P)x2	3640	
	14 Disk Drives x2		(12D+2P)x2	4120	
	18 Disk Drives x2		(16D+2P)x2	4530	
	30 Disk Drives x2		(28D+2P)x2	5490	
	3 Disk Drives x2	RAID 5	(2D+1P)x2	1640	
	5 Disk Drives x2		(4D+1P)x2	1850	
	9 Disk Drives x2		(8D+1P)x2	2330	
	11 Disk Drives x2		(10D+1P)x2	2610	
	13 Disk Drives x2		(12D+1P)x2	2880	
	16 Disk Drives x2		(15D+1P)x2	3220	
	4 Disk Drives x2	RAID 1+0	(2D+2D)x2	2950	
	8 Disk Drives x2		(4D+4D)x2	5840	
	16 Disk Drives x2		(8D+8D)x2	12160	
	2 Disk Drives x2	RAID 1	(1D+1D)x2	1510	
	AMS2500	4 Disk Drives x2	RAID 6	(2D+2P)x2	3160
		6 Disk Drives x2		(4D+2P)x2	3430
10 Disk Drives x2		(8D+2P)x2		3980	
14 Disk Drives x2		(12D+2P)x2		4460	
18 Disk Drives x2		(16D+2P)x2		4870	
30 Disk Drives x2		(28D+2P)x2		5840	
3 Disk Drives x2		RAID 5	(2D+1P)x2	1780	
5 Disk Drives x2			(4D+1P)x2	2060	
9 Disk Drives x2			(8D+1P)x2	2540	
11 Disk Drives x2			(10D+1P)x2	2810	
13 Disk Drives x2			(12D+1P)x2	3020	
16 Disk Drives x2			(15D+1P)x2	3290	
4 Disk Drives x2		RAID 1+0	(2D+2D)x2	3290	
16 Disk Drives x2			(8D+8D)x2	13330	
2 Disk Drives x2			RAID 1	(1D+1D)x2	1640

*1 : The drive capacity values are calculated as 1 G byte =1,000,000,000 bytes. This definition is different from that calculated as 1 k byte =1,024 bytes, which are actually displayed on PCs that you are using.
The RAID group capacity values displayed in the Hitachi Storage Navigator Modular 2 are calculated as 1 k byte =1,024 bytes.

‡1 : Two RAID groups = one RAID group/controller0 and one RAID group/controller1.

**Table 6.1.3.5 Standard Times Required for Forced Parity Correction for Two RAID Groups (Flash Drive)
(without Host I/O, Two RAID Group) (‡1)**

				Unit : min
Item	Disk Drives (G byte) (‡1)			195.82
AMS2300 AMS2100	4 Disk Drives x2	RAID 6	(2D+2P)x2	310
	6 Disk Drives x2		(4D+2P)x2	330
	10 Disk Drives x2		(8D+2P)x2	390
	14 Disk Drives x2		(12D+2P)x2	430
	18 Disk Drives x2		(16D+2P)x2	490
	30 Disk Drives x2		(28D+2P)x2	590
	3 Disk Drives x2	RAID 5	(2D+1P)x2	190
	5 Disk Drives x2		(4D+1P)x2	210
	9 Disk Drives x2		(8D+1P)x2	250
	11 Disk Drives x2		(10D+1P)x2	290
	13 Disk Drives x2		(12D+1P)x2	310
	16 Disk Drives x2		(15D+1P)x2	350
	4 Disk Drives x2	RAID 1+0	(2D+2D)x2	310
	8 Disk Drives x2		(4D+4D)x2	650
	16 Disk Drives x2		(8D+8D)x2	1270
2 Disk Drives x2	RAID 1	(1D+1D)x2	170	
AMS2500	4 Disk Drives x2	RAID 6	(2D+2P)x2	350
	6 Disk Drives x2		(4D+2P)x2	370
	10 Disk Drives x2		(8D+2P)x2	430
	14 Disk Drives x2		(12D+2P)x2	470
	18 Disk Drives x2		(16D+2P)x2	510
	30 Disk Drives x2		(28D+2P)x2	610
	3 Disk Drives x2	RAID 5	(2D+1P)x2	190
	5 Disk Drives x2		(4D+1P)x2	230
	9 Disk Drives x2		(8D+1P)x2	270
	11 Disk Drives x2		(10D+1P)x2	310
	13 Disk Drives x2		(12D+1P)x2	330
	16 Disk Drives x2		(15D+1P)x2	350
	4 Disk Drives x2	RAID 1+0	(2D+2D)x2	350
	16 Disk Drives x2		(8D+8D)x2	1390
	2 Disk Drives x2		RAID 1	(1D+1D)x2

*1 : The drive capacity values are calculated as 1 G byte =1,000,000,000 bytes. This definition is different from that calculated as 1 k byte =1,024 bytes, which are actually displayed on PCs that you are using.
The RAID group capacity values displayed in the Hitachi Storage Navigator Modular 2 are calculated as 1 k byte =1,024 bytes.

‡1 : Two RAID groups = one RAID group/controller0 and one RAID group/controller1.

- NOTE :
- The data in [Table 6.1.4](#), to [Table 6.1.4.4](#) indicates the standard times required for forced parity correction for two RAID groups when 146 G bytes, 500 G bytes, and 200 G bytes Disk Drives are used. The times required for recovery processing varies in proportion to Disk Drive capacity.
 - The standard times required for Forced Parity Correction for SAS (SED) is the same as that for SAS Disk Drives. Refer to [Table 6.1.4](#).

**Table 6.1.4 Standard Times Required for Forced Parity Correction for Two RAID Groups^(‡1)
(3.5-type SAS Disk Drive) (When Host I/Os Are Executed)**

	RAID level		Capacity ^(*1)	Host performance	Parity correction
AMS2300 AMS2100 (142.61 Gbytes HDU used)	RAID 6	(4D+2P)x2	533.8 Gbytes	850 IOPS	260 min
		(28D+2P)x2	3736.8 Gbytes	750 IOPS	450 min
	RAID 5	(4D+1P)x2	533.8 Gbytes	1300 IOPS	180 min
		(15D+1P)x2	2001.9 Gbytes	1250 IOPS	260 min
	RAID 1+0	(2D+2D)x2	266.9 Gbytes	1350 IOPS	310 min
(8D+8D)x2		1067.7 Gbytes	1340 IOPS	1140 min	
RAID 1	(1D+1D)x2	133.4 Gbytes	460 IOPS	350 min	
AMS2010 (439.44 Gbytes HDU used)	RAID 6	(4D+2P)x2	1757.7 Gbytes	850 IOPS	810 min
		(28D+2P)x2	12304.3 Gbytes	750 IOPS	1390 min
	RAID 5	(4D+1P)x2	1757.7 Gbytes	1300 IOPS	560 min
		(15D+1P)x2	6591.6 Gbytes	1250 IOPS	810 min
	RAID 1+0	(2D+2D)x2	878.8 Gbytes	1350 IOPS	960 min
(8D+8D)x2		3515.5 Gbytes	1340 IOPS	3520 min	
RAID 1	(1D+1D)x2	439.4 Gbytes	460 IOPS	1080 min	
AMS2500 (142.61 Gbytes HDU used)	RAID 6	(4D+2P)x2	533.8 Gbytes	2000 IOPS	310 min
		(28D+2P)x2	3736.8 Gbytes	2660 IOPS	490 min
	RAID 5	(4D+1P)x2	533.8 Gbytes	2640 IOPS	230 min
		(15D+1P)x2	2001.9 Gbytes	3530 IOPS	280 min
	RAID 1+0	(2D+2D)x2	266.9 Gbytes	2450 IOPS	360 min
(8D+8D)x2		1067.7 Gbytes	3690 IOPS	1270 min	
RAID 1	(1D+1D)x2	133.4 Gbytes	2070 IOPS	270 min	

*1 : The drive capacity values are calculated as 1 G byte =1,000,000,000 bytes. This definition is different from that calculated as 1 k byte =1,024 bytes, which are actually displayed on PCs that you are using.

The RAID group capacity values displayed in the Hitachi Storage Navigator Modular 2 are calculated as 1 k byte =1,024 bytes.

‡1 : Two RAID groups = one RAID group/controller0 and one RAID group/controller1

**Table 6.1.4.1 Standard Times Required for Forced Parity Correction for Two RAID Groups^{‡1)}
(2.5-type SAS Disk Drive) (When Host I/Os Are Executed)**

	RAID level		Capacity ^(*)	Host performance	Parity correction
AMS2300 AMS2100 (287.62 Gbytes HDU used)	RAID 6	(4D+2P)x2	1067.6 Gbytes	850 IOPS	520 min
		(28D+2P)x2	7473.6 Gbytes	750 IOPS	900 min
	RAID 5	(4D+1P)x2	1067.6 Gbytes	1300 IOPS	360 min
		(15D+1P)x2	4003.8 Gbytes	1250 IOPS	520 min
	RAID 1+0	(2D+2D)x2	533.8 Gbytes	1350 IOPS	620 min
		(8D+8D)x2	2135.4 Gbytes	1340 IOPS	2280 min
RAID 1	(1D+1D)x2	266.8 Gbytes	460 IOPS	700 min	
AMS2010 (575.30 Gbytes HDU used)	RAID 6	(4D+2P)x2	1171.8 Gbytes	850 IOPS	540 min
		(28D+2P)x2	8202.9 Gbytes	750 IOPS	930 min
	RAID 5	(4D+1P)x2	1171.8 Gbytes	1300 IOPS	380 min
		(15D+1P)x2	4394.4 Gbytes	1250 IOPS	540 min
	RAID 1+0	(2D+2D)x2	585.9 Gbytes	1350 IOPS	640 min
		(8D+8D)x2	2343.7 Gbytes	1340 IOPS	2350 min
RAID 1	(1D+1D)x2	293.0Gbytes	460 IOPS	720 min	
AMS2500 (287.62 Gbytes HDU used)	RAID 6	(4D+2P)x2	1067.6 Gbytes	2000 IOPS	620 min
		(28D+2P)x2	7473.6 Gbytes	2660 IOPS	980 min
	RAID 5	(4D+1P)x2	1067.6 Gbytes	2640 IOPS	460 min
		(15D+1P)x2	4003.8 Gbytes	3530 IOPS	560 min
	RAID 1+0	(2D+2D)x2	533.8 Gbytes	2450 IOPS	720 min
		(8D+8D)x2	2135.4 Gbytes	3690 IOPS	2540 min
RAID 1	(1D+1D)x2	266.8 Gbytes	2070 IOPS	540 min	

*1 : The drive capacity values are calculated as 1 G byte =1,000,000,000 bytes. This definition is different from that calculated as 1 k byte =1,024 bytes, which are actually displayed on PCs that you are using.

The RAID group capacity values displayed in the Hitachi Storage Navigator Modular 2 are calculated as 1 k byte =1,024 bytes.

‡1 : Two RAID groups = one RAID group/controller0 and one RAID group/controller1

**Table 6.1.4.2 Standard Times Required for Forced Parity Correction for Two RAID Groups^{‡1)}
(SATA Disk Drive) (When Host I/Os Are Executed)**

	RAID level		Capacity ^(*)	Host performance	Parity correction
AMS2300 AMS2100 (491.25 Gbytes HDU used)	RAID 6	(4D+2P)x2	915.3 Gbytes	630 IOPS	1310 min
		(28D+2P)x2	6407.1 Gbytes	880 IOPS	1720 min
	RAID 5	(4D+1P)x2	915.3 Gbytes	790 IOPS	1040 min
		(15D+1P)x2	3432.3 Gbytes	1000 IOPS	1100 min
	RAID 1+0	(2D+2D)x2	457.7 Gbytes	660 IOPS	1830 min
		(8D+8D)x2	1830.6 Gbytes	1000 IOPS	5280 min
RAID 1	(1D+1D)x2	228.8 Gbytes	470 IOPS	1370 min	
AMS2010 (983.69 Gbytes HDU used)	RAID 6	(4D+2P)x2	3934.7 Gbytes	630 IOPS	2620 min
		(28D+2P)x2	27543.3 Gbytes	880 IOPS	3440 min
	RAID 5	(4D+1P)x2	3934.7 Gbytes	790 IOPS	2080 min
		(15D+1P)x2	14755.3 Gbytes	1000 IOPS	2200 min
	RAID 1+0	(2D+2D)x2	1967.3 Gbytes	660 IOPS	3660 min
		(8D+8D)x2	7869.5 Gbytes	1000 IOPS	10560 min
RAID 1	(1D+1D)x2	983.69 Gbytes	470 IOPS	2740 min	
AMS2500 (491.25 Gbytes HDU used)	RAID 6	(4D+2P)x2	915.3 Gbytes	1090 IOPS	1690 min
		(28D+2P)x2	6407.1 Gbytes	1880 IOPS	1500 min
	RAID 5	(4D+1P)x2	915.3 Gbytes	1270 IOPS	1440 min
		(15D+1P)x2	3432.3 Gbytes	1990 IOPS	1280 min
	RAID 1+0	(2D+2D)x2	457.7 Gbytes	1010 IOPS	2570 min
		(8D+8D)x2	1830.6 Gbytes	1830 IOPS	6370 min
RAID 1	(1D+1D)x2	228.8 Gbytes	650 IOPS	10450 min	

*1 : The drive capacity values are calculated as 1 G byte =1,000,000,000 bytes. This definition is different from that calculated as 1 k byte =1,024 bytes, which are actually displayed on PCs that you are using.

The RAID group capacity values displayed in the Hitachi Storage Navigator Modular 2 are calculated as 1 k byte =1,024 bytes.

‡1 : Two RAID groups = one RAID group/controller0 and one RAID group/controller1

**Table 6.1.4.3 Standard Times Required for Forced Parity Correction for Two RAID Groups^{‡1)}
(SAS7.2K Disk Drive) (When Host I/Os Are Executed)**

	RAID level		Host performance	Parity correction
	RAID level			
AMS2300 AMS2100 AMS2010 (1,956.94 Gbytes HDU used)	RAID 6	(4D+2P)x2	800 IOPS	3920 min
		(28D+2P)x2	710 IOPS	6790 min
	RAID 5	(4D+1P)x2	1230 IOPS	2710 min
		(15D+1P)x2	1180 IOPS	3920 min
	RAID 1+0	(2D+2D)x2	1280 IOPS	4670 min
		(8D+8D)x2	1270 IOPS	17200 min
RAID 1	(1D+1D)x2	430 IOPS	5280 min	
AMS2500 (1,956.94 Gbytes HDU used)	RAID 6	(4D+2P)x2	1900 IOPS	4670 min
		(28D+2P)x2	2520 IOPS	7390 min
	RAID 5	(4D+1P)x2	2500 IOPS	3470 min
		(15D+1P)x2	3350 IOPS	4220 min
	RAID 1+0	(2D+2D)x2	2320 IOPS	5430 min
		(8D+8D)x2	3500 IOPS	19170 min
	RAID 1	(1D+1D)x2	1960 IOPS	4070 min

‡1 : Two RAID groups = one RAID group/controller0 and one RAID group/controller1

**Table 6.1.4.4 Standard Times Required for Forced Parity Correction for Two RAID Groups^{‡1)} (Flash Drive)
(When Host I/Os Are Executed)**

	RAID level		Capacity ^(*)	Host performance	Parity correction
AMS2300 AMS2100 (195.82 Gbytes HDU used)	RAID 6	(4D+2P)x2	725.4 Gbytes	2500 IOPS	380 min
	RAID 5	(4D+1P)x2	725.4 Gbytes	4000 IOPS	280 min
	RAID 1+0	(2D+2D)x2	362.6 Gbytes	4000 IOPS	400 min
	RAID 1	(1D+1D)x2	181.3 Gbytes	3000 IOPS	220 min
AMS2500 (195.82 Gbytes HDU used)	RAID 6	(4D+2P)x2	725.4 Gbytes	4000 IOPS	440 min
	RAID 5	(4D+1P)x2	725.4 Gbytes	7000 IOPS	300 min
	RAID 1+0	(2D+2D)x2	362.6 Gbytes	7000 IOPS	480 min
	RAID 1	(1D+1D)x2	181.3 Gbytes	6000 IOPS	240 min

*1 : The drive capacity values are calculated as 1 G byte =1,000,000,000 bytes. This definition is different from that calculated as 1 k byte =1,024 bytes, which are actually displayed on PCs that you are using.

The RAID group capacity values displayed in the Hitachi Storage Navigator Modular 2 are calculated as 1 k byte =1,024 bytes.

Conditions of measurement of a time required for the forced parity correction are as follows.

- Each of all LUs belongs to different RAID group.
- Only one LU per CTL is restored and an host I/O of random reading (75%) and writing (25%) of 4-kbyte data TAG8 is executed for all the LUs.

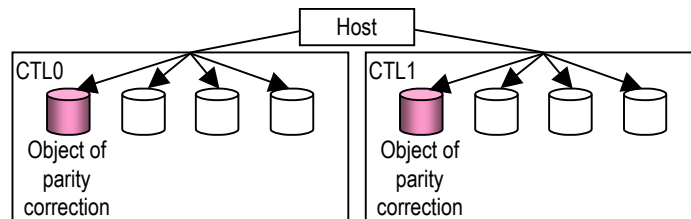

‡1 : Two RAID groups = one RAID group/controller0 and one RAID group/controller1

6.1.4 The Power cannot be Turned Off : Case 1 (The Number of PIN Data is Too Large)

(The planned shutdown cannot be performed due to the Disk Drive/Control Unit failure)

[WEB Information Message display]

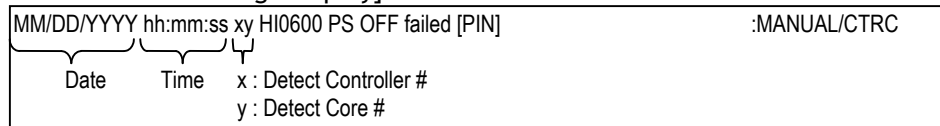

[Recovery method]

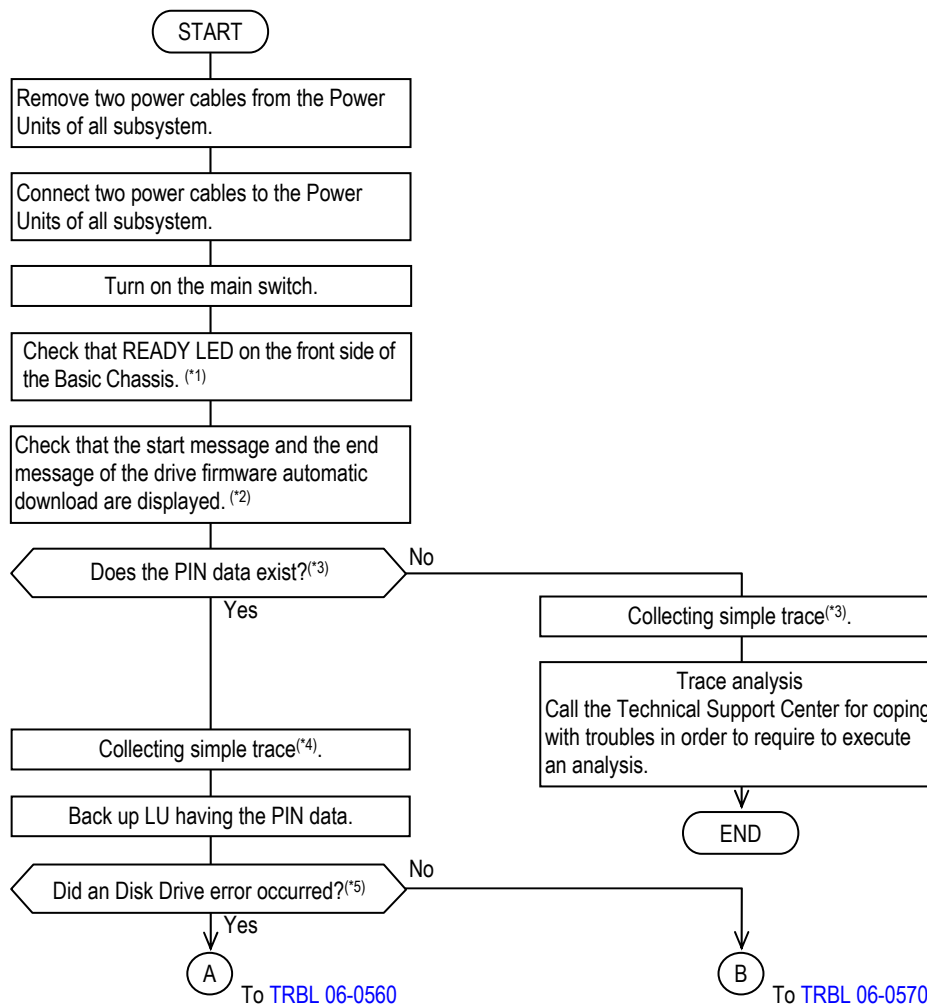

*1 : Wait if the READY LED (green) on the front of the Basic Chassis is blinking at high speed (for the maximum of 30 to 50 minutes, or 40 to 60 minutes in case of the RKH), or the WARNING LED (orange) is blinking at high speed (for the maximum of 30 to 85 minutes).

*2 : When the drive firmware version of the disk drive is new, the start message and completion message of the drive firmware automatic download are not displayed. To check the drive firmware automatic download, refer to [Firmware "1.6 \(4\) Checking the start message and end message of the automatic download \(FIRM 01-0890\)"](#).

*3 : Checking the presence of PIN data is performed by the Maintenance function of Hitachi Storage Navigator Modular 2. Refer to ["10.2.3 Displaying Logical Unit Failure Data Information" \(TRBL 10-0100\)](#).

*4 : For the collection simple trace, refer to ["7.3 Collecting Simple Trace" \(TRBL 07-0040\)](#).

*5 : For checking a Disk Drive error, refer to ["8.2 \(2\) Trouble analysis based on LED indication of Disk Drive" \(TRBL 08-0160\)](#) or ["Chapter 4. Trouble Analysis by WEB Connection" \(TRBL 04-0000\)](#).

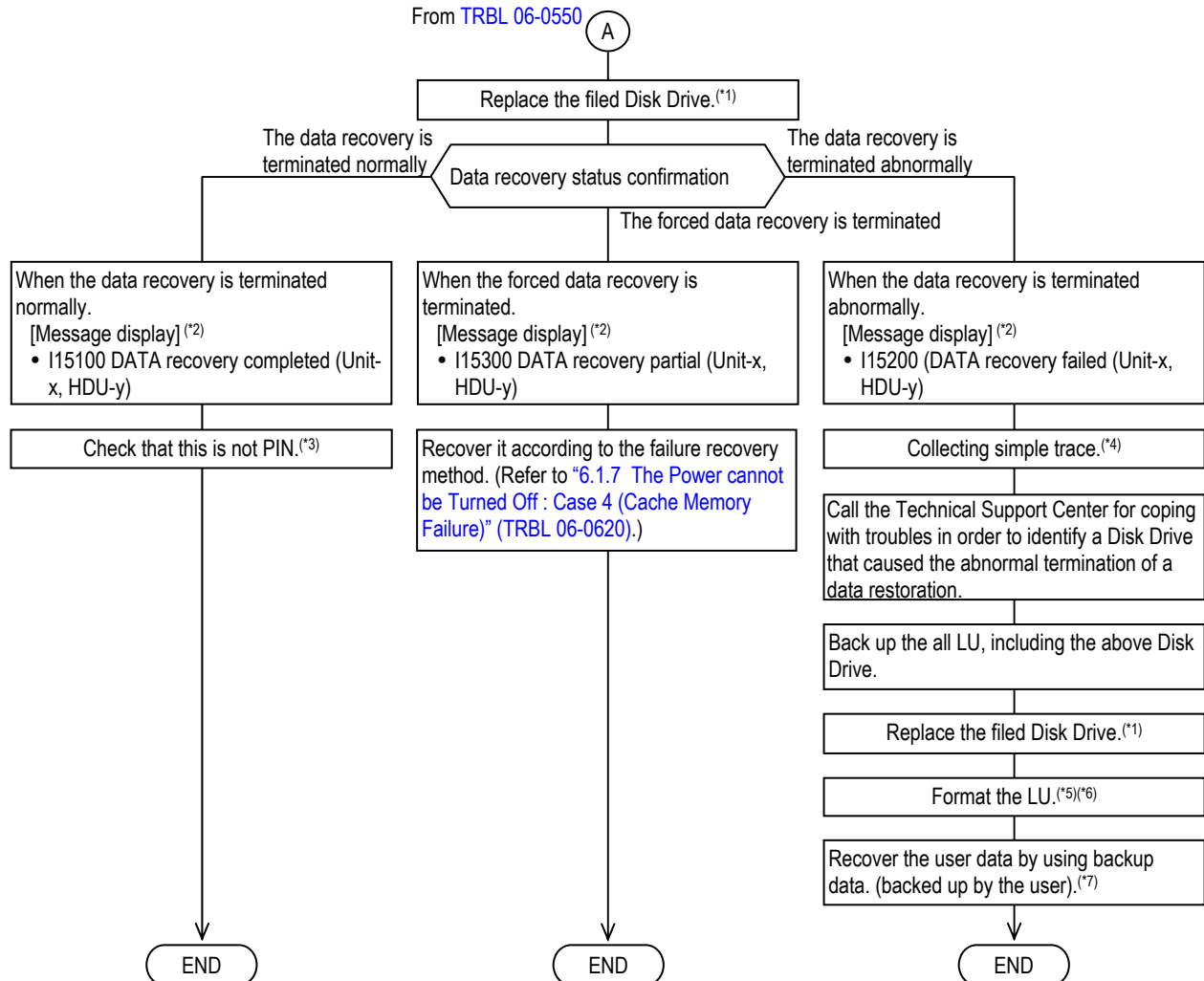

*1 : For the replacement of the Disk Drive, refer to the Replacement “2.2.1 Replacing Disk Drive” (REP 02-0030).

*2 : For the connection of the WEB, refer to “Chapter 3. Before Starting WEB Connection” (TRBL 03-0000).

*3 : Checking the presence of PIN data is performed by the Maintenance function of Hitachi Storage Navigator Modular 2. Refer to “10.2.3 Displaying Logical Unit Failure Data Information” (TRBL 10-0100).

*4 : For the Collection simple trace, refer to “7.3 Collecting Simple Trace” (TRBL 07-0040).

*5 : There may be a case that the LU formatting fails. In this case, request a user to check if a sense code is reported in the log of a host computer. When the reported sense code is “05-9552” or “05-9577”, the LU concerned is an object of ShadowImage in-system replication, TrueCopy remote replication, TrueCopy Extended Distance or Copy-on-write SnapShot. Therefore, request a user to release the pair and execute the LU formatting again after it is released. (Refer to System Parameter “3.3 [Procedure ©-F] Formatting LU” (SYSPR 03-0290).)

Also, the backup restoration cannot be done for the LU whose access attribute is set as other than Read/Write by Data Retention Utility because it cannot be formatted or written.

*6 : Check with the user whether the Dynamic Provisioning function is used, and if it is used, request the user to recover the DP pool.

Moreover, check with the customer for the format status of the DP volume, and if the DP volume is unformatted, perform the LU format.

*7 : Check with the user whether the LU to be restored from the backup data is using the Dynamic Provisioning function.

If it is used, restore the backup data according to the user’s instruction.

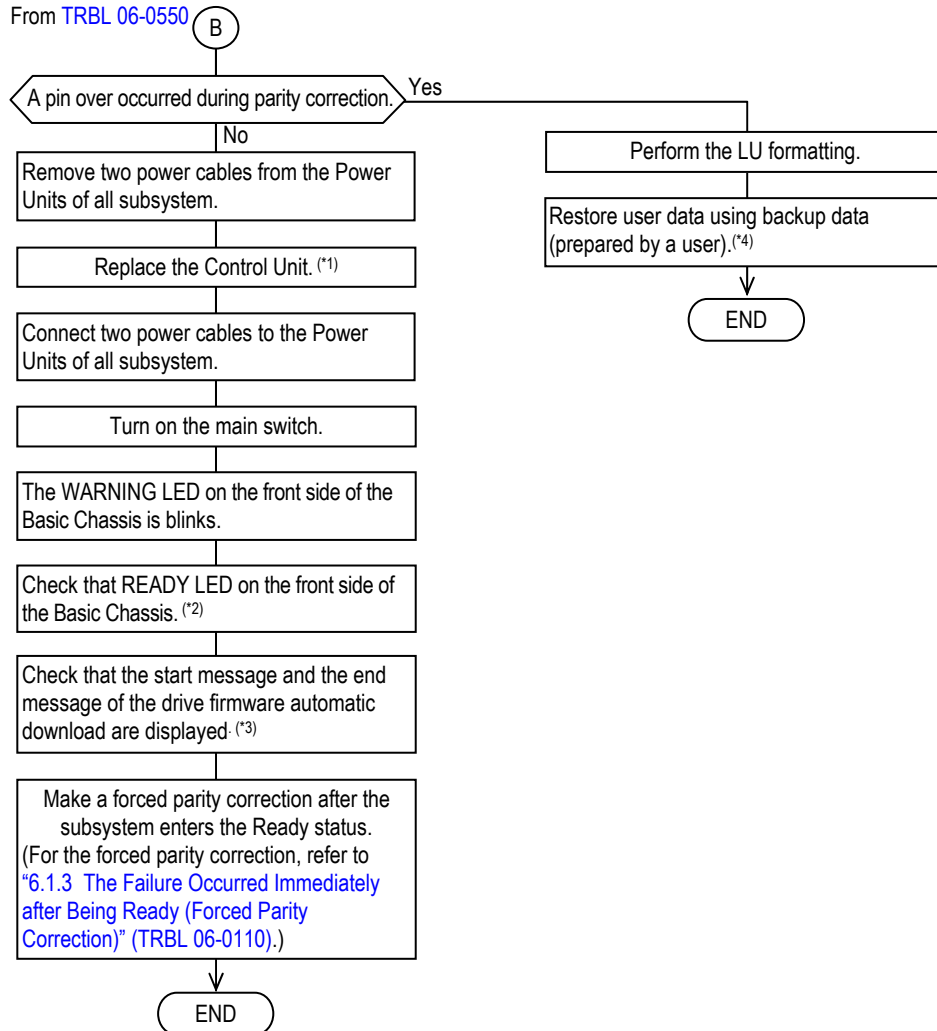

- *1 : For the replacement of the Control Unit, refer to the [Replacement "2.2.5 Replacing Control Unit" \(REP 02-0450\)](#).
- *2 : Wait if the READY LED (green) on the front of the Basic Chassis is blinking at high speed (for the maximum of 30 to 50 minutes, or 40 to 60 minutes in case of the RKH), or the WARNING LED (orange) is blinking at high speed (for the maximum of 30 to 85 minutes).
- *3 : When the drive firmware version of the disk drive is new, the start message and completion message of the drive firmware automatic download are not displayed. To check the drive firmware automatic download, refer to [Firmware "1.6 \(4\) Checking the start message and end message of the automatic download \(FIRM 01-0890\)"](#).
- *4 : Check with the user whether the LU to be restored from the backup data is using the Dynamic Provisioning function. If it is used, restore the backup data according to the user's instruction.

6.1.5 The Power cannot be Turned Off : Case 2 (Hardware Failure)

(It tried to store the PIN data in the Disk Drive at the time of the planned shutdown, but it cannot POWER OFF because a hardware failure occurred)

[WEB Information Message display]

MM/DD/YYYY	hh:mm:ss	xy	W36000 PIN write error	:MANUAL/STRC
Date	Time	x : Detect Controller #	y : Detect Core #	

[Recovery method]

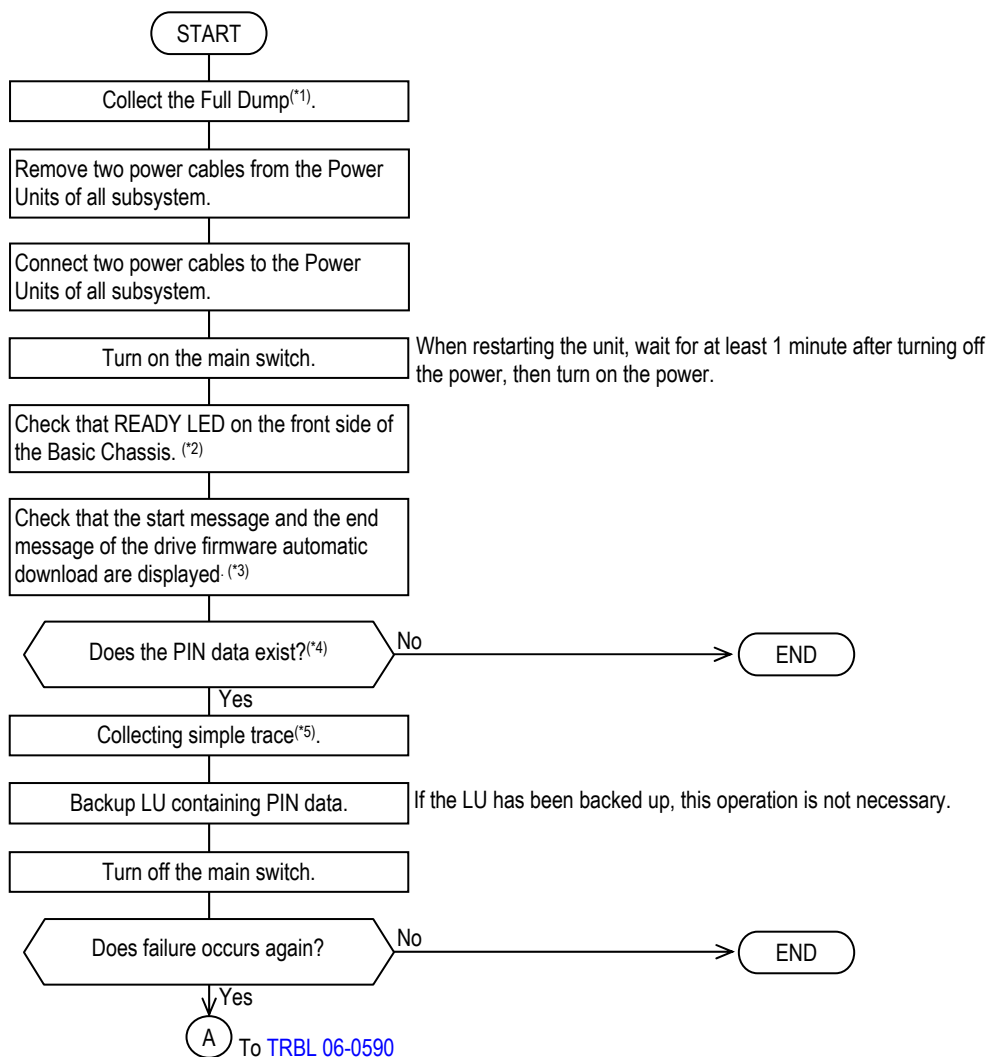

*1 : For the collection Full Dump, refer to “7.5 Collecting Full Dump” (TRBL 07-0140).

*2 : Wait if the READY LED (green) on the front of the Basic Chassis is blinking at high speed (for the maximum of 30 to 50 minutes, or 40 to 60 minutes in case of the RKH), or the WARNING LED (orange) is blinking at high speed (for the maximum of 30 to 85 minutes).

*3 : When the drive firmware version of the disk drive is new, the start message and completion message of the drive firmware automatic download are not displayed. To check the drive firmware automatic download, refer to [Firmware “1.6 \(4\) Checking the start message and end message of the automatic download \(FIRM 01-0890\)”](#).

*4 : Checking the presence of PIN data is performed by the Maintenance function of Hitachi Storage Navigator Modular 2. Refer to “10.2.3 Displaying Logical Unit Failure Data Information” (TRBL 10-0100).

*5 : For the Collection simple trace, refer to “7.3 Collecting Simple Trace” (TRBL 07-0040).

From TRBL 06-0580

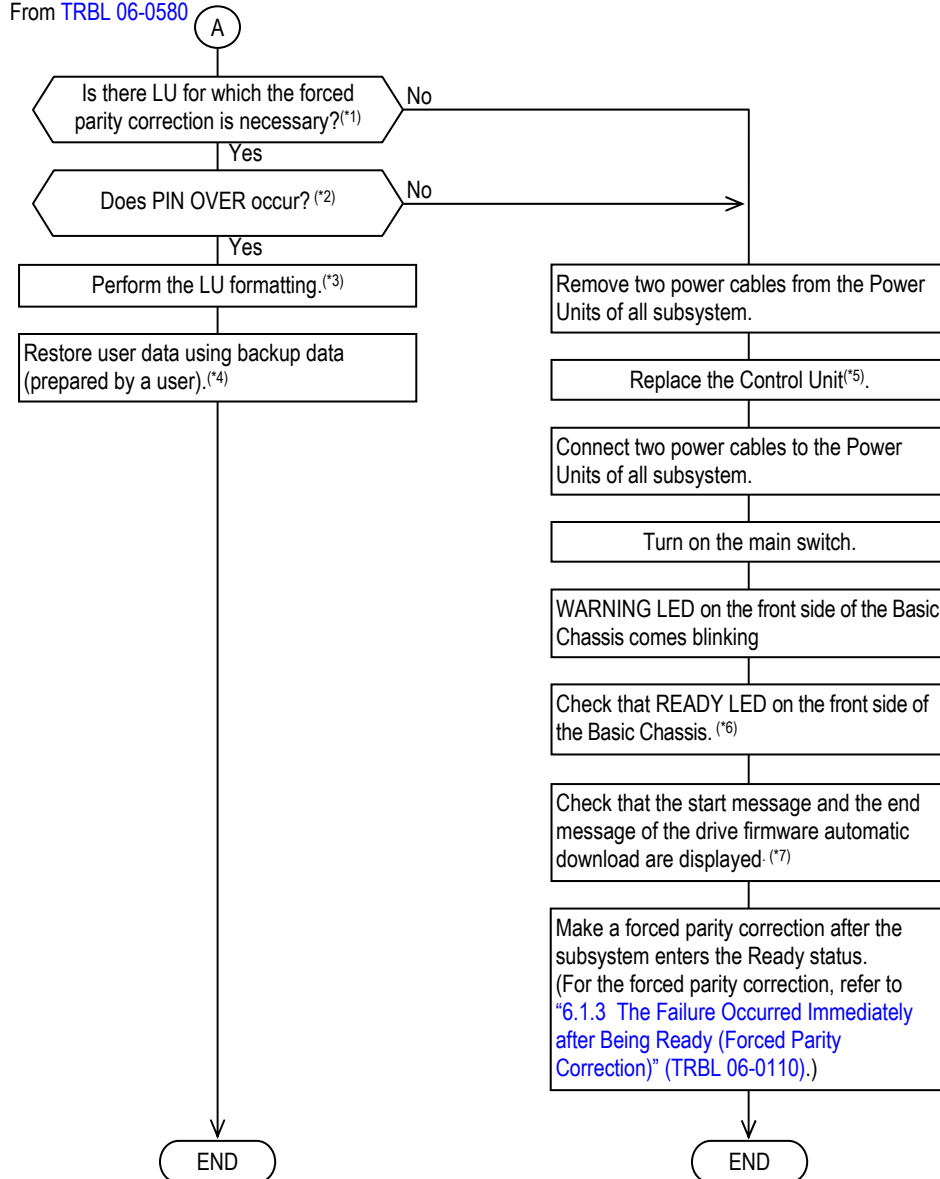

*1 : The message code “W3D000 Forced parity correction LU is detected” is displayed in the Information Message on the WEB, and the WARNING LED (orange) on the Basic Chassis (front side of the subsystem) lights on or blinks.

*2 : The message codes “W3G000”, “W3H000”, “W3J000”, “W3K000”, “W3L000” and “W3M000” are displayed in the Information Message on the WEB, and the WARNING LED (orange) on the Basic Chassis (front side of the subsystem) lights on or blinks.

*3 : For the LU format, refer to the [System Parameter “3.3 \[Procedure ③-F\] Formatting LU” \(SYSPR 03-0290\)](#).

*4 : Check with the user whether the LU to be restored from the backup data is using the Dynamic Provisioning function. If it is used, restore the backup data according to the user’s instruction.

*5 : For the replacement of the Control Unit, refer to the [Replacement “2.2.5 Replacing Control Unit” \(REP 02-0450\)](#).

*6 : Wait if the READY LED (green) on the front of the Basic Chassis is blinking at high speed (for the maximum of 30 to 50 minutes, or 40 to 60 minutes in case of the RKH), or the WARNING LED (orange) is blinking at high speed (for the maximum of 30 to 85 minutes).

*7 : When the drive firmware version of the disk drive is new, the start message and completion message of the drive firmware automatic download are not displayed. To check the drive firmware automatic download, refer to [Firmware “1.6 \(4\) Checking the start message and end message of the automatic download \(FIRM 01-0890\)”](#).

6.1.6 The Power cannot be Turned Off : Case 3 (Control Unit Failure)

(Planned shutdown cannot be performed because all the Disk Drives to which inheritance information is to be saved disappeared due to a DMA double error or a disk quintuple error.)

[WEB Information Message display]

MM/DD/YYYY	hh:mm:ss	xy	W0S000	PS OFF	failed [NO HDU]	:MANUAL/STRC
Date	Time	x : Detect Controller #			y : Detect Core #	

[Recovery method]

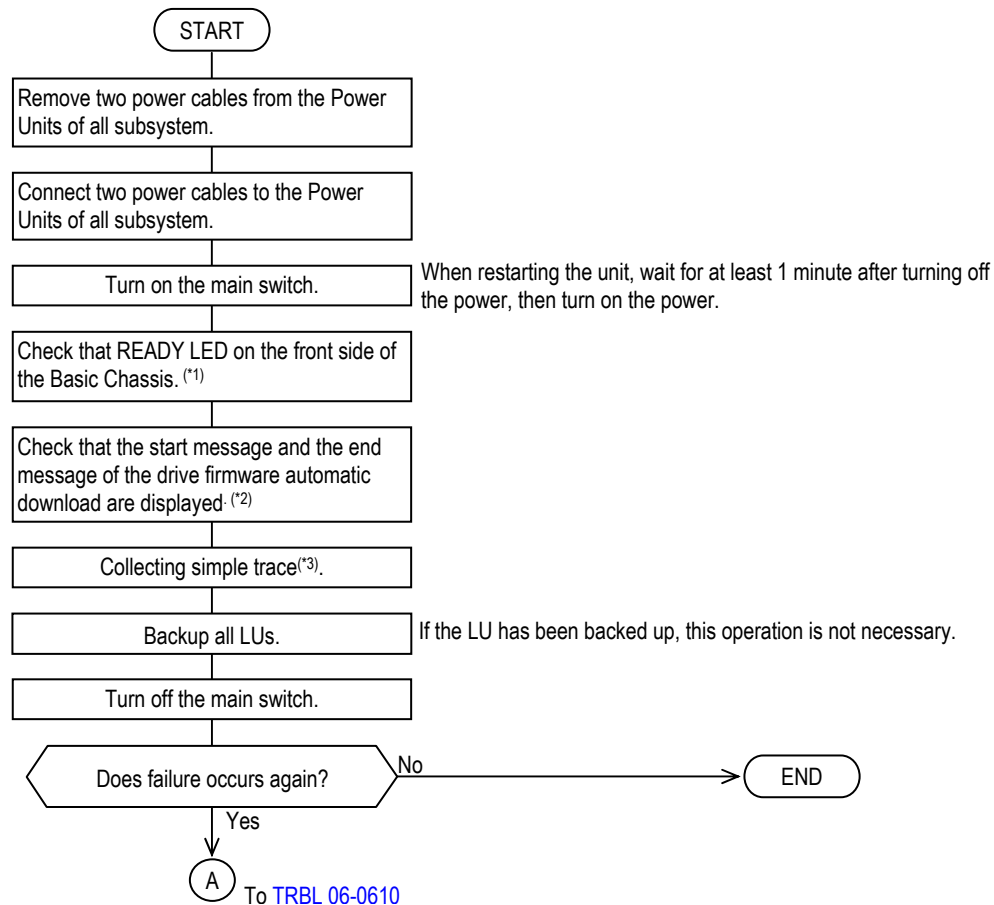

*1 : Wait if the READY LED (green) on the front of the Basic Chassis is blinking at high speed (for the maximum of 30 to 50 minutes, or 40 to 60 minutes in case of the RKH), or the WARNING LED (orange) is blinking at high speed (for the maximum of 30 to 85 minutes).

*2 : When the drive firmware version of the disk drive is new, the start message and completion message of the drive firmware automatic download are not displayed. To check the drive firmware automatic download, refer to [Firmware "1.6 \(4\) Checking the start message and end message of the automatic download \(FIRM 01-0890\)"](#).

*3 : For the Collection simple trace, refer to ["7.3 Collecting Simple Trace" \(TRBL 07-0040\)](#).

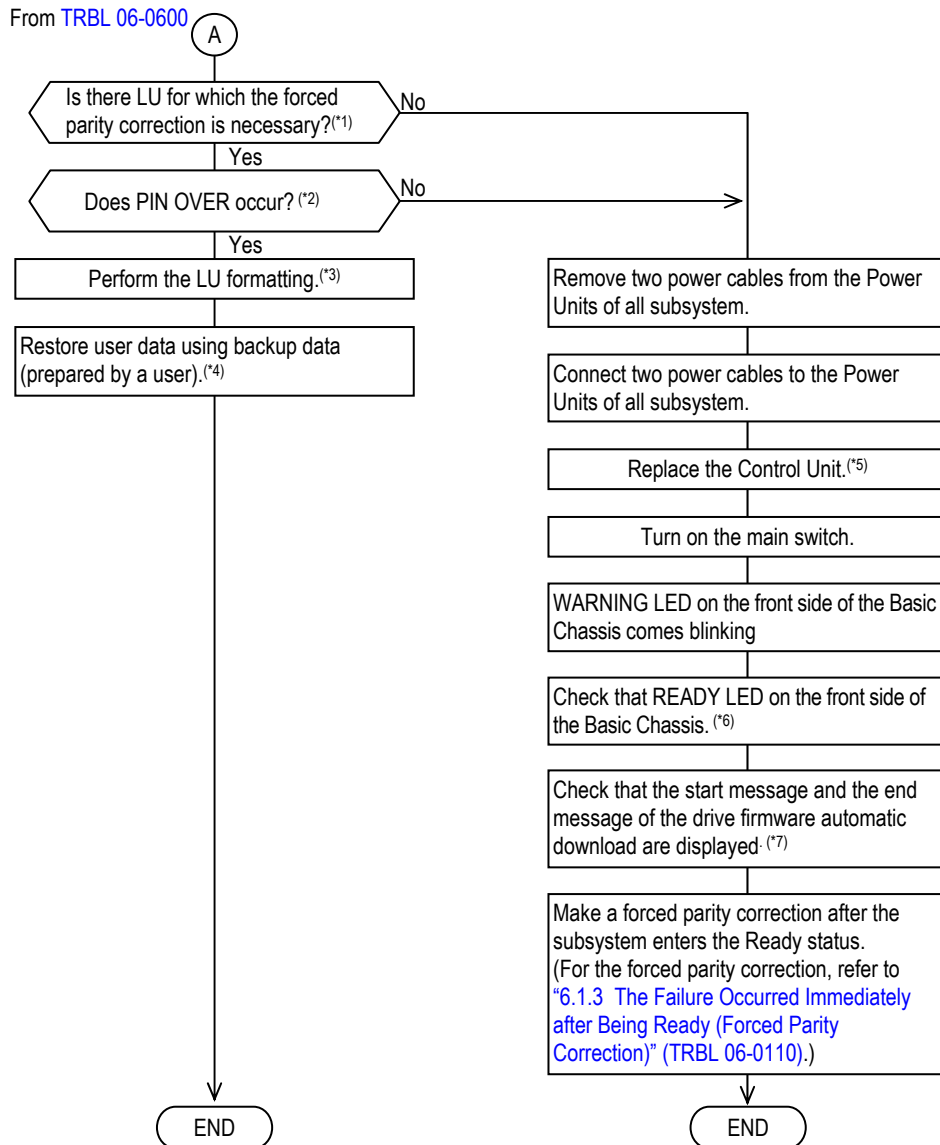

*1 : The message code “W3D000 Forced parity correction LU is detected” is displayed in the Information Message on the WEB, and the WARNING LED (orange) on the Basic Chassis (front side of the subsystem) lights on or blinks.

*2 : The message codes “W3G000”, “W3H000”, “W3J000”, “W3K000”, “W3L000” and “W3M000” are displayed in the Information Message on the WEB, and the WARNING LED (orange) on the Basic Chassis (front side of the subsystem) lights on or blinks.

*3 : For the LU format, refer to the [System Parameter “3.3 \[Procedure ③-F\] Formatting LU” \(SYSPR 03-0290\)](#).

*4 : Check with the user whether the LU to be restored from the backup data is using the Dynamic Provisioning function.

If it is used, restore the backup data according to the user’s instruction.

*5 : For the replacement of the Control Unit, refer to the [Replacement “2.2.5 Replacing Control Unit” \(REP 02-0450\)](#).

*6 : Wait if the READY LED (green) on the front of the Basic Chassis is blinking at high speed (for the maximum of 30 to 50 minutes, or 40 to 60 minutes in case of the RKH), or the WARNING LED (orange) is blinking at high speed (for the maximum of 30 to 85 minutes).

*7 : When the drive firmware version of the disk drive is new, the start message and completion message of the drive firmware automatic download are not displayed. To check the drive firmware automatic download, refer to [Firmware “1.6 \(4\) Checking the start message and end message of the automatic download \(FIRM 01-0890\)”](#).

6.1.7 The Power cannot be Turned Off : Case 4 (Cache Memory Failure)

(The PIN data cannot be saved because a Cache memory or other failure occurs, and the planned shutdown cannot be performed)

[WEB Information Message display]

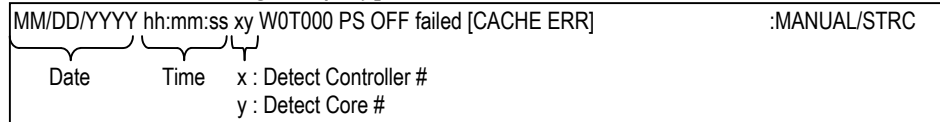

[Recovery method]

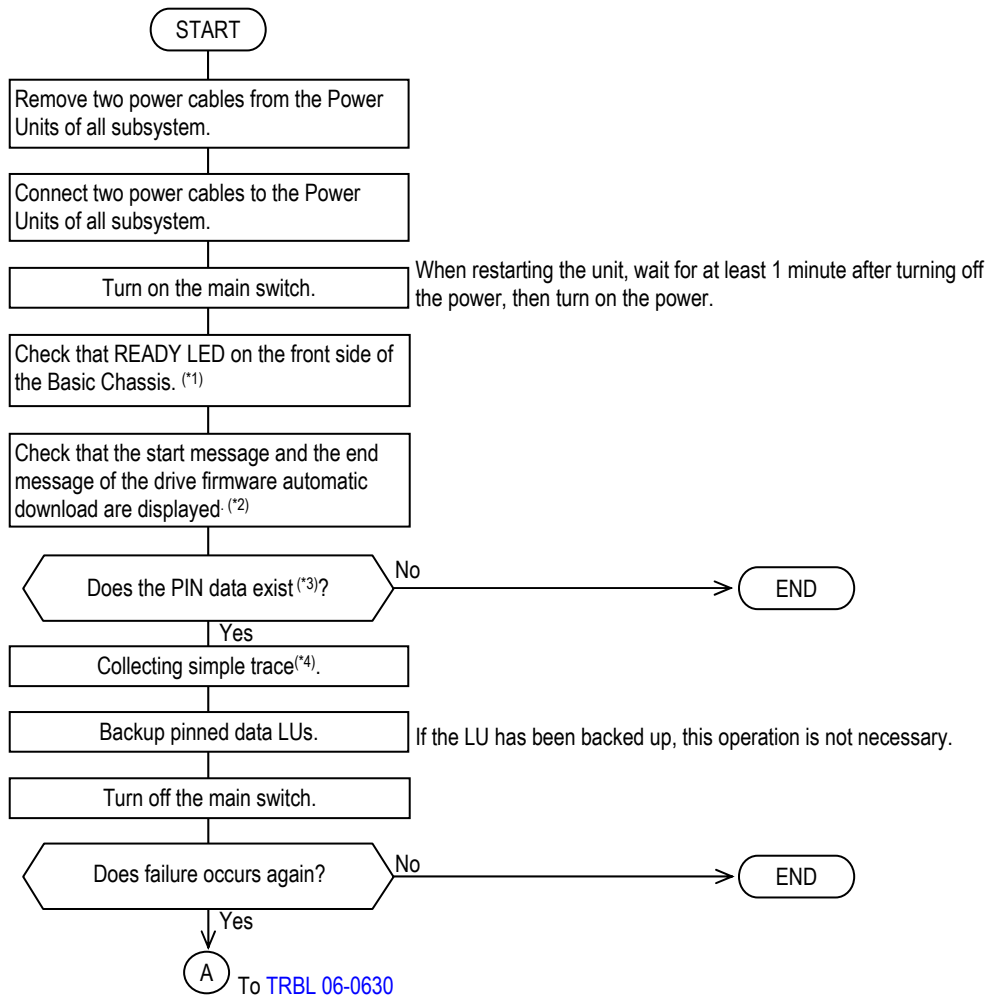

*1 : Wait if the READY LED (green) on the front of the Basic Chassis is blinking at high speed (for the maximum of 30 to 50 minutes, or 40 to 60 minutes in case of the RKH), or the WARNING LED (orange) is blinking at high speed (for the maximum of 30 to 85 minutes).

*2 : When the drive firmware version of the disk drive is new, the start message and completion message of the drive firmware automatic download are not displayed. To check the drive firmware automatic download, refer to [Firmware "1.6 \(4\) Checking the start message and end message of the automatic download \(FIRM 01-0890\)"](#).

*3 : Checking the presence of PIN data is performed by the Maintenance function of Hitachi Storage Navigator Modular 2. Refer to ["10.2.3 Displaying Logical Unit Failure Data Information" \(TRBL 10-0100\)](#).

*4 : For the Collection simple trace, refer to ["7.3 Collecting Simple Trace" \(TRBL 07-0040\)](#).

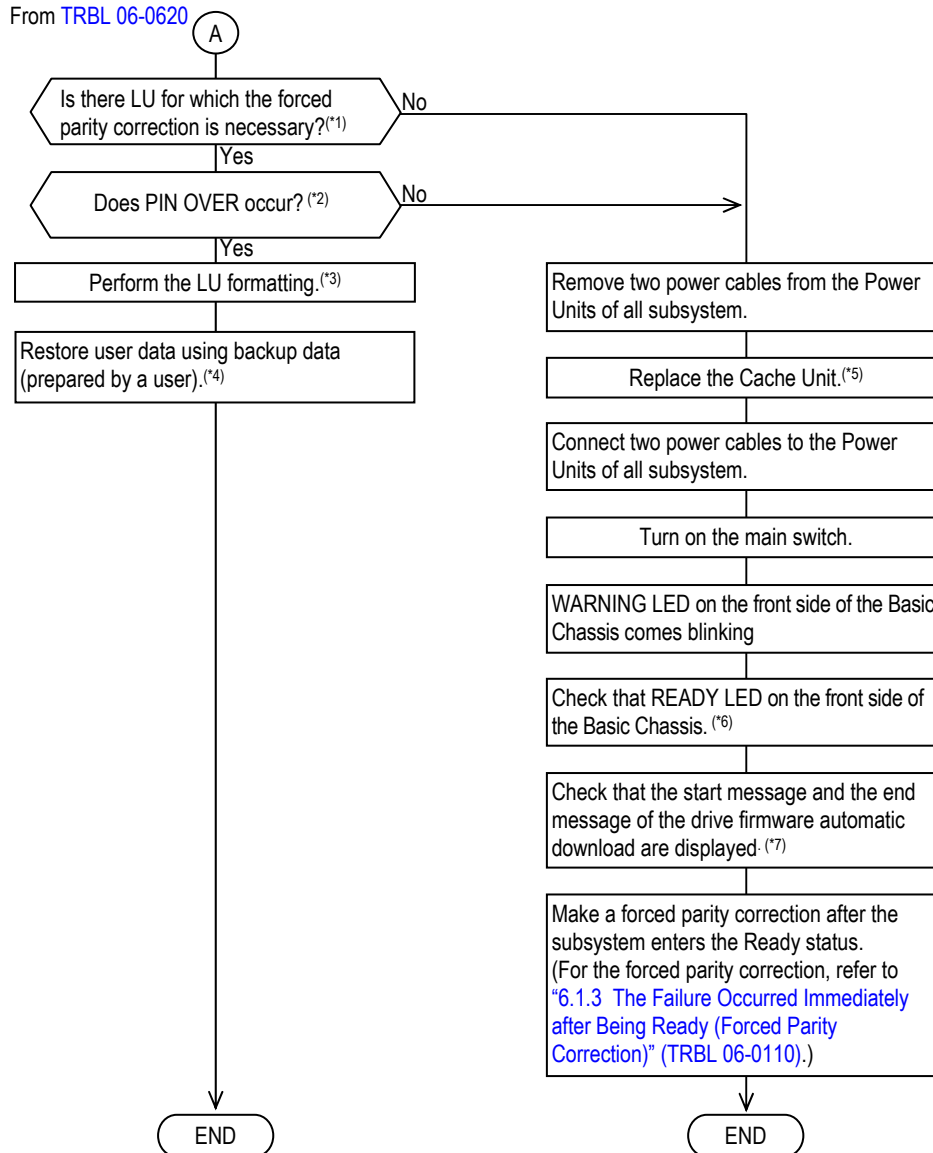

- *1 : The message code “W3D000 Forced parity correction LU is detected” is displayed in the Information Message on the WEB, and the Warning LED (orange) on the Basic Chassis (front side of the subsystem) lights on or blinks.
- *2 : The message codes “W3G000”, “W3H000”, “W3J000”, “W3K000”, “W3L000” and “W3M000” are displayed in the Information Message on the WEB, and the WARNING LED (orange) on the Basic Chassis (front side of the subsystem) lights on or blinks.
- *3 : For the LU format, refer to the [System Parameter “3.3 \[Procedure ③-F\] Formatting LU” \(SYSPR 03-0290\)](#).
- *4 : Check with the user whether the LU to be restored from the backup data is using the Dynamic Provisioning function.
If it is used, restore the backup data according to the user’s instruction.
- *5 : For the replacement of the Cache Unit, refer to the [Replacement “2.2.6 Replacing Cache Unit” \(REP 02-0640\)](#).
- *6 : Wait if the READY LED (green) on the front of the Basic Chassis is blinking at high speed (for the maximum of 30 to 50 minutes, or 40 to 60 minutes in case of the RKH), or the WARNING LED (orange) is blinking at high speed (for the maximum of 30 to 85 minutes).
- *7 : When the drive firmware version of the disk drive is new, the start message and completion message of the drive firmware automatic download are not displayed. To check the drive firmware automatic download, refer to [Firmware “1.6 \(4\) Checking the start message and end message of the automatic download \(FIRM 01-0890\)”](#).

6.1.8 Data Recovery does not Terminate Normally : Case 1 (Read Error)

When a read error occurred in the copy source during the correction copy or copy back, the recovery procedure differs depending on the case that the forced recovery is executed or the data recovery terminated abnormally.

- (1) When a read error occurred in the copy source during the correction copy or copy back, and the forced recovery was executed
 Forced recovery When attempting to read the data which was recovered forcibly, it is reported as a read error.

[WEB Information Message display]

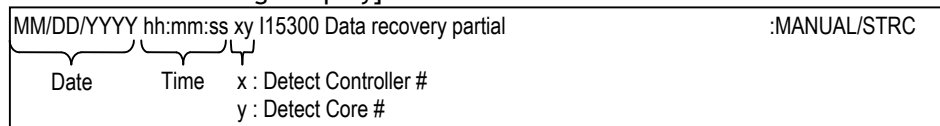

[Recovery method]

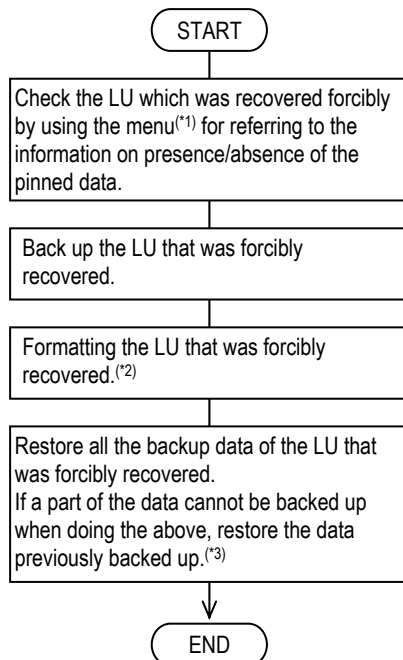

*1 : Checking the presence of PIN data is performed by the Maintenance function of Hitachi Storage Navigator Modular 2. Refer to “10.2.3 Displaying Logical Unit Failure Data Information” (TRBL 10-0100).

*2 : There may be a case that the LU formatting fails. In this case, request a user to check if a sense code is reported in the log of a host computer. When the reported sense code is “05-9552” or “05-9577”, the LU concerned is an object of ShadowImage in-system replication, TrueCopy remote replication, TrueCopy Extended Distance or Copy-on-write SnapShot. Therefore, request a user to release the pair and execute the LU formatting again after it is released. (Refer to System Parameter “3.3 [Procedure ©-F] Formatting LU” (SYSPR 03-0290).)

Also, the backup restoration cannot be done for the LU whose access attribute is set as other than Read/Write by Data Retention Utility because it cannot be formatted or written.

*3 : Check with the user whether the LU to be restored from the backup data is using the Dynamic Provisioning function.

If it is used, restore the backup data according to the user’s instruction.

- (2) When a read error occurred in the copy source during the correction copy or copy back, and the data recovery terminated abnormally

[WEB Information Message display]

MM/DD/YYYY	hh:mm:ss	xy	115200 Data recovery failed (Unit-x, HDU-y)	:MANUAL/STRC
Date	Time	x : Detect Controller #		
		y : Detect Core #		

[Recovery method]

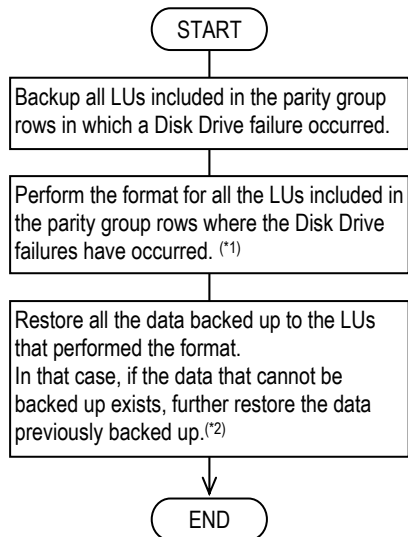

*1 : There may be a case that the LU formatting fails. In this case, request a user to check if a sense code is reported in the log of a host computer. When the reported sense code is “05-9552” or “05-9577”, the LU concerned is an object of ShadowImage in-system replication, TrueCopy remote replication, TrueCopy Extended Distance or Copy-on-write SnapShot. Therefore, request a user to release the pair and execute the LU formatting again after it is released. (Refer to [System Parameter “3.3 \[Procedure ©-F\] Formatting LU” \(SYSPR 03-0290\).](#))

Also, the backup restoration cannot be done for the LU whose access attribute is set as other than Read/Write by Data Retention Utility because it cannot be formatted or written.

*2 : Check with the user whether the LU to be restored from the backup data is using the Dynamic Provisioning function.

If it is used, restore the backup data according to the user’s instruction.

This page is for editorial purpose only.

[Recovery method]

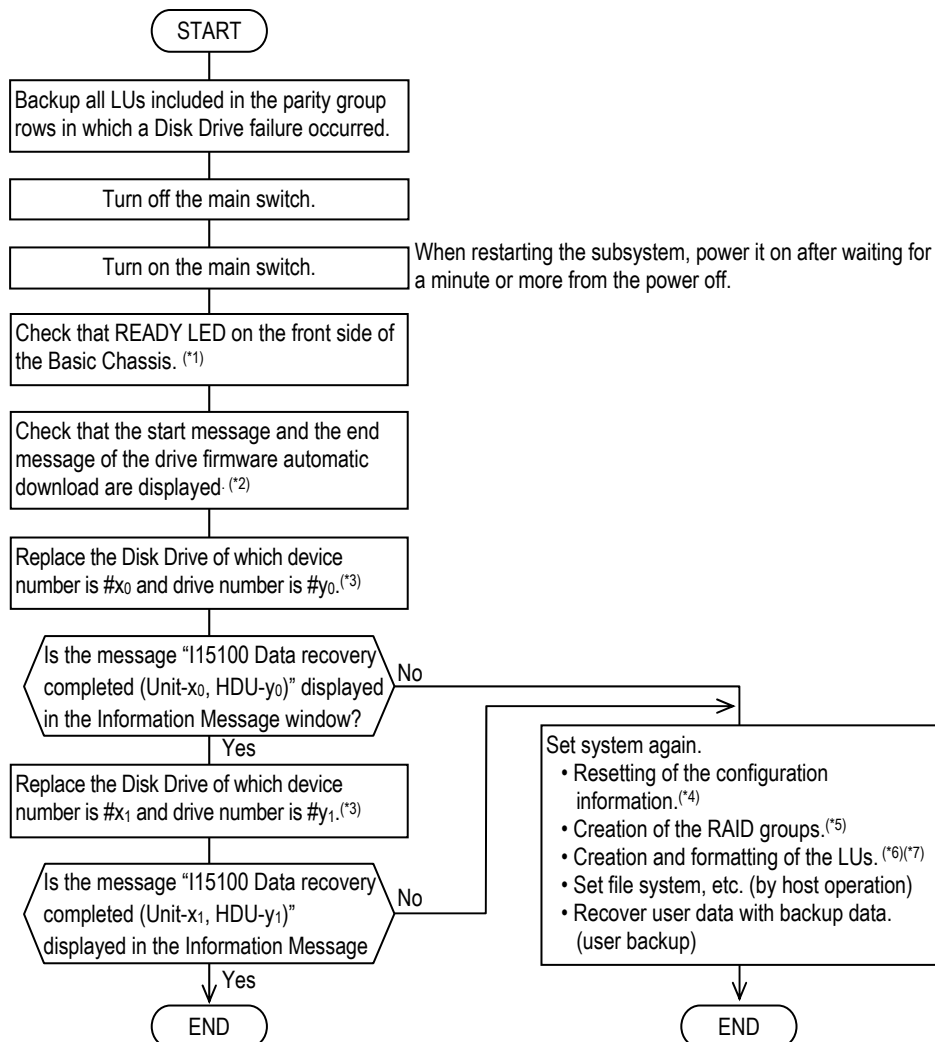

*1 : Wait if the READY LED (green) on the front of the Basic Chassis is blinking at high speed (for the maximum of 30 to 50 minutes, or 40 to 60 minutes in case of the RKH), or the WARNING LED (orange) is blinking at high speed (for the maximum of 30 to 85 minutes).

*2 : When the drive firmware version of the disk drive is new, the start message and completion message of the drive firmware automatic download are not displayed. To check the drive firmware automatic download, refer to [Firmware "1.6 \(4\) Checking the start message and end message of the automatic download \(FIRM 01-0890\)"](#).

*3 : Any of W09zab and W0Azab is displayed as the message code of the Disk Drive failure. Also, when a failure occurs in the Spare Disk Drive in use, any of W0Bzab and W0Czab is displayed as the message code. Refer to [Replacement "2.2.1 Replacing Disk Drive" \(REP 02-0030\)](#).

*4 : Refer to [System Parameter "4.2 Configuration Settings" \(SYSPR 04-0020\)](#).

*5 : Refer to [System Parameter "3.2 RAID Group Setting" \(SYSPR 03-0030\)](#).

*6 : There may be a case that the LU formatting fails. In this case, request a user to check if a sense code is reported in the log of a host computer. When the reported sense code is "05-9552" or "05-9577", the LU concerned is an object of ShadowImage in-system replication, TrueCopy remote replication, TrueCopy Extended Distance or Copy-on-write SnapShot. Therefore, request a user to release the pair and execute the LU formatting again after it is released. (Refer to [System Parameter "3.3 \[Procedure ©-F\] Formatting LU" \(SYSPR 03-0290\)](#).)

Also, the backup restoration cannot be done for the LU whose access attribute is set as other than Read/Write by Data Retention Utility because it cannot be formatted or written.

*7 : Check with the user whether the Dynamic Provisioning function is used, and if it is used, request the user to create a DP pool and a DP volume.

6.1.10 Data Recovery does not Terminate Normally : Case 3 (Spare Disk Drive Failure)

(A Spare Disk failure occurred while the correction is copied and the recovery failed.)

[WEB Information Message display]

(1) Example of SAS/SAS(SED) Spare Disk trouble.

MM/DD/YYYY hh:mm:ss xy I15200 Data recovery failed (Unit-x ₁ , HDU-y ₁)	:MANUAL/STRC
MM/DD/YYYY hh:mm:ss xy W0Bzab Spare HDU alarm (Unit-x ₁ , HDU-y ₁ , Type-c)	:MANUAL/STRC
MM/DD/YYYY hh:mm:ss xy I15000 Data recovery started (Unit-x ₁ , HDU-y ₁)	
MM/DD/YYYY hh:mm:ss xy W09zab HDU alarm (Unit-x ₀ , HDU-y ₀ , Type-c)	:MANUAL/STRC

Date
Time
x : Detect Controller #
y : Detect Core #

- Failure occurred the Spare Disk (Unit#x₀, Disk Drive#y₀).
- Recovery start the Spare Disk (Unit#x₁, Disk Drive#y₁).
- Failure occurred the Spare Disk (Unit#x₁, Disk Drive#y₁).
- Failure occurred the Spare Disk (Unit#x₁, Disk Drive#y₁).

(2) Example of SATA Spare Disk trouble.

MM/DD/YYYY hh:mm:ss xy I15200 Data recovery failed (Unit-x ₁ , HDU-y ₁)	:MANUAL/STRC
MM/DD/YYYY hh:mm:ss xy W0Czab Spare HDU alarm (Unit-x ₁ , HDU-y ₁ , Type-c)	:HDU /STRC
MM/DD/YYYY hh:mm:ss xy I15000 Data recovery started (Unit-x ₁ , HDU-y ₁)	
MM/DD/YYYY hh:mm:ss xy W0Azab HDU alarm (Unit-x ₀ , HDU-y ₀ , Type-c)	:HDU /STRC

Date
Time
x : Detect Controller #
y : Detect Core #

- Failure occurred the Disk Drive (Unit#x₀, Disk Drive#y₀).
- Recovery start the Spare Disk (Unit#x₁, Disk Drive#y₁).
- Failure occurred the Spare Disk (Unit#x₁, Disk Drive#y₁).
- Failure occurred the Spare Disk (Unit#x₁, Disk Drive#y₁).

[Recovery method]

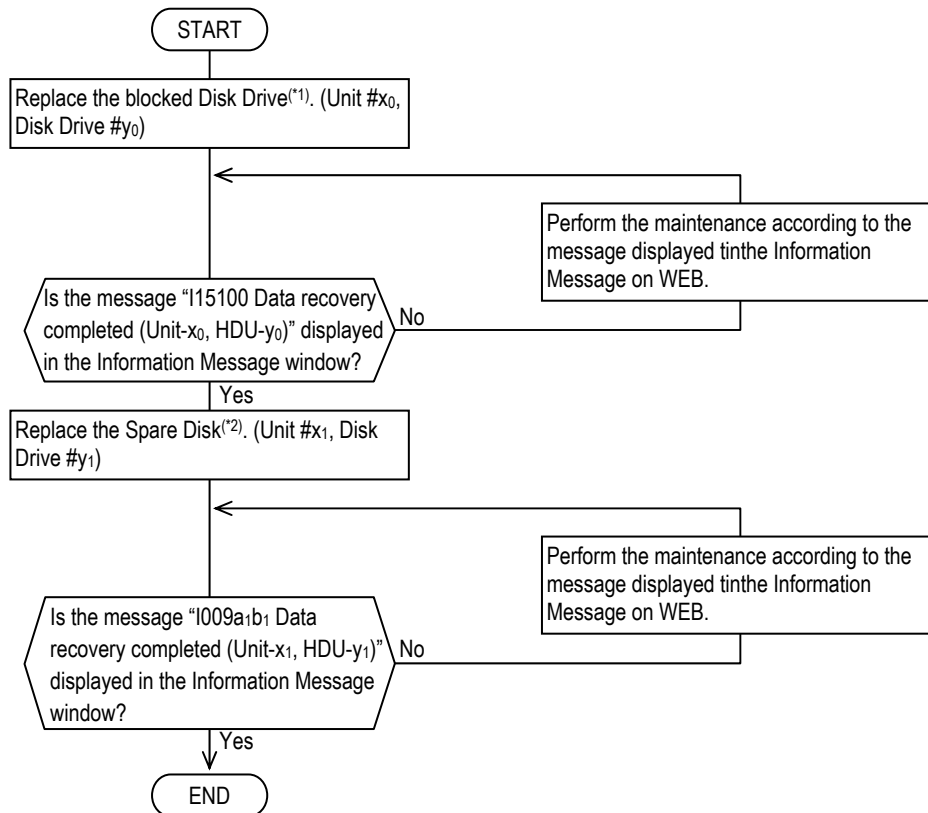

*1 : Any of W09zab and W0Azab is displayed as the message code of the Disk Drive failure. Also, when a failure occurs in the Spare Disk Drive in use, any of W0Bzab and W0Czab is displayed as the message code. For the replacement of the Disk Drive, refer to the [Replacement "2.2.1 Replacing Disk Drive" \(REP 02-0030\)](#).

*2 : Any of W0Bzab and W0Czab is displayed as the message code of the Spare Disk Drive failure. For the replacement of the Spare Disk Drive, refer to the [Replacement "2.2.1 Replacing Disk Drive" \(REP 02-0030\)](#).

6.1.11 A Failure Occurred during Operation : Case 1 (PIN Over)

[WEB Information Message display]

```

MM/DD/YYYY hh:mm:ss xy W3G000 PIN is over directory threshold[write through](DIR-x)
MM/DD/YYYY hh:mm:ss xy W3H000 PIN is over directory threshold[write will not run](DIR-x)
MM/DD/YYYY hh:mm:ss xy W3J000 PIN is over partition threshold[write through](DIR-x,PTT-xx)
MM/DD/YYYY hh:mm:ss xy W3K000 PIN is over partition threshold[write will not run](DIR-x,PTT-xx)
MM/DD/YYYY hh:mm:ss xy W3L000 PIN is over RAID group threshold[write through](DIR-x,RG-xx)
MM/DD/YYYY hh:mm:ss xy W3M000 PIN is over RAID group threshold[write will not run](DIR-x,RG-xx)
    
```

Date Time x : Detect Controller #
y : Detect Core #

[Recovery method]

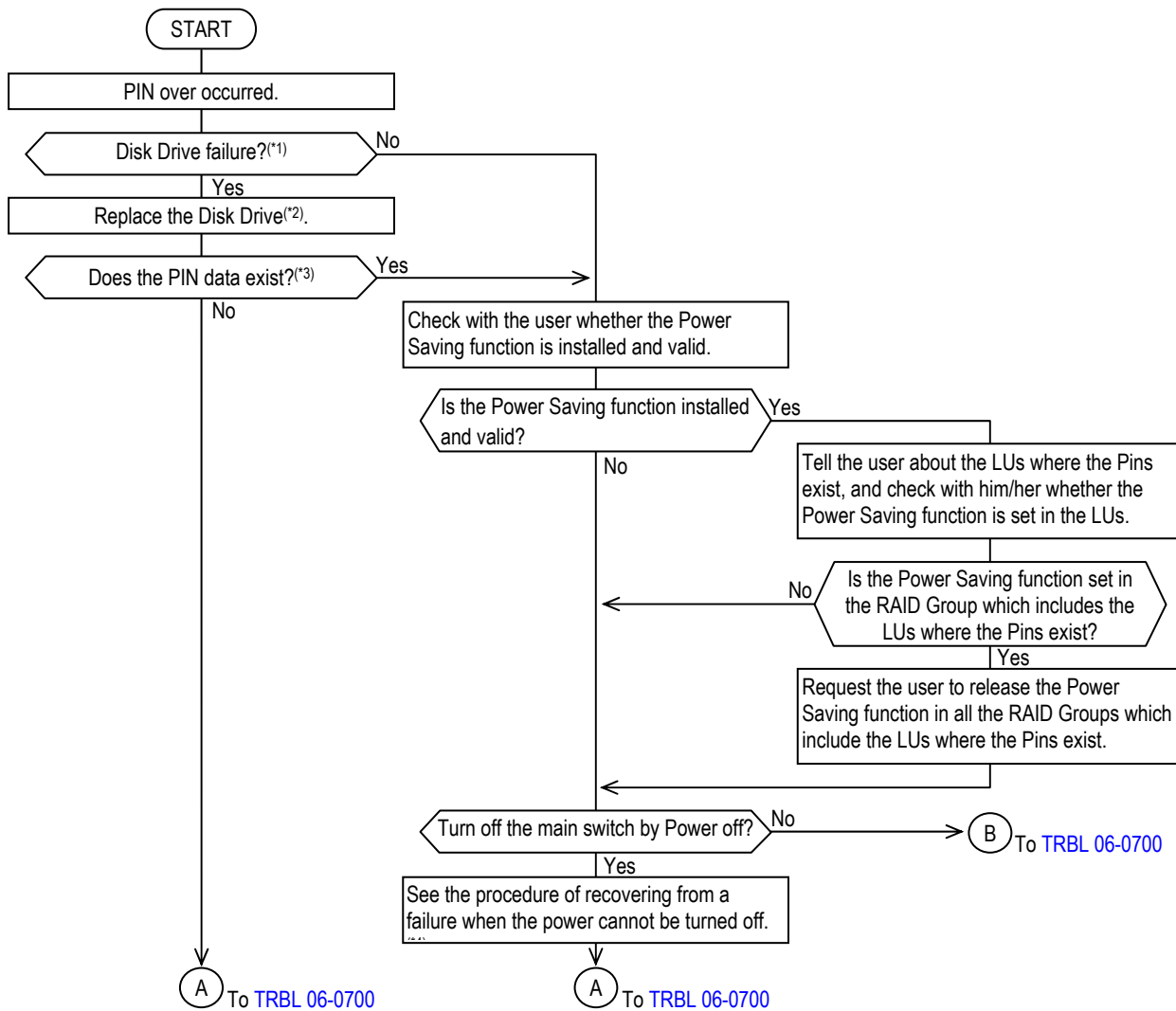

*1 : For checking a Disk Drive error, refer to "8.2 (2) Trouble analysis based on LED indication of Disk Drive" (TRBL 08-0160) or "Chapter 4. Trouble Analysis by WEB Connection" (TRBL 04-0000).

*2: For the replacement of the failed component, refer to the Replacement "Chapter 2. Parts Replacement" (REP 02-0000).

*3 : Checking the presence of PIN data is performed by the Maintenance function of Hitachi Storage Navigator Modular 2. Refer to "10.2.3 Displaying Logical Unit Failure Data Information" (TRBL 10-0100).

*4 : Refer to "6.1.4 The Power cannot be Turned Off : Case 1 (The Number of PIN Data is Too Large)" (TRBL 06-0550) to "6.1.7 The Power cannot be Turned Off : Case 4 (Cache Memory Failure)" (TRBL 06-0620).

From TRBL 06-0690

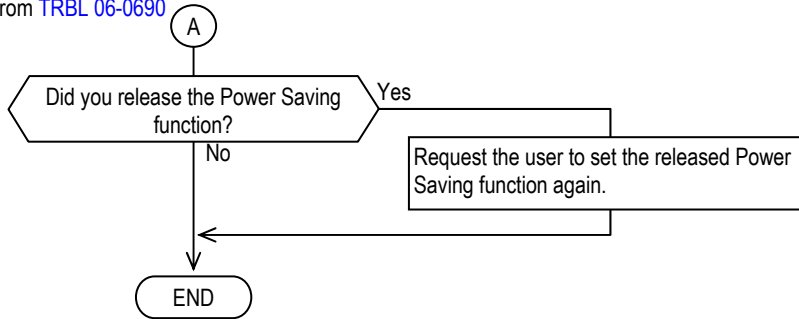

From TRBL 06-0690

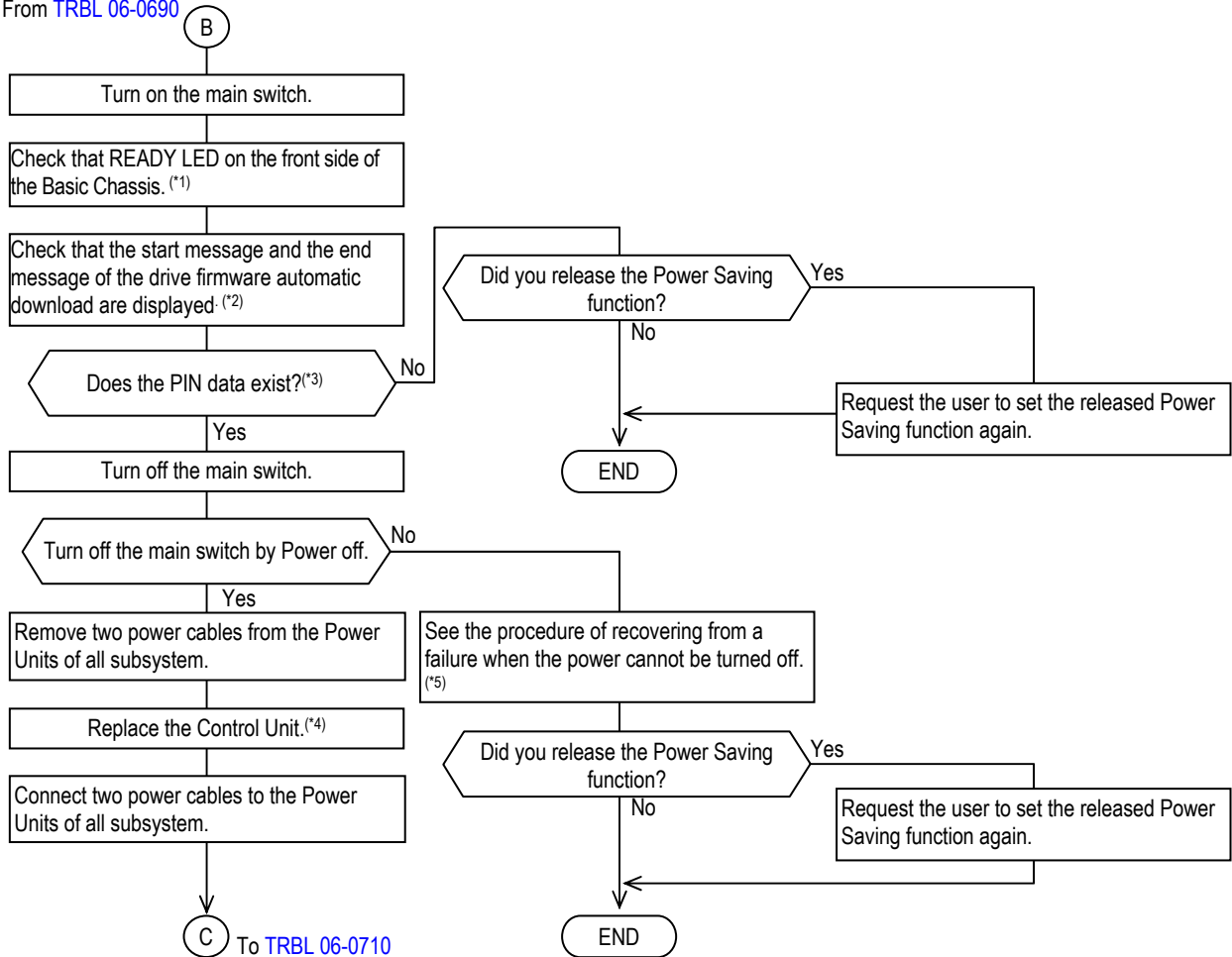

- *1 : Wait if the READY LED (green) on the front of the Basic Chassis is blinking at high speed (for the maximum of 30 to 50 minutes, or 40 to 60 minutes in case of the RKH), or the WARNING LED (orange) is blinking at high speed (for the maximum of 30 to 85 minutes).
- *2 : When the drive firmware version of the disk drive is new, the start message and completion message of the drive firmware automatic download are not displayed. To check the drive firmware automatic download, refer to [Firmware “1.6 \(4\) Checking the start message and end message of the automatic download \(FIRM 01-0890\)”](#).
- *3 : When restarting the subsystem, power it on after waiting for a minute or more from the power off.
- *4 : For the replacement of the failed component, refer to the [Replacement “Chapter 2. Parts Replacement” \(REP 02-0000\)](#)
- *5 : Refer to [“6.1.4 The Power cannot be Turned Off : Case 1 \(The Number of PIN Data is Too Large\)” \(TRBL 06-0550\)](#) to [“6.1.7 The Power cannot be Turned Off : Case 4 \(Cache Memory Failure\)” \(TRBL 06-0620\)](#).

From TRBL 06-0700

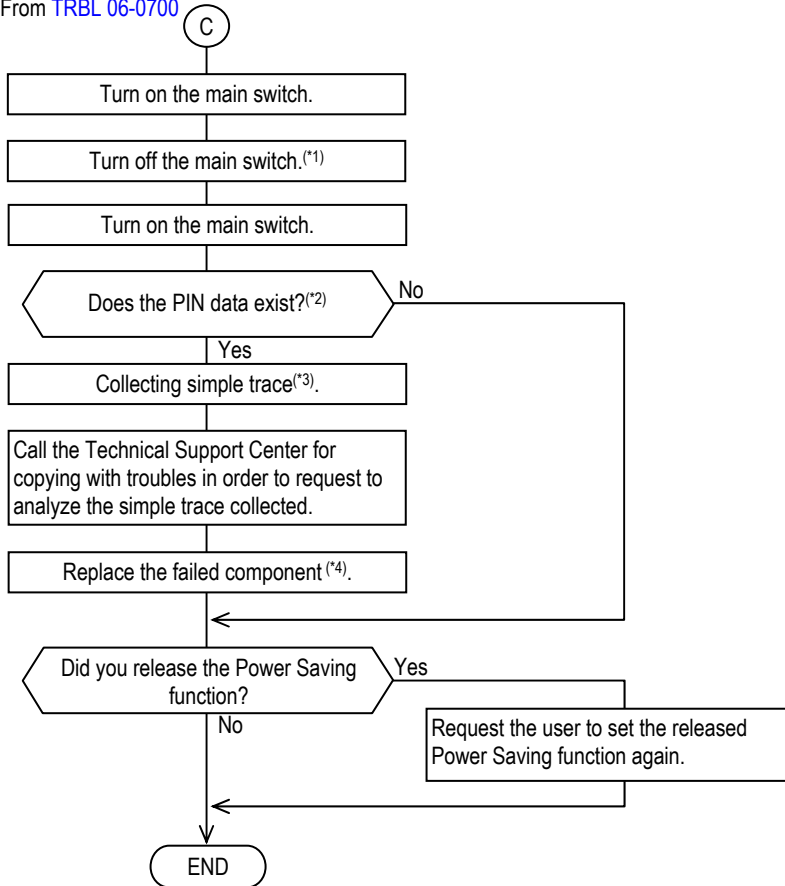

*1 : To write pinned data on a drive, replace the Control Unit, and then execute the deliberate shutdown.

*2 : Checking the presence of PIN data is performed by the Maintenance function of Hitachi Storage Navigator Modular 2. Refer to “10.2.3 Displaying Logical Unit Failure Data Information” (TRBL 10-0100).

*3 : For the Collection simple trace, refer to “7.3 Collecting Simple Trace” (TRBL 07-0040).

*4 : For the replacement of the failed component, refer to the Replacement “Chapter 2. Parts Replacement” (REP 02-0000).

6.1.12 A Failure Occurred during Operation : Case 2 (LA/LRC Error)

[WEB Information Message display]

Any one of the following is displayed.

MM/DD/YYYY hh:mm:ss xy W0N00x Parity generation LA error [DRR] (CTL-x)	:MANUAL/DMP
MM/DD/YYYY hh:mm:ss xy W0V0xy LA error [errcode:LUN] (D-PT-00,CTL=x, TRNS-y)	:MANUAL/STRC
MM/DD/YYYY hh:mm:ss xy W0W0xy LA error [errcode:LUN] (D-PT-01,CTL=x, TRNS-y)	:MANUAL/ STRC
MM/DD/YYYY hh:mm:ss xy W0Y0xy LA error [errcode:LBA] (H-PT-00,CTL=x, TRNS-y)	:MANUAL/ STRC
MM/DD/YYYY hh:mm:ss xy W0Z0xy LA error [errcode:LBA] (H-PT-01,CTL=x, TRNS-y)	:MANUAL/ STRC
MM/DD/YYYY hh:mm:ss xy W100xy LA error [errcode:LUN] (D-PT-00,CTL=x, TRNS-y)	:MANUAL/STRC
MM/DD/YYYY hh:mm:ss xy W120xy LA error [errcode:LUN] (D-PT-01,CTL=x, TRNS-y)	:MANUAL/ STRC
MM/DD/YYYY hh:mm:ss xy W130xy LA error [errcode:LBA] (H-PT-00,CTL=x, TRNS-y)	:MANUAL/ STRC
MM/DD/YYYY hh:mm:ss xy W140xy LA error [errcode:LBA] (H-PT-01,CTL=x, TRNS-y)	:MANUAL/ STRC
MM/DD/YYYY hh:mm:ss xy W150xy LA error [errcode:LUN] (D_PT-02, CTL-x, TRNS-y)	:MANUAL/STRC
MM/DD/YYYY hh:mm:ss xy W160xy LA error [errcode:LUN] (D_PT-03, CTL-x, TRNS-y)	:MANUAL/ STRC
MM/DD/YYYY hh:mm:ss xy W170xy LA error [errcode:LBA] (D_PT-02, CTL-x, TRNS-y)	:MANUAL/ STRC
MM/DD/YYYY hh:mm:ss xy W180xy LA error [errcode:LBA] (D_PT-03, CTL-x, TRNS-y)	:MANUAL/ STRC
MM/DD/YYYY hh:mm:ss xy W190xy LA error [errcode:LUN] (H_PT-02, CTL-x, TRNS-y)	:MANUAL/STRC
MM/DD/YYYY hh:mm:ss xy W1A0xy LA error [errcode:LUN] (H_PT-03, CTL-x, TRNS-y)	:MANUAL/ STRC
MM/DD/YYYY hh:mm:ss xy W1B0xy LA error [errcode:LBA] (H_PT-02, CTL-x, TRNS-y)	:MANUAL/ STRC
MM/DD/YYYY hh:mm:ss xy W1C0xy LA error [errcode:LBA] (H_PT-03, CTL-x, TRNS-y)	:MANUAL/ STRC
MM/DD/YYYY hh:mm:ss xy W1D0xy LRC error [errcode:LUN] (D-PT-00,CTL=x, TRNS-y)	:MANUAL/ STRC
MM/DD/YYYY hh:mm:ss xy W1E0xy LRC error (D-PT-01,CTL=x, TRNS-y)	:MANUAL/ STRC
MM/DD/YYYY hh:mm:ss xy W1F0xy LRC error (D_PT-02, CTL-x, TRNS-y)	:MANUAL/ STRC
MM/DD/YYYY hh:mm:ss xy W1G0xy LRC error (D_PT-03, CTL-x, TRNS-y)	:MANUAL/ STRC
MM/DD/YYYY hh:mm:ss xy W1H0xy LRC error (H_PT-02, CTL-x, TRNS-y)	:MANUAL/ STRC
MM/DD/YYYY hh:mm:ss xy W1J0xy LRC error (H_PT-03, CTL-x, TRNS-y)	:MANUAL/ STRC
MM/DD/YYYY hh:mm:ss xy W1K00x Data transfer check error [SEGPOSERR] (CTL-x)	:MANUAL/DMP
MM/DD/YYYY hh:mm:ss xy W1V0xy LRC error (H-PT-00, CTL=x, TRNS-y)	:MANUAL/ STRC
MM/DD/YYYY hh:mm:ss xy W1W0xy LRC error (H-PT-01,CTL=x,TRNS-y)	:MANUAL/ STRC

Date

Time

x : Detect Controller #

y : Detect Core #

x : Controller# (0-1), y : Transfer direction (R : Read, W : Write)

xx : DMA#(0-F)

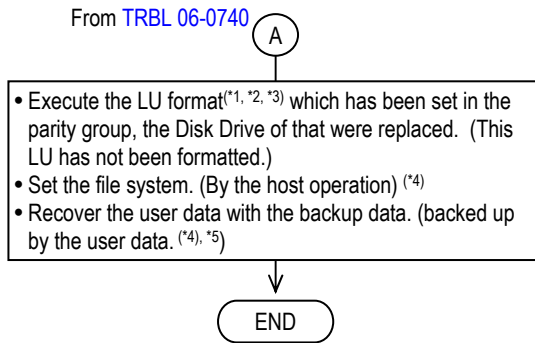

*1 : For the operating procedure, refer to the [System Parameter “3.3 Setting of LU” \(SYSPR 03-0130\)](#).

*2 : There may be a case that the LU formatting fails. In this case, request a user to check if a sense code is reported in the log of a host computer. When the reported sense code is “05-9552” or “05-9577”, the LU concerned is an object of ShadowImage in-system replication, TrueCopy remote replication, TrueCopy Extended Distance or Copy-on-write SnapShot. Therefore, request a user to release the pair and execute the LU formatting again after it is released. (Refer to [System Parameter “3.3 \[Procedure ③-F\] Formatting LU” \(SYSPR 03-0290\)](#).)

Also, the backup restoration cannot be done for the LU whose access attribute is set as other than Read/Write by Data Retention Utility because it cannot be formatted or written.

*3 : Check with the user whether the Dynamic Provisioning function is used, and if it is used, request the user to recover the DP pool.

Moreover, check with the customer for the format status of the DP volume, and if the DP volume is unformatted, perform the LU format.

*4 : Request the customer and the SE for the work.

*5 : Check with the user whether the LU to be restored from the backup data is using the Dynamic Provisioning function.

If it is used, restore the backup data according to the user’s instruction.

6.1.14 A Failure Occurred during Operation : Case 4 (Incomplete Writing)

(The command for reassignment was sent from a host computer to an LU of RAID 0. Or, the write uncompleted area was registered because a read impossible area was found during the RAID group expansion.)

[WEB Information Message display]

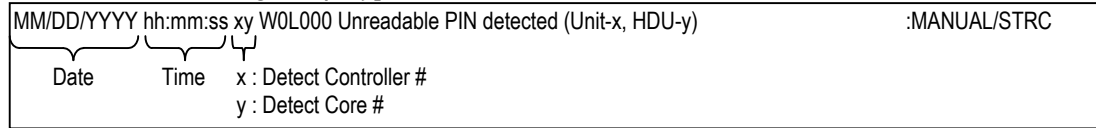

[Recovery method]

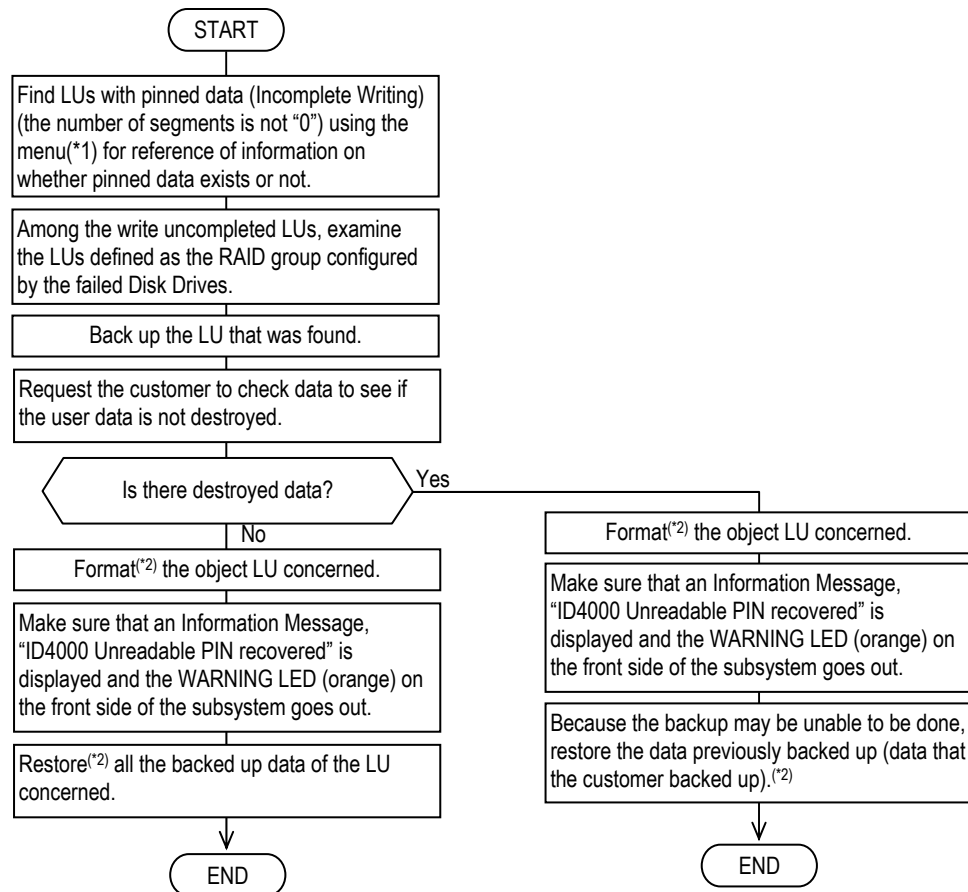

*1 : Checking the presence of PIN data is performed by the Maintenance function of Hitachi Storage Navigator Modular 2. Refer to ["10.2.3 Displaying Logical Unit Failure Data Information" \(TRBL 10-0100\)](#).

*2 : Concerning the backup and restoration, request the customer to do them.

However, check with the user whether the LU to be restored from the backup data is using the Dynamic Provisioning function, and if it is used, restore the backup data according to the user's instruction.

*3 : There may be a case that the LU formatting fails. In this case, request a user to check if a sense code is reported in the log of a host computer. When the reported sense code is "05-9552" or "05-9577", the LU concerned is an object of ShadowImage in-system replication, TrueCopy remote replication, TrueCopy Extended Distance or Copy-on-write SnapShot. Therefore, request a user to release the pair and execute the LU formatting again after it is released (refer to [System Parameter "3.3 \[Procedure ③-F\] Formatting LU" \(SYSPR 03-0290\)](#)).

Also, the backup restoration cannot be done for the LU whose access attribute is set as other than Read/Write by Data Retention Utility because it cannot be formatted or written.

6.1.15 The Incomplete Write Area was Registered in the Restored VOL

(The write incomplete area was registered in the P-VOL because there was the unreadable area in the pool LU during the restoration of the P-VOL of Copy-on-write SnapShot. Or the incomplete write area was registered in the S-VOL because there was the unreadable area in the pool LU when restoring the S-VOL due to S-VOL-Takeover as a result of executing the horctakeover command with TrueCopy Extended Distance.)

(1) In case of the failure with Copy-on-write SnapShot

[WEB Information Message display]

MM/DD/YYYY	hh:mm:ss	xy	I6D300 Unreadable PIN resided (Unit-x, HDU-y, LU-z)	:MANUAL/STRC
Date	Time	x : Detect Controller # y : Detect Core #	Pool LU Disk Drive ^(*1) Primary VOL ^(*2)	

[Recovery method]

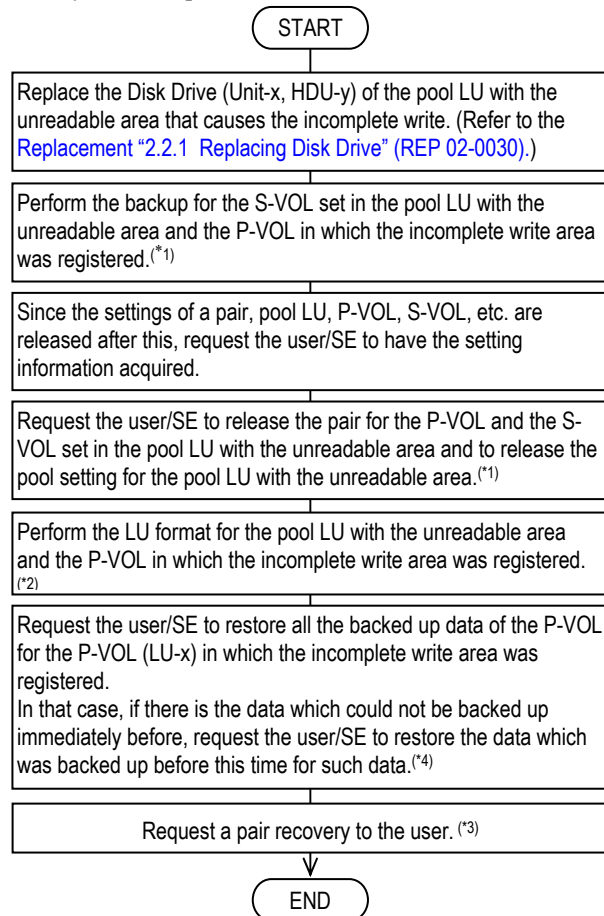

*1 : If the pair release is performed, the data of the S-VOL is lost. Therefore, be sure to execute the backup of the S-VOL before performing the pair release.

*2 : For the LU format, refer to the [System Parameter "3.3 \[Procedure ③-F\] Formatting LU" \(SYSPR 03-0290\)](#).

*3 : The secondary VOL data backed up and the primary VOL have the same capacity. Therefore, do not restore the secondary VOL data backed up for the secondary VOL, which executed pair setting again. Also, execute ①setting of the pool, ②setting of the P-VOL, ③setting of the V-VOL and ④pair formation to restore the pair.

*4 : Check with the user whether the LU to be restored from the backup data is using the Dynamic Provisioning function. If it is used, restore the backup data according to the user's instruction.

(2) In case of the failure with TrueCopy Extended Distance

[WEB Information Message display]

MM/DD/YYYY	hh:mm:ss	xy	I6D300 Unreadable PIN resisted (Unit-x, HDU-y, LU-z)	:MANUAL/STRC
Date	Time	x : Detect Controller # y : Detect Core #	Pool LU Disk Drive ^(*1) Primary VOL ^(*2)	

[Recovery method]

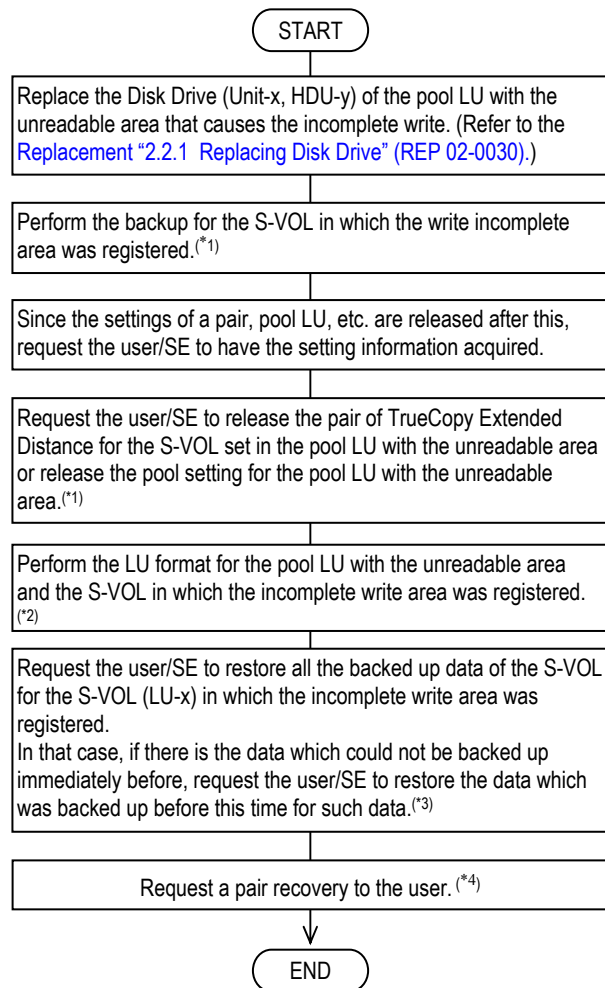

*1 : If the pair release is performed, the data of which the previous cycle was determined and saved in the pool LU was lost. Therefore, be sure to execute the backup of the S-VOL before performing the pair release.

*2 : For the LU format, refer to the [System Parameter "3.3 \[Procedure ③-F\] Formatting LU" \(SYSPR 03-0290\)](#).

*3 : Check with the user whether the LU to be restored from the backup data is using the Dynamic Provisioning function.

If it is used, restore the backup data according to the user's instruction.

*4 : Execute ① setting of the pool LU and ② pair formation to restore the pair.

- (1) Check the status of the pair of the Modular Volume Migration
 - (a) Start the Hitachi Storage Navigator Modular 2.
 - (b) Put a checkmark to the array subsystem to set, press the [Ctrl] key, [Shift] key and [E] key at the same time, and change the operation mode to “Maintenance Mode”.^{†1)}

Check that “Maintenance Mode” is displayed in [Operation Mode] on the top of the main window.

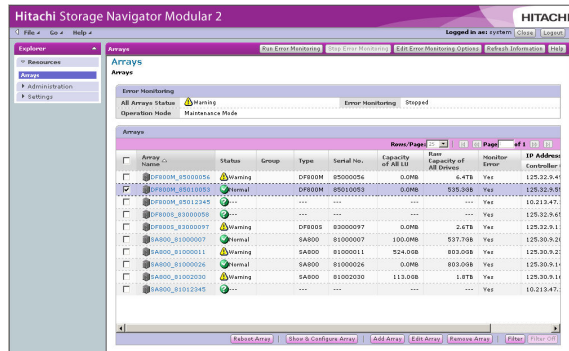

- (c) Click the array subsystem name, and open the unit window.

NOTE : There is a case that the LAN Port Number is changed. When the main screen is not displayed even though the icon of the array subsystem is clicked, use the changed LAN Port Number, and execute it again. (Refer to [System Parameter “1.2 LAN Port Number Change by Hitachi Storage Navigator Modular 2” \(SYSPR 01-0120\).](#))

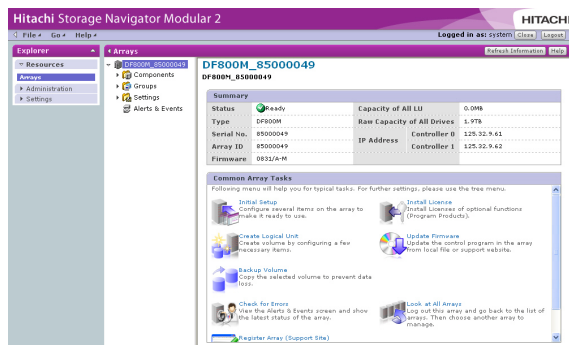

†1 : When the array subsystem to operate is not registered, click the blank area (other than buttons and characters) in the “Arrays” window, and press the [Ctrl] key, [Shift] key and [E] key at the same time.

- (d) Select [Settings] - [Advanced Settings] on the unit window, and click the [Open Advanced Settings] button.

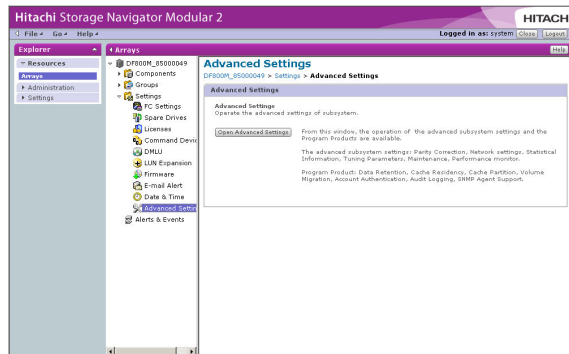

- (e) Select [Volume Migration] - [Pair] of the tree.
The list of the pairs and the information of each pair are displayed.

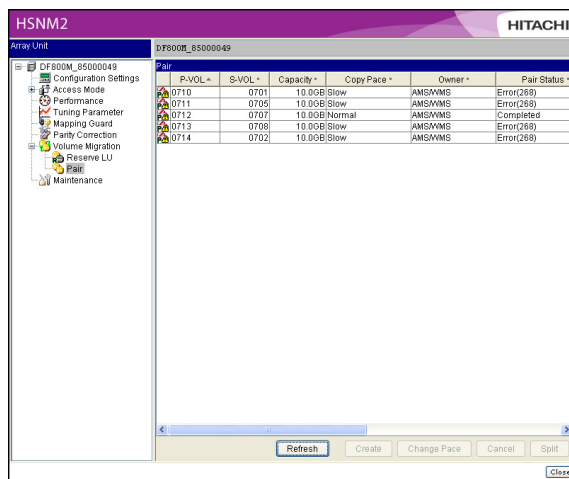

- (f) When the Modular Volume Migration terminated abnormally and the pair changed to PSUE, “Error (failure factor code)” is displayed in [Pair Status]. The pair displayed [Error] in [Pair Status] is the pair whose Modular Volume Migration terminated abnormally.
- (g) Check the failure factor code for each pair whose Modular Volume Migration terminated abnormally referring to [Pair Status]. (Refer to [Message “Chapter 10. Failure Factor Codes of the Modular Volume Migration” \(MSG 10-0000\)](#) for the details.)

6.1.17 Path Blockade Occurs in the TrueCopy remote replication/TrueCopy Extended Distance Function

When the pair of TrueCopy remote replication and the pair of TrueCopy Extended Distance share the Path, the Path blockade can be recovered by satisfying the recovery condition of each program product.

(1) Procedure for recovery from path detachment

(a) General flowchart of procedure for recovery from path detachment

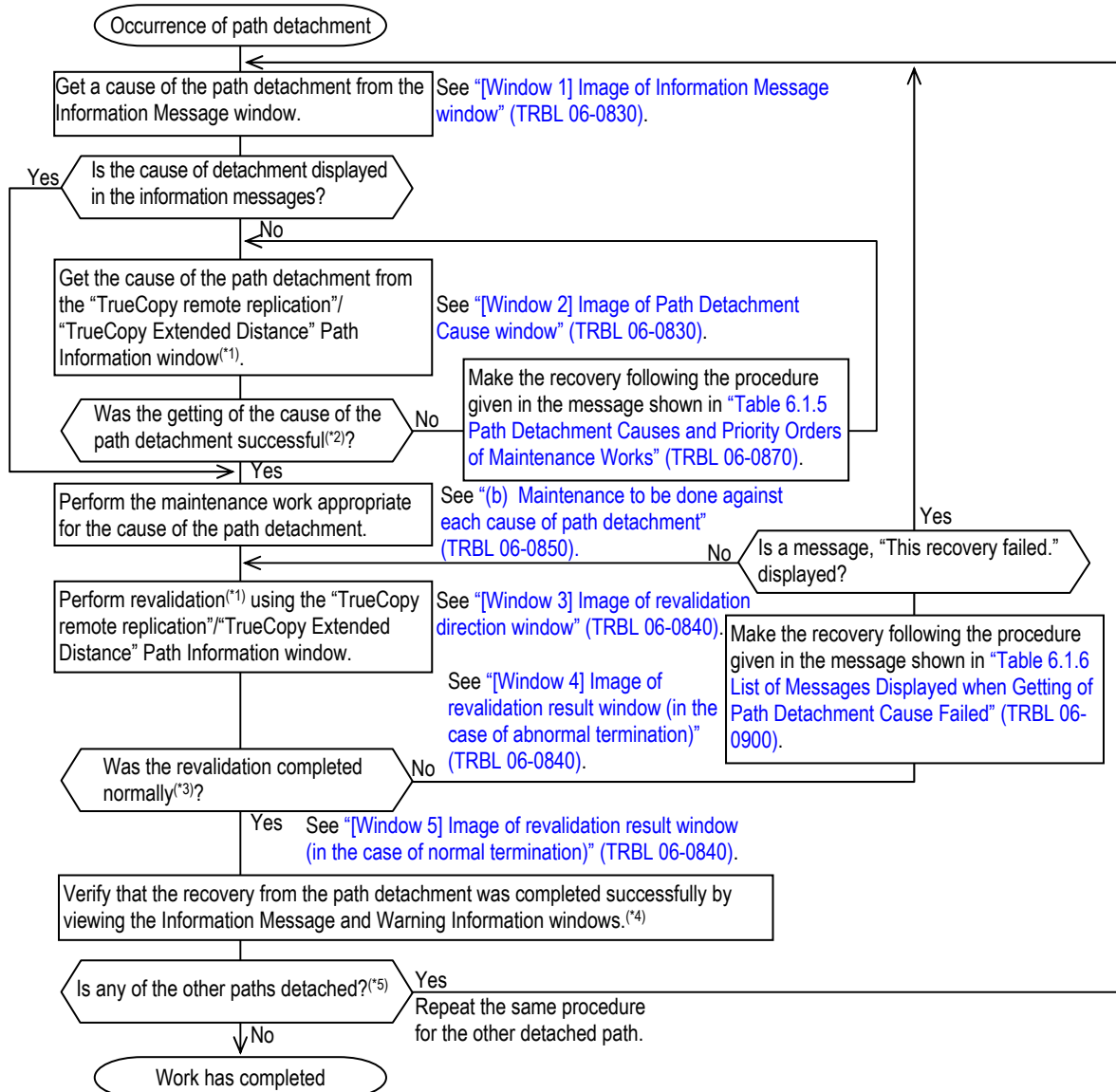

*1 : The recovery from the path detachment may have been made by virtue of the automatic path recovery function. When a message informing of the completion of the recovery is displayed in the Information Message window, no revalidation is necessary. If the recovery has not been made, be sure to perform the revalidation.

*2 : For the message when the acquisition of the cause of the path detachment was unsuccessful, refer to ["Table 6.1.5 Path Detachment Causes and Priority Orders of Maintenance Works" \(TRBL 06-0870\)](#).

*3 : For the message when the revalidation is performed, refer to ["Table 6.1.6 List of Messages Displayed when Getting of Path Detachment Cause Failed" \(TRBL 06-0900\)](#).

*4 : When the PATH blockade recovers, "I030xy Path recovered by web operation (Remote-x, Path-y)", or "I031xy Path recovered automatically (Remote-x, Path-y)" is displayed in the Information Message on WEB, and the display of "W0K0xy Path alarm (Remote-x, Path-y) disappears from the Warning Information on WEB.

*5 : Other system PATH indicates Path-1 when the PATH which recovered the PATH blockade is Path-0, and Path-0 when the PATH which recovered the PATH blockade is Path-1.

The example of the WEB window when the PATH blockade of TrueCopy remote replication occurs is shown below.

[Window 1] Image of Information Message window

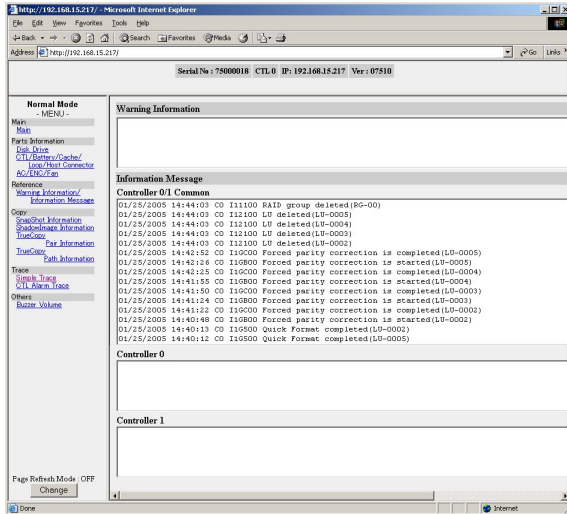

[Window 2] Image of Path Detachment Cause window

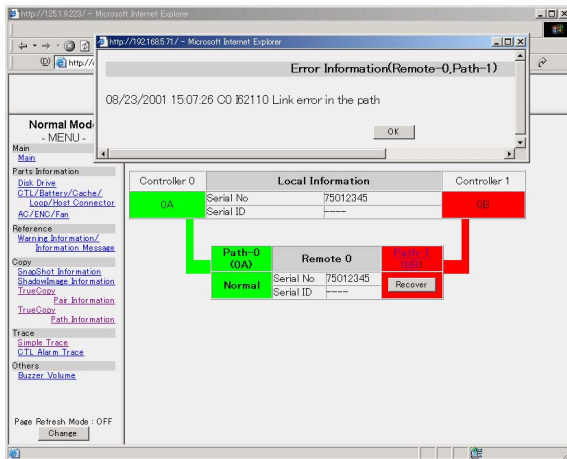

[Window 3] Image of revalidation direction window

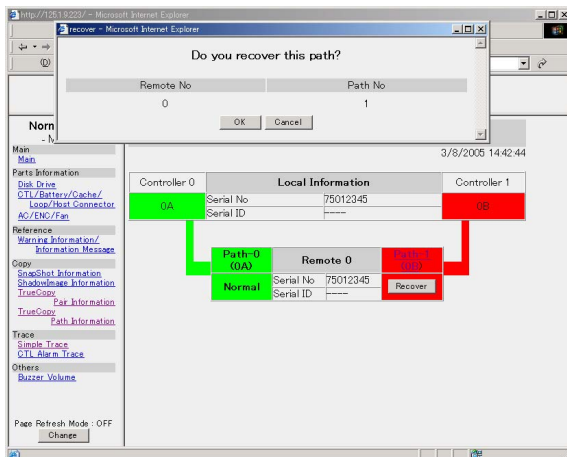

[Window 4] Image of revalidation result window (in the case of abnormal termination)

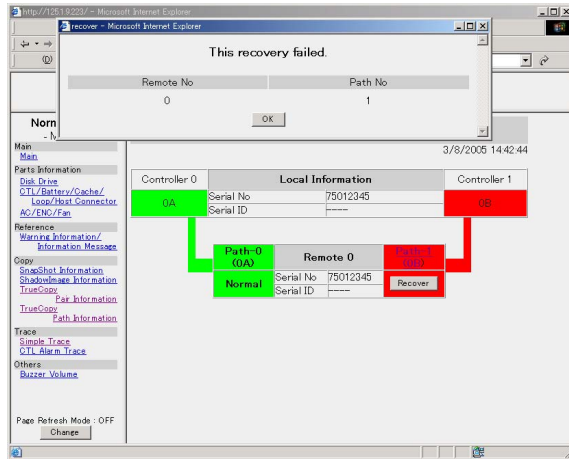

[Window 5] Image of revalidation result window (in the case of normal termination)

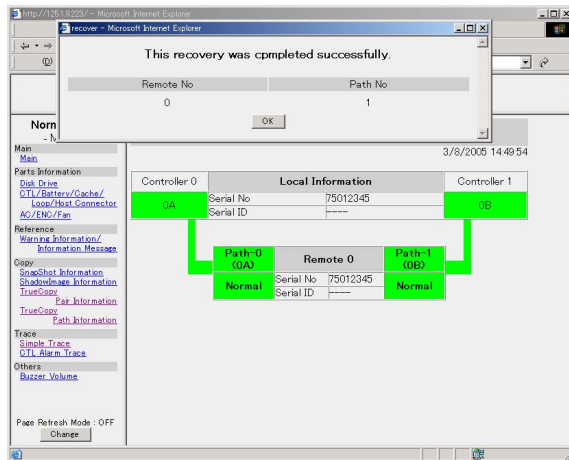

(b) Maintenance to be done against each cause of path detachment

The failed part cannot be ascertained depending on the type of the failure because the path detachment is a route failure.

Therefore, this manual only defines zones where a failure occurs for each path connection form and make the priority order of the zones and parts within the each zone clear.

[Procedure 1] Make sure of the path connection form.

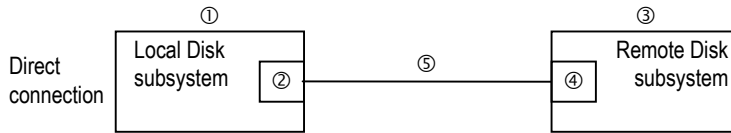

- ① : Local Disk subsystem main body
- ② : Local Disk subsystem interface
- ③ : Remote Disk subsystem main body
- ④ : Remote Disk subsystem interface
- ⑤ : Connecting cable between the Disk subsystem's

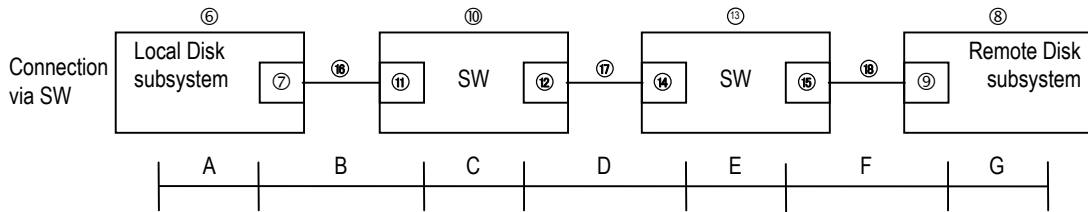

- ⑥ : Local Disk subsystem main body
 - ⑦ : Local Disk subsystem interface
 - ⑧ : Remote Disk subsystem main body
 - ⑨ : Remote Disk subsystem interface
 - ⑩ : Local side SW
 - ⑪ : Local side GBIC of the local side SW
 - ⑫ : Remote side GBIC of the local side SW
 - ⑬ : Remote side SW
 - ⑭ : Local side GBIC of the remote side SW
 - ⑮ : Remote side GBIC of the remote side SW
 - ⑯ : Connection cable between the local Disk subsystem and the local side SW
 - ⑰ : Connection cable between the local side SW and the remote side SW
 - ⑱ : Connection cable between the remote Disk subsystem and the remote side SW
- Zone A : ⑥
 - Zone B : ⑦ ⑪ ⑯
 - Zone C : ⑩
 - Zone D : ⑫ ⑭ ⑰
 - Zone E : ⑬ ⑮ ⑱
 - Zone F : ⑨
 - Zone G : ⑧

[Procedure 2] Perform a maintenance work referring to the priority order of zones and parts shown in [Table 6.1.5](#) according to a cause of the path detachment.

- NOTE :
- Every time when a part is replaced from the order with a high priority, go to “[Procedure 3]” (TRBL 06-0900), and perform the revalidation in the TrueCopy Path Information window of the WEB following “(1) (a) [General flowchart of procedure for recovery from path detachment](#)” (TRBL 06-0820).
 - The maintenance method varies depending on the reference number (① to ⑨) that represents each part.

The maintenance method corresponding to each number is shown below.

①③⑥⑧ → Since a failure of some kind has occurred in each DF800

subsystem, perform a maintenance work according to the LED indications or the Information Message on WEB.

②④⑦⑨ → Replacement of the I/F portion is required.

When replacing the I/F portion, an entire CTL must be replaced in the case of the part of the basic port (Port #0) because the part is integrated with the CTL, whereas only the Interface Board is to be replaced in the case of the part of the added port (Port #1).

Other than the above → Replacement the SW main body, the GBIC, or the cable.

Table 6.1.5 Path Detachment Causes and Priority Orders of Maintenance Works

No.	Message text	Path detachment cause	Failure symptom	Priority order of maintenance objects ^{*1)}	Path recovery method
1	Link error in the attached link (Port-x)	The threshold value of the route failure counter on the local side was exceeded.	<ul style="list-style-type: none"> A link down was detected. A link failure was detected. 	Direct : ② → ④ → ⑤ SW : B → C	<ul style="list-style-type: none"> The path revalidation from the WEB must be done.
2	Link error in the path	The threshold value of the path route failure counter was exceeded.	<ul style="list-style-type: none"> An illegal transferred data length was detected. 	Direct : ② → ④ → ⑤ SW : B → F → D → C → E	
3	Link down time-out (Port-x)	The link down time of the path set for the port concerned elapsed longer than 15 seconds.	<ul style="list-style-type: none"> The link down time of the port for which a path has already been set elapsed longer than 15 seconds. 	Direct : ② → ④ → ⑤ SW : B → C	<ul style="list-style-type: none"> Automatic recovery
4	Path not connected	<ul style="list-style-type: none"> The remote Disk subsystem concerned is not connected. The firmware is not supported 	<ul style="list-style-type: none"> No remote Disk subsystem, for which a path was to be set, existed on the loop though a log-in was requested. The WWN which has been set was not registered in the SW. <In the case of RKS configuration> At either following condition, the path was detached. <ul style="list-style-type: none"> The firmware of the remote side DF (RKS) is not updated. The 4Gbps FC Interface Board on remote or local DF (RKS) was not added. <ul style="list-style-type: none"> The PATH was set by connecting the array subsystem of the H/W revision 0100 whose firmware is less than Ver.0890/A to the array subsystem of the H/W revision 0200. 	Direct : a → ④ → ③ → ② → ⑤ SW : a → G → F → D → E → C a : Firstly, check if the remote Disk subsystem is connected and if the connection is correctly made.	<ul style="list-style-type: none"> Automatic recovery Replace to the firmware whose firmware version is Ver.0890/A or more
5	Path login failed	The log-in to the path concerned failed.	<ul style="list-style-type: none"> Though a log-in to a port expected to exist was attempted, it failed because allowable number of retrials were not successful. 	Direct : ④ → ② → ⑤ SW : G → F → D → B → E → C (F : ⑨ → ⑮ → ⑯)	<ul style="list-style-type: none"> The path revalidation from the WEB must be done.

*1 : A numeral and alphabetic character denote a part and zone respectively.

- Priority order of failed parts in each zone (a zone contains more than one part) is shown below.

Zone B : ⑥ → ⑦ → ⑧

Zone D : → →

Zone F : → ⑩ →

No.	Message text	Path detachment cause	Failure symptom	Priority order of maintenance objects ^{*1)}	Path recovery method
6	Path login resource shortage	Resource of the path concerned was insufficient.	• Insufficiency of the resource was reported in a response made at the time of the log-in. (The insufficient resource means that 128 log-in's have already been made for the port when 128 log-in's per port are allowed.)	Direct : ④ SW : ⑨ The system configuration is illegal. (Propriety of the system configuration must be checked by an SE or a user.)	• The path revalidation from the WEB must be done.
7	Fabric connection failed (Port-x)	Switch trouble	• The FLOGI sequence terminated abnormally. (Sending and response of FLOGI/ PLOGI/ RCS_ID/ RFT_ID/ PRT_ID/ SCR/RSCN terminated abnormally.)	Direct : None SW : B → C	• The path revalidation from the WEB must be done.
8	RSP not ready (Key [02], Code [xxyy])	Command RSP failure (Failure of the command issued from a Disk subsystem to another Disk subsystem)	Not Ready	Direct : ③ SW : ⑧	• The path revalidation from the WEB must be done.
9	RSP medium error (Key [03], Code [xxyy])		Medium Error	Direct : ③ SW : ⑧	
10	RSP hard error (Key [04], Code [xxyy])		Hard Error	Direct : ③ SW : ⑧	
11	RSP illegal request (Key [05], Code [xxyy])		Illegal Request	Direct : ① → ③ SW : ⑥ → ⑧	
12	RSP abort command P (Key [0B], Code [xxyy])		Aborted Command (path)	Direct : ④ → ② → ⑤ SW : F → B → D → E → C	
13	RSP abort command C (Key [0B], Code [xxyy])		Aborted Command (CTL)	Direct : ③ SW : ⑧	
14	RSP miscompare (Key [0E], Code [xxyy]) RSP status error [xx] RSP other field error RSP etc. (Key [xx])	Others	Direct : ① → ③ SW : ⑥ → ⑧		
15	Command time out ⑮ ⑯	Command time-out (Failure of the command issued from a Disk subsystem to another Disk subsystem)	• Two or more times of time-out were detected in execution of the same command.	Direct : ④ → ② → ⑤ SW : G → F → D → B → E → C (F : ⑨ → →)	• The path revalidation from the WEB must be done.
16	Remote sequence number error	Inconsistency of the remote Disk subsystem sequence No.	• The sequence No. of the remote Disk subsystem is inconsistent.	Direct : ③ SW : ⑧	• The path revalidation from the WEB must be done.
17	Path alarm for CTL alarm (Remote-x, Path-y)	CTL detachment	• A detachment of the own controller occurred.	Direct : ① SW : ⑥	• Automatic recovery
18	Port un-mounting error	Non-installation of the port	• The port is not installed.	Direct : ② SW : ⑦	• The path revalidation from the WEB must be done.

*1 : A numeral and alphabetic character denote a part and zone respectively.

- Priority order of failed parts in each zone (a zone contains more than one part) is shown below.

Zone B : ⑤ → ⑦ → ⑧

Zone D : → →

Zone F : → ⑨ →

No.	Message text	Path detachment cause	Failure symptom	Priority order of maintenance objects ^{*1)}	Path recovery method
19	Remote option disable [TrueCopy Basic]	Locking of the remote Disk subsystem [TrueCopy remote replication]	• The [TrueCopy remote replication] priced optional function of the remote Disk subsystem is locked.	Direct : ③ SW : ⑧	• The path revalidation from the WEB must be done
20	Remote option disable [TrueCopy Extended Distance]	Locking of the remote Disk subsystem [TrueCopy Extended Distance]	• The [TrueCopy Extended Distance] priced optional function of the remote Disk subsystem is locked.	Direct : ③ SW : ⑧	• The path revalidation from the WEB must be done
21	Remote pate setting unsupported on the remote Subsystem	The function for setting paths between subsystems of different models is not supported.	• The function for setting paths between subsystems with different system settings is not supported.	Direct : ③ SW : ⑧	• The path revalidation from the WEB must be done • Update the firmware of the remote subsystem.

*1 : A numeral and alphabetic character denote a part and zone respectively.

• Priority order of failed parts in each zone (a zone contains more than one part) is shown below.

Zone B : ⑤ → ⑦ → ⑧

Zone D : → →

Zone F : → ⑨ →

[Procedure 3] Proceed to the procedure subsequent to “(1) (a) General flowchart of procedure for recovery from path detachment” (TRBL 06-0820).

When the getting of the path detachment cause has failed or the revalidation has terminated abnormally, perform a maintenance work following the recovery procedure shown in Table 6.1.6 and Table 6.1.7 according to the message displayed.

Table 6.1.6 List of Messages Displayed when Getting of Path Detachment Cause Failed

No.	Sub-window message	Meaning of message	Recovery method
1	Cannot get alarm information because specified function is lock.	The cause cannot be get because the [TrueCopy remote replication] or [TrueCopy Extended Distance] function is locked.	Unlock and validate the [TrueCopy remote replication] or [TrueCopy Extended Distance] function and get the cause of the path detachment again.
2	Cannot get alarm information because it is booting now.	The cause cannot be get because the subsystem is being booted.	Get the cause of the path detachment again after the subsystem enters the Ready status.
3	Cannot get alarm information because it does not register for remote equipment.	The cause cannot be get because the specified remote DF number is illegal.	Update the browser. If the path is still detached, get the cause of the path detachment again.
4	Cannot get alarm information because specified function is disable.	The cause cannot be get because the [TrueCopy remote replication] or [TrueCopy Extended Distance] function is invalid although it is unlocked.	Validate the [TrueCopy remote replication] or [TrueCopy Extended Distance]function and get the cause of the path detachment again.
5	Cannot get alarm information because it does not register for this path.	The cause cannot be get because the specified path does not exist.	Update the browser. If the path is still detached, get the cause of the path detachment again.
6	Cannot get alarm information because this path's status is normally.	The cause cannot be get because the specified path has already become normal.	Update the browser. If the path is still detached, get the cause of the path detachment again.

Table 6.1.7 List of Messages Displayed when Path is Revalidated

No.	Sub-window message	Meaning of message	Recovery method
1	Do you recover this path?	Do you want to revalidate the specified path?	—
2	Executing...	The revalidation of the specified path is being executed.	—
3	This recovery was completed successfully.	The revalidation of the specified path was completed normally.	—
4	This recovery failed.	The revalidation of the specified path terminated abnormally.	It is presumed that the path was detached owing to another cause or the replaced part was not correct. Perform a maintenance work again following the procedure against the path detachment.
5	Cannot recover this path because specified function is lock.	The path revalidation cannot be done because the [TrueCopy remote replication] or [TrueCopy Extended Distance] function is locked.	Unlocked and validate the [TrueCopy remote replication] or [TrueCopy Extended Distance] function and execute the path revalidation again.
6	Cannot recover this path because it is booting now.	The path revalidation cannot be done because the subsystem is being booted.	Execute the path revalidation again after the subsystem enters the Ready status.
7	Cannot recover this path because it does not register for this remote equipment.	The path revalidation cannot be done because the specified remote DF number is illegal.	Execute the path revalidation again after updating the browser.
8	Cannot recover this path because CTL is alarm.	The path revalidation cannot be done because the controller is detached.	Execute the path revalidation again after recovering the controller from the detachment.
9	Cannot recover this path because specified function is disable.	The path revalidation cannot be done because the [TrueCopy remote replication] or [TrueCopy Extended Distance] function is invalid though it is unlocked.	Execute the path revalidation again after validating the [TrueCopy remote replication] or [TrueCopy Extended Distance] function.
10	Cannot recover this path because it does not register for this path.	The path revalidation cannot be done because the specified path does not exist.	Execute the path revalidation again after updating the browser.
11	Cannot recover this path because this path's status is normally.	The path revalidation cannot be done because the specified path has already become normal.	Execute the path revalidation again after updating the browser.
12	Cannot recover this path because it is executing LU Format.	The path revalidation cannot be done because an LU formatting is being executed.	Execute the path revalidation again after the LU formatting is completed.
13	Cannot recover this path because it is executing Synchronized cache.	The path revalidation cannot be done because the SyncCache command is being executed.	Execute the path revalidation again after the execution of the SyncCache command is completed.
14	Cannot recover this path because it is executing Array unit shutdown.	The path revalidation cannot be done because the pseudo-deliberate shutdown is being executed.	Execute the path revalidation again after the pseudo-deliberate shutdown has been completed.
15	Cannot recover this path because Power OFF>	The path revalidation cannot be done because the deliberate shutdown is being executed.	Execute the path revalidation again after starting up the subsystem.

6.1.18 Recovery Method for Disk Drives which Skipped Drive Firmware Replacement

[WEB Information Message display]

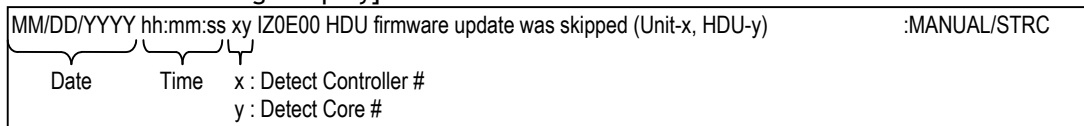

[Recovery method]

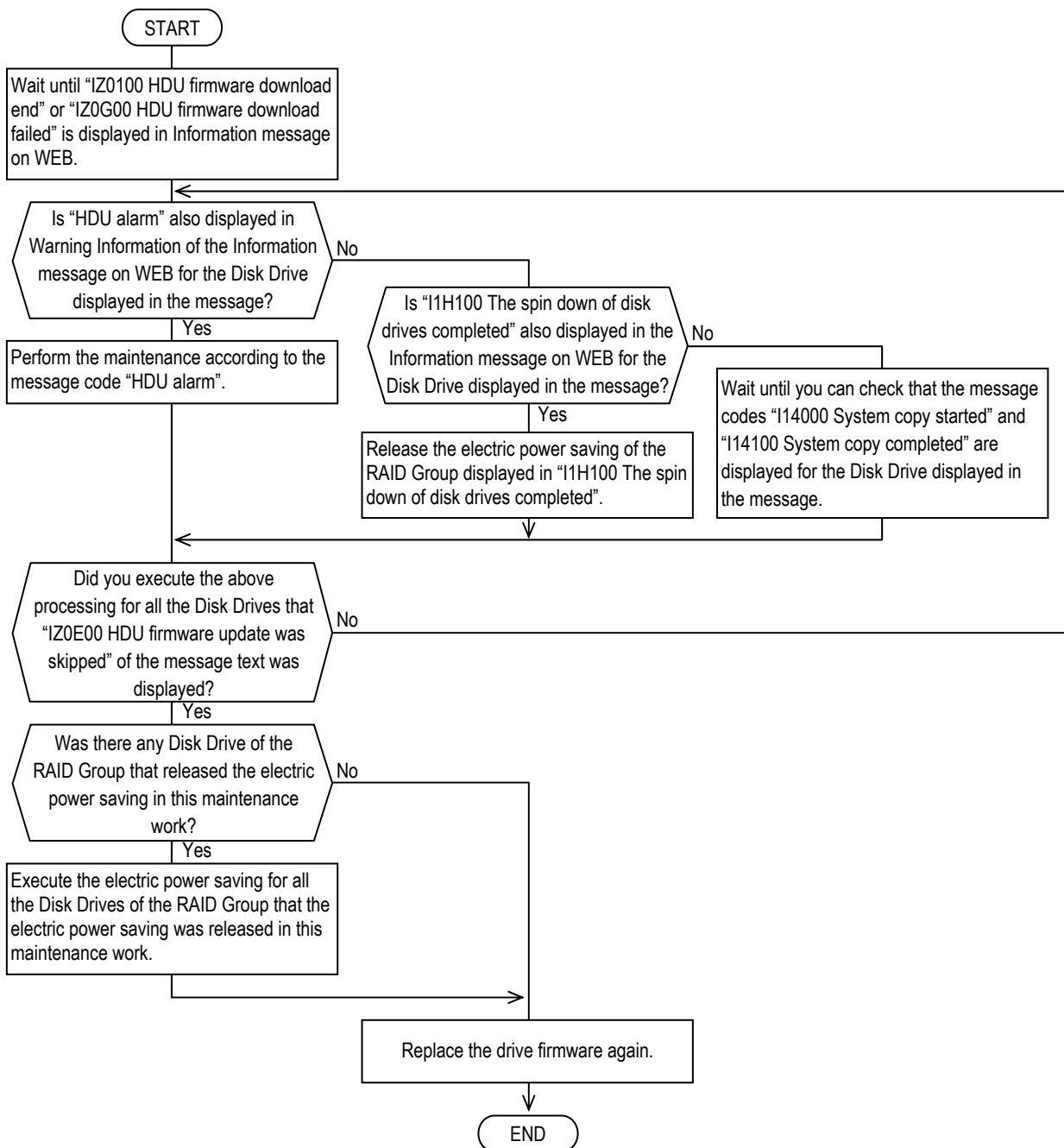

6.1.19 Recovery Method when the Subsystem Down of the Array Occurred due to the Incorrect ENC Cable Connection

[WEB Information Message display]

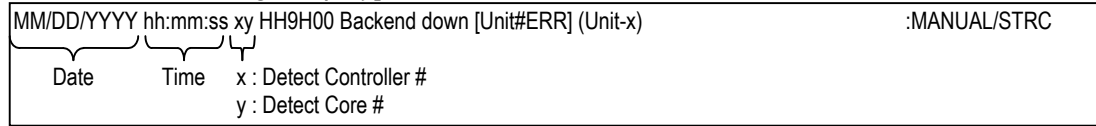

[Recovery method]

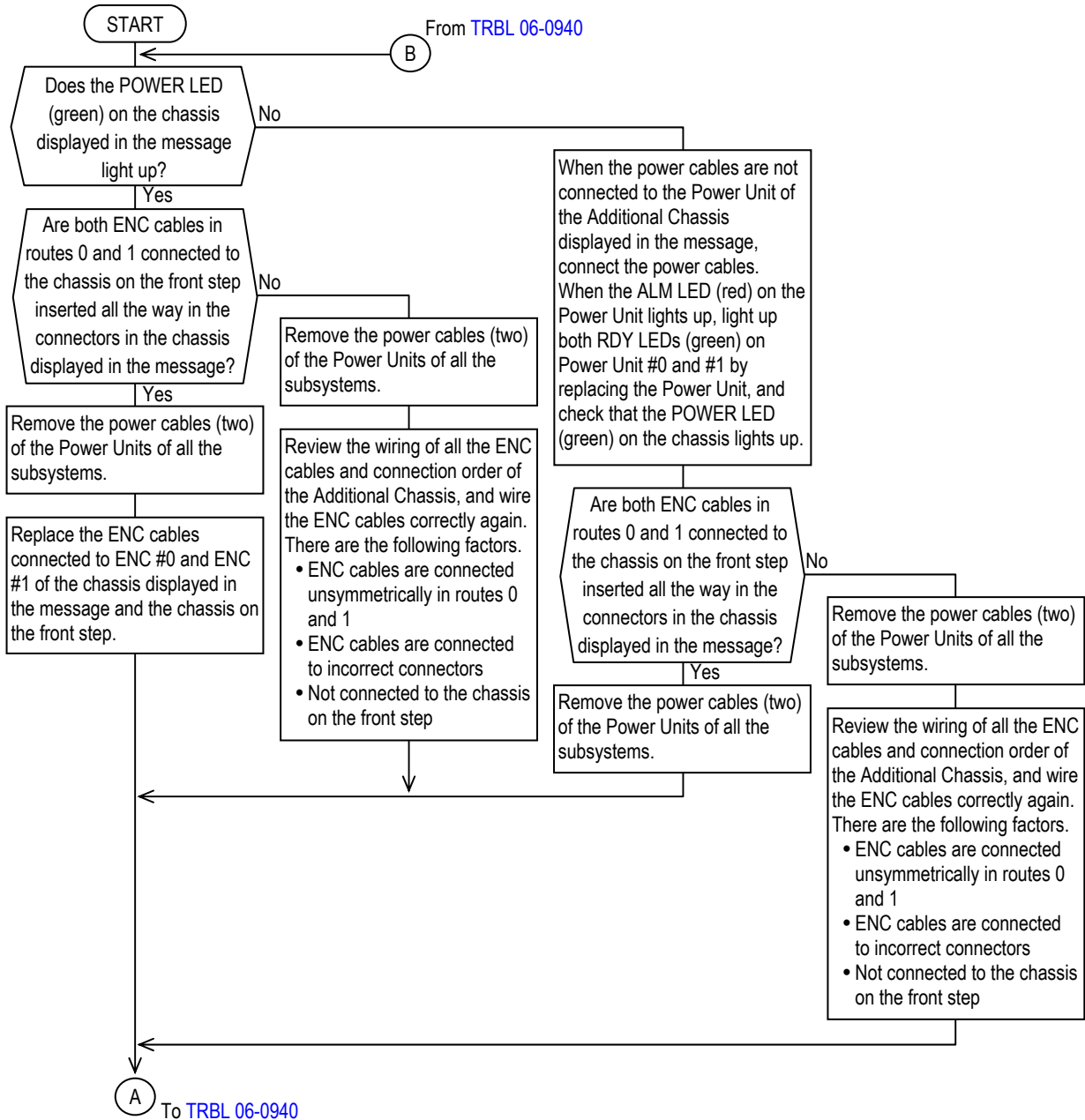

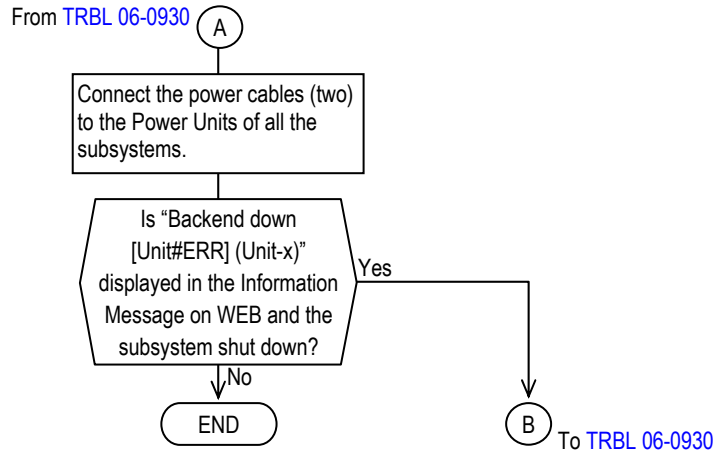

6.1.20 Recovery Method when a Power Unit Failure of the Additional Chassis Occurred

[WEB Information Message display]

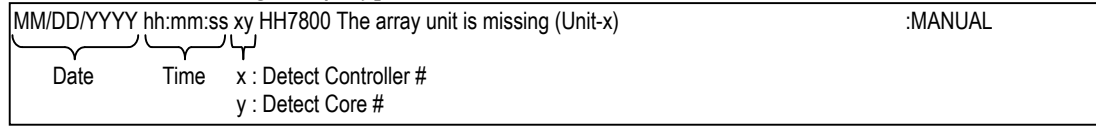

[Recovery method]

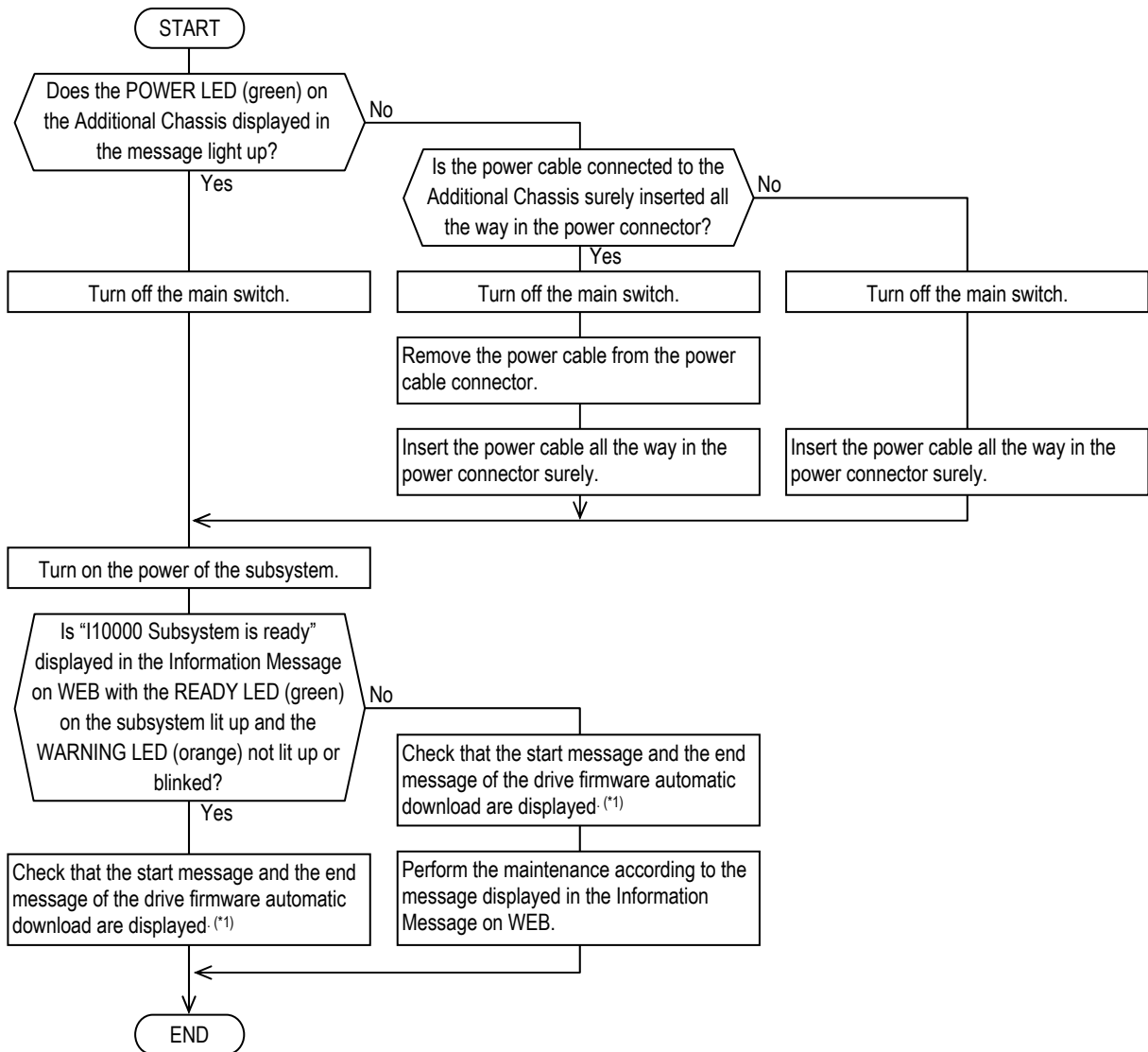

*1 : When the drive firmware version of the disk drive is new, the start message and completion message of the drive firmware automatic download are not displayed. To check the drive firmware automatic download, refer to [Firmware "1.6 \(4\) Checking the start message and end message of the automatic download \(FIRM 01-0890\)"](#).

6.1.21 Recovery Method when the Creation of the SSL User Certificate File Failed

[WEB Information Message display]

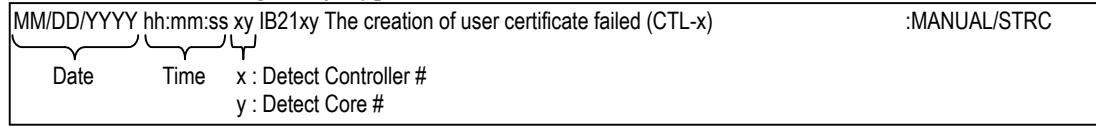

[Recovery method]

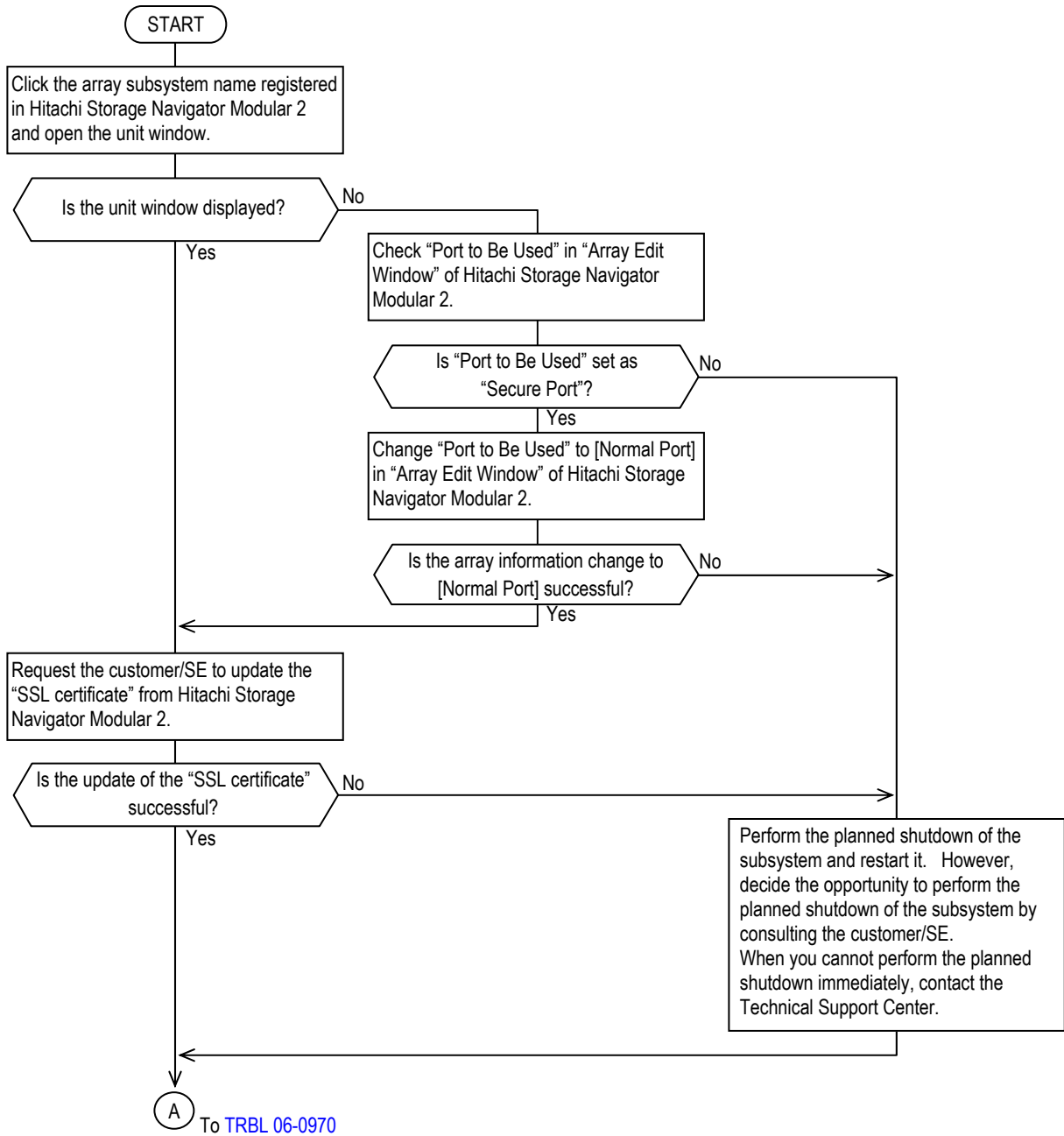

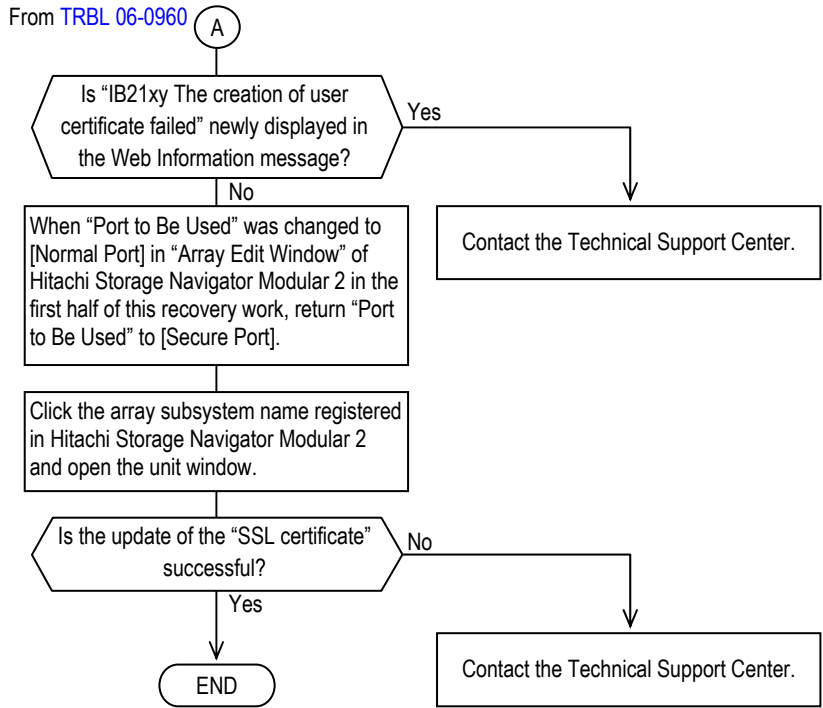

6.1.22 Recovery Method when Detecting the Mismatch of the Control Unit Model Names between the Control Units

[WEB Information Message display]

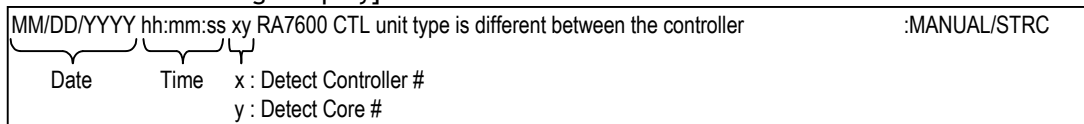

[Recovery method]

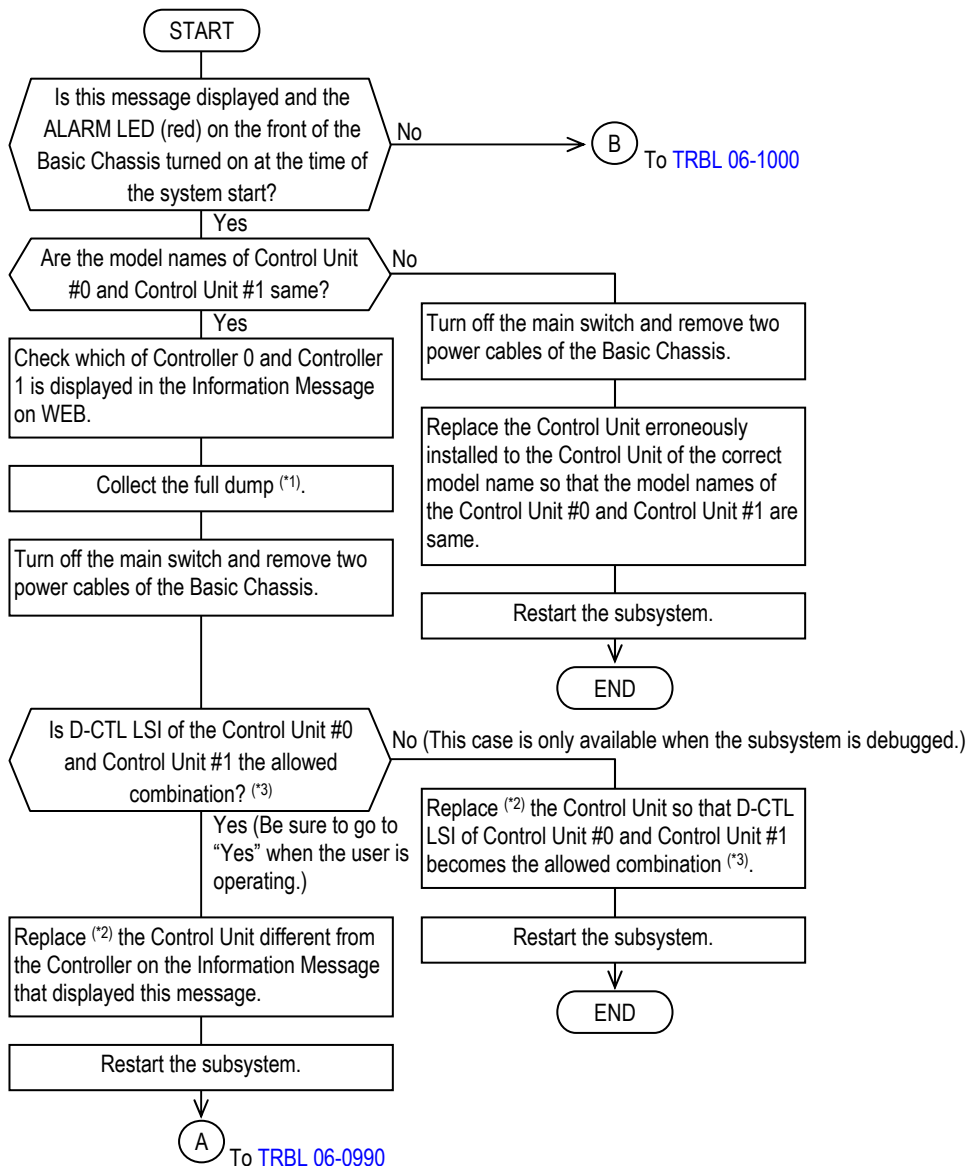

*1 : For the collection Full Dump, refer to “7.5 Collecting Full Dump” (TRBL 07-0140).

*2 : For the replacement of the Control Unit, refer to the Replacement “2.2.5 Replacing Control Unit” (REP 02-0450).

*3 : The allowed combination of the Control Units (CTL-0 : CTL-1)

D-CTL 1st revision: D-CTL 1st revision, D-CTL 2nd revision: D-CTL 2nd revision, and the combination is free in D-CTL 3rd revision or more.

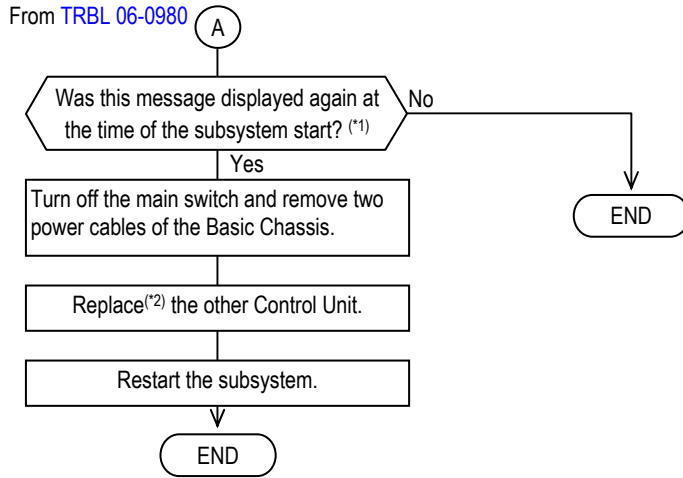

*1 : For the replacement of the Control Unit, refer to the Replacement “2.2.5 Replacing Control Unit” (REP 02-0450).

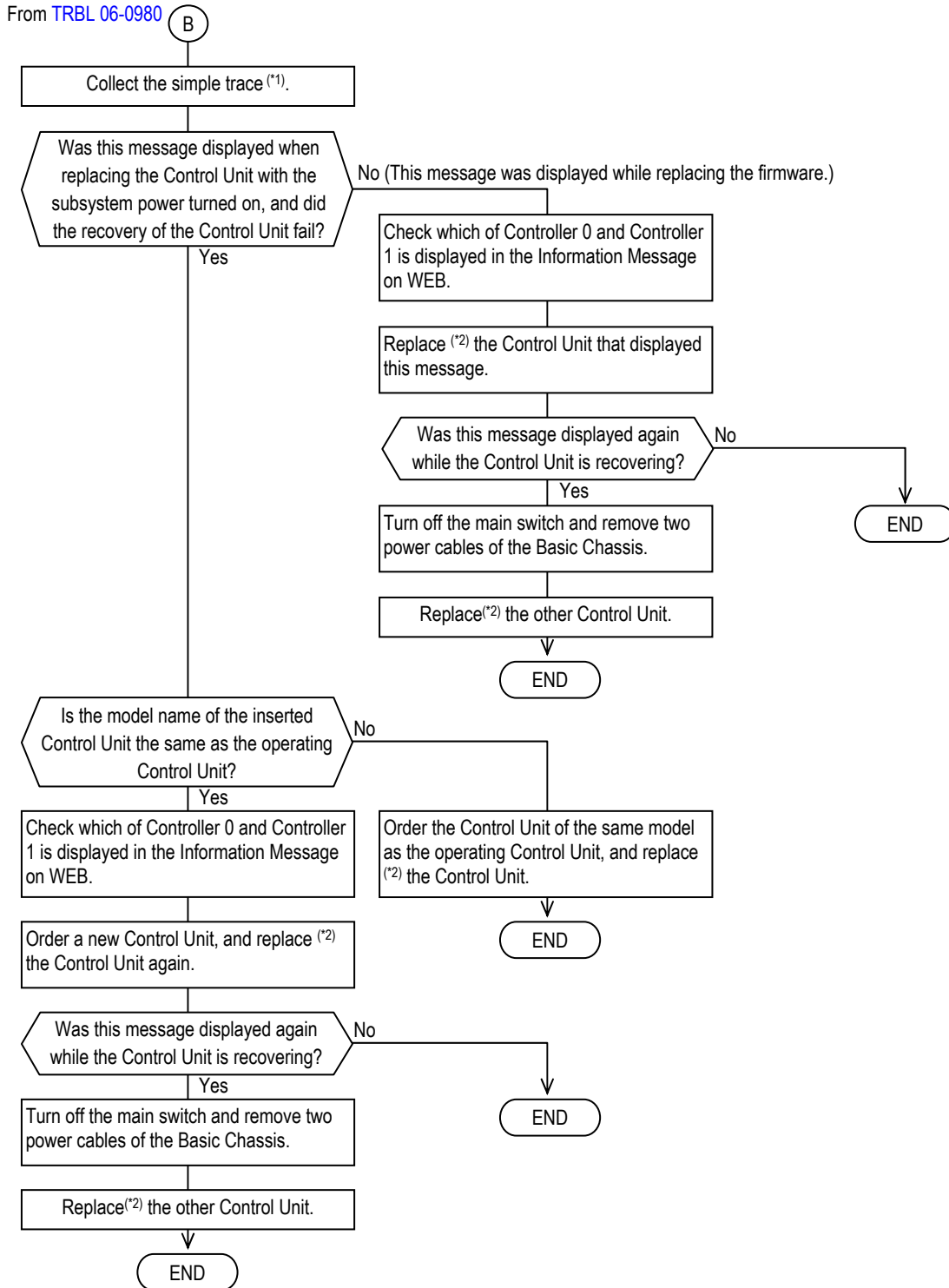

*1 : For the Collection simple trace, refer to “7.3 Collecting Simple Trace” (TRBL 07-0040).

*2 : For the replacement of the Control Unit, refer to the Replacement “2.2.5 Replacing Control Unit” (REP 02-0450).

6.1.23 Recovery Method when an Error of the Additional Battery Box Connection was Detected

[WEB Information Message display]

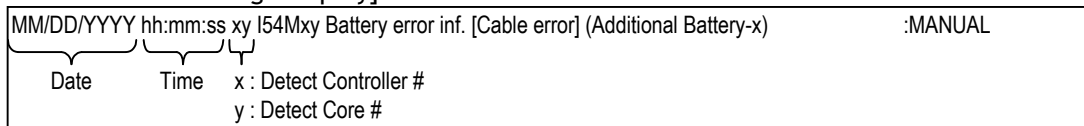

[Recovery method]

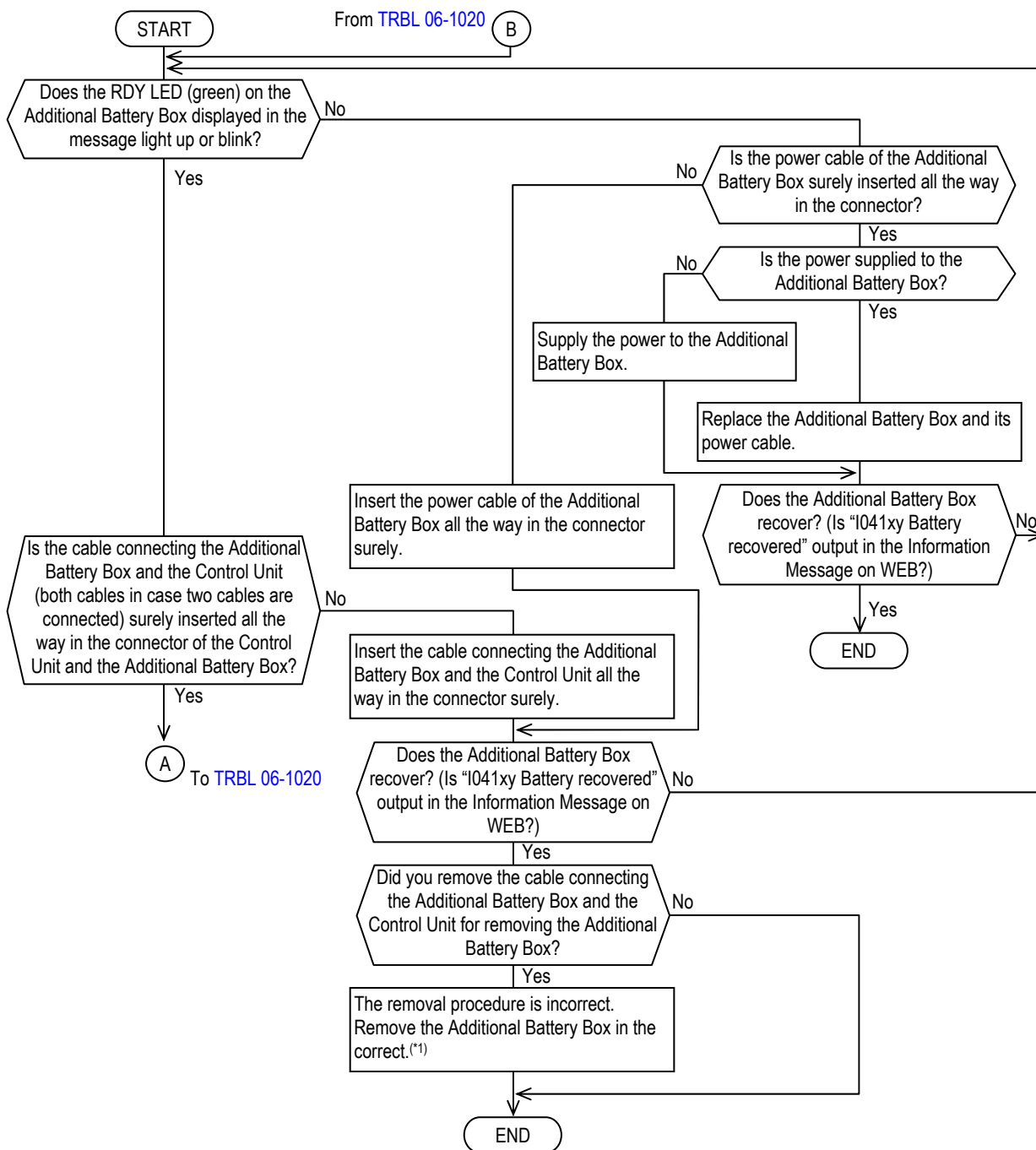

*1 : For the removing the Additional Battery Box, refer to Addition/Removal/Relocation "2.4.8 Removing a Additional Battery Box" (ADD 02-0484).

From TRBL 06-1010

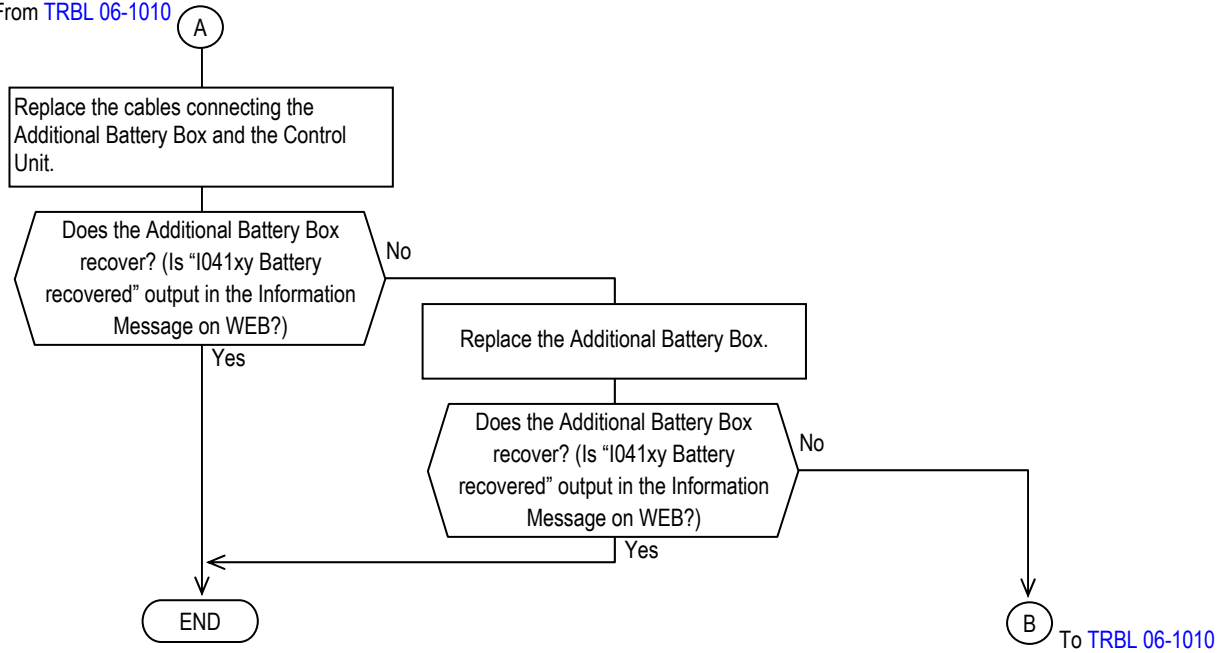

6.1.24 Recovery Method when the Spin-up of the System Drive Failed

[WEB Information Message display]

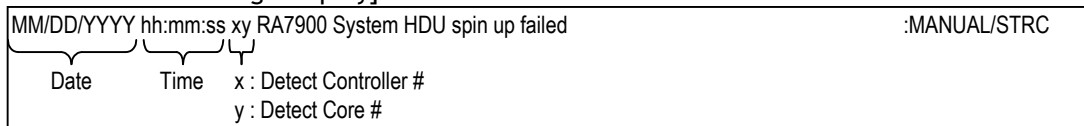

[Recovery method]

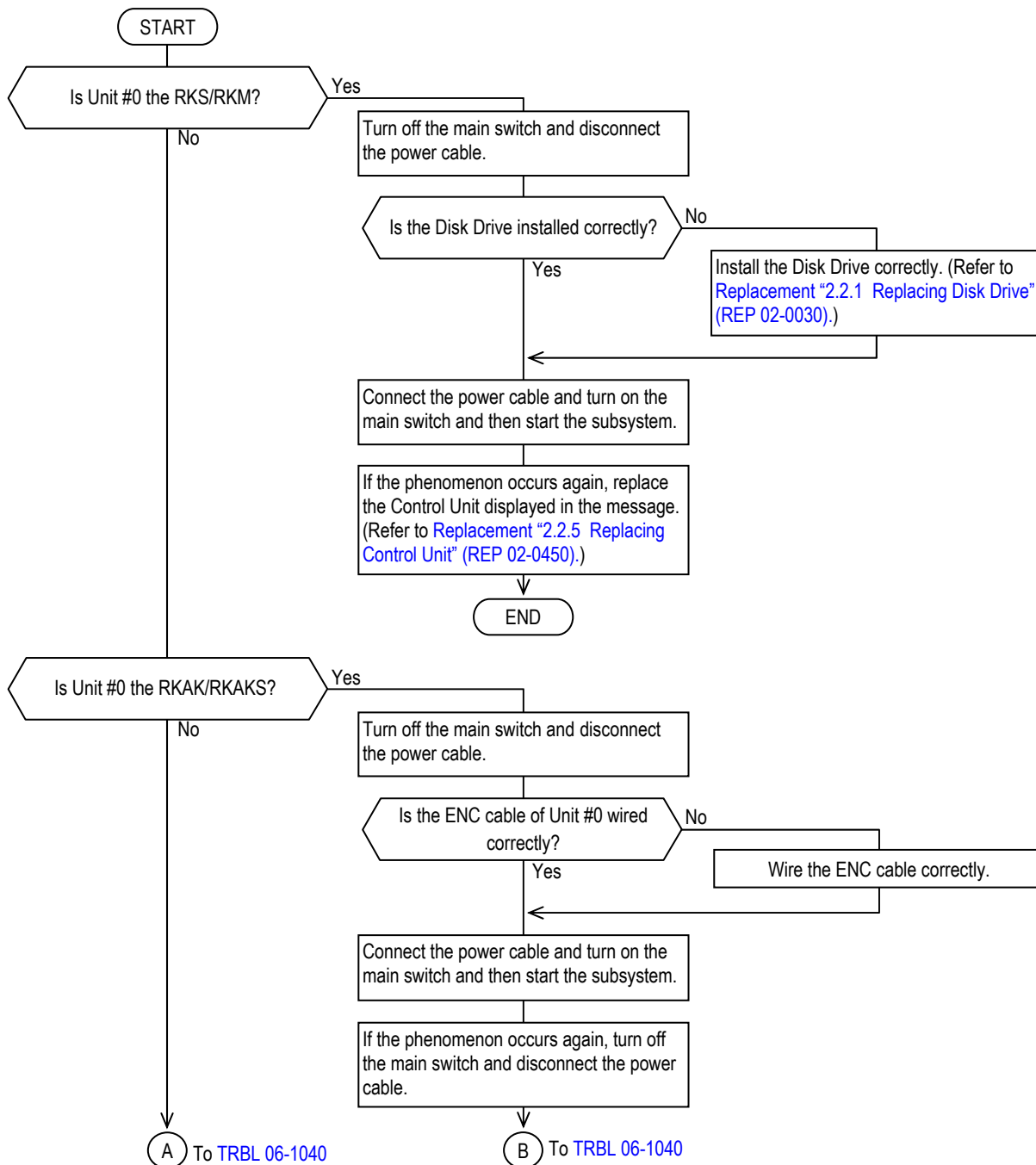

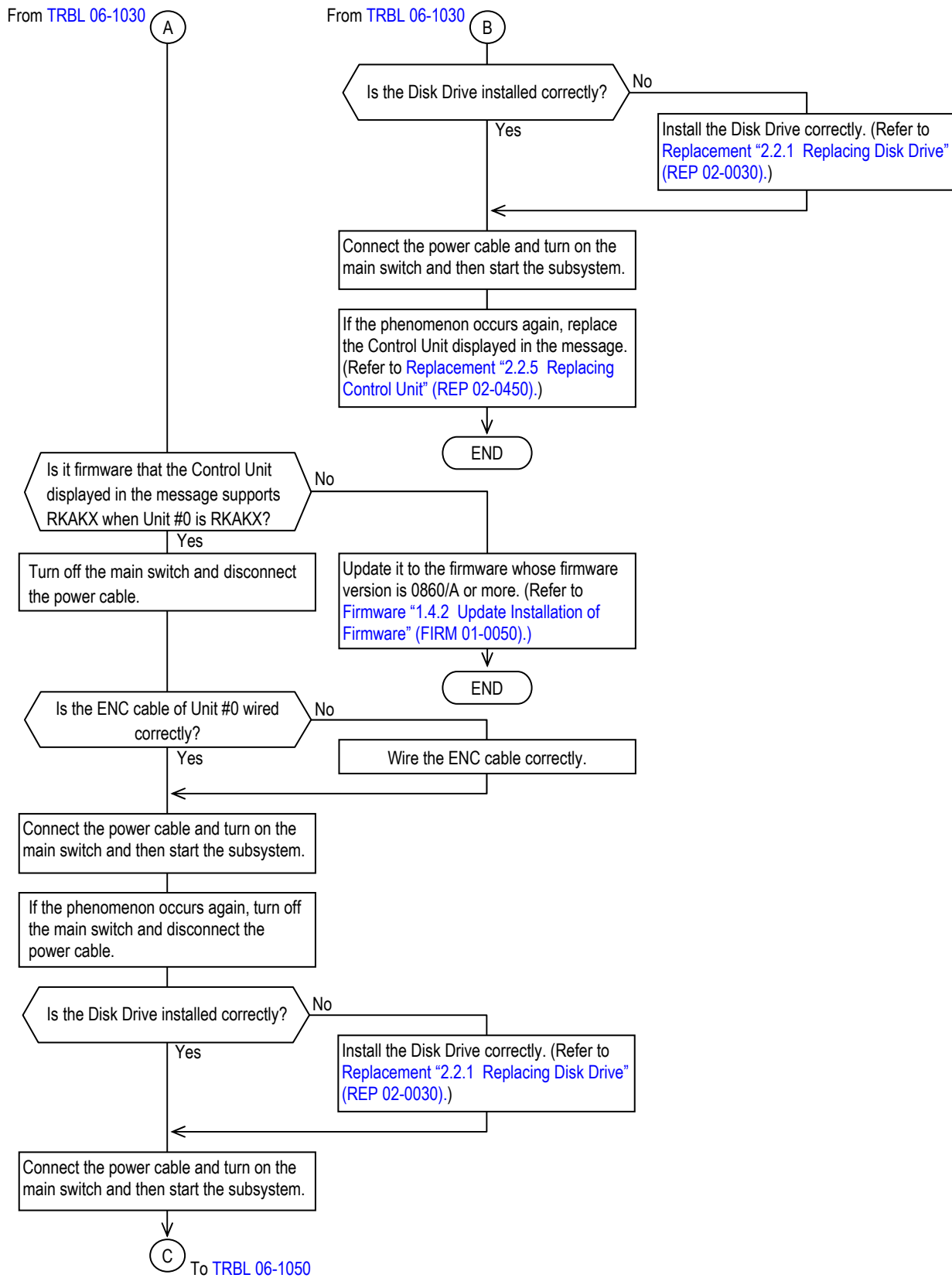

From TRBL 06-1040



If the phenomenon occurs again, replace the Control Unit displayed in the message.
(Refer to [Replacement "2.2.5 Replacing Control Unit" \(REP 02-0450\)](#).)

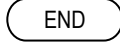

6.1.25 Recovery Method when the Subsystem went Down because the Load of the DP Management Information

[WEB Information Message display]

MM/DD/YYYY	hh:mm:ss	xy	H0F200	The staging of the management information of DP pool failed	:MANUAL/STRC
Date	Time	x : Detect Controller # y : Detect Core #			

- NOTE :
- When the READY LED (green) on the front side of the Basic Chassis is lights off, refer to [“Chapter 8. Trouble Analysis by LED Indication” \(TRBL 08-0000\)](#) to recover the failures.
 - The recovery method shown below is for the case where blockades of both Controllers in a dual Controller configuration occur.
 - The ALARM LED (red) on the front side of the Basic Chassis comes on and the both controllers are detached. As to the ALM LED (red) on the controller PCBA, only the ALM LED (red) on one of the controllers, in which the failure was detected earlier, comes on.
Make sure on which controller the ALM LED (red) is on because the recovery work is to be done starting from the controller whose ALM LED (red) is on.

[Recovery method]

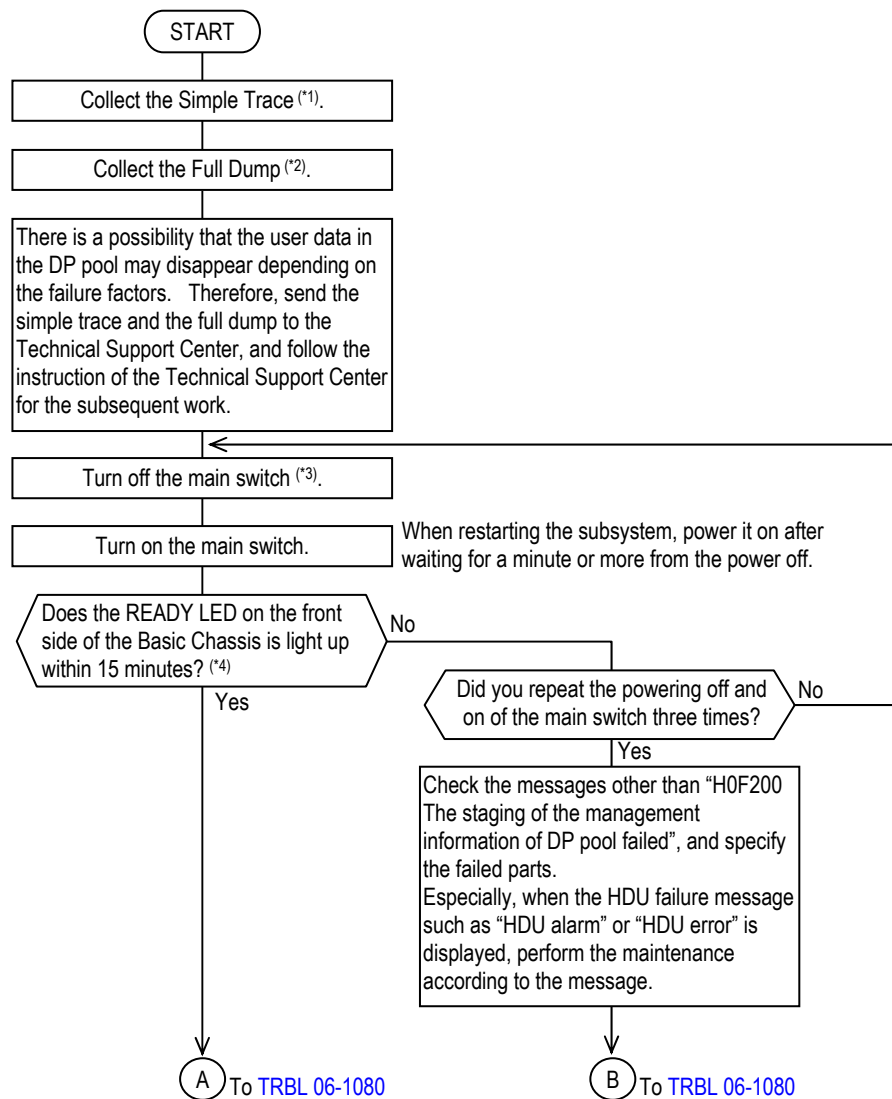

*1 : For the collection Simple Trace, refer to “7.3 Collecting Simple Trace” (TRBL 07-0040).

*2 : For the collection Full Dump, refer to “7.5 Collecting Full Dump” (TRBL 07-0140).

*3 : When the ALARM LED (red) on the front of the Basic Chassis does not go out even if the main switch was turned off and five minutes or more passed, remove the power cables from the Power Unit once. After a while, install the power cables in the Power Unit.

*4 : Wait if the READY LED (green) on the front of the Basic Chassis is blinking at high speed (for the maximum of 30 to 50 minutes, or 40 to 60 minutes in case of the RKH), or the WARNING LED (orange) is blinking at high speed (for the maximum of 30 to 85 minutes).

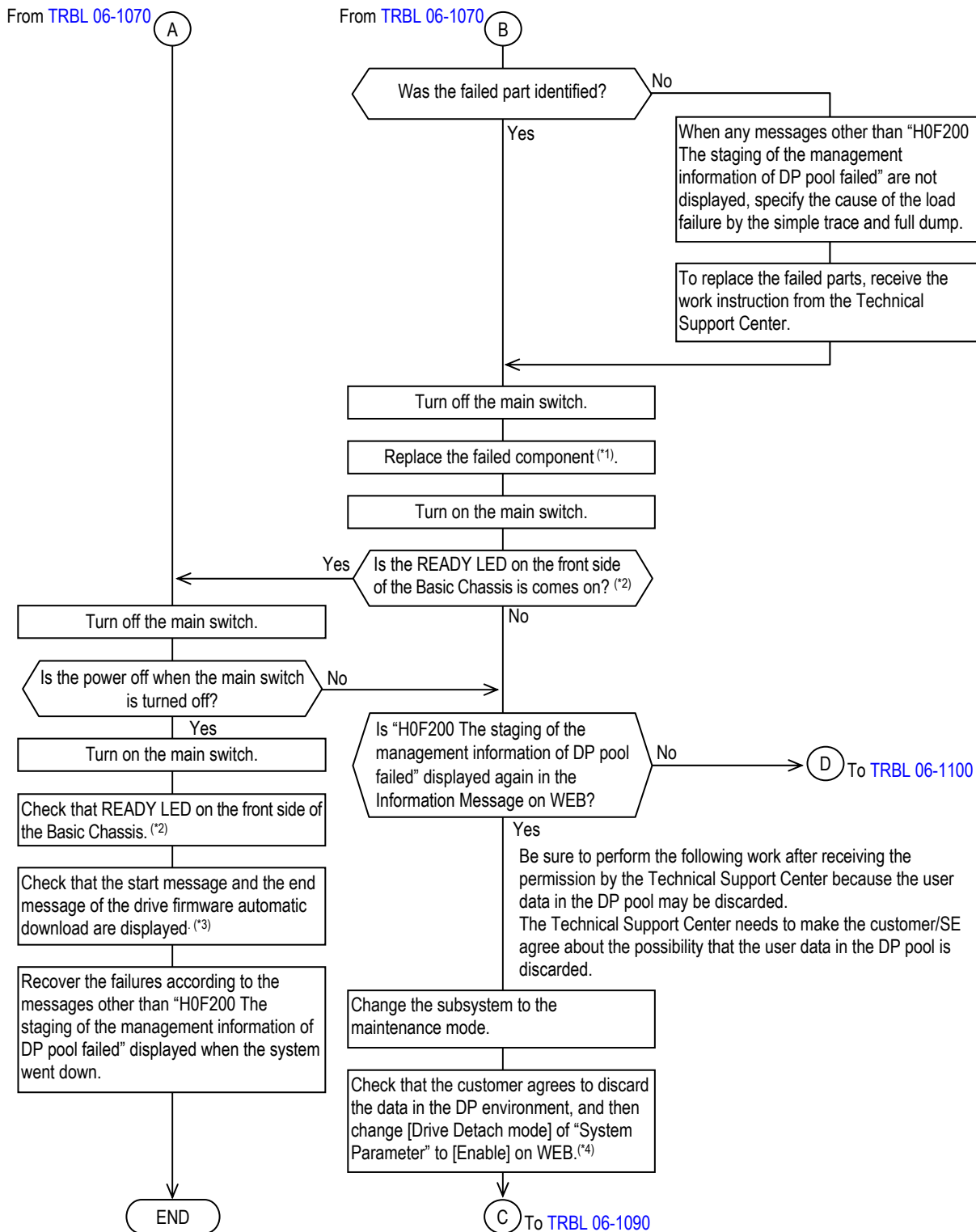

*1 : For the replacement of the failed component, refer to Replacement "Chapter 2. Parts Replacement" (REP 02-0000).
 *2 : Wait if the READY LED (green) on the front of the Basic Chassis is blinking at high speed (for the maximum of 30 to 50 minutes, or 40 to 60 minutes in case of the RKH), or the WARNING LED (orange) is blinking at high speed (for the maximum of 30 to 85 minutes).
 *3 : When the drive firmware version of the disk drive is new, the start message and completion message of the drive firmware automatic download are not displayed. To check the drive firmware automatic download, refer to Firmware "1.6 (4) Checking the start message and end message of the automatic download (FIRM 01-0890)".
 *4 : Refer to WEB "3.2.1 Subsystem" (WEB 03-0070) for setting the Drive Detach mode.

From TRBL 06-1080

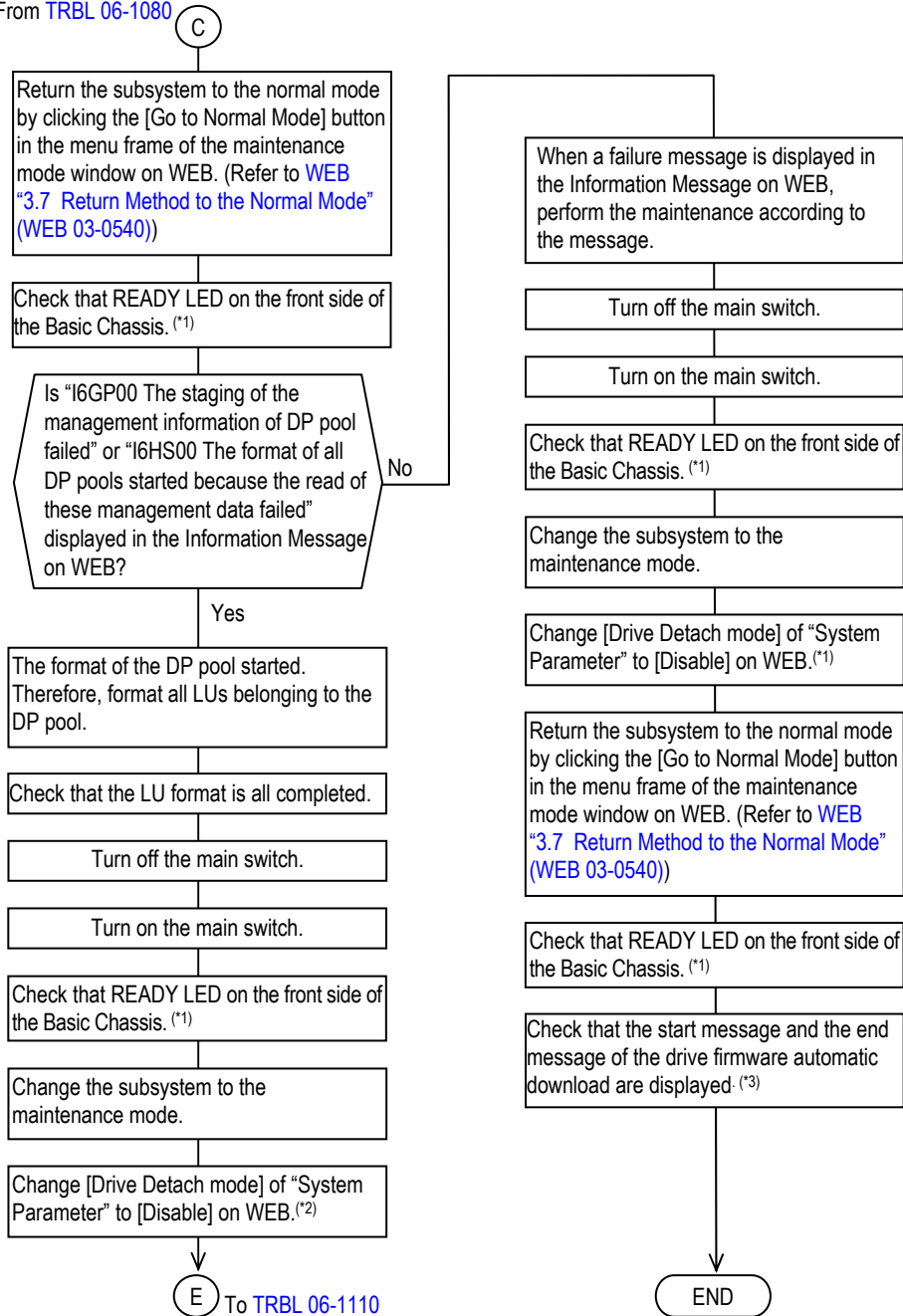

*1 : Wait if the READY LED (green) on the front of the Basic Chassis is blinking at high speed (for the maximum of 30 to 50 minutes, or 40 to 60 minutes in case of the RKH), or the WARNING LED (orange) is blinking at high speed (for the maximum of 30 to 85 minutes).

*2 : Refer to WEB "3.2.1 Subsystem" (WEB 03-0070) for setting the Drive Detach mode.

*3 : When the drive firmware version of the disk drive is new, the start message and completion message of the drive firmware automatic download are not displayed. To check the drive firmware automatic download, refer to Firmware "1.6 (4) Checking the start message and end message of the automatic download (FIRM 01-0890)".

From TRBL 06-1080

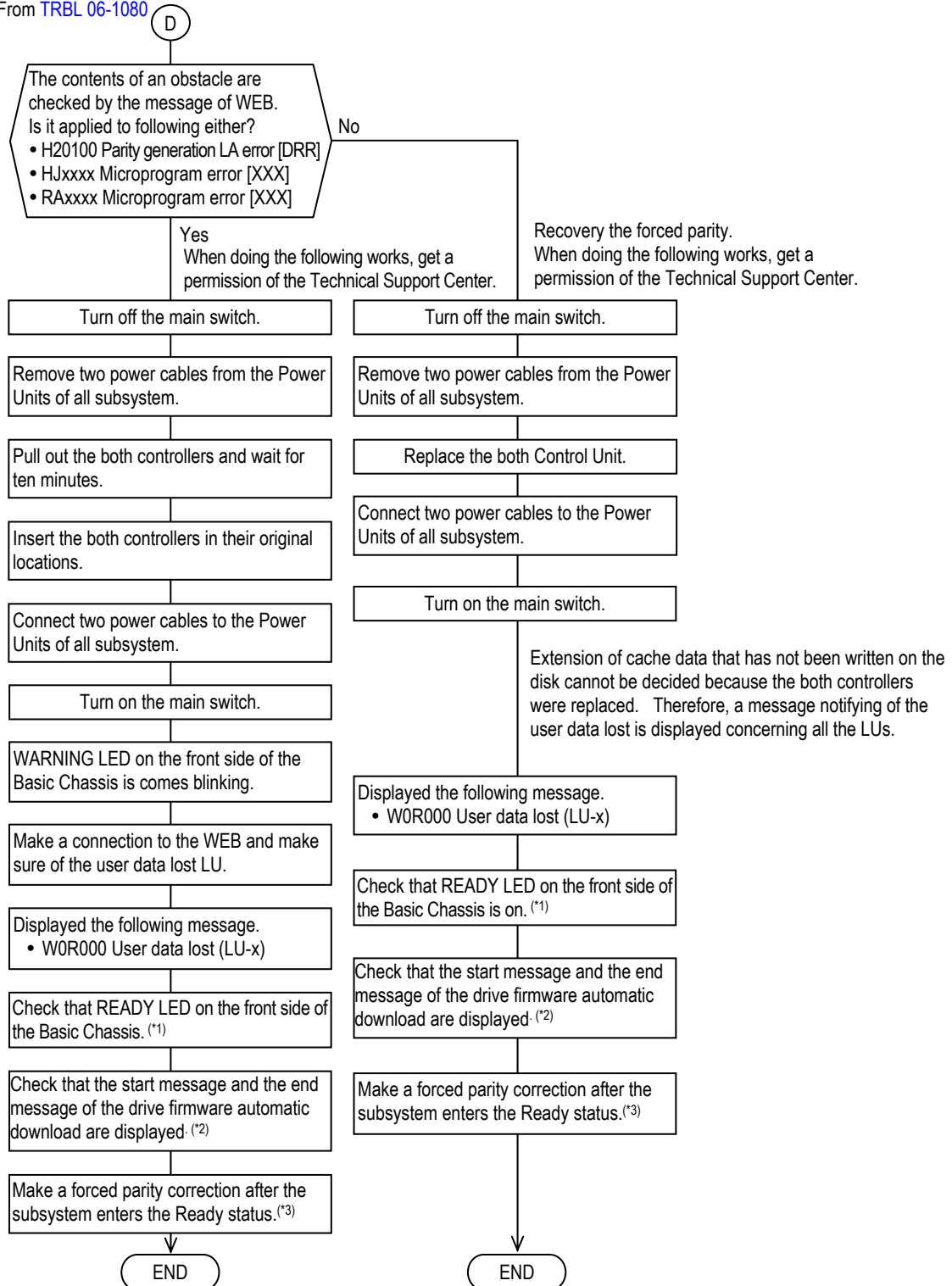

*1 : Wait if the READY LED (green) on the front of the Basic Chassis is blinking at high speed (for the maximum of 30 to 50 minutes, or 40 to 60 minutes in case of the RKH), or the WARNING LED (orange) is blinking at high speed (for the maximum of 30 to 85 minutes).

*2 : When the drive firmware version of the disk drive is new, the start message and completion message of the drive firmware automatic download are not displayed. To check the drive firmware automatic download, refer to [Firmware "1.6 \(4\) Checking the start message and end message of the automatic download \(FIRM 01-0890\)"](#).

*3 : For the forced parity correction, refer to Item "6.1.3 The Failure Occurred Immediately after Being Ready (Forced Parity Correction)" (TRBL 06-0110).

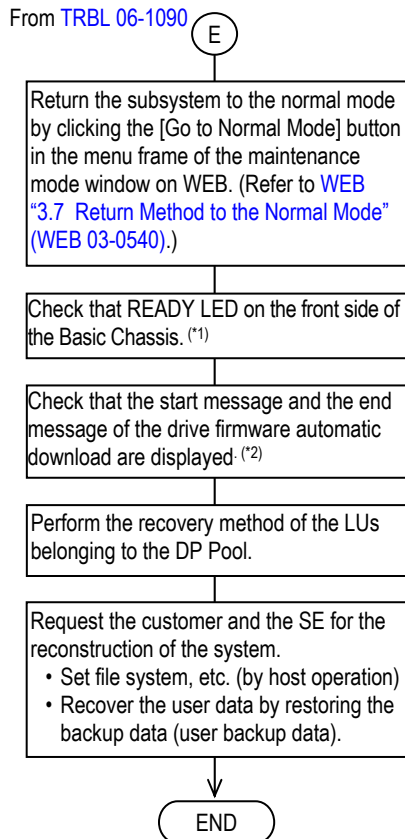

*1 : Wait if the READY LED (green) on the front of the Basic Chassis is blinking at high speed (for the maximum of 30 to 50 minutes, or 40 to 60 minutes in case of the RKH), or the WARNING LED (orange) is blinking at high speed (for the maximum of 30 to 85 minutes).

*2 : When the drive firmware version of the disk drive is new, the start message and completion message of the drive firmware automatic download are not displayed. To check the drive firmware automatic download, refer to Firmware "1.6 (4) Checking the start message and end message of the automatic download (FIRM 01-0890)".

6.1.26 Recovery Method when the Firmware Detected an Error of the DP Management Information and the Control Unit was Blocked

[WEB Information Message display]

MM/DD/YYYY	hh:mm:ss	xy	HOF600	The firmware has detected the error data	
				in the DP management information of the array	:MANUAL/FDMP
Date	Time	x : Detect Controller # y : Detect Core #			

[Recovery method]

- (1) Collect the Control Unit blockade trace of the Control Unit displayed in the message. (Refer to [“7.4 Collecting CTL Alarm Trace” \(TRBL 07-0090\)](#).)
- (2) Request the Technical Support Center for the analysis, and inform the customer/SE of the analysis result.
- (3) Explain the possibility that the user data loss may have occurred in the logical units of the DP Pool due to a failure of the subsystem and the following maintenance work may cause a user data loss by discarding the dirty data to the customer/SE, and ask him/her for accepting the maintenance work.

Perform the following work after obtaining the permission from the Technical Support Center.

- (4) When the message is output from both Control Units or the ALARM LED (red) on the front of the Basic Chassis lights up, the DP management information in the Cache memory of the subsystem has an error. Inform the customer/SE of “The user data (dirty data) in the Cache memory of the subsystem is discarded”. In this case, go to the procedure [\(7\)](#).
When the message is only output from one Control Unit and the other Control Unit is operating (ALARM LED (red) on the front of the Basic Chassis goes out), go to the next procedure.
- (5) Request the customer/SE for “Since the DP management information in the Cache memory of the subsystem has an error, the user data (dirty data) in the Cache memory of the subsystem is discarded. Therefore, the operation of the customer who is using this subsystem is stopped to backup the user data”.
When the customer/SE backs up the user data, request him/her to start the backup from the data of the logical units which do not use the DP pool first and backup the data of the logical units which used the DP pool at last.
- (6) Wait until the customer/SE stops the operation and backs up the user data. While the customer/SE backs up the data of the logical units which use the DP pool, the operating Control Unit may be blocked due to an error of the management information of the DP Pool and the subsystem may go down. In this case, inform the customer/SE of “The user data of the logical units of the DP Pool cannot be backed up anymore”.
- (7) Collect the full dump of both Control Units. (Refer to [“7.5 Collecting Full Dump” \(TRBL 07-0140\)](#).)
When changing the mode to the maintenance mode, the subsystem stops the Control Unit without the message output.

- (8) Remove both Control Units from the Basic Chassis (the user data (dirty data) in the Cache memory disappears).
- (9) Turn off the main switch.
- (10) Remove the power cables from the Basic Chassis.
- (11) Remove both Control Units from the Basic Chassis (the user data (dirty data) in the Cache memory disappears).
- (12) Install both Control Units in the Basic Chassis after waiting for about one minute.
- (13) Connect the power cables to the Basic Chassis.
- (14) Turn on the main switch.
- (15) Check that the READY LED (green) on the front of the Basic Chassis is on.
The READY LED (green) on the front of the Basic Chassis may blink at high speed (for the maximum of 30 to 50 minutes, or 40 to 60 minutes in case of the RKH) before it lights up.
- (16) When “W0R000 User data lost” or “W3D000 Forced parity correction LU is detected” is displayed in the Information Message on WEB, perform the maintenance referring to [“6.1.3 The Failure Occurred Immediately after Being Ready \(Forced Parity Correction\) \(TRBL 06-0110\)”](#).
- (17) Request the customer/SE to verify the file if can be read or it is the most recent for all the logical units which used the DP Pool.
When the files which cannot be read or not the most recent are confirmed, request the customer/SE to restore the file from the backup data, format the logical units which have the problems, and restore the backup data.

6.1.27 Recovery Method when the Disk Drive Serial Number Acquired at the time of Starting the Subsystem and the Serial Number of the Configuration Information do not Match

[WEB Information Message display]

MM/DD/YYYY	hh:mm:ss	xy	HH9R00	Two or more HDUs have serial number problem	:MANUAL/STRC
MM/DD/YYYY	hh:mm:ss	xy	I6GV00	Move drive (Unit-x1, HDU-y1) to slot (Unit-x2, HDU-y2) because of serial number problem	:MANUAL/STRC
		x		Detect Controller #	
		y		Detect Core #	

[Recovery method]

One or more messages “I6GV00 Move drive (Unit-x1, HDU-y1) to slot (Unit-x2, HDU-y2) because of serial number problem” are displayed in WEB Information Message at the same time as this message. For all those messages, check the Disk Drive slot # (Unit-x1, HDU-y1) currently installed and the Disk Drive slot # (Unit-x2, HDU-y2) to be originally installed. The following three procedures are for the recovery.

(1) When the Disk Drives in the chassis are all replaced

When trying to replace the Disk Drive according to all the displayed messages “I6GV00 Move drive (Unit-x1, HDU-y1) to slot (Unit-x2, HDU-y2) because of serial number problem”, if all the Disk Drives in certain chassis A and in certain chassis B are all replaced, the ENC cables connected to the chassis A and chassis B are connected incorrectly.

- (a) Do not replace the Disk Drives in chassis A and chassis B, review the connection of the ENC cables, and connect the ENC cables correctly again.
- (b) Turn off the main switch.
- (c) Remove the power cables of all the chassis.
- (d) Connect the power cables of all the chassis.
- (e) Turn on the subsystem power.

(2) When the Disk Drive is installed in the Disk Drive slot (Unit-x2, HDU-y2)

In case when trying to replace the Disk Drive to the Disk Drive slot (Unit-x2, HDU-y2) according to all the displayed messages “I6GV00 Move drive (Unit-x1, HDU-y1) to slot (Unit-x2, HDU-y2) because of serial number problem”, the Disk Drive is already installed in the Disk Drive slot (Unit-x2, HDU-y2) and the message indicating to which slot the Disk Drive slot (Unit-x2, HDU-y2) is moved is not displayed.

- (a) Remove the Disk Drive from the Disk Drive slot (Unit-x2, HDU-y2).
- (b) Check with the administrator of the subsystem configuration to which slot the Disk Drive installed in the Disk Drive slot (Unit-x2, HDU-y2) is installed or if it cannot be installed.
- (c) Replace the Disk Drive in the Disk Drive slot (Unit-x1, HDU-y1) to the Disk Drive slot (Unit-x2, HDU-y2).
- (d) Turn off the main switch.
- (e) Remove the power cables of all the chassis.
- (f) Connect the power cables of all the chassis.
- (g) Turn on the subsystem power.

- (3) Other than the above-mentioned (1) and (2)
 - (a) Replace the Disk Drive to the Disk Drive slot (Unit-x2, HDU-y2) according to all the displayed message "I6GV00 Move drive (Unit-x1, HDU-y1) to slot (Unit-x2, HDU-y2) because of serial number problem".
 - (b) Turn off the main switch.
 - (c) Remove the power cables of all the chassis.
 - (d) Connect the power cables of all the chassis.
 - (e) Turn on the subsystem power.

6.1.28 Procedure for Starting the Subsystem by Removing the Failed Disk Drive when the Subsystem is not Ready

[Recovery method]

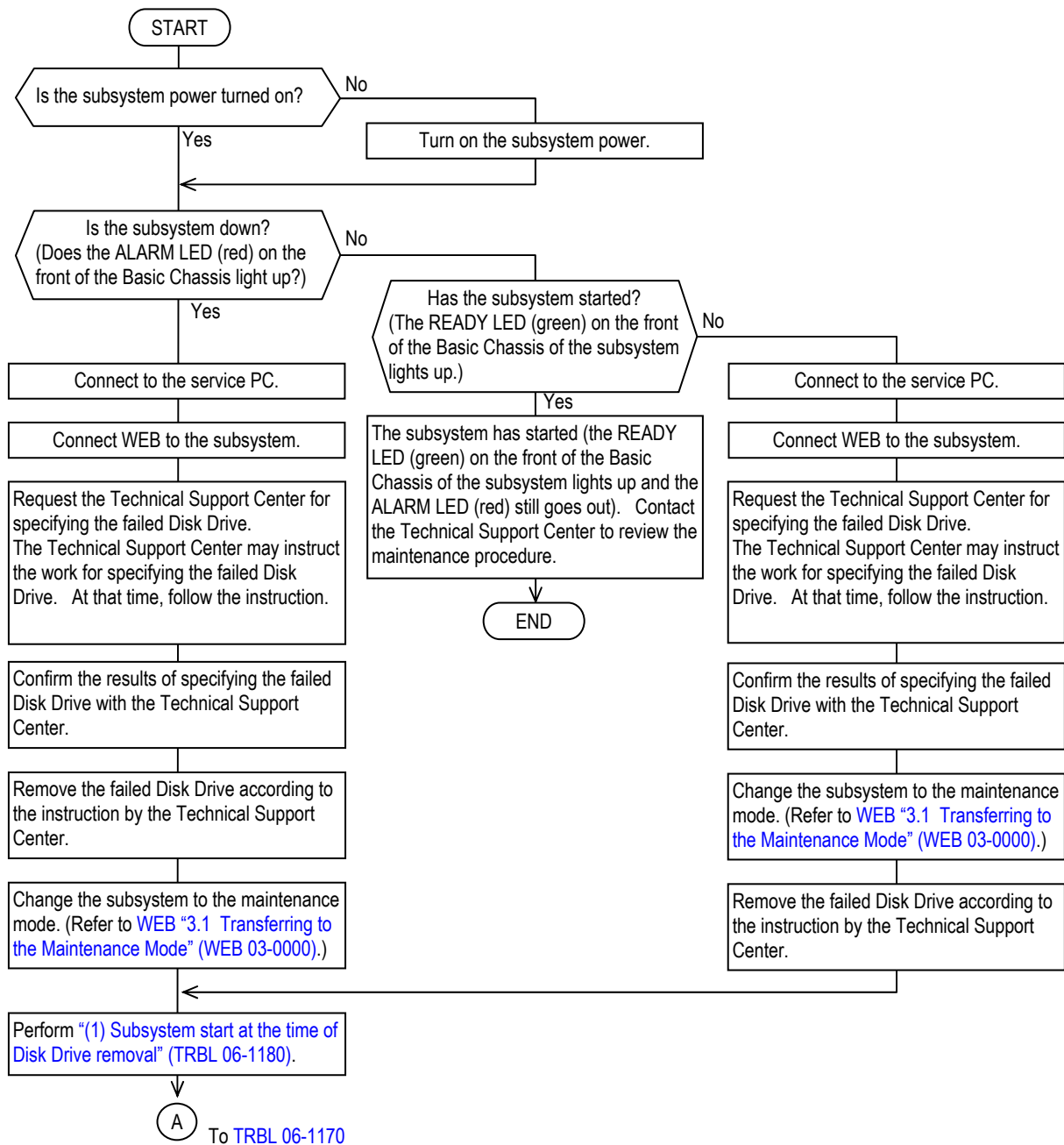

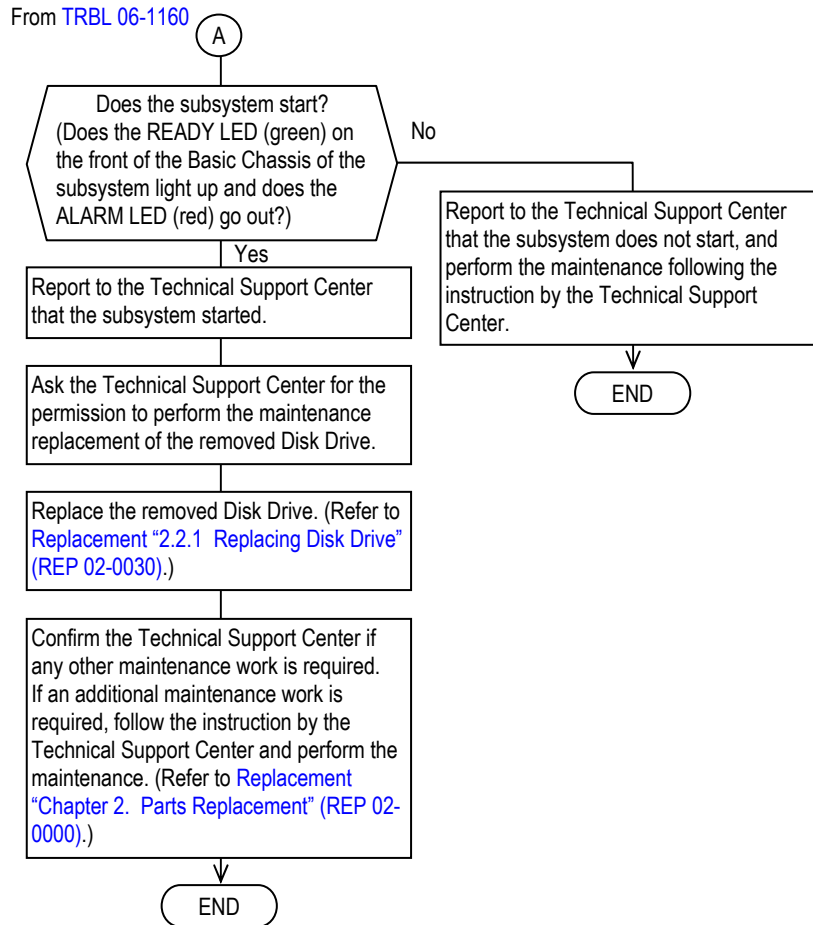

- (1) Subsystem start at the time of Disk Drive removal
 - (a) Click “Other” in the WEB window.

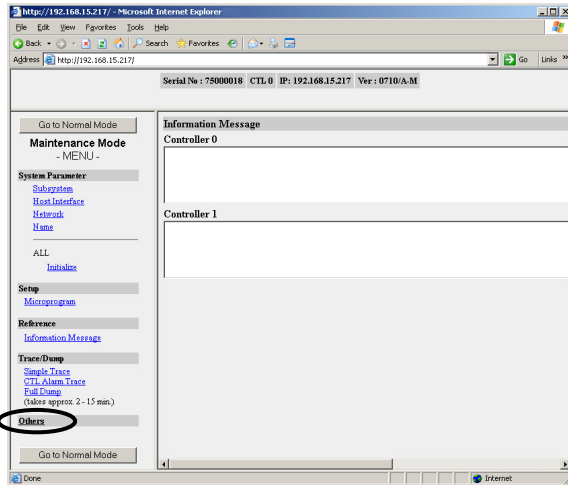

- (b) The current setting (current value) is displayed.

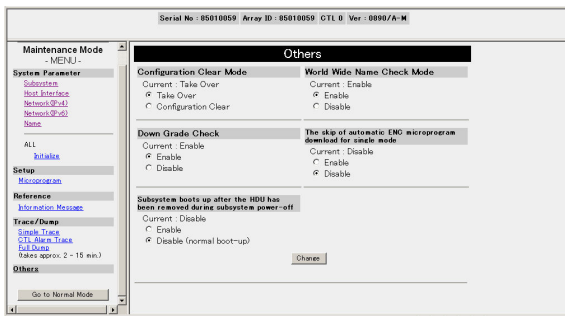

- (c) Click “Enable” of “Subsystem boots up after HDU has been removed during subsystem power-off”.

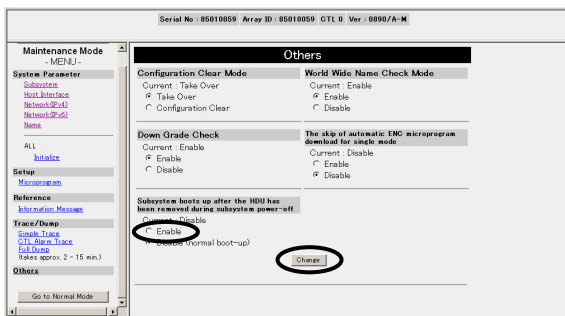

- (d) Click [Change].
- (e) Check that “Current” of “Subsystem boots up after HDU has been removed during subsystem power-off” is displayed as “Enable”.
- (f) Click [Go To Normal Mode] and start the subsystem. The button of [Go To Normal Mode] is in the top and down on the menu window. Please select either button.

6.1.29 Failure Determination and Recovery Methods of Fibre Channel Port Path

[WEB Information Message display]

MM/DD/YYYY hh:mm:ss xy I6GZ00 The number of the channel port error has exceeded the threshold (PortXX) :MANUAL/STRC		
Date	Time	x : Detect Controller # y : Detect Core #

[Recovery method]

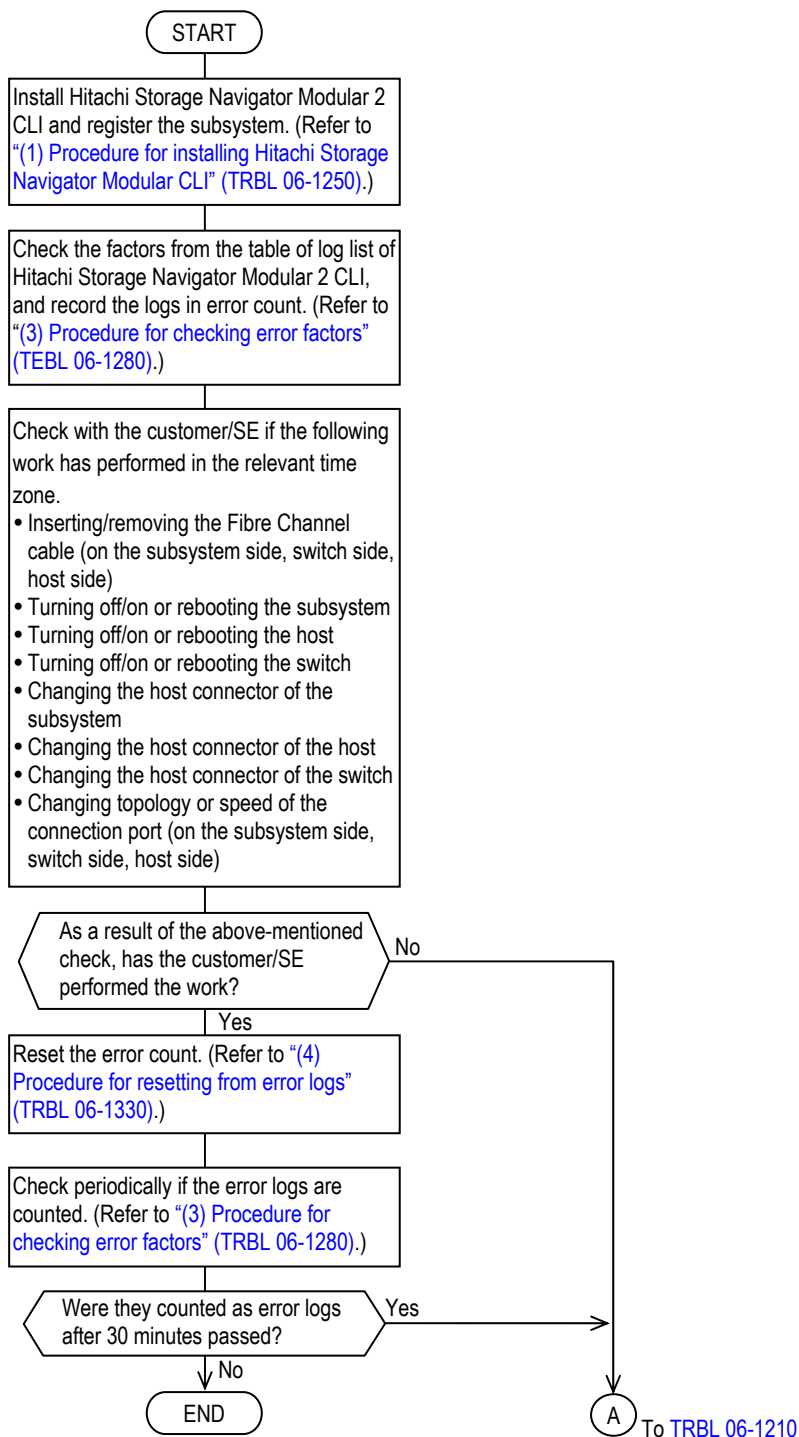

From TRBL 06-1200, TRBL 06-1220,
TRBL 06-1230, TRBL 06-1240

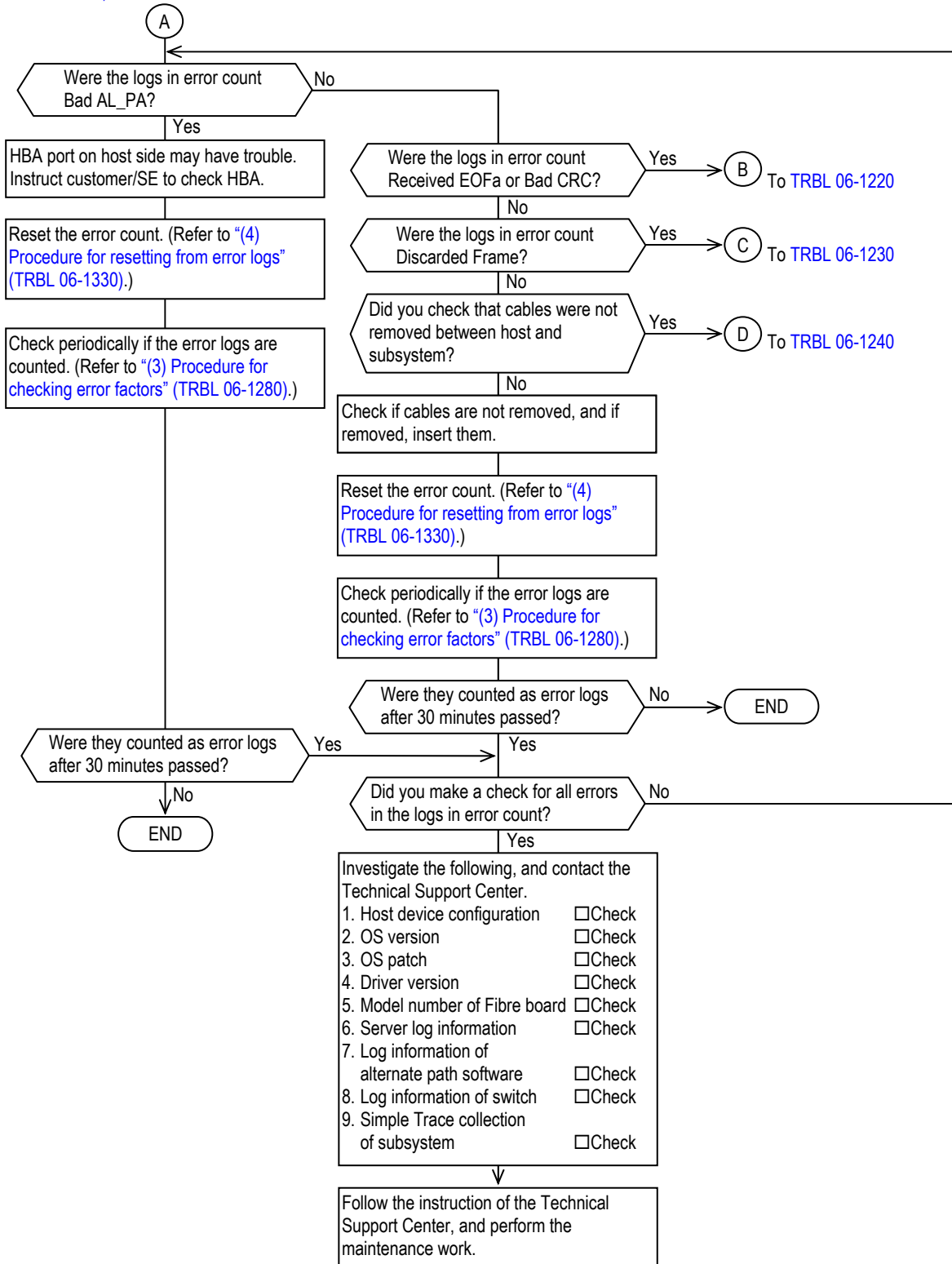

From TRBL 06-1210

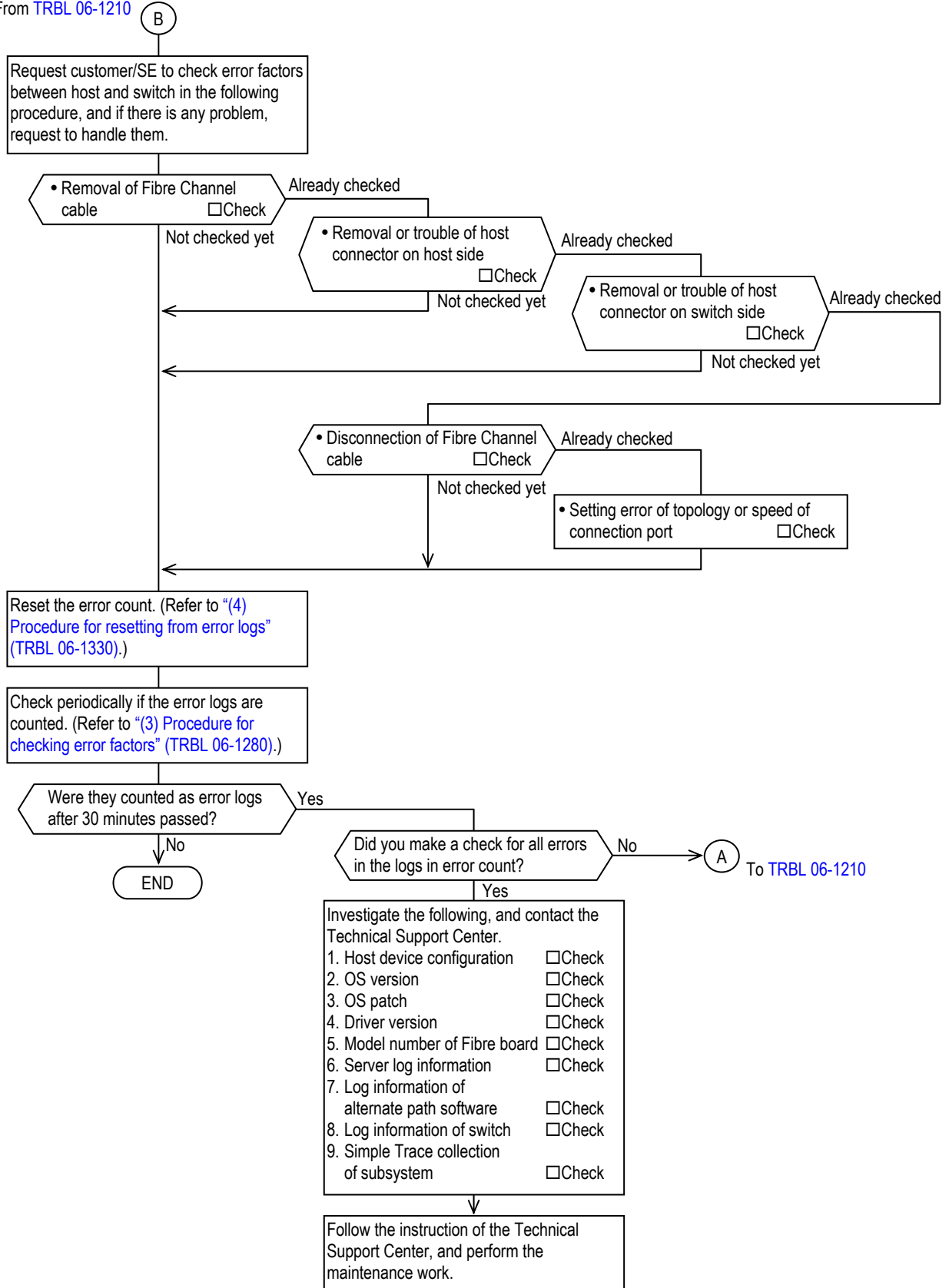

From TRBL 06-1210

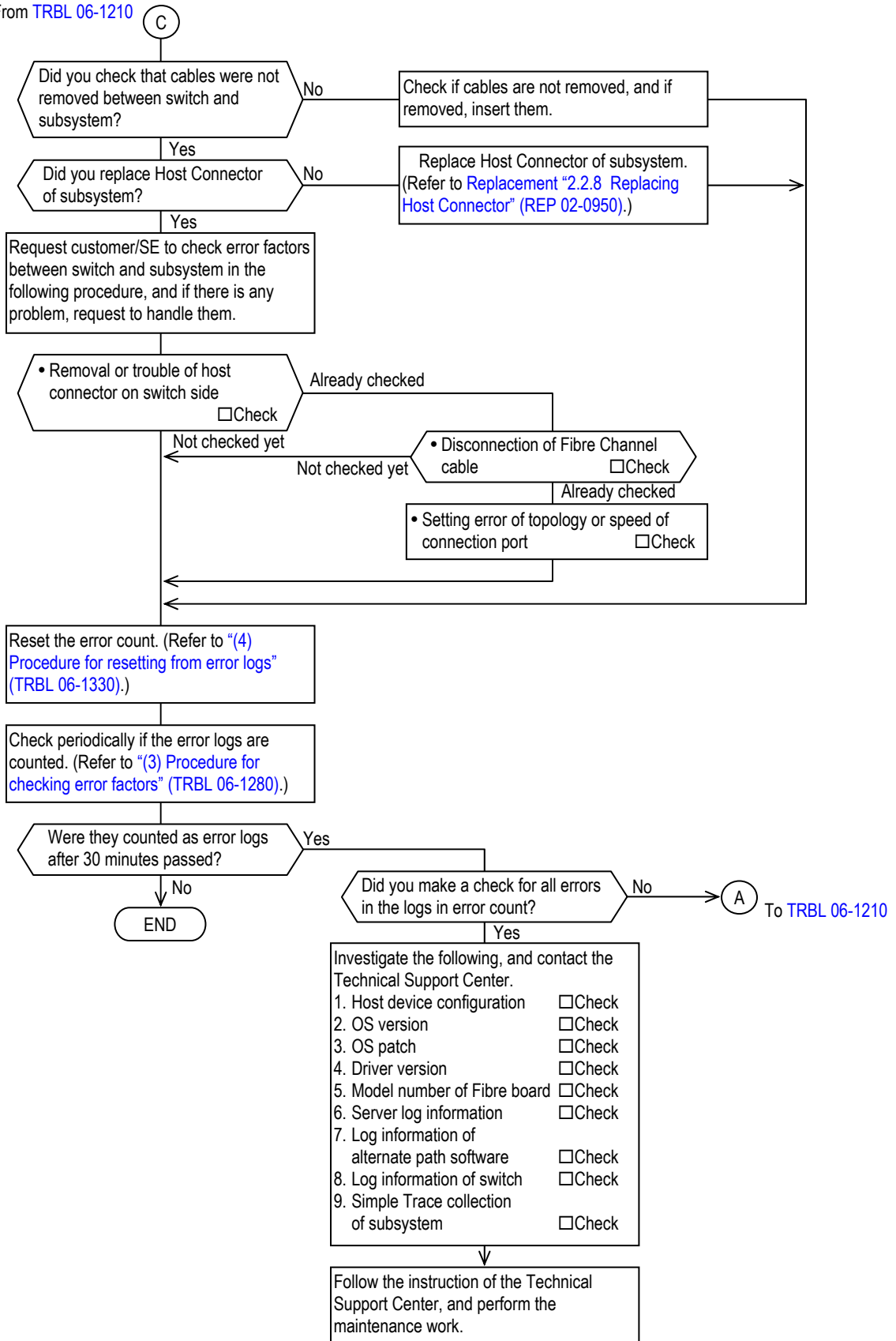

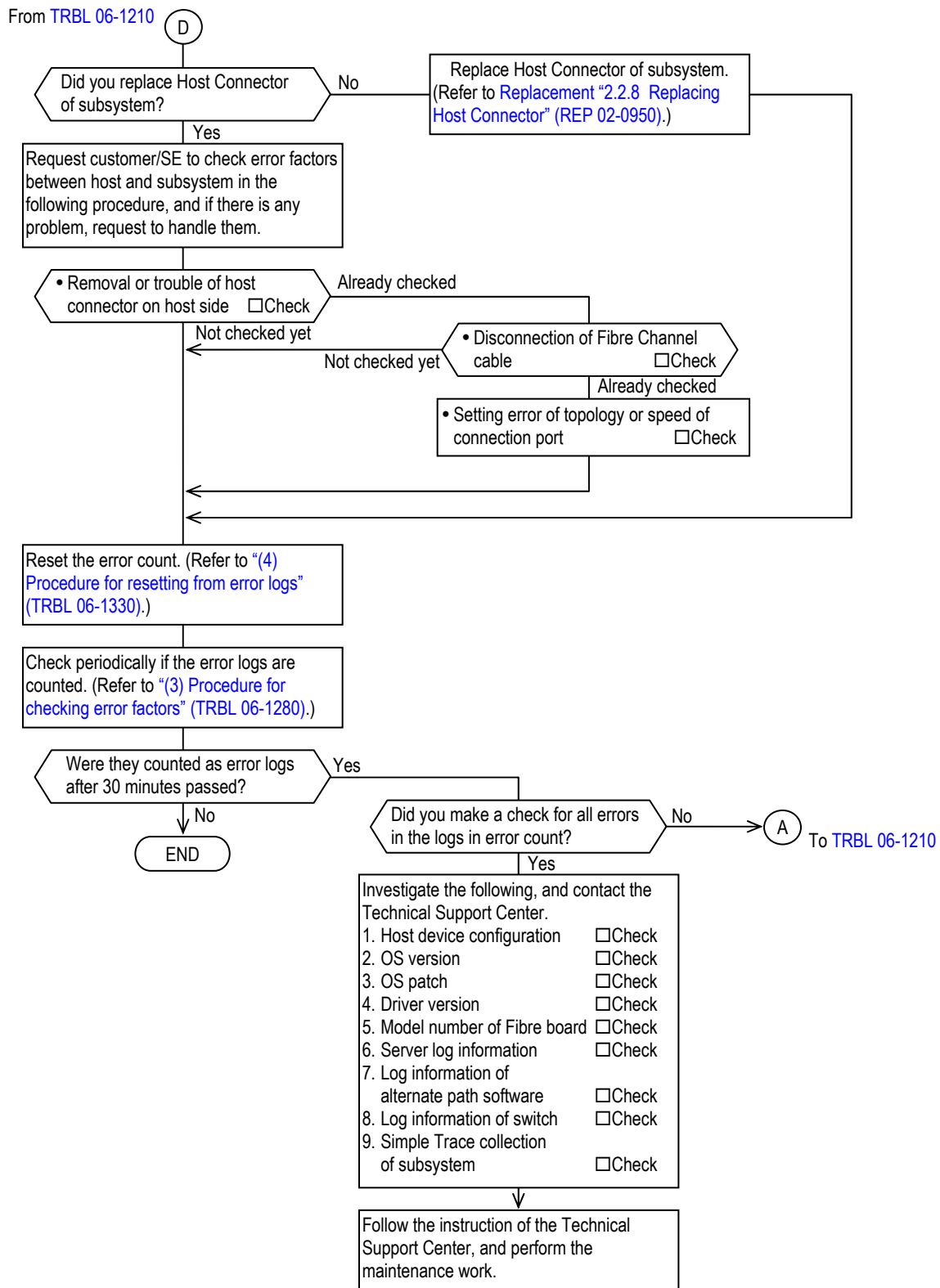

(1) Procedure for installing Hitachi Storage Navigator Modular CLI

- (a) Start the PC, then boot up Windows.
- (b) Execute the HSNM2-xxxx-W-CLI.exe in the program\hsnm2_win_CLI directory of the provided CD-R. (The portion xxxx of file names varies with the version of Navigator, etc.)
- (c) Execute the startsnmen.bat, which is a Windows batch file that is used to start Navigator. A prompt window will be displayed and Navigator commands can be executed from this window.

```
set STONAVM_HOME=.  
set LANG=ja
```

NOTE : When executing commands from locations other than a directory in which Navigator has been installed, edit the STONAVM_HOME environment variable of the startsnmen.bat in the developed file. Set up the install directory of Navigator in the STONAVM_HOME environment variable. However, if the LANG environment variable is not specified, Navigator operates in English language mode.

Example : If Navigator has been installed in C:\Storage Navigator Modular 2 CLI.

```
set STONAVM_HOME=C:\Storage Navigator Modular 2 CLI  
set LANG=ja  
command.com
```

- (d) Perform registration of subsystem (auunitadd command).

(2) Command of Fibre Channel Port Error

Describes the Format, Description or Options of auloginfo command.

(a) Command name

auloginfo Referencing/Setting/Resetting the Log Information

(b) Format

```
auloginfo -unit unit_name -refer -porterror [ ctl_no port_no ]
          [ -item [ threshold ]
            [ portinfo ]
            [ errorinfo ]
            [ todayinfo ] ]
```

```
auloginfo -unit unit_name -set -porterror ctl_no port_no
          -threshold num
```

```
auloginfo -unit unit_name -reset -porterror ctl_no port_no
          -item errorinfo
```

(c) Description

This command references, sets, or resets the log information.

(d) Options

-unit unit_name

Specify the name of the array unit for which to reference, set, or reset the log information.

Specify the name in less than or equal to 64 characters using alphanumeric characters, special symbols “- (minus)”, “_ (underline)”, “. (period)”, “@”, or “ (space)”.

Space in front and in the rear of the character string is removed.

-refer

References the log information.

-set

Sets the log information.

-reset

Resets the log information.

-porterror ctl_no port_no

References, sets, or resets the log information of the specified port.

When the -refer option is specified:

When the specification is omitted, error information of all the ports are displayed.

ctl_no : Controller number (0, 1)

port_no: Port number (A, B, C, D, E, F, G, H)

-item [threshold] [portinfo] [errorinfo] [todayinfo]

When the -refer option is specified:

Specify a item you want to refer to.

When the specification is omitted, all the item are displayed.

One or more of the items can be specified.

When the -reset option is specified:

Specify a item you want to reset to.

threshold: Threshold of error alert

portinfo : Port information

errorinfo: Error information

todayinfo: Today's error information

-threshold num

Specify the threshold of error count for the alert.

When 0 is specified, the error alert is not carried out.

(3) Procedure for checking error factors

(a) Display of error factors

auloginfo – unit unit_name –refer –porterror [ctl_no port_no] [-item [threshold] [portinfo] [errorinfo] [todayinfo]]

(b) Error contents

No.	Name	Error contents
1	Loss Of Signal	Indicates that optical signal is cut off.
2	Bad Received Character	Indicates that 8-bit/10-bit conversion failed.
3	Loss of Synchronization	Indicates that synchronization of signal failed.
4	Link Failure	Indicates the following link failures. <ul style="list-style-type: none"> • Status that cannot detect optical input signal • Status that cannot detect synchronous pattern passed 100 ms or more • Status that cannot detect lip signal at the time of loop configuration
5	Discarded Frame	Indicates that frame was discarded by receiving illegal frame.
6	Received EOFa	Indicates that frame was received from destination port but EOF delimiter was disabled.
7	Bad CRC	Indicates that CRC error occurred in frame received from destination port.
8	OLS/NOS Received	Indicates that it was issued for initializing when remote port detected error (PointToPoint connection only)
9	LIPf Received	Indicates that it was issued for initializing when remote port detected error (loop connection only).
10	Bad AL_PA	Indicates that OPEN was transmitted but OPEN was received as is (at the time of loop connection only).
11	Link Down	Indicates that status was changed from normal to Initialization, Loop Fail states or OFFLINE state.

(c) The count method for every error factor

No.	Name	Treatment at the time of counting up
1	Loss Of Signal	Equivalent to the actual number of times of occurrence
2	Bad Received Character	Treat the actual number of times of occurrence as "0" or "1 in case it is other than 0"
3	Loss of Synchronization	The value of which the actual number of times of occurrence is "divided by 256"
4	Link Failure	Equivalent to the actual number of times of occurrence
5	Discarded Frame	Equivalent to the actual number of times of occurrence
6	Received EOFa	Equivalent to the actual number of times of occurrence
7	Bad CRC	Equivalent to the actual number of times of occurrence
8	OLS/NOS Received	The value of which the actual number of times of occurrence is "divided by 512"
9	LIPf Received	Equivalent to the actual number of times of occurrence
10	Bad AL_PA	Equivalent to the actual number of times of occurrence
11	Link Down	The value of which the actual number of times of occurrence is "divided by 256"

The error count is automatically reset to "0" in the following conditions.

- When the subsystem is stopped
- For the port of the failed Control Unit when a Control Unit failure occurs

(d) External reasons for error occurrence

No.	Name	Occurrence factors	Causes
1	Loss Of Signal	Quality loss in the optical signals of the connection destination and local port	<ul style="list-style-type: none"> • The connection cable coming-out • The connection cable disconnection (contact failure)
2	Bad Received Character	Quality loss in the optical signals of the connection destination and local port	<ul style="list-style-type: none"> • The destination host connector coming-out or failure
3	Loss of Synchronization	Quality loss in the optical signals of the connection destination and local port	<ul style="list-style-type: none"> • Error in speed setting/topology
4	Link Failure	Quality loss in the optical signals of the connection destination and local port	<ul style="list-style-type: none"> • Host connector failure on the subsystem side <p>It is detected when the connection configuration is changed (cable connection change, reboot and powering-on/off on the connection destination)</p>
5	Discarded Frame	<ul style="list-style-type: none"> • The problem with the output Frame on the connection destination • The problem with the input Frame on the subsystem 	<ul style="list-style-type: none"> • The connection cable coming-out • The connection cable disconnection (contact failure) • The destination host connector coming-out or failure • Error in speed setting/topology • Host connector failure on the subsystem side
6	Received EOFa	The problem with the signal quality between host and switch	<ul style="list-style-type: none"> • The connection cable coming-out • The connection cable disconnection (contact failure) • The host connector coming-out between host and switch or failure • Error in speed setting/topology
7	Bad CRC	The problem with the signal quality between host and switch	<ul style="list-style-type: none"> • The connection cable coming-out • The connection cable disconnection (contact failure) • The Host side/Switch side host connector coming-out or failure • Error in speed setting/topology • Host connector failure on the subsystem side
8	OLS/NOS Received	Quality loss in the optical signals of the connection destination and local port	<ul style="list-style-type: none"> • The connection cable coming-out • The connection cable disconnection (contact failure)
9	LIPf Received	Quality loss in the optical signals of the connection destination and local port	<ul style="list-style-type: none"> • The destination host connector coming-out or failure • Error in speed setting/topology • Host connector failure on the subsystem side <p>It is detected when the connection configuration is changed (cable connection change, reboot and powering-on/off on the connection destination)</p>
10	Bad AL_PA	<ul style="list-style-type: none"> • HBA port failure • The poor quality of the HBA port signal 	It may be a HBA failure.

No.	Name	Occurrence factors	Causes
11	Link Down	Quality loss in the optical signals of the connection destination and local port	<ul style="list-style-type: none"> • The connection cable coming-out • The connection cable disconnection (contact failure) • The destination host connector coming-out or failure • Error in speed setting/topology • Host connector failure on the subsystem side <p>It is detected when the connection configuration is changed (cable connection change, reboot and powering-on/off on the connection destination)</p>

(e) Displaying information of all ports (all ports)

auloginfo -unit unit_name -refer -porterror

```

C:\Program Files\Storage Navigator Modular 2 CLI>auloginfo -unit 101-102 -refer -porterror
Port Error
Threshold
Port Threshold
0A 1
0B 0
1A 0
1B 0

Port Information
Port Alert Time
0A 2010/02/08 23:55
0B None
1A None
1B None

Error Information : Alert Timing
Port 0A
Alert Time : 2010/02/08 23:55
Threshold : 1
Transfer Rate
Setting : Auto
Current : 4Gbps
Topology : Loop
Error Count
Total Loss of Bad Received Loss of Link Discarded Received OLS/NOS LIPf
5882 Signal Character 5885 Synchronization Failure Frame EOfa Bad CRC Received Received Bad AL_PA Link Down
0 1 0 8 0 0 0 0 5 0 0 3

Port 0B
None
Port 1A
None
Port 1B
None

Error Information : 2010/02/09
Port 0A
Error Count
Total(00:00-24:00) : 0
Detail
Time Total Loss of Bad Received Loss of Link Discarded Received OLS/NOS LIPf
00:00-00:30 0 0 0 0 0 0 0 0 0 0 0 0
00:30-01:00 0 0 0 0 0 0 0 0 0 0 0 0
01:00-01:30 0 0 0 0 0 0 0 0 0 0 0 0
01:30-02:00 0 0 0 0 0 0 0 0 0 0 0 0
    
```

(f) Displaying information of all ports (specified port)

auloginfo -unit unit_name -refer -porterror ctl_no port_no

```
C:\Program Files\Storage Navigator Modular 2 CLI>auloginfo -unit 101-102 -refer -porterror 0 A
Port Error
Threshold
Port   Threshold
0A     1

Port Information
Port   Alert Time
0A     2010/02/08 23:55

Error Information : Alert Timing
Port 0A
Alert Time : 2010/02/08 23:55
Threshold : 1
Transfer Rate
Setting : Auto
Current : 4Gbps
Topology : Loop
Error Count
      Total      Loss of      Bad Received      Loss of      Link      Discarded      Received      Bad CRC      OLS/NOS      LIPf      Bad AL_PA      Link Down
      5882      Signal      Character      Synchronization      Failure      Frame      EDfA      0      Received      Received      0      0
      5882      1      5865      8      0      0      0      0      5      0      0      3

Error Information : 2010/02/09
Port 0A
Error Count
Total(00:00-24:00) : 0
Detail
      Time      Total      Loss of      Bad Received      Loss of      Link      Discarded      Received      Bad CRC      OLS/NOS      LIPf      Bad AL_PA      Link Down
      00:00-00:30      0      0      0      0      0      0      0      0      0      0      0      0
      00:30-01:00      0      0      0      0      0      0      0      0      0      0      0      0
      01:00-01:30      0      0      0      0      0      0      0      0      0      0      0      0
      01:30-02:00      0      0      0      0      0      0      0      0      0      0      0      0
      02:00-02:30      0      0      0      0      0      0      0      0      0      0      0      0
      02:30-03:00      0      0      0      0      0      0      0      0      0      0      0      0
      03:00-03:30      0      0      0      0      0      0      0      0      0      0      0      0
      03:30-04:00      0      0      0      0      0      0      0      0      0      0      0      0
      04:00-04:30      0      0      0      0      0      0      0      0      0      0      0      0
      04:30-05:00      0      0      0      0      0      0      0      0      0      0      0      0
      05:00-05:30      0      0      0      0      0      0      0      0      0      0      0      0
      05:30-06:00      0      0      0      0      0      0      0      0      0      0      0      0
      06:00-06:30      0      0      0      0      0      0      0      0      0      0      0      0
      06:30-07:00      0      0      0      0      0      0      0      0      0      0      0      0
      07:00-07:30      0      0      0      0      0      0      0      0      0      0      0      0
      07:30-08:00      0      0      0      0      0      0      0      0      0      0      0      0
      08:00-08:30      0      0      0      0      0      0      0      0      0      0      0      0
      08:30-09:00      0      0      0      0      0      0      0      0      0      0      0      0
      09:00-09:30      0      0      0      0      0      0      0      0      0      0      0      0
      09:30-10:00      0      0      0      0      0      0      0      0      0      0      0      0
      10:00-10:30      0      0      0      0      0      0      0      0      0      0      0      0
      10:30-11:00      0      0      0      0      0      0      0      0      0      0      0      0
      11:00-11:30      0      0      0      0      0      0      0      0      0      0      0      0
      11:30-12:00      0      0      0      0      0      0      0      0      0      0      0      0
      12:00-12:30      0      0      0      0      0      0      0      0      0      0      0      0
      12:30-13:00      0      0      0      0      0      0      0      0      0      0      0      0
      13:00-13:30      0      0      0      0      0      0      0      0      0      0      0      0
```

(g) Displaying error factor

auloginfo -unit unit_name -refer -porterror [ctl_no port_no] -item errorinfo

```
C:\Program Files\Storage Navigator Modular 2 CLI>auloginfo -unit 101-102 -refer -porterror 0 A -item errorinfo
Port Error
Error Information : Alert Timing
Port 0A
Alert Time : 2010/02/08 23:55
Threshold : 1
Transfer Rate
Setting : Auto
Current : 4Gbps
Topology : Loop
Error Count
      Total      Loss of      Bad Received      Loss of      Link      Discarded      Received      Bad CRC      OLS/NOS      LIPf      Bad AL_PA      Link Down
      5882      Signal      Character      Synchronization      Failure      Frame      EDfA      0      Received      Received      0      0
      5882      1      5865      8      0      0      0      0      5      0      0      3

C:\Program Files\Storage Navigator Modular 2 CLI>
```

(h) Displaying information of port status

auloginfo -unit unit_name -refer -porterror [ctl_no port_no] -item portinfo

```
C:\Program Files\Storage Navigator Modular 2 CLI>auloginfo -unit 101-102 -refer -porterror 0 A -item portinfo
Port Error
Port Information
Port   Alert Time
0A     2010/02/08 23:55

C:\Program Files\Storage Navigator Modular 2 CLI>
```

(i) Displaying information every 30 minutes

auloginfo -unit unit_name -refer -porterror [ctl_no port_no] -item todayinfo

```
C:\Program Files\Storage Navigator Modular 2 CLI>auloginfo -unit 101-102 -refer -porterror 0 A -item todayinfo
Port Error
Error Information : 2010/02/09
Port 0A
Error Count
Total(00:00-24:00) : 0
Detail
```

Time	Total	Loss of Signal	Bad Received Character	Loss of Synchronization	Link Failure	Discarded Frame	Received EDFA	Bad CRC	OLS/NGS Received	LIPF Received	Bad AL_PA	Link Down
00:00-00:30	0	0	0	0	0	0	0	0	0	0	0	0
00:30-01:00	0	0	0	0	0	0	0	0	0	0	0	0
01:00-01:30	0	0	0	0	0	0	0	0	0	0	0	0
01:30-02:00	0	0	0	0	0	0	0	0	0	0	0	0
02:00-02:30	0	0	0	0	0	0	0	0	0	0	0	0
02:30-03:00	0	0	0	0	0	0	0	0	0	0	0	0
03:00-03:30	0	0	0	0	0	0	0	0	0	0	0	0
03:30-04:00	0	0	0	0	0	0	0	0	0	0	0	0
04:00-04:30	0	0	0	0	0	0	0	0	0	0	0	0
04:30-05:00	0	0	0	0	0	0	0	0	0	0	0	0
05:00-05:30	0	0	0	0	0	0	0	0	0	0	0	0
05:30-06:00	0	0	0	0	0	0	0	0	0	0	0	0
06:00-06:30	0	0	0	0	0	0	0	0	0	0	0	0
06:30-07:00	0	0	0	0	0	0	0	0	0	0	0	0
07:00-07:30	0	0	0	0	0	0	0	0	0	0	0	0
07:30-08:00	0	0	0	0	0	0	0	0	0	0	0	0
08:00-08:30	0	0	0	0	0	0	0	0	0	0	0	0
08:30-09:00	0	0	0	0	0	0	0	0	0	0	0	0
09:00-09:30	0	0	0	0	0	0	0	0	0	0	0	0
09:30-10:00	0	0	0	0	0	0	0	0	0	0	0	0
10:00-10:30	0	0	0	0	0	0	0	0	0	0	0	0
10:30-11:00	0	0	0	0	0	0	0	0	0	0	0	0
11:00-11:30	0	0	0	0	0	0	0	0	0	0	0	0
11:30-12:00	0	0	0	0	0	0	0	0	0	0	0	0
12:00-12:30	0	0	0	0	0	0	0	0	0	0	0	0
12:30-13:00	0	0	0	0	0	0	0	0	0	0	0	0
13:00-13:30	0	0	0	0	0	0	0	0	0	0	0	0
13:30-14:00	0	0	0	0	0	0	0	0	0	0	0	0
14:00-14:30	Not Collected	---	---	---	---	---	---	---	---	---	---	---
14:30-15:00	Not Collected	---	---	---	---	---	---	---	---	---	---	---
15:00-15:30	0	0	0	0	0	0	0	0	0	0	0	0
15:30-16:00	0	0	0	0	0	0	0	0	0	0	0	0
16:00-16:30	0	0	0	0	0	0	0	0	0	0	0	0
16:30-17:00	Not Collected	---	---	---	---	---	---	---	---	---	---	---
17:00-17:30	Not Collected	---	---	---	---	---	---	---	---	---	---	---
17:30-18:00	Not Collected	---	---	---	---	---	---	---	---	---	---	---
18:00-18:30	Not Collected	---	---	---	---	---	---	---	---	---	---	---
18:30-19:00	Not Collected	---	---	---	---	---	---	---	---	---	---	---
19:00-19:30	Not Collected	---	---	---	---	---	---	---	---	---	---	---
19:30-20:00	Not Collected	---	---	---	---	---	---	---	---	---	---	---
20:00-20:30	Not Collected	---	---	---	---	---	---	---	---	---	---	---
20:30-21:00	Not Collected	---	---	---	---	---	---	---	---	---	---	---
21:00-21:30	Not Collected	---	---	---	---	---	---	---	---	---	---	---
21:30-22:00	Not Collected	---	---	---	---	---	---	---	---	---	---	---
22:00-22:30	Not Collected	---	---	---	---	---	---	---	---	---	---	---
22:30-23:00	Not Collected	---	---	---	---	---	---	---	---	---	---	---
23:00-23:30	Not Collected	---	---	---	---	---	---	---	---	---	---	---
23:30-24:00	Not Collected	---	---	---	---	---	---	---	---	---	---	---

```
C:\Program Files\Storage Navigator Modular 2 CLI>
```

(j) Displaying set threshold value

auloginfo -unit unit_name -refer -porterror [ctl_no port_no] -item threshold

```
C:\Program Files\Storage Navigator Modular 2 CLI>auloginfo -unit 101-102 -refer -porterror 0 A -item threshold
Port Error
Threshold
Port Threshold
0A 1

C:\Program Files\Storage Navigator Modular 2 CLI>
```

(4) Procedure for resetting from error logs

(a) Resetting error factor

```
auloginfo -unit unit_name -reset -porterror ctl_no port_no -item errorinfo
```

(b) Example of window display

```
C:\Program Files\Storage Navigator Modular 2 CLI>auloginfo -unit 101-102 -reset -porterror 0 E -item errorinfo
Are you sure you want to reset the log information? (y/n [n]): y
The log information has been reset successfully.
```

(5) Setting threshold value

(a) Setting threshold value

```
auloginfo -unit unit_name -set -porterror ctl_no port_no -threshold threshold_num
```

(b) Example of window display

```
C:\Program Files\Storage Navigator Modular 2 CLI>auloginfo -unit 101-102 -set -porterror 0 F -threshold 1
Are you sure you want to set the log information? (y/n [n]): y
The log information has been set successfully.
```

6.1.30 Recovery Method when the Multiple Suspected Failed Parts were Detected in the Backend

This section describes the actions to be taken in case where a failed part could not be identified by backend automatic diagnostic and the suspected failed parts were narrowed down only up to two parts.

[WEB Information Message display]

MM/DD/YYYY	hh:mm:ss	xy	W40000	Backend route warning has been detected (Path-x, Route-y)	:MANUAL/STRC
Date		Time	x: Detect Controller #	y: Detect Core #	
MM/DD/YYYY	hh:mm:ss	xy	I5H4AB	The search for the failure part of backend route error ended (Path-x, Route-y)	
MM/DD/YYYY	hh:mm:ss	xy	W40000	Backend route warning has been detected (Path-x, Route-y)	:MANUAL/STRC
MM/DD/YYYY	hh:mm:ss	xy	I5JEab	Suspected failure part has been detected (Unit-x, HDU-y)	:HDU
MM/DD/YYYY	hh:mm:ss	xy	I5JDe0	Suspected failure part has been detected (Unit-x, ENC-y)	:ENC
MM/DD/YYYY	hh:mm:ss	xy	I5H3AB	The search for the failure part of backend route error started (Path-x, Route-y)	

[Recovery method]

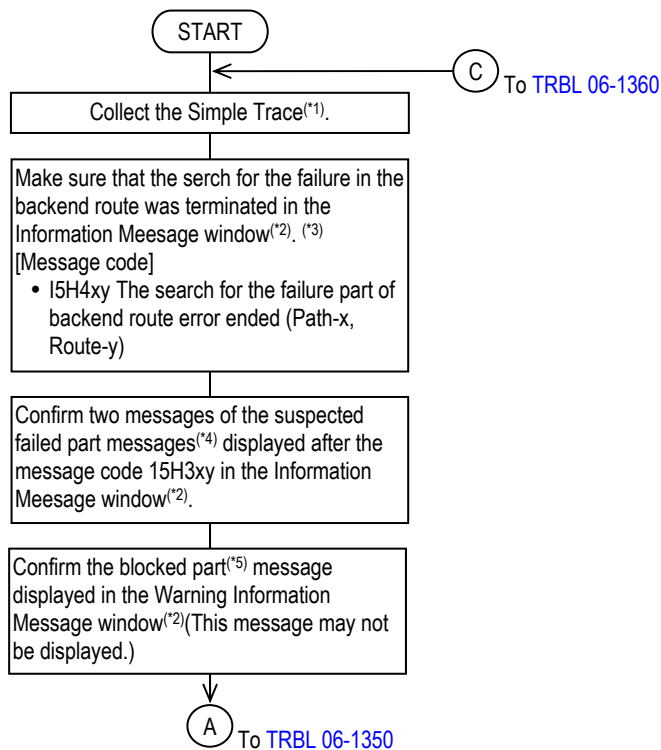

*1 : For the simple trace collection, refer to “7.3 Collecting Simple Trace” (TRBL 07-0040).

*2 : For the connection of the WEB, refer to “Chapter 3. Before Starting WEB Connection” (TRBL 03-0000).

*3 : When the Control Unit # (Route # displayed in the message code I5H3xy) which displays this message is blocked after the search for the failure in the backend route starts (message code I5H3xy), the termination message (message code I5H4xy) is not displayed on the Information Message. Perform the next work.

*4 : Suspected failed part message:

- I5JCzx Suspected failure part has been detected (CTL-x)
- I5JDe0 Suspected failure part has been detected (Unit-x, ENC-y)
- I5JEab Suspected failure part has been detected (Unit-x, HDU-y)

*5 : Blocked part message:

- W01z0x CTL alarm (CTL-x)
- W09zab HDU alarm (Unit-x, HDU-y, Type-c)
- W0Fze0 ENC alarm (Unit-x, ENC-y)

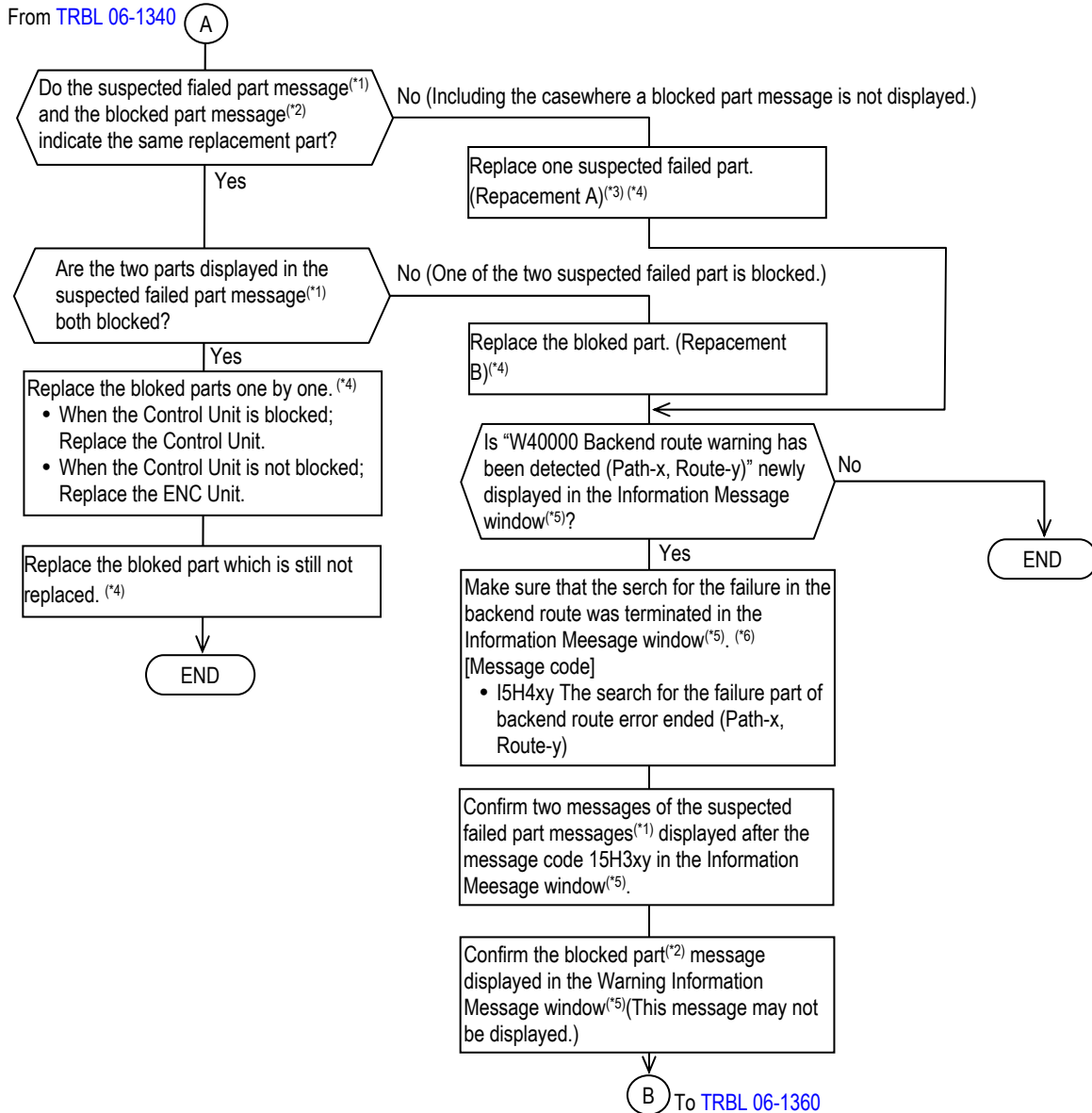

*1 : Suspected failed part message:

- I5JCzx Suspected failure part has been detected (CTL-x)
- I5JDe0 Suspected failure part has been detected (Unit-x, ENC-y)
- I5JEab Suspected failure part has been detected (Unit-x, HDU-y)

*2 : Blocked part message:

- W01z0x CTL alarm (CTL-x)
- W09zab HDU alarm (Unit-x, HDU-y, Type-c)
- W0Fze0 ENC alarm (Unit-x, ENC-y)

*3 : Contact the Technical Support Center, and confirm the replacement order of the suspected failed part.

The two suspected failed part displayed cannot be determined. Replace the part displayed after the message code I5H3xy first. However, when "I5JCzx Suspected failure part has been detected (CTL-x)" and "I5JEab Suspected failure part has been detected (Unit-x, HDU-y)" are displayed after I5JCzx message, it is possible to replace the Disk Drive first considering the effect on the customer's operation and the maintenance work.

*4 : For the part replacement, refer to [Replacement "Chapter 2. Parts Replacement" \(REP 02-0000\)](#).

*5 : For the connection of the WEB, refer to ["Chapter 3. Before Starting WEB Connection" \(TRBL 03-0000\)](#).

*6 : When the Control Unit # (Route # displayed in the message code I5H3xy) which displays this message is blocked after the search for the failure in the backend route starts (message code I5H3xy), the termination message (message code I5H4xy) is not displayed on the Information Message. Perform the next work.

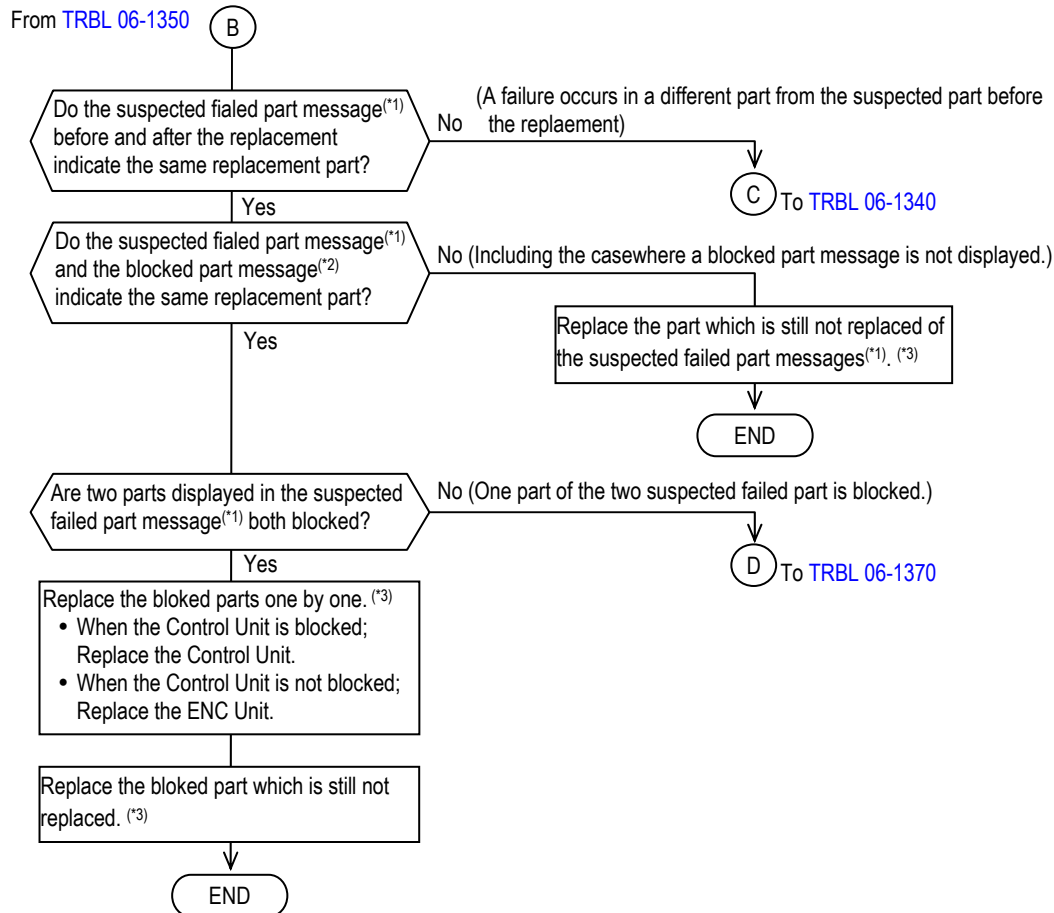

*1 : Suspected fialed part message:

- I5JCzx Suspected failure part has been detected (CTL-x)
- I5JDe0 Suspected failure part has been detected (Unit-x, ENC-y)
- I5JEab Suspected failure part has been detected (Unit-x, HDU-y)

*2 : Blocked part message:

- W01z0x CTL alarm (CTL-x)
- W09zab HDU alarm (Unit-x, HDU-y, Type-c)
- W0Fze0 ENC alarm (Unit-x, ENC-y)

*3 : For the part replacement, refer to Replacement "Chapter 2. Parts Replacement" (REP 02-0000).

From TRBL 06-1360

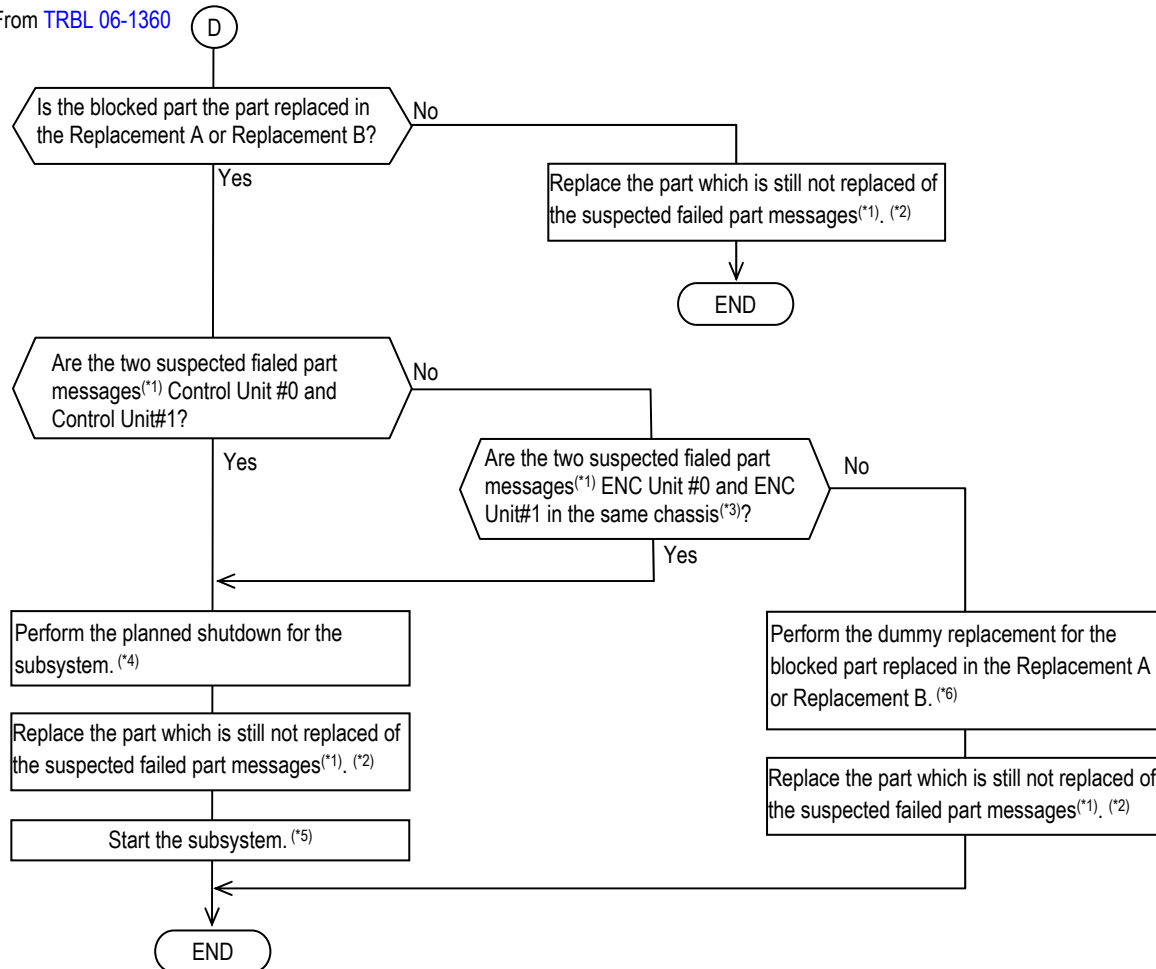

*1 : Suspected failed part message:

- I5JCzx Suspected failure part has been detected (CTL-x)
- I5JDe0 Suspected failure part has been detected (Unit-x, ENC-y)
- I5JEab Suspected failure part has been detected (Unit-x, HDU-y)

*2 : For the part replacement, refer to [Replacement “Chapter 2. Parts Replacement” \(REP 02-0000\)](#).

*3 : It is the same chassis when the Unit # in the message code I5JDe0 is the same.

*4 : Refer to [Installation “1.5.2 Subsystem Power Off \(Sequential Shutdown\)” \(INST 01-0160\)](#).

*5 : Refer to [Installation “1.5.1 Subsystem Power On” \(INST 01-0140\)](#).

*6 : To remove the part concerned once, and then to reinstall it after waiting for 20 seconds or more.

6.1.31 Recovery Method when Write to the Cache Data (Pseudo Planned Shutdown) Failed in the LT Short Version SELF HEATRAN System

The recovery method differs depending on the message displayed at the same time as the message of “HSA10x SELF HEATRAN: The destage of cache data failed (CTL-x)”.

[WEB Information Message display]

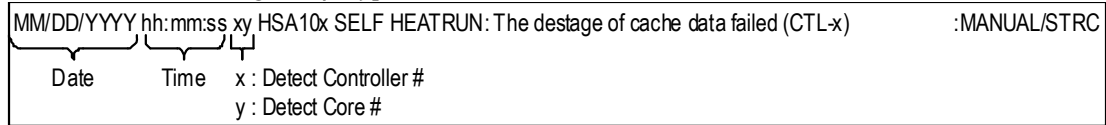

[Recovery method]

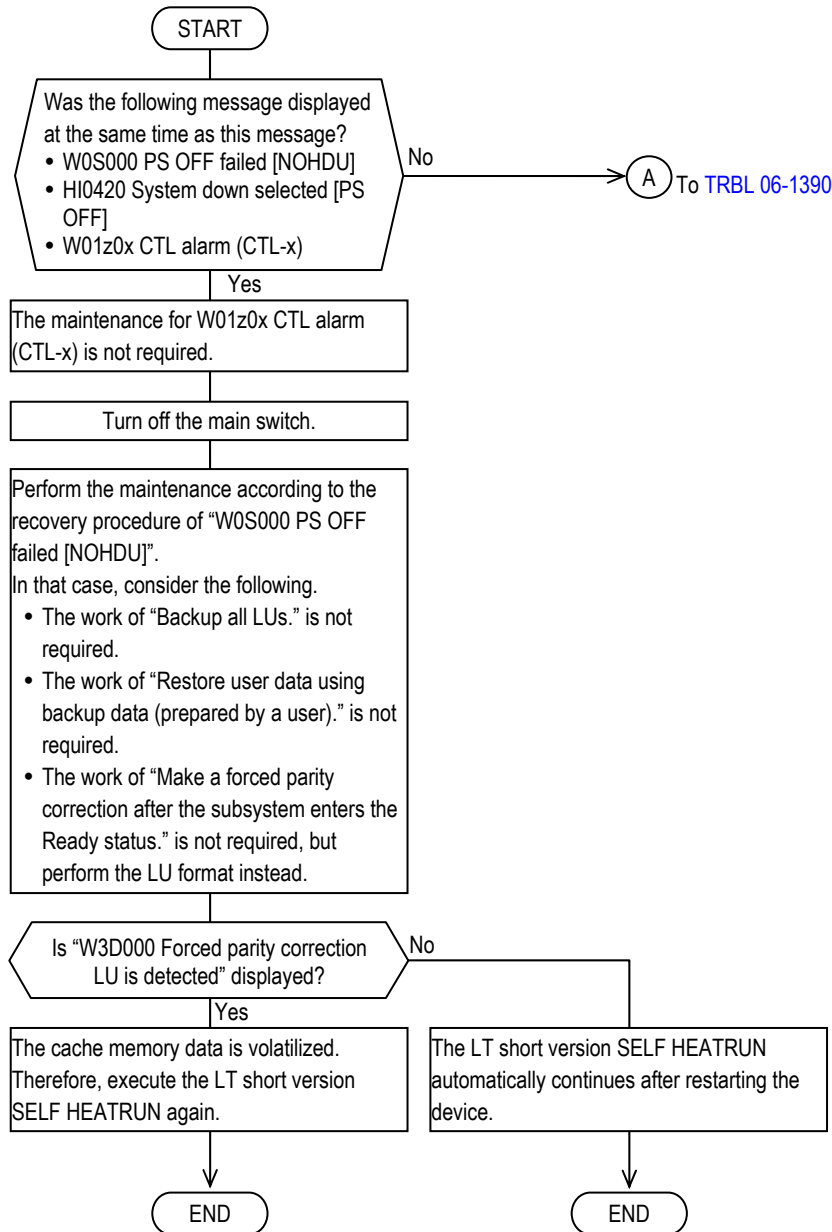

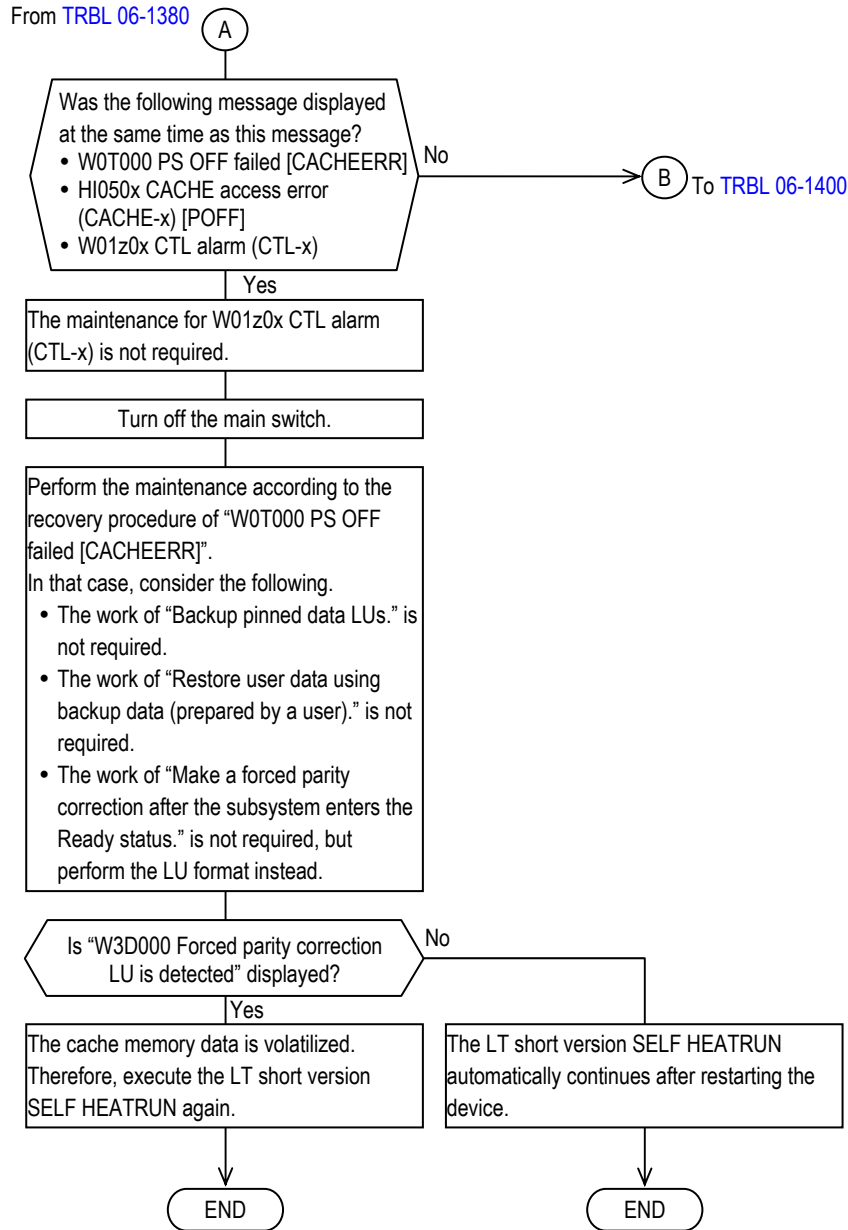

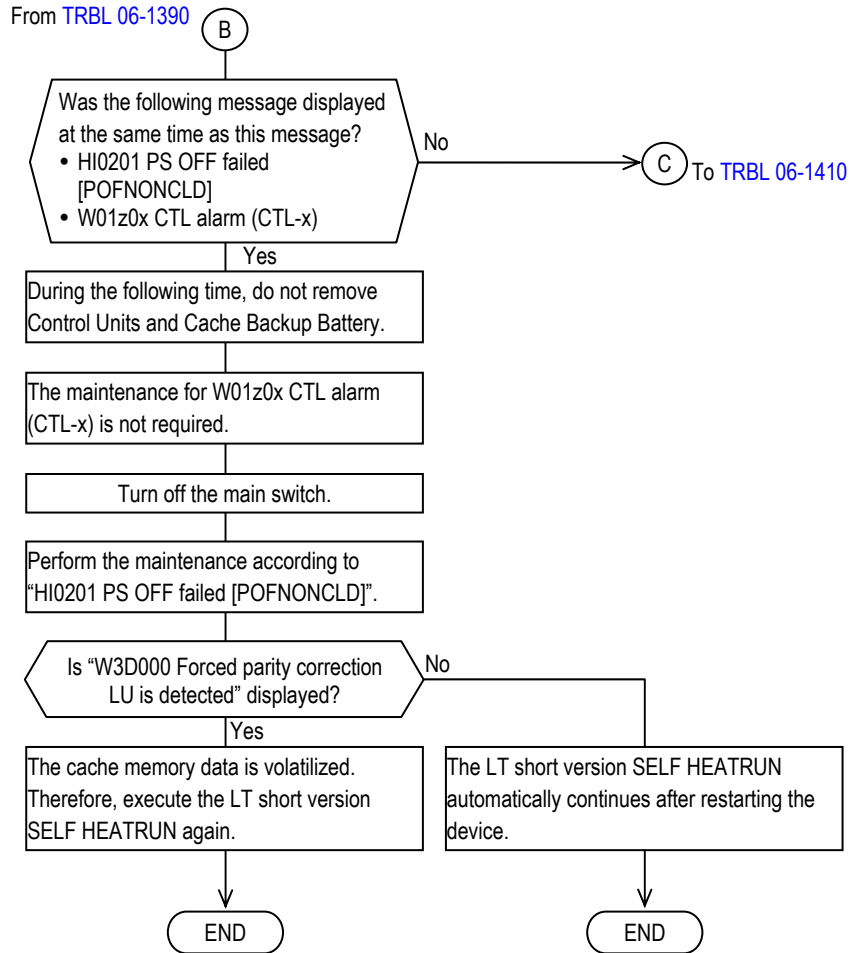

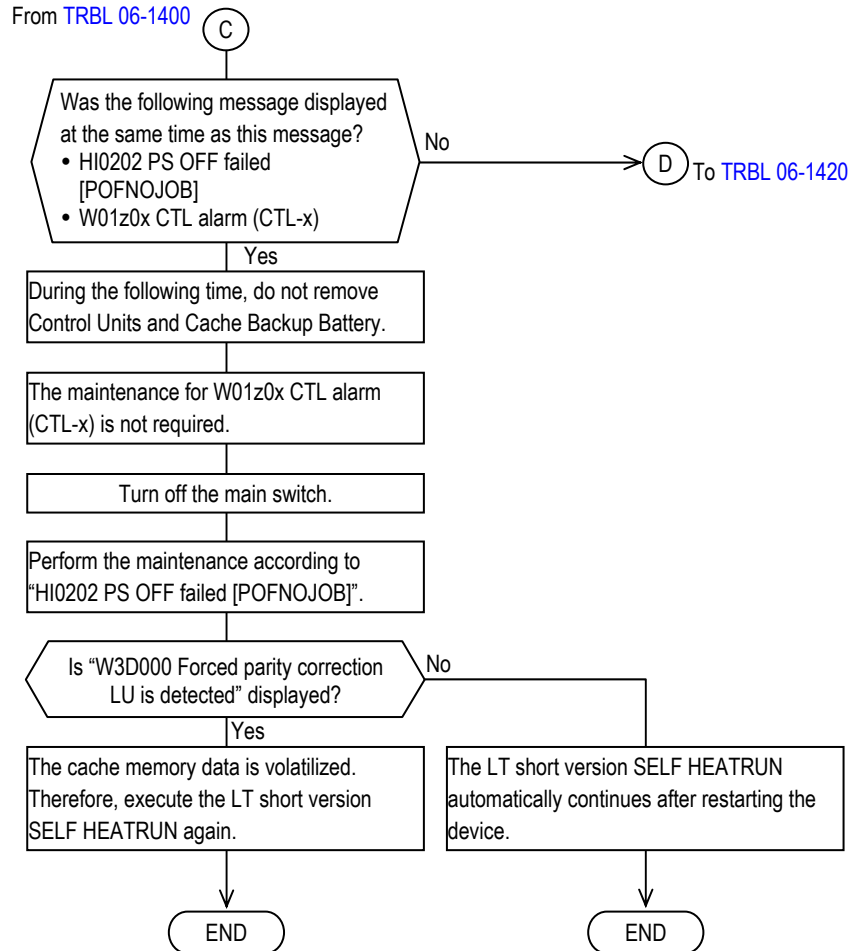

From TRBL 06-1410

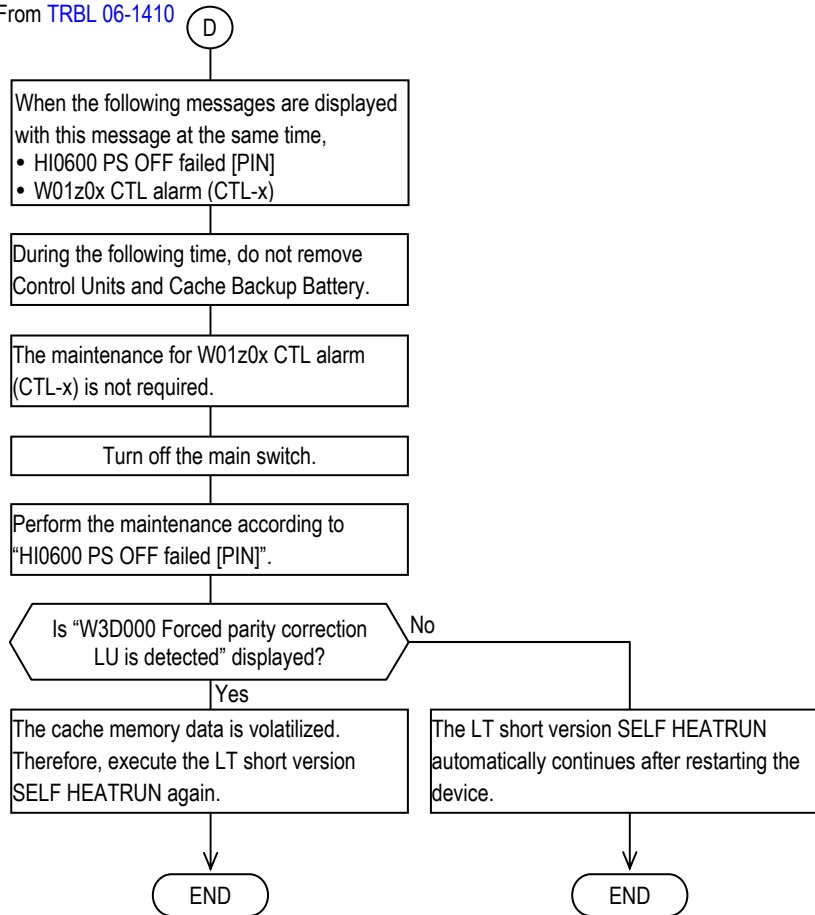

6.1.32 Recovery Method when the Version Downgrade to the Firmware which does not Support the SATA Drives Failed

[WEB Information Message display]

MM/DD/YYYY	hh:mm:ss	xy	R54R00 Down grade install NG [There is RAID group or DP pool with SATA HDDs of 2TB or more]	:MANUAL/STRC
Date	Time	x : Detect Controller # y : Detect Core #		

[Recovery method]

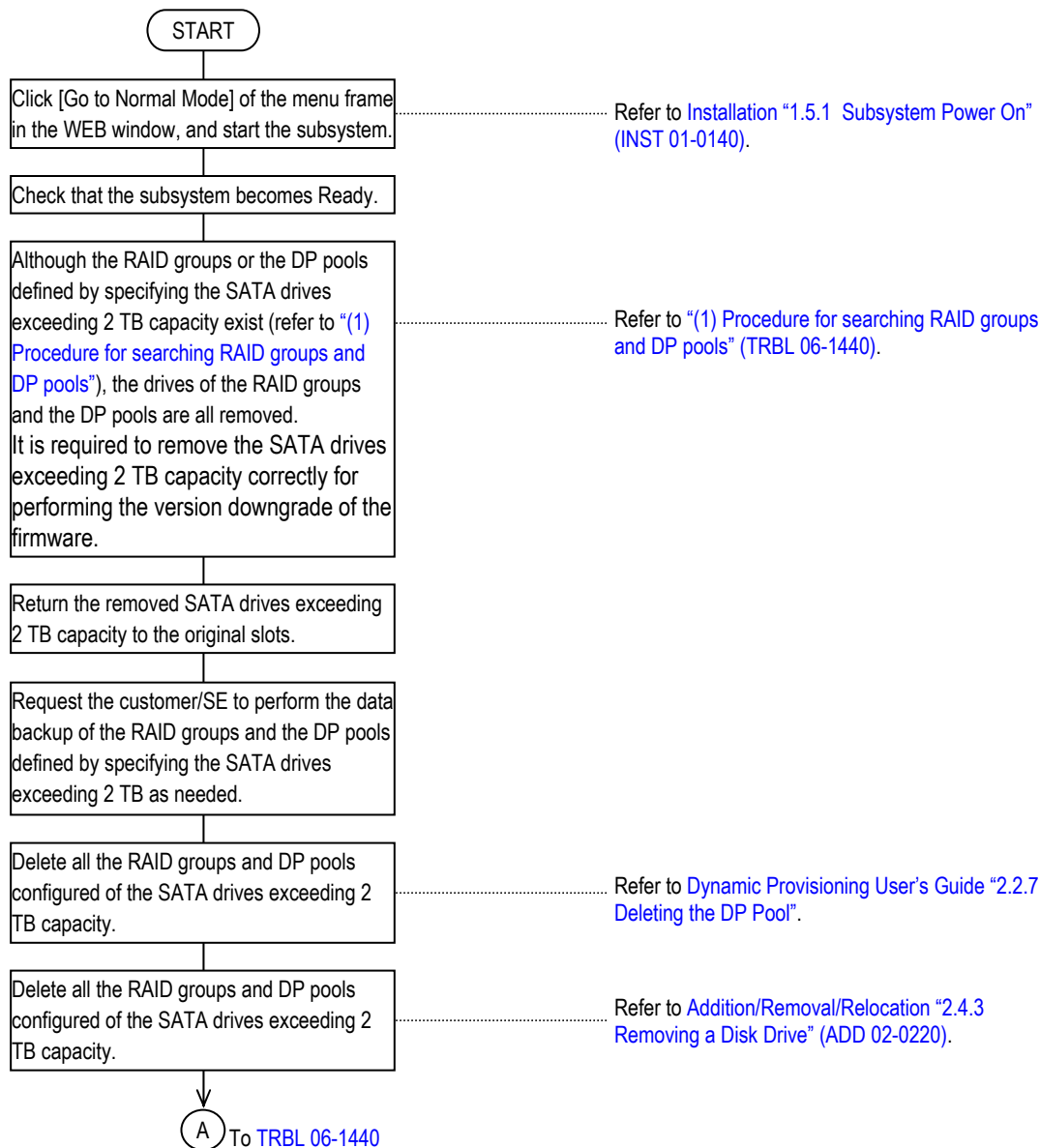

(c) Click the array subsystem name, and open the unit window.

NOTE : There is a case that the LAN Port Number is changed. When the main screen is not displayed even though the icon of the array subsystem is clicked, use the changed LAN Port Number, and execute it again. (Refer to [System Parameter “1.2 LAN Port Number Change by Hitachi Storage Navigator Modular 2” \(SYSPR 01-0120\).](#))

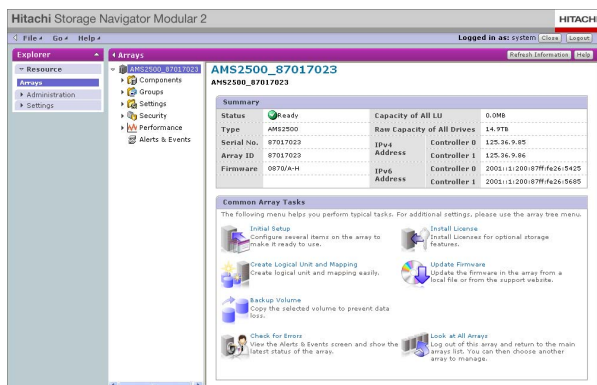

(d) Select [Groups] - [Logical Units] on the unit window, and click the [RAID Groups] tab.

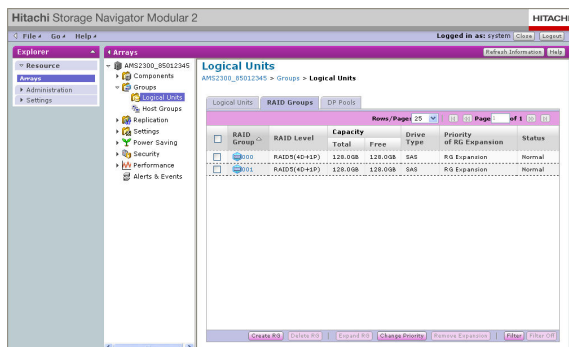

(e) Sort out all the RAID groups exceeding 2 TB capacity in the calculation result of “Capacity (whole) / Number of Data Disks (x part of RAID level (xD+yP)).

(f) When the [DP Pools] tab is displayed, open the [DP Pools] tab.

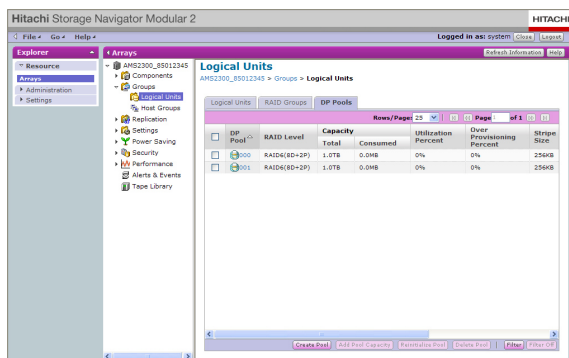

- (g) Sort out all the DP pools exceeding 2 TB capacity in the calculation result of “Capacity (whole) / Number of Data Disks (x part of RAID level (xD+yP))”.
- (h) The RAID groups and the DP groups sorted out in (e) and (g) are configured of the SATA drives exceeding 2 TB capacity.

6.1.33 The Recovery Method when the Copy-Back Operates Regardless of the Copy-Back-Less Setting if Power Saving is Enabled and Performs the Drive Restoration

This phenomenon has effective Power Saving of array, and when it is in the following states, it may occur.

- When the Spare Disk is set to the system drive^(#1)
- When the Spare Disk have been set for other than the system drives^(#1) and the Disk Drive failure restoration operated in the firmware less than 08C4/A in the past (the operation is as shown in (1) and the Spare Disks are set for the system drives^(#1).)

This procedure needs to be executed according to the instruction from the Technical Support Center. Contact the Technical Support Center.

(1) The mechanism of phenomenon generating

The Power Saving function does not operate in the RAID group which includes the system drive^(#1). Therefore, when the Power Saving function is enabled, if the drive restoration operates using the Spare Disk set for the system drive, the copy-back (Spare Drive Operation Mode is “Fixed”) operates even in the copy-back-less setting.

In case of the firmware less than 08C4/A, even if the Spare Disk is not set in the system drive^(#1) but the Spare Drive Operation Mode is in the copy-back-less setting, when a failure occurs in the system drive^(#1) and the drive restoration operates using the Spare Disk set in the position other than the system drive^(#1), in case of the Spare Drive Operation Mode is in the copy-back-less setting, the Spare Disk migrate to the system drive^(#1).

As a result, if using the Spare Disk in the system drive^(#1) when executing the drive restoration after this drive restoration operation, the copy-back is surely operated.

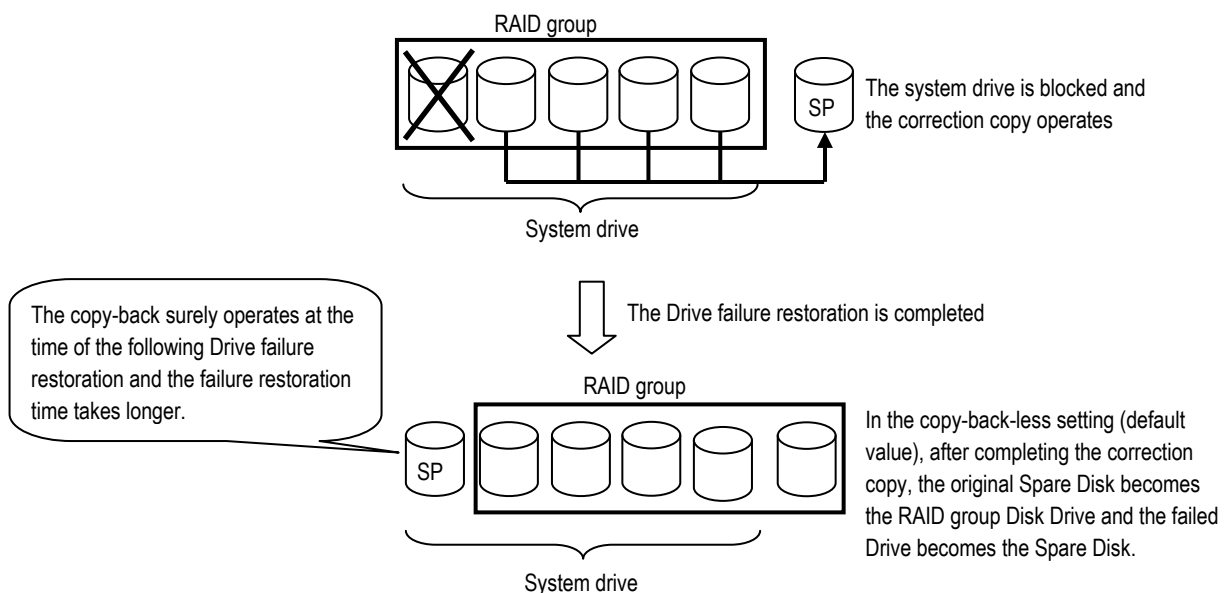

Figure 6.1.2 Substitution of a Spare Disk

*1 : System drives correspond to Disk Drives #0 to #4 in RKM/RKS, Disk Drives #0 to #4 of Unit ID#0 in RKAK/RKAKS connected to RKH, or Disk Drives #A0 to #A4 in RKAKX.

(2) The outline of recovery method

For recovering from this phenomenon, it is required to change the Spare Disks^(#1) set for the system drives to other than system drives^(#1).

This recovery procedure migrates the Spare Disks gathered to the included in the RAID group system drives^(#1) to the Disk Drives other than the system drives^(#1) by performing the dynamicsparing of the Spare Disk set for the system drive^(#1) with the Disk Drive of the RAID group to avoid the copy-back operation regardless of the Spare Drive Operation Mode by gathering the Spare Disk regardless of the Spare Drive Operation Mode.

NOTE: This procedure should invalidate the Power Saving function.

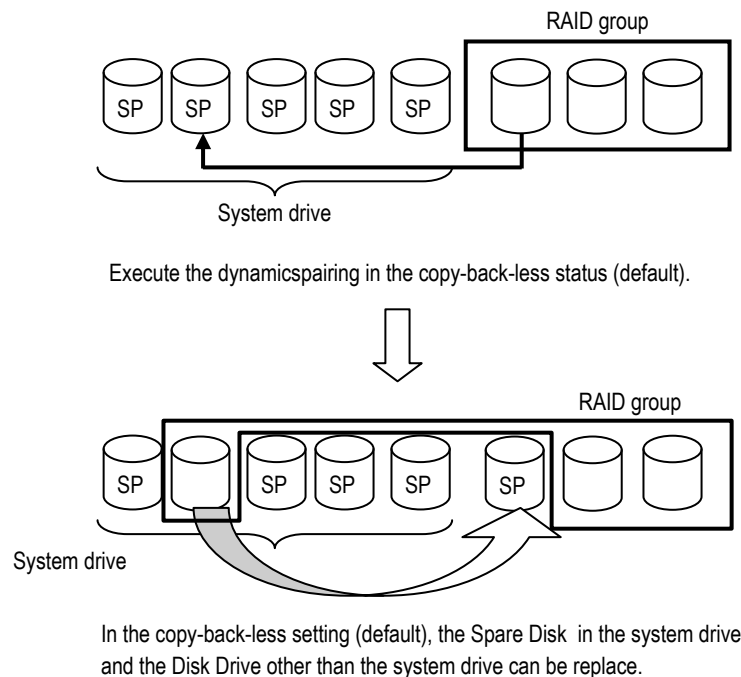

Figure 6.1.3 The move method of a Spare Disk

NOTE : This procedure needs to be executed according to the instruction from the Technical Support Center. Contact the Technical Support Center.

*1 : System drives correspond to Disk Drives #0 to #4 in RKM/RKS, Disk Drives #0 to #4 of Unit ID#0 in RKAK/RKAKS connected to RKH, or Disk Drives #A0 to #A4 in RKAKX.

This page is for editorial purpose only.

Chapter 7. Collecting Error Information

When any failure occurs, the information on it saved in the Control Unit can be collected.

The purpose of this function is to facilitate pursuit of factors of failures and shorten the time consumed for analysis of them.

The failure information is collected by the following three methods.

(1) Collection Simple Trace

Use the normal or maintenance mode using a Web browser to download the trace information and configuration information from the controller to the browser terminal.

You can collect a simple trace while the device is running. You can also collect it when the ALARM LED (red) is lit on the device.

For details of the procedure for the collection, refer to [“7.3 Collecting Simple Trace” \(TRBL 07-0040\)](#).

(2) Collecting CTL Alarm Trace

The controller contains information about the time when the controller is shut down. Use the normal or maintenance mode using a Web browser to download this information from the controller to the browser terminal.

The CTL alarm trace can be collected after recovering the blocked controller.

For details of the procedure for the collection, refer to [“7.4 Collecting CTL Alarm Trace” \(TRBL 07-0090\)](#).

NOTE : When the Control Unit to be connected to WEB is blocked, the WEB connection may not be performed for ten minutes usually (for the maximum of 60 minutes) from the time when the Control Unit was blocked because the CTL alarm trace is being created.

(3) Collecting Full Dump

The information saved in the Controller is downloaded to the browser terminal by using the maintenance mode of WEB.

Controller 0/1 Common

MM/DD/YYYY hh:mm:ss xy □□□□□□ ○○○○○○○○○○○○	: △△△△△△/◆◆◆◆◆◆
MM/DD/YYYY hh:mm:ss xy □□□□□□ ○○○○○○○○○○○○	: △△△△△△/◆◆◆◆◆◆
	:

For details of the procedure for the collection, refer to [“7.5 Collecting Full Dump” \(TRBL 07-0140\)](#).

The failure information is collected by different methods, depending on the configuration and condition of the unit.

Collect the failure information securely according to [“7.2 Judge Collection of Failure Information” \(TRBL 07-0020\)](#).

7.1 Time to Collect Failure Information

Collect the failure information in the following cases.

- (1) A failure was reported to the work-station server, client for maintenance, WEB browser, or Hitachi Storage Navigator Modular 2.
- (2) The WARNING LED (orange) on the front of the Basic Chassis blinked or lit up.
- (3) The ALARM LED (red) on the front of the Basic Chassis lit up.

7.2 Judge Collection of Failure Information

(1) Flow of judgment of collection of failure information for system having single Control Unit (without a redundancy Control Unit)

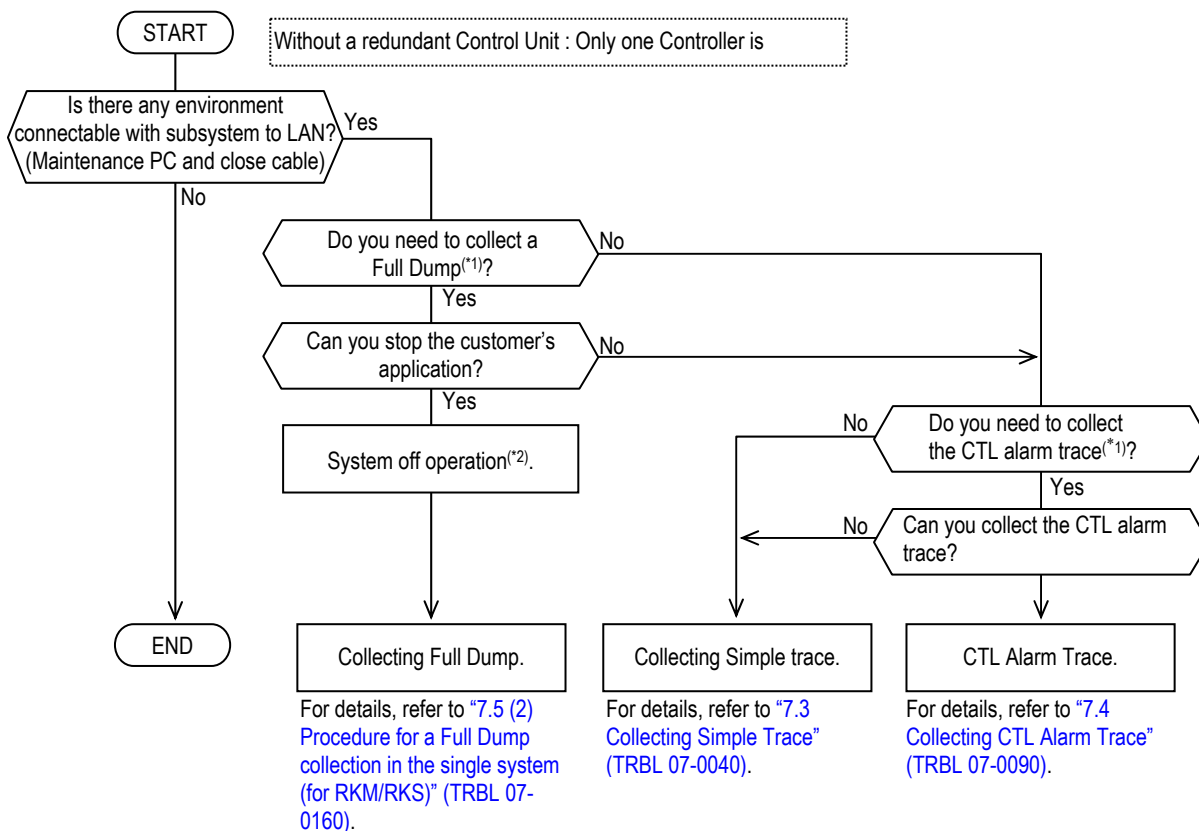

*1 : How to determine whether you need to collect the Full Dump and controller shutdown trace for a log message

① See the last five characters (124th to 128th characters) in the log message.

(For details about the log messages, refer to "4.3 Confirm Log Messages" (TRBL 04-0100).)

② /STRC : You need to collect the Simple Trace.

/CTRC : You need to collect the CTL Alarm Trace.

/FDMP : You need to collect the Full Dump.

*2 : When the power control mode is Remote (when the rotary switch is set to 2, 4, 5, 6, or 8), take care that the subsystem power is also turned off if the host computer is powered off. (Refer to the Installation "1.6 Setting the Power Control Mode (Local/Remote Mode)" (INST 01-0170). When the subsystem is powered off, a Full Dump cannot be done.)

When the mode is Remote, perform the Full Dump in the state in which no access (I/O) from the host computer is made. (Refer to "7.5 Collecting Full Dump" (TRBL 07-0140).)

(2) Flowchart for determining to produce a memory dump in the case of the dual configuration.
(with the redundant Control Unit.)

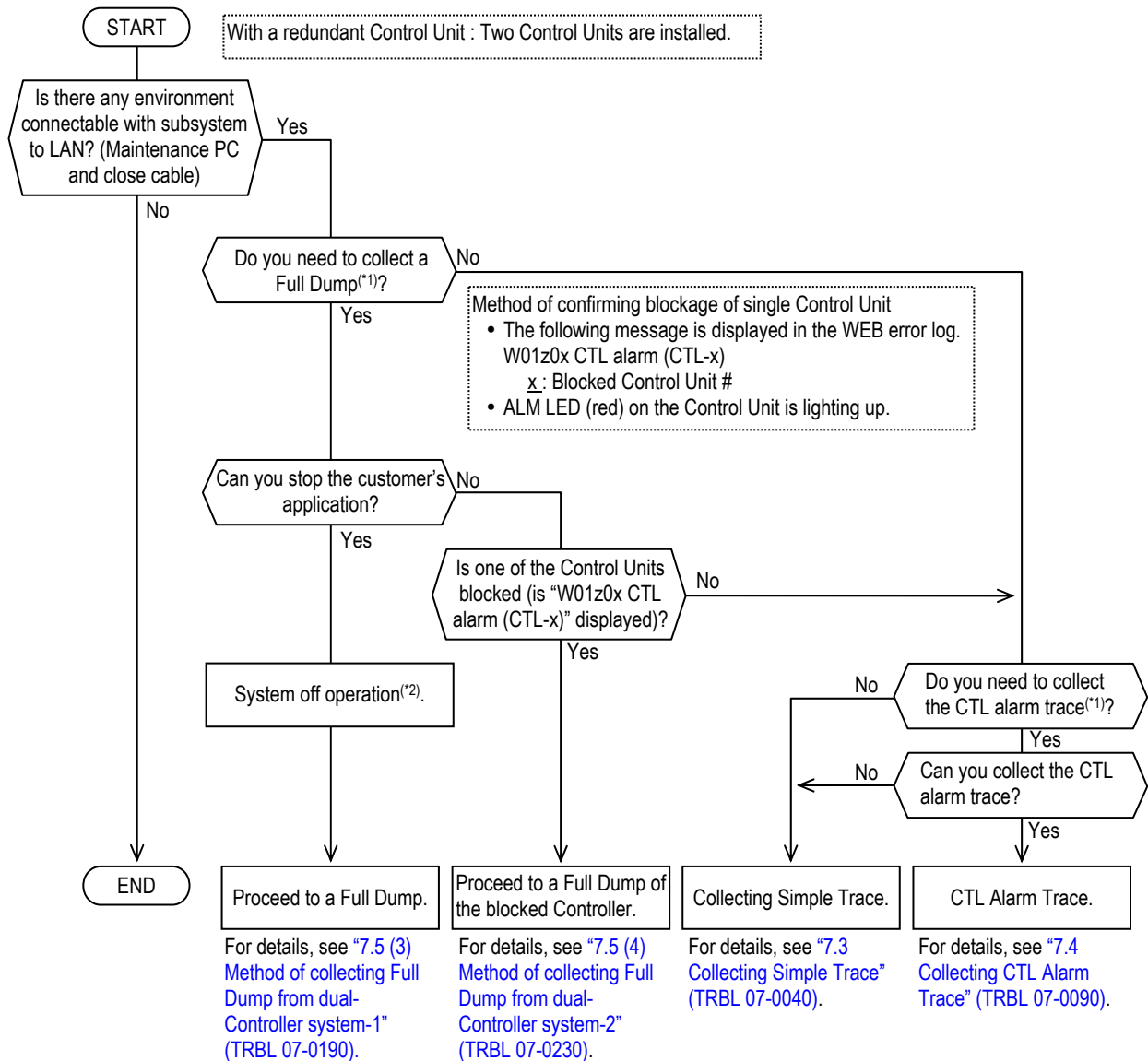

*1 : How to determine whether you need to collect the Full Dump and controller shutdown trace for a log message

- ① See the last five characters (124th to 128th characters) in the log message.
(For details about the log messages, refer to "4.3 Confirm Log Messages" (TRBL 04-0100).)
- ② /STRC : You need to collect the Simple Trace.
/CTRC : You need to collect the CTL Alarm Trace.
/FDMP : You need to collect the Full Dump.

*2 : When the power control mode is Remote (when the rotary switch is set to 2, 4, 5, 6, or 8), take care that the subsystem power is also turned off if the host computer is powered off. (Refer to the Installation "1.6 Setting the Power Control Mode (Local/Remote Mode)" (INST 01-0170). When the subsystem is powered off, a Full Dump cannot be done.)

When the mode is Remote, perform the Full Dump in the state in which no access (I/O) from the host computer is made. (Refer to "7.5 Collecting Full Dump" (TRBL 07-0140).)

7.3 Collecting Simple Trace

Using Simple Trace Collection, the trace information stored in the controller and the configuration information are collected.

The method of collecting the simple trace is shown below.

(1) Before collecting the simple trace

(a) Items to be prepared

Collection is performed using the Normal mode or Maintenance mode of WEB, or Hitachi Storage Navigator Modular 2.

For collecting the simple trace, a maintenance PC requires disk space of no less than 40 M bytes.

(b) Connect the Device LAN Port for maintenance and the PC terminal with a LAN-cross-cable.

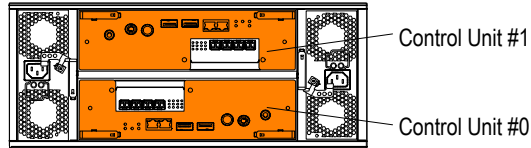

Control Unit RKM/RKEM/RKS/RKES/RKEXS/RKEXS8F Location (Rear view)

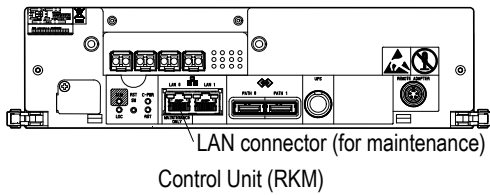

Control Unit (RKM)

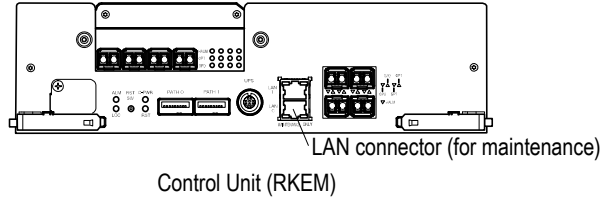

Control Unit (RKEM)

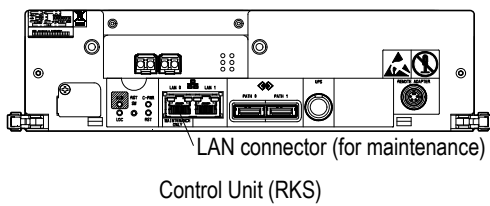

Control Unit (RKS)

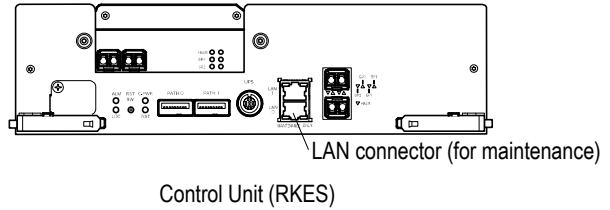

Control Unit (RKES)

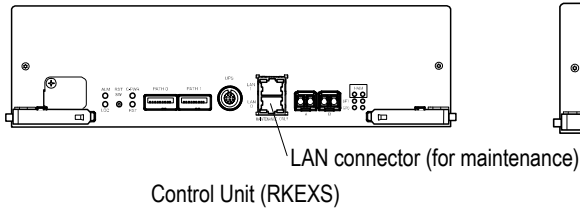

Control Unit (RKEXS)

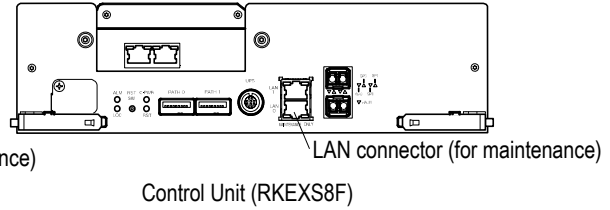

Control Unit (RKEXS8F)

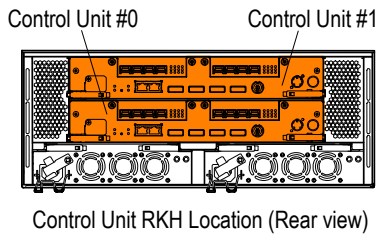

Control Unit RKH Location (Rear view)

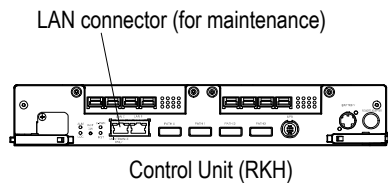

Control Unit (RKH)

Figure 7.3.1 LAN Connector Position

(c) Simple Trace needs to be collected from both controllers.

The first file name during the collection is as follows:

NOTE : If the following setting applies to Internet Explorer 8.0 or more, the Simple Trace collection may not be completed.

- The TCP/IP setting of the network may include a non-responding DNS server and an unnecessary default gateway with the Smart Screen filter setting enabled. In this case, check that the Smart Screen filter setting is disabled. Refer to the manual of the using browser for how to check the setting.

(i) When the firmware version is 0897/H or more;

Serial number and the trace collection starting time

(year/month/day/hour/minute/seconds) are added to the first file name.

smpL_trc0_XXXXXXXX_YYYYMMDDhhmmss_0E.dat

XXXXXXXX : Trace collection serial number

YYYYMMDDhhmmss : Trace collection starting time

(year/month/day/hour/minute/seconds)

- The first file name when the collection from Control Unit #0 fits in a file
“smpL_trc0_XXXXXXXX_YYYYMMDDhhmmss_0E.dat”
- The first file name when the collection from Control Unit #1 fits in a file
“smpL_trc1_XXXXXXXX_YYYYMMDDhhmmss_0E.dat”
- The first file names when the collection from Control Unit #0 fits in two files
“smpL_trc0_XXXXXXXX_YYYYMMDDhhmmss_0S.dat”
“smpL_trc0_XXXXXXXX_YYYYMMDDhhmmss_1E.dat”
- The first file names when the collection from Control Unit #1 fits in two files
“smpL_trc1_XXXXXXXX_YYYYMMDDhhmmss_0S.dat”
“smpL_trc1_XXXXXXXX_YYYYMMDDhhmmss_1E.dat”
- The first file names when the collection from Control Unit #0 fits in three files
“smpL_trc0_XXXXXXXX_YYYYMMDDhhmmss_0S.dat”
“smpL_trc0_XXXXXXXX_YYYYMMDDhhmmss_1C.dat”
“smpL_trc0_XXXXXXXX_YYYYMMDDhhmmss_2E.dat”
- The first file names when the collection from Control Unit #1 fits in three files
“smpL_trc1_XXXXXXXX_YYYYMMDDhhmmss_0S.dat”
“smpL_trc1_XXXXXXXX_YYYYMMDDhhmmss_1C.dat”
“smpL_trc1_XXXXXXXX_YYYYMMDDhhmmss_2E.dat”

(ii) When the firmware version is 0890/A or more and less than 0897/H;

- The first file name when the collection from Control Unit #0 fits in a file
“smpL_trc0_0E.dat”
- The first file name when the collection from Control Unit #1 fits in a file
“smpL_trc1_0E.dat”
- The first file names when the collection from Control Unit #0 fits in two files
“smpL_trc0_0S.dat”
“smpL_trc0_1E.dat”

- The first file names when the collection from Control Unit #1 fits in two files
 - “smpL_trc1_0S.dat”
 - “smpL_trc1_1E.dat”
 - The first file names when the collection from Control Unit #0 fits in three files
 - “smpL_trc0_0S.dat”
 - “smpL_trc0_1C.dat”
 - “smpL_trc0_2E.dat”
 - The first file names when the collection from Control Unit #1 fits in three files
 - “smpL_trc1_0S.dat”
 - “smpL_trc1_1C.dat”
 - “smpL_trc1_2E.dat”
- (iii) When the firmware version is less than 0890/A;
- The first file name during the collection from Control Unit #0
“smpL_trc0.dat”.
 - The first file name during the collection from Control Unit #1
“smpL_trc1.dat”.
- (d) Check that the READY LED (green) on the front of the Basic Chassis is not blinking at high speed.
When the READY LED (green) on the front of the Basic Chassis is blinking at high speed, wait for the maximum of 30 to 50 minutes (or 40 to 60 minutes in case of the RKH) until the READY LED (green) lights up because the automatic download of the ENC firmware is being executed.
- (e) Check that the WARNING LED (orange) on the front of the Basic Chassis (RKM/RKS/RKH) is not blinking at high speed.
When the WARNING LED (orange) on the front of the Basic Chassis is blinking at high speed, wait for the maximum of 30 to 85 minutes until the WARNING LED (orange) on the front of the Basic Chassis goes out and the READY LED (green) lights up because the update of the flash program or the automatic download of the ENC firmware at the time of turning the power on in the single controller configuration is being executed. There is no problem if it blinks slowly (at intervals of one second).
- (f) Clear the cache of the browser following the procedure shown below so that the old data, which was collected at the preceding time, should not be saved.
- In the case of Internet Explorer, select the [Tools] - [Internet Options] - [General] - [Temporary Internet files] - [Delete Files] in this order.
 - In the case of Netscape, select the [Edit] - [Preferences] - [Cache] - [Clear Cache] in this order.

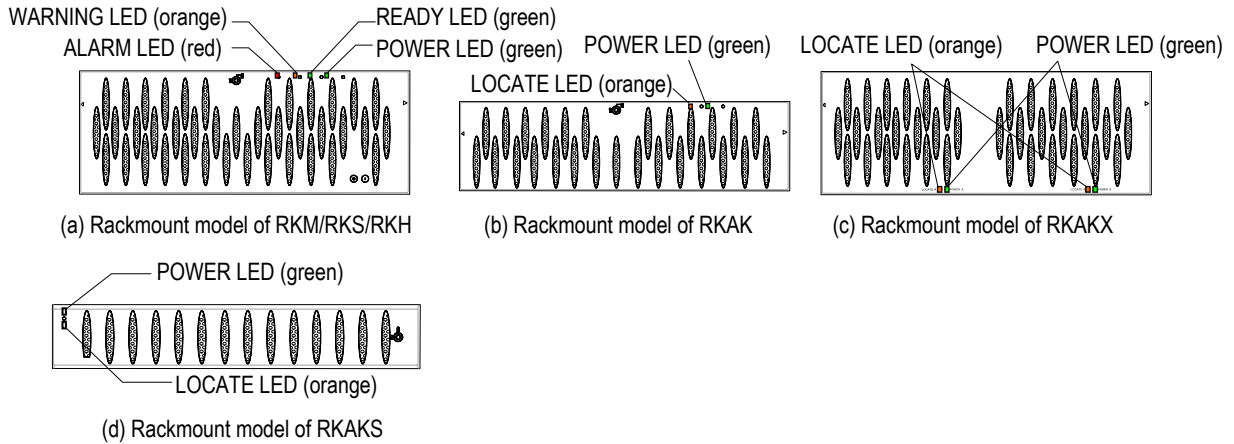

Figure 7.3.2 Indication Locations and Names of LED (Front Bezel)

(2) Procedure for a simple trace collection by WEB

When collecting from the Hitachi Storage Navigator Modular 2, refer to (3).

(a) Enter the IP address of the LAN connector for maintenance, to which the service PC is connected, from the browser. When the Web has already been connected, update the page by pressing the Update button. (For the procedure for connecting the Web, refer to [“Chapter 3. Before Starting WEB Connection” \(TRBL 03-0000\)](#).)

(b) When Windows XP Service Pack2, Windows 2003 Service Pack1 or Windows Vista is used in the OS of the maintenance PC, collect the simple trace after changing the setting of the following Internet Explorer.

- Select [Tools] - [Internet Options] from the Internet Explorer menu.
- Select the [Privacy] tab, check [Blocked pop-up] of [Pop-up block], and click the [Set] button.
- Set [Filter level] to [Medium] in the [Setting pop-up block] window and click the [Close] button.
- Select [OK] button in the [Internet Options] window.

(c) Collect the simple trace according to the WEB and the following procedure.

Click “Simple Trace” in the menu frame.

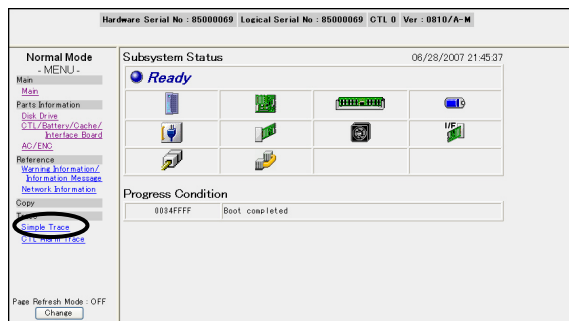

- (d) When the “Simple Trace” is clicked, the following window is displayed.



- (e) When the [OK] button is clicked, the following window is displayed.

NOTE : If the window update (e.g.: pressing F5 key) is performed in this window, the automatic update stops and so that the trace collection does not make progress. When the automatic update stops due to the window update, close this window and, after 20 minutes or more elapse, perform the simple trace collection again.

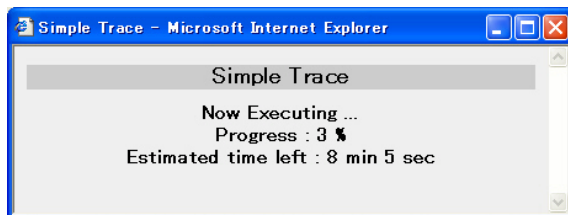

- (f) The following window is displayed. Click the [Download] button.



- (g) Please click [Save], if it is continued. Please click [Cancel], if it is stopped.

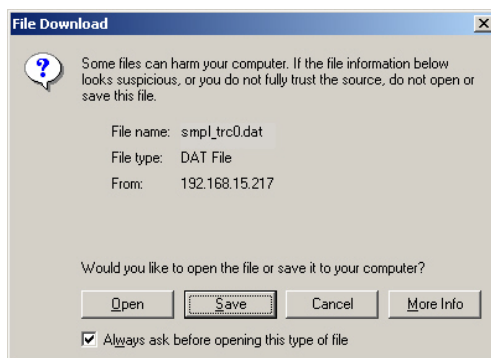

†1 : There may be a case where the first file name is given as “smpL_trc0xxx.dat..dat” depending on the setting of the PC. In this case, “.dat” is deleted or any other name.

- (h) If the following window is displayed. Please click [Save] after file name is setting, if it is continued. †1) Please click [Cancel], if it is stopped.

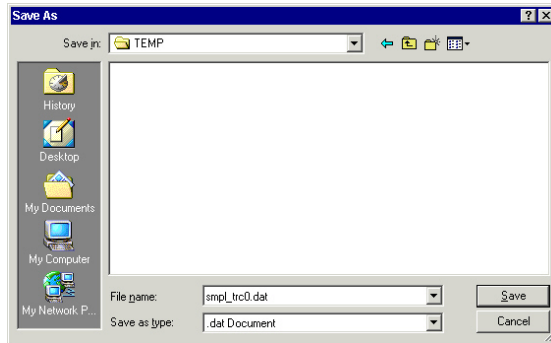

- (i) The following window is displayed during execution download.

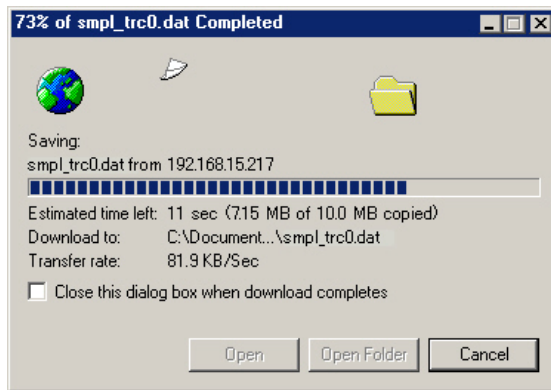

- (j) When the downloading completes, the progress indicating message window is closed.

- (k) If all traces cannot be collected, the following window is displayed.

Click the [Continue], and then collect traces in the next file beginning from the step (e).

NOTE : When performing an array boot or simple trace collection from the same Control Unit in the same array in the following window without clicking the [Continue], a error window is displayed, and the trace cannot be collected.

When all the traces can't be collected on the first time.



When all the traces can't be collected on the second time.



†1 : There may be a case where the first file name is given as "smpL_trc0xxxx.dat..dat" depending on the setting of the PC. In this case, ".dat" is deleted or any other name.

- (l) The following window appears when all traces are collected.
Click the [Close] button.

NOTE : When the firmware version is 0890/A or more, verify that the number of files described in the window is the same as the number of the files actually collected.

- When the firmware version is less than 0890/A



- When the firmware version is 0890/A or more
When all traces can be collected in one file



When all traces can be collected in two files



In this procedure Simple trace is collected by WEB Normal mode. Similarly, Simple trace can be collected by WEB Maintenance mode through Menu Frame.

For entering Maintenance mode, refer to the [WEB "3.1 Transferring to the Maintenance Mode" \(WEB 03-0000\)](#).

- (3) Procedure for a simple trace collection by Hitachi Storage Navigator Modular 2
- Connect to the subsystem from the Hitachi Storage Navigator Modular 2. (Refer to the [System Parameter “1.1 Procedure for Connecting Hitachi Storage Navigator Modular 2 with the Subsystem” \(SYSPR 01-0020\).](#))
 - Collect the simple trace according to the following procedure.
Start the Hitachi Storage Navigator Modular 2. Select the array subsystem to be collected, and click the “Alert & Event” in the tree.

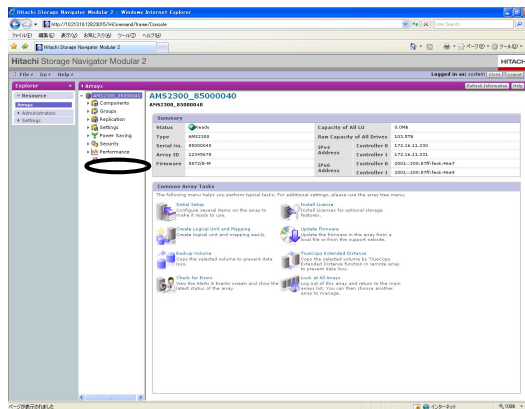

- Click the [Collect Trace] button in the [Alert & Event] window.

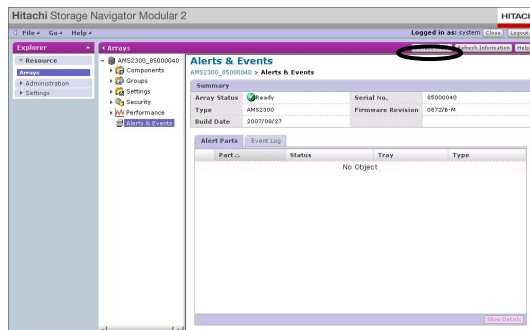

- The following window is displayed.

NOTE : If the window update (e.g.: pressing F5 key) is performed in this window, the automatic update stops and so that the trace collection does not make progress. When the automatic update stops due to the window update, close this window and, after 20 minutes or more elapse, perform the simple trace collection again.

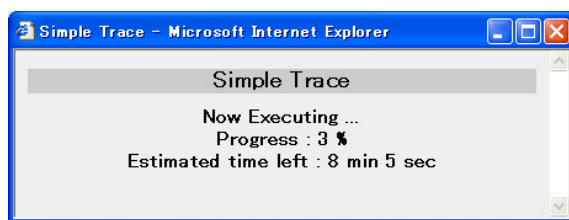

(e) The following window is displayed. Click the [Download] button.



(f) Please click [Save], if it is continued. Please click [Cancel], if it is stopped.

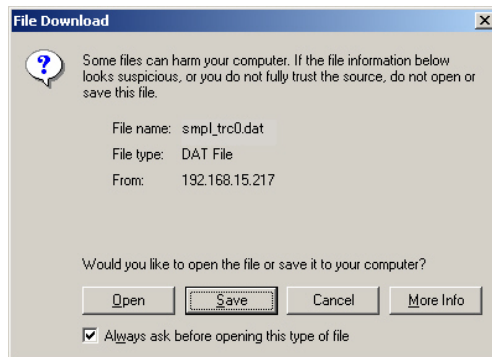

(g) If the following window is displayed. Please click [Save] after file name is setting, if it is continued.^(†1) Please click [Cancel], if it is stopped.

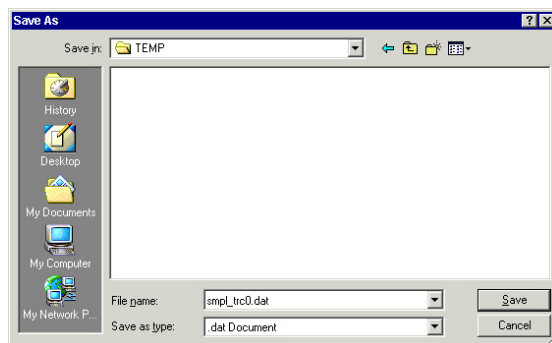

(h) The following window is displayed during execution download.

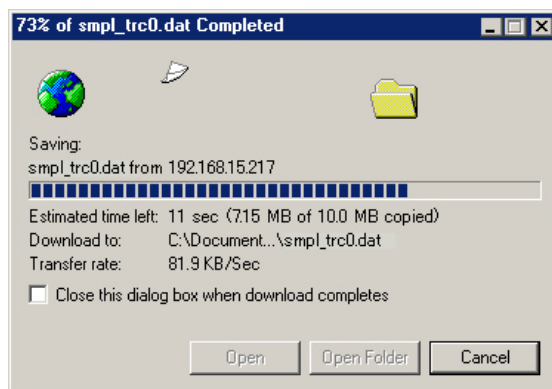

^{†1} : There may be a case where the first file name is given as “smp1_trc0xxxx.dat..dat” depending on the setting of the PC. In this case, “.dat” is deleted or any other name.

- (i) When the downloading completes, the progress indicating message window is closed.
- (j) If all traces cannot be collected, the following window is displayed.
Click the [Continue], and then collect traces in the next file beginning from the step (e).

NOTE : When performing an array boot or simple trace collection from the same Control Unit in the same array in the following window without clicking the [Continue], a error window is displayed, and the trace cannot be collected.

When all the traces can't be collected on the first time.

When all the traces can't be collected on the second time.

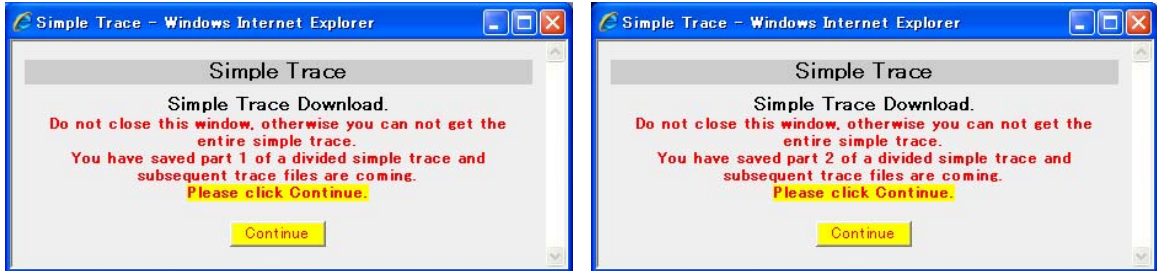

- (k) The following window appears when all traces are collected. Click the [Close] button.

NOTE : When the firmware version is 0890/A or more, verify that the number of files described in the window is the same as the number of the files actually collected.

- When the firmware version is less than 0890/A



- When the firmware version is 0890/A or more and when the Hitachi Storage Navigator Modular 2 is Ver.9.00 or more
When all traces can be collected in one file



When all traces can be collected in two files

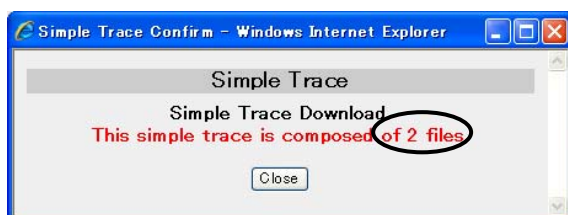

7.4 Collecting CTL Alarm Trace

Through the CTL Alarm Trace collection, detailed information (the CTL Alarm Trace) on the immediately previous Controller blockade stored in the Controller is collected. It may not be collected depending on the types of the failures which cause the controller blockade.

NOTE : When the Control Unit to be connected to WEB is blocked, the WEB connection may not be performed for ten minutes usually (for the maximum of 60 minutes) from the time when the Control Unit was blocked because the CTL alarm trace is being created.

Since the above-mentioned CTL Alarm Trace information is taken over from the blocked Control Unit to the replaced Control Unit, it can be collected after the Control Unit is recovered from the failure. Even after the collection, the information remains until the controller blockade trace is rewritten in the next controller blockade. If the Control Unit is blocked while collecting the CTL Alarm Trace may not be collected normally. Therefore, in this case, collect the CTL Alarm Trace again.

The method of collecting the CTL Alarm Trace is shown below.

(1) Before collecting the CTL Alarm Trace

(a) Items to be prepared

The CTL Alarm Trace is collected in the normal mode or the maintenance mode of the WEB. For connecting to the WEB, a maintenance PC terminal with Browser installed is necessary. For collecting the CTL Alarm Trace, disk space of 520 M bytes per one Control Unit is required. (260 M bytes for temporary data and 260 M bytes for Full Dump data)

(b) Connect the Device LAN Port for maintenance and the PC terminal with a LAN cross cable.

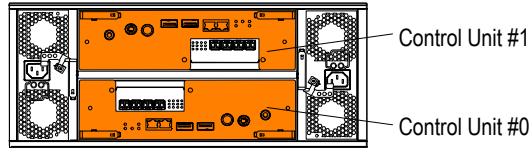

Control Unit RKM/RKEM/RKS/RKES/RKEXS/RKEXS8F Location (Rear view)

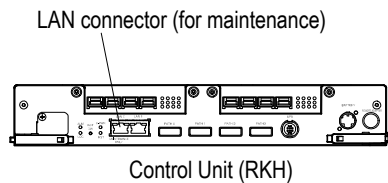
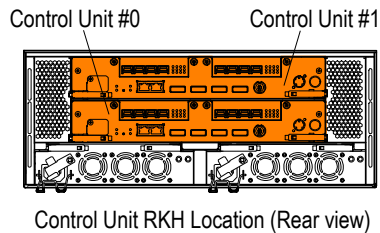
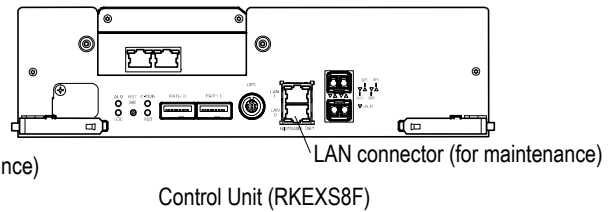
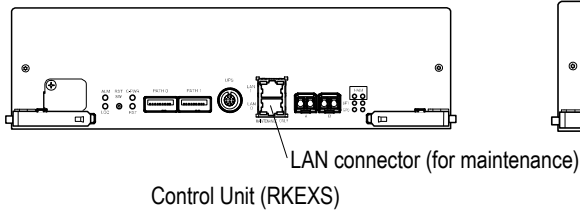
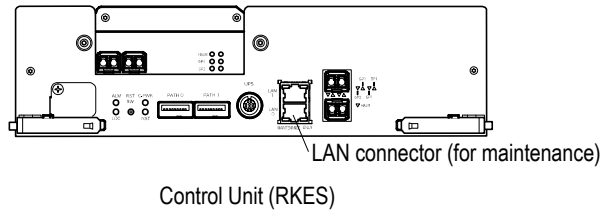
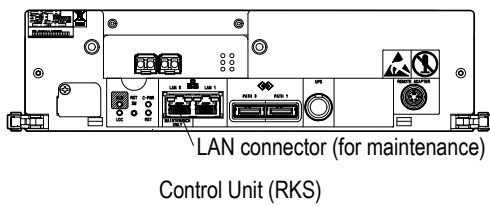
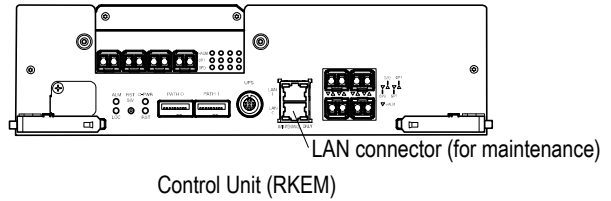
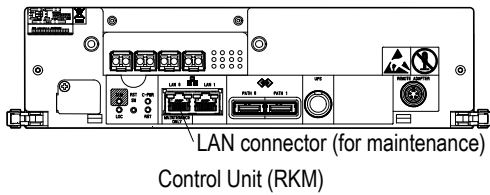

Figure 7.4.1 LAN Connector Position

This page is for editorial purpose only.

(c) Collect the CTL Alarm Trace information from each Control Unit.

Save the files collected from different controllers into different directories or put different names to them so that you will see from which controller they were collected.

(d) Check that the READY LED (green) on the front of the Basic Chassis is not blinking at high speed.

When the READY LED (green) on the front of the Basic Chassis is blinking at high speed, wait for the maximum of 30 to 50 minutes (or 40 to 60 minutes in case of the RKH) until the READY LED (green) lights up because the automatic download of the ENC firmware is being executed.

(e) Check that the WARNING LED (orange) on the front of the Basic Chassis (RKM/RKS/RKH) is not blinking at high speed.

When the WARNING LED (orange) on the front of the Basic Chassis is blinking at high speed, wait for the maximum of 30 to 85 minutes until the WARNING LED (orange) on the front of the Basic Chassis goes out and the READY LED (green) lights up because the update of the flash program or the automatic download of the ENC firmware at the time of turning the power on in the single controller configuration is being executed. There is no problem if it blinks slowly (at intervals of one second).

(f) Clear the cache of the browser following the procedure shown below so that the old data, which was collected at the preceding time, should not be saved.

- In the case of Internet Explorer, select the [Tools] - [Internet Options] - [General] - [Temporary Internet files] - [Delete Files] in this order.
- In the case of Netscape, select the [Edit] - [Preferences] - [Cache] - [Clear Cache] in this order.

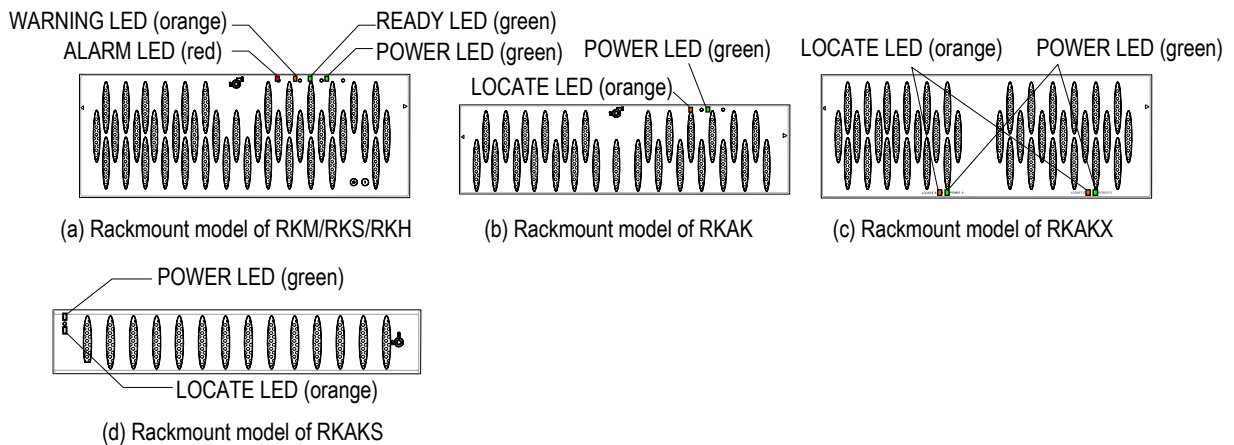
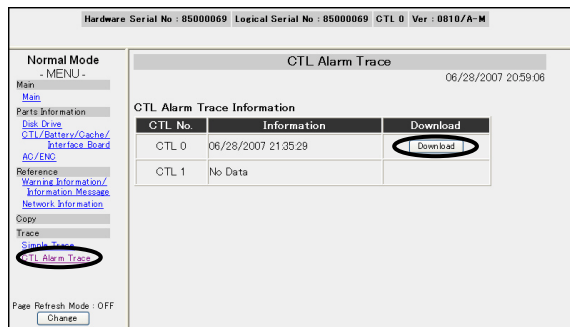

Figure 7.4.2 Indication Locations and Names of LED (Front Bezel)

(2) Procedure for collecting a CTL Alarm Trace

- (a) Enter the IP address of the LAN connector for maintenance, to which the service PC is connected, from the browser. When the Web has already been connected, update the page by pressing the Update button. (For the procedure for connecting the Web, refer to “Chapter 3. Before Starting WEB Connection” (TRBL 03-0000).)
- (b) When Windows XP Service Pack2, Windows 2003 Service Pack1 or Windows Vista is used in the OS of the maintenance PC, collect the CTL Alarm Trace after changing the setting of the following Internet Explorer.
 - Select [Tools] - [Internet Options] from the Internet Explorer menu.
 - Select the [Privacy] tab, check [Blocked pop-up] of [Pop-up block], and click the [Set] button.
 - Set [Filter level] to [Medium] in the [Setting pop-up block] window and click the [Close] button.
 - Select [OK] button in the [Internet Options] window.
- (c) Collect the memory dump according to the WEB and the following procedure. Click “CTL Alarm Trace” in the menu frame. The CTL Alarm Trace Information window is displayed when the CTL alarm trace information is present.



The following is displayed as contents of the information.

[Not Ready] : A status in which the trace area is not established in the subsystem

[Not Data] : A status in which the CTL Alarm trace information is not present or being generated

[MM/DD/20XY hh:mm:ss] . : A status in which the CTL alarm trace information is present

NOTE : When “Not Ready” or “No Data” is displayed on the description of “Information”, or when the date of the information is different from that of the collection of this time, the CTL alarm trace may not be collected normally. Connect the Maintenance PC to the LAN port of the blocked Control Unit, and collect the simple trace.

If simple trace cannot be obtained through detached Controller, connect the Maintenance PC to the Controller at the opposite side, and collect the simple trace.

- (d) To download the CTL Alarm trace information, press the “Download” button on the Control Unit side to be collected in “CTL Alarm Trace information”.

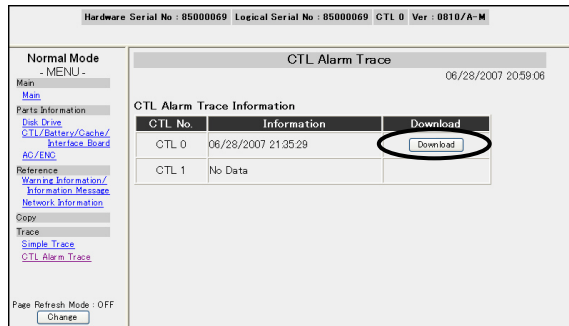

- (e) The following window is displayed. Please click [Save], if it is continued. Please click [Cancel], if it is stopped.

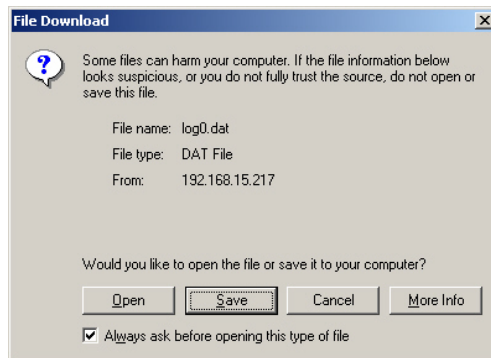

- (f) If the following window is displayed. Please click [Save] after file name is setting, if it is continued.^(†1) Please click [Cancel], if it is stopped.

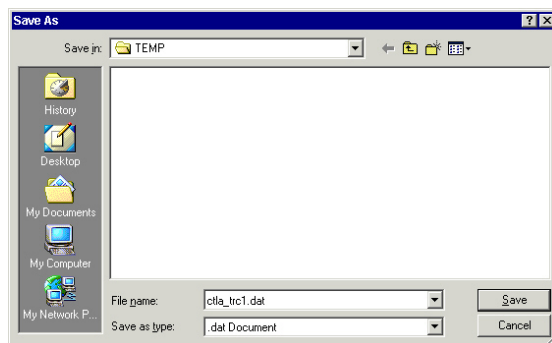

^{†1} : There may be a case where the default file name is given as “ctla_trc0.dat.dat” depending on the setting of the PC. In this case, “.dat” is deleted or any other name.

(g) The following window is displayed during execution download.

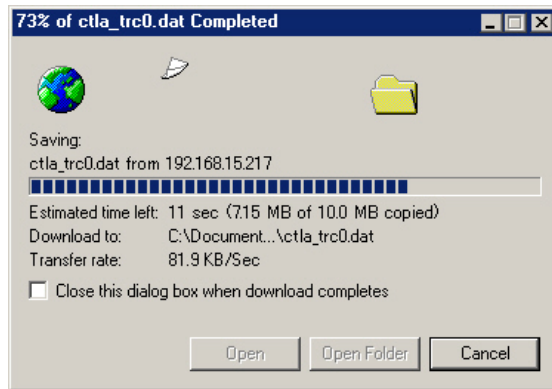

(h) When the downloading completes, the progress indicating message window is closed.

In this procedure is collected by WEB Normal mode. Similarly, CTL Alarm Trace can be collected by WEB Maintenance mode through Menu Frame.

For entering Maintenance mode refer to [WEB "3.1 Transferring to the Maintenance Mode"](#) (WEB 03-0000).

7.5 Collecting Full Dump

The method of collecting the Full Dump is shown below.

(1) Before collecting the Full Dump

(a) Items to be prepared

The Full Dump is collected in the maintenance mode of the WEB.

For connecting to the WEB, a maintenance PC terminal with Browser installed is necessary. For collecting the Full Dump, disk space of 3.6 G bytes per one Control Unit is required. (1.8 G bytes for temporary data and 1.8 G bytes for Full Dump data)

The Full Dump collection time may take longer than usual depending on the setting of the maintenance PC, so that check the setting of the maintenance PC again (refer to “Chapter 3. Before Starting WEB Connection” (TRBL 03-0000)).

(b) Connect the LAN-Connector for maintenance and the LAN-Connector of Maintenance PC with a LAN-cross-cable.

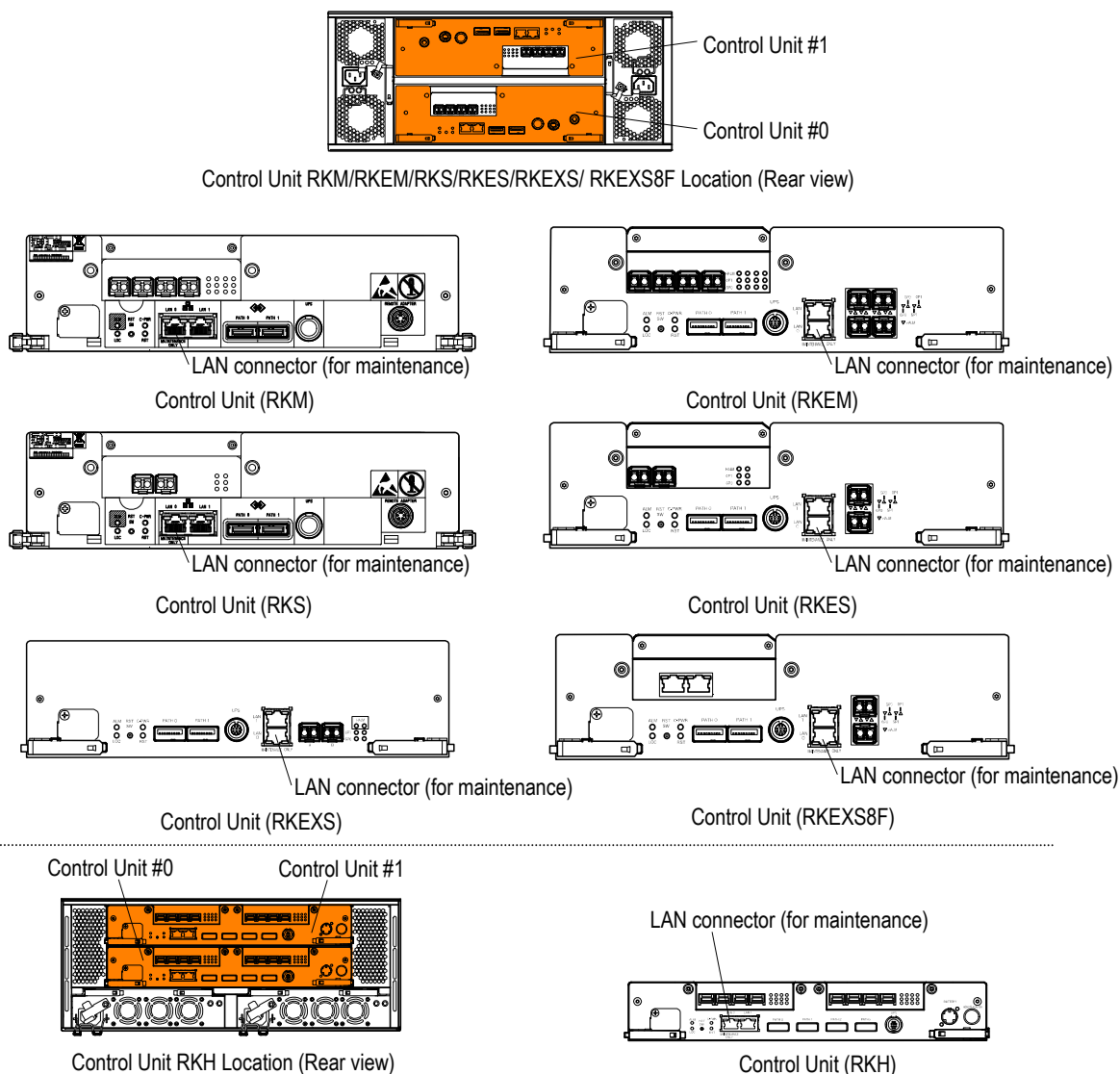

Figure 7.5.1 LAN Connector Location

(c) Collect the Full Dump information from each Control Unit.

Save the files collected from different controllers into different directories or put different names to them so that you will see from which controller they were collected.

(d) Check that the READY LED (green) on the front of the Basic Chassis is not blinking at high speed.

When the READY LED (green) on the front of the Basic Chassis is blinking at high speed, wait for the maximum of 30 to 60 minutes (or 40 to 60 minutes in case of the RKH) until the READY LED (green) lights up because the automatic download of the ENC firmware is being executed.

(e) Check that the WARNING LED (orange) on the front of the Basic Chassis (RKM/RKS/RKH) is not blinking at high speed.

When the WARNING LED (orange) on the front of the Basic Chassis is blinking at high speed, wait for the maximum of 30 to 85 minutes until the WARNING LED (orange) on the front of the Basic Chassis goes out and the READY LED (green) lights up because the update of the flash program or the automatic download of the ENC firmware at the time of turning the power on in the single controller configuration is being executed. There is no problem if it blinks slowly (at intervals of one second).

(f) Clear the cache of the browser following the procedure shown below so that the old data, which was collected at the preceding time, should not be saved.

- In the case of Internet Explorer, select the [Tools] - [Internet Options] - [General] - [Temporary Internet files] - and [Delete Files] in this order.
- In the case of Netscape, select the [Edit] - [Preferences] - [Cache] - [Clear Cache] in this order.

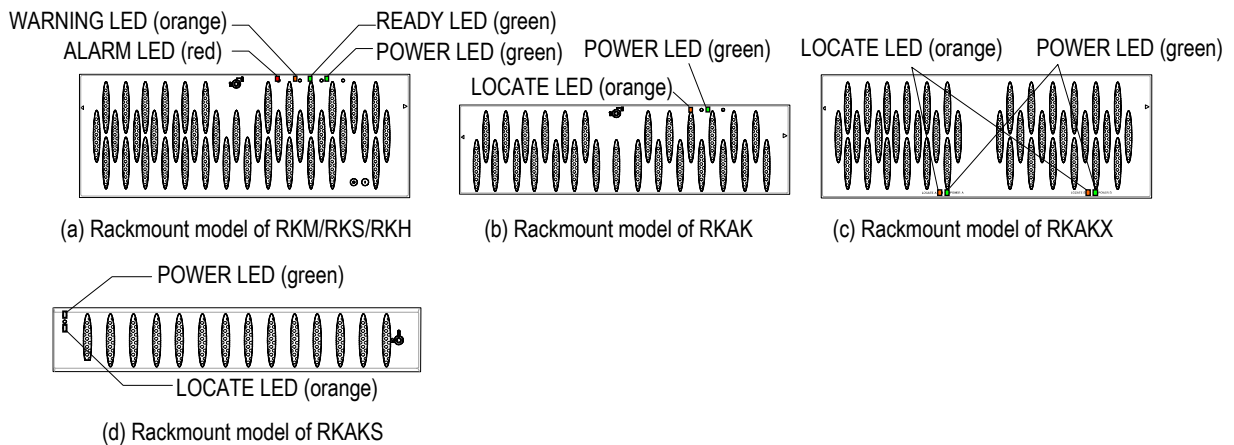

Figure 7.5.2 Indication Locations and Names of LED (Front Bezel)

(2) Procedure for a Full Dump collection in the single system (for RKM/RKS)

NOTE : • In the subsystem where the Power Saving of the priced option is used, when RAID group whose power saving status is “Normal (command monitoring)” exists, do not change to the Maintenance Mode. Change to the Maintenance Mode after completing the spin-down, or have the user perform the spin-down or spin-up instruction, and then change to the Maintenance Mode after there is no RAID group whose power saving status is “Normal (command monitoring)”.

- The appropriate Control Unit is blocked by pushing down the RST SW on the Control Unit. As this prevents you from accessing the subsystem from the higher level device, verify the effects on your customer’s operation.

- (a) Please push the RST SW of Control Unit. (While pressing RST SW, the RST LED (orange) is on.) Use a tool with a thin tip (a precise screwdriver, etc.) because the hole of RST SW is small (3 mm in diameter). (The Controller enters the WEB maintenance mode.)

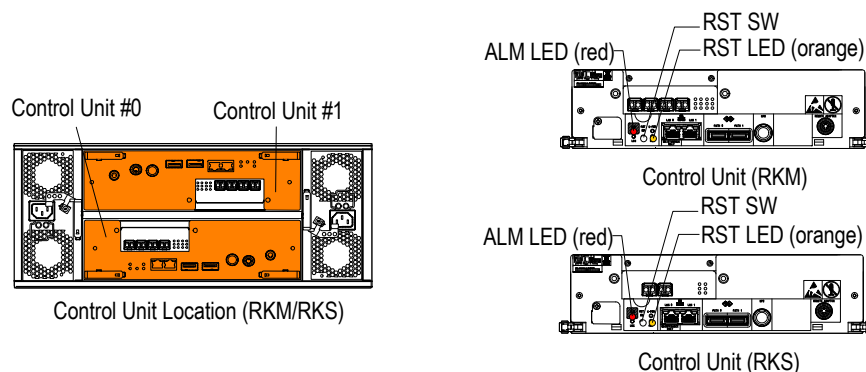
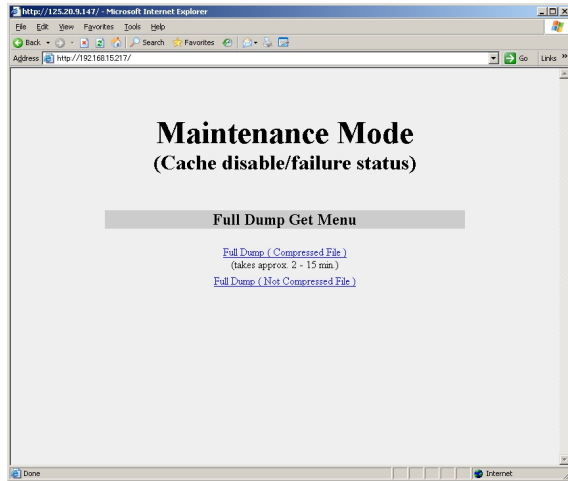

Figure 7.5.3 Indication Locations of Control Unit

- (b) Enter the IP address of the LAN connector for maintenance, to which the service PC is connected, from the browser. When the Web has already been connected, update the page by pressing the Refresh button or click the [View] - [Refresh]. (For the procedure for connecting the Web, refer to “Chapter 3. Before Starting WEB Connection” (TRBL 03-0000).) A [User Name] and a [Password] may be requested at the time of Web connection or Web operation. In that case, input “maintenance” for the [User Name] and “hosyu9500” for the [Password].

The cache memory access failure occurs when the following window is displayed. Refer to WEB “3.1.1 WEB Operation in the Maintenance Mode during the Cache Memory Access Failure” (WEB 03-0050).



- (c) Collect the Full Dump according to the WEB and the following procedure. Please click “Full Dump”.

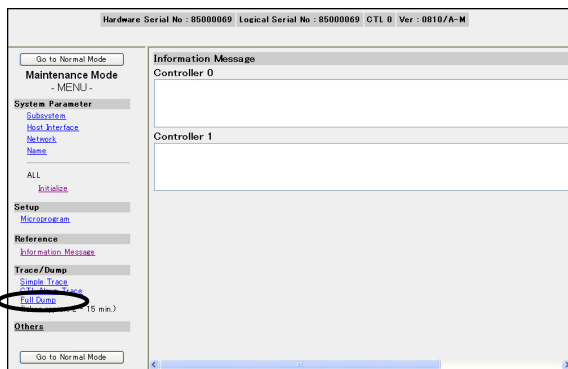

- (d) The following window is displayed. Please click [Save], if it is continued. Please click [Cancel], if it is stopped.

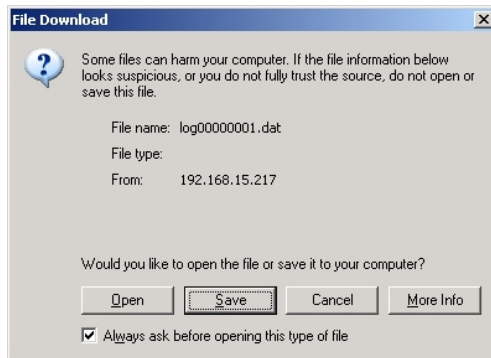

- (e) If the following window is displayed. Please click [Save] after file name is setting, if it is continued. †1 Please click [Cancel], if it is stopped.

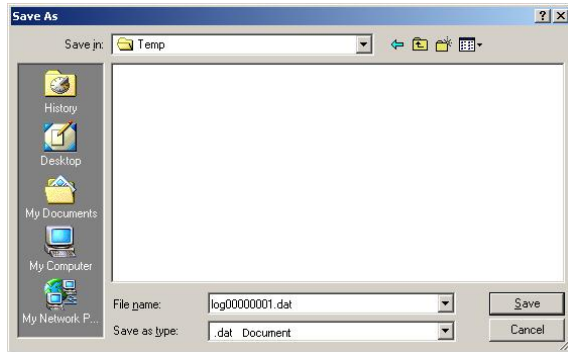

- (f) The following window is displayed during execution download. There is no problem although it is displayed that the presumption remaining time is uncertain.

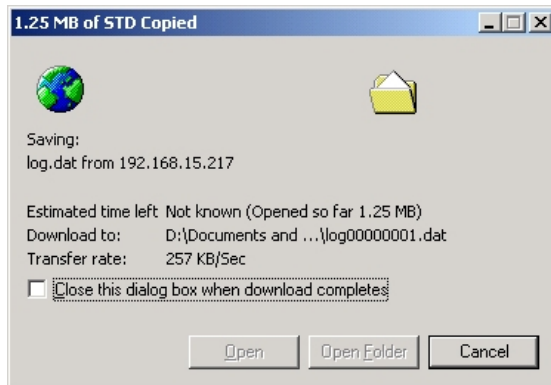

- (g) When the downloading completes, the progress indicating message window is closed.

There is no problem although it is displayed that the presumption remaining time is uncertain in the dialog box during the download.

†1 : There may be a case where the default file name is given as "logx.dat.dat" depending on the setting of the PC. In this case, ".dat" is deleted or any other name. (x: Controller serial numbers)

(3) Method of collecting Full Dump from dual-Controller system-1

Interrupting the customer operation and collecting Full Dump information of the both Control Units under dual system configuration

NOTE : • In the subsystem where the Power Saving of the priced option is used, when RAID group whose power saving status is “Normal (command monitoring)” exists, do not change to the Maintenance Mode. Change to the Maintenance Mode after completing the spin-down, or have the user perform the spin-down or spin-up instruction, and then change to the Maintenance Mode after there is no RAID group whose power saving status is “Normal (command monitoring)”.

- The appropriate Control Unit is blocked by pushing down the RST SW on the Control Unit. As the blockage in both Control Units prevents you from accessing the subsystem from the higher level device, verify the effects on your customer's operation.
- When the Full Dump is collected with the Control Unit blocked, it is necessary to collect the Full Dump from the Control Unit that is blocked.

- (a) Press the RST SW of the blocked Control Unit. (If both Control Units are normal or blocked, press the RST SW of either one.) (While pressing RST SW, the RST LED (orange) is on.) Use a tool with a thin tip (a precise screwdriver, etc.) because the hole of RST SW is small (3 mm in diameter).

Wait for a while (about ten seconds) and check that the ALM LED (red) of the Control Unit lights up. Within ten seconds after the ALM LED (red) lights up, press the RST SW of the other Control Unit.

When ten seconds or longer pass after the ALM LED (red) of the Control Unit concerned comes on, return to the beginning of the step (a) and execute the procedure over again. (When the above procedure is executed, the both Control Units enter the Maintenance mode of the WEB.)

The ALM LED (red) on the Control Unit of which RST SW was pressed first goes off, and READY LED (green) on the Front Bezel goes off.

(a) Rackmount model of RKH/RKM/RKS

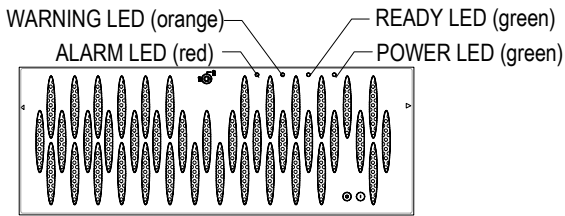

(b) Control Unit Location

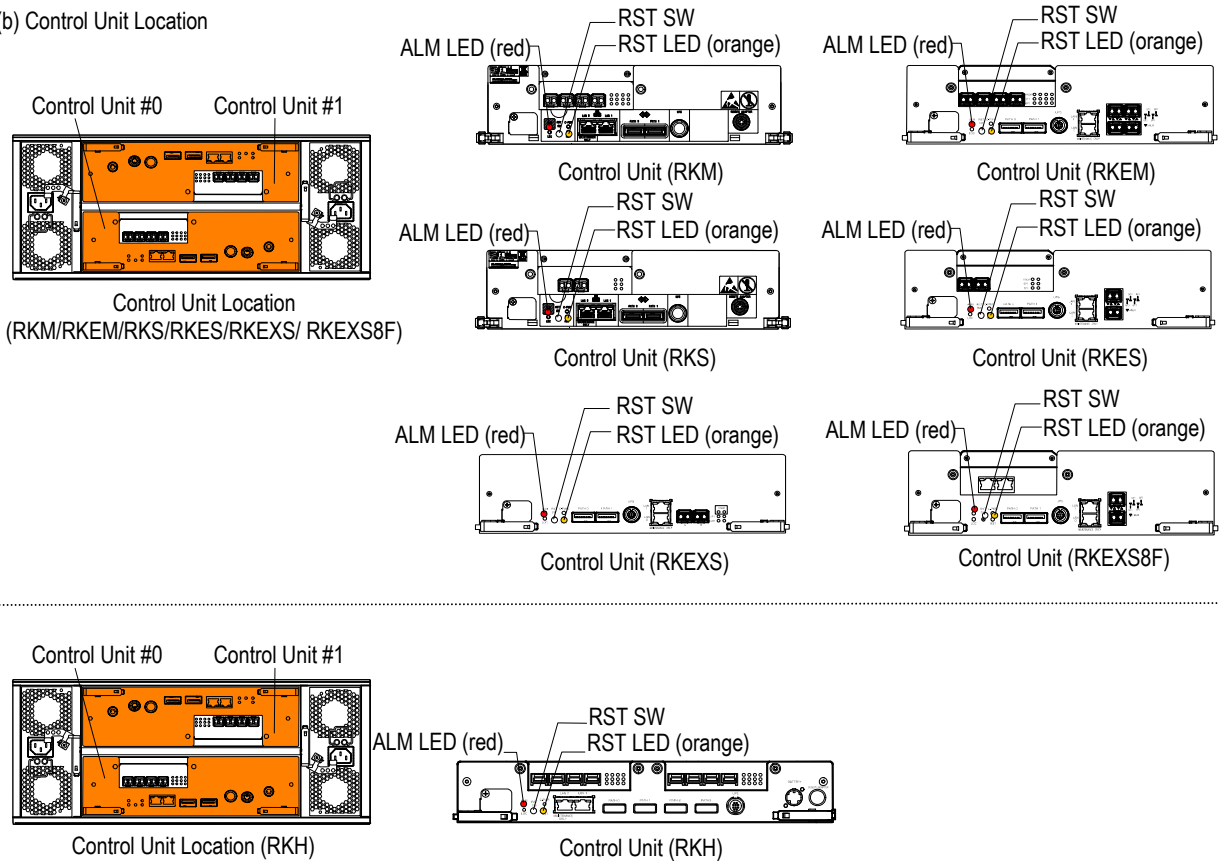

Figure 7.5.4 Indication Locations of Control Unit

This page is for editorial purpose only.

- (b) Input the IP address of the controller from which the Full Dump will be collected, through the browser. If the system has been connected to the WEB, press the “Refresh” button to update the page.

A [User Name] and a [Password] may be requested at the time of Web connection or Web operation. In that case, input “maintenance” for the [User Name] and “hosyu9500” for the [Password].

The cache memory access failure occurs when the following window is displayed. Refer to WEB “3.1.1 WEB Operation in the Maintenance Mode During the Cache Memory Access Failure” (WEB 03-0050).

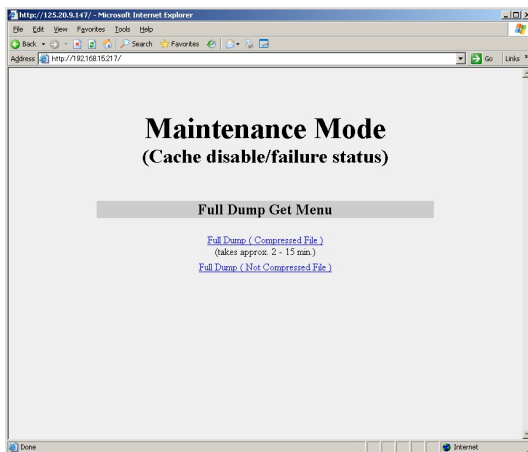

- (c) Collect the Full Dump according to the WEB and the following procedure. Please click “Full Dump”.

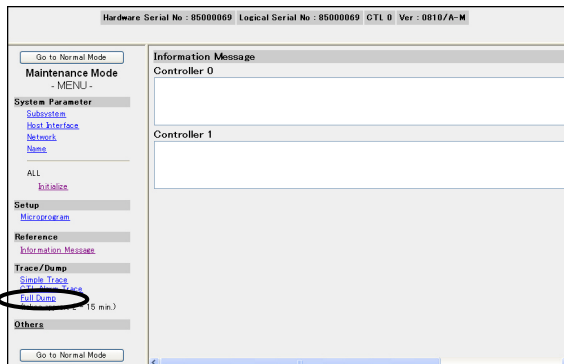

- (d) The following window is displayed. Please click [Save], if it is continued. Please click [Cancel], if it is stopped.

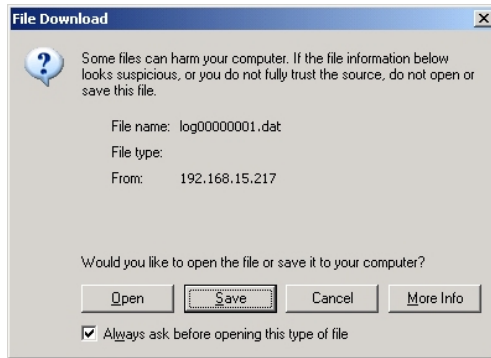

- (e) If the following window is displayed. Please click [Save] after file name is setting, if it is continued.^(†1) Please click [Cancel], if it is stopped.

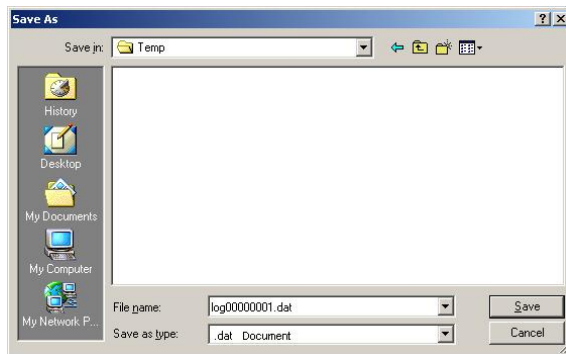

- (f) The following window is displayed during execution download. There is no problem although it is displayed that the presumption remaining time is uncertain.

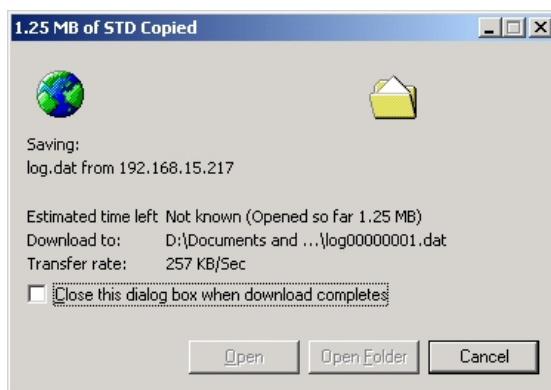

- (g) When the downloading completes, the progress indicating message window is closed.

There is no problem although it is displayed that the presumption remaining time is uncertain in the dialog box during the download.

^{†1} : There may be a case where the default file name is given as “logx.dat.dat” depending on the setting of the PC. In this case, “.dat” is deleted or any other name.

- (h) Return to (b) and collect the Full Dump from the other Control Unit.
(Save the Full Dump files collected from different Control Units into different directories or put different names to them so that you will see from which controller they were collected.)

(4) Method of collecting Full Dump from dual-Controller system-2

Collecting Full Dump information of detached Control Unit under dual system configuration

NOTE : • In the subsystem where the Power Saving of the priced option is used, when RAID group whose power saving status is “Normal (command monitoring)” exists, do not change to the Maintenance Mode. Change to the Maintenance Mode after completing the spin-down, or have the user perform the spin-down or spin-up instruction, and then change to the Maintenance Mode after there is no RAID group whose power saving status is “Normal (command monitoring)”.

- Collect the Full Dump from only the blocked Control Unit. (The ALM LED (red) of the blocked controller is lighting up.)

(a) Press the RST SW of the blocked Control Unit. (While pressing RST SW, the RST LED (orange) is on.)

Use a tool with a thin tip (a precise screwdriver, etc.) because the hole of RST SW is small (3 mm in diameter). (The Control Unit will be set in the maintenance mode of the WEB.)

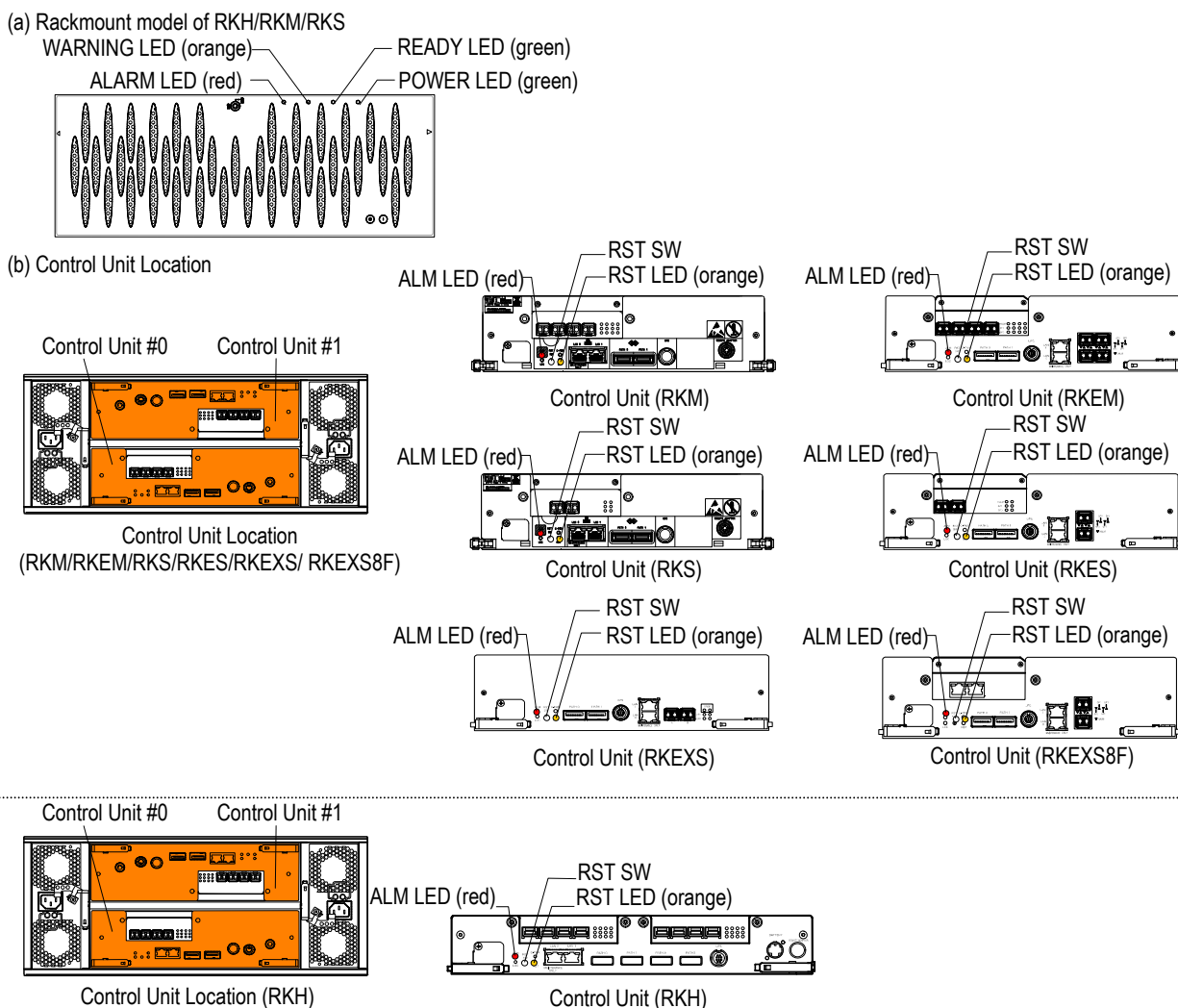

Figure 7.5.5 Indication Locations of Control Unit

- (b) Input the IP address of the Control Unit from which the blocked Control Unit, through the browser.

If the system has been connected to the WEB, press the update button to update the page.

A [User Name] and a [Password] may be requested at the time of Web connection or Web operation. In that case, input “maintenance” for the [User Name] and “hosyu9500” for the [Password].

The cache memory access failure occurs when the following window is displayed. Refer to WEB “3.1.1 WEB Operation in the Maintenance Mode during the Cache Memory Access Failure” (WEB 03-0050).

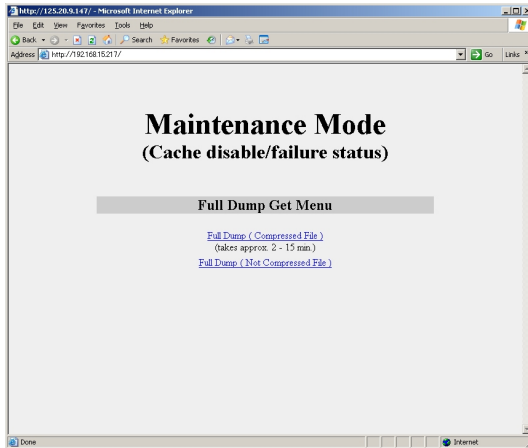

- (c) Collect the Full Dump according to the WEB and the following procedure.

Click “Full Dump” in the menu frame of “Trace/Dump”.

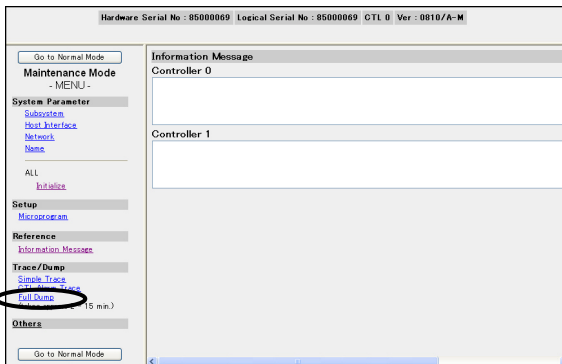

The following dialog is displayed. Click the [Save] button.

If the following dialog is not displayed even after five minutes passed, click the [Close] button on the upper right of the browser and close the browser. After that, open the browser again and retry from the procedure (b).

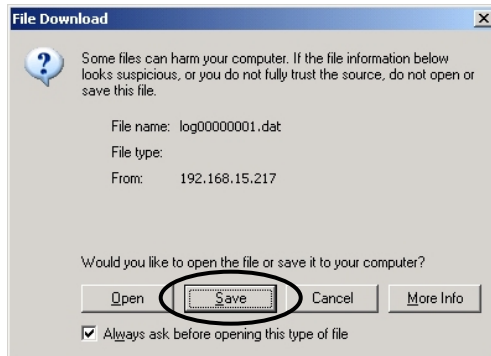

Select the place to save the file and file name (Default file name: logx.dat <x:Controller serial numbers>) and click [Save]^(#1).

When the download is not completed^(#2) or the message window is not displayed even after five minutes passed, click the [Close] button on the upper right of the browser and close the browser. After that, open the browser again and retry from the procedure (b).

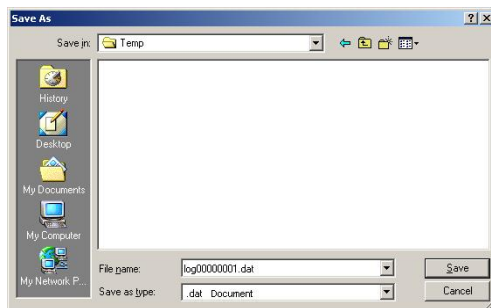

The down-loading is started and the progress indicating message window is displayed.

When the down-loading completes, the progress indicating message window is closed.

There is no problem although it is displayed that the presumption remaining time is uncertain in the dialog box during the download.

#1 : There may be a case where the default file name is given as "logx.dat.dat" depending on the setting of the PC. In this case, ".dat" is deleted or any other name.

#2 : Refer to the content displayed in "Full Dump" in "Trace/Dump" listed in the menu frame of WEB for the standard at time that the download of the Full Dump is completed.

Chapter 8. Trouble Analysis by LED Indication

8.1 Trouble Analysis by LED Indication of Front Bezel

(1) LED positions on Front Bezel

The positions on LED's are shown below.

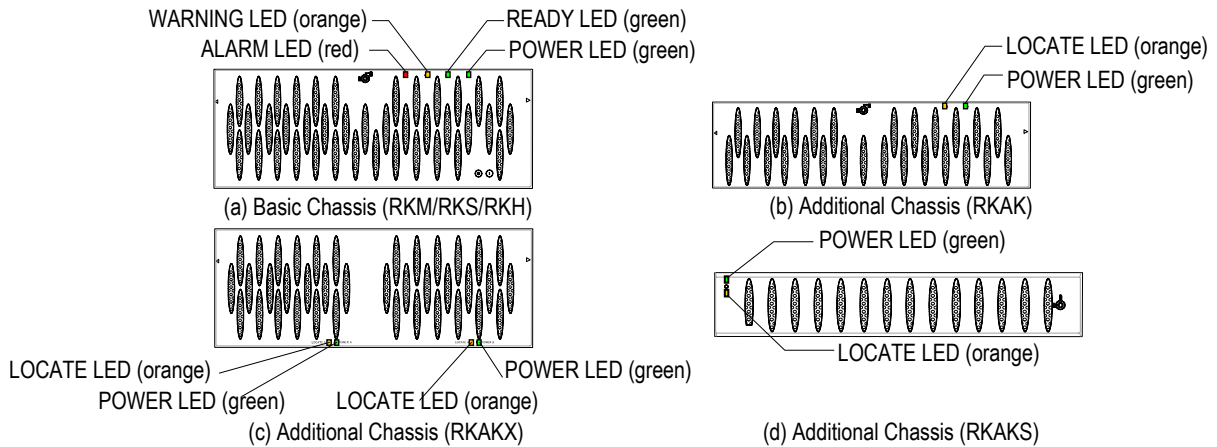

Figure 8.1.1 Locations and Name of LED

(2) Trouble analysis procedure

The states of the units indicated by the LED indication patterns of the Front Bezel and the actions to take against them are shown below.

Table 8.1.1 LED Indication Patterns on Front Bezel

(○ : On ✧ : Blinking × : Off — : Not depend)

No	LEDs						State of unit	Actions to take	Failure
	Basic Chassis				Additional Chassis				
	ALARM (red)	WARNING (orange)	READY (green)	POWER (green)	POWER (green)	LOCATE (orange)			
1 ^(*)	×	×	○	○	○	×	Normal.	Recovery operation is not necessary.	—
2	×	×	×	×	—	×	<ul style="list-style-type: none"> Power cables are not connected to the Power Units. Trouble of the Power Unit Trouble of two FAN Units Short failure of each part 	Analyze the failure following "8.1 (3) (a) Trouble analysis on the indication on the POWER LED of Basic Chassis. (When the POWER LED is not on)" (TRBL 08-0040).	Parts failure: (Basic Chassis) Drive failure: (Basic Chassis)
	○	×	×	○	×	×		Analyze the failure following "8.1 (3) (b) Trouble analysis on the indication on the POWER LED of Additional Chassis. (Not POWER LED on)" (TRBL 08-0100).	Parts failure: (Additional Chassis) Drive failure: (Additional Chassis)

*1 : This is not a failure status

(○ : On ✧ : Blinking × : Off — : Not depend)

No	LEDs						State of unit	Actions to take	Failure
	Basic Chassis				Additional Chassis				
	ALARM (red)	WARNING (orange)	READY (green)	POWER (green)	POWER (green)	LOCATE (orange)			
3	○	×	×	×	×	×	<ul style="list-style-type: none"> Is it an error of the Power Unit system Dual failure of the Control Units or the ENC Units 	<ol style="list-style-type: none"> Check that power cable is connected correctly. Check LED indication of Power Unit. (Refer to "8.2 (3) Trouble analysis based on LED indication of Power Unit" (TRBL 08-0170).) Check LED indication of Control Unit. (Refer to "8.2 (5) Trouble analysis based on LED indication of Control Unit" (TRBL 08-0190).) Check LED indication of ENC Unit. (Refer to "8.2 (7) Trouble analysis based on LED indication of ENC Unit" (TRBL 08-0290).) 	Parts failure.
4	×	×	×	○	—	—	<p>An error occurred during the power-on processing or at the time of powering on.</p>	<ol style="list-style-type: none"> Check LED indication of Control Unit. (Refer to "8.2 (5) Trouble analysis based on LED indication of Control Unit" (TRBL 08-0190).) If ALM LED (red) of one Control Unit or more does not light up, wait READY LED (green) to light up (for at least 10 min). Proceed to "Chapter 3. Before Starting WEB Connection" (TRBL 03-0000), and then detect a failure with WEB. 	<p>Parts failure. (Basic Chassis)</p> <hr/> <p>Failure must be detected with WEB.</p>
5	✧ ^(*) (Slowly blinking)	×	×	○	—	—	<p>A serious failure occurred while power on. Example: User data was lost.</p>	<p>Proceed to "Chapter 3. Before Starting WEB Connection" (TRBL 03-0000), and then detect a failure with WEB.</p>	Failure must be detected with WEB.

*1 : Slowly blinking

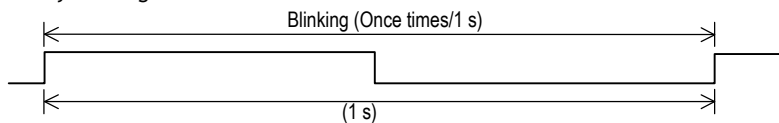

(○ : On ✧ : Blinking × : Off — : Not depend)

No	LEDs						State of unit	Actions to take	Failure
	Basic Chassis				Additional Chassis				
	ALARM (red)	WARNING (orange)	READY (green)	POWER (green)	POWER (green)	LOCATE (orange)			
6	○	×	×	○	—	—	A failure occurred during self-test at time when power is turned on.	Check LED indication of Control Unit. (Refer to "8.2 (5) Trouble analysis based on LED indication of Control Unit" (TRBL 08-0190).)	Parts failure. (Basic Chassis)
7	×	○	○	○	○	×	A failure which does not stop operation occurred in Basic Chassis.	Check LED indication of each Basic Chassis part. (Refer to "8.2 Trouble Analysis by LED Indication of Each Part" (TRBL 08-0150)).	Parts error. (Basic Chassis)
						○	A failure which does not stop operation occurred in Additional Chassis. (*1)		
8	×	✧(*2) (Slowly blinking)	○	○	—	—	A failure which does not stop operation occurred in unit (It must be detected with WEB).	Proceed to "Chapter 3. Before Starting WEB Connection" (TRBL 03-0000), and then detect a failure with WEB.	Failure must be detected with WEB.
9	○	✧(*2) (Slowly blinking)	×	○	—	—	A failure which does not stop operation occurred in unit.	Proceed to "Chapter 3. Before Starting WEB Connection" (TRBL 03-0000), and then detect a failure with WEB.	Failure must be detected with WEB.
10	—	✧(*3) (Fast blinking)	—	—	—	—	Latest revision maintenance function of flash program is executed.	Wait until fast blinking stops.	No error.

*1 : Under the following conditions, Additional Chassis WARNING LED could not light up. However, the each part's ALARM LED or ALM LED lights up. (Excluding the condition (2) below.)

- (1) When the ALM LED of the ENC Unit came on before the subsystem became ready during startup of the subsystem.
- (2) When the ALM LED of the ENC Unit came on and the ENC Unit was pulled out.
- (3) When the failed ENC Unit was replaced and the ALM LED of the ENC Unit came on after that (However, the ALM LED is on immediately after the ENC Unit is inserted. If the ALM LED does not go out after one minute elapses, the replaced ENC Unit should be judged out of order.)

*2 : Slowly blinking

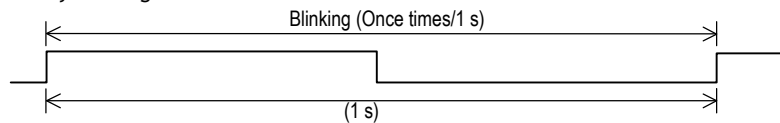

*3 : Fast blinking

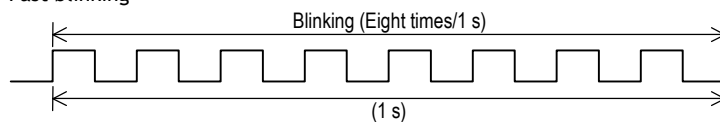

(○ : On ✧ : Blinking × : Off — : Not depend)

No	LEDs						State of unit	Actions to take	Failure
	Basic Chassis				Additional Chassis				
	ALARM (red)	WARNING (orange)	READY (green)	POWER (green)	POWER (green)	LOCATE (orange)			
11	×	✧ ^(*1) (Fast blinking + Slowly blinking)	○	○	—	—	The most recent revision maintenance function of the flash program is being executed, and the failure (it must be detected with WEB), which allows the subsystem to operate, occurs.	Wait until fast blinking stops. Then, proceed to "Chapter 3. Before Starting WEB Connection" (TRBL 03-0000), and detect the failure with WEB.	Failure must be detected with WEB.
12	×	×	✧ ^(*2) (Slowly blinking)	○	—	—	The ENC firmware download or Drive firmware download process is completed.	Restart a device.	—
13	×	○	✧ ^(*2) (Slowly blinking)	○	—	—	The ENC firmware download or Drive firmware download process is terminated abnormally.	Proceed to "Chapter 3. Before Starting WEB Connection" (TRBL 03-0000), and detect a failure with WEB.	Failure must be detected with WEB.
14	×	×	✧ ^(*3) (Fast blinking)	○	—	—	The ENC firmware is being automatic downloaded.	Wait as it is until there is no high-speed blinking (for the maximum of 30 to 50 minutes, but for the maximum of 40 to 60 minutes in case of the RKH).	—
15	×	○	×	×	—	—	A fan failure of the basic chassis occurs in the status that the main Power Unit is OFF.	<ul style="list-style-type: none"> In case of the RKM/RKS, replace the Power Unit whose ALM LED is on. In case of the RKH, replace the FAN Unit whose ALM LED is on. 	Parts error. (Basic Chassis)
16	×	—	×	×	×	○	A fan failure of the additional chassis occurs in the status that the main Power Unit is OFF.	Replace the Power Unit whose ALM LED is on.	Parts error. (Additional Chassis)
17 (*3)	—	—	—	—	—	○	When adding the chassis with the power turned on, it indicates the addition source.	Recovery operation is unnecessary.	—

*1 : Fast blinking + Slowly blinking

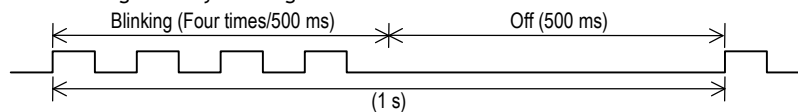

*2 : Slowly blinking

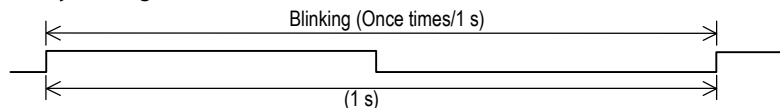

*3 : Fast blinking

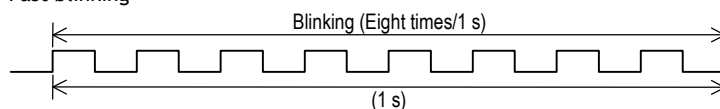

*3 : This is not a failure status.

(3) Trouble analysis by the indication of the POWER LED

Analyze the cause of the POWER LED failure following the flowchart.

(a) Trouble analysis on the indication on the POWER LED of Basic Chassis. (When the POWER LED is not on)

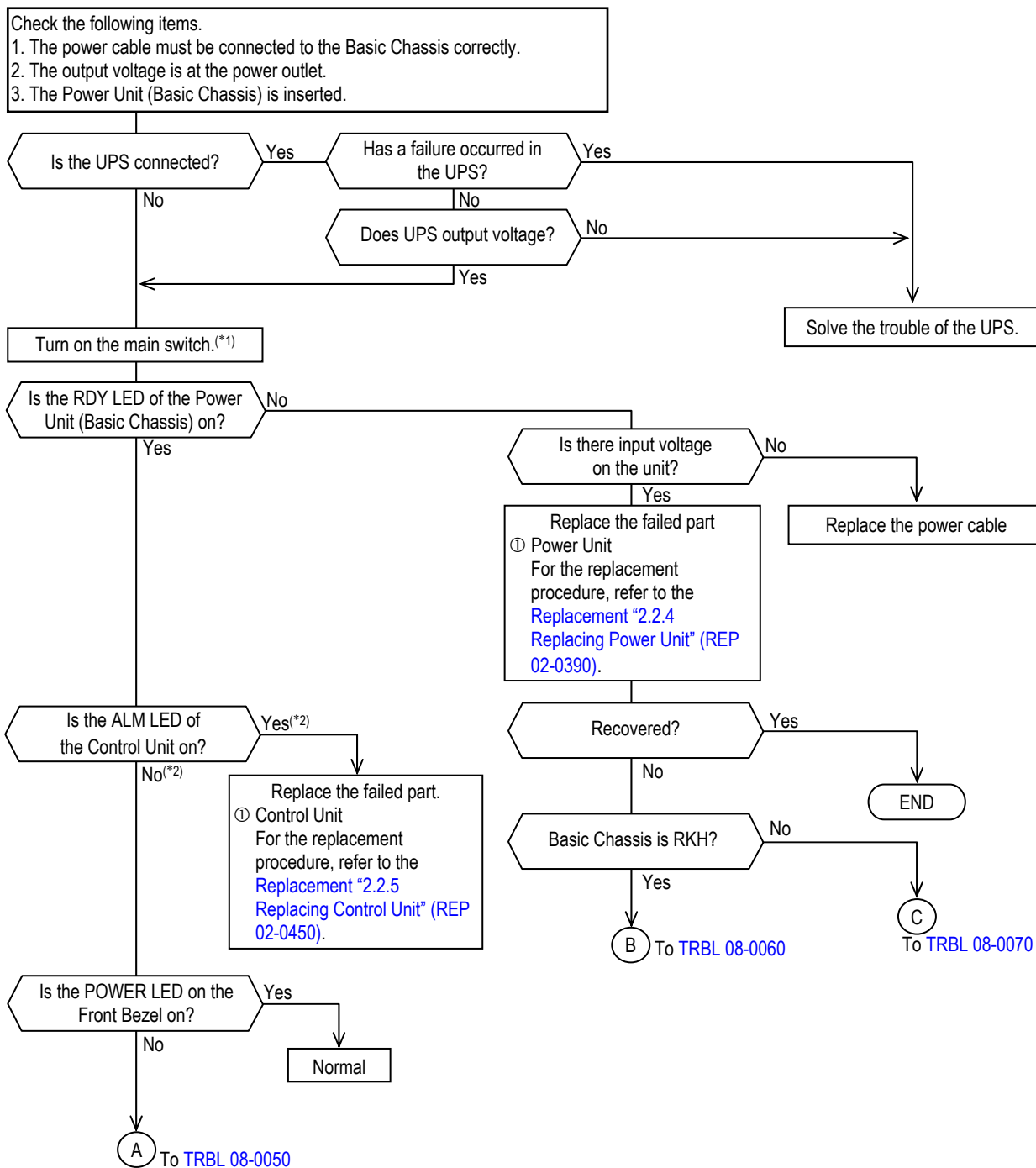

*1 : This operation is not needed when the main switch have already been turned on.

*2 : The ALM LED (red) of the Control Unit is on until the subsystem becomes ready, however, this does not mean that the Control Unit is faulty. If the ALM LED (red) does not go out after the subsystem has become ready, replace the Control Unit.

From TRBL 08-0040

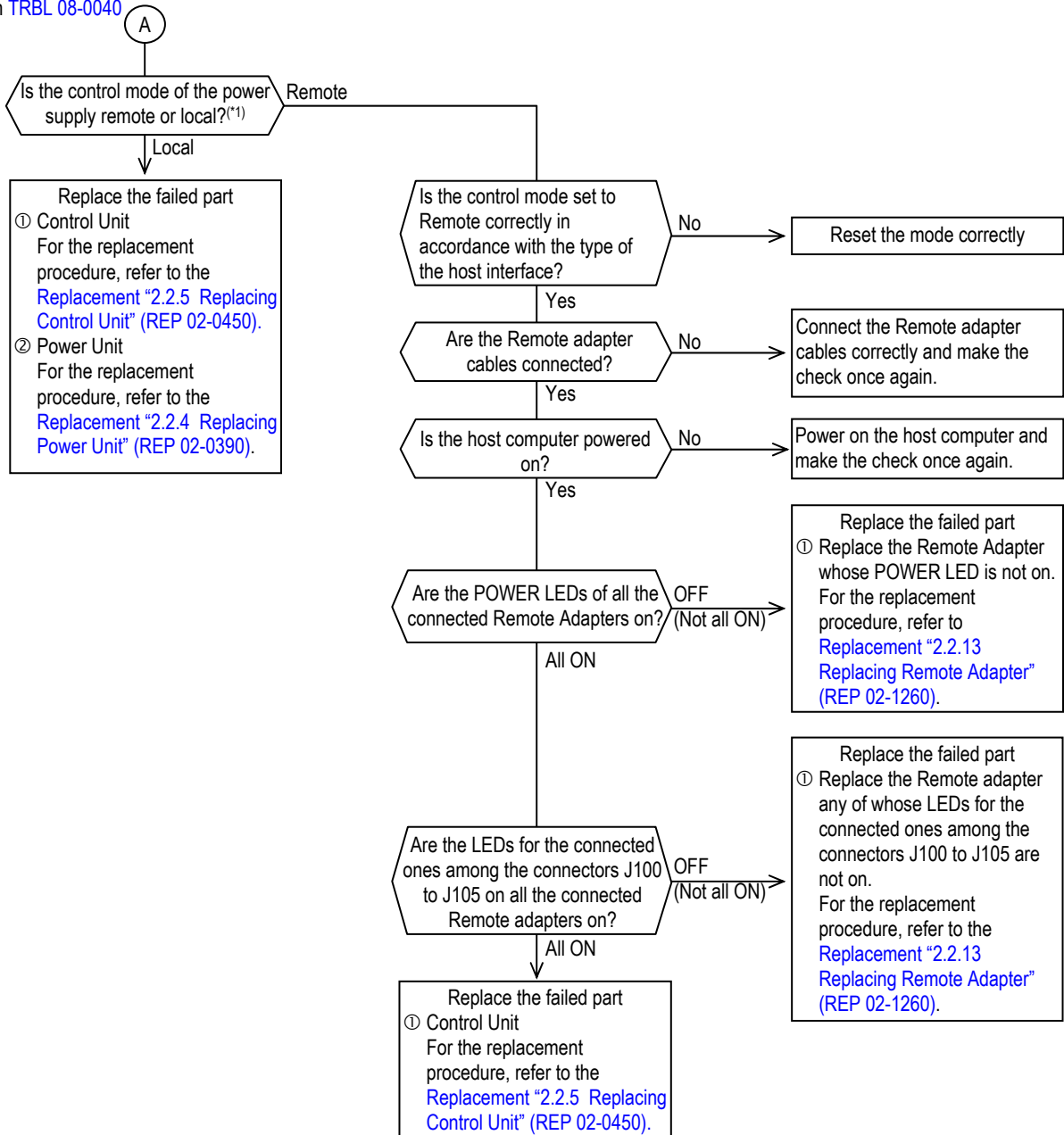

*1 : For checking of Setting the Power Control Mode, refer to Installation "1.6 Setting the Power Control Mode (Local/Remote Mode)" (INST 01-0170).

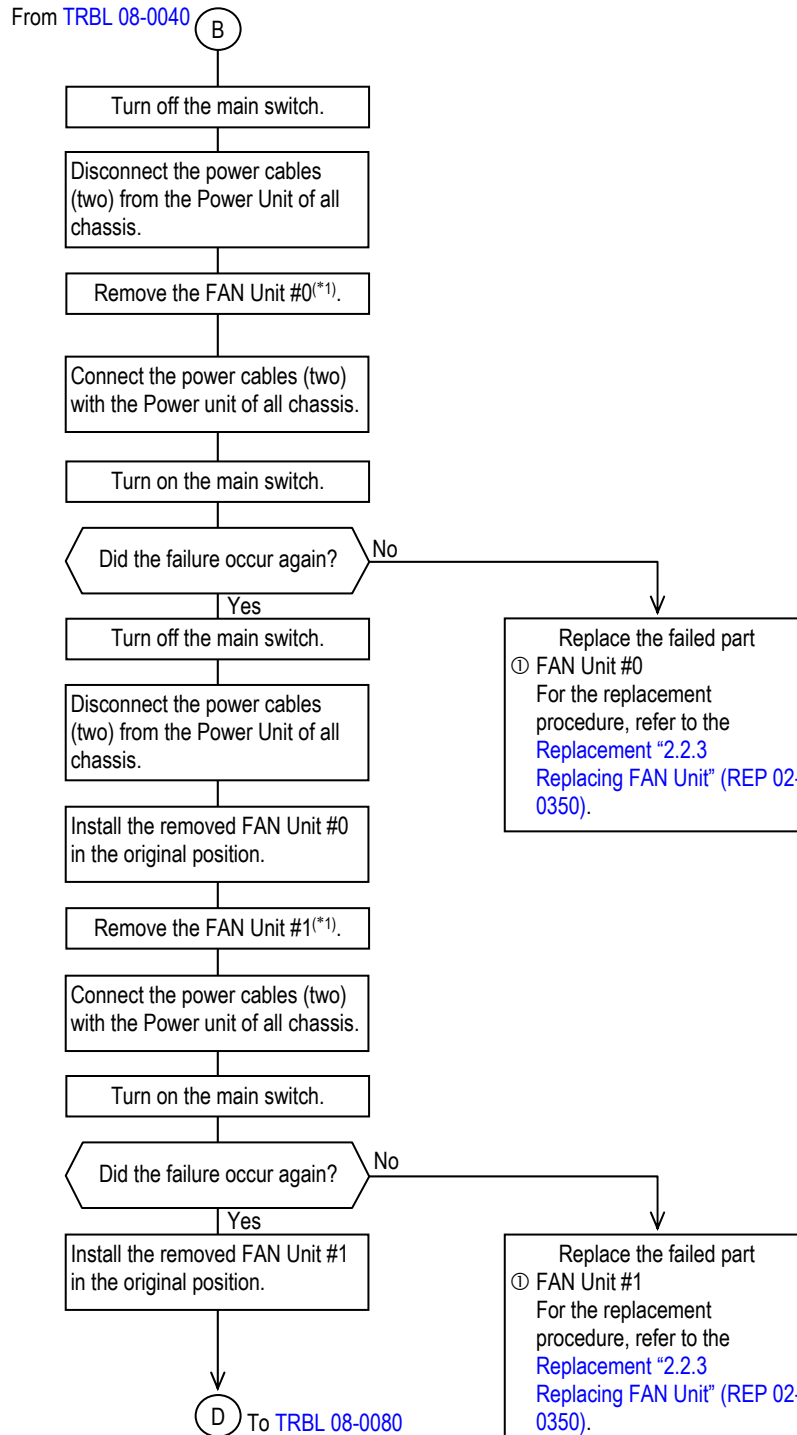

*1 : If leaving it as this part removed for 10 or more minutes, the thermal alarm is detected and the subsystem stops. Check the condition within 10 minutes and turn off the power supply.

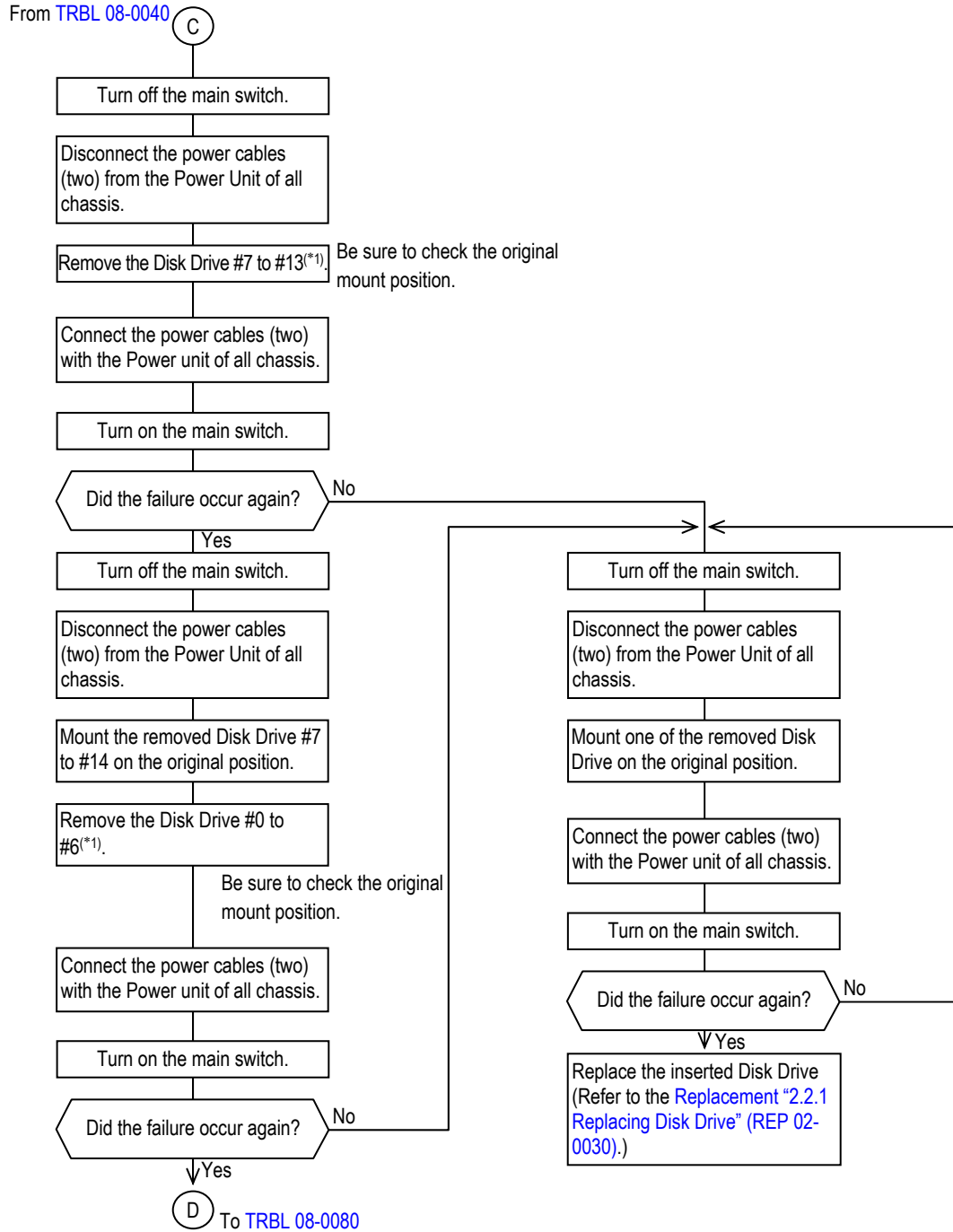

*1 : If leaving it as this part removed for 10 or more minutes, the thermal alarm is detected and the subsystem stops. Check the condition within 10 minutes and turn off the power supply.

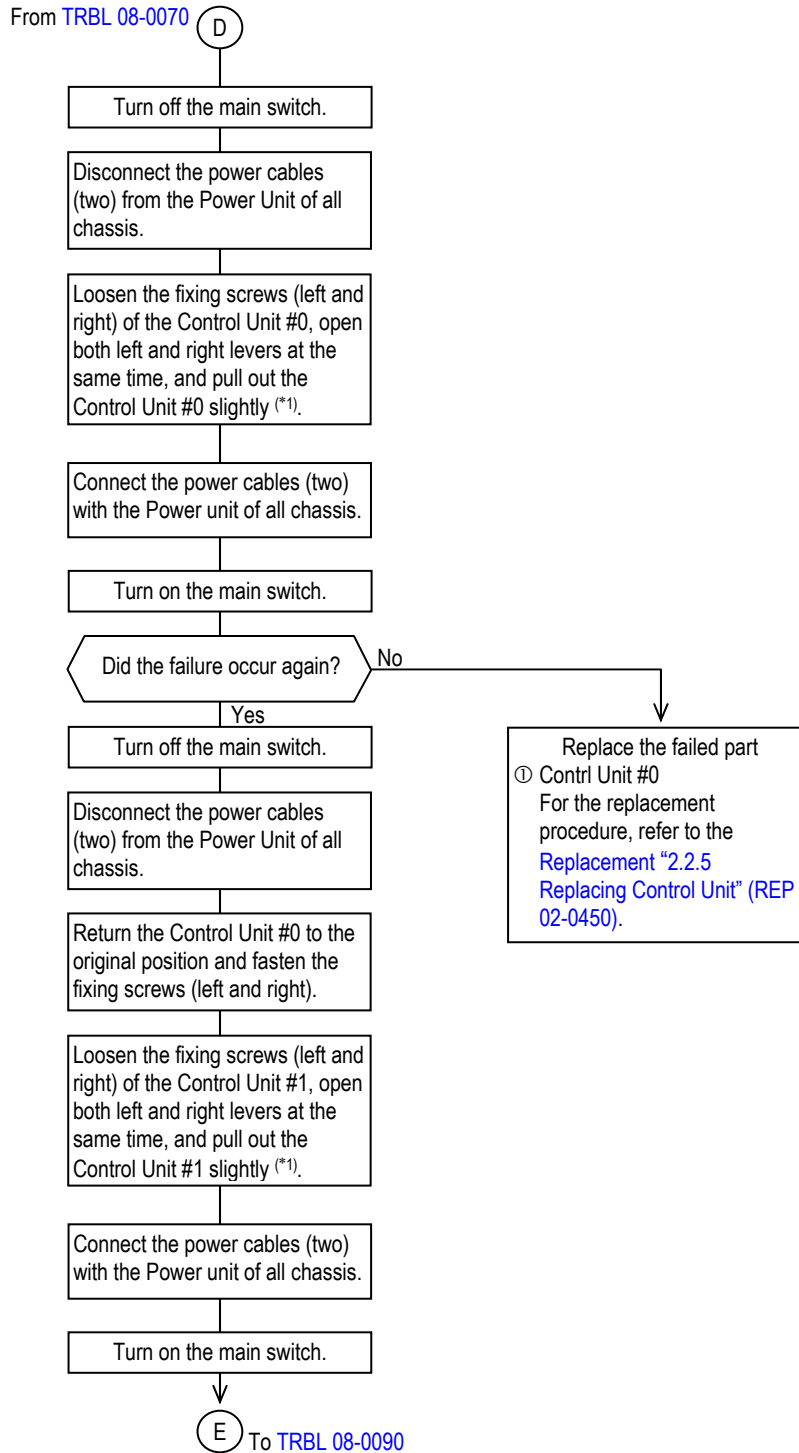

*1 : If leaving it as this part removed for 10 or more minutes, the thermal alarm is detected and the subsystem stops. Check the condition within 10 minutes and turn off the power supply.

From TRBL 08-0080

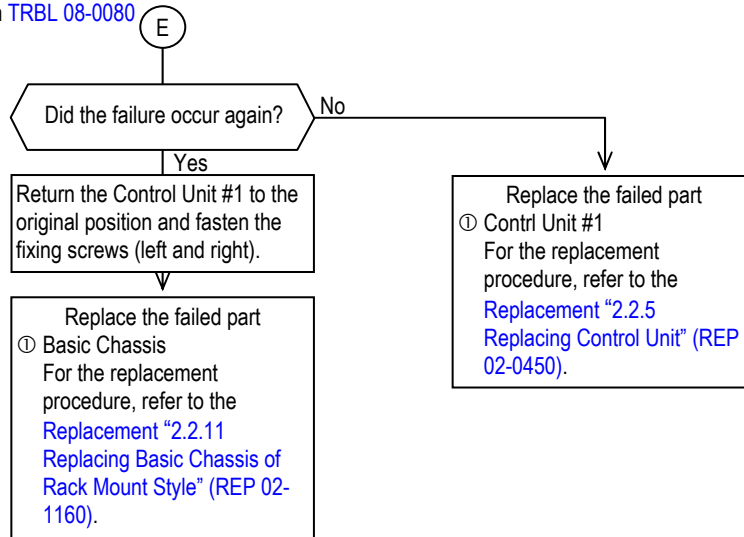

(b) Trouble analysis on the indication on the POWER LED of Additional Chassis. (Not POWER LED on)

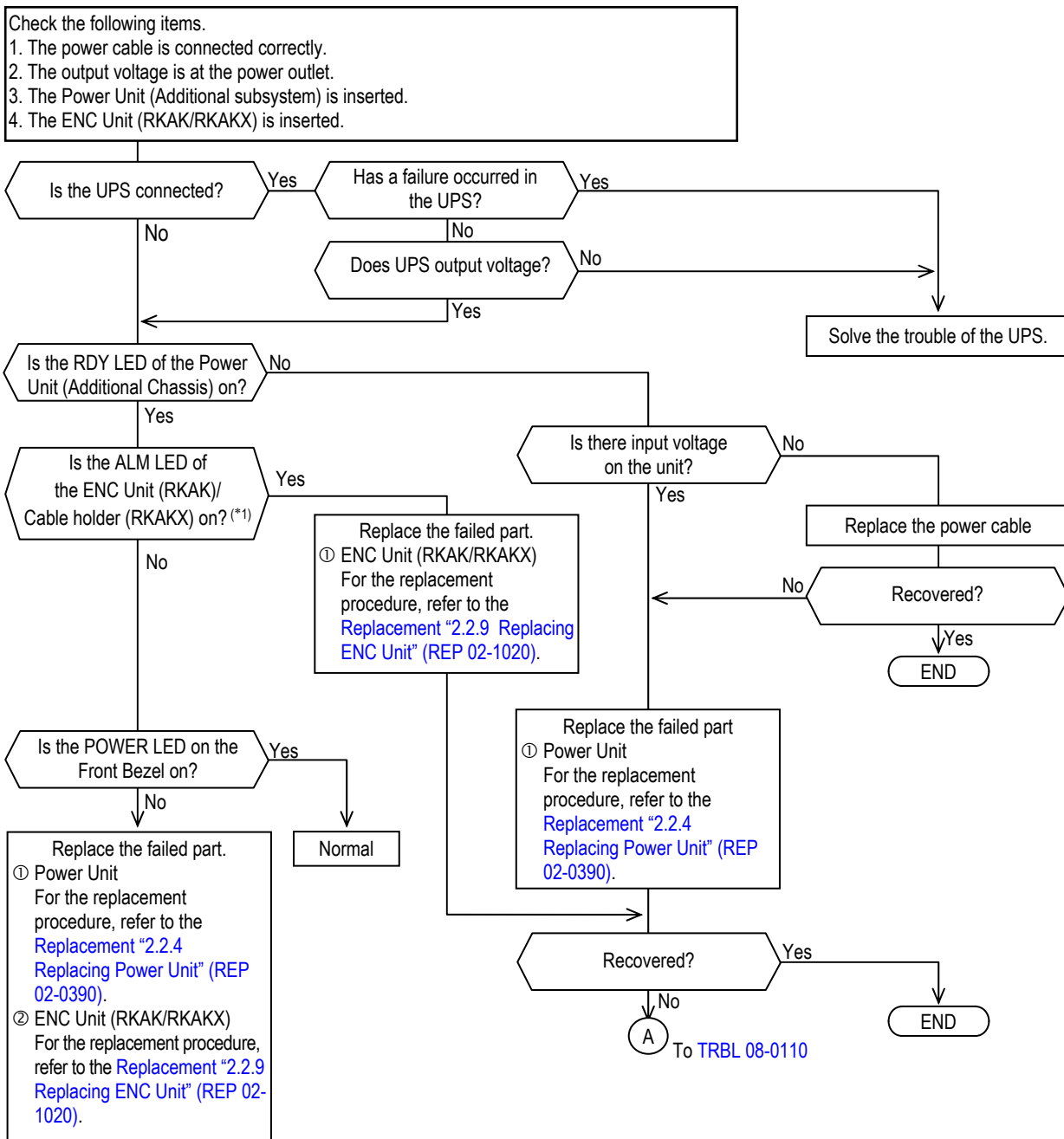

*1 : The ALM LED of the ENC Unit is on until the subsystem becomes ready, however, this does not mean that the ENC Unit is faulty. If the ALM LED of the subsystem which has become ready does not go out, replace the ENC Unit.

From TRBL 08-0100

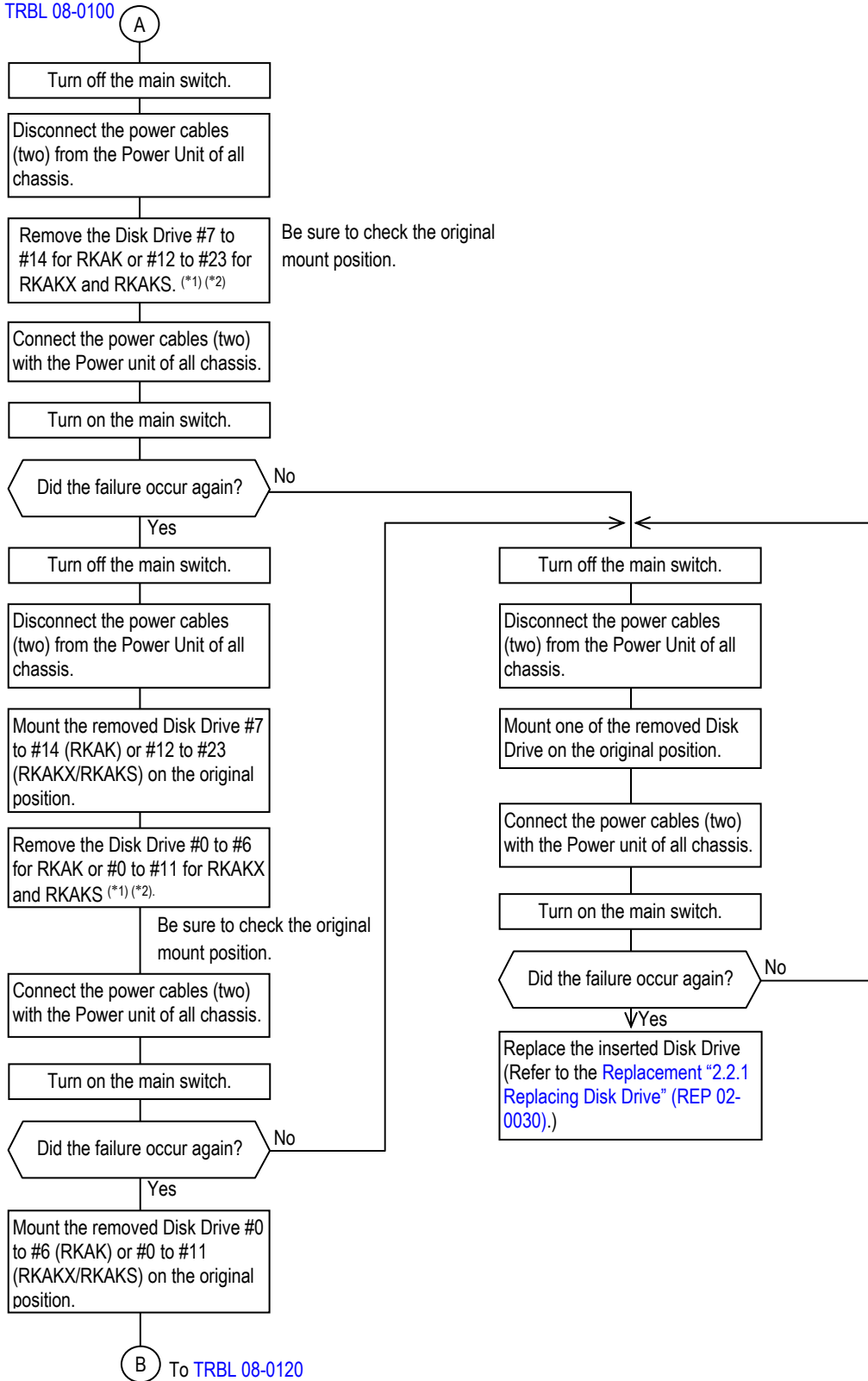

*1 : Additional Chassis of Disk Drive nearest to Basic Chassis.

*2 : If leaving it as this part removed for 10 or more minutes, the thermal alarm is detected and the subsystem stops. Check the condition within 10 minutes and turn off the power supply.

From TRBL 08-0110

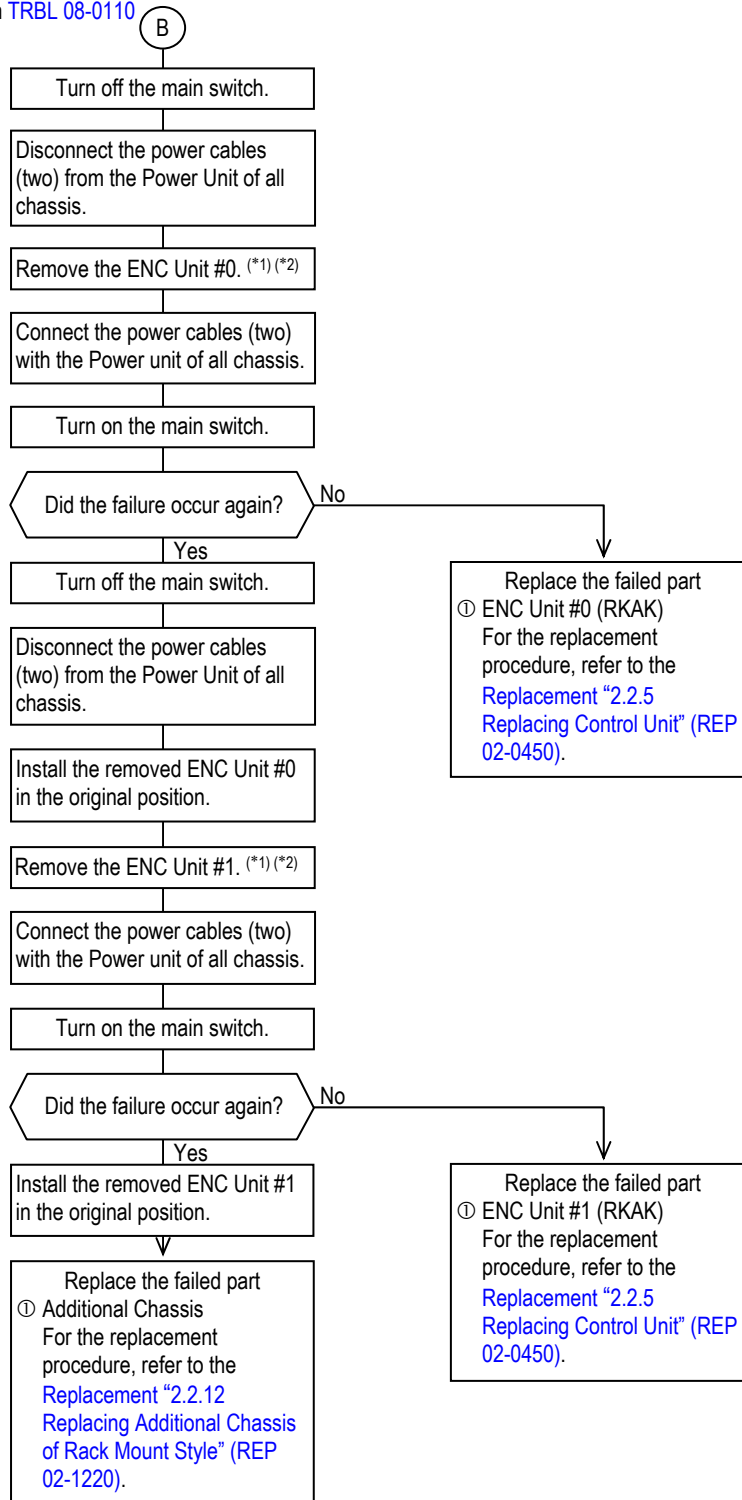

*1 : Additional Chassis of Disk Drive nearest to Basic Chassis.

*2 : If leaving it as this part removed for 10 or more minutes, the thermal alarm is detected and the subsystem stops. Check the condition within 10 minutes and turn off the power supply.

(4) Trouble analysis based on the indication of READY LED (When in the Fibre Channel interface)
Analyze the cause of the READY LED failure following the flowchart.

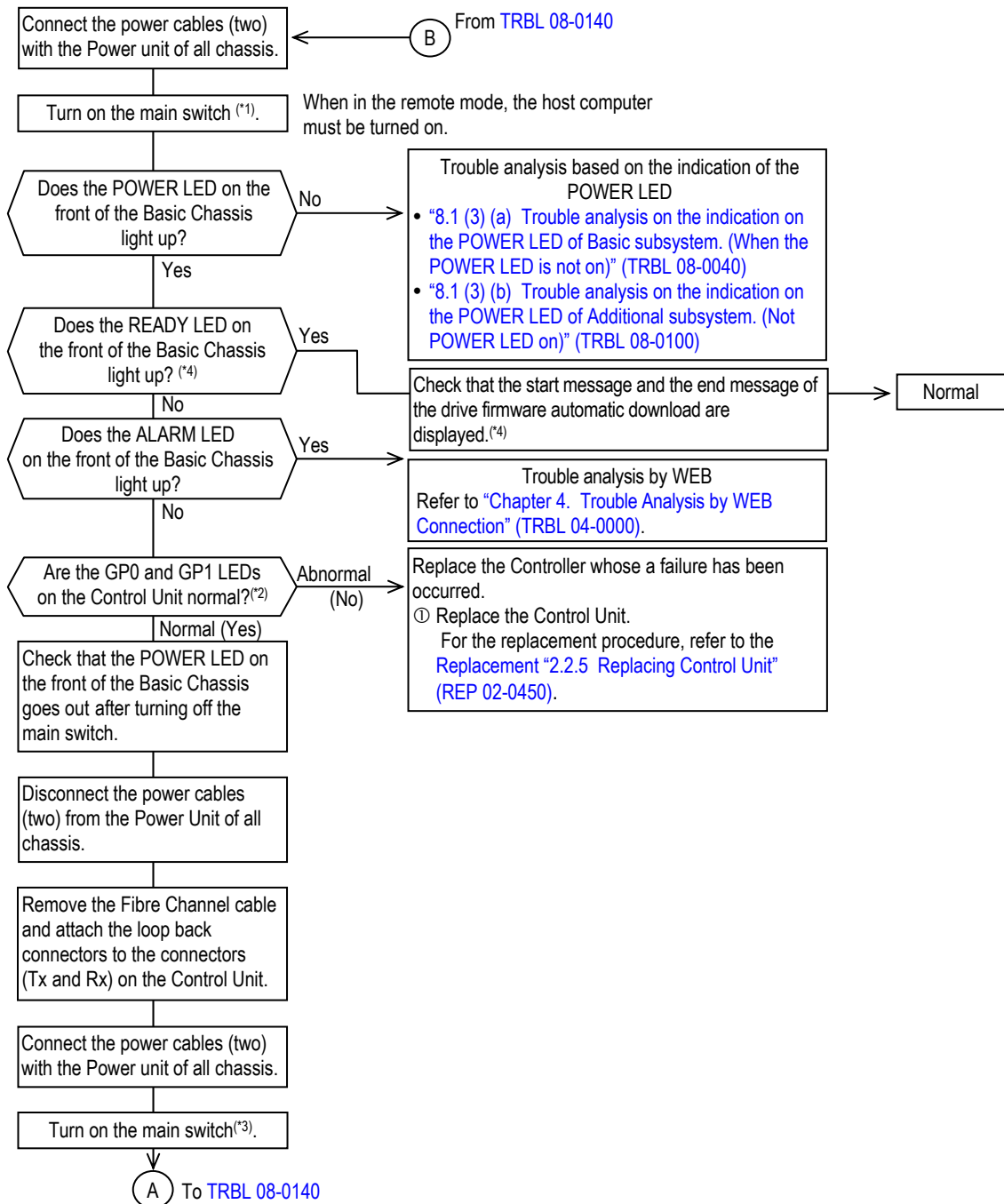

*1 : This operation is not needed when the main switch have already been turned on.

*2 : Refer to "Table 8.2.7 LED Indication Patterns on FC Interface Connector" in "8.2 (5-3) LED Indication Pattern on Control Unit (FC Interface Connector part) (RKEM/RKES/RKEXS/RKEXS8F)" (TRBL 08-0231).

*3 : When the mode is Remote, change it to Local.

*4 : Wait if the READY LED (green) on the front of the Basic Chassis is blinking at high speed (for the maximum of 30 to 50 minutes, or 40 to 60 minutes in case of the RKH), or the WARNING LED (orange) is blinking at high speed (for the maximum of 30 to 85 minutes).

*5 : When the drive firmware version of the disk drive is new, the start message and completion message of the drive firmware automatic download are not displayed. To check the drive firmware automatic download, refer to Firmware "1.6 (4) Checking the start message and end message of the automatic download (FIRM 01-0890)".

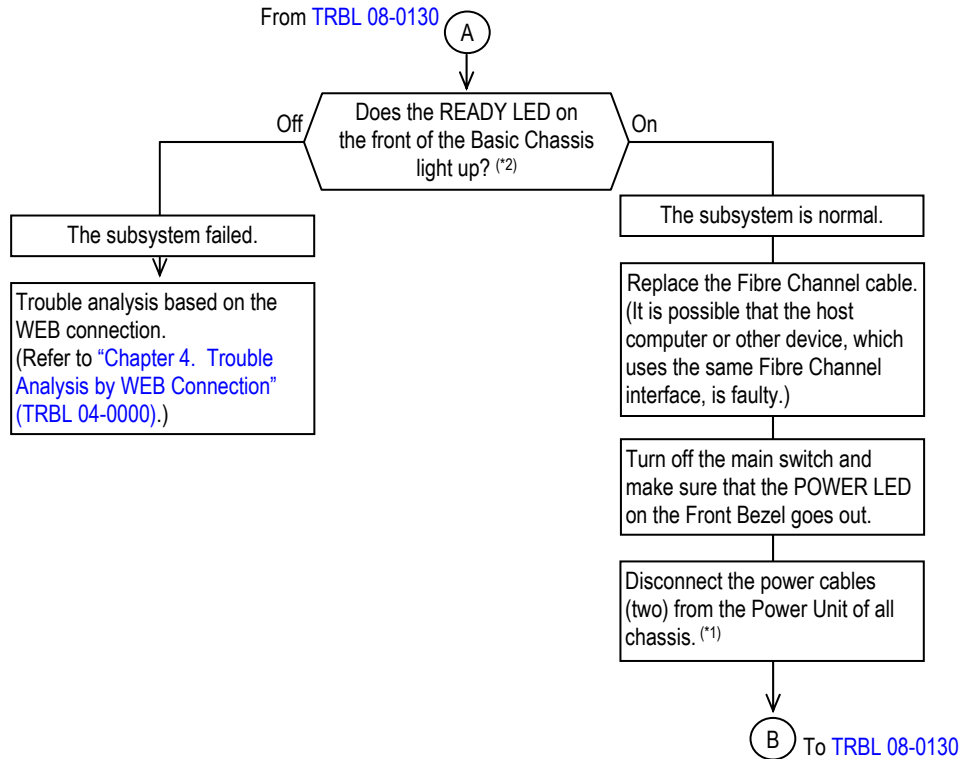

- *1 : Return the Remote/Local setting as it was. It may take three minutes at the longest until the READY LED (green) comes on after the main switch is turned on. For the setting of the Remote/Local mode, refer to the [Installation "1.6 Setting the Power Control Mode \(Local/Remote Mode\)" \(INST 01-0170\)](#).
- *2 : Wait if the READY LED (green) on the front of the Basic Chassis is blinking at high speed (for the maximum of 30 to 50 minutes, or 40 to 60 minutes in case of the RKH), or the WARNING LED (orange) is blinking at high speed (for the maximum of 30 to 85 minutes).

8.2 Trouble Analysis by LED Indication of Each Part

Check whether a failure has occurred in each part or not.

(1) Trouble analysis based on LED indication of Cache Backup Battery

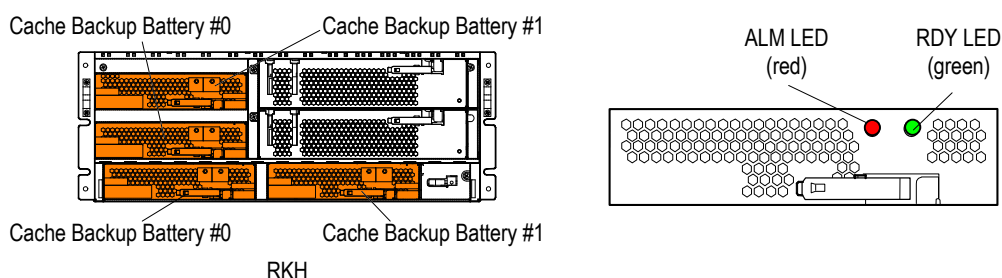
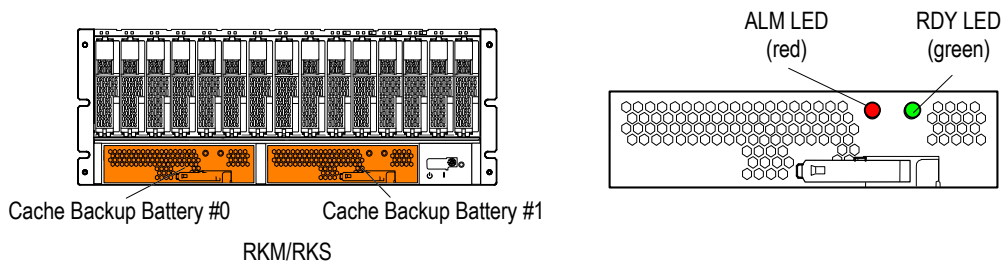

Table 8.2.1 LED Indication Patterns on Cache Backup Battery

(○ : On ◇ : Blinking × : Off — : Not depend)

No.	LEDs		Cause or status	Action(s) to be taken	Reference page
	ALM (red)	RDY (green)			
1 (*1)	×	○	Normal. (Full charge)	Recovery operation is unnecessary	—
2 (*2)	×	◇(*4)	Not Full charge.		
3	—	◇(*5)	1. Battery voltage is abnormal. 2. Battery temperature abnormal. 3. The Cache Backup Battery is in the state of the over discharge.	Replace the Cache Backup Battery.	Replacement "2.2.2 Replacing Cache Backup Battery" (REP 02-0280)
4	○(*3)	—	Logic part control error in the Cache Backup Battery.		

*1 : The Backup time is Guaranteed in the state of 1.

*2 : This is not a failure status.

*3 : If the ALM LED on the Cache Backup Battery lights on, be sure to replace the Cache Backup Battery (it cannot be recharged).

*4 : Indication of status with LED.

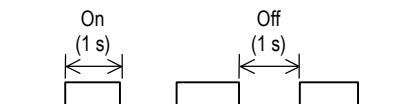

*5 : Indication of status with LED.

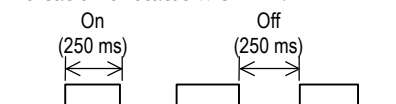

(2) Trouble analysis based on LED indication of Disk Drive

(2-1) Disk Drive for the RKM/RKS/RKAK

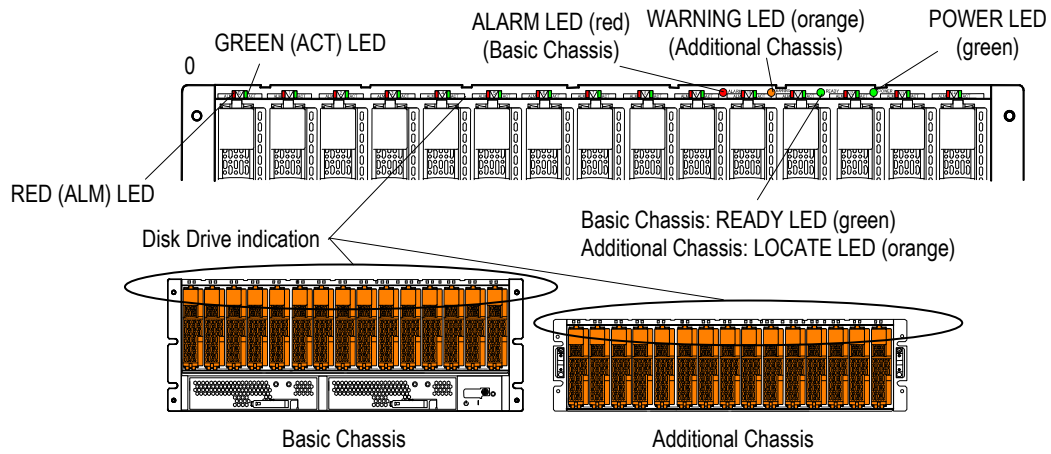

Table 8.2.2 LED Indication Patterns on Disk Drive

(○ : On ◇ : Blinking × : Off — : Not depend)

No.	LEDs		Cause or status	Action(s) to be taken	Reference page
	Green (ACT)	Red (ALM)			
1 (*1)	◇	—	SAS/SAS(SED)/SATA : The Disk Drive is being accessed. SAS/SAS(SED) : The Disk Drive is being spun up.	This is not a problem.	—
2 (*1)	○	×	SAS/SAS(SED) : Completed spin up. SATA : Power on.	This is not a problem.	—
3 (*1)	×	—	SAS/SAS(SED) : Spin down state. SATA : Power off.	This is not a problem.	—
4	—	○	A failure that makes the Disk Drive of lighting LED unable to operate occurred in it.	1. When the WARNING LED (orange) of Basic Chassis is blinking, refer to the LOG Message by WEB connection, and check the backup status to the Spare Disk. (*2). 2. Replace the Disk Drive.	Replacement "2.2.1 Replacing Disk Drive" (REP 02-0030)

*1 : This is not a failure status.

*2 : In the case of the recovery failure to the Spare Disk Drive, the recovery failure to the replacement Disk Drive, or the write incomplete recovery, the WARNING LED (orange) on the front of the Basic Chassis blinks. The WARNING LED (orange) on the front of the Basic Chassis lights up referring to the log message on WEB.

*3 : ACT LED indication of the SAS/SAS(SED) Disk Drive and the SATA Disk Drive.

Power	OFF	ON				OFF	ON
Spin Up/Down	Down	Up		Down		Up	
Being Spin Up/Access		Up	Access	Access		Up	
ACT LED SAS/SAS(SED)	OFF	Blinking	ON/Blinking	OFF/Blinking	OFF	Blinking ON/Blinking	
ACT LED SATA	OFF		ON/Blinking	OFF/Blinking	OFF	ON/Blinking	

(2-2) Disk Drive for the RKAKX

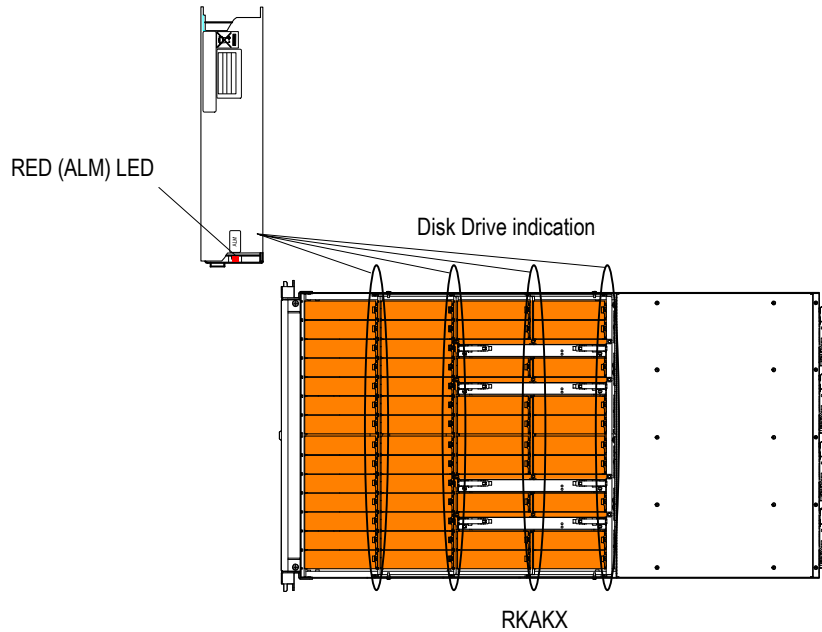

Table 8.2.2.1 LED Indication Patterns on Disk Drive

(○ : On ⇨ : Blinking × : Off — : Not depend)

No.	LEDs	Cause or status	Action(s) to be taken	Reference page
	Red (ALM)			
1	○	A failure that makes the Disk Drive of lighting LED unable to operate occurred in it.	1. When the WARNING LED (orange) of Basic Chassis is blinking, refer to the LOG Message by WEB connection, and check the backup status to the Spare Disk. ^(*) 2. Replace the Disk Drive.	Replacement "2.2.1 Replacing Disk Drive" (REP 02-0030)

*1 : In the case of the recovery failure to the Spare Disk Drive, the recovery failure to the replacement Disk Drive, or the write incomplete recovery, the WARNING LED (orange) on the front of the Basic Chassis blinks. The WARNING LED (orange) on the front of the Basic Chassis lights up referring to the log message on WEB.

(2-3) Disk Drive for the RKAKS

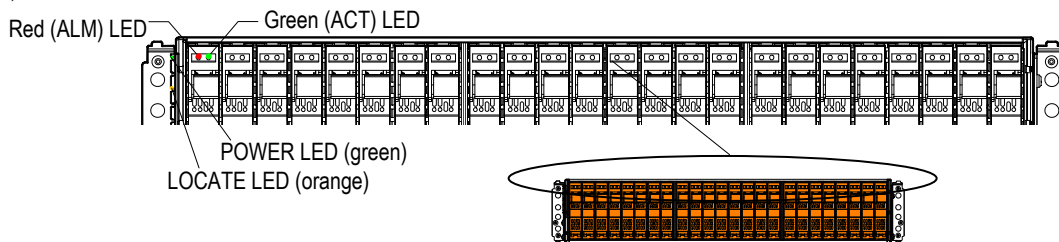

Table 8.2.2 LED Indication Patterns on Disk Drive

(○ : On ◇ : Blinking × : Off — : Not depend)

No.	LEDs		Cause or status	Action(s) to be taken	Reference page
	Green (ACT)	Red (ALM)			
1 (*1)	◇	—	SAS : The Disk Drive is being accessed. SAS : The Disk Drive is being spun up.	This is not a problem.	—
2 (*1)	○	×	SAS : Completed spin up.	This is not a problem.	—
3 (*1)	×	—	SAS : Spin down state.	This is not a problem.	—
4	—	○	A failure that makes the Disk Drive of lighting LED unable to operate occurred in it.	1. When the WARNING LED (orange) of Basic Chassis is blinking, refer to the LOG Message by WEB connection, and check the backup status to the Spare Disk.(*2). 2. Replace the Disk Drive.	Replacement "2.2.1 Replacing Disk Drive" (REP 02-0030)

*1 : This is not a failure status.

*2 : In the case of the recovery failure to the Spare Disk Drive, the recovery failure to the replacement Disk Drive, or the write incomplete recovery, the WARNING LED (orange) on the front of the Basic Chassis blinks. The WARNING LED (orange) on the front of the Basic Chassis lights up referring to the log message on WEB.

*3 : ACT LED indication of the SAS Disk Drive.

Power	OFF	ON		OFF	ON
Spin Up/Down	Down	Up	Down		Up
Being Spin Up/Access		Up	Access	Access	Up
ACT LED SAS	OFF	Blinking	ON/Blinking	OFF/Blinking	OFF
					Blinking ON/Blinking

(3) Trouble analysis based on LED indication of Power Unit

(a) Power Unit

NOTE : When the RDY LED (green) is off, it shows that a failure has occurred even if the fan rotating.

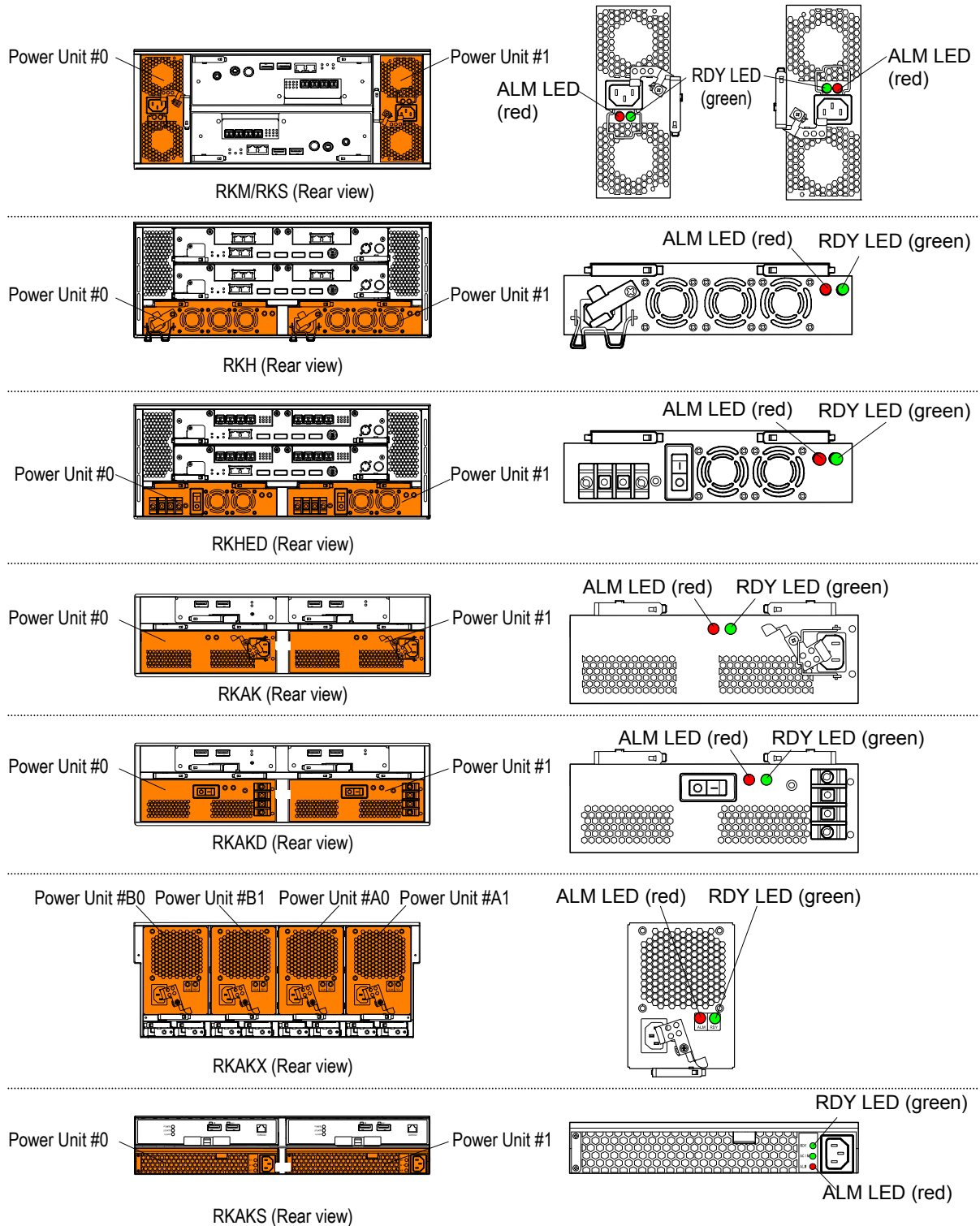

Table 8.2.3 LED Indication Patterns on Power Unit

(○ : On ✧ : Blinking × : Off — : Not depend)

No.	LEDs		Cause or status	Action(s) to be taken	Reference page
	RDY (green)	ALM (red)			
1 (*1)	○	×	This shows the normal operation of the Power Unit.	This is not a problem.	—
2	×	×	In resting.	Check the connection of the power cable. 1. If the RDY LED (green) is kept off, replace the Power Unit.	Replacement "2.2.4 Replacing Power Unit" (REP 02-0390)
3	×	○	In trouble.	Replace the Power Unit.	Replacement "2.2.4 Replacing Power Unit" (REP 02-0390)
4	○	○			

*1 : This is not a failure status.

This page is for editorial purpose only.

(4) Trouble analysis based on LED indication of FAN Unit

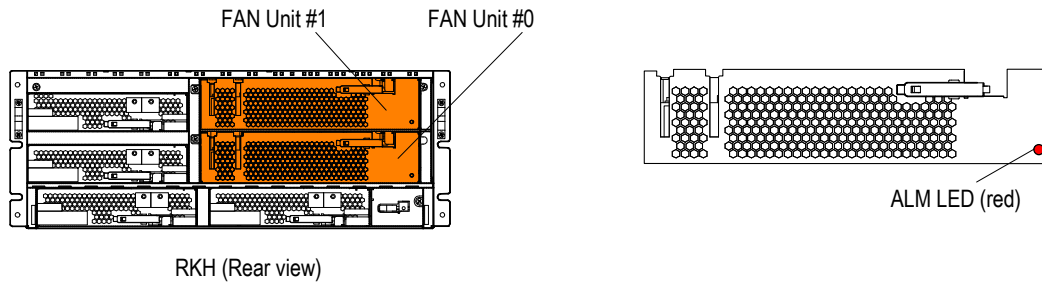

NOTE : While the ALM LED of a FAN Unit is on, when a Control Unit has been blocked (the ALM LED (red) is on), be sure to correct the Control Unit blockade failure first.

Table 8.2.4 LED Indication Patterns on FAN Unit

(○ : On ⇨ : Blinking × : Off — : Not depend)

No.	LED	Cause or status	Action(s) to be taken	Reference age
	ALM (red)			
1 (*1)	×	This shows that the FAN Units are normal.	This is not a problem.	—
2	○	This shows that there is a trouble in the FAN Units.	Replace the FAN Unit.	Replacement "2.2.3 Replacing FAN Unit" (REP 02-0350)

*1 : This is not a failure status.

(5) Trouble analysis based on LED indication of Control Unit
 (5-1) LED Indication Pattern on Control Unit (Cache memory, CPU, LAN)
 (RKM/RKEM/RKS/RKES/RKEXS/RKEXS8F/RKH)

NOTE : If all the LEDs on the Control Unit are turned off, connect to WEB (Refer to “Chapter 3. Before Starting WEB Connection” (TRBL 03-0000)) and check if the control unit is blocked. If the Control Unit is blocked, replace the blocked Control Unit. (Refer to the Replacement “2.2.5 Replacing Control Unit” (REP 02-0450).)

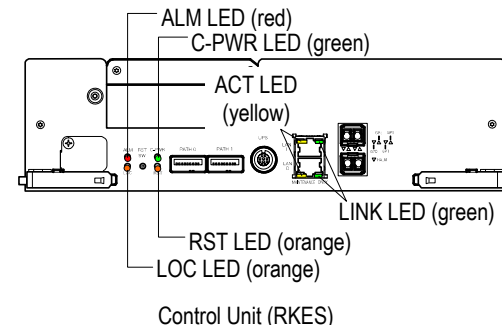
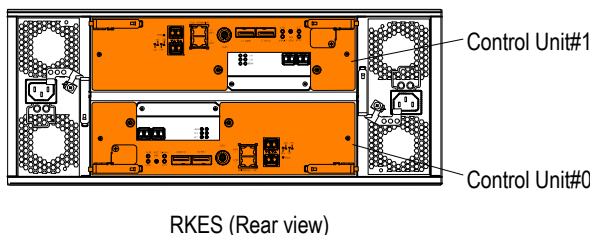
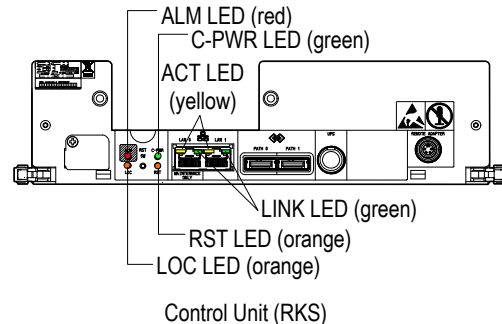
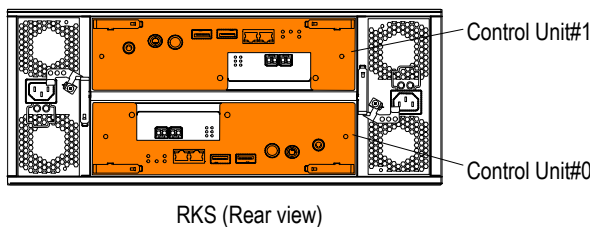
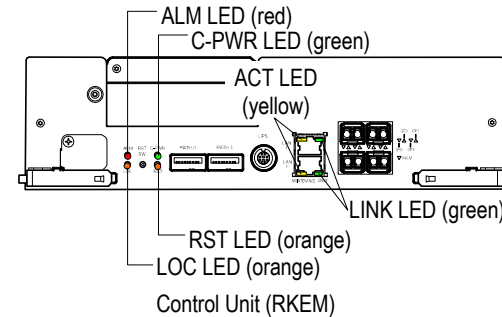
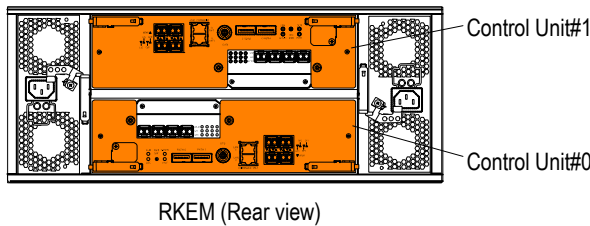
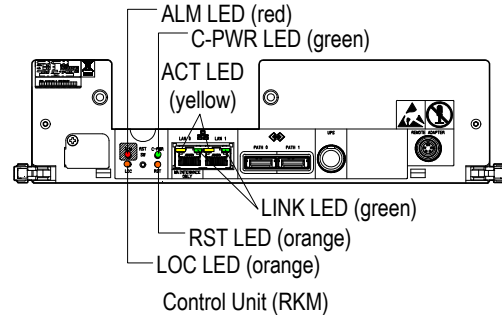
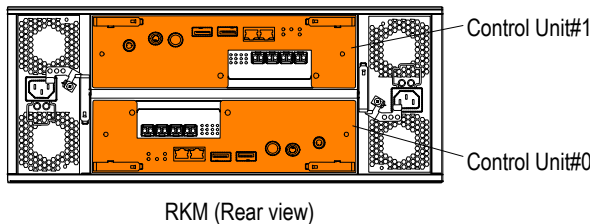

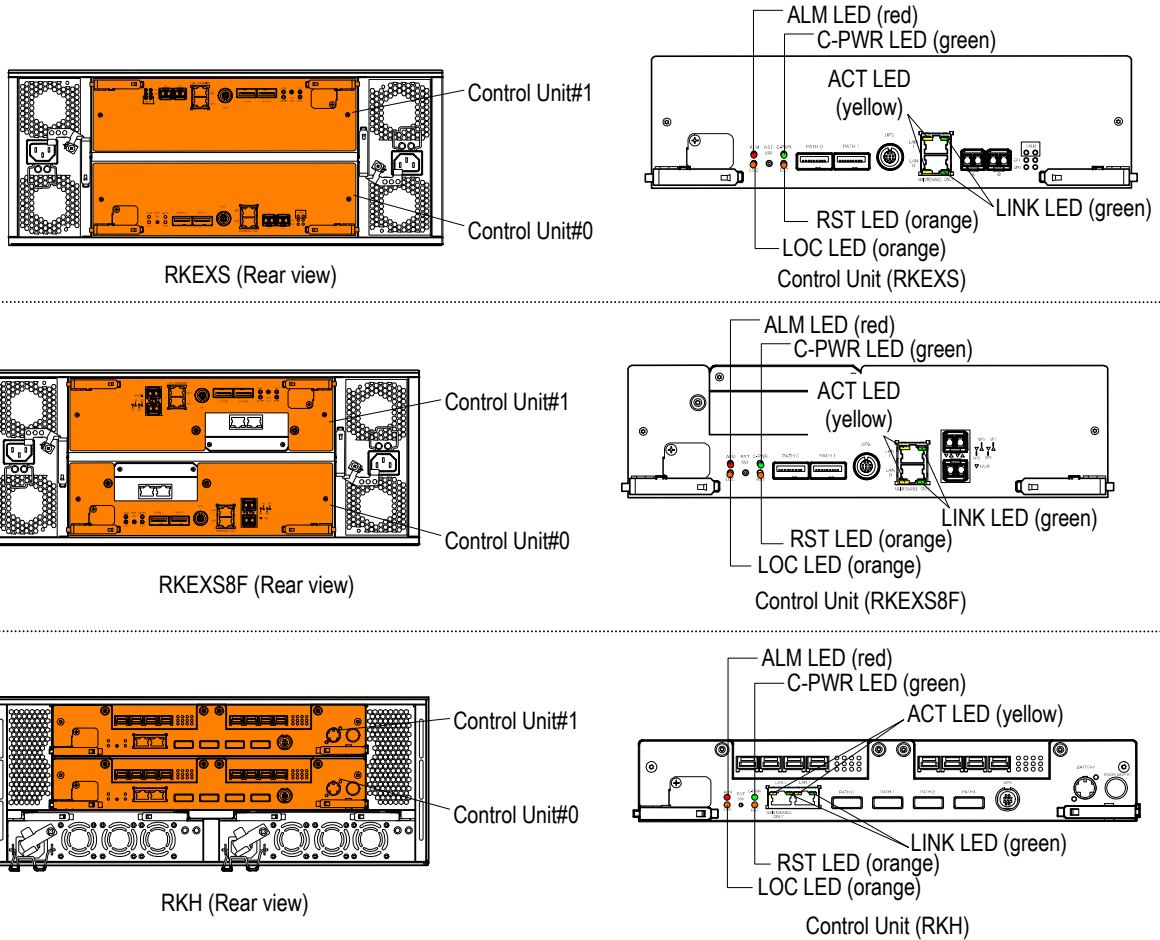

Table 8.2.5 LED Indication Pattern-1 on Control Unit

(○ : On ✧ : Blinking × : Off — : Not depend)

No.	LEDs					Cause or status	Action(s) to be taken	Reference page
	C-PWR (green)	ALM (red)	RST (orange)	LINK (green)	ACT (yellow)			
1 (*1)	○	—	—	—	—	It is shown that the Cache memory is being backed up because a sequential shutdown was not executed normally.	Cancel the cache backing up.(Refer to the procedure for canceling the backing up of the Cache memory on page.)	Replacement "1.1.2 Checking Cache Memory in the Back-up State" (REP 01-0040)
2 (*1)	×	—	—	—	—	This shows that the Cache memory is not being backed up.	This is not a problem.	—
3 (*1)	—	—	○	—	—	The LED comes on when the controller is being reset in the following cases. <ul style="list-style-type: none"> • During power-on reset • During reset for WEB maintenance mode • During reboot process 	This is not a problem.	—

*1 : This is not a failure status.

(○ : On ✧ : Blinking × : Off — : Not depend)

No.	LEDs					Cause or status	Action(s) to be taken	Reference page
	C-PWR (green)	ALM (red)	RST (orange)	LINK (green)	ACT (yellow)			
4	—	—	○	—	—	The LED comes on when the controller is being reset in the following cases. <ul style="list-style-type: none"> • DC-DC converter failure • Reset circuit failure 	Connect it to WEB (Refer to "Chapter 3. Before Starting WEB Connection" (TRBL 03-0000).), and replace the Control Unit if the Control Unit blockade message is displayed. However, this message is not displayed when it is the single controller. Replace the Control Unit concerned.	Replacement "2.2.5 Replacing Control Unit" (REP 02-0450)
5 (*1)	—	—	—	○	—	This shows that the linkage of LAN is normal.	This is not a problem.	—
6 (*1)	—	—	—	—	○	This shows that data is being transferred via LAN.	This is not a problem.	—
7	—	—	—	×	—	The LINK LED does not light on though the iSCSI cable in the active status is connected.	Check the LAN cable. If it is normal, replace the Control Unit.	Replacement "2.2.5 Replacing Control Unit" (REP 02-0450)
8	—	○	—	—	—	A failure that makes the Control Unit unable to operate occurred in it.	① Connect PC to WEB (Refer to "Chapter 3. Before Starting WEB Connection" (TRBL 03-0000).) and check the message, then follow the instruction. <ol style="list-style-type: none"> 1. Replace the Control Unit. 2. If the operation is not recovered, replace the following items in order. Replace the Cache Unit. 	Message "Chapter 1. Before Starting Trouble Analysis" (MSG 01-0000) Replacement "2.2.5 Replacing Control Unit" (REP 02-0450) Replacement "2.2.6 Replacing Cache Unit" (REP 02-0640)

*1 : This is not a failure status.

(5-2) LED Indication Pattern-2 on Control Unit (Power supply, ENC)
 (RKM/RKEM/RKS/RKES/RKEXS/RKEXS8F/RKH)

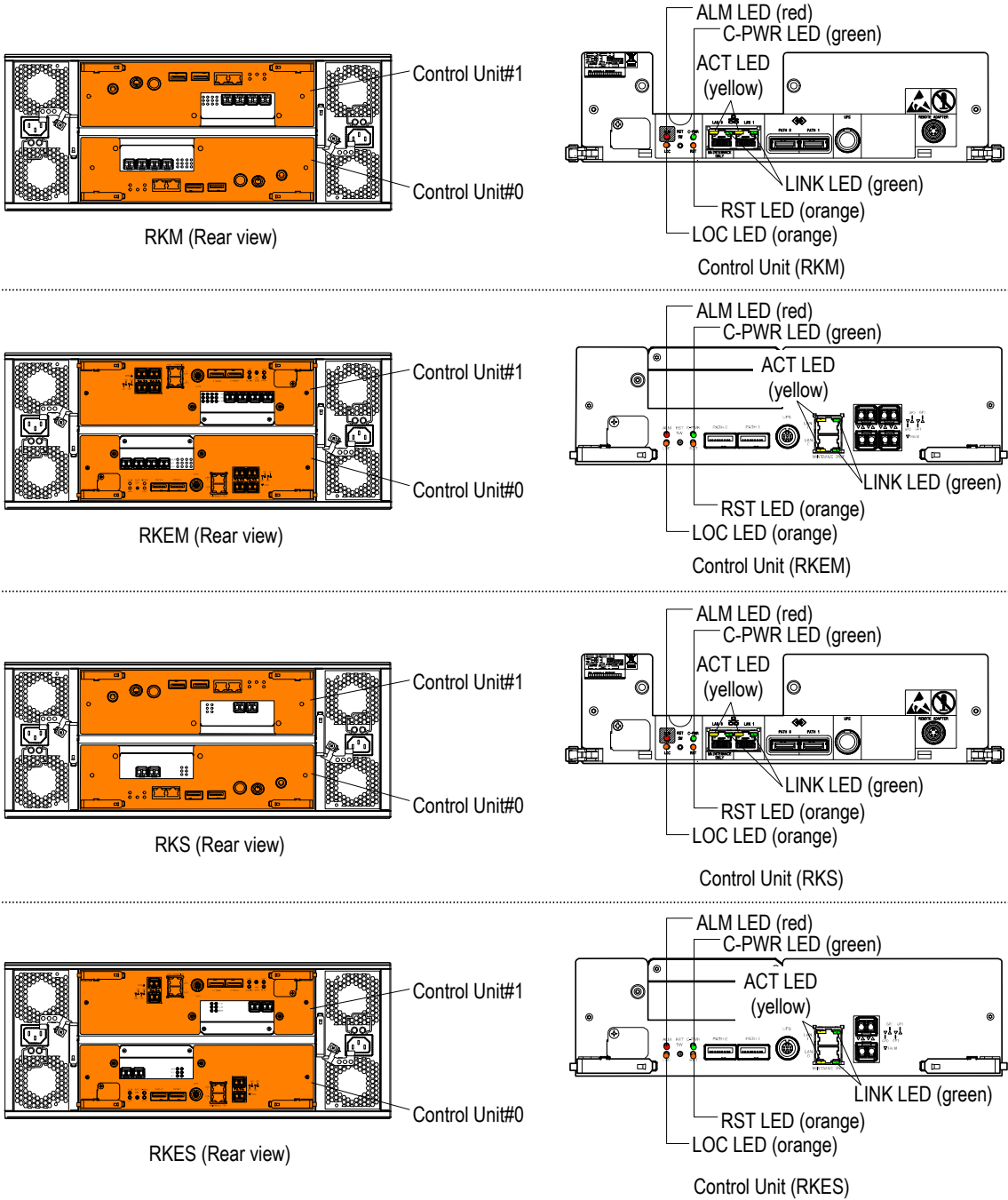

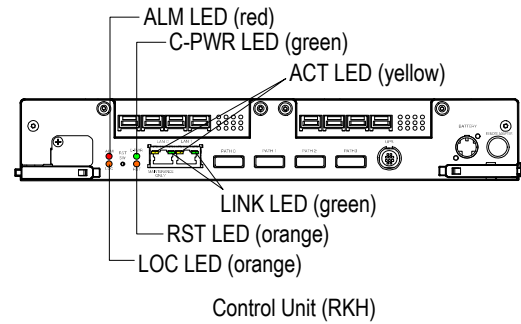
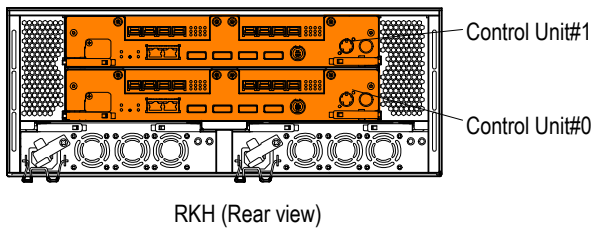
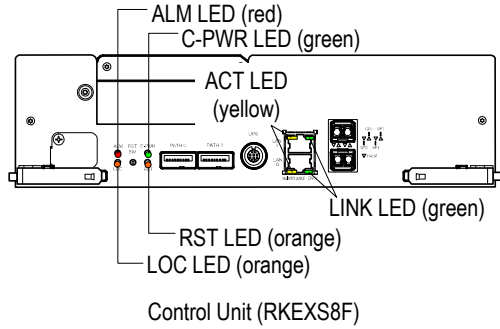
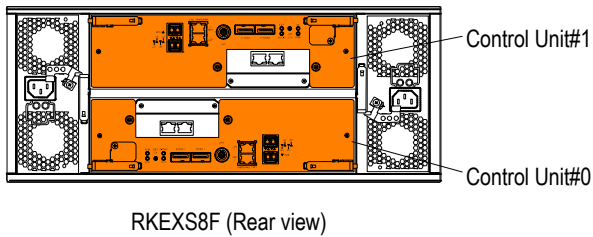
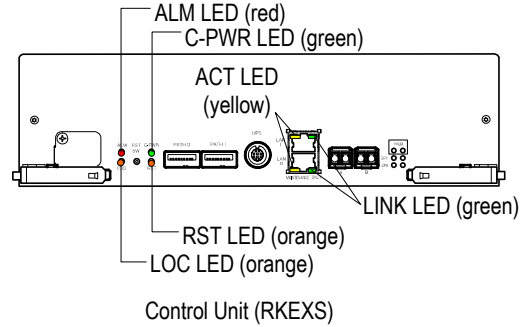
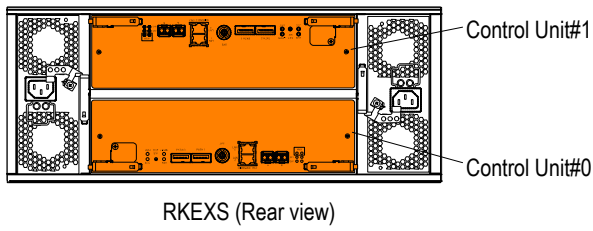

Table 8.2.6 LED Indication Pattern-2 on Control Unit

This page is for editorial purpose only.

(○ : On ◇ : Blinking × : Off — : Not depend)

No.	LEDs LOC (orange)	Cause or status	Action(s) to be taken	Reference page
1	◇ ^(*1) (Six)	Voltage on the controller is abnormal. (Resetting of the Control Unit cannot be cancelled.)	1. Clean it when the air vent of the subsystem is clogged. 2. If there is a thing in front of the Front Bezel, move it. 3. Perform the dummy replacement. ^(*2) 4. When it is not released even if the dummy replacement is performed, replace the Control Unit.	Replacement "Chapter 3. Periodic Maintenance" (REP 03-0000) Replacement "2.2.5 Replacing Control Unit" (REP 02-0450)
2	○	ENC Unit CUDG error is occurred. • ENC firmware (BOOT section) detects CUDG error • ENC firmware detects RAM error	Replace the Control Unit.	Replacement "2.2.5 Replacing Control Unit" (REP 02-0450)
3	◇ ^(*3) (Once)	ENC Unit CUDG error is occurred. • SRAM error		
4	◇ ^(*3) (Twice)	ENC Unit CUDG error is occurred. • ENC Unit error		
5	◇ ^(*3) (Three)	ENC Unit CUDG error is occurred. • Firmware error in flash memory.		
6	◇ ^(*3) (Four)	ENC Unit CUDG error is occurred. • Hard error		
7	○	When adding the chassis with the power turned on, it indicates the addition source (this is not an error).		

*1 : Indication of status with LED.

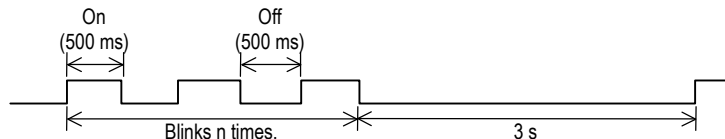

*2 : This means that the part concerned is removed, and it is reinstalled after 20 seconds or more passed.

*3 : Indication of status with LED.

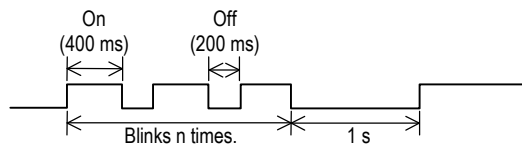

(5-3) LED Indication Pattern on Control Unit (FC Interface Connector part)
(RKEM/RKES/RKEXS/RKEXS8F)

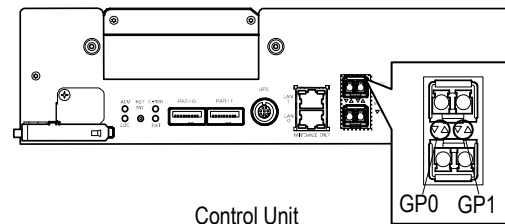
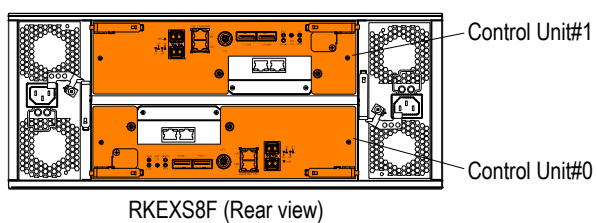
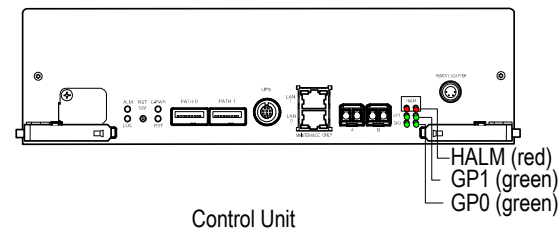
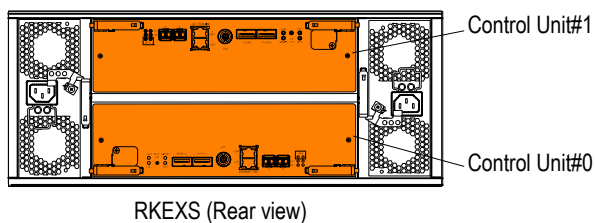
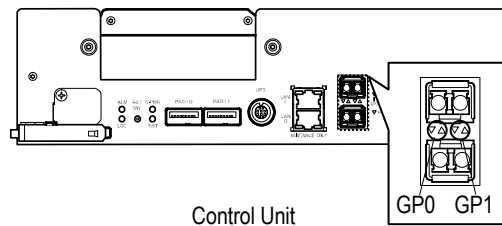
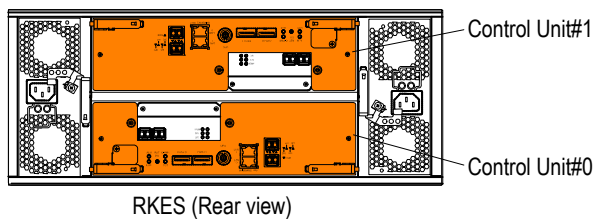
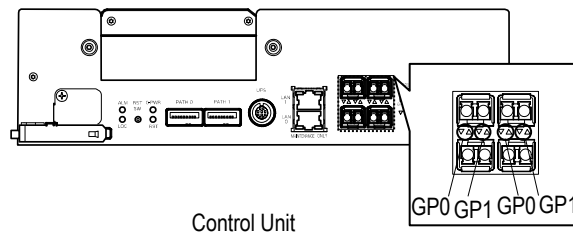
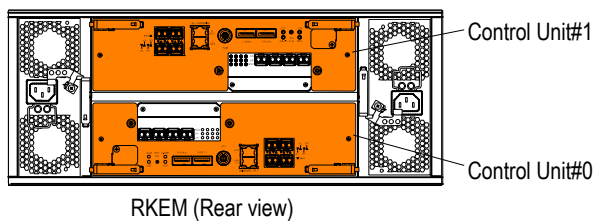

Table 8.2.7 LED Indication Patterns on FC Interface Connector

(○ : On ◇ : Blinking × : Off — : Not depend)

No.	LEDs ^(*1)			Cause or status	Action(s) to be taken	Reference page
	HALM (red)	GP1 (green/Red)	GP0 (green/Red)			
1 (*2)	×	○	○	Link-up state.	This is not a problem.	—

*1 : HALM LED does not exist on the RKEM and RKES.

The GP0 LED and GP1 LED of the RKEM and RKES light/blink in red during the HALM, in all other cases, in green.

*2 : This is not a failure status.

(○ : On ✧ : Blinking × : Off — : Not depend)

No.	LEDs ^(*)			Cause or status	Action(s) to be taken	Reference page
	HALM (red)	GP1 (green)	GP0 (green)			
2 (*2)	×	×	×	<ul style="list-style-type: none"> Interface is in initial state. Interface is in reset state. Loop port is bypassed. 	<p>This is not a problem.</p> <p>It shows the status such as the subsystem is starting up.</p> <p>However, it is abnormal if this status continues.</p>	—
3 (*2)	×	○	×	Loop (Link) is being initialized.	<p>This is not a problem.</p> <p>It shows the status such as the host computer is rebooted.</p> <p>However, it is abnormal if this status continues.</p>	—
4	×	×	○	Link failed.	<ol style="list-style-type: none"> There is no problem even if it is in this status when Fibre Channel Cable is not connected. When rebooting the host computer and the like, it is not abnormal even if it becomes this status. Check the connections of the following Fibre Channel interfaces. <ul style="list-style-type: none"> Fibre Channel Cable Fibre Channel Switch Host Adapter GBIC (When Host Adapter or Fibre Channel switch is connected) Check if the port setting (transfer speed) and the upper node setting (transfer speed) are consistent. Check if the port setting (Topology) and the upper node setting (Topology) are the same. Check if it links up by replacing the equipment listed below sequentially. <ul style="list-style-type: none"> Host Connector FC Interface Board When there is a possibility of a failure on the host node side, replace the equipment listed below sequentially and check if it links up. <ul style="list-style-type: none"> Fibre Channel Cable Fibre Channel Switch Host Adapter GBIC (When Host Adapter or Fibre Channel switch is connected) 	<p>Hitachi Storage Navigator Modular 2 Help "FC Settings"</p> <p>Replacement "2.2.8 Replacing Host Connector" (REP 02-0950)</p> <p>Replacement "2.2.7 Replacing Interface Board" (REP 02-0800)</p>

*1 : HALM LED does not exist on the RKEM and RKES.

The GP0 LED and GP1 LED of the RKEM and RKES light/blink in red during the HALM, in all other cases, in green.

*2 : This is not a failure status.

(○ : On ✧ : Blinking × : Off — : Not depend)

No.	LEDs ^(*)			Cause or status	Action(s) to be taken	Reference page
	HALM (red)	GP1 (green)	GP0 (green)			
5	×	✧	○	Link failure often occurs.	1. When rebooting the host computer and the like, it is not abnormal even if it becomes this status. 2. Check the connections of the following Fibre Channel interfaces. <ul style="list-style-type: none"> • Fibre Channel Cable • Fibre Channel Switch • Host Adapter • GBIC (When Host Adapter or Fibre Channel switch is connected) 3. Check if the port setting (transfer speed) and the upper node setting (transfer speed) are consistent. 4. Check if the port setting (Topology) and the upper node setting (Topology) are the same. 5. Check if it links up by replacing the equipment listed below sequentially. <ul style="list-style-type: none"> • Host Connector • FC Interface Board 6. When there is a possibility of a failure on the host node side, replace the equipment listed below sequentially and check if it links up. <ul style="list-style-type: none"> • Fibre Channel Cable • Fibre Channel Switch • Host Adapter • GBIC (When Host Adapter or Fibre Channel switch is connected) 	Hitachi Storage Navigator Modular 2 Help "FC Settings" Replacement "2.2.8 Replacing Host Connector" (REP 02-0950) Replacement "2.2.7 Replacing Interface Board" (REP 02-0800)
6	×	○	✧	Loop (Link) is often initialized.		
7	×	✧	✧	Link failure often occurs. Loop (Link) is often initialized.		
8 (*2)	○	—	—	The host connector is defective.	Replace the host connector of which the LED lights on.	Replacement "2.2.8 Replacing Host Connector" (REP 02-0950)

*1 : HALM LED does not exist on the RKEM and RKES.

The GP0 LED and GP1 LED of the RKEM and RKES light/blink in red during the HALM, in all other cases, in green.

*2 : For the RKEM and RKES, the GP0 LED and GP1 LED light up in red at the same time, and it indicates the HALM.

This page is for editorial purpose only.

(6) LED Indication Patterns on Interface Board

(a) FC Interface Board

NOTE : When the ALM LED (red) on the Control Unit lights up, the LED pattern indication and the failure status in [Table 8.2.7](#) may not match.

Check the failure status after turning off the ALM LED (red) on the Control Unit.

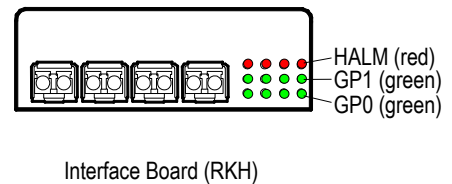
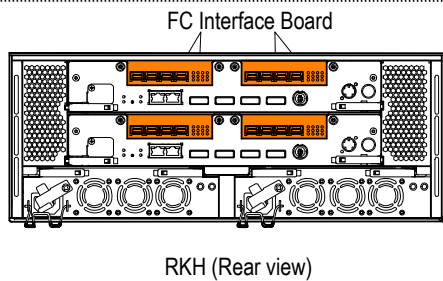
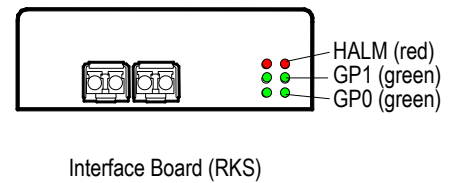
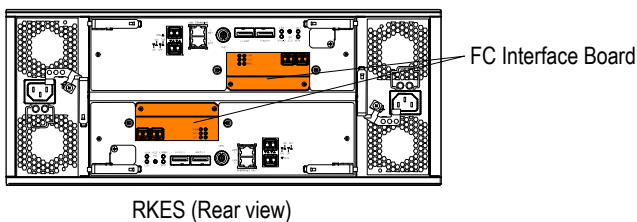
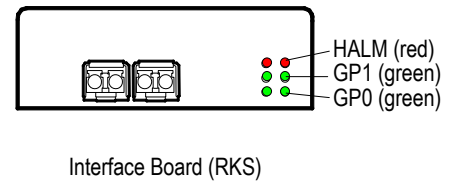
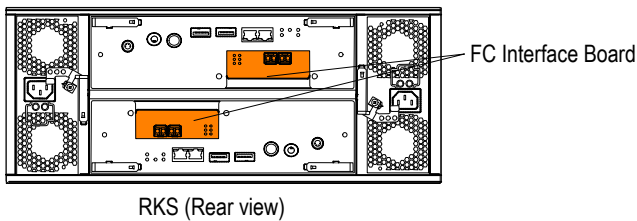
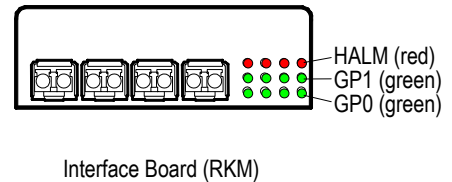
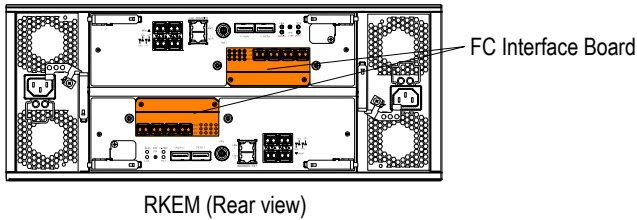
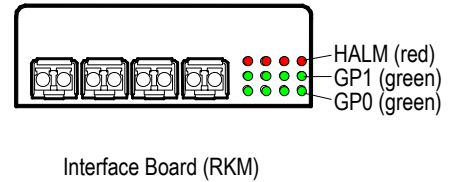
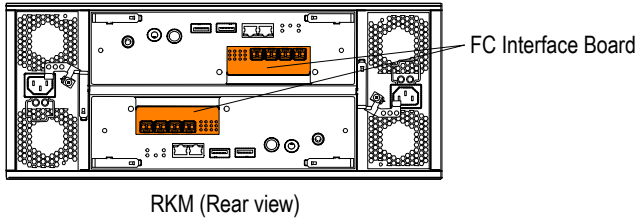

Table 8.2.7.1 LED Indication Patterns on FC Interface Board

(○ : On ◇ : Blinking × : Off — : Not depend)

No.	LEDs			Cause or status	Action(s) to be taken	Reference page
	HALM (red)	GP1 (green)	GP0 (green)			
1 (*1)	×	○	○	Link-up state.	This is not a problem.	—
2 (*1)	×	×	×	<ul style="list-style-type: none"> • Interface is in initial state. • Interface is in reset state. • Loop port is bypassed. 	<p>This is not a problem.</p> <p>It shows the status such as the subsystem is starting up.</p> <p>However, it is abnormal if this status continues.</p>	—
3 (*1)	×	○	×	Loop (Link) is being initialized.	<p>This is not a problem.</p> <p>It shows the status such as the host computer is rebooted.</p> <p>However, it is abnormal if this status continues.</p>	—
4	×	×	○	Link failed.	<ol style="list-style-type: none"> 1. There is no problem even if it is in this status when Fibre Channel Cable is not connected. 2. When rebooting the host computer and the like, it is not abnormal even if it becomes this status. 3. Check the connections of the following Fibre Channel interfaces. <ul style="list-style-type: none"> • Fibre Channel Cable • Fibre Channel Switch • Host Adapter • GBIC (When Host Adapter or Fibre Channel switch is connected) 4. Check if the port setting (transfer speed) and the upper node setting (transfer speed) are consistent. 5. Check if the port setting (Topology) and the upper node setting (Topology) are the same. 6. Check if it links up by replacing the equipment listed below sequentially. <ul style="list-style-type: none"> • Host Connector • FC Interface Board 7. When there is a possibility of a failure on the host node side, replace the equipment listed below sequentially and check if it links up. <ul style="list-style-type: none"> • Fibre Channel Cable • Fibre Channel Switch • Host Adapter • GBIC (When Host Adapter or Fibre Channel switch is connected) 	<p>Hitachi Storage Navigator Modular 2 Help "FC Settings"</p> <p>Replacement "2.2.8 Replacing Host Connector" (REP 02-0950)</p> <p>Replacement "2.2.7 Replacing Interface Board" (REP 02-0800)</p>

*1 : This is not a failure status.

(○ : On ✧ : Blinking × : Off — : Not depend)

No.	LEDs			Cause or status	Action(s) to be taken	Reference page
	HALM (red)	GP1 (green)	GP0 (green)			
5	×	✧	○	Link failure often occurs.	<ol style="list-style-type: none"> When rebooting the host computer and the like, it is not abnormal even if it becomes this status. Check the connections of the following Fibre Channel interfaces. <ul style="list-style-type: none"> Fibre Channel Cable Fibre Channel Switch Host Adapter GBIC (When Host Adapter or Fibre Channel switch is connected) Check if the port setting (transfer speed) and the upper node setting (transfer speed) are consistent. Check if the port setting (Topology) and the upper node setting (Topology) are the same. Check if it links up by replacing the equipment listed below sequentially. <ul style="list-style-type: none"> Host Connector FC Interface Board When there is a possibility of a failure on the host node side, replace the equipment listed below sequentially and check if it links up. <ul style="list-style-type: none"> Fibre Channel Cable Fibre Channel Switch Host Adapter GBIC (When Host Adapter or Fibre Channel switch is connected) 	Hitachi Storage Navigator Modular 2 Help "FC Settings" Replacement "2.2.8 Replacing Host Connector" (REP 02-0950) Replacement "2.2.7 Replacing Interface Board" (REP 02-0800)
6	×	○	✧	Loop (Link) is often initialized.		
7	×	✧	✧	Link failure often occurs. Loop (Link) is often initialized.		
8	○	—	—	The host connector is defective.	Replace the host connector of which the LED lights on.	Replacement "2.2.8 Replacing Host Connector" (REP 02-0950)

(b) 1G bps iSCSI Interface Board

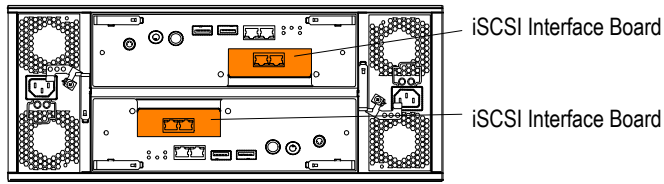

RKM (Rear view)

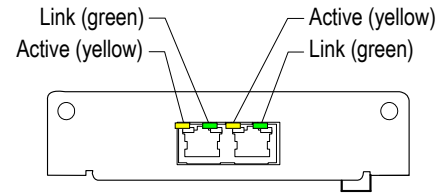

iSCSI Interface Board

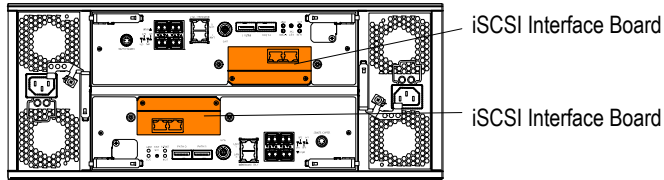

RKEM (Rear view)

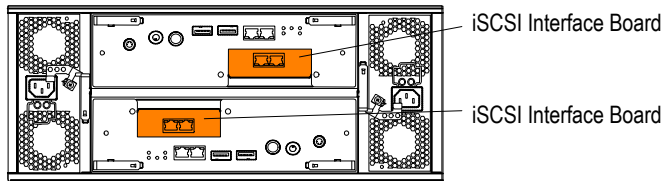

RKS (Rear view)

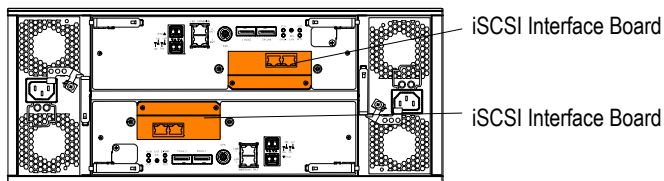

RKES/RKEXS8F (Rear view)

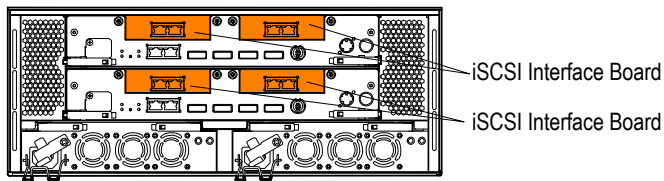

RKH (Rear view)

Table 8.2.8 LED Indication Patterns on iSCSI Interface Board

(○ : On ✧ : Blinking × : Off — : Not depend)

No.	LEDs		Cause or status	Action(s) to be taken	Reference page
	Link (green)	Active (yellow)			
1 (*1)	○	—	This indicates that the link status is normal.	This is not a problem.	—

*1 : This is not a failure status.

(○ : On ☆ : Blinking × : Off — : Not depend)

No.	LEDs		Cause or status	Action(s) to be taken	Reference page
	Link (green)	Active (yellow)			
2	×	—	The LINK LED does not light on though the iSCSI interface cable in the active status is connected.	Check the LINK LED for every work of ① to ⑤. Terminate the work if the LINK LED lights up.	—
				① Check the power status of the host computer, Switch or NIC, which is connected to the iSCSI Interface Board. When the Power Unit of the host computer, Switch or NIC is turned off, request the customer to turn on the Power Unit.	—
				② Check if the both terminals of the iSCSI interface cable are connected to the connectors. If the iSCSI interface cable connection is loosened, connect it firmly again.	—
				③ Check with the customer if the port transfer speed of the HBA, Switch or NIC, which is connected to the iSCSI Interface Board, is 1Gbps ^{*1} . If the port transfer speed is other than 1 Gbps ^{*1} , request the customer to make it 1 Gbps ^{*1} .	—
				④ Replace the iSCSI Interface Board.	Replacement "2.2.7 Replacing Interface Board" (REP 02-0800)
			⑤ It is thought that there is a problem in the trouble of the HBA, Switch or NIC, which is connected to the iSCSI Interface Board, or the iSCSI interface cable. Request the customer to replace the part.	—	
3	☆	—	Although the active iSCSI interface cable is connected, the LINK LED blinks.	The status such as the devices connected to the iSCSI Interface Board are being started is shown. However, it is abnormal when this status continues.	—
				Check the LINK LED for every work of ① to ④. Terminate the work if the LINK LED lights up.	—
				① Check if the both terminals of the iSCSI interface cable are connected to the connectors. If the iSCSI interface cable connection is loosened, connect it firmly again.	—
				② Check with the customer if the port transfer speed of the HBA, Switch or NIC, which is connected to the iSCSI Interface Board, is 1Gbps ^{*1} . If the port transfer speed is other than 1 Gbps ^{*1} , request the customer to make it 1 Gbps ^{*1} .	—
				③ Replace the iSCSI Interface Board.	Replacement "2.2.7 Replacing Interface Board" (REP 02-0800)
			④ It is thought that there is a problem in the trouble of the HBA, Switch or NIC, which is connected to the iSCSI Interface Board, or the iSCSI interface cable. Request the customer to replace the part.	—	

*1 : The HBA, Switch or NIC, whose port transfer speed is other than 1Gbps, cannot be connected to the iSCSI Interface Board.

(c) 10G bps iSCSI Interface Board

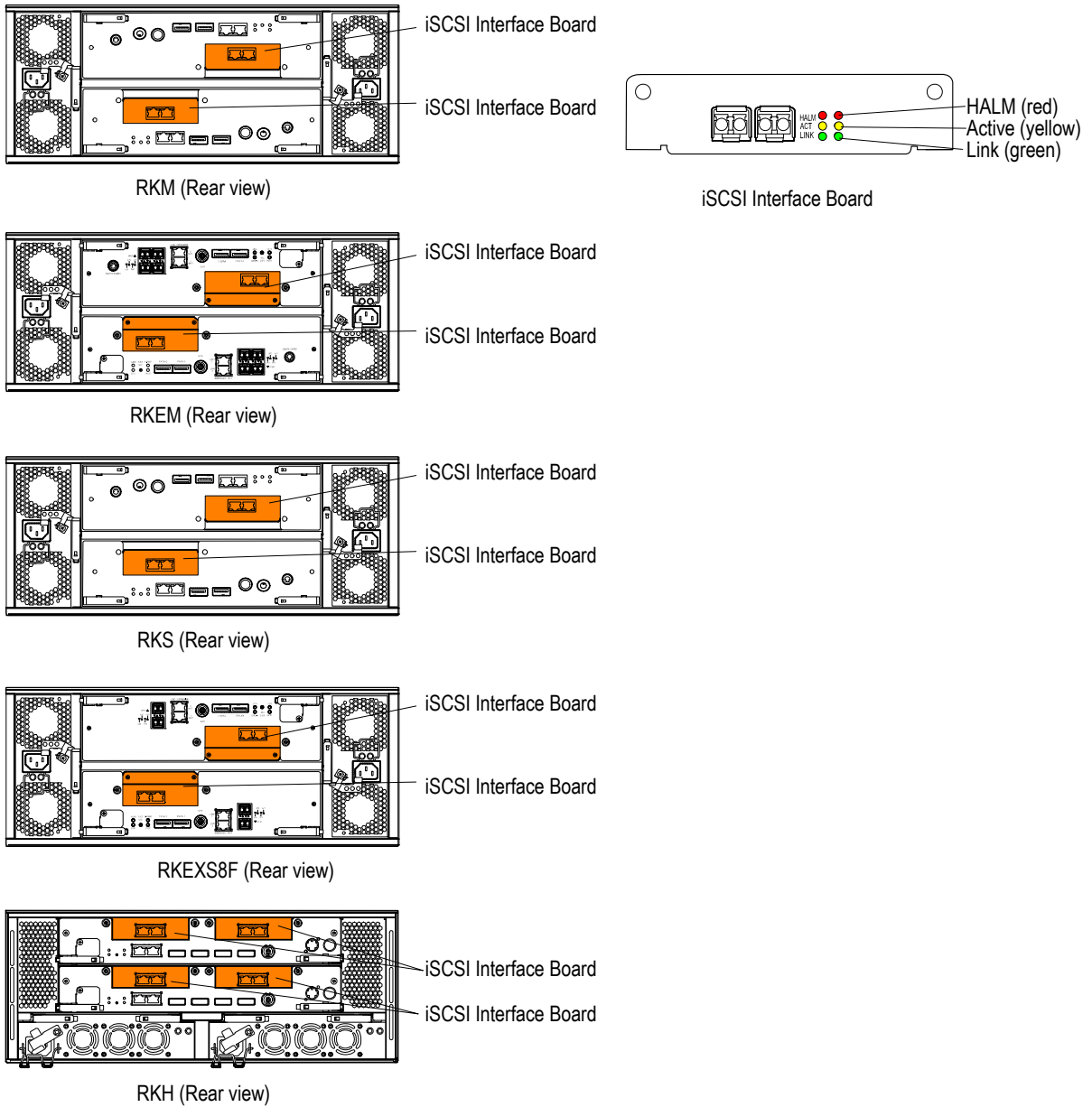

Table 8.2.8.1 LED Indication Patterns on iSCSI Interface Board

(○ : On ✧ : Blinking × : Off — : Not depend)

No.	LEDs			Cause or status	Action(s) to be taken	Reference page
	HALM (red)	Act (green)	Link (green)			
1 (*1)	×	—	○	This indicates that the link status is normal.	This is not a problem.	—

*1 : This is not a failure status.

(○ : On ✧ : Blinking × : Off — : Not depend)

No.	LEDs			Cause or status	Action(s) to be taken	Reference page
	HALM (red)	Act (green)	Link (green)			
2	×	—	×	The LINK LED does not light on though the iSCSI interface cable in the active status is connected.	<p>Check the LINK LED for every work of ① to ⑤. Terminate the work if the LINK LED lights up.</p> <p>① Check the power status of the host computer, Switch or NIC, which is connected to the 10G iSCSI Interface Board. When the Power Unit of the host computer, Switch or NIC is turned off, request the customer to turn on the Power Unit.</p> <p>② Check if the both terminals of the iSCSI interface cable are connected to the connectors. If the iSCSI interface cable connection is loosened, connect it firmly again.</p> <p>③ Check with the customer if the port transfer speed of the HBA, Switch or NIC, which is connected to the iSCSI Interface Board, is 10Gbps^{(*)1}. If the port transfer speed is other than 10 Gbps^{(*)2}, request the customer to make it 10 Gbps^{(*)2}.</p> <p>④ Check if it links up by replacing the equipment listed below sequentially.</p> <ul style="list-style-type: none"> • Host Connector • 10G bps iSCSI Interface Board <p>⑤ It is thought that there is a problem in the trouble of the HBA, Switch or NIC, which is connected to the iSCSI Interface Board, or the iSCSI interface cable. Request the customer to replace the part.</p>	— — — Replacement "2.2.8 Replacing Host Connector" (REP 02-0950) Replacement "2.2.7 Replacing Interface Board" (REP 02-0800) —

*1 : This is not a failure status.

*2 : The HBA, Switch or NIC, whose port transfer speed is other than 1Gbps, cannot be connected to the iSCSI Interface Board.

(○ : On ✧ : Blinking × : Off — : Not depend)

No.	LEDs			Cause or status	Action(s) to be taken	Reference page
	HALM (red)	Act (green)	Link (green)			
3	×	—	✧	Although the active iSCSI interface cable is connected, the LINK LED blinks.	The status such as the devices connected to the iSCSI Interface Board are being started is shown. However, it is abnormal when this status continues. Check the LINK LED for every work of ① to ④. Terminate the work if the LINK LED lights up.	—
					① Check if the both terminals of the iSCSI interface cable are connected to the connectors. If the iSCSI interface cable connection is loosened, connect it firmly again.	—
					② Check with the customer if the port transfer speed of the HBA, Switch or NIC, which is connected to the iSCSI Interface Board, is 10Gbps ^(*) . If the port transfer speed is other than 10 Gbps ^(*) , request the customer to make it 10 Gbps ^(*) .	Replacement "2.2.8 Replacing Host Connector" (REP 02-0950) Replacement "2.2.7 Replacing Interface Board" (REP 02-0800)
					③ Check if it links up by replacing the equipment listed below sequentially. • Host Connector • 10G bps iSCSI Interface Board	—
				④ It is thought that there is a problem in the trouble of the HBA, Switch or NIC, which is connected to the iSCSI Interface Board, or the iSCSI interface cable. Request the customer to replace the part.	—	
4	○	—	—	The host connector is defective.	Replace the host connector of which the LED lights on.	Replacement "2.2.8 Replacing Host Connector" (REP 02-0950)

*1 : The HBA, Switch or NIC, whose port transfer speed is other than 1Gbps, cannot be connected to the iSCSI Interface Board.

This page is for editorial purpose only.

(7) Trouble analysis based on LED indication of ENC Unit

(7-1) RKAK

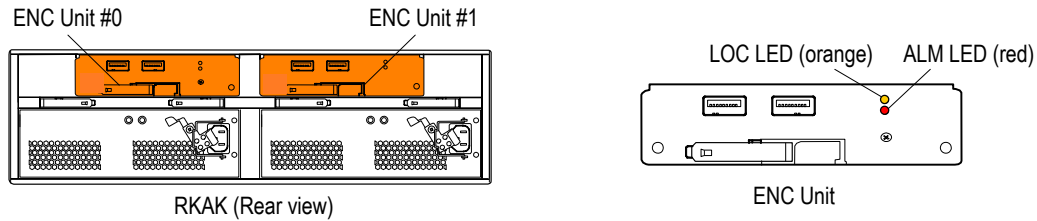

Table 8.2.9 LED Indication Patterns on ENC Unit (RKAK)

(○ : On ◇ : Blinking × : Off — : Not depend)

No.	LEDs		Cause or status	Action(s) to be taken	Reference page
	ALM (red)	LOC (orange)			
1 (*1)	×	×	Normal.	Recovery operation is unnecessary.	—
2	—	○	ENC unit CUDG error is occurred. • ENC firmware (BOOT section) detects CUDG error • ENC firmware detects RAM error • ENC Unit configuration error.	Replace the ENC Unit.	Replacement "2.2.9 Replacing ENC Unit" (REP 02-1020)
3	—	◇(*2) (Once time)	ENC unit CUDG error is occurred. • SRAM error		
4	—	◇(*2) (Twice time)	ENC unit CUDG error is occurred. • ENC Unit error		
5	—	◇(*2) (Three time)	ENC unit CUDG error is occurred. • Firmware error in flash memory.		
6	○	—	A failure that makes the ENC Unit unable to operate occurred in it.		
7 (*1)	×	○(*3)	<ul style="list-style-type: none"> When adding the chassis with the power turned on, it indicates the addition source. The chassis location display is performed from the Storage Navigator Modular 2. 	<ul style="list-style-type: none"> If the chassis is being added, the LOCs will go out when the chassis addition is completed. When the LOCs light up by the instruction of the chassis location display, perform the instruction of disabling the chassis location display from the Hitachi Storage Navigator Modular 2. 	<p>—</p> <p>Addition/Removal/Relocation "1.6.2 (8)" (ADD 01-0770)</p>

*1 : This is not a failure status.

*2 : Indication of status with LED.

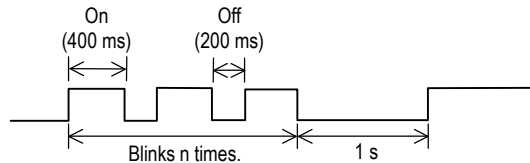

*3 : The LOCs on the ENC Unit #0 and #1 light up.

(7-2) RKAKX

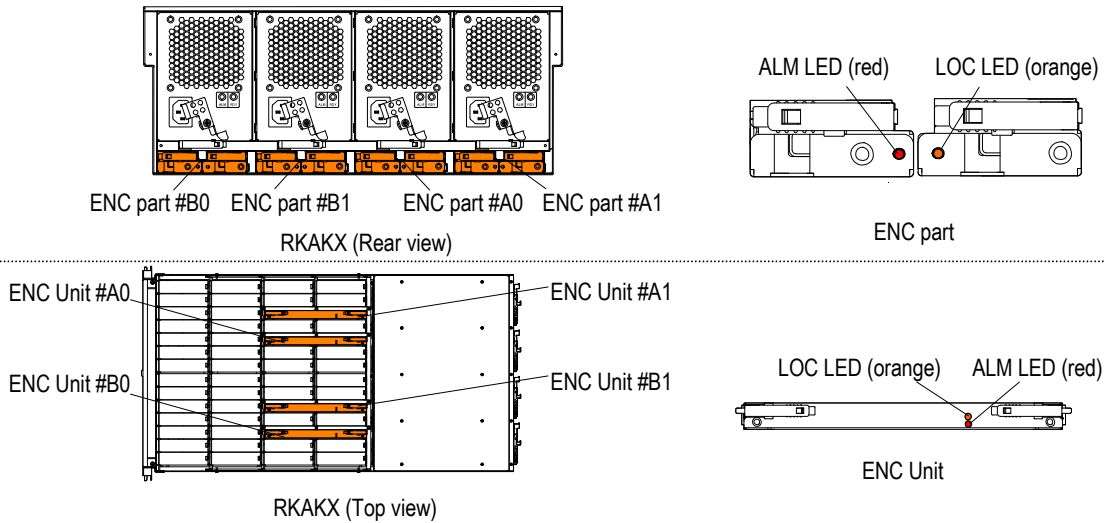

Table 8.2.9.1 LED Indication Patterns on ENC Unit (RKAKX)

(○ : On ◇ : Blinking × : Off — : Not depend)

No.	LEDs		Cause or status	Action(s) to be taken	Reference page
	ALM (red)	LOC (orange)			
1 (*1)	×	×	Normal.	Recovery operation is unnecessary.	—
2	—	○	ENC unit CUDG error is occurred. • ENC firmware (BOOT section) detects CUDG error • ENC firmware detects RAM error • ENC Unit configuration error.	Replace the ENC Unit.	Replacement "2.2.9 Replacing ENC Unit" (REP 02-1020)
3	—	◇ ^(*2) (Once time)	ENC unit CUDG error is occurred. • SRAM error		
4	—	◇ ^(*2) (Twice time)	ENC unit CUDG error is occurred. • ENC Unit error		
5	—	◇ ^(*2) (Three time)	ENC unit CUDG error is occurred. • Firmware error in flash memory.		
6	○	—	A failure that makes the ENC Unit unable to operate occurred in it.		

*1 : This is not a failure status.

*2 : Indication of status with LED.

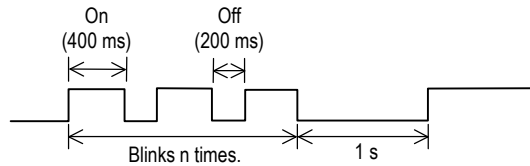

(○ : On ✧ : Blinking × : Off — : Not depend)

No.	LEDs		Cause or status	Action(s) to be taken	Reference page
	ALM (red)	LOC (orange)			
7 (*1)	×	○ ^(*2)	<ul style="list-style-type: none"> When adding the chassis with the power turned on, it indicates the addition source. 	<ul style="list-style-type: none"> If the chassis is being added, the LOCs will go out when the chassis addition is completed. 	—
			<ul style="list-style-type: none"> The chassis location display is performed from the Storage Navigator Modular 2. 	<ul style="list-style-type: none"> When the LOCs light up by the instruction of the chassis location display, perform the instruction of disabling the chassis location display from the Hitachi Storage Navigator Modular 2. 	Addition/Removal/Relocation "1.6.2 (8)" (ADD 01-0770)

*1 : This is not a failure status.

*2 : The LOCs on the ENC Unit #A0 and #A1 or #B0 and #B1 light up.

(7-3) RKAKS

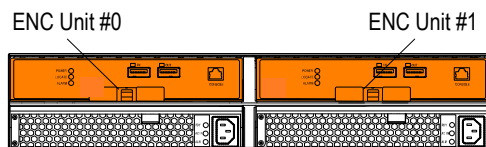

RKAKS (Rear view)

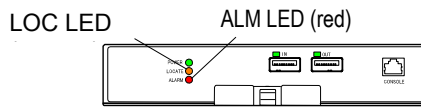

ENC Unit

Table 8.2.9.2 LED Indication Patterns on ENC Unit (RKAKS)

(○ : On ◇ : Blinking × : Off — : Not depend)

No.	LEDs		Cause or status	Action(s) to be taken	Reference page
	ALM (red)	LOC (orange)			
1 (*1)	×	×	Normal.	Recovery operation is unnecessary.	—
2	—	○	ENC unit CUDG error is occurred. • ENC firmware (BOOT section) detects CUDG error • ENC firmware detects RAM error • ENC Unit configuration error.	Replace the ENC Unit.	Replacement "2.2.9 Replacing ENC Unit" (REP 02-1020)
3	—	◇(*2) (Twice time)	ENC unit CUDG error is occurred. • ENC Unit error		
4	—	◇(*2) (Three time)	ENC unit CUDG error is occurred. • Firmware error in flash memory.		
5	○	—	A failure that makes the ENC Unit unable to operate occurred in it.		
6 (*1)	×	○(*3)	<ul style="list-style-type: none"> When adding the chassis with the power turned on, it indicates the addition source. The chassis location display is performed from the Storage Navigator Modular 2. 	<ul style="list-style-type: none"> If the chassis is being added, the LOCs will go out when the chassis addition is completed. When the LOCs light up by the instruction of the chassis location display, perform the instruction of disabling the chassis location display from the Hitachi Storage Navigator Modular 2. 	Addition/Removal/Relocation "1.6.2 (8)" (ADD 01-0770)

*1 : This is not a failure status.

*2 : Indication of status with LED.

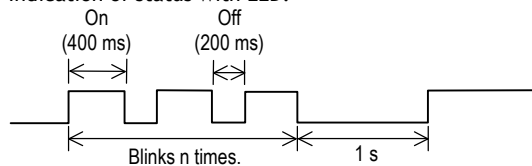

*3 : The LOCs on the ENC Unit #0 and #1 light up.

This page is for editorial purpose only.

(8) Trouble analysis based on LED indication of Remote Adapter

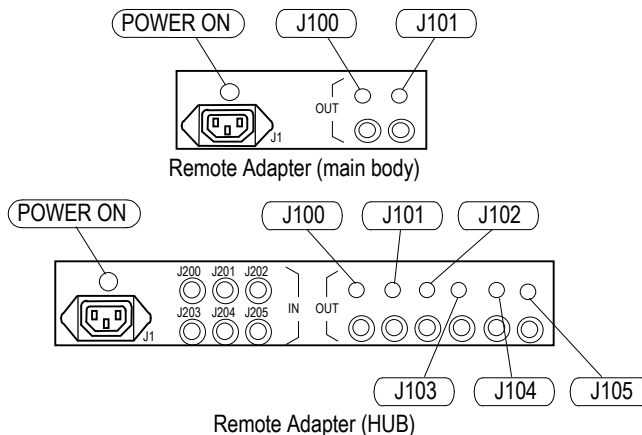

Table 8.2.10 LED Indication Patterns on Remote Adapter

(○ : On ◇ : Blinking × : Off — : Not depend)

No.	LEDs		Cause or status	Action(s) to be taken	Reference page
	Power ON (green)	J100~J105 (green)			
1 (*1)	○	○	The remote adapter is operable and outputs the Remote On signal.	This is not a trouble.	—
2	○	×	The Remote Adapter is operable in the case where the Remote Adapter cable is not connected.	This is not a trouble.	—
			The Remote On signal is not output in the case where the Remote Adapter cable is connected.	Check the cable connection.	—
3	×	○	The POWER ON LED is out of order.	Replace the Remote Adapter	Replacement "2.2.13 Replacing Remote Adapter" (REP 02-1260)
4	×	×	The remote adapter is not in operation.	Check the connection of the power cable. If the cable is connected, replace the Remote Adapter.	

*1 : This is not a failure status.

(9) Trouble analysis based on LED indication of Additional Battery Box

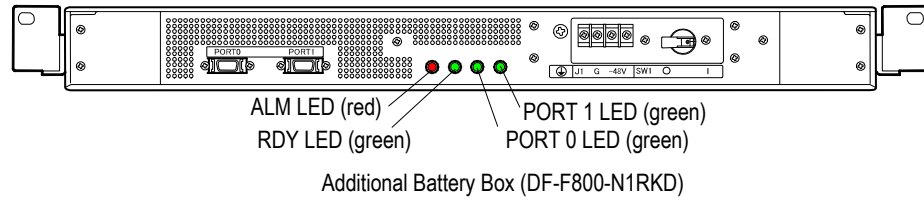
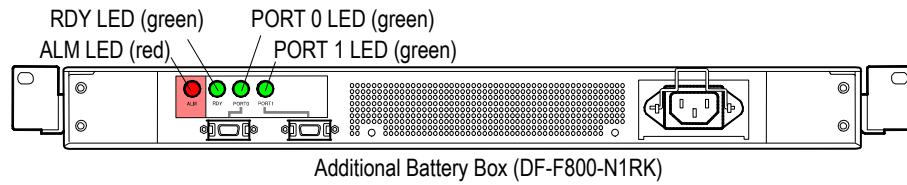
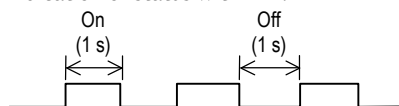

Table 8.2.11 LED Indication Patterns on Additional Battery Box

(○ : On ◇ : Blinking × : Off — : Not depend)

No.	LEDs				Cause or status	Action(s) to be taken	Reference page
	PORT 0 (green)	PORT 1 (green)	RDY (green)	ALM (red)			
1	×	×	×	×	The power is not supplied to the Additional Battery Box.	Check the LINK LED for every work of ① to ③. Terminate the work if the RDY LED lights up. ① Check that the power cable is connected with the Additional Battery Box.	—
						② Check the supply of the electric power.	—
						③ Replace the Additional Battery Box.	Replacement "2.2.14 Replacing an Additional Battery Box" (REP 02-1280)
2	—	—	◇(*1)	×	Charged up when start-up	Recovery operation is unnecessary	—
3	—	—	○	×	Normal.	Recovery operation is unnecessary	—
4	×	○	—	○	1. Cable bad connection of PORT 0. 2. The failure of the PORT 0 connector occurs.	Check the LINK LED for every work of ① to ③. Terminate the work if the ALM LED goes out. ① Check the connection of the cable of PORT 0.	—
						② Replace the Connect cable.	—
						③ Replace the Additional Battery Box.	Replacement "2.2.14 Replacing an Additional Battery Box" (REP 02-1280)
5	○	×	—	○	1. Cable bad connection of PORT 1. 2. The failure of the PORT 1 connector occurs.	Check the LINK LED for every work of ① to ③. Terminate the work if the ALM LED goes out. ① Check the connection of the cable of PORT 1.	—
						② Replace the Connect cable.	—
						③ Replace the Additional Battery Box.	Replacement "2.2.14 Replacing an Additional Battery Box" (REP 02-1280)
6	—	—	◇(*2)	○	1. Battery circuit is abnormal. 2. Battery voltage is abnormal.	Replace the Additional Battery Box.	Replacement "2.2.14 Replacing an Additional Battery Box" (REP 02-1280)

*1 : Indication of status with LED.



*2 : Indication of status with LED.

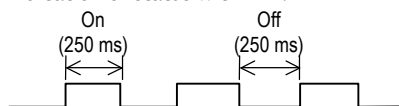

This page is for editorial purpose only.

Chapter 9. Data Collection when a Failure Occurs in Program Product (P.P.)

9.1 Locating Failed Part

Identify a part which presents the phenomenon using [Table 9.1.1](#) and execute an appropriate procedure. Collect a trace from the DF800 in every case.

Table 9.1.1 Program Product To be Recovered

No.	Program product	Type	Object for maintenance (*1)	Related part			Related manual
				Basic firmware	Host computer	Monitoring	
1	Hitachi Storage Navigator Modular 2	P-002D-J401	③	○	–	○	• Hitachi Storage Navigator Modular 2 (for GUI) User's Guide
2	ShadowImage in-system replication (include RAID Manager)	P-002D-J411/ P-002D-J411W	①,②	○	○	–	• ShadowImage in-system replication User's Guide • RAID Manager User's Guide
3	TrueCopy remote replication (include RAID Manager)	P-002D-J412/ P-002D-J412W	①,②	○	○	–	• TrueCopy remote replication User's Guide • RAID Manager User's Guide
4	TrueCopy Extended Distance (include RAID Manager)	P-002D-J415/ P-002D-J415W	①,②	○	○	–	• TrueCopy Extended Distance User's Guide • RAID Manager User's Guide
5	Copy-on-write SnapShot (include RAID Manager)	P-002D-J410/ P-002D-J410W	①,②	○	○	–	• Copy-on-write SnapShot User's Guide • RAID Manager User's Guide
6	Data Retention Utility (include RAID Manager)	P-002D-J409/ P-002D-J409W	①,②	○	○	–	• Data Retention Utility User's Guide • RAID Manager User's Guide
7	LUN Manager	P-002D-J408/ P-002D-J408W	①	○	–	–	• LUN Manager User's Guide
8	Cache Residency Manager	P-002D-J405	①	○	–	–	• Cache Residency Manager User's Guide
9	SNMP Agent Support Function	P-002D-J403	①	○	–	–	• SNMP Agent Support Function User's Guide
10	Password Protection	P-002D-J402	①	○	–	–	• Password Protection User's Guide
11	Performance Monitor	P-002D-J406	①	○	–	–	• Performance Monitor User's Guide

*1 : ①: DF800 main body (Refer to “[9.1.1 When a Failure Occurs in the DF800 Main Body](#)” (TRBL 09-0020).)

②: Host system server connected to the DF800 (Refer to “[9.1.2 When a Failure Occurs in a Host System Server](#)” (TRBL 09-0020).)

③: Server for monitoring and setting connected to the DF800 (Refer to “[9.1.3 When a Failure Occurs in a Server for Monitoring and Setting](#)” (TRBL 09-0020).)

No.	Program product	Type	Object for maintenance (*1)	Related part			Related manual
				Basic firmware	Host computer	Monitoring	
12	Cache Partition Manager	P-002D-J407	①	○	–	–	• Cache Partition Manager User's Guide
13	In-System Replication Bundle	P-002D-J413/ P-002D-J413W	①	○	–	–	• ShadowImage in-system replication User's Guide • Copy-on-write SnapShot User's Guide • RAID Manager User's Guide
14	Modular Volume Migration	P-002D-J416/ P-002D-J416W	①,②	○	○	–	• Modular Volume Migration User's Guide • RAID Manager User's Guide
15	Account Authentication	P-002D-J417	①	○	–	–	• Account Authentication User's Guide
16	Audit Logging	P-002D-J418	①	○	–	–	• Audit Logging User's Guide
17	Power Saving	P-002D-J419	①	○	–	–	• Power Saving User's Guide
18	TrueCopy Modular Distributed	P-002D-J422	①	○	–	–	• TrueCopy Modular Distributed User's Guide
19	Dynamic Provisioning	P-002D-J423/ P-002D-J423W	①	○	–	–	• Dynamic Provisioning User's Guide
20	Data At Rest Encryption	P-002D-J427/ P-002D-J427W	①	○	–	–	• Data At Rest Encryption User's Guide

*1 : ①: DF800 main body (Refer to “9.1.1 When a Failure Occurs in the DF800 Main Body” (TRBL 09-0020).)

②: Host system server connected to the DF800 (Refer to “9.1.2 When a Failure Occurs in a Host System Server” (TRBL 09-0020).)

③: Server for monitoring and setting connected to the DF800 (Refer to “9.1.3 When a Failure Occurs in a Server for Monitoring and Setting” (TRBL 09-0020).)

In the cases of a difficult failure that has a complicated relation with the system configuration, also collect information on configurations of the system and the DF800 and types of program products being used because they may be important.

9.1.1 When a Failure Occurs in the DF800 Main Body

Take recovery actions referring to [“Chapter 1. Flowchart for Troubleshooting” \(TRBL 01-0000\)](#) in the Maintenance Manual for Maintenance.

9.1.2 When a Failure Occurs in a Host System Server

(1) In the case of RAID Manager

- ① If a failure has occurred in the DF800, give priority to investigation of it (see [“Troubleshooting”](#)).
- ② Getting an error message
In the case where an error occurs when a command is input, an error cord and an error message are output in the following line.
A format of a set of an error cord and message is shown below.
[EX-xxxxxx] error message text
Refer to [Section 5.2, “RAID Manager User’s Guide”](#). Refer to an error message and recovery measures given based on the error code.
- ③ Collecting the SYS log
Check the system log because an error message may be written in it.
Since information on the error code, [HORM-xxx], is related to [RAID Manager User’s Guide](#), refer to [Section 5.2, “System Log and Command Error Message”](#) and follow instructions given in it.
- ④ For the log peculiar to the product, refer to [Appendix B, “Log File for Maintenance and Trace Function”](#) in the [“RAID Manager User’s Guide”](#) and collect the information.

9.1.3 When a Failure Occurs in a Server for Monitoring and Setting

(1) In the case of Hitachi Storage Navigator Modular 2

- ① Taking an action following an error message
Since an error message is displayed when an error occurs in operation of Hitachi Storage Navigator Modular 2, take a recovery action following the message.
- ② Collecting log files
Collect log files of Hitachi Storage Navigator Modular 2
Get all files that are subordinate to the log directory under the program installation directory of Hitachi Storage Navigator Modular 2 together with the log directory.
When no log directory exists under the program installation directory of Hitachi Storage Navigator Modular 2, get all files that are subordinate to the log directory under the directory, for which the environmental variable is specified as STONAVM_HOME, together with the log directory.
- ③ Getting operation environment
Get a version number, operation environment (OS and model) and operation of Hitachi Storage Navigator Modular 2.

9.2 List of Data to be Collected when a P.P. Failure Occurs

Table 9.2.1 List of Data of Program Product (to be Recovered) to be Collected

Legend: ○: Collection is needed.

No.	Program product (P.P.)	Subsystem main body trace	Information needed to be collected			
			P.P LOG	SYS LOG	P.P message	Getting of operation environment
1	Hitachi Storage Navigator Modular 2	○	Get all files that are subordinate to the following log directories together with the log directories. The storage directory A log directory under the program installation directory of Hitachi Storage Navigator Modular 2. When the directory described above does not exist, a log directory under the directory for which the environmental variable is specified as STONAVM_HOME.	–	○	P.P. version Operation environment (OS and model) Connection configuration diagram Operation details
2	ShadowImage in-system replication (include RAID Manager)	○	(See Table 9.2.2)			
3	TrueCopy remote replication (include RAID Manager)	○				
4	TrueCopy Modular Distributed	○				
5	TrueCopy Extended Distance (include RAID Manager)	○				
6	Copy-on-write SnapShot (include RAID Manager)	○				
7	Data Retention Utility (include RAID Manager)	○				
8	LUN Manager	○	–	○	–	P.P. version Operation environment (OS and model) Connection configuration diagram Operation details
9	Cache Residency Manager	○	–	–	–	–
10	SNMP Agent Support Function	○	–	–	–	–
11	Password Protection	○	–	–	–	–
12	Performance Monitor	○	–	○	–	P.P. version Operation environment (OS and model) Connection configuration diagram Operation details
13	Cache Partition Manager	○	–	○	–	P.P. version Operation environment (OS and model) Connection configuration diagram Operation details

Legend: ○: Collection is needed.

No.	Program product (P.P.)	Subsystem main body trace	Information needed to be collected			
			P.P LOG	SYS LOG	P.P message	Getting of operation environment
14	Modular Volume Migration	○	(See Table 9.2.2)			
15	Account Authentication	○	–	–	–	–
16	Audit Logging	○	–	–	–	–
17	Power Saving	○	–	–	–	–
18	Dynamic Provisioning	○	–	–	–	P.P. version Operation environment (OS and model) Connection configuration diagram Operation details
19	Data At Rest Encryption	○	–	–	–	–

Table 9.2.2 List of Collection Information on Program Product Related to RAID Manager

No.	Program product	Information to be collected	Collection method/Storage	
1	ShadowImage in-system replication (include RAID Manager)	Trace (dump) of subsystem	Refer to "Chapter 7. Collecting Error Information" (TRBL 07-0000) .	
		RAID Manager log	Collect all the files under the directory specified with the following environmental variables for each operation process/instance. The environmental variables can be referred to using the set or echo command. \$HORCM_LOG (operation log, error log, trace, core) \$HPRCC_LOG (command log) \$HPRCC_LOGS (start log) < Examples of reference to the environmental variable > Unix family: "set", "echo \$HORCM_LOG", etc. Windows family: "set," "set HORC," etc. When the environmental variable above is not specified, collect all files under the following directories will be collected. /HORCM/log* *: Instance number /HORCM/log/curlog For the details, refer to Appendix B, "Log File and Trace Function" in the "RAID Manager User's Guide".	
		Configuration definition file	UNIX family	/etc/horcm*conf *: Instance number
			Windows family	Windows installation drive, \WINNT\horcm*conf *: Instance number
		System log file (PP failure message)	UNIX family	Syslog
			Windows family	Eventing
System configuration diagram	Request of a user			
Host OS revision	Request of a user			
2	TrueCopy remote replication (include RAID Manager)	Trace (dump) of two units of subsystem which make-up a pair	Refer to "Chapter 7. Collecting Error Information" (TRBL 07-0000) .	
		RAID Manager log	Collect all the files under the directory specified with the following environmental variables for each operation process/instance. The environmental variables can be referred to using the set or echo command. \$HORCM_LOG (operation log, error log, trace, core) \$HPRCC_LOG (command log) \$HPRCC_LOGS (start log) < Examples of reference to the environmental variable > Unix family: "set", "echo \$HORCM_LOG", etc. Windows family: "set," "set HORC," etc. When the environmental variable above is not specified, collect all files under the following directories will be collected. /HORCM/log* *: Instance number /HORCM/log/curlog For the details, refer to Appendix B, "Log File and Trace Function" in the "RAID Manager User's Guide".	
		Configuration definition file	UNIX family	/etc/horcm*conf *: Instance number
			Windows family	Windows installation drive, \WINNT\horcm*conf *: Instance number
		System log file (PP failure message)	UNIX family	Syslog
			Windows family	Eventing
System configuration diagram	Request of a user.			
Host OS revision	Request of a user.			

No.	Program product	Information to be collected	Collection method/Storage	
3	TrueCopy Extended Distance (include RAID Manager)	Trace (dump) of two units of subsystem which make-up a pair	Refer to "Chapter 7. Collecting Error Information" (TRBL 07-0000) .	
		RAID Manager log	Collect all the files under the directory specified with the following environmental variables for each operation process/instance. The environmental variables can be referred to using the set or echo command. \$HORCM_LOG (operation log, error log, trace, core) \$HPRCC_LOG (command log) \$HPRCC_LOGS (start log) < Examples of reference to the environmental variable > Unix family: "set", "echo \$HORCM_LOG", etc. Windows family: "set," "set HORC," etc. When the environmental variable above is not specified, collect all files under the following directories will be collected. /HORCM/log* *: Instance number /HORCM/log/curlog For the details, refer to Appendix B, "Log File and Trace Function" in the "RAID Manager User's Guide".	
		Configuration definition file	UNIX family	/etc/horcm*conf *: Instance number
			Windows family	Windows installation drive, \WINNT\horcm*conf *: Instance number
		System log file (PP failure message)	UNIX family	Syslog
			Windows family	Eventing
System configuration diagram	Request of a user.			
Host OS revision	Request of a user.			
4	Copy-on-write SnapShot (include RAID Manager)	Trace (dump) of subsystem	Refer to "Chapter 7. Collecting Error Information" (TRBL 07-0000) .	
		RAID Manager log	Collect all the files under the directory specified with the following environmental variables for each operation process/instance. The environmental variables can be referred to using the set or echo command. \$HORCM_LOG (operation log, error log, trace, core) \$HPRCC_LOG (command log) \$HPRCC_LOGS (start log) < Examples of reference to the environmental variable > Unix family: "set", "echo \$HORCM_LOG", etc. Windows family: "set", "set HORC", etc. When the environmental variable above is not specified, collect all files under the following directories will be collected. /HORCM/log* *: Instance number /HORCM/log/curlog For the details, refer to Appendix B, "Log File and Trace Function" in the "RAID Manager User's Guide".	
		Configuration definition file	UNIX family	/etc/horcm*conf *: Instance number
			Windows family	Windows installation drive, \WINNT\horcm*conf *: Instance number
		System log file (PP failure message)	UNIX family	Syslog
			Windows family	Eventing
System configuration diagram	Request of a user			
Host OS revision	Request of a user			

No.	Program product	Information to be collected	Collection method/Storage
5	Data Retention Utility (include RAID Manager)	Trace (dump) of subsystem	Refer to "Chapter 7. Collecting Error Information" (TRBL 07-0000) .
		RAID Manager log	Collect all the files under the directory specified with the following environmental variables for each operation process/instance. The environmental variables can be referred to using the set or echo command. \$HORCM_LOG (operation log, error log, trace, core) \$HPRCC_LOG (command log) \$HPRCC_LOGS (start log) < Examples of reference to the environmental variable > Unix family: "set", "echo \$HORCM_LOG", etc. Windows family: "set", "set HORC", etc. When the environmental variable above is not specified, collect all files under the following directories will be collected. /HORCM/log* *: Instance number /HORCM/log/curlog For the details, refer to Appendix B, "Log File and Trace Function" in the "RAID Manager User's Guide".
		Configuration definition file	UNIX family /etc/horcm*conf *: Instance number Windows family Windows installation drive, \WINNT\horcm*conf *: Instance number
		System log file (PP failure message)	UNIX family Syslog Windows family Eventing
		System configuration diagram	Request of a user
		Host OS revision	Request of a user
6	Modular Volume Migration (include RAID Manager)	Trace (dump) of subsystem	Refer to "Chapter 7. Collecting Error Information" (TRBL 07-0000) .
		RAID Manager log	Collect all the files under the directory specified with the following environmental variables for each operation process/instance. The environmental variables can be referred to using the set or echo command. \$HORCM_LOG (operation log, error log, trace, core) \$HPRCC_LOG (command log) \$HPRCC_LOGS (start log) < Examples of reference to the environmental variable > Unix family: "set", "echo \$HORCM_LOG", etc. Windows family: "set", "set HORC", etc. When the environmental variable above is not specified, collect all files under the following directories will be collected. /HORCM/log* *: Instance number /HORCM/log/curlog For the details, refer to Appendix B, "Log File and Trace Function" in the "RAID Manager User's Guide".
		Configuration definition file	UNIX family /etc/horcm*conf *: Instance number Windows family Windows installation drive, \WINNT\horcm*conf *: Instance number
		System log file (PP failure message)	UNIX family Syslog Windows family Eventing
		System configuration diagram	Request of a user
		Host OS revision	Request of a user

Chapter 10. Trouble Analysis by Failure Monitoring Function

10.1 Trouble Analysis by SNMP Agent Support Function

The SNMP Agent Support Function notifies a network monitoring personal computer or workstation, in which the SNMP manager program is installed, of failures of the disk array system via the SNMP (Simple Network Management Protocol). This section explains the trouble analysis operation to be performed when the SNMP Agent Support Function is used.

10.1.1 Maintenance with TRAP Codes

(1) Ascertaining failure information

An example of an output by the TRAP issued by the disk array system. (a) is an example of output by HP OpenView/NetM-COMET. (b) is an example of output by SunNet Manager.

(a) Example of trapped output by HP OpenView/NetM*COMET

If an error occurs, the following screen is popped up.

	fan Failure event		
Jan 25 (FRI), 2008 4p.m. 21 minutes 15 seconds			
fan	<input type="button" value="OK"/>		

“Error event” in the “Event Category” box changes to “■”. Double-clicking this box displays an Error Event browser. For detailed information refer to the browser.

	Event Category		
<input checked="" type="checkbox"/> Error event <input type="checkbox"/> Threshold event <input type="checkbox"/> Status event <input type="checkbox"/> Setting event <input type="checkbox"/> Application warning event <input type="checkbox"/> All events			
[Read only]			

Error Event Browser				
File	Action	View		Help
Significance	Date	Source	Message	
Important warning area	2008/01/25 16:21:15	DF800	Trap:generic 6 specific:3 args (0):	
1 Event - Dangerous:0 Serious warning:1 Warning:0 Caution:0 Normal:0				

(b) Example of trapped output by SunNet Manager

Event/Trap Report-DF800

Save Device name: _____

Remarks 6 1 _____ 6

Fri Jan 25 13:29:06 2008 [DF800] : Trap :

sequence=1

receive-time=Fri Jan 25 13:29:06 2008

version=0

community=public

enterprise=Hitach,Ltd..system. storage. dfraid. dfraid

Lan

source-time=00:00:00.00

trap-type=Fan_Failure

Trap name

(2) Trouble analysis method

Perform maintenance referring to the output examples in (1) and according to Table 10.1.1, “Recovery Method for Each Trap Code”. (Refer to [Message “Chapter 6. Warning Messages” \(MSG 06-0000\)](#).)

Table 10.1.1 Recovery Method for Each Trap Code

No.	Generic Trap Code	Specific Trap Code	Trap name	Description	Recovery methods
1	0	0	coldStart	Power-on, Unlocking the SNMP Agent Support Function or changing the setting of the SNMP Agent Support Function by rebooting the subsystem	This is not an error. Recovery operation is not necessary.
2	1	0	warmStart	Changing the setting of the SNMP Agent Support Function in the status that the subsystem power is turned on	This is not an error. Recovery operation is not necessary.
3	4	0	authentication-Failure	Invalid SNMP access (The community name set for the subsystem differs from the community name accessed by the SNMP manager)	Change the community name set for the subsystem or the community name accessed by the SNMP manager so that they match. When changing the community name set for the subsystem, refer to “SNMP Agent Support Function User’s Guide”. When changing the community name accessed by the SNMP manager, refer to the manual of each manager.
4	6	1	subsystemDown	Controller down	It is shown that a failure occurred and the subsystem stopped. For the detailed failure information, refer to the display of the WEB log message of the subsystem.
5	6	2	driveFailure	Disk shutdown (Both SAS/SAS(SSED) drive and SATA drives)	It is shown that any of the failures occurred. Message code : W09zab HDU alarm (Unit-x, HDU-y, Type-c) Perform the maintenance corresponding to the message code referring to the WEB log message of the subsystem for the details.
6	6	3	fanFailure	Fan failure	It is shown that any of the failures occurred. Message code : W05z00 FAN alarm (Unit-x, FAN-y) W06z00 FAN alarm (CTL-Unit, FAN-x) Perform the maintenance corresponding to the message code referring to the WEB log message of the subsystem for the details.
7	6	4	powerSupply-Failure	Power supply failure	It is shown that any of the failures occurred. Message code : W07zy0 PS alarm (Unit-w, PS-x) W08zy0 PS alarm (CTL-Unit, PS-x) Perform the maintenance corresponding to the message code referring to the WEB log message of the subsystem for the details.

No.	Generic Trap Code	Specific Trap Code	Trap name	Description	Recovery methods
8	6	5	batteryFailure	Battery voltage error	<p>It is shown that any of the failures occurred. Message code : W03z0x Battery alarm (Battery-x) W3Tzxy Battery alarm (Additional Battery-y)</p> <p>The information corresponding to <u>x</u> is not notified regarding the trap. Perform the maintenance corresponding to the message code referring to the WEB log message of the subsystem for the details.</p>
9	6	7	upsFailure	UPS error	<p>Perform the maintenance instructed. Message code : W0Hz0x UPS alarm (UPS-x)</p> <p>The information corresponding to <u>x</u> is not notified regarding the trap.</p>
10	6	9	backupCircuitFailure	Battery circuit failure	<p>Perform the maintenance instructed. Message code : W0400x Battery back up circuit alarm (CTL-x)</p> <p>The information corresponding to <u>x</u> in the manual is not notified regarding the trap. Perform the maintenance corresponding to the message code referring to the WEB log message of the subsystem for the details.</p>
11	6	10	otherControllerFailure	Another side controller blockade (For dual configuration only)	<p>Perform the maintenance instructed. Message code : W01z0x CTL alarm (CTL-x)</p> <p>The information corresponding to <u>x</u> in the manual is not notified regarding the trap. Perform the maintenance corresponding to the message code referring to the WEB log message of the subsystem for the details.</p> <p>When this trap is displayed following the No.14 "microprogram Replacement executed", it does not mean a failure because it is reported owing to the firmware replacement.</p>
12	6	11	warning	A Warning was issued in the disk array system.	<p>It is shown that a failure indicated by a message code with "W" at the top. For the detailed failure information, refer to the display of the WEB log message of the subsystem. Perform the maintenance instructed for message code W#####. "#####" is optional.</p>
13	6	12	spareDriveFailure	Spare Disk blockade (Both SAS/SAS(SSED) drive and SATA drives)	<p>It is shown that any of the failures occurred. Message code : W0Bzab Spare HDU alarm (Unit-x, HDU-y, Type-c)</p> <p>Perform the maintenance corresponding to the message code referring to the WEB log message of the subsystem for the details.</p>
14	6	14	encFailure	ENC failure	<p>It is shown that any of the failures occurred. Message code : W0Fze0 ENC alarm (Unit-x, ENC-y)</p> <p>Perform the maintenance corresponding to the message code referring to the WEB log message of the subsystem for the details.</p>

No.	Generic Trap Code	Specific Trap Code	Trap name	Description	Recovery methods
15	6	16	PathFailure	Path detachment	Perform the maintenance instructed. Message code : W0K0xy Path alarm (Remote-x, Path-y) The information corresponding to xy in the manual is not notified regarding the trap. Perform the maintenance corresponding to the message code referring to the WEB log message of the subsystem for the details.
16	6	20	hostConnector-Failure	Host connector blockade	Perform the maintenance instructed. Message code : W0Pz0f Host connector alarm (Portxy) Perform the maintenance corresponding to the message code referring to the WEB log message of the subsystem for the details.
17	6	250	interfaceBoard-Failure	Interface board blockade	Perform the maintenance instructed. Message code : W3Rxyz Interface Board alarm(CTL-w, I/F-z) Perform the maintenance corresponding to the message code referring to the WEB log message of the subsystem for the details.
18	6	251	additionalBattery-Failure	Additional battery failure	It is shown that any of the failures occurred. Message code : W3Tzxy Battery alarm (Additional Battery-y) The information corresponding to x is not notified regarding the trap. Perform the maintenance corresponding to the message code referring to the WEB log message of the subsystem for the details.
19	6	300	psueShadowImage	PSUE (When ShadowImage is used)	It is shown that PSUE occurred. Refer to WEB, Hitachi Storage Navigator Modular 2.
20	6	301	psueSnapShot	PSUE (When SnapShot is used)	It is shown that PSUE occurred. Refer to WEB, Hitachi Storage Navigator Modular 2.
21	6	302	psueTrueCopy	PSUE (When TrueCopy is used)	It is shown that PSUE occurred. Refer to WEB, Hitachi Storage Navigator Modular 2.
22	6	303	psueTrueCopy-ExtendedDistance	PSUE (When TrueCopyExtendedDistance is used)	It is shown that PSUE occurred. Refer to WEB, Hitachi Storage Navigator Modular 2.
23	6	304	psueModular-VolumeMigration	PSUE (When ModularVolumeMigration is used)	It is shown that PSUE occurred. Refer to WEB, Hitachi Storage Navigator Modular 2.
24	6	305	dataPool-ThresholdOver	Threshold over of POOL	It is shown that POOL threshold was exceeded. Refer to WEB, Hitachi Storage Navigator Modular 2.
25	6	306	dataPoolNoFree	No empty area of POOL.	It is shown that POOL threshold was exceeded. Refer to WEB, Hitachi Storage Navigator Modular 2.
26	6	307	CycleTime-ThresholdOver	Cycle time threshold over	It is shown that cycle time threshold was exceeded. Refer to WEB, Hitachi Storage Navigator Modular 2.
27	6	308	luFailure	Drive multiple trouble	It is shown that any of the failures occurred. Message code : I30100 HDU error(Unit-x,HDU-y) Perform the maintenance corresponding to the message code referring to the WEB log message of the subsystem for the details.

No.	Generic Trap Code	Specific Trap Code	Trap name	Description	Recovery methods
28	6	309	replaceAirFilterBezel	Alert for DC power supply filter replacement	It is shown that the replacement time comes described in: Message code : Please replace the Air Filter of Bezel Perform the maintenance corresponding to the message code referring to the WEB log message of the subsystem for the details.
29	6	310	dpPoolEarlyAlert	Early alert for pool capacity depletion	It is shown that the following occurred: Message code : I6GH00 DP Pool Consumed Capacity Early Alert (Pool-x) Ask the customer/SE to add the DP pool capacity referring to the "Dynamic Provisioning User's Guide".
30	6	311	dpPoolDepletionAlert	Depletion alert for pool capacity depletion	It is shown that the following occurred: Message code : I6GI00 DP Pool Consumed Capacity Depletion Alert(Pool-x) Ask the customer/SE to add the DP pool capacity referring to the "Dynamic Provisioning User's Guide".
31	6	312	dpPoolCapacityOver	Pool capacity depletion	It is shown that the following occurred: Message code : I6GJ00 DP Pool Consumed Capacity Over (Pool-x) Ask the customer/SE to add the DP pool capacity referring to the "Dynamic Provisioning User's Guide".
32	6	313	overProvisioningWarningThreshold	Fore alert for over provisioning	It is shown that the following occurred: Message code : I6GK00 Over Provisioning Ratio Forewarning (Pool-x) Ask the customer/SE to add the DP pool capacity referring to the "Dynamic Provisioning User's Guide".
33	6	314	overProvisioningLimitThreshold	Over alert for over provisioning	It is shown that the following occurred: Message code : I6GL00 Over Provisioning Ratio Overwarning (Pool-x) Ask the customer/SE to add the DP pool capacity referring to the "Dynamic Provisioning User's Guide".
34	6	316	portErrorThresholdOver	Over the port error threshold	A failure occurred in the path of the Fibre Channel port, and the failure detection count exceeded the threshold value. Refer to "6.1.29 Failure Determination and Recovery Methods of Fibre Channel Port Path" (TRBL 06-1200).
35	6	318	hddCalibration	Executing the update of the HDD Calibration Correction Table	It is shown that the following occurred: Message code : I30E00 HDU calibration was detected(Unit-XX,HDU-YY) Perform the maintenance corresponding to the message code referring to the WEB log message of the subsystem for the details.
36	6	325	arrayRebootRequestForDPPoolInvalid	Array reboot is requested because the DP pool management table is invalid	It is shown that the following occurred: Message code : I6N500 DP management information may be invalid, Please reboot the array with power cycle Perform the maintenance corresponding to the message code referring to the WEB log message of the subsystem for the details.

No.	Generic Trap Code	Specific Trap Code	Trap name	Description	Recovery methods
37	6	326	DPPoolInformationInvalid	The DP pool management table is invalid	It is shown that the following occurred: Message code : I6N600 DP management information is invalid (DP Pool-x) Perform the maintenance corresponding to the message code referring to the WEB log message of the subsystem for the details.

10.1.2 Maintenance with MIB (df Regression) Values

(1) Confirming error information

Examples of output caused by a trap issued by the subsystem are shown below. (a) is an example of output by HP OpenView/NetM*COMET. (b) is an example of output by SunNet Manager.

For MIB values, refer to “Table 10.1.3 dfRegressionStatus Value Corresponding to Each Failure” (TRBL 10-0070).

(a) Example of MIB value output by HP OpenView/NetM*COMET

The screenshot shows the 'MIB Browse' window with the following fields and controls:

- Node name or IP address:** hsp1FSsw
- Community name:** (empty)
- MIB object ID:** terprises.hitachi.systemExMib.storageExMib.dfraidExMib.dfraidLanExMib.dfWarningCondition
- MIB tree:** dfRegressionStatus (highlighted), dfPreventiveMaintenanceInformation, dfWarningReserve1, dfWarningReserve2
- Navigation buttons:** Move tree upward, Move tree downward, Details, Inquiry start (highlighted), Inquiry quit, Graph
- MIB interface:** (empty)
- SNMP set value:** (empty)
- Setting (Set):** (button)
- MIB value:** 0:1048576
- Message:** Note : Community "public" is used for node DF800.
- Bottom buttons:** Close, Reselect, Save..., Help

Annotations with arrows point to:

- The MIB value field (0:1048576) with the label "dfRegressionStatus value".
- The Reselect button with the label "IP address or registered host model name".

(b) Example of MIB value output by SunNet Manager

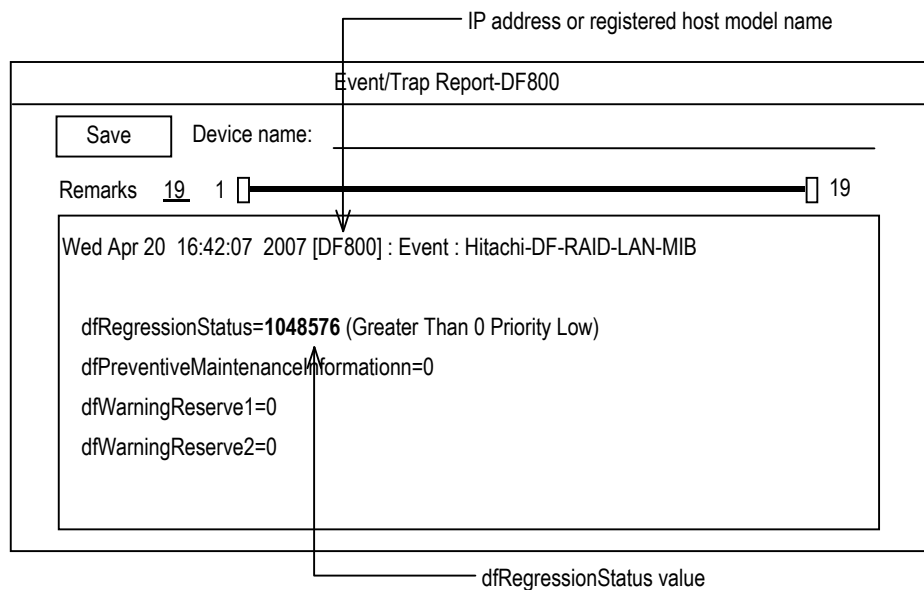

Table 10.1.2 Format of dfRegressionStatus

Bit	7	6	5	4	3	2	1	0
0	0	I/F board	0	Host Connector	0	0	0	Cache
1	0	0	Additional Battery	Fan	BK	0	PS	Battery
2	0	0	0	0	0	Path	0	UPS
3	CTL	Warning	0	0	ENC	D-Drive	S-Drive	Drive

When a regression is applied to the part concerned, turn on the corresponding bit. Value of the object corresponding to each failure status is shown in [“Table 10.1.3 dfRegressionStatus Value Corresponding to Each Failure” \(TRBL 10-0070\)](#).

Table 10.1.3 dfRegressionStatus Value Corresponding to Each Failure

No.	Bit location		Object value (in decimal)	Description
	Byte	Bit		
1	—	—	0	Array normal status
2	3	0	1	Drive blockade
3	3	1	2	Drive (spare drive) blockade
4	3	2	4	Drive (data drive) blockade
5	3	3	8	ENC alarm
6	3	6	64	Warned array
7	3	7	128	Mate controller blockade
8	2	0	256	UPS alarm
9	2	1	-	-
10	2	2	1024	Path blockade
11	1	0	65536	Battery alarm
12	1	1	131072	Power supply failure
13	1	3	524288	Battery charging circuit alarm
14	1	4	1048576	Fan alarm
15	1	5	2097152	Additional battery failure
16	0	0	16777216	Cache partial blockade
17	0	1	-	-
18	0	2	-	-
19	0	3	-	-
20	0	4	268435456	Host connector alarm
21	0	5	-	-
22	0	6	1073741824	Interface board alarm

When two or more failed parts exist, the object value is the sum of each object value.

Example : When failures occur in the battery and the fan, the object value is “1114112 (65536+1048576)”.

The object value converted into binary form corresponds to the format shown in “[Table 10.1.2 Format of dfRegressionStatus](#)” (TRBL 10-0060).

(2) Troubleshooting procedure

Perform a maintenance by associating the item in the description column in “[Table 10.1.3 dfRegressionStatus Value Corresponding to Each Failure](#)” (TRBL 10-0070) with the contents of “[Table 10.1.1 Recovery Method for Each Trap Code](#)” (TRBL 10-0020).

10.2 Trouble Analysis by Hitachi Storage Navigator Modular 2

The Hitachi Storage Navigator Modular 2 notifies of failures of the disk array system by the failure monitoring function.

This section explains the trouble analysis operation to be performed when the Hitachi Storage Navigator Modular 2 is used.

10.2.1 Maintenance with the Hitachi Storage Navigator Modular 2 (GUI Version)

(1) Display of subsystem status and maintenance

A screen which indicates the status of Array device under Hitachi Storage Navigator Modular 2 is shown below.

When clicking the [Alerts & Events] in the tree, the window which displays alert parts will be displayed.

When a failure occurs in the array subsystem, the alert parts will be displayed in the [Alerts & Events] window.

Replace the parts that are displayed.

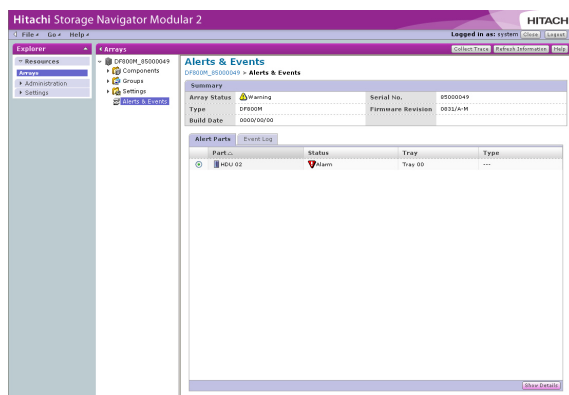

10.2.2 Hitachi Storage Navigator Modular 2 Maintenance Function

Maintenance functions of the Hitachi Storage Navigator Modular 2 are listed in Table 10.2.2.

Table 10.2.2 Hitachi Storage Navigator Modular 2 Maintenance Function List

No	Classification	Function name	Outline of function	Notes
1	Display of logical unit failure data information	Display of logical unit failure data information	The segments for each logical unit are displayed.	—
2	Setting a prefetch size	Setting prefetch information	It sets a prefetch staging size by the RAID levels, a next starting opportunity and host data transfer access size.	Prefetch information is set at an optimum value on shipment. If the setting is changed unpreparedly, it will affect performance and may interfere with operation:
3	Setting a threshold	Setting a threshold for preventive maintenance	It sets a threshold for the number of failures of a disk controlled by preventive maintenance.	—
4	Drive maintenance	Detach	Blocks a specified drive forcibly.	—
		Data reconstruction	When the drive restoration option was set automatically, reconstruct the data in the Disk Drive by specifying the drive position of the Disk Drive after replacing the failed Disk Drive.	—
		Copyback	Copies data from a spare drive to a specified drive.	—
		Dynamic sparing	Copies data forcibly from a specified drive to a spare drive, and then blocks the specified drive.	—
		System copy	Copies the system area of a system drive from another system drive.	—
5	Setting a mode for reporting to the host	Setting a mode for reporting to the host using an SSB	When the Warning status of the array subsystem occurred, etc., the mode to report with SSB is set.	—
6	System Upgrade	System Upgrade	When upgrading a subsystem, with reference to the variety of information of partner equipment, the information is set as self-equipment.	—
7	Setting SATA Drive Options	SATA Drive Options	Refer to or set up the Sweep function and the SMART function, which are the SATA options.	—
8	Setting SATA Drive Restore Options	SATA Drive Restore Options	Refer to or set up the restoration size of the SATA correction copy.	—
9	Replacing the Online ENC firmware	Download and replacing of ENC firmware.	Download the ENC firmware to the array subsystem, and replace it.	—
10	Setting the drive performance delay diagnosis function	Setting the drive performance delay diagnosis function	Refer to or set the operation mode of the drive performance delay diagnosis function.	—
11	Setting the drive firmware download	Setting the automatic download of the drive firmware	Refer to or set Enabled/Disabled for the automatic download of the drive firmware.	—
12	Display of the temperature in the Basic Unit	Display of the temperature in the Basic Unit	The latest temperature in the Basic Unit is displayed.	—
13	Setting the host reservation forced release function	Setting the reservation forced release function	The reservation status by the H-LUN is displayed. When it is determined that the reservation release is needed, execute the release.	When the reservation release is wrongly executed, LU exclusion cannot be performed, data corruption can occur.

No	Classification	Function name	Outline of function	Notes
14	Checking presence/absence of LRC error block	LRC check	Check the presence/absence of the LRC error block of the LU which was determined that the LRC check is necessary.	The performance may be affected. Use it only when instructed so.

This page is for editorial purpose only.

10.2.3 Displaying Logical Unit Failure Data Information

The PIN information of each logical unit is displayed.

- (1) Start the Hitachi Storage Navigator Modular 2.
- (2) Put a checkmark to the array subsystem to set, press the [Ctrl] key, [Shift] key and [E] key at the same time, and change the operation mode to “Maintenance Mode”.^(†1)

It is displayed as “maintenance mode” in [Operation Mode] of the upper part of the window, and Hitachi Storage Navigator Modular 2 is operated in the maintenance mode.

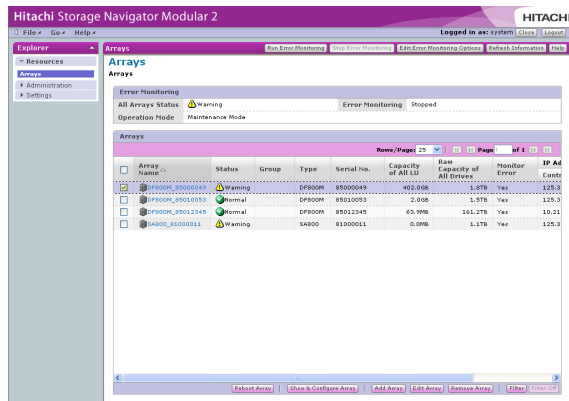

- (3) Click the array subsystem name, and open the unit window.

NOTE : There is a case that the LAN Port Number is changed. When the main screen is not displayed even though the icon of the array subsystem is clicked, use the changed LAN Port Number, and execute it again. (Refer to [System Parameter “1.2 LAN Port Number Change by Hitachi Storage Navigator Modular 2” \(SYSPR 01-0120\).](#))

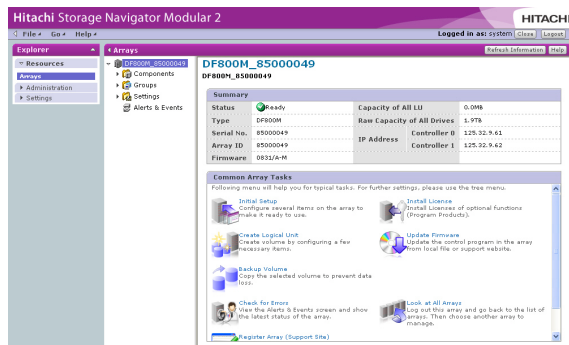

†1 : When the array subsystem to operate is not registered, click the blank area (other than buttons and characters) in the “Arrays” window, and press the [Ctrl] key, [Shift] key and [E] key at the same time.

- (4) Select [Settings] - [Advanced Settings] on the unit window, and click the [Open Advanced Settings] button.

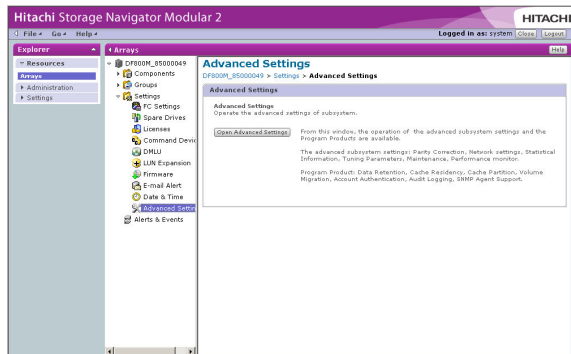

- (5) Select the [Maintenance] on the applet window, and click the [Set] button. Maintenance dialog box is displayed.

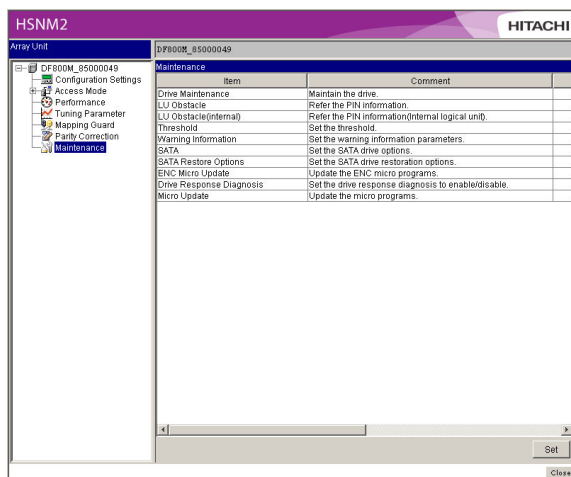

- (6) Click the LU Obstacle tab on the Maintenance dialog box.

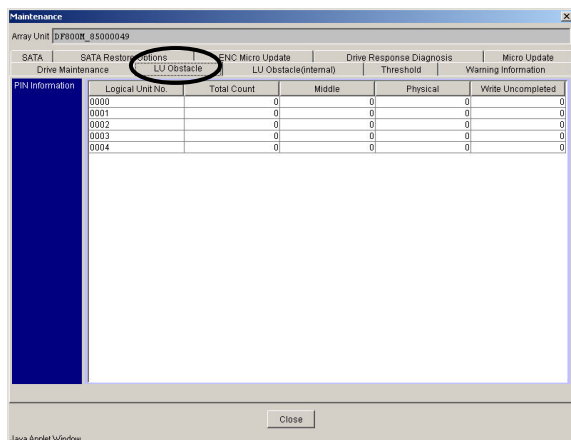

The number of segments, including PIN, in each logical unit is displayed.

- (7) Click the [Close] button.

10.2.4 Setting Pre-fetch Information

A prefetch staging size for each RAID level, next starting opportunity and host data transfer access size are set.

- (1) When the version of Hitachi Storage Navigator Modular 2 is Ver. 6.02 or more…… [TRBL 10-0120](#)
- (2) When the version of Hitachi Storage Navigator Modular 2 is less than Ver. 6.02 … [TRBL 10-0141](#)

(1) When the version of Hitachi Storage Navigator Modular 2 is Ver. 6.02 or more

(a) Start the Hitachi Storage Navigator Modular 2.

(b) Put a checkmark to the array subsystem to set, press the [Ctrl] key, [Shift] key and [E] key at the same time, and change the operation mode to “Maintenance Mode”.^(#1)

It is displayed as “maintenance mode” in [Operation Mode] of the upper part of the window, and Hitachi Storage Navigator Modular 2 is operated in the maintenance mode.

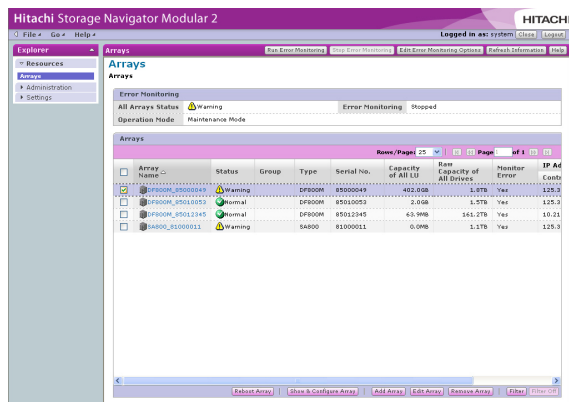

(c) Click the array subsystem name, and open the unit window.

NOTE : There is a case that the LAN Port Number is changed. When the main screen is not displayed even though the icon of the array subsystem is clicked, use the changed LAN Port Number, and execute it again. (Refer to [System Parameter “1.2 LAN Port Number Change by Hitachi Storage Navigator Modular 2” \(SYSPR 01-0120\).](#))

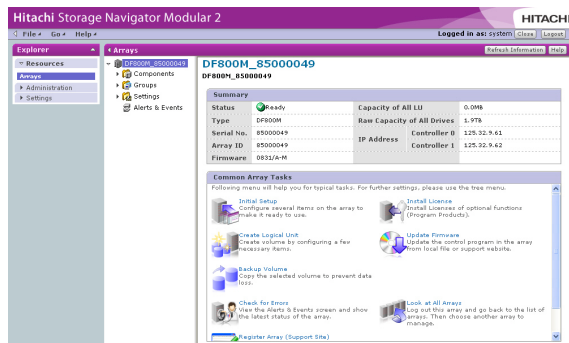

^{#1} : When the array subsystem to operate is not registered, click the blank area (other than buttons and characters) in the “Arrays” window, and press the [Ctrl] key, [Shift] key and [E] key at the same time.

(d) Select [Performance] - [Tuning Parameters], and select [Multi Stream].

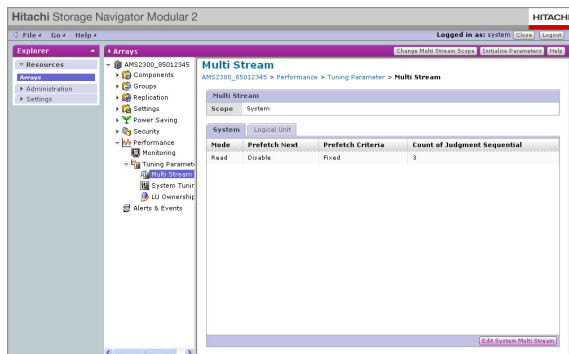

NOTE : The prefetch staging size, next starting opportunity and host data transfer access size are set at optimum values. If the setting is changed unpreparedly, it will affect performance and may interfere with operation. When changing them, contact the manufacturer in advance.

(e) Select the [System] tab.

(f) Click the [Edit System Multi Stream] button.

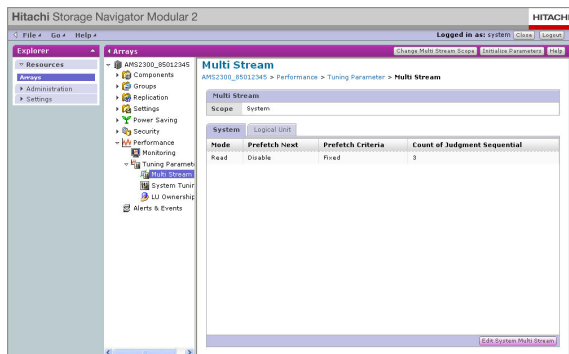

(g) The parameter in the system Multi Stream window is set.

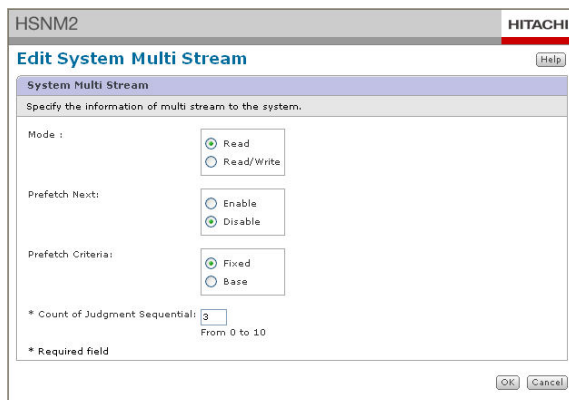

(h) Check that the set contents are correct.

If the [Cancel] button is clicked, the change content is cancelled.

Click the [OK] button to terminate the setting.

(i) Check the contents of the confirmation message window, and click the [Close] button.

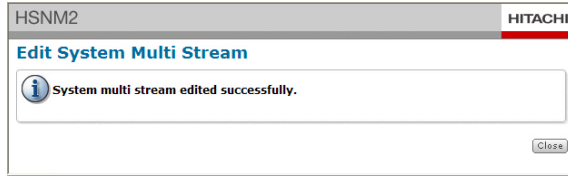

(j) Check that the content set in the Multi Stream window is reflected.

(2) When the version of Hitachi Storage Navigator Modular 2 is less than Ver. 6.02

(a) Start the Hitachi Storage Navigator Modular 2.

(b) Put a checkmark to the array subsystem to set, press the [Ctrl] key, [Shift] key and [E] key at the same time, and change the operation mode to “Maintenance Mode”.^(†1)

It is displayed as “maintenance mode” in [Operation Mode] of the upper part of the window, and Hitachi Storage Navigator Modular 2 is operated in the maintenance mode.

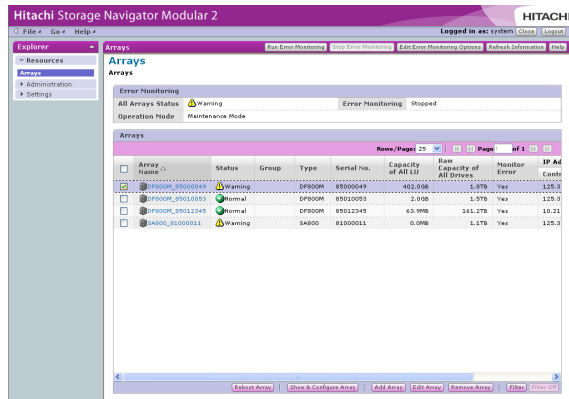

(c) Click the array subsystem name, and open the unit window.

NOTE : There is a case that the LAN Port Number is changed. When the main screen is not displayed even though the icon of the array subsystem is clicked, use the changed LAN Port Number, and execute it again. (Refer to [System Parameter “1.2 LAN Port Number Change by Hitachi Storage Navigator Modular 2” \(SYSPR 01-0120\).](#))

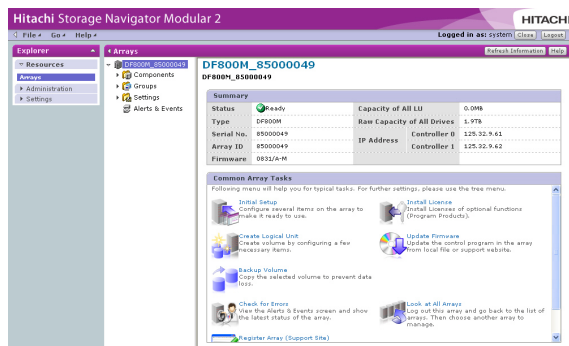

^{†1} : When the array subsystem to operate is not registered, click the blank area (other than buttons and characters) in the “Arrays” window, and press the [Ctrl] key, [Shift] key and [E] key at the same time.

- (d) Select [Settings] - [Advanced Settings] on the unit window, and click the [Open Advanced Settings] button.

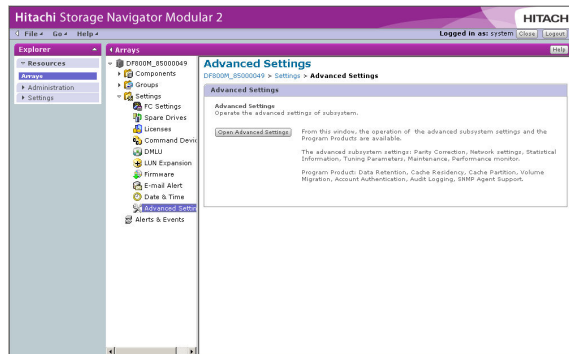

- (e) Select the [Turning Parameter] on the applet window, and click the [Set] button.

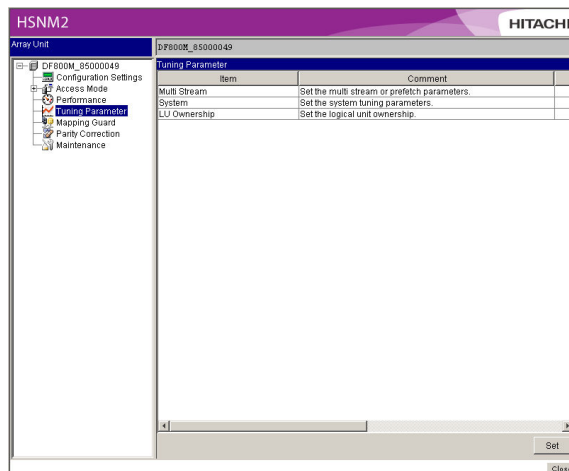

- (f) Click the [Multi Stream] tab on the Tuning Parameter dialog box.

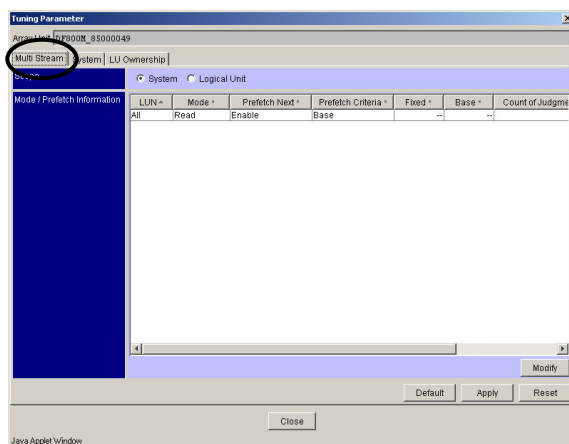

NOTE : The prefetch staging size, next starting opportunity and host data transfer access size are set at optimum values. If the setting is changed unpreparedly, it will affect performance and may interfere with operation. When changing them, contact the manufacturer in advance.

- (g) Select the LUN you want to modify the prefetch size, click the [Modify] button.
(h) Specify the Prefetch Multi Stream (System), click the [OK] button.

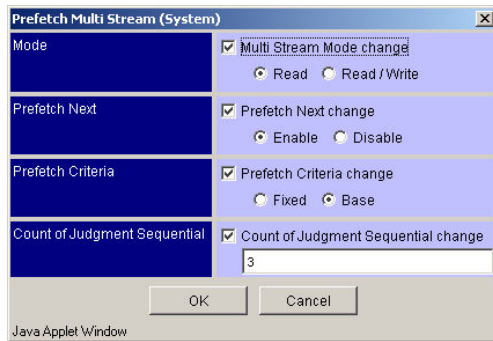

- (i) Check if the settings that have been made are correct and click the [Apply] button.
(j) A message asking you to verify the setting is displayed. Click the [OK] button.

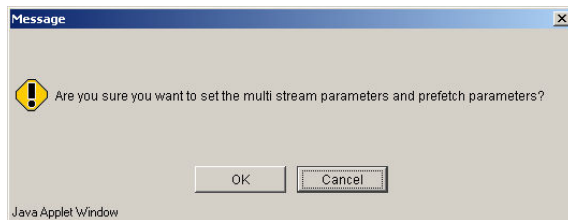

- (k) When the setting is completed, the following message is displayed. Click the [OK] button.



- (l) Click the [Close] button on the Tuning Parameter dialog box.

This page is for editorial purpose only.

10.2.5 Setting a Threshold for Preventive Maintenance

A threshold for the number of drive failure managed in preventive maintenance is set.

- (1) Start the Hitachi Storage Navigator Modular 2.
- (2) Put a checkmark to the array subsystem to set, press the [Ctrl] key, [Shift] key and [E] key at the same time, and change the operation mode to “Maintenance Mode”.^(†1)

It is displayed as “maintenance mode” in [Operation Mode] of the upper part of the window, and Hitachi Storage Navigator Modular 2 is operated in the maintenance mode.

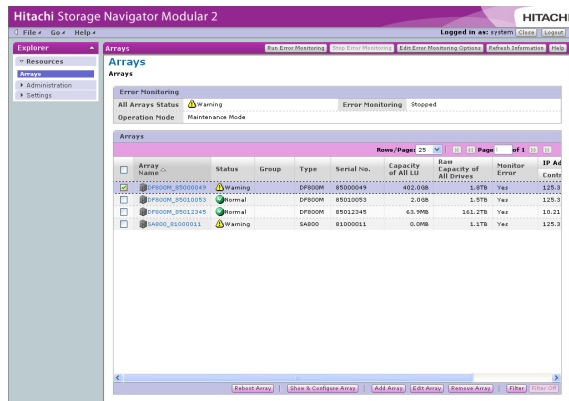

- (3) Click the array subsystem name, and open the unit window.

NOTE : There is a case that the LAN Port Number is changed. When the main screen is not displayed even though the icon of the array subsystem is clicked, use the changed LAN Port Number, and execute it again. (Refer to [System Parameter “1.2 LAN Port Number Change by Hitachi Storage Navigator Modular 2” \(SYSPR 01-0120\).](#))

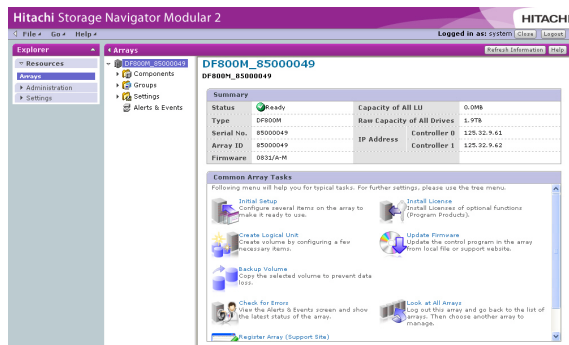

†1 : When the array subsystem to operate is not registered, click the blank area (other than buttons and characters) in the “Arrays” window, and press the [Ctrl] key, [Shift] key and [E] key at the same time.

- (4) Select [Settings] - [Advanced Settings] on the unit window, and click the [Open Advanced Settings] button.

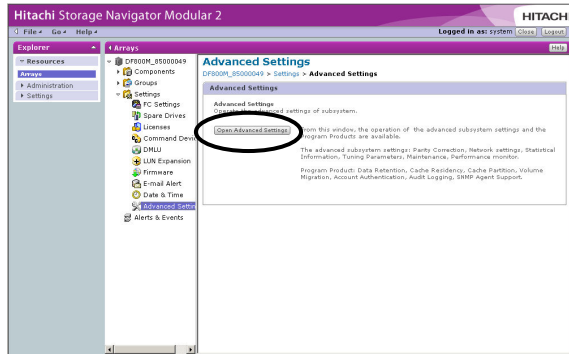

- (5) Select the [Maintenance] on the applet window, and click the [Set] button. Maintenance dialog box is displayed.

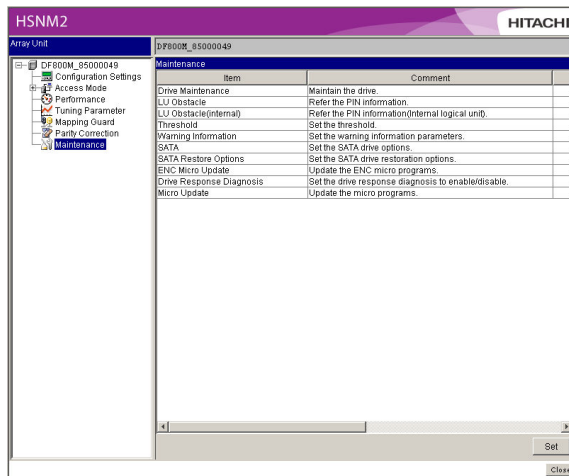

(6) Click the Threshold tab on the Maintenance dialog box.

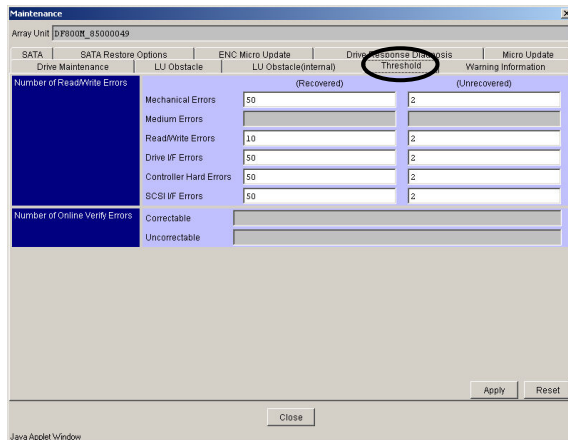

- Number of Read/Write Errors : Specifies a threshold of a read/write error.
 - Mechanical Errors : Accumulated number of mechanical error occurrences
 - Medium Errors : Accumulated number of medium error occurrences
 - Read/Write Errors : Accumulated number of read/write error occurrences
 - Drive I/F Errors : Accumulated number of drive interface error occurrences
 - Controller Hard Errors : Accumulated number of controller hardware error occurrences
 - SCSI I/F Errors : Accumulated number of SCSI interface error occurrences
- Number of Online Verify Errors : Specifies a threshold of a read/write error.
 - Correctable : Accumulated number of occurrences of correctable error in on-line verify execution
 - Uncorrectable : Accumulated number of occurrences of uncorrective error in on-line verify execution

A threshold is specified in the range of 1 to 65,535 with 1 as a unit. If you specify 0, it will not be an object of preventive maintenance.

NOTE : A threshold is set at an optimum value : If the setting is changed unpreparedly, it may perform preventive maintenance operation outside the range of it or may not operate even though there is an object for it: When changing it, contact the manufacturer in advance.

(7) Change the value and click the [Apply] button.

(8) A confirming message appears. Click the [OK] button.

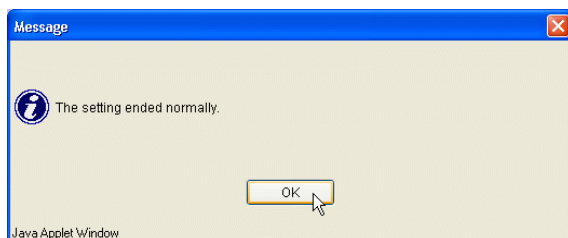

(9) Click the [Close] button.

10.2.6 Drive Maintenance

Performs maintenance functions on drives mounted in array units such as blocking a drive forcibly and instructing to restore.

- (1) Start the Hitachi Storage Navigator Modular 2.
- (2) Put a checkmark to the array subsystem to set, press the [Ctrl] key, [Shift] key and [E] key at the same time, and change the operation mode to “Maintenance Mode”.^(#1)

It is displayed as “maintenance mode” in [Operation Mode] of the upper part of the window, and Hitachi Storage Navigator Modular 2 is operated in the maintenance mode.

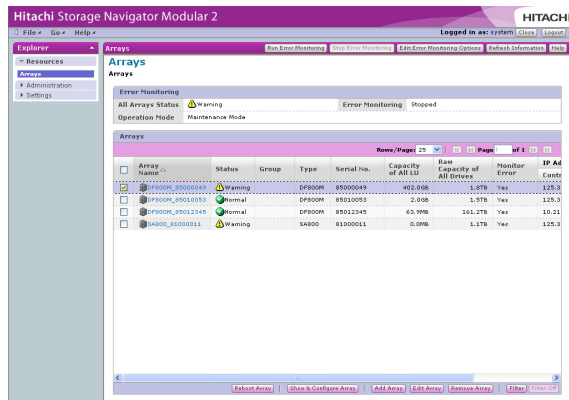

- (3) Click the array subsystem name, and open the unit window.

NOTE : There is a case that the LAN Port Number is changed. When the main screen is not displayed even though the icon of the array subsystem is clicked, use the changed LAN Port Number, and execute it again. (Refer to [System Parameter “1.2 LAN Port Number Change by Hitachi Storage Navigator Modular 2” \(SYSPR 01-0120\)](#).)

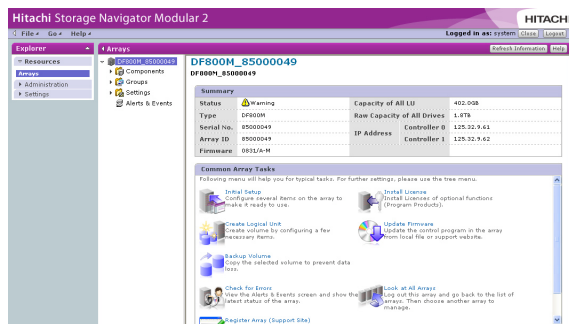

^{#1} : When the array subsystem to operate is not registered, click the blank area (other than buttons and characters) in the “Arrays” window, and press the [Ctrl] key, [Shift] key and [E] key at the same time.

- (4) Select [Settings] - [Advanced Settings] on the unit window, and click the [Open Advanced Settings] button.

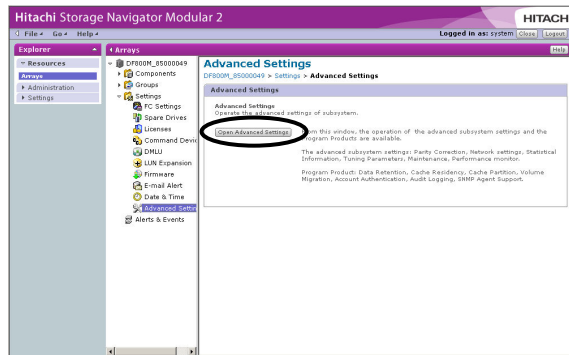

- (5) Select the [Maintenance] on the applet window, and click the [Set] button.

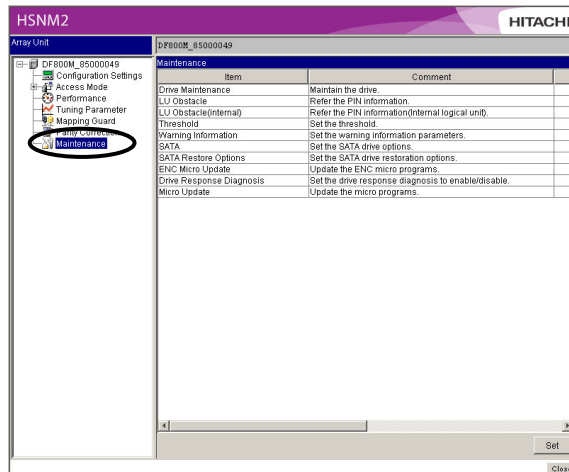

(6) Click the Drive Maintenance tab on the Maintenance dialog box.

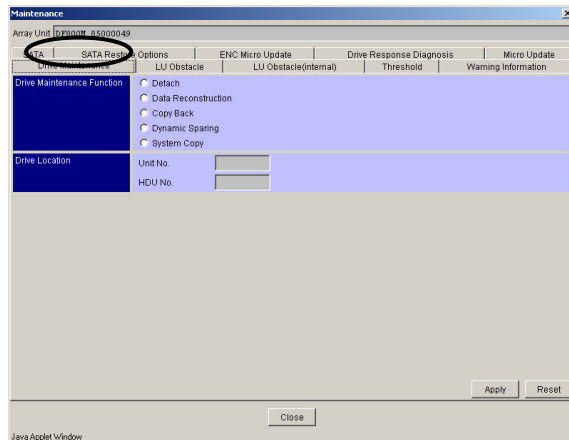

- Drive Maintenance Function:
 - Detach : Blocks a drive specified in the Drive Location box forcibly.
 - Copy Back : Copies data from a spare drive to a drive specified in the Drive Location box.
 - Dynamic Sparing : Copies data forcibly from a drive specified in the Drive Location box to a spare drive.
 - System Copy : Copies the system area from the current system drive to a system drive specified in the Drive Location box.
- Drive Location:
 - Unit No. : Unit No. of a drive on which to perform a maintenance function
 - HDU No. : HDU No. of a drive on which to perform a maintenance function

(7) If you click the [Apply] button, a selected function will be performed.

(8) Click the [Close] button.

This page is for editorial purpose only.

10.2.7 Setting a Mode for Reporting to the Host Using an SSB

This setting specifies a mode for reporting an SSB to the host when a trouble such as a failure in a part of the disk array system occurs.

- (1) Start the Hitachi Storage Navigator Modular 2.
- (2) Put a checkmark to the array subsystem to set, press the [Ctrl] key, [Shift] key and [E] key at the same time, and change the operation mode to “Maintenance Mode”.^(#1)

It is displayed as “maintenance mode” in [Operation Mode] of the upper part of the window, and Hitachi Storage Navigator Modular 2 is operated in the maintenance mode.

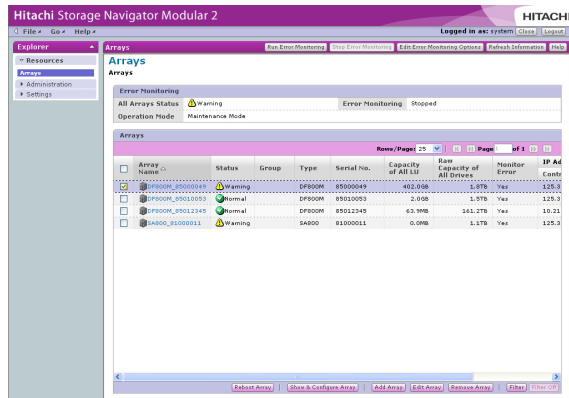

- (3) Click the array subsystem name, and open the unit window.

NOTE : There is a case that the LAN Port Number is changed. When the main screen is not displayed even though the icon of the array subsystem is clicked, use the changed LAN Port Number, and execute it again. (Refer to [System Parameter “1.2 LAN Port Number Change by Hitachi Storage Navigator Modular 2” \(SYSPR 01-0120\)](#).)

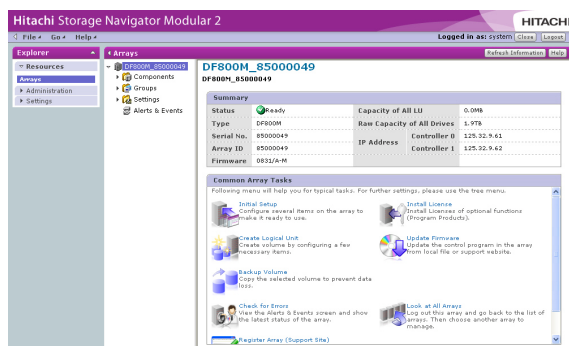

#1 : When the array subsystem to operate is not registered, click the blank area (other than buttons and characters) in the “Arrays” window, and press the [Ctrl] key, [Shift] key and [E] key at the same time.

- (4) Select [Settings] - [Advanced Settings] on the unit window, and click the [Open Advanced Settings] button.

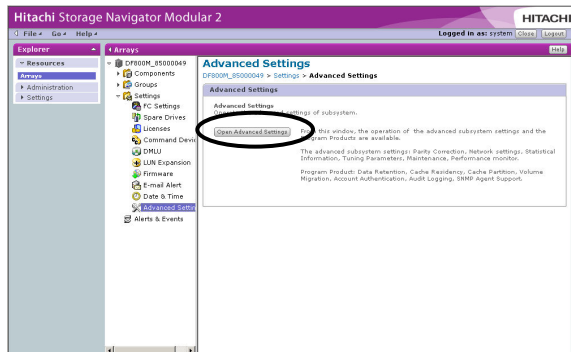

- (5) Select the [Maintenance] on the applet window, and click the [Set] button. Maintenance dialog box is displayed.

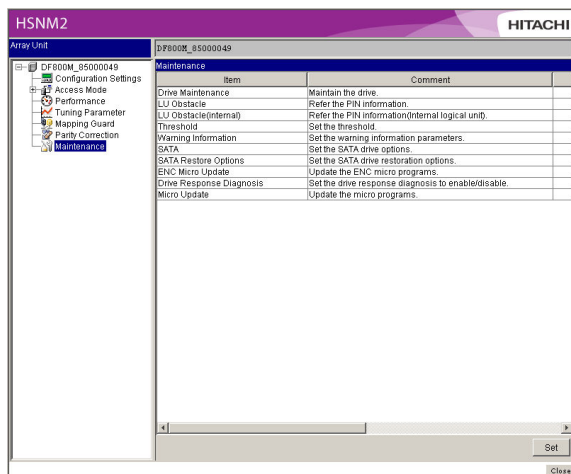

(6) Click the Warning Information tab on the Maintenance dialog box.

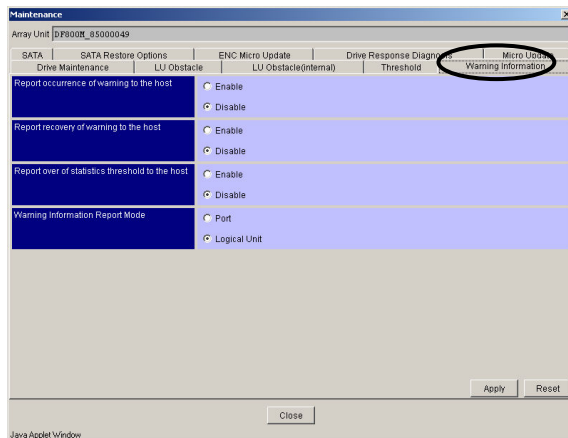

- Report occurrence of warning to the host : Reporting an SSB to the host when a failure that causes a warning occurs.
- Report recovery of warning to the host : Reporting an SSB to the host when the subsystem recovers from a failure which caused a warning.
- Report over of statistics threshold to the host : Reporting an SSB to the host when any of the statistical data exceeds its threshold value.
- Warning Information Report Mode:
 - Port : Reports the failure information of the port.
 - Logical Unit : Reports the failure information of the port, initiator, and logical unit.

(7) Click on an item you want to set to validate it, and then click the [Apply] button.

(8) A confirming message appears. Click the [OK] button.

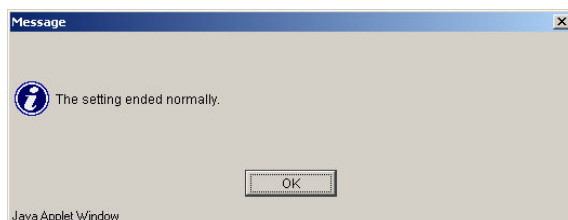

(9) Click the [Close] button.

10.2.8 Setting SATA Drive Options

Refer to or set the SATA drive option.

- (1) Start the Hitachi Storage Navigator Modular 2.
- (2) Put a checkmark to the array subsystem to set, press the [Ctrl] key, [Shift] key and [E] key at the same time, and change the operation mode to “Maintenance Mode”.^(†1)

It is displayed as “maintenance mode” in [Operation Mode] of the upper part of the window, and Hitachi Storage Navigator Modular 2 is operated in the maintenance mode.

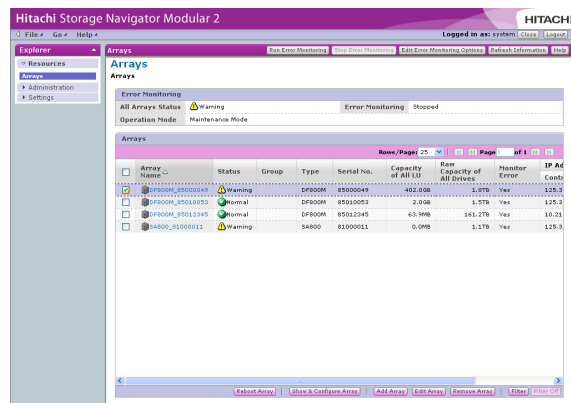

- (3) Click the array subsystem name, and open the unit window.

NOTE : There is a case that the LAN Port Number is changed. When the main screen is not displayed even though the icon of the array subsystem is clicked, use the changed LAN Port Number, and execute it again. (Refer to [System Parameter “1.2 LAN Port Number Change by Hitachi Storage Navigator Modular 2” \(SYSPR 01-0120\).](#))

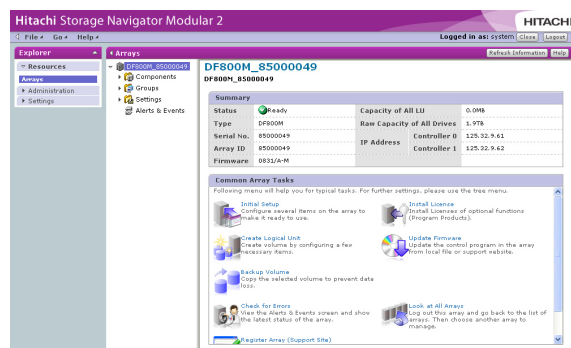

†1 : When the array subsystem to operate is not registered, click the blank area (other than buttons and characters) in the “Arrays” window, and press the [Ctrl] key, [Shift] key and [E] key at the same time.

- (4) Select [Settings] - [Advanced Settings] on the unit window, and click the [Open Advanced Settings] button.

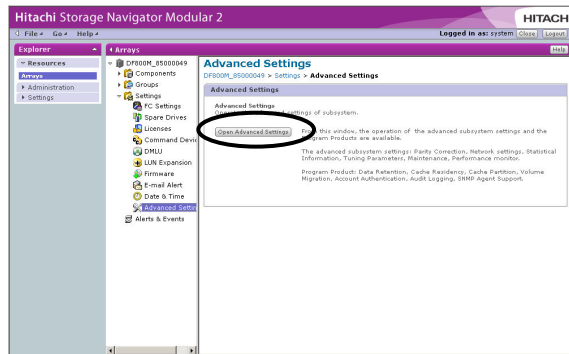

- (5) Select the [Maintenance] on the applet window, and click the [Set] button. Maintenance dialog box is displayed.

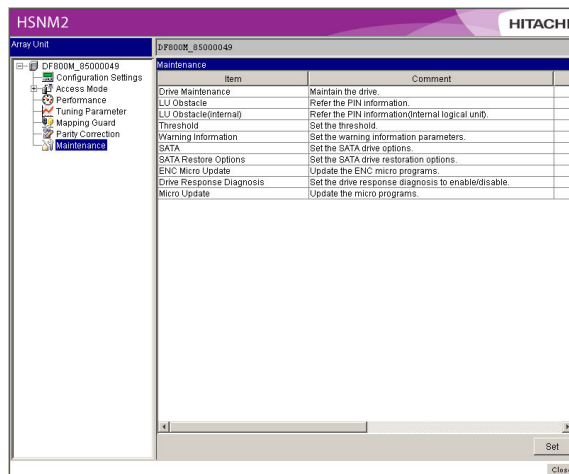

(6) Click the SATA tab on the Maintenance dialog box.

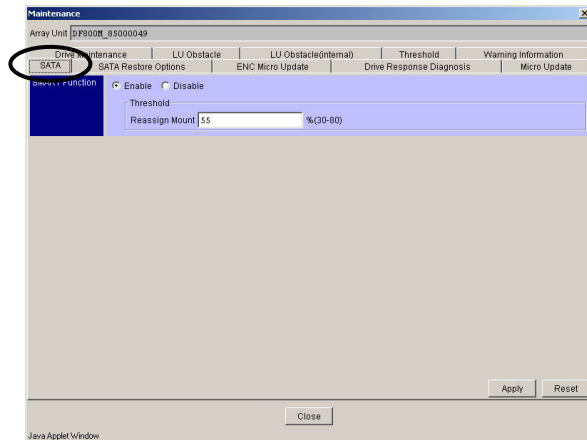

- SMART Function:

Enable/Disable : Make a selection whether to enable or disable the SMART Function.

Threshold : Specify the threshold value of the Reassign Mount to start the dynamic sparing.

(7) Change the value and click the [Apply] button.

(8) A confirming message appears. Click the [OK] button.

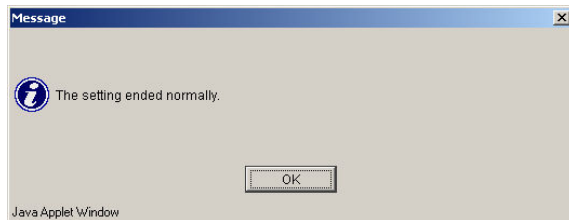

(9) Click the [Close] button.

10.2.9 Setting SATA Drive Restore Options

Refer to or set the SATA drive restore option.

- (1) Start the Hitachi Storage Navigator Modular 2.
- (2) Put a checkmark to the array subsystem to set, press the [Ctrl] key, [Shift] key and [E] key at the same time, and change the operation mode to “Maintenance Mode”.^(‡1)

It is displayed as “maintenance mode” in [Operation Mode] of the upper part of the window, and Hitachi Storage Navigator Modular 2 is operated in the maintenance mode.

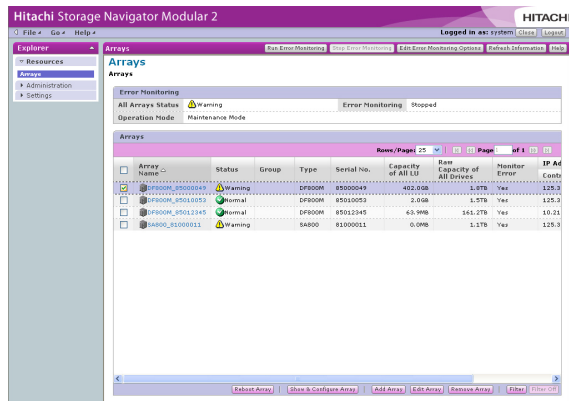

- (3) Click the array subsystem name, and open the unit window.

NOTE : There is a case that the LAN Port Number is changed. When the main screen is not displayed even though the icon of the array subsystem is clicked, use the changed LAN Port Number, and execute it again. (Refer to [System Parameter “1.2 LAN Port Number Change by Hitachi Storage Navigator Modular 2” \(SYSPR 01-0120\).](#))

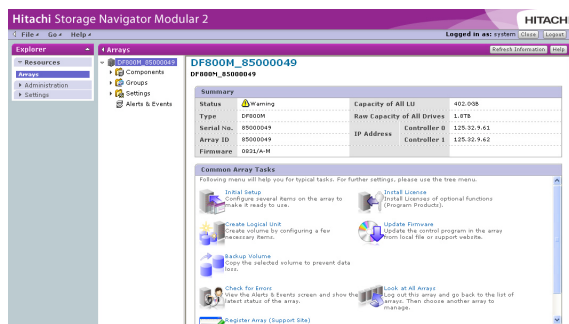

‡1 : When the array subsystem to operate is not registered, click the blank area (other than buttons and characters) in the “Arrays” window, and press the [Ctrl] key, [Shift] key and [E] key at the same time.

- (4) Select [Settings] - [Advanced Settings] on the unit window, and click the [Open Advanced Settings] button.

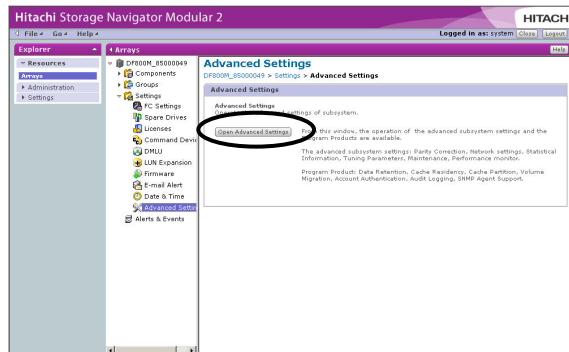

- (5) Select the [Maintenance] on the applet window, and click the [Set] button. Maintenance dialog box is displayed.

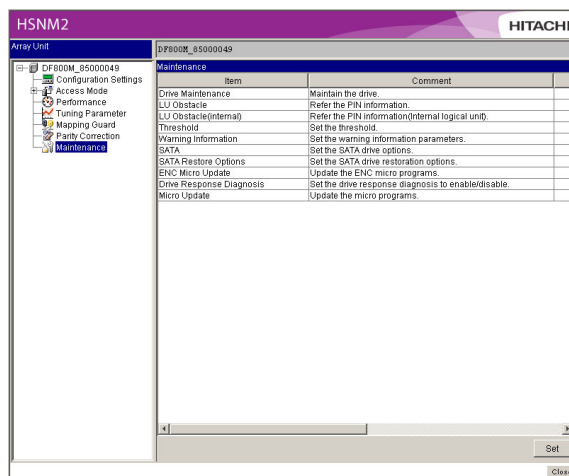

- (6) Click the SATA Restore Options tab on the Maintenance dialog box.

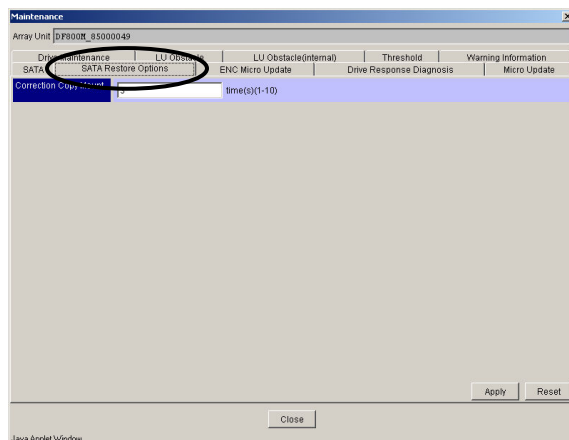

- Correction Copy Mount : Specify the size of data to be restored at a time with by means of a correction copy as a multiple n of the SAS/SAS(SED) drive capacity.

- (7) Change the value and click the [Apply] button.

(8) A confirming message appears. Click the [OK] button.



(9) Click the [Close] button.

This page is for editorial purpose only.

10.2.10 Replacing the Online ENC Firmware

The function downloads and replaces the ENC firmware in the array unit. When replacing the ENC firmware, download it, and then replace it.

Perform the replacement work of the ENC firmware referring to the following Chapter.

- [Chapter 12. Procedure for Online ENC Firmware Download \(TRBL 12-0000\)](#)

- (1) Start the Hitachi Storage Navigator Modular 2.
- (2) Put a checkmark to the array subsystem to set, press the [Ctrl] key, [Shift] key and [E] key at the same time, and change the operation mode to “Maintenance Mode”.^(#1)

It is displayed as “maintenance mode” in [Operation Mode] of the upper part of the window, and Hitachi Storage Navigator Modular 2 is operated in the maintenance mode.

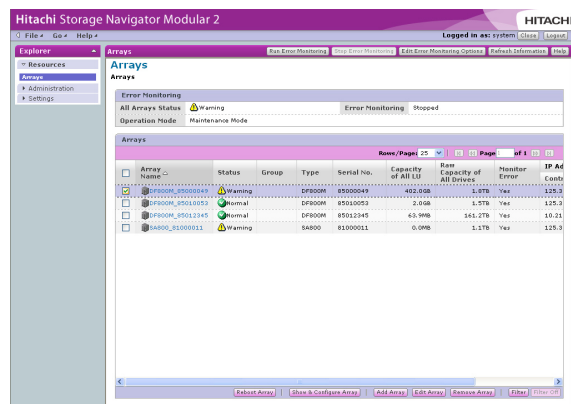

- (3) Click the array subsystem name, and open the unit window.

NOTE : There is a case that the LAN Port Number is changed. When the main screen is not displayed even though the icon of the array subsystem is clicked, use the changed LAN Port Number, and execute it again. (Refer to [System Parameter “1.2 LAN Port Number Change by Hitachi Storage Navigator Modular 2” \(SYSPR 01-0120\)](#).)



#1 : When the array subsystem to operate is not registered, click the blank area (other than buttons and characters) in the “Arrays” window, and press the [Ctrl] key, [Shift] key and [E] key at the same time.

- (4) Select [Settings] - [Advanced Settings] on the unit window, and click the [Open Advanced Settings] button.

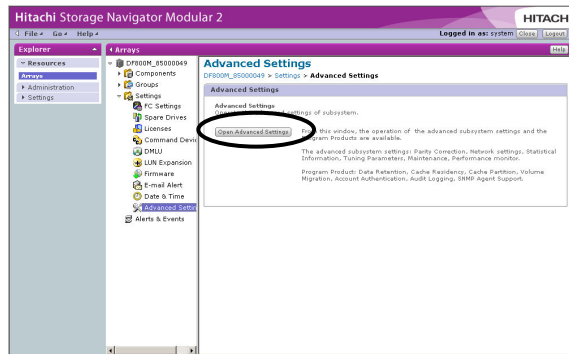

- (5) Select the [Maintenance] on the applet window, and click the [Set] button. Maintenance dialog box is displayed.

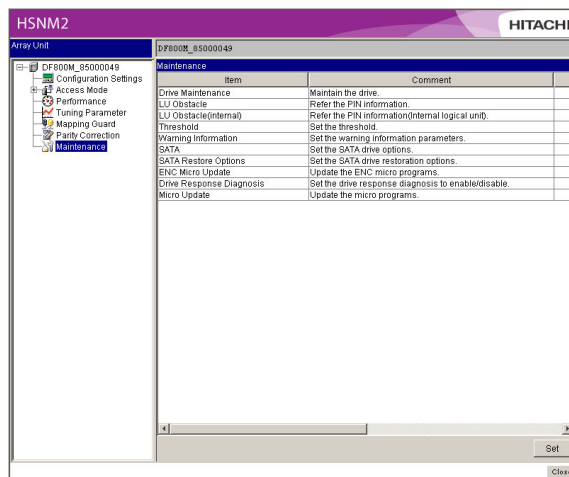

(6) Click the [ENC Micro Update] tab on the Maintenance dialog box.

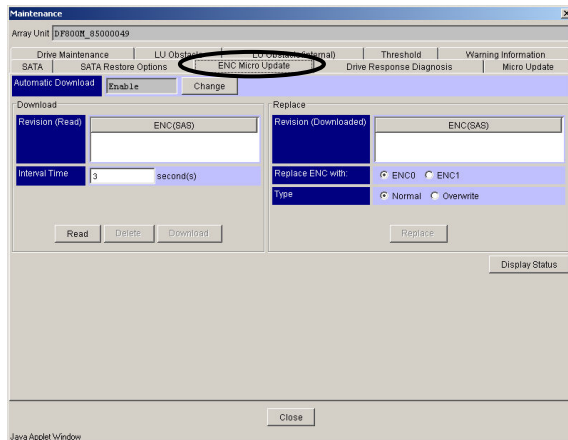

- Automatic Download : Specify whether or not to download the ENC firmware automatically. When you replace the ENC firmware manually, make the automatic downloading invalid using the changing button.
- Revision (Read) : The revisions (ENC <SAS>) for the Basic Chassis that have been already read are displayed. If they have not been read, nothing is displayed.
- Interval Time : Interval time for download. Specify the time between one second and 60 seconds. For the LAN connection, when the interval time is specified as 3 seconds, the download requires approximately 9 minutes. The time required for the execution varies with the network status and depends on the I/Os issued by the host. When the interval time is specified as one second longer, the time required for the download is prolonged by 3 minutes. This function can be used during execution of the I/O instructed by the host. However, when the download function is executed, I/O performance of the host is reduced. To enhance performance, specify a longer interval time.
- Revision (Downloaded) : The revisions (ENC <SAS>) for the Basic Chassis that have been already downloaded are displayed. If they have not been downloaded, nothing is displayed.
- Replace ENC with : Specify the ENC whose firmware is to be replaced.
- Type : Specify the Normal or Overwrite.

When no firmware is read, the Delete and Download buttons are displayed in gray and cannot be selected.

(7) Click the [Close] button.

10.2.11 Drive Performance Delay Diagnostic Function

If it is clear that the performance delay problem is caused by the drive, setting this function notifies the drive number of which caused the problem through the message and executes the dynamic sparing.

- (1) Start the Hitachi Storage Navigator Modular 2.
- (2) Put a checkmark to the array subsystem to set, press the [Ctrl] key, [Shift] key and [E] key at the same time, and change the operation mode to “Maintenance Mode”.^(‡1)

It is displayed as “maintenance mode” in [Operation Mode] of the upper part of the window, and Hitachi Storage Navigator Modular 2 is operated in the maintenance mode.

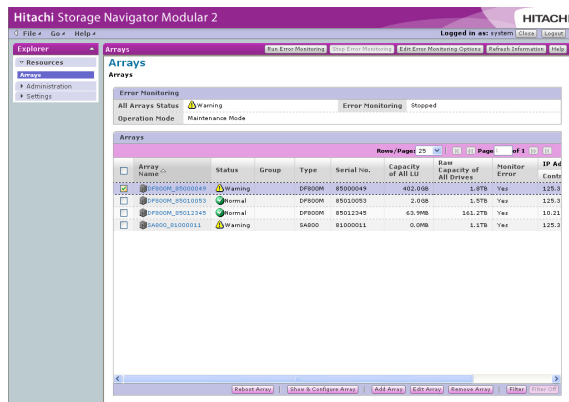

- (3) Click the array subsystem name, and open the unit window.

NOTE : There is a case that the LAN Port Number is changed. When the main screen is not displayed even though the icon of the array subsystem is clicked, use the changed LAN Port Number, and execute it again. (Refer to [System Parameter “1.2 LAN Port Number Change by Hitachi Storage Navigator Modular 2” \(SYSPR 01-0120\).](#))

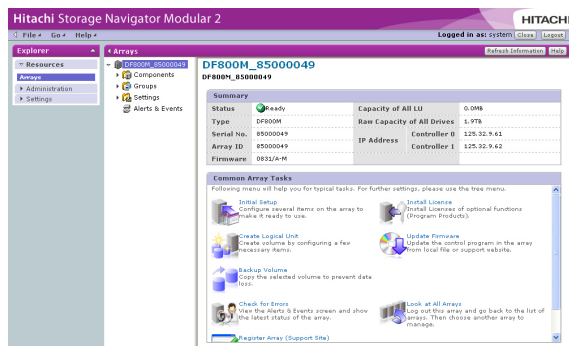

‡1 : When the array subsystem to operate is not registered, click the blank area (other than buttons and characters) in the “Arrays” window, and press the [Ctrl] key, [Shift] key and [E] key at the same time.

- (4) Select [Settings] - [Advanced Settings] on the unit window, and click the [Open Advanced Settings] button.

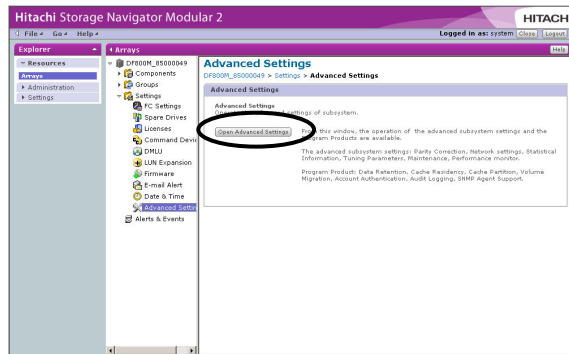

- (5) Select the [Maintenance] on the applet window, and click the [Set] button. Maintenance dialog box is displayed.

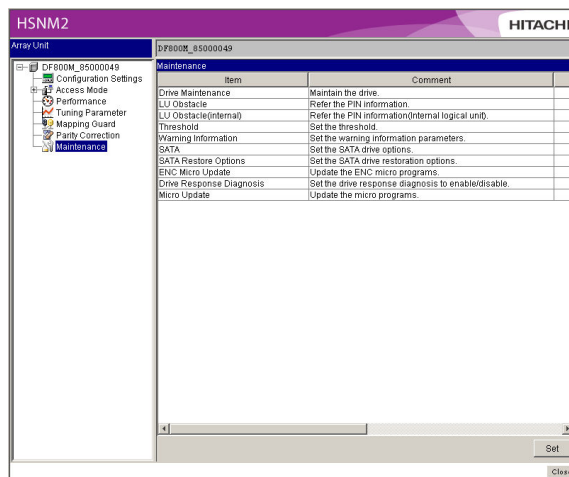

(6) Click the [Drive Response Diagnosis] tab on the Maintenance dialog box.

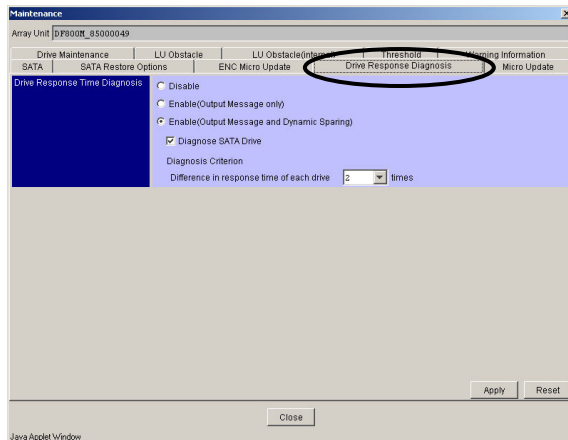

- Disable : The drive response time is not diagnosed.

- Enable (Output Message only):

The drive response time is diagnosed and a number of the drive that caused the response delay is displayed in a message.

Diagnose SATA Drive:

Fill the check box when you want to diagnose the SATA drives.

Difference in response time of each drive:

The response time difference of the normal drive and the delay drive to specify the delay drive in the same RAID group.

NOTE : Specify 2 for the value of Difference in response time of each drive. If setting the value other than 2, contact the Technical Support Center.

- Enable (Output Message and Dynamic Sparring):

The drive response time is diagnosed, a number of the drive that caused the response delay is displayed in a message, and the dynamic sparing is executed.

Diagnose SATA Drive:

Fill the check box when you want to diagnose the SATA drives.

Difference in response time of each drive:

The response time difference of the normal drive and the delay drive to specify the delay drive in the same RAID group.

NOTE : Specify 2 for the value of Difference in response time of each drive. If setting the value other than 2, contact the Technical Support Center.

(7) Click the [Apply] button.

(8) A confirming message appears. Click the [OK] button.



(9) Click the [Close] button.

10.2.12 Setting the Drive Firmware Download

Set whether to download the firmware automatically for the drive in the array subsystem.

- (1) Start Hitachi Storage Navigator Modular 2.
- (2) Check the array subsystem to set in the main window and press the [Ctrl] key, [Shift] key and [E] key at the same time to change the operation mode to “maintenance mode”. (#1)
“Maintenance Mode” is displayed in [Operation Mode] in the upper side of the window and Hitachi Storage Navigator Modular 2 operates in the maintenance mode.

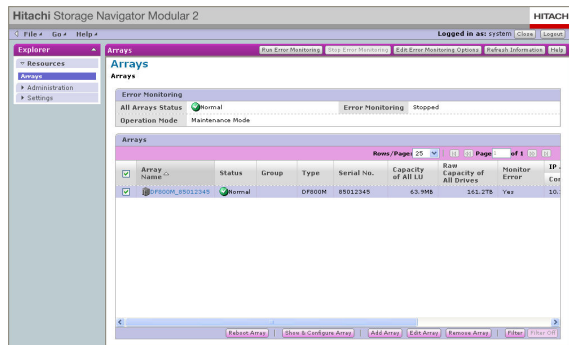

- (3) Click the array subsystem name of the array subsystem to display the maintenance information and open the unit window.

NOTE : There is a case that the LAN Port Number is changed. When the main screen is not displayed even though the icon of the array subsystem is clicked, use the changed LAN Port Number, and execute it again. (Refer to [System Parameter “1.2 LAN Port Number Change by Hitachi Storage Navigator Modular 2” \(SYSPR 01-0120\).](#))

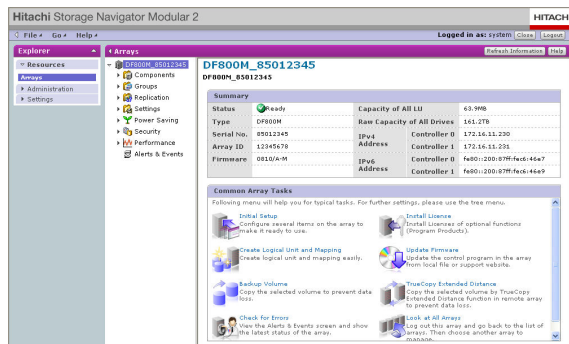

#1 : When the array subsystem to operate is not registered, click the blank area (other than buttons and characters) in the “Arrays” window, and press the [Ctrl] key, [Shift] key and [E] key at the same time.

- (4) Select [Settings] - [Advanced Settings] in the unit window and click the [Open Advanced Settings] button.

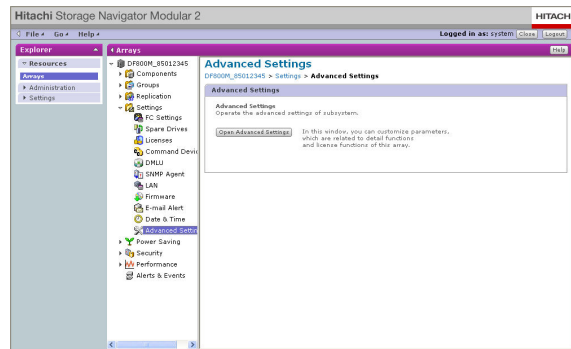

- (5) Select [Maintenance] in the applet window and click the [Settings] button displayed at the lower right of the window.

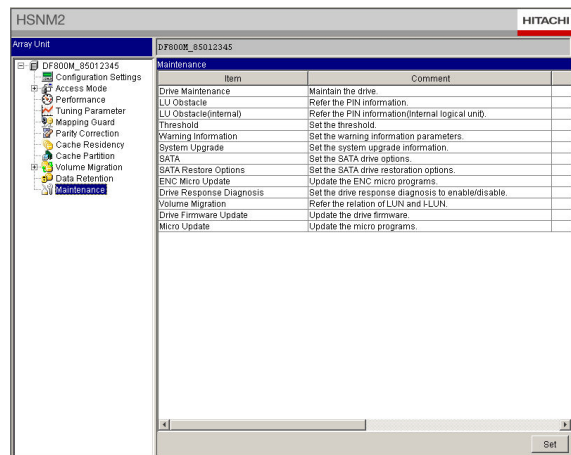

(6) The Maintenance dialog is displayed. Click the [Drive Firmware Update] tab.

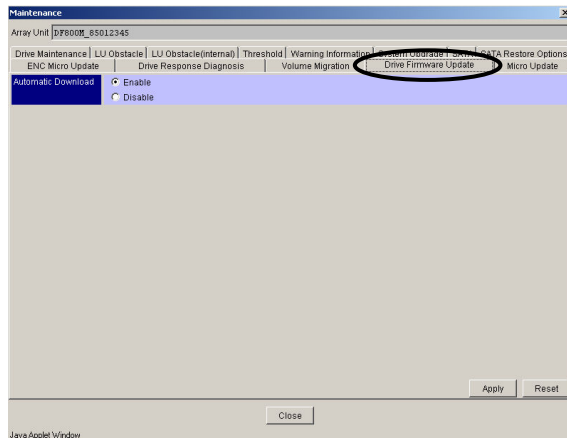

- Enabled

The drive firmware is downloaded automatically. Refer to [Firmware “1.6 Checking the Start and End of the Drive Firmware Automatic Download \(FIRM 01-0860\)”](#).

- Disabled

The automatic download of the drive firmware is not executed. If this mode is disabled during the drive firmware automatic download, the automatic download is interrupted.

(7) Click the [Apply] button.

(8) A normal termination message appears. Click the [OK] button.

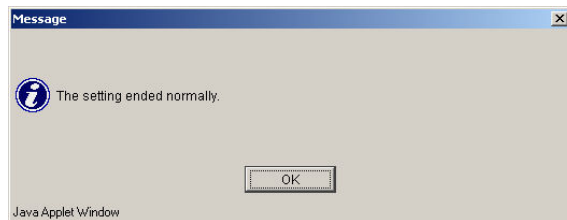

(9) Click the [Close] button.

10.2.13 Displaying Temperature in the Basic Unit

The latest temperature in the Basic Unit is displayed.

- (1) Start the Hitachi Storage Navigator Modular 2.
- (2) Check the array subsystem to set in the main window and press the [Ctrl] key, [Shift] key and [E] key at the same time to change the operation mode to “maintenance mode”. (#1)
“Maintenance Mode” is displayed in [Operation Mode] in the upper side of the window and Hitachi Storage Navigator Modular 2 operates in the maintenance mode.

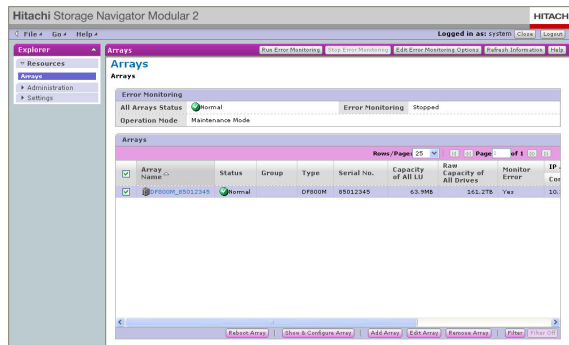

- (3) Click the array subsystem name of the array subsystem to display the maintenance information and open the unit window.

NOTE : There is a case that the LAN Port Number is changed. When the main screen is not displayed even though the icon of the array subsystem is clicked, use the changed LAN Port Number, and execute it again. (Refer to [System Parameter “1.2 LAN Port Number Change by Hitachi Storage Navigator Modular 2” \(SYSPR 01-0120\).](#))

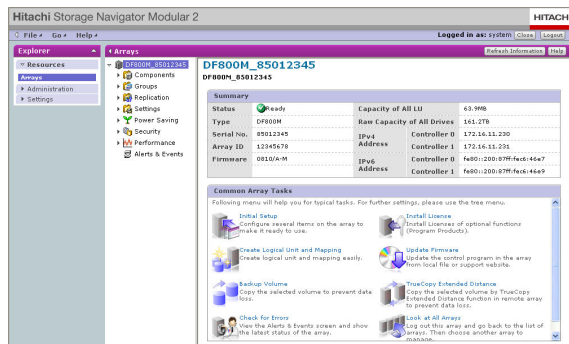

#1 : When the array subsystem to operate is not registered, click the blank area (other than buttons and characters) in the “Arrays” window, and press the [Ctrl] key, [Shift] key and [E] key at the same time.

- (4) Select [Settings] - [Advanced Settings] in the unit window and click the [Open Advanced Settings] button.

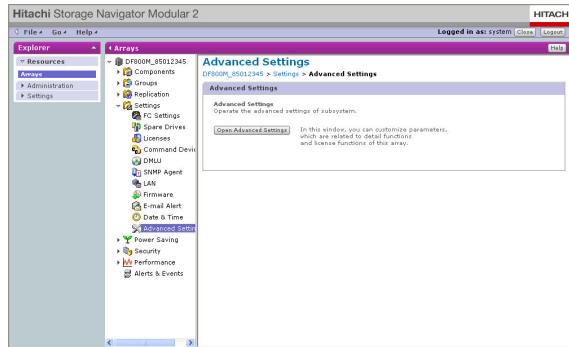

- (5) Select the [Maintenance] on the applet window, and click the [Set] button. Maintenance dialog box is displayed.

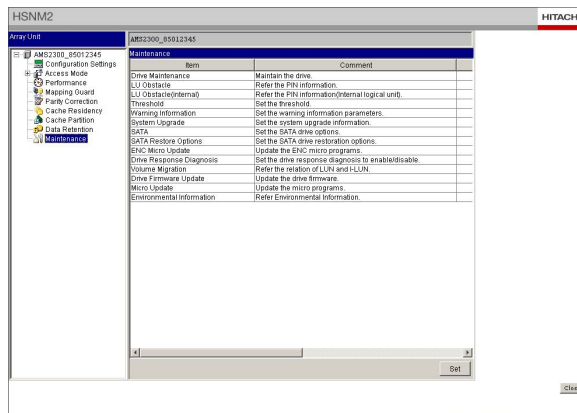

(6) Click the [Environmental Information] tab on the Maintenance dialog box.

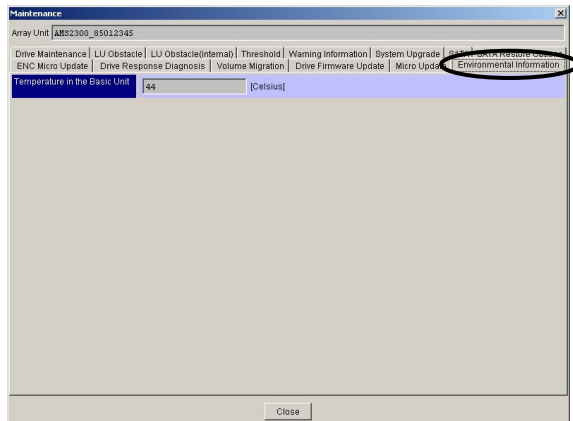

The latest temperature in the Basic Unit is displayed.

For the temperature other than the effective temperature range (over 0 degrees Celsius and lower than 100 degrees Celsius), "out of range" is displayed in the Temperature in the Basic Unit.

When the temperature has never been taken, "- -" is displayed in the Temperature in the Basic Unit.

After waiting 10 seconds, retry the procedure (5), and update the display of Temperature in the Basic Unit.

(7) Click the [Close] button.

- (4) Select [Settings] - [Advanced Settings] in the unit window and click the [Open Advanced Settings] button.

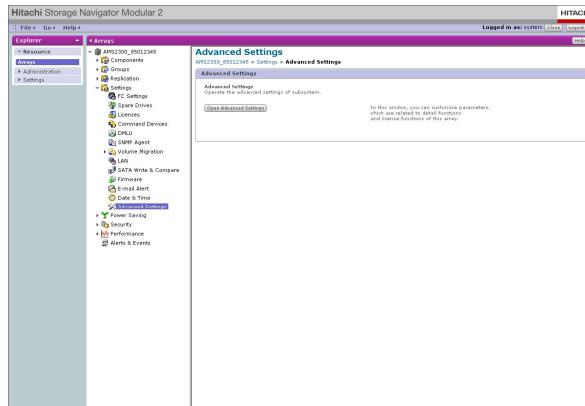

- (5) Select the [Maintenance] on the applet window, and click the [Set] button on the bottom right corner of the window.

Maintenance dialog box is displayed.

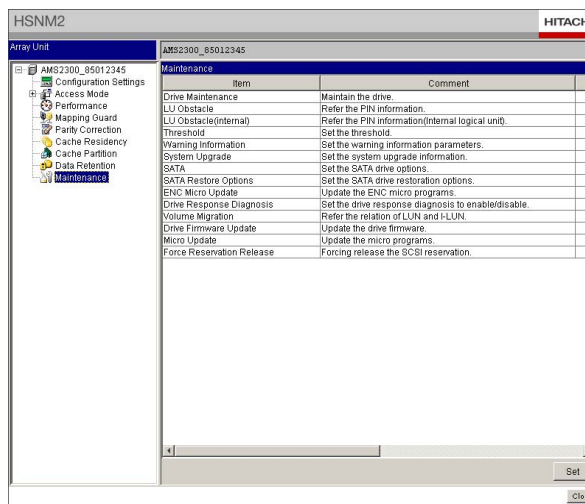

- (6) Click the [Force Reservation Release] tab on the Maintenance dialog box. On this tab, the path and reservation status of the H-LUN can be checked.

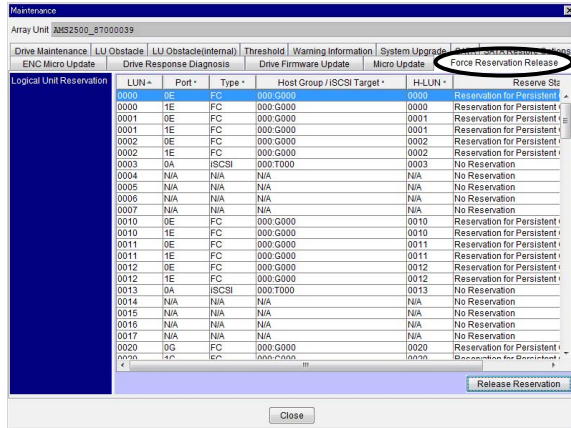

- (7) To release the reservation, click the [Release Reservation] button.

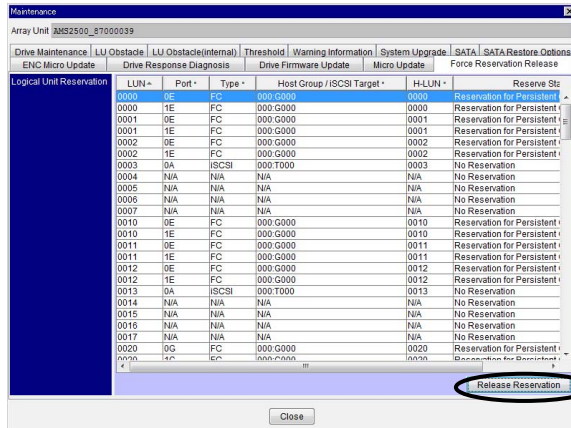

- (8) The Force Reservation Release dialog for the mapping list of the selected H-LUN is displayed. After confirming the contents in the window, click the [OK] button.

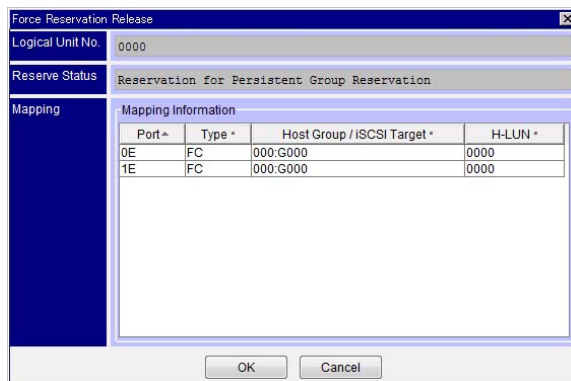

- (9) After confirming whether it is OK to release the reservation, check the [OK to release] checkbox, and click the [OK] button.

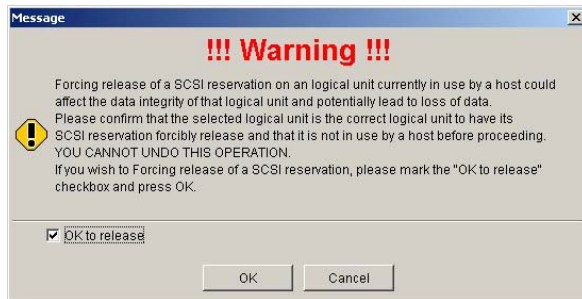

- (10) Click the [OK] button.

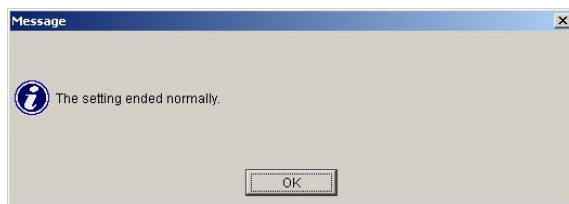

This page is for editorial purpose only.

Chapter 11. Procedure for the iSCSI System Failure Determination on the Disk Array System Side

When a failure occurs in the communication by the iSCSI protocol between the host computer and the disk array system, determine if there is a failure in the host interface part of the disk array system according to the following flow.

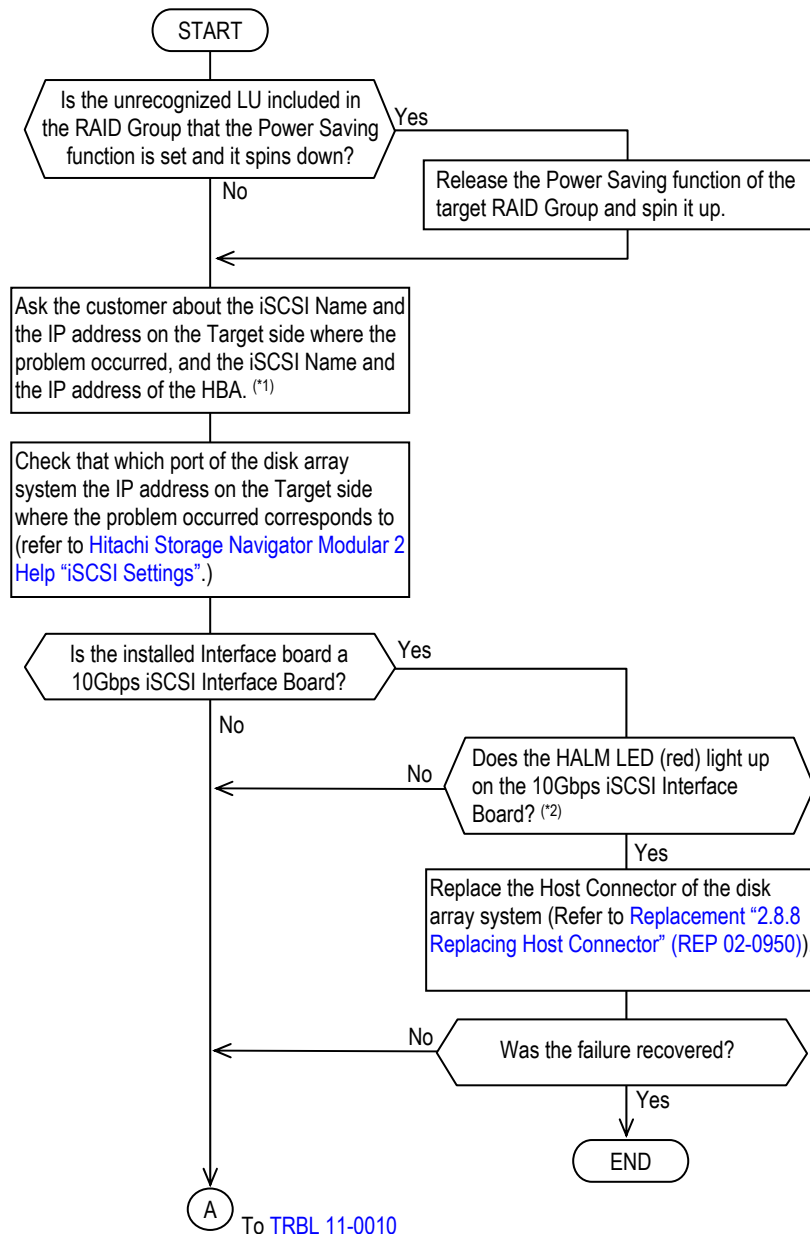

*1 : The setting of the network device becomes the work of which the system administrator or the network administrator takes charge.

*2 : It is in the status of [Item 4 on Table 8.2.8.1](#) in ["8.2 \(6\) \(c\) 10Gbps iSCSI Interface Board"](#) (TRBL 08-0281).

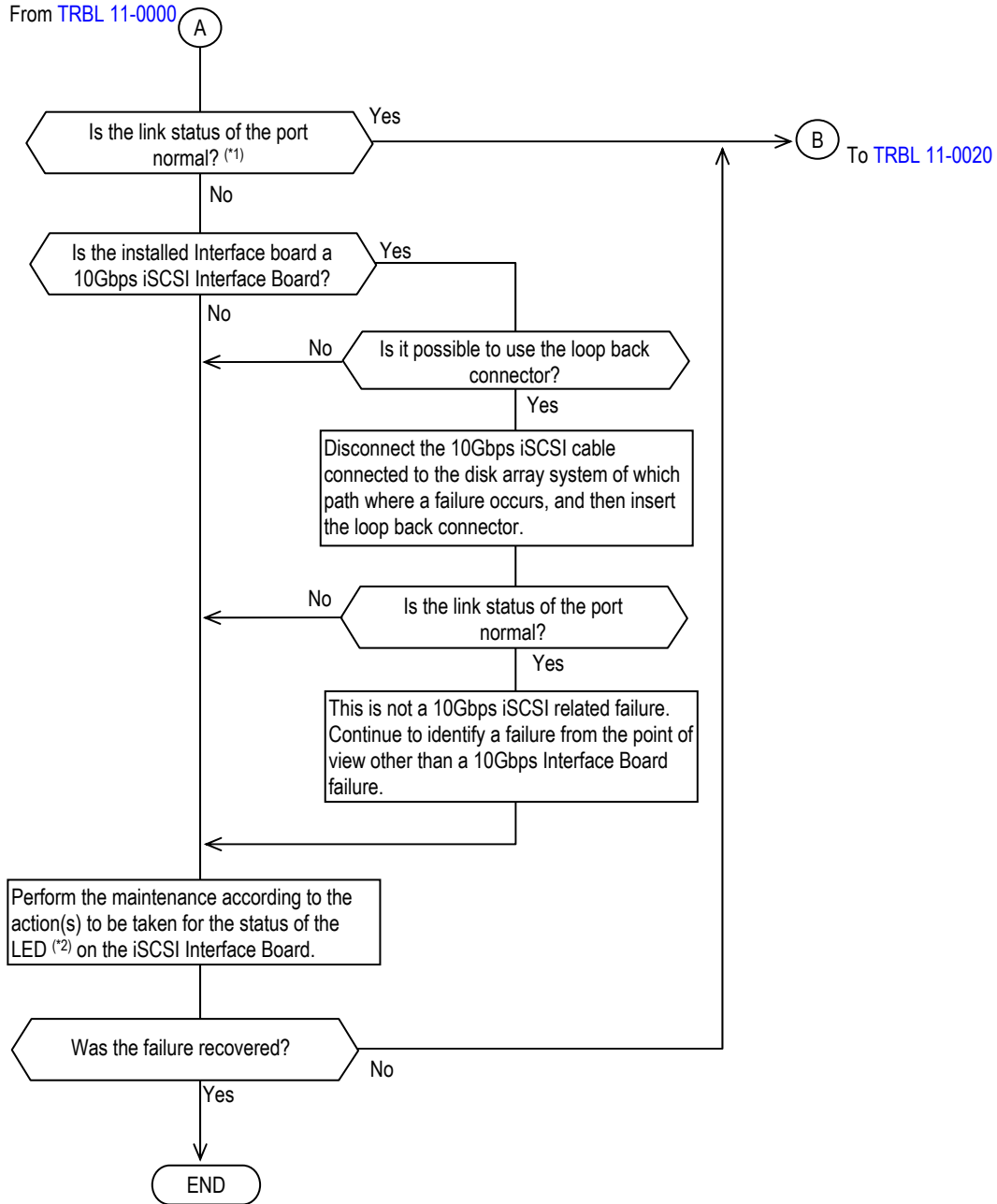

*1 : It is in the status of [Item 1 on Table 8.2.8](#) in “8.2 (6) (b) 1Gbps iSCSI Interface Board” (TRBL 08-0270).

*2 : It is in the status of [Item 2 on Table 8.2.8](#) in “8.2 (6) (b) 1Gbps iSCSI Interface Board” (TRBL 08-0270).

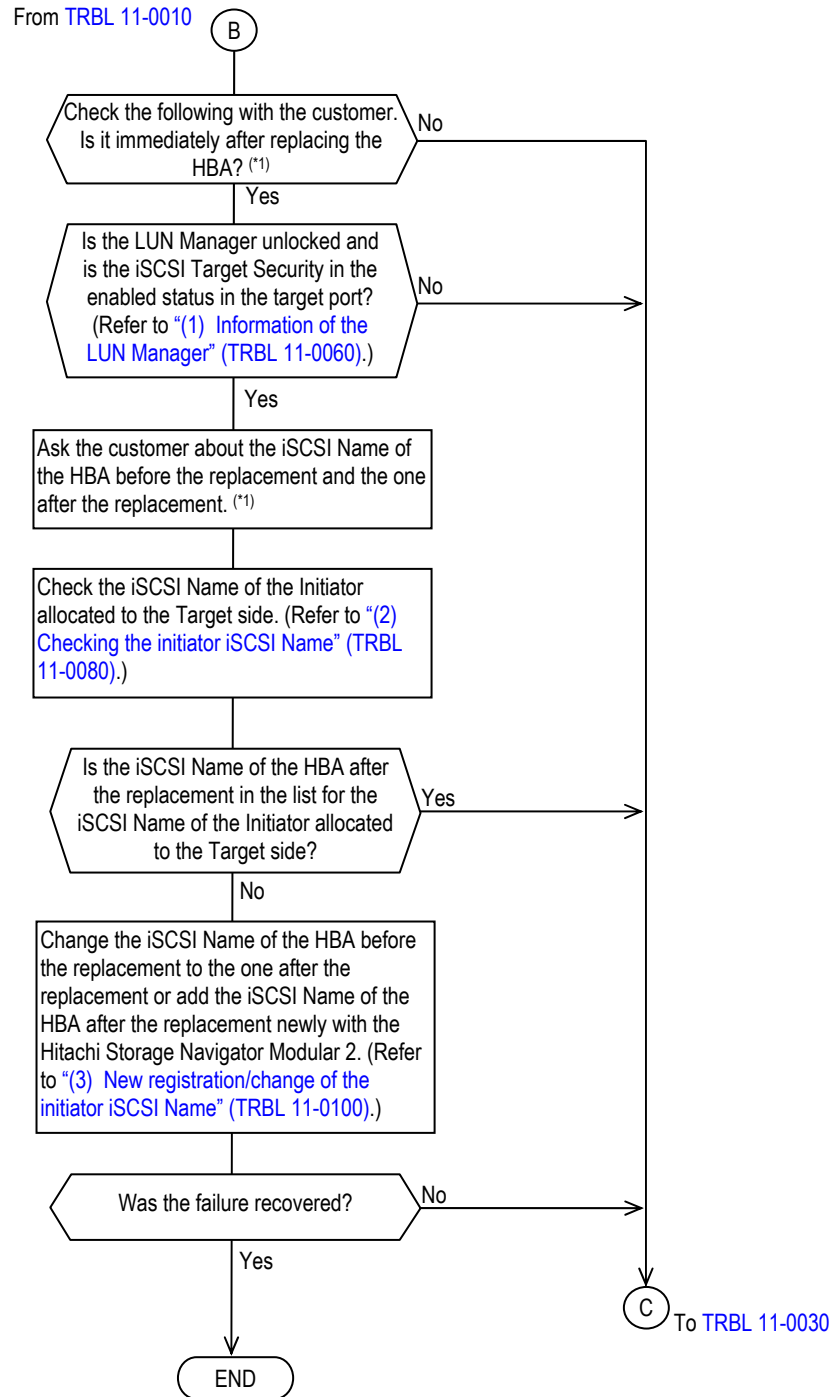

*1 : The setting of the network device becomes the work of which the system administrator or the network administrator takes charge.

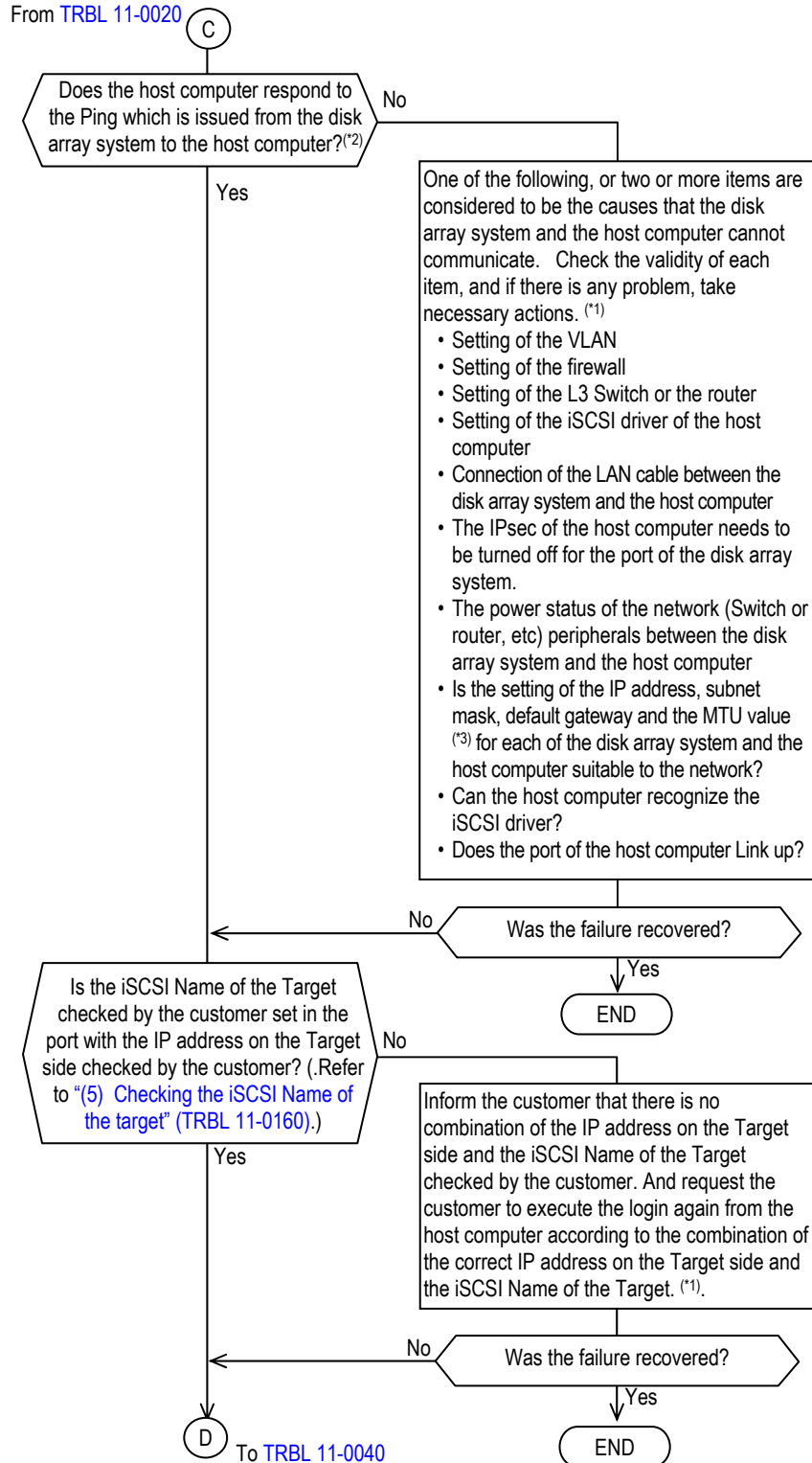

*1 : The setting of the network device becomes the work of which the system administrator or the network administrator takes charge.

*2 : Refer to System Parameter "4.2 (13) Sending Ping" (SYSPR 04-0600) for the confirmation method of the Ping.

*3 : The MTU value needs to be set as the same value for all the devices (host computer, Switch, disk array system, etc.) in the LAN network environment. However, the DF800 cannot be set. (Refer to Hitachi Storage Navigator Modular 2 Help "iSCSI Settings".)

From TRBL 11-0030

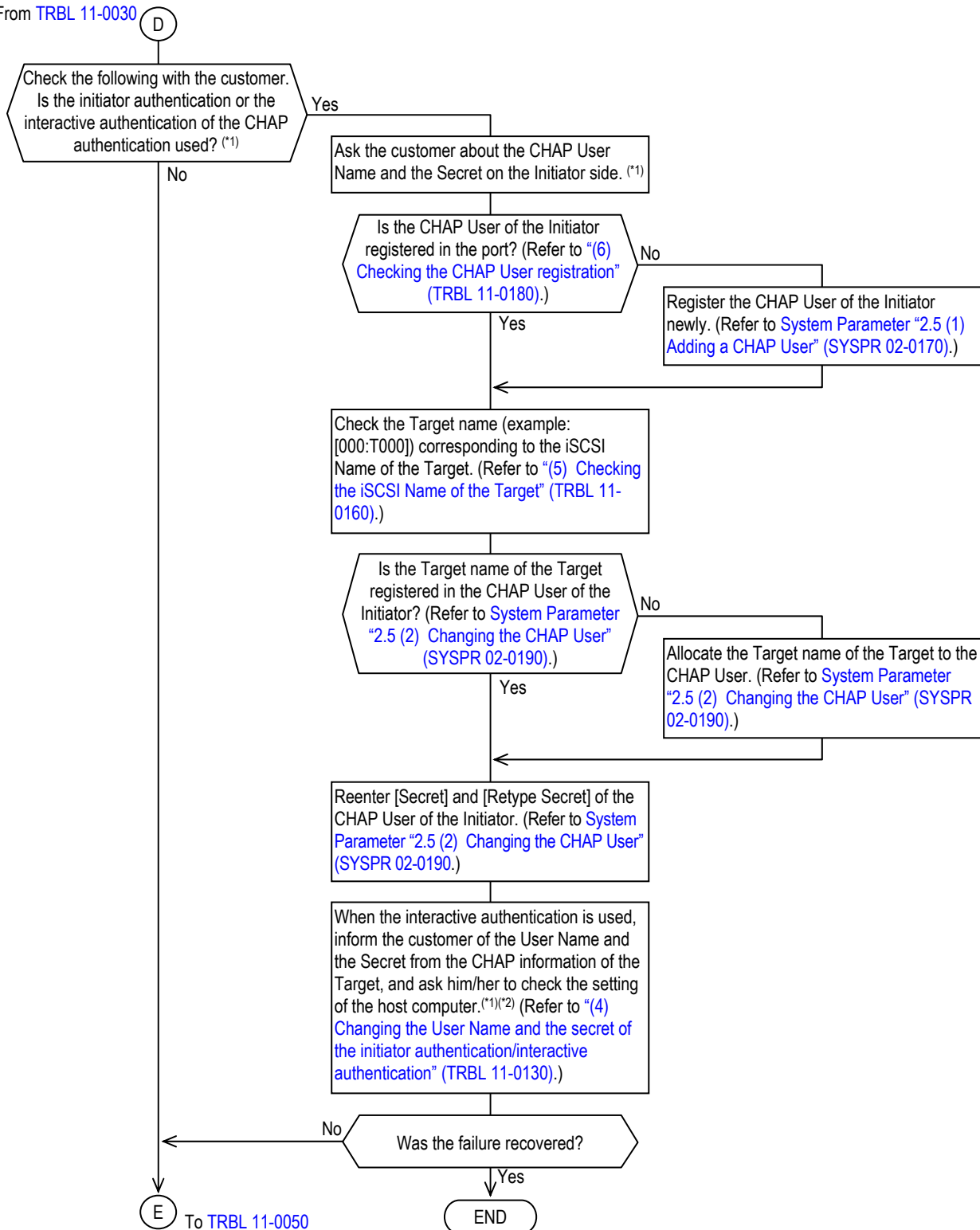

*1 : The setting of the network device becomes the work of which the system administrator or the network administrator takes charge.

*2 : When the Microsoft iSCSI Software initiator is used, it is not necessary to check the User Name of the Target on the Initiator side.

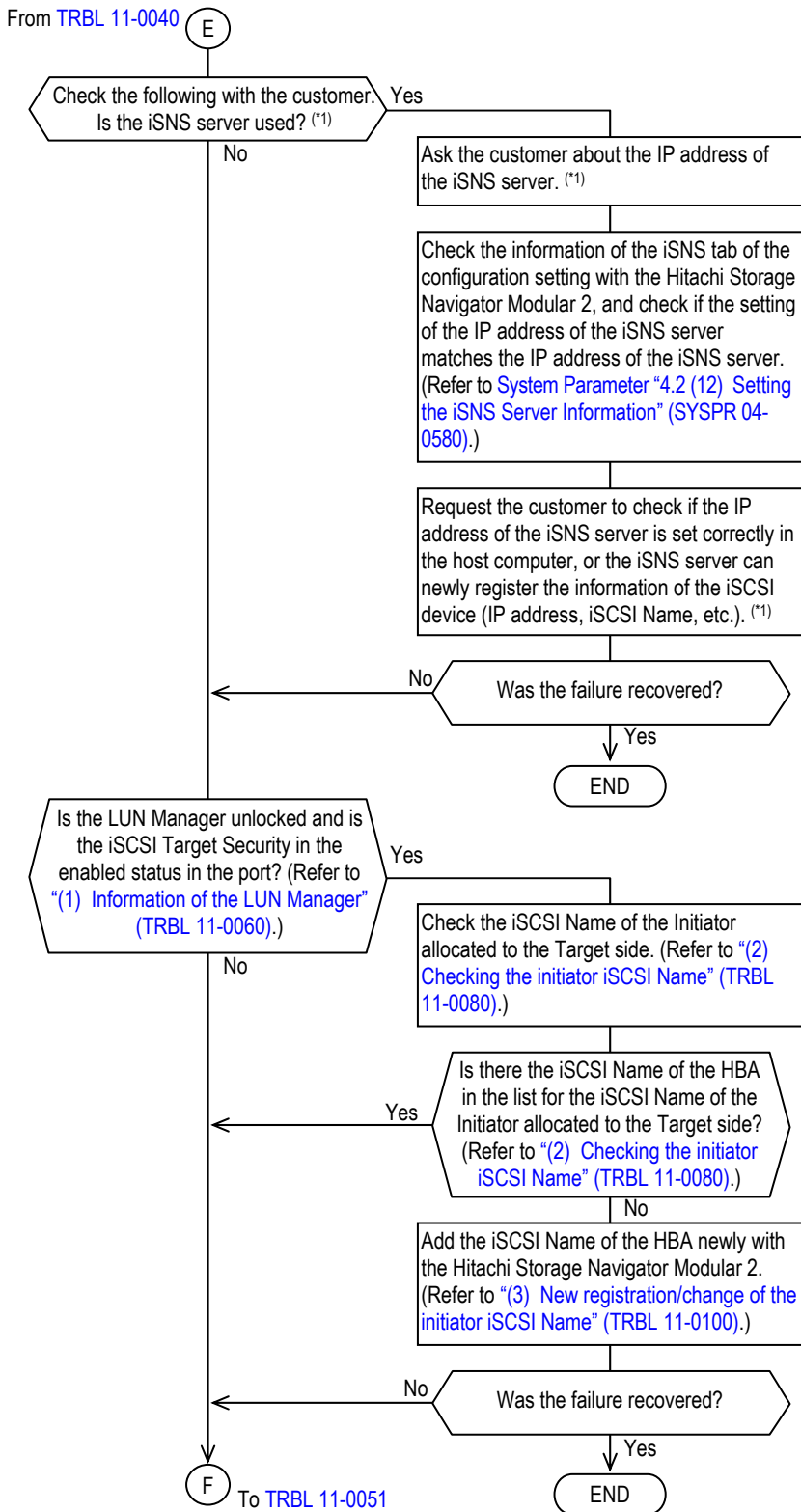

*1 : The setting of the network device becomes the work of which the system administrator or the network administrator takes charge.

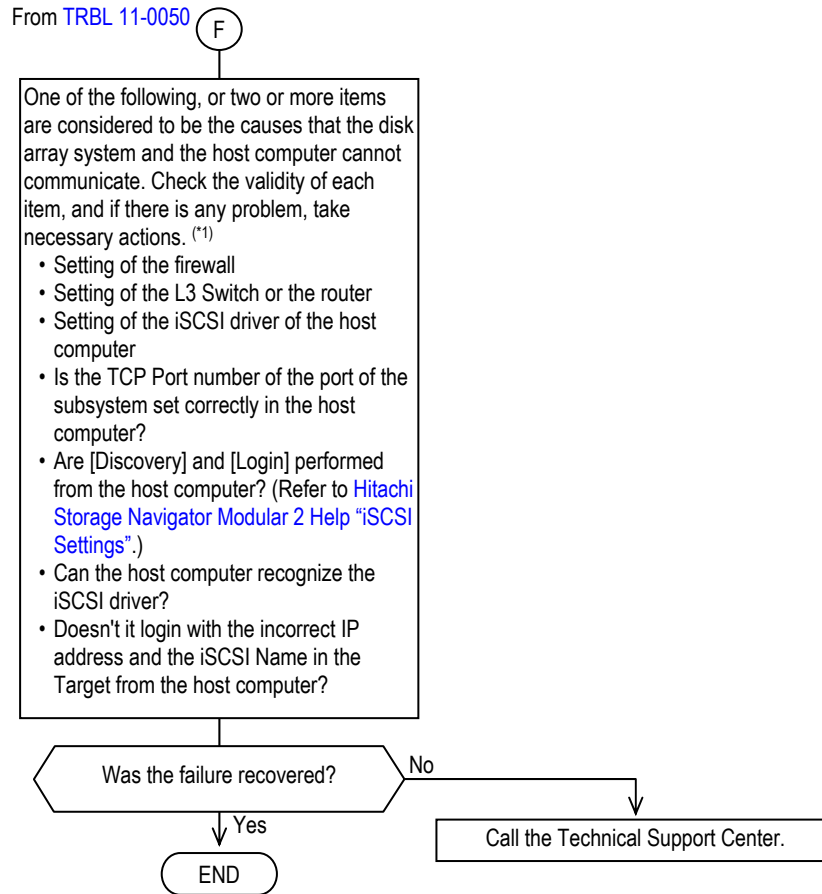

*1 : The setting of the network device becomes the work of which the system administrator or the network administrator takes charge.

This page is for editorial purpose only.

(1) Information of the LUN Manager

- (a) Turn on the power supply.
- (b) Start Hitachi Storage Navigator Modular 2, put a checkmark to the array subsystem to set, press the [Ctrl] key, [Shift] key and [E] key at the same time, and change the operation mode to “Maintenance Mode”. (#1)

Check that “Maintenance Mode” is displayed in [Operation Mode] on the top of the main window.

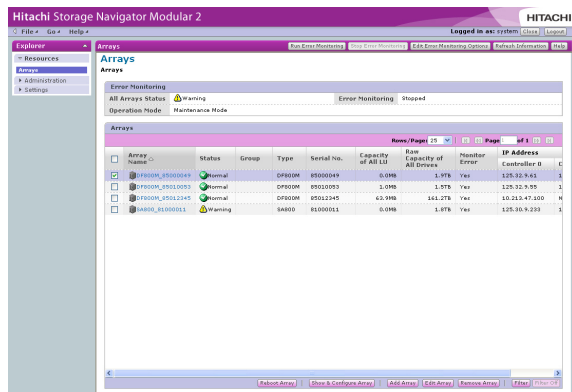

- (c) Click the array subsystem name, and open the unit window.

NOTE : When the main window is not displayed even if you select the array subsystem, check that the LAN port number is not changed. (Refer to [System Parameter “1.2 LAN Port Number Change by Hitachi Storage Navigator Modular 2” \(SYSPR 01-0120\)](#).) Use the changed LAN Port Number, and execute it again.

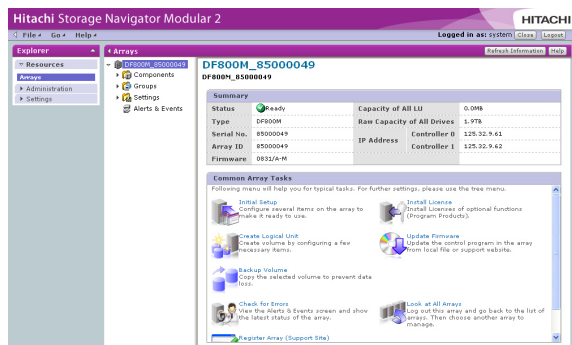

#1 : When the array subsystem to operate is not registered, click the blank area (other than buttons and characters) in the “Arrays” window, and press the [Ctrl] key, [Shift] key and [E] key at the same time.

- (d) Select [Groups] - [iSCSI Targets] on the unit window, and click the [iSCSI Target Security] tab. If [Enable iSCSI Target Security] is “Yes”, LUN Manager is unlocked and valid.

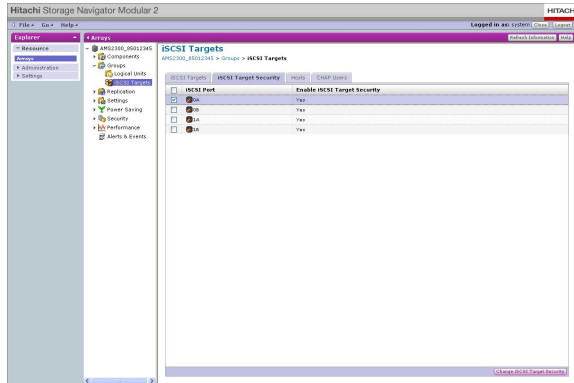

(2) Checking the initiator iSCSI Name

(a) Turn on the power supply.

(b) Start Hitachi Storage Navigator Modular 2, put a checkmark to the array subsystem to set, press the [Ctrl] key, [Shift] key and [E] key at the same time, and change the operation mode to “Maintenance Mode”.^{†1}

Check that “Maintenance Mode” is displayed in [Operation Mode] on the top of the main window.

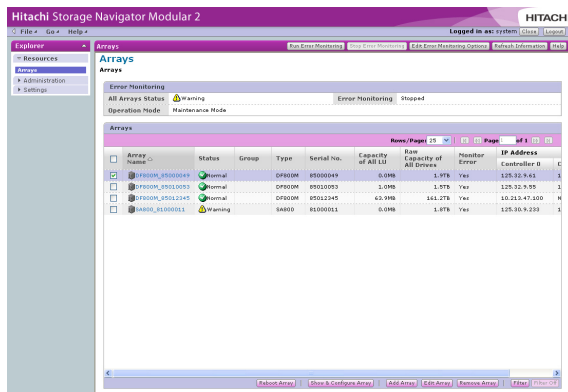

(c) Click the array subsystem name, and open the unit window.

NOTE : When the main window is not displayed even if you select the array subsystem, check that the LAN port number is not changed. (Refer to [System Parameter “1.2 LAN Port Number Change by Hitachi Storage Navigator Modular 2” \(SYSPR 01-0120\)](#).) Use the changed LAN Port Number, and execute it again.

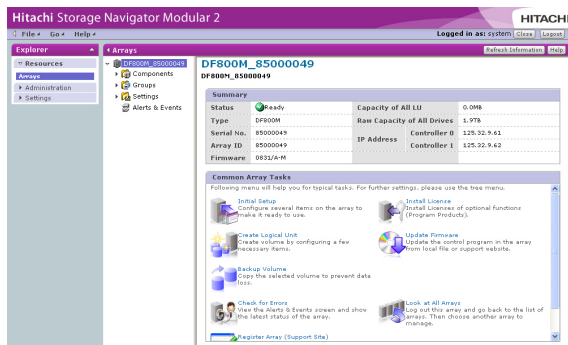

^{†1} : When the array subsystem to operate is not registered, click the blank area (other than buttons and characters) in the “Arrays” window, and press the [Ctrl] key, [Shift] key and [E] key at the same time.

(3) New registration/change of the initiator iSCSI Name

(a) Turn on the power supply.

(b) Start Hitachi Storage Navigator Modular 2, put a checkmark to the array subsystem to set, press the [Ctrl] key, [Shift] key and [E] key at the same time, and change the operation mode to “Maintenance Mode”.^{†1}

Check that “Maintenance Mode” is displayed in [Operation Mode] on the top of the main window.

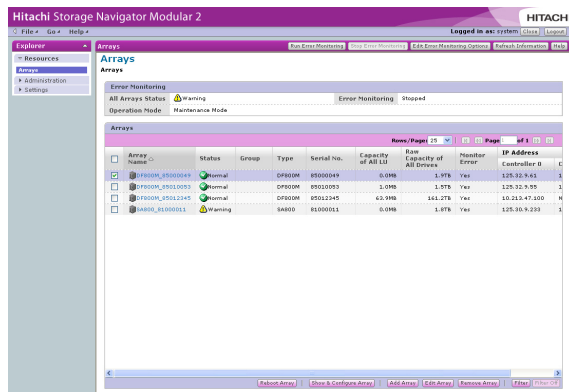

(c) Click the array subsystem name, and open the unit window.

NOTE : When the main window is not displayed even if you select the array subsystem, check that the LAN port number is not changed. (Refer to [System Parameter “1.2 LAN Port Number Change by Hitachi Storage Navigator Modular 2” \(SYSPR 01-0120\)](#).) Use the changed LAN Port Number, and execute it again.

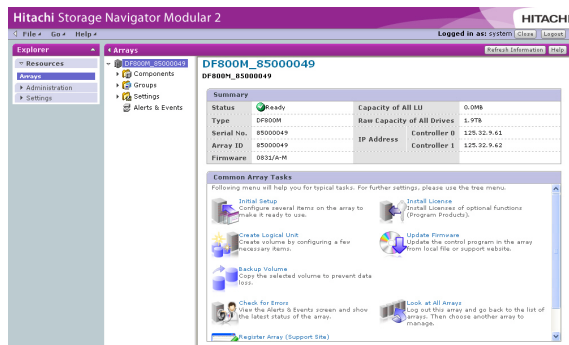

^{†1} : When the array subsystem to operate is not registered, click the blank area (other than buttons and characters) in the “Arrays” window, and press the [Ctrl] key, [Shift] key and [E] key at the same time.

- (d) Select [Groups] - [iSCSI Targets] on the unit window, and click the [iSCSI Target Security] tab. If [Enable iSCSI Target Security] is “Yes”, LUN Manager is unlocked and valid.

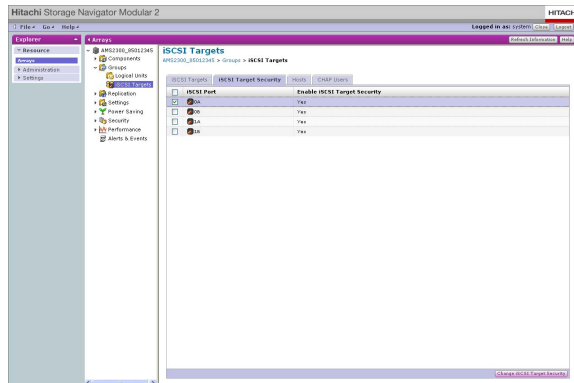

- (e) Check that the target security of the specified port became [Yes].
 (f) Select [iSCSI Targets].

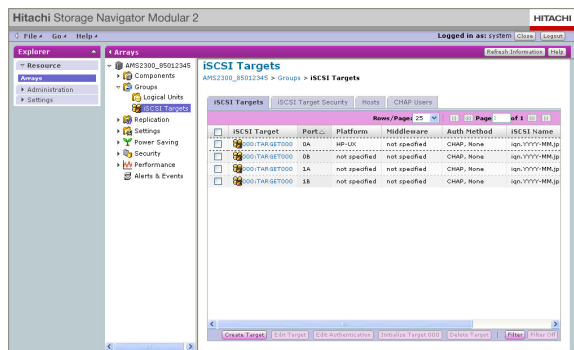

(4) Changing the User Name and the secret of the initiator authentication/interactive authentication

(a) Turn on the power supply.

(b) Start Hitachi Storage Navigator Modular 2, put a checkmark to the array subsystem to set, press the [Ctrl] key, [Shift] key and [E] key at the same time, and change the operation mode to “Maintenance Mode”.^{†1}

Check that “Maintenance Mode” is displayed in [Operation Mode] on the top of the main window.

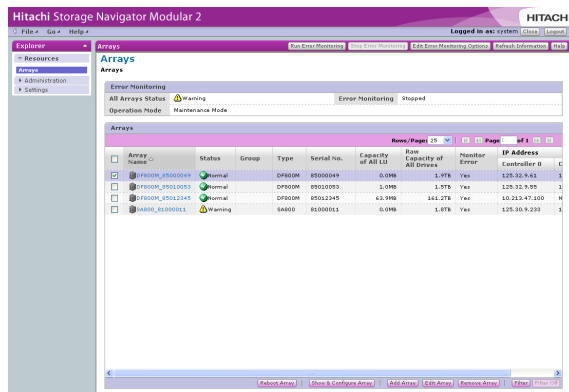

(c) Click the array subsystem name, and open the unit window.

NOTE : When the main window is not displayed even if you select the array subsystem, check that the LAN port number is not changed. (Refer to [System Parameter “1.2 LAN Port Number Change by Hitachi Storage Navigator Modular 2” \(SYSPR 01-0120\)](#).) Use the changed LAN Port Number, and execute it again.

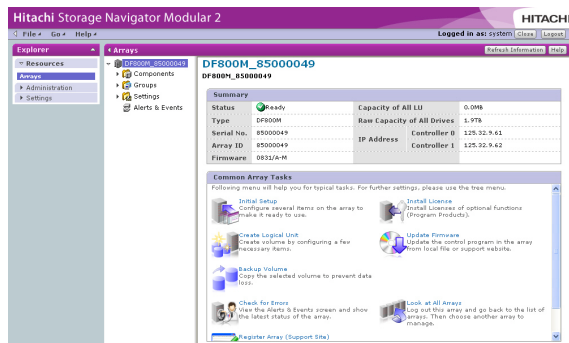

^{†1} : When the array subsystem to operate is not registered, click the blank area (other than buttons and characters) in the “Arrays” window, and press the [Ctrl] key, [Shift] key and [E] key at the same time.

(d) Select the [Groups] - [iSCSI Targets] on the unit window.

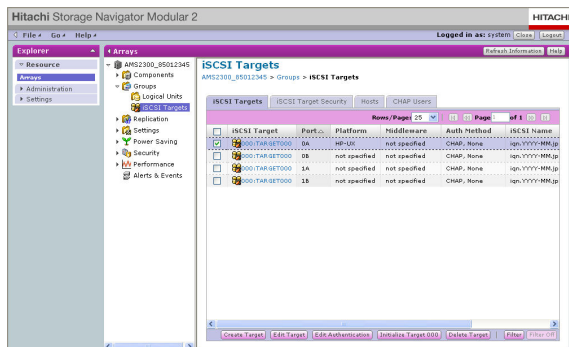

(e) Select the [CHAP Users] tab.

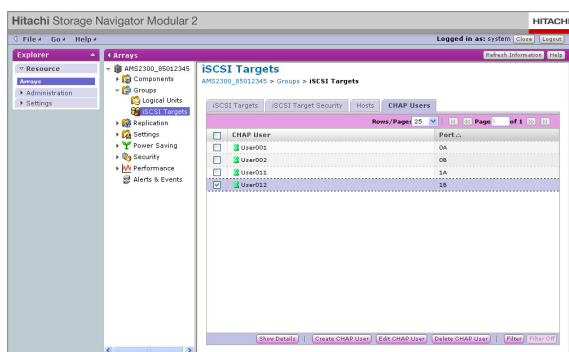

(f) Select the [CHAP Users], and click the [Edit CHAP User] button.

The Edit CHAP User dialog is displayed.

(g) Enter “User Name” and “Secret” which are the same with those on the host computer side in [User Name], [Secret] and [Retype Secret] in the Edit CHAP User dialog, and click the [OK] button.

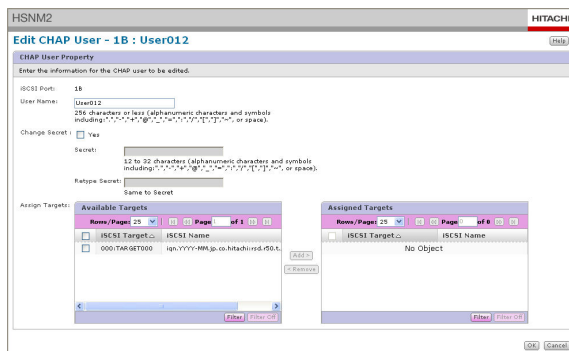

(h) The confirmation window is displayed. Click the [Close] button.

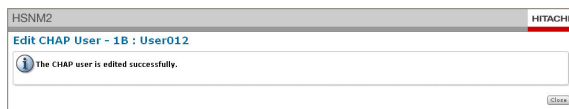

- (i) Select the [iSCSI Targets] tab.
- (j) Double clicking the port which changes the information of the interactive authentication.
Click the [Authentication] tab.

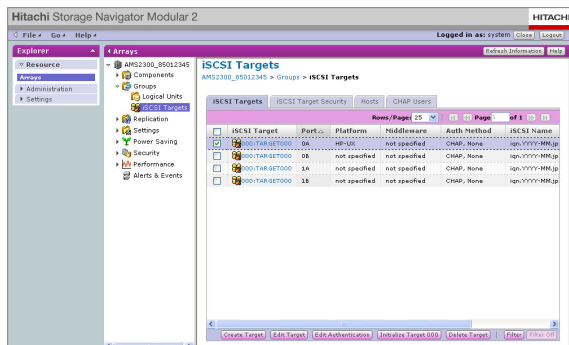

- (k) Click the [Edit Authentication] button.
The Target dialog is displayed.

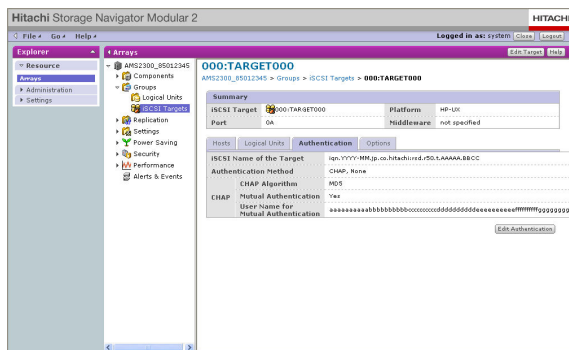

- (l) When the interactive authentication is [Enable], change [User Name] and [Secret] which are the same with those on the host computer.

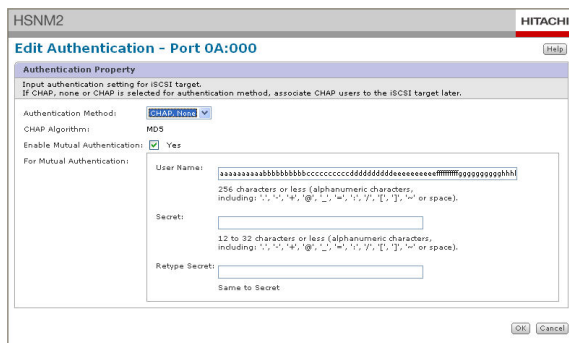

- (m) Click the [OK] button.
- (n) The confirmation window is displayed. Click the [OK] button.

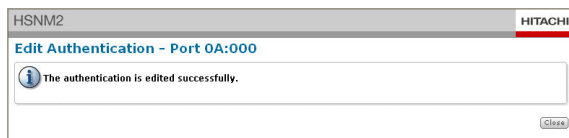

(5) Checking the iSCSI Name of the target

(a) Turn on the power supply.

(b) Start Hitachi Storage Navigator Modular 2, put a checkmark to the array subsystem to set, press the [Ctrl] key, [Shift] key and [E] key at the same time, and change the operation mode to “Maintenance Mode”. (#1)

Check that “Maintenance Mode” is displayed in [Operation Mode] on the top of the main window.

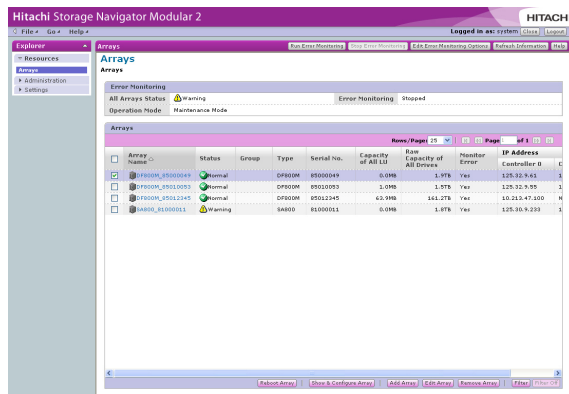

(c) Click the array subsystem name, and open the unit window.

NOTE : When the main window is not displayed even if you select the array subsystem, check that the LAN port number is not changed. (Refer to [System Parameter “1.2 LAN Port Number Change by Hitachi Storage Navigator Modular 2” \(SYSPR 01-0120\)](#).) Use the changed LAN Port Number, and execute it again.

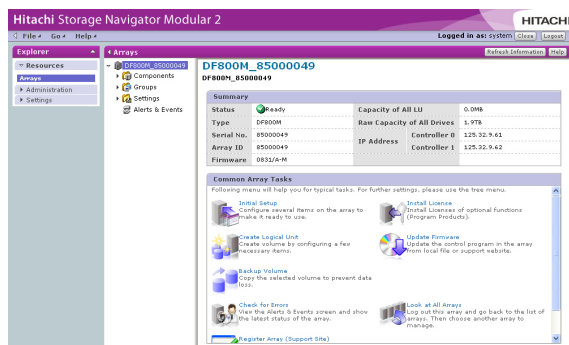

#1 : When the array subsystem to operate is not registered, click the blank area (other than buttons and characters) in the “Arrays” window, and press the [Ctrl] key, [Shift] key and [E] key at the same time.

(d) Check the iSCSI Name.

Select [Groups] - [iSCSI Targets] on the unit window, and click the [iSCSI Targets] tab.

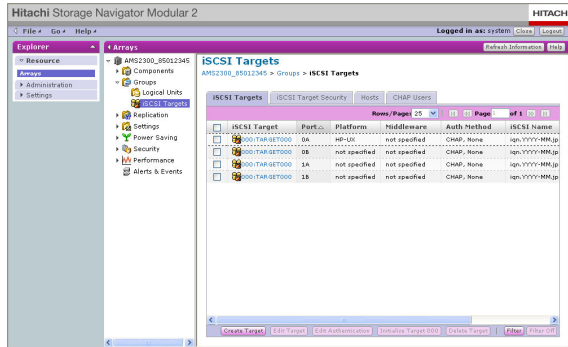

(6) Checking the CHAP User registration

(a) Turn on the power supply.

(b) Start Hitachi Storage Navigator Modular 2, put a checkmark to the array subsystem to set, press the [Ctrl] key, [Shift] key and [E] key at the same time, and change the operation mode to “Maintenance Mode”.^{†1}

Check that “Maintenance Mode” is displayed in [Operation Mode] on the top of the main window.

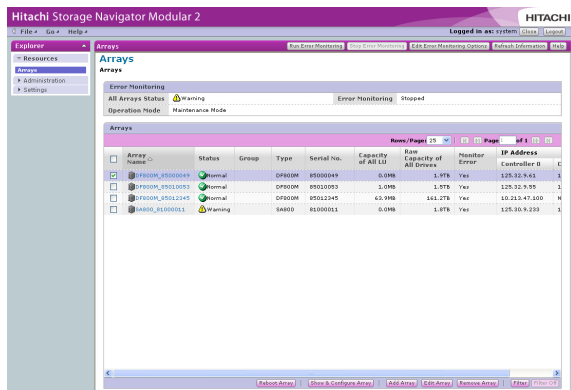

(c) Click the array subsystem name, and open the unit window.

NOTE : When the main window is not displayed even if you select the array subsystem, check that the LAN port number is not changed. (Refer to [System Parameter “1.2 LAN Port Number Change by Hitachi Storage Navigator Modular 2” \(SYSPR 01-0120\)](#).) Use the changed LAN Port Number, and execute it again.

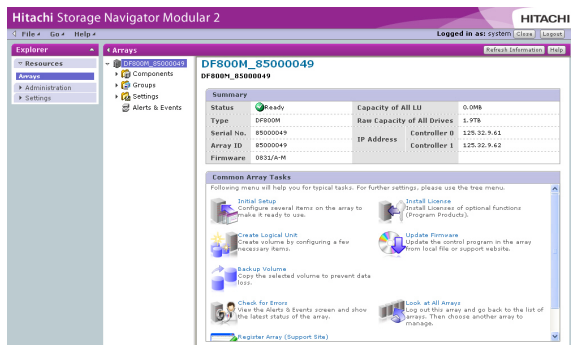

^{†1} : When the array subsystem to operate is not registered, click the blank area (other than buttons and characters) in the “Arrays” window, and press the [Ctrl] key, [Shift] key and [E] key at the same time.

- (d) Select the [Groups] - [iSCSI Targets] on the unit window, and click the [CHAP Users] tab.
- (e) Check that there is the list of the CHAP User by clicking [CHAP User].

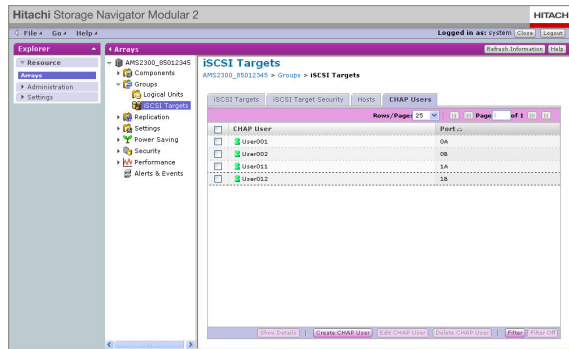

Chapter 12. Procedure for Online ENC Firmware Download

12.1 Outline of Online ENC Firmware Download

This describes the method of downloading the ENC firmware from the PC used for maintenance through the firmware without replacing the hard parts when the ENC firmware version-up is required.

[Possibility of the ENC firmware download depending on whether the host I/O instruction is required or not]

The following table shows possibility of the ENC firmware download depending on whether the host I/O instruction is required or not.

Item	Issue of the host I/O instruction		Note
	Required (online state)	Not required (offline state)	
Offline ENC Firmware Download	Not executable	Executable	
Online ENC Firmware Download	Executable	Executable	

12.2 Preconditions for Online ENC Firmware Download

- (1) To perform the Online ENC Firmware Download using Hitachi Storage Navigator Modular 2, a service terminal is required. Besides, have the maintenance manual with you in order to cope with a failure that occurs during the Online ENC Firmware Download.
- (2) State of the subsystem must be normal as shown below. Otherwise, an error message will be output when Hitachi Storage Navigator Modular 2 issues an instruction for the replacement.
 - Both of the controllers are normal.
 - All the ENC are normal.
- (3) The Online ENC Firmware Download supports the dual controller configuration only. Do not apply the procedure for the case of the single controller configuration to the Online ENC Firmware Download.

12.3 Restriction and Notes of Online ENC Firmware Download

12.3.1 Restriction

- (1) Do not remove or insert any parts, for maintenance or any other reason, during Online ENC Firmware Download.

Inserting or removing parts during Online ENC Firmware Download may cause a fault. If parts are inserted or removed during Online ENC Firmware Download and a fault results, action the Online ENC Firmware Download.

- (2) Do not alter the disk array architecture during Online ENC Firmware Download. Altering the disk array architecture during Online ENC Firmware Download may cause download to fail.
- (3) If maintenance personnel download an Online ENC Firmware Download when one of the ENC firmware already installed is defective or there is an ENC hardware error, the ENC firmware exchange may fail. At this time, perform the maintenance according to the message displayed in the Information Message, and then follow this procedure manual to perform the Online ENC Firmware Download again.
- (4) When each automatic diagnosis function operates due to the backend failures, the Online ENC Firmware Download fails.
In such a case, perform the Online ENC Firmware Download again after removing the failed part.
- (5) Do not execute the deliberate shutdown or power turning off when the online ENC download is terminated abnormally because the ENC firmware (part for the boot) may be damaged. When the download is terminated abnormally, issue the download instruction again through Hitachi Storage Navigator Modular 2 after removing a failed part. If the online ENC download is terminated abnormally in spite of the operation above, replace the ENC.
If the deliberate shutdown or power turning off is executed after the abnormal termination of the download, the ENC may be detached at the time of the next boot of the subsystem. If it occurs, replace the ENC following the maintenance manual.
- (6) Be sure to set the automatic download function to “Disable” before performing the online ENC firmware download.
Be sure to set it to “Enable” again after executing the online ENC firmware download.
- (7) When you executed the planned shutdown during the online ENC firmware download, remove the power cables of all the connected chassis, reconnect them, and then turn on the main switch on the front. If the subsystem is started up without performing the operation above, the ENC is detached. If it is detached, replace the ENC following the maintenance manual.
- (8) Do not execute the online ENC firmware download while rewriting the drive firmware (“IZ0000 HDU firmware download start” is displayed in the Information Message on WEB). Execute the online ECN firmware download after checking that “IZ0100 HDU firmware download end” is displayed in the Information Message on WEB.

12.3.2 Precautions

- (1) Although the WARN LED (orange) on the front of the basic chassis of the array subsystem which uses the priced option lights up, if only “W0GM00 SENC which may attach restrictions on Power Saving function was detected” is displayed in Warning Information on WEB, the installation of the ENC firmware is executable.

12.4 Time Required for Online ENC Firmware Download

For the Disk Array System, the standard time of working hours required for executing the online ENC firmware download function is shown below. The working hours of [Table 12.4.1](#) show the time from starting the replacement of the ENC firmware for ENC#0 or ENC#1 by the Hitachi Storage Navigator Modular 2 to the end of the replacement.

Table 12.4.1 Standard of the Time Required for the Download of the ENC for ENC#0 or ENC#1

Model	Target chassis for ENC firmware download	Working hours	
		Standard	Maximum
AMS2010	Only Basic Chassis	7 minutes	20 minutes
	Only Additional Chassis		
	Basic Chassis and Additional Chassis		
AMS2100	Only Basic Chassis	7 minutes	20 minutes
	Only Additional Chassis		
	Basic Chassis and Additional Chassis		
AMS2300	Only Basic Chassis	7 minutes	20 minutes
	Only Additional Chassis		
	Basic Chassis and Additional Chassis		
AMS2500	Only Basic Chassis	6 minutes	20 minutes
	Only Additional Chassis	7 minutes	20 minutes
	Basic Chassis and Additional Chassis	12 minutes	30 minutes

12.5 Before Starting Online ENC Firmware Download

The PC that is used for maintenance and connected to the LAN must be used to download Online ENC Firmware Download. Before beginning Online ENC Firmware Download, confirm/prepare the following:

- (1) After referring to the web connection procedures in the [WEB “Chapter 1. Before Using Web” \(WEB 01-0000\)](#), prepare 1 PC on which a web browser has been installed and that can be used in a LAN.
- (2) Set the service PC up. (See [Firmware “1.3 Preparation for Installation of Firmware” \(FIRM 01-0020\)](#).)
- (3) Prepare a CD-ROM of the specified revision for firmware installation.
- (4) Execute the installer of the CD-ROM and store the unified version directory^(‡1) under the directory, “C:\diskarray-microprogram\microprogram.”
- (5) If a failure occurs during the ENC firmware download, it is required to see the recovery measures. Prepare the [“Message”](#), and perform the recovery work following the manual.

‡1 : For the unified version directory, refer to [“12.5.1 Hierarchy of ENC Firmware Storage Directories” \(TRBL 12-0060\)](#).

12.5.1 Hierarchy of ENC Firmware Storage Directories

The hierarchical structure of ENC firmware storage ZIP file (08xxx.zip) directories is shown in [Table 12.5.1](#).

When the ZIP file is stored from the CD-ROM which stores the firmware under the directory, “C:\diskarray-microprogram\microprogram.” and unzipped, the directories shown in [Table 12.5.1](#) are displayed.

Table 12.5.1 ZIP File Directory Hierarchy

First stratum	Second stratum	Third stratum	Fourth stratum
Unified version directory	DF800EH	disk 01 - disk X	Firmware file
		fmins	
	DF800EM	disk 01 - disk X	
		fmins	
	DF800ES	disk 01 - disk X	
		fmins	
	DF800EXS	disk 01 - disk X	
		fmins	
	DF800M	disk 01 - disk X	
		fmins	
DF800S	disk 01 - disk X		
	fmins		
DF800H	disk 01 - disk X		
	fmins		
drvfirm	DKR2F-VIPERAP	Drive firmware file	
	:		
ENC	ENC firmware file	-	

12.6 Procedure for Online ENC Firmware Download

The procedure that must be followed in order to download Online ENC Firmware Download does not support single controllers.

12.6.1 Flowchart

The procedure for the maintenance operation is shown below.

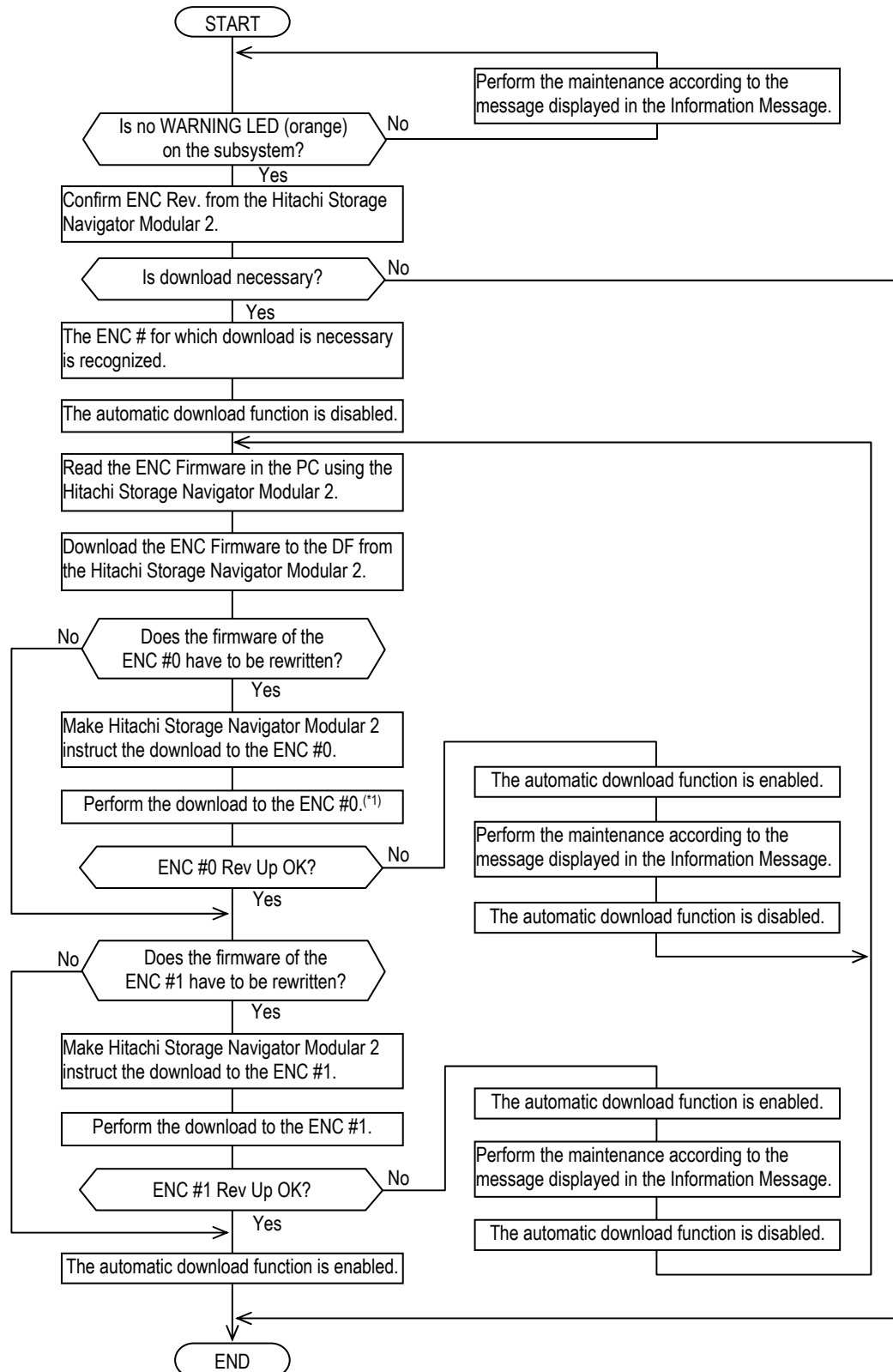

*1 : The ALM LED(red) on the ENC lights on during the ENC firmware download.

12.6.2 Connecting the PC Used for Maintenance

The maintenance LAN connector and the LAN connector of the PC used for maintenance must be connected using a LAN cross cable. Follow the procedure shown below to make the necessary connection.

(1) Confirm the following before connecting the PC used for maintenance:

Check the following LEDs before connecting the PC used for maintenance:

- POWER LED (green) confirmation:

Confirm that the POWER LED (green) located on the top of the front bezel is lit.

If the POWER LED (green) is not lit, refer to the “Chapter 8. Trouble Analysis by LED Indication” (TRBL 08-0000) for details on how to correct the error.

- WARNING LED (orange)/LOCATE LED (orange) confirmation:

Confirm that the WARNING LED (orange)/LOCATE LED (orange) located on the top of the front bezel is not lit.

If the WARNING LED (orange)/LOCATE LED (orange) is lit or blinking, refer to the “Chapter 8. Trouble Analysis by LED Indication” (TRBL 08-0000) for details on how to correct the error.

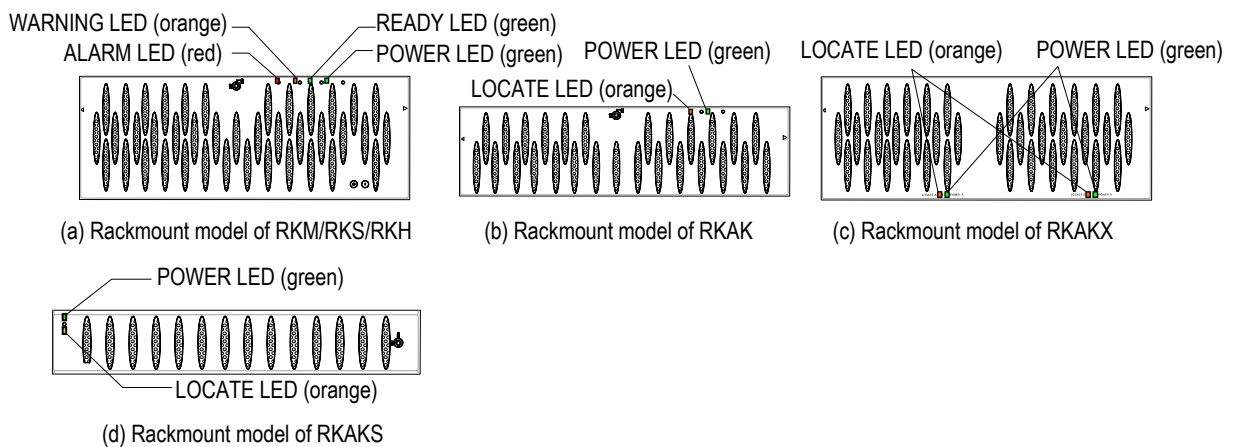

Figure 12.6.1 Locations and Name of LED

(2) Preparing the maintenance terminal for use

Table 12.6.1 Preparing the Maintenance Terminal

Item Number	Customer Environment	Terminal used for maintenance	Preparation
1	Uses controller's maintenance-use LAN connector	Use the LAN to connect the PC that is being carried and will be used for maintenance.	<ul style="list-style-type: none"> • PC used for maintenance • LAN cross cable

(3) Controller to be connected

With dual system architecture, the browser connection is identical no matter which controller is connected. First, connect to controller #0.

If controller #0 is closed, subsequent information can only be referenced on the controller #1 side. If controller #0 is closed, connect to controller #1.

(4) Connecting the procedures of the PC Used for Maintenance

- (a) Remove the cover located above the controller on the unit. Using the LAN cable, connect the maintenance LAN connector and the connector of the PC used for maintenance.

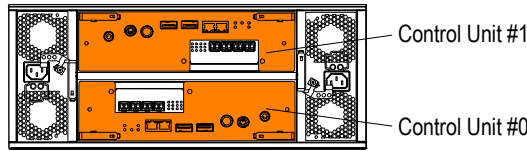

Control Unit RKM/RKEM/RKS/RKES/RKEXS/RKEXS8F Location (Rear view)

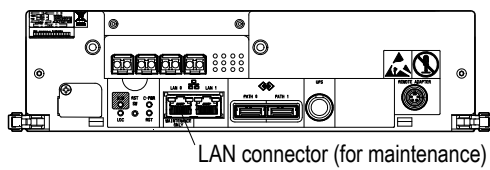

Control Unit (RKM)

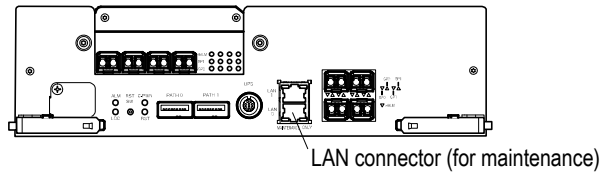

Control Unit (RKEM)

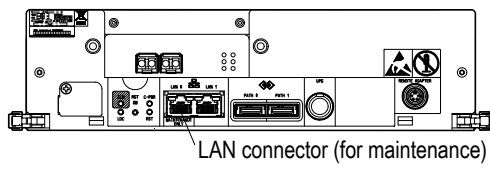

Control Unit (RKS)

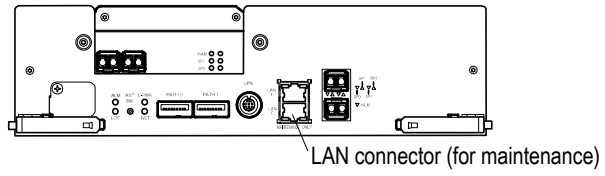

Control Unit (RKES)

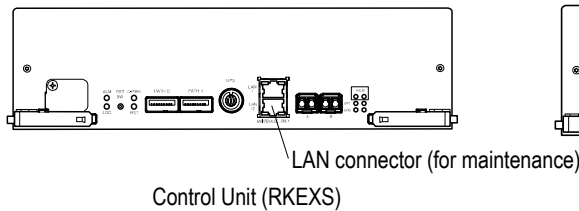

Control Unit (RKEXS)

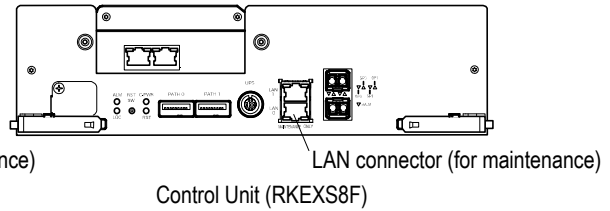

Control Unit (RKEXS8F)

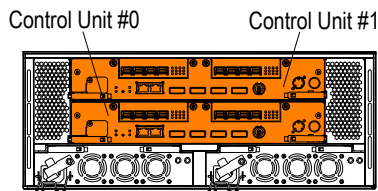

Control Unit RKH Location (Rear view)

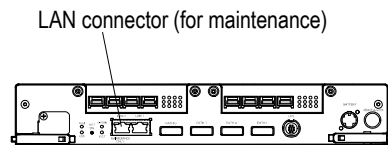

Control Unit (RKH)

Figure 12.6.2 LAN Connector Position

- (b) Start up the maintenance PC.
- (c) Change the IP address of the network parameter for the maintenance PC.
- (c-1) In case of the IPv4 environment
- (i) Make the setting of the IP Address to be set to the PC as Item 1 in [Table 12.6.2](#).
 - CTL0: 10.0.0.16 (Input example : http://10.0.0.16/)
 - (ii) If it is not connectable, by setting the values of Item 2 to Item 5 in [Table 12.6.2](#), specify the connectable value and perform the WEB connection.
 - According to the setting value of “Maintenance PC” of Items 2 to 5 on [Table 12.6.2](#), set the IP Address and the Subnet Mask of the Maintenance PC.
 - According to the “Array (LAN port for maintenance)” information of Items 2 to 5 on [Table 12.6.2](#), enter into “Address” of the WEB browser and connect with the array.
 - (iii) If not connected yet, refer to [“3.4 Procedure for Specifying Maintenance Port IP Address” \(TRBL 03-0130\)](#).

Table 12.6.2 Operating Environment (IPv4)

No.	Subsystem (LAN port for maintenance)		Maintenance PC	
	IP Address	Subnet Mask	IP Address	Subnet Mask
1	CTL 0: 10.0.0.16 CTL 1: 10.0.0.17 (At the time of shipment)	255.255.255.0 (At the time of shipment)	10.0.0.2 to 0.0.0.9	255.255.255.0
2	CTL 0: 192.168.0.16 CTL 1: 192.168.0.17	255.255.255.0	192.168.0.2 to 192.168.0.9	255.255.255.0
3	CTL 0: 192.168.233.16 CTL 1: 192.168.233.17	255.255.255.0	192.168.233.2 to 192.168.233.9	255.255.255.0
4	CTL 0: 172.23.211.16 CTL 1: 172.23.211.17	255.255.255.0	172.23.211.2 to 172.23.211.9	255.255.255.0
5	CTL 0: 10.197.181.16 CTL 1: 10.197.181.17	255.255.255.0	10.197.181.2 to 10.197.181.9	255.255.255.0

- (b-2) In case of the IPv6 environment
- (i) Make the setting of the IP Address to be set to the PC as Item 1 in [Table 12.6.3](#).
 - CTL0: fe80::16 (Input example : http://[fe80::16]/)
 - When connecting on WEB by the IPv6 address, put the address in brackets ([]).
 - (ii) If it is not connectable, set the value of Item 2 in [Table 12.6.3](#), and perform the WEB connection.
 - According to the setting value of “Maintenance PC” of Item 2 on [Table 12.6.3](#), set the IP Address and the Subnet Mask of the Maintenance PC.
 - According to the “Array (LAN port for maintenance)” information of Item 2 on [Table 12.6.3](#), enter into “Address” of the WEB browser and connect with the array.
 - (iii) If not connected yet, refer to [“3.4 Procedure for Specifying Maintenance Port IP Address” \(TRBL 03-0130\)](#).

Table 12.6.3 Operating Environment (IPv6)

No.	Subsystem (LAN port for maintenance)		Maintenance PC	
	IP Address	Length of Subnet Prefix	IP Address	Subnet Mask
1	CTL0: fe80::16 CTL1: fe80::17 (At the time of shipment)	64 (At the time of shipment)	Automatic	Automatic
2	CTL 0: fe80::f6 CTL 1: fe80::f7	64	Automatic	Automatic

- Manual change of the network parameter of the Maintenance port
When the User management port is set as the same network address as the Maintenance port, the communication cannot be made normally. Prepare five patterns of the network parameter fixed values to be used in the Maintenance port, and change the network parameter fixed values to be used in the Maintenance port manually by the network parameter of the User management port. Therefore, in the work other than the installation work of the array at shipment, the maintenance LAN Port for the WEB connection is set to any of Items 1 to 5 in [Table 12.6.2](#) in case of the IPv4 environment and set to either Item 1 or 2 in [Table 12.6.3](#) in case of the IPv6 environment.

NOTE : When the network address of the LAN device, which is connected via the Gateway in the extension of the User management port, is the same as that of the Maintenance port, the communication cannot be made normally because of the conflict between them.

Therefore, use a value other than the network address set to the maintenance port for the LAN device connected to the port for the user management via Gateway. Or change the IP address of the maintenance port to a value other than the network address of the LAN device connected via Gateway by Hitachi Storage Navigator Modular 2. (Refer to [System Parameter “4.2 \(4\) Setting of Maintenance LAN” \(SYSPR 04-0160\)](#).)

- (d) Make sure that negotiation of Maintenance PC is set to auto negotiation.
To check negotiation of Maintenance PC, refer to [“3.1 \(6\) Procedure for setting negotiation” \(TRBL 03-0050\)](#).

This page is for editorial purpose only.

12.6.3 Online ENC Firmware Download

The procedure for downloading the ENC firmware using Hitachi Storage Navigator Modular 2 is shown below. According to the procedure, the following operations are performed in due order.

- ① Checking the revision.
- ② The automatic download function is disabled.
- ③ Reading the ENC firmware.
- ④ Instructing for the download to the subsystem (from the Hitachi Storage Navigator Modular 2 to the subsystem main memory).
- ⑤ Instructing for the replacement of the ENC firmware (from the subsystem main memory to the ENC).
- ⑥ The automatic download function is enabled.

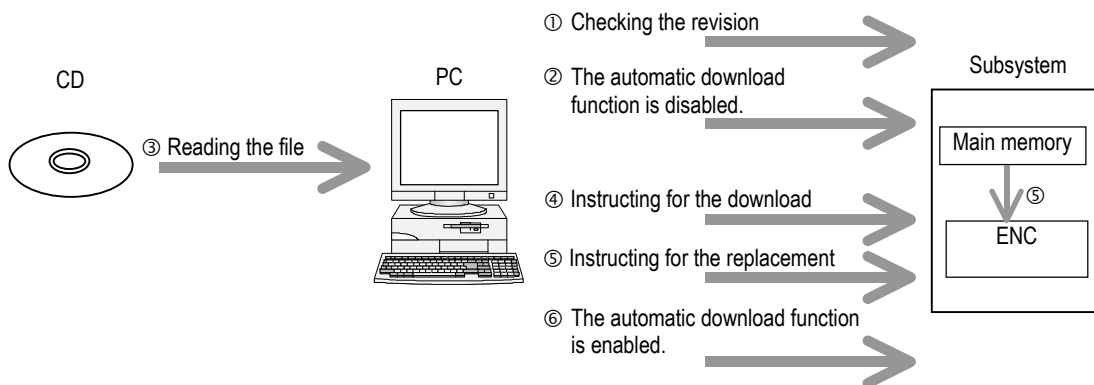

Figure 12.6.3 Procedure for ENC Firmware Download

(1) Checking the revision

(a) Start the Hitachi Storage Navigator Modular 2.

(b) Put a checkmark to the array subsystem to set, press the [Ctrl] key, [Shift] key and [E] key at the same time, and change the operation mode to “Maintenance Mode”.^(†1)

It is displayed as “maintenance mode” in [Operation Mode] of the upper part of the window, and Hitachi Storage Navigator Modular 2 is operated in the maintenance mode.

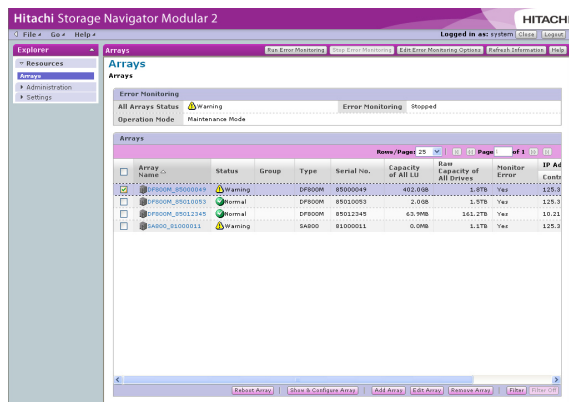

(c) Click the array subsystem name, and open the unit window.

NOTE : There is a case that the LAN Port Number is changed. When the main screen is not displayed even though the icon of the array subsystem is clicked, use the changed LAN Port Number, and execute it again. (Refer to [System Parameter “1.2 LAN Port Number Change by Hitachi Storage Navigator Modular 2” \(SYSPR 01-0120\).](#))

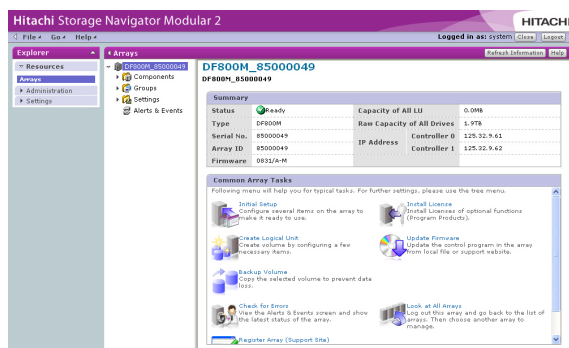

†1 : When the array subsystem to operate is not registered, click the blank area (other than buttons and characters) in the “Arrays” window, and press the [Ctrl] key, [Shift] key and [E] key at the same time.

- (d) Select [Settings] - [Advanced Settings] on the unit window, and click the [Open Advanced Settings] button.

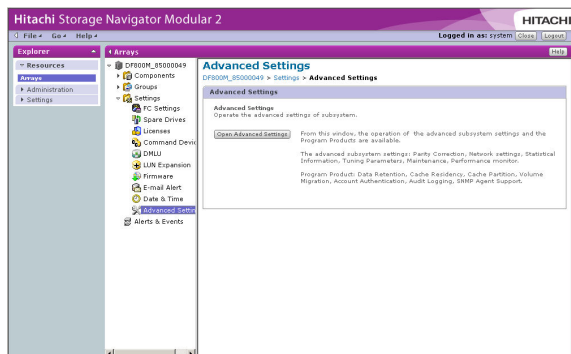

- (e) Select the [Maintenance] on the applet window, and click the [Set] button. Maintenance dialog box is displayed.

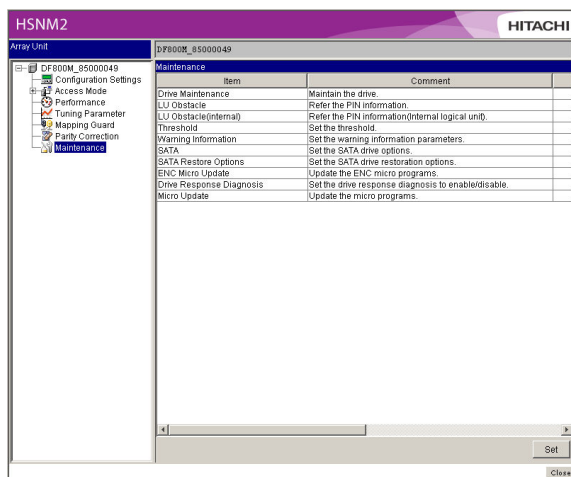

- (f) Select the [ENC Micro Update] tab in the Hitachi Storage Navigator Modular 2 maintenance window.

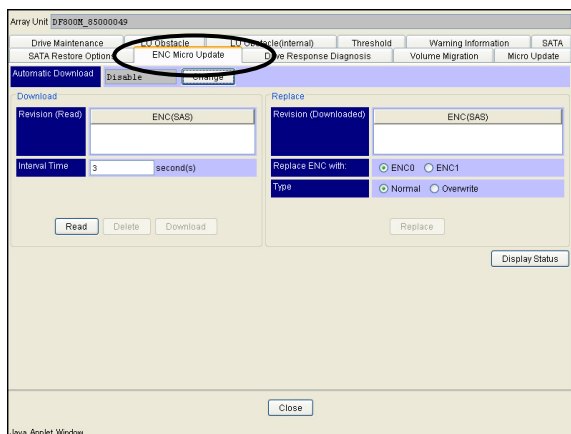

(g) Display the revision of the current ENC firmware by selecting the [Display Status] button.

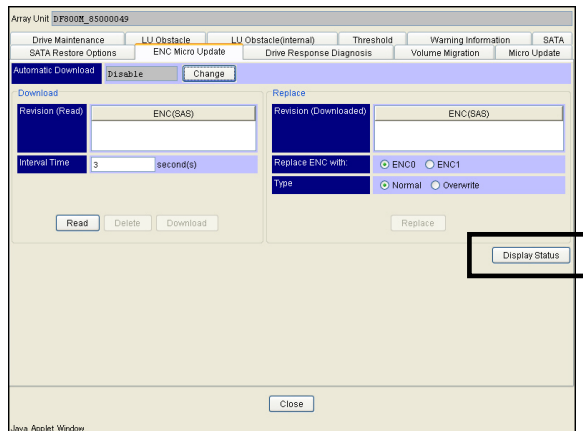

(h) Check the revision of the current ENC firmware.

Check both [ENC0] tab and [ENC1] tab in the window. If the revisions of ENC #0 and #1 are both same as the revisions to be downloaded or new revisions, the download of the ENC firmware is not required. Therefore, terminate the operation.

When either or both of the revision of the ENC #0 and #1 are older than the revision to be downloaded, go to the Step (2).

You can refer to the revision of the ENC firmware to be downloaded in the text file in the zip file of the firmware distributed by the CD-R in advance.

Decompress the zip file to "C:\diskarray-microprogram\maicroprogram".

- In the case of RKEXS/RKS/RKES/RKM/RKEM/RKH/RKEH/RKAK/RKAKX
"C:\diskarray-microprogram\microprogram\Folder Name of Decompressed
Firmware\ENC\S8LIST.TXT

Open the above-mentioned text file, and the one described in the first row is the ENC firmware revision.

Examples of S8LIST.TXT

061003(SM) ← The numbers of the leading six digits indicate the ENC firmware revision.

S8_REV.DAT

S8_FIRM.WTB

Compare it with the revision displayed in ENC(SAS) in the window.

- In the case of RKAKS

“C:\diskarray-microprogram\microprogram\Folder Name of Decompressed
Firmware\ENC\S3LIST.TXT

Open the above-mentioned text file, and the one described in the first row is the ENC
firmware revision.

Examples of S3LIST.TXT

070218(S3) ← The numbers of the leading six digits indicate the ENC firmware revision.

S3_REV.DAT

S3_FIRM.WTB

Compare it with the revision displayed in ENC(SAS) in the window.

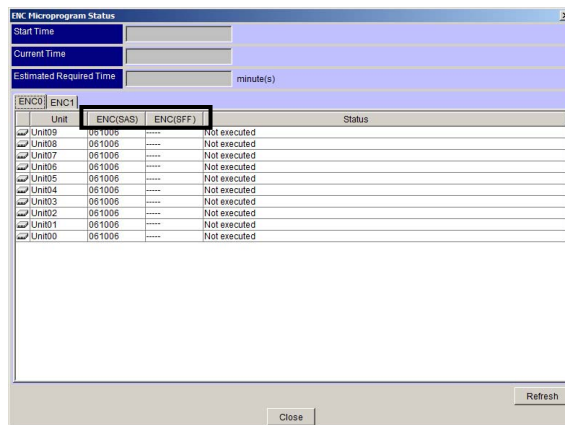

The screenshot shows a window titled "ENC Microprogram Status". It contains a table with columns for Unit, ENC(SAS), ENC(SFF), and Status. The table lists units from Unit09 down to Unit00, all with an ENC(SAS) value of 061006 and a status of "Not executed".

Unit	ENC(SAS)	ENC(SFF)	Status
Unit09	061006	----	Not executed
Unit08	061006	----	Not executed
Unit07	061006	----	Not executed
Unit06	061006	----	Not executed
Unit05	061006	----	Not executed
Unit04	061006	----	Not executed
Unit03	061006	----	Not executed
Unit02	061006	----	Not executed
Unit01	061006	----	Not executed
Unit00	061006	----	Not executed

This page is for editorial purpose only.

(2) The automatic download function is disabled.

(a) Select the [ENC Micro Update] tab in the Hitachi Storage Navigator Modular 2 maintenance window.

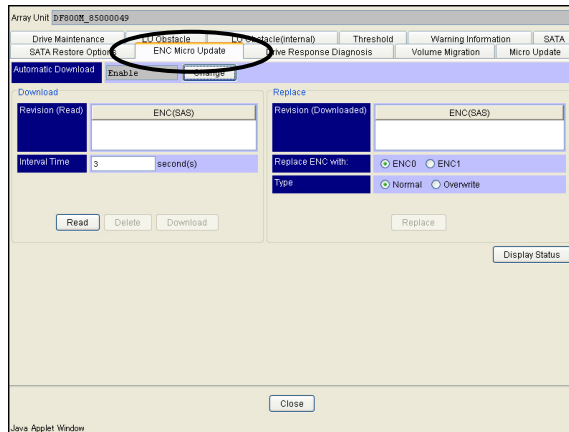

(b) Click the [Change] button on the “Automatic Download”.

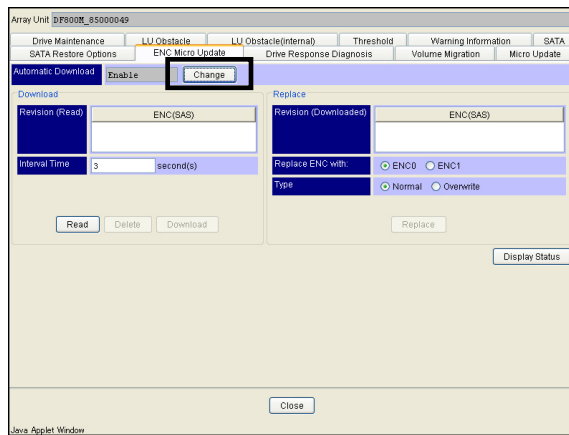

(c) Selected [Disable] in the Automatic Download window.

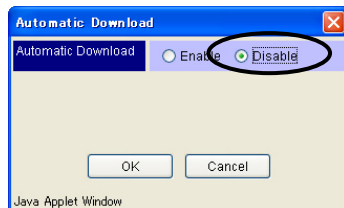

Click the [OK] button.

(d) The configuration message dialog box appears. Click the [OK] button.

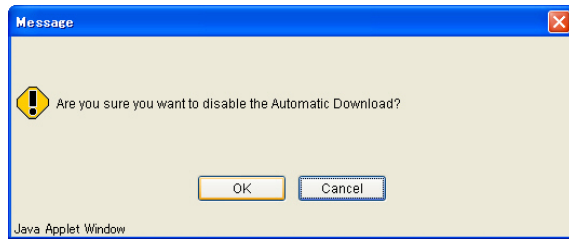

(e) When the set is completed normally. Click the [OK] button.

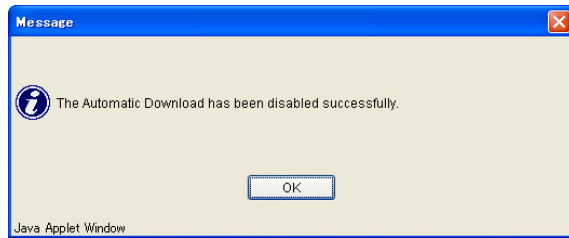

- (3) Reading the ENC firmware (It is described as a procedure to the ENC #0.)
- (a) Check that the [Type] is the Normal version, select the [Read] button on the [ENC Micro Update] tab.
- When [Overwrite] is selected, specify [Normal].
- Select [Overwrite] only when there is the instruction to select it.

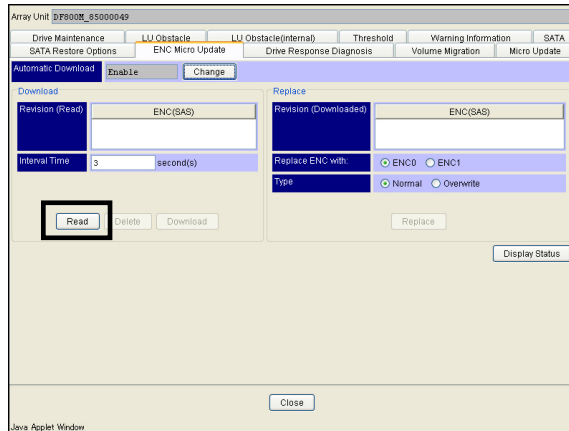

- (b) The “Configuration Message” dialog box appears. Click the [OK] button.

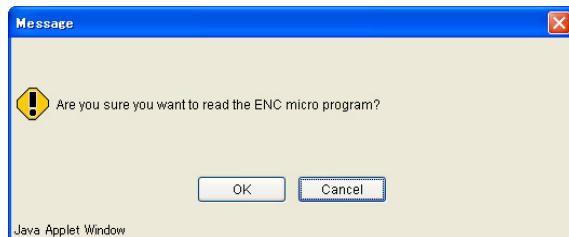

- (c) Specify the unified version directory^(†1) to the [Path], and click the [OK] button.

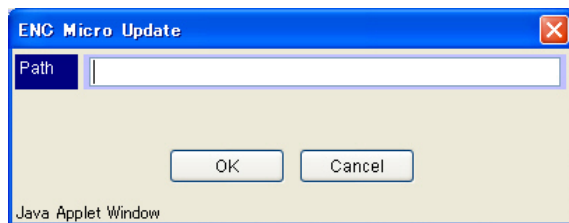

- (d) When the download of the file is completed, click the [OK] button.

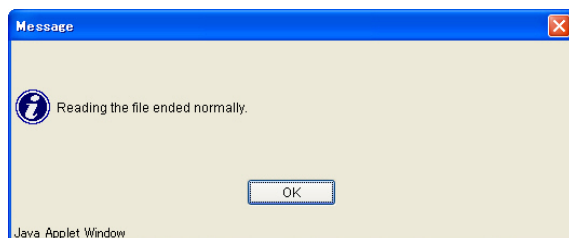

†1 : For the unified version directory, refer to “12.5.1 Hierarchy of ENC Firmware Storage Directories” (TRBL 12-0060).

- (e) The revision of the ENC firmware that has been read in is displayed in the [ENC Micro Update] tab. Make sure that the revision of the displayed ENC firmware is the same as that to be downloaded. If they are not the same, read in the ENC firmware again.

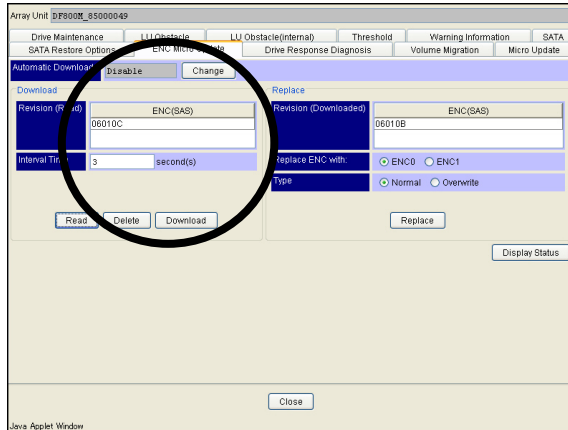

- (4) Instructing for the download to the disk array unit
 - (a) Download the ENC firmware that has been read in the Hitachi Storage Navigator Modular 2 to the disk array unit.
To perform the download, enter the [Interval Time] and press the [Download] button. Three seconds or more of the default value are recommended to avoid the influence on the host I/O for the [Interval Time].

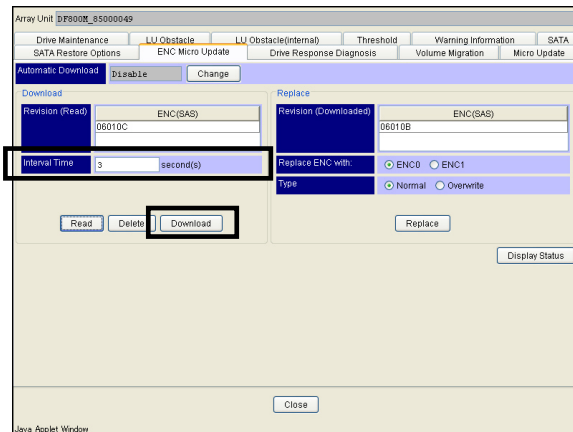

- (b) The “Configuration Message” dialog box appears. Click the [OK] button.

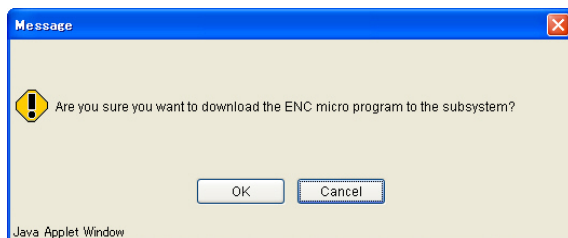

- (c) During the download, a dialog box showing that the download is in progress is displayed. When the [Cancel] button is clicked, the download is aborted and the window is returned to the [ENC Micro Update] tab.

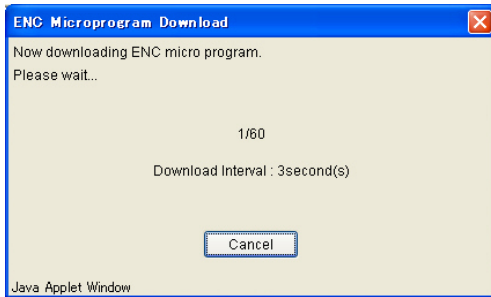

- (d) When the download is completed normally, click the [OK] button.

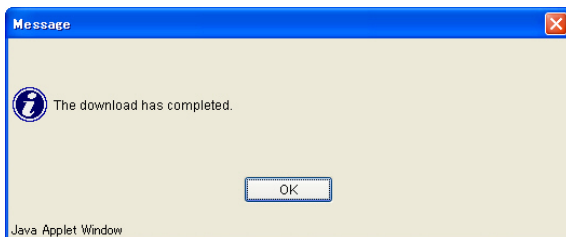

- (e) When the window is returned to the [ENC Micro Update] tab, the revision of the firmware that has been downloaded is displayed.

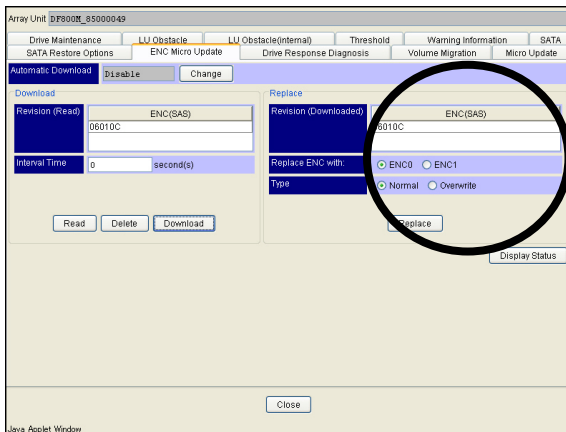

- (5) Instructing for the replacement of the ENC firmware
- (a) When starting the download of the ENC firmware, specify the number of the ENC whose firmware is to be replaced and click the [Replace] button.

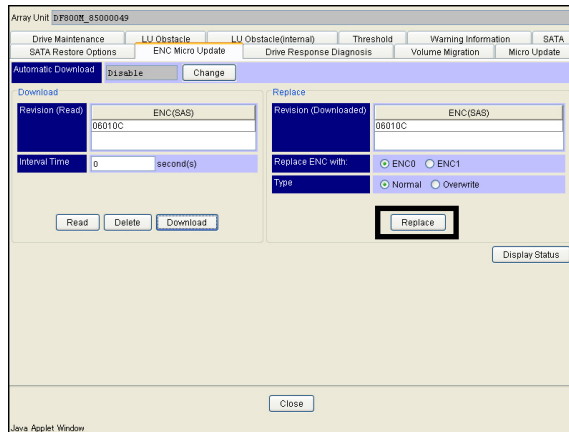

- (b) The “Configuration Message” dialog box appears. Click the [OK] button.

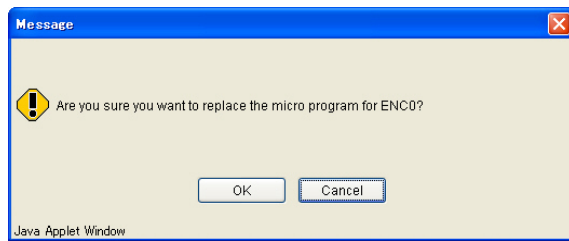

- (c) When the [OK] button is clicked, the window is returned to the original window of Step (a).

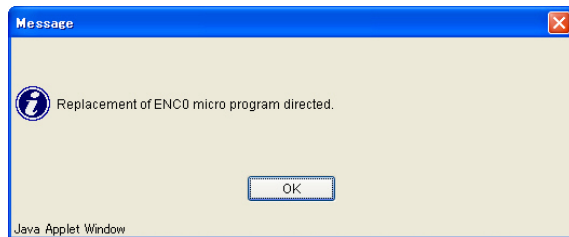

- (d) Display the current progress state of the ENC firmware downloading by selecting the [Display Status] button.

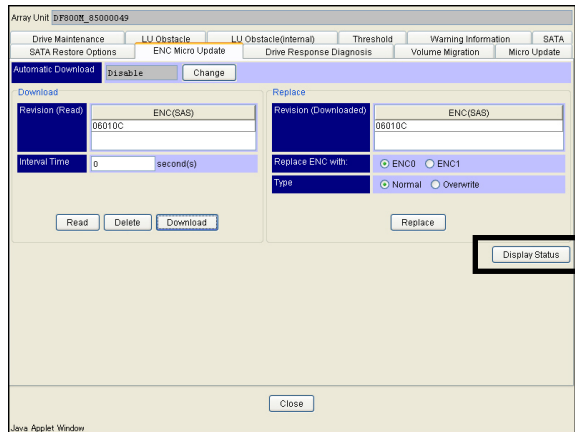

- (e) Make sure of the current progress state of the ENC firmware downloading.

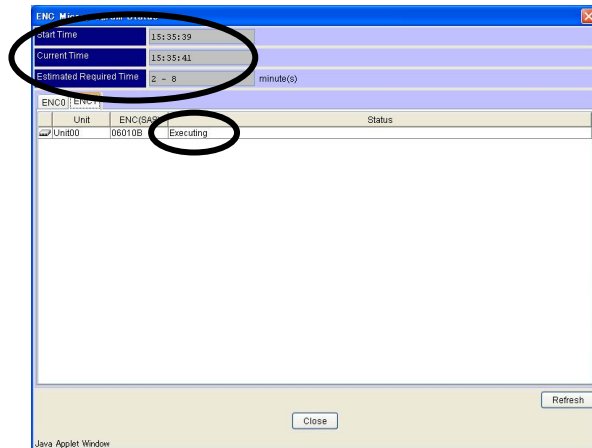

When the download of the other ENC is necessary, return to the “(3) Reading the ENC firmware” (TRBL 12-0160) and work.

If the download is unnecessary, go to the “(6) The automatic download function is enabled.” (TRBL 12-0210).

(6) The automatic download function is enabled.

When the function is changed from [Disable] to [Enable], check if the automatic download is required again. Therefore, the start and termination messages of the automatic download are displayed.

(a) Select the [ENC Micro Update] tab in the Hitachi Storage Navigator Modular 2 maintenance window.

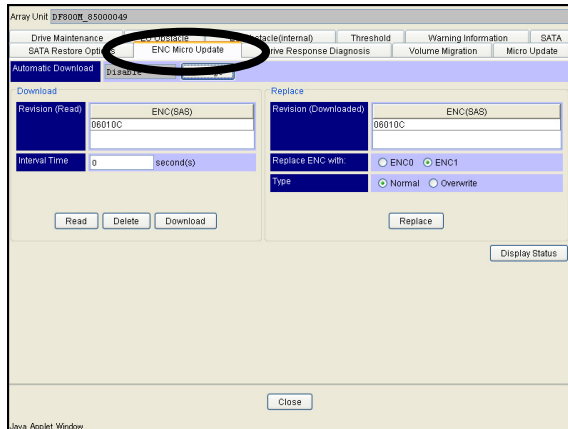

(b) Press the [Change] button on the “Automatic Download”.

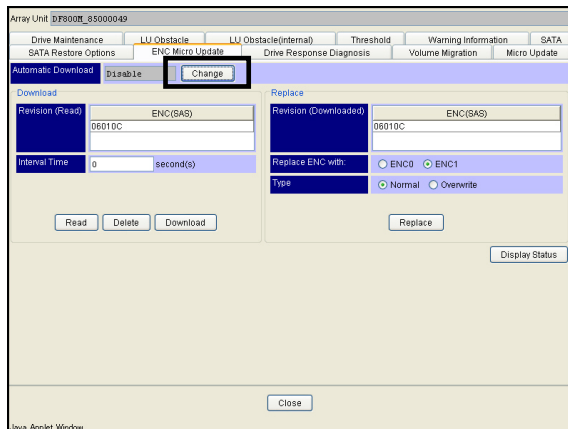

(c) Selected [Enable] in the Automatic Download window.

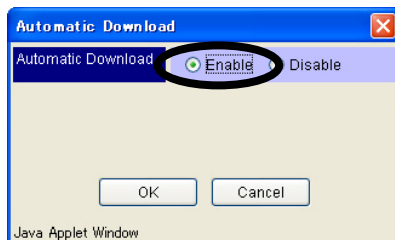

Press the [OK] button.

(d) The configuration message dialog box appears. Click the [OK] button.

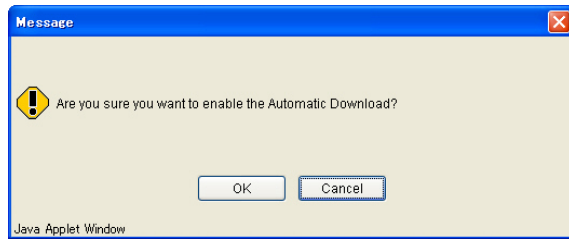

(e) When the set is completed normally. Click the [OK] button.



(7) Deleting the file

- (a) When deleting the ENC firmware that has been read in the Hitachi Storage Navigator Modular 2, click the [Delete] button.

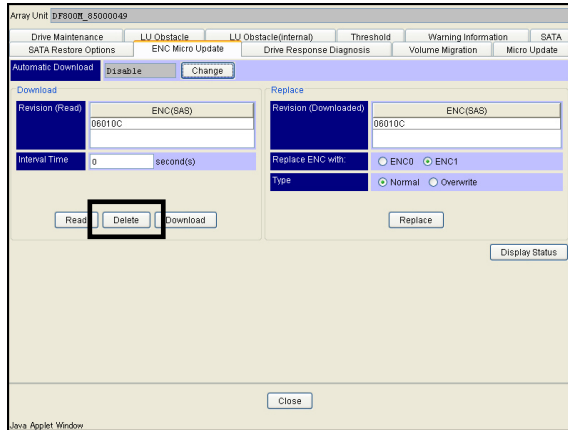

- (b) The “Configuration Message” dialog box appears. Click the [OK] button.

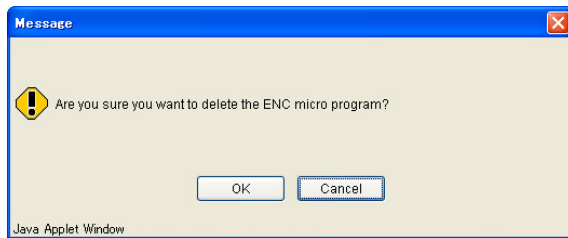

- (c) When the deletion of the firmware is completed normally, click the [OK] button.

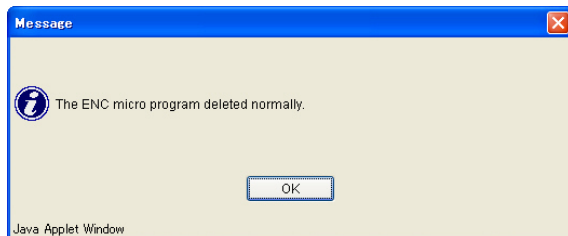

- (d) If it returns to the [Enc Micro Update] tab, the revision, which has already been read, displays a blank column.

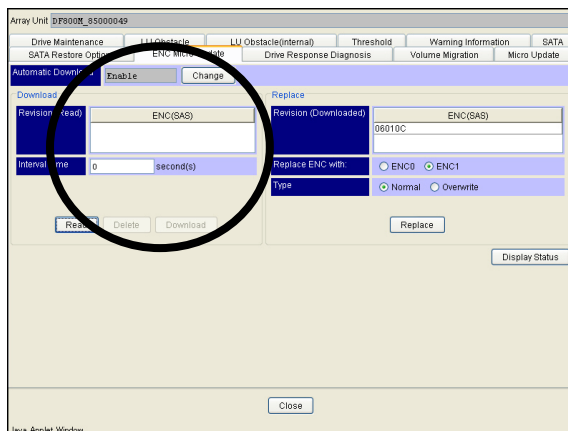

12.7 Procedure for Displaying ENC Firmware Revision Using Web

The revision of the ENC firmware can be looked up using not only Hitachi Storage Navigator Modular 2 but also the Web.

The window for displaying the ENC firmware revision is displayed through an entry of the following URL into the Web browser using the PC connected to the disk array system.

[http://\[IP address of a controller\]/encmicro](http://[IP address of a controller]/encmicro)

Entries of a [User's Name] and [Password] may be required when connecting or operating the Web. In such a case, enter [maintenance] as a user's name and [hosyu9500] as a password.

- Select [ENC Information] from the [Menu] in the window displaying the ENC firmware revision.

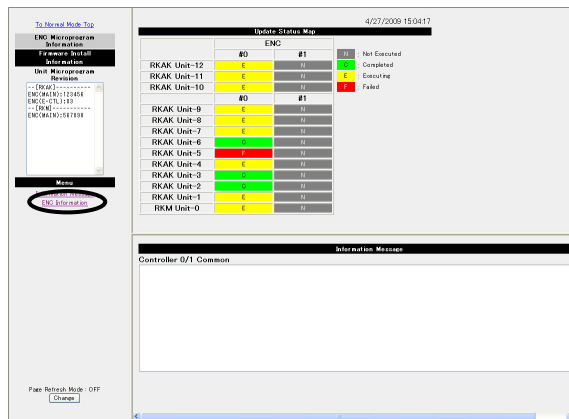

- The ENC firmware revision is displayed.

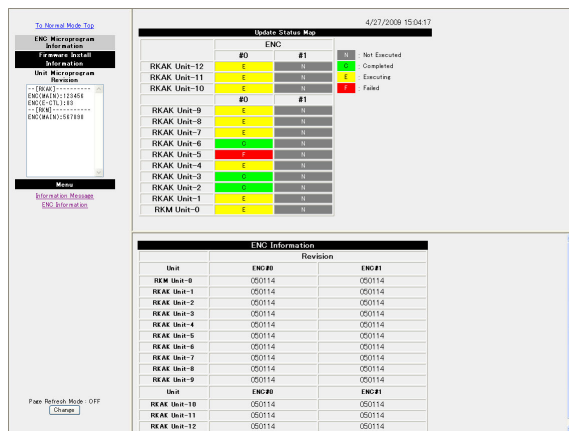

This page is for editorial purpose only.

Chapter 13. Procedure for Offline ENC Firmware Download

13.1 Offline ENC Firmware Download Overview

This document explains how to use the firmware to download ENC firmware from the PC used for maintenance without replacing any hardware parts in the event of an ENC Firmware malfunction.

13.2 Offline ENC Firmware Download Prerequisites

- (1) A maintenance terminal is required to connect to the web and download ENC firmware. Keep the maintenance manual at hand in order to be prepared for errors that may occur during ENC Firmware download.
- (2) To download the ENC firmware making a connection to the Web, it is required to connect the LAN connector of the Controller 0. If the Controller 1 is connected, the ENC firmware cannot be downloaded.
- (3) Either HDD #0 or HDD #2 must be installed at each unit in the disk array when downloading ENC firmware for ENC #0. Either HDD #1 or HDD #3 must be installed at each unit in the disk array when downloading ENC firmware for ENC #1. In addition, ENC #0 and ENC #1 must be installed at each Additional Chassis. Attempting ENC firmware download when the aforementioned are not installed may cause a subsystem to go down. In the event of a subsystem error, restart the ENC firmware download after confirming that the required HDDs and ENC units have been installed.
- (4) Maintenance personnel must only use the ENC firmware download function when the subsystem is offline. The following tasks and situations will occur during Offline ENC Firmware download procedures:
 - Maintenance personnel must perform the planned stop of the disk array system on the measurement screen.
 - Maintenance personnel must start the disk array in start mode (ENC Micro-Download Mode).
 - The disk array system may reboot automatically.

If the ENC firmware download is performed when the system is online, abnormal termination will result. The host computer may also detect I/O errors and refuse to recognize LUs, which will cause business applications to stop responding. If any of the aforementioned errors occurs, take the system offline and restart the ENC firmware.

Also, stop the failure monitoring such as the E-mail Alert Function, the PC ASSIST, the SNMP monitoring, the failure monitoring of the Hitachi Storage Navigator Modular 2, the Hi-Track monitoring, etc.

And, restart the failure monitoring after completing the download of the ENC firmware.

Offline is used to explain the situation detailed below.

The host computer neither accesses the disk array unit nor recognizes the LU, does not execute a drive restoration (dynamic sparing, copy back, and/ or correction copy), LU formatting, pair creation/resynchronization of ShadowImage in-system replication, and restoration of Copy-on-write Snapshot within the disk array unit and does not execute the resynchronization of TrueCopy remote replication between the disk array units. If the host computer will not access the disk array system, either all power to the host computer is turned off or the host computer is ready but the disk array system, including direct fiber optic cable connections and switches, is physically disconnected.

- (5) Do not download ENC firmware if the ENC unit is not installed at the Additional Chassis. If the ENC unit opposite the number of the ENC firmware to be downloaded is removed or if an ENC firmware download is attempted when the ENC unit is uninstalled, a loop switch fault on the drive side will result, causing the subsystem to go down.
- (6) Confirm that the subsystem is ready and there is not an error other than an ENC error in the subsystem. If an ENC firmware is downloaded when there is an error other than an ENC error in the subsystem, the download may result in an abnormal shutdown. When an abnormal shutdown occurs, confirm the subsystem's status on the web, and, after addressing the error, restart the ENC firmware download.
- (7) In order to prevent user data loss and other problems that may occur when the Offline ENC Firmware download function is used, perform the planned stop of the subsystem before attempting to download the ENC firmware. After the subsystem boots up again, download the ENC firmware once the subsystem is in the system ready status.
Be aware that the ENC firmware download function can be used without performing the planned stop. The ENC firmware download function cannot be used when the subsystem is in one of the statuses listed below. When the subsystem is in one of the following statuses, refer to the maintenance manual for instructions on how to properly correct the error. After the error has been corrected, restart the ENC firmware download.
 - Forced parity recovery is required.
 - User data is stored in the cache.
- (8) When the READY LED (green) on the Front Bezel of a Basic disk array unit is blinking quickly, the ENC firmware is being downloaded. Therefore, start the downloading after the READY LED (green) becomes kept on.
- (9) When the WARNING LED (orange) on the front of the Basic Chassis is blinking at high speed, do not perform the work. The automatic download of the ENC firmware or the update of the flash program is being executed. Perform the work after checking that the WARNING LED (orange) on the front of the Basic Chassis goes out and the READY LED (green) lights up.
- (10) When the TrueCopy remote replication is enabled, and the array subsystem, which the ENC firmware download is to be performed, is a remote disk subsystem, perform the ENC firmware download after changing the pair status (S-VOL) of TrueCopy remote replication to PSUS. However, although a path blockade occurs if the ENC firmware download is performed, the pair blockade is automatically recovered by turning on the power supply of the array subsystem after performing the ENC firmware download.
After the offline ENC firmware download is completed, set the pair status (S-VOL) of the TrueCopy remote replication to previous state.
Also, if the ENC firmware download is performed, the following phenomena occur.
 - Both paths of the TrueCopy remote replication are blocked. The notice of E-mail Alert Function and SNMP Agent Support Function and TRAP occur at the time of the path blockade. Perform the notice and the check to the Failure Monitoring Department in advance. The path blockade automatically recovers after restarting.
 - When the pair status of the TrueCopy remote replication is PAIR or COPY, the pair status changes to PSUE.

- (11) When the TrueCopy Extended Distance is enabled, and the array subsystem, which the ENC firmware download is to be performed, is a remote disk subsystem, perform the ENC firmware download after changing the pair status (S-VOL) of TrueCopy Extended Distance to PSUS. However, although a path blockade occurs if the ENC firmware download is performed, the pair blockade is automatically recovered by turning on the power supply of the array subsystem after performing the ENC firmware download.
- After the offline ENC firmware download is completed, set the pair status (S-VOL) of the TrueCopy Extended Distance to previous state.
- Also, if the ENC firmware download is performed, the following phenomena occur.
- Both paths of the TrueCopy Extended Distance are blocked. The notice of E-mail Alert Function and SNMP Agent Support Function and TRAP occur at the time of the path blockade. Perform the notice and the check to the Failure Monitoring Department in advance. The path blockade automatically recovers after restarting.
 - When the pair status of the TrueCopy Extended Distance is PAIR or COPY, the pair status changes to PSUE.
- (12) When it sets to the mode that executes the offline ENC firmware replacement and the array subsystem starts, the Disk Drives, which were spun down due to the Power Saving of the priced option, spin up.
- When the array subsystem normally starts and it becomes the Ready status after completing the offline ENC firmware replacement, the Disk Drives set to the Power Saving spin down.
- (13) It is required to install JRE 1.6 in the service PC to download the ENC firmware. When the version other than JRE 1.6 is installed in the service PC, the procedure may not be performed normally. When the version other than JRE 1.6 is installed, be sure to uninstall the JRE and then install JRE 1.6. After completing the procedure, return it to the original JRE.

13.3 Restriction and Notes of Offline ENC Firmware Download

- (1) Do not remove or insert any parts, for maintenance or any other reason, during Offline ENC firmware download.

Inserting or removing parts during ENC firmware download may cause a fault. If parts are inserted or removed during ENC firmware download and a fault results, retry the ENC firmware download.

Do not download ENC firmware if the ENC unit is not installed at the Additional Chassis. If an ENC firmware download is attempted when ENC is not installed at the Additional Chassis, a loop switch error will result at the drive side, causing the system to go down.

- (2) Do not alter the disk array architecture during offline ENC firmware download. Altering the disk array architecture during ENC firmware download may cause download to fail.
- (3) If maintenance personnel download an offline ENC firmware when one of the ENC firmware already installed is defective or there is an ENC hardware error, the ENC firmware exchange may fail. If a failure occurs, correct the error by retrying the ENC firmware download in accordance with the procedure manual and/or perform the maintenance according to the message displayed in the Information Message.
- (4) After downloading an ENC firmware, the ALARM LED (red) on the ENC unit that performed the download will light up. This means that the ENC is automatically rebooting after the ENC firmware was downloaded and does not indicate an error. After the ENC firmware download, remove the power cables, reconnect them, and check that the array subsystem restarts normally and the ENC firmware is updated according to the offline ENC firmware download procedure.
- (5) When returning the revision of the ENC firmware to the previous one after downloading the firmware because of its trouble, etc., it is required to invalidate the automatic downloading function before downloading the firmware.
For the procedure for invalidating the automatic downloading function, [“13.9 Procedure for Invalidating the Automatic ENC Firmware Downloading Function” \(TRBL 13-0410\)](#).
- (6) When it sets to the mode that executes the offline ENC firmware replacement and the array subsystem starts, the Disk Drives, which were spun down due to the Power Saving of the priced option, spin up.
When the array subsystem normally starts and it becomes the Ready status after completing the offline ENC firmware replacement, the Disk Drives set to the Power Saving spin down.

13.4 Offline ENC Firmware Download Time

The table below shows the amount of time required to download an ENC firmware in the disk array system. These figures do not include the amount of time required for the system (including the host computer) to go online. The working hours of Table 13.4.1 show the time from instructing the download of the ENC firmware for ENC#0 or ENC#1 by WEB to the end of the download.

Table 13.4.1 Standard of the Time Required for the Off-line ENC Firmware Download of the AMS2300/AMS2100/AMS2010

#	Item	Operation time	
		Standard	Maximum
	Target chassis for ENC firmware download	Only Basic Chassis Only Additional Chassis Optional combination	
	ENC firmware download task		
1	Host I/O stop	Varies with system architecture.	
2	Planned stop	1 minute	3 minutes
3	Subsystem startup	4 minutes	6 minutes
	ENC #0 side firmware download		
4	Disk array system reboot	4 minutes	6 minutes
5	ENC #0 side download	4 minutes	8 minutes
6	Subsystem startup	4 minutes	6 minutes
	ENC #1 side firmware download		
7	Disk array system reboot	4 minutes	6 minutes
8	ENC #1 side download	4 minutes	8 minutes
9	Subsystem startup	4 minutes	6 minutes
10	Total	29 minutes	49 minutes

Table 13.4.2 Standard of the Time Required for the Off-line ENC Firmware Download of the AMS2500

#	Item	Operation time			
		Only Additional Chassis		Basic Chassis and Additional Chassis	
		Standard	Maximum	Standard	Maximum
		ENC firmware download task			
1	Host I/O stop				
2	Planned stop	2 minutes	6 minutes	2 minutes	6 minutes
3	Subsystem startup	5 minutes	8 minutes	5 minutes	8 minutes
		ENC #0 side firmware download			
4	Disk array system reboot	5 minutes	8 minutes	5 minutes	8 minutes
5	ENC #0 side download	4 minutes	8 minutes	5 minutes	10 minutes
6	subsystem startup	5 minutes	8 minutes	5 minutes	8 minutes
		ENC #1 side firmware download			
7	Disk array system reboot	5 minutes	8 minutes	5 minutes	8 minutes
8	ENC #1 side download	4 minutes	8 minutes	5 minutes	10 minutes
9	subsystem startup	5 minutes	8 minutes	5 minutes	8 minutes
10	Total	29 minutes	49 minutes	37 minutes	66 minutes

13.5 Before Beginning an Offline ENC Firmware Download

Before beginning ENC firmware download, confirm/prepare the following:

- (1) After referring to the web connection procedures in the [WEB “Chapter 1. Before Using Web” \(WEB 01-0000\)](#), prepare 1 PC on which a web browser has been installed and that can be used in a LAN.
The PC that is used for maintenance and connected to the LAN must be used to download ENC firmware.
- (2) Set the service PC up. (See [Firmware “1.3 Preparation for Installation of Firmware” \(FIRM 01-0020\)](#).)
- (3) Prepare a CD-ROM of the specified revision for firmware installation.
- (4) ENC firmware can only be downloaded when the system is off (when the host I/O is stopped). (When the LU formatting, drive restoration (dynamic sparing, copy back, and/or correction copy), pair creation/resynchronization of ShadowImage in-system replication, or restore of Copy-on-write Snapshot, or copying of TrueCopy remote replication is in progress, perform the downloading after the operation above is completed.)
- (5) Execute the installer of the CD-ROM, and save the unified version directory^(‡1), where the ENC firmware is stored, under the directory “C:\diskarray-microprogram\microprogram”.
- (6) If a failure occurs during the ENC firmware download, it is required to see the recovery measures. Prepare the “[Message](#)”, and perform the recovery work following the manual.
- (7) When you return the firmware to the original firmware after downloading it due to ENC firmware trouble, etc., it is required to disable the automatic download function and then perform the offline ENC firmware download. Refer to “[13.9 Procedure for Invalidating the Automatic ENC Firmware Downloading Function](#)” (TRBL 13-0410) for the method to disable the automatic download function.
- (8) Stop the failure monitoring such as the E-mail Alert Function, the PC ASSIST, the SNMP monitoring, the failure monitoring of the Storage Navigator Modular 2, the Hi-Track monitoring, etc.
And, restart the failure monitoring after completing the download of the ENC firmware.
- (9) Confirm that the subsystem is ready and there is not an error other than an ENC error in the subsystem. If an ENC firmware is downloaded when there is an error other than an ENC error in the subsystem, the download may result in an abnormal shutdown. When an abnormal shutdown occurs, confirm the subsystem’s status on the web, and, after addressing the error, restart the ENC firmware download.

‡1 : For the unified version directory, refer to “[13.5.1 Hierarchy of ENC Firmware Storage Directories](#)” (TRBL 13-0100).

- (10) In order to prevent user data loss and other problems that may occur when the Offline ENC Firmware download function is used, perform the planned stop of the subsystem before attempting to download the ENC firmware. After the subsystem boots up again, download the ENC firmware once the subsystem is in the system ready status.
- Be aware that the ENC firmware download function can be used without performing the planned stop. The ENC firmware download function cannot be used when the subsystem is in one of the statuses listed below. When the subsystem is in one of the following statuses, refer to the maintenance manual for instructions on how to properly correct the error. After the error has been corrected, restart the ENC firmware download.
- Forced parity recovery is required.
 - User data is stored in the cache.
- (11) When the READY LED (green) on the Front Bezel of a Basic disk array unit is blinking quickly, the ENC firmware is being downloaded. Therefore, start the downloading after the READY LED (green) becomes kept on.
- (12) When the WARNING LED (orange) on the front of the Basic Chassis is blinking at high speed, do not perform the work. The automatic download of the ENC firmware or the update of the flash program is being executed. Perform the work after checking that the WARNING LED (orange) on the front of the Basic Chassis goes out and the READY LED (green) lights up.
- (13) When the TrueCopy remote replication is enabled, and the array subsystem, which the ENC firmware download is to be performed, is a remote disk subsystem, perform the ENC firmware download after changing the pair status (S-VOL) of TrueCopy remote replication to PSUS. However, although a path blockade occurs if the ENC firmware download is performed, the pair blockade is automatically recovered by turning on the power supply of the array subsystem after performing the ENC firmware download.
- Also, if the ENC firmware download is performed, the following phenomena occur.
- Both paths of the TrueCopy remote replication are blocked. The notice of E-mail Alert Function and SNMP Agent Support Function and TRAP occur at the time of the path blockade. Perform the notice and the check to the Failure Monitoring Department in advance. The path blockade automatically recovers after restarting.
 - When the pair status of the TrueCopy remote replication is PAIR or COPY, the pair status changes to PSUE.

(14) When the TrueCopy Extended Distance is enabled, and the array subsystem, which the ENC firmware download is to be performed, is a remote disk subsystem, perform the ENC firmware download after changing the pair status (S-VOL) of TrueCopy Extended Distance to PSUS. However, although a path blockade occurs if the ENC firmware download is performed, the pair blockade is automatically recovered by turning on the power supply of the array subsystem after performing the ENC firmware download.

Also, if the ENC firmware download is performed, the following phenomena occur.

- Both paths of the TrueCopy Extended Distance are blocked. The notice of E-mail Alert Function and SNMP Agent Support Function and TRAP occur at the time of the path blockade. Perform the notice and the check to the Failure Monitoring Department in advance. The path blockade automatically recovers after restarting.
- When the pair status of the TrueCopy Extended Distance is PAIR or COPY, the pair status changes to PSUE.

(15) When Power Saving of the priced option is used, if you perform the download of the ENC firmware after executing the spin-down and before completing it, the spin-down may fail because of the recognition processing of the host when the array subsystem starts. Check that there is no RAID Group whose power saving status is “Normal (command monitoring)” after executing the spin-down, and then perform the download of the ENC firmware.

If the spin-down fails, execute the spin-down again.

13.5.1 Hierarchy of ENC Firmware Storage Directories

The hierarchical structure of ENC firmware storage ZIP file (08xxx.zip) directories is shown in [Table 13.5.1](#).

When the ZIP file is stored from the CD-ROM which stores the firmware under the directory, “C:\diskarray-microprogram\microprogram.” and unzipped, the directories shown in [Table 13.5.1](#) are displayed.

Table 13.5.1 ZIP File Directory Hierarchy

First stratum	Second stratum	Third stratum	Fourth stratum
Unified version directory	DF800EH	disk 01 - disk X	Firmware file
		fmins	
	DF800EM	disk 01 - disk X	
		fmins	
	DF800ES	disk 01 - disk X	
		fmins	
	DF800EXS	disk 01 - disk X	
		fmins	
	DF800M	disk 01 - disk X	
		fmins	
	DF800S	disk 01 - disk X	
		fmins	
DF800H	disk 01 - disk X		
	fmins		
drvfirm	DKR2F-VIPERAP	Drive firmware file	
	:		
ENC	ENC firmware file	-	

13.6 Offline ENC Firmware Download Procedure (Dual Controller)

The procedure that must be followed in order to download ENC firmware differs depending on whether RKM/RKS use single or dual controller configuration. For details on using dual controller configuration when downloading ENC firmware, refer to “[13.6.1 Flowchart \(General\)](#)” (TRBL 13-0120). For details on using single controller configuration when downloading ENC firmware, refer to “[13.7 Offline ENC Firmware Download Procedure \(Single Controller\)](#)” (TRBL 13-0320). For details on the ENC firmware download operation for the AMS2500, refer to “[13.6. Offline ENC Firmware Download Procedure \(Dual Controller\)](#)” (TRBL 13-0110).

13.6.1 Flowchart (General)

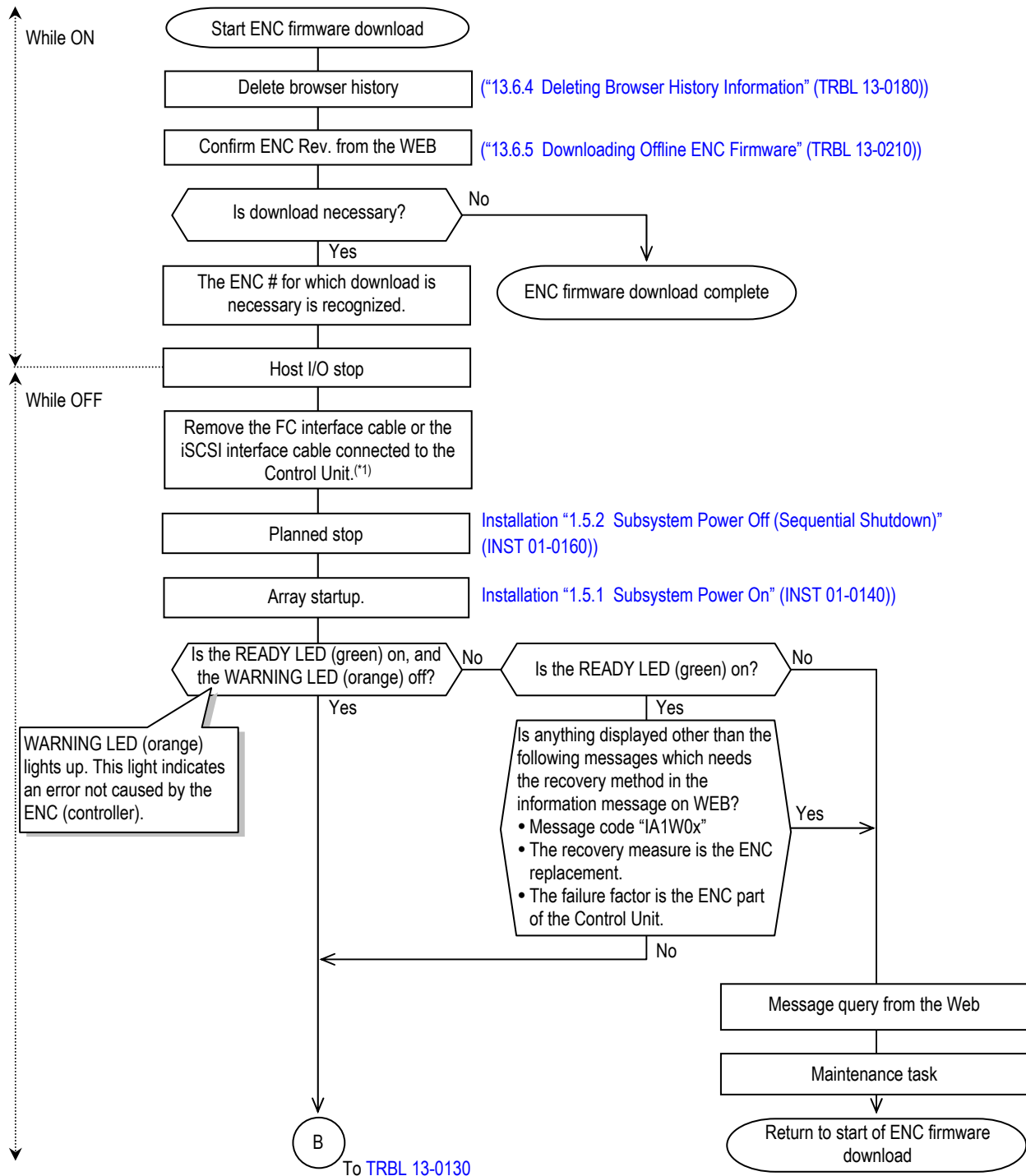

*1 : When removing the Fibre Channel Interface cables, pull out the Fibre Channel interface cables completely from the host connectors. If the Fibre Channel Interface cables are inserted half in the host connectors, the Control Unit continues to detect the Fibre Channel failures, and the I/O processing of the Control Unit may be deteriorated.

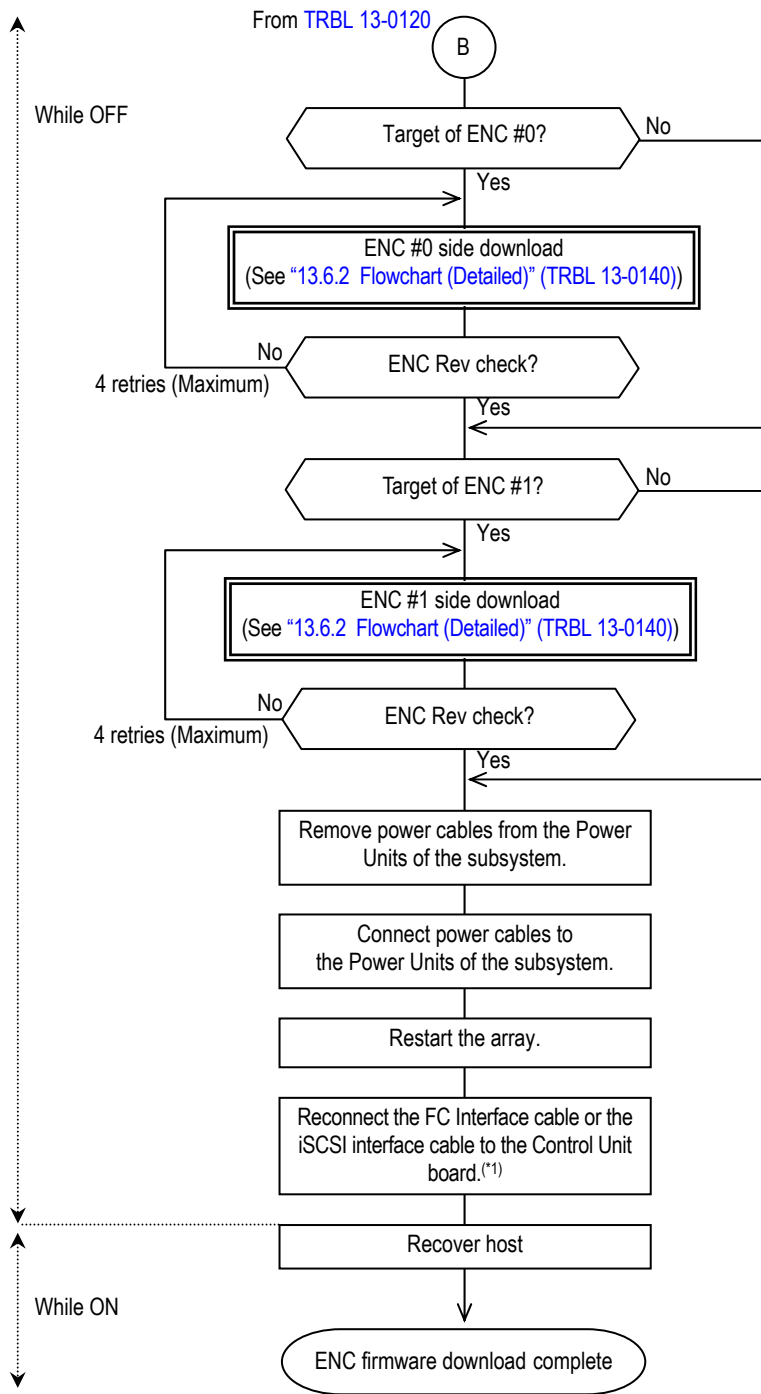

*1 : When connecting the Fibre Channel interface cables, insert the Fibre Channel interface cables until they are fixed to the host connectors.

If the Fibre Channel Interface cables are inserted half in the host connectors, the Control Unit continues to detect the Fibre Channel failures, and the I/O processing of the Control Unit may be deteriorated.

13.6.2 Flowchart (Detailed)

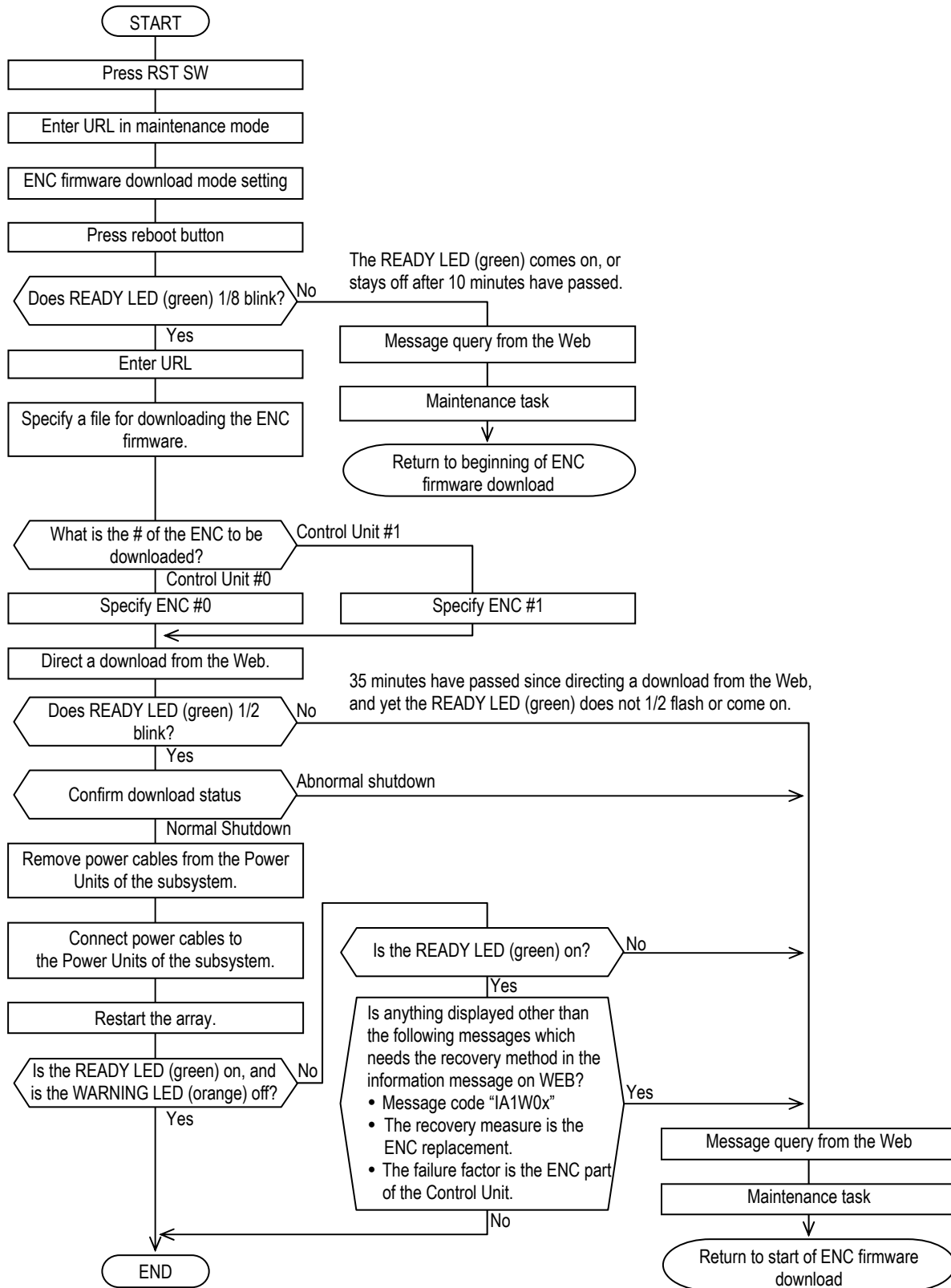

13.6.3 Connecting the PC Used for Maintenance

The maintenance LAN connector and the LAN connector of the PC used for maintenance must be connected using a LAN cross cable. Follow the procedure shown below to make the necessary connection.

(1) Confirm the following before connecting the PC used for maintenance:

Check the following LEDs before connecting the PC used for maintenance:

- POWER LED (green) confirmation:

Confirm that the POWER LED (green) located on the top of the front bezel is lit.

If the POWER LED (green) is not lit, refer to the [“Chapter 8. Trouble Analysis by LED Indication” \(TRBL 08-0000\)](#) for details on how to correct the error.

- WARNING LED (orange)/LOCATE LED (orange) confirmation:

Confirm that the WARNING LED (orange)/LOCATE LED (orange) located on the top of the front bezel is not lit.

If the WARNING LED (orange)/LOCATE LED (orange) is lit or blinking, refer to the [“Chapter 8. Trouble Analysis by LED Indication” \(TRBL 08-0000\)](#) for details on how to correct the error.

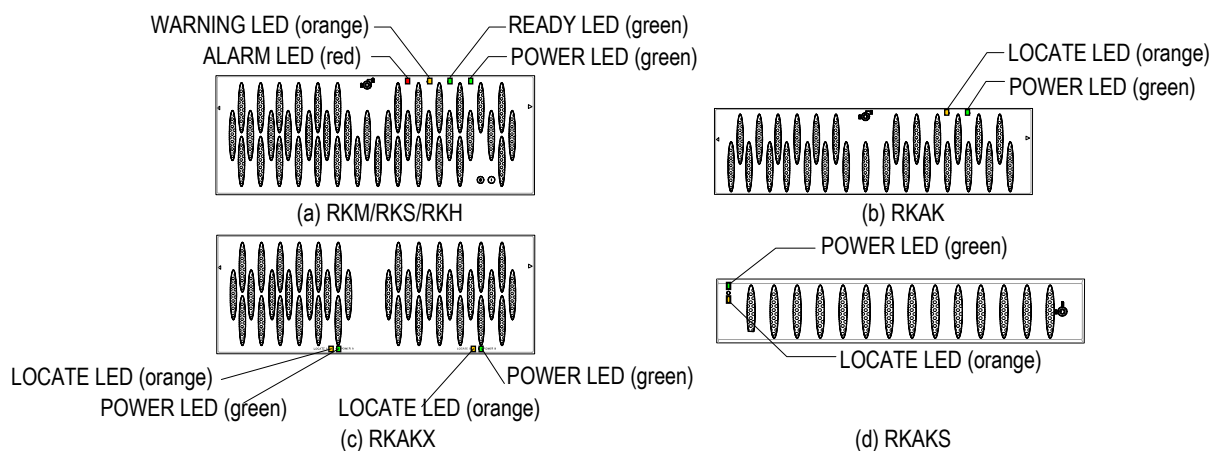

Figure 13.6.1 Locations and Name of LED

(2) Preparing the maintenance terminal for use

Table 13.6.1 Preparing the Maintenance Terminal

Item Number	Customer Environment	Terminal used for maintenance	Preparation
1	Uses controller's maintenance-use LAN connector	Use the LAN to connect the PC that is being carried and will be used for maintenance.	<ul style="list-style-type: none"> • PC used for maintenance • LAN cross cable

(3) Controller to be connected

With dual system architecture, the browser connection is identical no matter which controller is connected. First, connect to controller #0.

If controller #0 is closed, subsequent information can only be referenced on the controller #1 side. If controller #0 is closed, connect to controller #1.

When performing the offline ENC firmware downloading, however, perform it through the Controller #0. The firmware is not downloaded through the Controller #1.

(4) Procedure to connect portable maintenance PC to WEB

- (a) Remove the cover on the Control Unit. Connect the LAN-Connector for maintenance and the LAN-Connector of Maintenance PC with a LAN-cross-cable.

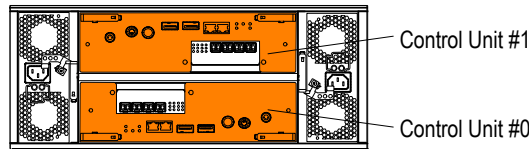

Control Unit RKM/RKEM/RKS/RKES/RKEXS/RKEXS8F Location (Rear view)

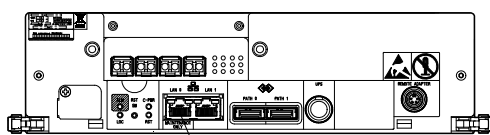

LAN connector (for maintenance)
Control Unit (RKM)

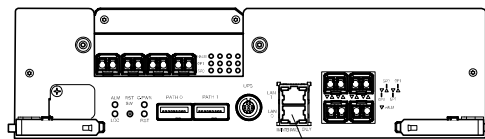

LAN connector (for maintenance)
Control Unit (RKEM)

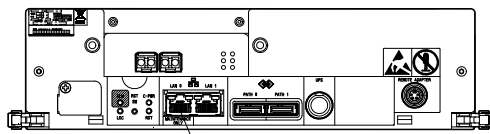

LAN connector (for maintenance)
Control Unit (RKS)

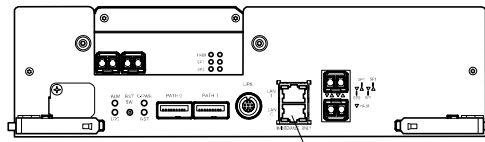

LAN connector (for maintenance)
Control Unit (RKES)

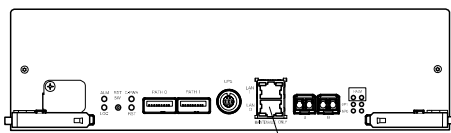

LAN connector (for maintenance)
Control Unit (RKEXS)

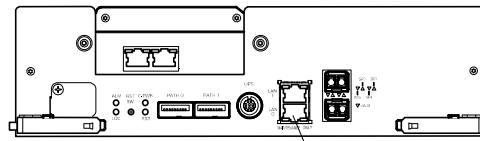

LAN connector (for maintenance)
Control Unit (RKEXS8F)

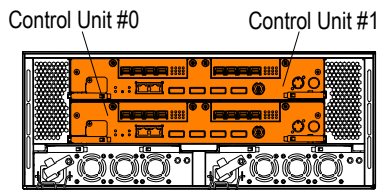

Control Unit RKM/RKEM/RKS/RKES/RKEXS/RKEXS8F Location (Rear view)

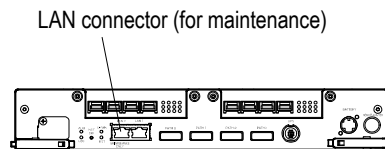

LAN connector (for maintenance)
Control Unit (RKH)

Figure 13.6.2 LAN Connector Position

- (b) Start Up the Maintenance PC.
- (c) Change the IP address of the network parameter for the maintenance PC.
When connecting with IPv4 protocol, set Item1 of [Table 13.6.2](#) to the IP address set to the PC. If the maintenance PC cannot be connected, set the value in No.2 to No.5.
- (c-1) In case of the IPv4 environment
- (i) Make the setting of the IP Address to be set to the PC as Item 1 in [Table 13.6.2](#).
 - CTL0: 10.0.0.16 (Input example : http://10.0.0.16/)
 - (ii) If it is not connectable, by setting the values of Item 2 to Item 5 in [Table 13.6.2](#), specify the connectable value and perform the WEB connection.
 - According to the setting value of “Maintenance PC” of Items 2 to 5 on [Table 13.6.2](#), set the IP Address and the Subnet Mask of the Maintenance PC.
 - According to the “Array (LAN port for maintenance)” information of Items 2 to 5 on [Table 13.6.2](#), enter into “Address” of the WEB browser and connect with the array.
 - (iii) If not connected yet, refer to [“3.4 Procedure for Specifying Maintenance Port IP Address” \(TRBL 03-0130\)](#).

Table 13.6.2 Operating Environment (IPv4)

No.	Subsystem (LAN port for maintenance)		Maintenance PC	
	IP Address	Subnet Mask	IP Address	Subnet Mask
1	CTL 0: 10.0.0.16 CTL 1: 10.0.0.17 (At the time of shipment)	255.255.255.0 (At the time of shipment)	10.0.0.2 to 0.0.0.9	255.255.255.0
2	CTL 0: 192.168.0.16 CTL 1: 192.168.0.17	255.255.255.0	192.168.0.2 to 192.168.0.9	255.255.255.0
3	CTL 0: 192.168.233.16 CTL 1: 192.168.233.17	255.255.255.0	192.168.233.2 to 192.168.233.9	255.255.255.0
4	CTL 0: 172.23.211.16 CTL 1: 172.23.211.17	255.255.255.0	172.23.211.2 to 172.23.211.9	255.255.255.0
5	CTL 0: 10.197.181.16 CTL 1: 10.197.181.17	255.255.255.0	10.197.181.2 to 10.197.181.9	255.255.255.0

- (b-2) In case of the IPv6 environment
- (i) Make the setting of the IP Address to be set to the PC as Item 1 in [Table 13.6.3](#).
 - CTL0: fe80::16 (Input example : http://[fe80::16]/)
 - When connecting on WEB by the IPv6 address, put the address in brackets ([]).
 - (ii) If it is not connectable, set the value of Item 2 in [Table 13.6.3](#), and perform the WEB connection.
 - According to the setting value of “Maintenance PC” of Item 2 on [Table 13.6.3](#), set the IP Address and the Subnet Mask of the Maintenance PC.
 - According to the “Array (LAN port for maintenance)” information of Item 2 on [Table 13.6.3](#), enter into “Address” of the WEB browser and connect with the array.
 - (iii) If not connected yet, refer to [“3.4 Procedure for Specifying Maintenance Port IP Address” \(TRBL 03-0130\)](#).

Table 13.6.3 Operating Environment (IPv6)

No.	Subsystem (LAN port for maintenance)		Maintenance PC	
	IP Address	Length of Subnet Prefix	IP Address	Subnet Mask
1	CTL0: fe80::16 CTL1: fe80::17 (At the time of shipment)	64 (At the time of shipment)	Automatic	Automatic
2	CTL 0: fe80::f6 CTL 1: fe80::f7	64	Automatic	Automatic

- Manual change of the network parameter of the Maintenance port
When the User management port is set as the same network address as the Maintenance port, the communication cannot be made normally. Prepare five patterns of the network parameter fixed values to be used in the Maintenance port, and change the network parameter fixed values to be used in the Maintenance port manually by the network parameter of the User management port. Therefore, in the work other than the installation work of the array at shipment, the maintenance LAN Port for the WEB connection is set to any of Items 1 to 5 in [Table 13.6.2](#) in case of the IPv4 environment and set to either Item 1 or 2 in [Table 13.6.3](#) in case of the IPv6 environment.

NOTE : When the network address of the LAN device, which is connected via the Gateway in the extension of the User management port, is the same as that of the Maintenance port, the communication cannot be made normally because of the conflict between them.

Therefore, use a value other than the network address set to the maintenance port for the LAN device connected to the port for the user management via Gateway. Or change the IP address of the maintenance port to a value other than the network address of the LAN device connected via Gateway by Hitachi Storage Navigator Modular 2. (Refer to [System Parameter “4.2 \(4\) Setting of Maintenance LAN” \(SYSPR 04-0160\)](#).)

- (d) Make sure that negotiation of Maintenance PC is set to auto negotiation.
To check negotiation of Maintenance PC, refer to [“3.1 \(6\) Procedure for setting negotiation” \(TRBL 03-0050\)](#).

This page is for editorial purpose only.

13.6.4 Deleting Browser History Information

Boot up the browser on the PC used for maintenance and delete history information.

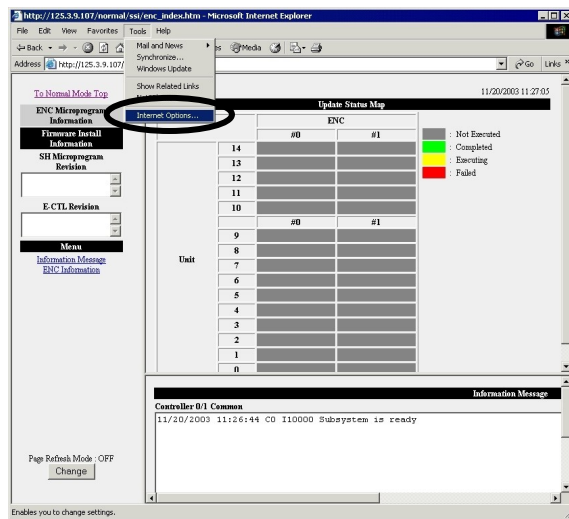

(1) Internet Explorer

(a) From the menu, select [Tool] - [Internet Options].

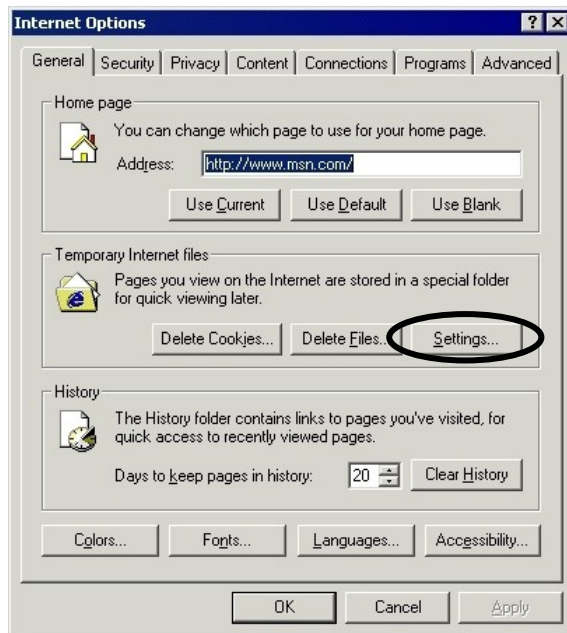

(b) Click the [Delete Files] button, which is located on the Temporary Internet File section of the general tag.

(c) A dialog box will be displayed. Check [Delete all offline content] and click the [OK] button.



(2) Netscape

(a) From the menu, select [Edit] - [Preferences].

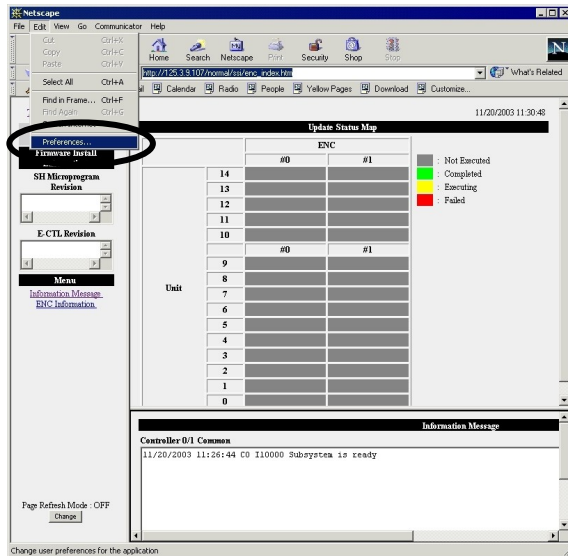

(b) From categories, select [Details] - [Cache]. Click the [Clear memory cache] button.

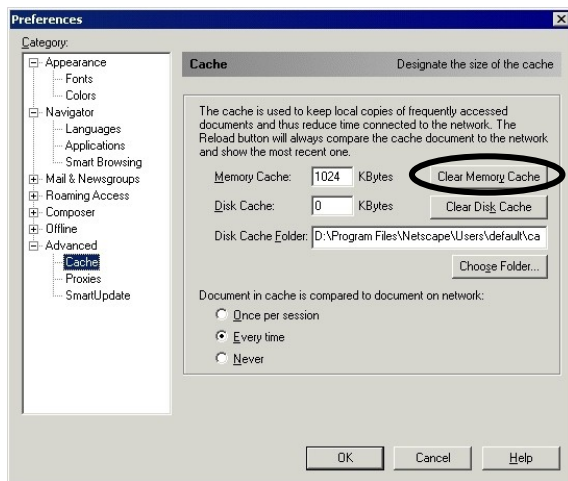

(c) A dialog box will be displayed. Click the [OK] button.

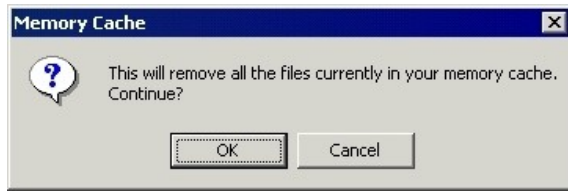

(d) Click the [Clear Disk Cache] button to display dialog box. Click the [OK] button.

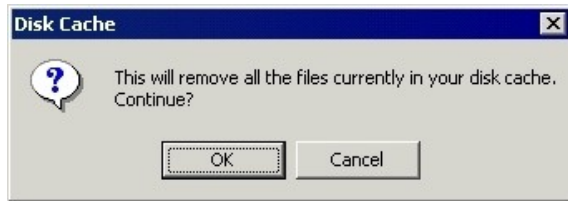

13.6.5 Downloading Offline ENC Firmware

- (1) While the disk array system is on, enter the following URL in the browser of the PC used for maintenance: “http:// subsystem maintenance LAN port IP address/encmicro”. A screen showing the ENC Firmware revision will be displayed.

At the time when the Web is connected or operated, entries of [User Name] and [Password] may be required. In such a case, enter [maintenance] as a user name and [hosyu9500] as a password.

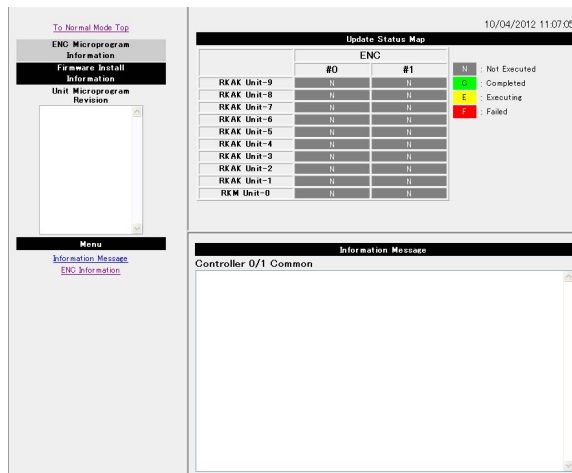

- (2) Click [ENC Information] in the menu section, and check revision of the current ENC firmware displayed in [ENC Information].

When the revision of the ENC #0 and #1 are both the same as the revisions to be downloaded or new revisions, it is not necessary to download the ENC firmware, so that terminate the work.

When either or both of the revision of the ENC #0 and #1 are older than the revision to be downloaded, go to the Step (3).

You can refer to the revision of the ENC firmware to be downloaded in the text file in the zip file of the firmware distributed by the CD-R in advance.

Decompress the zip file to “C:\diskarray-microprogram\maicroprogram”.

- In the case of RKEXS/RKS/RKES/RKM/RKEM/RKH/RKEH/RKAK/RKAKX
“C:\diskarray-microprogram\microprogram\Folder Name of Decompressed Firmware\ENC\S8LIST.TXT

Open the above-mentioned text file, and the one described in the first row is the ENC firmware revision.

Examples of S8LIST.TXT

061003(SM) ← The numbers of the leading six digits indicate the ENC firmware revision.

S8_REV.DAT

S8_FIRM.WTB

Compare it with the revision displayed in ENC(SAS) in the window.

- In the case of In the case of RKAKS
 “C:\diskarray-microprogram\microprogram\Folder Name of Decompressed
 Firmware\ENC\S3LIST.TXT
 Open the above-mentioned text file, and the one described in the first row is the ENC
 firmware revision.

Examples of S3LIST.TXT

070218(S3) ← The numbers of the leading six digits indicate the ENC firmware revision.

S3_REV.DAT

S3_FIRM.WTB

Compare it with the revision displayed in ENC(SAS) in the window.

The screenshot shows two windows from a Hitachi management interface. The top window is titled 'Update Status Map' and shows a table of units and their update status. The bottom window is titled 'ENC Information' and shows a table of units with their ENC revision details.

Update Status Map

Unit	ENC		Status
	#0	#1	
RKAK Unit-9	N	N	Net Executed
RKAK Unit-8	N	N	Completed
RKAK Unit-7	N	N	Executing
RKAK Unit-6	N	N	Failed
RKAK Unit-5	N	N	
RKAK Unit-4	N	N	
RKAK Unit-3	N	N	
RKAK Unit-2	N	N	
RKAK Unit-1	N	N	
RKM Unit-0	N	N	

ENC Information

Unit	Revision			
	ENC#0		ENC#1	
	ENC(SAS)	ENC(SFF)	ENC(SAS)	ENC(SFF)
RKM Unit-0	061006		061006	
RKAK Unit-1	061006		061006	
RKAK Unit-2	061006		061006	
RKAK Unit-3	061006		061006	
RKAK Unit-4	061006		061006	
RKAK Unit-5	061006		061006	
RKAK Unit-6	061006		061006	
RKAK Unit-7	061006		061006	
RKAK Unit-8	061006		061006	
RKAK Unit-9	061006		061006	

This page is for editorial purpose only.

- (3) When the downloading of the ENC firmware is required, make sure that none of the host I/O, LU formatting, drive restoration (dynamic sparing, copy back, or correction copy), pair creation/resynchronization of ShadowImage in-system replication, resynchronization of Copy-on-write Snapshot, and copying of TrueCopy remote replication is not in progress, and then perform the deliberate shutdown of the disk array system.

When Power Saving of the priced option is used, if you perform the planned shutdown of the array subsystem after executing the spin-down and before completing it, the spin-down may fail because of the recognition processing of the host when the array subsystem starts.

Check that there is no RAID Group whose power saving status is “Normal (command monitoring)” after executing the spin-down, and then perform the planned shutdown of the array subsystem.

If the spin-down fails, execute the spin-down again.

After normal completion of the planned stop, reboot the disk array system and confirm that the READY LED (green) is lit and that the WARNING LED (orange) is blinking.

- (4) Press the RST SW on each controller and proceed to the maintenance mode.

- (a) Proceeding to the Maintenance Mode

The method used to proceed to the maintenance mode differs depending on whether the READY LED (green) or the ALARM LED (red), both of which are located on the top of the front bezel (RKH/RKM/RKS) is lit.

- If the READY LED (green) is lit, proceed to Step (ii) of the procedures.
- If the ALARM LED (red) is lit, wait 3 minutes before proceeding to Step (ii).
- If neither the READY LED (green) nor the ALARM LED (red) lights up after the power to the subsystem has been turned on for 10 minutes, follow the procedure listed below.

- (i) Confirm that the WARNING LED (orange) on the front bezel is not blinking at a high rate of speed (in 125 ms intervals).

If the WARNING LED (orange) is blinking at a high rate of speed, wait for up to 80 seconds. The LED will stop blinking.

There is no error if the LED is blinking at a low rate of speed (once per second).

- (ii) Perform the change to the maintenance mode.

- Single controller

Press the RST SW on the single controller (the RST LED (orange) will light up while the RST SW is pressed).

- Dual controller

- ① Press the RST SW on controller #0 (the RST LED (orange) will light up while the RST SW is pressed).

- ② Press the RST SW on controller #1 (within 10 seconds of the first time the ALM LED (red) on controller #0 lights up).

If the ALM LED (red) on controller #0 has not lit up by this point, turn the power to the subsystem off and back on without removing the controller, return to Step (a), and repeat the procedure.

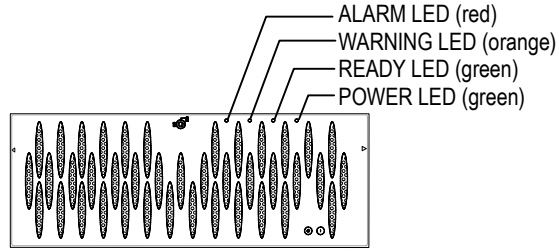

Front

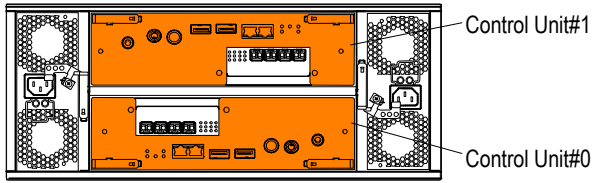

RKM (Rear view)

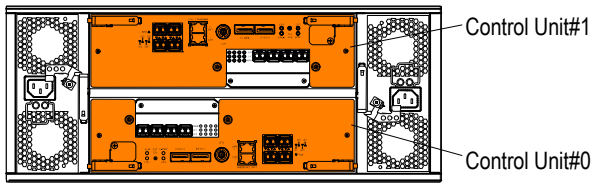
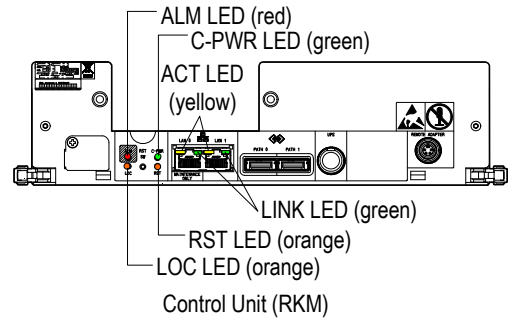

RKEM (Rear view)

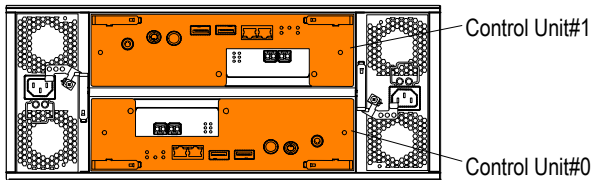
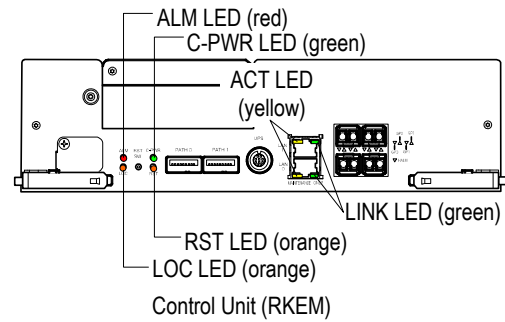

RKS (Rear view)

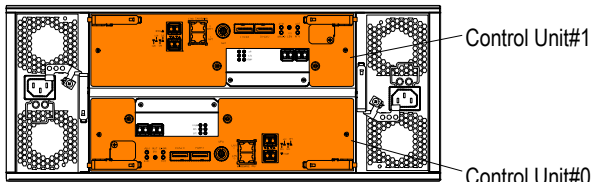
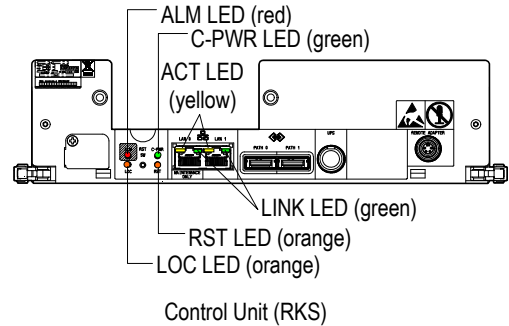

RKES (Rear view)

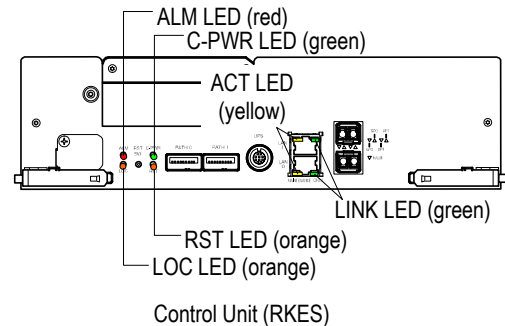

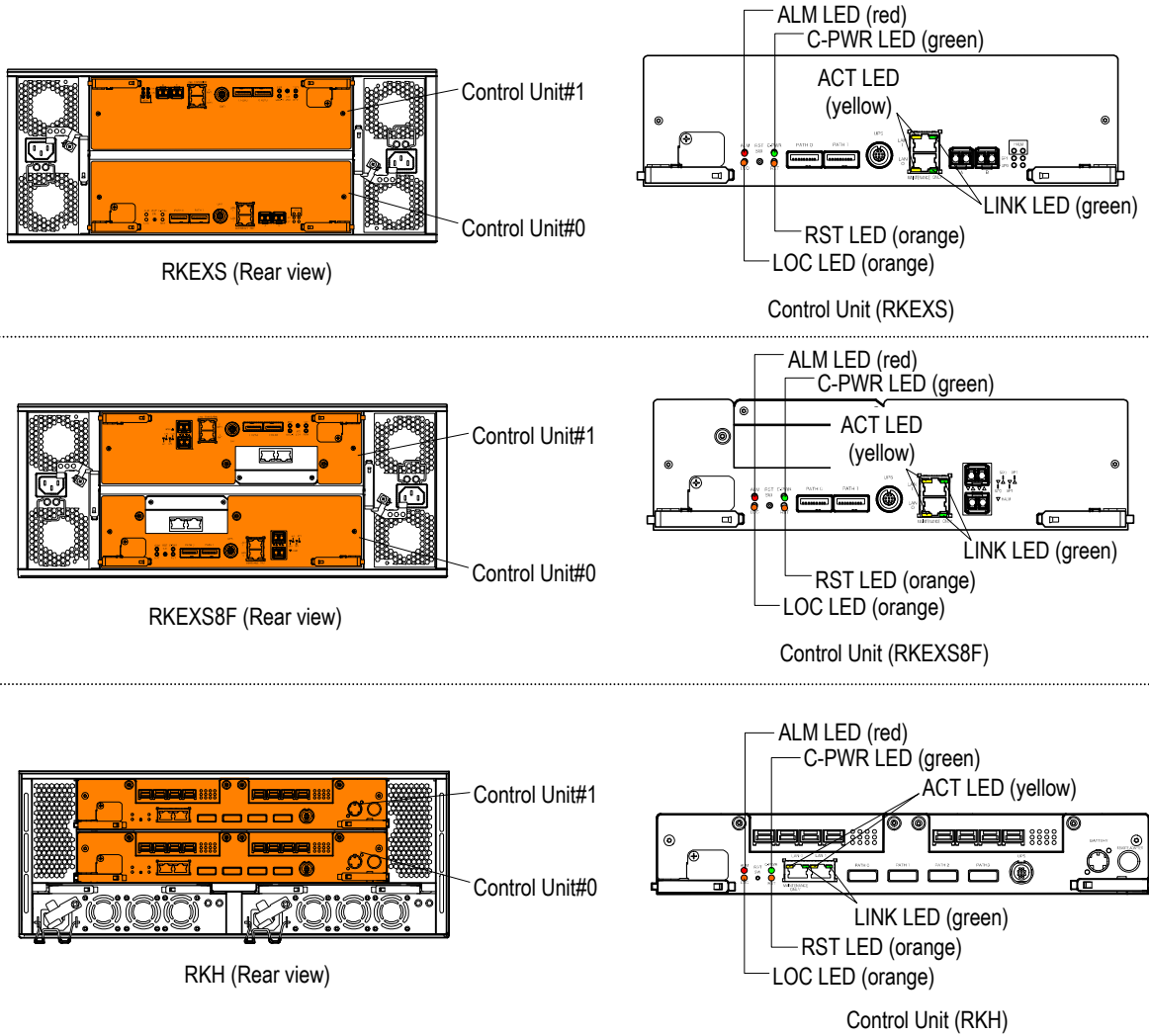

Figure 13.6.3 Indication Position

This page is for editorial purpose only.

NOTE : • The Control Unit will remain closed while the subsystem is in the maintenance mode. No commands from the host computer can be performed during this time.

To recover, you must reboot the Control Unit.

The subsystem will proceed to the maintenance mode once the ALM LED (red) on Control Unit #0 and the READY LED (orange) on the front bezel are both lit.

- Using DNS at the network TCP/IP settings increases the time it takes to connect to the network. To expedite connections, set “Do not use DNS”. Refer to the instruction manual of the PC in use for details on how to make settings.
- The subsystem cannot connect to the network if the browser is set to use the proxy server. Confirm that the browser is set not to use it. Refer to the instruction manual of the browser in use for details on how to confirm settings.

(5) Enter the following URL in the browser of the PC used for maintenance: “http://subsystem maintenance LAN port IP address/encmicro”. The bootup settings screen for firmware download will be displayed.

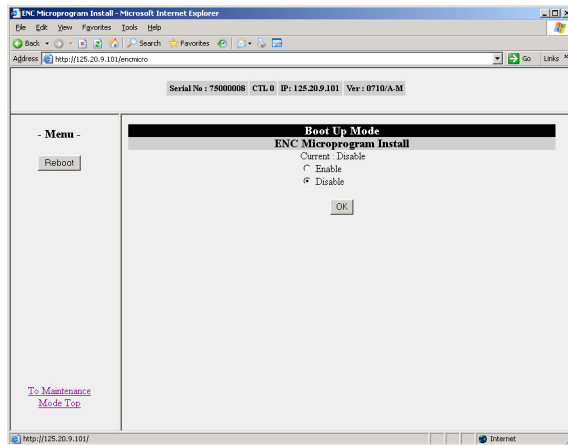

(6) Change the Boot Up Mode to Enable and click the [OK] button. Confirm that Enable has been selected.

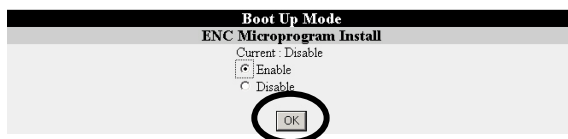

- (7) Click the [Reboot] button on the menu. Reboot the subsystem according to the instructions provided by the dialog box.

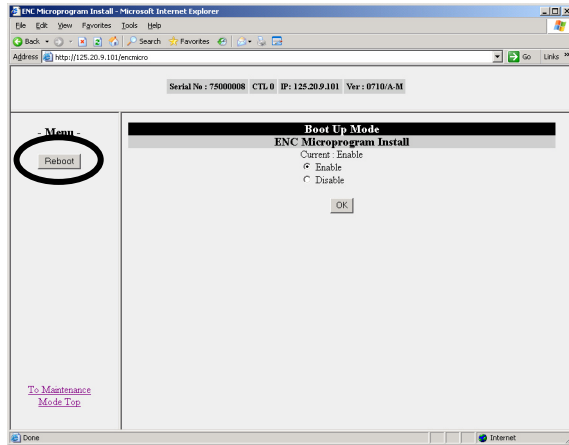

- (8) When the READY LED (green) on the subsystem starts to blink for 1/8 seconds, enter the following URL in order to display the ENC firmware download screen (Java applet):
 “http://subsystem maintenance LAN port IP address/encmicro”.^(#1) If the READY LED (green) blinks for less than 1/8 seconds, enter the following URL in the browser in order to confirm the subsystem’s status: “http://subsystem maintenance LAN port IP Address” and correct the error in accordance with the maintenance manual.

If the READY LED (green) on the subsystem lights up instead of blinking for 1/8 seconds, enter the following URL in the browser of the PC used for maintenance in order to display the information screen for the ENC firmware: “http:// subsystem maintenance LAN port IP address/encmicro”. Refer to the “Information Message” displayed. Refer to the maintenance manual for details on how to correct it.

When the following message is displayed, it is necessary to click ActiveX Control with a mouse and to change it into the active status.

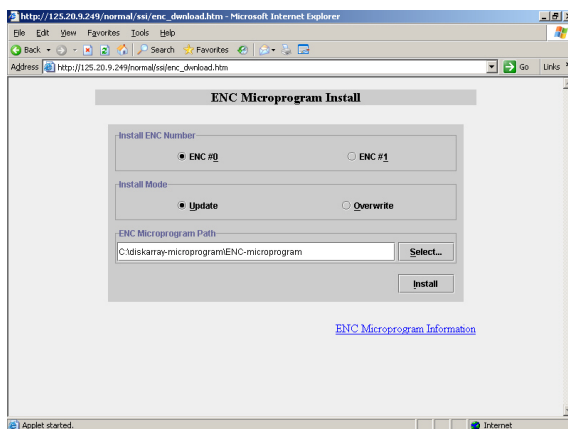
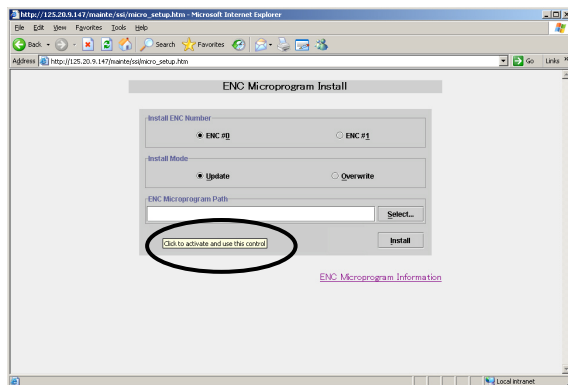

^{#1} : The Disk Drives, which were spun down due to the Power Saving of the priced option, are also spinning up.

Specify the unified version directory^(†1) by clicking the [Select...] button on the ENC Firmware Downloading panel.

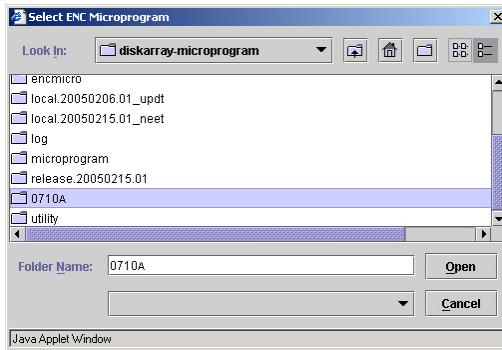

(9) The ENC number in which the ENC firmware is downloaded from [Install ENC Number] is checked.

Also, check that [Update] of [Install Mode] is selected. Specify it for [Update] when [Overwrite] is selected. Select [Overwrite] only when there is an instruction.

The download procedure from ENC #0 is shown in this procedure.

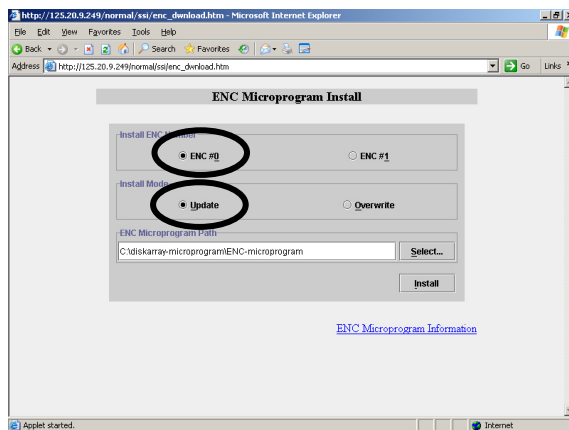

Click the [Install] button to display the dialog box in which the number of the ENC to be downloaded can be confirmed. Check the ENC number to be downloaded and click the [OK] button.

Update mode window

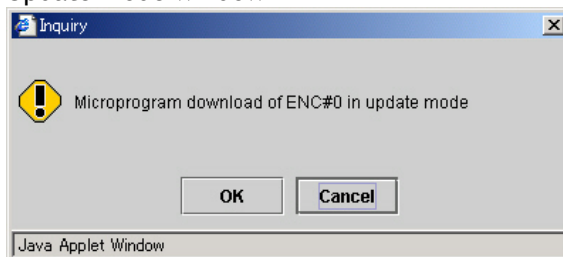

Overwrite mode window

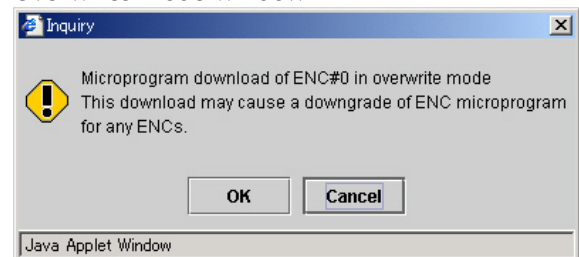

†1 : For the unified version directory, refer to “13.5.1 Hierarchy of ENC Firmware Storage Directories” (TRBL 13-0100).

- (10) The “dialog box for the confirmation of the ENC firmware Rev.” will be displayed. If there is no error in Rev. to be downloaded, click the [OK] button. The transfer of the ENC firmware file will begin.

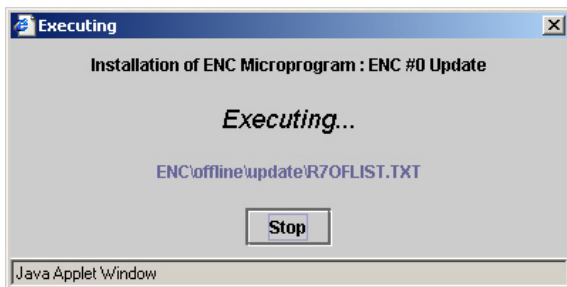
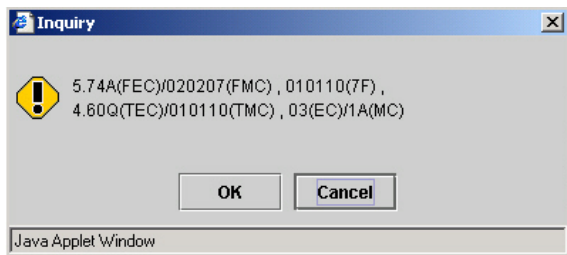

- (11) If all the ENC Firmware file transfers are accepted normally, the “ENC microprogram download start” dialog box will be displayed. Click the [OK] button. The download of the ENC firmware will begin.

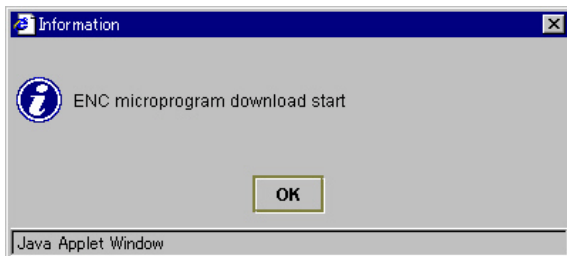

- (12) Click [ENC Microprogram Information] to display the ENC firmware download status view screen. The progress of the ENC firmware download can be confirmed at this screen.

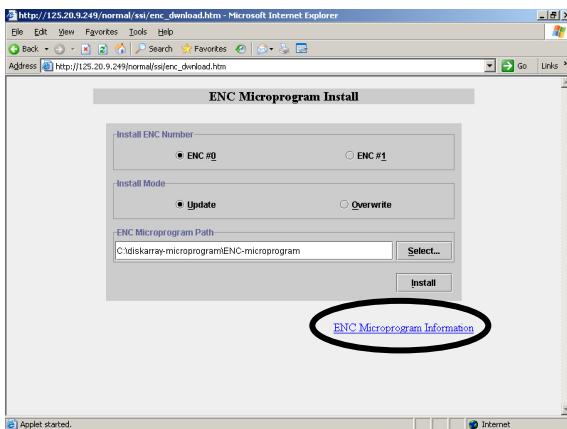

A message indicating the download status can be confirmed by clicking “Information Message” on the menu.

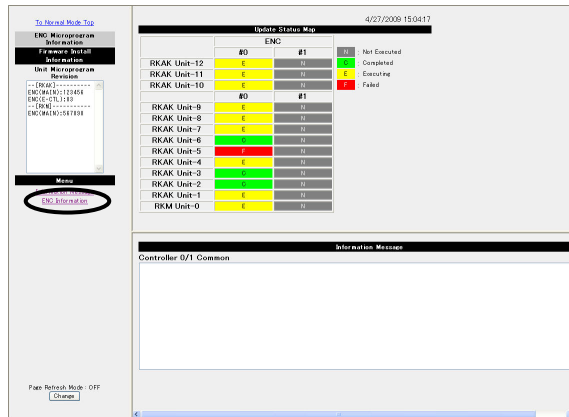

When the download starts, “IZY20x ENC#x microprogram download start” is displayed in the “Information Message” column.

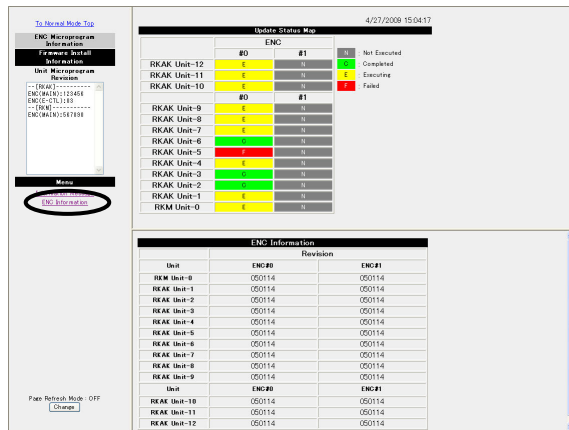

Download status is indicated by different colors on the “Update Status Map” and “ENC Information”. The status indicated by each color is as shown on the table below.

Screen (color)	Status
Gray	Not targeted for download
Green	Download complete
Yellow	Downloading
Red	The downloading failed (a failure occurred) or it was attempted for firmware outside the range to be downloaded (*1).

*1 : When it is intended to download only a part of the ENC firmware, a window, which shows the status of the ENC of a disk array unit having firmware outside the range to be downloaded, may be displayed in red. In this case, you can see which of the above is the case in point by checking whether or not a failure has occurred referring to the “Information Message” for a message as shown below.

- (13) After all ENC firmware installation is complete, “IZY40x ENC#x microprogram download complete” will be displayed in “Information Message” and the READY LED (green) on the subsystem will blink for 1/2 seconds.

NOTE : After an ENC firmware download has been completed normally, the ENC ALARM of the ENC that downloaded the firmware will light up.

This light means that the ENC has rebooted automatically and does not indicate an error.

If the message “IZY40x ENC#x microprogram download complete” is not displayed or if the READY LED (green) on the subsystem don’t blink for 1/2 seconds 35 minutes after the message “IZY20x ENC#x microprogram download start” is displayed, refer to (See Step (12)) and refer to the maintenance manual for details on how to correct the error. If an error message is displayed between “IZY20x ENC#x microprogram download start” and “IZY40x ENC#x microprogram download complete”, correct the error in accordance with the instructions in the error message.

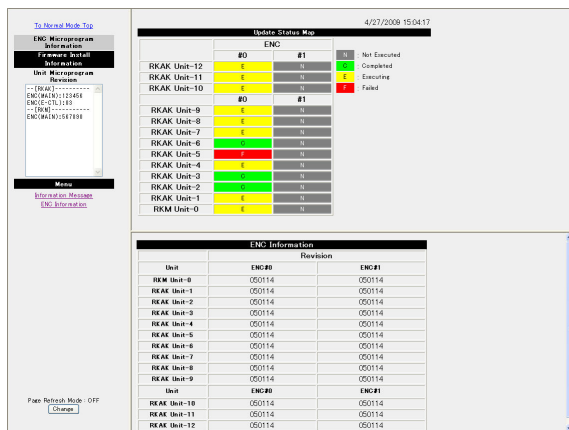

- (14) Remove the power cables of all chassis of the array subsystem, reconnect them, turn it on again, and turn on the main switch to restart. When it becomes READY, check that the WARNING LED (orange) is turned off. If the subsystem does not become Ready or the WARNING LED (orange) does not light up/blink, refer to the maintenance manual for details on how to correct the error.

Next, enter the following URL in the browser: “http://IP address/encmicro”, click “ENC Information” on the menu, and confirm that the Revs of the ENC firmware that were downloaded are equivalent to or greater than the Revs that were overwritten.

The screenshot shows a web interface for ENC information. On the left is a navigation menu with options like 'To Home Page', 'ENC Microprogram Information', 'Firmware Install', 'Unit Microprogram Information', 'Unit Microprogram Revision', 'Menu', 'Information Message', and 'ENC Information'. The main content area is titled 'Unit Status Map' and contains two tables. The first table, 'ENC', shows the status of units RKAK Unit-0 through RKAK Unit-12 and RKM Unit-0. The second table, 'ENC Information', shows the revision details for units REW Unit-0 through REW Unit-12 and RKAK Unit-0 through RKAK Unit-12.

Unit Status Map			
ENC			
#0	ENC	#1	Sts
RKAK Unit-12	0	0	Not Executed
RKAK Unit-11	0	0	Completed
RKAK Unit-10	0	0	Executing
RKAK Unit-9	0	0	Failed
#0	ENC	#1	Sts
RKAK Unit-8	0	0	Not Executed
RKAK Unit-7	0	0	Completed
RKAK Unit-6	0	0	Executing
RKAK Unit-5	0	0	Failed
RKAK Unit-4	0	0	Not Executed
RKAK Unit-3	0	0	Completed
RKAK Unit-2	0	0	Executing
RKAK Unit-1	0	0	Failed
RKM Unit-0	0	0	Not Executed

ENC Information		
Unit	ENC#0	ENC#1
REW Unit-0	05014	05014
REW Unit-1	05014	05014
REW Unit-2	05014	05014
REW Unit-3	05014	05014
REW Unit-4	05014	05014
REW Unit-5	05014	05014
REW Unit-6	05014	05014
REW Unit-7	05014	05014
REW Unit-8	05014	05014
REW Unit-9	05014	05014
Unit	ENC#0	ENC#1
RKAK Unit-10	05014	05014
RKAK Unit-11	05014	05014
RKAK Unit-12	05014	05014

- (15) When the download is necessary for the other ENC, repeat (4) to (14) of “13.6.5 Downloading Offline ENC Firmware” (TRBL 13-0210), and download the ENC firmware.

This screenshot is identical to the one above, showing the 'Unit Status Map' and 'ENC Information' tables for the array subsystem.

13.7 Offline ENC Firmware Download Procedure (Single Controller)

This procedure is explained below, with the mounted controller as controller #0.

- For RKM/RKS only

Since the RKM/RKS ENC forms a single unit with the controller, download ENC #0 only.

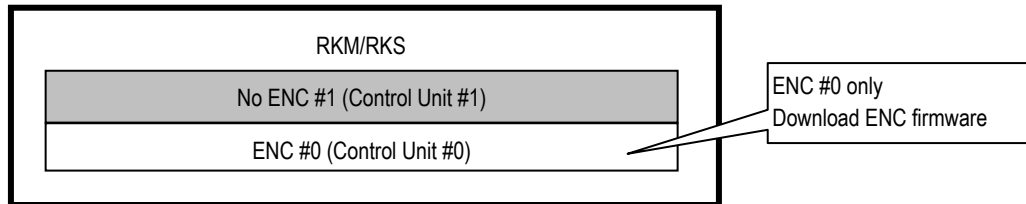

- For RKM+RKAK/RKAKS

RKS+RKAK/RKAKS

Although RKM/RKS has only ENC #0, RKAK/RKAKS includes both ENC #0 and ENC #1.

Therefore, it is necessary to download to both ENC #0 and ENC #1.

13.7.1 Flowchart (General)

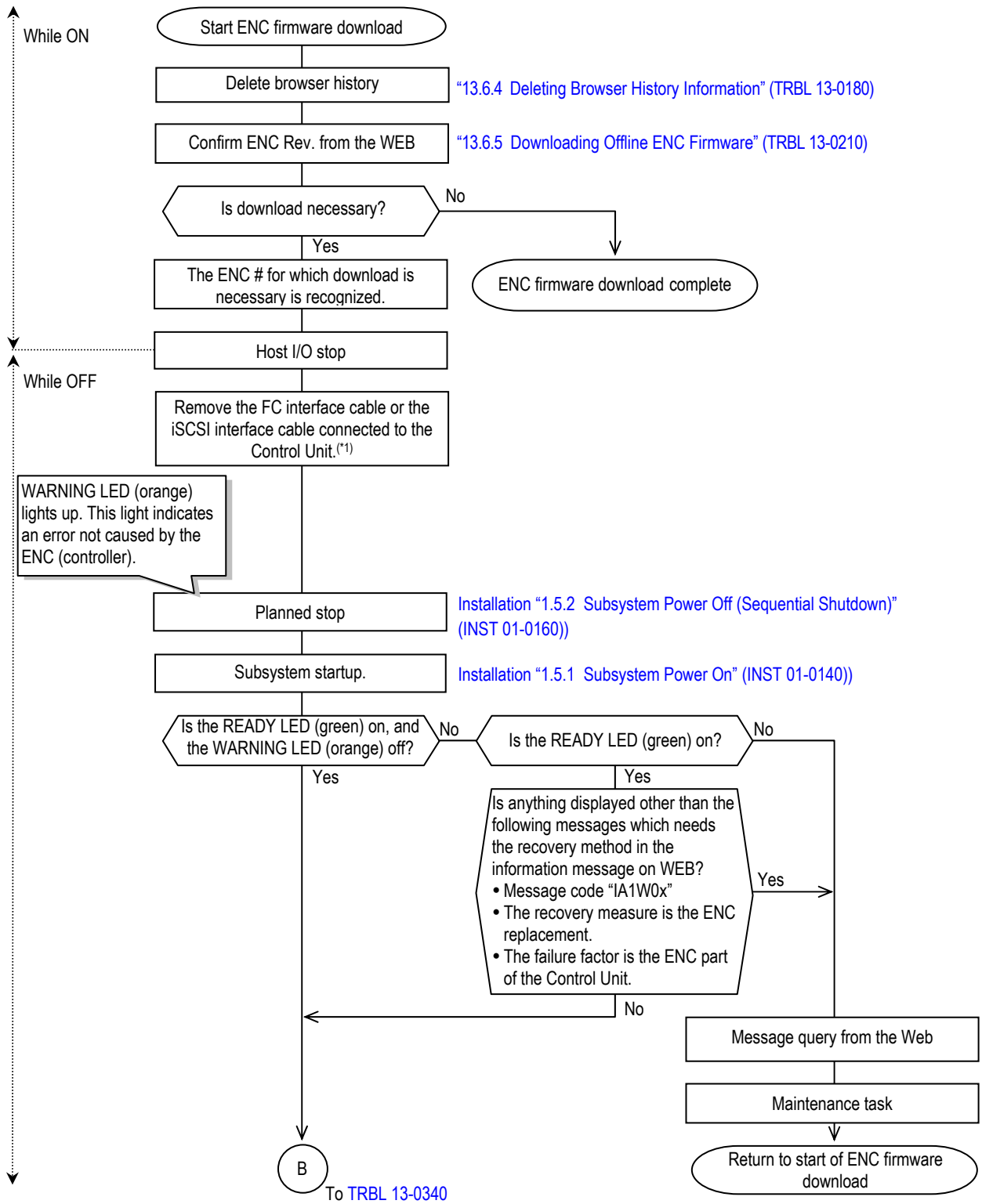

*1 : When removing the Fibre Channel Interface cables, pull out the Fibre Channel interface cables completely from the host connectors. If the Fibre Channel Interface cables are inserted half in the host connectors, the Control Unit continues to detect the Fibre Channel failures, and the I/O processing of the Control Unit may be deteriorated.

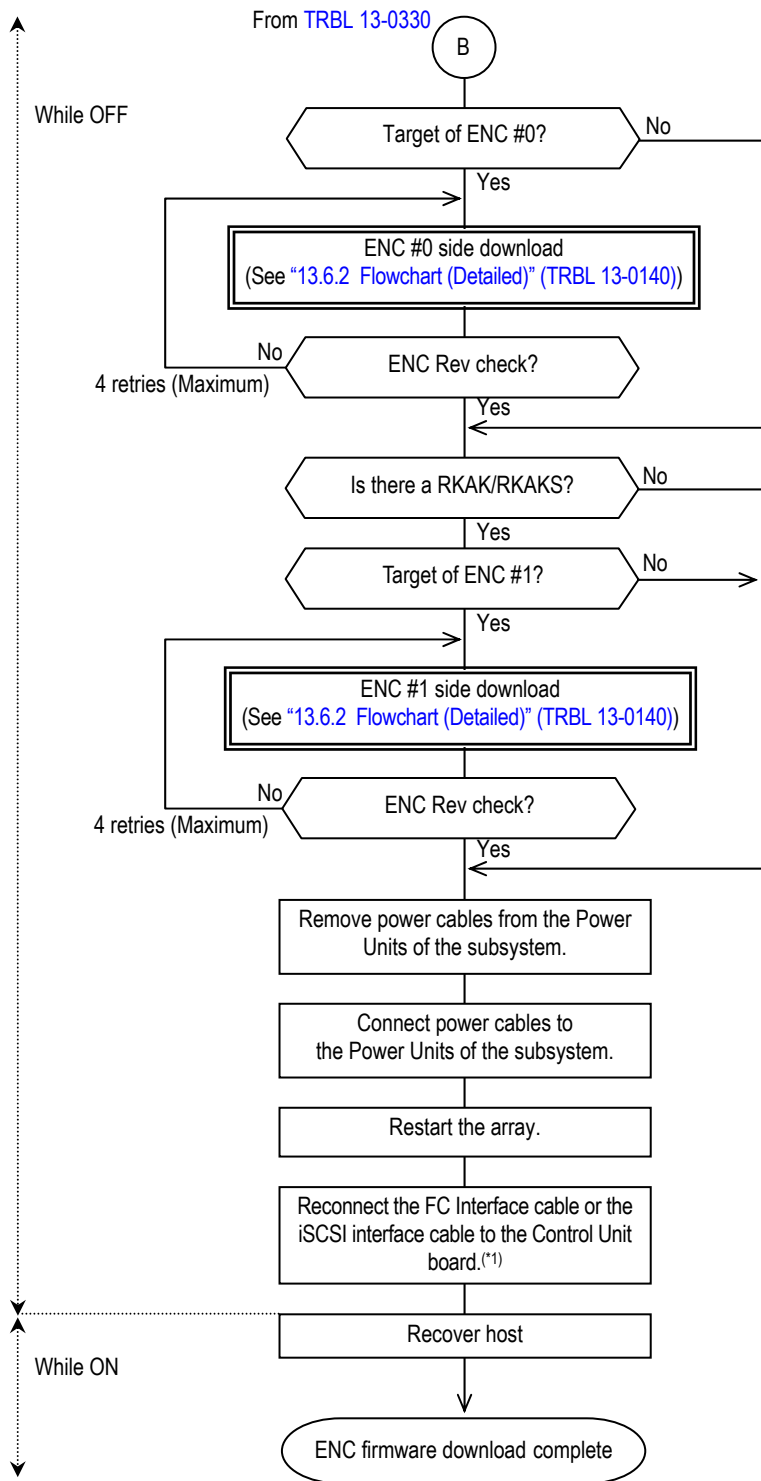

*1 : When connecting the Fibre Channel interface cables, insert the Fibre Channel interface cables until they are fixed to the host connectors. If the Fibre Channel Interface cables are inserted half in the host connectors, the Control Unit continues to detect the Fibre Channel failures, and the I/O processing of the Control Unit may be deteriorated.

13.7.2 Flowchart (Detailed)

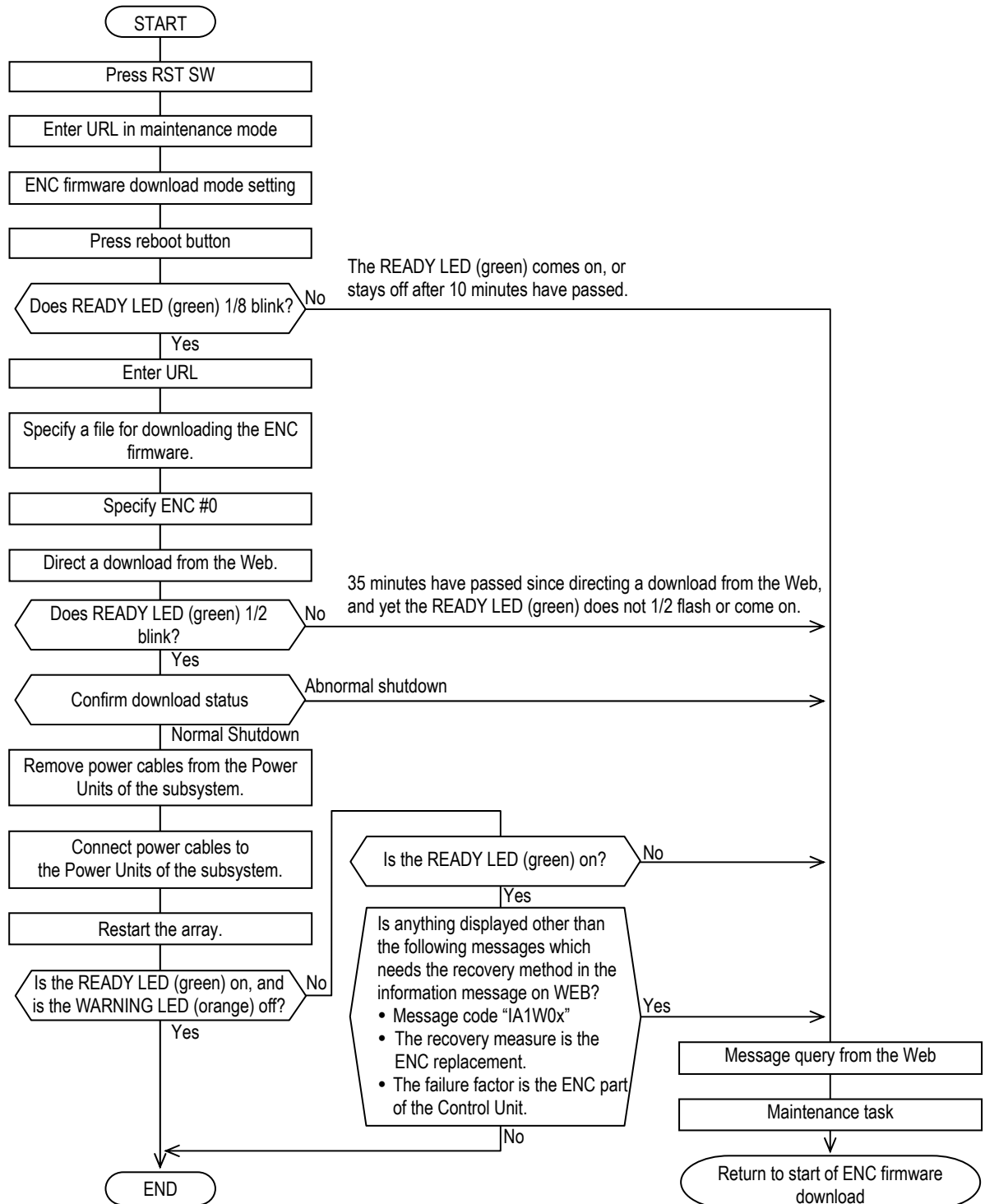

13.7.3 Offline ENC Firmware Download Procedure Screen (Single Controller)

The download procedure of the ENC firmware is the same procedure as the dual Control Unit. (Refer to [“13.6 Offline ENC Firmware Download Procedure \(Dual Controller\)”](#) (TRBL 13-0110).)

- (1) Use a LAN cross cable to connect the LAN connector used for maintenance to the LAN connector of the PC used for maintenance. (Refer to [“13.6.3 Connecting the PC Used for Maintenance”](#) (TRBL 13-0150).)
- (2) Start the browser on the PC used for maintenance, and delete the history. (See [“13.6.4 Deleting Browser History Information”](#) (TRBL 13-0180).)
- (3) Download the ENC firmware. (Refer to [“13.6.5 Downloading Offline ENC Firmware”](#) (TRBL 13-0210).)

13.8 Offline ENC Firmware Download Web Display Screen

13.8.1 URLs

The ENC firmware Rev. display screen is displayed by entering the following URL in the Web browser of the PC connected to DF. (ENC firmware download status reference screen during ENC firmware download.)

<http://controller IP address/encmicro>

At the time when the Web is connected or operated, entries of [User Name] and [Password] may be required. In such a case, enter [maintenance] as a user name and [hosyu9500] as a password.

13.8.2 Web Screen Image

A Web screen image of the ENC firmware Rev. display as it appears in Internet Explorer is shown below.

After the INQUIRY information is fixed, enter the URL to display the following screen. In the figure below, the left side is called the Side frame, the top right half is called the Top frame, and the bottom half is called the Select frame.

The screenshot shows a web interface for monitoring the ENC firmware update status. The interface is divided into three main frames:

- Side frame (1):** Contains navigation links like "To Normal Mode Top", "ENC Microprogram Information", "Firmware Install Information", "Unit Microprogram Revision", and "Menu". It also displays unit information for ENC (W#1) and ENC (W#2).
- Top frame (2):** Displays the "Update Status Map" for ENC. It includes a table with columns for unit ID, status, and completion/execution status. The table shows units RKAK Unit-12 through RKAK Unit-0, with various status indicators (E, N, G, F) and completion/execution status (N, C, E, F).
- Select frame (3):** Displays an "Information Message" for "Controller 0/1 Common".

Update Status Map			
ENC			
#0	#1		
RKAK Unit-12	E	N	N : Not Executed
RKAK Unit-11	E	N	C : Completed
RKAK Unit-10	E	N	E : Executing
			F : Failed
#0	#1		
RKAK Unit-9	E	N	
RKAK Unit-8	E	N	
RKAK Unit-7	E	N	
RKAK Unit-6	G	N	
RKAK Unit-5	F	N	
RKAK Unit-4	E	N	
RKAK Unit-3	G	N	
RKAK Unit-2	G	N	
RKAK Unit-1	E	N	
RKM Unit-0	E	N	

13.8.3 Side Frame and Top Frame Image Screen Details

The details of the side frame and top frame are shown below.

① Displays the top page of the normal mode screen.

② Displays the Rev. of the ENC firmware file.

③ Displays the date/time the page was updated.

④ Explains the colors displayed in the status map.
 Gray : Not Executed
 Green : Completed
 Yellow : Executing
 Red : A failure occurred or the firmware concerned was outside the range to be downloaded

Update Status Map			4/27/2009 16:51:05
ENC			
#0	#1	#2	
RKAK Unit-12	E	N	Not Executed
RKAK Unit-11	E	N	Completed
RKAK Unit-10	E	N	Executing
RKAK Unit-9	N	N	Failed

⑤ Status map
 Uses colors to display the status of ENC firmware downloads. Also, by clicking a cell, displays information for the corresponding ENC number in the select frame.

⑥ Displays the selected items in the select frame.

⑦ For turning the 5-second refresh mode on and off.

Displayed in this frame.

13.8.4 Select Frame Image Screen Details

The details of the select frame are shown below.

One of the following two patterns is displayed, depending on settings.

- (1) The select frame screen when an Information Message is selected is shown below.

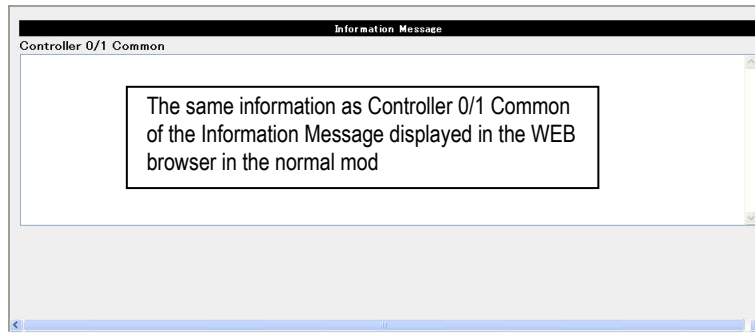

- (2) The select frame screen when ENC Information is selected is shown below.

① ENC Unit number

② Displays the Rev. of the ENC firmware.

ENC Information		
	Revision	
Unit	ENC#0	ENC#1
RKM Unit-0	050114	050114
RKAK Unit-1	050114	050114
RKAK Unit-2	050114	050114
RKAK Unit-3	050114	050114
RKAK Unit-4	050114	050114
RKAK Unit-5	050114	050114
RKAK Unit-6	050114	050114
RKAK Unit-7	050114	050114
RKAK Unit-8	050114	050114
RKAK Unit-9	050114	050114
Unit	ENC#0	ENC#1
RKAK Unit-10	050114	050114
RKAK Unit-11	050114	050114
RKAK Unit-12	050114	050114

13.9 Procedure for Invalidating the Automatic ENC Firmware Downloading Function

When returning the revision of the ENC firmware to the previous one after downloading the firmware because of its trouble, etc., it is required to invalidate the automatic downloading function before downloading the firmware.

Execute the following procedure using Storage Navigator Modular 2.

- (1) Hitachi Storage Navigator Modular 2 is started.
- (2) Put a checkmark to the array subsystem to set, press the [Ctrl] key, [Shift] key and [E] key at the same time, and change the operation mode to “Maintenance Mode”.^(†1)

It is displayed as “maintenance mode” in [Operation Mode] of the upper part of the window, and Hitachi Storage Navigator Modular 2 is operated in the maintenance mode.

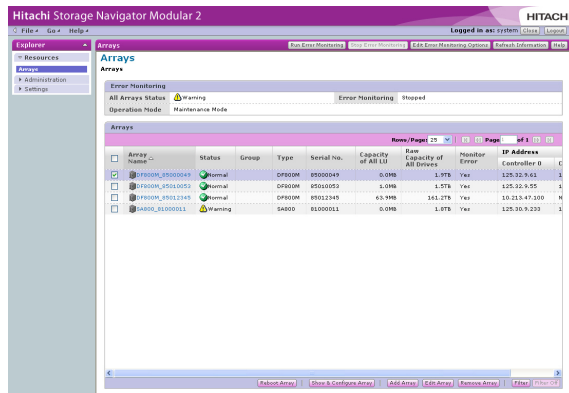

- (3) Click the array subsystem name, and open the unit window.

NOTE : When the main window is not displayed even if you select the array subsystem, check that the LAN port number is not changed. (Refer to [System Parameter “1.2 LAN Port Number Change by Hitachi Storage Navigator Modular 2” \(SYS-PR 01-0120\)](#).) Use the changed LAN Port Number, and execute it again.

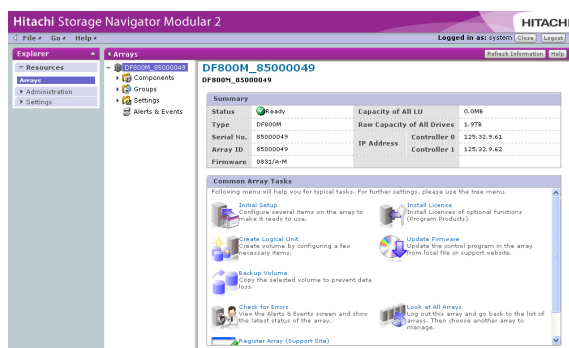

^{†1} : When the array subsystem to operate is not registered, click the blank area (other than buttons and characters) in the “Arrays” window, and press the [Ctrl] key, [Shift] key and [E] key at the same time

(4) Select [Settings] - [Advanced Settings], and click the [Open Advanced Settings] button.

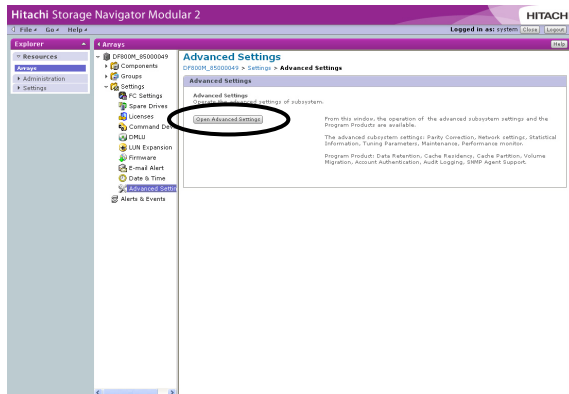

(5) Select the [Maintenance] on the applet window, and click the [Set] button.

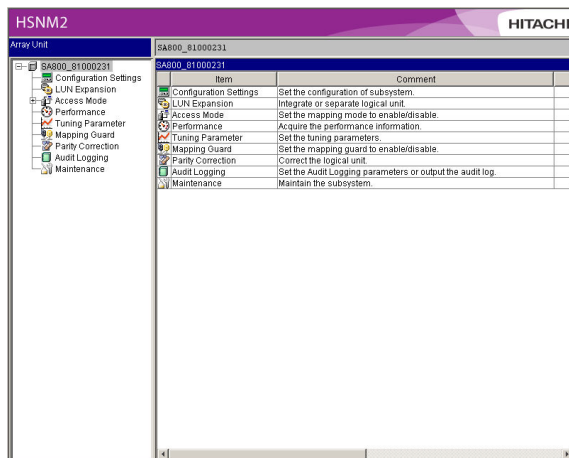

(6) Click the [ENC Micro Update] tab on the Maintenance dialog box.

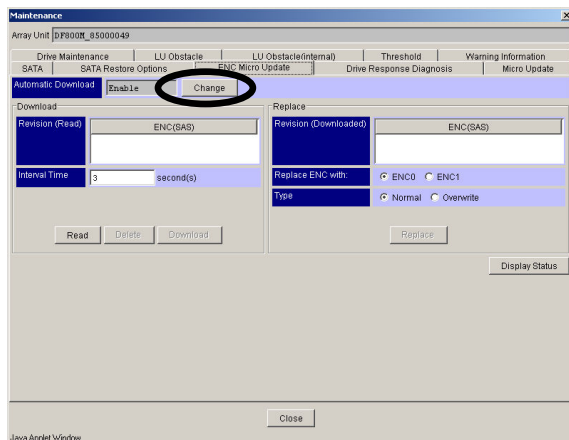

(7) Click the [Change] button on the “Automatic Download”.

(8) Selected [Disable] in the Automatic Download window.

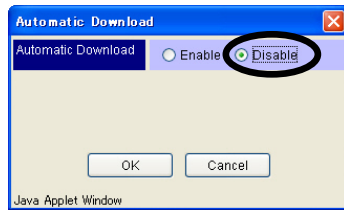

(9) Click the [OK] button.

(10) The configuration message dialog box appears. Click the [OK] button.

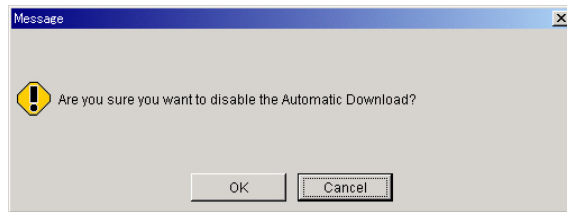

(11) When the set is completed normally. Click the [OK] button.

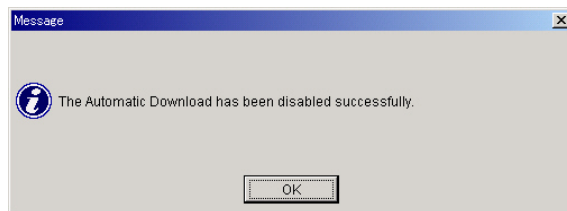

Chapter 14. Procedure for Replacing the Online Drive Firmware

14.1 Overview of the Online Drive Firmware Replacement Function

If the firmware also exists in the Disk Drive itself installed in the chassis and trouble corrections and specification changes occur as well as the main body of the array firmware, the firmware is updated. Replace the firmware by issuing the write buffer command to the Disk Drives.

The firmware of Disk Drives is replaced one by one based on the drive configuration information. Moreover, the function can replace the firmware of all drives (made by Hitachi and made by Seagate) currently supported with the disk array system.

The firmware differs for every vender, capacity, etc. Therefore, in the case of performing firmware update, it may be necessary to perform firmware update several times.

NOTE : When the firmware version is 0852/A or more, the drive firmware automatic download function replaces the drive firmware automatically.

Refer to [Firmware “1.6 Checking the Start and End of the Drive Firmware Automatic Download \(FIRM 01-0860\)”](#) for the detail.

14.2 Prerequisites

- (1) The SATA Disk Drive is out of the firmware replacement target and only the SAS/SAS(SED) Disk Drive, SAS7.2K Disk Drives, and Flash Drives is the firmware replacement target.
- (2) It is recommended for the customer to backup the user data in advance.
It is recommended for the customers to backup the user data before starting the work to prepare in the contingency such as the user data may be lost if the operation is mistaken and the Disk Drive does not operate after replacing the drive firmware.
- (3) We recommend you work on this in the time zone with a low load of host I/O.
- (4) The firmware, which can be replaced by one drive firmware replacement, is only one type of the firmware.
- (5) The firmware replacement overwrites the firmware to be replaced in the targeted Disk Drive. The Disk Drive with the same revision of the firmware before and after the replacement does not write the firmware. The Disk Drive which the revision of the firmware before and after the replacement differs overwrites the firmware regardless of the update/version downgrade.
- (6) Perform the drive firmware replacement in the status where the array subsystem is not subsystem warning.
For example, when the array subsystem has an ENC blockade, the drive firmware replacement cannot be performed.
Be sure to perform the drive firmware replacement after recovering the ENC blockade.
- (7) The blocked Disk Drives are not the target of the firmware replacement.
- (8) The Disk Drives and Spare Disk Drives (used and unused) in which the RAID Group and logical unit are undefined are the target of the replacement.
- (9) The Disk Drives which are spun down or powered off by the Power Saving function are out of the firmware replacement target, and a message to the effect that the replacement was skipped is displayed (IZ0E00 HDU firmware update was skipped (Unit-x, HDU-y)).
- (10) The Disk Drives belonging to the parity group under degeneration (one Disk Drive is blocked in the parity group) are out of the firmware replacement target, and a message to the effect that the updated was skipped is displayed (IZ0E00 HDU firmware update was skipped (Unit-x, HDU-y)). However, although RAID0 has no redundancy, it is the target of the firmware replacement.
- (11) It is required to install JRE 1.6 in the service PC to replacement the drive firmware. When the version other than JRE 1.6 is installed in the service PC, the procedure may not be performed normally. When the version other than JRE 1.6 is installed, be sure to uninstall the JRE and then install JRE 1.6. After completing the procedure, return it to the original JRE.

14.3 Restrictions

- (1) The replacement parts cannot be inserted or removed during the drive firmware replacement. It does not recover even if the replacement parts are inserted during the drive firmware replacement. Also, when the replacement parts are removed during the firmware replacement, the parts may not be blocked or the drive firmware replacement may be terminated abnormally.

14.4 Online Drive Firmware Replacement Time

The standard of the working hours taken for executing online drive firmware replacement in the array subsystem is shown below. The working hours in Table 14.4.1 shows the time from starting the drive firmware replacement on WEB to completing the replacement.

Table 14.4.1 Standard of Time Required for Drive Firmware Replacement for Disk Drive

Model	Working Hours	
	Standard	Maximum
AMS2010	1.5 × (Number of Disk Drives) minutes	100 minutes
AMS2100		260 minutes
AMS2300		400 minutes
AMS2500		800 minutes

14.5 Before Replacing the Online Drive Firmware

Do the following preparation before replacing the drive firmware.

- (1) Refer to [WEB “Chapter 1. Before Using Web” \(WEB 01-0000\)](#) and, prepare a PC that supports the LAN environment by means of the Web browser installed in it.
In the drive firmware replacement work, it is required to check the execution result from the service PC connected by LAN.
- (2) Prepare the drive firmware CD-R.
- (3) It is recommended for the customer to backup the user data in advance.
It is recommended for the customers to backup the user data before starting the work to prepare in the contingency such as the user data may be lost if the operation is mistaken and the Disk Drive does not operate after replacing the drive firmware.
- (4) Perform the drive firmware replacement in the status where the array subsystem is not subsystem Warning.
For example, when the array subsystem has an ENC blockade, the drive firmware replacement cannot be performed.
Be sure to perform the drive firmware replacement after recovering the ENC blockade.

14.6 Procedure for Replacing the Online Drive Firmware

14.6.1 Replacing Procedure

(1) Environment setting

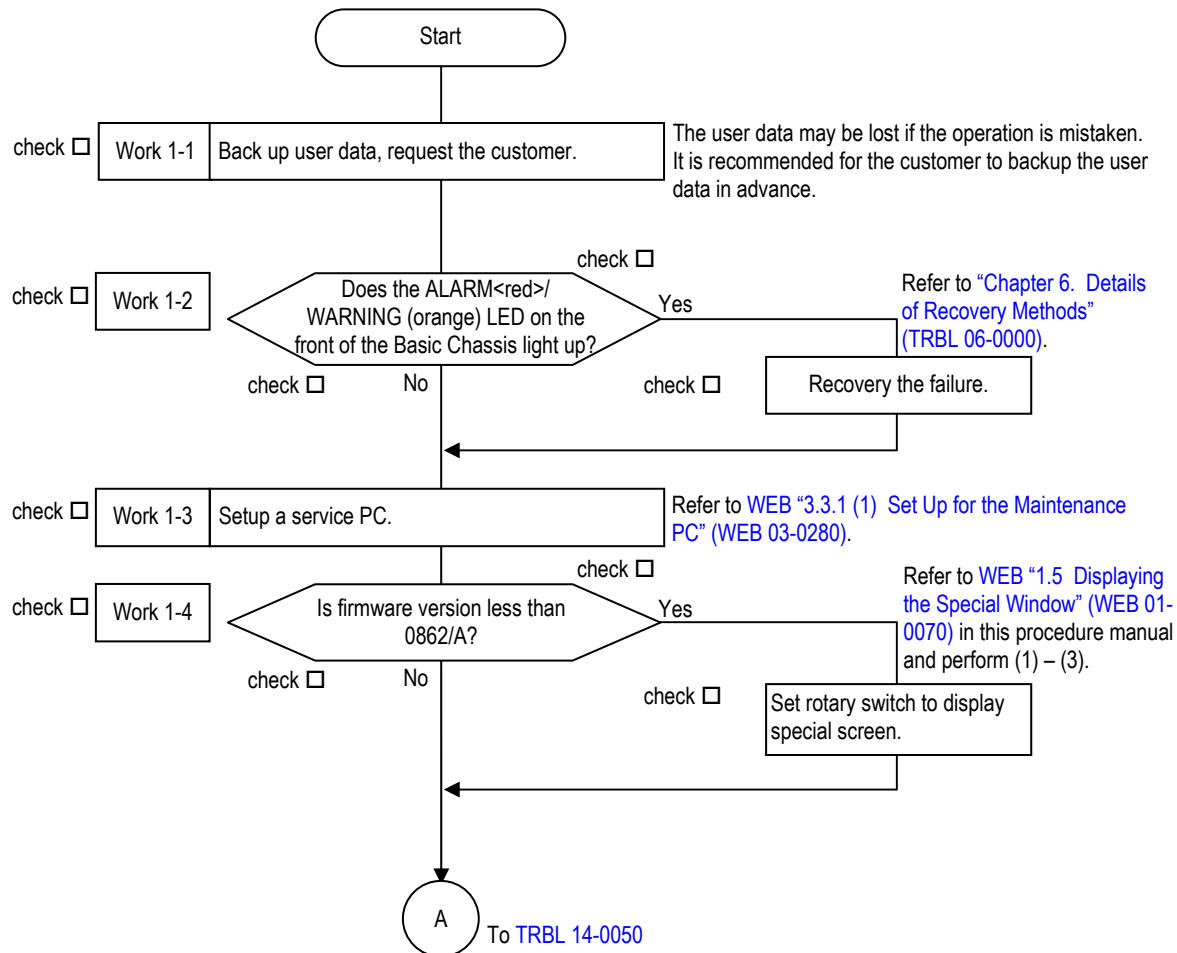
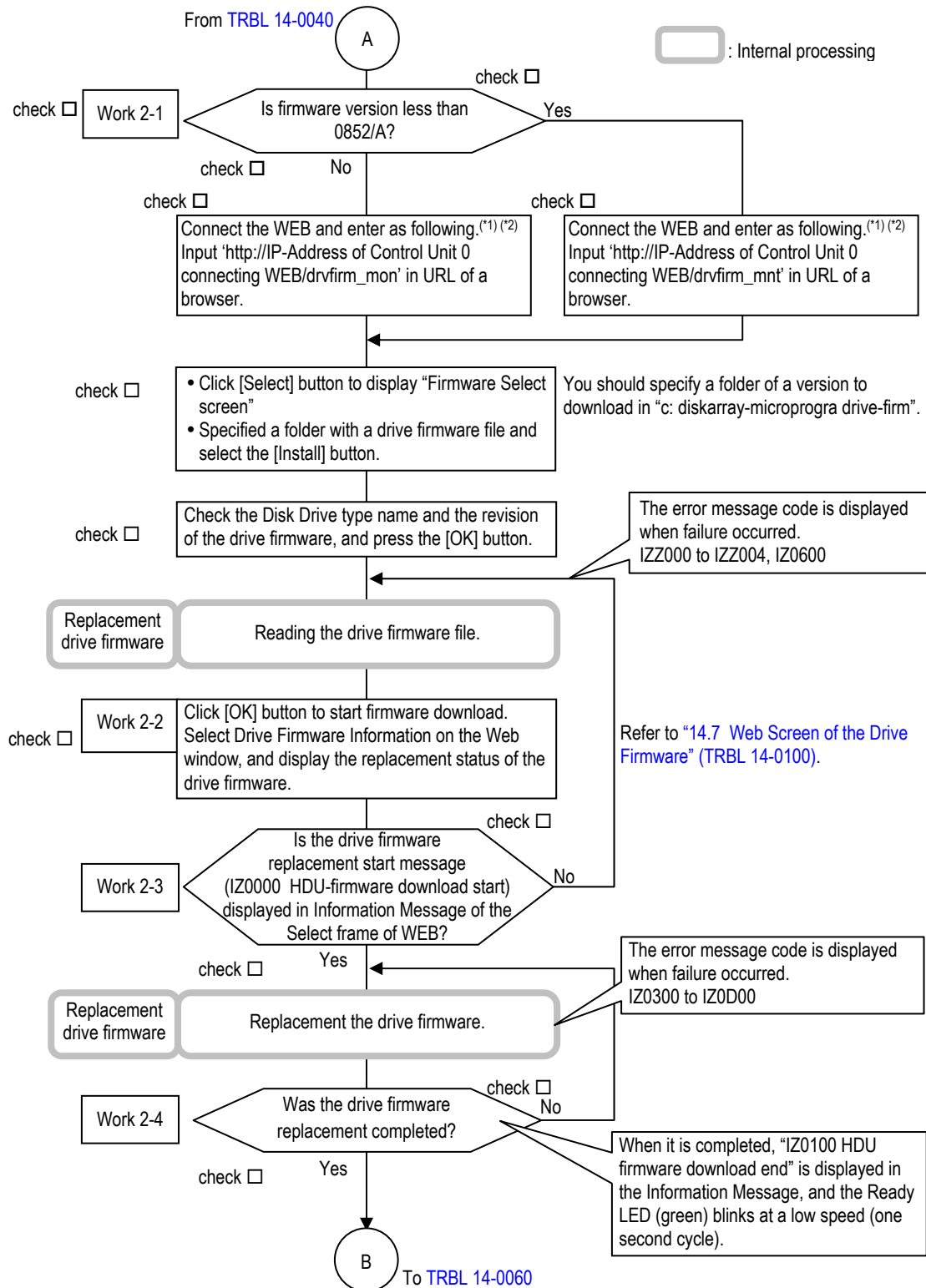

Figure 14.6.1 Environment Setting

(2) Replacing the drive firmware



*1 : For WEB Connection procedure, refer to "Chapter 3. Before Starting WEB Connection" (TRBL 03-0000).

*2 : For window change, refer to "14.6.2 Procedure Screen" (TRBL 14-0070).

Figure 14.6.2 Check of Operation (Before Replacement)

(3) Check of operation (after replacement)

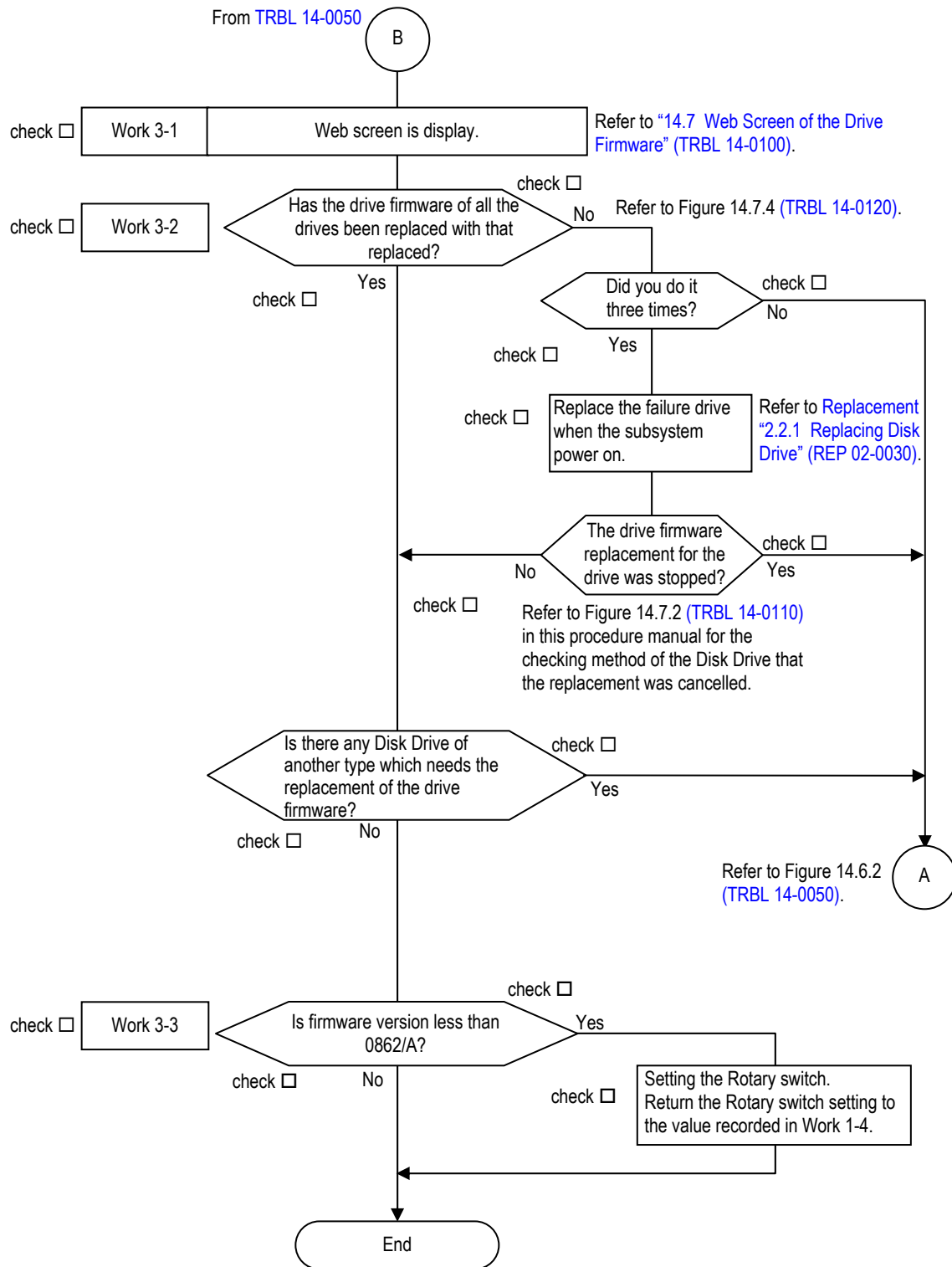

Figure 14.6.3 Check of Operation (After Replacement)

14.6.2 Procedure Screen

- (1) The online drive firmware replacing procedure differs depending on the firmware revision.
 - When the less than Ver.0852/A
Enter the IP-Address/drvfirm_mon of the Control Unit 0 connecting http://WEB in URL of the browser.
 - When the Ver.0852/A or more
Enter the IP-Address/drvfirm_mnt of the Control Unit 0 connecting http://WEB in URL of the browser.

Since the dialog to input the network password is displayed, enter “maintenance” for [User Name] and “hosyu9500” for [Password], and press the [OK] button.



Figure 14.6.4 Network Password Screen

- (2) The Java applet (Drive Firmware Install) is displayed. Click the [Select] button.
When the following message is displayed, it is necessary to click ActiveX Control with a mouse and to change it into the active status.

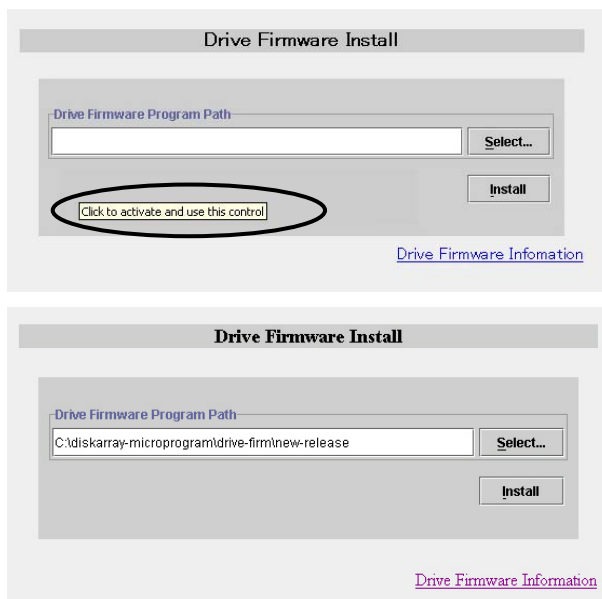

Figure 14.6.5 Java Applet (Drive Firmware Install)

- (3) Specify the folder in which the drive firmware is stored.

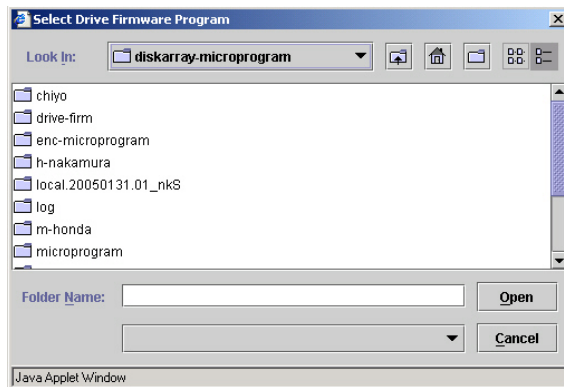

Figure 14.6.6 Firmware Select Screen

- (4) Click the [Install] button on the Figure 14.6.7, a confirmation message is displayed. Click the [OK] button when satisfactory. (Install is started)

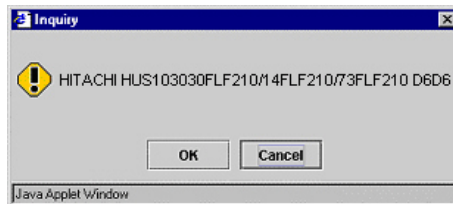

Figure 14.6.7 Confirmation Message

NOTE : When the following “Executing...” dialog is displayed, do not press [Drive Firmware Information] in the Drive Firmware Install window of (2). If you press [Drive Firmware Information], the drive firmware replacement is not completed.



Figure 14.6.8 Installing Firmware

NOTE : When the following dialog is displayed even if you press the [Install] button in the Drive Firmware Install window, do it again from the procedure (1) specifying IP-Address of Control Unit #1.



Figure 14.6.9 Error Dialog

- (5) When a file transfer is received normally, since a confirmation screen will be displayed, click the [OK] button.

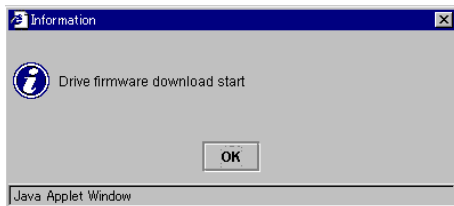

Figure 14.6.10 Confirmation Screen

- (6) Click the [Drive Firmware Information]; the replacement state of a drive firmware is displayed.

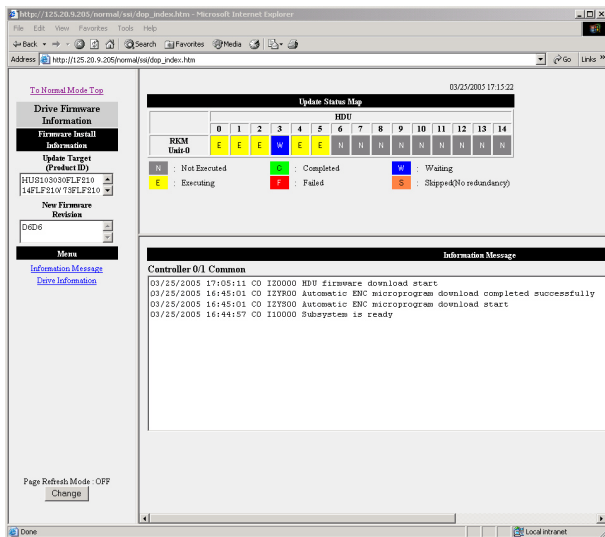

Figure 14.6.11 Drive Firm Information (in Progress)

- (7) When the installation to all the drives is completed, select “Drive Information” of the Side frame. And, see Revision of Drive Information and check that the drive firmware is replaced.

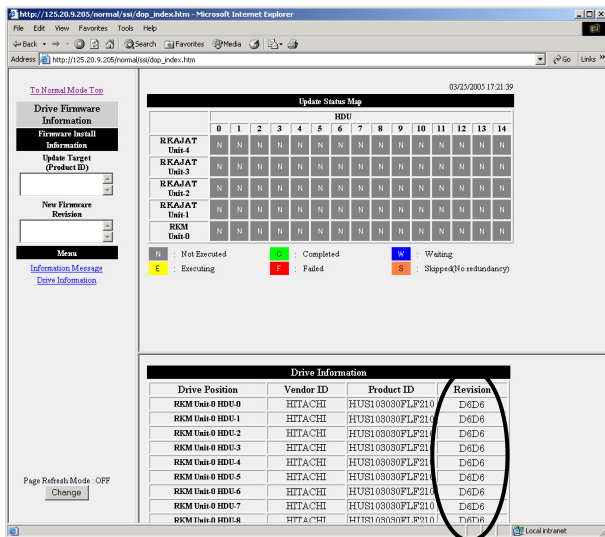

Figure 14.6.12 Completed Drive Firmware Replacement (The Screen of AMS2100 is Shown as an Example.)

14.7 Web Screen of the Drive Firmware

14.7.1 URL

Entering the following URL in the Web browser using a PC connected with the subsystem displays the window that shows the drive firmware revision. (It can be displayed even when the drive firmware replacement is not being executed.) (Refer to “Chapter 3. Before Starting WEB Connection” (TRBL 03-0000).)

IP address/drvfirm of the Control Unit 0 connecting http://WEB

14.7.2 Web Screen Image

Image of the Web window, which shows the drive firmware, displayed by means of Internet Explorer is shown below.

When URL is input after the INQUIRY information on the Disk Drive is decided, the window of Figure 14.7.1 is displayed.

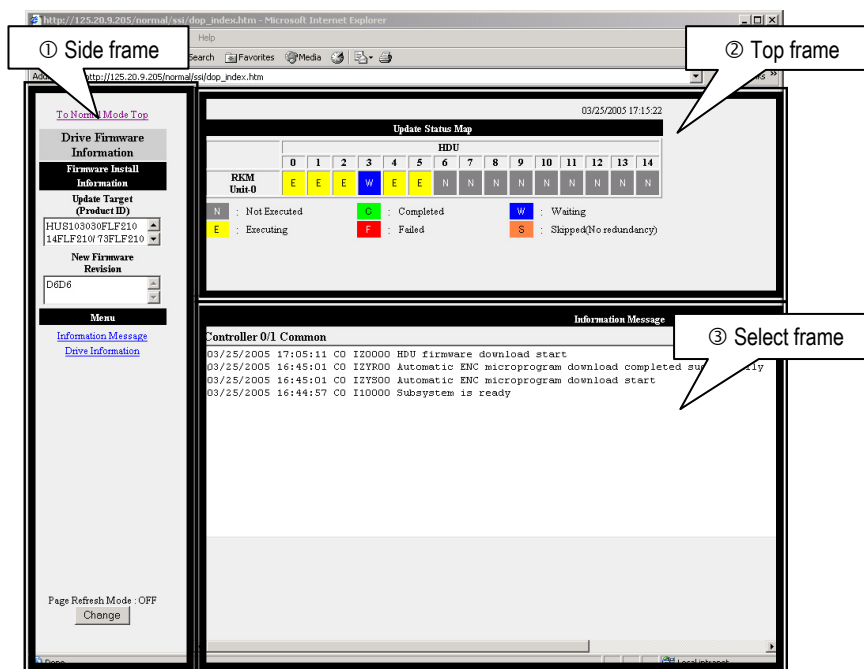

Figure 14.7.1 Status of Drive Firm Revision Screen (1)

(1) Detail of Side Frame and Top Frame

Details of Side Frame and Top Frame are shown in Figure 14.7.2.

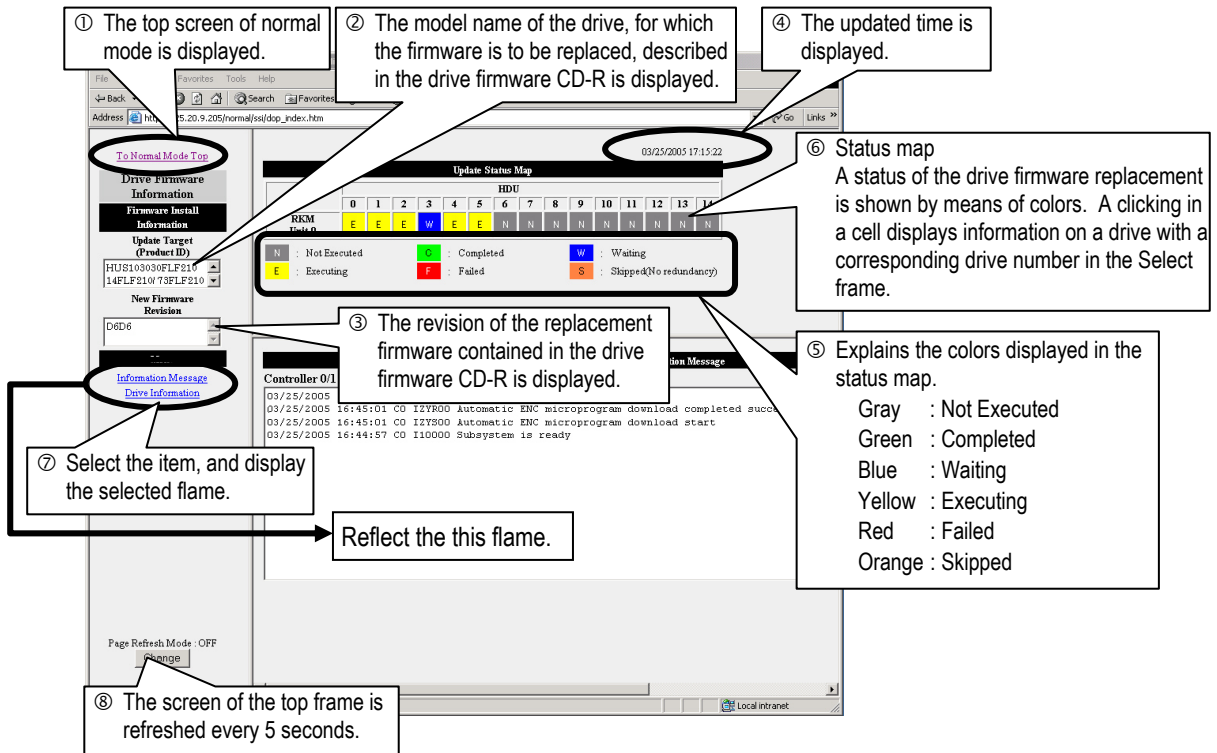

Figure 14.7.2 Status of Drive Firm Revision Screen (2)

(2) Detail of Select Frame

Details of Side Frame and Top Frame are shown in Figure 14.7.3 and Figure 14.7.4.

You can select the following two patterns.

The Select frame window display when selecting the Information Message item of the Side frame is shown in Figure 14.7.3.

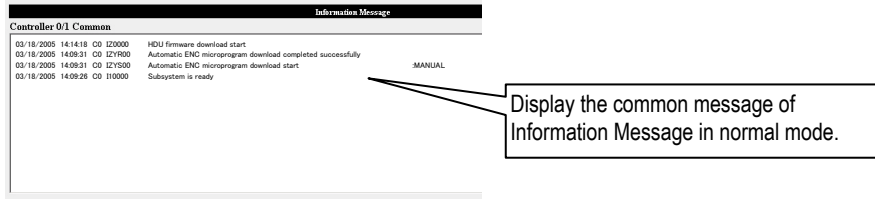

Figure 14.7.3 Status of Drive Firm Revision Screen (3)

The Select frame window display when selecting the Drive Information item of the Side frame is shown in Figure 14.7.4.

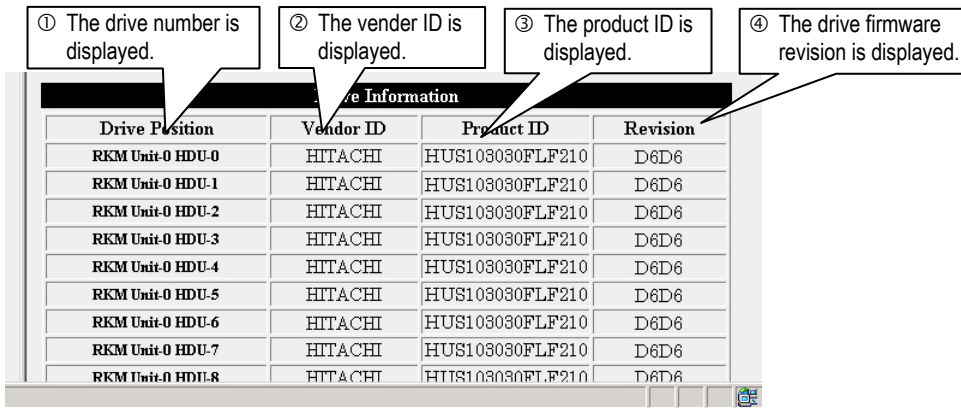

Figure 14.7.4 Status of Drive Firm Revision Screen (4)

14.8 Method of Checking the Drive Firmware Revision

There are three kinds of revision check methods of a drive firmware.

14.8.1 The Check Method by WEB Connection

- (1) Connect the controller#0 side to the network and input the IP address of the controller#0 as “address” of the WEB browser.

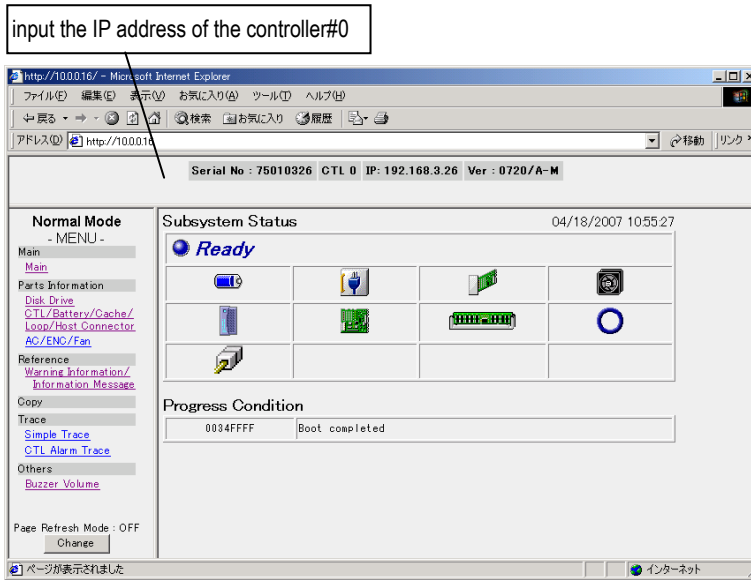

- (2) Input “drivefirm” following an IP address. (Drive farm revision state screen is displayed.)
<http://IP Address /drvfirm>

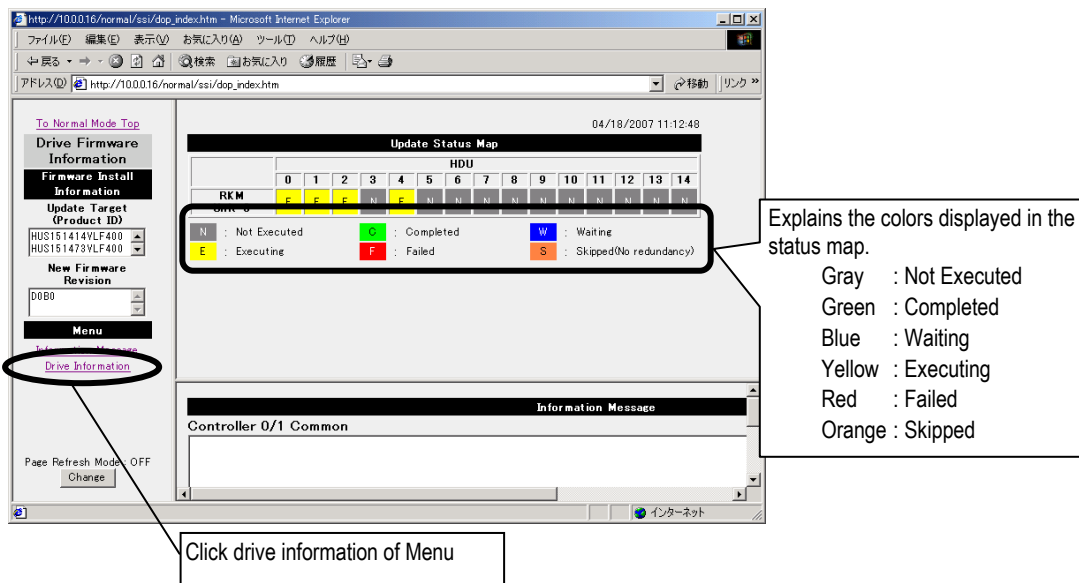

(3) Click “Drive Information” of Menu. (The model name of a mounted drive and firm revision are displayed.)

Drive Information			
Drive Position	Vendor ID	Product ID	Revision
RKM Unit-0 HDU-0	HITACHI	HUS151414VLF400	D0B0
RKM Unit-0 HDU-1	HITACHI	HUS151414VLF400	D0B0
RKM Unit-0 HDU-2	HITACHI	HUS151414VLF400	D0B0
RKM Unit-0 HDU-3	HITACHI	HUS151414VLF400	D0B0
RKM Unit-0 HDU-4	HITACHI	HUS151414VLF400	D0B0

14.8.2 The Check Method by Trace Analysis

Refer to a message worksheet.

The screenshot shows a software window titled "TDCONV Ver. 080E - DF700TR" displaying a message worksheet. The worksheet contains a table of drive information. Four callout boxes with numbered circles point to specific data points in the table:

- ① The drive number is displayed. (Points to the 'Drive Type' column)
- ② The vender ID is displayed. (Points to the 'VENDOR' column)
- ③ The product ID is displayed. (Points to the 'PRODUCT_ID' column)
- ④ The drive firmware revision is displayed. (Points to the 'PR_REV' column)

A fifth callout box labeled "Message worksheet." points to the entire table area. The table data is as follows:

[HDD]Unit	VENDOR	PRODUCT_ID	PR_REV	SERIAL
Drive Type [0][0]==>	HITACHI	HUS151414VLF400	D0B0	JAVH66XK
Drive Type [1][0]==>	HITACHI	HUS151414VLF400	D0B0	JAVL275K
Drive Type [2][0]==>	HITACHI	HUS151414VLF400	D0B0	JAVL26BK
Drive Type [3][0]==>	HITACHI	HUS151414VLF400	D0B0	JAVM04AK
Drive Type [4][0]==>	HITACHI	HUS151414VLF400	D0B0	JAVJ7UMK

14.8.3 The Procedure to Check the Drive Firmware Revision Using the Hitachi Storage Navigator Modular 2

The screenshot displays the Hitachi Storage Navigator Modular 2 interface. The main window shows the properties for a drive labeled "HDU 00" in a "Tray 00". The "Properties" section is expanded to show the following details:

Property	Value
Part	SAS HDU 00
Tray	Tray 00
Status	Normal
Part Type	SAS
Part Number	AJH300
Part Serial No.	3LM0M8LA
RPM	15000RPM
Vendor ID	SEAGATE
Product ID	DKS2E-K300SS
Firmware Revision	4C53

Four callouts are present:

- ① The drive number is displayed. (Points to "HDU 00" in the Part field)
- ② The vendor ID is displayed. (Points to "SEAGATE" in the Vendor ID field)
- ③ The product ID is displayed. (Points to "DKS2E-K300SS" in the Product ID field)
- ④ The drive firmware revision is displayed. (Points to "4C53" in the Firmware Revision field)

This page is for editorial purpose only.

Chapter 15. Procedure for Replacing the Offline Drive Firmware

15.1 Overview of the Offline Drive Firmware Replacement Function

If the firmware also exists in the Disk Drive itself installed in the chassis and trouble corrections and specification changes occur as well as the main body of the array firmware, the firmware is updated. Replace the firmware by issuing the write buffer command to the Disk Drives.

The firmware update function replaces the firmware of Disk Drives simultaneously by considering the redundancy of the RAID configuration. Moreover, the function can replace the firmware of all drives (made by Hitachi and made by Seagate) currently supported with the disk array system.

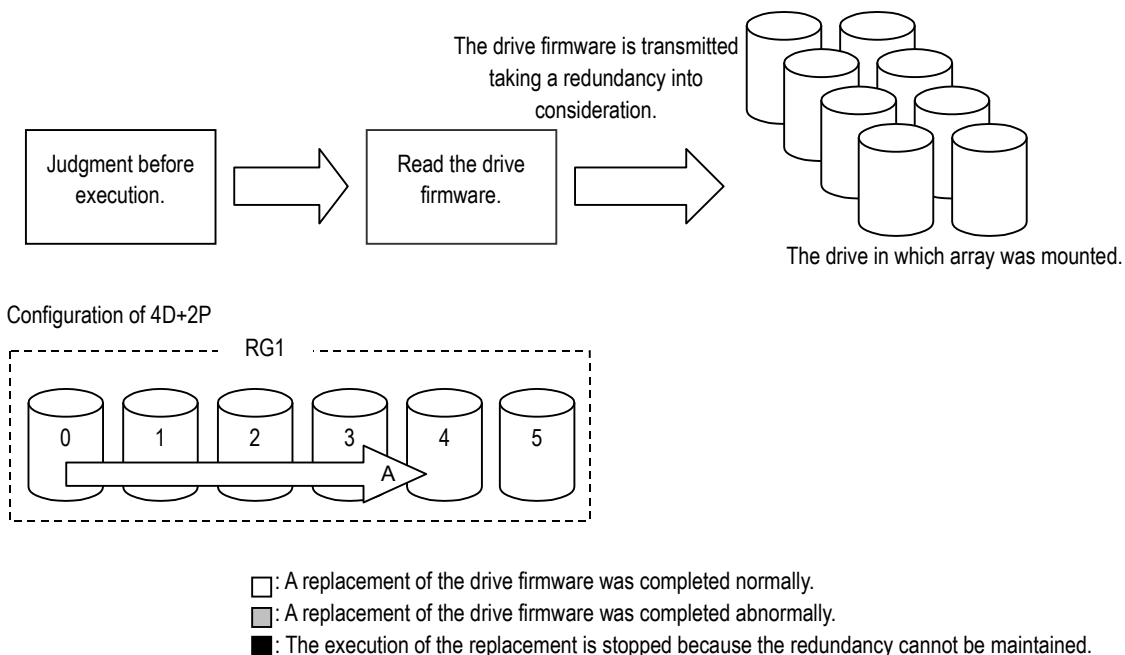

2 configuration of 4D+1P (Failure occurred at drive 3.)

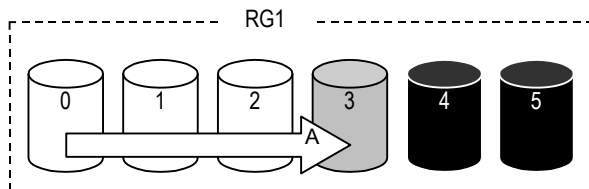

In the RAID group 1, the firmware replacement for the drive 3 in which a failure has occurred terminates abnormally and the replacement for the drive 4 and 5 are stopped before it is replacement because the redundancy of the RAID group 1 cannot be maintained.

When the replacement of one drive firmware among Disk Drives that configure the RAID group because it is the RAID level 6 terminates abnormally, there is redundancy of the data but safety of the data is emphasized, so that the drive firmware replacement cancelled at that time.

Figure 15.1.1 Outline (1)

The firmware differs for every vendor, capacity, etc. Therefore, in the case of performing firmware update, it may be necessary to perform firmware update several times.

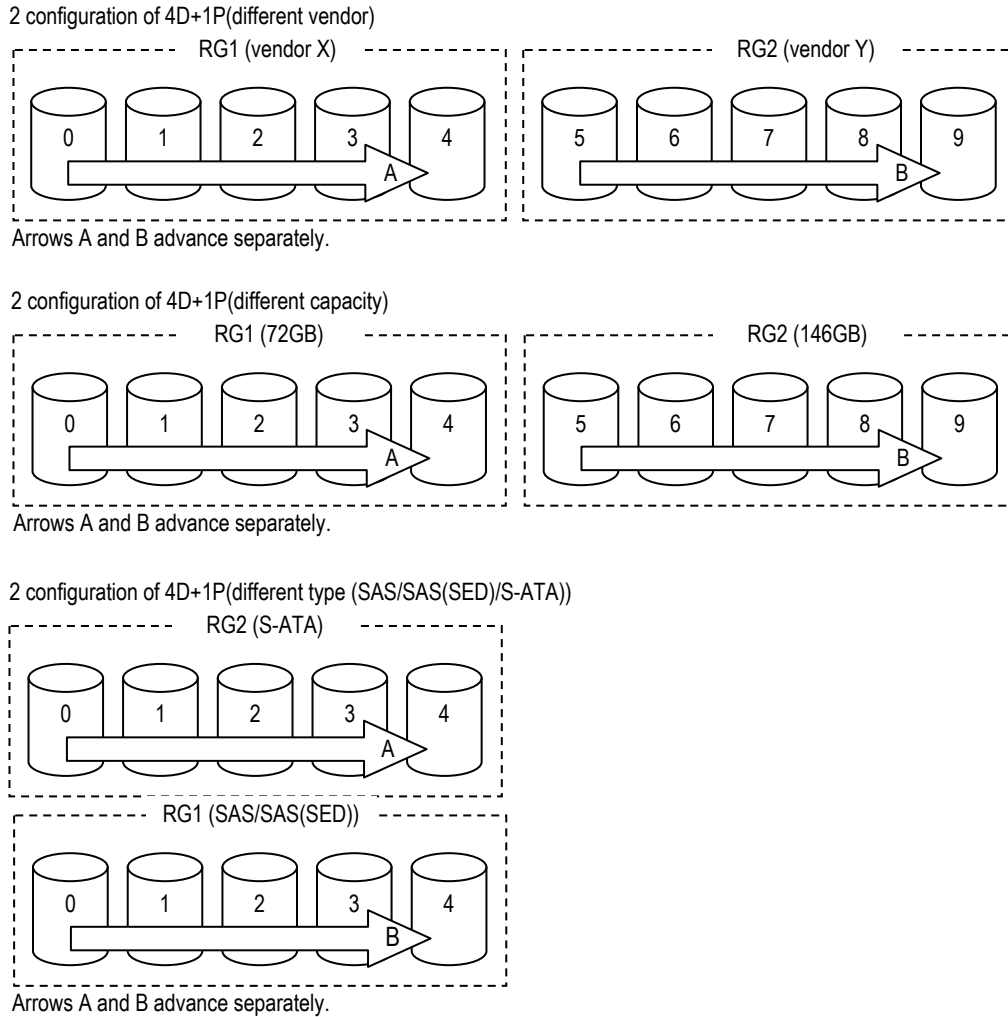

Figure 15.1.2 Outline (2)

15.2 Prerequisites

- (1) It is recommended for the customer to backup the user data in advance.
It is recommended for the customers to backup the user data before starting the work to prepare in the contingency such as the user data may be lost if the operation is mistaken and the Disk Drive does not operate after replacing the drive firmware.
- (2) The drive firmware replacement is off-line work, and turning on/off the power supply of the array subsystem is also repeated several times.
The drive firmware replacement cannot be executed with the dirty data (the user data which is not written in the Disk Drive) maintained in the Cache memory. Therefore, before performing the drive firmware replacement, ask the customer to stop the operation of the host computer, and remove the interface cable connected to the array subsystem. Also, stop the failure monitoring such as E-main Alert Function, ASSIST-PC monitoring, SNMP monitoring or Hi-Track monitoring.
- (3) The firmware, which can be replaced by one drive firmware replacement, is only one type of the firmware.
- (4) The firmware replacement overwrites the firmware to be replaced in the targeted Disk Drive. The Disk Drive with the same revision of the firmware before and after the replacement does not write the firmware. The Disk Drive which the revision of the firmware before and after the replacement differs overwrites the firmware regardless of the update/version downgrade.
- (5) Perform the drive firmware replacement in the status where the array subsystem is not subsystem warning.
For example, when the array subsystem has an ENC blockade, the drive firmware replacement cannot be performed.
Be sure to perform the drive firmware replacement after recovering the ENC blockade.
- (6) When the TrueCopy remote replication is enabled, and the array subsystem, which the drive firmware replacement is to be performed, is a remote disk subsystem, perform the drive firmware replacement after changing the pair status (S-VOL) of TrueCopy remote replication to PSUS.
However, although a path blockade occurs if the drive firmware replacement is performed, the pair blockade is automatically recovered by turning on the power supply of the array subsystem after performing the drive firmware replacement.
After the drive firmware replacement is completed, set the pair status (S-VOL) of TrueCopy remote replication to previous state.
Also, if the drive firmware replacement is performed, the following phenomena occur.
 - Both paths of the TrueCopy remote replication are blocked. The notice of E-mail Alert Function and SNMP Agent Support Function and TRAP occur at the time of the path blockade. Perform the notice and the check to the Failure Monitoring Department in advance. The path blockade automatically recovers after restarting.
 - When the pair status of the TrueCopy remote replication is PAIR or COPY, the pair status changes to PSUE.

- (7) When the TrueCopy Extended Distance is enabled, and the array subsystem, which the drive firmware replacement is to be performed, is a remote disk subsystem, perform the drive firmware replacement after changing the pair status (S-VOL) of TrueCopy Extended Distance to PSUS.

However, although a path blockade occurs if the drive firmware replacement is performed, the pair blockade is automatically recovered by turning on the power supply of the array subsystem after performing the drive firmware replacement.

After the drive firmware replacement is completed, set the pair status (S-VOL) of TrueCopy Extended Distance to previous state.

Also, if the drive firmware replacement is performed, the following phenomena occur.

- Both paths of the TrueCopy Extended Distance are blocked. The notice of E-mail Alert Function and SNMP Agent Support Function and TRAP occur at the time of the path blockade. Perform the notice and the check to the Failure Monitoring Department in advance. The path blockade automatically recovers after restarting.
- When the pair status of the TrueCopy Extended Distance is PAIR or COPY, the pair status changes to PSUE.

- (8) When it sets to the mode that executes the drive firmware replacement and the array subsystem starts, the Disk Drives, which were spun down due to the Power Saving of the priced option, spin up.

When the array subsystem normally starts and it becomes the Ready status after completing the drive firmware replacement, the Disk Drives set to the Power Saving spin down.

- (9) It is required to install JRE 1.6 in the service PC to replacement the drive firmware. When the version other than JRE 1.6 is installed in the service PC, the procedure may not be performed normally. When the version other than JRE 1.6 is installed, be sure to uninstall the JRE and then install JRE 1.6. After completing the procedure, return it to the original JRE.

15.3 Restrictions

- (1) If a failure is detected in the Disk Drive during the drive firmware replacement, the ALARM LED (red) does not light up.
Check the Disk Drive where the failure occurred in the information message on WEB or at the time of turning on the power supply of the array system after the drive firmware replacement.
- (2) The replacement parts cannot be inserted or removed during the drive firmware replacement. It does not recover even if the replacement parts are inserted during the drive firmware replacement. Also, when the replacement parts are removed during the firmware replacement, the parts may not be blocked or the drive firmware replacement may be terminated abnormally.
- (3) When it sets to the mode that executes the drive firmware replacement and the array subsystem starts, the Disk Drives, which were spun down due to the Power Saving of the priced option, spin up.
When the array subsystem normally starts and it becomes the Ready status after completing the drive firmware replacement, the Disk Drives set to the Power Saving spin down.

15.4 Offline Drive Firmware Replacement Time

The working hours taken for executing the drive firmware replacement in the array subsystem is shown below. This does not include the time taken for making the whole system (including the host computer) offline. The working hours in [Table 15.4.1](#) to [Table 15.4.4](#) shows the time from instructing the drive firmware replacement on WEB to completing the download.

Table 15.4.1 Standard of Time Required for Offline Drive Firmware Replacement of AMS2010

No.	Item	Working Hours	
		Standard	Maximum
Drive firmware replacement work			
1	Hot I/O stop	Differs depending on the system configuration.	
2	Planned shutdown	1 minutes	3 minutes
3	Subsystem start	4 minutes	6 minutes
4	Disk array system reboot	4 minutes	6 minutes
5	Drive firmware replacement	$1.5 \times (\text{Number of disk drives}) / (\text{Number of RAID Groups})$ minutes	100 minutes
6	Subsystem start	4 minutes	6 minutes
7	Total	Depends on the number of Disk Drives and RAID Groups.	121 minutes

Table 15.4.2 Standard of Time Required for Offline Drive Firmware Replacement of AMS2100

No.	Item	Working Hours	
		Standard	Maximum
Drive firmware replacement work			
1	Hot I/O stop	Differs depending on the system configuration.	
2	Planned shutdown	1 minutes	3 minutes
3	Subsystem start	4 minutes	6 minutes
4	Disk array system reboot	4 minutes	6 minutes
5	Drive firmware replacement	$1.5 \times (\text{Number of disk drives}) / (\text{Number of RAID Groups})$ minutes	260 minutes
6	Subsystem start	4 minutes	6 minutes
7	Total	Depends on the number of Disk Drives and RAID Groups.	281 minutes

Table 15.4.3 Standard of Time Required for Offline Drive Firmware Replacement of AMS2300

No.	Item	Working Hours	
		Standard	Maximum
Drive firmware replacement work			
1	Hot I/O stop	Differs depending on the system configuration.	
2	Planned shutdown	1 minutes	3 minutes
3	Subsystem start	4 minutes	6 minutes
4	Disk array system reboot	4 minutes	6 minutes
5	Drive firmware replacement	$1.5 \times (\text{Number of disk drives}) / (\text{Number of RAID Groups})$ minutes	400 minutes
6	Subsystem start	4 minutes	6 minutes
7	Total	Depends on the number of Disk Drives and RAID Groups.	421 minutes

Table 15.4.4 Standard of Time Required for Offline Drive Firmware Replacement of AMS2500

No.	Item	Working Hours	
		Standard	Maximum
Drive firmware replacement work			
1	Hot I/O stop	Differs depending on the system configuration.	
2	Planned shutdown	2 minutes	6 minutes
3	Subsystem start	5 minutes	8 minutes
4	Disk array system reboot	5 minutes	8 minutes
5	Drive firmware replacement	$1.5 \times (\text{Number of disk drives}) /$ $(\text{Number of RAID Groups})$ minutes	800 minutes
6	Subsystem start	5 minutes	8 minutes
7	Total	Depends on the number of Disk Drives and RAID Groups.	830 minutes

15.5 Before Replacing the Offline Drive Firmware

Do the following preparation before replacing the drive firmware.

- (1) Refer to [WEB “Chapter 1. Before Using Web” \(WEB 01-0000\)](#) and, prepare a PC that supports the LAN environment by means of the Web browser installed in it.

In the drive firmware replacement work, it is required to check the execution result from the service PC connected by LAN.

- (2) Prepare the drive firmware CD-R.
- (3) When the items shown below are performed, the drive firmware cannot be replaced, so that, replace it after the items are completed.

- Format is in progress.
- DP pool Format is in progress.
- Pair creation or resynchronization of ShadowImage-in-system replication is in progress.
- Pair creation or resynchronization of TrueCopy remote replication/TrueCopy Extended Distance is in progress.
- Restoration of Copy-on-write SnapShot is in progress.
- Restoration of the drives (dynamic sparing, copy back or correction copy) is in progress.
- During the RAIG group expansion
- System copy is in progress.

- (4) It is recommended for the customer to backup the user data in advance.

It is recommended for the customers to backup the user data before starting the work to prepare in the contingency such as the user data may be lost if the operation is mistaken and the Disk Drive does not operate after replacing the drive firmware.

- (5) Perform the drive firmware replacement in the status where the array subsystem is not subsystem Warning.

For example, when the array subsystem has an ENC blockade, the drive firmware replacement cannot be performed.

Be sure to perform the drive firmware replacement after recovering the ENC blockade.

- (6) When the TrueCopy remote replication is enabled, and the array subsystem, which the drive firmware replacement is to be performed, is a remote disk subsystem, perform the drive firmware replacement after changing the pair status (S-VOL) of TrueCopy remote replication to PSUS.

However, although a path blockade occurs if the drive firmware replacement is performed, the pair blockade is automatically recovered by turning on the power supply of the array subsystem after performing the drive firmware replacement.

After the drive firmware replacement is completed, set the pair status (S-VOL) of TrueCopy remote replication to previous state.

Also, if the drive firmware replacement is performed, the following phenomena occur.

- Both paths of the TrueCopy remote replication are blocked. The notice of E-mail Alert Function and SNMP Agent Support Function and TRAP occur at the time of the path blockade. Perform the notice and the check to the Failure Monitoring Department in advance. The path blockade automatically recovers after restarting.
- When the pair status of the TrueCopy remote replication is PAIR or COPY, the pair status changes to PSUE.

- (7) When the TrueCopy Extended Distance is enabled, and the array subsystem, which the drive firmware replacement is to be performed, is a remote disk subsystem, perform the drive firmware replacement after changing the pair status (S-VOL) of TrueCopy Extended Distance to PSUS.

However, although a path blockade occurs if the drive firmware replacement is performed, the pair blockade is automatically recovered by turning on the power supply of the array subsystem after performing the drive firmware replacement.

After the drive firmware replacement is completed, set the pair status (S-VOL) of TrueCopy Extended Distance to previous state.

Also, if the drive firmware replacement is performed, the following phenomena occur.

- Both paths of the TrueCopy Extended Distance are blocked. The notice of E-mail Alert Function and SNMP Agent Support Function and TRAP occur at the time of the path blockade. Perform the notice and the check to the Failure Monitoring Department in advance. The path blockade automatically recovers after restarting.
- When the pair status of the TrueCopy Extended Distance is PAIR or COPY, the pair status changes to PSUE.

- (8) When Power Saving of the priced option is used, if you perform the drive firmware replacement after executing the spin-down and before completing it, the spin-down may fail because of the recognition processing of the host when the array subsystem starts.

Check that there is no RAID Group whose power saving status is “Normal (command monitoring)” after executing the spin-down, and then perform the drive firmware replacement.

If the spin-down fails, execute the spin-down again.

15.6 Procedure for Replacing the Offline Drive Firmware

15.6.1 Replacing Procedure

(1) Environment setting

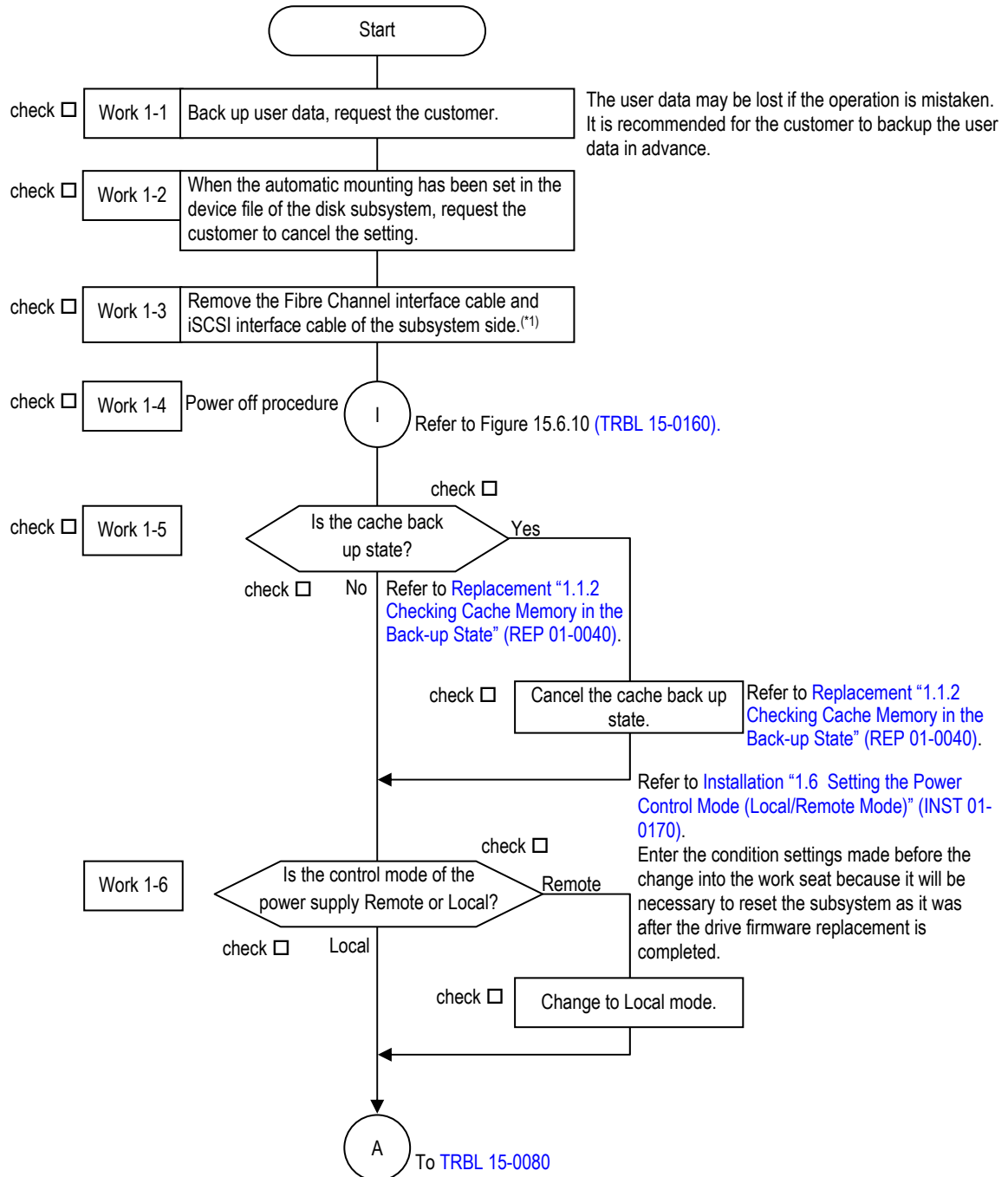

*1 : When removing the Fibre Channel Interface cables, pull out the Fibre Channel interface cables completely from the host connectors. If the Fibre Channel Interface cables are inserted half in the host connectors, the Control Unit continues to detect the Fibre Channel failures, and the I/O processing of the Control Unit may be deteriorated.

Figure 15.6.1 Environment Setting

(2) Check of operation (before replacement)

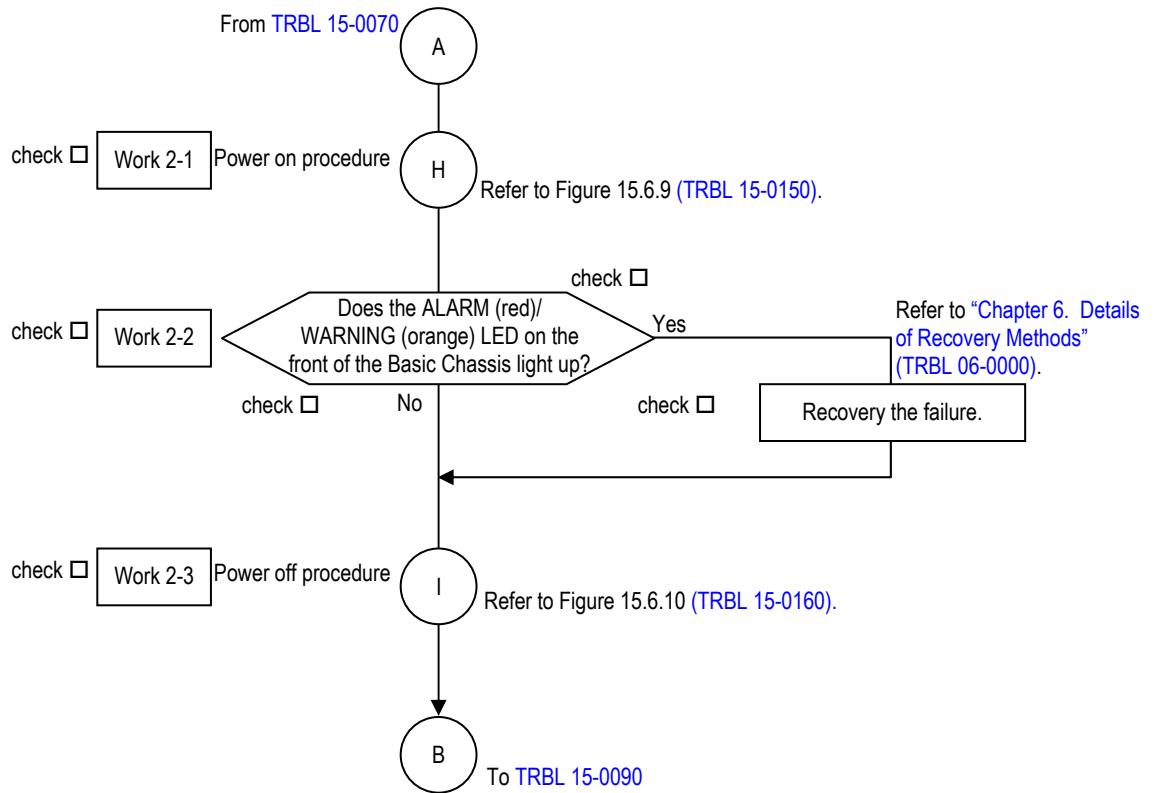

Figure 15.6.2 Check of Operation (Before Replacement)

(3) Replacing the drive firmware (For the detail screens of procedure, refer to the for “15.6.2 Procedure Screen” (TRBL 15-0170).)

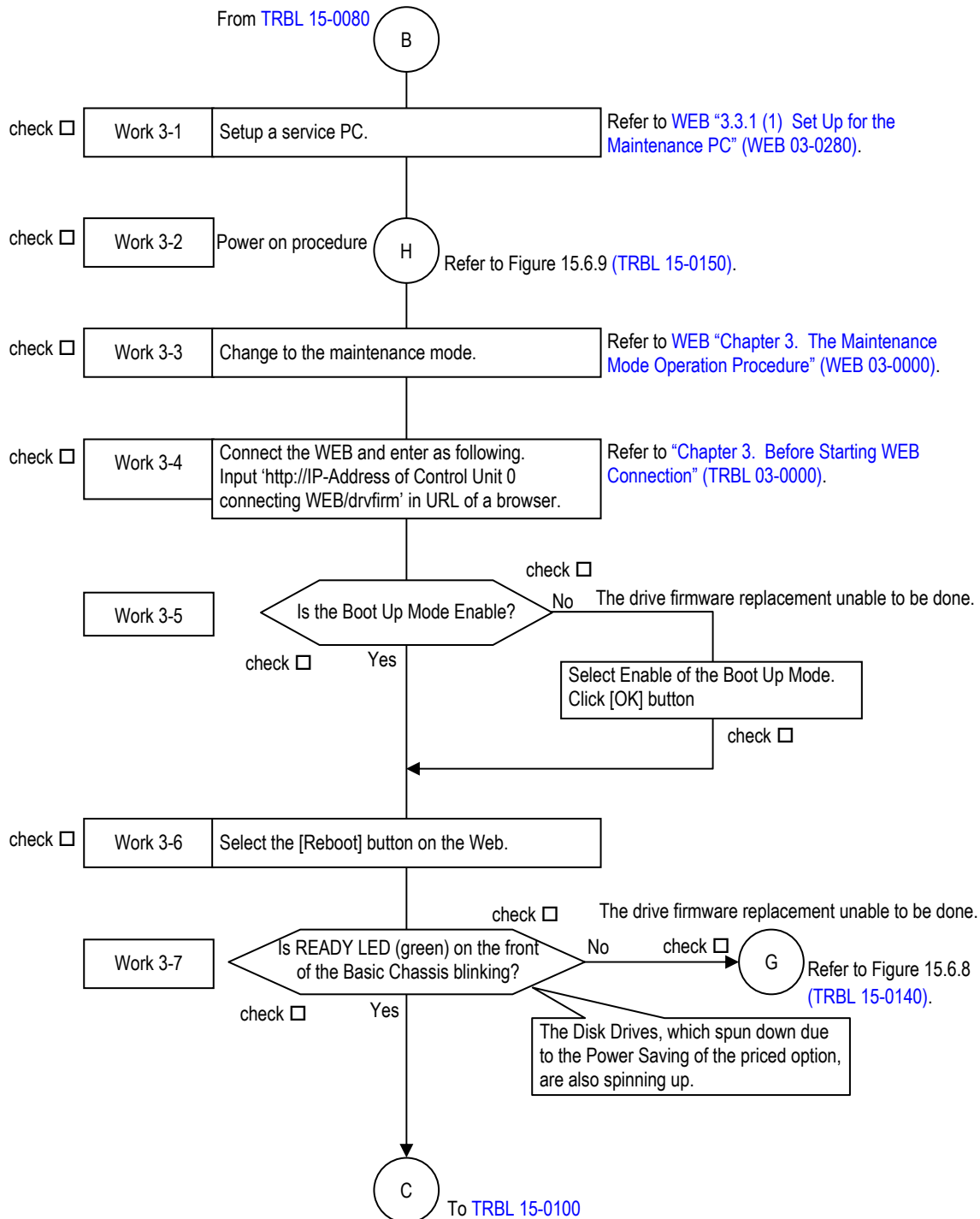

Figure 15.6.3 Replacement the Drive Firmware (1)

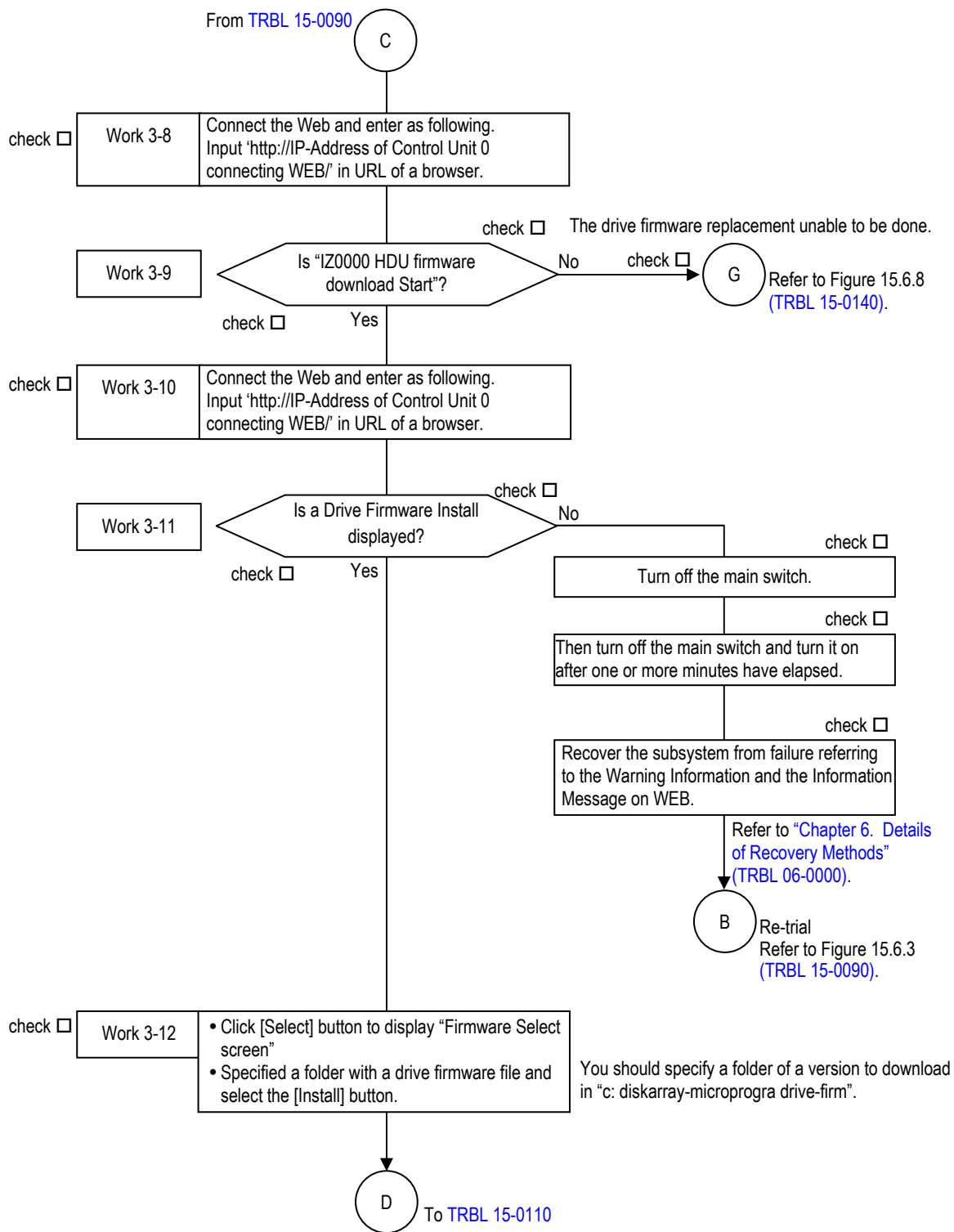

Figure 15.6.4 Replacement the Drive Firmware (2)

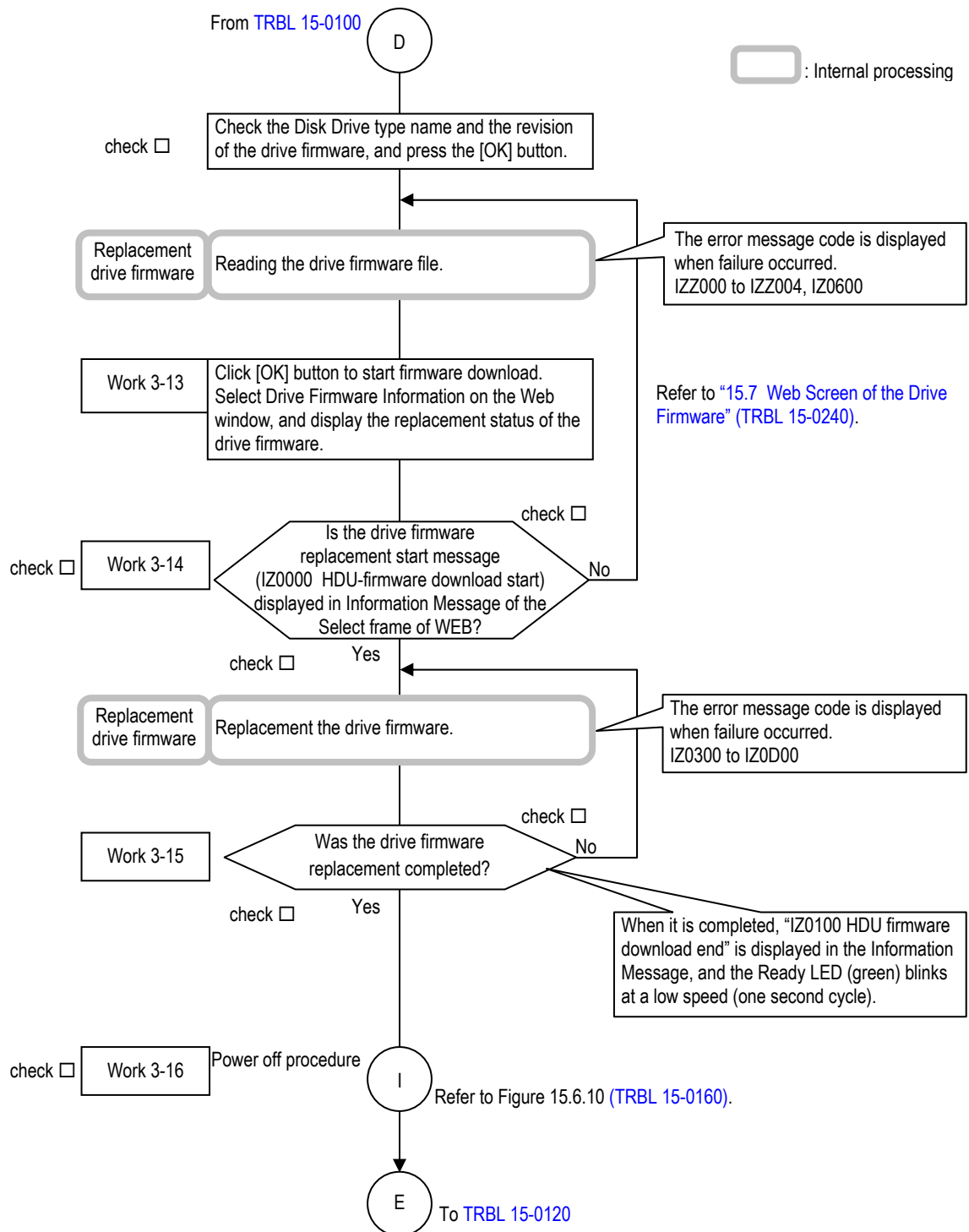

Figure 15.6.5 Replacement the Drive Firmware (3)

(4) Check of operation (after replacement)

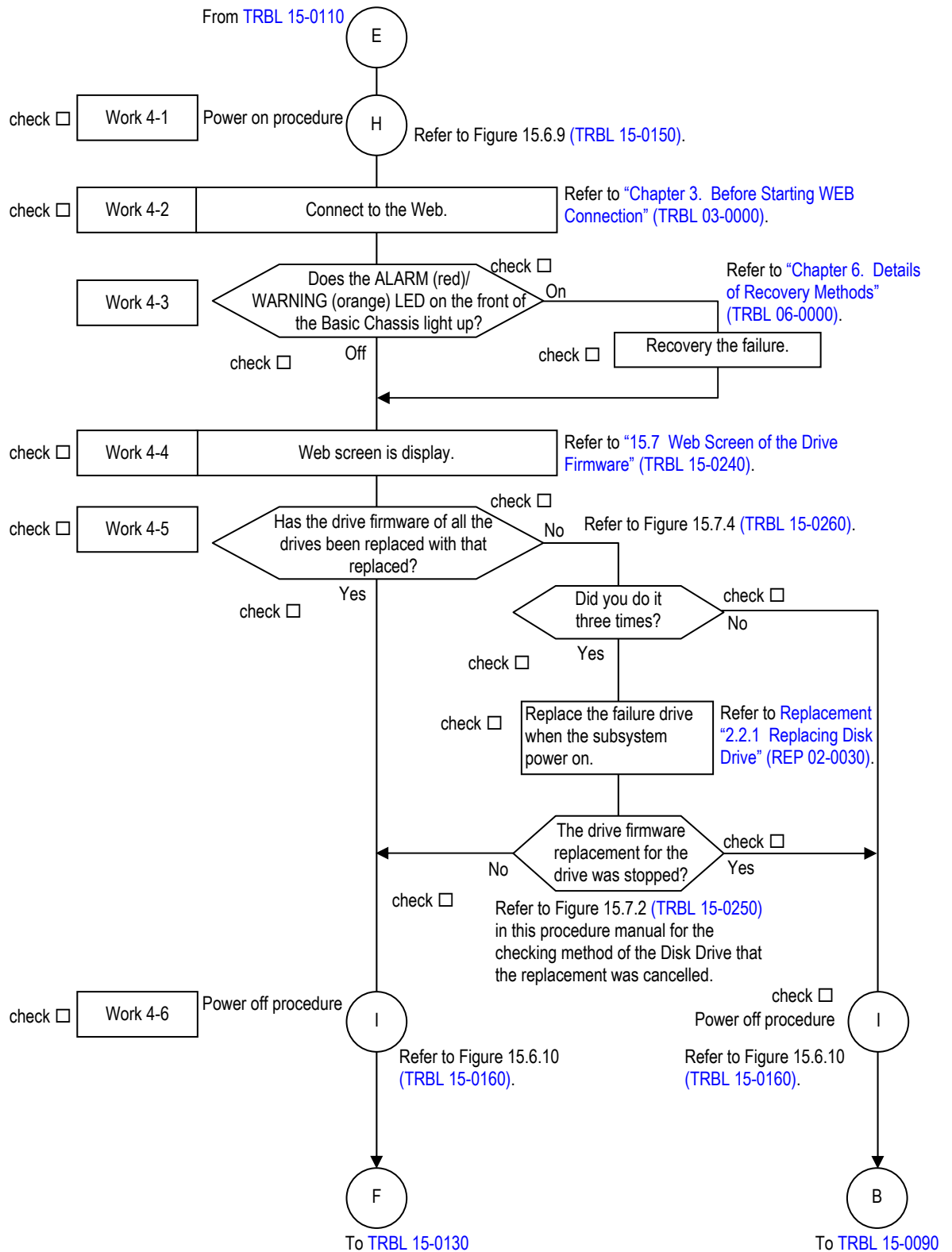
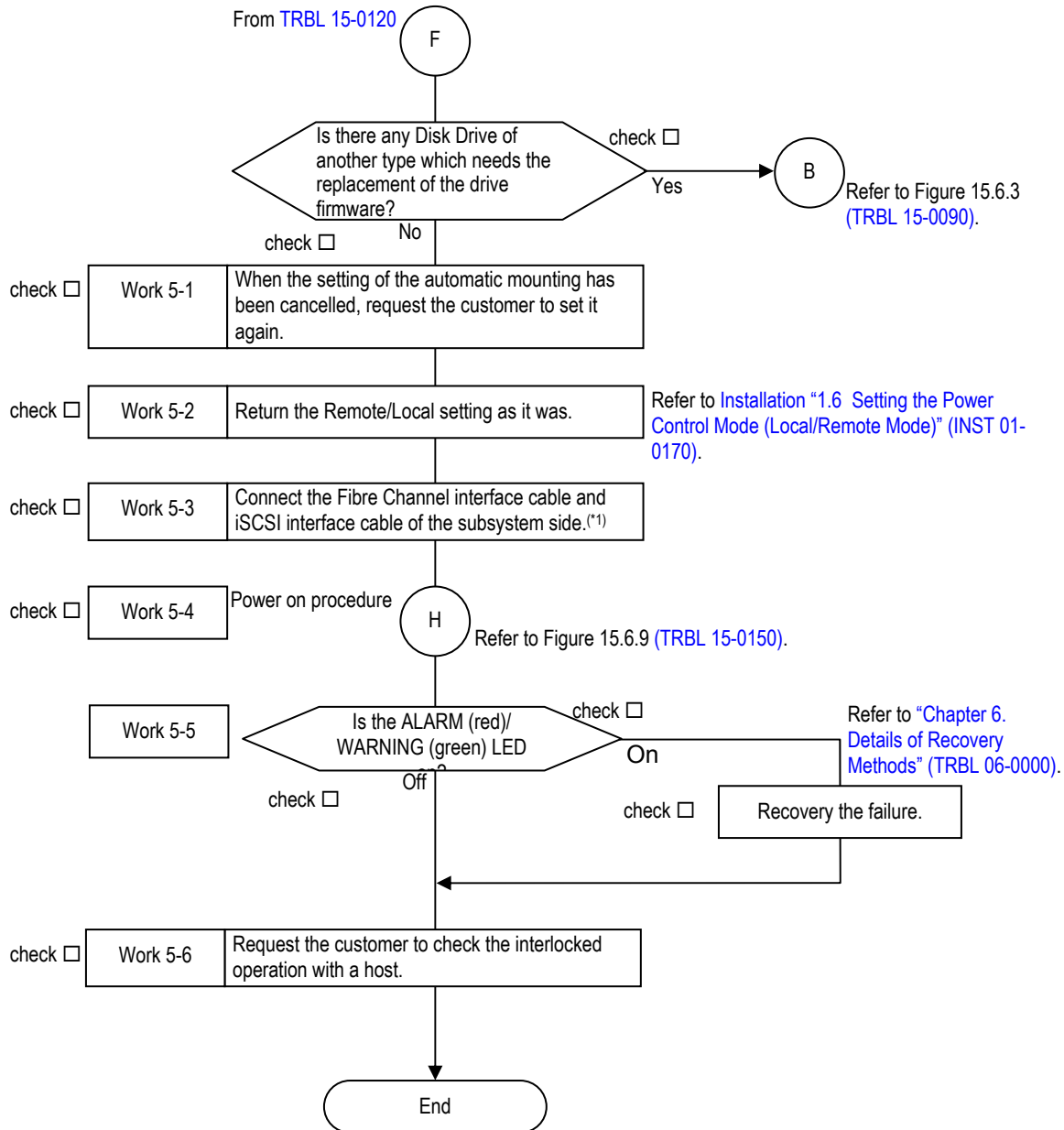

Figure 15.6.6 Check of Operation (After Replacement)

(5) Recovery environment



*1 : When connecting the Fibre Channel interface cables, insert the Fibre Channel interface cables until they are fixed to the host connectors.
 If the Fibre Channel Interface cables are inserted half in the host connectors, the Control Unit continues to detect the Fibre Channel failures, and the I/O processing of the Control Unit may be deteriorated.

Figure 15.6.7 Recovery Environment

(6) Recovery action against an error that makes the drive firmware replacement unable to be done

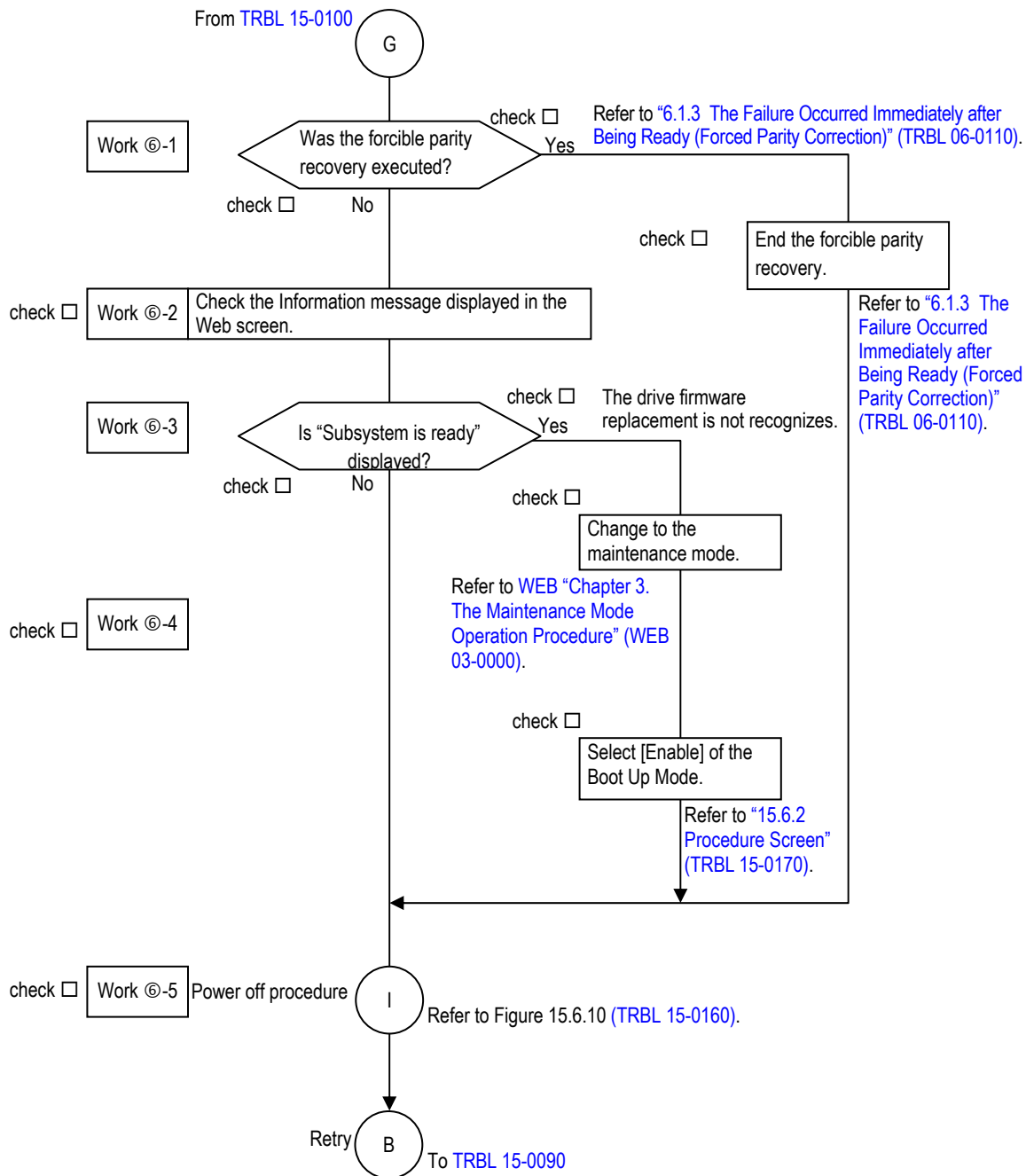
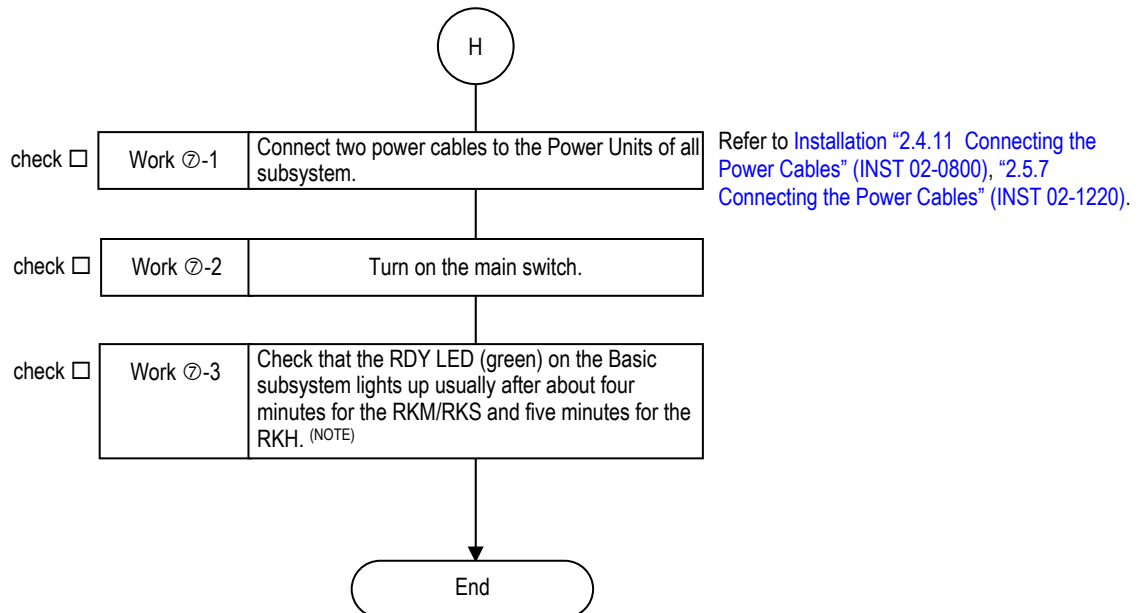

Figure 15.6.8 Recovery Action Against an Error that Makes the Drive Firmware Replacement Unable to be done

(7) Power on procedure



NOTE : When the RDY LED (green) on the front of the Basic Chassis is blinking at high-speed, the RDY LED (green) on the front of the Basic Chassis lights up after it blinks for the maximum of 30 to 50 minutes and 40 to 60 minutes for the RKH because the automatic download of the ENC firmware is operating.

Also, when the WARNING LED (orange) on the front of the Basic Chassis is blinking at high speed, the RDY LED (green) on the front of the Basic Chassis lights up after the WARNING LED (orange) on the front of the Basic Chassis blinks at high speed for the maximum of 30 to 85 minutes because the update of the flash program or the automatic download of the ENC firmware at the time of turning the power on is operating in the single controller configuration.

If the ALARM LED (red) on the Basic Chassis or the WARN LED (orange) on the Basic Chassis and the additional chassis lights on, refer to Maintenance Manual “8.1 Trouble Analysis by LED Indication of Front Bezel” (TRBL 08-0000).

The Disk Drives, which were spun down due to the Power Saving of the priced option, spin up while the array subsystem is starting. When the array subsystem becomes the Ready status, the Disk Drives set to the Power Saving immediately spin down.

Figure 15.6.9 Power On Procedure

(8) Power off procedure

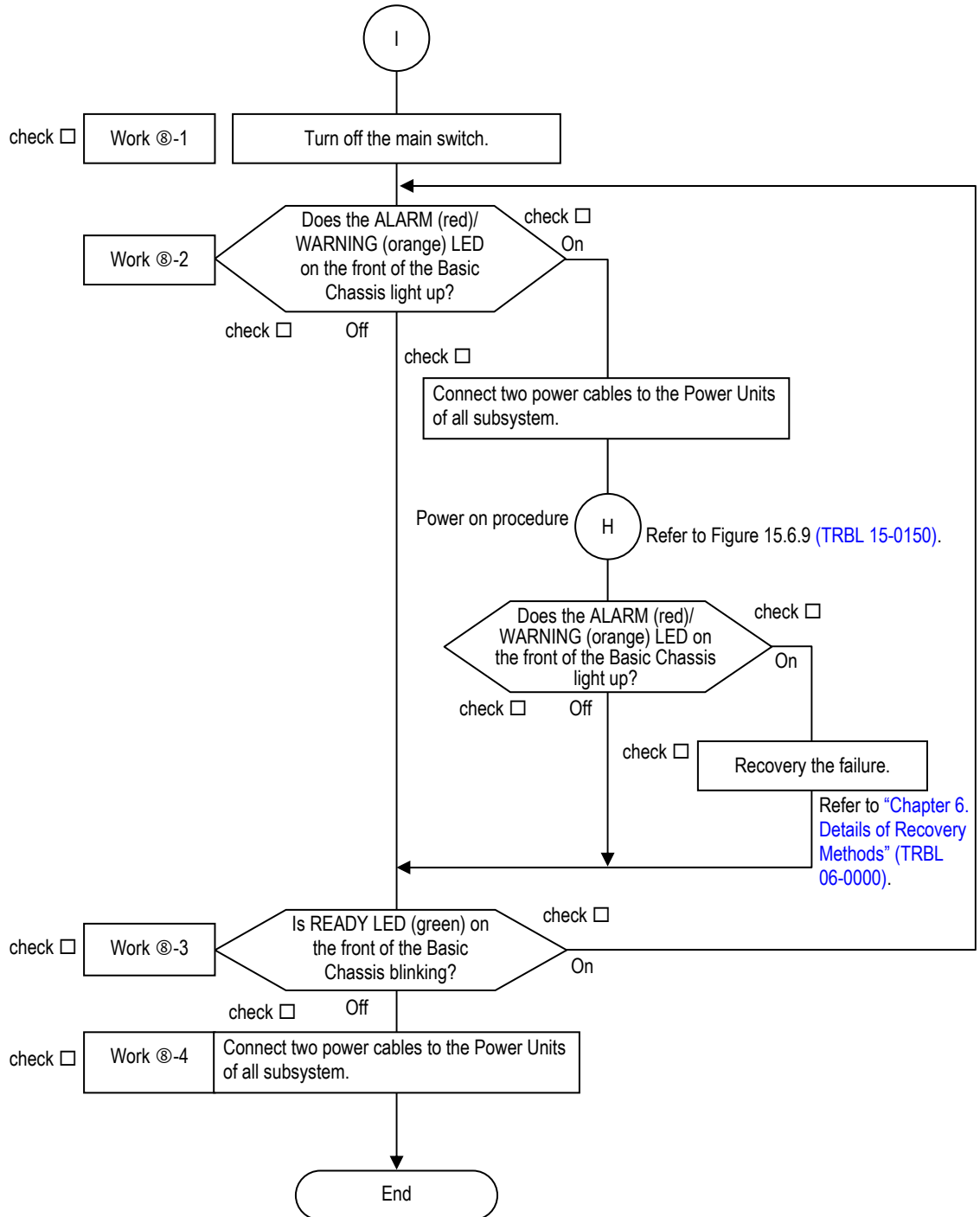

Figure 15.6.10 Power Off Procedure

15.6.2 Procedure Screen

- (1) When the drive starts a spin-up, change to the maintenance mode. (Refer to [WEB “Chapter 3. The Maintenance Mode Operation Procedure” \(WEB 03-0000\)](#).)
- (2) Input ‘http://IP-Address of Control Unit 0 connecting WEB/drvfirm’ in URL of a browser. (Refer to [“Chapter 3. Before Starting WEB Connection” \(TRBL 03-0000\)](#).)

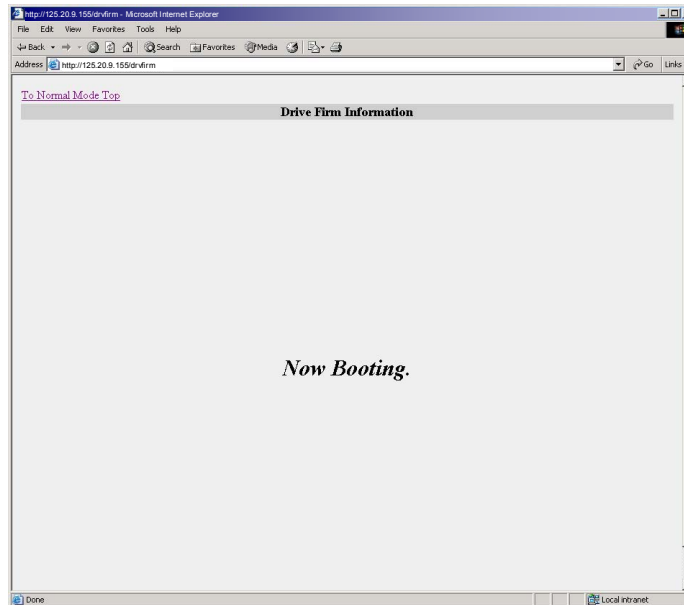

Figure 15.6.11 Booting

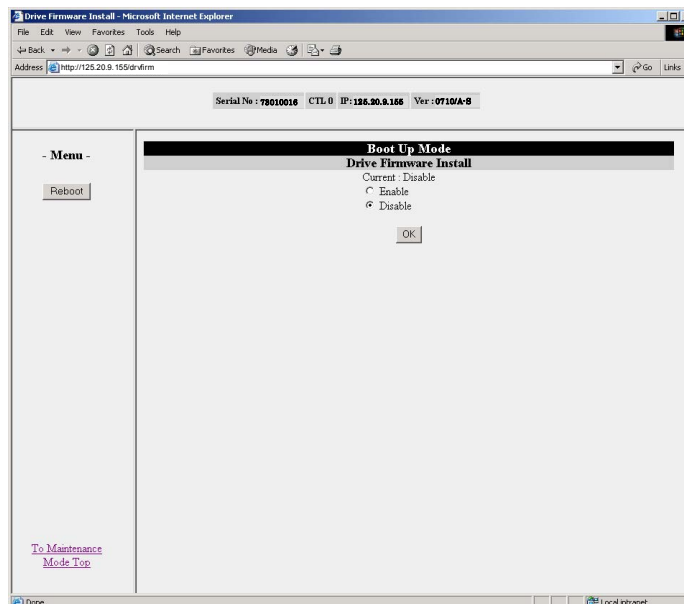

Figure 15.6.12 After Booting (Boot Up Mode)

- (3) When the “Enter Network Password” is displayed, enter [User Name] and [Password] and click the [OK] button.

User Name: maintenance

Password: hosyu9500



Figure 15.6.13 Network Password Screen

- (4) When Figure 15.6.12 is displayed, select [Enable] on the [Boot Up Mode] and click the [OK] button.



Figure 15.6.14 After Booting (Boot Up Mode: Enlargement Figure)

- (5) After select [Enable], click the [Reboot] button.



Figure 15.6.15 Reboot Button (Enlargement Figure of Figure 15.6.12)

- (6) Click the [OK] button on the System Restart screen.

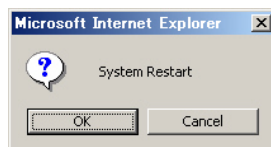

Figure 15.6.16 System Restart Screen



Figure 15.6.17 Rebooting

- (7) If the READY LED <green> on the front of the Basic Chassis is blinking, input “http://IP-Addressof the Control Unit 0 connecting WEB/” in URL of a browser, and check that the message of “IZ0000 HDU firmware download start” is displayed in Information Message.

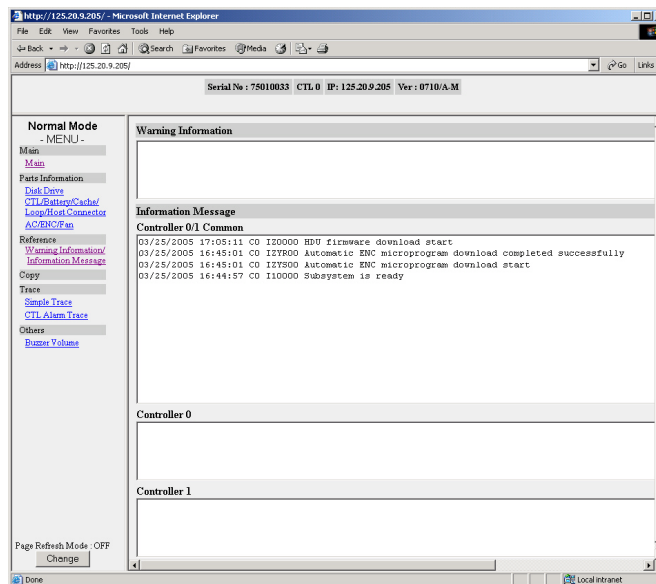

Figure 15.6.18 Web Browser

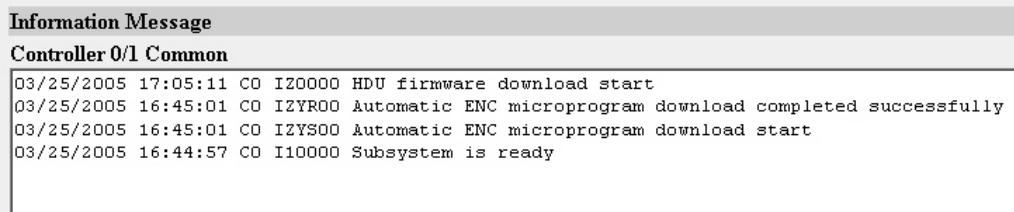

Figure 15.6.19 Web Browser (Information Message)

- (8) Input “http://IP-Address of Control Unit 0 connecting WEB/drvfirm” in URL of a browser.
When the “Enter Network Password” is displayed, enter [User Name] and [Password] and click the OK button.
The Java applet (Drive Firmware Install) is displayed. Click the [Select] button.
When the following message is displayed, it is necessary to click ActiveX Control with a mouse and to change it into the active status.

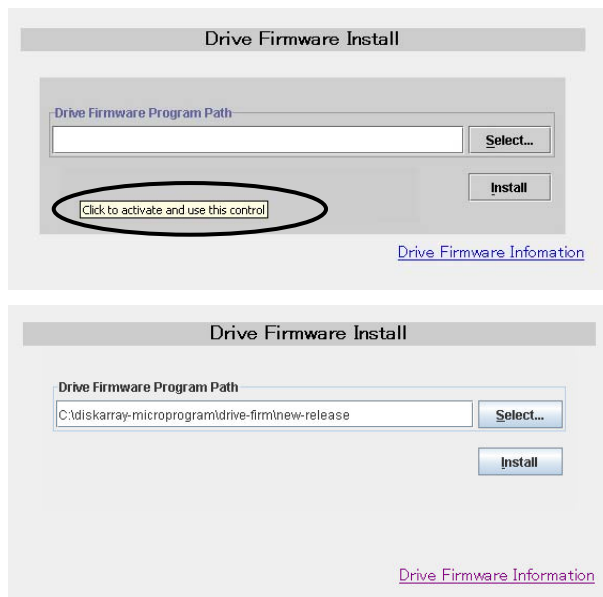

Figure 15.6.20 Java Applet (Drive Firmware Install)

- (9) Specify the folder in which the drive firmware is stored.

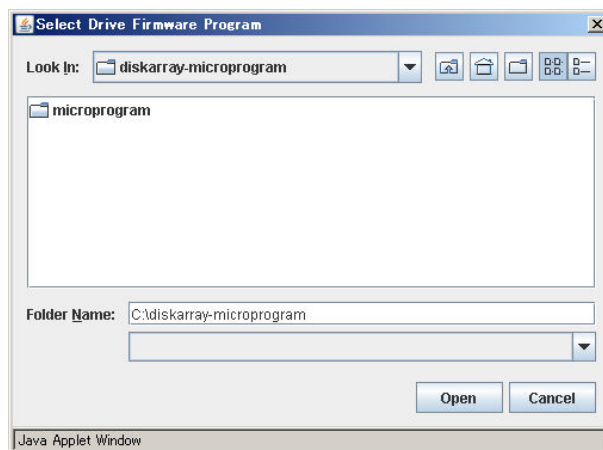

Figure 15.6.21 Firmware Select Screen

- (10) Click the [Install] button on the [Figure 15.6.22](#), a confirmation message is displayed. Click the [OK] button when satisfactory. (Install is started)



Figure 15.6.22 Confirmation Message



Figure 15.6.23 Installing Firmware

- (11) When a file transfer is received normally, since a confirmation screen will be displayed, click the [OK] button.

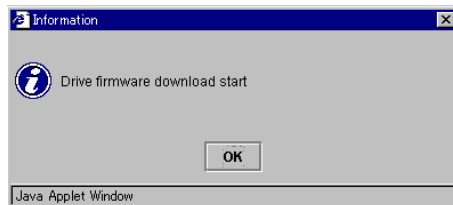

Figure 15.6.24 Confirmation Screen

- (12) Click the [Drive Firmware Information]; the replacement state of a drive firmware is displayed.

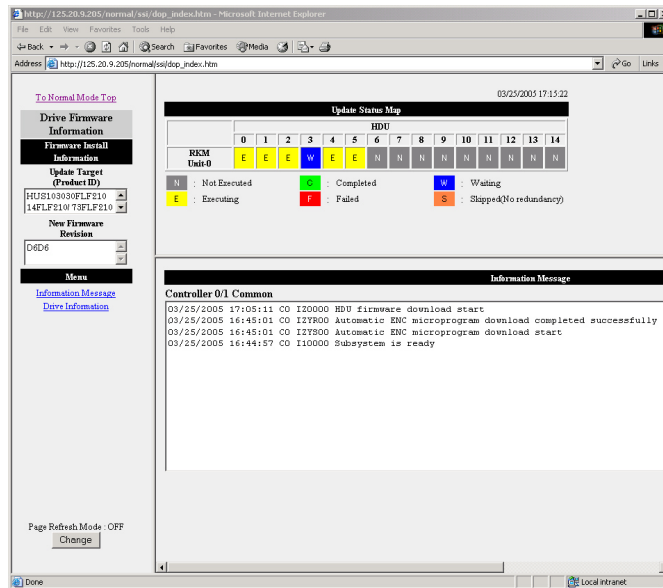

Figure 15.6.25 Drive Firm Information (in Progress)

- (13) When the installation in all Disk Drives is completed, after remove the power cables, turn on the power of the array subsystem again. (Refer to [Installation “1.5.1 Subsystem Power On” \(INST 01-0140\)](#) for the procedure for turning on the power.)

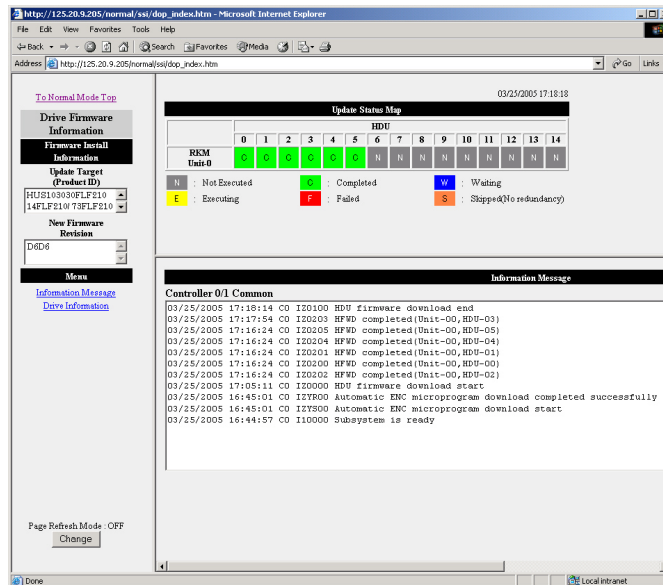

Figure 15.6.26 Drive Firm Information (Completed)

- (14) After the subsystem becomes READY, input 'http://IP-Address of Control Unit 0 connecting WEB/drvfirm' in URL of a browser.
- Then, select "Drive Information" of the Side frame.
- And, see Revision of Drive Information and check that the drive firmware is replaced.

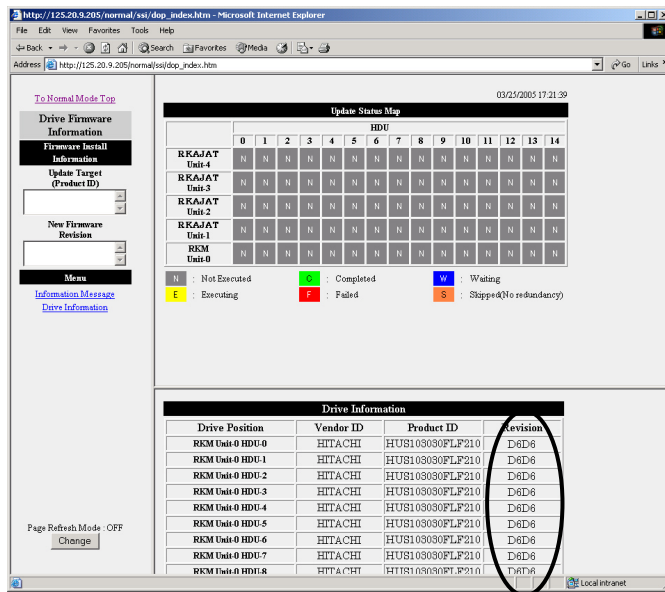

Figure 15.6.27 Completed Drive Firmware Replacement (The Screen of AMS2100 is Shown as an Example.)

15.7 Web Screen of the Drive Firmware

15.7.1 URL

Entering the following URL in the Web browser using a PC connected with the subsystem displays the window that shows the drive firmware revision. (It can be displayed even when the drive firmware replacement is not being executed.) (Refer to “Chapter 3. Before Starting WEB Connection” (TRBL 03-0000).)

IP address/drvfirm of the Control Unit 0 connecting http://WEB

15.7.2 Web Screen Image

Image of the Web window, which shows the drive firmware, displayed by means of Internet Explorer is shown below.

When URL is input after the INQUIRY information on the Disk Drive is decided, the window of Figure 15.7.1 is displayed.

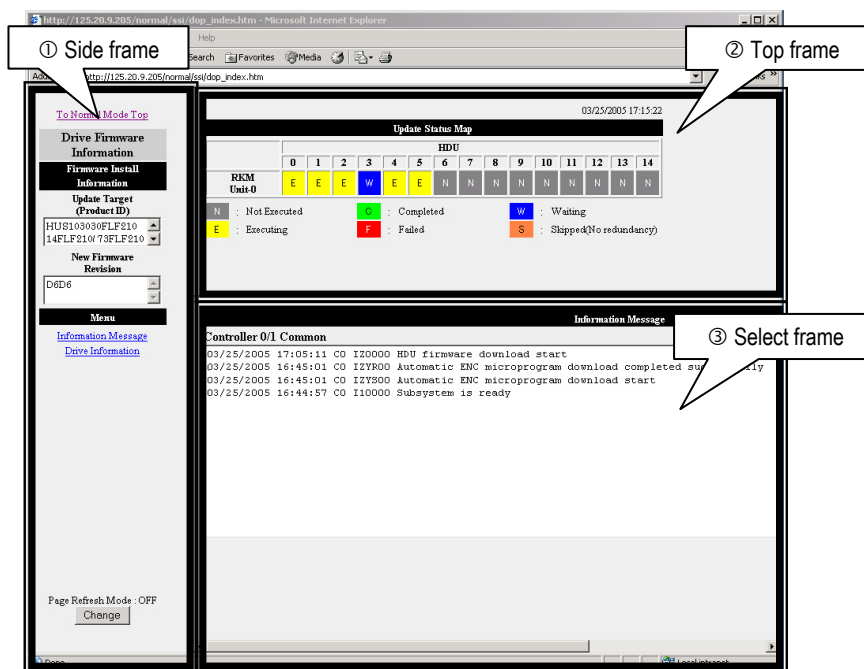

Figure 15.7.1 Status of Drive Firm Revision Screen (1)

(1) Detail of Side Frame and Top Frame

The screenshot shows a web-based interface for drive firmware updates. It includes a navigation menu on the left, a main content area with a status map, and a log of update activities. Callouts provide detailed explanations for key features:

- ①** The top screen of normal mode is displayed. (Points to 'To Normal Mode Top' link)
- ②** The model name of the drive, for which the firmware is to be replaced, described in the drive firmware CD-R is displayed. (Points to 'Update Target (Product ID)')
- ③** The revision of the replacement firmware contained in the drive firmware CD-R is displayed. (Points to 'New Firmware Revision')
- ④** The updated time is displayed. (Points to the timestamp '03/25/2005 17:15:22')
- ⑤** Explains the colors displayed in the status map.
 - Gray : Not Executed
 - Green : Completed
 - Blue : Waiting
 - Yellow : Executing
 - Red : Failed
 - Orange : Skipped
- ⑥** Status map: A status of the drive firmware replacement is shown by means of colors. A clicking in a cell displays information on a drive with a corresponding drive number in the Select frame.
- ⑦** Select the item, and display the selected frame. (Points to 'Information Message Drive Information' link)
- ⑧** The screen of the top frame is refreshed every 5 seconds. (Points to 'Page Refresh Mode: OFF Change')

Additional callouts include 'Reflect the this frame.' pointing to the log area and 'Controller 0/1' pointing to the log header.

Figure 15.7.2 Status of Drive Firm Revision Screen (2)

(2) Detail of Select Frame

Details of Side Frame and Top Frame are shown in [Figure 15.7.3](#) and [Figure 15.7.4](#).

You can select the following two patterns.

The Select frame window display when selecting the Information Message item of the Side frame is shown in [Figure 15.7.3](#).

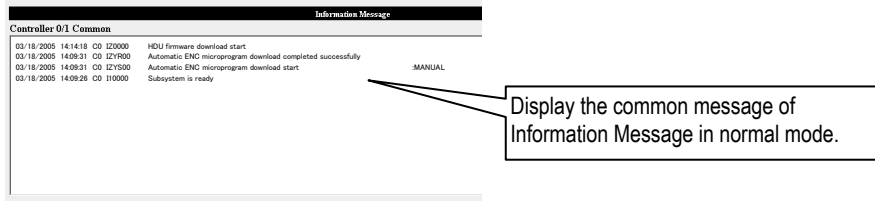

Figure 15.7.3 Status of Drive Firm Revision Screen (3)

The Select frame window display when selecting the Drive Information item of the Side frame is shown in [Figure 15.7.4](#).

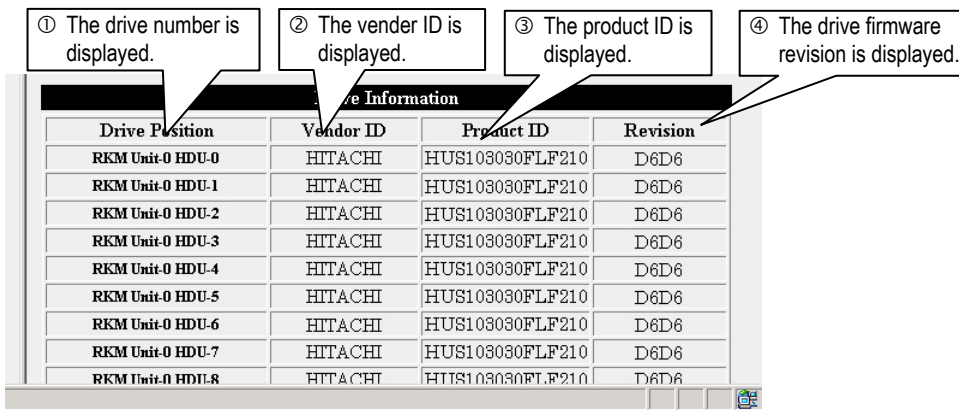

Figure 15.7.4 Status of Drive Firm Revision Screen (4)

15.8 Method of Checking the Drive Firmware Revision

There are three kinds of revision check methods of a drive firmware.

15.8.1 The Check Method by WEB Connection

- (1) Connect the controller#0 side to the network and input the IP address of the controller#0 as “address” of the WEB browser.



- (2) Input “drivefirm” following an IP address. (Drive farm revision state screen is displayed.)
<http://IP Address /drvfirm>

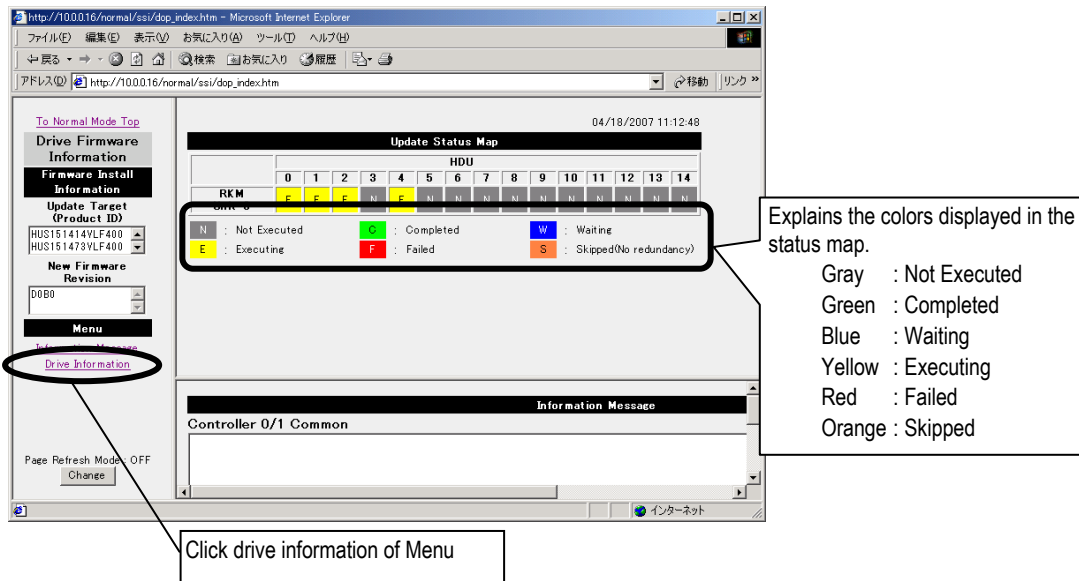

(3) Click “Drive Information” of Menu. (The model name of a mounted drive and firm revision are displayed.)

Drive Information			
Drive Position	Vendor ID	Product ID	Revision
RKM Unit-0 HDU-0	HITACHI	HUS151414VLF400	D0B0
RKM Unit-0 HDU-1	HITACHI	HUS151414VLF400	D0B0
RKM Unit-0 HDU-2	HITACHI	HUS151414VLF400	D0B0
RKM Unit-0 HDU-3	HITACHI	HUS151414VLF400	D0B0
RKM Unit-0 HDU-4	HITACHI	HUS151414VLF400	D0B0

15.8.2 The Check Method by Trace Analysis

Refer to a message worksheet.

The screenshot shows a software interface with a message log. The log contains several entries for 'pdevtype.txt' and 'oprprg.txt'. A table within the log displays drive information for five different drive types (0, 1, 2, 3, 4). Callouts point to specific fields in the table:

- ① The drive number is displayed. (Points to the 'Drive Type' column)
- ② The vender ID is displayed. (Points to the 'VENDOR' column)
- ③ The product ID is displayed. (Points to the 'PRODUCT_ID' column)
- ④ The drive firmware revision is displayed. (Points to the 'PR_REV' column)

A callout at the bottom left points to the 'MESSAGE(C:\D:\ALL\CTL\ALL\HG\INFO\HG_MAP\HG_SEC\RSV\INFO\TG\INFO\TG_MAP\TG_SEC)' path, labeled 'Message worksheet.'

[HDD]Unit	VENDOR	PRODUCT_ID	PR_REV	SERIAL
Drive Type [0][0]==>	HITACHI	HUS151414VLF400	D0B0	JAVH66XK
Drive Type [1][0]==>	HITACHI	HUS151414VLF400	D0B0	JAVL275K
Drive Type [2][0]==>	HITACHI	HUS151414VLF400	D0B0	JAVL26BK
Drive Type [3][0]==>	HITACHI	HUS151414VLF400	D0B0	JAVM04AK
Drive Type [4][0]==>	HITACHI	HUS151414VLF400	D0B0	JAVJ7UMK

15.8.3 The Procedure to Check the Drive Firmware Revision Using the Hitachi Storage Navigator Modular 2

The screenshot displays the 'Properties' window for a drive in Hitachi Storage Navigator Modular 2. The window title is 'HDU 00 Tray 00'. The 'Properties' table lists the following information:

Property	Value
Part	SAS HDU 00
Tray	Tray 00
Status	Normal
Part Type	SAS
Part Number	AJH300
Part Serial No.	3LM0M8LA
RPM	15000RPM
Vendor ID	SEAGATE
Product ID	DKS2E-K300SS
Firmware Revision	4C53

Four callout boxes provide the following information:

- ① The drive number is displayed. (Points to 'HDU 00' in the Part field)
- ② The vendor ID is displayed. (Points to 'SEAGATE' in the Vendor ID field)
- ③ The product ID is displayed. (Points to 'DKS2E-K300SS' in the Product ID field)
- ④ The drive firmware revision is displayed. (Points to '4C53' in the Firmware Revision field)

