



**Hitachi TagmaStore®
Adaptable Modular Storage 200™
User and Reference Guide**

Notice: No part of this publication may be reproduced or transmitted in any form or by any electronic or mechanical means, including photocopying and recording, or stored in a database or retrieval system for any purpose without the express written permission of Hitachi Data Systems Corporation (hereinafter referred to as “Hitachi Data Systems”).

Hitachi Data Systems reserves the right to make changes to this document at any time without notice and assumes no responsibility for its use. Hitachi Data Systems products and services can only be ordered under the terms and conditions of Hitachi Data Systems’ applicable agreements. All of the features described in this document may not be currently available. Refer to the most recent product announcement or contact your local Hitachi Data Systems sales office for information on feature and product availability.

This document contains the most current information available at the time of publication. When new and/or revised information becomes available, this entire document will be updated and distributed to all registered users.

Trademarks

Hitachi Data Systems is a registered trademark and service mark of Hitachi, Ltd., and the Hitachi Data Systems design mark is a trademark and service mark of Hitachi, Ltd.

TagamaStore is a registered trademark of Hitachi Data Systems Corporation.

Egenera and BladeFrame are registered trademarks of Egenera, Inc.

Emulex is a registered trademark of Emulex Corporation.

MC/ServiceGuard is a registered trademark of the Hewlett-Packard Development Company, L.P.

Pentium is a registered trademark of Intel Corporation.

AIX and RS/6000 are registered trademarks of International Business Machines Corporation.

Linux is a registered trademark of Linus Torvalds.

Microsoft, Windows, and Windows NT, are registered trademarks, and Windows Server is a trademark of Microsoft Corporation.

Netscape and Netscape Navigator are registered trademarks of Netscape Communications Corporation in the U.S. and other countries.

Oracle is a registered trademark of Oracle Corporation.

QLogic is a registered trademark of QLogic Corporation.

Java, Solaris, Sun, Sun Enterprise, and Sun Fire are trademarks of Sun Microsystems, Inc.

VERITAS is a registered trademark, and VERITAS Cluster Server, VERITAS Database Edition, and VERITAS Volume Manager are trademarks of VERITAS Software Corporation.

All other brand or product names are or may be registered trademarks, trademarks, or service marks of and are used to identify products or services of their respective owners.

Notice of Export Controls

Export of technical data contained in this document may require an export license from the United States government and/or the government of Japan. Please contact the Hitachi Data Systems Legal Department for any export compliance questions.

China RoHS



The indication is given based on the Requirements for Controlling Pollution Caused by Electronic Information Products Regulation

Hazardous & toxic substances table

Part Name	Toxic and Hazardous Substances and Elements					
	Lead (Pb)	Mercury (Hg)	Cadmium (Cd)	Hexavalent Chromium (Cr(VI))	Polybrominated biphenyls (PBB)	Polybrominated diphenyl ethers (PBDE)
RKS	×	○	○	○	○	○
RKAJ	×	○	○	○	○	○
RKAJAT	×	○	○	○	○	○
RKNAS	×	○	○	○	○	○

○: Indicates that this toxic or hazardous substances contained in all of the homogeneous materials for this part is below this limit requirement in SJ/T 11363-2006.

×: Indicates that this toxic or hazardous substances contained in at least one of the homogeneous materials used for this part is above the limit requirement in SJ/T 11363-2006.

Document Revision Level

Revision	Date	Description
MK-95DF713-00	June 2005	Initial Release
MK-95DF713-01	September 2005	Revision 1, supersedes and replaces MK-95DF713-00
MK-95DF713-02	November 2005	Revision 2, supersedes and replaces MK-95DF713-01
MK-95DF713-03	January 2006	Revision 3, supersedes and replaces MK-95DF713-02
MK-95DF713-04	February 2006	Revision 4, supersedes and replaces MK-95DF713-03
MK-95DF713-05	April 2006	Revision 5, supersedes and replaces MK-95DF713-04
MK-95DF713-06	April 2006	Revision 6, supersedes and replaces MK-95DF713-05
MK-95DF713-07	May 2006	Revision 7, supersedes and replaces MK-95DF713-06
MK-95DF713-08	August 2006	Revision 8, supersedes and replaces MK-95DF713-07
MK-95DF713-09	August 2006	Revision 9, supersedes and replaces MK-95DF713-08
MK-95DF713-10	January 2007	Revision 10, supersedes and replaces MK-95DF713-09
MK-95DF713-14	May 2007	Revision 13, supersedes and replaces MK-95DF713-10

Changes in this Revision

(V7.1)

- Changed the table in .China RoHS
- Changed section .1.2.2
- Added Note 3 to .Table 2.9 and .Table 2.10
- Added Note to .Table 2.11
- Changed section .4.3
- Updated .Table 8.2
- Updated Note 4 in .Table C.1
- Updated Note 4 in .Table C.2
- Updated Note 3 in .Table C.3
- Changed .Figure D.1
- Added Note to .Figure D.1
- Changed .Table D.1

(V7.5)

- Changed Notes for .Figure 4.1, .Figure 4.2, .Figure 4.3, .Figure 4.4, .Figure 4.5, .Figure 4.6, .Figure 4.7, .Figure 4.8, .Figure 4.9, .Figure 4.10, .Figure 4.11, and .Figure 4.12
- Changed section .4.6.1 and .4.6.2

- Changed Table 4.4 and Table 4.5
- Updated Note in section 7.4.7
- Changed Table C.1 and Table C.2
- Added Table F.28, Table F.29, Table F.30, and Table F.31
- Changed Table I.2

Preface

This document describes the physical, functional, and operational characteristics of the Hitachi TagmaStore® AMS200 subsystem. This document also provides operation instructions, installation details, and configuration planning information for the AMS200 subsystem.

This document assumes the following:

- The user is familiar with the Hitachi TagmaStore® Adaptable Modular Storage AMS200 storage system.
- The user is familiar with the Windows® operating system.

This storage system complies with FDA radiation performance standards 21CFR, subchapter J.

Note: For further information, please contact your Hitachi Data Systems account team, or visit the Hitachi Data Systems worldwide web site at <http://www.hds.com>.

Notice: The use of Hitachi TagmaStore AMS200 subsystem and all other Hitachi Data Systems products is governed by the terms of your agreement(s) with Hitachi Data Systems.

Software Version

This document revision applies to Hitachi TagmaStore AMS/WMS version 3.5 and higher.

EMI Regulation

This equipment has been tested and found to comply with the limits for a Class A digital device, pursuant to Part 15 of the FCC Rules. These limits are designed to provide reasonable protection against harmful interference when the equipment is operated in a commercial environment. This equipment generates, uses, and can radiate radio frequency energy and, if not installed and used in accordance with the instruction manual, may cause harmful interference in which case the user will be required to correct the interference at his own expense. Testing was done with shielded cables. Therefore, in order to comply with the FCC regulations, you must use shielded cables with your installation.

If trouble occurs in a different configuration, the user may be requested to take appropriate preventive measures. The EMI test was done in the following configuration:

- AMS200-RKS+H1J
- AMS200-RKS+RKAJ+H2J

Convention for Storage Capacity Values

Storage capacity values for hard disk drives (HDDs) on the TagmaStore AMS/WMS are calculated based on the following values:

- 1 KB = 1,000 bytes
- 1 MB = 1,000² bytes
- 1 GB = 1,000³ bytes
- 1 TB = 1,000⁴ bytes

Storage capacity values for logical devices (LDEVs) on the TagmaStore AMS/WMS are calculated based on the following values:

- 1 KB = 1,024 bytes
- 1 MB = 1,024² bytes
- 1 GB = 1,024³ bytes
- 1 TB = 1,024⁴ bytes
- 1 block = 512 bytes

Referenced Documents

Hitachi TagmaStore® Adaptable Modular Storage and Workgroup Modular Storage:

- *Cache Residency Manager Software User's Guide*, MK-95DF716
- *Storage Navigator Modular Graphical User Interface (GUI) User's Guide*, MK-95DF711
- *Storage Navigator Modular Command Line Interface (CLI) User's Guide*, MK-95DF712
- *ShadowImage™ In-System Replication Software User's Guide*, MK-95DF709
- *TrueCopy™ Synchronous Remote Replication Software User's Guide*, MK-95DF710
- *Copy-on-Write Snapshot User's Guide*, MK-95DF708
- *Performance Monitor Software User's Guide*, MK-95DF706
- *Hitachi Data Systems Global 19-Inch Rack Reference Guide*, MK-93DF665

Comments

Please send us your comments on this document. Make sure to include the document title, number, and revision. Please refer to specific section(s) and paragraph(s) whenever possible.

- **E-mail:** doc.comments@hds.com
- **Fax:** 858-695-1186
- **Mail:**
Technical Writing, M/S 35-10
Hitachi Data Systems
10277 Scripps Ranch Blvd.
San Diego, CA 92131

Thank you! (All comments become the property of Hitachi Data Systems Corporation.)

Contents

Chapter 1	Overview of the AMS200 Storage System	1
1.1	Introducing the AMS Storage Systems	2
1.2	Overview Features	2
1.2.1	High Data Availability	3
1.2.2	Connectivity	3
1.2.3	Scalability	4
1.2.4	Performance Reporting and Monitoring	4
1.2.5	Reliability, Availability, and Serviceability	5
1.2.6	Hitachi Freedom Storage™ and Hitachi Freedom Data Networks™	5
1.3	Rack-Mount Model	6
1.4	Floor Model	6
Chapter 2	Planning for Installation and Operation	9
2.1	User Responsibilities	10
2.2	Safety Precautions	11
2.2.1	Symbol Marks	11
2.2.2	Repair, Modification, and Disassembly	12
2.2.3	Precautions for Using Equipment	12
2.2.4	Inspection and Cleaning Precautions	15
2.2.5	Emergency Precautions	16
2.2.6	Warning Notices	16
2.2.7	Warning Label Locations	17
2.3	General Specifications and Requirements	23
2.3.1	Dimensions and Weight	24
2.3.2	Service Clearance Requirements	24
2.3.3	Floor Load Rating	25
2.3.4	Internal Logic Specifications	26
2.3.5	Cable Function	26
2.4	Environmental Specifications and Requirements	27
2.4.1	Environmental Hazards	27
2.4.2	Temperature and Humidity Requirements	28
2.4.3	Input Power and Insulation Performance Specifications	28
2.4.4	Air Flow Requirements	31
2.4.5	Vibration and Shock Tolerances	31
2.4.6	Reliability	31
Chapter 3	Powering On/Off Procedure	37
3.1	AMS200 Rack-Mount Model	38
3.1.1	Storage System Power On	38
3.1.2	Storage System Power Off	39
3.1.3	Stop/Start/Restart of NAS OS	40
3.2	AMS200 Floor Model	47
3.2.1	Storage System Power On	47
3.2.2	Storage System Power Off	48

Chapter 4	Storage System Architecture and Components	49
4.1	Configuration Block Diagrams	50
4.1.1	AMS200 Rack-Mount Model	50
4.1.2	AMS200 Floor Model	55
4.2	Redundant Power Supplies	65
4.3	Fibre Channel Interface	65
4.3.1	Mini-HUB	65
4.3.2	Connection Specifications	66
4.3.3	Fibre Channel Configuration	68
4.3.4	Host Direct Connection for AMS200	69
4.4	NAS Interface	70
4.5	ISCSI Interface	70
4.5.1	Setting iSCSI Information	70
4.6	Array Frame	71
4.6.1	AMS200 Rack-Mount Model	71
4.6.2	Floor Model	73
4.7	Component Names, Locations, and Functions	75
4.7.1	Front Bezel Component Locations and Functions	75
4.7.2	Component Locations	77
4.7.3	Switch Locations and Functions	79
4.7.4	Connector Locations and Functions	80
4.7.5	LED Locations and Functions	83
Chapter 5	Functional and Operational Characteristics	93
5.1	New AMS200 Features and Capabilities	94
5.2	Raid Implementations	95
5.3	Cache Management	96
5.4	Logical Units (LUs)	98
5.5	Open Systems Features and Functions	100
5.5.1	Open Systems Middleware	100
5.5.2	Logical Unit Mapping	100
5.6	Data Management Features and Functions	100
5.6.1	Cache Residency Manager Function	100
5.6.2	LUN Manager Function	101
5.6.3	Data Retention Utility Function	101
5.6.4	LUN Expansion Function	101
5.6.5	Password Protection Function	101
5.6.6	Account Authentication Function	101
5.6.7	Audit Logging Function	102
5.7	Copy Solution Features and Functions	102
5.7.1	TrueCopy Remote Replication Function	102
5.7.2	ShadowImage In-System Replication Function	102
5.7.3	Copy-On-Write Snapshot Function	102
5.7.4	Modular Volume Migration Function	103
5.7.5	NAS Backup Restore Modular Function	103
5.7.6	NAS Sync Image Modular Function	103
5.8	Performance Management Features and Functions	103
5.8.1	Performance Monitor Function	103
5.8.2	Cache Partition Manager Function	103

5.9	NAS Features and Functions	104
5.9.1	NAS Data Control Modular Function	104
5.9.2	NAS File Sharing Modular Function	104
5.9.3	NAS Manager Modular Function	104
5.9.4	NAS Backup Restore Modular Function	104
5.9.5	NAS Sync Image Modular Function	104
5.9.6	NAS Anti-Virus Agent Modular Function	104
5.10	iSCSI Features and Functions	105
5.10.1	CHAP Authentication	105
5.10.2	iSNS Client	105
Chapter 6	Configuring the AMS200 Storage System	107
6.1	Overview of Configuration	108
6.1.1	Open Systems Configuration	108
6.1.2	Defining LUNs	108
6.1.3	Fibre Channel Interface Addressing	108
6.1.4	iSCSI Interface Addressing	110
6.1.5	Alternate Pathing	110
6.1.6	NAS Configuration	112
6.2	Configuring LAN Interfaces of the AMS200 Storage System	113
6.2.1	Setting the IP Addresses	114
6.3	Configuring the AMS200 Storage System	115
6.4	Registering the AMS200 Storage System for Control by Storage Navigator-Modular	116
6.5	Configuring the AMS200 Storage System for the Desired Application	116
6.6	AMS200 Storage System General Configuration	117
Chapter 7	Configuring Storage on the AMS200 Storage System	119
7.1	Software Composition	121
7.1.1	Microprogram	121
7.1.2	System Parameters	121
7.1.3	Configuration Information	121
7.1.4	SNMP Information	122
7.1.5	Storage for Parameters	122
7.2	Setting Fibre Channel Information	122
7.3	Setting iSCSI Information	124
7.3.1	Setting iSCSI Port Information	124
7.3.2	Setting the iSNS Server Information	125
7.3.3	Sending a Ping	127
7.4	Determining Space and RAID Level Requirements	128
7.4.1	Setting a Spare Disk	130
7.4.2	Canceling a Spare Disk Setting	133
7.4.3	Setting a RAID Group	133
7.4.4	Deleting a RAID Group	136
7.4.5	Setting a Logical Unit	139
7.4.6	Deleting the Last Logical Unit	143
7.4.7	Formatting a Logical Unit	145
7.4.8	Changing the Format Mode	150
7.4.9	Changing the Default Controller in Charge of an LU	152
7.5	Setting Host Group Information	153

7.5.1	Setting Mapping Information	153
7.6	Setting Target Information.....	156
7.6.1	Changing the Target Information	157
7.6.2	7.6.2 Initializing the Target 0	158
7.6.3	Setting Mapping Information	160
7.7	Setting CHAP Authentication	163
7.7.1	Adding a CHAP User	163
7.7.2	Changing the CHAP User.....	165
7.7.3	Deleting the CHAP User	166
7.7.4	Changing the Two-Way Authentication Information	168
7.8	Transferring Configurations from One Array to Another	169
7.9	Storing Configuration Data.....	170
7.9.1	System Parameter Information.....	170
7.9.2	RAID Group/LU information.....	171
7.9.3	Port/Host Group Information.....	172
7.9.4	NAS System LU/User LU Information	174
7.9.5	LAN information	174
7.10	Applying Configuration Data to another AMS200 Storage System.....	175
7.10.1	System Parameters.....	175
7.10.2	RAID Group/Logical unit.....	177
7.10.3	Port/Host Group	177
7.10.4	LAN Information	178
7.11	Setting Host Connection Parameters	179
7.11.1	Simple Setting	179
7.11.2	Detailed Setting for Each Host Connection.....	184
7.12	Setting the Storage System when using Special Mode	185
7.13	Changing the Network Parameter.....	187
7.14	Changing the Auto Diagnosis Threshold for Fibre Channel Loop	193
7.15	7.15 Changing the IP Address for the Maintenance Port	195
7.16	Setting the System LU and User LU in the NAS System	199
7.16.1	Setting the System LU	200
7.16.2	Setting the User LU	202
7.17	Setting the NNC Management LAN Port Information in the NAS System	205
7.18	Setting the Time Zone	210

Chapter 8 Troubleshooting 213

8.1	Troubleshooting Based on LED Indications	214
8.1.1	The POWER LED Does Not Turn on.....	215
8.1.2	The POWER LED Turned Off	216
8.1.3	If READY LED Does Not Turn On or has Turned On Once then Off	217
8.1.4	The Alarm LED Turned On.....	218
8.1.5	The WARNING LED has Turned on or Blinks	219
8.1.6	The WARNING LED Has Turned On or Blinks.....	220
8.2	Web Overview.....	220
8.2.1	Operational Environment	220
8.2.2	Characteristics of Network Functions When Connecting with the Web.....	223
8.3	Web Operational Procedures	224
8.3.1	Connecting to the Network using a LAN Interface	224
8.3.2	Window Outlines.....	224
8.3.3	Main window in Normal Mode	228

8.3.4	Status Display of Replaceable Components	230
8.3.5	Information Message	238
8.3.6	Setting the Buzzer Sound Volume.....	239
8.3.7	Clear Specified Factors of NNC Partial Alarm.....	240
8.4	Troubleshooting Using a Web Connection	243
8.4.1	Checking Subsystem Status	243
8.4.2	Checking the Progress Condition Display	244
8.4.3	Checking Component Status	245
8.4.4	Checking Log Messages	246
8.4.5	Troubleshooting Using Messages	248
8.4.6	8.46 Reading Failure Information.....	254
8.5	Determining Failure of Network Side in NAS System.....	258
8.6	Determining Failure of Local Tape in NAS System.....	260
8.7	Connecting Failure in Connection with the Web	265
8.7.1	Collecting Simple Trace	265
8.7.2	NAS Log Collection	268
8.7.3	NAS Dump Generation	271
8.8	Determining Network Side Failure of an iSCSI System.....	278
8.9	Changing the LAN Port Number using the Storage Navigator Modular	280
8.9.1	Changing the LAN Port Number	280
8.9.2	Changing the LAN Port Number	281
8.9.3	Troubleshooting	286
8.10	8.10 Calling the Hitachi Data Systems Support Center	288
Chapter 9	Periodic Maintenance.....	289
	Acronyms and Abbreviations.....	291
	Appendix B System Parameter Settings List.....	297
	Appendix C Basic Specifications of the Storage System.....	307
	Appendix D Interfaces	317
D.1	Fibre Channel Connection Specifications	317
D.2	Ethernet Connection Specifications	343
	Appendix E Remote Adapter Specifications.....	347
E.1	Remote Adapter Specifications.....	347
E.2	Remote Adapter Dimensions	348

Appendix F Storage Capacities Corresponding to RAID Levels and Configurations	349
Appendix G Port Address Mapping Table	373
Appendix H Power Cables	377
Appendix I Number of Logical Blocks	379
Appendix J Using LUN Security or LUN Management on a Fabric Switch Connection	385
J.1 FC Interface Board is Not Added to Control Unit	385
J.1 FC Interface Board is Added to Control Unit	386

List of Figures

Figure 2.1	Positions and Contents of Labels on Floor Model RKS+H1HJ.....	18
Figure 2.2	Positions and Contents of Labels on Rack-Mount Model RKS+RKAJ/RKAJAT+H2J.19	
Figure 2.3	Positions and Contents of Labels on Rack-Mount Model RKS	20
Figure 2.4	Positions and Contents of Labels on Rack-Mount Model RKNAS.....	21
Figure 2.5	Positions and Contents of Labels on Rack-Mount Model RKAJ.....	22
Figure 2.6	Positions and Contents of Labels on Rack-Mount Model RKAJAT	23
Figure 3.1	Subsystem Power On/Off (Example: Floor [RKS+ RKAJ+H2J).....	48
Figure 4.1	RKS System Configuration (Interface board not added).....	50
Figure 4.2	RKS System Configuration (FC interface board added).....	51
Figure 4.3	RKS System Configuration (iSCSI interface board added).....	52
Figure 4.4	RKS and RKNAS System Configuration.....	53
Figure 4.5	RKAJ System Configuration	54
Figure 4.6	RKAJAT System Configuration.....	55
Figure 4.7	Floor Model AMS200 System Configuration (FC interface board not added)	56
Figure 4.8	Floor Model AMS200 System Configuration (FC Interface board added)	57
Figure 4.9	Floor Model AMS200 System Configuration (iSCSI interface board added)	58
Figure 4.10	Floor Model AMS200 System Configuration (Interface board not added)	59
Figure 4.11	Floor Model AMS200 System Configuration (FC interface board added).....	60
Figure 4.12	Floor Model AMS200 System Configuration (iSCSI Interface board added)	61
Figure 4.13	System Configuration of the Floor Model (When Interface board is not added)	62
Figure 4.14	System Configuration of the Floor Model (When FC Interface board is added)	63
Figure 4.15	System Configuration of the Floor Model (When iSCSI Interface board is added)	64
Figure 4.16	AMS200 FC Connector.....	65
Figure 4.17	RKS, RKA, and RKA/RKAJAT Front Bezel Component Locations	75
Figure 4.18	RKNAS Front Bezel Component Locations	77
Figure 4.19	RKS Component Locations.....	78
Figure 4.20	RKAJ Component Locations.....	78
Figure 4.21	RKAJAT Component Locations.....	78
Figure 4.22	Panel Assembly Switch Location	79
Figure 4.23	Power Unit Switch Locations	80
Figure 4.24	RKNAS Switch Locations	80
Figure 4.25	ENC Unit Connector Locations.....	81
Figure 4.26	Power Unit Connector Locations	81
Figure 4.27	Control Unit Connector Locations.....	82
Figure 4.28	RKNAS Connector Locations.....	83
Figure 4.29	Disk Drive Display LED Locations	84
Figure 4.30	Disk Drive Display (RKAJ., RKAJAT) LED Locations	85
Figure 4.31	Battery Backup Unit LED Locations	86
Figure 4.32	ENC Unit LED Locations.....	86
Figure 4.33	SENC Unit LED Locations	87
Figure 4.34	Power Unit LED Locations	88
Figure 4.35	Fan Assembly LED Locations.....	89
Figure 4.36	Control Unit LED Locations.....	89
Figure 4.37	RKNAS LED Locations (front).....	91
Figure 4.38	RKNAS LED Locations (rear).....	92
Figure 5.1	Logical Units (without FC interface board addition to control unit).....	98
Figure 5.2	Logical Units (with FC interface board addition to control unit).....	98
Figure 5.3	Logical Units (With iSCSI interface board addition to control unit).....	99
Figure 5.4	Logical Units (NAS Model).....	99

Figure 6.1	Fibre Channel Port-to-LUN Addressing (FC interface board not added)	109
Figure 6.2	Fibre Channel Port-to-LUN Addressing (FC interface board added)	109
Figure 6.3	iSCSI Port-to-LUN Addressing (iSCSI interface board installed)	110
Figure 6.4	Alternate Pathing (FC interface board not added)	111
Figure 6.5	Alternate Pathing (FC interface board added)	111
Figure 6.6	Alternate Pathing (iSCSI interface board added)	112
Figure 7.1	Logical Status Tab	134
Figure 7.2	Logical Status Tab (NAS)	135
Figure 7.3	RAID Group Dialog Box	135
Figure 7.4	RAID Group Updated	136
Figure 7.5	RAID Group Updated (NAS)	136
Figure 7.6	Setting the Logical Unit Dialog Box	141
Figure 7.7	Logical Unit Dialog (detail)	142
Figure 7.8	Select Area	143
Figure 8.1	LAN Connector Location	224
Figure 8.2	Main Window Outline	225
Figure 8.3	Main Window Outline (NAS)	225
Figure 8.4	Main Window Outline (iSCSI)	226
Figure 8.5	Subsystem Condition Display	228
Figure 8.6	Component Status Window	230
Figure 8.7	Component Status Window (Controller/Battery/Cache/Loop/Host Computer)	231
Figure 8.8	Component Status Window (AC/ENC/FAN)	231
Figure 8.9	NNC Information Window	232
Figure 8.10	Revision Information Window	237
Figure 8.11	Warning Information Window	238
Figure 8.12	Information Message Window	239
Figure 8.13	Buzzer Volume Window	240
Figure 8.14	Subsystem Status Window	243
Figure 8.15	Progress Condition Display	244
Figure 8.16	Replace Part Summary Window (HDD)	245
Figure 8.17	NNC Information Window	246
Figure 8.18	Information Message Screen	247
Figure 8.19	Configuration Diagram	257
Figure 8.20	Configuration Diagram	264
Figure 8.21	LAN Port Number Setting	281
Table B.1	Host Connection Parameters	298
Table B.2	Host Connection Parameters	300
Table B.3	Host Connection Parameters	302
Table B.4	Host Connection Parameters	303
Table B.5	Host Connection Parameters	305
Table C.1	AMS200 Floor Model Basic Specifications	307
Figure D.1	Fibre Channel Connection Specifications	317
Figure D.2	Cable Side Connector	318
Figure D.3	Connector Shape	319
Table D.2	Ordered Set	319
Table D.3	SOF Delimiters	321
Table D.4	EOF Delimiters	322
Table D.5	Frame Format	324
Table D.6	Frame Format	325
Table D.7	Frame Format	326

Table D.8	Link Control Frames.....	328
Table D.9	Link Service Frames Supported by AMS200.....	329
Table D.10	Information Unit.....	330
Table D.11	Frame Header Format	331
Table D.12	FCP_CMND Payload.....	332
Table D.13	FCP_LUN Format.....	334
Table D.14	FC-4 Device Data Frame.....	335
Table D.15	Link Initialization Process.....	336
Table D.16	Link Initialization Process.....	341
Table D.17	Response when Receiving ELS without PLOGI.....	343
Table D.18	Response when Receiving ELS without PLOGI.....	344
Figure D.4	Connector Type on Cable Side	344
Figure D.5	Connector Type on Subsystem Side	344
Table E.1	Remote Adapter Specifications	347
Figure E.1	Remote Adapter Dimensions.....	348
Table F.1	List of Capacities Corresponding to RAID0 (72 GB).....	349
Table F.2	List of Capacities Corresponding to RAID1 (72 GB).....	350
Table F.3	List of Capacities Corresponding to RAID5 (72 GB).....	350
Table F.4	List of Capacities Corresponding to RAID6 (72 GB).....	351
Table F.5	List of Capacities Corresponding to RAID1+0 (72 GB).....	352
Table F.6	List of Capacities Corresponding to RAID0 (146 GB)	353
Table F.7	List of Capacities Corresponding to RAID1 (146 GB)	353
Table F.8	List of Capacities Corresponding to RAID5 (146 GB)	354
Table F.9	List of Capacities Corresponding to RAID6 (146 GB)	355
Table F.10	List of Capacities Corresponding to RAID1+0 (146 GB)	356
Table F.11	List of Capacities Corresponding to RAID0 (300 GB)	357
Table F.12	List of Capacities Corresponding to RAID1 (300 GB)	358
Table F.13	List of Capacities Corresponding to RAID5 (300 GB)	358
Table F.14	List of Capacities Corresponding to RAID6 (300 GB)	359
Table F.15	List of Capacities Corresponding to RAID1+0 (300 GB)	360
Table F.16	List of Capacities Corresponding to RAID1 (250 GB)	360
Table F.17	List of Capacities Corresponding to RAID5 (250 GB)	361
Table F.18	List of Capacities Corresponding to RAID6 (250 GB)	362
Table F.19	List of Capacities Corresponding to RAID1+0 (250 GB)	363
Table F.20	List of Capacities Corresponding to RAID1 (400 GB)	363
Table F.21	List of Capacities Corresponding to RAID5 (400 GB)	364
Table F.22	List of Capacities Corresponding to RAID6 (400 GB)	365
Table F.23	List of Capacities Corresponding to RAID1+0 (400 GB)	366
Table F.24	List of Capacities Corresponding to RAID1 (500 GB)	366
Table F.25	List of Capacities Corresponding to RAID5 (500 GB)	367
Table F.26	List of Capacities Corresponding to RAID6 (500 GB)	368
Table F.27	List of Capacities Corresponding to RAID1+0 (500 GB)	369
Table F.28	List of Capacities Corresponding to RAID1 (750 GB)	369
Table F.29	List of Capacities Corresponding to RAID5 (750 GB)	370
Table F.30	List of Capacities Corresponding to RAID6 (750 GB)	371
Table F.31	List of Capacities Corresponding to RAID1+0 (750 GB)	372
Table G.1	Limits for TIDs on Operating Systems	373
Table G.2	Port Addresses for HP-UX	373
Table G.3	Port Addresses for Solaris.....	374
Table G.4	Port Addresses for Windows NT (Fibre Board: Emulex®).....	375

Table G.5	Port Addresses for Windows NT (Fibre Board: Qlogic®)	376
Table H.1	J1H Power Cable	377
Figure H.1	J1H Power Cable	377
Table H.2	J2H Power Cable	377
Figure H.2	J2H Power Cable	377
Table H.3	J2H5 and J2H10 Power Cables	378
Figure H.3	J2H5 and J2H10 Power Cables	378
Table I.1	Number of Logical Blocks and RAID Levels	379
Table I.2	Number of Logical Blocks of One Parity Group	382

List of Tables

Hazardous & toxic substances table	iv
Table 1.1 Fibre Cable Length	4
Table 2.1 Caution Statements	16
Table 2.2 Symbols Contained in Warning Labels.....	17
Table 2.3 AMS200 Dimensions and Weight of Rack-Mount Model	24
Table 2.4 AMS200 Dimensions and Weight of Floor Model	24
Table 2.5 AMS200 Dimensions and Weight of NAS Unit	24
Table 2.6 Internal Logic Specification of AMS200 Rack-Mount Model	26
Table 2.7 Principal Functions of AMS200 Cables.....	27
Table 2.8 Environmental Specifications.....	28
Table 2.9 Input Power and Insulation Performance Specifications for Rack-Mount Model	29
Table 2.10 Input Power and Insulation Performance Specifications for Floor Model.....	30
Table 2.11 Input Power and Insulation Performance Specifications for NAS Unit	30
Table 2.12 Vibration and Shock Tolerances.....	31
Table 2.13 Reliability of AMS200 Rack-Mount Model (RKS/RKAJ)	31
Table 2.14 Reliability of AMS200 Rack-Mount Model (RKS/RKAJAT)	33
Table 2.15 Reliability of AMS200 Floor Model	34
Table 4.1 Fibre Cable Length	65
Table 4.2 Available Host Connectors of Each Topology Setting and Connection Method .	66
Table 4.3 Available Fibre Channel Connection Configuration	68
Table 4.4 Basic Specifications of Rack-Mount Model.....	72
Table 4.5 Basic Specifications of the Floor Model.....	74
Table 4.6 RKS, RKA, and RKA/RKAJAT Front Bezel Component Functions	76
Table 4.7 RKNAS Front Bezel Component Functions	77
Table 4.8 Panel Assembly Switch Functions	79
Table 4.9 Power Unit Switch Functions	80
Table 4.10 RKNAS Switch Functions.....	80
Table 4.11 ENC Unit Connector Functions	81
Table 4.12 Power Unit Connector Functions.....	82
Table 4.13 Control Unit Connector Functions	82
Table 4.14 RKNAS Connector Functions	83
Table 4.15 Disk Drive Display LED Functions.....	84
Table 4.16 Disk Drive Display (RKAJ, RKAJAT) LED Functions.....	85
Table 4.17 Battery Backup Unit LED Functions.....	86
Table 4.18 ENC Unit LED Functions	87
Table 4.19 SENC Unit LED Functions	88
Table 4.20 Power Unit LED Functions.....	89
Table 4.21 Fan Assembly LED Functions.....	89
Table 4.22 Control Unit LED Functions	90
Table 4.23 RKNAS LED Functions (front)	92
Table 4.24 RKNAS LED Functions (rear)	92
Table 5.1 Rack-Mount and Floor Model RAID Specifications	96
Table 5.2 Floor Model RAID Specifications.....	96
Table 5.3 Rack-Mount Model Cache Specifications.....	97
Table 5.4 Floor Model Cache Specifications.....	97
Table 7.1 Storage for Parameters.....	122
Table 7.2 Formatting Message	150
Table 7.3 Simple Setting Item List.....	183

Table 7.4	Additional Parameter Setting Items	184
Table 7.5	Capacity Restriction of System LU.....	199
Table 8.1	Web Operational Environment	221
Table 8.2	AMS200 WEB Function Supported Browser/Version	221
Table 8.3	Network Parameters	223
Table 8.4	Patrol Lamp Display	228
Table 8.5	Exchange Parts Status Display.....	229
Figure 8.7	Component Status Window (Controller/Battery/Cache/Loop/Host Computer).....	231
Figure 8.8	Component Status Window (AC/ENC/FAN).....	231
Figure 8.9	NNC Information Window	232
Figure 8.10	Revision Information Window	237
Figure 8.11	Warning Information Window.....	238
Table 8.6	Message Code Types	248
Table 8.7	Flash Detected Messages	250
Table 8.8	Progress Messages (continues on next page).....	251
Table 8.8	Progress Messages (continues on next page).....	252
Table 8.8	Progress Messages (continued)	253
Table 8.9	Warning Messages	253
Table 8.10	Failure Messages.....	253
Table 8.11	How to Read Failure Information (Continues to the next page)	254
Table 8.11	How to Read Failure Information (Continues to the next page)	255
Table 8.11	How to Read Failure Information (Continued).....	257
Table 8.12	Collection Mode	268
Table B.1	Host Connection Parameters	298
Table B.2	Host Connection Parameters	300
Table B.3	Host Connection Parameters	302
Table B.4	Host Connection Parameters	303
Table B.5	Host Connection Parameters	305
Table C.1	AMS200 Floor Model Basic Specifications	307
Table C.1	AMS200 Floor Model Basic Specifications (Continued).....	309
Table C.2	AMS200 Rackmount Model Basic Specifications.....	312
Table C.2	AMS200 Rackmount Model Basic Specifications (Continued)	313
Table C.2	AMS200 Rackmount Model Basic Specifications (Continued)	315
Table C.3	Basic Specifications of RKNAS	316
Table D.1	Cable Specification	318
Table D.2	Ordered Set	319
Table D.3	SOF Delimiters	321
Table D.4	EOF Delimiters	322
Table D.5	Frame Format.....	324
Table D.6	Frame Format.....	325
Table D.7	Frame Format.....	326
Table D.8	Link Control Frames.....	328
Table D.9	Link Service Frames Supported by AMS200.....	329
Table D.10	Information Unit.....	330
Table D.11	Frame Header Format	331
Table D.12	FCP_CMND Payload.....	332
Table D.13	FCP_LUN Format.....	334
Table D.14	FC-4 Device Data Frame.....	335
Table D.15	Link Initialization Process.....	336
Table D.16	Link Initialization Process.....	341

Table D.17	Response when Receiving ELS without PLOGI.....	343
Table D.18	Response when Receiving ELS without PLOGI.....	344
Table E.1	Remote Adapter Specifications	347
Table F.1	List of Capacities Corresponding to RAID0 (72 GB).....	349
Table F.2	List of Capacities Corresponding to RAID1 (72 GB).....	350
Table F.3	List of Capacities Corresponding to RAID5 (72 GB).....	350
Table F.4	List of Capacities Corresponding to RAID6 (72 GB).....	351
Table F.4	List of Capacities Corresponding to RAID6 (72 GB) (Continued)	352
Table F.5	List of Capacities Corresponding to RAID1+0 (72 GB).....	352
Table F.6	List of Capacities Corresponding to RAID0 (146 GB)	353
Table F.7	List of Capacities Corresponding to RAID1 (146 GB)	353
Table F.8	List of Capacities Corresponding to RAID5 (146 GB)	354
Table F.9	List of Capacities Corresponding to RAID6 (146 GB)	355
Table F.9	List of Capacities Corresponding to RAID6 (146 GB) (Continued).....	356
Table F.10	List of Capacities Corresponding to RAID1+0 (146 GB)	356
Table F.11	List of Capacities Corresponding to RAID0 (300 GB)	357
Table F.12	List of Capacities Corresponding to RAID1 (300 GB)	358
Table F.13	List of Capacities Corresponding to RAID5 (300 GB)	358
Table F.14	List of Capacities Corresponding to RAID6 (300 GB)	359
Table F.14	List of Capacities Corresponding to RAID6 (300 GB) (Continued).....	360
Table F.15	List of Capacities Corresponding to RAID1+0 (300 GB)	360
Table F.16	List of Capacities Corresponding to RAID1 (250 GB)	360
Table F.17	List of Capacities Corresponding to RAID5 (250 GB)	361
Table F.18	List of Capacities Corresponding to RAID6 (250 GB)	362
Table F.18	List of Capacities Corresponding to RAID6 (250 GB) (Continued).....	363
Table F.19	List of Capacities Corresponding to RAID1+0 (250 GB)	363
Table F.20	List of Capacities Corresponding to RAID1 (400 GB)	363
Table F.21	List of Capacities Corresponding to RAID5 (400 GB)	364
Table F.22	List of Capacities Corresponding to RAID6 (400 GB)	365
Table F.22	List of Capacities Corresponding to RAID6 (400 GB) (Continued).....	366
Table F.23	List of Capacities Corresponding to RAID1+0 (400 GB)	366
Table F.24	List of Capacities Corresponding to RAID1 (500 GB)	366
Table F.25	List of Capacities Corresponding to RAID5 (500 GB)	367
Table F.26	List of Capacities Corresponding to RAID6 (500 GB)	368
Table F.27	List of Capacities Corresponding to RAID1+0 (500 GB)	369
Table F.28	List of Capacities Corresponding to RAID1 (750 GB)	369
Table F.29	List of Capacities Corresponding to RAID5 (750 GB)	370
Table F.30	List of Capacities Corresponding to RAID6 (750 GB)	371
Table F.31	List of Capacities Corresponding to RAID1+0 (750 GB)	372
Table G.1	Limits for TIDs on Operating Systems	373
Table G.2	Port Addresses for HP-UX	373
Table G.3	Port Addresses for Solaris	374
Table G.4	Port Addresses for Windows NT (Fibre Board: Emulex®)	375
Table G.5	Port Addresses for Windows NT (Fibre Board: Qlogic®)	376
Table H.1	J1H Power Cable	377
Table H.2	J2H Power Cable	377
Table H.3	J2H5 and J2H10 Power Cables	378
Table I.1	Number of Logical Blocks and RAID Levels	379
Table I.1	Number of Logical Blocks and RAID Levels (continued)	380
Table I.1	Number of Logical Blocks and RAID Levels (continued)	381

Table I.2	Number of Logical Blocks of One Parity Group	382
Table I.2	Number of Logical Blocks of One Parity Group (continued)	383

Chapter 1 Overview of the AMS200 Storage System

This chapter includes the following:

- Introduction to the AMS Storage Systems (see section 1.1)
- Overview of AMS Features (see section 1.2)
- Rack-Mount Model (see section 1.3)
- Floor Model (section 1.4)

This chapter provides information on the Fibre, NAS, and iSCSI models. The following table illustrates sections that provide an explanation for each model.

- **Fibre model:** Connects disk array subsystem to a host computer with Fibre Channel interface.
- **NAS model:** Connects NAS Unit connected to disk array subsystem to a host computer with LAN interface.
- **iSCSI model:** Connects disk array subsystem to a host computer with iSCSI interface.

Sections		Fibre	NAS	iSCSI
1.1	Introducing the AMS Storage Systems	○	○	○
1.2	Overview Features	○	○	○
	1.2.1 High Data Availability	○	○	○
	1.2.2 Connectivity	○	○	○
	1.2.3 Scalability	○	○	○
	1.2.4 Performance Reporting and Monitoring	○	○	○
	1.2.5 Reliability, Availability, and Serviceability	○	○	○
	1.2.6 Hitachi Freedom Storage™ and Hitachi Freedom Data Networks™	○	○	○
1.3	Rack-Mount Model	○	○	○
1.4	Floor Model	○	—	○

○: An explanation is provided.

—: An explanation is not provided.

1.1 Introducing the AMS Storage Systems

Hitachi Data Systems networked storage solutions are designed to manage, maintain, and protect one of your company's most valuable assets - its data. HDS' scalable, high-performance systems can help your business manage its existing data and lay a flexible foundation for the future, while reducing the cost and complexity of satisfying the continuing demand for storage expansion and optimizing system performance and providing the high availability your applications require. No matter what the size of your organization or its challenges, HDS can tailor a lasting solution, ensuring that your company realizes the maximum business benefits of Application Optimized Storage™ solutions from Hitachi Data Systems.

Hitachi Data Systems works with hundreds of customers to understand their needs and requirements, and builds systems as described above to implement storage solutions to meet those requirements. HDS understands customer issues and bases storage solutions on how customer applications use data. Each application has unique requirements in terms of data access, performance, and retention. This calls for strategic alignment of application requirements with storage attributes. The result is better information performance and availability at reduced cost.

This approach—Application Optimized Storage™—integrates a portfolio of hardware, software, and services, enabling businesses to optimize their storage assets for diverse application requirements. That means current applications function smoothly as new ones are added with no disruption or downtime. In an era when huge amounts of data must be available 24/7 and retained longer, Hitachi Data Systems provides a competitive edge. Application Optimized Storage solutions are cost-effective, easy to deploy, and able to deliver maximum value today.

Hitachi TagmaStoreT Adaptable Modular Storage and TagmaStore Workgroup Modular Storage systems are scalable, high-performance, and high-availability storage systems that are rated the best in their category. Leveraging many high-end storage features such as cache partitioning and RAID-6, this family of products addresses needs across a broad range of organizations ranging in size from small and mid-sized businesses (SMBs) through mid-sized organizations and entry level enterprises which generate fast-growing amounts of data. These systems meet specific application requirements, including those for Microsoft Exchange and Oracle Financials, and provide high availability and performance in a small footprint. In addition to meeting the requirements of SMBs, these systems can also be deployed in tiered storage configurations in large enterprises, complementing the Hitachi Data Systems Universal Storage Platform and the Network Storage Controller.

The following sections in this chapter describe the features of one of the four HDS midrange storage systems available to provide the storage solutions described above.

1.2 Overview Features

The Hitachi TagmaStore® Adaptable Modular Storage AMS200 storage system (hereafter referred to as the AMS200) is available in two models: the floor model and the rack-mount model.

There are two types of the AMS200 floor model. The first type is a combination of the DF700-RKS (hereafter referred to as the RKS) and the floor standing kit DF-F700-H1J (hereafter referred to as the Floor [RKS+H1J] Model). The second type is a combination of the RKS, the DF700-RKAJ (hereafter referred to as RKAJ)/the DF700-RKAJAT (hereafter referred to as RKAJAT), and the floor standing kit DF-F700-H2J (hereafter referred to as the Floor [RKS+RKAJ/RKAJAT+H2J] Model).

The AMS200 rack-mount model is a subsystem that combines the RKS, RKAJ/RKAJAT, and the DF-700-RKNAS2G (hereafter referred to as RKNAS). For information regarding model types, see sections 1.2 and 1.3.

The following AMS200 subsystem features are discussed in this section:

- High Data Availability
- Connectivity
- Scalability
- Performance Reporting and Monitoring
- Reliability, Availability, and Serviceability
- Hitachi Freedom Storage™ and Hitachi Freedom Data Networks™

1.2.1 High Data Availability

The AMS200 is designed for high performance and protection of user data. See section 1.2.5 for additional information on the reliability and availability features of the Hitachi AMS200 subsystem.

1.2.2 Connectivity

The Hitachi AMS200 subsystem provides connectivity to most open systems through a standard Fibre Channel interface or Network interfaces. The following describes the features of Fibre Channel and Ethernet.

- **High-Speed Data Transfer**

Fibre Channel: When using the Fibre Channel for the host interface, the AMS200 subsystem can transfer data between the host computer and the subsystem at a maximum speed of 200 MB/sec. (400 M bytes/s when the optional interface is connected). Throughput can be accessed by connecting multiple devices through the Fibre Channel Switch even when accessing multiple hosts.

Ethernet: With the 1 G bps Ethernet connection, the subsystem can transfer data between host computer and the subsystem at a maximum speed of 100 M bytes/s per port via a network. Enough throughput can be obtained even when having multiple access to the multiple devices connected to the same network.

- **Cable**

Fibre Channel: With Fibre Channel, the storage system can use 50/125 μm, 62.5/125 μm multimode Fibre Cable as defined in Table 1.1.

Table 1.1 Fibre Cable Length

Data transfer rate (MB/s)	100	200	400
Max 50/125 μm multimode Fibre Cable length	500 m	300 m	150 m
Max 62.5/125 μm multimode Fibre Cable length	300 m	150 m	70 m

Ethernet: With Ethernet, the subsystem can be located up to 100 meters from the host. The subsystem can be installed in the location far from the host.

- **Number of Connectable Devices**

Fibre Channel: The AMS1000 subsystem supports systems that can connect up to 126 fibre channel devices by using the fibre channel interface and connecting the FC-AL and the FC-SW.

iSCSI: The subsystem supports systems that can connect up to 256 hosts for a physical port by using the switch.

- **Security Function**

Fibre Channel and Ethernet: When the system is configured to connect multiple hosts, a function is provided which rejects a boot by any host except a specified host. This function can prevent access from an illegal host.

1.2.3 Scalability

The architecture of the AMS200 enables the user to scale the subsystem to meet a wide range of capacity and performance requirements:

- You can construct a variety of systems; for example, a system with 15 disk drives can be configured using a single RKS, or a more complex system can be set up using the maximum of 105 disk drives, expanded by connecting up to 6 RKAJs/RKAJATs to the RKS.
- Up to 15 spare disks can be set up in any location. Use the system effectively by configuring each spare disk in a disk drive slot left unused due to system construction.
- From the host computer, the subsystem can be used as a single large-scale disk drive or as 512 logical disks (LUs) maximum.

1.2.4 Performance Reporting and Monitoring

The Storage Navigator-Modular program provides the capability to either monitor the disk array in real-time or to collect historical data regarding the performance of the disk array.

1.2.5 Reliability, Availability, and Serviceability

The AMS200 subsystem is not expected to fail in any way that would interrupt user access to data. The AMS200 can sustain single component failures and still continue to provide full access to all stored user data.

Note: While access to user data will not normally be compromised, the failure of any single key component may degrade performance.

The reliability, availability, and serviceability features of the AMS200 subsystem include:

- **High-Availability capability.** The AMS200 subsystem provides high-availability capability for all critical components. The AMS200 uses component and function redundancy to provide high availability for many subsystem components.

The Controller of the AMS200 subsystem increases data reliability by adding original 8-byte data assurance codes to data from a host computer by automatically generating them, writing them in the disk drive together with the data, and checking them when reading the data. On the data bus in the controller, the automatic generation of the data assurance codes and the check are executed to enhance data reliability in data distribution/concentration control, particular to that disk array.

This function monitors potential disk failure. Before failure occurs, the data copy operation can be automatically performed in the background. The dynamic sparing feature enables the subsystem to replace the spare disk due to redundancy (excluding RAID0 configuration) and provides high reliability.

- **Redundant power supply systems.** Each AMS200 unit has a set of two power supplies. Each power supply can provide power for the entire subsystem in the unlikely event of power supply failure. The power supplies of each set can be connected across power boundaries so that each set can continue to provide power if a power outage occurs. Each unit of the AMS200 can sustain the loss of a single power supply and still continue operation.
- **High capacity cache.** The AMS200 subsystem supports 2 GBs high capacity cache per controller. Writing completion can be reported to the host system when data is written to cache.

1.2.6 Hitachi Freedom Storage™ and Hitachi Freedom Data Networks™

Hitachi Data Systems' end-to-end Storage Solutions give you the freedom to locate storage wherever it makes the greatest business sense to do so and protect your investment in currently installed components. Made possible by the advent and proliferation of high-speed technologies, storage area networks break the traditional server/storage bond and enable total connectivity. As a result, you can consolidate large storage pools shareable across the enterprise, centralize management, and dramatically improve storage utilization while reducing costs.

Hitachi Data Systems' Storage Solutions enable you to increase data availability, counter spiraling information management costs, and take advantage of the speed and flexibility of Storage technology. In addition to supporting the Storage Networking Industry Association's open-systems standards, HDS Storage Solutions reduce total cost of ownership by minimizing support costs and downtime, and optimizing server and storage configurations.

The benefits of Hitachi Data Systems' Storage Solutions include:

- Server/storage system scalability.
- Improved information access.
- Enhanced application/backup performance.
- Increased resource manageability and reliability.
- Higher availability.

Hitachi Freedom Data Networks™ (FDN) responds to the challenge of open architecture and multiple platforms. FDN is the locus of Hitachi's long-term vision for offering businesses complete freedom of choice in establishing data-centric enterprise networks, encompassing storage, switches, servers, management software, protocols, services, and networks developed by Hitachi, our alliance partners, and third party providers.

FDN facilitates:

- Consolidation of server and storage resources.
- Data sharing across the enterprise.
- Centralized resource and data management.
- Superior data security.
- Increased availability and scalability.
- Business continuity and disaster recovery.

For further information on Freedom Storage and Freedom Data Networks, please contact your Hitachi Data Systems account team, or visit Hitachi Data Systems online at www.hds.com.

1.3 Rack-Mount Model

The rack-mount model is composed of a single RKS or a combination of the RKS, RKAJ/RKAJAT, and RKNAS mounted on a rack frame. The RKS is capable of mounting up to 15 disk drives; a controller to perform RAID control on the drives is included. The RKAJ/RKAJAT is capable of mounting up to 15 disk drives and controls the drives through a connection with an RKS. The RKAJ/RKAJAT is provided with no controller.

1.4 Floor Model

There are two floor model styles:

- Floor (RKS+H1J) Model
- Floor (RKS+RKAJ/RKAJAT +H2J) Model

The Floor (RKS+H1J) Model is capable of mounting up to 15 disk drives and includes a controller to perform RAID control on the drives. The Floor (RKS+RKAJ/RKAJAT +H2J) model is capable of mounting up to 30 disk drives and includes a controller to perform RAID control on the drives.

Note: For the specifications of the Floor model, see Chapter 1.

Chapter 2 Planning for Installation and Operation

This chapter provides information for planning and preparing a site before and during installation of the Hitachi AMS200 subsystem. Please read this chapter carefully before beginning your installation planning.

Note: The general information in this chapter is provided to assist in installation planning and is not intended to be complete. The internal AMS200 installation and maintenance documents used by Hitachi Data Systems personnel contain complete specifications. The exact electrical power interfaces and requirements for each site must be determined and verified to meet the applicable local regulations. For further information on site preparation for AMS200 installations, contact your Hitachi Data Systems account team or the Hitachi Data Systems Support Center.

This chapter includes the following:

- User Responsibilities (section 2.1)
- Safety Precautions (section 2.2)
- General Specifications and Requirements (section 2.3)
- Environmental Specifications and Requirements (section 2.4)

This chapter provides information on the Fibre, NAS, and iSCSI models. The following table illustrates sections that provide explanations for each model.

- **Fibre model:** Connects disk array subsystem to a host computer with Fibre Channel interface.
- **NAS model:** Connects NAS Unit connected to disk array subsystem to a host computer with LAN interface.
- **iSCSI model:** Connects disk array subsystem to a host computer with iSCSI interface.

Sections		Fibre	NAS	iSCSI
2.1	User Responsibilities	○	○	○
2.2	2.2.1 Symbol Marks	○	○	○
	2.2.2 Repair, Modification, and Disassembly	○	○	○
	2.2.3 Precautions for Using the Equipment	○	○	○
	2.2.4 Inspection and Cleaning Precautions	○	○	○
	2.2.5 Emergency Precautions	○	○	○
	2.2.6 Warning Notices	○	○	○
	2.2.7 Warning Label Locations	○	○	○
2.3	2.3.1 Dimensions and Weight	○	○	○
	2.3.2 Service Clearance Requirements	○	○	○
	2.3.3 1 Floor Load Rating for the AMS200 Rack-Mount Model	○	○	○
	2.3.3 1 Floor Load Rating for the AMS200 Floor Model	○	—	○
	2.3.4 Internal Logic Specifications	○	○	○
	2.3.5 Cable Function	○	○	○
2.4	2.4.1 Environmental Hazards	○	○	○
	2.4.2 Temperature and Humidity Requirements	○	○	○
	2.4.3 Input Power and Insulation Performance Specifications	○	○	○
	2.4.4 Air Flow Requirements	○	○	○
	2.4.5 Vibration and Shock Tolerances	○	○	○
	2.4.6 Reliability	○	○	○

- : An explanation is provided.
 —: An explanation is not provided.

2.1 User Responsibilities

Before the AMS200 subsystem arrives for installation, you must provide the following items to ensure proper installation and configuration:

- Physical space necessary for proper subsystem function and maintenance activity.
- Electrical input power
- Connectors and receptacles
- Air conditioning
- Floor ventilation areas (recommended but not required)
- Cable access holes

2.2 Safety Precautions

When using the AMS200 disk array subsystem, follow these cautionary procedures:

- Perform operations in accordance with the instructions or procedures described in this manual.
- Follow the cautionary notes written on labels affixed to the equipment.
- Follow the cautionary notes written in this manual.
- This disk array is a **class 1 laser system** which does not emit a hazardous laser beam. Operate this subsystem using the instructions included in this guide; do not perform operations that are not specified. Otherwise, unexpected failures or accidents may result.

It is impossible to describe every hazard that may exist with this equipment. Please be aware of hazards not described in this manual. Work safely.

The following information is included in this section:

- Symbol marks
- Repair, modification, and disassembly
- Precautions for using the equipment
- Precautions for inspection and cleaning
- Emergency precautions
- Warning notices

2.2.1 Symbol Marks

The warning labels which appear on the subsystem and/or in this guide indicate potential safety hazards. When you see these symbols, observe the safety instructions that follow:



This is the safety alert symbol. It is used to alert you to potential personal injury hazards. Obey all safety messages that follow this symbol to avoid possible injury or death.



Indicates an imminently hazardous situation which, if not avoided, will result in death or serious injury.



Indicates a potentially hazardous situation which, if not avoided, could result in death or serious injury.



Indicates a potentially hazardous situation which, if not avoided, may result in minor or moderate injury.



Indicates a potentially hazardous situation which, if not avoided, may result in property damage.

2.2.2 Repair, Modification, and Disassembly

Users must not repair, remodel, or disassemble the equipment. Such actions may cause hazardous conditions for the user and/or the equipment.

2.2.3 Precautions for Using Equipment

Use special precautions for the following:

- Equipment
- Cables
- Air vents
- Battery unit
- Nickel-Hydrde rechargeable battery instructions
- Miscellaneous and other

2.2.3.1 Equipment

- If you notice unusual heat generation, odors, or smoke emission, shut off the power feed to the equipment and contact the Customer Engineer. Leaving such conditions unattended may result in hazardous physical conditions and equipment failure.
- Avoid physical disruption to the equipment. This may result in hazardous physical conditions and equipment failure.
- Do not place heavy objects on top of the disk array. Avoid using the equipment for any use other than its original purpose; otherwise, an injury or equipment failure may result.

2.2.3.2 Cables

- Avoid obstructing walkways when routing cables.
- Do not allow heavy material to be placed on cables. Do not place cables near any apparatus that generates heat. Do not step on or subject cables or connectors to shearing or pulling forces; the cable jacket can be damaged and can break, resulting in an electric shock, fire, or loss of data.
- Make sure that electrical and signal cables are clean before connecting them. Any dirt on a connector should be removed before inserting the connector into a socket.
- When working on a machine which has a grounding terminal, verify that the terminal is properly connected to the facility's ground.

2.2.3.3 Air Vents

- Make certain that the air vents are free of obstruction. They should be inspected periodically.
- Do not place metallic material such as paper clips or any combustible material such as paper into or near the air vents. This may result in electric shock or fire.

2.2.3.4 Battery Unit

Observe the following when handling the battery:

- Do not disassemble or tamper with the battery.
- Do not allow the battery to be physically damaged. If the battery is physically damaged, have it replaced as soon as possible.
- Do not connect the two terminals of the battery directly to each other; this will create a short circuit.
- Do not tamper with cable insulation.
- Do not connect the battery to any equipment other than the AMS200 subsystem.
- Do not expose the battery to high temperatures.
- Use only the specified battery.

2.2.3.5 Nickel-Hydrate Rechargeable Battery Instructions

These instructions explain what you must observe when you use a nickel-hydrate rechargeable battery (hereinafter it is referred to as the battery). If you use the battery incorrectly, it can overheat ignite, burst or explode, damaging and deteriorating its performance/life. Read and follow the instructions below:



- Do not disassemble the case; do not modify it or peel off the label. There are high voltage parts inside: if you attempt any of these actions, this can result in electrical shock or burning.
- Do not disassemble the battery; this can cause short circuits inside or outside of the battery. If the components are exposed to the air, the battery can overheat, burst or ignite. Disassembling the battery can expose you to alkaline solution, which can be dangerous.
- Do not cut the output cable. Do not modify the connector. If you attempt any of these actions, an electrical shock or burn can result. A short-circuit may cause abnormal chemical reactions inside the battery which leads to overheating, bursting or ignition.
- Follow the instructions when you recharge the battery pack. If you recharge it in a way different from specified here, it may cause the following problems: The battery may become charged excessively; excessive current may be produced; or the battery cannot be recharged. As a result, the battery may leak, become overheated, burst, or ignite.
- Do not use excessive force when you connect the battery pack to the charger or other devices. If you cannot connect it easily, check that the positive and negative positions are correct for the connector. If you connect the battery in reverse, it will be charged incorrectly and abnormal chemical reactions may occur inside. As a result, the battery may become overheated, burst or ignite.
- Do not connect the battery to a power receptacle. If you apply an excessive amount of voltage to the battery, it may produce excessive current making the battery overheat, burst or ignite.
- Do not use or leave the battery where the temperature can become high, such as, near a fire or a heating element. High temperatures can damage the battery's separator, which may cause short circuit, making it overheat, burst or ignite.
- Do not incinerate or heat the battery pack. If you do so, the insulator may melt, the safety fuse/mechanism may be damaged, or the electrolyte may gush out. As a result, the battery can burst, explode or ignite.
- Do not connect the negative terminal to the positive with metal wire. Do not carry or store the battery with other metal parts. This can cause a short circuit or produce an excessive current which can cause the battery to leak, overheat, burst or ignite.
- Do not let the battery become wet by soaking it in the water or seawater. If the battery becomes wet, a short circuit can occur and an excessive amount of current can be produced, causing abnormal chemical reactions inside. As a result, the battery may become overheated, burst or ignite.
- Do not nail or hammer the battery. The battery may be broken or dented and a short circuit may occur inside. As a result, the battery may become overheated, burst or ignite.
- Do not solder directly to the battery. If you do so, heat will melt the insulator and damage the safety fuse/mechanism. As a result, the battery may leak or may become overheated, burst or ignite.

 **Warning**

- If you find anything strange or unusual with the battery when you use/carry/store it, remove the battery from the device and stop using it. For example, strange smells, strange colors, or deformation are a sign you must stop using the battery.
- If it takes longer than the specified time to complete recharging, stop recharging the battery; otherwise, the battery may become overheated, burst or ignite.

If the battery leaks and gets into your eyes, immediately flush your eyes with clean water (tap water) and do not rub your eye. Visit the doctor immediately. If you do not seek any treatment for your eyes, problems may occur later. Because the battery uses highly concentrated alkaline as electrolyte, it can burn; you may lose your sight if it makes contact with your eyes. If the battery's liquid contacts your skin or eyes, you must flush them with plenty of clean water and visit a doctor at once.

2.2.3.6 Miscellaneous and Other

When a failure occurs in the unit, take action according to the procedures recommended in this manual. If the difficulty does not correspond to the corrective measures documented in this manual, contact the Customer Engineer.

2.2.4 Inspection and Cleaning Precautions

- If a maintenance activity requires that the unit be powered off, make sure that the power-off sequence described in the manual is performed before proceeding with maintenance.
- Do not work on the unit in a damp or flooded environment.
- Do not obstruct access to the unit with parts or tools.
- When performing the work with the door open, take off metal watches or jewelry to prevent electric shock. If you wear metal-frame glasses, do not touch the equipment.
- Ensure that loose clothing, jewelry, or hair do not become tangled in moving components.
- There are high-voltage parts in the equipment. Observe the cautionary statements in the manual to make sure that high-voltage components are not touched during maintenance. Another person should be on alert to shut off the power feed to the equipment.
- After the power feed to the equipment is shut off, electricity remains in the equipment for a period of time. Therefore, do not touch any components other than those indicated in this manual.
- The equipment can become extremely hot. Do not touch any part other than those indicated in this manual.
- When working with the door open, wear cotton gloves to prevent your hands from touching sharp objects.

2.2.5 Emergency Precautions

Follow these emergency precautions for the following:

- Electric Shock
- Fire

2.2.5.1 Electric Shock

- DO NOT immediately touch the person struck by electricity. You could be the second victim.
- To shut off the electric flow to a victim, disconnect the power feed cable of the equipment. In spite of this action, electricity may not be shut off. Separate the victim from the current source by using a non-conductive material such as dry wooden bar.
- Call an ambulance.
- When the victim has lost consciousness, practice artificial respiration on the victim. To prepare for such a case, learn how to practice artificial respiration.
- When the victim's heart has stopped, give a heart massage. This treatment should only be conducted by a person who has been trained and qualified.

2.2.5.2 Fire

- To shut off the electric flow to the equipment, pull out the power feed cable. This will terminate the power supply.
- If a fire cannot be extinguished when the electric flow has been shut off, use fire-fighting procedures and contact the fire department.

2.2.6 Warning Notices

2.2.6.1 Caution Statements

Caution statements described in this manual and the pages where they appear are listed below. Caution statements are indicated by the caution symbol:

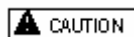

Table 2.1 Caution Statements

Statement	Corresponding Page
Cooling fans rotate at a high speed. Keep body parts and loose clothing away from the cooling fans.	_15
When cleaning, take care not to touch electrically charged parts. Electric shock may result.	_15, _16



2.2.7 Warning Label Locations

Warning labels are pasted on sections of equipment which require special care. Read the messages and observe the warning procedures. They are shown in the following figures:

- Floor Model RKS+H1J
- Floor Model RKS+RKAJ/RKAJAT+H2J
- Rack-Mount Model RKS
- Rack-Mount Model RKAJ/RKAJAT

Table 2.2 lists and describes the symbols contained in warning labels.

Table 2.2 Symbols Contained in Warning Labels

Symbol Mark	Description
	Caution-electric shock.
	Caution-very hot.

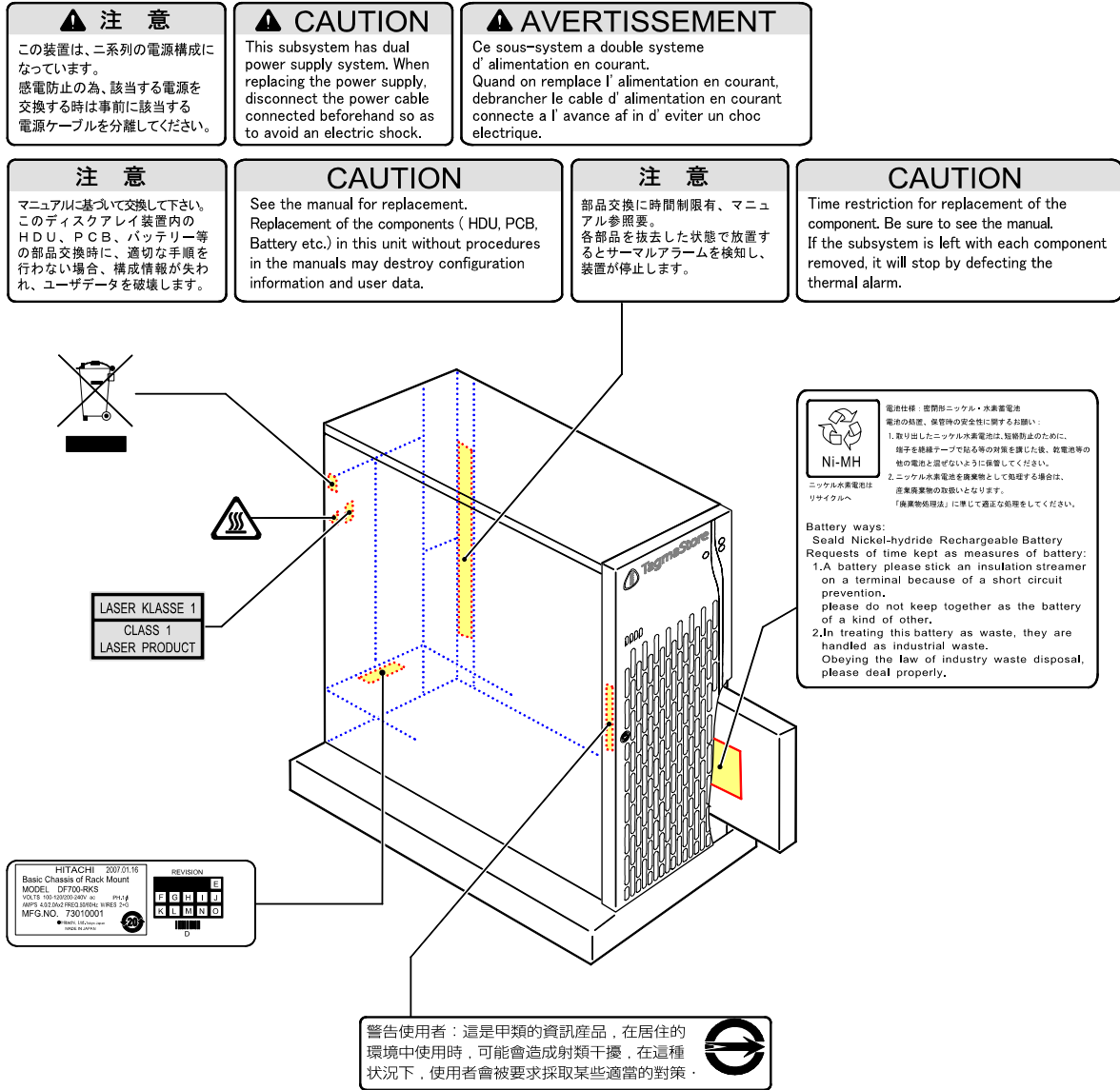

Figure 2.1 Positions and Contents of Labels on Floor Model RKS+H1HJ

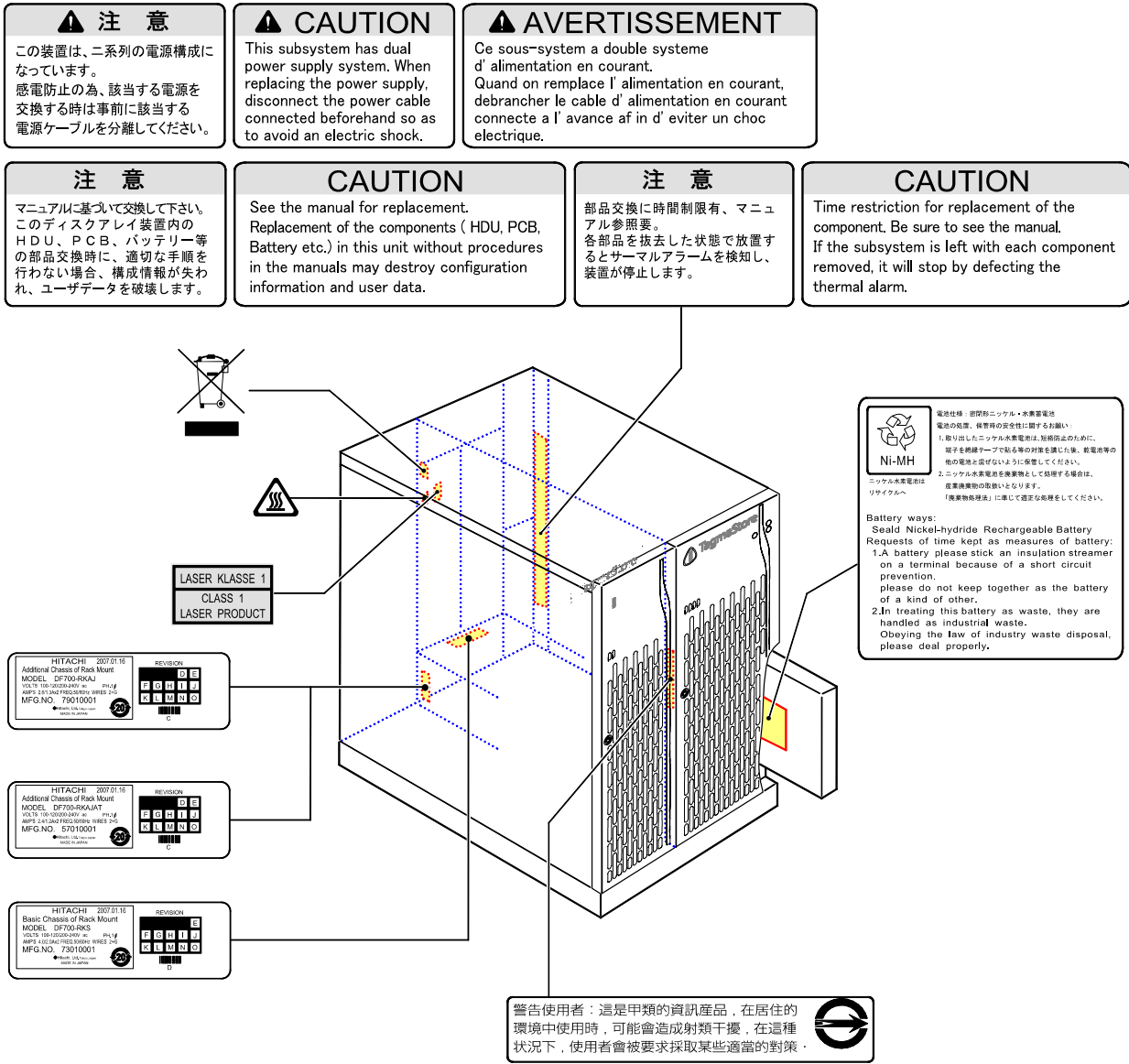

Figure 2.2 Positions and Contents of Labels on Rack-Mount Model RKS+RKAJ/RKAJAT+H2J

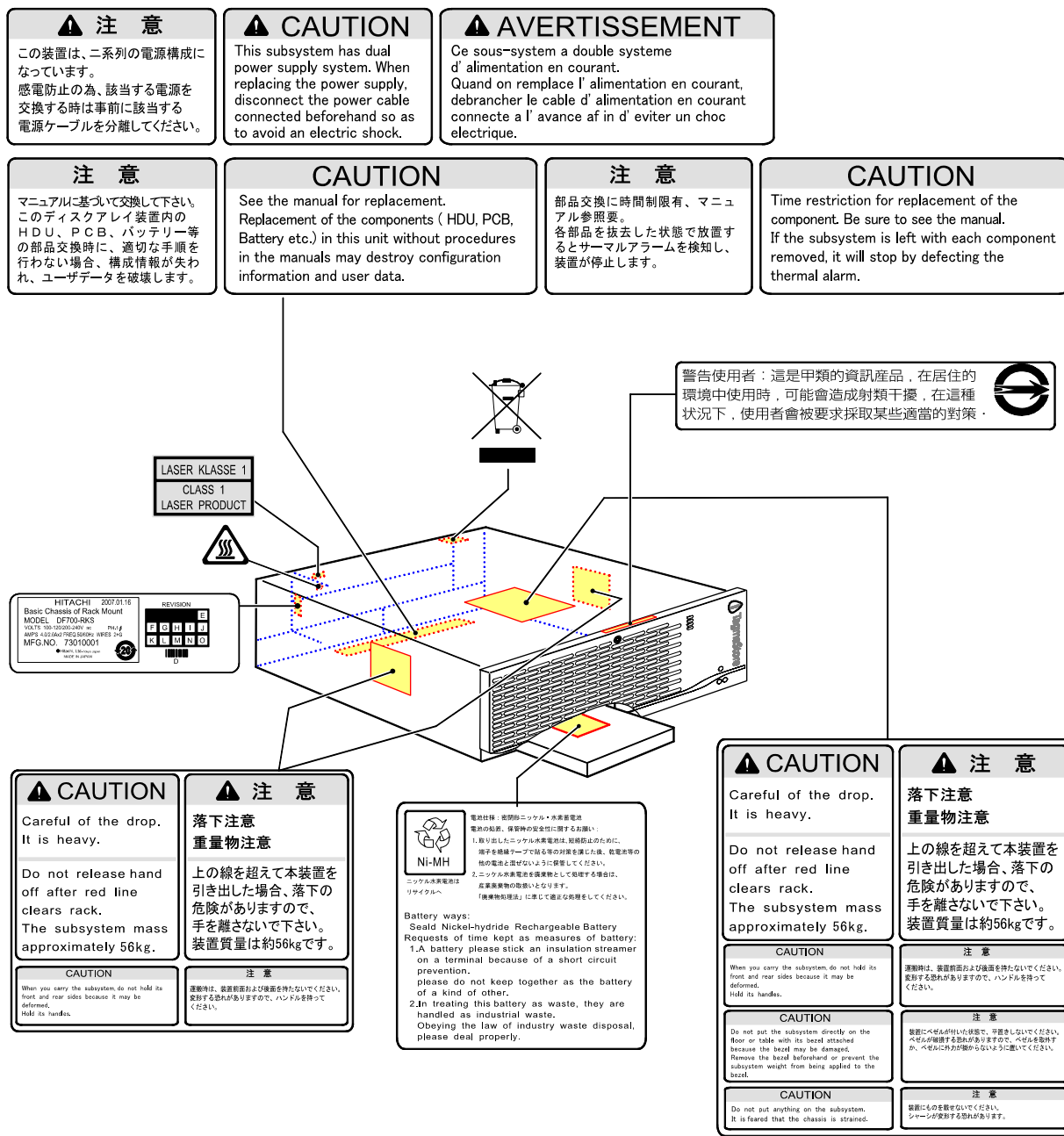

Figure 2.3 Positions and Contents of Labels on Rack-Mount Model RKS

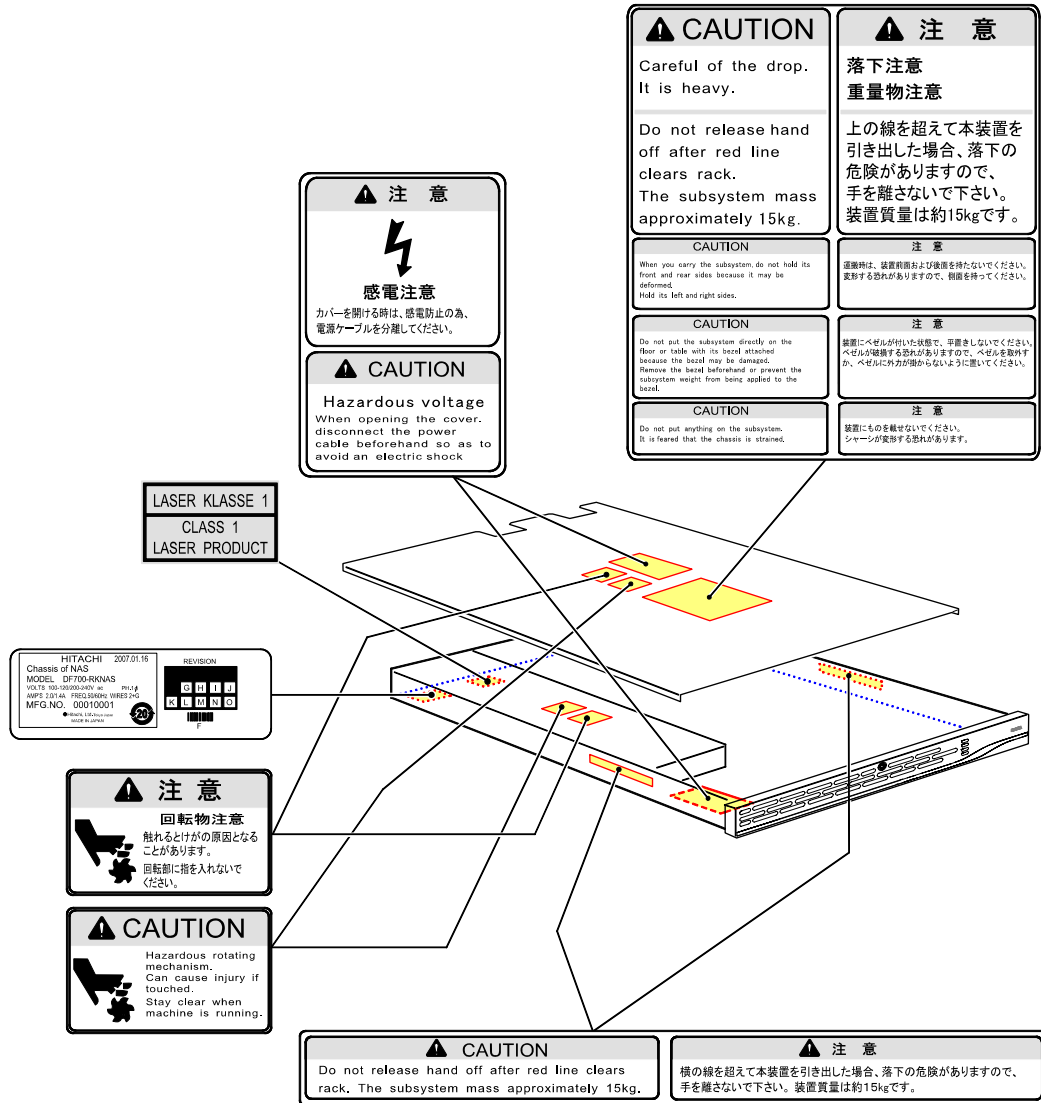

Figure 2.4 Positions and Contents of Labels on Rack-Mount Model RKNAS

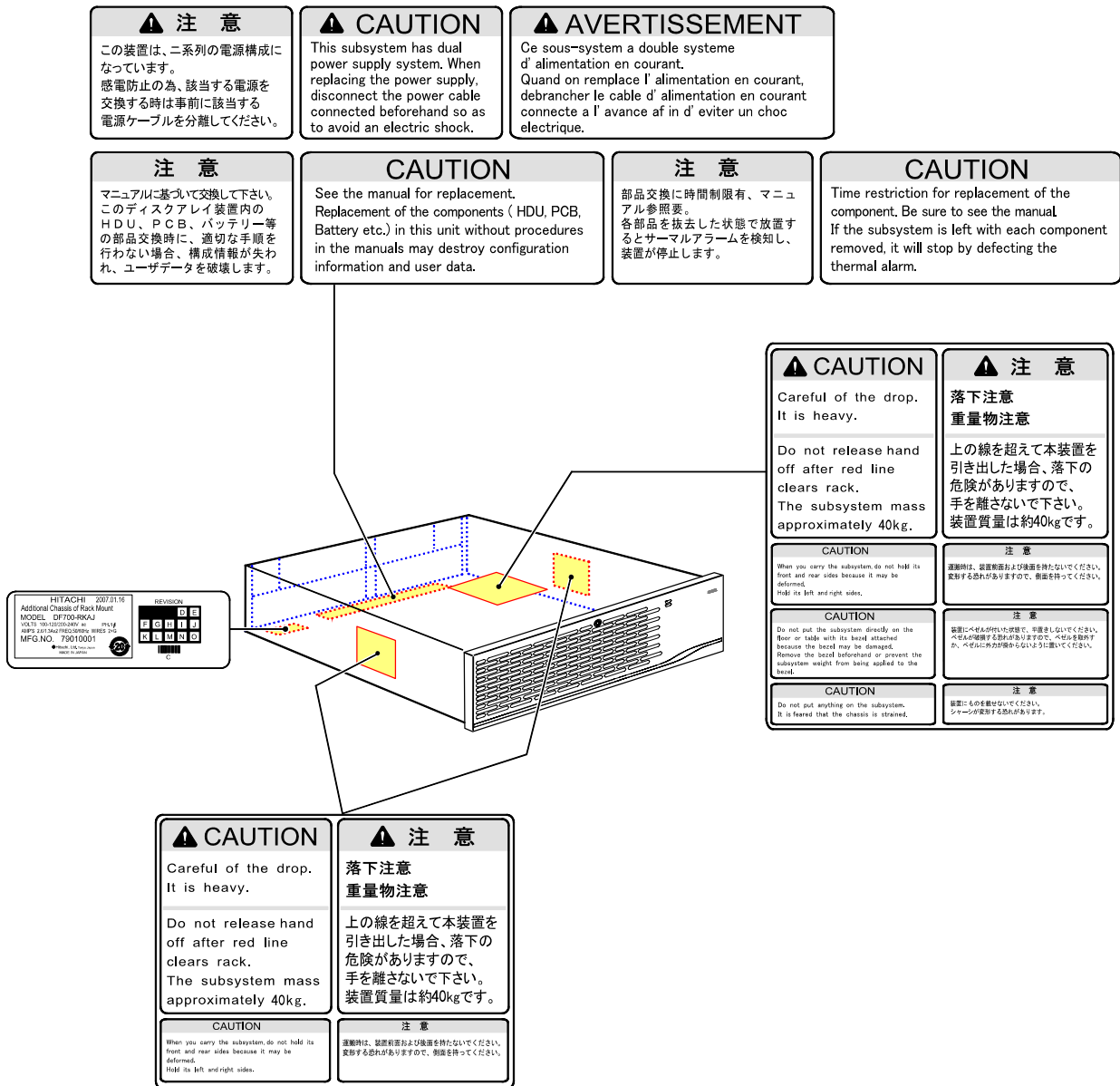

Figure 2.5 Positions and Contents of Labels on Rack-Mount Model RKAJ

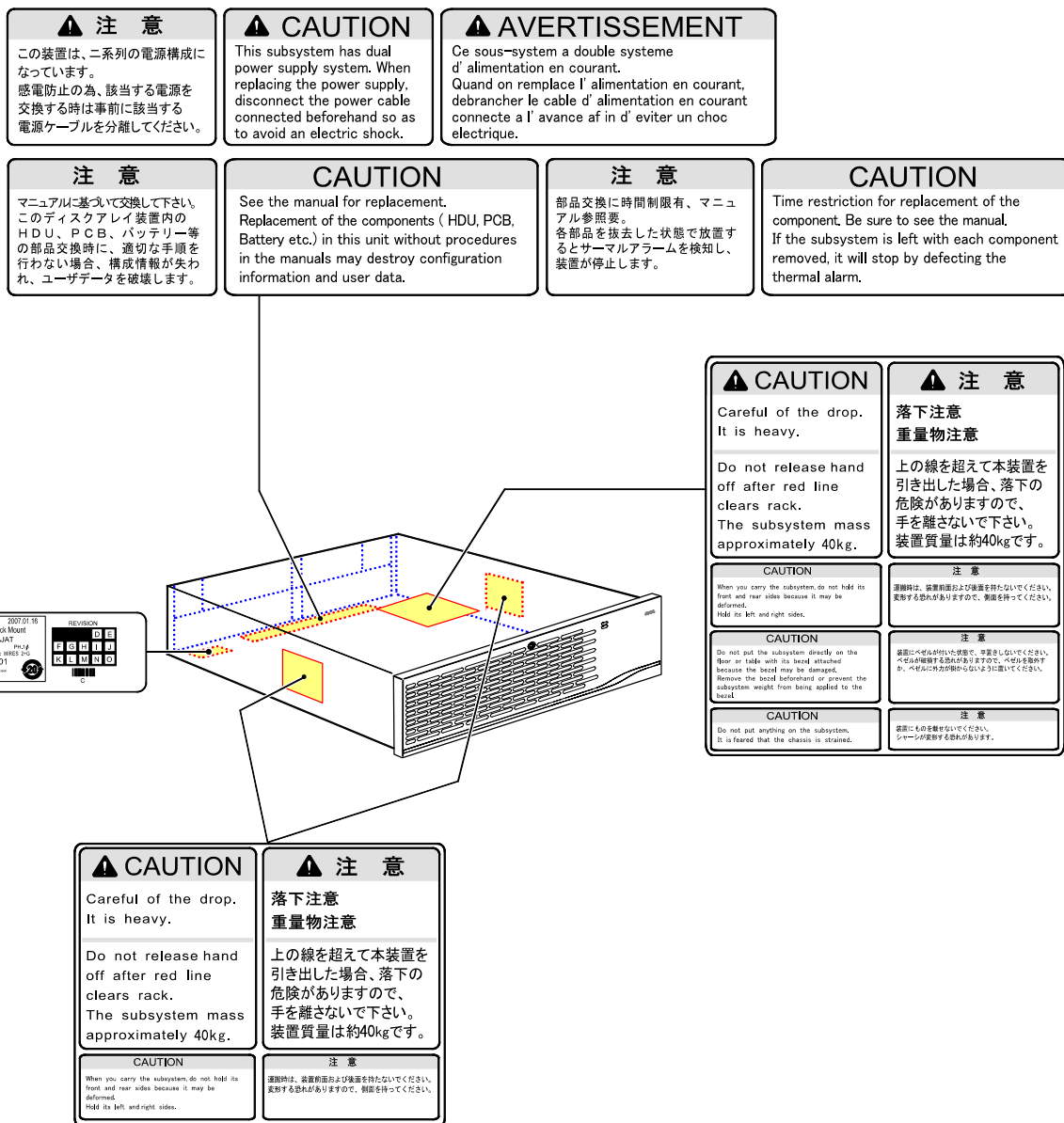

Figure 2.6 Positions and Contents of Labels on Rack-Mount Model RKAJAT

2.3 General Specifications and Requirements

This section describes the general specifications and requirements for the AMS200 subsystem. The following are included:

- Dimensions and weight
- Service clearance requirements
- Floor load rating
- Internal logic specifications
- Cable requirements

2.3.1 Dimensions and Weight

The following table illustrates the dimensions and weight of the AMS200 rack-mount model and the AMS200 floor model.

Table 2.3 AMS200 Dimensions and Weight of Rack-Mount Model

Item	Model	Rack-Mount Model		
		RKS	RKAJ	RKAJAT
Physical Specifications	Chassis size (W×D×H) (mm)	483×650×174	483×650×129	
	Mass (kg)	56 approx	40 approx	
	Acoustic noise (dB)	57 approx	60 approx	
	Required height (EIA unit)	4	3	

Table 2.4 AMS200 Dimensions and Weight of Floor Model

Item	Model	Floor Model	
		Floor (RKS+H1J) Model	Floor (RKS+RKAJ/RKAJAT+H2J) Model
Physical Specifications	Chassis size (W×D×H) (mm)	260×737×540	309×737×540
	Mass (kg)	70 approx	115 approx
	Acoustic noise (dB)	56 approx	59 approx

Table 2.5 AMS200 Dimensions and Weight of NAS Unit

Item	Model	RKNAS
Physical Specifications	Chassis size (W×D×H) (mm)	483×650×43
	Mass (kg)	15 approx
	Acoustic noise (dB)	60 approx

2.3.2 Service Clearance Requirements

The following figure shows the floor area required for installing the equipment. Install the equipment in a place with the area shown in the figure to avoid problems such as inadequate service clearance or insufficient ventilation. All distances in the following figure are stated in millimeters (mm).

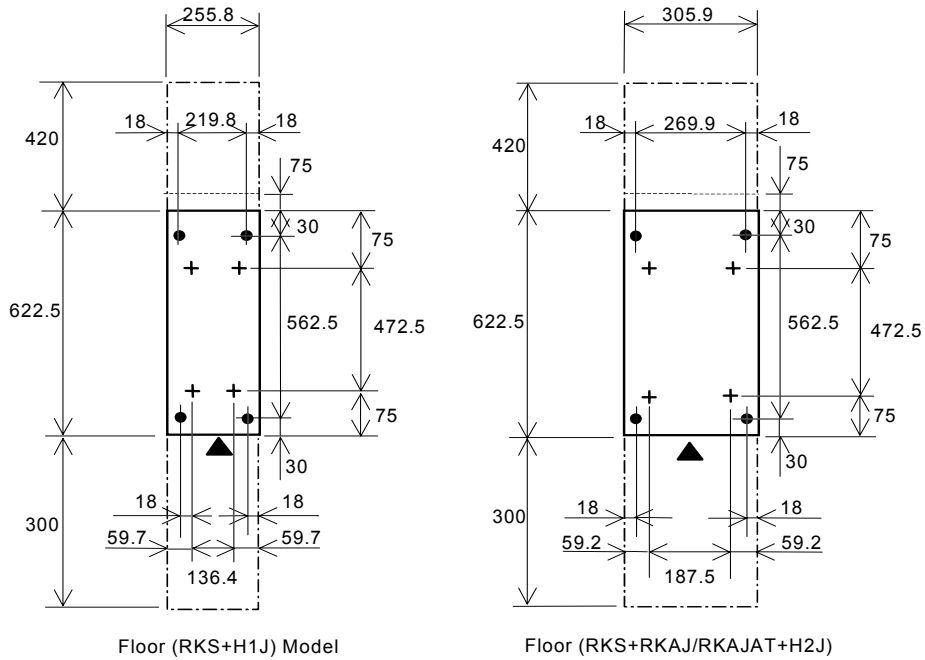
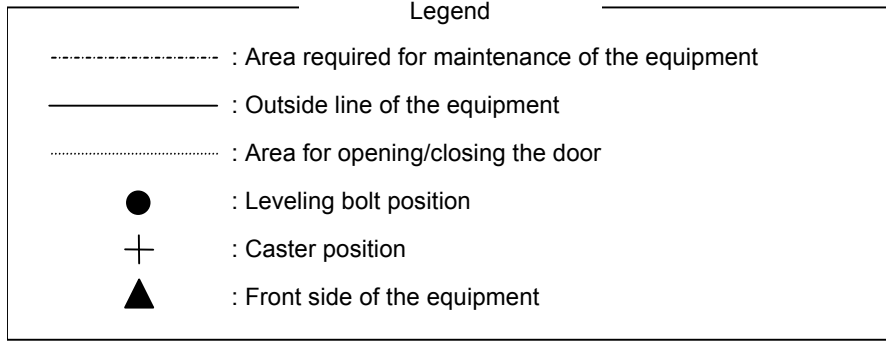

2.3.3 Floor Load Rating

This section includes:

- Floor load rating for the AMS200 rack-mount model
- Floor load rating for the AMS200 floor model

2.3.3.1 Floor Load Rating for AMS200 Rack-Mount Model

In the maximum configuration, the rack-mount model can be configured with 1 RKS and 6 additional units (RKAJs/RKAJATs and RKNAS). The total weight of the subsystem in this configuration is 530 kg.

Note: For information about the global rack-mount model, refer to the *Hitachi Data Systems Global 19-Inch Rack Reference Guide* (MK-93DF772).

2.3.3.2 Floor Load Rating for AMS200 Floor Model

The Floor (RKS+H1J) Model contains up to 2 controller boards and up to 15 disk drives. The maximum configuration weighs 70 kg. To ensure adequate load-bearing capacity, plan for the maximum configuration.

The Floor (RKS+RKAJ/RKAJAT+H2J) Model contains up to 2 controller boards and up to 30 disk drives. The maximum configuration weights 115kg. To ensure adequate load-bearing capacity, plan for the maximum configuration.

2.3.4 Internal Logic Specifications

The following table lists the internal logic specifications of the AMS200.

Table 2.6 Internal Logic Specification of AMS200 Rack-Mount Model

Item		Specification	
		RKS	RKNAS
Internal logic	Control CPU	Power PC7447A (500 MHz)	Intel LV-Xeon 2.8GHz
Specification	Control memory	Flash memory: 16 M bytes L2 cache memory: 512 k bytes SDRAM: 1 G bytes	Bios: 1 M bytes L2 cache memory: 1M bytes
	Data assurance method	Data bus: Parity Cache memory: ECC (1 bit for correction, 2 bits for detection) Disk drive: Data assurance code	Data bus: Through-parity Cache memory: ECC (1 bit for correction, 2 bits for detection)

Notes:

- RKAJ/RKAJAT is not included in these specifications.
- For information about the global rack-mount model, refer to the *Hitachi Data Systems Global 19-Inch Rack Reference Guide (MK-93DF772)*.

2.3.5 Cable Function

The following table lists the principal functions of the AMS200 and RKNAS cables. Fibre channel cables are available from Hitachi Data Systems.

Table 2.7 Principal Functions of AMS200 Cables

Cable	Principal Use
Fibre Channel cable	Connect with a host or HBA/Switch.
LAN cable (Cross/Straight)	Connect the PCs for user, monitoring and maintenance. Connect with a host or a HAB for Ethernet. (When iSCSI interface and RKNAS are connected.) Connect between RKS and RKNAS for maintenance management.
ENC (ENCLOSURE) cable	Connect between the subsystems with Fibre Channel (FC_AL).
NAS interface cable	Connect between RKS and RKNAS for NAS control. (When RKNAS is connected.)

2.4 Environmental Specifications and Requirements

To maintain optimal AMS200 performance, the AMS200 subsystem must be installed in a proper environment. This section discusses the following necessary environmental specifications and requirements:

- Environmental hazards
- Temperature and humidity requirements
- Input power and insulation performance specifications
- Air flow requirements
- Vibration and shock tolerances
- Reliability

2.4.1 Environmental Hazards

DO NOT install the subsystem in the places described below; the life of equipment functioning will be shortened and equipment failures will occur. Avoid the following:

- Direct sunlight exposure
- Temperature and humidity variation (for example, near an air conditioner).
- Close proximity to a device that generates electrical noise and motion (for example, air conditioner that is not grounded and washing machine motor).
- Close proximity to an apparatus that generates a strong magnetic field.
- Excessive dust
- Frequent vibrations
- An inclined floor

Note: Do not store or install the equipment in a high temperature environment of 40 degrees centigrade or more; battery life will be shortened.

2.4.2 Temperature and Humidity Requirements

Table 2.8 lists the temperature and humidity requirements for the AMS200 subsystem.

Table 2.8 Environmental Specifications

Item		Specification
Temperature	In operation (°C)	10 to 40
	In non-operation (°C)	-10 to 50
	In transport/storage (°C)	-30 to 60
	Temperature change rate (°C/h)	10 or less
Humidity	In operation (%)	8 to 80
	In non-operation (%)	8 to 90
	Maximum wet bulb temperature (°C)	29 (non-condensing)
Altitude	In operation (m)	-300 to 3,000
	In non-operation (m)	-300 to 12,000

2.4.3 Input Power and Insulation Performance Specifications

The following tables list the input power and insulation performance specifications for the AMS200 rack-mount models and the AMS200 floor model.

Conductors shall be provided with 30 A over current protection in accordance with Article 240 of the National Electrical Code, ANSI/NFPA 70, and the Canadian Electrical Code, Part 1, CSA C22.1, Section 14.

Table 2.9 Input Power and Insulation Performance Specifications for Rack-Mount Model

Item		Model	Rack-Mount Model			
			RKS	RKAJ	RKAJAT	
Input power specification	Input voltage (V)	AC 100/200 (100-120/200-240)				
	Frequency (Hz)	50/60 ± 1				
	Number of phases, cabling	Single-phase with protective grounding				
	Steady-state current (A) (Note 1) (Note 2)	4.0×2/2.0×2	2.6×2/1.3×2	2.4×2/1.2×2		
	Breaking current (A)	16.0	10.0			
	Required power (Note 3)	Steady state (VA)	800 or less	520 or less	480 or less	
		Starting state (VA)	800 or less	560 or less	480 or less	
	Heat value (kJ/h)	2,880 or less	1,875 or less	1,730 or less		
Insulation performance	Insulation withstand voltage	AC 1,500 V (10 mA, 1 min)				
	Insulation resistance	DC 500 V, 10 M Ω or more				

Note 1: Power current of Nx2 described above is required for operation by a single power supply unit.

Note 2: It indicates the current consumption in the usual state. When a power supply failure occurs, the power consumption is provided by the single power supply for the subsystem.

Note 3: The correct power factor for the AMS200 is “0.90 - 0.96”. The manual incorrectly states the value as “1”.

Table 2.10 Input Power and Insulation Performance Specifications for Floor Model

Item	Model	Floor Model			
		Floor (RKS+H1J) Model	Floor (RKS+RKAJ +H2J) Model	Floor (RKS+RKAJAT +H2J) Model	
Input power specification	Input voltage (V)	AC 100/200 (100-120/200-240)			
	Frequency (Hz)	50/60 ± 1			
	Number of phases, cabling	Single-phase with protective grounding			
	Steady-state current (A) (Note 1) (Note 2)	4.0×2/2.0×2	4.0×2+2.6×2/2.0×2+1.3×2	4.0×2+2.4×2/2.0×2+1.2×2	
	Breaking current (A)	16.0			
	Required power (Note 3)	Steady state (VA)	800 or less	1,320 or less	1,280 or less
		Starting state (VA)	800 or less	1,360 or less	1,280 or less
Heat value (kJ/h)	2,880 or less	4,755 or less	4,610 or less		
Insulation performance	Insulation withstand voltage	AC 1,500 V (10 mA, 1 min)	AC 1,500 V (100 mA, 1 min)		
	Insulation resistance	DC 500 V, 10 M Ω or more			

Note 1: Power current of Nx2 described above is required for operation by a single power supply unit.

Note 2: The current value in the operation by a single power supply unit is same as that in the operation by both power supply units.

Note 3: The correct power factor for the AMS200 is “0.90 - 0.96”. The manual incorrectly states the value as “1”.

Table 2.11 Input Power and Insulation Performance Specifications for NAS Unit

Item	Model	RKNAS
Input power specification	Input voltage (V)	AC 100/200 (100-120/200-240)
	Frequency (Hz)	50/60 ± 1
	Number of phases, cabling	Single-phase with protective grounding
	Steady-state current (A)	2.0/1.4
	Breaking current (A)	10.0
	Required power (Note)	Steady state (VA)
Starting state (VA)		280 or less
Heat value (kJ/h)	1,010 or less	
Insulation performance	Insulation withstand voltage	AC 1,500 V (10 mA, 1 min)
	Insulation resistance	DC 500 V, 10 M Ω or more

Note : The correct power factor for the RKNAS is “0.70 - 0.90”. The manual incorrectly states the value as “1”.

2.4.4 Air Flow Requirements

The AMS200 subsystem is air-cooled. Air must enter the subsystem through the airflow intakes at the front of each subsystem and must be exhausted out of the back.

2.4.5 Vibration and Shock Tolerances

Table 2.12 lists the vibration and shock tolerance data for the AMS200 subsystem. The AMS200 can tolerate vibration and shock within these limits and continue to perform normally. The user should consider these requirements if installing the AMS200 near large generators located on the floor above or below the AMS200 subsystem. Generators or any other source of vibration, if not insulated or shock-mounted, can cause excessive vibration that may affect the subsystem.

Table 2.12 Vibration and Shock Tolerances

Item		Specification
Vibration	In operation (m/s ²)	2.5 or less (5 to 300Hz)
	In non-operation (m/s ²)	5.0 or less (5 to 300Hz)
	In transport (packed) (m/s ²)	5.0 or less
Impact	In operation (m/s ²)	20 or less
	In non-operation (m/s ²)	50 or less
	In transport (packed) (m/s ²)	80 or less
Angle at which the subsystem will turn over (°)		15 or less

2.4.6 Reliability

The reliability of the AMS200 is described in the following tables. The following reliability does not change even when the RKNAS is connected to the system.

Table 2.13 Reliability of AMS200 Rack-Mount Model (RKS/RKAJ)

Item	Model	Rack-Mount Model	
		RKS	RKAJ

Reliability	MTBDL (Mean Time Between Data Lost) (Note)	<p>About 20 million hour or longer (in RAID 5 configuration)</p> <p>RAID 6 configuration</p> $\frac{(\text{MTBF of the disk drive})^3}{n(n-1)(n-2) \times \text{Number of Parity group} \times \text{MTTR}^2}$ <p>RAID 5 configuration:</p> $\frac{(\text{MTBF of the disk drive})^2}{n(n-1) \times \text{Number of Parity group} \times \text{MTTR}}$ <p>RAID 0 configuration</p> $\frac{\text{MTBF of the disk drive}}{n \times \text{Number of Parity group}}$ <p>RAID 1 or RAID1+0 configuration</p> $\frac{(\text{MTBF of the disk drive})^2}{n \times 1 \times \text{Number of Parity group} \times \text{MTTR}}$ <p>MTTR: Mean Time To Repair n: Number of the mounted disk drive/Parity group</p>
	Drop in package (JIS Z 0200-1997)	No abnormality must be caused by a free drop of level IV.
	Radio frequency radiation	Conforms to FCC Class A
	Instantaneous power failure	10 ms (100% dip)

Note: The value of the MTBDL is calculated in the following configuration: RAID 5:68 sp ((15D+1P)(4group+4(spare))). This value varies on user's system configuration.

Table 2.14 Reliability of AMS200 Rack-Mount Model (RKS/RKAJAT)

Item	Model	Rack-Mount Model	
		RKS	RKAJAT
Reliability	MTBDL (Mean Time Between Data Lost) (Note)	About 5 million hour or longer (in RAID5 configuration) RAID 6 configuration: $\frac{(\text{MTBF of the disk drive})^2}{n(n-1) \times \text{Number of Parity group} \times \text{MTTR}}$ RAID 5 configuration: $\frac{(\text{MTBF of the disk drive})^2}{n(n-1) \times \text{Number of Parity group} \times \text{MTTR}}$ RAID 1 or RAID1+0 configuration: $\frac{(\text{MTBF of the disk drive})^2}{n \times 1 \times \text{Number of Parity group} \times \text{MTTR}}$ MTR: Mean Time To Repair n: Number of the mounted disk drive/Parity group	
	Drop in package (JIS Z 0200-1997)	No abnormality must be caused by a free drop of level IV.	
	Radio frequency radiation	Conforms to FCC Class A.	
	Instantaneous power failure	10 ms (100% dip).	

Note: The value of the MTBDL is calculated in the following configuration: RAID 5:68 sp ((15D+1P)(4group+4(spare))). This value varies on user's system configuration.

Table 2.15 Reliability of AMS200 Floor Model

Item	Model	Floor Model		
		Floor (RKS+H1J) Model	Floor (RKS+RKAJ+H2J) Model	Floor (RKS+RKAJAT+H2J) Model
Reliability	MTBDL (Mean Time Between Data Lost) (Note)	About 20 million hour or longer (in RAID 5 configuration) RAID 6 configuration: $\frac{(\text{MTBF of the disk drive})^3}{n(n-1)(n-2) \times \text{Number of Parity group} \times \text{MTTR}^2}$ RAID 5 configuration: $\frac{(\text{MTBF of the disk drive})^2}{n(n-1) \times \text{Number of Parity group} \times \text{MTTR}}$ RAID0 configuration: $\frac{\text{MTBF of the disk drive}}{n \times \text{Number of Parity group}}$ RAID1, RAID1+0 configuration: $\frac{(\text{MTBF of the disk drive})^2}{n \times 1 \times \text{Number of Parity group} \times \text{MTTR}}$ MTTR: Mean Time To Repair n: Number of the mounted disk drive/Parity group		
	Drop in package (JIS Z 0200-1997)	No abnormality must be caused by a free drop of level IV.		
	Radio frequency radiation	Conforms to FCC Class A		
	Instantaneous power failure	10 ms (100% dip)		

Note: The value of the MTBDL is calculated in the following configuration: RAID 5:68 sp ((15D+1P)(4group+4(spare))). This value varies on user's system configuration.

Chapter 3 Powering On/Off Procedure

The disk drive may emit audible mechanical sounds when the disk drive is started (spun up), immediately after the subsystem is powered on and powered off (spun down). However, this does not indicate a problem. Unless the WARNING or ALARM LED of the basic frame lights or blinks you may use the subsystem.

This section describes power on/off procedures for the following:

- AMS200 Rack-Mount Model (section 3.1)
- AMS200 Floor Model (section 3.2)

This chapter provides the information on the Fibre, NAS, and iSCSI models. The following table illustrates the sections that provide the explanation for each model. According to the customer's model, please read the required section.

- **Fibre model:** Connects disk array subsystem to a host computer with Fibre Channel interface.
- **NAS model:** Connects NAS Unit connected to disk array subsystem to a host computer with LAN interface.
- **iSCSI model:** Connects disk array subsystem to a host computer with iSCSI interface.

Sections		Fibre	NAS	iSCSI
3.1	3.1.1 Storage System Power On	○	○	○
	3.1.2 Storage System Power Off	○	○	○
	3.1.3 Stop/Start/Restart of the NAS OS	—	○	—
3.2	3.2.1 Storage System Power On	○	—	○
	3.2.2 Storage System Power Off	○	—	○

- : The explanation is provided.
- : The explanation is not provided.

Note: If the subsystem is restarted when the disk array subsystem is used as the remote side of TrueCopy remote replication, the following occurs:

- Both paths of TrueCopy remote replication are blocked.
A notice regarding SNMP Agent Support Function and TRAP occurs in path blockade mode. Perform the functions in the notice and check the Failure Monitoring Department in advance. Path blockade automatically recovers after restarting.
- If the pair status of TrueCopy remote replication is PAIR or COPY, the pair status transmits to PSUE.

When the disk array subsystem must be restarted, transmit the pair status of TrueCopy remote replication to PSUS, and then restart the subsystem.

Note: If the array subsystem connected to the NAS Unit is restarted, the cluster between the NAS Units stops. When the array subsystem is unavoidably restarted, execute it after stopping the cluster between the NAS Units and stopping the NAS OS of both NAS Units. Start the cluster between the NAS Units again after completing the restart for the array subsystem.

3.1 AMS200 Rack-Mount Model

The following steps describe power on/off procedures for the AMS200 rack-mount model.

Note: For information about the global rack-mount model, refer to the *Hitachi Data Systems Global 19-Inch Rack Reference Guide (MK-93DF772)*.

3.1.1 Storage System Power On

Note: The EALM lamp (red) of the controller (on the rear side of the subsystem) may come on between subsystem power-on and Ready status. However, it is not a problem if the EALM lamp (red) goes out during this period of time.

To power on the subsystem:

1. Verify that the main switch is turned off.
2. Verify that the AC power unit switch of each power unit is turned off.
3. Verify that the circuit breaker (CB1) is turned off.
4. When the RKNAS is mounted on the rack, verify that the AC Power Unit Switch of the power unit on the RKNAS is turned off.
5. Turn on the circuit breaker (CB1) of the PDB.
6. Turn on the AC power unit switch of the power unit on RKNAS.
7. Turn on the AC power unit switch of the power unit on RKAJ/RKAJAT.

Note: When two or more disk drives are not installed on the additional disk drive unit side, shut off the power to the RKAJ/RKAJAT power unit.

8. Turn on the AC power unit switch of the power unit on RKS.
9. Turn on the main switch.
10. Verify that the READY LED (green) on the RKM lights within five minutes. When the RKNAS is connected to the AMS200, verify that the READY LED (green) on the RKNAS lights another three minutes later. If the READY LED (green) on the RKM blinks at a high pace, it blinks for up to 15 minutes because the download of the ENC/SENC firmware is executed. Verify that the READY LED (green) on the RKM lights in 30 to 50 minutes at a maximum. Even when the READY LED (green) on the RKM blinks at high speed, the subsystem is operational.

For a dual controller configuration, if the WARNING LED (orange) on the RKM blinks at high speed, wait until the READY LED (green) on the RKM lights because an update of the flash program is executed.

For a single controller configuration, when the WARNING LED (orange) on the RKM blinks at high speed, wait until the READY LED (green) on the RKM lights because an update of the flash program or the automatic download of the ENC/SENC firmware at the time of powering-on is executed. When an automatic download of the ENC/SENC is in operation, the WARNING LED (orange) blinks for up to 30 to 85 minutes, then the READY LED (green) lights.

If the ALARM LED (red) or WARNING LED (orange) lights or blinks slowly.

Notes:

- The EALM lamp (red) of the control unit (on the rear side of the subsystem) may come on between the powering on of the subsystem and entry into the Ready status of the RKS. However, this is not a problem if the EALM lamp (red) goes out until the subsystem enters the Ready status.
- A NAS system cannot be accessed from a host computer even though the READY LED of NAS unit illuminates. A NAS system accepts access from a host computer only when of "ACTIVE" NAS OS Condition.

3.1.2 Storage System Power Off

Note: If you stop the array storage system while the array storage system is used as the remote side of TrueCopy remote replication or TrueCopy Extended Distance, the following may occur:

- The paths of TrueCopy remote replication or TrueCopy Extended Distance are blocked.
- The failure monitoring program (ASSIST-PC), the E-MAIL ASSIST function, notice of SNMP Agent Support Function and the TRAP will occur at the time of the path block. Provide an advance check and notice to the Failure Monitoring. The path blockade will recover automatically after starting the array storage system.
- When the pair status of TrueCopy remote replication or TrueCopy Extended Distance is PAIR or COPY, the pair status changes to PSUE.
- When you stop the array storage system, change the pair status to PSUS, and then stop the array storage system.

To power off the subsystem:

1. Turn off the main switch.
2. Verify that the POWER LED (green) on the panel of the RKS is off.
3. Turn off the AC power unit switch of the power unit.
4. When the RKNAS is mounted on the rack, turn off the AC Power Unit Switch of the power unit on RKNAS.
5. Turn off the circuit breaker (CB1) of the PDB.

Note: When storing the subsystem without turning on the power for long periods, request that the Customer Engineer turn off the battery of the subsystem. For details on how to store the subsystem, refer to Chapter 9.

3.1.3 Stop/Start/Restart of NAS OS

Stop/Start/Restart of the NAS OS and NNC (NAS unit) status display is performed using Storage Navigator Modular.

To power off the subsystem:

1. Click the **Logical Status** tab on the Unit window.
2. Click **NAS**.

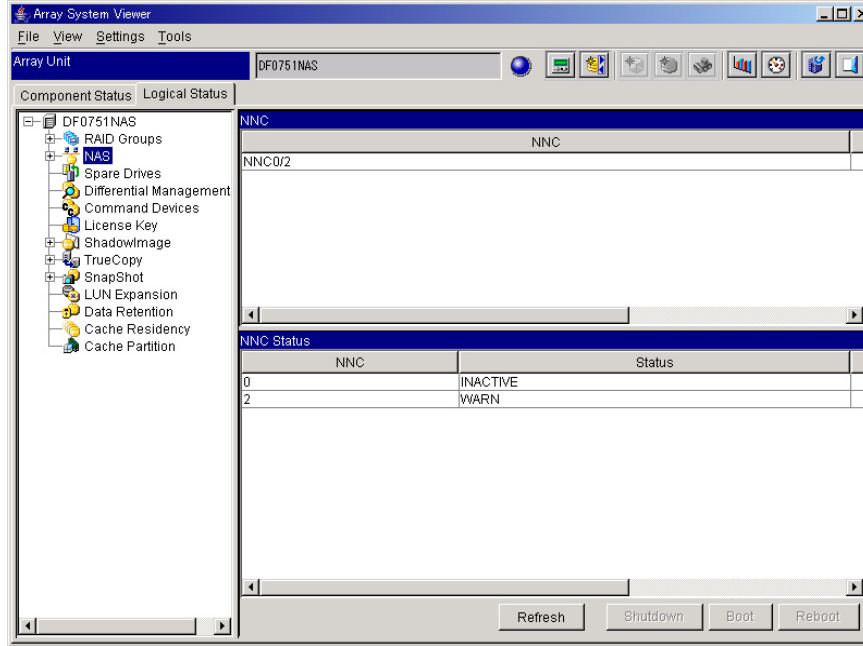

- **NNC Status:** Displays NAS OS status.

○: Operation enabled - : Operation disabled (**Note 3**)

Image	Status	Stop	Start	Restart
NEW	The NAS OS is not installed.	-	-	-
INST	The NAS OS is in installation process.	-	-	-
ACTIVE	The NAS OS is in operation and the Node is in operation.	○ (Note 2)	○	○
STOP (Note 4)	The NAS OS is normally stopped.	-	○	○
DOWN	The NAS OS is abnormally stopped.	-	○	○
BOOT	The NAS OS is in start process.	○	-	○
SHUTDOWN	The NAS OS is in stop process.	-	○	○
INACTIVE	The NAS OS is in operation and the Node is stopped.	○	○	○
DUMP	A NAS Dump is being collected.	○	○	○
HUNGUP	The NAS OS is hung-up.	-	○	○

WARN	The NAS Manager is not installed, or the NAS OS is in operation and the status of the Node is unknown.	○	○	○
DISUSE	The Control Unit is blocked, so the NAS OS of the NNC concerned cannot be used. (Notes 1)	-	-	-

Note 1: It is necessary to recover the blocked status of the Control Unit connected to the NAS Unit on the side where “DISUSE” is displayed.

Note 2: Only when the status of both NAS units in the cluster is "ACTIVE", NAS OS can be stopped.

Note 3: The button of Storage Navigator Modular can be clicked, but the processing is not executed.

Note 4: When "STOP" is displayed, the NAS OS has already stopped. However, the NAS unit takes 10 seconds after "STOP" is displayed to be completely powered off. When you perform an operation after this, wait 10 seconds after "STOP" is displayed and perform the operation.

- **Button**

Button Name	Operation
Shutdown	Put the NAS OS into the stop status.
Boot	Start the NAS OS.
Reboot	Restart the NAS OS which is in the stop status. The operation is not different from the "Boot" button.
Refresh	Update the display information to the latest information.

Note: When starting the NAS OS, do not specify anything for the Boot Option.

Stopping NAS OS

Note: The NAS OS can be stopped only when the status of both NAS Units in the cluster is “ACTIVE.” When the NAS OS stop/start status of a NNC (NAS Unit) is “STOP” or “DOWN”, the NAS OS is already stopped.

Note: Before attempting to stop the NAS OS from Storage Navigator Modular at either of the following times, ensure that the cluster and the resource group are available (see details below).

- Immediately after the power supply of the array subsystem was started
- If the NAS cluster was started from NAS Manager Modular

If the NAS OS is stopped at any time other than as described above, you may not be able to perform a subsequent cluster or resource group operation. For example, an attempt to stop a cluster from NAS Manager Modular may fail if the NAS Unit is not stopped. In this case, from Storage Navigator Modular, restart the NAS OS in the unit that is stopped.

Checking status of the cluster and resource group: The cluster and the resource group are available when the cluster status is “ACTIVE.” The resource group status can be either “Online” or “Offline”)

- Refer to the NAS Manager Modular User’s Guide “4.5.7 Viewing resource group status” for checking the status of the resource group.
- Refer to the NAS Manager Module User’s Guide “4.5.3 Viewing the status of a cluster and nodes” for checking the cluster status.

To stop the NAS OS:

1. Click **NNC** (NAS Unit) to stop the NAS OS from the NNC Status.

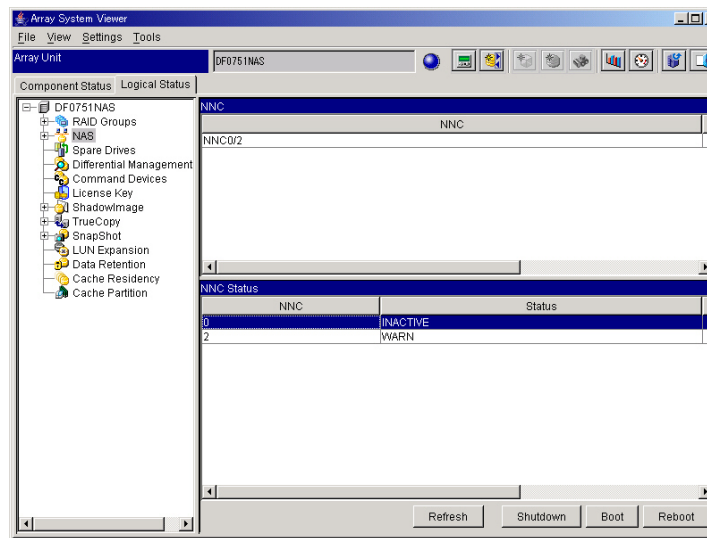

2. Click **Shutdown** in the lower right corner of the window.
3. A confirmation message box displays. Click **OK**.

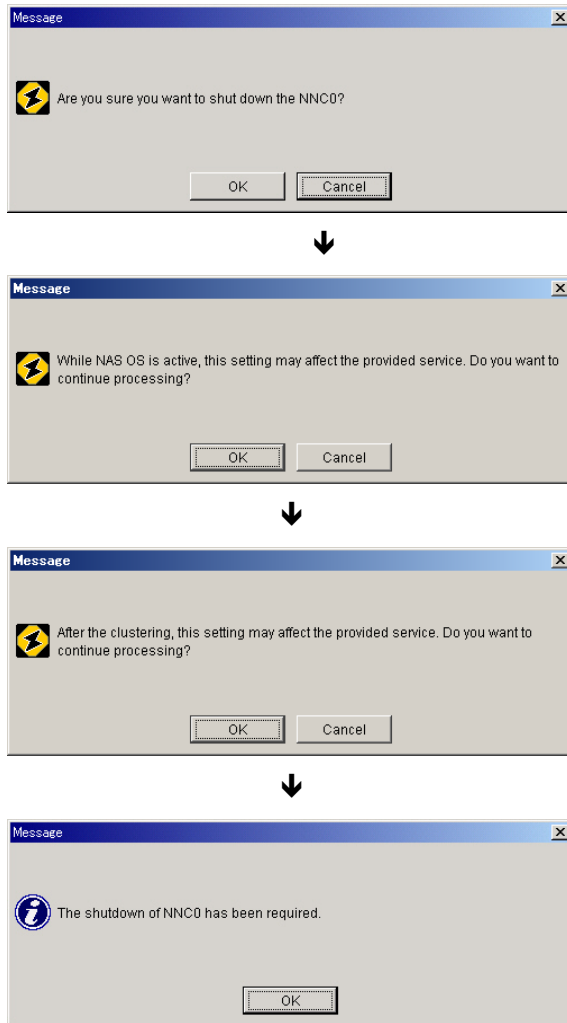

4. Ensure the status of the NNC (NAS Unit) that stopped the NAS OS is **STOP**.

Starting NAS OS

Note: When the status of the NNC (NAS Unit) to start the NAS OS is “NEW”, it cannot start because the NAS OS is not installed. When “Status” is other than “NEW”, “STOP”, and “DOWN”, the NAS OS has already started.

To start NAS OS:

1. Click **NNC (NAS Unit)** to start the NAS OS from the NNC Status.

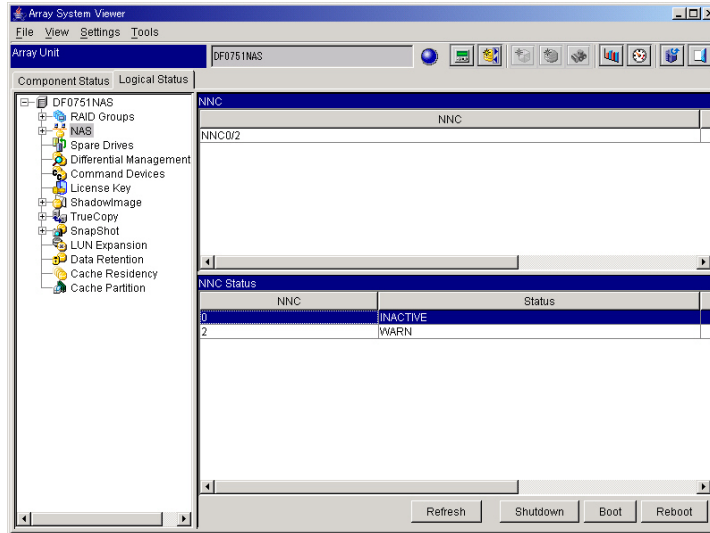

2. Click **Boot** in the lower right corner of the window.
3. On the Message box, click **OK**.

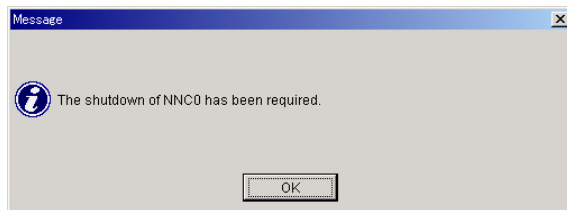
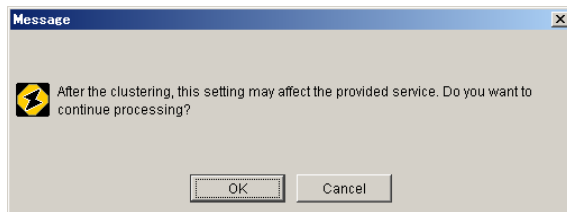
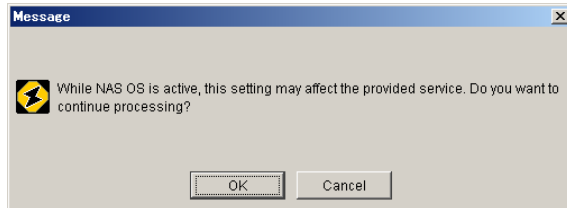
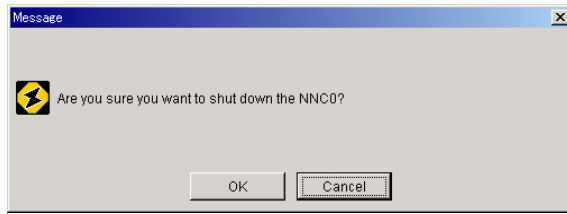

4. A confirmation message box displays. Click **OK**.
5. Ensure the status of the NNC (NAS Unit) that started the NAS OS is either **INACTIVE** or **ACTIVE**.

A NAS system accepts access from a host computer only in the “ACTIVE” NAS OS Condition.

Restarting the OS

Note: When the status of the NNC (NAS Unit) to restart the NAS OS is “STOP” or “DOWN”, the NAS OS has already stopped. Please execute it according to Starting the NAS OS.

Note: When restarting the NAS OS from Storage Navigator Modular at either of the following times, ensure that the cluster and the resource group are available (see details below).

- Immediately after the power supply of the array subsystem was started
- If the NAS cluster was started from NAS Manager Modular

If the NAS OS is restarted at any time other than as described above, you may not be able to perform a subsequent cluster or resource group operation. For example, an attempt to stop a cluster from NAS Manager Modular may fail if the NAS Unit is not started. In this case, from Storage Navigator Modular, restart the NAS OS in the unit that is not restarted.

Checking status of the cluster and resource group: The cluster and the resource group are available when the cluster status is “ACTIVE.” The resource group status can be either “Online” or “Offline”).

- Refer to the NAS Manager Modular User’s Guide “4.5.7 Viewing resource group status” for checking the status of the resource group.
- Refer to the NAS Manager Module User’s Guide “4.5.3 Viewing the status of a cluster and nodes” for checking the cluster status.

To restart NAS OS:

1. Click **NNC (NAS Unit)** to restart the NAS OS from the NNC Status.

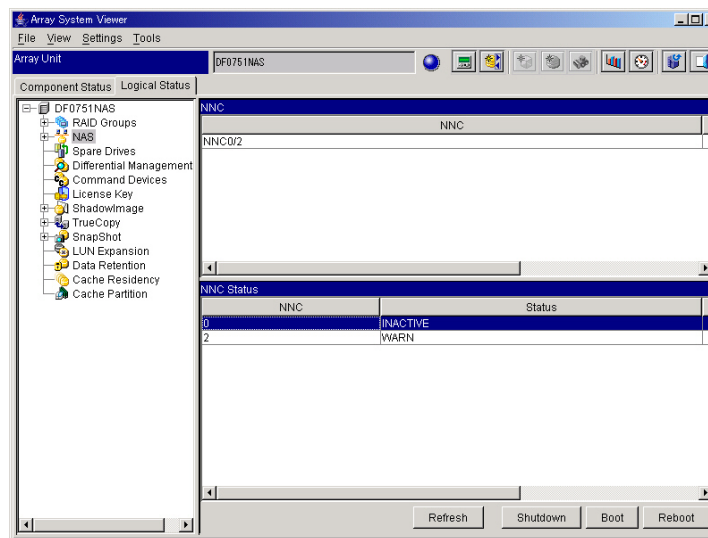

2. Click **Reboot** in the lower right corner of the window.
3. The **Boot Option** setting window is displayed. Click **OK**.

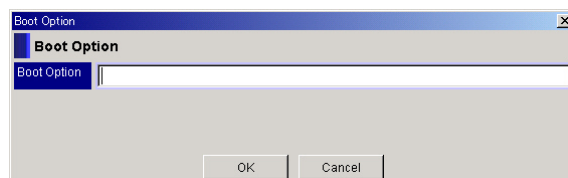

4. On the Message box, click **OK**.

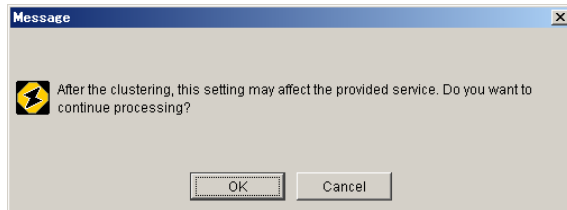
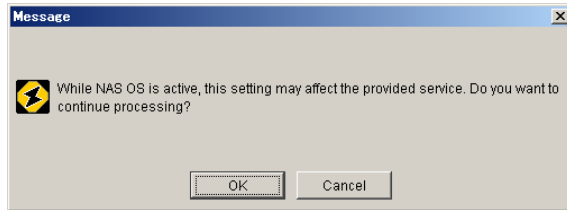
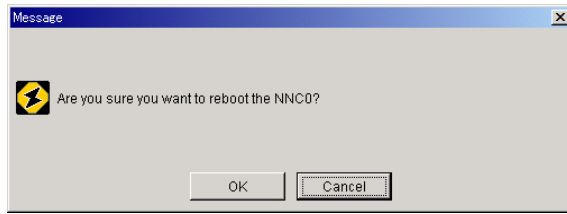

5. Ensure the Status of the NNC (NAS Unit) that restarted the NAS OS is either **INACTIVE** or **ACTIVE**.

A NAS system accepts access from a host computer only in the “ACTIVE” NAS OS Condition.

3.2 AMS200 Floor Model

The following steps describe power on/off procedures for the AMS200 floor model.

3.2.1 Storage System Power On

Note: The EALM lamp (red) of the controller (on the rear side of the subsystem) may come on between subsystem power-on and Ready status. However, it is not a problem if the EALM lamp (red) goes out during this period of time.

To power on the subsystem:

1. Verify that the main switch is turned off.
2. Verify that the AC power unit switch of the power unit is turned off.
3. Turn on the AC Power Unit Switch of the power unit on RKAJ/RKAJAT.

Note: When two or more disk drives are not installed on the additional disk drive unit side, shut off the power to the power unit (RKAJ/RKAJAT).

4. Turn on the AC Power Unit Switch of the power unit on RKS.

5. Turn on the main switch.
6. Verify that the READY LED (green) lights within five minutes. If the READY LED (green) blinks rapidly, the ENC firmware is downloaded. Even when the READY LED (green) blinks, the subsystem is operational. If the ALARM LED (red) or WARNING LED (orange) lights or blinks slowly, see section 8.1.

Note: The EALM lamp (red) of the control unit (on the rear side of the subsystem) may come on between subsystem power-up and entry into the Ready status. However, it is not a problem if the EALM lamp (red) goes out until the subsystem enters the Ready status.

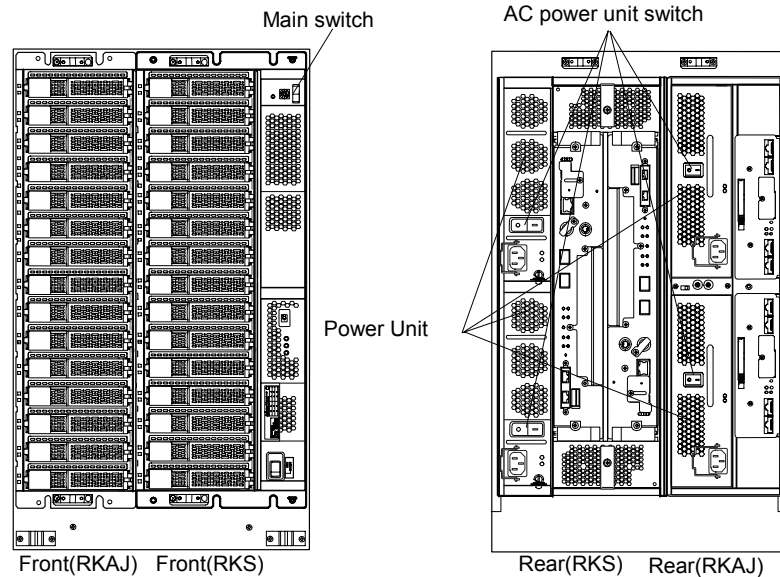

Figure 3.1 Subsystem Power On/Off (Example: Floor [RKS+ RKAJ+H2J])

3.2.2 Storage System Power Off

To power off the subsystem:

1. Turn off the main switch.
2. Verify that the POWER LED (green) on the panel is off.
3. Turn off the AC power unit switch of the power unit.

Note: When storing the subsystem without turning on the power for long periods, request that the Customer Engineer turn off the battery of the subsystem. For details on how to store the subsystem, see Chapter 9.

Chapter 4 Storage System Architecture and Components

This chapter includes the following:

- Configuration Block Diagrams (section .4.1)
- Redundant Power Supplies (section .4.2)
- Fibre Channel Interface (section .4.3)
- NAS Interface (section .4.4)
- iSCSI Interface (section .4.5)
- Array Frames (section .4.6)
- Component Names, Locations, and Functions (section .4.7)

This chapter provides information on the Fibre, NAS, and iSCSI models. The following table illustrates sections that provide an explanation for each model.

- **Fibre model:** Connects disk array subsystem to a host computer with Fibre Channel interface.
- **NAS model:** Connects NAS Unit connected to disk array subsystem to a host computer with LAN interface.
- **iSCSI model:** Connects disk array subsystem to a host computer with iSCSI interface.

Sections		Fibre	NAS	iSCSI
4.1	4.1.1 AMS 200 Rack-Mount Model	○	○	○
	4.1.2 AMS200 Floor Model	○	–	○
4.2	Redundant Power Supplies	○	○	○
4.3	Fibre Channel Interface	○	–	–
4.4	NAS Interface	–	○	–
4.5	iSCSI Interface	–	–	○
4.6	4.6.1 AMS200 Rack-Mount Model	○	○	○
	4.6.2 Floor Model	○	–	○
4.7	4.7.1 Front Bezel Component Locations and Functions	○	○	○
	4.7.2 Component Locations	○	○	○
	4.7.3 Switch Locations and Functions	○	○	○
	4.7.4 Connector Locations and Functions	○	○	○
	4.7.5 LED Locations and Functions	○	○	○

○: The explanation is provided.

–: The explanation is not provided.

4.1 Configuration Block Diagrams

This section includes block diagrams for the following:

- AMS200 rack-mount model
- AMS200 floor model

4.1.1 AMS200 Rack-Mount Model

The configuration block diagrams of the Rack-Mount models are shown below. The RKS/RKAJ/RKAJAT can mount up to 15 disk drives. (The RKS has a controller that can control up to 105 disk drives as RAID.) The disk drives can be assigned to data disk(s), parity disk(s) (mirror disk(s)) depending on the RAID level. Up to 15 spare disks can be mounted in any location within the configuration.

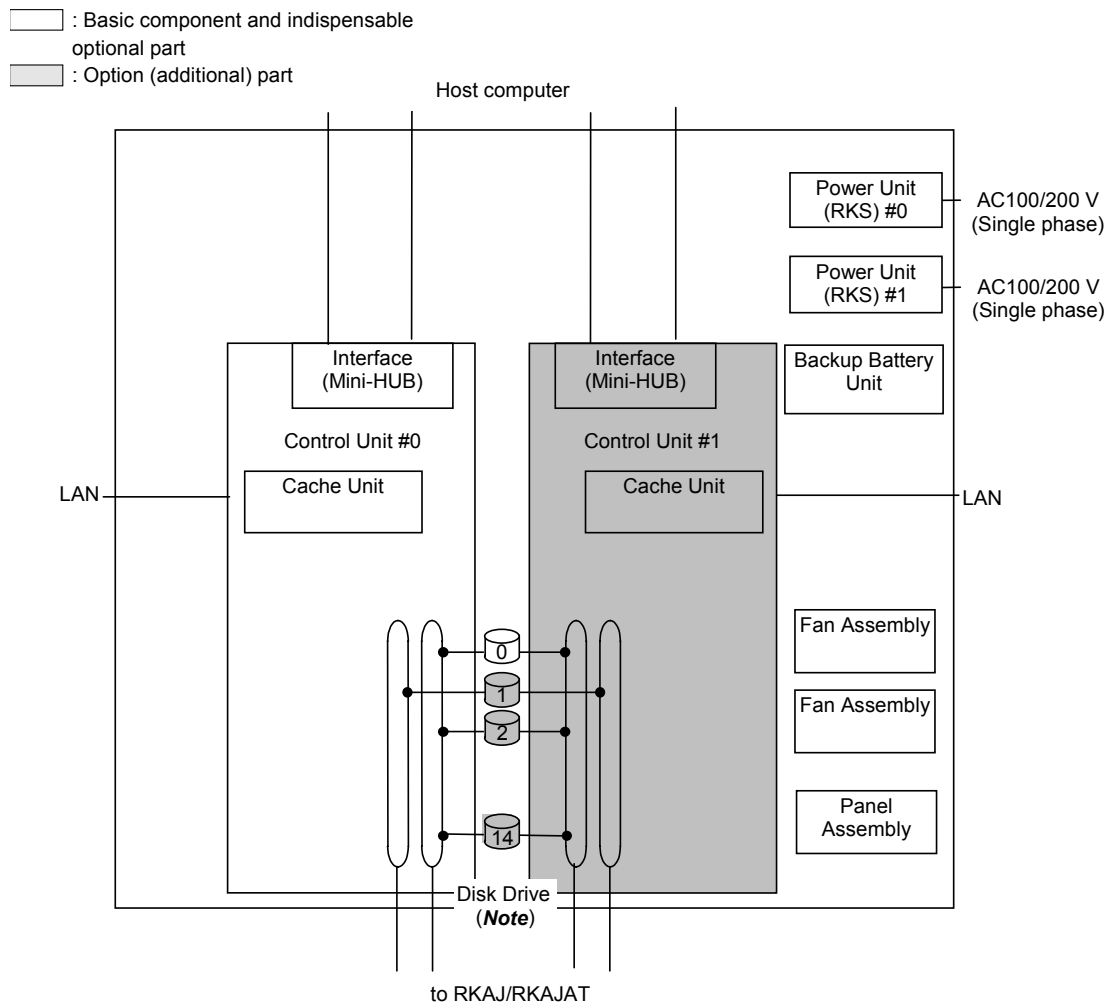

Figure 4.1 RKS System Configuration (Interface board not added)

Note: Disk drive: DF-F700-AGF72, DF-F700-AGH72, DF-F700-AGF146, DF-F700-AGH146, DF-F700-AGF300, and DF-F700-AGH300.

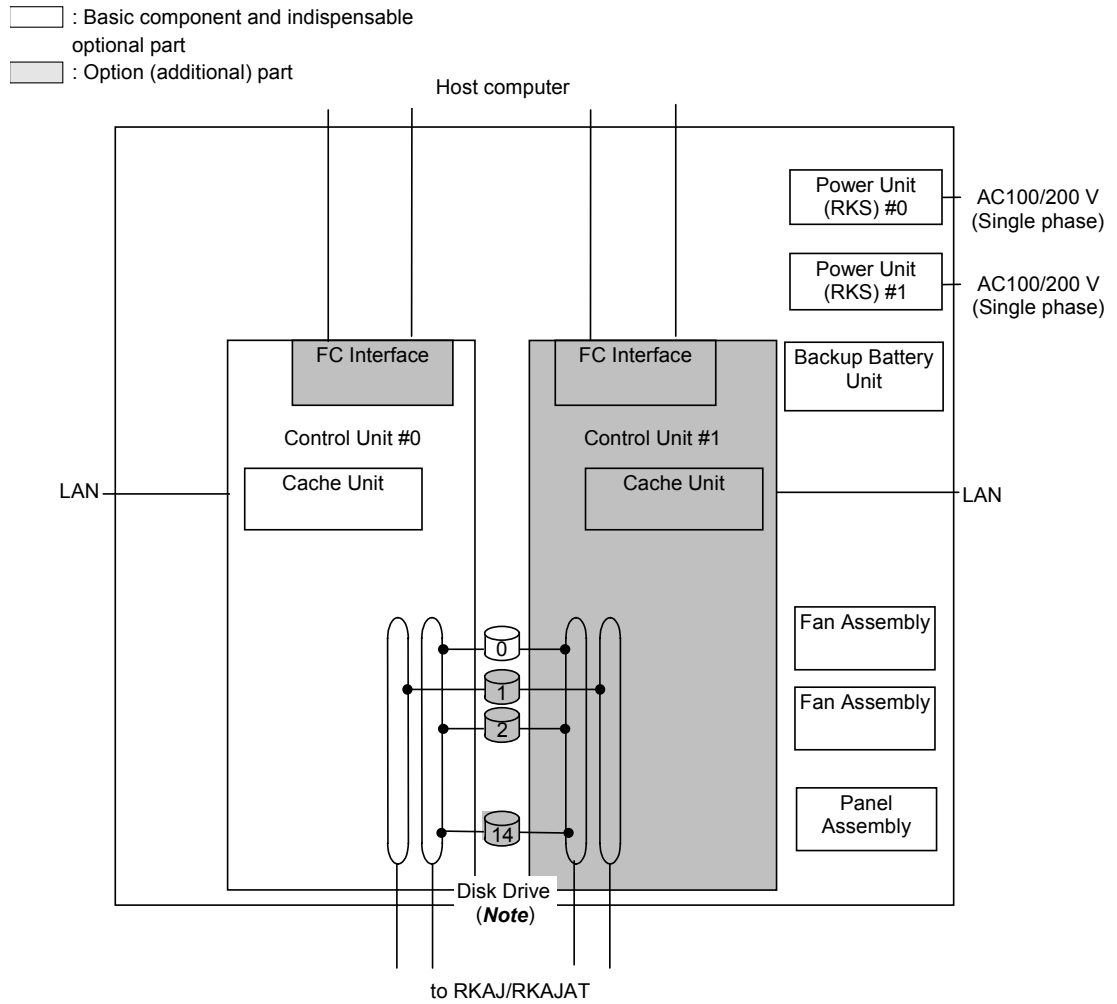

Figure 4.2 RKS System Configuration (FC interface board added)

Note: Disk drive: DF-F700-AGF72, DF-F700-AGH72, DF-F700-AGF146, DF-F700-AGH146, DF-F700-AGF300, and DF-F700-AGH300.

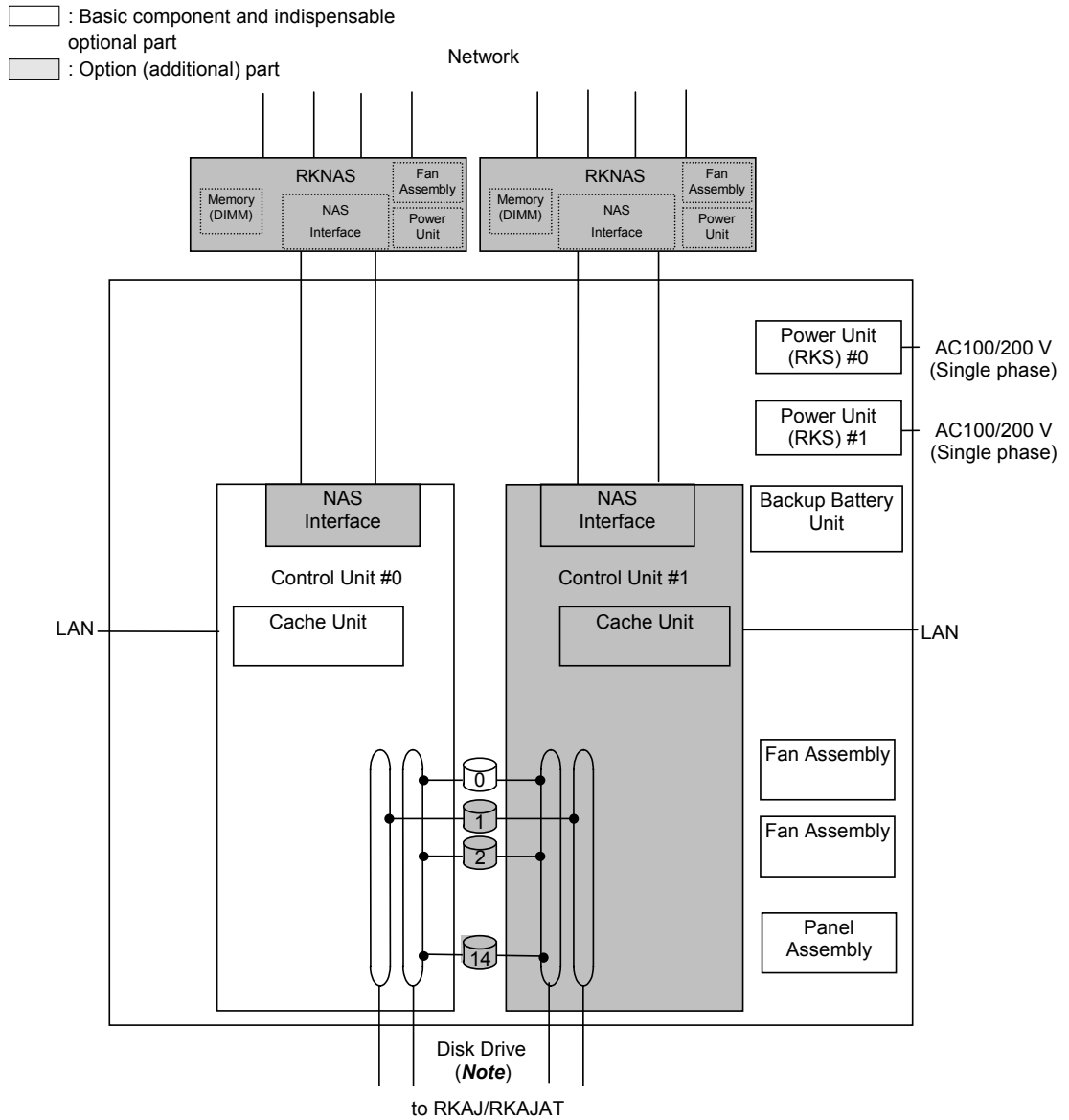

Figure 4.3 RKS System Configuration (iSCSI interface board added)

Note: Disk drive: DF-F700-AGF72, DF-F700-AGH72, DF-F700-AGF146, DF-F700-AGH146, DF-F700-AGF300, and DF-F700-AGH300.

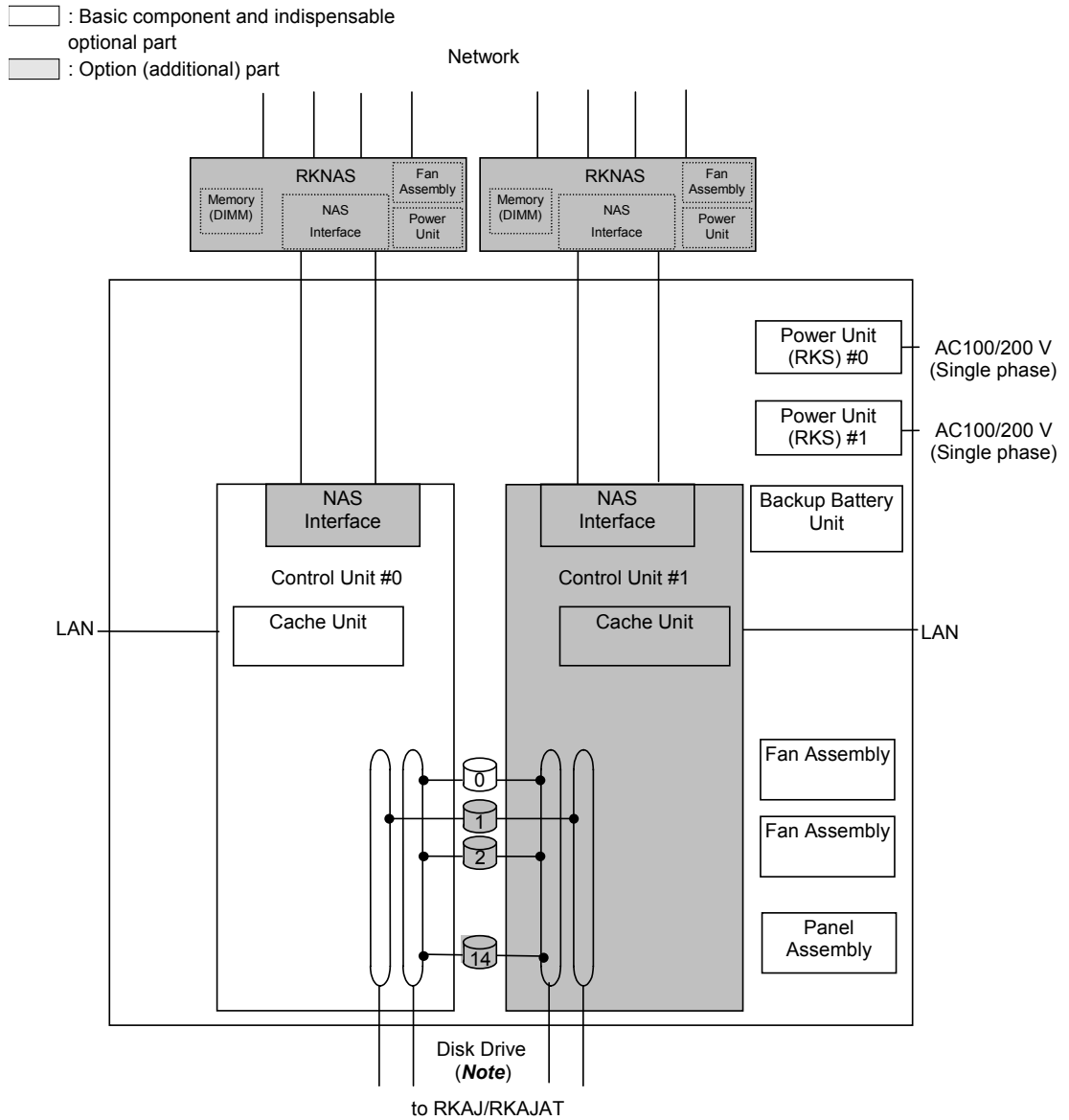

Figure 4.4 RKS and RKNAS System Configuration

Note: Disk drive: DF-F700-AGF72, DF-F700-AGH72, DF-F700-AGF146, DF-F700-AGH146, DF-F700-AGF300, and DF-F700-AGH300.

: Basic component and indispensable optional part
 : Option (additional) part

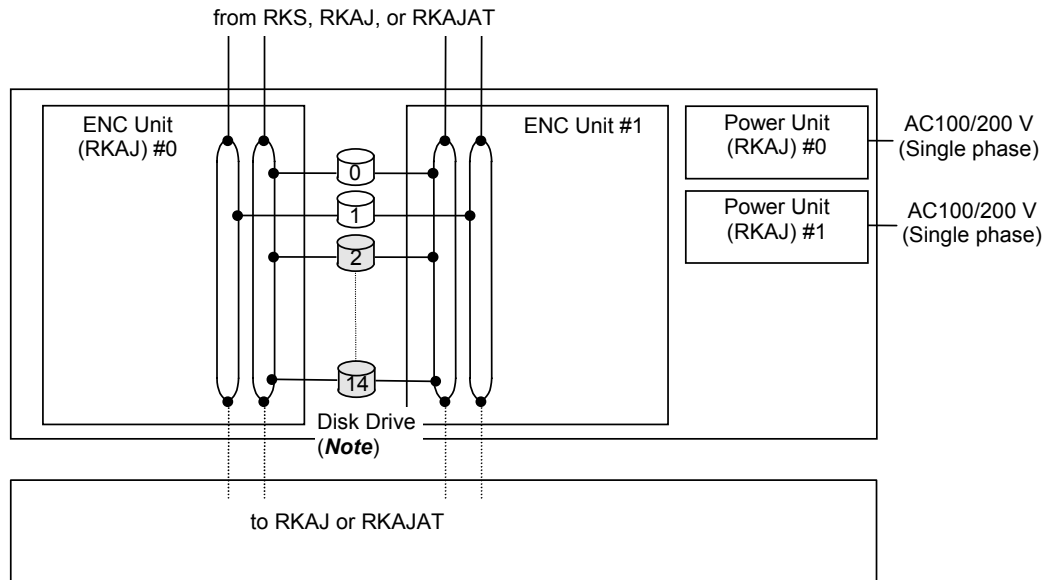

Figure 4.5 RKAJ System Configuration

Note: Disk drive: Disk drive: DF-F700-AGF72, DF-F700-AGH72, DF-F700-AGF146, DF-F700-AGH146, DF-F700-AGF300, and DF-F700-AGH300.

- : Basic component and indispensable optional part
- : Option (additional) part

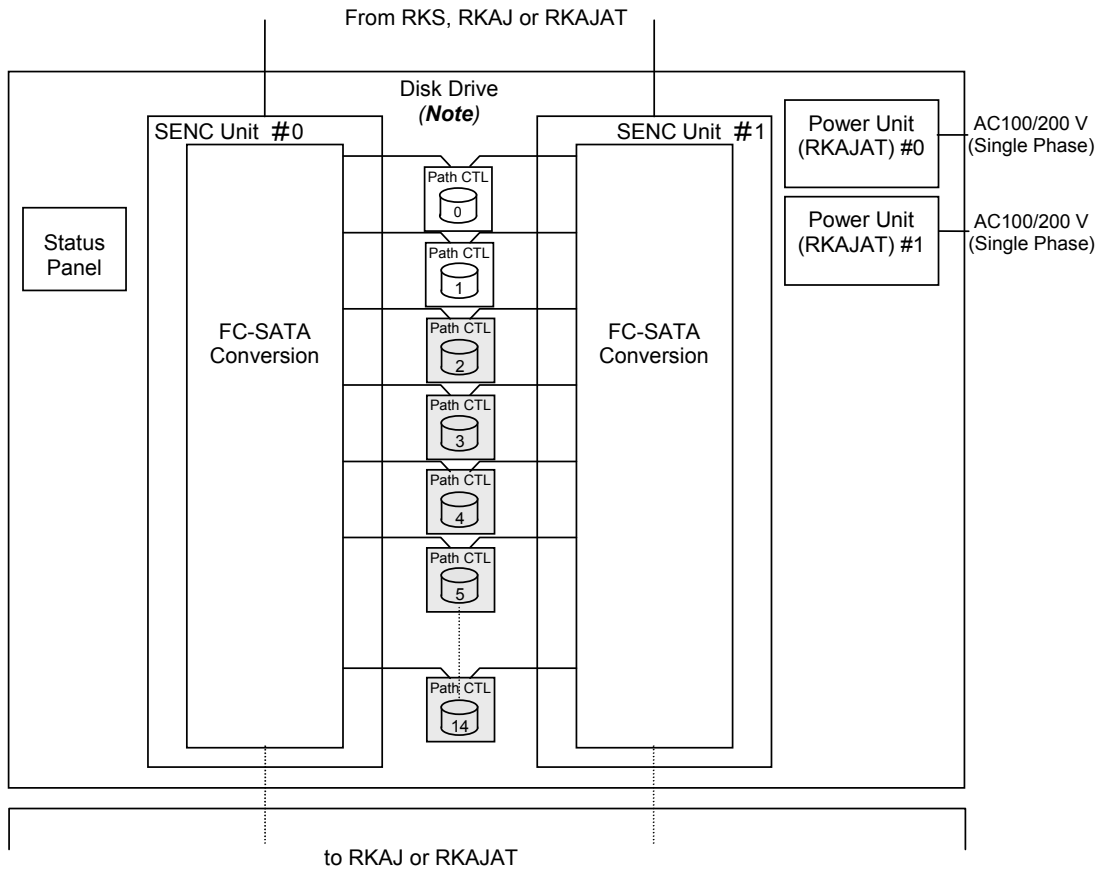

Figure 4.6 RKAJAT System Configuration

Note: Disk drive: DF-F700-ATE250R and DF-F700-ATE400R, DF-F700-ATE500R, and DF-F700-ATE750R.

4.1.2 AMS200 Floor Model

The configuration block diagrams of the Floor Models are shown below.

The Floor (RKS+H1J) Model accommodates up to 15 disk drives. The Floor (RKS+RKAJ/RKAJAT +H2J) Model accommodates up to 30 disk drives. The disk drives can be assigned to data disk(s), parity disk(s) and (mirror disk(s)) depending on the RAID level.

Up to 15 spare disks (Floor [RKS+H1J] Model: up to 1) can be mounted in any locations within the configuration.

: Basic component and indispensable optional part
 : Option (additional) part

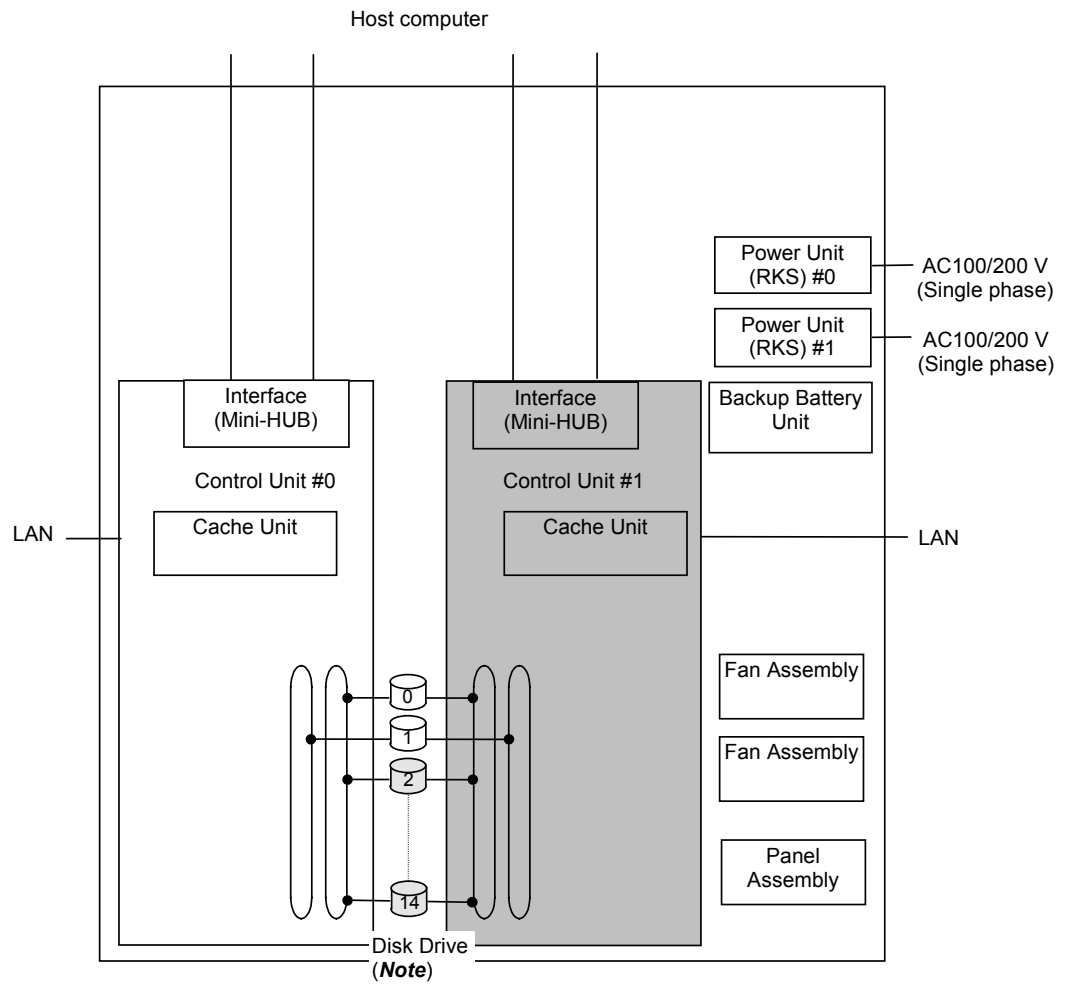

Figure 4.7 Floor Model AMS200 System Configuration (FC interface board not added)

Note: Disk Drive: DF-F700-AGF72, DF-F700-AGH72, DF-F700-AGF146, DF-F700-AGH146, DF-F700-AGF300, and DF-F700-AGH300.

: Basic component and indispensable optional part
 : Option (additional) part

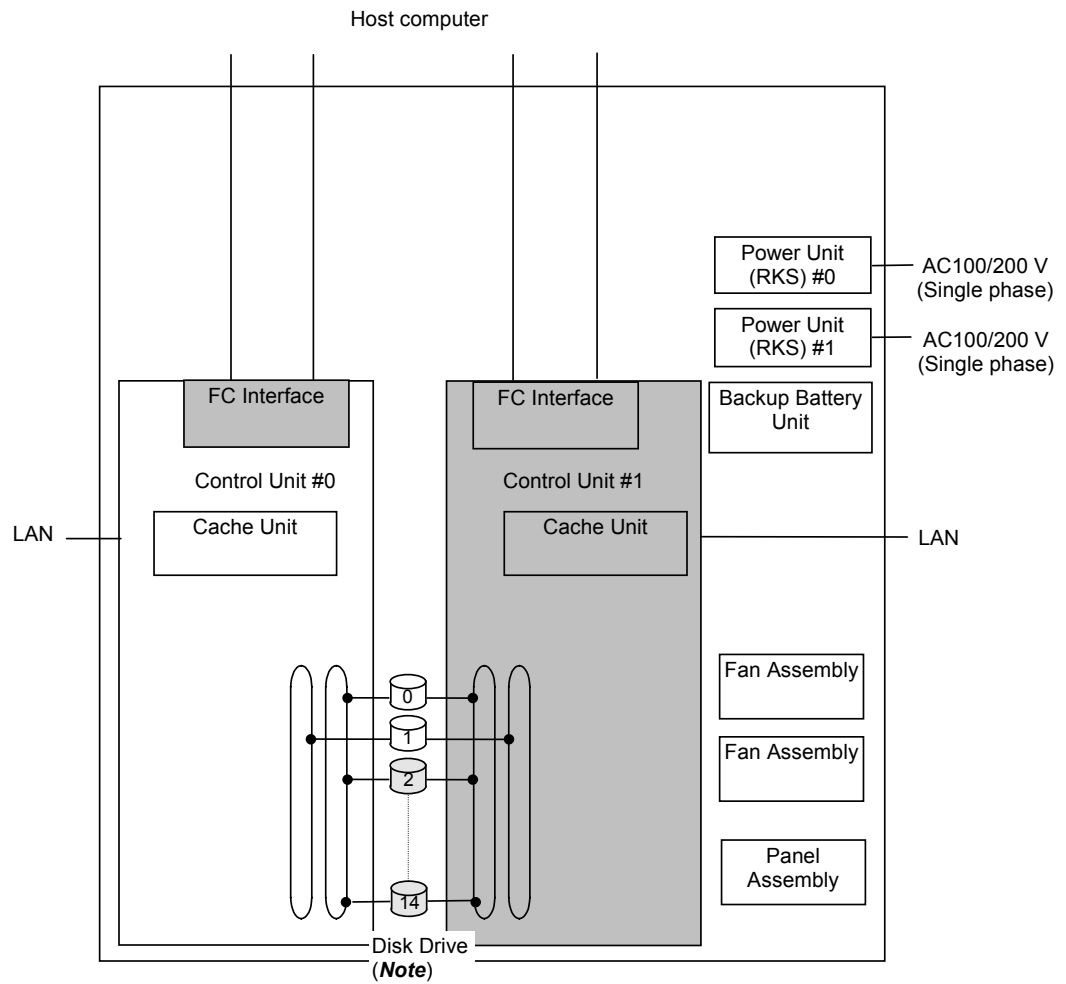

Figure 4.8 Floor Model AMS200 System Configuration (FC Interface board added)

Note: Disk Drive: DF-F700-AGF72, DF-F700-AGH72, DF-F700-AGF146, DF-F700-AGH146, DF-F700-AGF300, and DF-F700-AGH300.

: Basic component and indispensable optional part
 : Option (additional) part

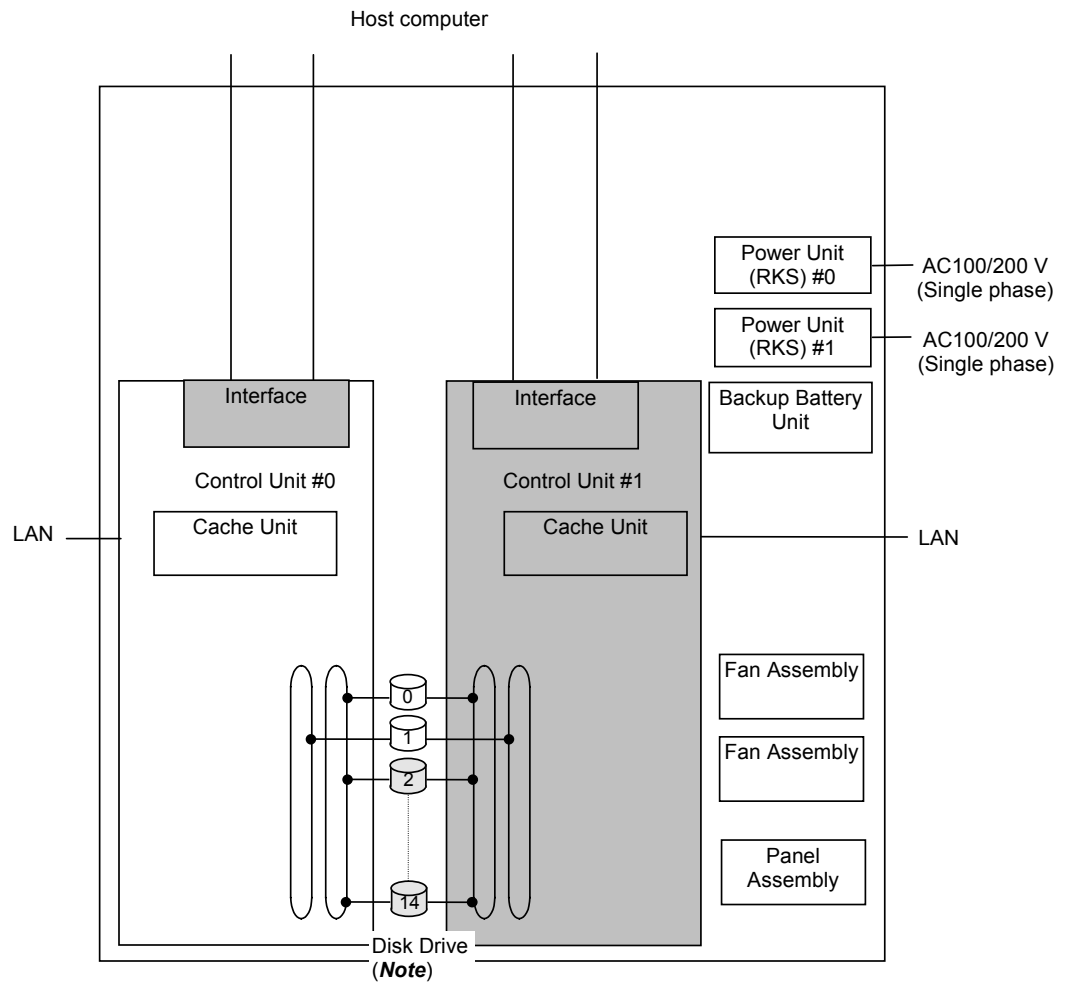

Figure 4.9 Floor Model AMS200 System Configuration (iSCSI interface board added)

Note: DF-F700-AGF72, DF-F700-AGH72, DF-F700-AGF146, DF-F700-AGH146, DF-F700-AGF300, and DF-F700-AGH300.

: Basic component and indispensable optional part
 : Option (additional) part

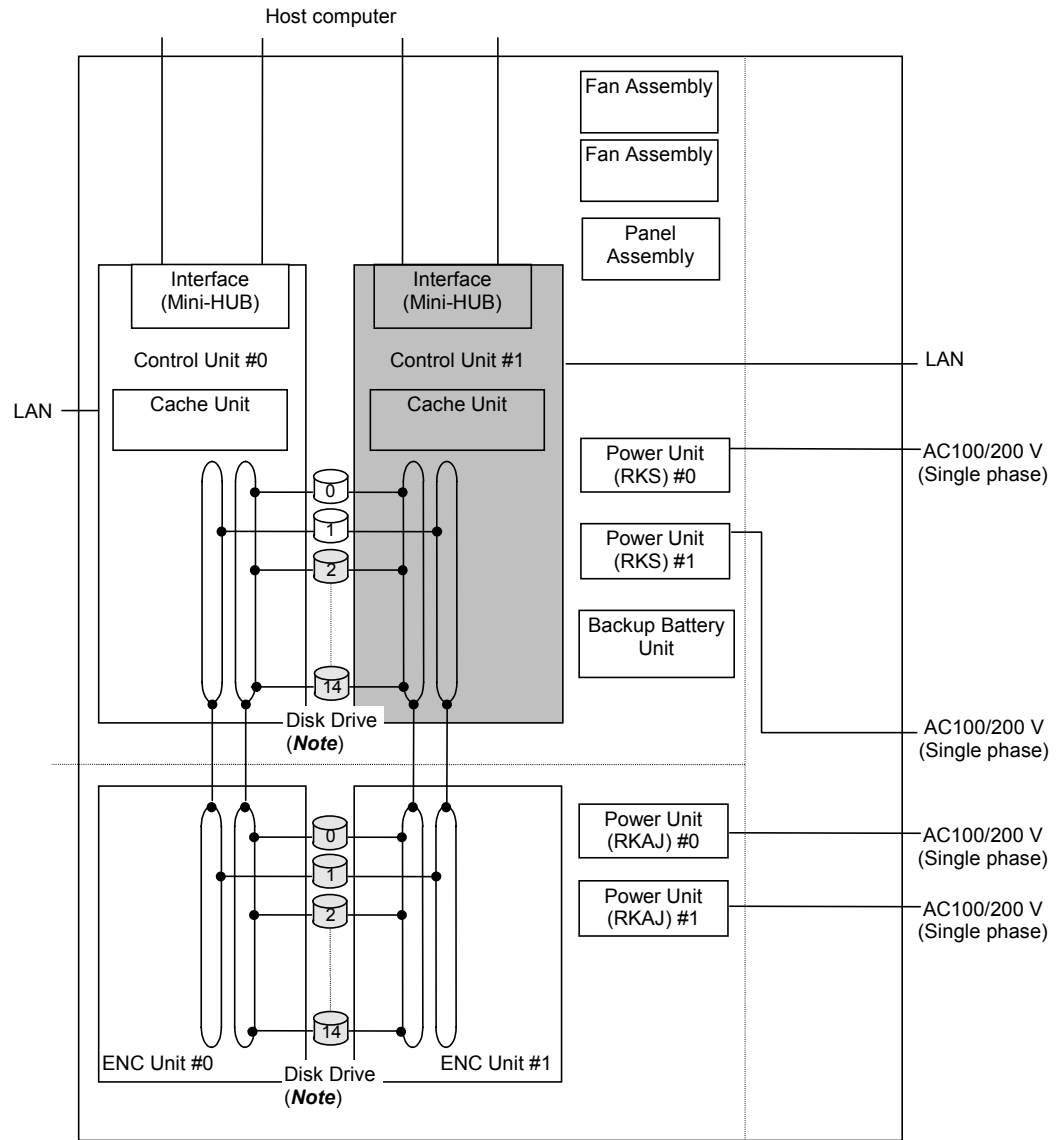

Figure 4.10 Floor Model AMS200 System Configuration (Interface board not added)

Note: Disk Drive: DF-F700-AGF72, DF-F700-AGH72, DF-F700-AGF146, DF-F700-AGH146, DF-F700-AGF300, and DF-F700-AGH300.

- : Basic component and indispensable optional part
- : Option (additional) part

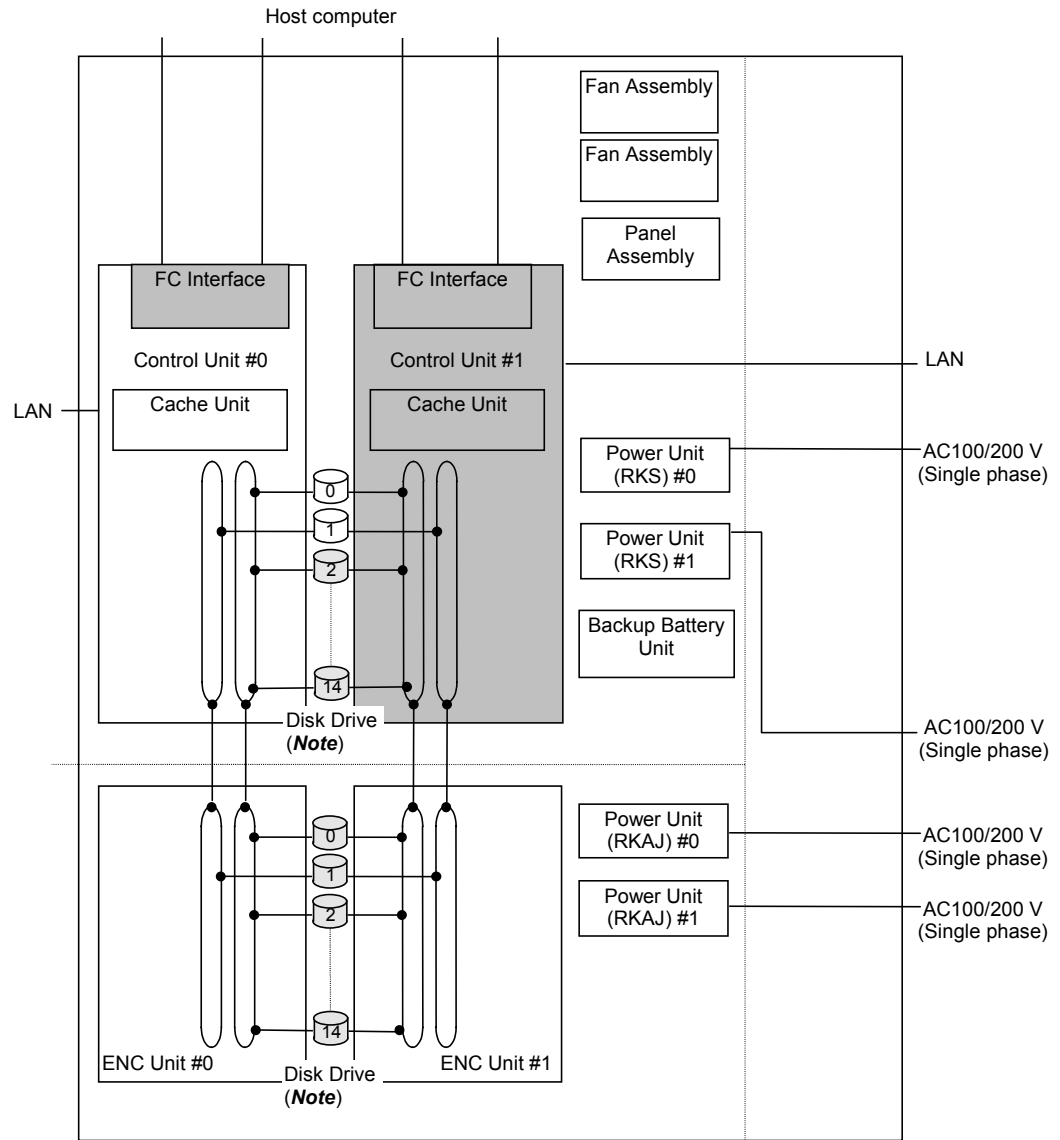

Figure 4.11 Floor Model AMS200 System Configuration (FC interface board added)

Note: Disk Drive: DF-F700-AGF72, DF-F700-AGH72, DF-F700-AGF146, DF-F700-AGH146, DF-F700-AGF300, and DF-F700-AGH300

- : Basic component and indispensable optional part
- : Option (additional) part

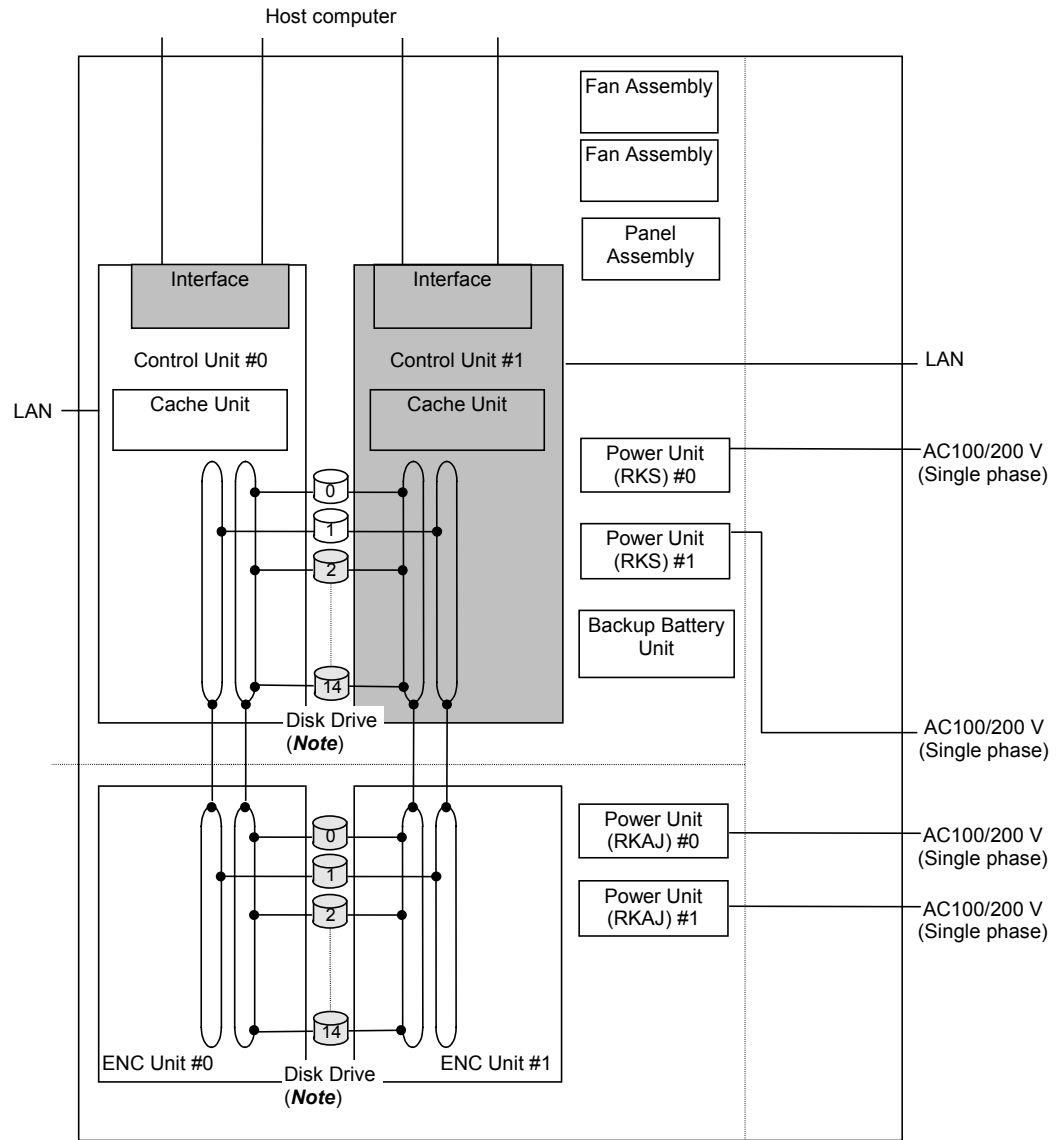

Figure 4.12 Floor Model AMS200 System Configuration (iSCSI Interface board added)

Note: Disk Drive: DF-F700-AGF72, DF-F700-AGH72, DF-F700-AGF146, DF-F700-AGH146, DF-F700-AGF300, and DF-F700-AGH300

□ : Basic component and indispensable optional part
 ■ : Option (additional) part

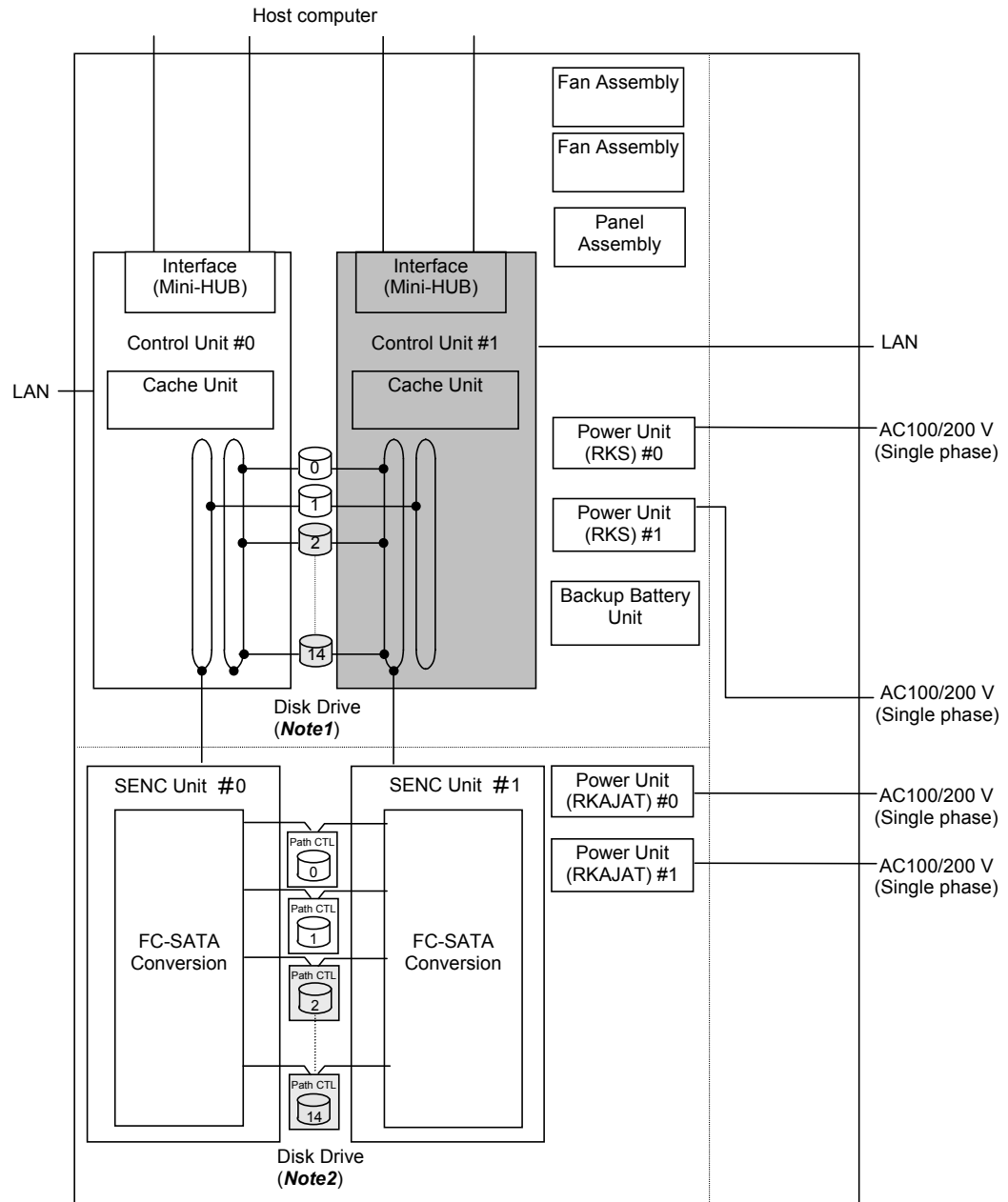

Figure 4.13 System Configuration of the Floor Model (When Interface board is not added)

Note1: Disk Drive: DF-F700-AGF72, DF-F700-AGH72, DF-F700-AGF146, DF-F700-AGH146, DF-F700-AGF300, and DF-F700-AGH300

Note2: Disk Drive: DF-F700-ATE250R, DF-F700-ATE400R, DF-F700-ATE500R, and DF-F700-ATE750R

□ : Basic component and indispensable optional part
 ■ : Option (additional) part

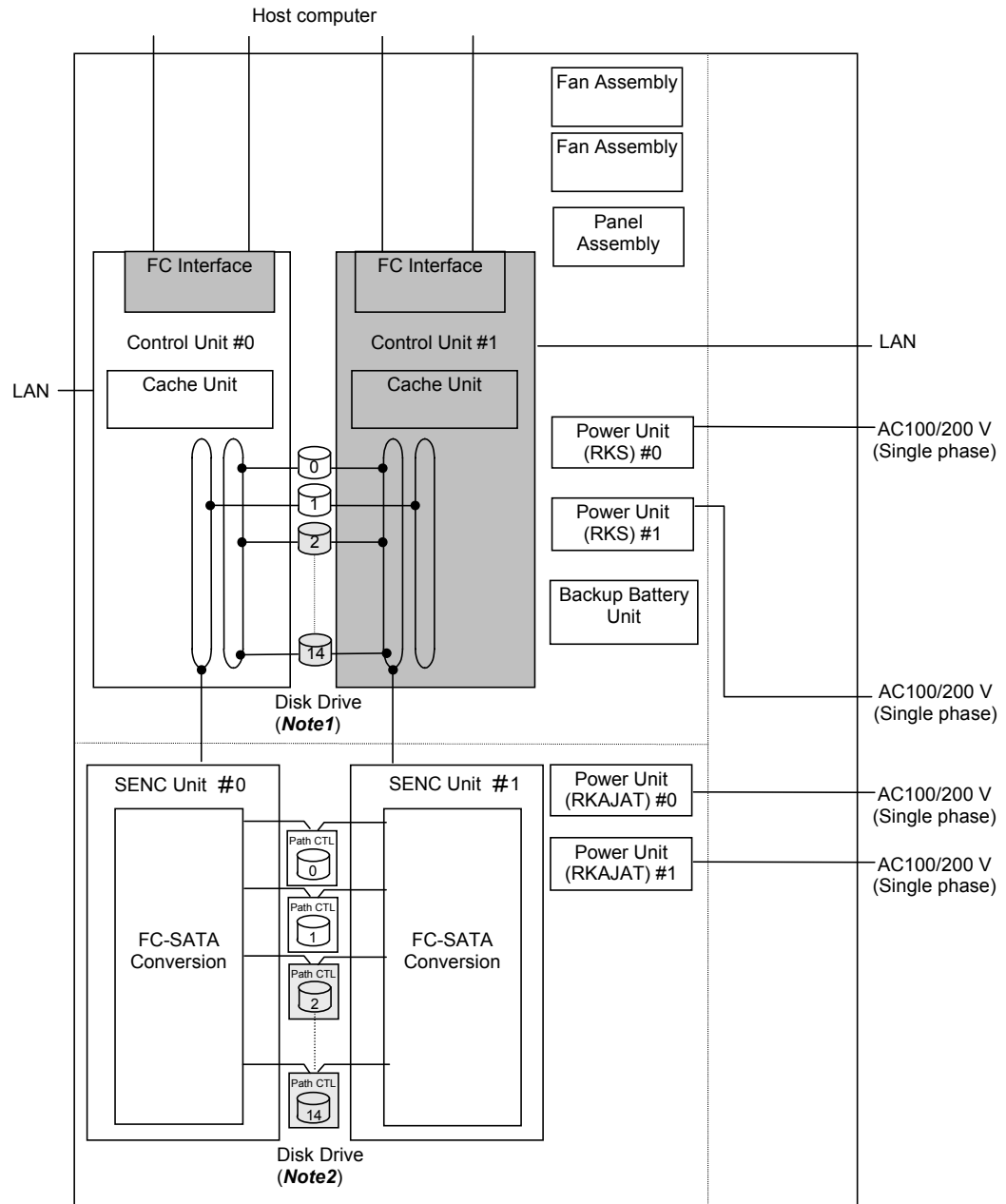

Figure 4.14 System Configuration of the Floor Model (When FC Interface board is added)

Note1: Disk Drive: DF-F700-AGF72, DF-F700-AGH72, DF-F700-AGF146, DF-F700-AGH146, DF-F700-AGF300, and DF-F700-AGH300

Note2: Disk Drive: DF-F700-ATE250R, DF-F700-ATE400R, DF-F700-ATE500R, and DF-F700-ATE750R

□ : Basic component and indispensable optional part
 ■ : Option (additional) part

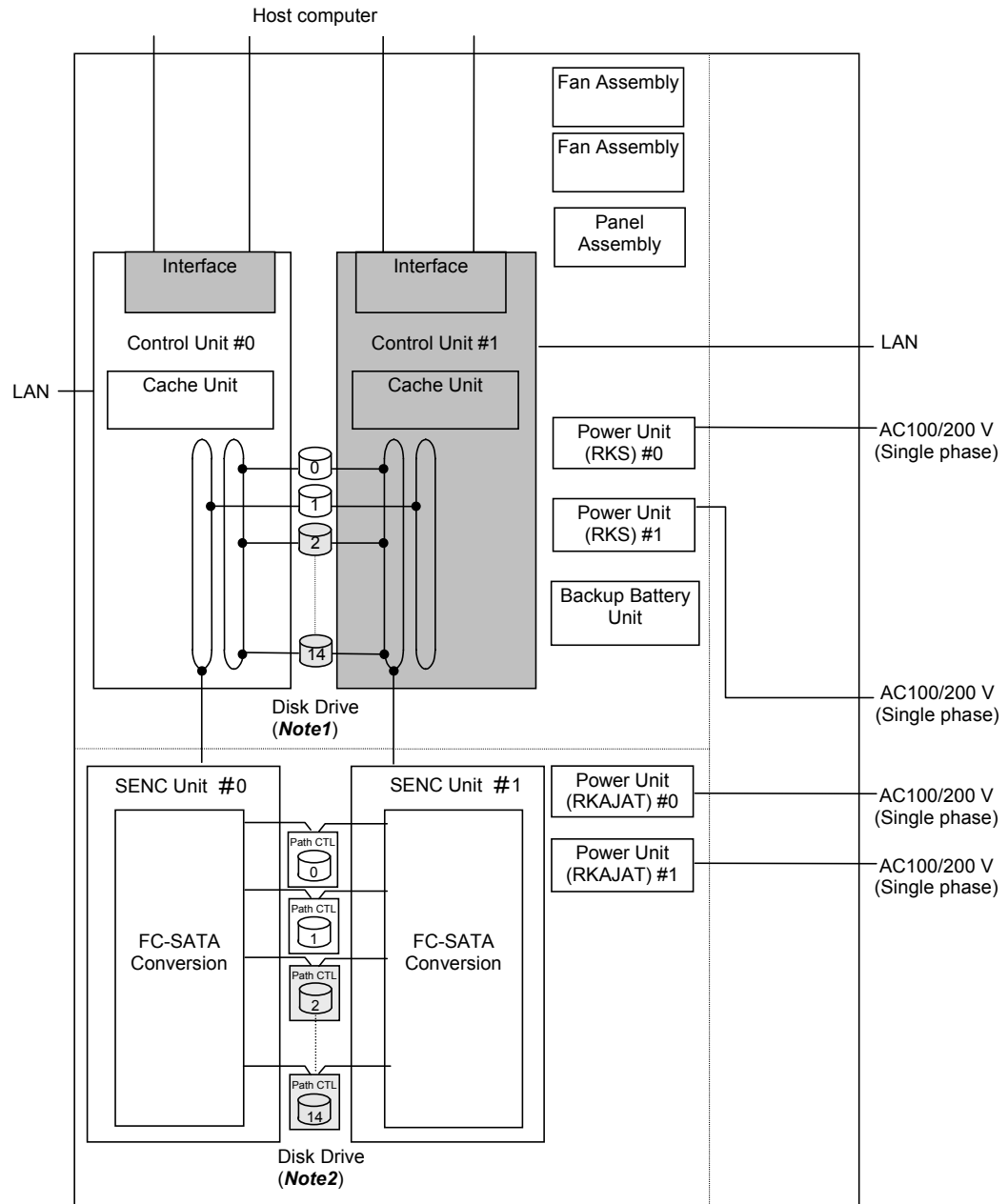

Figure 4.15 System Configuration of the Floor Model (When iSCSI Interface board is added)

Note1: Disk Drive: DF-F700-AGF72, DF-F700-AGH72, DF-F700-AGF146, DF-F700-AGH146, DF-F700-AGF300, and DF-F700-AGH300

Note2: Disk Drive: DF-F700-ATE250R, DF-F700-ATE400R, DF-F700-ATE500R, and DF-F700-ATE750R

4.2 Redundant Power Supplies

Each AMS200 unit is powered by its own set of redundant power supplies, and each power supply is able to provide power for the entire RKS unit, should it become necessary. Because of this redundancy, the AMS200 subsystem can sustain the loss of a power supply and still continue operation. To make use of this capability, the two power supplies of each AMS200 unit should be connected either to dual power sources or to different power panels, so if there is a power failure on one of the sources, the AMS200 subsystem can continue full operations using power from the alternate source.

RKNAS has no redundancy of power supplies.

4.3 Fibre Channel Interface

The AMS200 subsystem supports open system operations. The AMS200 subsystem supports up to 2 fibre-channel ports. Each AMS200 Fibre Channel interface is capable of operating at data transfer speeds of up to 200 MB/sec. The AMS200 extends up to 4 Fibre Channel ports by adding optional an FC interface board. The AMS200 supports shortwave multimode optical cables. With these shortwave fibre channel cables, the AMS200 subsystem can use 50/125 μm , 62.5/125 μm multimode Fibre Cable as defined in Table 4.1:

Table 4.1 Fibre Cable Length

Data transfer rate (MB/s)	100	200	400
Max 50/125 μm multimode Fibre Cable length	500 m	300 m	150 m
Max 62.5/125 μm multimode Fibre Cable length	300 m	150 m	70 m

4.3.1 Mini-HUB

When the FC interface board is not added to the control unit, the host interface of the AMS200 has a Mini-HUB in the control unit, and enhances one port to two host connectors. However, the link status between the host and AMS200 is recognized as one port.

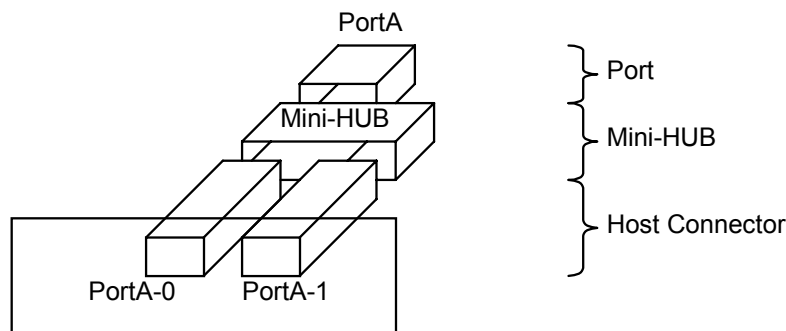

Figure 4.16 AMS200 FC Connector

4.3.2 Connection Specifications

4.3.2.1 When the FC Interface Board is Not Added

The host connector that can be used varies, depending on the topology setting of the AMS200 and the destination of the Fibre Channel cable connection. Table 4.2 shows available host connector of each topology setting and connection method.

Table 4.2 Available Host Connectors of Each Topology Setting and Connection Method

No.	AMS200 Topologies	AMS200 Transfer Rate	Direct Connection to Host	Switch Connection	Direct Connection to TagmaStore USP/NSC (Note)
1	Loop	Auto	Host Connector 0	Not Supported	Host Connector #0
		1 Gbps/2 Gbps	Host Connector 0 and 1		
2	Point-to-Point	Auto/1 Gbps/2 Gbps	Not Supported	Host Connector #0	Not Supported

Note: TagmaStore USP is an abbreviation for TagmaStore Universal Storage Platform, the high-end model in the TagmaStore product line. TagmaStore NSC is an abbreviation for the TagmaStore Network Storage Controller, a high-end midrange or entry-level enterprise system. Both models support virtualization of attached storage systems.

When connecting the AMS200 directly to the host, the Loop topology is set to the port:

- Connect the AMS200 to the host connector 0, when the transfer rate of AMS200 is Auto. (Do not connect anything to the host connector 1.)
- Both host connectors 0 and 1 are available, when the transfer rate of AMS200 is 1 Gbps or 2 Gbps.
- The port that the Point-to-Point topology has been set to cannot be connected directly to the host, TagmaStore USP or 9900V.

When connecting the AMS200 to the Switch, the Point-to-Point topology is set to the port:

- Connect the AMS200 to the host connector 0. (Do not connect it to the host connector 1.)
- The port that the Loop topology has been set to cannot be connected to the Switch.

When connecting the AMS200 directly to the TagmaStore USP or 9900V, the Loop topology is set to the port:

- Connect it to the host connector 0. (Do not connect anything to the host connector 1.)
- The port that the Point-to-Point topology has been set to cannot be connected directly to TagmaStore USP or 9900V.

4.3.2.2 When the FC Interface Board is Added

The available Fibre Channel connection configuration varies, depending on the topology setting of the AMS200 and the destination of the Fibre Channel cable connection. The following table shows available Fibre Channel connection of each topology setting and connection method.

Table 4.3 Available Fibre Channel Connection Configuration

No.	AMS 200 Topologies	AMS 200 Transfer Rate	Direct Connection to Host	Switch Connection	Direct Connection to TagmaStore USP/NSC (<i>Note</i>)
1	Loop	Auto/1 Gbps/2 Gbps/4 Gbps	Host Connector 0 and 1	Not Supported	Host Connector 0 and 1
2	Point-to-Point	Auto/1 Gbps/2 Gbps/4 Gbps	Not Supported	Host Connector 0 and 1	Not Supported

Note: TagmaStore USP is an abbreviation for TagmaStore Universal Storage Platform, the high-end model in the TagmaStore product line. TagmaStore NSC is an abbreviation for the TagmaStore Network Storage Controller, a high-end midrange or entry-level enterprise system. Both models support virtualization of attached storage systems.

When connecting the AMS200 directly to the host, the Loop topology is set to the port:

- The port that the Point-to-Point topology has been set to cannot be connected directly to the host, TagmaStore USP or 9900V.

When connecting the AMS200 to the Switch, the Point-to-Point topology is set to the port:

- The port that the Loop topology has been set to cannot be connected to the Switch.

4.3.3 Fibre Channel Configuration

4.3.3.1 When the FC Interface Board is Not Added

The following Fibre Channel information is not set for each host connector that connects to the AMS200 Fibre Channel:

- Port Address
- Topology
- Transfer Rate
- Adding a Host Group
- Host Group Options
- LU Mapping Information

4.3.3.2 When the FC Interface Board is Added

The host connectors that connect the AMS 200 Fibre Channel interface cable configure the respectively independent port. The information described in section 4.3.3.1 is set for each host connector.

Note: Set the "Transfer Rate" of Fibre Channel to the value corresponding to the transfer rate of devices connected directly with an array subsystem according to the following table. When the AMS200 is connected directly and externally with the TagmaStore Universal Storage Platform/TagmaStore Network Storage Controller, set the port transfer rate of both the TagmaStore Universal Storage Platform/TagmaStore Network Storage Controller and the AMS200 to the fixed transfer rate (the same value for the TagmaStore Universal Storage Platform and the AMS200 selecting any one of 1G bps, 2 Gbps, or 4 Gbps.).

Transfer Rate of Devices Connected with an Array Subsystem	Transfer Rate of an Array Subsystem
1G bps	1G bps
2G bps	2G bps
4G bps	4G bps
Auto (Maximum speed 4G bps)	4G bps
Auto (Maximum speed 2G bps)	2G bps
Auto (Maximum speed unknown)	Auto

Note: When connecting the AMS200 directly and externally with the TagmaStore Universal Storage Platform/TagmaStore Network Storage controller, set the topologies of the both devices to "Loop".

4.3.4 Host Direct Connection for AMS200

When connecting the AMS200 ports set to the Loop topology directly to both side 0 and side 1 of the host connector (FC interface board addition; side A and side B), consider the following:

4.3.4.1 When the FC Interface Board is Not Added

- **Exclusive Access to the Logical Unit:** LU mapping cannot be set for each host connector of AMS200. It is necessary to set the access path between hosts and logical units according to the assignment of the logical units to the hosts using LUN Manager.
- **Transfer Rate of the Host:** The transfer rate of the AMS200 is set for the port. Both host connectors 0 and 1 must be connected to the hosts with the same transfer rate.

4.3.4.2 When the FC Interface Board is Added

One host connector configures one port.

- **Exclusive access to Logical Unit**

LU mapping can be processed for each port. Therefore, set the accessible logical unit for each port using the LU mapping function.

- **Transfer rate of host**

The transfer rate for the AMS200 is set for each port. The host connector (side A and side B) can be connected respectively to hosts with different transfer rates.

4.4 NAS Interface

The AMS200 provides up to 8 LAN ports and supports 1000 BASE-T for Gigabit LAN and 100 Mbps-BASE-TX. The AMS200 supports transfer rates of 100 Mbytes/s and 10 Mbytes/s, and controls data transmission using the CSMA/CD method.

Note: See section D.2 for the supported conditions of switch and so on in this subsystem.

4.5 iSCSI Interface

The AMS200 provides 4 iSCSI ports by adding an optional iSCSI interface board. The iSCSI interface is capable of operating at data transfer speed of up to 100 M bytes/s. The AMS200 supports Ethernet (1000Base-TX). With the HBA for iSCSI, Generic NIC + Software initiator, and Network Switch, the AMS200 subsystem can be located up to 100 meters.

Connect the switch based on the 1000BASE-T(full-duplex). Use the LAN cable with the following types and shapes.

- Cable type: category 5e or category 6
- Connector shape: RJ-45

When you connect the physical port of the switch directly with the host and iSCSI port of the AMS200, do not set the Spanning Tree protocol function to ON. It may cause communication interference.

4.5.1 Setting iSCSI Information

The following iSCSI information is set for iSCSI ports. When the iSCSI interface board is not added to the control unit, this information is not set for each host connector that connects the AMS200 Fibre Channel.

- iSCSI Port IP address
- iSNS Server

- Adding target
- Target option

4.6 Array Frame

The following array frames are described in this section:





- AMS200 rack-mount model
- AMS200 floor model

4.6.1 AMS200 Rack-Mount Model

Each RKS unit contains the physical disk drives, including the disk array groups and the dynamic spare disk drives. Each rack frame has dual power plugs, which should be attached to two different power sources or power panels.

The AMS200 can be configured with 1 RK and up to 6 RKAJ units for a total of 105 GB disk drives at a maximum of 28.1 Tbytes RAID5(14D+1P) (using the 287.6 G disk drive). The AMS200 can also be configured with 1 RKS and up to 6 RKAJAT units for a total of 105 disk drives at a maximum of 65.9 Tbytes RAID5(14D+1P) (using the 737.4 G disk drive).

Table 4.4 Basic Specifications of Rack-Mount Model

Item		Model	Rack-Mount Model			
			RKS	RKAJ	RKAJAT	RKNAS
Configuration	Configuration		1 RKS	1RKAJ	1RKAJAT	1RKNAS
	System appearance					
Disk drive used	Disk drive size (W×D×H) (mm)		101.6×146.1×25.4			–
	Data capacity (G byte) (Note 1)		71.3/143.3/287.6		245.7/393.4/491.9/737.4	–
	Rotational speed (min ⁻¹)		10,000/15,000		7,200	–
	Maximum mountable quantity(unit)		15			–
Host interface	Interface type		2 G bps Fibre Channel Optical (Non-OFC) (Note 3) 1 Gbps iSCSI (Ethernet) (Note 5)	–		1Gbps Ethernet
	Data transfer speed (i.e. maximum speed for transfer to host)		200 M bytes/s (Fibre Channel) (Note 4) 100 M bytes/s (iSCSI) (Note 5)	–		100 Mbytes/s (Ethernet)
Host interface	Number of host connectors	Single controller	Fibre Channel: 1 (Note 2) iSCSI: 2 (Note 5)	–		–
		Dual controller	Fibre Channel: 2 (Note 2) iSCSI: 4 (Note 5)	–		8 (4 for 1RKNAS)
	Transferred block size (bytes)		512	–		

Note 1: This value of storage capacity is calculated as 1 Gbyte = 1,000,000,000 bytes. (This definition is different from 1 Kbyte = 1,024 bytes.)

Note 2: When FC interface board is not added, one port configures one Mini-HUB, and extends to two host connectors. When FC interface board is added, control unit implements two ports and two host connectors. One port configures FC interface independent of another port, and implements one host connector.

Note 3: When the FC interface board is added, the interface type supports 4 Gbps Fibre Channel Optical (Non-OFC).

Note 4: When the FC interface board is added, a maximum data transfer rate is 400 MB/s (Fibre Channel) depending on the host I/O condition.

Note 5: Indicates the value of when iSCSI interface board is added to the control unit.

Note 6: For additional information about the global rack-mount model, refer to *the Hitachi Data Systems Global 19-Inch Rack Reference Guide (MK-92DF772)*.

4.6.2 Floor Model

Each floor model contains physical disk drives, including the disk array groups and the dynamic spare disk drives. Additionally, each floor model has dual power plugs, which should be attached to two different power sources or power panels.

Floor (RKS+H1J) Model can be configured with 15 disk drives at a maximum of 4.0 Tbytes RAID5 (using the 287.6 Gbyte disk drive).

Floor (RKS+RKAJ+H2J) Model can be configured with 30 disk drives at a maximum of 8.0 Tbytes RAID5 (using the 287.6 Gbyte disk drive).

The floor model (RKS+RKAJAT+H2J) can be configured with 30 disk drives at a maximum of 14.3 Tbytes RAID5 (using the 300 G (for RKS) and 737.4 G (for RKAJAT) disk drives).

Table 4.5 Basic Specifications of the Floor Model

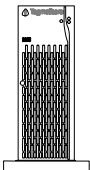
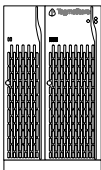
Item	Model	Floor Model		
		Floor (RKS+H1J) Model	Floor (RKS+RKAJ+H2J) Model	Floor (RKS+RKAJAT+H2J) Model
Configuration	Configuration	1 RKS+Floor setting kit (DF-F700-H1J)	1 RKS+1RKAJ+Floor setting kit (DF-F700-H2J)	1 RKS+1 RKAJAT+ Floor setting kit (DF-F700-H2J)
	System appearance			
Disk drive used	Disk drive size (W×D×H) (mm)	101.6×146.1×25.4		
	Data capacity (G byte) (Note 1)	71.3/143.3/287.6		RKS: 71.3/143.3/287.6 RKAJAT: 245.7/393.4/491.9/737.4
	Rotational speed (min ⁻¹)	10,000/15,00		RKS: 10,000/15,000 RKAJAT: 7,200
	Maximum mountable quantity (unit)	15	30	
Host interface	Interface type	2 G bps Fibre Channel Optical (Non-OFC) (Note 3) 1 G bps iSCSI (Ethernet) (Note 5)		
	Data transfer speed (i.e. maximum speed for transfer to host)	200 M bytes/s (Fibre Channel) (Note 4) 100 M bytes/s (iSCSI) (Note 5)		
	Number of host connectors	Single controller	Fibre Channel: 2 (Note 2) iSCSI: 2 (Note 5)	
		Dual controller	Fibre Channel: 4 (Note 2) iSCSI: 4 (Note 5)	
Transferred block size (bytes)	512			

Note 1: This value of storage capacity is calculated as 1 Gbyte = 1,000,000,000 bytes. (This definition is different from 1 Kbyte = 1,024 bytes.)

Note 2: When the FC interface board is not added, one port configures one Mini-HUB, and extends to two host connectors. When the FC interface board is added, control unit implements two ports and two host connectors. One port configures FC interface independent of another port, and implements one host connector.

Note 3: When the FC interface board is added, the interface type supports 4 Gbps Fibre Channel Optical (Non-OFC).

Note 4: When the FC interface board is added, a maximum data transfer rate can be 400 MB/s (Fibre Channel) depending on the host I/O condition.

Note 5: Indicates the value of when iSCSI interface board is added to the control unit.

4.7 Component Names, Locations, and Functions

This section includes the following:

- Front bezel component locations and functions
- RKS, RKAJ, and RKAJAT component locations
- Switch locations and functions
- Connector locations and functions
- LED locations and functions

4.7.1 Front Bezel Component Locations and Functions

This section illustrates and describes the locations and functions for the front bezel.

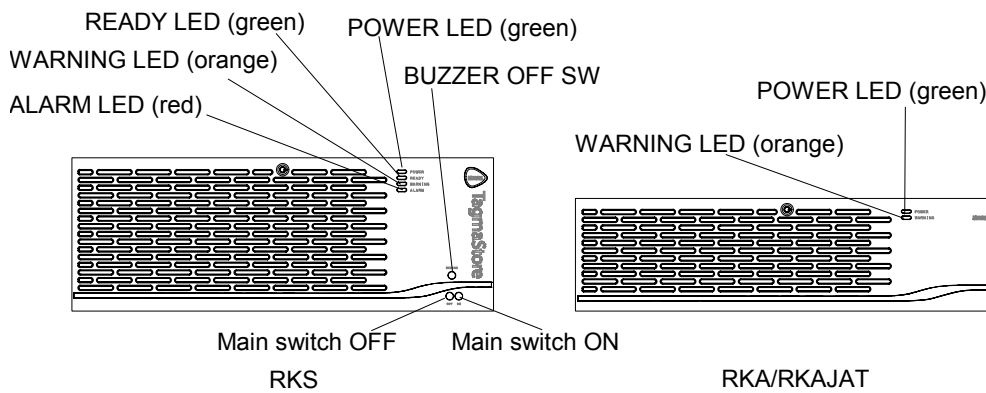
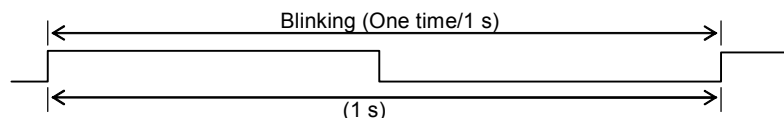

Figure 4.17 RKS, RKA, and RKA/RKAJAT Front Bezel Component Locations

Table 4.6 RKS, RKA, and RKA/RKAJAT Front Bezel Component Functions

Name	Function
ALARM LED (red)	<p>Lighting: Indicates that a failure has occurred which makes the subsystem inoperable.</p> <p>Blinking: Low-speed blinking (Note 1): Indicates that a serious failure has occurred while the power is on.</p>
WARNING LED (orange)	<p>Lighting Indicates that a failure occurred, but the subsystem is currently operational.</p> <p>Blinking Low-speed blinking (Note 1): Indicates that a failure which does not stop operation occurred in the unit (it must be deleted with WEB). High-speed blinking (Note 2): In dual configuration, it indicates that the update of the flash program is executed. In single configuration, it indicates that the update of the flash program or the automatic download of the ENC/SENC firmware at the time of powering-on is executed.</p>
READY LED (green)	<p>Lighting: Indicates that the subsystem is operational.</p> <p>Blinking: High-speed blinking (Note 2): Indicates that the download of the ENC/SENC firmware is executed. (The READY LED may blink for up to 15 minutes. Even if the READY LED blinks, the subsystem is operational.) Low-speed blinking (Note 1): Indicates that the offline download processing ended. (It is displayed during the maintenance work.)</p>
POWER LED(green)	Indicates that the power is supplied to the subsystem.
Main switch on	ON: Turns on the power.
Main switch off	OFF Turns off the power.
BUZZER OFF SW	Press this switch when the buzzer sounds to stop the beep. When a serious hardware failure occurs, (electrical surges of both power supplies and so on), the buzzer does not stop even when the button is pushed.

Note 1: Low-speed blinking:



Note 2: High-speed blinking:

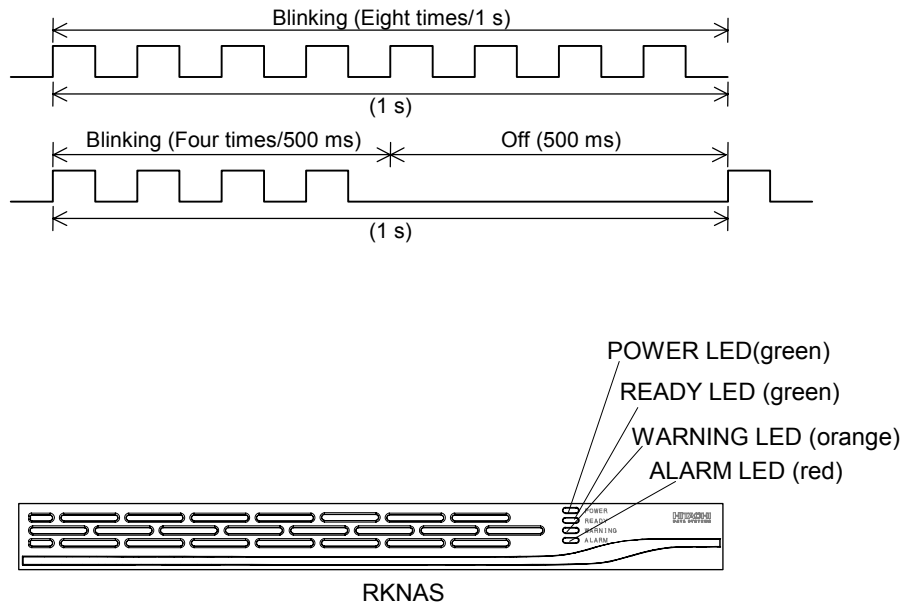

Figure 4.18 RKNAS Front Bezel Component Locations

Table 4.7 RKNAS Front Bezel Component Functions

Name	Function
ALARM LED (red)	Indicates that a failure has occurred which makes the RKNAS inoperable.
WARNING LED (orange)	Indicates that a failure occurred, but RKNAS is currently operational.
READY LED (green)	Indicates that the RKNAS can be operated. (Note)
POWER LED (green)	Indicates that the power is supplied to the RKNAS.

Note: When the READY LED on the NAS Unit lights, the NAS unit cannot be accessed from a host computer. A NAS system accepts access from a host computer only in the "ACTIVE" NAS OS state.

4.7.2 Component Locations

The locations of the RKS, RKAJ, and RKAJAT components are shown in the following diagrams:

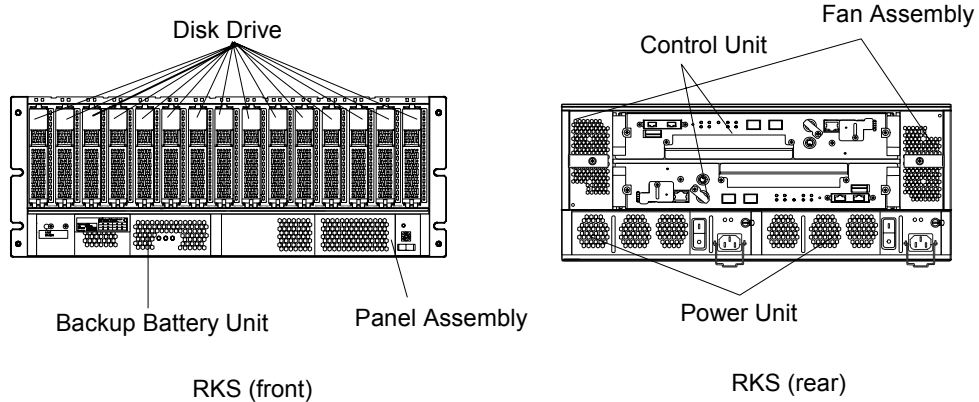

Figure 4.19 RKS Component Locations

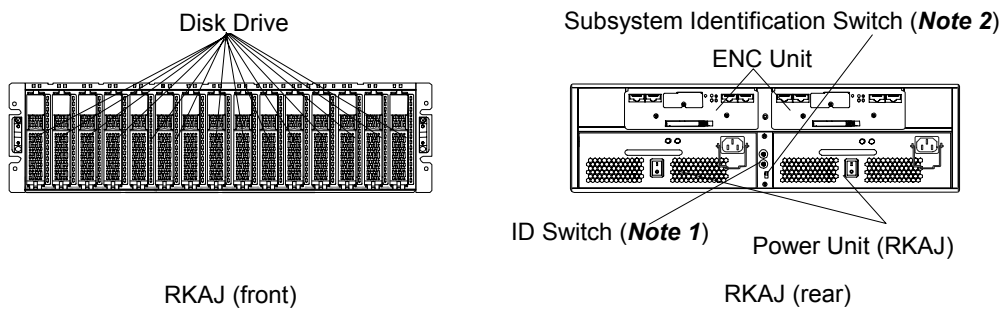

Figure 4.20 RKAJ Component Locations

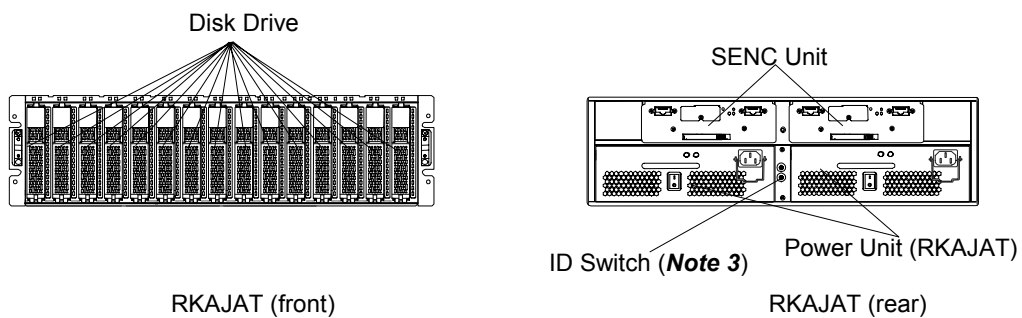

Figure 4.21 RKAJAT Component Locations

Note 1: Sets the device ID of the RKAJ.

Note 2: The switch has been set on the S side.

Note 3: Sets the device ID of the RKAJAT.

4.7.3 Switch Locations and Functions

This section illustrates and describes the locations and functions for switches in the following hardware components:

- Panel assembly
- Backup battery unit
- Power unit
- RKNAS

4.7.3.1 Panel Assembly

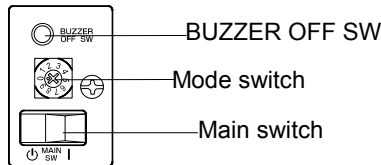

Figure 4.22 Panel Assembly Switch Location

Table 4.8 Panel Assembly Switch Functions

Switch	Function
Main switch	Turns on/off the power: : Power on ⏻: Power off
Mode switch	Sets the local/remote mode or USP connection by the combination of turning on and off of the four mode switches.
BUZZER OFF SW	Pressing this switch while the buzzer sounds stops the beep. When a serious hardware failure occurs, (electrical surges of both power supplies and so on), the buzzer does not stop even when the button is pushed.

4.7.3.2 Power Unit

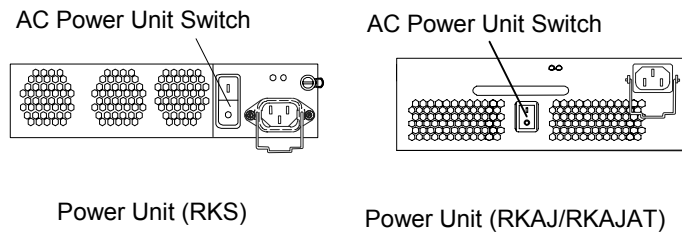

Figure 4.23 Power Unit Switch Locations

Table 4.9 Power Unit Switch Functions

Switch	Function
AC Power Unit Switch	Controls the power applied to the subsystem.

4.7.3.3 RKNAS

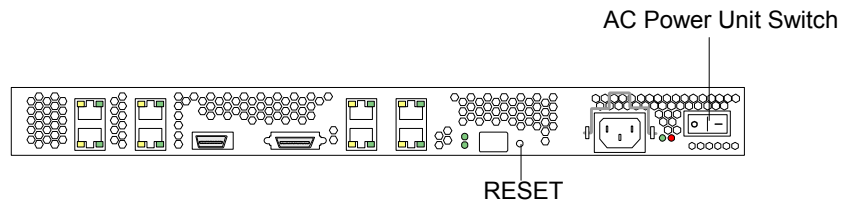

Figure 4.24 RKNAS Switch Locations

Table 4.10 RKNAS Switch Functions

Switch	Function
AC Power Unit Switch	Controls the power applied to the RKNAS
RESET	Used to reset the RKNAS.

4.7.4 Connector Locations and Functions

This section illustrates and describes the locations and functions for connectors in the following hardware components:

- ENC unit
- Power unit
- Control unit

- RKNAS

4.7.4.1 ENC Unit

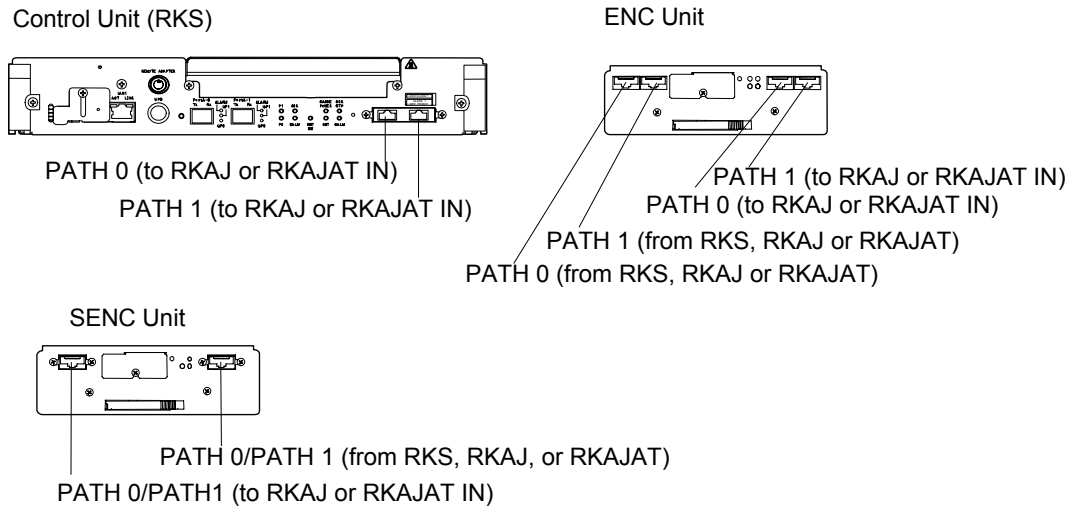

Figure 4.25 ENC Unit Connector Locations

Table 4.11 ENC Unit Connector Functions

Connector	Function
PATH 0	Connection connector for RKAJ Unit ID = 0n (n=0,1,2....E) Connection connector for RKAJAT Unit ID = 2n (n=0,1,2....E)
PATH 1	Connection connector for RKAJ Unit ID =0n (n=0,1,2....E) Connection connector for RKAJAT Unit ID =3n (n=0,1,2....E)

4.7.4.2 Power Unit

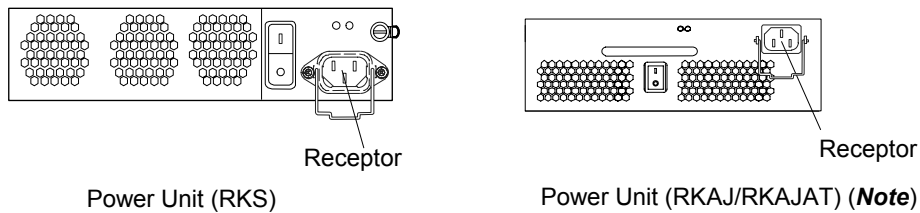

Figure 4.26 Power Unit Connector Locations

Table 4.12 Power Unit Connector Functions

Connector	Function
Receptor	Power cable receptacle on the unit side.

4.7.4.3 Control Unit

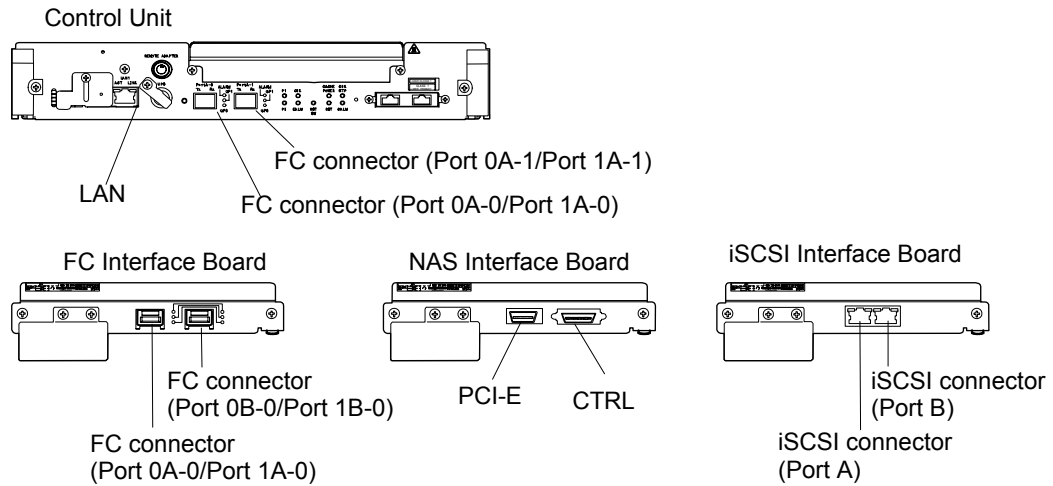

Figure 4.27 Control Unit Connector Locations

Table 4.13 Control Unit Connector Functions

Connector	Function
FC connector	Connector for a Fibre channel interface cable.
LAN	Connector used to connect a LAN cable.
PCI-E	Connector for a PCI-E cable.
CTRL	Connector for a CTRL cable.
iSCSI	Connector for an iSCSI interface cable.

4.7.4.4 RKNAS

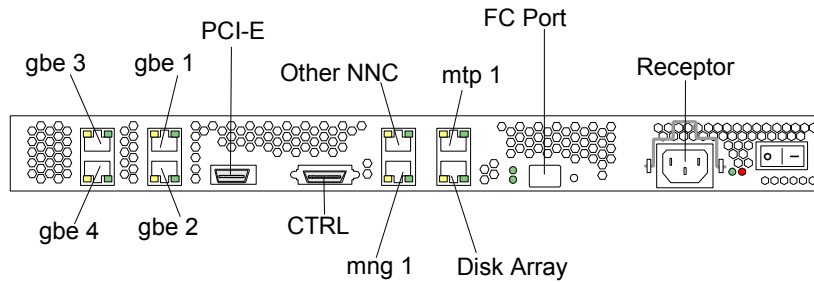

Figure 4.28 RKNAS Connector Locations

Table 4.14 RKNAS Connector Functions

Connector	Function
Receptor (J1)	Power cable receptacle on the RKNAS side.
gbe 1	Connector used to connect LAN cable: gbe 1.
gbe 2	Connector used to connect LAN cable: gbe 2.
gbe 3	Connector used to connect LAN cable: gbe 3.
gbe 4	Connector used to connect LAN cable: gbe 4.
PCI-E	Connector for a PCI-E cable.
CTRL	Connector for a CTRL cable.
mng 1	Connector used to connect a LAN cable for user management.
Other NNC	Connector used to connect a LAN cable for connecting with another RKNAS in the cluster configuration.
Disk Array	Connector used to connect with the LAN port for maintenance in the DF Controller.
mtp 1	Connector for the LAN for maintenance.
FC Port	Connector for the backup subsystem.

4.7.5 LED Locations and Functions

This section illustrates and describes the locations and functions of LEDs in the following hardware components:

- Disk drive display
- Battery backup unit
- ENC unit

- SENC unit
- Power unit
- Fan assembly
- Control unit
- RKNAS

4.7.5.1 Disk Drive Display (RKS)

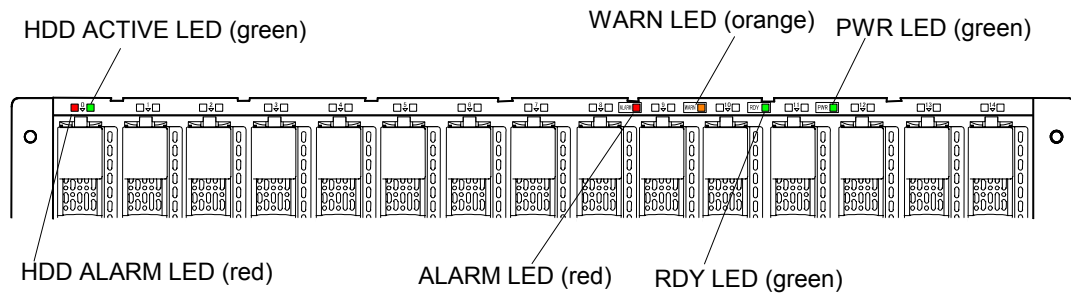

Figure 4.29 Disk Drive Display LED Locations

Table 4.15 Disk Drive Display LED Functions

LED	Function
HDD ACTIVE LED (green)	When on or flashing, it indicates that the disk drive is operational.
HDD ALARM LED (red)	When on, it indicates that a failure occurred in the disk drive; the disk drive is inoperable.
ALARM LED (red)	Lighting: When on, it indicates that a failure occurred in the unit; the unit is inoperable. Blinking: Low-speed blinking (Note 1): Indicates that a serious failure has occurred while the power is on.
RDY LED (green)	Lighting: When on, it indicates that the unit is operable. Blinking: High-speed blinking (Note 2): Indicates that the download of the ENC/SENC firmware is executed. (The READY LED may blink for up to 15 minutes. Even if the READY LED blinks, the subsystem is operational.) Low-speed blinking (Note 1): Indicates that the offline download processing ended. (It is displayed during the maintenance work.)
WARNING LED (orange)	Lighting When on, it indicates that a failure occurred in the unit; the unit is inoperable. Blinking Low-speed blinking (Note 1): Indicates that a failure which does not stop operation occurred in unit (It must be deleted with WEB). High-speed blinking (Note 2): In dual configuration, it indicates that the update of the flash program is executed. In single configuration, it indicates that the update of the flash program or

	the automatic download of the ENC/SENC firmware at the time of powering-on is executed.
PWR LED (green)	When on, it indicates that electricity is supplied to the unit.

Note 1: Low-speed blinking:

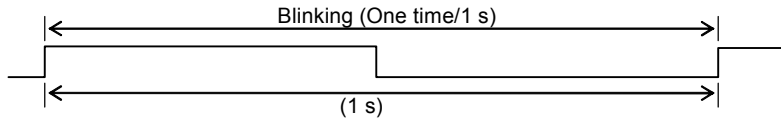

Note 2: High-speed blinking:

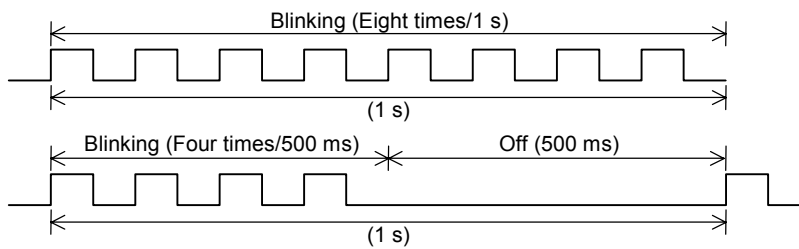

4.7.5.2 Disk Drive Display (RKAJ, RKAJAT)

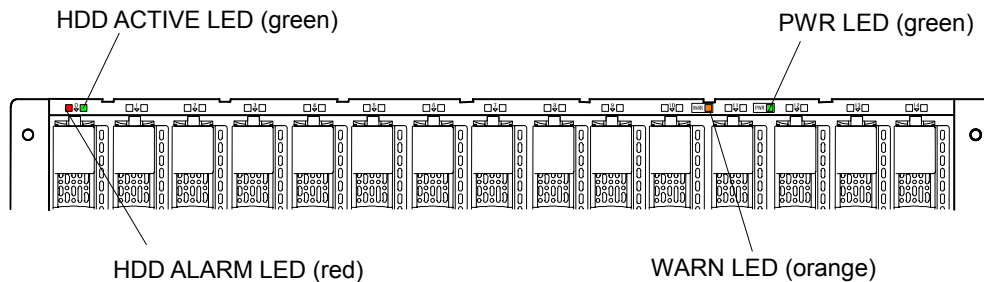

Figure 4.30 Disk Drive Display (RKAJ., RKAJAT) LED Locations

Table 4.16 Disk Drive Display (RKAJ, RKAJAT) LED Functions

LED	Function
HDD ACTIVE LED (green)	When on or flashing, it indicates that the disk drive is operational.
HDD ALARM LED (red)	When on, it indicates that a failure occurred in the disk drive; the disk drive is inoperable.
WARN LED (orange)	When on, it indicates that a failure occurs in the unit, so the unit is inoperable.
PWR LED (green)	When on, it indicates that electricity is supplied to the unit.

4.7.5.3 Battery Backup Unit

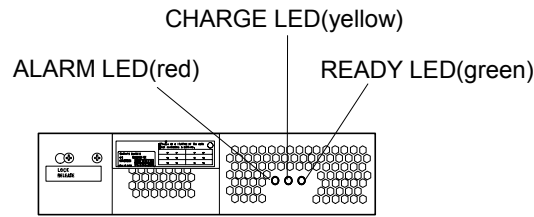

Figure 4.31 Battery Backup Unit LED Locations

Table 4.17 Battery Backup Unit LED Functions

LED	Function
READY LED (green)	The green LED indicates the overall condition of the battery as follows. On: normal status Flashing: charging status during start-up Off: abnormal status
CHARGE LED (yellow)	The yellow LED indicates the charging status of the battery. On: Battery is charging
ALARM LED (red)	The red LED indicates that a failure has occurred in the battery. On: a failure has occurred Flashing: Warning of impending failure Off: Normal status

4.7.5.4 ENC Unit

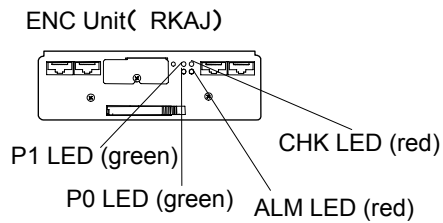
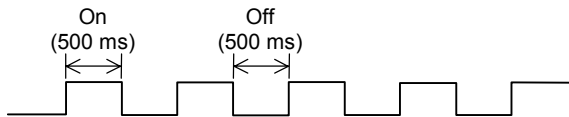

Figure 4.32 ENC Unit LED Locations

Table 4.18 ENC Unit LED Functions

LED	Function
P1 LED (green)	When on, it indicates that the link status of FC-AL (loop 1 side) is normal.
P0 LED (green)	When on, it indicates that the link status of FC-AL (loop 0 side) is normal.
ALM LED (red)	When on, it indicates that a failure occurs in the ENC Unit, so the ENC Unit is inoperable.
CHK LED (red)	<p>It indicates, according to the number of times the LED flashes, what voltage is abnormal.</p> <p>Low-Speed blinking (Note 1) Once: Logic +5 V voltage is abnormal. Twice: Logic +12 V voltage is abnormal. Five times: Battery is abnormal. Six times: ENC unit Logic+2.5V voltage is abnormal.</p> <p>The following blinking is fast because ENC microprogram detects CUDG error.</p> <p>High-speed blinking (Note 2) Once: SRAM error. Twice: ENC hard error. Three times: Microprogram error in flash memory.</p> <p>Not blinking: Boot section error of ENC microprogram, RAM error, or ENC hard configuration error.</p>

Note 1: Normal blinking:



Note 2: High-speed blinking (CHK LED):

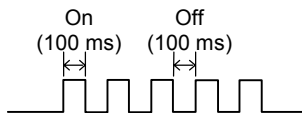

4.7.5.5 SENC Unit

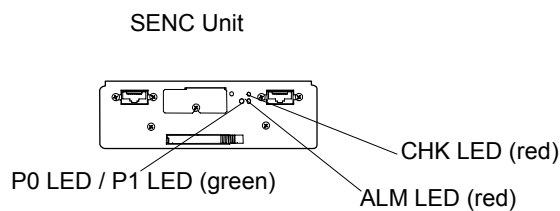
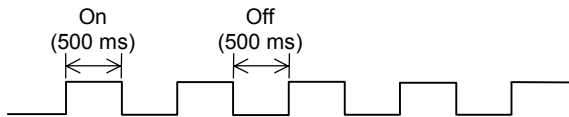

Figure 4.33 SENC Unit LED Locations

Table 4.19 SENC Unit LED Functions

LED	Function
P0 LED/P1 LED (green)	When on, it indicates that the link status of FC-AL (loop 0 or loop 1 side) is normal.
ALM LED (red)	When on, it indicates that a failure occurs in the SENC Unit.
CHK LED (red)	<p>After turning on the power, it blinks for about 10 seconds (while CUDG is being executed). However, this blinking does not indicate an abnormal state. It indicates error factors by the frequency of blinks.</p> <p>Low-speed blinking (Note 1): Twice: CUDG error in SENC Eight times: Selector circuit of the fan is abnormal.</p> <p>Lighting: CUDG error in BOOT section of SENC</p> <p>High-speed blinking (Note 2): Five times: Fixed data error in flash memory. Six times: Significant surface error in flash memory Seven times: SUM check error in flash memory</p>

Note 1: Normal blinking:



Note 2: High-speed blinking:

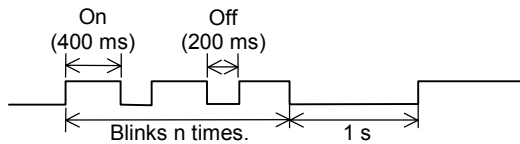

4.7.5.6 Power Unit

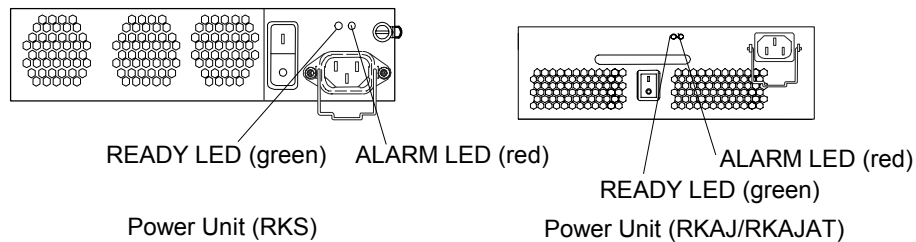

Figure 4.34 Power Unit LED Locations

Table 4.20 Power Unit LED Functions

LED	Function
READY LED (green)	When on, it indicates the operating normally.
ALARM LED (red)	When on, it indicates the abnormal or in a stop state.

4.7.5.7 Fan Assembly

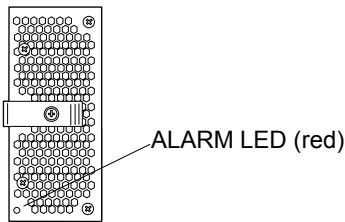

Figure 4.35 Fan Assembly LED Locations

Table 4.21 Fan Assembly LED Functions

LED	Function
ALARM LED (red)	When on or off, it indicates the operating status of the fan assembly. On: It is abnormal. Off: It is operating normally or in a stop state.

4.7.5.8 Control Unit

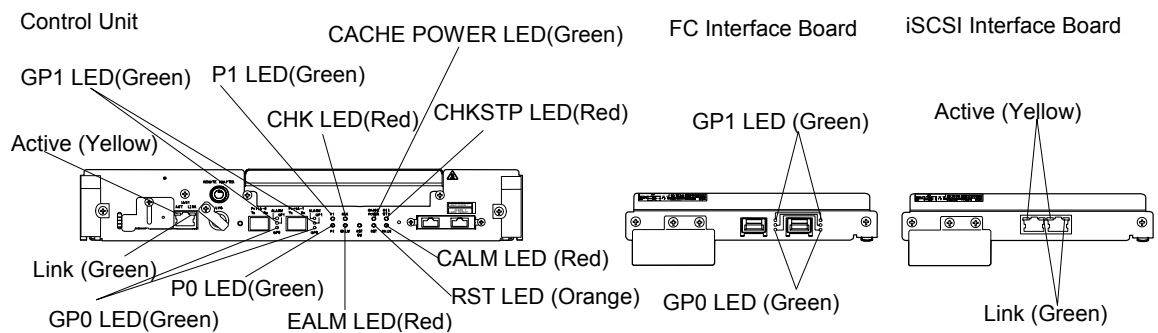
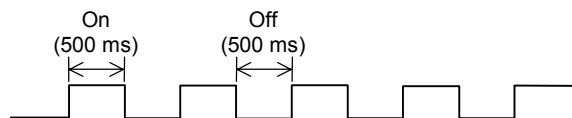

Figure 4.36 Control Unit LED Locations

Table 4.22 Control Unit LED Functions

LED	Function
P1 LED (green)	When on, it indicates that the link status of FC-AL (loop 1 side) is normal.
P0 LED (green)	When on, it indicates that the link status of FC-AL (loop 0 side) is normal.
EALM LED (red)	Indicates error factors by the lighting or blinking pattern. Lighting: When on, it indicates that a failure occurs in the controller (ENC side), so the controller is inoperable. Blinking: Normal blinking (Note 1) (CHK LED is on): An exceptional process error detected by the ENC microprogram. High-speed blinking (Note 2) (CHK LED is on): An exceptional process error detected by the ENC microprogram. (stack over) Normal blinking: (Note 1) (CHK LED is off): Indicates that FLASH write is performed during the ENC microprogram download. (It is not in the abnormal status.)
CHK LED (red)	It indicates error factors by means of number of blinks: Low-Speed blinking (Note 3) Once: Drive +5 V voltage is abnormal. Twice: Drive +12 V voltage is abnormal. Five times: Battery is abnormal. Six times: Voltage on the controller is abnormal. (Reset of the controller is not canceled) Seven times: BS 12 V voltage is abnormal. Nine times: Fan assembly is abnormal. The following blinking is fast because ENC microprogram detects CUDG error: High-speed blinking (Note 4) Once: SRAM error. Twice: ENC hard error. Three times: Microprogram error in flash memory. Not blinking: Boot section error of ENC microprogram, RAM error, or ENC hard configuration error.
CACHE POWER LED (green)	When on or off, it indicates the status of the cache memory backup operation. On: Backup operation is in execution. Off: Backup operation is not in execution.
RST LED (orange)	When on, it indicates that the controller is resetting.
CALM LED (red)	When on, it indicates that a failure occurs in the controller (CTL side), so the controller is inoperable.
GP0 LED (green)	It indicates the status of the interface installed in the controller is normal.
GP1 LED (green)	It indicates the status of the interface installed in the controller is normal.
CHKSTP LED (red)	When on, it indicates that a failure occurs in the controller (CTL side), so the controller is inoperable.
Active (yellow)	When on, it indicates that data is being transferred.
Link (green)	When on, it indicates that the link status is normal.

Note 1: Normal blinking:



Note 2: High-speed blinking (EALM LED):

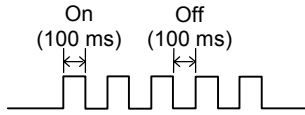

Note 3: Low-speed blinking:

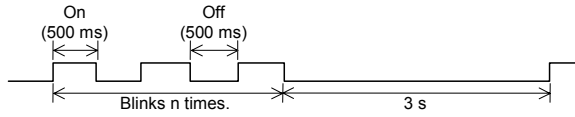

Note 4: High-speed blinking (CHK LED):

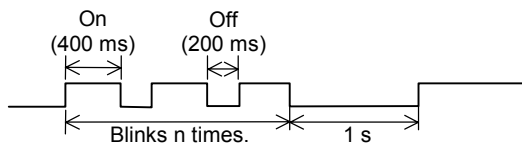

4.7.5.9 RKNAS

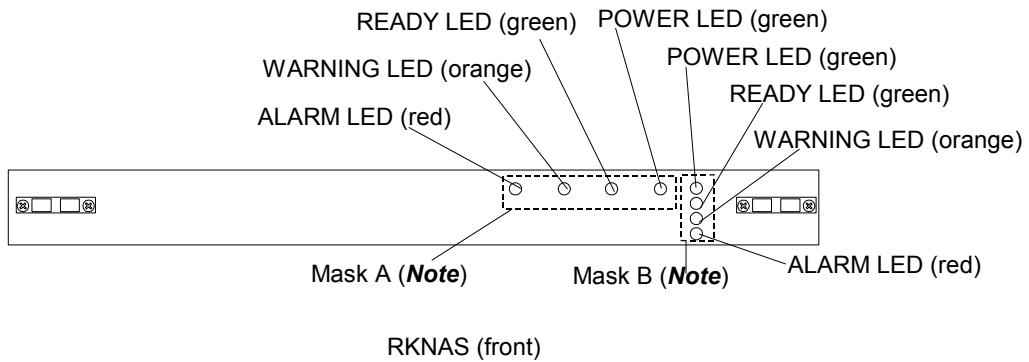

Note: Mask A or Mask B has been affixed.

Figure 4.37 RKNAS LED Locations (front)

Table 4.23 RKNAS LED Functions (front)

LED	Function
ALARM LED (red)	Indicates that a failure has occurred which makes the RKNAS inoperable.
WARNING LED (orange)	Indicates that a failure occurred, but RKNAS is currently operational.
READY LED (green)	Indicates that the RKNAS can be operated.
POWER LED (green)	Indicates that the power is supplied to the RKNAS.

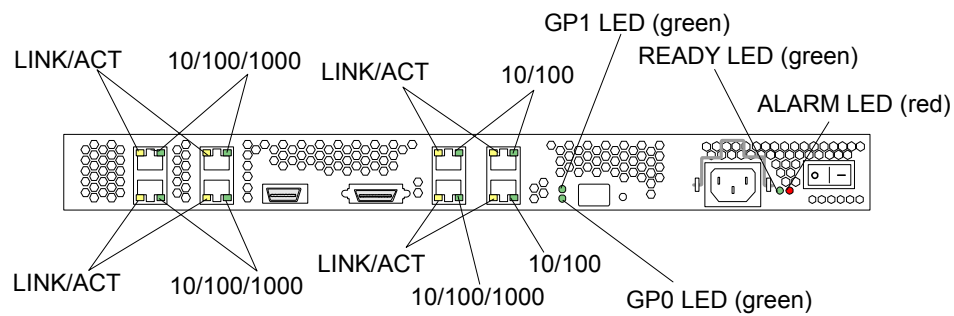

Note: Mask A or Mask B has been affixed.

Figure 4.38 RKNAS LED Locations (rear)

Table 4.24 RKNAS LED Functions (rear)

LED	Function
LINK/ACT	Indicates that the LAN for management is linked or transferring the data. Green: linked Yellow: during the data transfer
10/100/1000	Indicates the transfer rate of the LAN for management Off: 10 M, Yellow: 100M, Orange: 1000M
10/100	Indicates the transfer rate of the LAN for management Off: 10 M, Green: 100M
READY LED (green)	When on, it indicates that the AC/DC power supply operates normally. When off, it indicates that the AC/DC power supply is abnormal or in a stop state.
ALARM LED (red)	When on, it indicates that a failure occurs in the AC/DC power supply.
GP0 LED (green)/ GP1 LED (green)	It indicates the status of the interface installed in the controller is normal.

Chapter 5 Functional and Operational Characteristics

This chapter includes a description of the following:

- New AMS200 Features and Capabilities (section 5.1)
- RAID Implementations (section 5.2)
- Cache Management (section 5.3)
- Logical Units (section 5.4)
- Open System Features and Functions (section 5.5)
- Data Management Features and Functions (section 5.6)
- Copy Solution Features and Functions (section 5.7)
- Performance Management Features and Functions (section 5.8)
- NAS Features and Functions (section 5.9)
- iSCSI Features and Functions (section 5.10)

This chapter provides information on the Fibre, NAS, and iSCSI models. The following table illustrates sections that provide an explanation for each model.

- **Fibre model:** Connects disk array subsystem to a host computer with Fibre Channel interface.
- **NAS model:** Connects NAS Unit connected to disk array subsystem to a host computer with LAN interface.
- **iSCSI model:** Connects disk array subsystem to a host computer with iSCSI interface.

Sections		Fibre	NAS	iSCSI
5.1	New AMS200 Features and Capabilities	○	○	○
5.2	RAID Implementations	○	○	○
5.3	Cache Management	○	○	○
5.4	Logical Units (LUs)	○	○	○
5.5	5.5.1 Open System Middleware	○	–	○
	5.5.2 LUN Management	○	–	○
5.6	5.6.1 Cache Residency Manager Function	○	○	○
	5.6.2 LUN Manager Function	○	–	○
	5.6.3 Data Retention Utility Function	○	–	○
	5.6.4 LUN Expansion Function	○	○	○
	5.6.5 Password Protection Function	○	○	○
	5.6.6 Account Authentication Function	○	○	○
	5.6.7 Audit Logging Function	○	○	○
5.7	5.7.1 TrueCopy Remote Replication Function	○	–	–
	5.7.2 ShadowImage In-System Replication Function	○	–	○
	5.7.3 Copy-On-Write Snapshot Function	○	–	○
	5.7.4 Modular Volume Migration Function	○	○	○
	5.7.5 NAS Backup Restore Modular Function	–	○	–
	5.7.6 NAS SyncImage Modular Function	–	○	–
5.8	5.8.1 Performance Monitor Function	○	○	○
	5.8.2 Cache Partition Manager Function	○	○	○
5.9	NAS Features and Functions	–	○	–
5.10	iSCSI Features and Functions	–	–	○

- : The explanation is provided.
 –: The explanation is not provided.

5.1 New AMS200 Features and Capabilities

The Hitachi AMS200 subsystem offers the following new or improved features and capabilities, which distinguish the AMS200 subsystem from the 9200 subsystem:

- Up to 15 spare disks installable (floor RKS+H1JModel: up to 1).
- 512 logical unit numbers maximum.
- Multiple parity groups allocatable for one RAID group.

- 25 RAID groups maximum.
- The drive interface supports 2 Gbps Fibre Channel.
- A maximum of 4 Gbytes high capacity cache is supported in the dual configuration. It improves the cache percent hit rate.
- The file sharing function supported by connecting to the NAS unit
- 1 Gbps iSCSI supported by adding iSCSI interface.

5.2 Raid Implementations

The AMS200 subsystem supports RAID0, RAID1, RAID 5, RAID 6, and RAID1+0. RKAJAT does not support RAID0.

- RAID0 group stripes data across all disk drives in the group to attain higher throughput. There is no sparing disk drive function with this configuration.

Notes on Using RAID0:

- When a failure occurs in a disk drive, data cannot be restored internally within the disk array because RAID0 has no redundancy of data; therefore, although the host receives an error message, the data is left in its current state.
 - Unlike with an independent disk drive, error block management (assignment of alternative block for the independent disk drive with the Reassign Blocks command) is not done. Therefore, when a RAID0 disk drive becomes inaccessible due to a failure, all the LUs in the RAID0 configuration including the failed disk drive become inaccessible. Restoration of user data with backup data is essential after replacing the failed disk drive.
 - Do not allow RAID0 to coexist with the other RAID group; do not form a group with two or more RAID0 systems. An example = $(4D + 1P) \times 2 + 2D$.
 - Each time a failure occurs in a RAID0 disk drive, data that cannot be written into the disk drive (pinned data) is accumulated in the cache.
 - When the amount of accumulated data exceeds a certain value, a write I/O instructed to the other RAID group cannot be accepted and the system goes down. (In this case, restoration of user data and resynchronization of a file system using the backup data are required for the entire subsystem; therefore, the time necessary for recovery is lengthy.)
 - Do not adopt the RAID0 configuration to its fullest extent. Consider the above notes when building the configuration.
- RAID1+0 groups provide data redundancy like RAID1 by copying all the contents of two disk drives to another pair. Different from RAID1, data striping is performed for a maximum of 16 sets of two disk drives.
 - RAID1 array groups consist of at least two disk drives in a mirrored configuration. Data is mirrored across the groups of two adjacent drives. The stripe consists of two data chunks.
 - RAID5 applies 2 to 15 data disks and has a parity disk which performs the data striping.

- RAID 6 applies 2 to 28 data disks, and has two parity disks performing the data stripping. Configuration with two parity disks provides redundancy that can sustain two point failures.

The RAID specification is shown in the following table:

Table 5.1 Rack-Mount and Floor Model RAID Specifications

Item	Model		Rack-Mount Model		
			RKS	RKAJ	RKAJAT
RAID specifications	RAID level		0/1/5/6/1+0		1/5/6/1+0
	RAID Configuration (unit of addition)	RAID0	2D~15D		–
		RAID1	1D+1D		
		RAID 5	2D+1P~14D+1P		
		RAID 6	2D+2P~13D+2P		
		RAID 1+0	2D+2D~7D+7D		

Note: For information about the global rack-mount model, refer to the *Hitachi Data Systems Global 19-Inch Rack Reference Guide (MK-93DF772)*.

Table 5.2 Floor Model RAID Specifications

Item	Model		Floor Model		
			Floor (RKS+H1J) Model	Floor (RKS+RKAJ+H2J) Model	Floor (RKS+RKAJAT+H2J) Model
RAID specifications	RAID level		0/1/5/6/1+0		1/5/6/1+0
	RAID Configuration (unit of addition)	RAID0	2D~15D	2D~16D	–
		RAID1	1D+1D		
		RAID 5	2D+1P~14D+1P	2D+1P~15D+1P	
		RAID 6	2D+2P~15D+2P	2D+2P~15D+2P	
		RAID 1+0	2D+2D~7D+7D	2D+2D~8D+8D	

5.3 Cache Management

Cache management features include the following:

- Data is stored in cache when reading and writing; it is dynamically managed, depending on the workload read and write I/O characteristics. A high percent cache hit rate is expected, due to transaction processing (data is updated after it is referenced). System throughput is increased by the reduced data writing time.

- Writing completion is reported to the host at the same time the data is written onto the cache; the write operation onto the disk will be asynchronously performed later. The host can perform the next process without waiting for the write operation onto disk.
- The data written onto the cache is saved in the event of an electric power failure due to the nonvolatile cache. The data is assured for 24 hours on the full charge of a standard configuration.
- One specified logical unit on each controller can be resident in cache. High throughput can be realized for the specified logical unit since a 100% cache percent hit rate is expected when reading and writing from the host.

Cache specifications are shown in the following tables:

Table 5.3 Rack-Mount Model Cache Specifications

Item	Model	Rack-Mount Model	
		RKS	RKAJ
Cache specifications	Capacity (M bytes/CTL)	1,024 to 2,048	-
	Control method	Read LRU (Notes) /Write after	-
	Battery backup	Provided	-
	Backup duration (h)	24 (When cache of 2,048 M bytes/CTL is installed)	-

Notes:

- LRU is an abbreviation for Least Recently Used.
- For information about the global rack-mount model, refer to the *Hitachi Data Systems Global 19-Inch Rack Reference Guide (MK-93DF772)*.

Table 5.4 Floor Model Cache Specifications

Item	Model	Floor Model		
		Floor (RKS+H1J) Model	Floor (RKS+RKAJ+H2J) Model	Floor (RKS+RKAJAT+H2J) Model
Cache specifications	Capacity (M bytes/CTL)	1,024 to 2,048		
	Control method	Read LRU/Write after (Note)		
	Battery backup	Provided		
	Backup duration (h)	24 (When cache of 2,048 MB/CTL is installed)		

Note: LRU is an abbreviation for Least Recently Used.

5.4 Logical Units (LUs)

The AMS200 supports up to 512 LUNs. Each LU is identified by fibre-channel port ID and LUN number. However, up to 256 LUs can be assigned to a host group.

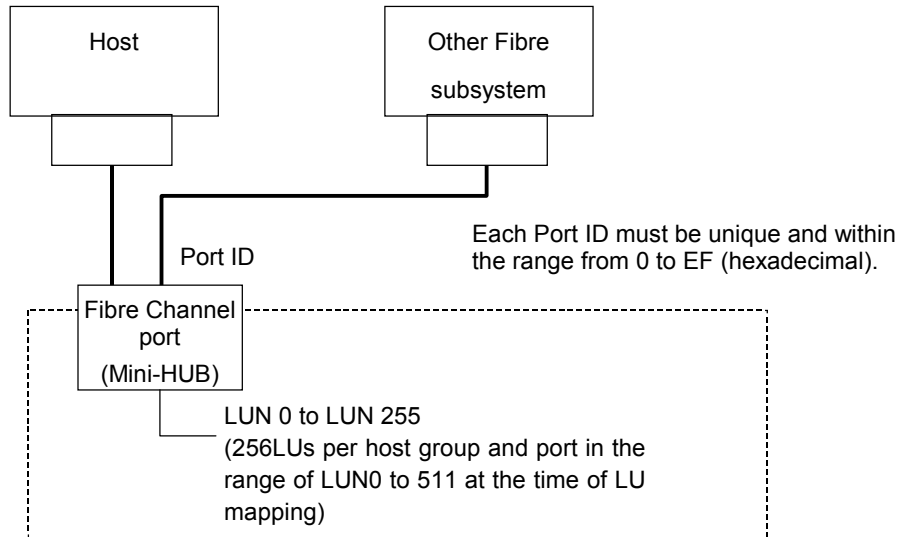

Figure 5.1 Logical Units (without FC interface board addition to control unit)

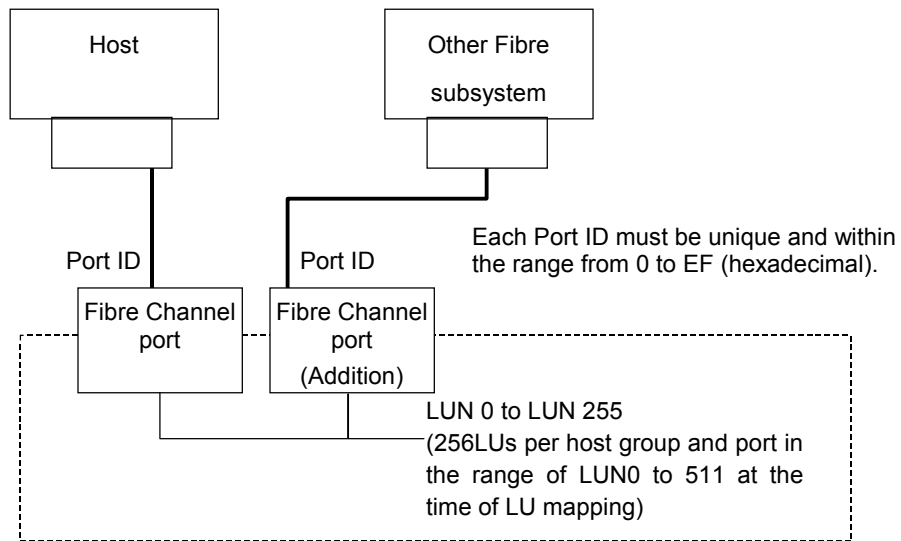

Figure 5.2 Logical Units (with FC interface board addition to control unit)

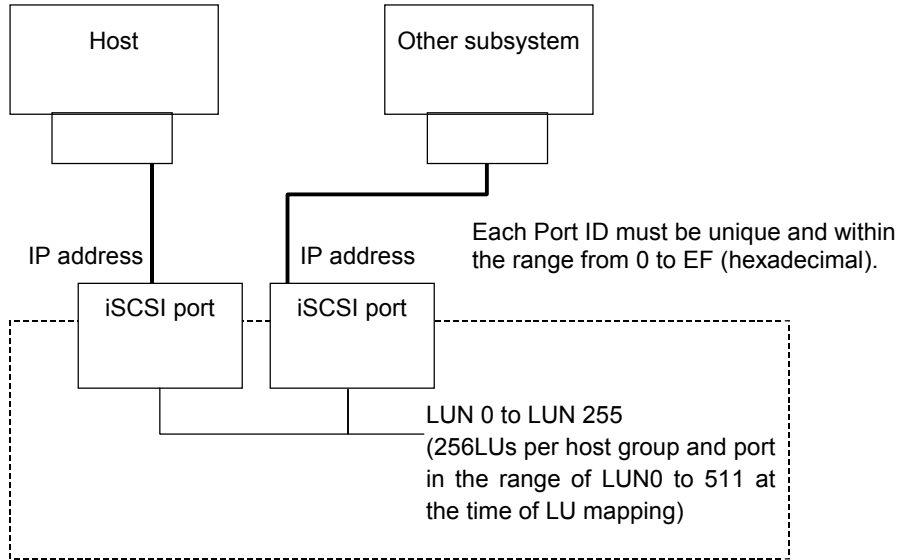

Figure 5.3 Logical Units (With iSCSI interface board addition to control unit)

When the AMS200 is used as a NAS model, nine logical units need to be assigned as system LUs. A maximum of 503 logical units can be set for a user LU.

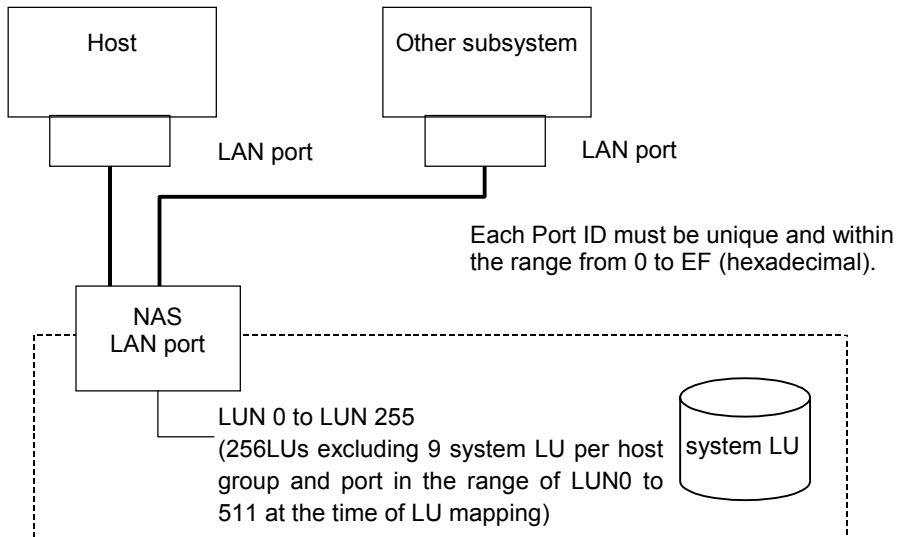

Figure 5.4 Logical Units (NAS Model)

5.5 Open Systems Features and Functions

The AMS200 subsystem offers many features and functions specifically for the open-systems environment. The AMS200 subsystem also supports important open-system functions, such as fibre-channel arbitrated-loop (FC-AL) and fabric topologies, command tag queuing, multi initiator I/O, and most industry-standard software and middleware products which provide host fail-over, I/O path fail-over, and logical volume management functions.

5.5.1 Open Systems Middleware

Open-system middleware products provide host fail-over capability, I/O path fail-over support, and logical volume management in the open-systems environment. Middleware is not usually supplied as part of the basic operating system.

5.5.2 Logical Unit Mapping

Each LUN can be assigned to multiple fibre-channel ports or iSCSI ports to provide I/O path fail-over with middleware support.

5.6 Data Management Features and Functions

These features include:

- Cache Residency Manager Function
- LUN Manager Function
- Data Retention Utility Function
- LUN Expansion Function
- Password Protection Function
- Account Authentication Function
- Audit Logging Function

5.6.1 Cache Residency Manager Function

The Cache Residency Manager function ensures that all data in an LU is stored in cache memory. All read/write commands to the LU can be executed by cache hit 100% without accessing the drive. The system throughput is improved when this function is applied to an LU that contains data accessed frequently because no latency period is needed to access the disk drive.

5.6.2 LUN Manager Function

The LUN Manager has four main functions: Fibre security control and host group (for Fibre Channel interface), or iSCSI security control and target (for iSCSI interface).

- **Fibre Channel Interface**

The Fibre security control function controls the access from specific hosts or specific commands.

This function enables the subsystem to respond to each connected host (even within the same port) by grouping connected hosts within a port and setting the logical unit mapping and the Host Connection mode for each host group.

- **iSCSI Interface**

The iSCSI security function controls access from specified hosts or specific commands.

The target group function enables the subsystem to respond to each connected host (even within the same port) by grouping the connected hosts within a port and setting the local unit mapping and Host Connection mode for each group. Up to 128 targets can be set for one port. Authentication can be performed for each target by using the CHAP authentication concurrently.

5.6.3 Data Retention Utility Function

The Data Retention Utility feature prevents the logical unit (volume) from being accessed illegally by the host.

5.6.4 LUN Expansion Function

The LUN Expansion function expands the size of a logical unit (volume) accessed by a host computer by combining multiple logical units (volumes) internally.

5.6.5 Password Protection Function

The Password Protection function restricts the number of Storage Navigator Modular users who are allowed to access a disk array subsystem; it also prevents simultaneous access from multiple users.

5.6.6 Account Authentication Function

The Account Authentication function authenticates login to the array unit based on the account information registered by the user and controls the access to the subsystem resource. This prevents the illegal operation by the unauthorized person.

5.6.7 Audit Logging Function

The Audit Logging function generates a syslog to audit the event when the user performs the setting operation for the disk array subsystem, and outputs the syslog to the external server.

5.7 Copy Solution Features and Functions

The AMS200 subsystem provides features and functions which allow you to maintain remote and subsystem internal copies of all user data on the AMS200 storage subsystem for data backup or duplication. These features include:

- TrueCopy Remote Replication Function
- ShadowImage In-System Replication Function
- Copy-On-Write Snapshot Function
- Modular Volume Migration Function
- NAS Backup Restore Modular Function
- NAS Sync Image Modular Function

5.7.1 TrueCopy Remote Replication Function

The Synchronous TrueCopy feature enables you to maintain remote copies of all user data on the Hitachi AMS200 storage subsystem for data backup or duplication. The duplicated volumes are created between subsystems that are connected with a Fibre Channel interface.

5.7.2 ShadowImage In-System Replication Function

The Hitachi Data Systems ShadowImage In-System Replication function enables you to maintain subsystem-internal copies of all user data on the AMS200 storage subsystem for purposes such as data backup or duplication. The duplicated volumes are created within the same AMS200 subsystem as the primary volume.

ShadowImage In-System Replication operations are non-disruptive and allow the primary (main) volume of each volume pair to remain online to all hosts for both read and write I/O operations. Once established, ShadowImage In-System Replication operations continue unattended to provide asynchronous internal data backup. Usability is further enhanced through a resynchronization capability that reduces data duplication requirements and backup time, thereby increasing user productivity.

5.7.3 Copy-On-Write Snapshot Function

The Hitachi Copy-On-Write Snapshot feature enables you to maintain a logical copy of logical units (volumes) at a point in time between the disk array subsystems.

5.7.4 Modular Volume Migration Function

The Modular Volume Migration function migrates the LU which receives the host operation to another RAID group within a disk array subsystem.

5.7.5 NAS Backup Restore Modular Function

The NAS Backup Restore Modular function protects data that is shared in the NAS Modular system. The NAS Backup Restore Modular function provides the following functions to protect data:

- Snapshot Function
- Backup Restore Function

5.7.6 NAS Sync Image Modular Function

The NAS Sync Image Modular function creates a snapshot which enables data to recover to the state that existed, prior to changes. This data can be recovered even when file system data shared in the NAS Modular system was accidentally changed.

5.8 Performance Management Features and Functions

This feature includes:

- Performance Monitor functions
- Cache Partition Manager functions

5.8.1 Performance Monitor Function

The Performance Monitor acquires information about the performance of RAID groups and logical units, etc. of the subsystem. It also acquires utilization rates of resources such as hard disk drives and processors built in the subsystem. This information is displayed with line graphs in the monitor.

5.8.2 Cache Partition Manager Function

This function is to enhance the performance by cache area division, segment size specification, and assignment for separate LU.

5.9 NAS Features and Functions

The AMS200 and RKNAS combination enables different servers connected via the LAN to share data easily using the NFS/CIFS protocol of the LAN (GbE) interface. The AMS200 supports the following functions:

- NAS Data Control Modular
- NAS File Sharing Modular
- NAS Manager Modular
- NAS Backup Restore Modular Function
- NAS Sync Image Modular Function
- NAS Anti Virus Agent Modular

5.9.1 NAS Data Control Modular Function

The NAS Data Control Modular function provides the basic functions of NAS system.

5.9.2 NAS File Sharing Modular Function

The NAS File Sharing Modular function provides the operating system function of NAS system.

5.9.3 NAS Manager Modular Function

The NAS Manager Modular function provides the setup, operation and management functions for the NAS system.

5.9.4 NAS Backup Restore Modular Function

Refer to section 5.7.5 NAS Backup Restore Modular Function.

5.9.5 NAS Sync Image Modular Function

Refer to section 5.7.6 NAS Sync Image Modular Function.

5.9.6 NAS Anti-Virus Agent Modular Function

The NAS Anti-Virus Agent Modular function provides the NAS system with virus scan functions such as scan server registration, scan condition setting, and virus scan function start/stop.

5.10 iSCSI Features and Functions

1 Gbps iSCSI is supported by adding iSCSI interface to the AMS200. The AMS200 supports the following functions:

- CHAP Authentication
- iSNS Client

5.10.1 CHAP Authentication

User authentication is performed for each target.

5.10.2 iSNS Client

The iSNS client function enables you to use iSCSI device discovery, state change notification on the network easily.

Chapter 6 Configuring the AMS200 Storage System

This chapter includes the following:

- Overview of Configuration (section 6.1)
- Configuring the LAN Interface of the AMS200 Storage System (section 6.2)
- Configuring the AMS200 Storage System (section 6.3)
- Registering the AMS200 Storage System for Control by Storage Navigator-Modular (section 6.4)
- Configuring the AMS200 Storage System for the Desired Application (section 6.5)
- AMS200 Storage System General Configuration (section 6.6)

This chapter provides information on the Fibre, NAS, and iSCSI models. The following table illustrates sections that provide an explanation for each model.

- **Fibre model:** Connects disk array subsystem to a host computer with Fibre Channel interface.
- **NAS model:** Connects NAS Unit connected to disk array subsystem to a host computer with LAN interface.
- **iSCSI model:** Connects disk array subsystem to a host computer with iSCSI interface.

Sections		Fibre	NAS	iSCSI
6.1	6.1.1 Open Systems Configuration	○	–	○
	6.1.2 Defining LUNs	○	○	○
	6.1.3 Fibre Channel Interface Addressing	○	–	○
	6.1.4 iSCSI Interface Addressing	–	–	○
	6.1.5 Alternate Pathing	○	–	○
	6.1.6 NAS Configuration	–	○	–
6.2	Configuring the LAN Interfaces Addressing	○	○	○
6.3	Configuring the AMS 200 Storage System	○	○	○
6.4	Registering the AMS 200 Storage System for Control by Storage Navigator – Modular	○	○	○
6.5	Configuring the AMS 200 Storage System for the Desired Application	○	○	○
6.6	General Configuration of the AMS 200 Storage System	○	○	○

○: The explanation is provided.

–: The explanation is not provided.

6.1 Overview of Configuration

This section includes the following information on configuration:

- Open Systems Configuration
- Defining LUNs
- Fibre Channel Interface Addressing
- iSCSI Interface Addressing
- Alternate Pathing
- NAS Configuration

6.1.1 Open Systems Configuration

- Fibre Channel

The AMS200 subsystem uses the HP 9000 series, Sun Fire™ series, Sun Enterprise™ series, RS/6000® Family, and each vendor PC (HP-UX, Solaris™, AIX® IRIX tru64, Linux®, Windows® 2000, Windows 2003) as a supported platform. For each open system, installation is required.

- iSCSI

The AMS200 uses Linux, Windows 2003, and Windows XP as a supported platform. For each open system, installation is required.

6.1.2 Defining LUNs

The Storage Navigator Modular software enables the user to define the LUN mapping for each device and reconfigure the mapping at any time. For further information on Storage Navigator Modular, please refer to the *Hitachi TagmaStore® Adaptable Modular Storage and Workgroup Modular Storage Navigator Modular Graphical User Interface (GUI) User's Guide* (MK-95DF711) to use a GUI interface. See the *Hitachi TagmaStore® Adaptable Modular Storage and Workgroup Modular Storage Navigator Modular Command Line Interface (CLI)* (MK-95DF712) to use the CLI version.

6.1.3 Fibre Channel Interface Addressing

One Fibre Channel port is assigned a target ID by addressing port ID. The AMS200 can address up to 256 logical unit numbers for one port. Host computer accesses to the logical unit with the required logical unit number by identifying the port of disk array subsystem using target ID. The following figure illustrates fibre channel port addressing and logical unit number assignment.

6.1.3.1 When the FC Interface Board is Not Added

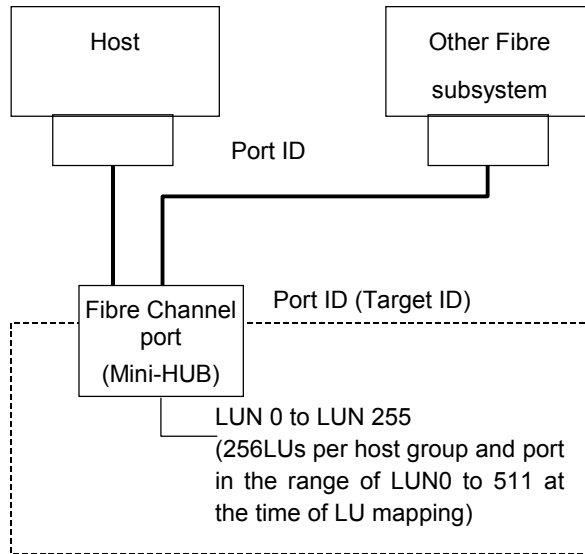

Figure 6.1 Fibre Channel Port-to-LUN Addressing (FC interface board not added)

6.1.3.2 When the FC Interface Board is Added

The AMS200 host interface implements two ports and two host connectors. One Fibre Channel port configures the FC interface independent of another Fibre Channel port, and implements one host connector.

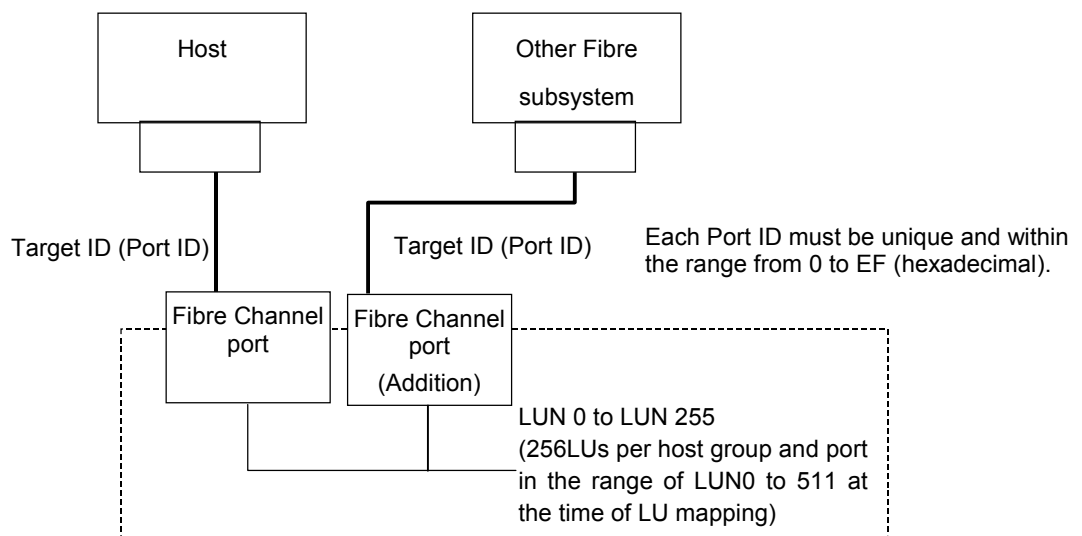

Figure 6.2 Fibre Channel Port-to-LUN Addressing (FC interface board added)

6.1.4 iSCSI Interface Addressing

The AMS200 supports 4 iSCSI ports by adding iSCSI interface board. The iSCSI port is assigned a target ID by addressing port ID. The AMS200 can address up to 256 logical unit numbers for one port. Host computer accesses to the logical unit with the required logical unit number by identifying the port of disk array subsystem using target ID. The following figure illustrates iSCSI port addressing and logical unit number assignment.

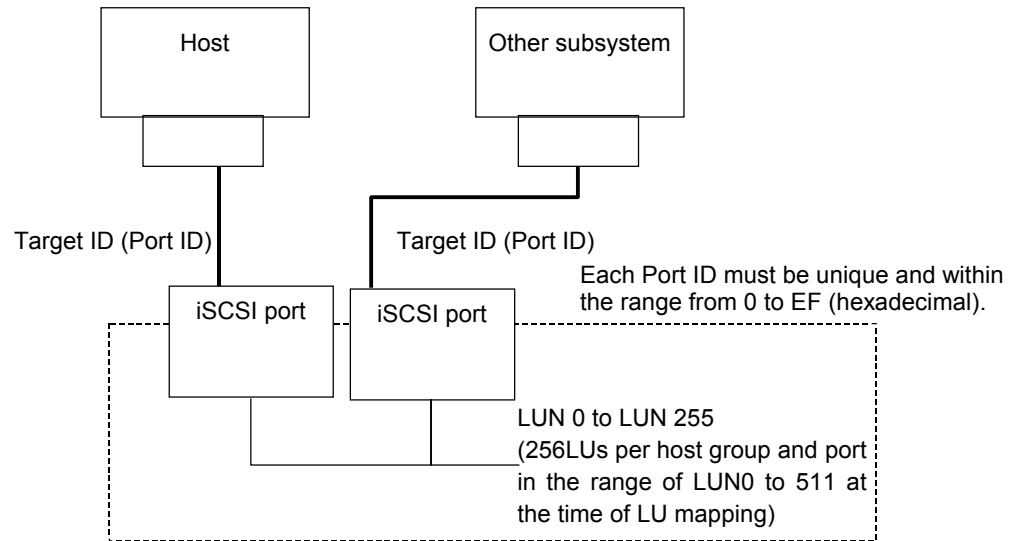

Figure 6.3 iSCSI Port-to-LUN Addressing (iSCSI interface board installed)

6.1.5 Alternate Pathing

The user should plan for alternate pathing to ensure the highest data availability. The AMS200 provides up to 2 fibre channel ports or to accommodate alternate pathing for host attachment. The following figure shows a sample of alternate pathing.

6.1.5.1 When the FC Interface Board is Not Added to the Control Unit

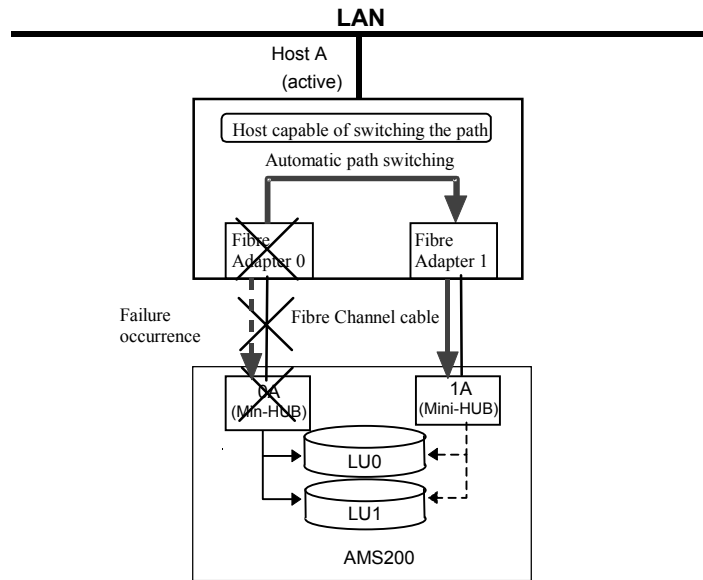

Figure 6.4 Alternate Pathing (FC interface board not added)

6.1.5.2 When the FC Interface Board is Added to the Control Unit

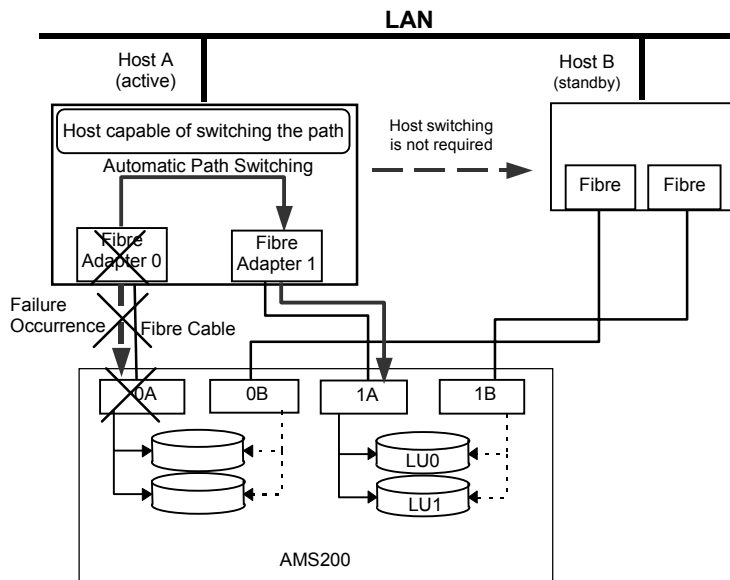

Figure 6.5 Alternate Pathing (FC interface board added)

6.1.5.3 When the iSCSI Interface Board is Added to the Control Unit

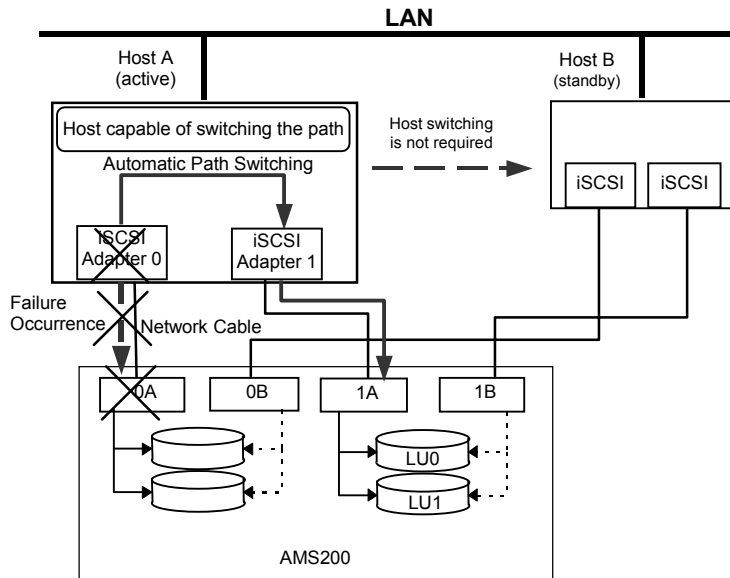

Figure 6.6 Alternate Pathing (iSCSI interface board added)

6.1.6 NAS Configuration

NAS Modular system operation management software includes management software on the PC (Storage Navigator Modular, NAS Setup, and WEB browser) and NAS Manager Modular.

Operation management (NAS OS, disk array subsystem) on the disk array side from the NAS OS (NAS File Sharing Modular, NAS Data Control Modular) is performed by maintenance software on the PC. Operation management on the host side from the NAS OS (file system, fail-over function) is performed by NAS Manager Modular.

The system administrator gives instructions to the NAS Manager Modular using the WEB browser from the NAS management console. The NAS Manager Modular, which receives the instruction, performs the instructions coordinating with NAS OS or other software.

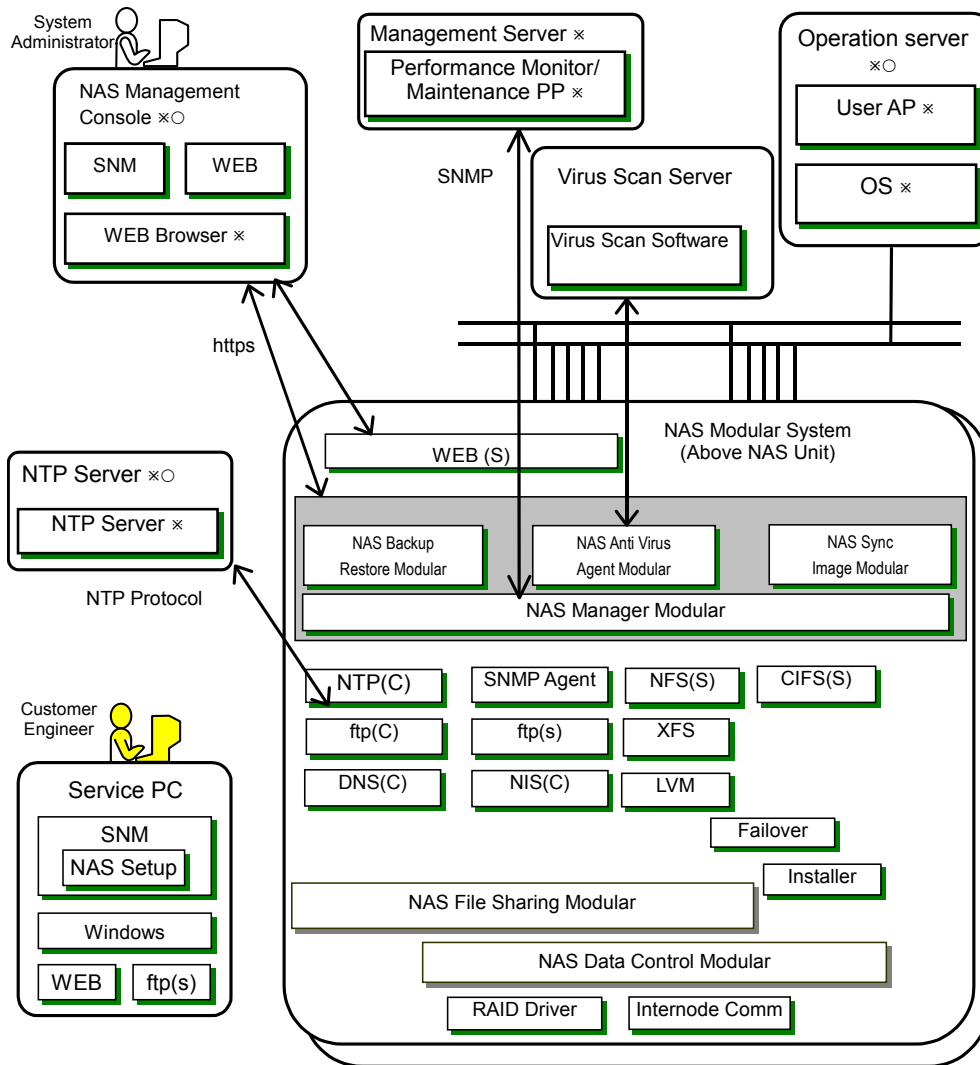

Explanatory notes: (S): Server
(C): Client
*: Indicates a product other than NAS-related products. User needs to prepare the product separately.
○: Indicates a server that is indispensable to the operation.

TagmaStore AMS200

6.2 Configuring LAN Interfaces of the AMS200 Storage System

When you use the following applications or functions via a LAN port of subsystem, the following settings are required;

Application / Function	Setting
- Obtaining subsystem information on WEB browser	1. IP address Setting
- SNMP Agent Support Function	2. Negotiation Setting
- Referring information and setting parameters on Storage Navigator Modular	1. IP address Setting 2. Negotiation Setting

If these settings are incorrect, the communication cannot be made normally.

Note: Set these settings after an array subsystem becomes Ready.

6.2.1 Setting the IP Addresses

The factory IP address settings are:

- IP address of controller: 192.168.0.16
- Subnet mask: 255.255.255.0
- Default gateway: 0.0.0.0

Use Storage Navigator Modular to set or change these IP addresses (refer to section 7.13).

If you set these addresses without using the DHCP function, note the following:

- Do not use the values: '0', '127' or '255' in the first field of the IP address. For example, you cannot set 0.xxx.xxx.xxx, 127.xxx.xxx.xxx, or 255.xxx.xxx.xxx.
- The following IP addresses are reserved for the NAS unit. You cannot assign these addresses to the management LAN port or the data LAN port of the NAS unit.
 - 172.29.1.xxx
 - 172.29.2.xxx
 - 172.29.3.xxx
 - 172.29.4.xxx
- Be sure to set the subnet mask correctly. Note that you cannot use a discontinuous one-bit IP address. An example of this is 255.0.255.0
- Do not use the values 0 or 255 to set the host or default gateway IP addresses. For example, when a subnet mask is 255.255.255.0, you cannot set 192.168.0.0 as the IP address and 192.168.0.255 for and default gateway address.
- Set the same IP address for both the host and the default gateway. For example, when the subnet mask is 255.255.255.0 and the IP address is 192.168.0.16, you cannot set 192.168.1.1 as the default gateway.
- Set the individual IP addresses for the user port and the maintenance port. For example, when a subnet mask is 255.255.255.0 and IP address of maintenance port is 10.0.0.16, you cannot set 10.0.0.xxx for user port.

Note: If no default gateway address is specified, set "0.0.0.0".

Note: When the IP address of the LAN device which is connected via the gateway to the user management port is the same as the IP address of the maintenance port, the communication may fail because of the conflict between them. If this happens, change either the IP address of the LAN device or the IP address of the maintenance port (refer to section 7.16).

- Negotiation Setting

Each controller is shipped with auto negotiation mode (10M/100M/half-duplex/full-duplex). Negotiation can be set or changed by Storage Navigator Modular. (Refer to section 7.13.)

Note: For best performance, set the negotiation settings of the subsystem to be the same as the negotiation settings of the device connected to the LAN port. If the negotiation of the subsystem is different from the negotiation of the device connected to LAN port, the throughput or response performance of network communication may decrease and the control Unit may not communicate with the destination device across a network.

- LAN Port Number Setting

The subsystem is shipped with LAN port number set “2000”. Use Storage Navigator Modular to set or change these IP addresses (refer to section 8.8)

Note: If you do not know the LAN port number, see the section titled “Confirming the LAN Port Number with Web” in section 8.9, and follow the instructions to obtain the LAN port number.

6.3 Configuring the AMS200 Storage System

The following steps must be performed to configure the disk array:

1. Verify that the subsystem is connected to the LAN.
2. Install Storage Navigator-Modular on the system that will be used as the management PC/Server.

See the *Hitachi TagmaStore® Adaptable Modular Storage and Workgroup Modular Storage Navigator Modular Graphical User Interface (GUI) User's Guide (MK-95DF711)* to use a GUI interface. See the *Hitachi TagmaStore® Adaptable Modular Storage and Workgroup Modular Storage Navigator Modular Command Line Interface (CLI) (MK-95DF712)* to use the CLI version.

Refer to the section titled **Installing Storage Navigator-Modular** for instructions on how to install the program.

3. Register the disk array for control by Storage Navigator-Modular.
4. Set the system parameters using the appropriate installation guide for the desired host platform(s).
5. Reboot the disk array to complete the configuration.

Note: If the subsystem is configured when the disk array subsystem is used as the remote side of TrueCopy Remote Replication, the following occurs:

- Both paths of TrueCopy Remote Replication are blocked.
The notice of SNMP Agent Support Function and TRAP occur at the time of the path blockade. Perform the notice and the check to the Failure Monitoring Department in advance. The path blockade automatically recovers after restarting.

- If the pair status of TrueCopy Remote Replication is PAIR or COPY, the pair status transits to PSUE.

When the disk array subsystem must be configured, transit the pair status of TrueCopy Remote Replication to PSUS, and then configure the subsystem.

Note: If the setting operation is performed for the array unit connected to the NAS unit, the cluster between the NAS Units stops. When the setting operation for the array subsystem is unavoidably performed, execute it after stopping the cluster between the NAS Units and stopping the NAS OS of both NAS Units. Start the cluster between the NAS Units again after completing the setting operation for the array subsystem.

6.4 Registering the AMS200 Storage System for Control by Storage Navigator-Modular

To operate the array unit from Storage Navigator-Modular, register the array unit. You cannot temporarily register a non-existing array unit:

1. From the Edit menu, click **Add Automatically**.
2. On the **Add Array Unit Automatically** dialog box, enter the IP address for the **From:** and **To:** boxes of the IP Addresses to Search of Search Array Unit. Click **Start**.
3. The result of the search displays.
Select the name that you want to register, and click the  button.
The selected array unit is moved from the **Search Results** list to the **Array Units to Add** list.
4. Click **OK**.
5. A message displays requesting confirmation to add the subsystems. Click **OK**.
6. The **Result** window displays. Click **Close**.

6.5 Configuring the AMS200 Storage System for the Desired Application

Before configuring the AMS200 make sure that you know the following:

- The required RAID level, based on performance and pricing criteria.
- The number and size of LUNs you wish to create.
- The controller path you wish to use to access the data on the LUNs.
- If there are any special options that need to be set that are specific to the host platform(s) being used. These will be detailed in the Host Installation Manual for the host platform being used.

6.6 AMS200 Storage System General Configuration

Activating Management mode in Storage Navigator-Modular will enable you to do a general configuration of the AMS200 subsystem. Before it is possible to configure the AMS200, management mode must be enabled in Storage Navigator-Modular. Otherwise, it is only possible to monitor the status of the AMS200.

To enable Management Mode:

1. From the **Tools** menu, click **Operation Mode**, and then click **Set Password**.
2. Enter **Old Password**, **New Password** and **New Password** (for confirmation) and click **OK**.
Specify a password of up to 12 alphanumeric characters.
3. On the **Tools** menu, select **Operation Mode**, and then click **Change**. Alternatively, click **Change Mode** on the tool bar.
4. When the **Password-input** window displays, enter a password and click **OK**. **Management Mode** displays in Operation Mode in the upper part of the Main window. The Storage Navigator-Modular program operates in Management Mode.

Chapter 7 Configuring Storage on the AMS200 Storage System

The process of configuring storage on the AMS200 subsystem involves the following sub-processes:

- Software Composition (section 7.1)
- Setting Fibre Channel Information (section 7.2)
- Setting iSCSI Information (section 7.3)
- Determining Space and RAID Level Requirements (section 7.4)
- Setting Host Group Information (section 7.5)
- Setting Target Information (section 7.6)
- Setting CHAP Authentication (section 7.7)
- Transferring Configurations from One Array to Another (section 7.8)
- Storing Configuration Data (section 7.9)
- Applying Configuration Data to an Additional AMS200 Storage System (section 7.10)
- Setting Host Connection Parameters (section 7.11)
- Setting the Storage System when Using Special Mode (section 7.12)
- Changing the Network Parameter (section 7.13)
- Changing the Auto diagnosis Threshold for Fibre Channel Loop (section 7.14)
- Changing the IP Address for the Maintenance Port (section 7.15)
- Setting the System LU and User LU in the NAS System (section 7.16)
- Setting the NNC Management LAN Port Information in the NAS System (section 7.17)
- Setting the Time Zone (section 7.18)

This chapter provides information on the Fibre, NAS, and iSCSI models. The following table illustrates sections that provide an explanation for each model.

- **Fibre model:** Connects disk array subsystem to a host computer with Fibre Channel interface.
- **NAS model:** Connects NAS Unit connected to disk array subsystem to a host computer with LAN interface.
- **iSCSI model:** Connects disk array subsystem to a host computer with iSCSI interface.

Sections		Fibre	NAS	iSCSI
7.1	7.1.1 Microprogram	○	○	○
	7.1.2 System Parameters	○	○	○
	7.1.3 Configuration Information	○	○	○
	7.1.4 SNMP Information	○	○	○
	7.1.5 Storage for Parameters	○	○	○
7.2	Setting Fibre Channel Information	○	–	–
7.3	Setting iSCSI	–	–	○
7.4	7.4.1 Setting a Spare Disk	○	○	○
	7.4.2 Canceling a Spare Disk Setting	○	○	○
	7.4.3 Setting a RAID Group	○	○	○
	7.4.4 Deleting a RAID Group	○	○	○
	7.4.5 Setting a Logical Unit	○	○	○
	7.4.6 Deleting the Last Logical Unit	○	○	○
	7.4.7 Formatting a Logical Unit	○	○	○
	7.4.8 Changing the Format Mode	○	○	○
	7.4.9 Changing the Default Controller in Charge of an LU	○	○	○
7.5	7.5.1 Setting Mapping Information	○	–	–
7.6	7.6.1 Changing Target Information	–	–	○
7.7	Setting CHAP authentication information	–	–	○
7.8	Transferring Configuration	○	○	○
7.9	Storing Configuration Data	○	○	○
7.10	Applying Configuration Data to Another AMS 200 Storage System	○	○	○
7.11	7.11.1 Simple Setting	○	–	○
	7.11.2 Detailed Setting for Each Host Connection	○	–	○
7.12	Setting the Storage System When Using Special Mode	○	○	○
7.13	Changing the Network Parameter	○	○	○
7.14	Changing the Auto diagnosis Threshold for Fibre Channel Loop	○	○	○
7.15	Changing the IP Address for the Maintenance Port	○	○	○
7.16	Setting the System LU and User LU in the NAS System	–	○	–
7.17	Setting the NNC Management LAN Port Information in the NAS System	–	○	–
7.18	Setting Time Zone	○	○	○

○: The explanation is provided.

–: The explanation is not provided.

7.1 Software Composition

This section includes the following:

- Microprogram
- System parameters
- Configuration information
- SNMP information
- Storage for parameters

7.1.1 Microprogram

A microprogram controls basic hardware operations which accompany the execution of given instructions performed by a CPU. The version of the microprogram is controlled by the following numerical format: **xxxxx/xx**.

The microprogram **07xxx/xx** (x is optional), is available. However, /x may not be included in the microprogram version number or another control system may control the microprograms.

NAS model has NAS OS and BIOS. NAS OS controls file service and NAS management function. The version is managed by the following numerical format: **xx-xx-xx** (x is optional). BIOS controls RKNAS initialization and NAS unit full memory dump (hereinafter referred to as NAS dump) collection function. The version is managed by the following numerical format: **xxxxxxxx** (x is optional).

7.1.2 System Parameters

System parameters are necessary to start the subsystem (from turning on the main switch of RKS to generation of the RDY LED (green) of RKS). System parameters are stored in flash memory. They can be backed up to a disk drive. When the system parameter changes, make a backup copy on the disk drive.

7.1.3 Configuration Information

The configuration information is a record of customer data on the subsystem, such as the RAID configuration and LU capacity. The configuration information exists in the disk drive when the main switch is turned off; it is transmitted onto the main memory of the controller when the main switch is turned on. When configuration information is changed, the information on the disk drive is updated simultaneously.

7.1.4 SNMP Information

The SNMP parameter enables the SNMP function to operate effectively. When SNMP information activates the SNMP function, the template contained in the SNMP information (in the SNMP directory on the provided CD-R) is edited and registered in the subsystem.

7.1.5 Storage for Parameters

The storage areas where the parameters on the controller are stored are described in Table 7.1.

Table 7.1 Storage for Parameters

No.	Parameter	Storage	Description
1	Fixed Part Program Flash Program System Parameters	Flash Memory (and backup FD)	The parameters are stored in flash memory. No provision of storage against a power shut off is required for the parameters because flash memory can retain information when power is shut off. Parameters can be backed up to the following: <ul style="list-style-type: none">▪ Fixed part program: N/A.▪ Flash program: Automatically backed up to the system area.▪ System parameters: Automatically backed up to the disk drive.
2	Microprogram Configuration Information SNMP Information	Disk Drive (System Area)	Generally, information in a RAM is erased when the main switch is turned off. Therefore, the subsystem also stores the parameters used on the RAM on the disk drive. (An area is reserved in the disk drive to store them. This area is called the system area.) The system area is provided on the disk drives #0 to #4 in the RKS frame. Therefore, the system area has redundancy for disk drives #0 to #4 in the RKS frame.

7.2 Setting Fibre Channel Information

Follow the steps below to set and display fibre channel information.

The Fibre Channel information setting is performed in Management mode of the Storage Navigator Modular. Therefore, the operation mode of Storage Navigator Modular needs to be switched from Normal mode to Management Mode. (Refer to section 6.6.) In Normal mode, you can only monitor the status of AMS200, but you cannot change the settings.

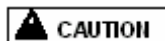

Back up all data before performing this procedure. (If a mistake in operation is made, user data in the subsystem can be lost.)

Note: Depending on the Fibre Channel interface cable connection pattern, the setting value needs to be considered. Refer to section 4.3.2.

1. Turn on the power supply.

Note: If the power supply has already been turned on, proceed to the next step.

2. Start the Storage Navigator-Modular program and set the operation mode in **Management Mode**.
3. Click the icon of an array unit on the Main window and select the **Settings** menu. Click **Display Details** or click **Display Details** on the tool bar.
4. On the **Tools** menu, select **Configuration Settings** or click **Configuration Settings** on the tool bar.
5. Click the **Fibre Channel** tab.
6. Set a **Port Address**, **Topology Information**, and **Transfer Rate**:
 - **Port Address:** Port address is displayed as a hexadecimal number.
 - **Topology Information:** Indicates the topology status.
 - **Transfer Rate:** Select 1 Gbps, 2 Gbps, 4 Gbps (at the time of adding FC interface board) or Auto.

Note: Set the "Transfer Rate" of Fibre Channel to the same value as the transfer rate of devices connected directly with an array subsystem. When the AMS200 is connected directly and externally with the TagmaStore Universal Storage Platform, set the port transfer rate of both the TagmaStore Universal Storage Platform and the AMS200 to the fixed transfer rate (the same value for the TagmaStore Universal Storage Platform and the AMS200 selecting any one of 1G bps, 2 Gbps, or 4 Gbps.).

Transfer Rate of Devices Connected with Array Subsystem	Transfer Rate of an Array Subsystem
1G bps	1G bps
2G bps	2G bps
4G bps	4G bps
Auto (Note1)	Auto (Note1)

Note 1: When an array subsystem is connected to any of the following external storage devices, set the transfer rate of devices to other than "Auto", and set the transfer rate of the array subsystem to the same transfer rate as the transfer rate of the devices to which it is connected.

- TagmaStore Universal Storage Platform
- TagmaStore Network Storage Controller
- Lightning 9900V directly

Note2 : Set the transfer rate of an array subsystem as follows.

Transfer Rate of Devices (maximum speed)	Transfer Rate of an Array Subsystem
Auto (2G bps)	2G bps
Auto (4G bps)	4G bps

Auto (unknown)	Auto
----------------	------

7. Make the setting for the other ports in the same way as step 6.
8. Click **Apply**.
9. A confirmation message displays. After verifying that the I/O operation initiated by the host has stopped, click **OK**.
10. A message displays stating the setting is completed. Click **OK**.

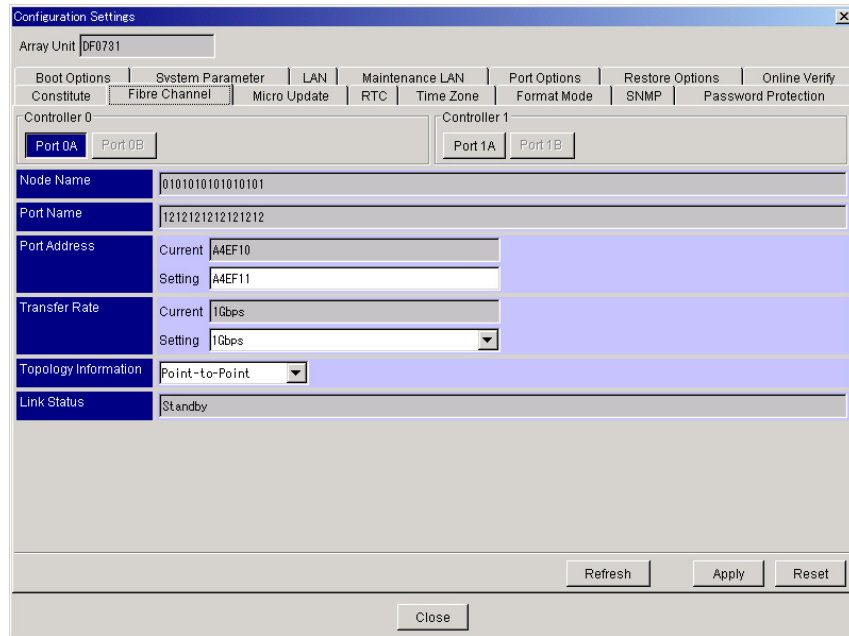

7.3 Setting iSCSI Information

7.3.1 Setting iSCSI Port Information

To set iSCSI port information, follow these steps:

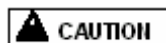

Back up all data before performing this procedure. (If a mistake in operation is made, user data in the subsystem can be lost.)

1. Turn on the power supply.

Note: If the power supply has already been turned on, proceed to the next step.
2. Start the Storage Navigator-Modular program and set the operation mode in **Management Mode**.
3. Click the icon of an array unit on the Main window and select the **Settings** menu. Click **Display Details** or click **Display Details** on the tool bar.

4. On the **Tools** menu, click **Configuration Settings** or click **Configuration Settings** on the tool bar.
5. Click the **iSCSI** tab.

Configuration Settings

Array Unit: DF700M_75000018

Boot Options | System Parameter | LAN | Maintenance LAN | Port Options | Restore Options

Online Verify | Constitute | **iSCSI** | iSNS | Ping | Micro Update | RTC | Time Zone | Format Mode | SNMP

Controller 0 | Controller 1

Port 0A | Port 0B | Port 1A | Port 1B

Network	IP Address	192.168.0.200
	Subnet Mask	255.255.255.0
	Default Gateway	0.0.0.0
	Port Number	3260
	Keep Alive Timer(sec.)	60
	MTU	1500
	Ether Address	00:00:87:68:0B:00
	Result	Normal

Refresh Apply Reset

Close

6. Set a **IP Address**, **Subnet Mask**, **Default Gateway**, **Port Number**, and **Keep Alive Timer(sec.)**.
 - **IP Address:** Specify IP address.
 - **Subnet Mask:** Specify subnet mask.
 - **Default Gateway:** Specify default gateway address.
 - **Port Number:** Specify port number. The default is 3260.
 - **Keep Alive Timer(sec.):** Specify Keep Alive Timer. The default is 60 seconds.
7. Make the setting for the other ports in the same way as step 6.
8. Click **Apply**.
9. A confirmation message displays. After verifying that the I/O operation initiated by the host has stopped, click **OK**.
10. A message displays stating that the setting is completed. Click **OK**.

7.3.2 Setting the iSNS Server Information

iSNS (Internet Storage Name Service) provides the same function as the Name Server of the Fabric Switch on the Fibre Channel interface. The iSNS information enables the host as iSCSI initiator to discover the iSCSI Name of the target with the specified IP address. The use of the iSNS is optional for the iSCSI. When using the iSNS, the disk array subsystem registers the iSCSI port information on the iSNS Server

1. From the **Tools** menu, select **Configuration Settings** or click **Configuration Settings** on the tool bar.
2. Click the **iSNS** tab.

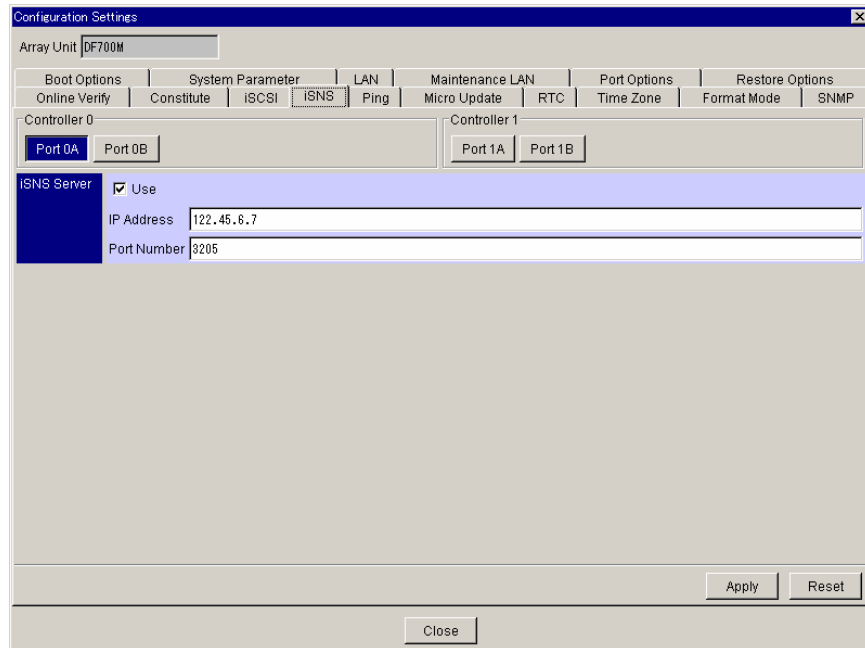

- **iSNS Server:** Specify whether to use iSNS Server or not. When using the iSNS server, specify the **IP Address** and **Port Number** of the iSNS Server.
3. Click **Apply**.
 4. A confirmation message displays. Click **OK**.

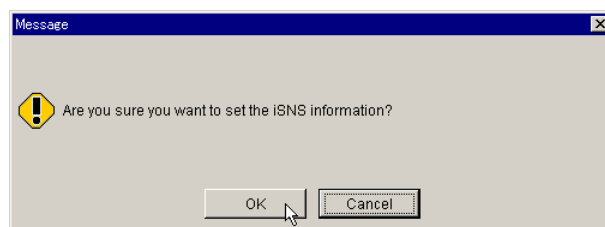

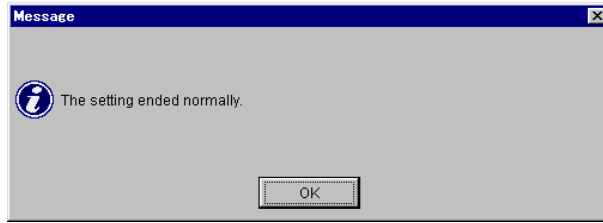

7.3.3 Sending a Ping

To send the ping to the initiator (host) and display the result of the sending, follow these steps:

1. From the **Tools** menu, select the **Configuration Settings** or click **Configuration Settings** on the tool bar.
2. Click the **Ping** tab.

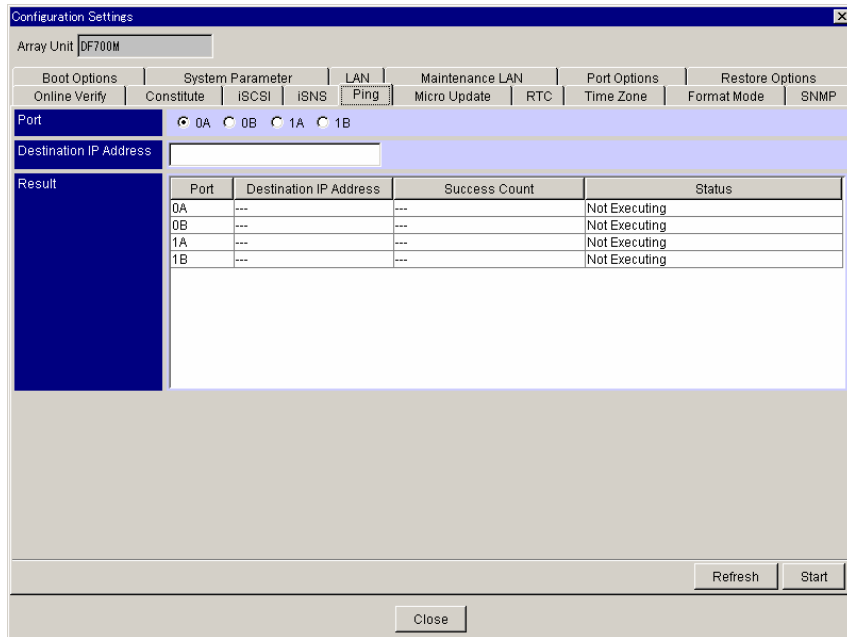

- **Port:** Select the port to send ping.
 - **Destination IP Address:** Specify the IP Address of the initiator.
3. Click **Start**.
 4. The following message displays. Click **OK**.

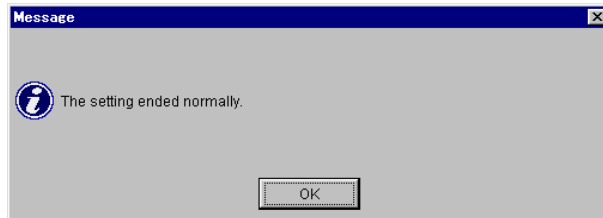
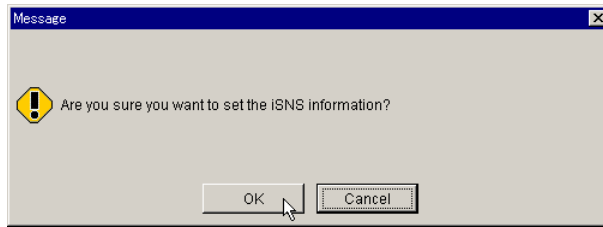

The result displays.

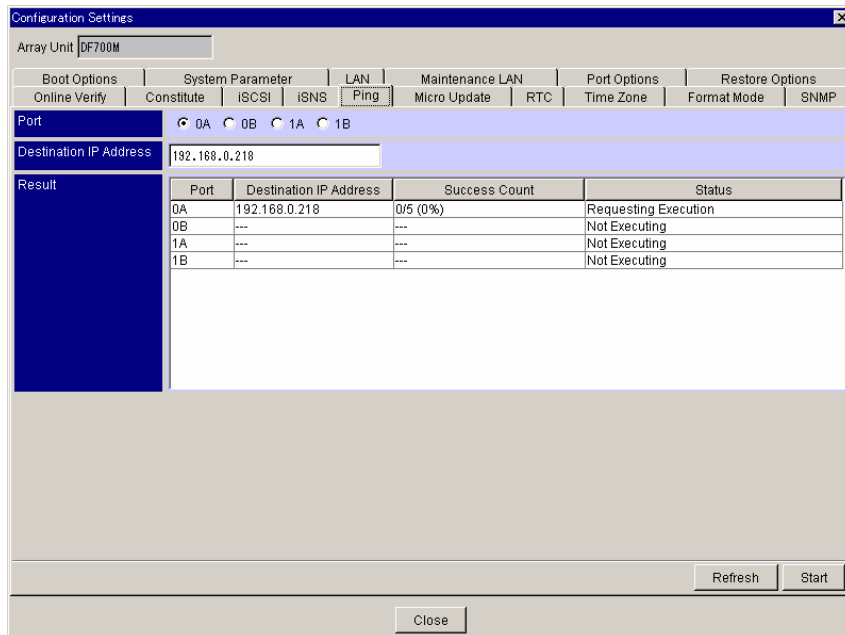

- As necessary, click **Refresh** to display the latest information.

7.4 Determining Space and RAID Level Requirements

This process will depend on the customer requirements, however Hitachi Data Systems recommends certain configuration guidelines that will provide good performance and adequate protection of data integrity in most circumstances.

This function can be used in the device ready state (Read/Write cannot be executed from the host in operation. When a host command is received, Not Ready is reported to the host computer).

This section includes:

- Setting a spare disk
- Canceling a spare disk setting
- Setting a RAID group
- Deleting a RAID group
- Setting a Logical unit
- Deleting the last logical unit
- Formatting a logical unit
- Change of the controller in charge of a default LU

7.4.1 Setting a Spare Disk

To set a spare disk, follow these steps:

1. Turn on the power supply.
Note: If the power supply has been turned on, proceed to the next step.
2. Start the Storage Navigator-Modular program, and set the operation mode to **Management Mode**.
3. Double-click the icon of an array unit in the Main window. Once the array unit information displays, select the **Settings** menu.
4. On the **Settings** menu, click **Display Details** or click **Display Details** on the tool bar.
5. Click the **Logical Status** tab on the Unit window.

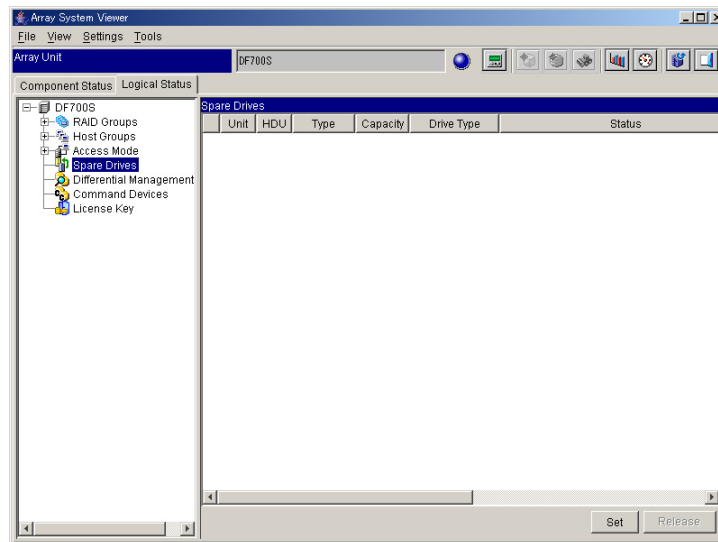

(NAS)

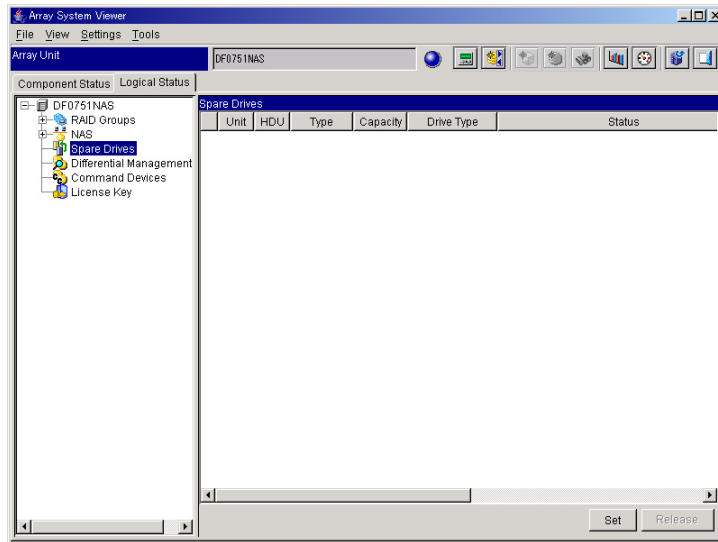

6. Double-click the **Spare Drives** icon.
7. Click **Set**. The **Spare Drives** dialog box displays.

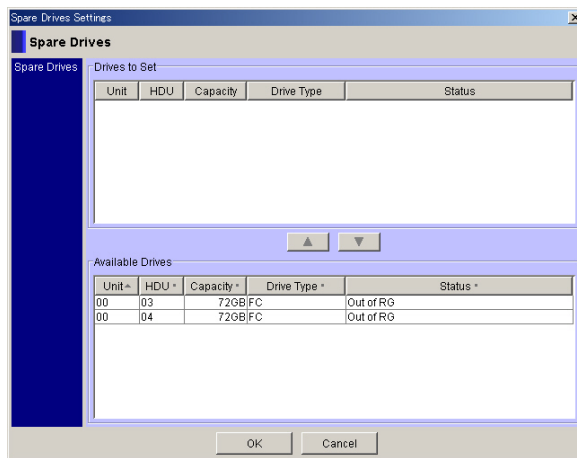

8. Select the HDU that you want to set as a spare drive from the **Available Drives** list and click the  button.
The selected HDU is moved to the **Drives to Set** list.

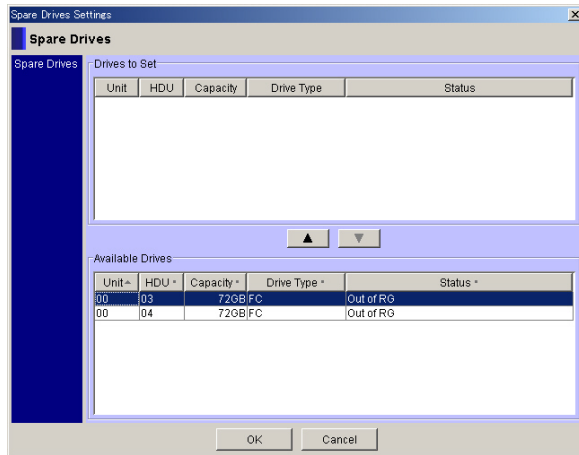

9. Click **OK**.
10. A message indicating that the setting is complete displays. Click **OK**.
11. A **Result** window displays indicating the setting is completed. Click **Close**.

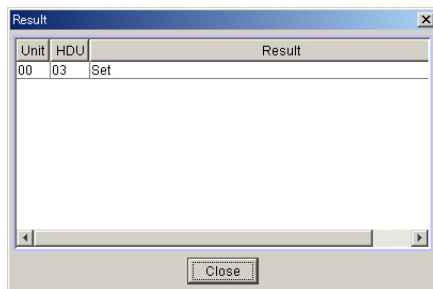

The spare drive setting is updated and the following window displays.

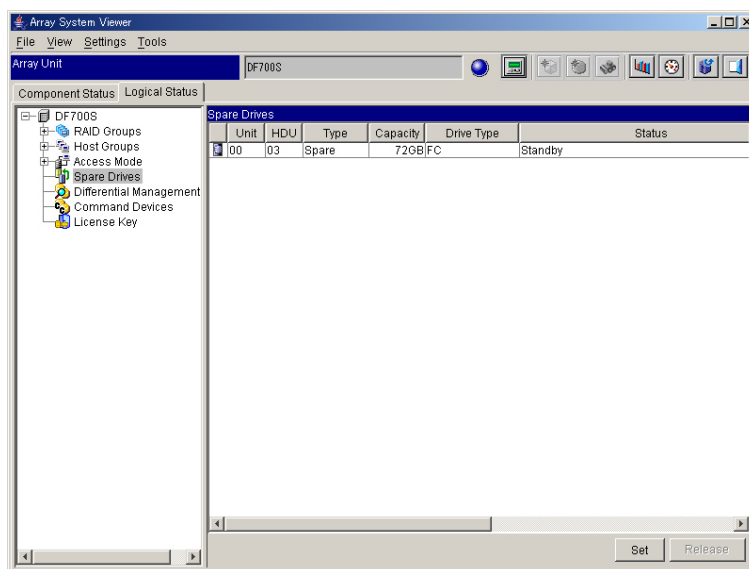

(NAS)

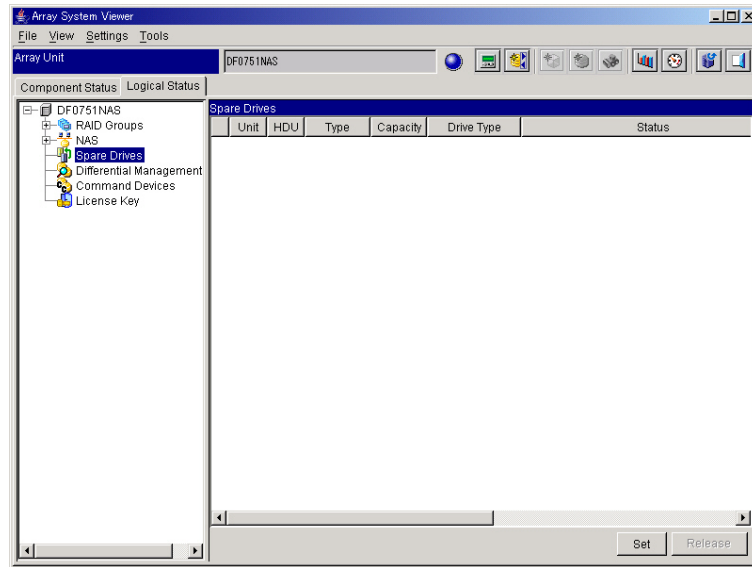

7.4.2 Canceling a Spare Disk Setting

To cancel a spare disk setting:

1. Click the **Logical Unit** tab on the Unit window.
2. Select the **Spare Drives**.
3. Select the spare drive to be canceled, and then click **Release**.
4. The confirmation message for spare drive canceled displays. Click **OK**.
5. A message displays stating the setting is complete. Click **Close**.

7.4.3 Setting a RAID Group

Note: It is recommended that you set at least four RAID Groups for the RAID group used when the NAS unit is connected. This sets the NAS system LU for the usual operation, the NAS system LU for backup, and the NAS user LU into another RAID Group.

Note: The RAID group can be created by selecting one drive from the FC and SATA drives. Be sure they are not spare disks or blocked. The disk drives of the even numbered slots are allocated to Loop #0 and odd numbered slots are allocated to Loop #1. To ensure better load distribution, evenly select disks from both odd and even numbered slots. Also, evenly select drives in the basic and additional chassis.

To set a RAID group, follow these steps:

1. Turn on the power supply.

Note: If the power supply has been turned on, proceed to the next step.
2. Start the Storage Navigator-Modular program, and set the operation mode to **Management Mode**.

3. Click the icon of an array unit on the Main window, select the **Settings** menu, and then click **Display Details**. Alternately, click **Display Details** on the tool bar.
4. Click the **Logical Status** tab.
5. From the **Settings** menu, click **RAID Group**, and then click **Settings**. Alternatively, click **RAID Group Settings** in the tool bar.
This operation can also be completed from the context menu of the **RAID Groups** box.
6. On the **RAID Group** dialog box, select or enter the **RAID Level**, **Drive Configuration**(**Drive Type**, **Drive Capacity**, **Combination**, and **Parity Groups**), and then click **OK**. For the Drives, select **Automatic Selection**.
7. A confirmation message displays. Click **OK**.
8. If the RAID group setting is not successful, delete the affected RAID group, and try creating the RAID group again.

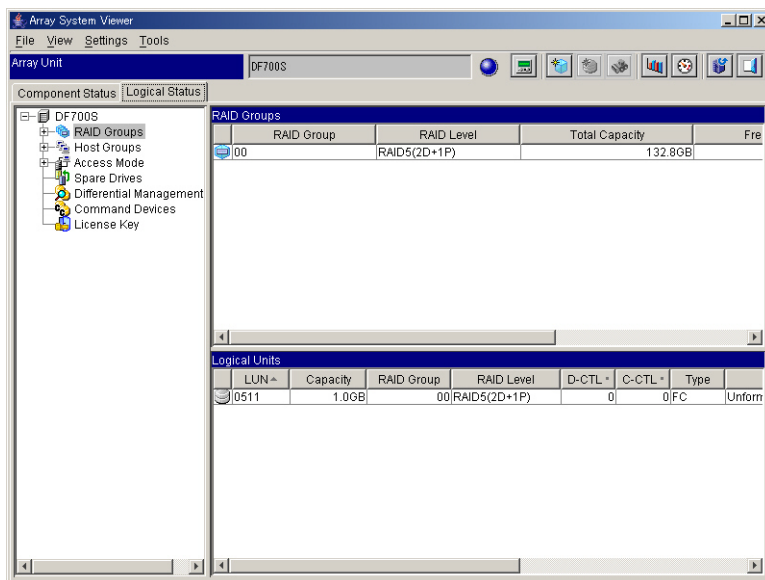

Figure 7.1 Logical Status Tab

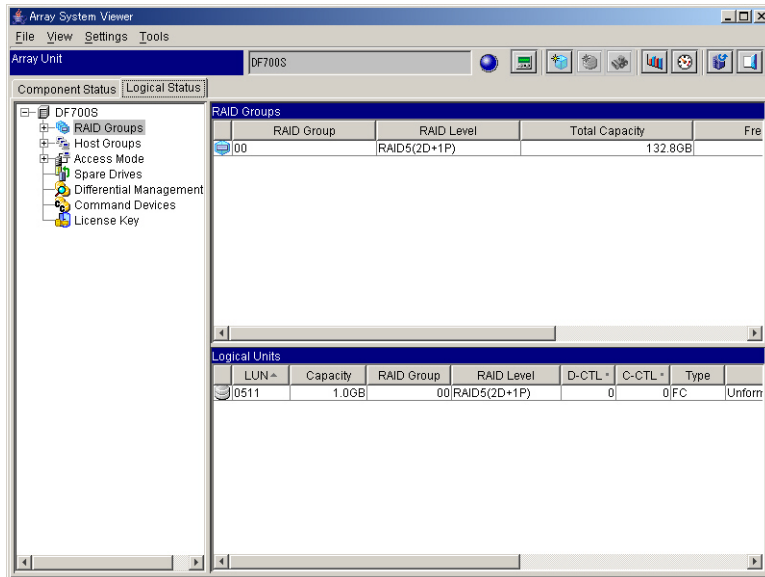

Figure 7.2 Logical Status Tab (NAS)

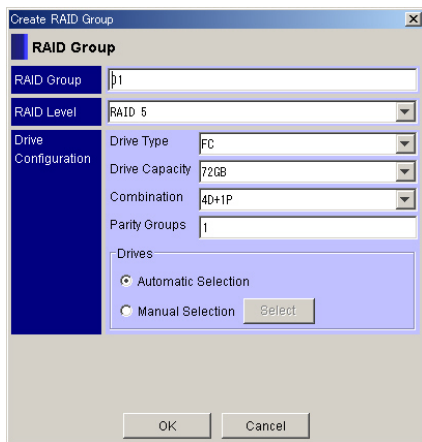

Figure 7.3 RAID Group Dialog Box

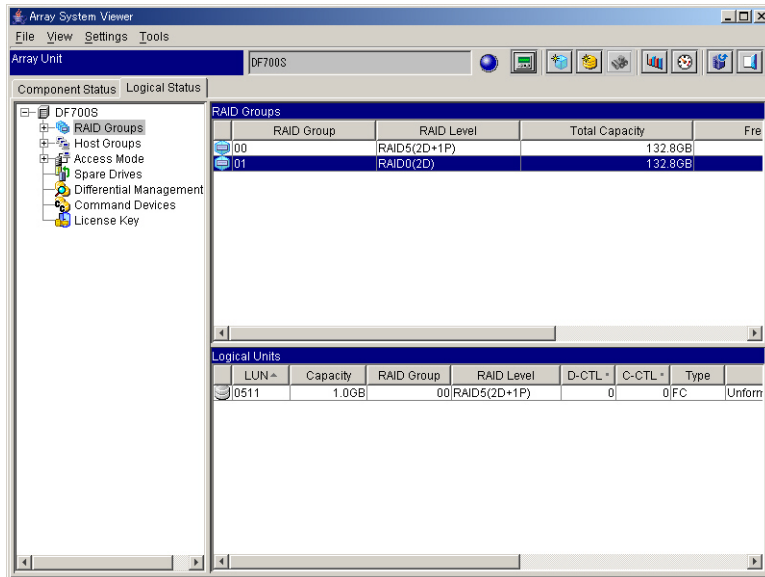

Figure 7.4 RAID Group Updated

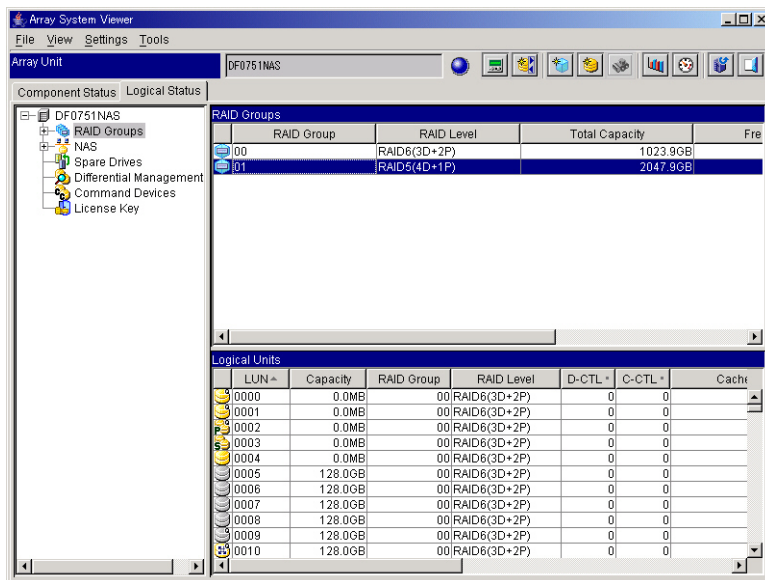
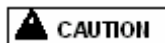

Figure 7.5 RAID Group Updated (NAS)

7.4.4 Deleting a RAID Group



All user data on all LUNs will be lost if all RAID groups are deleted. Back up the user data before performing this operation.

Note: Even if the logical unit is defined in the RAID group to be deleted, the RAID group can be deleted. However, when the following logical units are defined in the RAID group, the RAID group cannot be deleted. Delete all the LUs from the RAID group, then delete the RAID group.

- Command Device
- DMLU
- Paired LU of the ShadowImage In-System Replication
- Paired LU of the Copy-on-write SnapShot
- Pooled LU of the Copy-on-write SnapShot
- Paired LU of TrueCopy Remote Replication
- Sub LU of the Unified LU
- NAS System LU
- NAS User LU
- Reserved LU of the Modular Volume Migration

Note: If LU whose pair status of the Modular Volume Migration is COPY exists in the RAID group to be deleted, the RAID group cannot be deleted. Delete the RAID group after the pair status of the Modular Volume Migration transits to PSUS.

Note: The RAID group cannot be deleted when LU that applies to any of the following exists in the RAID group to be deleted:

In the Data Retention Utility setting,

- the Attribute is set to "Read Only, Protect", or "Can't Guard".
- the S-VOL is set to "Disable" (the LU is inhibited from being set to S-VOL).
- the Mode is set to "Read Capacity 0 (Zer) ", or "hiding from Inquiry Command Mode (Zer/Inv)".

Delete the LU after setting the **Attribute** to "Read/Write", the **S-VOL** to "Enable(the LU can be set to S-VOL)", and the **Mode** to " --- (un-specifying)".

To delete a RAID Group, follow these steps:

1. Click the **Logical Status** tab on the Unit window.
2. Select the RAID group to be deleted from the **RAID Groups**.
3. From the **Settings** menu, click **RAID Group** and then click **Delete**.
4. A message displays requesting confirmation to delete the selected RAID groups. Depending on whether there are formatted logical units in the RAID group or not, the message description is different. Click **OK**.
 - When no logical unit exists in the RAID Group:

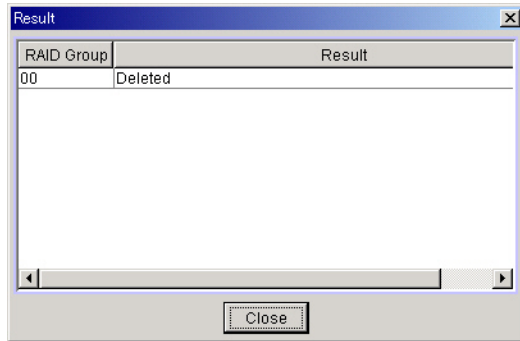
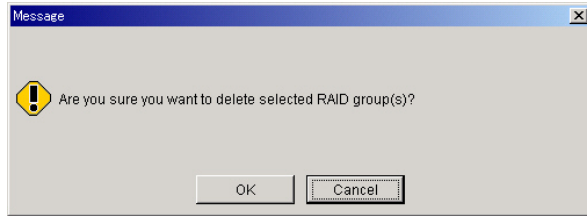

When a logical unit exists in the RAID Group:

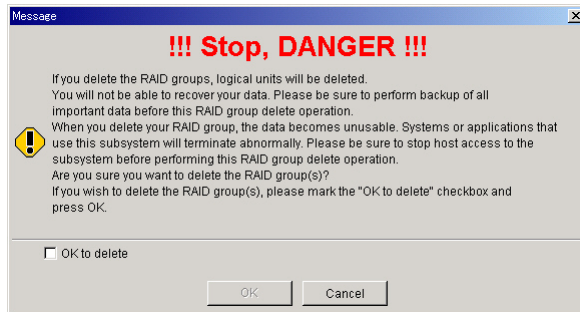
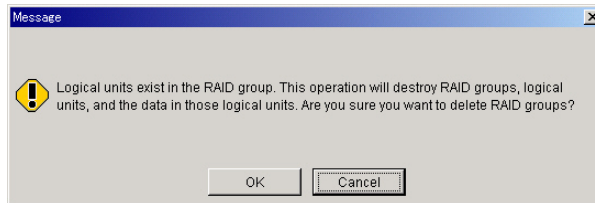
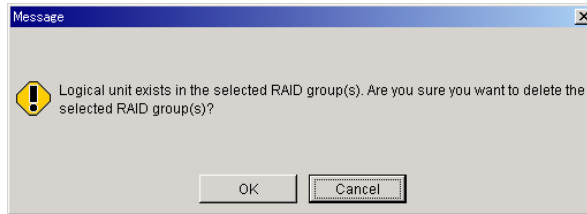

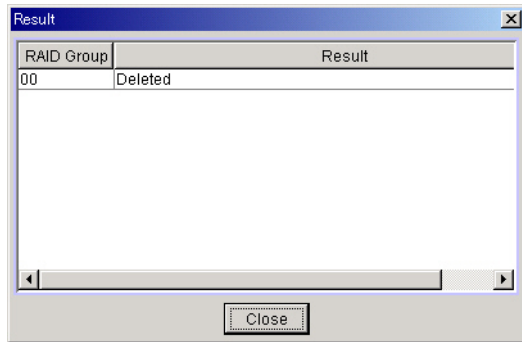

7.4.5 Setting a Logical Unit

Note: You can create settings for the only system LU when the AMS200 is connected to the NAS in accordance with the following restrictions:

No.	Internal LU Number (Note 1)	System LU	Capacity Restriction		Control unit in charge (Note 2)
			Bytes Designation	Block Designation	
1	0	For system disk (CTL 0)	14,013 M bytes (or more)	28,698,624 blocks (or more)	0
2	1	For system disk (CTL 1)	14,013 M bytes (or more)	28,698,624 blocks (or more)	1
3	2	For volume for storing dump (CTL 0)	4,925 M bytes (or more)	10,086,400 blocks (or more)	0
4	3	For volume for storing dump (CTL 1)	4,925 M bytes (or more)	10,086,400 blocks (or more)	1
5	4	For command device	35 M bytes (or more)	71,680 blocks (or more)	0
6	5	For the work for storing the dump edit result.	4,195 M bytes (or more)	8,591,360 blocks (or more)	0
7	6	For the system sharing volume	2,537 M bytes (or more)	5,195,776 blocks (or more)	0
8	7	For the volume for back-upping a shared volume	2,537 M bytes (or more)	5,195,776 blocks (or more)	0
9	8	For the volume 2 for back-upping a shared volume	2,537 M bytes (or more)	5,195,776 blocks (or more)	0

Note 1: The internal LU Number is the recommended value to use. However, using a value other than those described above will not cause a problem in system operation.

Note 2: Control unit in charge is recommended value. If value other than the values described above is set, there is no problem in system operation.

Note: It is recommended that system LU and user LU when the AMS200 is connected to the NAS are created in different RAID groups respectively.

Note: When enabling the ShadowImage I/O switch mode, create a system LU and a P-VOL of the ShadowImage at the time of NAS connection in different RAID groups respectively.

Note: When an array subsystem and a host computer are connected with the Fibre Channel interface, the logical unit of the array subsystem must be set to 0 (zero) or it will not be recognized by the host computer. When using this host computer, create a logical unit set to 0 or map the logical unit to Host LUN (H-LUN) 0.

To set a logical unit, follow these steps:

1. Turn on the power supply.

Note: If the power supply has already been turned on, proceed to the next step.
2. Start the Storage Navigator-Modular program, and set the operation mode to **Management Mode**.
3. Click the icon of an array unit on the Main window, select the **Settings** menu, and then click **Display Details**. Alternatively, click **Display Details** on the tool bar.
4. Click the **Logical Status** tab on the Unit window.

- Click the icon of a RAID group from which you would like to create the Logical Unit. On the **Settings** menu, click **Logical Unit** and click **Settings**. Alternately, click **Logical Unit Settings** on the tool bar.

This operation can also be completed from the context menu of the **Logical Unit** dialog box. The **Logical Unit** dialog box displays.

- On the **Logical Unit** dialog box, enter or select **Logical Unit No.**, **Default Controller**, and **Size**. Click **OK**.
- A created logical unit number displays for the **Logical Unit No.** and the RAID group number in which logical units are defined for the **RAID Group**. Additionally, a logical unit capacity that can be created displays.

Note: To specify a size explicitly in figures, select a unit to specify the size from among the GB, MB, and Block. Specify the size to be allocated in decimal number. The subsystem can be divided into a maximum of 2,048 logical units.

Note: The logical unit number can be set to any value when the logical unit is created. The number with the lowest value of the unallocated numbers is automatically allocated to the logical unit number.

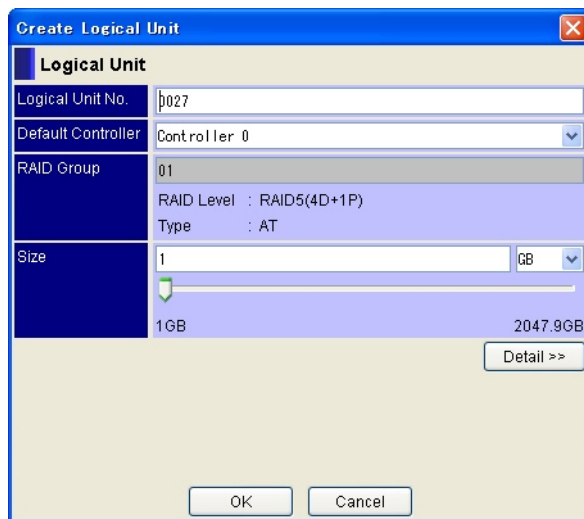

Figure 7.6 Setting the Logical Unit Dialog Box

When creating a logical unit again in the area where the logical unit was deleted, the free area needs to be selected to create a logical unit in the user data area. Click the **Detail** button to display the Logical Unit Detail dialog box.

Note: If there are noncontiguous areas in the RAID group where you are creating an LU, create an LU in the area with the largest free space. An LU is created in the contiguous address area and cannot be created across areas. However, when an LU is deleted, the space in the user area that it occupied is left free and is available for use by a new LU. Therefore, instead of using the default address, you can create an LU in any of the free spaces that exist in the user area, as long as the free space is large enough to hold the LU that you are creating.

Note: If you delete multiple LUs whose addresses are not contiguous, a free space will be left where each of the LUs were. However, because the free spaces are located separately in the user data area, you cannot create a new LU that uses all the free spaces together.

To create a logical unit in the same area where a logical unit was deleted:

1. Click **Select** in the Logical Unit Detail dialog box.
In the Select Area window, the free areas in the user data area are displayed.
2. In the Select Area window, select the free area to create a logical unit, and click the **OK** button.
3. Set the capacity of the new LU within the range displayed in the Logical Unit dialog (detail) box.

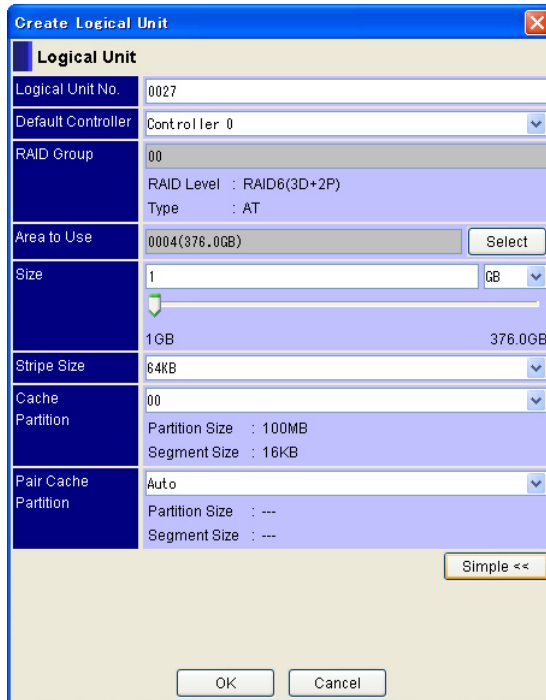

Figure 7.7 Logical Unit Dialog (detail)

The example for the Select Area window is shown below. The areas indicated in No.0000, No.0001, No.0002, and No.0003 in this window are the free areas produced by deleting a logical unit before. In these areas, logical unit can be created again within the range of capacity. The area with the biggest number (No.0004) is the unused free area.

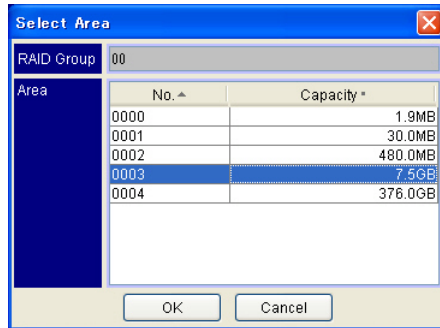

Figure 7.8 Select Area

8. After the setting is complete, click **OK**.
9. The logical unit settings are updated and the Create Logical Unit dialog box displays.
10. The When the subsystem is configured with a mixture of Fibre Channel and NAS interface, be sure to do LU mapping for the created logical unit. For details on how to do LU mapping, see section 7.5.1.

7.4.6 Deleting the Last Logical Unit

To delete the last logical unit, follow these steps:

1. Select the **Logical Status** tab on the Unit window.
2. From the Unit window, select the icon of logical unit to be deleted.
3. On the **Settings** menu, select **Logical Unit** and click **Delete**.

Note: The logical units being used in the NAS system may be unable to be deleted.

Note: The logical units defined below cannot be deleted. Delete all the LUs from the RAID group, and then delete the RAID group.

- Command Device
- DMLU
- Paired LU of the ShadowImage In-System Replication
- Paired LU of the Copy-on-write SnapShot
- Pooled LU of the Copy-on-write SnapShot
- Paired LU of the TrueCopy Remote Replication
- Sub LU of the Unified LU
- NAS System LU
- NAS User LU
- Reserved LU of the Modular Volume Migration

Note: When a logical unit is deleted, the space in the user area that it occupied is left free and is available for use by a new LU. Therefore, instead of using the default address, you can create an LU in any of the free spaces that exist in the user area, as long as the free space is large enough to hold the LU that you are creating.

Note: If a paired LU whose pair status of the Modular Volume Migration is COPY exists, the LU cannot be deleted. Delete the LU after the pair status of the Modular Volume Migration transits to PSUS.

Note: The LU cannot be deleted when LU exists that applies to any of the following:

In the Data Retention Utility setting,

- the Attribute is set to "Read Only, Protect", or "Can't Guard".
- the S-VOL is set to "Disable" (the LU is inhibited from being set to S-VOL).
- the Mode is set to "Read Capacity 0 (Zer) ", or "hiding from Inquiry Command Mode (Zer/Inv)".

Delete the LU after setting the **Attribute** to "Read/Write", the **S-VOL** to "Enable(the LU can be set to S-VOL)", and the **Mode** to " --- (un-specifying)".

4. A confirmation message displays indicating whether selected logical units should be deleted or not. Depending on whether the logical units to be deleted are formatted or not, the message description is different. Click **OK**.

The logical unit information in which the logical unit has been deleted is updated and the window displays.

When no formatted logical unit exists:

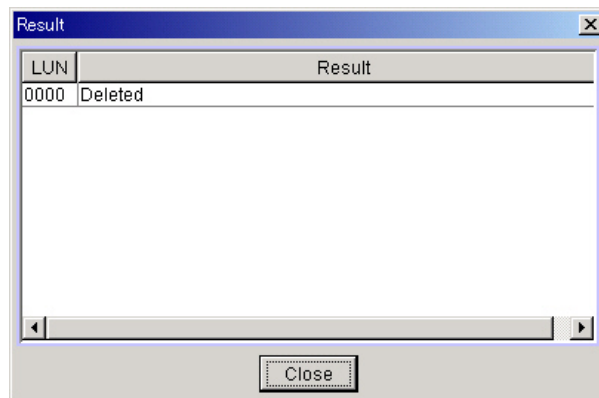
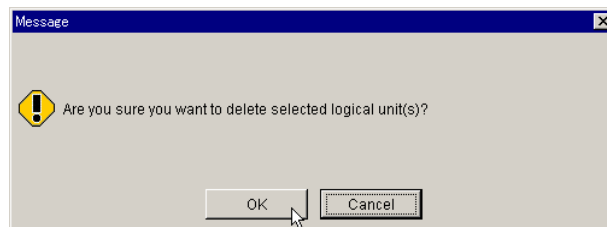

When formatted logical unit exists:

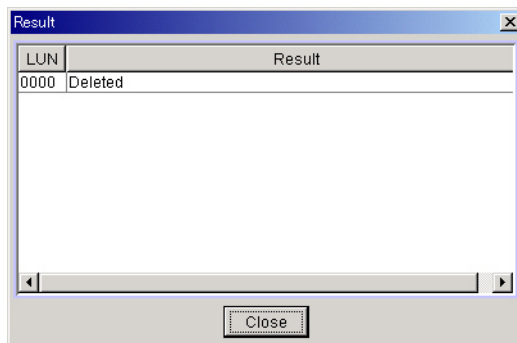
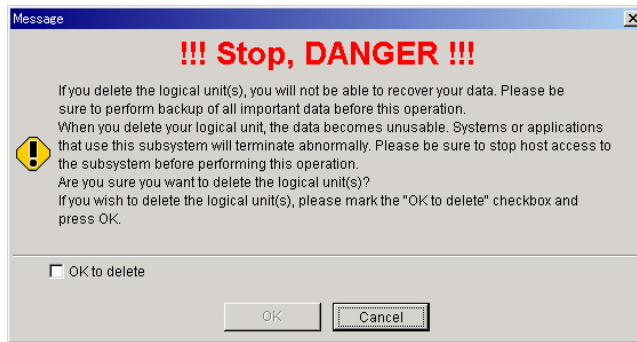
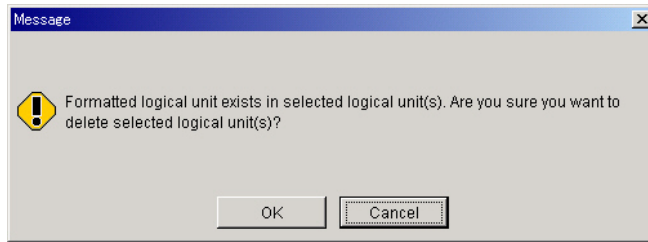

7.4.7 Formatting a Logical Unit

Note: When logical units are formatted, the user data will be initialized and completely deleted before the formatting takes place.

Note: For the logical unit that is being formatted in the background, it is best to perform operations to the host installation.

If a volatile failure for data in cache memory occurs due to subsystem power-off during formatting, the logical unit will be unformatted and data can be lost. Therefore, host installation operation should be performed from the first step for the logical unit.

Notes:

- Formatting will impact the host access performance, especially on the logical unit being formatted and on the logical unit in the same RAID group as the logical unit being formatted. Do formatting during off-hours with less host access.
When formatting a logical unit in the same RAID group as a NAS system LU, do not boot or reboot the NAS OS. This could result in boot failure or could increase the boot time of the NAS OS.
- When performing a fail-over or fail-back between clusters at the time of NAS connection, verify whether the LU is currently being formatted or not. If the LU is being formatted, change the **Format Priority Mode** to **Host**. When performing the formatting while the fail-over or fail-back is in execution, change the **Format Priority Mode** to **Host**. Unless the **Format Priority Mode** is changed to **Host**, the fail-over or fail-back will terminate abnormally.
If you change the Format Priority Mode during fail-over or fail-back, be sure to change the setting back to its original state (usually to **Normal**) after the fail-over or fail-back is complete. For details on how to change the **Format Priority Mode**, refer to section 7.4.8 Changing the Format Mode.

Note: In the following cases, LU cannot be formatted. When you perform the formatting, follow the way of dealing with each problem.

- LU format cannot be performed for the P-VOL or S-VOL of the ShadowImage in-system replication, or TrueCopy remote replication. Release the PAIR and then format the LU.
- LU format cannot be performed for the P-VOL or V-VOL(SnapShot image) of the Copy-on-write SnapShot. Release the PAIR and format the LU.
- The Sub LU of the unified LU cannot be formatted. Specify the Main LU of the unified LU and perform the formatting. When you want to format the Sub LU of the unified LU, format the Sub LU after separating the Sub LU from the unified LU.
- LU format cannot be performed for the P-VOL or S-VOL that is performing the Modular Volume Migration. Format the LU after the Modular Volume Migration is complete. When you want to format the LU immediately, cancel the Modular Volume Migration, and format the LU.
- The LU registered in a data pool cannot be formatted. Delete the LU from the data pool, and then format the LU.
- In any of the following cases, the LU format cannot be performed:
In the Data Retention Utility,
 - "Read Only" or "Protect" is set for the LU access attribute.
 - "Read Capacity 0(Zer)" or "hiding from Inquiry Command Mode(Zer/inv)" is set for the Mode.
 - "Disable(the LU is inhibited from being set to S-VOL)" is set for the S-VOL
"Disable(the LU is inhibited from being set to S-VOL)" is set for the S-VOL
- LU format cannot be performed for the NAS system LU or User LU. Release the LU from the allocation for the NAS system LU or NAS user LU, and then format the LU.
- Multiple logical units may not be formatted if their total capacity exceeds 56 Terabytes. Therefore, when selecting multiple units for formatting, ensure that their total capacity is less than 56 Terabytes.

Format

This mode enables the subsystem to start its operation earlier by formatting the specified LU in the background to make it usable by a host. Up to 512 LUs can be specified for formatting. This number can also be increased; however, the number of LUs that can be simultaneously formatted in the background is six per CTL. When executing formatting, the Storage Navigator-Modular program can perform operations (such as a RAID group creation) while the formatting is being executed.

When the Storage Navigator-Modular program is terminated while formatting is executed, the formatting function is continued. When the Storage Navigator-Modular program is terminated while formatting is executed, the formatting progress is displayed by percentage in the logical unit status column when the Storage Navigator-Modular program is activated again.

When the host I/O is executed for the LU in formatting, Format completion may be delayed; from the 99 % progress status, it may take 400 seconds (maximum).

To format a logical unit, follow these steps:

1. Click the icon of a logical unit in the Unit window. On the **Settings** menu, select **Logical Unit**, and then click **Format**.

Note: When you select multiple logical units, hold down the **Ctrl** key and click the icons of the logical units to format.

- When a logical unit is incorrectly specified, press **Cancel** and redo processing by selecting a logical unit to be reformatted.

Note: In the ShadowImage In-System Replication, TrueCopy Remote Replication, or Copy-on-Write Snapshot, PAIR cannot be defined for the LU being formatted. LU defined as PAIR cannot be formatted.

2. A confirmation message displays and asks you to confirm whether the selected logical units may be formatted or not. Check the message, and click **OK**. Depending on whether there are formatted logical units among the logical units or not, the message description is different.

When there is no formatted logical unit:

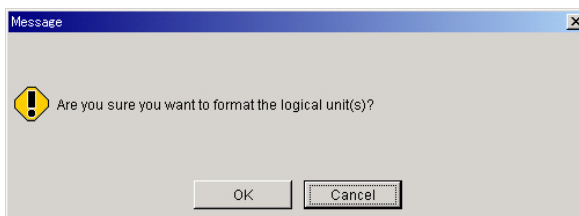

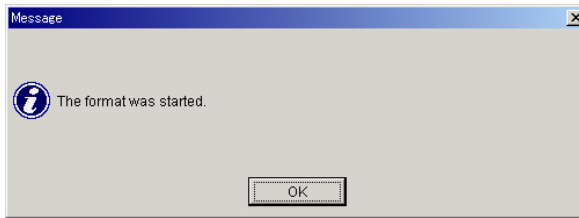

When there is a formatted logical unit:

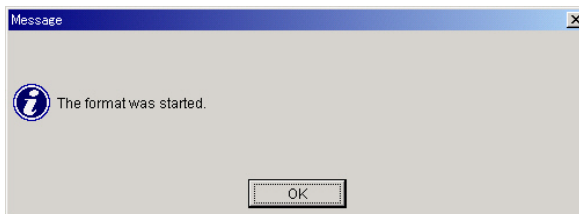
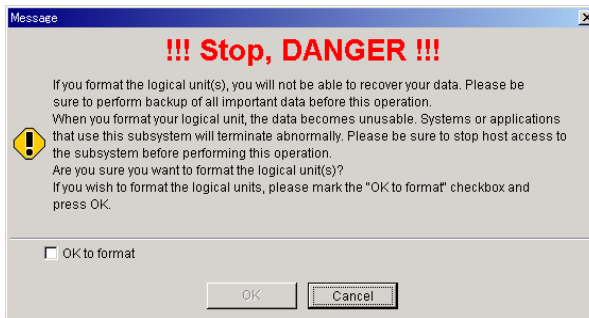
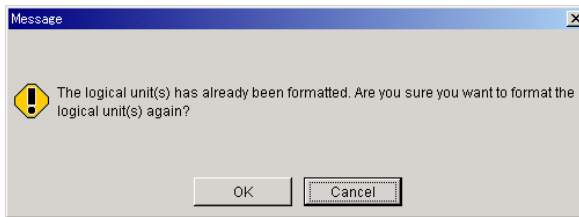

The progress rate of formatting process in the background displays in the Status box. The progress rate of formatting process is not displayed automatically.

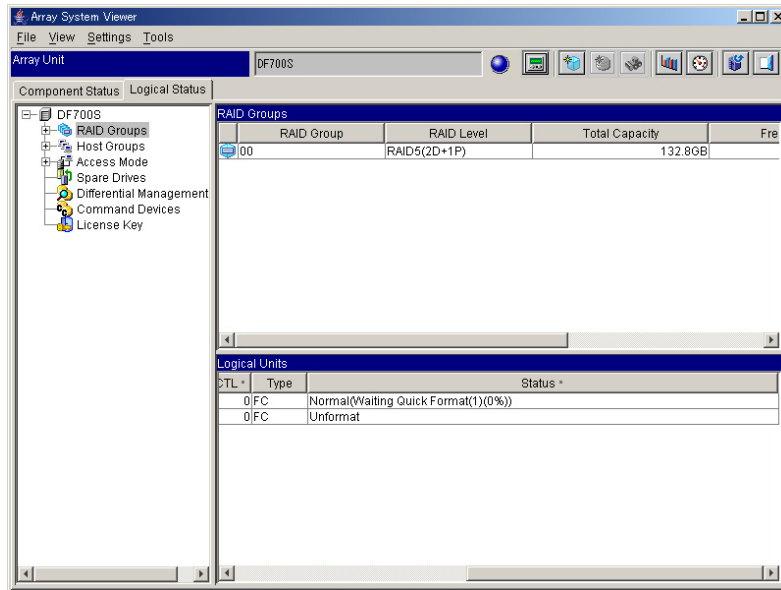

(NAS)

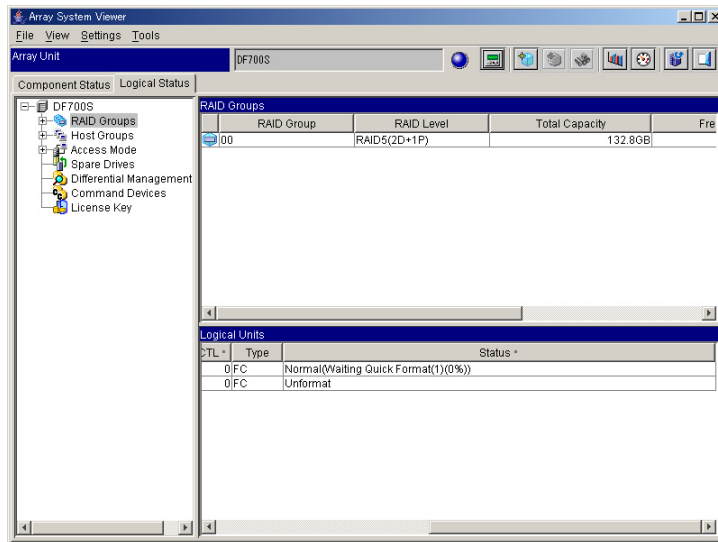

To confirm the latest progress rate, refresh the display by clicking **Refresh**.

3. **Normal** displays in the **Status** box. (When the formatting is in execution, the progress status displays.)

If formatting is terminated abnormally, review the results. The formatted logical information is updated and the window displays.

Table 7.2 Formatting Message

Displayed	Action to Take
02-xxxx, 03-xxxx, 04-xxxx or 0B-xxxx	For the above code, a hardware fault is assumed. If the fault is not recovered after re-execution, contact Hitachi Data Systems.
05-xxxx	For the above code, an operation error is assumed. Upon checking the following items and re-execute processing. If the error is not recovered, contact Hitachi Data Systems.
05-2500 or 05-2581	Is logical unit 0 defined?
05-2600	In spite of none of drive mounted states, is ALL RAID specified and is a logical unit specified for ALL CAPA formatted?
05-2580	Is an attempt made to define a logical unit exceeding the capacity of the defined RAID group?
0B-FD01	Switching a controller in charge of a logical unit occurred during formatting. Check the controller in charge and re-execute formatting from the controller in charge.
DMEA000006 or DMEA000007	Drive failure recovery or ShadowImage-In-System Replication, TrueCopy Synchronous Remote Replication, and/or Copy-on-Write Snapshot may be in operation. Check the status of the subsystem.

7.4.8 Changing the Format Mode

This mode enables the subsystem to set the priority of host access and the format for the format in the background.

To set the **Format Priority Mode**, follow these steps:

1. On the **Tools** menu, select **Configuration Settings** or click **Configuration Settings** on the tool bar.
2. Click the **Format Mode** tab.
3. Click the desired radio button from the **Format Priority Mode**.

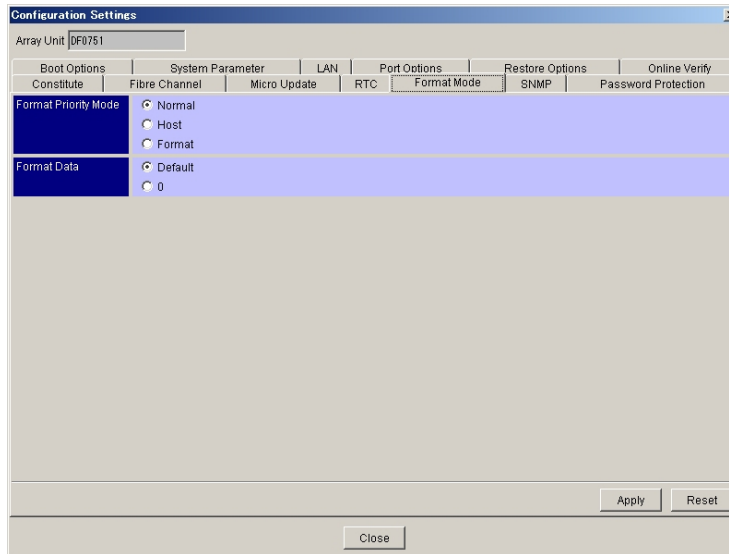

The following provides an explanation for each Format Priority mode.

No.	Mode	Explanation
1	Normal (Default)	In the Normal mode, when the load of the host I/O is low, the format processing is executed continuously. If the load is high, the format processing is executed during every available interval.
2	Host	When the Format Priority mode is set to Normal, the copy/restoration performance may be significantly deteriorated if the format is performed during the copy/restoration of ShadowImage in-system replication, TrueCopy remote replication, TrueCopy Extended Distance, or Copy-on-write SnapShot. In that case, limit the operation of the formatting by setting the Format Priority mode to "Host." The format processing is then executed only during available intervals according to the load of the host I/O. This reduces the deterioration of the host I/O performance.
3	Format	The Format mode restricts the host access to a minimum, allowing the online format to complete quickly during the addition of a disk drive or during the recovery work after dual failures of the Disk Drive. The format processing is executed regardless of the load of the host I/O. The host access performance may be deteriorated when the Format mode is set because the host I/O processing decreases substantially.

Note: Formatting using the **Format Priority Mode** allows the subsystem to minimize the effects from host access and complete the format promptly. This applies to the online format during the disk addition of a drive, or during recovery work from a two point disk drive failure. When using this mode, host access performance may be significantly affected because the **Format** option of the **Format Priority Mode** restricts commands from host.

In the following cases, do not set the **Format Priority Mode** to **Format**; it may cause a significant deterioration in host access performance or a command time out.

- Accessing the host in which the logical unit is in the same RAID group as logical unit being formatted
- Formatting while using ShadowImage In-System Replication, TrueCopy Remote Replication, or Copy-on-Write Snapsh

4. When the setting is complete, click **Apply** on the **Configuration Setting** window. The following message displays, click **OK**.

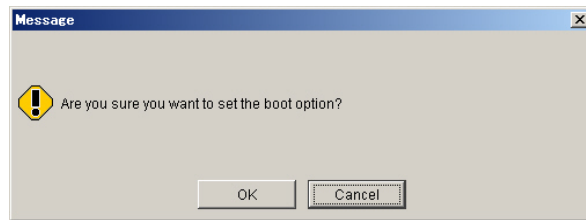

When the **Format Priority Mode** is set to **Format**, the following message is displayed. Click the **OK** button.

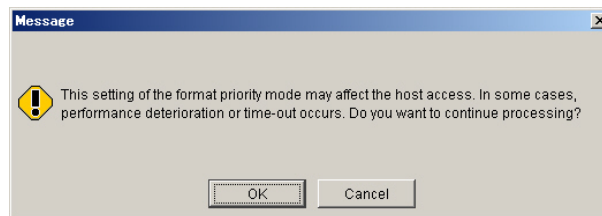

5. A message displays when the setting is complete, click **OK**. Click **Close** on the **Configuration Settings** window.

Note: The **Format Mode** tab includes the **Format Data** items, from which format data can be selected. Normally, use the Default. Use the **0(zero)** in the Format Data only when it is necessary to clear the logical unit to **0(zero)** at the time of connecting to TagmaStore USP/TagmaStore NSC.

7.4.9 Changing the Default Controller in Charge of an LU

Note: The controller in charge of a default LU can be changed only for the dual active mode configuration of a dual system.

To change the controller in charge of a default LU, follow these steps:

1. Turn on the power supply.
Note: If the power supply has already been turned on, proceed to the next step.
2. Start the Storage Navigator-Modular program and set the operation mode in **Management Mode**.
3. Double-click the icon of an array unit on the Main window. Select the **Settings** menu, and then click **Display Details**. Alternately, click **Display Details** on the tool bar.
4. Click the **Logical Status** tab on the Unit window.
5. Select the logical unit for which you want to change the Change Default Controller.
6. On the **Settings** menu, click **Logical Unit** and the click **Change Default Controller**. A message displays requesting confirmation to change the default controller.
7. Click **OK**. The default controller in charge of a logical unit will be changed.

8. A message displays stating that the setting is complete. Click **OK**.

7.5 Setting Host Group Information

In the AMS200, the Host Connection Mode, the mapping information of Logical Unit, and LUN security information are set to the group of hosts, not to the host. This enables you to select the host computer to which the subsystem is connected depending on each group of hosts.

Host groups support only the **000:G000**.

Up to 128 host groups can be set when the LUN Manager is used.

Note: When an array subsystem and a host computer are connected with the Fibre Channel interface, the logical unit of the array subsystem must be set to 0 (zero) or it will not be recognized by the host computer. When using this host computer, create a logical unit set to 0 or map the logical unit to Host LUN (H-LUN) 0.

7.5.1 Setting Mapping Information

To set mapping information:

1. On the Unit window, click the **Logical Status** tab.
2. Double-click **Access Mode**, and select **Mapping Mode**.

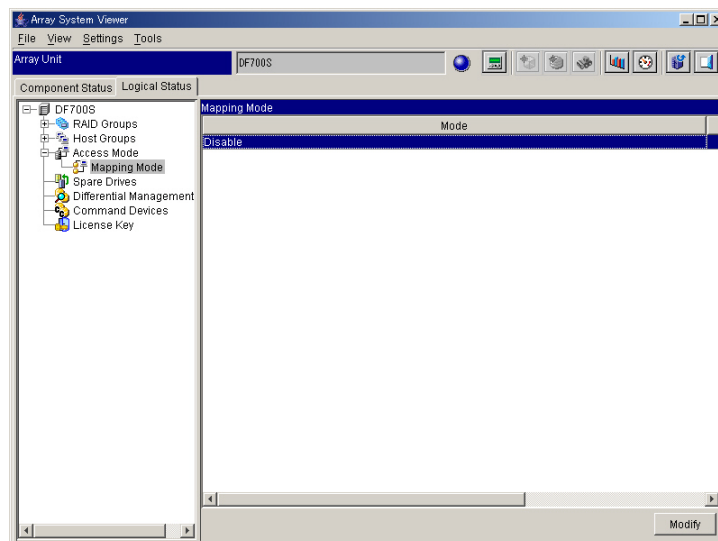

3. On the **Mode** list, select **Disable**, and then click **Modify**.



4. On the **Mapping Mode** dialog box, click the **Enable** radio button, and then click **OK**.
5. A confirmation message displays. Click **OK**.

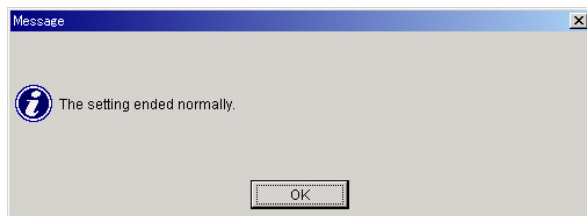
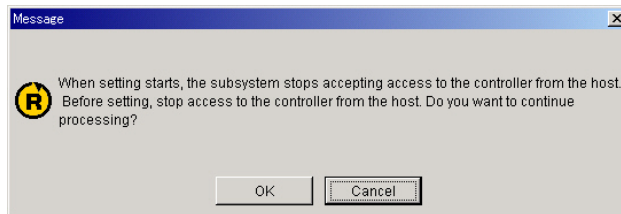
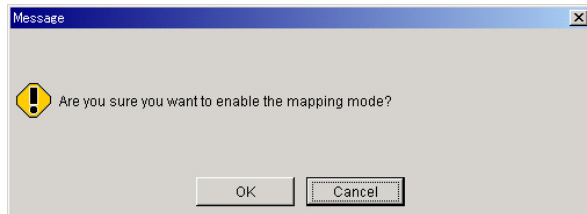

6. On the Unit window, double click **Host Groups**, and then double-click the **Port** which you want to set for the connection mode with the host. Display **000:G000** by double-clicking **Port**.
7. Display the Option and Logical Unit by clicking **000:G000**, and then click **Logical Unit**.

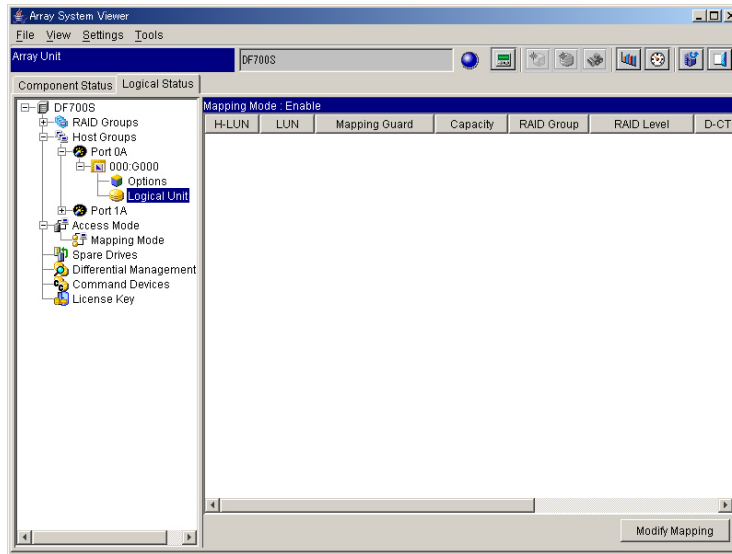

8. Click **Modify Mapping**. The **Mapping** dialog box displays.

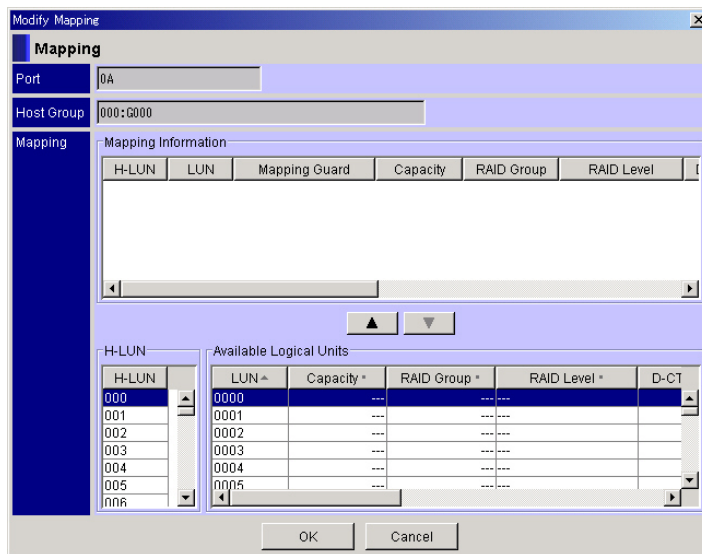

9. Select one H-LUN from the H-LUN list, select an LUN that you want to map for the H-LUN from the **Available Logical Units** list, and then click the  button. The selected H-LUN and LUN will be moved to the **Mapping Information** list.
10. Repeat step 9 to complete the **Mapping Information** list.
11. A confirmation message displays. Click **OK**.

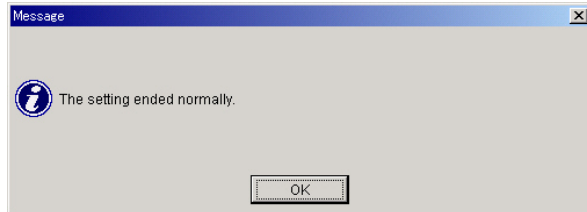
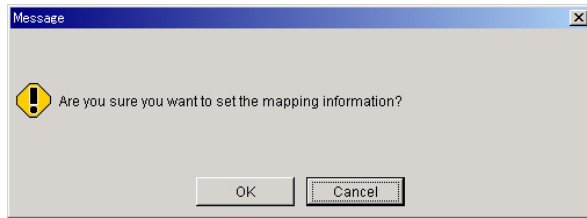

The mapping information is updated and the following window displays.

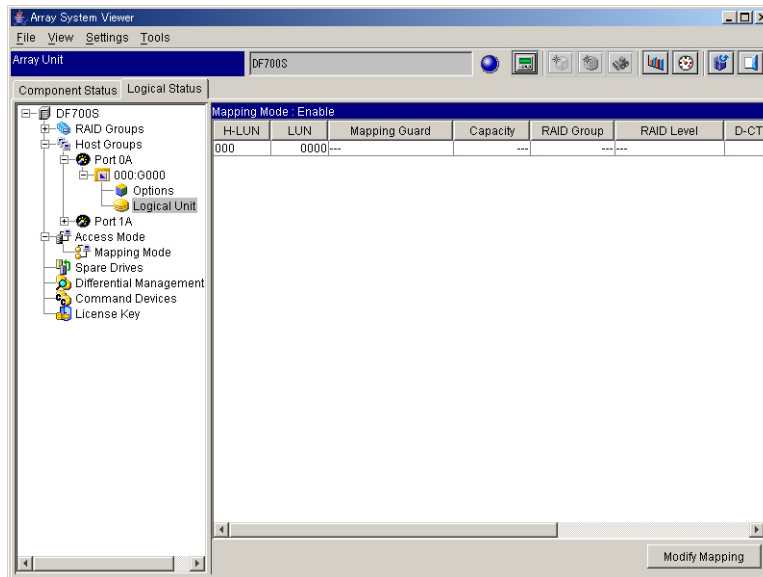

12. Make the setting for the other ports in the same way as described previously.

7.6 Setting Target Information

In the AMS200, the Host Connection Mode, the mapping information of Logical Unit, and LUN security and iSCSI User information for authentication are set to the targets, not to the ports at the time of iSCSI interface addition. This enables you to select the host computer to which the subsystem is connected, depending on each target.

For targets, only the 000:T000 is supported.

Up to 256 targets can be set when the LUN Manager (an extra cost optional feature) is used.

7.6.1 Changing the Target Information

To change the iSCSI Name, Alias, Authentication Method, and CHAP User information of Two-Way Authentication about the Target:

1. Click the **Logical Status** tab on the Unit window.
2. Click **Port**.
3. Select the Target to be changed from the **Target** list.
4. Click **Modify**.

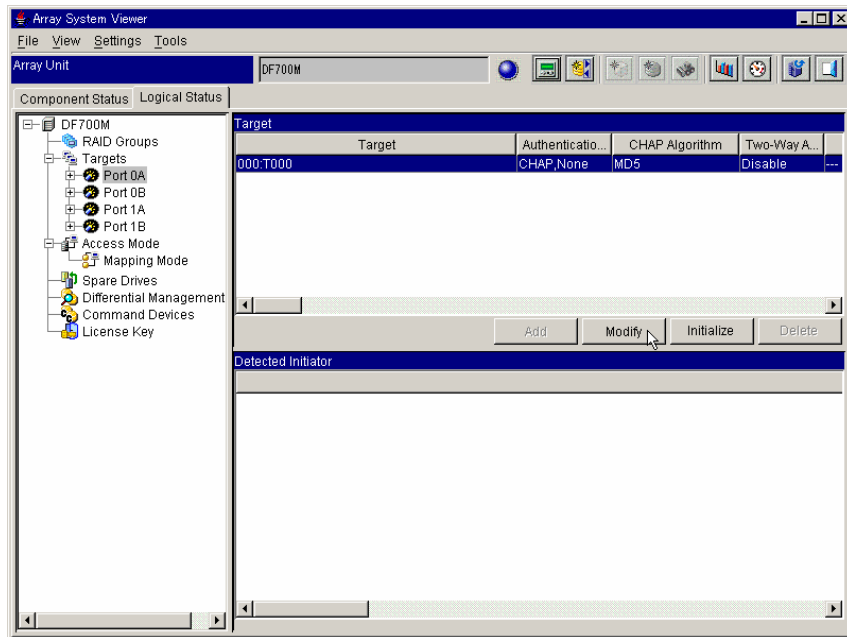

The **Target** dialog is displayed.

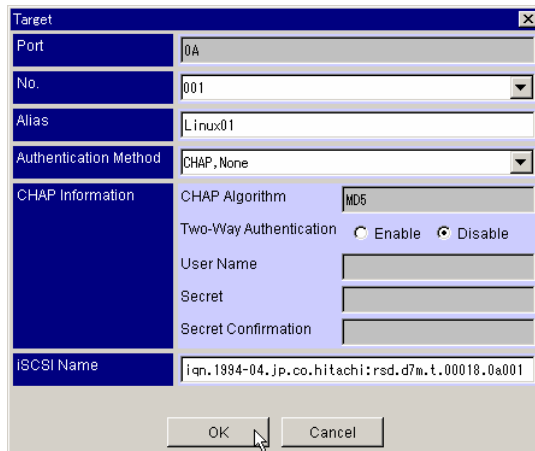

5. On the **Target** dialog box, enter the alias and iSCSI Name.
6. Select the authentication method from the drop-down list:

- **Alias:** Enter the alias of the Target with 32 or less alphanumeric character. (Excluding \, /, : , , ;, *, ?, “, <, >, | and ‘)
Spaces at the top or end are ignored. An identical name cannot be used in an identical Port.
 - **Authentication Method:** Select the CHAP, None, or CHAP, None.
 - **iSCSI Name:** Enter the name of the iSCSI Name with 233 or less alphanumeric character. A period (.), hyphen (-), and colon (:) can be used.
7. Click **OK**.
 8. The confirmation message displays. Click **OK**.

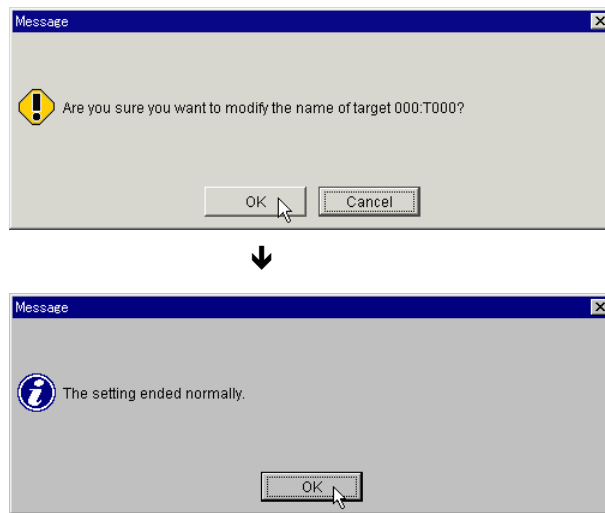

7.6.2 7.6.2 Initializing the Target 0

1. Click the **Logical Status** tab on the Unit window.
2. Click **Port**.
3. Select the Target to be initialized from the **Target** list.
4. Click **Initialize**.

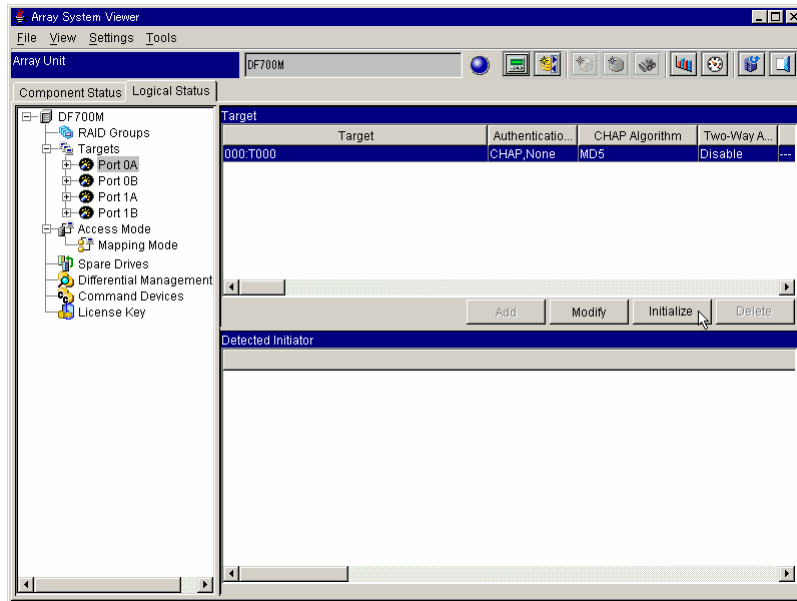

5. The confirmation message displays. Click OK.

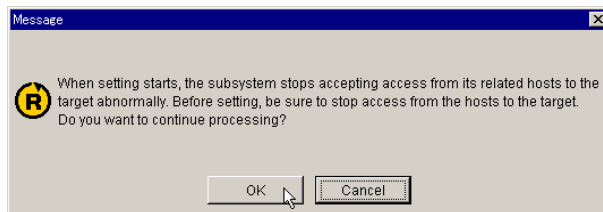
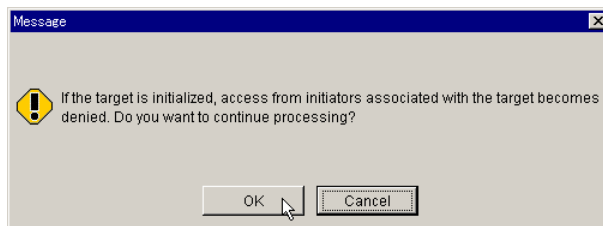
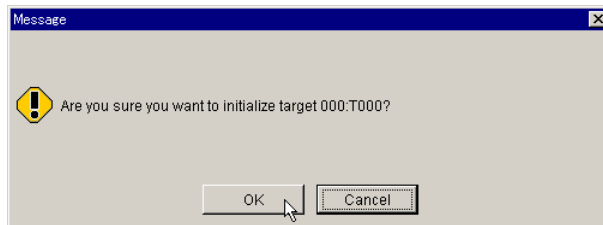

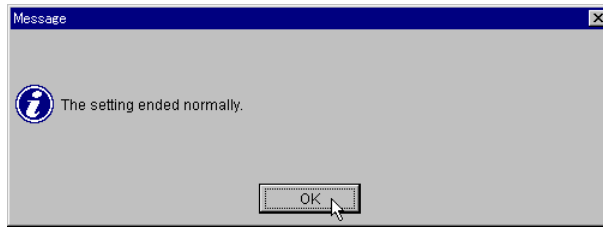

7.6.3 Setting Mapping Information

1. Click the **Logical Status** tab on the Unit window.
2. Double-click the **Access Mode**, and click the **Mapping Mode**.
3. On the **Mode** list, select the **Disable**. Click **Modify**.

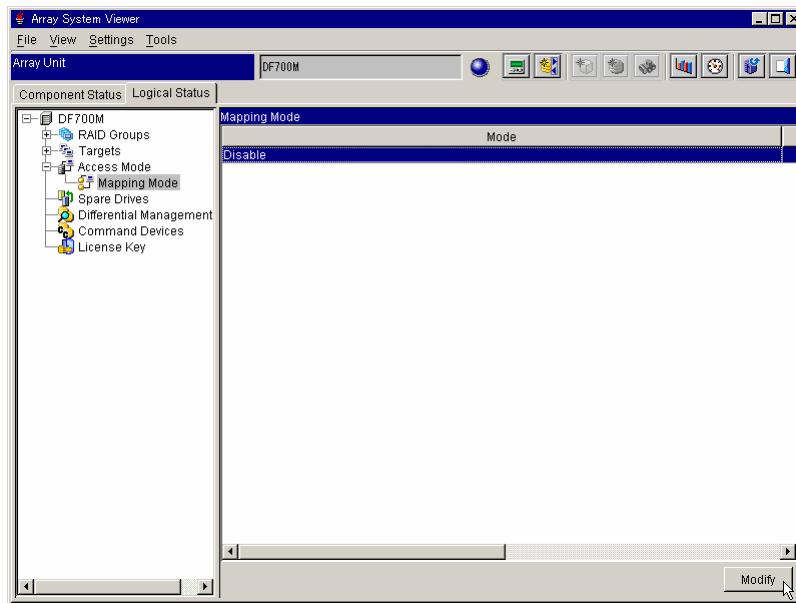

Mapping Mode dialog box is displayed.

4. On the **Mapping Mode** dialog box, click the **Enable** radio button, and then click **OK**.

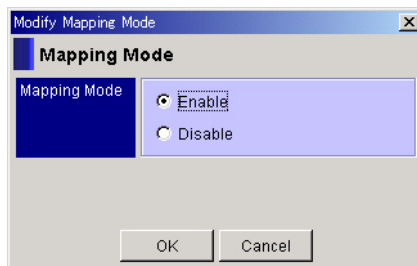

5. A confirmation message displays, click **OK**.

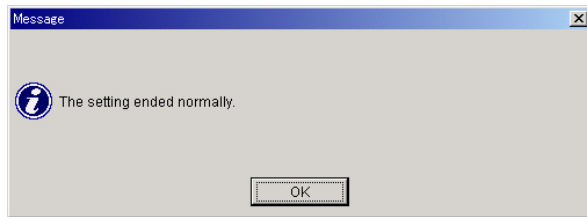
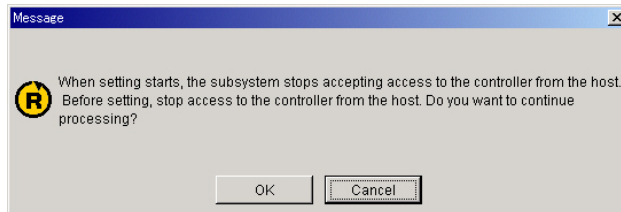
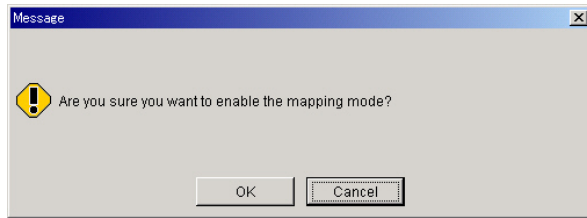

6. On the Unit window, double-click the **Target**, and double-click the **Port** that you want to set for the connection mode with the host. Display **000:T000** by double-clicking the **Port**.
7. Display the Options and Logical Unit by clicking **000:T000**, then click **Logical Unit**.

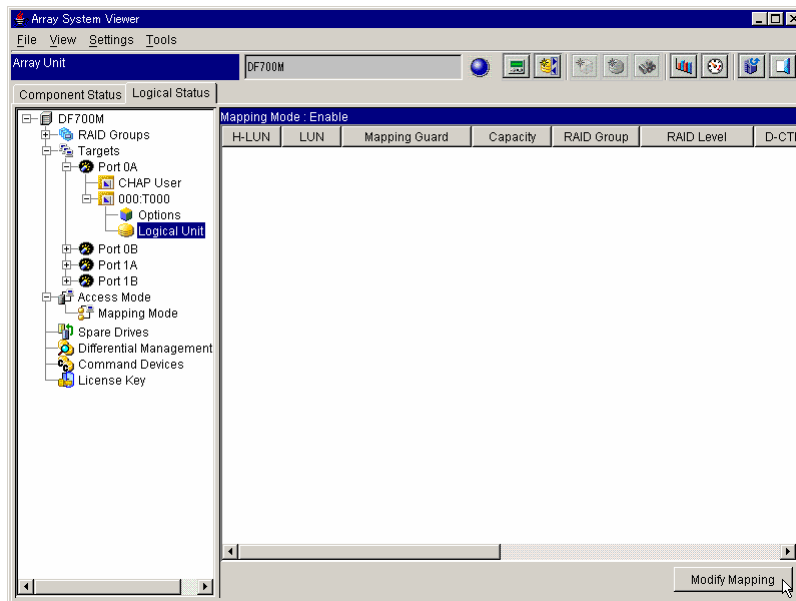

8. Click **Modify Mapping**. The **Mapping** dialog box displays.

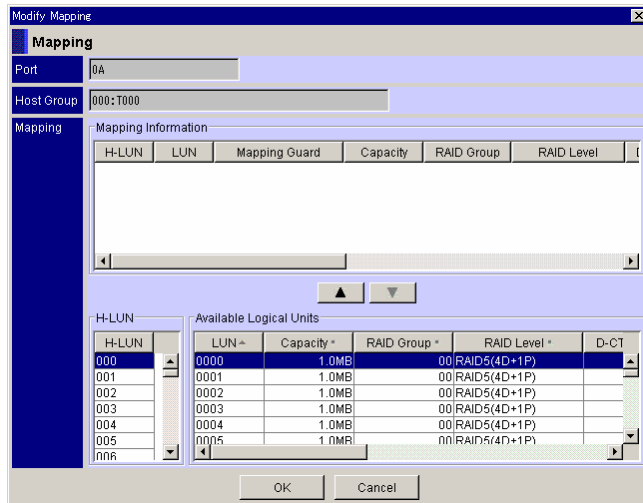

9. Select one H-LUN from the H-LUN list, select an LUN that you want to map for the H-LUN from the **Available Logical Units** list, and click  button. The selected H-LUN and LUN will be moved to the **Mapping Information** list.
10. Repeat step 9 to complete the **Mapping Information** list.
11. A confirmation message displays, click **OK**.

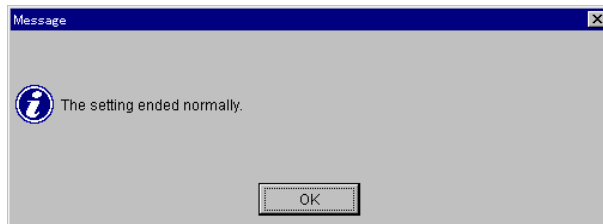
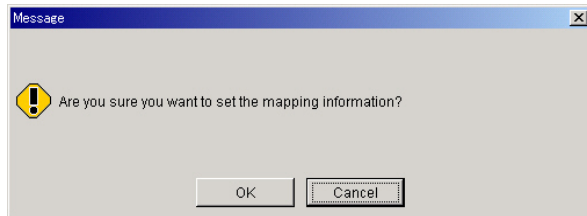

The mapping information is updated and the following window displays.

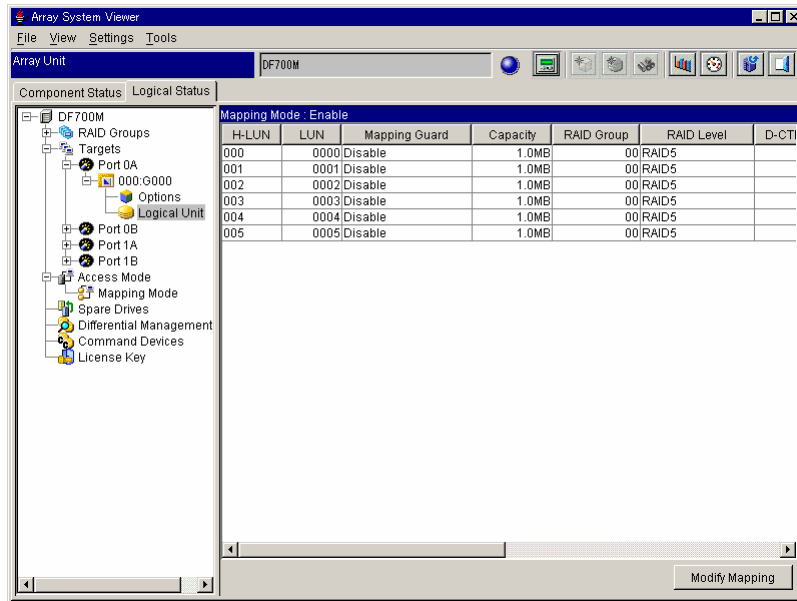

12. Set the settings for the other ports using the same procedure.

7.7 Setting CHAP Authentication

The disk array subsystem can authenticate both the iSCSI User Initiator Authentication and Two-Way Authentication (Target Authentication) with the CHAP (Challenge Handshake Authentication Protocol). This can prevent the unauthorized access from the host (or by the user of the host).

Set the same iSCSI User information (User Name/Secret) on both the host side and the disk array subsystem side for Initiator Authentication. Set the same iSCSI User information (User Name/Secret) on both the host side and the disk array subsystem side for Two-Way Authentication (Target Authentication).

7.7.1 Adding a CHAP User

To authenticate the initiator, set the CHAP User to the port and assign it to the Target. The CHAP User can register up to 512 users for each iSCSI port.

1. Click the **Logical Status** tab on the Unit window.
2. Double-click the Port to which you want to add the CHAP User and click **CHAP User**.
3. Click **Add**.

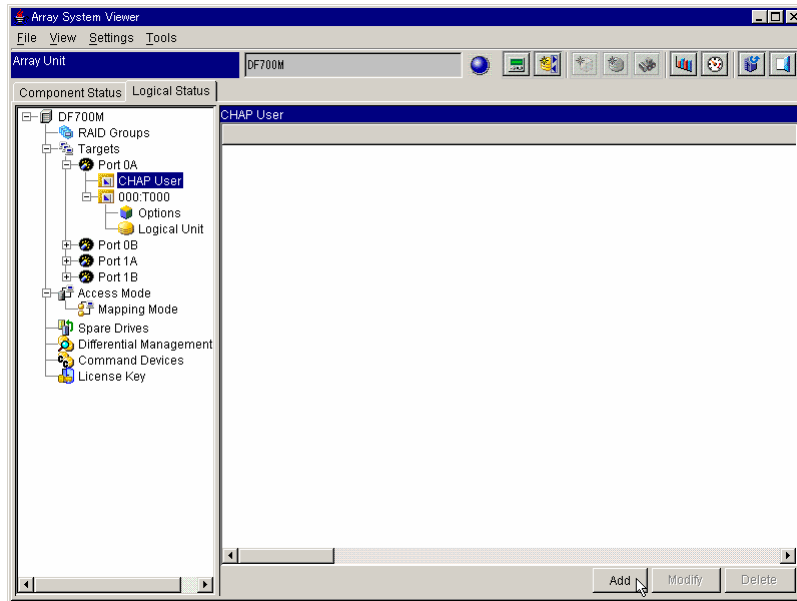

The CHAP User dialog box displays.

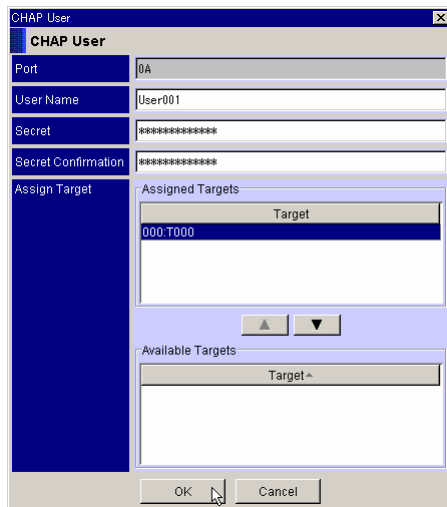

4. On the **CHAP User** dialog box, enter the **User Name**, **Secret**, and **Secret Confirmation**.
 - **User Name:** Enter the name of the User with 256 or less alphanumeric character. The following symbols can be used: (. - + @ _ = : / [] , ~ (space))
 - **Secret:** Enter the Secret from 12 through 32 alphanumeric characters. The following symbols can be used: (. - + @ _ = : / [] , ~ (space))
 - **Secret Confirmation:** Enter the characters that enter into the **Secret**.
5. From the **Available Targets** list, select the Target to be assigned, click the  button.
6. Click **OK**.
7. A confirmation message displays. Click **OK**.

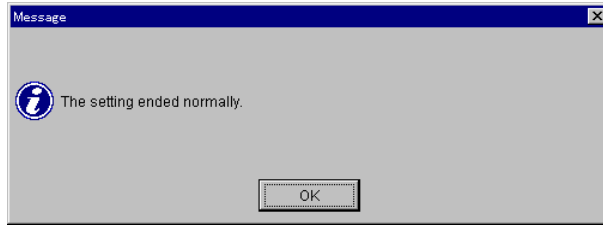

7.7.2 Changing the CHAP User

1. Click the **Logical Status** tab on the Unit window.
2. Double-click the Port of which you want to change the CHAP User, and then click the **CHAP User**.
3. Click the **CHAP User** to be changed from the **CHAP User** list.
4. Click **Modify**.

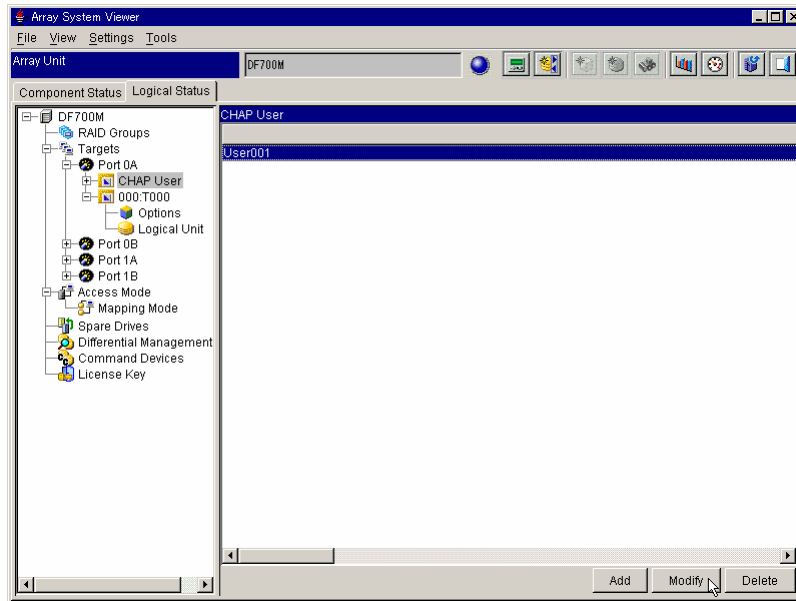

The **CHAP User** dialog box displays.

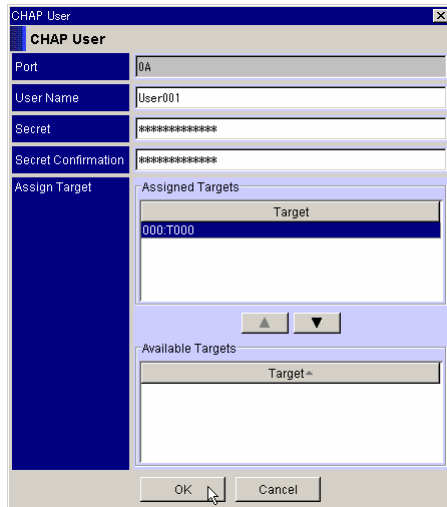

5. As necessary, enter **User Name**, **Secret**, and **Secret Confirmation**.
6. As necessary, change the assigned Target, and then click **OK**.
7. The confirmation message displays. Click **OK**.

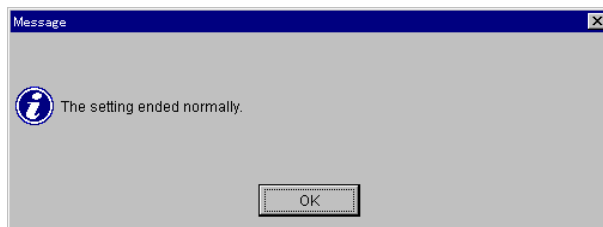

7.7.3 Deleting the CHAP User

To delete the CHAP user:

1. Click the **Logical Status** tab on the Unit window.
2. Double-click the Port you want to delete and click **CHAP User**.
3. Click the **CHAP User** to be deleted from the **CHAP User** list.
4. Click **Delete**.

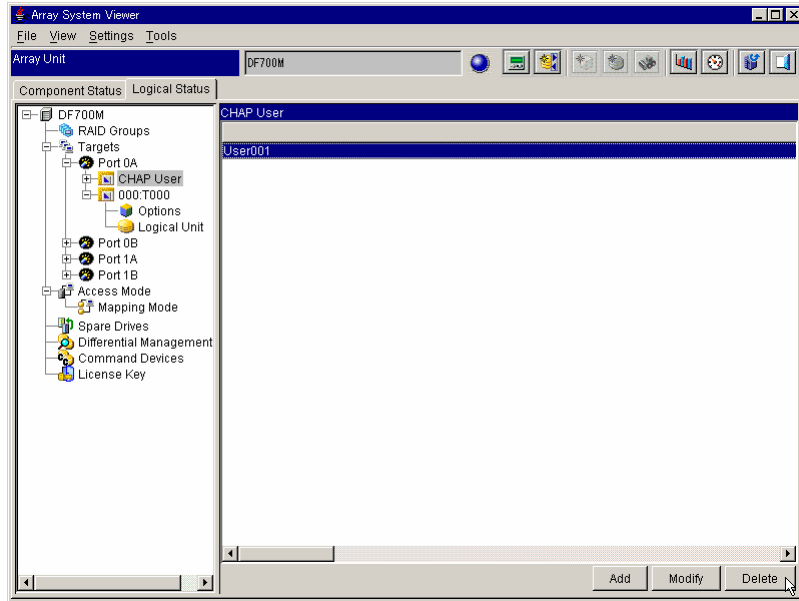

5. The confirmation message displays. Click OK.

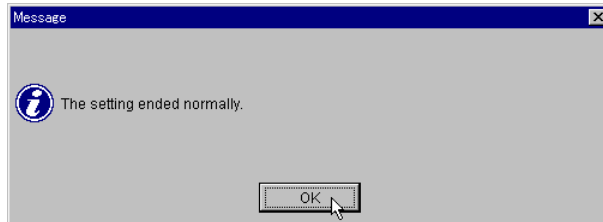
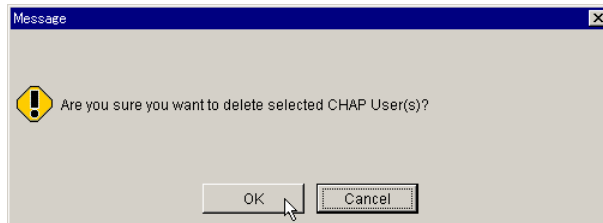

7.7.4 Changing the Two-Way Authentication Information

To change the two-way authentication information:

1. Click the **Logical Status** tab on the Unit window.
2. Click **Port**.
3. Select the Target to be changed about Two-Way Authentication from the **Target** list.
4. Click **Modify**.

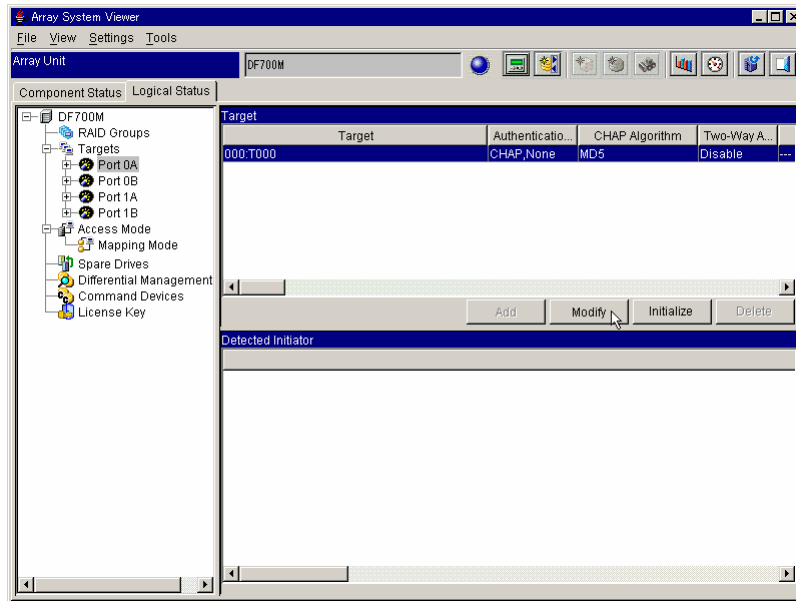

The **Target** dialog box displays.

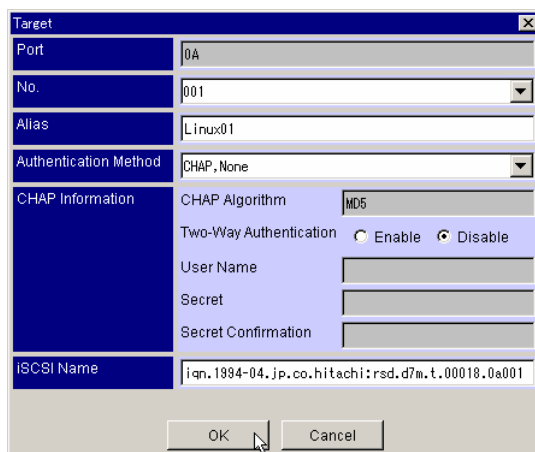

5. On the **Target** dialog box, click the **Two-Way Authentication** radio button.
 - **User Name:** Enter the name of the User with 256 or less alphanumeric character. The following symbols can be used: (. - + @ _ = : / [] , ~ (space))

- **Secret:** Enter the Secret from 12 through 32 alphanumeric characters. The following symbols can be used.
6. Click **OK**.
 7. The confirmation message displays. Click **OK**.

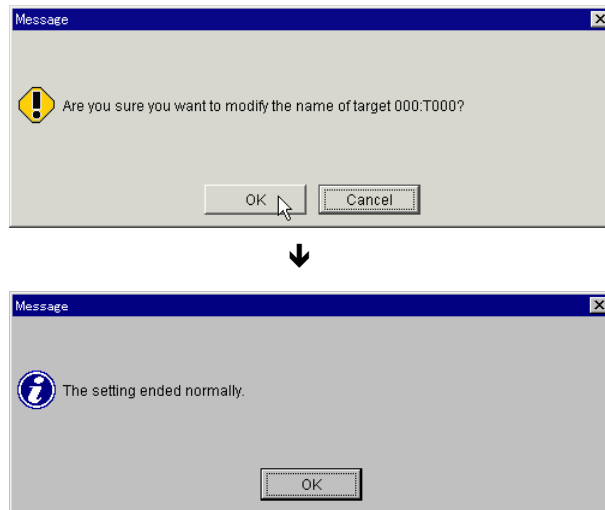

7.8 Transferring Configurations from One Array to Another

Output the configuration information of the array unit in a text file or set configuration using a text file. The configuration information output in a text file includes the status of the system parameters, RAID group/logical unit, port/host group information, the constituent parts of the array unit and LAN parameters. The configuration to be set includes the system parameters and RAID group/logical unit, port/host group information, and LAN parameter. The status of the constituent parts of the array unit cannot be set.

Configuration information is handled with separate text files for the system parameters, for RAID group/logical unit, for port/host group information, and for LAN parameters.

Copying configuration information between array units can be executed by outputting a text file of the configuration from an array unit, then using the output text file to set another array unit.

Editing a text file to set an array unit can be executed, but it is recommended that this function be used for the configuration of the same array unit. To change the configuration, use individual functions.

7.9 Storing Configuration Data

This section includes the following:

- System parameter information
- RAID group/LU information
- Port/host group information

7.9.1 System Parameter Information

To output the setting of the system parameters for an array unit in text form to a specified file:

1. From the **Tools** menu, click **Configuration Settings**, or click **Configuration Settings** on the tool bar.
2. Click the **Constitute** tab.
3. Check the System Parameters in the **Select Configuration Information** box.

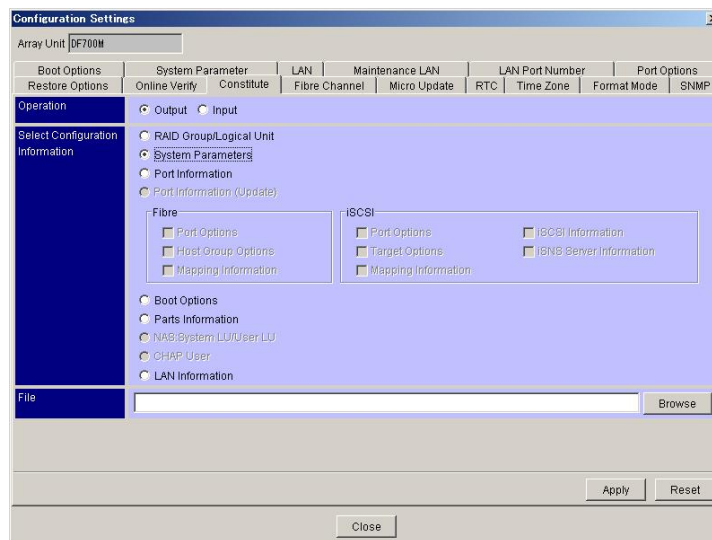

4. Click **Browse**. Specify the directory and file name to which the configuration file will be output for the File box.
5. Click **Apply**.
6. When a message box displays confirming the system parameter information is output with the specified file name, click **OK**.

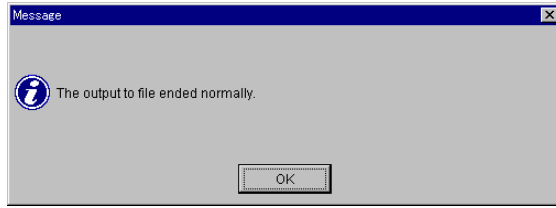

System parameter information is saved in the form of a text file with the specified file name.

7.9.2 RAID Group/LU information

To output the RAID group/logical unit definition information already set in an array unit to a specified file in a text format:

1. From the **Tools** menu, click **Configuration Settings** or click **Configuration Settings** on the tool bar.
2. Click the **Constitute** tab.
3. Check the **RAID Group/Logical Unit** in the **Select Configuration Information** box.

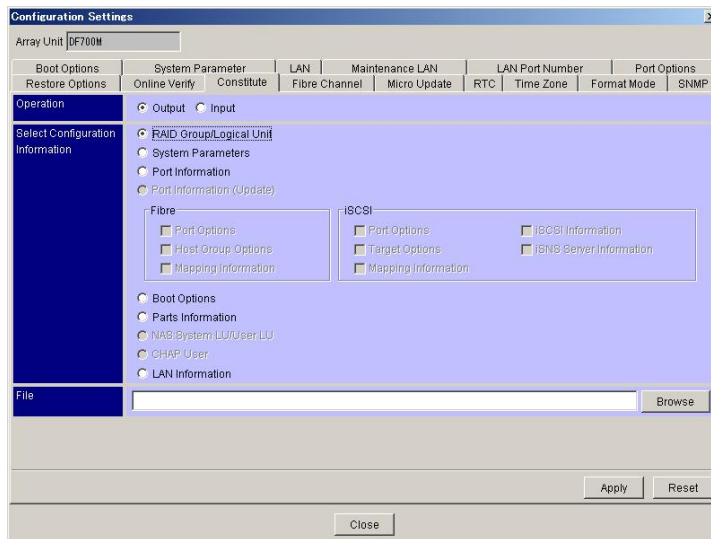

4. Click **Browse**, and then specify the directory and file name to output the file of the configuration.
5. Click **Apply**.

6. A message box displays confirming the system parameter information is output with the specified file name. Click **OK**.

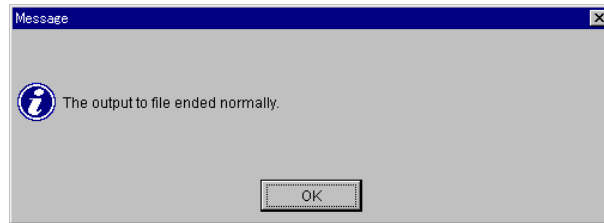

RAID group/LU information is saved in the form of a text file with the specified file name.

7.9.3 Port/Host Group Information

This setting is not required for the NAS system.

To output Port/Host group definition information previously set in an array unit to a specified file in a text format:

1. From the **Tools** menu, click **Configuration Settings** or click **Configuration Settings** on the tool bar.
2. Click the **Constitute** tab.
3. Check the **Port/Host Group** in the **Select Configuration Information** box.

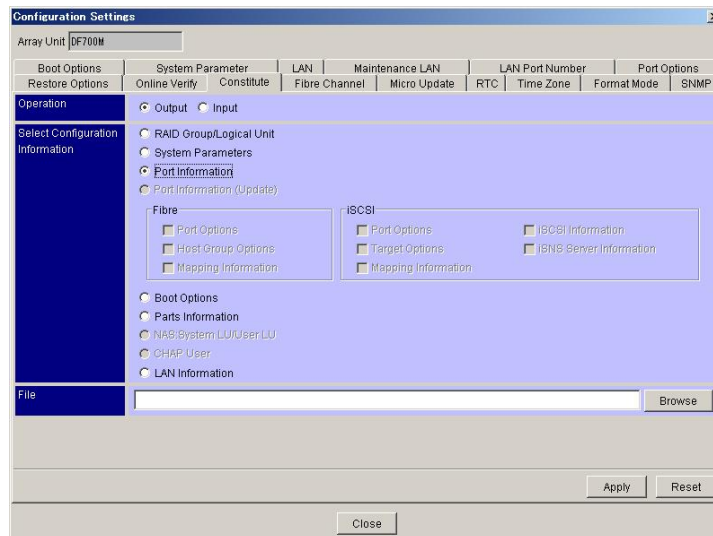

4. Click **Browse**, and then specify the directory and file name to output the file of the configuration for the File.
5. Click **Apply**.

6. A message box displays confirming the system parameter information is output with the specified file name. Click **OK**.

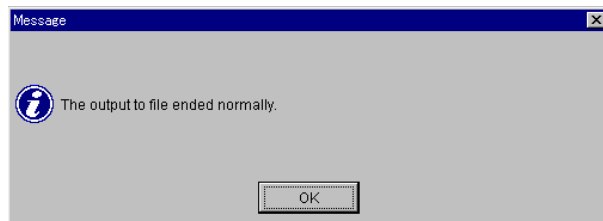

Port/Host group information is saved in the form of a text file with the specified file name.

7.9.4 NAS System LU/User LU Information

This setting is required only for the NAS system.

To output NAS System LU/User LU information already set in an array unit to a specified file in a text format:

1. From the **Tools** menu, click **Configuration Settings** or click **Configuration Settings** on the tool bar.
2. Click the **Constitute** tab.
3. Check the **NAS: System LU/User LU** in the **Select Configuration Information** box.

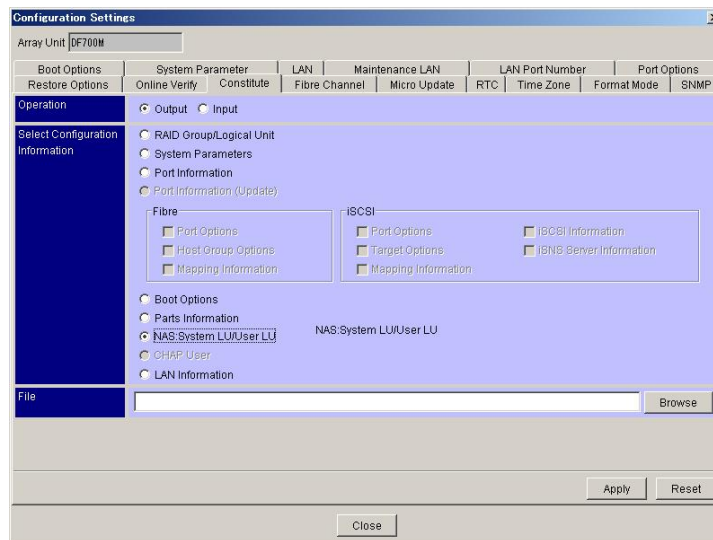

4. Click **Browse**, and then specify the directory and file name to output the file of the configuration for the File.
5. Click **Apply**.
6. A message box displays confirming the system parameter information is output with the specified file name. Click **OK**.

NAS System LU/User LU information is saved in the form of a text file with the specified file name.

7.9.5 LAN information

To output LAN information already set in an array unit to a specified file in a text format:

1. On the **Tools** menu, click **Configuration Settings** or click **Configuration Settings** in the tool bar.
2. Click the **Constitute** tab.
3. Check the **LAN Information** in the **Select Configuration Information** box.

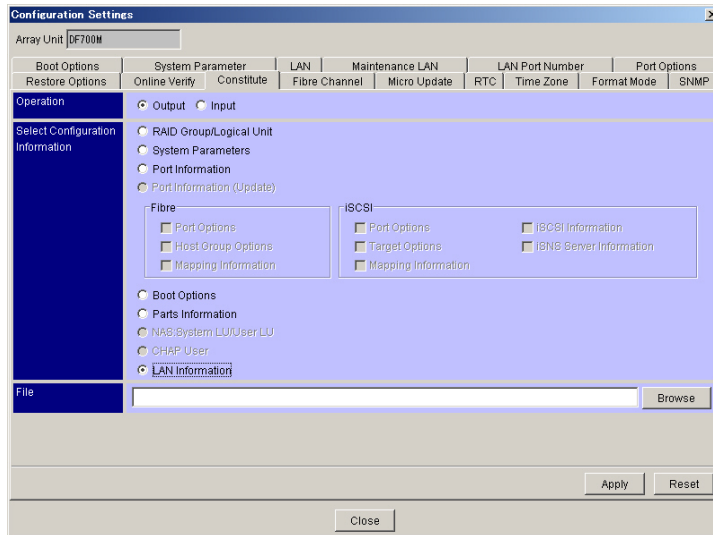

4. Click **Browse**, and specify the directory and file name to output the file of the configuration for the **File**.
5. Click **Apply**.
7. A message box displays confirming the system parameter information is output with the specified file name. Click **OK**.

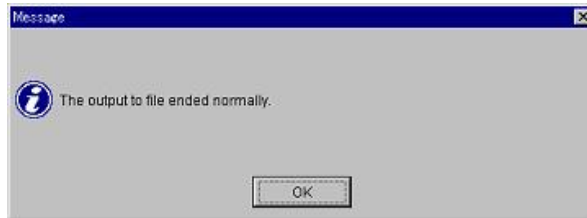

LAN information is saved in the form of a text file with the specified file name.

7.10 Applying Configuration Data to another AMS200 Storage System

This section includes the following:

- System parameters
- RAID group/logical unit
- Port/host group

7.10.1 System Parameters

Use the modes discussed in this section only when recommended by a Hitachi Data Systems Host or Optional Product installation guide.

Set the system parameters in the array unit with the information described in the file. If you set the system parameters using a file that was output when a priced optional feature is in an unlocked state, the setting may terminate abnormally. To set system parameters, use a file that was output when all priced optional features are in a locked state.

For a dual system, the setting cannot be executed if one of the controllers is detached. Confirm that the array unit is operating normally.

While the system parameters are being set, the array unit cannot execute commands from the host. The functions of Storage Navigator-Modular can no longer work with the exception of the Wizard for setting the system parameters and failure monitoring. After setting, restart the array unit. Confirm that it is operating successfully, and then connect to the host and the Storage Navigator-Modular management program.

Note: If the system parameter is set when the disk array subsystem is used as the remote side of TrueCopy Remote Replication, the following occurs:

- Both paths of TrueCopy Remote Replication are blocked. A notice regarding SNMP Agent Support Function and TRAP occurs in path blockade mode. Perform the functions in the notice and check the Failure Monitoring Department in advance.
- If the pair status of TrueCopy Remote Replication is PAIR or COPY, the pair status transits to PSUE.

When the system parameter must be set, transit the pair status of TrueCopy Remote Replication to PSUS, and then set the system parameter.

Note: If the system parameter setting operation is performed for the array unit connected to the NAS unit, the cluster between the NAS Units stops. When the system parameter setting operation for the array subsystem is unavoidably performed, execute it after stopping the cluster between the NAS Units and stopping the NAS OS of both NAS Units. Start the cluster between the NAS Units again after completing the system parameter setting operation.

1. Edit the file for which you will set system parameters to set the array unit. This file has a specified format. The format of the file is the same as that of the file output by the array unit. To format a file, refer to the file output in section 7.9.
2. From the **Tools** menu, click **Configuration Settings** or click **Configuration Settings** on the tool bar.
3. Click the **Constitute** tab.
4. Click the **Input** radio button in the **Operation** box.
5. Click the **System Parameter** radio button in the **Select Configuration Information** box.
6. Click **Browse**, and then specify the directory and file name of the file that describes the system parameters edited in 1. The specified file name displays in the text box.
7. Click **Apply**.

Note: To validate the set system parameters, restart the array unit. The previous settings stay valid until restarting. The array unit cannot access the host until the reboot is completed and the system restarts. Therefore, be certain the host has stopped accessing data before beginning the restart process.

7.10.2 RAID Group/Logical unit

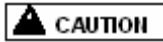

Ensure you back up all data before performing this procedure. **All user data is lost when the logical unit is deleted.**

Set the array unit according to the RAID group/logical unit setting information described in a file. If the setup of RAID group/logical unit is configured and completed, all user data previous data will be lost; RAID group/logical unit configuration as specified in the file will be set after deleting the current RAID group/logical unit. If user data is needed, configure the setting after backing up the system.

1. Edit the file for which you will set system parameters to set the array unit. This file has a specified format. The format of the file is the same as that of the file output by the array unit. To format a file, refer to the file output in section .7.9.
2. From the **Tools** menu, click **Configuration Settings** or click **Configuration Settings** on the tool bar.
3. Click the **Constitute** tab.
4. Click the **Input** radio button in the **Operation** box.
5. Click the **RAID Group/Logical Unit** radio button in the **Select Configuration Information** box.
6. Click **Browse**, and then specify the directory and name of the file that describes the RAID group definition and logical unit definition edited in 1. The specified file name displays in the text box.
7. Click **Apply**.

To check the configuration, click the **Logical Status** tab.

7.10.3 Port/Host Group

This setting is not required for the NAS system.

1. Edit the file for which you will set system parameters to set the array unit. This file has a specified format. The format of the file is the same as that of the file output by the array unit. To format a file, refer to the file output in section .7.9.
2. From the **Tools** menu, click **Configuration Settings** or click **Configuration Settings** on the tool bar.

3. Click the **Constitute** tab.
4. Click the **Input** radio button in the **Operation** box.
5. Click the **Port/Host Group** radio button in the **Select Configuration Information** box.
6. Select the item that you want to set from the Setting Information for Input. If nothing is selected, an error occurs. (If the LUN Manager function is enabled, WWN information also displays in the Setting Information for Input.)
7. Click **Browse**, and then specify the directory and name of the file to which the Port/Host Group information is input for the File box.
8. Click **Apply**.
9. Port/Host Group information is entered in the specified file name. A confirmation message box displays, click **OK**.
10. A message box indicating that the setting that has been made displays, click **OK**.

7.10.4 LAN Information

1. On the **Tools** menu, click **Configuration Settings** or click **Configuration Settings** in the tool bar.
2. Click the **Constitute** tab.
3. Click the **Input** radio button in the **Operation**.
4. Check the **LAN Information** in the **Select Configuration Information** box.
5. Click **Browse**, and specify the directory and name of the file.
6. Click **Apply**.
The setting confirmation window is displayed. Click **OK**.
7. The following message appears.
Click **OK** to close the Unit window.

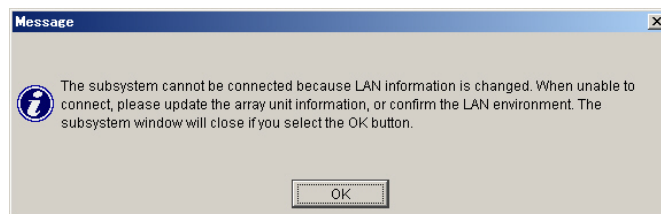

Note: When you input LAN Information file, note the following:

- If the **Maintenance Port IP Address Automatic Change Mode** is **ON** in the file, then the IP address of the maintenance port written in the file will be ignored. However, do not delete the setting of the maintenance port written in the file.
- If **Maintenance Port IP Address Automatic Change Mode** is **OFF** in the file, then only the network address for the IP address of the maintenance port written in the file is reflected.

7.11 Setting Host Connection Parameters

There are two methods for setting options:

- **Simple Setting for Connecting to the Host Computer**

When using the simple setting, select the environmental elements of the host computer to be connected. When the selection is made, the host group options (host connection mode 1 and 2) necessary for the host computer to be connected are set automatically.

- **Detailed Setting for Each Host Connection**

When using the detailed setting, directly set the necessary host group options (host connection mode 1 and 2) in the same way as the conventional one.

The host group Information does not need to be set for the NAS system.

7.11.1 Simple Setting

Set the host group options (host connection mode 1 and 2) that are necessary for the host computer to be connected. To do this, select the environmental elements of the host, such as platform, alternative path, fail-over, and additional parameter. Some host environments require a detailed setting as well as the simple setting. For details, refer to Table B.2.

1. In the Unit window, click the **Logical Status** tab.
2. Double-click **Host Groups** or **Target** (when iSCSI interface board is added). Double-click the **Port** that you want to set for the connection mode with the host to display **000:G000**.
3. Display the Options and Logical Unit by double-clicking **000:G000**, and select the **Options**.

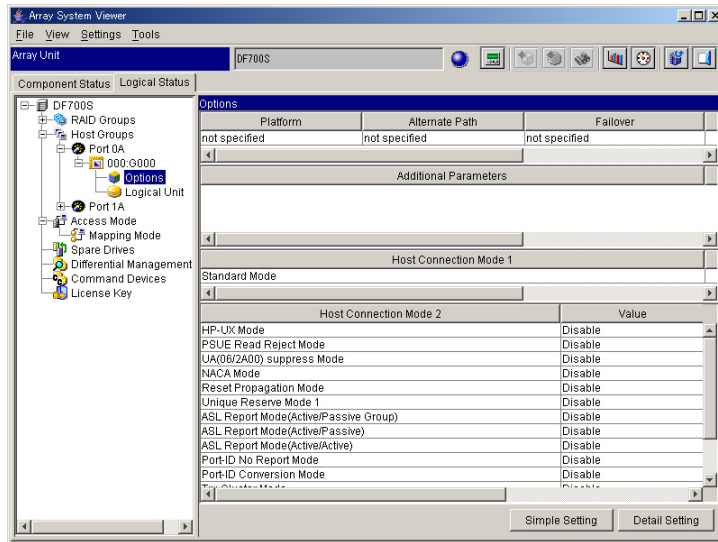

4. Click **Simple Setting**. The **Options (Simple)** dialog box displays.

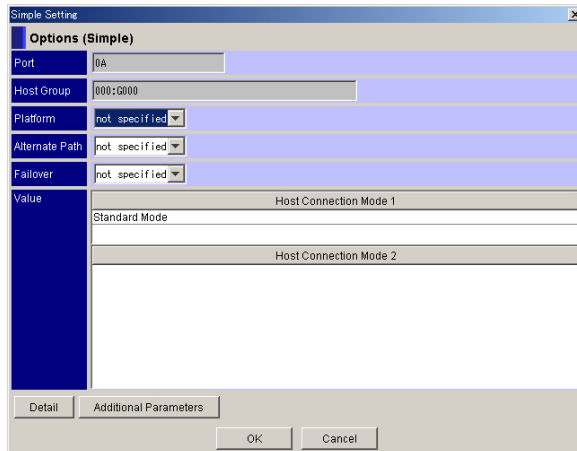

5. Select **Platform**, **Alternative Path**, and **Fail-Over** according to an environment of the host to be connected.
6. Click **Additional Parameters**. The **Additional Parameters Property** dialog box displays. Select items as necessary, and then click **OK**:

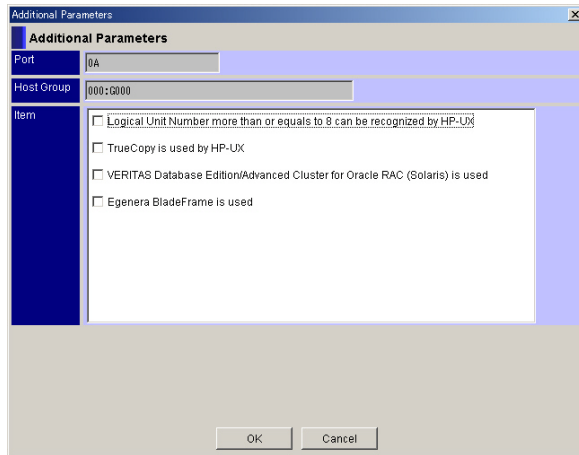

7. Click **Detail** as needed. Select **Host Connection Mode 1** and **Host Connection Mode 2**, and then click **OK**.

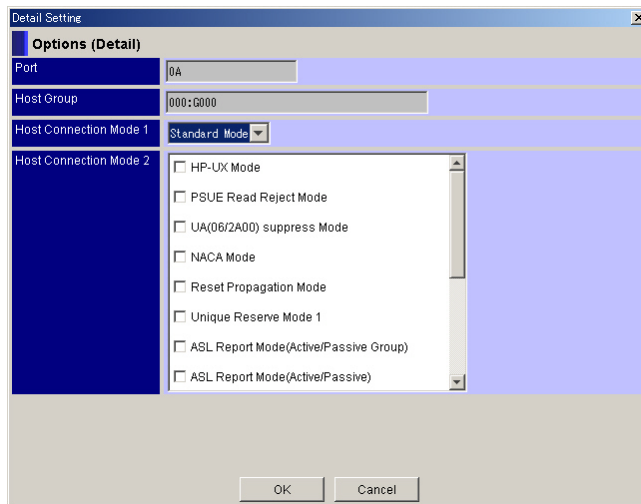

8. On the **Option (Simple)** dialog box, click **OK**.
9. A confirmation message box displays. Click **OK**.

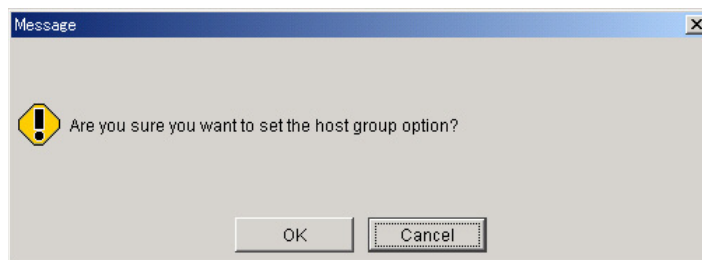

10. A message box displays requesting you to verify an I/O requested by the host has been stopped. Stop it and click **OK**. (If the system administrator has not stopped I/O on the host side, clicking this button will stop all I/O processes.).

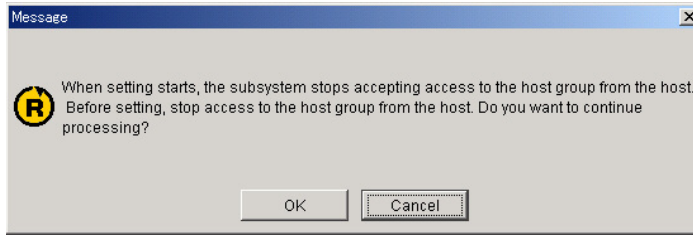

11. A message box displays stating the setting is complete. Click OK.

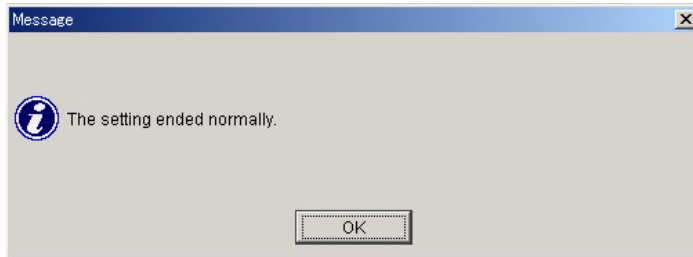

12. The setting displays.

Verify that the selected host environment (platform, alternative path, and fail-over) and the Additional Parameter are reflected in the display. When you have set host connection mode 1 and 2 directly, verify that the mode that has been set is reflected in the display:

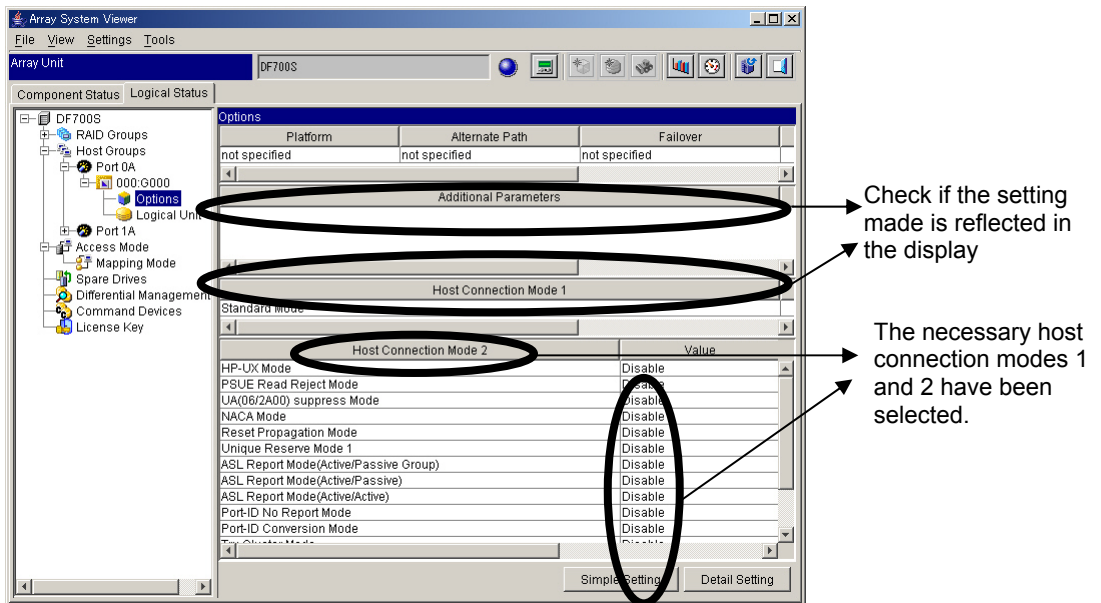

13. Set the settings for the rest of the ports in the same way.

Table 7.3 Simple Setting Item List

No.	Menu Item	Description		Factory Setting
		Parameters	Selection Method	
1	Platforms	Not specified	Select one of items	Not specified
		HP-UX		
		Solaris™		
		AIX®		
		Windows NT®		
1	Platforms	Windows NT®	Select one of items	Not specified
		Windows 2003		
		Linux®		
		Tru64®		
2	Alternate Path	Not specified	Select one of items	Not specified
		PV Link		
		HDLM		
		VxVM		
		MPxIO		
3	Fail-over	Not specified	Select one of items	Not specified
		MC/ServiceGuard®		
		Sun™ Cluster		
		VCS		
		HACMP		
		MSCS		
		TruCluster		

Table 7.4 Additional Parameter Setting Items

No.	Menu Item	Description		Factory Setting
		Parameters	Selection Method	
1	Additional Parameter	Logical Unit Numbers more than or equal to 8 can be recognized by HP-UX	Selection	Not selected
		TrueCopy is used by HP-UX (see <i>Note</i>)	Selection	Not selected
		VERITAS Database Edition™/Advanced Cluster for Oracle® RAC (Solaris) is used	Selection	Not selected
		Egenera® BladeFrame® is used	Selection	Not selected

Note: True Copy displayed on parameter means TrueCopy Remote Replication.

7.11.2 Detailed Setting for Each Host Connection

This operation is performed using the Storage Navigator-Modular.

The following describes the procedure for setting a subsystem when the host group option setting is required for a combination that simple setting does not have.

Follow these steps:

1. On the Unit window, click the **Logical Status** tab.
2. Double-click the **Host Groups** or **Target** (when iSCSI interface board is added). Display the **000:G000** by double-click the **Port** which you want to set for the connection mode with the host.
3. Display the Option and Logical Unit by double-clicking the **000:G000**, and then select the **Option**.

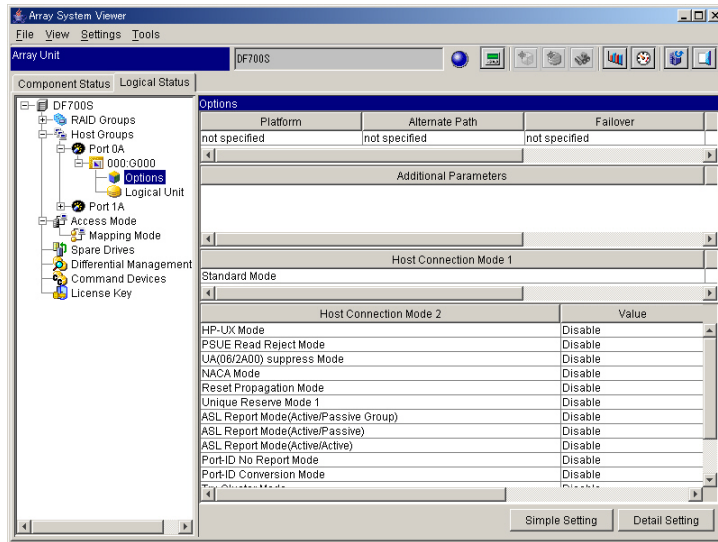

4. Click **Detail Setting**.
Perform the operation corresponding to the model to be set.
5. Perform the setting for the other ports in the same way as described above.

7.12 Setting the Storage System when using Special Mode

This operation (using the subsystem in drive blockade mode) is performed using Storage Navigator-Modular.

Note: If the special mode is set when the disk array subsystem is used as the remote side of TrueCopy Remote Replication, the following occurs:

- Both paths of TrueCopy Remote Replication are blocked.
A notice regarding SNMP Agent Support Function and TRAP occurs in path blockade mode. Perform the functions in the notice and check the Failure Monitoring Department in advance.
- If the pair status of TrueCopy Remote Replication is PAIR or COPY, the pair status transits to PSUE.

When the special mode must be set, transit the pair status of TrueCopy Remote Replication to PSUS, and then set the special mode.

Note: If the special mode setting operation is performed for the array unit connected to the NAS unit, the cluster between the NAS Units stops. When the special mode setting operation for the array subsystem is unavoidably performed, execute it after stopping the cluster between the NAS Units and stopping the NAS OS of both NAS Units. Start the cluster between the NAS Units again after completing the special mode setting operation for the array subsystem.

1. From the **Tools** menu, click **Configuration Settings**. Alternately, click **Configuration Settings** on the tool bar.
2. Click the **Boot Option** tab.
3. For the **Drive Detach Mode**, click the **Enable** radio button.

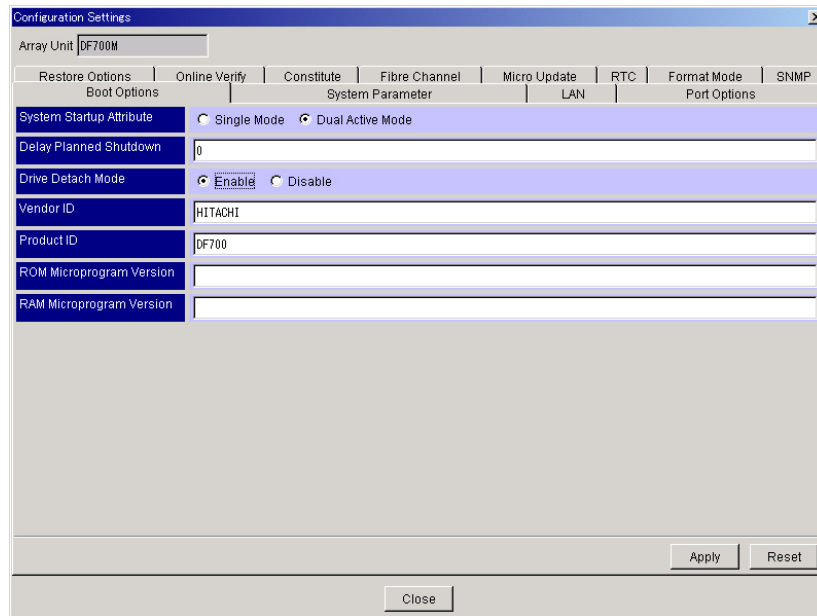

4. Click **Apply**.
5. A confirmation message box displays. Click **OK**.

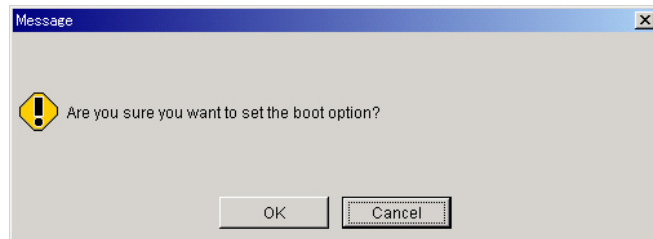

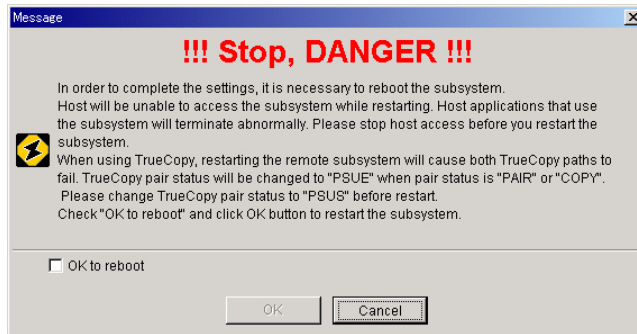

When restarting the array unit, the time the array unit restarts will be displayed. It takes approximately 4 to 15 minutes to restart the array unit.

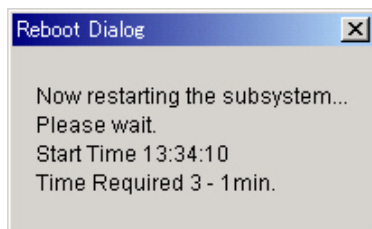

Note: Depending on the status of array unit, the array unit may take time to respond. If the array unit does not respond after 15 minutes or more, check the status of the array unit.

7.13 Changing the Network Parameter

Set a network parameter from the Storage Navigator-Modular.

Note: When the network address of the LAN device, which is connected via the Gateway in the extension of the User management port, is the same as that of the Maintenance port, communication cannot be made due to the conflict between them. If this occurs, set the network address to be other than the maintenance port in the LAN device which is connected via the Gateway in the extension of the User management port, or set the maintenance port other than the network address of LAN device which is connected via the Gateway. (See section 7.16.)

Note: A LAN setting cannot be performed when LAN access (such as Storage Navigator Modular, WEB, and SNMP) is provided for the LAN port to be set. Perform the LAN setting after stopping LAN access to the LAN port to be set.

When the WEB window is opened for the LAN port to be set, the LAN setting cannot be performed. Close the WEB window.

When the **Apply** button is clicked although there is the LAN access, an error message is displayed.

According to the error message, refer to “netstat.inf” file in the directory where Storage Navigator Modular is installed, stop the LAN access to the LAN port to be set, and try again.

1. Turn on the power supply.

2. Start the Storage Navigator Modular and set the operation mode in the **Management Mode** (Refer to the *Storage Navigator Modular (for GUI) User's Guide*).
3. Click the icon of an array unit on the Main window and select the **File** menu. Click **Open** or click the **Display Details** button on the tool bar.

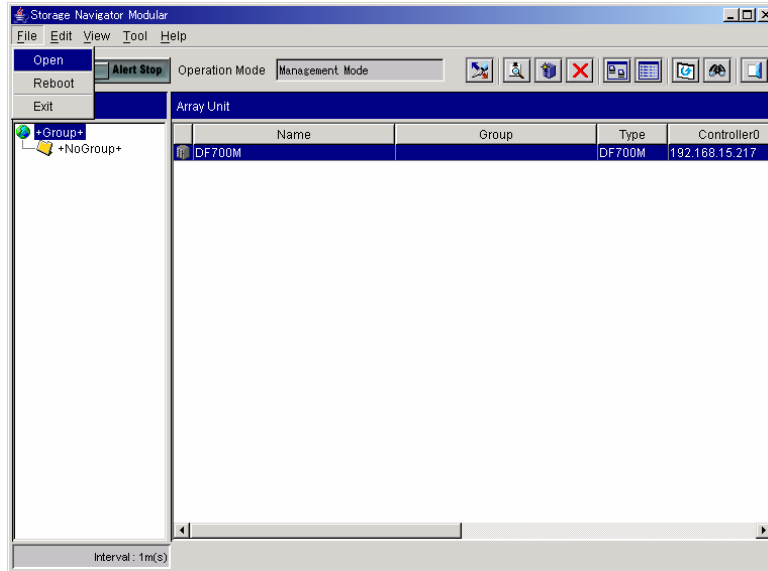

4. On the **Tools** menu, click **Configuration Settings** or click the **Configuration Settings** button on the tool bar.

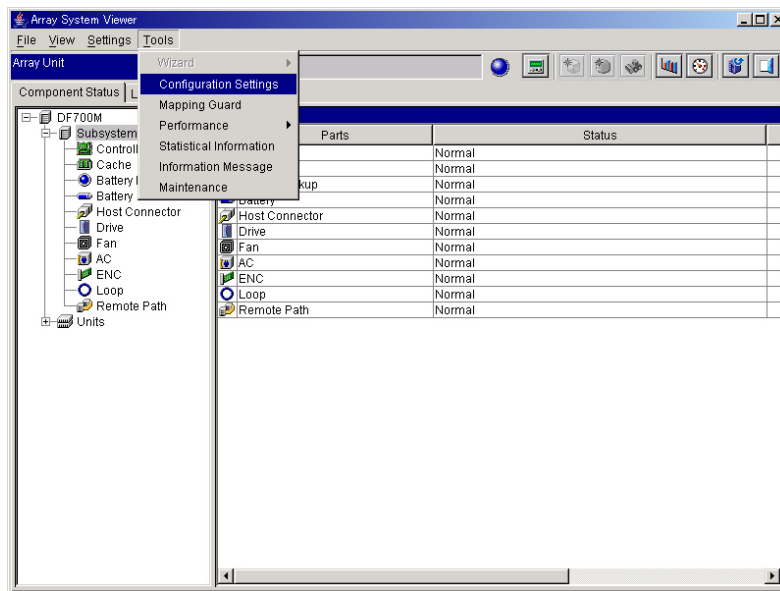

5. Click the **LAN** tab. Select **Set now without reboot**. When you want to change the DHCP function, select **Set with reboot**. See the Notes following the next illustration for additional information.

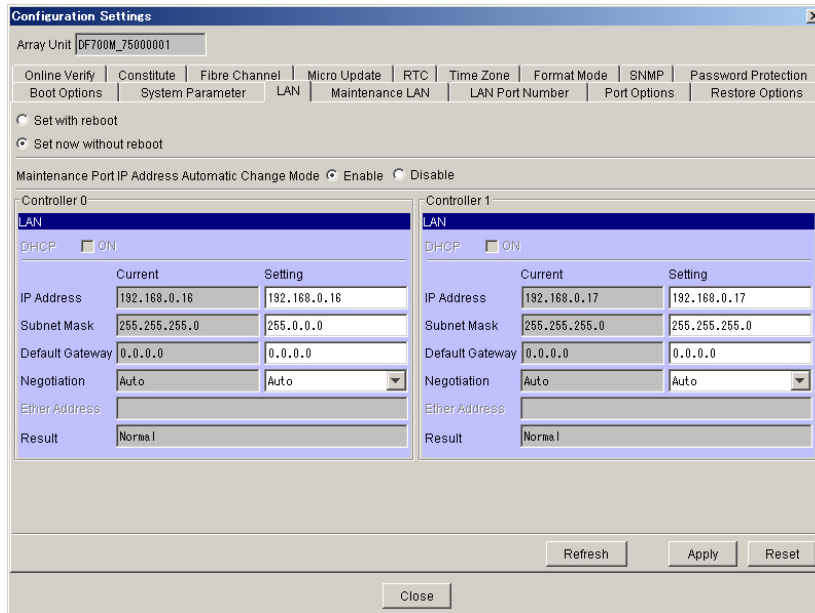

Note 1: The dialog box does not immediately display the changed values after you enter the LAN information and click Apply, because the values are not yet applied to the subsystem. You must reboot the system to apply the values. When the reboot is complete, the dialog box displays the new values.

Note 2: Do not perform the LAN setting with the subsystem reboot when the READY LED (green) blinks at high speeds (A maximum of 40 to 60 minutes).

Note 3: When the array subsystem connected to the NAS unit is rebooted, the cluster between the NAS units stops. When the array subsystem is unavoidably rebooted, execute it after stopping the cluster between the NAS units and stopping the NAS OS of both NAS units.

Start the cluster between the NAS Units again after completing the array subsystem reboot.

Note 4: When the array subsystem to be restarted is remote disk subsystem with the TrueCopy Remote Replication enabled, restart the array subsystem after the TrueCopy Remote Replication pair status (S-VOL) transits to the PSUS.

If a restart is executed, it becomes a path blockade and a notice regarding SNMP Agent Support Function and TRAP occurs. Perform the functions in the notice and the check the Failure Monitoring Department in advance. Path blockade of TrueCopy Remote Replication automatically recovers after restarting.

6. Set the Maintenance Port IP Address Automatic Change Mode.

Note 1: If the Maintenance Port IP Address Automatic Change Mode is enabled, the IP address of the maintenance port is changed automatically by the IP address of the user management port as follows.

- 10.xxx.xxx.xxx --- CTL0: 192.168.0.16, CTL1: 192.168.0.17
- other than 10.xxx.xxx.xxx --- CTL0: 10.0.0.16, CTL1: 10.0.0.17

However, in the case of following, this option cannot be selected.

- “DHCP” is enabled.

- using the NAS model.

Note2: If the **Maintenance Port IP Address Automatic Change Mode** is enabled when the IP address changes, the maintenance port may be set temporarily. Verify that the following IP addresses are not used in the maintenance LAN port network.

No.	Current IP address of user management port	Setting IP address of user management port	Temporarily IP address of maintenance port
1	172.xxx.xxx.xxx	10.xxx.xxx.xxx	CTL0: 192.168.0.16, CTL1: 192.168.0.17
2	other than 172.xxx.xxx.xxx	other than 10.xxx.xxx.xxx	CTL0: 10.0.0.16, CTL1: 10.0.0.17
3	10.xxx.xxx.xxx	172.xxx.xxx.xxx	CTL0: 192.168.0.16, CTL1: 192.168.0.17
4	other than 10.xxx.xxx.xxx	other than 172.xxx.xxx.xxx	CTL0: 172.23.211.16, CTL1: 172.23.211.17
5	other than 10.xxx.xxx.xxx, and other than 172.xxx.xxx.xxx	172.xxx.xxx.xxx	CTL0: 10.0.0.16, CTL1: 10.0.0.17
6	other than 10.xxx.xxx.xxx, and other than 172.xxx.xxx.xxx	other than 172.xxx.xxx.xxx	CTL0: 172.23.211.16, CTL1: 172.23.211.17

7. Set the LAN Information.

Note1: The head value of IP Address, ‘0’, ‘127’ and ‘255’ cannot be specified. If any one of these values is set, an error will result when clicking **Apply** in the **Parameter** window.

Note2: If the **Maintenance Port IP Address Automatic Change Mode** is disabled, you cannot set the IP address or the default gateway address with the same network address that is used for the user-managed port. If the IP address is set, an error will occur when **Apply** is clicked on the **Parameter** screen. When the network parameter of the maintenance port or the user-managed port is being changed, you cannot change the setting of the user-managed port network parameter. An error will occur when **Apply** is clicked on the **Parameter** window during a setting change.

Note3: When you use the **Change maintenance port IP address automatically** option, select **Set with reboot array unit**. When this option is enabled, the maintenance port is automatically changed to any of the following addresses, depending on the IP address of the user management port:

- CTL0: 10.0.0.16 or 192.168.0.16
- CTL1: 10.0.0.17 or 192.168.0.17

However, in any of the following cases, this option cannot be selected.

- the microprogram is less than Ver.0733 and the Storage Navigator Modular is less than Ver.3.30.
- “Set now” is selected.
- “DHCP” checkbox is checked.
- using the NAS model.

Note 4: Conform the negotiation of subsystem to the negotiation of the device connected to the subsystem. If the negotiation of subsystem is different from the negotiation of the device connected to the subsystem, the communication cannot be made normally.

		Device Connected to the Subsystem				
		Auto	10Mbps Half	10Mbps Full	100Mbps Half	100Mbps Full
Subsystem	Auto	○	×	×	×	×
	10Mbps Half	×	○	×	×	×
	10Mbps Full	×	×	○	×	×
	100Mbps Half	×	×	×	○	×
	100Mbps Full	×	×	×	×	○

○: Available for communication ×: Not available for operation

- Click **Apply** on the **Configuration Settings** window after the setting is completed. Close the Unit window, and verify that the Storage Navigator Modular can connect to the subsystem with the set IP address. (Refer to section 6.4.)
When the setting change is applied, if the Storage Navigator Modular does not connect to the subsystem after at least 5 minutes, connect to the subsystem with the previous IP address. Follow the message on the **LAN** setting window.

No.	Display in the Setting Result	Failure and Measure
1	---	An unexpected setting result value was received from through Storage Navigator Modular. Press the Refresh button again to refresh the display. When the "---" is displayed no matter how many times the update is repeated, make the setting again. If the same information is displayed in spite of the above operation, contact the maintenance personnel.
2	Setting in progress	The setting is being changed. Wait for about 5 minutes, and then press the Refresh button again to refresh the display. If the same information is displayed no matter how many times the update is repeated, contact the maintenance personnel.
3	Abnormal (Time-out of the waiting for the connection)	The setting could not be changed because the effective connection was set for the maintenance port. When the failure monitor service is used with the ASSIST through a maintenance port connection, contact the maintenance personnel. In cases other than the above case, make the setting again. If the same information is displayed in spite of the above operation, contact the maintenance personnel.
4	Abnormal (Occurrence of a DF internal failure.)	The setting could not be changed because the processing could not continue inside the subsystem. When a failure occurs in the subsystem, contact the maintenance personnel. When no failure occurs in the subsystem, make the setting again. If the same information is displayed in spite of the above operation, contact the maintenance personnel.

When the **Apply** button is clicked although there is the LAN access, an error message is displayed. According to the error message, refer to "netstat.inf" file in the directory where Storage Navigator Modular is installed, stop the LAN access to the LAN port to be set, and try again.

```

netstat.inf - Notepad
File Edit Format Help
Date: 2006/05/02 Tue 14:00:30.333

CTLO
Local Address      Foreign Address    State
192.168.0.16: 2000  192.168.0.70: 3001  4:ESTABLISHED
10.0.0.16: 80    10.0.0.150: 3010  4:ESTABLISHED

CTL1
Local Address      Foreign Address    State
10.0.0.17: 80    10.0.0.151: 3020  4:ESTABLISHED

```

Local Address: IP address of the subsystem and LAN port number

Foreign Address: IP address of PC and LAN port number connecting with the subsystem

State: status of TCP connection

Regardless of "Status" in the netstat.inf file, stop the all appreciation currently connecting from "Foreign address"

- 0:CLOSE : There are no connections
- 2:SYN_SENT : Waiting for reply of connection request
- 3:SYN_RCVD : Waiting for confirmation of connection reply
- 4:ESTABLISHED : Establishing connection
- 5:CLOSE_WAIT : Waiting for request of connection termination from application
- 6:FIN_WAIT_1 : Waiting for request of connection termination, or waiting for reply of connection termination sent
- 7:CLOSING : Waiting for reply of request for connection termination
- 8:LAST_ACK : Waiting for confirmation of request for connection termination
- 9:FIN_WAIT_2 : Waiting for request of connection termination
- 10:TIME_WAIT : Waiting for connection termination
- 99:--- : The status which is not assumed

7.14 Changing the Auto Diagnosis Threshold for Fibre Channel Loop

The auto diagnosis threshold for Fibre Channel loop on the drive side of the subsystem can be changed to any number within a range from 1 to 255. The default value is "10". However, this threshold is not normally changed.

This operation is performed using Storage Navigator-Modular.

1. Turn on the power supply.
2. Start the Storage Navigator Modular and set the operation mode in **Management Mode**. Refer to the *Hitachi TagmaStore® Adaptable Modular Storage and Workgroup Modular Storage Navigator Modular Graphical User Interface (GUI) User's Guide (MK-95DF711)*.
3. Click the icon of an array unit on the Main window and select the **File** menu. Click the **Open** or click the **Display Details** button on the toolbar.

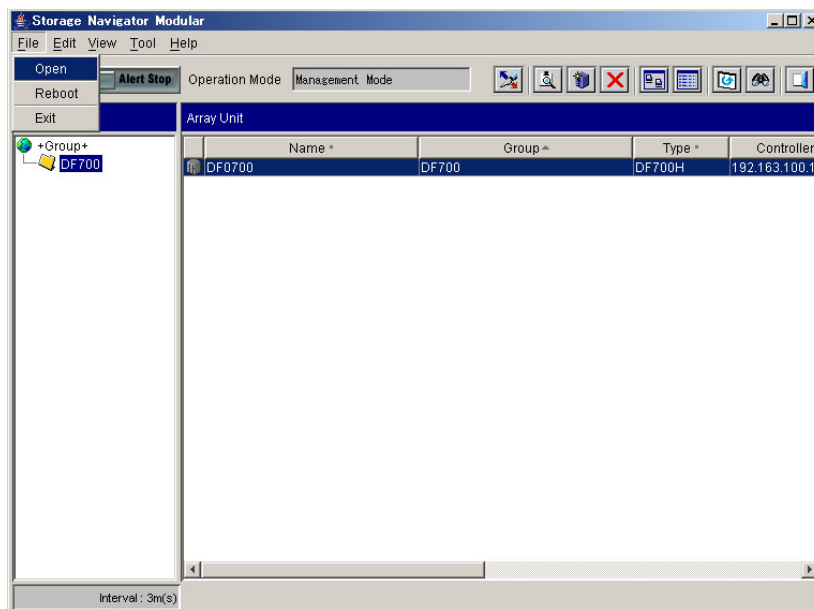

4. On the **Tools** menu, click the **Configuration Settings**. Or, click the **Configuration Settings** button in the tool bar.

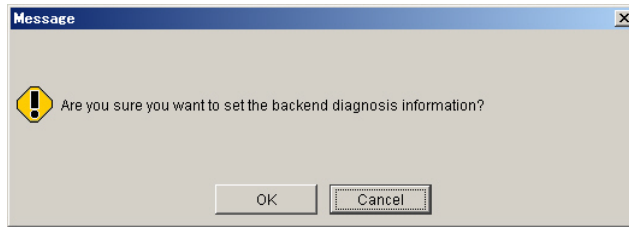

9. A message indicating the completion of changing the Auto Diagnosis Threshold is displayed. Click the **OK** button.

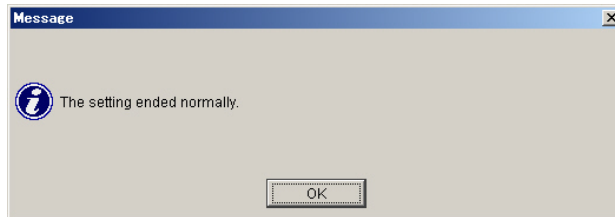

10. Verify that the Auto Diagnosis Threshold has been changed.

7.15 7.15 Changing the IP Address for the Maintenance Port

This operation is performed using the Storage Navigator Modular.

Note: The IP address for the maintenance port is used for the maintenance work performed by the maintenance personnel when a failure occurs. Use one of the following network addresses as an IP address for the maintenance port; "10.0.0.xxx", "192.168.0.xxx", "192.168.233.xxx", "172.23.211.xxx", "10.197.181.xxx". Do not use the same network address used for maintenance port for other user-managed ports. Do not change the IP address for the maintenance port, if its change is not needed.

Do not change the IP address for the maintenance port, if the change is not absolutely needed.

Note: If the user management port is set incorrectly, the setting of the maintenance port will fail, and an error may be displayed. Set the value of the user management port according to the error message. (Refer to section 7.13.)

Note: If the **Maintenance Port IP Address Automatic Change Mode** is enabled when the IP address changes, the maintenance port may be set temporarily. Verify that the following IP addresses are not used in the maintenance LAN port network.

If you change the maintenance LAN setting, set the **Maintenance Port IP Address Automatic Change Mode** to **Disable**. (Refer to section 7.13.)

To change the IP address for the maintenance port, follow these steps:

1. Turn on the power supply.
2. Start the Storage Navigator Modular and set the operation mode to **Management Mode**. Refer to the *Hitachi TagmaStore® Adaptable Modular Storage and Workgroup Modular Storage Navigator Modular Graphical User Interface (GUI) User's Guide (MK-95DF711)*.

- Click the icon of an array unit on the Main window, and then select the **File** menu. Click **Open**. Alternatively, click **Display Details** on the tool bar.

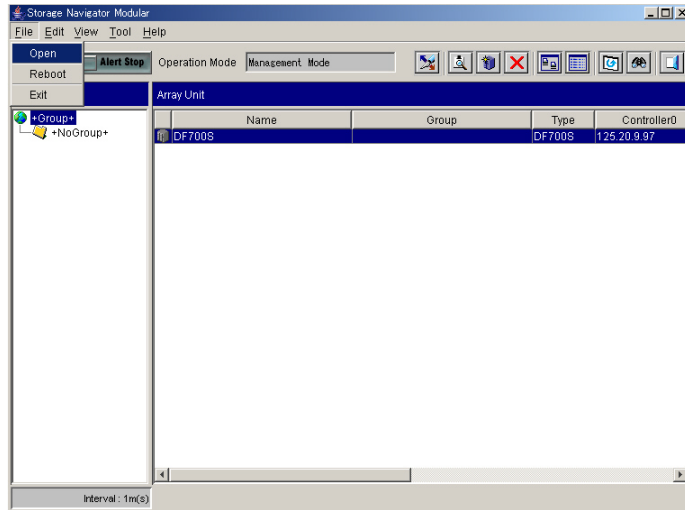

- From the **Tools** menu, click **Configuration Settings** or click **Configuration Settings** on the tool bar.

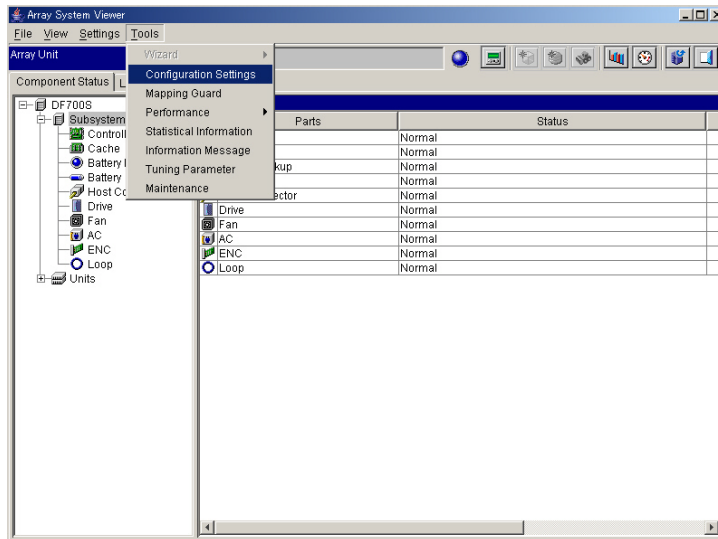

- click the **Maintenance LAN** tab on the **Configuration Settings** window.

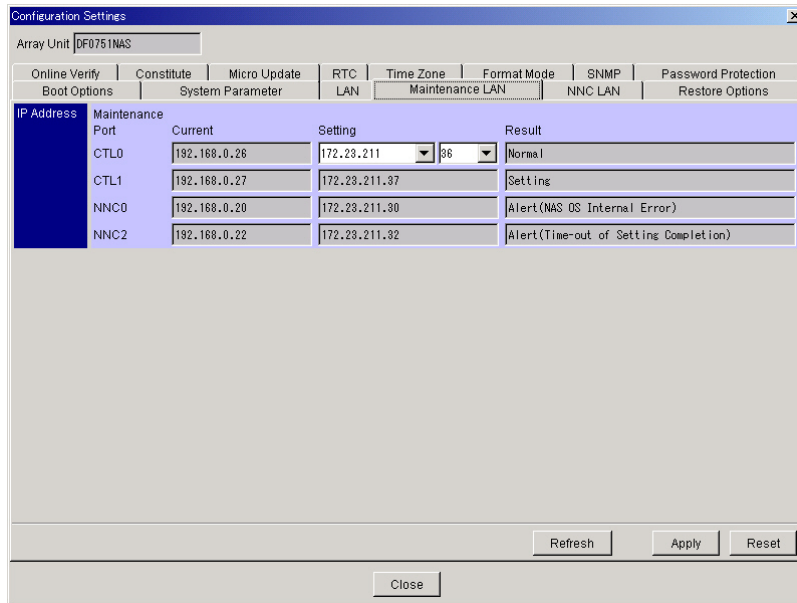

6. Set the **Maintenance LAN Information**.

Note: The IP address which has the same network address as the IP address currently set for the user-managed port or the NNC management port has cannot be set. In the event that this IP address is set, an error will occur when clicking the **Apply** on the **Parameter** window. When the network parameter of the maintenance port, the user-managed port or the NNC management port is changed, the setting of the user-managed port network parameter cannot be changed. An error occurs when **Apply** is clicked on the **Parameter** window during the setting change.

7. Click **Apply** on the **Configuration Settings** window after the setting is completed.
8. A confirmation message box displays. Click **OK**.

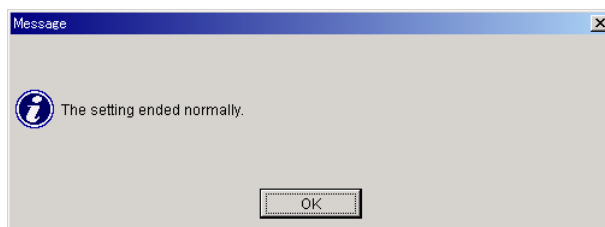

9. When all the Current values are the same as the set value on the **Configuration Settings** window, and **Normal** is displayed on the **Result** window, the setting is completed.
If the Setting is displayed in the **Result** window, click **Refresh** on the **Configuration Settings** window after a brief interval.

When the setting does not terminate correctly, the following messages will be displayed in the **Result** window.

No.	Display in Result	Failure and Measure
1	---	An unexpected setting result value was received from through Storage Navigator Modular. Press the Refresh button again to refresh the display. When the "---" is displayed how many times the above operation repeated, make the setting again. If the same information is displayed in spite of the above operation, contact the maintenance personnel.
2	Setting	The setting is being changed. Wait for about 5 minutes, and then press the Refresh button again to refresh the display. If the same information is displayed no matter how many times the update is repeated, contact the maintenance personnel.
3	Alert (Time-out of Disconnection)	The setting could not be changed because the effective connection was set for the maintenance port. When the failure monitor service is used with the ASSIST through a maintenance port connection, contact the maintenance personnel. Except for the above case, make the setting again. If the same information is displayed in spite of the above operation, contact the maintenance personnel.
4	Alert (Internal Error)	The setting could not be changed because the processing could not continue inside the subsystem. When a failure occurs in the subsystem, contact the maintenance personnel. When no failure occurs in the subsystem, make the setting again. If the same information is displayed in spite of the above operation, contact the maintenance personnel.
5	Not Specified	The setting has not completed yet because the NAS unit is activating. Wait until the NAS unit becomes normal, press the Refresh button again to refresh the display. If the same information is displayed no matter how many times the update is repeated, contact the maintenance personnel.
6	Setting Reserved	The setting has not been completed because the NAS unit stops. The setting will be made when the NAS unit is restarted. Wait until the NAS unit restarts, and press the Refresh button again to refresh the display. If the same information is displayed no matter how many times the update is repeated, contact the maintenance personnel.
7	Alert (Time-out of Setting Completion)	There was no response regarding the setting from the NAS unit although a certain period of time passed. When a failure occurs in the subsystem or in the NAS unit, contact the maintenance personnel. When no failure occurs in the subsystem or in the NAS unit, make the setting again. If the same information is displayed in spite of the above operation, contact the maintenance personnel.
8	Alert (NAS OS Internal Error)	The setting could not be changed because a failure occurred inside the NAS OS. When a failure occurs in the NAS unit, contact the maintenance personnel. When no failure occurs in the NAS unit, make the setting again. If the same information is displayed in spite of the above operation, contact the maintenance personnel.

No.	Display in Result	Failure and Measure
9	Alert (Time-out of Setting)	The setting could not be changed because a time out occurred inside the NAS OS during the setting. When a failure occurs in the NAS unit, contact the maintenance personnel. When no failure occurs in the NAS unit, make the setting again. If the same information is displayed in spite of the above operation, contact the maintenance personnel.
10	Alert (Segment Duplication)	The network address intended to be set has already been used for a port of the NAS unit. Set other IP address of the maintenance port. When the same information id displayed no matter which IP address is specified, set the maintenance port ID address, which has been set before the change, again, and change the duplicate IP address of the port.

7.16 Setting the System LU and User LU in the NAS System

This operation is performed using the Storage Navigator Modular. Refer to the *Hitachi TagmaStore® Adaptable Modular Storage and Workgroup Modular Storage Navigator Modular Graphical User Interface (GUI) User's Guide (MK-95DF711)*.

The capacity of system LU is restricted to the capacity listed in Table 7.5.

Table 7.5 Capacity Restriction of System LU

No.	System LU	Capacity Restriction	
		Byte Designation	Block Designation
1	For system disk (CTL 0)	15 G bytes (or more)	28,698,624 blocks (or more)
2	For system disk (CTL 1)	15 G bytes (or more)	28,698,624 blocks (or more)
3	For volume for storing dump (CTL 0)	5 G bytes (or more)	10,086,400 blocks (or more)
4	For volume for storing dump (CTL 1)	5 G bytes (or more)	10,086,400 blocks (or more)
5	For command device (Note)	35 M bytes (or more)	71,680 blocks (or more)
6	For the work for storing the dump edit result.	5 G bytes (or more)	8,591,360 blocks (or more)
7	For the system sharing volume	3 G bytes (or more)	5,195,776 blocks (or more)
8	For the volume for back-upping a shared volume	3 G bytes (or more)	5,195,776 blocks (or more)
9	For the volume 2 for back-upping a shared volume	3 G bytes (or more)	5,195,776 blocks (or more)

Note: It is required to use the extra-cost option such as ShadowImage In-System Replication Copy-on-write SnapShot, TrueCopy Remote Replication and Backup Restore.

7.16.1 Setting the System LU

To set the System LU:

1. On the Unit window, click the **Logical Status** tab.
2. Display the NNC0/2 by double-clicking the **NAS**.
3. Display the System and User by double-clicking the **NNC0/2**, and click **System**.
A list of system LU is displayed.

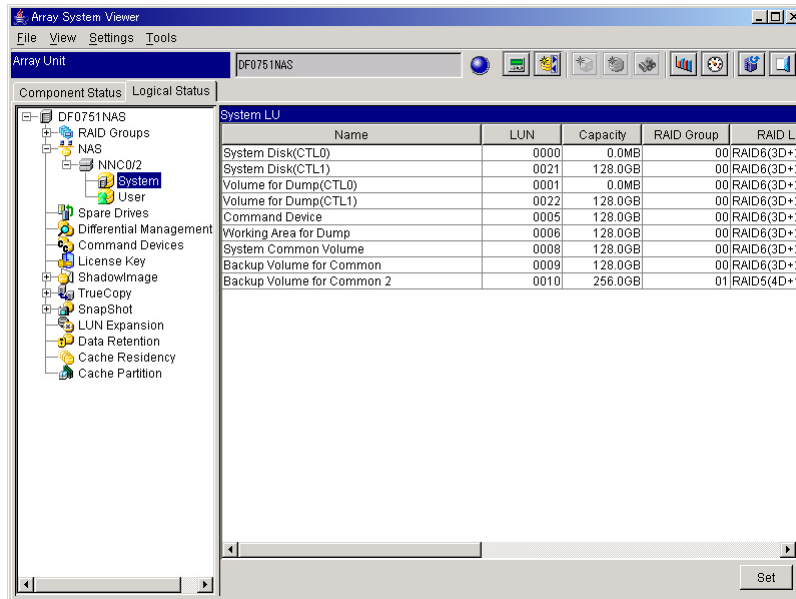

4. Click **Set** in the lower right portion of the window.
The **System LU** dialog box displays.
5. Click **Select** for the system LU that you want to set.

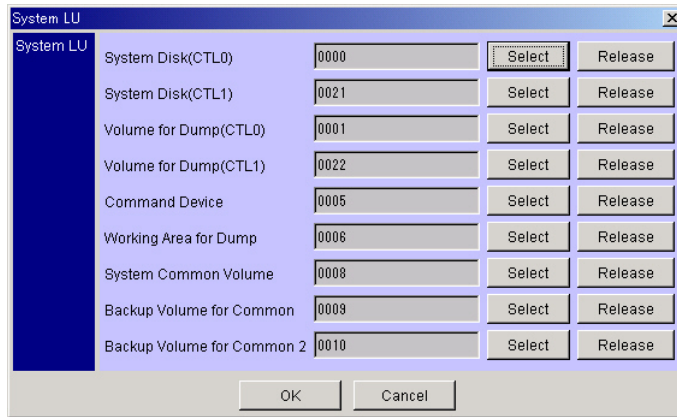

6. The **Select Logical Unit** dialog box displays. Select the LUNs to be assigned, click **OK**.

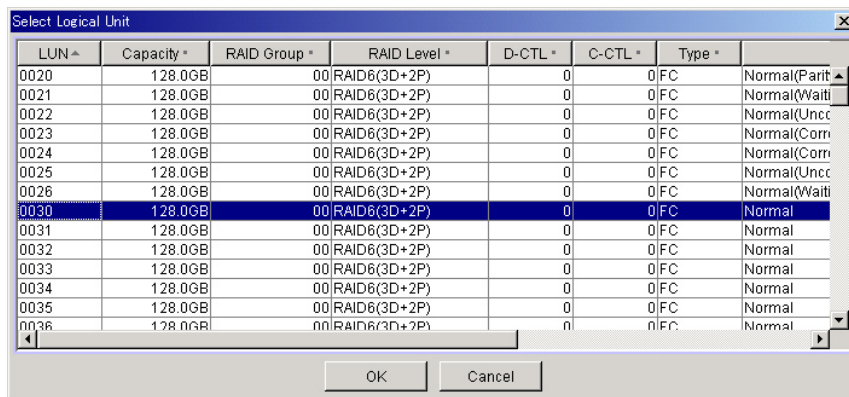

7. Verify that the selected LU(s) was (were) reflected to the **System LU** dialog box, and click **OK**.

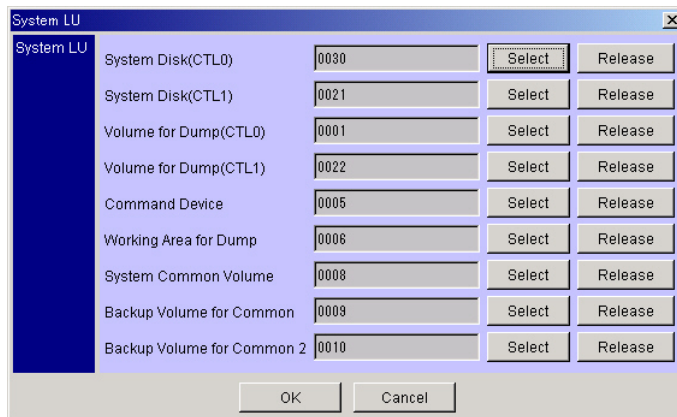

8. A confirmation message displays, click **OK**.

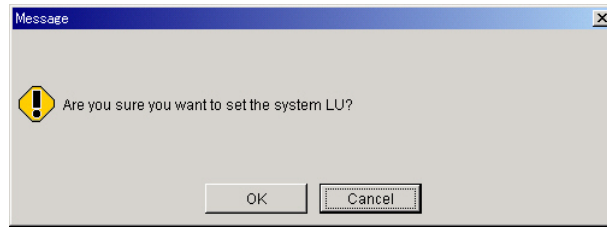

7.16.2 Setting the User LU

Before cancelling the setting of the user LU for NAS, check the status of the user LU device file. If the device file of the user LU is reserved for the copy destination of the file system, release the device file before canceling the setting. Refer to the **NAS Backup Restore Modular User's Guide** for information about reserving and releasing a device file.

To set the User LU:

1. On the Unit window, click the **Logical Status** tab.
2. Display the NNC0/2 by double-clicking the **NAS**.
3. Display the System and User by double-clicking the **NNC0/2**, and click **User**.

A list of system LU displays.

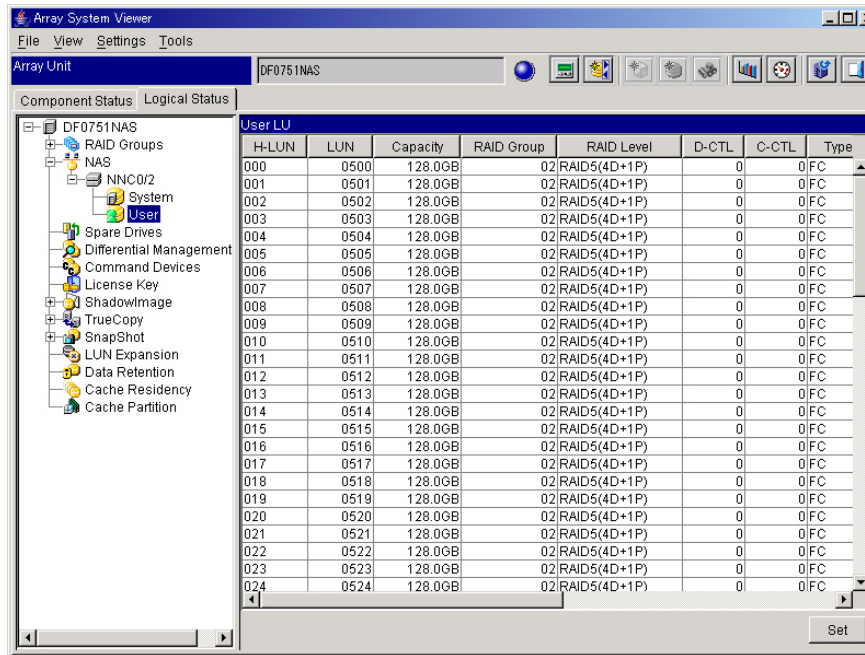

- Click **Set** in the lower right portion of the window.
The **User LU** dialog box displays.
- Select one H-LUN from the H-LUN list in the **User LU** dialog box, select a LUN that you want to assign for the H-LUN from the **Available Logical Units** list, and click  button.

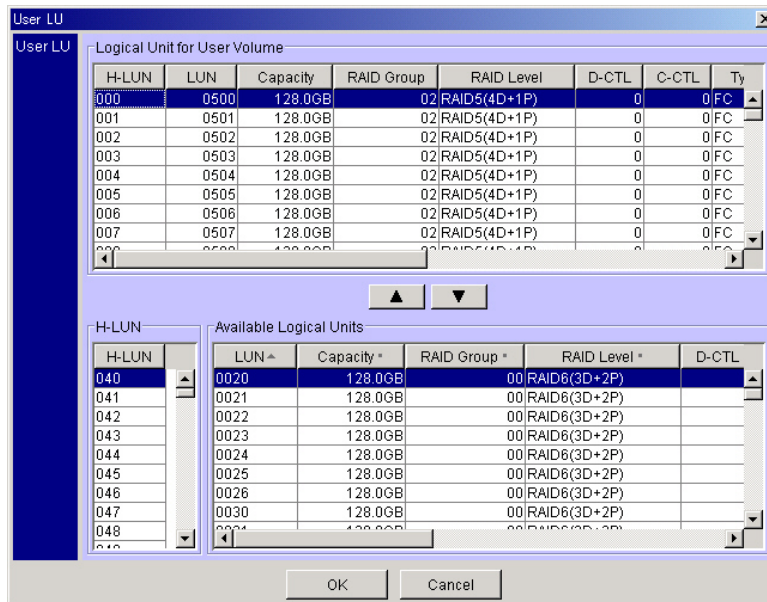

- The selected H-LUN and LUN will be moved to the **Logical Unit for User Volume** list.
- Repeat step 4 until all the LUNs that you want to assign are moved to the **Logical Unit for User Volume**, click **OK**.

7. A confirmation message displays, click **OK**.

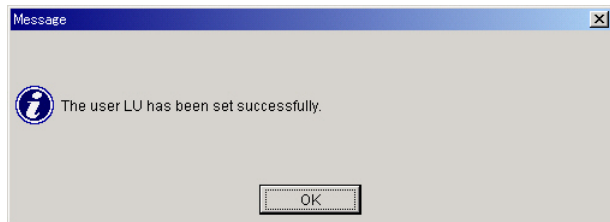
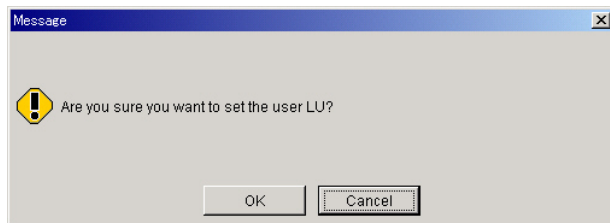

7.17 Setting the NNC Management LAN Port Information in the NAS System

This operation is performed using the Storage Navigator Modular.

To set the NNC management port in the network, follow these steps:

Note: Do not change the NNC Management LAN configuration (LAN cable connect/disconnect and so on) during the setting.

1. Turn on the power supply.
2. When the node in the cluster is **ACTIVE**, stop the cluster, and make the cluster **INACTIVE**.
3. Start the Storage Navigator Modular and set the operation mode in the Management Mode (Refer to the *Hitachi TagmaStore® Adaptable Modular Storage and Workgroup Modular Storage Navigator Modular Graphical User Interface (GUI) User's Guide* (MK-95DF711)).
4. Click the icon of an array unit on the Main window, and then select the **File** menu, click **Open**. Alternately, click **Display Details** in the tool bar.

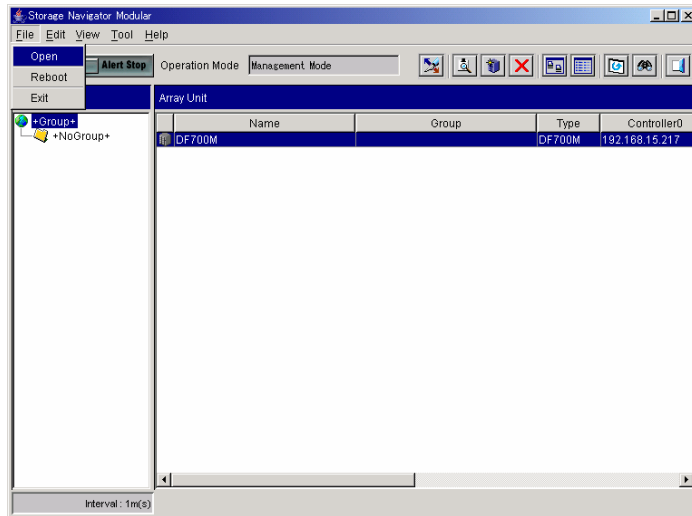

5. On the Tools menu, select **Configuration Settings** or click **Configuration Settings** in the tool bar.

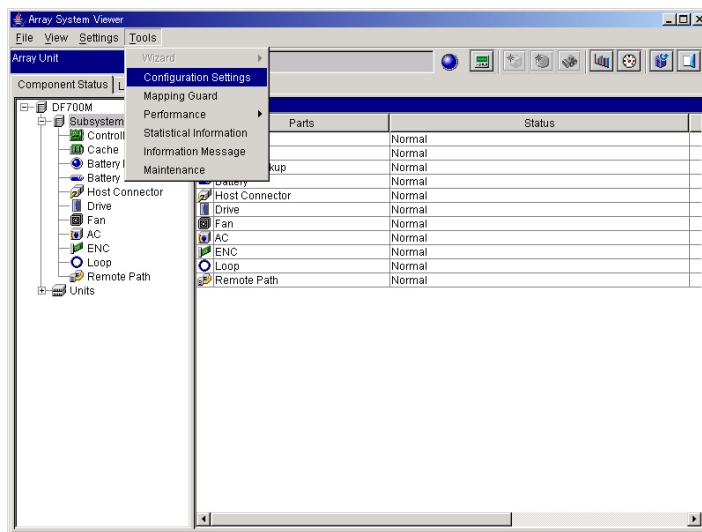

6. Click the **NNC LAN** tab on the Configuration Settings window.

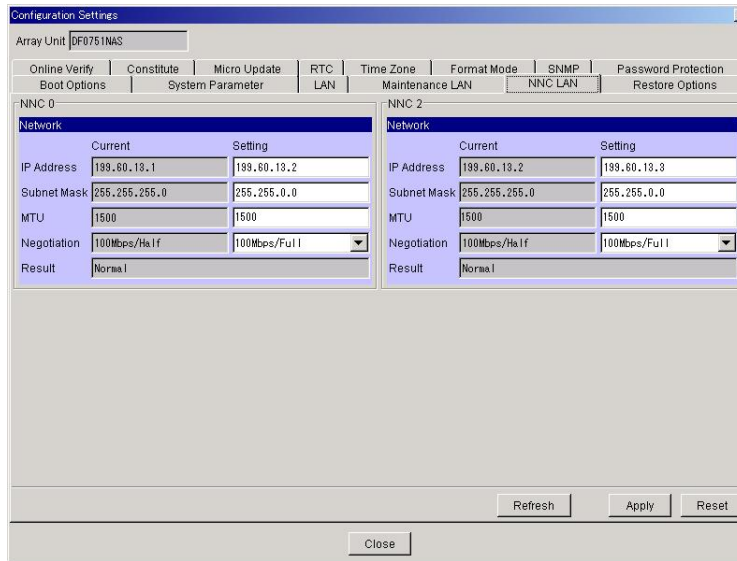

7. Set the LAN Information.

LAN information: Refer to and set the network setting of NNC management port.

- **IP Address:** Displays the current value of IP address and specifies the setting value.
- **Subnet Mask:** Displays the current value of subnet mask and specifies the setting value.
- **MTU:** Displays the current value of MTU and specifies the setting value. The setting value can be specified in the range of 1500 to 16110. The same value has to be set for both NNCs. The default value and the recommended value are "1500".
- **Negotiation:** Displays the current value of Negotiation and specifies the setting value.

8. Click **Apply** on the **Configuration Settings** window after the setting is completed.

9. A confirmation message displays, click **OK**.

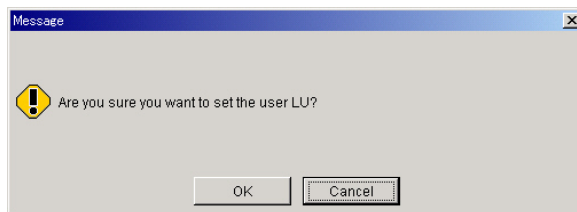

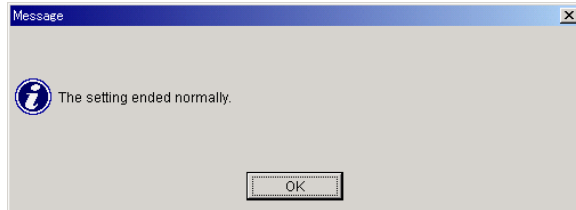
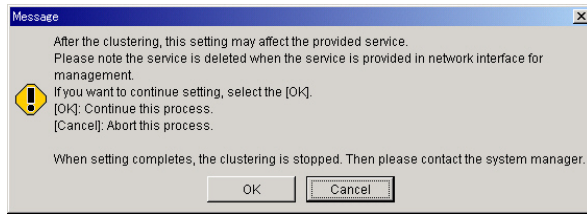

10. When all the Current values are the same as the set value on the **Configuration Settings** window, and the Normal is displayed on the **Result** window, the setting is completed. If the Setting is displayed in the **Result** window, click **Refresh** on the **Configuration Settings** window after a brief interval.

When the setting does not terminate correctly, the following messages will be displayed in the **Setting Result** window.

No.	Display in the Setting Result	Failure and Measure
1	---	An unexpected setting result value was received from through Storage Navigator Modular. Press the Refresh button again to refresh the display. When the "---" is displayed no matter how many times the update is repeated, make the setting again. If the same information is displayed in spite of the above operation, contact the maintenance personnel.
2	Setting	The setting is being changed. Wait for about 5 minutes, and then press the Refresh button again to refresh the display. If the same information is displayed no matter how many times the update is repeated, contact the maintenance personnel.
3	Alert (Corruption of Cluster Status)	The setting could not be changed because the status of the NAS unit in the cluster is not normal. Check the status of both NAS units in the cluster. If the NAS OS stops, start the NAS OS, and make the setting again. When a failure occurs in the subsystem or the NAS unit, contact the maintenance personnel. When no failure occurs in the subsystem or the NAS unit, make the setting again. If the same information is displayed no matter how many times the setting is repeated, contact the maintenance personnel.
4	Alert (Setting of System LU)	The setting could not be changed because the NAS OS is setting the system LU. Wait for about 25 minutes, make the setting again. If the same information is displayed no matter how many times the setting is repeated, contact the maintenance personnel.
5	Alert (Recovery of System LU)	The setting could not be changed because the NAS OS is recovering the system LU. Wait for about 15 minutes, make the setting again. If the same information is displayed no matter how many times the setting is repeated, contact the maintenance personnel.
6	Alert (Time-out of Setting Completion)	There was no response regarding the setting from the NAS unit although a certain period of time passed. When a failure occurs in the subsystem or in the NAS unit, contact the maintenance personnel. When no failure occurs in the subsystem or in the NAS unit, make the setting again. If the same information is displayed in spite of the above operation, contact the maintenance personnel.
7	Alert (NAS OS Internal Error)	The setting could not be changed because a failure occurred inside the NAS OS. When a failure occurs in the NAS unit, contact the maintenance personnel. When no failure occurs in the NAS unit, make the setting again. If the same information is displayed in spite of the above operation, contact the maintenance personnel.
8	Alert (Time-out of Setting)	The setting could not be changed because a time out occurred inside the NAS OS during the setting. When a failure occurs in the NAS unit, contact the maintenance personnel. When no failure occurs in the NAS unit, make the setting again. If the same information is displayed in spite of the above operation, contact the maintenance personnel.
9	Alert (Segment Duplication)	The network address intended to be set has already been used for a port of the NAS unit. Set other IP address of the maintenance port. When the same information is displayed no matter which IP address is specified, set the maintenance port ID address, which has been set before the change, again, and change the duplicate IP address of the port.

11. Reboot the NAS OS of both nodes.

7.18 Setting the Time Zone

This operation is performed using the Storage Navigator Modular.

When connecting the NAS unit, this operation is necessary. This operation is not necessary after the NAS unit is connected. If an NTP server is onsite and you wish to synchronize the clock of the array unit to the NTP server, execute this operation.

To set the time zone, follow these steps:

1. Turn on the power supply.
2. Start the Storage Navigator Modular and set the operation mode to **Management Mode**. Refer to the *Hitachi TagmaStore® Adaptable Modular Storage and Workgroup Modular Storage Navigator Modular Graphical User Interface (GUI) User's Guide (MK-95DF711)*.
3. Click the icon of an array unit on the Main window, and then select the **File** menu. Click **Open**. Alternatively, click **Display Details** in the tool bar.

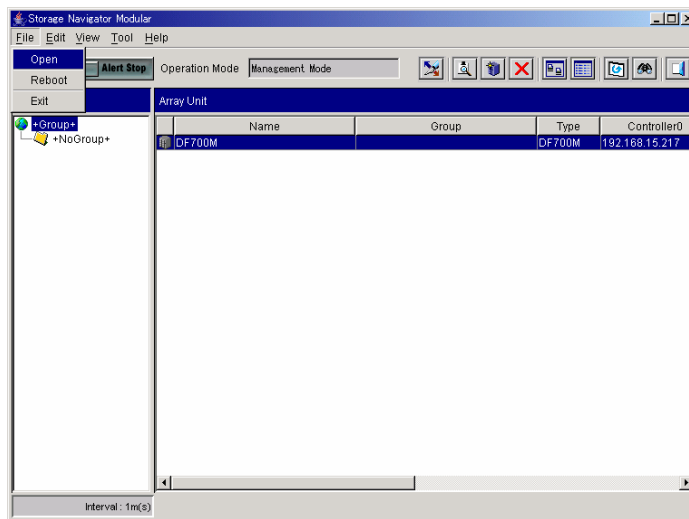

4. On the **Tools** menu, click **Configuration Settings** or click **Configuration Settings** in the tool bar.

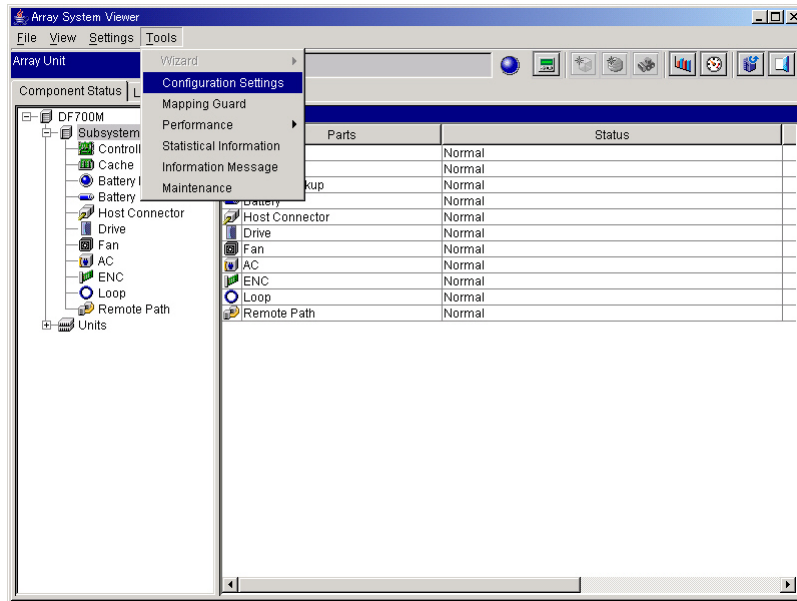

5. Click the **Time Zone** tab on the **Configuration Settings** window.

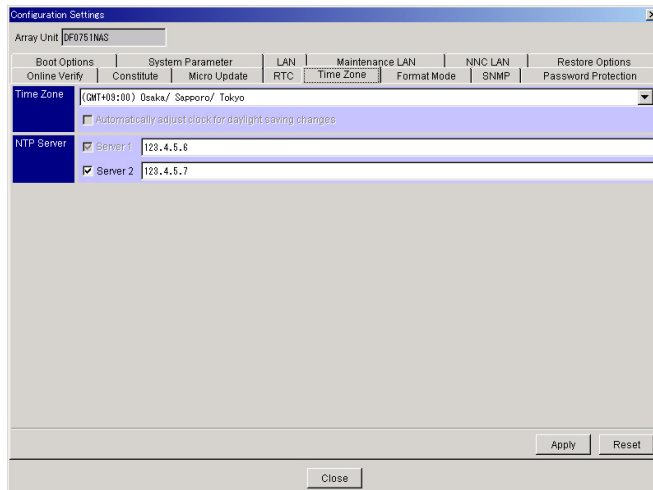

6. Set the IP addresses of **Time Zone** and **NTP Server**.
 - **Time Zone**: Refers to and sets the time zone.
Default value: (GMT+09:00) Osaka/ Sapporo/ Tokyo
Automatically adjust clock for daylight saving changes: Specifies whether to use the summer time.
 - **NTP Server**: Refers to and sets the IP address of the NTP server.

Note: Input is required for Server 1. Input is not indispensable to Server 2, because Server 2 is for standby.
7. Click **Apply** on the **Configuration Settings** window after the setting is completed.
8. A confirmation message displays, click **OK**.

Note: When the NAS OS stops, or is not installed, click **Cancel**.

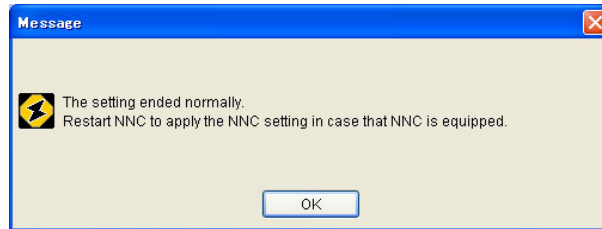
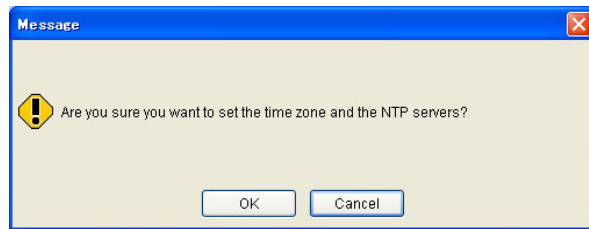

9. When the node in the cluster is **ACTIVE**, stop the cluster, and make the cluster **INACTIVE**.
10. Reboot the NAS OS of both nodes.

Chapter 8 Troubleshooting

This chapter includes the following:

- Troubleshooting Based on LED Indications (section .8.1)
- Web Overview (section .8.2)
- Web Operational Procedures (section .8.3)
- Troubleshooting Using a Web Connection (section .8.4)
- Determining Failure of Network Side in the NAS System (section .8.5)
- Determining Failure of Local Tape in NAS System (section .8.6)
- Connecting Failure Information in Connection with Web (section .8.7)
- Determining Failure on the Network Side of an iSCSI System (section .8.8)
- Calling the Hitachi Data Systems Support Center (section .8.9)

This chapter provides information on the Fibre, NAS, and iSCSI models. The following table illustrates sections that provide an explanation for each model.

- **Fibre model:** Connects disk array subsystem to a host computer with Fibre Channel interface.
- **NAS model:** Connects NAS Unit connected to disk array subsystem to a host computer with LAN interface.
- **iSCSI model:** Connects disk array subsystem to a host computer with iSCSI interface.

Sections		Fibre	NAS	iSCSI
8.1	8.1.1 The POWER LED Does Not Turn On	○	○	○
	8.1.2 The POWER LED Has Turned off	○	○	○
	8.1.3 If the READY LED Does Not Turn on, or the READY LED Has Turned on Once and then Turned off	○	○	○
	8.1.4 The Alarm LED Has Turned on	○	○	○
	8.1.5 The WARNING LED Has Turned on or Blinks	○	○	○
8.2	8.2.1 Operational Environment	○	○	○
	8.2.2 Characteristics of Network Functions	○	○	○
8.3	8.3.1 Connecting to the Network using a LAN Interface	○	○	○
	8.3.2 Window Outlines	○	○	○
	8.3.3 Main window in Normal Mode	○	○	○
	8.3.4 Status Display of Replaceable Components	○	○	○
	8.3.5 Information Message	○	○	○
	8.3.6 Setting the Buzzer Sound Volume	○	○	○
8.3	8.3.7 Clear Specified Factors of NNC Partial Alarm	–	○	–
8.4	8.4.1 Checking Storage System Status	○	○	○
	8.4.2 Checking the Progress Condition Display	○	○	○
	8.4.3 Checking Component Status	○	○	○
	8.4.4 Checking Log Messages	○	○	○
	8.4.5 Troubleshooting Using Messages	○	○	○
	8.4.6 Reading Failure Information	○	○	○
8.5	Determining Failure of Network Side in NAS System	–	○	–
8.6	Determining Failure of Local Tape in NAS System	–	○	–
8.7	8.7.1 Collecting Simple Trace	–	○	–
	8.7.2 NAS Log Collection	–	○	–
	8.7.3 NAS Dump generation	–	○	–
8.8	Determining Failure of Network Side in iSCSI system	–	–	○

○: An explanation is provided.

–: An explanation is not provided.

8.1 Troubleshooting Based on LED Indications

This section includes the following:

- The POWER LED does not turn on
- The POWER LED is turned off
- The READY LED does not turn on or the READY LED has turned on once, and then turned off
- The ALARM LED has turned on
- The WARNING LED has turned on or blinks

Note: If the subsystem is restarted when the disk array subsystem is used as the remote side of TrueCopy Remote Replication, the following occurs:

- Both paths of TrueCopy Remote Replication are blocked.
A notice regarding SNMP Agent Support Function and TRAP occurs in path blockade mode. Perform the functions in the notice and check the Failure Monitoring Department in advance. Path blockade automatically recovers after restarting.
- If the pair status of TrueCopy Remote Replication is PAIR or COPY, the pair status transits to PSUE.

When the disk array subsystem must be restarted, transmit the pair status of TrueCopy Remote Replication to PSUS, and then restart the subsystem.

Note: If the array subsystem connected to the NAS Unit is restarted, the cluster between the NAS Units stops. When the array subsystem is unavoidably restarted, execute it after stopping the cluster between the NAS Units and stopping the NAS OS of both NAS Units. Start the cluster between the NAS Units again after completing the restart for the array subsystem.

Note: There is a case where a NAS system cannot be accessed from a host computer even though the READY LED of NAS unit illuminates. A NAS system accepts access from a host computer only in case of "ACTIVE" NAS OS Condition.

8.1.1 The POWER LED Does Not Turn on

When the POWER LED does not turn on, follow these steps:

1. Set all the AC power unit switches on; set the main switch to on.
2. Is the POWER LED on the RKS on?
Yes: Go to step 11.
No: Power on the host computer.
3. Is the POWER LED on the RKS on?
Yes: Go to step 11.
No: Set the main switch to off; set the AC power unit switch to off.
4. Check the PDB to verify that electricity is supplied to the unit.
5. Verify that the AC cable is correctly connected to the plug socket and the equipment.
6. Set all the AC power unit switches to on; set the main switch to on.

7. Is the POWER LED on the RKS on?
Yes: Go to step 11.
No: Set the main switch to off; set the AC power unit switch to off.
8. Call your Customer Engineer. Go to step 11.
9. Is the READY LED on the RKS (and RKNAS) on?
Yes: Continue to use the equipment in its current operational state. When the READY LED (green) blinks continuously, it blinks for up to 15 minutes because the download of the ENC/SENC firmware is executed. The subsystem is operational even though the READY LED (green) is blinking.
No: Verify that READY LED does not turn on, or that READY LED has turned on once and then turned off.
10. Is the RKNAS connected?
Yes: If the POWER LED on the RKNAS does not light, set the AC power unit switch of the RKNAS to off, and call the Engineer.
No: Go to step 11.
11. End of the procedure.

8.1.2 The POWER LED Turned Off

When the POWER LED has turned off, follow these steps:

1. Is electricity supplied to the equipment?
Yes: Go to step 2.
No: Supply electricity to the unit, and then restart the unit. Go to step 2.
2. Verify that the AC cable is correctly connected to the plug socket.
3. Set the main switch to off, then set all the AC power unit switches to off.
4. After waiting for more than one minute, set all the AC power unit switches to on, then set the main switch to on.
5. Has the POWER LED on the RKS turned on?
Yes: Go to step 7.
No: Set the main switch to off, then set the AC power unit switch to off.
6. Call your Customer Engineer. Go to step 9.
7. Has the READY LED on the RKS turned on?
Yes: Continue to use the equipment in its current operational state. When the READY LED (green) blinks continuously, it blinks for up to 15 minutes because the download of the ENC/SENC firmware is executed. The subsystem is operational even though the READY LED (green) is blinking. Continue to use the equipment as it is.
No: See section 8.1.3.
8. Is the RKNAS connected?

Yes: If the POWER LED on the RKNAS does not light, set the AC power unit switch of the RKNAS to off, and call your Customer Engineer.

No: Go to step 9.

9. End of the procedure.

8.1.3 If READY LED Does Not Turn On or has Turned On Once then Off

If the READY LED does not turn on, or the READY LED has turned on once and then turned off, follow these steps:

1. Is the POWER LED on the RKS on?

Yes: Go to step 2.

No: Go to step 4 in **The POWER LED Does Not Turn on.**

2. Is the ALARM LED on the RKS on?

Yes: Refer to: **The ALARM LED Has Turned on.**

No: Go to step 3.

3. Is the RKNAS connected?

Yes: Go to step 4.

No: Go to step 5.

4. Is the POWER LED on the RKNAS is on? And is the ALARM LED on the RKNAS off?

Yes: Go to step 5.

No:

- If the POWER LED on the RKNAS is not on, go to step 4 in **The POWER LED Does Not Turn on.**
- If the ALARM LED on the RKNAS is on, refer to **The ALARM LED Has Turned on.**

5. Does the READY LED (green) on the RKM blink at high speed?

Yes: Wait for up to 30 to 50 minutes until the READY LED (green) on the RKM lights because the automatic download of the ENC/SENC firmware is executed. Even when the READY LED (green) blinks, the subsystem is operational.

No:

- If your AMS200 is configured with dual controllers, go to step 6.
- If your AMS200 is configured with single controller, go to step 7.

6. In dual controller configuration, does the WARNING LED (orange) blink at high speed?

Yes: Wait until the WARNING LED (orange) on the RKM is off, and the READY LED (green) on the RKM lights because the update of the flash program is executed.

No: Go to step 8.

7. In single controller configuration, does the WARNING LED (orange) on the RKM blink at high speed?

Yes: Wait until the WARNING LED (orange) on the RKM is off, and the READY LED (green) on the RKM lights because the update of the flash program or the automatic download of the ENC/SENC firmware at the time of powering-on is executed. When the automatic download of the ENC/SENC is in operation, the WARNING LED (orange) blinks for up to 30 to 85 minutes, and then the READY LED (green) lights.

No: Go to step 8.

8. Turn off the main switch.
9. After waiting for more than one minute, set the AC power unit switch to on, and then set the main switch to on.
10. Has the READY LED on the RKS turned on?

Yes: Continue to use the equipment in its current operational state. When the READY LED (green) on the RKS blinks continuously, it blinks for up to 15 minutes because the download of the ENC/SENC firmware is executed. The subsystem is operational even though the READY LED (green) on the RKS is blinking.

Go to step 15.

No: Go to step 11.

11. Set the main switch to off, then set the AC power unit switch to off.
12. Is the RKNAS connected?
Yes: Go to step 13.
No: Go to step 14.
13. Is the READY LED on the RKNAS on?
Yes: Go to step 15.
No: Set the AC power unit switch of the RKNAS to off.
14. Call your Customer Engineer.
15. End of the procedure

8.1.4 The Alarm LED Turned On

When the ALARM LED has turned on, follow these steps:

1. Identify in which components the failure resides.
Note: Refer to section 4.7.5 to identify failed components whose LEDs indicate their respective failures.
2. Call your Customer Engineer and allow the equipment to remain in the present state.

8.1.5 The WARNING LED has Turned on or Blinks

When the WARNING LED has turned on or blinks, follow these steps:

1. Is your AMS200 configured with dual controllers?
Yes: Go to step 2.
No: Go to step 3.
2. In dual controller configuration, does the WARNING LED (orange) blink at high speed?
Yes: Wait until the WARNING LED (orange) on the RKM is off and the READY LED (green) on the RKM lights; the flash program is updated.
No: Go to step 3.
3. In single controller configuration, does the WARNING LED (orange) on the RKM blink at high speed?
Yes: Wait until the WARNING LED (orange) on the RKM is off. The READY LED (green) on the RKM lights because the flash program is updated or when powering on, the ENC/SENC firmware is automatically downloaded. When the ENC/SENC is automatically downloaded, the WARNING LED (orange) blinks for up to 30 to 85 minutes, then the READY LED (green) lights.
No: Go to step 3.
4. Does the WARNING LED on the RKM blink slowly?
Yes: Call your Customer Engineer. Go to step 13.
No: Go to step 5.
5. Is RKNAS connected?
Yes: Go to step 6.
No: Go to step 7.
6. Does the WARNING LED on the RKNAS blink?
Yes: Call your Customer Engineer. Go to step 13.
No: Go to step 7.
7. Is the READY LED on the RKM on?
Yes: Go to step 8.
No: Refer to section 8.1.3.
8. Is the RKNAS connected?
Yes: Go to step 9.
No: Go to step 10.
9. Is the READY LED on the RKNAS on?
Yes: Go to step 10.
No: Refer to section 8.1.3.
10. Identify in which components a failure resides in the RKM.

Note: Refer to section 4.7.5 to identify failed components whose LEDs indicate their respective failures.

11. Is the RKNAS connected?

Yes: Identify in which components a failure resides in the RKNAS.

No: Go to step 12.

12. Continue to use the equipment, and contact the Customer Engineer.

13. End of the procedure.

8.1.6 The WARNING LED Has Turned On or Blinks

When the WARNING LED has turned on or blinks, follow these steps:

1. Does the WARNING LED blink?

Yes: Call your Customer Engineer. Go to step 5.

No: Go to step 2.

2. Is the READY LED on?

Yes: Go to step 3.

No: Refer to section 8.1.3.

3. Identify in which components a failure resides.

Note: Refer to section 4.7.5 to identify failed components whose LEDs indicate their respective failures.

4. Continue to use the equipment and contact the Customer Engineer.

5. End of the procedure

8.2 Web Overview

This section includes the following:

- Operational environment
- Characteristics of network functions

8.2.1 Operational Environment

The Web operational environment and the necessary requirements are shown in the following tables.

Table 8.1 Web Operational Environment

No.	Item	Description
1	OS	Microsoft® Windows® 98/NT 4.0/2000/XP/2003, Solaris™ 8, IRIX 6.5, AIX4.3, 5.1.
2	PC	Pentium® (Pentium II(233 MHz or more) is recommended), Memory 40 MB or more (64 MB or more is recommended).
3	WS	Turbo Sparc 170 MHz, Memory 256 MB or more R10000 195MHz, Memory 128 MB or more.
4	Disk requirement	50 M bytes.

Table 8.2 AMS200 WEB Function Supported Browser/Version

No.	Platform	OS	Version	Browser	Version (Note)	Supported?	Java™ Applet Supported? (Notes 2 and 3)
1	WS	IRIX	6.5	Netscape Navigator®	4.76	Yes	No
			2.6	Netscape Navigator	4.76	Yes	No
		AIX	8	Netscape Navigator	4.76	Yes	No
			4.3	Mozilla	1.5	Yes	No
			5.1	Mozilla	1.7	Yes	No
2	PC	Windows	98	Internet Explorer	6.0	Yes	Yes
			NT/2000	Internet Explorer	6.0	Yes	Yes
			XP	Internet Explorer	6.0	Yes	Yes
			2003(IA32)	Internet Explorer	6.0	Yes	Yes
			2003(IA64)	Internet Explorer	6.0	Yes	No
				6.0 (32Bit)	Yes	Yes	
3	PC	Windows	98	Netscape Navigator	7.1 (J)	Yes	No
					7.2 (E)	Yes	No
			NT/2000/XP	Netscape Navigator	7.1 (J)	Yes	No
					7.2 (E)	Yes	No
			2003 (IA32/IA64)	Netscape Navigator	7.1 (J)	Yes	No
					7.2 (E)	Yes	No

Note: Service Pack 1 is included.

Notes on the Supported Browser:

For Windows 2003, the strict security level is set by default; therefore, the Web function is disabled. Change the security setting to enable the browser by following these steps:

1. On the browser (Internet Explorer), select **Tools** and **Internet Options**.
2. Click the **Security** tab, and then click **Custom Level**.
3. Specify **Medium** or lower for the **Custom Setting Reset**, and then click **Reset**.

Specifying a Medium setting solves the problem. However, if you want to use Windows 2003 and leave the security level as High, make the following settings for detailed items of the Custom Level:

- Enable **Active scripting** of Scripting.
 - Enable **Allow META REFRESH** of Miscellaneous.
 - Enable **File download** of Downloads.
 - Enable **Run ActiveX controls and plug-ins** of ActiveX controls and plug-ins.
- A new line may be started in a window depending on the setting of the browser. In this situation, make the character size smaller.

< Method of character size change >

For Internet Explorer: Select a middle or smaller size for the character size in the display.

For Netscape Navigator: Select the Reduction of Font Size in the Display and keep it selected until paragraphs are easily readable.

- An empty dialogue box may be displayed during operation in the Maintenance mode. In this situation, close the window by clicking on the “x” in the upper left corner of the dialogue box. Restart the browser, then retry from the entry of the URL.
- When a window size is changed while a page is displayed by Netscape®, the succeeding operation in Refresh mode may not be completed normally. In this situation, display the page again by clicking **Re-Display**.

- When using Netscape:
Memory cache: 1024 k bytes (default) or larger
Disk cache: 7680 k bytes (default) or larger

< Method of cache size setting >

Select the **Edition**, **Setting**, **Details**, and **Cache** in this order.

Specify sizes of the memory cache and disk cache.

- When obtaining trace information, etc., with Netscape, a sub-window which specifies the file download destination may not automatically close. In this situation, click **Close** on the upper right corner of the sub-window to close the sub-window after the download is complete.
- When using Netscape Navigator 7.x, select **Edit-Preference...-Advanced-HTTP Networking**, and set Use HTTP 1.0 in the **Direct Connection Options** and **Proxy Connection Options**. When this setting is omitted, the summary window is not displayed correctly.

- When collecting memory dump (Full Dump) using Netscape Navigator 4.7x, pay attention to free space on the PC because information to be downloaded will not be compressed.

8.2.2 Characteristics of Network Functions When Connecting with the Web

This section discusses the following network function characteristics when connecting with the Web:

- **LAN Interface**

The connector for 10Base-T/100Base-TX is equipped with the controller. 10Base-T/100Base-TX is selected automatically.

- **Network Parameter**

The AMS200 has the following network parameters; they can be set or changed by the Web browser or the Storage Navigator-Modular, concerning only port 1 (for user management) of each controller.

Table 8.3 Network Parameters

Network Parameter	Description	Factory Setting Value (<i>Note 1</i>)	
		Controller 0	Controller 1
		For User-managed Port	For User-managed Port
IP Address	The IP Address is changed/set up.	192.168.0.16 (<i>Note 1</i>)	192.168.0.17 (<i>Note 1</i>)
Subnet Mask	The Subnet Mask is changed/set up.	255.255.255.0 (<i>Note 3</i>)	255.255.255.0 (<i>Note 3</i>)
Default Gateway	The Default Gateway is changed/set up.	0.0.0.0	0.0.0.0
DHCP (<i>Note 2</i>)	Enable/Disable of the DHCP function is set up.	Off	Off

Note 1: Manage the IP Address after the IP Address is changed from the IP Address of factory setting.

Note 2: When the DHCP mode is validated, the IP Address is acquired from the DHCP server. If the DHCP server is not started up, or if the DHCP function has been wrongly set, the acquisition of the IP Address will fail, and the IP Address of the subsystem will remain 0.0.0.0. (This is a state in which Disk Array management program 2 or the Web cannot be used via a LAN.)

Note 3: In this case, you can acquire the IP Address by starting up the DHCP server or by setting the DHCP function correctly, when necessary.

8.3 Web Operational Procedures

This section contains the following information:

- Connecting to the network using a LAN interface.
- Window outlines
- Main window in Normal mode.
- Status display of replaceable components.
- Information message
- Setting the buzzer sound volume.

8.3.1 Connecting to the Network using a LAN Interface

To use a LAN interface, follow these steps:

- The connector for 10Base-T/100Base-TX is equipped with the controller. 10Base-T/100Base-TX is selected automatically.
- Connect the LAN cable with the LAN connector shown in Figure 8.1.

The following figure is an example, illustrating when the FC interface board is not added to the control unit.

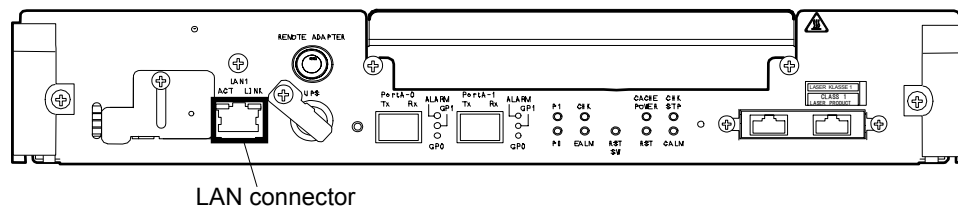

Figure 8.1 LAN Connector Location

Change the IP Address of the controller set up to the Address of the Web browser, to enter Normal Mode. Set the IP Address of the controller connected with the network as a dual system configuration. The status of the devices (both controllers) can be monitored from one controller.

8.3.2 Window Outlines

If the Normal Mode function is displayed and clicked in the Menu window, the chosen function can be executed. Figure 8.2 displays the Main window outline of Normal Mode.

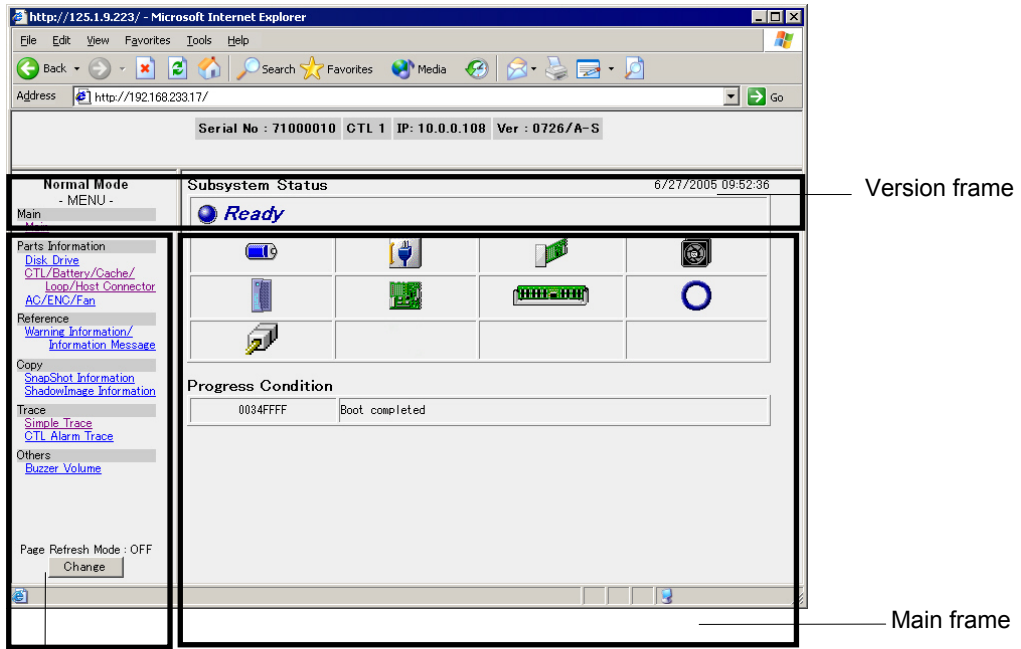

Figure 8.2 Main Window Outline
Menu frame

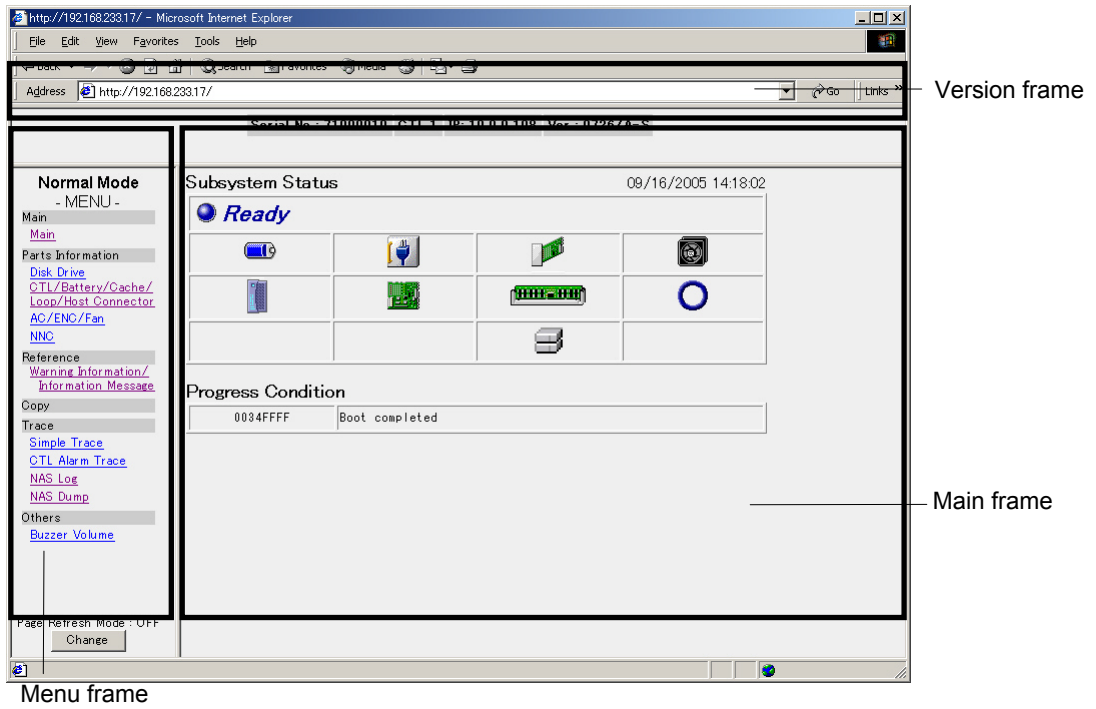

Figure 8.3 Main Window Outline (NAS)

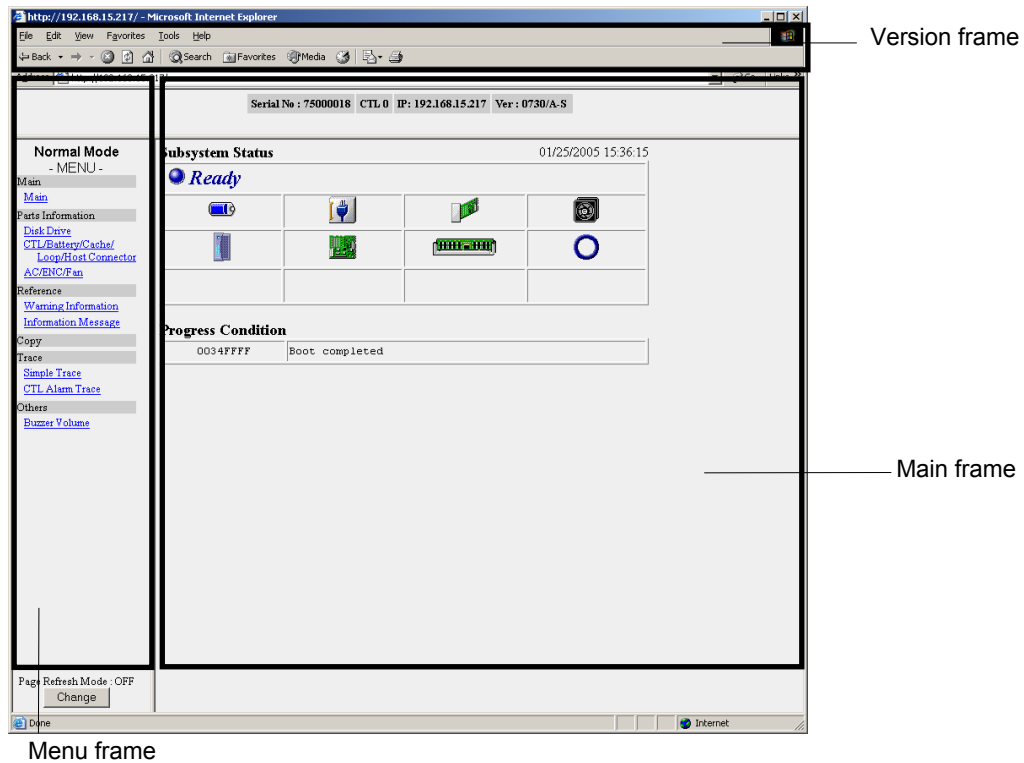

Figure 8.4 Main Window Outline (iSCSI)

This section includes the following:

- Menu frame
- Main frame
- Version frame

8.3.2.1 Menu Frame

If the Normal Mode is displayed with the menu frame, then clicked, the proper function is executed.

The main frame displays the following information:

- **Main:** The Main window of Normal Mode is displayed.
- **Parts Information:** The status of exchange parts is displayed.
 - Disk drive:** The status of disk drives is displayed.
 - CTL/Battery/Cache/Loop/Host Connector:** The status of controllers, cache, loop, and host connector is displayed.
 - AC/ENC/Fan:** The status of the power supply unit, ENC/SENC unit, and fan assembly is displayed.

- **Reference**

Warning Information: Fault information that was detected during device information status is displayed.

Information Message: Fault information, detected during device operation and device information status is displayed.

- **Trace**

Simple Trace: A window for collecting the Simple trace is displayed.

CTL Alarm Trace: A window for collecting the CTL Alarm trace is displayed.

- **Others**

Buzzer Volume: The window in which the Buzzer Volume is set up is displayed.

- **Page Refresh Mode:** This button sets up an on/off an automatic redisplay function. When clicked, the on/off mode changes:

- **OFF display:** This is not refreshed.
- **ON display:** The screen of the mainframe is refreshed every 5 seconds. The refresh time currently (RTC) is displayed on the right top.

Note: When the PC enters suspension status during operation while the **Page Refresh Mode** is set to **ON**, the Web may not operate correctly after the PC is released from suspension status. When the Web is connected for status monitoring, etc., set the power management of the PC so that the PC does not enter suspension status.

8.3.2.2 Main frame

The main frame displays the following information:

- **Subsystem Status:** The device status and the exchange parts status are displayed.
- **Progress Condition:** The Progress Condition as the device is booting is displayed.

8.3.2.3 Version Frame

The version frame displays the following information:

- **Web title:** The Web title set by a user is displayed. When it is not set, nothing is displayed.
- **Serial No:** The subsystem serial number is displayed.
- **CTL:** The connected controller number is shown.
- **IP:** The connected IP Address of the controller is shown.
- **Rev:** The device version of the microprogram is shown.

8.3.3 Main window in Normal Mode

The Main window of normal mode consists of the following:

- Patrol lamp
- Summary of exchange parts status
- Progress condition display
- Page refresh button

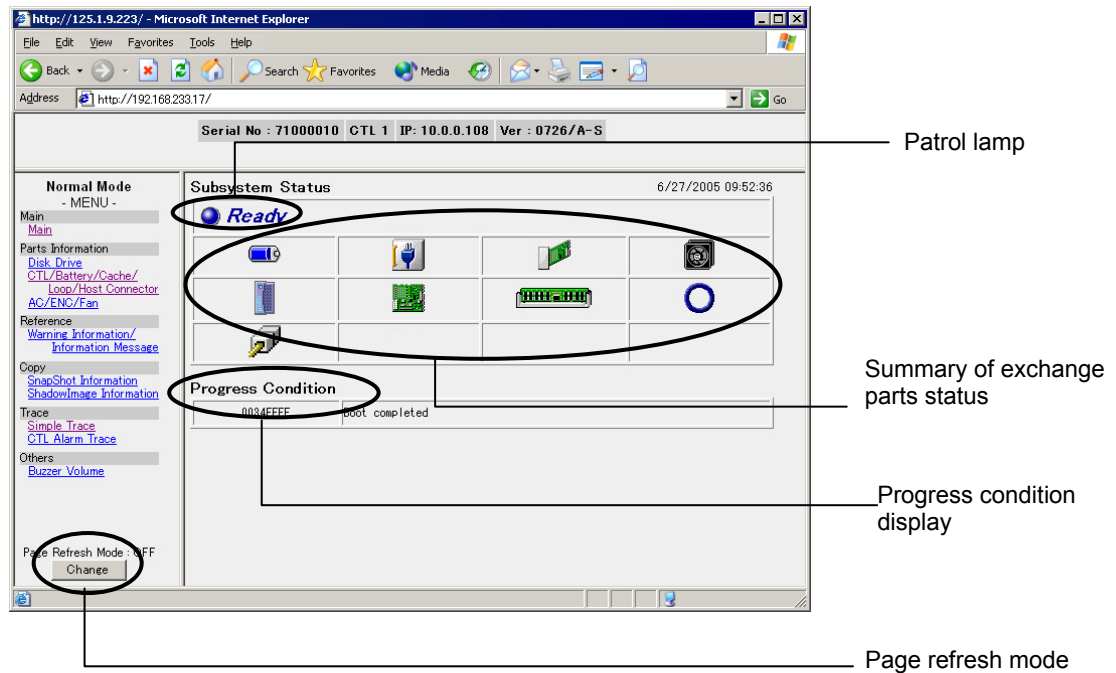

Figure 8.5 Subsystem Condition Display

8.3.3.1 Patrol Lamp

While monitoring the device, the status is displayed.



























Table 8.4 Patrol Lamp Display

Image	Status
<i>Booting...</i>	During the start
<i>Ready</i> blue	Normal
<i>Warning</i> yellow	Warning status
<i>Alarm</i> red	Alarm status

8.3.3.2 Summary of Exchange Parts Status

The summary of exchange parts status displays the condition of the exchange parts by changing the color. Detailed information of the specific part is displayed by clicking the part icon.

Table 8.5 Exchange Parts Status Display

Parts		Image		Notes
		Normal	Abnormal	
Power Unit		 blue	 red	—
Disk Drive	FC	 blue	 red	—
	S-ATA	 blue	 red	—
Cache Unit		 green	 red	—
Fan Assembly		 black	 red	—
Backup Battery Unit		 blue	 red	—
Control Unit		 green	 red	—
ENC Unit		 green	 red	—
SENC Unit		 green	 red	—
Fibre Loop on the drive side		 blue	 red	—
Remote Path		 orange	 red	When displayed in the TrueCopy Remote Replication function is effective. (Note)
Host Connector		 gray	 red	Displayed only in the Fibre configuration
NNC		 gray	 red	Displayed only in the NAS configuration

Note: A path blockage also occurred while using the Hitachi TrueCopy Synchronous Remote Replication function (even if the remote subsystem was off). The remote subsystem is turned on and automatically recovers when the remote subsystem is Ready. If a path blockage is not recovered (even when Ready), contact Hitachi Customer Service.

8.3.3.3 Progress Condition Display

The progress condition, as the device is booting, is displayed in the progress condition display box.

8.3.3.4 Page Refresh Button

This button sets the on/off function of the automatic redisplay function. If clicked, the on/off mode changes:

- **OFF** display: The window is not refreshed.
- **ON** display: The window of the mainframe is refreshed every 5 seconds. The refresh time currently (RTC) is displayed on the right top.

8.3.4 Status Display of Replaceable Components

The status display window of replaceable components displays the status of the Disk Drive, Control Unit, Cache Unit, Fiber Channel Loop on the drive side, Fan Assembly, Backup Battery Unit, Power Unit/Power Unit (DC), and ENC Unit that are implemented.

This window is not displayed if the component is not implemented. When the replaceable component has an abnormal status, a red image is displayed.

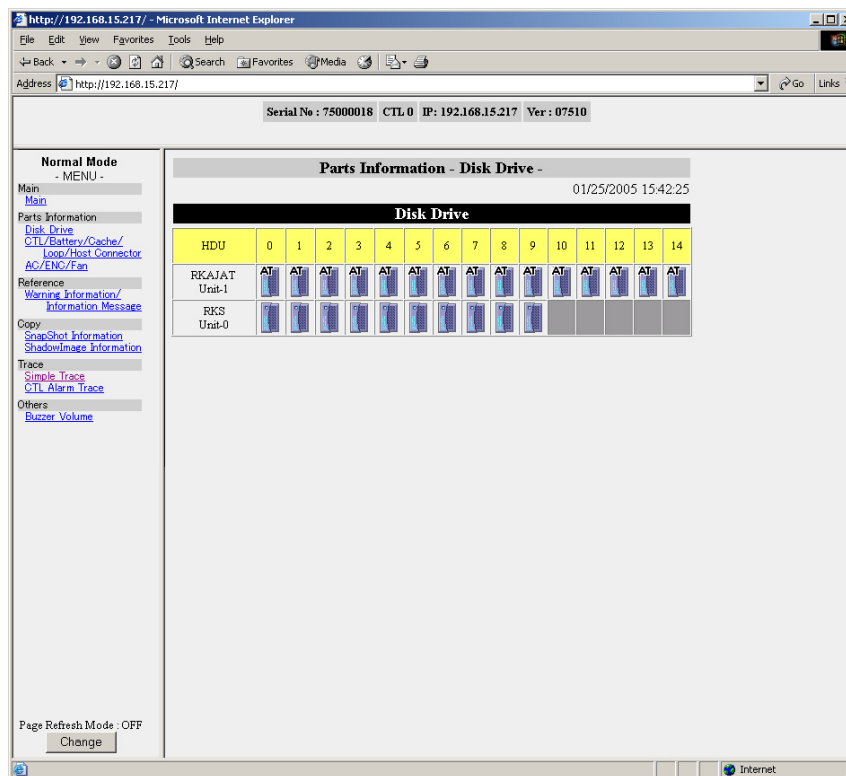

Figure 8.6 Component Status Window

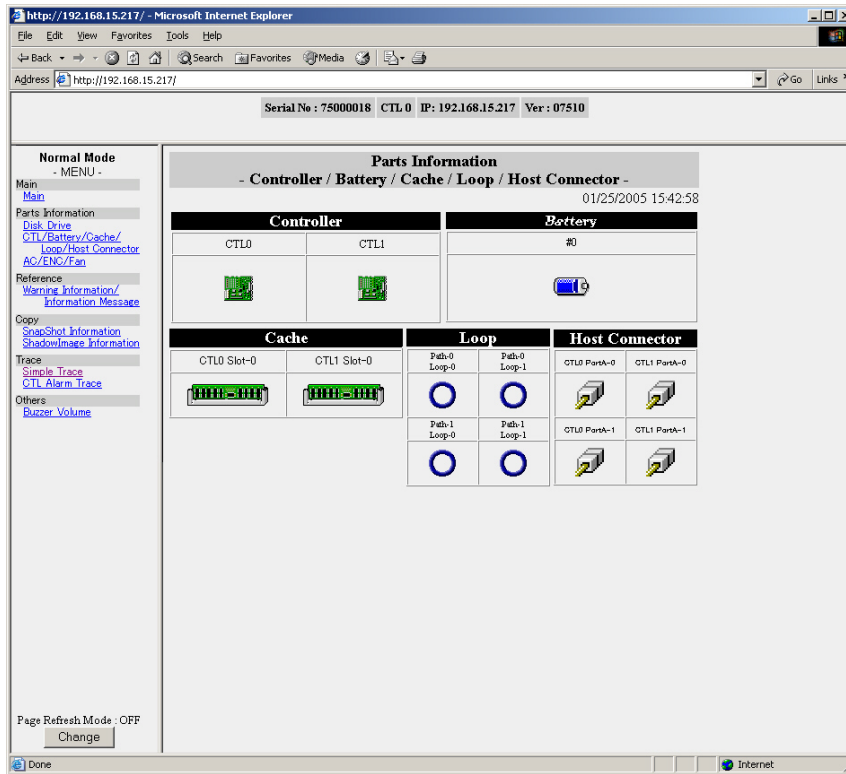

Figure 8.7 Component Status Window (Controller/Battery/Cache/Loop/Host Computer)

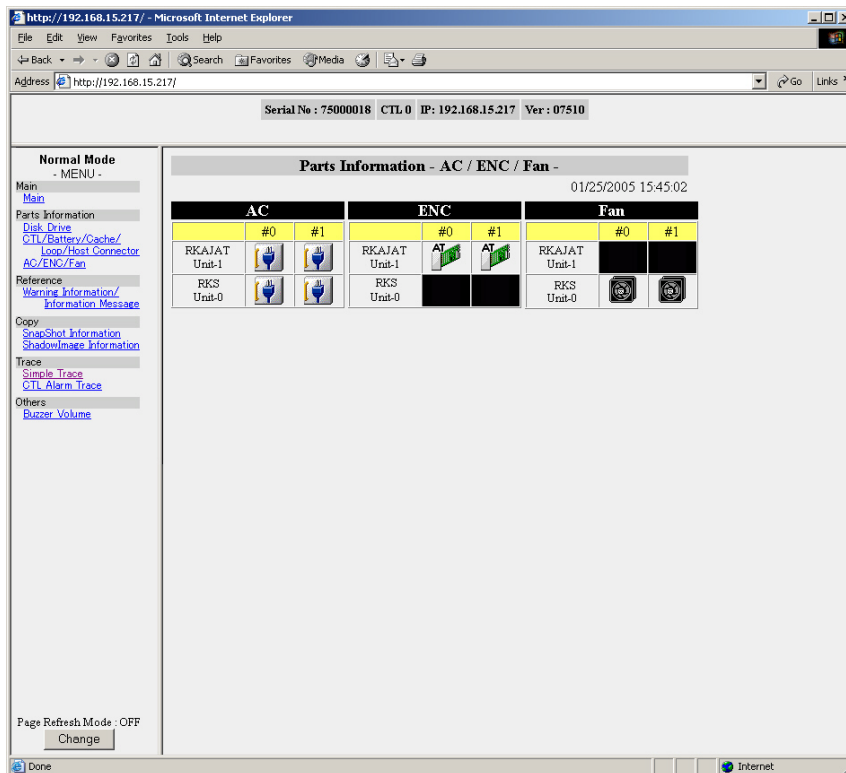

Figure 8.8 Component Status Window (AC/ENC/FAN)

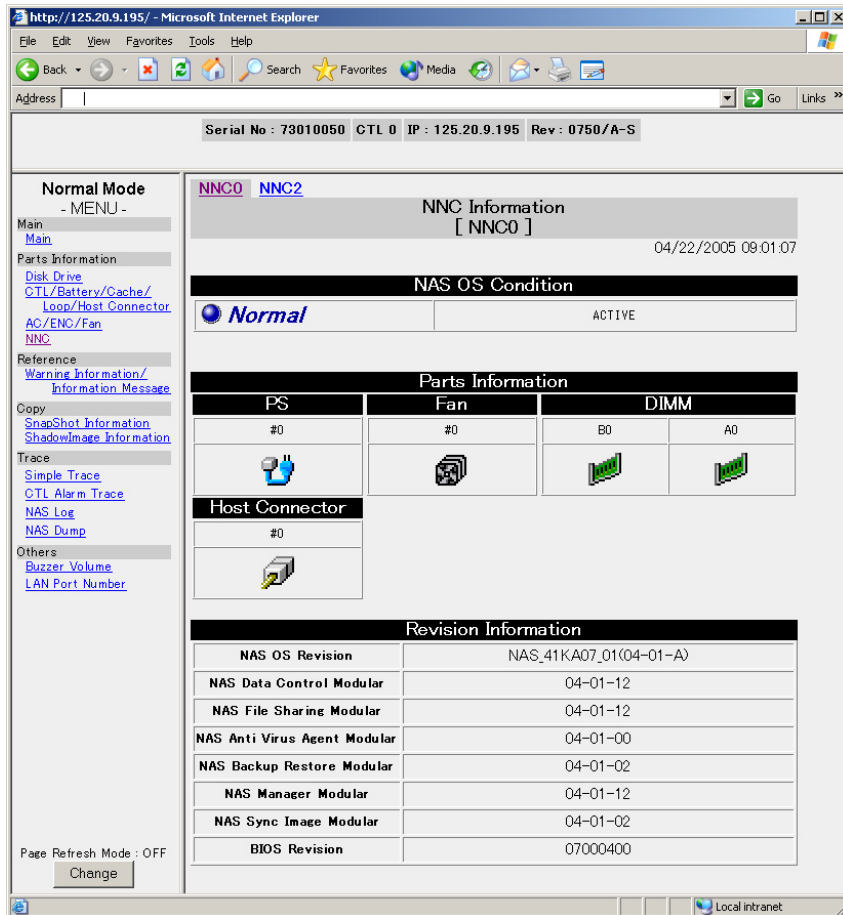







Figure 8.9 NNC Information Window



Disk Drive (FC):

Image	Status
 blue	Normal
 red	A fault has occurred to the disk drive.
 red and black	The disk drive port where the fault occurred is not implementing the disk drive.
No display	The disk drive is not implemented (the disk drive where the fault occurred was drawn out).



Disk Drive (S-ATA):

Image	Status
 blue	Normal
 red	Fault has occurred to the disk drive.
 red and black	Disk drive port that the fault occurred is not implementing the disk drive.
No display	Disk drive is not implemented (Except for the status where the disk drive that the fault occurred was drawn out).

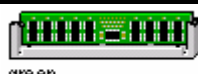

Control Unit:

Image	Status
 green	Normal
 red	Shutdown of the control unit (status where it is not implemented with the setting of the dual system configuration is included). (Control unit may be blocked when an FC interface board failure, a NAS interface board failure, a cache memory failure, a NAS control cable failure or a PCI Express cable failure occur.)
 yellow	Fault of the battery backup circuit.
No display	The fault has not occurred without being implemented with the setting of a single system configuration.



Cache Unit:

Image	Status
 green	Normal
 red	Fault (status when the unit is not implemented and the extracted fault cache unit is included).



Battery Backup Unit:

Image	Status
 blue	Normal
 red	There is a fault or the unit is not implemented.



Fan Assembly:

Image	Status
 black	Normal
 red	There is a fault or the fan assembly is not implemented. (The condition that an AC power supply is not supplied is contained.)



Power Unit/Power Unit:

Image	Status
 blue	Normal
 red	A fault occurred or the unit is not implemented. (The condition that an AC power supply/DC power supply is not supplied is contained).



ENC Unit:

Image	Status
 green	Normal
 red	It is fault occurred or not implemented.



SENC Unit:

Image	Status
 green	Normal
 red	A fault occurred or the unit is not implemented.

Fibre Channel Loop:



Image	Status
 blue	Normal
 red	Fault

Host Connector:

Image	Status
 gray	Normal
 red	Fault

Patrol Lamp:

Monitoring the device, the status is displayed.



Image	Status
 Ready blue	Normal
 Warning yellow	Warning status
 Alarm red	Alarm status

NAS OS Condition:



The NAS OS condition is displayed.

Display	Status
NEW	NAS OS has not been installed.
INST	NAS OS is being installed.
ACTIVE	NAS OS is in operation, and node is in operation.
STOP	NAS OS stops normally.
DOWN	NAS OS stops abnormally.
BOOT	NAS OS is in boot processing.
SHUTDOWN	NAS OS is in stop processing.
INACTIVE	NAS OS is in operation, and node stops.
DUMP	NAS Dump is being collected.
HUNGUP	Hung-up status.
WARN	NAS Manager has not been installed, or NAS OS is in operation and node status is unknown.
DISUSE	Control unit is blocked because the NAS OS of the appropriate NNC (NAS unit) cannot be used.



NNC PS:

Image	Status
 blue	Normal
 red	Fault



NNC DIMM:

Image	Status
 green	Normal
 red	Fault

NNC FAN:

Image	Status
 black	Normal
 red	Fault

NNC Host Connector:

Image	Status
 white	Normal
 red	Fault

Revision Information

NAS OS Revision: Indicates the NAS OS revision.

BIOS Revision: Indicates BIOS Revision.

For the NAS OS not installed (NEW), during installation (INST), in boot processing (BOOT), NAS OS installation failure, the following window will be displayed.

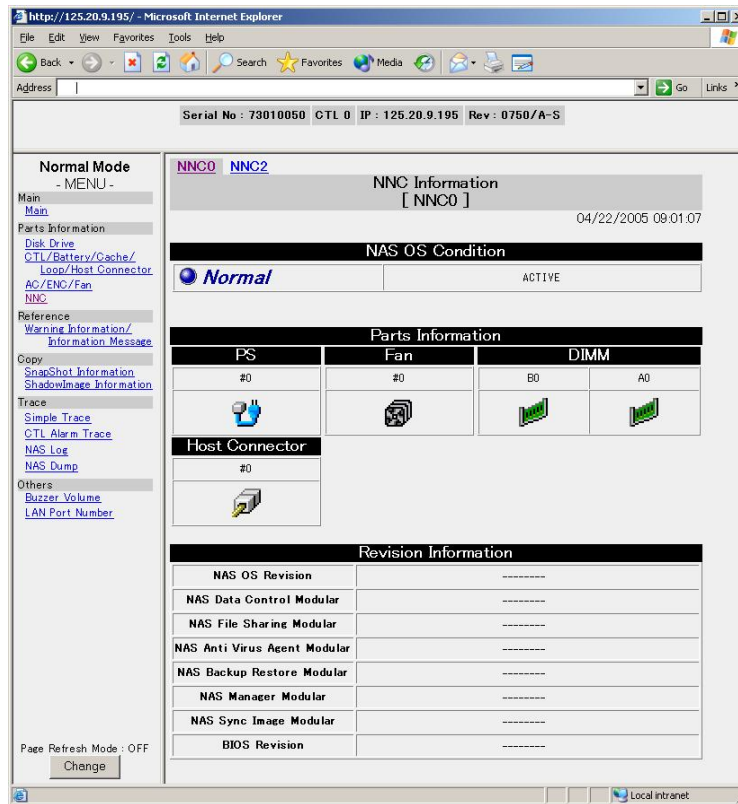

Figure 8.10 Revision Information Window

To check the parts status by message, select **Warning Information** from the menu frame in the Main window.

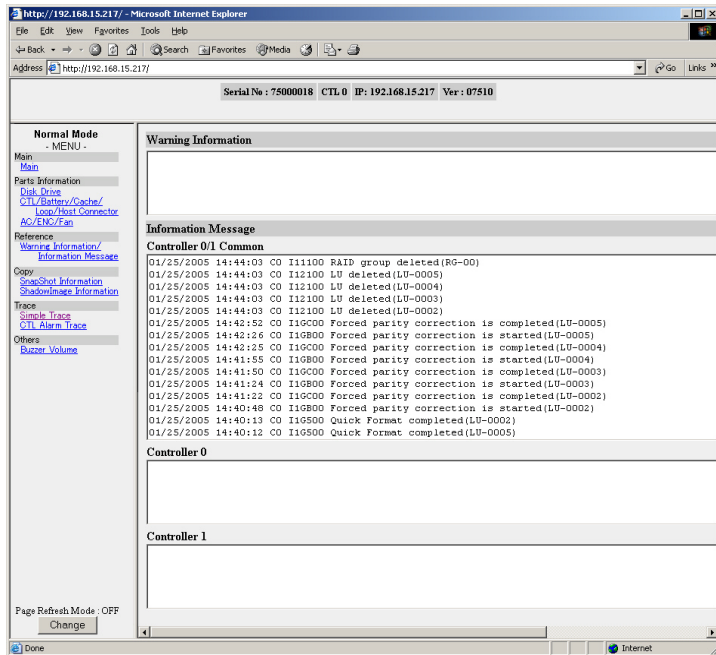

Figure 8.11 Warning Information Window

8.3.5 Information Message

Fault information and status information of the device that detected it during the device operation are displayed.

Fault information and status information after the device completes a boot are displayed in the **Controller 0/1 Common** box.

Fault information and status information as the device is booting are displayed in the box of **Controller 0** and **Controller 1**.

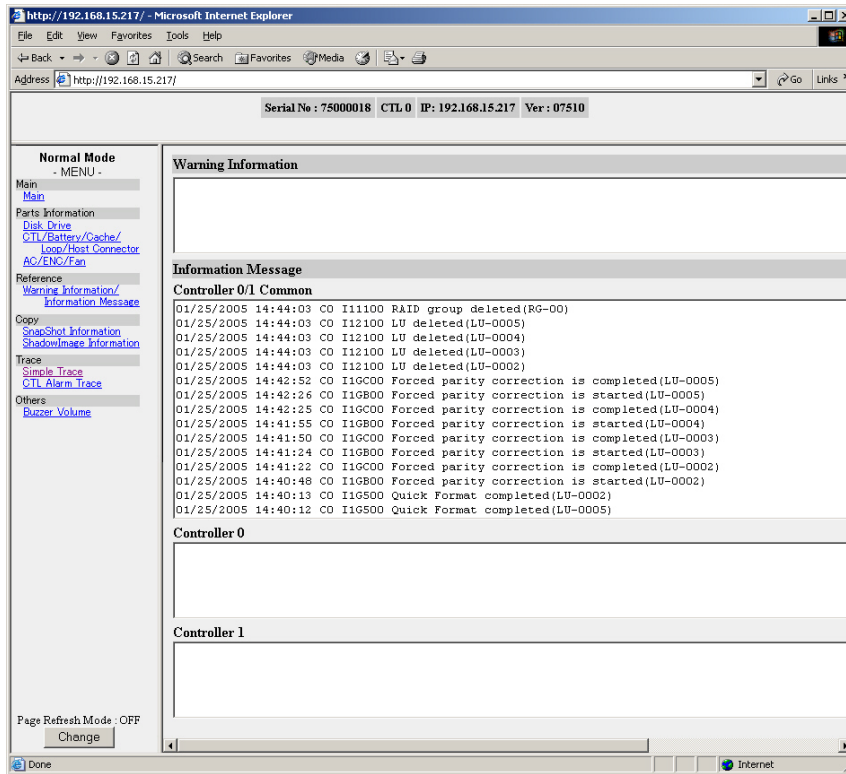

Figure 8.12 Information Message Window

8.3.6 Setting the Buzzer Sound Volume

Note: Set the buzzer volume for the environment in which I/Os from a host are not issued while the system is maintained or before the host is started up.

The buzzer volume can be adjusted for 5 stages. Click the **Buzzer Volume** of the menu frame to enter into the buzzer volume-setting window. If the buzzer volume is designated with the radio button and **OK** is clicked, the buzzer volume is changed.

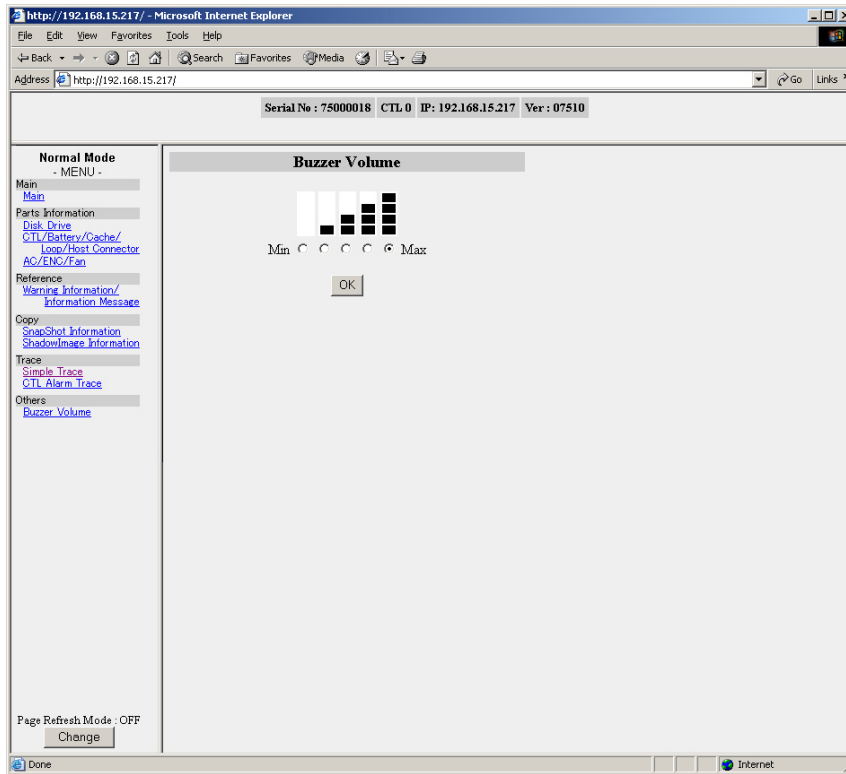

Figure 8.13 Buzzer Volume Window

8.3.7 Clear Specified Factors of NNC Partial Alarm

The Warning status of the control unit may not be released when the WARNING LEDs on the array subsystem and the NAS unit are lighting up even though the recovery works for some specific NNC partial alarms.

Release the Warning status of the control unit and turn off each WARNING LED according to the following procedures. The **Clear specified factors of NNC partial alarm** can be executed only to the NNC (NAS unit) connected to the control unit.

1. Before operating, clear specified factors of NNC partial alarm.
2. Click the List of clearable factors.

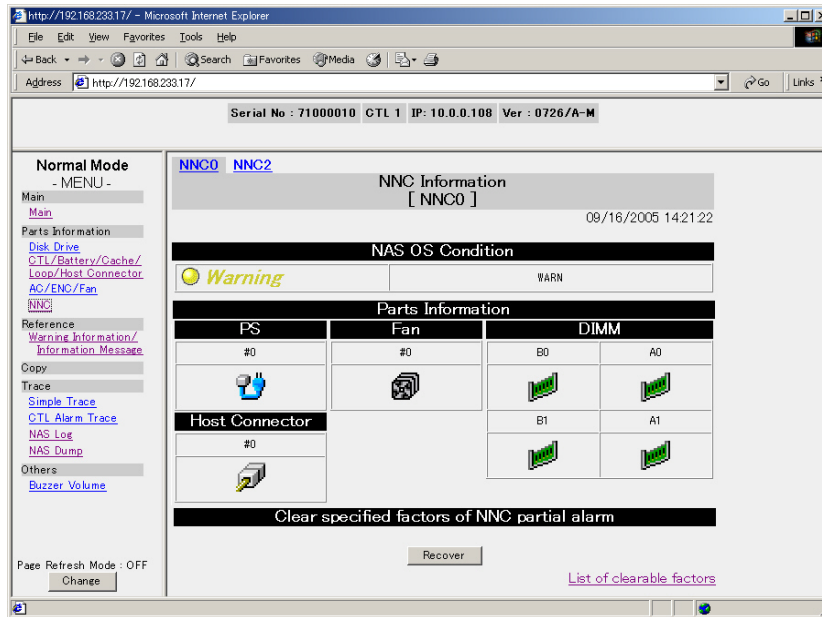

3. Verify the lists of failure factors are displayed.

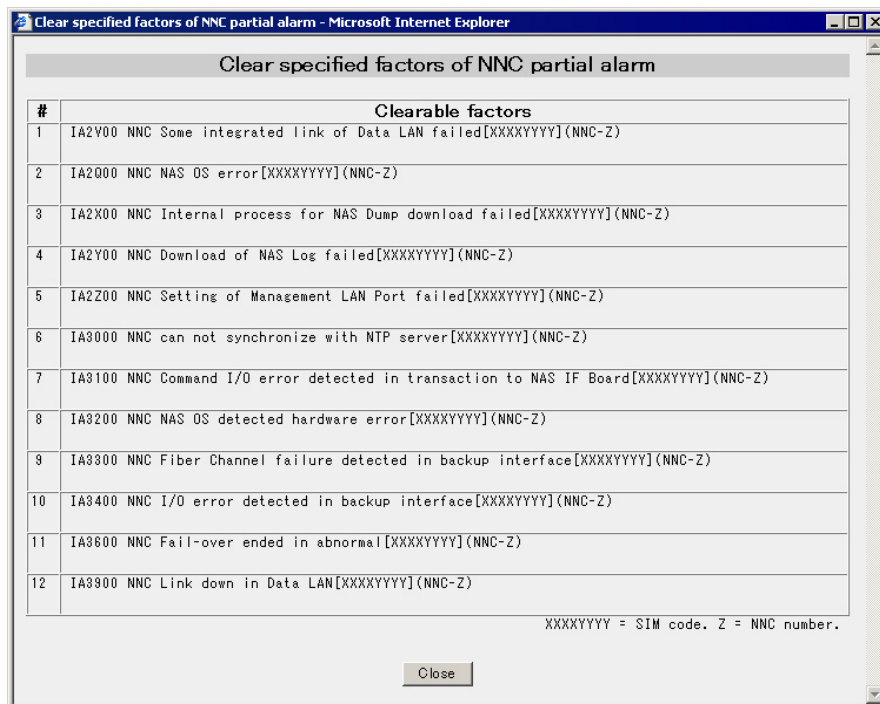

4. Clear specified factors of NNC partial alarm.
5. Click Recovery.

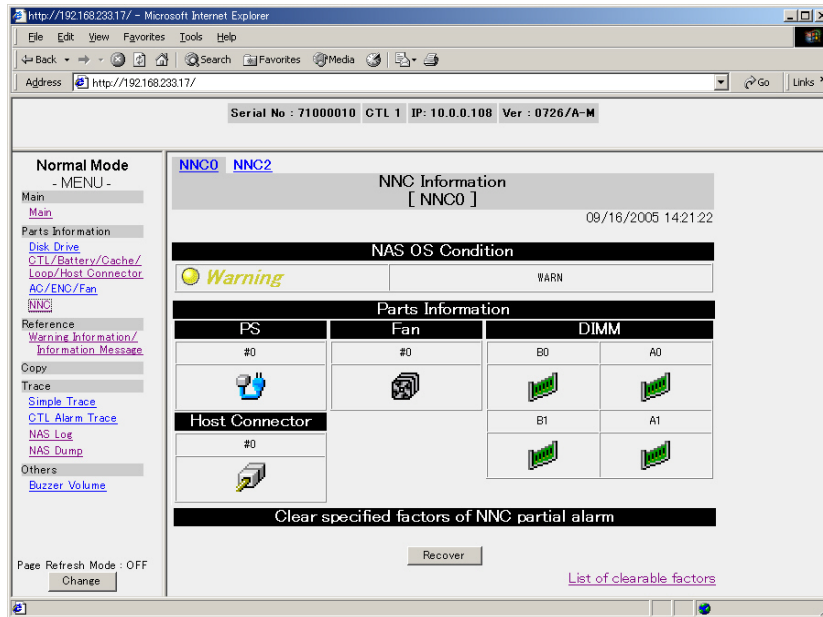

6. A Message box displays asking you to verify the setting is displayed. Click **OK**.

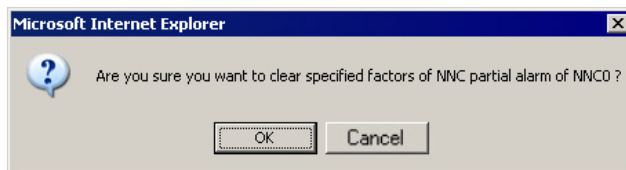

7. Check the NNC partial alarm recovery. When the **Clear specified factors of NNC partial alarm** is completed normally.

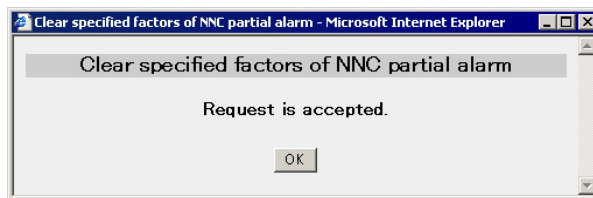

8. Click **OK**.
9. Click **Warning Information** on the Menu window, and check that the indication of the partial alarm is turned off.

If the array subsystem was booting at the time of clicking **Recovery**.

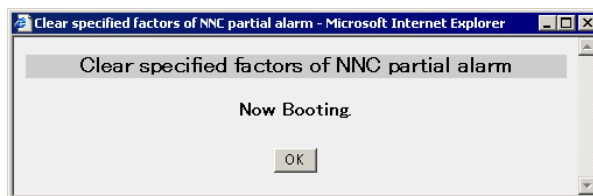

10. Click **OK**. Execute this again after the array subsystem is in the **READY** status.

8.4 Troubleshooting Using a Web Connection

This section includes the following:

- Checking subsystem status, see section 8.4.1
- Checking the progress condition display, see section 8.4.2
- Checking component status, see section 8.4.3
- Checking log messages, see section 8.4.4
- Troubleshooting by using messages, see section 8.4.5
- Reading failure information, see section 8.4.6

8.4.1 Checking Subsystem Status

Check the position of the failed part of the unit on the Main window in the normal mode of the Web.

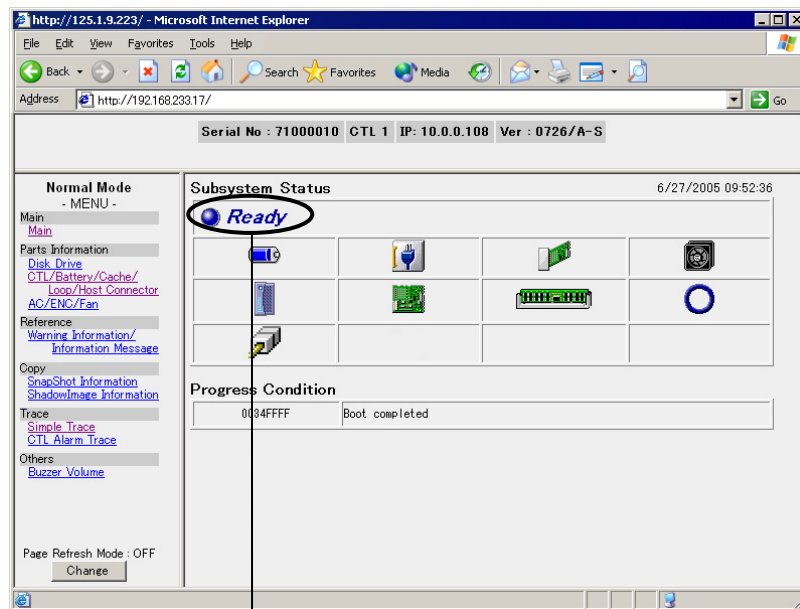

Subsystem Status

Figure 8.14 Subsystem Status Window

Subsystem Status:

Booting	Ready	Warning	Alarm
<i>Booting...</i> black	<i>Ready</i> blue	<i>Warning</i> yellow	<i>Alarm</i> red

8.4.2 Checking the Progress Condition Display

If **Booting...** is indicated in the window (the controller is being started up), the progress of the start-up operation can be confirmed according to the following procedure:

1. Turn on the page refresh mode (click **On**).

The window is updated automatically at 5-second intervals. (If the **Off** button of the Page Refresh Mode is activated, this operation is not necessary.)

If the Page Refresh Mode is not activated in the Main window, click the **Update** button of the browser to update the window.

2. Observe the condition-in-progress within the window.

If the start-up operation is completed, **Boot completed** is indicated in this part.

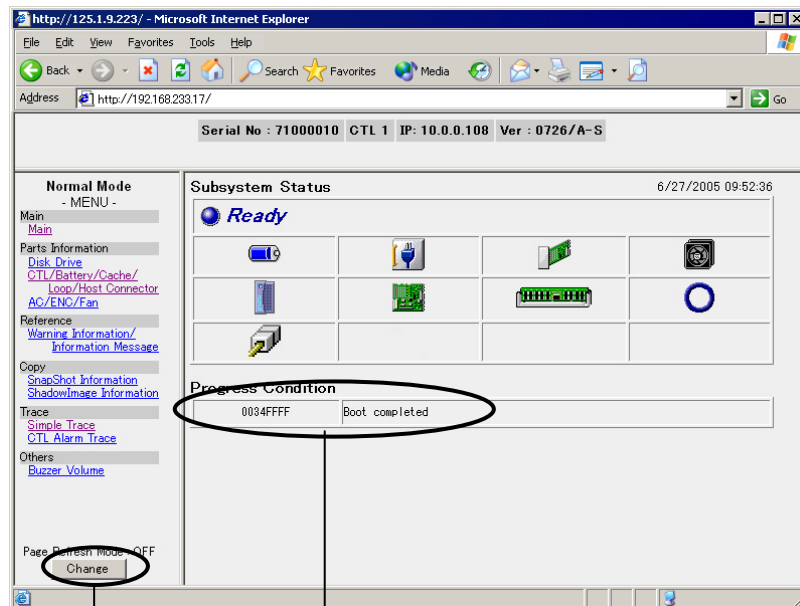

Figure 8.15 Progress Condition Display

Progress Condition display

Page Refresh Mode

8.4.3 Checking Component Status

Click each part of **Replace Part Summary** in the Main window; the following window displays and the state of the part is displayed.

In this example, the selected (clicked) part is at the head of the window. You can also select this window by clicking the **Parts Information** menu in the Main window. In this window, you can confirm the state of each part in detail. If a part fails, its corresponding icon turns red.

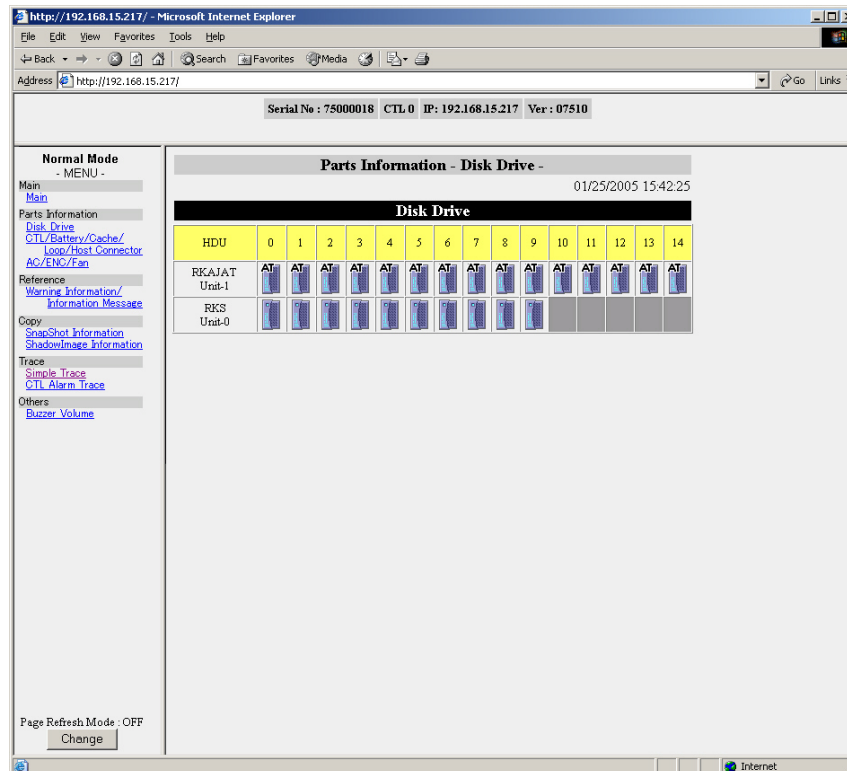

Figure 8.16 Replace Part Summary Window (HDD)

The following window is displayed only when used in the NAS unit.

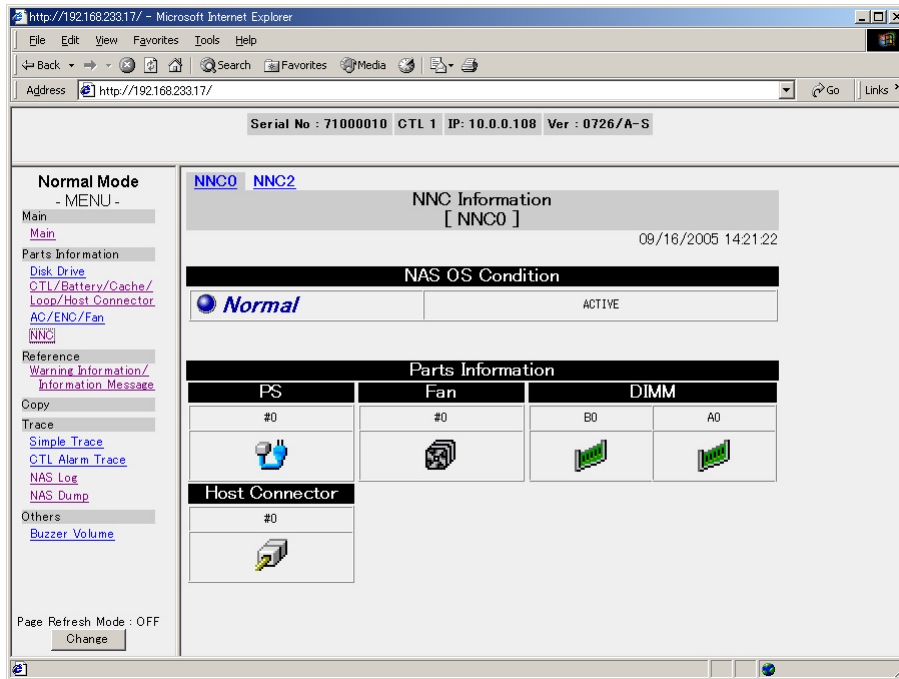

Figure 8.17 NNC Information Window

8.4.4 Checking Log Messages

To check log messages:

1. Click the **Information Message** menu in the main window.

The Information Message window appears.

2. In the Information Message window, identify the cause of the failure and confirm the recovery measures.

The information on the detected failures during operation of the unit and the state of the unit are displayed in the above window.

The information on the failures and the state at the start-up time of the unit is displayed for each Controller in the **Controller 0** and **Controller 1** boxes.

- Flash/RAM Micro Detection Message

The Flash/RAM micro detection message is displayed in the **Controller 0/1 Common**, **Controller 0**, or **Controller 1** box, as shown in the following example. The latest one is shown on the top line.

Note: The date and time the RTC is set in the detection controller is displayed in this message. If the RTC is different from one control to another, the displayed time of occurrence may differ within messages (the message on the upper line is issued prior to the message on the lower line).

In this example, the latest message is also indicated at the top.

Example:

```
MM/DD/YYYY HH:MM:SS Cx ●●●●●● ○○○○○○○○○○ : ■■■■■■/◆◆◆◆
MM/DD/YYYY HH:MM:SS Cx ●●●●●● ○○○○○○○○○○ : ■■■■■■/◆◆◆◆
:
```

MM/DD/YYYY: Confirmed data

HH:MM:SS: Confirmed times

Cx: Error detected Controller #

●●●●●●: Message code (Rxxxxx: flash-detected messages, lxxxxx: progress messages, Wxxxxx: warning messages, Hxxxxx: failure messages)

○○○○○○○○○○ Message text (any number of letters)

■■■■■■: Recovery measures code

◆◆◆◆: Collecting failure information code

8.4.5 Troubleshooting Using Messages

The contents of each failure detected during operation are reported by a message. The failures detected during operation and the state of the unit, after the main switch of this unit is turned on, are reported.

The five types of message codes are displayed in the following table:

Table 8.6 Message Code Types

Message code	Measures
018xxxx	Errors detected by CUDG
Rxxxx	Flash detected messages
lxxxx	Progress messages
Wxxxx	Warning messages
Hxxxx	Failure messages

8.4.5.1 Errors Detected by CUDG

When the Errors detected by CUDG are displayed, call your Customer Engineer.

8.4.5.2 Flash Detected Messages

When the following Flash detected messages are displayed, follow the instructions to resolve the problem.

Table 8.7 Flash Detected Messages

Message code	Message Text	Recovery Measures
RA00xx	Microprogram error [FLS]	Restarting the equipment
RA7000	Microprogram revision mismatch	
RB0000	Upload system error	Check the microprogram you want to install and install it over again.
RB0600	No micro program	Perform the new installation upgrade.
RB0A00	Upload file SUM check error	A sum check error occurred in a read file during a upload. Check the microprogram you want to install and install it over again.
RB0E00	Up grade check NG	The upgrade check of the microprogram failed. (An upgrade version of a microprogram does not conform to the microprogram being upgraded.) Do a new install of the microprogram.
RB3000	File size error	Check the microprogram you wish to install.
RB3100	File open error	
RB3200	File read error	
RB3500	Bad block ID	
RB3600	Bad LBA in START 600 DAT	
RB7000	Program size too large	
RB8000	Old microprogram exists	
RB8300	Empty system retry full install	The update installation cannot be executed because a system does not exist in the disk drive. Execute a new installation.
RBA000	Down grade check NG	The present microprogram version cannot be updated to a specified microprogram version. Check the work procedure. Execute a new installation.

When a Flash detected message other than those shown above is displayed, inform your Customer Engineer of the message code.

8.4.5.3 Progress Messages

When the following Progress messages are displayed, follow the instructions to resolve the problem.

Table 8.8 Progress Messages (continues on next page)

Message Code	Message Text	Recovery Measures
I031xy	Path recovered automatically	The path recovered automatically. (x: Remote DF# (0), y: Path # (0 or 1))
I10000	Subsystem is ready	The unit is ready.
I11000	All raid group initialized	All RAID groups were deleted.
I111xx	RAID group deleted (RG-xx)	All LUs were deleted. (xx: RAID group# (0-14))
I12000	ALL LU initialized	All LUs were deleted. (This is also displayed when the LU#0 is created.)
I12100	LU deleted (LU-xxx)	LUs were deleted. (xxx: LU# (0-511))
I12200	LU format completed (LU-xxx)	LU formatting was completed. (xxx: LU# (0-511))
I12400	LU format start (LU-xxx)	An LU formatting was started. (xxx: LU# (0-511))
I12500	Unified LUs separated (Uni: LU-xxx)	Dissolution of all LU unification (to dissolve unification of all the unified LUs and to split them into internal LUs) was executed. (xxx: LU# (0 to 511) of a unified LU to be split)
I12600	Last LU separated from unified LU (Uni: LU-xxx)	A separation of a final LU of a unified LU (to separate the last one of the internal LUs which have been combined with a unified LU) was executed. (xxx: LU# (0 to 511) of a unified LU to be split)
I12700	LU reappeared (Uni: LU-xxx)	An internal LU(s) was validated again through splitting of all unified LUs or a separation of a final LU. (xxx: An LU# (0 to 511) of an internal LU which has been separated and validated)
I15Axy	Dynamic sparing start (Unit-x, HDU-y) [zzzzzzzzzz]	Dynamic sparing started. (x: Unit ID# (0-14), y: Disk drive# (RKS=0-13, RKAJ=0-14), z: Detailed code)
I17002	Default LU-CTL change failed [PS OFF]	Set the equipment in the ready state and turn off the power, then turn on the power again
I17003	Default LU-CTL change failed [HOT]	Use the system as it is
I17004	Default LU-CTL change failed [LU] Permanent LU	
I1A00x	Permanent LU disable (Default CTL-x)	Set the equipment in the ready state and turn off the power, then turn on the power again
I1A10x	Permanent LU deleted (Default CTL-x)	LU residence is deleted. (When RAID group/LU is deleted) (x: Default Controller# (0 or 1))
I1A30x	Permanent LU enable (Default CTL-x)	The FlashAccess function was turned on. (x: Default Controller# (0 or 1))

Table 8.8 Progress Messages (continues on next page)

Message Code	Message Text	Recovery Measures
I1B100	Forced parity correction completed	Forced parity recovery processing was finished.
I1C0xy	Loop diagnostic start (Path-x, Loop-y)	Loop diagnosis was started. (x: Path# (0 or 1), y: Loop# (0 or 1))
I1C1xy	Loop diagnostic end (Path-x, Loop-y)	Loop diagnosis was finished. (x: Path# (0 or 1), y: Loop# (0 or 1))
I1E000	Online verify completed [odd unit]	Check of the frames with even numbers was completed in the online verification.
I1E100	Online verify completed [even unit]	Check of the frames with odd numbers was completed in the online verification.
I61D00	Shutdown warning	Turn off power supply by main switch.
IA100x	NNC power on (NNC-x)	NNC power supply was turned on. x: NNC # (0-3)
IA110x	NNC boot started (NNC-x)	NNC boot was started. x: NNC # (0-3)
IA120x	NNC is ready (NNC-x)	NNC is ready. x : NNC # (0-3)
IA130x	NNC shutdown started (NNC-x)	NNC shutdown was started. x : NNC # (0-3)
IA140x	NNC shutdown completed (NNC-x)	NNC shutdown was completed. x : NNC # (0-3)
IA150x	NNC power off (NNC-x)	NNC power supply was turned off. x : NNC # (0-3)
IA1P0x	NNC NAS OS installation completed (CTL-x, NNC-y)	NAS OS installation on the NNC. was completed x : Controller # (0-1) y : NNC # (0-3)
IA1Q0x	NNC NAS OS installation started (CTL-x, NNC-y)	NAS OS installation on the NNC was started. x : Controller # (0-1) y : NNC # (0-3)
IA1T0x	NNC NAS dump process started (NNC-x)	NNC Dump collection was started. x : NNC # (0-3)
IA1U0x	NNC recovered from partial alarm (NNC-x)	NNC was recovered from a partial error. x : NNC # (0-3)
IA1V0x	NNC recovered (NNC-x)	NNC was recovered from an error. x : NNC # (0-3)
IA2R00	NNC PCI Express link recovered [x] (NNC-y)	The link of the NNC PCI Express was recovered. x : Failed part code y : NNC # (0-3)

Table 8.8 Progress Messages (continued)

Message Code	Message Text	Recovery Measures
IA2V00 (Note1)	NNC Some integrated link of Data LAN failed [xy] (NNC-z)	Identify failed part by checking the LED beside the data LAN port. Confirm if the LAN cable is firmly connected to the LAN port and if there is no failure in network switch. If there are some failures, get rid of them.
IA3000 (Note1)	NNC can not synchronize with NTP server [xy] (NNC-z)	Check the NTP server settings and network configuration, and then change them if necessary.
IA3300 (Note1)	NNC Fibre Channel failure detected in backup interface [xy] (NNC-z)	Check if the backup device is firmly connected to the NNC (NAS Unit) displayed in this message. If the backup device is not connected firmly, reconnect it firmly.
IA3400 (Note1)	NNC I/O error detected in backup interface [xy] (NNC-z)	
IA3900 (Note1)	NNC Link down in Data LAN [xy] (NNC-z)	Identify failed part by checking the LED beside the data LAN port. Confirm if the LAN cable is firmly connected to the LAN port and if there is no failure in network switch. If there are some failures, get rid of them.

Note1: After getting rid of the failure, execute it according to “8.3.7 Clear Specified Factors of NNC Partial Alarm”.

Note2: When a Progress message other than those shown above is displayed, inform your Customer Engineer of the message code.

8.4.5.4 8.4.5.4 Warning Messages

When the following Warning messages are displayed, follow the instructions to resolve the problem.

Table 8.9 Warning Messages

Message Code	Message Text	Recovery Measures
W03200	Battery SW off	Turn on the battery unit switch.

When a Warning messages other than those shown above is displayed, inform your Customer Engineer of the message code.

8.4.5.5 Failure Messages

When the following Failure messages are displayed, follow the instructions and resolve the problem.

Table 8.10 Failure Messages

Message Code	Message Text	Recovery Measures
--------------	--------------	-------------------

HI0201	PS OFF failed [POFNONCLD]	Turn on PS, then off again.
HI0202	PS OFF failed [POFNOJOB]	

When a Warning messages other than those shown above is displayed, inform your Customer Engineer of the message code.

8.4.6 8.46 Reading Failure Information

- The history of the unit, after it is turned on, is displayed in the **Information Message**.
- The **Subsystem is Ready** message displays the time when the unit is ready. Messages sent after the power is turned on until the unit is ready are displayed prior to this message. Messages sent after the unit is ready are displayed after this message.
- Carefully observe the following: **Wxxxxx** (Warning message), **Hxxxxx** (Failure message), and **Rxxxxx** (Flash detection message).
- The following messages are displayed when failures occur and when they are solved. If the recovery message is displayed after a failure occurrence message, the failure has been solved.

Table 8.11 How to Read Failure Information (Continues to the next page)

No.	Description	Failure detected messages		Failure recovery messages	
1	Controller error/recovery	W00100	CTL alarm (CTL-x)	I0010x	CTL recovered (CTL-x)
2	Battery error/recovery	W03000 W0300x	Battery alarm	I00300	Battery recovered
		W03100 W0310x	Battery removed	I0030x	Battery recovered (Battery-x)
		W03200 W0320x	Battery SW off		
		W03300 W0330x	Battery Thermal alarm		
3	Battery backup circuit error/ recovery	W0340x	Battery backup circuit alarm (CTL-x)	I0040x	Battery backup circuit recovered (CTL-x)
4	Fan error/recovery	W040xy	FAN alarm (Unit-x, FAN-y)	I005xy	FAN recovered (Unit-xx, FAN-y)
		W04100	FAN alarm (CTL-Unit, FAN-x)	I00500	FAN recovered (CTL-Unit, FAN-x)
5	Power supply error/ recovery	W050xy	PS alarm (Unit-x, PS-y)	I006xy	PS recovered (Unit-x, PS-y)
		W0G400	PS alarm [RKA] (Unit-x, PS-y)		
		W0G500	PS alarm [RKAAT] (Unit-x, PS-y)		

		W0G600	PS alarm [RKAJ] (Unit-x, PS-y)		
		W0G700	PS alarm [RKAJAT] (Unit-x, PS-y)		
		W05100	PS alarm (CTL-Unit, PS-x)	I00600	PS recovered (CTL-Unit, FAN-x)

Table 8.11 How to Read Failure Information (Continues to the next page)

No.	Description	Failure detected messages		Failure recovery messages	
6	Disk Drive error/recovery	W060AT	SATA HDU alarm (Unit-x, HDU-y)	I007xy	HDU recovered (Unit-x, HDU-y)
		W060xy	HDU alarm (Unit-x, HDU-y)		
		W0GG00	HDU alarm [RKA] (Unit-x, HDU-y)		
		W0GH00	HDU alarm [RKAJ] (Unit-x, HDU-y)		
7	Spare Disk error/recovery	W061AT	SATA Spare HDU alarm (Unit-x, HDU-y)	I009xy	Spare HDU recovered (Unit-x, HDU-y)
		W061xy	Spare HDU alarm (Unit-x, HDU-y)		
		W0GJ00	Spare HDU alarm [RKA] (Unit-x, HDU-y)		
		W0GK00	Spare HDU alarm [RKAJ] (Unit-x, HDU-y)		
8	Loop error/recovery	W080xy	Loop alarm (Path-x, Loop-y)	I00Axy	Loop recovered (Path-x, Loop-y)
9	ENC Unit error/SENC Unit error/recovery	W090AT	SENC alarm (Unit-x, ENC-y)	I00Bxy	ENC recovered (Unit-x, ENC-y)
		W090xy	ENC alarm (Unit-x, ENC-y)		
		W0GA00	ENC alarm [RKA] (Unit-x, ENC-y)		
		W0GB00	SENC alarm [RKAAT] (Unit-x, ENC-y)		
		W0GC00	ENC alarm [RKAJ] (Unit-x, ENC-y)		
		W0GD00	SENC alarm [RKAJAT] (Unit-x, ENC-y)		
10	UPS	W0C000	UPS alarm (UPS-x)	I00D00	UPS recovered (UPS-x)
11	Path failure (detachment)/recovery	W0F0xy	Path alarm (Remote-x, Path-y)	I030xy	Path recovered by web operation (Remote-x, Path-y)
				I031xy	Path recovered automatically

12	Occurrence/ rectification of an incomplete writing	W0G0xy	Unreadable PIN detected (Unit-x, HDU-y)	I04000	Unreadable PIN recovered
		W0G100	Unreadable PIN detected (Unit-*, HDU-*)		
13	Issue/callback of a resident LU off warning	W440xy	Permanent LU warning (CTL-x, ERR-y)	I1A2xy	Permanent LU warning recovered (CTL-x, ERR-y)

Table 8.11 How to Read Failure Information (Continued)

No.	Description	Failure detected messages		Failure recovery messages	
14	Excess/rectification of the threshold value of the number of pinned sub-segments	W49100	PIN is over directory threshold [write through] (DIR-x)	I6EG00	PIN over recovered [directory threshold] (DIR-x)
		W49300	PIN is over partition threshold [write through] (DIR-x, PTT-y)	I6EH00	PIN over recovered [partition threshold] (DIR-x, PTT-y)
		W49500	PIN is over RAID group threshold [write through] (DIR-x, RG-y)	I6EJ00	PIN over recovered [RAID group threshold] (DIR-x, RG-y)
15	The DM-LU failure/recovery	W49700	DM-LU write disable (LU-x)	I6EM00	DM-LU recovered (LU-x)
		W49800	All DM-LU write disabled		
16	The host connector failure/recovery	W0G300	Host connector alarm (Portxy-z)	I53A00	Host connector recovered (Portxy-z)
17	NNC (NAS Unit) failure and recovery	W5000x	NNC alarm (NNC-x)	IA1V0x	NNC recovered (NNC-x)
18	NNC (NAS Unit) partial failure and recovery	W5010x	NNC partial alarm (NNC-x)	IA1U0x	NNC recovered from partial alarm (NNC-x)

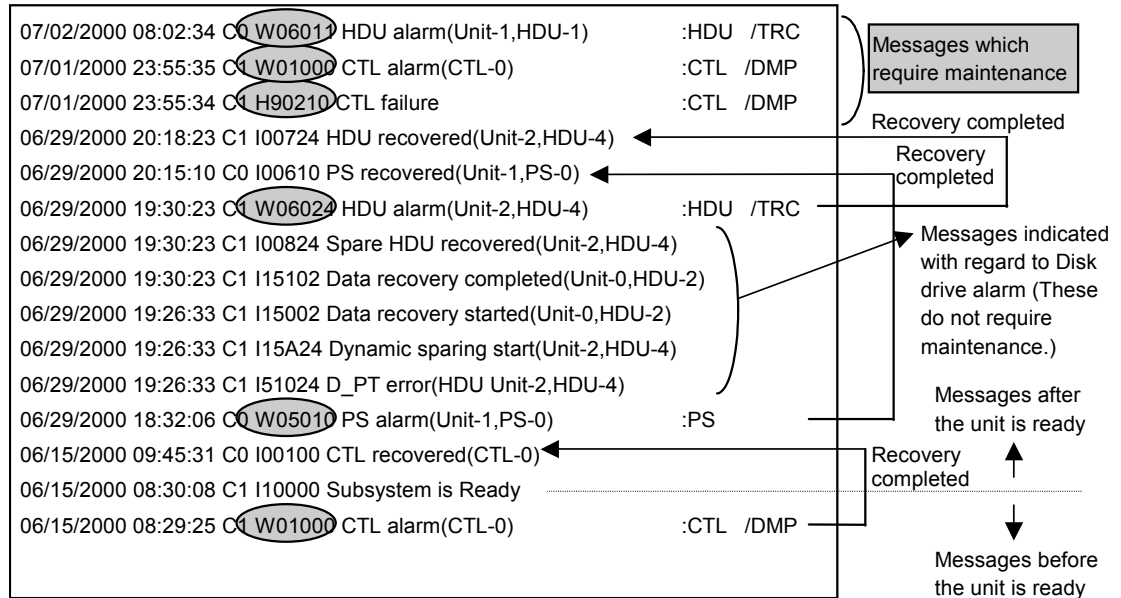
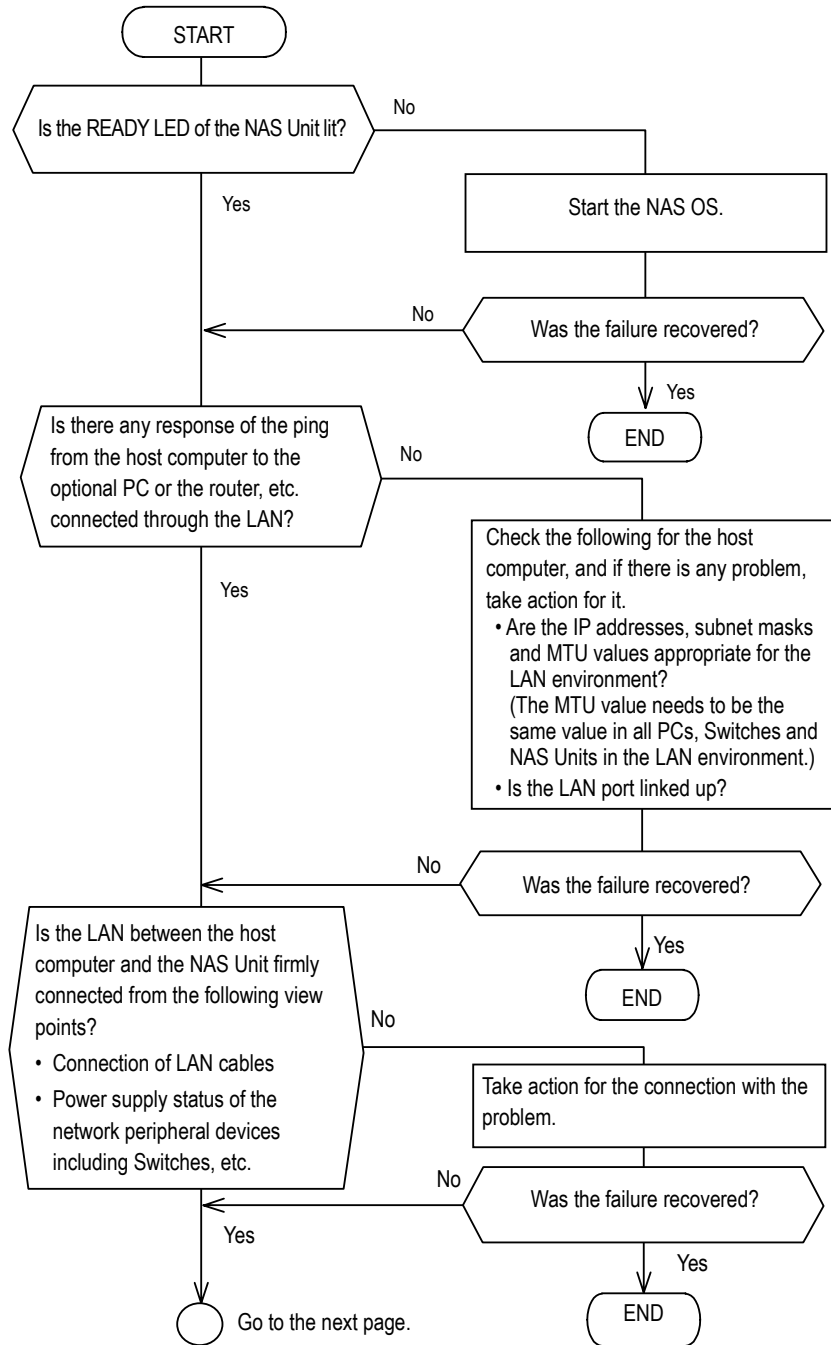

Figure 8.19 Configuration Diagram

Message Analysis Example

8.5 Determining Failure of Network Side in NAS System

When a failure occurs in the LAN environment between the host computer and the NAS Modular subsystem, or the NAS Modular subsystem, it is determined whether there is a failure in the NAS Modular subsystem according to the following flow.



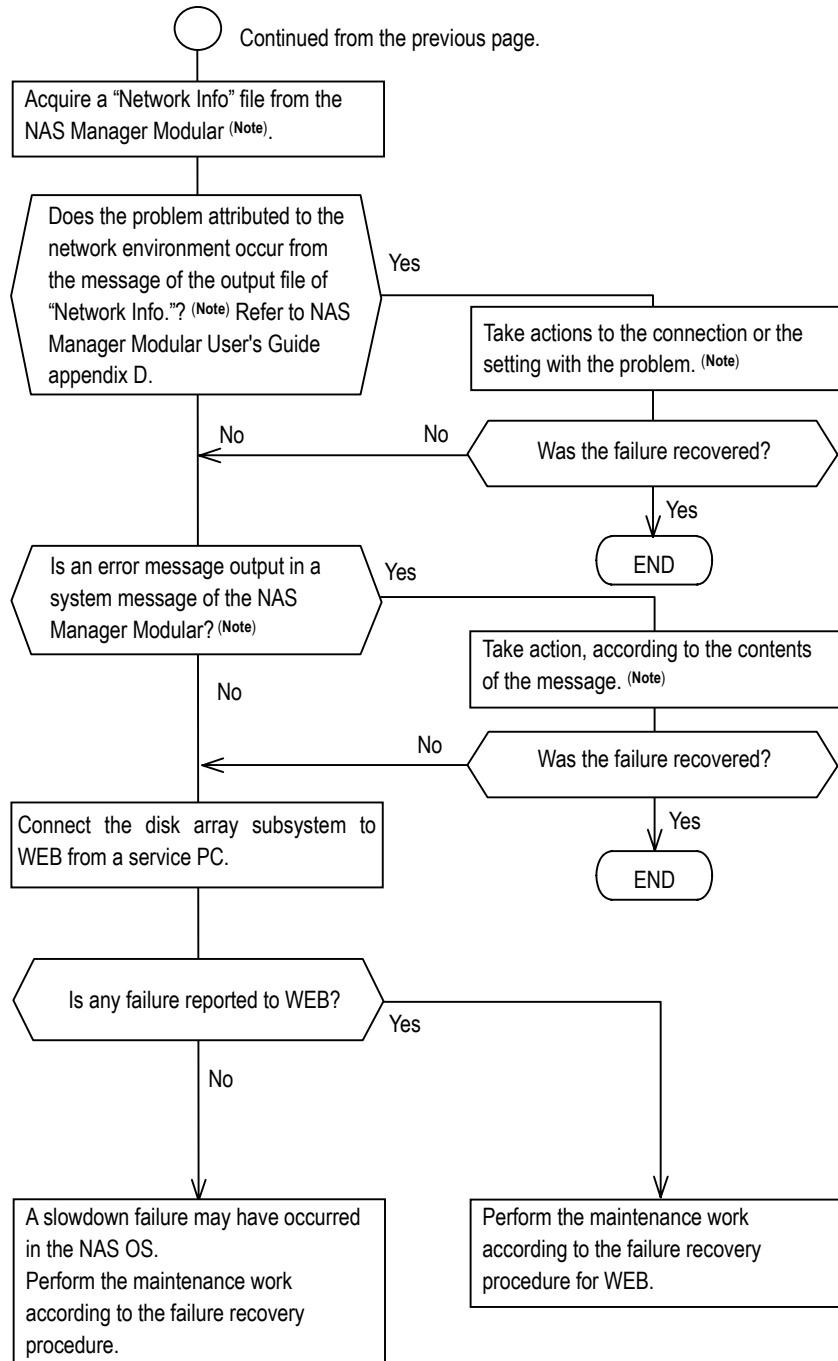

Note : Work to use NAS Manager Modular becomes charge of the system administrator.
The system administrator must cooperate with the maintenance member.

8.6 Determining Failure of Local Tape in NAS System

Determine failures between the NAS unit and the local tape and between the NAS unit and the Backup server according to the following flow. Before determining failures, verify that the user setting is made correctly on the Backup server.

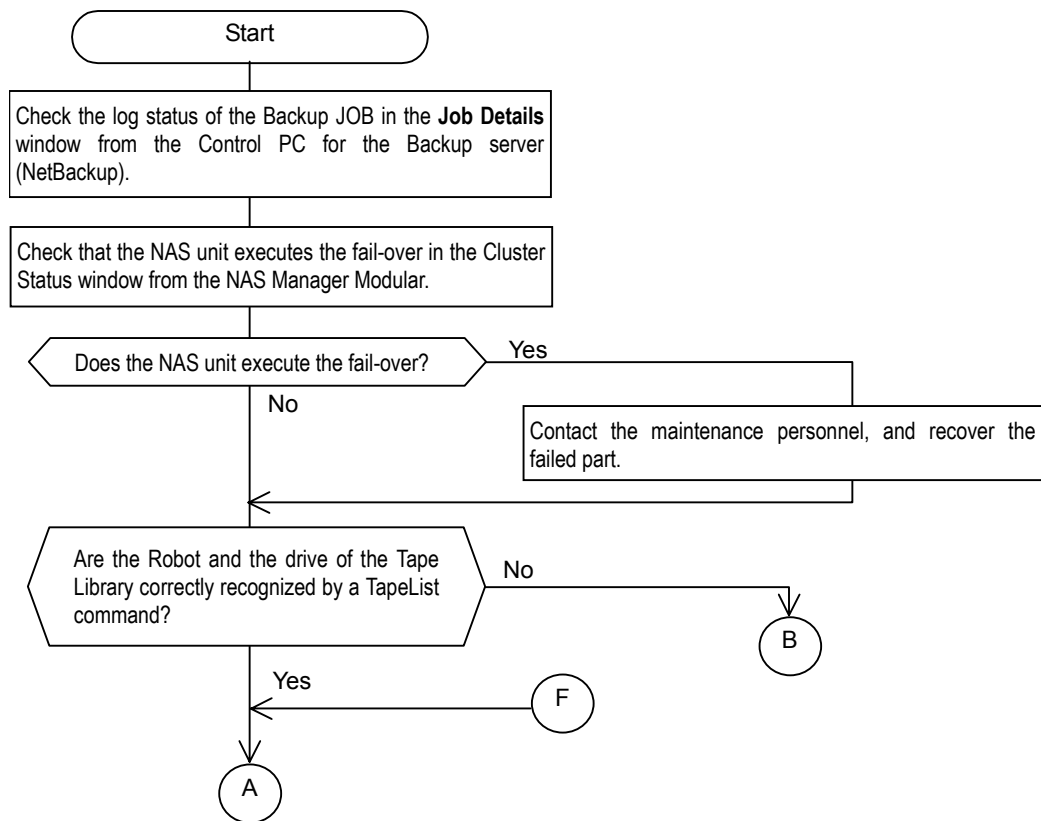
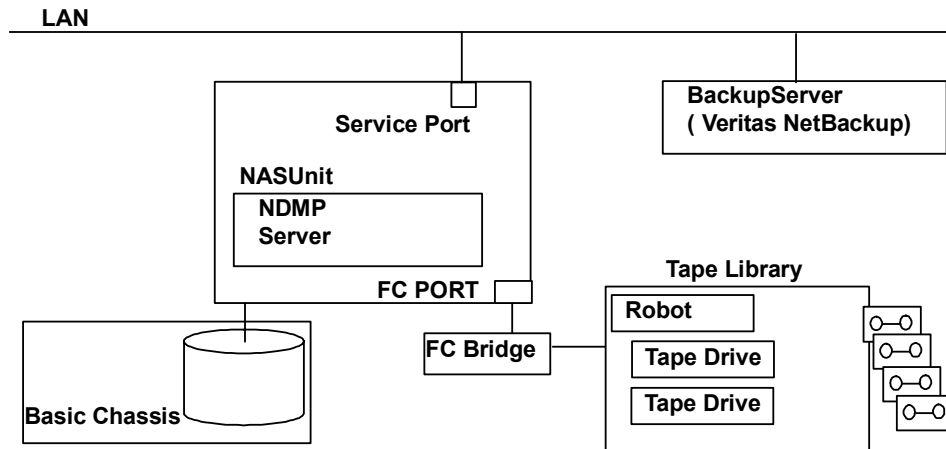

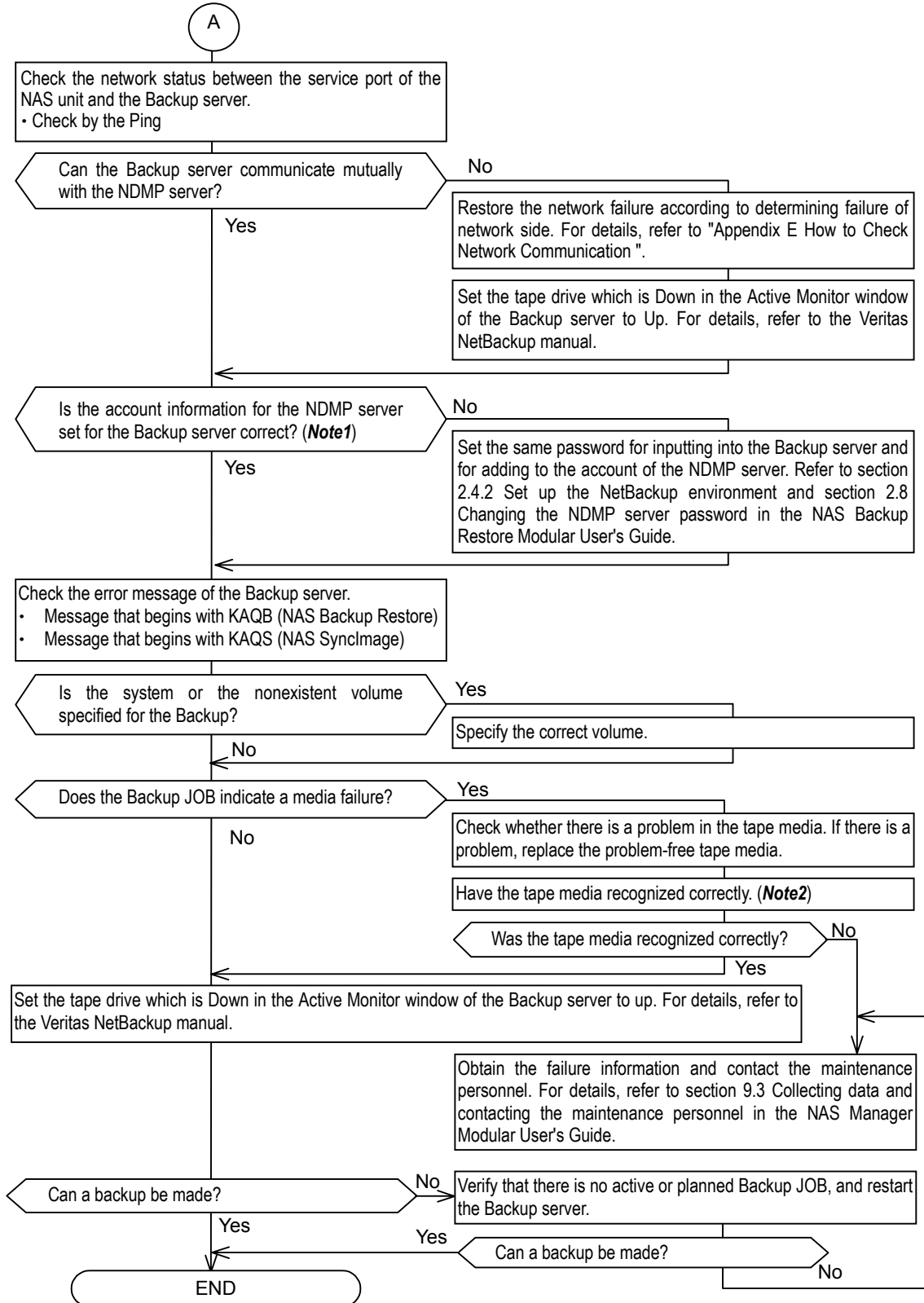

Note 1: In the CLI operation of the NetBackup, perform the `set_ndmp_attr-verify<NDMP server name>`. If "Login was successful" is displayed, the account information is correct.

Note 2: Select the **Update volume configuration** in the **Robot Inventory** registered in the Backup server (Veritas NetBackup) and click the **Start** button.

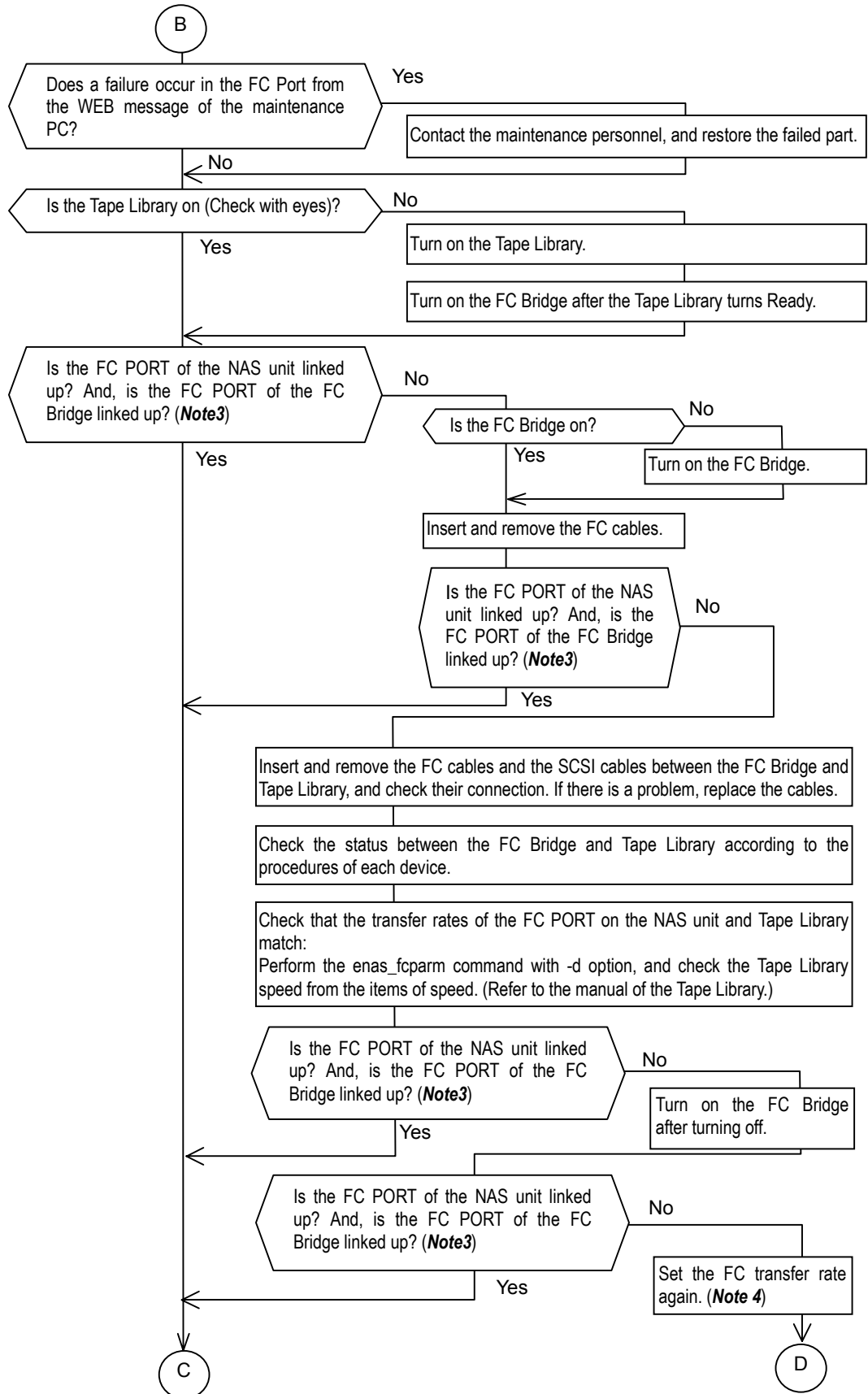

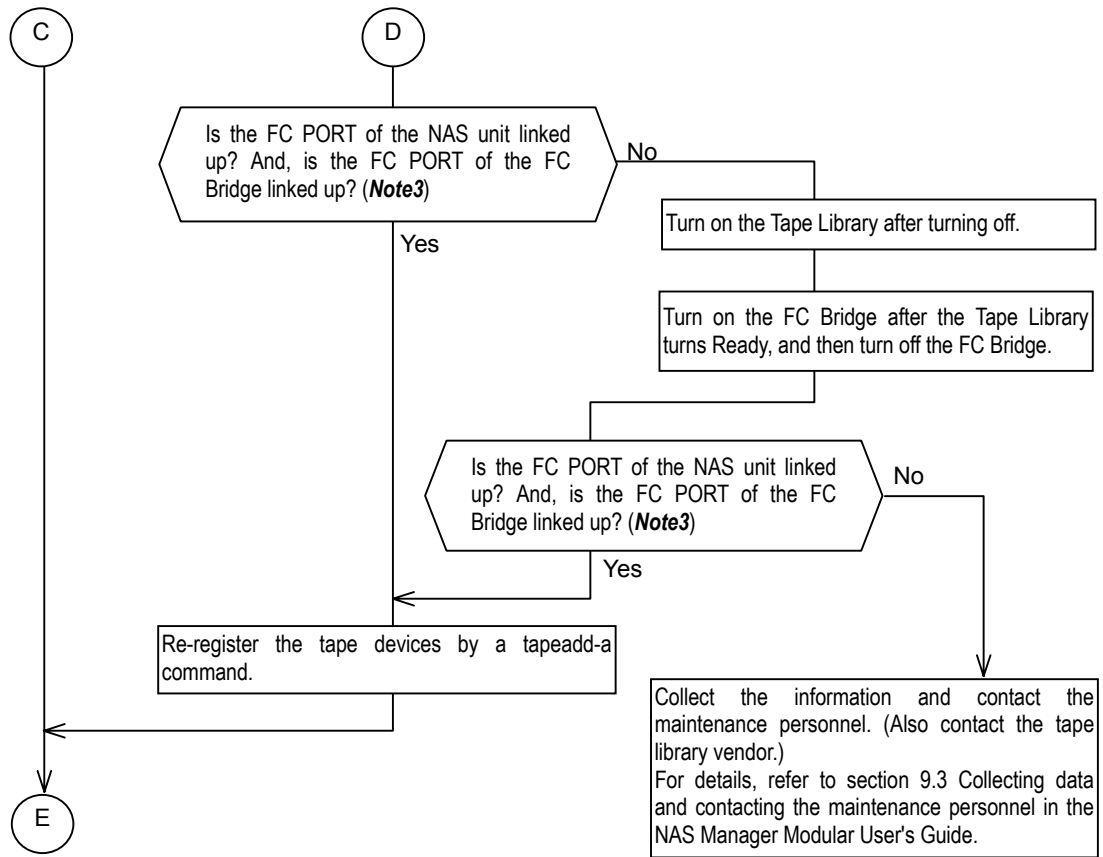

Note3: The conditions that the FC link is correct are the following (1) and (2).

- (1) The LED of the FC PORT on the FC bridge lights.
- (2) FC PORT is linked up by the following procedures (Refer to the NAS Manager Modular User's Guide).
 - (a) Display the List of RAS Information (List of Messages) by selecting the **RAS Management** from the **Main Menu**.
 - (b) Confirm the latest one with the following "Message ID":
 - KAQG35060-I: The connection to FC Port was linked up.
 - KAQG35061-W: The connection to FC Port was linked down.

Note4: Perform the entry into the NAS Manager Modular by ssh.

- (1) Delete all the tape drives registered by `tapedel` command.
- (2) Reset the FC PORT transfer rate to 2 Gb/s by `enas_fcparm -s 2` command, and restart the FC PORT.
- (3) Verify that the transfer rate was reflected by `enas_fcparm -d` command.

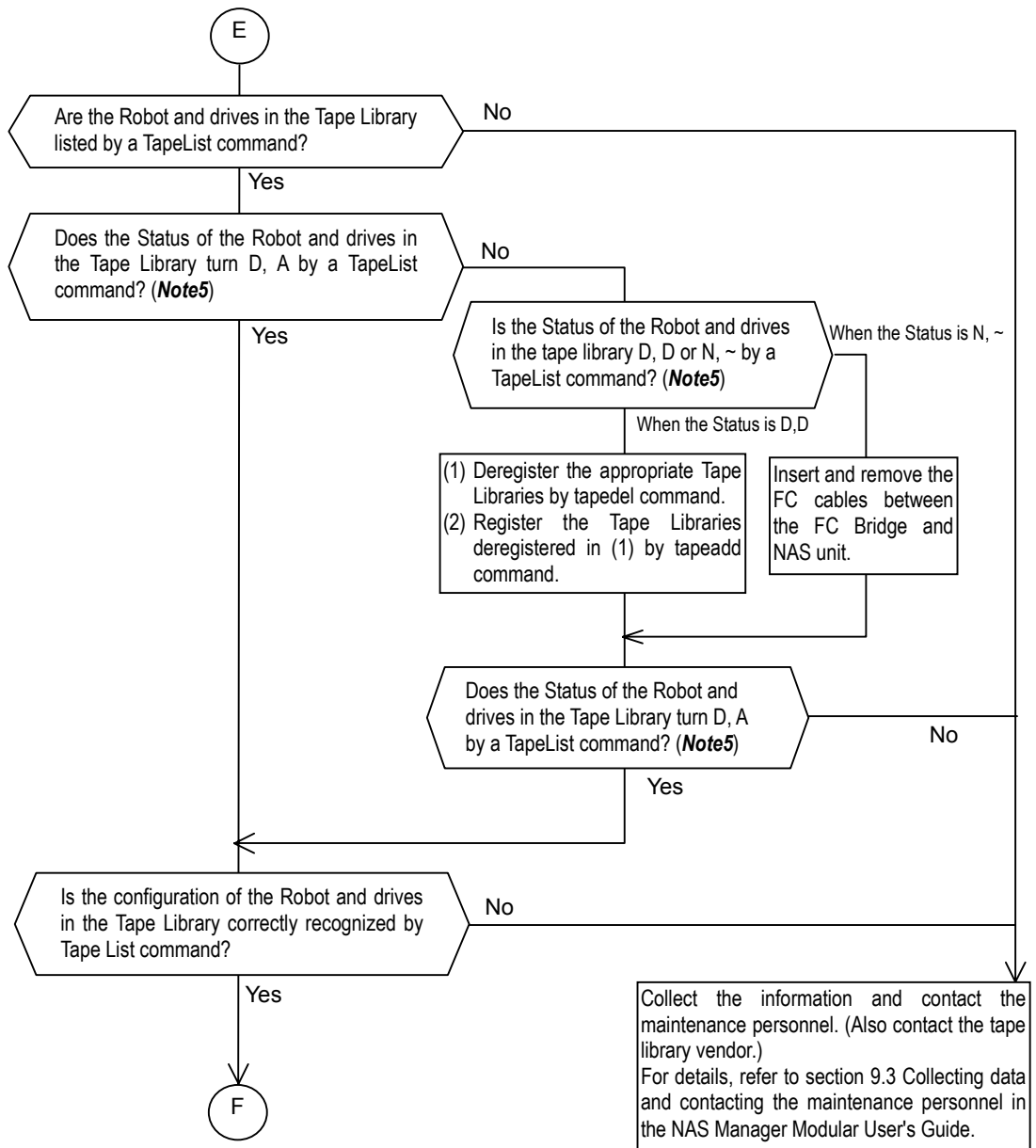

Note 5: Check the "Status" part in the following list.

It is correct that each device can be seen, and the status is D, A.

```

nasroot@D710001515:~$ sudo tapelist
Mar 23 11:58:56 KAQB11500-1 tapelist command execution has started.
Mar 23 11:58:56 KAQB12225-1 The list of tape device information will now be displayed.
LUN Model      Type          Status Path
-----
0 L40          Medium Changer D,A /dev/enas/100000e00202d78e/sg00
1 Ultrium 2-SCSI Sequential- Access D,A /dev/enas/100000e00202d78e/nst01
2 Ultrium 2-SCSI Sequential- Access D,A /dev/enas/100000e00202d78e/nst02
3 Ultrium 2-SCSI Sequential- Access D,A /dev/enas/100000e00202d78e/nst03
4 Ultrium 2-SCSI Sequential- Access D,A /dev/enas/100000e00202d78e/nst04
Mar 23 11:58:56 KAQB11500-1 tapelist command has finished.
nasroot@D710001515:~$
  
```

Figure 8.20 Configuration Diagram

8.7 Connecting Failure in Connection with the Web

8.7.1 Collecting Simple Trace

This function is used to download current trace information. To perform the download, a free capacity of approximately 20 MB is required in the PC.

Simple Trace of both the Control Units can be collected through one Control Unit. It is not necessary to collect from both the controllers. (When it is collected from Control Unit #0, File name is “smpL_trc0.dat”. When collected from Control Unit #1, file name is “smpL_trc1.dat.”)

1. Click **Simple Trace** in the menu frame.

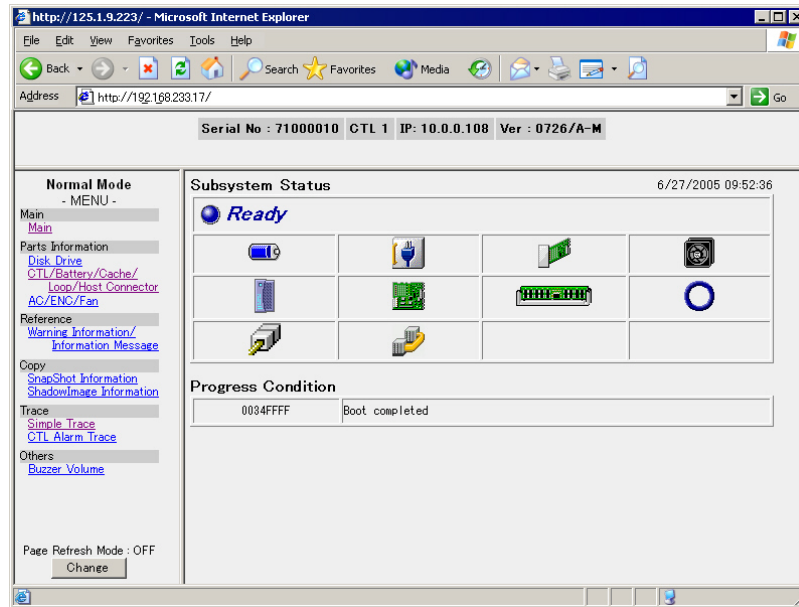

2. When **Simple Trace** is clicked, the following message box displays.



3. When **OK** is clicked, the following message box displays.



4. The following message box displays. Click **Download**.

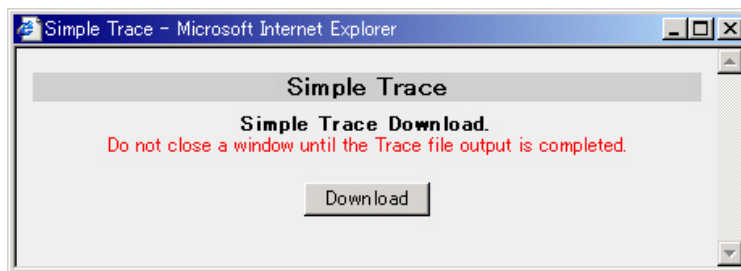

5. Click **Save** if it is continued. Click **Cancel** if it is stopped.

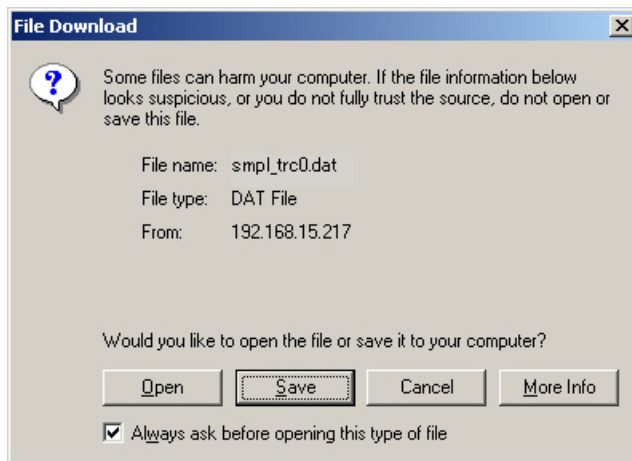

6. Click **Save** after setting the file name if it is continued. Click **Cancel** if it is stopped.

Note: There may be a case where the default file name is given as “ctla_trc0.dat.dat” depending on the setting of the PC. In this case, reset the file name to “ctla_trc0.dat” or any other name.

Click Cancel if it is stopped.

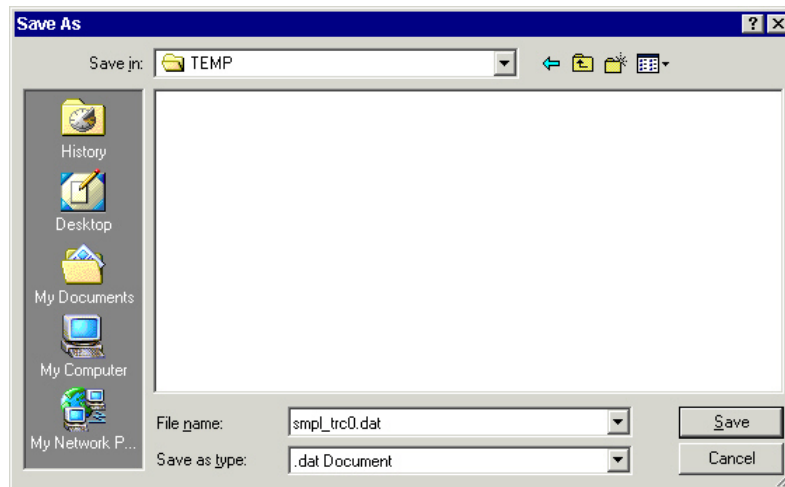

7. The message box displays during execution download.

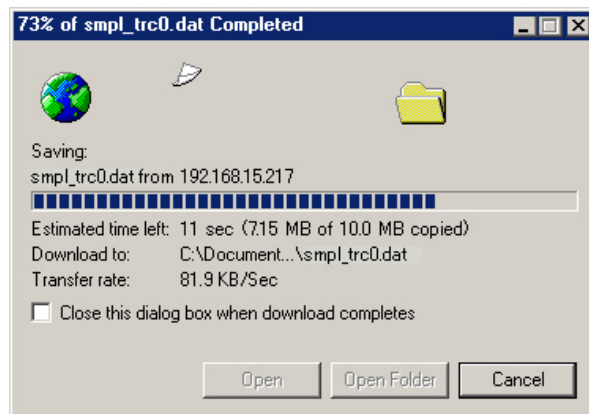

8. Click Close.

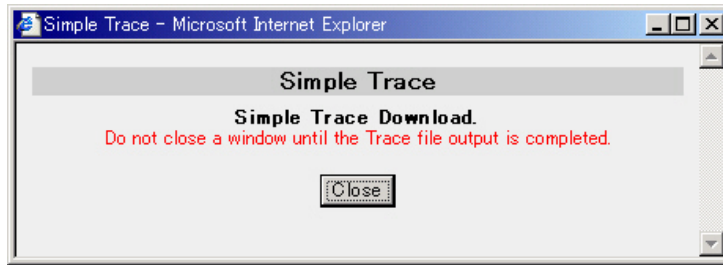

8.7.2 NAS Log Collection

This function downloads the log information on the present NAS OS. The free capacity of approximately 4 MB in the Normal Mode, 12 MB in the Detail Mode and 150 M bytes in the Full Mode is required on the PC for downloading.

The NAS Log can collect only the information on the NNC (NAS unit) connected to the Control Unit. When no special instruction is given, collect the NAS log in Full Mode when a failure occurs.

Table 8.12 Collection Mode

	Collection Mode		
	Normal Mode	Detail Mode	Full Mode
Use	Collect it only when there is a special instruction. (It is limited to when the remote collection of Full Mode and Detail Mode is impossible on the capacity side.)	Collect it only when there is a special instruction. (It is limited to when the remote collection of Full Mode is impossible on the capacity side.)	Collect "Full Mode" uniformly unless otherwise instructed.
Capacity (Rough Indication)	About 4 MB per NNC	About 12 MB per NNC	About 150 MB per NNC
Collection time (Rough Indication)	About 1 minute per NNC	About 1 minute per NNC	About 4 minutes per NNC

Notes:

- For one control unit, do not collect the next NAS Log until the NAS Log collection processing is complete. The operation is not assured when NAS Log collection is performed at the same time from multiple WEBs and external application.
- To require the access information between clusters for the analysis operation, collect NAS Logs of both NAS units in the cluster.
- When NAS Log is acquired from PC connected to the LAN for management, access to both the user-managed port of disk array subsystem and the management port of the NAS unit from the PC. (It is recommended that both IP addresses be in the same segment.)

1. Click **NAS Log** in Trace of the menu frame.

2. Click Collection Mode.

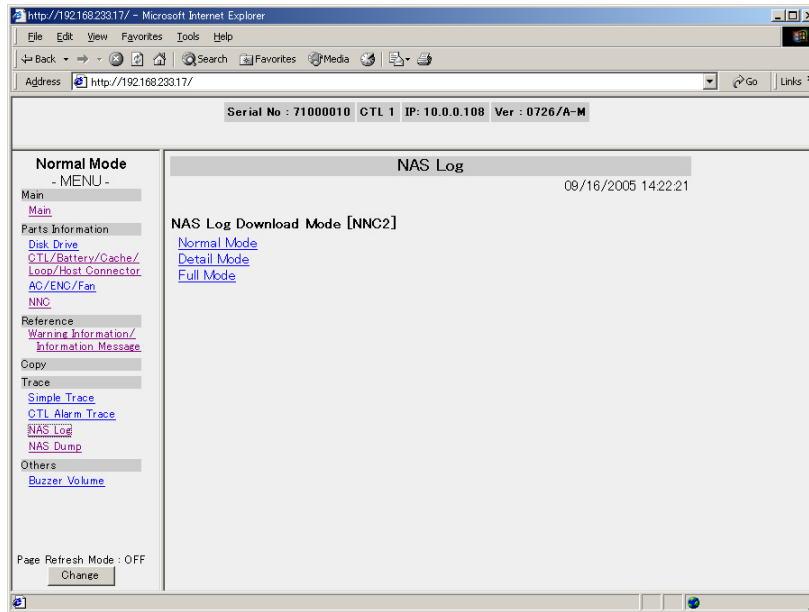

3. The confirmation message displays. Click OK.

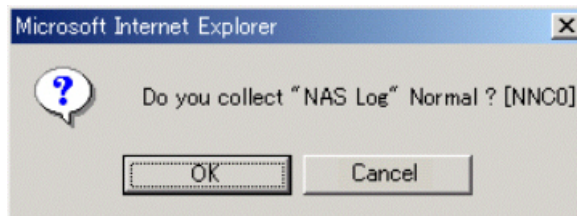

The following message box displays.

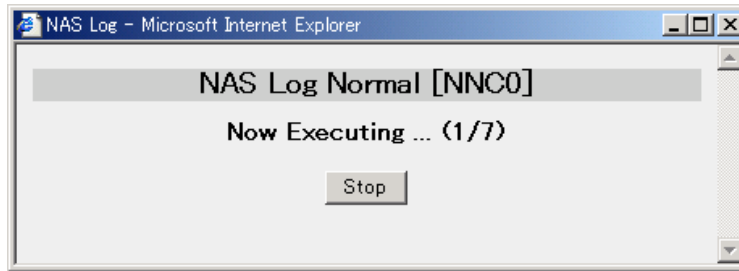

4. The following message box displays when ending. Click **Download**.

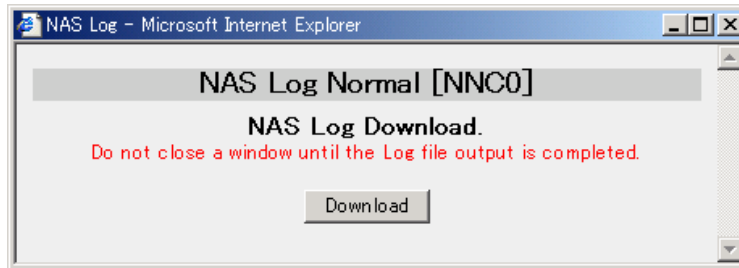

Note: Do not close this message box while you download the NAS Log into the service PC. The NAS Log may not be able to be collected when closing it.

5. The following dialog box displays. Click **Save**.

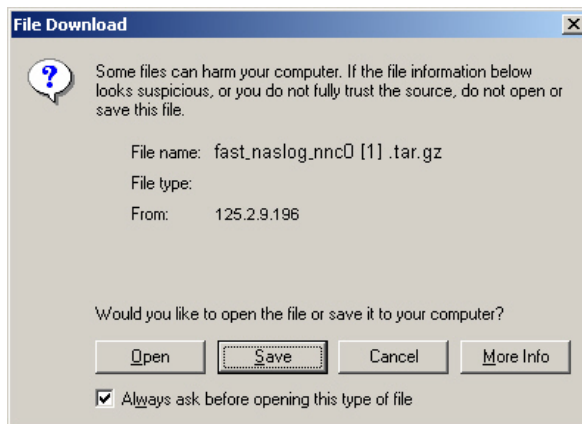

6. Specify the storage location of the file and the file name, and click **Save**.

A file name can be changed to “optional file name.tar.gz”. A default file name is as follows in the collection mode.

Collection Mode			
	Normal Mode	Detail Mode	Full Mode
NNC 0	fast_naslog_nnc0[1].tar.gz	naslog_nnc0[1].tar.gz	full_naslog_nnc0[1].tar.gz
NNC 2	fast_naslog_nnc2[1].tar.gz	naslog_nnc2[1].tar.gz	full_naslog_nnc2[1].tar.gz

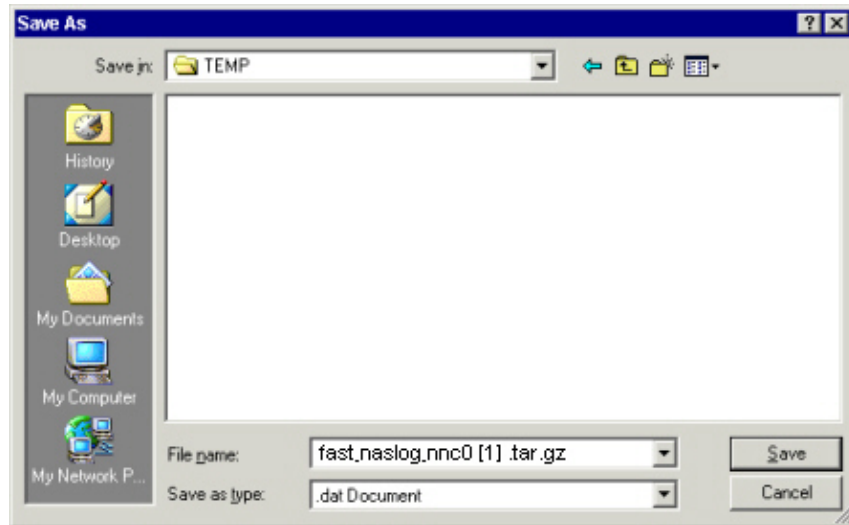

The download starts and the progress message box displays.

7. When the download completes, click **Close**.

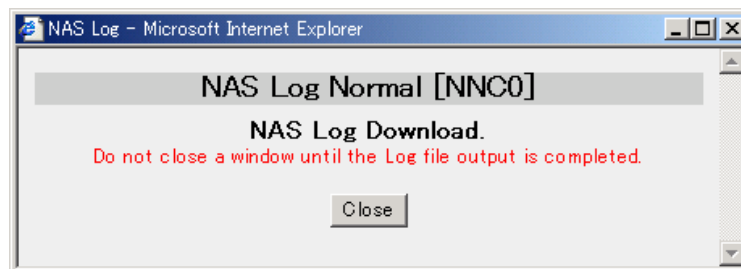

8.7.3 NAS Dump Generation

This function generates the full memory information on the present NNC (NAS unit) and collects it in the Disk Drive. The full memory information on the NNC (NAS unit) is not downloaded in the PC at the NAS Dump generation opportunity. The generation of the NAS Dump can be executed only in the NNC (NAS unit) connected to the Control Unit.

8.7.3.1 Generating NAS Dump

1. Click **NAS Dump** in Trace of the menu frame.
2. Click **Collecting the NAS Dump**.

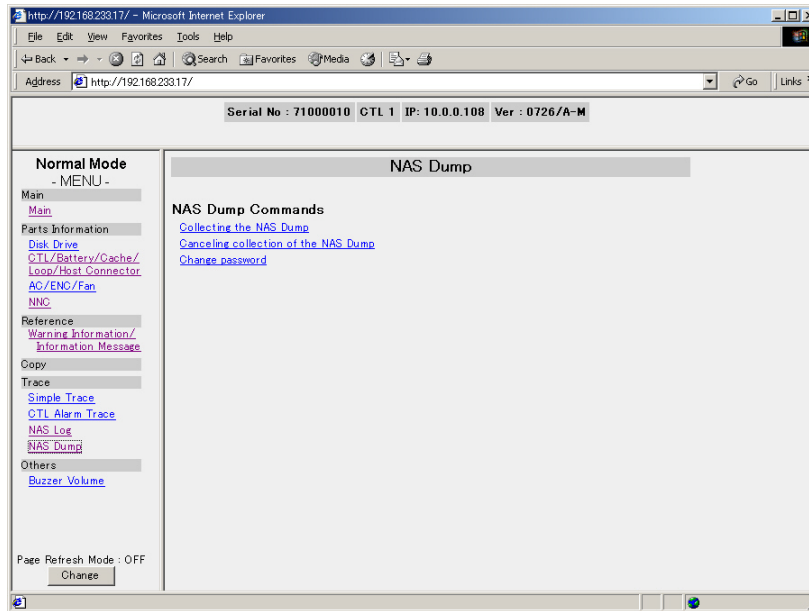

3. The confirmation message displays. Click **OK**.

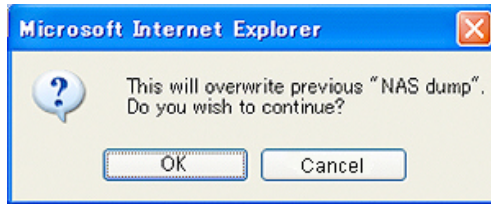

4. Enter the registered password, and then click **OK**.
(The default password is "user=NAS")

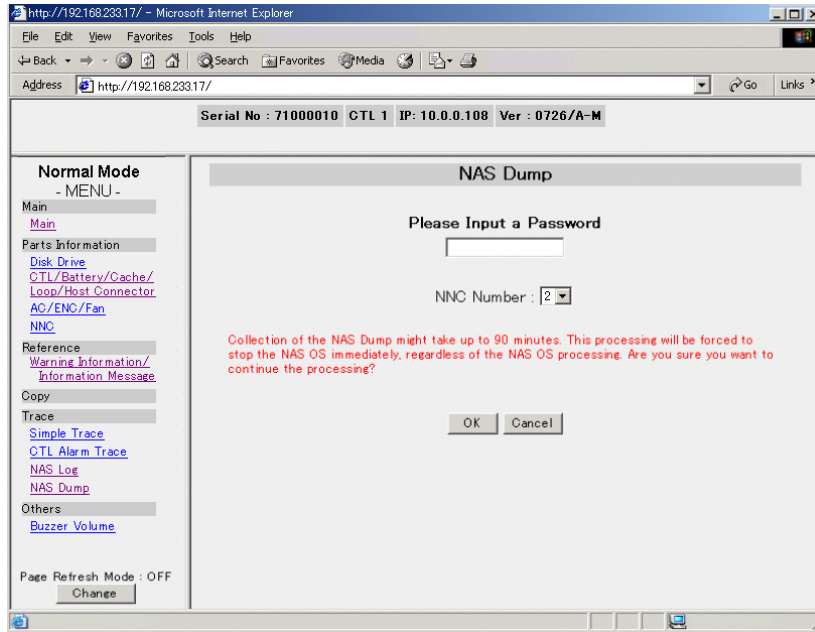

5. The following window is displayed. Click **OK**.

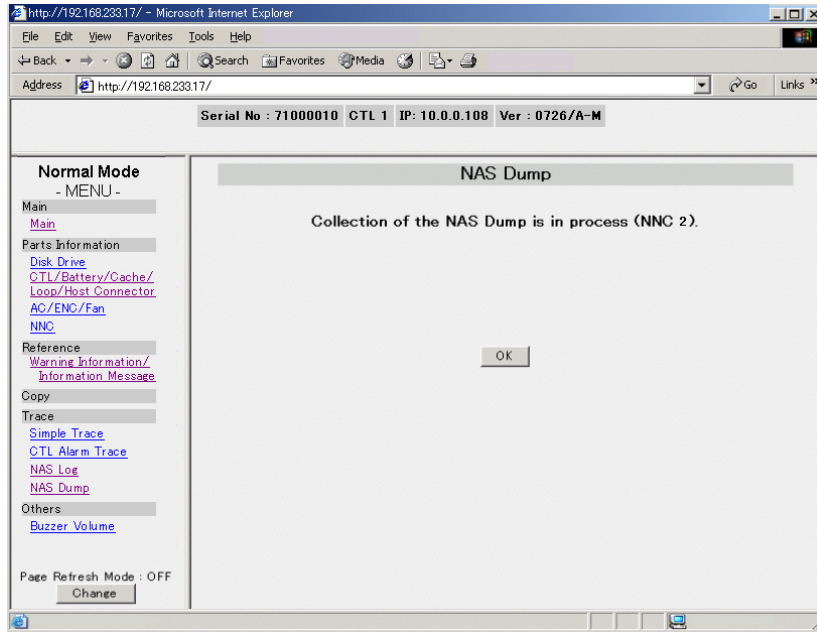

8.7.3.2 Suspension of the NAS Dump Generation

1. Click Canceling collection of the NAS Dump.

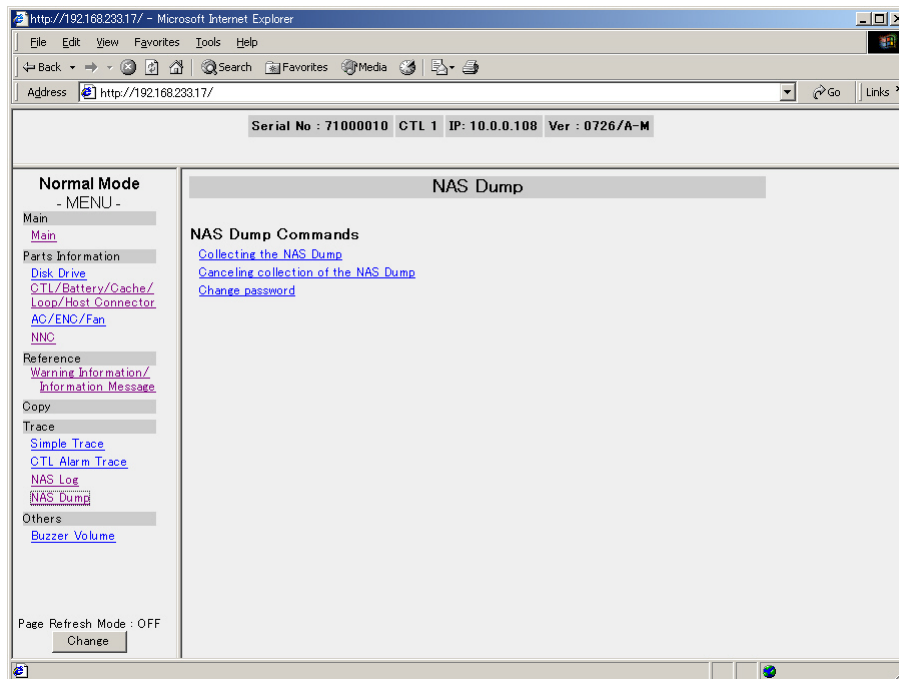

2. Specify the NNC (NAS Unit), which suspends the NAS Dump flushing, as “NNC Number”, and click Set.

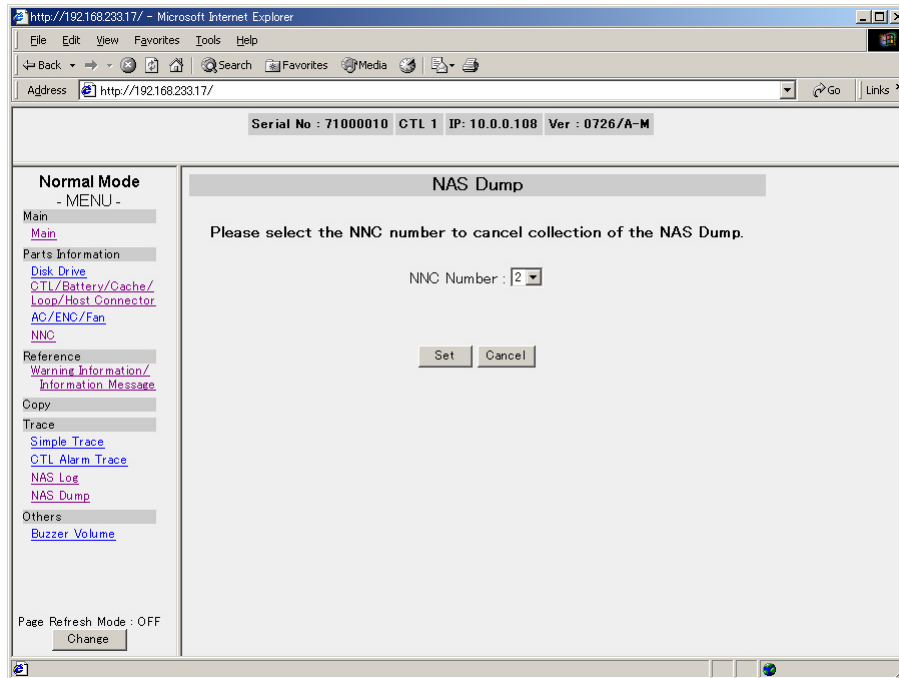

3. The message box displays. Click OK.



4. A suspension completion window is displayed. Click OK.

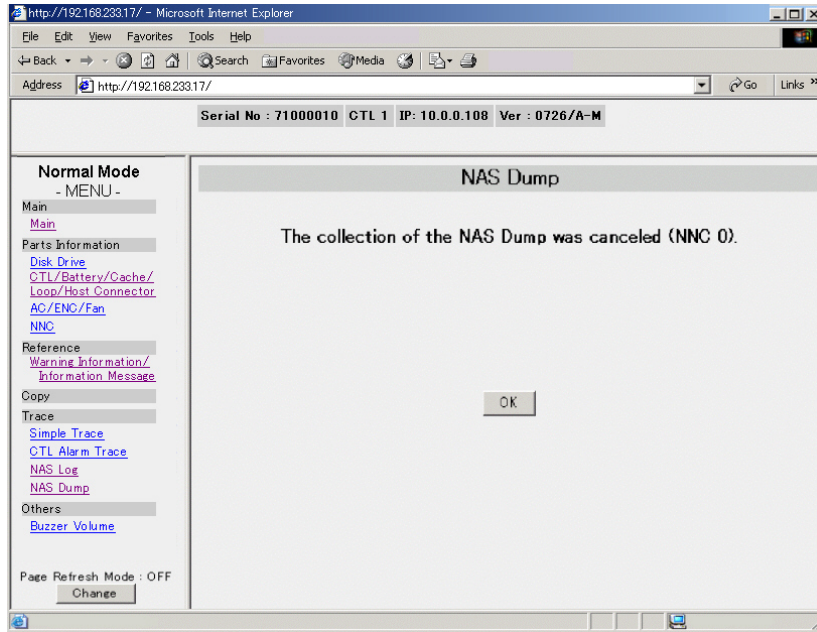

8.7.3.3 Registration and Change of the Password

1. Click Change password.

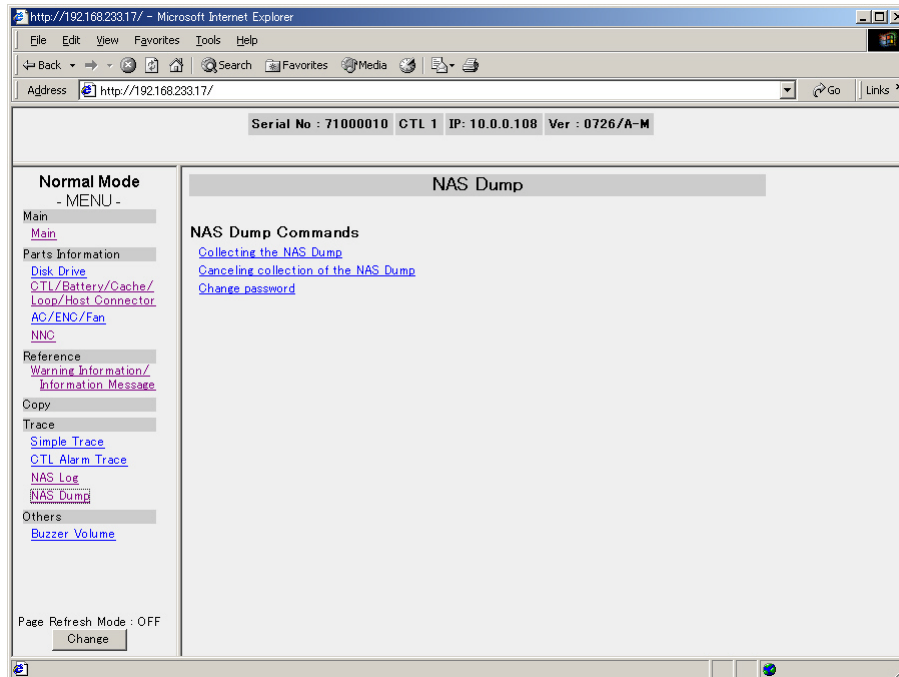

2. Input the **Old Password**, **New Password** and **Re-enter New Password** (one to eight digits in half size alphanumeric character) and then click **OK**.

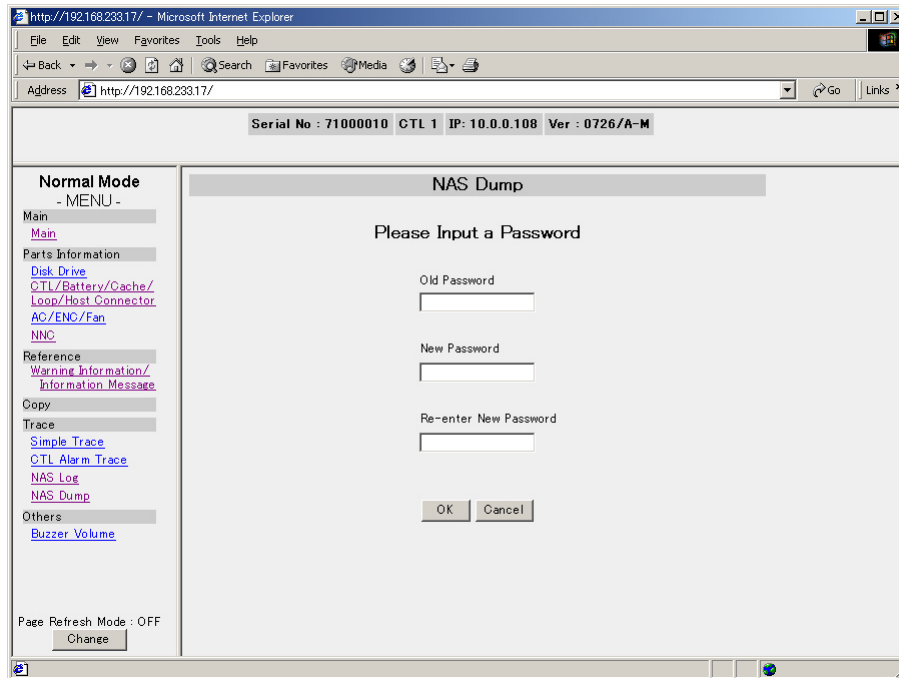

3. The window, indicating the completion of the password registration, is displayed. Click **OK**.

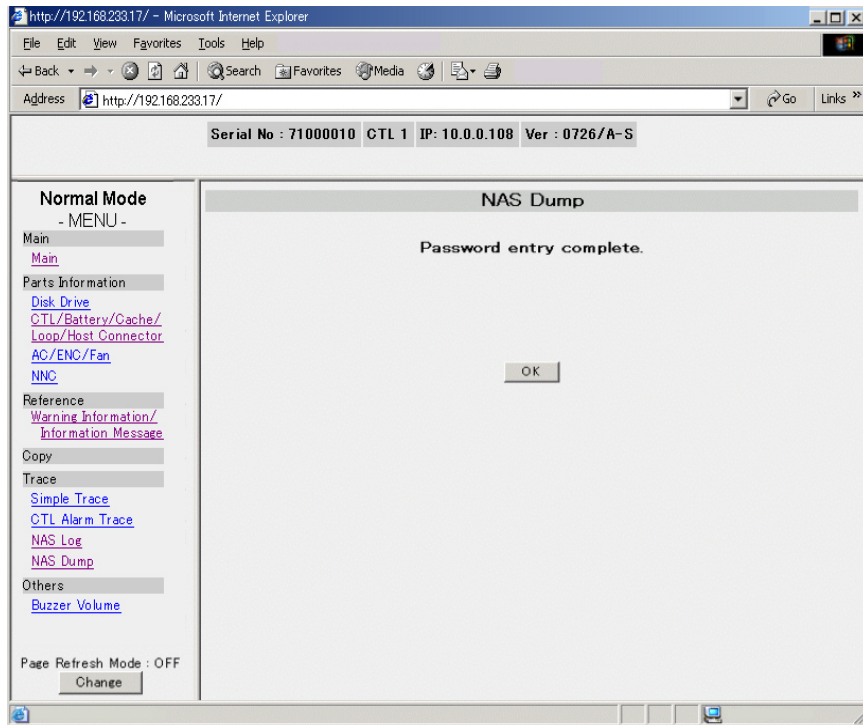

8.8 Determining Network Side Failure of an iSCSI System

One of the following or two or more items are considered to be the causes that the host computer cannot communicate with the disk array subsystem. Check the validity of each item, and take necessary actions if there is any problem.

- The link status of LAN port in host computer is normal.
- All the Network peripherals (Switch, router, and NIC etc.) are powered on. If not, turn on the power.
- All the LAN cables between host computer and disk array subsystem are connected to the connector. If the LAN cable is connected loosely, connect it tightly.
- The port transfer rate of the HBA, Switch or NIC connected to the disk array subsystem is 1 Gbps. The port transfer rate of the disk array subsystem is 1 Gbps rate, and the communication mode is full-duplex.
- The VLAN setting is correct.
- The firewall setting is correct.
- The setting for L3 Switch or router is correct.
- The setting for the iSCSI driver of host computer is correct.
- The IPsec of the host computer is disabled for the iSCSI port of the disk array subsystem. The IPsec of the host computer needs to be disabled for the iSCSI port of the disk array subsystem.

- The setting of the IP address, subnet mask, default gateway and MTU value for both the disk array subsystem and the host computer meets the network. The MTU value needs to be set as the same value for all the devices (host computer, Switch, disk array subsystem, etc.) in the LAN network. The MTU value of DF700 is static and it is 1,500.
- The host computer recognizes the iSCSI driver.
- Doesn't it login with the correct IP address or the correct iSCSI Name of the Target is executed by the host computer.
- The TCP Port number of the iSCSI port of the subsystem is set correctly in the host computer.
- The "Discovery "and "Login" are executed by the host computer.
- The IP address of the iSNS server is set correctly in the host computer and disk array subsystem when iSCSI System has iSNS server.
- The iSNS server can newly register the information of the iSCSI device (IP address and iSCSI Name, etc.) when iSCSI System has iSNS server.
- The CHAP User of the Initiator is registered in the iSCSI port of the disk array subsystem when the Initiator authentication of the CHAP authentication is applied to the iSCSI System. If not, register the CHAP User of the Initiator newly.
- The Target name (e.g., [000:T000]) of the Target is registered in the CHAP User of the Initiator at the disk array subsystem when the Initiator authentication of the CHAP authentication is applied to the iSCSI System.
- The User Name and its Secret of the Target are set correctly in the host computer when the Initiator authentication of the CHAP authentication is applied to the iSCSI System.
- The iSCSI Name of HBA on the assigned Initiator list of the Initiator at the disk array subsystem is assigned to the Target of the disk array subsystem when Target security of LUN Manager is enabled in the iSCSI port of the disk array subsystem. If not, assign the iSCSI Name of the HBA to the Target.

8.9 Changing the LAN Port Number using the Storage Navigator Modular

When the array subsystem cannot be accessed from the Storage Navigator Modular due to the duplication of the LAN port number, access to the array subsystem will be possible by changing the LAN port number which the Storage Navigator Modular uses.

When "Inspect skinny" option, which is the VoIP function option of Cisco firewall, is enabled, the Storage Navigator Modular cannot access to the array subsystem through the firewall. In this case, it is necessary to change the LAN port number.

8.9.1 Changing the LAN Port Number

- Prerequisites

The LAN port number can be changed by the Storage Navigator Modular only when the prerequisites described below are all satisfied:

- Microprogram Version 0726/E or later
- Storage Navigator Modular Version 2.61 or later
The CLI is not supported in this version.
- The Storage Navigator Modular is available connecting to the LAN port of both control units.

Note: It is possible to change the LAN port number for every control unit from the user port management port.

- Restrictions

The LAN port number cannot be changed in the following conditions:

- While the LAN port to be changed is used in the other application or the failure monitor.
In this case, change the LAN port number after stopping the program that is activated.

- Points of Concern

When using this function, consider the following points:

- Use the number not used in the connected network in the range of 1024 to 49151 for the LAN port number that can be changed.
- When the HiCommand is used, the setting needs to be changed.
- When the initialization of the array subsystem and initial setup of the microprogram are performed, the set LAN port number returns to the initial value(2000).
- When returning the microprogram version to the Version 0726/E or earlier after changing the LAN port number to the number other than 2000, return the LAN port number to 2000, and then return the microprogram version to the Version 0726/E or earlier.

- When returning the Storage Navigator Modular version to the Version 2.61 or earlier after changing the LAN port number to the number other than 2000, return the LAN port number to 2000, and then return the Storage Navigator Modular version to the Version 2.61 or earlier.
- When changing the LAN port number, set the same LAN port number for both control units, and change the port number of all the array subsystems at the site concerned to the same number.
- When the LAN port number set to the array subsystem and the LAN port number described in the services file in the control PC to be connected do not correspond, the control PC cannot be connected to the LAN port of array subsystem. When the control PC cannot be connected to the LAN port of array subsystem after changing the LAN port number, check the LAN port number of the array subsystem and the LAN port number described in the services file in the service PC.

8.9.2 Changing the LAN Port Number

1. On the **Settings** menu, select **Configuration Settings** or click **Configuration Settings** button in the tool bar.
2. Click the **LAN Port Number** tab.

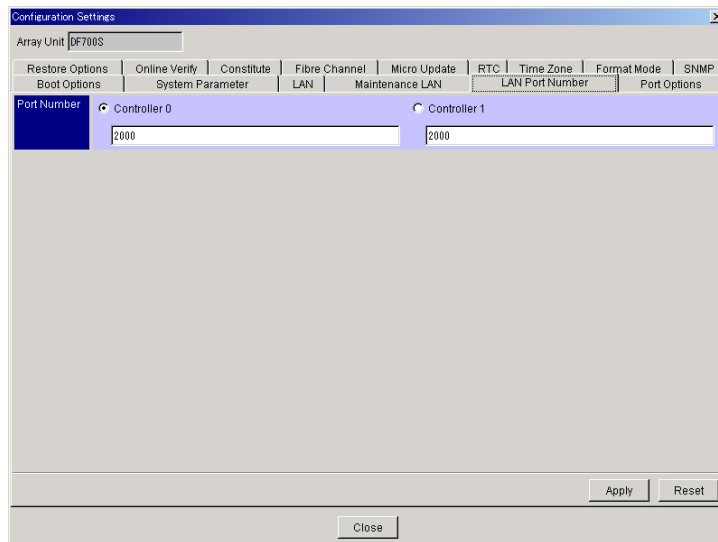
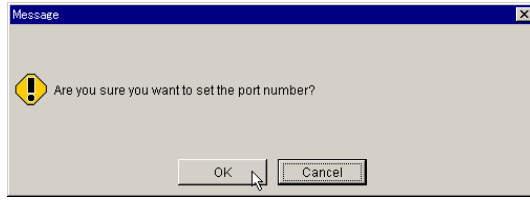
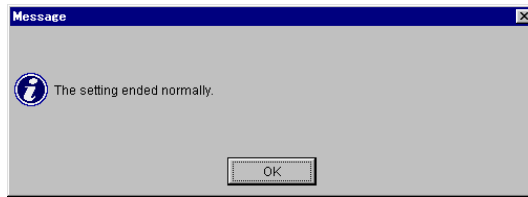

Figure 8.21 LAN Port Number Setting

3. Click the **Controller 1** radio button, enter the port number to be set for the text field. Use the port number that is not used for the OS which activates the Storage Navigator Modular or other applications.
4. Click the **Apply** button.
5. A confirmation message appears, click **OK**.



6. A message indicating completion of setting is displayed. Click **OK**.



7. A confirmation message is displayed. Check that the LAN port number set in the Web browser is correct. Click **OK**.

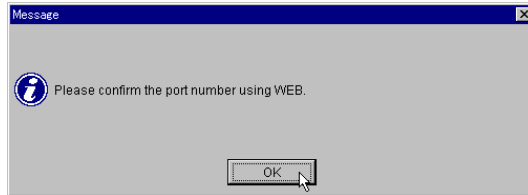

- Confirming the LAN Port Number with Web
 - a) Enter the IP address of the array subsystem in the Web browser.
 - b) Click the LAN Port Number.

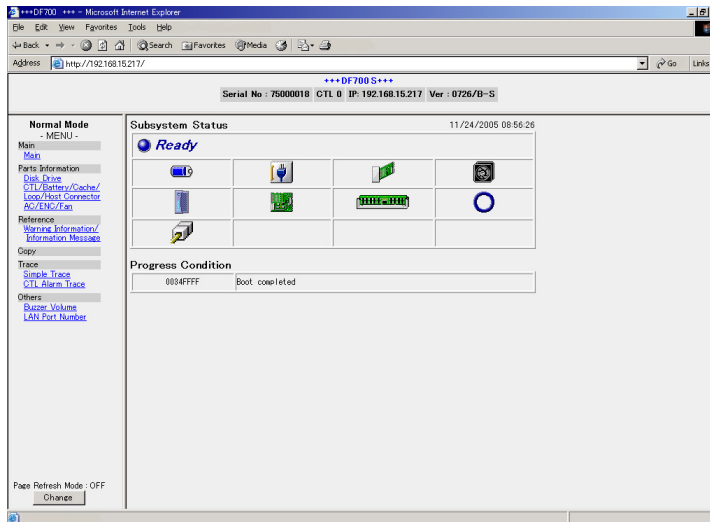

- c) Check that it corresponds with the set LAN port number.

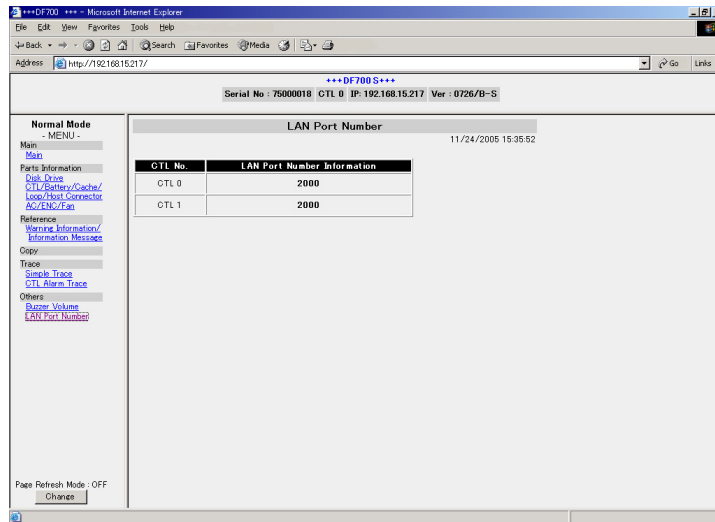

8. A confirmation message appears, click the **Cancel** button.

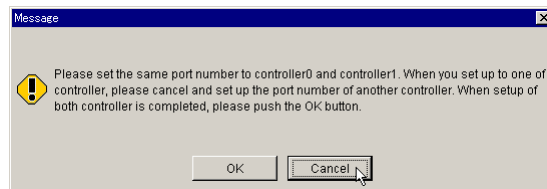

9. Click the **Controller 0** radio button, enter the port number to be set for the text field. Enter the value set for the **Controller1**.

10. A confirmation message appears. Click **OK**.

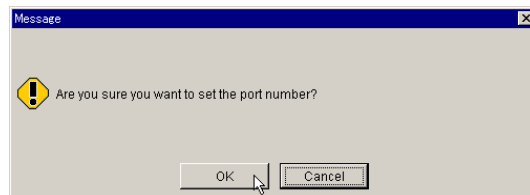

11. A message indicating completion of setting is displayed. Click **OK**.

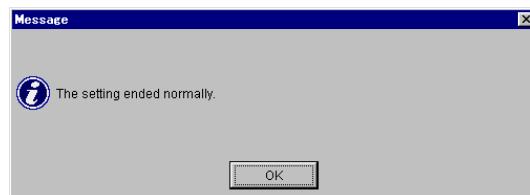

12. A confirmation message is displayed. Check that the LAN port number set in the Web browser is correct.

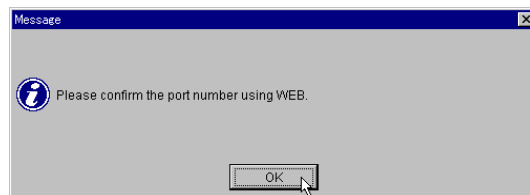

13. A confirmation message appears. Click **OK**.

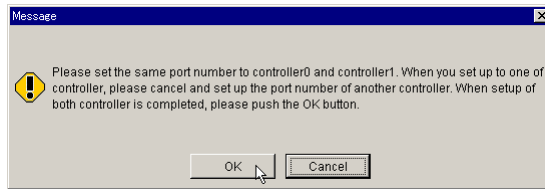

14. A confirmation message appears. Click **OK**.
Unit screen will be closed by clicking **OK**.

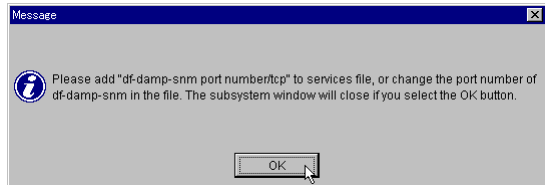

15. Edit the services file, and then check that the Storage Navigator Modular can be activated again.

- Examples of the services file (Windows 2000/XP)

1. Open the services file (For the Windows 2000: C:\WINNT\system32\drivers\etc\services, For Windows XP: C:\WINDOWS\system32\drivers\etc\services) with a text editor such as Widows Notepad.
2. Add the LAN port number which the Storage Navigator Modular uses referencing to the following example, and overwrite and save it.

When adding it to the last line, a return code is required at the end of the input line.

```
# Copyright (c) 1993-1999 Microsoft Corp.
#
# This file contains port numbers for well-known services defined by IANA
#
# Format:
#
# <service name> <port number>/<protocol> [aliases...] [#<comment>]
#
echo          7/tcp
echo          7/udp
:
:
radacct       1813/udp                #RADIUS accounting protocol
df-damp-snm   2001/tcp
fsd           2049/udp   nfs          #NFS server
knetd         2053/tcp                #Kerberos de-multiplexor
man           9535/tcp                #Remote Man Server
```

- Examples of the services file (Unix OS)

1. Open the services file (/etc/services) with a text editor such as vi.
2. Add the LAN port number which the Storage Navigator Modular uses referencing to the following example, and save it.

When adding it to the last line, a return code is required at the end of the input line.

```

# /etc/services:
# $Id: services,v 1.31 2002/04/03 16:53:20 notting Exp $
#
# Network services, Internet style
#
# Note that it is presently the policy of IANA to assign a single well-known
# port number for both TCP and UDP; hence, most entries here have two entries
# even if the protocol doesn't support UDP operations.
# Updated from RFC 1700, ``Assigned Numbers'' (October 1994). Not all ports
# are included, only the more common ones.
#
# The latest IANA port assignments can be gotten from
# http://www.iana.org/assignments/port-numbers
# The Well Known Ports are those from 0 through 1023.
# The Registered Ports are those from 1024 through 49151
# The Registered Ports are those from 1024 through 49151
#
# Each line describes one service, and is of the form:
#
# service-name port/protocol [aliases ...] [# comment]

tcpmux      1/tcp          # TCP port service multiplexer
tcpmux      1/udp          # TCP port service multiplexer
:
:
gdp-port    1997/tcp        # Cisco Gateway Discovery Protocol
gdp-port    1997/udp        # Cisco Gateway Discovery Protocol
df-damp-snm 2001/tcp
nfs         2049/tcp    nfsd
nfs         2049/udp    nfsd

```

8.9.3 Troubleshooting

When a problem occurs during the LAN port number change work, recover it according to the following procedure.

- When the either control unit failed (Or, when the LAN port number for every control unit)
 - In this case, perform the LAN port number setting change connecting a LAN cable only to the control unit to be set.
1. Set the LAN port number of the control unit to be set to the services file. If it is unknown, check it using the Web browser.
 2. Connect a LAN cable only to the control unit to be set, and register it in the Storage Navigator Modular with the IP address of the control concerned.
 3. Start the Storage Navigator Modular.
 4. On the **Settings** menu, select **Configuration Settings** or click **Configuration Settings** button in the tool bar.
 5. Click the **LAN Port Number** tab.
 6. Click the radio button of the control unit to be set, and enter the LAN port number to be set for the text field.
 - It is recommended to set the LAN port number of the other control unit which has already performed the setting change.
 7. Click the **Apply** button.

8. A confirmation message appears. Click **OK**.

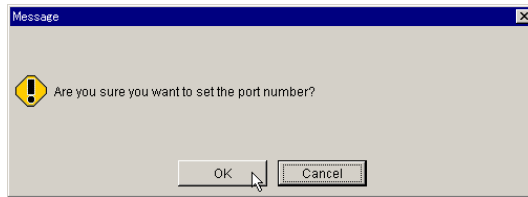

9. A message indicating completion of setting is displayed. Click **OK**.

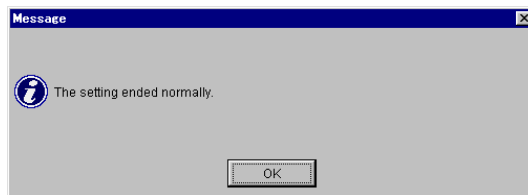

10. A confirmation message is displayed. Check that the LAN port number set in the Web browser is correct.

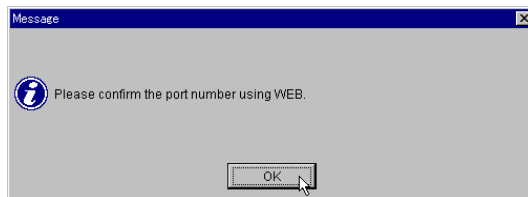

11. A confirmation message appears. Click **OK**.

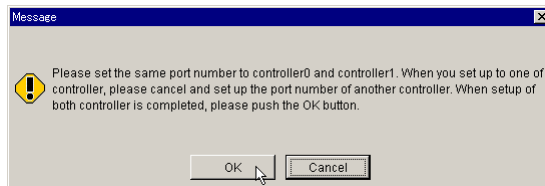

12. A confirmation message appears. Click **OK**.
Unit screen will be closed by clicking **OK**.

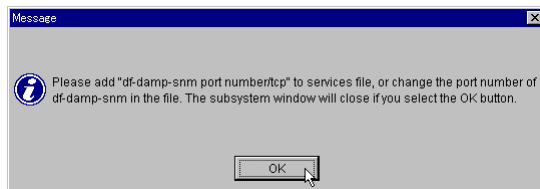

13. Edit the services file to change it to the new LAN port number, and then check that the Storage Navigator Modular can be activated again.

- Although the LAN port number of the services files and the LAN port number set to the array subsystem are same, the Storage Navigator Modular cannot be connected to the array subsystem.
 - Check the LAN port number of the services file and the LAN port number of the array subsystem by the Web browser again.
 - If the Storage Navigator Modular cannot be connected to the array subsystem yet, check the LAN connection such as the IP address or LAN cable.

- The Storage Navigator Modular cannot have already been connected to the array subsystem.
 - Check the LAN port number with a Web browser. If the same LAN port address is set for both control units, register the same LAN port number in the services file, and start the Storage Navigator Modular.
 - If the Storage Navigator Modular cannot be accessed to the array subsystem in spite of the execution of the above operation, the LAN port number may be duplicated with other devices. When this is verified, connect the LAN crossing cable directly to the LAN port of the control unit in the array subsystem, and change the LAN port number setting. Perform the either control unit fail procedure for every control unit.

8.10 8.10 Calling the Hitachi Data Systems Support Center

If you need to call the Hitachi Data Systems Support Center, provide as much information about the problem as possible, including:

- The circumstances surrounding the error or failure.
- The exact content of any error messages displayed on the host system(s).

The worldwide Hitachi Data Systems Support Centers are:

- Hitachi Data Systems North America/Latin America
San Diego, California, USA
1-800-446-0744
- Hitachi Data Systems Europe
Contact Hitachi Data Systems Local Support
- Hitachi Data Systems Asia Pacific
North Ryde, Australia
011-61-2-9325-3300

Chapter 9 Periodic Maintenance

If the subsystem is not energized for longer than six months, the battery may over-discharge and unrecoverable damage may result. In this case, the battery should be charged at least once every six months for longer than six hours. Alternatively, the subsystem can be stored with the switch of the battery turned off. However, even when the switch is turned off, the battery discharges naturally. The battery should be charged once every six months for longer than six hours because spontaneous discharge occurs.

The following Appendices provide information on the Fibre, NAS, and iSCSI models. The following table illustrates sections that provide an explanation for each model.

- **Fibre model:** Connects disk array subsystem to a host computer with Fibre Channel interface.
- **NAS model:** Connects NAS Unit connected to disk array subsystem to a host computer with LAN interface.
- **iSCSI model:** Connects disk array subsystem to a host computer with iSCSI interface.

Sections		Fibre	NAS	iSCSI
Appendix A	Glossary and Acronyms and Abbreviations	○	○	○
Appendix B	System Parameter Setting List	○	–	○
Appendix C	Basic Specifications of the Storage System	○	○	○
Appendix D	D.1 Fibre Channel Connection Specifications	○	–	○
	D.2 Ethernet Connection Specifications	–	○	–
Appendix E	E.1 Remote Adapter Specifications	○	○	○
	E.2 Remote Adapter Dimensions	○	○	○
Appendix F	List of Storage Capacities Corresponding to RAID Levels and Configurations	○	○	○
Appendix G	Port Address Mapping Table	○	–	–
Appendix H	Power Cables	○	○	○
Appendix I	Number of Logical Blocks	○	○	○
Appendix J	Using LUN Security or LUN Management on a Fabric Switch Connection	○	–	–

- : The explanation is provided.
 –: The explanation is not provided.

Acronyms and Abbreviations

Acronym	Expansion
A	Ampere
AL-PA	arbitrated loop-physical address
AMS	Adaptable Modular Storage
API	application programming interface
ASTM	American Society for Testing Materials
ATA	Advanced Technology Attachment standard
ATM	asynchronous transfer mode
BC	business continuity
BS	Basic (power) supply
BSA	bus adapter
BTU	British thermal unit
CCI	command control interface
CEC	Canadian Electroacoustic Community
CFW	cache fast write
CHAP	challenge handshake authentication protocol
CIFS	common internet file system
CKD	count-key data
CLI	command line interface
CSA	Canadian Standards Association
CSV	comma separated value
CTG	consistency group
CTL	controller
CU	controller unit
CUDG	control unit diagnosis
dB(A)	decibel (A-weighted)

D-CNT	default (owner) controller
DAMP	Disk Array Management Program
DDL	data definition language
DHCP	dynamic host configuration protocol
DKC	disk controller unit
DLM	data lifecycle management
DM-LU	differential management logical unit
DRAM	dynamic random access memory
DWDM	dense wavelength division multiplexer
EMI	electromagnetic interference
EPO	emergency power-off
FC	fibre channel
FC-AL	fibre channel-arbitrated loop
FCC	Federal Communications Commission
FCP	fibre-channel protocol
Gbps	gigabit per second
HA	high availability
HACMP	high availability cluster multi-processing
HBA	host bus adapter
HDLM	Hitachi Dynamic Link Manager
HORCM	Hitachi Open Remote Copy Manager
H-LUN	host logical unit
H-RAIN	heterogeneous redundant array of independent nodes
HSN	hierarchical star network
HWM	high water mark
IDE	integrated drive electronics; see also ATA.
IIS	Internet Information Service

IOPS	input output operations per second
IOS	internet work operating system
iSCSI	internet small computer system interface
JRE	Java 2 runtime environment
LCP	local control port
LD	logical device
LDEV	logical device
LDM	logical device manager
LIP	loop initialization primitive
LRU	least recently used
LUN	logical unit number
LUSE	LU size expansion
LVI	logical volume image
LVM	logical volume manager
MCU	main control unit
NDMP	Network Data Management Protocol
MDB	master directory block
MIB	message information block
μP	microprocessor
MR	magneto-resistive
MU	mirror unit
MVS	multiple virtual storage
MVS/ESA	multiple virtual storage /enterprise systems architecture
MVS/XA	multiple virtual storage /extended architecture
NAS	network attached storage
NBU	NetBackup (a Symantec product)
NEC	National Electrical Code

NFS	network file system
NIC	network interface card
NIS	network information service
NNC	network node controller
NSC	network storage controller
NTP	network time protocol
NVS	nonvolatile storage
OCI	Oracle Call Interface
ODM	object data manager
OFC	open fibre control
ORM	online read margin
OSI	open systems interconnection
PCI	power control interface
PDL	product documentation library
PFUS	pool full status
POSIX	portable operating system interface
PPRC	peer-to-peer remote copy
PSUE	pair suspended-error status
PSUS	pair suspended-split
PSUS(N)	pair suspended - not restored status
PV	physical volume
P-VOL	primary volume
RAID	redundant array of independent disks
RC	reference code
RCU	remote control unit
RPO	recovery point objective
RTC	real-time clock

RTO	recovery time objective
SAN	storage-area network
SATA	serial ATA
SCSI	small computer system interface
SIM	service information message
SM	shared memory module
SMB	server message block
SMTP	simple mail transfer protocol
SNIA	Storage Networking Industry Association
SNMP	simple network management protocol
SONET	synchronous optical network
SSL	secure socket layer
SSWS	suspend for swapping S-VOL
S-VOL	secondary volume
TID	target identifier
TPOF	tolerable points of failure
UDP	user diagram protocol
UL	Underwriters' Laboratories
USP	Universal Storage Platform
VCS	Veritas Cluster Server™
VDE	Verband Deutscher Elektrotechniker
VIB	volume information block
VOLID	volume identifier
V-VOL	virtual volume (Snapshot Image)
VxVM	Veritas Volume Manager
WDM	wavelength division multiplexing

Appendix B System Parameter Settings List

The following table lists the parameter settings using the Storage Navigator-Modular.

System Parameter		Description
1	System Startup Attribute	Depends on System Configuration
2	Drive Detach mode enable	Disable (Standard setting)
3	Turbo LU Warning	Disable (Standard setting)
4	Operation if the Processor failures Occurs	Reset a Fault (Standard setting)
5	ROM Microprogram Version	No change is needed
6	RAM Microprogram Version	No change is needed
7	Write & Verify Executing Mode	On (Standard setting)
8	DHCP (Note 2)	OFF (Standard setting)
9	Maintenance Port IP Address	To be set according to the network setting
10	IP Address	To be set according to the network setting
11	Subnet Mask	To be set according to the network setting
12	Default Gateway	To be set according to the network setting
Host Group		
1	LU Mapping Mode	Depends on the System Configuration (Note 1)
Target (Note 3)		
1	LU Mapping Mode	Depends on the System Configuration

Note 1: When the AMS200 is connected, the logical unit which is not wanted to be accessed by the port must be masked by means of the LU mapping mode.

Note 2: When the DHCP mode is validated, the IP Address is acquired from the DHCP server. If the DHCP server is not started up or the DHCP function has been set incorrectly, the acquisition of the IP Address will fail and the IP Address of the subsystem will remain "0.0.0.0". (This is a state in which Storage Navigator-Modular or the Web cannot be used via a LAN.)

Note 3: Effective only when the iSCSI interface is added.

Table B.1 Host Connection Parameters

Host Group Option- Simple Setting						
Platforms	HP-UX					
Alternate Path	None		PV Link		VxVM (Note 1)	
Fail Over	None	MC/ Service Guard	None	MC/ Service Guard	None	
Detail Setting: The following parameters will be selected automatically according to simple setting.						
Host Connection Mode 1 (Select one of these modes)	Standard Mode	✓	✓	✓	✓	✓
	Open VMS Mode					
	Wolfpack Mode					
	TRESPASS Mode					
Host Connection Mode 2 (Multiple selections)	HP-UX Mode					
	PSUE Read Reject Mode					
	UA(06/2A00) Suppress Mode					
	NACA Mode					
	HISUP OFF Mode					
	Reset Propagation Mode					
	Unique Reserve Mode 1					
	ASL Report Mode (Active/Passive Group)					
	ASL Report Mode (Active/Passive)					
	ASL Report Mode (Active/Active)					
	Port ID No Report Mode					
	Port ID Conversion Mode					
	TruCluster Mode					
	Product Serial Response Mode					
	Same Node Name Mode					
CCHS Conversion Mode						
SPC-2 Mode						
Additional Parameter: Select these parameters only when you use the appropriate function. When selected, the following parameters belonged to the appropriate Host Connection Mode will be selected automatically.						
Logical Unit Number more than or equals to 8 can be recognized by HP-	HP-UX Mode (Note 2)					
TrueCopy is used by HP-UX (Note 3)	PSUE Read Reject Mode					
VERITAS Database Edition™/Advanced Cluster for Oracle® RAC (Solaris™) is used	Not Selected					
Egenera® BladeFrame® Is used	Not Selected					

✓: Parameter that is selected automatically by simple setting.

blank: Parameter that is selected manually if needed.

Note: When making the simple setting of the host group options, select items shown on gray backgrounds. Only when using the combination not described in the simple setting, select the required parameter from detail settings.

Note 1: When using VERITAS Volume Manager™ (VxVM), Array Support Library (ASL) for AMS/WMS Series is required. Please download from the Web window of VERITAS®.

Note 2: Up to 256 logical units from logical unit number 0 to logical unit number 255 can be mapped for each host group. However, the maximum number of logical units a server can recognize is different depending on the platform.

Note 3: TrueCopy displayed on parameter means TrueCopy Remote Replication.

Table B.2 Host Connection Parameters

Host Group Option- Simple Setting										
Platforms	Solaris									
Alternate Path	None			HDLM <i>(Note 1)</i>		VxVM <i>(Note 2)</i>		MpxIO <i>(Note 5)</i>		
Fail Over	None	Sun™ Cluster	VCS <i>Note3</i>	None	Sun™ Cluster	None	VCS <i>Note3</i>	None	Sun™ Cluster	
Detail Setting: The following parameters will be selected automatically according to simple setting.										
Host Connection Mode 1 (Select one of these modes)	Standard Mode	✓	✓	✓	✓	✓	✓	✓	✓	✓
	Open VMS Mode									
	Wolfpack Mode									
	TRESPASS Mode									
Host Connection Mode 2 (Multiple selections)	HP-UX Mode									
	PSUE Read Reject Mode									
	UA(06/2A00) Suppress Mode									
	NACA Mode									
	HISUP OFF Mode									
	Reset Propagation Mode									
	Unique Reserve Mode 1									
	ASL Report Mode (Active/Passive Group)									
	ASL Report Mode (Active/Passive)									
	ASL Report Mode (Active/Active)									
	Port ID No Report Mode									
	Port ID Conversion Mode									
	TruCluster Mode									
	Product Serial Response Mode									
	Same Node Name Mode									
CCHS Conversion Mode										
SPC-2 Mode										
Additional Parameter: Select these parameters only when you use the appropriate function. When selected, the following parameters belonged to the appropriate Host Connection Mode will be selected automatically.										
Logical Unit Number more than or equals to 8 can be recognized by HP-UX				Not Selected						
TrueCopy is used by HP-UX <i>(Note 7)</i>				Not Selected						
Host Group Option- Simple Setting										
VERITAS Database Edition/Advanced Cluster for Oracle RAC (Solaris) is used				Not Selected	Unique Reserve Mode 1 <i>(Note 6)</i>	Not Selected	Unique Reserve Mode 1 <i>(Note 6)</i>	Not Selected		
Egenera BladeFrame Is used				Not Selected						

✓: Parameter that is selected automatically by simple setting.
blank: Parameter that is selected manually if needed.

Note: When making the simple setting of the host group options, select items shown on gray backgrounds. Only when using the combination not described in the simple setting, select the required parameter from detail settings.

Note 1: When using Hitachi Dynamic Link Manager (HDLM), take notice of the following:
(1) Vendor ID: If this text is changed, it cannot be managed by HDLM. Do not change this text.
(2) Serial Number: When the multiple storages of same types exist, a different Serial Number needs to be allocated for each disk array subsystem.

Note 2: When using VERITAS Volume Manager (VxVM), Array Support Library (ASL) for AMS/WMS Series is required. Please download from the Web window of VERITAS.

Note 3: VERITAS Cluster Server™.

Note 4: The combination of the Sun Cluster and HDLM needs to set the **Reset Propagation Mode** depending on the HDLM version. Verify the Hardware note of the HDLM, and then set the Reset Propagation Mode from the detail setting.

Note 5: SUN Multi Path (MPxIO).

Note 6: When using VERITAS Storage Foundation For Oracle RAC or the IO fencing function supported from the VCS Ver4.0, the Unique Reserve Mode 1 needs to be set.

Note 7: TrueCopy displayed on parameter means TrueCopy Remote Replication.

Table B.3 Host Connection Parameters

Host Group Option- Simple Setting							
Platforms	AIX®						
Alternate Path	None		HDLM (Note 1)		VxVM (Note 2)		
Fail Over	None	HACMP	None	HACMP	None	VCS (Note 3)	
Detail Setting: The following parameters will be selected automatically according to simple setting.							
Host Connection Mode 1 (Select one of these modes)	Standard Mode	✓	✓	✓	✓	✓	✓
	Open VMS Mode						
	Wolfpack Mode						
	TRESPASS Mode						
Host Connection Mode 2 (Multiple selections)	HP-UX Mode						
	PSUE Read Reject Mode						
	UA(06/2A00) Suppress Mode	✓	✓	✓	✓	✓	✓
	NACA Mode	✓	✓	✓	✓	✓	✓
	HISUP OFF Mode						
	Reset Propagation Mode		✓		✓		
	Unique Reserve Mode 1						
	ASL Report Mode (Active/Passive Group)						
	ASL Report Mode (Active/Passive)						
	ASL Report Mode (Active/Active)						
	Port ID No Report Mode						
	Port ID Conversion Mode						
	TruCluster Mode						
	Product Serial Response Mode						
	Same Node Name Mode						
CCHS Conversion Mode							
SPC-2 Mode							
Additional Parameter: Select these parameters only when you use the appropriate function. When selected, the following parameters belonged to the appropriate Host Connection Mode will be selected automatically.							
Logical Unit Number more than or equals to 8 can be recognized by HP-UX	Not Selected						
TrueCopy is used by HP-UX (Note 5)	Not Selected						
VERITAS Database Edition/Advanced Cluster for Oracle RAC (Solaris) is used	Not Selected					Unique Reserve Mode 1 (Note 4)	
Egenera BladeFrame Is used	Not Selected						

✓: Parameter that is selected automatically by simple setting.

blank: Parameter that is selected manually if needed.

Note: When making the simple setting of the host group options, select items shown on gray backgrounds. Only when using the combination not described in the simple setting, select the required parameter from detail settings.

Note 1: When using Hitachi Dynamic Link Manager (HDLM), take notice of the following:
 (1) Vendor ID: If this text is changed, it cannot be managed by HDLM. Do not change this text.

(2) Serial Number: When the multiple storages of same types exist, a different Serial Number needs to be allocated for each disk array subsystem.

Note 2: When using VERITAS Volume Manager (VxVM), Array Support Library (ASL) for AMS/WMS Series is required. Please download from the Web window of VERITAS.

Note 3: VERITAS Cluster Server.

Note 4: When using VERITAS Storage Foundation For Oracle RAC or the IO fencing function supported from the VCS Ver4.0, the Unique Reserve Mode 1 needs to be set.

Note 5: TrueCopy displayed on parameter means TrueCopy Remote Replication.

Table B.4 Host Connection Parameters

Host Group Option								
Simple Setting								
Platforms	Windows [®] 2000/2003							
Alternate Path	None		HDLM (Note 1)		VxVM (Note 2)			
Fail Over	None	MSCS	None	MSCS	None	VCS	MSCS	
Detail Setting: The following parameters will be selected automatically according to simple setting.								
Host Connection Mode 1 (Select one of these modes)	Standard Mode	✓		✓	✓	✓	✓	✓
	Open VMS Mode							
	Wolfpack Mode		✓					
	TRESPASS Mode							
Host Connection Mode 2 (Multiple selections)	HP-UX Mode							
	PSUE Read Reject Mode							
	UA(06/2A00) Suppress Mode							
	NACA Mode							
	HISUP OFF Mode							
	Reset Propagation Mode		✓		✓		✓	✓
	Unique Reserve Mode 1							
	ASL Report Mode (Active/Passive Group)							
	ASL Report Mode (Active/Passive)							
	ASL Report Mode (Active/Active)							
	Port ID No Report Mode							
	Port ID Conversion Mode							
	TruCluster Mode							
	Product Serial Response Mode							
	Same Node Name Mode							
CCHS Conversion Mode								

Host Group Option							
	SPC-2 Mode						
Additional Parameter: Select these parameters only when you use the appropriate function. When selected, the following parameters belonged to the appropriate Host Connection Mode will be selected automatically.							
Logical Unit Number more than or equals to 8 can be recognized by HP-UX				Not Selected			
TrueCopy is used by Hp-UX (Note 3)				Not Selected			
VERITAS Database Edition/Advanced Cluster for Oracle RAC (Solaris) is used				Not Selected			
Egenera BladeFrame Is used				Not Selected			

✓: Parameter that is selected automatically by simple setting.

blank: Parameter that is selected manually if needed.

Note: When making the simple setting of the host group options, select items shown on gray backgrounds. Only when using the combination not described in the simple setting, select the required parameter from detail settings.

Note 1: When using Hitachi Dynamic Link Manager (HDLM), take notice of the following:

(1) Vendor ID: If this text is changed, it cannot be managed by HDLM. Do not change this text.

(2) Serial Number: When the multiple storages of same types exist, a different Serial Number needs to be allocated for each disk array subsystem.

Note 2: When using VERITAS Volume Manager (VxVM), Array Support Library (ASL) for AMS/WMS Series is required. Please download from the Web window of VERITAS.

Note 3: TrueCopy displayed on parameter means TrueCopy Remote Replication.

Table B.5 Host Connection Parameters

Host Group Option									
Simple Setting									
Platforms	Linux [®]					Tru64		Others Not specified	
Alternate Path	None		HDLM	VxVM (Note 1)		None		None	
Fail Over	None	VCS (Note 2)	None	None	VCS (Note 2)	None	Tru Cluster	None	
Detail Setting: The following parameters will be selected automatically according to simple setting.									
Host Connection Mode 1 (Select one of these modes)	Standard Mode	✓	✓	✓	✓	✓	✓	✓	✓
	Open VMS Mode								
	Wolfpack Mode								
	TRESPASS Mode								
Host Connection Mode 2 (Multiple selections)	HP-UX Mode								
	PSUE Read Reject Mode								
	UA(06/2A00) Suppress Mode								
	NACA Mode								
	HISUP OFF Mode								
	Reset Propagation Mode								
	Unique Reserve Mode 1								
	ASL Report Mode (Active/Passive Group)								
	ASL Report Mode (Active/Passive)								
	ASL Report Mode (Active/Active)								
	Port ID No Report Mode								
	Port ID Conversion Mode								
	TruCluster Mode							✓	
	Product Serial Response Mode								
	Same Node Name Mode								
CCHS Conversion Mode									
SPC-2 Mode									
Additional Parameter: Select these parameters only when you use the appropriate function. When selected, the following parameters belonged to the appropriate Host Connection Mode will be selected automatically.									
Logical Unit Number more than or equals to 8 can be recognized by HP-UX	Not Selected					Not Selected		Not Selected	
TrueCopy is used by Hp-UX (Note 4)	Not Selected					Not Selected		Not Selected	
VERITAS Database Edition/Advanced Cluster for Oracle RAC (Solaris) is used	Not Selected	Unique Reserve Mode (Note 3)	Not Selected	Not Selected	Unique Reserve Mode (Note 3)	Not Selected		Not Selected	
Egenera BladeFrame Is used	Not Selected					Not Selected		Not Selected	

✓: Parameter that is selected automatically by simple setting.

blank: Parameter that is selected manually if needed.

Note: When making the simple setting of the host group options, select items shown on gray backgrounds. Only when using the combination not described in the simple setting, select the required parameter from detail settings.

Note 1: When using VERITAS Volume Manager (VxVM), Array Support Library (ASL) for AMS/WMS Series is required. Please download from the Web window of VERITAS.

Note 2: VERITAS Cluster Server.

Note 3: When using VERITAS Storage Foundation For Oracle RAC or the IO fencing function supported from the VCS Ver4.0, the Unique Reserve Mode 1 needs to be set.

Note 4: TrueCopy displayed on parameter means TrueCopy Remote Replication.

Appendix C Basic Specifications of the Storage System

Basic specifications of AMS200 are shown in this chapter.

The AMS200 basic specifications are listed and described in Table C.1 and Table C.2, and the basic specifications of RKNAS is listed and described in Table C.3 .

Table C.1 AMS200 Floor Model Basic Specifications

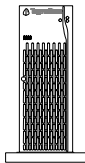
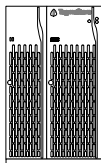
Item		Model	Floor Model		
			Floor (RKS+H1J) Model	Floor (RKS+RKAJ+H2J) Model	Floor (RKS+RKAJAT+H2J) Model
Configuration	Subsystem appearance				
Disk Drive	Disk drive size (W×D×H) (mm)	101.6×146.1×25.4			
	Data capacity (G byte) (Note 1)	71.3/143.3/287.6		RKS: 71.3/143.3/287.6 RKAJAT: 245.7/393.4/ 491.9/737.4	
	Rotational speed (min-1)	10,000/15,000		RKS: 10,000/15,000 RKAJAT: 7,200	
	Maximum mountable quantity (unit)	15	30		
Host Interface	Interface type		2 G bps Fibre Channel Optional (Non-OFC) (Note 3) 1 G bps iSCSI (1000 Base-T) (Note 5)		
	Data transfer speed (i.e. maximum speed for transfer to host)		200 M bytes/s (Fibre Channel) (Note 4) 100 M bytes/s (iSCSI) (Note 5)		
	Number of host connectors	Single controller	Fibre Channel: 2 (Note 2) iSCSI: 2 (Note 5)		
		Dual controller	Fibre Channel: 4 (Note 2) iSCSI: 4 (Note 5)		
	Transferred block size (bytes)		512		

Note 1: The values of storage capacity are calculated as 1 GB = 1,000,000,000 bytes. This definition is different from that (1 KB = 1,024 bytes) shown on the PCs you are using.

Note 2: When FC interface board is not added, one port configures one Mini-HUB, and extends to two host connectors.

When FC interface board is added, control unit implements two ports and two host connectors. One port configures FC interface independent of another port, and implements one host connector.

Note 3: When FC interface board is added, the interface type supports 4 Gbps Fibre Channel Optical (Non-OFC).

Note 4: When FC interface board is added, a maximum data transfer rate can be 400 MB/s (Fibre Channel) depending on the host I/O condition.

Note 5: Indicates the value when the iSCSI interface board is added to the control unit.

Table C.1 AMS200 Floor Model Basic Specifications (Continued)

Item	Model		Floor Model		
			Floor (RKS+H1J) Model	Floor (RKS+RKAJ+H2J) Model	Floor (RKS+RKAJAT+H2J) Model
RAID Specifications (Note 1)	RAID Level (Note 2)		0/1/5/6/1+0		1/5/6/1+0
	RAID Configuration (unit of addition)	RAID 0	2D to 15D	2D to 16D	-
		RAID 1	1D+1D		
		RAID 5	2D+1P to 14D+1P	2D+1P to 15D+1P	
		RAID 6	2D+2P to 13D+2P	2D+2P to 28D+2P	
		RAID 1+0	2D+2D to 7D+7D	2D+2D to 8D+8D	
Internal Logic Specifications	Control CPU		Power PC7447A (500 M Hz)		
	Control memory		Flash memory: 16 M bytes L2 Cache memory: 512 k bytes SDRAM: 1 G bytes		
	Data assurance method		Data bus: Parity Cache memory: ECC (1 bit for correction, 2 bits for detection) Disk drive: Data assurance code		
Physical Specifications	Start-up time (min)		Standard: 3 (Note 8)		
	Chassis size (W×D×H) (mm)		260×737×540	309×737×540	
	Mass (kg) (Note 3)		70 approx.	115 approx.	
	Acoustic noise (dB) (Note 7)		56 approx.	59 approx.	
	Required height (EIA unit)		-		
Input Power Specifications	Input voltage (V)		AC 100/200 (100 to 120/200 to 240)		
	Frequency (Hz)		50/60 ±1		
	Number of phases, cabling		Single-phase with protective grounding		
	Steady-state current (A) (Note 5) (Note 6)		4.0×2/2.0×2	4.0×2+2.6×2/2.0×2+1.3×2	4.0×2+2.4×2/2.0×2+1.2×2
	Breaking current (A)		16.0		
	Heat value (kJ/h)		2,880 or less	4,755 or less	4,610 or less
	Required power (Note 4)	Steady state (VA)	800 or less	1,320 or less	1,280 or less
		Starting state (VA)	800 or less	1,360 or less	1,280 or less

Note 1: D: Data disk, P: Parity disk

Note 2: Although the subsystem with a configuration of RAID6, RAID 5, RAID 1, or RAID 1+0 provides data reliability enhanced by means of redundancy, a possibility remains that user data is lost due to an unexpected failure of a host computer or hardware/software of the subsystem itself. Therefore, users are requested to back up all data for restoration in the event that original data is lost.

In some instances RAID 0+1 is described in place of RAID 1+0, however, it has the same meaning as RAID 1+0.

Note 3: Value of maximum configuration (in cases where all the mountable disk drives and controllers are mounted).

Note 4: Power requirement in the case of the maximum configuration is shown. When planning facilities such as the uninterruptible power supply (UPS) specify the power factor as 100% for calculation. Value at 100 V/200 V is shown.

(Example: 300 W=300 VA)

The actual required power may exceed the value shown in the table when the tolerance is included.

The correct power factor for the AMS200 is “0.90 - 0.96”. The manual incorrectly states the value as “1”.

Note 5: Power current of N×2 described in this table is required for operation by a single power supply unit.

Note 6: When one of the two power supply units fails, another power supply unit requires electric current for the two power supply units. Therefore, plan the power supply facility in which the current carrying capacity of one of the power supply units is a total capacity of the two power supply units.

Note 7: A noise emitted at the time of start is not included.

Note 8: The start-up time may be longer than 3 minutes depending on the configuration.

Table C.1 AMS200 Floor Model Basic Specifications (Continued)

Item		Floor Model		
		Floor (RKS+H1J) Model	Floor (RKS+RKAJ+H2J) Model	Floor (RKS+RKAJAT+H2J) Model
Model				
Cache Specifications	Capacity (M bytes/CTL)	1,024, 2,048		
	Control method	Read LRU/Write after		
	Battery backup	Provided		
	Backup duration (h) <i>(Note 1)</i>	24 (When cache of 2,048 M bytes/CTL)		
Maintenance Specifications/ Antifault Specifications	Spare disk	Up to fifteen of mounted Disk drives can be set to Spare disks		
	Display function	Status LEDs (POWER, READY, WARNING, and ALARM), LED of maintenance part		
Insulation Performance	Insulation withstand voltage	AC 1,500 V (10 mA, 1 min)	AC 1,500 V (100 mA, 1 min)	
	Insulation resistance	DC 500 V, 10 M W or more		

Note 1:

- Non-volatility of data in the cache memory is ensured against power trouble such as a sudden power failure. It transfers data in the Cache memory to disk drives by turning off the power normally and prevents the battery charge from being wasted.
- When the subsystem enters the Cache Backup mode, a warning light (orange LED) informs of a possible voltage drop in the battery when the subsystem is started. It shows that the remaining capacity of the battery is not sufficient, and in this state, the subsystem operates disabling the Write Cache function automatically.



When the battery is charged, the warning indication stops, and the subsystem continues the operation enabling the Write Cache function.

The warning indication stops within a maximum of 6 hours. Even during a warning indication, normal operation is assured. However, the operation is performed in the Write-Through mode and the R/W performance is lowered because the Write Cache function is disabled.

The battery is subject to the effects of environmental temperature; therefore, avoid using a battery in unnecessarily continuous operation at a high temperature.

- If the subsystem is not energized for more than six months, the over discharging of the battery occurs and it may cause the battery and unrecoverable damage. In this case, the battery must be energized more than six hours at least once six months.

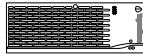
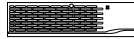
Table C.2 AMS200 Rackmount Model Basic Specifications

Item		Model	Rackmount Model		
			RKS	RKAJ	RKAJAT
Configuration	Configuration		1 RKS	1 RKAJ	1 RKAJAT
	Subsystem appearance				
Disk Drive	Disk drive size		101.6×146.1×25.4		
	Data capacity (G byte) (Note 1)		71.3/143.3/287.6		245.7/393.4/491.9/737.4
	Rotational speed (min ⁻¹)		10,000/15,000		7,200
	Maximum mountable quantity (unit)		15		
Host Interface	Interface type		2 G bps Fibre Channel Optional (Non-OFC) (Note 3)	-	
			1 G bps iSCSI (1000 Base-T) (Note 5)		
	Data transfer speed (i.e. maximum speed for transfer to host)		200 M bytes/s (Fibre Channel) (Note 4)	-	
			100 M bytes/s (iSCSI) (Note 5)		
	Number of host connectors	Single controller		Fibre Channel: 2 (Note 2)	-
			iSCSI: 2 (Note 5)		
	Dual controller		Fibre Channel: 4 (Note 2)	-	
			iSCSI: 4 (Note 5)		
	Transferred block size (bytes)		512	-	

Note 1: The values of storage capacity are calculated as 1 GB = 1,000,000,000 bytes. This definition is different from that (1 KB = 1,024 bytes) shown on the PCs you are using.

Note 2: When FC interface board is not added, one port configures one Mini-HUB, and extends to two host connectors.

When FC interface board is added, control unit implements two ports and two host connectors. One port configures FC interface independent of another port, and implements one host connector.

Note 3: When FC interface board is added, the interface type supports 4 Gbps Fibre Channel Optical (Non-OFC).

Note 4: When FC interface board is added, a maximum data transfer rate can be 400 MB/s (Fibre Channel) depending on the host I/O condition.

Note 5: Indicates the value when the iSCSI interface board is added to the control unit.

Table C.2 AMS200 Rackmount Model Basic Specifications (Continued)

Item	Model		Rackmount Model		
			RKS	RKAJ	RKAJAT
RAID Specifications (Note 1)	RAID level (Note 2)		0/1/5/6/1+0		1/5/6/1+0
	RAID configuration (unit of addition)	RAID 0	2D to 15D	2D to 16D	
		RAID 1	1D+1D		
		RAID 5	2D+1P to 14D+1P	2D+1P to 15D+1P	
		RAID 6	2D+2P to 13D+2P	2D+2P to 28D+2P	
		RAID 1+0	2D+2D to 7D+7D	2D+2D to 8D+8D	
Internal Logic Specifications	Control CPU		Power PC7447A (500 M Hz)	-	
	Control memory		Flash memory: 16 M bytes L2 Cache memory: 512 k bytes SDRAM: 1 G bytes	-	
	Data assurance method		Data bus: Parity Cache memory: ECC (1 bit for correction, 2 bits for detection) Disk drive: Data assurance code	-	
Physical Specifications	Start-up time (min)		Standard: 3 (Note 8)		
	Chassis size (W×D×H) (mm)		483×650×174	483×650×129	
	Mass (kg) (Note 3)		56 approx.	40 approx.	
	Acoustic noise (dB) (Note 7)		57 approx.	60 approx.	
	Required height (EIA unit)		4	3	
Input Power Specifications	Input voltage (V)		AC 100/200 (100 to 120/200 to 240)		
	Frequency (Hz)		50/60 ±1		
	Number of phases, cabling		Single-phase with protective grounding		
	Steady-state current (A) (Note 5) (Note6)		4.0×2/2.0×2	2.6×2/1.3×2	2.4×2/1.2×2
	Breaking current (A)		16.0	10.0	
	Heat value (kJ/h)		2,880 or less	1,875 or less	1,730 or less
	Required power (Note 4)	Steady state (VA)	800 or less	520 or less	480 or less
		Starting state (VA)	800 or less	560 or less	480 or less

Note 1: D: Data disk, P: Parity disk

Note 2: Although the subsystem with a configuration of RAID6, RAID 5, RAID 1, or RAID 1+0 provides data reliability enhanced by means of redundancy, a possibility remains that user data is lost due to an unexpected failure of a host computer or hardware/software of the subsystem itself. Therefore, users are requested to back up all data for restoration in the event that original data is lost.

In some instances RAID 0+1 is described in place of RAID 1+0, however, it has the same meaning as RAID 1+0.

Note 3: Value of maximum configuration (in cases where all the mountable disk drives and controllers are mounted).

Note 4: Power requirement in the case of the maximum configuration is shown. When planning facilities such as the uninterruptible power supply (UPS) specify the power factor as 100% for calculation. Value at 100 V/200 V is shown.

(Example: 300 W=300 VA)

The actual required power may exceed the value shown in the table when the tolerance is included.

The correct power factor for the AMS200 is "0.90 - 0.96". The manual incorrectly states the value as "1".

Note 5: Power current of N×2 described in this table is required for operation by a single power supply unit.

Note 6: When one of the two power supply units fails, another power supply unit requires electric current for the two power supply units. Therefore, plan the power supply facility in which the current carrying capacity of one of the power supply units is a total capacity of the two power supply units.

Note 7: A noise emitted at the time of start is not included.

Note 8: The start-up time may be longer than 3 minutes depending on the configuration.

Table C.2 AMS200 Rackmount Model Basic Specifications (Continued)

Item		Model	Rackmount Model		
			RKS	RKAJ	RKAJAT
Cache Specifications	Capacity (M bytes/CTL)		1,024, 2,048	-	
	Control method		Read LRU/Write after	-	
	Battery backup		Pro vided	-	
	Backup duration (h) (Note 1)		24 (When cache of 2,048 M bytes/CTL)	-	
Maintenance Specifications/ Antifault Specifications	Spare disk		Up to fifteen of mounted Disk drives can be set to Spare disks		
	Display function		Status LEDs (POWER, READY, WARNING, and ALARM), LED of maintenance part		
Insulation Performance	Insulation withstand voltage		AC 1,500 V (10 mA, 1 min)		
	Insulation resistance		DC 500 V, 10 M W or more		

Note 1:

- Non-volatility of data in the cache memory is ensured against power trouble such as a sudden power failure. It transfers data in the Cache memory to disk drives by turning off the power normally and prevents the battery charge from being wasted.
- When the subsystem enters the Cache Backup mode, a warning light (orange LED) informs of a possible voltage drop in the battery when the subsystem is started. It shows that the remaining capacity of the battery is not sufficient, and in this state, the subsystem operates disabling the Write Cache function automatically.

When the battery is charged, the warning indication stops, and the subsystem continues the operation enabling the Write Cache function.

The warning indication stops within a maximum of 6 hours. Even during a warning indication, normal operation is assured. However, the operation is performed in the Write-Through mode and the R/W performance is lowered because the Write Cache function is disabled.

The battery is subject to the effects of environmental temperature; therefore, avoid using a battery in unnecessarily continuous operation at a high temperature.

- If the subsystem is not energized for more than six months, the over discharging of the battery occurs and it may cause the battery and unrecoverable damage. In this case, the battery must be energized more than six hours at least once six months.

The following table lists and describes the basic specifications of RKNAS.

Table C.3 Basic Specifications of RKNAS

Items		RKNAS Specifications	
Configuration	Configuration	1 RKNAS	
	Subsystem appearance		
Physical specifications	Start-up time (min)	Standard: 3 (Note 2)	
	Chassis size (W×D×H) (mm)	483×650×43	
	Mass (kg)	15 approx.	
	Acoustic noise (dB) (Note 1)	60 approx.	
	Required height (EIA unit)	1	
Input power specifications	Input voltage (V)	AC 100/200 (100 to 120/200 to 240)	
	Frequency (Hz)	50/60 ±1	
	Number of phases, cabling	Single-phase with protective grounding	
	Steady-state current (A)	2.0/1.4	
	Breaking current (A)	10.0	
	Heat value (kJ/h)	1,010 or less	
	Required power (Note 3)	Steady state (VA)	280 or less
		Starting state (VA)	280 or less

Note 1: No noise is emitted during start-up.

Note 2: The start-up time may be longer than 3 minutes depending on the configuration.

Note 3: Power requirement in the case of the maximum configuration is shown. When planning facilities such as the uninterruptible power supply (UPS) specify the power factor as 100% for calculation. Value at 100 V/200 V is shown.

(Example: 300 W=300 VA)

The actual required power may exceed the value shown in the table when the tolerance is included.

The correct power factor for the RKNAS is “0.70 - 0.90”. The manual incorrectly states the value as “1”.

Appendix D Interfaces

Fibre Channel (Non-OFC) and Ethernet connections are used for Interface with the host computer. The AMS200 provides a Fibre Channel interface with the control unit as standard. The NAS unit and iSCSI interface provides an Ethernet interface as standard.

D.1 Fibre Channel Connection Specifications

D.1.1 System Configuration

Connecting the host computer and the AMS200 through the FC-SW enables you to configure a system that is logically connected with more devices than the combined number of ports. However, the maximum number of I/O processing ports for the AMS200 host computer is up to 128.

The maximum number of I/O processing ports for the host computer and TrueCopy remote replication is 128.

When constructing a system with the FC-AL or AC-SW:

- If you use the least Fibre Channel devices connected with a Fibre Channel loop, you will have superior higher performance.
- Since high-speed serial data transfer is performed via Fibre Channel, use high-quality Fibre Channel cables which conform to the FC-PH standard.

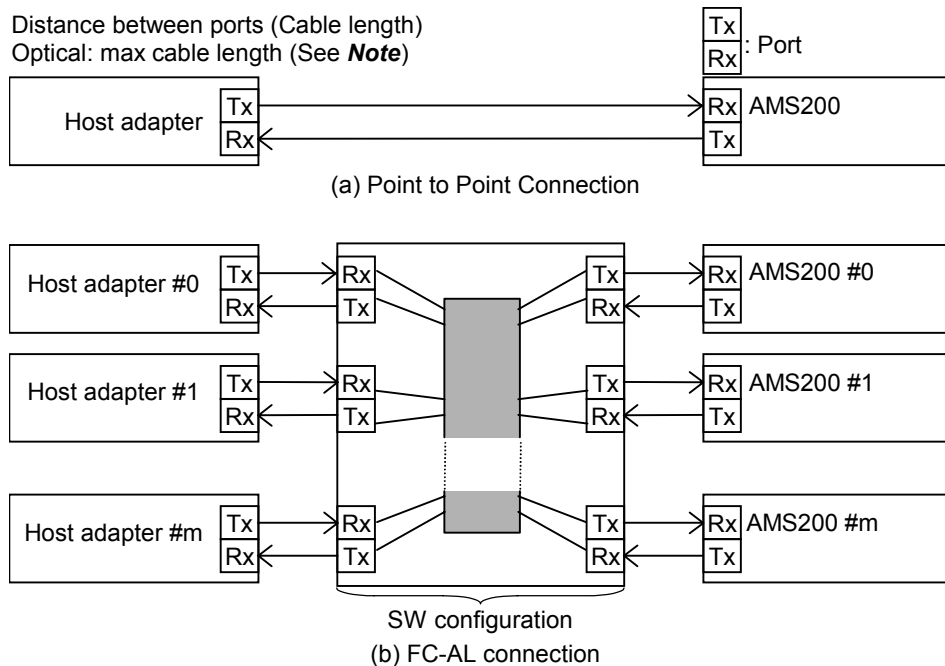

Figure D.1 Fibre Channel Connection Specifications

Note:

Data transfer rate (MB/s)	100	200	400
Max 50/125 μm multimode Fibre Cable length	500 m	300 m	150 m
Max 62.5/125 μm multimode Fibre Cable length	300 m	150 m	70 m

D.1.2 Cable

Table D.1 shows specifications of the Fibre Channel interface cable. Figure D.2 shows the type of connector for the optical interface on the cable side.

Table D.1 Cable Specification

Cable Type	Interface Type	Cable Node Name	Nominal		
			Cable	Connector	
				One Side	Other Side
SC-LC cable	Optical	Equivalent to Sumitomo 3M 170AC-AAAA-XXX	50/125 μm , 62.5/125 μm Multimode Wavelength: 850 nm	SC connector (JIS C 5973)	LC connector
LC-LC cable				LC connector	LC connector

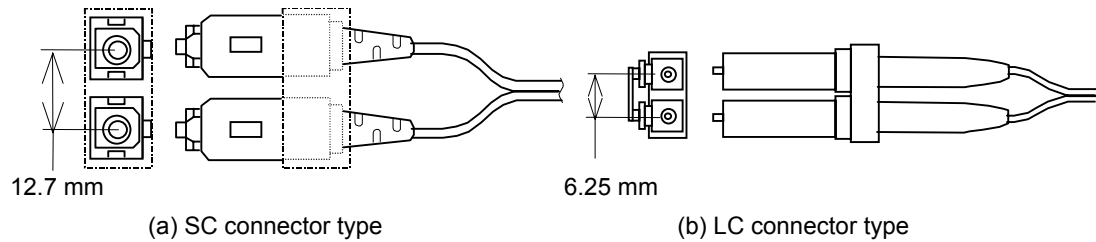

Figure D.2 Cable Side Connector

D.1.3 Connector on Storage System Side

Figure D.3 displays the type of connector for the optical interface on the subsystem side.

- **LC Connector Type:**

Connector type: LC duplex receptacle connector.
Interval: 6.25 mm flat type two rows.

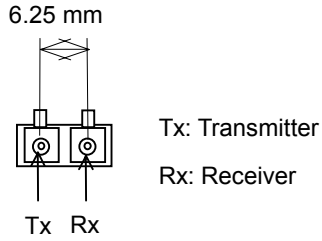

LC connector type

Figure D.3 Connector Shape

D.1.4 Ordered Set

Table D.2 displays the Ordered Sets defined by the Fibre Channel interface.

Table D.2 Ordered Set

No.	Classification	Name
1	Frame Delimiters	SOF (Start of Frame)
2		EOF (End of Frame)
3	Primitive Signals	IDLE
4		R_RDY (Receiver_Ready)
5		ARBx (Arbitrate)
6		OPNyx (Open full-duplex)
7		OPNy (Open half-duplex)
8		OPNfr (Open broadcast replicate)
9		OPNyr (Open selective replicate)
10		CLS (Close)
11		MRKtx (Mark)
12		Primitive Sequence
13	OLS (Off-line)	
14	LR (Link Reset)	
15	LRR (Link Reset Response)	
16	LIP (Loop Initialization)	
17	LPEyx (Loop Port Enable)	
18	LPEfx (Loop Port Enable all)	
19	LPByx (Loop Port Bypass)	

- **Frame Delimiters**

The Frame Delimiter is an Ordered Set that immediately precedes or follows a frame context, and consists of the SOF (Start of Frame) and the EOF (End of Frame).

- **SOF (Start of Frame)**

The SOF delimiter is an Ordered Set that immediately precedes the context of a frame. There are following SOF delimiters, shown in the Table D.3, based on the service class, etc.

Table D.3 SOF Delimiters

No.	Name	Meaning	Remarks
1	SOFc1	A frame delimiter to be used to require the exclusive connection of the Class 1 service. Since the subsystem does not support the Class 1 service yet, it responds with R_RJT (Class not Supported) as to the frame.	—
2	SOFi1	A frame delimiter to be used when starting the sequence following the exclusive connection of the Class 1 service. Since the subsystem does not support the Class 1 service yet, it responds with R_RJT (Class not Supported) as to the frame.	—
3	SOFi2	This is used for the first frame that starts the sequence of the Class 2 service. Since the subsystem does not support the Class 2 service yet, it responds with R_RJT (Class not Supported) as to the frame.	—
4	SOFi3	This is used for the first frame that starts the sequence of the Class 3 service.	—
5	SOFn1	This is used for frames other than the first frame of the sequence of the Class 1 service. Since the subsystem does not support the Class 1 service yet, it responds with R_RJT (Class not Supported) as to the frame.	—
6	SOFn2	This is used for frames other than the first frame of the sequence of the Class 2 service. Since the subsystem does not support the Class 2 service yet, it responds with R_RJT (Class not Supported) as to the frame.	—
7	SOFn3	This is used for frames other than the first frame of the sequence of the Class 3 service.	—

■ **EOF (End of Frame)**

The EOF delimiter is an Ordered Set that immediately follows the context of a frame. There are following EOF delimiters, shown in the Table D.4, based on the service class, etc.

Table D.4 EOF Delimiters

No.	Name	Meaning	Remarks
1	EOFt	This shows that the sequence of the SEQ_ID which is owned by a frame.	—
2	EOFdt	This is used to cancel the exclusive connection. This identifies the final ACK of the sequence and shows that the sequence of the SEQ_ID owned by a frame has completed.	Class 1 is not supported.
3	EOFn	This is used when no other EOF delimiter (EOFt or EOFdt) which shows valid frame contents is required.	—
4	EOFdti	When the EOFdt has illegal contents, it is replaced with the EOFdti.	—
5	EOFni	When the EOFt or EOFn has illegal contents, it is replaced with the EOFni.	—
6	EOFfa	This is used to terminate a partial frame owing to an error occurred during a transfer. A receiver must abandon the frame without making any response.	—

■ **Primitive Signals**

A Primitive Signal a signal that has special meaning. The following Primitive Signals are defined.

IDLE:

An IDLE is a Primitive Signal transmitted on the link to indicate an operational Port facility is ready for frame transmission and reception. The IDLE is transferred when no frame, R_RDY, or primitive sequence is being transferred on a link.

R_RDY (Receiver Ready):

The R_RDY indicates that a single Class 1 connect-request (SOFc1), Class 2, or Class 3 frame was received and that the interface buffer which received the frame is available for further frame reception.

ARBx (Arbitrate) --- FC-AL:

An ARBx is a Primitive Signal transmitted on a Loop by a participating L_Port to request access to the Loop. It may be sent instead of the IDLE when the AMS200 is connected to the FC-AL.

OPNyx (Open full-duplex) --- FC-AL:

An OPNyx is a Primitive Signal transmitted on a Loop by a participating L_Port to indicate that it is ready for Data and Link Control frame transmission and reception.

OPNyy (Open half-duplex) --- FC-AL:

An OPNyy is a Primitive Signal transmitted on a Loop by a participating N_Port to indicate that it is ready for Data and Link Control frame transmission and Link Control frame reception.

OPNfr (Open broadcast replicate) --- FC-AL:

An OPNyy is a Primitive Signal transmitted on a Loop by a participating L_Port which desires to communicate with all participating L_Ports on the Loop.

OPNyr (Open selective replicate) --- FC-AL:

An OPNyr is a Primitive Signal transmitted on a Loop by a participating L_Port which desires to communicate with a subset of L_Ports on the Loop.

CLS (Close) --- FC-AL:

A CLS is sent by the L_Port. When the L_Port sends the CLS, it does not transfer the frame and the R_RDY to the current circuit. The CLS shows that the control of the loop is ready to be abandoned or has already been abandoned.

MRKtx (Mark) --- FC-AL:

A MRKtx is a Primitive Signal transmitting on a Loop by a master control point to synchronize other Nodes.

■ Primitive Sequences

A Primitive sequences form an ordered set and they are transferred repeatedly and continuously while the certain condition exists. Types of the primitive sequence are shown below.

NOS (Not Operational):

The NOS Primitive Sequence is transmitted to indicate that the Port transmitting this Sequence has detected a Link Failure condition or is Off-line, waiting for OLS to be received.

OLS (Off-line):

The OLS Primitive Sequence is transmitted to indicate that the port transmitting this Sequence is:

- Initiating the Link Initialization Protocol,
- Receiving and recognizing NOS, or
- Entering the Off-line State.

LR (Link Reset):

The LR Primitive Sequence is transmitted by a Port to initiate the Link Reset Protocol or to recover from a Link Time-out. Besides, the LR is possible to be sent when the N_Port which supports the Class 1 service becomes unable to decide the connection status.

LRR (Link Reset Response):

The LRR Primitive Sequence is transmitted by a Port to indicate that it is receiving and recognizes the LR Primitive Sequence.

LIP (Loop Initialization) --- FC-AL:

The LIP Primitive Sequence is used by an L_Port to detect if it is part of a Loop or to recover from certain Loop errors.

LPEyx (Loop Port Enable) ---FC-AL:

The LPEyx is sent on the loop to reset the bypass circuit of the L_Port which was bypassed before and to put the L_Port in the enabled status.

LPEfx (Loop Port Enable all) --- FC-AL:

The LPEfx Primitive Sequence is transmitted on a Loop to reset all Bypass Circuit(s) that may have been previously set and enable all L_Port to participate on the Loop.

LPByx (Loop Port Bypass) --- FC-AL:

The LPByx Primitive Sequence is transmitted on a Loop to set the Bypass Circuit and to bypass an L_Port.

D.1.5 Frames

- **Frame Format**

Table D.5 displays the frame format used with Fibre Channel.

Table D.5 Frame Format

Start of Frame (SOF)	Frame Header	Data Field	CRC	End of Frame (EOF)
4 bytes	24 bytes	0 to 2112 bytes	4 bytes	4 bytes

Start of Frame:

The Start of Frame (SOF) delimiter is an Ordered Set that immediately precedes the frame context.

For the types of the SOF, refer to D.1.4).

Frame Header:

The Frame Header is used by the link control facility to control link operations, control device protocol transfers, and detect missing or out of order frames.

Data Field:

This field can take the following size depending on the frame type. (**Note**)

Link control frame: Data Field length = 0.

Data frame: Data Field length = 0 to 2112.

The optional header (**Note**) may be supplied at the top of the Data Field of the data frame.

The data described in the data frame is Data Field excluding the option header.

This portion is called payload.

Note: The frame type and presence or absence of the optional header are prescribed by the Frame Header.

CRC:

The CRC is the Cyclic Redundancy Check code for checking data in the Frame Header and Data Field.

End of Frame:

The End of Frame (EOF) is a frame delimiter for identifying the end of a frame.

- **Header**

The format of the Frame Header is shown in Table D.6.

Table D.6 Frame Format

Bits/Word	31 to 24	23 to 16	15 to 08	07 to 00
0	R_CTL	D_ID		
1	Reserved	S_ID		
2	TYPE	F_CTL		
3	SEQ_ID	DF_CTL	SEQ_CNT	
4	OX_ID		RX_ID	
5	Parameter			

R_CTL (Routing Control):

The R_CTL field is used to categorize the frame function. Classification into the link control frame and data frame is done by the R_CTL.

D_ID (Destination ID):

The D_ID field contains the address identifier of an N_Port or F_Port within the destination entity.

S_ID (Source ID):

The S_ID field contains the address identifier of an N_Port or F_Port within the source entity.

TYPE (Data Structure Type):

The TYPE field identifies the protocol of the frame content for Data Frames.

F_CTL (Frame Control):

The F_CTL field contains control information relating to the frame contents. The control information includes the Exchange Context, Sequence Context, etc.

SEQ_ID (Sequence ID):

The SEQ_ID field contains the SEQ_ID assigned by the Sequence Initiator, and it shall be unique for a specific D_ID and S_ID pair while the Sequence is Open.

DF_CTL (Data Field Control):

The DF_CTL field specifies the presence of optional headers at the beginning of the Data Field.

SEQ_CNT:

The SEQ_CNT field indicates the sequential order of Data Frame transmission within a single sequence or multiple consecutive sequences for the same Exchange.

OX_ID (Originator Exchange ID):

The OX_ID field identifies the Exchange ID assigned by the Originator of the Exchange. Each Exchange shall be assigned an identifier unique to the Originator or Originator-Responder Pair.

RX_ID (Responder Exchange ID):

The RX_ID is an identifier of the exchange assigned by the responder of the exchange. It is unique and locally significant for the responder.

Parameter:

In the link control frame, the parameter is used to transmit original information of the individual link control frame and in the data frame, it is used for the relative offset.

- **Header**

The presence of the Optional Headers is indicated by the DF_CTL field. The treatment of the Optional Headers with the AMS200 is shown in Table D.7.

Table D.7 Frame Format

No.	Name	Usage	Treatment with the Disk Array	Remarks
1	Expiration Security Header	Used to specify the expiration time, etc. of the frame.	Ignores this header and processes the command.	16 bytes
2	Network Header	Used by a bridge or a gateway node which interfaces to an external Network.	Ignores this header and processes the command.	16 bytes
3	Association Header	Used to identify the process or process group.	Ignores this header and processes the command.	32 bytes
4	Device Header	Used by the upper level protocol.	Ignores this header and processes the command.	16 bytes 32 bytes 64 bytes

The AMS200 does not add Optional Headers in a Data frame to be sent to other N_Ports. The host computer shall not add Optional Headers in a frame sent to the AMS200. If the Optional Headers are added in the Data frames sent to the subsystem, correct operation in the AMS200 is not guaranteed.

- **Link Control Frames**

Table D.8 displays the defined Link Control frames (FT-0) and supports Link Control frames. The AMS200 supports link service frames shown in Table D.9.

Table D.8 Link Control Frames

No.	Name	Meaning	Support
1	ACK_1 (Acknowledge_1)	Indicates that a single Data frame is being acknowledged.	○ (<i>Note</i>)
2	ACK_0 (Acknowledge_0)	Indicates that all Data frames of a Sequence are being acknowledged.	×
3	ACK_N (Acknowledge_N)	Indicates that N consecutive Data frames of a Sequence are being acknowledged.	×
4	P_RJT (N_Port Reject)	Indicates that delivery of a frame is being denied. A four byte reject action and reason code is contained in the Parameter field.	○
5	F_RJT (Fabric Reject)	Indicates that delivery of a frame is being denied. A four byte reject action and reason code is contained in the Parameter field.	○
6	P_BSY (N_Port Busy)	Indicates that the responding N_Port is temporarily occupied with other link activity and is not able to accept the frame. A reason code is contained in the Parameter field.	○
7	F_BSY (Fabric Busy)	Indicates that the fabric or the destination N_Port is temporarily occupied with other link activity and the fabric is unable to deliver the frame. A reason code is contained in bits 31-28 of the TYPE field.	○
8	LCR (Link Credit Reset)	Indicates that the N_Port specified by the S_ID requests that the N_Port specified by the D_ID reset any buffers containing Data frames from the S_ID in order to allow the S_ID to reset its end-to-end Credit to its Login value.	○

Note: Support for the ACK_1 is given in the limited case where the PLOGI of the Class 2 is used.

■ **Data Frames**

The Data frames defined include:

- **FC-4 Device_Data** is a frame which is used by the protocol prescribed by upper levels. (FCP Information Unit, etc.)
- **FC-4 Video_Data** is not supported by this equipment.
- **Link_Data** defines link services.

D.1.6 Link Service

Table D.9 Link Service Frames Supported by AMS200

No.	Classification	Name	Support	
			Issue	Receive
1	Basic Link Service	ABTS (Abort Sequence)	×	○
2		BA_ACC (Basic_Accept)	○	○
3		BA_RJT (Basic_Reject)	○	○
4		NOP (No Operation)	×	○
5		RMC (Remove Connection)	×	×
6	Extended Link Service	ABTX (Abort_Exchange)	×	×
7		ACC (Accept)	○	○
8		ADVC (Advice Credit)	×	×
9		ECHO (Echo)	×	×
10		ESTC (Estimate Credit)	×	×
11		PLOGI (N_Port Login)	○	○
12		LOGO (Logout)	○	○
13		LS_RJT (Link Service Reject)	○	○
14		FLOGI (Fabric Login)	○	○
15		RCS (Read Connection Status)	×	×
16		RES (Read Exchange Status Block)	×	×
17		RLS (Read Link Status)	×	○
18		RRQ (Reinstate Recovery Qualifier)	×	○
19		RSI (Request Sequence Initiative)	×	×
20		RSS (Read Sequence Status Block)	×	×
21		RTV (Read Time-out Value)	×	×
22		TEST (Test)	×	×
23		SCR (State Change Registration)	○	×
24		RSCN (Registered Status Change Notification)	○	○
25		FAN	×	○
26	Extended Link Service- Proc.	PRLI (Process Login)	×	○
27		PRLO (Process Logout)	○	○
28		SCN (State Change Notification)	×	×
29		TPLS (Test Process Login State)	×	×

No.	Classification	Name	Support	
			Issue	Receive
30	Extended Link	GAID (Get Alias_ID)	×	×
31	Service-Alias	FACT (Fabric Activate Alias_ID)	×	×
32		FDACT (Fabric Deactivate Alias_ID)	×	×
33		NACT (N_Port Activate Alias_ID)	×	×
34		NDACT (N_Port Deactivate Alias_ID)	×	×
35	Extended Link	QoS (Quality of Service Request)	×	×
36	Service-Class 4	RVCS (Read Virtual Circuit Status)	×	×
37	Extended Link Service - FC-AL	PDISC (Discover N_Port Service Parm)	×	○
38		FDISC (Discover F_Port Service Parm)	×	×
39		ADISC (Discover Address)	×	○
40		TPRLO (Third Party Process Logout)	×	○

D.1.7 FCP

■ Frame Format

AMS200 supports the 6 Information Units (IU) shown in Table D.10.

Table D.10 Information Unit

No.	Name	Meaning	Support
1	FCP_CMND	Transfers SCSI Command or Task Management	○
2	FCP_XFER_READY	Notifies FCP_DATA will be transferred.	○
3	FCP_DATA	Transfers Data.	○
4	FCP_RSP	Transfers Status Information	○
5	FCP_CMND+FCP_DATA	Transfers SCSI Command and the first Data within a single Information Unit. (Write Type Command.)	×
6	FCP_DATA+FCP_RSP	Transfers last Data and the Status Information within a single Information Unit. (Read Type Command.)	×

The format of the standard frame header used in the FCP is shown in Table D.11

Table D.11 Frame Header Format

Bits/Word	31 to 24	23 to 16	15 to 08	07 to 00
0	R_CTL	D_ID		
1	Reserved	S_ID		
2	TYPE	F_CTL		
3	SEQ_ID	DF_CTL	SEQ_CNT	
4	OX_ID		RX_ID	
5	RLTV_OFF			

R_CTL (Routing control):

This is used to identify the information category of the FCP frame.

- 1: FCP_DATA (Data In action, Data Out action).
- 5: FCP_XFER_RDY (Data delivery request).
- 6: FCP_CMND (Command/Task Management Request).
- 7: FCP_RSP (Command/Task Management Response).

D_ID (Destination ID):

This indicates the transmission destination of a frame. D_ID of the frame from the SCSI command issuer side (Exchange originator) is the target ID of SCSI-3.

S_ID:

This indicates the transmission destination of a frame. S_ID of the frame from the SCSI command issuer side (Exchange originator) is the initiator ID of SCSI-3.

TYPE (Data structure type):

In the TYPE field of all frames of the FCP sequence, 0x08 is set.

F_CTL (Frame control):

This consists of fields for controlling start of the sequence and exchange, and normal and abnormal terminations. For further details, refer to the FC-PH standard.

SEQ_ID (Sequence ID):

This indicates an order of the frames in the sequence. For further details, refer to the FC-PH standard.

DF_CTL (Data field control):

This indicates whether there is an optional header or not. The FCP requires no optional header.

OX_ID (Originator exchange ID):

This indicates the exchange ID on the starting side of the exchange (initiator) and corresponds to the tag number of SCSI-3. (0xFFFF cannot be specified.)

RX_ID (Responder exchange ID):

This indicates the exchange ID on the responding side of the exchange (target). Any value may be given to this. The responding side of the exchange can assign a unique value to OX_ID (tag).

RLTV_OFF (Relative offset):

In the FCP-DATA IU, the offset (offset on the buffer allocated by the host) of the top byte of the payload of each frame is set. In other IU frames, 0 is set.

- **FCP_CMND**

The FCP_CMND is sent from a host and is used for the task management instruction such as SCSI command issue and target reset. The payload of FCP_CMND is shown in Table D.12.

Table D.12 FCP_CMND Payload

Field Name	Definition	Size
FCP_LUN	Logical Unit Number	8 bytes
FCP_CNTL	byte 0: Reserved byte 1: Task Codes bit 7 to 3: Reserved bit 2 to 0: Task Attribute 000: SIMPLE_Q 001: HEAD_OF_Q 001: ORDERED_Q 100: ACA_Q (Not Supported) 101: UNTAGGED byte 2: Task Management Flags bit 7: TERMINATE TASK (Not Supported) bit 6: CLEAR ACA bit 5: TARGET RESET bit 4 to 3: Reserved bit 2: CLEAR TASK SET bit 1: ABORT TASK SET bit 0: Reserved byte 3: Execution Management Codes bit 7 to 2: Reserved bit 1: READ DATA bit 0: WRITE DATA	4 bytes
FCP_CDB	SCSI Command Descriptor Block	16 bytes
FCP_DL	Data Length	4 bytes

FCP_LUN:

The FCP_LUN field specifies the Logical Unit Number in which the issued SCSI Command is executed.

Table D.13 shows the format of the FCP_LUN field.

Table D.13 FCP_LUN Format

Byte	0	1	2	3	4	5	6	7
Logical unit number	0x00	LUN (Max.256)	0x00	0x00	0x00	0x00	0x00	0x00

FCP_CNTL:

The FCP_CNTL field contains the following control information.

Task Codes:

One of the following task attributes can be specified:

SIMPLE_QUEUE:

The SIMPLE_QUEUE attribute is specified when the task can be executed with the order that the array controller determines.

HEAD_OF_QUEUE:

The HEAD_OF_QUEUE attribute is specified when the task should be executed with the highest priority.

ORDERED_QUEUE:

The HEAD_OF_QUEUE attribute is specified when the task should be executed with the order of the task is issued.

ACA_QUEUE:

This attribute is not supported by the AMS200.

UNTAGGED:

This attribute shows that a command has no tag.

Task Management Flags:

One of the following Task Management Flags can be specified:

TERMINATE TASK:

This Task Management Flag is not supported by the AMS200.

CLEAR ACA:

Suspend the action of all the commands which is being executed with the Logical Unit from the host, or which is queuing, and then respond to ACA ACTIVE status. Also, release the Logical Unit from the ACA status.

TARGET RESET:

The TARGET RESET is used to clear all tasks in the AMS200. (Same as the SCSI-2 Bus Device Reset message.)

CLEAR TASK SET:

The CLEAR TASK SET is used to clear all tasks in the specified Logical Unit. (Same as the SCSI-2 Clear Queue message.)

ABORT TASK SET:

The ABORT TASK SET is used to clear all tasks in the specified Logical Unit for the Initiator (same as the SCSI-2 Abort message).
The ABORT TASK (same as the SCSI-2 Abort Tag message) is specified by the ABTS Link Service.

Execution Management:

The direction of the SCSI data transfer is specified in the Execution Management. The direction depends on the SCSI Command.

- **FCP_CDB**

The SCSI CDB (Command Descriptor Block) is contained in the FCP_CDB field.

The Command Link is not supported by the array controller. The Link bit shall be set to 0. When one of these bits is set to 1, the array controller terminates the command with a CHECK ONDITION status (Sense Key = ILLEGAL REQUEST).

- **FCP_DL**

The total length bytes of the SCSI data is set in the FCP_DL field. Data described with the number of bytes according to the data length set in the FCP_CDB is transferred irrespective of the value set in this field. The value in this field is checked when the status is sent, and the check result is reflected on the FCP_RSP.

D.1.8 FC-4 Device Data Frame/Name Server Request Commands

Table D.14 displays the FC-4 Device Data Frame/Name Server Request commands that the subsystem supports.

Table D.14 FC-4 Device Data Frame

No.	Name
1	FS_ACC
2	FS_RJT
3	RFT_ID (Register FC-4 TYPE)
4	RCS_ID (Register Class of Service)
5	RPT_ID (Register Port TYPE)
6	GPN_ID (Get Port Name)

D.1.9 Initialization Process

- **Link Initialization**

When the array unit is turned on and becomes ready, the AMS200 performs the Link Initialization process. The LR, LRR, NOS, OLS, and IDLE are exchanged between subsystem and the connected N_Port, and frames cannot be transmitted until the Active state.

The details of the Link Initialization process are shown in the Table D.15.

At the beginning, the AMS200 becomes OLS Transmit state, and the Link Initialization process continues until the Active state.

Table D.15 Link Initialization Process

Current State	Input and Next State					
	LR	LRR	NOS	OLS	IDLE	Los of Sync, Timeout
(OLS Transmit) Transmits OLS for min. 5 ms	(LR Receive)	State is not changed	(NOS Receive)	(OLS Receive)	State is not changed	(Wait for OLS)
(LR Receive) Transmits LRR	State is not changed	(LRR Receive)	(NOS Receive)	(OLS Receive)	(Active)	(NOS Transmit)
(OLS Receive) Transmits LR	(LR Receive)	(LRR Receive)	(NOS Receive)	State is not changed	State is not changed	(Wait for OLS)
(LRR Receive) Transmits IDLE	(LR Receive)	State is not changed	(NOS Receive)	(OLS Receive)	(Active)	(NOS Transmit)
(NOS Receive) Transmits OLS	(LR Receive)	State is not changed	State is not changed	(OLS Receive)	State is not changed	(NOS Transmit)
(Wait for OLS) Transmits NOS	(NOS Transmit)	(NOS Transmit)	(NOS Receive)	(OLS Receive)	State is not changed	State is not changed
(NOS Transmit) Transmits NOS	State is not changed	State is not changed	(NOS Receive)	(OLS Receive)	State is not changed	(NOS Transmit)
(Active)	(LR Receive)	(LRR Receive)	(NOS Receive)	(OLS Receive)	State is not changed	State is not changed

■ **Loop Initialization**

When the array unit is turned on and becomes ready and the Arbitrated Loop is detected, the AMS200 performs the Loop Initialization process.

The Loop Initialization is performed by ARBx (Arbitrate), LIP (Loop Initialization), CLS (Close), and the following Loop Initialization frames:

LISM: Select Master based on 8-byte Port_Name.

LIFA: Fabric Assign AL_PA bit map.

LIPA: Previously Acquired AL_PA bit map.

LIHA: Hard Assigned AL_PA bit map.

LISA: Soft Assigned AL_PA bit map.

LIRP: Report AL_PA position map.

LILP: Loop AL_PA position map.

The AMS200 transmits LIP first. When LIP is detected by the AMS200, the array controller transmits LISM. When the same LISM as the AMS200 has transmitted is received at the array controller, the subsystem becomes a Loop Master, and the subsystem transmits and receives ARBx, LIFA, LIPA, LIHA, LISA, LIRP, and LILP with address map, and determines the AL_PA of each L_Port. At the end of the Loop Initialization, the subsystem transmits and receives CLS.

When the AMS200 does not become a Loop Master, the transmission of LIFA, LIHA, LISA, LIRP, and LILP are initiated by the Loop Master. The AMS200 receives bit map information, and may add own AL_PA, and transmits it to the next L_Port. At the end of the Loop Initialization, the subsystem receives and transmits CLS.

D.1.10 Fibre Channel Sequence Example

- **FCP Information Unit**

Sending all data with one FCP_DATA:

Initiator IU	Direction	Target IU
FCP_CMND	----->	
	<-----	FCP_XFER_READY
	<-----	FCP_DATA
	<-----	FCP_RSP

Sending all data dividing them into two or more FCP_DATAs:

Initiator IU	Direction	Target IU
FCP_CMND	----->	
	<-----	FCP_XFER_READY
	<-----	FCP_DATA
	<-----	FCP_XFER_READY
	<-----	FCP_DATA
	<-----	FCP_XFER_READY
	<-----	FCP_DATA
	<-----	FCP_RSP

At the time of the Read Xfer Ready Disabled:

Initiator IU	Direction	Target IU
FCP_CMND	----->	
	<-----	FCP_XFER_DATA
	<-----	FCP_XFER_DATA
	<-----	FCP_RSP

The FCP_XFER_RDY is not sent before sending the FCP_XFER_DATA.

Write Commands

Sending all data with the one FCP_DATA:

Initiator IU	Direction	Target IU
FCP_CMND	----->	
	<-----	FCP_XFER_READY
FCP_DATA	----->	
	<-----	FCP_RSP

Sending all data with the two or more FCP_DATAs:

Initiator IU	Direction	Target IU
FCP_CMND	----->	
	<-----	FCP_XFER_READY
FCP_DATA	----->	
	<-----	FCP_XFER_READY
FCP_DATA	----->	
	<-----	FCP_XFER_READY
FCP_DATA	----->	
	<-----	FCP_RSP

At the time of the Xfer Ready Disabled (not supported):

Initiator IU	Direction	Target IU
FCP_CMND	----->	
FCP_DATA	----->	
	<-----	FCP_XFER_READY
FCP_DATA	----->	
	<-----	FCP_XFER_READY
FCP_DATA	----->	
	<-----	FCP_RSP

The FCP_XFER_RDY is not sent before sending the first FCP_DATA.

Control Commands

With no data transfer:

Initiator IU	Direction	Target IU
FCP_CMND	----->	
	<-----	FCP_RSP

Queue Full, Busy, and Check Condition (before data transfer):

Initiator IU	Direction	Target IU
FCP_CMND	----->	
	<-----	FCP_RSP

Status such as the Queue Full and Busy are stored in the FCP_RSP.

Task management FCP_CMND (Target, Reset, Clear Task Set, and Abort Task Set):

Initiator IU	Direction	Target IU
FCP_CMND	----->	
	<-----	FCP_RSP

- **Link service**

FLOGI, PLOGI, LOGO, PRLI, and PRLO.

When the command is accepted normally:

LS_Command	Direction	LS_Command
Host Login (PLOGI)	----->	
	<-----	Accept (ACC)

When the command is rejected:

LS_Command	Direction	LS_Command
Host Login (PLOGI)	----->	
	<-----	Link Service Reject (LS_RJT)

- **Loop Initialization**

When the subsystem becomes the loop master:

<AMS200>	Direction	
LIP, LIP	----->	
	<-----	LIP, LIP
LISM, LISM(*1)	----->	
	<-----	LISM, LISM
ARB (F0), ARB (F0)	----->	
	<-----	ARB (F0), ARB (F0)
LIFA	----->	
	<-----	LIFA
LIPA	----->	
	<-----	LIPA
LIHA	----->	
	<-----	LIHA
LISA	----->	
	<-----	LISA
LIRP	----->	
	<-----	LIRP
LILP	----->	
	<-----	LILP
CLS (Close)	----->	

Note 1: The subsystem becomes the loop master when it sends the LISM with AL_PA = EF and the same LISM is returned. The AL_PA is decided by the LIFA, LIPA, LIHA, LISA, LIRP, and LILP frames and the initialization is completed by the CLS.

When another loop master exists:

<AMS200>	Direction	
LIP, LIP	----->	
	<-----	LIP, LIP
LISM, LISM	----->	
	<-----	LISM, LISM
	<-----	ARB (F0), ARB (F0)
ARB (F0), ARB (F0)	----->	
	<-----	LIFA
LIFA	----->	
	<-----	LIPA
LIPA	----->	
	<-----	LIHA
LIHA	----->	
	<-----	LISA
LISA	----->	
	<-----	LIRP
LIRP	----->	
	<-----	LILP
LILP	----->	
	<-----	CLS (Close)

■ Fabric Connection

Table D.16 displays the basic sequence of the frame at the time of start-up when the subsystem is in the fabric connection.

Table D.16 Link Initialization Process

No	Opponent Party	Frame	Direction	Frame	<AMS200>
1	<Fabric>	FAN	→		Is monitoring the PR_TOV timer
			←	FLOGI	S_IDis issued with: PtoP=0x000000 FC_AL=0x0000AL_PA
		ACC	→		
2	<Name Server>		←	PLOGI	Logs in the name server.
		ACC	→		
3	<Name Server>		←	RCS_ID	Registers the support class.
		FS_ACC	→		
4	<Name Server>		←	RFT_ID	Registers the FC-4 type.
		FS_ACC	→		
5	<Name Server>		←	RPT_ID	Registers the type of own port as the N/NL.
		FS_ACC	→		
6	<Fabric Controller>		←	SCR	Receives and registers the RSCN.
		ACC	→		(=3: Full Registration)
7	<Fabric Controller>		←	RSCN	Requires a host computer for an issue of RSCN again. (ADR format = 0
		ACC	→		Affected N_Port ID = Own port address)

- Response when receiving the ELS without the PLOGI.

Table D.17 displays the response made when receiving the ELS without the PLOGI.

Table D.17 Response when Receiving ELS without PLOGI

Frame Received	Response	
	In FC_AL	In Point-to-Point (fabric) Connection
FCP_CMND	No response (frame is abandoned.)	No response (frame is abandoned.)
PLOGI	Usual operation (Response in normal state: ACC Response when an error occurs: LS_RJT)	Usual operation (Response in normal state: ACC Response when an error occurs: LS_RJT)
FLOGI	Response with ACC (N_Port)	Response with ACC (N_Port)
LOGO	Usual operation (Response in normal state: ACC Response when an error occurs: LS_RJT)	Usual operation (Response in normal state: ACC Response when an error occurs: LS_RJT)
PRLI	Response with LOGO	Response with LOGO
PRLO	Response with LOGO	Response with LOGO
ADISC	Response with LOGO	Response with LOGO
PDISC	Response with LOGO	Response with LOGO
TPRLO	Response with LOGO	Response with LOGO
Other	Response with LOGO	Response with LOGO

The following response is made while the basic sequence (FLOGI to RSCN) of the frame is being executed when the subsystem starts up in the fabric connection:

- When the received frame is the FAN, normal operation is done.
- When the received frame is the PLOGI, ADISC, or PDISC, a response is made with the LS_RJT.
- When the other frame is received, no response is made (the frame is abandoned).

D.2 Ethernet Connection Specifications

D.2.1 System Configuration

To configure this NAS system, use the switches complied with the following standards:

IEEE 802.1D STP
 IEEE 802.1w RSTP
 IEEE 802.3 CSMA/CD
 IEEE 802.3u Fast Ethernet
 IEEE 802.3z 1000BaseX
 IEEE 802.1Q Virtual LANs
 IEEE 802.3ad Dynamic LACP

RFC 768 UDP
 RFC 783 TFTP
 RFC 791 IP
 RFC 793 TCP
 RFC 1157 SNMP v1
 RFC 1213 MIB II
 RFC 1757 RMON
 RFC 1901 SNMP v2

- Cable

The following table lists and describes the cable specification for LAN interface and the connector type.

Table D.18 Response when Receiving ELS without PLOGI

Cable Type	Corresponding Transmission Band	Specification	
		Cable	Connector
Category 6	1000BASE-TX	UTP or STP (<i>Note</i>)	RJ-45

Note: HDS recommends that you use an STP cable that suppresses radio noise.

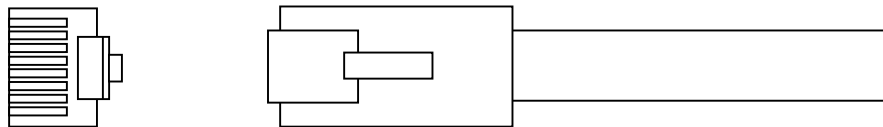

Figure D.4 Connector Type on Cable Side

- Connector Type on the Subsystem Side

The following figure shows the connector type for the LAN interface on the subsystem side.

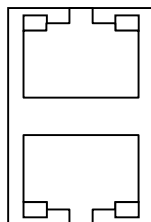

Figure D.5 Connector Type on Subsystem Side

D.2.2 Notes on iSCSI Connection

Do not change the host computer's registry(TCP/IP Stack), use the default value.

Appendix E Remote Adapter Specifications

E.1 Remote Adapter Specifications

Table E.1 Remote Adapter Specifications

Model	Item	Remote Adapter (Main Unit) (DF-F700-VR4A)	Remote Adapter (Hub) (DF-F700-VR4H)
Physical Specifications	Chassis size (W×D×H) (mm)	109×190×42	219×190×42
	Mass (kg)	1	2
Input power	Input voltage (V)	AC 100-120/200-240	
Specifications	Frequency (Hz)	50/60 ±1	
	Number of phases, cabling	Single-phase with protective grounding	
Steady-state current (A)		0.15	
Environmental specifications	Temperature (°C)	In operation: 10 to 40 In non-operation: -10 to 50 In transport/storage: -30 to 60	
	Humidity (%)	In operation: 8 to 80 In non-operation: 8 to 90 In transport/storage: 5 to 100	
	Vibration (m/s ²)	In operation: 2.5 or less (5 to 300Hz) In non-operation: 5.0 or less (5 to 300Hz) In transport/storage: 5.0 or less	
Insulation Performance	Insulation withstand voltage	AC1,500 V (10 mA, 1 min)	
	Insulation resistance	DC500 V, 10 M Ω or more	

E.2 Remote Adapter Dimensions

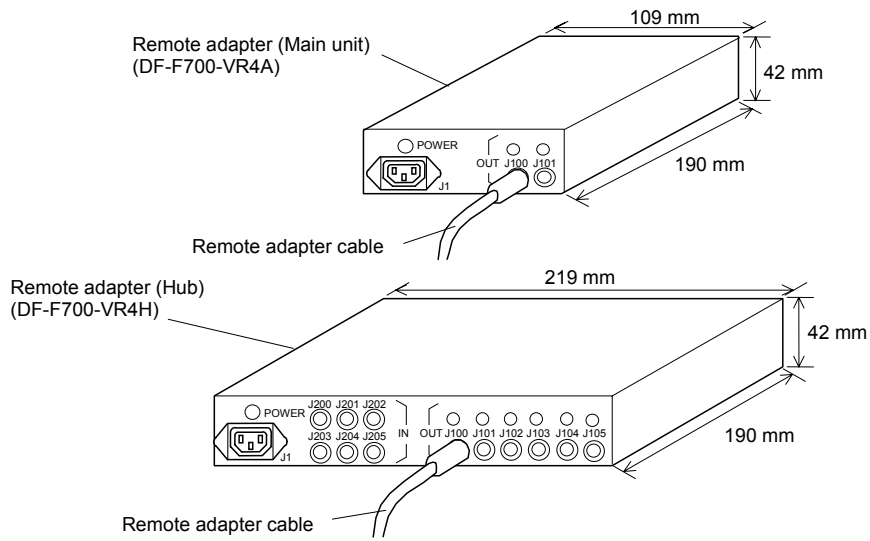

Figure E.1 Remote Adapter Dimensions

Appendix F Storage Capacities Corresponding to RAID Levels and Configurations

The upper and lower values in each cell show the number of mounted disk drives and disk capacity respectively. No spare disk is included.

Note: All values of storage capacities in the following tables are calculated as 1 GB = 1,000,000,000 bytes.

(This definition is different from 1 KB = 1,024 bytes.)

Table F.1 List of Capacities Corresponding to RAID0 (72 GB)

Disk capacity	71.3 GB							
	RKS		RKAJ					
Component unit								
Range	1		1	2	3	4	5	6
Total range of Disk drives	Min.	15 (Max)	30	45	60	75	90	105
2D	2 142.62	14 998.35	30 2139.33	44 3137.69	60 4278.67	74 5277.03	90 6418.01	104 7416.37
3D	3 213.93	15 1069.66	30 2139.33	45 3209.00	60 4278.67	75 5348.34	90 6418.01	105 7487.68
4D	4 285.24	12 855.73	28 1996.71	44 3137.69	60 4278.67	72 5134.41	88 6275.39	104 7416.37
5D	5 356.55	15 1069.66	30 2139.33	45 3209.00	60 4278.67	75 5348.34	90 6418.01	105 7487.68
6D	6 427.86	12 855.73	30 2139.33	42 2995.07	60 4278.67	72 5134.41	90 6418.01	102 7273.74
7D	7 499.17	14 998.35	28 1996.71	42 2995.07	56 3993.43	70 4991.78	84 5990.14	105 7487.68
8D	8 570.49	8 570.49	24 1711.47	40 2852.45	56 3993.43	72 5134.41	88 6275.39	104 7416.37
9D	9 641.80	9 641.80	27 1925.40	45 3209.00	54 3850.80	72 5134.41	90 6418.01	99 7059.81
10D	10 713.11	10 713.11	30 2139.33	40 2852.45	60 4278.67	70 4991.78	90 6418.01	100 7131.12
11D	11 784.42	11 784.42	22 1568.84	44 3137.69	55 3922.11	66 4706.54	88 6275.39	99 7059.81
12D	12 855.73	12 855.73	24 1711.47	36 2567.20	60 4278.67	72 5134.41	84 5990.14	96 6845.88
13D	13 927.04	13 927.04	26 1854.09	39 2781.13	52 3708.18	65 4635.23	78 5562.27	104 7416.37
14D	14 998.35	14 998.35	28 1996.71	42 2995.07	56 3993.43	70 4991.78	84 5990.14	98 6988.50
15D	15 1069.66	15 1069.66	30 2139.33	45 3209.00	60 4278.67	75 5348.34	90 6418.01	105 7487.68
16D	0 0.00	0 0.00	16 1140.98	32 2281.96	48 3422.94	64 4563.92	80 5704.90	96 6845.88

Table F.2 List of Capacities Corresponding to RAID1 (72 GB)

Disk Capacity	71.3 GB							
Component Unit	RKS			RKAJ				
Range	1		1	2	3	4	5	6
Total Range of Disk Drives	Min.	15 (Max)	30	45	60	75	90	105
1D+1D	2 71.31	14 499.17	30 1069.66	44 1568.84	60 2139.33	74 2638.51	90 3209.00	104 3708.18

Table F.3 List of Capacities Corresponding to RAID5 (72 GB)

Disk capacity	71.3 GB							
Component unit	RKS			RKAJ				
Range	1		1	2	3	4	5	6
Total range of Disk drives	Min.	15 (Max)	30	45	60	75	90	105
2D+1P	3 142.62	15 713.11	30 1426.22	45 2139.33	60 2852.45	75 3565.56	90 4278.67	105 4991.78
3D+1P	4 213.93	12 641.80	28 1497.53	44 2353.27	60 3209.00	72 3850.80	88 4706.54	104 5562.27
4D+1P	5 285.24	15 855.73	30 1711.47	45 2567.20	60 3422.94	75 4278.67	90 5134.41	105 5990.14
5D+1P	6 356.55	12 713.11	30 1782.78	42 2495.89	60 3565.56	72 4278.67	90 5348.34	102 6061.45
6D+1P	7 427.86	14 855.73	28 1711.47	42 2567.20	56 3422.94	70 4278.67	84 5134.41	105 6418.01
7D+1P	8 499.17	8 499.17	24 1497.53	40 2495.89	56 3494.25	72 4492.60	88 5490.96	104 6489.32
8D+1P	9 570.49	9 570.49	27 1711.47	45 2852.45	54 3422.94	72 4563.92	90 5704.90	99 6275.39
9D+1P	10 641.80	10 641.80	30 1925.40	40 2567.20	60 3850.80	70 4492.60	90 5776.21	100 6418.01
10D+1P	11 713.11	11 713.11	22 1426.22	44 2852.45	55 3565.56	66 4278.67	88 5704.90	99 6418.01
11D+1P	12 784.42	12 784.42	24 1568.84	36 2353.27	60 3922.11	72 4706.54	84 5490.96	96 6275.39
12D+1P	13 855.73	13 855.73	26 1711.47	39 2567.20	52 3422.94	65 4278.67	78 5134.41	104 6845.88
13D+1P	14 927.04	14 927.04	28 1854.09	42 2781.13	56 3708.18	70 4635.23	84 5562.27	98 6489.32
14D+1P	15 998.35	15 998.35	30 1996.71	45 2995.07	60 3993.43	75 4991.78	90 5990.14	105 6988.50
15D+1P	0 0.00	0 0.00	16 1069.66	32 2139.33	48 3209.00	64 4278.67	80 5348.34	96 6418.01

Table F.4 List of Capacities Corresponding to RAID6 (72 GB)

Disk capacity	71.3 GB							
Component unit	RKS		RKAJ					
Range	1		1	2	3	4	5	6
Total range of Disk drives	Min.	15 (Max)	30	45	60	75	90	105
2D+2P	4 142.62	12 427.86	28 998.35	44 1568.84	60 2139.33	72 2567.20	88 3137.69	104 3708.18
3D+2P	5 213.93	15 641.80	30 1283.60	45 1925.40	60 2567.20	75 3209.00	90 3850.80	105 4492.60
4D+2P	6 285.24	12 570.49	30 1426.22	42 1996.71	60 2852.45	72 3422.94	90 4278.67	102 4849.16
5D+2P	7 356.55	14 713.11	28 1426.22	42 2139.33	56 2852.45	70 3565.56	84 4278.67	105 5348.34
6D+2P	8 427.86	8 427.86	24 1283.60	40 2139.33	56 2995.07	72 3850.80	88 4706.54	104 5562.27
7D+2P	9 499.17	9 499.17	27 1497.53	45 2495.89	54 2995.07	72 3993.43	90 4991.78	99 5490.96
8D+2P	10 570.49	10 570.49	30 1711.47	40 2281.96	60 3422.94	70 3993.43	90 5134.41	100 5704.90
9D+2P	11 641.80	11 641.80	22 1283.60	44 2567.20	55 3209.00	66 3850.80	88 5134.41	99 5776.21
10D+2P	12 713.11	12 713.11	24 1426.22	36 2139.33	60 3565.56	72 4278.67	84 4991.78	96 5704.90
11D+2P	13 784.42	13 784.42	26 1568.84	39 2353.27	52 3137.69	65 3922.11	78 4706.54	104 6275.39
12D+2P	14 855.73	14 855.73	28 1711.47	42 2567.20	56 3422.94	70 4278.67	84 5134.41	98 5990.14
13D+2P	15 927.04	15 927.04	30 1854.09	45 2781.13	60 3708.18	75 4635.23	90 5562.27	105 6489.32
14D+2P	0 0.00	0 0.00	16 998.35	32 1996.71	48 2995.07	64 3993.43	80 4991.78	96 5990.14
15D+2P	0 0.00	0 0.00	17 1069.66	34 2139.33	51 3209.00	68 4278.67	85 5348.34	102 6418.01
16D+2P	0 0.00	0 0.00	18 1140.98	36 2281.96	54 3422.94	72 4563.92	90 5704.90	90 5704.90
17D+2P	0 0.00	0 0.00	19 1212.29	38 2424.58	57 3636.87	57 3636.87	76 4849.16	95 6061.45
18D+2P	0 0.00	0 0.00	20 1283.60	40 2567.20	60 3850.80	60 3850.80	80 5134.41	100 6418.01
19D+2P	0 0.00	0 0.00	21 1354.91	42 2709.82	42 2709.82	63 4064.74	84 5419.65	105 6774.56
20D+2P	0 0.00	0 0.00	22 1426.22	44 2852.45	44 2852.45	66 4278.67	88 5704.90	88 5704.90
21D+2P	0 0.00	0 0.00	23 1497.53	23 1497.53	46 2995.07	69 4492.60	69 4492.60	92 5990.14
22D+2P	0 0.00	0 0.00	24 1568.84	24 1568.84	48 3137.69	72 4706.54	72 4706.54	96 6275.39
23D+2P	0 0.00	0 0.00	25 1640.15	25 1640.15	50 3280.31	75 4920.47	75 4920.47	100 6560.63
24D+2P	0 0.00	0 0.00	26 1711.47	26 1711.47	52 3422.94	52 3422.94	78 5134.41	104 6845.88
25D+2P	0 0.00	0 0.00	27 1782.78	27 1782.78	54 3565.56	54 3565.56	81 5348.34	81 5348.34
26D+2P	0 0.00	0 0.00	28 1854.09	28 1854.09	56 3708.18	56 3708.18	84 5562.27	84 5562.27

Table F.4 List of Capacities Corresponding to RAID6 (72 GB) (Continued)

Disk capacity	71.3 GB							
Component unit	RKS		RKAJ					
Range	1		1	2	3	4	5	6
Total range of Disk drives	Min.	15 (Max)	30	45	60	75	90	105
27D+2P	0 0.00	0 0.00	29 1925.40	29 1925.40	58 3850.80	58 3850.80	87 5776.21	87 5776.21
28D+2P	0 0.00	0 0.00	30 1996.71	30 1996.71	60 3993.43	60 3993.43	90 5990.14	90 5990.14

Table F.5 List of Capacities Corresponding to RAID1+0 (72 GB)

Disk capacity	71.3 GB							
Component unit	RKS		RKAJ					
Range	1		1	2	3	4	5	6
Total range of Disk drives	Min.	15 (Max)	30	45	60	75	90	105
2D+2D	4 142.62	12 427.86	28 998.35	44 1568.84	60 2139.33	72 2567.20	88 3137.69	104 3708.18
3D+3D	6 213.93	12 427.86	30 1069.66	42 1497.53	60 2139.33	72 2567.20	90 3209.00	102 3636.87
4D+4D	8 285.24	8 285.24	24 855.73	40 1426.22	56 1996.71	72 2567.20	88 3137.69	104 3708.18
5D+5D	10 356.55	10 356.55	30 1069.66	40 1426.22	60 2139.33	70 2495.89	90 3209.00	100 3565.56
6D+6D	12 427.86	12 427.86	24 855.73	36 1283.60	60 2139.33	72 2567.20	84 2995.07	96 3422.94
7D+7D	14 499.17	14 499.17	28 998.35	42 1497.53	56 1996.71	70 2495.89	84 2995.07	98 3494.25
8D+8D	0 0.00	0 0.00	16 570.49	32 1140.98	48 1711.47	64 2281.96	80 2852.45	96 3422.94

Table F.6 List of Capacities Corresponding to RAID0 (146 GB)

Disk capacity	143.3 GB							
Component unit	RKS		RKAJ					
Range	1		1	2	3	4	5	6
Total range of Disk drives	Min.	15 (Max)	30	45	60	75	90	105
2D	2 286.61	14 2006.29	30 4299.19	44 6305.49	60 8598.39	74 10604.69	90 12897.59	104 14903.88
3D	3 429.91	15 2149.59	30 4299.19	45 6448.79	60 8598.39	75 10747.99	90 12897.59	105 15047.19
4D	4 573.22	12 1719.67	28 4012.58	44 6305.49	60 8598.39	72 10318.07	88 12610.98	104 14903.88
5D	5 716.53	15 2149.59	30 4299.19	45 6448.79	60 8598.39	75 10747.99	90 12897.59	105 15047.19
6D	6 859.83	12 1719.67	30 4299.19	42 6018.87	60 8598.39	72 10318.07	90 12897.59	102 14617.27
7D	7 1003.14	14 2006.29	28 4012.58	42 6018.87	56 8025.17	70 10031.46	84 12037.75	105 15047.19
8D	8 1146.45	8 1146.45	24 3439.35	40 5732.26	56 8025.17	72 10318.07	88 12610.98	104 14903.88
9D	9 1289.75	9 1289.75	27 3869.27	45 6448.79	54 7738.55	72 10318.07	90 12897.59	99 14187.35
10D	10 1433.06	10 1433.06	30 4299.19	40 5732.26	60 8598.39	70 10031.46	90 12897.59	100 14330.66
11D	11 1576.37	11 1576.37	22 3152.74	44 6305.49	55 7881.86	66 9458.23	88 12610.98	99 14187.35
12D	12 1719.67	12 1719.67	24 3439.35	36 5159.03	60 8598.39	72 10318.07	84 12037.75	96 13757.43
13D	13 1862.98	13 1862.98	26 3725.97	39 5588.95	52 7451.94	65 9314.93	78 11177.91	104 14903.88
14D	14 2006.29	14 2006.29	28 4012.58	42 6018.87	56 8025.17	70 10031.46	84 12037.75	98 14044.04
15D	15 2149.59	15 2149.59	30 4299.19	45 6448.79	60 8598.39	75 10747.99	90 12897.59	105 15047.19
16D	0 0.00	0 0.00	16 2292.90	32 4585.81	48 6878.71	64 9171.62	80 11464.53	96 13757.43

Table F.7 List of Capacities Corresponding to RAID1 (146 GB)

Disk Capacity	143.3 GBs							
Component Unit	RKS		RKAJ					
Range	1		1	2	3	4	5	6
Total Range of Disk Drives	Min.	15 (Max)	30	45	60	75	90	105
1D+1D	2 143.30	14 1003.14	30 2149.59	44 3152.74	60 4299.19	74 5302.34	90 6448.79	104 7451.94

Table F.8 List of Capacities Corresponding to RAID5 (146 GB)

Disk capacity	143.3 GB							
Component unit	RKS		RKAJ					
Range	1		1	2	3	4	5	6
Total range of Disk drives	Min.	15 (Max)	30	45	60	75	90	105
2D+1P	3 286.61	15 1433.06	30 2866.13	45 4299.19	60 5732.26	75 7165.33	90 8598.39	105 10031.46
3D+1P	4 429.91	12 1289.75	28 3009.43	44 4729.11	60 6448.79	72 7738.55	88 9458.23	104 11177.91
4D+1P	5 573.22	15 1719.67	30 3439.35	45 5159.03	60 6878.71	75 8598.39	90 10318.07	105 12037.75
5D+1P	6 716.53	12 1433.06	30 3582.66	42 5015.73	60 7165.33	72 8598.39	90 10747.99	102 12181.06
6D+1P	7 859.83	14 1719.67	28 3439.35	42 5159.03	56 6878.71	70 8598.39	84 10318.07	105 12897.59
7D+1P	8 1003.14	8 1003.14	24 3009.43	40 5015.73	56 7022.02	72 9028.31	88 11034.61	104 13040.90
8D+1P	9 1146.45	9 1146.45	27 3439.35	45 5732.26	54 6878.71	72 9171.62	90 11464.53	99 12610.98
9D+1P	10 1289.75	10 1289.75	30 3869.27	40 5159.03	60 7738.55	70 9028.31	90 11607.83	100 12897.59
10D+1P	11 1433.06	11 1433.06	22 2866.13	44 5732.26	55 7165.33	66 8598.39	88 11464.53	99 12897.59
11D+1P	12 1576.37	12 1576.37	24 3152.74	36 4729.11	60 7881.86	72 9458.23	84 11034.61	96 12610.98
12D+1P	13 1719.67	13 1719.67	26 3439.35	39 5159.03	52 6878.71	65 8598.39	78 10318.07	104 13757.43
13D+1P	14 1862.98	14 1862.98	28 3725.97	42 5588.95	56 7451.94	70 9314.93	84 11177.91	98 13040.90
14D+1P	15 2006.29	15 2006.29	30 4012.58	45 6018.87	60 8025.17	75 10031.46	90 12037.75	105 14044.04
15D+1P	0 0.00	0 0.00	16 2149.59	32 4299.19	48 6448.79	64 8598.39	80 10747.99	96 12897.59

Table F.9 List of Capacities Corresponding to RAID6 (146 GB)

Disk capacity	143.3 GB							
Component unit	RKS		RKAJ					
Range	1		1	2	3	4	5	6
Total range of Disk drives	Min.	15 (Max)	30	45	60	75	90	105
2D+2P	4 286.61	12 859.83	28 2006.29	44 3152.74	60 4299.19	72 5159.03	88 6305.49	104 7451.94
3D+2P	5 429.91	15 1289.75	30 2579.51	45 3869.27	60 5159.03	75 6448.79	90 7738.55	105 9028.31
4D+2P	6 573.22	12 1146.45	30 2866.13	42 4012.58	60 5732.26	72 6878.71	90 8598.39	102 9744.85
5D+2P	7 716.53	14 1433.06	28 2866.13	42 4299.19	56 5732.26	70 7165.33	84 8598.39	105 10747.99
6D+2P	8 859.83	8 859.83	24 2579.51	40 4299.19	56 6018.87	72 7738.55	88 9458.23	104 11177.91
7D+2P	9 1003.14	9 1003.14	27 3009.43	45 5015.73	54 6018.87	72 8025.17	90 10031.46	99 11034.61
8D+2P	10 1146.45	10 1146.45	30 3439.35	40 4585.81	60 6878.71	70 8025.17	90 10318.07	100 11464.53
9D+2P	11 1289.75	11 1289.75	22 2579.51	44 5159.03	55 6448.79	66 7738.55	88 10318.07	99 11607.83
10D+2P	12 1433.06	12 1433.06	24 2866.13	36 4299.19	60 7165.33	72 8598.39	84 10031.46	96 11464.53
11D+2P	13 1576.37	13 1576.37	26 3152.74	39 4729.11	52 6305.49	65 7881.86	78 9458.23	104 12610.98
12D+2P	14 1719.67	14 1719.67	28 3439.35	42 5159.03	56 6878.71	70 8598.39	84 10318.07	98 12037.75
13D+2P	15 1862.98	15 1862.98	30 3725.97	45 5588.95	60 7451.94	75 9314.93	90 11177.91	105 13040.90
14D+2P	0 0.00	0 0.00	16 2006.29	32 4012.58	48 6018.87	64 8025.17	80 10031.46	96 12037.75
15D+2P	0 0.00	0 0.00	17 2149.59	34 4299.19	51 6448.79	68 8598.39	85 10747.99	102 12897.59
16D+2P	0 0.00	0 0.00	18 2292.90	36 4585.81	54 6878.71	72 9171.62	90 11464.53	90 11464.53
17D+2P	0 0.00	0 0.00	19 2436.21	38 4872.42	57 7308.63	57 7308.63	76 9744.85	95 12181.06
18D+2P	0 0.00	0 0.00	20 2579.51	40 5159.03	60 7738.55	60 7738.55	80 10318.07	100 12897.59
19D+2P	0 0.00	0 0.00	21 2722.82	42 5445.65	42 5445.65	63 8168.47	84 10891.30	105 13614.12
20D+2P	0 0.00	0 0.00	22 2866.13	44 5732.26	44 5732.26	66 8598.39	88 11464.53	88 11464.53
21D+2P	0 0.00	0 0.00	23 3009.43	23 3009.43	46 6018.87	69 9028.31	69 9028.31	92 12037.75
22D+2P	0 0.00	0 0.00	24 3152.74	24 3152.74	48 6305.49	72 9458.23	72 9458.23	96 12610.98
23D+2P	0 0.00	0 0.00	25 3296.05	25 3296.05	50 6592.10	75 9888.15	75 9888.15	100 13184.20
24D+2P	0 0.00	0 0.00	26 3439.35	26 3439.35	52 6878.71	52 6878.71	78 10318.07	104 13757.43
25D+2P	0 0.00	0 0.00	27 3582.66	27 3582.66	54 7165.33	54 7165.33	81 10747.99	81 10747.99
26D+2P	0 0.00	0 0.00	28 3725.97	28 3725.97	56 7451.94	56 7451.94	84 11177.91	84 11177.91

Table F.9 List of Capacities Corresponding to RAID6 (146 GB) (Continued)

Disk capacity	143.3 GB							
Component unit	RKS		RKAJ					
Range	1		1	2	3	4	5	6
Total range of Disk drives	Min.	15 (Max)	30	45	60	75	90	105
27D+2P	0 0.00	0 0.00	29 3869.27	29 3869.27	58 7738.55	58 7738.55	87 11607.83	87 11607.83
28D+2P	0 0.00	0 0.00	30 4012.58	30 4012.58	60 8025.17	60 8025.17	90 12037.75	90 12037.75

Table F.10 List of Capacities Corresponding to RAID1+0 (146 GB)

Disk capacity	143.3 GB							
Component unit	RKS		RKAJ					
Range	1		1	2	3	4	5	6
Total range of Disk drives	Min.	15 (Max)	30	45	60	75	90	105
2D+2D	4 286.61	12 859.83	28 2006.29	44 3152.74	60 4299.19	72 5159.03	88 6305.49	104 7451.94
3D+3D	6 429.91	12 859.83	30 2149.59	42 3009.43	60 4299.19	72 5159.03	90 6448.79	102 7308.63
4D+4D	8 573.22	8 573.22	24 1719.67	40 2866.13	56 4012.58	72 5159.03	88 6305.49	104 7451.94
5D+5D	10 716.53	10 716.53	30 2149.59	40 2866.13	60 4299.19	70 5015.73	90 6448.79	100 7165.33
6D+6D	12 859.83	12 859.83	24 1719.67	36 2579.51	60 4299.19	72 5159.03	84 6018.87	96 6878.71
7D+7D	14 1003.14	14 1003.14	28 2006.29	42 3009.43	56 4012.58	70 5015.73	84 6018.87	98 7022.02
8D+8D	0 0.00	0 0.00	16 1146.45	32 2292.90	48 3439.35	64 4585.81	80 5732.26	96 6878.71

Table F.11 List of Capacities Corresponding to RAID0 (300 GB)

Disk capacity	287.6 GB							
Component unit	RKS		RKAJ					
Range	1		1	2	3	4	5	6
Total range of Disk drives	Min.	15 (Max)	30	45	60	75	90	105
2D	2 575.25	14 4026.80	30 8628.85	44 12655.65	60 17257.71	74 21284.51	90 25886.57	104 29913.37
3D	3 862.88	15 4314.42	30 8628.85	45 12943.28	60 17257.71	75 21572.14	90 25886.57	105 30201.00
4D	4 1150.51	12 3451.54	28 8053.60	44 12655.65	60 17257.71	72 20709.25	88 25311.31	104 29913.37
5D	5 1438.14	15 4314.42	30 8628.85	45 12943.28	60 17257.71	75 21572.14	90 25886.57	105 30201.00
6D	6 1725.77	12 3451.54	30 8628.85	42 12080.40	60 17257.71	72 20709.25	90 25886.57	102 29338.11
7D	7 2013.40	14 4026.80	28 8053.60	42 12080.40	56 16107.20	70 20134.00	84 24160.80	105 30201.00
8D	8 2301.02	8 2301.02	24 6903.08	40 11505.14	56 16107.20	72 20709.25	88 25311.31	104 29913.37
9D	9 2588.65	9 2588.65	27 7765.97	45 12943.28	54 15531.94	72 20709.25	90 25886.57	99 28475.23
10D	10 2876.28	10 2876.28	30 8628.85	40 11505.14	60 17257.71	70 20134.00	90 25886.57	100 28762.85
11D	11 3163.91	11 3163.91	22 6327.82	44 12655.65	55 15819.57	66 18983.48	88 25311.31	99 28475.23
12D	12 3451.54	12 3451.54	24 6903.08	36 10354.62	60 17257.71	72 20709.25	84 24160.80	96 27612.34
13D	13 3739.17	13 3739.17	26 7478.34	39 11217.51	52 14956.68	65 18695.85	78 22435.03	104 29913.37
14D	14 4026.80	14 4026.80	28 8053.60	42 12080.40	56 16107.20	70 20134.00	84 24160.80	98 28187.60
15D	15 4314.42	15 4314.42	30 8628.85	45 12943.28	60 17257.71	75 21572.14	90 25886.57	105 30201.00
16D	0 0.00	0 0.00	16 4602.05	32 9204.11	48 13806.17	64 18408.22	80 23010.28	96 27612.34

Table F.12 List of Capacities Corresponding to RAID1 (300 GB)

Disk Capacity	287.6 GB							
Component Unit	RKS			RKAJ				
Range	1		1	2	3	4	5	6
Total Range of Disk Drives	Min.	15 (Max)	30	45	60	75	90	105
1D+1D	2 287.62	14 2013.40	30 4314.42	44 6327.82	60 8628.85	74 10642.25	90 12943.28	104 14956.68

Table F.13 List of Capacities Corresponding to RAID5 (300 GB)

Disk capacity	287.6 GB							
Component unit	RKS			RKAJ				
Range	1		1	2	3	4	5	6
Total range of Disk drives	Min.	15 (Max)	30	45	60	75	90	105
2D+1P	3 575.25	15 2876.28	30 5752.57	45 8628.85	60 11505.14	75 14381.42	90 17257.71	105 20134.00
3D+1P	4 862.88	12 2588.65	28 6040.20	44 9491.74	60 12943.28	72 15531.94	88 18983.48	104 22435.03
4D+1P	5 1150.51	15 3451.54	30 6903.08	45 10354.62	60 13806.17	75 17257.71	90 20709.25	105 24160.80
5D+1P	6 1438.14	12 2876.28	30 7190.71	42 10067.00	60 14381.42	72 17257.71	90 21572.14	102 24448.43
6D+1P	7 1725.77	14 3451.54	28 6903.08	42 10354.62	56 13806.17	70 17257.71	84 20709.25	105 25886.57
7D+1P	8 2013.40	8 2013.40	24 6040.20	40 10067.00	56 14093.80	72 18120.60	88 22147.40	104 26174.20
8D+1P	9 2301.02	9 2301.02	27 6903.08	45 11505.14	54 13806.17	72 18408.22	90 23010.28	99 25311.31
9D+1P	10 2588.65	10 2588.65	30 7765.97	40 10354.62	60 15531.94	70 18120.60	90 23297.91	100 25886.57
10D+1P	11 2876.28	11 2876.28	22 5752.57	44 11505.14	55 14381.42	66 17257.71	88 23010.28	99 25886.57
11D+1P	12 3163.91	12 3163.91	24 6327.82	36 9491.74	60 15819.57	72 18983.48	84 22147.40	96 25311.31
12D+1P	13 3451.54	13 3451.54	26 6903.08	39 10354.62	52 13806.17	65 17257.71	78 20709.25	104 27612.34
13D+1P	14 3739.17	14 3739.17	28 7478.34	42 11217.51	56 14956.68	70 18695.85	84 22435.03	98 26174.20
14D+1P	15 4026.80	15 4026.80	30 8053.60	45 12080.40	60 16107.20	75 20134.00	90 24160.80	105 28187.60
15D+1P	0 0.00	0 0.00	16 4314.42	32 8628.85	48 12943.28	64 17257.71	80 21572.14	96 25886.57

Table F.14 List of Capacities Corresponding to RAID6 (300 GB)

Disk capacity	287.6 GB							
Component unit	RKS		RKAJ					
Range	1		1	2	3	4	5	6
Total range of Disk drives	Min.	15 (Max)	30	45	60	75	90	105
2D+2P	4 575.25	12 1725.77	28 4026.80	44 6327.82	60 8628.85	72 10354.62	88 12655.65	104 14956.68
3D+2P	5 862.88	15 2588.65	30 5177.31	45 7765.97	60 10354.62	75 12943.28	90 15531.94	105 18120.60
4D+2P	6 1150.51	12 2301.02	30 5752.57	42 8053.60	60 11505.14	72 13806.17	90 17257.71	102 19558.74
5D+2P	7 1438.14	14 2876.28	28 5752.57	42 8628.85	56 11505.14	70 14381.42	84 17257.71	105 21572.14
6D+2P	8 1725.77	8 1725.77	24 5177.31	40 8628.85	56 12080.40	72 15531.94	88 18983.48	104 22435.03
7D+2P	9 2013.40	9 2013.40	27 6040.20	45 10067.00	54 12080.40	72 16107.20	90 20134.00	99 22147.40
8D+2P	10 2301.02	10 2301.02	30 6903.08	40 9204.11	60 13806.17	70 16107.20	90 20709.25	100 23010.28
9D+2P	11 2588.65	11 2588.65	22 5177.31	44 10354.62	55 12943.28	66 15531.94	88 20709.25	99 23297.91
10D+2P	12 2876.28	12 2876.28	24 5752.57	36 8628.85	60 14381.42	72 17257.71	84 20134.00	96 23010.28
11D+2P	13 3163.91	13 3163.91	26 6327.82	39 9491.74	52 12655.65	65 15819.57	78 18983.48	104 25311.31
12D+2P	14 3451.54	14 3451.54	28 6903.08	42 10354.62	56 13806.17	70 17257.71	84 20709.25	98 24160.80
13D+2P	15 3739.17	15 3739.17	30 7478.34	45 11217.51	60 14956.68	75 18695.85	90 22435.03	105 26174.20
14D+2P	0 0.00	0 0.00	16 4026.80	32 8053.60	48 12080.40	64 16107.20	80 20134.00	96 24160.80
15D+2P	0 0.00	0 0.00	17 4314.42	34 8628.85	51 12943.28	68 17257.71	85 21572.14	102 25886.57
16D+2P	0 0.00	0 0.00	18 4602.05	36 9204.11	54 13806.17	72 18408.22	90 23010.28	90 23010.28
17D+2P	0 0.00	0 0.00	19 4889.68	38 9779.37	57 14669.05	57 14669.05	76 19558.74	95 24448.43
18D+2P	0 0.00	0 0.00	20 5177.31	40 10354.62	60 15531.94	60 15531.94	80 20709.25	100 25886.57
19D+2P	0 0.00	0 0.00	21 5464.94	42 10929.88	42 10929.88	63 16394.82	84 21859.77	105 27324.71
20D+2P	0 0.00	0 0.00	22 5752.57	44 11505.14	44 11505.14	66 17257.71	88 23010.28	88 23010.28
21D+2P	0 0.00	0 0.00	23 6040.20	23 6040.20	46 12080.40	69 18120.60	69 18120.60	92 24160.80
22D+2P	0 0.00	0 0.00	24 6327.82	24 6327.82	48 12655.65	72 18983.48	72 18983.48	96 25311.31
23D+2P	0 0.00	0 0.00	25 6615.45	25 6615.45	50 13230.91	75 19846.37	75 19846.37	100 26461.83
24D+2P	0 0.00	0 0.00	26 6903.08	26 6903.08	52 13806.17	52 13806.17	78 20709.25	104 27612.34
25D+2P	0 0.00	0 0.00	27 7190.71	27 7190.71	54 14381.42	54 14381.42	81 21572.14	81 21572.14
26D+2P	0 0.00	0 0.00	28 7478.34	28 7478.34	56 14956.68	56 14956.68	84 22435.03	84 22435.03

Table F.14 List of Capacities Corresponding to RAID6 (300 GB) (Continued)

Disk capacity	287.6 GB							
Component unit	RKS			RKAJ				
Range	1		1	2	3	4	5	6
Total range of Disk drives	Min.	15 (Max)	30	45	60	75	90	105
27D+2P	0 0.00	0 0.00	29 7765.97	29 7765.97	58 15531.94	58 15531.94	87 23297.91	87 23297.91
28D+2P	0 0	0 0.00	30 8053.60	30 8053.60	60 16107.20	60 16107.20	90 24160.80	90 24160.80

Table F.15 List of Capacities Corresponding to RAID1+0 (300 GB)

Disk capacity	287.6 GBs							
Component unit	RKS			RKAJ				
Range	1		1	2	3	4	5	6
Total range of Disk drives	Min.	15 (Max)	30	45	60	75	90	105
2D+2D	4 575.25	12 1725.77	28 4026.80	44 6327.82	60 8628.85	72 10354.62	88 12655.65	104 14956.68
3D+3D	6 862.88	12 1725.77	30 4314.42	42 6040.20	60 8628.85	72 10354.62	90 12943.28	102 14669.05
4D+4D	8 1150.51	8 1150.51	24 3451.54	40 5752.57	56 8053.60	72 10354.62	88 12655.65	104 14956.68
5D+5D	10 1438.14	10 1438.14	30 4314.42	40 5752.57	60 8628.85	70 10067.00	90 12943.28	100 14381.42
6D+6D	12 1725.77	12 1725.77	24 3451.54	36 5177.31	60 8628.85	72 10354.62	84 12080.40	96 13806.17
7D+7D	14 2013.40	14 2013.40	28 4026.80	42 6040.20	56 8053.60	70 10067.00	84 12080.40	98 14093.80
8D+8D	0 0.00	0 0.00	16 2301.02	32 4602.05	48 6903.08	64 9204.11	80 11505.14	96 13806.17

Table F.16 List of Capacities Corresponding to RAID1 (250 GB)

Disk Capacity	245.7 GBs						
Component Unit	RKAJAT						
Range	1		2	3	4	5	6
Total Range of Disk Drives	Min.	15 (Max)	30	45	60	75	90
1D+1D	2 245.74	14 1720.22	30 3686.18	44 5406.41	60 7372.37	74 9092.59	90 11058.56

Table F.17 List of Capacities Corresponding to RAID5 (250 GB)

Disk capacity	245.7 GB						
Component unit	RKAJAT						
Range	1		2	3	4	5	6
Total range of Disk drives	Min.	15 (Max)	30	45	60	75	90
2D+1P	3 491.49	15 2457.45	30 4914.91	45 7372.37	60 9829.83	75 12287.29	90 14744.75
3D+1P	4 737.23	12 2211.71	28 5160.66	44 8109.61	60 11058.56	72 13270.28	88 16219.23
4D+1P	5 982.98	15 2948.95	30 5897.90	45 8846.85	60 11795.80	75 14744.75	90 17693.70
5D+1P	6 1228.72	12 2457.45	30 6143.64	42 8601.10	60 12287.29	72 14744.75	90 18430.94
6D+1P	7 1474.47	14 2948.95	28 5897.90	42 8846.85	56 11795.80	70 14744.75	84 17693.70
7D+1P	8 1720.22	8 1720.22	24 5160.66	40 8601.10	56 12041.55	72 15481.99	88 18922.43
8D+1P	9 1965.96	9 1965.96	27 5897.90	45 9829.83	54 11795.80	72 15727.74	90 19659.67
9D+1P	10 2211.71	10 2211.71	30 6635.14	40 8846.85	60 13270.28	70 15481.99	90 19905.42
10D+1P	11 2457.45	11 2457.45	22 4914.91	44 9829.83	55 12287.29	66 14744.75	88 19659.67
11D+1P	12 2703.20	12 2703.20	24 5406.41	36 8109.61	60 13516.02	72 16219.23	84 18922.43
12D+1P	13 2948.95	13 2948.95	26 5897.90	39 8846.85	52 11795.80	65 14744.75	78 17693.70
13D+1P	14 3194.69	14 3194.69	28 6389.39	42 9584.09	56 12778.78	70 15973.48	84 19168.18
14D+1P	15 3440.44	15 3440.44	30 6880.88	45 10321.32	60 13761.77	75 17202.21	90 20642.65
15D+1P	0 0.00	0 0.00	16 3686.18	32 7372.37	48 11058.56	64 14744.75	80 18430.94

Table F.18 List of Capacities Corresponding to RAID6 (250 GB)

Disk capacity	245.7 GB						
Component unit	RKAJAT						
Range	1		2	3	4	5	6
Total range of Disk drives	Min.	15 (Max)	30	45	60	75	90
2D+2P	4 491.49	12 1474.47	28 3440.44	44 5406.41	60 7372.37	72 8846.85	88 10812.82
3D+2P	5 737.23	15 2211.71	30 4423.42	45 6635.14	60 8846.85	75 11058.56	90 13270.28
4D+2P	6 982.98	12 1965.96	30 4914.91	42 6880.88	60 9829.83	72 11795.80	90 14744.75
5D+2P	7 1228.72	14 2457.45	28 4914.91	42 7372.37	56 9829.83	70 12287.29	84 14744.75
6D+2P	8 1474.47	8 1474.47	24 4423.42	40 7372.37	56 10321.32	72 13270.28	88 16219.23
7D+2P	9 1720.22	9 1720.22	27 5160.66	45 8601.10	54 10321.32	72 13761.77	90 17202.21
8D+2P	10 1965.96	10 1965.96	30 5897.90	40 7863.87	60 11795.80	70 13761.77	90 17693.70
9D+2P	11 2211.71	11 2211.71	22 4423.42	44 8846.85	55 11058.56	66 13270.28	88 17693.70
10D+2P	12 2457.45	12 2457.45	24 4914.91	36 7372.37	60 12287.29	72 14744.75	84 17202.21
11D+2P	13 2703.20	13 2703.20	26 5406.41	39 8109.61	52 10812.82	65 13516.02	78 16219.23
12D+2P	14 2948.95	14 2948.95	28 5897.90	42 8846.85	56 11795.80	70 14744.75	84 17693.70
13D+2P	15 3194.69	15 3194.69	30 6389.39	45 9584.09	60 12778.78	75 15973.48	90 19168.18
14D+2P	0 0.00	0 0.00	16 3440.44	32 6880.88	48 10321.32	64 13761.77	80 17202.21
15D+2P	0 0.00	0 0.00	17 3686.18	34 7372.37	51 11058.56	68 14744.75	85 18430.94
16D+2P	0 0.00	0 0.00	18 3931.93	36 7863.87	54 11795.80	72 15727.74	90 19659.67
17D+2P	0 0.00	0 0.00	19 4177.68	38 8355.36	57 12533.04	57 12533.04	76 16710.72
18D+2P	0 0.00	0 0.00	20 4423.42	40 8846.85	60 13270.28	60 13270.28	80 17693.70
19D+2P	0 0.00	0 0.00	21 4669.17	42 9338.34	42 9338.34	63 14007.51	84 18676.69
20D+2P	0 0.00	0 0.00	22 4914.91	44 9829.83	44 9829.83	66 14744.75	88 19659.67
21D+2P	0 0.00	0 0.00	23 5160.66	23 5160.66	46 10321.32	69 15481.99	69 15481.99
22D+2P	0 0.00	0 0.00	24 5406.41	24 5406.41	48 10812.82	72 16219.23	72 16219.23
23D+2P	0 0.00	0 0.00	25 5652.15	25 5652.15	50 11304.31	75 16956.47	75 16956.47
24D+2P	0 0.00	0 0.00	26 5897.90	26 5897.90	52 11795.80	52 11795.80	78 17693.70
25D+2P	0 0.00	0 0.00	27 6143.64	27 6143.64	54 12287.29	54 12287.29	81 18430.94
26D+2P	0 0.00	0 0.00	28 6389.39	28 6389.39	56 12778.78	56 12778.78	84 19168.18

Table F.18 List of Capacities Corresponding to RAID6 (250 GB) (Continued)

Disk capacity	245.7 GB						
Component unit	RKAJAT						
Range	1		2	3	4	5	6
Total range of Disk drives	Min.	15 (Max)	30	45	60	75	90
27D+2P	0 0.00	0 0.00	29 6635.14	29 6635.14	58 13270.28	58 13270.28	87 19905.42
28D+2P	0 0.00	0 0.00	30 6880.88	30 6880.88	60 13761.77	60 13761.77	90 20642.65

Table F.19 List of Capacities Corresponding to RAID1+0 (250 GB)

Disk capacity	245.7 GB						
Component unit	RKAJAT						
Range	1		2	3	4	5	6
Total range of Disk drives	Min.	15 (Max)	30	45	60	75	90
2D+2D	4 491.49	12 1474.47	28 3440.44	44 5406.41	60 7372.37	72 8846.85	88 10812.82
3D+3D	6 737.23	12 1474.47	30 3686.18	42 5160.66	60 7372.37	72 8846.85	90 11058.56
4D+4D	8 982.98	8 982.98	24 2948.95	40 4914.91	56 6880.88	72 8846.85	88 10812.82
5D+5D	10 1228.72	10 1228.72	30 3686.18	40 4914.91	60 7372.37	70 8601.10	90 11058.56
6D+6D	12 1474.47	12 1474.47	24 2948.95	36 4423.42	60 7372.37	72 8846.85	84 10321.32
7D+7D	14 1720.22	14 1720.22	28 3440.44	42 5160.66	56 6880.88	70 8601.10	84 10321.32
8D+8D	0 0.00	0 0.00	16 1965.96	32 3931.93	48 5897.90	64 7863.87	80 9829.83

Table F.20 List of Capacities Corresponding to RAID1 (400 GB)

Disk capacity	393.4 GB						
Component unit	RKAJAT						
Range	1		2	3	4	5	6
Total range of Disk drives	Min.	15 (Max)	30	45	60	75	90
1D+1D	2 393.45	14 2754.21	30 5901.88	44 8656.10	60 11803.77	74 14557.99	90 17705.66

Table F.21 List of Capacities Corresponding to RAID5 (400 GB)

Disk capacity	393.4 GB						
Component unit	RKAJAT						
Range	1		2	3	4	5	6
Total range of Disk drives	Min.	15 (Max)	30	45	60	75	90
2D+1P	3 786.91	15 3934.59	30 7869.18	45 11803.77	60 15738.37	75 19672.96	90 23607.55
3D+1P	4 1180.37	12 3541.13	28 8262.64	44 12984.15	60 17705.66	72 21246.80	88 25968.31
4D+1P	5 1573.83	15 4721.51	30 9443.02	45 14164.53	60 18886.04	75 23607.55	90 28329.06
5D+1P	6 1967.29	12 3934.59	30 9836.48	42 13771.07	60 19672.96	72 23607.55	90 29509.44
6D+1P	7 2360.75	14 4721.51	28 9443.02	42 14164.53	56 18886.04	70 23607.55	84 28329.06
7D+1P	8 2754.21	8 2754.21	24 8262.64	40 13771.07	56 19279.50	72 24787.93	88 30296.36
8D+1P	9 3147.67	9 3147.67	27 9443.02	45 15738.37	54 18886.04	72 25181.39	90 31476.74
9D+1P	10 3541.13	10 3541.13	30 10623.40	40 14164.53	60 21246.80	70 24787.93	90 31870.20
10D+1P	11 3934.59	11 3934.59	22 7869.18	44 15738.37	55 19672.96	66 23607.55	88 31476.74
11D+1P	12 4328.05	12 4328.05	24 8656.10	36 12984.15	60 21640.25	72 25968.31	84 30296.36
12D+1P	13 4721.51	13 4721.51	26 9443.02	39 14164.53	52 18886.04	65 23607.55	78 28329.06
13D+1P	14 5114.97	14 5114.97	28 10229.94	42 15344.91	56 20459.88	70 25574.85	84 30689.82
14D+1P	15 5508.42	15 5508.42	30 11016.85	45 16525.28	60 22033.71	75 27542.14	90 33050.57
15D+1P	0 0.00	0 0.00	16 5901.88	32 11803.77	48 17705.66	64 23607.55	80 29509.44

Table F.22 List of Capacities Corresponding to RAID6 (400 GB)

Disk capacity	393.4 GB						
Component unit	RKAJAT						
Range	1		2	3	4	5	6
Total range of Disk drives	Min.	15 (Max)	30	45	60	75	90
2D+2P	4 786.91	12 2360.75	28 5508.42	44 8656.10	60 11803.77	72 14164.53	88 17312.20
3D+2P	5 1180.37	15 3541.13	30 7082.26	45 10623.40	60 14164.53	75 17705.66	90 21246.80
4D+2P	6 1573.83	12 3147.67	30 7869.18	42 11016.85	60 15738.37	72 18886.04	90 23607.55
5D+2P	7 1967.29	14 3934.59	28 7869.18	42 11803.77	56 15738.37	70 19672.96	84 23607.55
6D+2P	8 2360.75	8 2360.75	24 7082.26	40 11803.77	56 16525.28	72 21246.80	88 25968.31
7D+2P	9 2754.21	9 2754.21	27 8262.64	45 13771.07	54 16525.28	72 22033.71	90 27542.14
8D+2P	10 3147.67	10 3147.67	30 9443.02	40 12590.69	60 18886.04	70 22033.71	90 28329.06
9D+2P	11 3541.13	11 3541.13	22 7082.26	44 14164.53	55 17705.66	66 21246.80	88 28329.06
10D+2P	12 3934.59	12 3934.59	24 7869.18	36 11803.77	60 19672.96	72 23607.55	84 27542.14
11D+2P	13 4328.05	13 4328.05	26 8656.10	39 12984.15	52 17312.20	65 21640.25	78 25968.31
12D+2P	14 4721.51	14 4721.51	28 9443.02	42 14164.53	56 18886.04	70 23607.55	84 28329.06
13D+2P	15 5114.97	15 5114.97	30 10229.94	45 15344.91	60 20459.88	75 25574.85	90 30689.82
14D+2P	0 0.00	0 0.00	16 5508.42	32 11016.85	48 16525.28	64 22033.71	80 27542.14
15D+2P	0 0.00	0 0.00	17 5901.88	34 11803.77	51 17705.66	68 23607.55	85 29509.44
16D+2P	0 0.00	0 0.00	18 6295.34	36 12590.69	54 18886.04	72 25181.39	90 31476.74
17D+2P	0 0.00	0 0.00	19 6688.80	38 13377.61	57 20066.42	57 20066.42	76 26755.23
18D+2P	0 0.00	0 0.00	20 7082.26	40 14164.53	60 21246.80	60 21246.80	80 28329.06
19D+2P	0 0.00	0 0.00	21 7475.72	42 14951.45	42 14951.45	63 22427.17	84 29902.90
20D+2P	0 0.00	0 0.00	22 7869.18	44 15738.37	44 15738.37	66 23607.55	88 31476.74
21D+2P	0 0.00	0 0.00	23 8262.64	23 8262.64	46 16525.28	69 24787.93	69 24787.93
22D+2P	0 0.00	0 0.00	24 8656.10	24 8656.10	48 17312.20	72 25968.31	72 25968.31
23D+2P	0 0.00	0 0.00	25 9049.56	25 9049.56	50 18099.12	75 27148.68	75 27148.68
24D+2P	0 0.00	0 0.00	26 9443.02	26 9443.02	52 18886.04	52 18886.04	78 28329.06
25D+2P	0 0.00	0 0.00	27 9836.48	27 9836.48	54 19672.96	54 19672.96	81 29509.44
26D+2P	0 0.00	0 0.00	28 10229.94	28 10229.94	56 20459.88	56 20459.88	84 30689.82

Table F.22 List of Capacities Corresponding to RAID6 (400 GB) (Continued)

Disk capacity	393.4 GB						
Component unit	RKAJAT						
Range	1		2	3	4	5	6
Total range of Disk drives	Min.	15 (Max)	30	45	60	75	90
27D+2P	0 0.00	0 0.00	29 10623.40	29 10623.40	58 21246.80	58 21246.80	87 31870.20
28D+2P	0 0.00	0 0.00	30 11016.85	30 11016.85	60 22033.71	60 22033.71	90 33050.57

Table F.23 List of Capacities Corresponding to RAID1+0 (400 GB)

Disk capacity	393.4 GB						
Component unit	RKAJAT						
Range	1		2	3	4	5	6
Total range of Disk drives	Min.	15 (Max)	30	45	60	75	90
2D+2D	4 786.91	12 2360.75	28 5508.42	44 8656.10	60 11803.77	72 14164.53	88 17312.20
3D+3D	6 1180.37	12 2360.75	30 5901.88	42 8262.64	60 11803.77	72 14164.53	90 17705.66
4D+4D	8 1573.83	8 1573.83	24 4721.51	40 7869.18	56 11016.85	72 14164.53	88 17312.20
5D+5D	10 1967.29	10 1967.29	30 5901.88	40 7869.18	60 11803.77	70 13771.07	90 17705.66
6D+6D	12 2360.75	12 2360.75	24 4721.51	36 7082.26	60 11803.77	72 14164.53	84 16525.28
7D+7D	14 2754.21	14 2754.21	28 5508.42	42 8262.64	56 11016.85	70 13771.07	84 16525.28
8D+8D	0 0.00	0 0.00	16 3147.67	32 6295.34	48 9443.02	64 12590.69	80 15738.37

Table F.24 List of Capacities Corresponding to RAID1 (500 GB)

Disk capacity	491.9 GB						
Component unit	RKAJAT						
Range	1		2	3	4	5	6
Total range of Disk drives	Min.	15	30	45	60	75	90
1D+1D	2 491.94	14 3443.59	30 7379.12	44 10822.71	60 14758.24	74 18201.83	90 22137.36

Table F.25 List of Capacities Corresponding to RAID5 (500 GB)

Disk capacity	491.9 GB						
Component unit	RKAJAT						
Range	1	2	3	4	5	6	
Total range of Disk drives	Min.	15	30	45	60	75	90
2D+1P	3 983.88	15 4919.41	30 9838.83	45 14758.24	60 19677.66	75 24597.07	90 29516.49
3D+1P	4 1475.82	12 4427.47	28 10330.77	44 16234.07	60 22137.36	72 26564.84	88 32468.14
4D+1P	5 1967.76	15 5903.29	30 11806.59	45 17709.89	60 23613.19	75 29516.49	90 35419.78
5D+1P	6 2459.70	12 4919.41	30 12298.53	42 17217.95	60 24597.07	72 29516.49	90 36895.61
6D+1P	7 2951.64	14 5903.29	28 11806.59	42 17709.89	56 23613.19	70 29516.49	84 35419.78
7D+1P	8 3443.59	8 3443.59	24 10330.77	40 17217.95	56 24105.13	72 30992.31	88 37879.49
8D+1P	9 3935.53	9 3935.53	27 11806.59	45 19677.66	54 23613.19	72 31484.25	90 39355.32
9D+1P	10 4427.47	10 4427.47	30 13282.42	40 17709.89	60 26564.84	70 30992.31	90 39847.26
10D+1P	11 4919.41	11 4919.41	22 9838.83	44 19677.66	55 24597.07	66 29516.49	88 39355.32
11D+1P	12 5411.35	12 5411.35	24 10822.71	36 16234.07	60 27056.78	72 32468.14	84 37879.49
12D+1P	13 5903.29	13 5903.29	26 11806.59	39 17709.89	52 23613.19	65 29516.49	78 35419.78
13D+1P	14 6395.23	14 6395.23	28 12790.47	42 19185.71	56 25580.95	70 31976.19	84 38371.43
14D+1P	15 6887.18	15 6887.18	30 13774.36	45 20661.54	60 27548.72	75 34435.90	90 41323.08
15D+1P	0 0.00	0 0.00	16 7379.12	32 14758.24	48 22137.36	64 29516.49	80 36895.61

Table F.26 List of Capacities Corresponding to RAID6 (500 GB)

Disk capacity	491.9 GB						
Component unit	RKAJAT						
Range	1	2	3	4	5	6	
Total range of Disk drives	Min.	15	30	45	60	75	90
2D+2P	4 983.88	12 2951.64	28 6887.18	44 10822.71	60 14758.24	72 17709.89	88 21645.42
3D+2P	5 1475.82	15 4427.47	30 8854.94	45 13282.42	60 17709.89	75 22137.36	90 26564.84
4D+2P	6 1967.76	12 3935.53	30 9838.83	42 13774.36	60 19677.66	72 23613.19	90 29516.49
5D+2P	7 2459.70	14 4919.41	28 9838.83	42 14758.24	56 19677.66	70 24597.07	84 29516.49
6D+2P	8 2951.64	8 2951.64	24 8854.94	40 14758.24	56 20661.54	72 26564.84	88 32468.14
7D+2P	9 3443.59	9 3443.59	27 10330.77	45 17217.95	54 20661.54	72 27548.72	90 34435.90
8D+2P	10 3935.53	10 3935.53	30 11806.59	40 15742.12	60 23613.19	70 27548.72	90 35419.78
9D+2P	11 4427.47	11 4427.47	22 8854.94	44 17709.89	55 22137.36	66 26564.84	88 35419.78
10D+2P	12 4919.41	12 4919.41	24 9838.83	36 14758.24	60 24597.07	72 29516.49	84 34435.90
11D+2P	13 5411.35	13 5411.35	26 10822.71	39 16234.07	52 21645.42	65 27056.78	78 32468.14
12D+2P	14 5903.29	14 5903.29	28 11806.59	42 17709.89	56 23613.19	70 29516.49	84 35419.78
13D+2P	15 6395.23	15 6395.23	30 12790.47	45 19185.71	60 25580.95	75 31976.19	90 38371.43
14D+2P	0 0.00	0 0.00	16 6887.18	32 13774.36	48 20661.54	64 27548.72	80 34435.90
15D+2P	0 0.00	0 0.00	17 7379.12	34 14758.24	51 22137.36	68 29516.49	85 36895.61
16D+2P	0 0.00	0 0.00	18 7871.06	36 15742.12	54 23613.19	72 31484.25	90 39355.32
17D+2P	0 0.00	0 0.00	19 8363.00	38 16726.01	57 25089.01	57 25089.01	76 33452.02
18D+2P	0 0.00	0 0.00	20 8854.94	40 17709.89	60 26564.84	60 26564.84	80 35419.78
19D+2P	0 0.00	0 0.00	21 9346.88	42 18693.77	42 18693.77	63 28040.66	84 37387.55
20D+2P	0 0.00	0 0.00	22 9838.83	44 19677.66	44 19677.66	66 29516.49	88 39355.32
21D+2P	0 0.00	0 0.00	23 10330.77	23 10330.77	46 20661.54	69 30992.31	69 30992.31
22D+2P	0 0.00	0 0.00	24 10822.71	24 10822.71	48 21645.42	72 32468.14	72 32468.14
23D+2P	0 0.00	0 0.00	25 11314.65	25 11314.65	50 22629.31	75 33943.96	75 33943.96
24D+2P	0 0.00	0 0.00	26 11806.59	26 11806.59	52 23613.19	52 23613.19	78 35419.78
25D+2P	0 0.00	0 0.00	27 12298.53	27 12298.53	54 24597.07	54 24597.07	81 36895.61
26D+2P	0 0.00	0 0.00	28 12790.47	28 12790.47	56 25580.95	56 25580.95	84 38371.43
27D+2P	0 0.00	0 0.00	29 13282.42	29 13282.42	58 26564.84	58 26564.84	87 39847.26
28D+2P	0 0.00	0 0.00	30 13774.36	30 13774.36	60 27548.72	60 27548.72	90 41323.08

Table F.27 List of Capacities Corresponding to RAID1+0 (500 GB)

Disk capacity	491.9 GB						
Component unit	RKAJAT						
Range	1		2	3	4	5	6
Total range of Disk drives	Min.	15	30	45	60	75	90
2D+2D	4 983.88	12 2951.64	28 6887.18	44 10822.71	60 14758.24	72 17709.89	88 21645.42
3D+3D	6 1475.82	12 2951.64	30 7379.12	42 10330.77	60 14758.24	72 17709.89	90 22137.36
4D+4D	8 1967.76	8 1967.76	24 5903.29	40 9838.83	56 13774.36	72 17709.89	88 21645.42
5D+5D	10 2459.70	10 2459.70	30 7379.12	40 9838.83	60 14758.24	70 17217.95	90 22137.36
6D+6D	12 2951.64	12 2951.64	24 5903.29	36 8854.94	60 14758.24	72 17709.89	84 20661.54
7D+7D	14 3443.59	14 3443.59	28 6887.18	42 10330.77	56 13774.36	70 17217.95	84 20661.54
8D+8D	0 0.00	0 0.00	16 3935.53	32 7871.06	48 11806.59	64 15742.12	80 19677.66

Table F.28 List of Capacities Corresponding to RAID1 (750 GB)

Disk capacity	737.4 GB						
Component unit	RKAJAT						
Range	1		2	3	4	5	6
Total range of Disk drives	Min.	15	30	45	60	75	90
1D+1D	2 737.49	14 5162.45	30 11062.39	44 16224.84	60 22124.78	74 27287.23	90 33187.17

Table F.29 List of Capacities Corresponding to RAID5 (750 GB)

Disk capacity	737.4 GB						
Component unit	RKAJAT						
Range	1	2	3	4	5	6	
Total range of Disk drives	Min.	15	30	45	60	75	90
2D+1P	3 1474.98	15 7374.92	30 14749.85	45 22124.78	60 29499.71	75 36874.64	90 44249.57
3D+1P	4 2212.47	12 6637.43	28 15487.35	44 24337.26	60 33187.17	72 39824.61	88 48674.52
4D+1P	5 2949.97	15 8849.91	30 17699.82	45 26549.74	60 35399.65	75 44249.57	90 53099.48
5D+1P	6 3687.46	12 7374.92	30 18437.32	42 25812.25	60 36874.64	72 44249.57	90 55311.96
6D+1P	7 4424.95	14 8849.91	28 17699.82	42 26549.74	56 35399.65	70 44249.57	84 53099.48
7D+1P	8 5162.45	8 5162.45	24 15487.35	40 25812.25	56 36137.15	72 46462.05	88 56786.95
8D+1P	9 5899.94	9 5899.94	27 17699.82	45 29499.71	54 35399.65	72 47199.54	90 58999.42
9D+1P	10 6637.43	10 6637.43	30 19912.30	40 26549.74	60 39824.61	70 46462.05	90 59736.92
10D+1P	11 7374.92	11 7374.92	22 14749.85	44 29499.71	55 36874.64	66 44249.57	88 58999.42
11D+1P	12 8112.42	12 8112.42	24 16224.84	36 24337.26	60 40562.10	72 48674.52	84 56786.95
12D+1P	13 8849.91	13 8849.91	26 17699.82	39 26549.74	52 35399.65	65 44249.57	78 53099.48
13D+1P	14 9587.40	14 9587.40	28 19174.81	42 28762.22	56 38349.62	70 47937.03	84 57524.44
14D+1P	15 10324.90	15 10324.90	30 20649.80	45 30974.70	60 41299.60	75 51624.50	90 61949.40
15D+1P	0 0.00	0 0.00	16 11062.39	32 22124.78	48 33187.17	64 44249.57	80 55311.96

Table F.30 List of Capacities Corresponding to RAID6 (750 GB)

Disk capacity	737.4 GB						
Component unit	RKAJAT						
Range	1		2	3	4	5	6
Total range of Disk drives	Min.	15	30	45	60	75	90
2D+2P	4 1474.98	12 4424.95	28 10324.90	44 16224.84	60 22124.78	72 26549.74	88 32449.68
3D+2P	5 2212.47	15 6637.43	30 13274.87	45 19912.30	60 26549.74	75 33187.17	90 39824.61
4D+2P	6 2949.97	12 5899.94	30 14749.85	42 20649.80	60 29499.71	72 35399.65	90 44249.57
5D+2P	7 3687.46	14 7374.92	28 14749.85	42 22124.78	56 29499.71	70 36874.64	84 44249.57
6D+2P	8 4424.95	8 4424.95	24 13274.87	40 22124.78	56 30974.70	72 39824.61	88 48674.52
7D+2P	9 5162.45	9 5162.45	27 15487.35	45 25812.25	54 30974.70	72 41299.60	90 51624.50
8D+2P	10 5899.94	10 5899.94	30 17699.82	40 23599.77	60 35399.65	70 41299.60	90 53099.48
9D+2P	11 6637.43	11 6637.43	22 13274.87	44 26549.74	55 33187.17	66 39824.61	88 53099.48
10D+2P	12 7374.92	12 7374.92	24 14749.85	36 22124.78	60 36874.64	72 44249.57	84 51624.50
11D+2P	13 8112.42	13 8112.42	26 16224.84	39 24337.26	52 32449.68	65 40562.10	78 48674.52
12D+2P	14 8849.91	14 8849.91	28 17699.82	42 26549.74	56 35399.65	70 44249.57	84 53099.48
13D+2P	15 9587.40	15 9587.40	30 19174.81	45 28762.22	60 38349.62	75 47937.03	90 57524.44
14D+2P	0 0.00	0 0.00	16 10324.90	32 20649.80	48 30974.70	64 41299.60	80 51624.50
15D+2P	0 0.00	0 0.00	17 11062.39	34 22124.78	51 33187.17	68 44249.57	85 55311.96
16D+2P	0 0.00	0 0.00	18 11799.88	36 23599.77	54 35399.65	72 47199.54	90 58999.42
17D+2P	0 0.00	0 0.00	19 12537.37	38 25074.75	57 37612.13	57 37612.13	76 50149.51
18D+2P	0 0.00	0 0.00	20 13274.87	40 26549.74	60 39824.61	60 39824.61	80 53099.48
19D+2P	0 0.00	0 0.00	21 14012.36	42 28024.72	42 28024.72	63 42037.09	84 56049.45
20D+2P	0 0.00	0 0.00	22 14749.85	44 29499.71	44 29499.71	66 44249.57	88 58999.42
21D+2P	0 0.00	0 0.00	23 15487.35	23 15487.35	46 30974.70	69 46462.05	69 46462.05
22D+2P	0 0.00	0 0.00	24 16224.84	24 16224.84	48 32449.68	72 48674.52	72 48674.52
23D+2P	0 0.00	0 0.00	25 16962.33	25 16962.33	50 33924.67	75 50887.00	75 50887.00
24D+2P	0 0.00	0 0.00	26 17699.82	26 17699.82	52 35399.65	52 35399.65	78 53099.48
25D+2P	0 0.00	0 0.00	27 18437.32	27 18437.32	54 36874.64	54 36874.64	81 55311.96
26D+2P	0 0.00	0 0.00	28 19174.81	28 19174.81	56 38349.62	56 38349.62	84 57524.44
27D+2P	0 0.00	0 0.00	29 19912.30	29 19912.30	58 39824.61	58 39824.61	87 59736.92
28D+2P	0 0.00	0 0.00	30 20649.80	30 20649.80	60 41299.60	60 41299.60	90 61949.40

Table F.31 List of Capacities Corresponding to RAID1+0 (750 GB)

Disk capacity	737.4 GB						
Component unit	RKAJAT						
Range	1		2	3	4	5	6
Total range of Disk drives	Min.	15	30	45	60	75	90
2D+2D	4 1474.98	12 4424.95	28 10324.90	44 16224.84	60 22124.78	72 26549.74	88 32449.68
3D+3D	6 2212.47	12 4424.95	30 11062.39	42 15487.35	60 22124.78	72 26549.74	90 33187.17
4D+4D	8 2949.97	8 2949.97	24 8849.91	40 14749.85	56 20649.80	72 26549.74	88 32449.68
5D+5D	10 3687.46	10 3687.46	30 11062.39	40 14749.85	60 22124.78	70 25812.25	90 33187.17
6D+6D	12 4424.95	12 4424.95	24 8849.91	36 13274.87	60 22124.78	72 26549.74	84 30974.70
7D+7D	14 5162.45	14 5162.45	28 10324.90	42 15487.35	56 20649.80	70 25812.25	84 30974.70
8D+8D	0 0.00	0 0.00	16 5899.94	32 11799.88	48 17699.82	64 23599.77	80 29499.71

Appendix G Port Address Mapping Table

Fibre channel physical addresses are converted to target IDs (TIDs) using a conversion table. The following table shows the current limits for TIDs on various operating systems.

Table G.1 Limits for TIDs on Operating Systems

Port	HP-UX		Solaris™		Windows NT® (SP4 or Later)	
	TID	LUN	TID	LUN	TID	LUN
Fibre	0 to 15	0 to 255	0 to 125	0 to 255	0 to 31	0 to 255

AL-PA is an abbreviation for Arbitrated Loop Physical Address and indicates the physical address for Fibre Channel. TID indicates the target ID.

Table G.2 Port Addresses for HP-UX

C0		C1		C2		C3		C4		C5		C6		C7	
ALPA	TID	ALPA	TID	ALPA	TID	ALPA	TID	ALPA	TID	ALPA	TID	ALPA	TID	ALPA	TID
EF	0	CD	0	B2	0	98	0	72	0	55	0	3A	0	25	0
E8	1	CC	1	B1	1	97	1	71	1	54	1	39	1	23	1
E4	2	CB	2	AE	2	90	2	6E	2	53	2	36	2	1F	2
E2	3	CA	3	AD	3	8F	3	6D	3	52	3	35	3	1E	3
E1	4	C9	4	AC	4	88	4	6C	4	51	4	34	4	1D	4
E0	5	C7	5	AB	5	84	5	6B	5	4E	5	33	5	1B	5
DC	6	C6	6	AA	6	82	6	6A	6	4D	6	32	6	18	6
DA	7	C5	7	A9	7	81	7	69	7	4C	7	31	7	17	7
D9	8	C3	8	A7	8	80	8	67	8	4B	8	2E	8	10	8
D6	9	BC	9	A6	9	7C	9	66	9	4A	9	2D	9	0F	9
D5	10	BA	10	A5	10	7A	10	65	10	49	10	2C	10	08	10
D4	11	B9	11	A3	11	79	11	63	11	47	11	2B	11	04	11
D3	12	B6	12	9F	12	76	12	5C	12	46	12	2A	12	02	12
D2	13	B5	13	9E	13	75	13	5A	13	45	13	29	13	01	13
D1	14	B4	14	9D	14	74	14	59	14	43	14	27	14	--	--
CE	15	B3	15	9B	15	73	15	56	15	3C	15	26	15	--	--

Table G.3 Port Addresses for Solaris

C0		C1		C2		C3		C4		C5		C6		C7	
ALPA	TID	ALPA	TID	ALPA	TID	ALPA	TID	ALPA	TID	ALPA	TID	ALPA	TID	ALPA	TID
EF	0	CD	16	B2	32	98	48	72	64	55	80	3A	96	25	112
E8	1	CC	17	B1	33	97	49	71	65	54	81	39	97	23	113
E4	2	CB	18	AE	34	90	50	6E	66	53	82	36	98	1F	114
E2	3	CA	19	AD	35	8F	51	6D	67	52	83	35	99	1E	115
E1	4	C9	20	AC	36	88	52	6C	68	51	84	34	100	1D	116
E0	5	C7	21	AB	37	84	53	6B	69	4E	85	33	101	1B	117
DC	6	C6	22	AA	38	82	54	6A	70	4D	86	32	102	18	118
DA	7	C5	23	A9	39	81	55	69	71	4C	87	31	103	17	119
D9	8	C3	24	A7	40	80	56	67	72	4B	88	2E	104	10	120
D6	9	BC	25	A6	41	7C	57	66	73	4A	89	2D	105	0F	121
D5	10	BA	26	A5	42	7A	58	65	74	49	90	2C	106	08	122
D4	11	B9	27	A3	43	79	59	63	75	47	91	2B	107	04	123
D3	12	B6	28	9F	44	76	60	5C	76	46	92	2A	108	02	124
D2	13	B5	29	9E	45	75	61	5A	77	45	93	29	109	01	125
D1	14	B4	30	9D	46	74	62	59	78	43	94	27	110	--	--
CE	15	B3	31	9B	47	73	63	56	79	3C	95	26	111	--	--

Table G.4 Port Addresses for Windows NT (Fibre Board: Emulex®)

C5(PhId5)				C4(PhId4)				C3(PhId3)				C2(PhId2)			C1(PhId1)			
TID	AL PA	TID	AL PA	TID	AL PA	TID	AL PA	TID	AL PA	TID	AL PA	TID	AL PA	TID	AL PA	TID	AL PA	TID
--	--	--	--	--	CC	15	--	--	98	15	--	--	56	15	--	--	27	15
--	--	--	E4	30	CB	14	B1	30	67	14	72	30	55	14	3C	30	26	14
--	--	--	E2	29	CA	13	AE	29	90	13	71	29	64	13	3A	29	25	13
--	--	--	E1	28	C9	12	AD	28	8F	12	6E	28	53	12	39	28	23	12
--	--	--	E0	27	C7	11	AC	27	88	11	6D	27	52	11	36	27	1F	11
--	--	--	DC	26	C6	10	AB	26	84	10	6C	26	51	10	35	26	1E	10
--	--	--	DA	25	C5	9	AA	25	82	9	6B	25	4E	9	34	25	1D	9
--	--	--	D9	24	C3	8	A9	24	81	8	6A	24	4D	8	33	24	1B	8
--	--	--	D6	23	BC	7	A7	23	80	7	69	23	4C	7	32	23	18	7
--	--	--	D5	22	BA	6	A6	22	7C	6	67	22	4B	6	31	22	17	6
--	--	--	D4	21	B9	5	A5	21	7A	5	66	21	4A	5	2E	21	10	5
--	--	--	D3	20	B6	4	A3	20	79	4	65	20	49	4	2D	20	0F	4
--	--	--	D2	19	B5	3	9F	19	76	3	63	19	47	3	2C	19	08	3
--	--	--	D1	18	B4	2	9E	18	75	2	5C	18	46	2	2B	18	04	2
--	EF	1	CE	17	B3	1	9D	17	74	1	5A	17	45	1	2A	17	02	1
--	E8	0	CD	16	B2	0	9B	16	73	0	59	16	43	0	29	16	01	0

Table G.5 Port Addresses for Windows NT (Fibre Board: Qlogic®)

C0(PhId0)				C1(PhId1)				C2(PhId2)				C3(PhId3)			
AL PA	TID	AL PA	TID	AL PA	TID	AL PA	TID	AL PA	TID	AL PA	TID	AL PA	TID	AL PA	TID
EF	0	CD	16	B2	0	98	16	72	0	55	16	3A	0	25	16
E8	1	CC	17	B1	1	67	17	71	1	64	17	39	1	23	17
E4	2	CB	18	AE	2	90	18	6E	2	53	18	36	2	1F	18
E2	3	CA	19	AD	3	8F	19	6D	3	52	19	35	3	1E	19
E1	4	C9	20	AC	4	88	20	6C	4	51	20	34	4	1D	20
E0	5	C7	21	AB	5	84	21	6B	5	4E	21	33	5	1B	21
DC	6	C6	22	AA	6	82	22	6A	6	4D	22	32	6	18	22
DA	7	C5	23	A9	7	81	23	69	7	4C	23	31	7	17	23
D9	8	C3	24	A7	8	80	24	67	8	4B	24	2E	8	10	24
D6	9	BC	25	A6	9	7C	25	66	9	4A	25	2D	9	0F	25
D5	10	BA	26	A5	10	7A	26	65	10	49	26	2C	10	08	26
D4	11	B9	27	A3	11	79	27	63	11	47	27	2B	11	04	27
D3	12	B6	28	9F	12	76	28	5C	12	46	28	2A	12	02	28
D2	13	B5	29	9E	13	75	29	5A	13	45	29	29	13	01	29
D1	14	B4	30	9D	14	74	30	59	14	43	30	27	14	--	--
CE	15	B3	31	9B	15	73	31	56	15	3C	31	26	15	--	--

Appendix H Power Cables

This section includes descriptions of the following power cables:

- J1H
- J2H
- J2H5 and J2H10

Table H.1 J1H Power Cable

Cable Name	Part #	Name	Quantity	Model	Applicable Safety Standard/ Rating
DF-F700-J1H Power cable	1	Cable	-	PVC code	UL and CSA
	2	Connector A	1	NEMA Standard 5-15 P	For AC 125 V (13 A or 15 A)
	3	Connector B	1	EN60320-C13	For standard use

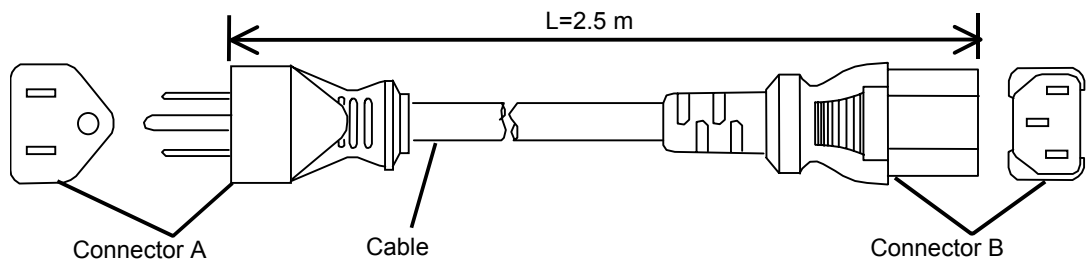

Figure H.1 J1H Power Cable

Table H.2 J2H Power Cable

Cable Name	Part #	Name	Quantity	Model	Applicable Safety Standard/ Rating
DF-F700-J2H Power cable	1	Cable	-	PVC code	UL and CSA
	2	Connector A	1	EN60324-C14	For AC 250 V (13 A or 15 A)
	3	Connector B	1	EN60324-C13	For rack frame

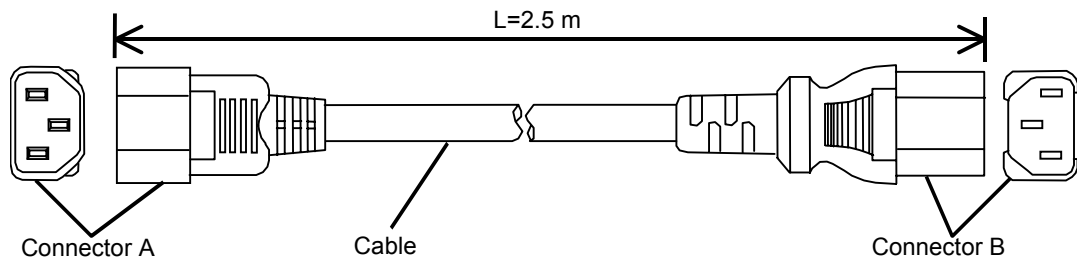

Figure H.2 J2H Power Cable

Table H.3 J2H5 and J2H10 Power Cables

Cable Name	Part #	Name	Quantity	Model	Applicable Safety Standard/ Rating
DF-F700-	1	Cable	-	CENELEC	UL and CSA
J2H5/J2H10	2	Connector A	1	EN60320-C14	For AC 250 V (13 A or 15 A)
Power cable	3	Connector B	1	EN60320-C13	For rack frame

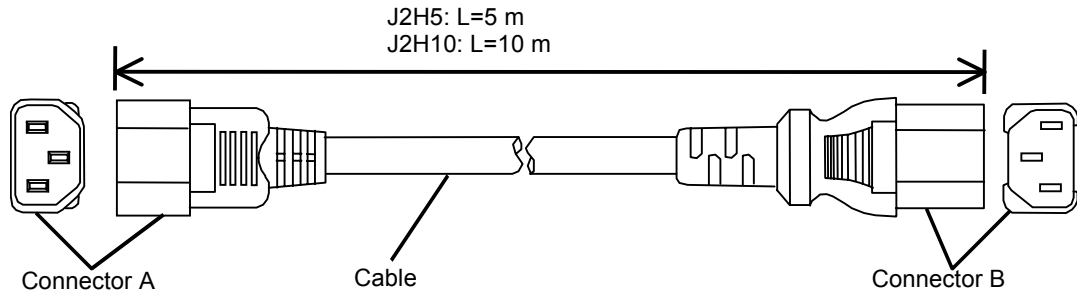

Figure H.3 J2H5 and J2H10 Power Cables

Appendix I Number of Logical Blocks

Set the number of logical blocks for each logical unit using the following multiples in accordance with RAID levels.

Note: All values of storage capacities in following tables are calculated as 1 GB = 1,000,000,000 bytes.

(This definition is different from 1 Kbyte = 1,024 bytes.)

A logical unit can divide all RAID groups into up to 512. Set the number of logical blocks set for each logical unit using the following multiples in accordance with RAID levels.

Table I.1 Number of Logical Blocks and RAID Levels

RAID Level		Logical Block Number
RAID0	(2D)	4096
	(3D)	6144
	(4D)	8192
	(5D)	10240
	(6D)	12288
	(7D)	14336
	(8D)	16384
	(9D)	18432
	(10D)	20480
	(11D)	22528
	(12D)	24576
	(13D)	26624
	(14D)	28672
	(15D)	30720
	(16D)	32768
RAID1	(1D+1D)	2048

Table I.1 Number of Logical Blocks and RAID Levels (continued)

RAID Level		Logical Block Number
RAID5	(2D+1P)	4096
	(3D+1P)	6144
	(4D+1P)	8192
	(5D+1P)	10240
	(6D+1P)	12288
	(7D+1P)	14336
	(8D+1P)	16384
	(9D+1P)	18432
	(10D+1P)	20480
	(11D+1P)	22528
	(12D+1P)	24576
	(13D+1P)	26624
	(14D+1P)	28672
	(15D+1P)	30720
RAID 6	(2D+2P)	4096
	(3D+2P)	6144
	(4D+2P)	8192
	(5D+2P)	10240
	(6D+2P)	12288
	(7D+2P)	14336
	(8D+2P)	16384
	(9D+2P)	18432
	(10D+2P)	20480
	(11D+2P)	22528
	(12D+2P)	24576
	(13D+2P)	26624
	(14D+2P)	28672
	(15D+2P)	30720
	(16D+2P)	32768
	(17D+2P)	34816
(18D+2P)	36864	
(19D+2P)	38912	
(20D+2P)	40960	

Table I.1 Number of Logical Blocks and RAID Levels (continued)

RAID Level		Logical Block Number
RAID 6	(21D+2P)	43008
	(22D+2P)	45056
	(23D+2P)	47104
	(24D+2P)	49152
	(25D+2P)	51200
	(26D+2P)	53248
	(27D+2P)	55296
	(28D+2P)	57344
RAID1+0	(2D+2D)	4096
	(3D+3D)	6144
	(4D+4D)	8192
	(5D+5D)	10240
	(6D+6D)	12288
	(7D+7D)	14336
	(8D+8D)	16384

The number of logical blocks for one parity group is shown next.

When dividing RAID groups into multiple logical units, set the sum total of the number of logical blocks of each logical unit below the number of logical blocks per parity shown below.

However, when creating multiple parity groups in each RAID group, set them below the number of logical blocks of one parity group multiplied by the number of parity groups. The number of logical blocks of one parity group is shown below.

Table I.2 Number of Logical Blocks of One Parity Group

Disk drive capacity		71.3 G bytes	143.3 G bytes	245.7 G bytes	287.6 G bytes	393.4 G bytes	491.9 G bytes	737.4 G bytes
RAID configuration								
RAID 0	(2D)	278,556,672	559,788,032	–	1,123,549,184	–	–	–
	(3D)	417,835,008	839,682,048	–	1,685,323,776	–	–	–
	(4D)	557,113,344	1,119,576,064	–	2,247,098,368	–	–	–
	(5D)	696,391,680	1,399,470,080	–	2,808,872,960	–	–	–
	(6D)	835,670,016	1,679,364,096	–	3,370,647,552	–	–	–
	(7D)	974,948,352	1,959,258,112	–	3,932,422,144	–	–	–
	(8D)	1,114,226,688	2,239,152,128	–	4,494,196,736	–	–	–
	(9D)	1,253,505,024	2,519,046,144	–	5,055,971,328	–	–	–
	(10D)	1,392,783,360	2,798,940,160	–	5,617,745,920	–	–	–
	(11D)	1,532,061,696	3,078,834,176	–	6,179,520,512	–	–	–
	(12D)	1,671,340,032	3,358,728,192	–	6,741,295,104	–	–	–
	(13D)	1,810,618,368	3,638,622,208	–	7,303,069,696	–	–	–
	(14D)	1,949,896,704	3,918,516,224	–	7,864,844,288	–	–	–
	(15D)	2,089,175,040	4,198,410,240	–	8,426,618,880	–	–	–
	(16D)	2,228,453,376	4,478,304,256	–	8,988,393,472	–	–	–
RAID 1	(1D+1D)	139,278,336	279,894,016	479,971,328	561,774,592	768,475,136	960,823,296	1,440,415,744
RAID 5	(2D+1P)	278,556,672	559,788,032	959,942,656	1,123,549,184	1,536,950,272	1,921,646,592	2,880,831,488
	(3D+1P)	417,835,008	839,682,048	1,439,913,984	1,685,323,776	2,305,425,408	2,882,469,888	4,321,247,232
	(4D+1P)	557,113,344	1,119,576,064	1,919,885,312	2,247,098,368	3,073,900,544	3,843,293,184	5,761,662,976
	(5D+1P)	696,391,680	1,399,470,080	2,399,856,640	2,808,872,960	3,842,375,680	4,804,116,480	7,202,078,720
	(6D+1P)	835,670,016	1,679,364,096	2,879,827,968	3,370,647,552	4,610,850,816	5,764,939,776	8,642,494,464
	(7D+1P)	974,948,352	1,959,258,112	3,359,799,296	3,932,422,144	5,379,325,952	6,725,763,072	10,082,910,208
	(8D+1P)	1,114,226,688	2,239,152,128	3,839,770,624	4,494,196,736	6,147,801,088	7,686,586,368	11,523,325,952
	(9D+1P)	1,253,505,024	2,519,046,144	4,319,741,952	5,055,971,328	6,916,276,224	8,647,409,664	12,963,741,696
	(10D+1P)	1,392,783,360	2,798,940,160	4,799,713,280	5,617,745,920	7,684,751,360	9,608,232,960	14,404,157,440
	(11D+1P)	1,532,061,696	3,078,834,176	5,279,684,608	6,179,520,512	8,453,226,496	10,569,056,256	15,844,573,184
	(12D+1P)	1,671,340,032	3,358,728,192	5,759,655,936	6,741,295,104	9,221,701,632	11,529,879,552	17,284,988,928
	(13D+1P)	1,810,618,368	3,638,622,208	6,239,627,264	7,303,069,696	9,990,176,768	12,490,702,848	18,725,404,672
	(14D+1P)	1,949,896,704	3,918,516,224	6,719,598,592	7,864,844,288	10,758,651,904	13,451,526,144	20,165,820,416
	(15D+1P)	2,089,175,040	4,198,410,240	7,199,569,920	8,426,618,880	11,527,127,040	14,412,349,440	21,606,236,160

Table I.2 Number of Logical Blocks of One Parity Group (continued)

Disk drive capacity		71.3 G bytes	143.3 G bytes	245.7 G bytes	292 G bytes	393.4 G bytes	491.9 G bytes	737.4 G bytes
RAID configuration								
RAID6	(2D+2P)	278,556,672	559,788,032	959,942,656	1,123,549,184	1,536,950,272	1,921,646,592	2,880,831,488
	(3D+2P)	417,835,008	839,682,048	1,439,913,984	1,685,323,776	2,305,425,408	2,882,469,888	4,321,247,232
	(4D+2P)	557,113,344	1,119,576,064	1,919,885,312	2,247,098,368	3,073,900,544	3,843,293,184	5,761,662,976
	(5D+2P)	696,391,680	1,399,470,080	2,399,856,640	2,808,872,960	3,842,375,680	4,804,116,480	7,202,078,720
	(6D+2P)	835,670,016	1,679,364,096	2,879,827,968	3,370,647,552	4,610,850,816	5,764,939,776	8,642,494,464
	(7D+2P)	974,948,352	1,959,258,112	3,359,799,296	3,932,422,144	5,379,325,952	6,725,763,072	10,082,910,208
	(8D+2P)	1,114,226,688	2,239,152,128	3,839,770,624	4,494,196,736	6,147,801,088	7,686,586,368	11,523,325,952
	(9D+2P)	1,253,505,024	2,519,046,144	4,319,741,952	5,055,971,328	6,916,276,224	8,647,409,664	12,963,741,696
	(10D+2P)	1,392,783,360	2,798,940,160	4,799,713,280	5,617,745,920	7,684,751,360	9,608,232,960	14,404,157,440
	(11D+2P)	1,532,061,696	3,078,834,176	5,279,684,608	6,179,520,512	8,453,226,496	10,569,056,256	15,844,573,184
	(12D+2P)	1,671,340,032	3,358,728,192	5,759,655,936	6,741,295,104	9,221,701,632	11,529,879,552	17,284,988,928
	(13D+2P)	1,810,618,368	3,638,622,208	6,239,627,264	7,303,069,696	9,990,176,768	12,490,702,848	18,725,404,672
	(14D+2P)	1,949,896,704	3,918,516,224	6,719,598,592	7,864,844,288	10,758,651,904	13,451,526,144	20,165,820,416
	(15D+2P)	2,089,175,040	4,198,410,240	7,199,569,920	8,426,618,880	11,527,127,040	14,412,349,440	21,606,236,160
	(16D+2P)	2,228,453,376	4,478,304,256	7,679,541,248	8,988,393,472	12,295,602,176	15,373,172,736	23,046,651,904
	(17D+2P)	2,367,731,712	4,758,198,272	8,159,512,576	9,550,168,064	13,064,077,312	16,333,996,032	24,487,067,648
	(18D+2P)	2,507,010,048	5,038,092,288	8,639,483,904	10,111,942,656	13,832,552,448	17,294,819,328	25,927,483,392
	(19D+2P)	2,646,288,384	5,317,986,304	9,119,455,232	10,673,717,248	14,601,027,584	18,255,642,624	27,367,899,136
	(20D+2P)	2,785,566,720	5,597,880,320	9,599,426,560	11,235,491,840	15,369,502,720	19,216,465,920	28,808,314,880
	(21D+2P)	2,924,845,056	5,877,774,336	10,079,397,888	11,797,266,432	16,137,977,856	20,177,289,216	30,248,730,624
(22D+2P)	3,064,123,392	6,157,668,352	10,559,369,216	12,359,041,024	16,906,452,992	21,138,112,512	31,689,146,368	
(23D+2P)	3,203,401,728	6,437,562,368	11,039,340,544	12,920,815,616	17,674,928,128	22,098,935,808	33,129,562,112	
(24D+2P)	3,342,680,064	6,717,456,384	11,519,311,872	13,482,590,208	18,443,403,264	23,059,759,104	34,569,977,856	
(25D+2P)	3,481,958,400	6,997,350,400	11,999,283,200	14,044,364,800	19,211,878,400	24,020,582,400	36,010,393,600	
(26D+2P)	3,621,236,736	7,277,244,416	12,479,254,528	14,606,139,392	19,980,353,536	24,981,405,696	37,450,809,344	
(27D+2P)	3,760,515,072	7,557,138,432	12,959,225,856	15,167,913,984	20,748,828,672	25,942,228,992	38,891,225,088	
(28D+2P)	3,899,793,408	7,837,032,448	13,439,197,184	15,729,688,576	21,517,303,808	26,903,052,288	40,331,640,832	
RAID1+0	(2D+2D)	278,556,672	559,788,032	959,942,656	1,123,549,184	1,536,950,272	1,921,646,592	2,880,831,488
	(3D+3D)	417,835,008	839,682,048	1,439,913,984	1,685,323,776	2,305,425,408	2,882,469,888	4,321,247,232
	(4D+4D)	557,113,344	1,119,576,064	1,919,885,312	2,247,098,368	3,073,900,544	3,843,293,184	5,761,662,976
	(5D+5D)	696,391,680	1,399,470,080	2,399,856,640	2,808,872,960	3,842,375,680	4,804,116,480	7,202,078,720
	(6D+6D)	835,670,016	1,679,364,096	2,879,827,968	3,370,647,552	4,610,850,816	5,764,939,776	8,642,494,464
	(7D+7D)	974,948,352	1,959,258,112	3,359,799,296	3,932,422,144	5,379,325,952	6,725,763,072	10,082,910,208
	(8D+8D)	1,114,226,688	2,239,152,128	3,839,770,624	4,494,196,736	6,147,801,088	7,686,586,368	11,523,325,952

Appendix J Using LUN Security or LUN Management on a Fabric Switch Connection

When using LUN Manager on a Fabric Switch connection:

- When connecting to the servers (HBA) or exchanging the HBA, connect to the servers (HBA) that access the Disk Array after the LUN Security or LUN Management settings, including WWN registration, are completed.
- Zoning on Fabric Switch must be set as shown below to disturb the access from HBA that cannot be accessed from the Disk Array by LUN Manager.

J.1 FC Interface Board is Not Added to Control Unit

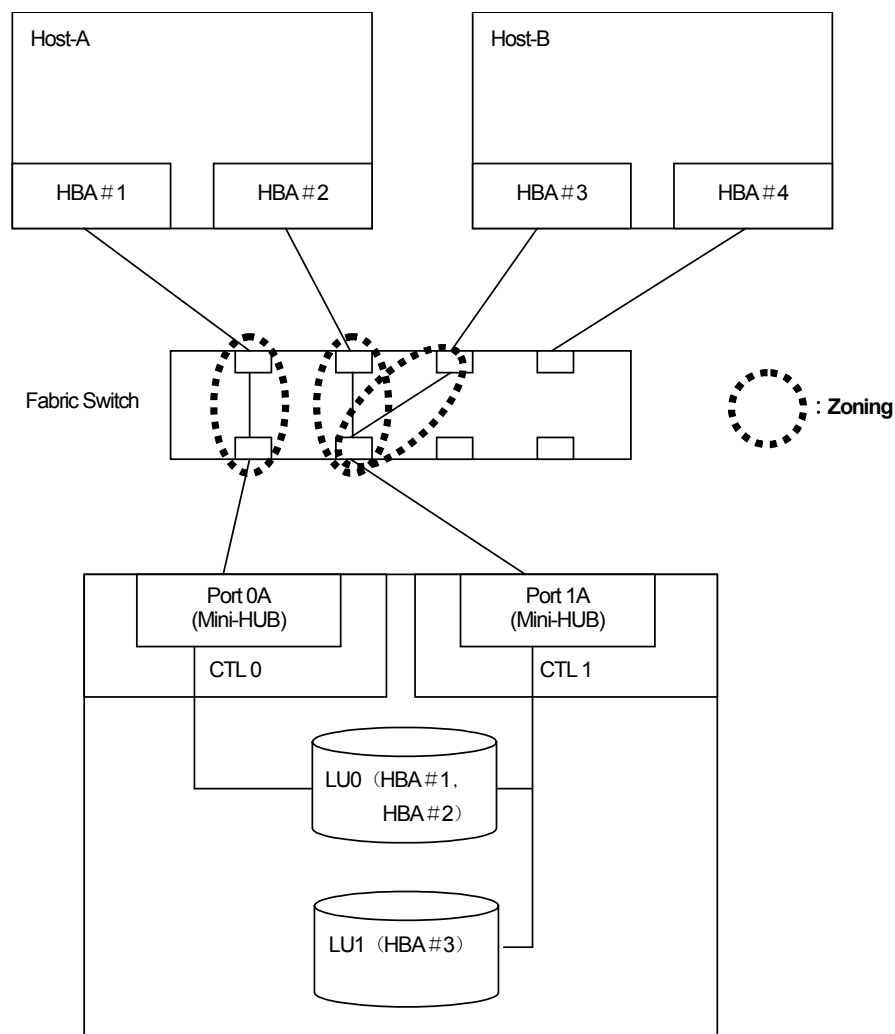

J.1 FC Interface Board is Added to Control Unit

