

**Hitachi TagmaStore®
Adaptable Modular Storage
and Workgroup Modular Storage
Storage Navigator Modular
Graphical User Interface (GUI)
User's Guide**

Notice: No part of this publication may be reproduced or transmitted in any form or by any means, electronic or mechanical, including photocopying and recording, or stored in a database or retrieval system for any purpose without the express written permission of Hitachi Data Systems Corporation (hereinafter referred to as “Hitachi Data Systems”).

Hitachi Data Systems reserves the right to make changes to this document at any time without notice and assumes no responsibility for its use. Hitachi Data Systems products and services can only be ordered under the terms and conditions of Hitachi Data Systems’ applicable agreements. All of the features described in this document may not be currently available. Refer to the most recent product announcement or contact your local Hitachi Data Systems sales office for information on feature and product availability.

This document contains the most current information available at the time of publication. When new and/or revised information becomes available, this entire document will be updated and distributed to all registered users.

Trademarks

Hitachi Data Systems is a registered trademark and service mark of Hitachi, Ltd., and the Hitachi Data Systems design mark is a trademark and service mark of Hitachi, Ltd.

TagmaStore is a registered trademark of Hitachi Data Systems Corporation.

Pentium is a registered trademark of Intel Corporation.

AIX is a registered trademark of International Business Machines Corporation.

Linux is a registered trademark of Linus Torvalds.

Windows and Windows NT are registered trademarks, and Windows Server is a trademark of Microsoft Corporation.

Red Hat is a registered trademark of Red Hat, Inc.

IRIX and SGI are registered trademarks of Silicon Graphics, Inc. in the United States.

Java, Solaris, and Sun are trademarks of Sun Microsystems, Inc.

UNIX is a registered trademark of The Open Group in the United States and other countries.

All other brand or product names are or may be trademarks or service marks of and are used to identify products or services of their respective owners.

Notice of Export Controls

Export of technical data contained in this document may require an export license from the United States government and/or the government of Japan. Contact the Hitachi Data Systems Legal Department for export compliance questions.

Document Revision Level

Revision	Date	Description
MK-95DF711-00	June 2005	Initial Release
MK-95DF711-01	September 2005	Revision 1, supersedes and replaces MK-95DF711-00
MK-95DF711-02	November 2005	Revision 2, supersedes and replaces MK-95DF711-01
MK-95DF711-03	January 2006	Revision 3, supersedes and replaces MK-95DF711-02
MK-95DF711-04	February 2006	Revision 4, supersedes and replaces MK-95DF711-03
MK-95DF711-05	March 2006	Revision 5, supersedes and replaces MK-95DF711-04
MK-95DF711-06	April 2006	Revision 6, supersedes and replaces MK-95DF711-05
MK-95DF711-07	April 2006	Revision 7, supersedes and replaces MK-95DF711-06
MK-95DF711-08	May 2006	Revision 8, supersedes and replaces MK-95DF711-07
MK-95DF711-09	June 2006	Revision 9, supersedes and replaces MK-95DF711-08
MK-95DF711-10P	October 2006	Preliminary release of revision 10
MK-95DF711-10	November 2006	Revision 10, supersedes and replaces MK-95DF711-09
MK-95DF711-11	January 2007	Revision 11, supersedes and replaces MK-95DF711-10
MK-95DF711-12	April 2007	Revision 12, supersedes and replaces MK-95DF711-11

Changes in this Revision

- Added support for Windows Server™ 2003 (R2) (section 2.2.2.1)
- Added support for Account Authorization (section 4.1)
- Revised instructions and screen shots in instructions for replacing the microcode (section 5.15.2)
- Revised instructions and screen shots in instructions for shutting down the NNC (section 10.4.1)
- Added support for DF700HE in instructions for setting the ACE tool (chapter 14)
- Added new section on registering the failure monitoring account (section 15.2)
- Revised section on error monitoring to support account authorization (section 15.3)

Preface

This document provides instructions for installing and using the Storage Navigator Modular program with the graphical user interface.

This document assumes the following:

- The user is familiar with the operating system and web browser software on the system hosting the Storage Navigator Modular software.
- The user has a background in data processing and understands storage subsystems and their basic functions.
- The user is familiar with the AMS/WMS subsystem and has read and understands the manuals for the subsystem.

Notes:

- In this document the term “Storage Navigator” refers to the Storage Navigator Modular GUI, unless otherwise noted.
- In this document instructions with a “CAUTION” label indicate that failure to follow the instructions could result in damage to the subsystem or potential loss of data.
- The Storage Navigator screens shown in this document were captured on a Windows® system with the Internet Explorer web browser. The Storage Navigator screens may display differently on other operating systems and browsers.
- For further information, please contact your Hitachi Data Systems account team, or visit the Hitachi Data Systems worldwide web site at <http://www.hds.com>.

Notice: The use of the Storage Navigator Modular program and all other Hitachi Data Systems products is governed by the terms of your agreement(s) with Hitachi Data Systems.

Software Version

This document revision applies to Hitachi TagmaStore® Adaptable Modular Storage and Workgroup Modular Storage Products version 7.10 and higher.

Comparing the Web, GUI, and CLI Versions of Storage Navigator Modular

Storage Navigator Modular software has three separate versions for managing Hitachi TagmaStore Adaptable Modular Storage and Workgroup Modular Storage: the Web version (described in this user guide), a graphical user interface (GUI) version, and a command line interface (CLI) version. Here is an overview:

Application	User Interface	Configuration	Comparisons	User Guide
Storage Navigator Modular for Web	Web browser	<ul style="list-style-type: none"> ▪ Operating system: Windows® ▪ Network: One or more storage subsystems, a Web server and Web client computer are connected through a LAN. ▪ Installation: The application is installed on the Web server. The Java™ runtime environment (for running Java applets in a browser) is installed on the Web client computer. ▪ Operation: User runs the program from a Web browser on the client computer. 	<ul style="list-style-type: none"> ▪ Used with HiCommand Device Manager software to help centrally manage storage subsystems. ▪ May also be used without HiCommand software. ▪ Requires a Web server. 	<i>Storage Navigator Modular for Web User's Guide</i> (MK-95DF719)
Storage Navigator Modular Graphical User Interface (GUI)	Traditional graphical user interface (GUI)	<ul style="list-style-type: none"> ▪ Operating system: Windows, or UNIX®/Linux® ▪ Network: Storage subsystems connect to the host computer through a LAN. 	GUI appearance is similar to Web version.	<i>Storage Navigator Modular Graphical User Interface (GUI) User's Guide</i> (MK-95DF711)
Storage Navigator Modular Command Line Interface (CLI)	Command line interface (CLI)	<ul style="list-style-type: none"> ▪ Installation and operation: Program is installed on and run from the host computer. 	For users who prefer the command line interface or want to run scripts.	<i>Storage Navigator Modular Command Line Interface (CLI) User's Guide</i> (MK-95DF712)

Convention for Storage Capacity Values

Storage capacity values for hard disk drives (HDDs) are calculated based on the following values:

- 1 KB (kilobyte) = 1,000 bytes
- 1 MB (megabyte) = 1,000² bytes
- 1 GB (gigabyte) = 1,000³ bytes
- 1 TB (terabyte) = 1,000⁴ bytes

Storage capacity values for logical units (LUs) are calculated based on the following values:

- 1 KB (kilobyte) = 1,024 bytes
- 1 MB (megabyte) = 1,024² bytes
- 1 GB (gigabyte) = 1,024³ bytes
- 1 TB (terabyte) = 1,024⁴ bytes

Referenced Documents

- *Hitachi TagmaStore AMS and WMS LUN Management User's Guide*, MK-95DF703
- *Hitachi TagmaStore AMS and WMS SNMP Agent User's Guide*, MK-95DF705
- *Hitachi TagmaStore AMS and WMS Password Protection User's Guide*, MK-95DF704
- *Hitachi TagmaStore AMS and WMS Error Codes*, MK-95DF788

Comments

Please send us your comments on this document. Make sure to include the document title, number, and revision. Please refer to specific section(s) and paragraph(s) whenever possible.

- E-mail: doc.comments@hds.com
- Fax: 858-695-1186
- Mail:
Technical Writing, M/S 35-10
Hitachi Data Systems
10277 Scripps Ranch Blvd.
San Diego, CA 92131

Thank you! (All comments become the property of Hitachi Data Systems Corporation.)

Contents

Chapter 1 Overview of TagmaStore® AMS and WMS

1.1 Overview of TagmaStore AMS and WMS	1
--	---

Chapter 2 Installing Storage Navigator

2.1 Connecting Storage Navigator to the Host.....	4
2.1.1 Connecting Through a LAN with a Hub.....	4
2.1.2 Connecting Through a LAN without a Hub.....	4
2.2 System Requirements	5
2.2.1 Hardware Requirements.....	5
2.2.2 Operating System Requirements	5
2.2.2.1 Windows®	5
2.2.2.2 Solaris™	6
2.2.2.3 SGI®	6
2.2.2.4 HP-UX	7
2.2.2.5 Red Hat® Linux®	7
2.3 Installing Storage Navigator.....	8
2.3.1 General Installation Requirements	8
2.3.1.1 Windows	8
2.3.1.2 Solaris	8
2.3.1.3 IRIX	9
2.3.1.4 HP-UX	9
2.3.1.5 Red Hat Linux	9
2.4 Updating Storage Navigator.....	10
2.4.1 Windows	10
2.4.2 Solaris	10
2.4.3 IRIX	10
2.4.4 HP-UX	11
2.4.5 Red Hat Linux	11
2.5 Uninstalling Storage Navigator	12
2.5.1 Windows	12
2.5.2 Solaris, IRIX, HP-UX, and Red Hat Linux	12

Chapter 3 Viewing the Storage Navigator Main Windows

3.1 Storage Navigator Main Window.....	14
3.1.1 Menu Bars and Toolbars	14
3.1.2 Tree View Box.....	17
3.1.3 List View Box.....	18
3.2 Array System Viewer Window.....	19
3.2.1 Component Status Tab	19
3.2.1.1 Subsystem View	19
3.2.1.2 Controller View	20
3.2.1.3 Cache View	21
3.2.1.4 Battery Backup View.....	22
3.2.1.5 Battery View	23
3.2.1.6 Drive View	24
3.2.1.7 Fan View	27
3.2.1.8 AC View	28
3.2.1.9 ENC View	29
3.2.1.10 Loop View	30

3.2.1.11	SATA Units View	31
3.2.1.12	Individual SATA Unit View	32
3.2.1.13	NNC View	33
3.2.1.14	Individual NNC (NNC Type2) Unit View	34
3.2.1.15	NNC Base View	35
3.2.1.16	NNC (Type2) DIMM View	36
3.2.1.17	NNC (Type2) PS View	37
3.2.1.18	NNC (Type2) Fan View	38
3.2.1.19	NNC (Type2) Extension Slot	39
3.2.1.20	NNC (Type2) Extension Slot3	40
3.2.1.21	NNC (Type2) Extension Card	41
3.2.1.22	NNC (Type2) Host Connector	42
3.2.1.23	Individual NNC (Type1) Unit View	43
3.2.1.24	NNC (Type1) DIMM View	44
3.2.1.25	NNC (Type1) PS View	45
3.2.1.26	NNC (Type1) Fan View	46
3.2.1.27	NNC (Type1) Host Connector View	47
3.2.1.28	Property Window	48
3.2.2	Logical Status Tab	49
3.2.2.1	RAID Groups View	50
3.2.2.2	Individual RAID Group View	51
3.2.2.3	Targets View	52
3.2.2.4	Individual Target Port View	53
3.2.2.5	Access Mode View	54
3.2.2.6	Mapping Mode View	55
3.2.2.7	Target Security View	56
3.2.2.8	Spare Drives View	57
3.2.2.9	Differential Management LU View	58
3.2.2.10	Command Devices View	59
3.2.2.11	License Key View	60
3.2.2.12	ShadowImage View	61
3.2.2.13	LUN Expansion View	63
3.2.2.14	Data Retention View	64
3.2.2.15	Cache Residency View	65

Chapter 4 Preparing for Storage Navigator Operations

4.1	Using Storage Navigator	68
4.2	Available Storage Navigator Functions	70
4.3	Starting and Stopping Storage Navigator	73
4.3.1	Launching from Windows	73
4.3.1.1	Launching from Installation Directory	73
4.3.1.2	Launching from a Different Directory	74
4.3.1.3	Specifying Automatic Launch of Error Monitoring	74
4.3.1.4	Specifying Automatic Display of Array System Viewer Window	75
4.3.2	Launching from Solaris™, IRIX®, HP-UX, or Red Hat® Linux®	76
4.3.2.1	Launching from Installation Directory	76
4.3.2.2	Launching from a Different Directory	76
4.3.3	Stopping Storage Navigator	76
4.4	Restarting the Subsystem	77
4.5	Changing Operation Mode	77
4.5.1	Changing from Normal Mode to Management Mode	77
4.5.2	Changing from Management Mode to Normal Mode	79
4.6	Managing Passwords	80
4.6.1	Registering or Changing a Password	80

4.6.2	Deleting the Password	80
4.7	Configuring Subsystems.....	81
4.7.1	Adding Subsystems Manually.....	81
4.7.2	Adding Subsystems Automatically	83
4.7.3	Modifying Array Unit Properties.....	85
4.7.4	Deleting a Registered Subsystem	85
4.7.5	Displaying Storage Navigator Version	85
4.8	Displaying Information Message	86
4.9	Setting and Releasing Spare Drives	87
4.9.1	Setting a Spare Drive	87
4.9.1.1	Releasing a Spare Drive	89
4.10	Setting and Releasing the Differential Management LU	90
4.10.1	Setting the Differential Management LU	90
4.10.2	Releasing a Differential Management LU	91
4.11	Setting and Releasing Command Devices	92
4.11.1	Setting a Command Devices	92
4.11.2	Modifying a Command Device	95
4.11.3	Releasing a Command Device	95
4.12	Enabling and Disabling the License Key for Optional Products.....	96
4.12.1	Installing Optional Features	96
4.12.2	De-installing the Optional Features	99
4.12.3	Enabling or Disabling Optional Features	100

Chapter 5 Configuring Storage Navigator

5.1	Configuration Settings Window Descriptions	102
5.1.1	Boot Options Tab	102
5.1.2	System Parameter Tab	103
5.1.3	LAN Tab	105
5.1.4	Maintenance LAN Tab.....	106
5.1.5	LAN Port Number Tab.....	107
5.1.6	Port Options Tab	108
5.1.7	Restore Options Tab	109
5.1.8	Online Verify Tab.....	111
5.1.9	Constitute Tab	112
5.1.10	iSCSI Tab	113
5.1.11	iSNS Tab.....	114
5.1.12	Ping Tab.....	115
5.1.13	Micro Update Tab	116
5.1.14	RTC Tab.....	117
5.1.15	Time Zone Tab.....	118
5.1.16	Format Mode Tab.....	119
5.1.17	SNMP Tab	120
5.1.18	Password Protection Tab.....	121
5.1.19	Backend Diagnosis Tab	122
5.2	Setting Boot Options	123
5.3	Setting System Parameters	125
5.4	Setting LAN Configuration.....	127
5.4.1	Setting Without Rebooting.....	127
5.4.2	Setting with a Reboot.....	129
5.5	Setting Maintenance Port IP Address	131
5.6	Setting LAN Port Number	132
5.7	Setting Port Options.....	135
5.8	Setting Restore Options	137
5.9	Setting Online Verify Mode.....	139

5.10	Outputting or Setting Configuration Information with Text Files (Constitute Tab)	140
5.10.1	Overview	140
5.10.2	Outputting Information to a Text File	140
5.10.3	Setting RAID/LU Configuration using a Text File	146
5.10.4	Setting Port or Host Group Configuration with a File	149
5.10.5	Setting CHAP User Information with a File	150
5.10.6	Setting Boot Option Information with a File	151
5.11	Setting NAS System LU or User LU Information with a File	152
5.11.1	Setting LAN Information with a File	153
5.12	Setting iSCSI Port Information	154
5.13	Setting iSNS Server Information	156
5.14	Pinging the Initiator Host	157
5.15	Updating the Microcode	159
5.15.1	Downloading Microcode	159
5.15.2	Replacing the Microcode	164
5.16	Setting the RTC	166
5.17	Setting the Time Zone and NTP Server	167
5.18	Setting Formatting Mode	168
5.19	Setting Fibre Channel Information	170
5.20	SNMP	172
5.21	Password Protection	172
5.22	Setting Backend Diagnosis Information	173
Chapter 6	RAID Group Operations	
6.1	Displaying RAID Group and Logical Unit Properties	176
6.2	Creating a RAID Group	178
6.3	Deleting a RAID Group	182
Chapter 7	Logical Unit Operations	
7.1	Creating a Logical Unit	186
7.1.1	Creating a Logical Unit Automatically	186
7.1.2	Constituting a Logical Unit Manually	189
7.1.3	Using the Wizard to Create Logical Units	191
7.2	Formatting a Logical Unit	193
7.3	Deleting a Logical Unit	196
7.4	Changing the Default Controller	200
7.5	Parity Correction	202
Chapter 8	Host Group Operations	
8.1	Setting Host Group Options	206
8.2	Setting the Mapping Guard	211
8.3	Specifying the Mapping Mode	212
8.4	Setting Mapping Information	214
Chapter 9	Setting Target Information	
9.1	Setting Target Options	218
9.2	Setting the Mapping Guard	223
9.3	Specifying the Mapping Mode	224
9.4	Setting the Mapping Information	226
9.5	Setting a CHAP User	229
9.5.1	Adding a CHAP User	229
9.5.2	Changing the CHAP User	231

9.5.3	Deleting the CHAP User	233
9.6	Setting Target Information.....	234
9.6.1	Changing Target Information	234
9.6.2	Initializing Target 0	237
Chapter 10	NAS Operations	
10.1	Setting the NNC LAN Information	240
10.2	Setting NAS System Logical Units	242
10.2.1	For NNC Type2	242
10.2.2	For NNC Type1	245
10.3	Setting NAS User Logical Units	249
10.4	Shutdown/Booting/Rebooting NNC	252
10.4.1	Shutdown the NNC	252
10.4.2	Booting the NNC	255
10.4.3	Rebooting the NNC	256
Chapter 11	Displaying Statistical Information	
11.1	Displaying the Controller Use Condition	260
11.2	Displaying the Numbers of Host Commands Received	261
11.3	Displaying the Command Execution Condition	262
11.4	Displaying the Cache Load Condition.....	263
Chapter 12	Acquiring Performance Information	
12.1	Setting a Collection of Performance Statistics	266
12.2	Outputting Statistics Information Automatically to a Text File.....	267
12.3	Outputting Performance Statistics Information Manually to a Text File.....	268
12.4	Outputting Performance Statistics Information Automatically to a Text File	276
Chapter 13	Tuning Parameters	
13.1	Multi Stream Tuning Parameters	280
13.2	Pre-Fetch Parameters.....	284
13.3	System Tuning Parameters.....	287
Chapter 14	ACE Tool	
14.1	Automatic Setting	290
14.2	Constituting a Cabinet using the Storage Navigator Output File.....	294
14.3	Cable Figure Detail.....	298
Chapter 15	Troubleshooting	
15.1	Error Monitoring	300
15.1.1	Setting Error Monitoring Options.....	300
15.1.1.1	Interval Time.....	300
15.1.2	E-Mail Report.....	301
15.1.3	Setting Additional Information on E-mail.....	303
15.1.4	Executing Application.....	304
15.2	Registering the Failure Monitoring Account	305
15.3	Error Monitoring	306
15.4	Checking Status	309
15.5	Troubleshooting.....	310
15.6	Calling the Hitachi Data Systems Support Center	311

Acronyms and Abbreviations 313

List of Figures

Figure 2.1	Connecting to a Host without a Hub	4
Figure 2.2	Connecting to a Host with a Hub	4
Figure 3.1	Storage Navigator Main Window	14
Figure 3.2	Component Status Tab, Subsystem View	19
Figure 3.3	Component Status Tab, Controller View.....	20
Figure 3.4	Component Status Tab, Cache View	21
Figure 3.5	Component Status Tab, Battery Backup View	22
Figure 3.6	Component Status Tab, Battery View.....	23
Figure 3.7	Component Status Tab, Drive View.....	24
Figure 3.8	Drive Configuration Window	26
Figure 3.9	Component Status Tab, Fan View.....	27
Figure 3.10	Component Status Tab, AC View.....	28
Figure 3.11	Component Status Tab, ENC View	29
Figure 3.12	Component Status Tab, Loop View	30
Figure 3.13	Component Status Tab, Units View.....	31
Figure 3.14	Component Status Tab, Individual SATA Unit View	32
Figure 3.15	Component Status Tab, NNC View.....	33
Figure 3.16	Component Status Tab, Individual NNC (Type2) Unit View.....	34
Figure 3.17	Component Status Tab, NNC Base View	35
Figure 3.18	Component Status Tab, DIMM (Type2) View	36
Figure 3.19	Component Status Tab, NNC (Type2) Fan View	38
Figure 3.20	Component Status Tab, NNC (Type2) Extension Slot View.....	39
Figure 3.21	Component Status Tab, NNC (Type2) Extension Slot3 View	40
Figure 3.22	Component Status Tab, NNC (Type2) Extension Card View.....	41
Figure 3.23	Component Status Tab, NNC (Type2) Host Connector View	42
Figure 3.24	Component Status Tab, Individual NNC (Type1) Unit View.....	43
Figure 3.25	Component Status Tab, DIMM (Type1) View	44
Figure 3.26	Component Status Tab, NNC (Type1) PS View	45
Figure 3.27	Component Status Tab, NNC (Type1) Fan View	46
Figure 3.28	Component Status Tab, NNC (Type1) Host Connector View.....	47
Figure 3.29	Property Window	48
Figure 3.30	Array System Viewer Window, Logical Status Tab	49
Figure 3.31	Logical Status Tab, RAID Groups View	50
Figure 3.32	Logical Status Tab, Individual RAID Group View.....	51
Figure 3.33	Logical Status Tab, Targets View	52
Figure 3.34	Logical Status Tab, Individual Target Port View	53
Figure 3.35	Logical Status Tab, Access Mode View	54
Figure 3.36	Logical Status Tab, Mapping Mode View	55
Figure 3.37	Logical Status Tab, Target Security View	56
Figure 3.38	Logical Status Tab, Spare Drives View	57
Figure 3.39	Logical Status Tab, Differential Management LU View.....	58
Figure 3.40	Logical Status Tab, Command Devices View	59
Figure 3.41	Logical Status Tab, License Key View	60
Figure 3.42	Logical Status Tab, ShadowImage View.....	61
Figure 3.43	Logical Status Tab, ShadowImage Pair View	62
Figure 3.44	Logical Status Tab, LUN Expansion View	63
Figure 3.45	Logical Status Tab, Data Retention View	64
Figure 3.46	Logical Status Tab, Cache Residency View	65
Figure 4.1	Editing the Startsm.bat File.....	74
Figure 4.2	Sample Unit Option	75

Figure 4.3	Sample IP Option.....	75
Figure 4.4	Sample Host Option.....	75
Figure 4.5	Normal Mode.....	77
Figure 4.6	Management Mode Password Window	78
Figure 4.7	Management Mode	78
Figure 4.8	User Mode Change Confirmation Dialog Box	79
Figure 4.9	Set Password Pop-up Menu	80
Figure 4.10	Password Window	80
Figure 4.11	Add Array Unit Window (Simple)	82
Figure 4.12	Add Array Unit Window (Detailed)	82
Figure 4.13	Add Array Unit Automatically Window (before search)	83
Figure 4.14	Add Array Unit Automatically Window (search results shown)	84
Figure 4.15	Add Array Unit Automatically Window (unit selected).....	84
Figure 4.16	Modify Array Unit Window	85
Figure 4.17	Information Message Dialog Box	86
Figure 4.18	Selecting a Spare Drive	87
Figure 4.19	Spare Drives Settings Window.....	88
Figure 4.20	Spare Drive Selected	88
Figure 4.21	Selecting a Differential Management LU	90
Figure 4.22	Select Logical Unit Window	91
Figure 4.23	Differential Management LU Set	91
Figure 4.24	Setting Command Devices	92
Figure 4.25	Command Devices Settings Window (before setting)	93
Figure 4.26	Command Devices Settings Window (after setting)	93
Figure 4.27	Command Device Set.....	94
Figure 4.28	Modify Command Devices Window	95
Figure 4.29	Selecting the License Key View.....	97
Figure 4.30	Install Options Dialog Box	97
Figure 4.31	Install Options Selection Window	97
Figure 4.32	Result Window.....	98
Figure 4.33	Restart Warning Dialog Box	98
Figure 4.34	De-install Options Dialog Box	99
Figure 5.1	Configuration Settings Window, Boot Options Tab	102
Figure 5.2	Configuration Settings Window, System Parameter Tab.....	103
Figure 5.3	Configuration Settings Window, LAN Tab	105
Figure 5.4	Configuration Settings Window, Maintenance LAN Tab.....	106
Figure 5.5	LAN Port Number Tab	107
Figure 5.6	Configuration Settings Window, Port Options Tab.....	108
Figure 5.7	Configuration Settings Window, Restore Options Tab	109
Figure 5.8	Configuration Settings Window, Online Verify Tab.....	111
Figure 5.9	Configuration Settings Window, Constitute Tab	112
Figure 5.10	Configuration Settings Window, iSCSI Tab	113
Figure 5.11	Configuration Settings Window, iSNS Tab.....	114
Figure 5.12	Configuration Settings Window, Ping Tab.....	115
Figure 5.13	Configuration Settings Window, Micro Update Tab.....	116
Figure 5.14	Configuration Settings Window, RTC Tab	117
Figure 5.15	Configuration Settings Window, Time Zone Tab	118
Figure 5.16	Configuration Settings Window, Format Mode Tab	119
Figure 5.17	Configuration Settings Window, SNMP Tab	120
Figure 5.18	Configuration Settings Window, Password Protection Tab.....	121
Figure 5.19	Configuration Settings Window, Backend Diagnosis Tab.....	122
Figure 5.20	Setting Boot Options	124
Figure 5.21	Restart Warning Dialog Box.....	124

Figure 5.22	Setting System Parameters	126
Figure 5.23	Setting LAN Configuration without Rebooting	128
Figure 5.24	Confirm LAN Environment Warning Message	128
Figure 5.25	Setting LAN Configuration with a Reboot.....	130
Figure 5.26	Setting Maintenance Port IP Address.....	131
Figure 5.27	Setting LAN Port Number.....	133
Figure 5.28	Confirming Port Number	133
Figure 5.29	Set Same Port Number	133
Figure 5.30	Add to Services File	134
Figure 5.31	Adding Port Number to Services File (Windows® 2000).....	134
Figure 5.32	Setting Port Options	136
Figure 5.33	Stop I/O Warning Message	136
Figure 5.34	Setting the Drive Restore Option	138
Figure 5.35	Setting Online Verify Mode	139
Figure 5.36	Outputting Configuration Information to a Text File	141
Figure 5.37	System Parameter Output File Format.....	141
Figure 5.38	RAID Group/Logical Unit Configuration Output File	142
Figure 5.39	Host Group Information Output File.....	143
Figure 5.40	Boot Options Information Output File.....	143
Figure 5.41	NAS System/User LUs Information Output File	144
Figure 5.42	iSCSI Port Information Output File	145
Figure 5.43	LAN Information Output File.....	146
Figure 5.44	RAID/LU Configuration Data Deletion Warning Message	147
Figure 5.45	User Data Deletion Warning Message.....	148
Figure 5.46	Stop Host Access Warning Message (Port or Host Group Operations)	149
Figure 5.47	System and User LU Deletion Warning Message	152
Figure 5.48	Setting iSCSI Port Information.....	155
Figure 5.49	Stop Host Access Warning Message	155
Figure 5.50	Setting iSNS Server Information.....	156
Figure 5.51	Pinging Initiator Host	157
Figure 5.52	Host Access Delay Warning Message.....	158
Figure 5.53	Select Refresh Message.....	158
Figure 5.54	Ping Results	158
Figure 5.55	Downloading Microcode	161
Figure 5.56	Overwrite Microcode Confirmation Message (1).....	161
Figure 5.57	Overwrite Microcode Confirmation Message (2).....	161
Figure 5.58	Specify Path Window	162
Figure 5.59	Sample Path	162
Figure 5.60	Revision Read	162
Figure 5.61	Host Access Message	163
Figure 5.62	Microcode Download Window	163
Figure 5.63	Replacing Microcode	165
Figure 5.64	Replace Microcode Confirmation Message.....	165
Figure 5.65	Host Access Accepted Message.....	165
Figure 5.66	Setting RTC.....	166
Figure 5.67	Setting Time Zone.....	167
Figure 5.68	Setting Formatting Mode.....	169
Figure 5.69	Setting Fibre Channel Information.....	171
Figure 5.70	Host Access Warning Message	171
Figure 5.71	Setting Backend Diagnosis Information	173
Figure 6.1	Displaying RAID Group and LU Definitions.....	176
Figure 6.2	Displaying Drive Configuration	177
Figure 6.3	Create RAID Group Window (automatic selection).....	179

Figure 6.4	Create RAID Group Window (manual selection).....	179
Figure 6.5	Select Drives Dialog Box (before selecting drive).....	180
Figure 6.6	Select Drives Dialog Box (after selecting drive).....	180
Figure 6.7	Newly Created RAID Group	181
Figure 6.8	Logical Unit Warning Message.....	182
Figure 6.9	Delete User Data Warning Message	183
Figure 6.10	Delete RAID Group Result Window	183
Figure 10.1	Disk Array Subsystem to which NNC Option Added (management ports)	239
Figure 11.1	Displaying Controller Use Condition	260
Figure 11.2	Displaying Number of Host Command Received.....	261
Figure 11.3	Displaying Command Execution Condition	262
Figure 11.4	Displaying Cache Load Condition	263
Figure 15.1	Setting Error Monitoring Options	300
Figure 15.2	Setting Additional Information on E-Mail	303
Figure 15.3	Monitoring Account Information Window	305
Figure 15.4	Starting Error Monitoring	306
Figure 15.5	Checking the Status of Subsystem Components.....	309

List of Tables

Table 3.1	File Functions	14
Table 3.2	Edit Functions.....	14
Table 3.3	View Functions.....	15
Table 3.4	Tool Functions	15
Table 3.5	Help Functions	15
Table 3.6	Tool Bar Icons.....	15
Table 3.7	Settings Functions.....	16
Table 3.8	Tools Functions	16
Table 3.9	RAID Group Icons	17
Table 3.10	Logical Unit Icons.....	17
Table 3.11	Icons in List View Box.....	18
Table 3.12	Status Bar Descriptions	18
Table 3.13	Controller Icons.....	20
Table 3.14	Cache Icons.....	22
Table 3.15	Battery Backup Icons	23
Table 3.16	Battery Icons	24
Table 3.17	Data Drive Icons	25
Table 3.18	Fan Icons.....	27
Table 3.19	Enclosure/SENC Icons.....	29
Table 3.20	Loop Icons	30
Table 3.21	NNC Icons	33
Table 3.22	NNC Base (Type2) Icons	35
Table 3.23	NNC DIMM (Type2) Icons.....	36
Table 3.24	Component Status Tab, NNC (Type2) PS View	37
Table 3.25	NNC PS (Type2) Icons	37
Table 3.26	NNC (Type2) Fan Icons.....	38
Table 3.27	NNC (Type2) Extension Slot Icons.....	39
Table 3.28	NNC (Type2) Extension Slot Icons.....	40
Table 3.29	NNC (Type2) Extension Card Icons.....	41
Table 3.30	NNC (Type2) Host Connector Icons	42
Table 3.31	NNC (Type1) DIMM Icons.....	44
Table 3.32	NNC PS (Type1) Icons	45
Table 3.33	NNC (Type1) Fan Icons.....	46
Table 3.34	NNC Host (Type1) Connector Icons	47
Table 3.35	Spare Drive Icons	57
Table 4.1	Restrictions on using Multiple Management Programs for Single Array.....	69
Table 4.2	Storage Navigator Functions (continued on the following pages)	70
Table 5.1	CHAP User Information Format.....	150
Table 7.1	Usage for Logical Units	191
Table 15.1	List of E-Mail Subjects.....	301

Chapter 1 Overview of TagmaStore® AMS and WMS

1.1 Overview of TagmaStore AMS and WMS

The TagmaStore Adaptable Modular Storage (AMS) and Workgroup Modular Storage (WMS) provide scalable, cost-effective modular storage for Microsoft Exchange Server and other business applications. You can use the AMS or WMS to implement storage consolidation, first SAN deployment, backup, or data archiving.

The AMS and WMS enable you to meet compliance requirements, protect your data, and reduce recovery times, while benefiting from flexible storage solutions that allow you to manage your data growth. The centralized storage infrastructure allows you to reduce the complexity and cost of your storage management. Fully redundant and hot-swappable components let you to keep applications online, while within-system volume replication and incremental copy functions allow for frequent backups. The available RAID-6 architecture gives you high availability and rapid RAID group rebuild, while the Hi-Track “call home” service and remote maintenance functions provide the security of 24/7 support from expert service professionals.

You can partition and dedicate cache to maximize the performance of high-I/O operations. You can leverage the AMS or WMS together with the enterprise-class TagmaStore Universal Storage Platform (USP) or Network Storage Controller (NSC) to implement a tiered storage solution to manage the data lifecycle. Simple SAN and SAN Starter solutions allow easy deployment. SAN-attached servers can use diskless boot, and Network Attached Storage (NAS) applications allow for high-capacity storage.

Chapter 2 Installing Storage Navigator

This chapter discusses the following topics:

- Connecting Storage Navigator to the host (section 2.1)
- System Requirements (section 2.2)
- Installing Storage Navigator (section 2.3)
- Updating Storage Navigator (section 2.4)
- Uninstalling Storage Navigator (section 2.5)

2.1 Connecting Storage Navigator to the Host

You can connect the Storage Navigator to a host through a LAN with or without a hub.

2.1.1 Connecting Through a LAN with a Hub

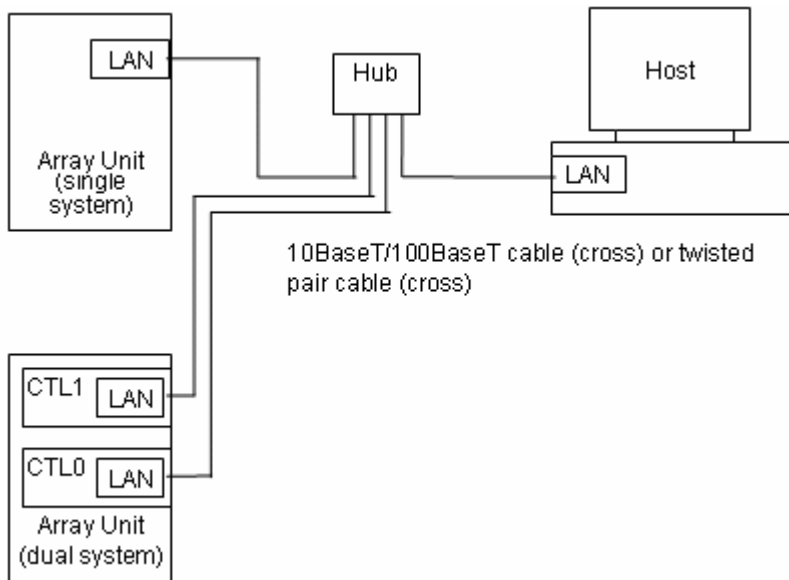

Figure 2.1 Connecting to a Host without a Hub

Note: If an array unit is already connected to a LAN, connect the host to the same network.

2.1.2 Connecting Through a LAN without a Hub

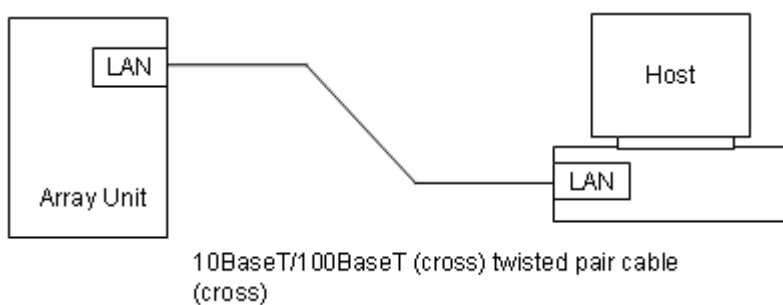

Figure 2.2 Connecting to a Host with a Hub

2.2 System Requirements

2.2.1 Hardware Requirements

Storage Navigator Modular has the following hardware requirements:

- Hitachi Storage Navigator Modular subsystem(s)
- One or more Storage Navigator computers. A web browser is required.
- LAN cables and connection: 10BaseT/100BaseT. Use twisted pair crossover cable if array unit is connected directly to a host; use twisted pair cable if array unit is connected via a hub.
- Network adapter
- License keys for Storage Navigator and other features.
- TCP/IP Port. Storage Navigator uses port number 2000. If you change the port number, you must add “df-damp-snm port number/TCP” to the OS services, and change the port number of the subsystem. When the subsystem port number is set to 2000, it can be connected to the LAN even if another port number is registered in the services file.

2.2.2 Operating System Requirements

2.2.2.1 Windows®

- Operating system: Windows® 98, Windows NT®, Windows® 2000, Windows® XP, Windows Server™ 2003 or Windows Server™ 2003 (R2):
 - Windows 98 requires MSIME 98-98-SRI.
 - DirectX version 8.1 or later
- Processor (CPU): Pentium® II, III, IV (233 MHz or more is recommended.)
- Monitor:
 - 800 x 600 is required; 1,024 x 768 or more is recommended.
 - 256 colors or more
- Memory: 256 MB (512 MB or more is recommended.)
- Available hard drive space: 50.3 MB max (A free capacity of 100 MB or more is required.)
- Web browser
- Java™ Runtime Environment: j2re-1.4.2_07

2.2.2.2 Solaris™

- Sun™ server/workstation
- Operating system: Solaris 7, 8, 9
- CPU: UltraSPARC or better
- Memory: 256 MB (512 MB or more is recommended.)
- Disk capacity: 72.7 MB max (A free capacity of 100 MB or more is required.)
- Network adapter
- Monitor:
 - Resolution 800 x 600, 1,024 x 768 or more is recommended.
 - 256 color or more
 - If the screen color is uneven, use the `/usr/sbin/fbconfig` command with a `-prconf` option to enlarge the color depth.
- LAN connection: 10BaseT/100BaseT. Use twisted pair crossover cable if array unit is connected directly to a host; use twisted pair cable if array unit is connected via a hub.
- Java Runtime Environment: J2re 1.4.2_07

2.2.2.3 SGI®

- SGI server/workstation
- Operating system: IRIX® 6.5
- CPU: R10000 or more is recommended.
- Memory: 256 MB (512 MB or more is recommended.)
- Disk capacity: 9.12 MB max (A free capacity of 100 MB or more is required.)
- Network adapter
- Monitor:
 - Resolution 800 x 600, 1,024 x 768 or more is recommended.
 - 256 color or more
- LAN connection: 10BaseT/100BaseT. Use twisted pair crossover cable if array unit is connected directly to a host; use twisted pair cable if array unit is connected via a hub.
- Java Runtime Environment: JRE 1.4.1

2.2.2.4 HP-UX

- HP server/workstation
- HP-UX 11.0
- CPU: PA8000 or more is recommended.
- Memory: 256 MB (512 MB or more is recommended.)
- Disk capacity: 119 MB max (A free capacity of 200 MB or more is required.)
- Network adapter
- Monitor:
 - Resolution 800 x 600, 1,024 x 768 or more is recommended.
 - 256 color or more
- LAN connection: 10BaseT/100BaseT. Use twisted pair crossover cable if array unit is connected directly to a host; use twisted pair cable if array unit is connected via a hub.
- Java Runtime Environment: RTE1.4.2_07

2.2.2.5 Red Hat® Linux®

- Operating system: Red Hat Linux 7.3, 8.0
- Kernel version:
 - Red Hat Linux 7.3: 2.4.18-3
 - Red Hat Linux 8.0: 2.4.18-14
- glibc version:
 - Red Hat Linux 7.3: 2.2.5-34
 - Red Hat Linux 8.0: 2.3.2-4.80.6
- CPU: Pentium® II, III, IV (233 MHz or more is recommended.)
- Memory: 256 MB (512 MB or more is recommended.)
- Disk capacity: 67.6 MB max (Free capacity of 100 MB or more is required.)
- Network adapter
- Monitor:
 - Resolution 800 x 600, 1,024 x 768 or more is recommended.
 - 256 color or more
- LAN connection: 10BaseT/100BaseT. Use twisted pair crossover cable if array unit is connected directly to a host; use twisted pair cable if array unit is connected via a hub.
- Java Runtime Environment: J2re 1.4.2_07

2.3 Installing Storage Navigator

2.3.1 General Installation Requirements

- If you are using a 9200 Storage Array, make sure that the **ERROR INF** is set to **OFF**, or Storage Navigator could either fail to connect or end abnormally. This is the default.
- Do not install Storage Navigator in a host that is connected to the storage array, because a high I/O load could cause a command time-out on the host side or an abnormal termination on the Manager side.
- At least one logical unit must be configured in the array unit, to make all of the Storage Navigator functions available.
- When you install Resource Manager, it overrides the AMS/WMS error monitoring. To restore error monitoring to the AMS/WMS, select **Edit → Modify → Do Not Modify Registration Information**.
- The Storage Navigator GUI program is operated by JAVA. For Windows, Solaris, HP-UX, and Red Hat Linux, JRE is packed.

2.3.1.1 Windows

1. Start the Storage Navigator computer, then boot up Windows.
2. Navigate to the `stonavm_win` directory in the CD ROM and launch the `.exe` file.

2.3.1.2 Solaris

1. Start a Sun server/workstation, and start up a session in the common desktop environment.
2. Create a new directory (e.g., `/usr/stonavm`) for installing Storage Navigator. Copy the `SNM-xxxx-S-GUI.tar` file, located in the `stonavm_sol` directory of the provided CD-ROM, into the newly created directory.
(“xxxx” indicates the variable part of the file name)
3. Extract the `SNM-xxxx-S-GUI.tar` file. A sample command is as follows:

```
tar xvf SNM-xxxx-S-GUI.tar
```
4. Log in again.

2.3.1.3 IRIX

1. Start an SGI server/workstation.
2. Create a new directory e.g., `/usr/stonavm`) for installing Storage Navigator. Copy the **SNM-xxxx-I-GUI.tar** file, located in the `stonavm_iris` directory of the provided CD-ROM, onto the newly created directory. “xxxx” indicates the variable part of the file name.
3. Extract the **SNM-xxxx-I-GUI.tar** file. A sample command is as follows:

```
tar xvf SNM-xxxx-I-GUI.tar
```

4. You will need to change scripts in `startsnm` (a shell script used to start Storage Navigator) in the extracted file to set a path to JRE™ in the `DEFAULT_JAVAHOME` variable. This is usually in the installation directory, named approximately as follows: **JRE™ 1.4.1**. For example, if JRE™ has been installed in `/usr/local/JRE1.4.1`, the command would be:

```
DEFAULT_JAVAHOME=/usr/local/JRE1.4.1
```

5. Log in again.

2.3.1.4 HP-UX

1. Start an HP server/workstation.
2. Create a new directory (*example:* `/usr/stonavm`) for installing the Storage Navigator. Copy the **SNM-xxxx-H-GUI.tar** file, in the `stonavm_hpux` directory of the provided CD-ROM, into the created directory on the hard disk drive. “xxxx” indicates the variable part of the file name.
3. Extract the **SNM-xxxx-H-GUI.tar** file. A sample command is as follows:

```
tar xvf SNM-xxxx-H-GUI.tar
```

4. Log in again.

2.3.1.5 Red Hat Linux

1. Start the Storage Navigator computer, and start up a session in the common desktop environment.
2. Create a new directory (e.g., `/usr/stonavm`) for installing the Storage Navigator. Copy the **SNM-xxxx-L-GUI.tar** file, in the `stonavm_linux` directory of the provided CD-ROM into the newly created directory. “xxxx” indicates the variable part of the file name.
3. Extract the **SNM-xxxx-L-GUI.tar** file. A sample command is as follows:

```
tar xvf SNM-xxxx-L-GUI.tar
```

4. Log in again.

2.4 Updating Storage Navigator

2.4.1 Windows

1. Stop all instances of Storage Navigator.
3. Navigate to the `stonavm_win` directory in the CD ROM and launch the `.exe` file.
2. The updated Storage Navigator can be run without restarting Windows.

2.4.2 Solaris

1. Stop all instances of Storage Navigator.
2. Copy the `SNM-xxxx-S-GUI.tar` file, in the `stonavm_sol` directory of the provided CD-ROM, to the hard disk. "xxxx" indicates the variable part of the file name.
3. Extract the `SNM-xxxx-S-GUI.tar` file. A sample command is as follows:

```
tar xvf SNM-xxxx-S-GUI.tar
```
4. The updated Storage Navigator can be run without restarting Solaris.

2.4.3 IRIX

1. Stop all instances of Storage Navigator.
2. Copy the `SNM-xxxx-I-GUI.tar` file, in the `stonavm_irix` directory of the provided CD-ROM, to the hard disk. "xxxx" indicates the variable part of the file name.
3. Extract the `SNM-xxxx-I-GUI.tar` file. A sample command is as follows:

```
tar xvf SNM-xxxx-I-GUI.tar
```
4. The updated Storage Navigator can be run without restarting IRIX.

2.4.4 HP-UX

1. Stop all instances of Storage Navigator.
2. Copy the **SNM-xxxx-H-GUI.tar** file, in the **stonavm_hpux** directory of the provided CD-ROM, to the hard disk. “xxxx” indicates the variable part of the file name.
3. Extract the **SNM-xxxx-H-GUI.tar** file. A sample command is as follows:

```
tar xvf SNM-xxxx-H-GUI.tar
```
4. The updated Storage Navigator can be run without restarting HP-UX.

2.4.5 Red Hat Linux

1. Stop all instances of Storage Navigator.
2. Copy the **SNM-xxxx-L-GUI.tar** file, in the **stonavm_linux** directory of the provided CD-ROM, to the hard disk. (“xxxx” indicates the variable part of the file name.)
3. Extract the **SNM-xxxx-L-GUI.tar** file. A sample command is as follows:

```
tar xvf SNM-xxxx-L-GUI.tar
```
4. The updated Storage Navigator can be run without restarting Red Hat Linux.

2.5 Uninstalling Storage Navigator

2.5.1 Windows

1. Delete Storage Navigator using the **Add and Delete Application** icon on the **Control Panel**.
2. Delete the directory used for Storage Navigator from the hard disk drive.

2.5.2 Solaris, IRIX, HP-UX, and Red Hat Linux

Remove the Storage Navigator software and delete the directory.

Chapter 3 Viewing the Storage Navigator Main Windows

This chapter discusses the following topics

- The Storage Navigator Main Window (section 3.1)
- The Array System Viewer Window (section 3.2)

3.1 Storage Navigator Main Window

The Storage Navigator Main window (see Figure 3.1) displays when you launch Storage Navigator.

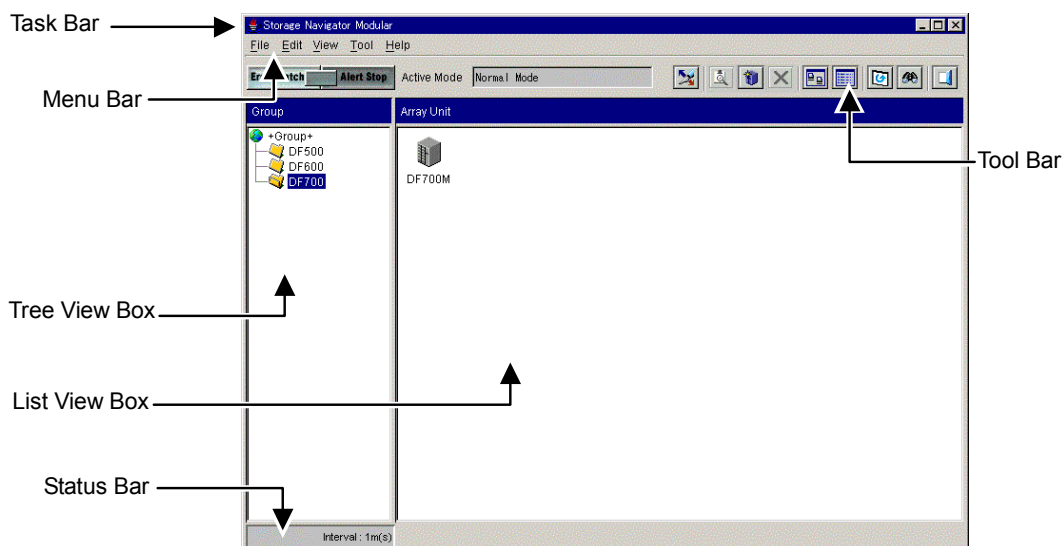

Figure 3.1 Storage Navigator Main Window

3.1.1 Menu Bars and Toolbars

Table 3.1 File Functions



Menu	Tool Bar	Function
Open		Displays the Array System Viewer window.
Reboot	—	Reboot the subsystem.
Exit		Terminates Storage Navigator.

Table 3.2 Edit Functions



Menu	Tool Bar	Function
Add		Registers the subsystem.
Add Automatically	—	Registers the subsystem automatically.
Modify	—	Changes the registration contents of the subsystem.
Delete		Deletes the registration of an array unit, which is registered in the Storage Navigator.
Monitoring	—	Sets the Monitoring Enable or Disable.

Table 3.3 View Functions



Menu	Tool Bar	Function
Icon		Displays the property of the subsystem by an icon.
Detail		Displays the property of the subsystem in detail.
Refresh	—	Updates the view to the current subsystem status.

Table 3.4 Tool Functions



Menu	Tool Bar	Function	
Operation Mode	Change		Changes the active mode.
	Set Password	—	Sets the password.
Error Monitoring	Execution		Executes the error monitoring.
	Scheduled Execution	—	Starts the error monitoring.
	Stop	—	Stops the error monitoring.
	Options		Displays the Monitoring Options window.
	Account	—	Registers the failure monitoring account.
Ace Tool	—	Navigates the Back-end configuration.	

Table 3.5 Help Functions

Menu	Tool Bar	Function
Version	—	Displays the revision of the Storage Navigator.

Table 3.6 Tool Bar Icons



Menu	Tool Bar	Function
Exit		Terminates the Array System Viewer window.
Properties	—	Displays the property of the subsystem.
Drive Configuration	—	Displays the drive configuration of the subsystem.
Refresh		Refreshes the Array System Viewer window.

Table 3.7 Settings Functions







Menu		Tool Bar	Function
RAID Group	Create		Displays the RAID group settings window.
	Delete	—	Deletes specified RAID group.
Logical Unit	Create		Displays the logical unit settings window.
	Format		Formats the logical unit (Max. 6).
	Change Default Controller	—	Changes default controller of logical unit.
	Parity Correction	—	Corrects the logical unit parity.
	Delete	—	Deletes specified logical unit.

Table 3.8 Tools Functions

Menu	Tool Bar	Function
Wizard		Starts the logical unit wizard.
Configuration Settings		Displays the configuration settings window.
Mapping Guard	—	Displays the LU mapping guard settings window.
Performance Output File		Outputs the performance of the subsystem.
Settings	—	Sets the collection of performance statistics.
Statistical Information		Displays the statistics information of the subsystem.
Information Message	—	Displays the information message of the subsystem.
Tuning Parameter	—	Displays the tuning parameter settings window.
ACE Tool	—	Navigates the Back-end configuration.

3.1.2 Tree View Box

- The **Tree View** box displays names of the registered array units.
 - Double clicking on **Group +** displays a list of the registered array units in that group.
 - Selecting a particular group icon displays the array units for that specific group.

Table 3.9 RAID Group Icons











Display	Status
 Blue	Normal
 Blue	Normal

Table 3.10 Logical Unit Icons

Display	Status
 Yellow	Formatted logical unit.
 Gray	Unformatted logical unit.
 Red	Blockaded logical unit.
 Pink	Regressed logical unit.
 Light Yellow	Invalidated formatted logical unit.
 Light Gray	Invalidated unformatted logical unit.
 Light Pink	Invalidated regressed logical unit.
 Yellow	Quick formatted logical unit or quick format standby logical unit.
 Yellow (9200 only)	Parity recovered logical unit or parity recovery standby logical unit.

3.1.3 List View Box

- The **List View** box displays icons representing the array group(s) selected in the **Tree View** box. The icon will be one of the following:

Table 3.11 Icons in List View Box







 Gray	Subsystem is booting up, and is not performing error monitoring.
 Gray + Blue	Normal
 Gray + Yellow	Warning
 Gray	Subsystem is down, powered off, or there is a communication error.

Table 3.12 Status Bar Descriptions

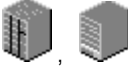
Status Bar	Description
 Interval : 1m(s)	Error Monitoring is stopped.
 Running Interval : 1m(s)	Error Monitoring is running.
 Wait Interval : 1m(s)	Error Monitoring in the interval

3.2 Array System Viewer Window

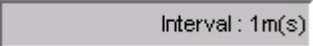
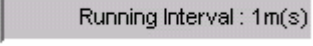
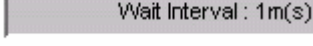
Access the **Array System Viewer** window by selecting a storage array in the **List View** box, and then either selecting **File → Open** or clicking the **Open** icon () on the tool bar. The **Component Status** tab (see section 3.2.1) is the default view. The **Logical Status** tab (see section 3.2.1.28) is the alternate view.

To update the component display, select **View → Refresh**, or click the **Refresh** icon () in the tool bar.

3.2.1 Component Status Tab

If you click the **Component Status** tab on the **Array System Viewer** window, you can view the status of various subsystem components.

3.2.1.1 Subsystem View

Click the **Subsystem** icon, to view the status of the components of the entire subsystem, see Figure 3.2.

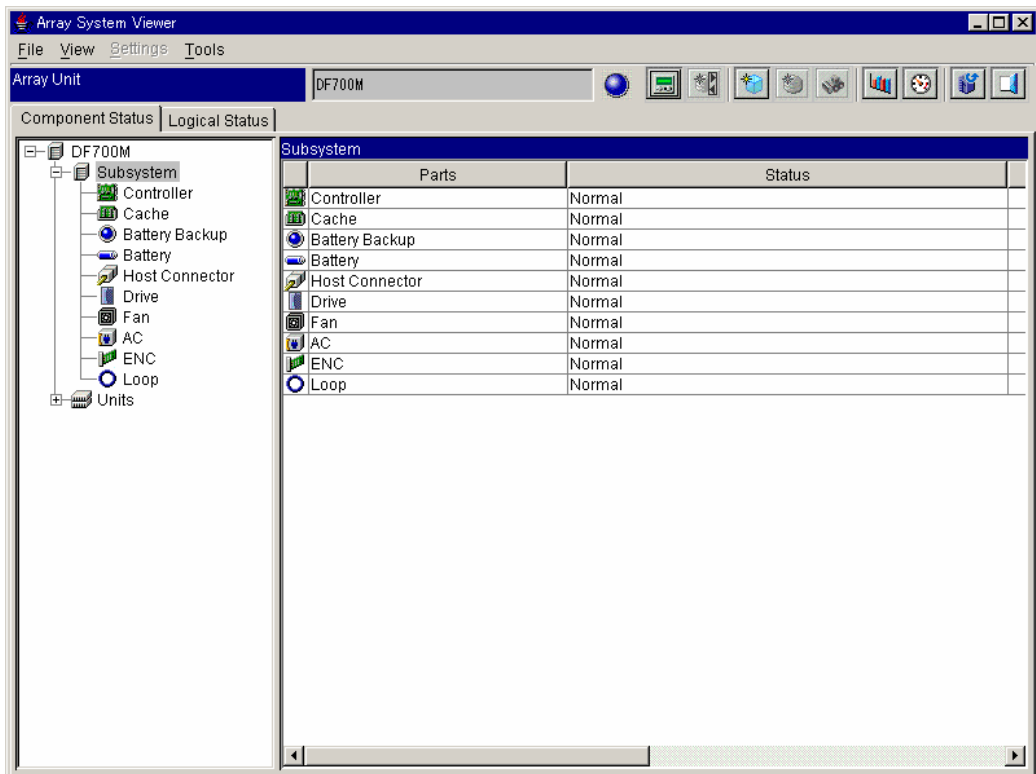

Figure 3.2 Component Status Tab, Subsystem View

3.2.1.2 Controller View

Click the **Controller** icon, to view the controller status, see Figure 3.3

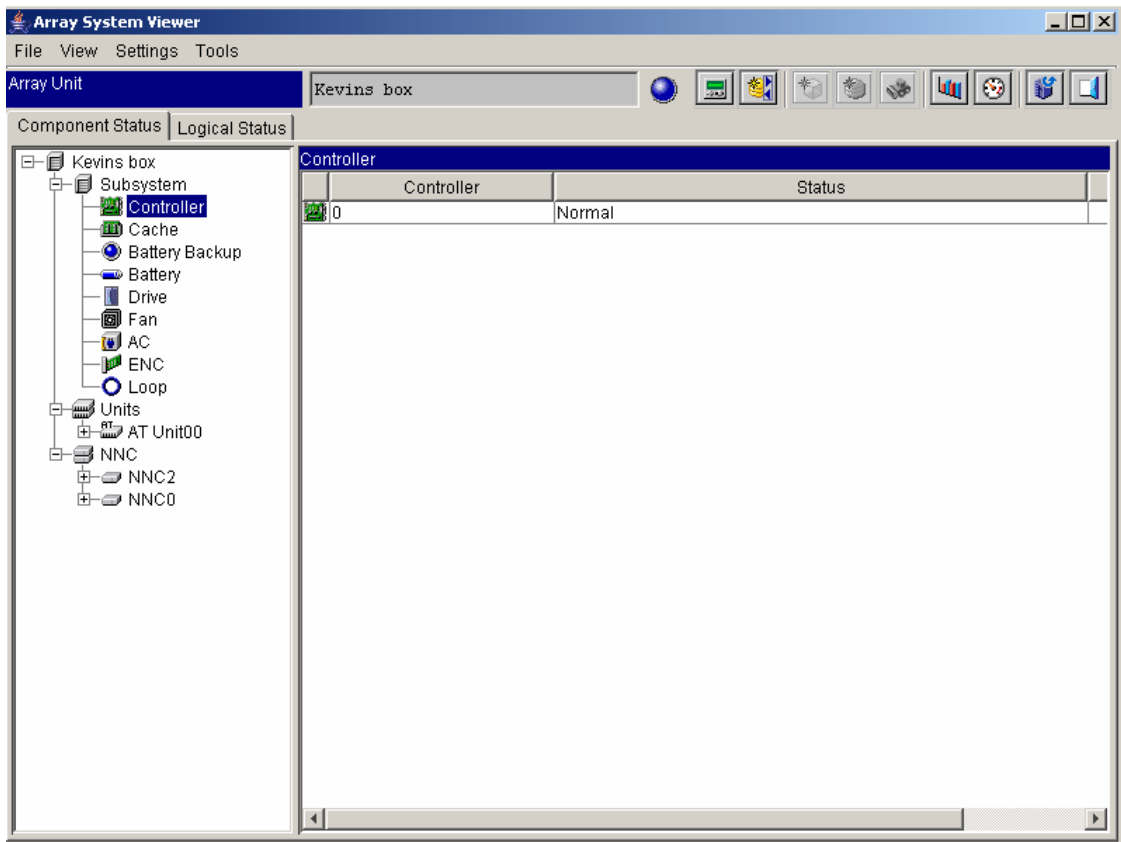





Figure 3.3 Component Status Tab, Controller View

- **Controller:** Controller No.
- **Status:** Status:
 - **Normal:** Normal
 - **Warning:** Cache or Battery Backup failure
 - **Detach:** Detached
 - **Reconst:** Reconfiguring

Table 3.13 Controller Icons

Display	Status
 Green	Normal
 Yellow	Failure
 Red	Blockade

3.2.1.3 Cache View

Click the **Cache** icon, to view the detailed status of the cache, see Figure 3.4.

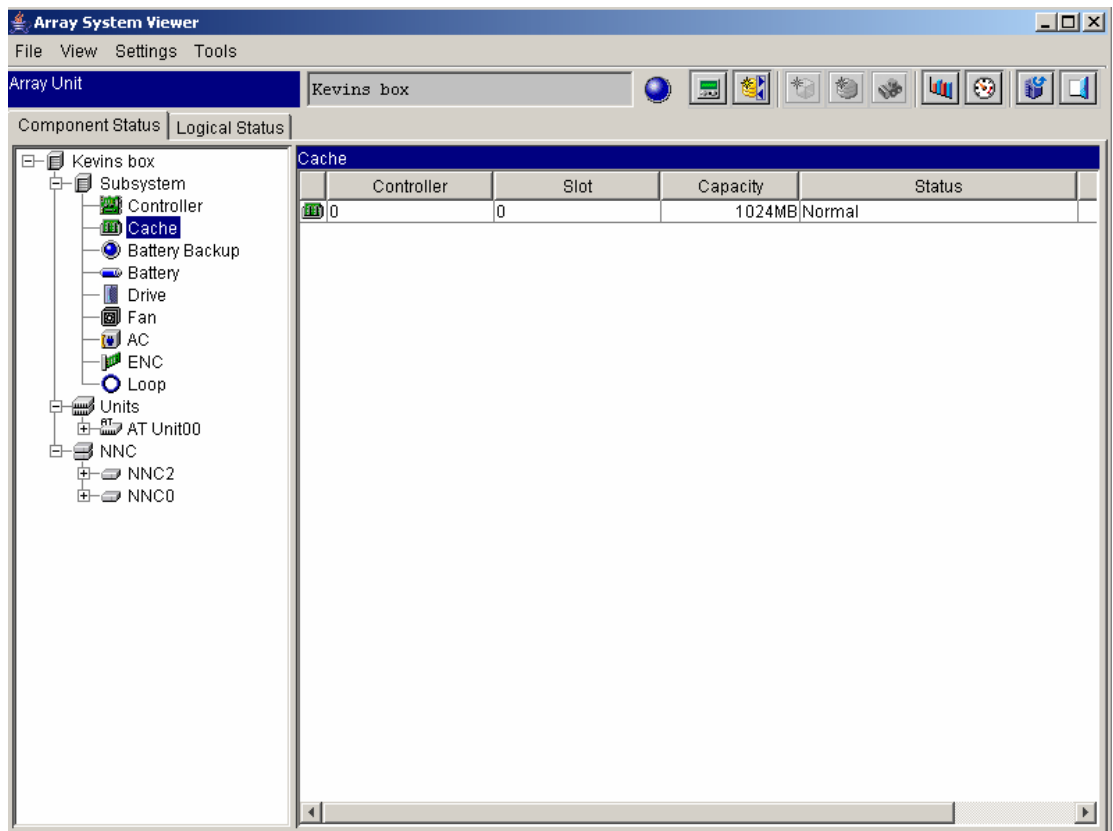





Figure 3.4 Component Status Tab, Cache View

- **Controller:** Controller No.
- **Slot:** Slot No.
- **Capacity:** Cache memory capacity
- **Status:** Status:
 - **Normal:** Normal
 - **Detached:** Detached
 - **Nothing:** Not installed

Table 3.14 Cache Icons

Display	Status
 Blue	Normal
 Red	Failure
	Not installed

3.2.1.4 Battery Backup View

Click the **Battery Backup** icon, to view the detailed status of the battery backup, see Figure 3.5.

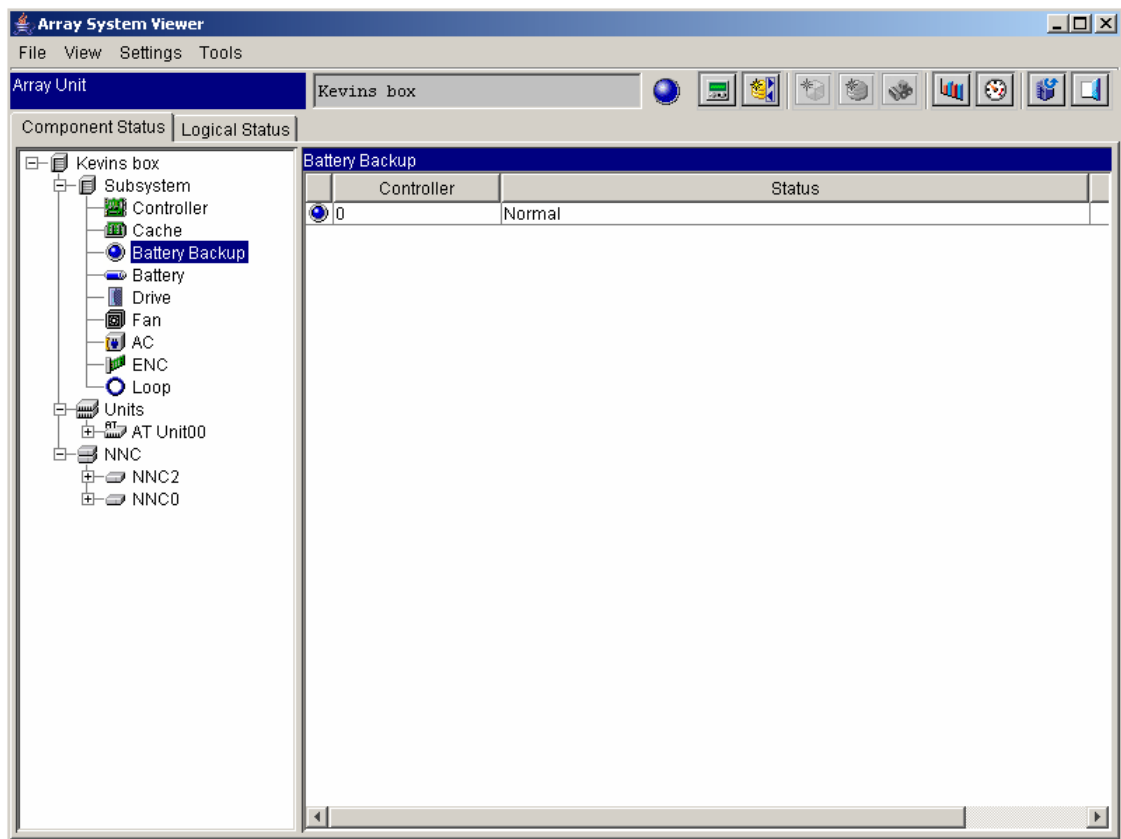



Figure 3.5 Component Status Tab, Battery Backup View

- **Controller:** Controller No.
- **Status:** Status:
 - **Normal:** Normal
 - **Alarm:** Failure

Table 3.15 Battery Backup Icons

Display	Status
 Blue	Normal
 Yellow	Failure

3.2.1.5 Battery View

Click the **Battery** icon, to view the detailed status of the battery, see Figure 3.6.

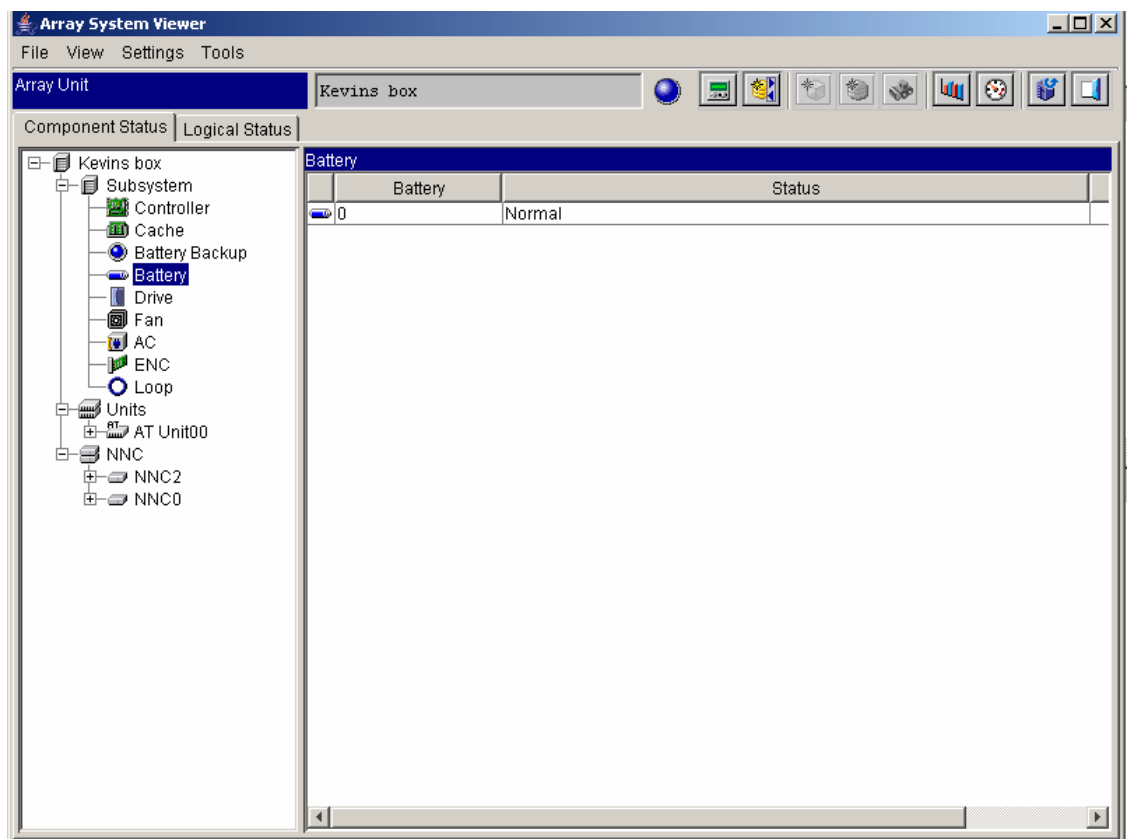



Figure 3.6 Component Status Tab, Battery View

- **Battery:** Battery No.
- **Status:** Status:
 - **Normal:** Normal
 - **Alarm:** Failure

Table 3.16 Battery Icons

Display	Status
 Blue	Normal
 Red	Failure

3.2.1.6 Drive View

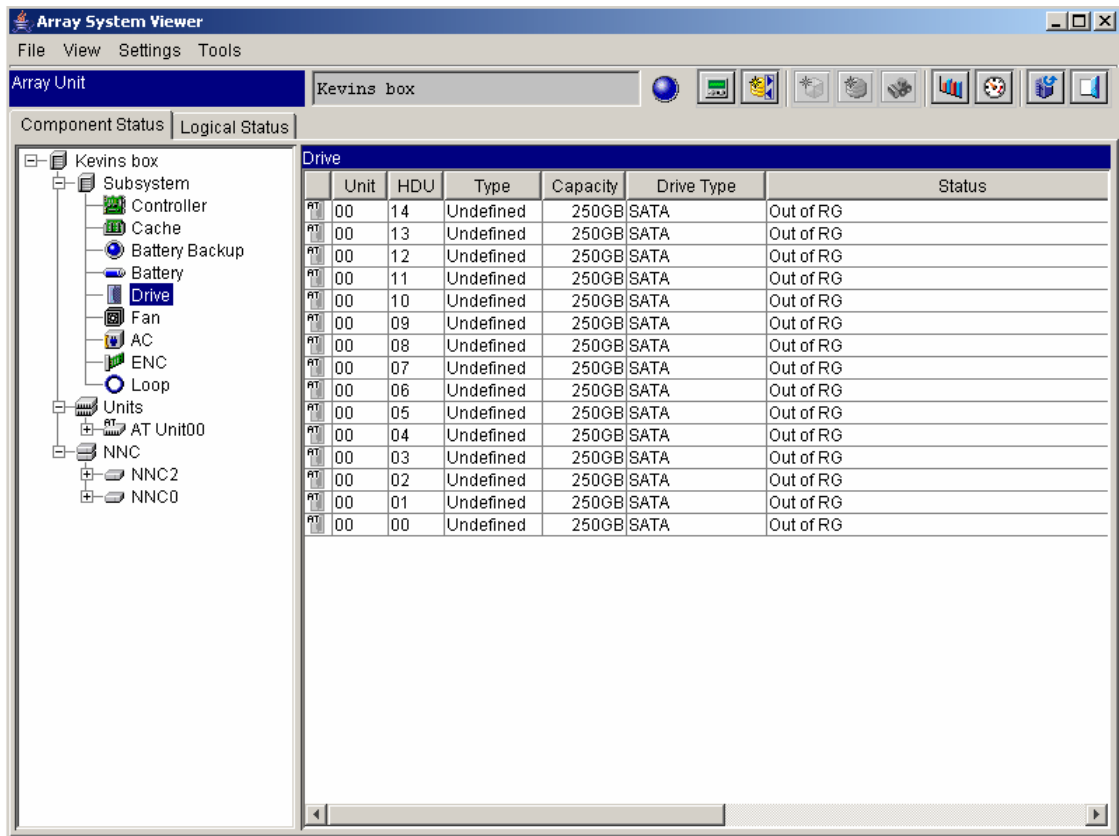















Figure 3.7 Component Status Tab, Drive View

- **Unit:** Unit No.
- **HDU:** HDU No.
- **Type:** Drive using form:
 - **Data:** Data drive
 - **Spare:** Spare drive
 - **Undefine:** Normal (LU not defined)
- **Capacity:** Storage capacity of a drive
- **Drive Type:** Drive type (FC or SATA)
- **Status:** Drive status:
 - **Normal:** Normal
 - **Detached:** Blockade
 - **Detached (Unmount):** The drive in the blockade status is not installed.
 - **Standby:** Normal (LU not defined)
 - **Out of RG:** Normal (RAID not defined)
 - **Unmount:** The drive is not installed.
 - **Recovery:** Under recovery (correction copy or copy-back in progress)
 - **Waiting:** Spare drive not used
- **Vendor ID:** Vendor ID of drive (display determined by drive mounting and status)
- **Product ID:** Product ID of drive (display determined by drive mounting and status)
- **Revision:** Drive firmware revision (display determined by drive mounting and status)
- **Serial No.:** Serial No. of a drive (display determined by drive mounting and status)

Table 3.17 Data Drive Icons

FC Drive	SATA Drive	Status
 Purple		<ul style="list-style-type: none"> ▪ Normal (there is a formatted LU)
 Yellow		<ul style="list-style-type: none"> ▪ Collection reconstruction status ▪ Copy-back status from the spare disk
 Red		<ul style="list-style-type: none"> ▪ Blockade. Disk Drive is blocked.
 Gray		<ul style="list-style-type: none"> ▪ RAID group defined, LU not defined ▪ LU defined, unformatted
 Red + Black		<ul style="list-style-type: none"> ▪ Not mounted in the blockade status
 Purple + Black		<ul style="list-style-type: none"> ▪ RAID group defined, drive not mounted
		<ul style="list-style-type: none"> ▪ RAID group not defined, drive mounted
No indication		<ul style="list-style-type: none"> ▪ RAID group not defined, drive not mounted ▪ Not supported location

If you right-click on a drive in the **Drive View** and select **Display Drive Configuration**, the **Drive Configuration** window displays a detailed view of the selected drive (see Figure 3.8).

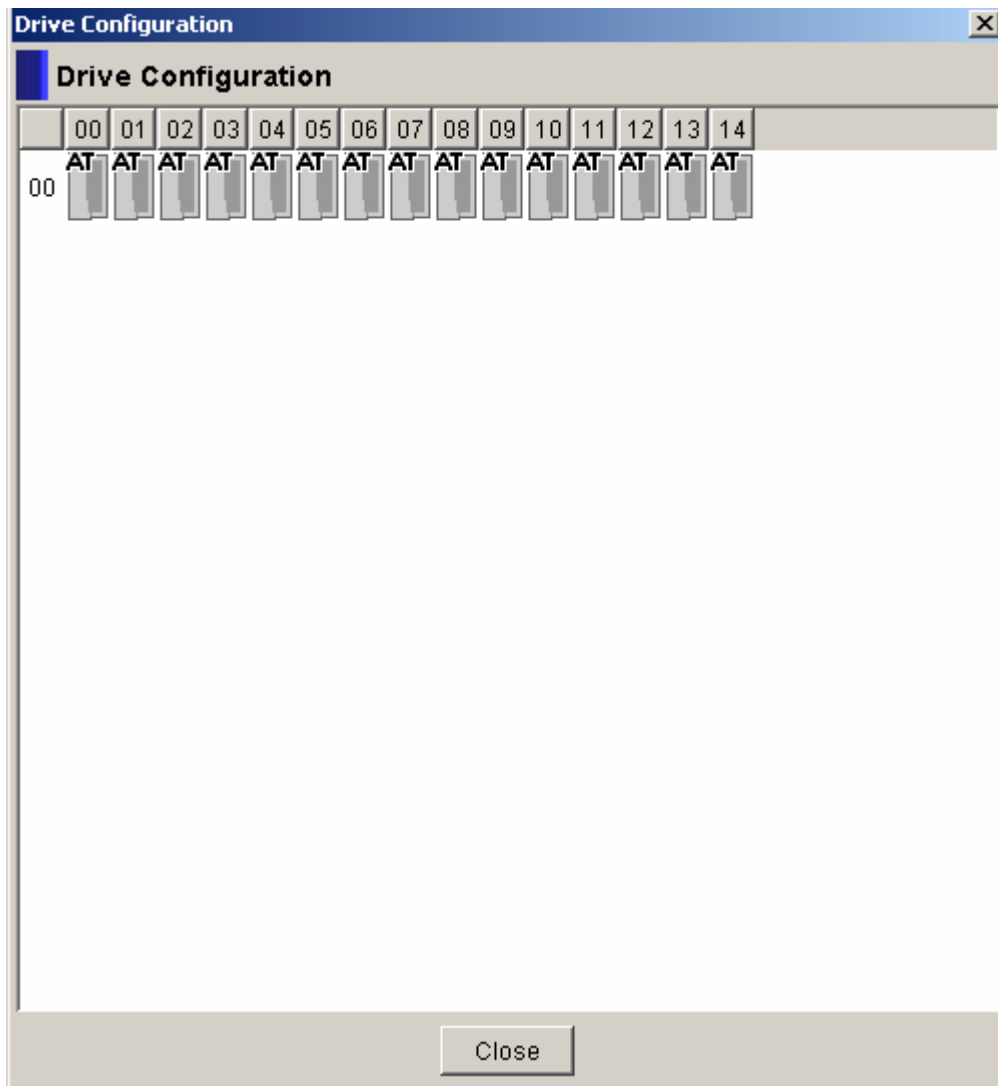

Figure 3.8 Drive Configuration Window

3.2.1.7 Fan View

Click the Fan icon, to view the detailed status of the fan, see Figure 3.9

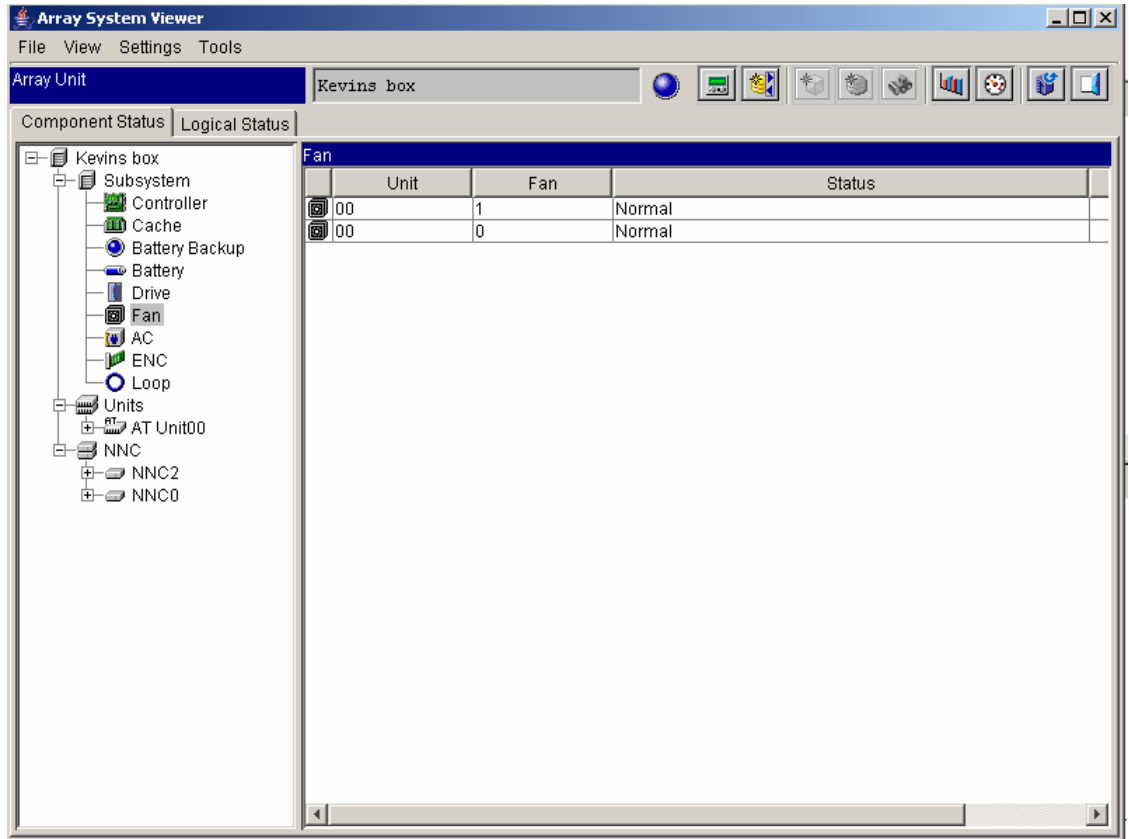



Figure 3.9 Component Status Tab, Fan View

- **Unit:** Unit No.
- **Fan:** Fan No.
- **Status:** Status:
 - **Normal:** Normal
 - **Alarm:** Failure

Table 3.18 Fan Icons

Display	Status
 Black	Normal
 Red	Failure

3.2.1.8 AC View

Click the AC icon, to view the detailed status of the AC, see Figure 3.10.

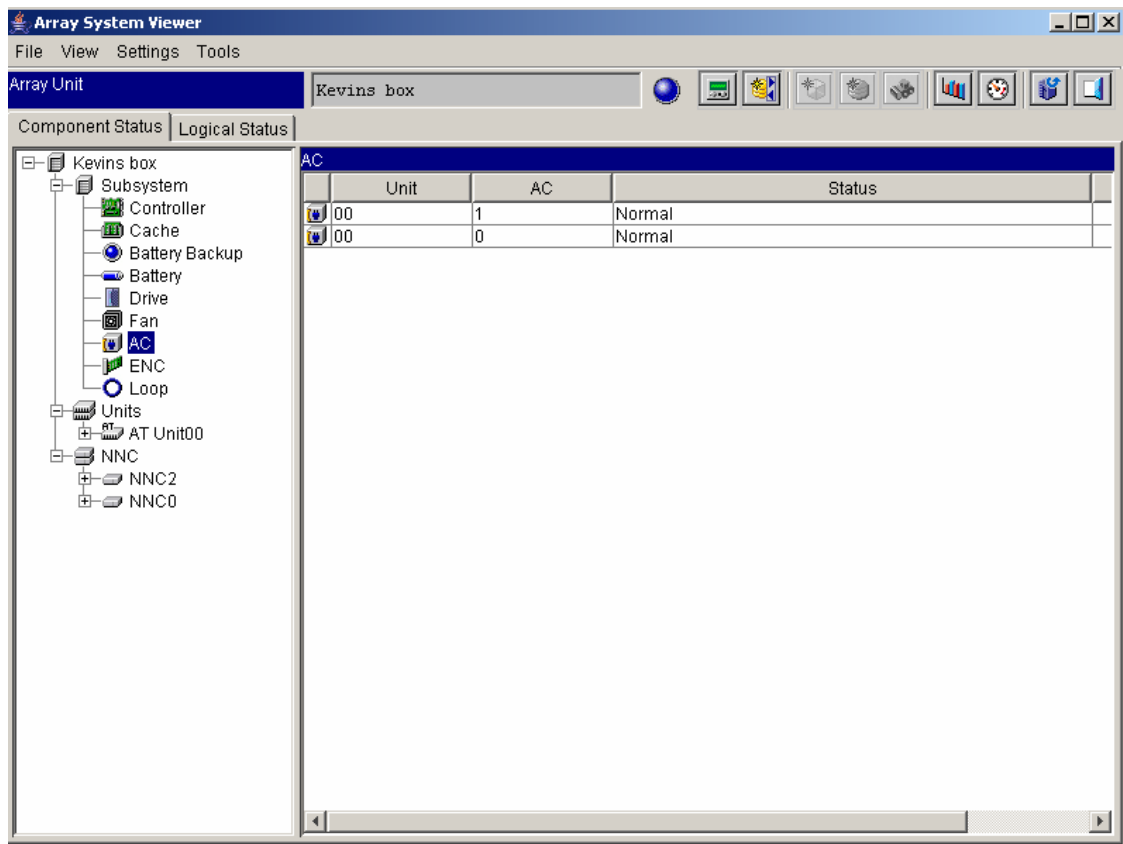

Figure 3.10 Component Status Tab, AC View

- **Unit:** Unit No.
- **AC:** AC No.
- **Status:** Status:
 - **Normal:** Normal
 - **Alarm:** Failure

3.2.1.9 ENC View

Click the ENC icon, to view the detailed status of the ENC, see Figure 3.11.

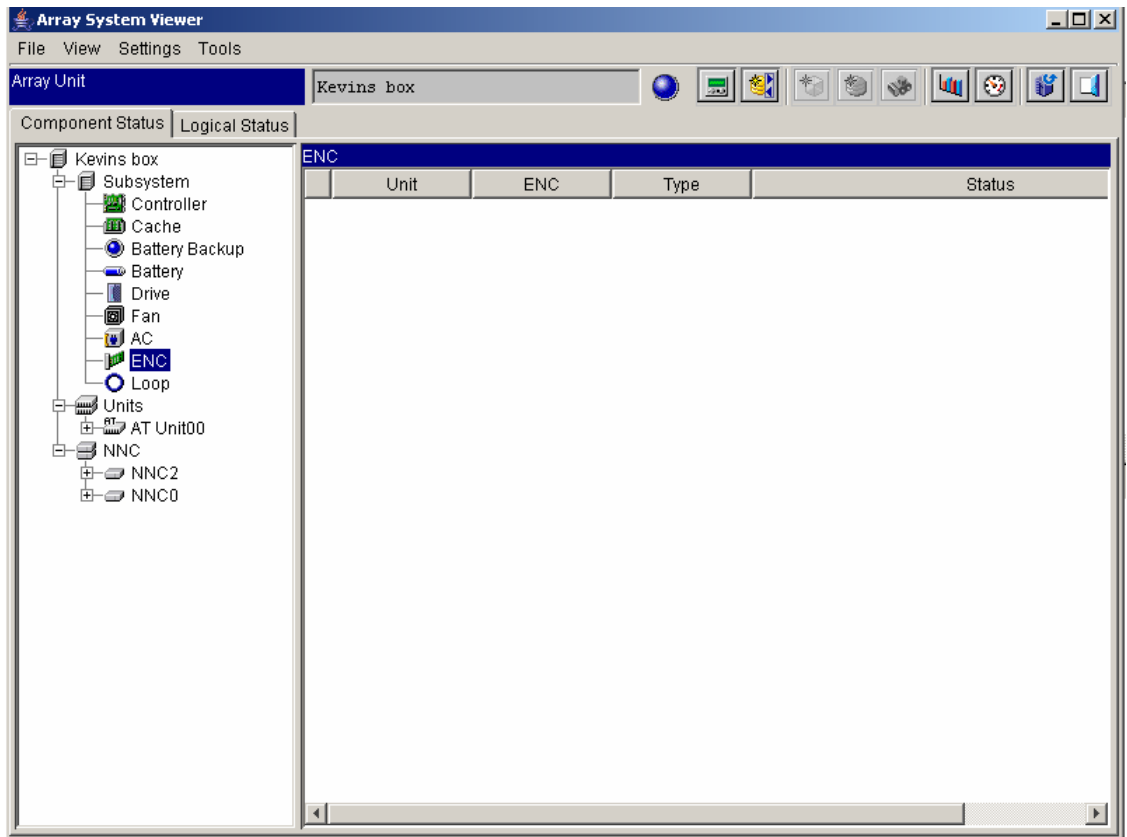





Figure 3.11 Component Status Tab, ENC View

- **Unit:** Unit No.
- **ENC:** ENC No.
- **Type:** Enclosure type (ENC or SENC)
- **Status:** Status:
 - **Normal:** Normal
 - **Alarm:** Failure

Table 3.19 Enclosure/SENC Icons

ENC	SENC	Status
 Green		Normal
 Red		Failure

Note: AT displayed at the upper left of an icon indicates a SENC.

3.2.1.10 Loop View

Click the **Loop** icon, to view the detailed status of the loop, see Figure 3.12.

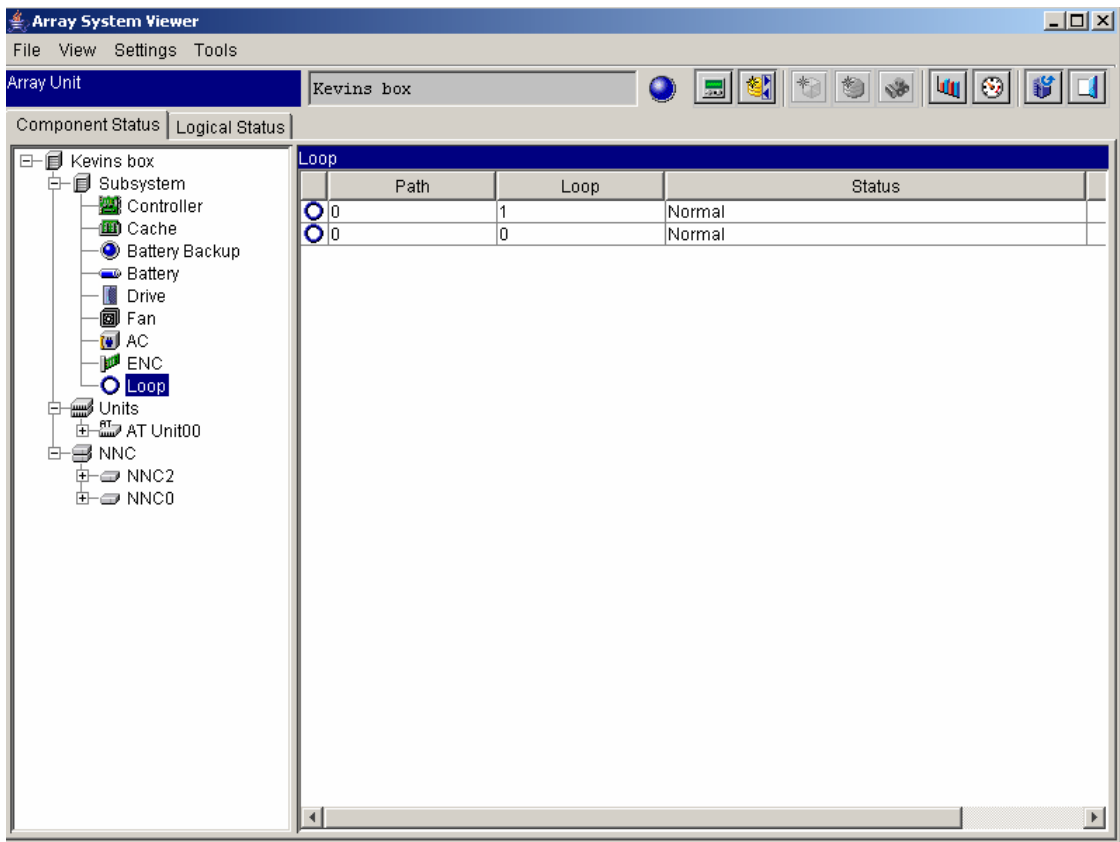



Figure 3.12 Component Status Tab, Loop View

- **Path:** Path No.
- **Loop:** Loop No.
- **Status:** Status:
 - **Normal:** Normal
 - **Alarm:** Failure

Table 3.20 Loop Icons

Display	Status
 Blue	Normal
 Red	Failure

3.2.1.11 SATA Units View

Click the Units icon, for a general view of the SATA units in the subsystem, see Figure 3.13.

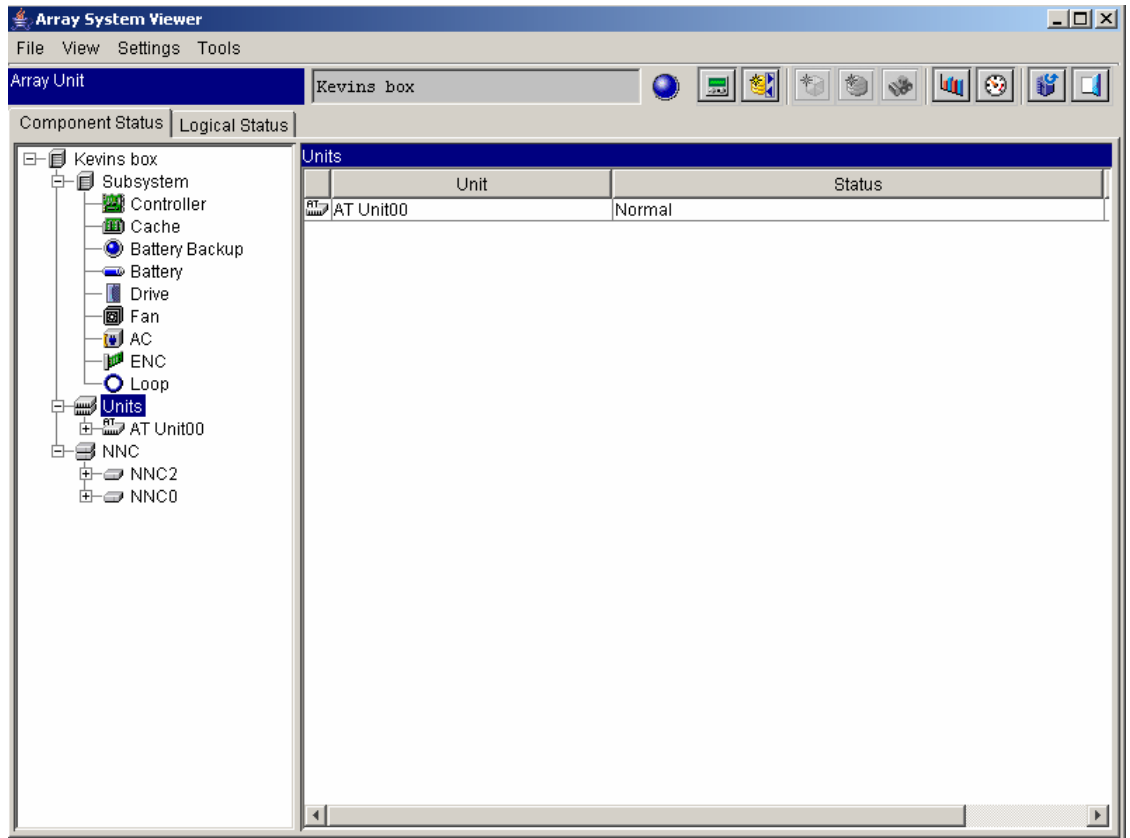

Figure 3.13 Component Status Tab, Units View

3.2.1.12 Individual SATA Unit View

Click the icon for an individual unit, to view the status of that SATA unit, see Figure 3.14. The status icons for the individual components are the same as those for the subsystem box, which were previously discussed in sections 3.2.1.1 through 3.2.1.10.

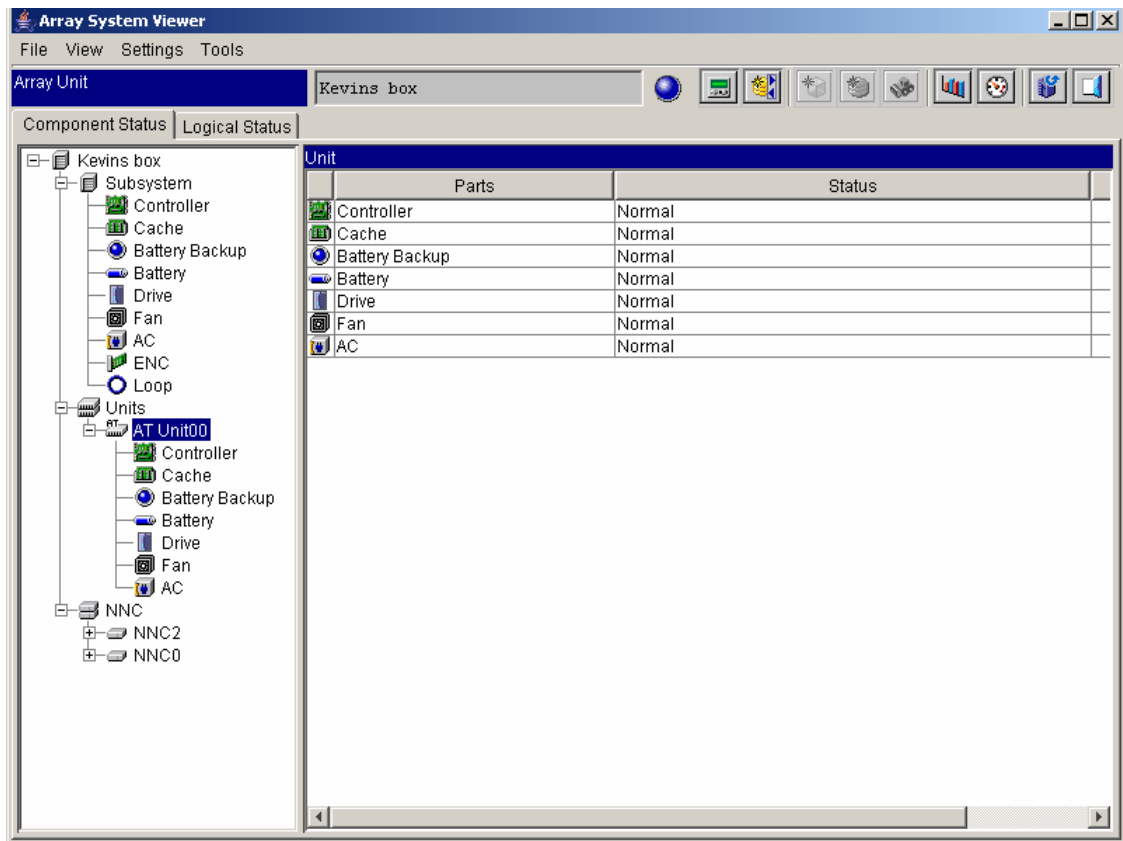

Figure 3.14 Component Status Tab, Individual SATA Unit View

3.2.1.13 NNC View

Click the NNC icon, for an overall view of the status of the NNC components, see Figure 3.15.

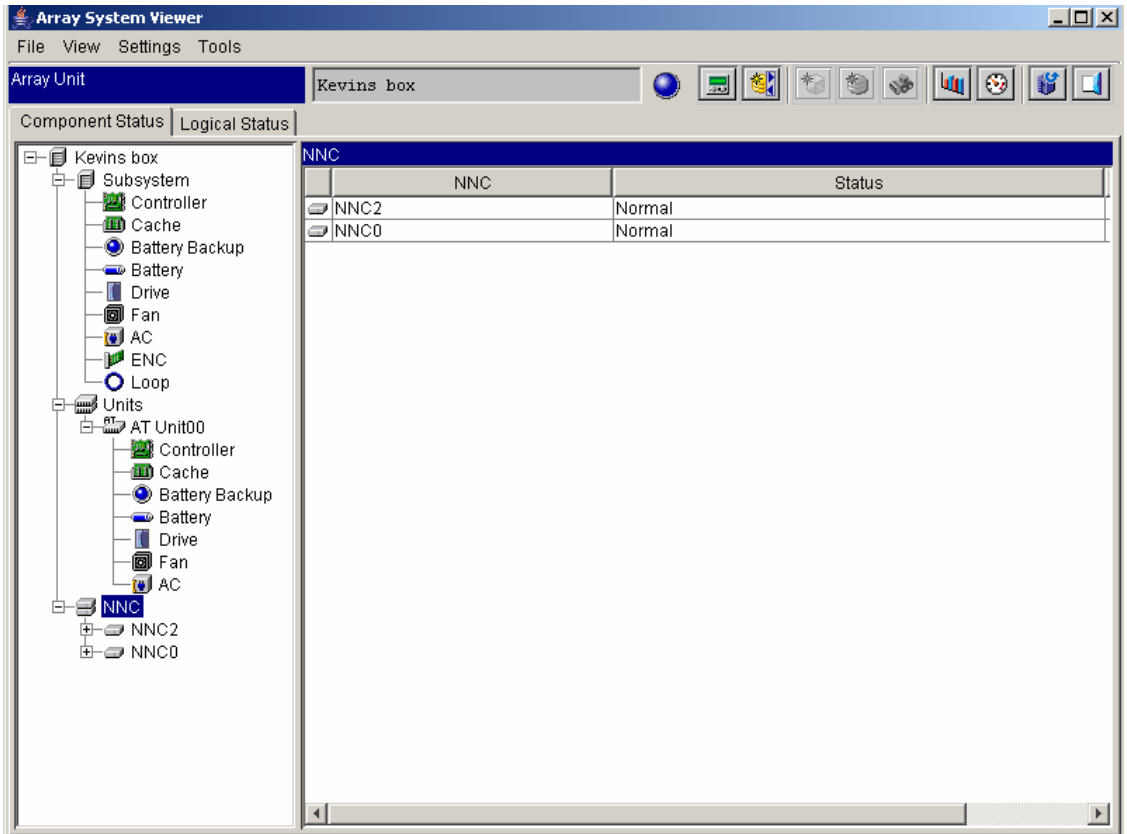





Figure 3.15 Component Status Tab, NNC View

Table 3.21 NNC Icons

Display	Status
 Gray	Normal
 Gray+Yellow	Alarm
 Red	Blockade

3.2.1.14 Individual NNC (NNC Type2) Unit View

Select the individual NNC unit icon to view its status. See Figure 3.16.

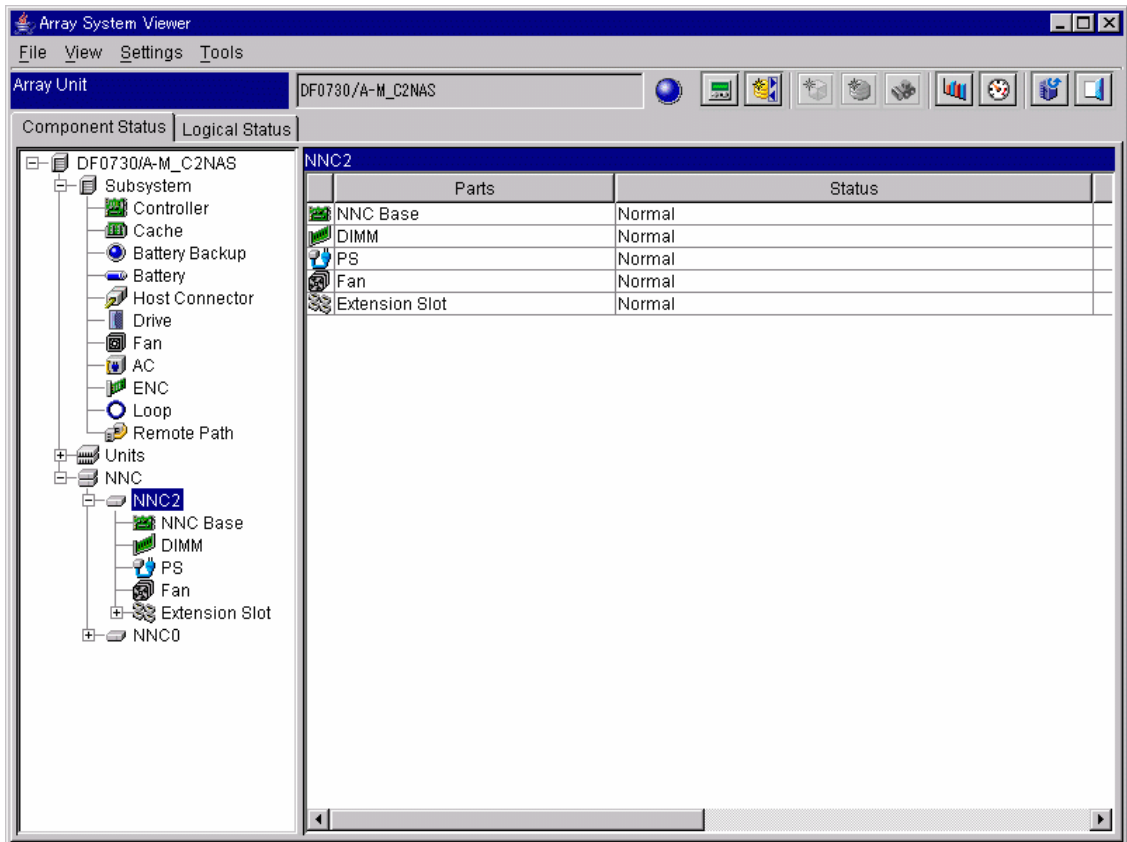

Figure 3.16 Component Status Tab, Individual NNC (Type2) Unit View

3.2.1.15 NNC Base View

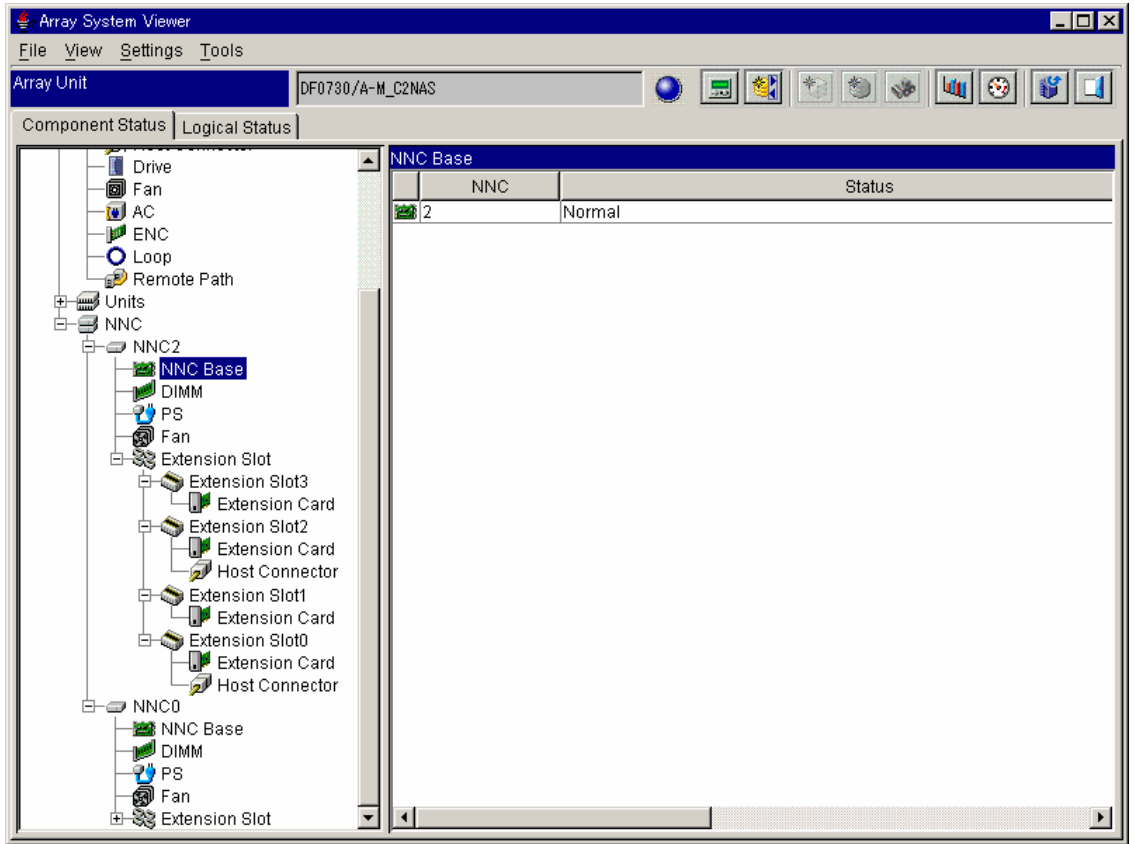



Figure 3.17 Component Status Tab, NNC Base View

- **NNC:** NNC No.
- **Status:** Status:
 - **Normal:** Normal
 - **Alarm:** Failure

Table 3.22 NNC Base (Type2) Icons

Display	Status
 Green	Normal
 Red	Failure

3.2.1.16 NNC (Type2) DIMM View

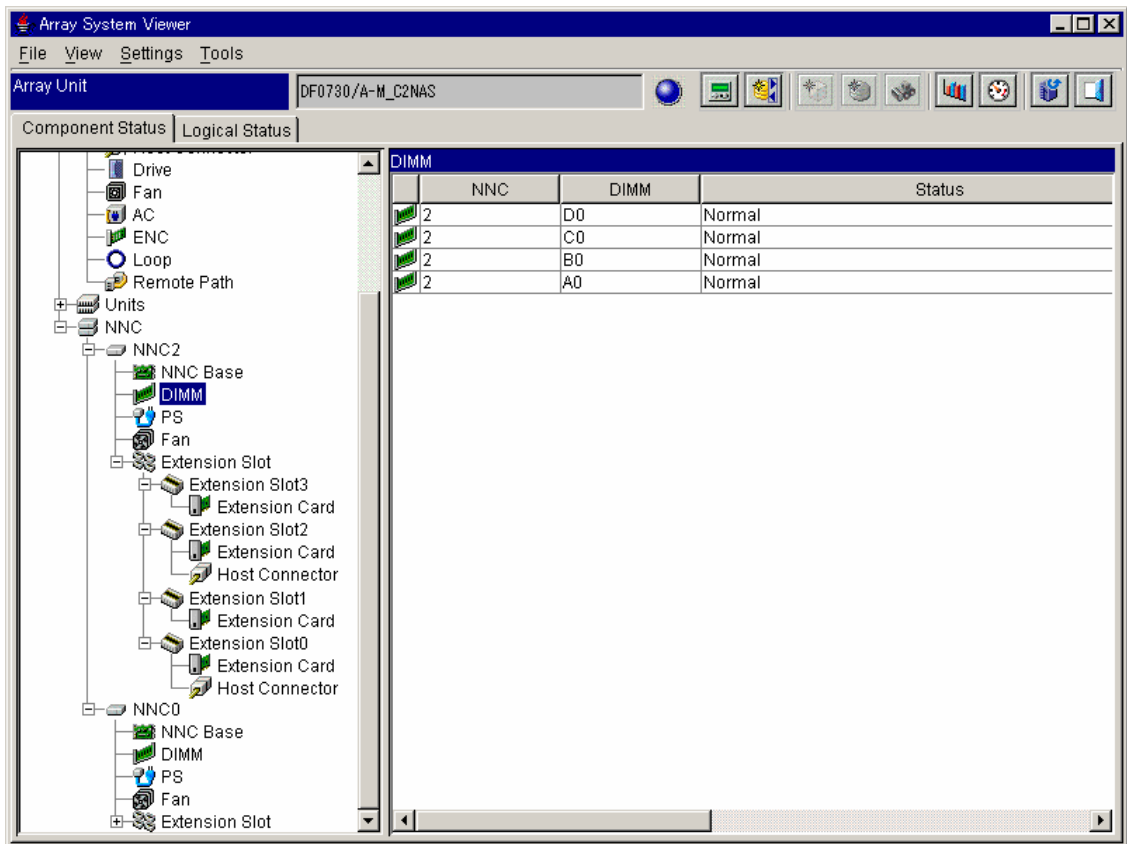

Figure 3.18 Component Status Tab, DIMM (Type2) View

- **NNC:** NNC No.
- **DIMM:** DIMM No.
- **Status:** Status:
 - **Normal:** Normal
 - **Alarm:** Failure

Table 3.23 NNC DIMM (Type2) Icons

Display	Status
Green	Normal
Red	Failure

3.2.1.17 NNC (Type2) PS View

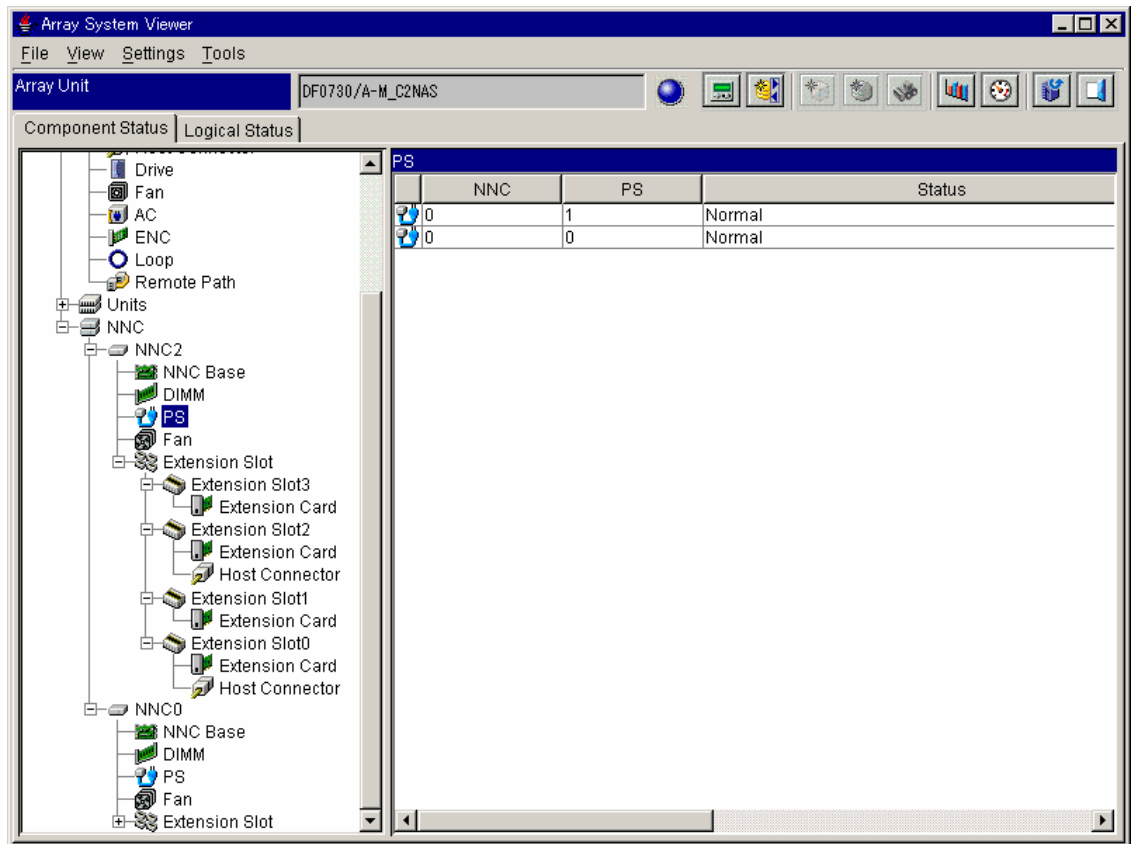



Table 3.24 Component Status Tab, NNC (Type2) PS View

- **NNC:** NNC No.
- **PS:** PS No.
- **Status:** Status:
 - **Normal:** Normal
 - **Alarm:** Failure

Table 3.25 NNC PS (Type2) Icons

Display	Status
 Blue	Normal
 Red	Failure

3.2.1.18 NNC (Type2) Fan View

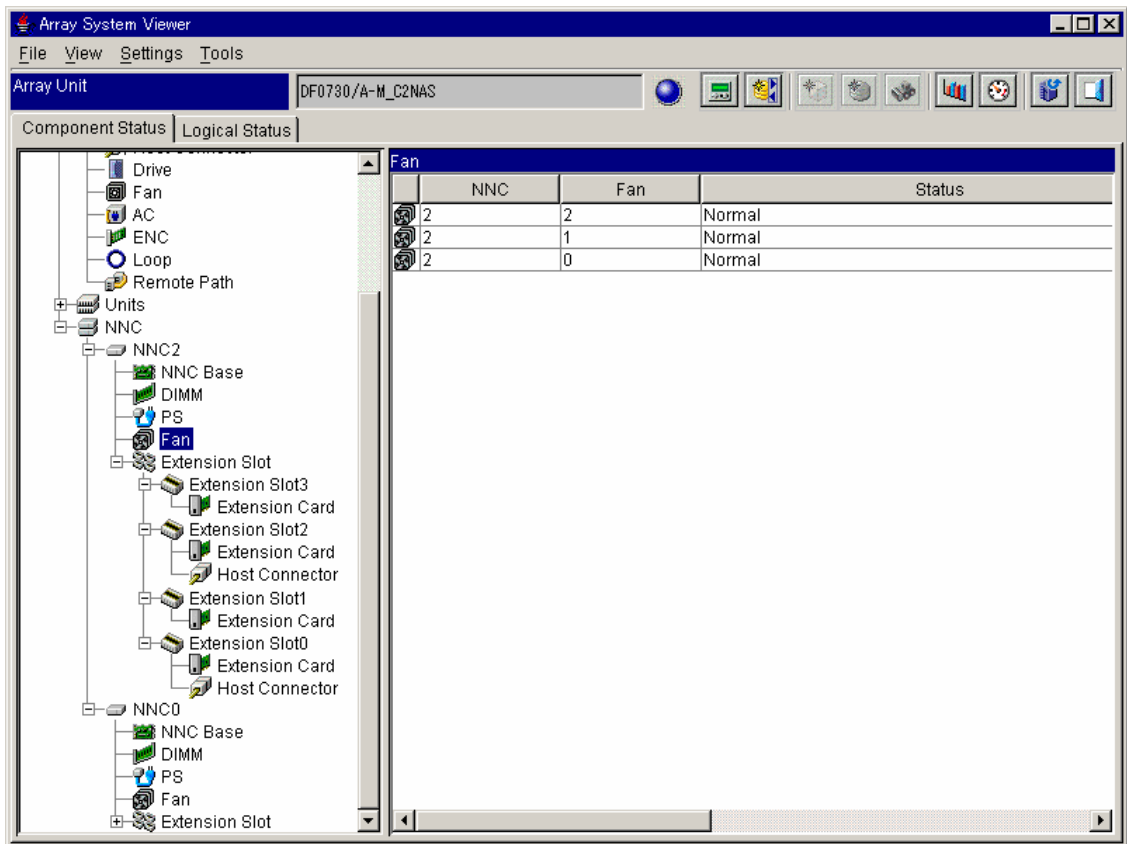

Figure 3.19 Component Status Tab, NNC (Type2) Fan View

- **NNC:** NNC No.
- **Fan:** Fan No.
- **Status:** Status:
 - **Normal:** Normal
 - **Alarm:** Failure

Table 3.26 NNC (Type2) Fan Icons

Display	Status
Black	Normal
Red	Failure

3.2.1.19 NNC (Type2) Extension Slot

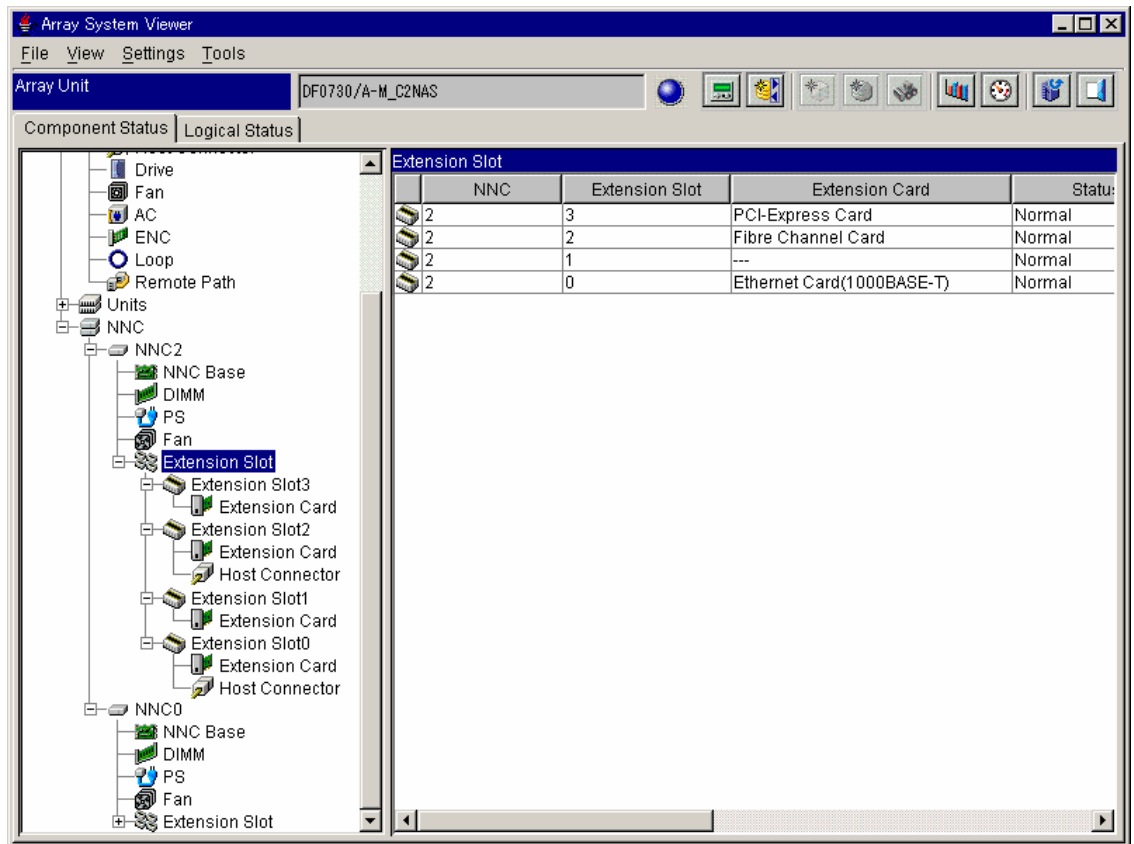



Figure 3.20 Component Status Tab, NNC (Type2) Extension Slot View

- **NNC:** NNC No.
- **Extension Slot:** Extension Slot No.
- **Extension Card:** Extension Card type
- **Status:** Status:
 - **Normal:** Normal
 - **Alarm:** Failure

Table 3.27 NNC (Type2) Extension Slot Icons

Display	Status
 Gray	Normal
 Red	Failure

3.2.1.20 NNC (Type2) Extension Slot3

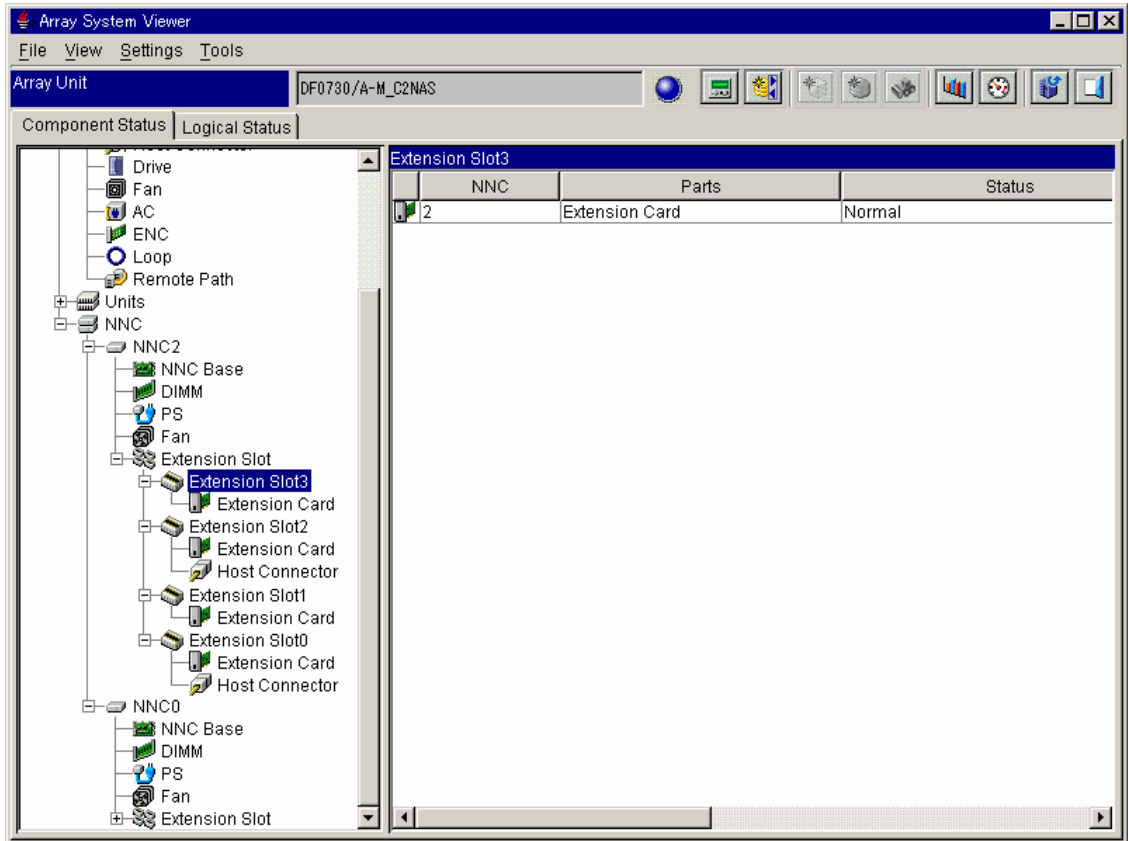



Figure 3.21 Component Status Tab, NNC (Type2) Extension Slot3 View

- **NNC:** NNC No.
- **Parts:** Parts type
- **Status:** Status:
 - **Normal:** Normal
 - **Alarm:** Failure

Table 3.28 NNC (Type2) Extension Slot Icons

Display	Status
 Gray	Normal
 Red	Failure

3.2.1.21 NNC (Type2) Extension Card

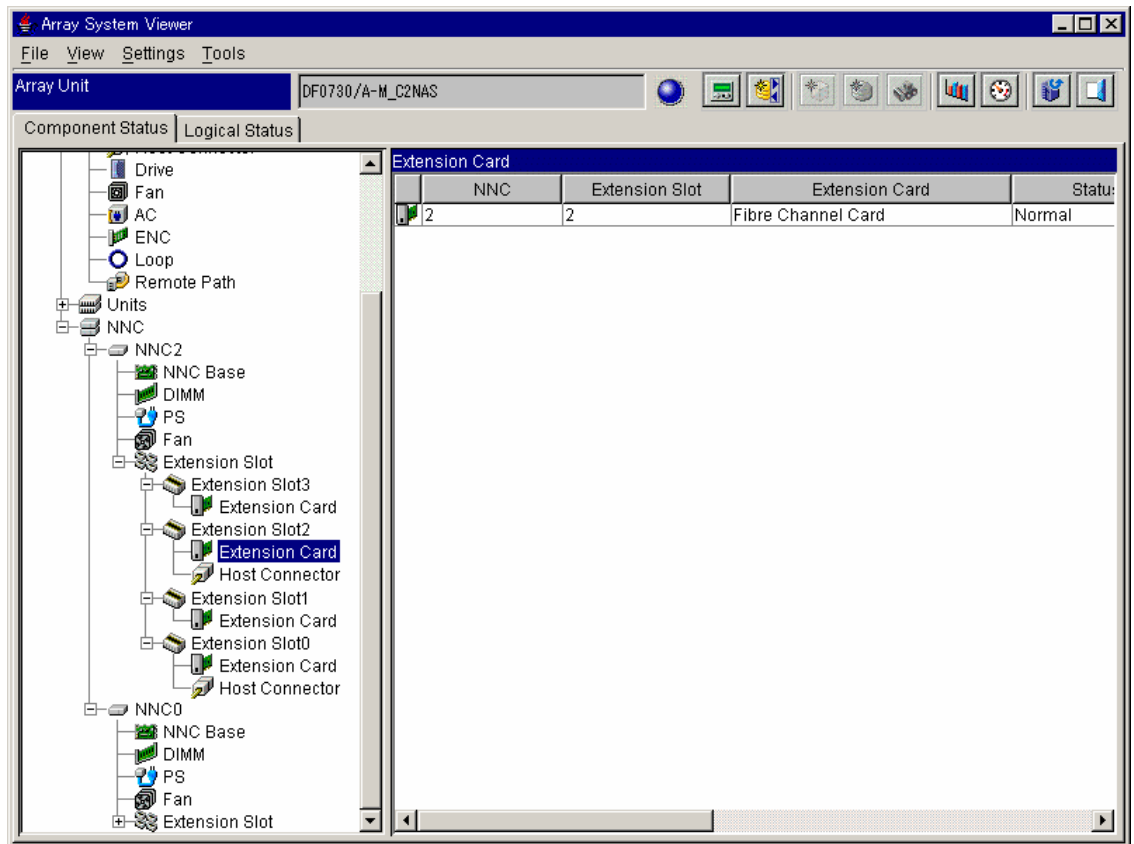



Figure 3.22 Component Status Tab, NNC (Type2) Extension Card View

- **NNC:** NNC No.
- **Extension Slot:** Extension Slot No.
- **Extension Card:** Extension Card type
- **Status:** Status:
 - **Normal:** Normal
 - **Alarm:** Failure

Table 3.29 NNC (Type2) Extension Card Icons

Display	Status
 Green	Normal
 Red	Failure

3.2.1.22 NNC (Type2) Host Connector

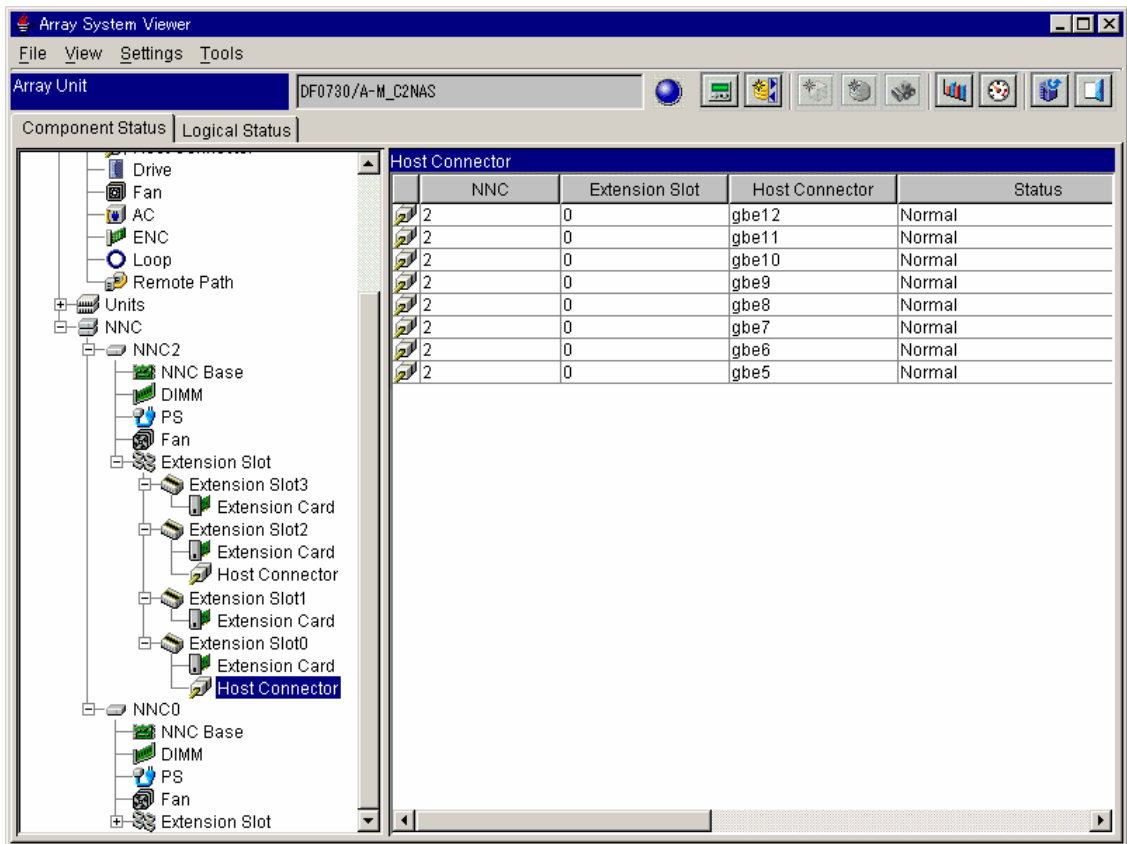



Figure 3.23 Component Status Tab, NNC (Type2) Host Connector View

- **NNC:** NNC No.
- **Extension Slot:** Extension Slot No.
- **Host Connector:** Host Connector No.
- **Status:** Status:
 - **Normal:** Normal
 - **Alarm:** Failure

Table 3.30 NNC (Type2) Host Connector Icons

Display	Status
 Gray	Normal
 Red	Failure

3.2.1.23 Individual NNC (Type1) Unit View

Click the icon for an individual NNC unit, to see the status of that NNC unit, see Figure 3.24.

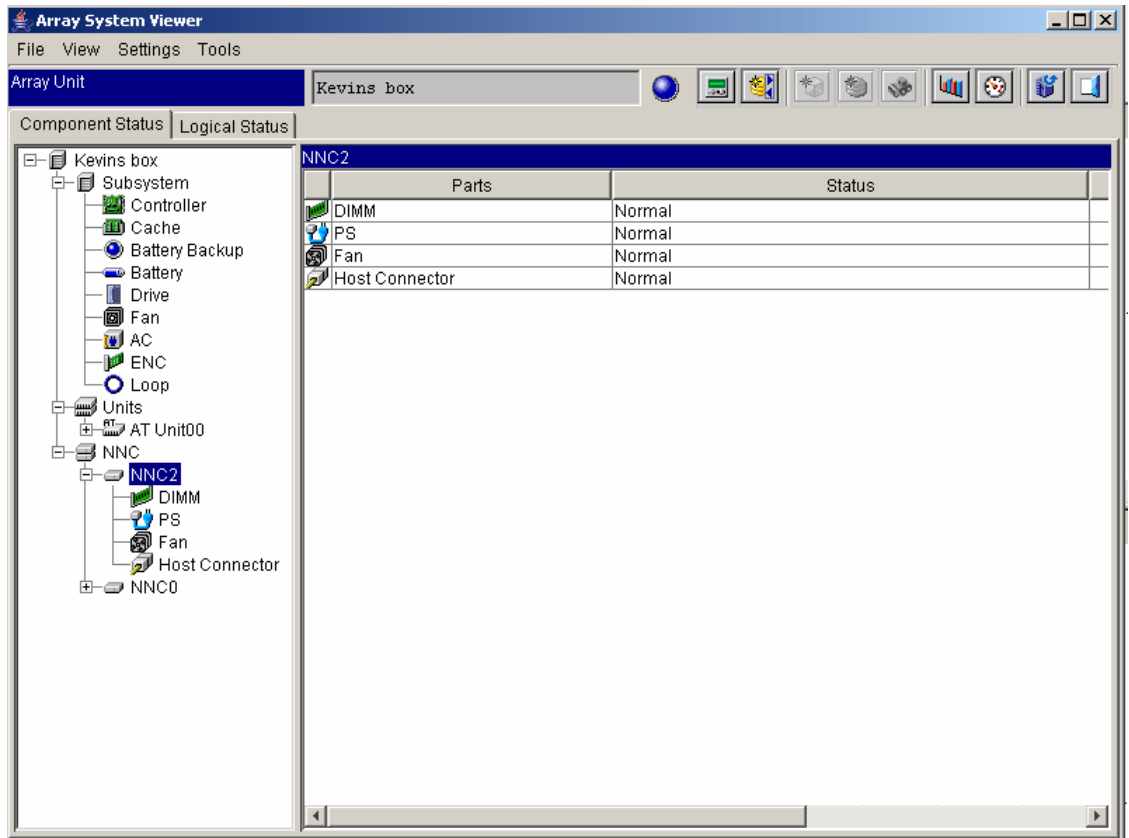

Figure 3.24 Component Status Tab, Individual NNC (Type1) Unit View

3.2.1.24 NNC (Type1) DIMM View

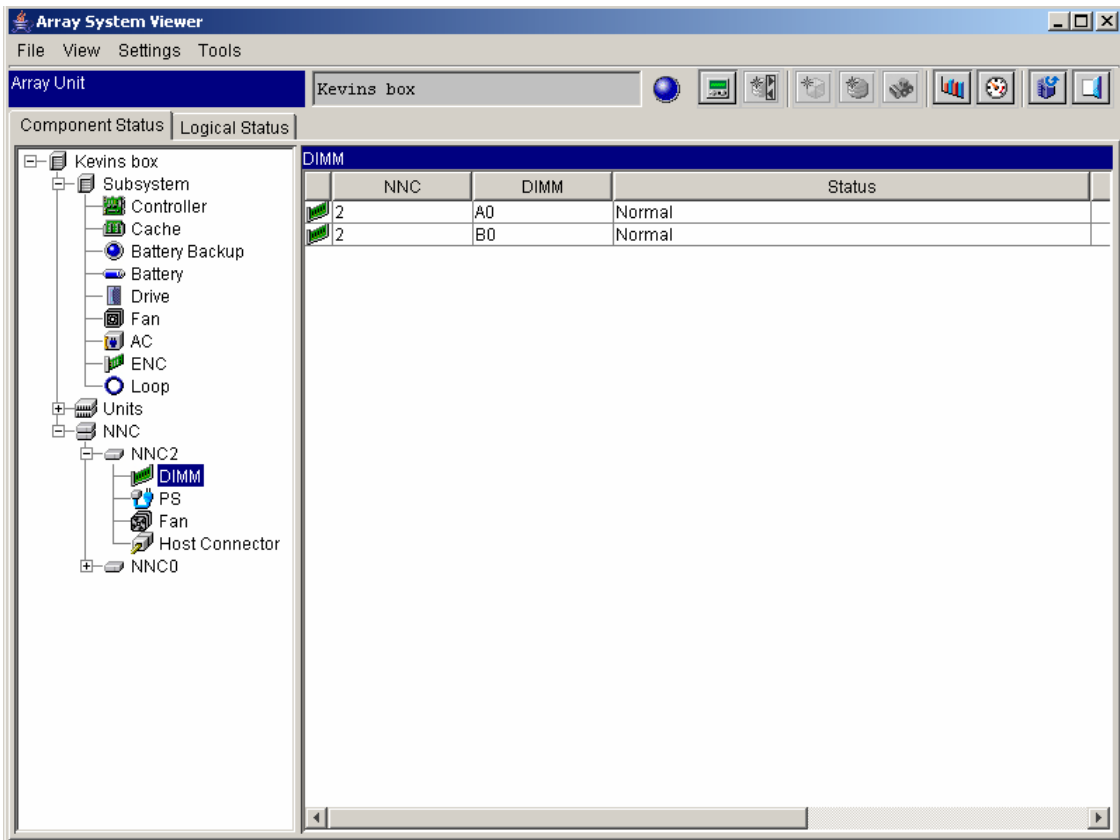

Figure 3.25 Component Status Tab, DIMM (Type1) View

- **NNC:** NNC No.
- **DIMM:** DIMM No.
- **Status:** Status:
 - **Normal:** Normal
 - **Alarm:** Failure

Table 3.31 NNC (Type1) DIMM Icons

Display	Status
Green	Normal
Red	Failure

3.2.1.25 NNC (Type1) PS View

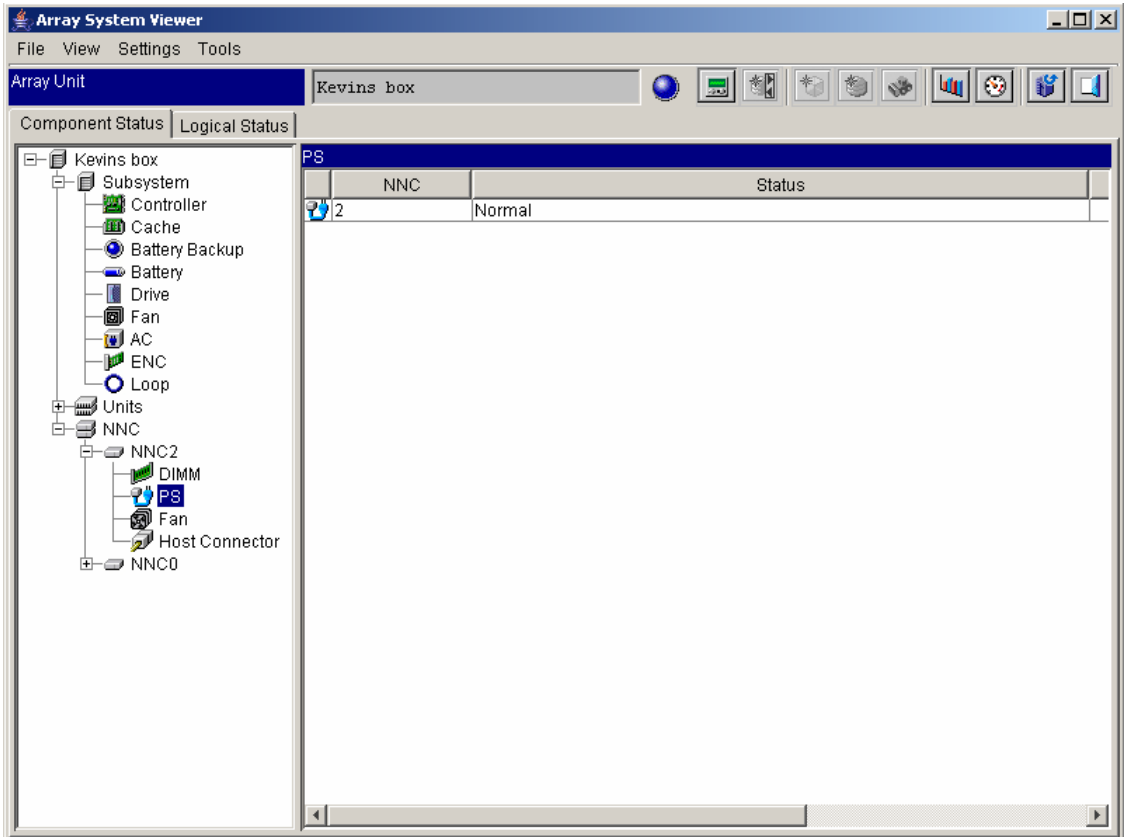



Figure 3.26 Component Status Tab, NNC (Type1) PS View

- **NNC:** NNC No.
- **Status:** Status:
 - **Normal:** Normal
 - **Alarm:** Failure

Table 3.32 NNC PS (Type1) Icons

Display	Status
 Blue	Normal
 Red	Failure

3.2.1.26 NNC (Type1) Fan View

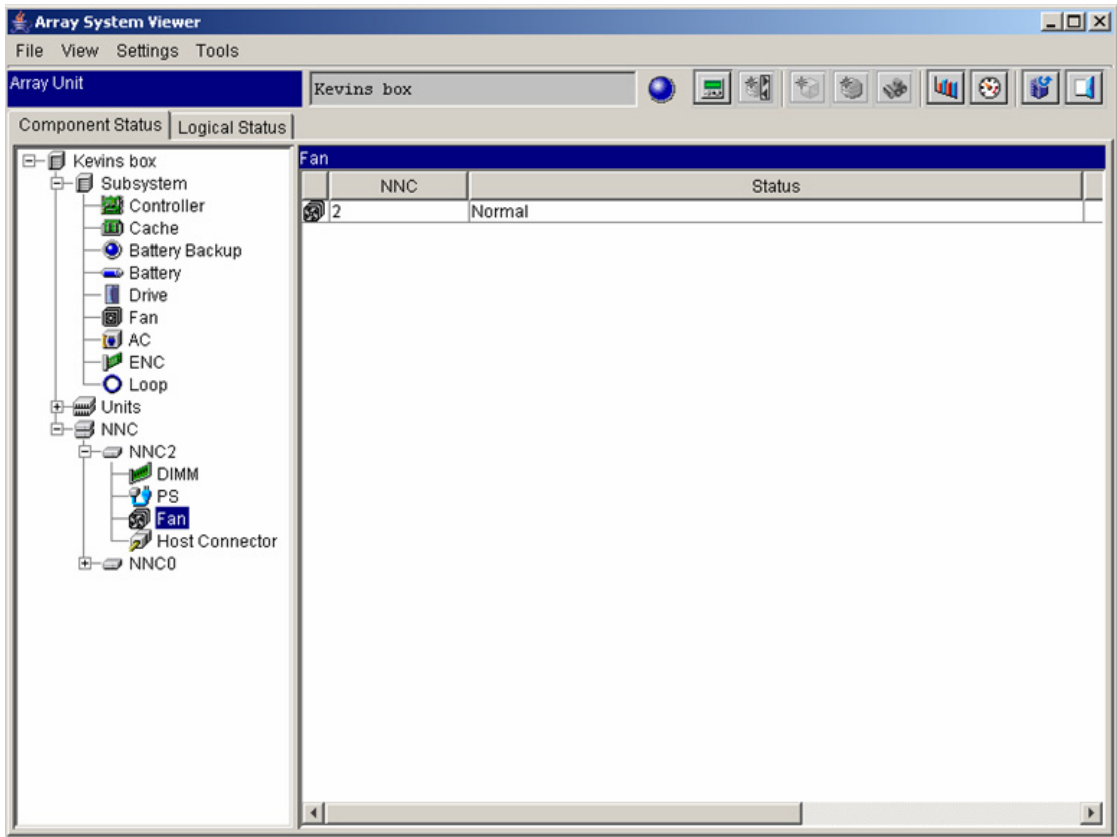

Figure 3.27 Component Status Tab, NNC (Type1) Fan View

- **NNC:** NNC No.
- **Status:**
 - **Normal:** Normal
 - **Alarm:** Failure

Table 3.33 NNC (Type1) Fan Icons

Display	Status
Black	Normal
Red	Failure

3.2.1.27 NNC (Type1) Host Connector View

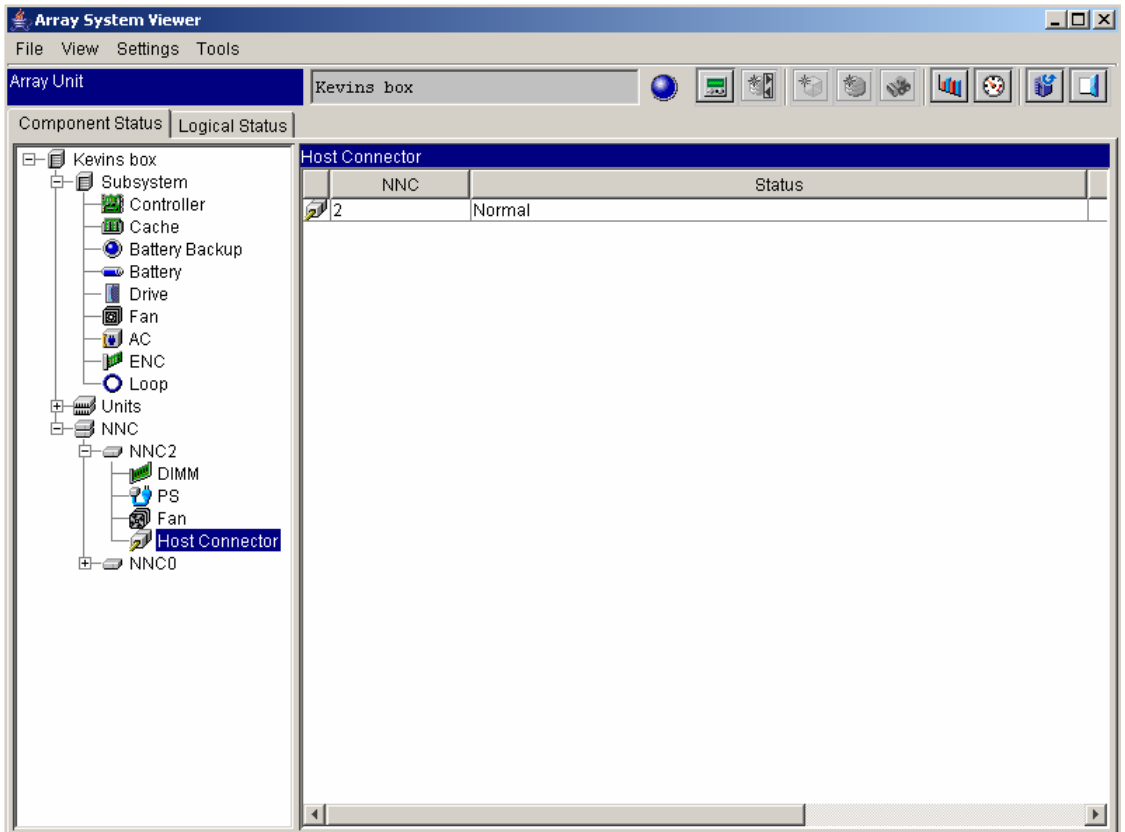



Figure 3.28 Component Status Tab, NNC (Type1) Host Connector View

- **NNC:** NNC No.
- **Status:** Status:
 - **Normal:** Normal
 - **Alarm:** Failure

Table 3.34 NNC Host (Type1) Connector Icons

Display	Status
 Gray	Normal
 Red	Failure

3.2.1.28 Property Window

To display the **Property** window, from the **Components** tab, select **View → Properties**.

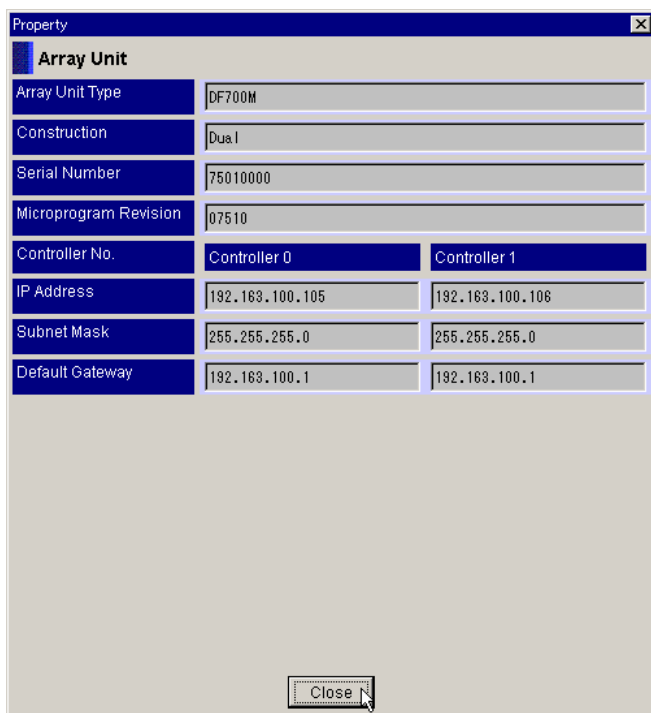

Figure 3.29 Property Window

- **Array Unit Type:** Subsystem type
- **Construction:** Configuration type of the subsystem
- **Serial Number:** Serial number of the subsystem
- **Microcode Revision:** Micro program revision of the subsystem
- **Controller No.:** Controller No.
- **IP Address:** IP address of each controller
- **Subnet Mask:** Subnet Mask of each controller
- **Default Gateway:** Default gateway of each controller

3.2.2 Logical Status Tab

Click the **Subsystem** icon, to view the logical status of the entire subsystem, see Figure 3.30

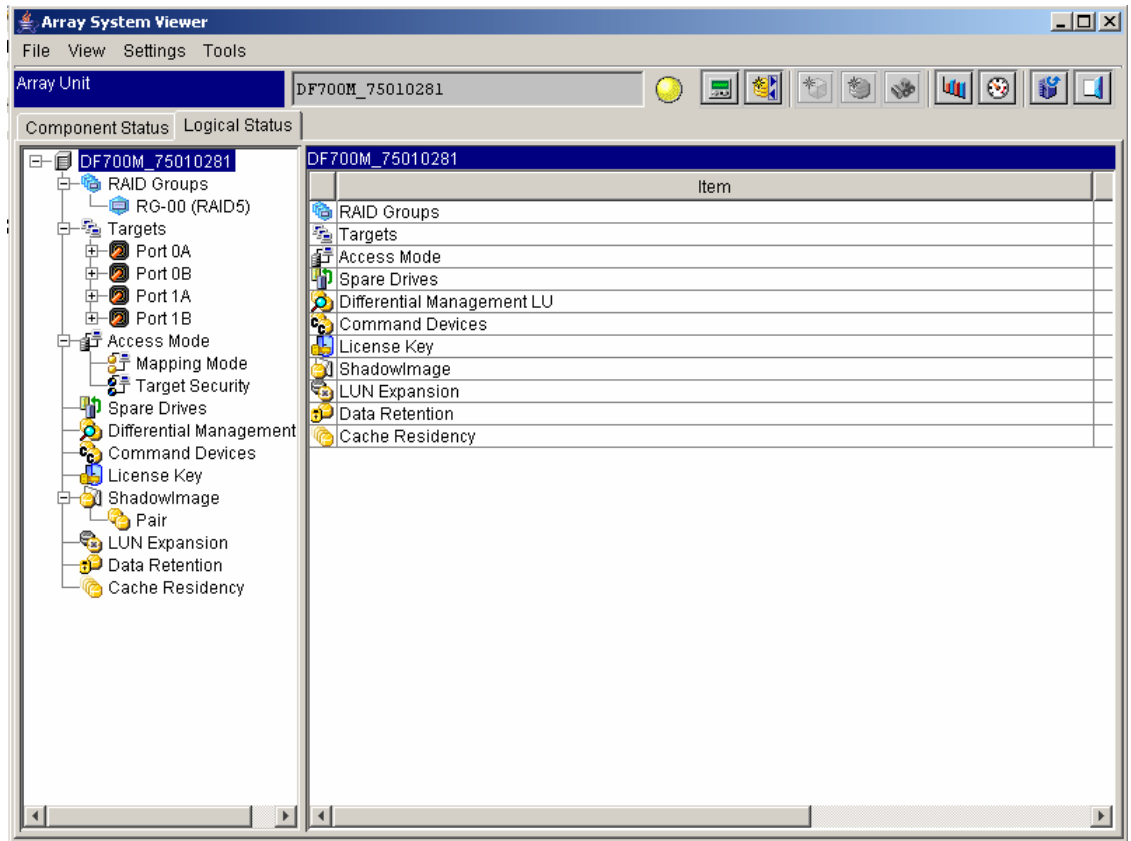

Figure 3.30 Array System Viewer Window, Logical Status Tab

3.2.2.1 RAID Groups View

Click the **RAID Groups** icon, to view the logical status of all RAID groups in the subsystem, see Figure 3.31.

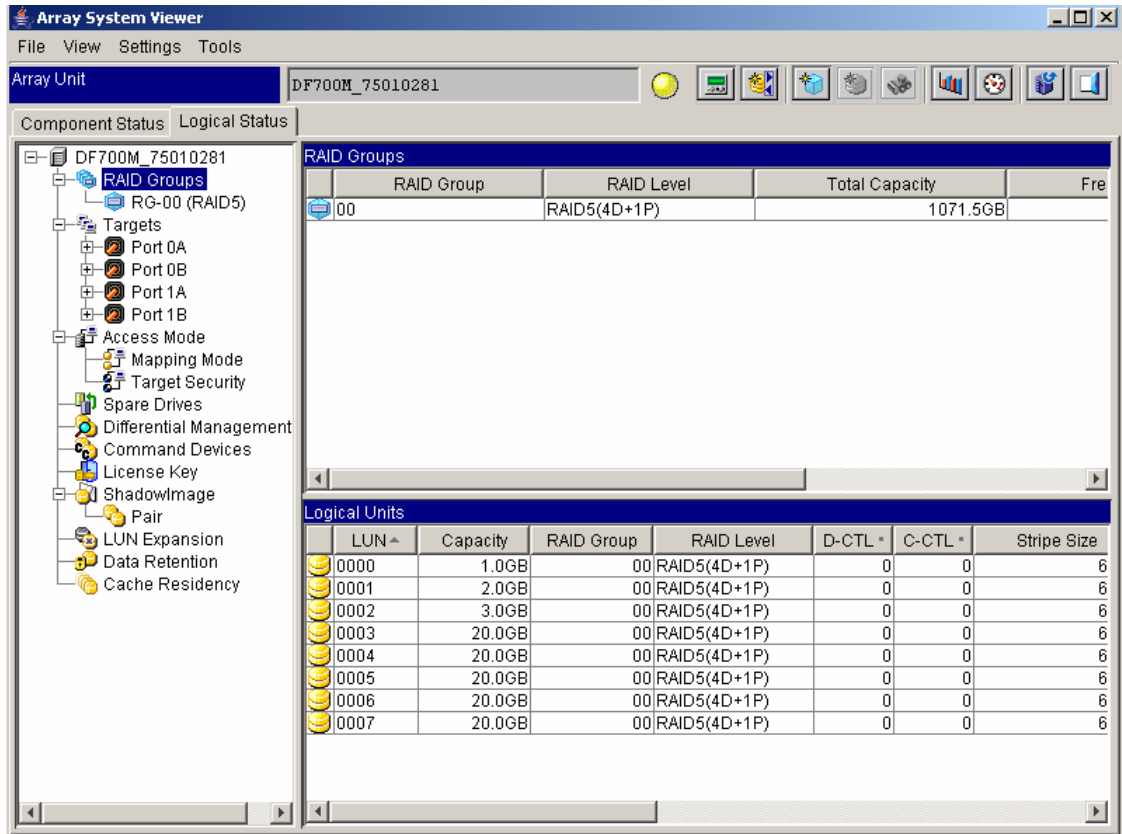

Figure 3.31 Logical Status Tab, RAID Groups View

3.2.2.2 Individual RAID Group View

Select an individual RAID group to view the status of that group, see Figure 3.32.

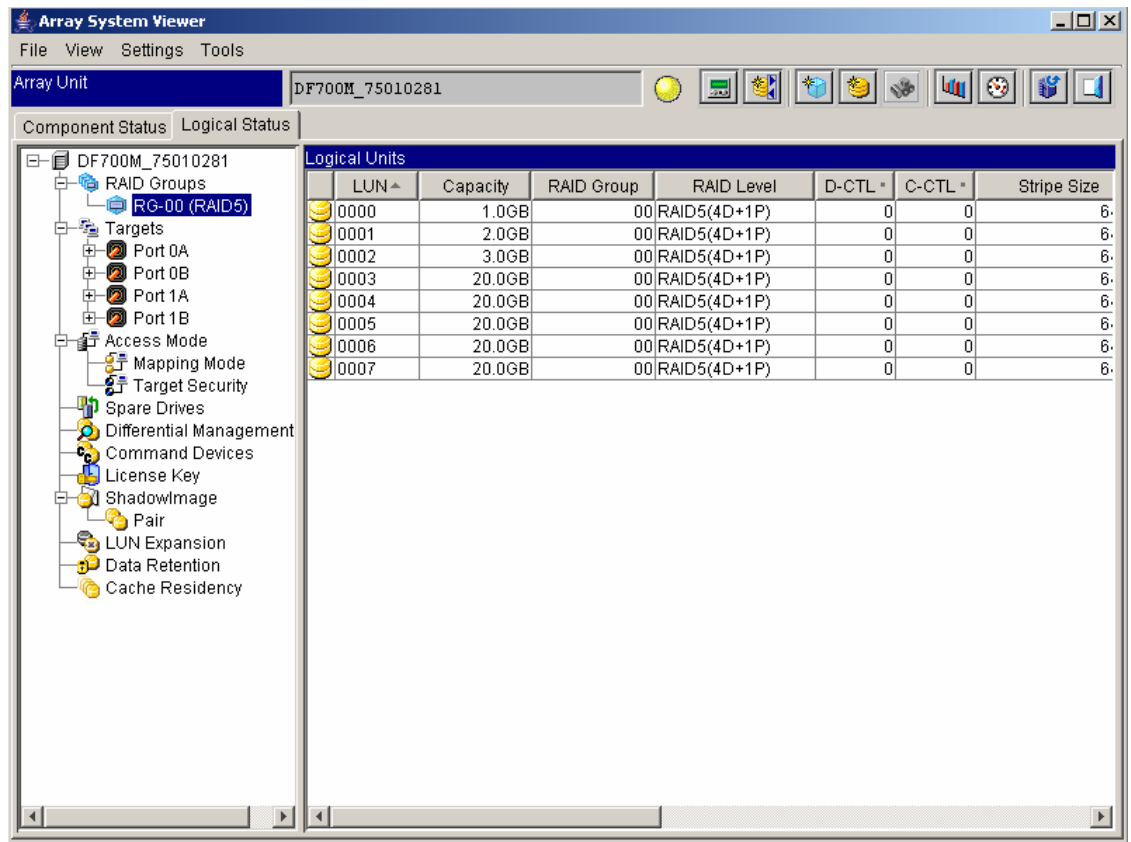

Figure 3.32 Logical Status Tab, Individual RAID Group View

3.2.2.3 Targets View

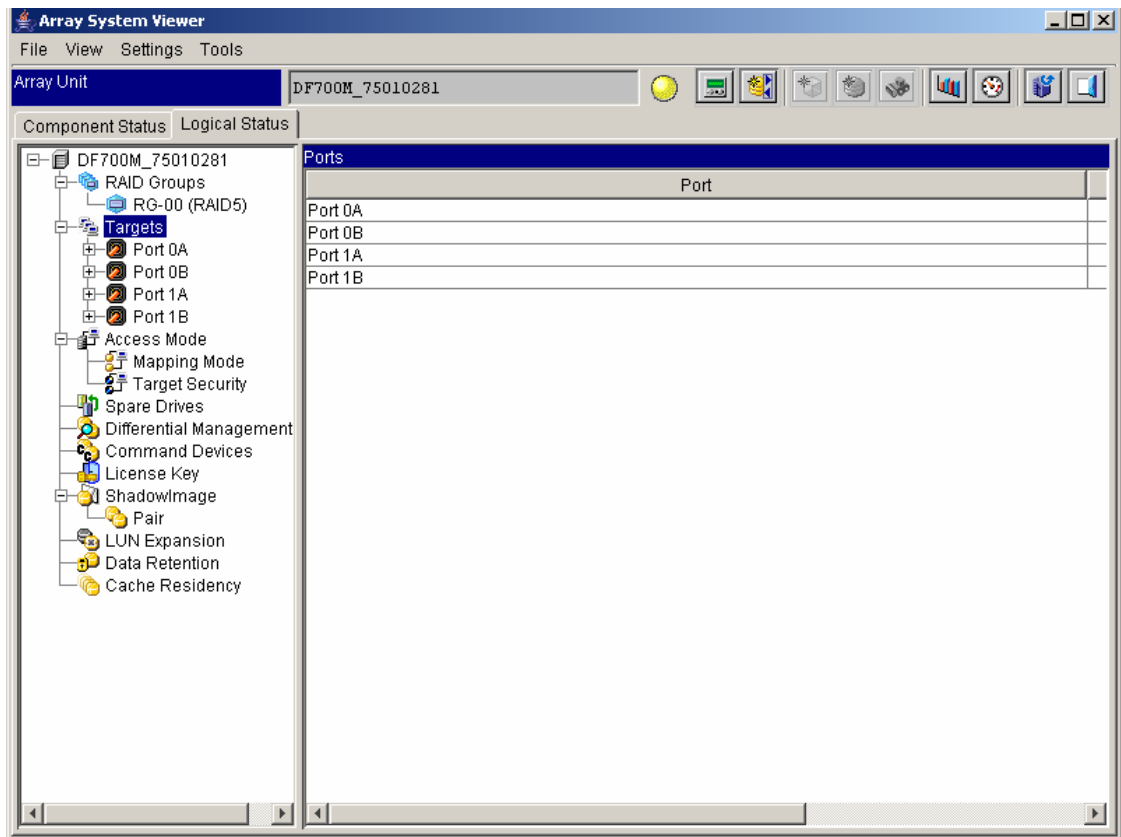

Figure 3.33 Logical Status Tab, Targets View

3.2.2.4 Individual Target Port View

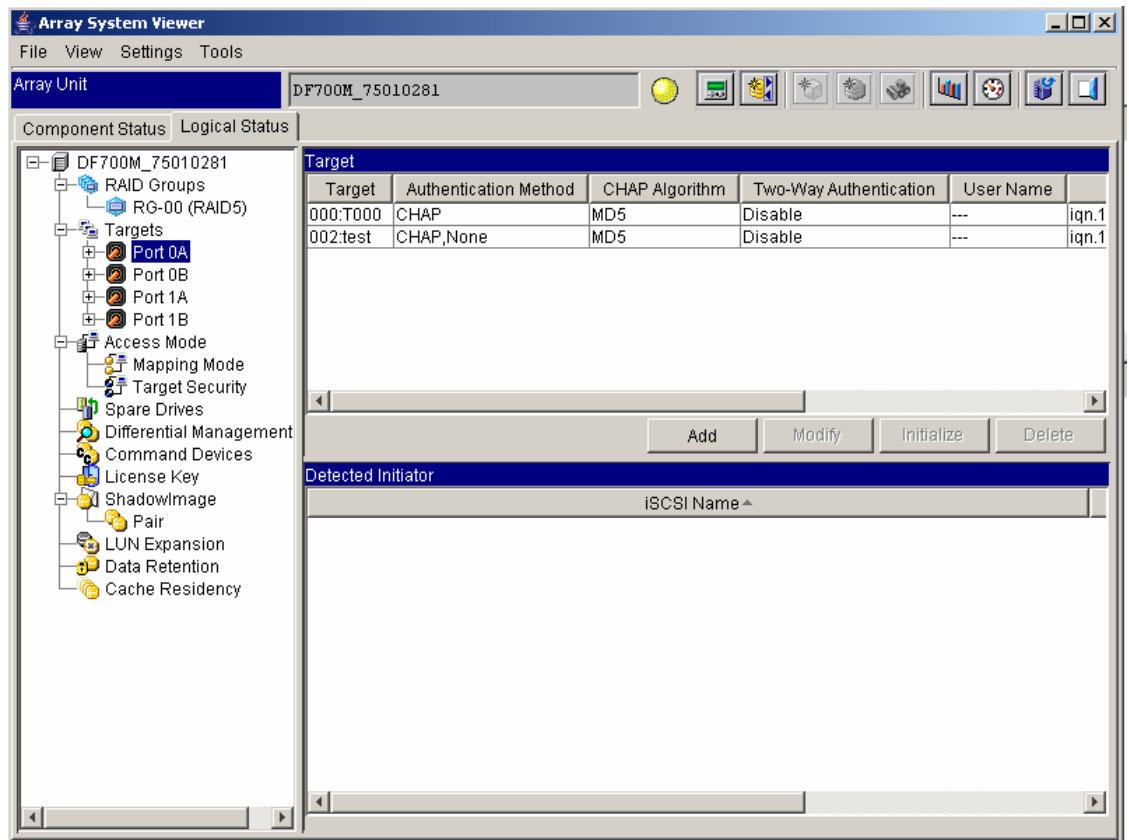

Figure 3.34 Logical Status Tab, Individual Target Port View

3.2.2.5 Access Mode View

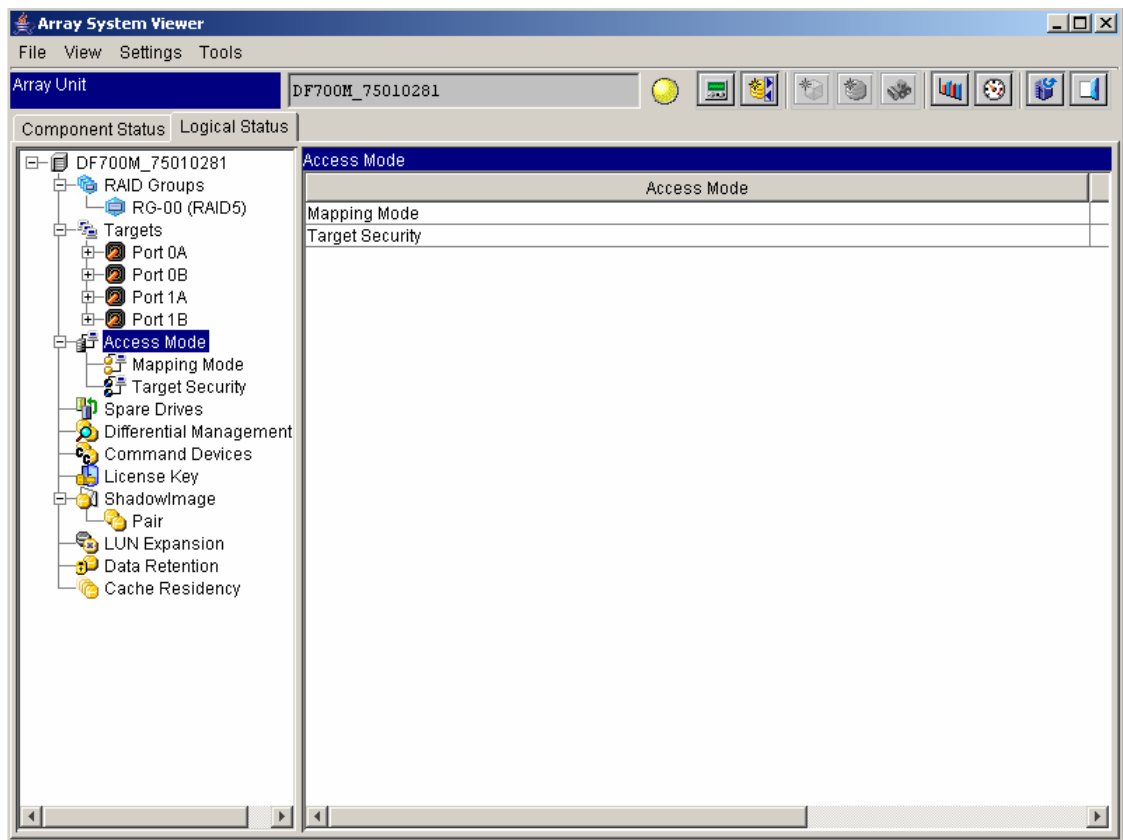

Figure 3.35 Logical Status Tab, Access Mode View

3.2.2.6 Mapping Mode View

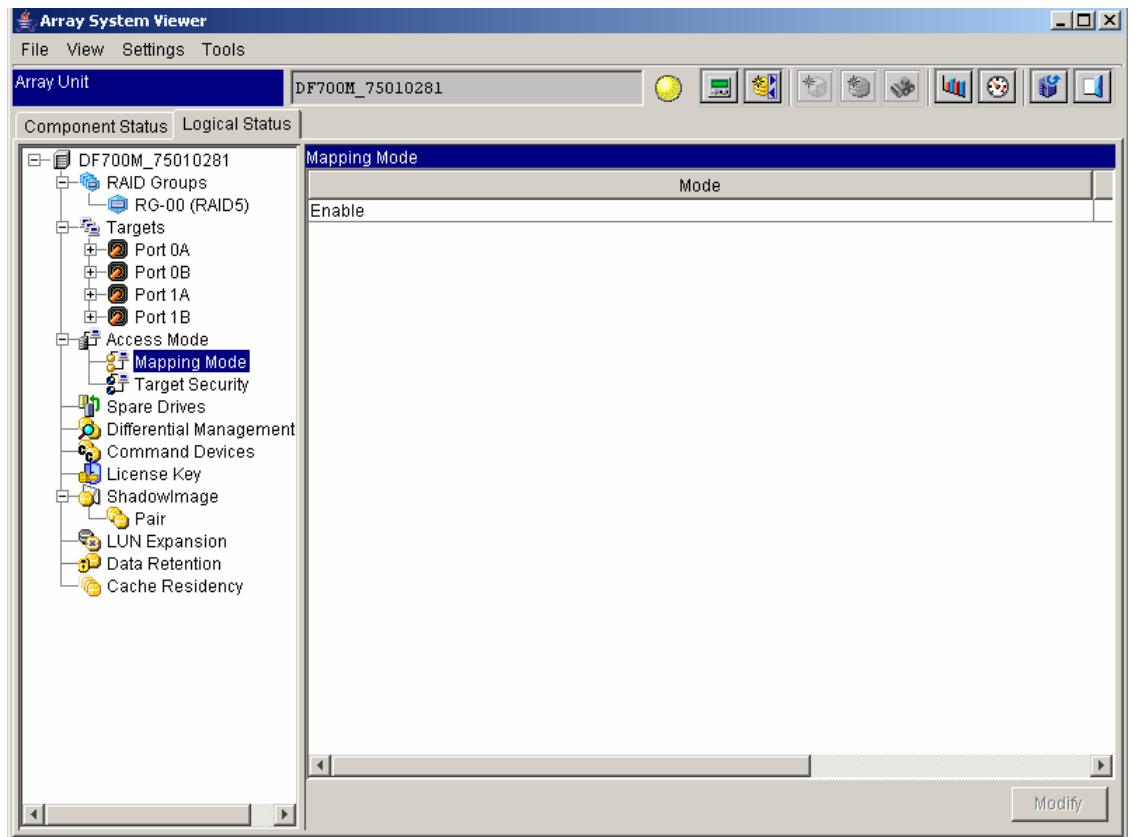

Figure 3.36 Logical Status Tab, Mapping Mode View

3.2.2.7 Target Security View

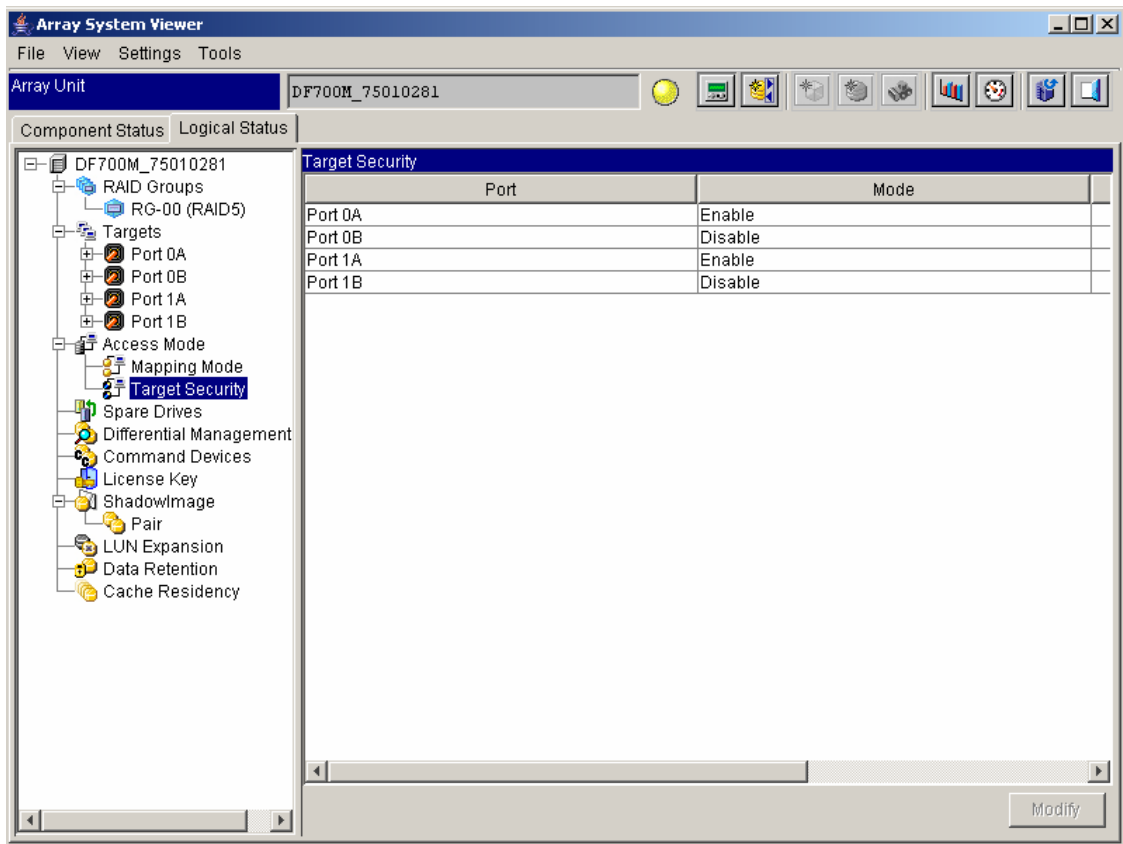

Figure 3.37 Logical Status Tab, Target Security View

3.2.2.8 Spare Drives View

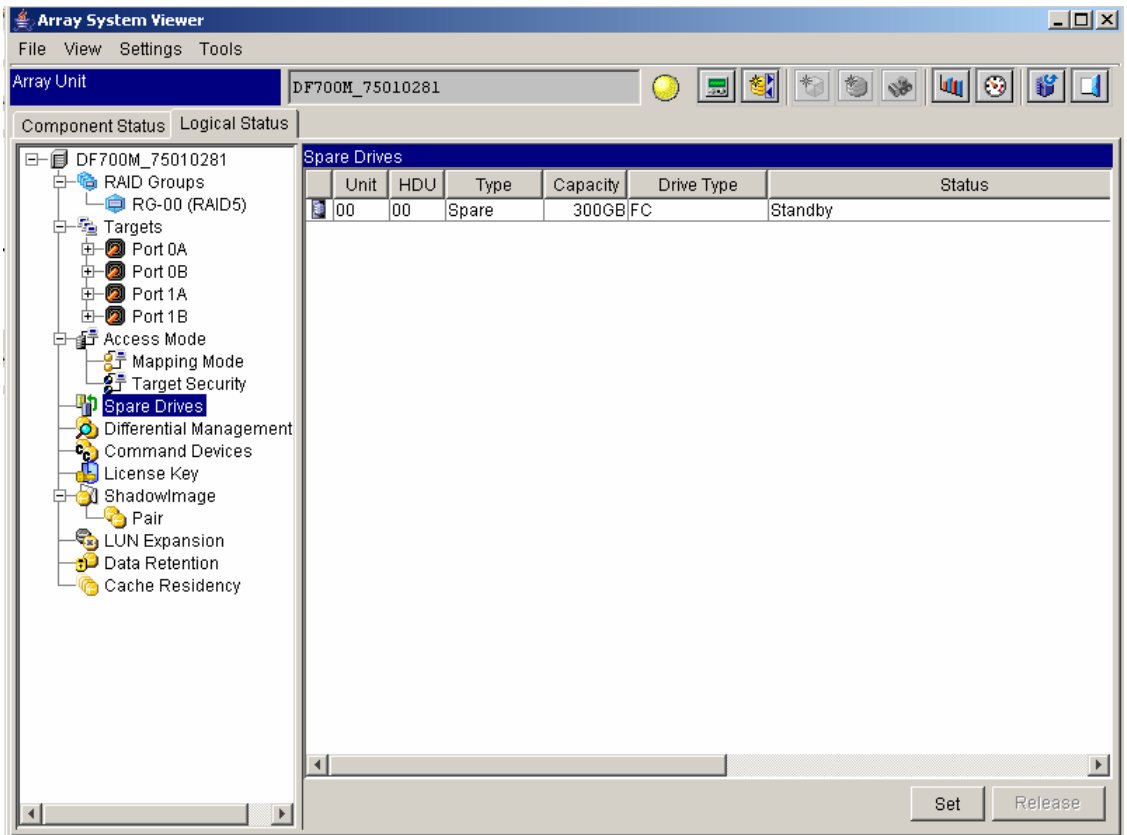











Figure 3.38 Logical Status Tab, Spare Drives View

Table 3.35 Spare Drive Icons

FC Drive	SATA Drive	Status
 Purple		<ul style="list-style-type: none"> Spare drive in use
 Yellow		<ul style="list-style-type: none"> Data reconstruction to spare drive Copy-back from spare disk to data disk
 Purple + Black		<ul style="list-style-type: none"> Waiting
 Red		<ul style="list-style-type: none"> Busy or Disk Drive Detached for Restoring
 Red + Black		<ul style="list-style-type: none"> Spare disk not mounted though Use of Spare Disk is set as subsystem

Note: AT displayed at the upper left of an icon indicates a SATA drive.

3.2.2.9 Differential Management LU View

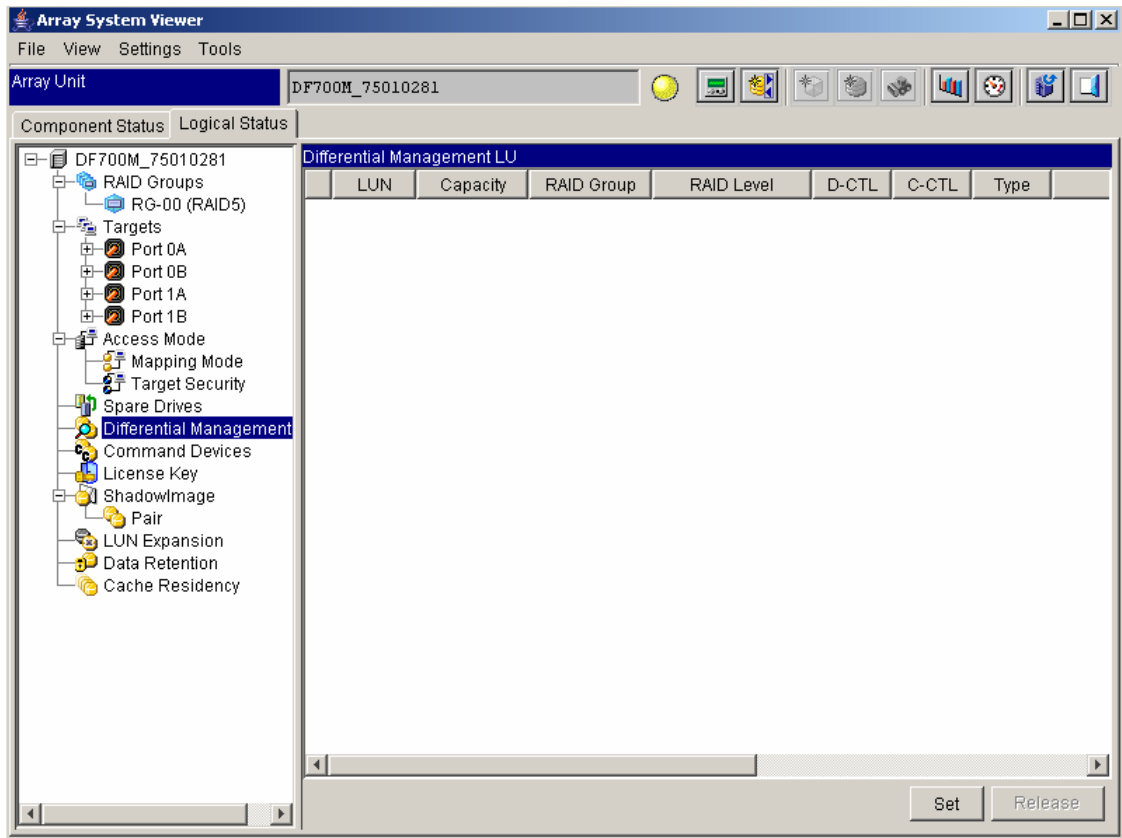

Figure 3.39 Logical Status Tab, Differential Management LU View

3.2.2.10 Command Devices View

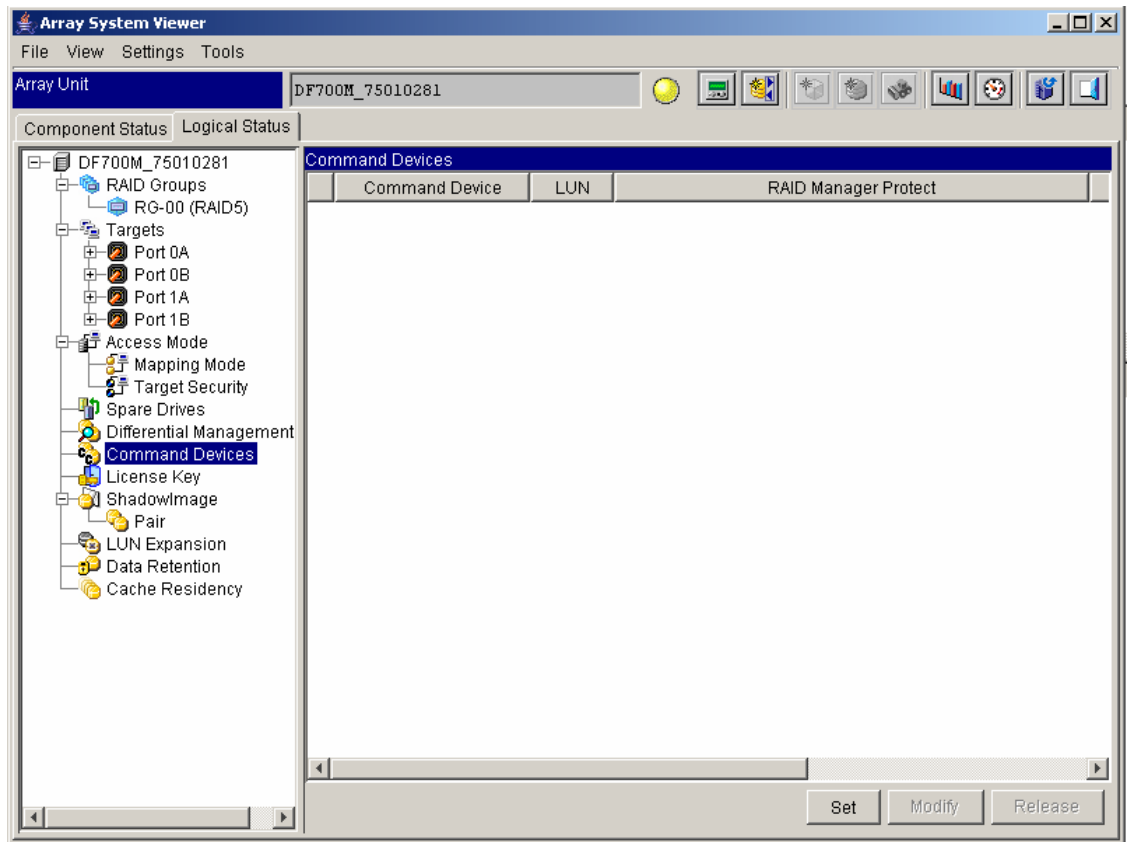

Figure 3.40 Logical Status Tab, Command Devices View

3.2.2.11 License Key View

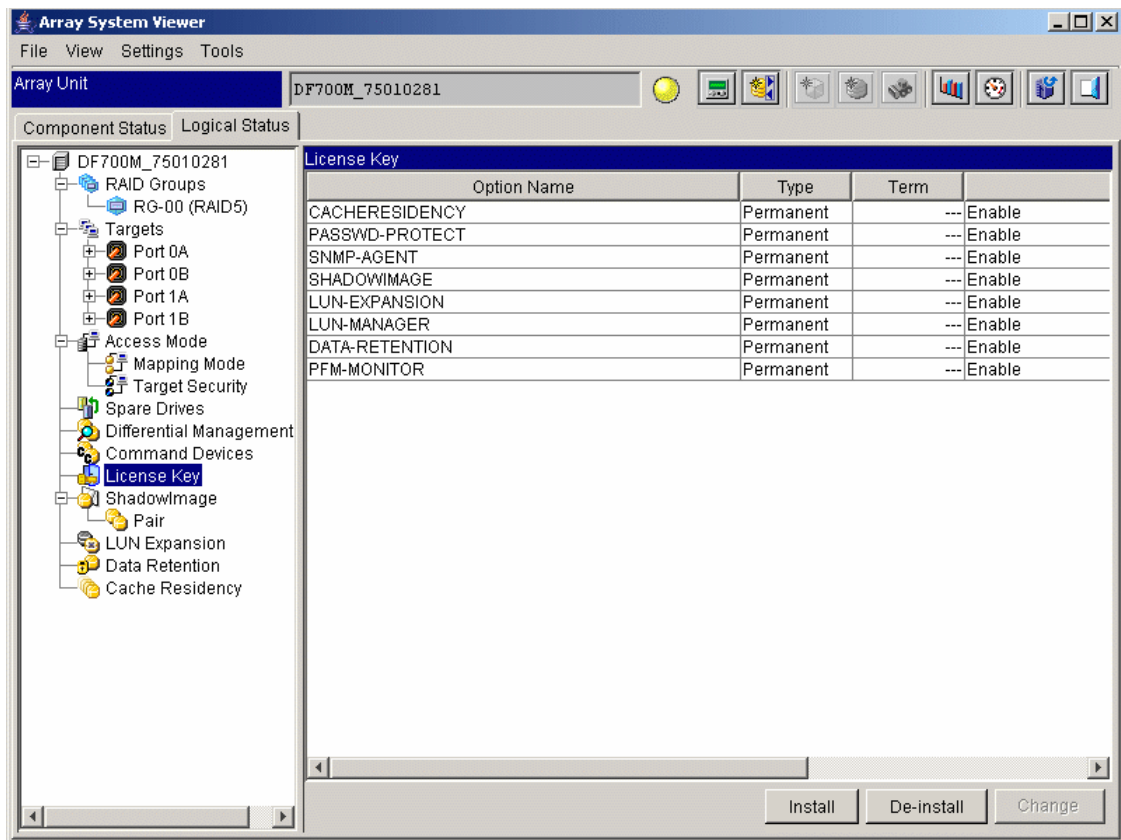

Figure 3.41 Logical Status Tab, License Key View

3.2.2.12 ShadowImage View

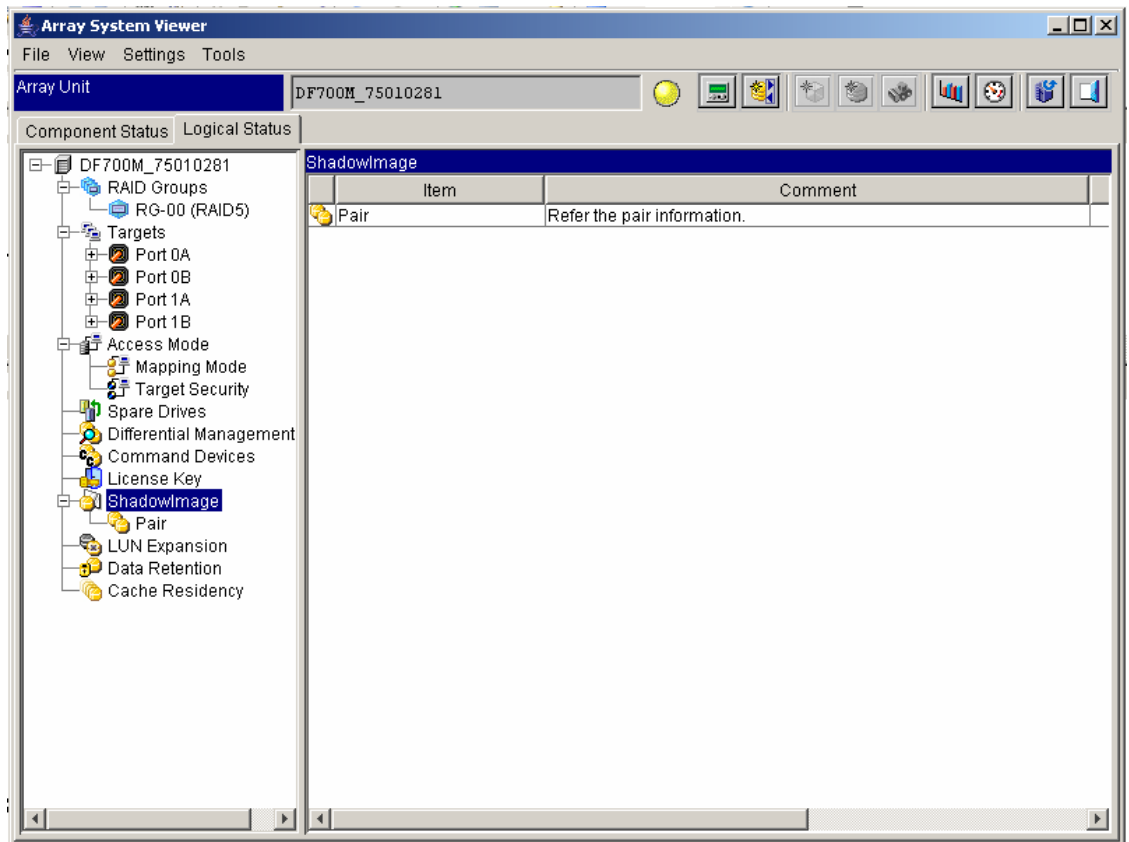

Figure 3.42 Logical Status Tab, ShadowImage View

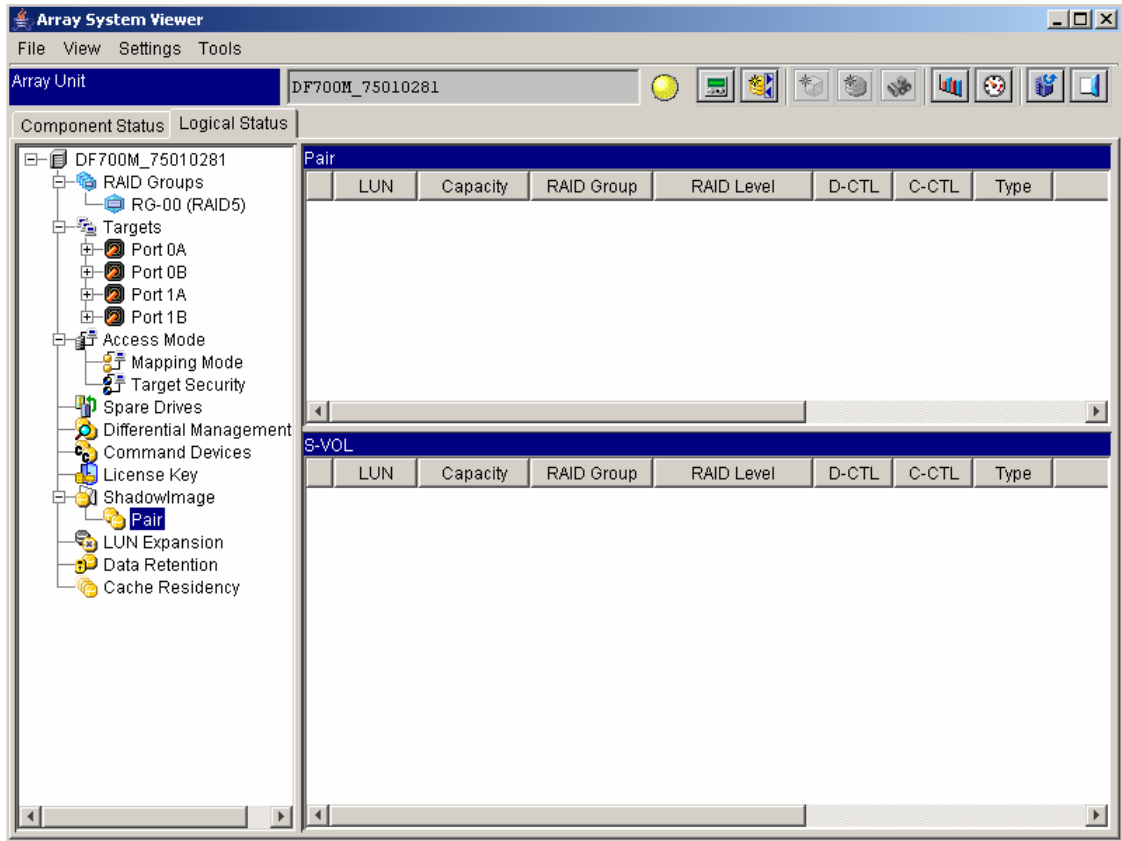

Figure 3.43 Logical Status Tab, ShadowImage Pair View

3.2.2.13 LUN Expansion View

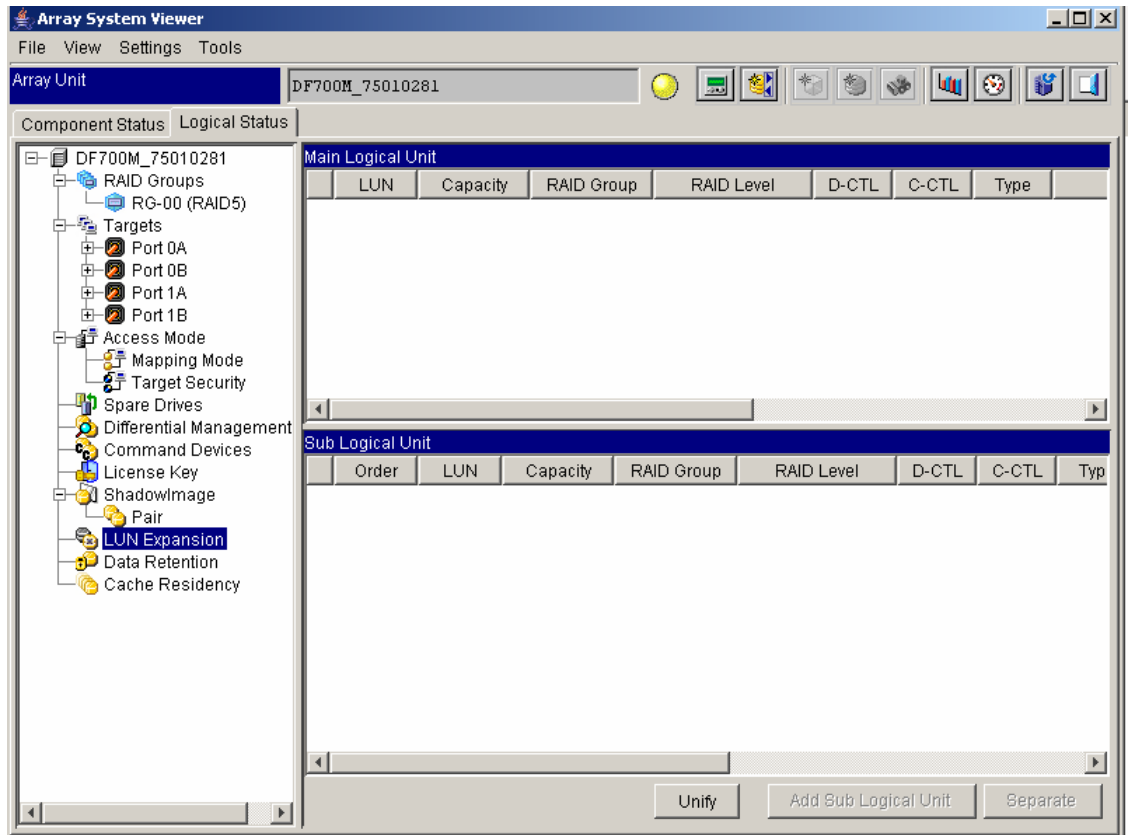

Figure 3.44 Logical Status Tab, LUN Expansion View

3.2.2.14 Data Retention View

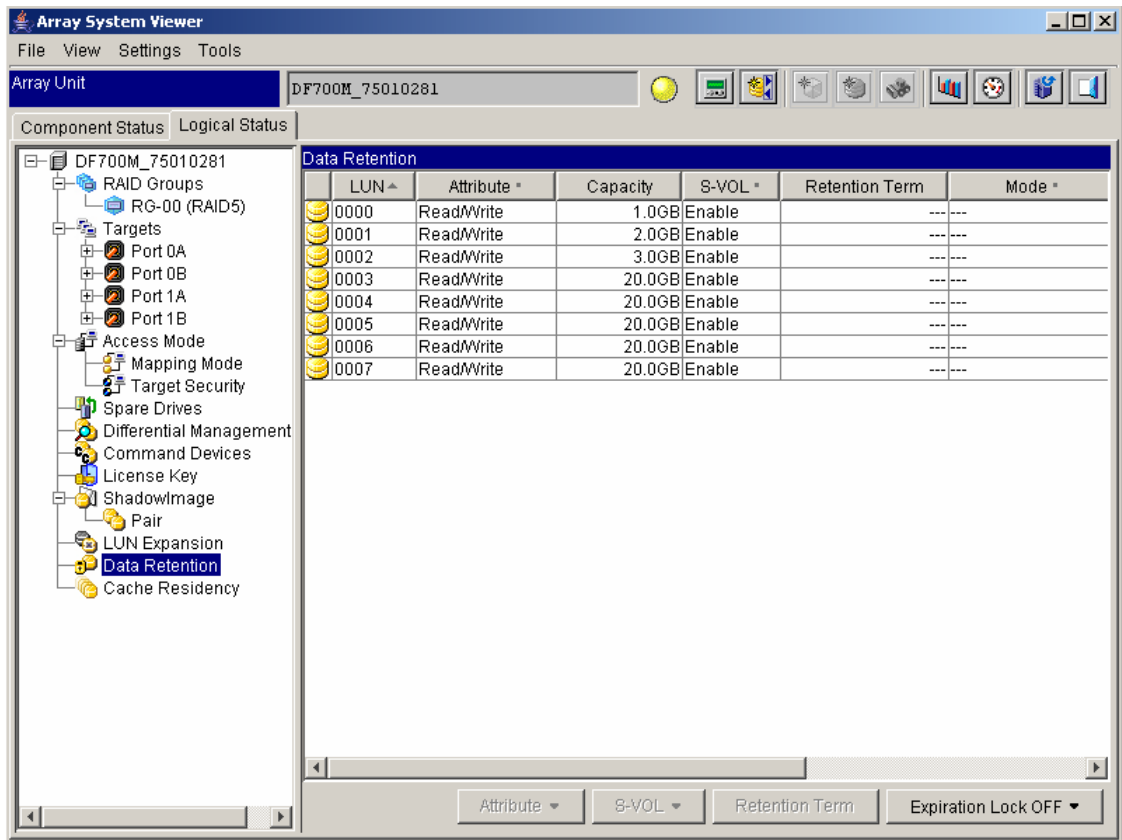

Figure 3.45 Logical Status Tab, Data Retention View

3.2.2.15 Cache Residency View

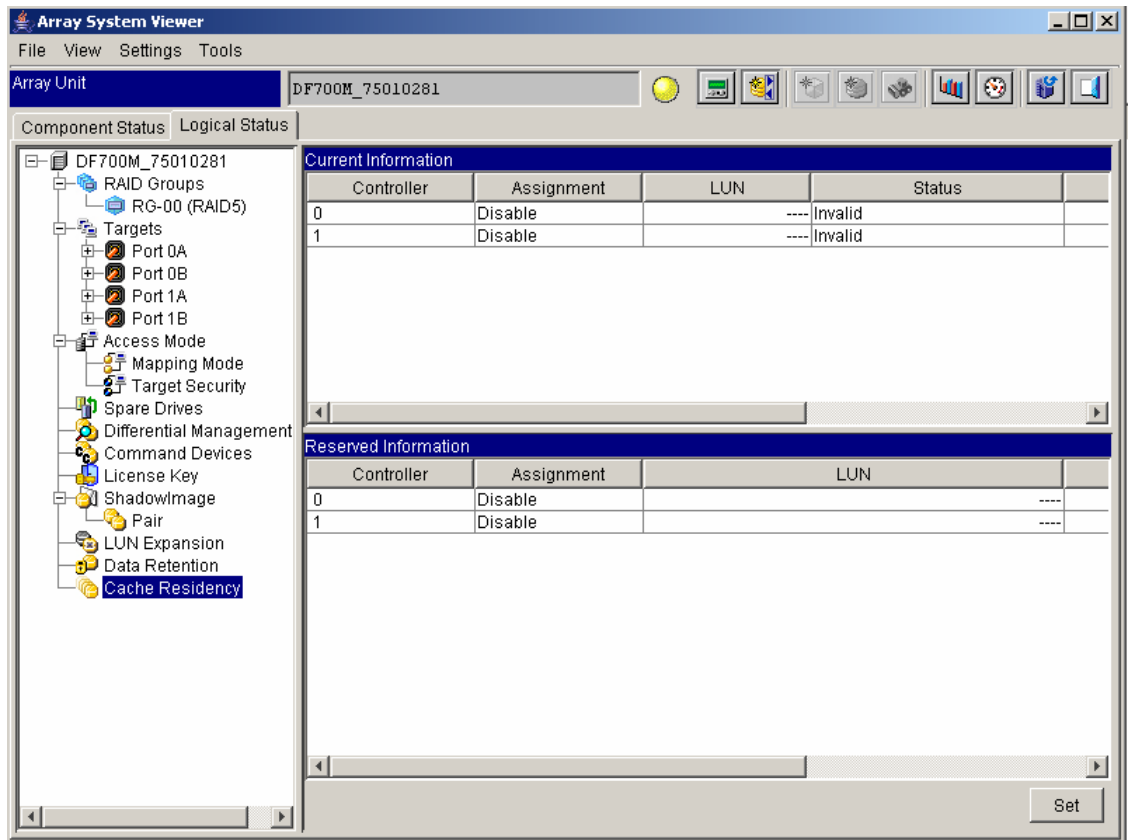

Figure 3.46 Logical Status Tab, Cache Residency View

Chapter 4 Preparing for Storage Navigator Operations

This chapter discusses the following topics:

- Using Storage Navigator (section 4.1)
- Available Storage Navigator functions (section 4.2)
- Starting and Stopping Storage Navigator (section 4.3)
- Restarting the subsystem (section 4.4)
- Changing operation mode (section 4.5)
- Managing passwords (section 4.6)
- Configuring subsystems (section 4.7)
- Displaying an information message (section 4.8)
- Setting and releasing spare drives (section 4.9)
- Setting and releasing the differential management LU (section 4.10)
- Setting and releasing command devices (section 4.11)
- Enabling and disabling the license key for optional products (section 4.12)

4.1 Using Storage Navigator

Please note the following

- If you are using Windows®, you must disable Windows power management so that the PC does not enter the low power mode suspension state.
- Close all **Array System Viewer** windows when you are performing error monitoring.
- If you update the display after certain operations or by selecting **refresh**, some host group names in the tree view are displayed with “...” in the suffix.

Example: “000:HGOA-000 → 000:HGOA...”

Execute **refresh** or **expand** the tree again, and the tree view will display the hidden information.

- When connecting the disk array subsystem with Storage Navigator via a LAN, depending on the LAN environment, the disk array subsystem may not be connected due to data transfer time-out. When Storage Navigator cannot connect with the disk array subsystem, verify that the connection is correct by using the `ping` command, etc. If the response to the `ping` command is normal, the LAN environment may affect the data transfer. The length of data to be transferred can be changed with the `lanconf.inf` file in the directory in which Storage Navigator is installed. The default setting is **32768**. Change the setting to **16384** or **8192** in that order, or to a **multiple of 1024**, and then retry. The new setting becomes effective during the next operation (restarting Storage Navigator is not required). Storage Navigator operations may take extensive time, depending on the setting. If the connection cannot be made after the settings are changed, review the LAN environment.
- Do not use the reserved words discrete for each OS or device names that indicate the input/output destinations as a file name when a file is output. Windows includes “con”, “pm”, “aux”, etc. and UNIX® includes “/dev*”, etc. For example, when `con.txt` is specified as an output file name, an error message is displayed in a window.
- If you are connecting Storage Navigator to a subsystem using a LAN, the TCP/IP port number is 2000. If you are using version 0726/E or later, this port can be changed. If you cannot connect, verify the TCP/IP port number. See section 5.4 for more information on configuring the port number.
- If the subsystem has Account Authorization enabled and it either terminates abnormally or does not respond within the normal session time-out, do one of the following:
 - If a confirmation message has displayed, respond to the message.
 - If no confirmation message displays, re-log in to the subsystem.

Table 4.1 lists the restrictions on concurrent use of other programs.

Table 4.1 Restrictions on using Multiple Management Programs for Single Array

Program Name	Concurrent Use Supported	Concurrent Use Not Supported
Storage Navigator Modular	<ul style="list-style-type: none"> ▪ Storage Navigator Modular (<i>Note</i>) ▪ SNMP Agent ▪ zWeb Server 	<ul style="list-style-type: none"> ▪ DAMP GUI ▪ DAMP for Web
DAMP GUI	<ul style="list-style-type: none"> ▪ SNMP Agent ▪ DAMP Web Server 	<ul style="list-style-type: none"> ▪ Storage Navigator Modular ▪ DAMP GUI ▪ DAMP for Web
DAMP (Web)	<ul style="list-style-type: none"> ▪ SNMP Agent ▪ DAMP Web Server 	<ul style="list-style-type: none"> ▪ Storage Navigator Modular ▪ DAMP GUI ▪ DAMP for Web
SNMP Agent	<ul style="list-style-type: none"> ▪ Storage Navigator Modular ▪ DAMP GUI ▪ DAMP for Web ▪ SNMP Agent ▪ DAMP Web Server 	
Disk Array Unit Web Server	<ul style="list-style-type: none"> ▪ Storage Navigator Modular ▪ DAMP GUI ▪ DAMP for Web ▪ SNMP Agent ▪ DAMP Web Server 	

Note: You can have two concurrent instances of Storage Navigator Modular, provided that they are not connected to the same array system. If one instance terminates forcibly, that may affect the other instance.

4.2 Available Storage Navigator Functions

Table 4.2 lists the available functions for Storage Navigator. The functions that are available are determined by whether you are in normal mode or management mode. Normal mode is the default, but you can change it in the startup window before you connect to the storage array. Except for error monitoring, you should not operate Storage Navigator while you are online, because your connection may time out.

Table 4.2 Storage Navigator Functions (continued on the following pages)

Category	Function Name	Description	Usability During Operation	Normal Mode	Management Mode
Configuration display	Component status display	Displays the status of a component such as drive and fan by using an icon.	Yes	Yes	Yes
	Property display	Displays the status about system components of an array unit, RAID, logical units, etc.	Yes	Yes	Yes
RAID group definition	RAID group creation	Used to add a RAID group. You can set a new RAID group by specifying its disk number, RAID level, and group range for the RAID group to be created.	Yes	No	Yes
	RAID group deletion	Deletes a defined RAID group or a specified RAID group. User data is deleted.	No	No	Yes
LU definition	LU creation	Used to add a logical unit (LU). A new logical unit is added by specifying its capacity. Must be added in numerical order.	Yes	No	Yes
	LU deletion	Deletes the last defined logical unit (LU). User data is deleted.	No	No	Yes
	LU formatting	Required to make a defined logical unit (LU) accessible by the host. Writes null data to the specified logical unit, and deletes user data.	No /Yes	No	Yes
	Change of default controller in charge of an LU	Used to change the default controller in charge of an logical unit (LU) as follows: CTL0 → CTL1 and CTL1 → CTL0 Array unit must be restarted to implement the setting.	Yes	No	Yes
	Parity Correction	Restore the logical unit in which the parity error has occurred.	Yes	No	Yes
Setting the selection	LU creation	Creation of the logical units using a Wizard	Yes	No	Yes

Category	Function Name	Description	Usability During Operation	Normal Mode	Management Mode
Setting the selection	Setting up spare disk drive	Sets up spare disk drives.	Yes	No	Yes
	Differential Management LU	Sets up the differential management LU	Yes	No	Yes
	Command device	Sets up the command devices	Yes	No	Yes
	Setup and display of the priced optional features	Opens/closes the priced optional features key and sets and displays the enable/disable condition.	Yes	No	Yes
Configuration Setting	Setting the boot option	Sets up the boot option. Subsystem must be restarted to implement the setting.	No	No	Yes
	Setting and display of the Fibre Channel information	Sets and displays port addresses and security information, etc.	No	No	Yes
	System parameter	Sets up the System parameters.	Yes	No	Yes
	Port option	Sets up the port options.	Yes	No	Yes
	Setting the drive restoration option	Use the default mode unless necessary or you could affect performance. Sets automatic or non-automatic start for the following: <ul style="list-style-type: none"> ▪ Drive restoration mode ▪ Start of copy-back ▪ Start of correction copy, ▪ Time interval restoring processing unit size ▪ Dynamic sparing mode. 	No	No	Yes
	On-line verify setting	Determines whether the online verify setting is on or off, and sets the interval. Use caution, or performance could be affected.	No	No	Yes
	LAN configuration information setting	Sets the IP Address, Sub Net Mask, Default Gateway Address, and the DHCP mode.	Yes	No	Yes
	Setup and display of RTC	Sets and displays the date and time.	Yes	No	Yes

Category	Function Name	Description	Usability During Operation	Normal Mode	Management Mode
Configuration Setting	Configuration information file output and its setup by use of a file.	Outputs system parameters and RAID group/logical unit configuration information to a file individually. Sets system parameters and RAID group/logical unit configuration information using a file. Subsystem must be restarted to implement the settings. Deletes user data.	Yes	Yes	Yes
	Microcode replacement	Downloads and updates the microcode of the subsystem. Subsystem must be restarted to implement the settings.	No / Yes	No	Yes
Statistical information display	Controller use information display	Displays previous statistical information by selecting a related item.	Yes	Yes	Yes
Performance	Command operation status display	Outputs the command operation status during a certain period or a specified period to the file in the text format.	Yes	Yes	Yes
Error monitoring	Report when a failure occurs and controller status display	Polls the subsystem and displays the status. If an error is detected, it is output into a log file and sent by e-mail. A specified application is started. Contact the Hitachi Data Systems Technical Support Center for any failures.	Yes	Yes	Yes

4.3 Starting and Stopping Storage Navigator

4.3.1 Launching from Windows

4.3.1.1 Launching from Installation Directory

1. Either double click the **Storage Navigator - Modular** icon () on the desktop, or from the **Start** menu, select **Programs** then **Storage Navigator - Modular**. When the **startsnm.bat** file is executed, Storage Navigator starts.

Note: When Storage Navigator is used on Windows 98, 2000, or XP, an error may occur in which the menu display is disabled by a menu bar operation with the mouse. If this occurs, disable the pointer trail or the pointer shadow for the **Mouse** properties in the **Control Panel**.

2. If the menu still does not display, disable the **Scheme** for the **Pointers** tab in the **Mouse** properties. It is also possible that the menu display may be disabled due to erroneous settings.
3. If the menu still does not display, set the color properties value to 65536 or less. It is also possible that the menu display may be disabled due to erroneous settings. If the menu display remains disabled, set the color properties value to 65536 or less.
4. The Storage Navigator program starts in normal mode and the Main panel appears.

Example:

If the Storage Navigator has been installed in C:\Storage Navigator Modular GUI:

```
set STONAVM_HOME=C:\Storage Navigator Modular GUI
java -classpath .\stonavm.jar;.\AceTool.jar
jp.co.Hitachi.str.diskarray.gui.ConmanFrame %1 %2 %3 %4 %5 %6 %7 %8
```

WARNING: The command prompt is displayed. Although it is not related to Storage Navigator options, do not close it, or Storage Navigator will terminate forcibly. If you do not need it, minimize it.

4.3.1.2 Launching from a Different Directory

Edit the `STONAVM_HOME` environment variable of `startsnm.bat` in the extracted file.

1. Set up the Storage Navigator installation in the `STONAVM_HOME` variable environment.

Note: When the Storage Navigator program is started from a batch file, use the Storage Navigator installation directory. When Storage Navigator is used on Windows 98, it may terminate abnormally due to an insufficient area for the environmental variable, etc.

2. If activation fails, change a property of `startsnm.bat`. To change it, open the property and set the **Initial environment** of the **Memory** tab for **1,024**.
3. The Storage Navigator program starts in normal mode and the Main window displays.

4.3.1.3 Specifying Automatic Launch of Error Monitoring

You automatically start error monitoring on startup by modifying the `startup.bat` file. This only works for Windows.

1. Open the bat file to boot the Storage Navigator.
2. Specify the `-check` option in the `startsnm.bat` file (see Figure 4.1).
3. Prepare a shortcut to the Storage Navigator startup bat file for the “Startup”.
4. When Windows is rebooted, Storage Navigator is started in an error monitoring executing status.

```
java -classpath .\stonavm.jar;.\AceTool.jar  
jp.co.hitachi.str.diskarray.gui.ConmanFrame %1 %2 %3 %4 %5 %6 %7 %8 -check
```

Parameter for error monitoring 

Figure 4.1 Editing the Startsnm.bat File

4.3.1.4 Specifying Automatic Display of Array System Viewer Window

You can automatically display the **Array System Viewer** window (see Figure 3.30) on startup by modifying the `startsnm.bat` file. This only works for Windows.

1. When the Storage Navigator is started, the bat file is opened.
2. Specify the following options in the execution file of the bat file.
 - `unit`: Registered name of the subsystem (see Figure 4.2)
 - `ip`: IP address of controller 0 or controller 1 of the registered the subsystem (see Figure 4.3)
 - `host`: Host name of controller 0 or controller 1 of the registered the subsystem (see Figure 4.4)

```
java -classpath .\stonavm.jar;.\AceTool.jar  
jp.co.hitachi.str.diskarray.gui.ConmanFrame %1 %2 %3 %4 %5 %6 %7 %8 -unit DF700M
```

Parameter for screen display ———→

Name of the subsystem to be display ———→

Figure 4.2 Sample Unit Option

```
java -classpath .\stonavm.jar;.\AceTool.jar  
jp.co.hitachi.str.diskarray.gui.ConmanFrame %1 %2 %3 %4 %5 %6 %7 %8 -ip 192.168.1.100
```

Parameter for screen display ———→

IP address of the subsystem to be display ———→

Figure 4.3 Sample IP Option

```
java -classpath .\stonavm.jar;.\AceTool.jar  
jp.co.hitachi.str.diskarray.gui.ConmanFrame %1 %2 %3 %4 %5 %6 %7 %8 -host DF700M
```

Parameter for screen display ———→

Host name of the subsystem to be display ———→

Figure 4.4 Sample Host Option

4.3.2 Launching from Solaris™, IRIX®, HP-UX, or Red Hat® Linux®

4.3.2.1 Launching from Installation Directory

Launch the `startsnm` shell script from the Storage Navigator installation directory.

Example:

If Storage Navigator has been installed in `/usr/stonavm`:

```
#STONAVM_HOME environment variable
```

```
STONAVM_HOME=/usr/stonavm
```

```
export STONAVM_HOME
```

4.3.2.2 Launching from a Different Directory

1. Edit the `STONAVM_HOME` environment variable of `startsnm` in the extracted file before logging in again.
2. Set up the install directory of Storage Navigator in the `STONAVM_HOME` environment variable.

Note: Depending on the environment setting of the server/workstation, correct character fonts may not be displayed on window. The standard font size is 12. If the characters are not displayed correctly, set the font to a different size. To complete this setting, insert a one space character, following the last line `$JAVABIN $EXECJAVA` in `startsnm`, and add `"-xfont#" (#: a font size)`.

4.3.3 Stopping Storage Navigator

To stop Storage Navigator, close the **Array System Viewer** window, then either select on **File → Exit**, or click the **Exit** icon () on the tool bar.

4.4 Restarting the Subsystem

WARNING: Rebooting requires stopping I/O from the host.

WARNING: If you are using TrueCopy or TrueCopy Extended Distance and you are required to reboot the subsystem, change the pair status to PSUS before you reboot.

WARNING: If you are using a NAS, you must also stop the clusters between NAS units. When restarting the subsystem, you must restart the clusters.

To restart the subsystem:

1. On the Storage Navigator Main window, click the icon of a subsystem, then select **File → Reboot**.
2. Rebooting requires stopping I/O from the host. If you are using TrueCopy or TrueCopy Extended Distance, change the pair status to PSUS before you reboot. Stop I/O from the host and click **OK** on the confirmation messages.
3. Restarting should take between 4 and 15 minutes. Click **OK** on the confirmation message when the restart is complete.

4.5 Changing Operation Mode

Storage Navigator has two operation modes:

- Normal mode allows you to view the subsystem configuration and status.
- Management mode allows you to view the subsystem configuration and status, and set the subsystem configuration.

4.5.1 Changing from Normal Mode to Management Mode

When you log into Storage Navigator in Normal mode, **Normal Mode** is displayed in **Operation Mode** in the upper part of the Main window.

To change from Normal mode to Management mode:

1. Either select **Tool → Operation Mode → Change**, or click the **Change Operation Mode** icon () in the tool bar
2. Enter your password on the **Management Mode Password** window (see Figure 4.6) and click **OK**.
3. **Management Mode** will display on the window (see Figure 4.7).

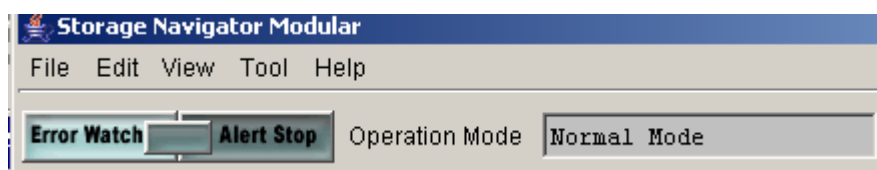

Figure 4.5 Normal Mode

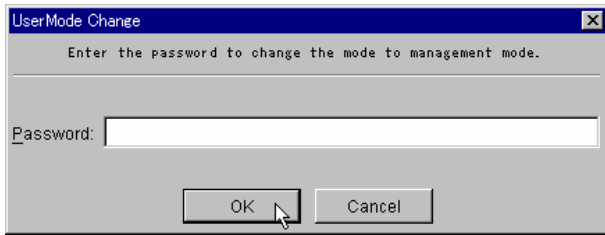

Figure 4.6 Management Mode Password Window

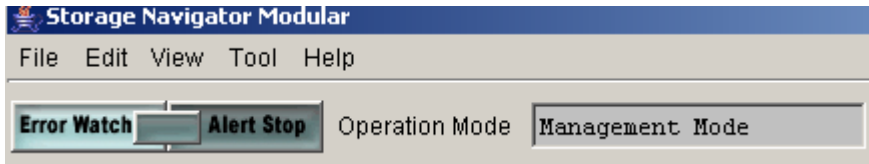



Figure 4.7 Management Mode

4.5.2 Changing from Management Mode to Normal Mode

To change from Management mode to Normal mode:

1. Either select **Tool → Operation Mode → Change**, or click the **Change Operation Mode** icon () in the tool bar.
2. Click **OK** on the **User Mode Change** confirmation dialog box (see Figure 4.8).
3. **Normal Mode** will display on the window.

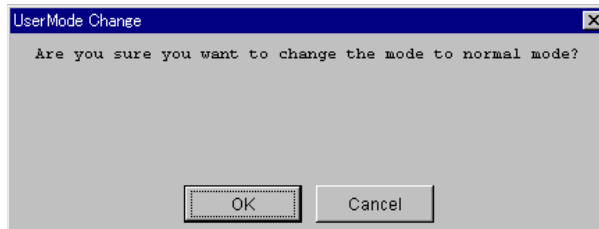

Figure 4.8 User Mode Change Confirmation Dialog Box

4.6 Managing Passwords

Before undertaking any Storage Navigator operations, you must first register a password.

4.6.1 Registering or Changing a Password

To register or change a password:

1. Open the Storage Navigator Main window (see Figure 3.1) and change to Management mode.
2. On the **Tool** menu, select **Operation Mode** → **Set Password** (see Figure 4.9).
3. The **Password** window displays (see Figure 4.10).
4. Enter the new password twice, using up to 12 alphanumeric characters, and click **OK**.



Figure 4.9 Set Password Pop-up Menu

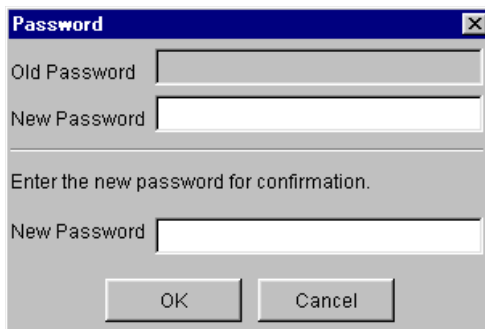

Figure 4.10 Password Window

4.6.2 Deleting the Password

To delete the password, you must uninstall and reinstall the Storage Navigator. Refer to sections 2.5 for instructions on uninstalling Storage Navigator, and section 2.3 for instructions on installing Storage Navigator.

Note: To save the information of the registered array unit, back up the `utlprm.inf` file and `utlprm2.inf` file the Storage Navigator installation directory. Reinstall Storage Navigator in the same directory, the restore the files to the installation directory.

4.7 Configuring Subsystems

Before undertaking any Storage Navigator operations, you must first register one or more storage array units.

WARNING: If Resource Manager 9500V/9520V for Web (Web DAMP) is installed, Storage Navigator Modular cannot recognize the subsystem unless you do the following before you register the subsystem with Storage Navigator Modular.

1. Install Storage Navigator Modular.
2. Copy **utlprm.inf** from the Web DAMP folder (typically C:\Program Files\DA Manager Web) to the Storage Navigator Modular Web installation folder (typically C:\Program Files\Storage Navigator Modular Web).
3. Start Storage Navigator Modular.
4. Enter Management mode.
5. From the **Edit** menu, select **Modify**. The **Modify Array Unit** window displays.
6. Click **OK**.

4.7.1 Adding Subsystems Manually

1. Open the Storage Navigator Main window (refer to Figure 3.1) and change to Management mode.
2. Open the **Add Array Unit** window by one of the following methods:
 - On the **Edit** menu, click **Add**.
 - On the toolbar, click **Add** ()
 - If you already have a registered subsystem, from the List view box, right-click on a subsystem icon and click **Add**.
3. For a simple registration, the **TCP/IP Simple Connection** dialog box is displayed. Input the IP address of the controller 0 and/or controller 1 and click **OK**.
4. For a detailed registration, click **Detail** and input the following information:
 - Select **TCP/IP**.
Note: RS232C is not supported on the AMS/WMS.
 - Input the **IP Address or Host Name or Port**.
Note: If you have a dual system, specify the information for the connected controller side only.
 - **Name:** Specify the registered name of the subsystem, up to 16 alphanumeric characters or characters (-, _, @, ., space code) except numbers.
 - **Group:** Specify up to 16 alphanumeric characters or characters except numbers (-, _). This is only necessary if two or more subsystems are being controlled as a group. The maximum registered number of groups is 200.
 - **Error Monitoring:** Specify whether or not to perform error monitoring.
 - **Check (ON display):** Error monitoring
 - **No check (OFF display):** No error monitoring
5. Click **OK** to register the information, and then click **OK** on the confirmation message.

6. The Storage Navigator Main window displays the updated information.

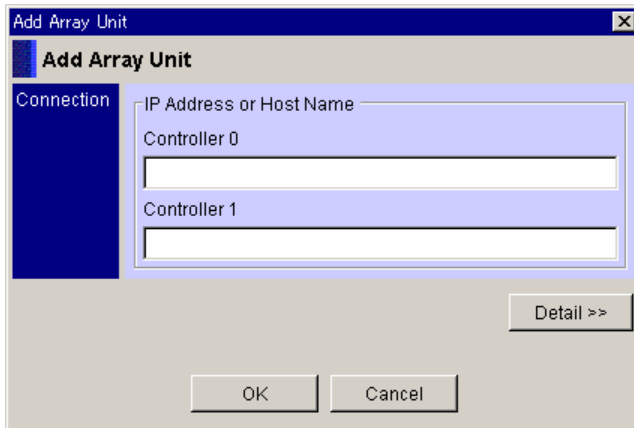

Figure 4.11 Add Array Unit Window (Simple)

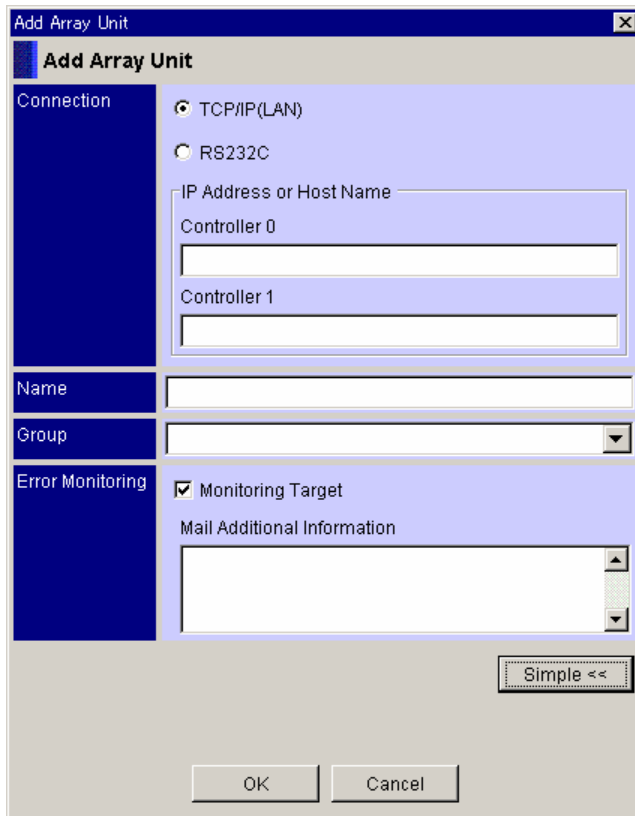

Figure 4.12 Add Array Unit Window (Detailed)

4.7.2 Adding Subsystems Automatically

1. Open the Storage Navigator Main window (refer to Figure 3.1) and change to Management mode.
2. Open the **Add Array Unit Automatically** window by selecting **Edit → Add Automatically** (see Figure 4.13).
3. In the **Search Array Unit** window, enter the range of IP addresses in the **From** and **To** boxes and click **Start**.
Note: This will search your entire network, so this could take some time.
4. The search results will be displayed once the search is finished (see Figure 4.14). In the **Add Array Unit** window, select the name you want to register and click the **▲** button to move the selected subsystem from the **Search Results** list to the **Array Units to Add** list.
5. Click **OK** to implement the action, and then click **Close** on the confirmation message.

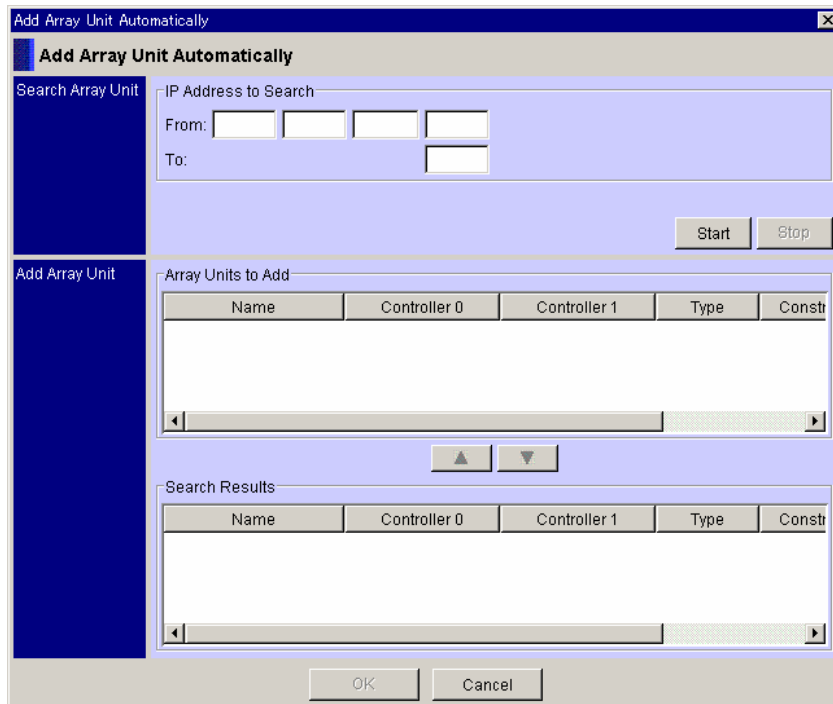

Figure 4.13 Add Array Unit Automatically Window (before search)

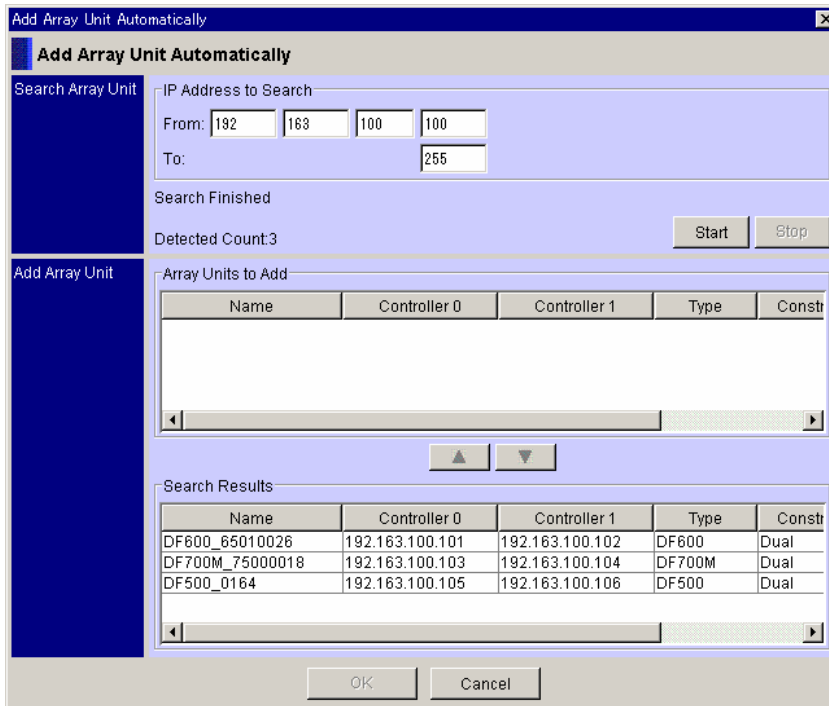

Figure 4.14 Add Array Unit Automatically Window (search results shown)

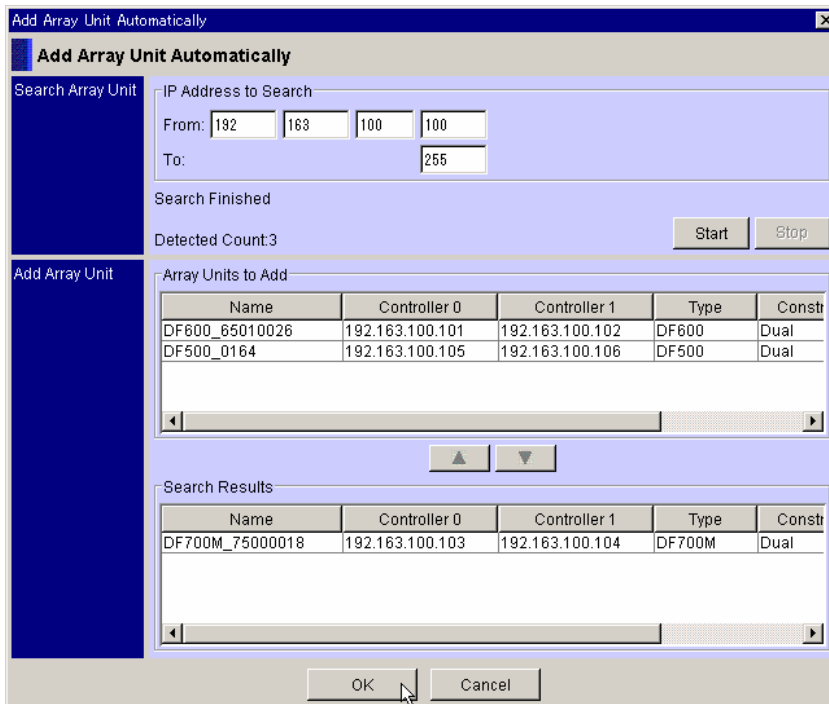

Figure 4.15 Add Array Unit Automatically Window (unit selected)

4.7.3 Modifying Array Unit Properties

1. On the Storage Navigator Main window, open the **Modify Array Unit** window (see Figure 4.16) by one of the following methods:
 - On the **Edit** menu, select **Modify**.
 - Right-click on a registered subsystem, and select **Modify**.
2. Modify the registration as desired, click **OK** to implement the changes, and then click **OK** on the confirmation message.

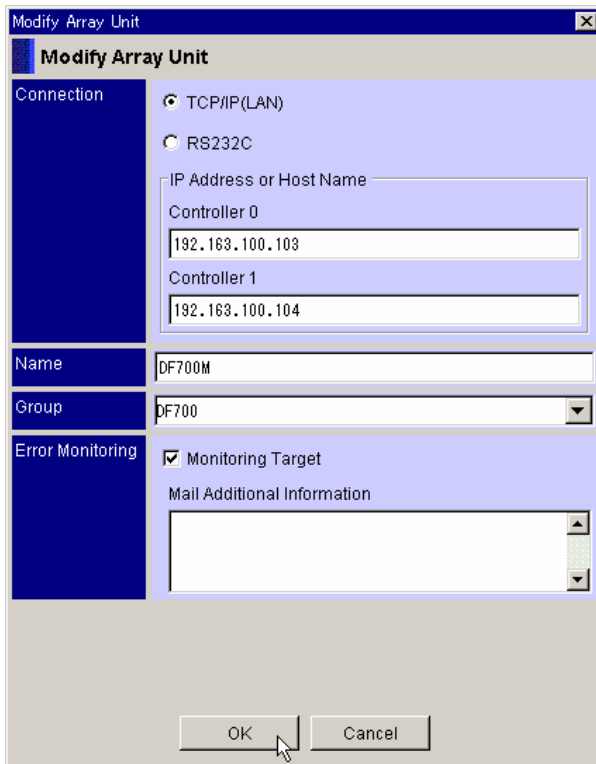

Figure 4.16 Modify Array Unit Window

4.7.4 Deleting a Registered Subsystem

1. Select a subsystem icon on the Storage Navigator, and do one of the following:
 - On the **Edit** menu, click **Delete**.
 - Click the **Delete** icon (✖) in the tool bar
 - Right-click the subsystem and select **Delete**.
2. Click **OK** to implement the change, and then click **Close** on the confirmation message.

4.7.5 Displaying Storage Navigator Version

1. On the **Help** menu, select **Version** to display the **Version** window.
2. Click **OK** to return to the main window.

4.8 Displaying Information Message

1. Display the **Information Message** dialog box (see Figure 4.17) by one of the following methods:
 - From the Storage Navigator Main window, select **Tools** → **Information Message**.
 - Click a lamp icon (🔦) in the **Array Unit** window.
2. Fault and status information are displayed in the appropriate box

Note: If you are using IRIX, do not select the center mouse button, because you could accidentally copy a character string from your clipboard onto the dialogue box. If this occurs, close and then re-open the dialogue box.

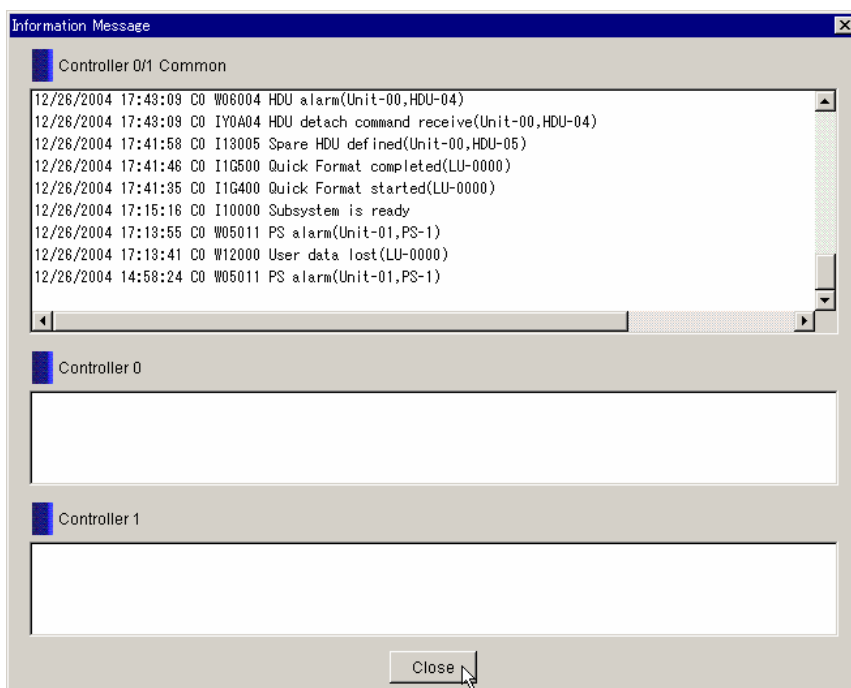



Figure 4.17 Information Message Dialog Box

4.9 Setting and Releasing Spare Drives

4.9.1 Setting a Spare Drive

To set up a spare drive:

1. Click the **Logical Status** tab on the **Array System Viewer** window (see Figure 4.18).
2. From the **Tree View**, click the **Spare Drives** icon, and then click **Set** on the lower right of the window to display the **Spare Drives Settings** window (see Figure 4.19).
3. In **Available Drives** list, select **HDU** number you want to set the spare drives, and click the  button. The selected **HDU** number moves to the **Drives to Set** list (see Figure 4.20).
4. Click **OK** to implement the change, and then click **OK** on the confirmation message.
5. The **Result** window is displayed. Click **Close**.

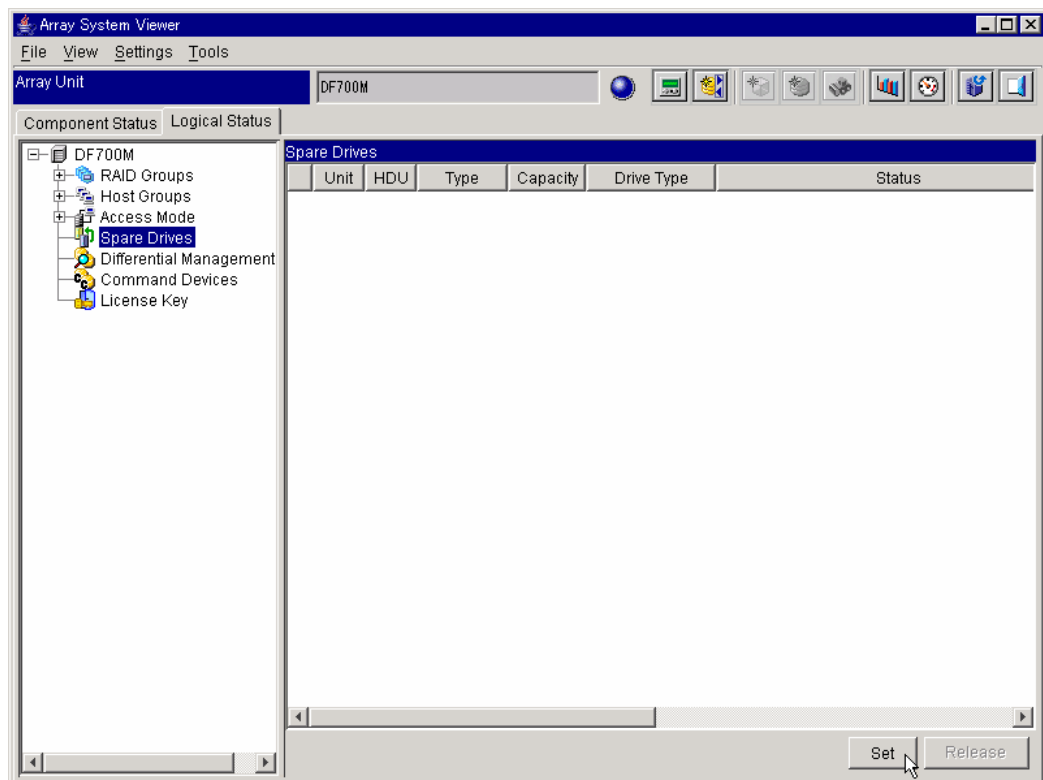

Figure 4.18 Selecting a Spare Drive

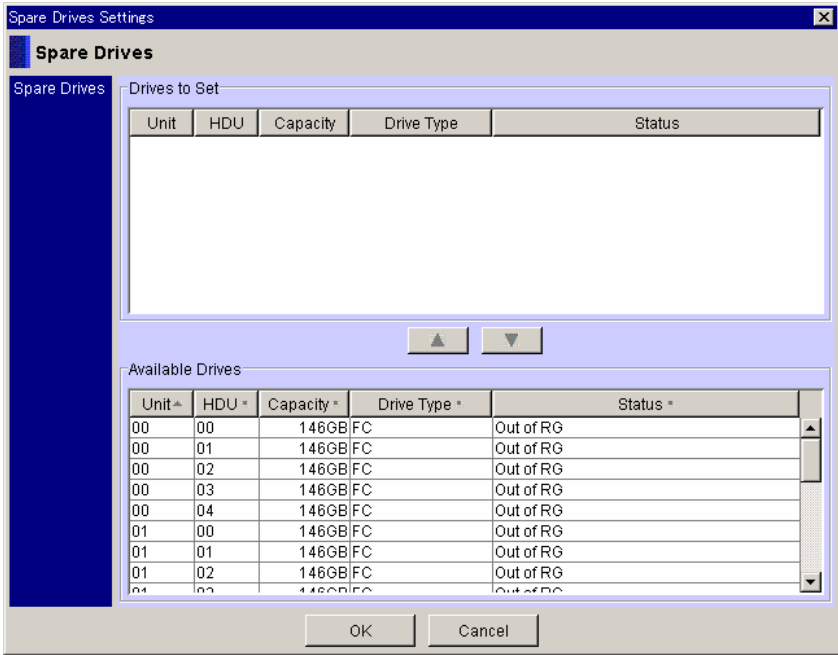

Figure 4.19 Spare Drives Settings Window

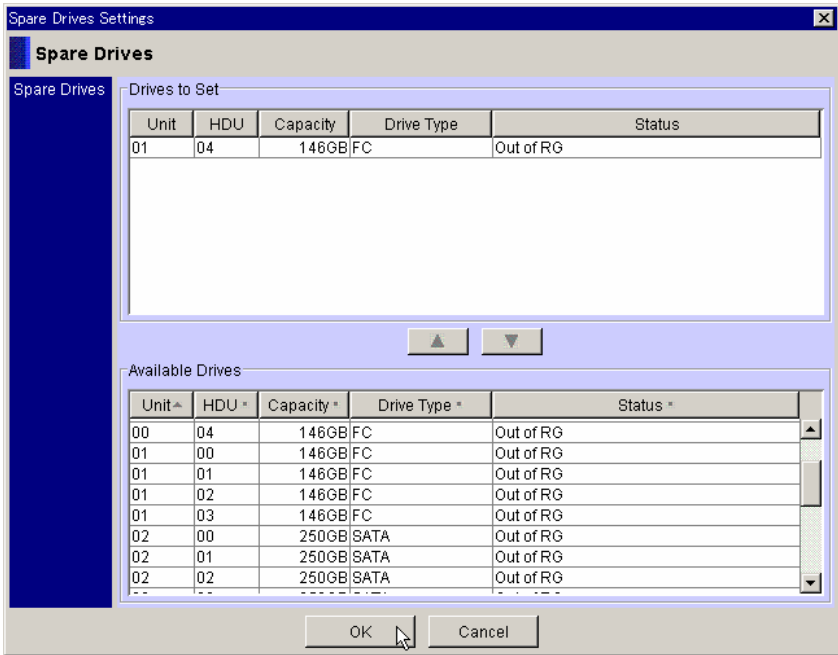
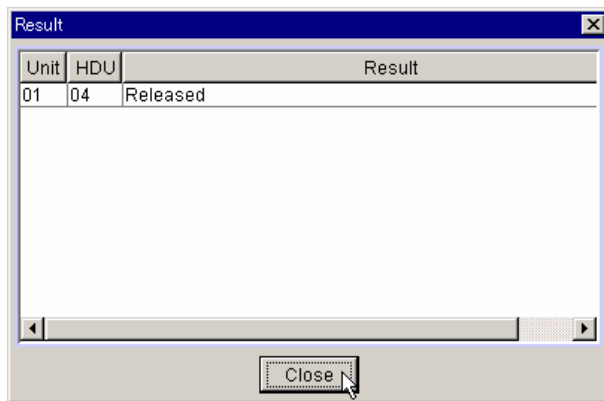

Figure 4.20 Spare Drive Selected

4.9.1.1 Releasing a Spare Drive

To release a spare drive:

1. Click the **Logical Status** tab on the **Array System Viewer** window.
2. From the **Tree View**, click the **Spare Drives** icon (refer to Figure 4.18).
3. Select the desired hard drive unit (HDU), and click **Release** on the lower right of the window.
4. Click **OK** on the confirmation message.
5. The **Result** window is displayed. Click **Close**.



4.10 Setting and Releasing the Differential Management LU

You will need to set a Differential Management LU, which stores the differential data when the volume is copied. The Differential Management LU is treated in the same way as the other logical units, but is not recognized by the host because it is hidden.

The minimum size of a Differential Management LU is 5 GB, and you can set either one or two LUs. If you set two, the second one is used for mirroring.

4.10.1 Setting the Differential Management LU

1. On the **Array System Viewer** window, click the **Logical Status** tab (see Figure 3.30).
2. Click the **Differential Management LU** icon (see Figure 4.21)
3. Click **Set**.
4. The **Select Logical Unit** window displays (see Figure 4.22).
5. Select the desired LUN, and click **OK** to implement the change.
6. Click **OK** on both confirmation messages.
7. The **Logical Status** tab will display the changes (see Figure 4.23)

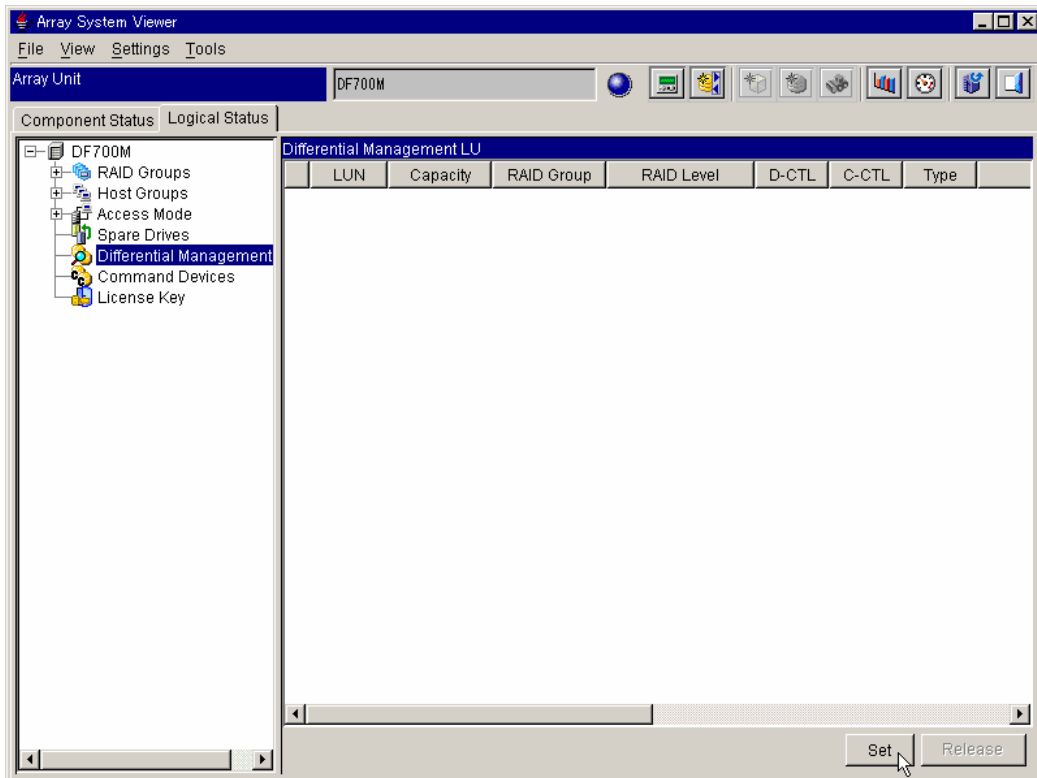

Figure 4.21 Selecting a Differential Management LU

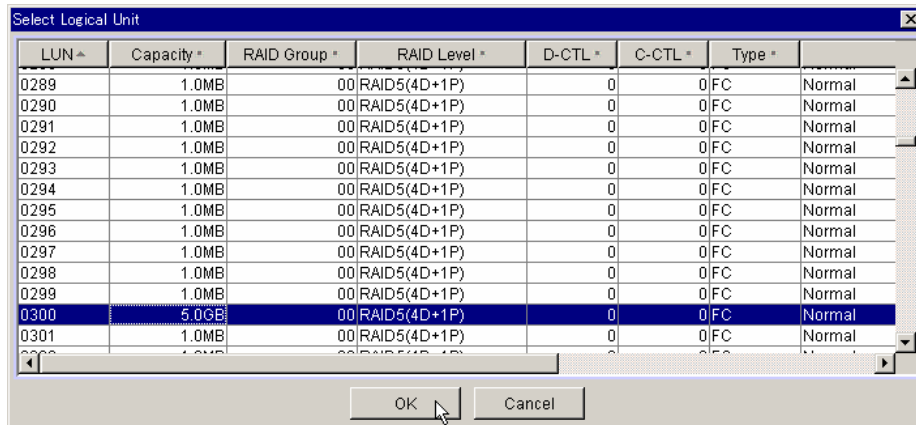

Figure 4.22 Select Logical Unit Window

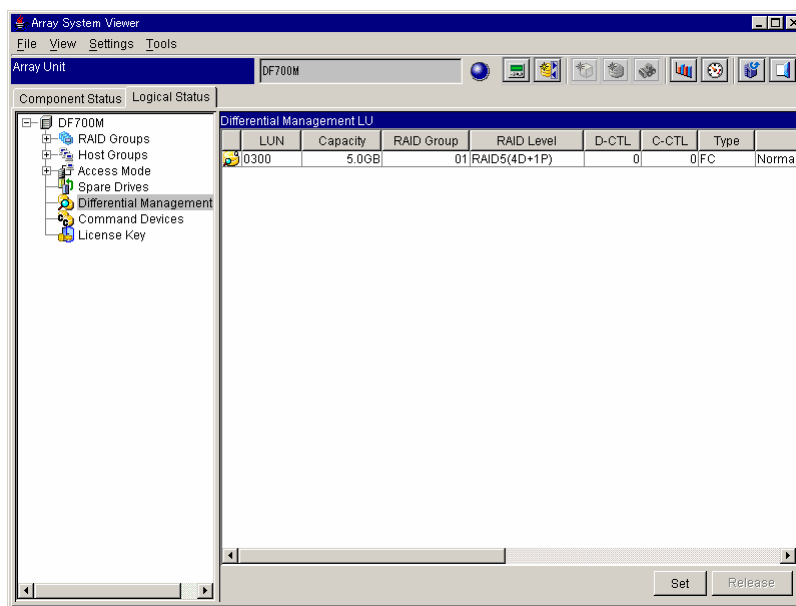

Figure 4.23 Differential Management LU Set

4.10.2 Releasing a Differential Management LU

1. On the **Array System Viewer** window, click the **Logical Status** tab (see Figure 3.30).
2. Click the **Differential Management LU** icon (see Figure 4.21)
3. Select the desired LUN, and click **Release**.
4. Click **OK** on both confirmation messages.

4.11 Setting and Releasing Command Devices

You can designate up to two command devices, each of which must be 33 MB or greater.

4.11.1 Setting a Command Devices

1. On the **Array System Viewer** window, click the **Logical Status** tab (see Figure 3.30).
2. Click the **Command Devices** icon to display the **Command Devices Settings** window (see Figure 4.24).
3. Click **Set** to display the **Command Devices Settings** window (see Figure 4.25).
4. In **Available Logical Units** list, select the desired LUN, and click the  button to move that LUN to the **Command Devices to Set** list (see Figure 4.26).
5. Click **OK** on both confirmation messages.

The **Logical Status** tab displays the new command device (see Figure 4.27).

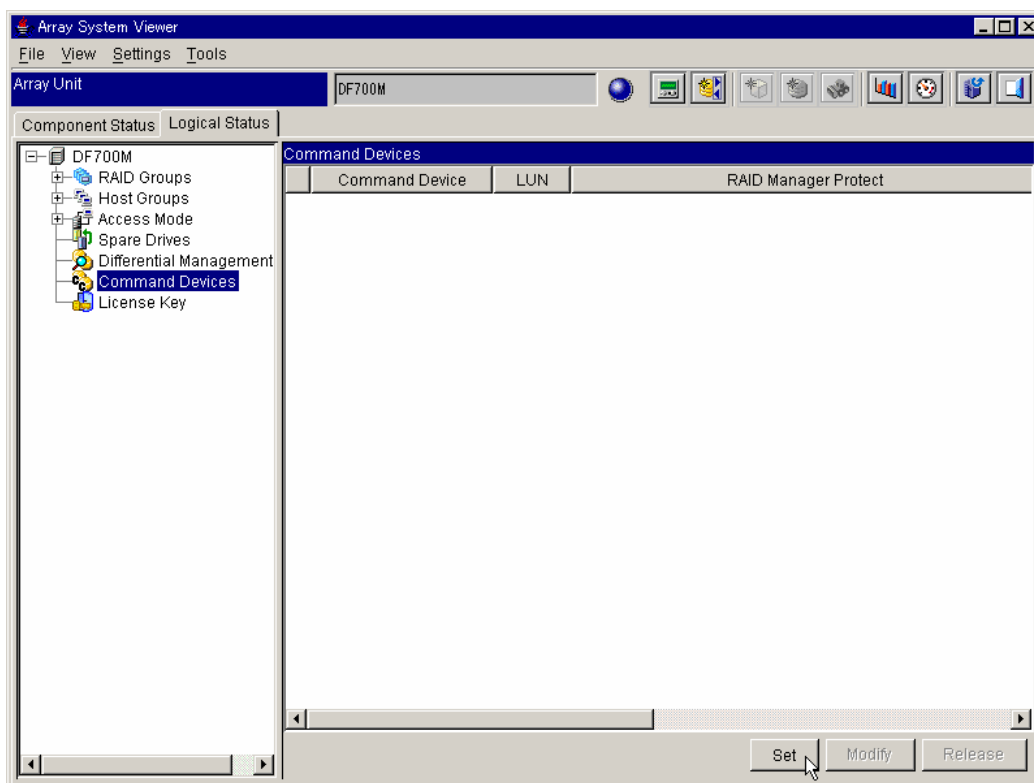

Figure 4.24 Setting Command Devices

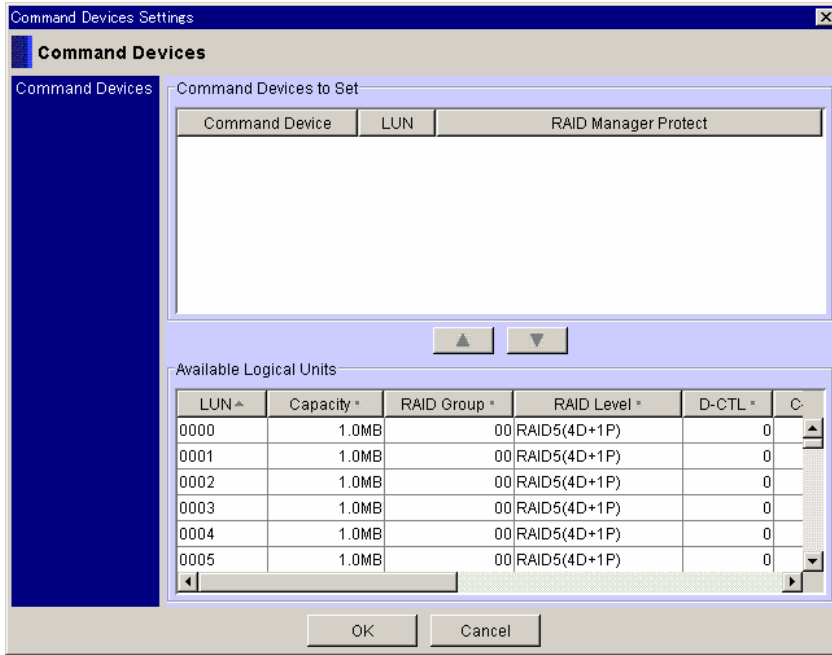

Figure 4.25 Command Devices Settings Window (before setting)

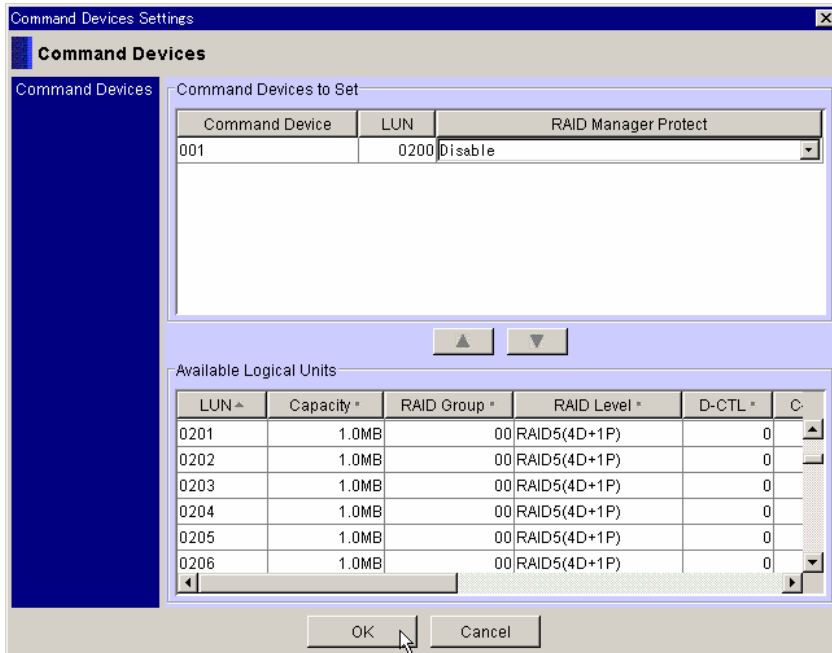

Figure 4.26 Command Devices Settings Window (after setting)

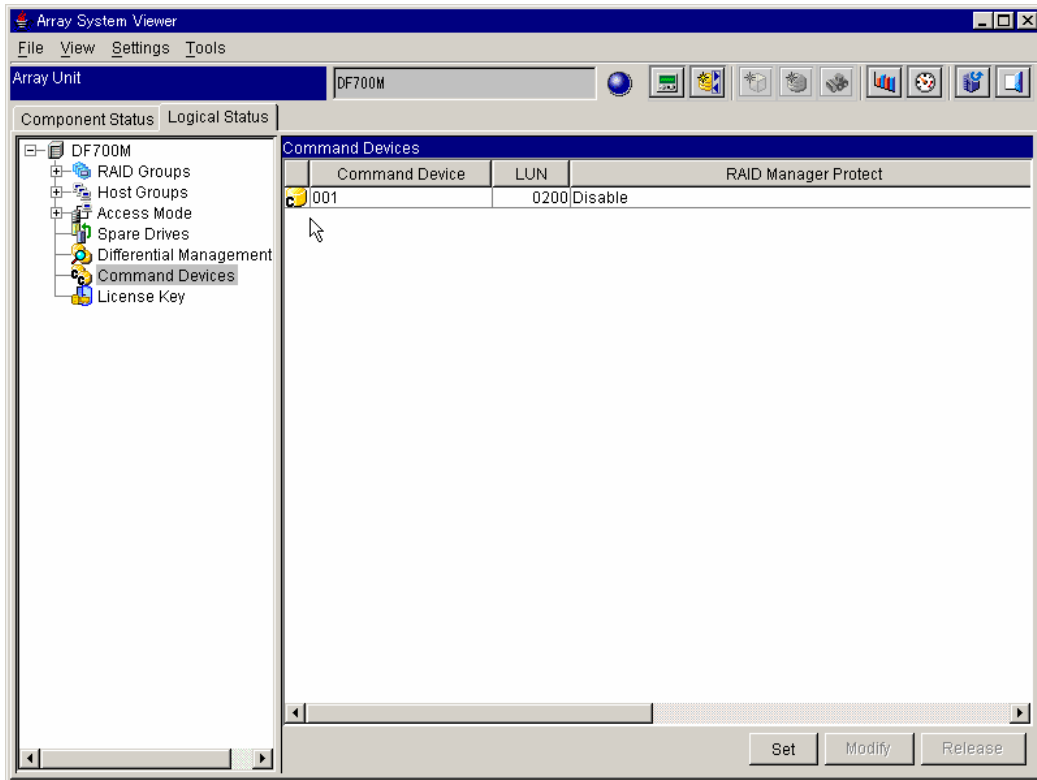

Figure 4.27 Command Device Set

4.11.2 Modifying a Command Device

1. Click the **Logical Status** tab on the **Array System Viewer** window, and then click the **Command Devices** icon (refer to Figure 4.24).
2. Select the desired **Command Device** number, and then click **Modify** to display the **Modify Command Devices** window (see Figure 4.28).
3. In the **RAID Manager Protect** drop-down list, select **Disable** or **Enable**, and then click **OK** on both confirmation messages.

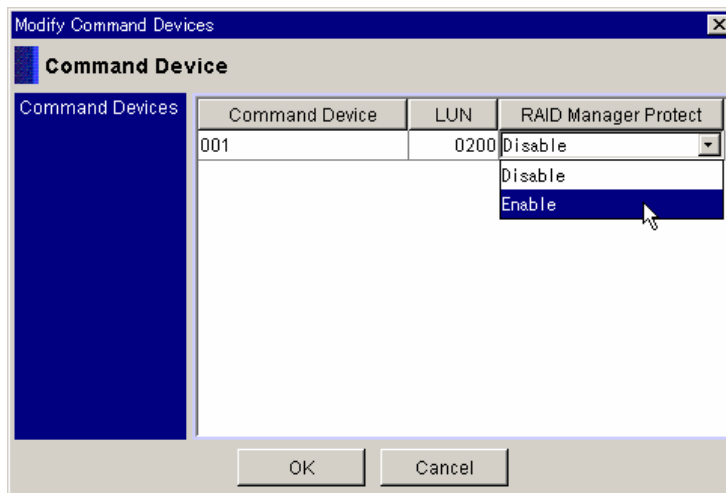

Figure 4.28 Modify Command Devices Window

4.11.3 Releasing a Command Device

1. Click the **Logical Status** tab on the **Array System Viewer** window, and then click the **Command Devices** icon (refer to Figure 4.24).
2. Select the **Command Device** number you want to release the command devices, and then click **Release**.
3. Click **OK** on both confirmation messages.

4.12 Enabling and Disabling the License Key for Optional Products

4.12.1 Installing Optional Features

WARNING: Depending on which options are being installed, this operation may require stopping I/O from the host and rebooting.

WARNING: If you are using TrueCopy or TrueCopy Extended Distance and you are required to reboot the subsystem, change the pair status to PSUS before you reboot.

WARNING: If you are using a NAS, you must also stop the clusters between NAS units. When restarting the subsystem, you must restart the clusters.

1. Click the **Logical Status** tab on the **Array System Viewer** window (see Figure 3.30), and then click the **License Key** icon (see Figure 4.29).
2. Click **Install** to display the **Install Options** dialog box (see Figure 4.30).
3. If you are using a key code to install options, do the following:
 - Click the **Key Code** radio button.
 - Enter the key code(s).
 - Click **OK** on the confirmation message.
4. If you are using a key file, do the following:
 - Click the **Key File** radio button, and then use **Browse** to specify the path to the key file.
 - Click **OK**, to open the **Install Options** dialog box (see Figure 4.31).
 - Select or de-select the desired options, then click **OK** on the confirmation message.
 - Click **Close** to display the **Result** window (see Figure 4.32).
5. Depending on which options have been installed, you may need to restart the subsystem in order to install the option. If restarting is not necessary, a confirmation message will display. Click **OK**.
6. If restarting is necessary, the **Restart Warning** dialog box will display (see Figure 4.33). Stop host access before continuing. If you are using TrueCopy or TrueCopy Extended Distance, change the pair status to PSUS before you reboot. Check **OK to reboot**, and then click **OK** on the **Warning** dialog box.
7. Restarting the subsystem should take between 4 and 15 minutes.
8. Click **OK** on the confirmation message. The **Array System Viewer** window closes, and you are returned to the **Main** window.

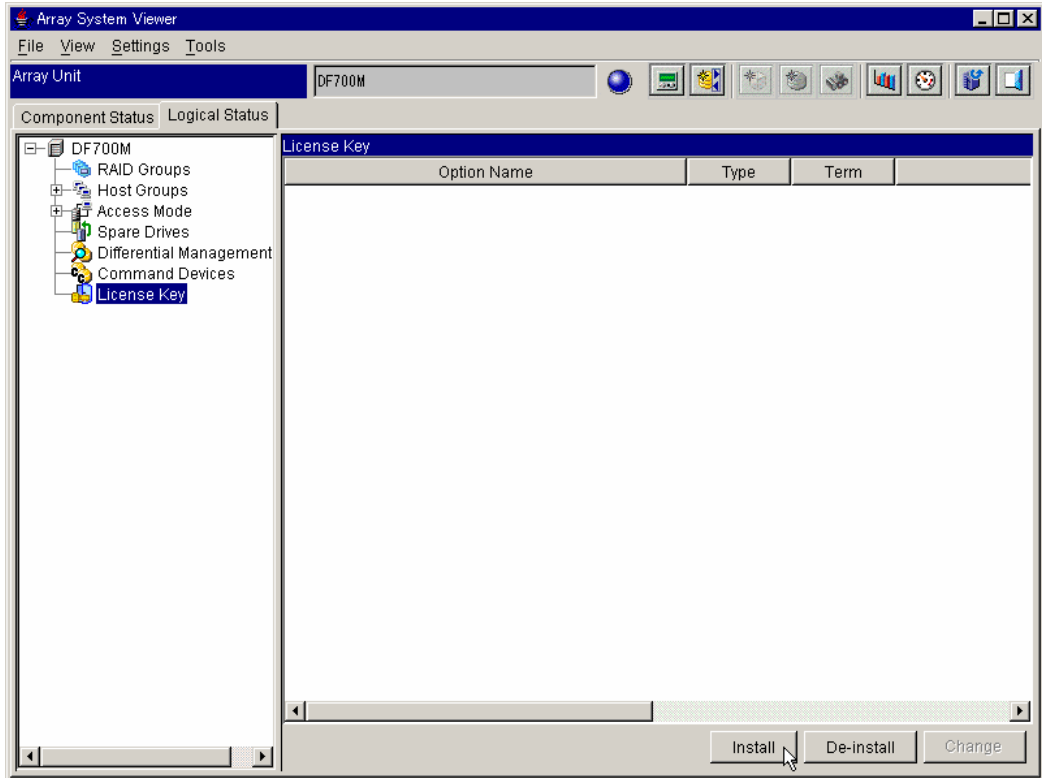

Figure 4.29 Selecting the License Key View

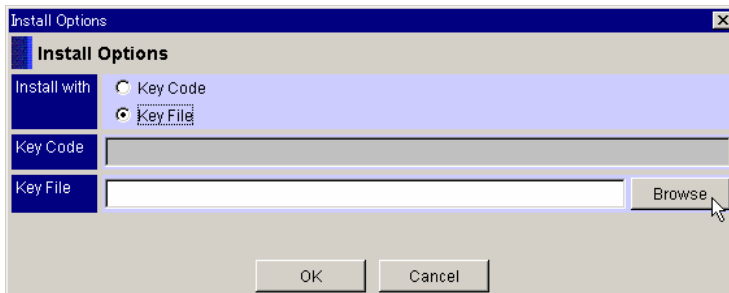

Figure 4.30 Install Options Dialog Box

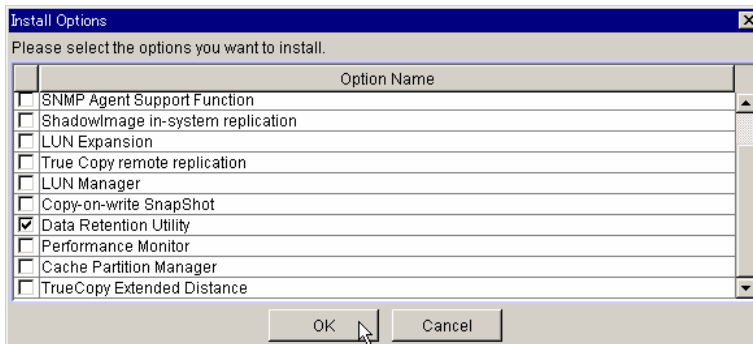

Figure 4.31 Install Options Selection Window

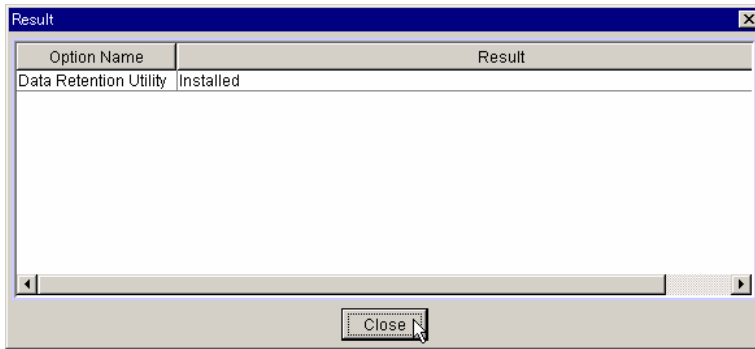

Figure 4.32 Result Window

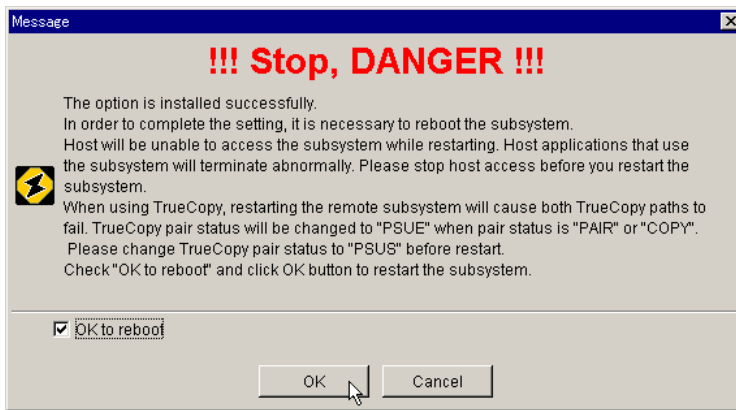

Figure 4.33 Restart Warning Dialog Box

4.12.2 De-installing the Optional Features

WARNING: Depending on which options are being de-installed, this operation may require stopping I/O from the host and rebooting.

WARNING: If you are using TrueCopy or TrueCopy Extended Distance and you are required to reboot the subsystem, change the pair status to PSUS before you reboot.

WARNING: If you are using a NAS, you must also stop the clusters between NAS units. When restarting the subsystem, you must restart the clusters.

1. Click the **Logical Status** tab on the **Array System Viewer** window (see Figure 3.30), and then click the **License Key** icon (see Figure 4.29).
2. Click **De-install** to display the **De-install Options** dialog box (see Figure 4.34).
3. Enter the key code and click **OK** on both confirmation windows.
4. Depending on which options have been de-installed, you may need to restart the subsystem in order to de-install the option. If restarting is not necessary, a confirmation message will display. Click **OK**.
5. If restarting is necessary, the **Restart Warning** dialog box will display (see Figure 4.33). Stop host access before continuing. If you are using TrueCopy or TrueCopy Extended Distance, change the pair status to PSUS before you reboot. Check **OK to reboot**, and then click **OK** on the **Warning** dialog box.
6. If you are using TrueCopy or TrueCopy Extended Distance, change the pair status to PSUS before you reboot. Click **OK** to continue.
7. Restarting the subsystem should take between 4 and 15 minutes.
8. Click **OK** on the confirmation message. The **Array System Viewer** window closes, and you are returned to the Main window.

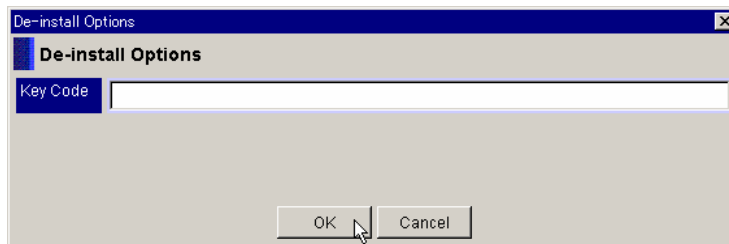

Figure 4.34 De-install Options Dialog Box

4.12.3 Enabling or Disabling Optional Features

WARNING: This operation may require stopping I/O from the host and rebooting.

WARNING: If you are using TrueCopy or TrueCopy Extended Distance and you are required to reboot the subsystem, change the pair status to PSUS before you reboot.

WARNING: If you are using a NAS, you must also stop the clusters between NAS units. When restarting the subsystem, you must restart the clusters.

After releasing the key of the priced optional feature, set enable or disable for this feature.

1. Click the **Logical Status** tab on the **Array System Viewer** window (see Figure 3.30), and then click the **License Key** icon (see Figure 4.29).
2. Select the priced optional features to be either enabled or disabled up, and then select the **Change**.
3. Click **OK** on the confirmation window.
4. A window displays, confirming the priced optional features have been set up. Depending on the option, the subsystem needs to be restarted in order to validate the setup. If the subsystem supports restarting, a message confirming a restart request will be displayed. Click **OK** to restart.
5. Depending on which options have been de-installed, you may need to restart the subsystem in order to de-install the option. If restarting is not necessary, a confirmation message will display. Click **OK**.
6. If restarting is necessary, the **Restart Warning** dialog box will display (see Figure 4.33). Stop host access before continuing. If you are using TrueCopy or TrueCopy Extended Distance, change the pair status to PSUS before you reboot. Check **OK to reboot**, and then click **OK** on the **Warning** dialog box.
7. If you are using TrueCopy or TrueCopy Extended Distance, change the pair status to PSUS before you reboot. Click **OK** to continue.
8. Restarting the subsystem should take between 4 and 15 minutes.
9. Click **OK** on the confirmation message. The **Array System Viewer** window closes, and you are returned to the Main window.

Chapter 5 Configuring Storage Navigator

The **Configuration Settings** window allows you to tailor your system configuration to your individual needs. Which tab views are available is determined by your individual setup.

This chapter discusses the following topics:

- The Configuration Settings Window descriptions (section 5.1)
- Setting Boot Options (section 5.2)
- Setting System Parameters (section 5.3)
- Setting LAN Connection (section 5.4)
- Setting Maintenance Port IP Address (section 5.5)
- Setting LAN Port Number (section 5.6)
- Setting Port Options (section 5.7)
- Setting Restore Options (section 5.8)
- Setting Online Verify Modes (section 5.9)
- Outputting or Setting Configuration Information Using Text Files (section 5.10)
- Setting iSCSI Port information (section 5.12)
- Setting iSNS Server Information (section 5.13)
- Pinging the Initiator Host (section 5.14)
- Updating the Microcode (section 5.15)
- Setting the RTC (section 5.16)
- Setting the Time Zone and NTP Server (section 5.17)
- Setting Format Mode (section 5.18)
- Setting Fibre-Channel Information (section 5.19)
- Setting SNMP Parameters (section 5.20)
- Setting Password Protection (section 5.21)
- Setting Backend Diagnosis (section 5.22)

5.1 Configuration Settings Window Descriptions

5.1.1 Boot Options Tab

Configuration Settings

Array Unit: DF700M

Online Verify	Constitute	Micro Update	RTC	Time Zone	Format Mode	SNMP	Backend Diagnosis
Boot Options	System Parameter	LAN	Maintenance LAN	LAN Port Number	NNC LAN	Restore Options	

System Startup Attribute: Single Mode Dual Active Mode

Delay Planned Shutdown: 0 min.

Drive Detach Mode: Enable Disable

Vendor ID: HITACHI

Product ID: DF800F

ROM Microprogram Version:

RAM Microprogram Version:

Apply Reset

Close

Figure 5.1 Configuration Settings Window, Boot Options Tab

- **System Startup Attribute:** Select the configuration of the subsystem:
 - **Single Mode:** Single configuration
 - **Dual Active Mode:** Dual active configuration
- **Delay Planned Shutdown:** Specify the time in minutes to delay the execution of the planned shutdown when the main switch has turned off. The applicable range is from 0 to 60 minutes.
- **Drive Detach Mode:** Validates the drive blockade mode.
- **Vendor ID:** Enter a vendor name with eight characters. When the name consists of less than seven characters, make an eight-character entry by filling the reset with space(s). The default value set in HITACHI Δ . (Δ Denotes a space.)
- **Product ID:** Enter a model name with 16 characters. When the name consists of less than 16 characters, make a 16-character entry by filling the reset with space(s).
- **ROM Microcode Version:** Specifies a microcode version of a ROM reported by inquiry command.
- **RAM Microcode Version:** Specifies a microcode version of a RAM reported by inquiry command.

5.1.2 System Parameter Tab

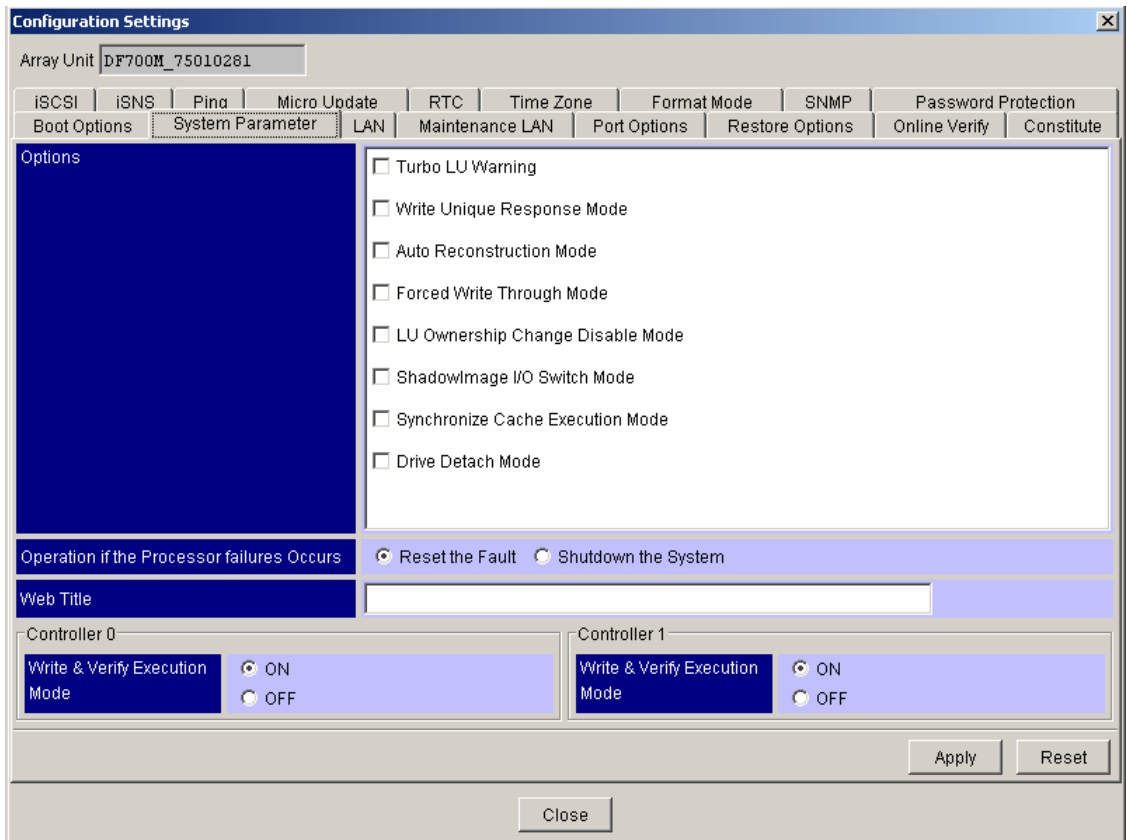

Figure 5.2 Configuration Settings Window, System Parameter Tab

- **Options:** Set the optional function(s) according to the configuration of the subsystem:
 - **Turbo LU Warning:** When the Turbo LU function is invalidated, a warning is reported.
 - **Write Unique Response Mode:** Validates the Write Unique Response Mode.
 - **Auto Reconstruction Mode:** Validates the Auto Reconstruction Mode.
 - **Forced Write Through Mode:** Validates the Forced Write Through Mode.
 - **LU Ownership Change Disable Mode:** Validates the LU Ownership Change Disable Mode.
 - **ShadowImage I/O Switch Mode:** Validates the ShadowImage I/O Switch Mode.
 - **Synchronize Cache Execution Mode:** Validates the Synchronize Cache Execution Mode.
 - **Drive Detach Mode:** Validates the Drive Detach Mode.
- **Operation if the processor failure occurs:** Sets the operation to be performed when a processor failure occurs:
 - **Reset the fault:** Resets a failure and restarts the controller.
 - **Shutdown the system:** Shuts the subsystem down.

- **Web Title:** If the home page of the subsystem is displayed with the browser, it specifies a character string displayed on the title bar of the browser. Enter up to 32 one-byte coded alphanumeric or characters (except for the ' (single quotation mark), " (double quotation mark), and \ (backslash) symbols) other than numeric.
- **Write & Verify Execution Mode:** Set the write & verify execution mode of the controller 0/1:
 - **ON:** Executes write and verify.
 - **OFF:** Does not execute write and verify.

5.1.3 LAN Tab

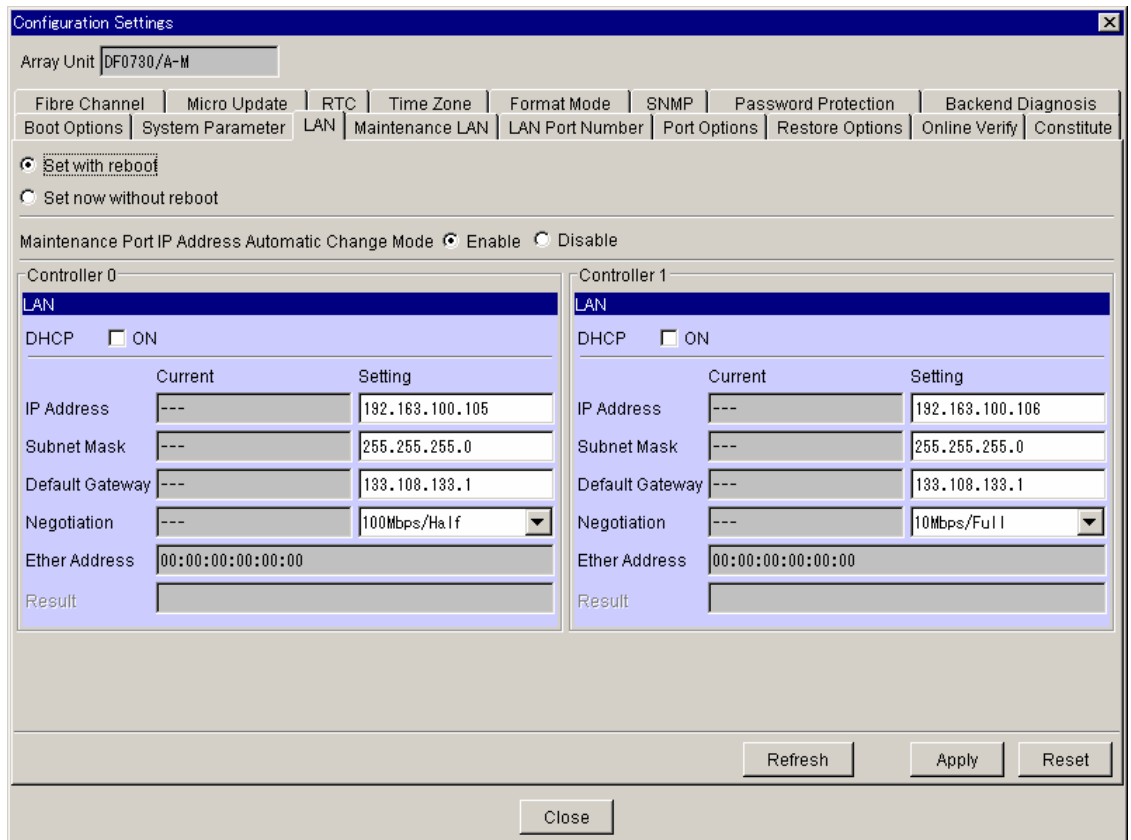

Figure 5.3 Configuration Settings Window, LAN Tab

5.1.4 Maintenance LAN Tab

Configuration Settings

Array Unit: DF700M_75010031

Restore Options | Online Verify | Constitute | Fibre Channel | Micro Update | RTC | Time Zone | Format Mode | SNMP
Boot Options | System Parameter | LAN | Maintenance LAN | NNC LAN | Port Options

IP Address	Maintenance Port	Current	Setting	Result
	CTL0	10.0.0.16	10.0.0.16	Normal
	CTL1	10.0.0.17	10.0.0.17	Normal
	NNC0	0.0.0.0	10.0.0.10	Not Specified
	NNC2	0.0.0.0	10.0.0.12	Not Specified

Refresh Apply Reset

Close

Figure 5.4 Configuration Settings Window, Maintenance LAN Tab

5.1.5 LAN Port Number Tab

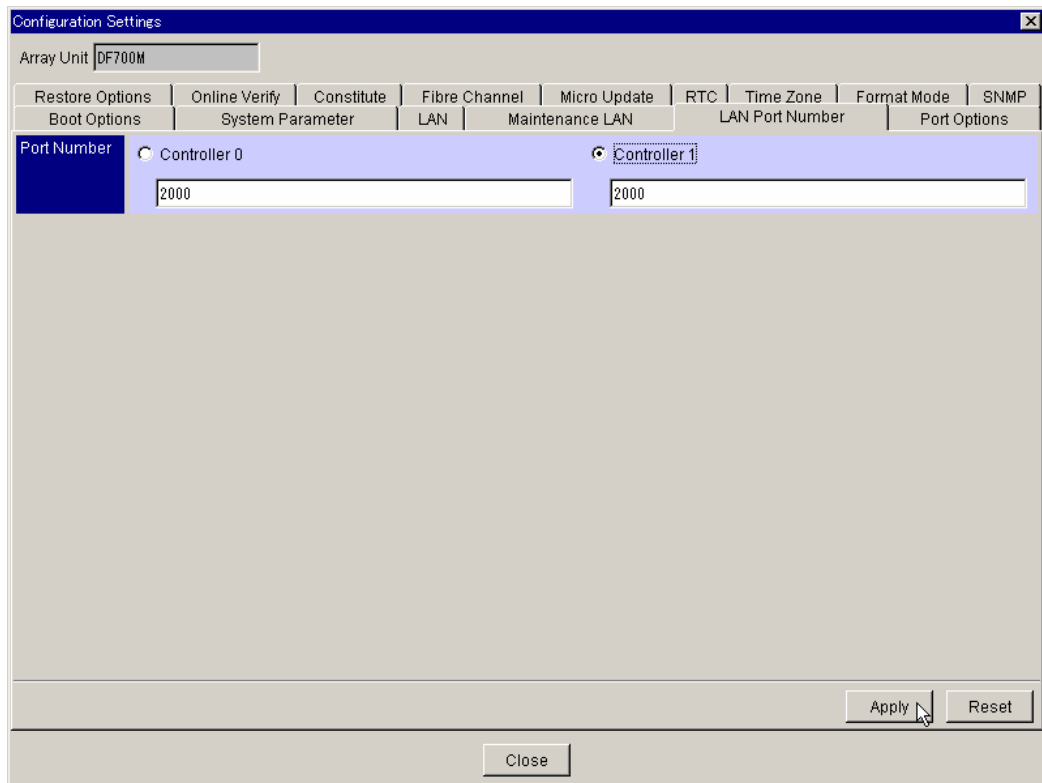

Figure 5.5 LAN Port Number Tab

5.1.6 Port Options Tab

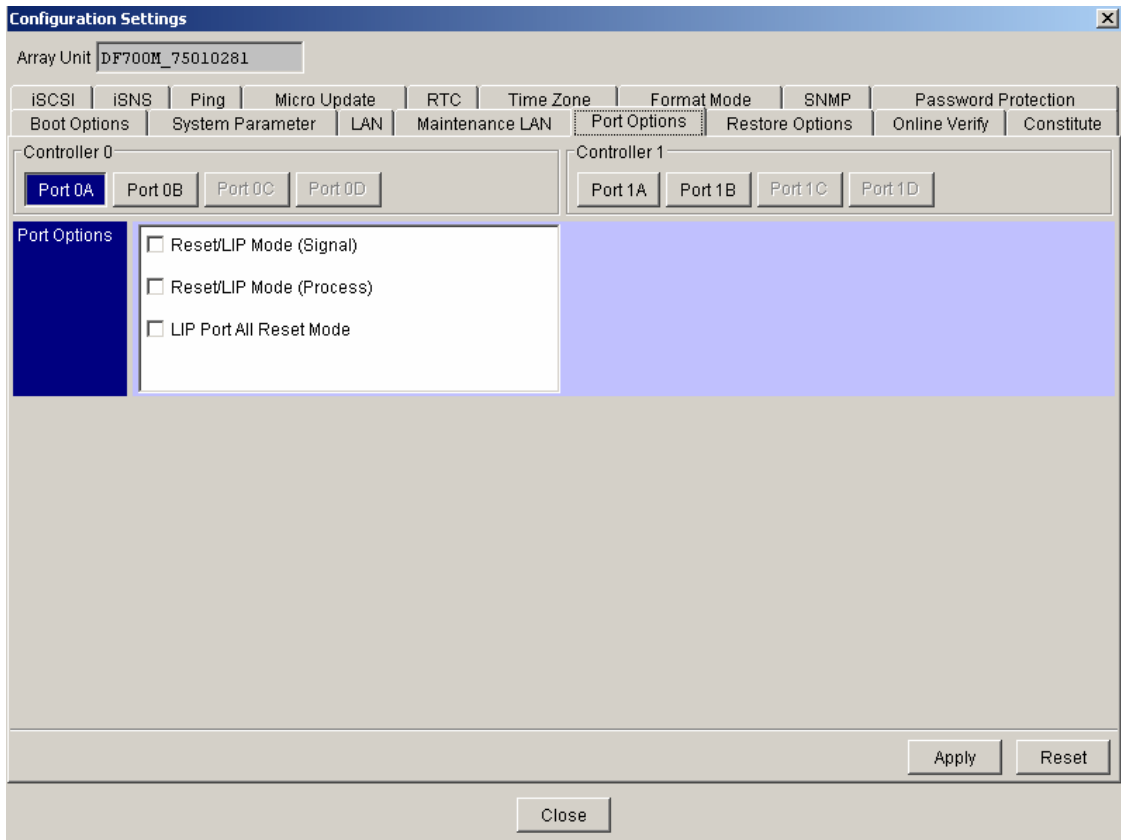

Figure 5.6 Configuration Settings Window, Port Options Tab

- **Port Options:** Sets the port options :
 - **Reset/LIP Mode (Signal):** The mode to transmit Reset/LIP signals to other ports.
 - **Reset/LIP Mode (Process):** The mode to transmit reset processing to other ports.
 - **LIP Port ALL Reset Mode:** The mode to execute reset on receiving LIP.

Note: Reset/LIP Mode (signal) is enabled if the Reset/LIP Mode (Process) is set. Port Option can be multiply set, but depending on the setting, it may not function properly. If it is to be set, please refer to the appended manual of the subsystem and set only the applicable parameters.

5.1.7 Restore Options Tab

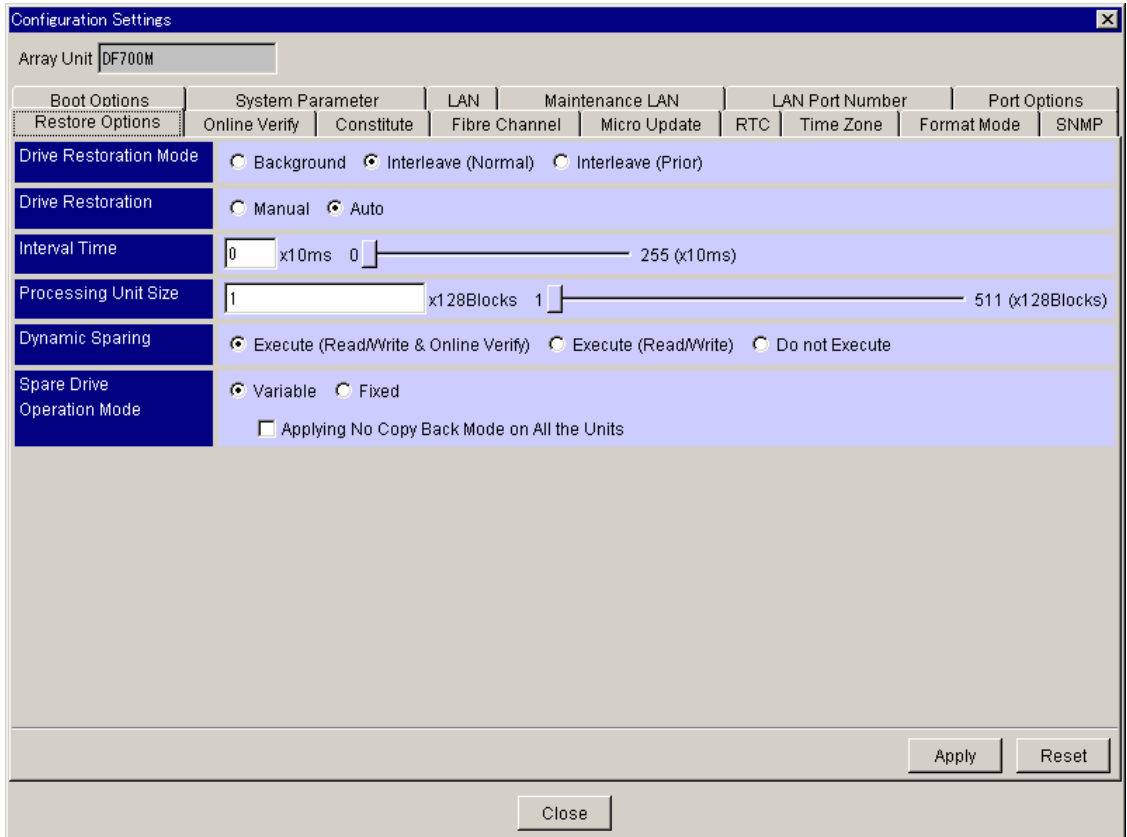

Figure 5.7 Configuration Settings Window, Restore Options Tab

- **Drive Restoration Mode:** Specify a mode in which drives are to be restored:
 - **Background:** Executes drive restoration while host I/O processing is not executed.
 - **Interleave (Normal):** Restores the drive at preset time intervals (specified as “Interval Time”) giving preference to a host command (restores after executing the command).
 - **Interleave (Prior):** Restores the drive at preset time intervals (specified as “Interval Time”) taking preference over a host command.
- **Drive Restoration:** Instructs whether to start the following operations automatically or manually. The operations concerned are data restoration to the failed drive or to the spare drive, copy back of the data from the spare drive to the original drive, and dynamic sparing:
 - **Manual:** Starts restoring data and copying by manual operations.
 - **Auto:** Automatically starts restoration of data and copying.
- **Interval Time:** Specify a time interval of drive restoration. The default interval time is 10×10 ms and drive restoration is executed at intervals of 100 ms. Specify a multiplication factor 0 to 255 in a unit of 10 ms.

- **Processing Unit Size:** Specify the size of the data block to be restored. The value of the range of 1 to 511 is specified by the multiple of 128. The minimum value is 128, which restores 65-kB data in a single operation. When Interleave mode is specified, the function restores data of a processing unit size specified here, waits for a time interval specified here, then starts the next data restoration.
- **Dynamic Sparing:** Specify a mode for data restoration for the spare drive when the error occurrence count controlled by preventive maintenance exceeds the threshold value:
 - **Execute (Read/Write & Online Verify):** When the error occurrence count in **Read/Write Error** or **Online Verify Error**, **Threshold Value Over** and **Start of Dynamic Sparing** are displayed on the panel and data restoration is performed for the spare drive (when the spare drive is not used), and the error disk is blocked.
 - **Execute (Read/Write):** When the error occurrence count in **Read/Write Error** exceeds the threshold value, **Threshold Value Over** and **Start of Dynamic Sparing** are displayed on the panel and data restoration is performed for the spare disk in the spare drive (when the spare disk is not used), and the error disk is blocked.
When the error occurrence count in **Online Verify Error** exceeds the threshold value, **Threshold Value Over** is displayed on the panel but **Dynamic Sparing** is not performed.
 - **Do not Execute:** When the error occurrence count in **Read/Write Error** or **Online Verify Error** exceeds the threshold value, **Threshold Value Over** is displayed on the panel but **Dynamic Sparing** is not performed.
- **Spare Drive Operation Mode:** Specify the spare drive operation mode:
 - **Variable:** When a failed drive is replaced, the new drive becomes a spare drive.
 - **Applying No Copy Back Mode on All the Units:** Specify whether or not to apply copy back mode.
 - **Fixed:** The drive that has been set in section 4.9.1 becomes a fixed spare drive (a former way).

5.1.8 Online Verify Tab

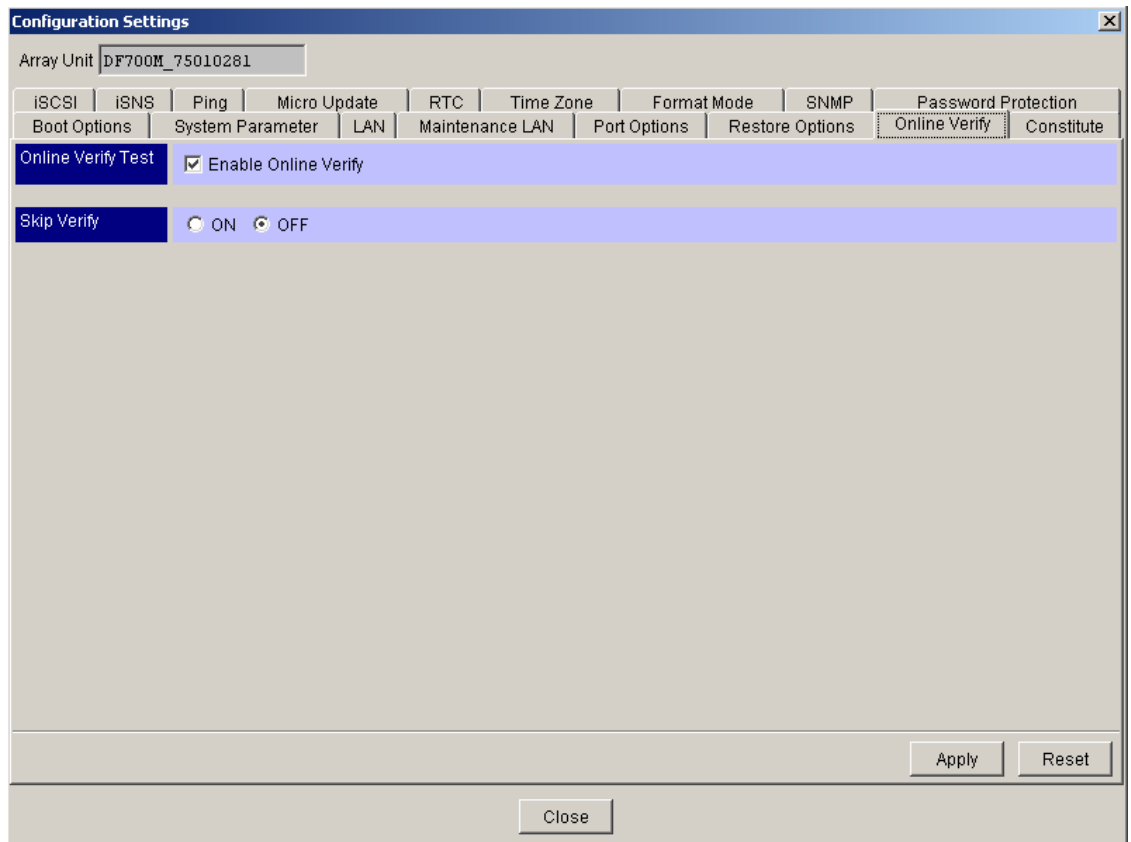

Figure 5.8 Configuration Settings Window, Online Verify Tab

5.1.9 Constitute Tab

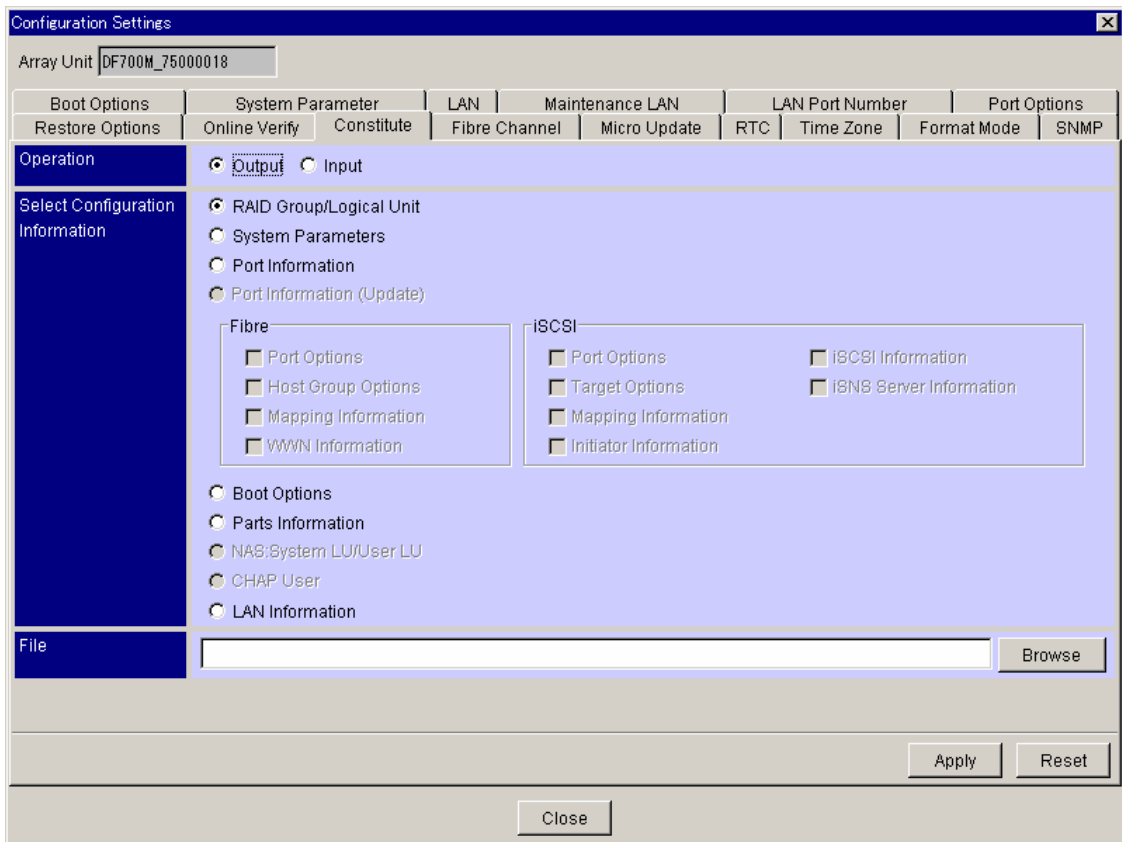

Figure 5.9 Configuration Settings Window, Constitute Tab

5.1.10 iSCSI Tab

Configuration Settings

Array Unit: DF700M

System Parameter: iSCSI (selected)

Controller 0: Port 0A, Port 0B

Controller 1: Port 1A, Port 1B

Network	IP Address	192.168.0.200
	Subnet Mask	255.255.255.0
	Default Gateway	0.0.0.0
	Port Number	3260
	Keep Alive Timer(sec.)	60
	MTU	1500
	Ether Address	00:00:07:66:0B:00
	Result	Normal

Buttons: Refresh, Apply, Reset, Close

Figure 5.10 Configuration Settings Window, iSCSI Tab

5.1.11 iSNS Tab

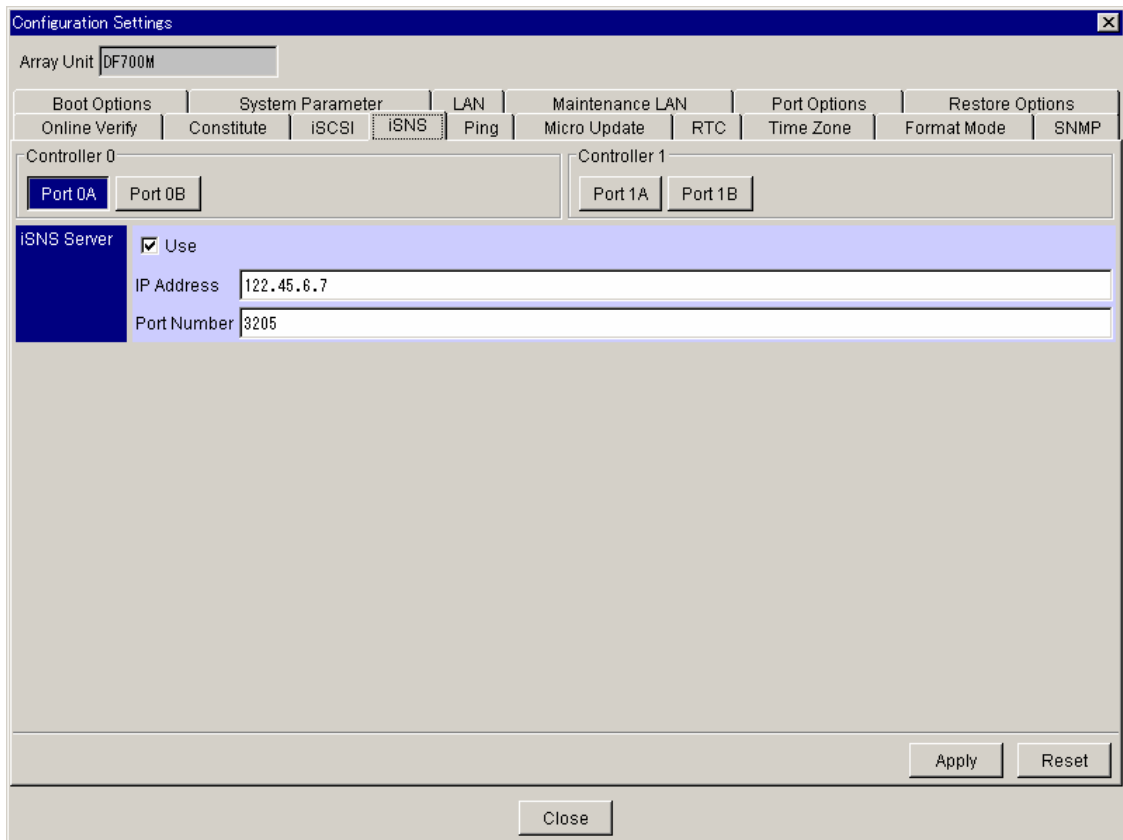

Figure 5.11 Configuration Settings Window, iSNS Tab

- **iSNS Server:**
 - **Use:** Specify whether to use the iSNS server or not. When use the iSNS server, specify the **IP Address** and **Port Number** of the iSNS server.

5.1.12 Ping Tab

Configuration Settings

Array Unit: DF700M_75010281

Boot Options | System Parameter | LAN | Maintenance LAN | Port Options | Restore Options | Online Verify | Constitute
iSCSI | iSNS | Ping | Micro Update | RTC | Time Zone | Format Mode | SNMP | Password Protection

Port/
Destination IP Address

Port 0A
 Port 0B
 Port 1A
 Port 1B

Result

Port	Destination IP Address	Success Count	Status
0A	---	---	Not Executing
0B	---	---	Not Executing
1A	---	---	Not Executing
1B	---	---	Not Executing

Refresh Start

Close

Figure 5.12 Configuration Settings Window, Ping Tab

- **Port:** Select the port to be sending ping.
- **Destination IP Address:** Specify the IP address of the initiator.

5.1.13 Micro Update Tab

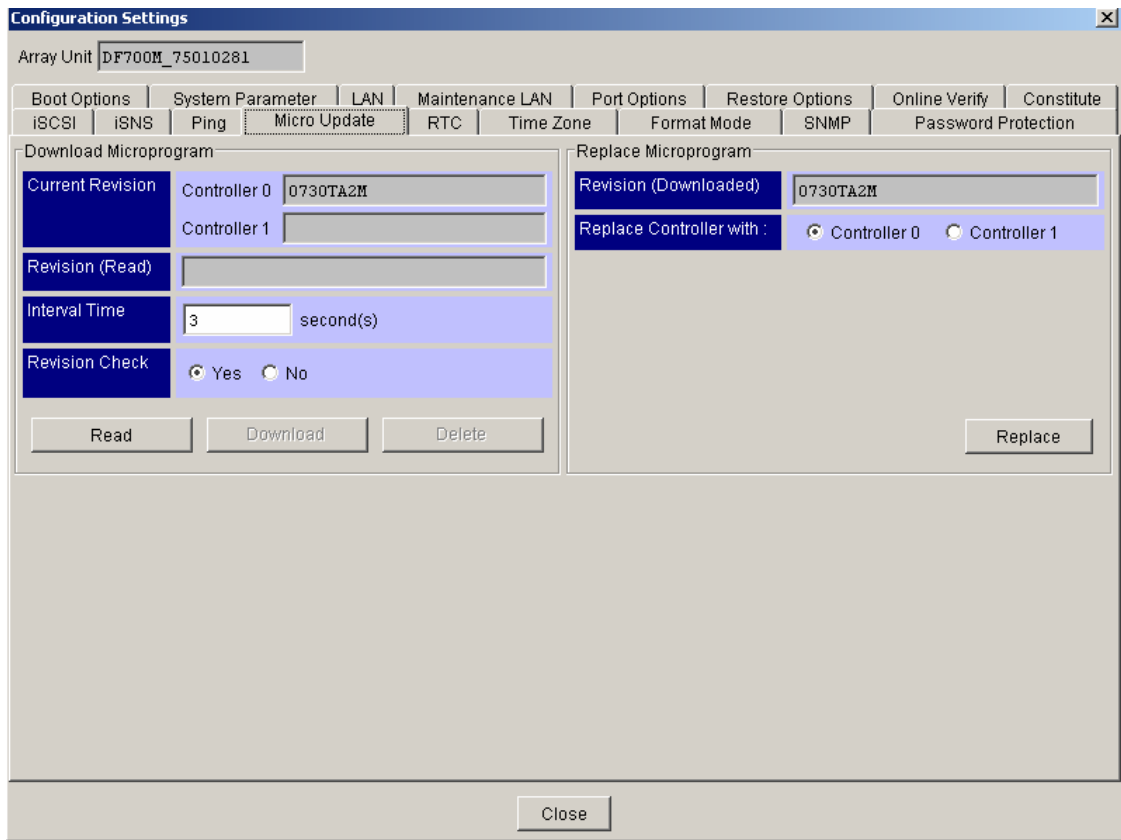

Figure 5.13 Configuration Settings Window, Micro Update Tab

5.1.14 RTC Tab

Configuration Settings

Array Unit: DF700M_75010281

Boot Options | System Parameter | LAN | Maintenance LAN | Port Options | Restore Options | Online Verify | Constitute
iSCSI | iSNS | Ping | Micro Update | **RTC** | Time Zone | Format Mode | SNMP | Password Protection

Setting: Manual Auto

Date: 2005 / 12 / 14

Time: 16 : 08 : 05

Apply Reset

Close

Figure 5.14 Configuration Settings Window, RTC Tab

- **Setting:** Select **Manual** or **Auto**:
 - **Manual:** Set the date and time.
 - **Auto:** Set the time of the Storage Navigator computer.
- **Date:** Displays the date.
- **Time:** Displays the time.

5.1.15 Time Zone Tab

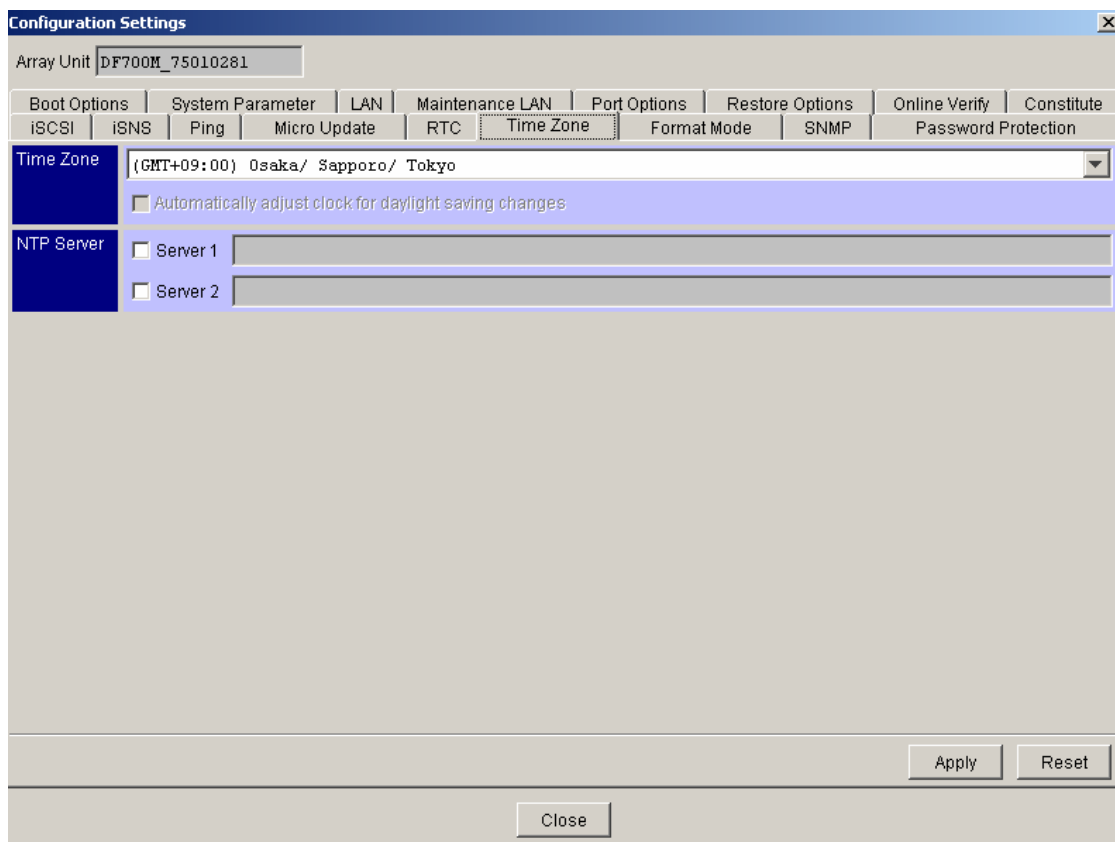

Figure 5.15 Configuration Settings Window, Time Zone Tab

- **Time Zone:** Select a time zone from the **Time Zone** drop-down list.
Automatically adjust clock for daylight saving changes: Specify whether to use the daylight saving or not.
- **NTP Server:** Specify the IP address of the NTP server.

5.1.16 Format Mode Tab

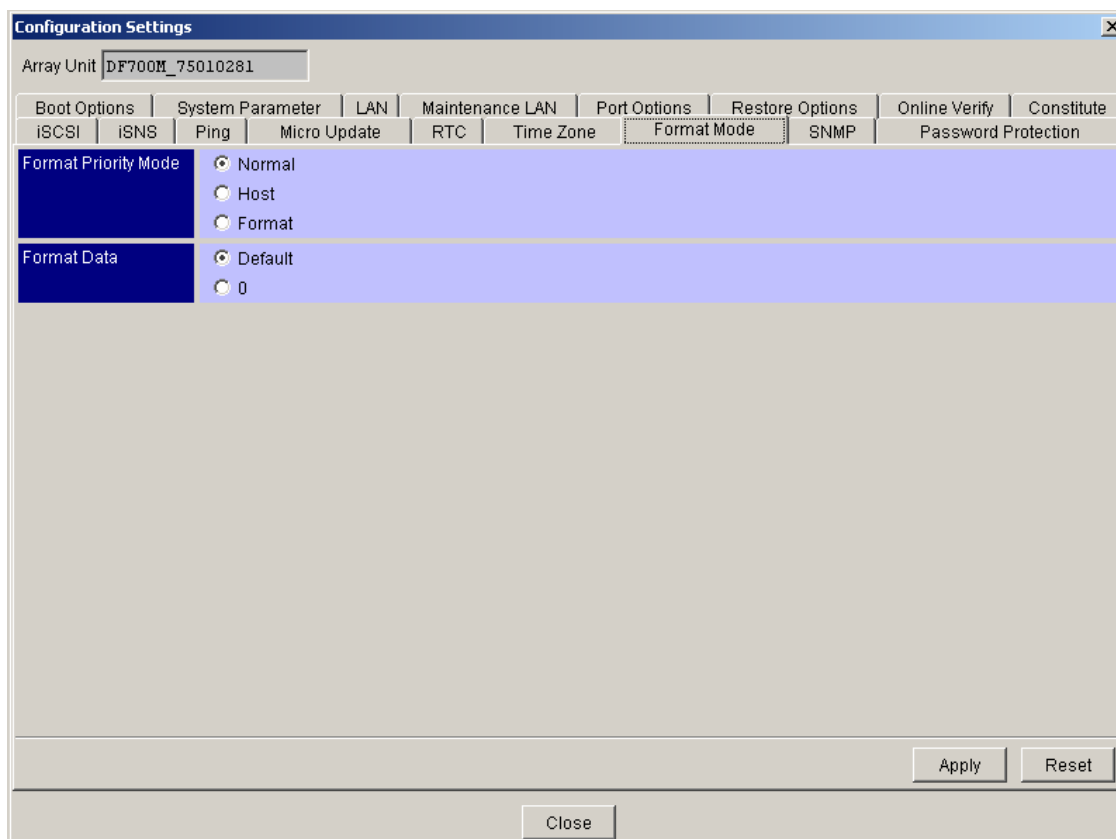

Figure 5.16 Configuration Settings Window, Format Mode Tab

- **Format Priority Mode:** Specify a format priority mode:
 - **Normal:** Formats at an idle time when no host I/O is executed.
 - **Host:** Host's I/O is executed preferentially.
 - **Format:** Subsystem formats are done preferentially.
- **Format Data:** Specify a data format.

5.1.17 SNMP Tab

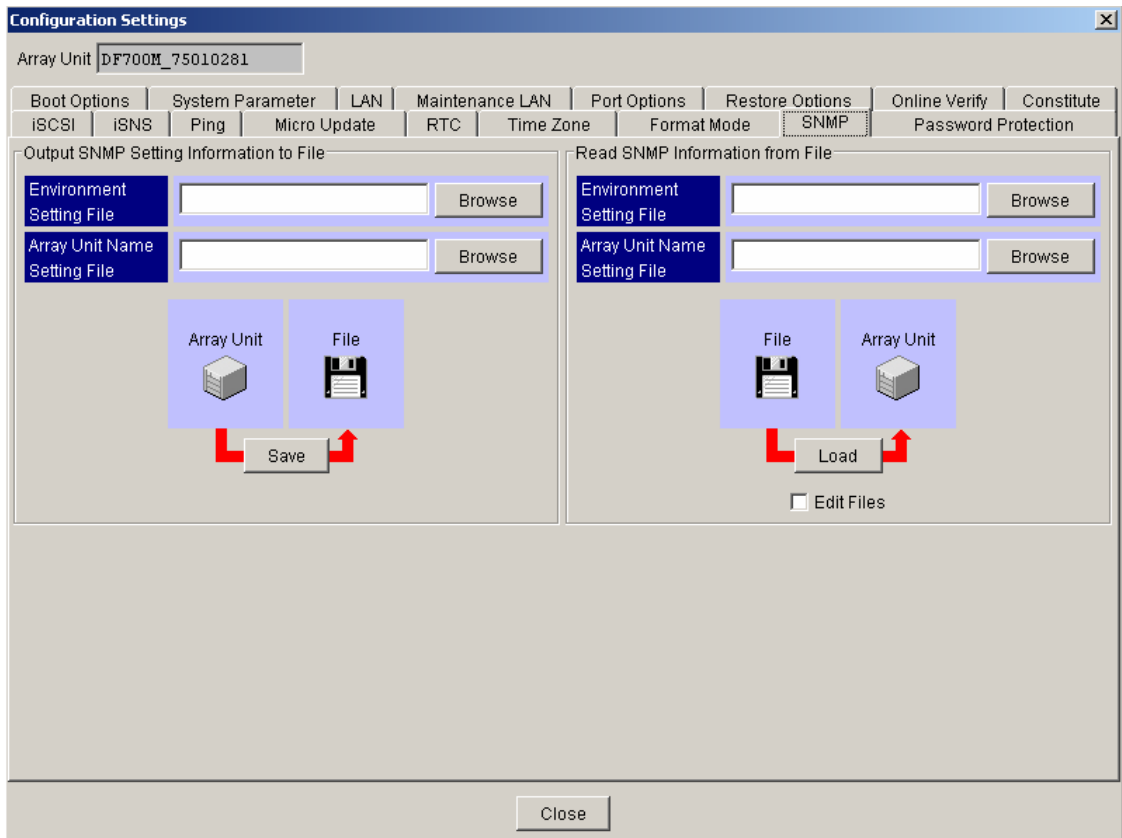

Figure 5.17 Configuration Settings Window, SNMP Tab

For more information on configuring SNMP settings, see *Hitachi TagmaStore Adaptable Modular Storage SNMP Agent User's Guide (MK-95DF705)*.

5.1.18 Password Protection Tab

Configuration Settings

Array Unit: DF700M_75010281

Boot Options	System Parameter	LAN	Maintenance LAN	Port Options	Restore Options	Online Verifv	Constitute
iSCSI	iSNS	Ping	Micro Update	RTC	Time Zone	Format Mode	SNMP
Password Protection							

Operation menu

Register User ID Change User ID Delete User ID Change Password

User IDs

0

User ID

Old User ID

New User ID

Password

Old Password

New Password

Check Password

Apply Reset

Close

Figure 5.18 Configuration Settings Window, Password Protection Tab

5.1.19 Backend Diagnosis Tab

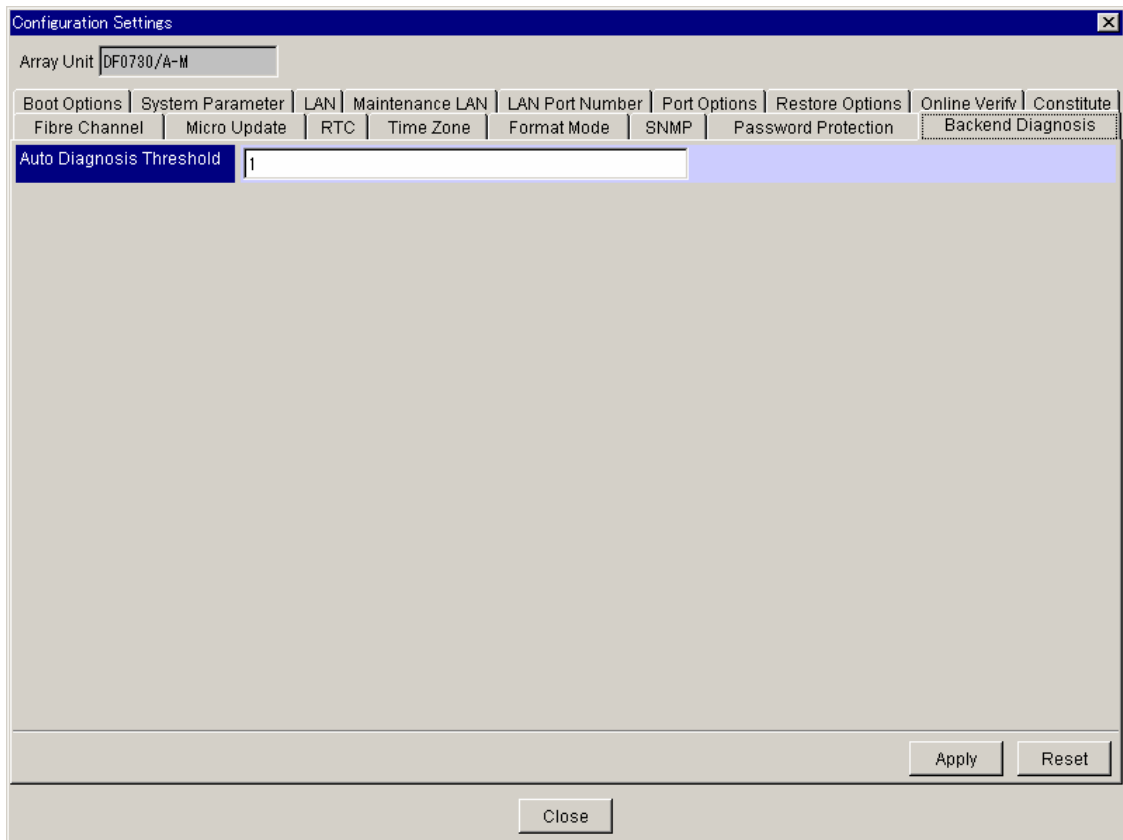



Figure 5.19 Configuration Settings Window, Backend Diagnosis Tab

5.2 Setting Boot Options

WARNING: This operation will require stopping I/O from the host and rebooting.

WARNING: If you are using TrueCopy or TrueCopy Extended Distance and you are required to reboot the subsystem, change the pair status to PSUS before you reboot.

WARNING: If you are using a NAS, you must also stop the clusters between NAS units. When restarting the subsystem, you must restart the clusters.

1. Access the **Array System Viewer** window by selecting a storage array in the **List View** box, and then do one of the following:
 - Select **File → Open**
 - Click the **Open** icon () on the tool bar.
2. Open the **Configuration Settings** window by one of the following methods:
 - From the **Tools** menu, select **Configuration Settings**.
 - Click the **Configuration Settings** icon () in the tool bar.
3. Click the **Boot Options** tab (see Figure 5.20). For a detailed description of the **Boot Options** tab, refer to section 5.1.1.
4. Select the system startup attribute:
 - Single Mode:** Single configuration
 - Dual Active Mode:** Dual active configuration
5. You can specify an amount of time to delay a shutdown after the main switch is turned off. You can specify from 0 to 60 minutes.
6. Specify the drive detach mode as either enabled or disabled.
7. Specify the vendor name, using up to eight characters. If you use less than eight characters, enter spaces after the characters to total eight.
8. Specify the model name, using up to sixteen characters. If you use less than sixteen characters, enter spaces after the characters to total sixteen.
9. Specify the ROM microcode version that will be reported in response to an inquiry command.
10. Specify the RAM microcode version that will be reported in response to an inquiry command.
11. Click **Apply** after you have completed the settings, and then click **OK** on the confirmation message.
12. If restarting is necessary, the Restart Warning dialog box will display (see Figure 5.21). Stop host access before continuing. If you are using TrueCopy or TrueCopy Extended Distance, change the pair status to PSUS before you reboot. Check **OK to reboot**, and then click **OK** on the Warning dialog box.
13. Rebooting should take between 4 and 15 minutes.
14. Once the reboot is successfully completed, click **OK** on the confirmation message.

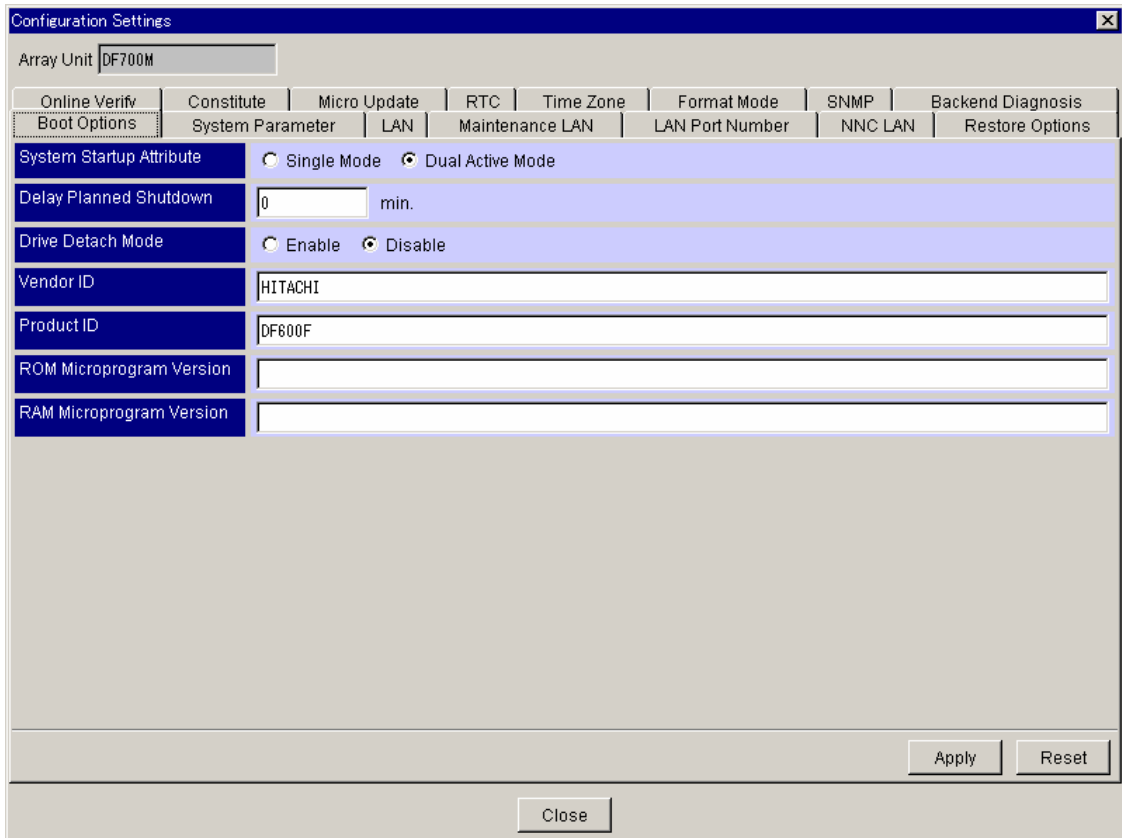

Figure 5.20 Setting Boot Options

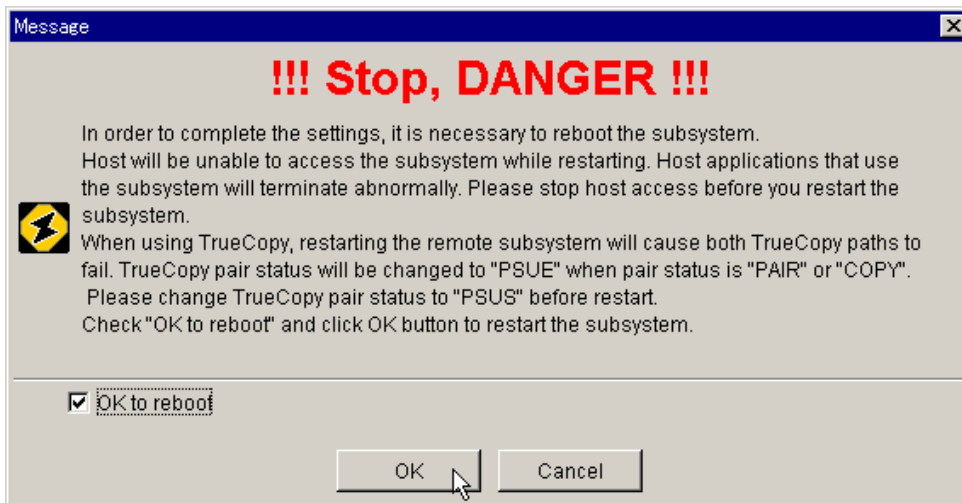



Figure 5.21 Restart Warning Dialog Box

5.3 Setting System Parameters

This operation does not require a reboot.

1. Access the **Array System Viewer** window by selecting a storage array in the list view box, and then do one of the following:
 - Select **File → Open**
 - Click the **Open** icon () on the tool bar.
2. Open the **Configuration Settings** window by one of the following methods:
 - From the **Tools** menu, select **Configuration Settings**.
 - Click the **Configuration Settings** icon () in the tool bar.
3. Click the **System Parameter** tab (see Figure 5.22). For a detailed description of the **System Parameter** tab, refer to section 5.1.2.
4. Click the **Turbo LU Warning** checkbox if you want a warning if the Turbo LU function is invalidated.
5. Click the **Write Unique Response Mode** checkbox if you want to implement this mode.
6. Click the **Auto Reconstruction Mode** checkbox if you want to implement this mode.
7. Click the **Forced Write Through Mode** checkbox if you want to implement this mode.
8. Click the **LU Ownership Change Disable Mode** checkbox if you want to implement this mode.
9. Click the **ShadowImage I/O Switch Mode** checkbox if you want to implement this mode.
10. Click the **Synchronize Cache Execution Mode** checkbox if you want to implement this mode.
11. Click the **Drive Detach Mode** checkbox if you want to implement this mode.
12. In the **Operation if the processor failure occurs** checkbox, select one of the following:
 - Reset the fault:** Resets a processor failure and restarts the controller.
 - Shutdown the system:** Shuts the subsystem down when a processor failure occurs.
13. In the **Web Title** text box, you can specify the character string that displays on the browser title bar when you access the subsystem home page. You can enter up to 32 alphanumeric characters. You may not use the ' (single quotation mark), " (double quotation mark), or \ (backslash) symbol).
14. For each controller, set the **Write & Verify Execution Mode** either to **On** or **Off**.
15. Click **Apply**, and then click **OK** on the confirmation messages.

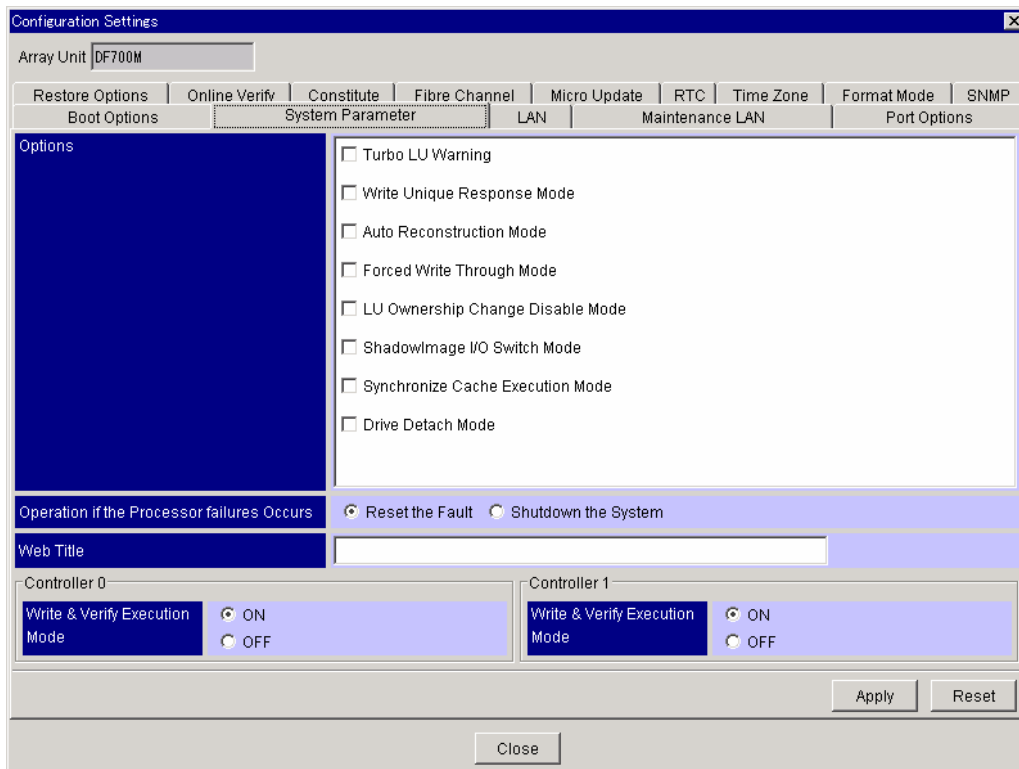



Figure 5.22 Setting System Parameters

5.4 Setting LAN Configuration

5.4.1 Setting Without Rebooting

To set the LAN configuration of the subsystem without rebooting:

1. Access the **Array System Viewer** window by selecting a storage array in the **List View** box, and then do one of the following:
 - Select **File → Open**
 - Click the **Open** icon () on the tool bar.
2. Open the **Configuration Settings** window by one of the following methods:
 - From the **Tools** menu, click **Configuration Settings**.
 - Click the **Configuration Settings** icon () in the tool bar.
3. Click the **LAN** tab (see Figure 5.23). For a detailed description of the **LAN** tab, refer to section 5.1.3.
4. Click **Set now without reboot**.
5. In the **Maintenance Port IP Address Automatic Change Mode** field, select either **Enable** or **Disable**.

Note: If you click **Enable**, you cannot use the **Maintenance LAN** tab to set the maintenance port.
6. The new settings are displayed in the LAN boxes.
7. Click **Apply**, and then click **OK** on both confirmation messages.
8. If the subsystem cannot be connected, the **Confirm LAN Environment** warning message displays (see Figure 5.24). If this displays, change the connection IP address.

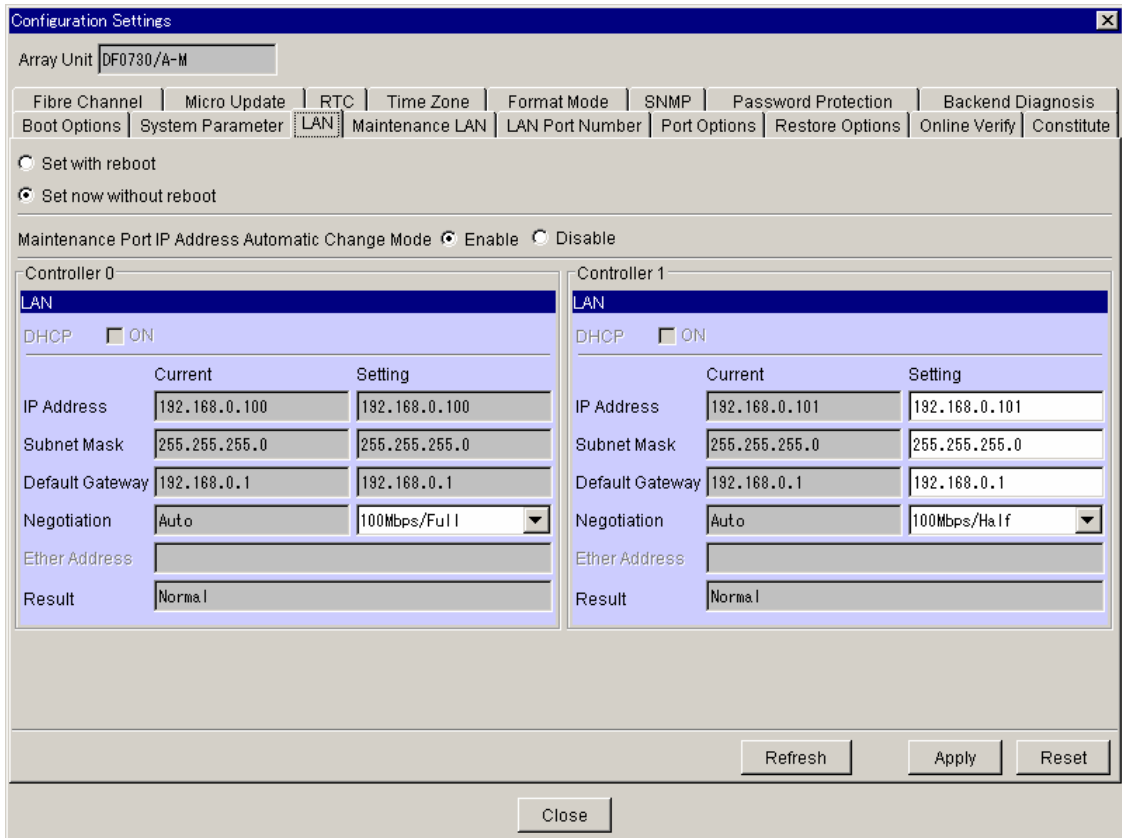

Figure 5.23 Setting LAN Configuration without Rebooting

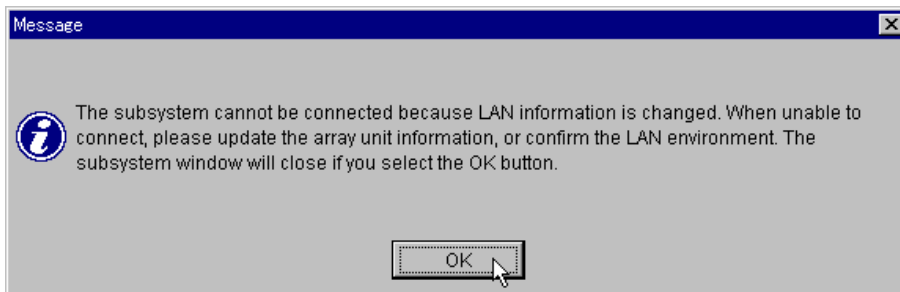

Figure 5.24 Confirm LAN Environment Warning Message



5.4.2 Setting with a Reboot

WARNING: This operation will require stopping I/O from the host and rebooting.

WARNING: If you are using TrueCopy or TrueCopy Extended Distance and you are required to reboot the subsystem, change the pair status to PSUS before you reboot.

WARNING: If you are using a NAS, you must also stop the clusters between NAS units. When restarting the subsystem, you must restart the clusters.

To set the LAN configuration of the subsystem with a reboot:

1. Access the **Array System Viewer** window by selecting a storage array in the **List View** box, and then do one of the following:
 - Select **File** → **Open**
 - Click the **Open** icon () on the tool bar.
2. Open the **Configuration Settings** window by one of the following methods:
 - From the **Tools** menu, click **Configuration Settings**.
 - Click the **Configuration Settings** icon () in the tool bar.
3. Click the **LAN** tab (see Figure 5.25). For a detailed description of the **LAN** tab, refer to section 5.1.3.
4. Click **Set with reboot**.
5. For each controller, do the following:
 - Specify whether or not the maintenance port IP address will be set automatically.
 - Specify whether to enable DHCP mode by using the checkbox.
 - Specify the IP address, subnet mask, default gateway, and negotiation by entering the information into the text boxes. You cannot change the Ether Address field.
6. Click **Apply**.
7. If restarting is necessary, the **Restart Warning** dialog box will display (see Figure 5.21). Stop host access before continuing. If you are using TrueCopy or TrueCopy Extended Distance, change the pair status to PSUS before you reboot. Check **OK to reboot**, and then click **OK** on the **Warning** dialog box.
8. Rebooting should take between 4 and 15 minutes.

Note: To validate the LAN information, restart the array unit. The previous settings stay valid until restarting. The array unit cannot access the host until the reboot is completed and the system restarts. Therefore, be certain the host has stopped accessing data before beginning the restart process.

Note: If the LAN configuration information is modified, an error message (Interface Error) may be displayed without displaying a restart completion message when restarting is initiated. When an error message is displayed after the LAN configuration information is modified and a restarting is directed to be done, close the Unit window, make a change in the information that has been registered through the Main window, and then open the Unit window again.

9. Reboot should take between 4 and 15 minutes. Once it is completed, click **OK** on the confirmation message.

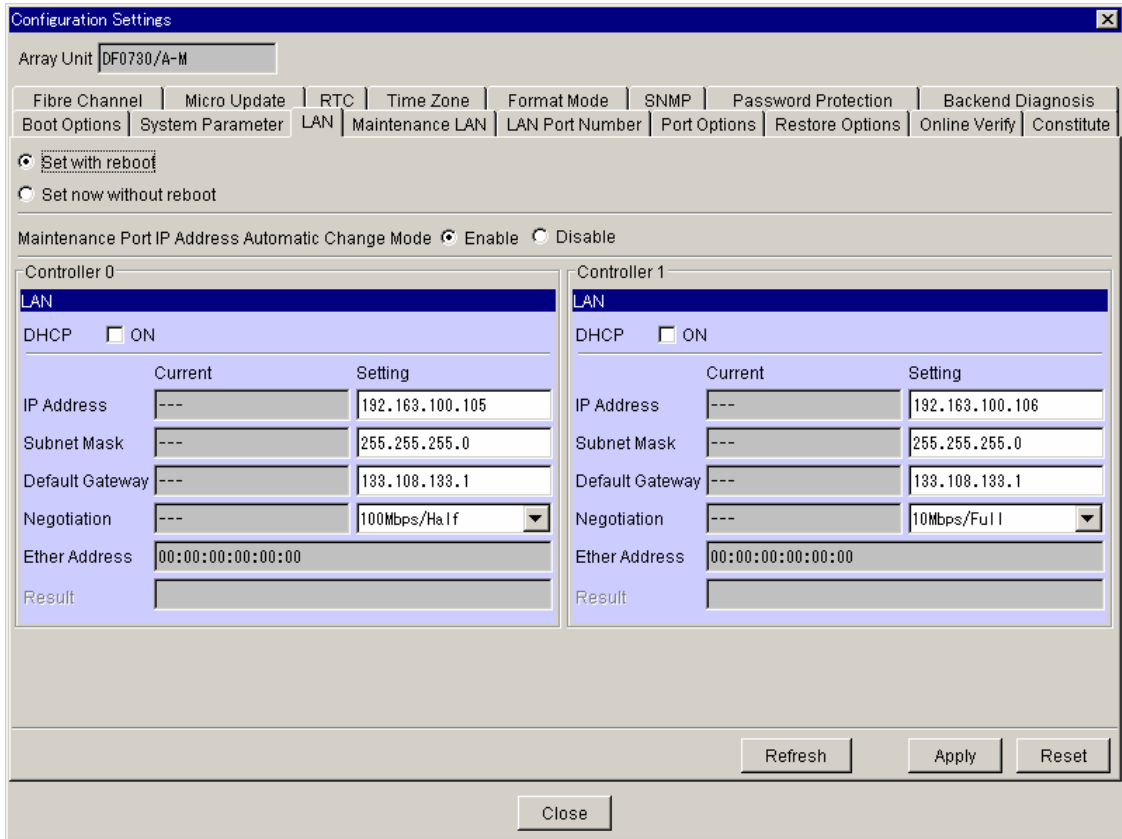

Figure 5.25 Setting LAN Configuration with a Reboot

5.5 Setting Maintenance Port IP Address

Note: The Maintenance Port IP address is set at the factory, so under ordinary circumstances it should not be necessary to change it. This action does not require a reboot.

To set the maintenance port IP address:

1. Access the **Array System Viewer** window by selecting a storage array in the **List View** box, and then do one of the following:

- Select **File → Open**
- Click the **Open** icon () on the tool bar.

2. Open the **Configuration Settings** window by one of the following methods:

- From the **Tools** menu, select **Configuration Settings**.
- Click the **Configuration Settings** icon () in the tool bar.

3. Click the **Maintenance LAN** tab (see Figure 5.25). For a detailed description of the **Maintenance LAN** tab, refer to section 5.1.4.

4. In the **Setting** text box, input the Maintenance Port IP address.

Note: If you previously selected **Enable** in the **Maintenance Port IP Address Automatic Change Mode** field on the **LAN** tab, you cannot make settings on this tab.

5. Click **Apply**, and then click **OK** on the confirmation messages.

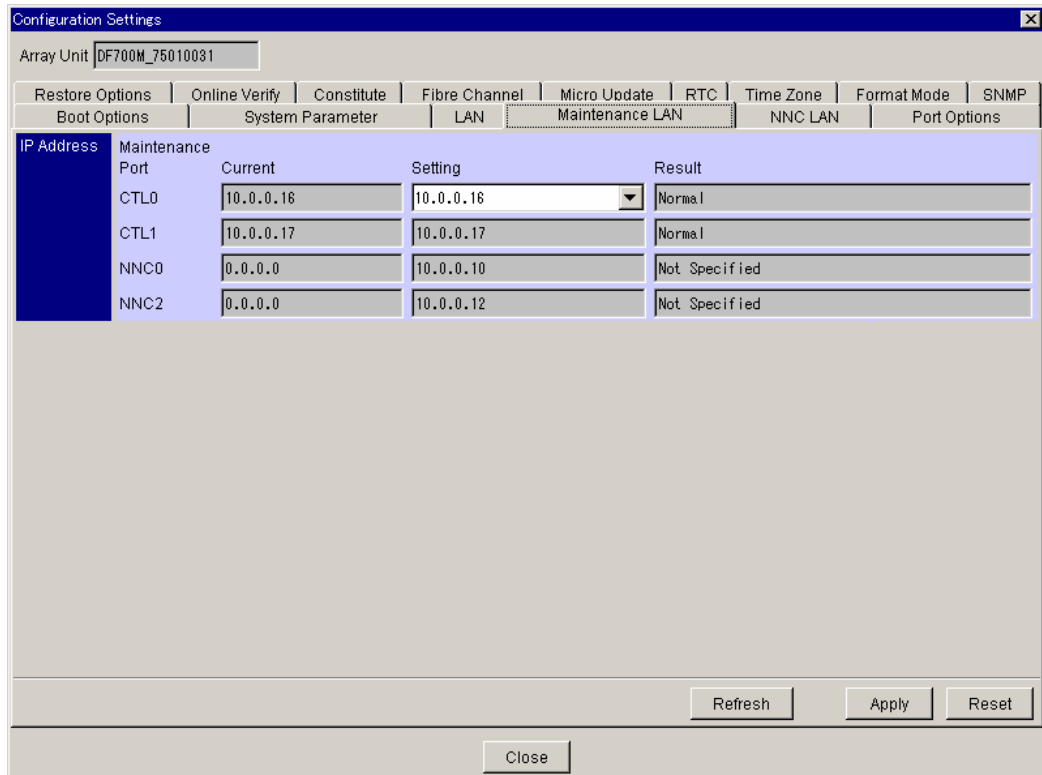



Figure 5.26 Setting Maintenance Port IP Address

5.6 Setting LAN Port Number

The port number can be set when the microcode version of the AMS500/AMS200/WMS100 array subsystem is 0726/E or later (9500V/9520V array subsystem is x65B/H or later) and the version of Navigator is 2.61 or later. The port number is set for each controller, but set both controllers without closing the setting window. After setting the both controllers, close the Unit screen and edit the services file of the OS that is operating Navigator. When the two or more disk array subsystems are registered, set all of them. The setting of the services file is enabled without closing the Main window.

Set the port number in a range of 1024 to 49151.

1. Access the **Array System Viewer** window by selecting a storage array in the **List View** box, and then do one of the following:
 - Select **File → Open**
 - Click the **Open** icon () on the tool bar.
2. Open the **Configuration Settings** window by one of the following methods:
 - From the **Tools** menu, select **Configuration Settings**.
 - Click the **Configuration Settings** icon () in the tool bar.
3. Click the **LAN Port Number** tab (see Figure 5.27).
4. In the **Port Number** dialog box, select **Controller 0** and enter an unused port number in the text box.
5. Click **Apply**, and click **OK** on the **Confirmation the Port Number** dialogue box.
6. On the **Set Same Port Number** dialogue box (see Figure 5.29), click **Cancel**.
7. Select **Controller 1** and enter the same port number in the text box.
8. The **Set Same Port Number** dialogue box displays again. Click **OK**.
9. Click **OK** on the **Add to Services File** dialogue box (see Figure 5.30).
10. Open a text editor and add the port number to the services file. A sample using Windows® 2000 is shown at Figure 5.31. When you add the port number to the last line, be sure to start a new line.

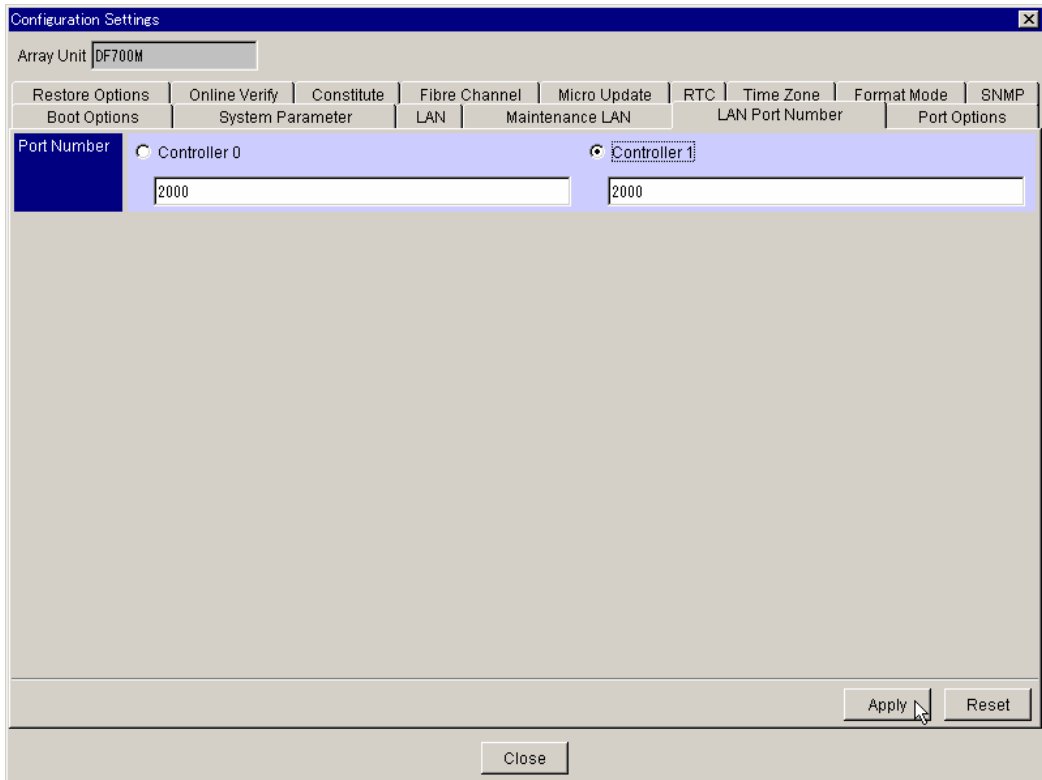

Figure 5.27 Setting LAN Port Number

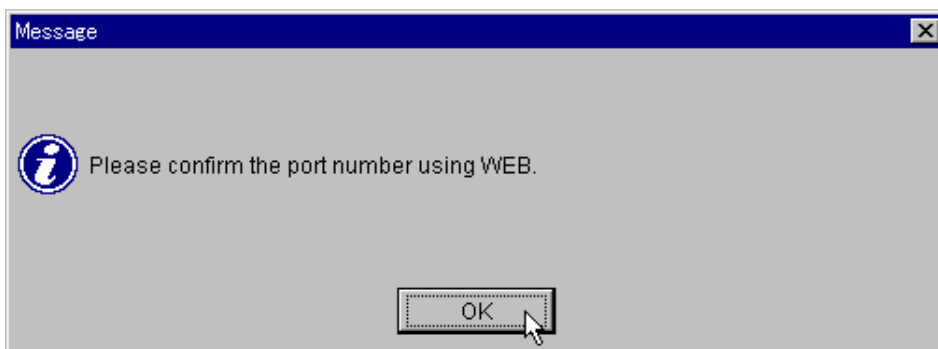

Figure 5.28 Confirming Port Number

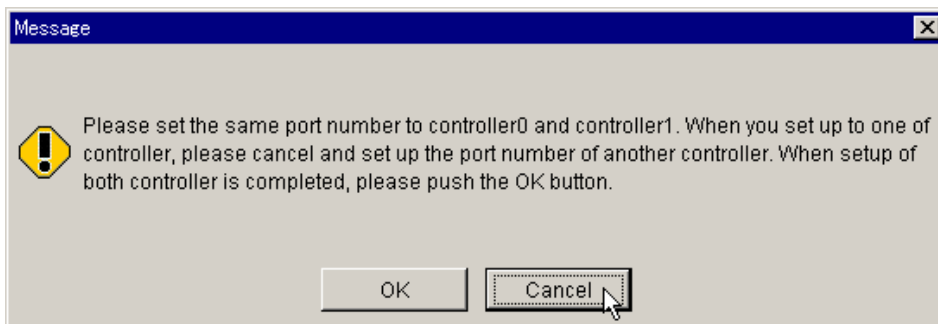

Figure 5.29 Set Same Port Number

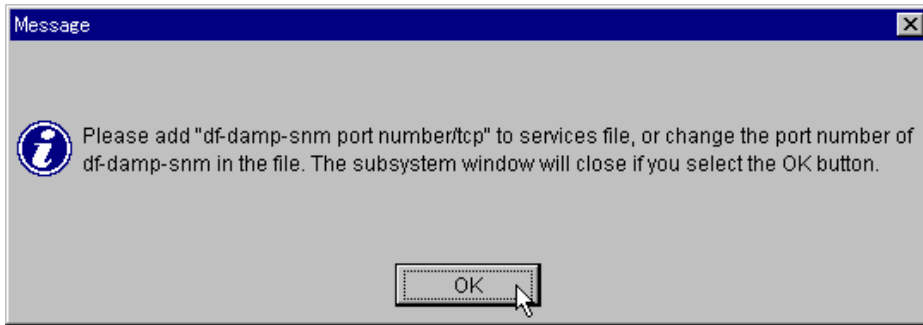

Figure 5.30 Add to Services File

```
# Copyright (c) 1993-1999 Microsoft Corp.
#
# This file contains port numbers for well-known services defined by IANA
#
# Format:
#
# <service name> <port number>/<protocol> [aliases...] [#<comment>]
#
echo          7/tcp
echo          7/udp
:
:
radacct       1813/udp          #RADIUS accounting protocol
nfsd          2049/udp          nfs          #NFS server
knetd         2053/tcp          #Kerberos de-multiplexor
man           9535/tcp          #Remote Man Server
df-damp-snm   23456/tcp
```



Figure 5.31 Adding Port Number to Services File (Windows® 2000)

5.7 Setting Port Options

WARNING: This operation will require stopping I/O from the host.

This setting becomes effective without a reboot.

To set the maintenance port IP address:

1. Access the **Array System Viewer** window by selecting a storage array in the **List View** box, and then do one of the following:
 - Select **File** → **Open**
 - Click the **Open** icon () on the tool bar.
2. Open the **Configuration Settings** window by one of the following methods:
 - From the **Tools** menu, select **Configuration Settings**.
 - Click the **Configuration Settings** icon () in the tool bar.
3. Click the **Port Options** tab (see Figure 5.25). For a detailed description of the **Port Options** tab, refer to section 5.1.4.
4. Select a port, and then set the following options:
 - **Reset/LIP Mode (Signal)** sets the mode to transmit Reset/LIP signals to other ports. This is only enabled if you set the **Reset/LIP Mode (Process)** (below).
 - **Reset/LIP Mode (Process)** sets the mode to transmit reset processing to other ports.
 - **LIP Port ALL Reset Mode** sets the mode to execute reset on receiving LIP.
5. You can set options on multiple ports, but be sure that you comply with the parameters that are in the applicable User and Reference Manual.
6. Click **Apply**, and then click **OK** on the confirmation message.
7. The **Stop I/O** warning message displays (see Figure 5.33), because host access will be disrupted during the port setting. Stop I/O from the host before continuing.
8. Once it is completed, click **OK** on the confirmation message.

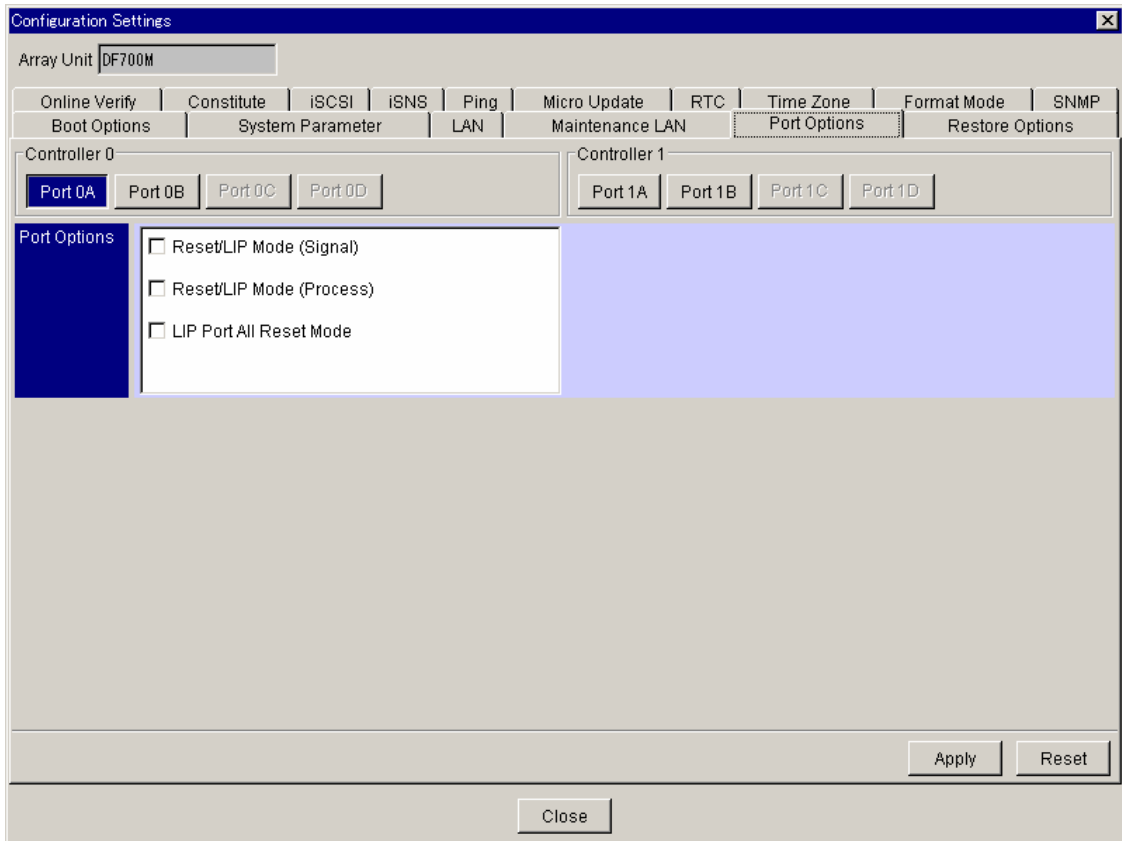

Figure 5.32 Setting Port Options

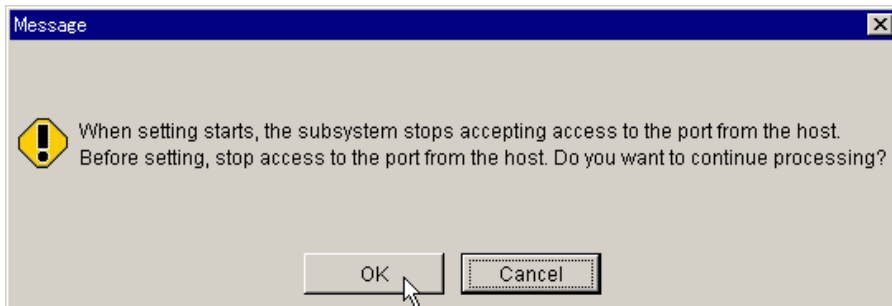



Figure 5.33 Stop I/O Warning Message

5.8 Setting Restore Options

Caution: Do not undertake this operation during a drive restoration, or the settings will not be effective.

This operation does not require a reboot.

1. Access the **Array System Viewer** window by selecting a storage array in the **List View** box, and then do one of the following:
 - Select **File** → **Open**
 - Click the **Open** icon () on the tool bar.
2. Open the **Configuration Settings** window by one of the following methods:
 - From the **Tools** menu, select **Configuration Settings**.
 - Click the **Configuration Settings** icon () in the tool bar.
3. Click the **Restore Options** tab (see Figure 5.25). For a detailed description of the **Restore Options** tab, refer to section 5.1.4.
4. In the **Online Restoration Mode** dialog box, select one of the following:
 - **Background** restores the drive while host I/O processing is not being executed.
 - **Interleave (Normal)** restores the drive at preset time intervals (specified as “Interval Time”) giving preference to a host command (restores after executing the command).
 - **Interleave (Prior)** restores the drive at preset time intervals (specified as “Interval Time”) taking preference over a host command.
5. In the **Drive Restoration** box, select whether drive restoration is set manually or automatically.
6. In the **Interval Time** box, specify a time interval for drive restoration. The default interval time is 10 (which is automatically multiplied by 10 ms), which makes the interval 100 ms. You can specify from 0 to 255, which will be automatically multiplied by 10 ms.
7. In the **Processing Unit Size** box, specify the size of the data block to be restored. You can specify a range from 1 to 511, which is automatically multiplied by 128. The minimum value of 1 (multiplied by 128) restores 65-kB data in a single operation. When Interleave mode is specified, the function restores data of a processing unit size specified here, waits for a time interval specified here, then starts the next data restoration.
8. In the **Dynamic Sparing** box, specify a mode for data restoration for the spare drive when the error occurrence count controlled by preventive maintenance exceeds the threshold value.
 - **Execute (Read/Write & Online Verify):** When the error occurrence count in **Read/Write Error** or **Online Verify Error**, **Threshold Value Over** and **Start of Dynamic Sparing** are displayed on the window and data restoration is performed for the spare drive (when the spare drive is not used), and the error disk is blocked.

- **Execute (Read/Write):** When the error occurrence count in **Read/Write Error** exceeds the threshold value, **Threshold Value Over** and **Start of Dynamic Sparing** are displayed on the window and data restoration is performed for the spare disk in the spare drive (when the spare disk is not used), and the error disk is blocked.
When the error occurrence count in **Online Verify Error** exceeds the threshold value, **Threshold Value Over** is displayed on the panel but Dynamic Sparing is not performed.
 - **Do not Execute:** When the error occurrence count in **Read/Write Error** or **Online Verify Error** exceeds the threshold value, **Threshold Value Over** is displayed on the window but Dynamic Sparing is not performed.
9. In the **Spare Drive Operation Mode** box, select one of the following:
- **Variable:** When a failed drive is replaced, the new drive becomes a spare drive.
 - **Applying No Copy Back Mode on All the Units:** Specify whether to apply the copy back mode.
 - **Fixed:** The drive that has been previously set becomes a fixed spare drive.
10. Click **Apply**, and then click **OK** on the confirmation messages.

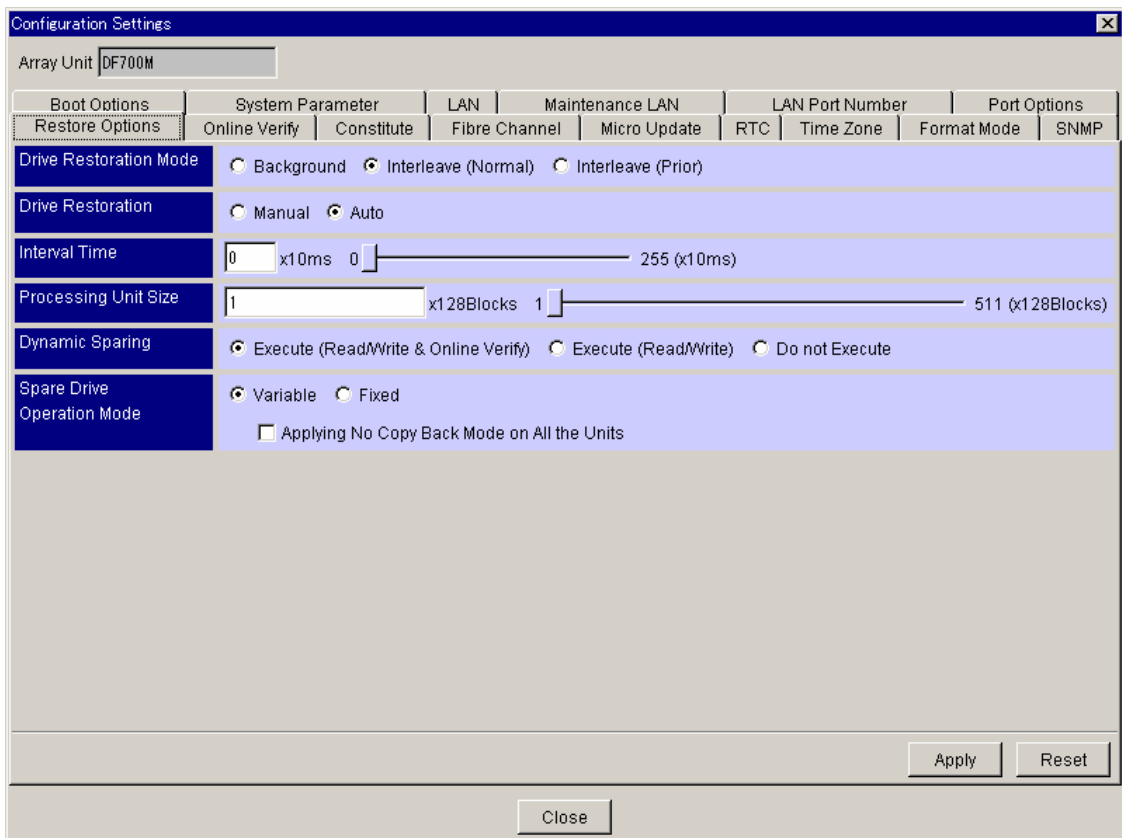



Figure 5.34 Setting the Drive Restore Option

5.9 Setting Online Verify Mode

This operation does not require a reboot.

1. Access the **Array System Viewer** window by selecting a storage array in the **List View** box, and then do one of the following:
 - Select **File → Open**
 - Click the **Open** icon () on the tool bar.
2. Open the **Configuration Settings** window by one of the following methods:
 - From the **Tools** menu, select **Configuration Settings**.
 - Click the **Configuration Settings** icon () in the tool bar.
3. Click the **Online Verify** tab (see Figure 5.35). For a detailed description of the **Online Verify** tab, refer to section 5.1.8.
4. Make the following settings:
 - **Online Verify Test:** Specify whether or not to execute an online verify test.
 - **Skip Verify:** Specify whether or not to ignore an online verify request.
5. Click **Apply**, and then click **OK** on the confirmation messages.

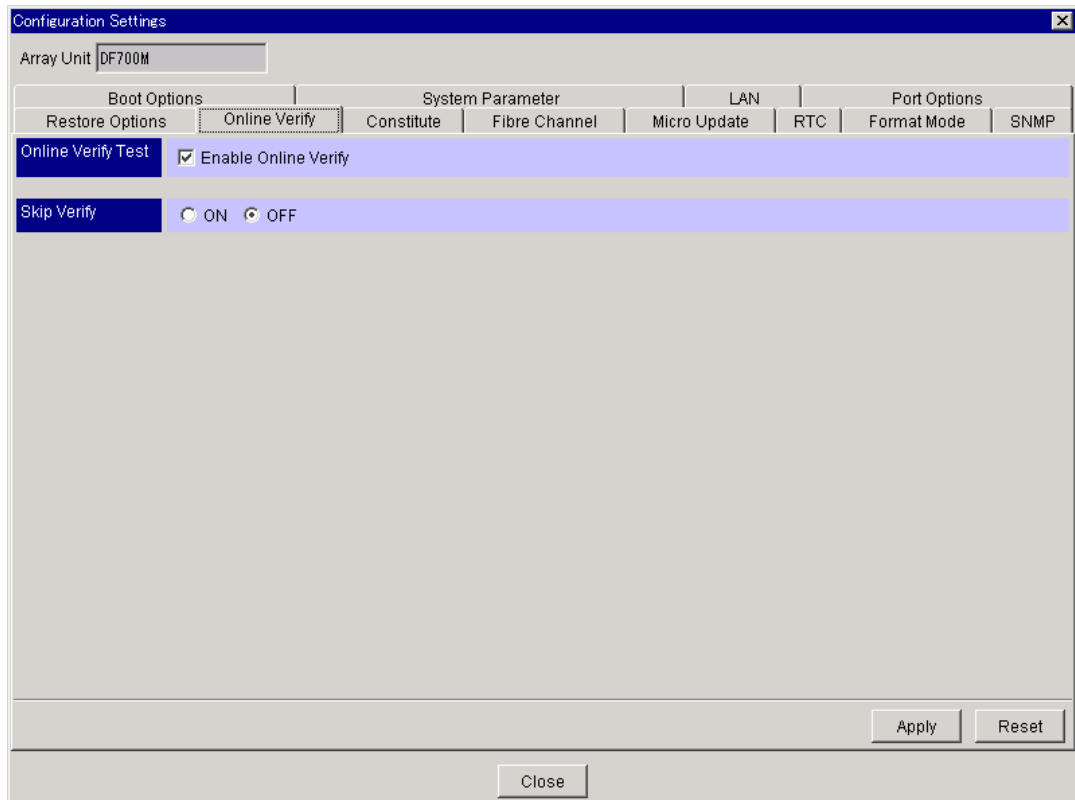

Figure 5.35 Setting Online Verify Mode

5.10 Outputting or Setting Configuration Information with Text Files (Constitute Tab)

5.10.1 Overview

You can use text files to either output or set the subsystem configuration information. You can output the following types of information with text files. Information you can output with text files includes the status of the subsystem, RAID groups, LUs, ports, host groups, and subsystem components. Information that can be set with text files includes system parameters, RAID groups, LUs, ports and host groups. You cannot set the configuration of subsystem components using a text file.



Separate text files are required. You can copy configuration information between subsystems by outputting a text file from the first system, and then using that text file to set the configuration of the second system.

Copying configuration information between subsystems can be executed by outputting a text file of the configuration from the subsystem, then using the output text file to set another subsystem. It is possible to edit a text file and then use that file to set the configuration, but as a general rule you should only do it for the same subsystem.

5.10.2 Outputting Information to a Text File

Caution: Before outputting configuration files, make sure that all optional features are locked.

To output configuration information to a text file:

1. Access the **Array System Viewer** window by selecting a storage array in the **List View** box, and then do one of the following:
 - Select **File** → **Open**
 - Click the **Open** icon () on the tool bar.
2. Open the **Configuration Settings** window by one of the following methods:
 - From the **Tools** menu, click **Configuration Settings**.
 - Click the **Configuration Settings** icon () in the tool bar.
3. Click the **Constitute** tab (see Figure 5.36). For a detailed description of the **Constitute** tab, refer to section. 5.1.9.
4. In the **Operation** dialog box, click **Output**.
5. In the **Select Configuration Information** box, select one of the following types of information to output:
 - RAID Group/Logical Unit
 - System Parameters
 - Port Information
 - Boot Options
 - Parts Information (not available when **Input** is selected)
 - NAS System LU/User LU
 - CHAP User (not available when **Output** is selected)

6. In the **File** box, either type in the file path or click **Browse** to specify the output destination file.
7. Click **Apply**, and then click **OK** on the confirmation message.
8. If you output system parameters, the file will resemble Figure 5.37.
9. If you output RAID Group/Logical Unit parameters, the file will resemble Figure 5.38.
10. If you output Host Group information, the file will resemble Figure 5.39.
11. If you output LAN information, the file will resemble Figure 5.43.

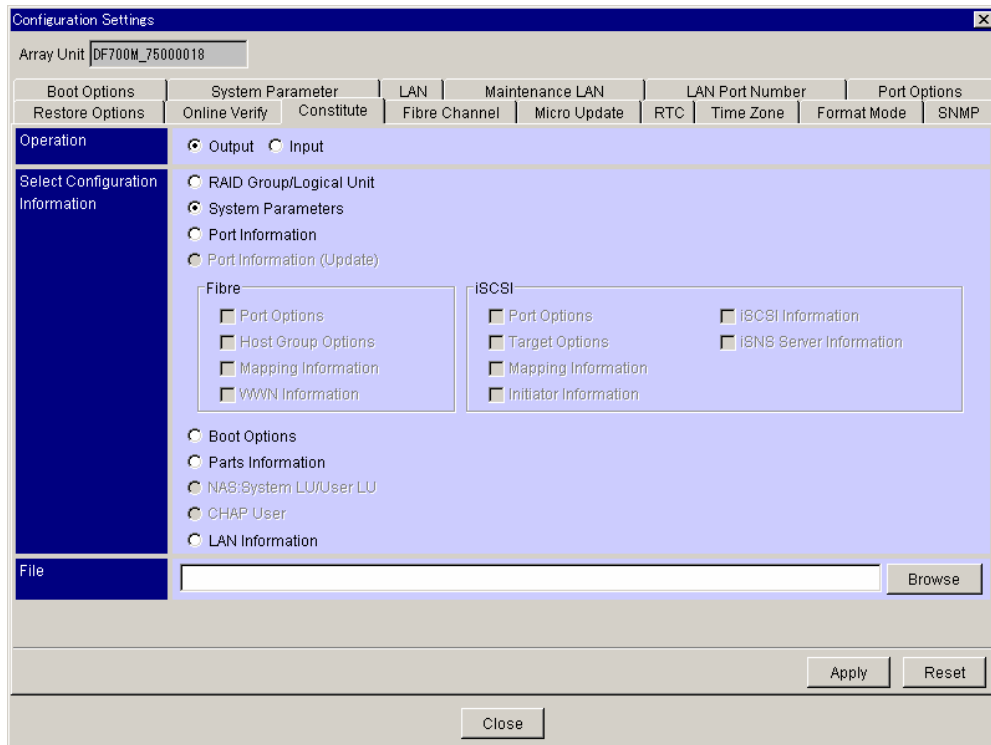

Figure 5.36 Outputting Configuration Information to a Text File

```

Online System parameter list.

DF Name : DF700M
Date : 2005/01/20 12:10:38
Micro Program Revision : 07510
Array Unit Type : DF700M
Serial Number : 75000018

---- Online System Parameter ----
Options
  Turbo LU Warning = OFF
  Write Unique Response Mode = OFF
  Auto Reconstruction Mode = OFF
  Forced Write Through Mode = OFF
  LU Ownership Change Disable Mode = OFF
  ShadowImage I/O Switch Mode = OFF
  Synchronize Cache Execution Mode = OFF
Operation if the Processor failures Occurs = Reset the Fault
Web Title = ""
---- CTL0 Parameter ----
Write & Verify Execution Mode = ON
---- CTL1 Parameter ----
Write & Verify Execution Mode = ON

```

Figure 5.37 System Parameter Output File Format

```

Array unit configuration information list.
DF Name : DF700M
Date : 2005/01/20 12:15:21
Micro Program Revision : 07510
Array Unit Type : DF700M
Serial Number : 75000018

---- RAID Configuration Information ----
---- RAID Configuration ----
RAID RAID Start Location Number of HDU Number of Free Capacity Type
Group Level [Unit No. HDU No.] in parity group parity group [block]
0 5 0 0 5 1 1081827328 FC
1 5 1 0 5 1 117478912 FC

-- End

---- RG-DRIVE Location ----
RAID Group position of drive belonging to RAID Group(Unit No.-HDU No.)
0 0-0 0-1 0-2 0-3 0-4
1 1-0 1-1 1-2 1-3 1-4

-- End

---- LU Configuration Information ----
LU Capacity Status Staging Number of Number of RAID RAID Number of Stripe Size Capacity Type
No. [block] [block] Current CTL DeFault CTL Group Level Cache Partition [KB] [MB/GB]
0 2097152 Normal 512 1 1 0 5 0 64 1.0 GB FC
1 2097152 Normal 512 0 0 0 5 0 64 1.0 GB FC
2 2097152 Normal 512 0 0 0 5 0 64 1.0 GB FC

-- End

---- Drive Configuration Information ----
Location Status Type Vendor ID Product ID Revision Serial Number Capacity Drive Type
Unit0 ,HDU0 Standby Data SEAGATE DKS2C-J146FC 4C00 3HY8V727 146GB FC
Unit0 ,HDU1 Normal Data SEAGATE DKS2C-J146FC 4C00 3HY8XZWM 146GB FC
Unit0 ,HDU2 Normal Data SEAGATE DKS2C-J146FC 4C00 3HY8XTS1 146GB FC

-- End

```

Figure 5.38 RAID Group/Logical Unit Configuration Output File

```

Configuration Information list.
DF Name : DF700M
Date : 2005/01/21 06:47:20
Micro Program Revision : 07510
Array Unit Type : DF700M
Serial Number : 75000018

---- CommonInformation ----
MappingMode = ON

---- CTL0 ----
---- PortA ----
---- PortOptions ----
Reset/LIP Mode(signal) = OFF
Reset/LIP Mode(Process) = OFF
LIP Port All Reset Mode = OFF

---- HostGroupList ----
---- HostGroupInformation ----
HostGroupNumber = 0

---- HostSystemConfiguration ----
Platform = not specified
Alternate Path = not specified
Failover = not specified
Additional Parameters
None

---- HostGroupOptions ----
Host Connection Mode 1 = Standard Mode
Host Connection Mode 2
HP-UX Mode = ON
PSUE Read Reject Mode = OFF
UA(06/2A00) suppress Mode = OFF
NACA Mode = OFF
Reset Propagation Mode = OFF
Unique Reserve Mode 1 = OFF
ASL Report Mode(Active/Passive Group) = OFF
ASL Report Mode(Active/Passive) = OFF
ASL Report Mode(Active/Active) = OFF
Port-ID No Report Mode = OFF
Port-ID Conversion Mode = OFF
Tru Cluster Mode = OFF
Product Serial Response Mode = OFF
Same Node Name Mode = OFF
CCHS Mode = OFF

---- LuMapping ----
H-LUN      LUN
0          0
1          1
2          2

-- HostGroupInformationEnd
-- HostGroupListEnd

```

Figure 5.39 Host Group Information Output File

```

Boot option list.
DF Name : DF700M_75000018
Date : 2006/04/12 09:52:09
Micro Program Revision : 0735/B-M
Array Unit Type : DF700M
Serial Number : 75000018

---- Boot Options ----
System Startup Attribute = Dual Active Mode
Delay Planned Shutdown = 0
Options
Drive Detach Mode = OFF
INQUIRY Information
Vendor ID = HITACHI
Product ID = DF600F
ROM Microprogram Version =
RAM Microprogram Version =

```

Figure 5.40 Boot Options Information Output File

```
NAS LU mapping information list.
DF Name : DF700H_77000002
Date : 2006/05/19 18:49:03
Micro Program Revision : 0750/A-H
Array Unit Type : DF700H
Serial Number : 77000002

---- NNC 1/3 Mapping Information ----
---- System LU Information ----
System LU                               LUN
System Disk(CTL0)                        0
System Disk(CTL1)                        1
Volume for Dump(CTL0)                   2
Volume for Dump(CTL1)                   3
Command Device                           4
Working Area for Dump                    5
System Common volume                     6
Backup volume for Common                  7
Backup volume for Common 2                8

-- Separator

---- User LU Information ----
H-LUN      LUN
  0         9
  1        10
  2        11
  3        12
  4        13
  5        14
  6        15
  7        16
  8        17
  9        18
 10       20

-- Separator

-- End
```

Figure 5.41 NAS System/User LUs Information Output File

```

Configuration Information list.
DF Name : DF700M_75010009
Date : 2006/05/19 18:50:37
Micro Program Revision : 0750/A-M
Array Unit Type : DF700M
Serial Number : 75010009

---- CommonInformation ----
MappingMode = OFF

---- CTL0 ----
---- PortA ----
PortType = iSCSI
---- iSCSIPortInformation ----
IPAddress = 192.168.0.200
SubnetMask = 255.255.255.0
DefaultGateway = 0.0.0.0
PortNumber = 3260
KeepAliveTimer = 60
MTU = 1500
EthernetAddress = 00:00:87:66:0B:00

---- PortOptions ----
Reset/LIP Mode(signal) = OFF
Reset/LIP Mode(Process) = OFF
LIP Port All Reset Mode = OFF

---- TargetList ----
---- TargetInformation ----
TargetNumber = 0
TargetAlias = "T000"
iSCSI Name = "iqn.1994-04.jp.co.hitachi:rsd.d7m.t.10009.0a000"
Authmethod = CHAP, None

---- HostSystemConfiguration ----
Platform = not specified
Alternate Path = not specified
Failover = not specified
Additional Parameters
None

---- TargetOptions ----
Host Connection Mode 1 = Standard Mode
Host Connection Mode 2
HP-UX Mode = OFF
PSUE Read Reject Mode = OFF
UA(06/2A00) suppress Mode = OFF
NACA Mode = OFF
HISUP OFF Mode = OFF
Reset Propagation Mode = OFF
Unique Reserve Mode 1 = OFF
ASL Report Mode(Active/Passive Group) = OFF
ASL Report Mode(Active/Passive) = OFF
ASL Report Mode(Active/Active) = OFF
Port-ID No Report Mode = OFF
Port-ID Conversion Mode = OFF
Tru Cluster Mode = OFF
Product Serial Response Mode = OFF
Same Node Name Mode = OFF
CCHS Mode = OFF
SPC-2 Mode = OFF

---- LuMapping ----
H-LUN      LUN
-- TargetInformationEnd
-- TargetListEnd
---- PortB ----
PortType = iSCSI
---- iSCSIPortInformation ----

```

Figure 5.42 iSCSI Port Information Output File

```

LAN parameter list.
DF Name : DF700M_75000018
Date : 2006/04/05 16:01:57
Micro Program Revision : 0735/A-M
Array Unit Type : DF700M
Serial Number : 75000018

---- User LAN Parameter ----
Maintenance Port IP Address Automatic Change Mode = ON
---- CTLO Parameter ----
DHCP = OFF
IP Address = 192.168.15.217
Subnet Mask = 255.255.255.0
Default Gateway = 192.168.15.3
Ether Address = 00:00:87:74:8E:62
---- CTL1 Parameter ----
DHCP = OFF
IP Address = 192.168.15.218
Subnet Mask = 255.255.255.0
Default Gateway = 192.168.15.3
Ether Address = 00:00:87:74:8E:03

---- Maintenance LAN Parameter ----
CTLO IP Address = 10.0.0.16
CTL1 IP Address = 10.0.0.17
NNC0 IP Address = 10.0.0.10
NNC2 IP Address = 10.0.0.12

```

Figure 5.43 LAN Information Output File

5.10.3 Setting RAID/LU Configuration using a Text File

WARNING: During this operation the subsystem cannot execute commands from the host, and cannot be operated with Storage Navigator. System parameters and failure monitoring will continue.

WARNING: If you are setting RAID group/logical unit configuration, all user data and the previous configuration will be deleted. Be sure to back up your data before continuing.

Caution: If you have a dual system, make sure that both controllers are attached and working normally.

1. The RAID Group/Logical Unit file has three parameters:
 - **RAID configuration information:** Specifies RAID level, RAID group number and RAID size. If the RAID group is not set, “-” is shown after **Level**, and no other parameters are set.
 - **LU configuration information:** Specifies logical unit number, logical unit capacity, pre-read capacity, number of controllers in current use, number of controllers in default use, RAID group number and RAID level, and logical unit status.



Specify the logical unit status as **normal**.

If you are allocating the full capacity of the RAID group to one logical unit, specify “All” in **Capacity**.

The controller number will become the same as the controller that is in default use, regardless of what is specified.

If you are specifying logical units of less than the maximum logical unit number, specify at the end that “After nn, not define” (nn: the last logical unit number + 1).

- **Drive information:** Sets the configuration of the HDU installed in the subsystem. If no HDU is installed, specify “Nothing”. If you specify a capacity larger than the installed HDU, it is regarded as an error and not set.

2. Access the **Array System Viewer** window by selecting a storage array in the **List View** box, and then do one of the following:
 - Select **File → Open**
 - Click the **Open** icon () on the tool bar.
3. Open the **Configuration Settings** window by one of the following methods:
 - From the **Tools** menu, select **Configuration Settings**.
 - Click the **Configuration Settings** icon () in the tool bar.
4. Click the **Constitute** tab (refer to Figure 5.36). For a detailed description of the **Constitute** tab, refer to section. 5.1.9.
5. In the **Operation** box, select **Input**.
6. In the **Select Configuration Information** box, click **RAID Group/Logical Unit**.
7. In the **File** box, either type in the file path or click **Browse** to specify the input destination file.
8. Click **Apply**, and then click **OK** on the confirmation message.
9. A warning message displays, stating that the current RAID/LU configuration will be deleted Figure 5.44. You should already have backed up your configuration information. Click **OK** to continue, or click **Cancel** to cancel.
10. A warning message displays, stating that user data in the affected logical units will be invalidated (see Figure 5.45). You should already have backed up your user information. Click **OK** to continue, or click **Cancel** to cancel.
11. Several status messages will display, noting the progress of the configuration setting. Once the process is complete, click **OK** on the confirmation message.

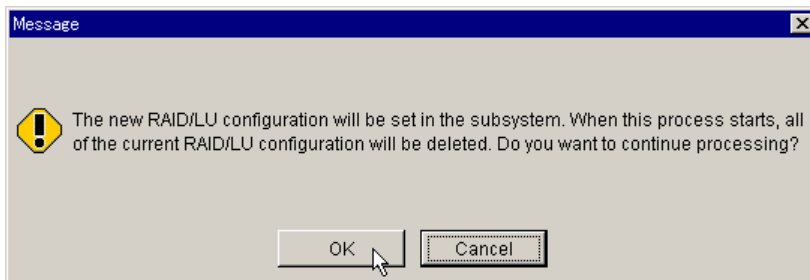

Figure 5.44 RAID/LU Configuration Data Deletion Warning Message

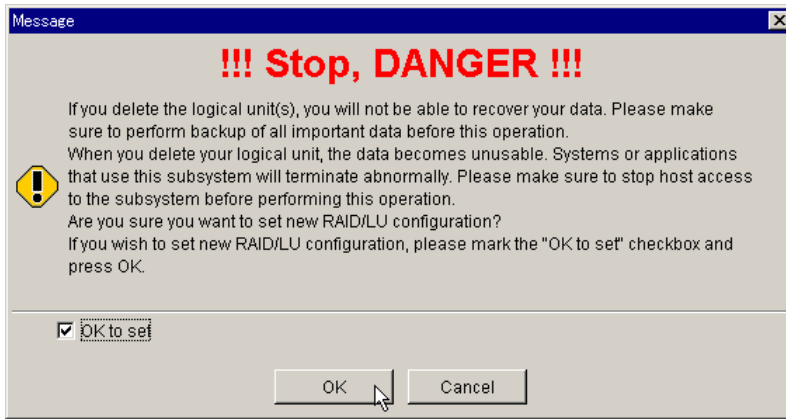



Figure 5.45 User Data Deletion Warning Message

5.10.4 Setting Port or Host Group Configuration with a File

WARNING: This operation will require stopping I/O from the host.

Caution: If you have a dual system, make sure that both controllers are attached and working normally.

1. Access the **Array System Viewer** window by selecting a storage array in the **List View** box, and then do one of the following:
 - Select **File → Open**
 - Click the **Open** icon () on the tool bar.
2. Open the **Configuration Settings** window by one of the following methods:
 - From the **Tools** menu, select **Configuration Settings**.
 - Click the **Configuration Settings** icon () in the tool bar.
3. Click the **Constitute** tab (refer to Figure 5.36). For a detailed description of the **Constitute** tab, refer to section. 5.1.9.
4. In the **Operation** box, click **Input**.
5. In the **Select Configuration Information** box, click **Port Information (Update)**.
6. In the **Setting Information for Input** box, select one or more of the following:
 - Port Options
 - Host Group Options
 - Mapping Information
 - WWN Information (available when the LUN Manager is enabled). Select the items that you will set from **Input**.
7. In the **File** box, either type in the file path or click **Browse** to specify the output destination file.
8. Click **Apply**. If you are setting ports or host groups, Figure 5.46 displays. Stop host access to the subsystem or host group, and then click **OK** to continue.
9. Once operations are complete, click **OK** on the confirmation messages.

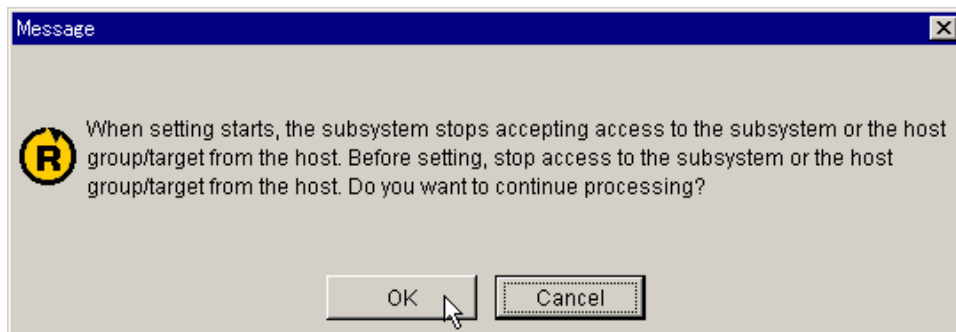

Figure 5.46 Stop Host Access Warning Message (Port or Host Group Operations)

5.10.5 Setting CHAP User Information with a File

Caution: If you have a dual system, make sure that both controllers are attached and working normally.



1. Access the **Array System Viewer** window by selecting a storage array in the **List View** box, and then do one of the following:
 - Select **File → Open**
 - Click the **Open** icon () on the tool bar.
2. Open the **Configuration Settings** window by one of the following methods:
 - From the **Tools** menu, select **Configuration Settings**.
 - Click the **Configuration Settings** icon () in the tool bar.
3. Click the **Constitute** tab (see Figure 5.36). For a detailed description of the **Constitute** tab, refer to section. 5.1.9.
4. In the **Operation** box, click **Input**.
5. In the **Select Configuration Information** box, click **CHAP User**.
6. Click **Browse**, specify the input directory and file name, and then click **Apply**.
7. Click **OK** on the confirmation message.

Table 5.1 lists the format of the CHAP User information setting file.

Table 5.1 CHAP User Information Format

File Contents	Descriptions
User name,secret,Target No. or alias ...	The lines are invalid until <CHAP User> appears.
<CHAP User>,,	The valid lines are from <CHAP User> to <END>.
<Port 0A>,,	The line specifies the port. (<Port ALL> specifies all ports)
hitachi-0,abcdefghij00,alias0	The first column is CHAP User, and the second column is Secret.
hitachi-1,abcdefghij01,alias1	The third row and the following are aliases of Target to assign.
#hitachi-1,abcdefghij01,alias1	The line with the first character of # is a comment line. (Invalid line)
hitachi-2,abcdefghij02,3	The Target number can be specified as the alias of Target.
<Port 0B>,,	
<Add CHAP User>,,	If <Add CHAP User> is specified, CHAP User is added.
hitachi-0,abcdefghij00,alias0	If nothing is specified, all CHAP Users are deleted, and then added.
hitachi-1,abcdefghij01,alias0,alias01,alias02	One or more Targets can be specified.
<Port 1A>,,	
<Port 1B>,,	
<END>,,	The line of <END> and the following are all invalid lines.



5.10.6 Setting Boot Option Information with a File

WARNING: This operation will require stopping I/O from the host and rebooting.

WARNING: If you are using TrueCopy or TrueCopy Extended Distance, change the pair status to PSUS before you reboot.



WARNING: If you are using a NAS, you must also stop the clusters between NAS units. When restarting the subsystem, you must restart the clusters.

Caution: If you have a dual system, make sure that both controllers are attached and operating normally.

1. Access the **Array System Viewer** window by selecting a storage array in the **List View** box, and then do one of the following:
 - Select **File** → **Open**
 - Click the **Open** icon () on the tool bar.
2. Open the **Configuration Settings** window by one of the following methods:
 - From the **Tools** menu, select **Configuration Settings**.
 - Click the **Configuration Settings** icon () in the tool bar.
3. Click the **Constitute** tab (see Figure 5.36). For a detailed description of the **Constitute** tab, refer to section. 5.1.9.
4. In the **Operation** box, select **Input**.
5. In the **Select Configuration Information** box, click **Boot Option**.
6. In the **File** box, either type in the file path or click **Browse** to specify the input destination file.
7. Click **Apply**, and then click **OK** on the confirmation message.
8. If restarting is necessary, the **Restart Warning** dialog box will display (see Figure 5.21). Stop host access before continuing. If you are using TrueCopy or TrueCopy Extended Distance, change the pair status to PSUS before you reboot. Check **OK to reboot**, and then click **OK** on the **Warning** dialog box.
9. Rebooting should take between 4 and 15 minutes to complete. You will see several progress messages. Once the restart is complete, click **OK** on the confirmation message.

5.11 Setting NAS System LU or User LU Information with a File

WARNING: This operation will delete the current system and user LUs. You should back up your existing configuration if you want to retain the information.

1. Access the **Array System Viewer** window by selecting a storage array in the **List View** box, and then do one of the following:
 - Select **File → Open**
 - Click the **Open** icon () on the tool bar.
2. Open the **Configuration Settings** window by one of the following methods:
 - From the **Tools** menu, select **Configuration Settings**.
 - Click the **Configuration Settings** icon () in the tool bar.
3. Click the **Constitute** tab (see Figure 5.36). For a detailed description of the **Constitute** tab, refer to section. 5.1.9.
4. In the **Operation** box, click **Input**.
5. In the **Select Configuration Information** box, click **NAS: System LU/User LU**.
6. In the **File** box, either type in the file path or click **Browse** to specify the input destination file.
7. Click **Apply**, and then click **OK** on the confirmation message.
8. The **System and User LU Deletion** warning message displays, warning you that your current system and user LU information will be deleted. If you want to retain the information, back up your configuration. Click **OK** to continue.
9. Once the process is complete, click **OK** on the confirmation message.

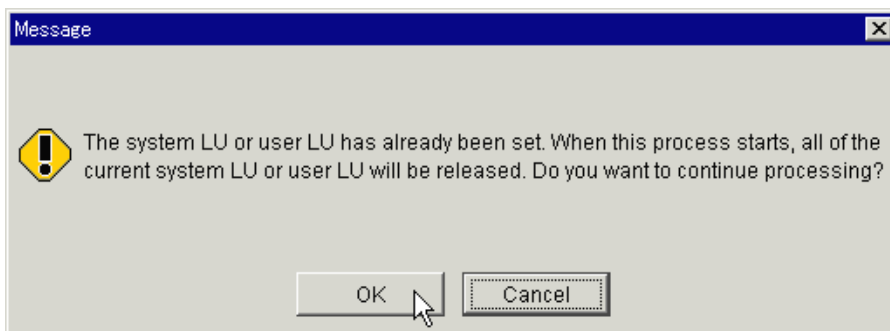



Figure 5.47 System and User LU Deletion Warning Message

5.11.1 Setting LAN Information with a File

Caution: If you have a dual system, make sure that both controllers are attached and working normally.

1. Access the **Array System Viewer** window by selecting a storage array in the **List View** box, and then do one of the following:
 - Select **File → Open**
 - Click the **Open** icon () on the tool bar.
2. Open the **Configuration Settings** window by one of the following methods:
 - From the **Tools** menu, select **Configuration Settings**.
 - Click the **Configuration Settings** icon () in the tool bar.
3. Click the **Constitute** tab (refer to Figure 5.36). For a detailed description of the **Constitute** tab, refer to section. 5.1.9.
4. In the **Select Configuration Information** box, click **LAN Information**.
5. In the **Operation** box, click **Input**. Make the following settings, if desired:
 - Maintenance Port IP Address Automatic Change Mode
 - IP Address
 - Subnet Mask
 - Default Gateway
 - Maintenance LAN Parameter (Network Address)
6. In the **File** box, either type in the file path or click **Browse** to specify the output destination file.
7. Click **Apply**, and then click **OK** on the confirmation message.

5.12 Setting iSCSI Port Information

WARNING: This operation will require stopping I/O from the host.

To set the iSCSI port information:

1. Open the **Configuration Settings** window by one of the following methods:
 - On the **Tools** menu, select **Configuration Settings**.
 - Click the **Configuration Settings** icon () in the tool bar.
2. Click the **iSCSI** tab (see Figure 5.48). For a detailed description of the **iSCSI** tab, refer to section 5.1.10.
3. Select a port, then in the **Network** box, set the following parameters:
 - IP address
 - Subnet mask
 - Default Gateway
 - Port number
 - Keep Alive Timer (sec)
 - The MTU, Ether Address, and Result text boxes are not available.
4. Click **Apply**, and then click **OK** on the confirmation message.
5. The **Stop Host Access** warning message displays (see Figure 5.49). Stop host I/O access, and then click **OK** to continue.
6. Once the process is complete, click **OK** on the confirmation message.

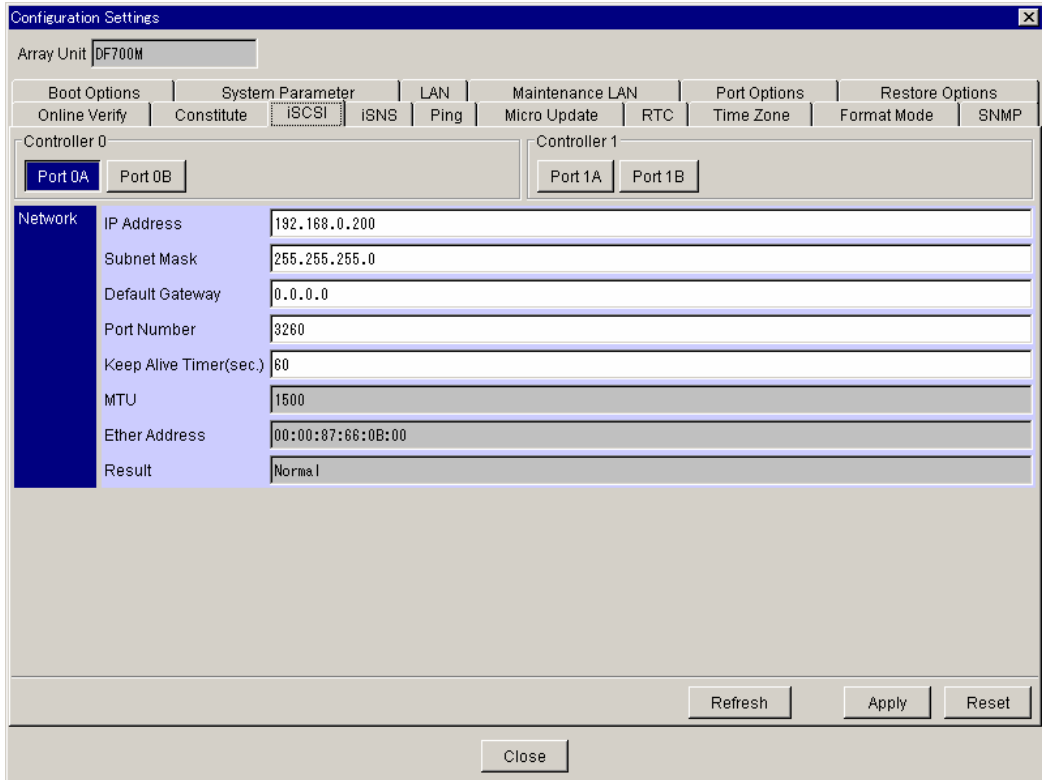

Figure 5.48 Setting iSCSI Port Information

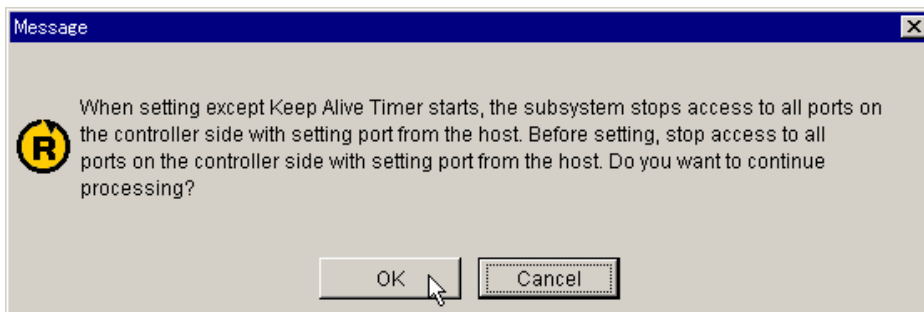



Figure 5.49 Stop Host Access Warning Message

5.13 Setting iSNS Server Information

To set the iSNS server information:

1. Access the **Array System Viewer** window by selecting a storage array in the List View box, and then do one of the following:
 - Select **File → Open**
 - Click the **Open** icon () on the tool bar.
2. Open the **Configuration Settings** window by one of the following methods:
 - From the **Tools** menu, select **Configuration Settings**.
 - Click the **Configuration Settings** icon () in the tool bar.
3. Click the **iSNS** tab (see Figure 5.50). For a detailed description of the **iSNS** tab, refer to section 5.1.11.
4. Select a port. In the **iSNS Server** box, enter the IP address and port number.
5. Click **Apply**, and then click **OK** on the confirmation message.
6. Once the process is complete, click **OK** on the confirmation message.

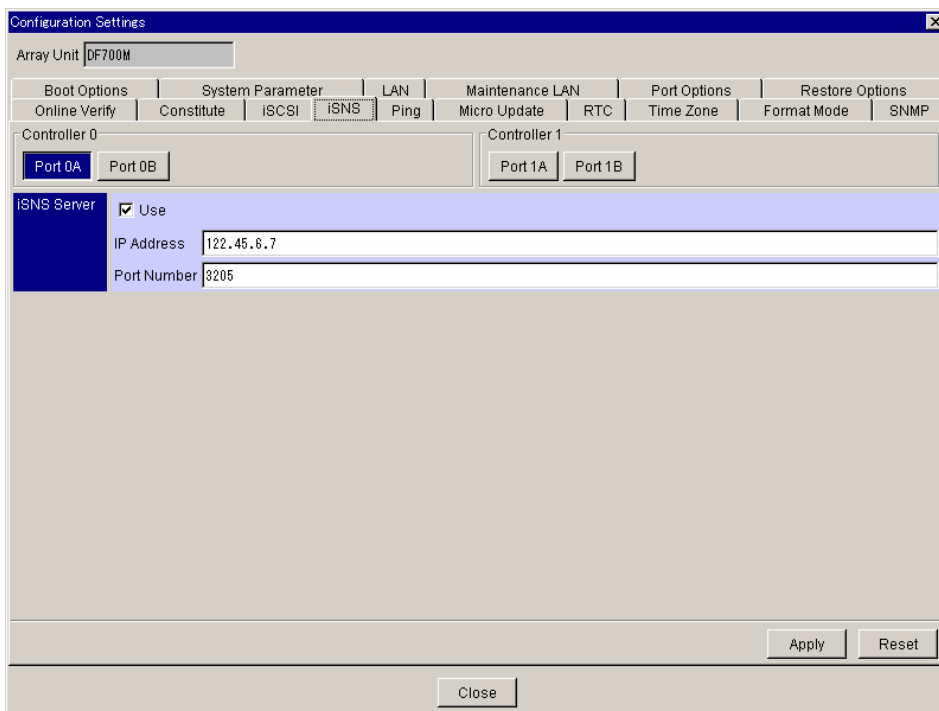



Figure 5.50 Setting iSNS Server Information

5.14 Pinging the Initiator Host

This operation pings the initiator (host) and displays the result.

1. Open the **Configuration Settings** window by one of the following methods:
 - On the **Tools** menu, select **Configuration Settings**.
 - Click the **Configuration Settings** icon () in the tool bar.
2. Click the **Ping** tab (see Figure 5.51). For a detailed description of the **Ping** tab, refer to section 5.1.12.
3. In the **Port** box, select the port that you want to ping.
4. In the **Destination IP Address** box, type in the IP address.
5. Click **Start**. The **Host Access Delay** warning message displays (see Figure 5.52). Click **OK**, and then click **OK** on the confirmation message.
6. Click **Refresh** to display the results of the ping.

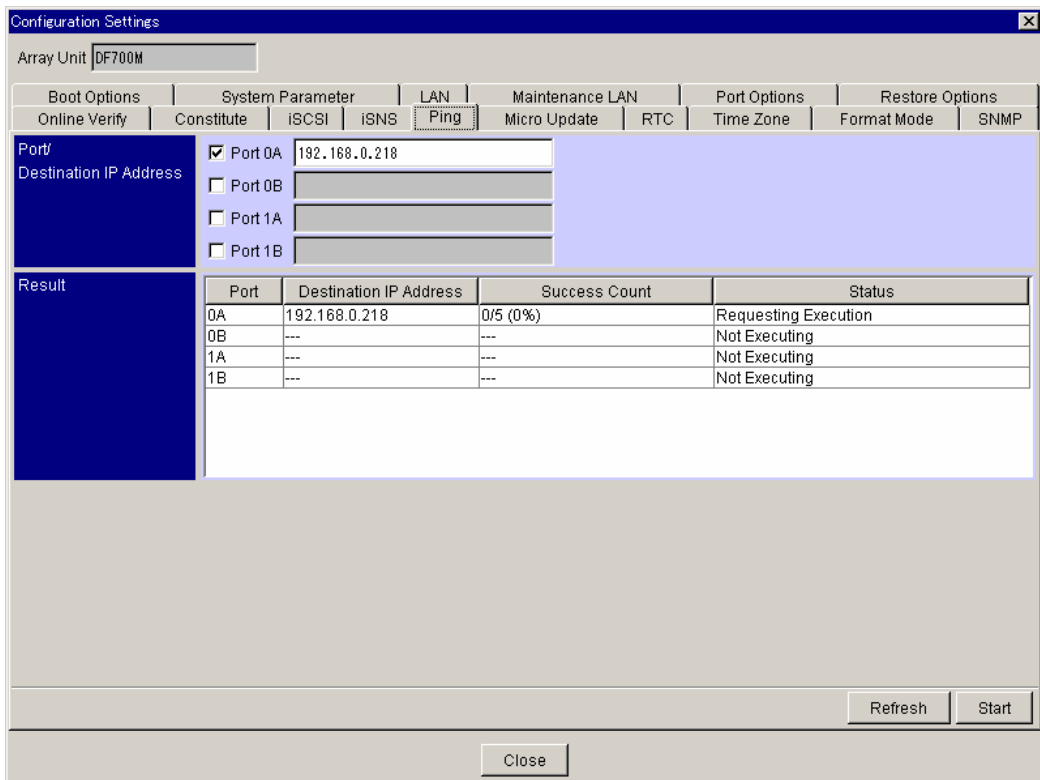

Figure 5.51 Pinging Initiator Host

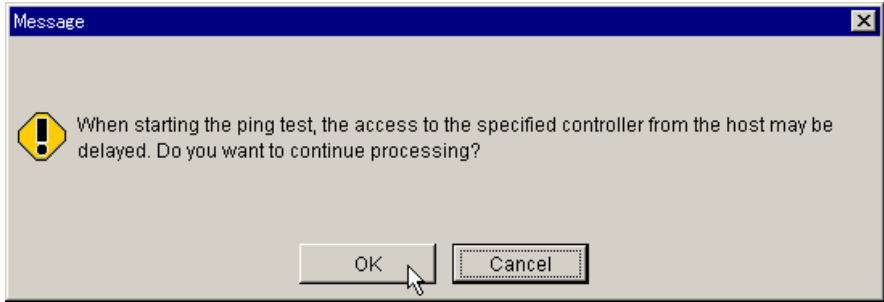

Figure 5.52 Host Access Delay Warning Message



Figure 5.53 Select Refresh Message

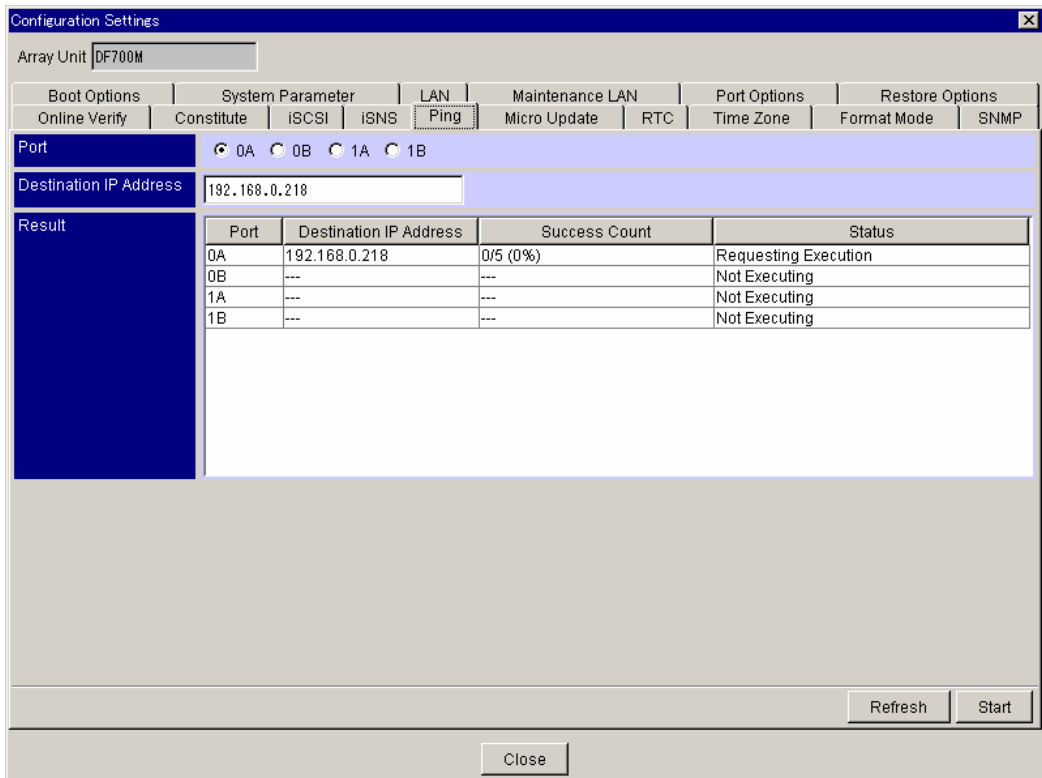

Figure 5.54 Ping Results

5.15 Updating the Microcode

The function downloads and replaces the microcode in the subsystem. When replacing the microcode, first download it, and then replace it.

Caution: If the microcode is read during a download, errors will occur during the download processing.

5.15.1 Downloading Microcode

WARNING: This operation will interrupt I/O from the host and may require rebooting the subsystem.

WARNING: If you are using TrueCopy or TrueCopy Extended Distance and you are required to reboot, change the pair status to PSUS before you reboot.

WARNING: If you do a hot replacement of the controller board before restarting the subsystem or replacing the microcode, the new controller may be blocked.

Caution: You should not download the microcode when the host has a high I/O load, or the download may terminate with a DMES05EA03 error message. If this occurs, retry the operation.

To download microcode:

1. If you are using Solaris™, IRIX®, HP-UX, or Red Hat® Linux® you will need to copy the microcode to the hard disk using a different directory. If you are using Windows, microcode is accessed from the CD-R and is not copied.

Note: For a directory where the Navigator is installed, do not copy the microcode directly to the CD-R. Create a sub-directory and copy it under this sub-directory. Specify the name of a directory in the hard disk drive to which the microcode is copied, with a one-byte coded alphanumeric.

2. Access the **Array System Viewer** window by selecting a storage array in the **List View** box, and then do one of the following:

- Select **File** → **Open**
- Click the **Open** icon () on the tool bar.

3. Open the **Configuration Settings** window by one of the following methods:

- From the **Tools** menu, select **Configuration Settings**.
- Click the **Configuration Settings** icon () in the tool bar.

4. Click the **Micro Update** tab (see Figure 5.55). For a detailed description of the **Micro Update** tab, refer to section 5.1.13.

5. Click **Read**. If a revision is displayed in the **Revision (Read)** box, the microcode has already been read.

Note: If you specify the microcode installed directory, all the microcodes are read automatically.

6. Click **OK** on the confirmation message to start the download.

7. If that version of the microcode has already been downloaded, a confirmation message displays asking if you want to overwrite the microcode (see Figure 5.56). Click **OK** to overwrite, and then click **OK** on the second confirmation message (see Figure 5.57).
8. On the **Specify Path** window (see Figure 5.58), specify the download directory by either entering the path or browsing to select the path, and then click **OK**. A sample path is shown in Figure 5.59.
9. Click **OK** on the confirmation message to continue. When the microcode is read, click **OK** on the confirmation message, and the version will display in the **Revision (Read)** field (see Figure 5.60).
10. Click the **Download**, and then click **OK** on the confirmation message.
11. On the **Host Access** message (see Figure 5.61), do one of the following:
 - Click **Yes** if you want the Storage Navigator to not be accessed by the host until after you click **OK** on the confirmation message when the microcode is replaced.
 - Click **No** if you want the Storage Navigator to be accessed by the host immediately after the microcode is replaced, and before you click **OK** on the confirmation message.
12. You will see several progress messages. You can abort the download by selecting **Cancel** on the **Microcode Download** window (see Figure 5.62). The download can be aborted. To abort the download halfway, click **Cancel**. A confirmation message is displayed. When **OK** is clicked, the download is aborted. When **Cancel** is clicked, the download is continued.
13. Once the process is complete, click **OK** on the confirmation message.
14. After the microcode is downloaded, you must either restart the subsystem or replace the microcode (see section 5.15.2).
15. If restarting is necessary, the Restart Warning dialog box will display (see Figure 5.21). Stop host access before continuing. If you are using TrueCopy or TrueCopy Extended Distance, change the pair status to PSUS before you reboot. Check **OK to reboot**, and then click **OK** on the **Warning** dialog box.

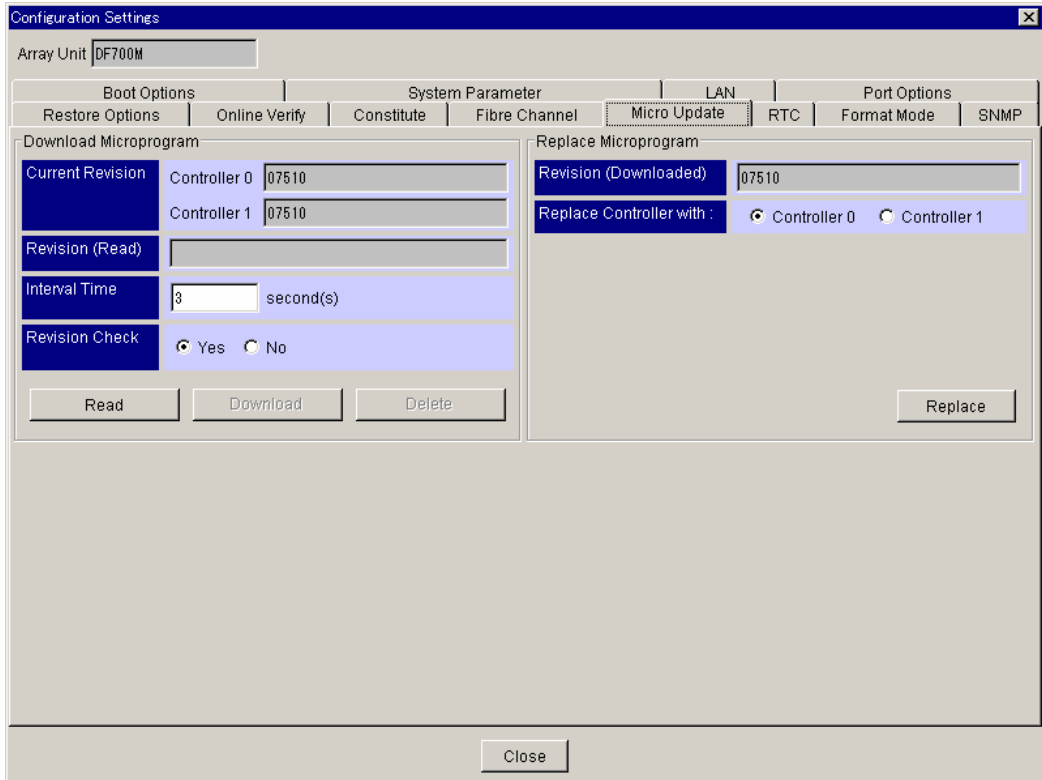

Figure 5.55 Downloading Microcode

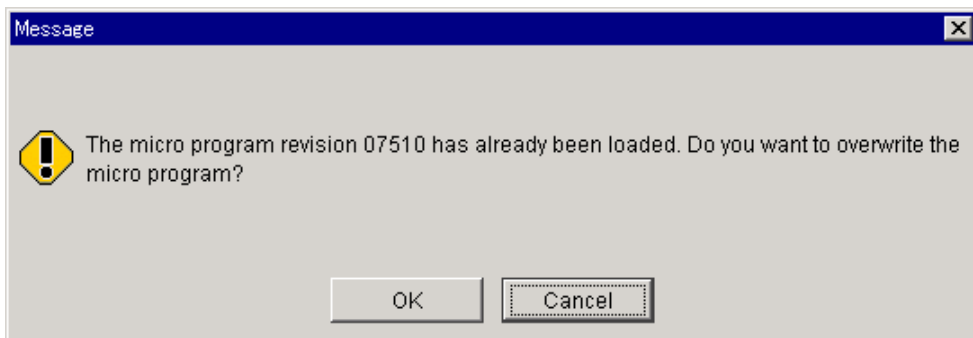

Figure 5.56 Overwrite Microcode Confirmation Message (1)

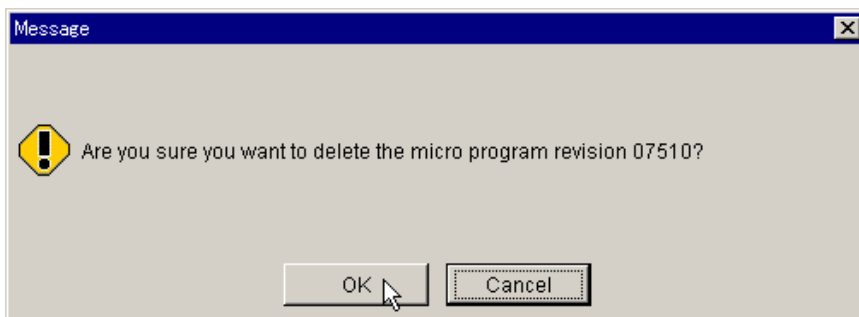

Figure 5.57 Overwrite Microcode Confirmation Message (2)

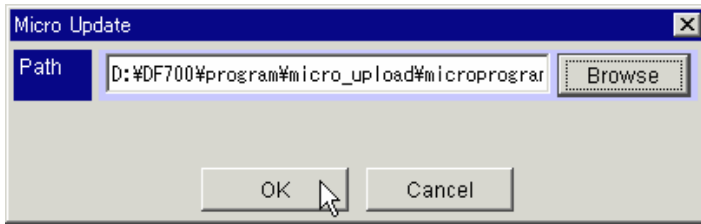

Figure 5.58 Specify Path Window

When using Windows®:

D:/DF700/program/micro_upload/microprogram/0710A

When using Solaris™, IRIX®, HP-UX®, or Red Hat Linux®:

/home/usr/DF700/program/micro_upload/microprogram/0710A

Directory in the hard disk in which the micro program is copied.

Figure 5.59 Sample Path

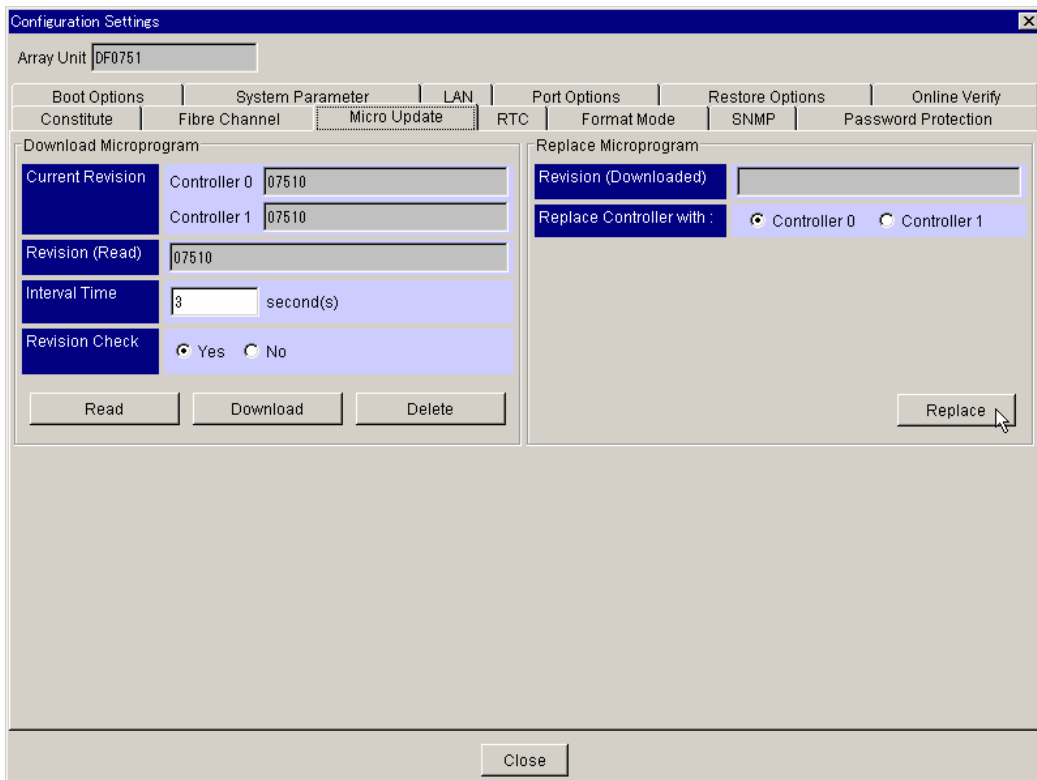

Figure 5.60 Revision Read

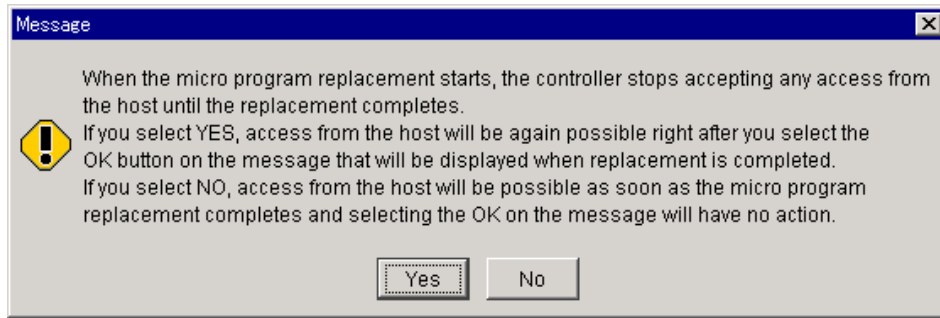

Figure 5.61 Host Access Message

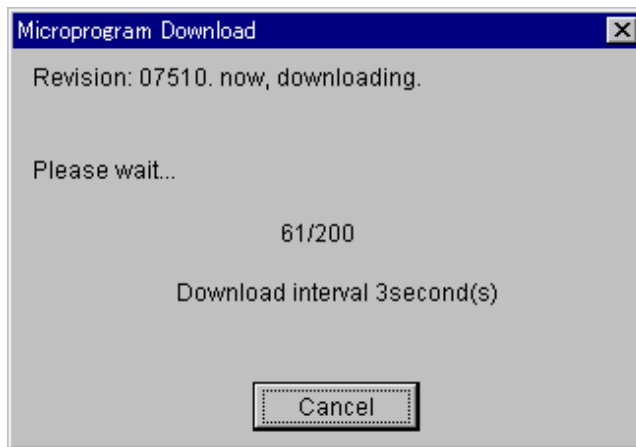



Figure 5.62 Microcode Download Window

5.15.2 Replacing the Microcode

WARNING: This operation will interrupt I/O from the host and may require rebooting the subsystem.

WARNING: If you are using TrueCopy or TrueCopy Extended Distance and you are required to reboot, change the pair status to PSUS before you reboot.

Important: You will need to replace the microcodes on both controllers, in the following order:

- If you are connected either to both controllers or only to controller 0, first replace controller 0, then replace controller 1.
 - If you are connected only to controller 1, first replace controller 1, then replace controller 0.
1. Access the **Array System Viewer** window by selecting a storage array in the **List View** box, and then do one of the following:
 - Select **File** → **Open**
 - Click the **Open** icon () on the tool bar.
 2. Open the **Configuration Settings** window by one of the following methods:
 - From the **Tools** menu, select **Configuration Settings**.
 - Click the **Configuration Settings** icon () in the tool bar.
 3. Click the **Micro Update** tab (see Figure 5.63). For a detailed description of the **Micro Update** tab, refer to section 5.1.13.
 4. Select the appropriate controller, click **Replace** button, and then click **OK** on the confirmation message (see Figure 5.64).
 5. If restarting is necessary, the **Restart Warning** dialog box will display (refer to Figure 4.33). Stop host access before continuing. If you are using TrueCopy or TrueCopy Extended Distance, change the pair status to PSUS before you reboot. Check **OK to reboot**, and then click **OK** on the **Warning** dialog box.
 6. The update should take up to 15 minutes. If you elected to have host access delayed during the microcode download (refer to section 5.15.1), clicking **OK** on the **Host Access Accepted** message will restore host access (see Figure 5.65). Otherwise, clicking **OK** will have no effect because host access will already be started.
 7. Click **OK** on the confirmation message when the update is completed.
 8. Repeat the above steps with the other controller.

Note: If you replace the microcode on only one of the controllers, the subsystem is placed in a warning status. Replacing the second controller will terminate the warning status.

Note: If you only replace the microcode on only one controller and the **Array System Viewer** window is closed, it is possible that the **Array System Viewer** window will stop opening. If this occurs, register a controller that is not having the microcode replaced, then replace the microcode on the second controller.

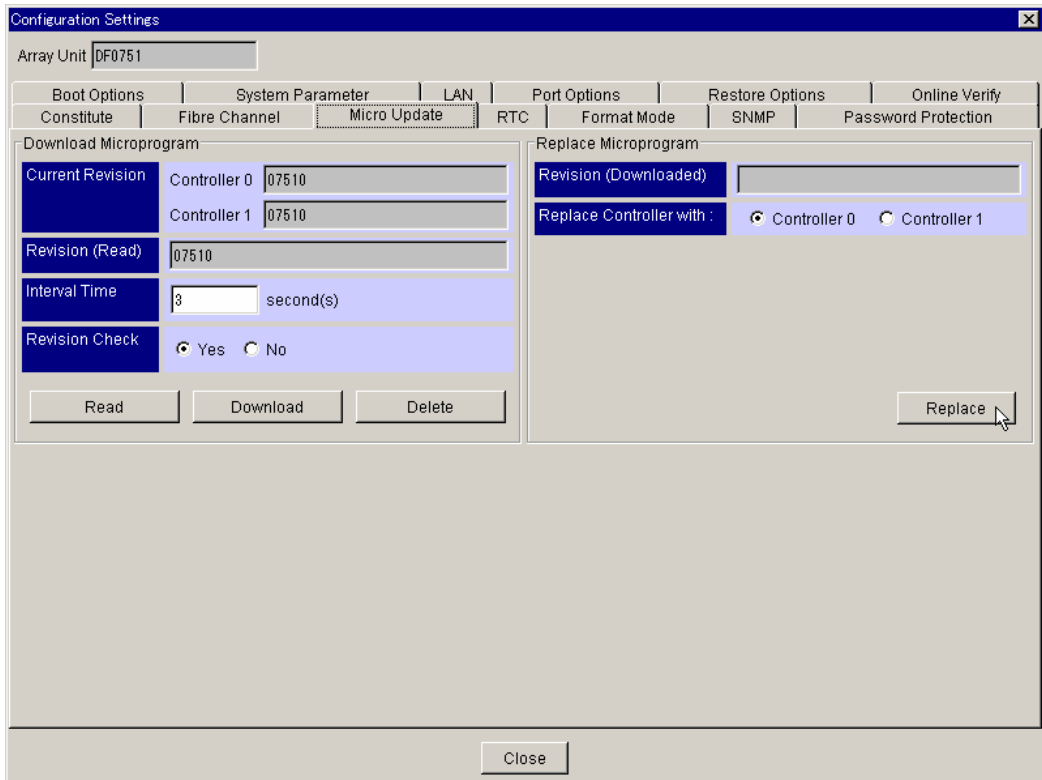

Figure 5.63 Replacing Microcode

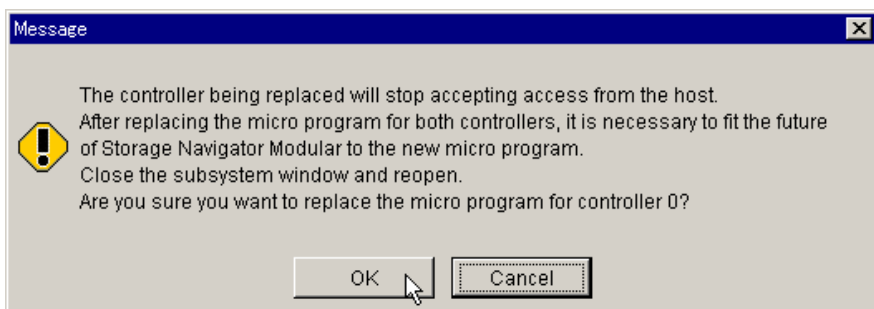



Figure 5.64 Replace Microcode Confirmation Message



Figure 5.65 Host Access Accepted Message

5.16 Setting the RTC

1. Access the **Array System Viewer** window by selecting a storage array in the **List View** box, and then do one of the following:
 - Selecting **File** → **Open**
 - Click the **Open** icon () on the tool bar.
2. Open the **Configuration Settings** window by one of the following methods:
 - From the **Tools** menu, select **Configuration Settings**.
 - Click the **Configuration Settings** icon () in the tool bar.
3. Select the **RTC** tab (see Figure 5.66). For a detailed description of the **RTC** tab, refer to section 5.1.14.
4. In the **Setting** box, select one of the following:
 - Click **Manual** if you want to manually update the settings.
 - Click **Auto** if you want the settings updated automatically to those on the Storage Navigator computer.
5. If you clicked **Manual**, enter the date and time.
6. Click **Apply**, and then click **OK** on the confirmation message.

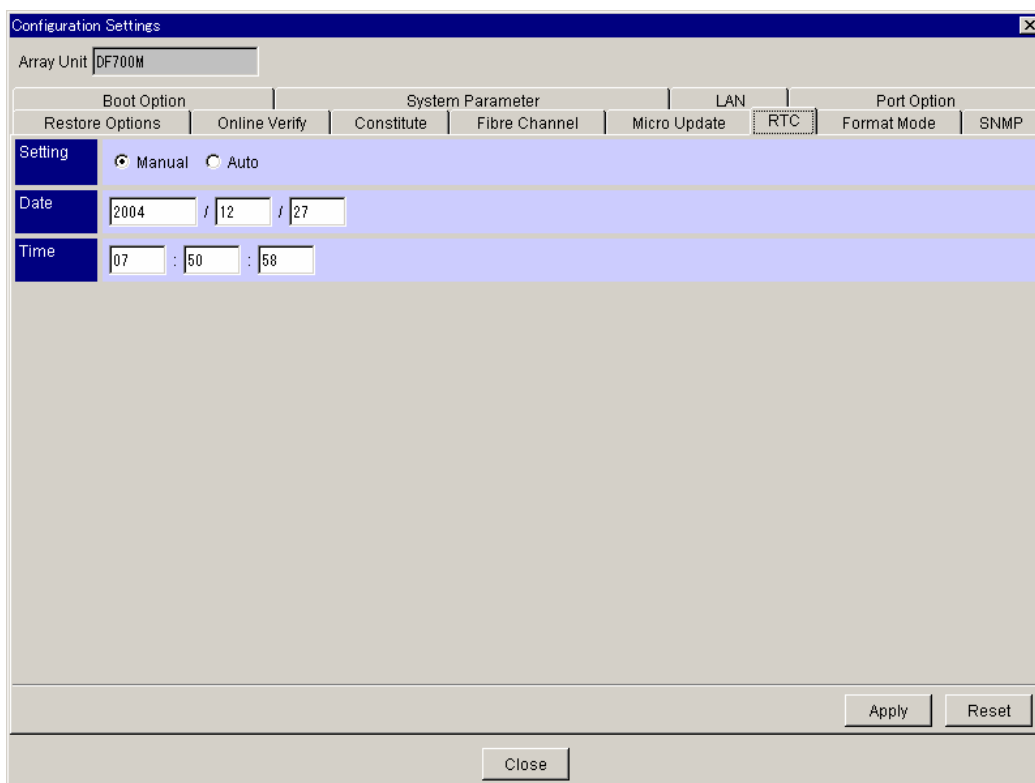



Figure 5.66 Setting RTC

5.17 Setting the Time Zone and NTP Server

To set the time zone:

1. Access the **Array System Viewer** window by selecting a storage array in the **List View** box, and then do one of the following:
 - Select **File → Open**
 - Click the **Open** icon () on the tool bar.
2. Open the **Configuration Settings** window by one of the following methods:
 - From the **Tools** menu, select **Configuration Settings**.
 - Click the **Configuration Settings** icon () in the tool bar. Click the **Time Zone** tab (see Figure 5.67). For a detailed description of the **Time Zone** tab, refer to section 5.1.15.
3. In the **Time Zone** box, do the following:
 - Select a time zone from the **Time Zone** drop-down list.
 - Click the checkbox if you want to automatically adjust the clock for daylight saving changes.
4. In the **NTP Server** box, specify the IP address of the NTP server.
5. Click **Apply**, and then click **OK** on the confirmation message.

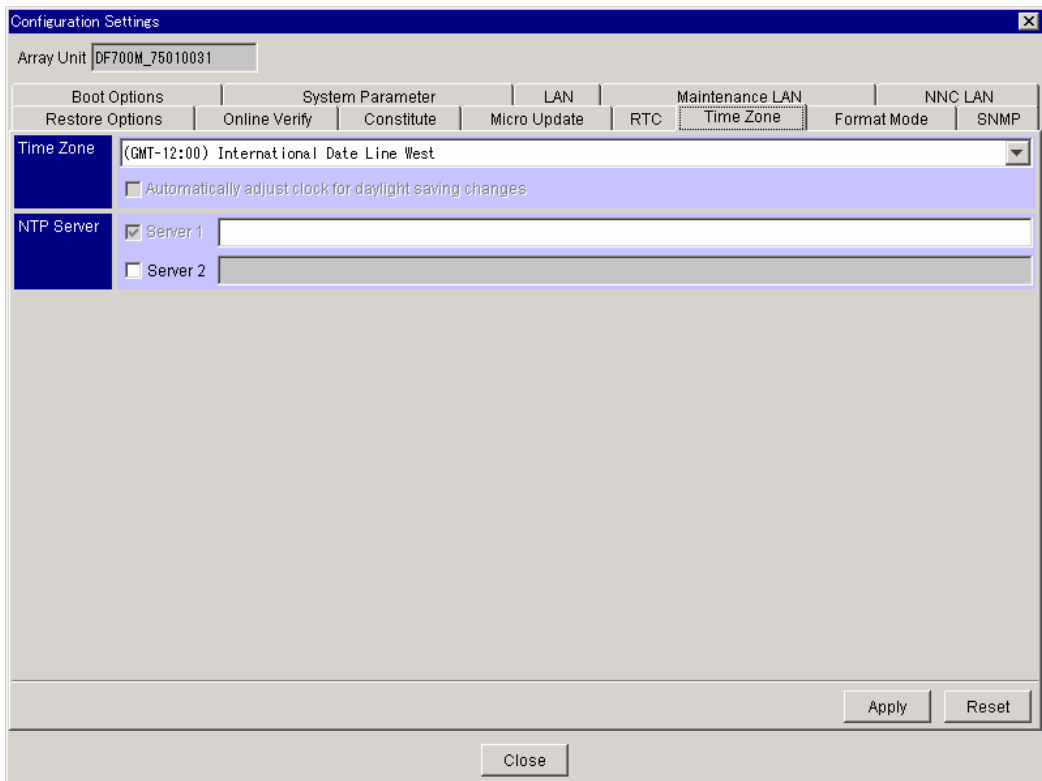



Figure 5.67 Setting Time Zone

5.18 Setting Formatting Mode

WARNING: This operation could affect I/O from the host.

1. Access the **Array System Viewer** window by selecting a storage array in the **List View** box, and then do one of the following:
 - Select **File → Open**
 - Click the **Open** icon () on the tool bar.
2. Open the **Configuration Settings** window by one of the following methods:
 - From the **Tools** menu, select **Configuration Settings**.
 - Click the **Configuration Settings** icon () in the tool bar.
3. Click the **Format Mode** tab (see Figure 5.68). For a detailed description of the **Format Mode** tab, refer to section 5.1.16.
4. In the **Format Priority Mode** box, select one of the following:
 - **Normal:** Formats at an idle time when no host I/O is executed.
 - **Host:** Host's I/O is executed preferentially.
 - **Format:** Subsystem formats are done preferentially.
5. In the **Format Data** box, select one of the following:
 - **Default**
 - **0**
6. After the setting is complete, click **Apply**.
7. A message displays stating that the setting is complete. Click **OK**.

Note: It may take time to complete the setting. Click **Refresh** to verify that the correct settings have been made.

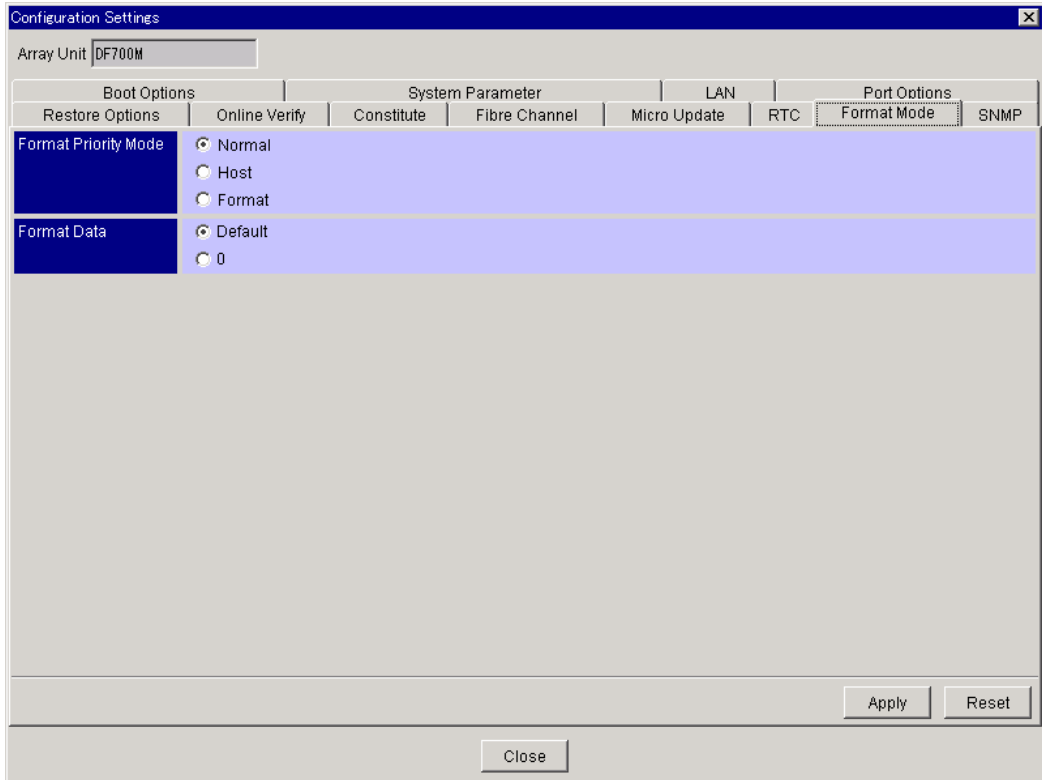
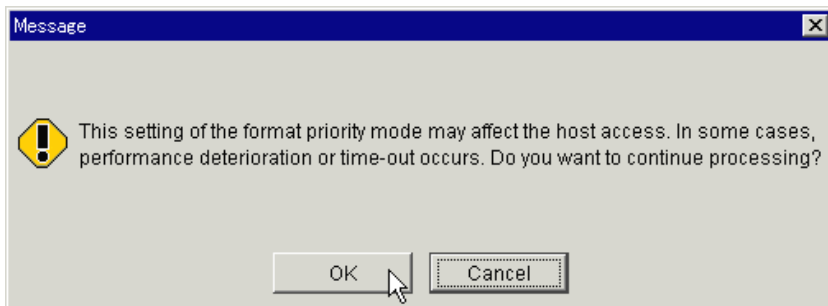
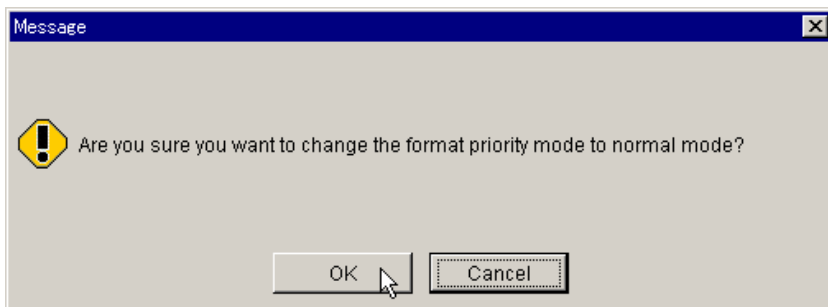



Figure 5.68 Setting Formatting Mode



5.19 Setting Fibre Channel Information

WARNING: This operation requires stopping I/O from the host.

1. Access the **Array System Viewer** window by selecting a storage array in the **List View** box, and then do one of the following:
 - Select **File → Open**
 - Click the **Open** icon () on the tool bar.
2. Open the **Configuration Settings** window by one of the following methods:
 - From the **Tools** menu, select **Configuration Settings**.
 - Click the **Configuration Settings** icon () in the tool bar.
3. Click the **Fibre Channel** tab (see Figure 5.69). For a detailed description of the **Fibre Channel** tab, refer to section 5.1.16.
4. In the **Port Address** box, type in the new setting for the port address. Enter 8 bytes of data hexadecimal (with 16 characters).
5. In the **Transfer Rate** box, select the value from the drop-down menu.
6. In the **Topology Information** box, select the value from the drop-down menu.
7. Click **Apply**, and then click **OK** on the confirmation message.
8. The **Host Access** warning message displays (see Figure 5.70). Make sure that host access to the port has been stopped, and then click **OK**.

Note: It may take time to complete the setting. Click **Refresh** to verify that the correct settings have been made.

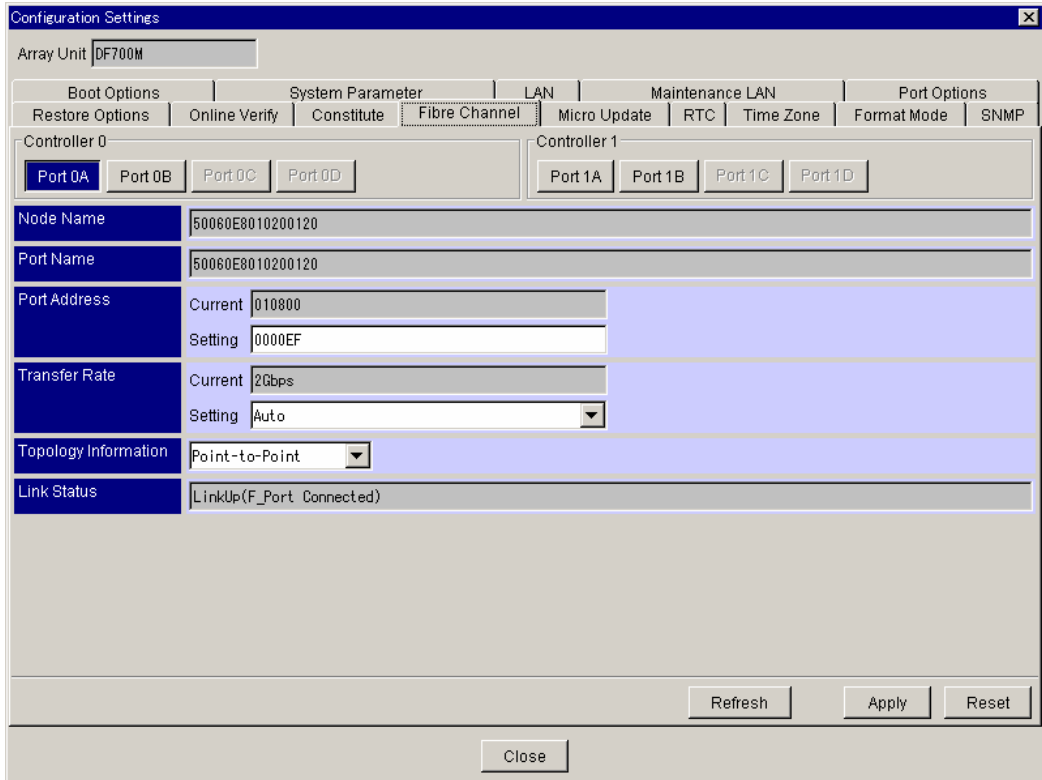

Figure 5.69 Setting Fibre Channel Information

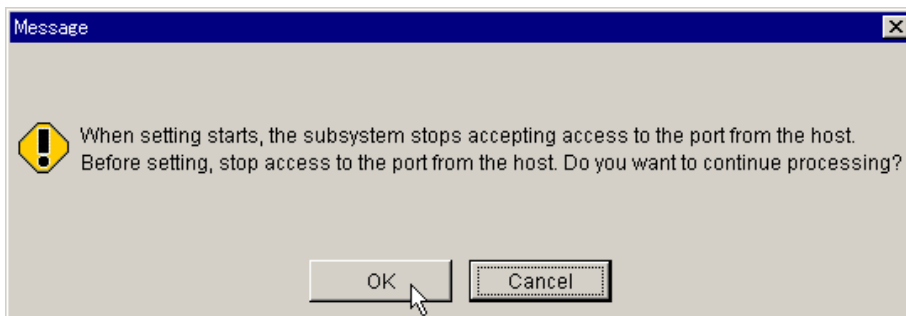

Figure 5.70 Host Access Warning Message



5.20 SNMP

For more information on configuring SNMP settings, see *Hitachi TagmaStore AMS and WMS SNMP Agent User's Guide* (MK-95DF705).

5.21 Password Protection

For more information on password protection, see *Hitachi TagmaStore AMS and WMS Password Protection User's Guide* (MK-95DF704).

5.22 Setting Backend Diagnosis Information

1. Access the **Array System Viewer** window by selecting a storage array in the **List View** box, and then do one of the following:
 - Select **File → Open**
 - Click the **Open** icon () on the tool bar.
2. Open the **Configuration Settings** window by one of the following methods:
 - From the **Tools** menu, select **Configuration Settings**.
 - Click the **Configuration Settings** icon () in the tool bar.
3. Click the **Backend Diagnosis** tab (see Figure 5.71).
4. In the **Auto Diagnosis Threshold** box, specify the value in a range of 1 to 255.
5. Click **Apply**, and then click **OK** on the confirmation message.

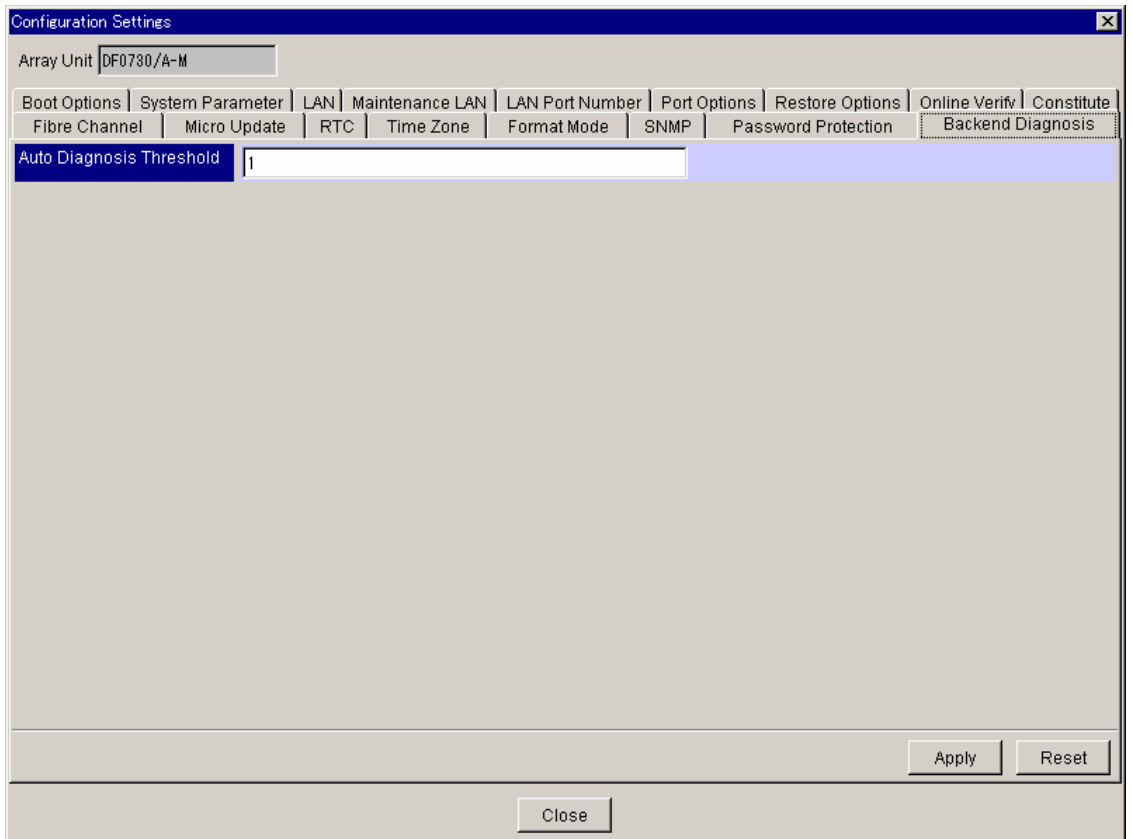



Figure 5.71 Setting Backend Diagnosis Information

Chapter 6 RAID Group Operations

This chapter discusses the following topics:

- Displaying RAID group and LU properties (section 6.1)
- Creating a RAID group (section 6.2)
- Deleting a RAID group (section 6.3)

6.1 Displaying RAID Group and Logical Unit Properties

1. Access the **Array System Viewer** window by selecting a storage array in the **List View** box, and then do one of the following:
 - Select **File → Open**
 - Click the **Open** icon () on the tool bar.
2. Click the **Logical Status** tab (refer to section 3.2.2 for a detailed description).
3. To display the RAID group status, click the **RAID Groups** icon (see Figure 6.1).
4. To display the drive configuration, select the **View** menu, and then select **Drive Configuration** (see Figure 6.2).

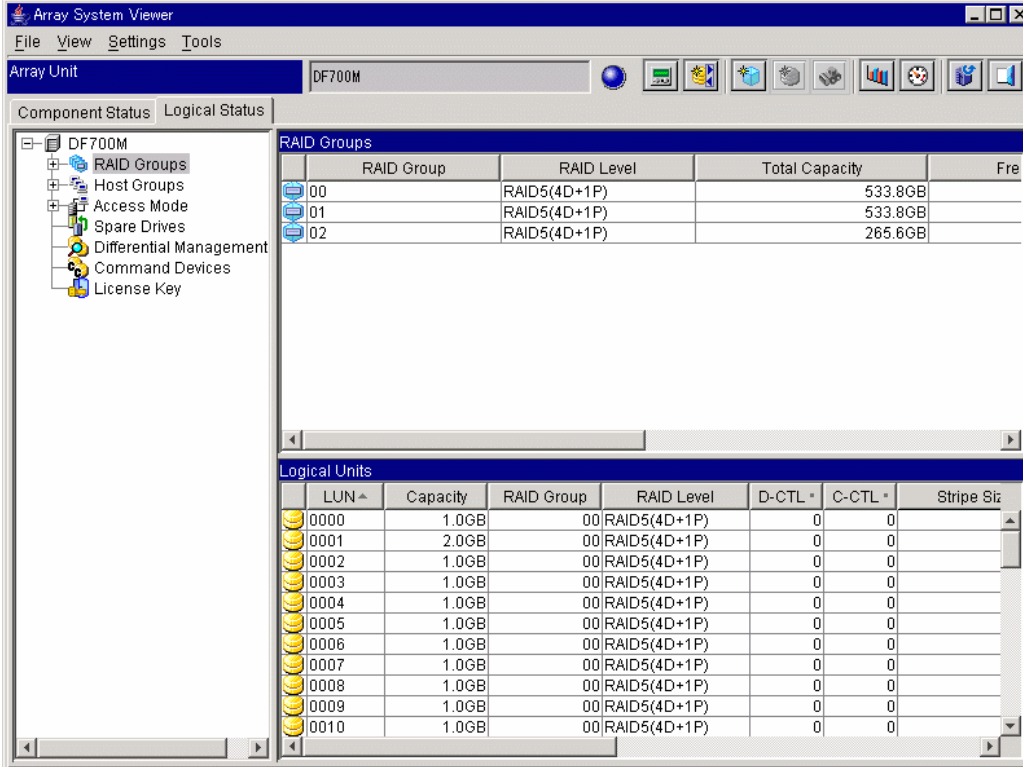

The screenshot shows the Array System Viewer window for array DF700M. The 'Logical Status' tab is active, and the 'RAID Groups' section is expanded in the left-hand tree view. The main area displays two tables: 'RAID Groups' and 'Logical Units'.

RAID Group	RAID Level	Total Capacity	Fre
00	RAID5(4D+1P)	533.8GB	
01	RAID5(4D+1P)	533.8GB	
02	RAID5(4D+1P)	265.6GB	

LUN	Capacity	RAID Group	RAID Level	D-CTL	C-CTL	Stripe Siz
0000	1.0GB	00	RAID5(4D+1P)	0	0	
0001	2.0GB	00	RAID5(4D+1P)	0	0	
0002	1.0GB	00	RAID5(4D+1P)	0	0	
0003	1.0GB	00	RAID5(4D+1P)	0	0	
0004	1.0GB	00	RAID5(4D+1P)	0	0	
0005	1.0GB	00	RAID5(4D+1P)	0	0	
0006	1.0GB	00	RAID5(4D+1P)	0	0	
0007	1.0GB	00	RAID5(4D+1P)	0	0	
0008	1.0GB	00	RAID5(4D+1P)	0	0	
0009	1.0GB	00	RAID5(4D+1P)	0	0	
0010	1.0GB	00	RAID5(4D+1P)	0	0	

Figure 6.1 Displaying RAID Group and LU Definitions

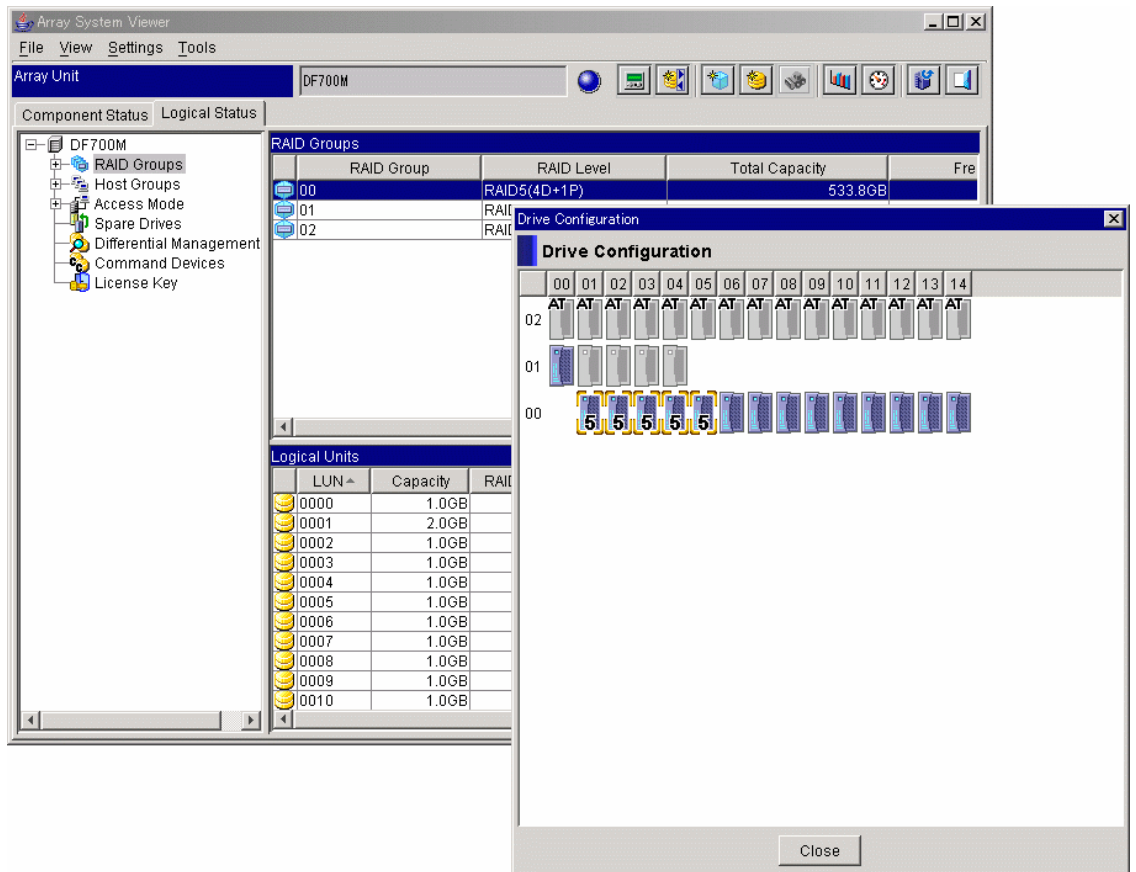





Figure 6.2 Displaying Drive Configuration

6.2 Creating a RAID Group

To create a new RAID group:

1. Access the **Array System Viewer** window by selecting a storage array in the **List View** box, and then do one of the following:
 - Select **File → Open**
 - Click the **Open** icon () on the tool bar.
2. Click the **Logical Status** tab (refer to section 3.2.2 for a detailed description).
3. Open the **Create RAID Group** window (see Figure 6.3) by one of the following methods:
 - From the **Settings** menu, select **RAID Group**, then click **Create**.
 - From the tool bar, click the **Create New RAID Group** icon ()
 - From the tool bar, click the **RAID Groups** icon, (**), select the **Context** menu, then select **.
4. Specify the following information:
 - RAID Level
 - Drive Type
 - Drive Capacity
 - Combination (RAID level configuration)
 - Parity Groups
5. To create a RAID group automatically, click the **Automatic Selection** radio button (see Figure 6.3), and then click **OK**.
6. To create a RAID group manually, do the following:
 - Click the **Manual Selection** radio button, and then click **Select** (see Figure 6.4) to open the **Select Drives** dialog box (see Figure 6.5).
 - In **Available Drives** list on the bottom of the window, select the **HDU** number, hold the Shift key down, and then click the up arrow button () to move that drive into the **Drives to Use** list (see Figure 6.6).
 - Click **OK**.
7. Click **OK** on the confirmation messages.
8. The **Logical Status** tab will display the new RAID group (see Figure 6.7).

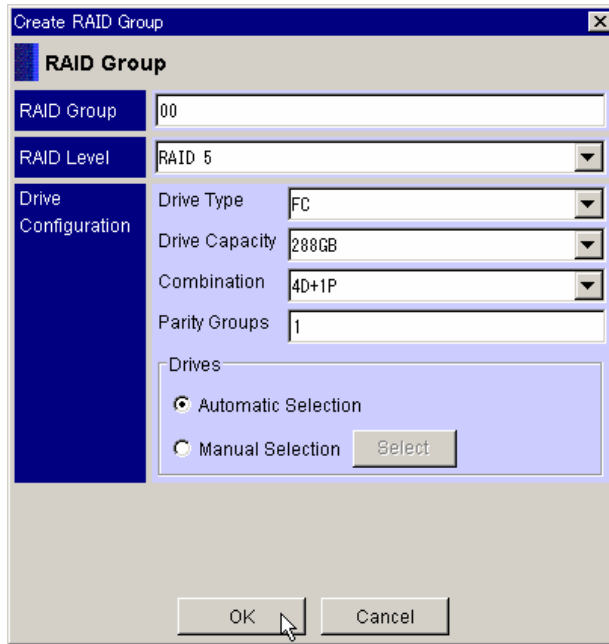

Figure 6.3 Create RAID Group Window (automatic selection)

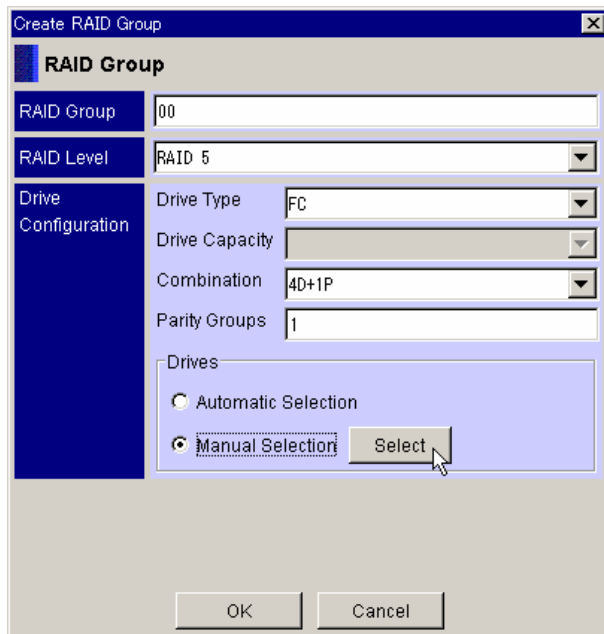

Figure 6.4 Create RAID Group Window (manual selection)

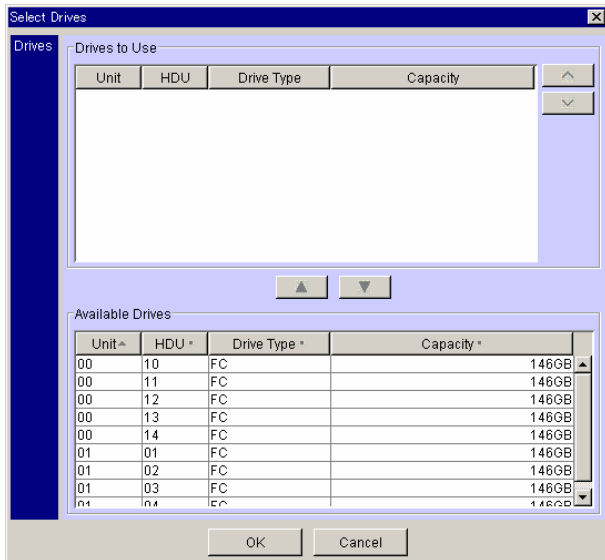

Figure 6.5 Select Drives Dialog Box (before selecting drive)

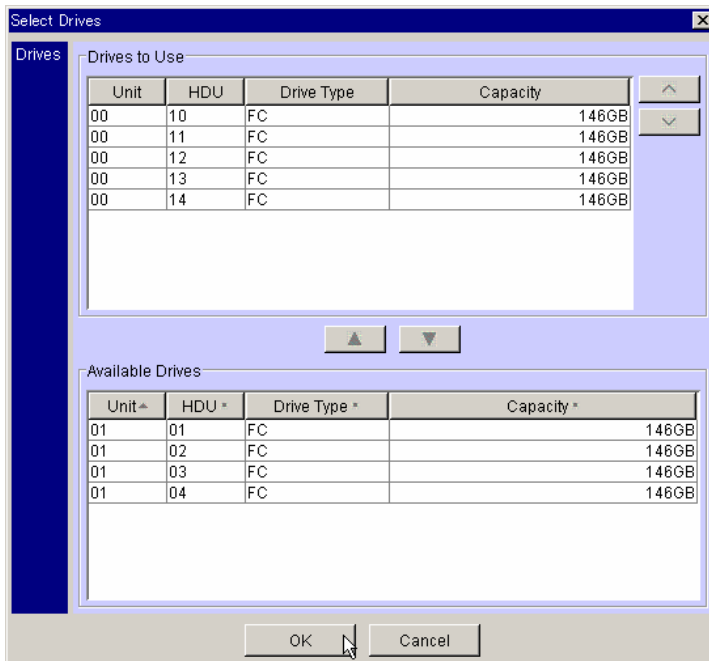

Figure 6.6 Select Drives Dialog Box (after selecting drive)

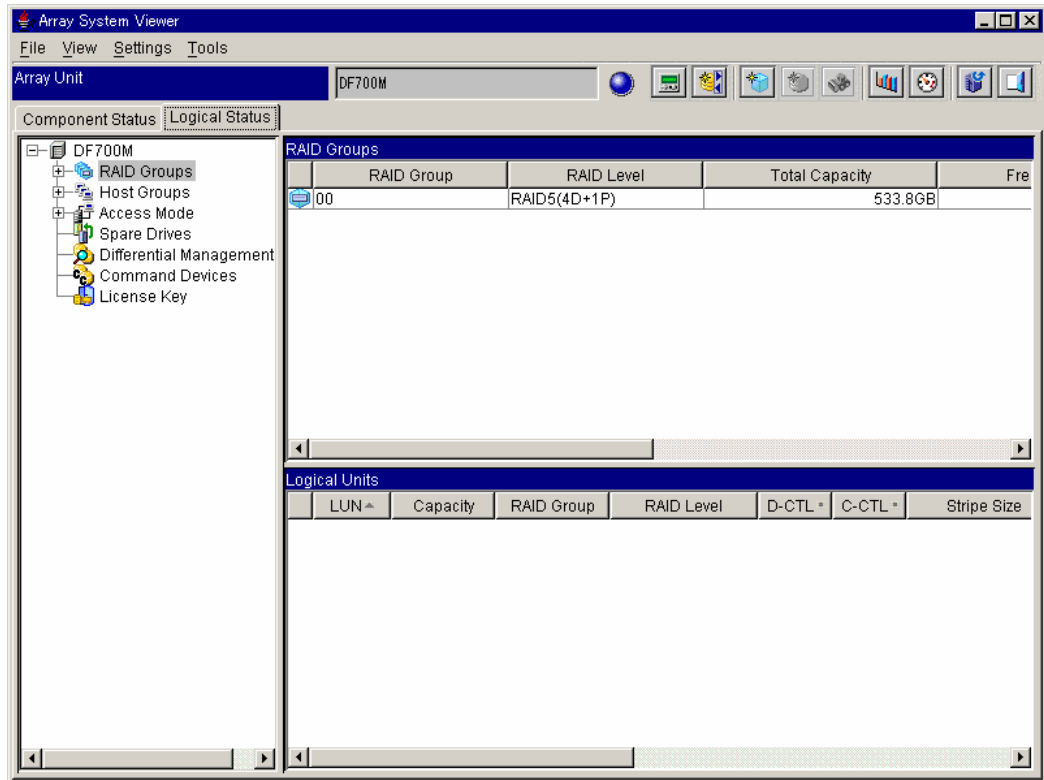



Figure 6.7 Newly Created RAID Group

6.3 Deleting a RAID Group

To delete a RAID group out of set RAID groups:

1. Access the **Array System Viewer** window by selecting a storage array in the **List View** box, and then do one of the following:
 - Select **File → Open**
 - Click the **Open** icon () on the tool bar.
2. Click the **Logical Status** tab (refer to section 3.2.2 for a detailed description).
3. Click the icon of the desired RAID group. If you want to delete more than one RAID group, hold the Shift key down and select the other groups.
4. On the **Settings** menu, click **RAID Group and Delete**, and then click **OK** on the confirmation message.
5. If there are no logical units in the RAID Group, click **OK** on the confirmation message.
6. If the RAID group contains one or more logical units, the **Logical Unit** warning messages will display (see Figure 6.8). Depending on the type of array group, you might not be able to delete the RAID group without first deleting the logical units in that group.
7. The **Delete User Data** warning message will display (see Figure 6.9). Deleting the RAID group will destroy any user data in that RAID group.
8. Click **Close** on the **Result** window (see Figure 6.10).

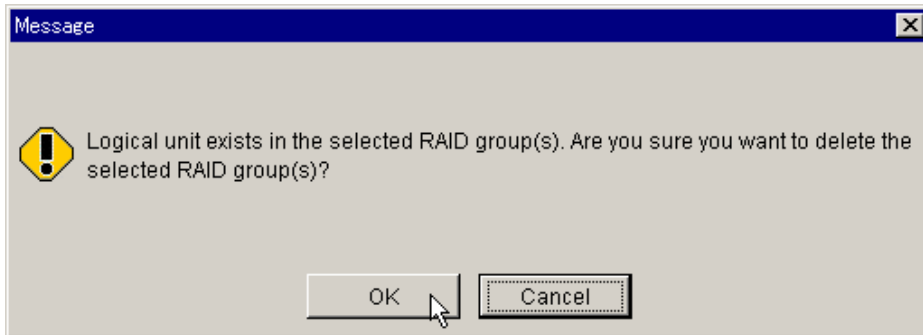

Figure 6.8 Logical Unit Warning Message



Figure 6.9 Delete User Data Warning Message

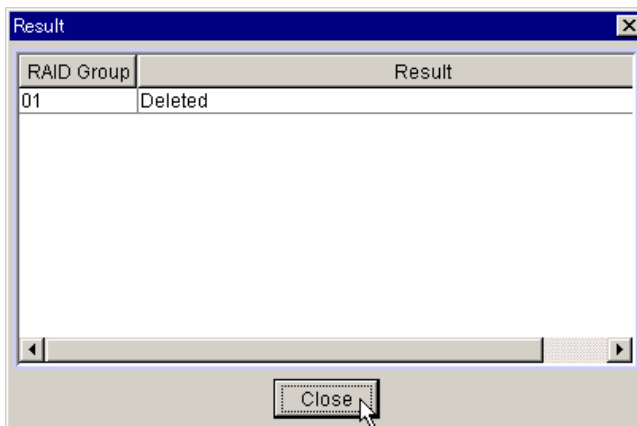

Figure 6.10 Delete RAID Group Result Window



Chapter 7 Logical Unit Operations

This chapter discusses the following topics:

- Creating a Logical Unit (section 7.1)
- Formatting a Logical Unit (section 7.2)
- Deleting a Logical Unit (section 7.3)
- Changing the Default Controller (section 7.4)
- Parity Correction (section 7.5)

7.1 Creating a Logical Unit

7.1.1 Creating a Logical Unit Automatically

1. Access the **Array System Viewer** window by selecting a storage array in the **List View** box, and then do one of the following:
 - Select **File → Open**
 - Click the **Open** icon () on the tool bar.
2. Click the **Logical Status** tab (refer to section 3.2.2 for a detailed description).
3. Click the icon of the desired RAID group.
4. Access the **Create Logical Unit** dialog box by doing one of the following:
 - On the **Settings** menu, click **Logical Unit** and click **Create**.
 - Click the **Create New Logical Unit** icon () on the tool bar.
 - Right-click on the selected RAID group and select **Create New Logical Unit**.
5. Input the following data:
 - Logical Unit No.
 - Default Controller
 - Size
6. The LU will be automatically created. You cannot change the RAID group from this window.
7. Click **OK** on the confirmation messages.

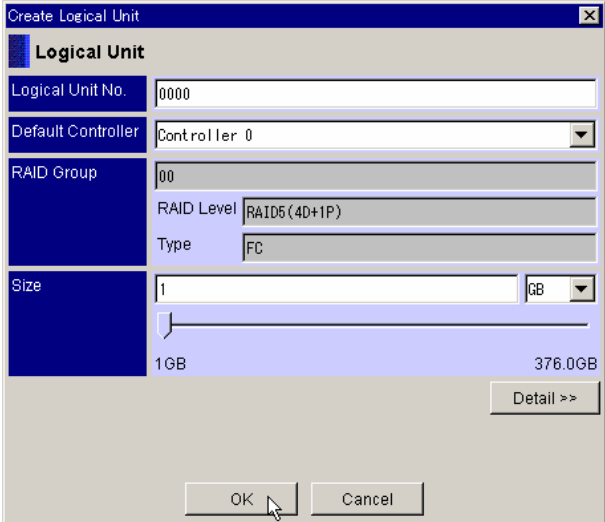

The screenshot shows the 'Create Logical Unit' dialog box with the following fields and values:

Field	Value
Logical Unit No.	0000
Default Controller	Controller 0
RAID Group	00
RAID Level	RAID6 (4D+1P)
Type	FC
Size	1 GB

Additional details shown in the dialog include a progress bar for the size field, a 'Detail >>' button, and 'OK' and 'Cancel' buttons at the bottom.

- Specify Number of **Block**, **MB**, or **GB** Increased.

To specify a value clearly, specify the allocation (number of blocks, MBs, or GBs). When you allocate all the remaining capacity of the RAID group concerned, specify a capacity displayed on the window.

Note: When a logical unit capacity is specified by the GB or MB, when the capacity is specified as the rightmost value of the slider, a logical unit with the whole free capacity of the RAID group to which the logical unit belongs is created. When a fractional capacity is included in the free capacity, a logical unit with a capacity including it is created. (You can see whether or not the free capacity has a fractional portion by viewing the Free Capacity field.) When you want to create a logical unit that does not have a fractional capacity, specify the logical unit using the other unit.

Note: The relation between MB and blocks is: 1 MB = 2,048 blocks. A fraction less than 2,048 blocks is omitted. The relationship between GB and MB is 1 GB = 1,024 MB. A fraction less than 1,023 MB is omitted.

Example:
 2,048,000 blocks = 1,000 MB
 2,049,024 blocks = 1,000 MB

- Specify the **Controller No.**

Select **Controller 0** or **Controller 1** to select the controller in charge of the logical unit. This is necessary with a dual system connection. It is not displayed with a single system connection.

Note: When dual active mode is selected in the dual system, the controller in charge of a logical unit must be selected to set up the logical unit. Perform the logical unit setting, including the selection of the controller referred to in the following diagram. When you change a controller in charge of the logical unit, refer to section 7.4.

Example:

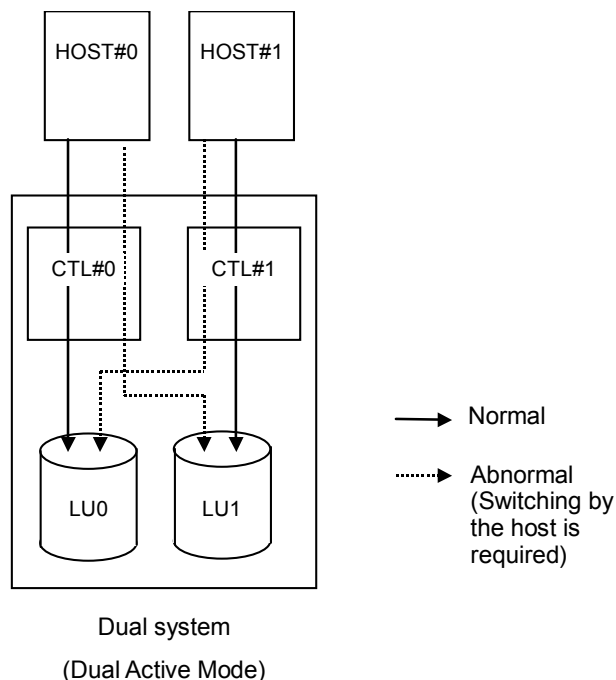

- **Dual Active Mode:** Select a controller to access from the host to the logical unit as the controller for the logical unit.

In the above drawing, CTL#0 is in charge of the logical unit0 and CTL#1 is in charge of the logical unit1 respectively. In this example, set up the logical unit by clicking optional button **CTL#0** to select logical unit0 and button **CTL#1** to select logical unit1 respectively.

The following is a recommendation for setting an environment in Dual Active mode:

- a) Assign all of the LUNs from even-numbered RAID groups and define them using Controller 0 as the owning controller.
- b) Assign all of the LUNs from odd-numbered RAID groups and define them using Controller 1 as the owning controller.
- c) To maintain best configuration practices, you must ensure that both controllers have approximately an equal number of logical units assigned. Also, assigning LUNs from RAID Groups using the odd/even format (using steps a and b, above) will ensure the best possible performance expectations.

DO NOT assign all of the even-numbered LUNs to Controller 0 and all of the odd-numbered LUNs to Controller 1. For performance reasons, it is always better to have all of the LUNs created from a RAID group assigned to the same controller.

7.1.2 Constituting a Logical Unit Manually

1. Click Detail.

Logical Unit

Logical Unit No. : 0000

Default Controller : Controller 0

RAID Group : 00

RAID Level : RAID5(4D+1P)

Type : FC

Area to Use : 0000 (531.8GB)

Size : 1 GB

Stripe Size : 64KB

Cache Partition : 00

Partition Size : 700MB

Segment Size : 16KB

Pair Cache Partition : Auto

Partition Size : ---

Segment Size : ---

2. Select a Logical Unit No. and Default Controller, and then input Size. Click Select.

Select Area

RAID Group : 01

Area No.	Capacity
0000	533.8GB

3. Select Area No. and then click OK.
4. Click OK.

5. A message displays stating the setting is complete. Click **OK**.

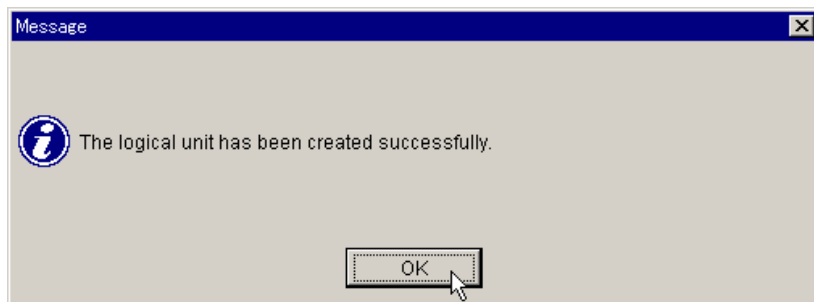
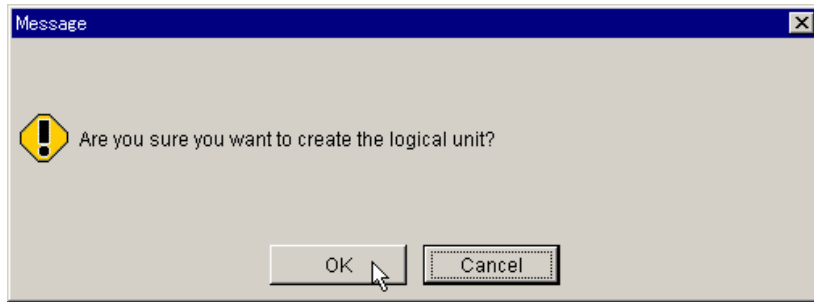

The logical unit information is updated and the following window is displayed.

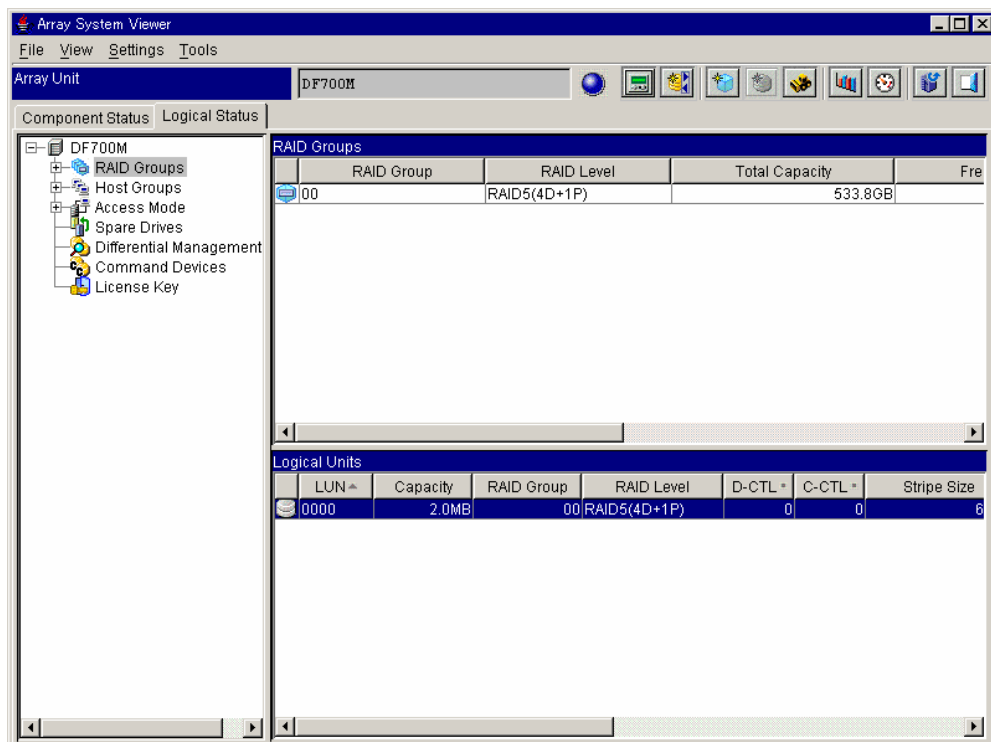

7.1.3 Using the Wizard to Create Logical Units

To create logical units using a wizard:

1. On the **Tools** menu, select **Wizard** → **Create Logical Units**.
2. On the **Select Usage** drop-down list, select logical unit usage. When you select usage, set to the suitable parameter (**Drive Type**, **RAID Level**, and **Parity**). If you want to customize the parameter, click **Customize** and select the parameter (**Drive Type**, **RAID Level**, and **Parity**).

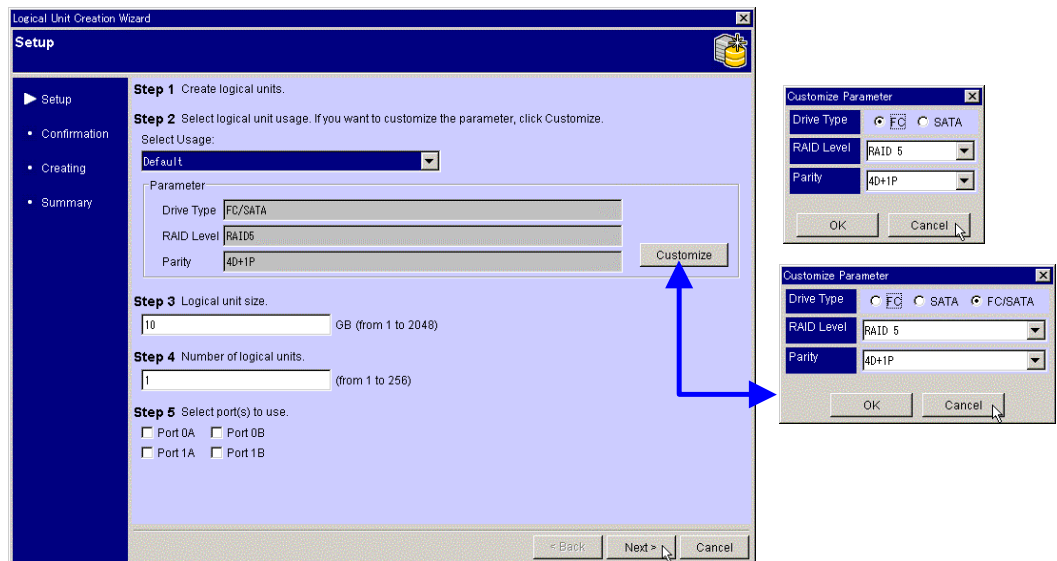
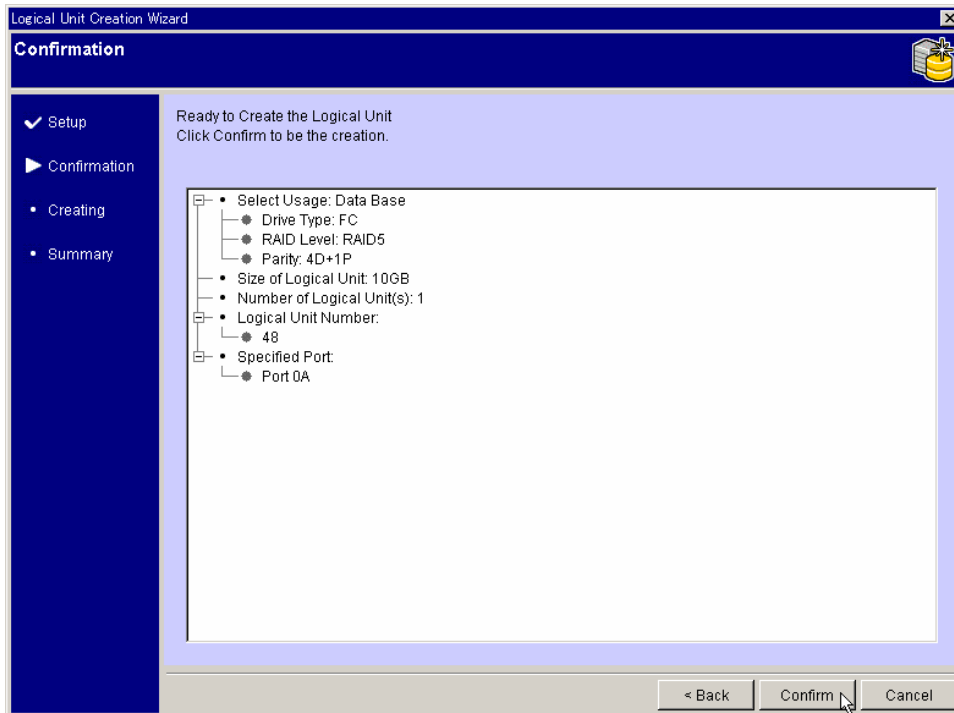

Table 7.1 Usage for Logical Units

Usage	Recommended RAID Configuration	Drive Type
Default	4D+1P	FC/SATA
Data Base	4D+1P	FC
File System	4D+1P	FC
Backup	8D+1P	FC
Archive	8D+1P	SATA
Archive2	8D+2P	SATA
Streaming	4D+1P	SATA
Digital Surveillance System	8D+1P	FC
High Performance Computing	4D+4D	FC

3. Specify the logical unit size, number of logical units, and port(s) to use.

4. Click **Next**.



5. The specification contents are displayed; when the specification contents are no problem, click **Confirm**. If you want to modify the contents, click **Back**.

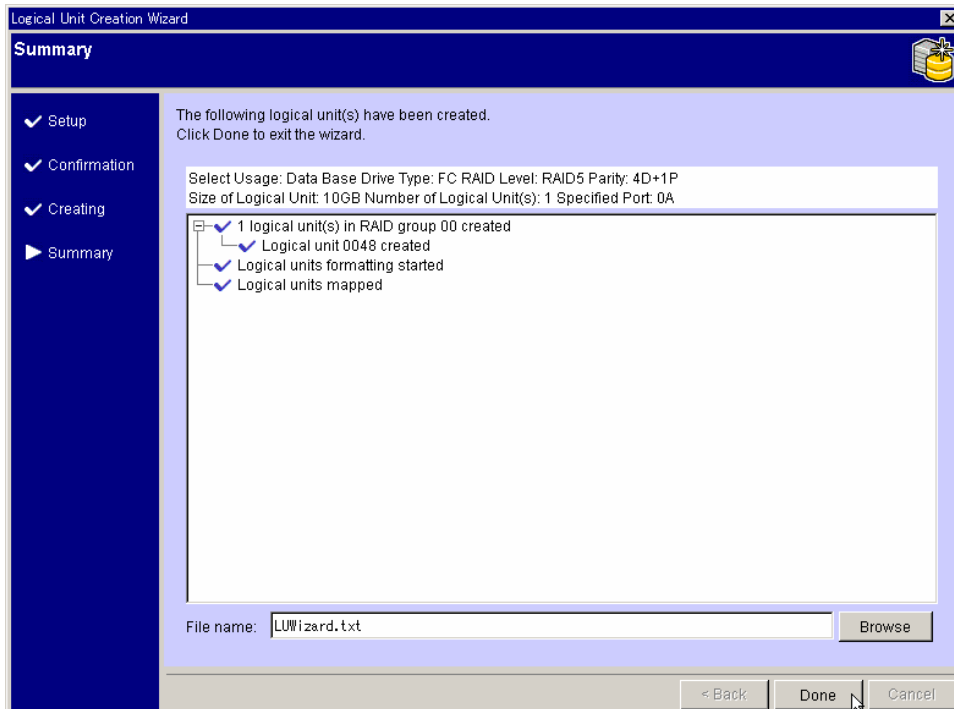

6. Click **Done**.

The logical unit information created with the wizard can be output to a text file. Input a file name into the **File name**, and then click **Done**.

7.2 Formatting a Logical Unit

- **Format:** If multiple logical units are specified, up to six logical units are formatted concurrently. A host I/O can be received even when formatting is being made.

When executing **Format**, specify the Priority mode as occasion demands. The **Format Priority Mode** can be set by selecting:

Logical Status → **Tools** → **Configuration Settings** → **Format Mode**

To format the logical unit:

1. Click the **Logical Status** tab on the **Array System Viewer** window.
2. Click the icon of a logical unit on the **Array System Viewer** window. On the context menu of the logical unit icon, click **Format**.

To select multiple logical units, hold down the Ctrl key and click the icons of the logical units that you want to format.

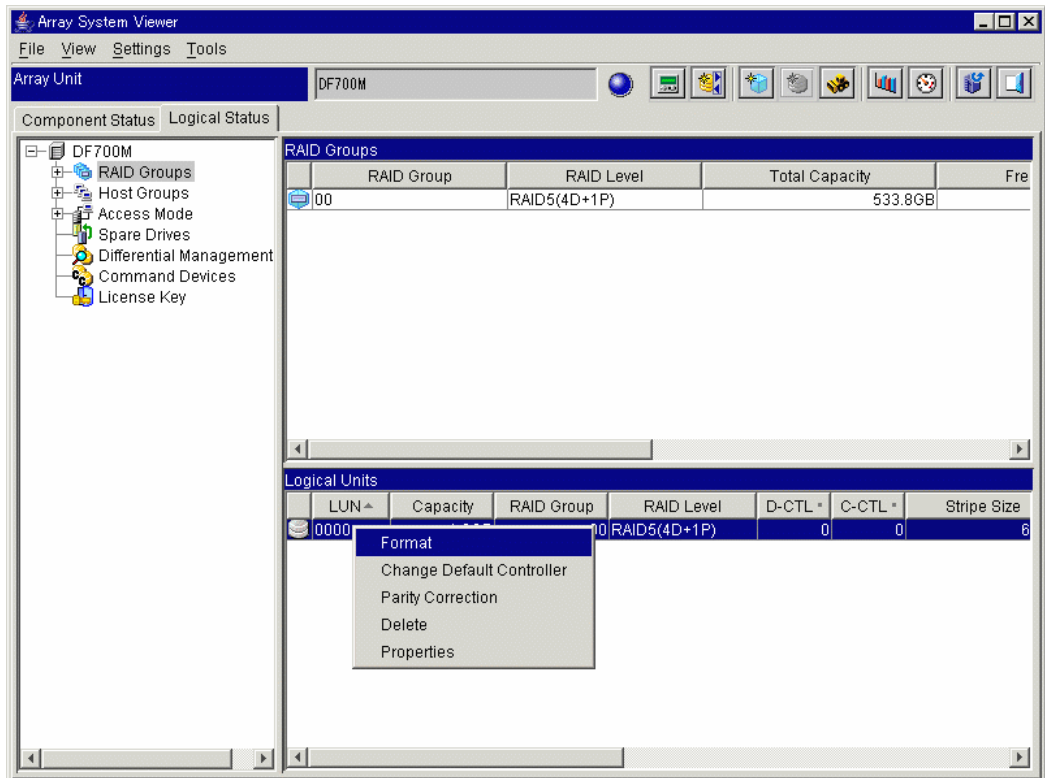

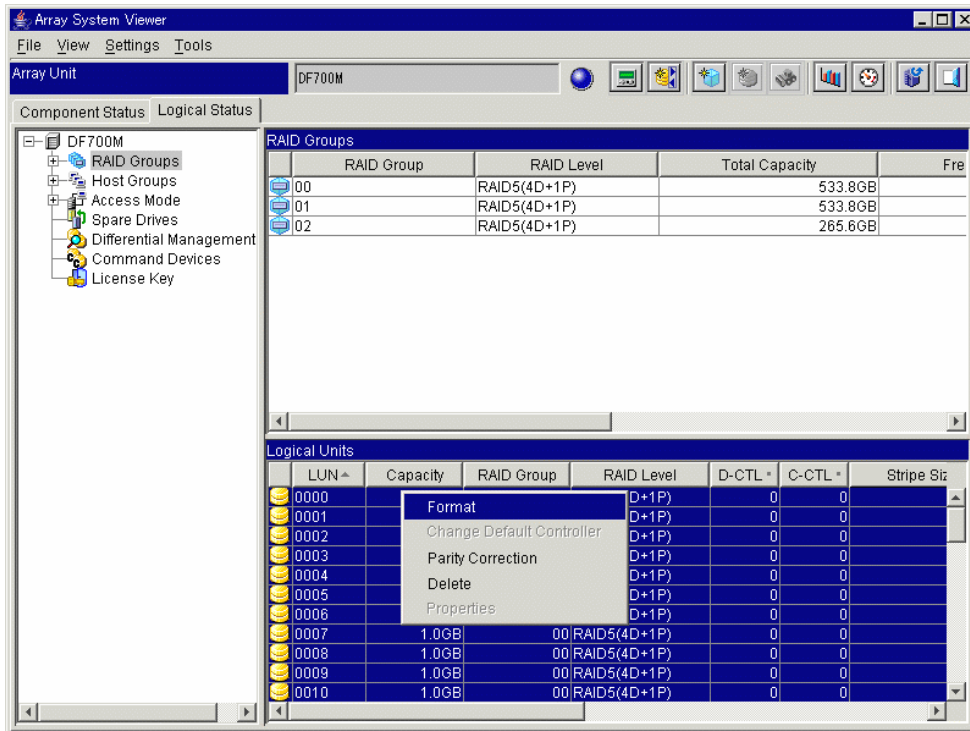

Note: Formatting may be interrupted under the following conditions:

- A host is rebooting
 - I/O path switching
 - Access to a logical unit of the non-ownership controller
3. A message displays requesting confirmation to format the selected logical units. Click **OK**.
- a) When there is no formatted logical unit:

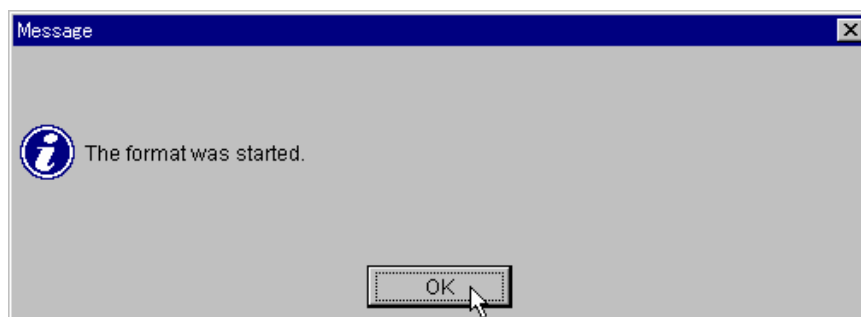
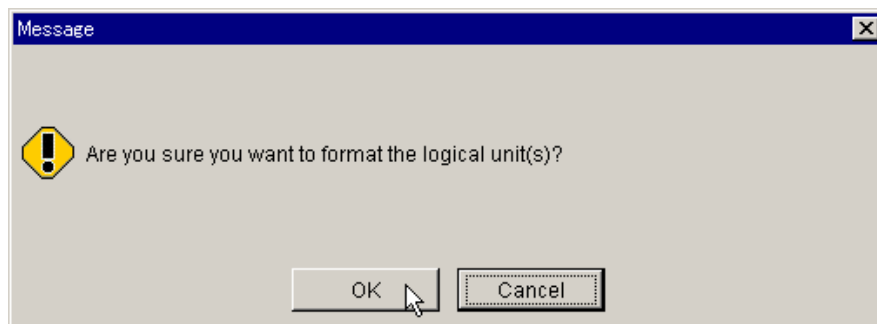

b) When there is a formatted logical unit:

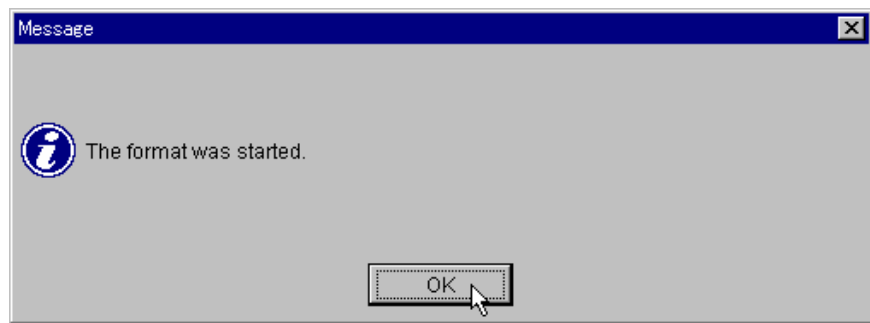
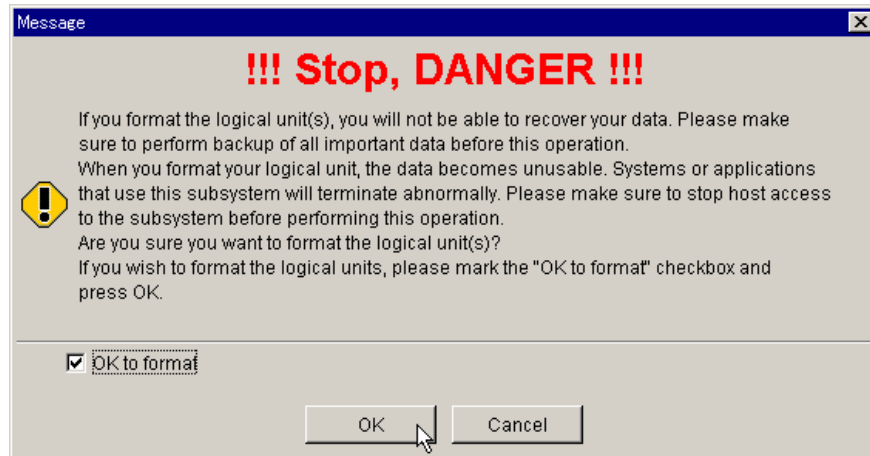

The formatted logical unit information is updated and the following window displays.

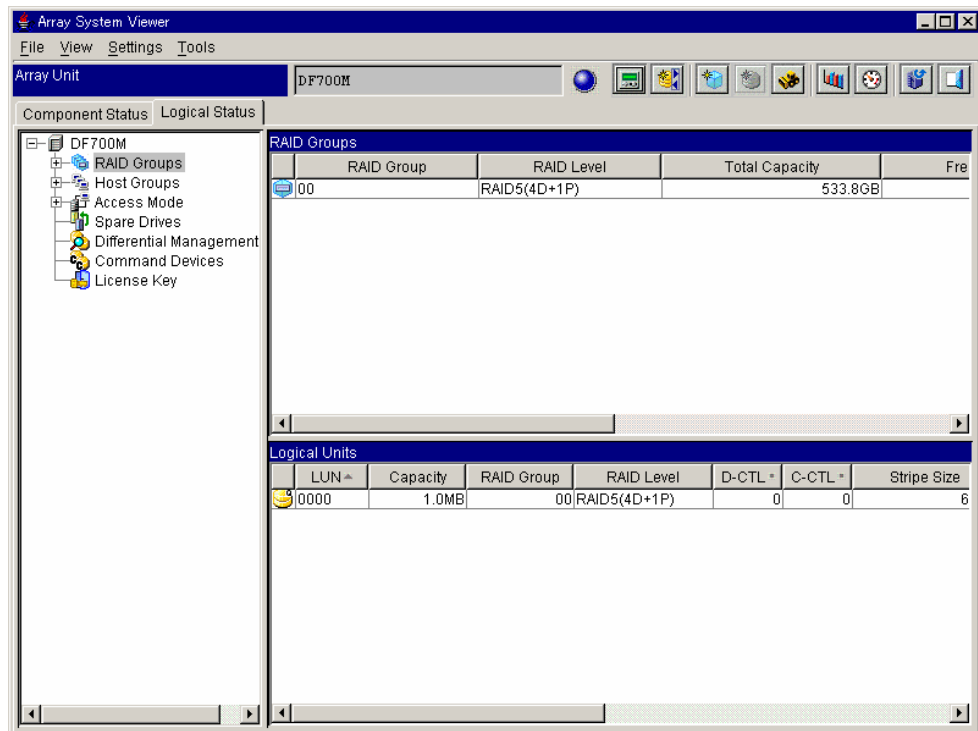

7.3 Deleting a Logical Unit

To delete a specified logical unit:

1. Click the **Logical Status** tab on the **Array System Viewer** window.
2. Click the **Logical Unit** icon in the **Array System Viewer** window. On the context menu of the **Logical Unit** icon, select **Delete**.

To select multiple logical units, hold down the Ctrl key and select the icons of logical units that you want to delete.

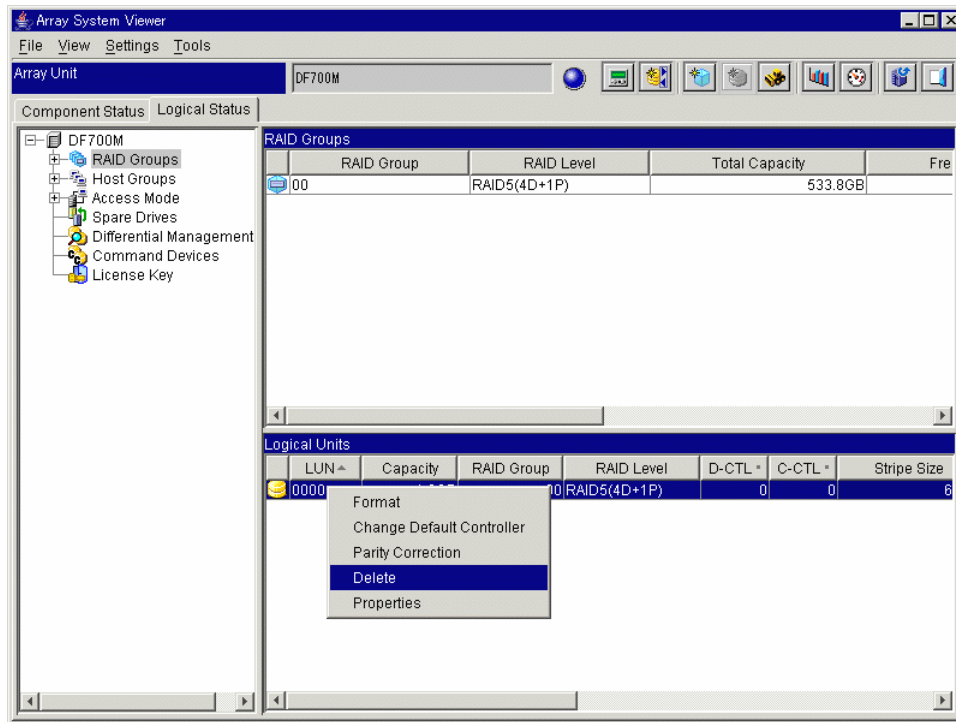

3. A message displays requesting confirmation to delete a specified logical unit. Click **OK**.
 - a) When a specified logical unit is not formatted:

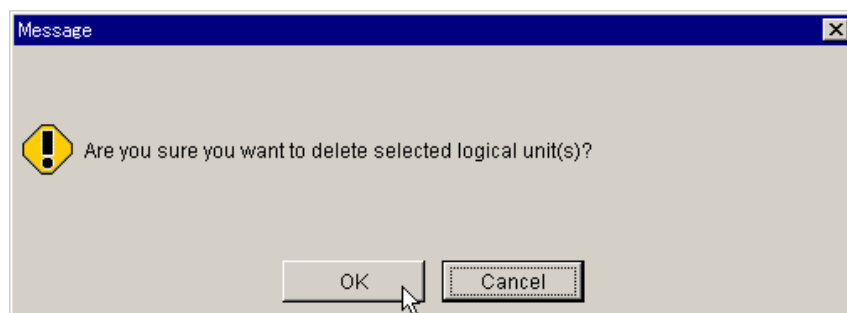

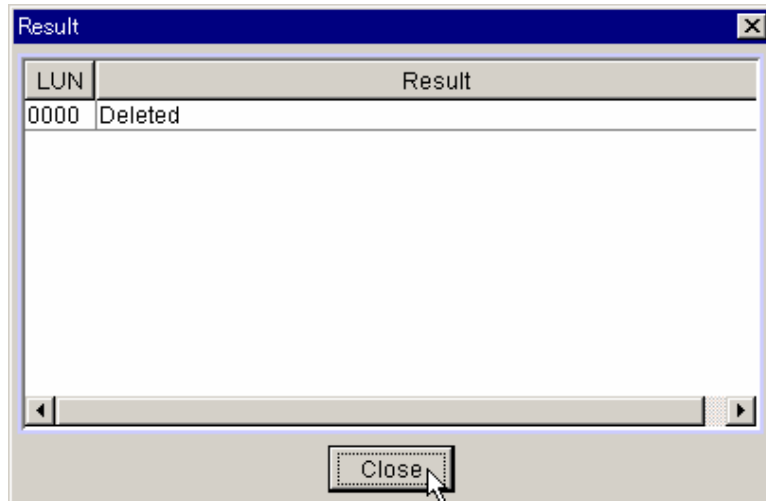

b) When a specified logical unit is formatted:

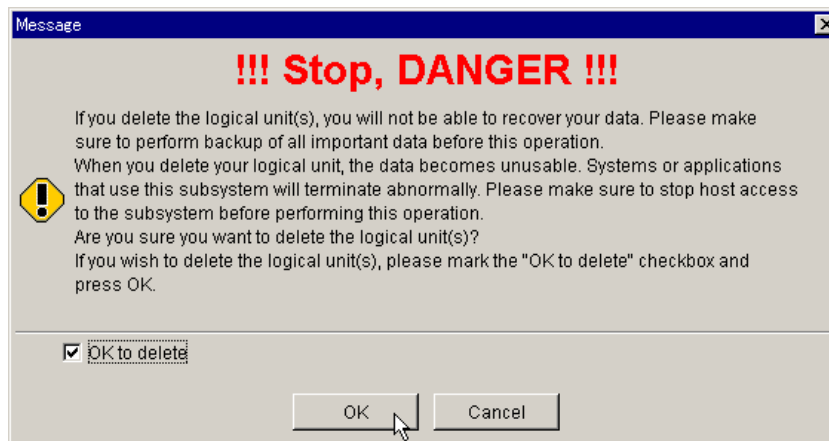
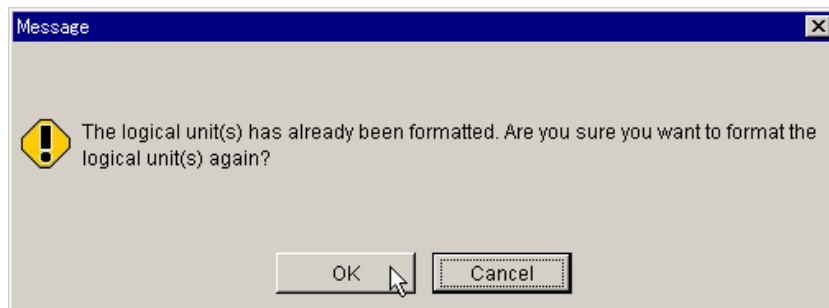

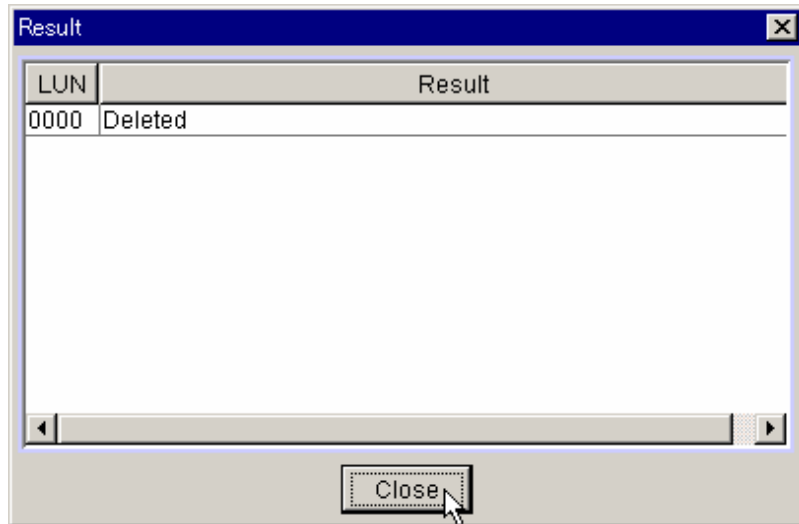

c) When the specified logical units is formatted (multiple logical units):

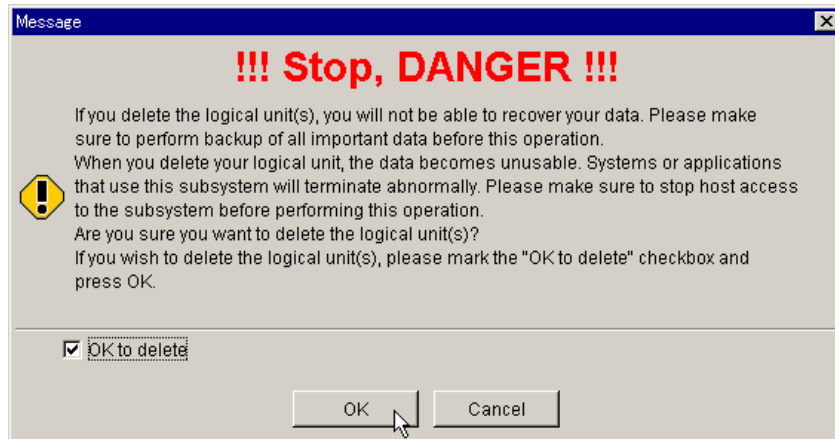
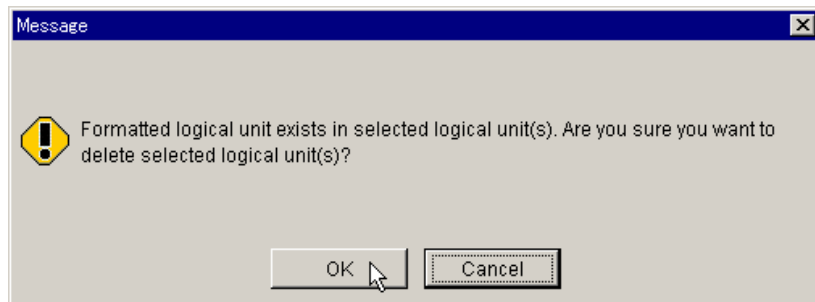

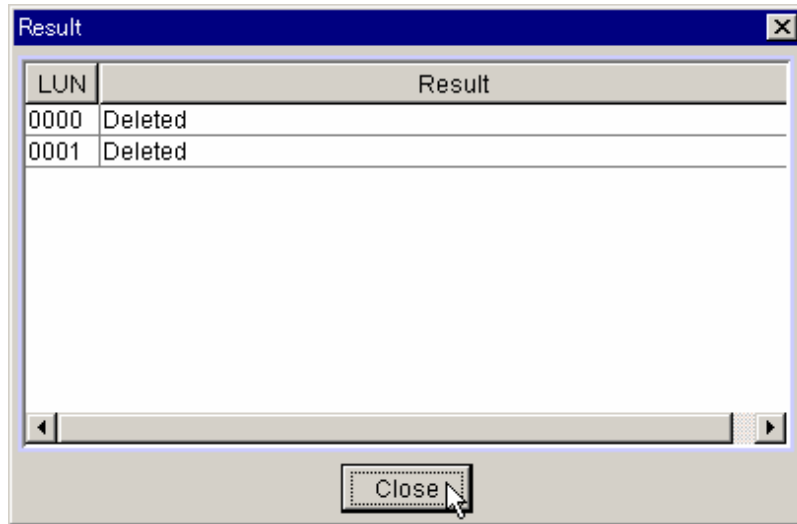

7.4 Changing the Default Controller

1. Click the **Logical Status** tab on the **Array System Viewer** window.
2. Click the **Logical Unit** icon in the **Array System Viewer** window. On the context menu of the **Logical Unit** icon, select **Change Default Controller**.

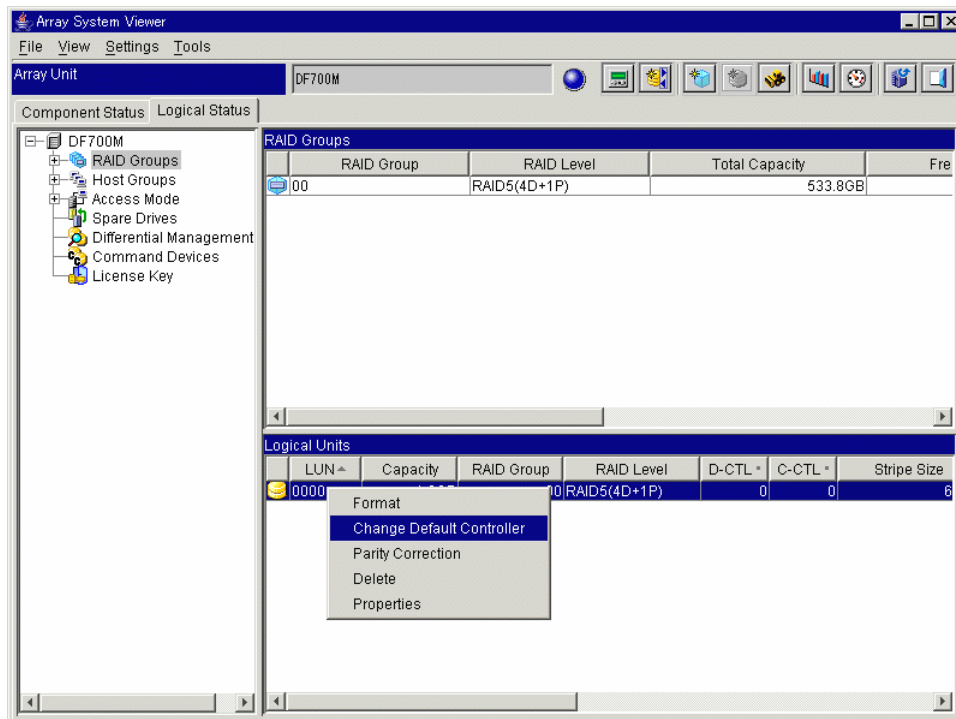

3. A message displays requesting confirmation to change the default controller in charge of a logical unit. Click **OK**.

The default controller in charge of the logical unit will be changed.

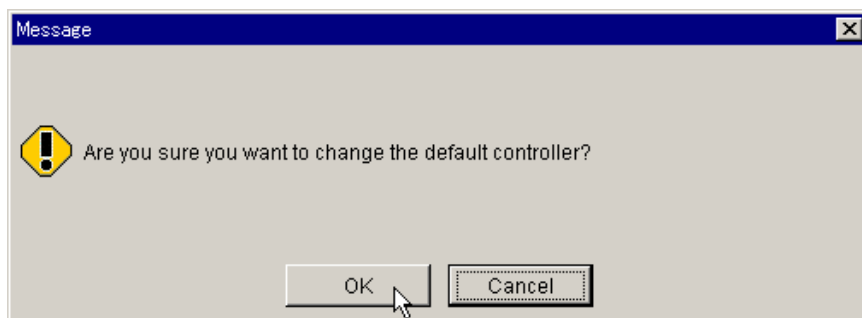

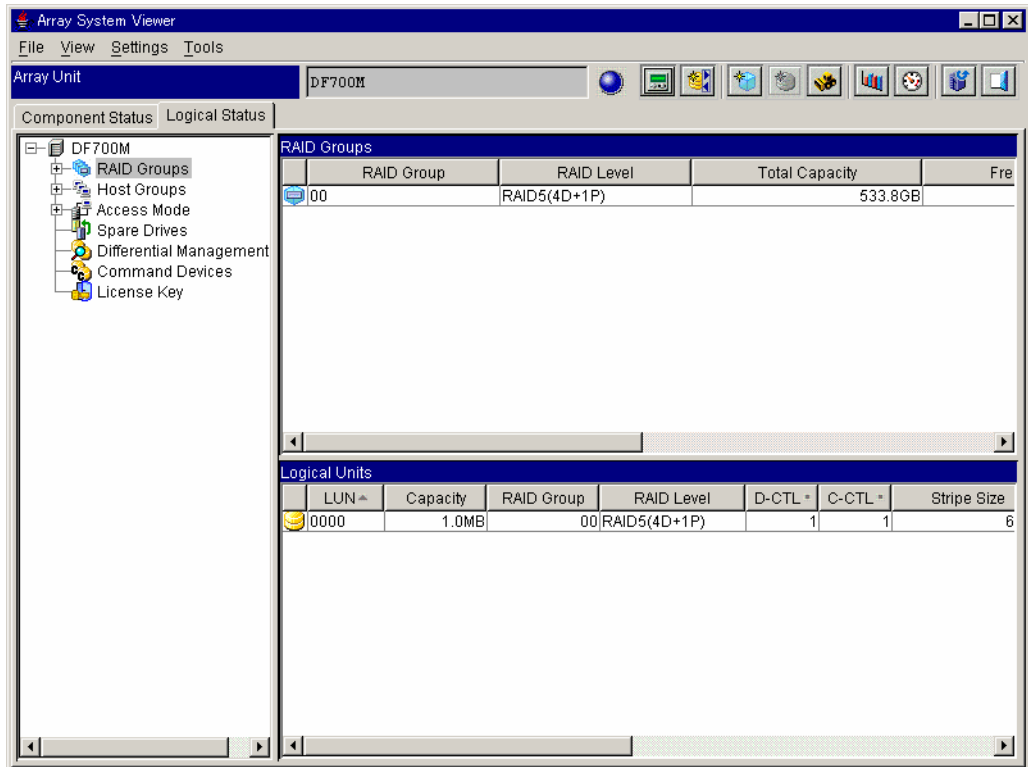
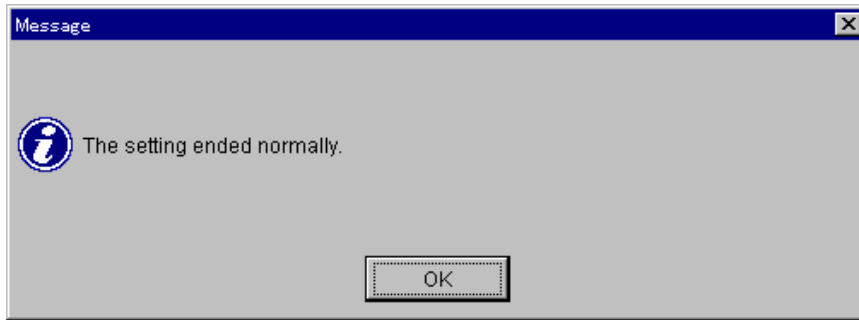

Note: Switching the default controller which owns the logical unit, changes the default controller currently displayed. When switching is executed twice, the specified controller is changed to the original default controller controlling the logical unit.

7.5 Parity Correction

Restore the logical unit in which the parity error has occurred. From the status of the logical unit, you can determine if a parity error has occurred.

1. Click the **Logical Status** tab on the **Array System Viewer** window.
2. Click the **Logical Unit** icon to which you want to correct parity, select **Logical Unit** in the **Settings** menu, and then select **Parity Correction**.

If the parity restoration is displayed in halftone, no parity error has occurred.

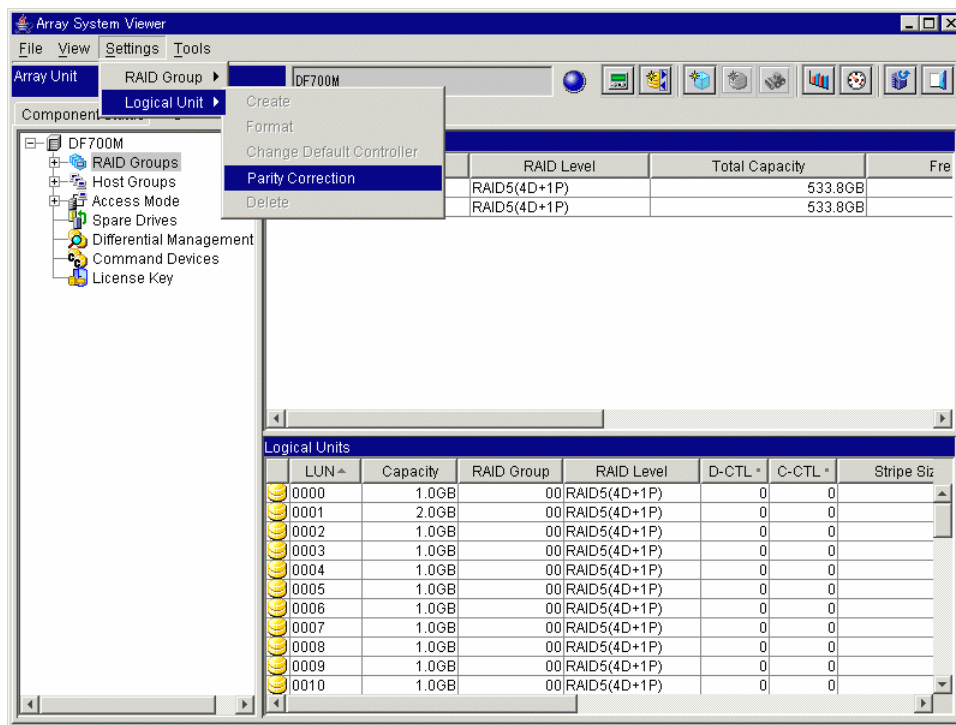

3. A message displays requesting confirmation to add unconnected logical units. Click **OK**. When **Cancel** is clicked, the parity restoration process is interrupted.

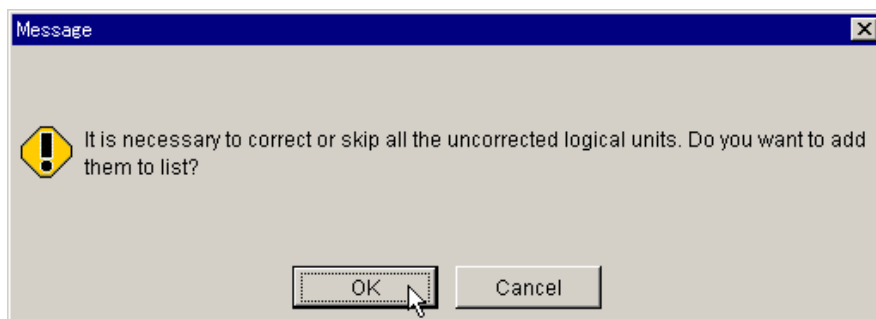

A list of unconnected logical units is displayed.

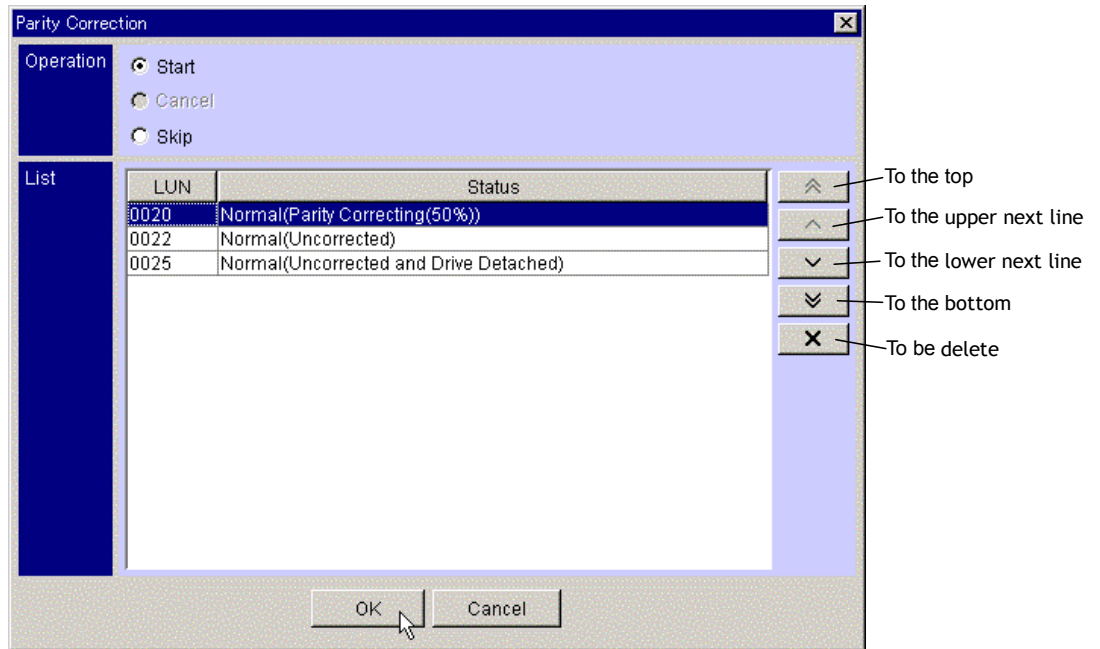

4. Change the order of the restoration process, when necessary.
(The logical unit listed at the top is processed first.)
5. Click the **Start** radio button in **Operation** and click **OK**.
6. A message displays, click **OK**.

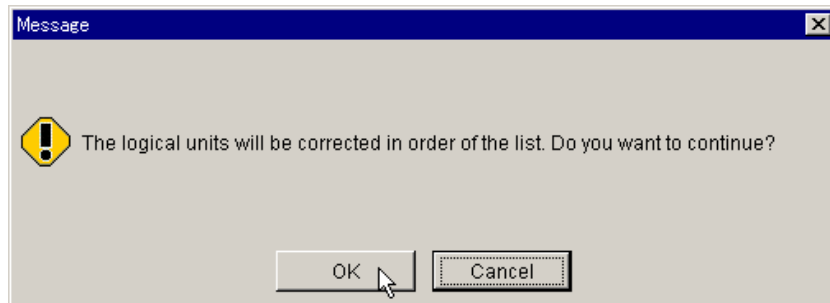

7. A message displays stating that parity correction is started. Click **OK**.

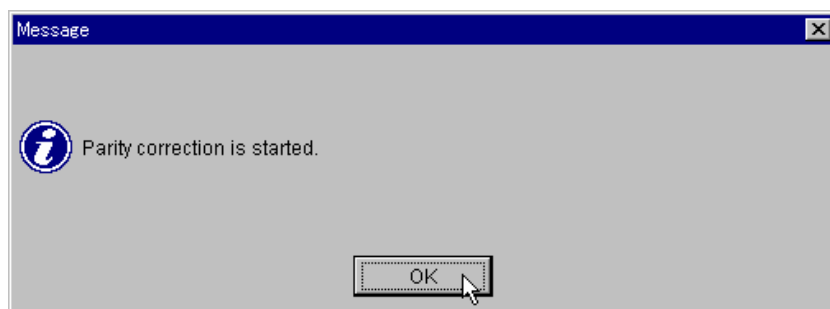

Storage Navigator only directs the process being performed. The microcode of the subsystem performs the specific operation.

The logical unit information is updated.

When **Skip** is clicked in the **Parity Correction** dialog box, the following message is displayed:

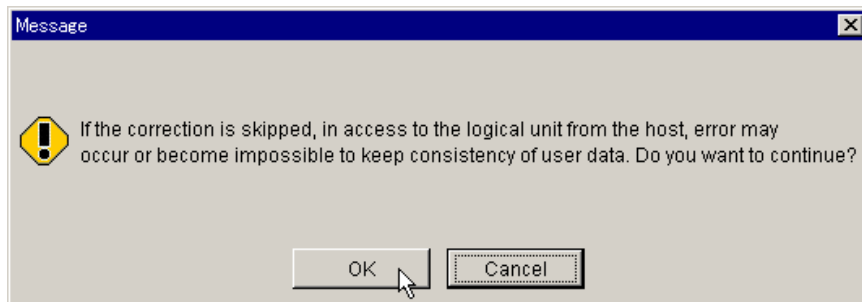

When **Cancel** is clicked in the **Parity Correction** dialog box, the following message is displayed:

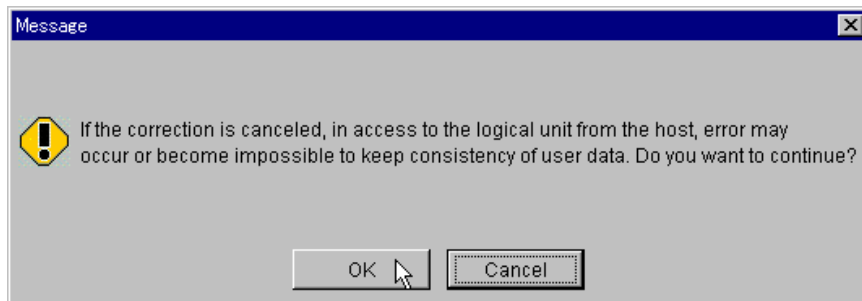

Chapter 8 Host Group Operations

Set host group 0 (000:G000) information, such as a host group option and mapping information. For information on creating a host group, refer to the *Hitachi TagmaStore AMS and WMS LUN Management User's Guide (MK-95DF703)*.

This chapter discusses the following topics:

- Setting Host Group Options (section 8.1)
- Setting the Mapping Guard (section 8.2)
- Specifying the Mapping Mode (section 8.3)
- Setting the Mapping Information (section 8.4)

8.1 Setting Host Group Options

1. Click the **Logical Status** tab on the Array System Viewer window.
2. Click the **Port** plus signs next to the **Host Groups**.
3. Click the plus sign next to **Port 0A**.
4. Click the plus sign next to **000:G000**, and then click **Options**.
5. Click **Simple Setting**.

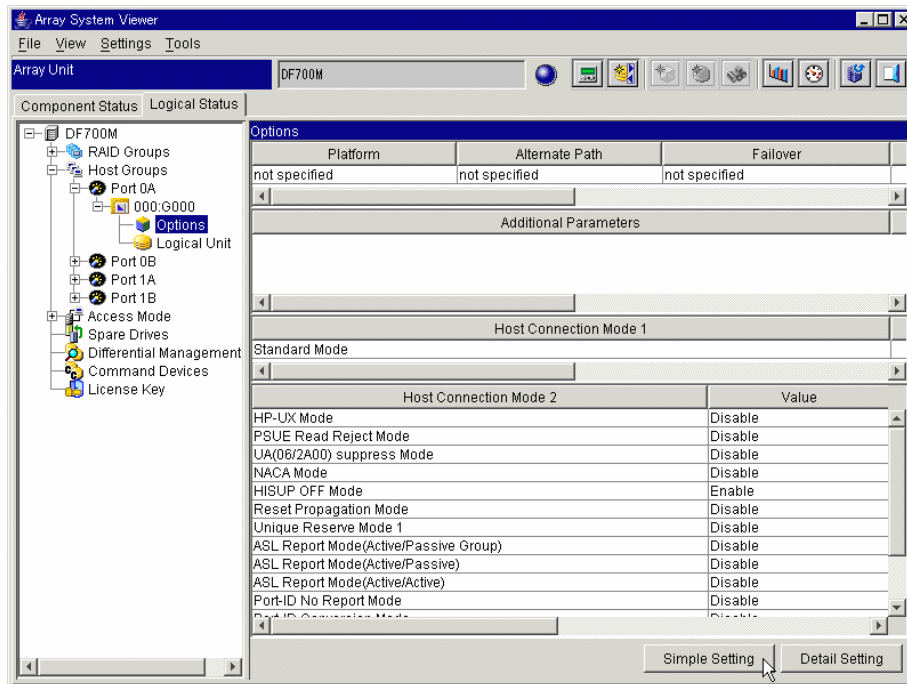

6. As necessary, click **Platform**, **Alternate path**, and **Failover**.
The combination, which can be chosen for every platform, is limited.

- **Platform:**
 - HP-UX
 - Solaris™
 - AIX®
 - Windows® 2000
 - Windows® 2003
 - Linux®
 - Tru64
 - not specified
 - Alternate path:
- **not specified:**
 - **PV Link:** Can be used by HP-UX.
 - **HDLM:** Can be used by Solaris, AIX, and Windows 2000/2003.
 - **VxVM:** Can be used by HP-UX, AIX, Solaris, Windows 2000/2003, and Linux.
 - **MPxIO:** Can be used by Solaris.
- **Failover:**
 - **not specified**
 - **MC/ServiceGuard:** Can be used by HP-UX.
 - **Sun™Cluster:** Can be used by Solaris.
 - **VCS:** Can be used by Solaris and Linux.
 - **HACMP:** Can be used by AIX.
 - **MSCS:** Can be used by Windows 2000/2003.
 - **Tru Cluster:** Can be used by Tru64.

7. Click **Additional Parameters**.

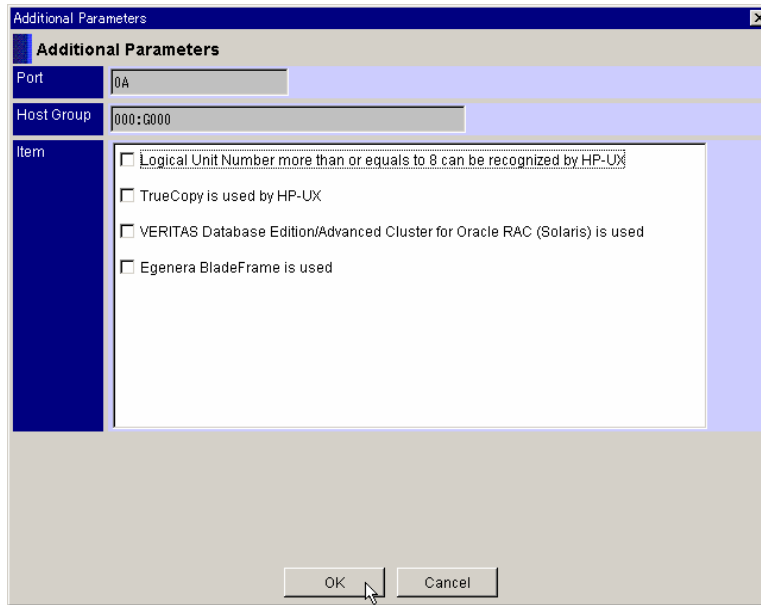

8. As necessary, click **Item** and then click **OK**.

9. Click **Detail**.

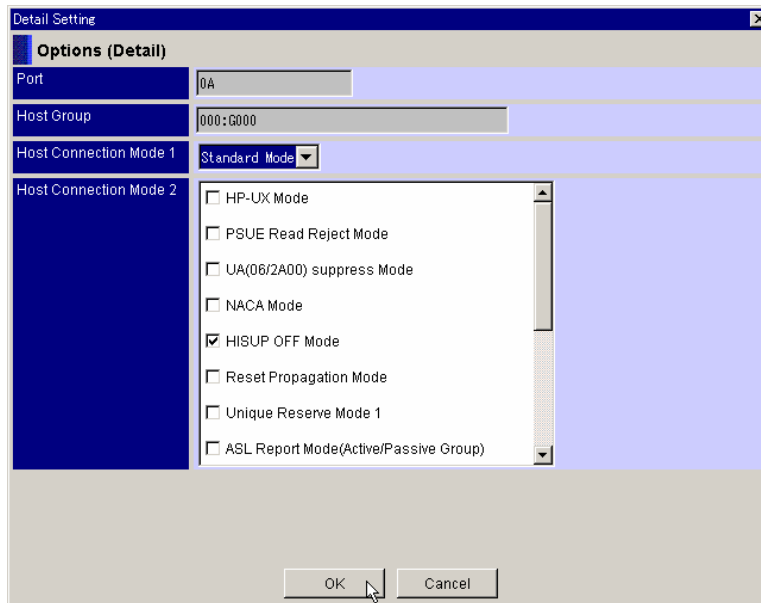

10. Select **Host Connection Mode 1** and **Host Connection Mode 2**. Select the **OK** button.

- **Host Connection Mode 1:**
 - **Normal Mode:** Open system emulation mode
 - **Open VMS Mode:** Open VMS mode
 - **TRESPASS Mode:** TRESPASS mode
 - **Wolfpack Mode:** Wolfpack mode
- **Host Connection Mode 2:**
 - **HP-UX Mode:** Enables the HP-UX Mode.
 - **PSUE Read Reject Mode:** Enables the PSUE Read Reject Mode.
 - **UA(60/2A00) Suppress Mode:** Suppresses the unit attention (06/2A00).
- **NACA Mode:** Enables the NACA (Normal Auto Contingent Allegiance) Mode. When enabled, this mode allows users who are using an AIX operating system to issue multiple queuing commands. This helps to improve performance, and is the recommended setting.

Technical description: NACA is an LU-level condition that is triggered when a command (with the NACA bit set to 1) completes with CHECK CONDITION. When NACA is triggered, it prevents all commands other than those with the NACA attribute from executing until the CLEAR ACA task management function is executed, while blocking all the other tasks already in the task set. ACA is one of the four task attributes - SIMPLE, ORDERED, HEAD OF QUEUE, and ACA.

 - **HISUP OFF Mode:** Enables the HISUP OFF Mode.
 - **Reset Propagation Mode:** The mode to propagate reset to other ports.
 - **Unique Reserve Mode 1:** Enables the Unique Reserve Mode 1.
 - **ASL Report Mode (Active/Passive Group):** Enables the ASL Report Mode (Active/Passive Group).
 - **ASL Report Mode (Active/Passive):** Enables the ASL Report Mode (Active/Passive).
 - **ASL Report Mode (Active/Active):** Enables the ASL Report Mode (Active/Active).
 - **Port-ID No Report Mode:** Enables the Port ID No Report Mode.
 - **Port-ID Conversion Mode:** Enables the Port ID Conversion Mode.
 - **Tru Cluster Mode:** Enables the Tru Cluster Mode.
 - **Product Serial Response Mode:** Enables the Product Serial Response Mode.
 - **Same Node Name Mode:** Enables the Same Node Name Mode.
 - **CCHS Mode:** Enables the CCHS convert.
 - **SPC-2 Mode:** Enables the SPC-2 Mode.

11. Click **OK**.

12. A confirmation message displays. Click **OK**.

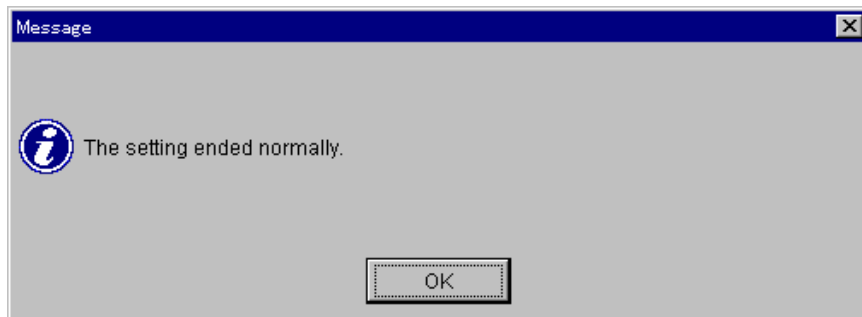
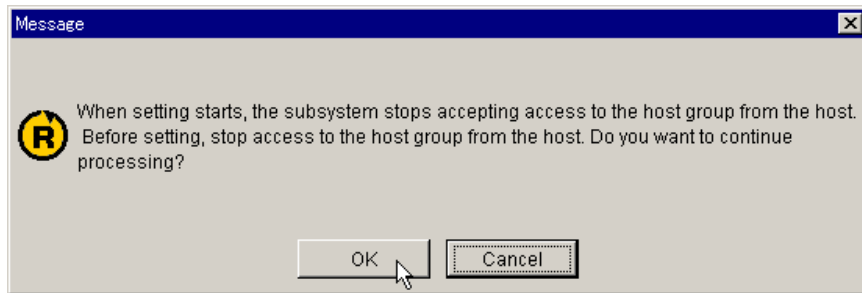
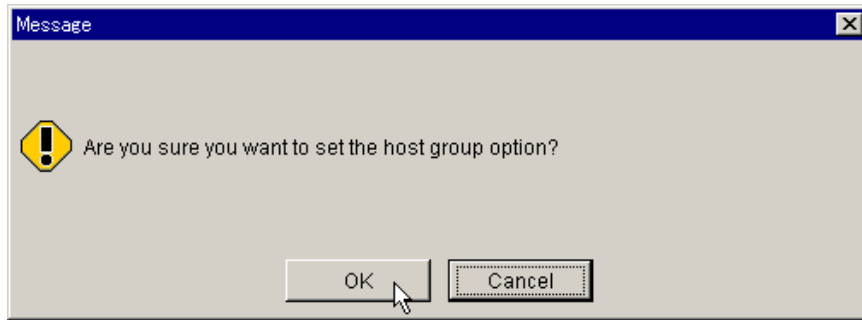

The modified host group options display.

8.2 Setting the Mapping Guard

If you enable the mapping guard, it will block users from performing mapping operations on that LU.

1. Click the **Logical Status** tab on the **Array System Viewer** window.
2. On the **Tools** menu, click **Mapping Guard**.

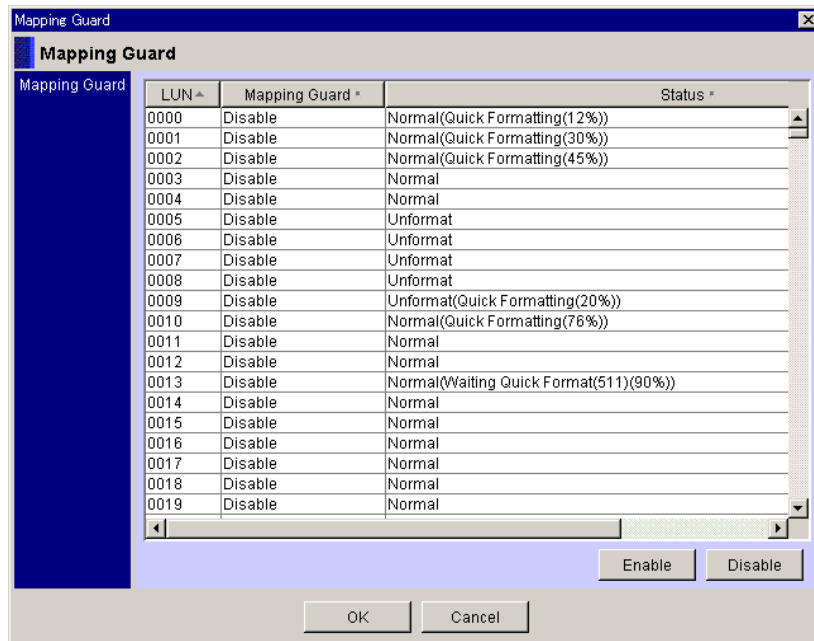

3. Select the **LUN** or **LUNS** for which you want to guard the mapping and click **Enable**, then click **OK**. A confirmation message displays. Click **OK**.

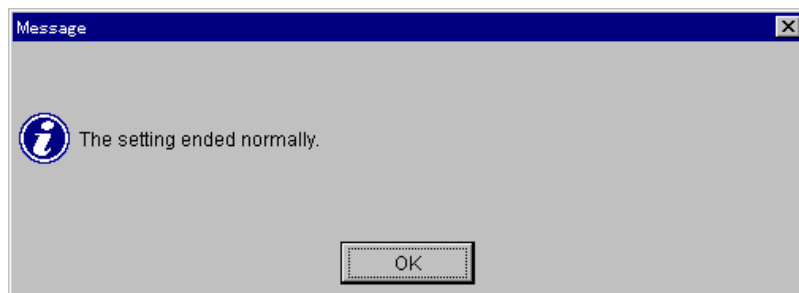
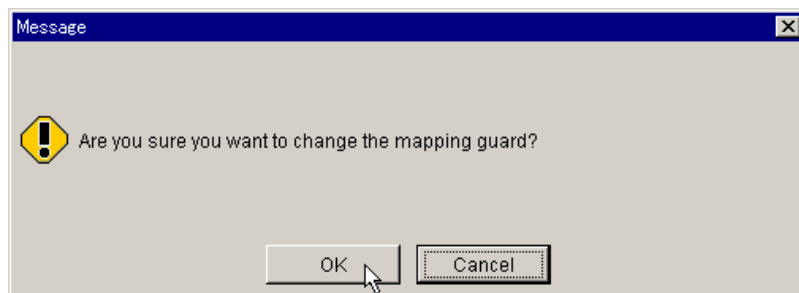

8.3 Specifying the Mapping Mode

Set the Mapping mode effective or ineffective.

1. Click the **Logical Status** tab on the **Array System Viewer** window.
2. Click the plus sign next to **Access Mode**, and then click **Mapping Mode**.

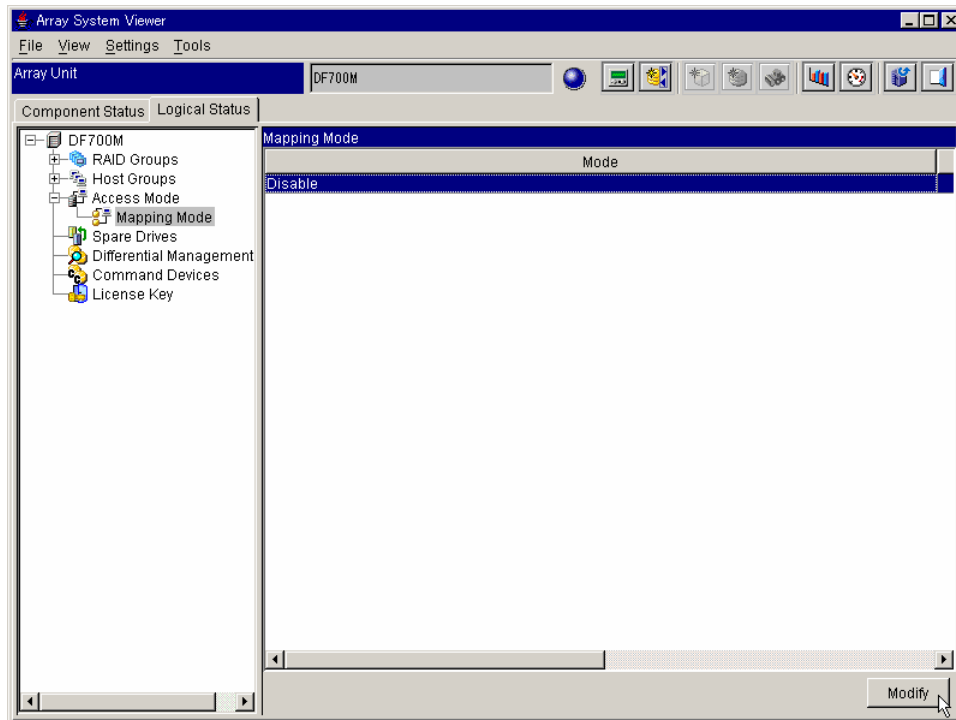

3. Click the **Disable** radio button on the **Mapping Mode** list, and then click **Modify**.

This operation can also be done from the context menu of the list view.

The **Mapping Mode** dialog box displays.

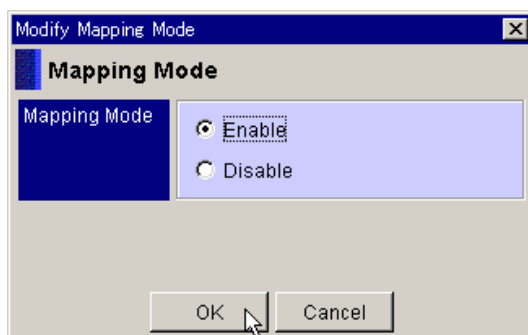

4. Click the **Enable** radio button, and then click **OK**.
5. A confirmation message displays. Click **OK**.

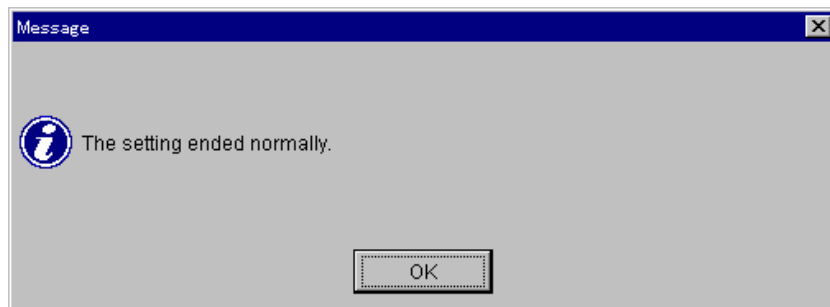
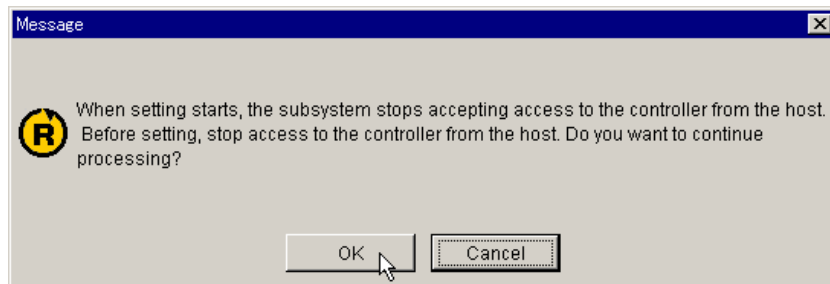
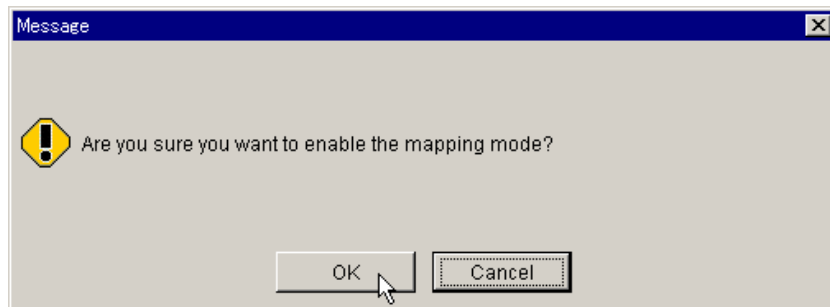

The setting information displays.

8.4 Setting Mapping Information

1. Click the **Logical Status** tab on the Array System Viewer window.
2. Click the **Port** plus sign next to the **000:G000**.
3. Click **Logical Unit** icon.

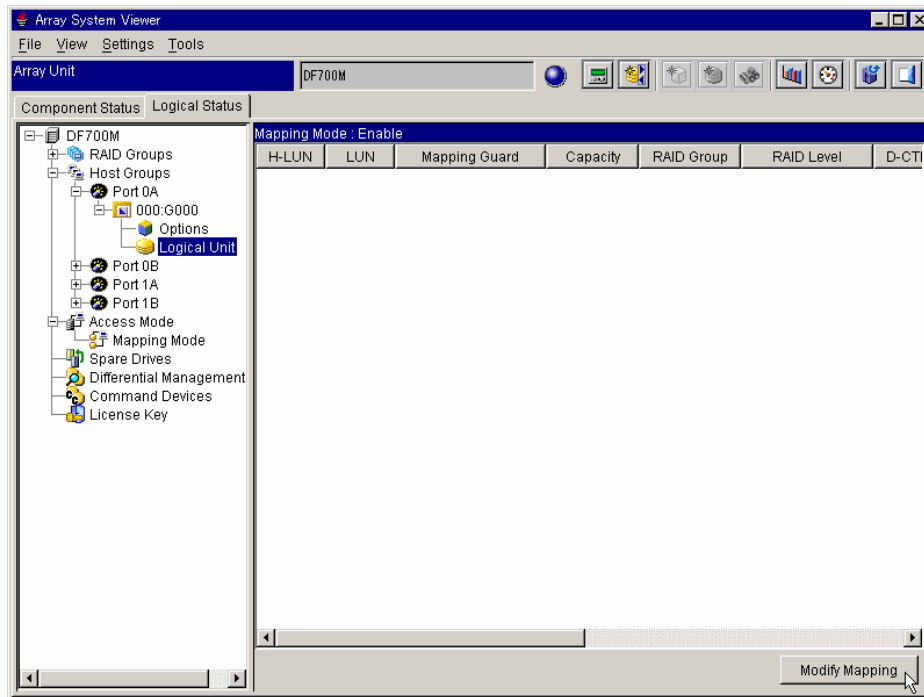

4. Click **Modify Mapping**.
The **Mapping Property** dialog displays.

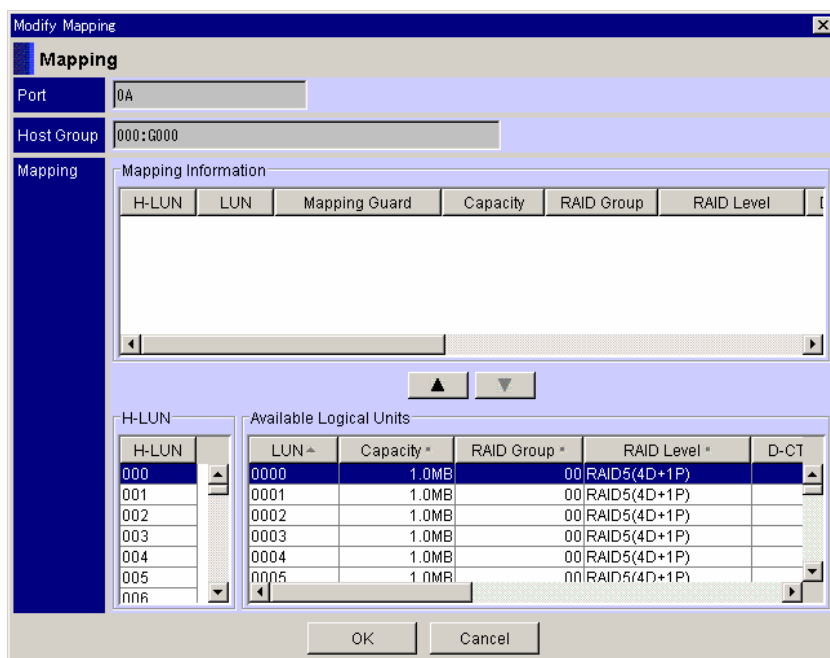

- Select one **H-LUN** to be added. Select one physical **LUN**, or several physical **LUNs**, and then click the  button. The added contents are displayed in the **Mapping Information** list.

Note: The **H-LUN** that is selected will be the first LUN number that will be represented on the host. Typically the starting host LUN number will be -0-. For example, if you select **HLUN -000-** and then select three physical **LUNs** (physical **LUNs** 0003, 0004, and 0005) under “Available Logical Units”, the host will see these **LUNs** as **LUNs** 0, 1, and 2. The **H-LUN** will always represent the starting LUN number you would like the host to see. The actual physical **LUNs** will be selected under “Available Logical Units”.

Note: For deletion, select the line to be deleted in **Mapping Information** list and click the  button. The deleted contents disappear from the display of **Mapping Information** list.

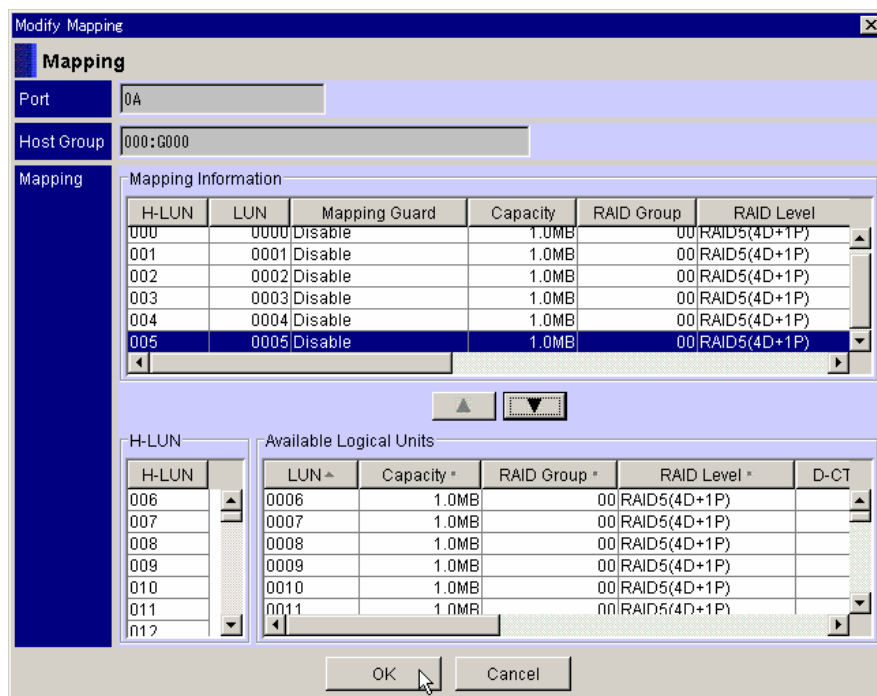

- Click **OK**.
- A confirmation message displays. Click **OK**.

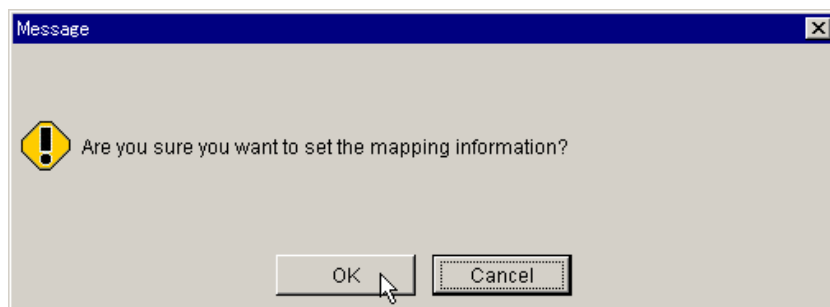

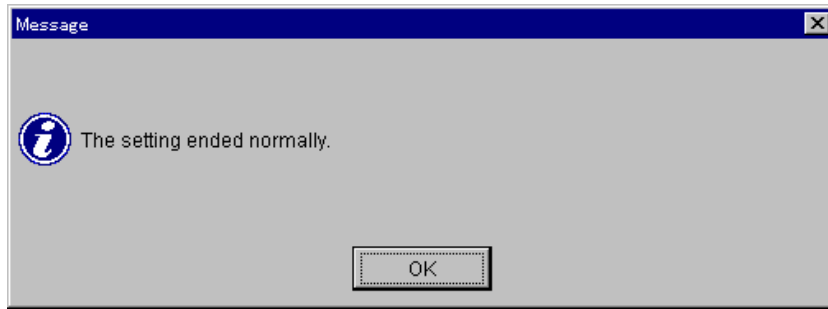

The set mapping information is updated and the following window displays.

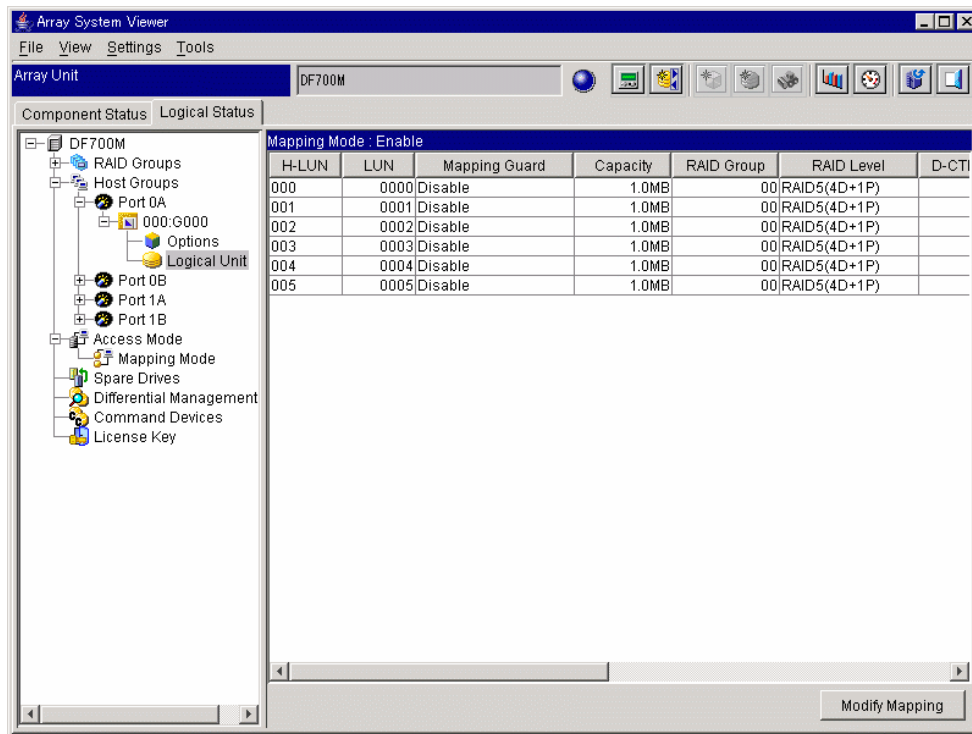

Chapter 9 Setting Target Information

Set Target 0 (000:T000) information, such as a target option and mapping information. For information on creating a target, refer to the *Hitachi TagmaStore AMS and WMS LUN Management User's Guide* (MK-95DF703).

This section discusses the following topics:

- Setting Target Options (section 9.1)
- Setting the Mapping Guard (section 9.2)
- Specifying the Mapping Mode (section 9.3)
- Setting the Mapping Information (section 9.4)
- Setting a CHAP User (section 9.5)
- Setting Target Information (section 9.6)

9.1 Setting Target Options

To set the target options:

1. Click the **Logical Status** tab on the **Array System Viewer** window.
2. Click the **Port** plus signs next to the **Targets**.
3. Click the plus sign next to **Port 0A**.
4. Click the plus sign next to **000:T000**, then click **Options**.
5. Click **Simple Setting**.

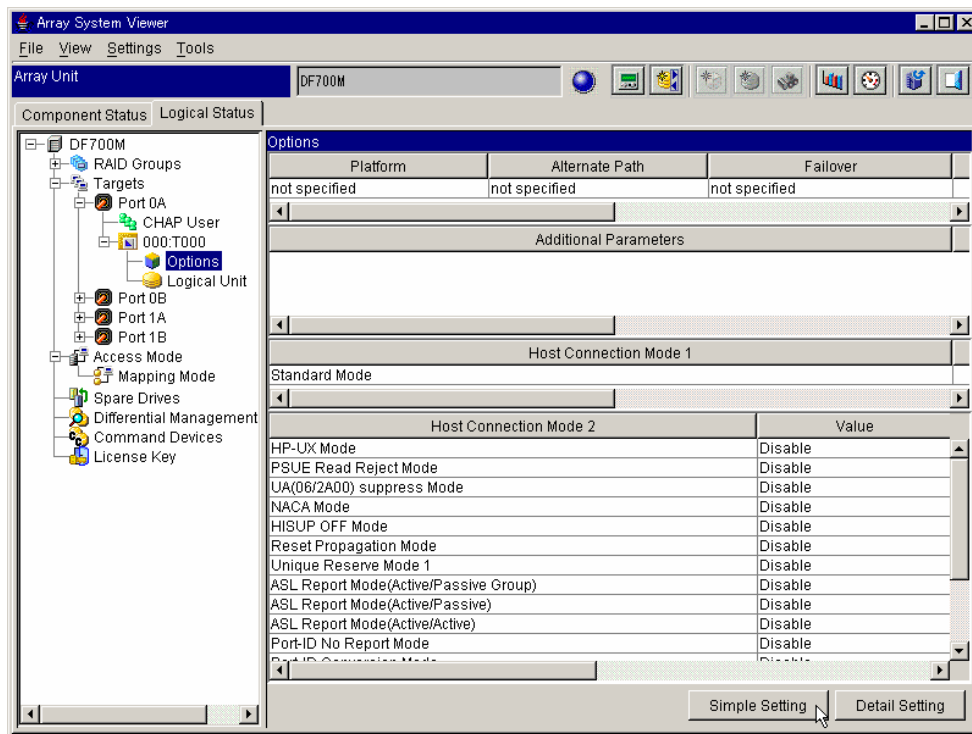

6. As necessary, select **Platform**, **Alternate path**, and **Failover**.
The combination, which can be chosen for every platform, is limited.

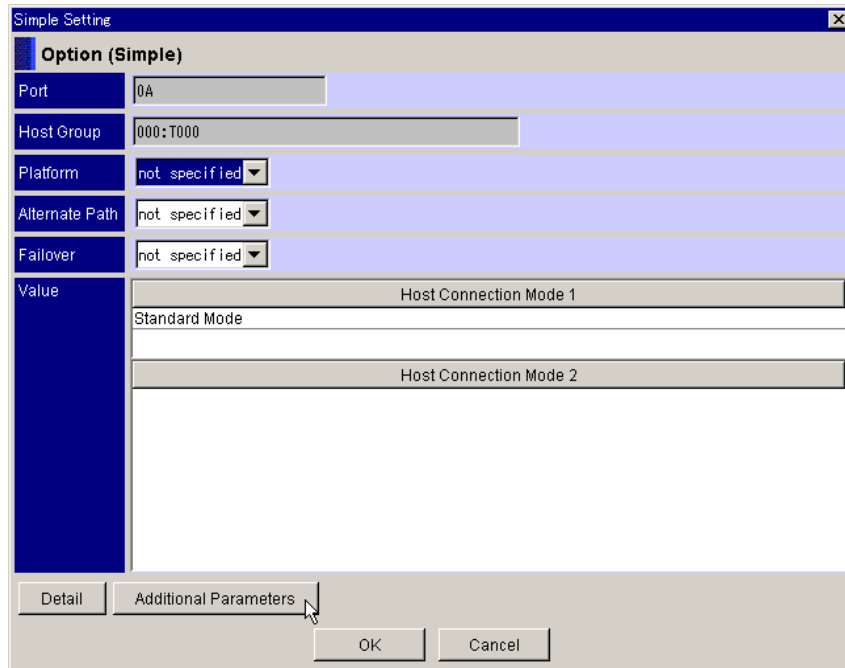

- **Platform:**
 - HP-UX
 - Solaris™
 - AIX®
 - Windows® 2000
 - Windows® 2003
 - Linux®
 - Tru64
 - not specified
- **Alternate path:**
 - not specified
 - PV Link: Can be used by HP-UX.
 - HDLM: Can be used by Solaris, AIX, and Windows 2000/2003.
 - VxVM: Can be used by HP-UX, AIX, Solaris, Windows 2000/2003, and Linux.
 - MPxIO: Can be used by Solaris.
- **Failover:**
 - not specified
 - MC/ServiceGuard: Can be used by HP-UX.
 - Sun™ Cluster: Can be used by Solaris.
 - VCS: Can be used by Solaris and Linux.
 - HACMP: Can be used by AIX.
 - MSCS: Can be used by Windows 2000/2003.
 - Tru Cluster: Can be used by Tru64.

7. Click **Additional Parameters**.

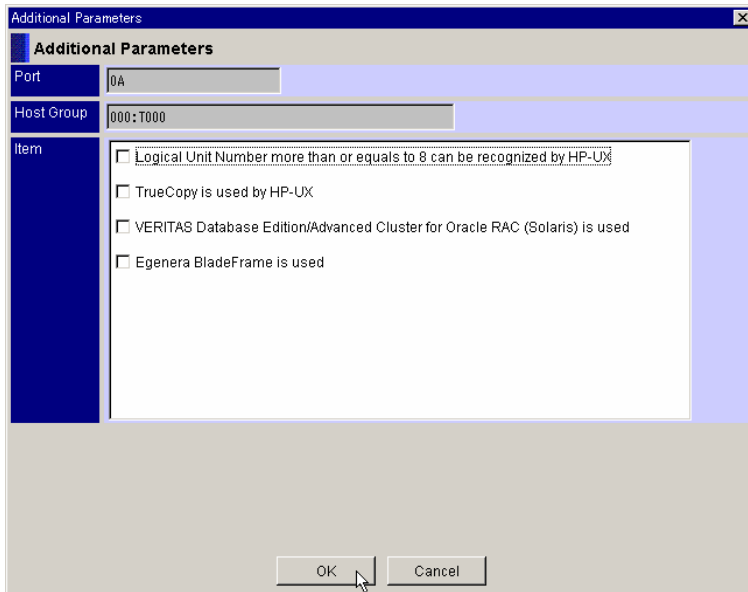

8. As necessary, click **Item** and click **OK**.

9. Click **Detail**.

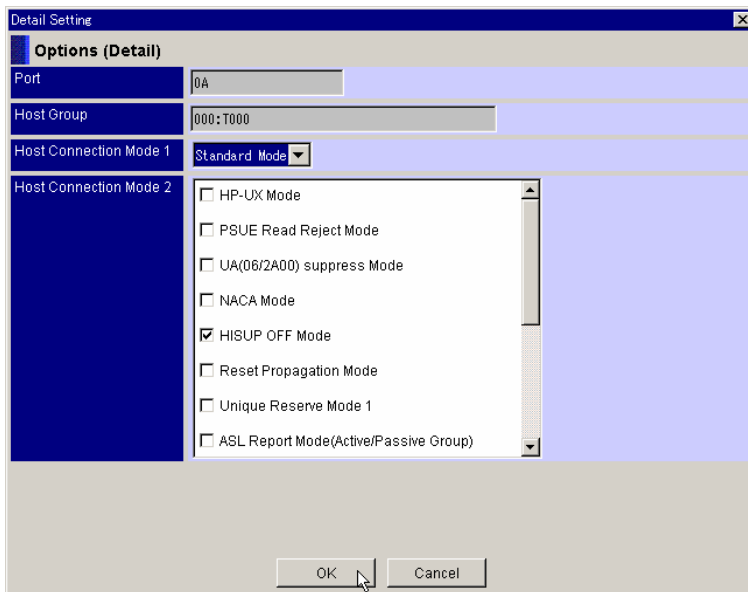

10. Click **Host Connection Mode 1** and **Host Connection Mode 2**. Click **OK**:

- **Host Connection Mode 1:**
 - Normal Mode: Open system emulation mode
 - Open VMS Mode: Open VMS mode
 - TRESPASS Mode: TRESPASS mode
 - Wolfpack Mode: Wolfpack mode

- **Host Connection Mode 2:**
 - HP-UX Mode: Enables the HP-UX Mode.
 - PSUE Read Reject Mode: Enables the PSUE Read Reject Mode.
 - UA(60/2A00) Suppress Mode: Suppresses the unit attention (06/2A00).
 - NACA Mode: Enables the NACA Mode.
 - HISUP OFF Mode: Enables the HISUP OFF Mode.
 - Reset Propagation Mode: The mode to propagate reset to other ports.
 - Unique Reserve Mode 1: Enables the Unique Reserve Mode 1.
 - ASL Report Mode (Active/Passive Group): Enables the ASL Report Mode (Active/Passive Group).
 - ASL Report Mode (Active/Passive): Enables the ASL Report Mode (Active/Passive).
 - ASL Report Mode (Active/Active): Enables the ASL Report Mode (Active/Active).
 - Port-ID No Report Mode: Enables the Port ID No Report Mode.
 - Port-ID Conversion Mode: Enables the Port ID Conversion Mode.
 - Tru Cluster Mode: Enables the Tru Cluster Mode.
 - Product Serial Response Mode: Enables the Product Serial Response Mode.
 - Same Node Name Mode: Enables the Same Node Name Mode.
 - CCHS Mode: Enables the CCHS convert
 - SPC-2 Mode: Enables the SPC-2 Mode.

11. Click **OK**.

12. A confirmation message displays. Click **OK**.

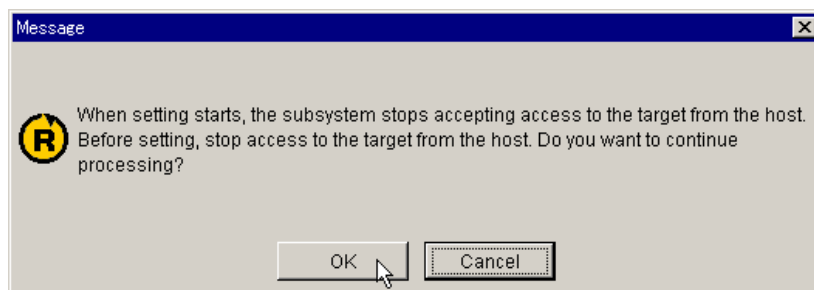
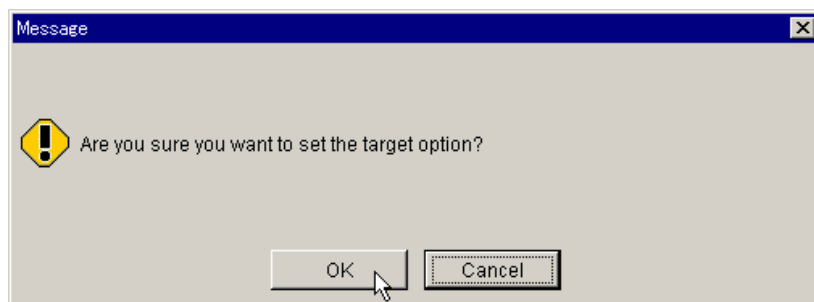

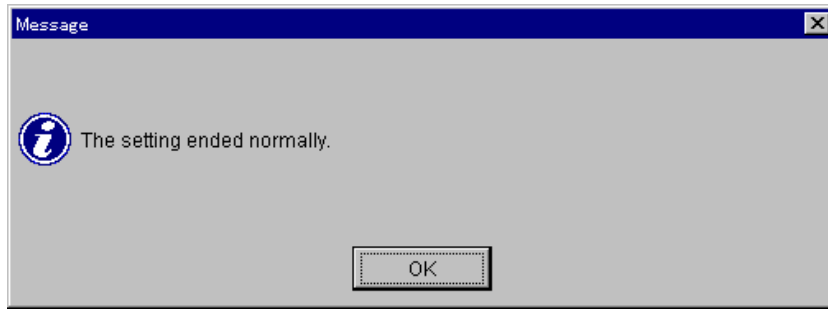

The modified target options display.

9.2 Setting the Mapping Guard

If you enable the mapping guard, it will block users from performing mapping operations on that LU.

1. Click the **Logical Status** tab on the **Array System Viewer** window.
2. On the **Tools** menu, select the **Mapping Guard**.

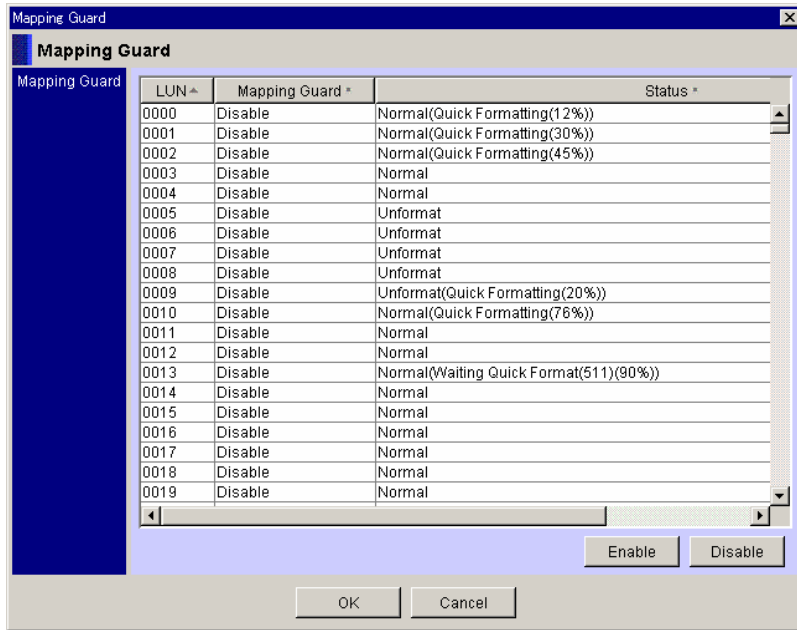

3. Select the **LUN** or **LUNS** for which you want to guard the mapping and click **Enable**, then click **OK**. A confirmation message displays. Click **OK**.

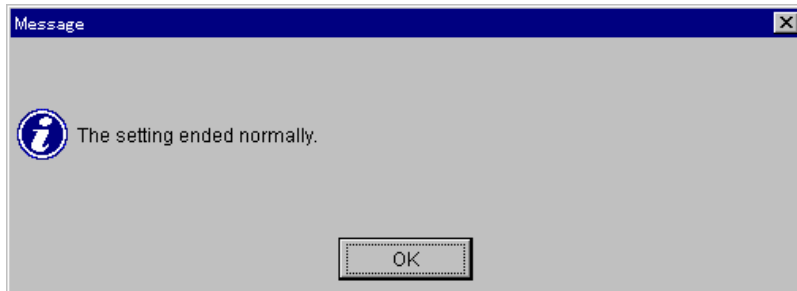
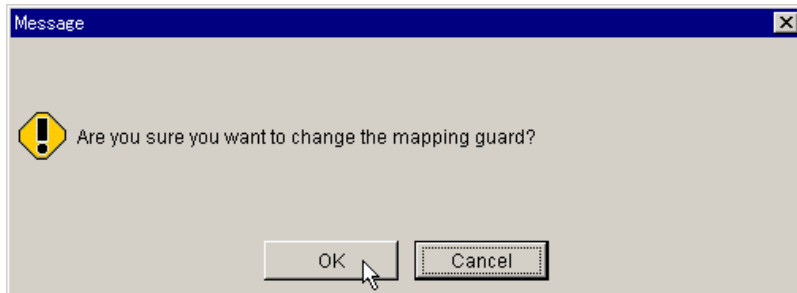

9.3 Specifying the Mapping Mode

Set the Mapping mode effective or ineffective.

1. Click the **Logical Status** tab on the **Array System Viewer** window.
2. Click the plus sign next to **Access Mode**, and then click **Mapping Mode**.

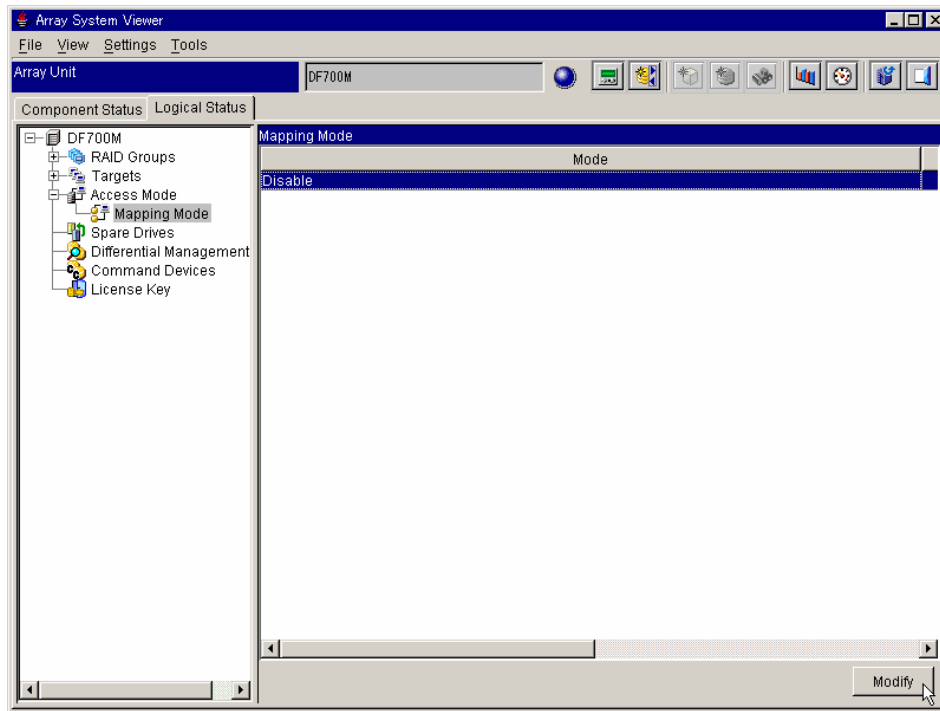

3. Click the **Disable** radio button on the **Mapping Mode** list, and then click **Modify**. (This operation can also be done from the **Context** menu of the **List View**.)

The **Mapping Mode** dialog displays.

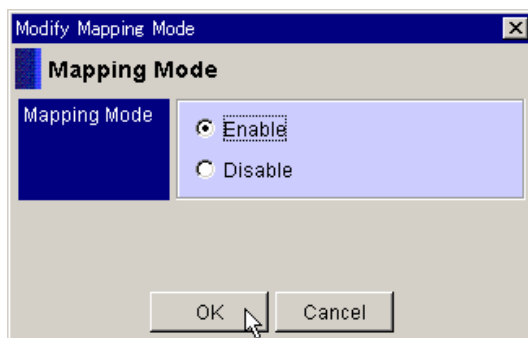

4. Click the **Enable** radio button, and then click **OK**.

5. A confirmation message displays. Click **OK**.

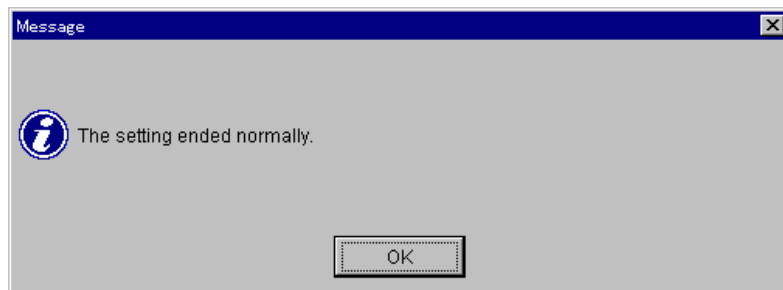
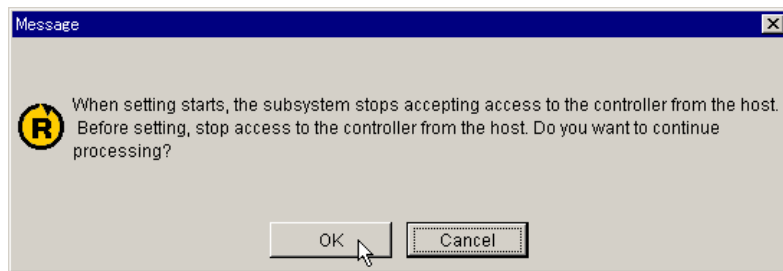
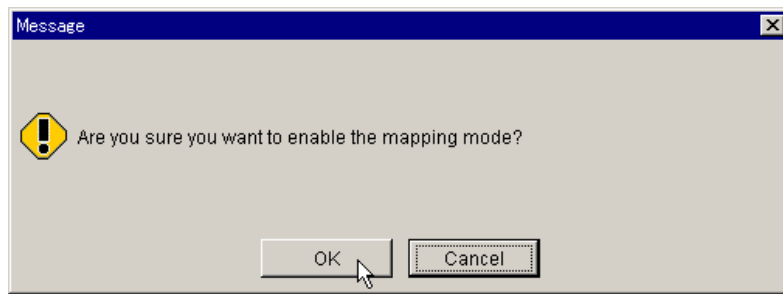

The setting information displays.

9.4 Setting the Mapping Information

1. Click the **Logical Status** tab on the Array System Viewer window.
2. Click the **Port** plus sign next to the **000:T000**.
3. Click **Logical Unit** icon.

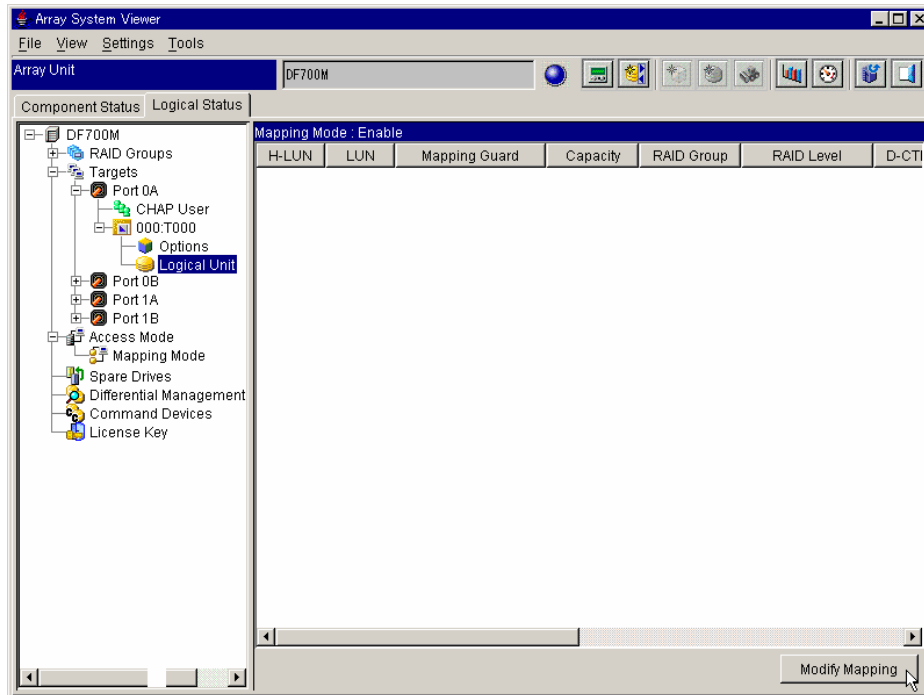

4. Click **Modify Mapping**.
The **Mapping Property** dialog box displays.

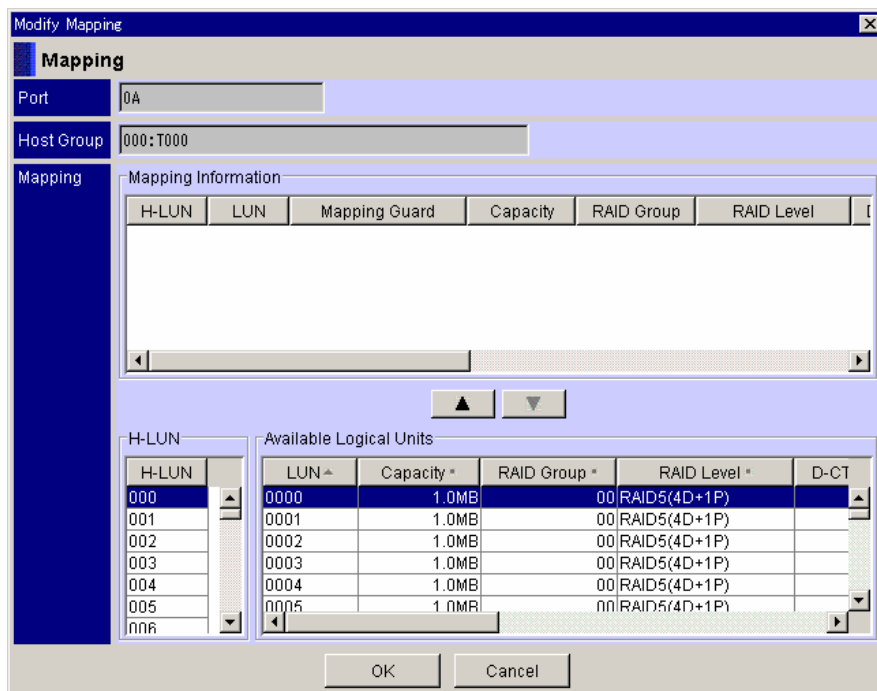

5. Select one **H-LUN** to be added. Select one physical **LUN**, or several physical **LUNs**, and then click the  button. The added contents are displayed in the **Mapping Information** list.

Note: The **H-LUN** that is selected will be the first LUN number that will be represented on the host. Typically the starting host LUN number will be -0-. For example, if you select **HLUN -000-** and then select three physical **LUNs** (physical **LUNs** 0003, 0004, and 0005) under **Available Logical Units**, the host will see these **LUNs** as **LUNs** 0, 1, and 2. The **H-LUN** will always represent the starting LUN number you would like the host to see. The actual physical **LUNs** will be selected under **Available Logical Units**.

Note: For deletion, select the line to be deleted in **Mapping Information** list and click the  button. The deleted contents disappear from the display of **Mapping Information** list.

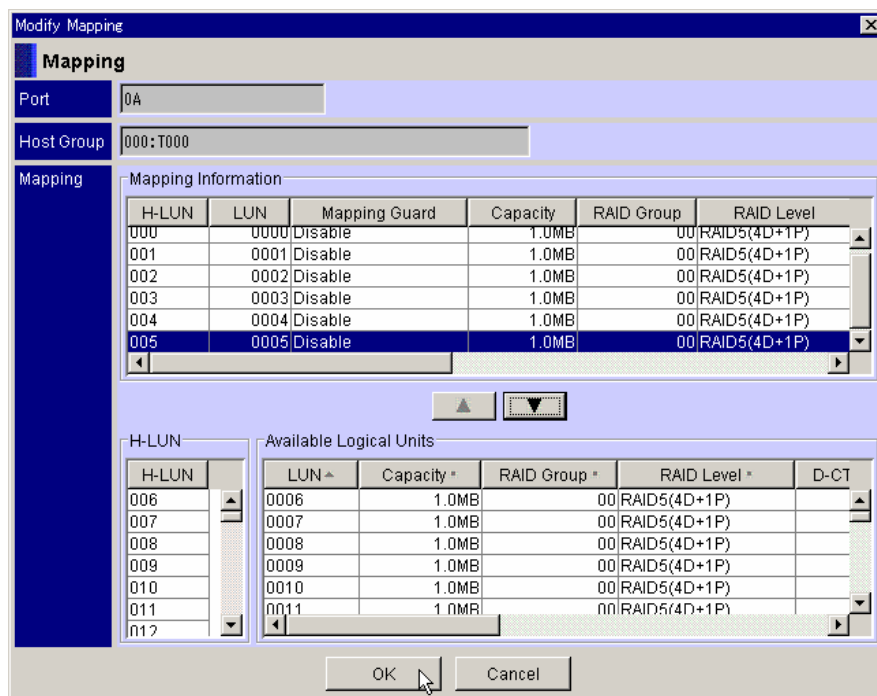

6. Click **OK**.
7. A confirmation message displays. Click **OK**.

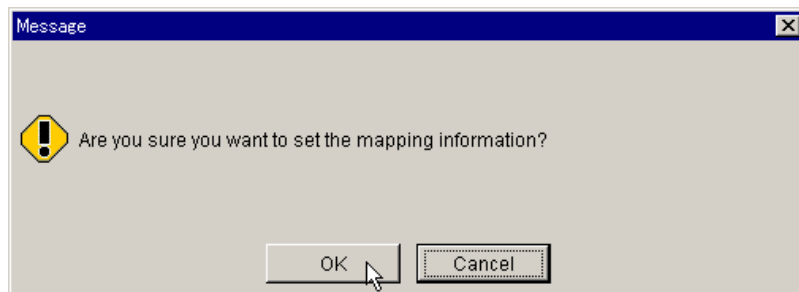

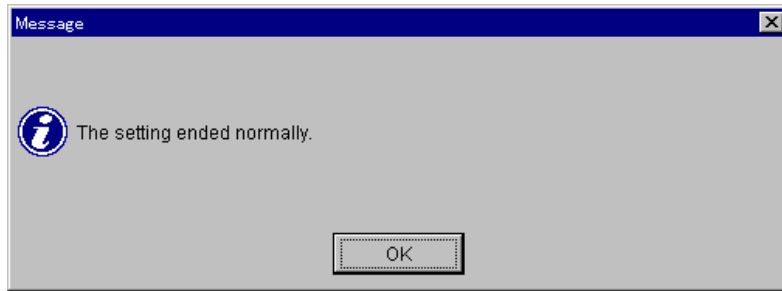

The set mapping information is updated and the following window displays.

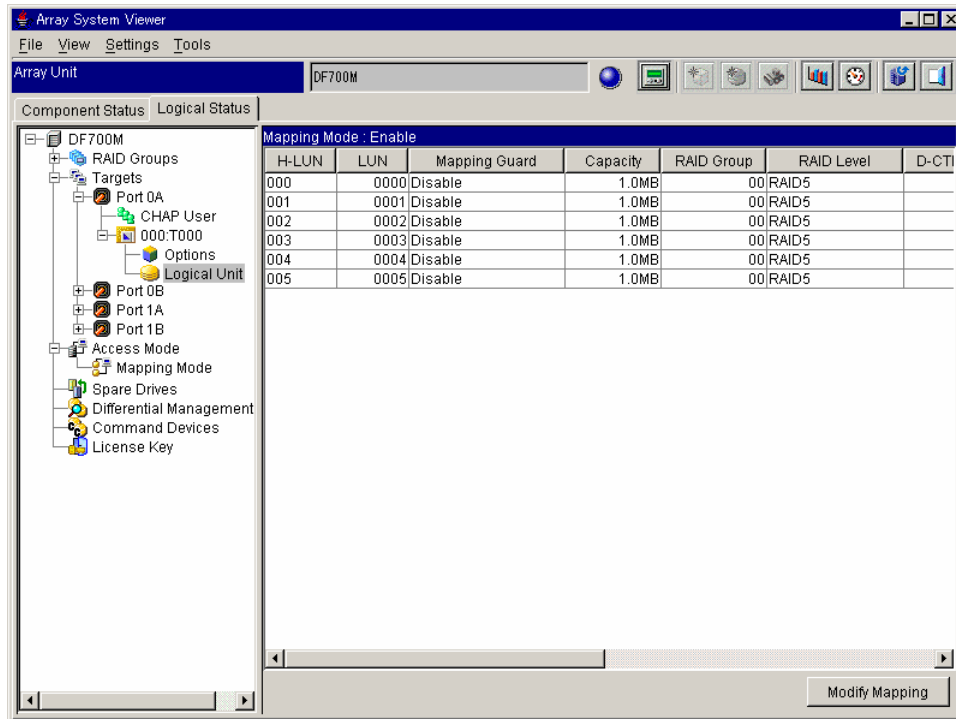

9.5 Setting a CHAP User

9.5.1 Adding a CHAP User

To add the CHAP user:

1. Click the **Logical Status** tab on the **Array System Viewer** window.
2. Click the **Port** plus signs next to the **CHAP User** and click **CHAP User**.

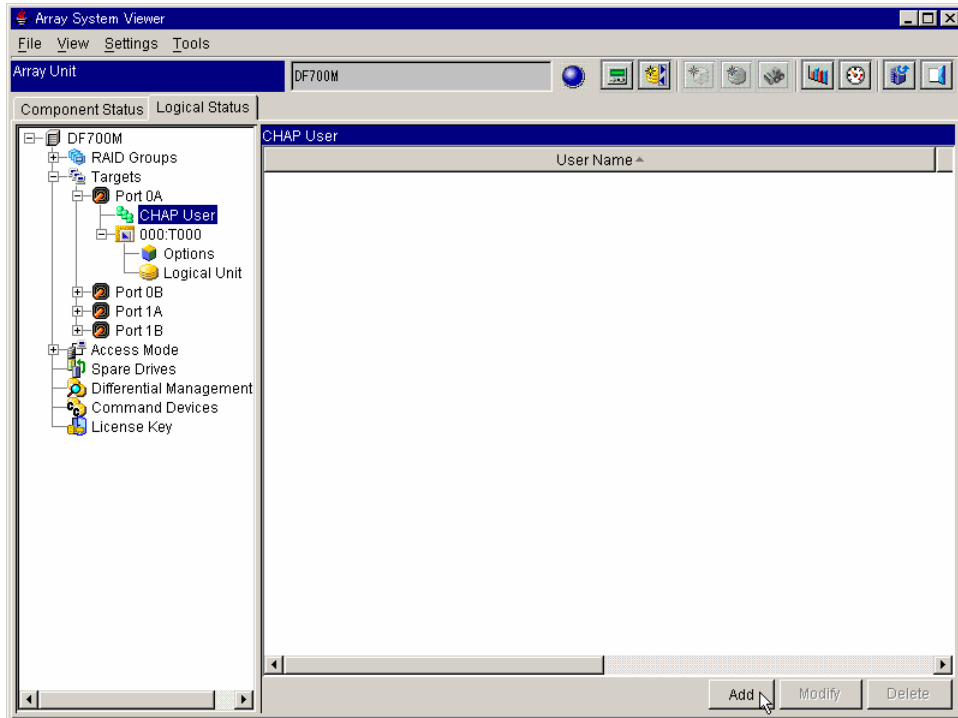

3. Click **Add**.
The **CHAP User** dialog box displays.

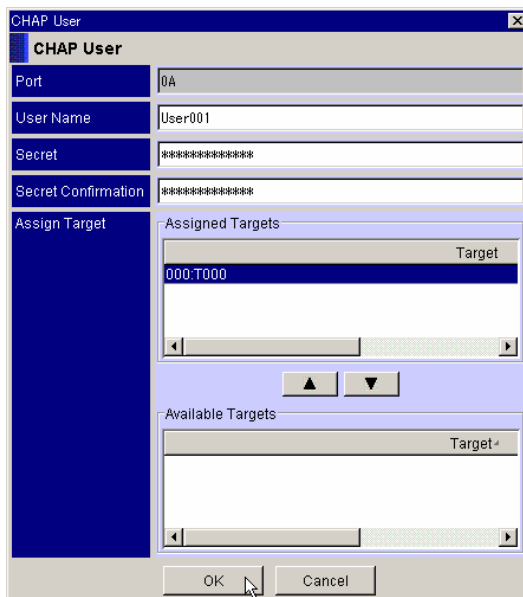

4. In the **CHAP User** dialog box, enter the **User Name**, **Secret**, and **Secret Confirmation**.
5. From the **Available Targets** list, select the target to be assigned, click the  button.
 - **User Name:** Enter the name of the User with 256 or less alphanumeric character. The following symbols can be used.
(. - + @ _ = : / [] ~ (space))
 - **Secret:** Enter the Secret from 12 through 32 alphanumeric characters. The following symbols can be used.
(. - + @ _ = : / [] ~ (space))
 - **Secret Confirmation:** Enter the characters that enter into the **Secret**.
6. Click **OK**.
7. A confirmation message displays. Click **OK**.

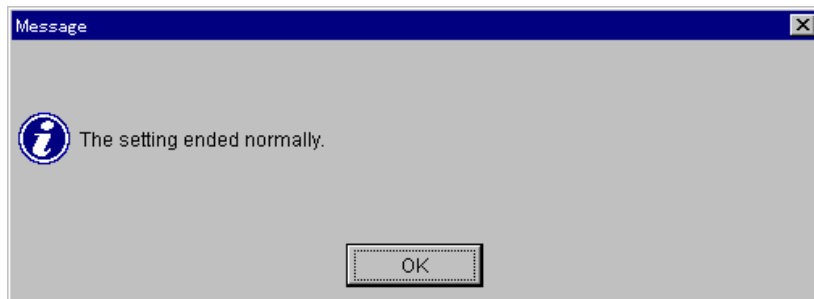
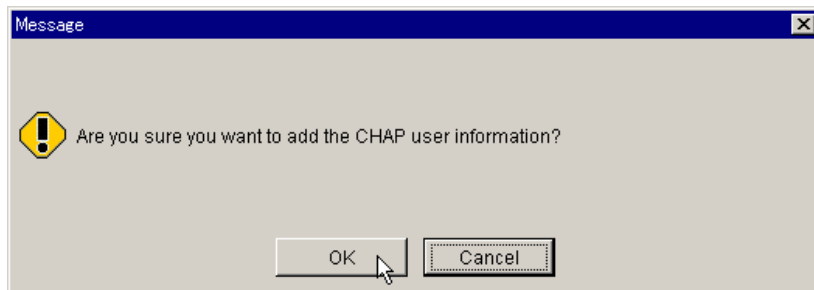

9.5.2 Changing the CHAP User

To change the CHAP user:

1. Click the **Logical Status** tab on the **Array System Viewer** window.
2. Click the **Port** plus signs next to the **CHAP User** and click **CHAP User**.

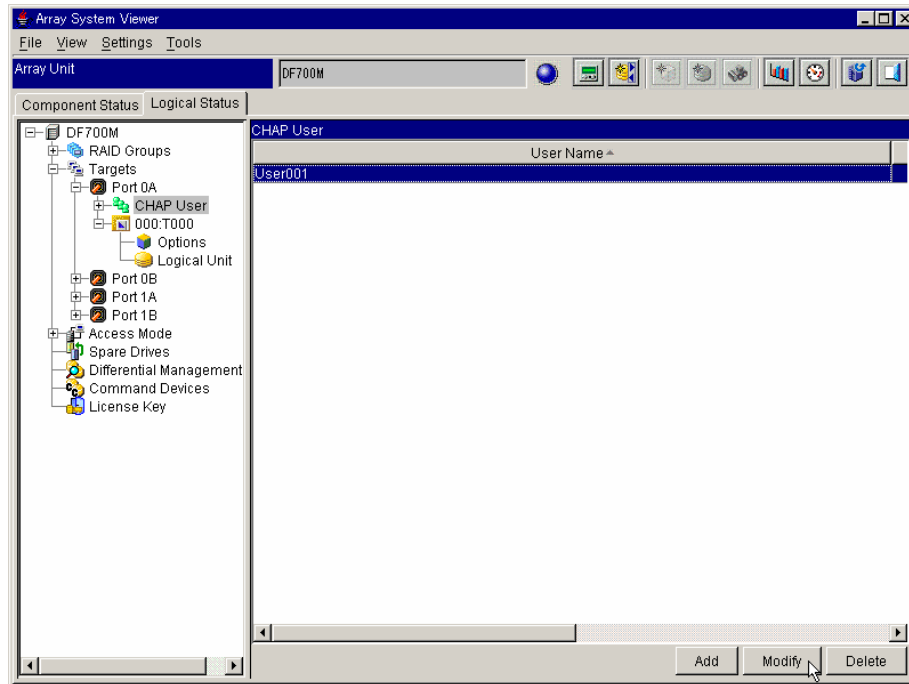

3. Select the **CHAP User** to be changed from the **CHAP User** list.
4. Click **Modify**.

The **CHAP User** dialog box displays.

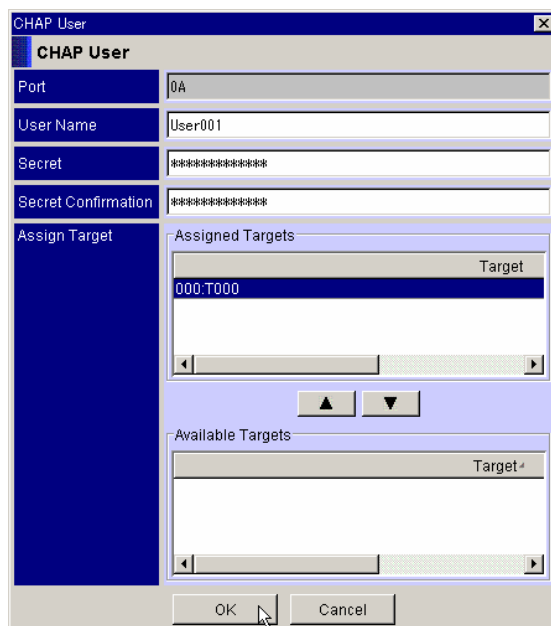

5. As necessary, enter the **User Name**, **Secret**, and **Secret Confirmation**.
6. As necessary, change the assigned target, and click **OK**.
7. A confirmation message displays. Click **OK**.

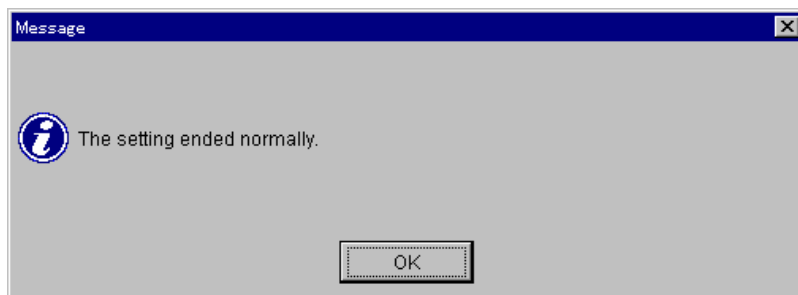
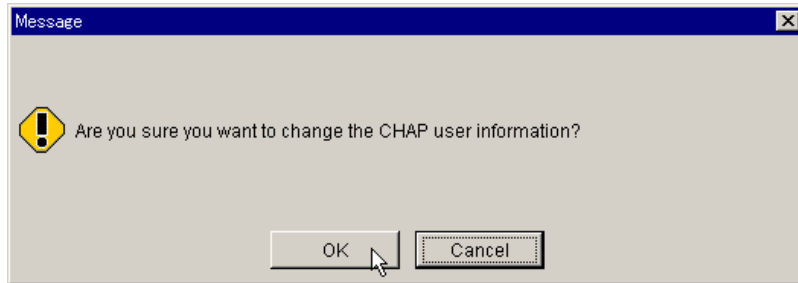

9.5.3 Deleting the CHAP User

To delete the CHAP user:

1. Click the **Logical Status** tab on the **Array System Viewer** window.
2. Click the **Port** plus signs next to the **CHAP User** and click **CHAP User**.
3. Select the **CHAP User** to be deleting from the **CHAP User** list.

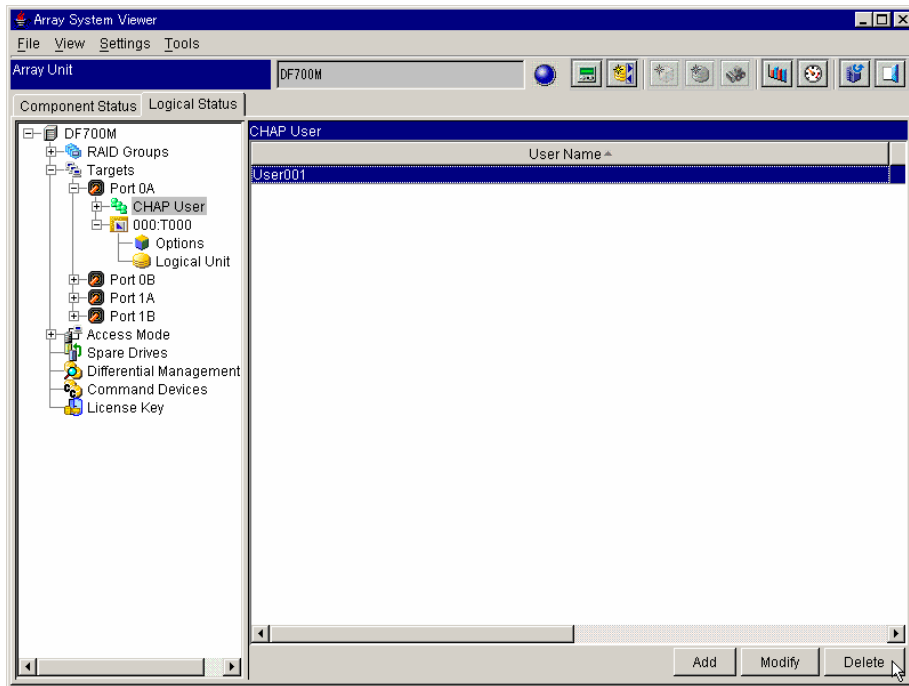

4. A confirmation message displays. Click **OK**.

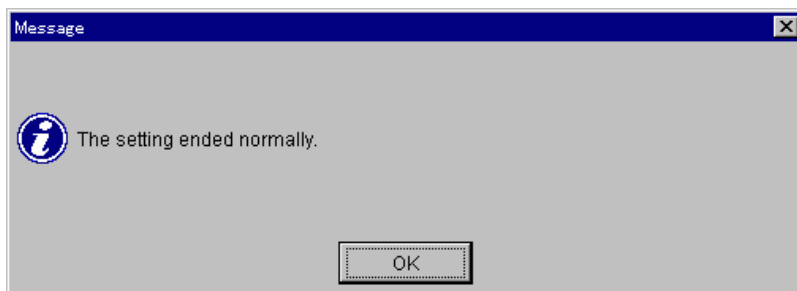
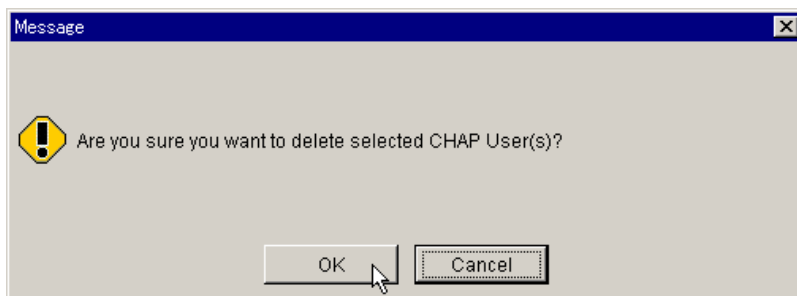

9.6 Setting Target Information

9.6.1 Changing Target Information

1. Click the **Logical Status** tab on the **Array System Viewer** window.
2. Click the **Port**.
3. Select the **Target** to be changed from the **Target** list.

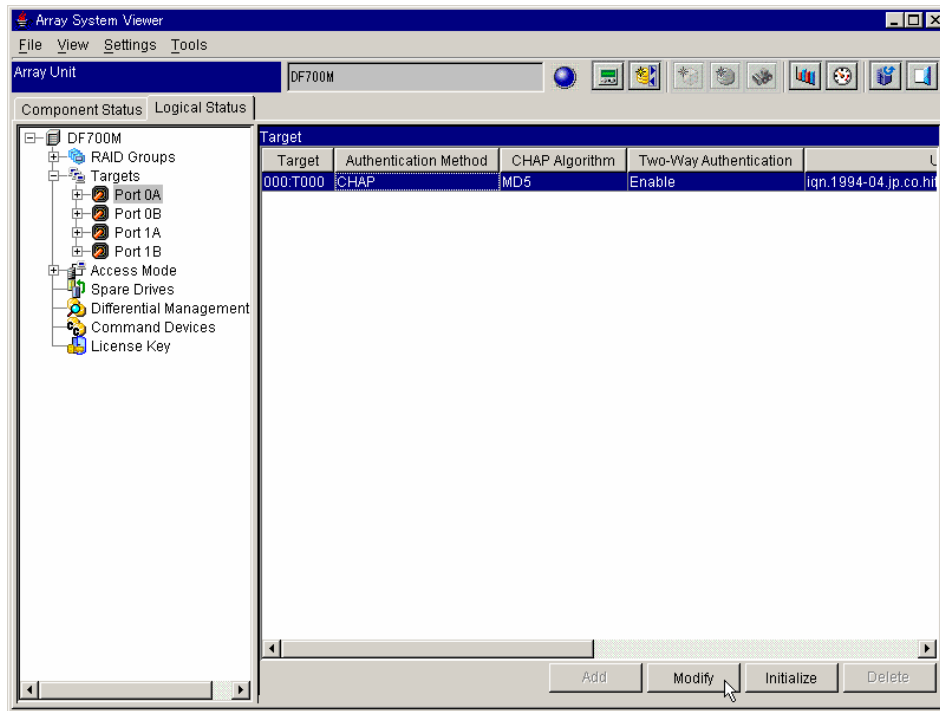

4. Click **Modify**.
The **Target** dialog box displays.

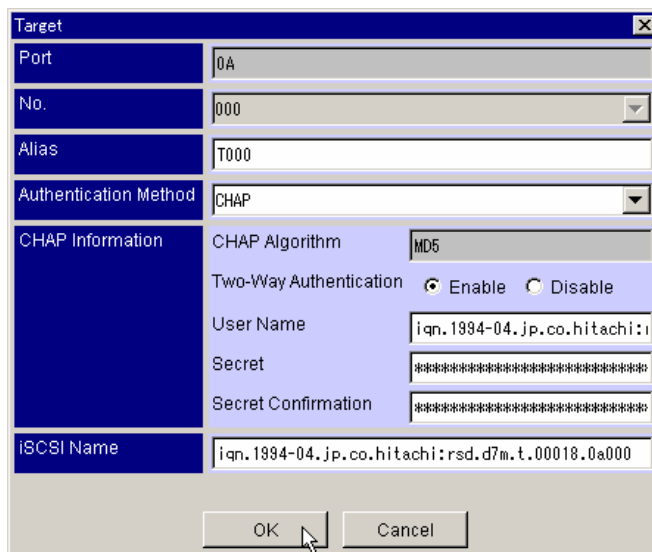

5. Enter the **Alias**, **Authentication Method**, **CHAP Information**, and **iSCSI Name**:
 - **Alias:** Enter the alias of the Target with 32 or less alphanumeric character:
(Excluding \, /, : , , , ; , * , ? , “ , < , > , | and ‘)
Spaces at the top or end are ignored. An identical name cannot be used in an identical Port.
 - **Authentication Method:** Select the **CHAP**, **None**, or **CHAP, None**.
 - **CHAP Information:**
 - **CHAP Algorithm:** Displayed MD5 always.
 - **Two-Way Authentication:** Select the **Enable** or **Disable** radio button.
When clicking the **Enable** radio button, specify the following items.
User Name: Enter the name of the User with 256 or less alphanumeric character. The following symbols can be used.
(. - + @ _ = : / [] ~ (space))
Secret: Enter the Secret from 12 through 32 alphanumeric characters. The following symbols can be used.
(. - + @ _ = : / [] ~ (space))
Secret Confirmation: Enter the characters that enter into the **Secret**.
 - **iSCSI Name:** Enter the name of the iSCSI Name with 223 or less alphanumeric character. A period (.), hyphen (-), and colon (:) can be used.
6. Click **OK**.
7. A confirmation message displays. Click **OK**.

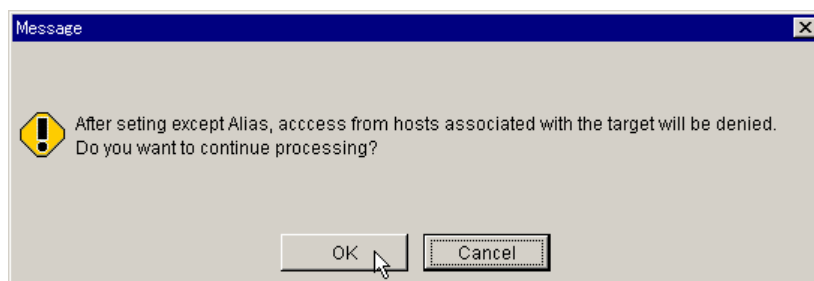
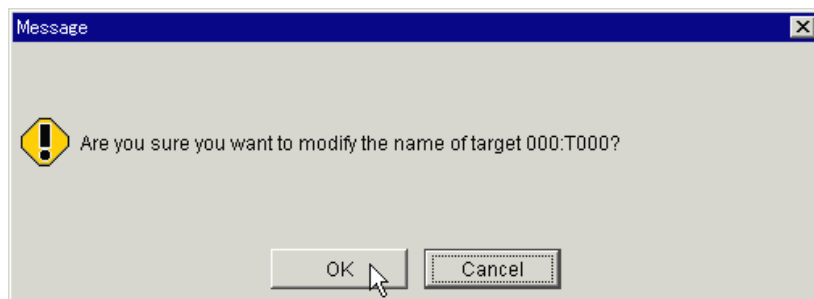

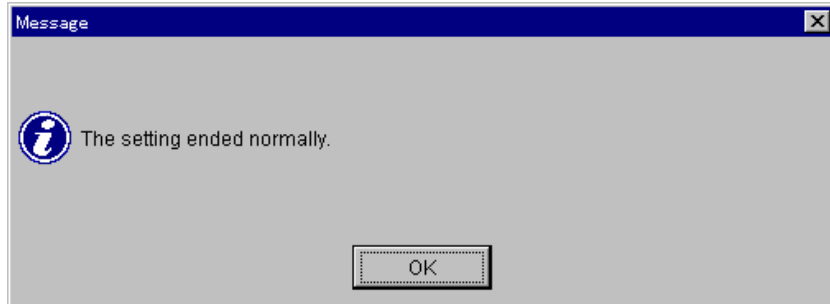
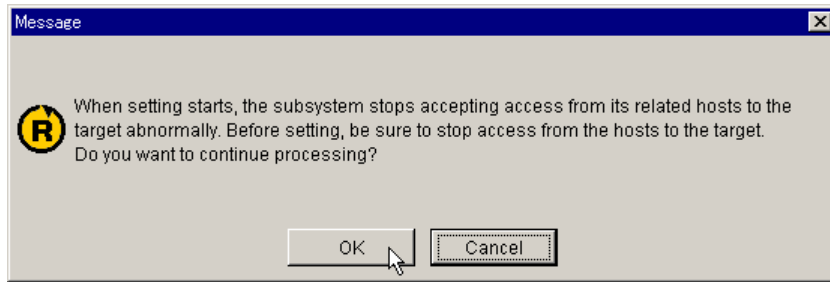

9.6.2 Initializing Target 0

1. Click the **Logical Status** tab on the **Array System Viewer** window.
2. Click the **Port**.
3. Select the **Target** to be initialized from the **Target** list.

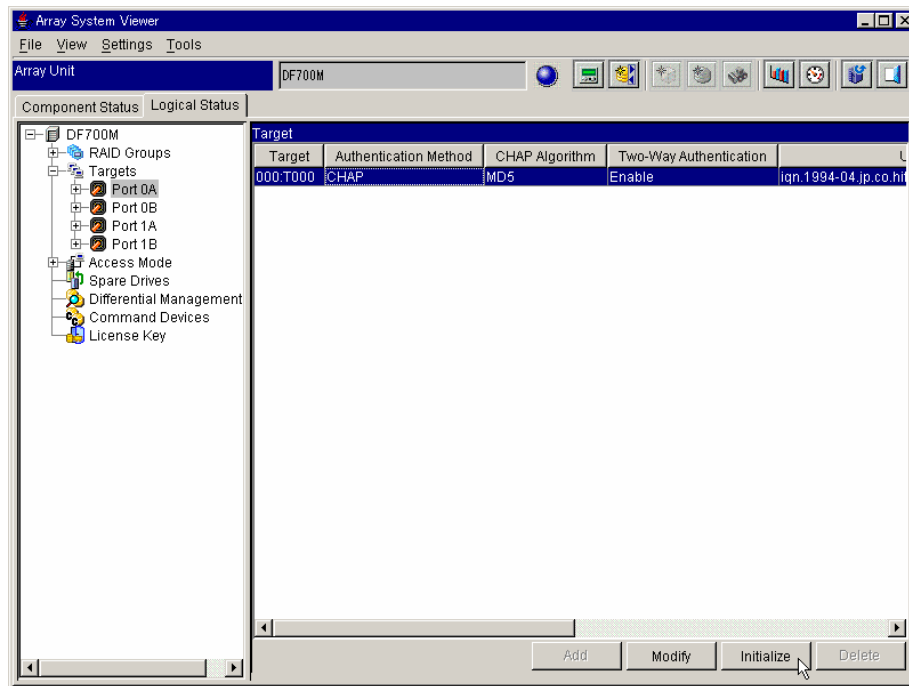

4. Click **Initialize**.

5. A confirmation message displays. Click **OK**.

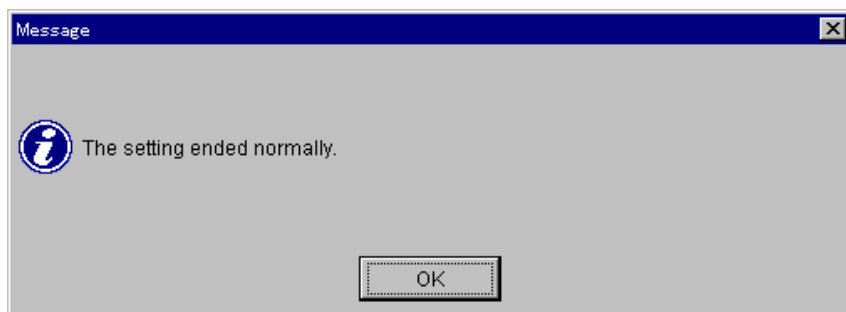
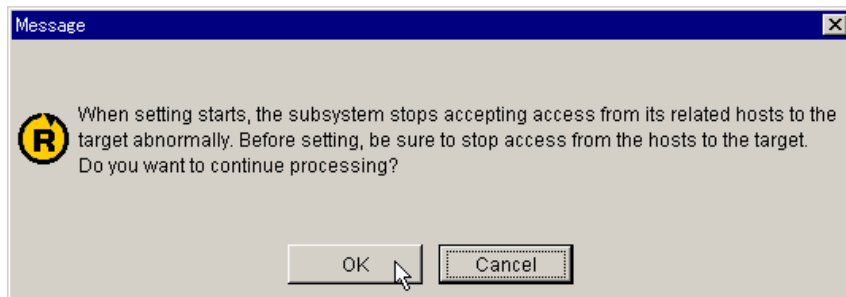
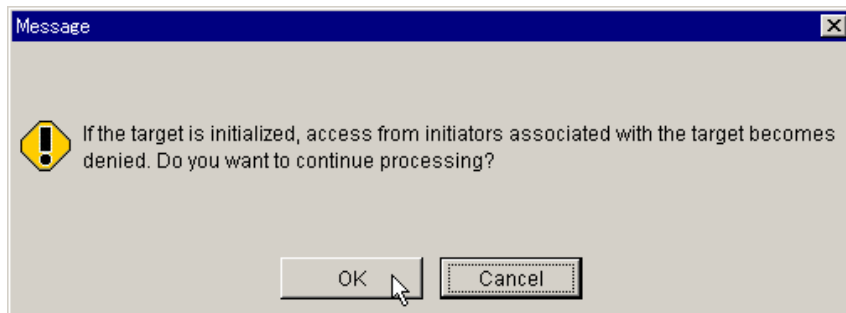
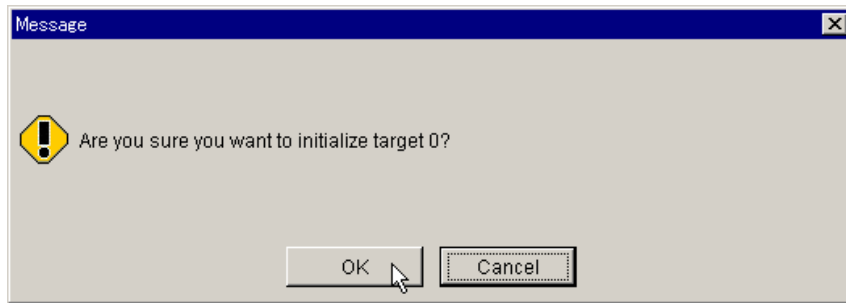

Chapter 10 NAS Operations

This section discusses the following topics:

- Setting NNC LAN Information (section 10.1)
- Setting NAS System Logical Units (section 10.2)
- Setting NAS User Logical Units (section 10.3)
- Shutdown/Booting/Rebooting NNC (section 10.4)

Figure 10.1 displays an example of a host computer connection, in which the Storage Navigator is installed, and the disk array subsystem to which the NNC option has been added.

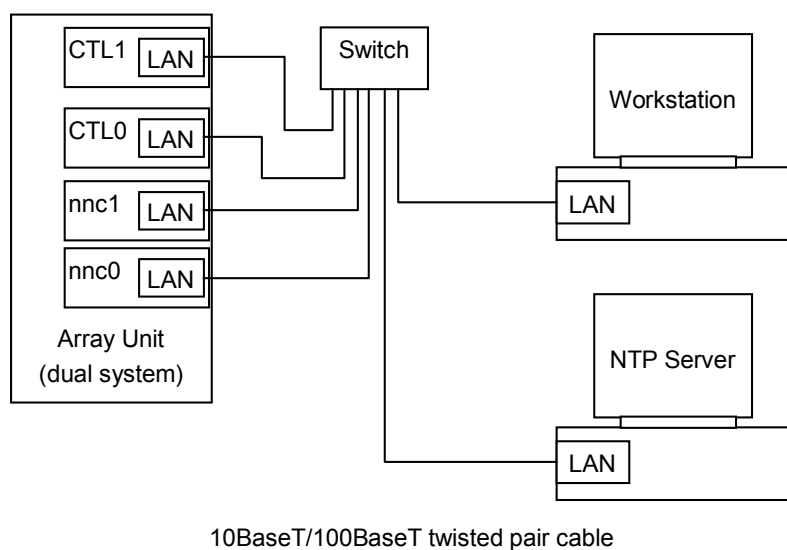



Figure 10.1 Disk Array Subsystem to which NNC Option Added (management ports)

10.1 Setting the NNC LAN Information

To set the NNC LAN information for management port:

Note: A cluster becomes a stop state when you change an IP address or subnet mask.

1. On the **Tools** menu, select **Configuration Settings**. Alternatively, click : **Configuration Settings** in the tool bar.
2. Click the **NNC LAN** tab.

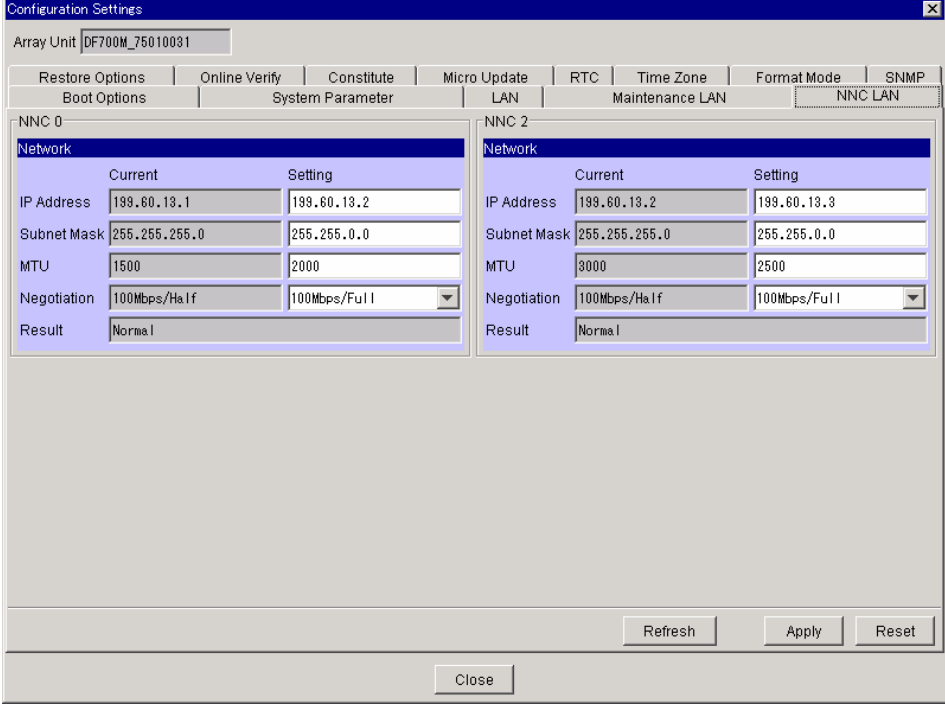

NNC 0			NNC 2		
Network			Network		
	Current	Setting		Current	Setting
IP Address	199.60.13.1	199.60.13.2	IP Address	199.60.13.2	199.60.13.3
Subnet Mask	255.255.255.0	255.255.0.0	Subnet Mask	255.255.255.0	255.255.0.0
MTU	1500	2000	MTU	3000	2500
Negotiation	100Mbps/Half	100Mbps/Full	Negotiation	100Mbps/Half	100Mbps/Full
Result	Normal		Result	Normal	

- **Network:** Specify **IP Address**, **Subnet Mask**, **MTU**, and **Negotiation**, which is part of the LAN information.
3. Click **Apply**.
4. A message displays. Click **OK**.

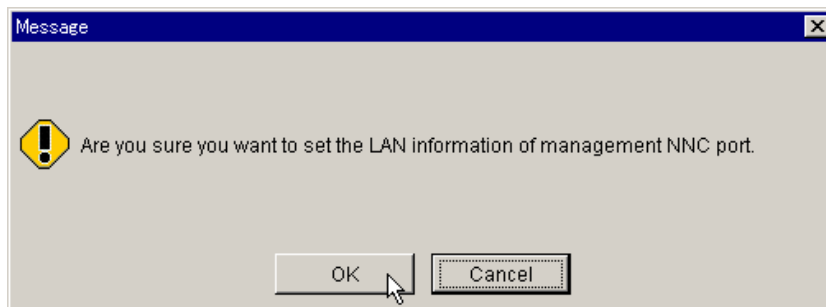

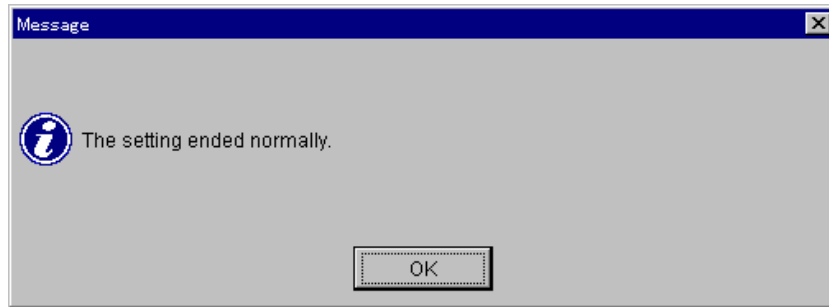
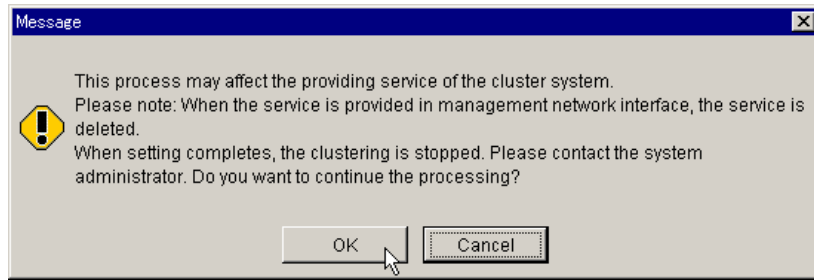

10.2 Setting NAS System Logical Units

Note: The NAS system logical units are usually set at the factory shipment, so that a user is not required to set them.

Nine logical units for the NAS system are required, and the following capacity is at least necessary. When no logical unit is available for allocating to the logical unit for the NAS system, create it referring to Figure 6.3.

For NNC Type2

Name	LUN	Capacity
System Disk(CTL0)	0000	29.0GB
System Disk(CTL1)	0100	29.0GB
Volume for Dump(CTL0)	0001	6.0GB
Volume for Dump(CTL1)	0101	6.0GB
Command Device	0005	35.0MB
Command Device(Secondary)	0007	35.0MB
System Common Volume	0008	6.0GB
Backup Volume for Common	0009	6.0GB
Backup Volume for Common 2	0010	6.0GB

For NNC Type1

Name	LUN	Capacity
System Disk(CTL0)	0000	15.0GB
System Disk(CTL1)	0100	15.0GB
Volume for Dump(CTL0)	0001	5.0GB
Volume for Dump(CTL1)	0101	5.0GB
Command Device	0005	35.0MB
Working Area for Dump	0006	5.0GB
System Common Volume	0008	3.0GB
Backup Volume for Common	0009	3.0GB
Backup Volume for Common 2	0010	3.0GB

To set the NAS system logical units:

10.2.1 For NNC Type2

1. Click the **Logical Status** tab on the Array System Viewer window.
2. Click the **NAS** plus signs next to the **NNC0/2**.
3. Click the **NNC0/2** plus signs next to the **System**.

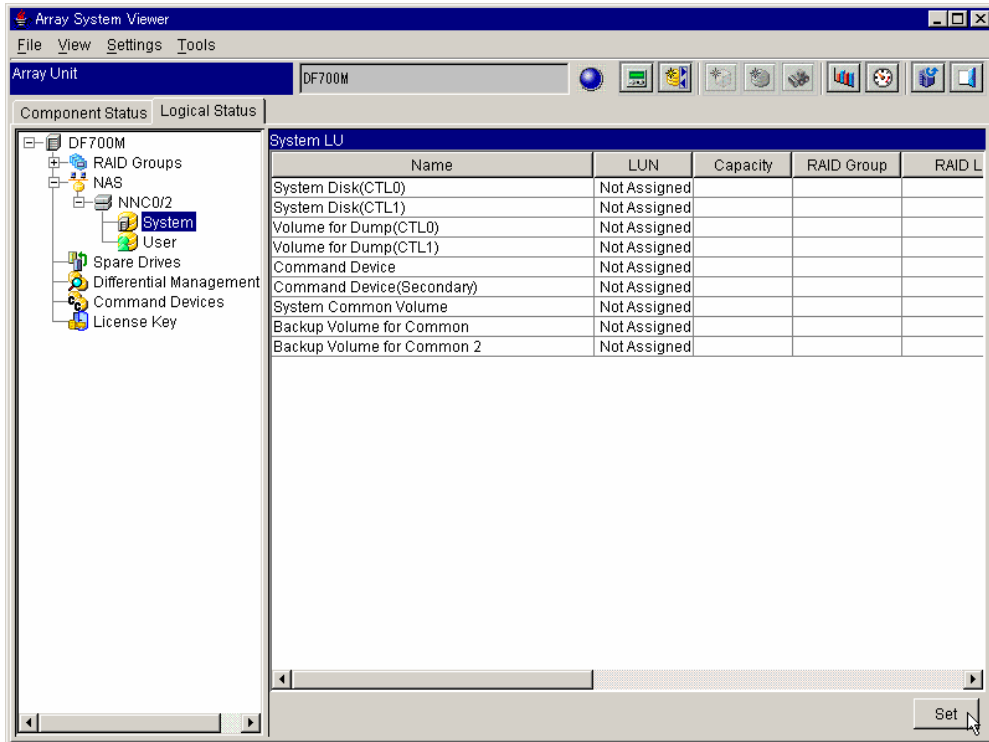

4. Click **Set**.

The **System LU** dialog box displays.

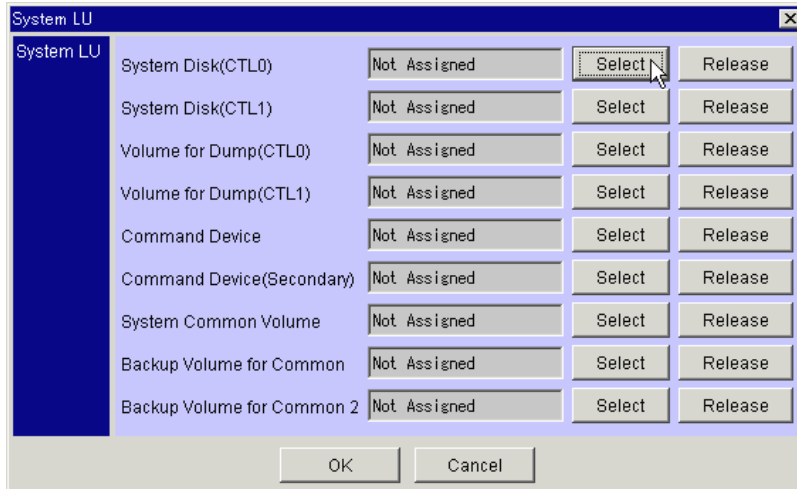

5. Click **Select** next to the wanted System LUs.

The **Select Logical Unit** dialog box displays.

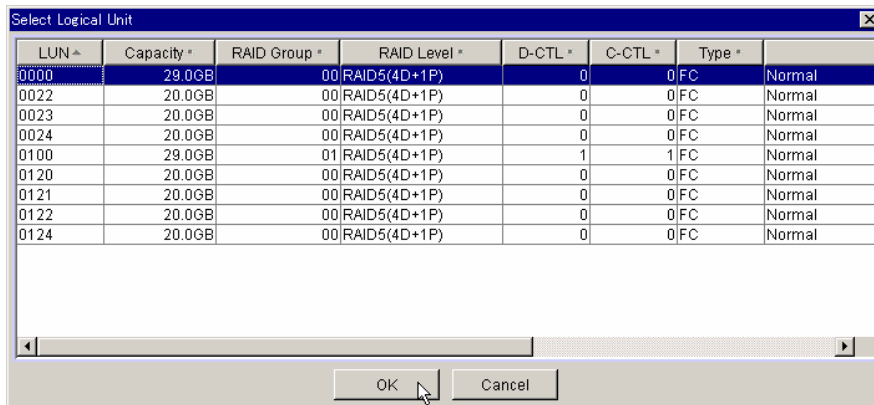

6. Click **LUN** to set the system LU, and then click **OK**.

The selected LUN displays.

7. Repeat steps 5 to 6 and complete a **System LU** list.

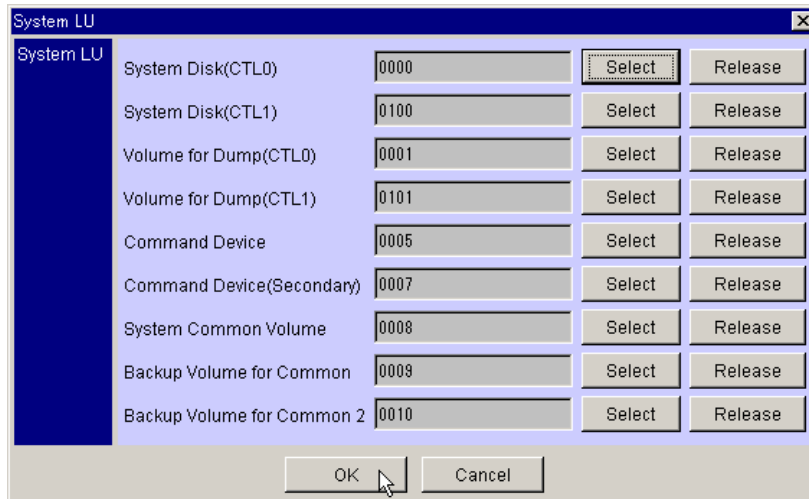

8. Click **OK**.
9. A message displays. Click **OK**.

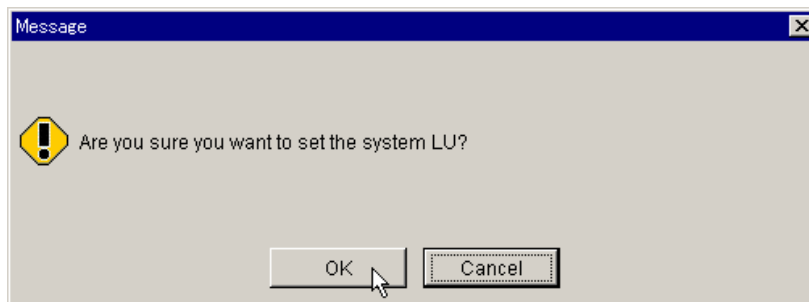

The set system LU is updated and the following window displays.

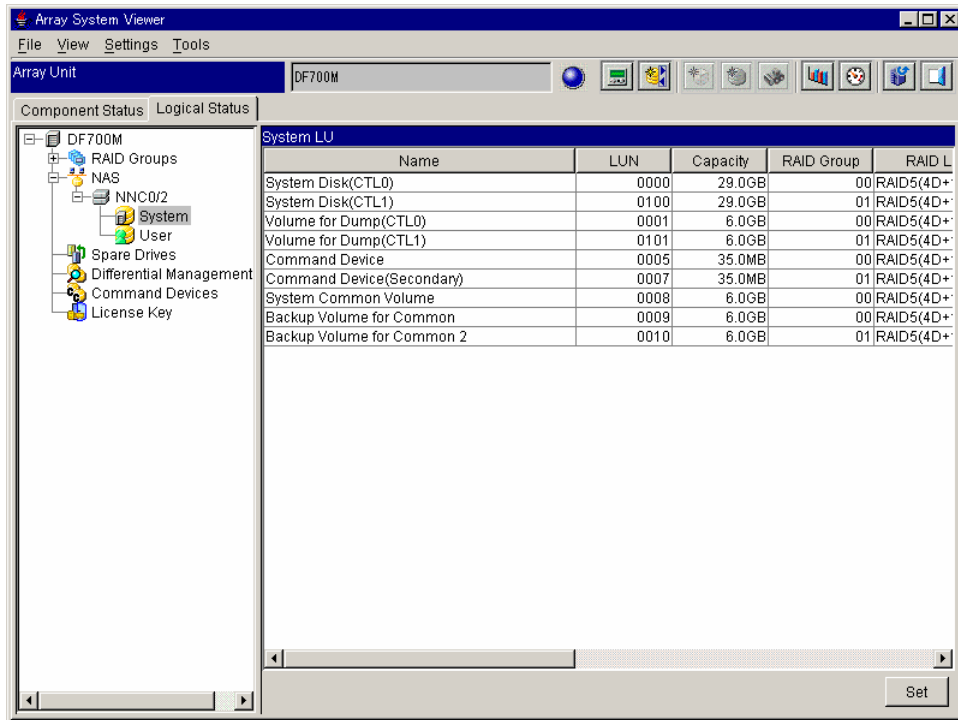

10.2.2 For NNC Type1

1. Click the **Logical Status** tab on the Array System Viewer window.
2. Click the **NAS** plus signs next to the **NNC0/2**.
3. Click the **NNC0/2** plus signs next to the **System**.

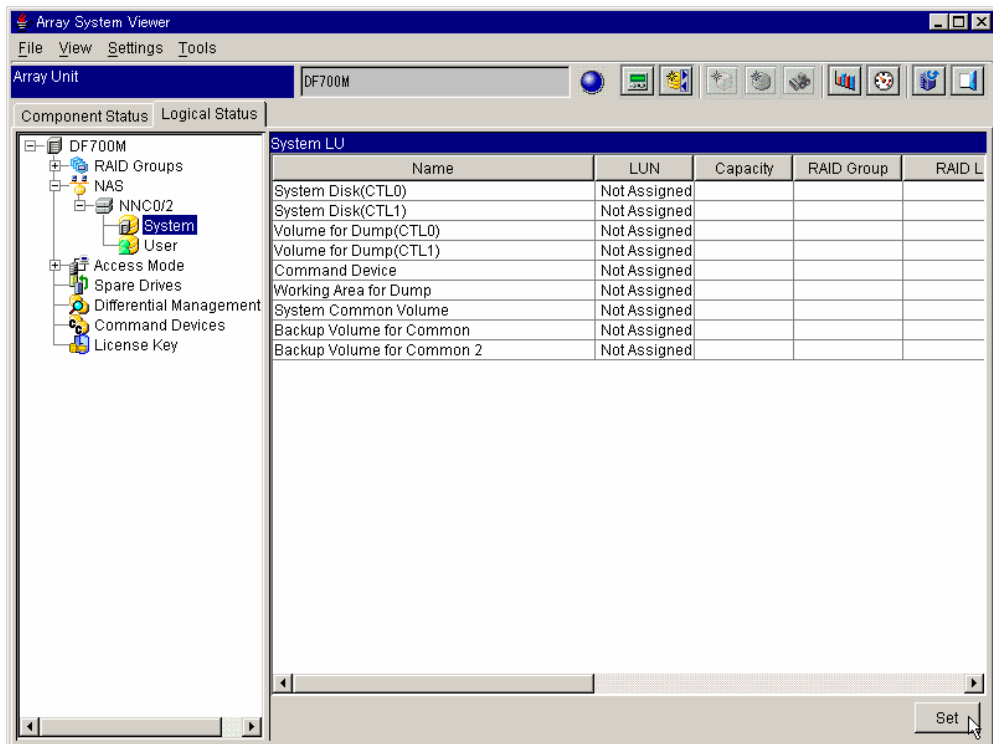

4. Click **Set**.

The **System LU** dialog box displays.

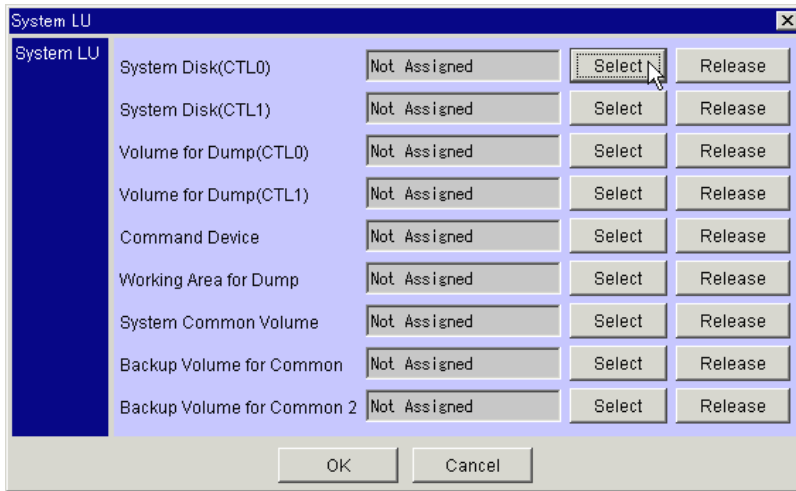

5. Click **Select** next to the wanted System LUs.

The **Select Logical Unit** dialog box displays.

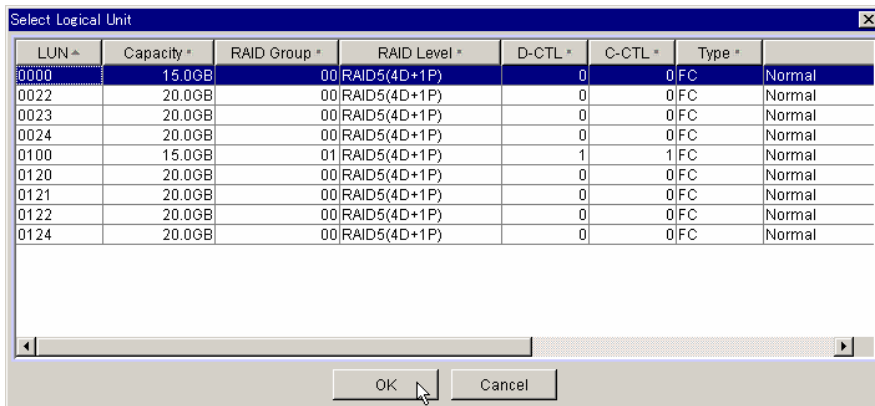

6. Click **LUN** to set the system LU, and then click **OK**.

The selected LUN displays.

7. Repeat steps 5 to 6 and complete a **System LU** list.

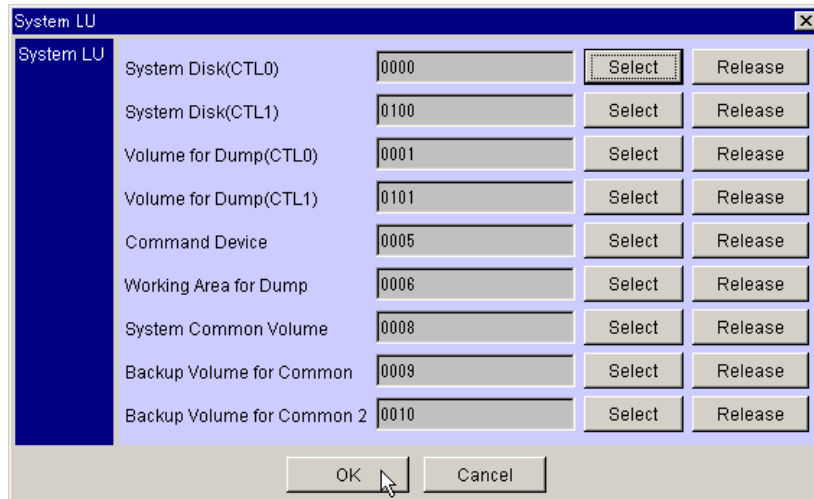

8. Click **OK**.
9. A message displays. Click **OK**.

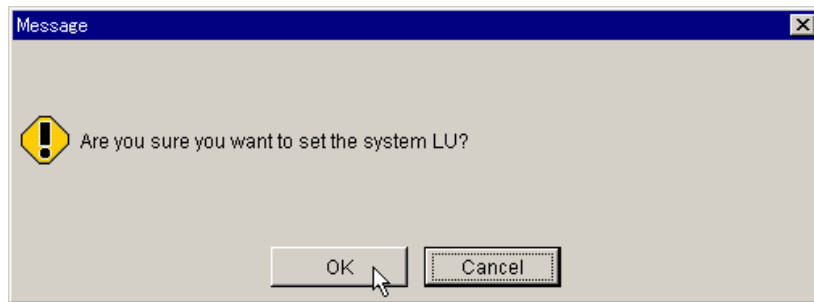

The set system LU is updated and the following window displays.

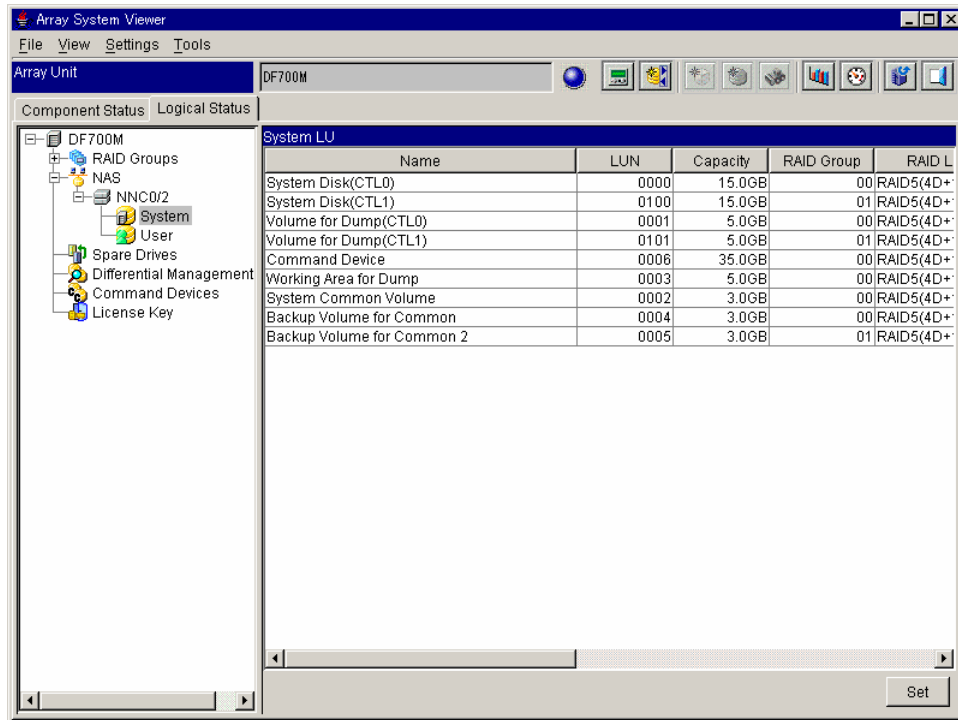

10.3 Setting NAS User Logical Units

When no logical unit is available for allocating to the logical unit for the NAS user, create it referring to section 7.1.

To set the NAS user logical units:

1. Click the **Logical Status** tab on the **Array System Viewer** window.
2. Click the **NAS** plus signs next to the **NNC0/2**.
3. Click the **NNC0/2** plus signs next to the **User**.

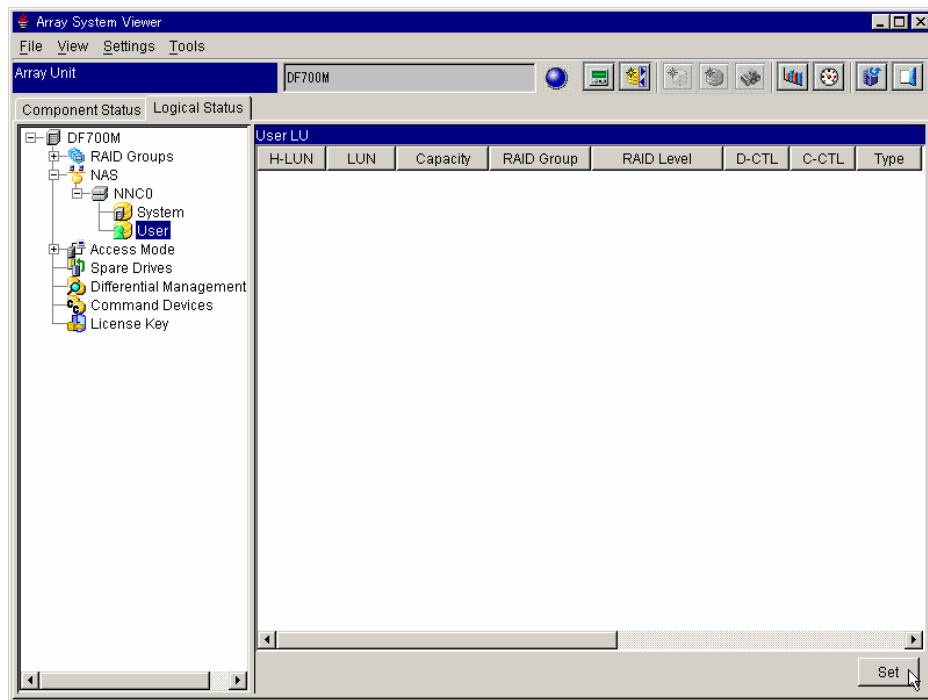

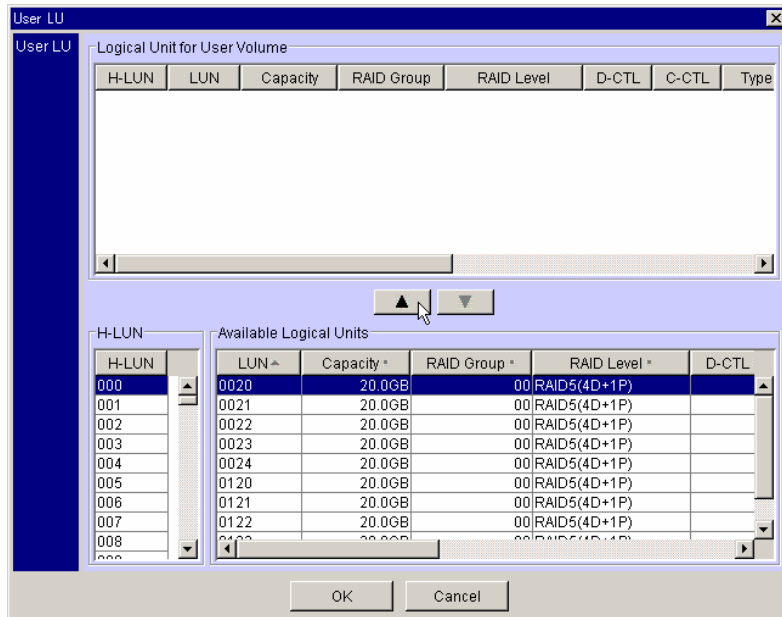

4. Click **Set**.

The **User LU** dialog box displays.

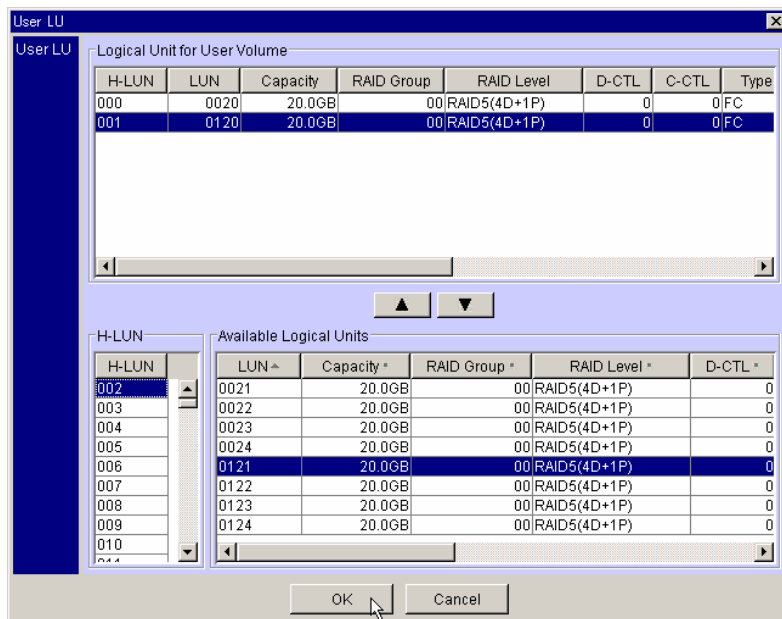

5. Select one H-LUN to be added. Select one LUN and click the  button. The added contents are displayed in Logical Unit for User Volume list.
6. Repeat step 5 and complete a User LU list.



To cancel the assigned user LU, select the H-LUN to be canceled in Logical Unit for User Volume list and click the  button.

The selected H-LUN moved to the Available Logical Units list.

7. Click OK.

8. A message displays. Click OK.

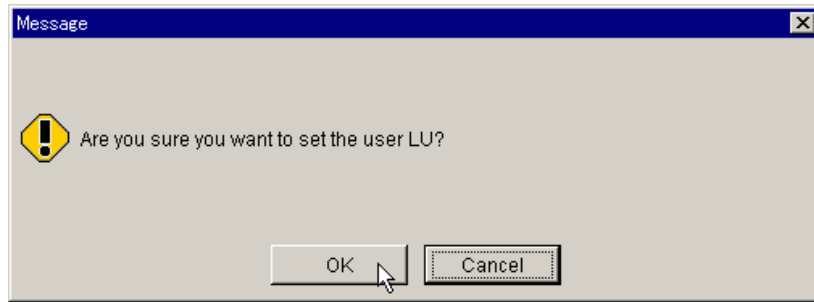

The set User LU is updated and the following window displays.

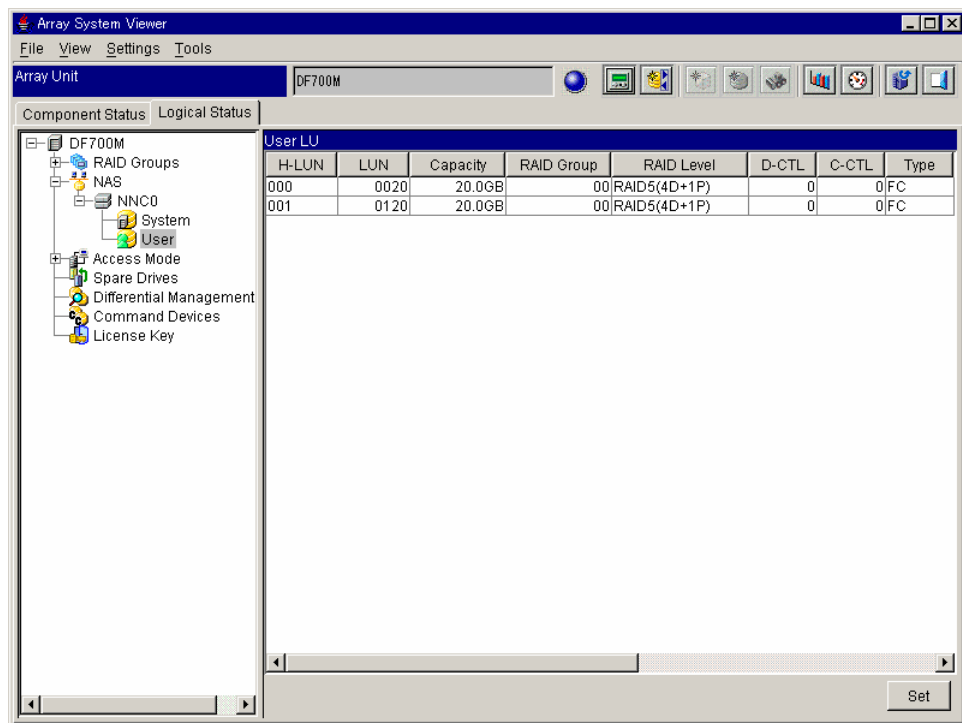

10.4 Shutdown/Booting/Rebooting NNC

10.4.1 Shutdown the NNC

To shutdown the NNC:

1. First make sure that the cluster status is **Active**, and the resource group status is either **online** or **offline**. If it is not, reboot the NNC.
2. Click the **Logical Status** tab on the **Array System Viewer** window.
3. Click the **NAS** icon; select the **NNC** number on the **NNC Status** list.

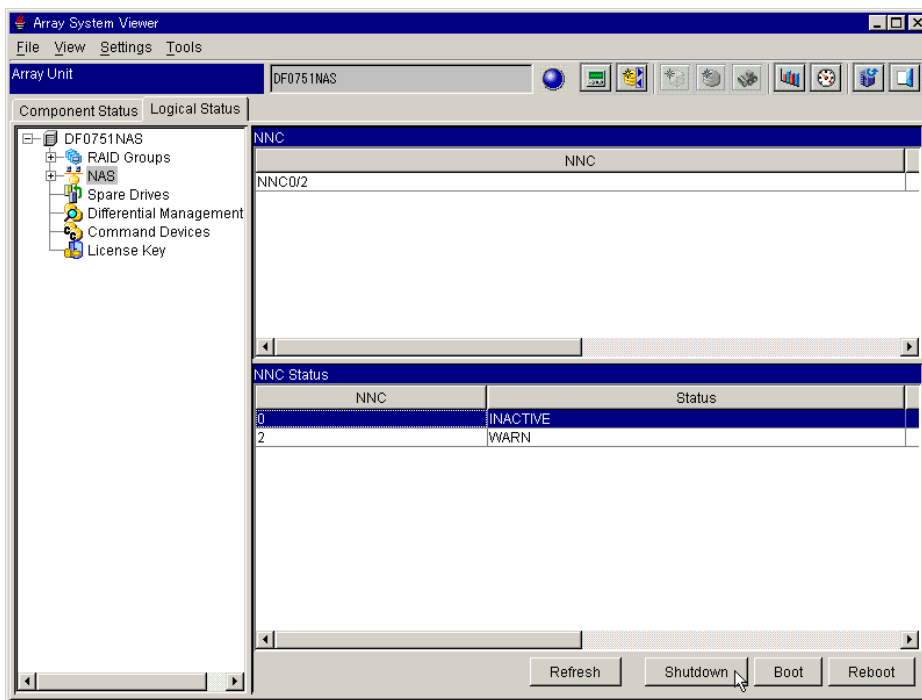

- **NNC Status:** Status of NAS OS:
 - **ACTIVE:** NAS OS is active and the Node is in operation.
 - **BOOT:** NAS OS is in boot process.
 - **DISUSE:** The controller is blocked.
 - **DOWN:** NAS OS is abnormally stopped.
 - **DUMP:** A NAS Dump is being collected.
 - **HUNGUP:** NAS OS is hung-up.
 - **INACTIVE:** NAS OS is in operation and the Node is stopped.
 - **INST:** NAS OS is in installation process.
 - **NEW:** NAS OS is not installed.
 - **SHUTDOWN:** NAS OS is in shutdown process.
 - **STOP:** NAS OS is normally stopped.
 - **WARN:** NAS Manager is not installed, or NAS OS is in operation and the status of the Node is unknown.

4. Click **Shutdown**.
5. A message displays. Click **OK**.

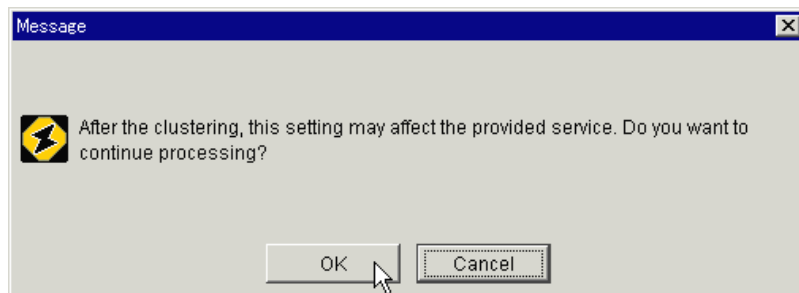
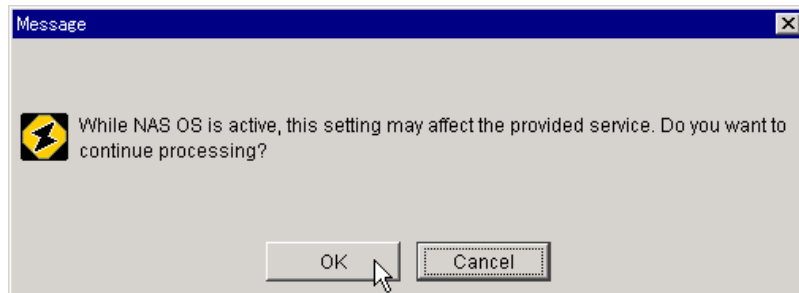
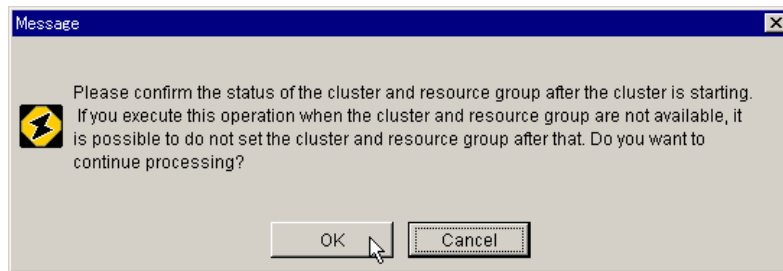
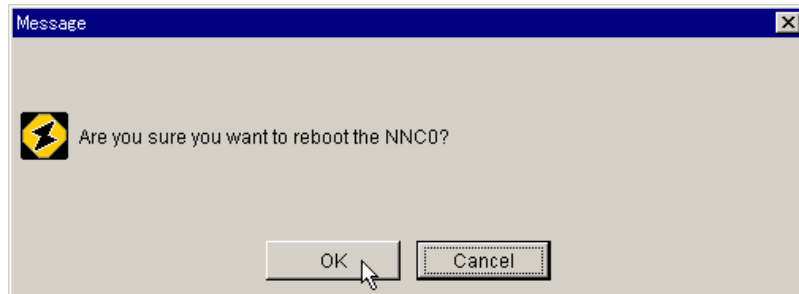



10.4.2 Booting the NNC

Note: There is no difference between the boot and reboot operations. Do not specify anything for the boot option.

To boot the NNC:

1. Click the **Logical Status** tab on the **Array System Viewer** window.
2. Click the **NAS** icon; select the **NNC** number on the **NNC Status** list.

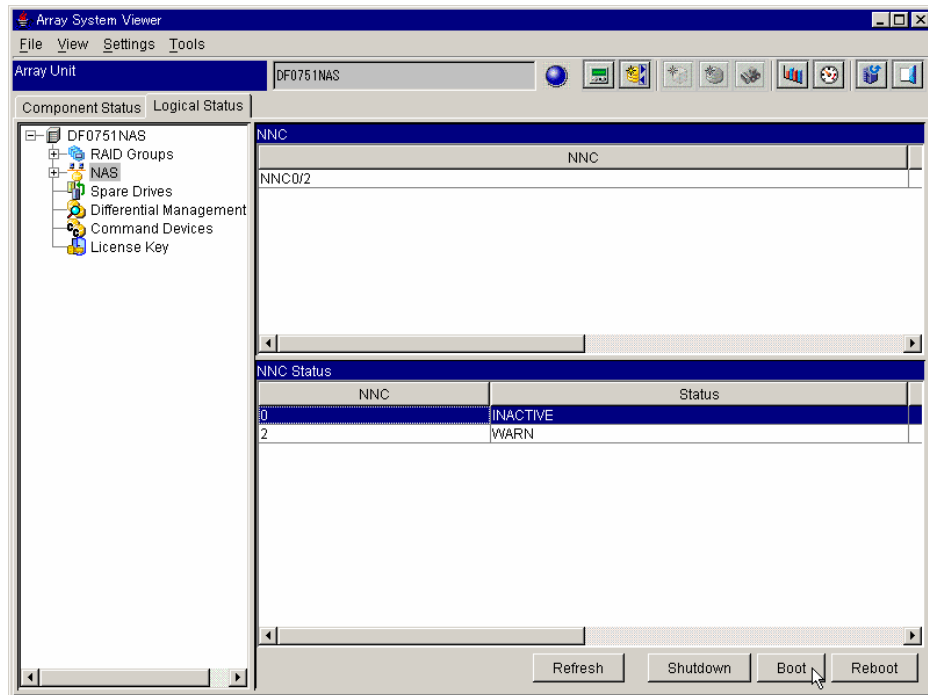

3. Click **Boot**.
4. A message displays. Click **OK**.

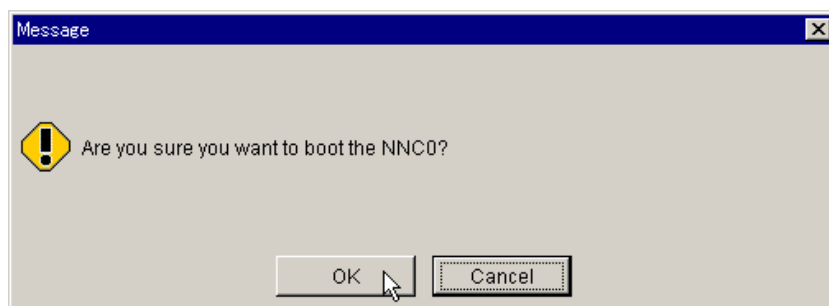



10.4.3 Rebooting the NNC

To reboot the NNC:

1. Click the **Logical Status** tab on the **Array System Viewer** window.
2. Click the **NAS** icon; select the **NNC** number on the **NNC Status** list.

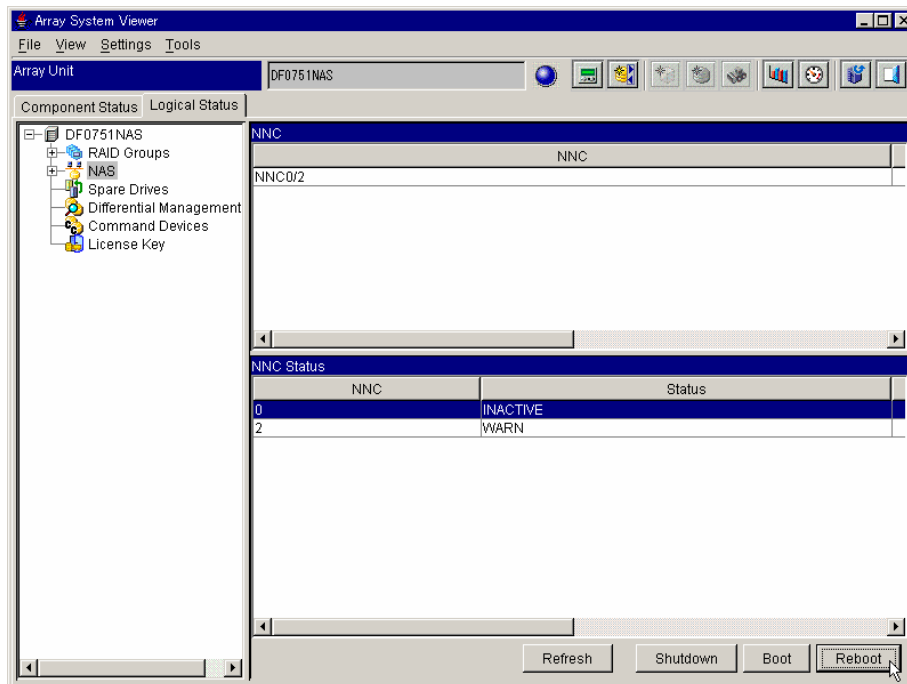

3. Click **Reboot**.
4. A message displays. Click **OK**.

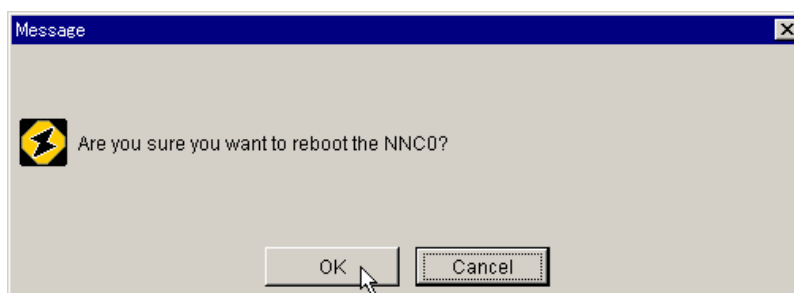

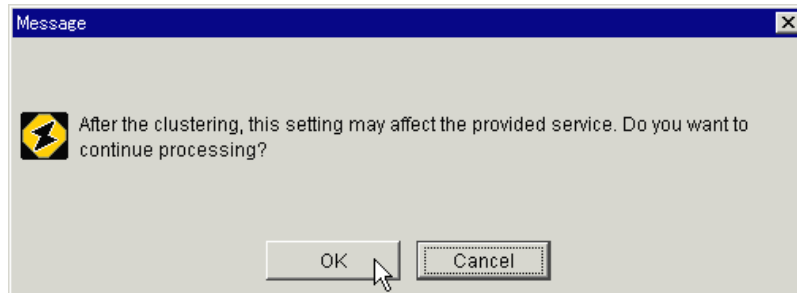
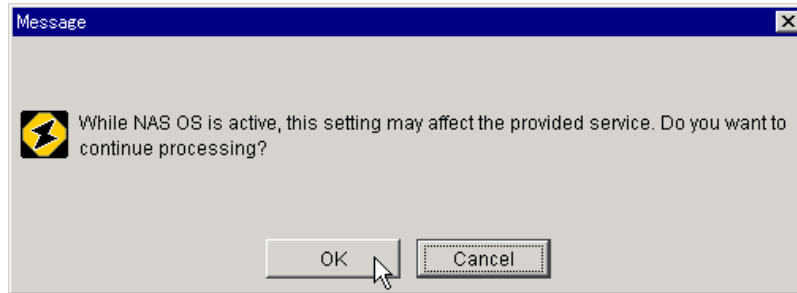
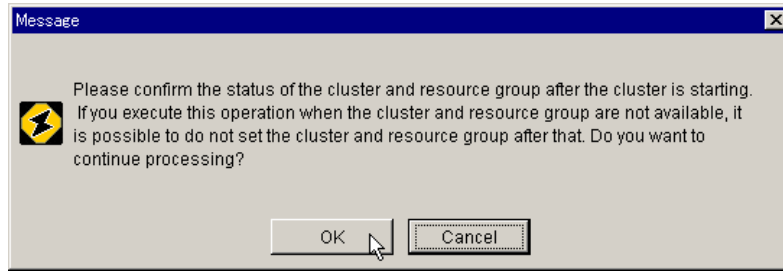

Chapter 11 Displaying Statistical Information

This section discusses the following topics:

- Displaying the Controller Use Condition (section 11.1)
- Displaying the Numbers of Host Commands Received (section 11.2)
- Displaying the Command Execution Condition (section 11.3)
- Displaying the Cache Load Condition (section 11.4)

11.1 Displaying the Controller Use Condition

- From the Tools menu, select **Statistical Information** or click : **Statistical Information** in the tool bar.

The **Controller Use Condition** window displays (see Figure 11.1).

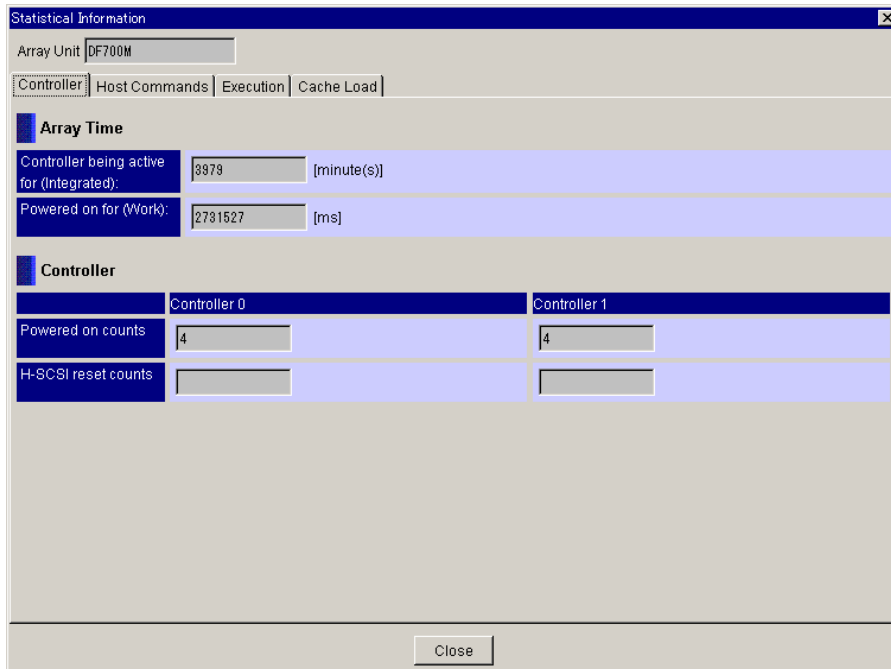

Figure 11.1 Displaying Controller Use Condition

- **Array Time**
 - **Controller being active for (Integrated):** Integrated active time of the array unit (minute). This is the accumulated time from the initial power-on to the power-off.
 - **Power on for (Work):** The accumulated time from the power-on of the subsystem to the present time. It is displayed by milliseconds.
- **Controller**
 - **Powered on counts:** Integrated number of power ON times (at interruption) of the controller
 - **H-SCSI reset counts:** Integrated number of host bus SCSI reset times (total of interruptions and messages) of the controller (Not supported)

11.2 Displaying the Numbers of Host Commands Received

- Click the Host Commands tab.

The screenshot shows a window titled 'Statistical Information' with a close button in the top right corner. Below the title bar, there is a text field for 'Array Unit' containing 'DF700M'. Below that, there are three tabs: 'Host Commands' (selected), 'Execution', and 'Cache Load'. The main area is divided into two panels, 'Controller 0' and 'Controller 1'. Each panel contains a table with columns for 'LU', 'Read', and 'Write'. The 'LU' column lists logical unit numbers from 0 to 13. The 'Read' and 'Write' columns show the accumulated number of received read and write commands, respectively. All values in the tables are 0. A 'Close' button is located at the bottom center of the window.

Controller 0				Controller 1			
LU	Read	Write		LU	Read	Write	
0	0	0	0	0	0	0	0
1	0	0	0	1	0	0	0
2	0	0	0	2	0	0	0
3	0	0	0	3	0	0	0
4	0	0	0	4	0	0	0
5	0	0	0	5	0	0	0
6	0	0	0	6	0	0	0
7	0	0	0	7	0	0	0
8	0	0	0	8	0	0	0
9	0	0	0	9	0	0	0
10	0	0	0	10	0	0	0
11	0	0	0	11	0	0	0
12	0	0	0	12	0	0	0
13	0	0	0	13	0	0	0

Figure 11.2 Displaying Number of Host Command Received

- **LU:** Logical unit number
- **Read:** Accumulated number of received read commands in each logical unit.
- **Write:** Accumulated number of received write commands in each logical unit.

11.3 Displaying the Command Execution Condition

- Click Execution tab.

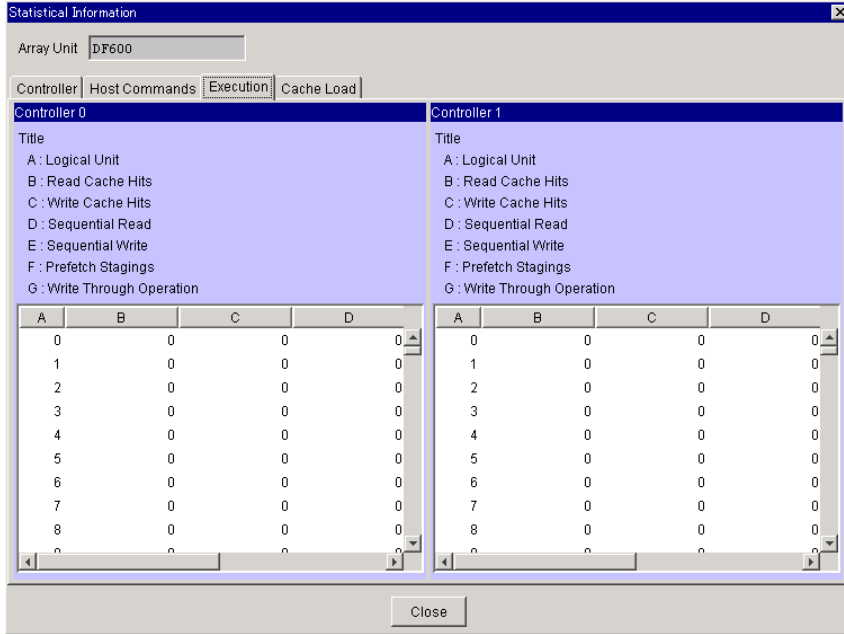

Figure 11.3 Displaying Command Execution Condition

- **A:Logical Unit:** Logical unit number
- **B:Read Cache Hits:** Total of READ commands (hitting cache or partially hitting cache)
- **C:Write Cache Hits:** Total of WRITE commands (cache read hits)
- **D:Sequential Read:** Total of READ commands (recognized as sequential reading)
- **E:Sequential Write:** Total of WRITE commands (recognized as sequential writing)
- **F:Prefetch Stagings:** Total of prefetch jobs executed
- **G:Write Through Operation:** Total of WRITE or WRITE & VERIFY commands (substituted by Write-Through operations)
- **H:Reassigned Blocks:** Number of re-assigned blocks (Not supported)

11.4 Displaying the Cache Load Condition

- Click Cache Load tab.

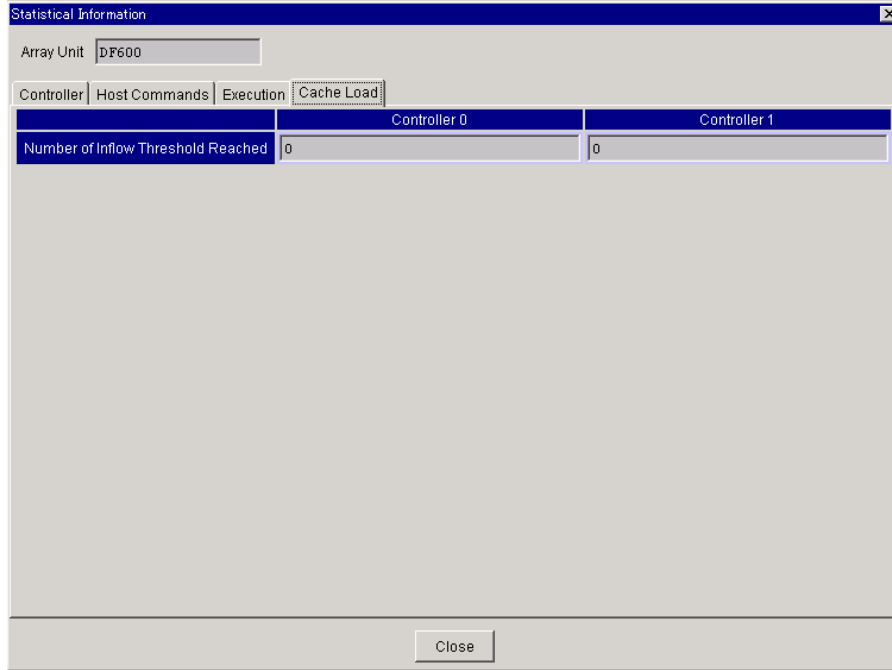

Figure 11.4 Displaying Cache Load Condition

- **Number of Inflow Threshold Reached:** Total number of occurrences of inflow limitations

This equipment manages the amount of data in cache as an inflow limit. When the host tries to write data exceeding this limit, an inflow limitation occurs. In this case, the write request from the host waits until part of write data is transferred to the drive.

Chapter 12 Acquiring Performance Information

In statistics information, the command operation state is output for each logical unit in the array unit. The command operation state consists of three types of data: the number of received commands, the number of cache-hit commands, and the cache hit rate for each Read or Write command.

This section includes:

- Setting a Collection of Performance Statistics (section 12.1)
- Outputting Statistics Information Automatically to a Text File (section 12.2)
- Outputting Performance Statistics Information Manually to a Text File (section 12.3)
- Outputting Performance Statistics Information Automatically to a Text File (section 12.4)

12.1 Setting a Collection of Performance Statistics

To select items from the collection of performance statistics:

1. On the **Tools** menu, select **Performance** → **Settings**.

The **Performance Statistics** dialog box displays.

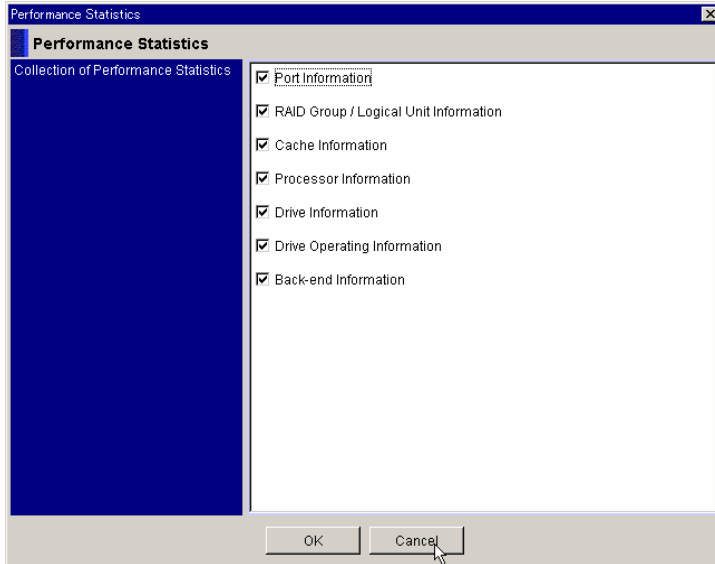

2. Select items from the **Collection of Performance Statistics**.

3. Click **OK**.

The following message displays. Click **OK**.

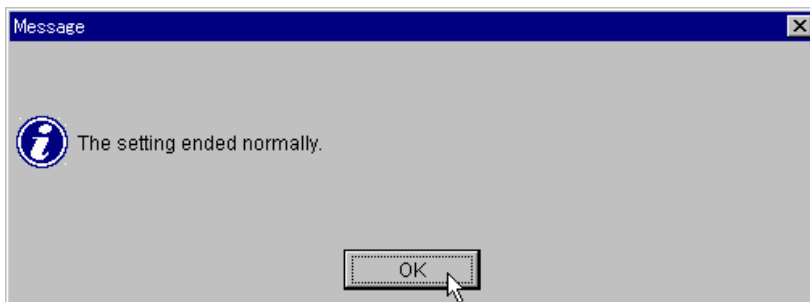
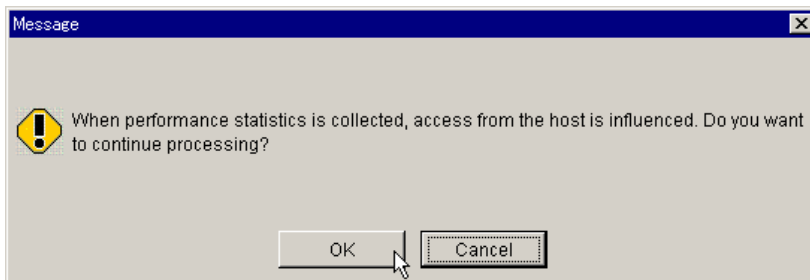

12.2 Outputting Statistics Information Automatically to a Text File

To select items from the collection of performance statistics:

On the Tools menu, select Performance → Settings.

The Performance Statistics dialog box displays.

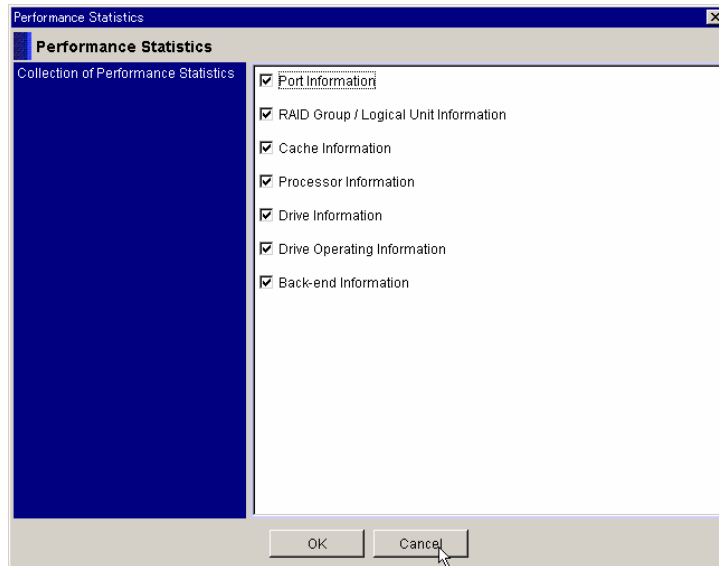

Select items from the **Collection of Performance Statistics**.

Click **OK**.

The following message displays. Click **OK**.

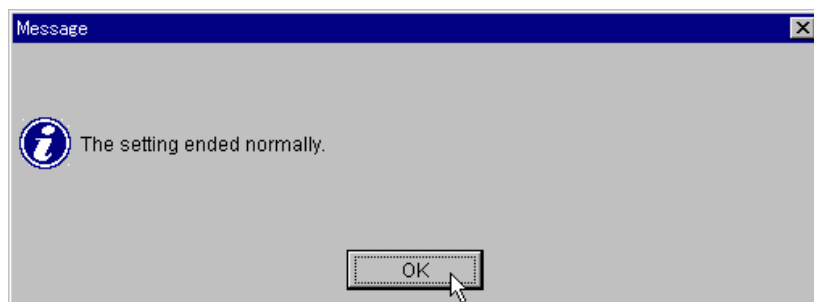
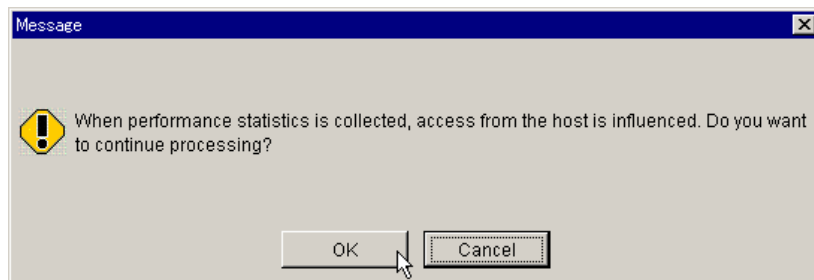

12.3 Outputting Performance Statistics Information Manually to a Text File

1. From the Tools menu, select **Performance** → **Output File** or click : **Performance** on the tool bar.



2. Select the name of the component (**Port**, **RAID Groups**, **Logical Unit**, **Cache**, **Processor**, **Drive**, **Drive Operation**, or **Back-end**), information that you need for each controller.
3. Specify the extent to be output clicking **Select**, excluding the **Cache** and **Processor**. When the extent is not specified, all is output. For example, when you want to specify an extent of information on the **Logical Unit**, click the **Logical Unit** icon, click **Select**, and then specify the extent of the **Logical Unit**.

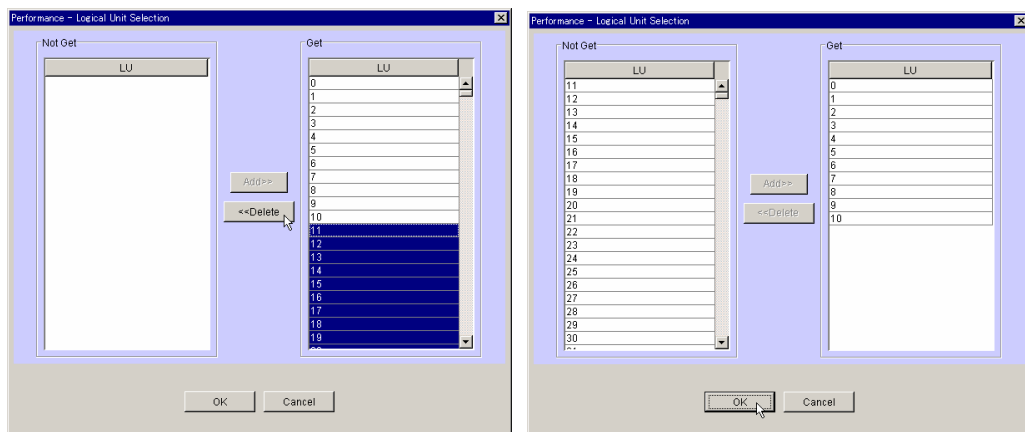

4. Select the number of the first one of LUs you do not want to output, scroll the LU numbers with the slider keeping the Shift key being pressed, and then select the number of the last LU.
5. Click **OK**.
6. Click the **Manual** radio button.

7. When you want to make an output as an addition to the information previously output, check the **Collectively output** check box. Do not check it when you want to overwrite the information previously output.
8. Specify the output directory or click **Browse**. If the output directory is omitted, it will be output to the directory where the Storage Navigator is installed.

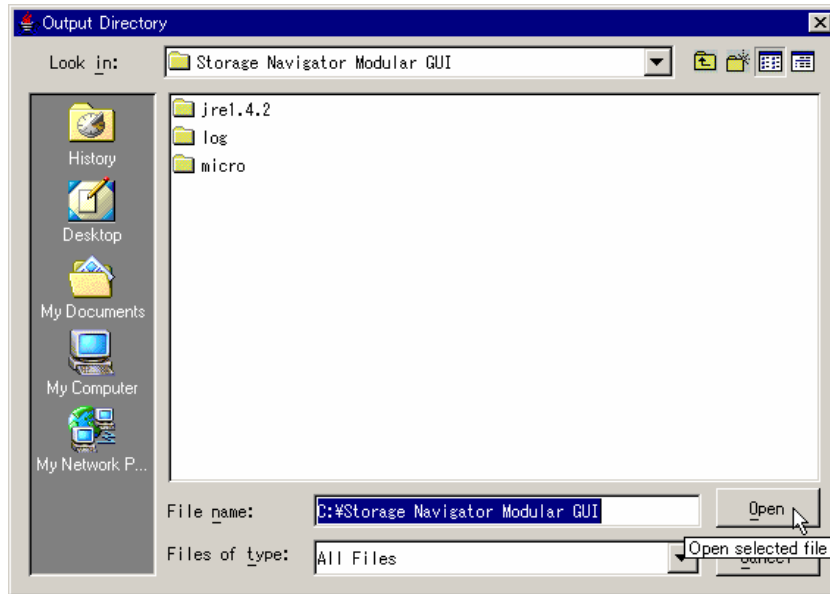

9. Click **Start**.
10. Click **Get Data**.

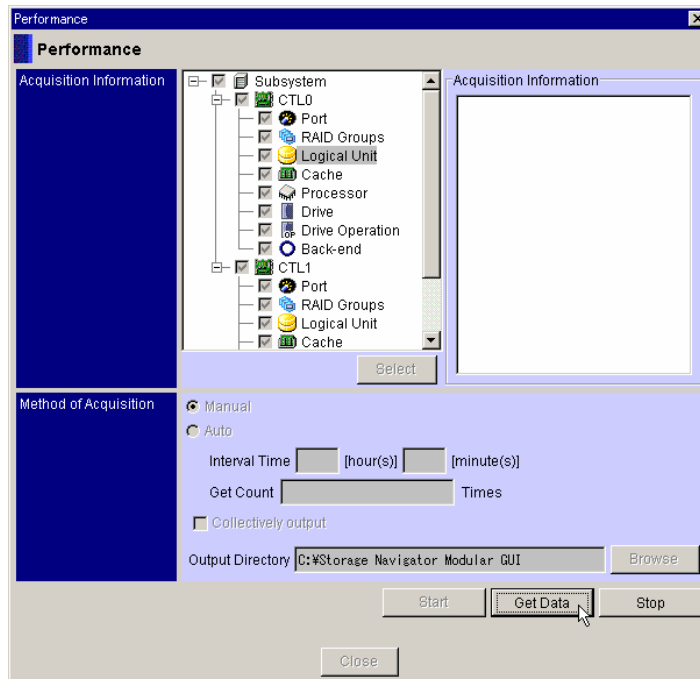

- a) When the **Collectively output** is not specified:
 These files are output in the text file format.
 : pfm\$\$\$\$\$.txt (\$\$\$\$\$: serial number from 00000 to 19999)

Note: Files are output with the names of pfm00000.txt to pfm19999.txt. After pfm19999.txt, pfm00000.txt is overwritten. Transfer necessary information to another directory.

The information is acquired according to the following timing.

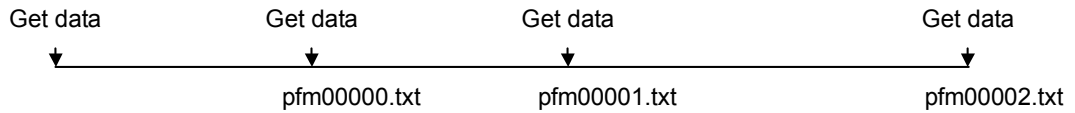

b) When the **Collectively output** is specified:

This file is output in the text file format (`pfm.txt`).

11. After the file processed is terminated, a confirmation message displays. Click **OK**.

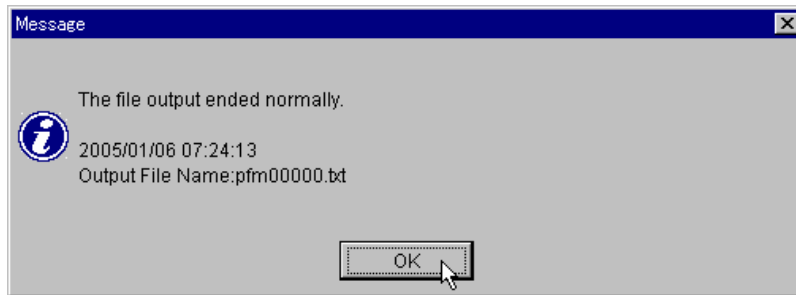

12. Click **Stop**.

When the single system is connected, only the information of the controller 0 side is collected.

Note: When the whole information is output to files once, the size of the output data is 500 kB for the AMS500. The data size varies in proportion to the number of times of outputs specified. To output the whole information to files 20,000 times using the AMS500 a disk capacity of approximately 10 GB is required.

No.	Output number	Information getting time
2005/01/31 11:57:48 - 2005/01/31 11:57:59		
--- Port Information ---		
CTL	Port	IO Rate(IOPS) Read Rate(IOPS) Write Rate(IOPS) Read Hit(%) Write Hit(%) Trans. Rate(MB/S) Read Trans. Rate(MB/S) Write Trans. Rate(MB/S)
0	A	0 0 0 0 0 0 0 0
0	B	0 0 0 0 0 0 0 0
1	A	0 0 0 0 0 0 0 0
1	B	0 0 0 0 0 0 0 0
CTL	Port	Read CMD Count Write CMD Count Read CMD Hit Count Write CMD Hit Count Read Trans. Size(MB) Write Trans. Size(MB)
0	A	0 0 0 0 0 0
0	B	0 0 0 0 0 0
1	A	0 0 0 0 0 0
1	B	0 0 0 0 0 0
--- RG Information ---		
CTL	RG	IO Rate(IOPS) Read Rate(IOPS) Write Rate(IOPS) Read Hit(%) Write Hit(%) Trans. Rate(MB/S) Read Trans. Rate(MB/S) Write Trans. Rate(MB/S)
0	0	0 0 0 0 0 0 0 0
0	1	0 0 0 0 0 0 0 0
1	0	0 0 0 0 0 0 0 0
1	1	0 0 0 0 0 0 0 0
CTL	RG	Read CMD Count Write CMD Count Read CMD Hit Count Write CMD Hit Count Read Trans. Size(MB) Write Trans. Size(MB)
0	0	0 0 0 0 0 0
0	1	0 0 0 0 0 0
1	0	0 0 0 0 0 0
1	1	0 0 0 0 0 0
--- LU Information ---		
CTL	LU	IO Rate(IOPS) Read Rate(IOPS) Write Rate(IOPS) Read Hit(%) Write Hit(%) Trans. Rate(MB/S) Read Trans. Rate(MB/S) Write Trans. Rate(MB/S)
0	0	0 0 0 0 0 0 0 0
0	1	0 0 0 0 0 0 0 0
0	2	0 0 0 0 0 0 0 0
CTL	LU	Read CMD Count Write CMD Count Read CMD Hit Count Write CMD Hit Count Read Trans. Size(MB) Write Trans. Size(MB)
0	0	0 0 0 0 0 0
0	1	0 0 0 0 0 0
0	2	0 0 0 0 0 0
CTL	LU	Read CMD Hit Count? Read CMD Hit Time(microsec.) Read CMD Hit Max Time(microsec.)
0	0	0 0 0
0	1	0 0 0
0	2	0 0 0
CTL	LU	Write CMD Hit Count? Write CMD Hit Time(microsec.) Write CMD Hit Max Time(microsec.)
0	0	0 0 0
0	1	0 0 0
0	2	0 0 0
CTL	LU	Read CMD Miss Count Read CMD Miss Time(microsec.) Read CMD Miss Max Time(microsec.)
0	0	0 0 0
0	1	0 0 0
0	2	0 0 0
CTL	LU	Write CMD Miss Count Write CMD Miss Time(microsec.) Write CMD Miss Max Time(microsec.)
0	0	0 0 0
0	1	0 0 0
0	2	0 0 0
CTL	LU	Read CMD Job Count Read CMD Job Time(microsec.) Read CMD Job Max Time(microsec.)
0	0	0 0 0
0	1	0 0 0
0	2	0 0 0
CTL	LU	Write CMD Job Count Write CMD Job Time(microsec.) Write CMD Job Max Time(microsec.)
0	0	0 0 0
0	1	0 0 0
0	2	0 0 0
CTL	LU	Read Hit Delay CMD Count(<300ms) Read Hit Delay CMD Count(300-499ms) Read Hit Delay CMD Count(500-999ms) Read Hit Delay CMD Count(1000ms-)
0	0	0 0 0 0
0	1	0 0 0 0
0	2	0 0 0 0
CTL	LU	Write Hit Delay CMD Count(<300ms) Write Hit Delay CMD Count(300-499ms) Write Hit Delay CMD Count(500-999ms) Write Hit Delay CMD Count(1000ms-)
0	0	0 0 0 0
0	1	0 0 0 0
0	2	0 0 0 0
CTL	LU	Read Miss Delay CMD Count(<300ms) Read Miss Delay CMD Count(300-499ms) Read Miss Delay CMD Count(500-999ms) Read Miss Delay CMD Count(1000ms-)
0	0	0 0 0 0
0	1	0 0 0 0
0	2	0 0 0 0
CTL	LU	Write Miss Delay CMD Count(<300ms) Write Miss Delay CMD Count(300-499ms) Write Miss Delay CMD Count(500-999ms) Write Miss Delay CMD Count(1000ms-)
0	0	0 0 0 0
0	1	0 0 0 0
CTL	LU	Read Job Delay CMD Count(<300ms) Read Job Delay CMD Count(300-499ms) Read Job Delay CMD Count(500-999ms) Read Job Delay CMD Count(1000ms-)
0	0	0 0 0 0
0	1	0 0 0 0
0	2	0 0 0 0
CTL	LU	Write Job Delay CMD Count(<300ms) Write Job Delay CMD Count(300-499ms) Write Job Delay CMD Count(500-999ms) Write Job Delay CMD Count(1000ms-)
0	0	0 0 0 0
0	1	0 0 0 0
0	2	0 0 0 0
CTL	LU	Tag Count
0	0	0
0	1	0
0	2	0

```

---- Cache Information ----
CTL Write Pending Rate(%)
0 0
1 0
2 0
CTL Clean Queue Usage Rate(%) Middle Queue Usage Rate(%) Physical Queue Usage Rate(%) Total Queue Usage Rate(%)
0 0 0 0
1 0 0 0 0
2 0 0 0 0
CTL Partition Write Pending Rate(%)
0 0
1 0
2 0
CTL Partition Clean Queue Usage Rate(%) Middle Queue Usage Rate(%) Physical Queue Usage Rate(%)
0 0 0 0
1 0 0 0
2 0 0 0
---- Processor Information ----
CTL Usage(%)
0 0
1 0
2 0
CTL Host-Cache Bus Usage Rate(%) Drive-Cache Bus Usage Rate(%) Processor-Cache Bus Usage Rate(%)
0 0 0 0
1 0 0 0
2 0 0 0
CTL Cache(DRR) Bus Usage Rate(%) Dual Bus Usage Rate(%) Total Bus Usage Rate(%)
0 0 0 0
1 0 0 0
2 0 0 0
---- Drive Information ----
CTL Unit HDU IO Rate(IOPS) Read Rate(IOPS) Write Rate(IOPS) Trans. Rate(MB/S) Read Trans. Rate(MB/S) Write Trans. Rate(MB/S) online verify Rate(IOPS)
0 0 0 0 0 0 0 0
1 0 0 1 0 0 0 0
2 0 0 2 0 0 0 0
CTL Unit HDU Read CMD Count Write CMD Count Read Trans. Size Write Trans. Size online verify CMD Count
0 0 0 0 0 0 13
1 0 0 1 0 0 13
2 0 0 2 0 0 13
---- Drive Operate Information ----
CTL Unit HDU Operating Rate(%) Tag count unload Time(min.)
0 0 0 0 2 0
1 0 0 1 0 0
2 0 0 2 0 0
---- Backend Information ----
CTL Path Loop IO Rate(IOPS) Read Rate(IOPS) Write Rate(IOPS) Trans. Rate(MB/S) Read Trans. Rate(MB/S) Write Trans. Rate(MB/S) online verify Rate(IOPS)
0 0 0 0 0 0 0 0
1 0 0 1 0 0 0 0
2 0 0 2 0 0 0 0
CTL Path Loop Read CMD Count Write CMD Count Read Trans. Size Write Trans. Size online verify CMD Count
0 0 0 0 0 0 39
1 0 0 1 0 0 0
2 0 0 2 0 0 26

```

- **No.:** Output number
- **Information getting time:** Time and date when the information is acquired.
- **CTL:** Controller number
- **Port:** Port number
- **IO Rate (IOPS):** Number of Read/Write commands received per second.
- **Read Rate (IOPS):** Number of Read commands received per second.
- **Write Rate (IOPS):** Number of Write commands received per second.
- **Read Hit (%):** Rate of the number of the Read commands, which could cache-hitting, out of the Read commands received in the specified period.
- **Write Hit (%):** Rate of the number of the Write commands, which could write data immediately to the cache, out of the Write commands received in the specified period.
- **Trans. Rate (MB/S):** Transfer size of Read/Write commands per second.
- **Read Trans. Rate (MB/S):** Transfer size of Read commands per second.
- **Write Trans. Rate (MB/S):** Transfer size of Write commands per second.
- **Read CMD Count:** Received number of Read commands.
- **Write CMD Count:** Received number of Write command.
- **Read CMD Hit Count:** Number of the Read commands that had been cache-hit.
- **Write CMD Hit Count:** Number of the Write commands, which could write data immediately to the cache.
- **Read Trans. Size (MB):** Transfer size of Read commands.
- **Write Trans. Size (MB):** Transfer size of Write commands.
- **RG:** RAID group number
- **LU:** Logical unit number
- **Read CMD Hit Count2:** Number of the Hit Read Special Path commands out of the read commands that made cache hits.
- **Read CMD Hit Time(microsec.):** The average response time of the Hit Read Special Path command.

- **Read CMD Hit Max Time(microsec.):** The maximum response time of the Hit Read Special Path command.
- **Write CMD Hit Count2:** Number of the Write Special Path commands out of the Write commands, which could write data immediately to the cache.
- **Write CMD Hit Time(microsec.):** The average response time of the Write Special Path command.
- **Write CMD Hit Max Time(microsec.):** The maximum response time of the Write Special Path command.
- **Read CMD Miss Count:** The number of the Miss Read Special Path commands out of the Read commands that made no cache hits.
- **Read CMD Miss Time(microsec.):** The average response time of the Miss Read Special Path command.
- **Read CMD Miss Max Time(microsec.):** The maximum response time of the Miss Read Special Path command.
- **Write CMD Miss Count:** The number of the Random Write Special Path commands that could complete the high-speed process up to the parity generation that is an extended process of the Write command.
- **Write CMD Miss Time(microsec.):** The average response time of the Random Write Special Path command.
- **Write CMD Miss Max Time(microsec.):** The maximum response time of the Random Write Special Path command.
- **Read CMD Job Count:** The number of the Read commands that could not perform the high-speed process.
- **Read CMD Job Time(microsec.):** The average response time of the Read command job.
- **Read CMD Job Max Time(microsec.):** The maximum response time of the Read command job.
- **Write CMD Job Count:** The number of the Write commands that could not perform the high-speed process.
- **Write CMD Job Time(microsec.):** The average response time of the Write command job.
- **Write CMD Job Max Time(microsec.):** The maximum response time of the Write command job.
- **Read Hit Delay CMD Count(<300ms):** The number of commands, whose response time is less than 300 ms, out of the Hit Read Special Path commands.
- **Read Hit Delay CMD Count(300-499ms):** The number of commands, whose response time is in a range of 300 ms to 499 ms, out of the Hit Read Special Path commands.
- **Read Hit Delay CMD Count(500-999ms):** The number of commands, whose response time is in a range of 500 ms to 999 ms, out of the Hit Read Special Path commands.
- **Read Hit Delay CMD Count(1000ms-):** The number of commands, whose response time is 1000 ms or more, out of the Hit Read Special Path commands.
- **Write Hit Delay CMD Count(<300ms):** The number of commands, whose response time is less than 300 ms, out of the Write Special Path commands.

- **Write Hit Delay CMD Count(300-499ms):** The number of commands, whose response time is in a range of 300 ms to 499 ms, out of the Write Special Path commands.
- **Write Hit Delay CMD Count(500-999ms):** The number of commands, whose response time is in a range of 500 ms to 999 ms, out of the Write Special Path commands.
- **Write Hit Delay CMD Count(1000ms-):** The number of commands, whose response time is 1000 ms or more, out of the Write Special Path commands.
- **Read Miss Delay CMD Count(<300ms):** The number of commands, whose response time is less than 300 ms, out of the Miss Read Special Path commands.
- **Read Miss Delay CMD Count(300-499ms):** The number of commands, whose response time is in a range of 300 ms to 499 ms, out of the Miss Read Special Path commands.
- **Read Miss Delay CMD Count(500-999ms):** The number of commands, whose response time is in a range of 500 ms to 999 ms, out of the Miss Read Special Path commands.
- **Read Miss Delay CMD Count(1000ms-):** The number of commands, whose response time is 1000 ms or more, out of the Miss Read Special Path commands.
- **Write Miss Delay CMD Count(<300ms):** The number of commands, whose response time is less than 300 ms, out of the Random Write Special Path commands.
- **Write Miss Delay CMD Count(300-499ms):** The number of commands, whose response time is in a range of 300 ms to 499 ms, out of the Random Write Special Path commands.
- **Write Miss Delay CMD Count(500-999ms):** The number of commands, whose response time is in a range of 500 ms to 999 ms, out of the Random Write Special Path commands.
- **Write Miss Delay CMD Count(1000ms-):** The number of commands, whose response time is 1000 ms or more, out of the Random Write Special Path commands.
- **Read Job Delay CMD Count(<300ms):** The number of commands, whose response time is less than 300 ms, out of the Read command job.
- **Read Job Delay CMD Count(300-499ms):** The number of commands, whose response time is in a range of 300 ms to 499 ms, out of the Read command job.
- **Read Job Delay CMD Count(500-999ms):** The number of commands, whose response time is in a range of 500 ms to 999 ms, out of the Read command job.
- **Read Job Delay CMD Count(1000ms-):** The number of commands, whose response time is 1000 ms or more, out of the Read command job.
- **Write Job Delay CMD Count(<300ms):** The number of commands, whose response time is less than 300 ms, out of the Write command job.
- **Write Job Delay CMD Count(300-499ms):** The number of commands, whose response time is in a range of 300 ms to 499 ms, out of the Write command job.
- **Write Job Delay CMD Count(500-999ms):** The number of commands, whose response time is in a range of 500 ms to 999 ms, out of the Write command job.
- **Write Job Delay CMD Count(1000ms-):** The number of commands, whose response time is 1000 ms or more, out of the Write command job.
- **Tag Count:** The maximum number of tags in the specified period.

- **Cache Write Pending Rate (%)**: Rate of cache usage capacity (middle+physical) within the cache capacity.
- **Cache Clean Queue Usage Rate (%)**: Rate of clean cache usage
- **Cache Middle Queue Usage Rate (%)**: Rate of middle cache usage
- **Cache Physical Queue Usage Rate (%)**: Rate of physical cache usage
- **Cache Total Queue Usage Rate (%)**: Rate of total cache usage
- **Partition**: Partition number
- **Usage (%)**: Operation rate of the processor
- **Host-Cache Bus Usage Rate (%)**: The use rate of the bus between the host and the cache.
- **Drive-Cache Bus Usage Rate (%)**: The use rate of the bus between the drive and the cache.
- **Processor-Cache Bus Usage Rate (%)**: The use rate of the bus between the processor and the cache.
- **Cache (DRR) Bus Usage Rate (%)**: The use rate of the bus between the parity generation circuit (DRR) and the cache.
- **Dual Bus Usage Rate (%)**: The use rate of the bus between the controllers.
- **Total Bus Usage Rate (%)**: The total use rate of the cache bus.
- **Unit**: Unit number
- **HDU**: HDU number
- **Online Verify. Rate (IOPS)**: Number of Online Verify commands per second
- **Online Verify CMD Count**: Number of Online Verify commands
- **Operating Rate (%)**: Operation rate of the drive
- **Tag Count**: Number of Tag
- **Unload Time (min.)**: Unload time of the drive
- **Path**: Path number
- **Loop**: Loop number

12.4 Outputting Performance Statistics Information Automatically to a Text File

Command operation state for each logical unit in the array unit is output at the specified intervals by the specified times.

1. From the **Tools** menu, select **Performance**. Alternatively, click : **Performance** in the tool bar.

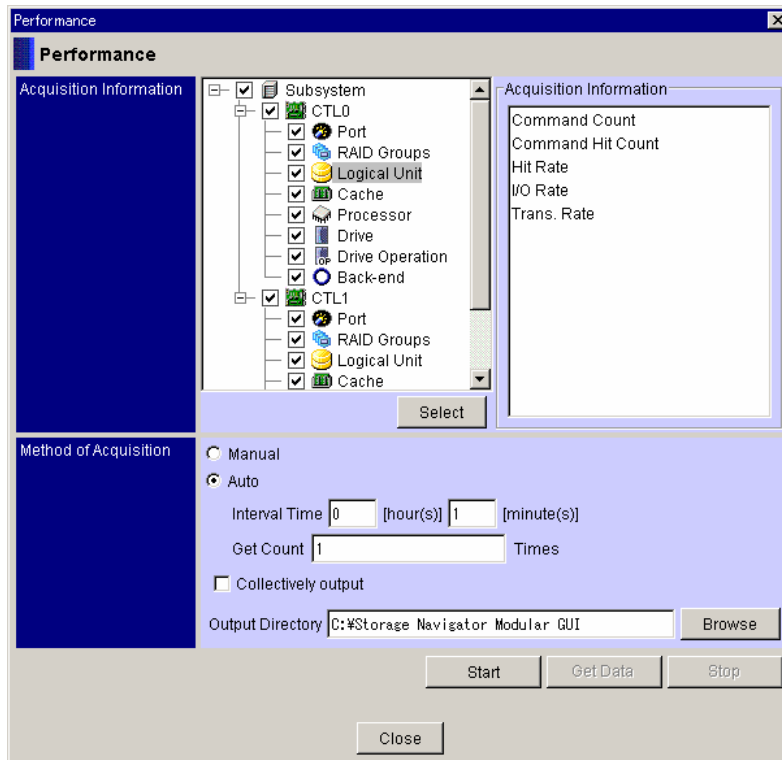

2. Select the name of the component (**Port**, **RAID Groups**, **Logical Unit**, **Cache**, **Processor**, **Drive**, **Drive Operation**, or **Back-end**), information on which you want to get, for each controller.
3. Specify the extent to be output clicking **Select**, excluding the **Cache** and **Processor**. When the extent is not specified, all is output. For example, when you want to specify an extent of information on the logical unit, click the **Logical Unit** icon, click **Select**, and then specify the extent of the logical unit.
4. Click the **Auto** radio button.
5. Specify the **Interval Time** and **Get Count** Times.
6. When you want to make an output as an addition to the information previously output, check the **Collectively output** check box. Do not check it when you want to overwrite the information previously output.

7. Input the output directory or click **Browse**. If the output directory is omitted, it will be output to the directory where the Storage Navigator is installed.

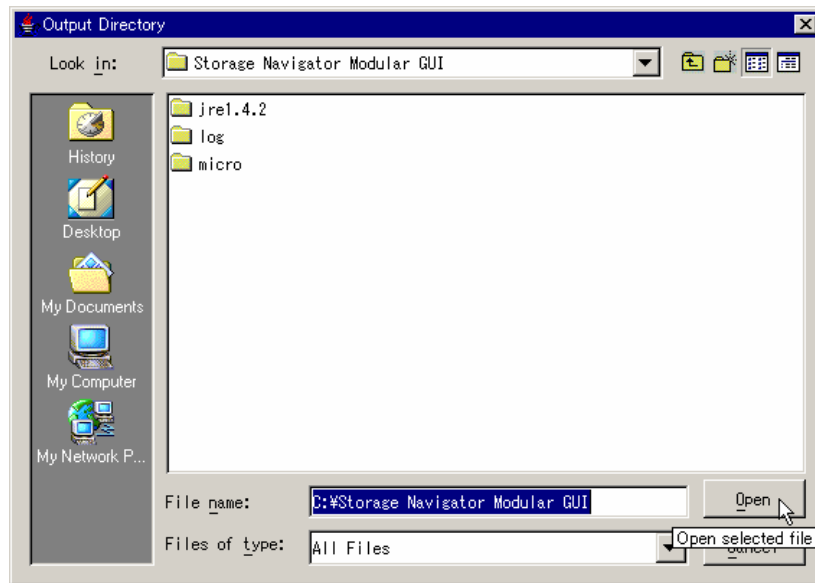

8. Click **Start**.

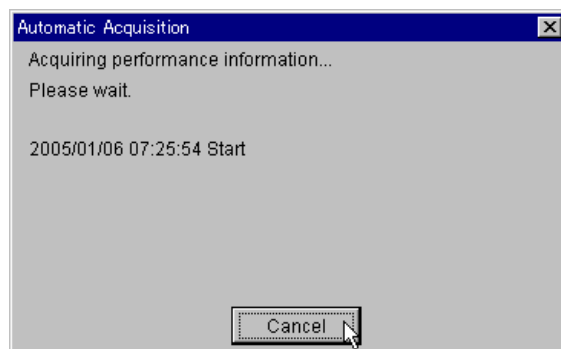

- a) When the **Collectively output** is not specified:

These files are output in the text file format.

: pfm\$\$\$\$\$.txt (\$\$\$\$: serial number from 00000 to 19999)

Note: Files are output with the names of pfm00000.txt to pfm19999.txt. After pfm19999.txt, pfm00000.txt is overwritten. Transfer necessary information to another directory.

- b) When the **Collectively output** is specified:

This file is output in the text file format (pfm.txt).

9. After the file processed is terminated, a confirmation message displays. Click **OK**.

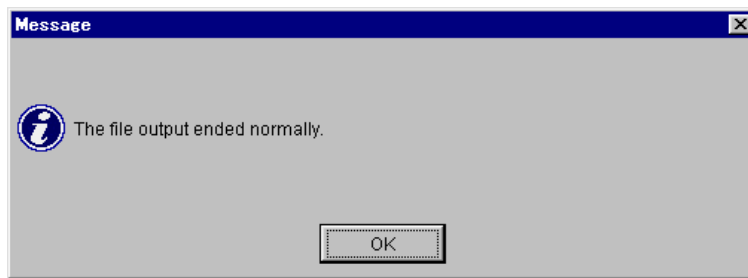

When the single system is connected, only the information of the controller 0 side is collected.

The format to the file to be retrieved is the same as that of the file retrieved manually.

Note: When the whole information is output to files once, the size of the output data is 500 kB in the cases of the AMS500. The data size varies in proportion to the number of times of outputs specified. To output the whole information to files 20,000 times using the AMS500, a disk capacity of approximately 10 GB is required.

Chapter 13 Tuning Parameters

The tuning parameters include parameters concerning the system and the logical unit.

This section discusses the following topics:

- Multi Stream Tuning Parameters (section 13.1)
- Pre-Fetch Parameters (section 13.2)
- System Tuning Parameters (section 13.3)

13.1 Multi Stream Tuning Parameters

1. From the Tools menu, select the Tuning Parameter on the Unit window. The Tuning Parameter window displays.

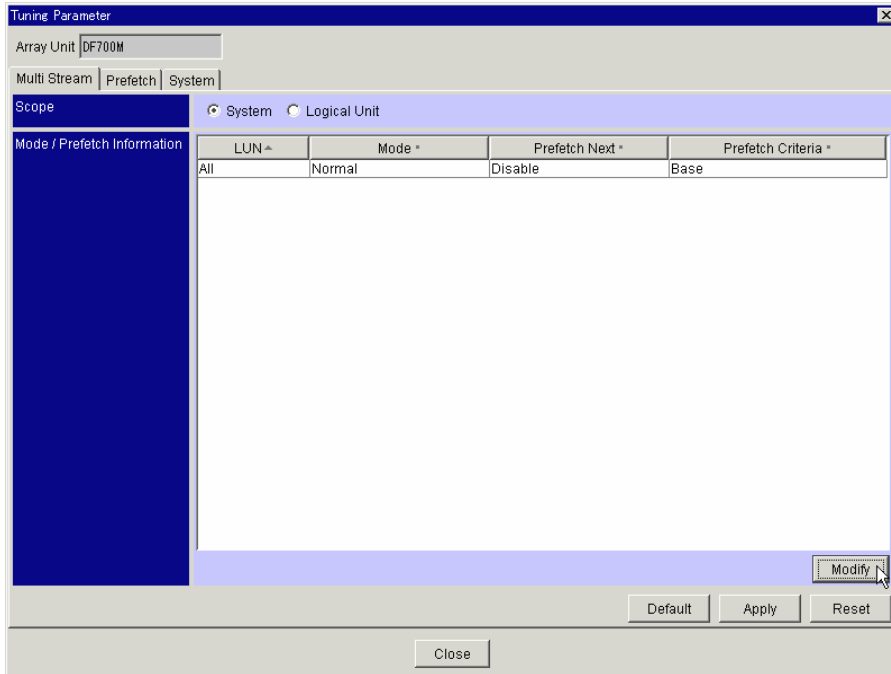

- **Scope:** Select **System** or **Logical Unit**.
 - **Mode / Prefetch Information:**
 - **LUN:** Displays **All**
 - **Mode:** Displays **Normal**, **Read**, **Write**, or **Read/Write**
 - **Prefetch Next:** Displays **Disable** or **Enable**
 - **Prefetch Criteria:** Displays **Base** or **Fixed**
2. When you want to modify the setting, click **Modify**. The **Prefetch Multi Stream (System)** dialog box displays.

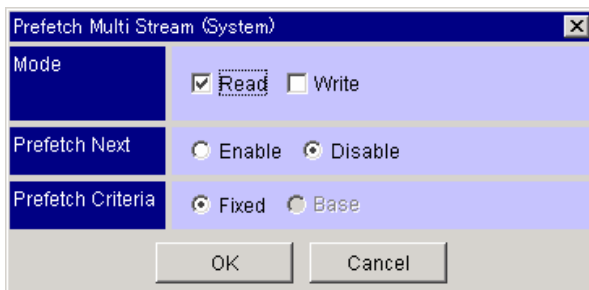

- **Mode:** Specify the mode:
 - **Read:** When you select the **Read** mode, specify the **Prefetch Next** Enable or Disable.
 - **Write:** When you select the **Write** mode, cannot specify the **Prefetch Next**.
 - **Prefetch Criteria:** Specify the pre-fetch criteria.
3. Specify the parameters; click **OK**.
 4. Click the **Logical Unit** on the **Scope**.

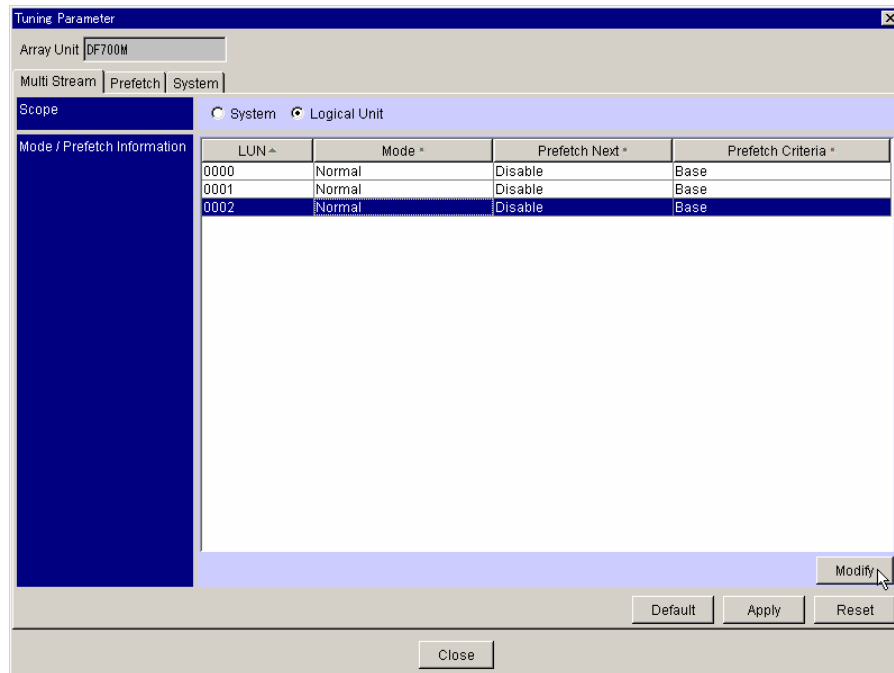

- **Scope:** Select **System** or **Logical Unit**.
 - **Mode / Prefetch Information:**
 - **LUN:** Displays logical unit number
 - **Mode:** Displays **Normal**, **Read**, **Write**, or **Read/Write**
 - **Prefetch Next:** Displays **Disable** or **Enable**
 - **Prefetch Criteria:** Displays **Base** or **Fixed**
5. Select the LUN to modify the setting. Then click **Modify**.

The Prefetch Multi Stream (Logical Unit) dialog box displays.

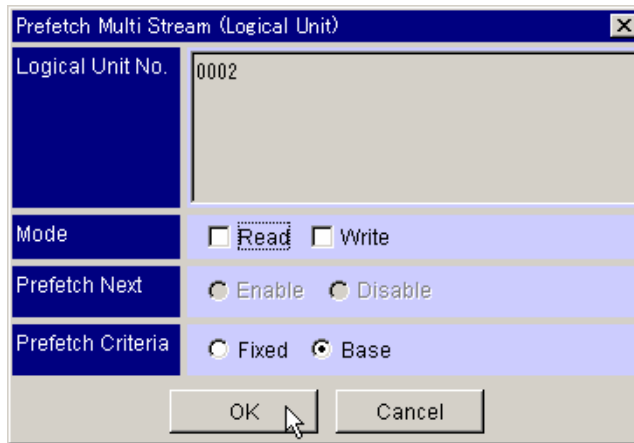

- **Logical Unit No.:** Displays the logical unit number.
 - **Mode:** Specify the mode:
 - **Read:** When you select the **Read** mode, specify the **Prefetch Next** Enable or Disable.
Note: You can specify only **Fixed** in the **Prefetch Criteria**.
 - **Write:** When you select the **Write** mode, cannot specify the **Prefetch Next**.
 - **Prefetch Criteria:** Specify the pre-fetch criteria.
6. Specify the parameters; click **OK**.
 7. Click **Apply**.
 8. A message displays stating that the setting is complete. Click **OK**.

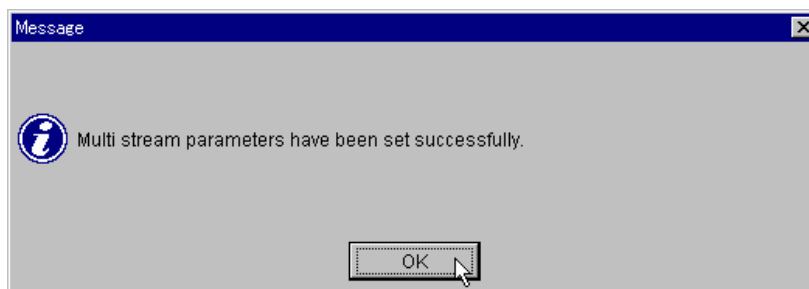
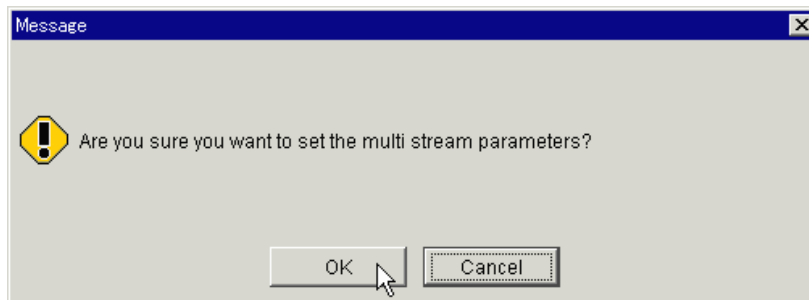

To initialize the Multi Stream parameters:

1. When you want to initialize the multi stream parameters, click **Default**.
2. A message displays stating that the setting is complete. Click **OK**.

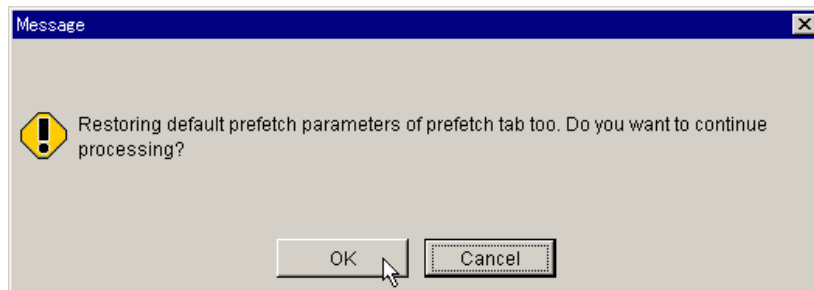
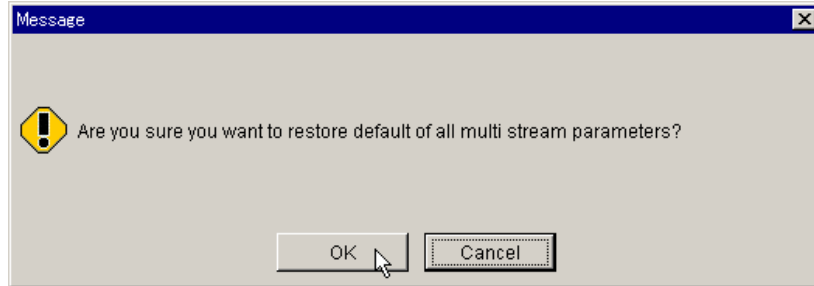

13.2 Pre-Fetch Parameters

1. From the **Tools** menu, select the **Tuning Parameter** on the Unit window.
The **Tuning Parameter** window displays.
2. Click the **Prefetch** tab.
The **Tuning Parameter** window displays.

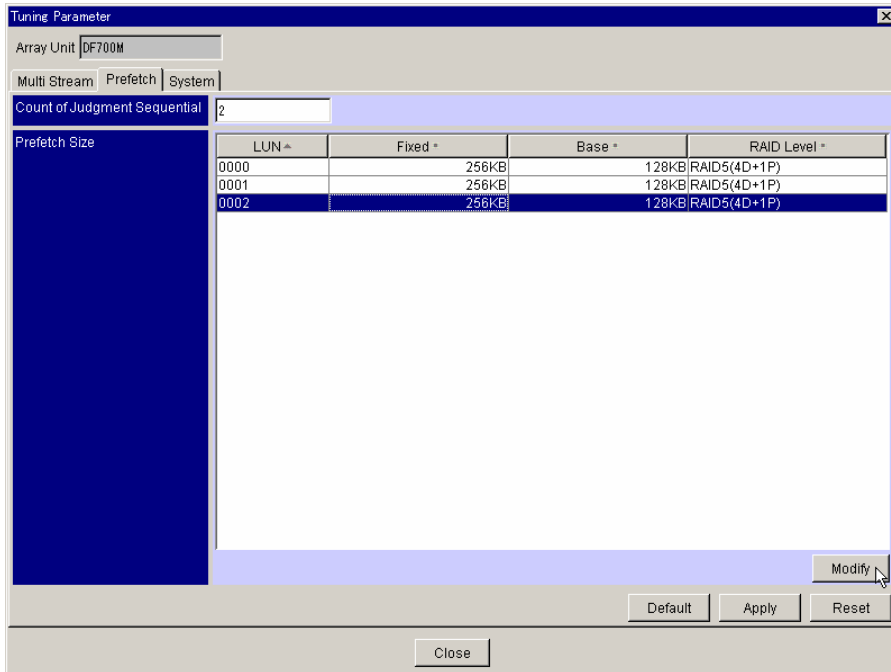

- **Count of Judgment Sequential:** Specify the count of judgment sequential.
3. Select the LUN you want to modify the pre-fetch size, and then click **Modify**.
The **Prefetch Staging Size** dialog box displays.

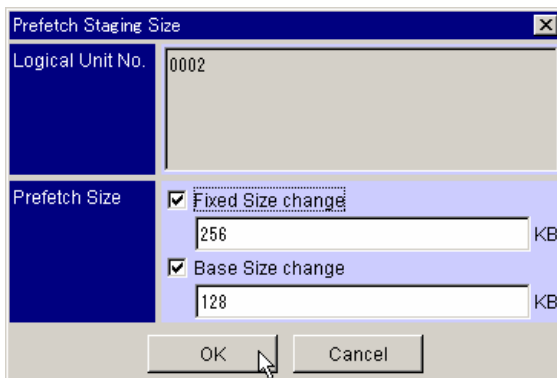

4. Specify the **Prefetch Size**, click **OK**.
5. Click **Apply**.

6. A message displays stating that the setting is complete. Click **OK**.

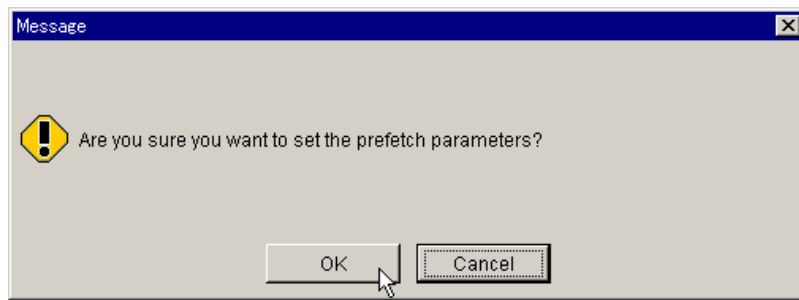

To initialize the prefetch parameters:

1. When you want to initialize the prefetch parameters, click **Default**.
2. A message displays stating that the setting is complete. Click **OK**.

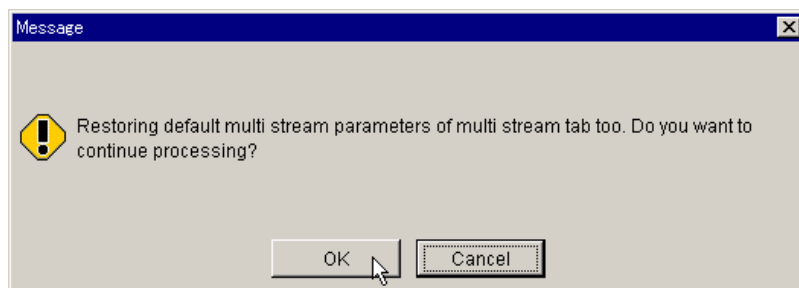
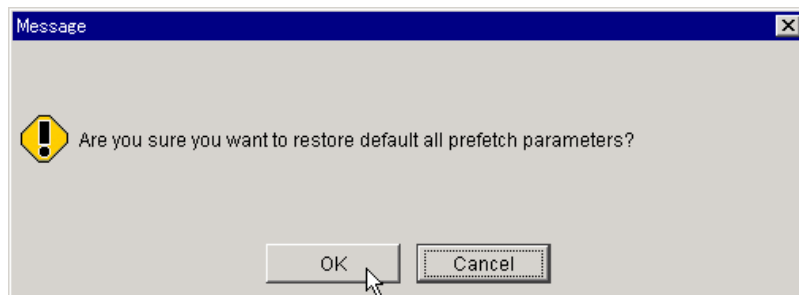



13.3 System Tuning Parameters

1. From the **Tools** menu, select the **Tuning Parameter** on the **Unit** window.
The **Tuning Parameter** window displays.
2. Click the **System** tab.

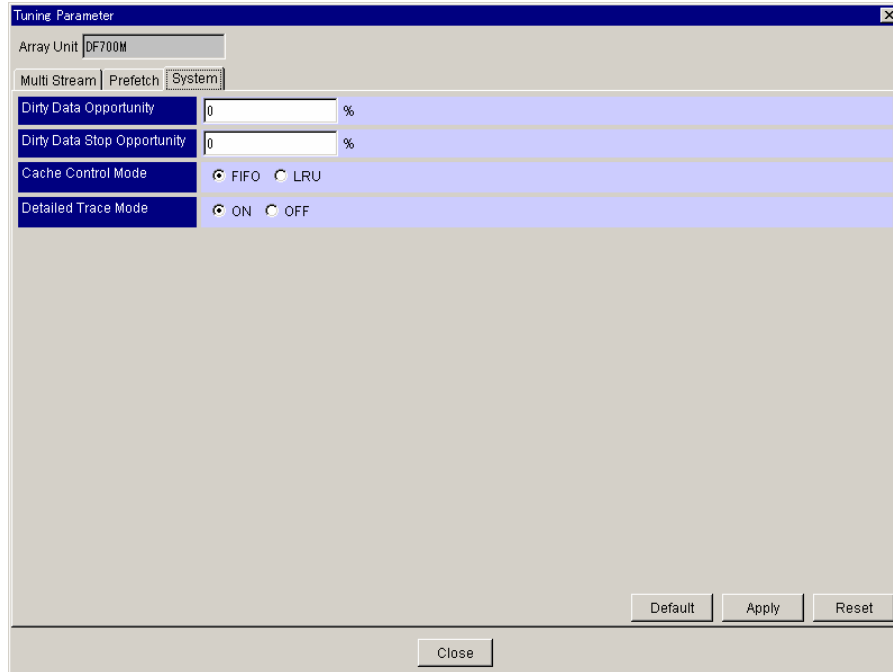

- **Dirty Data Opportunity:** Specify an occasion to de-stage dirty data (%).
 - **Dirty Data Stop Opportunity:** Specify an occasion to stop the de-staging of dirty data (%).
 - **Cache Control Mode:** Specify the cache control mode.
 - **Detailed Trace Mode:** Specify the detailed trace mode.
3. Click **Apply**.
 4. A message displays stating that the setting is complete. Click **OK**.

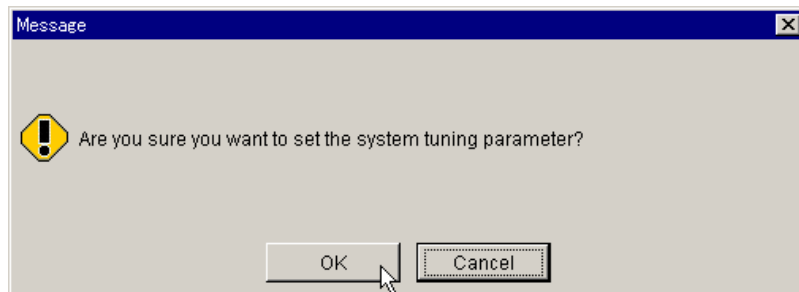



5. Initialize the System parameters
6. When you want to initialize the system parameters, click **Default**.
7. A message displays stating that the setting is complete. Click **OK**.

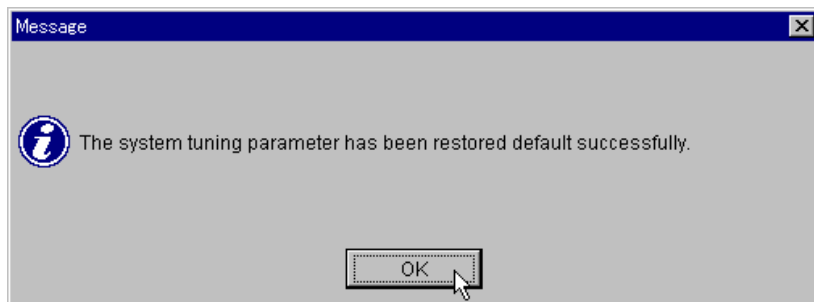
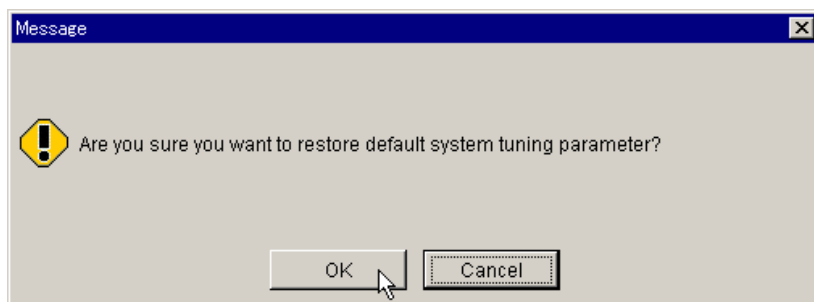

Chapter 14 ACE Tool

When you use the ACE Tool, you can get a connection diagram of the ENC wiring between the additional disk array units and addresses of the additional disk array units that have been set.

This section discusses the following topics:

- Automatic Setting (section 14.1)
- Constituting a Cabinet Using the Output File of Storage Navigator (section 14.2)
- Detail of the Cable Figure (section 14.3)

14.1 Automatic Setting

1. From the **Tool** menu, select the **ACE Tool** on the Main window.
The **Selection for the Subsystem Type** displays.

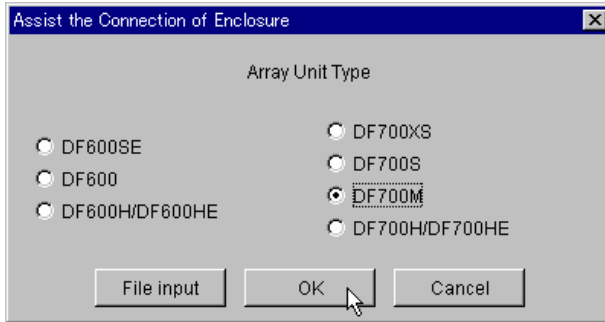

2. Select the subsystem you want to get the connection diagram of the ENC wiring between them and addresses of them that have been set, and then click **OK**.

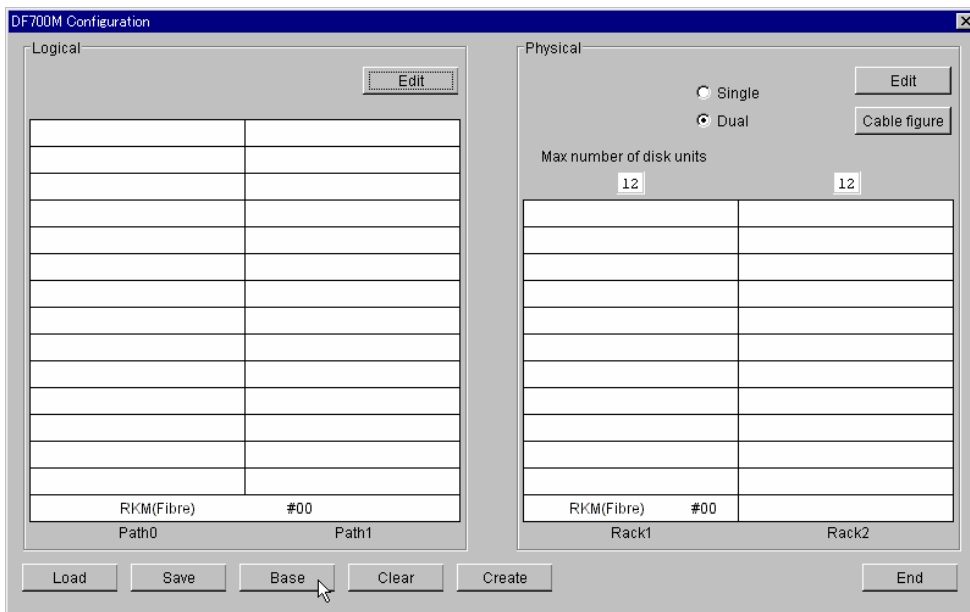

3. Click **Base**.

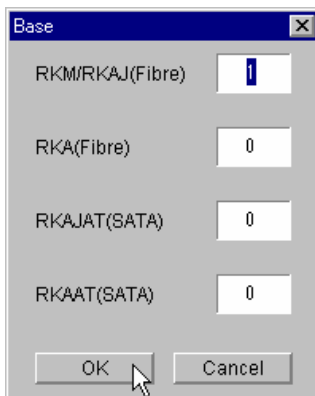

- Enter a number of disk array units connected to the RKM/RKAJ(Fibre), RKS/RKAJ(Fibre) or RKXS.

Note: The supported expansion cabinets of the DF700XS (WMS100) are currently RKAAT/RKAJAT, but select RKAAT for RKAATL and RKAJAT for RKAJATL. It is displayed as RKAAT for RKAATL and RKAJAT for RKAJATL.

- **DF700XS (WMS100):** The total number of the RKXS and RKAJAT(SATA)/RKAAT (SATA) is not more than 7; the RKXS is one.
- **DF700S (AMS200):** The total number of the RKS/RKAJs (Fibre) and RKAJATs (SATA) is not more than 7; the RKS/RKAJs(Fibre) is one or more.
- **DF700M (AMS500):** The total number of the RKM/RKAJs(Fibre) and RKA (Fibre)/RKAJATs (SATA)/RKAATs (SATA) is not more than 15; the RKM/RKAJs(Fibre) is one or more.
- **DF700H/DF700HE (AMS1000):** The total number of the RKAJs(Fibre) and RKA(Fibre)/RKAJATs (SATA)/RKAATs(SATA) is not more than 30; the RKAJs(Fibre) is one or more.

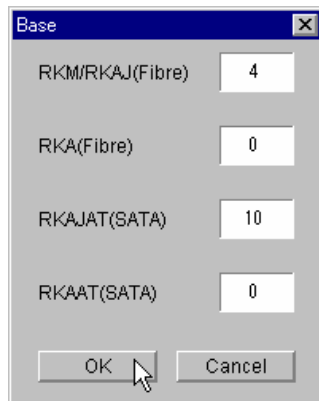

- Click **OK**.

The ENC wiring connection diagram and addresses of the additional disk array units that have been set are created automatically.

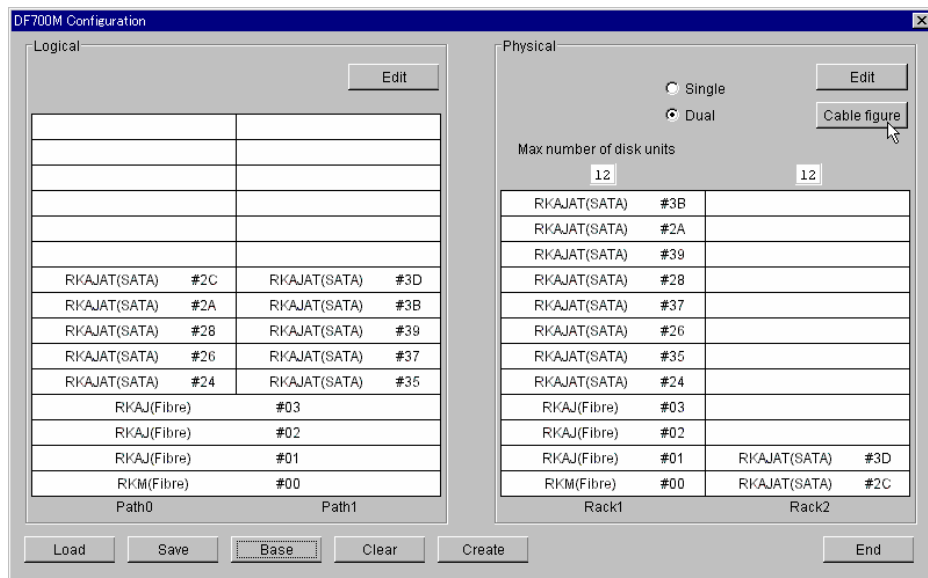

- Click **Cable figure**.

The Cable Figure displays.

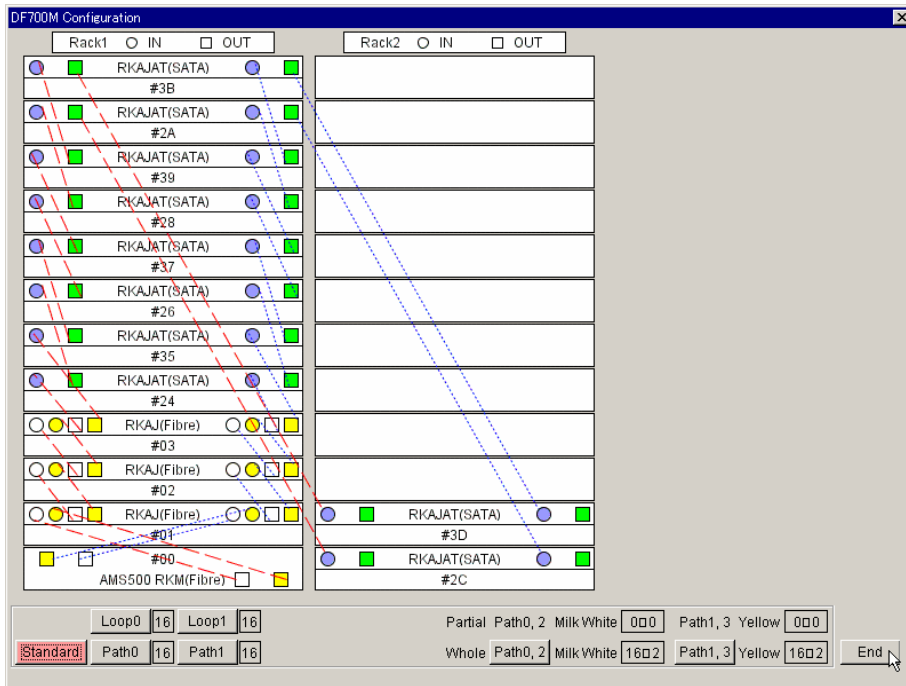

7. Copy and paste the wiring cable figure that has been created when necessary. Click **End**.

8. Save the information that has been set by clicking **Save**.

The **Save as** dialog box displays.

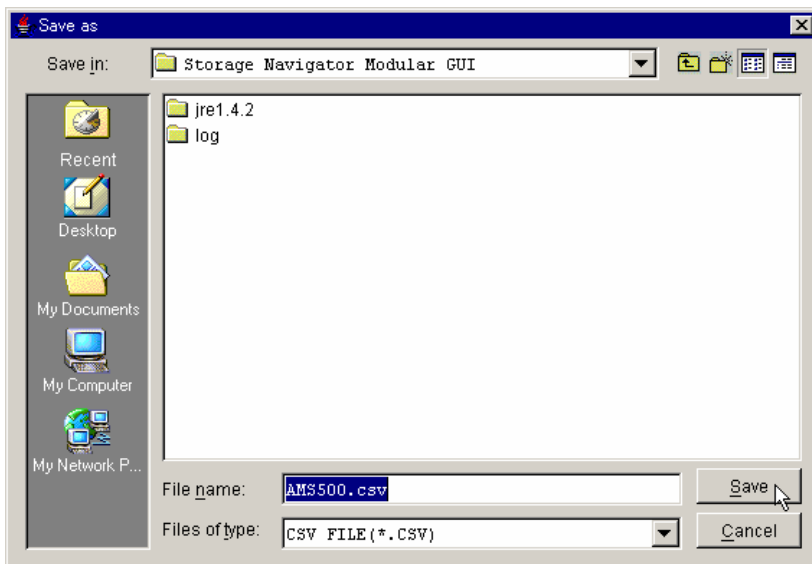

9. Specify the **File name** and click **Save**.



10. Click OK.

14.2 Constituting a Cabinet using the Storage Navigator Output File

When the ACE tool is started after the **Array System Viewer** window is opened, the wiring diagram is generated based on the information displayed in the **Array System Viewer** window.

1. From the **Tool** menu, select the **ACE Tool** on the Main window.

The **Selection the Subsystem Type** dialog box displays.

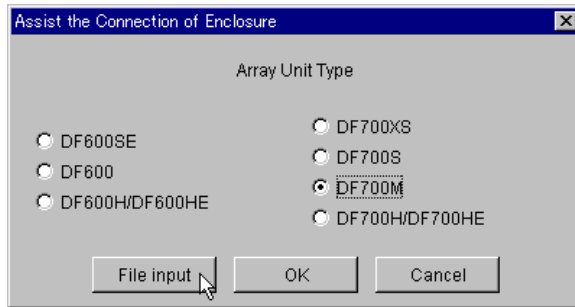

2. Click **File input**.

The **Open File** dialog box displays.

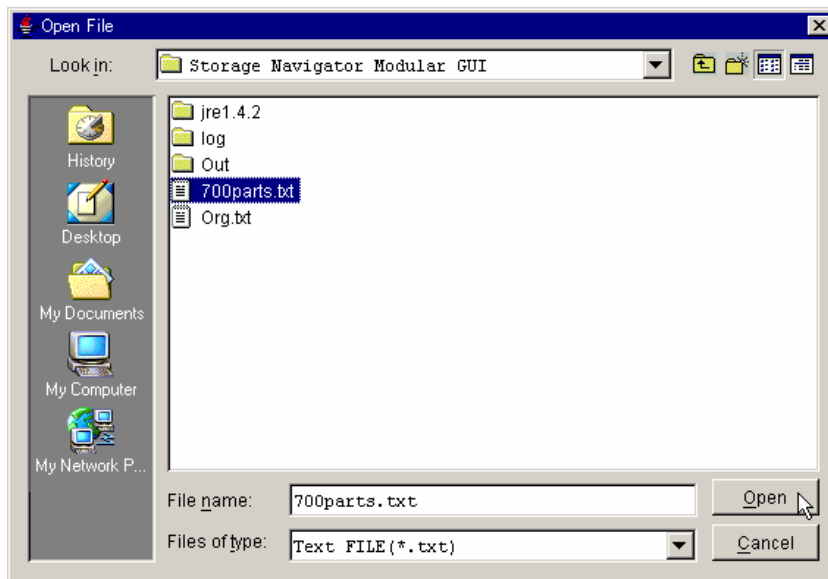

3. Specify the **File name** and click **Open**.

For AMS 200/500/1000: use the file of parts information.

For 9570V/9520V/1000: use the file of RAID group/logical unit definition information.

The **Max number of disk units** dialog box displays.



4. Since a number of disk array units (12) that can be mounted on the Rack1 and Rack2 are displayed, check it and click **OK**.

Configuration information displays.

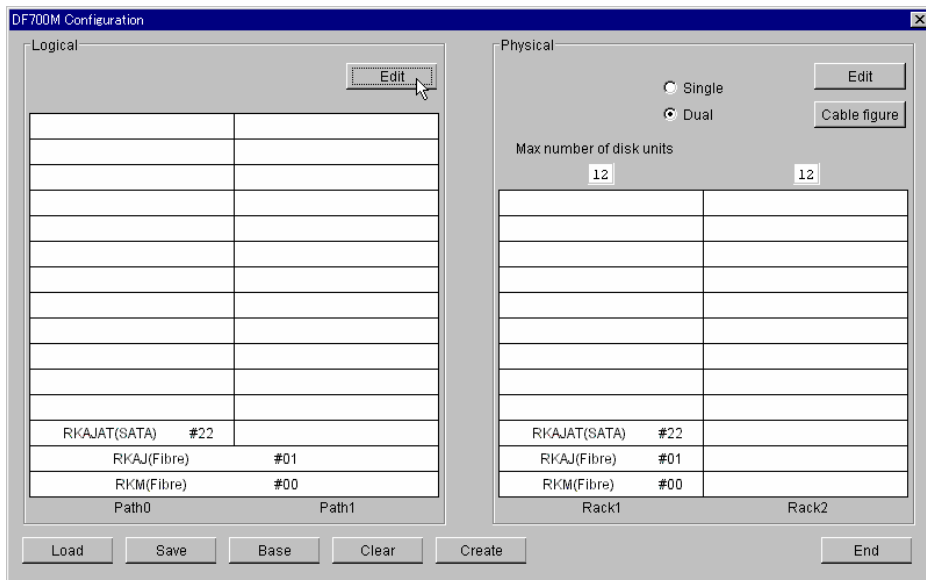

5. Click **Edit** on the left side (Logical section).

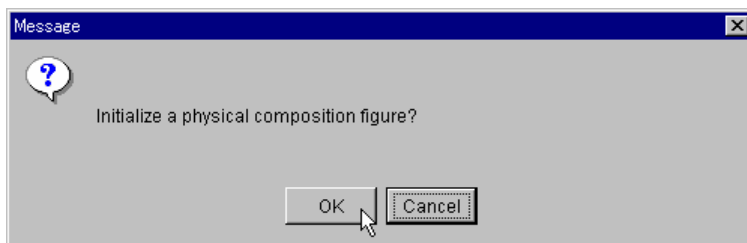

6. Click **OK**.

The **Configuration** window displays.

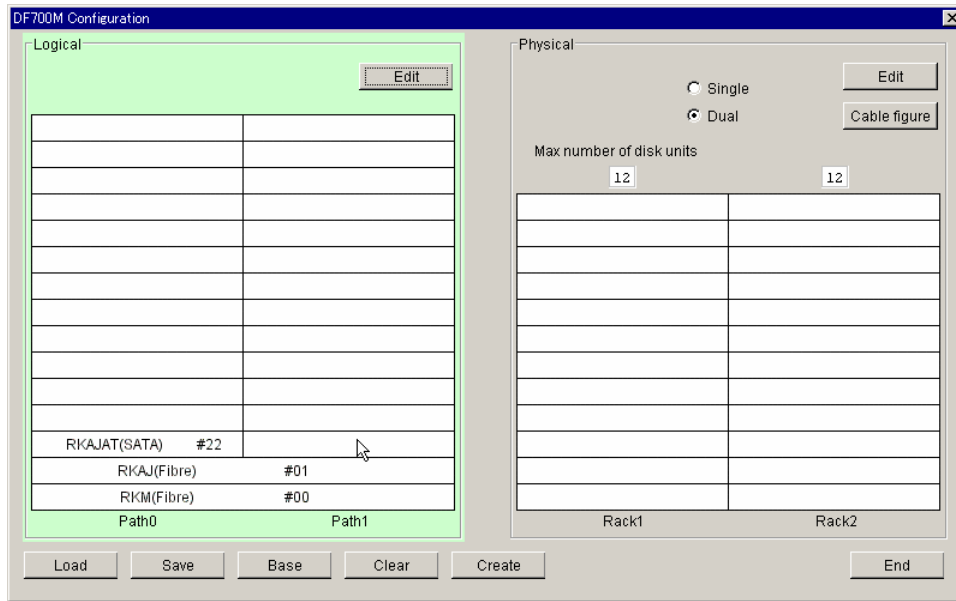

7. Select the location where you want to edit.

The **Unit Select** dialog box displays.

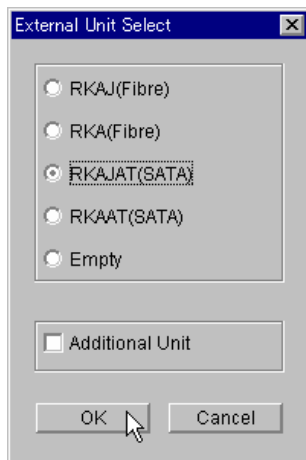

8. Specify the **RKAJ(Fibre)**, **RKAJAT(SATA)**, or **Empty**, and then click **OK** .

An error message is displayed, if you specify the location or disk array unit type that do not allow the rack addition. Specify the correct location and disk array unit type.

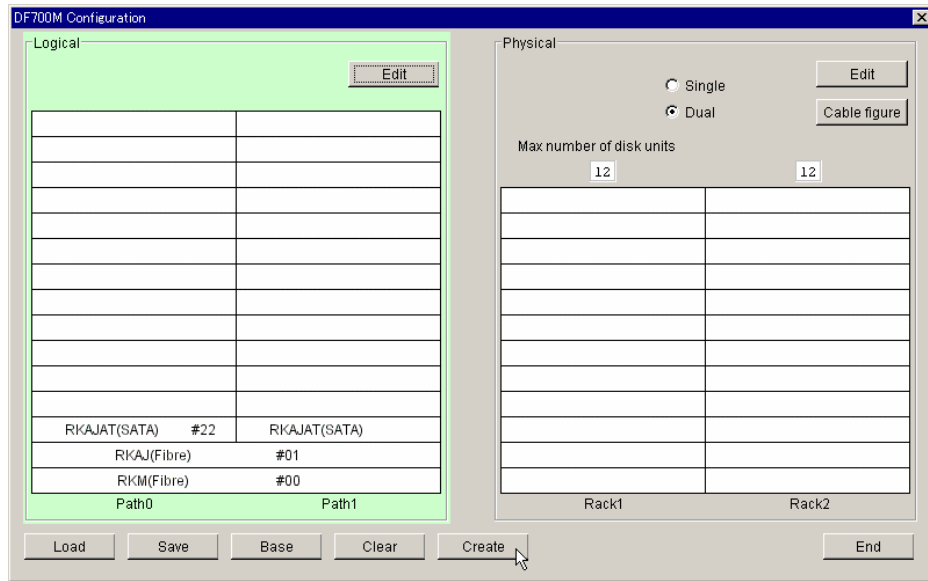

- Click **Create**.
The **Configuration** window is updated.

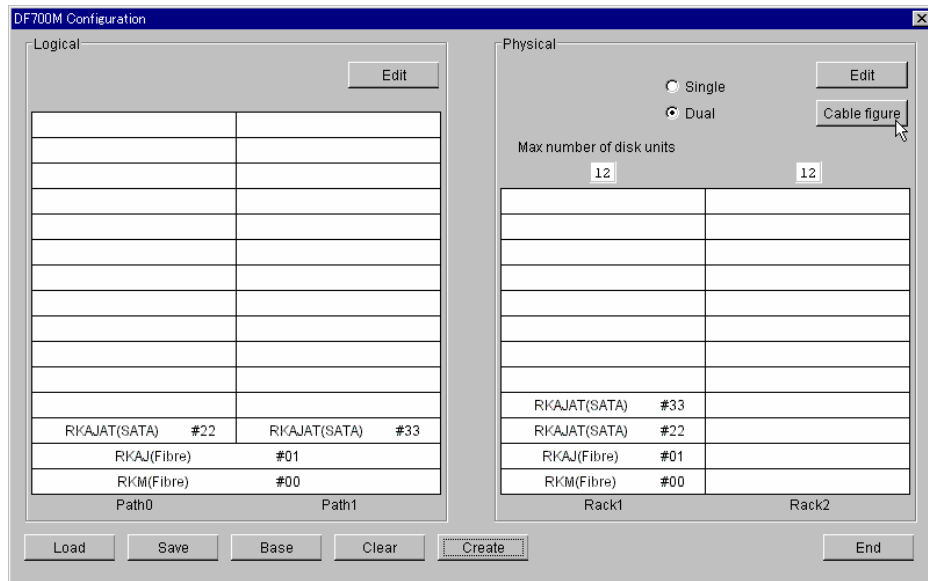

- Click **Cable figure**.

The Cable Figure window displays.

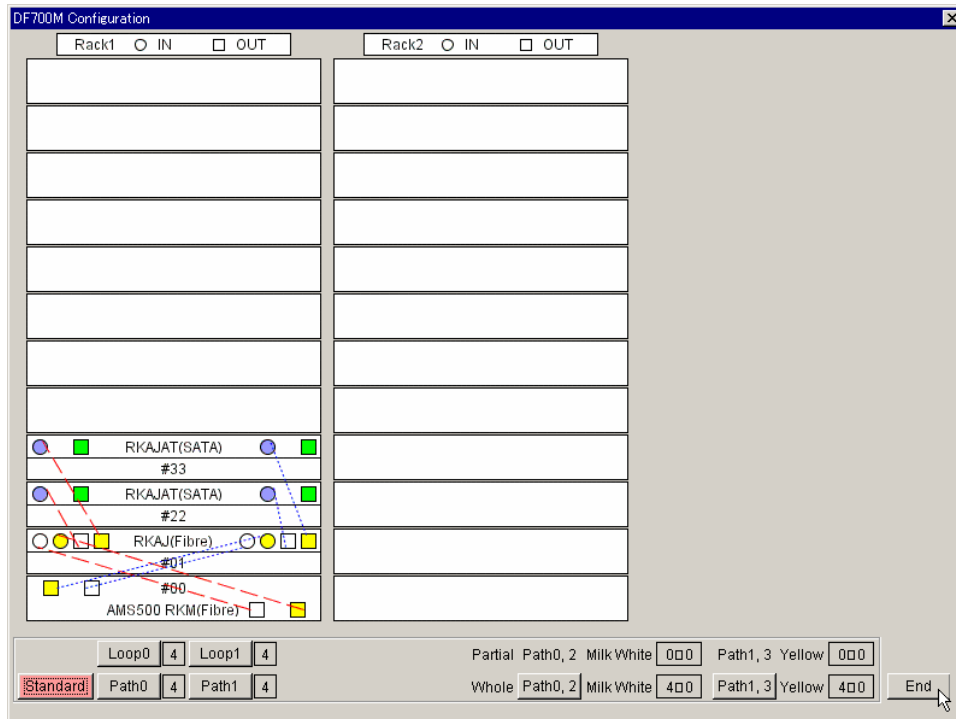

11. Copy and paste the wiring cable figure that has been created when necessary. Click End.
12. Click End.

14.3 Cable Figure Detail



- A: Number of cables of the Path 0
- B: Number of cables of the Path 1
- C: Color of the binders attached to the both ends of the ENC cable
- D: Number of cables of the Path 0
- E: A number of long inter-rack cables of the Path 0
- F: Number of cables of the Path 1
- G: A number of long inter-rack cables of the Path 1
- H: Number of cables of the Loop 0
- I: Number of cables of the Loop 1
- J: A number of cables of the Path 0 that are connected to the selected disk array units or added to the additional disk array unit.
- K: A number of long inter-rack cables of the Path 0 that are connected to the selected disk array units or added to the additional disk array unit.
- L: A number of cables of the Path 1 that are connected to the selected disk array units or added to the additional disk array unit.
- M: A number of long inter-rack cables of the Path 1 that are connected to the selected disk array units or added to the additional disk array unit.

Chapter 15 Troubleshooting

This section discusses the following topics:

- Error Monitoring (section 15.1)
- Registering the Failure Monitoring Account (15.2)
- Error Monitoring (section 15.3)
- Checking Status (section 15.4)
- Troubleshooting (section 15.5)
- Calling the Hitachi Data Systems Support Center (section 15.6)

15.1 Error Monitoring

15.1.1 Setting Error Monitoring Options

During error monitoring, when a failure is detected on the monitored array unit, E-Mail Report or one specified application can be started.

In **Error Alert Mode**, click the **E-Mail Error Report Enabled** check box and the **Execute Application** check box to enable them.

1. On the **Tool** menu, select **Error Monitoring → Options**. Alternatively, click : **Error Monitoring Options** in the tool bar (see Figure 15.1).

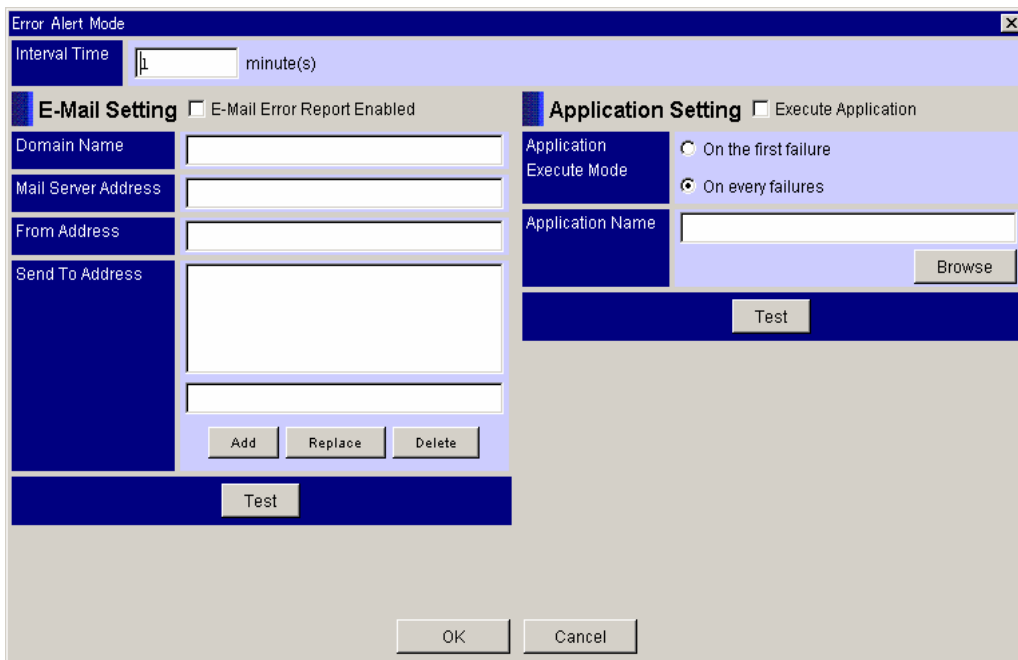

Figure 15.1 Setting Error Monitoring Options

15.1.1.1 Interval Time

1. Specify the interval time for error monitoring.

Specify **Interval Time** in the range of 1 minute to 720 minutes (12 hours). The interval means the time from an end of all target array unit monitoring until the start of the next monitoring.

2. Click **OK**.

The setting is validated without rebooting Storage Navigator.

15.1.2 E-Mail Report

When a failure is detected in the array unit, a text format log file is output to the same directory as the Storage Navigator execution file. Errors are also reported by e-mail when an error is detected, it is reported by e-mail. The source of the error is contained in the subject line. Table 15.1 shows a list of subjects. For the text of the error messages, please refer to *Hitachi TagmaStore AMS/WMS Error Codes (MK-96RD788)*.

Table 15.1 List of E-Mail Subjects

No.	Subject	Meaning
1	Disk	A drive blockade occurred (for 9200).
2	FC Disk	An FC drive blockade occurred (for 9500V).
3	SATA Disk	An SATA drive blockade occurred.
4	DC Power	A DC power supply failure occurred.
5	Battery	A battery voltage error occurred.
6	Fan	A fan failure occurred.
7	Controller	A controller blockade occurred. (This occurs only in the dual controller configuration.)
8	AC Power	An AC power supply error occurred.
9	Cache Memory	A cache failure occurred.
10	Cache Backup Circuit	A backup circuit failure occurred.
11	ENC	An enclosure error occurred.
12	SENC	A SENC error occurred.
13	Loop	A loop error occurred.
14	Path	A path blockade occurred.
15	Warning	The array unit entered the warning state.
16	Array connection	A failure occurred in the connection with the array unit. A power OFF or a failure occurred in the array unit.
17	Host Connector	A host connector error occurred (for AMS500/200).
18	NNC	An NNC blockade occurred (for AMS500/200).

1. Specify setting items in the E-Mail Report.
 - **E-Mail Error Report Enabled:** Specifies whether or not to execute E-Mail Report when an error is detected by error monitoring. When this item is checked off, E-Mail Report will be executed. **ON/OFF** is displayed on the right side, depending on whether a check mark exists or not.
 - **Domain Name:** Specifies a domain name. Specify it in 39 or less alphanumeric characters or in a code.
 - **Mail Server Address:** Specifies the IP address or host name of the mail server. Specify the host name in 99 or less alphanumeric characters.

- **From Address:** Specifies the mail address of the E-Mail sender. Specify it in 99 or less alphanumeric characters or in a code.
- **Send To Address:** Specifies the mail address of the E-Mail receiver. Specify it in 99 or less alphanumeric characters or in a code.

Up to 20 addresses can be set as receivers.

Add: Specify **Send To Address** in the text box above the **Add** button, and select **Add**. **Send To Address** added to the **Send To Address** list is displayed.

Replace: Select the **Send To Address** to be replaced in the **Send To Address** list. Specify **Send To Address** in the text box above the **Add** button, and click **Replace**. The replaced **Send To Address** is displayed in the **Send To Address** list.

Delete: Click **Send To Address** to be deleted in the **Send To Address** list, and click **Delete**. The deleted **Send To Address** disappears from the **Send To Address** list.

2. To verify the setting, click **Test**.

When the mail has been normally transmitted, a confirmation message displays. Click **OK**.

The following mail is transmitted to the set, **Send To Address**. Check the receipt of mail by **Send To Address**. If the mail has not been received, check the setting.

Subject: Storage Navigator Modular/Obstruction (test)

message: Day, Mon. dd hh:mm:ss yyyy/DF Name /Test message

Day: Day of the week **hh:mm:ss:** Hours, minutes, and seconds

Mon: Month **yyyy:** Year

dd: Date

3. Click **Close**.

The setting is validated without rebooting the Storage Navigator.

15.1.3 Setting Additional Information on E-mail

When registering or changing the properties of an array unit, you can add unique information on the e-mail header or on the unit trace information header.

- In the **Properties** window of the array unit, in the **Mail Additional Information** text box, enter the information in less than or equal to 64-byte characters (see Figure 15.2).

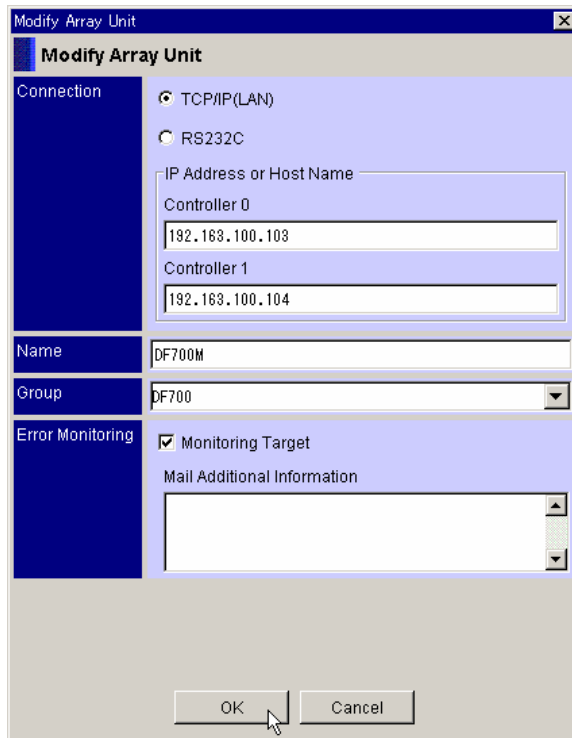

Figure 15.2 Setting Additional Information on E-Mail

The information set on E-Mail is added to the E-Mail attribute. The format is as follows:

Day, Mon. dd hh:mm:ss yyyy/DF Name/Additional Information/message text

To delete the information, select text and press the Delete key.

15.1.4 Executing Application

Execute Application is set so that another application may be started if an array unit error is detected when error monitoring is executed.

The application to be started activates the window; it displays the current size and position.

1. Set the necessary items to start an application.
 - **Execute Application:** Specifies whether or not to activate the application when a failure is detected by the error monitoring. The application is activated when the check box is selected. ON/OFF is displayed on the right side, depending on whether a check mark exists or not.
 - **Application Execute Mode:** Specifies an occasion to activate the application:
 - **On the first failure:** The specified application is activated when the first failure is detected after the error monitoring has been activated. When failures are detected continuously, the application is not activated. To activate the application again when a failure is detected after the application has been activated, terminate the error monitoring once and then restart it.
 - **On every failure:** The specified application is activated when a failure is detected after the error monitoring has been activated. When the same failure is detected while the error monitoring is executed, the application is not activated at the second and subsequent detections of it.

Note: When you select **On every failures**, the specified application is started upon detection of each error. Consequently, multiple specified applications may be started and the system may hang-up. Select **On the first failure**, and after occurrence of an error, stop error monitoring and restart it after a recovery from the error.

If an error is caused by starting the specified application during error monitoring, a message is displayed and error monitoring is suspended. When the message is closed, this monitoring will be continued.

- **Application Name:** Specifies a path and a file name of the application to be activated. When the file name is long, enclose it with the quotation marks (“ ”). When specifying a data file name of the application, if the data file is not in the same directory as Storage Navigator, specify the full path.
 - For Windows®:

Example 3: “c:\abc\application.exe(option)” “c:\abc\application.dat”

Path and file name of the application

Data file name of the application

- For Solaris™, IRIX®, HP-UX, or Red Hat® Linux®:

Example 1: /home/use/stonavm/go

Data file name of the application

2. To check the setting, click **Test**. Verify that the specified application is started.

15.2 Registering the Failure Monitoring Account

To register a failure monitoring account:

1. On the **Tool** menu, select **Error Monitoring** → **Account** to open the Monitoring Account Information window (see Figure 15.3).
2. In that window, do the following:
 - Select the **Enable** radio button on the **Monitoring Account** box
 - Enter the previously registered **User ID** and the **Password**.
3. The **Monitoring Test Result** list displays the array units that have validated failure monitoring enabled.
4. Test the validation by selecting the array unit from the list and clicking the **Test** button. The **Result** column should display **OK**.
5. Select the **OK** button, then select **OK** on the confirmation message. You do not need to reboot the Storage Navigator computer.
6. If a failure is detected in the array unit, a text format log file is output to the monitoring account and to the same directory as the Storage Navigator execution file. For a list of error messages, please refer to *Hitachi TagmaStore AMS/WMS Error Codes* (MK-96RD788).

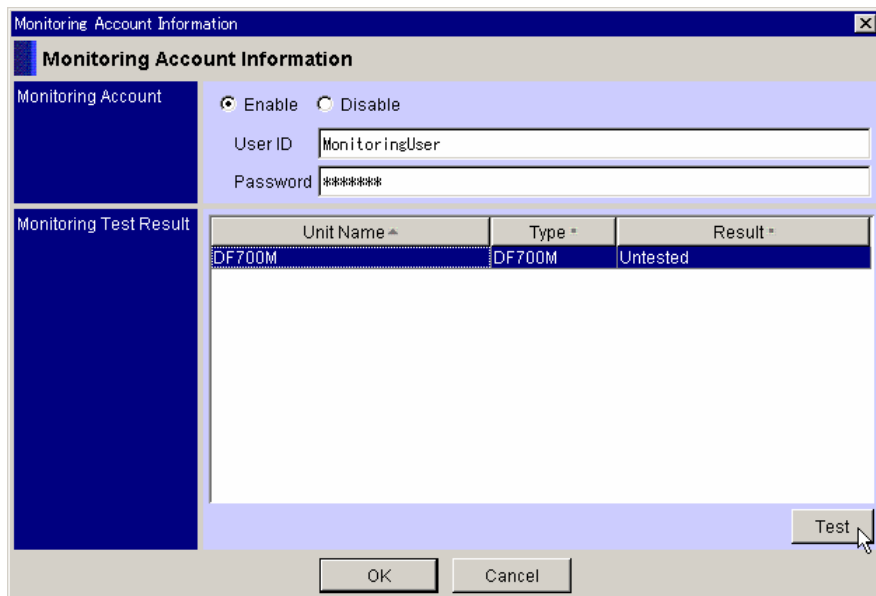

Figure 15.3 Monitoring Account Information Window

15.3 Error Monitoring

Error monitoring checks the component status of the array unit. This including drives, controller, battery, fan, power supply, and cache. Placing a check in the **Error Watch** box in registered array unit information enables error monitoring at an interval specified for the interval time.

Note: When you perform error monitoring, be sure to close the **Array System Viewer** window before starting the monitoring. If error monitoring is performed with the **Array System Viewer** window open, array units may not be monitored normally.

- Select  : **Error Watch** on the Main window (see Figure 15.4).

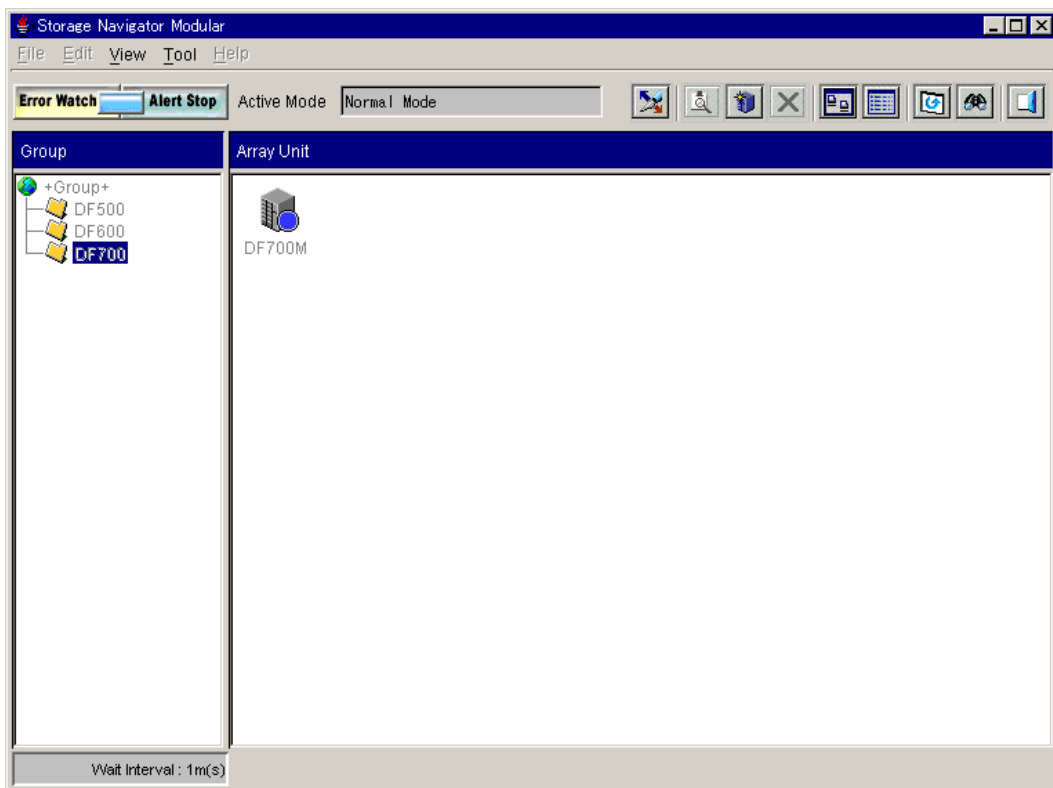

Figure 15.4 Starting Error Monitoring





Monitoring is started for the array unit for which “Error Alert” is specified.

The **Error Watch** button on the Main window displays  .

After the start of error monitoring, the monitoring status is displayed in the status bar. The icon displays a monitoring result of the array unit.





After error monitoring is performed for all the target array units, monitoring will be started again for these target array units after the lapse of the specified interval time.

The error monitoring status is displayed on the left side of the scroll bar in the following three states. In addition, the monitoring result of all the array units subject to monitoring is displayed with icons.





Monitoring Status	Display Characters	Character Color	Array Unit Status
Stop	Stop	 Gray	Error monitoring is not executed.
Monitoring	Monitoring	 Blue	Error monitoring is executed and all the target array units are normal.
	Monitoring	 Red	Error monitoring is executed and errors are detected in some of the target array units.
Waiting	Waiting	 Blue	Error monitoring is at the interval time and all the target array units that were previously monitored are normal.
	Waiting	 Red	Error monitoring is at the interval time and errors are detected in some of the target array units that were previously monitored.

As an error monitoring result, the status is displayed with the icon color of the array unit in the Main window.

Array Units in a Dual System

 Gray	<ul style="list-style-type: none"> Not monitored Monitored but failure to authenticate a user
 Gray + Blue	<ul style="list-style-type: none"> Normal
 Gray + Yellow	<ul style="list-style-type: none"> An error is detected. A communication error occurs in a controller.
 Gray	<ul style="list-style-type: none"> A power OFF or a failure of the array unit occurred. A communication error occurs in both controllers.

Array Units in a Single System

 Gray	<ul style="list-style-type: none"> Not monitored Monitored but failure to authenticate a user
 Gray + Blue	<ul style="list-style-type: none"> Normal
 Gray + Yellow	<ul style="list-style-type: none"> An error is detected.
 Gray	<ul style="list-style-type: none"> A power OFF or a failure of the array unit occurred. A communication error occurred.

1. To display the detail information of the array unit, stop error monitoring, select an array unit to be displayed, and click  : **Alert Stop**. The contents of display may be different depending on the relationship between **Error Alert** result and “Time”, because polling is performed.

When the icon has a **Caution** symbol displayed, this represents a communication disable status with the array unit; detailed information cannot be displayed.

2. Click  : **Alert Stop**, and **Error Alert** will be stopped. The icon of the array unit continues to display the last error-monitoring result.

Click the **Array Unit** icon in the Main window, and then select  : **Open** on the toolbar.

Note: When the icon has a **Caution** symbol displayed as an **Error Alert** result, this represents a connection disable status to the array unit or an information get disable status from the array unit. The causes are as follows:

Cause	Contents of Check
Communication line failure	Check the LAN line.
Connected array unit failure	Check the READY status of the array unit.
Too high I/O load from the host	Check the array unit operation status.
Execution of the logical unit format of the connected array unit, wizard setting of system parameter, or SNMP environment information setting	Check the array unit status or restart the array unit.

3. Check all of the above. After making sure that connection with the array unit displayed in **Caution** symbol has been enabled, start error monitoring.

If the icon of the array unit goes yellow because of controller blockage, the same status as that of the **Caution** symbol icon may be provided.

If error monitoring is performed, though the icon of the array unit is displayed with a **Caution** symbol, the icon of the normal array unit may be displayed with a **Caution** symbol. If the cause corresponds to “Too high I/O load from the host”, continue to execute monitoring.

If a drive whose display color is not blue in Unit Status on the **Array System Viewer** window (a drive that is not logical unit-formatted or an undefined spare drive) is pulled out, no error report will be made but it has no effect on the operation. Insert it once again.

If an error occurs, contact your Customer Engineer.

15.4 Checking Status

Check the status of array unit components: drives, controllers, batteries, fans, power supply and cache. A status check is done on an array unit for which the check box of the **Error Alert Flag** in “Array Unit Define” is selected.

- From the **View** menu, select **Refresh** (see Figure 15.5).

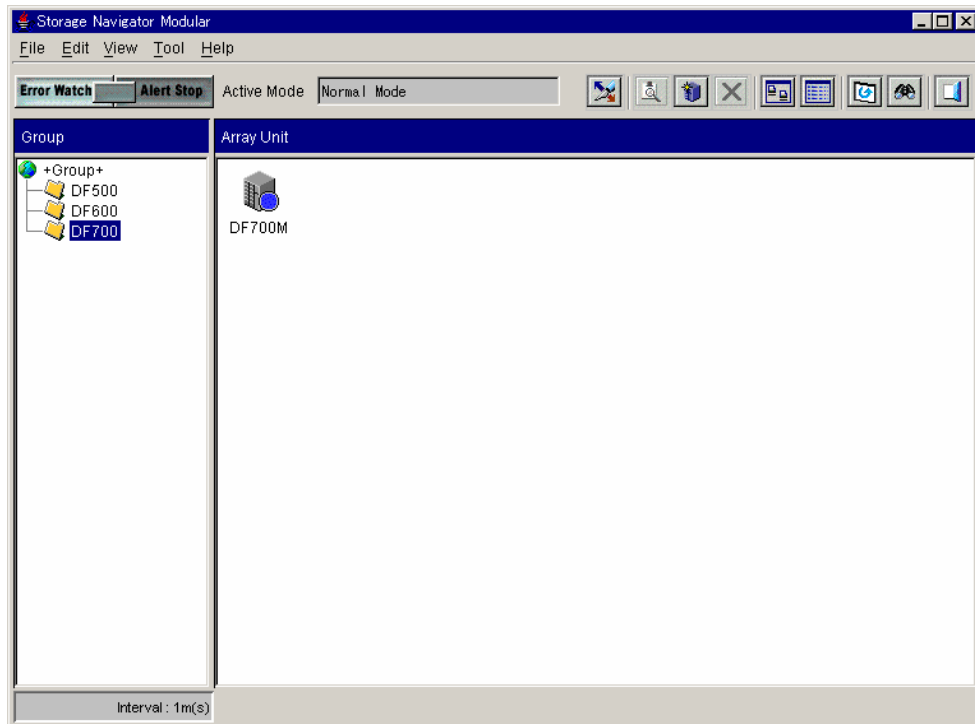

Figure 15.5 Checking the Status of Subsystem Components

The status of an array unit for which error monitoring is specified is checked. When checking begins, the icon of an array unit is displayed with the check result reflected into the icon.

The status check performs functions equivalent to those of error monitoring. When an error is detected in an array unit that has been checked, output of a log, sending of an E-Mail, and restarting of a specified application are performed in accordance with the settings of the monitor options.

15.5 Troubleshooting

The user is responsible for operation and normal maintenance of the computer(s) that host Storage Navigator software. Following are guidelines for troubleshooting Storage Navigator software operations:

- **Check the cabling and the LAN.** Verify that both the computer and LAN cabling are firmly attached, and that the LAN is operating properly.
- **Reboot the computer.** Close any programs that are not responding. If necessary, reboot the computer.
- If Storage Navigator does not succeed in connecting to the array unit, the following message may display:

An invalid response was received from the subsystem

This indicates that Storage Navigator may have been connected to the array unit while the array unit automatically rebooted. Connect to the array unit again after approximately three minutes.

- Storage Navigator may hang up in the following cases:
 - The communication with the connected array unit fails due to controller blockage, array unit failure, or disconnected LAN connection, etc., or the array unit receives a Reset/LIP from the host.
 - Other applications are working concurrently and memory utilization or a CPU use rate is high.
- If Storage Navigator hangs up, terminate it forcibly and check the array unit status and the connection status of the LAN. Reboot Storage Navigator once again.
- The Storage Navigator can open multiple **Array System Viewer** windows for one array unit. When multiple **Array System Viewer** windows are open, a shortage of memory may occur, depending on the configuration of the system in which the Storage Navigator has been installed; this results in program hang-ups. When opening **Array System Viewer** windows, open only one window to operate an array unit.

15.6 Calling the Hitachi Data Systems Support Center

If you need to call the Hitachi Data Systems Support Center, make sure you can provide as much information about the problem as possible. Include the circumstances surrounding the error or failure, the Storage Navigator configuration information, and the exact content of messages displayed on the Storage Navigator.

Worldwide Hitachi Data Systems Support Centers are:

- Hitachi Data Systems North America/Latin America
San Diego, California, USA
800-446-0744
- Hitachi Data Systems Europe
Contact Hitachi Data Systems Local Support
- Hitachi Data Systems Asia Pacific
North Ryde, Australia
61-2-9325-3300

Acronyms and Abbreviations

Acronym	Expansion
A	Ampere
AL-PA	arbitrated loop-physical address
AMS	Adaptable Modular Storage
API	application programming interface
ASTM	American Society for Testing Materials
ATA	Advanced Technology Attachment standard
ATM	asynchronous transfer mode
BC	business continuity
BS	Basic (power) supply
BSA	bus adapter
BTU	British thermal unit
CCI	command control interface
CEC	Canadian Electroacoustic Community
CFW	cache fast write
CHAP	challenge handshake authentication protocol
CIFS	common internet file system
CKD	count-key data
CLI	command line interface
CSA	Canadian Standards Association
CSV	comma separated value
CTG	consistency group
CTL	controller
CU	controller unit
CUDG	control unit diagnosis
dB(A)	decibel (A-weighted)
D-CNT	default (owner) controller
DAMP	Disk Array Management Program
DDL	data definition language
DHCP	dynamic host configuration protocol
DKC	disk controller unit
DLM	data lifecycle management
DM-LU	differential management logical unit
DRAM	dynamic random access memory
DWDM	dense wavelength division multiplexer
EMI	electromagnetic interference
EPO	emergency power-off
FC	fibre channel
FC-AL	fibre channel-arbitrated loop
FCC	Federal Communications Commission
FCP	fibre-channel protocol
Gbps	gigabit per second
HA	high availability
HACMP	high availability cluster multi-processing
HBA	host bus adapter

HDLM	Hitachi Dynamic Link Manager
HORCM	Hitachi Open Remote Copy Manager
H-LUN	host logical unit
H-RAIN	heterogeneous redundant array of independent nodes
HSN	hierarchical star network
HWM	high water mark
IDE	integrated drive electronics; see also ATA.
IIS	Internet Information Service
IOPS	input output operations per second
IOS	internet work operating system
iSCSI	internet small computer system interface
JRE	Java 2 runtime environment
LCP	local control port
LD	logical device
LDEV	logical device
LDM	logical device manager
LIP	loop initialization primitive
LRU	least recently used
LUN	logical unit number
LUSE	LU size expansion
LVI	logical volume image
LVM	logical volume manager
MCU	main control unit
NDMP	Network Data Management Protocol
MDB	master directory block
MIB	message information block
μP	microprocessor
MR	magneto-resistive
MU	mirror unit
MVS	multiple virtual storage
MVS/ESA	multiple virtual storage /enterprise systems architecture
MVS/XA	multiple virtual storage /extended architecture
NAS	network attached storage
NBU	NetBackup (a Symantec product)
NEC	National Electrical Code
NFS	network file system
NIC	network interface card
NIS	network information service
NNC	network node controller
NSC	network storage controller
NTP	network time protocol
NVS	nonvolatile storage
OCI	Oracle Call Interface
ODM	object data manager
OFC	open fibre control
ORM	online read margin
OSI	open systems interconnection

PCI	power control interface
PDL	product documentation library
PFUS	pool full status
POSIX	portable operating system interface
PPRC	peer-to-peer remote copy
PSUE	pair suspended-error status
PSUS	pair suspended-split
PSUS(N)	pair suspended - not restored status
PV	physical volume
P-VOL	primary volume
RAID	redundant array of independent disks
RC	reference code
RCU	remote control unit
RPO	recovery point objective
RTC	real-time clock
RTO	recovery time objective
SAN	storage-area network
SATA	serial ATA
SCSI	small computer system interface
SIM	service information message
SM	shared memory module
SMB	server message block
SMTP	simple mail transfer protocol
SNIA	Storage Networking Industry Association
SNMP	simple network management protocol
SONET	synchronous optical network
SSL	secure socket layer
SSWS	suspend for swapping S-VOL
S-VOL	secondary volume
TID	target identifier
TPOF	tolerable points of failure
UDP	user diagram protocol
UL	Underwriters' Laboratories
USP	Universal Storage Platform
VCS	Veritas Cluster Server™
VDE	Verband Deutscher Elektrotechniker
VIB	volume information block
VOLID	volume identifier
V-VOL	virtual volume (Snapshot Image)
VxVM	Veritas Volume Manager
WDM	wavelength division multiplexing

