

Hitachi Advanced Server HA810 G2

User Guide

This document is for the person who installs, administers, and troubleshoots servers and storage systems. Hitachi Vantara assumes you are qualified in the servicing of computer equipment and trained in recognizing hazards in products with hazardous energy levels.

2021 Hitachi, Ltd. All rights reserved.

No part of this publication may be reproduced or transmitted in any form or by any means, electronic or mechanical, including copying and recording, or stored in a database or retrieval system for commercial purposes without the express written permission of Hitachi, Ltd., or Hitachi Vantara LLC (collectively "Hitachi"). Licensee may make copies of the Materials provided that any such copy is: (i) created as an essential step in utilization of the Software as licensed and is used in no other manner; or (ii) used for archival purposes. Licensee may not make any other copies of the Materials. "Materials" mean text, data, photographs, graphics, audio, video and documents.

Hitachi reserves the right to make changes to this Material at any time without notice and assumes no responsibility for its use. The Materials contain the most current information available at the time of publication.

Some of the features described in the Materials might not be currently available. Refer to the most recent product announcement for information about feature and product availability, or contact Hitachi Vantara LLC at <https://support.hitachivantara.com/en-us/contact-us.html>.

Notice: Hitachi products and services can be ordered only under the terms and conditions of the applicable Hitachi agreements. The use of Hitachi products is governed by the terms of your agreements with Hitachi Vantara LLC.

By using this software, you agree that you are responsible for:

1. Acquiring the relevant consents as may be required under local privacy laws or otherwise from authorized employees and other individuals; and
2. Verifying that your data continues to be held, retrieved, deleted, or otherwise processed in accordance with relevant laws.

Notice on Export Controls. The technical data and technology inherent in this Document may be subject to U.S. export control laws, including the U.S. Export Administration Act and its associated regulations, and may be subject to export or import regulations in other countries. Reader agrees to comply strictly with all such regulations and acknowledges that Reader has the responsibility to obtain licenses to export, re-export, or import the Document and any Compliant Products.

Hitachi and Lumada are trademarks or registered trademarks of Hitachi, Ltd., in the United States and other countries.

AIX, AS/400e, DB2, Domino, DS6000, DS8000, Enterprise Storage Server, eServer, FICON, FlashCopy, GDPS, HyperSwap, IBM, Lotus, MVS, OS/390, PowerHA, PowerPC, RS/6000, S/390, System z9, System z10, Tivoli, z/OS, z9, z10, z13, z14, z/VM, and z/VSE are registered trademarks or trademarks of International Business Machines Corporation.

Active Directory, ActiveX, Bing, Excel, Hyper-V, Internet Explorer, the Internet Explorer logo, Microsoft, the Microsoft Corporate Logo, MS-DOS, Outlook, PowerPoint, SharePoint, Silverlight, SmartScreen, SQL Server, Visual Basic, Visual C++, Visual Studio, Windows, the Windows logo, Windows Azure, Windows PowerShell, Windows Server, the Windows start button, and Windows Vista are registered trademarks or trademarks of Microsoft Corporation. Microsoft product screen shots are reprinted with permission from Microsoft Corporation.

All other trademarks, service marks, and company names in this document or website are properties of their respective owners.

Copyright and license information for third-party and open source software used in Hitachi Vantara products can be found at <https://www.hitachivantara.com/en-us/company/legal.html>.

Preface

This document is for the person who installs, administers, and troubleshoots servers and storage systems. Hitachi Vantara assumes you are qualified in the servicing of computer equipment and trained in recognizing hazards in products with hazardous energy levels.

Please read this document carefully to understand how to use these products, and maintain a copy for your reference.

Accessing product documentation

Product user documentation is available on Hitachi Vantara Support Connect: <https://knowledge.hitachivantara.com/Documents>. Check this site for the most current documentation, including important updates that may have been made after the release of the product.

Getting help

Hitachi Vantara Support Connect is the destination for technical support of products and solutions sold by Hitachi Vantara. To contact technical support, log on to Hitachi Vantara Support Connect for contact information: https://support.hitachivantara.com/en_us/contact-us.html.

Hitachi Vantara Community is a global online community for Hitachi Vantara customers, partners, independent software vendors, employees, and prospects. It is the destination to get answers, discover insights, and make connections. Join the conversation today! Go to community.hitachivantara.com, register, and complete your profile.

Comments

Please send us your comments on this document to doc.comments@hitachivantara.com. Include the document title and number, including the revision level (for example, -07), and refer to specific sections and paragraphs whenever possible. All comments become the property of Hitachi Vantara LLC.

Thank you!

Table of Contents

Component identification	9
Front panel components	9
Front panel LEDs and buttons	10
UID button functionality	12
Front panel LED power fault codes	12
The Systems Insight Display LEDs.....	13
Systems Insight Display combined LED descriptions	14
Rear panel components.....	16
Rear panel LEDs.....	17
System board components	17
Heatsink and socket components.....	19
System maintenance switch descriptions.....	20
DIMM slot locations	20
DIMM label identification	21
Intel Optane persistent memory 200 series for label identification	22
Drive numbering.....	22
Basic Drive LED definitions	23
Hot-plug fans	24
DSC-25 2-port SFP28 card ports and LEDs	26
NS204i-p NVMe OS Boot Device components	27
NS204i-p NVMe OS Boot Device LED definitions.....	28
Operations.....	28
Power up the server	28
Power down the server	28
Extend the server from the rack.....	29
Remove the server from the rack.....	29
Remove the access panel.....	29
Install the access panel.....	30
Remove the hot-plug fan	30
Remove the primary PCI riser cage	31
Install the primary PCI riser cage	32
Remove the secondary PCI riser cage	33
Install the secondary PCI riser cage.....	34
Remove the 8SFF drive backplane	35

Removing the hard drive blank	35
Removing a hot-plug SAS/SATA/NVMe drive.....	36
Releasing the cable management arm	37
Accessing the Systems Insight Display.....	37
Setup.....	39
Optimum environment.....	39
Space and airflow requirements.....	39
Temperature requirements	40
Power requirements	40
Electrical grounding requirements.....	40
Connecting a DC power cable to a DC power source.....	41
Server warnings and cautions.....	42
Rack warnings	43
Identifying the contents of the server shipping carton	44
Installing hardware options	44
Installing the server into the rack.....	44
Operating system.....	45
Installing the operating system with Intelligent Provisioning.....	45
Selecting boot options in UEFI Boot Mode	45
Selecting boot options.....	46
Registering the server.....	46
Hardware options installation	47
Introduction	47
Installing a redundant hot-plug power supply.....	47
Energy pack options	48
Smart storage battery	48
Smart storage hybrid capacitor	48
Minimum firmware versions	48
Installing an energy pack.....	49
Memory options	50
Memory population information	50
DIMM-processor compatibility	50
Installing a DIMM.....	51
Intel Optane persistent memory 200 series	52
Installing a high-performance fan.....	55
Installing an 8SFF display port/USB/optical blank option.....	57
Installing the 4LFF display port/USB option	59

Drive options	60
Installing a hot-plug SAS, SATA or NVMe drive	61
Installing the 4LFF optical drive option	62
Installing an 8SFF optical drive	64
Installing a 2SFF SAS/SATA/NVMe drive cage	66
Primary PCI riser cage options	68
Installing an expansion board in slot 1	68
Installing an expansion board in slot 2	69
Installing an optional primary PCI riser board	71
Installing the NVMe M.2 riser option	72
Installing an accelerator or GPU in the primary riser cage	74
Secondary PCI riser options	76
Installing a secondary full-height PCI riser cage option	76
Installing a secondary low-profile PCIe slot riser cage option	79
Installing an expansion board in the secondary riser cage	80
Installing an accelerator or GPU in the secondary riser cage	84
Storage controller options	86
Installing a type-a smart array storage controller option	86
Installing a type-p storage controller option	88
Processor and heatsink options	92
Installing a processor heatsink assembly	92
Installing a high performance heatsink	94
Installing the Systems Insight Display power module	97
Installing an OCP 3.0 adapter card	101
Installing the serial cable option	102
Installing the Chassis Intrusion Detection switch option	103
Installing the DSP DSC-25 SFP28 card	104
Installing the NS204i-p G2 Boot Device option	107
Trusted Platform Module 2.0 option	108
Trusted Platform Module 2.0 guidelines	109
Installing and enabling the TPM 2.0 option	110
Cabling	115
Cabling guidelines	115
Front I/O cabling	116
Storage cabling	117
SFF cables	117
LFF cables	121

Software and configuration utilities	123
Server mode	123
Active Health System.....	123
iLO 5	124
iLO Federation	124
iLO Service Port	125
iLO RESTful API.....	125
RESTful Interface Tool	126
Intelligent Provisioning.....	126
Management security.....	126
Message Passing Interface	126
UEFI System Utilities	127
Selecting the boot mode.....	127
Secure Boot.....	128
Launching the Embedded UEFI Shell	128
Smart storage administrator.....	129
Smart storage administrator	129
USB support.....	130
External USB functionality	130
Redundant ROM support	130
Safety and security benefits	130
Keeping the system current	130
Updating firmware or system ROM	130
Drivers	132
Software and firmware	133
Operating system version support.....	133
Troubleshooting	133
NMI functionality	133
Troubleshooting resources	133
Removing and replacing the system battery.....	134
Specifications	135
Environmental specifications	135
Server specifications.....	135
Power supply specifications.....	136
500 W Flex Slot Platinum Hot-plug Low Halogen Power Supply.....	136
800 W Flex Slot Platinum Hot-plug Low Halogen Power Supply.....	137

800 W Flex Slot Titanium Hot-plug Low Halogen Power Supply	138
800 W Flex Slot Universal Hot-plug Low Halogen Power Supply	139
800 W Flex Slot -48 VDC Hot-plug Low Halogen Power Supply	139
1600 W Flex Slot Platinum Hot-plug Low Halogen Power Supply	141

Component identification

Front panel components

8SFF

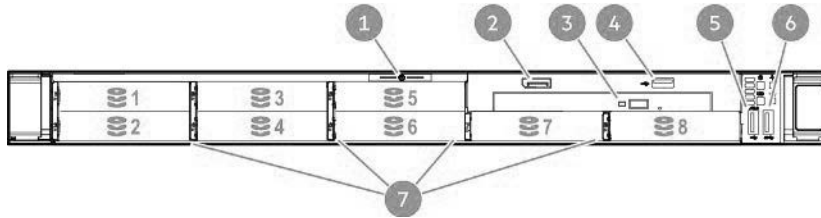

Item	Description
1	Serial number/iLO information pull tab
2	Display port (optional) ¹
3	Optical drive (optional) ¹
4	USB 2.0 port (optional) ¹
5	iLO Service Port ²
6	USB 3.0 port
7	Drive bays
¹ Optional 2SFF drive bays	
² The operating system does not recognize this port as a USB port.	

4LF

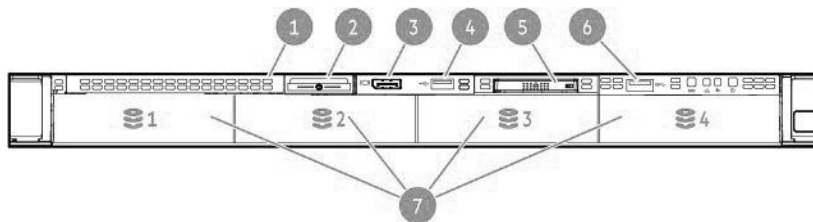

Item	Description
1	Optical drive blank (optional)
2	Serial number/iLO information pull tab
3	Display port (optional)

Item	Description
4	USB 2.0 port (optional)
5	Systems Insight Display (optional)
6	USB 3.0 port
7	Drive bays

Front panel LEDs and buttons

8SFF

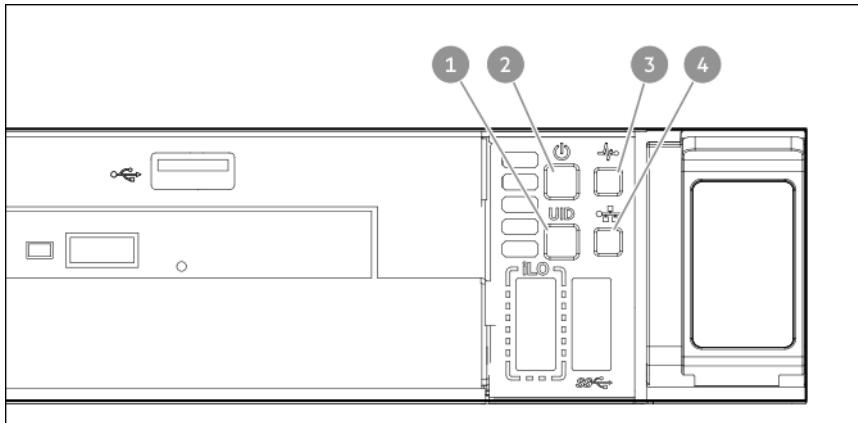

Item	Description	Status
1	UID button/LED ¹	Solid blue = Activated Flashing blue: 1 Hz = Remote management or firmware upgrade in progress 4 Hz = iLO manual reboot sequence initiated 8 Hz = iLO manual reboot sequence in progress Off = Deactivated
2	Power On/Standby button and system power LED ¹	Solid green = System on Flashing green = Performing power on sequence Solid amber = System in standby Off = No power present ²
3	Health LED ¹	Solid green = Normal

Item	Description	Status
		Flashing green = iLO is rebooting. Flashing amber = System degraded Flashing red = System critical ³
4	NIC status LED ¹	Solid green = Link to network Flashing green = Network active Off = No network activity
<p>¹ When all four LEDs described in this table flash simultaneously, a power fault has occurred.</p> <p>² Facility power is not present, power cord is not attached, no power supplies are installed, power supply failure has occurred, or the power button cable is disconnected.</p> <p>³ If the health LED indicates a degraded or critical state, review the system IML or use iLO to review the system health status.</p>		

4LF

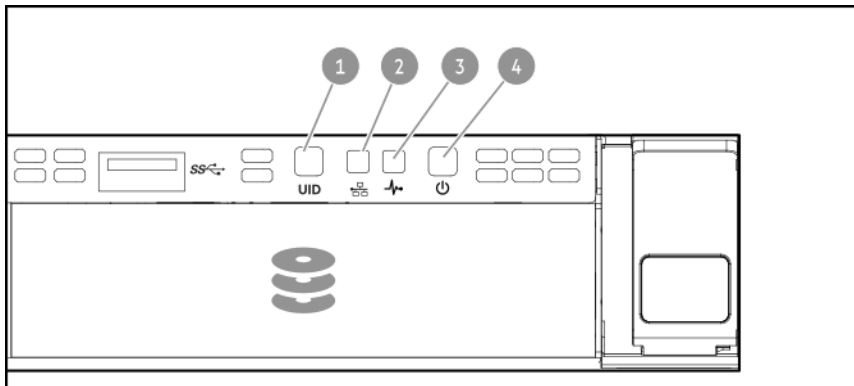

Item	Description	Status
1	UID button/LED ¹	Solid blue = Activated. Flashing blue <ul style="list-style-type: none"> 1 Hz = Remote management or firmware upgrade in progress 4 Hz = iLO manual reboot sequence initiated. 8 Hz = iLO manual reboot sequence in progress. Off = Deactivated.
2	NIC status LED ¹	Solid green = Link to network. Flashing green = Network active. Off = No network activity.

Item	Description	Status
3	Health LED ¹	Solid green = Normal. Flashing green = iLO is rebooting. Flashing amber = System degraded. Flashing red = System critical. ²
4	Power On/Standby button and system power LED ¹	Solid green = System on Flashing green = Performing power on sequence. Solid amber = System in standby. Off = No power present. ³
<p>¹ When all four LEDs described in this table flash simultaneously, a power fault has occurred.</p> <p>² To identify components in a degraded or critical state, see the <u>Systems Insight Display LEDs</u>, check iLO/BIOS logs, and reference the server troubleshooting guide.</p> <p>³ Facility power is not present, power cord is not attached, no power supplies are installed, power supply failure has occurred, or the power button cable is disconnected.</p>		

UID button functionality

The UID button can be used to display the Server Health Summary when the server will not power on. For more information, see the latest iLO 5 User Guide on the [Hitachi Vantara Website](#).

Front panel LED power fault codes

The following table provides a list of power fault codes, and the subsystems that are affected. Not all power faults are used by all servers.

Subsystem	LED behavior
System board	1 flash
Processor	2 flashes
Memory	4 flashes
Riser board PCIe slots	5 flashes
OCP adapter	5 flashes
Storage controller	6 flashes
System board PCIe slots	7 flashes
Power backplane	8 flashes
Storage backplane	9 flashes

Subsystem	LED behavior
Power supply	10 flashes
PCIe expansion cards installed in riser board	11 flashes
GPU card	13 flashes

The Systems Insight Display LEDs

The Systems Insight Display LEDs represent the system board layout. The display enables diagnosis with the access panel installed.

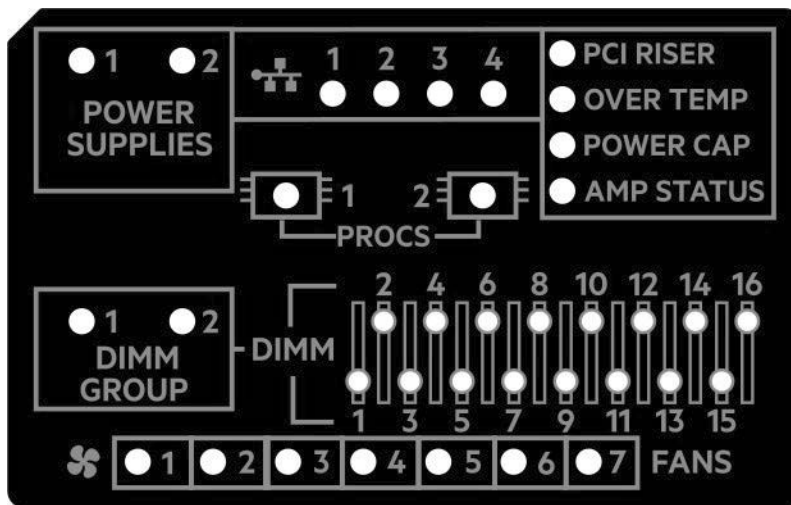

Description	Status
Processor LEDs	Off = Normal Amber = Failed processor
DIMM LEDs	Off = Normal Amber = Failed DIMM or configuration issue
Fan LEDs	Off = Normal Amber = Failed fan or missing fan
NIC LEDs1	Off = No link to network Solid green = Network link Flashing green = Network link with activity If power is off, the front panel LED is not active. For status, see Rear panel LEDs

Description	Status
Power supply LEDs	Off = Normal Solid amber = Power subsystem degraded, power supply failure, or input power lost.
PCI riser LED	Off = Normal Amber = Incorrectly installed PCI riser cage
Over temp LED	Off = Normal Amber = High system temperature detected
Power cap LED	Off = System is in standby, or no cap is set. Solid green = Power cap applied
Amp Status LED	Solid green = AMP mode enabled Solid amber = Failover Flashing amber = Invalid configuration
1 Embedded NIC ports are not equipped on the server. NIC LEDs on the Systems Insight Display will flash based on the network adapter port activity. In the case of a dual-port adapters, only NIC LED 1 and 2 will illuminate to correspond with the activity of the respective network ports.	

When the health LED on the front panel illuminates either amber or red, the server is experiencing a health event. For more information on the combination of these LEDs, see [Systems Insight Display combined LED descriptions](#).

Systems Insight Display combined LED descriptions

The combined illumination of the following LEDs indicates a system condition:

- Systems Insight Display LEDs
- System power LED
- Health LED

Systems Insight Display LED and color	Health LED	System power LED	Status
Processor (amber)	Red	Amber	One or more of the following conditions might exist: <ul style="list-style-type: none"> • Processor in socket X has failed. • Processor X is not installed in the socket. • Processor X is unsupported. • ROM detects a failed processor during POST.
Processor (amber)	Amber	Green	Processor in socket X is in a pre-failure condition.

Systems Insight Display LED and color	Health LED	System power LED	Status
DIMM (amber)	Red	Green	One or more DIMMs have failed.
DIMM (amber)	Amber	Green	DIMM in slot X is in a pre-failure condition.
Over temp (amber)	Amber	Green	The Health Driver has detected a cautionary temperature level.
Over temp (amber)	Red	Amber	The server has detected a hardware critical temperature level.
PCI riser (amber)	Red	Green	The PCI riser cage is not seated properly.
Fan (amber)	Amber	Green	One fan has failed or has been removed.
Fan (amber)	Red	Green	Two or more fans have failed or been removed.
Power supply (amber)	Red	Amber	Power supply (amber) Red Amber One or more of the following conditions might exist: <ul style="list-style-type: none"> • Only one power supply is installed, and that power supply is in standby. • Power supply fault. • System board fault.
Power supply (amber)	Amber	Green	One or more of the following conditions might exist: <ul style="list-style-type: none"> • Redundant power supply is installed and only one power supply is functional. • AC power cord is not plugged into redundant power supply. • Redundant power supply fault. • Power supply mismatch at POST or power supply mismatch through hot-plug addition.
Power cap (off)		Amber	Standby
Power cap (green)		Flashing green	Waiting for power
Power cap (green)		Green	Power is available

Systems Insight Display LED and color	Health LED	System power LED	Status
Power cap (flashing amber)		Amber	Power is not available

! **IMPORTANT:** If more than one DIMM slot LED is illuminated, further troubleshooting is required. Test each bank of DIMMs by removing all other DIMMs. Isolate the failed DIMM by replacing each DIMM in a bank with a known working DIMM.

Rear panel components

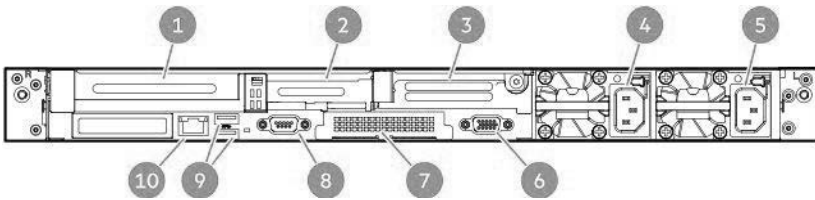

Item	Description
1	Slot 1 PCIe4
2	Slot 2 PCIe4
3	Slot 3 PCIe4 (optional - requires second processor)
4	Power supply 2 (PS2)
5	Power supply 1 (PS1)
6	(VGA) port
7	OCP 3.0 adapter (if equipped)
8	Serial port (optional)
9	USB 3.0 ports
10	iLO Management Port

Rear panel LEDs

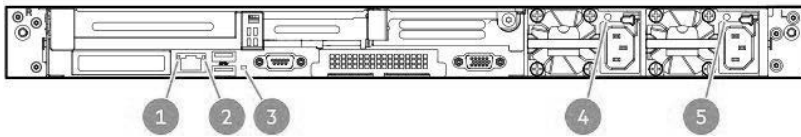

Item	Description	Status
1	iLO 5/standard NIC link LED	Solid green = Link exists. Off = No link exists
2	iLO 5/standard NIC activity LED	Solid green = Activity exists Flashing green = Activity exists Off = No activity exists.
3	UID LED Solid blue = Identification is activated.	Solid blue = Identification is activated Flashing blue = System is being managed remotely Off = Identification is deactivated.
4	Power supply 2 LED	Solid green = Normal Off = One or more of the following conditions exists: <ul style="list-style-type: none"> • AC power unavailable • Power supply failed • Power supply in standby mode • Power supply exceeded current limit.
5	Power supply 1 LED	Solid green = Normal Off = One or more of the following conditions exists: <ul style="list-style-type: none"> • AC power unavailable • Power supply failed • Power supply in standby mode • Power supply exceeded current limit.

System board components

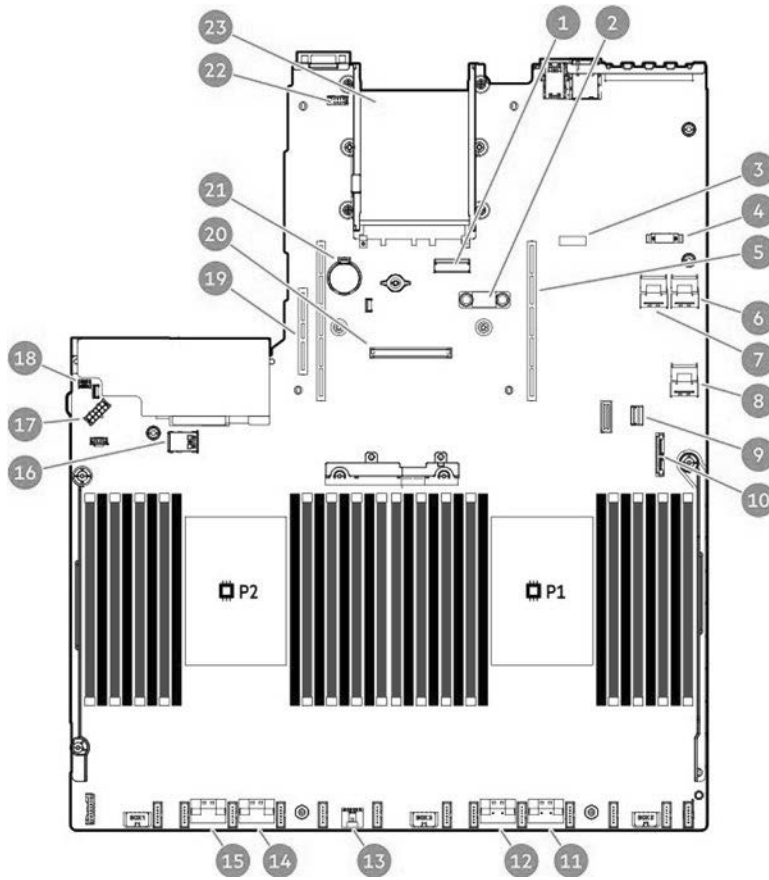

Item	Description
1	x8 Slimline connector
2	TPM connector
3	System maintenance switch
4	Front display port/USB 2.0 connector
5	Primary (processor 1) PCIe riser connector
6	x4 SATA port 2
7	x4 SATA port 1
8	x2 SATA port 3
9	Front power/USB 3.0 connector
10	SATA optical port 4
11	x8 NVMe port 2A

Item	Description
12	x8 NVMe port 1A
13	Energy pack connector
14	x8 NVMe port 2B
15	x8 NVMe port 1B
16	Dual internal USB 3.0 connector
17	Drive backplane power connector
18	Chassis Intrusion Detection connector
29	Secondary (processor 2) PCIe riser connector
20	Type-a storage controller slot
21	System battery
22	Serial port connector
23	OCP 3.0 adapter bay

Heatsink and socket components

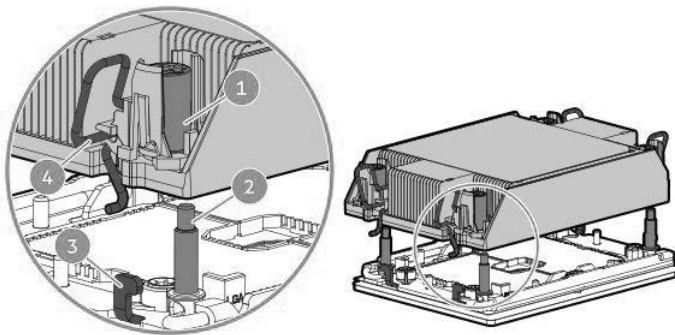

Item	Description
1	Heatsink nuts
2	Alignment screws
3	Latch tabs
4	Heatsink latches

System maintenance switch descriptions

Positions	Defaults	Functions
S1	Off	Off = iLO security is enabled. On = iLO security is disabled.
S2	Off	Reserved
S3	Off	Reserved
S4	Off	Reserved
S5 ¹	Off	Off = Power-on password is enabled.
S6 ^{1,2,3}	Off	Off = No function On = Restore default manufacturing settings
S7	Off	Reserved
S8	—	Reserved
S9	—	Reserved
S10	—	Reserved
S11	—	Reserved
S12	—	Reserved On = Power-on password is disabled.

¹To access the redundant ROM, set S1, S5, and S6 to On.

2. When the system maintenance switch position 6 is set to the On position, the system is prepared to restore all configuration settings to their manufacturing defaults.

3. When the system maintenance switch position 6 is set to the On position and Secure Boot is enabled, some configurations cannot be restored. For more information, see Secure Boot.

DIMM slot locations

DIMM slots are numbered sequentially (1 through 16) for each processor.

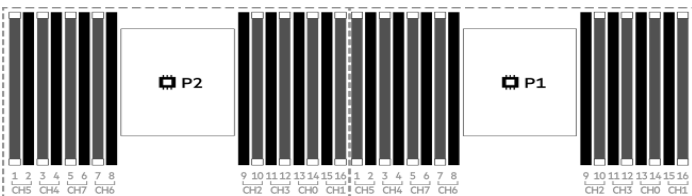

DIMM label identification

To determine DIMM characteristics, see the label attached to the DIMM. The information in this section helps you to use the label to locate specific information about the DIMM.

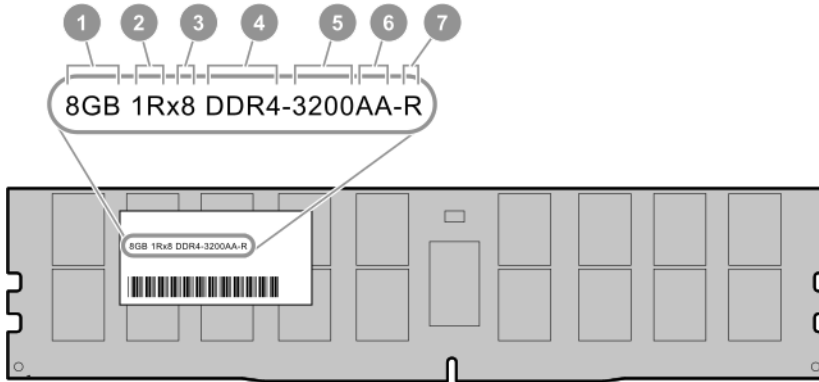

Item	Description	Examples
1	Capacity	8 GB 16 GB 32 GB 64 GB 128 GB 256 GB
2	Rank	1R = Single rank 2R = Dual rank 4R = Quad rank 8R = Octal rank
3	Data width on DRAM	x4 = 4-bit
4	Memory generation	PC4 = DDR4
5	Maximum memory speed	3200 MT/s
6	CAS latency	AA = CAS 22-22-22 AA = CAS 26-22-22 (for 3DS LRDIMM)
7	DIMM type	R = RDIMM (registered) L = LRDIMM (load reduced)

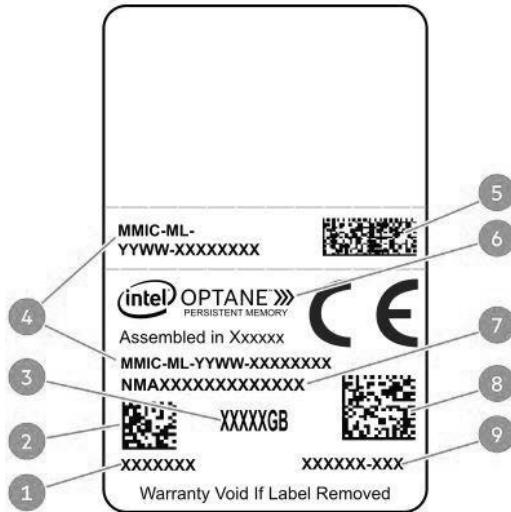

Intel Optane persistent memory 200 series for label identification

Item	Description	Example
1	Work Order Number	XXXXXX
2	Work Order Number Barcode	XXXXXX
3	Capacity	128 GB 256 GB 512 GB
4	Unique ID number	8089-A2-1802-1234567A
5	Serial Number and Part Number Barcode	S8089A218040000168APNMAXXXXXXXXXXXXX
6	Product Name	Intel® Optane™ persistent memory
7	Part Number	1234567A
8	Serial Number Barcode	8089-A2-1802-1234567A
9	PBA Number	XXXXXX-XXX

Drive numbering

8SFF and 8SFF + 2SFF device bay numbering

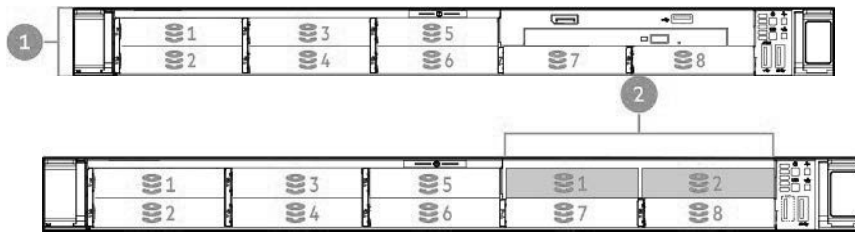

Item	Description
1	Box 1, bays 1-8
2	Box 2, bays 1 and 2

4 LFF device bay numbering

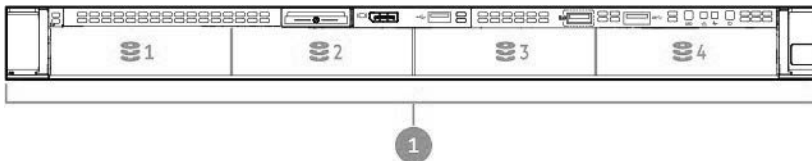

Item	Description
1	Box 1, bays 1-4

Basic Drive LED definitions

LFF low-profile drive carrier

The LFF low-profile drive carrier supports hot-plug SAS and SATA drives.

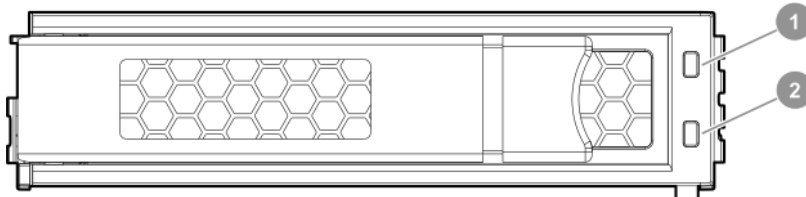

SFF basic drive carrier

The SFF basic drive carrier supports hot-plug SAS, SATA, and NVMe drives.

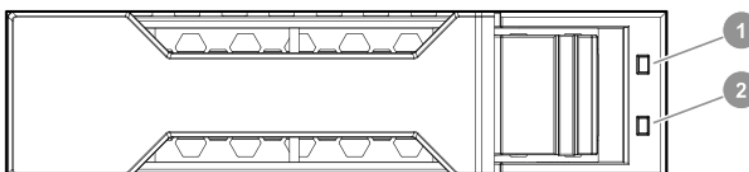

Item	LED	Status	Definition
1	Fault/Locate	Solid amber Solid blue Flashing amber/blue (1 flash per second) Flashing amber (1 flash per second)	<p>This drive has failed, is unsupported, or is invalid.</p> <p>The drive is operating normally and being identified by a management application.</p> <p>The drive has failed, or a predictive failure alert has been received for this drive. The drive has also been identified by a management application.</p> <p>A predictive failure alert has been received for this drive. Replace the drive as soon as possible.</p>
2	Online/Activity	Solid green Flashing green (1 flash per second) Flashing green (4 flashes per second) Off	<ol style="list-style-type: none"> The drive is doing one of the following: <ul style="list-style-type: none"> Rebuilding or performing a RAID Performing a stripe size migration Performing a capacity expansion Performing a logical drive extension Erasing Spare part activation The drive is operation normally and has activity. The drive is not configured by a RAID controller or is a spare drive.

Hot-plug fans

⚠ CAUTION: To avoid damage to server components, fan blanks must be installed in fan bays 1 and 2 in a single-processor configuration.

⚠ CAUTION: To avoid damage to the equipment, do not operate the server for extended periods of time if the server does not have the optimal number of fans installed. Although the server might boot, Hitachi Vantara does not recommend operating the server without the required fans installed and operating.

The valid fan configurations are listed in the following tables.

One-processor configuration

Fan bay 1	Fan bay 2	Fan bay 3	Fan bay 4	Fan bay 5	Fan bay 6	Fan bay 7
Fan blank	Fan blank	Fan	Fan	Fan	Fan	Fan

Two-processor configuration

Fan bay 1	Fan bay 2	Fan bay 3	Fan bay 4	Fan bay 5	Fan bay 6	Fan bay 7
Fan	Fan	Fan	Fan	Fan	Fan	Fan

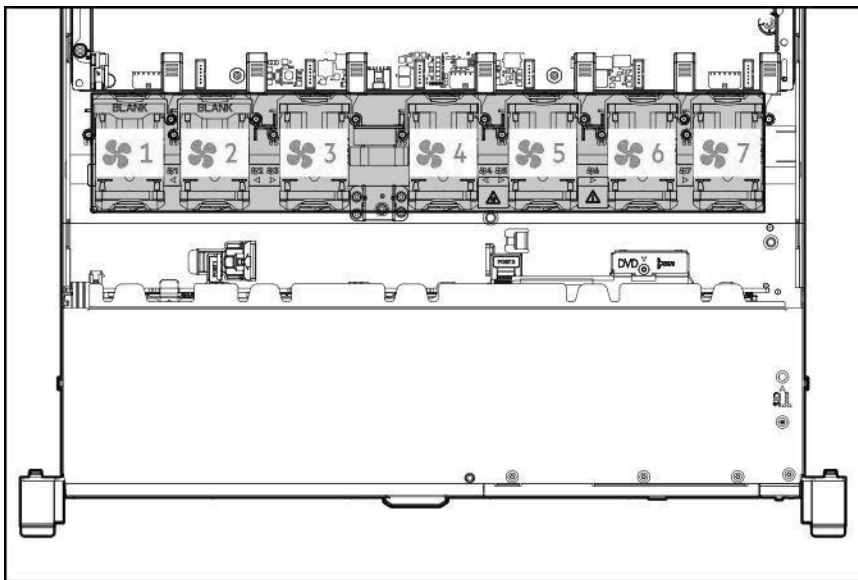

The loss of a single fan rotor (one standard fan) causes loss of redundancy. The loss of two fan rotors (two standard fans or one high performance fan) causes the server to initiate a shutdown.

The high-performance fans are required for some drive configurations. They are also required for ASHRAE-compliant configurations. For more information on ASHRAE-compliant configurations, contact customer support.

The server supports variable fan speeds. The fans operate at minimum speed until a temperature change requires a fan speed increase to cool the server. The server shuts down during the following temperature-related scenarios:

- At POST and in the OS, iLO performs an orderly shutdown if a cautionary temperature level is detected. If the server hardware detects a critical temperature level before an orderly shutdown occurs, the server performs an immediate shutdown.
- When the Thermal Shutdown feature is disabled in the BIOS/Platform Configuration (RBSU), iLO does not perform an orderly shutdown when a cautionary temperature level is detected. Disabling this feature does not disable the server hardware from performing an immediate shutdown when a critical temperature level is detected.

⚠ CAUTION: A thermal event can damage server components when the Thermal Shutdown feature is disabled in the BIOS/Platform Configuration (RBSU).

DSC-25 2-port SFP28 card ports and LEDs

Ports

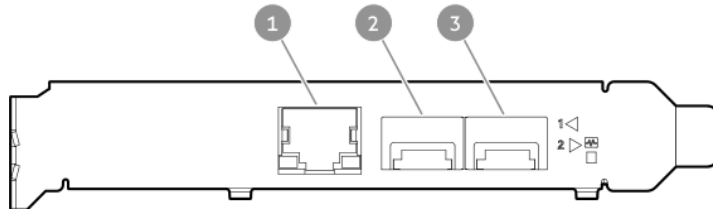

Table 1 Ports

Item	Ports	Description
1	Management port	1GbE RJ45
2	Network interface port	10/25G SFP+ based
3	Network interface port	10/25G SFP+ based

LEDs

The DSP DSC-25 2p SFP28 card is a dual-port, single-slot, half-height, half-length (HHHL) SFP28 network adapter. It has LEDs for Link (L) and Activity (A) for each port. A half-height bracket is shown in the following illustration with SFP 28 ports and LEDs.

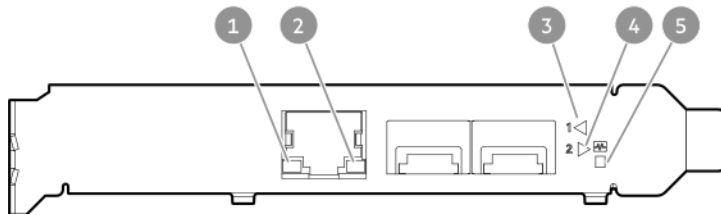
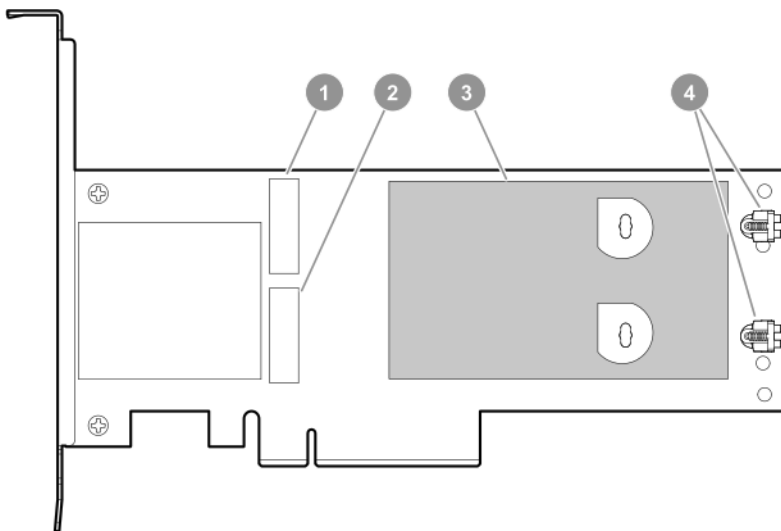

Table 2 LED indicators

Item	LED	Status	Description
1	Management Port Activity LED	Off Flashing	No activity Passing traffic; flashing frequency indicates traffic intensity
2	Management Port Link LED	Off Solid green	A link has not been established Valid Ethernet link
3	SFP Port 1 Link/Activity LED	Off Solid green Flashing green	A link has not been established Valid Ethernet link Passing traffic; flashing frequency indicates traffic intensity

Item	LED	Status	Description
		Solid amber	Link fault
4	SFP Port 2 Link/Activity LED	Off	A link has not been established
		Solid green	Valid Ethernet link
		Flashing green	Passing traffic; flashing frequency indicates traffic intensity
		Solid amber	Link fault
5	System status LED	Off	System is not powered
		Solid amber	Power is up, software has not booted yet
		Solid green	System is up and fully operational

NS204i-p NVMe OS Boot Device components



Item	Description
1	Drive bay 1
2	Drive bay 2
3	Thermal interface pad with removable liner
4	M.2 drive retaining latches

NS204i-p NVMe OS Boot Device LED definitions

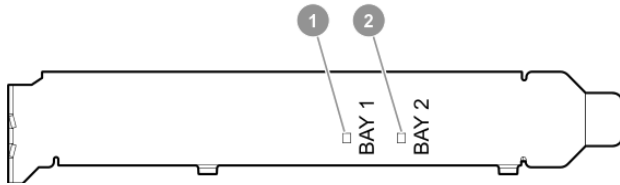

Item	Description	Fault LED status
1	Bay 1 LED	Off: Normal
2	Bay 2 LED	Flashing 1Hz: Drive predictive failure Amber: Drive failure

Operations

Power up the server

To power up the server, use one of the following methods:

- Press the Power On/Standby button.
- Use the virtual power button through iLO.

Power down the server

Before powering down the server for any upgrade or maintenance procedures, perform a backup of critical server data and programs.

! **IMPORTANT:** When the server is in standby mode, auxiliary power is still being provided to the system.

To power down the server, use one of the following methods:

- Press and release the Power On/Standby button.
- This method initiates a controlled shutdown of applications and the OS before the server enters standby mode.
- Press and hold the Power On/Standby button for more than 4 seconds to force the server to enter standby mode.
- This method forces the server to enter standby mode without properly exiting applications and the OS. If an application stops responding, you can use this method to force a shutdown.
- Use a virtual power button selection through iLO .
- This method initiates a controlled remote shutdown of applications and the OS before the server enters standby mode.

Before proceeding, verify that the server is in standby mode by observing that the system power LED is amber.

Extend the server from the rack

NOTE: If the cable management arm option is installed, you can extend the server without powering down the server or disconnecting peripheral cables and power cords. These steps are only necessary with the standard cable management solution.

Procedure

1. Power down the server.
2. Disconnect all peripheral cables and power cords.
3. Loosen the front panel thumbscrews.
4. Extend the server on the rack rails until the server rail-release latches engage.

 **WARNING:** To reduce the risk of personal injury or equipment damage, be sure that the rack is adequately stabilized before extending a component from the rack.

 **WARNING:** To reduce the risk of personal injury, be careful when pressing the server rail-release latches and sliding the server into the rack. The sliding rails could pinch your fingers.

5. After the installation or maintenance procedure, slide the server into the rack:
 - a. Slide the server fully into the rack.
 - b. Secure the server by tightening the thumbscrews.
6. Connect the peripheral cables and power cords.

Remove the server from the rack

To remove the server from a rack.

Procedure

1. **Power down the server.**
2. **Extend the server from the rack.**
3. Disconnect the cabling and remove the server from the rack. For more information, see the documentation that ships with the rack mounting option.
4. Place the server on a sturdy, level surface.

Remove the access panel

 **WARNING:** To reduce the risk of personal injury from hot surfaces, allow the drives and the internal system components to cool before touching them.

⚠ CAUTION: Do not operate the server for long periods with the access panel open or removed. Operating the server in this manner results in improper airflow and improper cooling that can lead to thermal damage.

Procedure

1. Power down the server.
2. Extend the server from the rack.

Open or unlock the locking latch, slide the access panel to the rear of the chassis, and remove the access panel.

Install the access panel

Procedure

1. Place the access panel on top of the server with the latch open.
Allow the panel to extend past the rear of the server approximately 1.25 cm (0.5 in).
2. Push down on the latch.

The access panel slides to a closed position.

Tighten the security screw on the latch, if needed.

Remove the hot-plug fan

Procedure

1. Observe the following alert:

⚠ IMPORTANT: After removing a high-performance (dual-rotor) fan, install or replace the fan within 60 seconds. Otherwise, the server will shut down gracefully.

2. Do one of the following:
 - Extend the server from the rack.
 - Remove the server from the rack.
3. Remove the access panel.

4. Remove the fan.

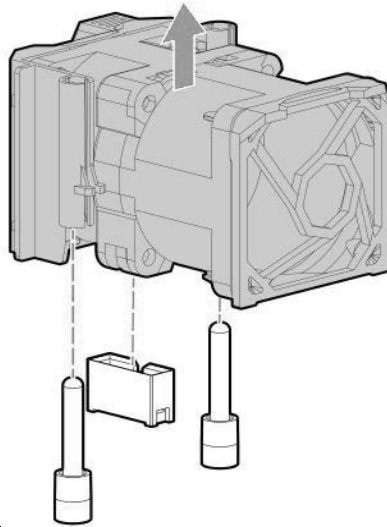

⚠ CAUTION: Do not operate the server for long periods with the access panel open or removed. Operating the server in this manner results in improper airflow and improper cooling that can lead to thermal damage.

ⓘ IMPORTANT: For optimum cooling, install fans in all primary fan locations.

To replace the component, reverse the removal procedure.

Remove the primary PCI riser cage

⚠ CAUTION: To prevent damage to the server or expansion boards, power down the server and remove all AC power cords before removing or installing the PCI riser cage.

Procedure

1. Back up all server data.
2. **Power down the server.**
3. Remove all power:
 - a. Disconnect each power cord from the power source.
 - b. Disconnect each power cord from the server.
4. Do one of the following:
 - a. Extend the server from the rack.
 - b. Remove the server from the rack.
5. Remove the access panel.

6. Remove the PCI riser cage.

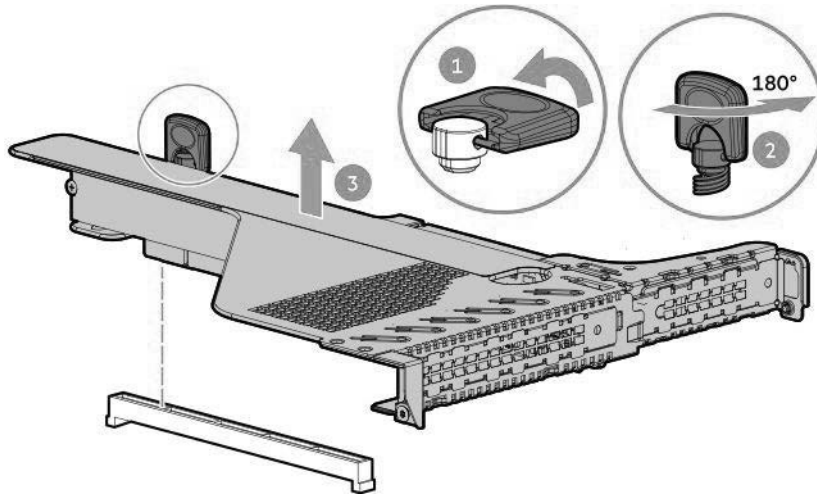

To replace the component, reverse the removal procedure.

Install the primary PCI riser cage

Procedure

1. Install the PCI riser cage.

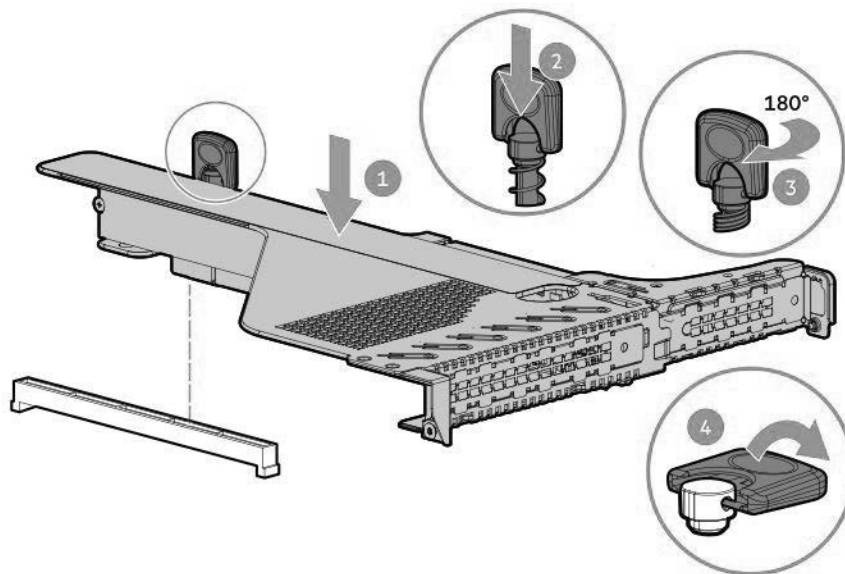

2. Install the access panel.
3. Install the server into the rack.
4. Connect each power cord to the server.
5. Connect each power cord to the power source.
6. Power up the server.

Remove the secondary PCI riser cage

Procedure

1. Observe the following alert:

⚠ CAUTION: To prevent damage to the server, power down the server and remove all AC power cords before removing or installing the PCI riser cage.

2. Back up all server data.
3. **Power down the server.**
4. Remove all power:
 - a. Disconnect each power cord from the power source.
 - b. Disconnect each power cord from the server.
5. Do one of the following:
 - a. **Extend the server from the rack.**
 - b. **Remove the server from the rack.**
6. **Remove the access panel.**
7. If needed, **remove the primary riser cage.**
8. Disconnect any cables connected to the riser cage.
9. Remove any expansion boards installed in the riser cage.

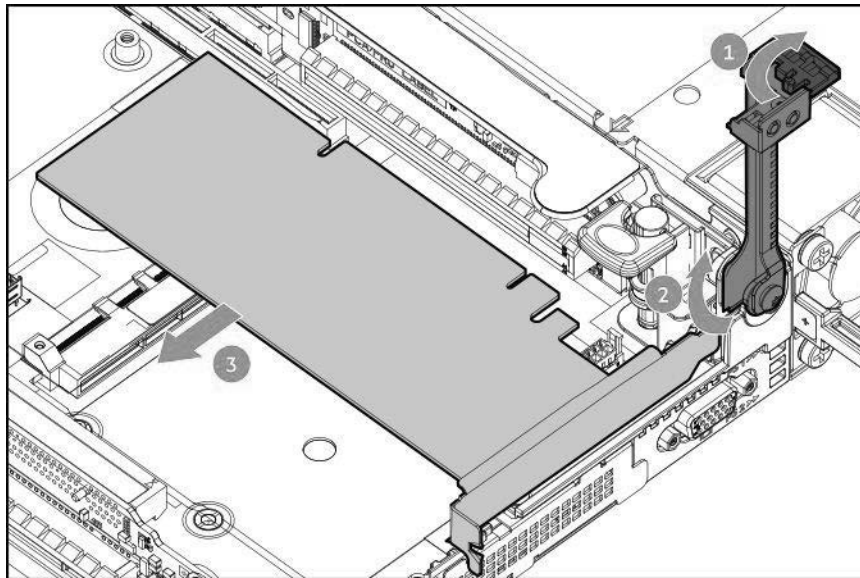

10. Remove the riser cage.

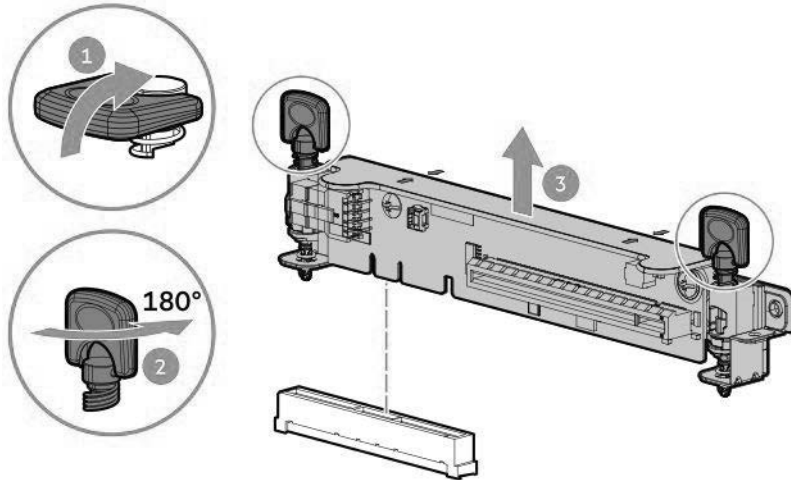

Install the secondary PCI riser cage

Procedure

1. Install the riser cage.

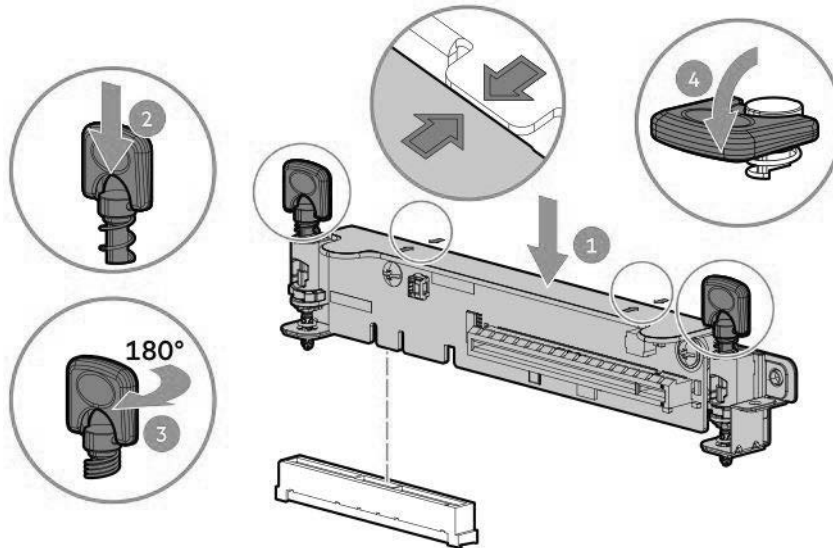

2. If needed, install expansion boards.
3. Install the access panel.
4. Install the server into the rack.
5. Connect each power cord to the server.
6. Connect each power cord to the power source.
7. Power up the server.

Remove the 8SFF drive backplane

Procedure

1. Back up all server data.
2. **Power down the server.**
3. Remove all power:
 - a. Disconnect each power cord from the power source.
 - b. Disconnect each power cord from the server.
4. Do one of the following:
 - a. **Extend the server from the rack.**
 - b. **Remove the server from the rack.**
5. **Remove the access panel.**
6. **Remove all drives.**
7. Disconnect and remove all cables connected to the drive backplane.
8. Remove the 8 SFF SAS/SATA drive backplane.

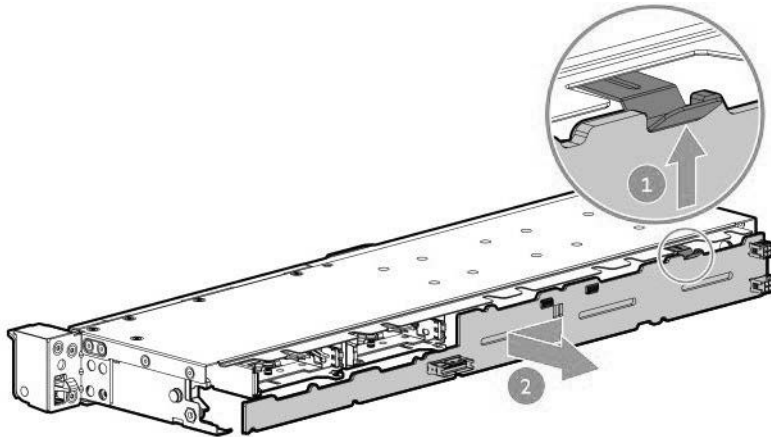

Removing the hard drive blank

△ CAUTION: To prevent improper cooling and thermal damage, do not operate the server unless all bays are populated with either a component or a blank.

Figure 1: Removing an SFF drive blank

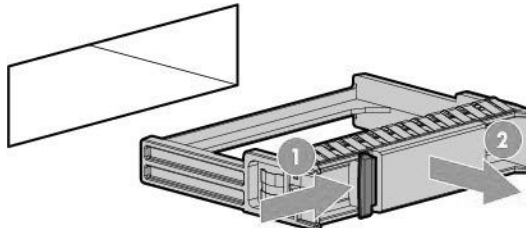
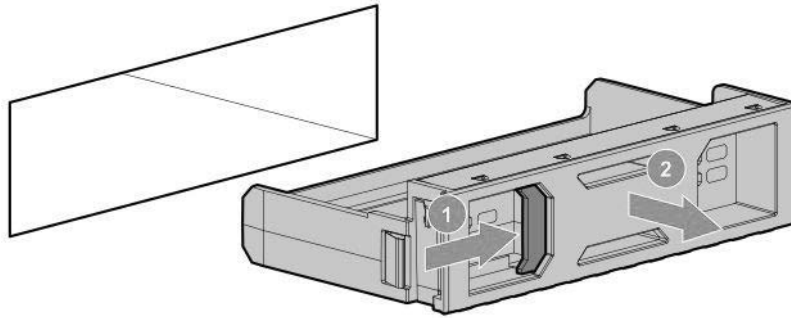

Figure 2: Removing an LFF drive blank



To replace the component, reverse the removal procedure.

Removing a hot-plug SAS/SATA/NVMe drive

CAUTION: For proper cooling, do not operate the server without the access panel, baffles, expansion slot covers, or blanks installed. If the server supports hot-plug components, minimize the amount of time the access panel is open.

1. Determine the status of the drive from the **hot-plug drive LED definitions**.
2. Back up all server data on the drive.
3. Remove the drive.

Figure 3: SFF drive

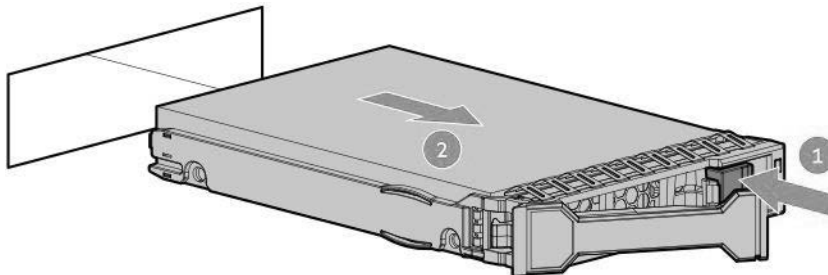
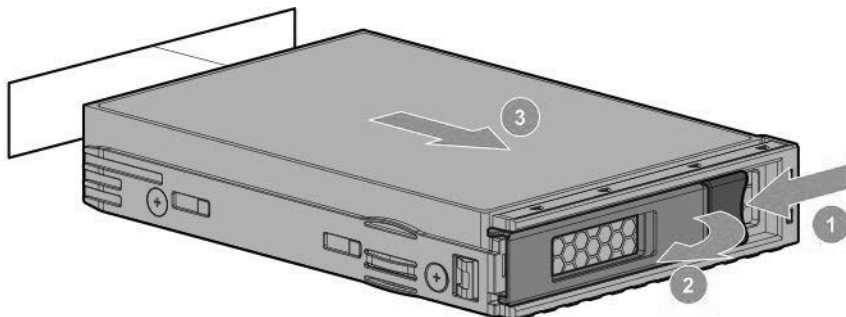
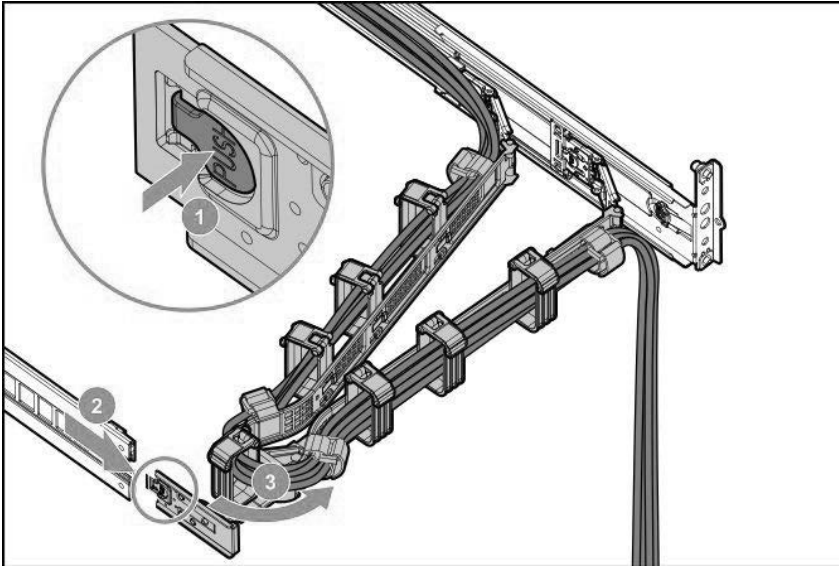

Figure 4: LFF drive



Releasing the cable management arm

Release the cable management arm and then swing the arm away from the rack.



Accessing the Systems Insight Display

To access the optional Systems Insight Display:

1. Press and release the panel.
2. After the display ejects, rotate the display to view the LEDs.

- 8SF

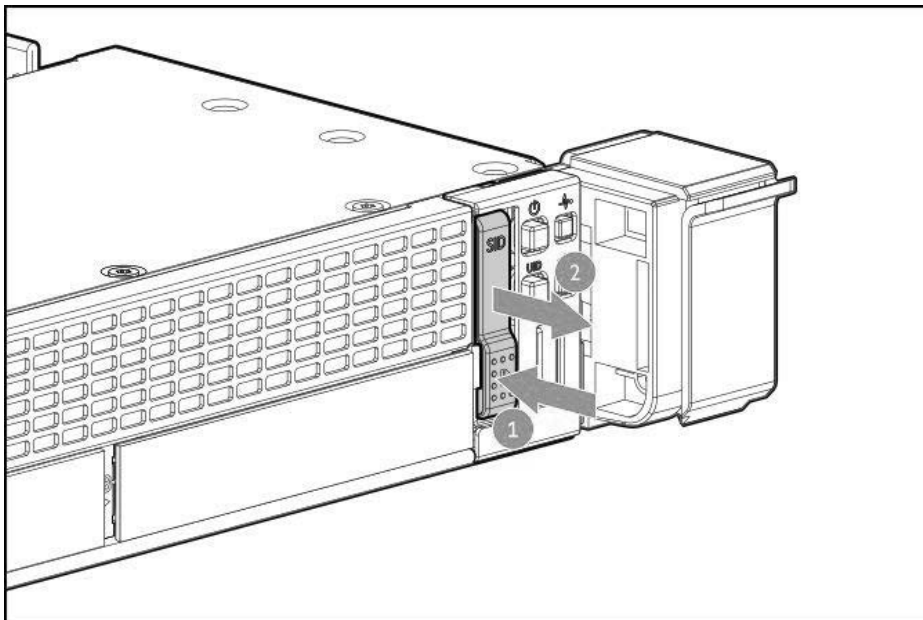

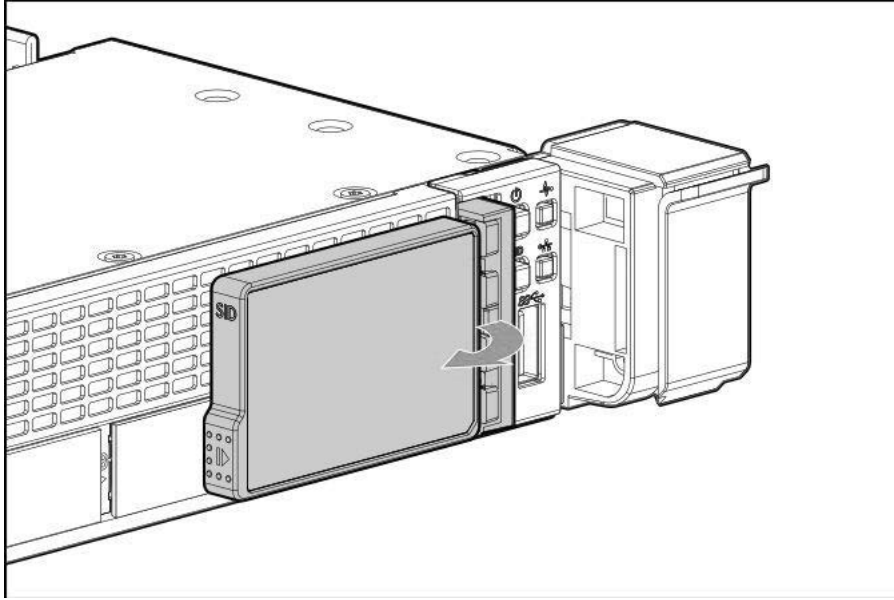

- 4LFF

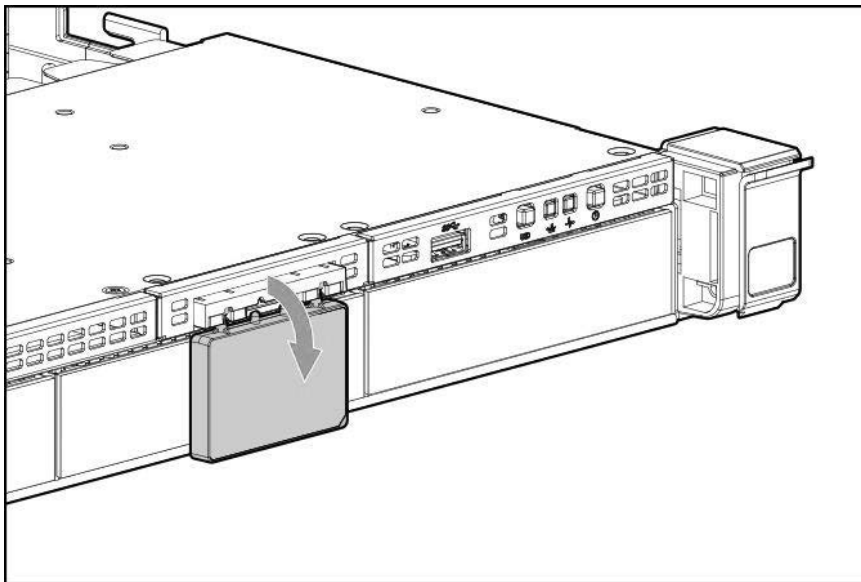

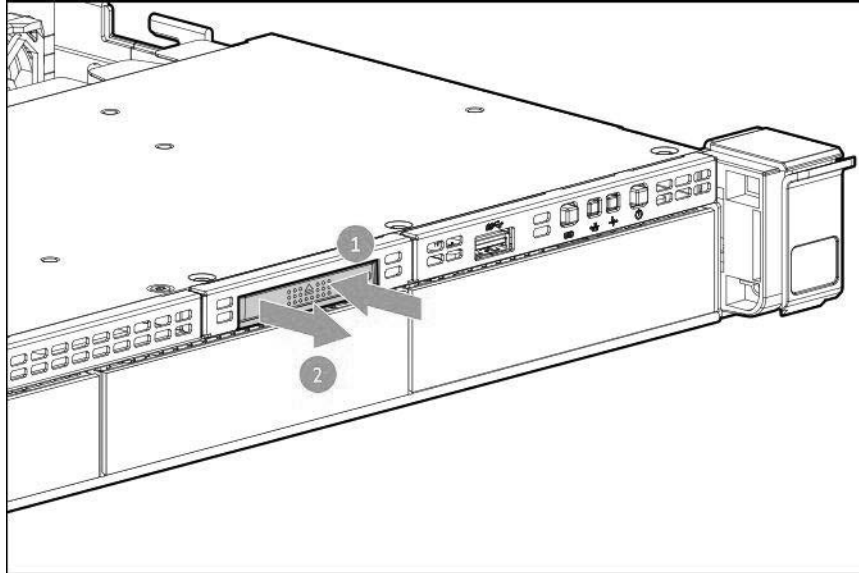

Setup

Optimum environment

When installing the server in a rack, select a location that meets the environmental standards described in this section.

Space and airflow requirements

To allow for servicing and adequate airflow, observe the following space and airflow requirements when deciding where to install a rack:

- Leave a minimum clearance of 63.5 cm (25 in) in front of the rack.
- Leave a minimum clearance of 76.2 cm (30 in) behind the rack.
- Leave a minimum clearance of 121.9 cm (48 in) from the back of the rack to the back of another rack or row of racks.

Hitachi Advanced Server product draws in cool air through the front door and expel warm air through the rear door. Therefore, the front and rear rack doors must be adequately ventilated to allow ambient room air to enter the cabinet, and the rear door must be adequately ventilated to allow the warm air to escape from the cabinet.

⚠ CAUTION: To prevent improper cooling and damage to the equipment, do not block the ventilation openings.

When vertical space in the rack is not filled by a server or rack component, the gaps between the components cause changes in airflow through the rack and across the servers. Cover all gaps with blanking panels to maintain proper airflow.

⚠ CAUTION: Always use blanking panels to fill empty vertical spaces in the rack. This arrangement ensures proper airflow. Using a rack without blanking panels results in improper cooling that can lead to thermal damage.

⚠ CAUTION: If a third-party rack is used, observe the following additional requirements to ensure adequate airflow and to prevent damage to the equipment:

- Front and rear doors—If the 42U rack includes closing front and rear doors, you must allow 5,350 sq cm (830 sq in) of holes evenly distributed from top to bottom to permit adequate airflow (equivalent to the required 64 percent open area for ventilation).
 - Side—The clearance between the installed rack component and the side panels of the rack must be a minimum of 7 cm (2.75 in)
-

Temperature requirements

To ensure continued safe and reliable equipment operation, install or position the system in a well-ventilated, climate- controlled environment.

The maximum recommended ambient operating temperature (TMRA) for most server products is 35°C (95°F). The temperature in the room where the rack is located must not exceed 35°C (95°F).

⚠ CAUTION: To reduce the risk of damage to the equipment when installing third-party options:

- Do not permit optional equipment to impede airflow around the server or to increase the internal rack temperature beyond the maximum allowable limits.
 - Do not exceed the manufacturer's TMRA.
-

Power requirements

Installation of this equipment must comply with local and regional electrical regulations governing the installation of information technology equipment by licensed electricians. This equipment is designed to operate in installations covered by NFPA 70, 1999 Edition (National Electric Code) and NFPA-75, 1992 (code for Protection of Electronic Computer/Data Processing Equipment). For electrical power ratings on options, refer to the product rating label or the user documentation supplied with that option.

⚠ WARNING: To reduce the risk of personal injury, fire, or damage to the equipment, do not overload the AC supply branch circuit that provides power to the rack. Consult the electrical authority having jurisdiction over wiring and installation requirements of your facility.

⚠ CAUTION: Protect the server from power fluctuations and temporary interruptions with a regulating uninterruptible power supply. This device protects the hardware from damage caused by power surges and voltage spikes and keeps the system in operation during a power failure.

Electrical grounding requirements

The server must be grounded properly for proper operation and safety. In the United States, you must install the equipment in accordance with NFPA 70, National Electric Code Article 250, as well as any local and regional building codes. In Canada, you must install the equipment in accordance with Canadian Standards Association,

CSA C22.1, Canadian Electrical Code. In all other countries, you must install the equipment in accordance with any regional or national electrical wiring codes, such as the International Electrotechnical Commission (IEC) Code 364, parts 1 through 7. Furthermore, you must be sure that all power distribution devices used in the installation, such as branch wiring and receptacles, are listed or certified grounding-type devices.

Because of the high ground-leakage currents associated with multiple servers connected to the same power source, Hitachi Vantara recommends the use of a PDU that is either permanently wired to the building's branch circuit or includes a nondetachable cord that is wired to an industrial-style plug. NEMA locking-style plugs or those complying with IEC 60309 are considered suitable for this purpose. Using common power outlet strips for the server is not recommended.

Connecting a DC power cable to a DC power source

WARNING: To reduce the risk of electric shock or energy hazards:

- This equipment must be installed by trained service personnel, as defined by the NEC and IEC 60950- 1, Second Edition, the standard for Safety of Information Technology Equipment.
 - Connect the equipment to a reliably grounded Secondary circuit source. A Secondary circuit has no direct connection to a Primary circuit and derives its power from a transformer, converter, or equivalent isolation device.
 - The branch circuit overcurrent protection must be rated 27 A.
-

 **WARNING:** When installing a DC power supply, the ground wire must be connected before the positive or negative leads.

 **WARNING:** Remove power from the power supply before performing any installation steps or maintenance on the power supply.

 **CAUTION:** The server equipment connects the earthed conductor of the DC supply circuit to the earthing conductor at the equipment. For more information, see the documentation that ships with the power supply.

 **CAUTION:** If the DC connection exists between the earthed conductor of the DC supply circuit and the earthing conductor at the server equipment, the following conditions must be met:

- This equipment must be connected directly to the DC supply system earthing electrode conductor or to a bonding jumper from an earthing terminal bar or bus to which the DC supply system earthing electrode conductor is connected.
- This equipment should be located in the same immediate area (such as adjacent cabinets) as any other equipment that has a connection between the earthed conductor of the same DC supply circuit and the earthing conductor, and also the point of earthing of the DC system. The DC system should be earthed elsewhere.
- The DC supply source is to be located within the same premises as the equipment.
- Switching or disconnecting devices should not be in the earthed circuit conductor between the DC source and the point of connection of the earthing electrode conductor.

To connect a DC power cable to a DC power source:

1. Cut the DC power cord ends no shorter than 150 cm (59.06 in).
2. If the power source requires ring tongues, use a crimping tool to install the ring tongues on the power cord wires.

! **IMPORTANT:** The ring terminals must be UL approved and accommodate 12 gauge wires.

! **IMPORTANT:** The minimum nominal thread diameter of a pillar or stud type terminal must be 3.5 mm (0.138 in); the diameter of a screw type terminal must be 4.0 mm (0.157 in).

3. Stack each same-colored pair of wires and then attach them to the same power source. The power cord consists of three wires (black, red, and green).

For more information, see the documentation that ships with the power supply.

Server warnings and cautions

! **WARNING:** This server is heavy. To reduce the risk of personal injury or damage to the equipment:

- Observe local occupational health and safety requirements and guidelines for manual material handling.
 - Get help to lift and stabilize the product during installation or removal, especially when the product is not fastened to the rails. Hitachi Vantara recommends that the minimum of two people are required for all rack server installations. If the server is installed higher than chest level, a third person may be required to help align the server.
 - Use caution when installing the server in or removing the server from the rack; it is unstable when not fastened to the rails.
-

! **WARNING:** To reduce the risk of personal injury from hot surfaces, allow the drives and the internal system components to cool before touching them.

! **WARNING:** To reduce the risk of personal injury, electric shock, or damage to the equipment, remove the power cord to remove power from the server. The front panel Power On/Standby button does not completely shut off system power. Portions of the power supply and some internal circuitry remain active until AC/DC power is removed.

! **WARNING:** To reduce the risk of fire or burns after removing the energy pack:

- Do not disassemble, crush, or puncture the energy pack.
- Do not short external contacts.

- Do not dispose of the energy pack in fire or water.
- Do not expose the energy pack to low air pressure as it might lead to explosion or leakage of flammable liquid or gas.
- Do not expose the energy pack to temperatures higher than 60°C (140°F).

After power is disconnected, battery voltage might still be present for 1s to 160s.

⚠ CAUTION: Protect the server from power fluctuations and temporary interruptions with a regulating uninterruptible power supply. This device protects the hardware from damage caused by power surges and voltage spikes and keeps the system in operation during a power failure.

⚠ CAUTION: Do not operate the server for long periods with the access panel open or removed. Operating the server in this manner results in improper airflow and improper cooling that can lead to thermal damage.

Rack warnings

⚠ WARNING: To reduce the risk of personal injury or damage to the equipment, be sure that:

- The leveling jacks are extended to the floor.
 - The full weight of the rack rests on the leveling jacks.
 - The stabilizing feet are attached to the rack if it is a single-rack installation.
 - The racks are coupled together in multiple-rack installations.
 - Only one component is extended at a time. A rack may become unstable if more than one component is extended for any reason.
-

⚠ WARNING: To reduce the risk of personal injury or equipment damage when unloading a rack:

- At least two people are needed to safely unload the rack from the pallet. An empty 42U rack can weigh as much as 115 kg (253 lb), can stand more than 2.1 m (7 ft) tall, and might become unstable when being moved on its casters.
 - Never stand in front of the rack when it is rolling down the ramp from the pallet. Always handle the rack from both sides.
-

⚠ WARNING: To reduce the risk of personal injury or damage to the equipment, adequately stabilize the rack before extending a component outside the rack. Extend only one component at a time. A rack may become unstable if more than one component is extended.

⚠ WARNING: When installing a server in a telco rack, be sure that the rack frame is adequately secured at the top and bottom to the building structure.

Identifying the contents of the server shipping carton

Unpack the server shipping carton and locate the materials and documentation necessary for installing the server. All the rack mounting hardware necessary for installing the server into the rack is included with the rack or the server.

The contents of the server shipping carton include:

- Server
- Power cord
- Hardware documentation and software products
- Rack-mounting hardware and documentation.

In addition to the supplied items, you might need:

- Operating system or application software
- Hardware options
- Screwdriver

Installing hardware options

Install any hardware options before initializing the server. For options installation information, refer to the option documentation. For server-specific information, refer to "Hardware options installation."

Installing the server into the rack

To install the server into a rack with square, round, or threaded holes, refer to the instructions that ship with the rack hardware kit.

⚠ WARNING: This server is heavy. To reduce the risk of personal injury or damage to the equipment:

- Observe local occupational health and safety requirements and guidelines for manual material handling.
 - Get help to lift and stabilize the product during installation or removal, especially when the product is not fastened to the rails. Hitachi Vantara recommends that a minimum of two people are required for all rack server installations. A third person may be required to help align the server if the server is installed higher than chest level.
 - Use caution when installing the server in or removing the server from the rack; it is unstable when not fastened to the rails.
-

⚠ CAUTION: Always plan the rack installation so that the heaviest item is on the bottom of the rack. Install the heaviest item first, and continue to populate the rack from the bottom to the top.

Procedure

1. Install the server and cable management arm into the rack. For more information, see the installation instructions that ship with the selected rail system.
2. Connect peripheral devices to the server. For more information, see [Rear panel components](#).
3. Connect the power cord to the rear of the server.

4. Use the hook-and-loop strap to secure the power cord.
5. Connect the power cord to the power source.

Operating system

This Advanced Server does not ship with provisioning media. Everything required to manage and install the system software and firmware is preloaded on the server.

To operate properly, the server must have a supported operating system. Attempting to run an unsupported operating system can cause serious and unpredictable results. For the latest information about supported operating systems, see <https://support.hitachivantara.com/en/user/answers/interoperability.html>

Failure to observe UEFI requirements for HA800 servers can result in errors installing the operating system, failure to recognize boot media, and other boot failures. For more information on these requirements, see the UEFI Requirements on the [Hitachi Vantara website](#).

To install an operating system on the server, use one of the following methods:

Intelligent Provisioning—For single-server deployment, updating, and provisioning capabilities. For more information, see [Installing the operating system with Intelligent Provisioning](#).

- Insight Control server provisioning—For multi-server remote OS deployment, use Insight Control server provisioning for an automated solution. For more information, contact customer support.

For additional system software and firmware updates, download the Service Pack for Hitachi Vantara from the [Hitachi Vantara website](#). Software and firmware must be updated before using the server for the first time, unless any installed software or components require an older version.

For more information, see Keeping the system current.

For more information on using these installation methods, see the [Hitachi Vantara website](#).

Installing the operating system with Intelligent Provisioning

Procedure

1. Connect the Ethernet cable between the network connector on the server and a network jack.
2. Press the Power On/Standby button.
3. During server POST, press F10.
4. Complete the initial Preferences and Registration portion of [Intelligent Provisioning](#).
5. At the Start screen, click Configure and Install.
6. To finish the installation, follow the onscreen prompts. An Internet connection is required to update the firmware and systems software.

Selecting boot options in UEFI Boot Mode

On servers operating in UEFI Boot Mode, the boot controller and boot order are set automatically.

Procedure

1. Press the Power On/Standby button.
2. During the initial boot:
 - To modify the server configuration ROM default settings, press the F9 key in the Advanced

Server POST screen to enter the UEFI System Utilities screen. By default, the System Utilities menus are in the English language.

- If you do not need to modify the server configuration and are ready to install the system software, press the F10 key to access Intelligent Provisioning.
- For more information on automatic configuration, see the UEFI documentation on the [Hitachi Vantara Website](#).

Selecting boot options

This server supports both Legacy BIOS Boot Mode and UEFI Boot Mode. On servers operating in UEFI Boot Mode, the boot controller and boot order are set automatically.

Procedure

1. Press the **Power On/Standby** button.
2. Do one of the following:
 - To enter the UEFI System Utilities screen and modify the server configuration ROM default settings, press the F9 key on the Advanced Server POST screen. Choose one of the following boot modes:
 - Legacy BIOS
 - UEFI (default)
 - If you do not need to modify the server configuration and are ready to install the system software, press the F10 key to access Intelligent Provisioning.

For more information on automatic configuration, see the UEFI documentation on the [Hitachi Vantara website](#).

Registering the server

Register the product at <https://support.hitachivantara.com/en/user/home.html>.

Hardware options installation

Introduction

Install any hardware options before initializing the server. If multiple options are being installed, read the installation instructions for all the hardware options to identify similar steps and streamline the installation process.

⚠ WARNING: To reduce the risk of personal injury from hot surfaces, allow the drives and the internal system components to cool before touching them.

⚠ CAUTION: To prevent damage to electrical components, properly ground the server before beginning any installation procedure. Improper grounding can cause electrostatic discharge.

Installing a redundant hot-plug power supply

Prerequisites

Before installing this option, be sure you have the following:

The components included with the hardware option kit

Procedure

1. Observe the following alerts:

⚠ CAUTION: All power supplies installed in the server must have the same output power capacity. Verify that all power supplies have the same part number and label color. The system becomes unstable and may shut down when it detects mismatched power supplies.

⚠ CAUTION: To prevent improper cooling and thermal damage, do not operate the server unless all bays are populated with either a component or a blank.

2. Access the product rear panel.
3. Remove the blank.

⚠ WARNING: To reduce the risk of personal injury from hot surfaces, allow the power supply or power supply blank to cool before touching it.

4. Insert the power supply into the power supply bay until it clicks into place.
5. Connect the power cord to the power supply.

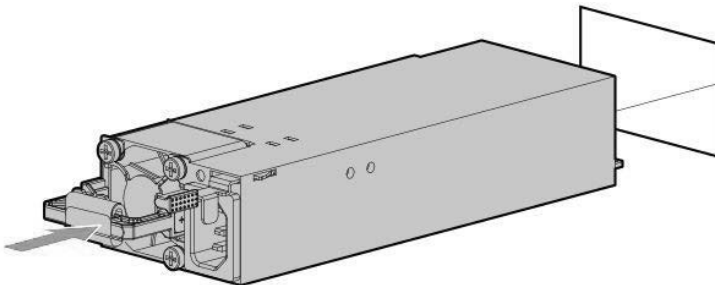

6. Route the power cord. Use best practices when routing power cords and other cables. A cable management arm is available to help with routing. To obtain a cable management arm, contact a Hitachi Vantara authorized reseller.
7. Connect the power cord to the AC power source.
8. Be sure that the power supply LED is green.

The installation is complete.

Energy pack options

Hitachi Vantara offers two backup power options to back up write cache content on the controllers in case of an unplanned server power outage.

- [Smart storage battery](#)
- [Smart storage hybrid capacitor](#)

Once installed, the status of the energy pack displays in iLO. For more information, see the iLO user guide on the [Hitachi Vantara website](#).

Smart storage battery

The Smart Storage battery supports the following devices:

Smart array SR controllers

A single 96W battery can support up to 24 devices.

After the battery is installed, it might take up to two hours to charge. Controller features requiring backup power are not re-enabled until the battery is capable of supporting the backup power.

This server supports the 96W Smart storage battery with the 145mm cable.

Smart storage hybrid capacitor

The Smart storage hybrid capacitor supports the following devices:

SmartRAID SR controllers

The capacitor pack can support up to two devices.

This server supports the Smart storage hybrid capacitor with the 145mm cable.

Before installing the Smart storage hybrid capacitor, verify that the system BIOS meets the minimum firmware requirements to support the capacitor pack.

! **IMPORTANT:** If the system BIOS or controller firmware is older than the minimum recommended firmware versions, the capacitor pack will only support one device.

The capacitor pack is fully charged after the system boots.

Minimum firmware versions

Product	Minimum firmware version
HA810 G2 Server	1.40

Product	Minimum firmware version
Smart array SR controllers	3.53

Installing an energy pack

Prerequisites

Before installing this option, be sure you that have the components included with the hardware option kit.

Procedure

1. **Power down the server.**
2. Remove all power:
 - a. Disconnect each power cord from the power source.
 - b. Disconnect each power cord from the server.
3. Do one of the following:
 - a. **Extend the server from the rack.**
 - b. **Remove the server from the rack.**
4. **Remove the access panel.**
5. Install the energy pack and connect the energy pack cable.

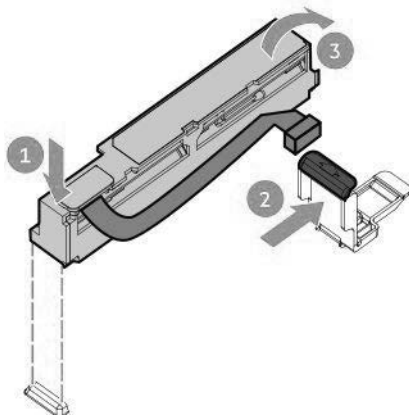

6. **Install the access panel.**
7. Install the server in the rack.
8. Connect each power cord to the server.
9. Connect each power cord to the power source.
10. **Power up the server.**
The installation is complete.

Memory options

ⓘ **IMPORTANT:** This server does not support mixing LRDIMMs and RDIMMs. Attempting to mix any combination of these DIMMs can cause the server to halt during BIOS initialization. All memory installed in the server must be of the same type.

Memory population information

For specific memory population information, contact customer support. see the memory population guidelines on the [Hitachi Vantara website](#).

DIMM-processor compatibility

The installed processor determines the type of DIMM that is supported in the server:

Third-generation Intel Xeon Scalable processors support DDR4-3200 DIMMs.

Mixing DIMM types is not supported. Install only the supported DDR4-3200 DIMMs in the server.

Installing a DIMM blank

Use the following table to decide if the thermal restrictions of the server require DIMM blanks in all open slots of your configuration.

Processor TDP	DIMM blank installation
105W to 140W	Recommended
230W to 270W	Recommended
150W to 270W	Required

Procedure

1. **Power down the server.**
2. Remove all power:
 - a. Disconnect each power cord from the power source.
 - b. Disconnect each power cord from the server.
3. Do one of the following:
 - a. **Extend the server from the rack.**
 - b. **Remove the server from the rack.**
4. **Remove the access panel.**
5. Open the DIMM slot latches.

6. Install the DIMM blank.

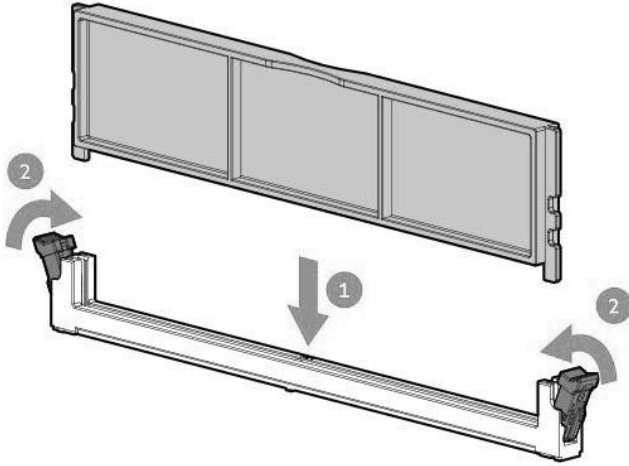

Installing a DIMM

The server supports up to 32 DIMMs.

Prerequisites

Before installing this option, make sure you have the following:

The components included the hardware option kit

Procedure

1. **Power down the server.**
2. Remove all power:
 - a. Disconnect each power cord from the power source.
 - b. Disconnect each power cord from the server.
3. Do one of the following:
 - a. **Extend the server from the rack.**
 - b. **Remove the server from the rack.**
4. **Remove the access panel.**
5. Open the DIMM slot latches.
6. Install the DIMM.

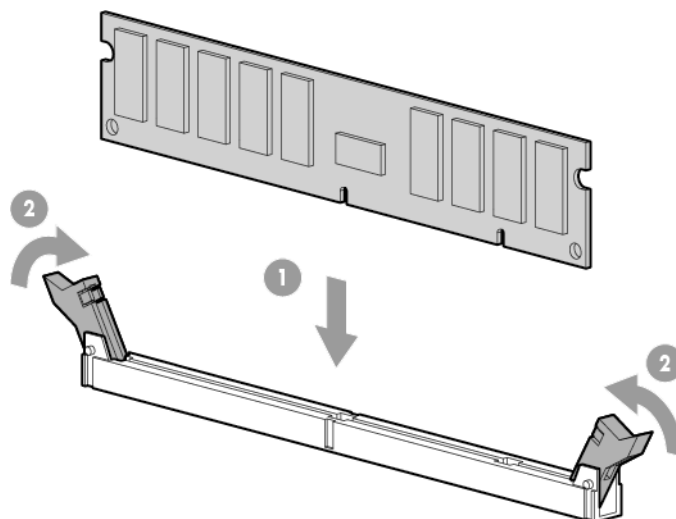

7. **Install the access panel.**

8. Install the server in the rack.

9. Connect each power cord to the server. Connect each power cord to the power source.

10. **Power up the server.**

Use the BIOS/Platform Configuration (RBSU) in the UEFI System Utilities to configure the memory mode.

For more information about LEDs and troubleshooting failed DIMMs, see **Systems Insight Display combined LED descriptions**.

Intel Optane persistent memory 200 series

Intel Optane persistent memory 200 series offers the flexibility to deploy memory as dense memory (Memory mode) or fast storage (App Direct mode) and enables per-socket memory capacity of up to 6.0 TB. Persistent memory modules, together with traditional volatile DRAM DIMMs, provide fast, high-capacity, cost-effective memory, and storage to transform big data workloads and analytics by enabling data to be stored, moved, and processed quickly.

Persistent memory modules use the standard DIMM form factor and are installed alongside DIMMs in a server memory slot. Intel Optane persistent memory 200 series is designed for use only with third-generation Intel Xeon Scalable processors, and is available in the following capacities:

- 128 GB
- 256 GB
- 512 GB

Persistent memory module-processor compatibility

Intel Optane persistent memory 200 series is supported only in servers with second-generation Intel Xeon Scalable processors installed.

System requirements for persistent memory module support

❗ **IMPORTANT:** Hitachi Vantara recommends that you implement best-practice configurations such as clustered configurations for high availability (HA).

Before installing persistent memory modules, make sure that the following components and software are available:

- A supported HA810 G2 Server using third-generation Intel Xeon Scalable processors.
- DDR4 Standard Memory RDIMMs or LRDIMMs (the number will vary based on your chosen configuration).
- Supported firmware and drivers:
 - System ROM version 1.40 or later
 - Server Platform Services (SPS) Firmware version 04.04.04.053
 - iLO 5 Firmware version 2.44
 - Innovation Engine Firmware version 1.0.0.20 or later

To download the latest firmware, see

<https://support.hitachivantara.com/en/user/answers/downloads.html#hardware-download>

- A supported operating system:
 - Windows Server 2016 with persistent memory drivers from Hitachi Vantara
 - Windows Server
 - Red Hat Enterprise Linux 7.9 and later
 - Red Hat Enterprise Linux 8.2 and later
 - SUSE Linux Enterprise Server 12 SP5 and later
 - SUSE Linux Enterprise Server 15 SP2 and later
 - VMware vSphere 7.0 U2 and later
 - VMware vSphere 6.7 U3 with P03Hardware and licensing requirements for optional encryption of the persistent memory modules:
- TPM 2.0 (local key encryption)
 - iLO Advanced License (remote key encryption) Key
 - Management server (remote key encryption)

For more information, see the Persistent Memory User Guide on the [Hitachi Vantara website](#).

Installing persistent memory modules

Use this procedure only for new persistent memory module installations. If you are migrating this persistent memory module from another server, see the Persistent Memory User Guide on the [Hitachi Vantara website](#).

Prerequisites

Before you perform this procedure, make sure that you have the following items available:

- The components included with the hardware option kit
- A T-10 Torx screwdriver might be needed to unlock the access panel.

Procedure

1. Observe the following alerts:

△ CAUTION: DIMMs and persistent memory modules are keyed for proper alignment. Align notches on the DIMM or persistent memory module with the corresponding notches in the slot before installing the component. Do not force the DIMM or persistent memory module into the slot. When installed properly, not all DIMMs or persistent memory modules will face in the same direction.

⚠ CAUTION: Electrostatic discharge can damage electronic components. Be sure you are properly grounded before beginning this procedure.

⚠ CAUTION: Failure to properly handle persistent memory modules can damage the component and the system board connector.

❗ IMPORTANT: Hitachi Vantara recommends that you implement best-practice configurations such as clustered configurations for high availability (HA).

2. Power down the server.
3. Remove all powers:
 - a. Disconnect each power cord from the power source.
 - b. Disconnect each power cord from the server.
4. Do one of the following:
 - a. Extend the server from the rack.
 - b. Remove the server from the rack.
5. Place the server on a flat, level work surface.
6. Remove the access panel.
7. Open the DIMM slot latches.
8. Install the persistent memory module.

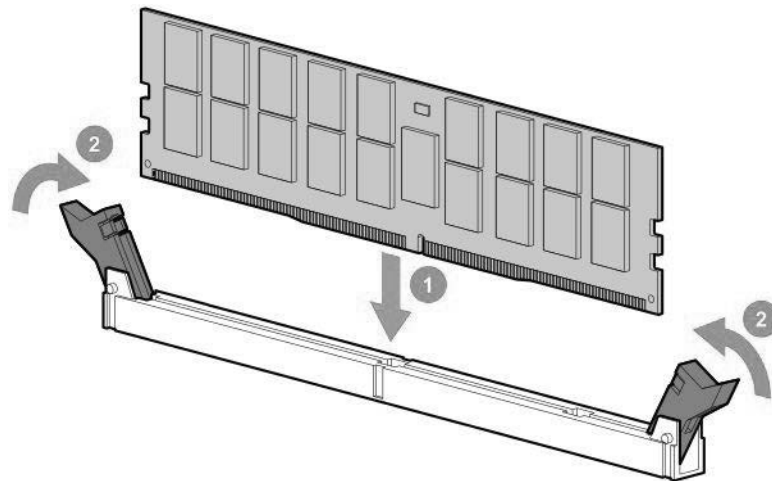

9. Install the access panel (**Install the access panel**).
10. Slide or install the server into the rack. If removed, reconnect all power cables.
11. Power up the server.
12. **Configure the server for Intel Optane persistent memory.**

Configuring the server for Intel Optane persistent memory 200 series

After installing persistent memory modules, configure the server for Intel Optane persistent memory.



IMPORTANT: Always follow recommendations from your software application provider for high-availability best practices to ensure maximum uptime and data protection.

A number of configuration tools is available, including:

- UEFI System Utilities—Configure the server by using the UEFI System Utilities through the Remote Console. To access the UEFI System Utilities, press F9 during POST.
- iLO RESTful API—Use the iLO RESTful API through tools such as the RESTful Interface Tool (ilorest) or other third-party tools.
For more information, see the Intel Optane persistent memory 200 series User Guide on the [Hitachi Vantara website](#).

Installing a high-performance fan

Certain hardware configurations require high-performance fans. To verify a specific configuration, contact customer support.

This kit meets extended ambient operating temperatures above 35 degrees Celsius. For more information about extended ambient configurations, contact customer support.

Prerequisites

Before installing this option, make sure you have the following:

The components included the hardware option kit

Procedure

1. Observe the following alert:



IMPORTANT: After removing a high-performance (dual-rotor) fan, install or replace the fan within 60 seconds. Otherwise, the server will shut down gracefully.

2. **Power down the server.**
3. Remove all power:
 - a. Disconnect each power cord from the power source.
 - b. Disconnect each power cord from the server.
4. Do one of the following:
 - a. **Extend the server from the rack.**
 - b. **Remove the server from the rack.**
5. **Remove the access panel.**

6. Remove all standard fans from the fan bays.

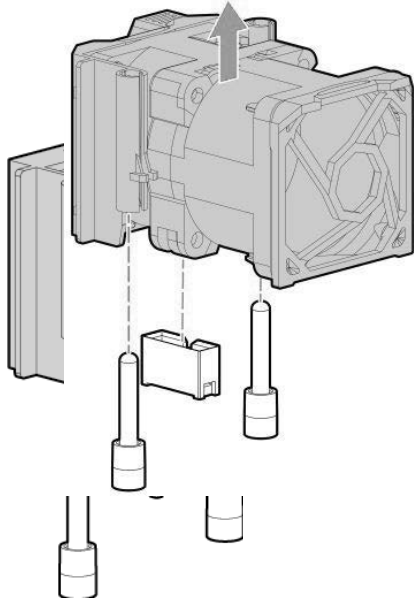

7. Remove fan blanks from the fan bays, if installed.
8. Install high-performance fans in each of the seven fan bays.
9. If needed, ensure each fan is securely installed by pressing the tab. Do not press on other areas of the fan.
10. Install the access panel (**Install the access panel**).

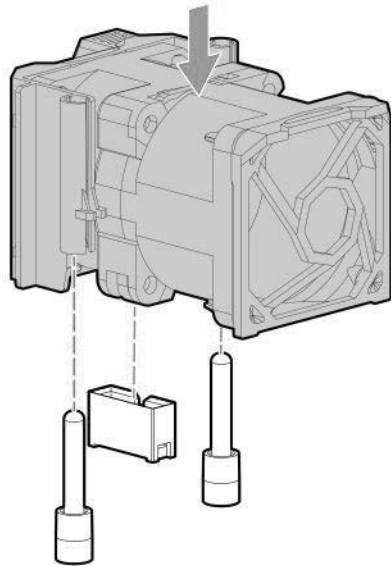

11. Slide the server into the rack.
12. Connect each power cord to the server.
13. Connect each power cord to the power source.
14. Power up the server (**Power up the server**).

Installing an 8SFF display port/USB/optical blank option

Prerequisites

Before installing this option, be sure that you have the following:

- The components included with the hardware option kit
- T-10 Torx screwdriver
- An optical drive, if installing

For more information, contact a Hitachi Vantara authorized reseller.

Procedure

1. Back up all server data.
2. **Power down the server.**
3. Remove all power:
 - a. Disconnect each power cord from the power source.
 - b. Disconnect each power cord from the server.
4. Do one of the following:
 - a. **Extend the server from the rack.**
 - b. **Remove the server from the rack.**

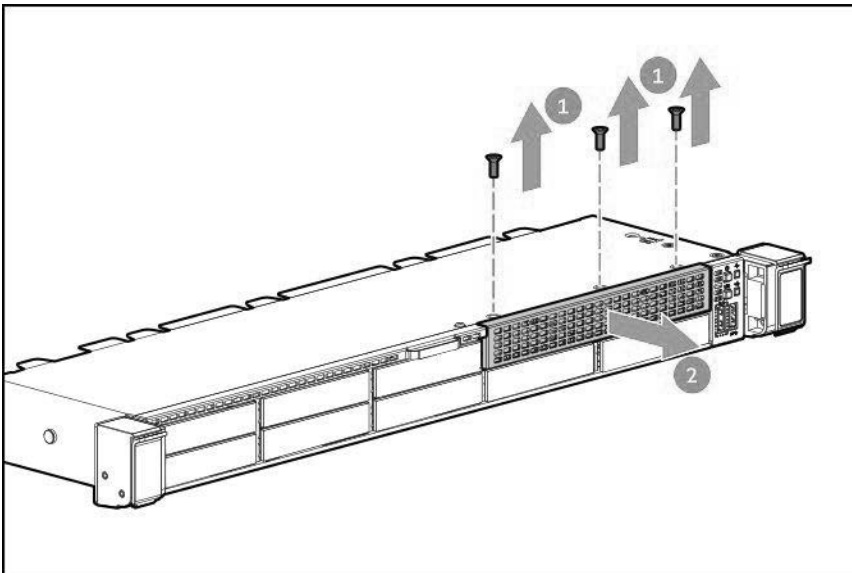

5. **Remove the access panel.**
6. Remove the bay blank.
7. Install the 8SFF display port/USB/optical blank option.

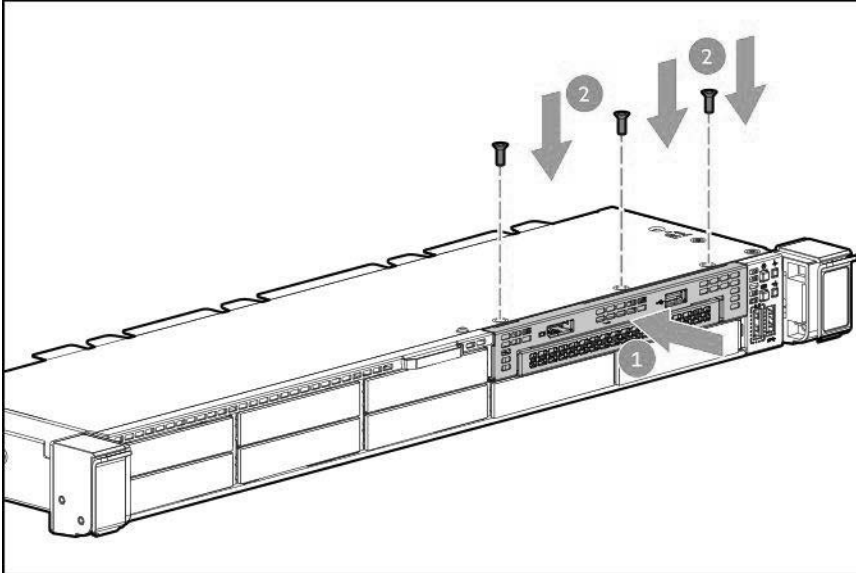

8. Route and connect the data cable.

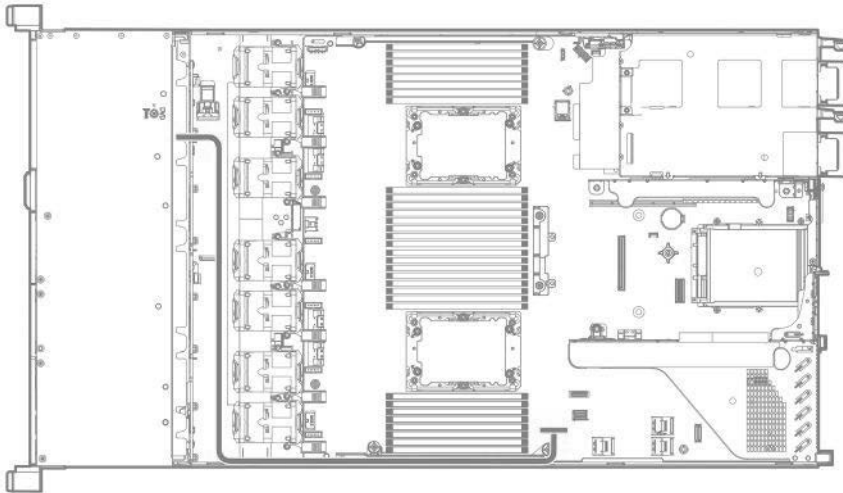

9. If needed, install an optical drive (**Installing an 8SFF optical drive**).
10. Install the access panel (**Install the access panel**).
11. Install the server in the rack.
12. Connect each power cord to the server.
13. Connect each power cord to the power source.
14. Power up the server (**Power up the server**).

Installing the 4LFF display port/USB option

Prerequisites

Before installing this option, be sure you have the following:

- The components included with the hardware option kit
- T-10 Torx screwdriver

Procedure

1. **Power down the server.**
2. Remove all power:
 - a. Disconnect each power cord from the power source.
 - b. Disconnect each power cord from the server.
3. Do one of the following:
 - a. **Extend the server from the rack.**
 - b. **Remove the server from the rack.**
4. **Remove the access panel.**

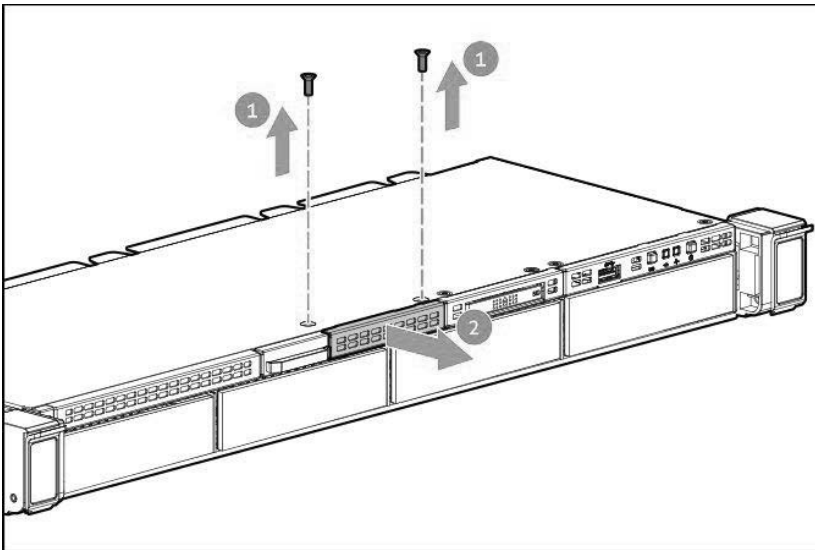

5. Using a Torx T-10 screwdriver, remove the 4LFF display port/USB blank.

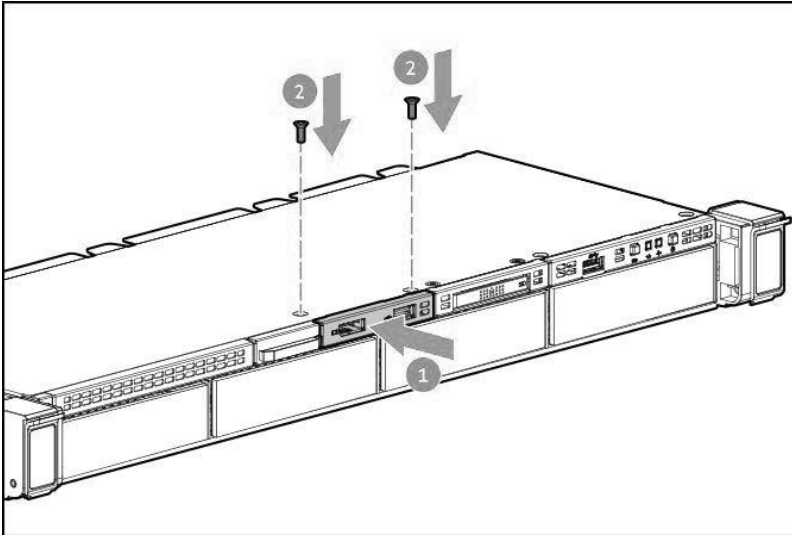

6. Install the 4LFF display port/USB module.
7. Route and connect the cable.

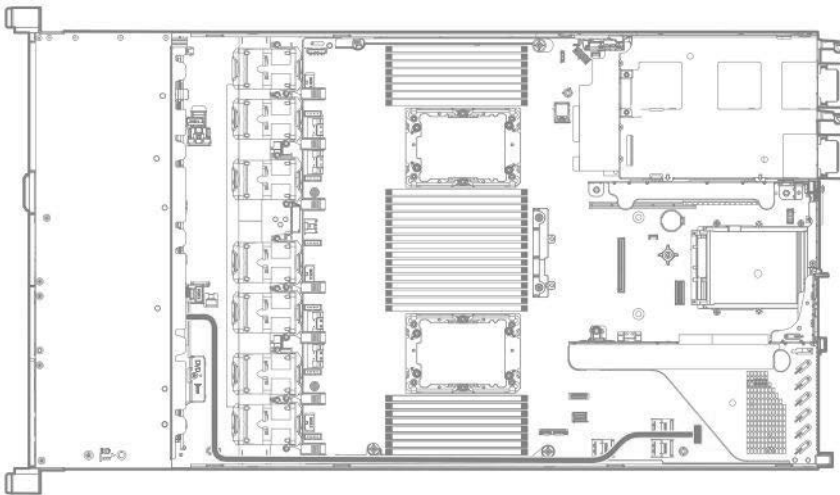

8. Install the access panel (**Install the access panel**).
9. Install the server in the rack.
10. Connect each power cord to the server. Connect each power cord to the power source.
11. Power up the server (**Power up the server**).

Drive options

Depending on the configuration, this server supports SAS, SATA, NVMe, and M.2 drives. When adding hard drives to the server, observe the following general guidelines:

- The system automatically sets all device numbers.
- For drive numbering, see **Drive bay numbering**.
- If using only one hard drive, install it in the bay with the lowest device number.

- To provide the greatest storage space efficiency, group identical capacity drives into the same drive array.
- The NVMe SSD is a PCIe bus device. Do not remove NVMe drives without allowing the device to cease activity. Removing the drive while active can cause data loss.

Installing a hot-plug SAS, SATA or NVMe drive

⚠ CAUTION: To prevent improper cooling and thermal damage, do not operate the server unless all drive and device bays are populated with either a component or a blank.

Procedure

1. Remove the drive blank:

- LFF drive blank

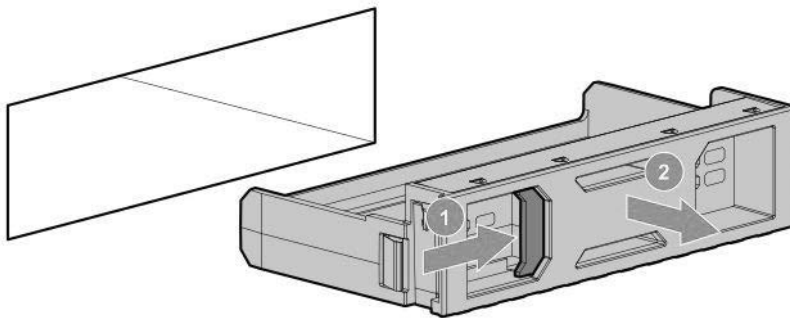

- SFF drive blank

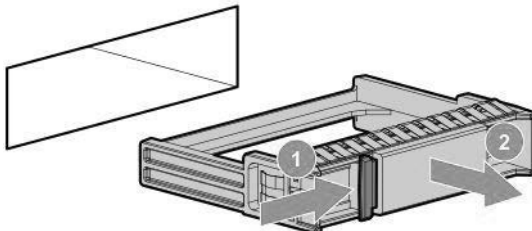

2. Prepare the drive.

- LFF drive

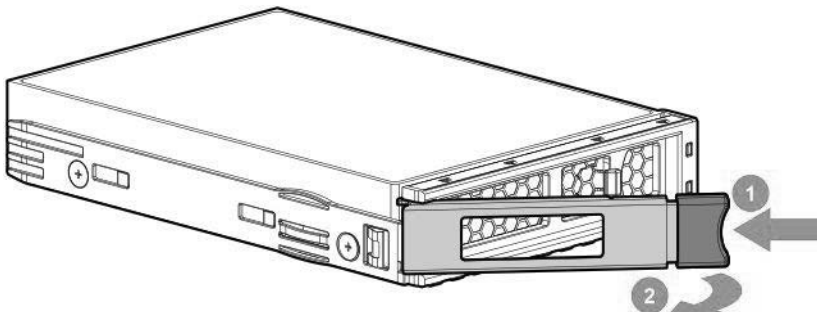

- SFF drive

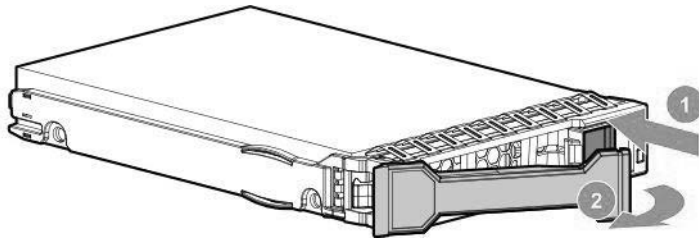

3. Install the drive.

- LFF drive

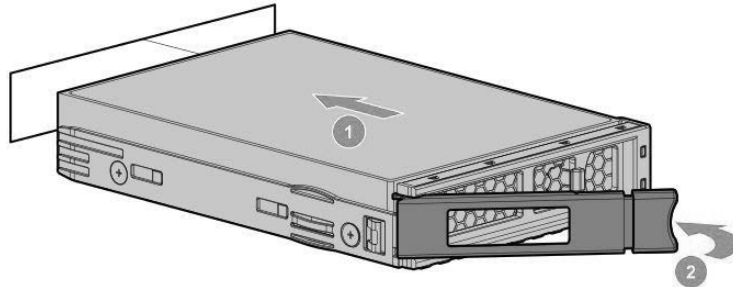

- SFF drive

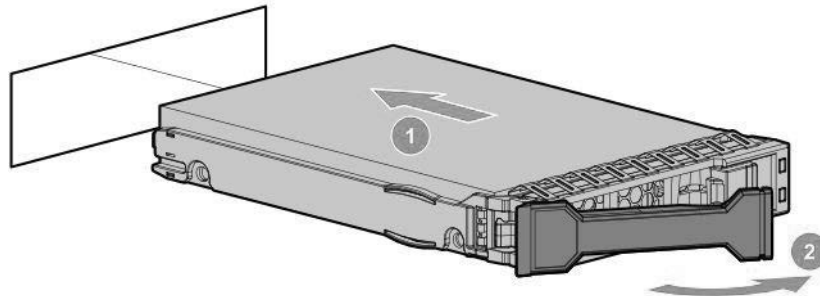

4. Determine the status of the drive from the drive LED definitions.

5. To configure drive arrays, contact customer support. **Installing the 4LFF optical drive option**

Prerequisites

Before installing this option, be sure that you have the following:

- The components included with the hardware option kit
- T-10 Torx screwdriver
- LFF optical cable option kit
- An optical drive

Procedure

1. Back up all server data.
2. **Power down the server.**
3. Remove all power:
 - a. Disconnect each power cord from the power source.

- b. Disconnect each power cord from the server.
4. Do one of the following:
 - a. **Extend the server from the rack.**
 - b. **Remove the server from the rack.**
5. **Remove the access panel.**
6. Remove the LFF optical drive bay blank.

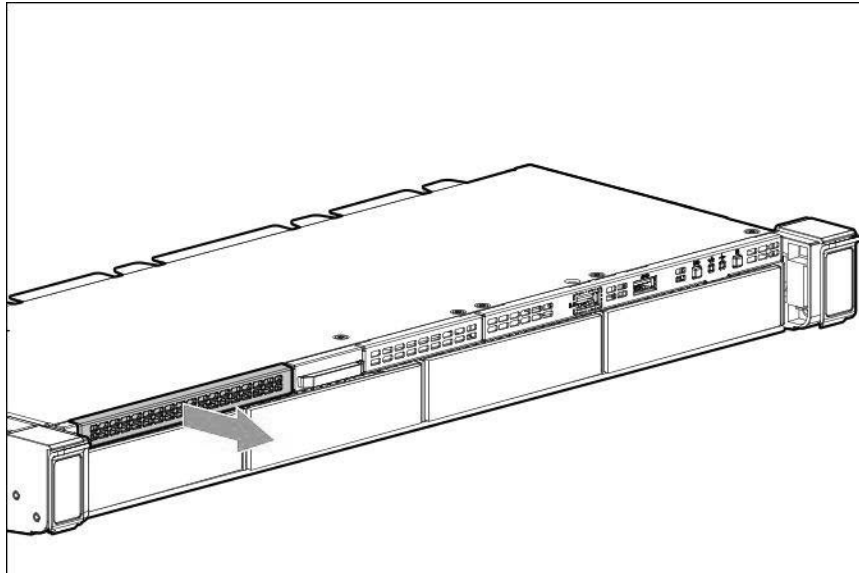

7. Install the optical drive.

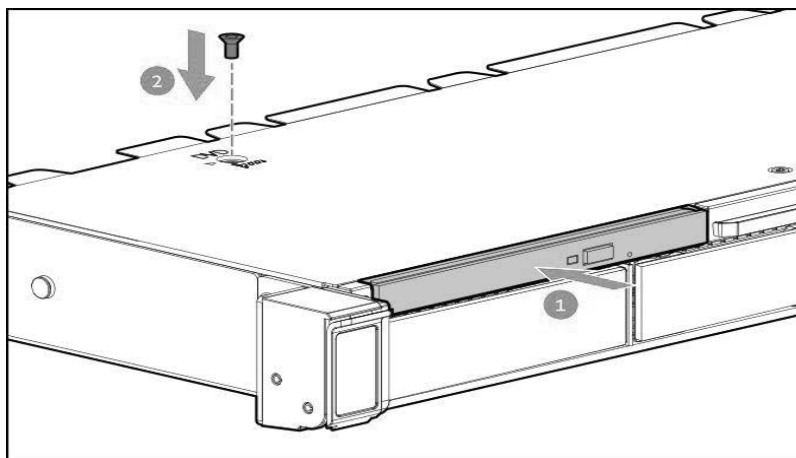

8. Connect the optical drive cable to the optical drive backplane and to the SATA optical/storage drive connector.

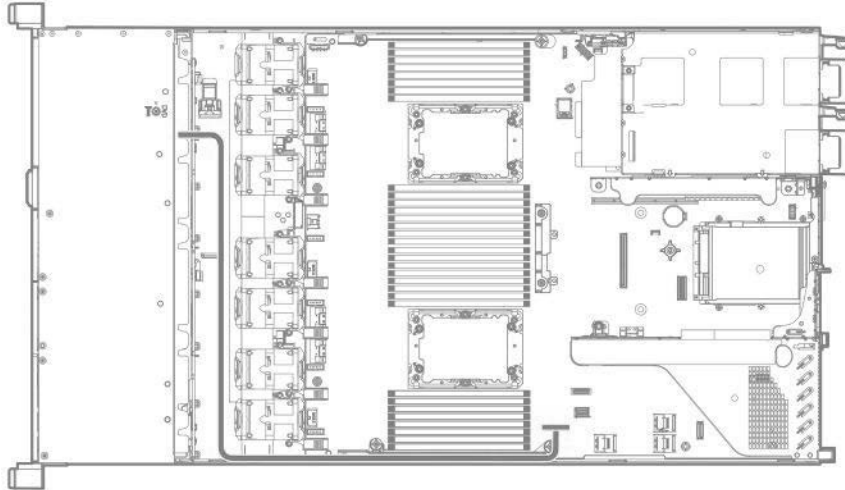

9. Install the access panel (**Install the access panel**).
10. Install the server in the rack.
11. Connect each power cord to the server.
12. Connect each power cord to the power source.
13. Power up the server.

Installing an 8SFF optical drive

Prerequisites

Be sure the 8SFF display port/USB/optical blank option is installed.

For more information, see **Installing an 8SFF display port/USB/optical blank option**.

Procedure

1. Remove the optical drive blank.

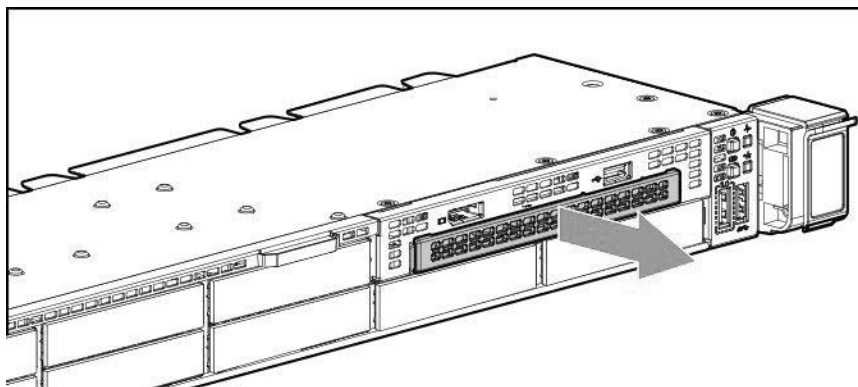

2. Install the optical drive.

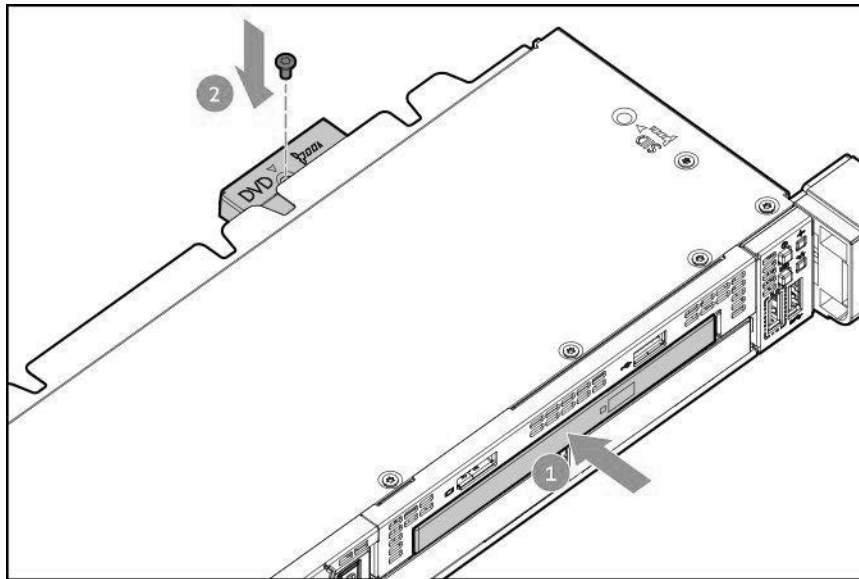

3. Connect the optical drive cable.

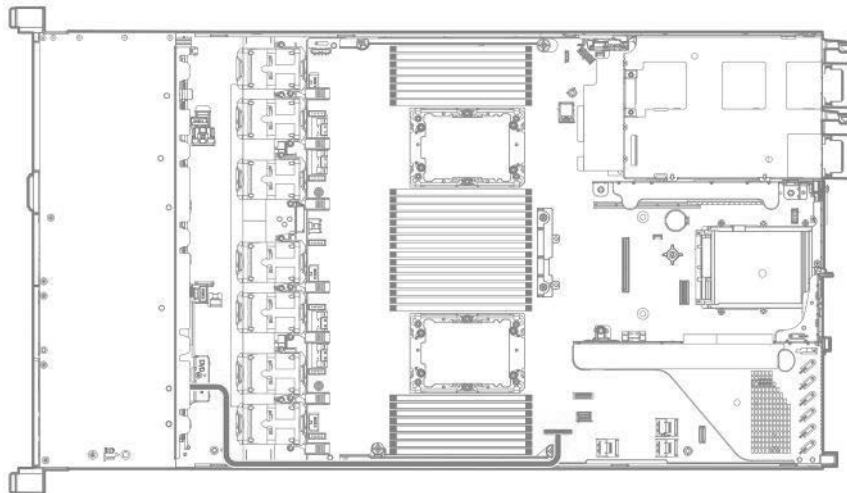

Installing a 2SFF SAS/SATA/NVMe drive cage

Prerequisites

Universal media bay options are compatible only with the 8SFF

Hitachi Vantara recommends installing the P816i-a controller to support 10 SAS/SATA drives. Be sure that you have the following:

- The components included with the option kit
- T-10 Torx screwdriver
- Additional cables, as needed.
- 2SFF SAS or SATA drives or blanks

Procedure

1. Back up all server data.
2. **Power down the server.**
3. Remove all power:
 - a. Disconnect each power cord from the power source.
 - b. Disconnect each power cord from the server.
4. Do one of the following:
 - a. **Extend the server from the rack.**
 - b. **Remove the server from the rack.**
5. **Remove the access panel.**
6. Remove the universal media bay blank.

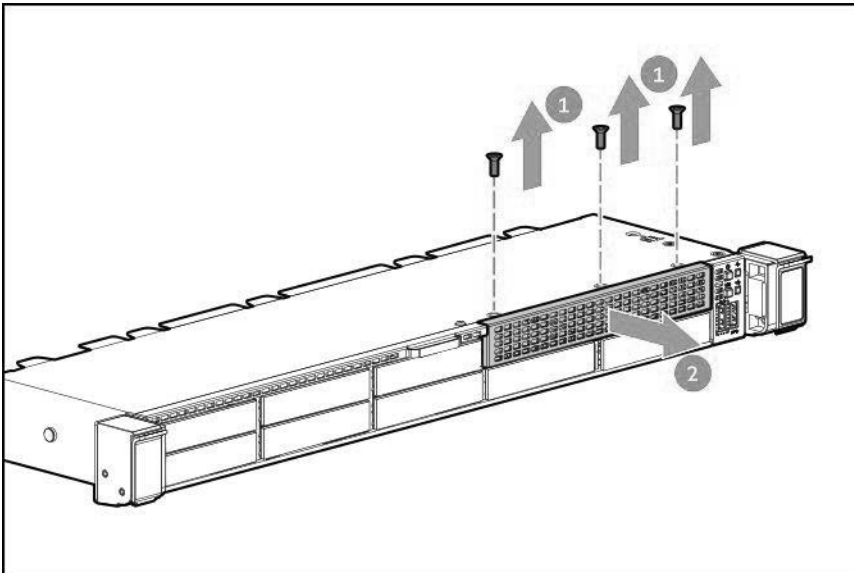

7. Install the 2SFF SAS/SATA drive cage.

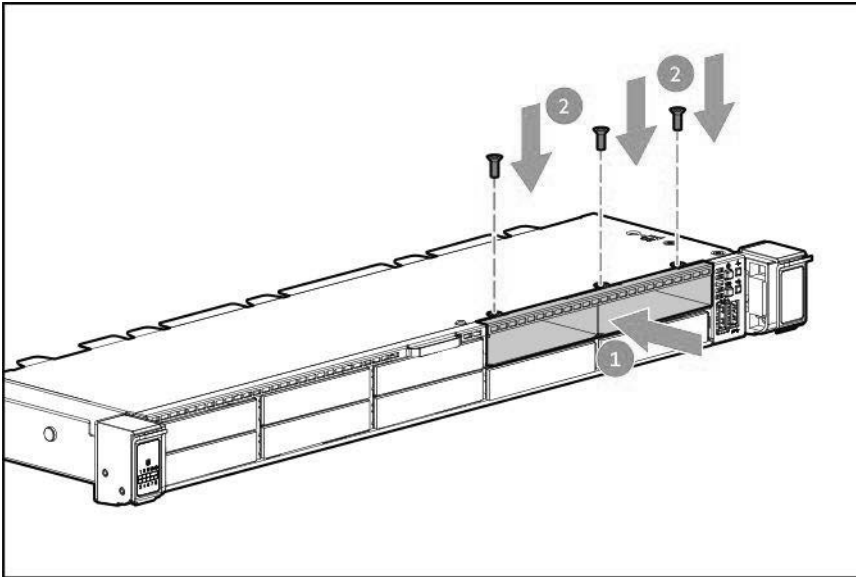

8. Route and connect the data cable.

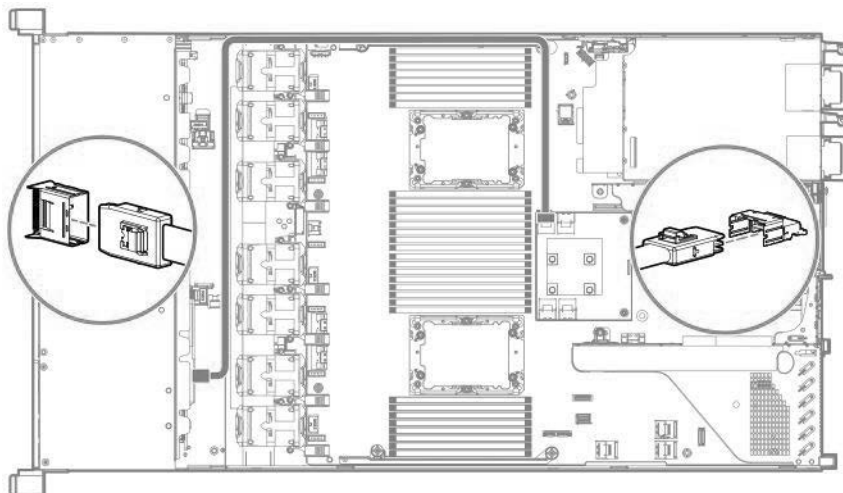

9. Route and connect the power cable.
10. **Install the access panel.**
11. Install the server in the rack.
12. Connect each power cord to the server
13. Connect each power cord to the power source.
14. **Power up the server.**
15. Install drives.

Primary PCI riser cage options

The primary PCI riser cage supports the following:

- Slot 1: Full-height, 3/4-length expansion boards up to 9.5"
- Slot 2:
 - Half-length, half-height expansion boards
 - 3/4-length expansion boards up to 9.5" when either a low-profile type-a controller or no controller is installed

Installing an expansion board in slot 1

Prerequisites

Before installing this option, be sure you have the following:

- The components included with the hardware option kit
- T-10 Torx screwdriver

Procedure

1. Observe the following alerts:



WARNING: To reduce the risk of personal injury from hot surfaces, allow the drives and the internal system components to cool before touching them.



CAUTION: To prevent damage to electrical components, properly ground the server before beginning any installation procedure. Improper grounding can cause electrostatic discharge.

2. Back up all server data.
3. **Power down the server.**
4. Remove all power:
 - a. Disconnect each power cord from the power source.
 - b. Disconnect each power cord from the server.
5. Do one of the following:
 - a. **Extend the server from the rack.**
 - b. **Remove the server from the rack.**
6. **Remove the access panel.**
7. **Remove the primary PCI riser cage.**
8. Install the expansion board.

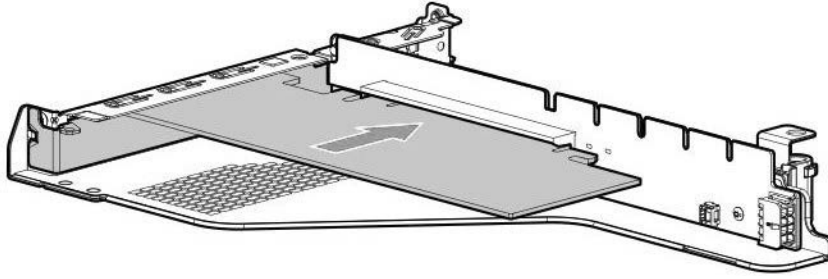

9. Connect any required internal or external cables to the expansion board.
10. **Install the primary PCI riser cage.**
11. **Install the access panel.**
12. Install the server in the rack.
13. Connect each power cord to the server.
14. Connect each power cord to the power source.
15. **Power up the server.**

Installing an expansion board in slot 2

Prerequisites

Before installing this option, be sure you have the following:

- The components included with the hardware option kit
- T-10 Torx screwdriver

Procedure

1. Observe the following alerts:

⚠ WARNING: To reduce the risk of personal injury from hot surfaces, allow the drives and the internal system components to cool before touching them.

⚠ CAUTION: To prevent damage to electrical components, properly ground the server before beginning any installation procedure. Improper grounding can cause electrostatic discharge.

2. Back up all server data.
3. **Power down the server.**
4. Remove all power:
 - a. Disconnect each power cord from the power source.
 - b. Disconnect each power cord from the server.
5. Do one of the following:
 - a. **Extend the server from the rack.**
 - b. **Remove the server from the rack.**
6. **Remove the access panel.**

7. **Remove the primary PCI riser cage.**
8. Remove the expansion slot blank.

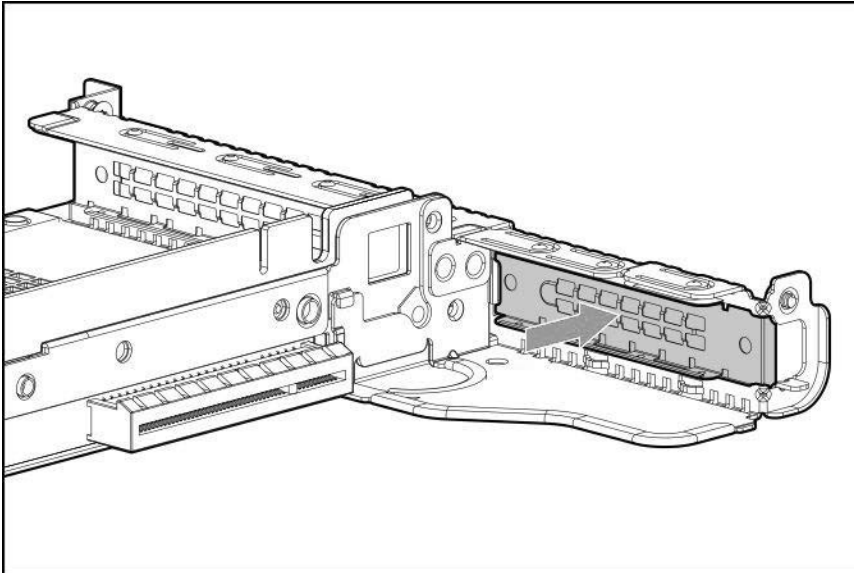

9. Use a T-10 Torx screwdriver to Install the expansion board.

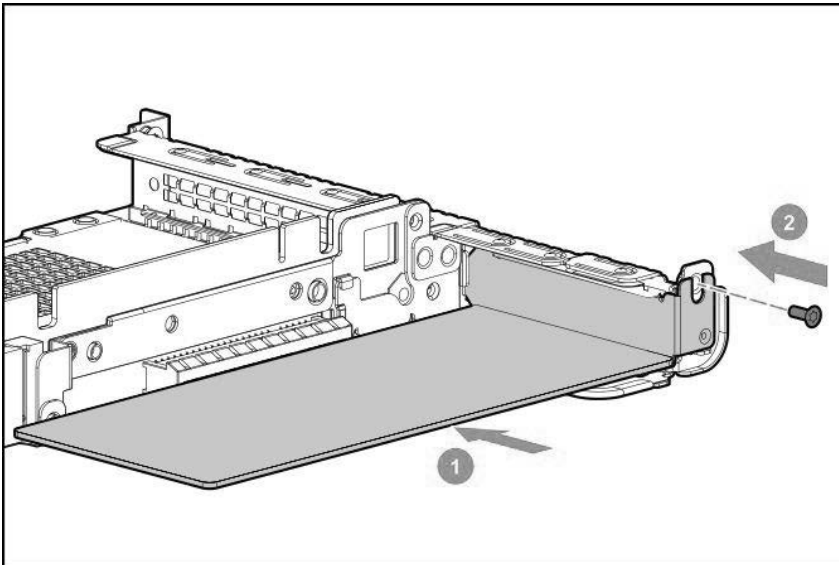

10. Connect any required internal or external cables to the expansion board.
11. **Install the primary PCI riser cage.**
12. Install the access panel.
13. Install the server in the rack.
14. Connect each power cord to the server.
15. Connect each power cord to the power source.
16. Power up the server.

Installing an optional primary PCI riser board

Prerequisites

Before installing this option, be sure you have the following:

- The components included with the hardware option kit
- T-15 Torx screwdriver

Procedure

1. Back up all server data.
2. **Power down the server.**
3. Remove all power:
 - a. Disconnect each power cord from the power source.
 - b. Disconnect each power cord from the server.
4. Do one of the following:
 - a. **Extend the server from the rack.**
 - b. **Remove the server from the rack.**
5. **Remove the access panel.**
6. **Remove the primary PCI riser cage.**
7. If needed, remove any expansion boards installed in the riser cage.

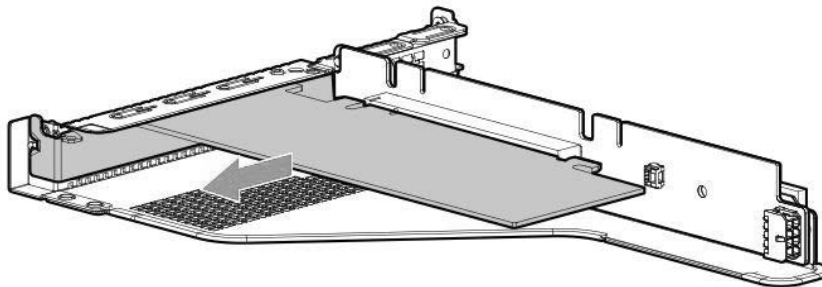

8. Remove the existing riser board from the PCI riser cage.

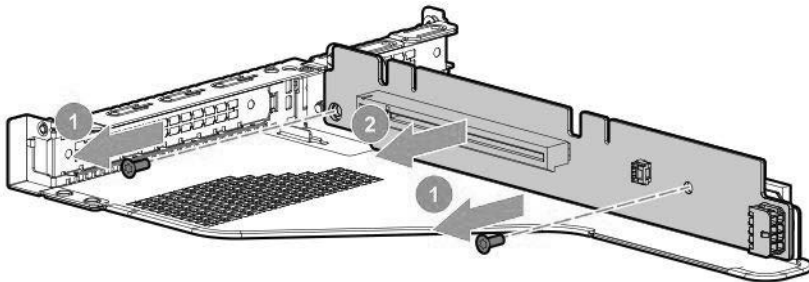

9. Install the optional riser board in the riser cage.

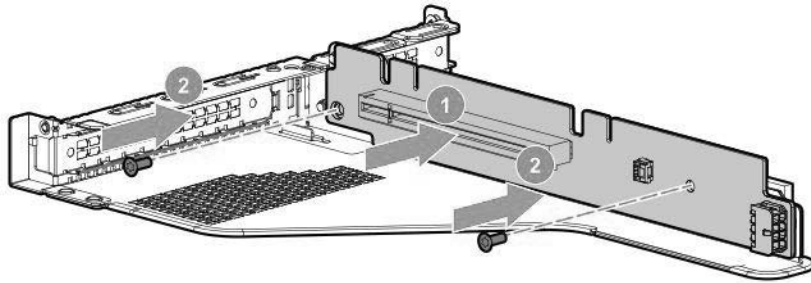

10. Install the following, as needed:
 - **Expansion boards**
 - **GPU**
 - **Controllers**
11. **Install the riser cage.**
12. **Install the access panel.**
13. Install the server in the rack.
14. Connect each power cord to the server.
15. Connect each power cord to the power source.
16. **Power up the server.**

Installing the NVMe M.2 riser option

Prerequisites

Before installing this option, be sure that you have the following:

- The components included with the hardware option kit
- M.2 drives
- T-15 Torx screwdriver

Procedure

1. **Power down the server.**
2. Remove all power:
 - a. Disconnect each power cord from the power source.
 - b. Disconnect each power cord from the server.
3. Do one of the following:
 - a. **Extend the server from the rack.**
 - b. **Remove the server from the rack.**
4. **Remove the access panel.**
5. **Remove the primary PCI riser cage.**

6. If needed, remove any expansion boards installed in the riser cage.

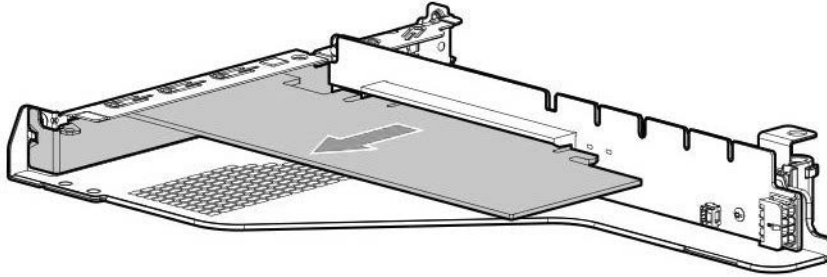

7. Remove the existing riser board from the riser cage.

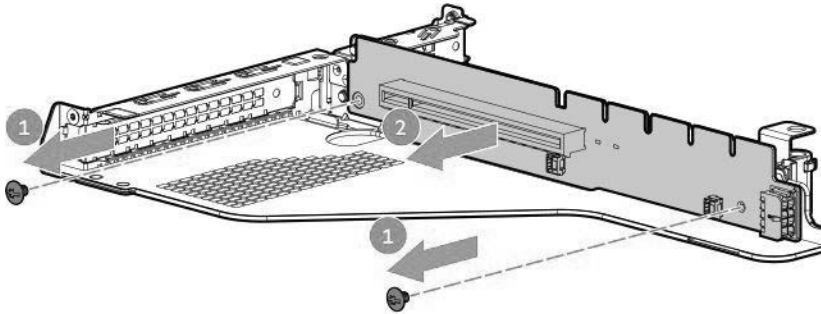

8. Install the M.2 riser board.

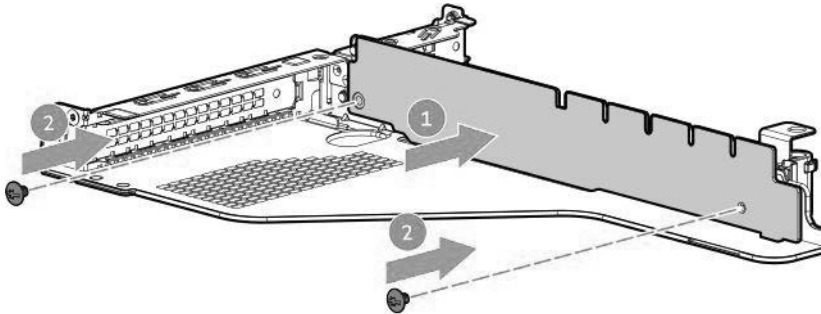

9. Remove the screw securing the standoff on the riser.
10. Install the M.2 drives.

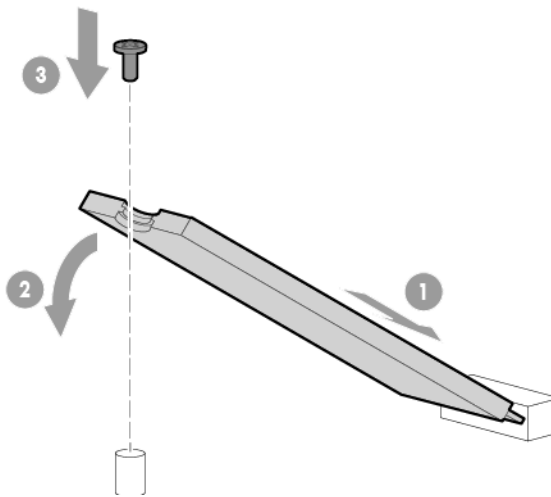

11. Install the following, as needed:
 - Expansion boards
 - Controllers
12. Install the primary PCI riser cage.
13. Install the server in the rack.

Installing an accelerator or GPU in the primary riser cage

Use these instructions to install accelerator options, including GPUs, in the server.

Prerequisites

This option requires the standard primary PCI riser cage.

Before installing this option, be sure that the power supplies support the installation of this option. For more information, contact customer support.

In addition, be sure that you have the following items:

- The components included with the hardware option kit
- CPU1 Cable Kit (If installing a high-powered GPU kit)

Procedure

1. Observe the following alerts:



WARNING: To reduce the risk of personal injury from hot surfaces, allow the drives and the internal system components to cool before touching them.



CAUTION: To prevent damage to electrical components, properly ground the server before beginning any installation procedure. Improper grounding can cause electrostatic discharge.

2. Back up all server data.
3. Power down the server.
4. Remove all power:
 - a. Disconnect each power cord from the power source.
 - b. Disconnect each power cord from the server.
5. Do one of the following:
 - a. Extend the server from the rack.
 - b. Remove the server from the rack.
6. Remove the access panel.
7. Remove the primary PCI riser cage.
8. Install the card in the x16 slot in the primary PCI riser cage position.
9. If installing a GPU requiring greater than 75 W, connect the power cable to the primary riser power connector.

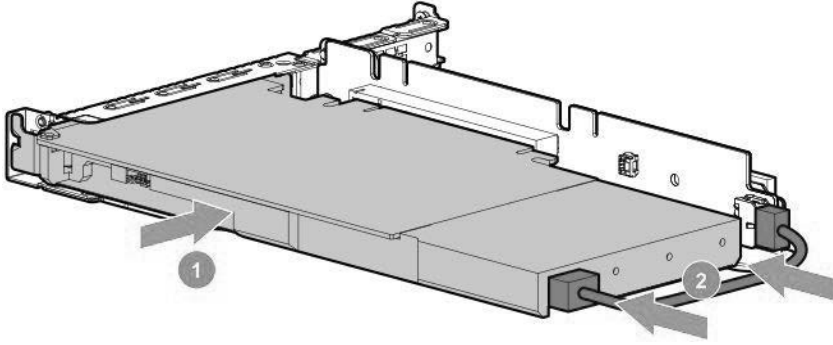

10. If the card requires rear support, install the GPU support bracket.

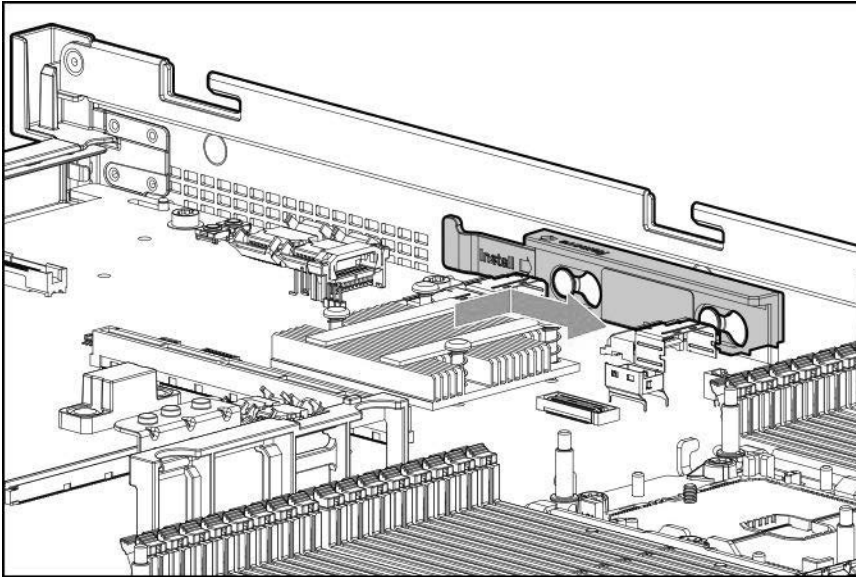

11. Install the riser cage (**Install the primary PCI riser cage**).

12. Install the access panel (**Install the access panel**).

13. Install the server in the rack.

14. Connect each power cord to the server.

15. Connect each power cord to the power source.

16. Power up the server (**Power up the server**).

Secondary PCI riser options

Installing a secondary full-height PCI riser cage option

When installed, this riser cage supports full-height, 3/4-length expansion boards up to 9.5". PCIe4 slot 2 is no longer available.

Prerequisites

This option requires a dual processor configuration.

Before installing this option, be sure you have the following:

- The components included with the hardware option kit
- Any expansion boards or controllers you plan to install
- T-10 Torx screwdriver
- T-15 Torx screwdriver

Procedure

1. **Power down the server.**
2. Remove all power:
 - a. Disconnect each power cord from the power source.
 - b. Disconnect each power cord from the server.
3. Do one of the following:
 - **Extend the server from the rack.**
 - **Remove the server from the rack.**
4. **Remove the access panel.**
5. Remove the primary PCI riser cage **Remove the primary PCI riser cage.**

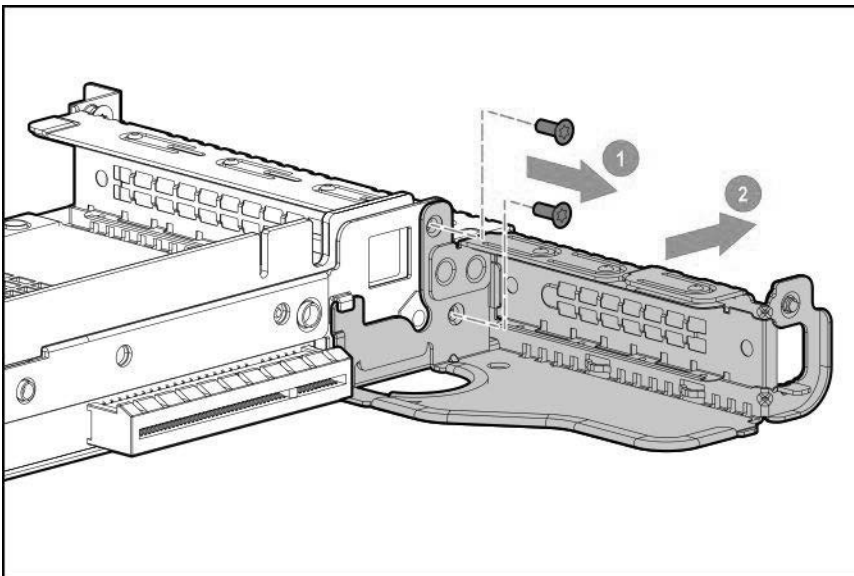

6. Use a T-10 Torx screwdriver to remove the slot 2 bracket from the primary riser cage.

7. If installed, remove the low-profile riser cage.

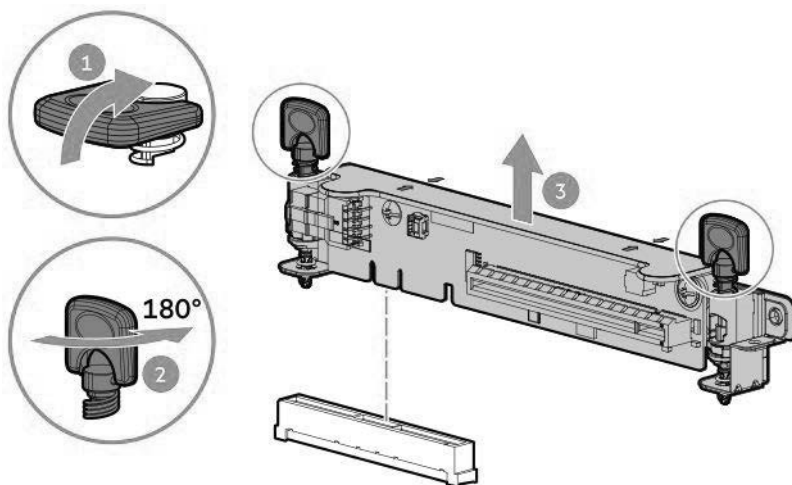

8. Lift and remove the secondary riser cage latch.
Use a T-15 Torx screwdriver to remove the riser cage screw.

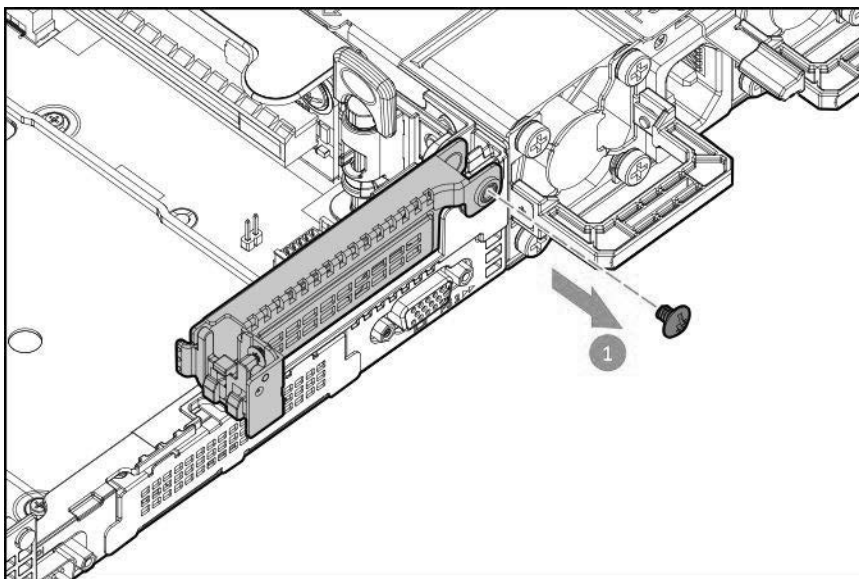

9. Install the full height PCIe x16 riser cage latch.
Use a T-15 Torx screwdriver to install the riser cage screw.

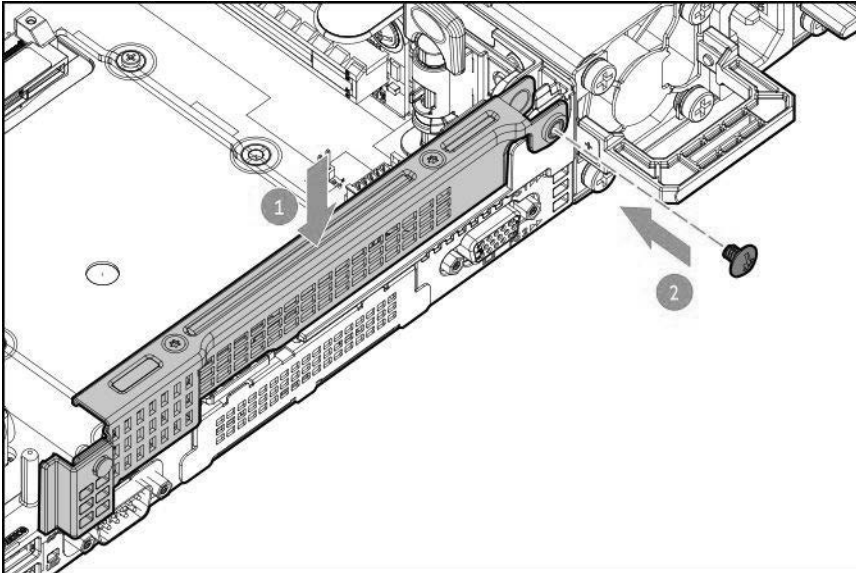

10. Install the riser cage.

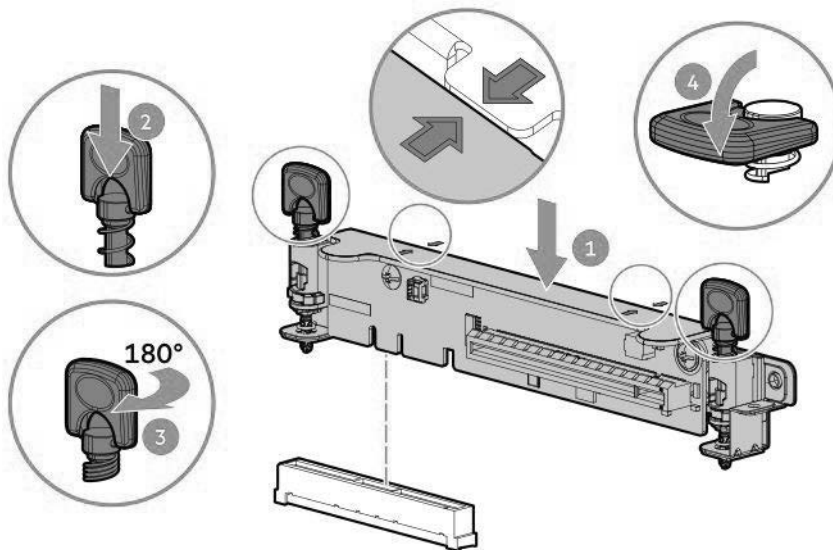

11. Install one of the following, as needed:
 - Expansion boards (Expansion boards)
 - GPU (GPU)
 - Controllers (**Controllers**)
12. Install the access panel (**Install the access panel**).
13. Install the server in the rack.
14. Connect each power cord to the server.
15. Connect each power cord to the power source.
16. Power up the server (**Power up the server**).

Installing a secondary low-profile PCIe slot riser cage option

When installed, this riser cage provides an additional low profile slot and supports half-length/half-height expansion boards.

Prerequisites

This option requires a dual processor configuration.

Before installing this option, be sure that you have the following: The components included with the hardware option kit

Procedure

1. Observe the following alerts:

 **WARNING:** To reduce the risk of personal injury from hot surfaces, allow the drives and the internal system components to cool before touching them.

 **CAUTION:** To prevent damage to electrical components, properly ground the server before beginning any installation procedure. Improper grounding can cause electrostatic discharge.

2. Back up all server data.
3. **Power down the server.**
4. Remove all power:
 - a. Disconnect each power cord from the power source.
 - b. Disconnect each power cord from the server.
5. Do one of the following:
 - a. **Extend the server from the rack.**
 - b. **Remove the server from the rack.**
6. **Remove the access panel.**
7. Install the secondary riser cage.

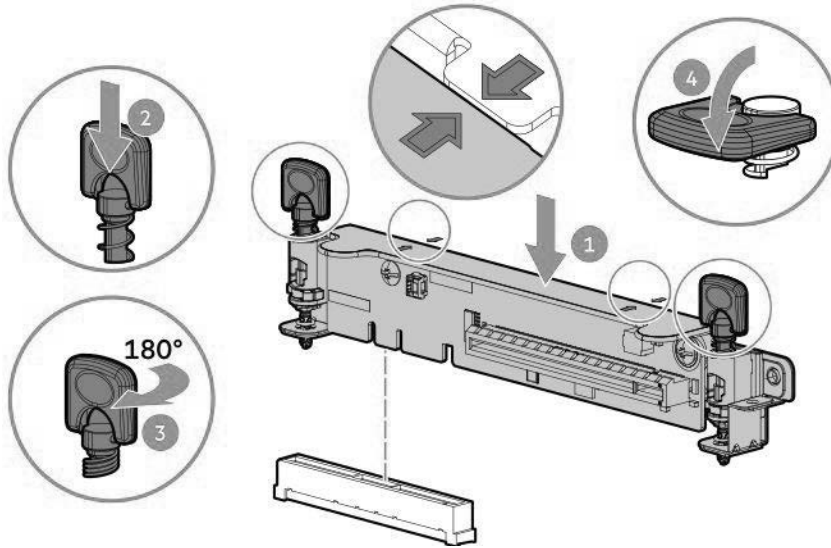

8. Install one of the following, as needed:
 - **Expansion boards**
 - **Controllers**
9. **Install the access panel.**
10. **Install the server into the rack.**
11. Connect each power cord to the server.
12. Connect each power cord to the power source.
13. **Power up the server.**

Installing an expansion board in the secondary riser cage

Prerequisites

Before installing this option, be sure that you have the following:

- The components included with the hardware option kit
- T-10 Torx screwdriver

Procedure

1. Observe the following alerts:

⚠ WARNING: To reduce the risk of personal injury from hot surfaces, allow the drives and the internal system components to cool before touching them.

⚠ CAUTION: To prevent damage to electrical components, properly ground the server before beginning any installation procedure. Improper grounding can cause electrostatic discharge.

2. Back up all server data.
3. **Power down the server.**

4. Remove all power:
 - a. Disconnect each power cord from the power source.
 - b. Disconnect each power cord from the server.
5. Do one of the following:
 - a. **Extend the server from the rack.**
 - b. **Remove the server from the rack.**
6. **Remove the access panel.**
7. Install a secondary riser cage:
 - **Low-profile**
 - **Full-height**

8. Remove the expansion slot blank:

A T-10 Torx screwdriver is required to remove the expansion slot blank.

- Half-length

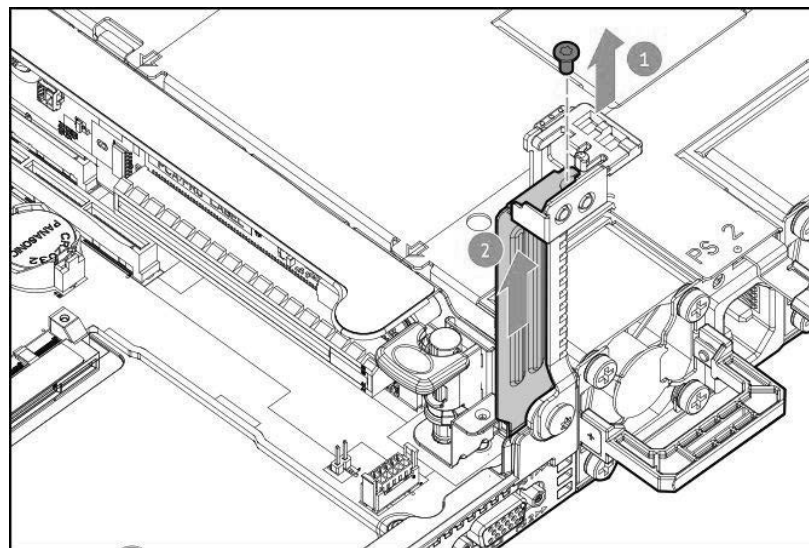
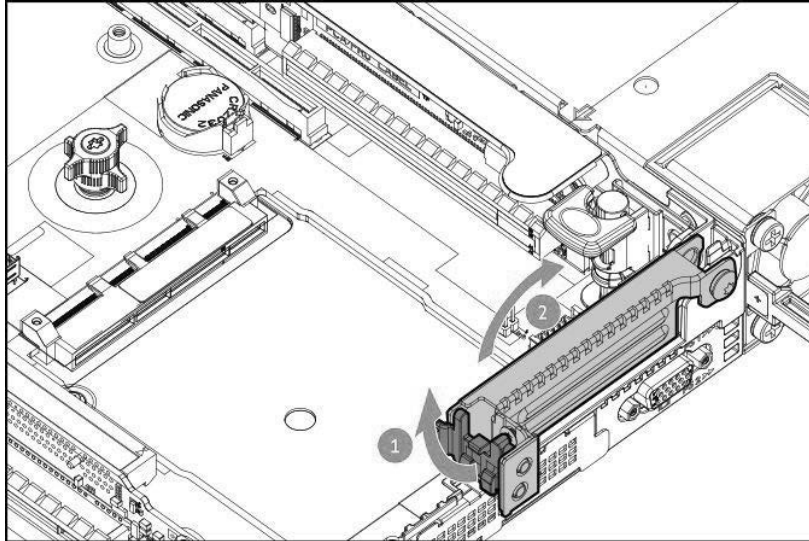

- Full-length

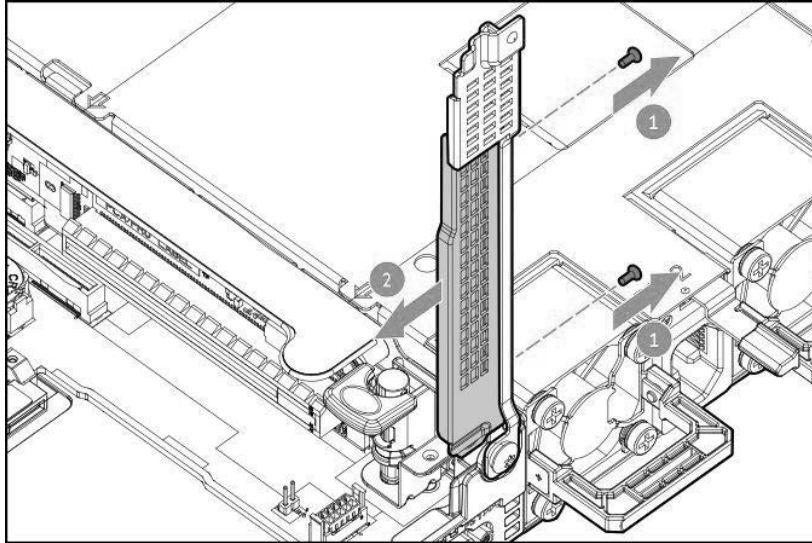

9. Install the expansion board.

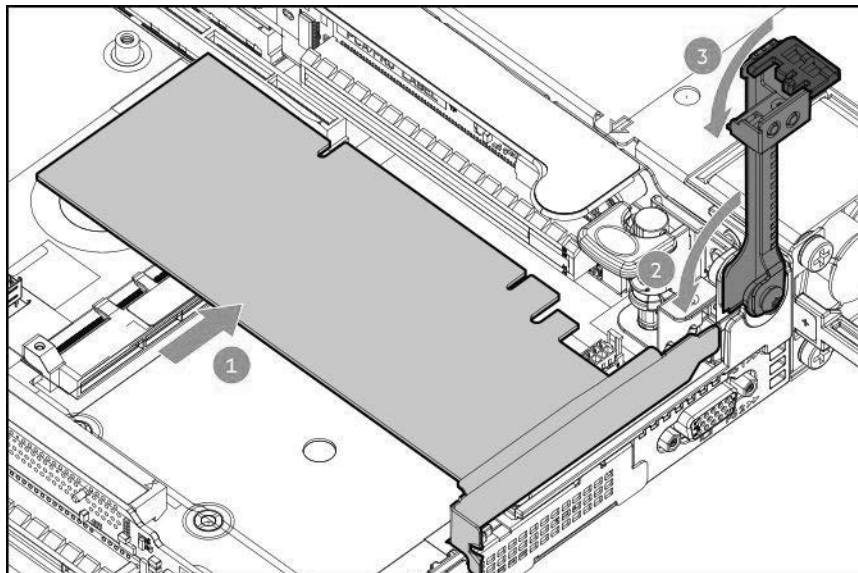

10. Connect any required internal or external cables to the expansion board.
11. **Install the access panel.**
12. Install the server in the rack.
13. Connect each power cord to the server.
14. Connect each power cord to the power source.
15. **Power up the server.**

Installing an accelerator or GPU in the secondary riser cage

Prerequisites

When installing a 3/4-length GPU, a low-profile type-a controller must be installed.

Before installing this option, do the following:

- Be sure that the power supplies support the installation of this option. For more information, contact customer support.
- Be sure that you have the following items:
 - The components included with the GPU enablement option kit
 - T-15 Torx screwdriver

Procedure

1. Observe the following alerts:

⚠ WARNING: To reduce the risk of personal injury from hot surfaces, allow the drives and the internal system components to cool before touching them.

⚠ CAUTION: To prevent damage to electrical components, properly ground the server before beginning any installation procedure. Improper grounding can cause electrostatic discharge.

2. Back up all server data.
3. **Power down the server.**
4. Remove all power:
 - a. Disconnect each power cord from the power source.
 - b. Disconnect each power cord from the server.
5. Do one of the following:
 - a. **Extend the server from the rack.**
 - b. **Remove the server from the rack.**
6. **Remove the access panel.**
7. If installed, remove the riser cage.

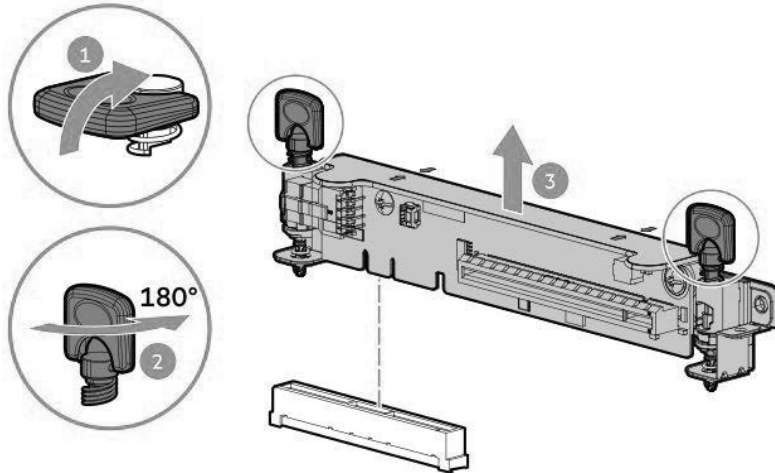

8. **Install the secondary full-height PCI riser cage.**
9. Remove the existing rear guide bracket from the card, if installed.
10. If installing a 3/4-length GPU, install the bracket supplied in the kit. A T-15 Torx screwdriver is required to install the bracket.

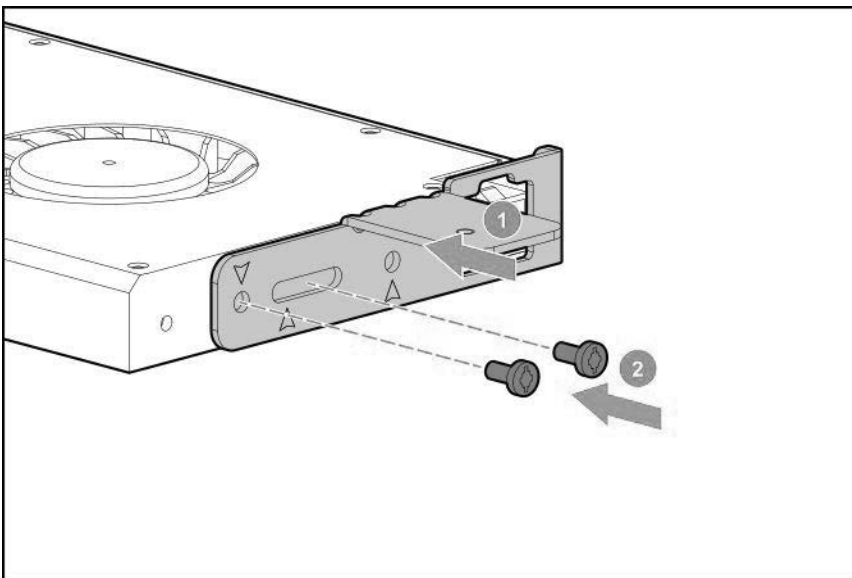

11. Install the card in the riser cage, and then connect any required cables, if applicable.
12. If installing a GPU requiring greater than 75 W, connect the power cable to the primary riser power connector.

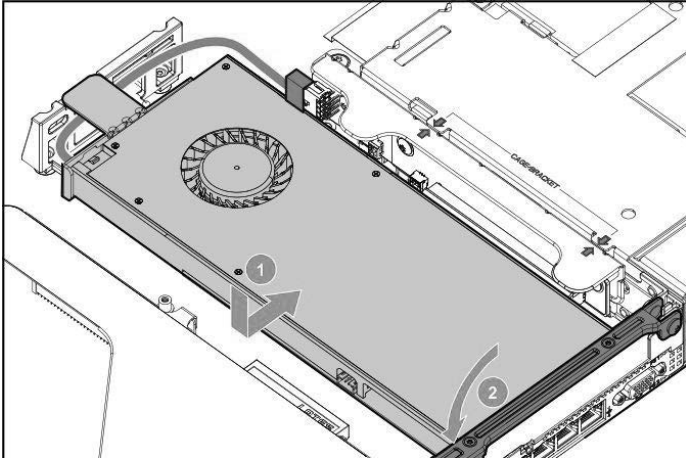

13. **Install the access panel.**
14. Install the server in the rack.
15. Connect each power cord to the server.
16. Connect each power cord to the power source.
17. **Power up the server.**

Storage controller options

The server supports the following storage controllers:

- Embedded controllers
Enabled through UEFI System Utilities and configured using either System Utilities or the Smart storage administrator (Intelligent Provisioning).
- Type-a controllers
Type-a controllers install in the type-a storage controller slot.
- Type-p controllers
Type-p controllers install in a PCIe expansion slot.

Installing a type-a smart array storage controller option

Prerequisites

Before installing this option, be sure that you have the following:

- The components included with the hardware option kit
- T-15 Torx screwdriver

Procedure

1. Observe the following alerts:

⚠ WARNING: To reduce the risk of personal injury from hot surfaces, allow the drives and the internal system components to cool before touching them.

CAUTION: To prevent damage to electrical components, properly ground the server before beginning any installation procedure. Improper grounding can cause electrostatic discharge.

2. Back up all server data.
3. **Power down the server.**
4. Remove all power:
 - a. Disconnect each power cord from the power source.
 - b. Disconnect each power cord from the server.
5. Do one of the following:
 - a. **Extend the server from the rack.**
 - b. **Remove the server from the rack.**
6. **Remove the access panel.**
7. Install the controller.

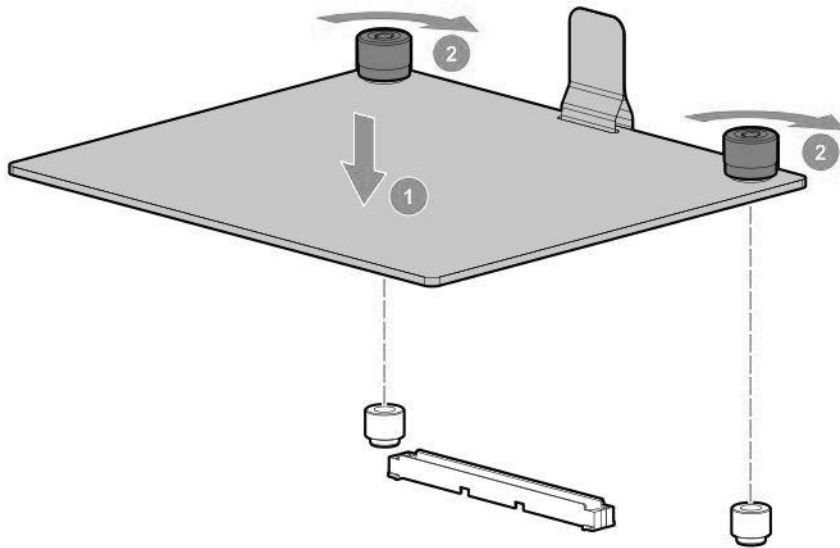

8. Connect the cables.
The diagrams below are examples.

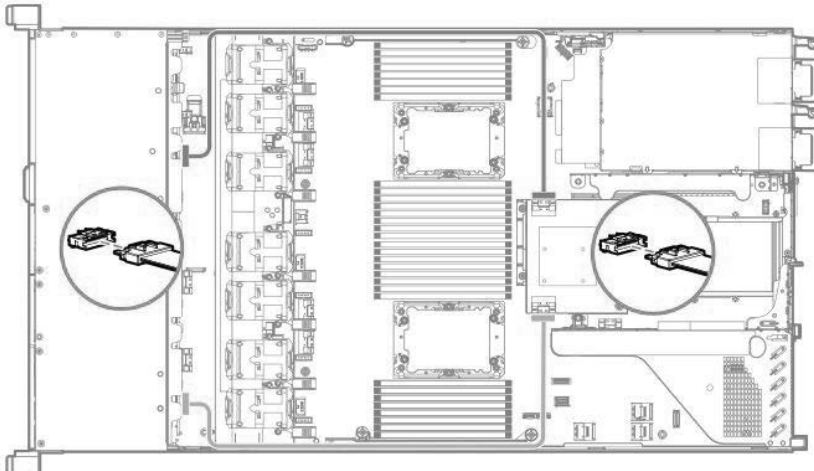

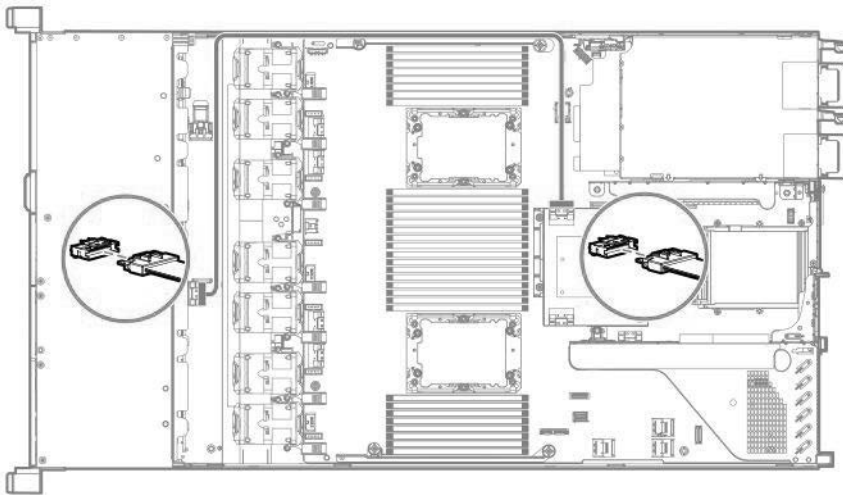
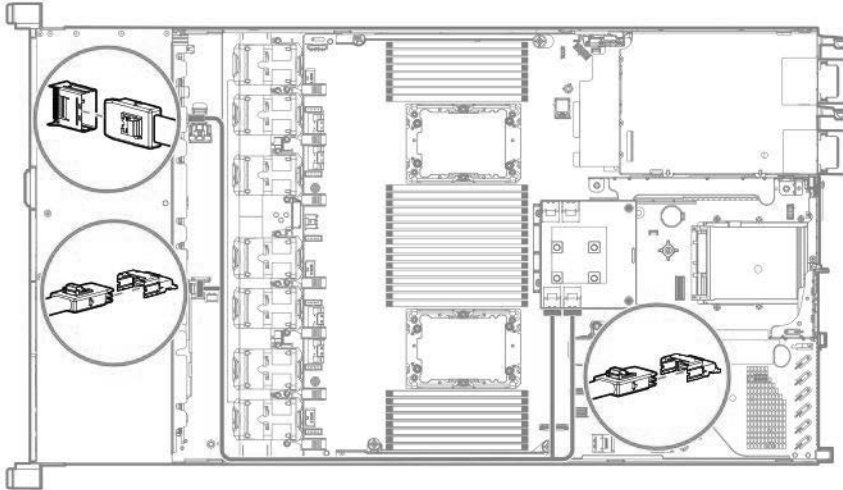

9. **Install the access panel.**
10. Install the server in the rack.
11. Connect each power cord to the server.
12. Connect each power cord to the power source.
13. **Power up the server.**

Installing a type-p storage controller option

Prerequisites

Before installing this option, be sure you that have the following:

- The components included with the hardware option kit
- T-10 Torx screwdriver

Procedure

1. Observe the following alerts:



WARNING: To reduce the risk of personal injury from hot surfaces, allow the drives and the internal system components to cool before touching them.



CAUTION: To prevent damage to electrical components, properly ground the server before beginning any installation procedure. Improper grounding can cause electrostatic discharge.

2. Back up all server data.
3. **Power down the server.**
4. Remove all power:
 - a. Disconnect each power cord from the power source.
 - b. Disconnect each power cord from the server.
5. Do one of the following:
 - a. **Extend the server from the rack.**
 - b. **Remove the server from the rack.**
6. **Remove the access panel!**
7. Do one of the following:
 - To install a controller in slot 1 of the primary riser:
 - a. **Remove the primary PCI riser cage.**
 - b. Install the controller.

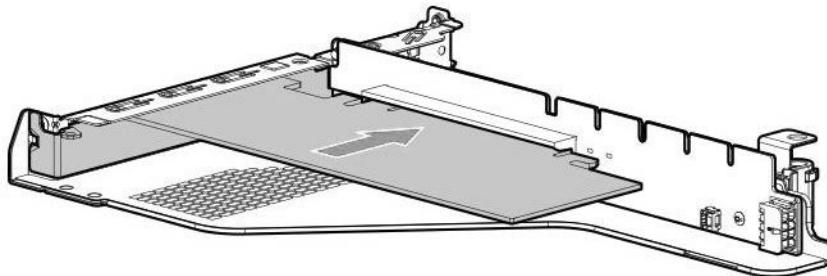

- To install a controller in slot 2 of the primary riser:
 - a. **Remove the primary PCI riser cage**
 - b. Remove the slot 2 blank.
 - c. Using a Torx T-10 screwdriver, install the controller.

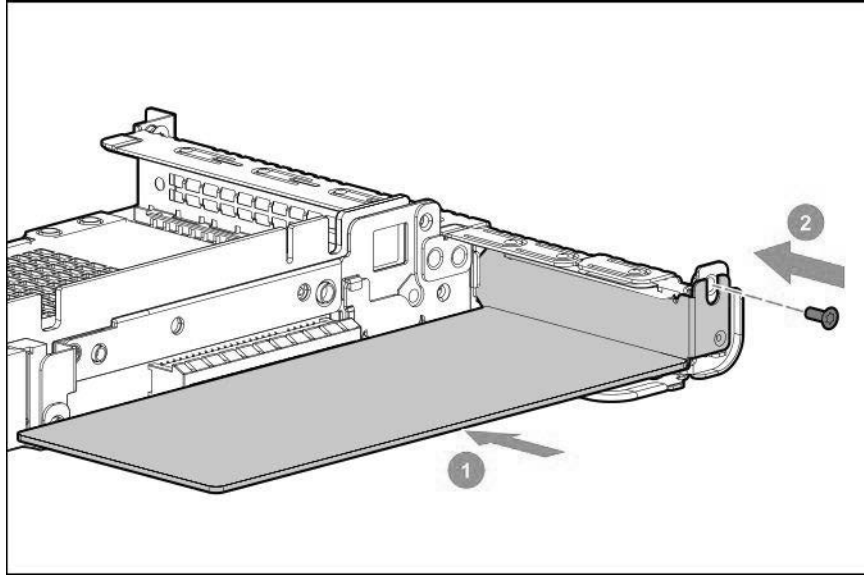

8. **Install the secondary PCI riser cage.**
9. Connect the cables.
 - 8SFF to type-p controller cabling example

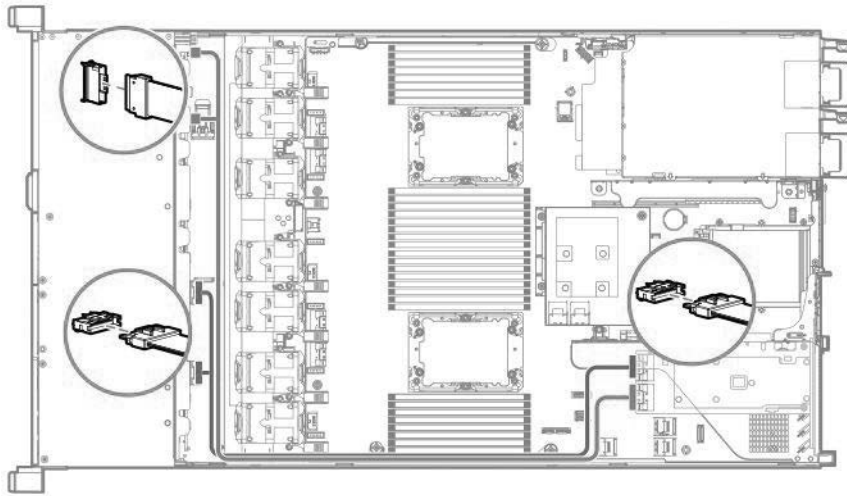

- 4LFF to a type-p slot 2 controller cabling example

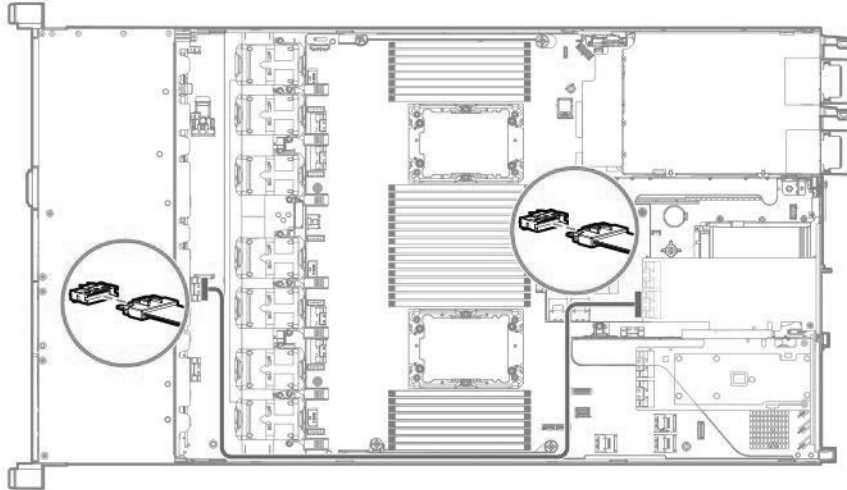

10. **Install the access panel.**
11. Install the server in the rack.
12. Connect each power cord to the server.
13. Connect each power cord to the power source.
14. **Power up the server.**

Processor and heatsink options

Installing a processor heatsink assembly

Prerequisites

Before installing this option, be sure that you have the following:

- The components included with the option kit
- T-30 Torx screwdriver

Procedure

1. Review the heatsink and socket components.
2. Observe the following alerts.

△ CAUTION: When handling the heatsink, always hold it along the top and bottom of the fins. Holding it from the sides can damage the fins.

△ CAUTION: To prevent possible server malfunction and damage to the equipment, multiprocessor configurations must contain processors with the same part number.

△ CAUTION: If installing a processor with a faster speed, update the system ROM before installing the processor. To download the latest firmware, see <https://support.hitachivantara.com/en/user/answers/downloads.html#hardware-download>

△ CAUTION: THE CONTACTS ARE VERY FRAGILE AND EASILY DAMAGED. To avoid damage to the socket or processor, do not touch the contacts.

3. Power down the server.
4. Remove all power:
 - a. Disconnect each power cord from the power source.
 - b. Disconnect each power cord from the server.
5. Do one of the following:
 - a. Extend the server from the rack.
 - b. Remove the server from the rack.
6. Remove the access panel.
7. If installing processors over 150W, install high performance fans.
8. Install the processor heatsink assembly:
 - a. Remove the dust cover from the socket.
 - b. Identify the front of server label on the heatsink.

- c. Align the assembly with the socket and gently lower it down until it sits on the socket.

Be sure the latches lock the heatsink into place. The heatsink and socket are keyed. The processor will only install one way.

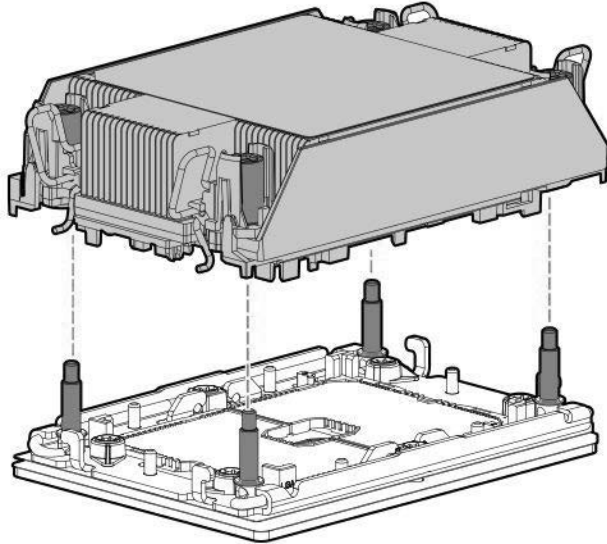

- d. Using a T-30 Torx screwdriver, tighten the nuts.

NOTE: Do not tighten the nuts more than 12 in-lbs. or 1.3Nm. Overtightening could crack or damage the nuts.

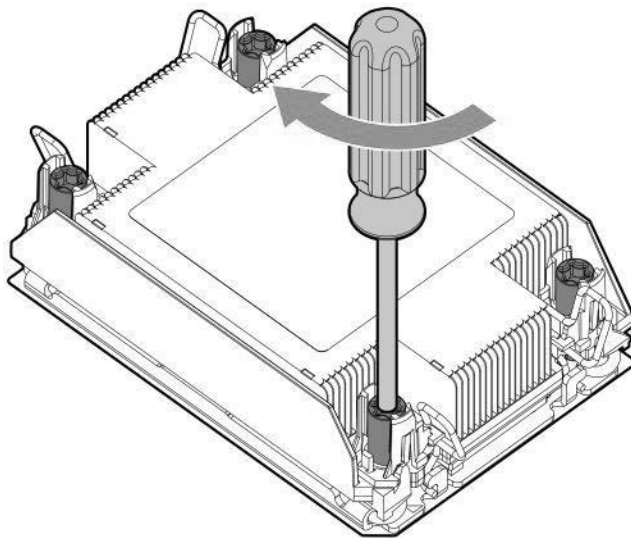

The installation is complete.

Installing a high performance heatsink

Prerequisites

-
- △ CAUTION:** Installing a high performance heatsink requires the installation of a processor assembly onto the heatsink. To avoid damage to server or components, do not remove or install the processor assembly when installing or replacing other heatsinks.
-

Before installing this option, be sure that you have the following:

- The components included with the hardware option kit
- T-30 Torx screwdriver

Procedure

1. Observe the following alerts.

-
- △ CAUTION:** The processor assembly must be removed and replaced as a unit. Do not remove the processor from the carrier.
-

-
- △ CAUTION:** When handling the heatsink, always hold it along the top and bottom of the fins. Holding it from the sides can damage the fins.
-

-
- △ CAUTION: THE CONTACTS ARE VERY FRAGILE AND EASILY DAMAGED.** To avoid damage to the socket or processor, do not touch the contacts.
-

2. **Power down the server.**
3. Remove all power:
 - a. Disconnect each power cord from the power source.
 - b. Disconnect each power cord from the server.
4. Do one of the following:
 - a. **Extend the server from the rack.**
 - b. **Remove the server from the rack.**
5. **Remove the access panel.**
6. Observe the following cautions.

-
- △ CAUTION:** Be sure to loosen each heatsink nut in the order indicated. Otherwise, damage might occur to the heatsink or processor.
-

⚠ CAUTION: Install the processor heatsink assembly as soon as possible after removing it. Do not leave the processor socket unpopulated for extended periods of time.

7. Remove the existing processor heatsink assembly:
 - a. Allow the heatsink to cool.
 - b. Using a T-30 Torx screwdriver, loosen the heatsink nuts.

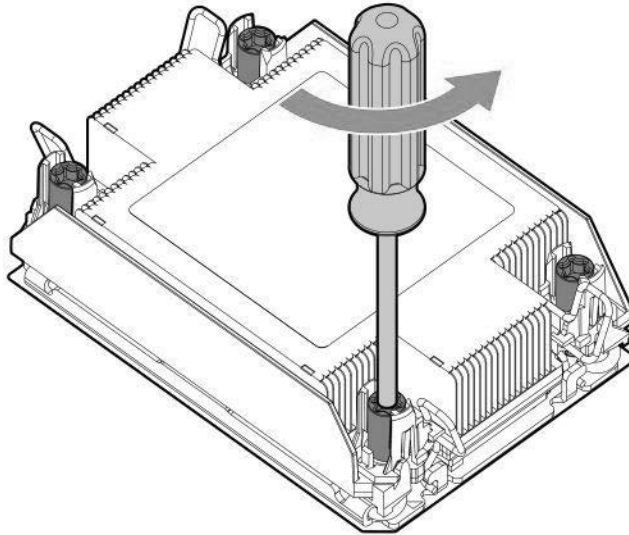

- c. Remove the processor heatsink assembly.

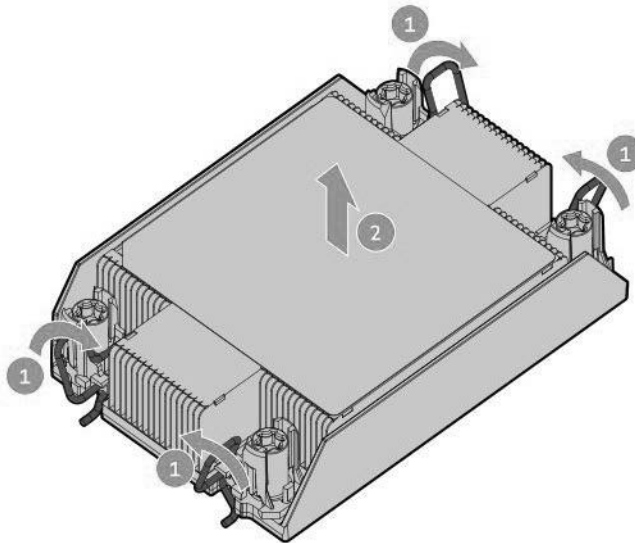

- d. Turn the processor heatsink assembly over and place it on a work surface with the processor assembly facing up.
8. Release the processor from the heatsink:

Be sure to unlatch all corners of the processor carrier. The processor remains attached to the carrier.

9. Using an alcohol wipe, remove the existing thermal grease from the processor and heatsink. Allow the alcohol to evaporate before continuing.

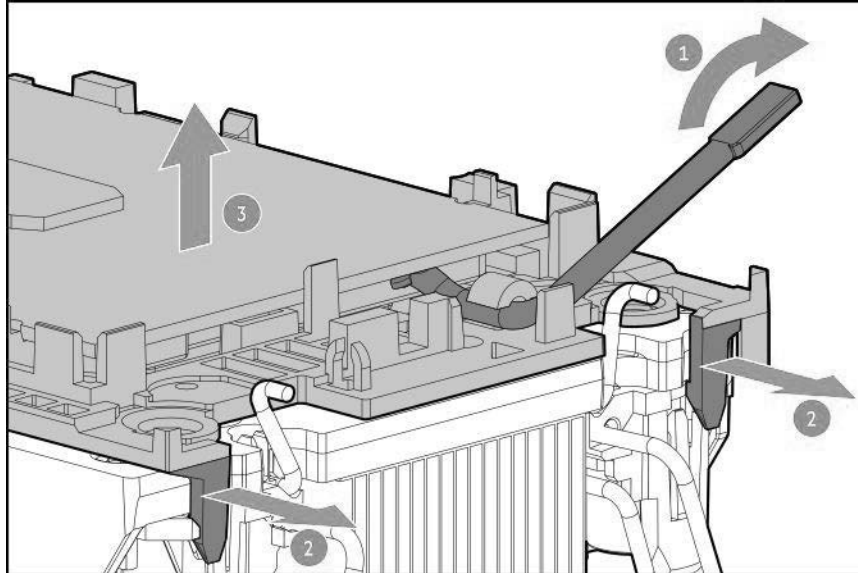

10. Remove the plastic cover protecting the thermal grease on the high performance heatsink.
11. Align the Pin 1 indicators on the processor and the heatsink, and then install the processor assembly to the heatsink.

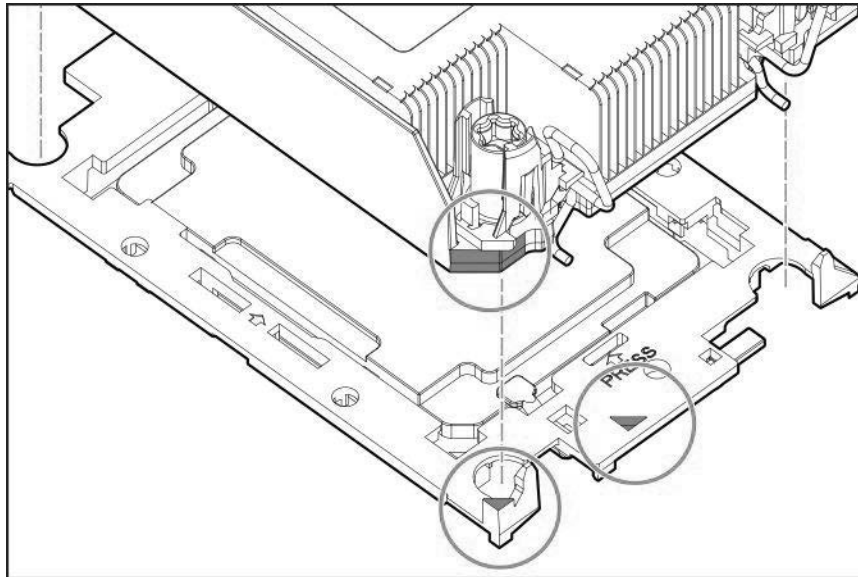

12. Install the processor heatsink assembly:
- Identify the front of server label on the heatsink.
 - Align the assembly with the alignment posts and gently lower it down until it sits on the socket. The processor heatsink assembly will only install one way.

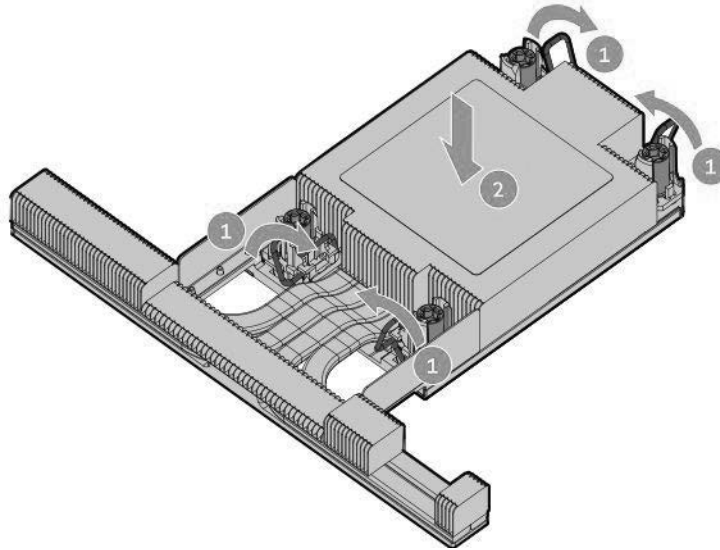

c. Using a T-30 Torx screwdriver, tighten the nuts.

NOTE: Do not tighten the nuts more than 12 in-lbs. or 1.3Nm. Overtightening could crack or damage the nuts.

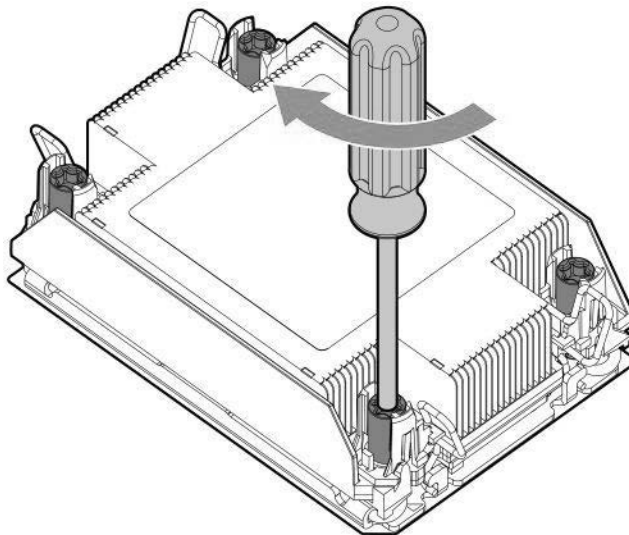

The installation is complete.

Installing the Systems Insight Display power module

Prerequisites

Before installing this option, be sure you have the following:

- The components included with the hardware option kit
- T-10 Torx screwdriver

Procedure

1. Observe the following alerts:



WARNING: To reduce the risk of personal injury from hot surfaces, allow the drives and the internal system components to cool before touching them.



CAUTION: To prevent damage to electrical components, properly ground the server before beginning any installation procedure. Improper grounding can cause electrostatic discharge.

2. Back up all server data.
3. **Power down the server.**
4. Remove all power:
 - a. Disconnect each power cord from the power source.
 - b. Disconnect each power cord from the server.
5. Do one of the following:
 - a. **Extend the server from the rack.**
 - b. **Remove the server from the rack.**
6. Remove the access panel **Remove the access panel.**
7. Disconnect the cable from the system board.

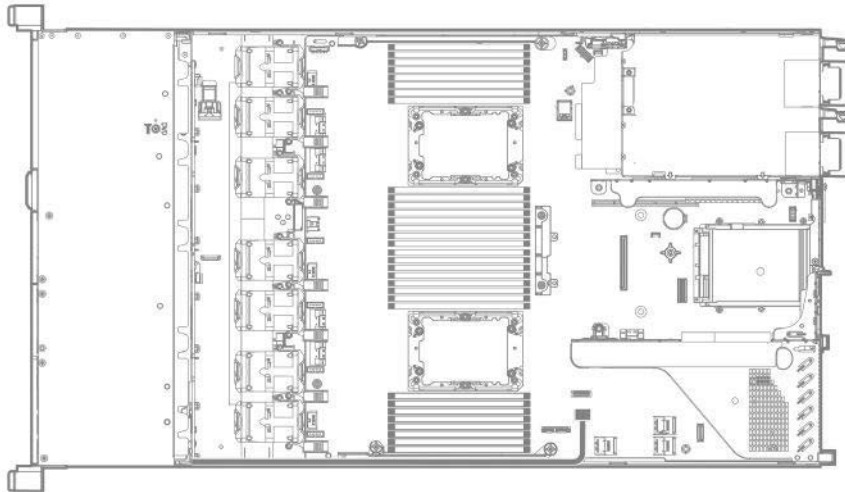

8. Using a Torx T-10 screwdriver, remove the Power/UID/USB assembly.

- SFF

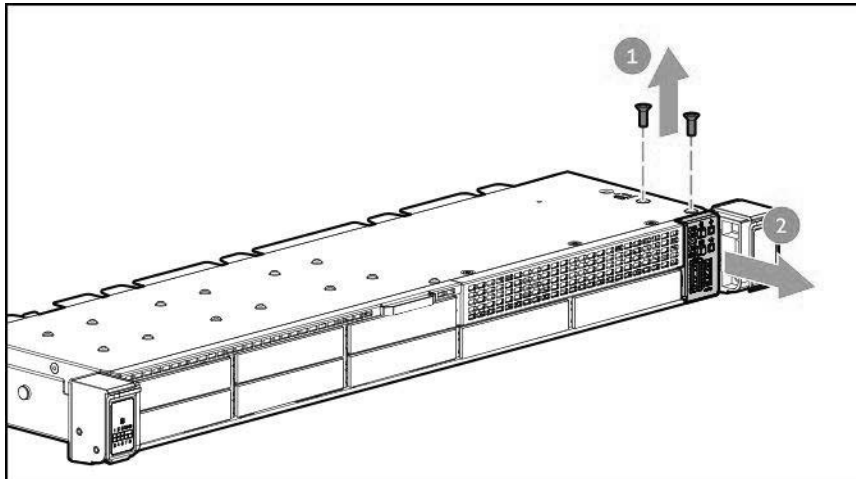

- 4 LFF

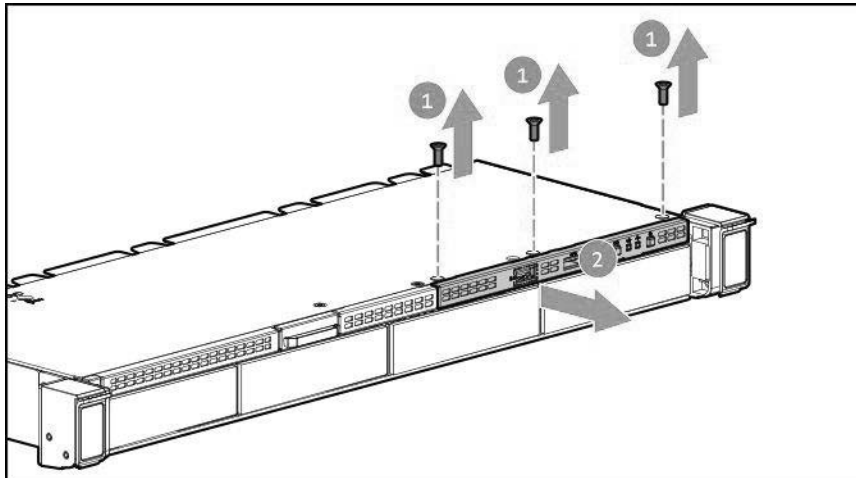

9. Guide the SID cable through the front of the server.

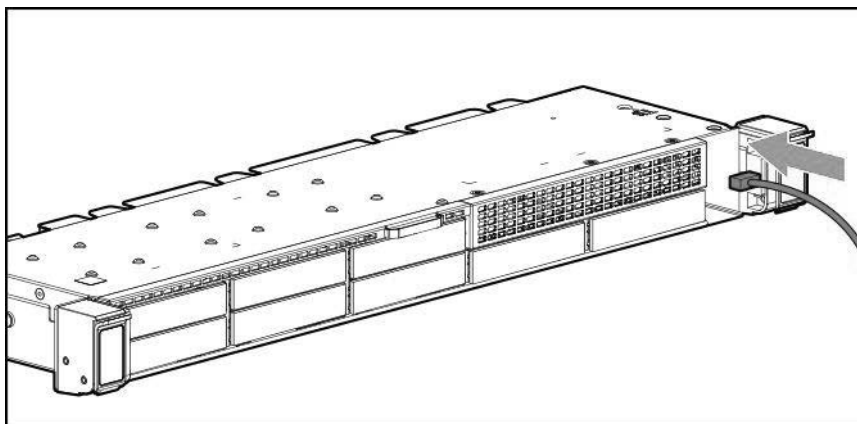

10. Install the SID module into the front panel. Using a T-10 Torx screwdriver, secure the module to the chassis with the screws from the kit.

- 8 SFF

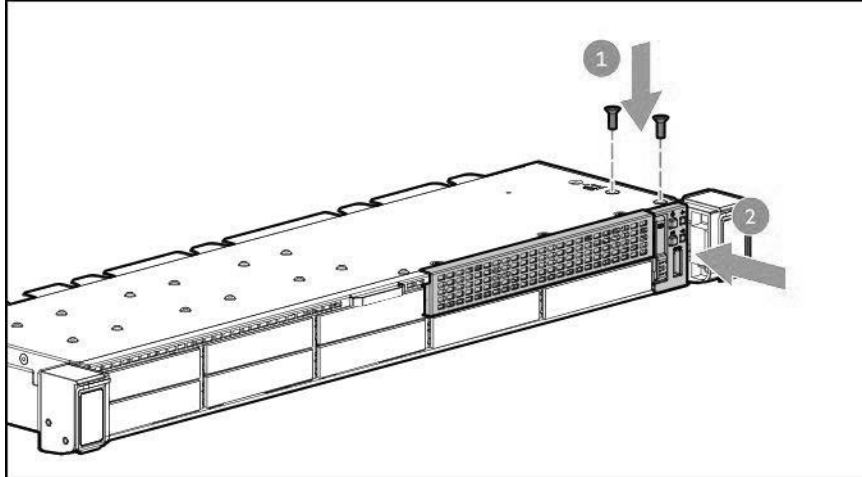

- 4 LFF

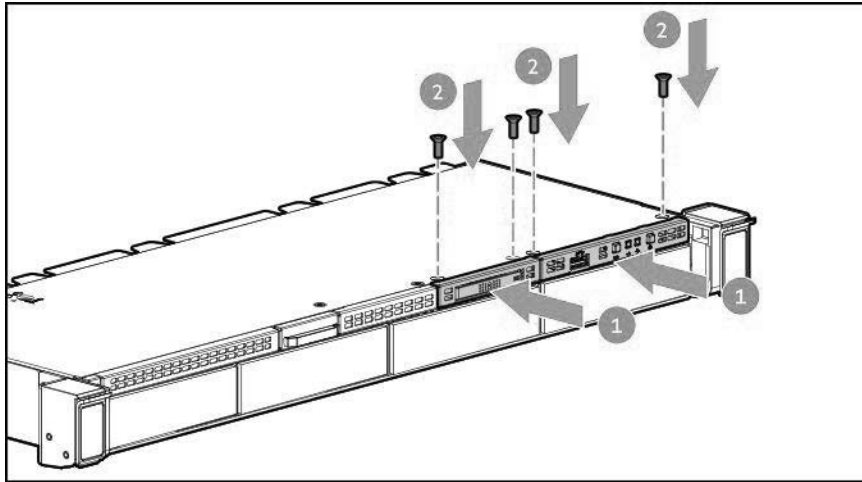

11. Connect the cable.

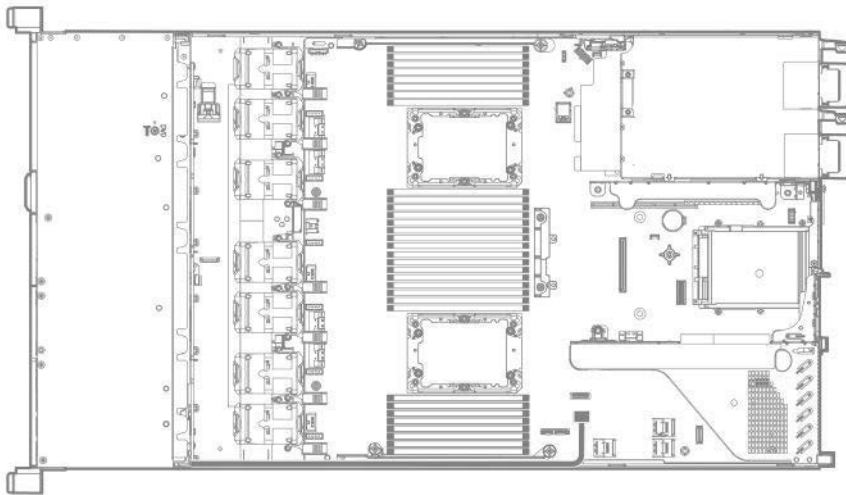

Installing an OCP 3.0 adapter card

Prerequisites

Before you begin this procedure, make sure that the components included with the hardware option kit are available.

Procedure

1. **Power down the server.**
2. Remove all power:
 - a. Disconnect each power cord from the power source.
 - b. Disconnect each power cord from the server.
3. Do one of the following:
 - **Extend the server from the rack.**
 - **Remove the server from the rack.**
4. **Remove the access panel.**
5. Remove the rear wall blank or riser.
6. Remove the OCP 3.0 adapter blank.

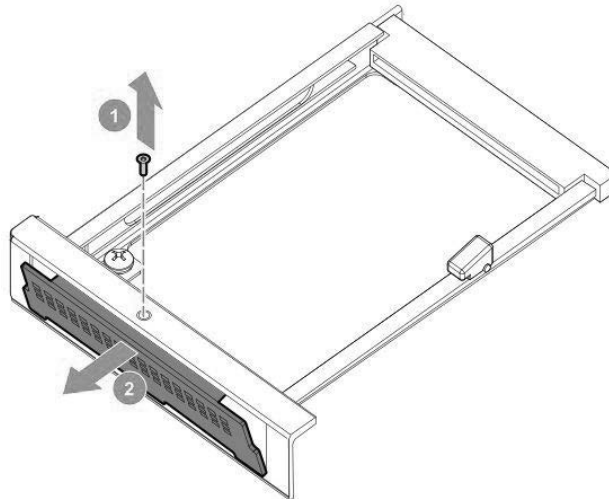

7. Install the OCP 3.0 adapter

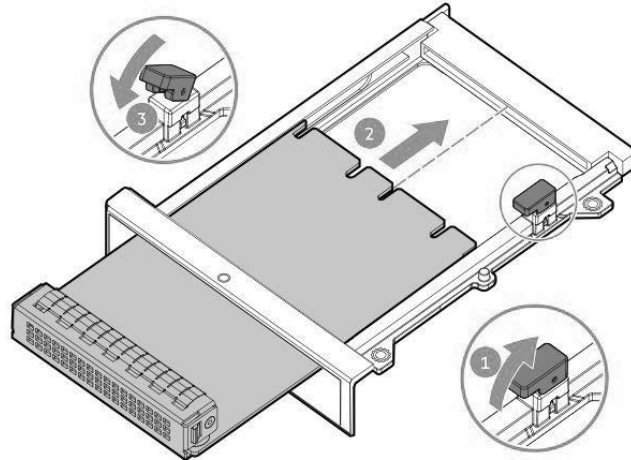

8. **Connect the cables.**
9. **Install the access panel.**
10. Slide the server into the rack.
11. Connect each power cord to the server.
12. Connect each power cord to the power source.
13. **Power up the server.**

Installing the serial cable option

Prerequisites

Before installing this option, be sure you have the following:

- The components included with the hardware option kit
- 5 mm socket

Procedure

1. Observe the following alerts:

⚠ WARNING: To reduce the risk of personal injury from hot surfaces, allow the drives and the internal system components to cool before touching them.

⚠ CAUTION: To prevent damage to electrical components, properly ground the server before beginning any installation procedure. Improper grounding can cause electrostatic discharge.

2. Back up all server data.
3. **Power down the server.**
4. Remove all power:
 - a. Disconnect each power cord from the power source.
 - b. Disconnect each power cord from the server.
5. Do one of the following:
 - a. **Extend the server from the rack.**

- b. **Remove the server from the rack.**
6. **Remove the access panel.**
7. Remove the serial port blank.
8. Connect the serial cable, and then secure the cable with screws.

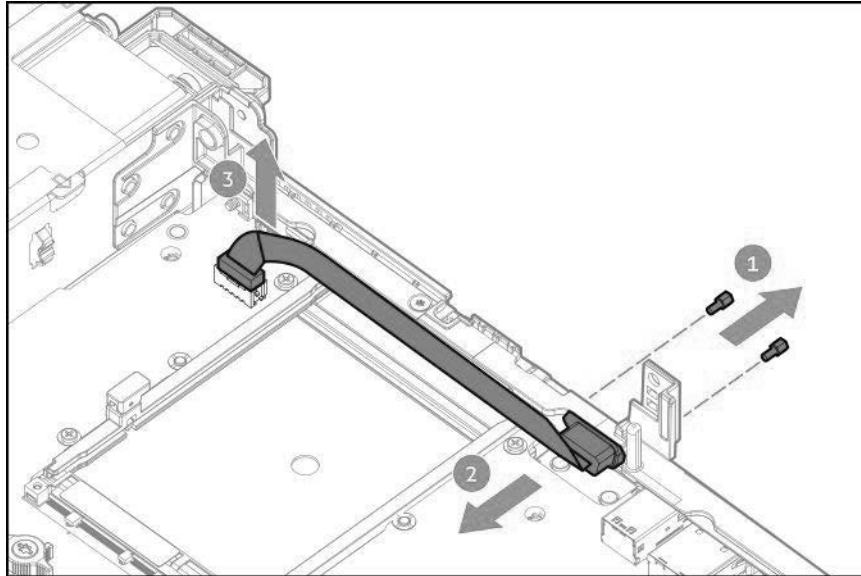

9. Remove the backing from the double-sided tape and press down where indicated.
10. Install the access panel (**Install the access panel.**).
11. Install the server in the rack.
12. Connect each power cord to the server.
13. Connect each power cord to the power source.
14. Power up the server (**Power up the server.**).

Installing the Chassis Intrusion Detection switch option

Prerequisites

- Before installing this option, be sure you have the following:
- The components included with the hardware option kit
- T-15 Torx screwdriver

Procedure

1. **Power down the server.**
2. Remove all power:
 - a. Disconnect each power cord from the power source.
 - b. Disconnect each power cord from the server.
3. Do one of the following:
 - a. **Extend the server from the rack.**

- b. **Remove the server from the rack.**
4. **Remove the access panel.**
5. Install the chassis intrusion detection switch behind the power supply bays.

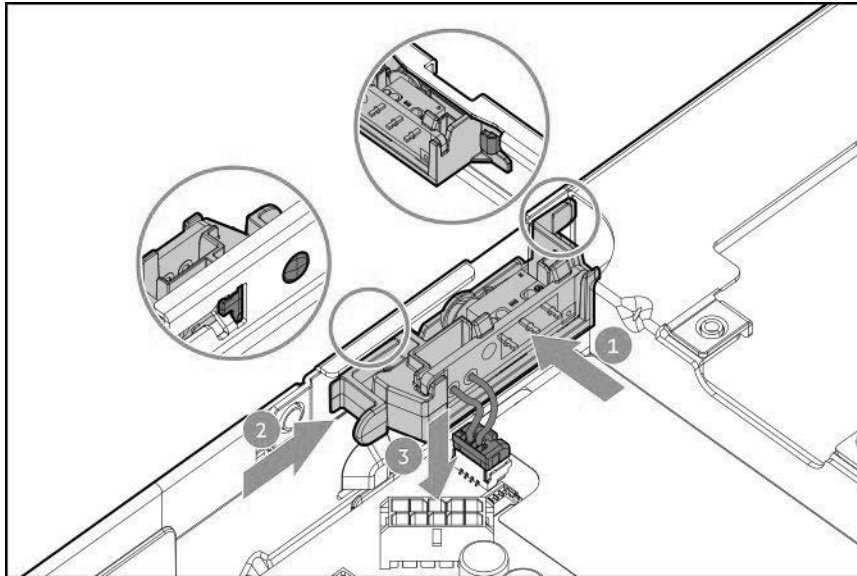

6. Install the access panel (Install the access panel).
7. Install the server in the rack.
8. Connect each power cord to the server.
9. Connect each power cord to the power source.
10. Power up the server (Power up the server).

Installing the DSP DSC-25 SFP28 card

Prerequisites

Before installing this option, be sure you have the following:

- The components included with the hardware option kit.
- T-10 Torx screwdriver.

Procedure

1. Observe the following alerts:

⚠ WARNING: To reduce the risk of personal injury from hot surfaces, allow the drives and the internal system components to cool before touching them.

⚠ CAUTION: A discharge of static electricity from a finger or other conductor might damage system boards or other static-sensitive devices. To prevent damage, observe antistatic precautions.

⚠ CAUTION: To prevent improper cooling and thermal damage, do not operate the server unless all PCI slots have either an expansion slot cover or an expansion board installed.

2. **Power down the server.**
3. Disconnect all power from the server.
4. **Extend the server from the rack.**
5. **Remove the server from the rack.**
6. Remove the primary PCIe riser cage.

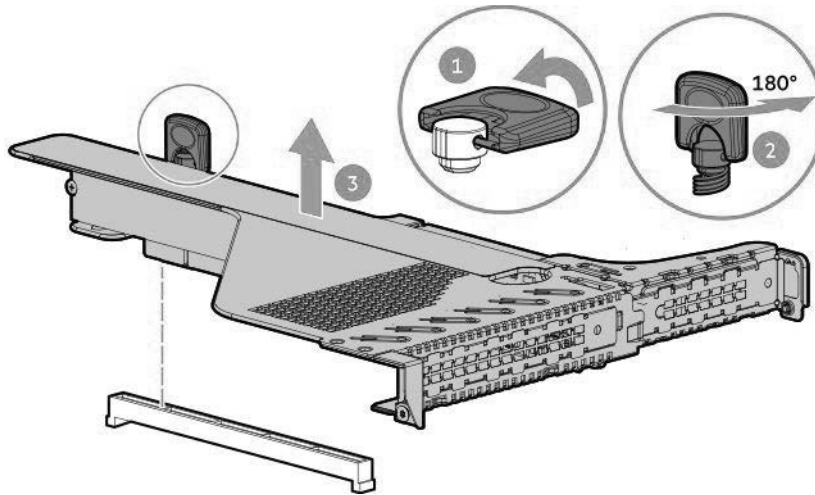

7. Remove the PCIe blank from slot 1 on the primary riser cage.

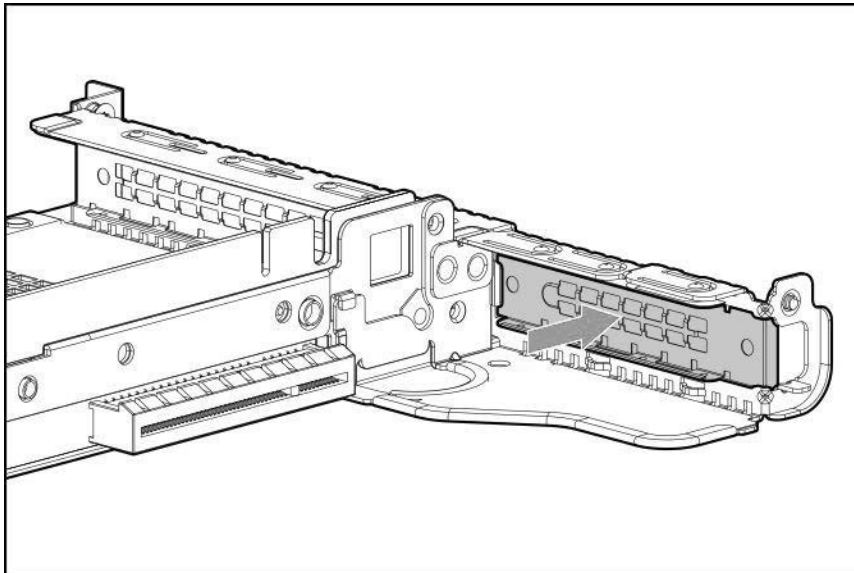

8. Install the DSC-25 card into the PCIe slot.

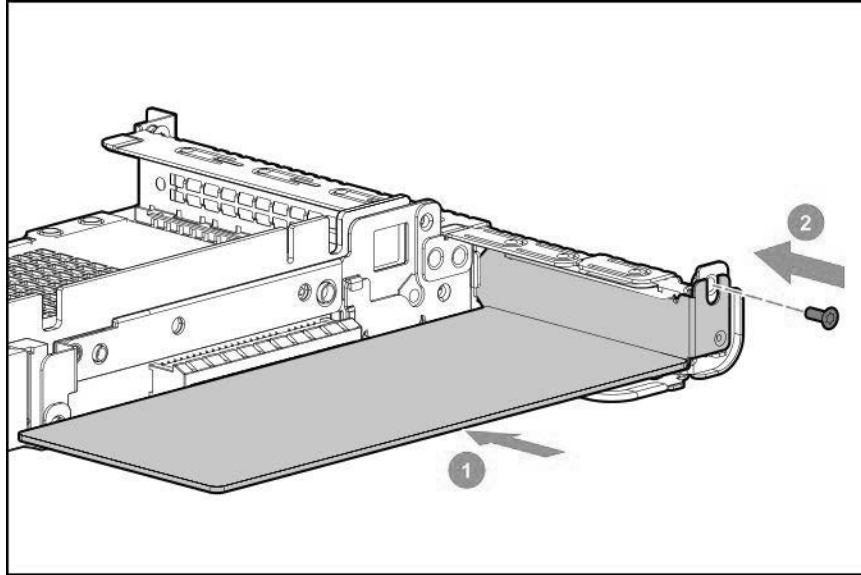

9. Install the PCIe riser cage into the server.

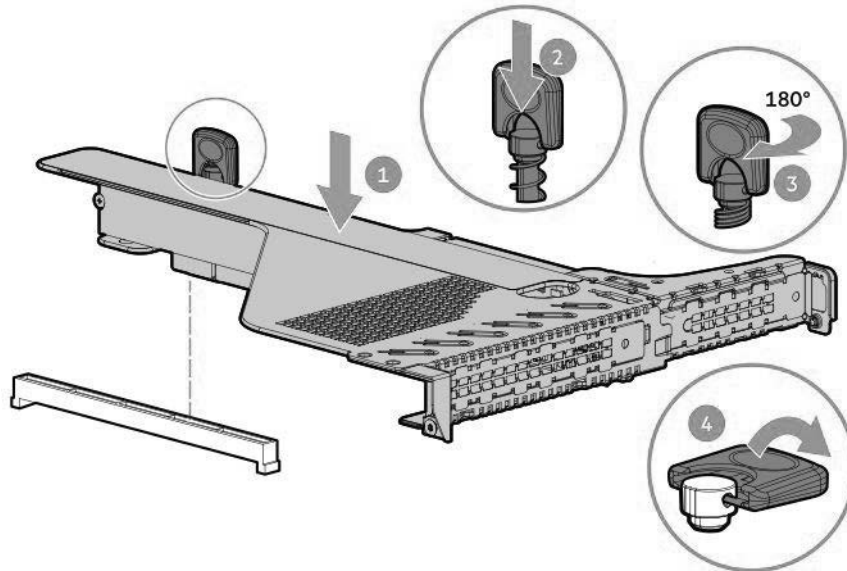

10. Install the server in the rack.
11. Connect each power cord to the server.
12. Connect each power cord to the power source.
13. **Power up the server.**

The installation is complete.

Installing the NS204i-p G2 Boot Device option

Prerequisites

Before beginning installation, ensure that the server is updated with the latest operating system firmware and drivers. Before installing this option, be sure you have the following:

- The components included with the hardware option kit.
- T-10 Torx screwdriver.

Procedure

Installing drives onto the boot device

1. Remove the liner from the thermal interface pad.

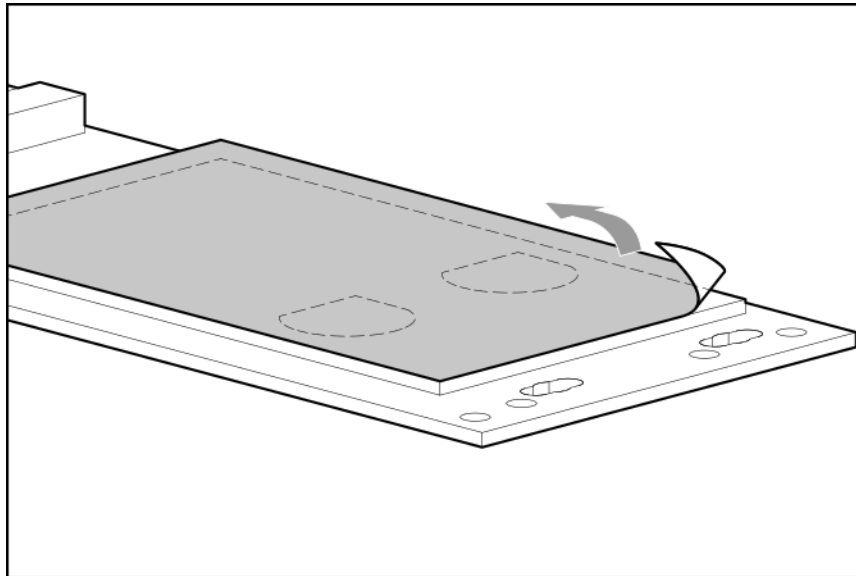

2. Install the drives.

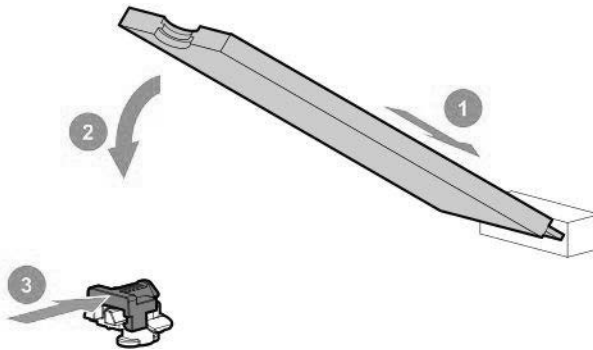

Installing the boot device

3. **Power down the server.**
4. Remove all power:
 - a. Disconnect each power cord from the power source.
 - b. Disconnect each power cord from the server.

5. **Extend the server from the rack.**
6. **Remove the server from the rack.**
7. Place the server on a flat, level work surface.
8. Select an available PCIe expansion slot that is x8 physical size and x4 electrical.
9. **Remove the riser cage (Remove the primary PCI riser cage or Remove the secondary PCI riser cage).**
10. Remove the expansion slot cover.

Save the retaining screw if one is present.

Install the boot device.

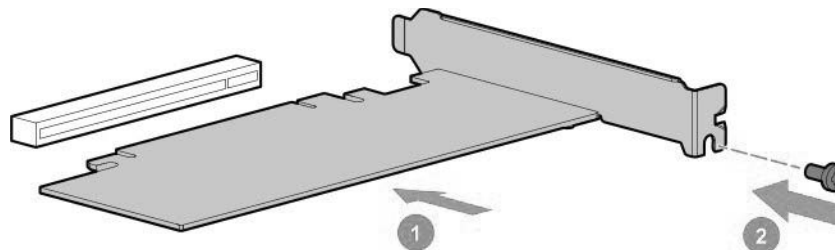

11. Install any components that were removed to access the expansion slot.
12. Install the server in the rack.
13. Connect each power cord to the server.
14. Connect each power cord to the power source.
15. **Power up the server.**

Deploying an operating system

16. Deploy a supported operating system to the boot device drive.

After the OS installation completes, the system automatically copies the operating system to the second, mirrored drive on the boot device.

17. Proceed with normal system setup and operation.

Trusted Platform Module 2.0 option

Overview

Use these instructions to install and enable an TPM 2.0 G2 Kit in a supported server.

This procedure includes three sections:

1. Installing the Trusted Platform Module board.
2. Enabling the Trusted Platform Module.
3. Retaining the recovery key or password.

Install the TPM 2.0 with specific operating system support such as Microsoft Windows Server 2012 R2 and later. For more information about operating system support, see Hitachi Vantara website. (For more information about Microsoft Windows BitLocker Drive Encryption feature, see the Microsoft website <https://www.microsoft.com>)

⚠ CAUTION: If the TPM is removed from the original server and powered up on a different server, data stored in the TPM including keys will be erased.

ⓘ IMPORTANT: In UEFI Boot Mode, the TPM 2.0 Kit can be configured to operate as TPM 2.0 (default) or TPM 1.2 on a supported server. In Legacy Boot Mode, the configuration can be changed between TPM 1.2 and TPM 2.0, but only TPM 1.2 operation is supported.

Trusted Platform Module 2.0 guidelines

⚠ CAUTION: Always observe the guidelines in this document. Failure to follow these guidelines can cause hardware damage or halt data access.

Hitachi Vantara SPECIAL REMINDER: Before enabling TPM functionality on this system, you must ensure that your intended use of TPM complies with relevant local laws, regulations and policies, and approvals or licenses must be obtained if applicable.

For any compliance issues arising from your operation/usage of TPM which violates the above mentioned requirement, you shall bear all the liabilities wholly and solely. Hitachi Vantara will not be responsible for any related liabilities.

When installing or replacing a TPM, observe the following guidelines:

- Do not remove an installed TPM. Once installed, the TPM becomes a permanent part of the system board.
- When installing or replacing hardware, Hitachi Vantara service providers cannot enable the TPM or the encryption technology. For security reasons, only the customer can enable these features.
- When returning a system board for service replacement, do not remove the TPM from the system board. When requested, Service provides a TPM with the spare system board.
- Any attempt to remove the cover of an installed TPM from the system board can damage the TPM cover, the TPM, and the system board.
- If the TPM is removed from the original server and powered up on a different server, all data stored in the TPM including keys will be erased.
- When using BitLocker, always retain the recovery key/password. The recovery key/password is required to complete Recovery Mode after BitLocker detects a possible compromise of system integrity.
- Hitachi Vantara is not liable for blocked data access caused by improper TPM use. For operating instructions, see the TPM documentation or the encryption technology feature documentation provided by the operating system.

Installing and enabling the TPM 2.0 option

Installing the Trusted Platform Module board

Preparing the server for installation

Procedure

1. Observe the following warnings:

⚠ WARNING: The front panel Power On/Standby button does not shut off system power. Portions of the power supply and some internal circuitry remain active until AC power is removed.

To reduce the risk of personal injury, electric shock, or damage to the equipment, remove power from the server:

- For rack and tower servers, remove the power cord.

⚠ WARNING: To reduce the risk of personal injury from hot surfaces, allow the drives and the internal system components to cool before touching them.

2. Update the system ROM.

Locate and download the latest ROM version from [Hitachi Vantara website](#). Follow the instructions on the website to update the system ROM.

3. Power down the server.

4. Remove all powers:

- a. Disconnect each power cord from the power source.
- b. Disconnect each power cord from the server.

5. Do one of the following:

- Extend the server from the rack.
- Remove the server from the rack.

6. Place the server on a flat, level work surface.

7. Remove the access panel.

8. If needed, remove any expansion boards installed in slot 3.

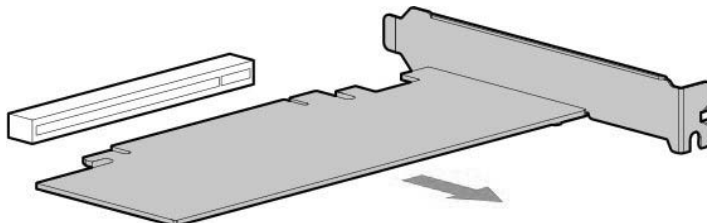

9. Remove the primary PCI riser cage.

10. Install the TPM board and cover.

Installing the TPM board and covers

Procedure

1. Observe the following alerts:

⚠ CAUTION: If the TPM is removed from the original server and powered up on a different server, data stored in the TPM including keys will be erased.

⚠ CAUTION: The TPM is keyed to install only in the orientation shown. Any attempt to install the TPM in a different orientation might result in damage to the TPM or system board.

2. Align the TPM board with the key on the connector, and then install the TPM board. To seat the board, press the TPM board firmly into the connector. To locate the TPM connector on the system board, see the server label on the access panel.

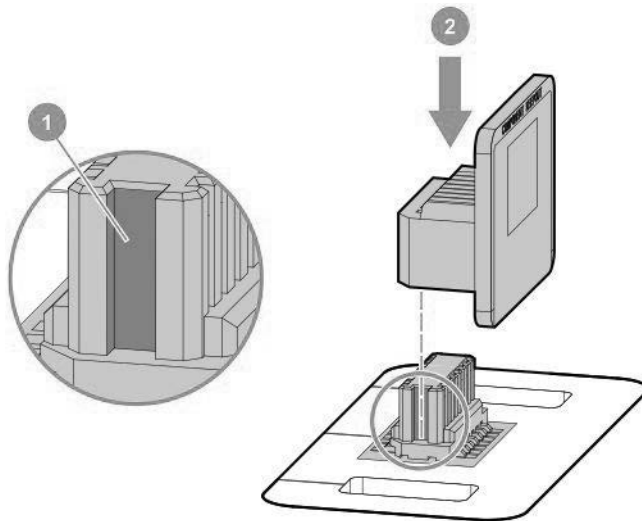

3. Install the TPM cover:
 - a. Line up the tabs on the cover with the openings on either side of the TPM connector.
 - b. To snap the cover into place, firmly press straight down on the middle of the cover.

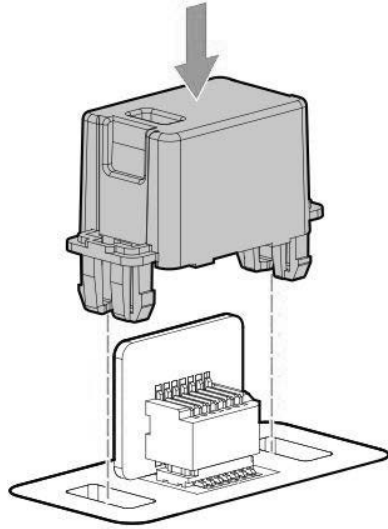

4. Proceed to **Preparing the server for operation.**

Preparing the server for operation

Procedure

1. Install any options or cables previously removed to access the TPM connector.
2. Install the access panel.
3. Do one of the following:
 - a. Install the server in the rack, if necessary.
 - b. Install the server in the enclosure.
4. Power up the server.
 - a. Connect the power cords (rack and tower servers).
 - b. Press the Power On/Standby button.

Enabling the Trusted Platform Module

When enabling the Trusted Platform module, observe the following guidelines:

- By default, the Trusted Platform Module is enabled as TPM 2.0 when the server is powered on after installing it.
- In UEFI Boot Mode, the Trusted Platform Module can be configured to operate as TPM 2.0 (default) or TPM 1.2.
- In Legacy Boot Mode, the Trusted Platform Module configuration can be changed between TPM 1.2 and TPM 2.0 (default), but only TPM 1.2 operation is supported.

Enabling the Trusted Platform Module as TPM 2.0

Procedure

1. During the server startup sequence, press the **F9** key to access **System Utilities**.
2. From the **System Utilities** screen, select **System Configuration > BIOS/Platform Configuration (RBSU) > Server Security > Trusted Platform Module options**.
3. Verify the following:
 - "Current TPM Type" is set to TPM 2.0.
 - "Current TPM State" is set to Present and Enabled.
 - "TPM Visibility" is set to Visible.
4. If changes were made in the previous step, press the F10 key to save your selection.
5. If F10 was pressed in the previous step, do one of the following:
 - If in graphical mode, click **Yes**.
 - If in text mode, press the **Y** key.
6. Press the **ESC** key to exit **System Utilities**.
7. If changes were made and saved, the server prompts for reboot request. Press the **Enter** key to confirm reboot.

If the following actions were performed, the server reboots a second time without user input. During this reboot, the TPM setting becomes effective.

 - Changing from TPM 1.2 and TPM 2.0
 - Changing TPM bus from FIFO to CRB
 - Enabling or disabling TPM
 - Clearing the TPM
8. Enable TPM functionality in the OS, such as Microsoft Windows BitLocker or measured boot. For more information, see the [Microsoft website](#).

Enabling the Trusted Platform Module as TPM 1.2

Procedure

1. During the server startup sequence, press the F9 key to access System Utilities.
2. From the System Utilities screen select System Configuration > BIOS/Platform Configuration (RBSU) > Server Security > Trusted Platform Module options.
3. Change the "TPM Mode Switch Operation" to TPM 1.2.
4. Verify that "TPM Visibility" is set to Visible.
5. Press the F10 key to save your selection.
6. When prompted to save the change in System Utilities, do one of the following:
 - If in graphical mode, click **Yes**.
 - If in text mode, press the **Y** key.

7. Press the **ESC** key to exit **System Utilities**.

The server reboots a second time without user input. During this reboot, the TPM setting becomes effective.

Enable TPM functionality in the OS, such as Microsoft Windows BitLocker or measured boot. For more information, see the [Microsoft website](#).

Retaining the BitLocker recovery key/password

The recovery key/password is generated during BitLocker setup, and can be saved and printed after BitLocker is enabled. When using BitLocker, always retain the recovery key/password. The recovery key/password is required to enter Recovery Mode after BitLocker detects a possible compromise of system integrity.

To help ensure maximum security, observe the following guidelines when retaining the recovery key/password:

- Always store the recovery key/password in multiple locations.
- Always store copies of the recovery key/password away from the server.
- Do not save the recovery key/password on the encrypted hard drive.

Cabling

Cabling guidelines

The cable colors in the cabling diagrams used in this chapter are for illustration purposes only. Observe the following guidelines when working with server cables.

Before connecting cables

- Note the port labels on the PCA components. Not all these components are used by all servers:
- System board ports
- Drive and power supply backplane ports
- Expansion board ports (controllers, adapters, expanders, risers, and similar boards)
- Note the label near each cable connector. This label indicates the destination port for the cable connector.
- Some data cables are prebent. Do not unbend or manipulate the cables.
- To prevent mechanical damage or depositing oil that is present on your hands, and other contamination, do not touch the ends of the connectors.

When connecting cables

- Before connecting a cable to a port, lay the cable in place to verify the length of the cable.
- Use the internal cable management features to properly route and secure the cables.
- When routing cables, be sure that the cables are not in a position where they can be pinched or crimped.
- Avoid tight bend radii to prevent damaging the internal wires of a power cord or a server cable. Never bend power cords and server cables tight enough to cause a crease in the sheathing.
- Make sure that the excess length of cables is properly secured to avoid excess bends, interference issues, and airflow restriction.
- To prevent component damage and potential signal interference, make sure that all cables are in their appropriate routing position before installing a new component and before closing up the server after hardware installation/maintenance.

When disconnecting cables

- Grip the body of the cable connector. Do not pull on the cable itself because this action can damage the internal wires of the cable or the pins on the port.
- If a cable does not disconnect easily, check for any release latch that must be pressed to disconnect the cable.

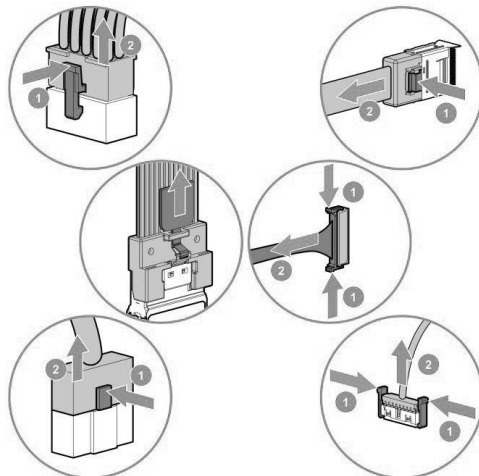

- Remove cables that are no longer being used. Retaining them inside the server can restrict airflow. If you intend to use the removed cables later, label and store them for future use.

Front I/O cabling

LFF Optical Disk Drive cabling

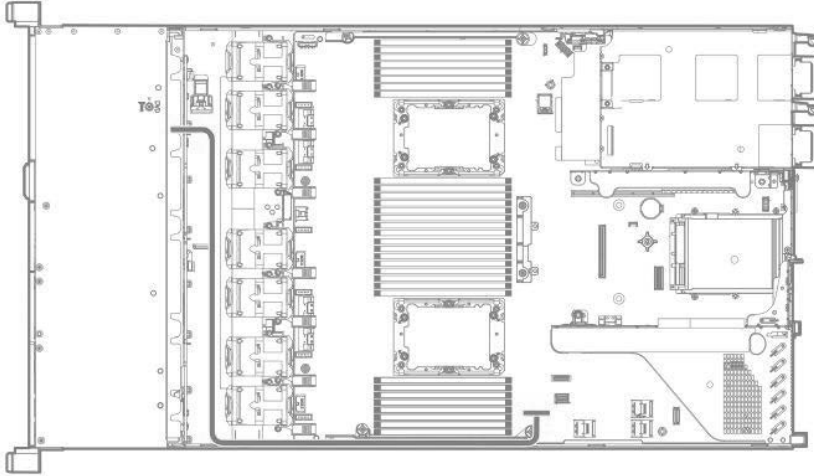

SFF Optical Disk Drive cabling

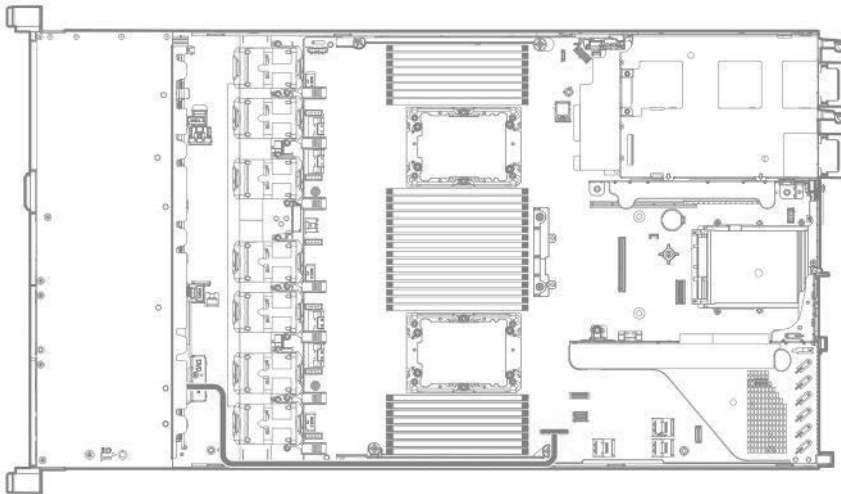

LFF front display port/USB cabling

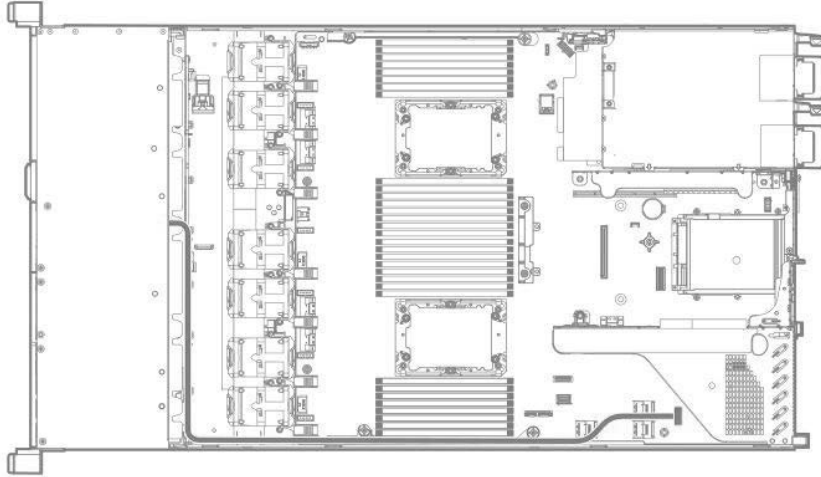

Front power/SID/USB cabling

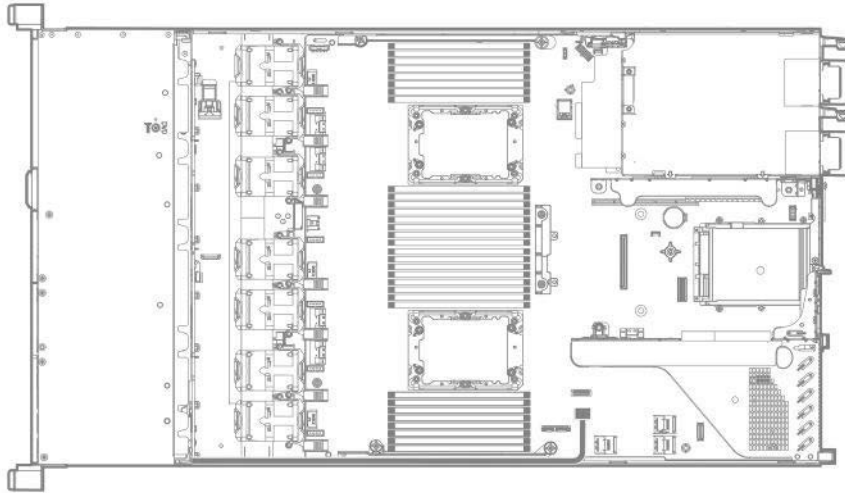

Storage cabling

SFF cables

Option kit	Cable part number	Connects from	Connects to
SFF internal cable kit	P20815-001	2SFF SAS/SATA backplane	Embedded SATA port 3
	P20816-001	8SFF SAS/SATA backplane	Embedded SATA ports 1/2
	P20817-001	2SFF SAS/SATA backplane	Type-a controller
	P26551-001	2SFF SAS/SATA backplane	Type-p controller
Direct attach NVMe cable kit	P20855-001	8SFF NVMe backplane	Embedded NVMe ports 1B/2B

Option kit	Cable part number	Connects from	Connects to
	P20856-001	8SFF NVMe backplane	Embedded NVMe ports 1A/2A
	P20857-001	2SFF NVMe backplane	Primary NVMe riser
	P26552-001	2SFF NVMe backplane	Embedded NVMe port 1A
Tri-mode NVMe cables	P20863-001	8SFF Tri-mode backplane	Type-p SR controller NVMe port 1
	P20864-001	8SFF Tri-mode backplane	Type-p SR controller NVMe port 2
	P20865-001	8SFF Tri-mode backplane	Type-p SR controller NVMe port 3
	P20866-001	8SFF Tri-mode backplane	Type-p SR controller NVMe port 4
	P20867-001	8SFF Tri-mode backplane	Type-p SR controller
	P20868-001	8SFF Tri-mode backplane	Type-p SR controller
	P20869-001	2SFF Tri-mode backplane	Type-p SR controller
	P20859-001	8SFF Tri-mode backplane	Type-p MR controller
	P26553-001	8SFF Tri-mode backplane	Type-a SR controller
OCP x16 enablement kit	P20847-001	Embedded Slimline Connector	Type-a or Type-p controller

8SFF x1 Tri-Mode U.3 backplane + 2SFF NVMe backplane to type-p Tri-Mode controller

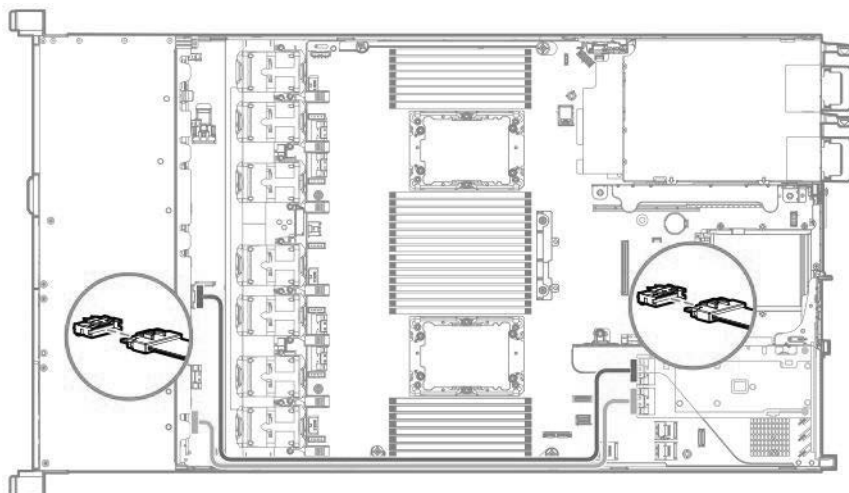

8SFF x4 + 2SFF backplanes to type-p controller

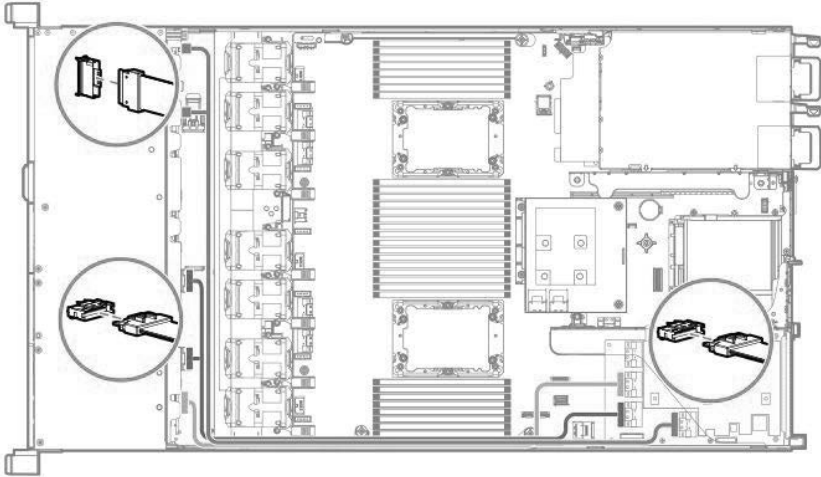

8SFF x4 + 2SFF backplanes to type-a and type-p controllers

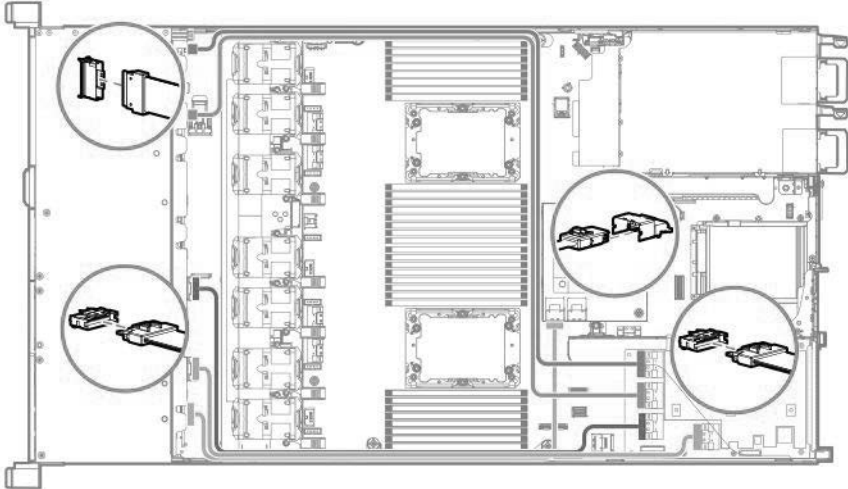

2SFF x4 backplane to primary NVMe riser

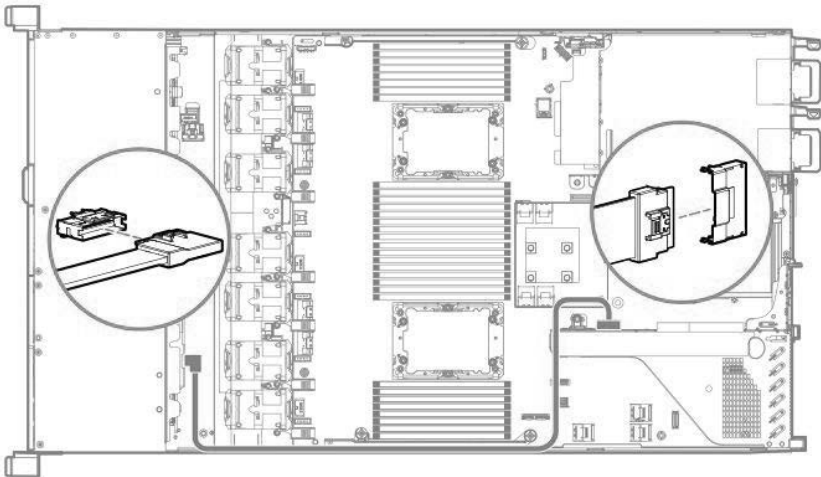

8SFF x1 Tri-Mode U.3 backplane to type-p controller on slot 2

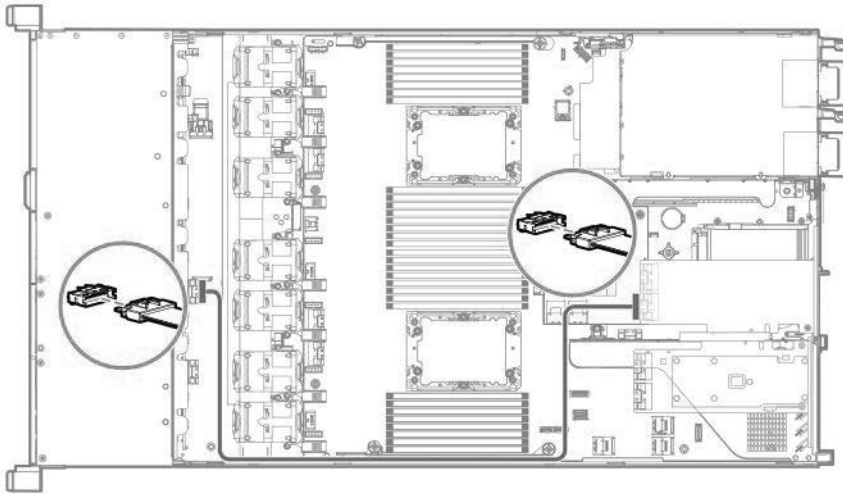

8SFF SAS/SATA backplane to system board and 2-port type-a controller

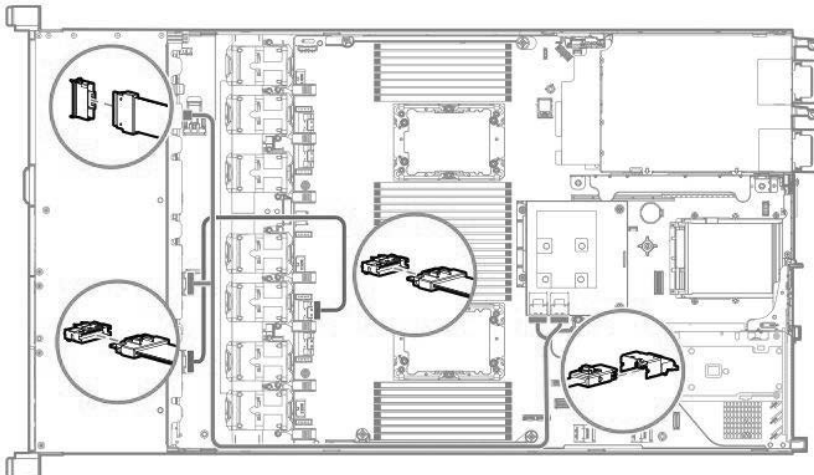

8SFF x4 backplane to 2-port type-p controller

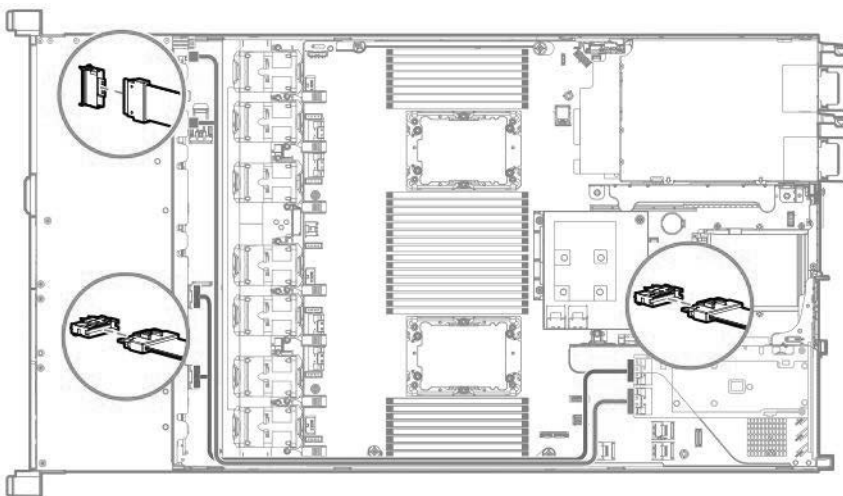

8SFF x4 backplane direct attach

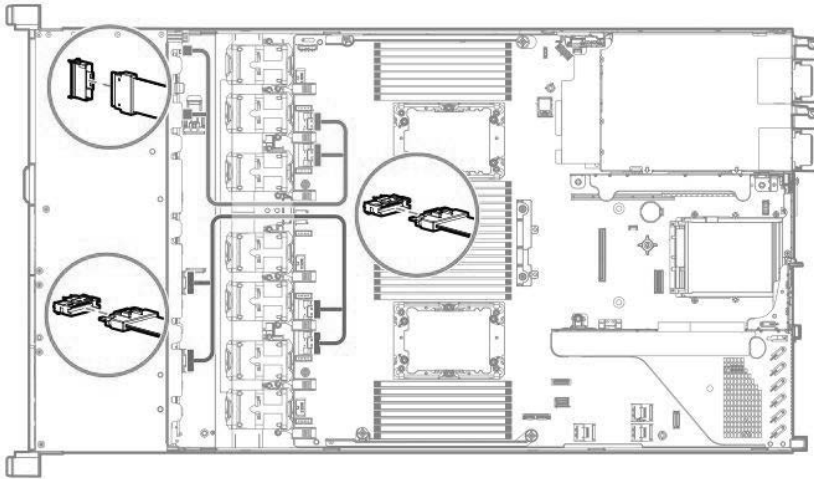

8SFF SAS/SATA backplane to embedded SATA

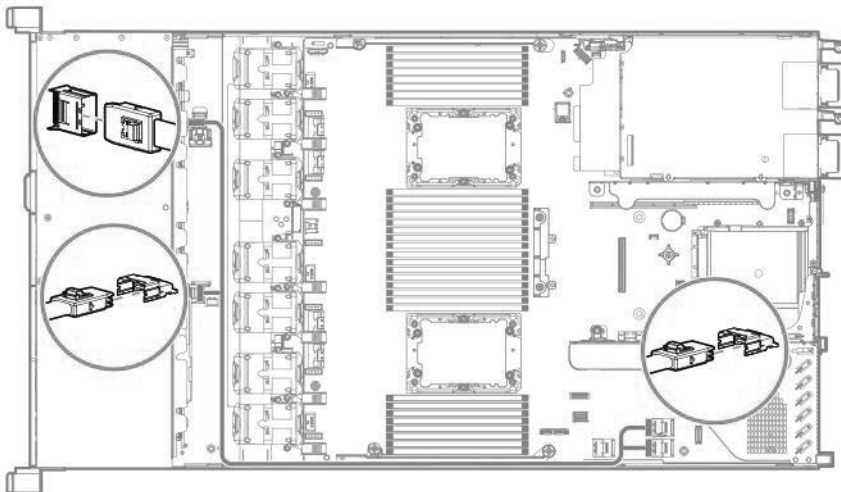

LFF cables

Option kit	Cable part number	Connects from	Connects to
LFF Internal Cable Kit	P20808-001	4LFF SAS/SATA	Embedded SATA port 2

4LFF backplane to controllers

4LFF to embedded SAS/SATA

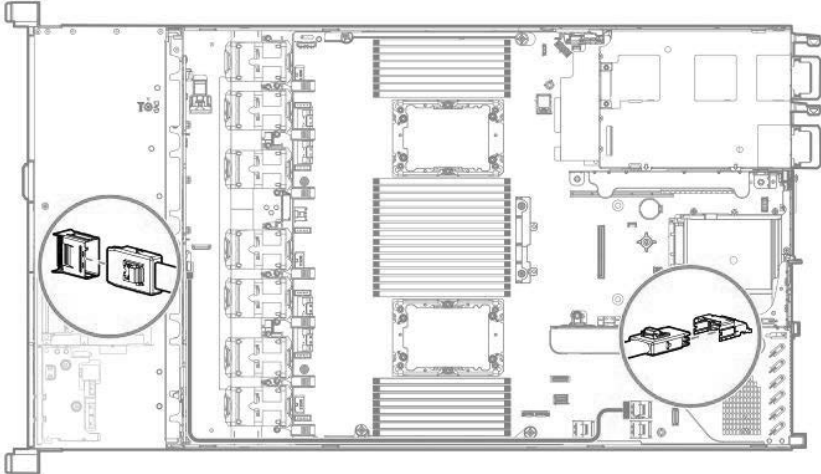

4LFF to type-a controller

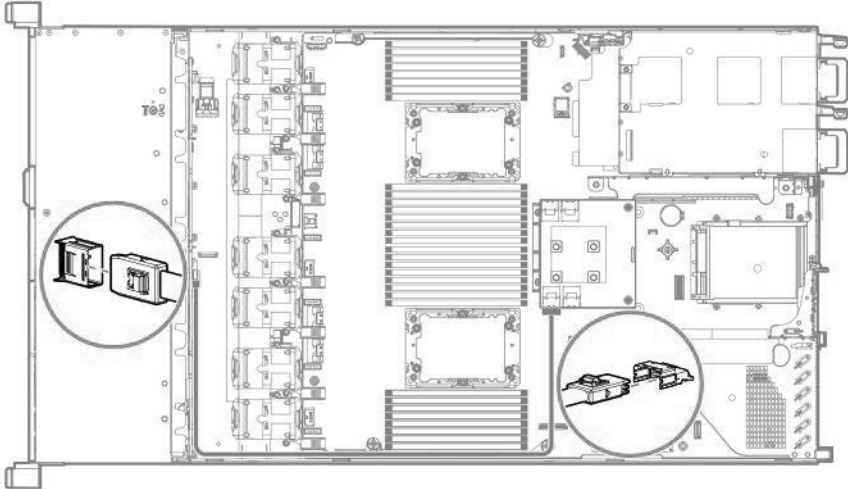

4LFF to type-p controller

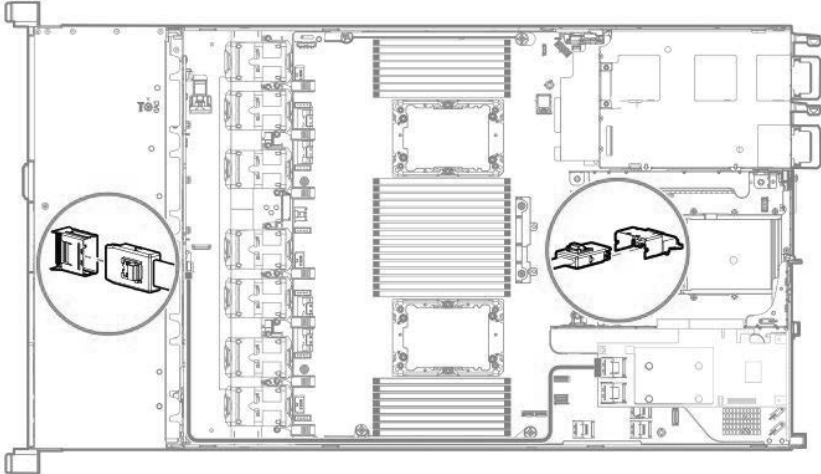

Software and configuration utilities

Server mode

The software and configuration utilities presented in this section operate in online mode, offline mode, or in both modes.

Software or configuration utility	Server mode
Active Health System	Online and Offline
iLO 5	Online and Offline
Smart storage administrator	Online and Offline
iLO RESTful API	Online and Offline
Intelligent Provisioning	Online and Offline
Service Pack for Hitachi Vantara	Online and Offline
Smart update manager	Online and Offline
UEFI System Utilities	Offline

Active Health System

The Active Health System monitors and records changes in the server hardware and system configuration.

The Active Health System provides:

- Continuous health monitoring of over 1600 system parameters
- Logging of all configuration changes
- Consolidated health and service alerts with precise time stamps
- Agentless monitoring that does not affect application performance

For more information about the Active Health System, see the iLO user guide at the following website:

<https://knowledge.hitachivantara.com/Documents/Servers>

Active Health System data collection

The Active Health System does not collect information about your operations, finances, customers, employees, or partners.

Examples of information that is collected:

- Server model and serial number
- Processor model and speed

- Storage capacity and speed
- Memory capacity and speed
- Firmware/BIOS and driver versions and settings

The Active Health System does not parse or change OS data from third-party error event log activities (for example, content created or passed through the OS).

Active Health System Log

The data collected by the Active Health System is stored in the Active Health System Log. The data is logged securely, isolated from the operating system, and separate from customer data. Host resources are not consumed in the collection and logging of Active Health System data.

When the Active Health System Log is full, new data overwrites the oldest data in the log.

It takes less than 5 minutes to download the Active Health System Log and send it to a support professional to help you resolve an issue.

When you download and send Active Health System data to Hitachi Vantara, you agree to have the data used for analysis, technical resolution, and quality improvements. The data that is collected is managed according to the privacy statement, available at <https://www.hitachivantara.com/en-us/company/legal/privacy.html>.

iLO 5

iLO 5 is a remote server management processor embedded on the system boards of supported Advanced Server products. iLO enables the monitoring and controlling of servers from remote locations. iLO management is a powerful tool that provides multiple ways to configure, update, monitor, and repair servers remotely.

For more information about iLO, see the iLO user guide at the following website:
<https://knowledge.hitachivantara.com/Documents/Servers>

iLO Federation

iLO Federation enables you to manage multiple servers from one system using the iLO web interface.

When configured for iLO Federation, iLO uses multicast discovery and peer-to-peer communication to enable communication between the systems in iLO Federation groups.

When you navigate to one of the iLO Federation pages, a data request is sent from the iLO system running the web interface to its peers, and from those peers to other peers until all data for the selected iLO Federation group is retrieved.

iLO supports the following features:

- Group health status—View server health and model information.
- Group virtual media—Connect URL-based media for access by a group of servers.
- Group power control—Manage the power status of a group of servers.
- Group power capping—Set dynamic power caps for a group of servers.
- Group firmware update—Update the firmware of a group of servers.

- Group license installation—Enter a license key to activate iLO licensed features on a group of servers.

Group configuration—Add iLO Federation group memberships for multiple iLO systems.

Any user can view information on iLO Federation pages, but a license is required for using the following features: Group virtual media, Group power control, Group power capping, Group configuration and Group firmware update. For more information about iLO Federation, see the iLO user guide at the following website: <https://knowledge.hitachivantara.com/Documents/Servers>

iLO Service Port

The Service Port is a USB port with the label iLO on supported servers.

When you have physical access to a server, you can use the Service Port to do the following:

- Download the Active Health System Log to a supported USB flash drive.

When you use this feature, the connected USB flash drive is not accessible by the host operating system.

Connect a client (such as a laptop) with a supported USB to Ethernet adapter to access the following:

- iLO web interface
- Remote console
- iLO RESTful API
- CLI

Hitachi Vantara recommends the USB to Ethernet Adapter (part number Q7Y55A). Hitachi Vantara recommends the Micro USB to USB Adapter (part number 789904-B21).

When you use the iLO Service Port:

- Actions are logged in the iLO event log.
- The server UID flashes to indicate the Service Port status.
You can also retrieve the Service Port status by using a REST client and the iLO RESTful API.
- You cannot use the Service Port to boot any device within the server, or the server itself.
- You cannot access the server by connecting to the Service Port.
- You cannot access the connected device from the server.

For more information about the iLO Service Port, see the iLO user guide at the following website <https://knowledge.hitachivantara.com/Documents/Servers>

iLO RESTful API

iLO includes the iLO RESTful API, which is Redfish API conformant. The iLO RESTful API is a management interface that server management tools can use to perform configuration, inventory, and monitoring tasks by sending basic HTTPS operations (GET, PUT, POST, DELETE, and PATCH) to the iLO web server.

To learn more about the iLO RESTful API, contact customer support.

For specific information about automating tasks using the iLO RESTful API, contact customer support.

RESTful Interface Tool

The RESTful Interface Tool (iLOREST) is a scripting tool that allows you to automate Advanced Server product management tasks. It provides a set of simplified commands that take advantage of the iLO RESTful API. You can install the tool on your computer for remote use or install it locally on a server with a Windows or Linux Operating System. The RESTful Interface Tool offers an interactive mode, a scriptable mode, and a file-based mode similar to CONREP to help decrease automation times.

Intelligent Provisioning

Intelligent Provisioning is a single-server deployment tool embedded in Advanced Server. Intelligent Provisioning simplifies server setup, providing a reliable and consistent way to deploy servers.

Intelligent Provisioning prepares the system for installing original, licensed vendor media and versions of OS software. Intelligent Provisioning also prepares the system to integrate optimized server support software from the Service Pack for Hitachi Vantara (SPV). SPV is a comprehensive systems software and firmware solution for Advanced Server, their enclosures. These components are preloaded with a basic set of firmware and OS components that are installed along with Intelligent Provisioning.

After the server is running, you can update the firmware to install additional components. You can also update any components that have been outdated since the server was manufactured.

To access Intelligent Provisioning:

- Press F10 from the POST screen and enter Intelligent Provisioning.
- From the iLO web interface using **Lifecycle Management. Lifecycle Management** allows you to access Intelligent Provisioning without rebooting your server.

Management security

HA800 G2 Server is built with some of the industry's most advanced security capabilities, out of the box, with a foundation of secure embedded management applications and firmware. The management security provided by embedded management products enables secure support of modern workloads, protecting your components from unauthorized access and unapproved use. The range of embedded management and optional software and firmware available with the iLO Advanced license provides security features that help ensure protection, detection, and recovery from advanced cyber-attacks. For more information, see HA800 G2 Security Reference Guide at [Hitachi Vantara website](#).

Message Passing Interface

The Message Passing Interface is an MPI development environment designed to enable the development and optimization of high-performance computing (HPC) Linux applications. The Message Passing Interface leverages a scalable MPI library and takes advantage of the underlying server infrastructure by boosting performance of existing MPI applications on Hitachi Vantara.

HPC clusters without requiring recompilation. For more information, contact customer support.

UEFI System Utilities

The UEFI System Utilities is embedded in the system ROM. Its features enable you to perform a wide range of configuration activities, including:

- Configuring system devices and installed options.
- Enabling and disabling system features.
- Displaying system information.
- Selecting the primary boot controller or partition.
- Configuring memory options.
- Launching other preboot environments.

Advanced Server products with UEFI can provide:

- Support for boot partitions larger than 2.2 TB. Such configurations could previously only be used for boot drives when using RAID solutions.
- Secure Boot that enables the system firmware, option card firmware, operating systems, and software collaborate to enhance platform security.
- UEFI Graphical User Interface (GUI)
- An Embedded UEFI Shell that provides a preboot environment for running scripts and tools.
- Boot support for option cards that only support a UEFI option ROM.

Selecting the boot mode

This server provides two Boot Mode configurations: **UEFI Mode** and **Legacy BIOS Mode**. Certain boot options require that you select a specific boot mode. By default, the boot mode is set to **UEFI Mode**. The system must boot in **UEFI Mode** to use certain options, including:

Secure Boot, UEFI Optimized Boot, Generic USB Boot, IPv6 PXE Boot, iSCSI Boot, NVMe Boot and Boot from URL

Fibre Channel/FCoE Scan Policy

NOTE: The boot mode you use must match the operating system installation. If not, changing the boot mode can impact the ability of the server to boot to the installed operating system.

Prerequisite

When booting to **UEFI Mode**, leave **UEFI Optimized Boot** enabled.

Procedure

1. From the System Utilities screen, select System Configuration > BIOS/Platform Configuration (RBSU) > Boot Options > Boot Mode.
2. Select a setting.
 - **UEFI Mode (default)**—Configures the system to boot to a UEFI compatible operating system.
 - **Legacy BIOS Mode**—Configures the system to boot to a traditional operating system in Legacy BIOS compatibility mode.

3. Save your setting.
4. Reboot the server.

Secure Boot

Secure Boot is a server security feature that is implemented in the BIOS and does not require special hardware. Secure Boot ensures that each component launched during the boot process is digitally signed and that the signature is validated against a set of trusted certificates embedded in the UEFI BIOS. Secure Boot validates the software identity of the following components in the boot process:

- UEFI drivers loaded from PCIe cards
- UEFI drivers loaded from mass storage devices
- Preboot UEFI Shell applications
- OS UEFI boot loaders When Secure Boot is enabled:
- Firmware components and operating systems with boot loaders must have an appropriate digital signature to execute during the boot process.
- Operating systems must support Secure Boot and have an EFI boot loader signed with one of the authorized keys to boot. For more information about supported operating systems, see <https://support.hitachivantara.com/en/user/answers/interoperability.html>

You can customize the certificates embedded in the UEFI BIOS by adding or removing your own certificates, either from a management console directly attached to the server, or by remotely connecting to the server using the iLO Remote Console.

You can configure Secure Boot:

- Using the **System Utilities** options described in the following sections.
- Using the iLO RESTful API to clear and restore certificates. For more information, contact customer support.
- Using the `secboot` command in the Embedded UEFI Shell to display Secure Boot databases, keys, and security reports.

Launching the Embedded UEFI Shell

Use the **Embedded UEFI Shell** option to launch the Embedded UEFI Shell. The Embedded UEFI Shell is a preboot command-line environment for scripting and running UEFI applications, including UEFI boot loaders. The Shell also provides CLI-based commands you can use to obtain system information, and to configure and update the system BIOS.

Prerequisites

Embedded UEFI Shell is set to **Enabled**.

Procedure

1. From the System Utilities screen, select Embedded Applications > Embedded UEFI Shell. The Embedded UEFI Shell screen appears.
2. Press any key to acknowledge that you are physically present.

This step ensures that certain features, such as disabling **Secure Boot** or managing the Secure Boot certificates using third-party UEFI tools, are not restricted.

3. If an administrator password is set, enter it at the prompt and press **Enter**. The Shell> prompt appears.
4. Enter the commands required to complete your task.
5. Enter the exit command to exit the Shell.

Smart storage administrator

SSA is the main tool for configuring arrays on smart array SR controllers. It exists in three interface formats: the SSA GUI, the SSA CLI, and SSA Scripting. All formats provide support for configuration tasks. Some of the advanced tasks are available in only one format.

The diagnostic features in SSA are also available in the standalone software Smart storage administrator Diagnostics Utility CLI.

During the initial provisioning of the server, an array is required to be configured before the operating system can be installed. You can configure the array using SSA.

SSA is accessible both offline (either through Intelligent Provisioning or as a standalone bootable ISO image) and online:

- Accessing SSA in the offline environment

 **IMPORTANT:** If you are updating an existing server in an offline environment, obtain the latest version of SSA through Service Pack for Hitachi Vantara before performing configuration procedures.

Using one of multiple methods, you can run SSA before launching the host operating system. In offline mode, users can configure or maintain detected and supported devices, such as optional smart array controllers and integrated smart array controllers. Some SSA features are only available in the offline environment, such as setting the boot controller and boot volume.

- Accessing SSA in the online environment

This method requires an administrator to download the SSA executables and install them. You can run SSA online after launching the host operating system.

For more information, see SSA online help.

Smart storage administrator

SSA is the main tool for configuring arrays on these controllers. It exists in three interface formats: the SSA GUI, the SSA CLI, and SSA Scripting. All formats provide support for configuration tasks. Some of the advanced tasks are available in only one format.

The diagnostic features in SSA are also available in the standalone software Smart storage administrator Diagnostics Utility CLI.

SSA is accessible both offline and online:

- Accessing SSA in the offline environment: Using one of multiple methods, you can run SSA before launching the host operating system. In offline mode, users can configure or maintain detected and supported Hitachi Advanced Server devices, such as optional controllers and integrated controllers. Some SSA features are only available in the offline environment, such as setting the boot controller or performing split-mirror operations.
- Accessing SSA in the online environment: This method requires an administrator to download the SSA executables and install them. You can run SSA online after launching the host operating system.

USB support

Hitachi Vantara G2 server supports all USB operating speeds depending on the device that is connected to the server.

External USB functionality

Hitachi Vantara provides external USB support to enable local connection of USB devices for server administration, configuration, and diagnostic procedures.

For additional security, external USB functionality can be disabled through USB options in UEFI System Utilities.

Redundant ROM support

The server enables you to upgrade or configure the ROM safely with redundant ROM support. The server has a single ROM that acts as two separate ROM images. In the standard implementation, one side of the ROM contains the current ROM program version, while the other side of the ROM contains a backup version.

NOTE: The server ships with the same version programmed on each side of the ROM.

Safety and security benefits

When you flash the system ROM, the flashing mechanism writes over the backup ROM and saves the current ROM as a backup, enabling you to switch easily to the alternate ROM version if the new ROM becomes corrupted for any reason. This feature protects the existing ROM version, even if you experience a power failure while flashing the ROM.

Keeping the system current

Updating firmware or system ROM

To update firmware or system ROM, use one of the following methods:

- The Firmware Update option in the **System Utilities**.
- The `fwupdate` command in the **Embedded UEFI Shell**.
- Service Pack for Hitachi Vantara
- Online flash components.

Service Pack for Hitachi Vantara

SPV is a systems software and firmware solution delivered as a single ISO file download. This solution uses SUM as the deployment tool and is tested and supports Hitachi Advanced Server, and infrastructure.

SPV, along with SUM, provides Smart Update system maintenance tools that systematically update Hitachi Advanced Server, and infrastructure.

SPV can be used in an online mode on a server running Windows, Linux, or VMware vSphere ESXi, or in an offline mode where the server is booted to an operating system included in the ISO file.

Smart update manager

SUM is an innovative tool for maintaining and updating the firmware, drivers, and system software of Hitachi Advanced Server, infrastructure, and associated options.

SUM identifies associated nodes you can update at the same time to avoid interdependency issues. Key features of SUM include:

- Discovery engine that finds installed versions of hardware, firmware, and software on nodes.
- SUM deploys updates in the correct order and ensures that all dependencies are met before deploying an update.
- Interdependency checking.
- Automatic and step-by-step Localhost Guided Update process.
- Web browser-based user interface.
- Ability to create custom baselines and ISOs.
- Support for iLO Repository (iLO 5 nodes only).
- Simultaneous firmware and software deployment for multiple remote nodes.
- Local offline firmware deployments with SPV deliverables.
- Extensive logging in all modes.

NOTE: Support for Integrity servers has been discontinued from SUM 8.x.

Updating firmware from the System Utilities

Use the **Firmware Updates** option to update firmware components in the system, including the system BIOS, NICs, and storage cards.

Procedure

1. Access the System ROM Flash Binary component for your server. Locate and download the latest ROM version from <https://support.hitachivantara.com/en/user/answers/downloads.html#hardware-download> or contact customer support.
2. Copy the binary file to a USB media or iLO virtual media.
3. Attach the media to the server.
4. Launch the System Utilities and select Embedded Applications > Firmware Update.
5. Select a device.
The Firmware Updates screen lists details about your selected device, including the current firmware version in use.
6. Select **Firmware** File.

7. Select the flash file in the File Explorer list.
The firmware file is loaded and the **Firmware Updates** screen lists details of the file in the Selected firmware file field.
8. Select **Image Description**, and then select a firmware image. A device can have multiple firmware images.
9. Select **Start** firmware update.

Updating the firmware from the UEFI Embedded Shell

Procedure

1. Access the System ROM Flash Binary component for your server. Locate and download the latest ROM version from <https://support.hitachivantara.com/en/user/answers/downloads.html#hardware-download> or contact customer support.
2. Copy the binary file to a USB media or iLO virtual media. Attach the media to the server.
3. Boot to the UEFI Embedded Shell.
4. To obtain the assigned file system volume for the USB key, enter map –r.
5. Change to the file system that contains the System ROM Flash Binary component for your server. Enter one of the fsx file systems available, such as fs0: or fs1:, and press Enter.
6. Use the cd command to change from the current directory to the directory that contains the binary file.
7. Flash the system ROM by entering fwupdate –d BIOS -f filename.
8. Reboot the server. A reboot is required after the firmware update in order for the updates to take effect and for hardware stability to be maintained.

Online Flash components

This component provides updated system firmware that can be installed directly on supported operating systems. Additionally, when used in conjunction with SUM, this Smart Component allows the user to update firmware on remote servers from a central location. This remote deployment capability eliminates the need for the user to be physically present at the server to perform a firmware update.

Drivers

ⓘ **IMPORTANT:** Always perform a backup before installing or updating device drivers.

Update drivers using any of the Following:

- Download the latest Service Pack for Hitachi Vantara (includes smart update manager)
 - Download smart update manager for Linux
 - Download specific drivers
-

Software and firmware

Update software and firmware before using the server for the first time, unless any installed software or components require an older version.

For system software and firmware updates, use one of the following sources:

- Download the SPV from the [Hitachi Vantara Website](#).
- Download individual drivers, firmware, or other system software components from the [Hitachi Vantara Website](#).

Operating system version support

For information about specific versions of a supported operating system, see <https://support.hitachivantara.com/en/user/answers/interoperability.html>

Troubleshooting

NMI functionality

An NMI crash dump enables administrators to create crash dump files when a system is hung and not responding to traditional debugging methods.

An analysis of the crash dump log is an essential part of diagnosing reliability problems, such as hanging operating systems, device drivers, and applications. Many crashes freeze a system, and the only available action for administrators is to cycle the system power. Resetting the system erases any information that could support problem analysis, but the NMI feature preserves that information by performing a memory dump before a hard reset.

To force the OS to initiate the NMI handler and generate a crash dump log, the administrator can use the iLO Generate NMI feature.

Troubleshooting resources

Troubleshooting resources are available for G2 server products in the following documents:

- Troubleshooting Guide for Hitachi Advanced Server HA800 G2 servers provide procedures for resolving common problems and comprehensive courses of action for fault isolation and identification, issue resolution, and software maintenance.
- Error Message Guide for Hitachi Advanced Server HA800 G2 servers provide a list of error messages and information to assist with interpreting and resolving error messages.

To access troubleshooting resources for your product, see the [Hitachi Vantara Website](#).

Removing and replacing the system battery

The system battery provides power to the real-time clock. If the server no longer automatically displays the correct date and time, you might need to replace the system battery.

⚠ WARNING: The computer contains an internal lithium manganese dioxide, a vanadium pentoxide, or an alkaline battery pack. A risk of fire and burns exists if the battery pack is not properly handled. To reduce the risk of personal injury:

- Do not attempt to recharge the battery.
 - Do not expose the battery to temperatures higher than 60°C (140°F).
 - Do not expose the battery to extremely low air pressure as it might lead to explosion or leakage of flammable liquid or gas.
 - Do not disassemble, crush, puncture, short external contacts, or dispose of in fire or water. Replace only with the spare designated for this product.
-

Procedure

1. **Power down the server.**
2. Remove all power:
 - Disconnect each power cord from the power source.
 - Disconnect each power cord from the server.
3. Do one of the following:
 - a. **Extend the server from the rack.**
 - b. **Remove the server from the rack.**
4. **Remove the access panel.**
5. **System board components.**
6. Remove the battery.

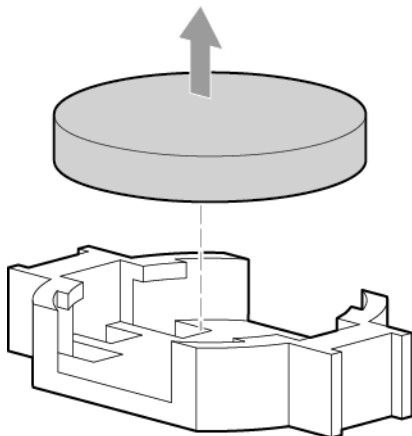

7. To replace the component, reverse the removal procedure.
8. Properly dispose of the old battery.

For more information about battery replacement or proper disposal, contact an authorized reseller or an authorized service provider.

Specifications

For more information on cable, power, environmental, compliance, and general specifications, contact customer support.

Environmental specifications

Specification	Value
Temperature range¹	—
Operating	10°C to 35°C (50°F to 95°F)
Nonoperating	-30°C to 60°C (-22°F to 140°F)
Relative humidity (noncondensing)	—
Operating	Minimum to be the higher (more moisture) of -12°C (10.4°F) dew point or 8% relative humidity Maximum to be 24°C (75.2°F) dew point or 90% relative humidity
Nonoperating	5% to 95% 38.7°C (101.7°F), maximum wet bulb temperature
1. All temperature ratings shown are for sea level. An altitude derating of 1.0°C per 304.8 m (1.8°F per 1000 ft) to 3048 m (10,000 ft) is applicable. No direct sunlight allowed. Maximum rate of change is 20°C per hour (36°F per hour). The upper limit and rate of change might be limited by the type and number of options installed.	

For certain approved hardware configurations, the supported system inlet temperature range is extended:

- 5°C to 10°C (41°F to 50°F) and 35°C to 40°C (95°F to 104°F) at sea level with an altitude derating of 1.0°C per every 175m (1.8°F per every 574 ft) above 900 m (2953 ft) to a maximum of 3048 m (10,000 ft).
- 40°C to 45°C (104°F to 113°F) at sea level with an altitude derating of 1.0°C per every 125 m (1.8°F per every 410 ft) above 900 m (2953 ft) to a maximum of 3048 m (10,000 ft).

For information about approved hardware configurations, contact customer support.

Server specifications

Specification	Value
Height	4.28 cm (1.68 in)
Depth, SFF	74.19 cm (29.21 in)

Specification	Value
Depth, LFF	74.19 cm (29.21 in)
Width	43.46 cm (17.11 in)
Weight, SFF minimum	13.29kg (29.29 lb)
Weight, SFF maximum	18.11 kg (39.92 lb)
Weight, LFF minimum	15.09 kg (33.27 lb)
Weight, LFF maximum	19.45 kg (42.88 lb)

Power supply specifications

Depending on the installed options and the regional location where the server was purchased, the server can be configured with one of the following power supplies:

- 500 W Flex Slot Platinum Hot-plug Low Halogen Power Supply
- 800 W Flex Slot Platinum Hot-plug Low Halogen Power Supply
- 800 W Flex Slot Titanium Hot-plug Low Halogen Power Supply
- 800 W Flex Slot Universal Hot-plug Low Halogen Power Supply
- 800 W Flex Slot -48 VDC Hot-plug Low Halogen Power Supply
- 1600 W Flex Slot Platinum Hot-plug Low Halogen Power Supply

500 W Flex Slot Platinum Hot-plug Low Halogen Power Supply

Specification	Value
Input requirements	—
Rated input voltage	100 VAC to 240 VAC 240 VDC for China only
Rated input frequency	50 Hz to 60 Hz Not applicable to 240 VDC
Rated input current	5.6 A at 100 VAC 2.7 A at 200 VAC 2.3 A at 240 VDC for China only
Maximum rated input power	557 W at 100 VAC 539 W at 200 VAC 537 W at 240 VDC for China only

Specification	Value
BTUs per hour	1902 at 100 VAC 1840 at 200 VAC 1832 at 240 VDC for China only
Power supply output	—
Rated steady-state power	500 W at 100 VAC to 127 VAC input 500 W at 100 VAC to 240 VAC input 500 W at 240 VDC input for China only
Maximum peak power	500 W at 100 VAC to 127 VAC input 500 W at 100 VAC to 240 VAC input 500 W at 240 VDC input for China only

800 W Flex Slot Platinum Hot-plug Low Halogen Power Supply

Specification	Value
Input requirements	—
Rated input voltage	100 VAC to 127 VAC 200 VAC to 240 VAC 240 VDC for China only
Rated input frequency	50 Hz to 60 Hz Not applicable to 240 VDC
Rated input current	9.1 A at 100 VAC 4.4 A at 200 VAC 3.6 A at 240 VDC for China only
Maximum rated input power	899 W at 100 VAC 867 W at 200 VAC 864 W at 240 VDC for China only
BTUs per hour	3067 at 100 VAC 2958 at 200 VAC 2949 at 240 VAC for China only
Power supply output	—
Rated steady-state power	800 W at 100 VAC to 127 VAC input 800 W at 100 VAC to 240 VAC input 800 W at 240 VDC input for China only

Specification	Value
Maximum peak power	800 W at 100 VAC to 127 VAC input 800 W at 100 VAC to 240 VAC input 800 W at 240 VDC input for China only

800 W Flex Slot Titanium Hot-plug Low Halogen Power Supply

Specification	Value
Input requirements	—
Rated input voltage	200 VAC to 240 VAC 240 VDC for China only
Rated input frequency	50 Hz to 60 Hz Not applicable to 240 VDC
Rated input current	4.3 A at 200 VAC 3.6 A at 240 VAC 3.6 A at 240 VDC for China only
Maximum rated input power	851 W at 200 VAC 848 W at 240 VAC 848 W at 240 VDC for China only
BTUs per hour	2905 at 200 VAC 2893 at 240 VAC 2893 at 240 VDC for China only
Power supply output	—
Rated steady-state power	800 W at 200 VAC to 240 VAC input 800 W at 240 VDC input for China only
Maximum peak power	800 W at 200 VAC to 240 VAC input 800 W at 240 VDC input for China only

800 W Flex Slot Universal Hot-plug Low Halogen Power Supply

Specification	Value
Input requirements	—
Rated input voltage	200 VAC to 277 VAC 380 VDC
Rated input frequency	50 Hz to 60 Hz
Rated input current	4.4 A at 200 VAC 3.8 A at 230 VAC 2.3 A at 380 VDC
Maximum rated input power	869 W at 200 VAC 865 W at 230 VAC 861 W at 277 VAC 863 W at 380 VDC
BTUs per hour	2964 at 200 VAC 2951 at 230 VAC 2936 at 277 VAC 2943 at 380 VDC
Power supply output	—
Rated steady-state power	800 W at 200 VAC to 277 VAC input
Maximum peak power	800 W at 200 VAC to 277 VAC input

800 W Flex Slot -48 VDC Hot-plug Low Halogen Power Supply

Specification	Value
Input requirements	—
Rated input voltage	-40 VDC to -72 VDC -48 VDC nominal input
Rated input current	22.1 A at -40 VDC input 18.2 A at -48 VDC input, nominal input 12.0 A at -72 VDC input

Specification	Value
Rated input power (W)	874 W at -40 VDC input 865 W at -48 VDC input, nominal input 854 W at -72 VDC input
Rated input power (BTUs per hour)	2983 at -40 VDC input 2951 at -48 VDC input, nominal input 2912 at -72 VDC input
Power supply output	—
Rated steady-state power (W)	800 W at -40 VDC to -72 VDC
Maximum peak power (W)	800 W at -40 VDC to -72 VDC
Maximum peak power	800 W at -40 VDC to -72 VDC input

⚠ WARNING: To reduce the risk of electric shock or energy hazards:

- This equipment must be installed by trained service personnel.
 - Connect the equipment to a reliably grounded secondary circuit source. A secondary circuit has no direct connection to a primary circuit and derives its power from a transformer, converter, or equivalent isolation device.
 - The branch circuit overcurrent protection must be rated 27 A.
-

⚠ CAUTION: This equipment is designed to permit the connection of the earthed conductor of the DC supply circuit to the earthing conductor at the equipment.

If this connection is made, all of the followings must be met:

- This equipment must be connected directly to the DC supply system earthing electrode conductor or to a bonding jumper from an earthing terminal bar or bus to which the DC supply system earthing electrode conductor is connected.
 - This equipment must be located in the same immediate area (such as adjacent cabinets) as any other equipment that has a connection between the earthed conductor of the same DC supply circuit and the earthing conductor, and also the point of earthing of the DC system. The DC system must be earthed elsewhere.
 - The DC supply source is to be located within the same premises as the equipment.
 - Switching or disconnecting devices must not be in the earthed circuit conductor between the DC source and the point of connection of the earthing electrode conductor.
-

1600 W Flex Slot Platinum Hot-plug Low Halogen Power Supply

Specifications	Value
Input requirements	—
Rated input voltage	200 VAC to 240 VAC 240 VDC for China only
Rated input frequency	50 Hz to 60 Hz
Rated input current	8.7 A at 200 VAC 7.5 A at 230 VAC
Maximum rated input power	1734 W at 200 VAC 1727 W at 230 VAC
Maximum rated input power	1734 W at 200 VAC 1727 W at 230 VAC
BTUs per hour	5918 at 200 VAC 5891 at 230 VAC
Power supply output	—
Rated steady-state power	1600 W at 200 VAC to 240 VAC input 1600 W at 240 VDC input
Maximum peak power	2200 W for 1 ms (turbo mode) at 200 VAC to 240 VAC input

Hitachi Vantara



Corporate Headquarters
2535 Augustine Drive
Santa Clara, CA 95054 USA
HitachiVantara.com | community.HitachiVantara.com

Contact Information
USA: 1-800-446-0744
Global: 1-858-547-4526
HitachiVantara.com/contact